

**TECHNICAL MANUAL
MAINTENANCE INSTRUCTIONS
UNIT MAINTENANCE
M1078 SERIES, 2 1/2-TON, 4 X 4,
LIGHT MEDIUM TACTICAL VEHICLES (LMTV)
VOLUME NO. 1 OF 5**

MODEL	NSN	EIC	
			HOW TO USE THIS MANUAL PAGE vii
TRK, CAR., LMTV, M1078 W/WN W/O WN	2320-01-360-1898 2320-01-354-3385	BHH BHD	GENERAL INFORMATION PAGE 1-1
TRK, VAN, LMTV, M1079 W/WN W/O WN	2320-01-360-1891 2320-01-354-3384	BHG BHE	EQUIPMENT DESCRIPTION AND DATA PAGE 1-6
TRK, CHAS, LMTV, M1080	2320-01-353-9098	BHC	SERVICE UPON RECEIPT PAGE 2-3
TRK, CAR., LMTV, AIR DROP, M1081 W/WN W/O WN	2320-01-360-1899 2320-01-355-3064	BHJ BHF	PREVENTIVE MAINTENANCE CHECKS AND SERVICES (PMCS) INTRODUCTION PAGE 2-6.1
			INTRODUCTION TO LOGIC TREE TROUBLESHOOTING PAGE 2-53
			ENGINE SYSTEM TROUBLESHOOTING PAGE 2-63
			FUEL SYSTEM TROUBLESHOOTING PAGE 2-101
			ELECTRICAL SYSTEM TROUBLESHOOTING PAGE 2-147

DISTRIBUTION STATEMENT A. Approved for public release; distribution is unlimited.

HEADQUARTERS, DEPARTMENTS OF THE ARMY AND THE AIR FORCE

JUNE 1998

WARNING SUMMARY

WARNING

EXHAUST GASES CAN KILL

1. **DO NOT** operate your vehicle engine in an enclosed area.
2. **DO NOT** idle vehicle engine with cab windows closed.
3. **DO NOT** drive vehicle with inspection plates or covers removed.
4. **BE ALERT** at all times for exhaust odors.
5. **BE ALERT** for exhaust poisoning symptoms, they are:
 - Headache
 - Dizziness
 - Sleepiness
 - Loss of Muscular Control
6. **IF YOU SEE** another person with exhaust poisoning symptoms:
 - Remove person from area.
 - Expose to open air.
 - Keep person warm.
 - Do not permit person to move.
 - Administer cardiopulmonary resuscitation, if necessary.*

* For cardiopulmonary resuscitation, refer to FM 21-11.

WARNING

Remove rings, bracelets, watches, necklaces, and any other jewelry before working around vehicle. Jewelry can catch on equipment and cause injury or short across electrical circuit and cause severe burns or electrical shock. Batteries can explode from a spark. Battery acid is harmful to skin and eyes. Always wear eye protection and rubber gloves when working with batteries.

WARNING

Battery acid (electrolyte) is extremely harmful. Always wear safety goggles and rubber gloves, and do not smoke when performing maintenance on batteries. Injury will result if acid contacts skin or eyes. Wear rubber apron to prevent clothing being damaged.

WARNING SUMMARY (CONT)

WARNING

Adhesives, solvents, and sealing compounds can burn easily, can give off harmful vapors, and are harmful to skin and clothing. To avoid injury or death, keep away from open fire and use in a well-ventilated area. If adhesive, solvent, or sealing compound gets on skin or clothing, wash immediately with soap and water. Failure to comply may result in injury to personnel.

WARNING

- Dry Cleaning Solvent (P-D-680) is TOXIC and flammable. Wear protective goggles and gloves; use only in well ventilated area; avoid contact with skin, eyes, and clothes, and do not breathe vapors. Keep away from heat or flame. Never smoke when using solvent; the flashpoint for Type I Dry Cleaning Solvent is 100 degrees F (38 degrees C) and for Type II is 130 degrees F (50 degrees C). Failure to comply may result in serious injury or death to personnel.
- If personnel become dizzy while using Dry Cleaning Solvent, immediately get fresh air and medical help. If Dry Cleaning Solvent contacts skin or clothes, flush with cold water. If Dry Cleaning Solvent contacts eyes, immediately flush eyes with water and get immediate medical attention. Failure to comply may result in injury to personnel.

WARNING

Diesel fuel is flammable. If fuel is spilled, clean it up immediately. Failure to comply may result in serious injury or death to personnel.

WARNING

After Nuclear, Biological, or Chemical (NBC) exposure of vehicle, all air filters shall be handled with extreme caution. Unprotected personnel may experience serious injury or death if residual toxic agents or radioactive material are present. If vehicle is exposed to chemical or biological agents, servicing personnel shall wear protective mask, hood, protective overgarments, and chemical protective gloves and boots in accordance with FM-3-4. All contaminated air filters shall be placed in double-lined plastic bags and moved swiftly to a segregation area away from the worksite. The same procedure applies for radioactive dust contamination. The Company NBC team should measure radiation prior to filter removal to determine extent of safety procedures required per the NBC Annex to the unit Standard Operating Procedures (SOP). The segregation area in which the contaminated air filters are temporarily stored shall be marked with appropriate NBC placards. Final disposal of contaminated air filters shall be in accordance with local SOP. Decontamination operation shall be in accordance with FM-3-5 and local SOP. Failure to comply may result in serious injury or death to personnel.

WARNING

Diesel fuel is flammable. Do not fill fuel tank with engine running, while smoking, or when near an open flame. Never overfill the tank or spill fuel. If fuel is spilled, clean it up immediately. Failure to comply may result in serious injury or death to personnel.

WARNING

Adhesive sealant MIL-S-46163 can damage your eyes. Wear safety goggles/glasses when using; avoid contact with eyes. If sealant contacts eyes, flush eyes with water and get immediate medical attention. Failure to comply may result in injury to personnel.

WARNING

Use care when removing/installing springs. Springs are under tension and can act as projectiles when being removed. Failure to comply can cause injury to personnel.

WARNING

Retaining rings are under tension and can act as projectiles when released causing severe eye injury. Use care when removing retaining rings. Failure to comply may result in injury to personnel.

WARNING

Ensure exhaust system is cool before performing maintenance. Failure to comply may result in injury to personnel.

WARNING

Wear appropriate eye protection when working under vehicle due to the possibility of falling debris. Failure to comply may result in injury to personnel.

WARNING

Do not operate LMTV vehicle with muffler removed. Toxic exhaust fumes may enter cab, resulting in serious injury or death to personnel.

WARNING

Do not work on fuel system when engine is hot; fuel can be ignited by a hot engine.

WARNING SUMMARY (CONT)

WARNING

Post signs that read "NO SMOKING WITHIN 50 FEET" when working with open fuel, fuel lines or fuel tanks. Failure to comply may result in injury to personnel or damage to equipment.

WARNING

Exhaust pipe, transmission oil lines, and transmission scavenge pump hose may be hot to the touch. Extreme care should be taken when checking exhaust pipe, transmission oil lines, and transmission scavenge pump hose for leaks. Failure to comply may result in injury to personnel.

WARNING

Compressed air used for cleaning purposes will not exceed 30 psi (207 Kpa). Use only with effective chip guarding and personal protective equipment (goggles/shield, gloves, etc). Failure to comply may result in injury to personnel.

WARNING

Wheel drum weighs approximately 90 lb (41 Kg). Use the aid of an assistant to help remove wheel drum. Failure to comply may result in injury to personnel.

WARNING

Wheel drum weighs approximately 90 lb (41 kg). Use the aid of an assistant to help install wheel drum. Failure to comply may result in injury to personnel.

WARNING

Brake shoes may be covered with dust. Breathing this dust may be harmful to your health. Do not use compressed air to clean brake shoes. Wear a filter mask approved for use against brake dust. Failure to comply may result in injury to personnel.

WARNING

Cage spring brake before air chamber is removed or severe injury to personnel will occur.

WARNING

Ensure air chamber is caged prior to installation. Failure to comply may result in injury to personnel.

WARNING

Ensure that tire is totally deflated before removing self-locking nuts. Failure to comply may result in serious injury or death to personnel.

WARNING

Spring brakes must be caged before attempting replacement of a rear axle wheel stud. Failure to comply may result in severe injury to personnel.

WARNING

Wear protective goggles to protect against possible injury from release of high pressure air. Failure to comply may result in injury to personnel.

WARNING

Prolonged contact with lubricating oil (MIL-L-2104) may cause a skin rash. Skin and clothing that come in contact with lubricating oil should be thoroughly washed immediately. Saturated clothing should be removed immediately. Areas in which lubricating oil is used should be well ventilated to keep fumes to a minimum. Failure to comply may result in injury to personnel.

WARNING

Hydraulic fluid (MIL-H-5606) is TOXIC. Wear protective goggles and gloves; use only in well ventilated area; avoid contact with skin, eyes, and clothes. Skin and clothing that come in contact with hydraulic oil should be washed immediately. Saturated clothing should be removed immediately. Failure to comply may result in injury to personnel.

WARNING

Wire rope can become frayed or contain broken wires. Wear heavy leather-palmed gloves when handling wire rope. Frayed or broken wires can injure hands. Failure to comply may result in injury to personnel.

WARNING

Never let moving wire rope slide through hands, even when wearing gloves. A broken wire could cut through gloves and cut hands.

WARNING SUMMARY (CONT)

WARNING

Wear appropriate eye protection when removing rivets. Failure to comply may result in injury to personnel.

WARNING

Wear appropriate eye protection when drilling holes. Failure to comply may result in injury to personnel.

WARNING

Wear leather gloves at all times when handling winch cable. Do not allow cable to slide through hands even with gloves on. Broken wires may cause injury to personnel.

WARNING

Use extreme caution when working around moving cable. Failure to do so may result in serious injury to personnel.

WARNING

Caution must be exercised while cab is raised. Ensure that locking mechanism is functioning properly before proceeding. Failure to comply may result in death or serious injury to personnel and damage to equipment.

WARNING

Coolant may be very hot and under pressure from engine operation. Ensure engine is cool before performing maintenance. Failure to comply may result in injury to personnel.

WARNING

Do not remove oil filter while engine is hot. Failure to comply may result in injury to personnel.

WARNING

Sling spreader weighs approximately 200 lbs (91 kgs). Attach a suitable lifting device prior to removal. Failure to comply may result in injury to personnel or damage to equipment.

WARNING

Remove all loose equipment from van body. Failure to comply may result in injury to personnel or damage to equipment.

WARNING

Van body weighs approximately 3,360 lbs (1525 kgs) empty. Attach a suitable lifting device prior to removal. Failure to comply may result in serious injury or death to personnel.

WARNING

Guide ropes must be attached at opposite corners of van body to aid in controlling van body during removal. Failure to comply may result in serious injury or death to personnel.

WARNING

Center of gravity will change depending on equipment installed in van body. Attach and adjust lifting device so that van body lifts level. Failure to comply may result in serious injury or death to personnel or damage to equipment.

WARNING

Pod frame weighs approximately 80 lbs (36 kgs). Attach a suitable lifting device prior to removal. Failure to comply may result in injury to personnel or damage to equipment.

WARNING

Do not install pod frame on van body for 72 hours after installing blind rivet nuts and spacers. Failure to comply may result in injury to personnel and/or damage to equipment.

WARNING

Goggles and gloves must be worn when working with glass. Failure to comply may result in injury to personnel.

WARNING SUMMARY (CONT)

WARNING

RH door assembly weighs approximately 85 lbs (39 kgs). Attach a suitable lifting device prior to removal. Failure to comply may result in injury to personnel or damage to equipment.

WARNING

LH door assembly weighs approximately 85 lbs (39 kgs). Attach a suitable lifting device prior to removal. Failure to comply may result in injury to personnel or damage to equipment.

WARNING

Wear appropriate eye protection when handling fluorescent lamps. Failure to comply may result in injury to personnel.

WARNING

Heavy objects/loads, such as tool boxes and heavy parts, must always be carried on the floor with the weight distributed as equally as possible between left and right sides of M1079 van. Failure to comply decreases the stability of the M1079 van and will increase the likelihood of a rollover.

Heavy cabinets must always be mounted as low as possible with the weight distributed as equally as possible between left and right sides of M1079 van. Remember to consider the weight of the items that will be stored in the cabinets. Failure to comply decreases the stability of the M1079 van and will increase the likelihood of a rollover.

Always keep in mind, when placing items inside the M1079 van, that heavier items must always be positioned as low as possible and the weight distributed as equally as possible between left and right sides of M1079 van. Failure to comply decreases the stability of the M1079 van and will increase the likelihood of a rollover.

WARNING

Extreme care must be taken when lowering gravel deflector. Coolant hoses could be pulled loose. Failure to comply could result in serious eye injury.

WARNING

- Do not open coolant fill cap if temperature reads above 110°F (43°C). Steam or hot coolant is under pressure. Failure to comply may result in injury to personnel.
- Pressure in reservoir tank must be released before removing cap. Failure to comply may result in injury to personnel.

WARNING

Heater weighs approximately 120 lbs (54 kgs). Use the aid of an assistant when lifting. Failure to comply may result in injury to personnel.

WARNING

200 amp alternator weighs approximately 70 lbs (32 kgs). The aid of an assistant is required to install 200 amp alternator. Failure to comply may result in injury to personnel.

WARNING

Light Material Handling Crane (LMHC) mast weighs approximately 110 lbs (50 kgs). Attach a suitable lifting device prior to installation. Failure to comply may result in injury to personnel or damage to equipment.

WARNING

Light Material Handling Crane (LMHC) boom assembly weighs approximately 150 lbs (68 kgs). Use an assistant when removing LMHC boom assembly. Failure to comply may result in injury to personnel.

WARNING SUMMARY (CONT)

WARNING

Light Material Handling Crane (LMHC) boom weighs approximately 60 lbs (27 kgs). Attach a suitable lifting device prior to removal. Failure to comply may result in injury to personnel or damage to equipment.

WARNING

Light Material Handling Crane (LMHC) weighs approximately 250 lbs (114 kgs). Attach a suitable lifting device prior to removal. Failure to comply may result in injury to personnel.

WARNING

Use care when removing/installing springs. Springs are under tension and can act as projectiles when released. Failure to comply may result in injury to personnel.

WARNING

Air conditioner weighs approximately 300 lbs (136 kg). Attach a suitable lifting device prior to installation. Failure to comply may result in injury to personnel.

WARNING

Ensure cargo bed is free of equipment and debris, and is not warped or damaged in any way. Failure to comply may result in serious injury or death to personnel or damage to equipment.

WARNING

S-280 shelter weighs approximately 1500 lbs (680 kgs) empty. Attach a suitable lifting device prior to installation. Failure to comply may result in serious injury or death to personnel or damage to equipment.

**CHANGE
NO. 3**

**HEADQUARTERS
DEPARTMENTS OF THE ARMY
AND THE AIR FORCE**
Washington, D.C., 10 February 2006

**TECHNICAL MANUAL
MAINTENANCE INSTRUCTIONS
UNIT MAINTENANCE
M1078 SERIES, 2 1/2-TON, 4x4,
LIGHT MEDIUM TACTICAL VEHICLE
(LMTV)**

VOLUME NO. 1 OF 5

TM 9-2320-365-20-1, 17 June 1998, is changed as follows:

1. Remove old pages and insert new pages as indicated below.
2. New or changed material is indicated by a vertical bar in the out margin of the page.
3. Added or revised illustrations are indicated by a vertical bar adjacent to the illustration.

Remove Pages

None

A thru M/(N Blank)

i thru ii

B-1 thru B-19/(B-20 Blank)

Insert Pages

Change 3 Transmittal/ Change 3 Authentication

A thru M/(N Blank)

i thru ii

B-1 thru B-20

Place this change sheet in the front of the publication for reference purposes.

By Order of the Secretary of the Army:

PETER J. SCHOOMAKER
General, United States Army
Chief of Staff

Official:



SANDRA R. RILEY
Administrative Assistant to the
Secretary of the Army
06019087

By Order of the Secretary of the Air Force:

JOHN P. JUMPER
General, United States Air Force
Chief of Staff

Official:

GREGORY S. MARTIN
General, United States Air Force
Commander, Air Force Materiel Command

Distribution:

To be distributed in accordance with the initial distribution number (IDN) 380934, requirements for Family of Medium Tactical Vehicles (FMTV) TM 9-2320-365-20-1.

**CHANGE
NO. 2**

**HEADQUARTERS
DEPARTMENTS OF THE ARMY
AND THE AIR FORCE**
Washington, D.C., 20 August 2005

**TECHNICAL MANUAL
MAINTENANCE INSTRUCTIONS
UNIT MAINTENANCE
M1078 SERIES, 2 1/2-TON, 4x4,
LIGHT MEDIUM TACTICAL VEHICLE
(LMTV)**

VOLUME NO. 1 OF 5

TM 9-2320-365-20-1, 17 June 1998, is changed as follows:

1. Remove old pages and insert new pages as indicated below.
2. New or changed material is indicated by a vertical bar in the out margin of the page.
3. Added or revised illustrations are indicated by a vertical bar adjacent to the illustration.

Remove Pages	Insert Pages	Remove Pages	Insert Pages
e thru h	e thru h	(H-22 Blank)	(H-22 Blank)
A thru J	A thru J	K-1 thru K-4	K-1 thru K-4
none	K thru M/(N Blank)	INDEX-5 thru INDEX-16	INDEX-5 thru INDEX-16
none	Change 2 Authentication Sheet	INDEX-19 thru INDEX-36	INDEX-19 thru INDEX-36
2-9 thru 2-12	2-9 thru 2-12	FO-1 FP-3/(FP-4 Blank)	FO-1 FP-3/(FP-4 Blank)
2-21 and 2-22	2-21 and 2-22	FO-1 FP-61/(FP-62 Blank)	FO-1 FP-61/(FP-62 Blank)
2-33 and 2-34	2-33 and 2-34	Metric Conversion Chart	Metric Conversion Chart
2-37 and 2-38	2-37 and 2-38	/PIN	/PIN
2-41 thru 2-48	2-41 thru 2-48		
2-51 and 2-52	2-51 and 2-52		
2-55 thru 2-62	2-55 thru 2-62		
2-129 thru 2-142	2-129 thru 2-142		
2-147 and 2-148	2-147 and 2-148		
2-325 thru 2-328	2-325 thru 2-328		
none	2-328.1 and 2-328.2		
2-329 thru 2-332	2-329 thru 2-332		
2-370.3 and 2-370.4	2-370.3 and 2-370.4		
2-370.5 thru 2-370.10	2-370.5 and 2-370.10		
none	2-408.1 thru 2-408.16		
2-409 and 2-410	2-409 and 2-410		
2-905 thru 2-918.6	2-905 thru 2-918.6		
none	2-918.7 thru 2-918.20		
2-919 and 2-920	2-919 and 2-920		
2-945 thru 2-1010	2-945 thru 2-1010		
B-5 and B-6	B-5 and B-6		
B-17 thru B-19/ (B-20 Blank)	B-17 thru B-19/ (B-20 Blank)		
C-1 thru C-4	C-1 thru C-4		
D-1 and D-2	D-1 and D-2		
D-5 and D-6	D-5 and D-6		
G-1 thru G-10	G-1 thru G-10		
G-11/(G-12 Blank)	G-11/(G-12 Blank)		
H-1 thru H-12	H-1 thru H-12		
H-15 thru H-21/	H-15 thru H-21/		

Place this change sheet in the front of the publication for reference purposes.

By Order of the Secretary of the Army:

Official:



SANDRA R. RILEY

*Administrative Assistant to the
Secretary of the Army*

0401503

PETER J. SCHOOMAKER
*General, United States Army
Chief of Staff*

DISTRIBUTION: To be distributed in accordance with the initial distribution number (IDN) 380934, requirements for TM 9-2320-365-20-1.

CHANGE
NO. 1

HEADQUARTERS
DEPARTMENTS OF THE ARMY
AND THE AIR FORCE

Washington, D.C., 1 July 2003

TECHNICAL MANUAL
MAINTENANCE INSTRUCTIONS
UNIT MAINTENANCE
M1078 SERIES, 2 1/2-TON, 4x4,
LIGHT MEDIUM TACTICAL VEHICLE
(LMTV)

VOLUME NO. 1 OF 5

TM 9-2320-365-20-1, 17 June 1998, is changed as follows:

1. Remove old pages and insert new pages as indicated below.
2. New or changed material is indicated by a vertical bar in the out margin of the page.
3. Added or revised illustrations are indicated by a vertical bar adjacent to the illustration.

Remove Pages	Insert Pages	Remove Pages	Insert Pages
i and j	i and j	2-317 thru 2-320	2-317 thru 2-320
none	A thru J	none	2-320.1 thru 2-320.8
i thru xi/(xii Blank)	i thru xii	2-321 thru 2-324	2-321 thru 2-324
2-1 thru 2-6	2-1 thru 2-6	none	2-324.1 thru 2-324.8
none	2-6.1 and 2-6.2	2-325 and 2-326	2-325 and 2-326
2-7 and 2-8	2-7 and 2-8	2-331 thru 2-344	2-331 thru 2-344
2-15 thru 2-22	2-15 thru 2-22	none	2-344.1 thru 2-344.6
2-53 thru 2-70	2-53 thru 2-69/(2-70 Blank)	2-345 and 2-346	2-345 and 2-346
2-71 thru 2-74	(2-71 Blank)/2-72 thru 2-74	none	2-346.1 thru 2-346.6
2-99/(2-100 Blank)	2-99 and 2-100	2-347 thru 2-356	2-347 thru 2-356
none	2-100.1 thru 2-100.7/(2-100.8 Blank)	none	2-356.1 thru 2-356.8
2-101 thru 2-106	2-101 thru 2-106	2-357 thru 2-370	2-357 thru 2-370
none	2-106.1 thru 2-106.8	none	2-370.1 thru 2-370.12
2-107 and 2-108	2-107 and 2-108	2-371 thru 2-376	2-371 thru 2-376
2-119 and 2-120	2-119 and 2-120	none	2-376.1 thru 2-376.14
2-129 thru 2-144	2-129 thru 2-144	2-377 thru 2-380	2-377 thru 2-380
none	2-144.1 thru 2-144.4	none	2-380.1 thru 2-380.26
2-145/(2-146 Blank)	2-145/(2-146 Blank)	2-381 thru 2-384	2-381 thru 2-384
2-147 thru 2-152	2-147 thru 2-152	none	2-384.1 thru 2-384.6
none	2-152.1 thru 2-152.6	2-385 and 2-386	2-385 and 2-386
2-153 thru 2-256	2-153 thru 2-256	2-389 thru 2-392	2-389 thru 2-392
none	2-256.1 thru 2-256.34	none	2-392.1 thru 2-392.4
2-257 thru 2-274	2-257 thru 2-274	2-393 and 2-394	2-393 and 2-394
none	2-274.1 thru 2-274.24	2-443 thru 2-460	2-443 thru 2-460
2-275 and 2-276	2-275/(2-276 Blank)	2-491 thru 2-496	2-491 thru 2-496
2-277 thru 2-298	none	none	2-496.1 and 2-496.2
2-299 and 2-300	(2-299 Blank)/2-300	2-497 thru 2-502	2-497 thru 2-502
2-301 thru 2-306	2-301 thru 2-306	none	2-502.1 and 2-502.2
none	2-306.1 thru 2-306.4	2-503 and 2-504	2-503 and 2-504
2-307 thru 2-312	2-307 thru 2-312	2-511 thru 2-518	2-511 thru 2-518
none	2-312.1 and 2-312.2	none	2-518.1 and 2-518.2
2-313 thru 2-316	2-313 thru 2-316	2-519 and 2-520	2-519 and 2-520
none	2-316.1 thru 2-316.4	2-541 and 2-542	2-541 and 2-542

Place this change sheet in the front of the publication for reference purposes.

Remove Pages

none
 2-543 thru 2-546
 none
 2-547 aand 2-548
 none
 2-549 thru 2-556
 none
 2-557 thru 2-560
 none
 2-561 thru 2-574
 none
 2-575 thru 2-578
 none
 2-579 thru 2-584
 none
 2-585 thru 2-594
 none
 2-595 and 2-596
 2-615 thru 2-622
 2-623 thru 2-626
 2-637 thru 2-674
 2-675 thru 2-686

 2-687 thru 2-690
 2-709 thru 2-714
 none
 2-715 and 2-716
 none
 2-717 and 2-718
 none
 2-719 thru 2-722
 none
 2-723 thru 2-726
 none
 2-727 thru 2-740
 2-749 thru 2-800
 2-803 thru 2-822
 2-905 thru 2-918
 none
 2-919 and 2-920
 2-1009 thru 2-1016
 none
 2-1017 and 2-1018
 A-1 thru A-4
 B-13 thru B-20
 C-3 and C-4
 D-1 thru D-5/(D-6 Blank)
 E3 and E4
 none
 G-1 thru G-10
 none
 H-1 thru H-8
 H-17 thru H-21/
 (H-22 Blank)
 none

Insert Pages

2-542.1 and 2-542.2
 2-543 and 2-546
 2-546.1 and 2-546.2
 2-547 and 2-548
 2-548.1 thru 2-548.6
 2-549 thru 2-556
 2-556.1 thru 2-556.4
 2-557 thru 2-560
 2-560.1 thru 2-560.6
 2-561 thru 2-574
 2-574.1 thru 2-574.2
 2-575 thru 2-578
 2-578.1 thru 2-578.14
 2-579 thru 2-584
 2-584.1 thru 2-584.64
 2-585 thru 2-594
 2-594.1 thru 2-594.20
 2-595 and 2-596
 2-615 thru 2-621/(2-622 Blank)
 (2-623 Blank)/2-624 thru 2-626
 2-637 thru 2-673/(2-674 Blank)
 (2-675 Blank)/2-676 thru
 2-685/(2-686 Blank)
 (2-687 Blank)/2-688 thru 2-690
 2-709 thru 2-714
 2-714.1 and 2-714.2
 2-715 and 2-716
 2-716.1 and 2-716.2
 2-717 and 2-718
 2-718.1 and 2-718.2
 2-719 thru 2-722
 2-722.1 and 2-722.2
 2-723 thru 2-726
 2-726.1 and 2-726.2
 2-727 thru 2-740
 2-749 thru 2-800
 2-803 thru 2-822
 2-905 thru 2-918
 2-918.1 thru 2-918.6
 2-919 and 2-920
 2-1009 thru 2-1016
 2-1016.1 thru 2-1016.10
 2-1017 and 2-1018
 A-1 thru A-4
 B-13 thru B-19/(B-20 Blank)
 C-3 and C-4
 D-1 thru D-6
 E3 and E4
 E-21 and E-22
 G-1 thru G-10
 G-11/(G-12 Blank)
 H-1 thru H-8
 H-17 thru H-21/
 (H-22 Blank)
 K-1 thru K-4

Remove Pages

INDEX-1 thru INDEX-38
 Index-39/(Index-40 Blank)
 DA Form 2028-2 Sample
 DA Form 2028-2
 DA Form 2028-2
 DA Form 2028-2
 FO-1 FP-1/(FP-2 Blank)
 thru FP-19/(FP-20 Blank)
 FO-1 FP-23/(FP-24 Blank)
 FO-1 FP-27/(FP-28 Blank)
 thru FP-61/(FP-62 Blank)
 FO-1 FP-65/(FP-66 Blank)
 and FP-67/(FP-68 Blank)
 Metric Conversion Chart
 Cover

Insert Pages

INDEX-1 thru INDEX-38
 none
 DA Form 2028 Sample
 DA Form 2028
 DA Form 2028
 DA Form 2028
 FO-1 FP-1/(FP-2 Blank)
 thru FP-19/(FP-20 Blank)
 FO-1 FP-23/(FP-24 Blank)
 FO-1 FP-27/(FP-28 Blank)
 thru FP-61/(FP-62 Blank)
 FO-1 FP-65/(FP-66 Blank)
 and FP-67/(FP-68 Blank)
 Metric Conversion Chart
 Cover

Place this change sheet in the front of the publication for reference purposes.

By Order of the Secretary of the Army:

JOHN M. KEANE
General, United States Army
Chief of Staff

Official:



JOEL B. HUDSON
Administrative Assistant to the
Secretary of the Army
0110102

DISTRIBUTION: To be distributed in accordance with the initial distribution number (IDN) 380934, requirements for TM 9-2320-365-20-1.

LIST OF EFFECTIVE PAGES

Insert latest changed pages. Destroy superseded pages.

NOTE: New or changed material is indicated by a vertical bar in the outer margin of the page.

Dates of issue for original and changed pages are:

Original 0 17 June 1998
 Change 1 1 July 2003
 Change 2 20 August 2005
 Change 3 10 February 2006

THE TOTAL NUMBER OF PAGES IN THIS PUBLICATION IS 5992, CONSISTING OF THE FOLLOWING:

Page No.	*Change No.	Page No.	*Change No.	Page No.	*Change No.
VOLUME 1					
		2-49 and 2-50.....	0	2-153 thru 2-256	1
Cover	1	2-51	2	2-256.1 thru 2-256.34 Added.....	1
Blank.....	0	2-52.....	0	2-257 thru 2-274	1
a thru e	0	2-53.....	1	2-274.1 thru 2-274.24 Added.....	1
f.....	2	2-54.....	0	2-275.....	1
g.....	0	2-55.....	1	2-276 Blank.....	1
h.....	2	2-56.....	2	2-277 thru 2-298 Deleted.....	1
i	1	2-57.....	1	2-299 Blank.....	1
j.....	0	2-58 and 2-59.....	2	2-300 thru 2-306	1
A thru M.....	3	2-60.....	1	2-306.1 thru 2-306.4 Added.....	1
N Blank Added	2	2-61 and 2-62.....	2	2-307 thru 2-312	1
i and ii	1	2-63 thru 2-69	1	2-312.1 and 2-312.2 Added.....	1
iii	0	2-70 Blank.....	1	2-313 thru 2-316	1
iv thru xii	1	2-71 Blank.....	1	2-316.1 thru 2-316.4 Added.....	1
1-1 thru 1-27.....	0	2-72 and 2-73.....	1	2-317 thru 2-320	1
1-28 Blank	0	2-74 thru 2-98	0	2-320.1 thru 2-320.8 Added.....	1
2-1 thru 2-6.....	1	2-99 and 2-100.....	1	2-321 thru 2-324	1
2-6.1 and 2-6.2 Added.....	1	2-100.1 thru 2-100.7 Added.....	1	2-324.1 thru 2-324.8 Added.....	1
2-7 and 2-8.....	1	2-100.8 Blank Added	1	2-325.....	1
2-9 thru 2-11	2	2-101 thru 2-106	1	2-326 thru 2-328	2
2-12 thru 2-15.....	0	2-106.1 thru 2-106.8 Added.....	1	2-328.1 and 2-328.2 Added.....	2
2-16 and 2-17	1	2-107	1	2-329 thru 2-331	2
2-18	0	2-108 thru 2-117	0	2-332 thru 2-344	1
2-19	1	2-118 Blank.....	0	2-344.1 thru 2-344.6 Added.....	1
2-20	0	2-119	1	2-345 and 2-346	1
2-21 and 2-22	2	2-120 thru 2-127	0	2-346.1 thru 2-346.6 Added.....	1
2-23 thru 2-32.....	0	2-128 Blank.....	0	2-347 thru 2-356	1
2-33	2	2-129	1	2-356.1 thru 2-356.8 Added.....	1
2-34 thru 2-36.....	0	2-130.....	2	2-357 thru 2-370	1
2-37	2	2-131	1	2-3701.1 thru 2-370.3	1
2-38 thru 2-40	0	2-132 thru 2-136	2	2-370.4 and 2-370.5	2
2-41	2	2-137	1	2-370.6 thru 2-370.9 Deleted.....	2
2-42	0	2-138 thru 2-140	2	2-370.10.....	1
2-43	2	2-141 thru 2-144	1	2-370.12 Added	1
2-44	0	2-144.1 thru 2-144.4 Added.....	1	2-371 thru 2-376	1
2-45	2	2-145.....	1	2-376.1 thru 2-376.14 Added.....	1
2-46	0	2-146 Blank.....	0	2-377 thru 2-380	1
2-47 and 2-48	2	2-147	2	2-380.1 thru 2-380.26 Added.....	1
		2-148 thru 2-152	1		
		2-152.1 thru 2-152.6 Added.....	1		

* Zero in this column indicates an original page.

LIST OF EFFECTIVE PAGES

Insert latest changed pages. Destroy superseded pages.

Page No.	*Change No.	Page No.	*Change No.	Page No.	*Change No.
2-381 thru 2-384.....	1	2-675 Blank.....	1	G-1.....	2
2-384.1 thru 384.6 Added	1	2-676 thru 2-685	1	G-2.....	1
2-385	1	2-686 Blank.....	1	G-3 thru G-7.....	2
2-386 thru 2-389.....	0	2-687 Blank.....	1	G-8.....	1
2-390 thru 2-392.....	1	2-688 and 2-689.....	1	G-9 thru G-11.....	2
2-392.1 thru 2-392.4 Added	1	2-690 thru 2-709	0	G-12 Blank Added	1
2-393	1	2-710 thru 2-714	1	H-1 thru H-6.....	2
2-394 thru 2-408.....	0	2-714.1 and 2-714.2 Added	1	H-7	0
2-408.1 thru 2-408.16 Added	2	2-715 and 2-716.....	1	H-8 thru H-10.....	2
2-409	2	2-716.1 and 2-716.2 Added	1	H-11	0
2-410 thru 2-443.....	0	2-717 and 2-718.....	1	H-12	2
2-444 thru 2-459.....	1	2-718.1 and 2-718.2 Added	1	H-13 thru H-15.....	0
2-460 thru 2-491.....	0	2-719 thru 2-722	1	H-16 thru H-18.....	2
2-492 thru 2-496.....	1	2-722.1 and 2-722.2 Added	1	H-19.....	1
2-496.1 and 2-496.2 Added	1	2-723 thru 2-726	1	H-20 and H-21	2
2-497 thru 2-502.....	1	2-726.1 and 2-726.2 Added	1	H-22 Blank.....	0
2-502.1 and 2-502.2 Added	1	2-727 thru 2-739	1	J-1	0
2-503	1	2-740 thru 2-749	0	J-2 Blank.....	0
2-504 thru 2-511.....	0	2-750 thru 2-799	1	K-1 Added.....	1
2-512 thru 2-518.....	1	2-800 thru 2-803	0	K-2 and K-3.....	2
2-518.1 and 2-518.2 Added	1	2-804 thru 2-821	1	K-4 Added.....	1
2-519	1	2-822 thru 2-905	0	INDEX-1 thru INDEX-4.....	1
2-520 thru 2-541.....	0	2-906 thru 2-918	2	INDEX-5.....	2
2-542	1	2-918.1 thru 2-918.6	2	INDEX-6.....	1
2-542.1 and 2-542.2 Added	1	2-918.7 thru 2-918.20 Added.....	2	INDEX-7 thru INDEX-11.....	2
2-543 thru 2-546.....	1	2-919.....	2	INDEX-12 and INDEX-13.....	1
2-546.1 and 2-546.2 Added	1	2-920 thru 2-945	0	INDEX-14 thru INDEX-16.....	2
2-547 and 2-548.....	1	2-946 thru 2-1009	2	INDEX-17 and INDEX-18.....	1
2-548.1 thru 2-548.6 Added	1	2-1010 thru 2-1016	1	INDEX-19.....	2
2-549 thru 2-556.....	1	2-1016.1 thru 2-1016.10 Added.....	1	INDEX-20.....	1
2-556.1 thru 2-556.4 Added	1	2-1017	1	INDEX-21 thru INDEX-25.....	2
2-557 thru 2-560.....	1	2-1018 thru 2-1085	0	INDEX-26.....	1
2-560.1 thru 2-560.6 Added	1	2-1086 Blank.....	0	INDEX-27 thru INDEX-35.....	2
2-561 thru 2-574.....	1	A-1.....	0	INDEX-36 thru INDEX-38.....	1
2-574.1 and 2-574.2 Added	1	A-2 and A-3.....	1	INDEX-39 Deleted	1
2-575 thru 2-578.....	1	A-4.....	0	INDEX-40 Blank Deleted.....	1
2-578.1 thru 2-578.14 Added	1	B-1.....	3	Glossary-1 and Glossary-2.....	0
2-579 thru 2-584.....	1	B-2.....	0	FO-1 FP-1.....	1
2-584.1 thru 2-584.64 Added	1	B-3 thru B-20.....	3	FO-1 FP-2 Blank.....	0
2-585 thru 2-594.....	1	C-1	0	FO-1 FP-3.....	2
2-594.1 thru 2-594.20 Added	1	C-2 thru C-4	2	FO-1 FP-4 Blank.....	0
2-595	1	D-1	1	FO-1 FP-5.....	1
2-596 thru 2-615.....	0	D-2	2	FO-1 FP-6 Blank.....	0
2-616 thru 2-621.....	1	D-3 thru D-5	1	FO-1 FP-7.....	1
2-622 Blank	1	D-6	2	FO-1 FP-8 Blank.....	0
2-623 Blank	1	E-1 and E-2.....	0	FO-1 FP-9.....	1
2-624 and 2-625.....	1	E-3 and E-4.....	1	FO-1 FP-10 Blank.....	0
2-626 thru 2-637.....	0	E-5 thru E-20.....	0		
2-638 thru 2-673.....	1	E-21 and E-22 Added	1		
2-674 Blank	1	F-1 thru F-8.....	0		

* Zero in this column indicates an original page.

LIST OF EFFECTIVE PAGES

Insert latest changed pages. Destroy superseded pages.

Page No.	*Change No.	Page No.	*Change No.	Page No.	*Change No.
FO-1 FP-11	1	FO-1 FP-61	2	2-1088 thru 2-1103	0
FO-1 FP-12 Blank	0	FO-1 FP-62 Blank	0	2-1104 thru 2-1107	1
FO-1 FP-13	1	FO-1 FP-63	0	2-1108 and 2-1175	0
FO-1 FP-14 Blank	0	FO-1 FP-64 Blank	0	2-1176 thru 2-1221	1
FO-1 FP-15	1	FO-1 FP-65	1	2-1222 thru 2-1229	0
FO-1 FP-16 Blank	0	FO-1 FP-66 Blank	0	2-1230 thru 2-1243	1
FO-1 FP-17	1	FO-1 FP-67	1	2-1244 thru 2-1357	0
FO-1 FP-18 Blank	0	FO-1 FP-68 Blank	0	2-1358 Blank	0
FO-1 FP-19	1	FO-2 FP-1	0	2-1359 and 2-1360	2
FO-1 FP-20 Blank	0	FO-2 FP-2 Blank	0	2-1361 Blank	0
FO-1 FP-21	0	FO-2 FP-3	0	2-1362 and 2-1363	0
FO-1 FP-22 Blank	0	FO-2 FP-4 Blank	0	2-1364 thru 2-1399	1
FO-1 FP-23	1	FO-2 FP-5	0	2-1400	2
FO-1 FP-24 Blank	0	FO-2 FP-6 Blank	0	2-1401	1
FO-1 FP-25	0	FO-2 FP-7	0	2-1402	2
FO-1 FP-26 Blank	0	FO-2 FP-8 Blank	0	2-1403 thru 2-1440	1
FO-1 FP-27	1	FO-3 FP-1	0	2-1441	2
FO-1 FP-28 Blank	0	FO-3 FP-2 Blank	0	2-1442 thru 2-1462	1
FO-1 FP-29	1	FO-3 FP-3	0	2-1462.1 and 2-1462.2 Added	1
FO-1 FP-30 Blank	0	FO-3 FP-4 Blank	0	2-1463 thru 2-1482	1
FO-1 FP-31	1	FO-3 FP-5	0	2-1482.1 thru 2-1482.42 Added	1
FO-1 FP-32 Blank	0	FO-3 FP-6 Blank	0	2-1483	1
FO-1 FP-33	1	FO-4 FP-1	0	2-1484 and 2-1485	0
FO-1 FP-34 Blank	0	FO-4 FP-2 Blank	0	2-1486	1
FO-1 FP-35	1	FO-4 FP-3	0	2-1486.1 thru 2-1486.4 Added	1
FO-1 FP-36 Blank	0	FO-4 FP-4 Blank	0	2-1487 thru 2-1521	1
FO-1 FP-37	1	FO-5 FP-1	0	2-1522 thru 2-1525	2
FO-1 FP-38 Blank	0	FO-5 FP-2 Blank	0	2-1526 thru 2-1568	1
FO-1 FP-39	1	FO-5 FP-3	0	2-1568.1 and 1568.2 Added	1
FO-1 FP-40 Blank	0	FO-5 FP-4 Blank	0	2-1569 thru 2-1593	1
FO-1 FP-41	1	FO-5 FP-5	0	2-1594	0
FO-1 FP-42 Blank	0	FO-5 FP-6 Blank	0	2-1595 and 2-1596	1
FO-1 FP-43	1	VOLUME 2		2-1596.1 thru 2-1596.29 Added	1
FO-1 FP-44 Blank	0	Cover	1	2-1596.30 Blank Added	1
FO-1 FP-45	1	Blank	0	2-1597 thru 2-1601	1
FO-1 FP-46 Blank	0	a thru e	0	2-1602 Blank	0
FO-1 FP-47	1	f	2	2-1603	1
FO-1 FP-48 Blank	0	g	0	2-1604 thru 2-1605	0
FO-1 FP-49	1	h	2	2-1606 Blank	0
FO-1 FP-50 Blank	0	i	1	2-1607	1
FO-1 FP-51	1	j	0	2-1608 thru 2-1643	0
FO-1 FP-52 Blank	0	A thru C	3	2-1644	2
FO-1 FP-53	1	D Blank	2	2-1645	1
FO-1 FP-54 Blank	0	i	1	2-1646	2
FO-1 FP-55	1	ii	0	2-1647	1
FO-1 FP-56 Blank	0	iii and iv	1	2-1648	2
FO-1 FP-57	1	v and vi Added	1	2-1649	1
FO-1 FP-58 Blank	0	2-1086.1 Added	1	2-1650	2
FO-1 FP-59	1	2-1086.2 Blank Added	1		
FO-1 FP-60 Blank	0	2-1087	1		

* Zero in this column indicates an original page.

LIST OF EFFECTIVE PAGES

Insert latest changed pages. Destroy superseded pages.

Page No.	*Change No.	Page No.	*Change No.	Page No.	*Change No.
2-1651.....	1	2-1853 Blank	1	2-2117 and 2-2118	1
2-1652.....	2	2-1854	2	2-2118.1 Added	1
2-1653.....	1	2-1855	1	2-2118.2 Blank Added	1
2-1654.....	2	2-1856 thru 2-1861.....	0	2-2118.3 thru 2-2118.7	
2-1655.....	1	2-1862 thru 2-1869.....	1	Added	1
2-1656.....	2	2-1870 Blank	1	2-2118.8 Blank Added	1
2-1657.....	1	2-1871 Blank	1	2-2118.9 and 2-2118.10	
2-1658.....	2	2-1872 and 2-1873.....	1	Added	1
2-1659.....	1	2-1874 thru 2-1893.....	0	2-2119.....	1
2-1660.....	2	2-1894 Blank	0	2-2120 Blank.....	0
2-1661.....	1	2-1895 thru 2-1901.....	1	2-2121.....	1
2-1662.....	2	2-1902 Blank	0	2-2122 thru 2-2125	0
2-1663.....	1	2-1903	1	2-2126 Blank.....	0
2-1664.....	2	2-1904 thru 2-1923.....	0	2-2127 thru 2-2132	0
2-1665.....	1	2-1924 Blank	0	2-2132.1 Added	1
2-1666 Blank.....	1	2-1925	1	2-2132.2 Blank Added	1
2-1667 and 2-1668 Deleted....	1	2-1926 thru 2-1943.....	0	2-2133.....	1
2-1669 Blank.....	1	2-1944 Blank	0	2-2134 thru 2-2136	0
2-1670 thru 2-1695	1	2-1945	1	3-1.....	1
2-1696 Blank.....	1	2-1946 thru 2-1951	0	3-2 thru 3-14	0
2-1697 Blank.....	1	2-1952 Blank	0	3-15 thru 3-17	1
2-1698 and 2-1699	1	2-1953	1	3-18 thru 3-21	0
2-1700 thru 2-1711	0	2-1954 thru 2-1957.....	0	3-22 Blank.....	0
2-1712.....	1	2-1958 Blank	0	A-1	0
2-1712.1 Added	1	2-1959 thru 2-1968.....	1	A-2 and A-3.....	1
2-1712.2 Blank Added	1	2-1968.1 thru 2-1968.18		A-4	0
2-1713 thru 2-1729	1	Added	1	B-1	3
2-1730 thru 2-1737	0	2-1969 and 2-1970.....	1	B-2	0
2-1738 thru 2-1742	1	2-1970.1 thru 2-1970.14.....	1	B-3 thru B-20	3
2-1742.1 thru 2-1742.30		2-1971 thru 2-1974.....	1	C-1	0
Added	1	2-1974.1 thru 2-1974.22		C-2 thru C-4.....	2
2-1743 thru 2-1747	1	Added	1	D-1	1
2-1748 thru 2-1751	0	2-1975	1	D-2	2
2-1752 Blank.....	0	2-1976 Blank	0	D-3 thru D-5.....	1
2-1753.....	1	2-1977 and 2-1978.....	2	D-6	2
2-1754 thru 2-1759	0	2-1979 thru 2-2013 Added	2	E-1 and E-2.....	0
2-1760 Blank.....	0	2-2014 Blank Added.....	2	E-3 and E-4.....	1
2-1761.....	1	2-2015 thru 2-2076 Deleted	1	E-5 thru E-20	0
2-1762 thru 2-1765	0	2-2077 Blank	1	E-21 and E-22 Added	1
2-1766 Blank.....	0	2-2078	1	F-1 thru F-8.....	0
2-1767 thru 2-1769	1	2-2079 thru 2-2113.....	0	G-1	2
2-1770 thru 2-1821	0	2-2114 Blank	0	G-2.....	1
2-1822 thru 2-1826	2	2-2115 and 2-2116.....	1	G-3 thru G-7.....	2
2-1827.....	1	2-2116.1 Added.....	1	G-8.....	1
2-1828.....	2	2-2116.2 Blank Added.....	1	G-9 thru G-11.....	2
2-1829.....	1	2-2116.3 thru 2-2116.9		G-12 Blank Added	1
2-1830.....	2	Added	1	H-1 thru H-6.....	2
2-1831.....	1	2-2116.10 Blank Added.....	1	H-7	0
2-1832 Blank.....	1	2-2116.11 and 2-2116.12		H-8 thru H-10.....	2
2-1833 thru 2-1852 Deleted....	1	Added	1		

* Zero in this column indicates an original page.

LIST OF EFFECTIVE PAGES

Insert latest changed pages. Destroy superseded pages.

Page No.	*Change No.	Page No.	*Change No.	Page No.	*Change No.
H-11	0	FO-1 FP-32 Blank	0	FO-3 FP-6 Blank	0
H-12	2	FO-1 FP-33	1	FO-4 FP-1	0
H-13 thru H-15	0	FO-1 FP-34 Blank	0	FO-4 FP-2 Blank	0
H-16 thru H-18	2	FO-1 FP-35	1	FO-4 FP-3	0
H-19	1	FO-1 FP-36 Blank	0	FO-4 FP-4 Blank	0
H-20 and H-21	2	FO-1 FP-37	1	FO-5 FP-1	0
H-22 Blank	0	FO-1 FP-38 Blank	0	FO-5 FP-2 Blank	0
J-1	0	FO-1 FP-39	1	FO-5 FP-3	0
J-2 Blank	0	FO-1 FP-40 Blank	0	FO-5 FP-4 Blank	0
K-1 Added	1	FO-1 FP-41	1	FO-5 FP-5	0
K-2 and K-3	2	FO-1 FP-42 Blank	0	FO-5 FP-6 Blank	0
K-4 Added	1	FO-1 FP-43	1	VOLUME 3	
INDEX-1	1	FO-1 FP-44 Blank	0	Cover	1
INDEX-2 thru INDEX-4	2	FO-1 FP-45	1	Blank	0
INDEX-5	1	FO-1 FP-46 Blank	0	a thru e	0
INDEX-6 thru INDEX-11	2	FO-1 FP-47	1	f	2
INDEX-12	1	FO-1 FP-48 Blank	0	g	0
Glossary-1 and Glossary-2	0	FO-1 FP-49	1	h	2
FO-1 FP-1	1	FO-1 FP-50 Blank	0	i	1
FO-1 FP-2 Blank	0	FO-1 FP-51	1	j	0
FO-1 FP-3	2	FO-1 FP-52 Blank	0	A thru D	3
FO-1 FP-4 Blank	0	FO-1 FP-53	1	i	1
FO-1 FP-5	1	FO-1 FP-54 Blank	0	ii	0
FO-1 FP-6 Blank	0	FO-1 FP-55	1	iii thru vi	1
FO-1 FP-7	1	FO-1 FP-56 Blank	0	4-1	1
FO-1 FP-8 Blank	0	FO-1 FP-57	1	4-2 thru 4-4	0
FO-1 FP-9	1	FO-1 FP-58 Blank	0	4-5	1
FO-1 FP-10 Blank	0	FO-1 FP-59	1	4-6 thru 4-8	0
FO-1 FP-11	1	FO-1 FP-60 Blank	0	4-9	1
FO-1 FP-12 Blank	0	FO-1 FP-61	2	4-10	0
FO-1 FP-13	1	FO-1 FP-62 Blank	0	4-10.1 and 4-10.2 Added	1
FO-1 FP-14 Blank	0	FO-1 FP-63	0	4-11	0
FO-1 FP-15	1	FO-1 FP-64 Blank	0	4-12 and 4-13	1
FO-1 FP-16 Blank	0	FO-1 FP-65	1	4-14	0
FO-1 FP-17	1	FO-1 FP-66 Blank	0	4-15	1
FO-1 FP-18 Blank	0	FO-1 FP-67	1	4-16 and 4-17	0
FO-1 FP-19	1	FO-1 FP-68 Blank	0	4-18	1
FO-1 FP-20 Blank	0	FO-2 FP-1	0	4-19 thru 4-41	0
FO-1 FP-21	0	FO-2 FP-2 Blank	0	4-42 and 4-43	1
FO-1 FP-22 Blank	0	FO-2 FP-3	0	4-44	0
FO-1 FP-23	1	FO-2 FP-4 Blank	0	4-45	1
FO-1 FP-24 Blank	0	FO-2 FP-5	0	4-46	0
FO-1 FP-25	0	FO-2 FP-6 Blank	0	4-47	1
FO-1 FP-26 Blank	0	FO-2 FP-7	0	4-48 thru 4-59	0
FO-1 FP-27	1	FO-2 FP-8 Blank	0	4-60	1
FO-1 FP-28 Blank	0	FO-3 FP-1	0	4-61 and 4-62	0
FO-1 FP-29	1	FO-3 FP-2 Blank	0	4-63	1
FO-1 FP-30 Blank	0	FO-3 FP-3	0	4-64 thru 4-68	0
FO-1 FP-31	1	FO-3 FP-4 Blank	0		
		FO-3 FP-5	0		

* Zero in this column indicates an original page.

LIST OF EFFECTIVE PAGES (CONT)

Insert latest changed pages. Destroy superseded pages.

Page No.	*Change No.	Page No.	*Change No.	Page No.	*Change No.
4-69.....	1	6-72.1 Added.....	1	7-119.....	1
4-70 thru 4-81.....	0	6-72.2 Blank Added.....	1	7-120 thru 7-142.....	0
4-82 thru 4-84.....	1	6-73 thru 6-78.....	1	7-143 and 7-144.....	1
4-85 thru 4-105.....	0	7-1 and 7-2.....	1	7-145.....	0
4-106 Blank.....	0	7-3 and 7-4.....	2	7-146 and 7-147.....	1
5-1.....	1	7-5 and 7-6.....	0	7-148.....	0
5-2 thru 5-6.....	0	7-7.....	2	7-149.....	1
5-7 and 5-8.....	1	7-8 and 7-9.....	1	7-150.....	0
5-9.....	0	7-10 thru 7-17.....	0	7-151.....	1
5-10 and 5-11.....	1	7-18.....	2	7-152 thru 7-159.....	0
5-12 and 5-13.....	0	7-19.....	0	7-160.....	1
5-14 and 5-15.....	1	7-20.....	2	7-160.1 Added.....	1
5-16 Blank.....	0	7-21 thru 7-24.....	0	7-160.2 Blank Added.....	1
6-1 thru 6-3.....	1	7-25 thru 7-31.....	1	7-161.....	1
6-4.....	0	7-32 thru 7-35.....	0	7-162 and 7-163.....	2
6-4.1 and 6-4.2 Added.....	1	7-36.....	1	7-164 and 7-165.....	1
6-5.....	1	7-36.1 thru 7-36.4 Added.....	1	7-166 thru 7-168.....	0
6-6.....	0	7-37 and 7-38.....	0	7-169.....	1
6-7.....	1	7-39.....	2	7-170 and 7-171.....	0
6-8 and 6-9.....	0	7-40.....	0	7-172.....	1
6-10 thru 6-13.....	1	7-41.....	1	7-173.....	0
6-14.....	0	7-42 thru 7-44.....	0	7-174.....	2
6-15 thru 6-18.....	1	7-45.....	1	7-175 thru 7-183.....	0
6-19.....	0	7-46 thru 7-51.....	0	7-184 thru 7-187.....	2
6-20 thru 6-22.....	1	7-52.....	1	7-188.....	0
6-22.1 Added.....	1	7-53 thru 7-55.....	0	7-189 and 7-190.....	1
6-22.2 Blank Added.....	1	7-56.....	1	7-191 and 7-192.....	0
6-23 thru 6-25.....	1	7-57.....	0	7-193.....	1
6-26 and 6-27.....	0	7-58.....	2	7-194.....	0
6-28.....	1	7-59 thru 7-62.....	0	7-195 thru 7-200.....	1
6-29 thru 6-31.....	0	7-63.....	2	7-200.1 and 7-200.2 Added.....	1
6-32.....	1	7-64.....	0	7-201 thru 7-203.....	1
6-33.....	0	7-65.....	1	7-204 thru 7-218.....	0
6-34.....	1	7-66.....	0	7-219 thru 7-223.....	1
6-35 thru 6-38.....	0	7-67 and 7-68.....	1	7-224 thru 7-228.....	0
6-39.....	1	7-69 thru 7-74.....	0	7-229 thru 7-231.....	1
6-40 thru 6-45.....	0	7-75.....	1	7-232.....	0
6-46.....	2	7-76 thru 7-78.....	0	7-233 thru 7-237.....	1
6-47 and 6-48.....	0	7-79.....	1	7-238.....	0
6-49.....	1	7-80.....	0	7-239.....	1
6-50 thru 6-52.....	0	7-81.....	2	7-240 thru 7-242.....	0
6-53.....	1	7-82 thru 7-86.....	0	7-243 and 7-244.....	1
6-54 thru 6-62.....	0	7-87 and 7-88.....	2	7-245.....	0
6-63.....	2	7-89.....	1	7-246.....	1
6-64 thru 6-66.....	0	7-90 thru 7-102.....	0	7-247 thru 7-253.....	0
6-67.....	1	7-103.....	1	7-254 thru 7-256.....	2
6-68 and 6-69.....	0	7-104.....	2	7-257 and 7-258.....	0
6-70.....	2	7-105 thru 7-107.....	0	7-259.....	1
6-71.....	1	7-108.....	2	7-260 thru 7-268.....	0
6-72.....	0	7-109 thru 7-118.....	0	7-269.....	1

* Zero in this column indicates an original page.

LIST OF EFFECTIVE PAGES (CONT)

Insert latest changed pages. Destroy superseded pages.

Page No.	*Change No.	Page No.	*Change No.	Page No.	*Change No.
7-270 thru 7-274	0	8-12	2	11-9 and 11-10	1
7-275 and 7-276	1	8-12.1 Added	1	11-11	0
7-277	0	8-12.2 Blank Added	1	11-12	1
7-278	1	8-13 thru 8-15	0	11-13	0
7-279	0	8-16	2	11-14	1
7-280	2	8-16.1 Added	1	11-15	0
7-281 and 7-282	0	8-16.2 Blank Added	1	11-16	1
7-283	2	8-17 thru 8-20	0	11-17 thru 11-20	0
7-284 and 7-285	0	8-20.1 Added	2	11-21	2
7-286	2	8-20.2 Blank Added	2	11-22 thru 11-30	0
7-286.1 Added	2	8-21 thru 8-31	0	11-31	1
7-286.2 Blank Added	2	8-32	2	11-32	0
7-287	0	8-33	0	11-33 thru 11-39	1
7-288	1	8-34 thru 8-40	1	11-40 thru 11-42	0
7-289	0	8-40.1 Added	1	11-43 thru 11-45	1
7-290 and 7-291	1	8-40.2 Blank Added	1	11-46	0
7-292 and 7-293	0	8-41 thru 8-47	1	11-47 thru 11-53	1
7-294	1	8-48 and 8-49	0	11-54	0
7-295 thru 7-297	0	8-50	1	11-55 thru 11-57	1
7-298	1	8-51 and 8-52	0	11-58	0
7-299 thru 7-302	0	8-53 and 8-54	1	11-58.1 and 11-58.2 Added	1
7-303 thru 7-316	1	8-55 thru 8-69 Added	1	11-59	1
7-316.1 thru 7-316.4 Added	1	8-70 Blank Added	1	11-60 Blank	1
7-317 and 7-318	1	9-1	1	11-61 and 11-62	1
7-319 thru 7-326	0	9-2	2	11-63 thru 11-65	0
7-327 and 7-328	1	9-2.1	2	11-66 thru 11-68	1
7-329	2	9-2.2	1	11-69	0
7-330 thru 7-342	0	9-2.3 and 9-2.4 Added	2	11-70 thru 11-72	1
7-343 thru 7-346	1	9-3 and 9-4	2	11-73	0
7-347 and 7-348	0	9-5 Added	1	11-74	1
7-349 and 7-350	1	9-6 Blank Added	1	11-75	0
7-350.1 and 7-350.2 Added	1	10-1	2	11-76 and 11-77	1
7-351	1	10-2	0	11-78 and 11-79	0
7-352 and 7-353	0	10-3 and 10-4	1	11-80 thru 11-83	1
7-354 thru 7-356	1	10-5	0	11-84 thru 11-86	0
7-357	0	10-6 and 10-7	1	11-86.1 Added	2
7-358 and 7-359	1	10-8	0	11-86.2 Blank Added	2
7-360	0	10-9	1	11-87 thru 11-90	2
7-361	1	10-10 and 10-11	0	11-91	1
7-362	0	10-12	2	11-92	0
7-363	1	10-13	0	11-93 and 11-94	1
7-364	0	10-14	1	11-95 and 11-96	0
7-365 thru 7-368	1	10-15 and 10-16	0	11-97 thru 11-104	1
7-369 thru 7-380	0	10-17	2	11-105	0
7-381 thru 7-383 Added	1	10-18	1	11-106	1
7-384 Blank Added	1	10-19 and 10-20	2	11-106.1 Added	1
8-1	1	10-21 thru 10-27 Added	2	11-106.2 Blank Added	1
8-2 thru 8-9	0	10-28 Blank Added	2	11-107	1
8-10	1	11-1	1	11-108 thru 11-110	0
8-11	0	11-2 thru 11-8	0	11-111 and 11-112	1

* Zero in this column indicates an original page.

LIST OF EFFECTIVE PAGES (CONT)

Insert latest changed pages. Destroy superseded pages.

Page No.	*Change No.	Page No.	*Change No.	Page No.	*Change No.
11-112.1 Added	1	13-13	2	G-1	2
11-112.2 Blank Added	1	13-14	0	G-2	1
11-113	0	13-15 thru 13-22	2	G-3 thru G-7	2
11-114 thru 11-116	1	13-23 and 13-24	0	G-8	1
11-117	0	13-25	2	G-9 and G-10	2
11-118 and 11-119	1	13-26	1	G-11	2
11-120 thru 11-122	0	13-27 and 13-28	2	G-12 Blank Added	1
11-123	1	13-28.1 and 13-28.2 Added	2	H-1 thru H-6	2
11-124	0	13-29 and 13-30	2	H-7	0
11-125 and 11-126	1	13-30.1 Added	2	H-8 thru H-10	2
11-127	0	13-30.2 Blank Added	2	H-11	0
11-128 and 11-129	1	13-31	2	H-12	2
11-130	0	13-32	1	H-13 thru H-15	0
11-131	1	13-33 and 13-34	1	H-16 thru H-18	2
11-132 and 11-133	0	13-35 and 13-36	2	H-19	1
11-134 and 11-135	1	13-37 and 13-38 Added	2	H-20 and H-21	2
11-136 thru 11-138	0	14-1 thru 14-8	1	H-22 Blank	0
11-139 thru 11-142	1	14-9 and 14-10 Deleted	1	J-1	0
11-143	0	14-11 Blank	1	J-2 Blank	0
11-144	1	14-12 thru 14-20	1	K-1 Added	1
11-144.1 thru 11-144.4 Added	1	14-20.1 thru 14-20.4 Added	1	K-2 and K-3	2
11-145 and 11-146	1	14-21	1	K-4 Added	1
12-1	2	14-22 thru 14-34	0	INDEX-1 thru INDEX-3	1
12-2	0	14-35 and 14-36	2	INDEX-4	2
12-3 and 12-4	2	14-37 and 14-38 Added	1	INDEX-5 and INDEX-6	2
12-5 thru 12-7	0	15-1	1	INDEX-7 thru INDEX-9	2
12-8	2	15-2	2	INDEX-10	1
12-9 thru 12-13	0	15-2.1 thru 15-2.3 Added	2	INDEX-11	2
12-14	2	15-2.4 Blank Added	2	INDEX-12	1
12-15	0	15-3	2	Glossary-1 and Glossary-2	0
12-16	1	15-4	1	FO-1 FP-1	1
12-16.1 Added	1	15-5 thru 15-13	0	FO-1 FP-2 Blank	0
12-16.2 Blank Added	1	15-14 Blank	0	FO-1 FP-3	2
12-17 thru 12-19	1	A-1	0	FO-1 FP-4 Blank	0
12-20 and 12-21	0	A-2 and A-3	1	FO-1 FP-5	1
12-22	1	A-4	0	FO-1 FP-6 Blank	0
12-23 and 12-24	0	B-1	3	FO-1 FP-7	1
12-25 and 12-26 Added	2	B-2	0	FO-1 FP-8 Blank	0
13-1	2	B-3 thru B-20	3	FO-1 FP-9	1
13-2 and 13-3	0	C-1	0	FO-1 FP-10 Blank	0
13-4	1	C-2 thru C-4	2	FO-1 FP-11	1
13-4.1 Added	1	D-1	1	FO-1 FP-12 Blank	0
13-4.2 Blank Added	1	D-2	2	FO-1 FP-13	1
13-5 thru 13-8	1	D-3 thru D-5	1	FO-1 FP-14 Blank	0
13-8.1 Added	1	D-6	2	FO-1 FP-15	1
13-8.2 Blank Added	1	E-1 and E-2	0	FO-1 FP-16 Blank	0
13-9 and 13-10	0	E-3 and E-4	1	FO-1 FP-17	1
13-11	2	E-5 thru E-20	0	FO-1 FP-18 Blank	0
13-12	0	E-21 and E-22 Added	1	FO-1 FP-19	1
		F-1 thru F-8	0		

* Zero in this column indicates an original page.

LIST OF EFFECTIVE PAGES

Insert latest changed pages. Destroy superseded pages.

Page No.	*Change No.	Page No.	*Change No.	Page No.	*Change No.
FO-1 FP-20 Blank	0	FO-2 FP-2 Blank	0	16-13 thru 16-15	0
FO-1 FP-21	0	FO-2 FP-3	0	16-16	2
FO-1 FP-22 Blank	0	FO-2 FP-4 Blank	0	16-17	0
FO-1 FP-23	1	FO-2 FP-5	0	16-18	2
FO-1 FP-24 Blank	0	FO-2 FP-6 Blank	0	16-19 thru 16-21	0
FO-1 FP-25	0	FO-2 FP-7	0	16-22	1
FO-1 FP-26 Blank	0	FO-2 FP-8 Blank	0	16-23	0
FO-1 FP-27	1	FO-3 FP-1	0	16-24 and 16-25	1
FO-1 FP-28 Blank	0	FO-3 FP-2 Blank	0	16-26 thru 16-30	0
FO-1 FP-29	1	FO-3 FP-3	0	16-31 and 16-32	1
FO-1 FP-30 Blank	0	FO-3 FP-4 Blank	0	16-33	0
FO-1 FP-31	1	FO-3 FP-5	0	16-34	1
FO-1 FP-32 Blank	0	FO-3 FP-6 Blank	0	16-35	2
FO-1 FP-33	1	FO-4 FP-1	0	16-36	1
FO-1 FP-34 Blank	0	FO-4 FP-2 Blank	0	16-37	0
FO-1 FP-35	1	FO-4 FP-3	0	16-38	1
FO-1 FP-36 Blank	0	FO-4 FP-4 Blank	0	16-39	2
FO-1 FP-37	1	FO-5 FP-1	0	16-40	0
FO-1 FP-38 Blank	0	FO-5 FP-2 Blank	0	16-40.1	2
FO-1 FP-39	1	FO-5 FP-3	0	16-40.2 Blank Added	1
FO-1 FP-40 Blank	0	FO-5 FP-4 Blank	0	16-41	1
FO-1 FP-41	1	FO-5 FP-5	0	16-42	0
FO-1 FP-42 Blank	0	FO-5 FP-6 Blank	0	16-42.1 Added	1
FO-1 FP-43	1	VOLUME 4		16-42.2 Blank Added	1
FO-1 FP-44 Blank	0	Cover	1	16-43 thru 16-55	1
FO-1 FP-45	1	Blank	0	16-56	2
FO-1 FP-46 Blank	0	a thru e	0	16-56.1 Added	2
FO-1 FP-47	1	f	2	16-56.2 Blank Added	2
FO-1 FP-48 Blank	0	g	0	16-57 and 16-58	2
FO-1 FP-49	1	h	2	16-59	0
FO-1 FP-50 Blank	0	i	1	16-60 thru 16-62	1
FO-1 FP-51	1	j	0	16-62.1 Added	1
FO-1 FP-52 Blank	0	A and B	3	16-62.2 Blank Added	1
FO-1 FP-53	1	C Added	2	16-63 thru 16-68	1
FO-1 FP-54 Blank	0	D Blank Added	2	16-69	2
FO-1 FP-55	1	i thru iv	1	16-70 thru 16-72	1
FO-1 FP-56 Blank	0	v Added	1	16-73 and 16-74	2
FO-1 FP-57	1	vi Blank Added	1	16-74.1 Added	2
FO-1 FP-58 Blank	0	16-1	1	16-74.2 Blank Added	2
FO-1 FP-59	1	16-2	2	16-75 thru 16-77	1
FO-1 FP-60 Blank	0	16-3 and 16-4	1	16-78	2
FO-1 FP-61	2	16-4.1 Added	1	16-79	0
FO-1 FP-62 Blank	0	16-4.2 Blank Added	1	16-80	1
FO-1 FP-63	0	16-5	1	16-81	0
FO-1 FP-64 Blank	0	16-6 and 16-7	0	16-82	1
FO-1 FP-65	1	16-8	2	16-83 thru 16-96	0
FO-1 FP-66 Blank	0	16-9	0	16-96.1 and 16-96.2 Added	1
FO-1 FP-67	1	16-10 thru 16-12	1	16-97	1
FO-1 FP-68 Blank	0	16-12.1	2		
FO-2 FP-1	0	16-12.2 Blank Added	1		

* Zero in this column indicates an original page.

LIST OF EFFECTIVE PAGES (CONT)

Insert latest changed pages. Destroy superseded pages.

Page No.	*Change No.	Page No.	*Change No.	Page No.	*Change No.
16-98 thru 16-104.....	0	18-1.....	2	E-1 and E-2.....	0
16-105 thru 16-110.....	1	18-2 thru 18-5.....	0	E-3 and E-4.....	1
16-110.1 and 16-110.2 Added	.1	18-6 thru 18-8.....	1	E-5 thru E-20.....	0
16-111.....	1	18-9 thru 18-22.....	0	E-21 and E-22 Added.....	1
16-112 thru 16-115.....	0	18-23 and 18-24.....	2	F-1 thru F-8.....	0
16-116 thru 16-119.....	1	18-24.1 thru 18-24.6 Added.....	2	G-1.....	2
16-120 thru 16-127.....	0	18-25.....	2	G-2.....	1
16-128 and 16-129.....	1	18-26 thru 18-29.....	0	G-3 thru G-7.....	2
16-130 thru 16-132.....	0	18-30.....	1	G-8.....	1
16-133.....	1	18-31.....	0	G-9 thru G-11.....	2
16-134 thru 16-139.....	0	18-32.....	1	G-12 Blank Added.....	1
16-140.....	1	18-33 thru 18-50.....	0	H-1 thru H-6.....	2
16-141 thru 16-143.....	0	18-51.....	1	H-7.....	0
16-144 thru 16-150.....	1	18-52 thru 18-55.....	0	H-8 thru H-10.....	2
16-151.....	0	18-56 and 18-57.....	1	H-11.....	0
16-152.....	1	18-58.....	2	H-12.....	2
16-153 thru 16-158.....	0	18-59 thru 18-67.....	0	H-13 thru H-15.....	0
16-159.....	1	18-68.....	1	H-16 thru H-18.....	2
16-160 thru 16-177.....	0	18-69 and 16-70.....	2	H-19.....	1
16-178 thru 16-180.....	1	18-71 Added.....	2	H-20 and H-21.....	2
16-181 thru 16-211.....	0	18-72 Blank Added.....	2	H-22 Blank.....	0
16-212.....	1	19-1.....	2	J-1.....	0
16-213 thru 16-289.....	0	19-2 thru 19-4.....	0	J-2 Blank.....	0
16-290 thru 16-302.....	1	19-5 thru 19-8.....	1	K-1 Added.....	1
16-303 thru 16-392.....	0	19-8.1 thru 19-8.10 Added.....	1	K-2 and K-3.....	2
16-393 thru 16-395.....	1	19-9 thru 19-20.....	1	K-4 Added.....	1
16-396 thru 16-415.....	0	19-20.1 thru 19-20.14 Added.....	1	INDEX-1.....	2
16-416.....	1	19-21.....	1	INDEX-2.....	1
16-417 thru 16-486.....	0	19-22 and 19-23.....	0	INDEX-3.....	2
16-487.....	2	19-24 and 19-25.....	1	INDEX-4 thru INDEX-7.....	1
16-488 Added.....	1	19-26 thru 19-46.....	0	INDEX-8 Blank.....	0
16-488.1 Added.....	2	19-47.....	1	Glossary-1 and Glossary-2.....	0
16-488.2 Blank Added.....	2	19-48 thru 19-50.....	0	FO-1 FP-1.....	1
16-489.....	2	19-51.....	2	FO-1 FP-2 Blank.....	0
16-490 thru 16-496 Added.....	1	19-52.....	1	FO-1 FP-3.....	2
16-497.....	2	19-53.....	0	FO-1 FP-4 Blank.....	0
16-498.....	2	19-54 thru 19-58.....	1	FO-1 FP-5.....	1
17-1.....	1	19-59 thru 19-64.....	0	FO-1 FP-6 Blank.....	0
17-2 thru 17-6.....	0	A-1.....	0	FO-1 FP-7.....	1
17-7 thru 17-9.....	1	A-2 and A-3.....	1	FO-1 FP-8 Blank.....	0
17-10 thru 17-12.....	0	A-4.....	0	FO-1 FP-9.....	1
17-13 and 17-14.....	1	B-1.....	3	FO-1 FP-10 Blank.....	0
17-15 thru 17-18.....	0	B-2.....	0	FO-1 FP-11.....	1
17-19 and 17-20.....	2	B-3 thru B-20.....	3	FO-1 FP-12 Blank.....	0
17-20.1 thru 17-20.4 Added.....	2	C-1.....	0	FO-1 FP-13.....	1
17-21.....	0	C-2 thru C-4.....	2	FO-1 FP-14 Blank.....	0
17-22.....	2	D-1.....	1	FO-1 FP-15.....	1
17-23 thru 17-27.....	0	D-2.....	2	FO-1 FP-16 Blank.....	0
17-28.....	1	D-3 thru D-5.....	1	FO-1 FP-17.....	1
17-29 and 17-30.....	0	D-6.....	2		

* Zero in this column indicates an original page.

LIST OF EFFECTIVE PAGES (CONT)

Insert latest changed pages. Destroy superseded pages.

Page No.	*Change No.	Page No.	*Change No.	Page No.	*Change No.
FO-1 FP-18 Blank	0	FO-1 FP-68 Blank	0	20-199	0
FO-1 FP-19	1	FO-2 FP-1	0	20-200 thru 20-204	2
FO-1 FP-20 Blank	0	FO-2 FP-2 Blank	0	20-204.1 and 20-204.2	
FO-1 FP-21	0	FO-2 FP-3	0	Added	2
FO-1 FP-22 Blank	0	FO-2 FP-4 Blank	0	20-205 thru 20-220	2
FO-1 FP-23	1	FO-2 FP-5	0	20-220.1 and 20-220.2	
FO-1 FP-24 Blank	0	FO-2 FP-6 Blank	0	Added	2
FO-1 FP-25	0	FO-2 FP-7	0	20-221 thru 20-223	2
FO-1 FP-26 Blank	0	FO-2 FP-8 Blank	0	20-224 thru 20-236	0
FO-1 FP-27	1	FO-3 FP-1	0	20-237 thru 20-250	2
FO-1 FP-28 Blank	0	FO-3 FP-2 Blank	0	20-251 thru 20-255	0
FO-1 FP-29	1	FO-3 FP-3	0	20-256	2
FO-1 FP-30 Blank	0	FO-3 FP-4 Blank	0	20-256.1 thru 20-256.8	
FO-1 FP-31	1	FO-3 FP-5	0	Added	2
FO-1 FP-32 Blank	0	FO-3 FP-6 Blank	0	20-257 thru 20-259	2
FO-1 FP-33	1	FO-4 FP-1	0	20-260 Blank	2
FO-1 FP-34 Blank	0	FO-4 FP-2 Blank	0	20-261 and 20-262 Deleted	2
FO-1 FP-35	1	FO-4 FP-3	0	20-263	2
FO-1 FP-36 Blank	0	FO-4 FP-4 Blank	0	20-264 thru 20-280	0
FO-1 FP-37	1	FO-5 FP-1	0	20-281	1
FO-1 FP-38 Blank	0	FO-5 FP-2 Blank	0	20-282 Blank	1
FO-1 FP-39	1	FO-5 FP-3	0	20-283 thru 20-312 Deleted	1
FO-1 FP-40 Blank	0	FO-5 FP-4 Blank	0	20-313 Blank	1
FO-1 FP-41	1	FO-5 FP-5	0	20-314	1
FO-1 FP-42 Blank	0	FO-5 FP-6 Blank	0	20-315 thru 20-318	1
FO-1 FP-43	1	VOLUME 5		20-319 thru 20-326	0
FO-1 FP-44 Blank	0	Cover	1	20-327 thru 20-330	1
FO-1 FP-45	1	Blank	0	20-331	0
FO-1 FP-46 Blank	0	a thru e	0	20-332	1
FO-1 FP-47	1	f	2	20-333	0
FO-1 FP-48 Blank	0	g	0	20-334	1
FO-1 FP-49	1	h	2	20-335 thru 20-343	0
FO-1 FP-50 Blank	0	i	1	20-344	1
FO-1 FP-51	1	j	0	20-345 thru 20-347	0
FO-1 FP-52 Blank	0	A and B	3	20-348 and 20-349	1
FO-1 FP-53	1	i thru iv	1	20-350 and 20-351	0
FO-1 FP-54 Blank	0	v Added	1	20-352 thru 20-354	1
FO-1 FP-55	1	vi Blank Added	1	20-355 thru 20-464	0
FO-1 FP-56 Blank	0	20-1	1	20-465 and 20-466	1
FO-1 FP-57	1	20-2	2	20-467 thru 20-471	0
FO-1 FP-58 Blank	0	20-2.1 Added	1	20-472 thru 20-475	1
FO-1 FP-59	1	20-2.2 Blank Added	1	20-476 thru 20-480	0
FO-1 FP-60 Blank	0	20-3	1	20-481 thru 20-486	2
FO-1 FP-61	2	20-4 Blank	1	20-486.1 Added	2
FO-1 FP-62 Blank	0	20-5 thru 20-184 Deleted	1	20-486.2 Blank Added	2
FO-1 FP-63	0	20-185	0	20-487 and 20-488	2
FO-1 FP-64 Blank	0	20-186 thru 20-188	2	20-489 thru 20-556 Added	2
FO-1 FP-65	1	20-188.1 and 20-188.2		21-1 thru 21-7	1
FO-1 FP-66 Blank	0	Added	2		
FO-1 FP-67	1	20-189 thru 20-198	2		

* Zero in this column indicates an original page.

LIST OF EFFECTIVE PAGES (CONT)

Insert latest changed pages. Destroy superseded pages.

Page No.	*Change No.	Page No.	*Change No.	Page No.	*Change No.
21-8.....	2	E-3 and E-4	1	FO-1 FP-18 Blank.....	0
21-8.1 and 21-8.2 Added.....	2	E-5 thru E-20	0	FO-1 FP-19.....	1
21-9.....	2	E-21 and E-22 Added.....	1	FO-1 FP-20 Blank.....	0
21-10 and 21-11	1	F-1 thru F-8	0	FO-1 FP-21	0
21-12 and 21-13	0	G-1	2	FO-1 FP-22 Blank.....	0
21-14 Blank.....	0	G-2	1	FO-1 FP-23	1
22-1.....	1	G-3 thru G-7	2	FO-1 FP-24 Blank.....	0
22-2 thru 22-5	0	G-8	1	FO-1 FP-25.....	0
22-6 Blank.....	0	G-9 thru G-11	2	FO-1 FP-26 Blank.....	0
23-1.....	1	G-12 Blank Added.....	1	FO-1 FP-27.....	1
23-2.....	0	H-1 thru H-6.....	2	FO-1 FP-28 Blank.....	0
23-3 and 23-4	1	H-7.....	0	FO-1 FP-29.....	1
23-5 thru 23-8	0	H-8 thru H-10.....	2	FO-1 FP-30 Blank.....	0
23-9 thru 23-11	1	H-11.....	0	FO-1 FP-31	1
23-12.....	0	H-12.....	2	FO-1 FP-32 Blank.....	0
23-13.....	1	H-13 thr H-15.....	0	FO-1 FP-33.....	1
23-14.....	0	H-16 thru H-18.....	2	FO-1 FP-34 Blank.....	0
23-15 and 23-16	1	H-19.....	1	FO-1 FP-35.....	1
23-17.....	0	H-20 and H-21	2	FO-1 FP-36 Blank.....	0
23-18.....	1	H-22 Blank.....	0	FO-1 FP-37	1
23-19.....	0	J-1	0	FO-1 FP-38 Blank.....	0
23-20.....	1	J-2 Blank	0	FO-1 FP-39.....	1
23-21 and 23-22	0	K-1 Added	1	FO-1 FP-40 Blank.....	0
23-23.....	1	K-2 and K-3	2	FO-1 FP-41	1
23-24 and 23-25	0	K-4 Added	1	FO-1 FP-42 Blank.....	0
23-26.....	1	INDEX-1	1	FO-1 FP-43.....	1
23-27.....	0	INDEX-2 and INDEX-3.....	2	FO-1 FP-44 Blank.....	0
23-28.....	1	INDEX-4	1	FO-1 FP-45.....	1
23-29 and 23-30	0	INDEX-5	2	FO-1 FP-46 Blank.....	0
23-31 and 23-32	1	INDEX-6	1	FO-1 FP-47	1
23-32.1 and 23-32.2 Added.....	1	INDEX-7 Deleted.....	1	FO-1 FP-48 Blank.....	0
23-33 and 23-34	1	INDEX-8 Blank Deleted.....	1	FO-1 FP-49.....	1
23-35 and 23-36 Added.....	1	Glossary-1 and Glossary-2	0	FO-1 FP-50 Blank.....	0
24-1.....	1	FO-1 FP-1	1	FO-1 FP-51	1
24-2.....	0	FO-1 FP-2 Blank	0	FO-1 FP-52 Blank.....	0
A-1	0	FO-1 FP-3	2	FO-1 FP-53.....	1
A-2 and A-3.....	1	FO-1 FP-4 Blank	0	FO-1 FP-54 Blank.....	0
A-4	0	FO-1 FP-5	1	FO-1 FP-55.....	1
B-1	3	FO-1 FP-6 Blank	0	FO-1 FP-56 Blank.....	0
B-2	0	FO-1 FP-7	1	FO-1 FP-57	1
B-3 thru B-20	3	FO-1 FP-8 Blank	0	FO-1 FP-58 Blank.....	0
C-1	0	FO-1 FP-9	1	FO-1 FP-59.....	1
C-2 thru C-4	2	FO-1 FP-10 Blank	0	FO-1 FP-60 Blank.....	0
C-3 and C-4	1	FO-1 FP-11	1	FO-1 FP-61	2
D-1	1	FO-1 FP-12 Blank	0	FO-1 FP-62 Blank.....	0
D-2.....	2	FO-1 FP-13	1	FO-1 FP-63.....	0
D-3 thru D-5	1	FO-1 FP-14 Blank	0	FO-1 FP-64 Blank.....	0
D-6.....	2	FO-1 FP-15	1	FO-1 FP-65.....	1
E-1 and E-2.....	0	FO-1 FP-16 Blank	0		
		FO-1 FP-17	1		

* Zero in this column indicates an original page.

LIST OF EFFECTIVE PAGES (CONT)

Insert latest changed pages. Destroy superseded pages.

Page No.	*Change No.	Page No.	*Change No.	Page No.	*Change No.
FO-1 FP-66 Blank	0				
FO-1 FP-67	1				
FO-1 FP-68 Blank	0				
FO-2 FP-1	0				
FO-2 FP-2 Blank	0				
FO-2 FP-3	0				
FO-2 FP-4 Blank	0				
FO-2 FP-5	0				
FO-2 FP-6 Blank	0				
FO-2 FP-7	0				
FO-2 FP-8 Blank	0				
FO-3 FP-1	0				
FO-3 FP-2 Blank	0				
FO-3 FP-3	0				
FO-3 FP-4 Blank	0				
FO-3 FP-5	0				
FO-3 FP-6 Blank	0				
FO-4 FP-1	0				
FO-4 FP-2 Blank	0				
FO-4 FP-3	0				
FO-4 FP-4 Blank	0				
FO-5 FP-1	0				
FO-5 FP-2 Blank	0				
FO-5 FP-3	0				
FO-5 FP-4 Blank	0				
FO-5 FP-5	0				
FO-5 FP-6 Blank	0				

* Zero in this column indicates an original page.

TECHNICAL MANUAL
NO. 9-2320-365-20-1

HEADQUARTERS
DEPARTMENTS OF THE ARMY
AND THE AIR FORCE
Washington, D.C., 17 June 1998

TECHNICAL ORDER
NO. 36A12-1B-1095-2-1

**Unit Maintenance Manual
M1078 SERIES, 2 1/2-TON, 4 x 4,
LIGHT MEDIUM TACTICAL VEHICLES (LMTV)
VOLUME NO. 1 OF 5**

MODEL	NSN	EIC
TRK, CAR., LMTV, M1078 W/WN W/O WN	2320-01-360-1898 2320-01-354-3385	BHH BHD
TRK, VAN, LMTV, M1079 W/WN W/O WN	2320-01-360-1891 2320-01-354-3384	BHG BHE
TRK, CHAS, LMTV, M1080	2320-01-353-9098	BHC
TRK, CAR., LMTV, AIR DROP, M1081 W/WN W/O WN	2320-01-360-1899 2320-01-355-3064	BHJ BHF

REPORTING ERRORS AND RECOMMENDING IMPROVEMENTS

You can help improve this publication. If you find any mistakes or if you know of a way to improve the procedures, please let us know. Submit your DA Form 2028 (Recommended Changes to Equipment Technical Publications), through the Internet, on the Army Electronic Product Support (AEPS) website. The Internet address is <http://aeeps.ria.army.mil>. If you need a password, scroll down and click on "ACCESS REQUEST FORM". The DA Form 2028 is located in the ONLINE FORMS PROCESSING section of the AEPS. Fill out the form and click on SUBMIT. Using this form on the AEPS will enable us to respond quicker to your comments and better manage the DA Form 2028 program. You may also mail, fax or Email a letter or DA Form 2028 direct to: AMSTA-LC-LPIT/TECH PUBS, TACOM-RI, 1 Rock Island Arsenal, Rock Island, IL 61299-7630. The email address is TACOM-TECH-PUBS@ria.army.mil. The fax number is DSN 793-0726 or Commercial (309) 782-0726.

DISTRIBUTION STATEMENT A. Approved for public release; distribution is unlimited.

TABLE OF CONTENTS

	Page
HOW TO USE THIS MANUAL	vi
CHAPTER 1 INTRODUCTION	1-1
Section I General Information	1-1
Section II Equipment Description and Data	1-5
Section III Principles of Operation	1-6

CHAPTER 2 VEHICLE MAINTENANCE..... 2-1

 Section I Repair Parts, Special Tools and Test, Measurement and Diagnostic Equipment..... 2-2

 Section II Service Upon Receipt 2-3

 Section III Preventative Maintenance and Services (PMCS) 2-6.1

 Section IV Troubleshooting 2-53

 Section V Maintenance Procedures 2-2127

CHAPTER 3 ENGINE MAINTENANCE 3-1

 Section I Introduction 3-2

 Section II Maintenance Procedures 3-2

CHAPTER 4 FUEL SYSTEM MAINTENANCE 4-1

 Section I Introduction 4-1

 Section II Maintenance Procedures 4-2

CHAPTER 5 EXHAUST SYSTEM MAINTENANCE..... 5-1

 Section I Introduction 5-1

 Section II Maintenance Procedures 5-2

CHAPTER 6 COOLING SYSTEM MAINTENANCE 6-1

 Section I Introduction 6-1

 Section II Maintenance Procedures 6-2

CHAPTER 7 ELECTRICAL SYSTEM MAINTENANCE 7-1

 Section I Introduction 7-2

 Section II Maintenance Procedures 7-3

CHAPTER 8 TRANSMISSION MAINTENANCE 8-1

 Section I Introduction 8-1

 Section II Maintenance Procedures 8-2

CHAPTER 9 PROPELLER SHAFT MAINTENANCE 9-1

 Section I Introduction 9-1

 Section II Maintenance Procedures 9-2

CHAPTER 10 FRONT AND REAR AXLE MAINTENANCE 10-1

 Section I Introduction 10-1

 Section II Maintenance Procedures 10-2

CHAPTER 11	BRAKE SYSTEM MAINTENANCE	11-1
Section I	Introduction	11-1
Section II	Maintenance Procedures	11-2
CHAPTER 12	WHEELS, TIRES, AND HUBS MAINTENANCE	12-1
Section I	Introduction	12-1
Section II	Maintenance Procedures	12-2
CHAPTER 13	STEERING SYSTEM MAINTENANCE	13-1
Section I	Introduction	13-1
Section II	Maintenance Procedures	13-2
CHAPTER 14	FRAME, TOWING ATTACHMENTS, AND DRAWBARS MAINTENANCE	14-1
Section I	Introduction	14-1
Section II	Maintenance Procedures	14-2
CHAPTER 15	SUSPENSION SYSTEM MAINTENANCE	15-1
Section I	Introduction	15-1
Section II	Maintenance Procedures	15-2
CHAPTER 16	BODY AND CAB MAINTENANCE	16-1
Section I	Introduction	16-2
Section II	Maintenance Procedures	16-3
CHAPTER 17	11K SELF-RECOVERY WINCH (SRW) MAINTENANCE	17-1
Section I	Introduction	17-2
Section II	Maintenance Procedures	17-3
CHAPTER 18	BODY, CHASSIS, AND ACCESSORY ITEMS MAINTENANCE	18-1
Section I	Introduction	18-1
Section II	Maintenance Procedures	18-2
CHAPTER 19	HYDRAULIC SYSTEM MAINTENANCE	19-1
Section I	Introduction	19-1
Section II	Maintenance Procedures	19-2
CHAPTER 20	SPECIAL PURPOSE KITS MAINTENANCE	20-1
Section I	Introduction	20-2
Section II	Maintenance Procedures	20-3
CHAPTER 21	ARMAMENT/SIGHTING AND FIRE CONTROL MATERIEL MAINTENANCE	21-1
Section I	Introduction	21-2
Section II	Maintenance Procedures	21-2
CHAPTER 22	ELECTRICAL ILLUMINATING EQUIPMENT MAINTENANCE	22-1
Section I	Introduction	22-1
Section II	Maintenance Procedures	22-2
CHAPTER 23	AIR SYSTEM MAINTENANCE	23-1
Section I	Introduction	23-1
Section II	Maintenance Procedures	23-2

TABLE OF CONTENTS (CONT)

CHAPTER 24 GAGES (NON-ELECTRICAL) MAINTENANCE 24-1

 Section I Introduction 24-1

 Section II Maintenance Procedures 24-2

APPENDIXES

 A. REFERENCES A-1

 B. MAINTENANCE ALLOCATION CHART B-1

 C. TOOLS IDENTIFICATION LIST C-1

 D. EXPENDABLE/DURABLE SUPPLIES AND MATERIALS LIST D-1

 E. ILLUSTRATED LIST OF MANUFACTURED ITEMS E-1

 F. TORQUE LIMITS F-1

 G. MANDATORY REPLACEMENT PARTS G-1

 H. LUBRICATION ORDER H-1

 J. ADDITIONAL AUTHORIZATION LIST (AAL) J-1

 K. TRANSMISSION/TRANSMISSION CONTROLS ADAPTABILITY CHART K-1

SUBJECT INDEX Index-1

GLOSSARY Glossary-1

LIST OF ILLUSTRATIONS

Figure No.	Figure Title	Page
1-1.	M1078 Truck, Cargo: 2 1/2-Ton, 4x4, Dropside	1-2
1-2.	M1079 Truck, Van: 2 1/2 ton, 4x4	1-3
1-3.	M1080 Truck, Chassis: 2 1/2-Ton, 4x4	1-4
1-4.	M1081 Truck, Cargo: 2 1/2-Ton, 4x4, Air Drop	1-5
1-5.	Powertrain	1-7
1-6.	Engine Air Intake System	1-9
1-7.	Fuel System	1-10
1-8.	Cooling System	1-12
1-9.	Electrical System	1-14
1-10.	Engine Starting System	1-15
1-11.	Service Lighting System	1-16
1-12.	Blackout Lighting System	1-17
1-13.	Instrument System	1-18
1-14.	Troubleshooting Aid	1-19
1-15.	Brake System	1-20
1-16.	Steering System	1-22
1-17.	11K Self-Recovery Winch (SRW)	1-23
1-18.	Air Transportability Hydraulic System	1-24
1-19.	Air System	1-26
2-1.	Circuit Breaker Locations	2-151
7-1.	Power Distribution Panel (PDP) Circuit Breakers, Diodes, and Relays	7-36
11-1.	Front Brake Shoe Service Criteria	11-4
11-2.	Rear Brake Shoe Service Criteria	11-11
11-3.	Rear Brake Air Hose Locations	11-97
11-4.	Rear Brake Control Air Hose Locations	11-99
11-5.	Front Brake Air Hose Locations	11-101
16-1.	M1079 Van Body Interior Accessory Mounting Hardpoints (Serial Numbers 001 through 190)	16-260
16-2.	M1079 Van Body Interior Accessory Mounting Hardpoints (Serial Numbers 191 and Higher)	16-261

LIST OF ILLUSTRATIONS (CONT)

Figure No.	Figure Title	Page
16-3.	M1079 Van Body Interior Accessory Mounting Hardpoints	16-262
16-4.	M1079 Van Body Interior Accessory Mounting Hardpoints	16-263
16-5.	M1079 Van Body Interior Accessory Mounting Hardpoints (Serial Numbers 001 through 190)	16-265
16-6.	M1079 Van Body Interior Accessory Mounting Hardpoints (Serial Numbers 191 and Higher)	16-266
17-1.	11K Self-Recovery Winch (SRW) Hydraulic Hose Locations	17-29
19-1.	Hydraulic Manifold PN HFC32598 Rear View	19-11
19-1.1.	Hydraulic Manifold PN 65234 Rear View	19-12
19-1.2.	Air Transportability Hydraulic Hose Locations	19-54
23-1.	Primary Air Supply Hose Locations	23-3
23-2.	Central Tire Inflation System (CTIS) Air Hose Locations	23-5
23-3.	Air Transportability Air Hose Locations	23-9
E-1.	Brake Adjusting Tool Support	E-4
E-2.	Brake Plunger Seal Driver	E-5
E-3.	Cab Support Tool Strut and Cab Rest	E-6
E-4.	Cab Support Tool Seat	E-7
E-5.	Cab Support Tool Seat Layout	E-8
E-6.	Cab Support Tool Assembly	E-9
E-7.	Headlight Adjustment Screen	E-10
E-8.	Lanyard Assembly	E-17
E-9.	CTIS Seal Driver	E-19
E-10.	Wheel Hub Grease Seal Driver	E-20
E-11.	Purge Valve Tool	E-22

LIST OF TABLES

Table No.	Table Title	Page
1-1.	Nomenclature Cross-Reference	1-6
2-1.	Preventive Maintenance Checks and Services	2-9
2-2.	Vehicle Troubleshooting	2-55
2-3.	Engine System Fault Index	2-63
2-4.	Fuel System Fault Index	2-101
2-5.	Exhaust System Fault Index	2-119
2-6.	Cooling System Fault Index	2-129
2-7.	Electrical System Fault Index	2-147
2-8.	Function to Circuit Breaker Cross Reference	2-152
2-8.1.	Circuit Breaker to Function Cross Reference	2-152.3
2-8.2.	Connector PX33 Ground Continuity Test	2-249
2-8.3.	Connector PX33 Continuity Test	2-251
2-8.4.	Speedometer Dip Switch Settings	2-344.1
2-8.5.	Speedometer Dip Switch Settings	2-345
2-9.	Deleted	
2-10.	Deleted	
2-11.	Deleted	
2-11.1.	Cab Clearance and Marker Light Connectors	2-565
2-11.2.	Cab Clearance and Marker Light Terminal Lugs	2-567
2-12.	Side and Rear Marker Light Connectors	2-581
2-12.1.	Side and Rear Marker Light Terminal Lugs	2-583

LIST OF TABLES (CONT)

Table No.	Table Title	Page
2-13.	Van Body Clearance/Marker Light Location and Connector Number	2-1107
2-14.	M1079 Blackout Light Locations and Connector Numbers	2-1225
2-15.	M1079 Emergency Light Locations and Connector Numbers	2-1233
2-16.	Transmission System Fault Index	2-1359
2-17.	Transmission Sump Oil Temperature Sensor Resistance Readings	2-1395
2-18.	WTEC II Cab Transmission Harness Transmission Solenoid Test Points	2-1401
2-19.	Connector P119 Transmission Solenoid Resistance Test Points	2-1403
2-20.	Transmission Solenoid Resistance Readings	2-1403
2-21.	Main Code 43 Sub Code 21 and 26 High Side Test Points	2-1405
2-22.	Main Code 43 Sub Code 21 and 26 Low Side Test Points	2-1407
2-23.	Transmission Solenoid F and G Resistance Test Points	2-1409
2-24.	Sub Code Range	2-1417
2-25.	WTEC II Cab Transmission Harness Continuity Check	2-1441
2-26.	Off-Going Clutch Pressure Tap	2-1447
2-27.	Clutch Pressure Tap	2-1451
2-28.	Off-Going Clutch Pressure Tap	2-1455
2-29.	Clutch Pressure Tap	2-1461
2-30.	Clutch Pressure Tap	2-1467
2-31.	Clutch Pressure Tap	2-1473
2-32.	Transmission Sump Oil Temperature Sensor Resistance Readings	2-1515
2-33.	WTEC III Cab Transmission Harness Transmission Solenoid Test Points	2-1523
2-34.	Connector P119 Transmission Solenoid Resistance Test Points	2-1525
2-35.	Transmission Solenoid Resistance Readings	2-1525
2-36.	Sub Code Range	2-1533
2-37.	WTEC III Cab Transmission Harness Continuity Check	2-1547
2-38.	Off-Going Clutch Pressure Tap	2-1553
2-39.	Clutch Pressure Tap	2-1557
2-40.	Off-Going Clutch Pressure Tap	2-1561
2-41.	Clutch Pressure Tap	2-1567
2-42.	Clutch Pressure Tap	2-1573
2-43.	Clutch Pressure Tap	2-1579
2-44.	Propeller Shaft Fault Index	2-1597
2-45.	PTO Fault Index	2-1603
2-46.	Brake System Fault Index	2-1607
2-47.	Air System Fault Index	2-1713
2-48.	Wheel Fault Index	2-1753
2-49.	Hydraulic System Fault Index	2-1761
2-50.	Central Tire Inflation System (CTIS) Fault Index	2-1767
2-51.	Axle Fault Index	2-1895
2-52.	Steering Fault Index	2-1903
2-53.	Suspension System Fault Index	2-1925
2-54.	11K Self-Recovery Winch (SRW) System Fault Index	2-1945
2-55.	Steering Hydraulic System Fault Index	2-1953
2-56.	Air Transport Components Fault Index	2-1959
2-57.	Special Purpose Kit Fault Index	2-1977
2-58.	Cab Tilt and Spare Tire Retainer Fault Index	2-2115
2-59.	Frame Fault Index	2-2121
7-1.	Power Distribution Panel (PDP) Relays	7-36.1
7-1.1.	Power Distribution Panel (PDP) Circuit Breakers	7-36.2
7-1.2.	Electrical Gages Connectors	7-89

LIST OF TABLES (CONT)

Table No.	Table Title	Page
7-2.	Rocker Switch Connectors	7-90
7-3.	M1081 Cab Clearance and Marker Light Connectors	7-230
7-4.	Cab Clearance and Marker Light Connectors	7-245
8-1.	WTEC II Diagnostic Code List and Description	8-10
8-2.	WTEC III Diagnostic Code List and Description	8-15
11-1.	Air Chamber Pressure Limits	11-60
11-2.	Rear Brake Air Hose Locations	11-97
11-3.	Rear Brake Control Air Hose Locations	11-99
11-4.	Front Brake Air Hose Locations	11-101
16-1.	M1079 Van Body Accessory Mounting Blind Rivet Nuts	16-259
16-2.	M1079 Interior Field Telephone Binding Post Wire Numbers	16-315
16-3.	M1079 24 VDC Binding Post Wire Numbers	16-326
16-4.	M1079 110 VAC Outlet Box Location and Wire Numbers	16-339
16-5.	M1079 Blackout Switch Location and Wire Numbers	16-368
16-6.	M1079 Blackout/Emergency Light Locations and Connectors	16-372
16-7.	M1079 Clearance and Marker Lights Location and Connectors	16-388
16-8.	M1079 Circuit Breakers and Wire Numbers	16-418
16-9.	M1079 Connector J173 Pin Letters and Wire Numbers	16-474
17-1.	11K Self-Recovery Winch (SRW) Hydraulic Hose Locations	17-29
19-1.	Air Transportability Hydraulic Hose Locations	19-54
23-1.	Primary Air Supply Hose Locations	23-3
23-2.	Central Tire Inflation System (CTIS) Air Hose Locations	23-5
23-3.	Air Transportability Air Hose Locations	23-9
E-1.	Pneumatic Tube Lengths	E-13
E-2.	Non-Metallic Electrical Cable Conduit Lengths	E-15
F-1.	Dry Torque Limits for SAE and ANSI Screws and Free Spinning Nuts	F-2
F-2.	Dry Torque Limits for SAE and ANSI Prevailing Torque Nuts	F-4
F-3.	Dry Torque Limits for Metric Screws and Free Spinning Nuts	F-5
F-4.	Dry Torque Limits for Metric Prevailing Torque Nuts	F-6
F-5.	Wet Torque Limits for SAE and ANSI Screws and Free Spinning Nuts	F-7

HOW TO USE THIS MANUAL

OVERVIEW

This technical manual (TM) is provided to help you maintain the LMTV at the Unit Maintenance level. Because of its size, it is divided into five volumes. Volumes 2, 3, 4, and 5 contain information which will assist you in the performance of Unit Maintenance on the LMTV. Volume 1 contains the following major sections in order of appearance:

- **WARNING SUMMARY.** Provides a summary of the most important warnings that apply throughout the manual.
- **TABLE OF CONTENTS.** Lists, for all volumes, the chapters, sections, appendixes, and indexes with page numbers in order of appearance.
- **CHAPTER 1, INTRODUCTION.** Describes the LMTV and provides equipment data.

OVERVIEW (CONT)

- **CHAPTER 2, VEHICLE MAINTENANCE.** This chapter contains information for finding tools; special tools; test, measurement, and diagnostic equipment (TMDE); and repair parts. It also contains the preventive maintenance checks and services (PMCS) and troubleshooting tables.
- **APPENDIX A, REFERENCES.** Lists publications used with the LMTV.
- **APPENDIX B, MAINTENANCE ALLOCATION CHART.** The maintenance allocation chart denotes the level of maintenance which performs specific maintenance tasks and the time required. It also lists tools and special tools required for each task.
- **APPENDIX C, TOOLS IDENTIFICATION LIST.** Lists equipment used in the performance of maintenance and references publications which contain information regarding the equipment.
- **APPENDIX D, EXPENDABLE/DURABLE SUPPLIES AND MATERIALS LIST.** Lists expendable and durable items used in the performance of maintenance.
- **APPENDIX E, ILLUSTRATED LIST OF MANUFACTURED ITEMS.** Illustrates and describes items that must be fabricated from bulk materials for repair of the LMTV.
- **APPENDIX F, TORQUE LIMITS.** Lists the standard torque values for specific attaching hardware.
- **APPENDIX G, MANDATORY REPLACEMENT PARTS.**
- **APPENDIX H, LUBRICATION ORDER.**
- **APPENDIX J, ADDITIONAL AUTHORIZATION LIST (AAL).**
- **APPENDIX K, TRANSMISSION/TRANSMISSION CONTROLS ADAPTABILITY CHART.**
- **SUBJECT INDEX.** Lists important subjects contained in volumes 1, 2, 3, 4, and 5 in alphabetical order and gives the associated paragraph number.

Volume 2 contains the following major sections in order of appearance:

- **WARNING SUMMARY.** Provides a summary of the most important warnings that apply throughout the manual.
- **CHAPTER 2, VEHICLE MAINTENANCE (CONT).**
- **CHAPTER 3, ENGINE MAINTENANCE.**
- **APPENDIX A, REFERENCES.** Lists publications used with the LMTV.
- **APPENDIX B, MAINTENANCE ALLOCATION CHART.** The maintenance allocation chart denotes the level of maintenance which performs specific maintenance tasks and the time required. It also lists tools and special tools required for each task.
- **APPENDIX C, TOOLS IDENTIFICATION LIST.** Lists equipment used in the performance of maintenance and references publications which contain information regarding the equipment.
- **APPENDIX D, EXPENDABLE/DURABLE SUPPLIES AND MATERIALS LIST.** Lists expendable and durable items used in the performance of maintenance.

- **APPENDIX E, ILLUSTRATED LIST OF MANUFACTURED ITEMS.** Illustrates and describes items that must be fabricated from bulk materials for repair of the LMTV.
- **APPENDIX F, TORQUE LIMITS.** Lists the standard torque values for specific attaching hardware.
- **APPENDIX G, MANDATORY REPLACEMENT PARTS.**
- **APPENDIX H, LUBRICATION ORDER.**
- **APPENDIX J, ADDITIONAL AUTHORIZATION LIST (AAL).**
- **APPENDIX K, TRANSMISSION/TRANSMISSION CONTROLS ADAPTABILITY CHART.**
- **SUBJECT INDEX.** Lists important subjects contained in volume 2 in alphabetical order and gives the associated paragraph number.

Volume 3 contains the following major sections in order of appearance:

- **WARNING SUMMARY.** Provides a summary of the most important warnings that apply throughout the manual.
- **CHAPTER 4, FUEL SYSTEM MAINTENANCE**
- **CHAPTER 5, EXHAUST SYSTEM MAINTENANCE**
- **CHAPTER 6, COOLING SYSTEM MAINTENANCE**
- **CHAPTER 7, ELECTRICAL SYSTEM MAINTENANCE**
- **CHAPTER 8, TRANSMISSION MAINTENANCE**
- **CHAPTER 9, PROPELLER SHAFT MAINTENANCE**
- **CHAPTER 10, FRONT AND REAR AXLE MAINTENANCE**
- **CHAPTER 11, BRAKE SYSTEM MAINTENANCE**
- **CHAPTER 12, WHEEL, TIRES, AND HUBS MAINTENANCE**
- **CHAPTER 13, STEERING SYSTEM MAINTENANCE**
- **CHAPTER 14, FRAME, TOWING ATTACHMENTS, AND DRAWBARS MAINTENANCE**
- **CHAPTER 15, SUSPENSION SYSTEM MAINTENANCE**
- **APPENDIX A, REFERENCES.** Lists publications used with the LMTV.
- **APPENDIX B, MAINTENANCE ALLOCATION CHART.** The maintenance allocation chart denotes the level of maintenance which performs specific maintenance tasks and the time required. It also lists tools and special tools required for each task.
- **APPENDIX C, TOOLS IDENTIFICATION LIST.** Lists equipment used in the performance of maintenance and references publications which contain information regarding the equipment.

OVERVIEW (CONT)

- **APPENDIX D, EXPENDABLE/DURABLE SUPPLIES AND MATERIALS LIST.** Lists expendable and durable items used in the performance of maintenance.
- **APPENDIX E, ILLUSTRATED LIST OF MANUFACTURED ITEMS.** Illustrates and describes items that must be fabricated from bulk materials for repair of the LMTV.
- **APPENDIX F, TORQUE LIMITS.** Lists the standard torque values for specific attaching hardware.
- **APPENDIX G, MANDATORY REPLACEMENT PARTS.**
- **APPENDIX H, LUBRICATION ORDER.**
- **APPENDIX J, ADDITIONAL AUTHORIZATION LIST (AAL).**
- **APPENDIX K, TRANSMISSION/TRANSMISSION CONTROLS ADAPTABILITY CHART.**
- **SUBJECT INDEX.** Lists important subjects contained in volume 3 in alphabetical order and gives the associated paragraph number.

Volume 4 contains the following major sections in order of appearance:

- **WARNING SUMMARY.** Provides a summary of the most important warnings that apply throughout the manual.
- **CHAPTER 16, BODY AND CAB MAINTENANCE**
- **CHAPTER 17, 11K SELF-RECOVERY WINCH (SRW) MAINTENANCE**
- **CHAPTER 18, BODY, CHASSIS, AND ACCESSORY ITEMS MAINTENANCE**
- **CHAPTER 19, HYDRAULIC SYSTEM MAINTENANCE**
- **APPENDIX A, REFERENCES.** Lists publications used with the LMTV.
- **APPENDIX B, MAINTENANCE ALLOCATION CHART.** The maintenance allocation chart denotes the level of maintenance which performs specific maintenance tasks and the time required. It also lists tools and special tools required for each task.
- **APPENDIX C, TOOLS IDENTIFICATION LIST.** Lists equipment used in the performance of maintenance and references publications which contain information regarding the equipment.
- **APPENDIX D, EXPENDABLE/DURABLE SUPPLIES AND MATERIALS LIST.** Lists expendable and durable items used in the performance of maintenance.
- **APPENDIX E, ILLUSTRATED LIST OF MANUFACTURED ITEMS.** Illustrates and describes items that must be fabricated from bulk materials for repair of the LMTV.
- **APPENDIX F, TORQUE LIMITS.** Lists the standard torque values for specific attaching hardware.
- **APPENDIX G, MANDATORY REPLACEMENT PARTS.**

- **APPENDIX H, LUBRICATION ORDER.**
- **APPENDIX J, ADDITIONAL AUTHORIZATION LIST (AAL).**
- **APPENDIX K, TRANSMISSION/TRANSMISSION CONTROLS ADAPTABILITY CHART.**
- **SUBJECT INDEX.** Lists important subjects contained in volume 4 in alphabetical order and gives the associated paragraph number.

Volume 5 contains the following major sections in order of appearance:

- **WARNING SUMMARY.** Provides a summary of the most important warnings that apply throughout the manual.
- **CHAPTER 20, SPECIAL PURPOSE KITS MAINTENANCE**
- **CHAPTER 21, ARMAMENT/SIGHTING AND FIRE CONTROL MATERIEL MAINTENANCE**
- **CHAPTER 22, ELECTRICAL ILLUMINATING EQUIPMENT MAINTENANCE**
- **CHAPTER 23, AIR SYSTEM MAINTENANCE**
- **CHAPTER 24, GAGES (NON-ELECTRICAL) MAINTENANCE**
- **APPENDIX A, REFERENCES.** Lists publications used with the LMTV.
- **APPENDIX B, MAINTENANCE ALLOCATION CHART.** The maintenance allocation chart denotes the level of maintenance which performs specific maintenance tasks and the time required. It also lists tools and special tools required for each task.
- **APPENDIX C, TOOLS IDENTIFICATION LIST.** Lists equipment used in the performance of maintenance and references publications which contain information regarding the equipment.
- **APPENDIX D, EXPENDABLE/DURABLE SUPPLIES AND MATERIALS LIST.** Lists expendable and durable items used in the performance of maintenance.
- **APPENDIX E, ILLUSTRATED LIST OF MANUFACTURED ITEMS.** Illustrates and describes items that must be fabricated from bulk materials for repair of the LMTV.
- **APPENDIX F, TORQUE LIMITS.** Lists the standard torque values for specific attaching hardware.
- **APPENDIX G, MANDATORY REPLACEMENT PARTS.**
- **APPENDIX H, LUBRICATION ORDER.**
- **APPENDIX J, ADDITIONAL AUTHORIZATION LIST (AAL).**
- **APPENDIX K, TRANSMISSION/TRANSMISSION CONTROLS ADAPTABILITY CHART.**
- **SUBJECT INDEX.** Lists important subjects contained in volume 5 in alphabetical order and gives the associated paragraph number.

FINDING INFORMATION

There are several ways to find the information you need in this manual. They are as follows:

- **FRONT COVER INDEX.** The front cover index contains a list of the most important topics contained in each volume. It features a black box at the right edge of the cover which corresponds with a black box on the page containing the topic. The topics listed on the front cover are highlighted in the table of contents with a box.
- **TABLE OF CONTENTS.** Lists chapters, sections, appendixes, and indexes with page numbers in order of appearance.
- **CHAPTER INDEXES.** List paragraphs contained in the individual chapters with paragraph and page numbers in order of appearance.
- **SYMPTOM INDEX.** Lists malfunctions contained in the troubleshooting table with page numbers in order of appearance.

TROUBLESHOOTING

Troubleshooting is contained in chapter 2. When a malfunction occurs, look at the symptom index for the vehicle troubleshooting table in chapter 2. Find the malfunction in the index. Turn to the page number listed for the malfunction in the troubleshooting table. Perform the steps required to correct the malfunction. If you can't find the malfunction, or the malfunction is not corrected, notify your supervisor.

MAINTENANCE

- **SCHEDULED MAINTENANCE.** Your scheduled maintenance is located in **Table 2-1. Preventive Maintenance Checks and Services.** These checks and services are mandatory at the intervals listed. Always follow the WARNINGS and CAUTIONS.
- **UNSCHEDULED MAINTENANCE.** Unscheduled maintenance is located in chapters 3 through 24. The PMCS and troubleshooting tables often reference you to these procedures. When you perform maintenance, look over the entire procedure before starting. Make sure you have the necessary tools and materials at hand. Always follow the WARNINGS and CAUTIONS.

FOLLOW THESE GUIDELINES WHEN USING THIS MANUAL:

- Become familiar with the entire maintenance procedure before beginning a maintenance task.
- Read all **WARNINGS** and **CAUTIONS** before performing any procedures.

CHAPTER 1 INTRODUCTION

	Page
Section I. GENERAL INFORMATION	1-1
1-1. SCOPE	1-1
1-2. MAINTENANCE FORMS, RECORDS, AND REPORTS	1-6
1-3. DESTRUCTION OF ARMY MATERIEL TO PREVENT ENEMY USE	1-6
1-4. OFFICIAL NOMENCLATURE, NAMES AND DESIGNATIONS	1-6
1-5. REPORTING EQUIPMENT IMPROVEMENT RECOMMENDATIONS (EIR)	1-6
1-6. WARRANTY INFORMATION	1-6
Section II. EQUIPMENT DESCRIPTION AND DATA	1-6
1-7. EQUIPMENT CHARACTERISTICS, CAPABILITIES, AND FEATURES	1-6
1-8. LOCATION AND DESCRIPTION OF MAJOR COMPONENTS	1-7
1-9. DIFFERENCES BETWEEN MODELS	1-7
Section III. PRINCIPLES OF OPERATION	1-7
1-10. POWERTRAIN	1-7
1-11. ENGINE AIR INTAKE SYSTEM	1-9
1-12. FUEL SYSTEM	1-10
1-13. COOLING SYSTEM	1-12
1-14. ELECTRICAL SYSTEM	1-14
1-15. BRAKE SYSTEM	1-20
1-16. STEERING SYSTEM	1-22
1-17. 11K SELF-RECOVERY WINCH (SRW)	1-23
1-18. AIR TRANSPORTABILITY HYDRAULIC SYSTEM	1-24
1-19. AIR SYSTEM	1-26

Section I. GENERAL INFORMATION

1-1. SCOPE

This chapter provides general information, equipment description, and principles of operation for the M1078 series Light Medium Tactical Vehicle (LMTV). The LMTV will herein be referred to as the vehicle.

a. Type of Manual: Unit Support Maintenance Instructions, TM 9-2320-365-20-1.

b. Model Numbers and Equipment Names. The vehicle model numbers and names are listed below:

M1078 Truck, Cargo: 2 1/2-Ton, 4x4, Dropside (Figure 1-1).

M1079 Truck, Van: 2 1/2-Ton, 4x4 (Figure 1-2).

M1080 Truck, Chassis: 2 1/2-Ton, 4x4 (Figure 1-3).

M1081 Truck, Cargo: 2 1/2-Ton, 4x4, Dropside, AIR DROP (Figure 1-4).

c. Purpose of Equipment. The LMTV series is a family of 4x4 wheeled vehicles. The purpose of these vehicles is as follows:

- (1) M1078 - Cargo hauling vehicle; can be outfitted for troop transport when equipped with a troopseat kit.
- (2) M1079 - Van; can be outfitted with communications equipment or shop equipment.
- (3) M1080 - Vehicle chassis; this chassis will accept a cargo bed or may be modified for special missions.
- (4) M1081 - Cargo hauling vehicle; can be airdropped and outfitted for troop transport when equipped with a troopseat kit.

1-1. SCOPE (CONT)

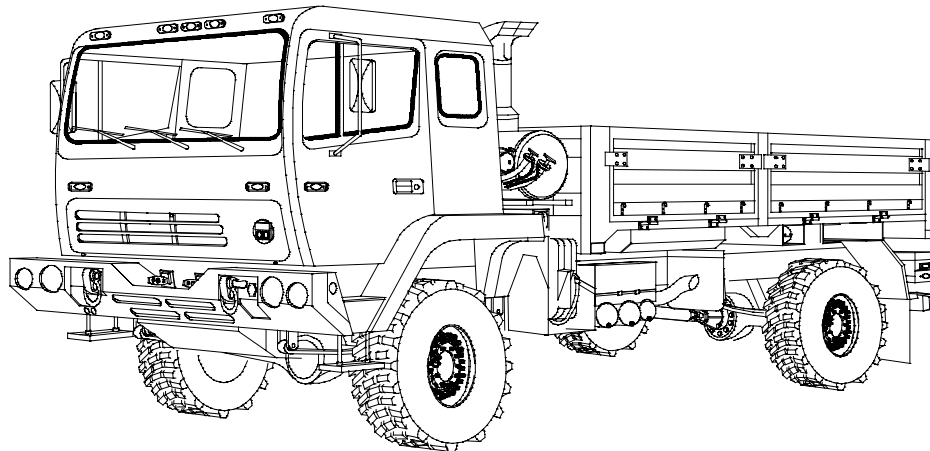

3A00001A

LEFT FRONT VIEW

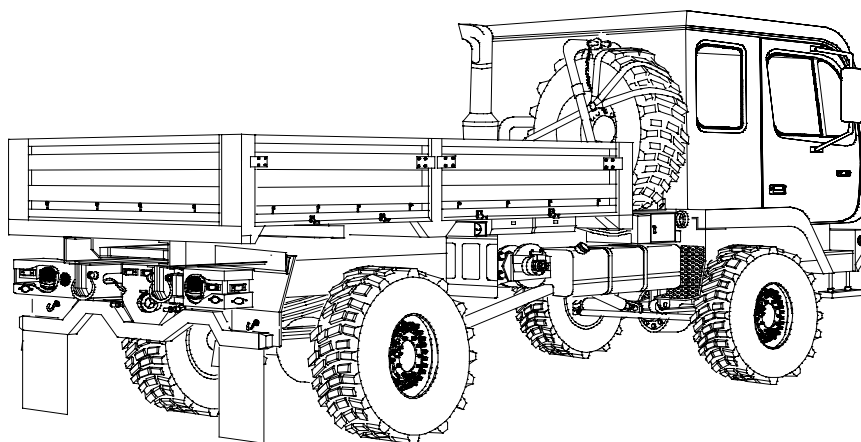

3A00002A

RIGHT REAR VIEW

Figure 1-1. M1078 Truck, Cargo: 2 1/2-Ton, 4x4, Dropside

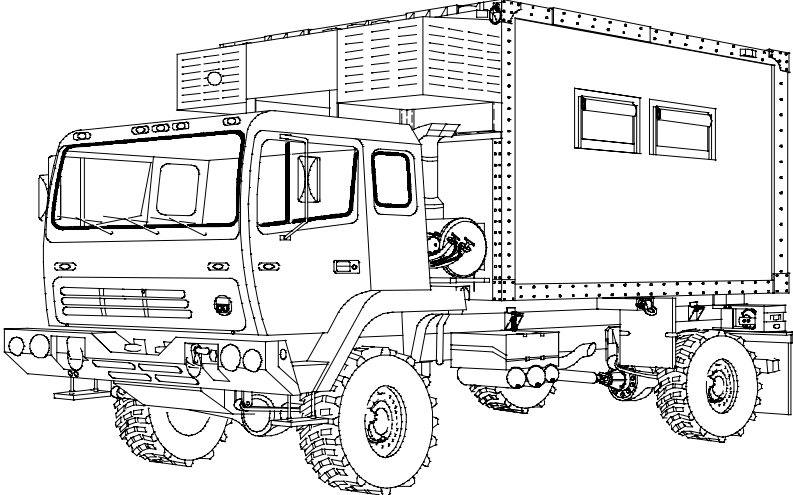

3A000031

LEFT FRONT VIEW

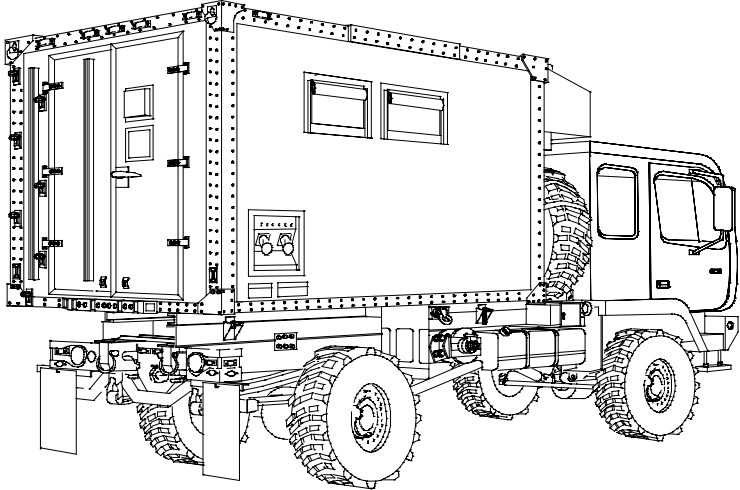

3A000041

RIGHT REAR VIEW

Figure 1-2. M1079 Truck, Van: 2 1/2 Ton, 4x4

1-1. SCOPE (CONT)

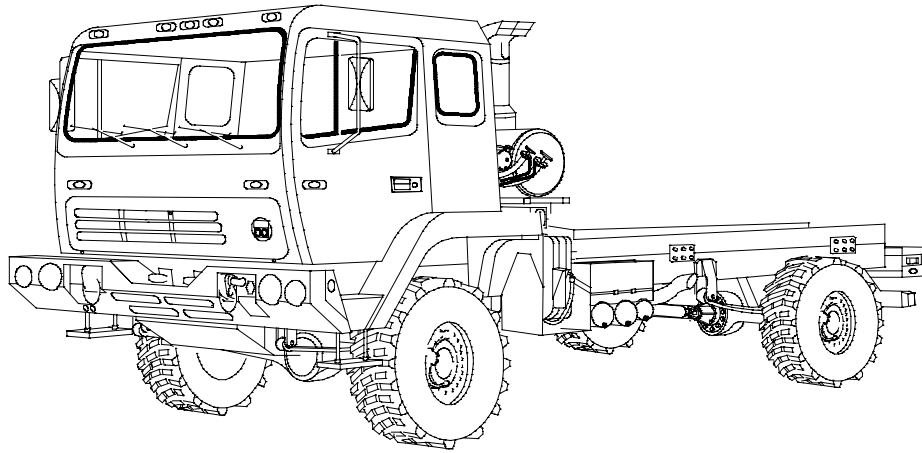

3A00005A

LEFT FRONT VIEW

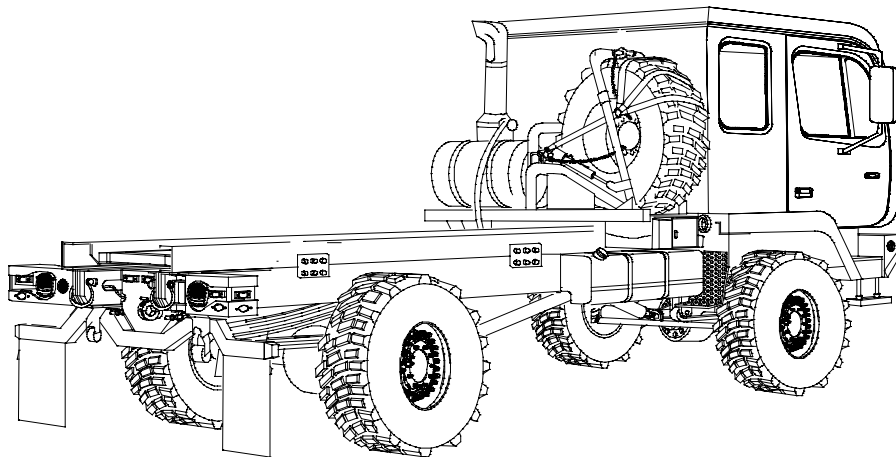

3A00006A

RIGHT REAR VIEW

Figure 1-3. M1080 Truck, Chassis: 2 1/2-Ton, 4x4

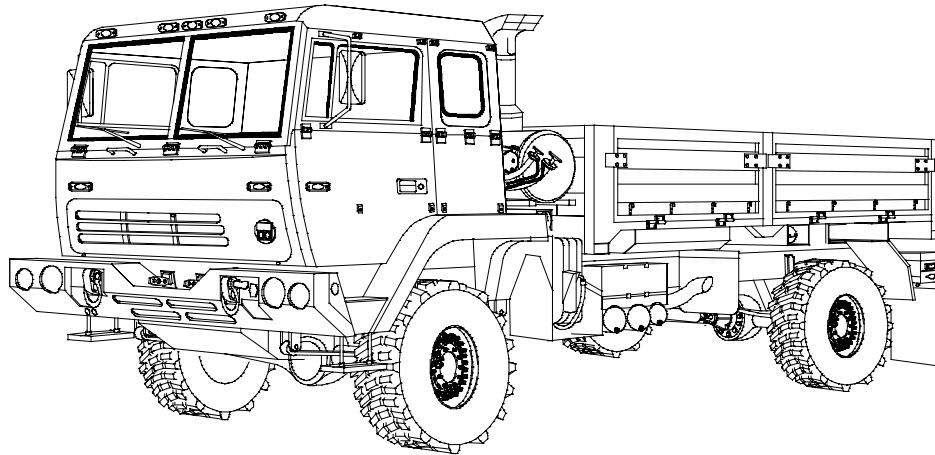

3A00007A

LEFT FRONT VIEW

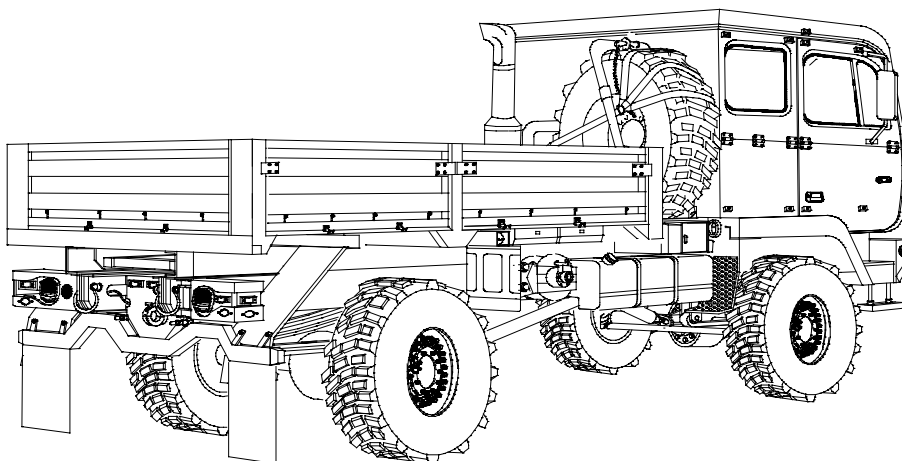

3A00008A

RIGHT REAR VIEW

Figure 1-4. M1081 Truck, Cargo: 2 1/2-Ton, 4x4, AIR DROP

1-2. MAINTENANCE FORMS, RECORDS, AND REPORTS

Department of the Army forms and procedures used for equipment maintenance will be those prescribed by (as applicable) DA Pam 738-750. The Army Maintenance Management Systems (TAMMS); DA Pam 738-751, Functional Users Manual for the Army Maintenance Management Systems; or AR 700-138. Army Logistics Readiness and Sustainability.

1-3. DESTRUCTION OF ARMY MATERIEL TO PREVENT ENEMY USE

Command decision, according to the tactical situation, will determine when the destruction plan of the M1078 vehicles will be accomplished. A destruction plan will be prepared by the using organization unless one has been prepared by a higher authority. For general destruction procedures for this equipment, refer to TM 750-224-6, Procedures for Destruction of Tank-Automotive Equipment to Prevent Enemy Use (U.S. Army Tank-automotive and Armaments Command).

1-4. OFFICIAL NOMENCLATURE, NAMES AND DESIGNATIONS

Table 1-1 lists the nomenclature cross-reference used in this manual.

Table 1-1. Nomenclature Cross-Reference

<u>Common Name</u>	<u>Official Nomenclature</u>
Cold Start System	Ether Quick-Start System
Engine Coolant	Antifreeze, Ethylene, Glycol, Inhibited
Gladhand	Quick-Disconnect Coupling
Vehicle	Light Medium Tactical Vehicle (LMTV)

1-5. REPORTING EQUIPMENT IMPROVEMENT RECOMMENDATIONS (EIR)

If your Light Medium Tactical Vehicle (LMTV) needs improvement, let us know. Send us an EIR. You, the user, are the only one who can tell us what you don't like about your equipment. Let us know why you don't like the design. Put it on an SF 368 (Quality Deficiency Report). Mail it to us at: Commander, U.S. Army Tank-automotive and Armaments Command, ATTN: AMSTA-TR-E/FMTV/312, Warren, MI 48397-5000. We'll send you a reply.

1-6. WARRANTY INFORMATION

Refer to M1078 Series Warranty Program Technical Bulletin, TB 9-2300-365-15, for complete warranty information covering the vehicle. Warranty starts on the date found in block 23, DA Form 2408-9, in the logbook. Report all defects in material or workmanship to your supervisor, who will take appropriate action.

Section II. EQUIPMENT DESCRIPTION AND DATA

1-7. EQUIPMENT CHARACTERISTICS, CAPABILITIES, AND FEATURES

Refer to TM 9-2320-365-10 for equipment characteristics, capabilities, and features.

1-8. LOCATION AND DESCRIPTION OF MAJOR COMPONENTS

Refer to TM 9-2320-365-10 for location and description of major components.

1-9. DIFFERENCES BETWEEN MODELS

Refer to TM 9-2320-365-10 for differences between models.

Section III. PRINCIPLES OF OPERATION

1-10. POWERTRAIN

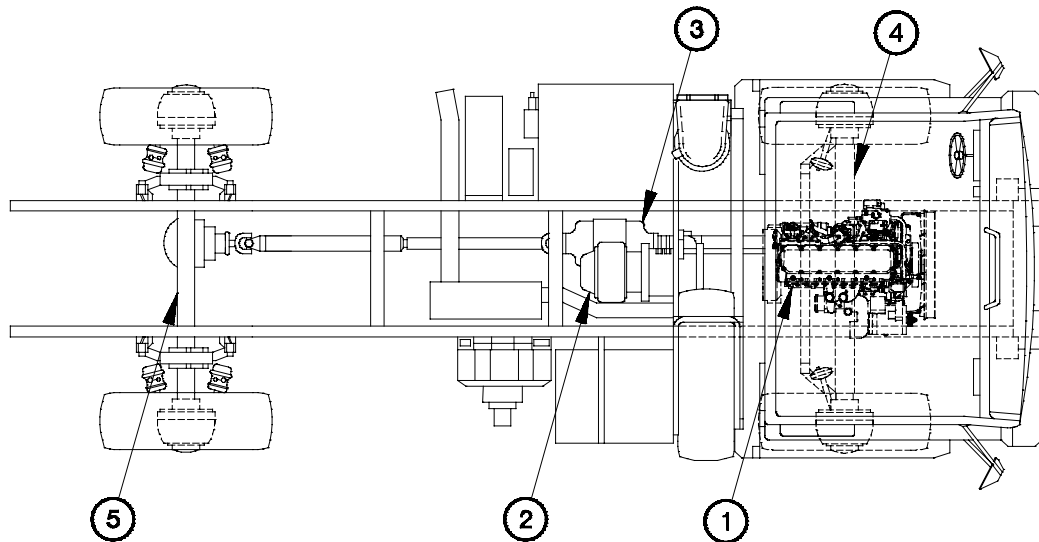

3A10001A

Figure 1-5. Powertrain

Power for the vehicle is provided by a diesel engine (1, Figure 1-5) which is coupled directly to an automatic transmission (2). Power from the automatic transmission is transferred to the transfer case (3) and on to the front steering and rear drive axles (4 and 5) through a series of drive shafts and universal joints. The vehicle drive train is enhanced by the use of an electronically controlled seven-speed transmission. The primary components of the Allison MD3070PT transmission consist of a control module located directly beneath the transmission main housing; a Throttle Position Sensor (TPS) which detects the percentage of throttle being used; and engine, turbine, and output speed sensors which, in combination with each other, send information to the transmission ECU to provide the smoothest possible shifting and allow the transmission ECU to monitor overall transmission performance. Transmission shift control is provided by one of two types of pushbutton shift selectors: The WTEC II Transmission ECU Pushbutton Shift Selector (TEPSS) which contains an integral transmission ECU or the WTEC III Transmission Pushbutton Shift Selector (TPSS) which is coupled to an external transmission ECU.

1-10. POWERTRAIN (CONT)

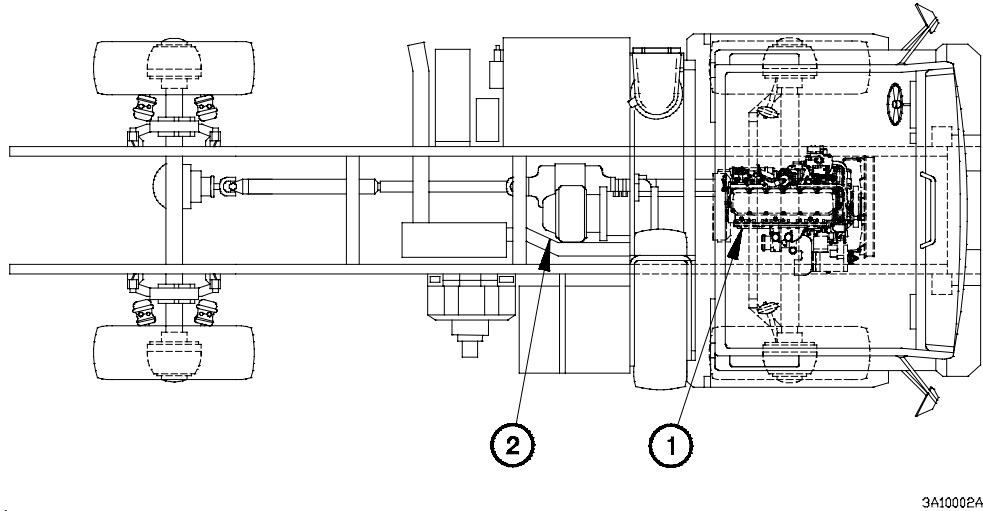

Figure 1-5. Powertrain (Cont)

- a. Engine.** The vehicle is equipped with a Caterpillar diesel engine, model 3116 ATAAC (Air-to Air After Cooler) (1, Figure 1-5), rated at 225 HP.
- b. Transmission.** The vehicle is equipped with an Allison automatic transmission, model MD3070PT (2, Figure 1-5). It is a fully automatic electronically controlled seven-speed close-ratio transmission.

(1) The TEPSS contains microprocessor based electronics, and is located in the instrument panel to the driver's left. The TPSS is located in the instrument panel to the driver's left, while the transmission ECU is located behind the kick panel. The ECU receives information, in the form of electrical signals from the various sensors, processes that information, then sends the appropriate signals to the solenoids which control transmission function. The ECU incorporates a diagnostic program which enables it to identify numerous actual and/or potential transmission problems. The TEPSS and TPSS are capable of displaying diagnostic codes in the Light Emitting Diode (LED) display on the pushbutton shift selector. These diagnostic codes are stored in the ECU for later retrieval. The pushbutton shift selector is used for selecting transmission range. The transmission defaults to Neutral (N) whenever electrical power is removed from the vehicle. The Drive (D) gear selection is used for normal driving conditions. The transmission will engage 2nd gear when D is selected and the vehicle is stopped. As the accelerator is depressed and speed increases, the transmission will automatically upshift through 3rd, 4th, 5th, 6th, and 7th gears. Low gear (1st gear), is available only by manual selection. Selecting a specific gear; for example, 3rd; will prevent the transmission upshifting past the selected gear. This is useful if road or load conditions require lower gear range operation. When road conditions improve or load is reduced, the shift selector can be returned to the normal (D) driving position. When electrical power is applied to the TEPSS and a fault is detected in the transmission controls, the TEPSS will emit an eight second series of beeps. When electrical power is applied to the TPSS and a fault is detected in the transmission controls, "--" will appear in the TPSS LED display. In either case, the transmission will not engage a range (forward or reverse) when D or Reverse (R) range is selected on the pushbutton shift selector. TM 9-2320-365-10 provides full operating instructions for the transmission.

(2) The transmission may include a Power Take-Off (PTO). The PTO powers a hydraulic pump which supplies hydraulic pressure for an 11K self-recovery winch (SRW).

c. Transfer Case. The transfer case (3, Figure 1-5) provides the transmission (2) with the seventh gear (low gear, or 1st gear) and delivers power from the transmission to the front and rear driveshafts. In normal driving conditions, the transfer case splits the output torque of the transmission, providing 70 percent of the torque to the rear output drive yoke and 30 percent to the front output drive yoke. In low gear the output torque of the transmission is split evenly, with 50 percent going to the front output yoke and 50 percent going to the rear.

d. Suspension. The suspension system is designed to maintain tire/ground contact in all types of terrain. The vehicle is equipped with 395/85R20 tires. The tires have a tread pattern designed to maximize traction on all types of terrain.

e. Axles. Front and rear axles (4 and 5, Figure 1-5) feature wheel end planetary drives designed to allow the vehicle to carry heavy loads. When the vehicle is operated in MODE, all axles become driving axles. When the vehicle is operated in MODE, 7th gear is unavailable.

1-11. ENGINE AIR INTAKE SYSTEM

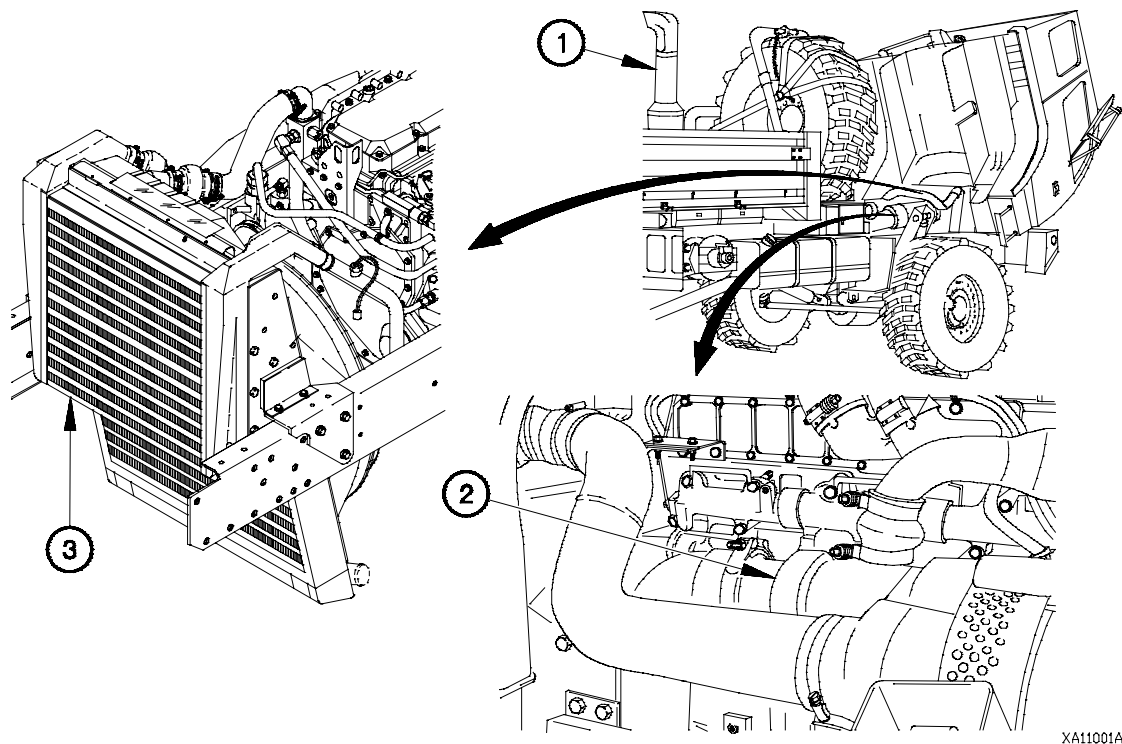

Figure 1-6. Engine Air Intake System

The engine air intake system consists of a dry-type air cleaner (1, Figure 1-6), turbocharger (2), and a charge air cooler (3). The turbocharger increases engine horsepower by delivering a higher volume of air to the engine. Engine exhaust gases flow through the turbocharger, causing a turbine wheel to spin. As the turbine wheel spins, a compressor wheel on the opposite end of the turbine wheel shaft spins and draws fresh air through the air cleaner. The compressor wheel compresses the air and delivers it to the charge air cooler. The air flows through the charge air cooler which cools the air before it is delivered to the engine cylinders. The charge air cooler allows a denser charge of air to be delivered to the engine, which also aids in increasing engine horsepower.

1-12. FUEL SYSTEM

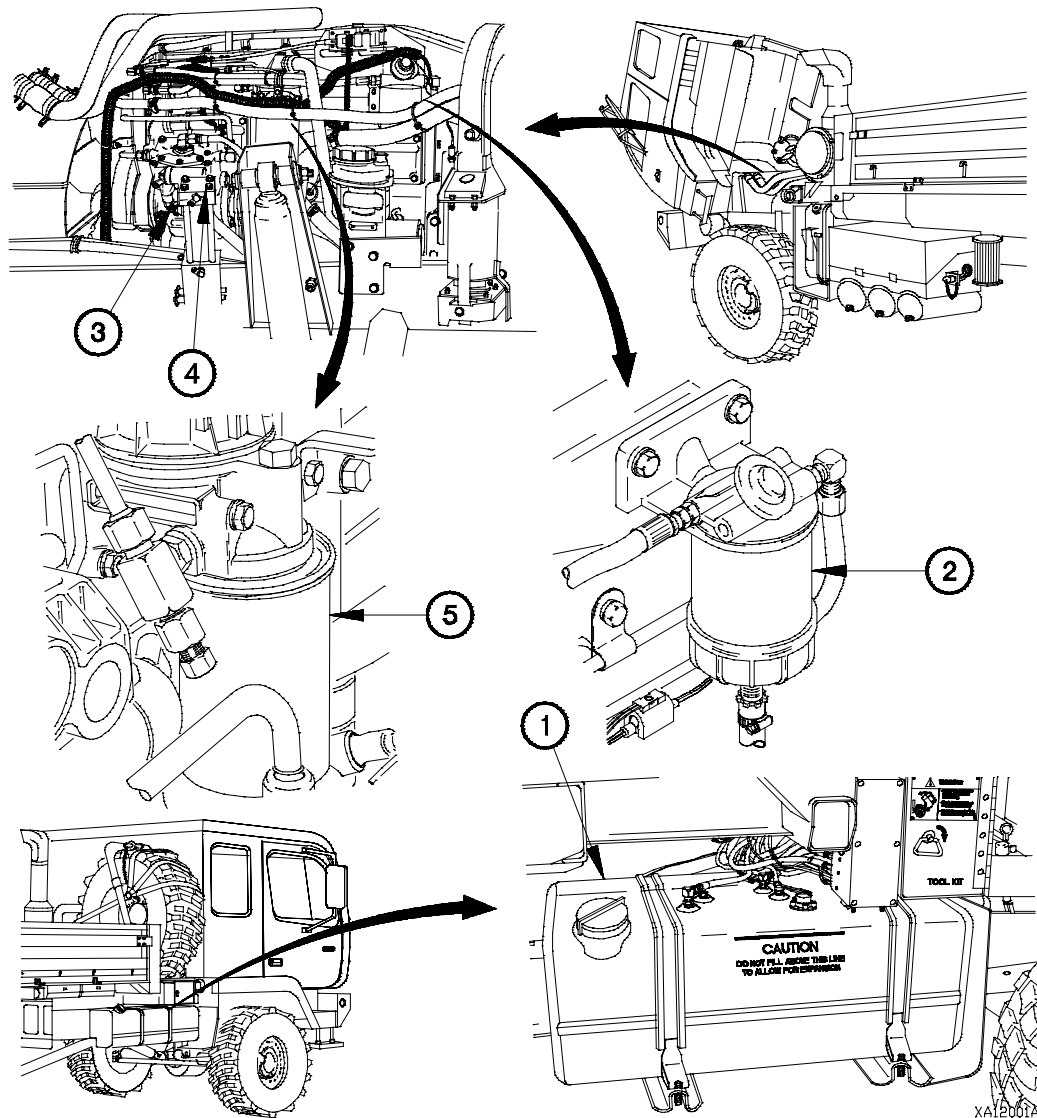
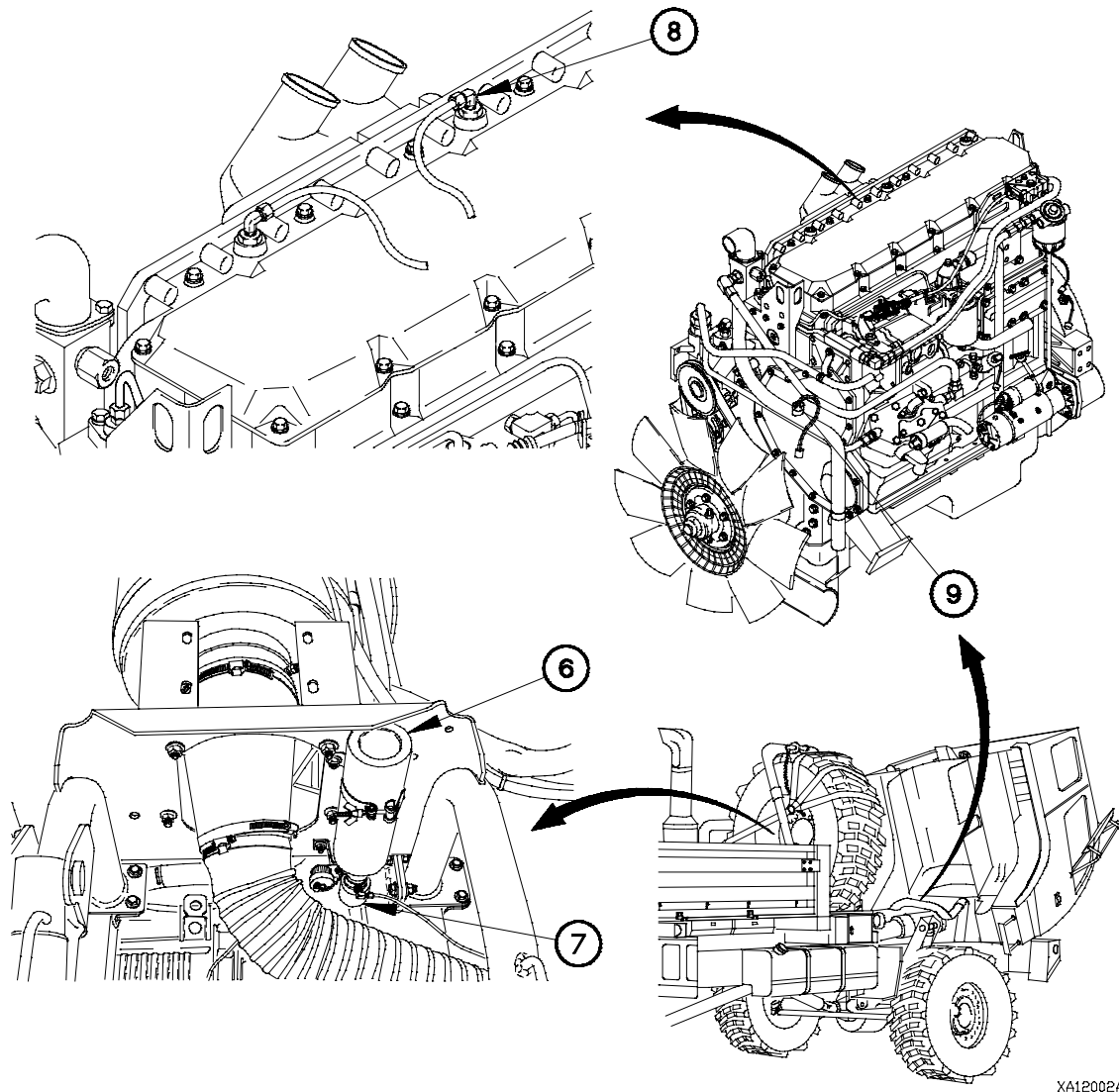

Figure 1-7. Fuel System

The primary components of the fuel system are the fuel tank (1, Figure 1-7), fuel priming pump and fuel/water separator (2), fuel shutoff solenoid (3), engine fuel governor (4), and secondary fuel filter (5). The mechanical fuel pump acts as an engine priming feature. The fuel/water separator removes water and large solid particles from the fuel before it is passed to the engine fuel governor. The fuel shutoff solenoid, when energized, frees the governor output shaft to move to the FUEL ON position. When electrical power is removed from the fuel shutoff solenoid, the governor output shaft is locked in the FUEL OFF position. The engine fuel governor contains a mechanical link to the fuel control linkage and fuel transfer pump. The engine fuel governor responds to input from the accelerator pedal and causes the fuel control rack to rotate, resulting in an increase or decrease in engine speed. The governor adjusts the amount of fuel delivered to the engine as engine speed changes. The secondary fuel filter removes finer particles from the fuel before it reaches the cylinder head. A fuel pressure regulator redirects excess fuel, through a fuel return hose, back to the fuel tank.



XA12002A

Figure 1-7. Fuel System (Cont)

Additionally, the vehicle is equipped with an ether quick start system designed for starting the engine when ambient temperatures are below 32°F (0°C). The ether quick start system is composed of an ether cylinder (6), ether valve (7), two ether nozzles (8), and an ether sensor switch (9). The ether sensor switch detects the temperature of the engine coolant and disables the ether valve above 32°F (0°C). The ether valve delivers a controlled charge of ether to the ether nozzles.

1-13. COOLING SYSTEM

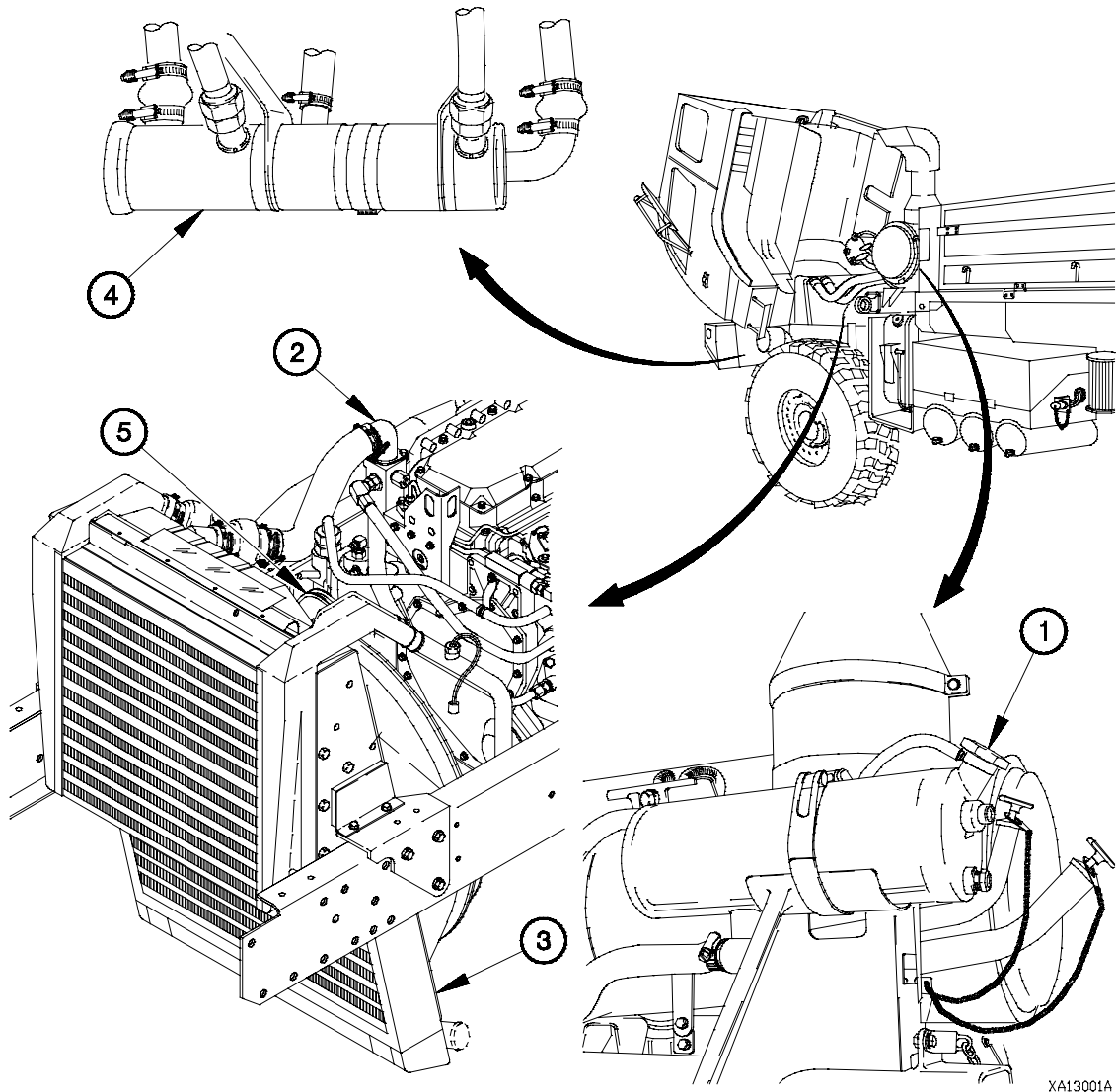

XA13001A

Figure 1-8. Cooling System

a. Cooling System. The pressurized cooling system protects the engine, transmission, and air compressor by providing a means of dissipating heat generated during operation of the vehicle. The radiator pressure cap (1, Figure 1-8), in combination with the ethylene glycol-based antifreeze, effectively raises the boiling point of the coolant to well above 212°F (100°C). The thermostat (2), located in a housing on the right side of the engine, helps the engine to warm up quickly by remaining closed until the coolant temperature reaches approximately 180°F (82°C). When the coolant reaches 199°F (93°C), the thermostat is fully open and coolant is circulated through the water jackets in the engine to maintain the correct operating temperature for the engine. Coolant is drawn from the radiator (3), through the transmission oil cooler (4), and circulated throughout the cooling system by the water pump (5). The water pump, located on the front of the engine toward the right side, is driven by two V-belts from the crankshaft pulley.

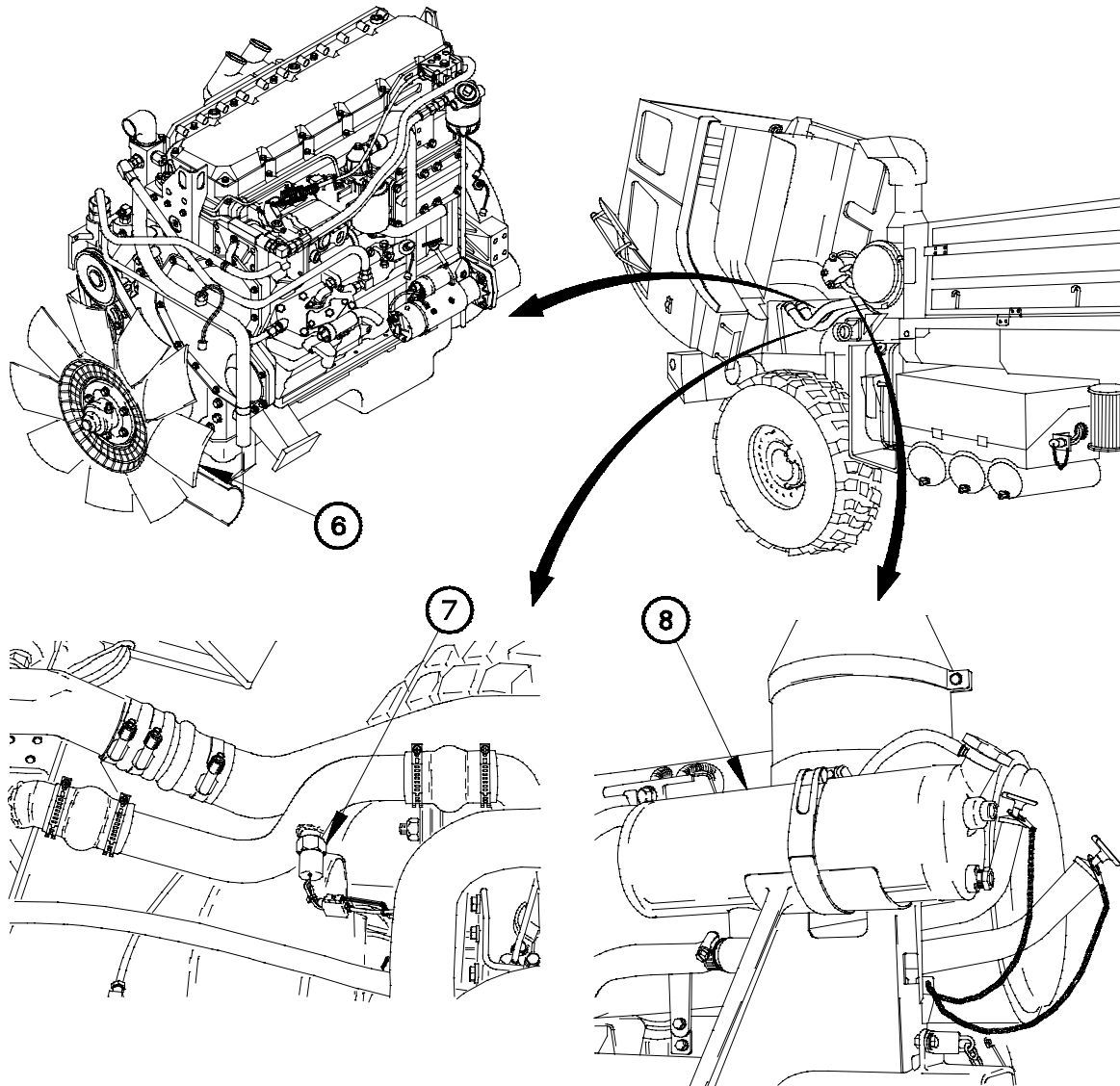

XA13002A

Figure 1-8. Cooling System (Cont)

An engine fan (6) with pneumatic clutch is activated by the water temperature switch (7). When this switch detects a high temperature condition, air pressure is removed from the fan clutch and the engine fan is engaged. Excess heat is drawn from the radiator by the flow of air created by the engine fan over the radiator cooling fins. A radiator overflow tank (8) is provided to allow for expansion of the coolant. The radiator overflow tank also serves as the point where new coolant is introduced into the cooling system.

1-14. ELECTRICAL SYSTEM

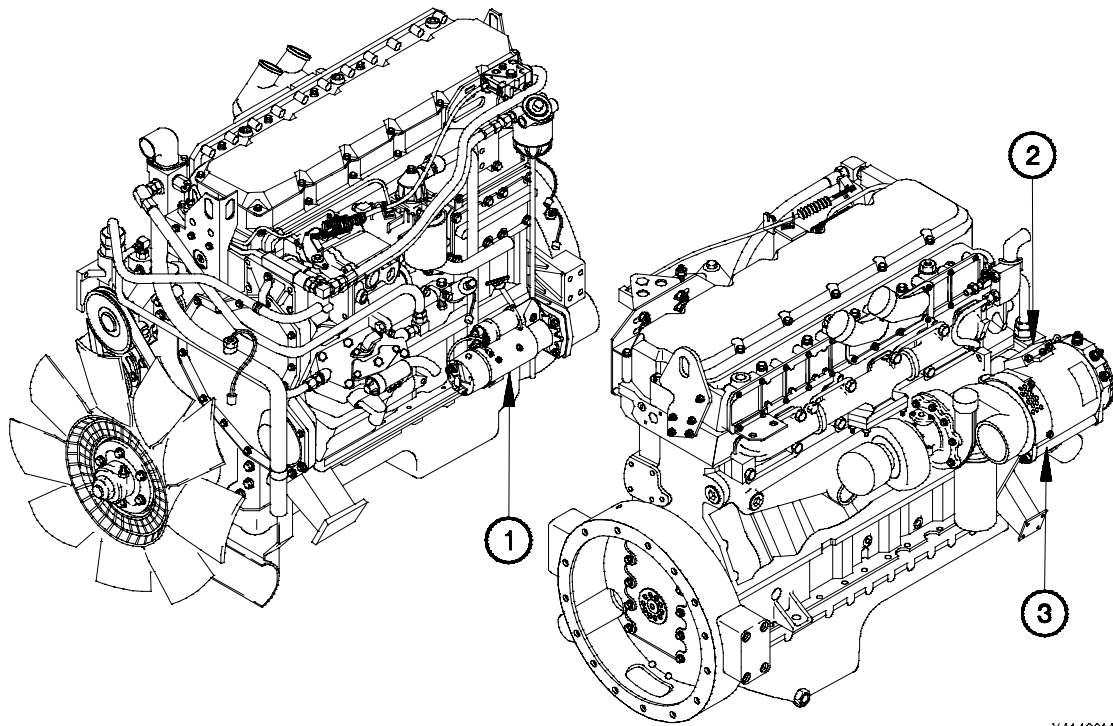

XA14001A

Figure 1-9. Electrical System

In the Electrical System, a heavy duty starting motor (1, Figure 1-9) is mounted on the engine flywheel housing and provides the cranking power necessary for starting the engine. The voltage regulator (2) maintains both a 14- and 28-volts level for proper battery charging. The alternator (3) provides sufficient amperage to operate all electrical components and charge the batteries during engine idling. Vehicle exterior lights are mounted in protective locations or are protected to prevent damage. Protection is provided for lights during cross country travel. Polycarbonate lenses are provided for all lights except the sealed beam headlights. The electrical system supplies all of the electrical power needed to operate the vehicle and trailer. The complete Electrical System is made up of the following subsystems:

- Power Storage and Generating
- Engine Starting and Stopping
- Service Lighting
- Blackout Lighting
- Accessory Lighting
- Instruments
- Indicator Lights and Alarm
- Troubleshooting Aid

a. Power Storage and Generating. Power storage for the vehicle consists of four 12-volt batteries. The four batteries are divided into two sets. Two batteries in each set are wired in parallel to produce higher amperage. The two sets are then wired in series to produce 24 volts Direct Current (DC). While the batteries can power all of the systems for a limited time, their primary purpose is to supply power to the engine starting system. Once the engine is running, the generating system provides electrical power for all of the systems. The engine driven alternator generates Alternating Current (AC) which is passed through a set of rectifiers that change it into DC current. This DC current is used to charge the batteries and is distributed to the electrical sub-systems of the vehicle. The voltage regulator adjusts alternator output to fit the needs of the electrical system.

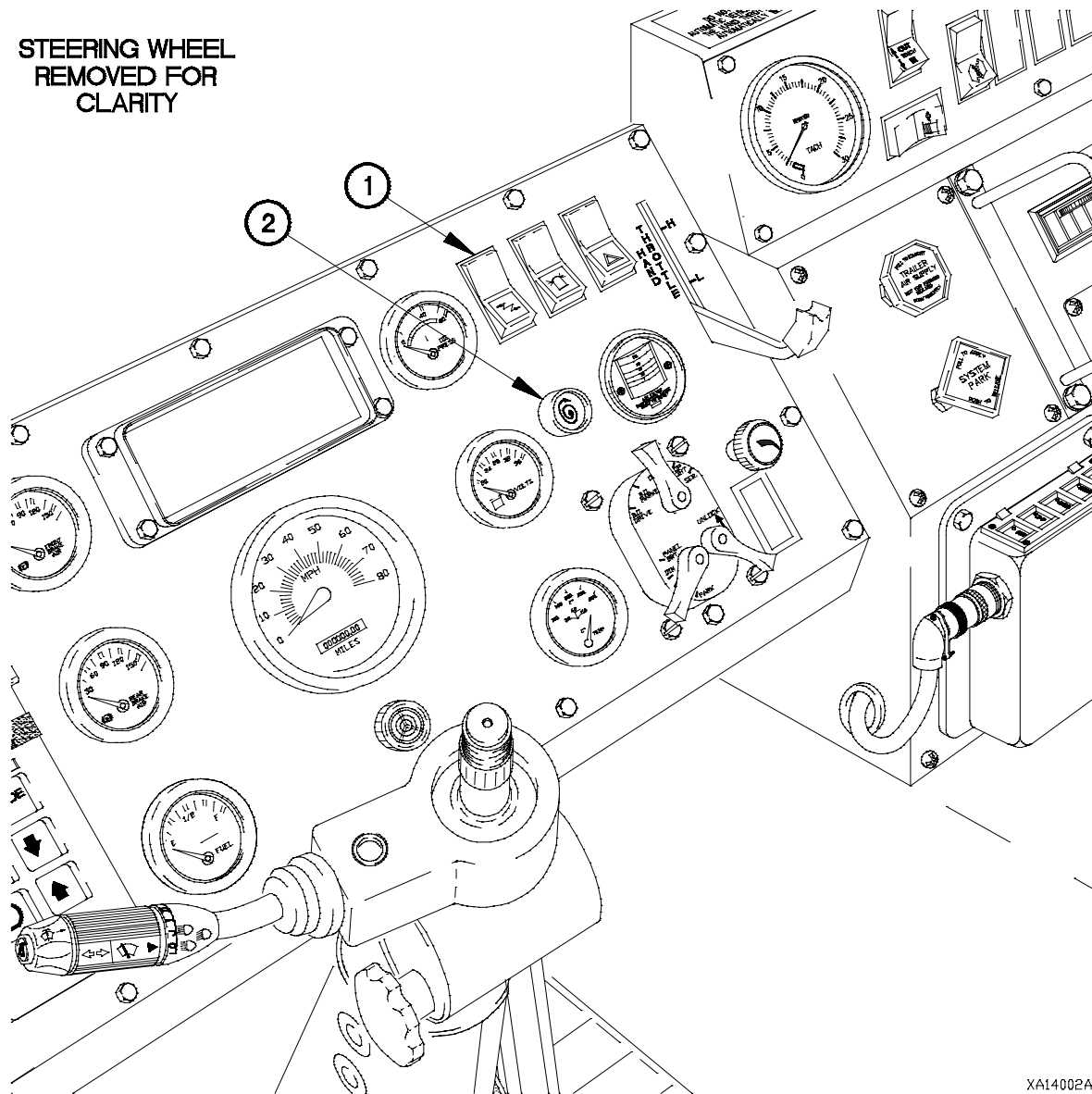
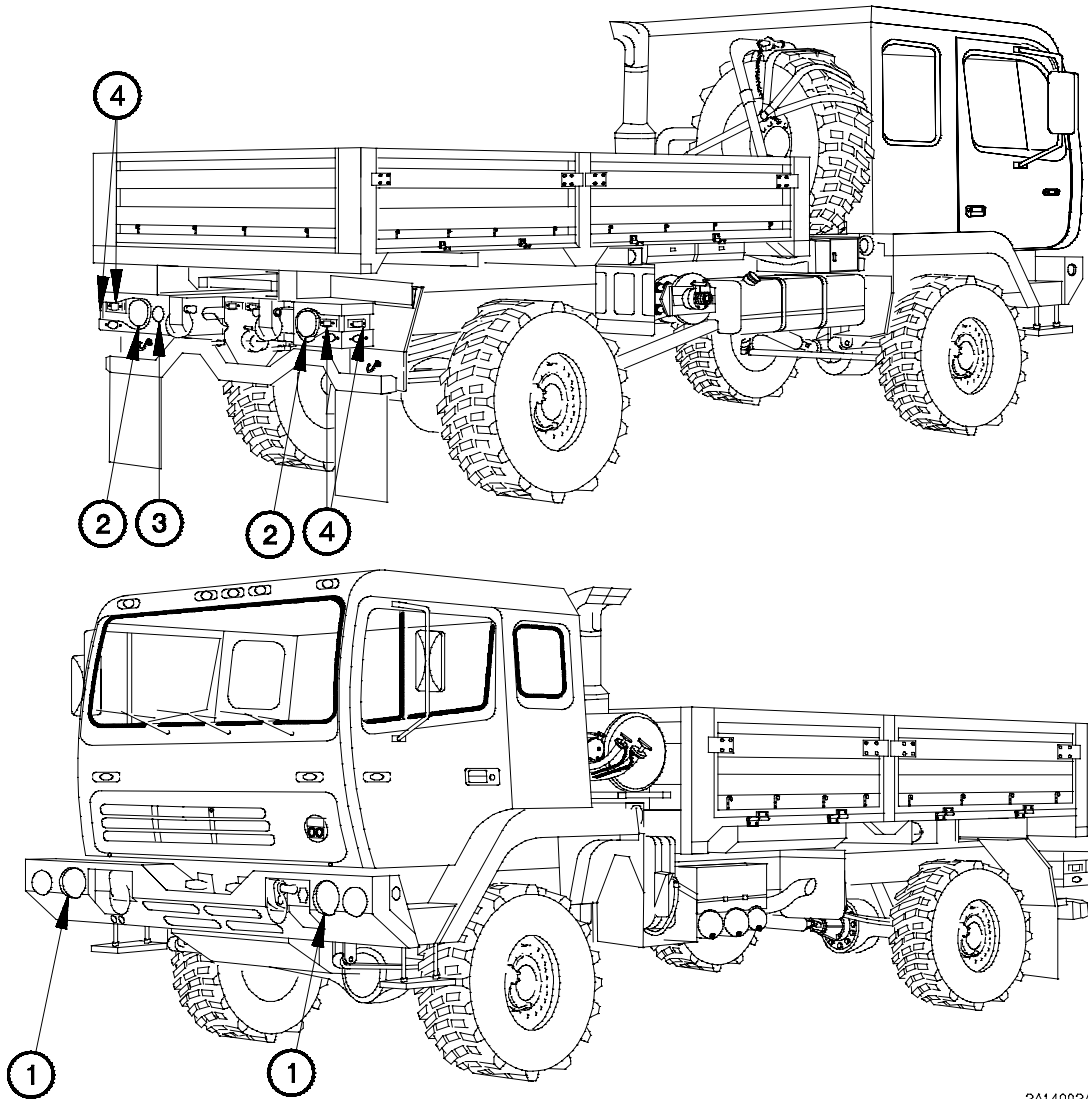

Figure 1-10. Engine Starting System.

b. Engine Starting and Stopping. The Engine Starting System uses the stored electrical energy of the batteries to the turn the starting motor. When the master power switch (1, Figure 1-10) is positioned to on and the starter pushbutton switch (2) is depressed, electrical power passes through the starter pushbutton to the auxiliary starter solenoid. The auxiliary starter solenoid draws electrical power directly from the batteries and sends it to the starting motor solenoid. When the starting motor solenoid is energized, electrical power from the batteries is supplied to the starting motor and the engine begins cranking. Positioning the master power switch to off stops the engine.

1-14. ELECTRICAL SYSTEM (CONT)



3A14003A

Figure 1-11. Service Lighting System

c. Service Lighting. The Service Lighting System includes the headlights (1, Figure 1-11), taillights (2), backup light (3), and clearance and marker lights (4). They are energized by positioning the main light switch to the appropriate position (TM 9-2320-365-10).

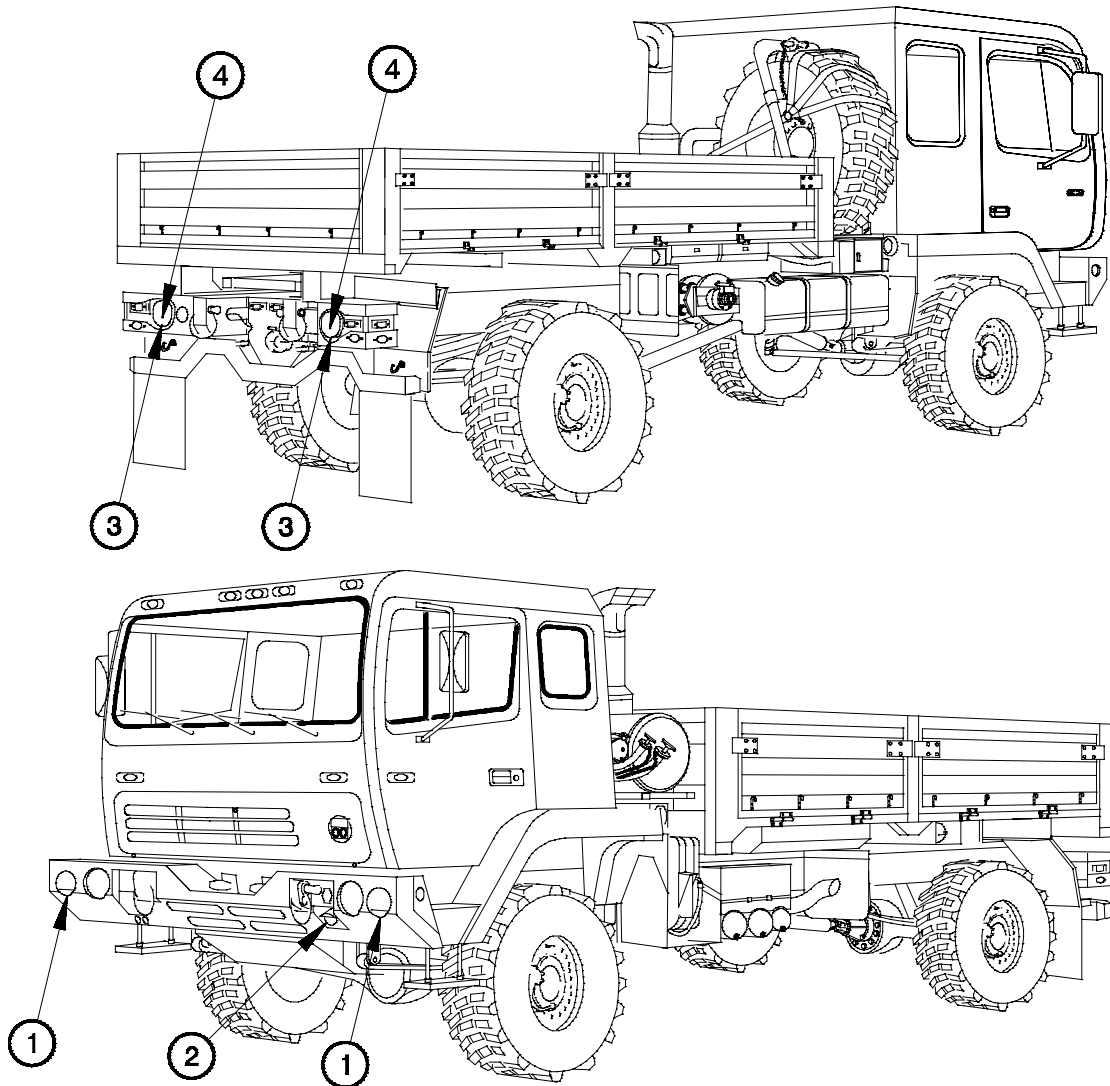

3A14004A

Figure 1-12. Blackout Lighting System

d. Blackout Lighting. The Blackout Lighting System includes the front blackout marker lights (1, Figure 1-12), blackout drive light (2), rear blackout marker lights (3), and blackout stop lights (4). These lights are energized by positioning the main light switch to the appropriate position (TM 9-2320-365-10).

e. Accessory Lighting. The accessory lighting on the vehicle is the warning light. This circuit is energized by positioning the appropriate switch (TM 9-2320-365-10) to on.

1-14. ELECTRICAL SYSTEM (CONT)

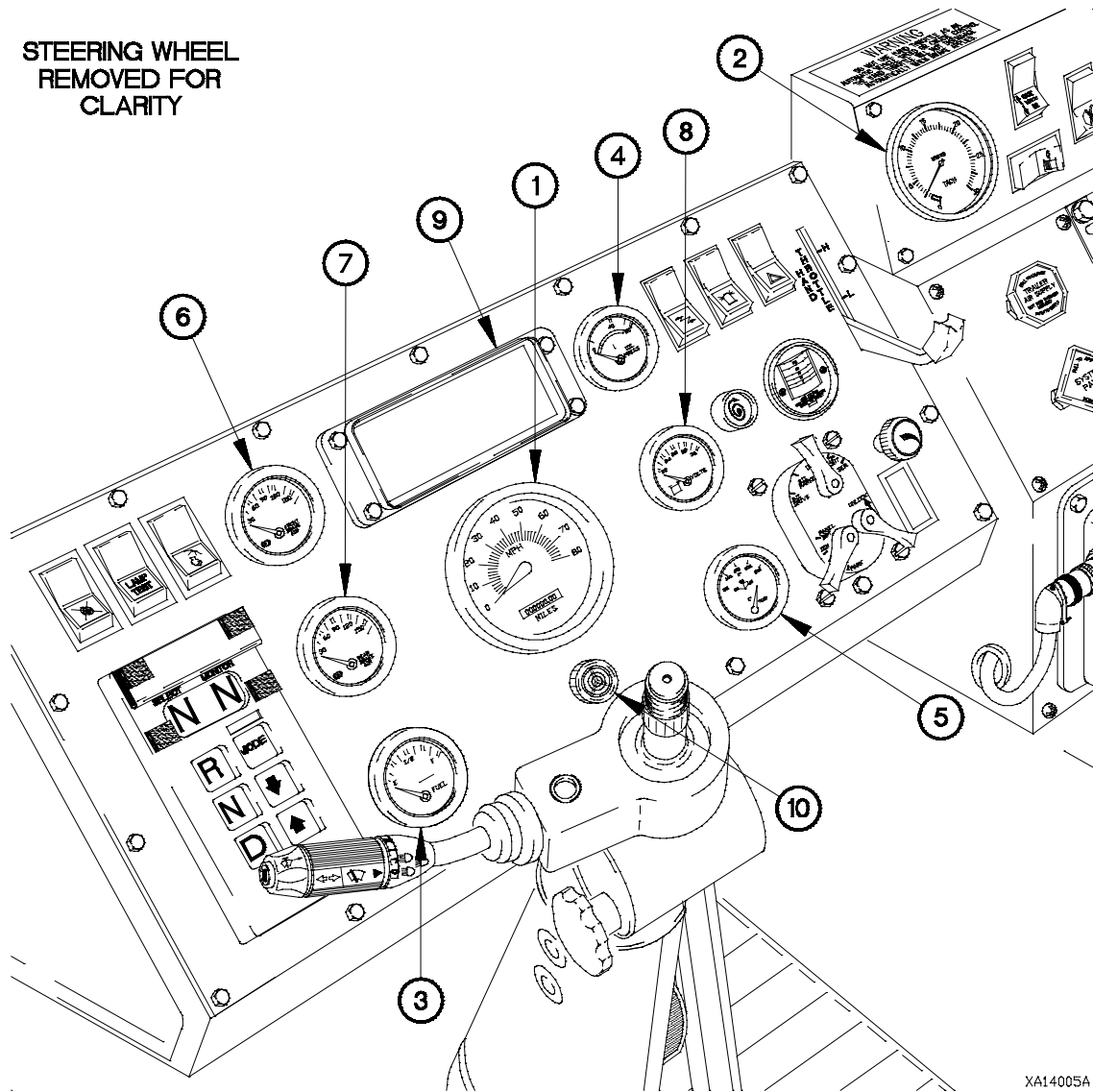
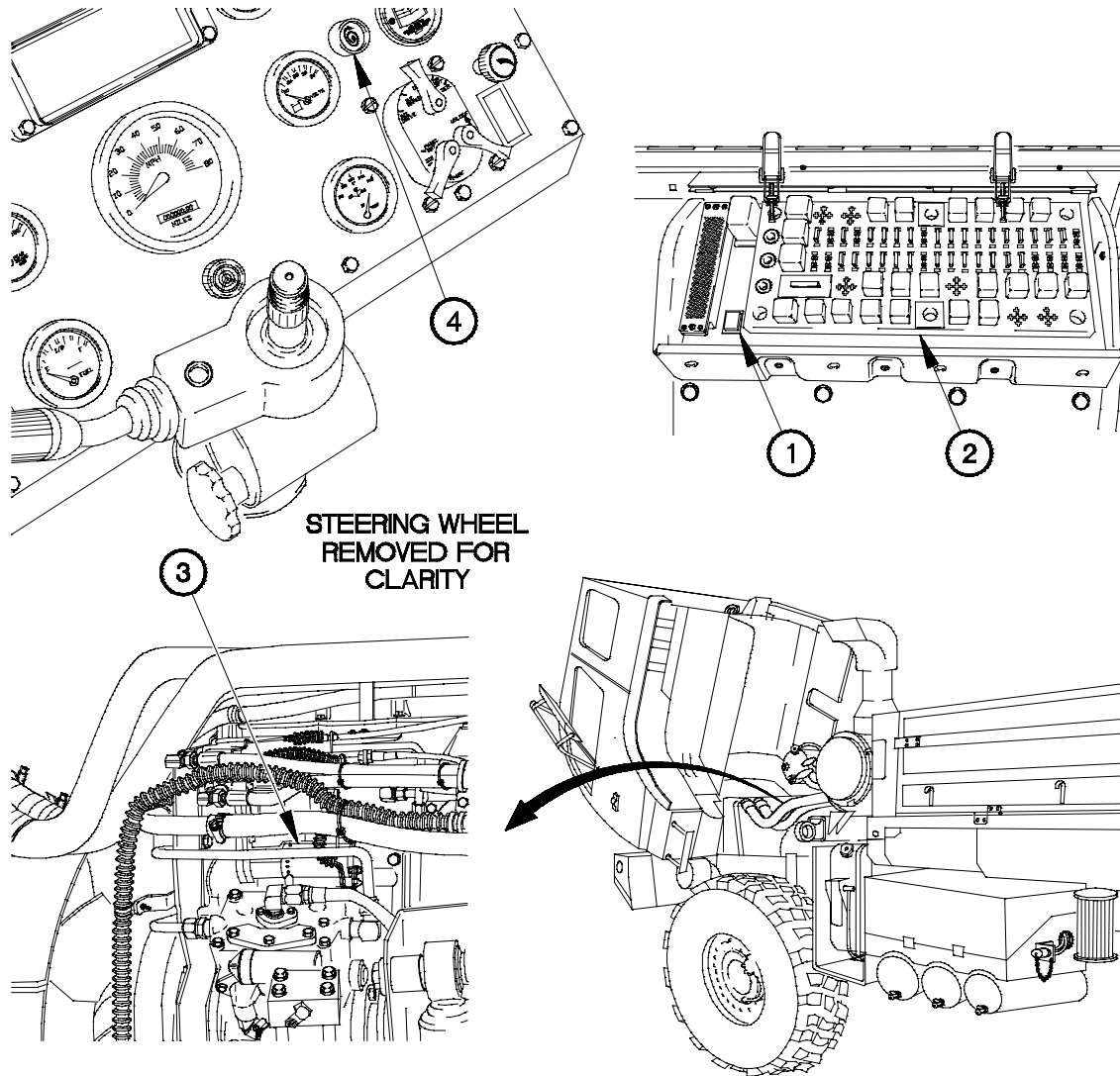

Figure 1-13. Instrument Panel

f. Instruments. The Instrument Panel includes all gages that provide the operator with information about vehicle condition and operating status. The speedometer (1, Figure 1-13) receives electrical input from the WTEC II Vehicle Interface Module (VIM) on vehicles equipped with WTEC II transmission controls. The speedometer receives electrical input from the WTEC III transmission ECU on vehicles equipped with WTEC III transmission controls. The WTEC II VIM and the WTEC III transmission ECU are both located behind the kick panel. Tachometer (2) input is provided by the engine speed sensor located on the engine flywheel housing. The fuel gage (3), oil pressure gage (4), water temperature gage (5), front brake air pressure gage (6), rear brake air pressure gage (7), and volts gage (8) receive electrical signals from sending units. The sending units respond to changes in fluid level, pressure, temperature, and DC current and send this information to the gages.

g. Indicator Lights and Alarms. The lighted indicator display (9) and audible alarm (10), located on the instrument panel assembly, are activated by switches located in various systems. These include, but are not limited to; master stop, low engine oil pressure, low air pressure, high water temperature, engine fan off, and high transmission oil temperature. When any of these switches are activated, they energize the proper indicator and/or alarm, alerting the operator of a potential problem or condition which needs to be monitored.



STEERING WHEEL
REMOVED FOR
CLARITY

XA14007A

Figure 1-14. Troubleshooting Aid

h. Troubleshooting Aid. A start inhibit switch (1, Figure 1-14), located on the Power Distribution Panel (PDP) (2), is provided as a troubleshooting aid for the Unit and DS Maintenance levels and as a maintenance tool at the GS Maintenance level to stop fuel flow at the fuel shutoff solenoid (3). By pressing the start inhibit switch first, the starter pushbutton (4) can be pressed and the engine cranked without allowing the engine to be started. The start inhibit switch is reset when the master power switch is positioned to off and then to on again.

1-15. BRAKE SYSTEM

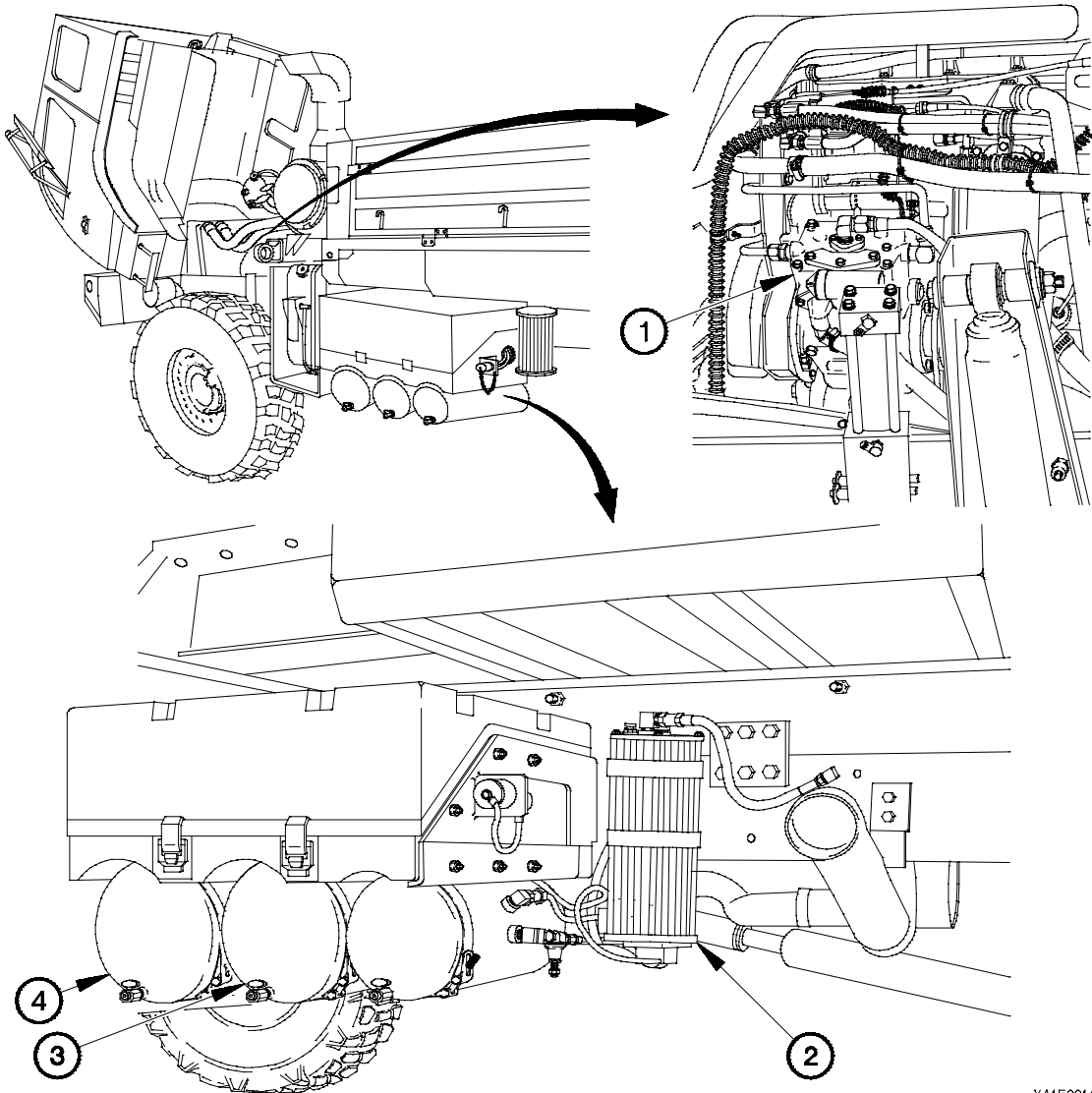

XA15001A

Figure 1-15. Brake System

The vehicle is equipped with an air brake system which complies with the Federal Motor Vehicle Safety Standard (FMVSS) 121. The brake system is made up of a number of components including an air compressor, air dryer, primary and secondary air tanks, and several valves which control the application and release of the brakes. The air compressor (1, Figure 1-15) supplies approximately 120 psi (827 kPa) to the air dryer (2). The air dryer contains a heating element and a desiccant cartridge to remove moisture from the air before it is delivered to the primary air tank (3) and secondary air tank (4).

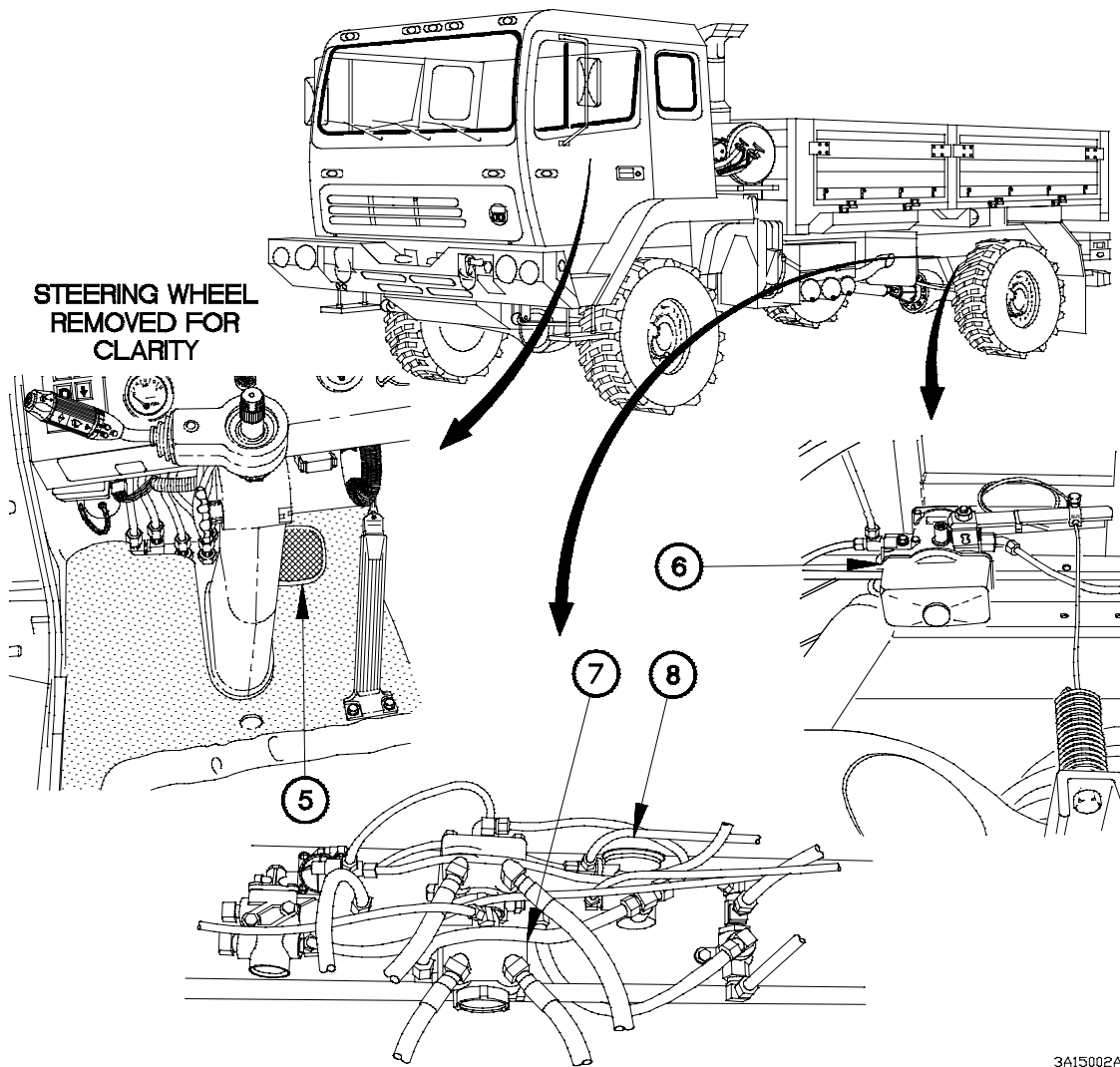

3A15002A

Figure 1-15. Brake System (Cont)

The foot control valve is operated by the brake pedal (5) and receives pressurized air from both the primary and secondary air tanks. The foot control valve is a dual activation design, with one set of ports supplying air to the front brakes from the secondary air tank and another set of ports supplying air to the rear brakes from the primary air tank. The plumbing between the primary and secondary air tanks is designed to allow controlled braking in the event of a failure in either the primary (rear brakes) or secondary (front brakes) brake circuit. Air from the foot control valve is supplied to the load sensing valve (6) which, in turn, controls air delivery to the relay valve (7). The load sensing valve is mounted on a crossmember and connected, by a spring and cable, to the rear axle. The arrangement of the load sensing valve provides a mechanical anti-lock feature to the rear brakes by sending less air to the rear brakes when the vehicle is not heavily loaded. The relay valve is used to provide the Operator with quicker brake response. An inversion valve (8) redirects air from the secondary brake circuit to the primary brake circuit in case of loss of pressure in the primary brake circuit. This feature allows control of the spring brakes and prevents early rear brake lock-up.

1-16. STEERING SYSTEM

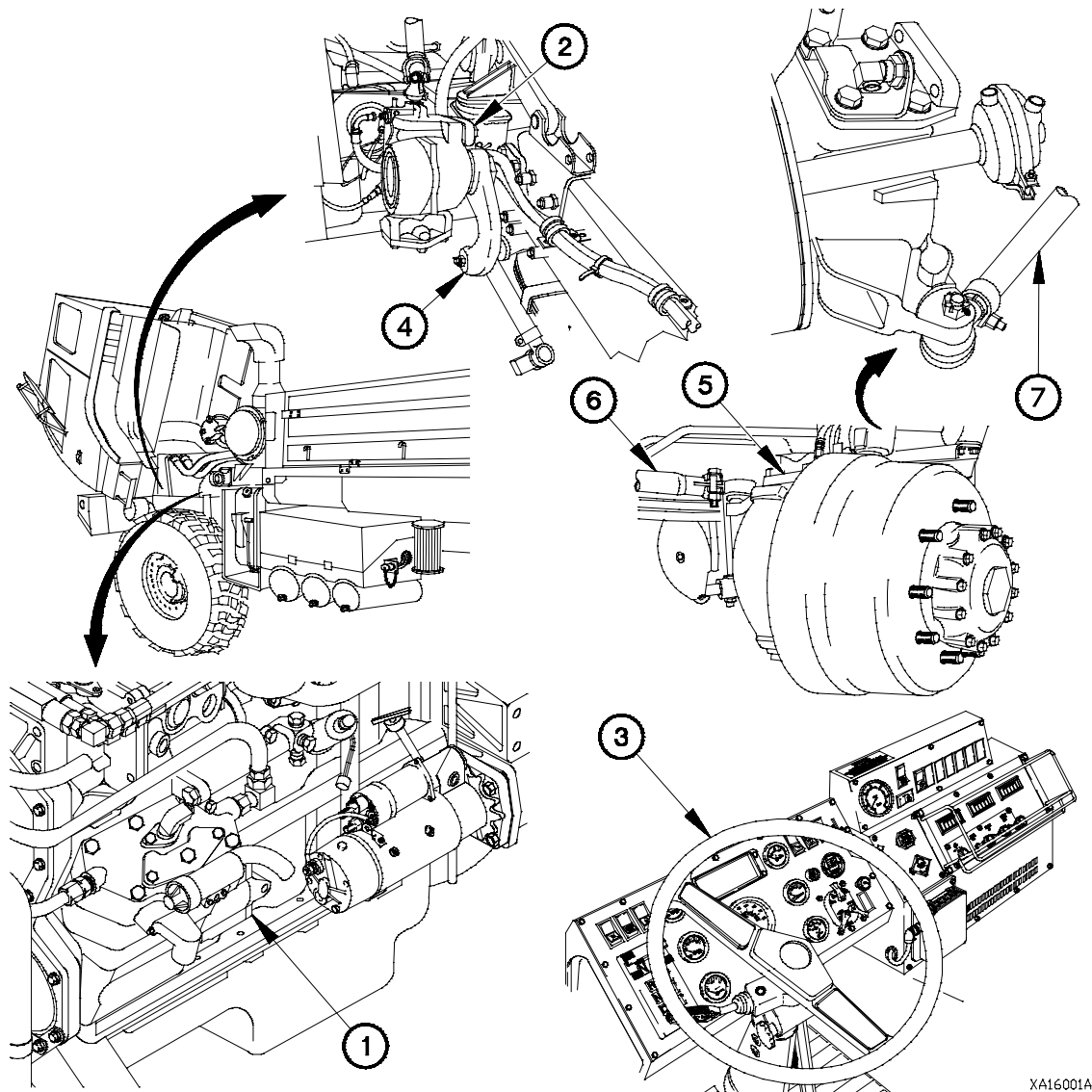

XA16001A

Figure 1-16. Steering System

The vehicle is equipped with hydraulically-assisted power steering. The power steering pump (1, Figure 1-16) is driven by a shaft at the rear of the air compressor. The steering gear box (2) is a recirculating ball design. The steering wheel (3) is linked to the steering gear box by a shaft and two universal joints. The power steering pump supplies constant hydraulic pressure to the steering gear box. The steering pitman arm (4) is attached to the left steering knuckle (5) by the drag link (6). The left and right steering knuckles are connected to each other by the tie-rod (7). Turning the steering wheel to the right causes the steering pitman arm to move toward the front of the vehicle and the front wheels to turn right. Turning the steering wheel to the left causes the steering pitman arm to move toward the rear of the vehicle and the front wheels to turn left. The tie-rod allows for front wheel toe-in adjustment.

1-17. 11K SELF-RECOVERY WINCH (SRW)
--

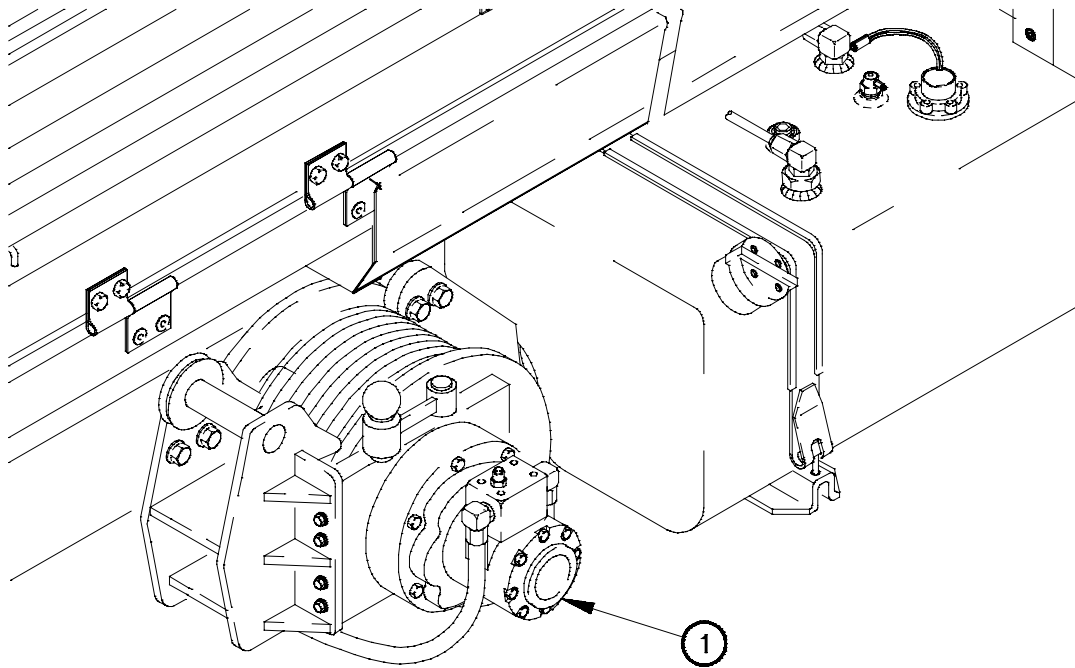

XA17001A

Figure 1-17. 11K Self-Recovery Winch (SRW)

When specified, the vehicle is equipped with an 11K Self-Recovery Winch (SRW) (1, Figure 1-17) mounted on the right frame rail. The SRW is rated for 11,000 lbs (48,924 N) pull when the winch drum has one full layer of cable. One full layer of cable is the minimum amount of cable that may be left on the drum when using the SRW. Pulling capacity is reduced with each layer of cable that is added to the winch drum. Pulling capacity with seven full layers of cable on the winch drum is 6,780 lbs (30,157 N). The SRW cable may be routed to the front or rear of the vehicle for recovery operations. The SRW is equipped with a fail-safe brake which is spring applied and hydraulically released. The fail-safe brake is automatically applied when hydraulic pressure falls below 270 psi (1,862 kPa). The fail-safe brake will hold the load until hydraulic pressure is restored. The winch control valve functions as a throttling valve when cable is being payed out. The winch control valve controls the flow of fluid to the winch motor. When cable is being pulled in, the winch control valve acts as a free flow check valve. The winch control valve is preset at the factory and is not to be adjusted under any circumstances.

1-18. AIR TRANSPORTABILITY HYDRAULIC SYSTEM

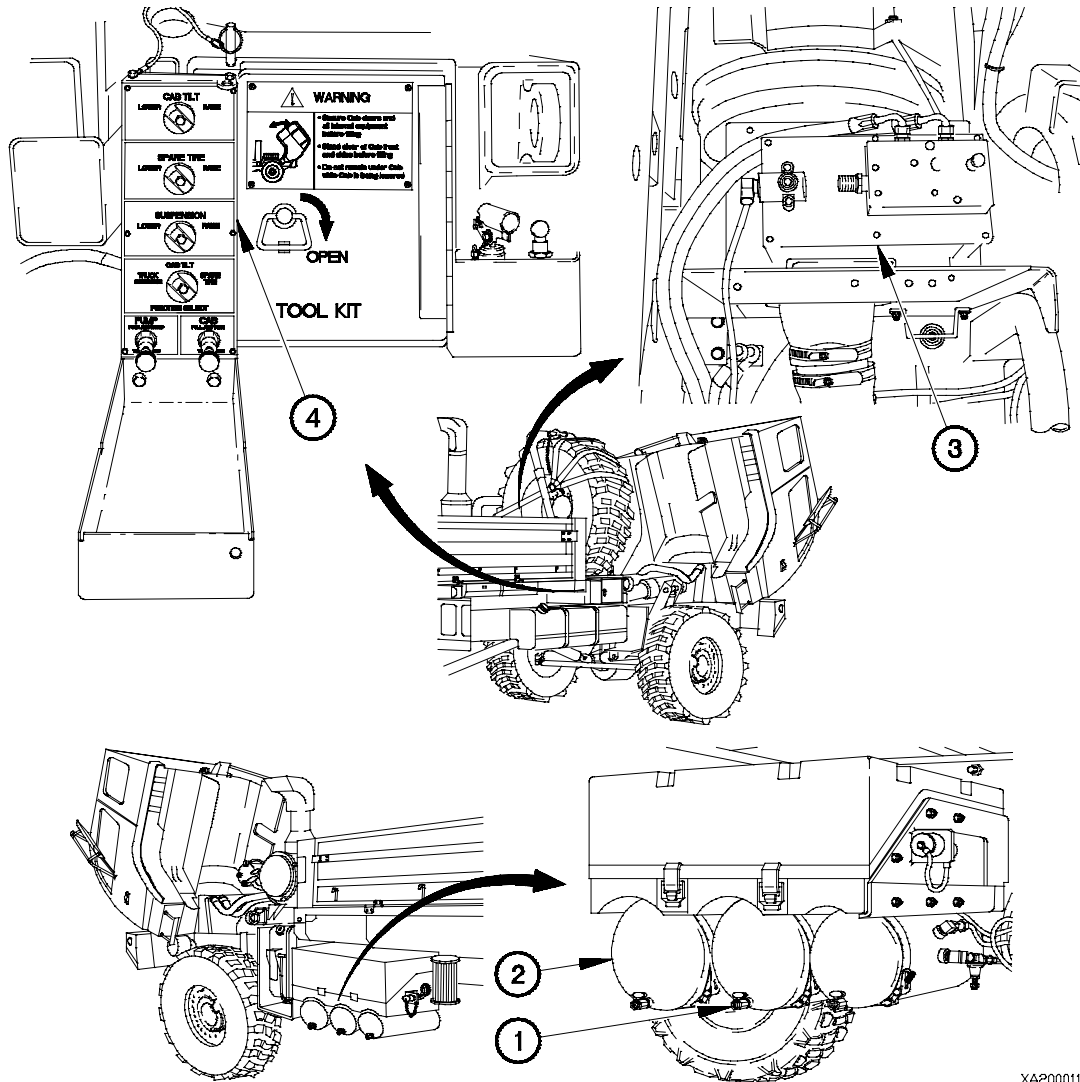

XA200011

Figure 1-18. Air Transportability Hydraulic System

The entire series of M1078 vehicles is equipped with a hydraulic system which allows the vehicle to be prepared for internal air transport in a short time by a minimum number of personnel. Air from the primary and secondary air tanks (1 and 2, Figure 1-18) powers the air/hydraulic power unit (3). The air/hydraulic power unit supplies hydraulic power to the rest of the system. The system is controlled by valves in the hydraulic manifold (4).

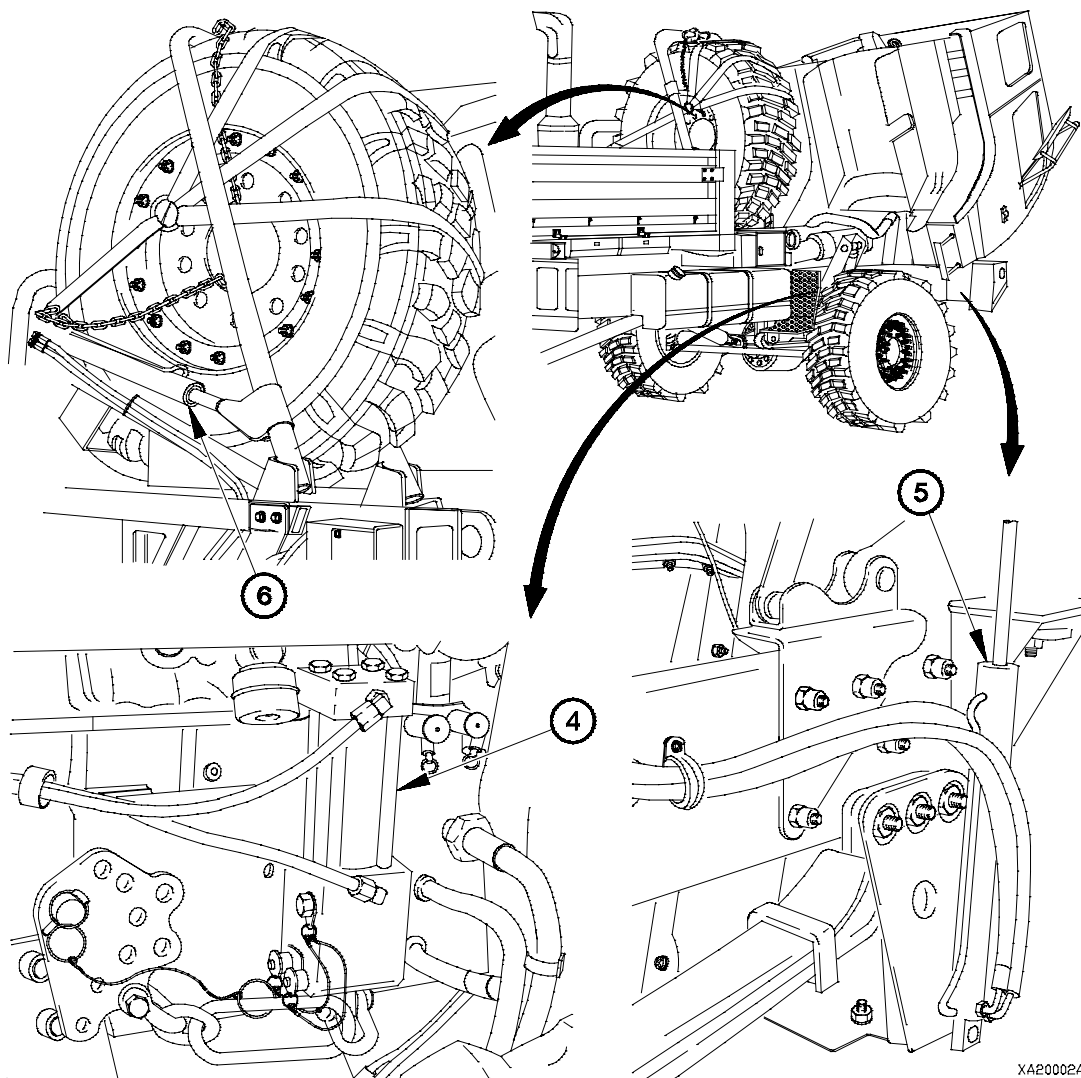

XA20002A

Figure 1-18. Air Transportability Hydraulic System (Cont)

Two suspension cylinders (4) mounted on the frame are used to compress the suspension so that the vehicle can be loaded into an aircraft. Valves on the hydraulic manifold control pressure to the cab tilt cylinder (5); to raise and lower the cab, and the spare tire retainer cylinder (6); to lower and raise the spare tire.

1-19. AIR SYSTEM

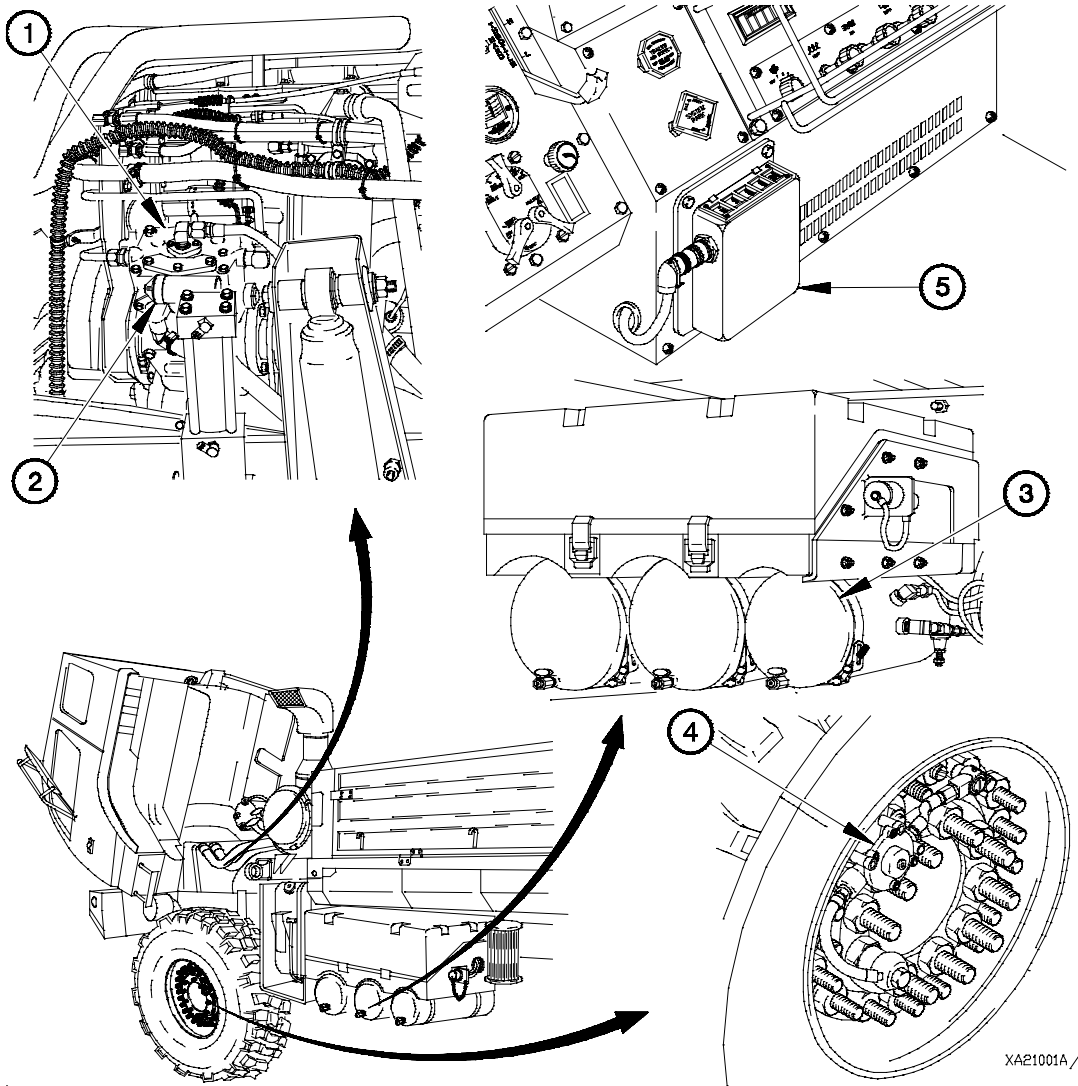

Figure 1-19. Air System

The air system provides clean, dry air for use in the air brake system and the Central Tire Inflation System (CTIS). The air system is pressurized by an engine driven air compressor (1, Figure 1-19) with a nominal output pressure of 125 psi (862 kPa). The system pressure is controlled by an unloading type pressure governor (2) which maintains the output pressure between 105 psi (724 kPa) and 125 psi (862 kPa). Air is supplied to the air brake portion of the air system from the primary and secondary air tanks. Air for the CTIS comes from the wet tank (3) and is supplied to the axles by the CTIS manifold valve (4). Air pressure in the tires is controlled by the CTIS Electronic Control Unit (ECU) (5). The CTIS ECU provides for four tire pressure settings.

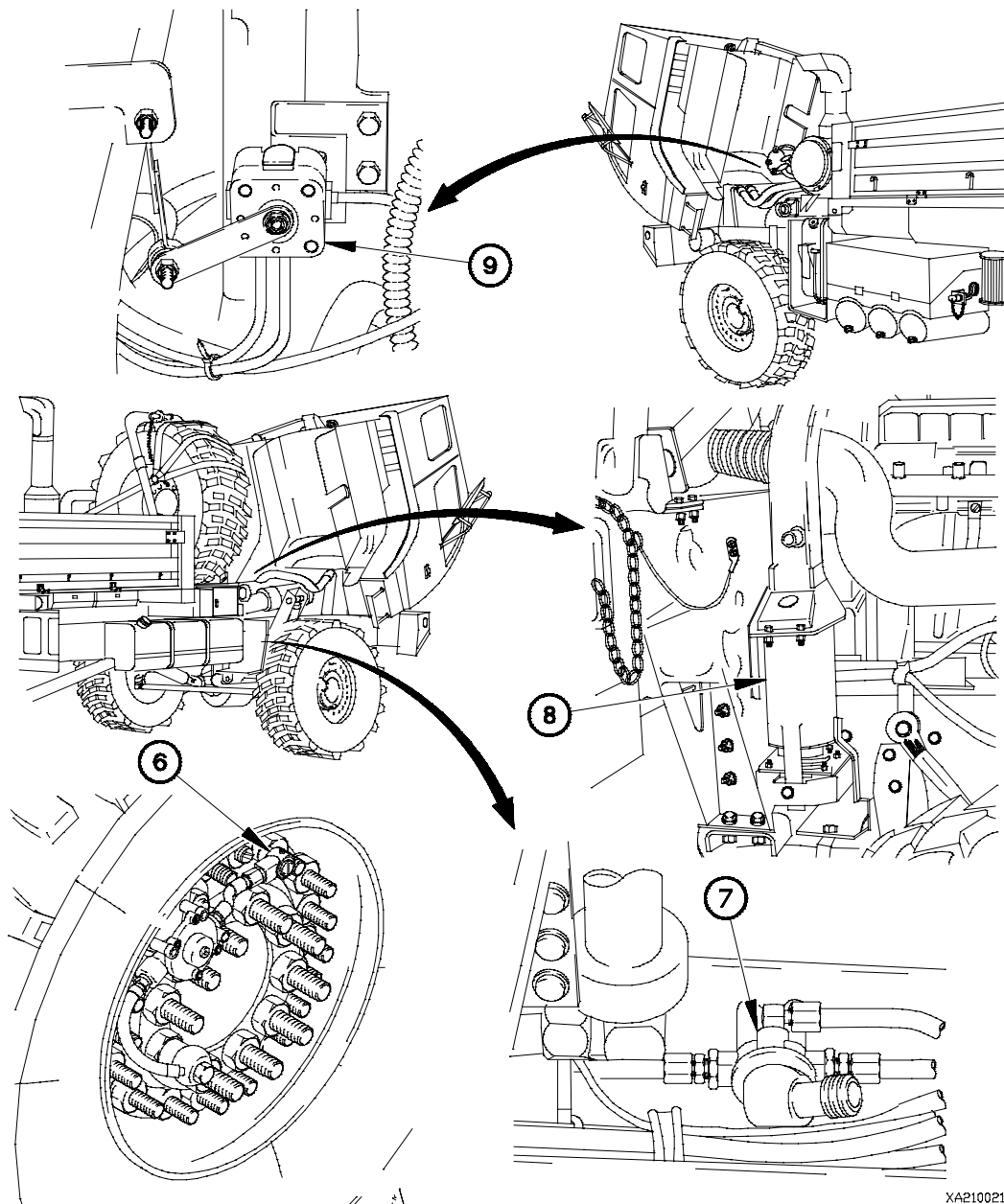

Figure 1-19. Air System (Cont)

Kneeling valves (6) on the front tires allow the front of the vehicle to be lowered for internal air transport. Quick release valves (7) are provided for each axle to exhaust air from the CTIS when the Operator selects a mode which requires a lower pressure setting. Air pressure is also used to keep the cab level through the use of air springs (8), mounted below the rear cab support, and a cab leveling valve (9). The air system has enough reserve capacity to keep the vehicle operational in the event of a partial system failure.

CHAPTER 2 VEHICLE MAINTENANCE

Section I. REPAIR PARTS, TOOLS, SPECIAL TOOLS, TEST, MEASUREMENT, AND DIAGNOSTIC EQUIPMENT (TMDE), AND SUPPORT EQUIPMENT	2-2
2-1. COMMON TOOLS AND EQUIPMENT	2-2
2-2. SPECIAL TOOLS, TMDE, AND SUPPORT EQUIPMENT	2-2
2-3. REPAIR PARTS	2-2
Section II. SERVICE UPON RECEIPT	2-3
2-4. UNPACKING AND DEPROCESSING	2-3
2-5. HAND RECEIPT MANUAL AND INVENTORY OF EQUIPMENT	2-3
2-6. SERVICE BEFORE OPERATION	2-3
Section III. PREVENTIVE MAINTENANCE CHECKS AND SERVICES (PMCS)	2-6.1
2-7. PREVENTIVE MAINTENANCE CHECKS AND SERVICES (PMCS) INTRODUCTION	2-6.1
2-8. GENERAL MAINTENANCE PROCEDURES	2-6.2
2-9. PREVENTIVE MAINTENANCE CHECKS AND SERVICES (PMCS) TABLE	2-7
Section IV. TROUBLESHOOTING	2-53
2-10. INTRODUCTION TO LOGIC TREE TROUBLESHOOTING	2-53
2-11. TROUBLESHOOTING INSTRUCTIONS	2-53
2-12. ENGINE SYSTEM TROUBLESHOOTING	2-63
2-13. FUEL SYSTEM TROUBLESHOOTING	2-101
2-14. EXHAUST SYSTEM TROUBLESHOOTING	2-119
2-15. COOLING SYSTEM TROUBLESHOOTING	2-129
2-16. ELECTRICAL SYSTEM TROUBLESHOOTING	2-147

Volume 2

2-16. ELECTRICAL SYSTEM TROUBLESHOOTING (CONT)	2-1087
2-17. TRANSMISSION SYSTEM TROUBLESHOOTING	2-1359
2-18. PROPELLER SHAFT TROUBLESHOOTING	2-1597
2-19. POWER TAKE OFF (PTO) TROUBLESHOOTING	2-1603
2-20. BRAKE SYSTEM TROUBLESHOOTING	2-1607
2-21. AIR SYSTEM TROUBLESHOOTING	2-1713
2-22. WHEEL TROUBLESHOOTING	2-1753
2-23. HYDRAULIC SYSTEM TROUBLESHOOTING	2-1761
2-24. CENTRAL TIRE INFLATION SYSTEM (CTIS) TROUBLESHOOTING	2-1767
2-25. AXLE TROUBLESHOOTING	2-1895
2-26. STEERING TROUBLESHOOTING	2-1903
2-27. SUSPENSION SYSTEM TROUBLESHOOTING	2-1925
2-28. 11K SELF-RECOVERY WINCH (SRW) SYSTEM TROUBLESHOOTING	2-1945
2-29. STEERING HYDRAULIC SYSTEM TROUBLESHOOTING	2-1953
2-30. AIR TRANSPORT TROUBLESHOOTING	2-1959
2-31. SPECIAL PURPOSE KIT TROUBLESHOOTING	2-1977
2-32. CAB TILT AND SPARE TIRE RETAINER ASSEMBLY TROUBLESHOOTING	2-2115
2-33. FRAME TROUBLESHOOTING	2-2121
Section V. MAINTENANCE PROCEDURES	2-2127
2-34. MAINTENANCE INTRODUCTION	2-2127
2-35. GROUND HANDLING	2-2127
2-36. GENERAL REMOVAL INSTRUCTIONS	2-2127
2-37. GENERAL DISASSEMBLY INSTRUCTIONS	2-2128
2-38. GENERAL CLEANING INSTRUCTIONS	2-2129

CHAPTER 2 VEHICLE MAINTENANCE (CONT)

Section V. MAINTENANCE PROCEDURES (CONT)

2-39. GENERAL INSPECTION INSTRUCTIONS	2-2132
2-40. GENERAL REPAIR INSTRUCTIONS	2-2132
2-41. GENERAL ASSEMBLY INSTRUCTIONS	2-2133
2-42. GENERAL INSTALLATION INSTRUCTIONS	2-2134
2-43. PREPARATION FOR STORAGE OR SHIPMENT INTRODUCTION	2-2134
2-44. PREPARATION FOR STORAGE OR SHIPMENT	2-2135
2-45. STORAGE MAINTENANCE PROCEDURES	2-2135

Section I. REPAIR PARTS, TOOLS, SPECIAL TOOLS, TEST, MEASUREMENT, AND DIAGNOSTIC EQUIPMENT (TMDE), AND SUPPORT EQUIPMENT

2-1. COMMON TOOLS AND EQUIPMENT
--

For authorized common tools and equipment, refer to the Modified Table of Organization and Equipment (MTOE), CTA 50-970, or CTA 8-100 as applicable to your unit.

2-2. SPECIAL TOOLS, TMDE, AND SUPPORT EQUIPMENT
--

For a listing of special tools, TMDE, and support equipment, refer to the Maintenance Allocation Chart (MAC), Appendix B, of this manual and to the Repair Parts and Special Tools List (RPSTL), TM 9-2320-365-24P.

2-3. REPAIR PARTS

Mandatory replacement parts are listed in Appendix G. Repair parts are listed and illustrated in the RPSTL, TM 9-2320-365-24P, covering Unit Maintenance repair parts and special tools for vehicle.

Section II. SERVICE UPON RECEIPT

2-4. UNPACKING AND DEPROCESSING

WARNING

- Heavy objects/loads, such as tool boxes and heavy parts, must always be carried on the floor with the weight distributed as equally as possible between left and right sides of M1079 van. Failure to comply decreases the stability of the M1079 van and will increase the likelihood of a rollover.
- Heavy cabinets must always be mounted as low as possible with the weight distributed as equally as possible between left and right sides of M1079 van. Remember to consider the weight of the items that will be stored in the cabinets. Failure to comply decreases the stability of the M1079 van and will increase the likelihood of a rollover.
- Always keep in mind, when placing items inside the M1079 van, that heavier items must always be positioned as low as possible and the weight distributed as equally as possible between left and right sides of M1079 van. Failure to comply decreases the stability of the M1079 van and will increase the likelihood of a rollover.

a. Unpacking. Upon receipt of a new vehicle, the receiving organization must see if it has been properly prepared for service and is in good condition. Inspect all assemblies, subassemblies, and accessories to be sure they are in proper working order (TM 9-2320-365-10). Secure, clean, and correctly adjust and/or lubricate as needed (Appendix H). Check all tools and equipment to be sure every item is accounted for (TM 9-2320-365-10-HR) in good condition, clean and properly mounted or stowed (TM 9-2320-365-10).

b. Deprocessing. Read "Processing and Deprocessing Record of Shipping, Storage and Issue of Vehicles and Spare Engines" tag, (DD Form 1397) and follow all precautions checked. This tag should be attached to the steering wheel or manual throttle control lever.

2-5. HAND RECEIPT MANUAL AND INVENTORY OF EQUIPMENT

When a new vehicle is first received by the using organization, it is necessary to inventory the vehicle equipment. For detailed procedures, refer to Hand Receipt Manual, TM 9-2320-365-10-HR.

2-6. SERVICE BEFORE OPERATION

a. General.

- (1) Refer to TM 9-2320-365-10 for operating instructions for the vehicle.
- (2) Upon receipt of a new, used, or reconditioned vehicle, the receiving organization must see if it has been properly prepared for service and is in good condition (TM 9-2320-365-10). Inspect all assemblies, subassemblies, and accessories to be sure they are in proper working order. Secure, clean, correctly adjust, and/or lubricate (TM 9-2320-365-10 and Appendix H) as needed. Check all tools and equipment to be sure every item is there (TM 9-2320-365-10-HR), in good condition, clean and properly mounted or stowed (TM 9-2320-365-10).
- (3) Follow general procedures for all services and inspections given in TM 9-2320-365-10.

2-6. SERVICE BEFORE OPERATION (CONT)

b. Inspection and Servicing Equipment.

NOTE

If vehicle has been driven to the using organization, most or all of the following work should have been done.

(1) When vehicle is received, inspect all items for damage that may have occurred during shipping and unloading operations. Pay close attention to any loose or missing nuts, bolts, screws, access plates, drain plugs, draincocks, oil plugs, assemblies, subassemblies, or components that may be easily lost or broken in transit. Check Basic Issue Items (BII) against checklist to make sure all items are accounted for and are in good condition (TM 9-2320-365-10-HR). Carefully list all discrepancies.

WARNING

- **Dry Cleaning Solvent P-D-680 is TOXIC and flammable. Wear protective goggles and gloves; use only in well-ventilated area; avoid contact with skin, eyes, and clothes, and do not breathe vapors. Keep away from open flame. Never smoke when using solvent; the flashpoint for Type I Dry Cleaning Solvent is 100°F (38°C) and for Type II is 130°F (50°C). Failure to comply may result in serious injury or death to personnel.**
 - **If personnel become dizzy while using Dry Cleaning Solvent, immediately get fresh air and medical help. If solvent contacts skin or clothes, flush with cold water. If solvent contacts eyes, immediately flush eyes with water and get immediate medical attention. Failure to comply may result in injury to personnel.**
- (2) Clean all exterior surfaces coated with rust-preventive compound with Dry Cleaning Solvent (Item 71, Appendix D).
 - (3) Perform the Semiannual Preventive Maintenance Checks and Services (PMCS), Table 2-1.
 - (4) Lubricate all points shown in Appendix H regardless of interval. Schedule services in accordance with DA Pam 738-750.
 - (5) Initial Service Intervals:
 - a. Initial 500 miles (805 km) of operation:
 - (1) Perform Front and Rear Axle oil change.
 - (2) Perform Front Axle Wheel end Planetary Hub oil change.
 - b. Initial 1,000 miles (1,609 km) of operation:

Tighten self-locking nuts on leaf spring U-bolt to 390-510 lb-ft (529-692 N·m), in 50 lb-ft (68 N·m) increments, in a crisscross pattern.
 - c. Initial 5,000 miles (8,045 km) of operation:
 - (1) Perform Engine oil and filter change.
 - (2) Perform Transmission oil and filter change.
 - (6) Activate battery if vehicle is delivered with dry-charged battery (TM 9-6140-200-14).

WARNING

Do not remove radiator cap when the engine is hot; steam and hot coolant can escape and burn personnel.

- (7) Check radiator coolant. Check if solution is adequate for expected climatic conditions. Refer to TB 750-651 for preparation of antifreeze solutions. Put tag near filler cap with type of antifreeze and degree of protection written on tag.

c. Special Service Instructions.

- (1) Vehicle Body and Sheet Metal Inspection (TM 9-2320-365-10).

- (a) Inspect body and sheet metal for evidence of damage during shipment.
- (b) Check doors, latches, and hinges on compartments for proper operation.
- (c) Check mounting hardware and tighten as necessary.

- (2) Vehicle Cab Inspection (TM 9-2320-365-10).

- (a) Inspect cab for evidence of damage during shipment.
- (b) Inspect windshields and window glass for cracks or other damage.
- (c) Check door latches, hinges, and windows for proper operation.
- (d) Check seats and seatbelts mounting hardware to ensure they are securely installed and tighten as necessary.
- (e) Check operator's seat adjustments to ensure they are functioning properly.
- (f) Unpin cab air springs, stow retaining pins, and inflate cab air springs (TM 9-2320-365-10, Preparation for Internal Air Transport).

- (3) Engine Inspection (TM 9-2320-365-10).

- (a) Inspect engine and cooling hose connections for evidence of leakage.
- (b) Remove any seals, plugs, or tape used to seal air inlets and ports on the engine during shipping.
- (c) Check crankcase oil level with dipstick.
- (d) Examine air cleaner element for dirty or restricted condition.
- (e) Check for obstructions to cooling air flow to radiator.

- (4) Transmission Inspection (TM 9-2320-365-10).

- (a) Check fluid level with dipstick.
- (b) Check external tubes and hoses for evidence of leakage.

2-6. SERVICE BEFORE OPERATION (CONT)

(5) Transfer Case Inspection (TM 9-2320-365-10).

- (a) Check level of lubricant at fill plug.
- (b) Inspect lubrication pump and external hoses for evidence of leakage.
- (c) Operate driveline control and observe drive power to front axle.
- (d) Inspect bolts on driveline U-joints.

(6) Electrical System Inspection (TM 9-2320-365-10).

- (a) Inspect battery cable connections and clean and tighten as necessary.
- (b) Check all lights for burned out lamps, loose connections, and dirty or broken lenses.
- (c) Check that alternator is charging batteries properly.
- (d) Check that all electrical equipment functions properly.

(7) Air System Inspection (TM 9-2320-365-10).

- (a) Drain any water from reservoirs.
- (b) Inspect all accessible air hose and tubing connections for leakage.

(8) Steering System Inspection (TM 9-2320-365-10).

- (a) Check steering hydraulic reservoir for proper fluid level.
- (b) Examine steering linkage and steering gear for damage incurred during shipment.
- (c) Examine steering hoses and connections for evidence of leakage.
- (d) Check steering system for proper operation during road test.

(9) Chassis and Front and Rear Axle Inspection (TM 9-2320-365-10).

- (a) Check all lubricant levels.
- (b) Check axle housing pressure vents to ensure freedom from foreign matter.

(10) Tire Inspection.

- (a) Check tire pressure (TM 9-2320-365-10).
- (b) Inspect tires for serious cuts, bubbles, cracks, bruises, dry-rot, foreign objects, or exposure of internal cords. Remove foreign objects lodged between treads (TM 9-2320-365-10).
- (c) Check all wheel mounting nuts for proper torque (para 12-4).

(11) Fuel System Inspection (TM 9-2320-365-10).

- (a) Check fuel level and replenish, if necessary.
- (b) Inspect fuel lines, connections, and filters for evidence of leakage.

Section III. PREVENTIVE MAINTENANCE CHECKS AND SERVICES (PMCS)

2-7. PREVENTIVE MAINTENANCE CHECKS AND SERVICES (PMCS) INTRODUCTION

This section contains Unit Maintenance PMCS requirements for the vehicle. The PMCS table contains checks and services necessary to ensure the vehicle is ready for operation. Using the PMCS table, perform maintenance at the specified intervals. Perform preventive maintenance checks and services in TM 9-2320-365-10 before doing the Unit preventive maintenance.

2-8. GENERAL MAINTENANCE PROCEDURES

WARNING

- **Dry Cleaning Solvent P-D-680 is TOXIC and flammable. Wear protective goggles and gloves; use only in well-ventilated area; avoid contact with skin, eyes, and clothes, and do not breathe vapors. Keep away from open flame. Never smoke when using solvent; the flashpoint for Type I Dry Cleaning Solvent is 100°F (38°C) and for Type II is 130°F (50°C). Failure to comply may result in serious injury or death to personnel.**
- **If personnel become dizzy while using Dry Cleaning Solvent, immediately get fresh air and medical help. If solvent contacts skin or clothes, flush with cold water. If solvent contacts eyes, immediately flush eyes with water and get immediate medical attention. Failure to comply may result in injury to personnel.**
 - a. Cleanliness.** Dirt, grease, oil, and debris only get in the way and may cover up a serious problem. Use Dry Cleaning Solvent (Item 71, Appendix D) on metal surfaces and soapy water on rubber.
 - b. Bolts, Nuts, and Screws.** Check bolts, nuts, and screws for obvious looseness, missing, bent, or broken condition and replace as necessary. If they cannot be checked with a tool, look for chipped paint, bare metal, or rust around bolt heads.
 - c. Welds.** Look for loose or chipped paint, rust, or gaps where parts are welded together. If a bad weld is found, notify your supervisor.
 - d. Electric Wires and Connectors.** Look for cracked or broken insulation, bare wires, and loose or broken connectors. Tighten loose connectors and ensure wires are in good shape.
 - e. Fluid Lines and Fittings.** Look for wear, damage, and leaks and make sure clamps and fittings are tight. Wet spots show leaks, but a stain around a fitting or connector can mean a leak. If connector or fitting is loose, tighten it. If something is broken or worn out, repair or replace per applicable procedure.

f. Fluid Leakage. It is necessary to know how fluid leakage affects the status of fuel, oil, coolant and the hydraulic systems. The following are definitions of the type/classes of leakage necessary to know in order to determine the status of the vehicle. Learn, then be familiar with them and REMEMBER - WHEN IN DOUBT, NOTIFY THE SUPERVISOR!

CAUTION

Equipment operation is allowable with minor leakage (Class I or II). Consideration must be given to the fluid capacity in the item/system being checked/inspected. When in doubt, notify the supervisor. When operating with Class I or II leaks, continue to check fluid levels as required in the PMCS. Class III leaks should be repaired per applicable procedure.

- (1) Class I. Seepage of fluid as indicated by wetness or discoloration not great enough to form drops.
- (2) Class II. Leakage of fluid great enough to form drops but not enough to cause drops to fall from item being checked/inspected.
- (3) Class III. Leakage of fluid great enough to form drops that fall from the item being checked/inspected.

g. Air System Components. Look for worn, damaged, or leaking components. Make sure clamps and fittings are tight. If a leak comes from a loose fitting or connector, tighten it. If something is broken or worn out, either repair or replace it.

h. Damage. Damage is defined as any condition that affects safety or would make the vehicle unserviceable for mission requirements.

2-9. PREVENTIVE MAINTENANCE CHECKS AND SERVICES (PMCS) TABLE

- a. Do the SEMIANNUAL PREVENTIVE MAINTENANCE (Table 2-1) once every six months.
- b. Refer to the specified technical manuals for preventive maintenance for special purpose kits.
- c. Always do the PREVENTIVE MAINTENANCE in the same order until it gets to be a habit. Once practiced, it will be easy to spot anything wrong in a hurry. Perform the checks and services listed in Table 2-1 in the order listed.
- d. If something does not work, troubleshoot with instructions in Section IV.
- e. If anything looks wrong and is too hard to fix, notify the supervisor.
- f. When doing preventive maintenance, take along the tools and supplies needed to make all the checks, including a clean cloth or two.

2-9. PREVENTIVE MAINTENANCE CHECKS AND SERVICES (PMCS) TABLE (CONT)

g. The following is a breakdown of the PMCS table:

(1) Item number column. Checks and services are numbered in a logical order for moving around the vehicle. The item number column is used a source of item numbers for the TM Number Column on DA Form 2404, Equipment Inspection and Maintenance Worksheet, for recording results of the PMCS.

(2) Items to be inspected. This column identifies the item to be inspected.

(3) Procedures column. This column contains all the information required to do the check/inspection. Art is integrated into the column to aid the user in identifying items. Whenever replacement parts or repair is recommended, reference is made to the applicable maintenance instructions.

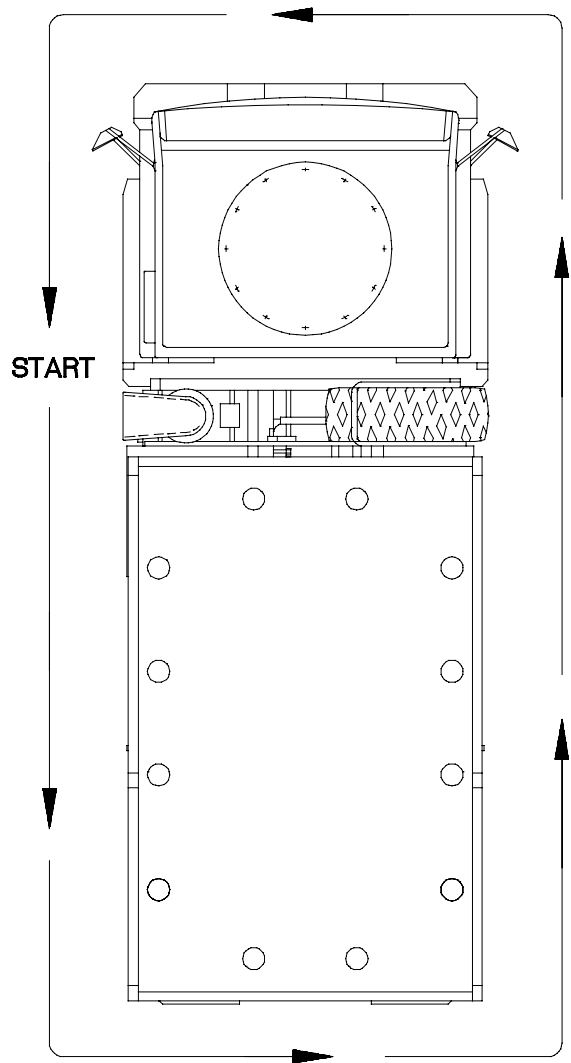

3BPM0011

Table 2-1. Preventive Maintenance Checks and Services

Item No.	Interval	<u>Location</u> Item to be Checked or Serviced	Procedure	Not Fully Mission Capable If:
1	Semiannual	Preservice Checks	<p style="text-align: center;">ROAD TEST</p> <p>Maintenance personnel will be with vehicle operator during the road test.</p> <p style="text-align: center;">NOTE</p> <p>Perform the following during road test.</p> <p>For road test, vehicle will be driven at least five miles over different ground to give enough time to detect any malfunctions.</p> <ul style="list-style-type: none"> a. Notice if starter engages smoothly and turns engine at normal cranking speed. b. Listen for unusual engine noise at idle, at operating speeds, and under acceleration. Be alert for excessive vibration and the smell of oil, fuel or exhaust. c. Check for transmission response to shifting and for smoothness of operation in all speed ranges. Be alert for unusual noises and difficulty in shifting in any speed range. d. Test for accelerator response. Observe for sticking pedal. e. With vehicle speed approximately 5 mph (8 kph) turn steering wheel to left, then right, to detect steering backlash, shimmy or freeplay of more than 1-1/2 in. (38 mm) in either direction. Vehicle should respond instantly. With vehicle moving on straight, level terrain, lightly hold steering wheel to check for pull and wandering. 	<ul style="list-style-type: none"> a. Starter inoperative or makes excessive grinding sound. b. Engine knocks, rattles or smokes excessively. c. Transmission shifts improperly, does not shift or makes excessive noises. d. Pedal sticking or binding. e. Steering binds, grabs, wanders or freeplay is more than 1-1/2 in. (38 mm) in either direction.

Table 2-1. Preventive Maintenance Checks and Services (Cont)

Item No.	Interval	<u>Location</u> Item to be Checked or Serviced	Procedure	Not Fully Mission Capable If:
1	Semiannual	Preservice Checks (CONT)	<p style="text-align: center;">NOTE</p> <p>Do not turn tires when turning wheel to check for steering wheel free play.</p> <p>f. Place a strip of tape around steering wheel at 12 O'clock position. Turn steering wheel right until resistance is felt. Place a ruler lightly against outer rim of steering wheel with end of ruler at one edge of tape. Turn steering wheel left until resistance is felt. Measure distance designated edge of tape has traveled. Maximum free play measured at outside rim of steering wheel is 2-1/2 in. (64 mm).</p> <p>g. Apply brake pedal with steady force. Vehicle should slow down and stop without pulling to one side or jerking. Release brake pedal. The brakes should release immediately and without difficulty.</p> <p>h. Observe vehicle response to road shocks, side sway or continuous bouncing indicates a malfunction.</p> <div style="border: 1px solid black; width: fit-content; margin: 10px auto; padding: 2px 10px;">CAUTION</div> <p>Do not hold steering wheel at full left or right position for longer than 10 seconds. Oil overheating and pump damage can result. Failure to comply may result in damage to equipment.</p> <p>i. With vehicle stopped, turn steering wheel to extreme left, then to extreme right to check for binding or jerking.</p> <p>j. Check engine operation at all speeds. Ensure that engine does not go over engine governed speed - (55 mph or 2600 rpm).</p>	<p>f. Steering wheel exceeds 2-1/2 in. (64 mm) free play.</p> <p>g. Brakes chatter, pull to one side, will not release, or do not work.</p> <p>h. Handling is unstable.</p> <p>i. Hard steering is evident.</p> <p>j. Engine exceeds or fails to reach governed speed.</p>

Table 2-1. Preventive Maintenance Checks and Services (Cont)

Item No.	Interval	<u>Location</u> Item to be Checked or Serviced	Procedure	Not Fully Mission Capable If:
2	Semiannual	WHEELS, HUBS, AND CTIS	<div style="border: 1px solid black; padding: 5px; text-align: center; margin-bottom: 10px;">WARNING</div> <p>Completely deflate tires before removing from axles only if there is obvious damage to wheel components. Removing damaged tires from axles without deflating tires may cause wheel components to separate. Failure to comply may result in serious injury or death to personnel.</p> <ol style="list-style-type: none"> a. Check wheels for obvious cracks around lug holes. If cracks are found, repair wheel (para 12-2). b. Replace any loose or damaged wheel studs (para 12-3). Tighten lugnuts (para 12-4). c. Check for oil leaks. d. Check wheels for CTIS air leaks. e. Remove manifold valve (para 12-5) and inspect manifold filter for damage. Clean any debris from manifold filter. 	<ol style="list-style-type: none"> a. Cracks are found around lug holes. b. More than one lugnut or wheel stud is damaged or missing. c. Class III leak is evident.

Table 2-1. Preventive Maintenance Checks and Services (Cont)

Item No.	Interval	Location Item to be Checked or Serviced	Procedure	Not Fully Mission Capable If:
3	Semiannual	SERVICE BRAKES	<div style="border: 1px solid black; padding: 5px; text-align: center; margin-bottom: 10px;">WARNING</div> <ul style="list-style-type: none"> • Brake shoes may be covered with dust. Breathing this dust may be harmful to your health. Do not use compressed air to clean brake shoes. Wear a filter mask approved for use against brake dust. Failure to comply may result in injury to personnel. • Wear appropriate eye protection when working under vehicle due to the possibility of falling debris. Failure to comply may result in injury to personnel. <p>a. Shut down engine (TM 9-2320-365-10) and drain primary air tank. Rear service brakes should not apply. If rear service brakes apply, inversion valve is inoperative. Replace inversion valve (para 11-12). If rear brakes are not applied, depress brake pedal. Depressing brake pedal should apply front brakes and control rear spring brakes through inversion valve and modulation of relay valve.</p>	<p>a. Rear portion of brake system fails.</p>

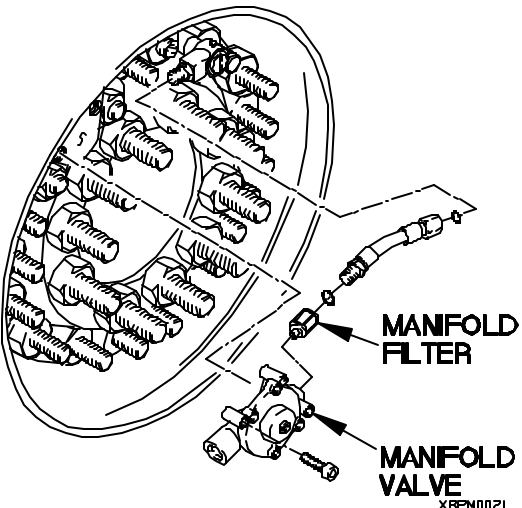
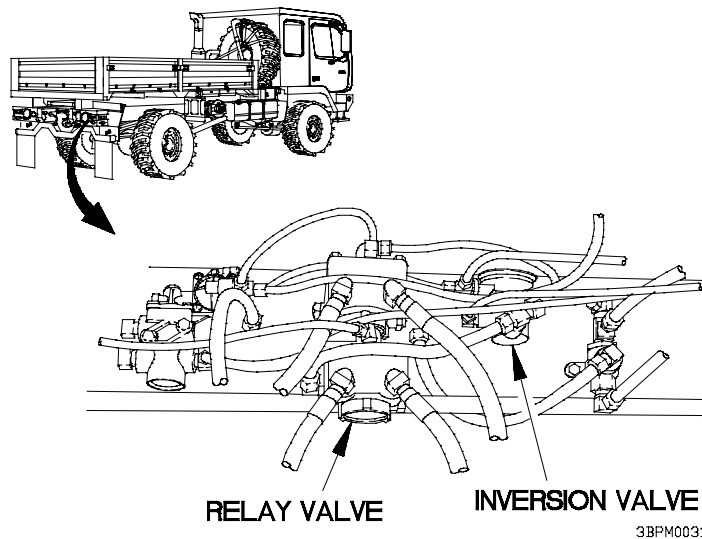

3BPM0031

Table 2-1. Preventive Maintenance Checks and Services (Cont)

Item No.	Interval	Location Item to be Checked or Serviced	Procedure	Not Fully Mission Capable If:
3	Semiannual	SERVICE BRAKES (CONT)	<ul style="list-style-type: none"> b. Inspect load sensing valve for signs of corrosion. c. Check security of mounting hardware. d. Check for air leaks around brake hose fittings. e. Inspect control cable for corrosion and abrasions. f. Check security of control cable upper and lower attaching hardware and adjust (para 11-10). g. Inspect brake air chambers for obvious cracks and corrosion. 	<ul style="list-style-type: none"> d. Air leaks are found. e. Control cable is damaged or missing. g. Brake air chamber leaks.

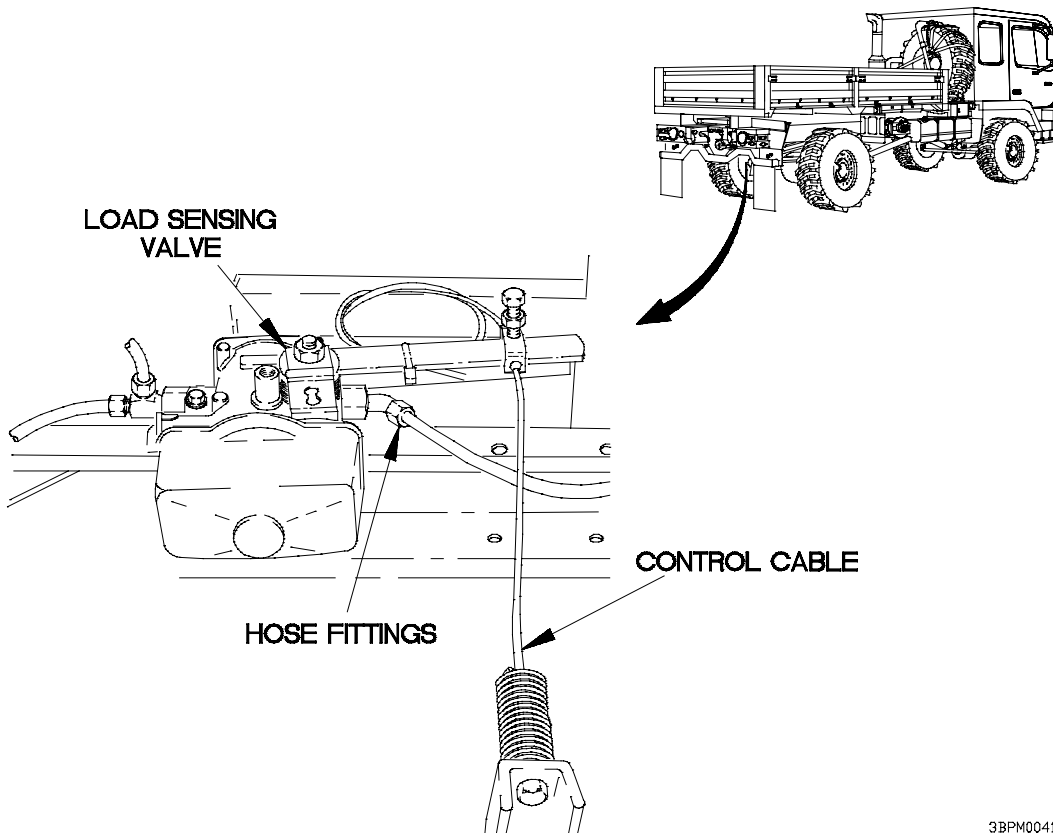

3BPM0041

Table 2-1. Preventive Maintenance Checks and Services (Cont)

Item No.	Interval	Location Item to be Checked or Serviced	Procedure	Not Fully Mission Capable If:
3	Semiannual	SERVICE BRAKES (CONT)	<p style="text-align: center;">WARNING</p> <p>Brake drums can become very hot during vehicle operations. Place hand near drum to check for excessive heat but do not touch drum. Failure to comply may result in injury to personnel.</p> <p style="text-align: center;">CAUTION</p> <p>Brake drum clearance must be checked along centerline of brake shoe. Failure to comply may result in damage to equipment.</p> <p style="text-align: center;">NOTE</p> <p>Over time a ridge will form on the outer edge of the brake shoes. This is normal and does not affect brake shoe serviceability.</p> <p>h. Examine and compare each brake drum for evidence of overheating. Excessive heating of brake drums may indicate a dragging brake shoe. Cool brake drums could mean improper adjustment, defective, or inoperative brakes, or rust on braking surfaces.</p>	<p>h. Brake drums are excessively hot, cool, or rusted.</p>

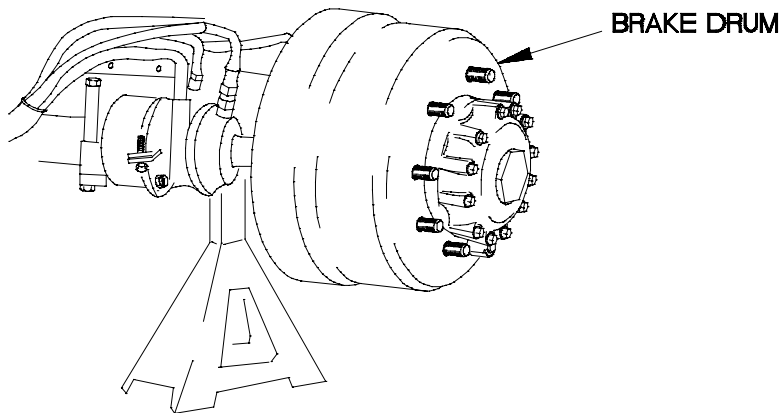

3BPM0051

Table 2-1. Preventive Maintenance Checks and Services (Cont)

Item No.	Interval	Location Item to be Checked or Serviced	Procedure	Not Fully Mission Capable If:
<p>3</p>	<p>Semiannual</p>	<p>SERVICE BRAKES (CONT)</p>	<div style="text-align: center;">  </div> <p>i. Check brake lining to brake drum clearance along centerline of shoe at scallop to ensure automatic adjusters are functioning properly. Clearance should be 0.020-0.040 (0.051-0.102 cm) maximum.</p> <div style="text-align: center; border: 1px solid black; padding: 5px; width: fit-content; margin: 10px auto;"> <p>WARNING</p> </div> <p>Do not allow grease or oil to contact brake linings. Linings can absorb grease and oil, causing early glazing and very poor braking action. Failure to comply may result in serious injury or death to personnel.</p> <p>j. Examine brake shoes for excessive brake lining wear and cracking (para 11-2 and 11-3).</p> <p>k. Inspect brake shoe return springs and hold-down clips for cracks.</p>	<p>i. Brake shoe adjustment is out of tolerance.</p> <p>j. Brake linings are cracked or excessively worn.</p> <p>k. Springs or clips are cracked or broken.</p>

Table 2-1. Preventive Maintenance Checks and Services (Cont)

Item No.	Interval	Location Item to be Checked or Serviced	Procedure	Not Fully Mission Capable If:
3	Semiannual	SERVICE BRAKES (CONT)	I. Inspect actuator plunger seals for cuts, tears, and leaks (para 11-4 and 11-5).	I. Plunger seals, adjusting pawl assembly, adjusting plunger or actuator are damaged.
4	Semiannual	SHOCK ABSORBERS AND SPRINGS	a. Inspect shock absorbers for oil leaks and damage.	a. Shock absorber is bent or leak greater than class I is evident.

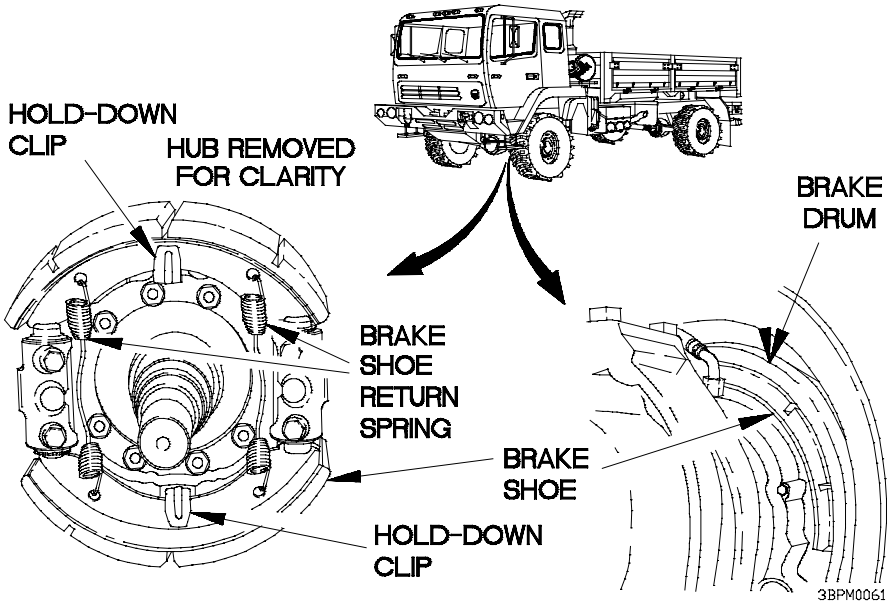
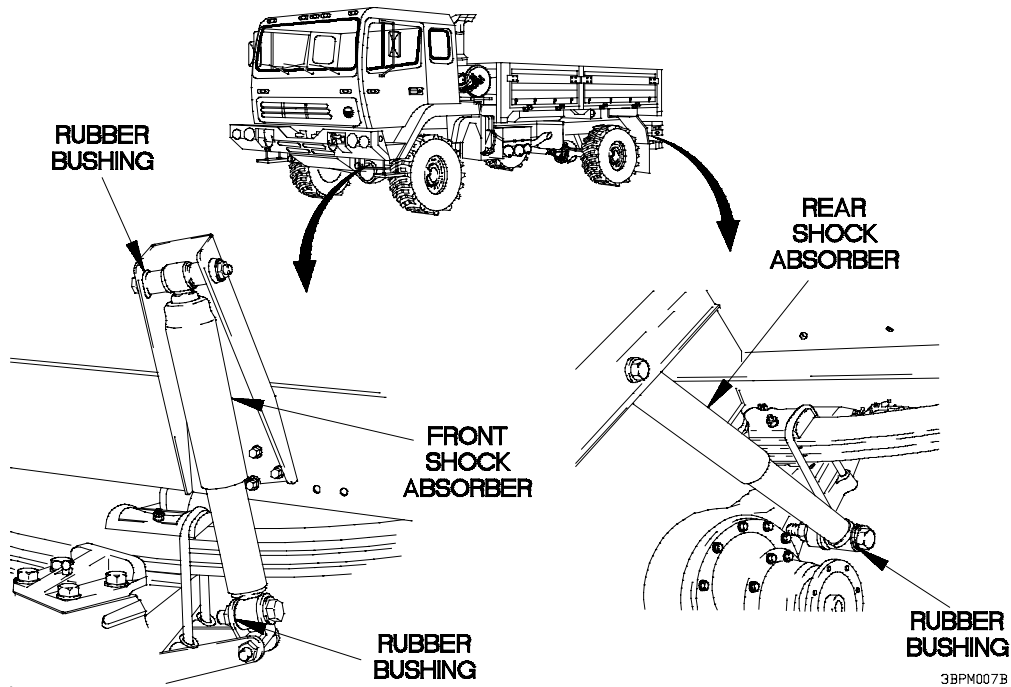

- b. Check shock absorber mounting hardware for security.
- c. Check rubber bushings for looseness which may result in inner sleeve contacting eye ring of shock absorber.

c. Rubber bushings are loose or inner sleeve is contacting eye ring of shock absorber.

Table 2-1. Preventive Maintenance Checks and Services (Cont)

Item No.	Interval	Location Item to be Checked or Serviced	Procedure	Not Fully Mission Capable If:
4	Semiannual	SHOCK ABSORBERS AND SPRINGS (CONT)	d. Inspect spring leaves, spring clips, saddles, saddle caps, and U-bolts for cracks or breaks.	d. Cracks or breaks are found.

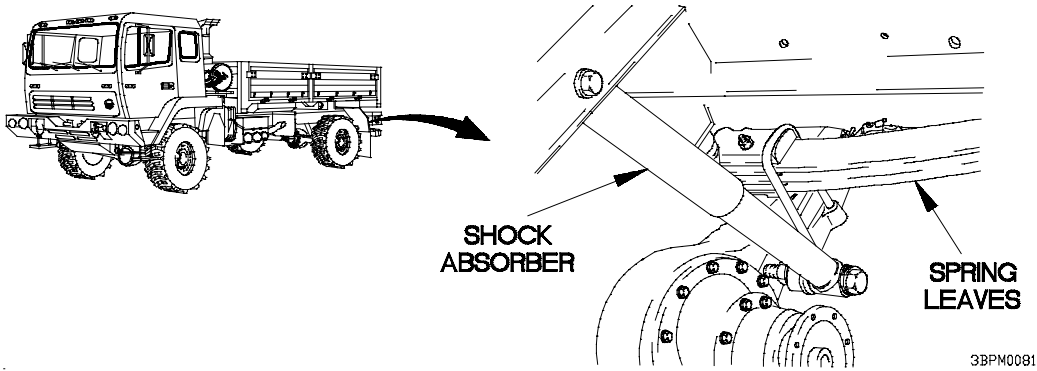

5	Semiannual	AXLES	<div style="border: 1px solid black; padding: 5px; text-align: center; margin-bottom: 10px;">WARNING</div> <p>Wear appropriate eye protection when working under vehicle due to the possibility of falling debris. Failure to comply may result in injury to personnel.</p> <p>Inspect axles for leaks around wheel end assemblies, pinion seal, drive yoke, and drain plug.</p>	Class III leak is evident.
---	------------	--------------	--	----------------------------

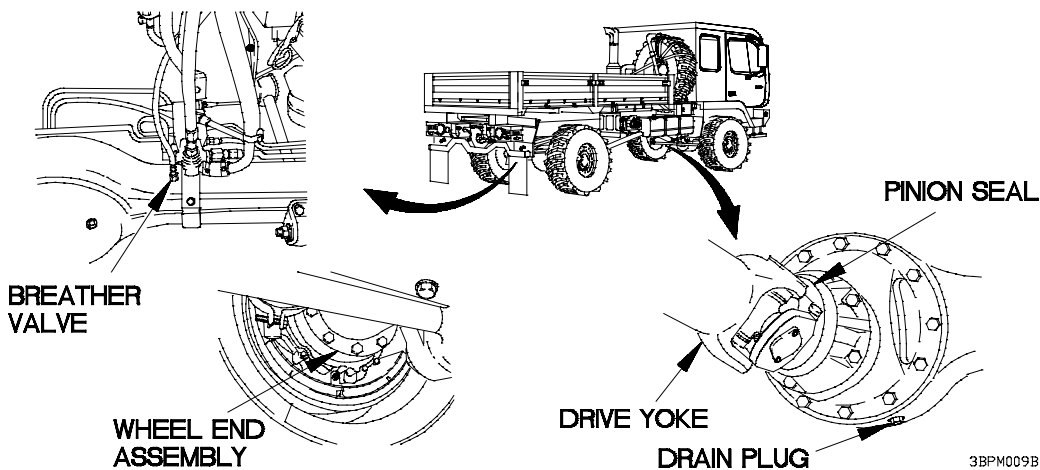

Table 2-1. Preventive Maintenance Checks and Services (Cont)

Item No.	Interval	Location Item to be Checked or Serviced	Procedure	Not Fully Mission Capable If:
6	Semiannual	AXLE BREATHER VALVES	<p>a. Inspect axle breather valves to ensure up and down movement.</p>	
<div style="border: 1px solid black; padding: 2px; display: inline-block;">WARNING</div>				
<ul style="list-style-type: none"> • Dry Cleaning Solvent (P-D-680) is TOXIC and flammable. Wear protective goggles and gloves; use only in well ventilated area; avoid contact with skin, eyes, and clothes, and do not breathe vapors. Keep away from heat or flame. Never smoke when using solvent; the flashpoint for Type I Dry Cleaning Solvent is 100°F (38°C) and for Type II is 130°F (50°C). Failure to comply may result in serious injury or death to personnel. • If personnel become dizzy while using cleaning solvent, immediately get fresh air and medical help. If dry cleaning solvent contacts skin or clothes, flush with cold water. If dry cleaning solvent contacts eyes, immediately flush eyes with water and get immediate medical attention. Failure to comply may result in injury to personnel. 				
			<p>b. Remove axle breather valve from fitting. Wash breather in dry cleaning solvent (Item 71, Appendix D) and allow to air dry.</p>	<p>b. Axle breather valve missing.</p>
<div style="border: 1px solid black; padding: 2px; display: inline-block;">WARNING</div>				
<p>Adhesives, solvents, and sealing compounds can burn easily, can give off harmful vapors, and are harmful to skin and clothing. Keep away from open fire and use in well-ventilated area. If adhesive, solvents, or sealing compound gets on skin or clothing, wash immediately with soap and water. Failure to comply may result in injury to personnel.</p>				
			<p>c. Coat threads of axle breather valve with antiseize compound (Item 14, Appendix D) and install axle breather valve in fitting.</p>	
<div style="display: flex; justify-content: space-around; align-items: flex-end;"> <div data-bbox="373 1428 730 1869" style="text-align: center;">  <p>BREATHER VALVE</p> </div> <div data-bbox="795 1449 1250 1680" style="text-align: center;">  </div> </div> <p style="text-align: right; font-size: small;">3BPM0101</p>				

Table 2-1. Preventive Maintenance Checks and Services (Cont)

Item No.	Interval	Location Item to be Checked or Serviced	Procedure	Not Fully Mission Capable If:
7	Semiannual	DRIVE SHAFTS	<div style="border: 1px solid black; padding: 5px; text-align: center; margin-bottom: 10px;">WARNING</div> <p>Wear appropriate eye protection when working under vehicle due to the possibility of falling debris. Failure to comply may result in injury to personnel.</p> <ul style="list-style-type: none"> a. Inspect U-joints for play, broken and missing lubrication fittings (Appendix H). b. Perform propeller shaft hinging inspection (para 9-3). c. Inspect all drive shafts for damage or obvious spline movement. 	<ul style="list-style-type: none"> a. Lubrication fittings, screws or lock tabs are broken or missing, or play is evident. b. Hinging reading is greater than 0.2 in. (.5 mm). c. Damage or obvious movement evident.

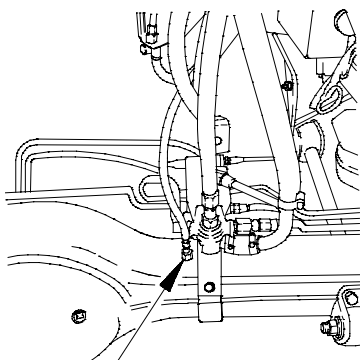
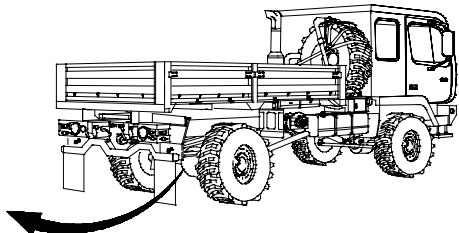
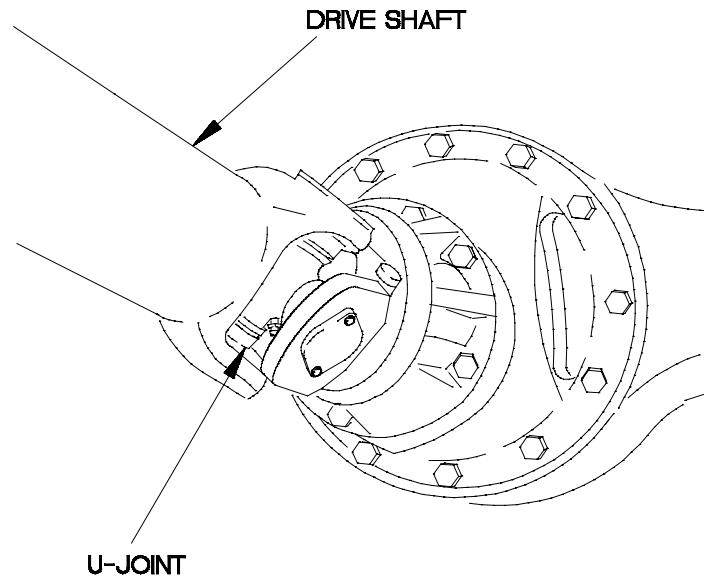

XBPM011B

Table 2-1. Preventive Maintenance Checks and Services (Cont)

Item No.	Interval	Location Item to be Checked or Serviced	Procedure	Not Fully Mission Capable If:
8	Semiannual	TRANSMISSION	<div style="border: 1px solid black; padding: 5px; text-align: center; margin-bottom: 10px;">WARNING</div> <p>Wear appropriate eye protection when working under vehicle due to the possibility of falling debris. Failure to comply may result in injury to personnel.</p> <ol style="list-style-type: none"> a. Check transmission for cracks, loose bolts, leaks, and damage. b. Check that transmission oil pan bolts and drain plug are tight. c. Inspect transmission output shaft seal for damage or leaks. 	<ol style="list-style-type: none"> a. Cracks, loose or missing bolts, or Class III leaks. b. Oil pan bolts or drain plug are loose or missing. c. Damage or Class III leaks are evident.

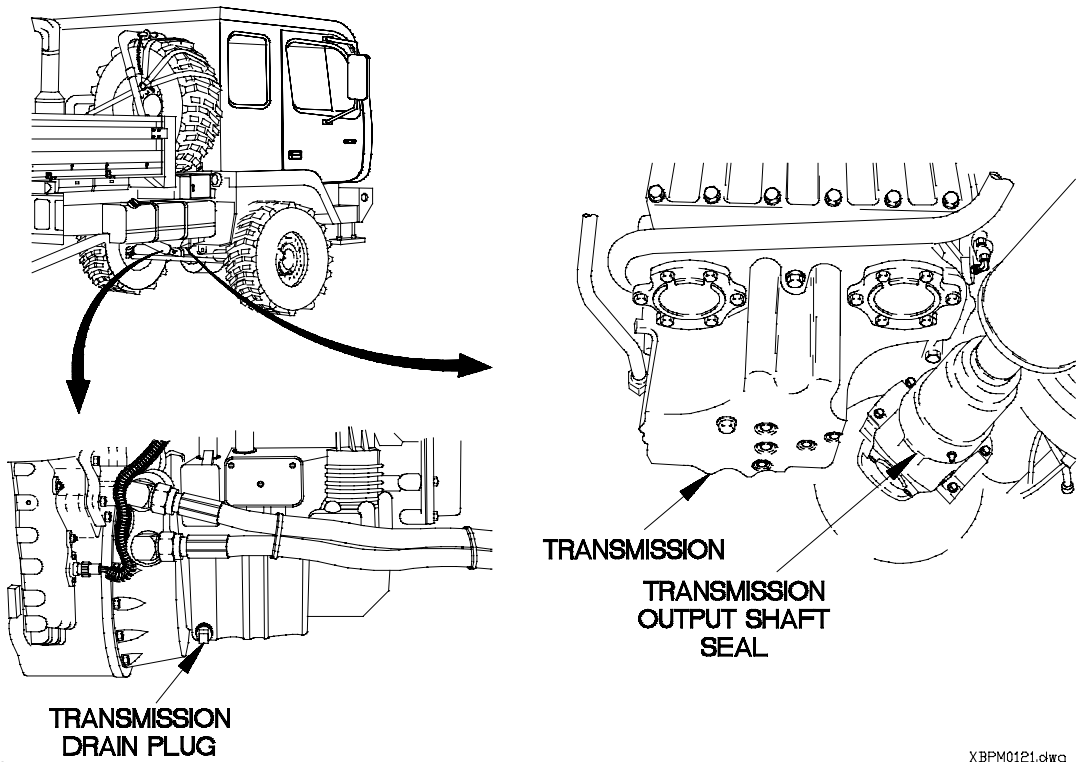

XBPM0121.dwg

Table 2-1. Preventive Maintenance Checks and Services (Cont)

Item No.	Interval	Location Item to be Checked or Serviced	Procedure	Not Fully Mission Capable If:
8	Semiannual	TRANSMISSION (Cont)	<p>d. Inspect transmission oil cooler tubes/hoses for leaks.</p> <p>e. Inspect scavenge pump hose for leaks.</p> 	<p>d. Class III leak is evident.</p> <p>e. Class III leak is evident.</p>
9	Semiannual	ENGINE MOUNTS	<p style="text-align: center;">WARNING</p> <p>Ensure engine is cool before performing maintenance. Failure to comply may result in injury to personnel.</p> <p>Check engine mounts for loose hardware or cracks.</p>	<p style="text-align: right; font-size: small;">XBPM0131</p> <p>Engine mounts are loose or damaged.</p>
10	Semiannual	ENGINE CRANK-CASE	<p style="text-align: center;">CAUTION</p> <p>Initial valve clearance adjustment on new engines, rebuilt engines, or remanufactured engines is required at initial 6,000 miles of engine operation. The adjustment is necessary due to the initial wear of the valve train components and seating of the valve train components. Notify DS Maintenance if initial valve clearance adjustment is required. Failure to comply may result in damage to equipment</p>	

Table 2-1. Preventive Maintenance Checks and Services (Cont)

Item No.	Interval	Location Item to be Checked or Serviced	Procedure	Not Fully Mission Capable If:
10	Semiannual	ENGINE CRANK-CASE (Cont)	<p style="text-align: center;">NOTE</p> <p style="text-align: center;">COLD TEMPERATURE OPERATION</p> <p>For operation of equipment in continuous temperatures below 0 F (-18 C), remove lubricants prescribed in the lubrication key for temperatures above 0 F (-18 C). Relubricate with lubricant specified in the lubrication key for temperatures 0 F to -50 F (-18 C to -46 C).</p> <ol style="list-style-type: none"> a. Start engine (TM 9-2320-365-10) and run for five minutes. b. Check for oil leaks around top of engine oil filter. c. Shut down engine (TM 9-2320-365-10). d. Check oil level on engine oil dipstick. e. Add engine oil, if required, to bring oil level to full mark on engine oil dipstick. 	

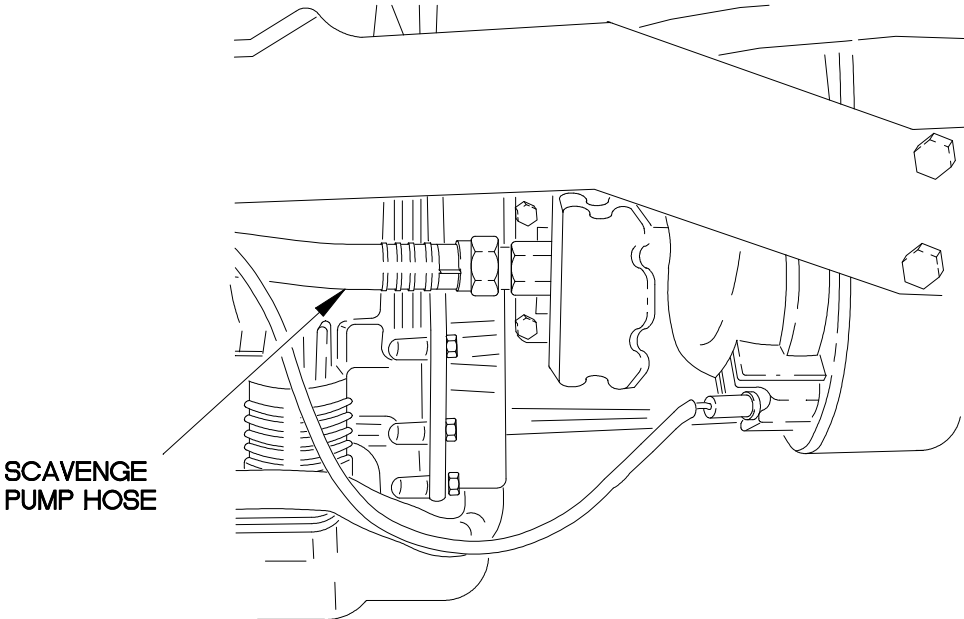
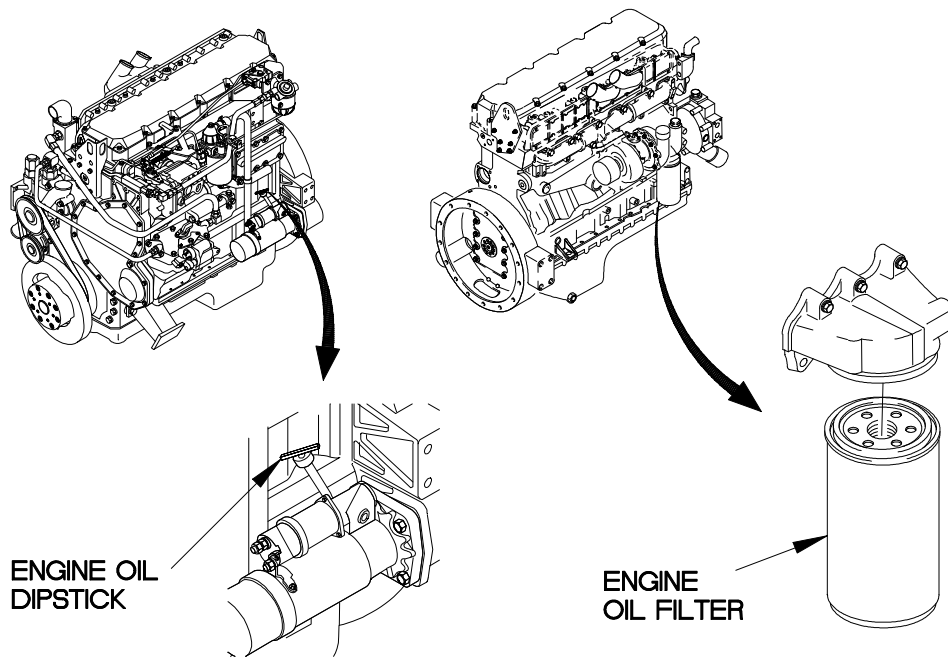

XBPM015B

Table 2-1. Preventive Maintenance Checks and Services (Cont)

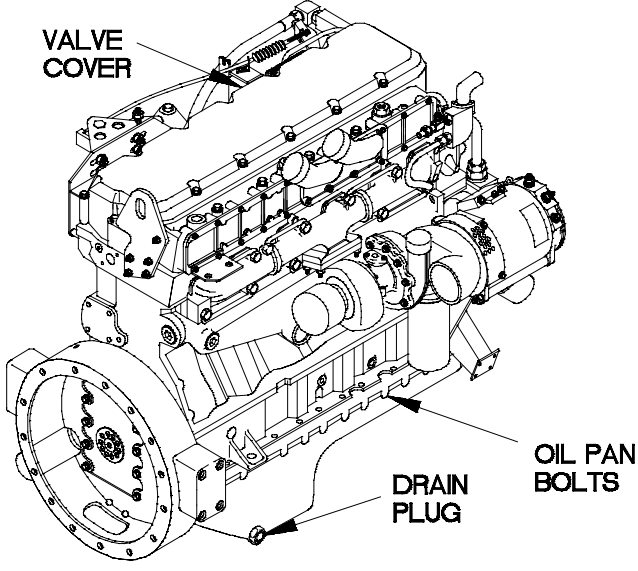
Item No.	Interval	Location Item to be Checked or Serviced	Procedure	Not Fully Mission Capable If:
10	Semiannual	ENGINE CRANK-CASE (Cont)	<p>f. Check oil pan bolts and oil pan drain plug for tightness.</p> <p>g. Check valve cover for evidence of oil leaks.</p>	<p>h. Drain plug or oil pan bolts are loose or missing.</p> <p>i. Class III leak is evident.</p>
				
11	Semiannual	ENGINE WIRING	Check all engine compartment wiring for frays, splits, missing insulation or poor connections.	Insulation missing. Frays, splits, poor connections evident.

XBPM0151.dwg

Table 2-1. Preventive Maintenance Checks and Services (Cont)

Item No.	Interval	Location Item to be Checked or Serviced	Procedure	Not Fully Mission Capable If:
12	Semiannual	AIR SYSTEM	<ul style="list-style-type: none"> a. Observe air dryer purge valve operation and ensure proper functioning. b. Inspect purge valve seal for cracks and leaks. c. Check wiring to heater portion of air dryer. Ensure there are no loose connections or frayed wires. 	<ul style="list-style-type: none"> c. Loose connection cannot be tightened or frayed wires are evident.

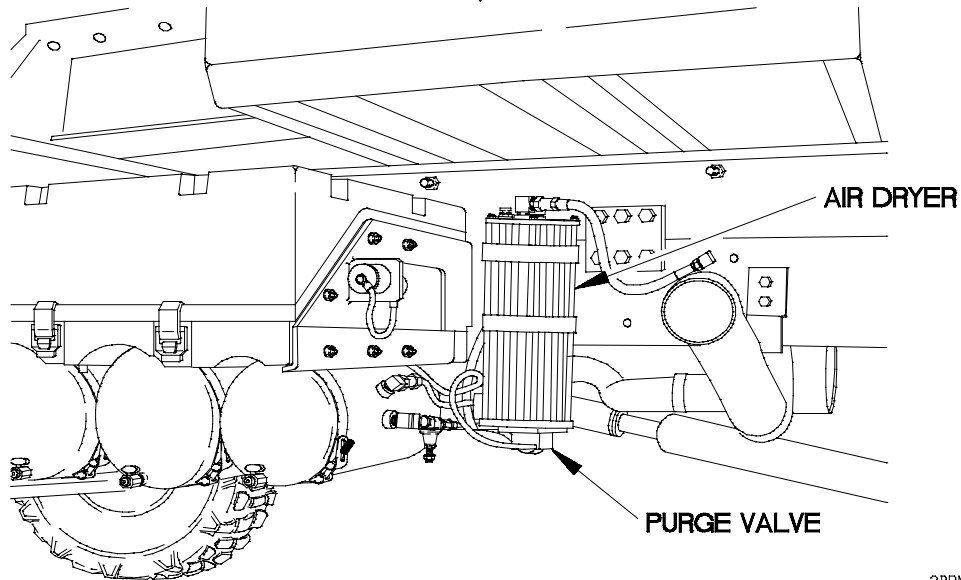
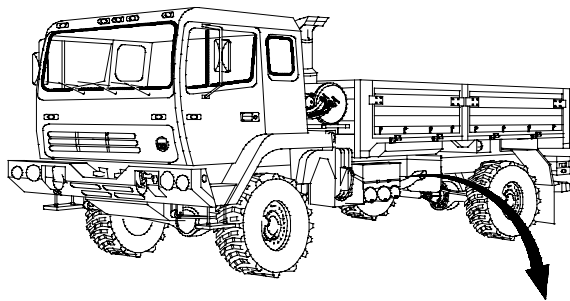

3BPM0161

Table 2-1. Preventive Maintenance Checks and Services (Cont)

Item No.	Interval	Location Item to be Checked or Serviced	Procedure	Not Fully Mission Capable If:
13	Semiannual	EXHAUST SYSTEM	<div style="border: 1px solid black; padding: 5px; text-align: center; margin-bottom: 10px;">WARNING</div> <p>The exhaust pipe and muffler can become very hot during vehicle operation. Be careful not to touch these parts with bare hands, or allow body to come in contact with pipe and muffler. Exhaust system parts can become hot enough to cause serious burns. Failure to comply may result in injury to personnel.</p> <p>a. Inspect exhaust manifold, exhaust pipes, muffler, and tailpipe for corrosion, carbon deposits, loose clamps, or leaking gaskets.</p>	

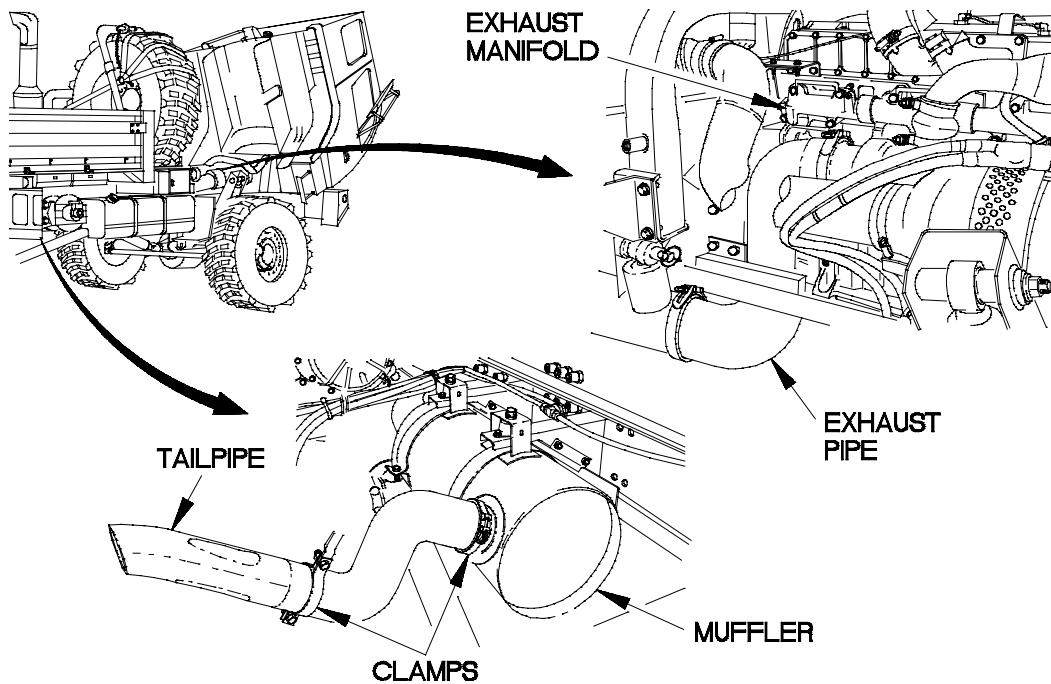

XBPM0171.dwg

Table 2-1. Preventive Maintenance Checks and Services (Cont)

Item No.	Interval	Location Item to be Checked or Serviced	Procedure	Not Fully Mission Capable If:
14	Semiannual	STABILIZER BAR	<ul style="list-style-type: none"> a. Check rear stabilizer bar for secure mounting. b. Inspect stabilizer rubber bushings for cracks and dry rot. 	

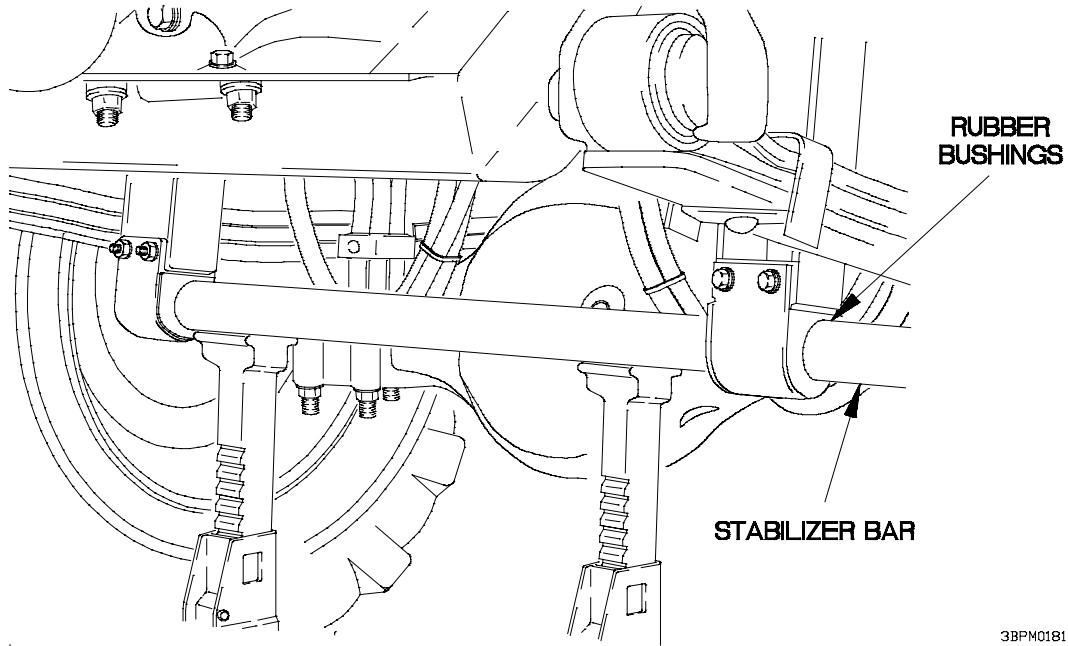

3BPM0181

Table 2-1. Preventive Maintenance Checks and Services (Cont)

Item No.	Interval	Location Item to be Checked or Serviced	Procedure	Not Fully Mission Capable If:
15	Semiannual	PINTLE TOWING HOOK	<ul style="list-style-type: none"> a. Check for free rotation and operation of pintle towing hook. b. Inspect pintle towing hook and mounting plate for cracks or loose hardware. c. Inspect pintle cotter pin for presence. 	

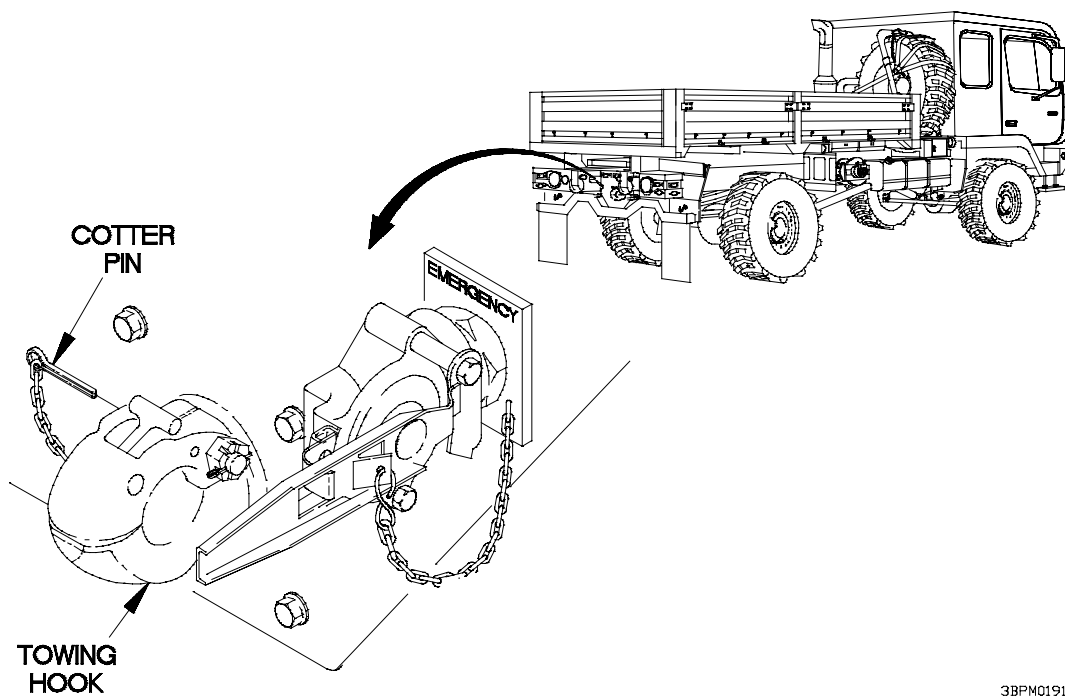

3BPM0191

Table 2-1. Preventive Maintenance Checks and Services (Cont)

Item No.	Interval	Location Item to be Checked or Serviced	Procedure	Not Fully Mission Capable If:
16	Semiannual	VEHICLE EXTERIOR	Inspect vehicle exterior for evidence of corrosion damage such as surface color change, surface separation, seam separation, blistered paint, rust through, in accordance with TB 43-0213.	
17	Semiannual	AIR CLEANER	<p>a. Remove air cleaner cover and examine air cleaner cover gasket for dry rot and/or missing sections.</p>	<p>a. Cover gasket is not intact or capable of making a good seal.</p>

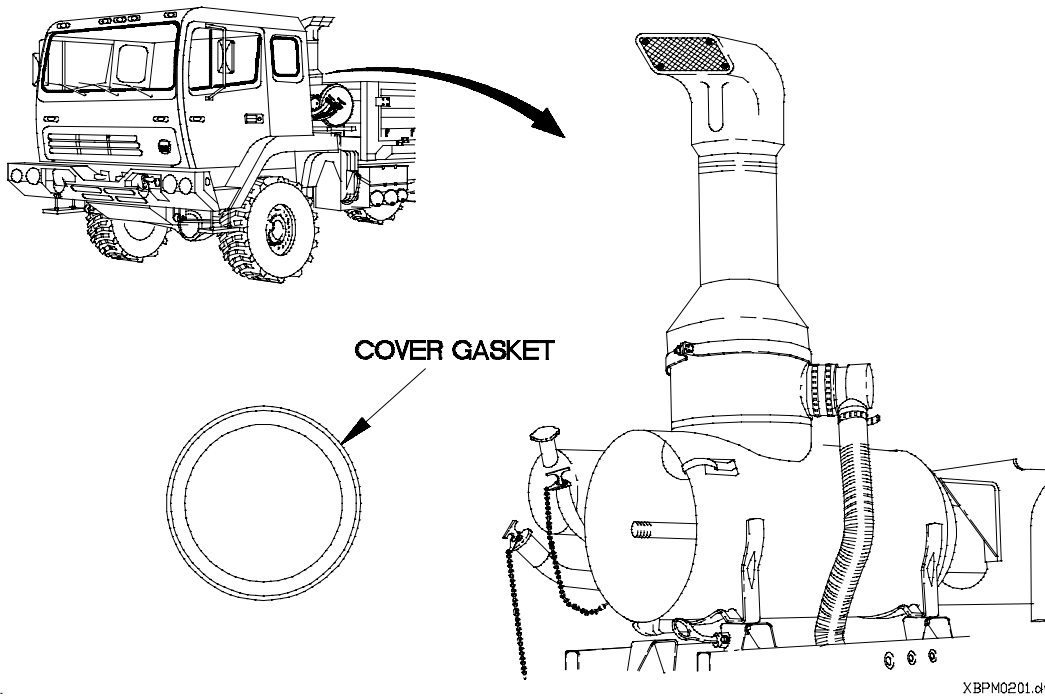

XBPM0201.dwg

Table 2-1. Preventive Maintenance Checks and Services (Cont)

Item No.	Interval	Location Item to be Checked or Serviced	Procedure	Not Fully Mission Capable If:
17	Semiannual	AIR CLEANER (CONT)	<p>b. Inspect air shutter by loosening one hose clamp, removing cover, and ensuring air shutter moves freely without binding or resistance.</p> <p>c. Inspect air shutter gasket for cracking and dry rot.</p> <p>d. Check security of clamps on particle extraction hose between air cleaner and tailpipe. Tighten if loose (35-45 lb-in. (4-5 N·m)), replace if broken. Examine particle extraction hose. Replace if excessively worn.</p>	<p>b. Air shutter binds or is stuck.</p> <p>c. Gasket is broken or dry rotted.</p> <p>d. Particle extraction pathway between air cleaner and tailpipe is not intact.</p>

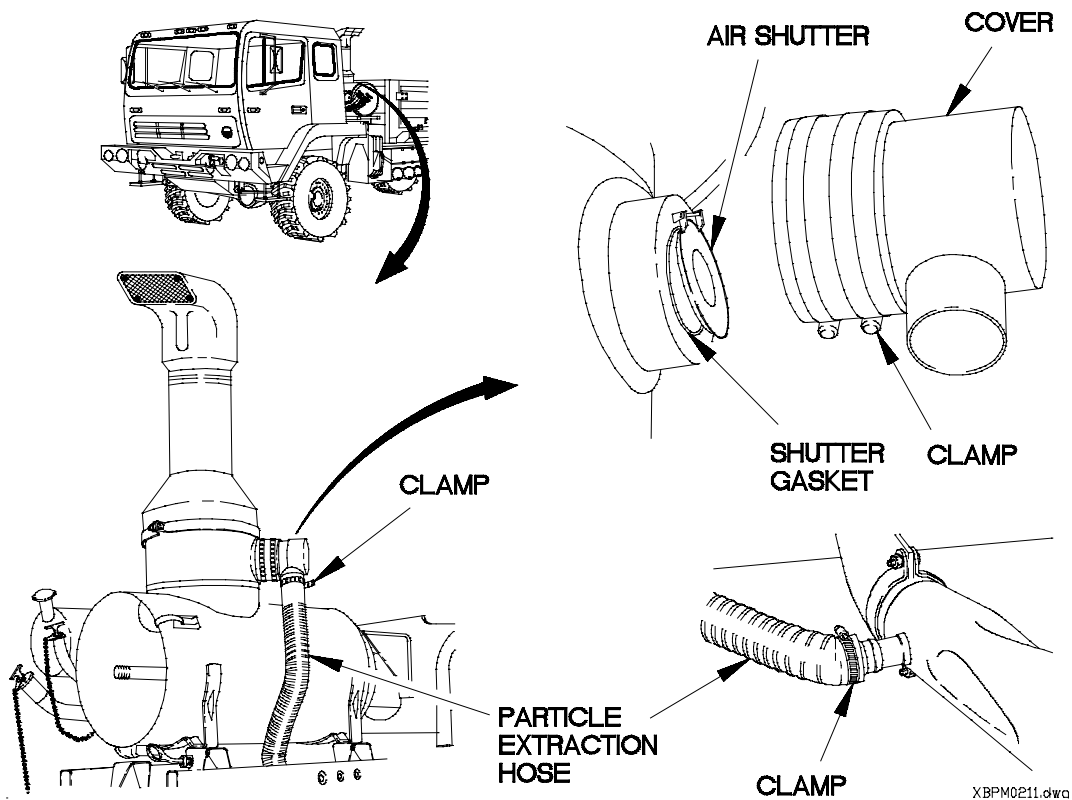
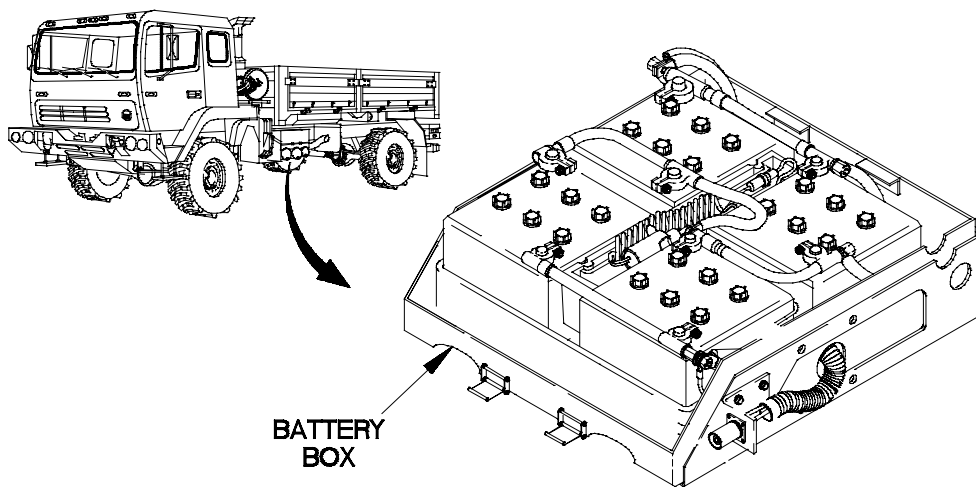

Table 2-1. Preventive Maintenance Checks and Services (Cont)

Item No.	Interval	Location Item to be Checked or Serviced	Procedure	Not Fully Mission Capable If:
18	Semiannual	BATTER- IES AND BATTERY BOX	<div style="border: 1px solid black; padding: 5px; text-align: center; margin-bottom: 10px;">WARNING</div> <ul style="list-style-type: none"> • Remove or disconnect batteries prior to performing maintenance in battery area or when working on electrical system. Failure to comply may result in severe electrical shock to personnel or damage to equipment. • Remove all jewelry such as rings, dog tags, bracelets, etc. If jewelry contacts battery terminal, a direct short may result in instant heating of tools, damage to equipment, and serious injury or death to personnel. Failure to comply may result in serious injury to personnel. • Wear safety glasses or goggles when checking batteries. Always check electrolyte level with engine shut down. Do not smoke or use exposed flame when checking battery; explosive gases are present and severe injury to personnel can result. Failure to comply may result in injury to personnel. <p>a. Inspect battery box for obvious signs of corrosion and for loose mounting hardware.</p>	



3BPM0221

Table 2-1. Preventive Maintenance Checks and Services (Cont)

Item No.	Interval	Location Item to be Checked or Serviced	Procedure	Not Fully Mission Capable If:
18	Semiannual	BATTERIES AND BATTERY BOX (CONT)	<p>b. Inspect external condition of batteries; check for cracks and loose or corroded terminal posts.</p> <p>c. Check and record specific gravity of each cell in all batteries.</p>	b. Batteries cracked.
 <p style="text-align: right; margin-right: 100px;">3BPM0231</p>				
			d. Inspect battery cables for corrosion, frays, splits, chafing and secure attachment.	d. Battery cables are worn, frayed or corroded.

Table 2-1. Preventive Maintenance Checks and Services (Cont)

Item No.	Interval	Location Item to be Checked or Serviced	Procedure	Not Fully Mission Capable If:
19	Semiannual	SPARE TIRE RETAINER	<ul style="list-style-type: none"> a. Inspect hydraulic hoses for cracks and abrasions. b. Inspect hydraulic cylinder for leaks around cylinder rod and fittings. Check cotter pins for presence. 	<ul style="list-style-type: none"> a. Class III leak is evident. b. Class III leak is evident.

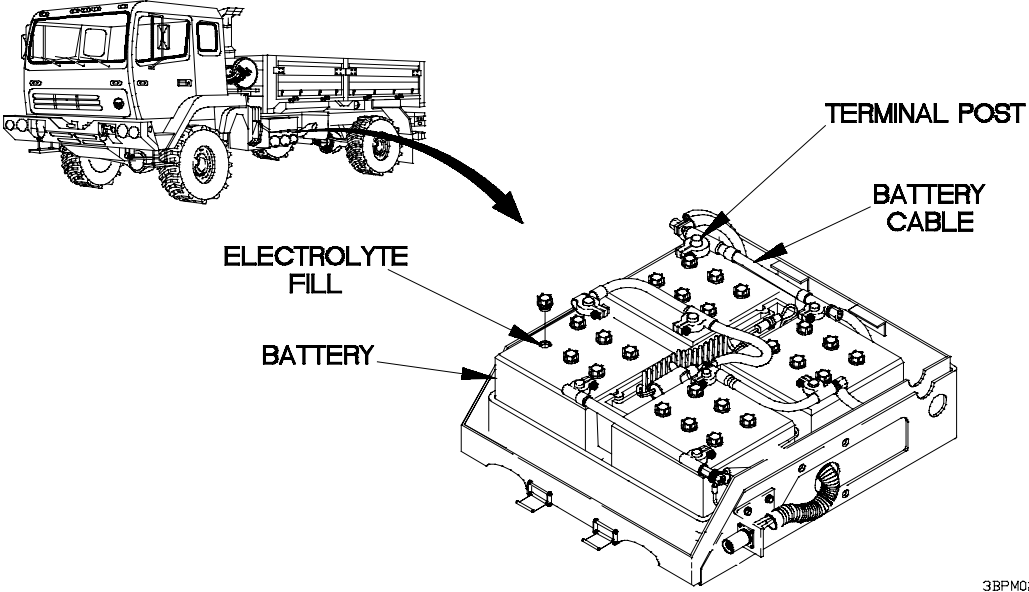
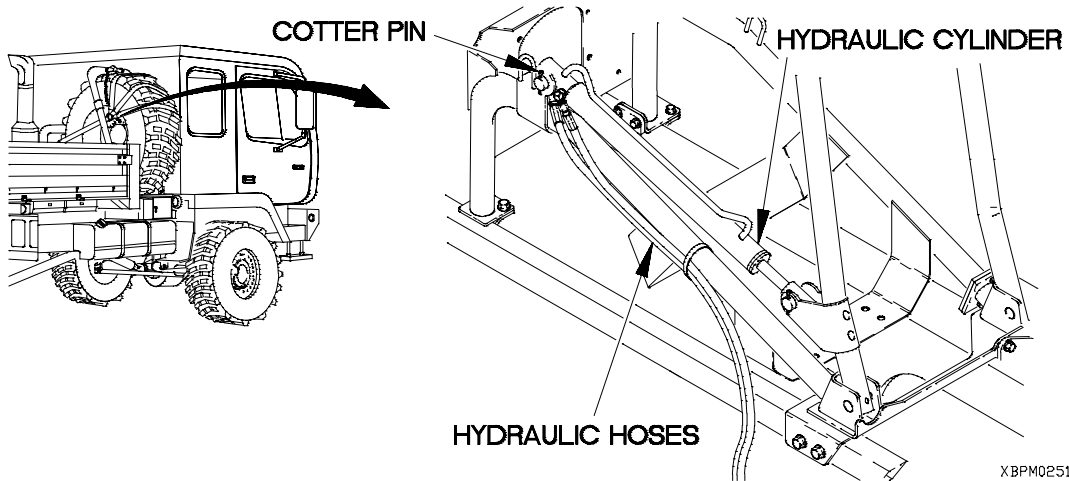
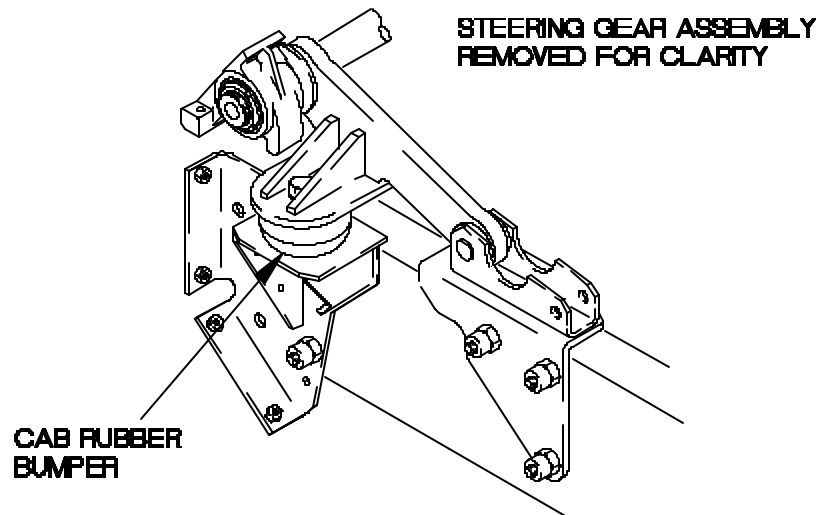

Table 2-1. Preventive Maintenance Checks and Services (Cont)

Item No.	Interval	Location Item to be Checked or Serviced	Procedure	Not Fully Mission Capable If:
20	Semiannual	CAB HYDR- AULIC CYLINDER	a. Inspect cab hydraulic cylinder for leakage around cylinder rod. b. Check security of attaching hardware at cylinder rod end and cotter pin for presence.	a. Class III leak is evident. b. Cab hydraulic cylinder is unsecured.



3BP10281

20a	Semiannual	CAB RUBBER BUMPER	Check cab rubber bumper for damage or excessive wear.	If cab rubber bumper is damaged or worn.
-----	------------	-------------------------	---	--

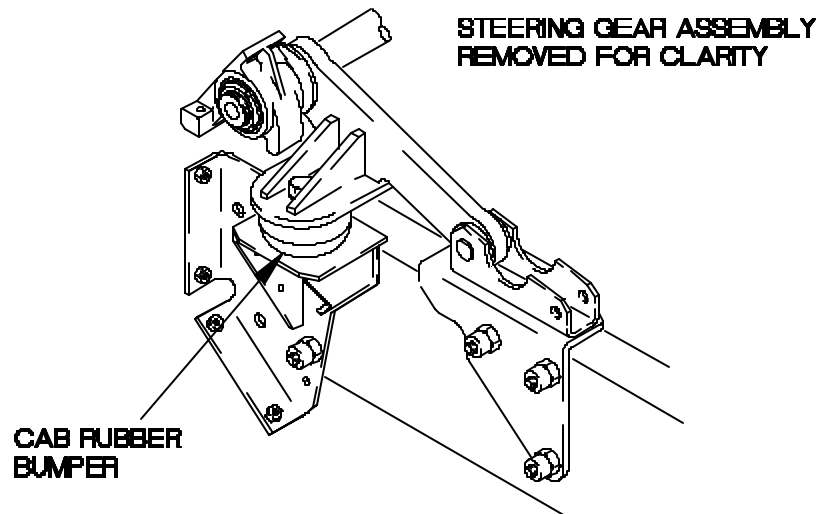

3BP10281

Table 2-1. Preventive Maintenance Checks and Services (Cont)

Item No.	Interval	Location Item to be Checked or Serviced	Procedure	Not Fully Mission Capable If:
21	Semiannual	CAB HYDR- AULIC LATCH	Check security of attaching hardware for hydraulic cab latch.	<p>a. If cab will not securely latch.</p> <p>b. Missing or loose hardware.</p>

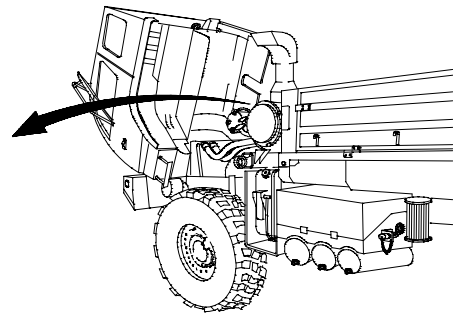
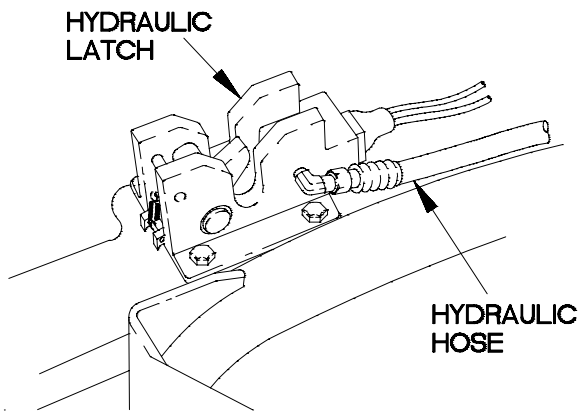

3BPM0271

Table 2-1. Preventive Maintenance Checks and Services (Cont)

Item No.	Interval	Location Item to be Checked or Serviced	Procedure	Not Fully Mission Capable If:
22	Semiannual	AIR/ HYDRAU- LIC POWER UNIT	Check air/hydraulic power unit reservoir and refill in accordance with Appendix H.	

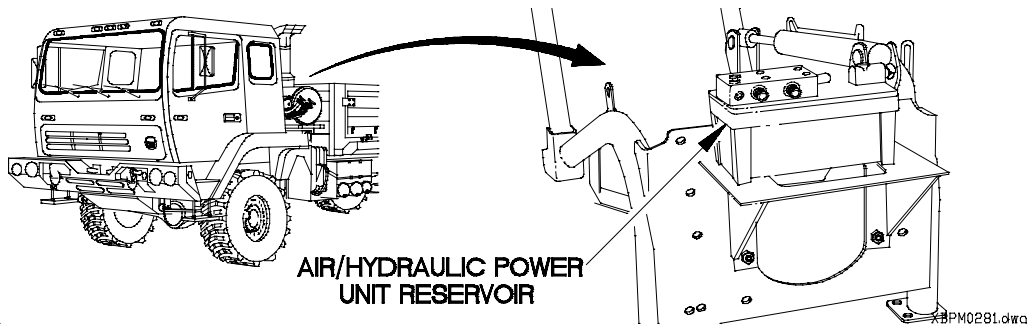

23	Semiannual	SUSPEN- SION CYLINDER	Check suspension cylinder for oil leaks and damage.	Class III leak is evident.
----	------------	--------------------------------------	---	----------------------------

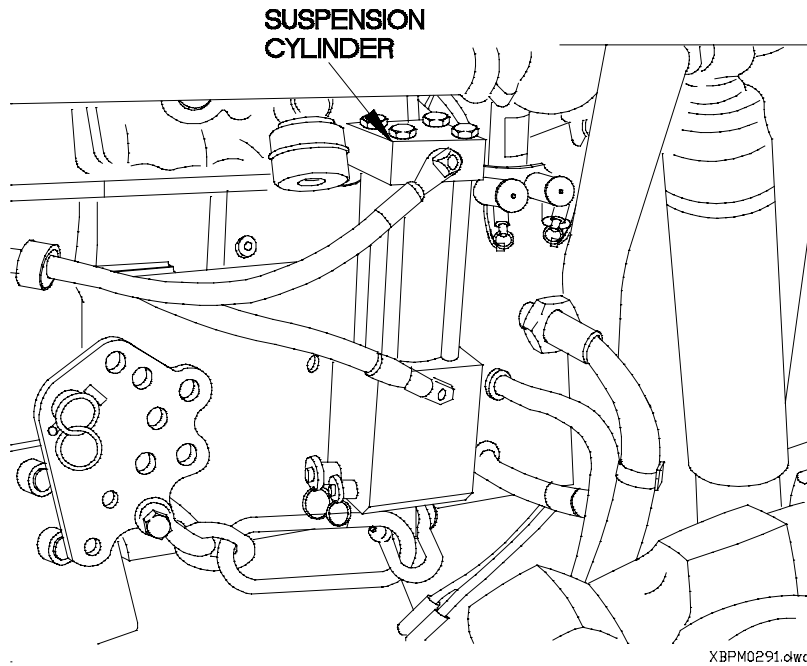
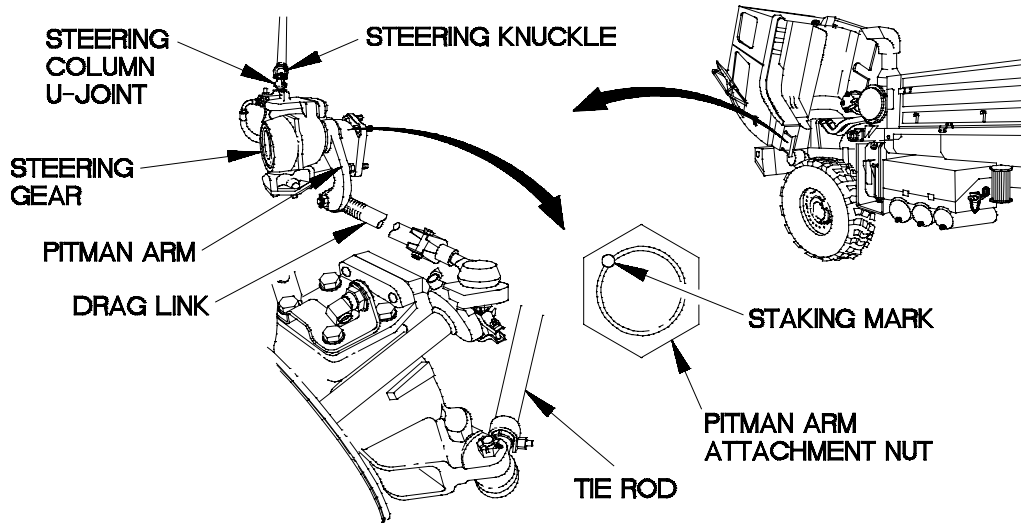

Table 2-1. Preventive Maintenance Checks and Services (Cont)

Item No.	Interval	Location Item to be Checked or Serviced	Procedure	Not Fully Mission Capable If:
24	Semiannual	STEERING SYSTEM	<p>a. Inspect steering column universal joint attachment hardware for security.</p> <p style="text-align: center;">NOTE</p> <p>Wheels must be centered before performing step b.</p> <p>b. Inspect staking of pitman arm attachment nut.</p> <p>c. Inspect power steering hoses for leaks, cracks, and chafing.</p> <p>d. Check steering gear mounting bolts for tightness.</p> <p>e. Check steering column U-joint, steering knuckles, tie rod, drag link, pitman arm, and steering gear for tightness, breaks, cracks, rust, and serviceability.</p>	<p>a. Universal joint is loose, broken, cracked, or hardware is missing.</p> <p>b. Pitman arm nut is loose.</p> <p>c. Class III leak is evident. Chafing is severe or hoses cracked.</p> <p>d. Bolts loose or missing.</p> <p>e. Bolts are loose. Breaks or cracks are evident.</p>



XBPM0301.dwg

Table 2-1. Preventive Maintenance Checks and Services (Cont)

Item No.	Interval	Location Item to be Checked or Serviced	Procedure	Not Fully Mission Capable If:
25	Semiannual	PULLEY DAMPER	Inspect pulley damper for dents.	Pulley damper is damaged.
26	Semiannual	ALTER-NATOR PULLEY	Inspect alternator pulley for dents, nicks, and cuts in flanges.	Pulley is damaged to the point that it affects belt wear.
27	Semiannual	ALTER-NATOR BRACK-ETS	<ul style="list-style-type: none"> a. Check for loose or cracked mounting hardware on alternator bracket and alternator pulley. b. Check idler pulley for dents, nicks, and cuts in flanges. 	<ul style="list-style-type: none"> a. Alternator bracket or idler pulley is cracked or loose. b. Pulley is damaged to the point that it affects belt wear.
28	Semiannual	ALTER-NATOR DRIVE BELTS	Check alternator drive belts for cracks, frays, and shiny spots.	Any drive belt has more than one crack 1/8 in. (3 mm) in depth or 50 percent of belt thickness, any fray more than 2 in. (51 mm) long, or has excessive play.

Table 2-1. Preventive Maintenance Checks and Services (Cont)

Item No.	Interval	Location Item to be Checked or Serviced	Procedure	Not Fully Mission Capable If:
29	Semiannual	THROT- TLE POSITION SENSOR	Check TPS for secure mounting.	TPS is not firmly mounted or securely attached to throttle lever.

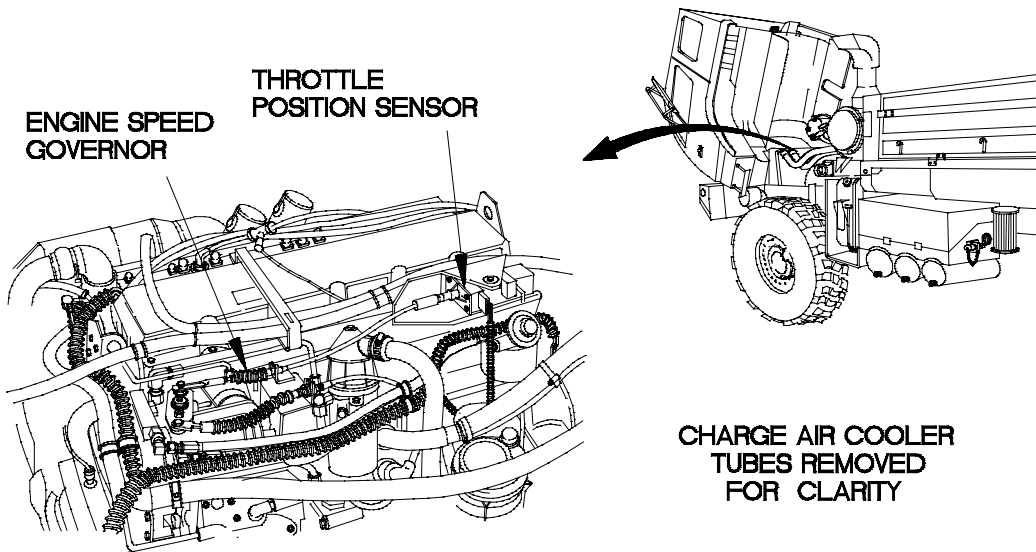

XBPM0321.dwg

30	Semiannual	ENGINE	<p>a. Inspect engine speed governor for loose mounting hardware.</p> <p>b. Check for fuel leaks around fittings and for abrasion of fuel hoses.</p>	<p>a. Mounting hardware is loose or missing.</p> <p>b. Fuel leaks are evident.</p>
----	------------	---------------	---	--

Table 2-1. Preventive Maintenance Checks and Services (Cont)

Item No.	Interval	Location Item to be Checked or Serviced	Procedure	Not Fully Mission Capable If:
30	Semiannual	ENGINE (Cont)	<ul style="list-style-type: none"> c. Check for oil leaks around fittings and for crimps in oil tubes. d. Check for secure attachment of throttle control cable. 	<ul style="list-style-type: none"> c. Class III leak is evident. d. Control cable is not securely attached.
31	Semiannual	TURBO-CHARGER	Check turbocharger oil tubes for leaks or crimping which would restrict oil flow.	Class III leak is evident.
32	Semiannual	CHARGE AIR COOLER TUBES	a. Inspect charge air cooler tube assembly for obvious signs of corrosion or cracking.	a. Charge air cooler tubing is cracked.

Table 2-1. Preventive Maintenance Checks and Services (Cont)

Item No.	Interval	Location Item to be Checked or Serviced	Procedure	Not Fully Mission Capable If:
32	Semiannual	CHARGE AIR COOLER TUBES (Cont)	<ul style="list-style-type: none"> b. Check all hose clamps between turbocharger and intake manifold and verify that they are tight (90-100 lb-in. (10-11 N-m)). c. Check turbocharger rubber charge air hoses for cracking and chafing. 	c. Rubber hose(s) is damaged.
 <p style="text-align: right; font-size: small;">XBPM0341.dwg</p>				
33	Semiannual	CHARGE AIR COOLER	<ul style="list-style-type: none"> a. Inspect charge air cooler for bent or clogged cooling fins. b. Check charge air cooler mounting for security and tighten any loose hardware. c. Inspect mounting brackets for cracks and damage. 	a. Charge air cooler is damaged.

Table 2-1. Preventive Maintenance Checks and Services (Cont)

Item No.	Interval	Location Item to be Checked or Serviced	Procedure	Not Fully Mission Capable If:
34	Semiannual	EXHAUST AND INTAKE MANIFOLDS	<p>a. Check exhaust manifold for damage, loose mounting bolts and for exhaust leaks.</p> <p>b. Check intake manifold for loose mounting bolts and damage.</p>	<p>a. Exhaust manifold is damaged, exhaust leaks, or mounting hardware is loose.</p> <p>b. Intake manifold is damaged. Mounting hardware is loose.</p>

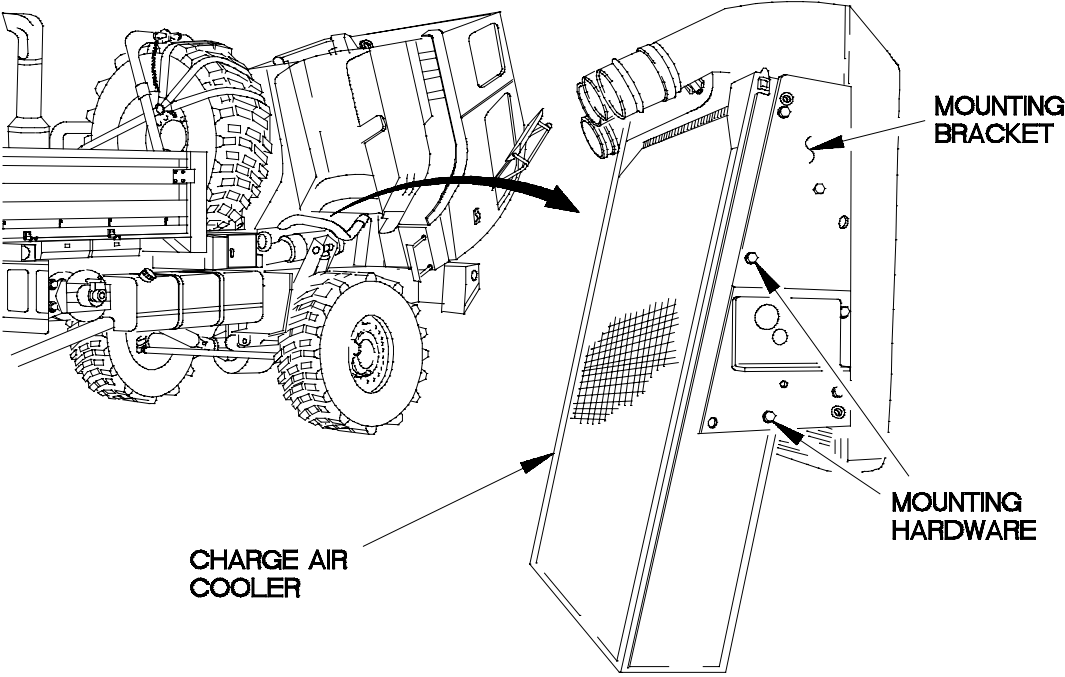
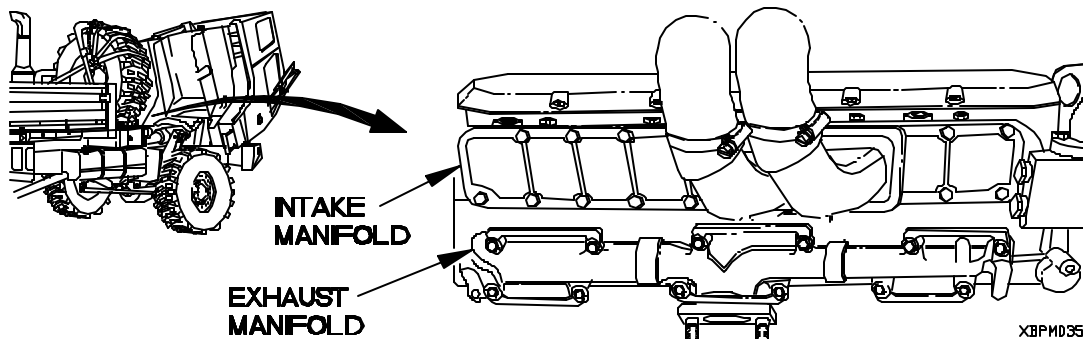

XBPMD351

35	Semiannual	ENGINE CRANKCASE BREATHER	<p>Inspect crankcase breather for oil leaks around base. Check security of mounting hardware.</p>	<p>Class III leak or loose or missing hardware are evident.</p>
----	------------	----------------------------------	---	---

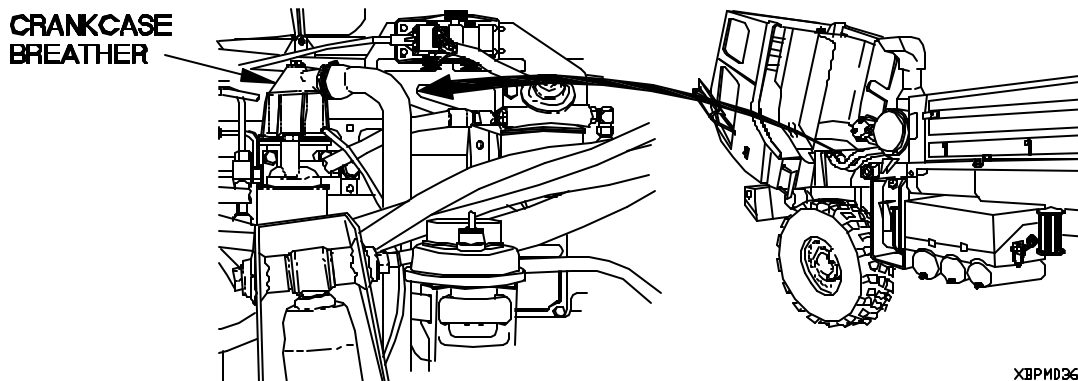

XBPMD361

Table 2-1. Preventive Maintenance Checks and Services (Cont)

Item No.	Interval	Location Item to be Checked or Serviced	Procedure	Not Fully Mission Capable If:
36	Semiannual	ENGINE WIRING	Check all engine wiring for signs of fraying, chafing, cracking, and burnt insulation.	Wiring is burned, cracked, frayed, or broken.
37	Semiannual	AIR COMPRESSOR AND GOVERNOR	<ul style="list-style-type: none"> a. Inspect air compressor and air compressor governor for leaks and loose hardware. b. Inspect air compressor oil tube for leaks and kinks/bends which would cause a restriction. c. Check air compressor coolant tubes for leaks and kinks/bends. 	<ul style="list-style-type: none"> a. Class III leak is evident or hardware is missing or loose. b. Class III leak, kinks or bends are evident. c. Class III leak, kinks or bends are evident.

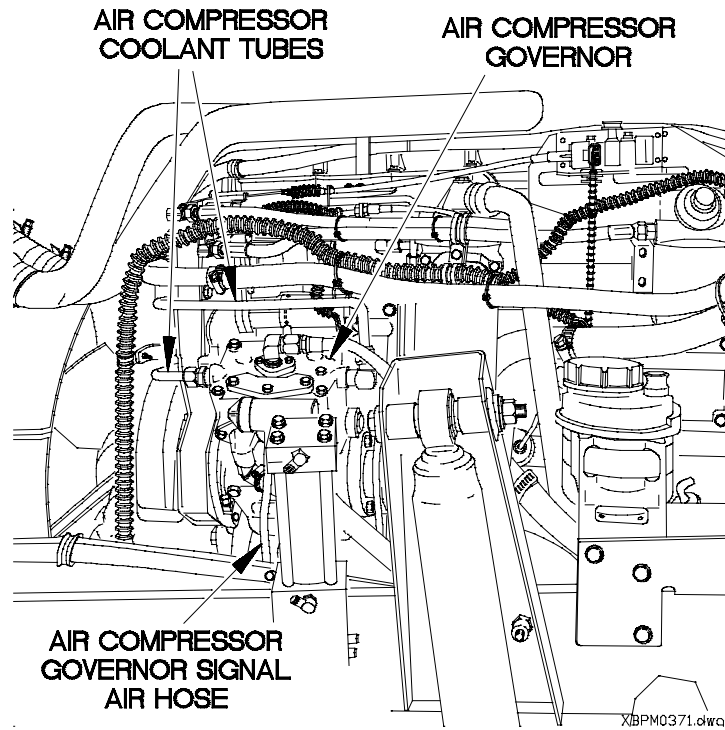

Table 2-1. Preventive Maintenance Checks and Services (Cont)

Item No.	Interval	Location Item to be Checked or Serviced	Procedure	Not Fully Mission Capable If:
38	Semiannual	COOLING SYSTEM	<div style="border: 1px solid black; padding: 5px; text-align: center; margin-bottom: 10px;">WARNING</div> <p>If vehicle has been operating, use extreme care to avoid being burned when removing radiator cap. Use heavy rags or gloves to protect hands. Turn radiator cap only one-quarter turn to the left and allow pressure to be relieved before fully removing cap. Failure to comply may result in injury to personnel.</p> <p>a. Check coolant condition. Test coolant to see if draining is necessary (TB 750-651).</p> <p>b. Replace coolant if required (Appendix H Note 7).</p>	
 <p>The diagram illustrates the radiator overflow tank assembly. It features two sight glasses: an upper one for checking the coolant level and a lower one for checking the coolant condition. The tank is labeled 'RADIATOR OVERFLOW TANK'. An inset drawing shows the tank's location on the front of the vehicle. The diagram is identified by the code 'XBP10281'.</p>				

Table 2-1. Preventive Maintenance Checks and Services (Cont)

Item No.	Interval	Location Item to be Checked or Serviced	Procedure	Not Fully Mission Capable If:
39	Semiannual	THERMO-STAT HOUSING	<ul style="list-style-type: none"> a. Check thermostat housing for loose mounting bolts and leaks around base. Tighten loose mounting bolts. b. Inspect upper coolant tube for cracks and splits. Refer to para 6-9 if clamps are found to be loose. c. Check for leaks around water temperature transducer and coolant temperature switch. 	<ul style="list-style-type: none"> a. Class III leak is evident. c. Class III leak is evident.

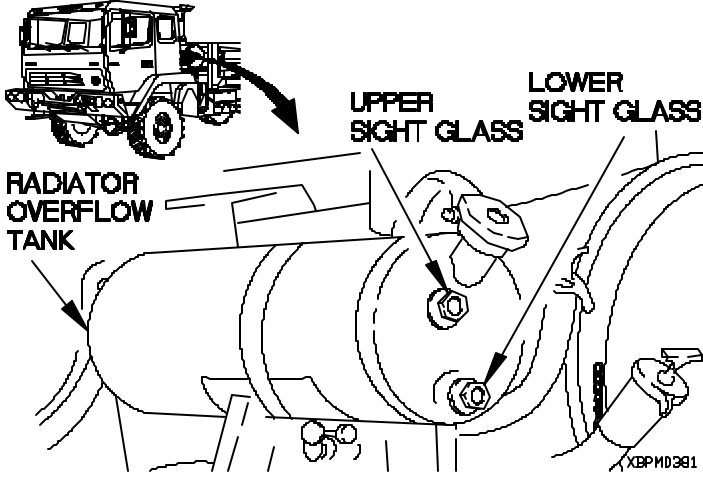
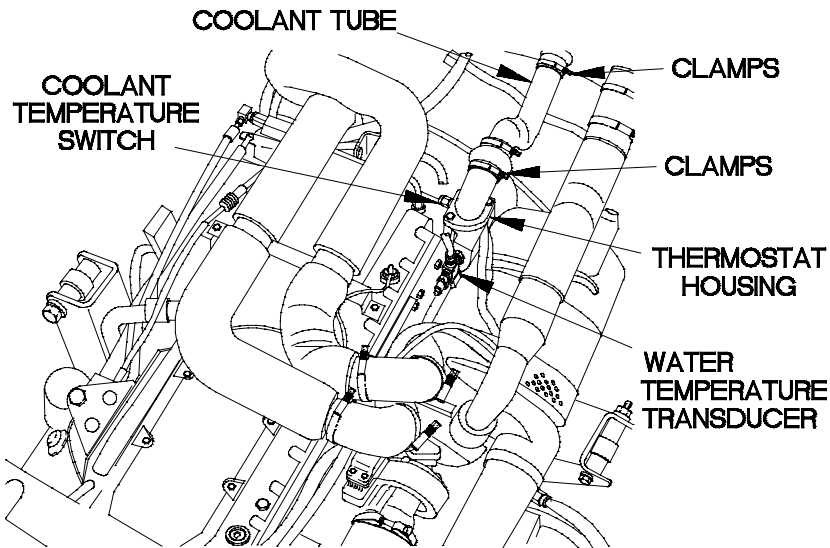

XBPM0391.dwg

Table 2-1. Preventive Maintenance Checks and Services (Cont)

Item No.	Interval	Location Item to be Checked or Serviced	Procedure	Not Fully Mission Capable If:
40	Semiannual	WATER PUMP	<p>a. Check security of water pump attachment bolts and hose clamps. Refer to para 6-12 if clamps are found to be loose.</p> <p>b. Inspect water pump for leaks around impeller shaft.</p> <p>c. Inspect water pump pulley and idler pulley for damage.</p> <div data-bbox="386 772 1234 1344" data-label="Image"> </div> <p>d. Check drive belt for cracks, frays, and shiny spots.</p>	<p>a. Bolts are stripped.</p> <p>b. Class III leak is evident.</p> <p>c. Water pump pulley or idler pulley is damaged to the point that it affects belt wear.</p> <p>d. Drive belt has more than one crack 1/8 in. (3 mm) in depth or 50 percent of belt thickness, any fray more than 2 in. (51 mm) long, or has excessive play.</p>

Table 2-1. Preventive Maintenance Checks and Services (Cont)

Item No.	Interval	Location Item to be Checked or Serviced	Procedure	Not Fully Mission Capable If:
41	Semiannual	FAN BLADE AND CLUTCH	<ul style="list-style-type: none"> a. Inspect fan for chipping, cracking, and missing fan blades. b. Inspect fan clutch for loose bolts (para 6-14). c. Check fan clutch air hose and fitting for leaks. 	<ul style="list-style-type: none"> a. Fan blades chipped, cracked, or missing. b. Loose or missing bolts.
42	Semiannual	RADIATOR	<ul style="list-style-type: none"> a. Check radiator for leaks and bent or clogged cooling fins. b. Check fan shroud for cracks and missing pieces. 	<ul style="list-style-type: none"> a. Class III leak is evident.

Table 2-1. Preventive Maintenance Checks and Services (Cont)

Item No.	Interval	Location Item to be Checked or Serviced	Procedure	Not Fully Mission Capable If:
43	Semiannual	FUEL/ WATER SEPARA- TOR	a. Inspect fuel/water separator assembly for dents and cracks that could cause leaks. b. Deleted.	a. Any leak is evident.

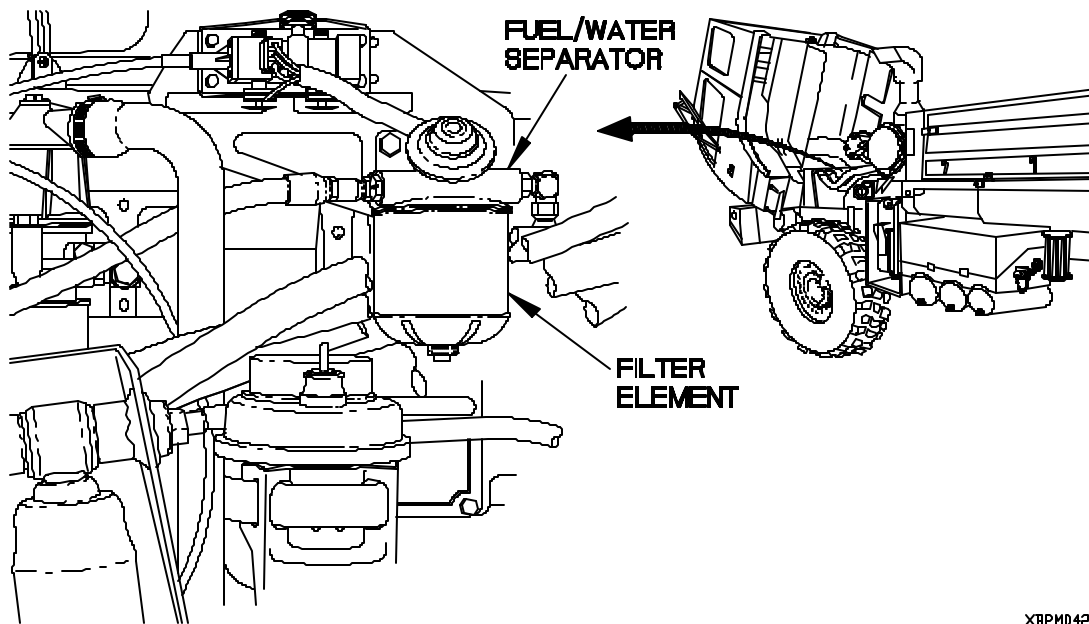

XBPM0421

Table 2-1. Preventive Maintenance Checks and Services (Cont)

Item No.	Interval	<u>Location</u> Item to be Checked or Serviced	Procedure	Not Fully Mission Capable If:
44	Semiannual	FRONT WHEEL ALIGNMENT	Check front wheel alignment (para 13-5).	Front wheels cannot be aligned.

Table 2-1. Preventive Maintenance Checks and Services (Cont)

Item No.	Interval	Location Item to be Checked or Serviced	Procedure	Not Fully Mission Capable If:
45	Semiannual	TRANSMISSION	<p>Check to see if any diagnostic codes are logged in WTEC II TEPSS (para 8-4) or WTEC III TPSS (para 8-5).</p> <ol style="list-style-type: none"> a. Perform Transmission Troubleshooting (para 2-17) for all diagnostic codes logged in WTEC II TEPSS or WTEC III TPSS. b. Clear all diagnostic codes from WTEC II TEPSS (para 8-4) or WTEC III TPSS (para 8-5). 	

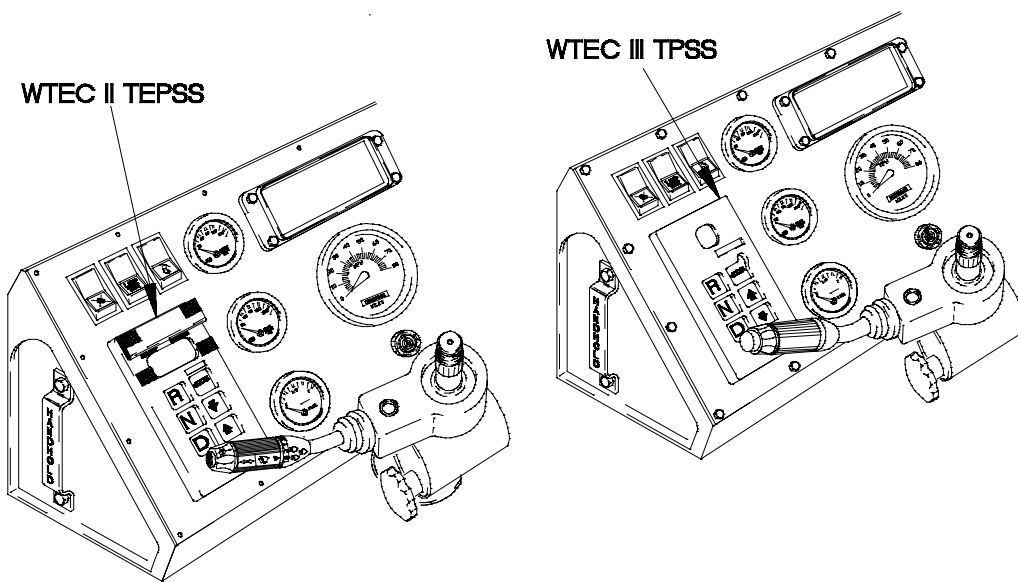

STEERING WHEEL REMOVED FOR CLARITY

3BPM0441

Table 2-1. Preventive Maintenance Checks and Services (Cont)

Item No.	Interval	Location Item to be Checked or Serviced	Procedure	Not Fully Mission Capable If:
46	Semiannual	HYDRAULIC RESERVOIR (If Equipped)	Inspect hydraulic reservoir for leaks, cracks, or dents.	Class III is evident.

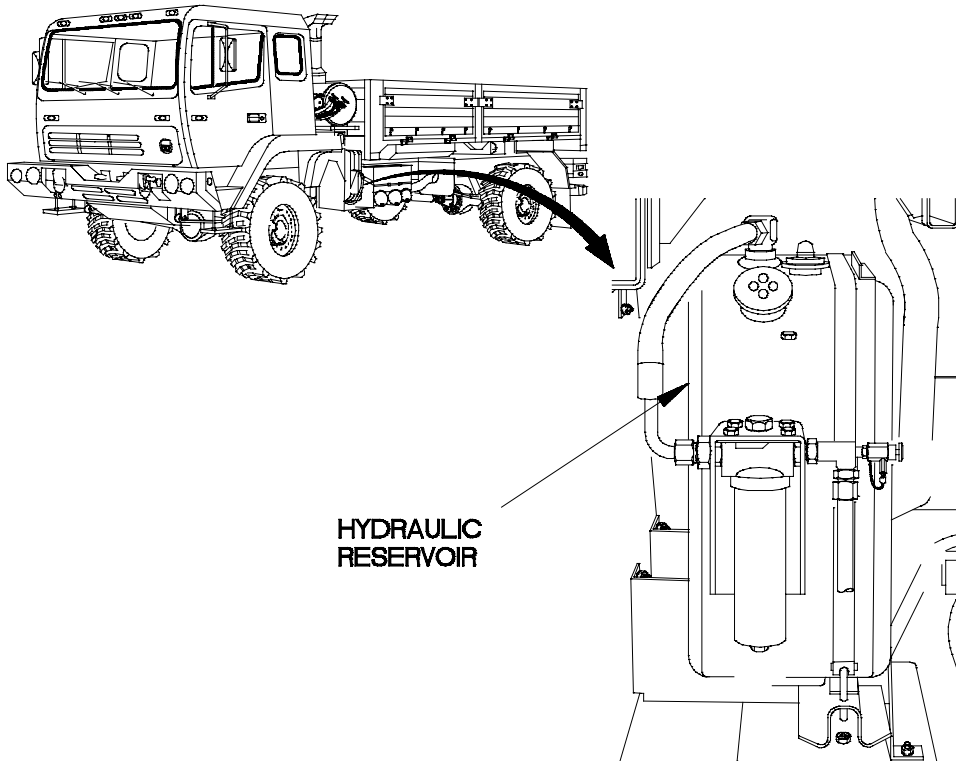

3BPM0451

Table 2-1. Preventive Maintenance Checks and Services (Cont)

Item No.	Interval	<u>Location</u> Item to be Checked or Serviced	Procedure	Not Fully Mission Capable If:
47	Deleted			

Table 2-1. Preventive Maintenance Checks and Services (Cont)

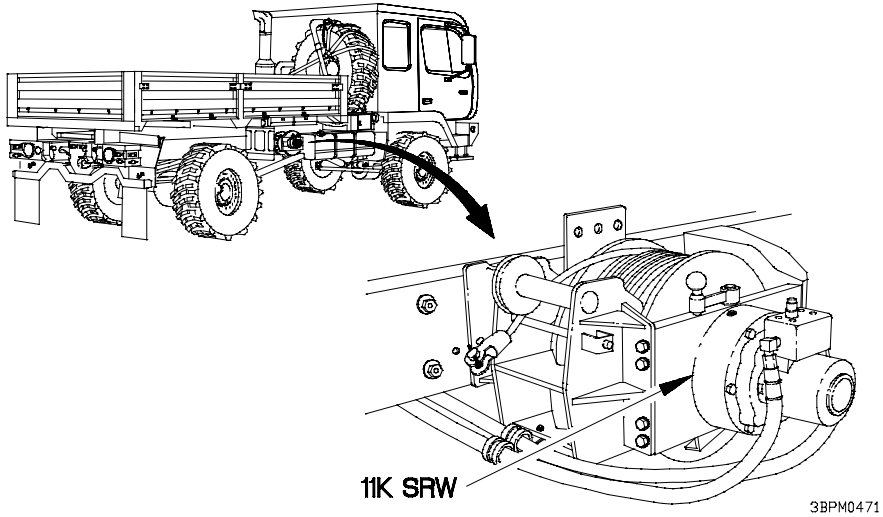
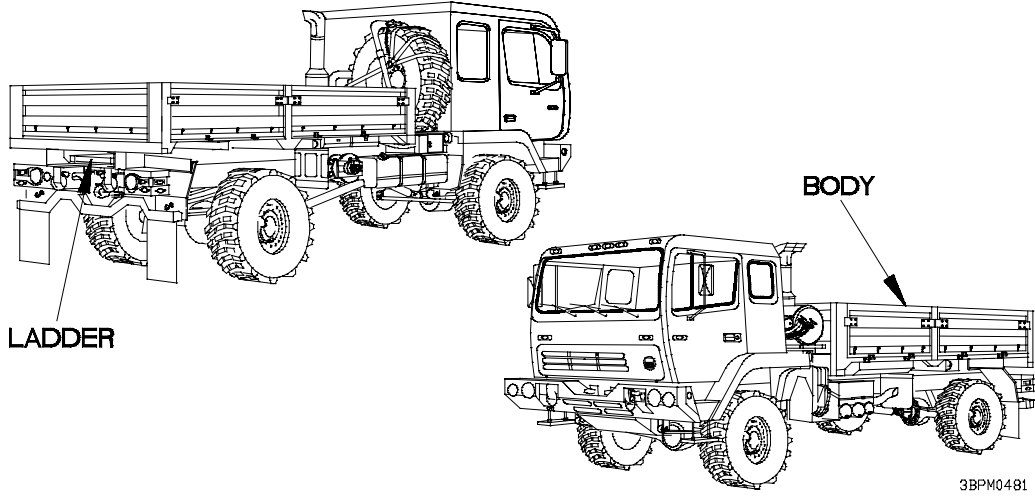
Item No.	Interval	Location Item to be Checked or Serviced	Procedure	Not Fully Mission Capable If:
48	Semiannual	11K SRW	Check security of 11K SRW mounting hardware.	Mounting hardware broken or missing.
				
49	Semiannual	CARGO BODY	<ul style="list-style-type: none"> a. Check cargo body for corrosion and damage. b. Inspect ladder for damage and cracks. 	
				

Section IV. TROUBLESHOOTING

2-10. INTRODUCTION TO LOGIC TREE TROUBLESHOOTING

This section contains step-by-step procedures for identifying, locating, isolating, and repairing equipment malfunctions.

This manual cannot list all malfunctions that may occur, nor all tests or inspections and corrective actions. If a malfunction is not listed or is not corrected by listed corrective actions, notify your supervisor.

2-11. TROUBLESHOOTING INSTRUCTIONS

a. Page Layout. Troubleshooting procedures are divided into logic tree pages and test pages.

- (1) A logic tree page is always a left-hand page, facing the test page on the right. The logic tree page provides the sequence of steps required to isolate a fault to a failed component. All critical information for decision making is on the left-hand page. Each logic tree page contains the following information:
 - (a) **INITIAL SETUP** - This box is located only on the first logic tree page of a fault. INITIAL SETUP lists tools, materials, references, personnel, and equipment needed to troubleshoot the fault.
 - (b) **KNOWN INFO** - This box is located in the top left-hand column. KNOWN INFO lists conditions and information that will eliminate specific components as the cause of the fault.
 - (c) **POSSIBLE PROBLEMS** - This box is located directly below KNOWN INFO. All of the system components that could cause a fault are listed in the POSSIBLE PROBLEMS box. The first component listed in the POSSIBLE PROBLEMS box is the one that will be tested at that step in the logic sequence. When one of the components is tested and found to operational, it is entered at the bottom of the KNOWN INFO box as OK.
 - (d) **QUESTION** - Each question, located in the middle column, refers to the first possible problem listed in POSSIBLE PROBLEMS. If the answer to the question is YES, proceed to the next step. If the answer is NO, follow the NO arrow to obtain directions for correcting the problem. If the step contains a WARNING or CAUTION message, a small shadow box is printed above the question. Text for WARNINGS or CAUTIONS is on the following right-hand page.
 - (e) **TEST OPTIONS** - This box is located in the top right-hand column. TEST OPTIONS lists tests available for testing parts suspected of failing. When the TEST OPTION is a VOLTAGE TEST, the voltage values listed are nominal values for a 12/24 VDC system. Some variation from these values should be expected. When the TEST OPTION is a CONTINUITY TEST, the expected reading is one of low resistance. If high resistance is noted, further testing should be performed to determine the cause.
 - (f) **REASON FOR QUESTION** - This box is located directly below TEST OPTIONS. It explains the purpose for the question in the middle column.
- (2) A test page is always a right-hand page, facing the logic tree page on the left. The test provides detailed instructions for testing the first component listed in the POSSIBLE PROBLEMS box. This test will also provide an answer for the question in the middle column. Note the arrow connecting the test on the right-hand page to the REASON FOR QUESTION. When possible, illustrations are included to provide visual details. Notes contain additional information for testing.

2-11. TROUBLESHOOTING INSTRUCTIONS (CONT)

b. How to Begin Troubleshooting.

- (1) Determine the symptom or condition that indicates a problem or failure. Troubleshooting is divided into symptoms peculiar to a vehicle system or component, for example: pneumatic system or engine. Refer to the **Table 2-2. Vehicle Troubleshooting.**
- (2) Go to the referenced page to begin troubleshooting. Open the manual flat so both the left-hand and right-hand pages are displayed before you. The information on both pages is important to resolve the problem or failure. However, the experienced technician can follow the left-hand page instructions and refer to the right-hand page when necessary.
- (3) Follow the Diagnostic Procedure. Answer question No. 1 on the left-hand page and follow the YES or NO path to either the remedy or the next question. If necessary, look on the right-hand page for test instructions and illustrations.
- (4) Observe warnings, cautions, and notes. The formatting and symbols used in this manual for warnings, cautions, and notes are as follows:

WARNING

This is the symbol for a warning statement. If you see the word WARNING above a question on the left-hand page, look on the right-hand page for the text of the message. WARNINGS describe a situation which could cause serious injury or death to personnel.

CAUTION

This is the symbol for a caution statement. If you see the word CAUTION above a question on the left-hand page, look on the right-hand page for the text of the message. CAUTIONS describe a situation which could cause damage to equipment.

NOTE

This is a symbol for a note. Notes are located directly above the test to which they refer. NOTES provide additional information for performing a test.

- c. Confidence Tests.** Before performing any STE/ICE-R test, a confidence test must be run to ensure proper operation of the STE/ICE-R. In addition, a confidence test must be performed after each use to ensure the STE/ICE-R is performing properly. Refer to TM 9-4910-571-12&P.
- d. Verifying Repair.** When troubleshooting, there is an additional step that must be performed after taking any corrective action. This step will show that the malfunction has been corrected, or that additional troubleshooting is required, example follows:

On malfunction q1. Wanders, pulls to one side, or shimmies; the question is asked "Are front shock absorbers secure and free from damage?". If the question was answered NO, the damaged shock absorber(s) was replaced. After replacing the damaged shock absorber(s), the vehicle must be checked to determine if the original malfunction is still present. If corrected, troubleshooting is completed. If malfunction is still present, continue troubleshooting.

Table 2-2. Vehicle Troubleshooting

<u>Malfunction</u>	Troubleshooting Procedure (Page)
--------------------	--

a. ENGINE SYSTEM TROUBLESHOOTING

a1. Engine Does Not Crank	2-64	■
a2. Engine Cranks But Does Not Start	2-68	
a3. Low Engine Oil Pressure	2-72	
a4. Engine Stalls at Low RPM	2-74	
a5. Engine Overspeeds on Start	2-80	
a6. Too Much Engine Vibration	2-82	■
a7. Coolant in Engine Lubrication Oil	2-84	
a8. Excessive Engine Oil Consumption	2-86	
a9. Engine Overheats	2-90	
a10. Excessive Black or Gray Exhaust Smoke	2-92	■
a11. White Exhaust Smoke	2-96	
a12. Low Engine Power	2-100	■

b. FUEL SYSTEM TROUBLESHOOTING

b1. Engine Cranks But Does Not Start or Engine Stalls After Starting	2-102
b2. Ether Starting Aid Does Not Operate	2-108
b3. Fuel Consumption Too High	2-112
b4. Accelerator Pedal Sticks	2-114

c. EXHAUST SYSTEM TROUBLESHOOTING

c1. Exhaust System Unusually Noisy or Vibrates Excessively During Engine Operation	2-120
c2. Exhaust Fumes in Cab	2-124

d. COOLING SYSTEM TROUBLESHOOTING

d1. Engine Overheats	2-130
d2. Oil in Cooling System	2-142
d3. Loss of Coolant	2-144

e. ELECTRICAL SYSTEM TROUBLESHOOTING

e1. Circuit Breaker Does Not Operate	2-150	
e2. Engine Does Not Crank	2-154	■
e3. 12 VDC and/or 24 VDC Circuits Do Not Operate	2-254	
e4. 24 VDC Circuits Do Not Operate	2-258	■
e5. Deleted		
e6. Engine Cranks But Does Not Start	2-300	
e7. FUEL Gage Does Not Operate or Is Inaccurate	2-308	
e8. WATER TEMP Gage Does Not Operate or Is Inaccurate	2-314	
e9. REAR BRAKE AIR Pressure Gage Does Not Operate or Is Inaccurate	2-318	
e10. FRONT BRAKE AIR Pressure Gage Does Not Operate or Is Inaccurate	2-322	■

Table 2-2. Vehicle Troubleshooting (Cont)

<u>Malfunction</u>	<u>Troubleshooting Procedure (Page)</u>
e. ELECTRICAL SYSTEM TROUBLESHOOTING (CONT)	
e11. Engine Oil Pressure Gage Does Not Operate or Is Inaccurate	2-326
e12. Speedometer Does Not Operate or Is Inaccurate	2-332
e13. VOLTS Gage Does Not Operate or Is Inaccurate	2-346
e14. Tachometer Does Not Operate or Is Inaccurate	2-348
e15. Audible Alarm Does Not Operate	2-358
e16. Troop Transport Audible Alarm Does Not Operate	2-362
e16A. Master Power Switch Does Not Shut Down Engine	2-370.4
e16B. Lamp Test Switch Does Not Illuminate	2-370.10
e17. Radiator Fan Off Switch Does Not Illuminate	2-372
e17A. Ether Start Switch Does Not Illuminate	2-376
e17B. Hazard Lights Switch Does Not Illuminate	2-376.4
e17C. Amber Warning Light Switch Does Not Illuminate	2-376.8
e17D. Master Power Switch Does Not Illuminate	2-376.12
e18. REAR BRAKE AIR Gage Does Not Illuminate	2-378
e18A. FUEL Gage Does Not Illuminate	2-380.2
e18B. FRONT BRAKE AIR Gage Does Not Illuminate	2-380.6
e18C. Speedometer Does Not Illuminate	2-380.10
e18D. VOLTS Gage Does Not Illuminate	2-380.14
e18E. WATER TEMP Gage Does Not Illuminate	2-380.18
e19. OIL PRESS Gage Does Not Illuminate	2-382
e20. Auxiliary Panel, Personnel Heater, and Instrument Panel Do Not Illuminate	2-386
e21. Tachometer Does Not Illuminate	2-390
e22. Auxiliary Panel Switch Does Not Illuminate	2-394
e23. Auxiliary Panel Does Not Illuminate	2-398
e24. High Engine Temperature Indicator Does Not Operate	2-402
e24A. High Engine Temperature Indicator Illuminates	2-408.2
e25. CTIS Overspeed Indicator Does Not Operate	2-410
e26. Chemical Detector Indicator Does Not Operate	2-424
e27. Left Turn Signal Indicator Does Not Operate	2-428
e28. Right Turn Signal Indicator Does Not Operate	2-432
e29. Turn Signal Indicators and High Beams On Indicator Do Not Operate	2-438
e30. High Beams Indicator Does Not Operate	2-440
e31. Parking Brake Indicator and/or Emergency Brake Indicator Does Not Illuminate	2-444
e32. PTO Indicator Does Not Operate	2-460
e33. Fan Off Indicator Does Not Operate	2-472
e34. WTEC II Transmission Temperature Indicator Does Not Operate	2-478
e35. WTEC III Transmission Temperature Indicator Does Not Operate	2-486
e36. Front Brake Air Indicator Does Not Illuminate When Air Pressure Is Below 65 PSI	2-492
e37. Rear Brake Air Indicator Does Not Illuminate When Air Pressure Is Below 65 PSI	2-498
e38. Engine Oil Pressure Indicator Does Not Operate	2-504
e39. Master Stop Indicator Does Not Operate	2-510
e40. One or Both Headlights (High and Low Beams) Do Not Illuminate	2-512
e41. One or Both Headlight Low Beams Do Not Illuminate	2-520
e42. One or Both Headlight High Beams Do Not Illuminate	2-526
e43. Parking Lights Do Not Illuminate	2-534
e44. LH Door and/or LH Front Marker Lights Do Not Illuminate	2-542
e45. RH Door and/or RH Front Marker Lights Do Not Illuminate	2-552
e46. One or More Cab Top Marker Lights Do Not Illuminate	2-562

Malfunction

e47.	Side and/or Rear Marker Lights Do Not Illuminate	2-576
e47A.	All Marker Lights Do Not Illuminate In Normal Mode	2-584.52 ■
e48.	One or Both Composite Taillights Do Not Illuminate	2-586
e49.	One or Both Front Blackout Marker Lights Do Not Illuminate	2-596
e50.	Blackout Drive Light Does Not Illuminate	2-606
e51.	One or Both Rear Blackout Marker Lights Do Not Illuminate	2-616
e52.	Warning Light Does Not Illuminate	2-626
e53.	Backup Light Does Not Illuminate	2-638
e54.	Blackout Marker Lights Do Not Illuminate	2-676
e54A.	Front Hazard Lights Do Not Illuminate	2-678
e55.	Rear Hazard Lights Do Not Illuminate	2-680
e56.	Front and Rear Hazard Lights Do Not Illuminate	2-682 ■
e57.	Front and Rear Turn Signals Do Not Operate	2-690
e58.	Left or Right Front Turn Signals Do Not Operate	2-702
e59.	One or Both Stoplights Do Not Illuminate	2-710 ■
e60.	One or Both Blackout Stoplights Do Not Illuminate	2-728 ■
e61.	Stoplights and Blackout Stoplights Do Not Operate	2-740
e62.	Trailer Marker/Taillights Do Not Illuminate	2-750 ■
e63.	Trailer Right Stop/Turn Light Does Not Illuminate	2-760
e64.	Trailer Left Stop/Turn Light Does Not Illuminate	2-770 ■
e65.	Trailer Blackout Marker Lights Do Not Illuminate	2-780
e66.	Trailer Blackout Stoplights Do Not Illuminate	2-790
e67.	Intervehicle Clearance Lights Do Not Operate	2-800
e68.	Intervehicle Left Turn Signal Does Not Illuminate	2-804 ■
e69.	Intervehicle Right Turn Signal Does Not Illuminate	2-810
e70.	Intervehicle Stoplights Do Not Illuminate	2-816 ■
e71.	Intervehicle Taillights Do Not Operate	2-822
e72.	Personnel Heater Control Illumination Does Not Operate	2-826
e73.	Personnel Heater Fan Does Not Operate	2-832
e74.	Windshield Washer Does Not Operate	2-838
e75.	Windshield Wiper Does Not Operate On Low Speed	2-850 ■
e76.	All Windshield Wiper Speeds Do Not Operate	2-858
e77.	Windshield Wiper Does Not Operate On Intermittent Speed	2-864 ■
e78.	Windshield Wiper Does Not Operate On High Speed	2-874 ■
e79.	Horn Does Not Operate	2-880
e80.	Chemical Alarm Does Not Operate	2-892
e81.	Chemical Detector Does Not Operate	2-900
e82.	Central Tire Inflation System (CTIS) Does Not Operate	2-906 ■
e83.	CTIS Does Not Inflate Tires	2-920
e84.	CTIS Does Not Deflate Tires	2-930
e85.	11K Self-Recovery Winch (SRW) Does Not Reel In or Pay Out	2-940
e86.	11K Self-Recovery Winch (SRW) Does Not Reel In	2-946
e87.	11K Self-Recovery Winch (SRW) Does Not Pay Out	2-958
e88.	PTO Does Not Operate	2-970
e89.	Electrical System Does Not Maintain a Charge	2-1010
e90.	WTEC II Transmission ECU Pushbutton Shift Selector (TEPSS) Illumination Does Not Dim	2-1018
e91.	Engine Fan Runs Constantly	2-1028
e92.	Engine Fan Does Not Turn Off Using Radiator Fan Off Switch	2-1036 ■
e93.	Ether Start Does Not Operate	2-1044
e94.	Excessive Condensation In Fuel	2-1060 ■
e95.	Radio Does Not Operate	2-1064
e96.	Start Inhibit Pushbutton Does Not Operate	2-1070

Table 2-2. Vehicle Troubleshooting (Cont)

Troubleshooting
Procedure
(Page)

Malfunction

e. ELECTRICAL SYSTEM TROUBLESHOOTING (CONT)

e97.	Air Dryer Does Not Operate	2-1076
e98.	Battery Tester Does Not Operate	2-1082

Volume 2

e99.	M1079 Fan Does Not Operate	2-1088
e100.	All M1079 Van Body Marker Lights Do Not Operate	2-1100
e101.	M1079 Van Body Clearance Marker Light Does Not Illuminate	2-1104
e102.	All M1079 Fluorescent Lights Do Not Operate	2-1108
e103.	M1079 Lighting Fixture(s) DS80 and/or DS81 Do Not Operate	2-1118
e104.	M1079 Lighting Fixture(s) DS82 and/or DS83 Do Not Operate	2-1134
e105.	M1079 110 VAC Outlet J233 Does Not Operate	2-1152
e106.	M1079 110 VAC Outlet J234 Does Not Operate	2-1160
e107.	M1079 110 VAC Outlet J235 Does Not Operate	2-1168
e108.	M1079 110 VAC Outlet J232 Does Not Operate in Normal Mode	2-1176
e109.	M1079 110 VAC Outlet J232 and J233 Do Not Operate in Blackout Override Mode	2-1190
e110.	M1079 110 VAC Outlet J231 Does Not Operate	2-1194
e111.	M1079 110 VAC Outlet J230 Does Not Operate	2-1208
e112.	M1079 Blackout Light(s) Does Not Operate	2-1222
e113.	M1079 Emergency Light(s) Does Not Illuminate	2-1230
e114.	M1079 Field Phone 1 and/or 2 Binding Post Does Not Operate	2-1244
e115.	M1079 Air Conditioner Does Not Operate	2-1264
e116.	M1079 Heater Does Not Operate	2-1276
e117.	M1079 24 VDC Binding Post(s) Does Not Operate	2-1296
e118.	M1079 Van Door Open Light Does Not Illuminate and Audible Alarm Does Not Operate	2-1324
e119.	M1079 110 VAC Power Does Not Operate	2-1338
e120.	M1079 Fluorescent Lights Do Not Operate In Blackout Override Mode	2-1352

f. TRANSMISSION SYSTEM TROUBLESHOOTING

f1.	WTEC II Transmission ECU Pushbutton Shift Selector (TEPSS) Emits Eight Seconds of Beeps and/or Transmission Does Not Shift Gears	2-1362
f2.	WTEC II Transmission ECU Pushbutton Shift Selector (TEPSS) Displays Main Code 22 Sub Code 14	2-1364
f3.	WTEC II Transmission ECU Pushbutton Shift Selector (TEPSS) Displays Main Code 22 Sub Code 15	2-1372
f4.	WTEC II Transmission ECU Pushbutton Shift Selector (TEPSS) Displays Main Code 22 Sub Code 16	2-1378
f5.	WTEC II Transmission ECU Pushbutton Shift Selector (TEPSS) Displays Main Code 24 and/or 33 and Any Sub Code	2-1384
f6.	WTEC II Transmission ECU Pushbutton Shift Selector (TEPSS) Displays Main Code 32 and Any Sub Code	2-1396
f7.	WTEC II Transmission ECU Pushbutton Shift Selector (TEPSS) Displays Main Code 41, 42, 44, 45, 66, and/or 69 and Any Sub Code	2-1400
f8.	WTEC II Transmission ECU Pushbutton Shift Selector (TEPSS) Displays Main Code 43 and Any Sub Code	2-1404

Malfunction

f9.	WTEC II Transmission ECU Pushbutton Shift Selector (TEPSS) Displays Main Code 52 and Any Sub Code	2-1410
f10.	WTEC II Transmission ECU Pushbutton Shift Selector (TEPSS) Displays Main Code 57 and Any Sub Code	2-1416
f11.	Transmission Unusually Noisy When Operating	2-1420
f12.	WTEC II Transmission ECU Pushbutton Shift Selector (TEPSS) Displays Main Code 21 and Any Sub Code	2-1430
f13.	WTEC II Transmission ECU Pushbutton Shift Selector (TEPSS) Displays Main Code 51 Sub Code 10, 12, 21, 43, 45, or 65	2-1444
f14.	WTEC II Transmission ECU Pushbutton Shift Selector (TEPSS) Displays Main Code 25 and Any Sub Code	2-1448
f15.	WTEC II Transmission ECU Pushbutton Shift Selector (TEPSS) Displays Main Code 53 and Any Sub Code	2-1452
f16.	WTEC II Transmission ECU Pushbutton Shift Selector (TEPSS) Displays Main Code 54 Sub Code 01, 07, 10, 12, 17, 21, 23, 27, 32, 34, 43, 45, 54, 56, 65, 70, 71, 72, 80, 81, 82, 83, 85, 86, 92, 93, 95, 96, or 97	2-1456
f17.	WTEC II Transmission ECU Pushbutton Shift Selector (TEPSS) Displays Main Code 55 and Any Sub Code	2-1462
f18.	WTEC II Transmission ECU Pushbutton Shift Selector (TEPSS) Displays Main Code 56 and Any Sub Code	2-1468
f19.	WTEC II Transmission ECU Pushbutton Shift Selector (TEPSS) Displays Main Code 13 and Any Sub Code	2-1474
f19A.	WTEC II Transmission ECU Pushbutton Shift Selector (TEPSS) Displays Main Code 23 and Any Sub Code	2-1482.2
f19B.	WTEC II Transmission ECU Pushbutton Shift Selector (TEPSS) Does Not Illuminate	2-1482.16
f20.	Metal Particles Found During Transmission Oil Change	2-1484
f21.	Transmission Does Not Shift or is Slow To Shift When Cold	2-1486
f22.	WTEC III Transmission Pushbutton Shift Selector (TPSS) Displays Main Code 22 Sub Code 14	2-1488
f23.	WTEC III Transmission Pushbutton Shift Selector (TPSS) Displays Main Code 22 Sub Code 15	2-1494
f24.	WTEC III Transmission Pushbutton Shift Selector (TPSS) Displays Main Code 22 Sub Code 16	2-1498
f25.	WTEC III Transmission Pushbutton Shift Selector (TPSS) Displays Main Code 24 and/or 33 and Any Sub Code	2-1504
f26.	WTEC III Transmission Pushbutton Shift Selector (TPSS) Displays Main Code 32 and Any Sub Code	2-1516
f27.	WTEC III Transmission Pushbutton Shift Selector (TPSS) Displays Main Code 42, 44, 45, 46, 66, and/or 69 and Any Sub Code	2-1522
f28.	WTEC III Transmission Pushbutton Shift Selector (TPSS) Displays Main Code 52 and Any Sub Code	2-1526
f29.	WTEC III Transmission Pushbutton Shift Selector (TPSS) Displays Main Code 57 and Any Sub Code	2-1532
f30.	WTEC III Transmission Pushbutton Shift Selector (TPSS) Displays Main Code 21 and Any Sub Code	2-1536
f31.	WTEC III Transmission Pushbutton Shift Selector (TPSS) Displays Main Code 51 and Any Sub Code	2-1550
f32.	WTEC III Transmission Pushbutton Shift Selector (TPSS) Displays Main Code 25 and Any Sub Code	2-1554
f33.	WTEC III Transmission Pushbutton Shift Selector (TPSS) Displays Main Code 53 and Any Sub Code	2-1558

Table 2-2. Vehicle Troubleshooting (Cont)

<u>Malfunction</u>	<u>Troubleshooting Procedure (Page)</u>
f. TRANSMISSION SYSTEM TROUBLESHOOTING (CONT)	
f34. WTEC III Transmission Pushbutton Shift Selector (TPSS) Displays Main Code 54 and Any Sub Code	2-1562
f35. WTEC III Transmission Pushbutton Shift Selector (TPSS) Displays Main Code 55 and Any Sub Code	2-1568
f36. WTEC III Transmission Pushbutton Shift Selector (TPSS) Displays Main Code 56 and Any Sub Code	2-1574
f37. WTEC III Transmission Pushbutton Shift Selector (TPSS) Displays Main Code 13 and Any Sub Code	2-1580
f38. WTEC III Transmission Pushbutton Shift Selector (TPSS) Indicator Displays "--" and/or Transmission Does Not Shift Gears	2-1594
f39. WTEC III Transmission Pushbutton Shift Selector (TPSS) Displays Main Code 23 and Any Sub Code	2-1596
f40. WTEC III Transmission Pushbutton Shift Selector (TPSS) Does Not Illuminate	2-1596.12
g. PROPELLER SHAFT TROUBLESHOOTING	
g1. Drive Shaft or Universal Joint Unusually Noisy When Operating	2-1598
h. POWER TAKE OFF (PTO) TROUBLESHOOTING	
h1. PTO Does Not Engage	2-1604
i. BRAKE SYSTEM TROUBLESHOOTING	
i1. Excessive Braking Distance	2-1608
i2. Rear Brakes Do Not Apply	2-1620
i3. Parking Brake Does Not Release	2-1644
i4. Front Brakes Overheat and/or Do Not Release	2-1670
i5. Vehicle Brakes Unevenly, Brakes Pull to One Side or Grab	2-1676
i6. Front Brakes Do Not Apply	2-1690
i7. Rear Brakes Overheat	2-1700
i8. Parking Brake Does Not Apply	2-1708
i9. Brake System Loses Air When Brakes Are Applied	2-1712
j. AIR SYSTEM TROUBLESHOOTING	
j1. Air System Loses Pressure During Operation/Slow, No, or Incorrect Air Pressure Buildup	2-1714
j2. Large Quantity of Moisture Expelled From Air Reservoirs	2-1730
j3. Air Dryer Purges Constantly	2-1734
j4. No Air Pressure Present at Rear Gladhands	2-1738
j5. Air System Pressure Builds Up More Than 120 PSI (827 kPa) (Compressor Fails to Unload) ..	2-1744
j6. Noisy Air Compressor Operation	2-1748
k. WHEEL TROUBLESHOOTING	
k1. Tires Wear Unevenly or Excessively	2-1754
k2. Wheel Wobbles or Shimmys	2-1758

Malfunction

I. HYDRAULIC SYSTEM TROUBLESHOOTING

- l1. Loss of Hydraulic Pressure (Single Stage Pump)..... 2-1762

m. CENTRAL TIRE INFLATION SYSTEM (CTIS) TROUBLESHOOTING

- m1. Two Steady Mode Lights Illuminate on Central Tire Inflation System (CTIS) ECU 2-1768
- m2. Four CTIS ECU Indicator Lights Flashing 2-1798
- m3. Five Central Tire Inflation System (CTIS) ECU Indicator Lights Flashing 2-1822
- m4. CTIS Repeatedly Resumes Cycling 30 Seconds After Indicator Lights Stop Flashing 2-1856
- m5. Central Tire Inflation System (CTIS) ECU Indicates No Fault Code But Fails
to Inflate or Deflate 2-1862
- m6. No Overspeed Warning Light and/or Overspeed Pressure Change 2-1874

n. AXLE TROUBLESHOOTING

- n1. Axle Differential(s) Noisy 2-1896

p. STEERING TROUBLESHOOTING

- p1. Hard to Steer 2-1904
- p2. Wanders, Pulls to One Side, or Shimmies 2-1910
- p3. Excessive Play When Turning Steering Wheel 2-1916
- p4. No Response When Turning Steering Wheel 2-1920

q. SUSPENSION SYSTEM TROUBLESHOOTING

- q1. Wanders, Pulls to One Side, or Shimmies 2-1926
- q2. Leans to One Side or Rear of Vehicle Sags 2-1940

r. 11K SELF-RECOVERY WINCH (SRW) SYSTEM TROUBLESHOOTING

- r1. 11K Self-Recovery Winch (SRW) Does Not Work 2-1946

s. STEERING HYDRAULIC SYSTEM TROUBLESHOOTING

- s1. Steering Hard or Does Not Work 2-1954

t. AIR TRANSPORT TROUBLESHOOTING

- t1. Cab Tilt, Spare Tire Retainer, and Suspension Compression Do Not Operate 2-1960
- t2. Suspension Does Not Compress and/or Return to Normal 2-1970
- t3. Cab Leveling Air Springs Do Not Operate 2-1972

u. SPECIAL PURPOSE KIT TROUBLESHOOTING

- u1. No Power To Digitization Rack 2-1978
- u2. No Power To Mobile Tracking System (MTS) Sense 2-1988
- u3. No Power To Enhanced Position Location Reporting System (EPLRS) 2-1994

Table 2-2. Vehicle Troubleshooting (Cont)

<u>Malfunction</u>	Troubleshooting Procedure (Page)
--------------------	---

u. SPECIAL PURPOSE KIT TROUBLESHOOTING (CONT)

u4.	No Power To Precision Lightweight Global Positioning System Receiver (PLGR)	2-1998
u5.	No Power To Drivers Visual Enhancement (DVE)	2-2002
u6.	No Power To SINCGAR/FORCE XXI Battle Command Brigade and Below (FBCB)	2-2006
u7.	No Power TO Mobile Tracking System (MTS)	2-2010
u8.	Deleted	
u9.	Deleted	
u10.	Deleted	
u11.	Deleted	
u12.	Deleted	
u13.	Deleted	
u14.	Deleted	
u15.	Deleted	
u16.	Deleted	
u17.	Deleted	
u18.	Troop Transport Alarm Does Not Operate	2-2078
u19.	Light Material Handling Crane (LMHC) Does Not Operate	2-2088
u20.	Light Material Handling Crane (LMHC) Hoist IN Does Not Operate	2-2106
u21.	Light Material Handling Crane (LMHC) Hoist OUT Does Not Operate	2-2110

v. CAB TILT AND SPARE TIRE RETAINER TROUBLESHOOTING

v1.	Cab Does Not Raise	2-2116
v2.	Cab Does Not Lower	2-2116.8
v3.	Spare Tire Retainer Does Not Raise	2-2118
v4.	Spare Tire Retainer Does Not Lower	2-2118.6

w. FRAME TROUBLESHOOTING

w1.	Tires Continue to Wear After Front End Alignment and/or Vehicle Drives Sideways Down Road	2-2122
-----	--	--------

2-12. ENGINE SYSTEM TROUBLESHOOTING

This paragraph covers Engine System Troubleshooting. The Engine System Fault Index, Table 2-3, lists faults for the engine system of the vehicle.

Table 2-3. Engine System Fault Index

Fault No.	Description	Page
a1.	Engine Does Not Crank	2-64
a2.	Engine Cranks But Does Not Start	2-68
a3.	Low Engine Oil Pressure	2-72
a4.	Engine Stalls at Low RPM	2-74
a5.	Engine Overspeeds on Start	2-80
a6.	Too Much Engine Vibration	2-82
a7.	Coolant in Engine Lubrication Oil	2-84
a8.	Excessive Engine Oil Consumption	2-86
a9.	Engine Overheats	2-90
a10.	Excessive Black or Gray Exhaust Smoke	2-92
a11.	White Exhaust Smoke	2-96
a12.	Low Engine Power	2-100

a1. ENGINE DOES NOT CRANK

INITIAL SETUP

Equipment Conditions

Engine shutdown (TM 9-2320-365-10).

Personnel Required

(2)

References

TM 9-6140-200-14
 TM 9-4910-571-12&P

Tools and Special Tools

Tool Kit, Genl Mech (Item 44, Appendix C)
 STE/ICE-R (Item 39, Appendix C)
 Multimeter, Digital (Item 22, Appendix C)
 Apron, Rubber (Item 3, Appendix C)
 Gloves, Rubber (Item 13, Appendix C)
 Goggles, Industrial (Item 15, Appendix C)
 Tester, Antifreeze and Battery (Item 41, Appendix C)

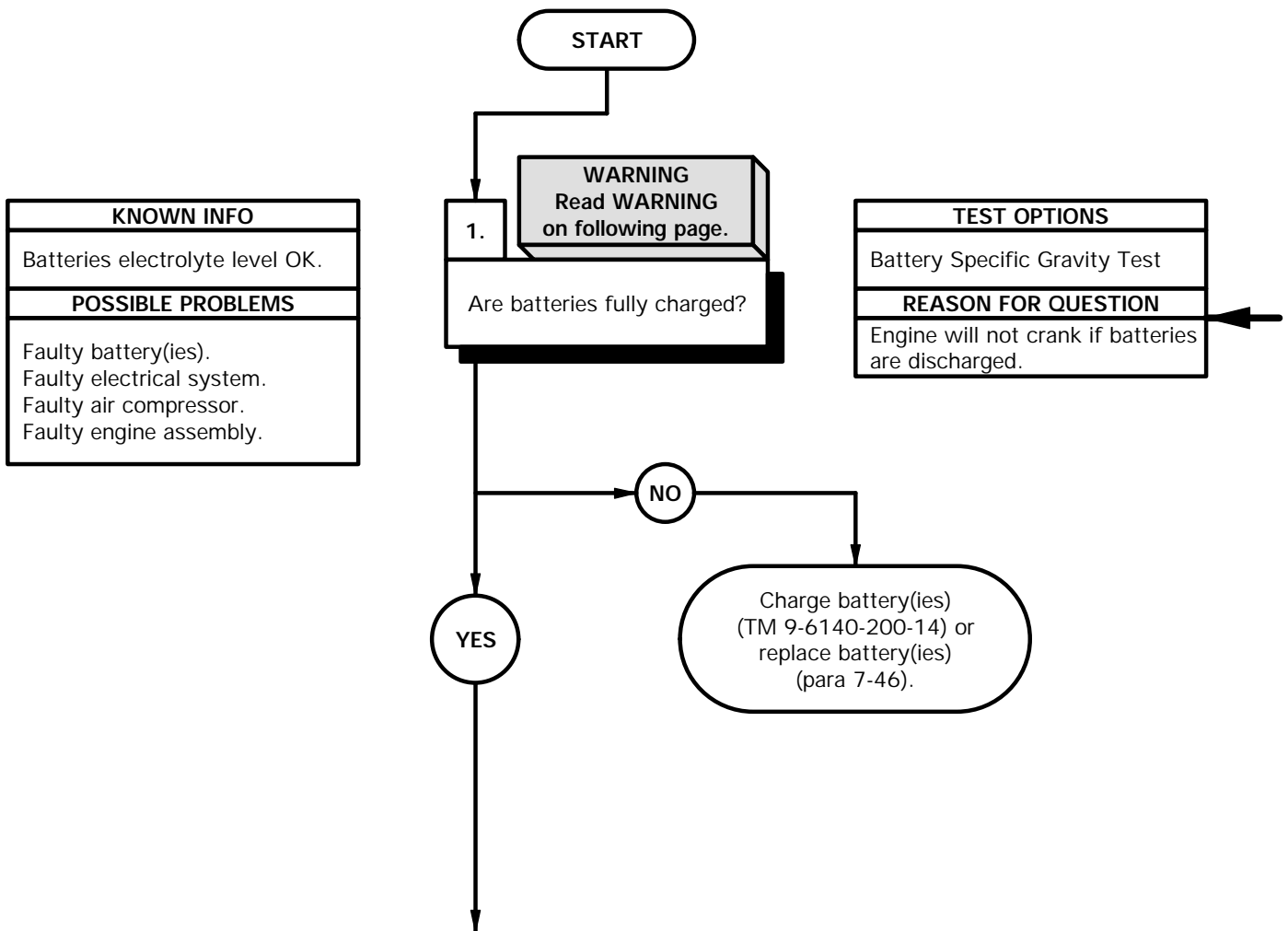

WARNING

Remove rings, bracelets, watches, necklaces, and any other jewelry before working around vehicle. Jewelry can catch on equipment and cause injury or short across electrical circuit and cause severe burns or electrical shock. Batteries can explode from a spark. Battery acid is harmful to skin and eyes. Always wear eye protection and rubber gloves when working with batteries.

Battery Specific Gravity Test

- (1) Remove battery box cover from battery box (TM 9-2320-365-10).
- (2) Remove four batteries from battery box (para 7-46).
- (3) Test batteries for serviceability (TM 9-6140-200-14).
- (4) Charge battery(ies) if discharged (TM 9-6140-200-14).
- (5) Replace battery(ies) if unserviceable (TM 9-6140-200-14).
- (6) Install four batteries in battery box (para 7-46).
- (7) Install battery box cover on battery box (TM 9-2320-365-10).

a1. ENGINE DOES NOT CRANK (CONT)

KNOWN INFO
Batteries electrolyte level OK. Battery(ies) OK.
POSSIBLE PROBLEMS
Faulty electrical system. Faulty air compressor. Faulty engine assembly.

2.
Can engine be turned manually?

TEST OPTIONS
Operational Test
REASON FOR QUESTION
This question eliminates possible problems and determines where troubleshooting continues.

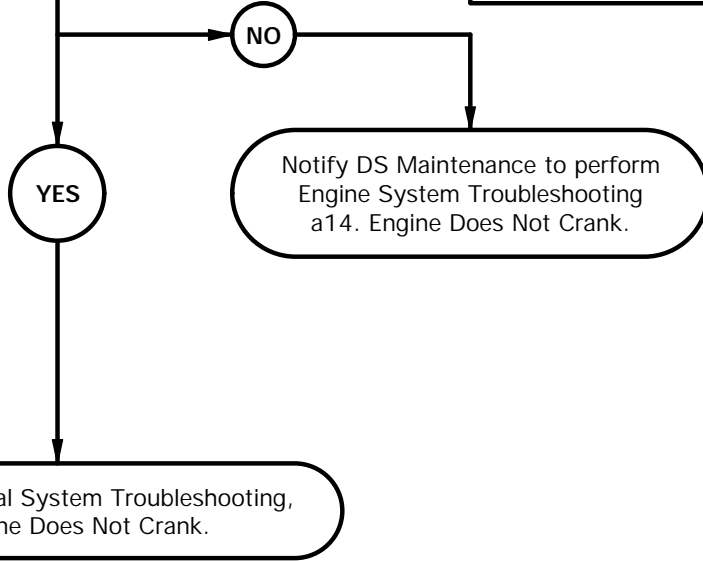

OPERATIONAL TEST

- (1) Raise cab (TM 9-2320-365-10).
- (2) Attempt to rotate engine by turning alternator pulley.
- (3) If engine can not be turned manually, notify DS Maintenance to perform Engine System Troubleshooting task a14. Engine Does Not Crank.
- (4) If engine can be turned manually, perform Electrical System Troubleshooting, e2. Engine Does Not Crank.
- (5) Lower cab (TM 9-2320-365-10).

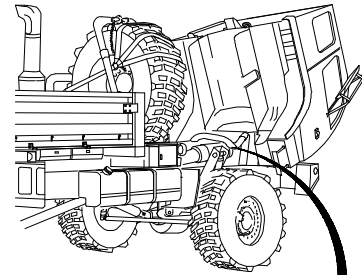

**RADIATOR,
FAN, FAN SHROUDS,
HOSES, AND BELTS
REMOVED FOR CLARITY**

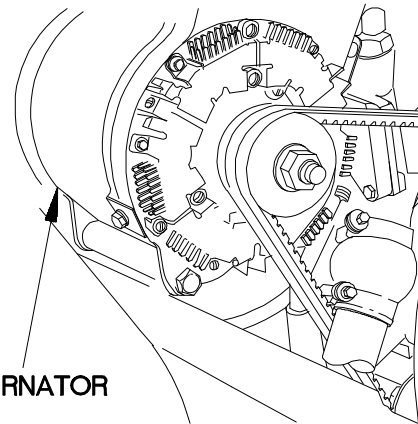

ALTERNATOR

Xba.0101b

a2. ENGINE CRANKS BUT DOES NOT START

INITIAL SETUP

Equipment Conditions

Engine shut down (TM 9-2320-365-10).

Personnel Required

(2)

Tools and Special Tools

Tool Kit, Genl Mech (Item 44, Appendix C)

STE/ICE-R (Item 39, Appendix C)

Pan, Drain (Item 24, Appendix C)

References

TM 9-4910-571-12&P

KNOWN INFO
Fuel quantity OK. Fuel/water separator is primed.
POSSIBLE PROBLEMS
Air cleaner hose or tube restricted or damaged. Faulty fuel system. Faulty electrical system.

TEST OPTIONS
Visual Inspection
REASON FOR QUESTION
Restricted or damaged air cleaner hose or tube may cause engine not to intake enough air to ignite fuel.

KNOWN INFO
Fuel quantity OK. Fuel/water separator is primed. Air cleaner hose or tube OK.
POSSIBLE PROBLEMS
Faulty fuel system. Faulty electrical system.

TEST OPTIONS
Fuel Return Hose Test
REASON FOR QUESTION
If fuel does not flow from fuel return hose, fuel system is faulty. If fuel does flow from fuel return hose, electrical system is faulty.

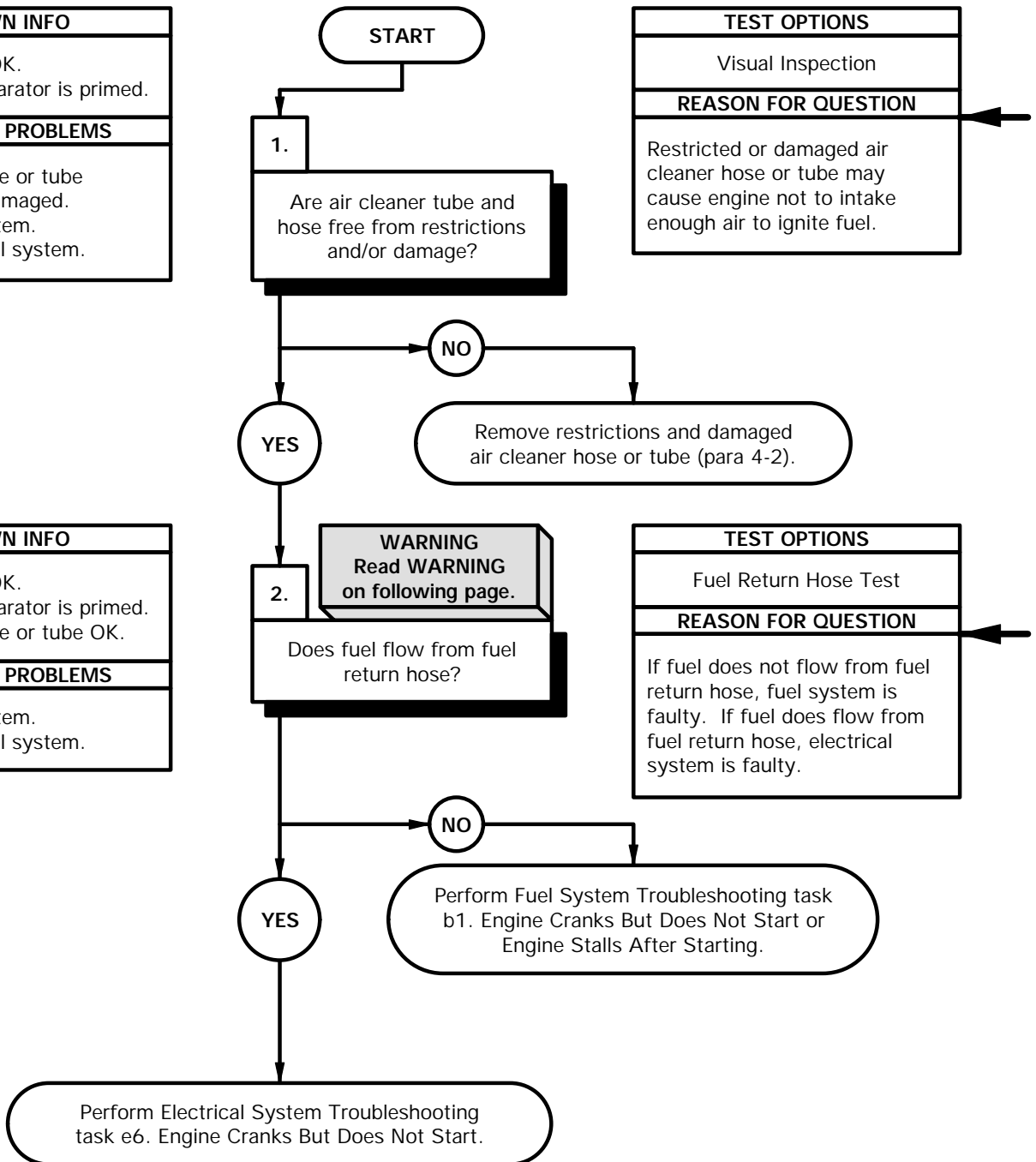

- (1) Raise cab (TM 9-2320-365-10).
- (2) Remove air cleaner hose and tube and inspect for restrictions and damage which would cause a loss of intake air (para 4-2).
- (3) Lower cab (TM 9-2320-365-10).

WARNING

Fuel is very flammable and can explode easily. To avoid serious injury or death, keep flame away from fuel and keep fire extinguisher within easy reach. When working with fuel, post signs that read **NO SMOKING WITHIN 50 FEET OF VEHICLE.**

FUEL RETURN HOSE TEST

- (1) Position drain pan under fuel tank.
- (2) Remove fuel return hose from fuel tank.
- (3) Place fuel hose in drain pan.

NOTE

Fuel should flow freely from fuel hose with no restriction.

- (4) Attempt to start engine (TM 9-2320-365-10) and observe fuel flow from fuel return hose.
- (5) If fuel does not flow from fuel return hose, perform Fuel System Troubleshooting task b1. Engine Cranks But Does Not Start or Engine Stalls After Starting.
- (6) If fuel does flow from fuel return hose, perform Electrical System Troubleshooting task e6. Engine Cranks But Does Not Start.
- (7) Install fuel return hose on fuel tank.

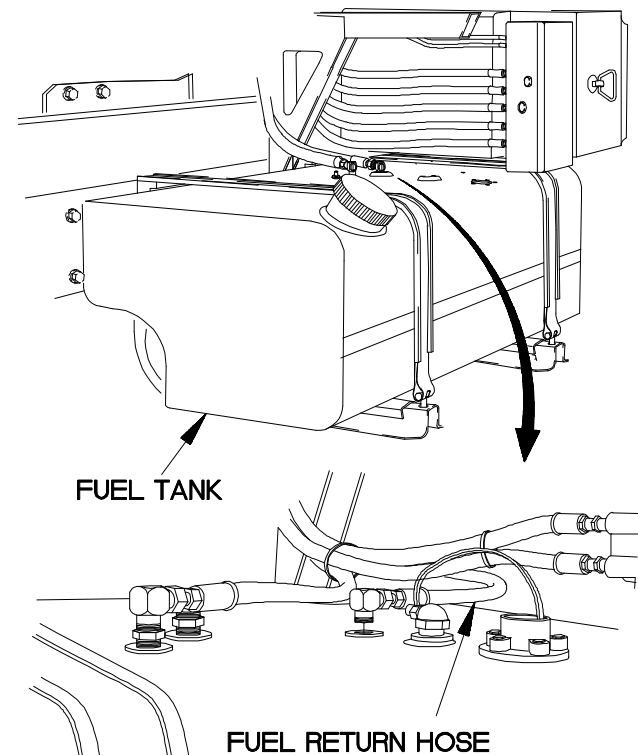
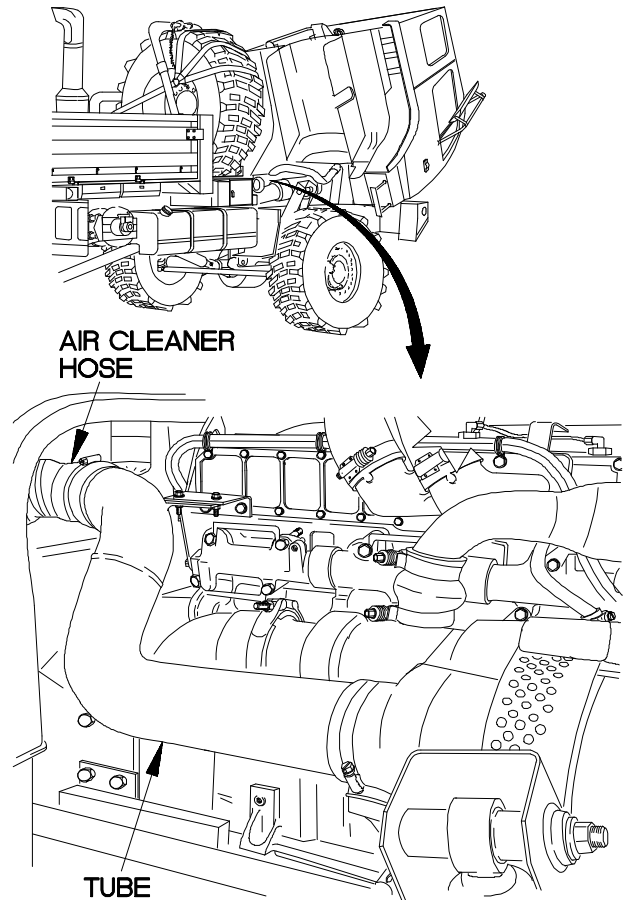

a3. LOW ENGINE OIL PRESSURE

INITIAL SETUP

Equipment Conditions

Engine shut down (TM 9-2320-365-10).

Tools and Special Tools

Tool Kit, Genl Mech (Item 44, Appendix C)
STE/ICE-R (Item 39, Appendix C)

References

TM 9-4910-571-12&P

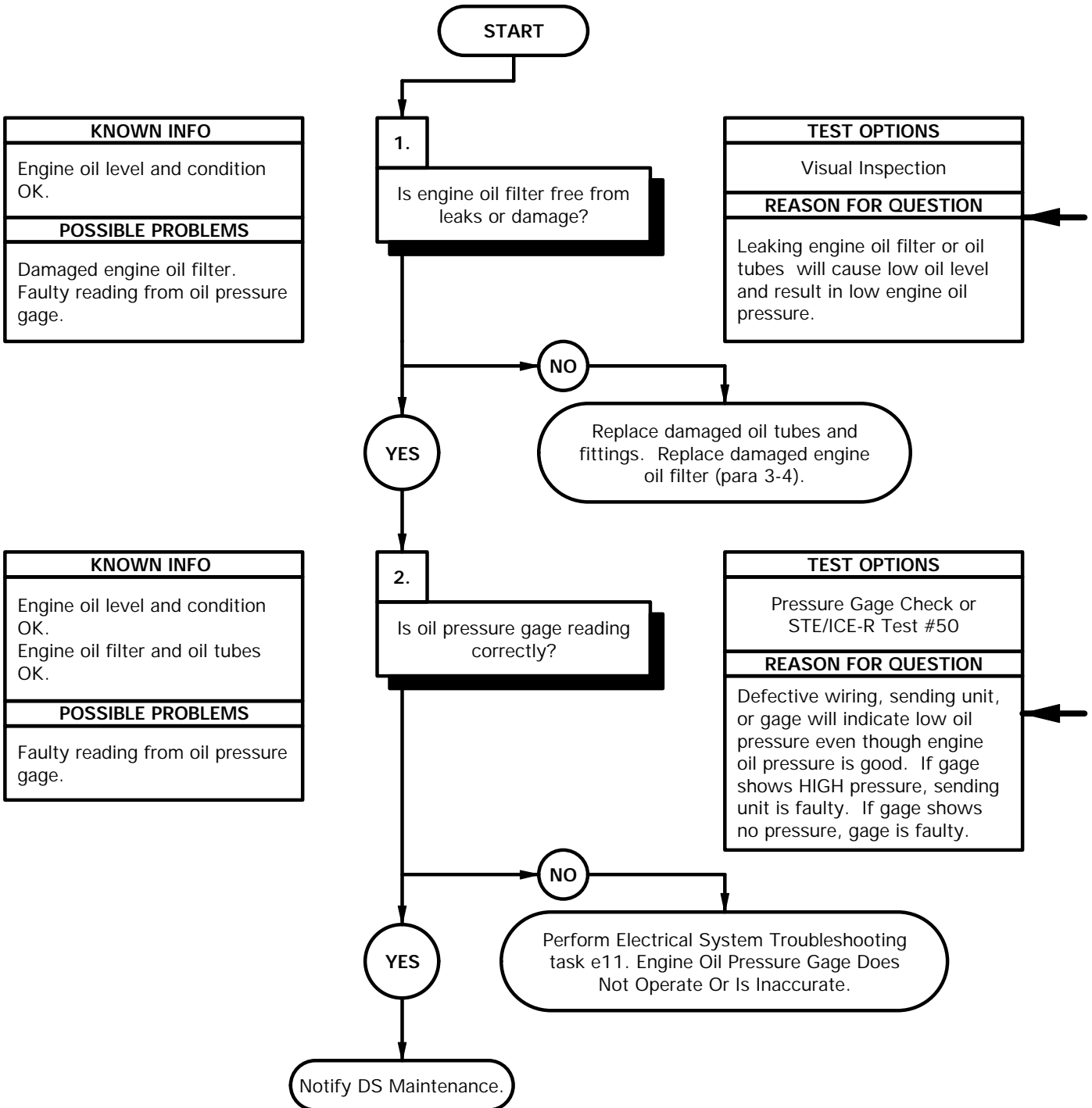

- (1) Raise cab (TM 9-2320-365-10).
- (2) Check engine oil filter for leaks and damage.
- (3) If engine oil filter is not free from leaks and damage, replace engine oil filter (para 3-4).

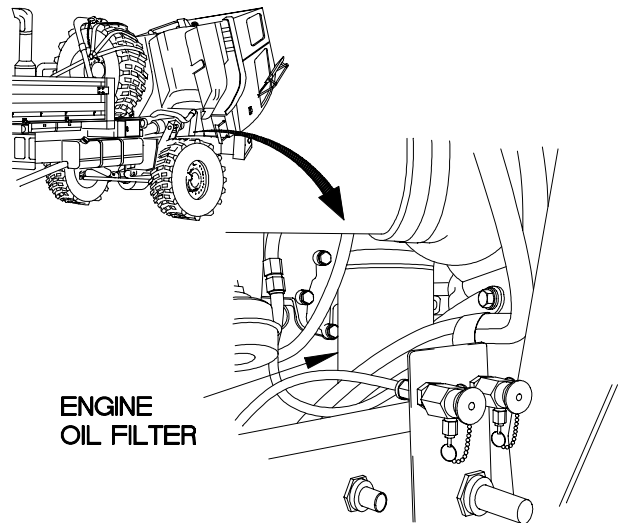

OIL PRESSURE GAGE

STEERING WHEEL
REMOVED FOR
CLARITY

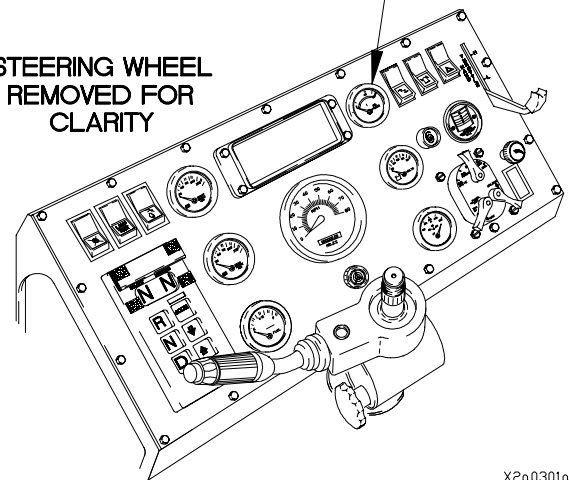

X2a0301a

PRESSURE GAGE CHECK

- (1) Lower cab (TM 9-2320-365-10).
- (2) Start engine (TM 9-2320-365-10).
- (3) Perform STE/ICE-R test #50.
- (4) Oil pressure gage should read 15 PSI (100 kPa) at 750 RPM and maximum at full load condition of 88 PSI (600 kPa).
- (5) If oil pressure gage does not read correctly, perform Electrical System Troubleshooting task e11. Engine Oil Pressure Gage Does Not Operate Or Is Inaccurate.
- (6) If oil pressure gage reads correctly, notify DS Maintenance.
- (7) Shut down engine (TM 9-2320-365-10).

a4. ENGINE STALLS AT LOW RPM	
INITIAL SETUP	
Equipment Conditions Engine shut down (TM 9-2320-365-10).	Tools and Special Tools Tool Kit, Genl Mech (Item 44, Appendix C) STE/ICE-R (Item 39, Appendix C)
References TM 9-4910-571-12&P	

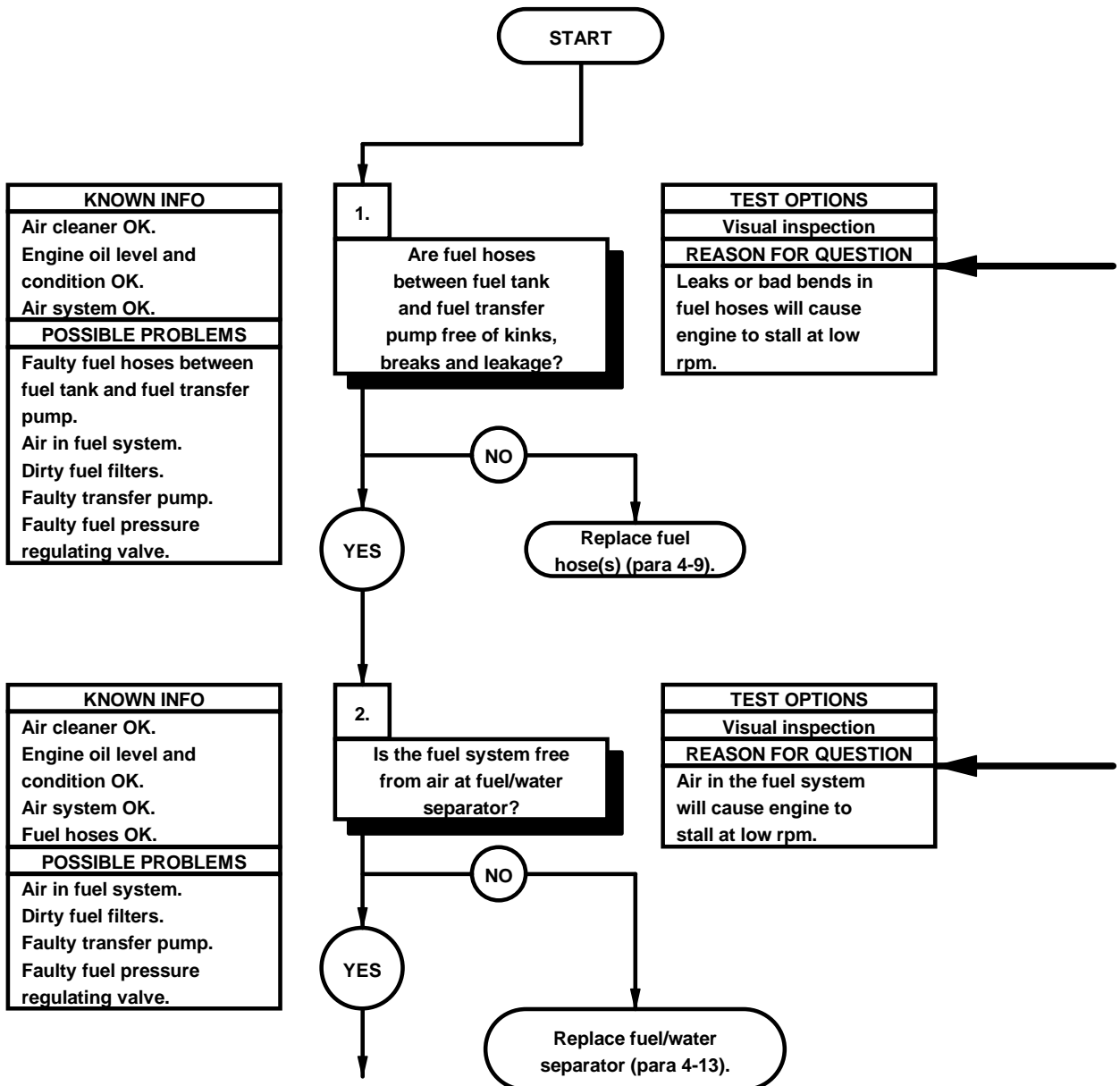

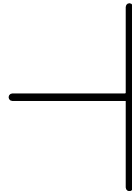

- (1) Raise cab (TM 9-2320-365-10).
- (2) Check fuel tank and fuel transfer pump hoses for kinks, looseness, and leakage.
- (3) If fuel hoses are not free from kinks or leaks, replace fuel hose(s) (para 4-9).

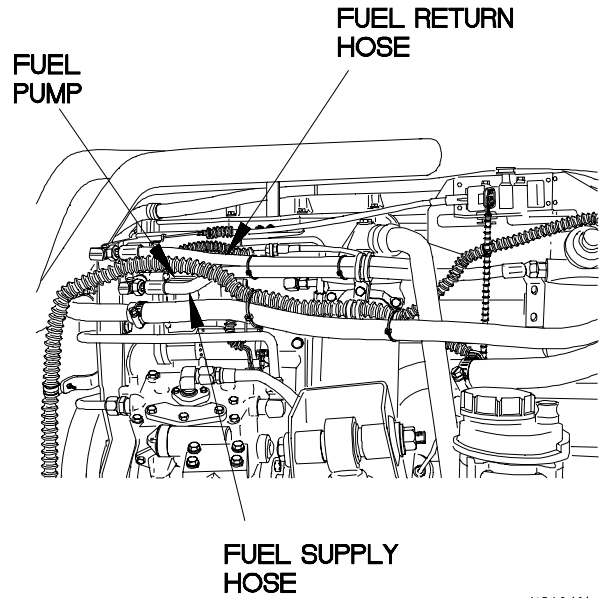

X2A0401-

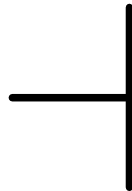

- (1) Push in fuel primer pump on fuel/water separator.
- (2) Pump fuel primer pump until resistance is felt to purge air from fuel system.
- (3) If no resistance is felt, replace fuel/water separator (para 4-13).

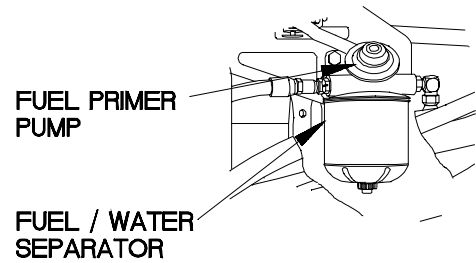
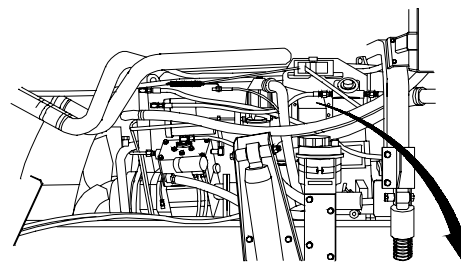

X2A0402A

a4. ENGINE STALLS AT LOW RPM (CONT)

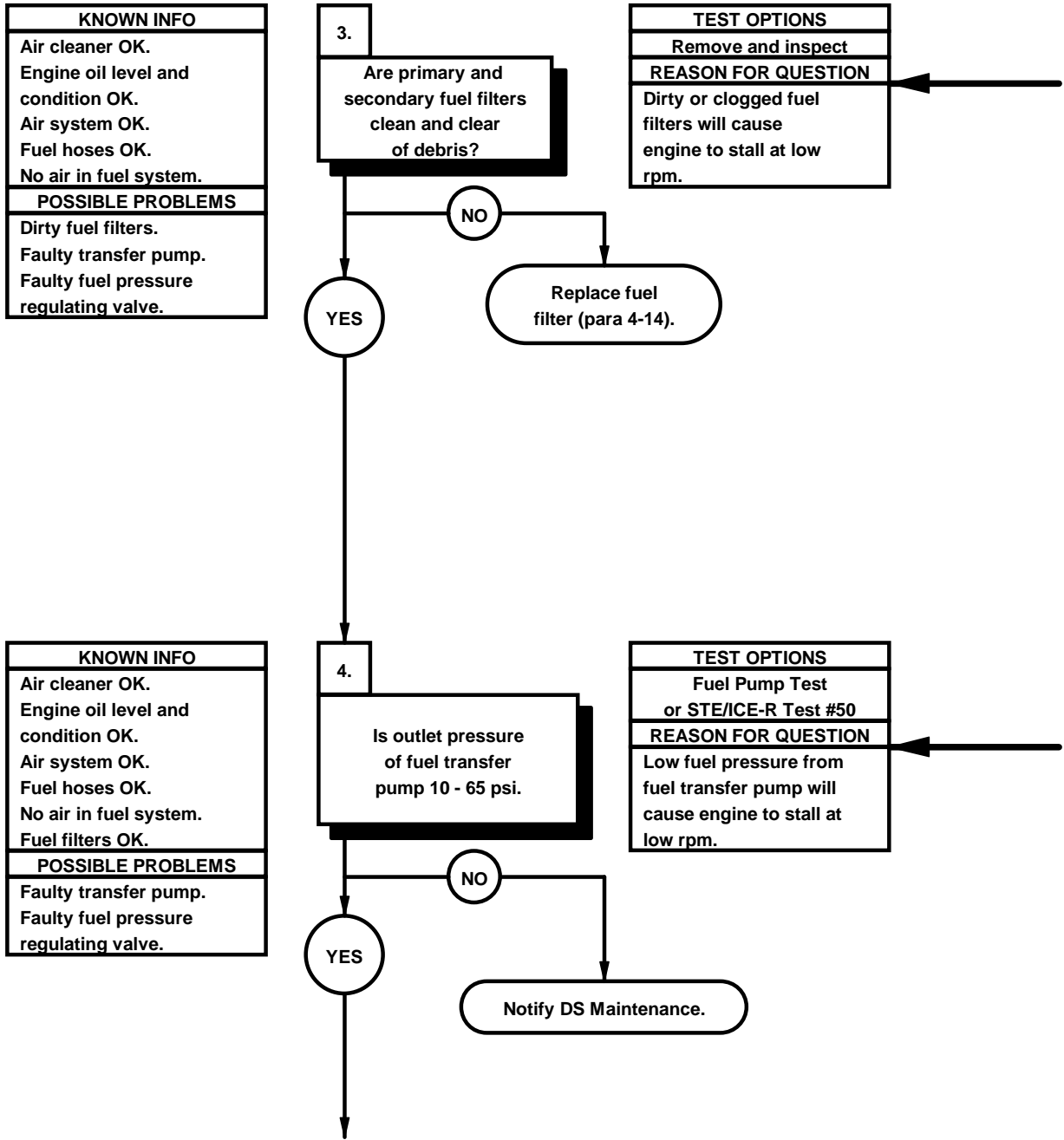

- (1) Check primary and secondary fuel filters for dirt and contamination.
- (2) Position drain pan under filter.
- (3) Remove filter element from base.
- (4) Inspect for clogs and debris.
- (5) If fuel filter is clogged, replace fuel filter (para 4-14).

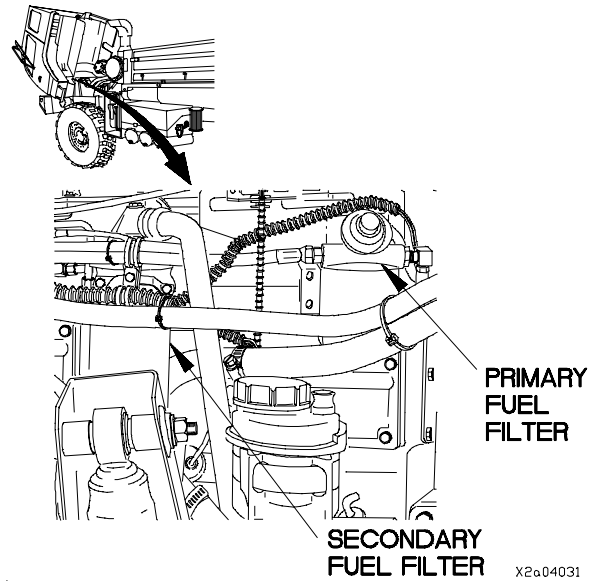

FUEL PUMP TEST

- (1) Remove inlet fuel tube from secondary fuel filter base.
- (2) Position drain pan under inlet fuel tube.
- (3) Attempt to start engine (TM 9-2320-365-10).
- (4) Check for fuel flow from inlet fuel tube while attempting to start engine.
- (5) If fuel does not flow from inlet fuel tube, notify DS Maintenance.
- (6) Install inlet fuel tube on secondary fuel filter base.

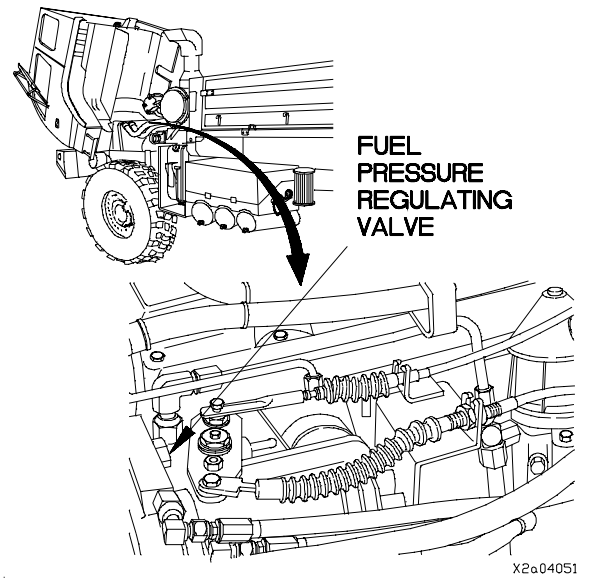

a4. ENGINE STALLS AT LOW RPM (CONT)

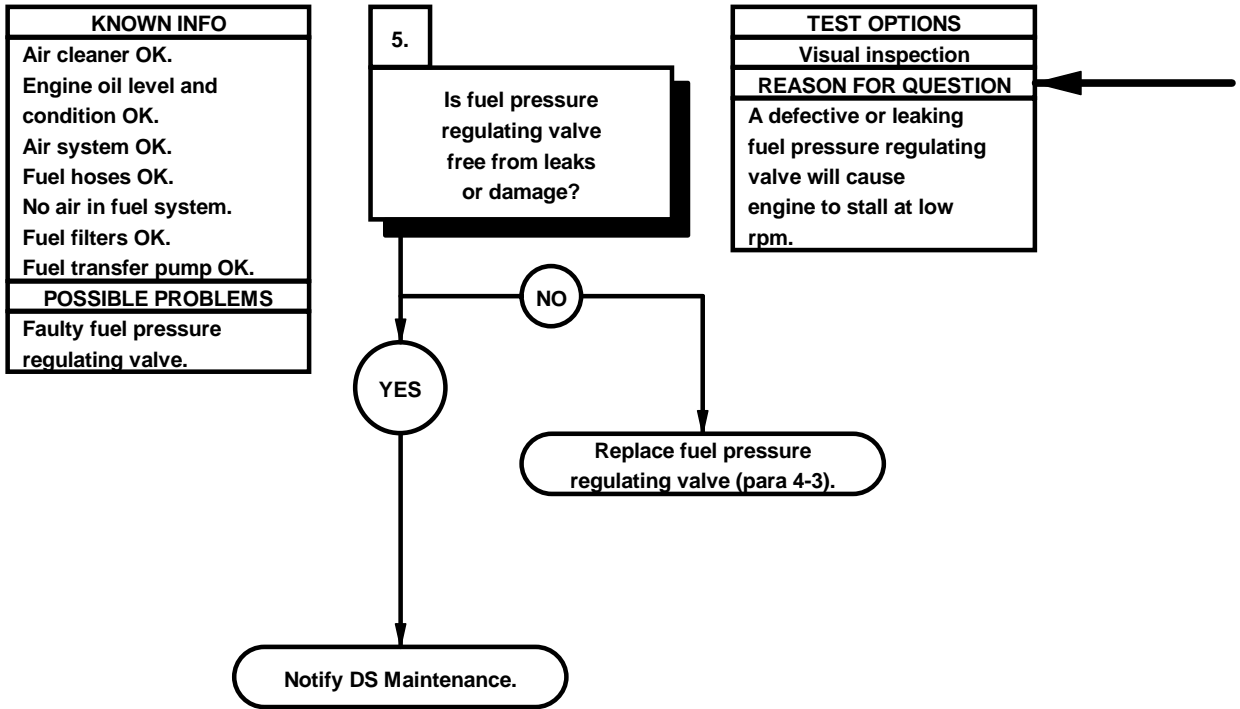

- (1) Check fuel pressure regulating valve for leaks or damage.
- (2) If fuel pressure regulating valve is damaged, replace fuel pressure regulating valve (para 4-3).
- (3) If fuel pressure regulating valve is free from leaks and damage, notify DS Maintenance.
- (4) Lower cab (TM 9-2320-365-10).

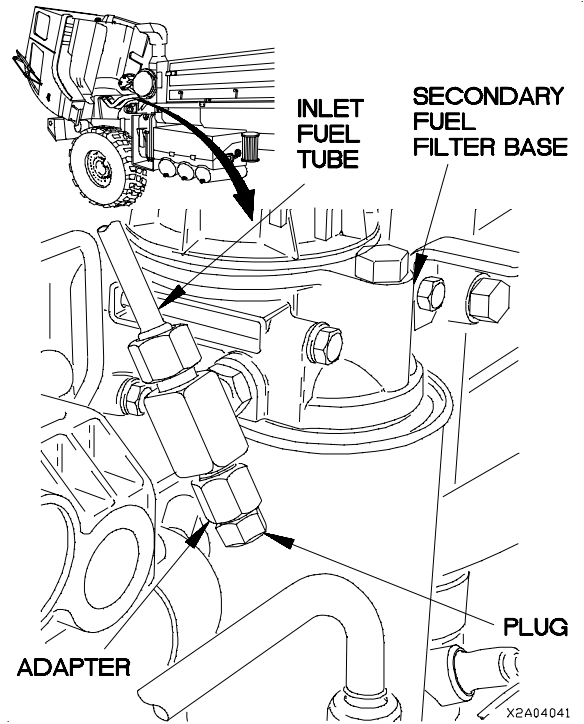

a5. ENGINE OVERSPEEDS ON START	
INITIAL SETUP	
Equipment Conditions Engine shut down (TM 9-2320-365-10).	Tools and Special Tools Tool Kit, Genl Mech (Item 44, Appendix C)

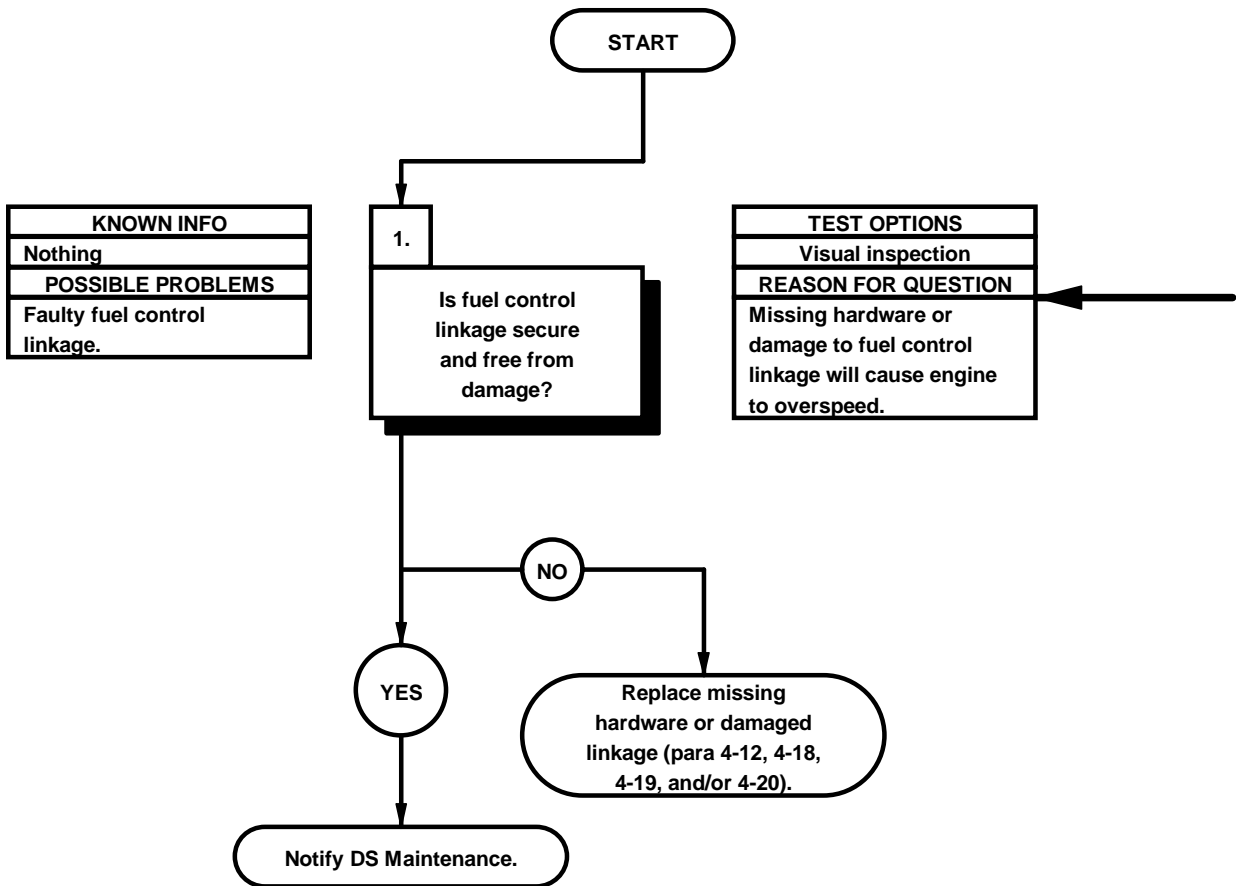

- (1) Remove instrument panel assembly for access (para 7-15).
- (2) Check fuel control linkage for improper assembly, missing hardware, and damaged parts.
- (3) Install instrument panel assembly (para 7-15).
- (4) Raise cab (TM 9-2320-365-10).
- (5) Check fuel control linkage for improper assembly, missing hardware, and damaged parts.
- (6) Lower cab (TM 9-2320-365-10).

MANUAL THROTTLE CONTROL LEVER

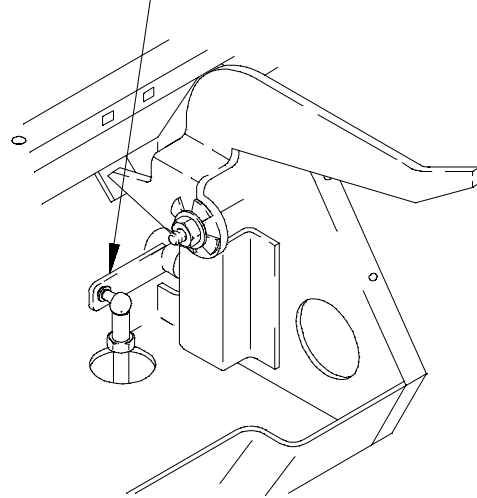

FUEL CONTROL LINKAGE

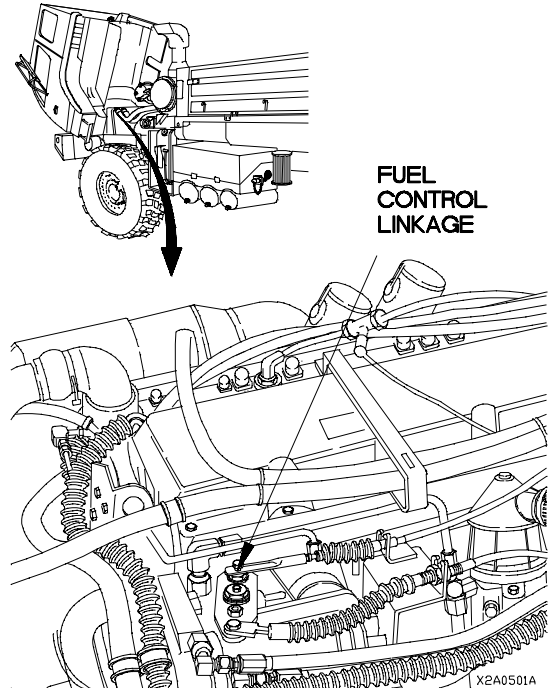

a6. TOO MUCH ENGINE VIBRATION	
INITIAL SETUP	
Equipment Conditions Engine shut down (TM 9-2320-365-10).	Tools and Special Tools Tool Kit, Genl Mech (Item 44, Appendix C)

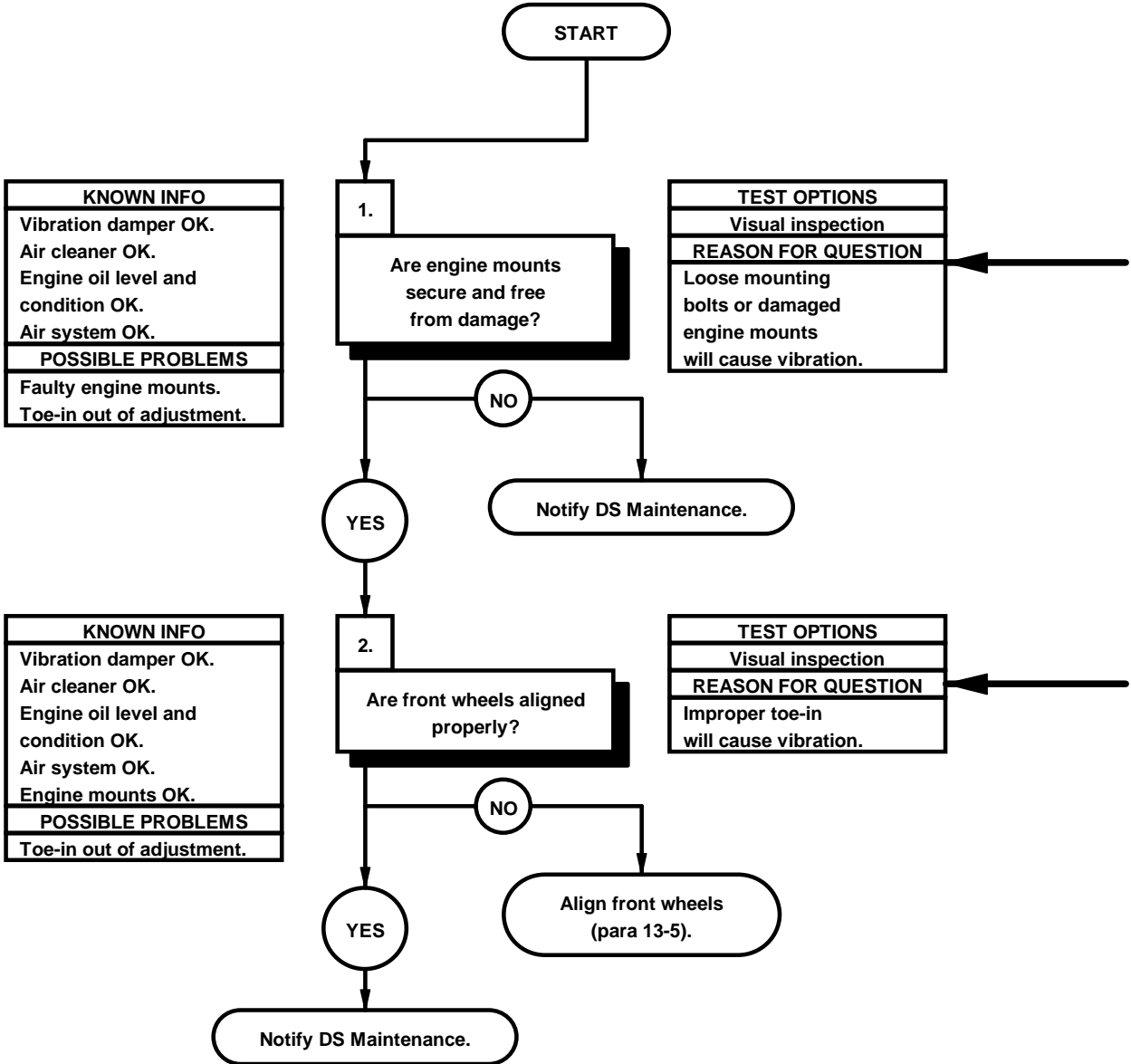

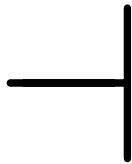

- (1) Check engine mounts for loose mounting hardware and damage.
- (2) If engine mounts are damaged or mounting hardware is loose, notify DS Maintenance.

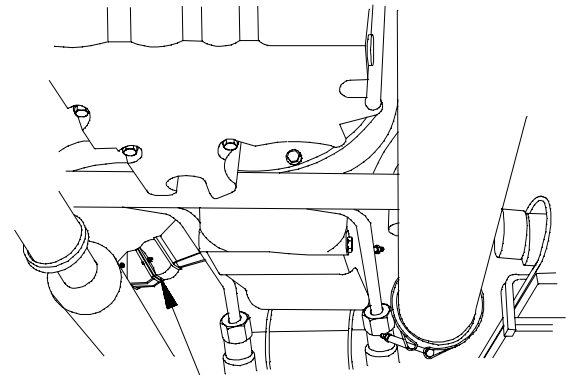
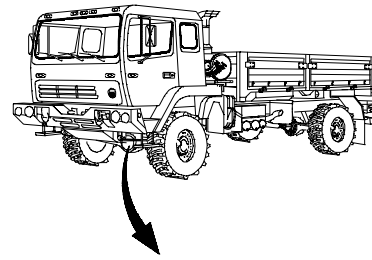

ENGINE MOUNT

32A0601A

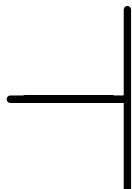

- (1) Check tires for uneven tire wear.
- (2) If uneven tire wear is found, align front wheels (para 13-5).
- (3) If front tires do not have uneven wear, notify DS Maintenance.

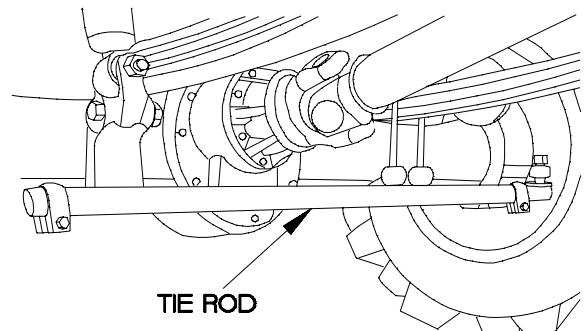
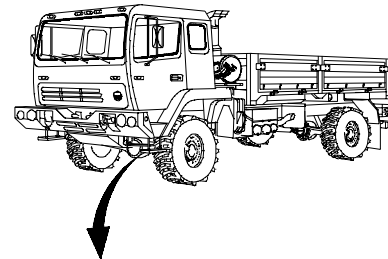

TIE ROD

32A0602A

a7. COOLANT IN ENGINE LUBRICATION OIL	
INITIAL SETUP	
Equipment Conditions Engine shut down (TM 9-2320-365-10).	Tools and Special Tools Tool Kit, Genl Mech (Item 44, Appendix C)

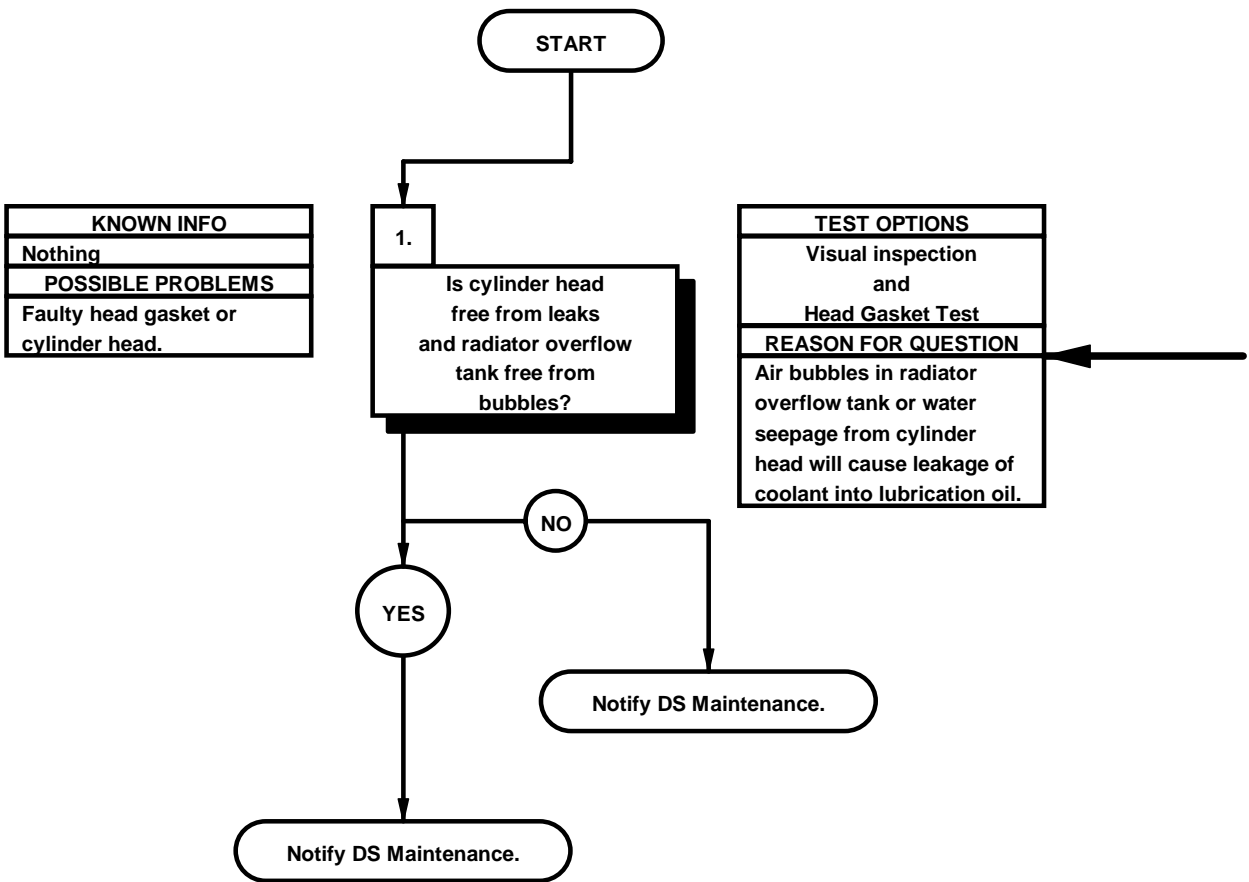

- (1) Raise cab (TM 9-2320-365-10).
- (2) Check sides of engine block at cylinder head for obvious signs of water leakage.
- (3) Lower cab (TM 9-2320-365-10).

HEAD GASKET TEST

- (1) Remove radiator cap.
- (2) Start engine (TM 9-2320-365-10).

NOTE

Air bubbles in the coolant are a sign of probable leakage at the head gasket.

- (3) Look for air bubbles in coolant.
- (4) Install radiator cap.
- (5) Shut down engine (TM 9-2320-365-10).

CYLINDER HEAD

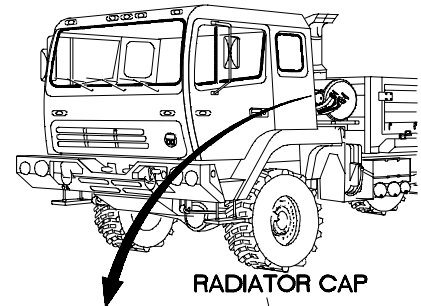
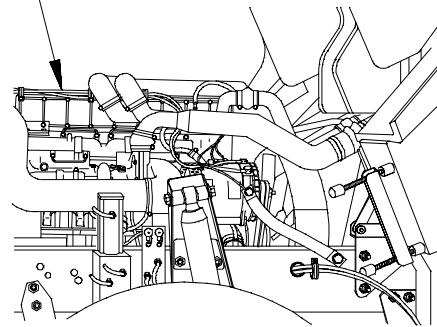

RADIATOR CAP

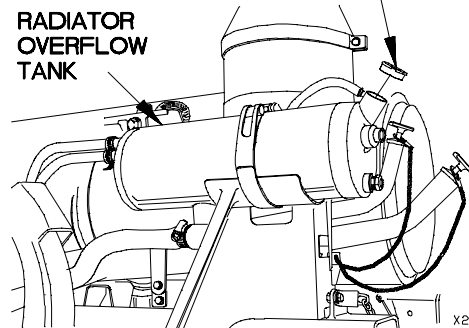

RADIATOR OVERFLOW TANK

X2A0701A

a8. EXCESSIVE ENGINE OIL CONSUMPTION	
INITIAL SETUP	
Equipment Conditions Engine shut down (TM 9-2320-365-10).	Tools and Special Tools Tool Kit, Genl Mech (Item 44, Appendix C)

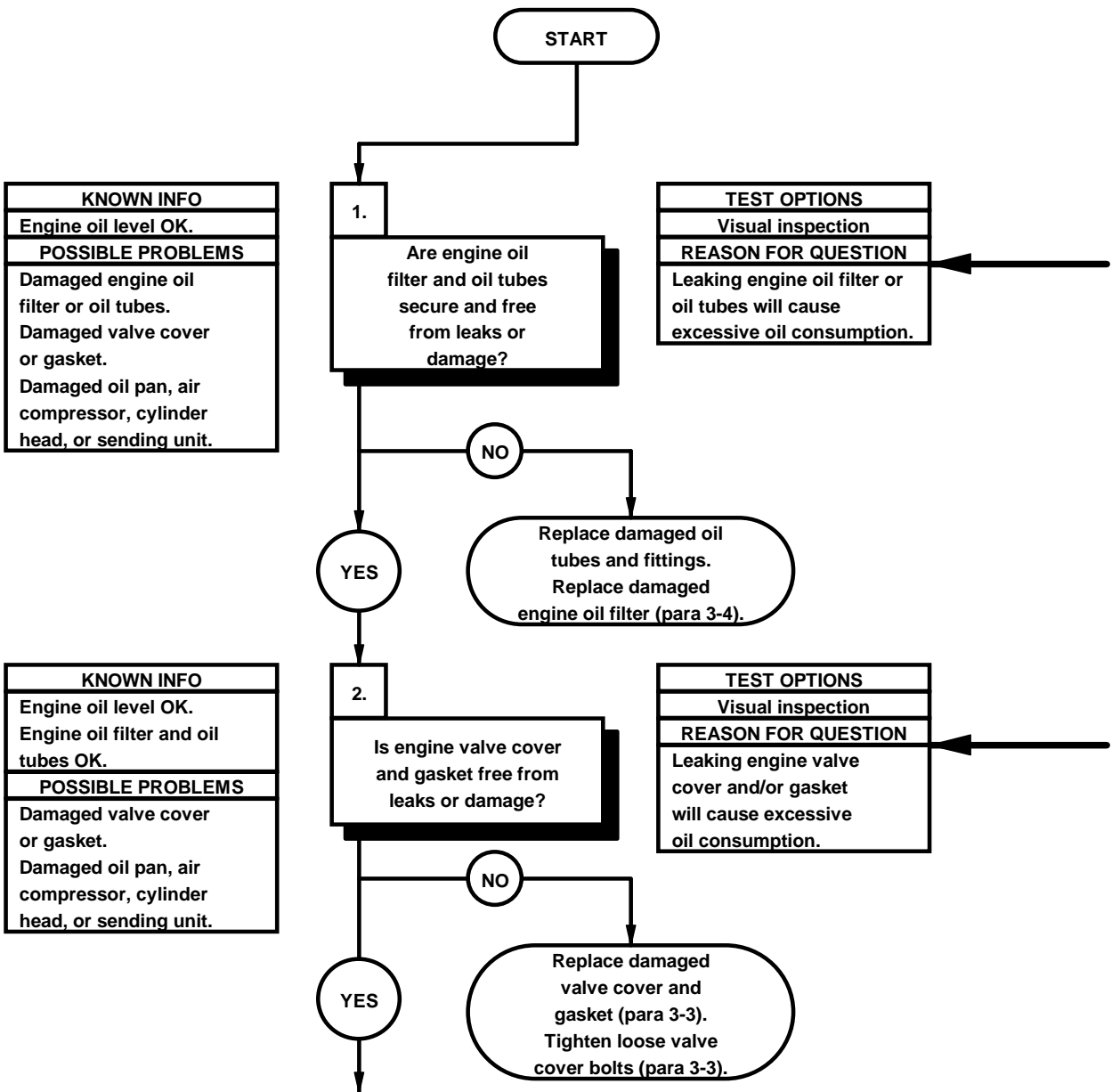

NOTE

Oil consumption is considered normal up to 12,000 mi (19,308 km) at a rate of one qt (one L) of oil per 45 gal (170 L) of fuel. After 12,000 mi (19,308 km), oil consumption is considered normal at a rate of one qt (one L) of oil per 60 gal (227 L) of fuel.

- (1) Raise cab (TM 9-2320-365-10).
- (2) Check engine oil filter and oil tubes for leakage or damage.
- (3) If engine oil filter is damaged, replace engine oil filter (para 3-4).

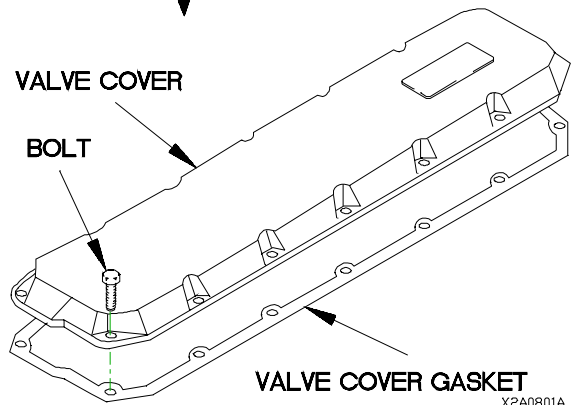
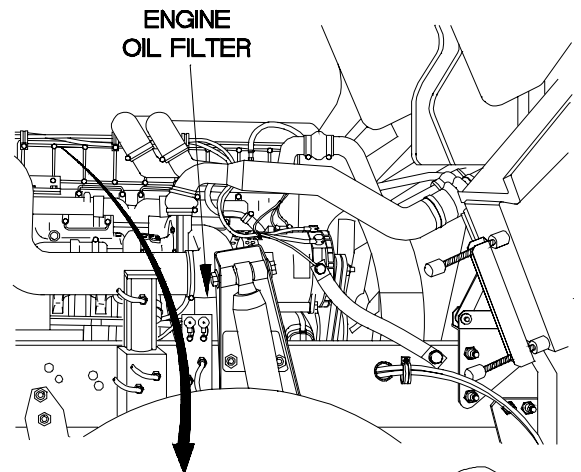

- (1) Check engine valve cover and gasket for leaks and damage.
- (2) If engine valve cover or gasket leaks, tighten loose valve cover bolts (para 3-3).
- (3) If engine valve cover or gasket is damaged, replace valve cover and gasket (para 3-3).

a8. EXCESSIVE ENGINE OIL CONSUMPTION (CONT)

KNOWN INFO
Engine oil level OK.
Engine oil filter and oil tubes OK.
Engine valve cover and gasket OK.

POSSIBLE PROBLEMS
Damaged oil pan, air compressor, cylinder head, or sending unit.

3.
Are oil pan, air compressor, cylinder head, or sending unit free from leaks or damage?

TEST OPTIONS
Visual inspection

REASON FOR QUESTION
Leaking oil pan, air compressor, cylinder head, or sending unit will cause excessive oil consumption.

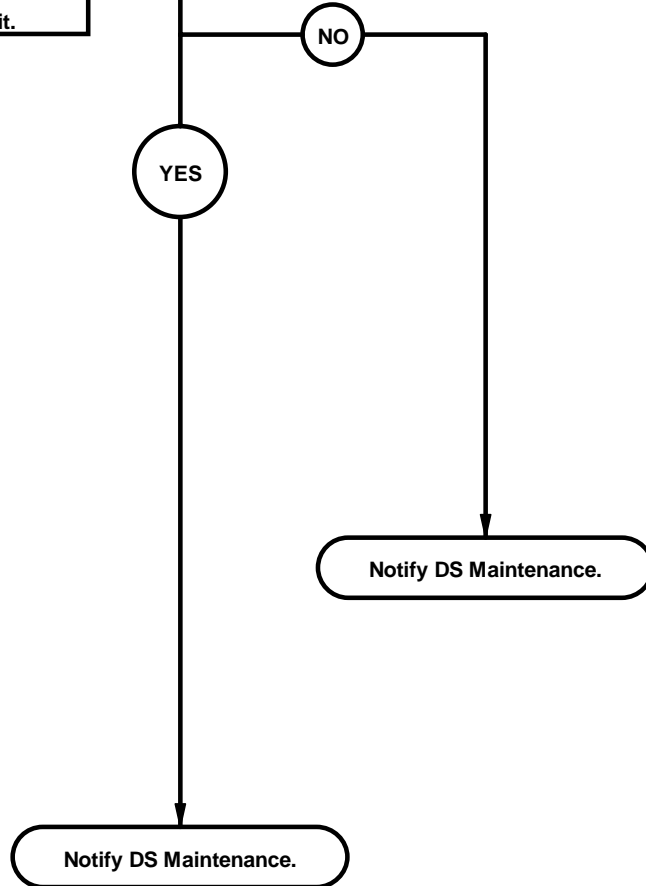

- (1) Check oil pan, air compressor, cylinder head, and sending unit for leakage or damage.
- (2) If oil pan, air compressor, cylinder head, or sending unit is leaking or damaged, notify DS Maintenance.
- (3) If oil pan, air compressor, cylinder head and sending unit are free from leaks and damage, notify DS Maintenance.
- (4) Lower cab (TM 9-2320-365-10).

CYLINDER HEAD

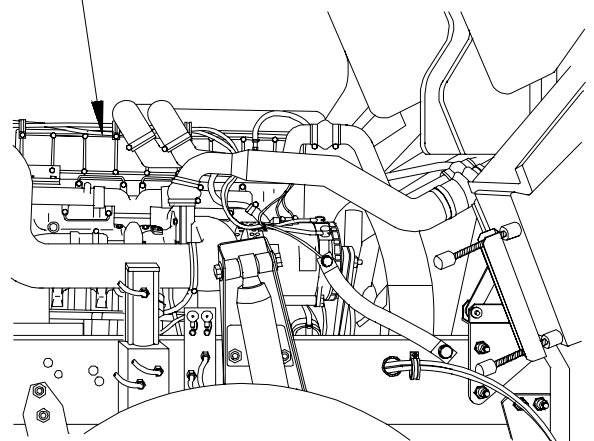

X2A0803A

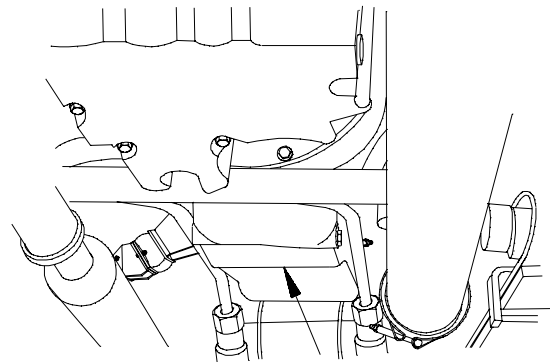

OIL PAN

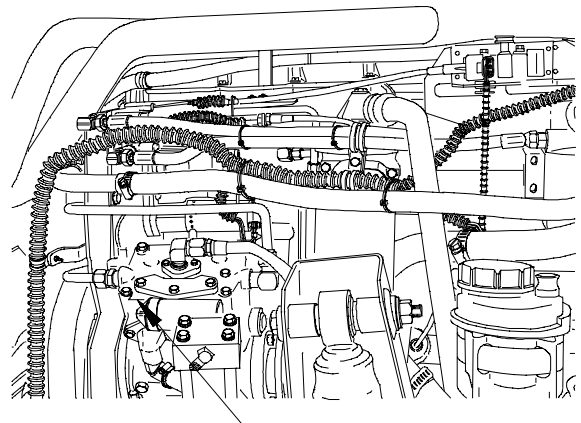

AIR COMPRESSOR

X2a08021

a9. ENGINE OVERHEATS	
INITIAL SETUP	
Equipment Conditions Engine shut down (TM 9-2320-365-10).	Tools and Special Tools Tool Kit, Genl Mech (Item 44, Appendix C) STE/ICE-R (Item 39, Appendix C)
References TM 9-4910-571-12&P	

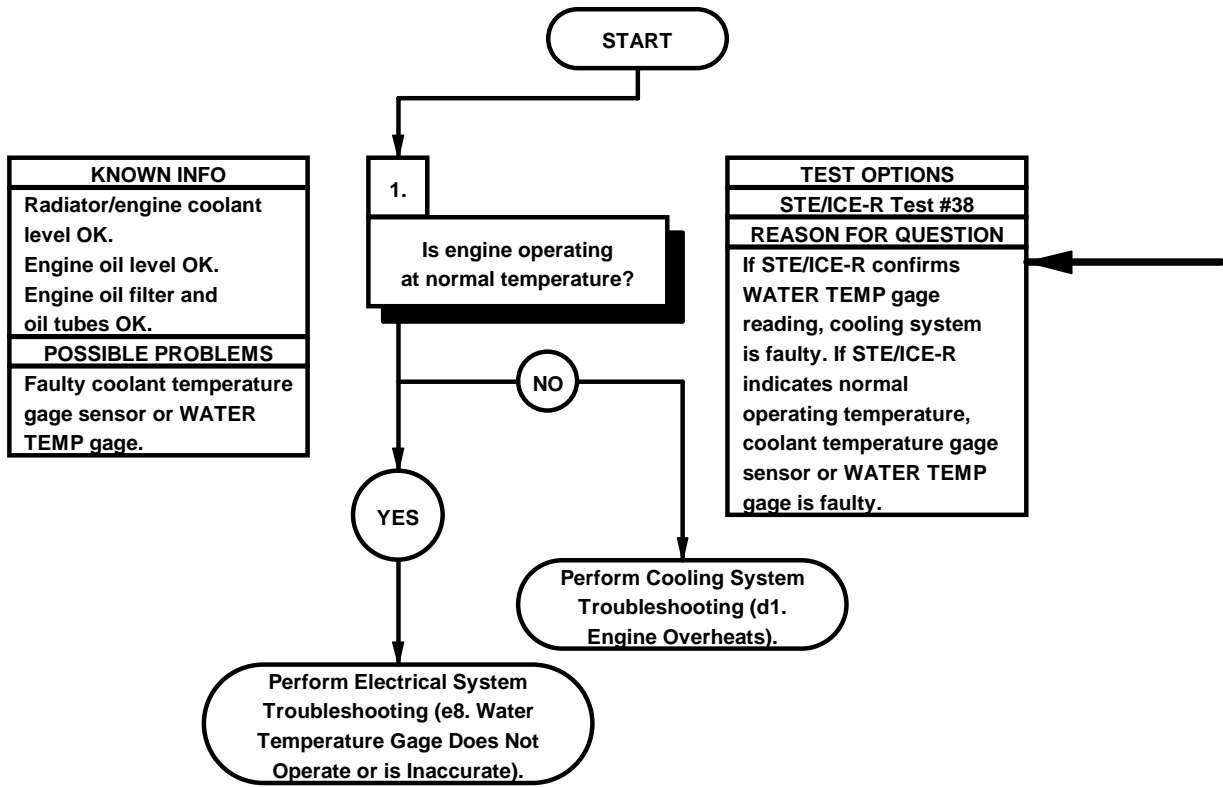

NOTE
 STE/ICE-R Test #38
 measures engine
 coolant temperature.

STE/ICE-R TEST #38

- (1) Hook up STE/ICE-R to DCA.
- (2) Press and hold the TEST button on the STE/ICE-R until -45 to +45 appears in the display. This will ensure that the test results are accurate.
- (3) Start engine (TM 9-2320-365-10) and raise engine idle until engine is at normal operating temperature, 180-205°F (82-96°C).
- (4) Coolant temperature should read between 160-210°F (71-99°C).
- (5) Record test results.
- (6) If coolant temperature is not 160-210°F (71-99°C), perform Cooling System Troubleshooting (d1. Engine Overheats).
- (7) If coolant temperature is 160-210°F (71-99°C), perform Electrical System Troubleshooting (e8. Water Temperature Gage Does Not Operate or is Inaccurate).
- (8) Shut down engine (TM 9-2320-365-10).
- (9) Remove STE/ICE-R from DCA.

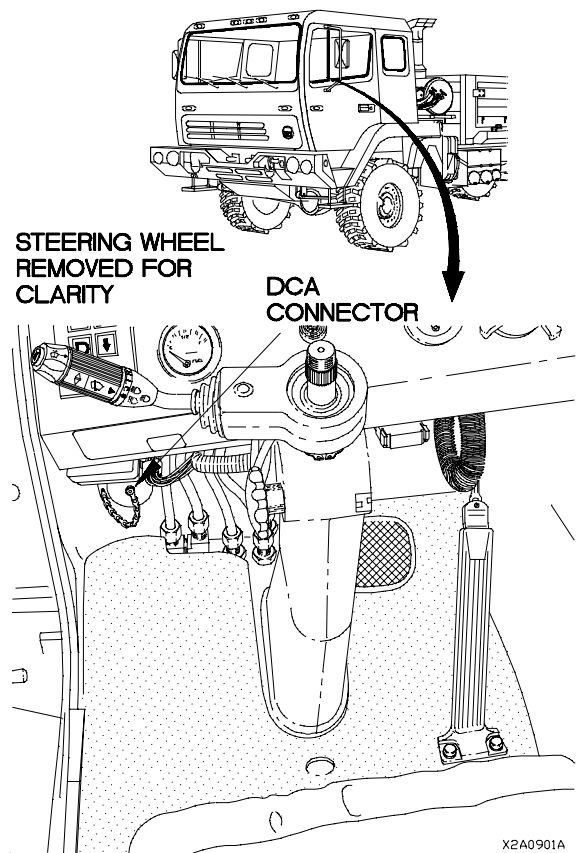

a10. EXCESSIVE BLACK OR GRAY EXHAUST SMOKE	
INITIAL SETUP	
Equipment Conditions Engine shut down (TM 9-2320-365-10).	Tools and Special Tools Tool Kit, Genl Mech (Item 44, Appendix C)

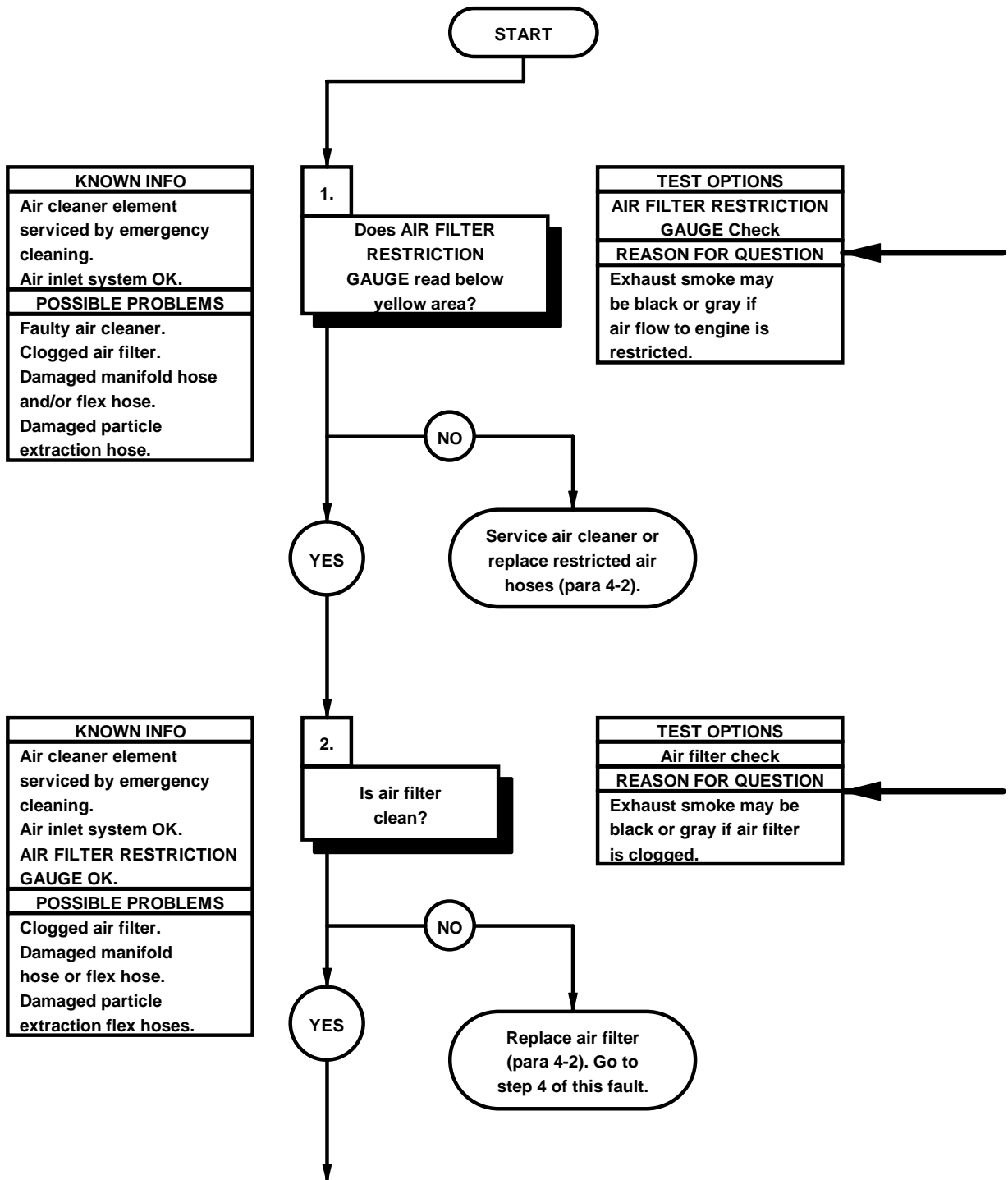

- AIR FILTER RESTRICTION GAUGE CHECK**
- (1) Check reading on AIR FILTER RESTRICTION GAUGE.
 - (2) Press RESET button on AIR FILTER RESTRICTION GAUGE if reading is between 15 and 20 (in yellow area) or above 20 (in red area).
 - (3) Start engine (TM 9-2320-365-10) and check AIR FILTER RESTRICTION GAUGE again.
 - (4) Shut down engine (TM 9-2320-365-10).

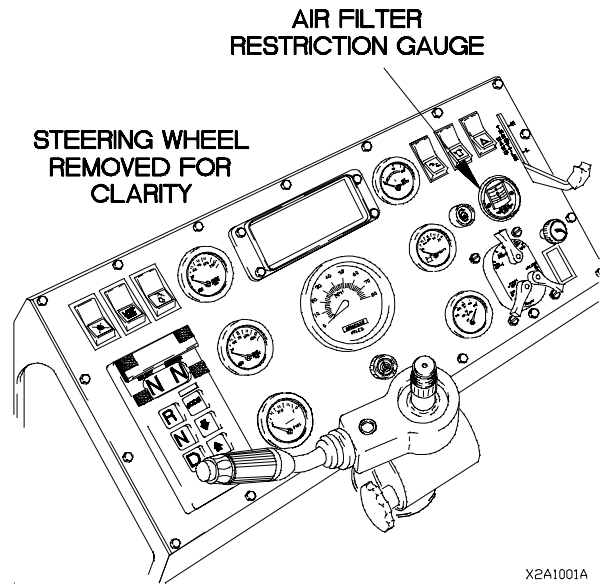

X2A1001A

- AIR FILTER CHECK**
- (1) Release three spring latches on intake air cleaner cover.
 - (2) Remove intake air cleaner cover.
 - (3) Remove air filter. Replace air filter if clogged (para 4-2).
 - (4) Install air filter.
 - (5) Install intake air cleaner cover.
 - (6) Install three spring latches into intake air cleaner cover.

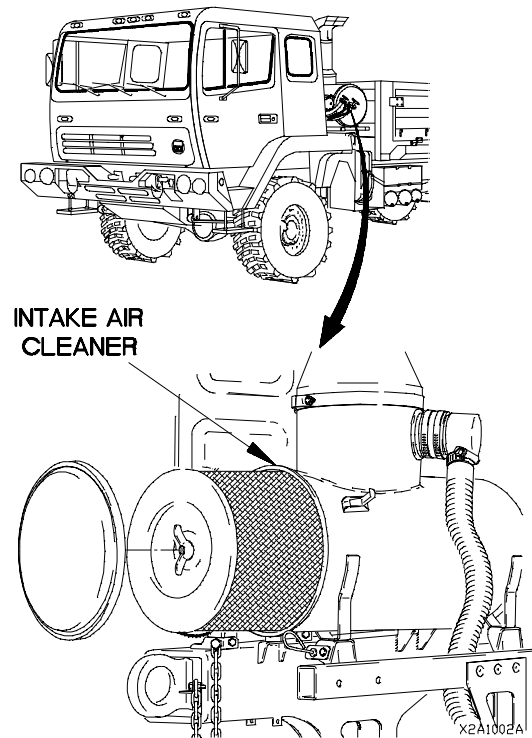

X2A1002A

a10. EXCESSIVE BLACK OR GRAY EXHAUST SMOKE (CONT)

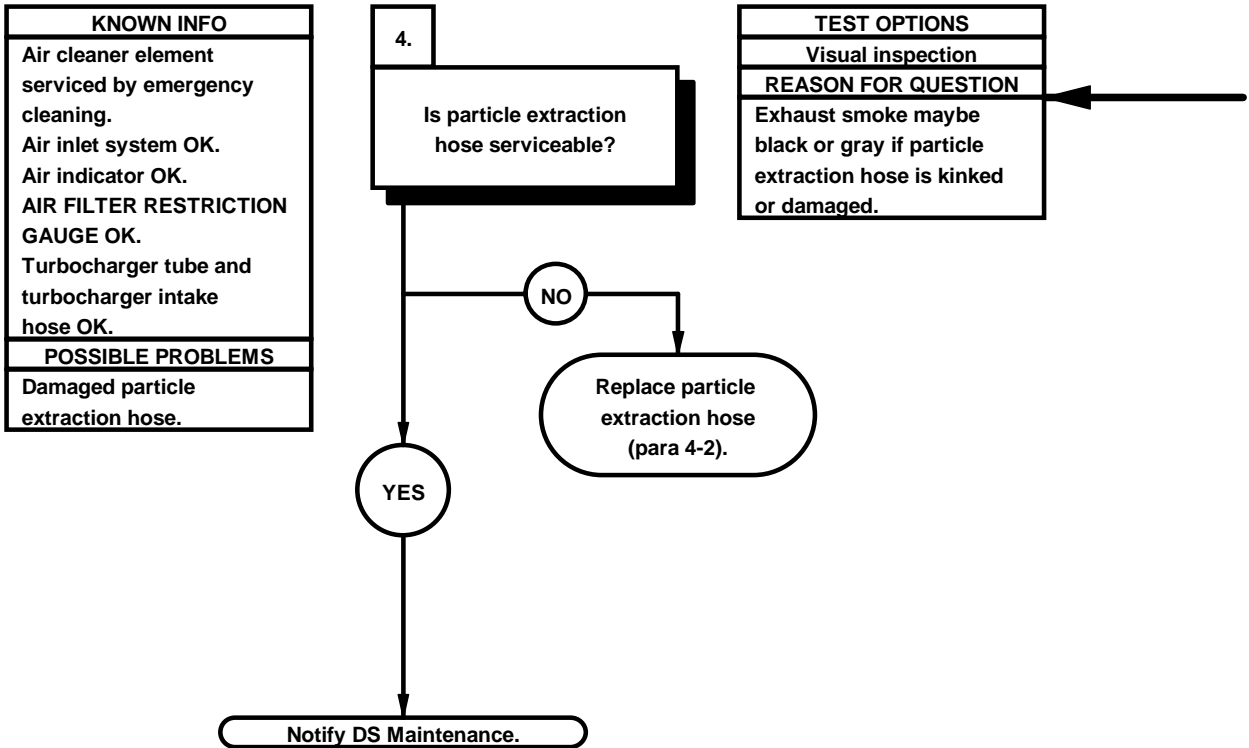
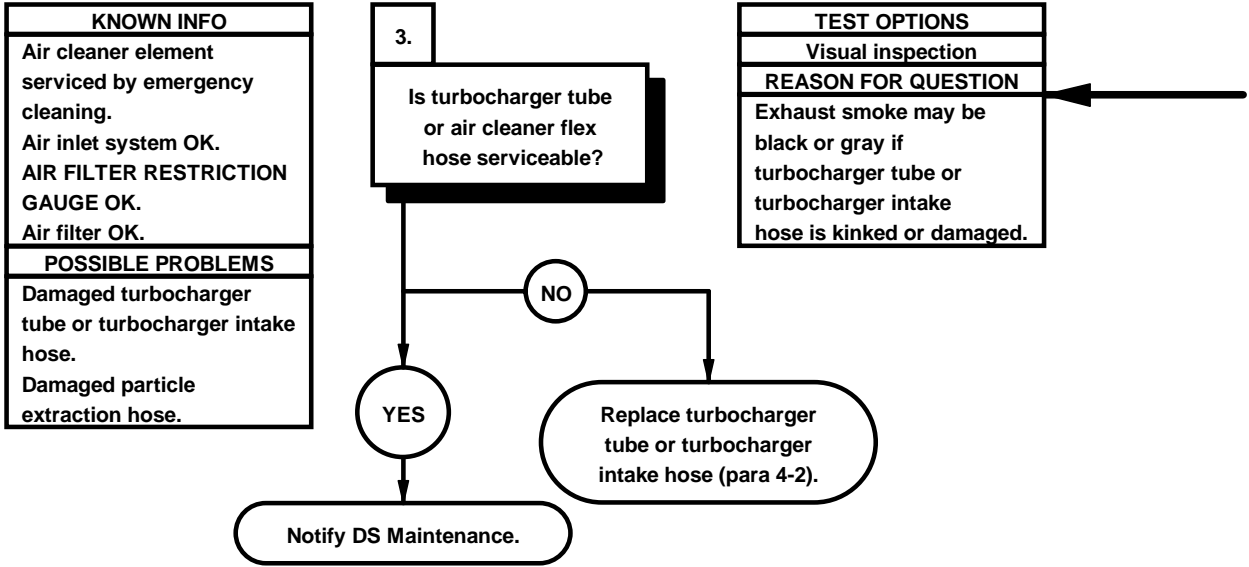

- (1) Raise cab (TM 9-2320-365-10).
- (2) Check turbocharger tube and turbocharger intake hose for kinks and damage.
- (3) If turbocharger tube or turbocharger intake hose is damaged, replace turbocharger tube or turbocharger intake hose (para 4-2).
- (4) If turbocharger tube and turbocharger intake hose are free from kinks and damage, notify DS Maintenance.
- (5) Lower cab (TM 9-2320-365-10).

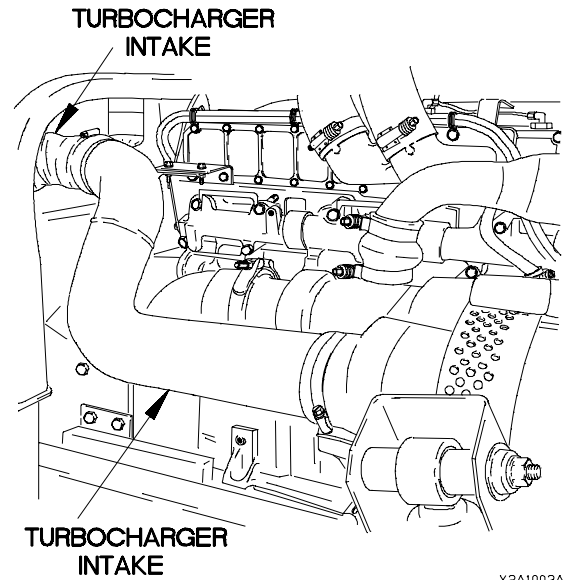

X2A1003A

- (1) Check particle extraction hose for kinks and damage.
- (2) If particle extraction hose is damaged, replace particle extraction hose (para 4-2).
- (3) If particle extraction hose is OK, notify DS Maintenance.

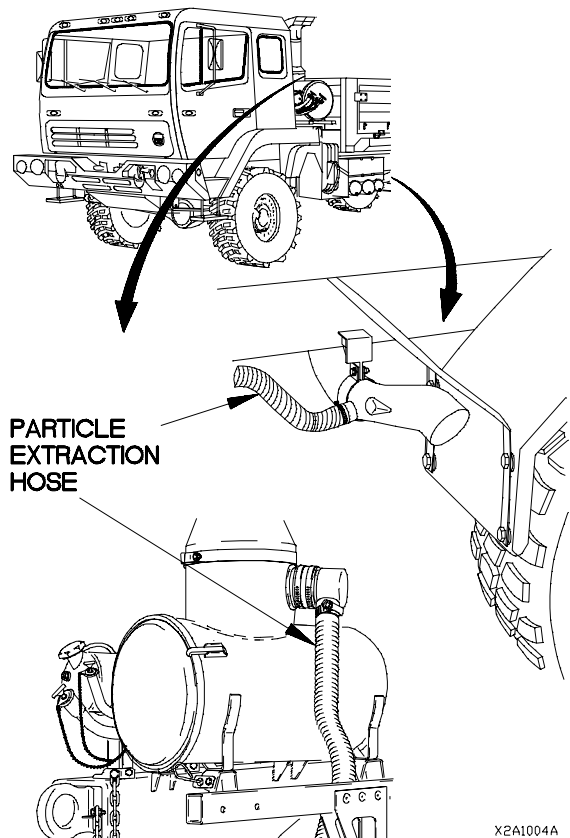

X2A1004A

a11. WHITE EXHAUST SMOKE	
INITIAL SETUP	
Equipment Conditions Engine shut down (TM 9-2320-365-10).	Tools and Special Tools Tool Kit, Genl Mech (Item 44, Appendix C) Container (Capacity 40 qt (38L)) Goggles, Industrial (Item 15, Appendix C)

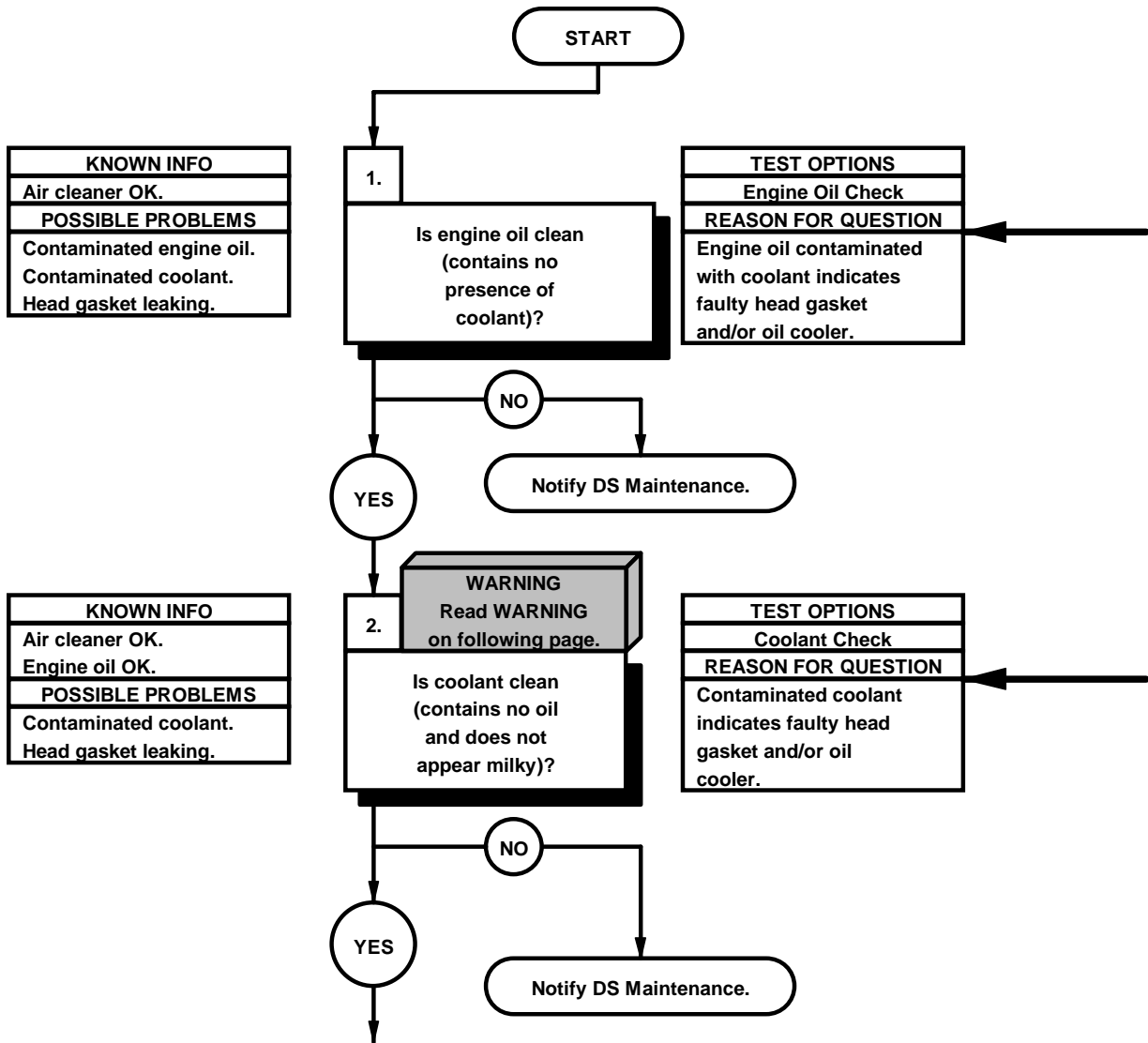

ENGINE OIL CHECK

- (1) Position container under engine oil pan.
- (2) Remove drain plug from engine oil pan and drain engine oil.
- (3) Observe condition of engine oil.
- (4) If engine oil is not clean, notify DS Maintenance.
- (5) Install drain plug in engine oil pan.
- (6) Refill engine with oil (Appendix H).

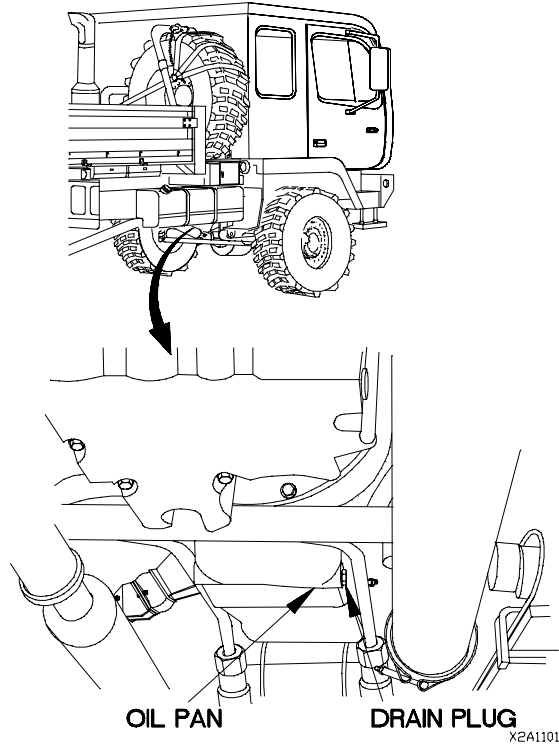

COOLANT CHECK

WARNING

Do not remove radiator cap when engine is warm. Coolant may be very hot and under pressure. Failure to comply may result in injury to personnel.

- (1) Remove radiator cap from radiator overflow tank.
- (2) Observe condition of coolant inside radiator overflow tank.
- (3) If coolant is not clean, notify DS Maintenance.
- (4) Install radiator cap on radiator overflow tank.

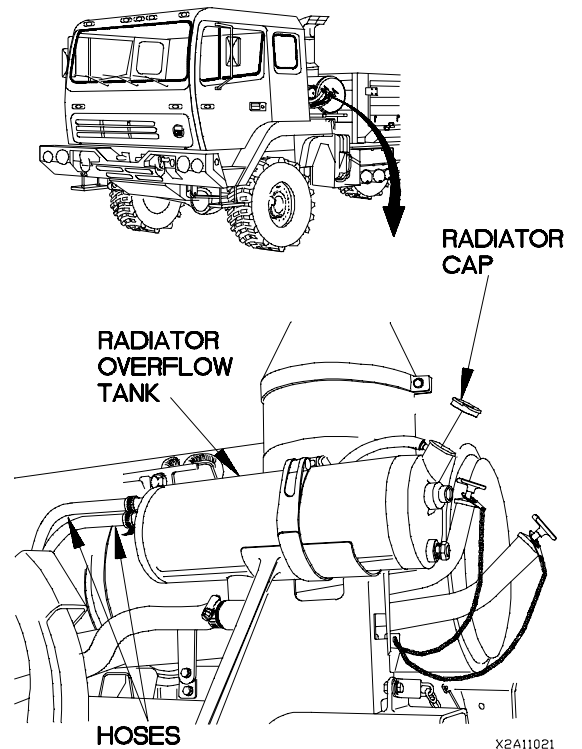

a11. WHITE EXHAUST SMOKE (CONT)

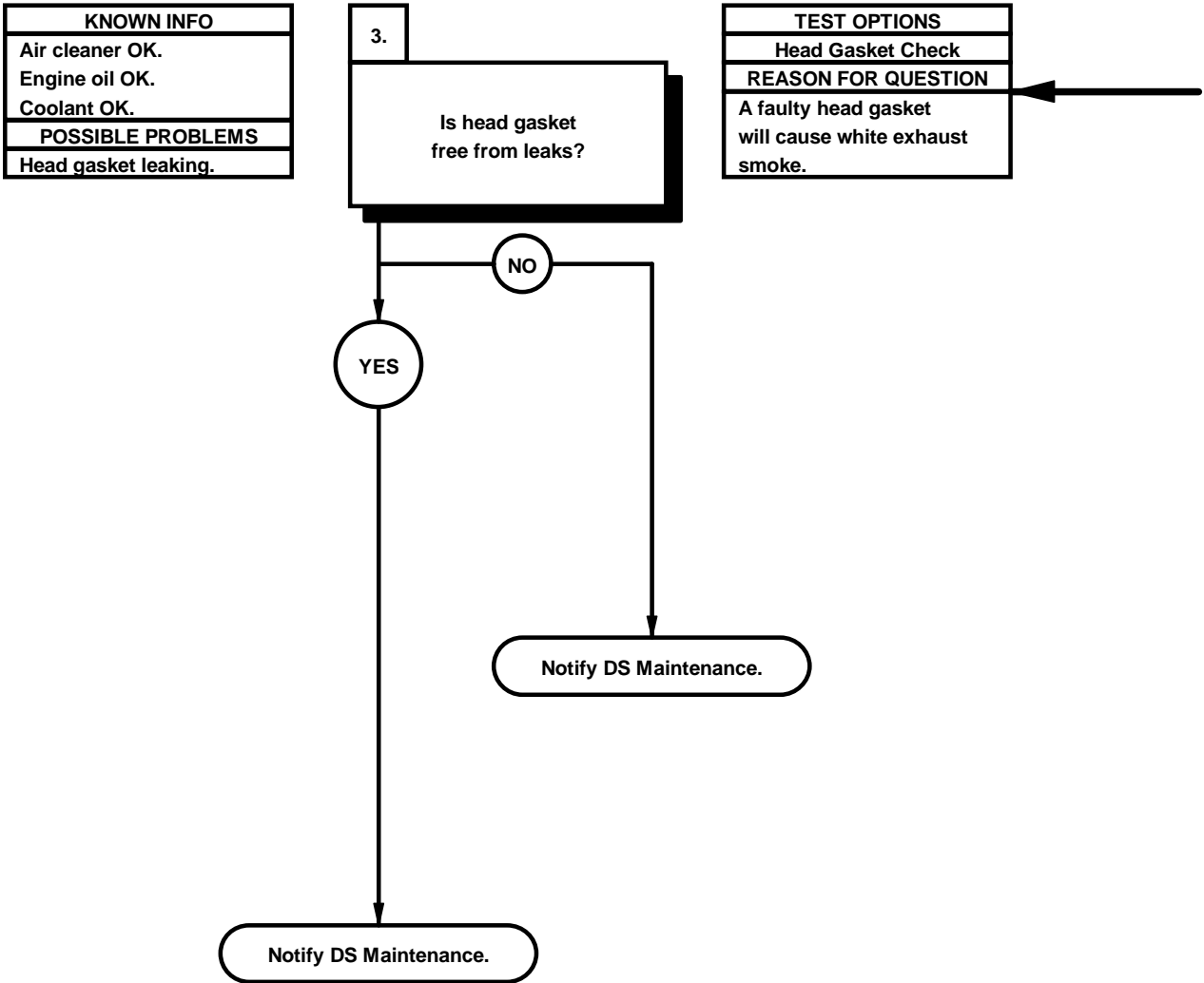

HEAD GASKET CHECK

- (1) Start engine (TM 9-2320-365-10).
- (2) Raise cab (TM 9-2320-365-10).
- (3) Check head gasket for leaks.
- (4) If head gasket is leaking, notify DS Maintenance.
- (5) If head gasket is not leaking and white exhaust smoke still exists, notify DS Maintenance.
- (6) Lower cab (TM 9-2320-365-10).
- (7) Shut down engine (TM 9-2320-365-10).

HEAD GASKET

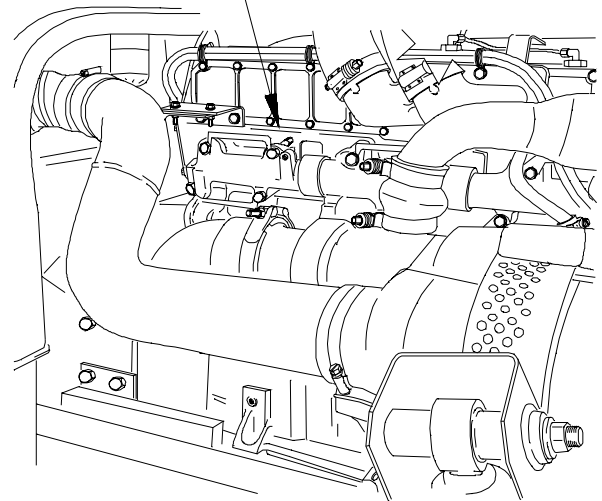

X2A1105-

a12. LOW ENGINE POWER

INITIAL SETUP

Equipment Conditions

Engine shut down (TM 9-2320-365-10).

Materials/Parts

Packing, Preformed (2) (Item 180, Appendix G)

Tools and Special Tools

Tool Kit, Genl Mech (Item 44, Appendix C)
STE/ICE-R (Item 39, Appendix C)

References

TM 9-4910-571-12&P

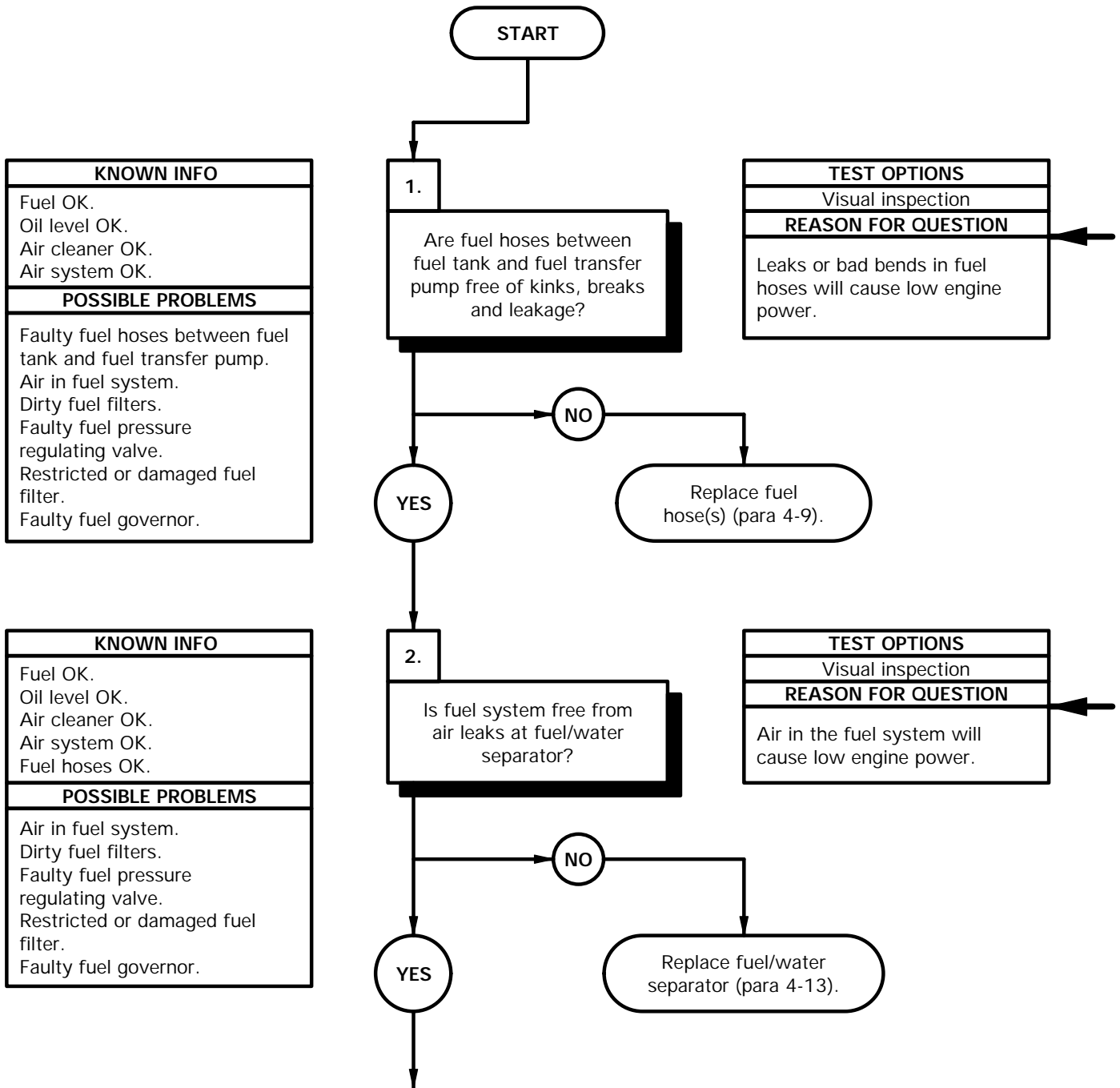

- (1) Raise cab (TM 9-2320-365-10).
- (2) Check fuel tank and fuel transfer pump hoses for kinks, looseness, and leakage.
- (3) If fuel hoses are not free from kinks or leaks, replace fuel hose(s) (para 4-9).

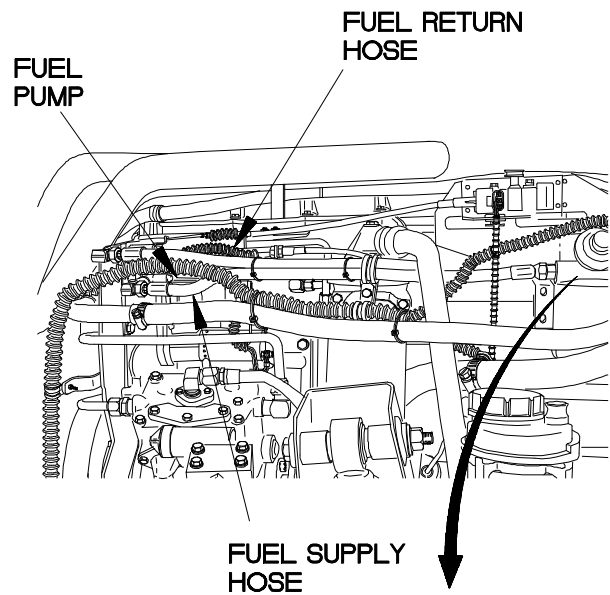

- (1) Push in fuel primer pump on fuel/water separator.
- (2) Pump fuel primer pump until resistance is felt to purge air from fuel system.
- (3) If no resistance is felt, replace fuel/water separator (para 4-13).

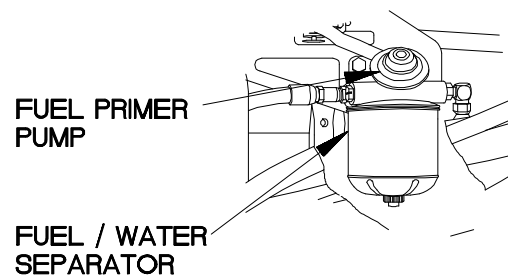

XBA1201B

a12. LOW ENGINE POWER (CONT)

KNOWN INFO
Fuel OK. Oil level OK. Air cleaner OK. Air system OK. Fuel hoses OK. No air in fuel system.
POSSIBLE PROBLEMS
Dirty fuel filters. Faulty fuel pressure regulating valve. Restricted or damaged fuel filter. Faulty fuel governor.

KNOWN INFO
Fuel OK. Oil level OK. Air cleaner OK. Air system OK. Fuel hoses OK. No air in fuel system. Fuel filters clean.
POSSIBLE PROBLEMS
Faulty fuel pressure regulating valve. Restricted or damaged fuel filter. Faulty fuel governor.

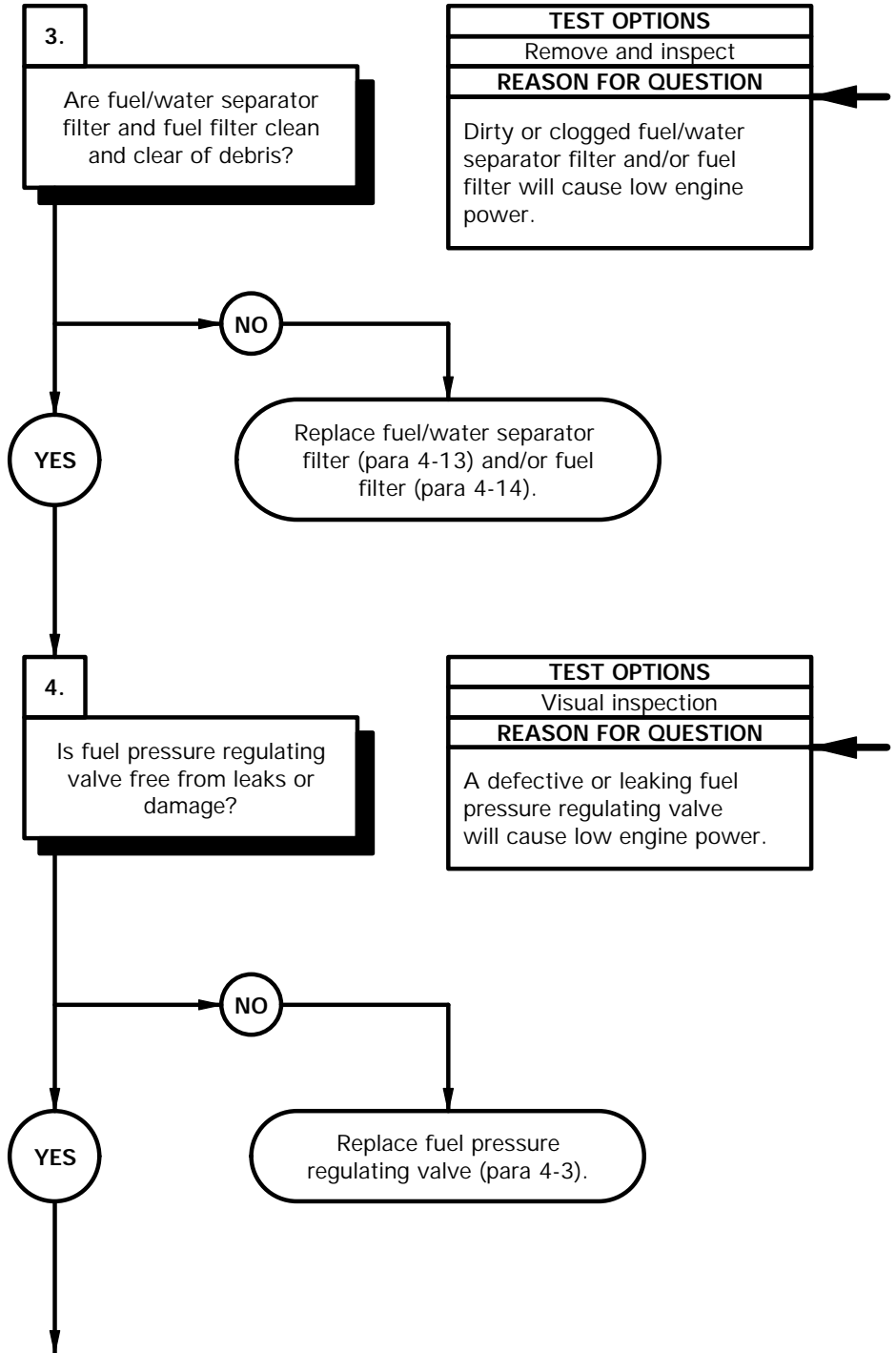

- (1) Check fuel/water separator filter and fuel filter for dirt and contamination.
- (2) Position drain pan under filter.
- (3) Remove filter element from base.
- (4) Inspect for clogs and debris.
- (5) If fuel water separator filter and/or fuel filter is clogged, replace fuel/water separator filter (para 4-13) and/or fuel filter (para 4-14).

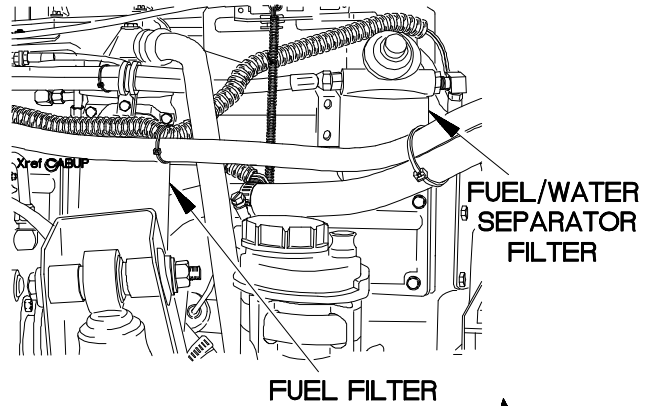

- (1) Check fuel pressure regulating valve for leaks or damage.
- (2) If fuel pressure regulating valve is damaged, replace fuel pressure regulating valve (para 4-3).

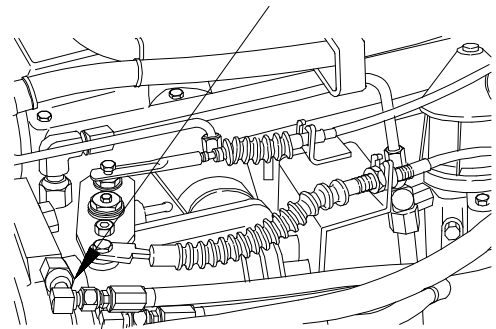
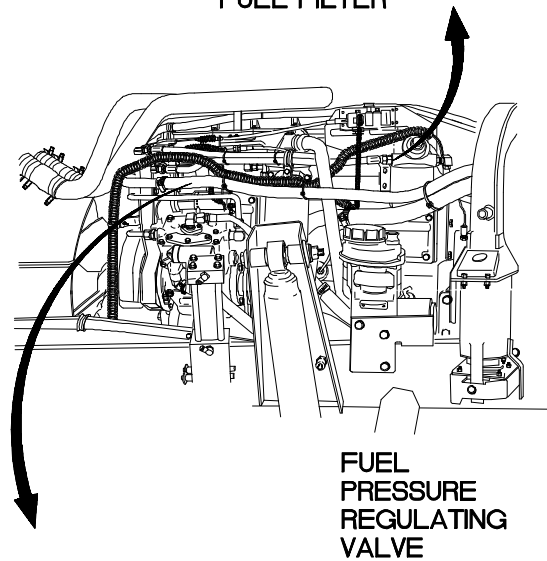

a12. LOW ENGINE POWER (CONT)

KNOWN INFO
Fuel OK. Oil level OK. Air cleaner OK. Air system OK. Fuel hoses OK. No air in fuel system. Fuel filters clean. Fuel pressure regulating valve OK.
POSSIBLE PROBLEMS
Faulty fuel governor. Restricted or damaged fuel filter.

5.

WARNING
Read **WARNING**
on following page.

Is outlet pressure of fuel transfer pump 39-58 psi?

TEST OPTIONS
Pressure Test or STE/ICE-R Test #50
REASON FOR QUESTION
Low fuel pressure from fuel transfer pump will cause low engine power.

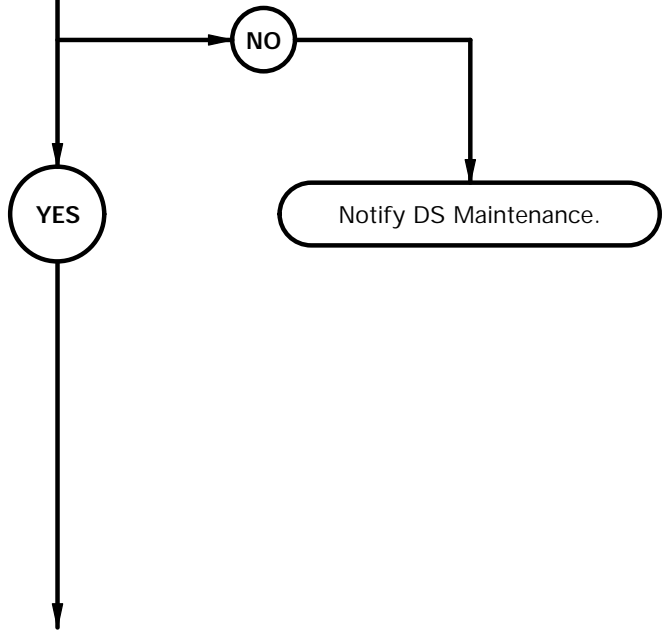

WARNING

Diesel fuel is flammable. If fuel is spilled, clean it up immediately. Failure to comply may result in serious injury or death to personnel.

PRESSURE TEST

- (1) Remove plug from adapter fitting on inlet side of fuel filter base.
- (2) Prepare STE/ICE-R Test #50 (TM 9-4910-571-12&P) to adapter fitting.
- (3) Start engine (TM 9-2320-365-10).
- (4) Perform STE/ICE-R Test #50 (TM 9-4910-571-12&P).
- (5) Raise idle speed to 2000 rpm for 10 seconds.
- (6) Pressure should read between 39 psi and 58 psi.
- (7) Record test results.
- (8) Shut down engine (TM 9-2320-365-10).
- (9) If pressure is below 39 psi, notify DS Maintenance.

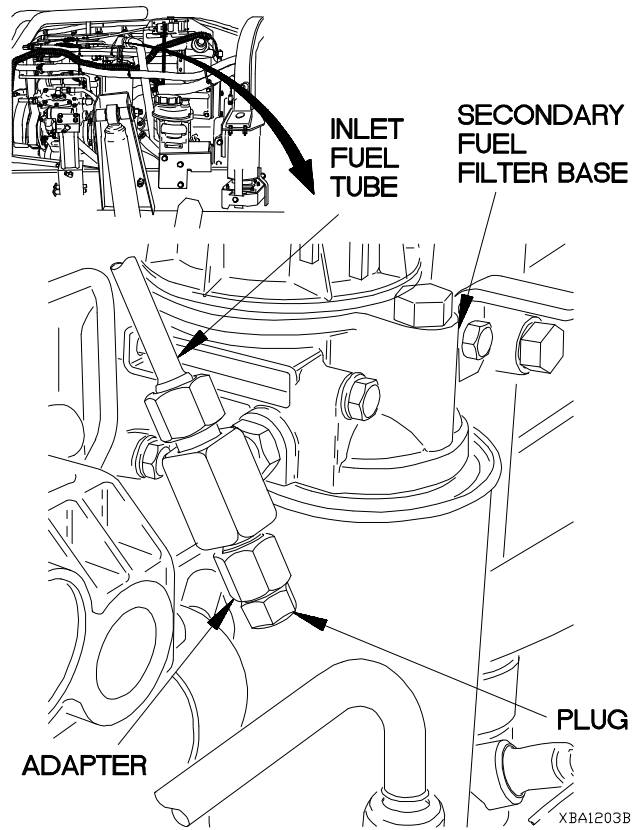

a12. LOW ENGINE POWER (CONT)

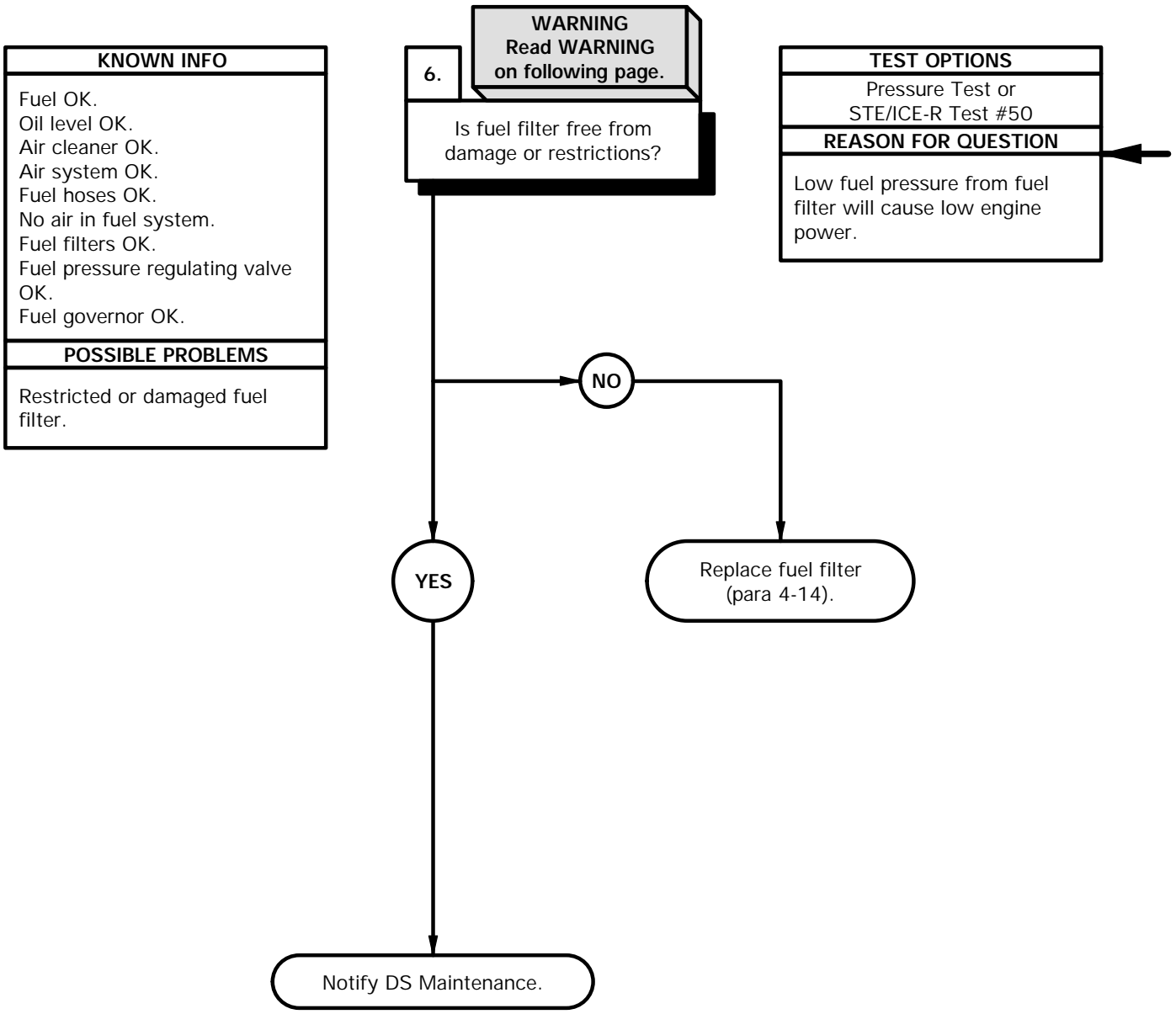

WARNING

Diesel fuel is flammable. If fuel is spilled, clean it up immediately. Failure to comply may result in serious injury or death to personnel.

PRESSURE TEST

- (1) Remove plug from tee fitting on outlet side of fuel filter base.
- (2) Remove adapter fitting from tee fitting on inlet side of fuel filter base.
- (3) Install plug in tee fitting on inlet side of fuel filter base.
- (4) Install adapter fitting in tee fitting on outlet side of fuel filter base.
- (5) Prepare STE/ICE-R Test #50 (TM 9-4910-571-12&P) to adapter fitting.
- (6) Start engine (TM 9-2320-365-10).
- (7) Perform STE/ICE-R Test #50 (TM 9-4910-571-12&P).
- (8) Raise idle speed to 2000 rpm for 10 seconds.
- (9) Pressure should read between 39 psi and 58 psi.
- (10) Record test results.
- (11) Shut down engine (TM 9-2320-365-10).
- (12) If test results indicate more than 10 psi pressure difference from results of step 5 of this fault, replace fuel filter (para 4-14).
- (13) Disconnect STE/ICE-R from adapter fitting.
- (14) Remove adapter fitting and preformed packing from tee fitting. Discard preformed packing.
- (15) Remove plug and preformed packing from tee fitting on inlet side of fuel filter base. Discard preformed packing.
- (16) Install preformed packing, adapter fitting, and plug in tee fitting on inlet side of fuel filter base.
- (17) Install preformed packing and plug in tee fitting on outlet side of fuel filter base.
- (18) Lower cab (TM 9-2320-365-10).

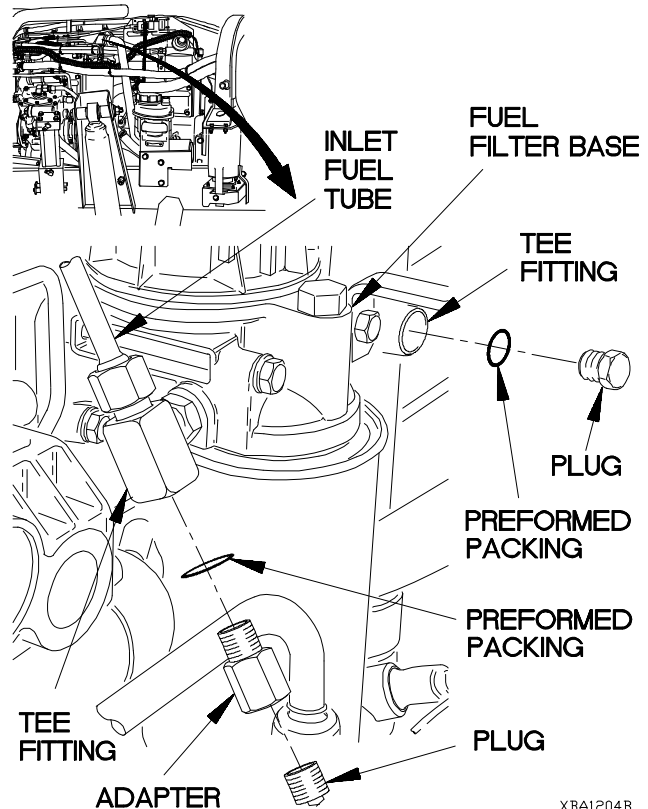

XBA1204B

2-13. FUEL SYSTEM TROUBLESHOOTING

This paragraph covers Fuel System Troubleshooting. The Fuel System Fault Index, Table 2-4, lists faults for the fuel system of the vehicle.

Table 2-4. Fuel System Fault Index

Fault No.	Description	Page
b1.	Engine Cranks But Does Not Start or Engine Stalls After Starting	2-102
b2.	Ether Starting Aid Does Not Operate	2-108
b3.	Fuel Consumption Too High	2-112
b4.	Accelerator Pedal Sticks	2-114

b1. ENGINE CRANKS BUT DOES NOT START OR ENGINE STALLS AFTER STARTING

INITIAL SETUP

Equipment Conditions

Engine shut down (TM 9-2320-365-10).
Cab Raised (TM 9-2320-365-10).

Materials/Parts

Ties, Cable, Plastic (Item 76, Appendix D)
Packing, Preformed (Item 157, Appendix G)
Packing, Preformed (2) (Item 180, Appendix G)

Tools and Special Tools

Tool Kit, Genl Mech (Item 44, Appendix C)
Pan, Drain (Item 24, Appendix C)

NOTE

If engine cranks but does not start perform Engine Troubleshooting (a2. Engine Cranks But Does Not Start) prior to beginning this task.

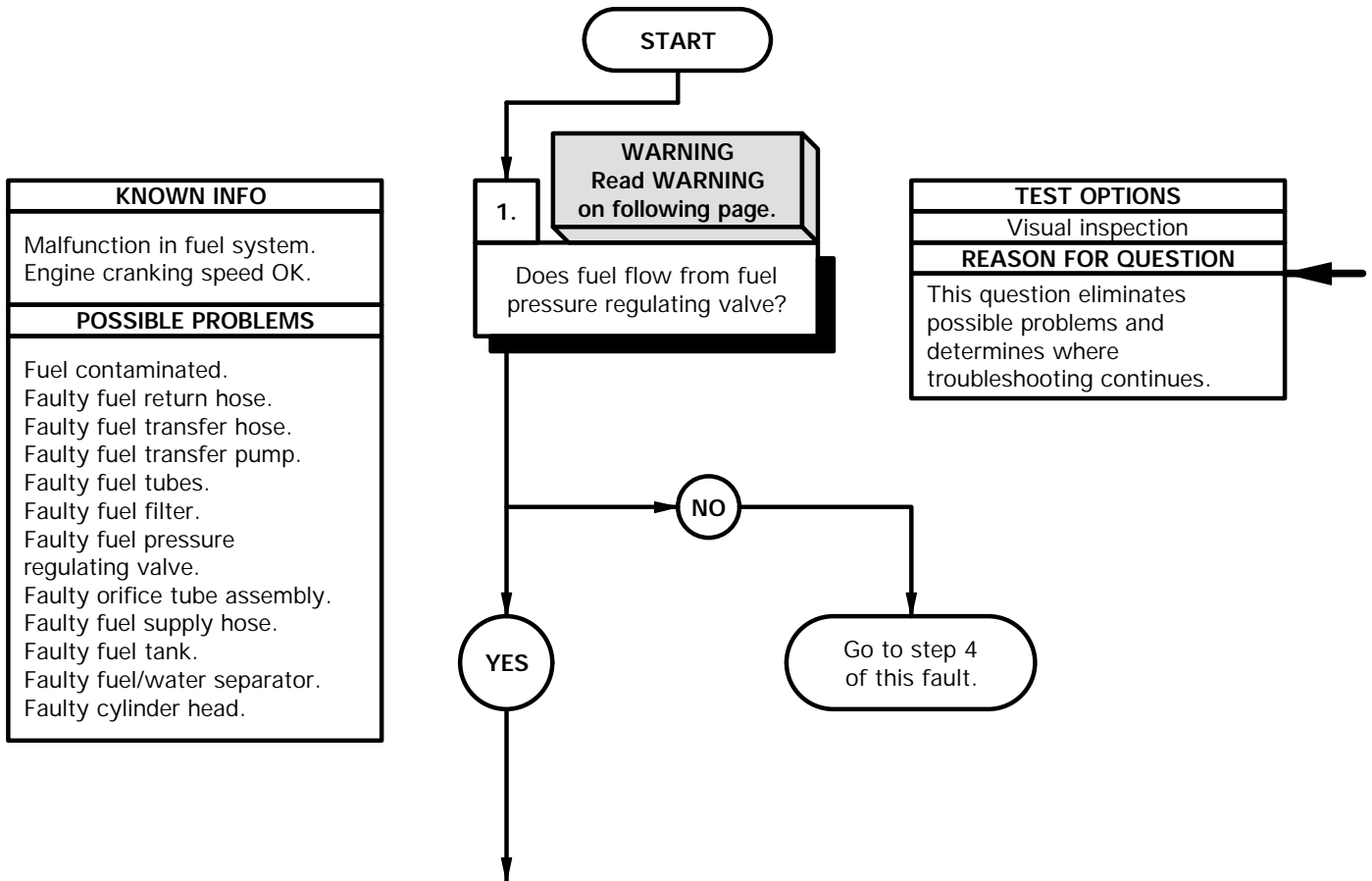

WARNING

Post signs that read "NO SMOKING WITHIN 50 FEET" when working with open fuel, fuel lines, or open fuel tanks. Failure to comply may result in injury to personnel or damage to equipment.

Diesel fuel is flammable. If fuel is spilled, clean up immediately. Failure to comply may result in serious injury or death to personnel.

NOTE

Remove plastic cable ties as required.

- (1) Perform Fuel System Bleeding (para 4-11).
- (2) If fuel flow is not present from fuel pressure regulating valve, go to step 4 of this fault.
- (3) If fuel flow is present, collect fuel sample.

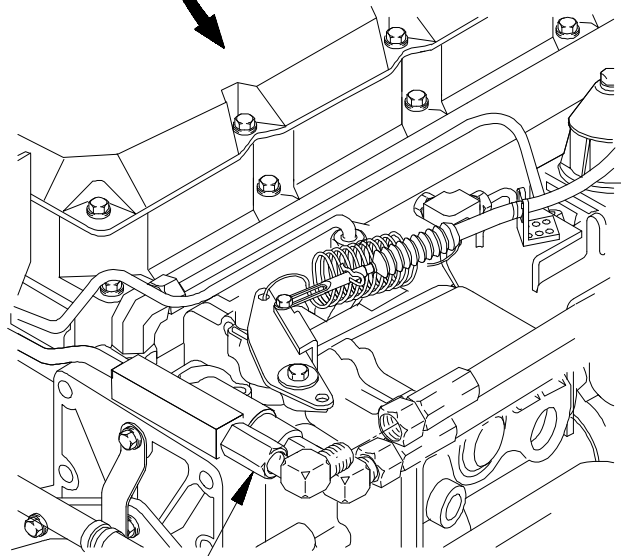
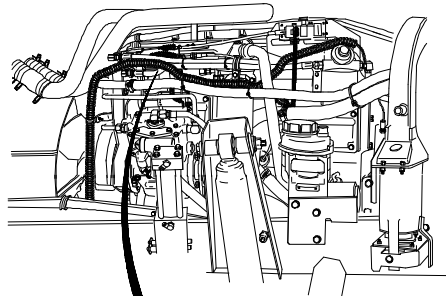

FUEL PRESSURE REGULATING VALVE

Xbb1001b

b1. ENGINE CRANKS BUT DOES NOT START OR ENGINE STALLS AFTER STARTING (CONT)

KNOWN INFO
Malfunction in fuel system. Engine cranking speed OK. Fuel transfer hose OK. Fuel tubes OK. Fuel filter OK. Fuel pressure regulating valve OK. Orifice tube assembly OK. Fuel supply hose OK. Fuel tank OK. Fuel/water separator OK. Cylinder head OK.
POSSIBLE PROBLEMS
Fuel contaminated. Faulty return hose. Faulty fuel transfer pump.

KNOWN INFO
Malfunction in fuel system. Engine cranking speed OK. Fuel transfer hose OK. Fuel tubes OK. Fuel filter OK. Fuel pressure regulating valve OK. Orifice tube assembly OK. Fuel supply hose OK. Fuel tank OK. Fuel/water separator OK. Cylinder head OK. Fuel contaminant free.
POSSIBLE PROBLEMS
Faulty return hose. Faulty fuel transfer pump.

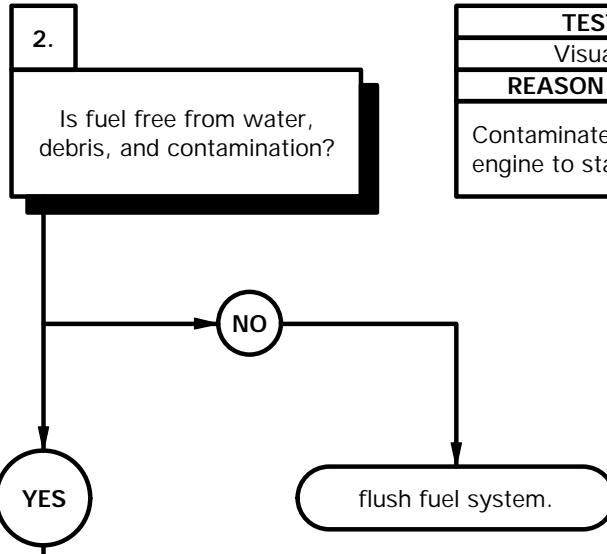

TEST OPTIONS
Visual inspection
REASON FOR QUESTION
Contaminated fuel may cause engine to stall after starting.

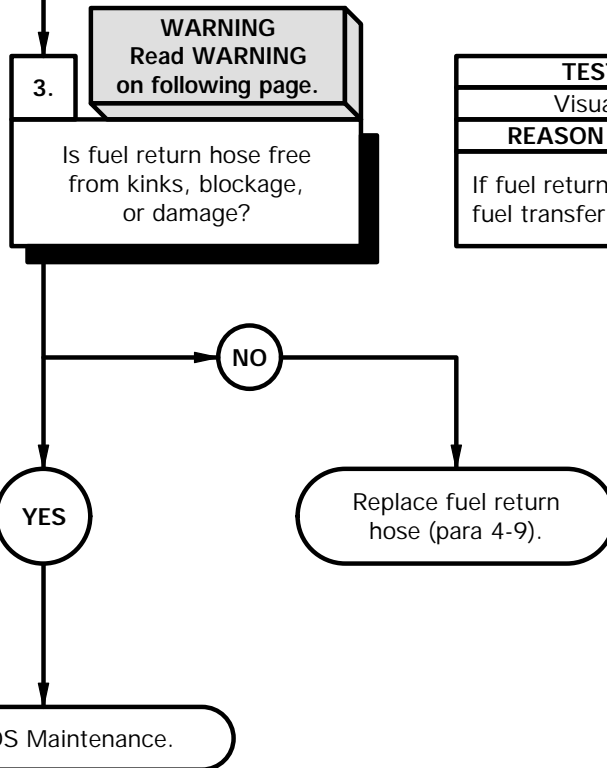

TEST OPTIONS
Visual inspection
REASON FOR QUESTION
If fuel return hose is OK, fuel transfer pump is faulty.

- (1) Check fuel sample from step 1 for water, debris, and contamination.
- (2) If fuel is not free from contamination, flush fuel tank, fuel hoses, and replace fuel filters.

WARNING

Compressed air used for cleaning purposes will not exceed 30 psi (207 Kpa). Use only with effective chip guarding and personal protective equipment (goggles/shield, gloves, etc). Failure to comply may result in injury to personnel.

Diesel fuel is flammable. If fuel is spilled, clean it up immediately. Failure to comply may result in serious injury or death to personnel.

- (1) Disconnect fuel return hose from fuel pressure regulating valve.
- (2) Disconnect fuel return hose from fuel tank.
- (3) Apply compressed air to one end of fuel return hose.
- (4) If compressed air does not flow freely through fuel return hose, replace fuel return hose (para 4-9).
- (5) If compressed air flows freely through fuel return hose, notify DS Maintenance.
- (6) Connect fuel return hose to fuel pressure regulating valve.
- (7) Connect fuel return hose to fuel tank.

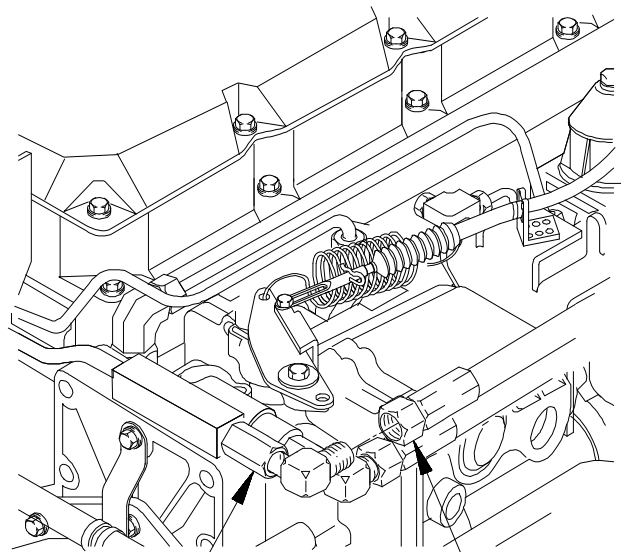

FUEL PRESSURE REGULATING VALVE

FUEL RETURN HOSE

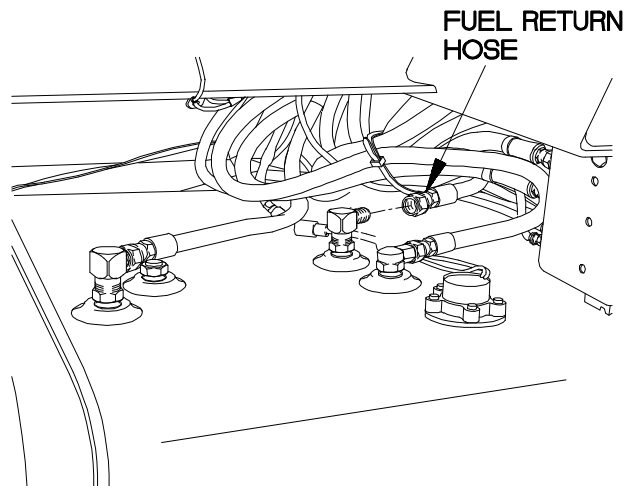

FUEL RETURN HOSE

X661002b

b1. ENGINE CRANKS BUT DOES NOT START OR ENGINE STALLS AFTER STARTING (CONT)

KNOWN INFO
Malfunction in fuel system. Engine cranking speed OK. Fuel return hose OK.
POSSIBLE PROBLEMS
Faulty fuel transfer hose. Faulty fuel transfer pump. Faulty fuel tubes. Faulty fuel filter. Faulty fuel pressure regulating valve. Faulty orifice tube assembly. Faulty fuel supply hose. Faulty fuel tank. Faulty fuel/water separator. Faulty cylinder head.

KNOWN INFO
Malfunction in fuel system. Engine cranking speed OK. Fuel return hose OK. Fuel supply hose OK. Fuel tank OK. Fuel/water separator OK.
POSSIBLE PROBLEMS
Faulty fuel transfer hose. Faulty fuel transfer pump. Faulty fuel tubes. Faulty fuel filter. Faulty fuel pressure regulating valve. Faulty orifice tube assembly. Faulty cylinder head.

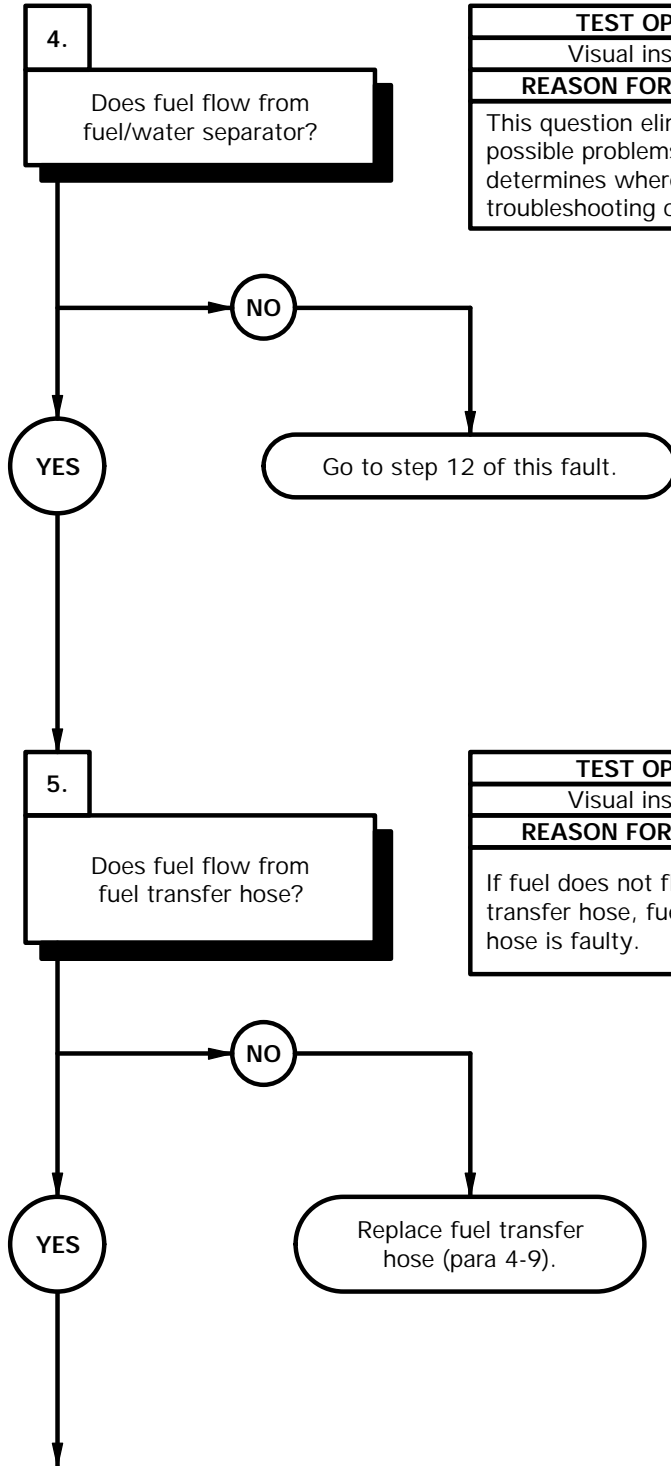

TEST OPTIONS
Visual inspection
REASON FOR QUESTION
This question eliminates possible problems and determines where troubleshooting continues.

TEST OPTIONS
Visual inspection
REASON FOR QUESTION
If fuel does not flow from fuel transfer hose, fuel transfer hose is faulty.

- (1) Disconnect fuel transfer hose from fuel/water separator.
- (2) Depress button on fuel/water separator as many times as necessary to get a steady stream of clear fuel.
- (3) If fuel does not flow from fuel/water separator, go to step 12 of this fault.
- (4) Connect fuel transfer hose to fuel/water separator.

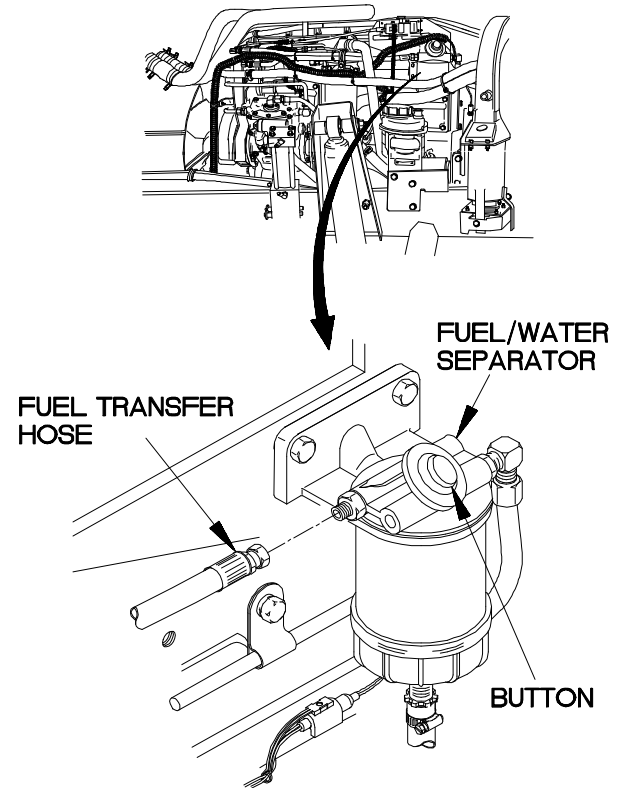

- (1) Disconnect fuel transfer hose from fuel transfer pump.
- (2) Depress button on fuel/water separator as many times as necessary to get a steady stream of clear fuel.
- (3) If fuel does not flow from fuel transfer hose, replace fuel transfer hose (para 4-9).
- (4) Connect fuel transfer hose to fuel transfer pump.

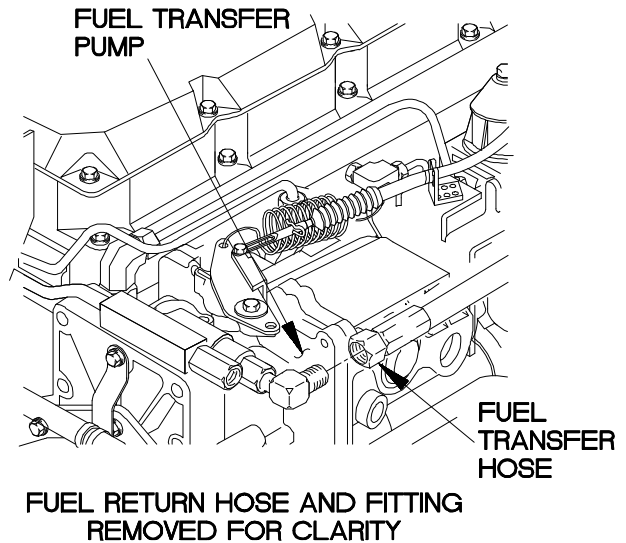

Xbb1003b

b1. ENGINE CRANKS BUT DOES NOT START OR ENGINE STALLS AFTER STARTING (CONT)

KNOWN INFO
Malfunction in fuel system. Engine cranking speed OK. Fuel return hose OK. Fuel supply hose OK. Fuel tank OK. Fuel/water separator OK. Fuel transfer hose OK.
POSSIBLE PROBLEMS
Faulty fuel transfer pump. Faulty fuel tubes. Faulty fuel filter. Faulty fuel pressure regulating valve. Faulty orifice tube assembly. Faulty cylinder head.

KNOWN INFO
Malfunction in fuel system. Engine cranking speed OK. Fuel return hose OK. Fuel supply hose OK. Fuel tank OK. Fuel/water separator OK. Fuel transfer hose OK. Fuel transfer pump OK.
POSSIBLE PROBLEMS
Faulty fuel tubes. Faulty fuel filter. Faulty fuel pressure regulating valve. Faulty orifice tube assembly. Faulty cylinder head.

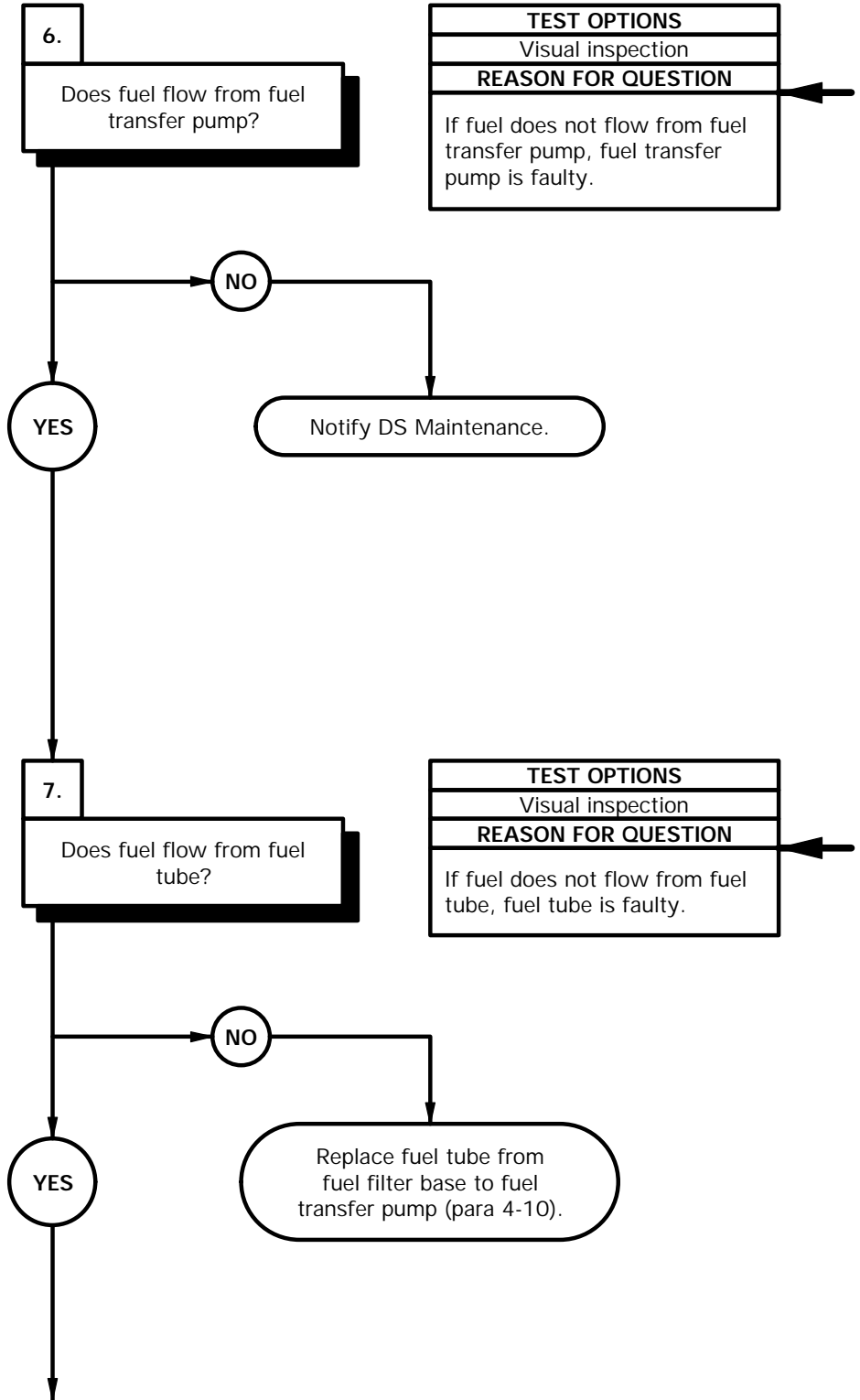

- (1) Disconnect fuel tube from fuel transfer pump. discard preformed packing.
- (2) Depress button on fuel/water separator as many times as necessary to get a steady stream of clear fuel.
- (3) If fuel does not flow from fuel transfer pump, notify DS Maintenance.
- (4) Install preformed packing and fuel tube on fuel transfer pump.

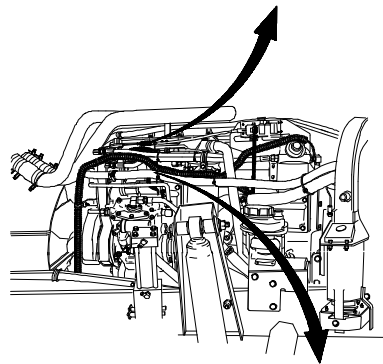
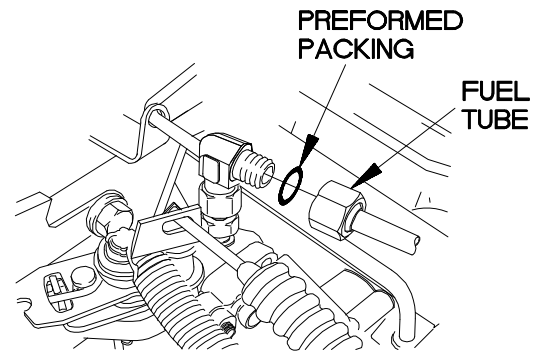

- (1) Remove plug from adapter fitting on inlet side of fuel filter base.
- (2) Depress button on fuel/water separator as many times as necessary to get a steady stream of clear fuel.
- (3) If fuel does not flow from fuel tube, replace fuel tube from fuel filter base to fuel transfer pump (para 4-10).
- (4) Install plug in adapter fitting on inlet side of fuel filter base.

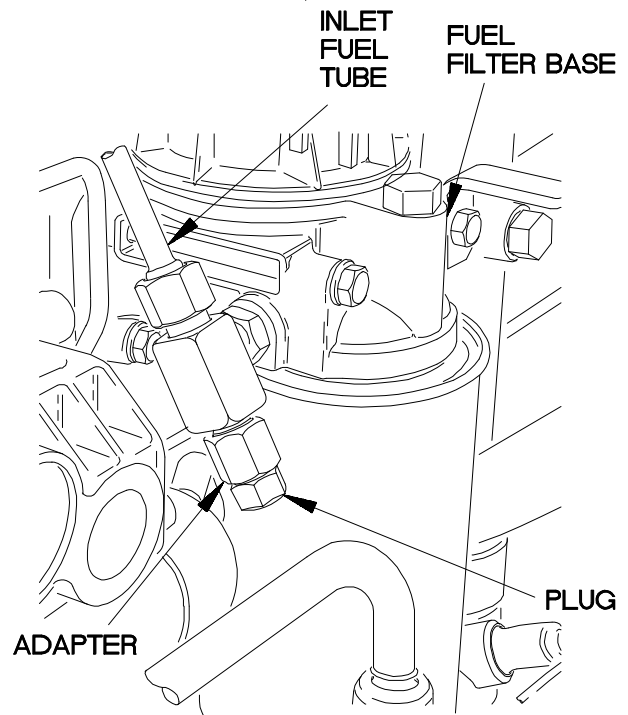

Xbb1004b

b1. ENGINE CRANKS BUT DOES NOT START OR ENGINE STALLS AFTER STARTING (CONT)

KNOWN INFO
Malfunction in fuel system. Engine cranking speed OK. Fuel return hose OK. Fuel supply hose OK. Fuel tank OK. Fuel/water separator OK. Fuel transfer pump OK. Fuel transfer hose OK.
POSSIBLE PROBLEMS
Faulty fuel filter. Faulty fuel tube. Faulty fuel pressure regulating valve. Faulty orifice tube assembly. Faulty cylinder head.

KNOWN INFO
Malfunction in fuel system. Engine cranking speed OK. Fuel return hose OK. Fuel supply hose OK. Fuel tank OK. Fuel/water separator OK. Fuel transfer hose OK. Fuel transfer pump OK. Fuel filter OK.
POSSIBLE PROBLEMS
Faulty fuel tube. Faulty fuel pressure regulating valve. Faulty orifice tube assembly. Faulty cylinder head.

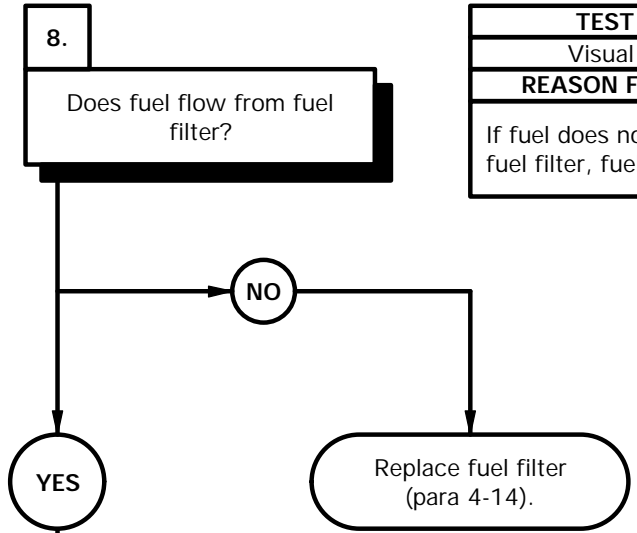

TEST OPTIONS
Visual inspection
REASON FOR QUESTION
If fuel does not flow from fuel filter, fuel filter is faulty.

TEST OPTIONS
Visual inspection
REASON FOR QUESTION
If fuel does not flow from fuel tube, fuel tube is faulty.

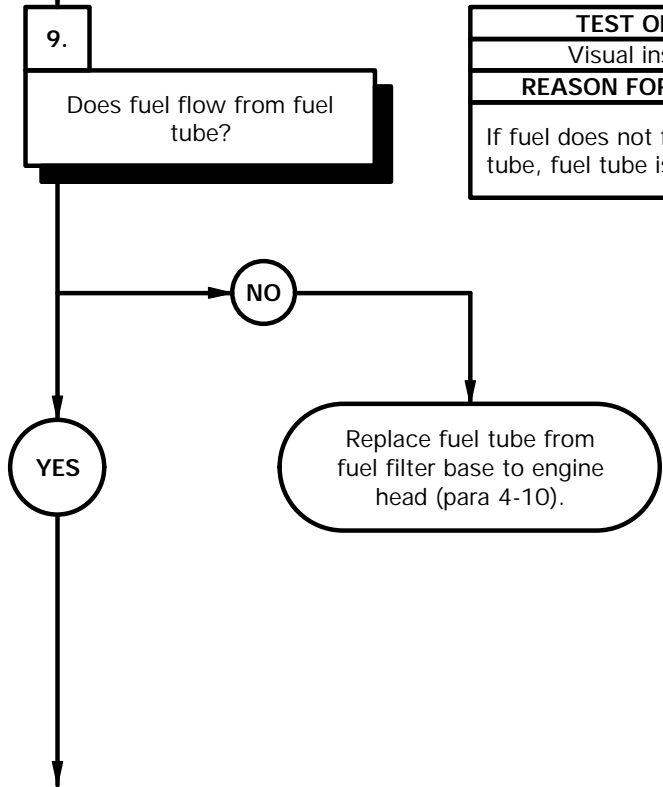

- (1) Remove plug and preformed packing from tee fitting on outlet side of fuel filter base. discard preformed packing.
- (2) Depress button on fuel/water separator as many times as necessary to get a steady stream of clear fuel.
- (3) If fuel does not flow from fuel filter, replace fuel filter (para 4-14).
- (4) Install preformed packing and plug in tee fitting on outlet side of fuel filter base.

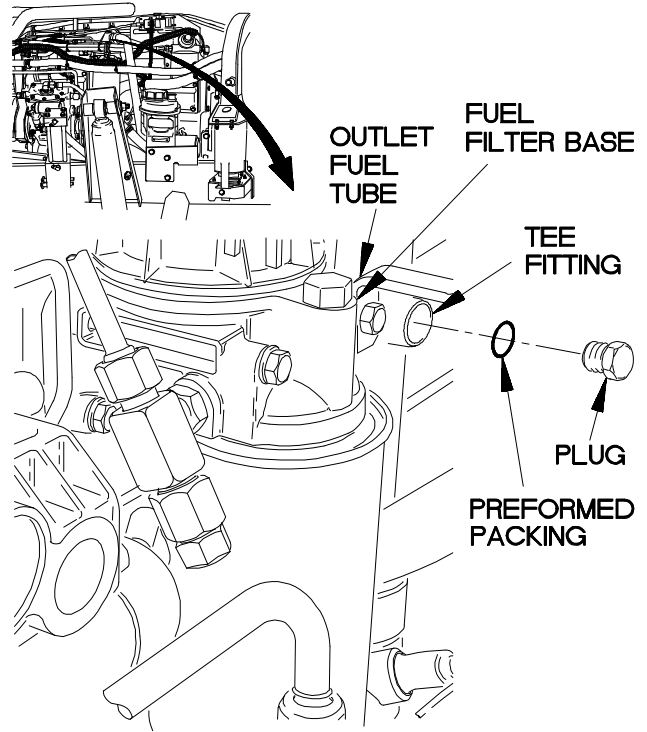

- (1) Disconnect fuel tube from cylinder head. Discard preformed packing.
- (2) Depress button on fuel/water separator as many times as necessary to get a steady stream of clear fuel.
- (3) If fuel does not flow from fuel tube, replace fuel tube from fuel filter base to cylinder head (para 4-10).
- (4) Install preformed packing and fuel tube on cylinder head.

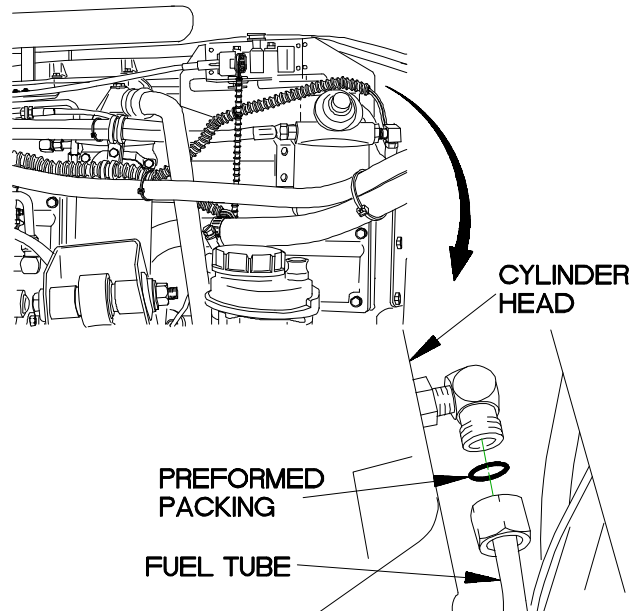

Xbb1005b

b1. ENGINE CRANKS BUT DOES NOT START OR ENGINE STALLS AFTER STARTING (CONT)

KNOWN INFO
Malfunction in fuel system. Engine cranking speed OK. Fuel return hose OK. Fuel supply hose OK. Fuel tank OK. Fuel/water separator OK. Fuel transfer pump OK. Fuel transfer hose OK. Fuel filter OK. Fuel tube OK.
POSSIBLE PROBLEMS
Faulty fuel pressure regulating valve. Faulty orifice tube assembly. Faulty cylinder head.

10.
Does fuel flow from orifice tube?

TEST OPTIONS
Visual inspection
REASON FOR QUESTION
If fuel flows from orifice tube, fuel pressure regulating valve is faulty.

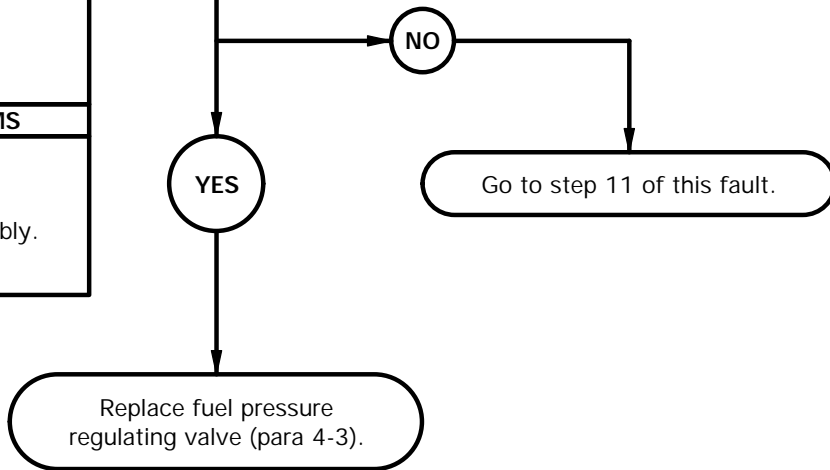

KNOWN INFO
Malfunction in fuel system. Engine cranking speed OK. Fuel return hose OK. Fuel supply hose OK. Fuel tank OK. Fuel/water separator OK. Fuel transfer pump OK. Fuel transfer hose OK. Fuel filter OK. Fuel tube OK. Fuel pressure regulating valve OK.
POSSIBLE PROBLEMS
Faulty orifice tube assembly. Faulty cylinder head.

11.
Does fuel flow from cylinder head?

TEST OPTIONS
Visual inspection
REASON FOR QUESTION
If fuel flow is not present, cylinder head is faulty. If fuel flow is present, orifice tube assembly is faulty.

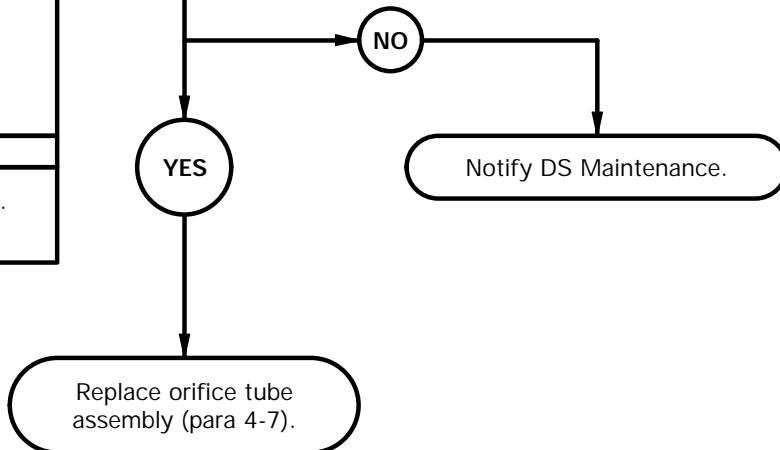

- (1) Remove fuel pressure regulating valve (para 4-3).
- (2) Depress button on fuel/water separator as many times as necessary to get a steady stream of clear fuel.
- (3) If fuel does not flow from orifice tube, go to step 11 of this fault.
- (4) If fuel flow is present, replace fuel pressure regulating valve (para 4-3).

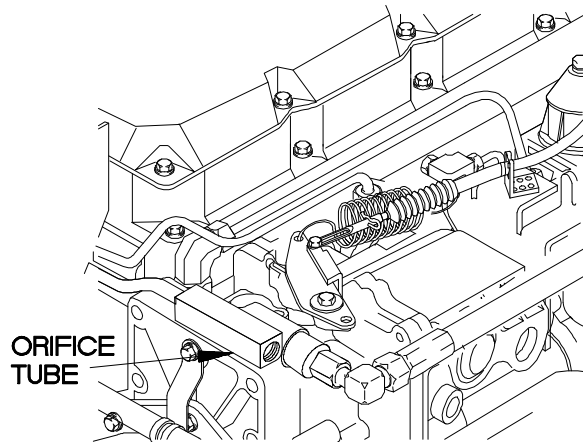

- (1) Remove orifice tube assembly (para 4-7).
- (2) Depress button on fuel/water separator as many times as necessary to get a steady stream of clear fuel.
- (3) If fuel does not flow from cylinder head, notify DS Maintenance.
- (4) If fuel flow is present, replace orifice tube assembly (para 4-7).
- (5) Install orifice tube assembly (para 4-7).
- (6) Install fuel pressure regulating valve (para 4-3).

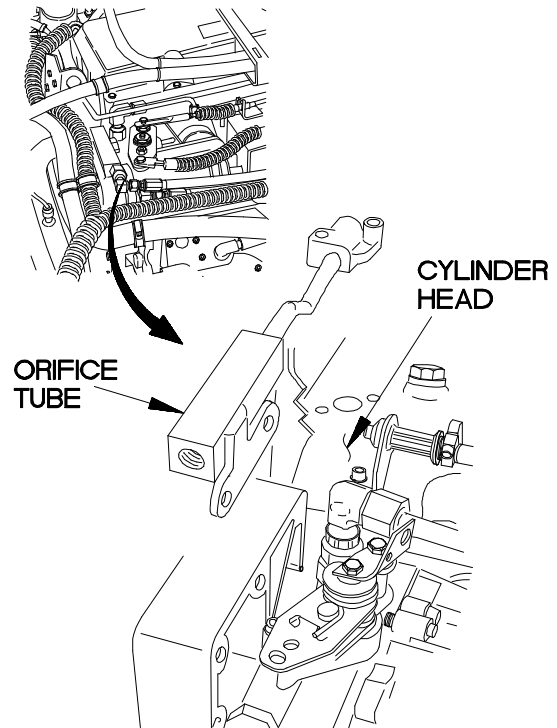

X661006b

b1. ENGINE CRANKS BUT DOES NOT START OR ENGINE STALLS AFTER STARTING (CONT)

KNOWN INFO
Malfunction in fuel system. Engine cranking speed OK. Fuel return hose OK. Fuel transfer pump OK. Fuel transfer hose OK. Fuel filter OK. Fuel tube OK. Fuel pressure regulating valve OK. Orifice tube assembly OK. Cylinder head OK.
POSSIBLE PROBLEMS
Faulty fuel supply hose. Faulty fuel tank. Faulty fuel/water separator.

KNOWN INFO
Malfunction in fuel system. Engine cranking speed OK. Fuel return hose OK. Fuel transfer pump OK. Fuel transfer hose OK. Fuel filter OK. Fuel tube OK. Fuel pressure regulating valve OK. Orifice tube assembly OK. Cylinder head OK. Fuel supply hose OK.
POSSIBLE PROBLEMS
Faulty fuel tank. Faulty fuel/water separator.

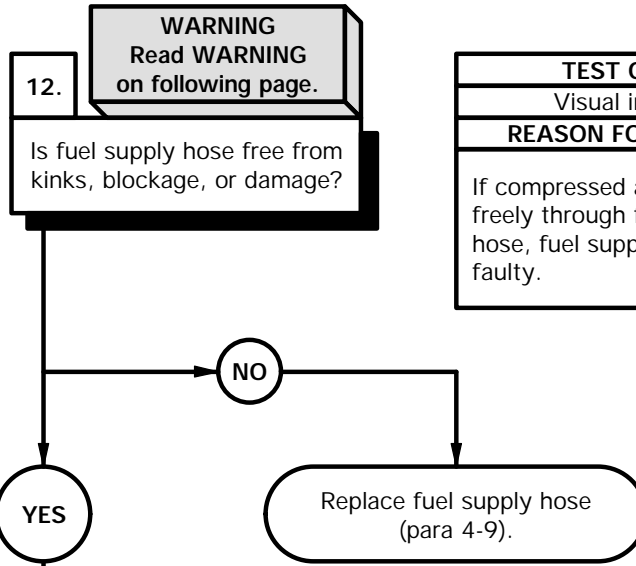

TEST OPTIONS
Visual inspection
REASON FOR QUESTION
If compressed air does not flow freely through fuel supply hose, fuel supply hose is faulty.

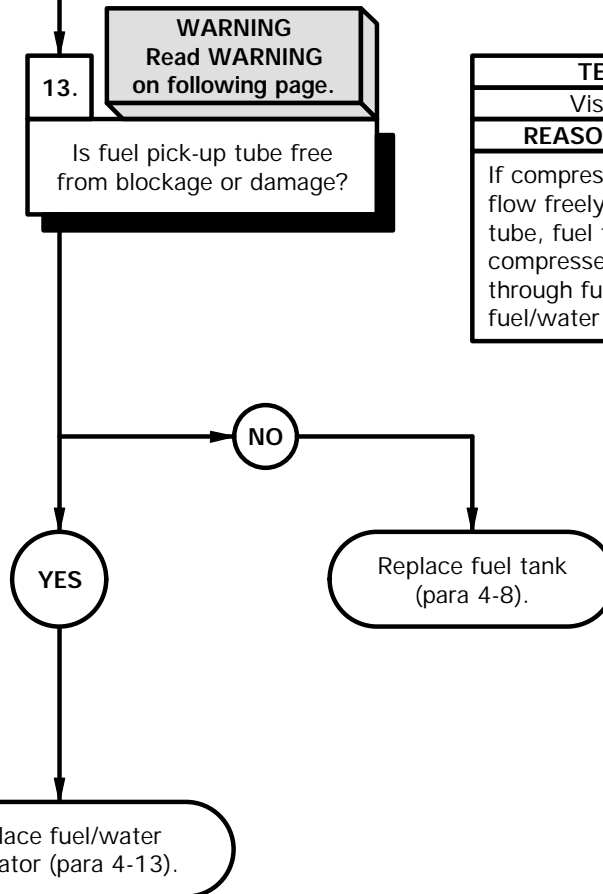

TEST OPTIONS
Visual inspection
REASON FOR QUESTION
If compressed air does not flow freely through fuel pick-up tube, fuel tank is faulty. If compressed air flows freely through fuel pick-up tube, fuel/water separator is faulty.

WARNING

Compressed air used for cleaning purposes will not exceed 30 psi (207 Kpa). Use only with effective chip guarding and personal protective equipment (goggles/shield, gloves, etc). Failure to comply may result in injury to personnel.

- (1) Disconnect fuel supply hose from fuel/water separator.
- (2) Disconnect fuel supply hose from fuel tank.
- (3) Apply compressed air to one end of fuel supply hose.
- (4) If compressed air does not flow freely through fuel supply hose, replace fuel supply hose (para 4-9).
- (5) Connect fuel supply hose to fuel/water separator.

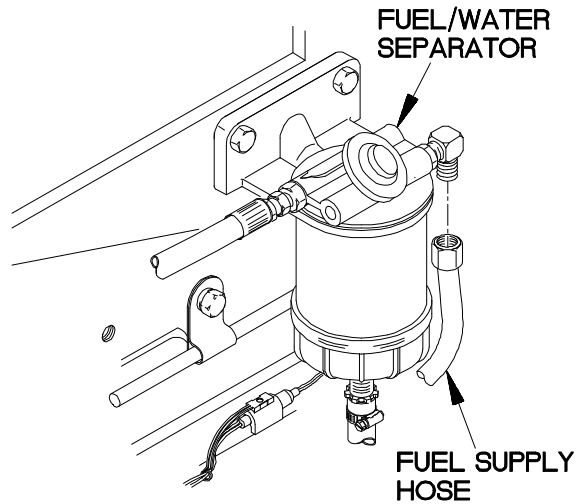

- (1) Remove fuel cap from fuel tank.
- (2) Apply compressed air to 90° degree fitting on fuel tank and listen for air bubbles in fuel tank.
- (3) If air flow is not present, replace fuel tank (para 4-8).
- (4) If air flow is present, replace fuel/water separator (para 4-13).
- (5) Connect fuel supply hose to fuel tank.
- (6) Install fuel cap on fuel tank.

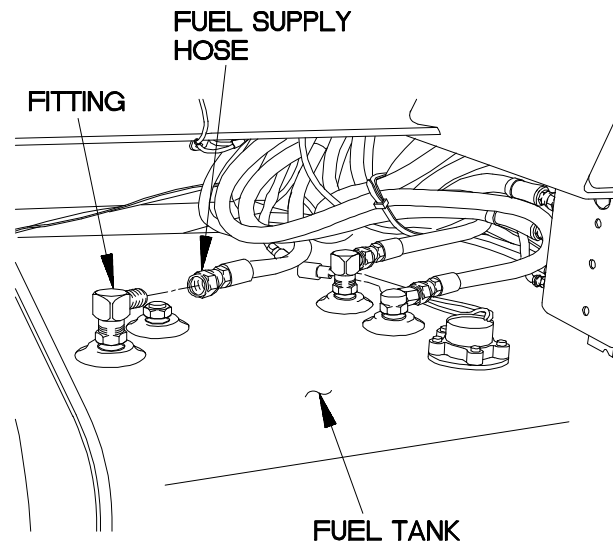

X661007b

b2. ETHER STARTING AID DOES NOT OPERATE
INITIAL SETUP
<p>Equipment Conditions Engine shut down (TM 9-2320-365-10). Spare tire lowered (TM 9-2320-365-10).</p>

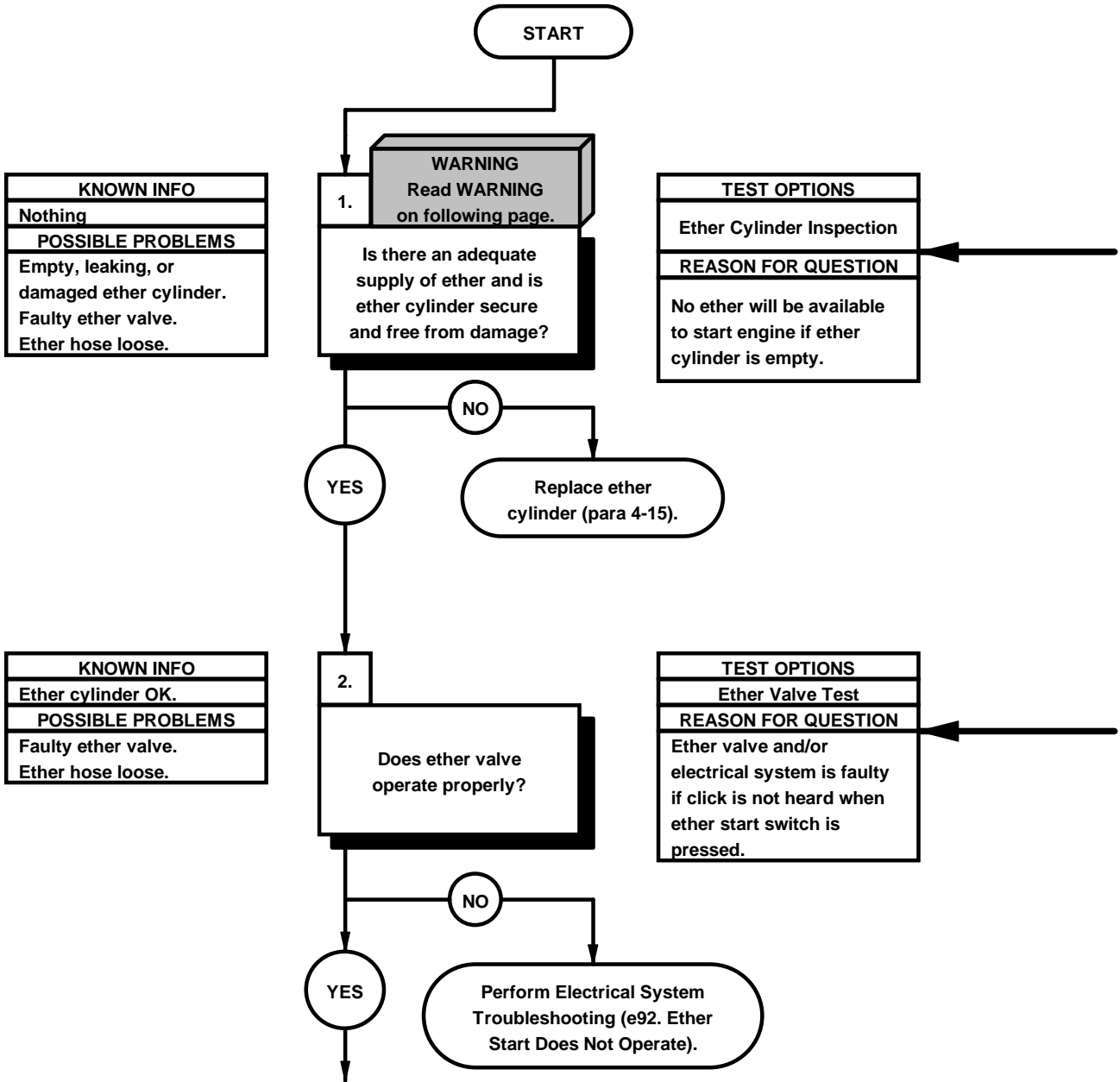

WARNING

Starting fluid is toxic and highly flammable. Container is pressurized. NEVER heat container and NEVER discharge starting fluid in confined areas or near open flame. Failure to comply may result in serious injury or death to personnel.

NOTE

Temperature at engine block must be below 100° F (38° C) before ether starting aid will work.

ETHER CYLINDER INSPECTION

- (1) Remove ether cylinder (para 4-15).
- (2) Shake ether cylinder to determine if ether is present.
- (3) Check ether cylinder for damage.
- (4) Install ether cylinder (para 4-15).

ETHER VALVE TEST

- (1) Position master power switch to on (TM 9-2320-365-10).
- (2) Press ether start switch (TM 9-2320-365-10) and listen for ether valve to click.
- (3) Position master power switch to off (TM 9-2320-365-10).

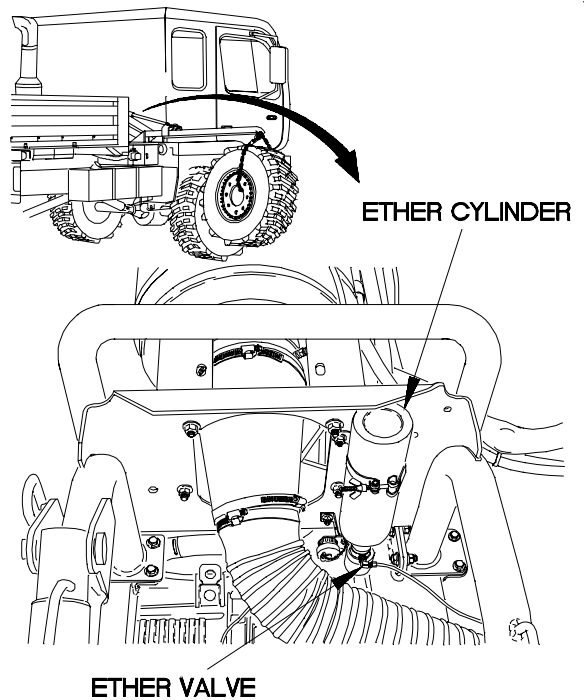

X2B0201A

b2. ETHER STARTING AID DOES NOT OPERATE (CONT)

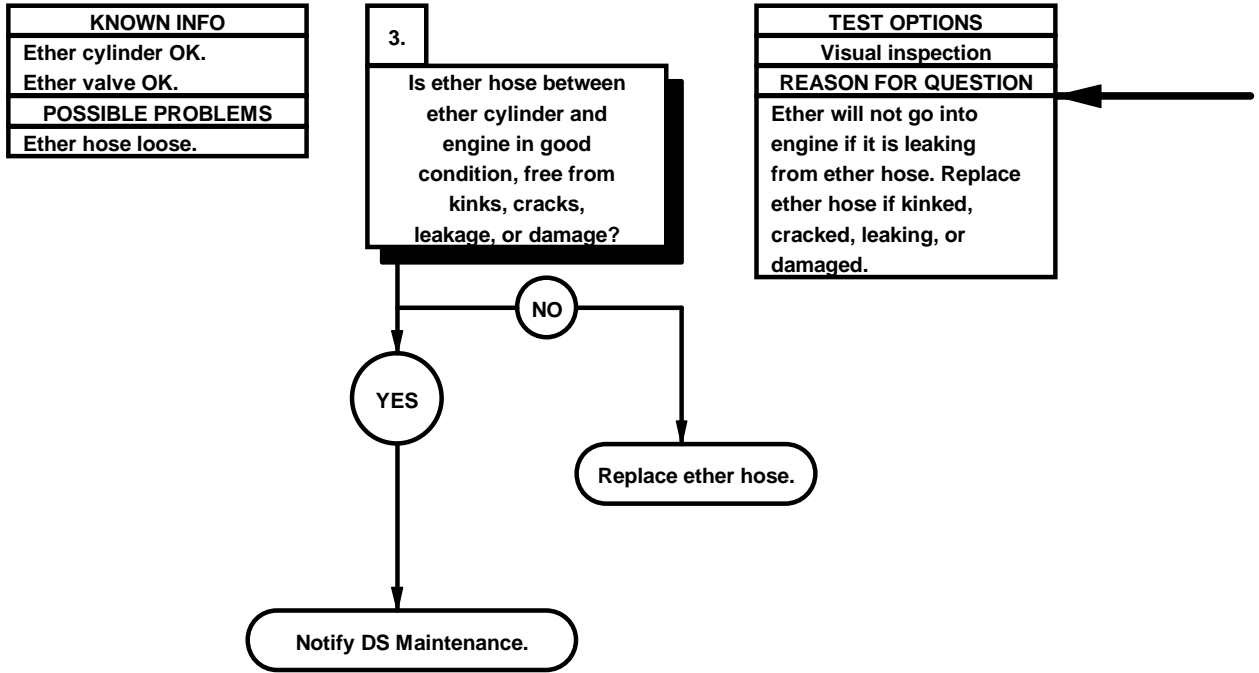

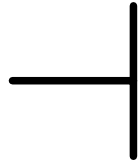

- (1) Raise cab (TM 9-2320-365-10).
- (2) Check ether hose between ether cylinder and engine for leaks and damage.
- (3) Lower cab (TM 9-2320-365-10).

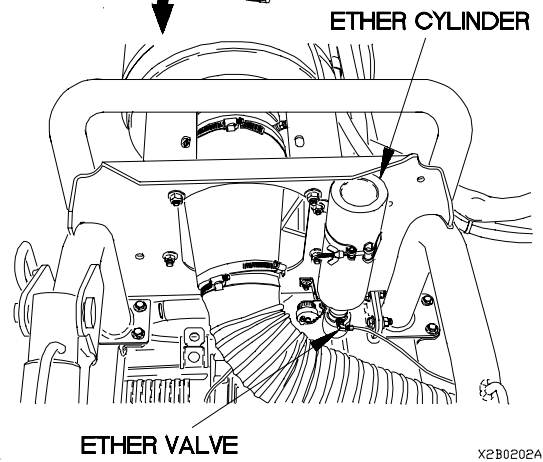
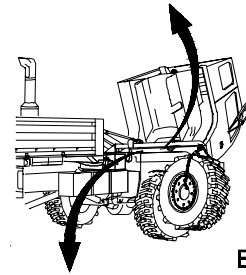
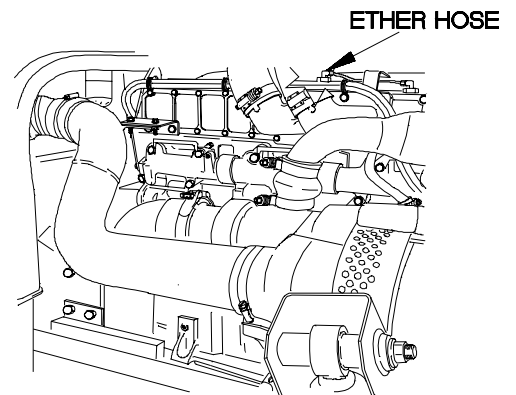

X2B0202A

b3. FUEL CONSUMPTION TOO HIGH
<p>INITIAL SETUP</p> <p>Equipment Conditions Engine shut down (TM 9-2320-365-10).</p>

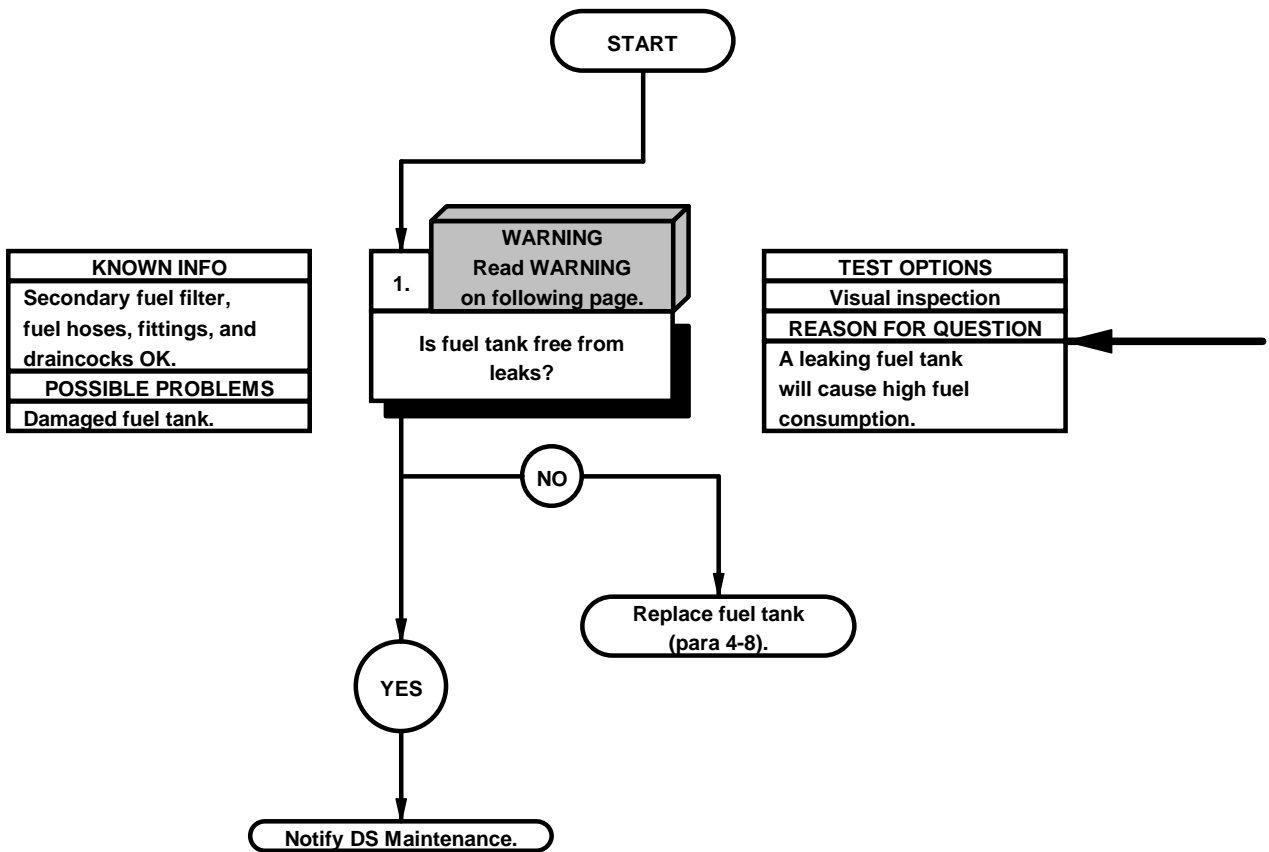

WARNING

Diesel fuel is flammable. If fuel is spilled, clean it up immediately. Failure to comply may result in serious injury or death to personnel.

- (1) Check fuel tank for damage, and for loose or missing mounting hardware.
- (2) If fuel tank is damaged, replace fuel tank (para 4-8).

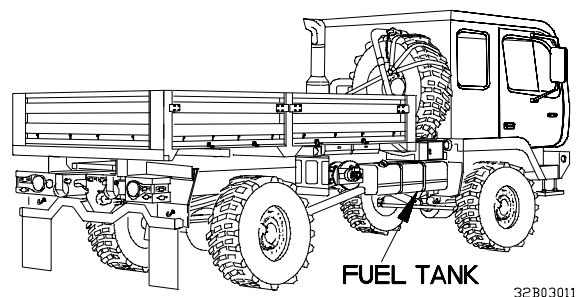

32B03011

b4. ACCELERATOR PEDAL STICKS	
INITIAL SETUP	
Equipment Conditions Engine shut down (TM 9-2320-365-10).	Tools and Special Tools Tool Kit, Genl Mech (Item 44, Appendix C)

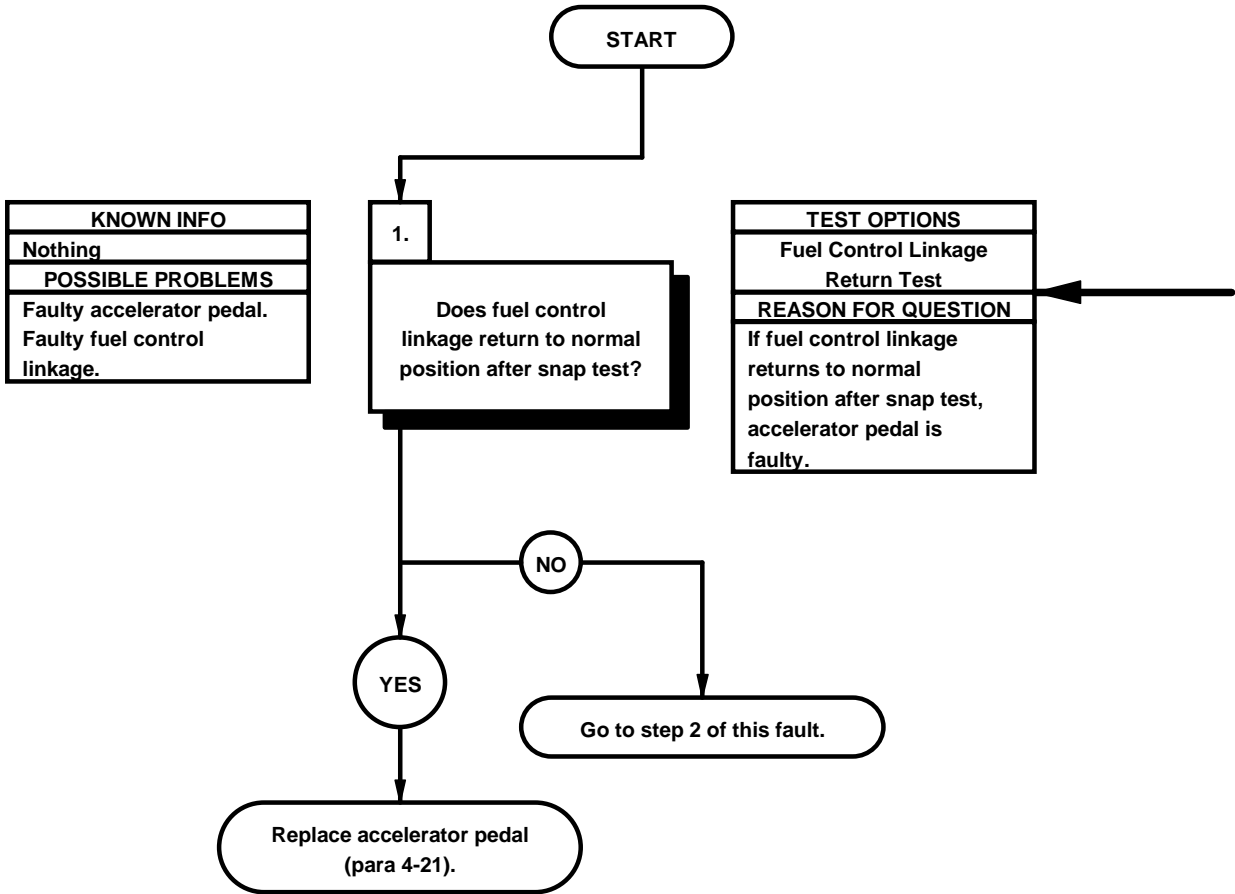

FUEL CONTROL LINKAGE RETURN TEST

- (1) Disconnect accelerator pedal from throttle control threaded rod (para 4-21).
- (2) Pull down throttle control threaded rod and release.
- (3) If throttle control threaded rod snapped back to normal position, replace accelerator pedal (para 4-21).
- (4) If throttle control threaded rod did not snap back to normal position, go to step 2 of this fault.
- (5) Connect accelerator pedal to throttle control threaded rod (para 4-21).

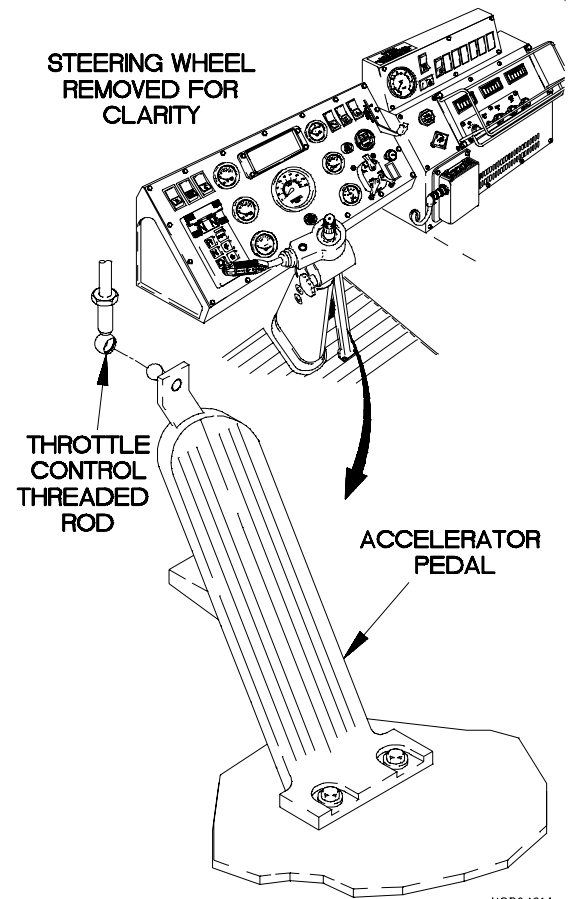

X2B0401A

b4. ACCELERATOR PEDAL STICKS (CONT)

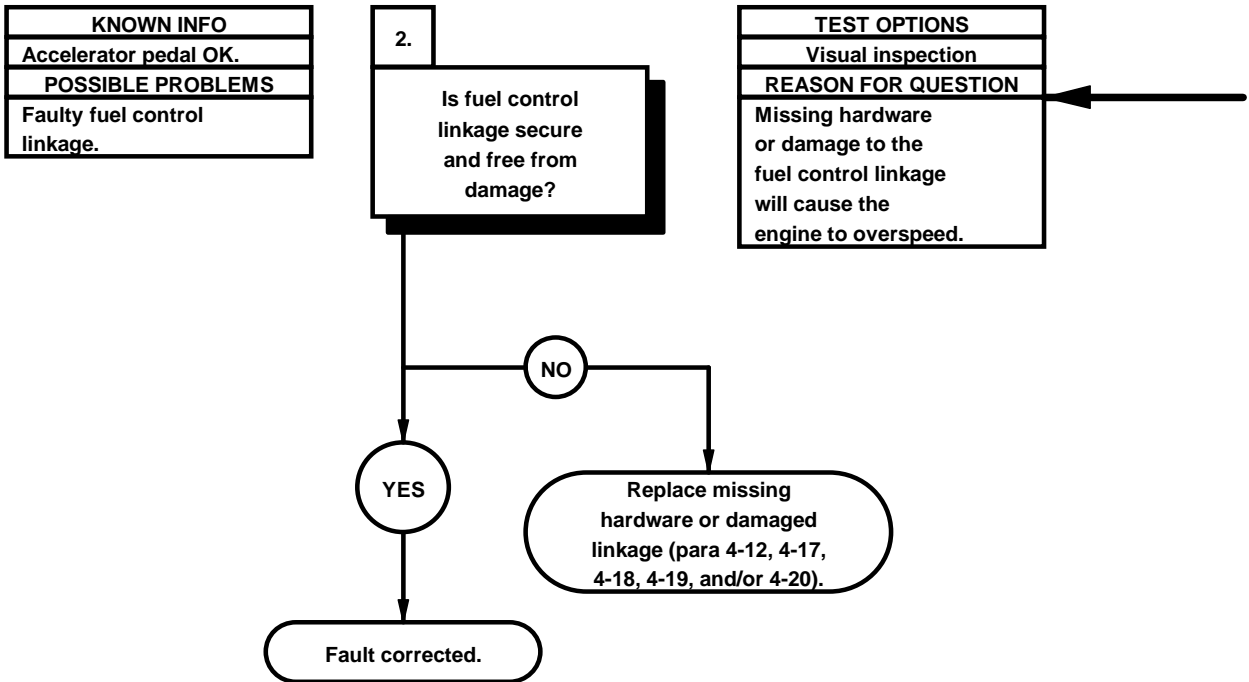

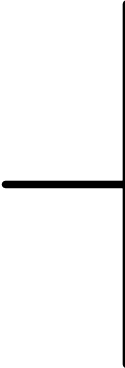
- 
- (1) Remove instrument panel assembly (para 7-15).
 - (2) Check fuel control linkage for improper assembly, missing hardware, damaged parts, and proper lubrication (para 4-17, 4-19, and 4-20).
 - (3) Install instrument panel assembly (para 7-15).
 - (4) Raise cab (TM 9-2320-365-10).
 - (5) Check fuel control linkage for improper assembly, missing hardware, and damaged parts (para 4-16, 4-12, and 4-18).
 - (6) Lower cab (TM 9-2320-365-10).

2-14. EXHAUST SYSTEM TROUBLESHOOTING

This paragraph covers Exhaust System Troubleshooting. The Exhaust System Fault Index, Table 2-5, lists faults for the exhaust system of the vehicle.

Table 2-5. Exhaust System Fault Index

Fault No.	Description	Page
c1.	Exhaust System Unusually Noisy or Vibrates Excessively During Engine Operation	2-120
c2.	Exhaust Fumes in Cab	2-124

c1. EXHAUST SYSTEM UNUSUALLY NOISY OR VIBRATES EXCESSIVELY DURING ENGINE OPERATION	
INITIAL SETUP	
Equipment Conditions Engine shut down (TM 9-2320-365-10). Cab raised (TM 9-2320-365-10).	Tools and Special Tools Tool Kit, Genl Mech (Item 44, Appendix C) Goggles, Industrial (Item 15, Appendix C)

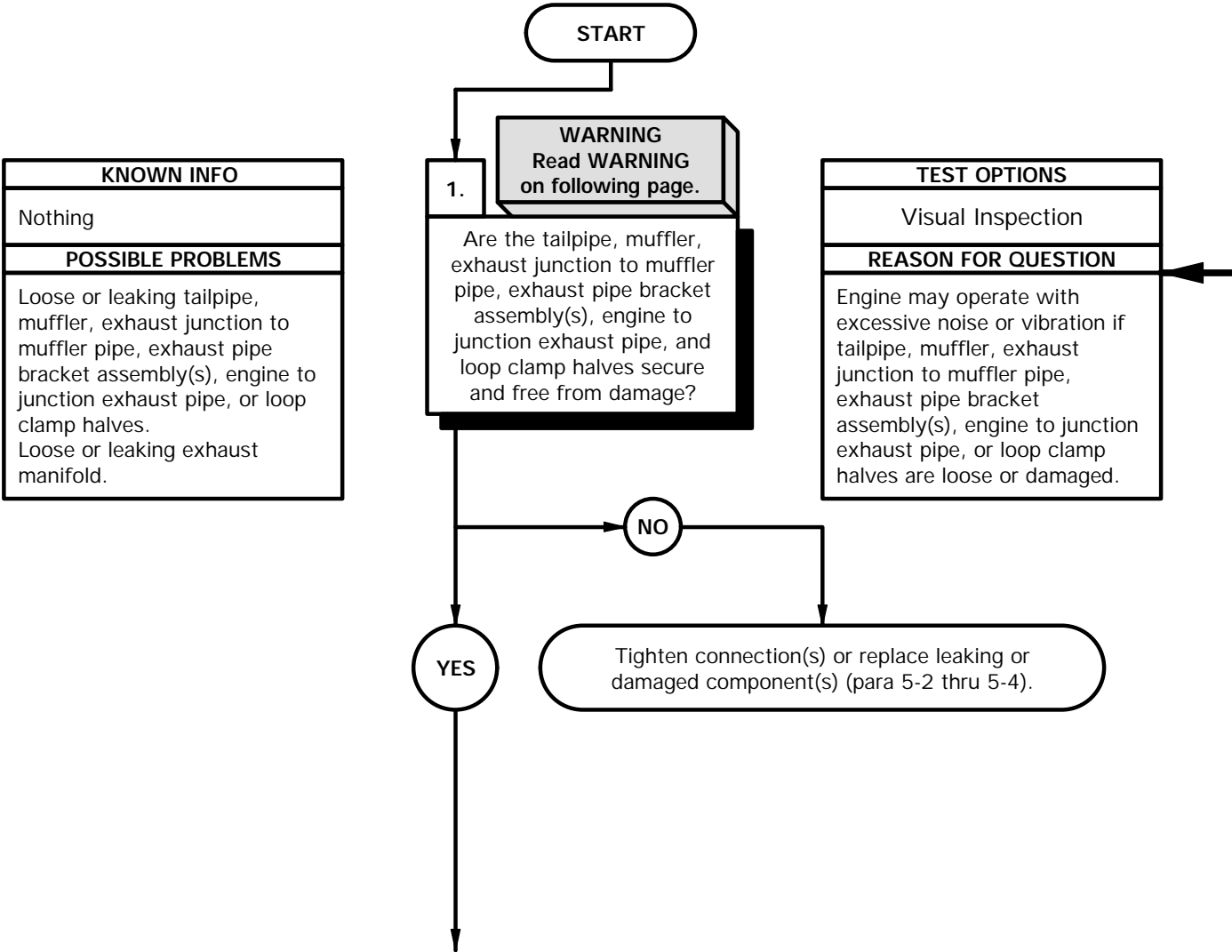

WARNING

Ensure exhaust system is cool before performing maintenance. Failure to comply may result in injury to personnel.

NOTE

Exhaust system component hardware has to be torqued. Refer to para 5-2 thru 5-4.

Check tailpipe, muffler, and exhaust pipes for loose connections and damage.

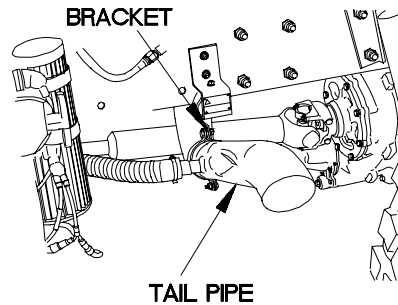
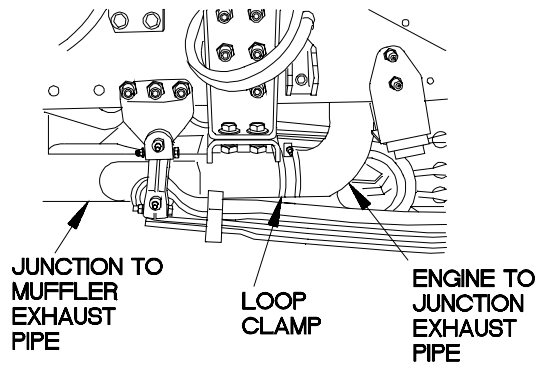
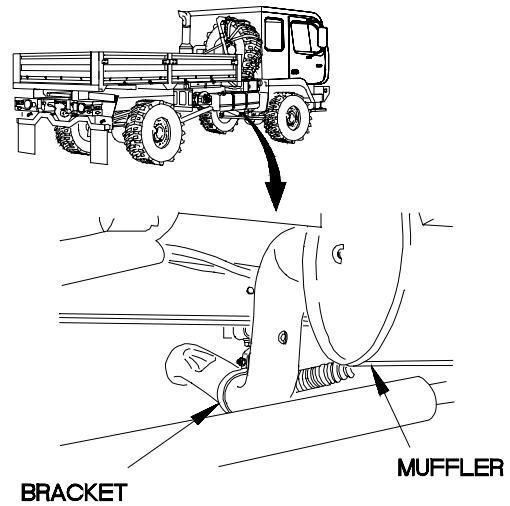

32C0101A

**c1. EXHAUST SYSTEM UNUSUALLY NOISY OR VIBRATES EXCESSIVELY DURING ENGINE OPERATION
(WITHOUT EXHAUST RESTRICTOR) (CONT)**

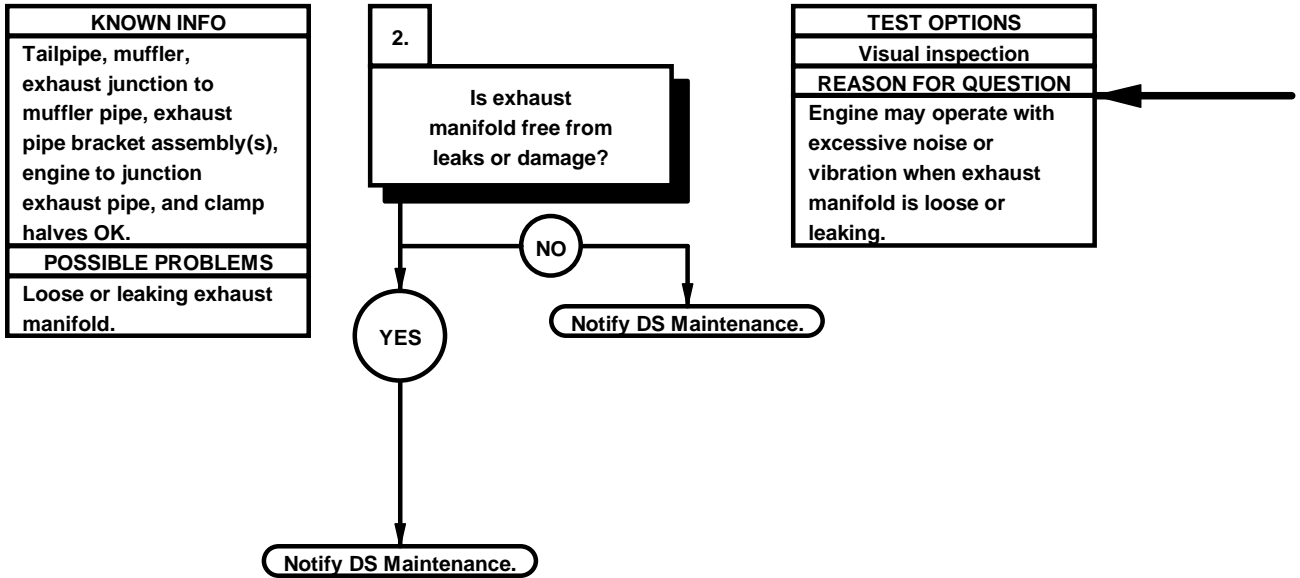

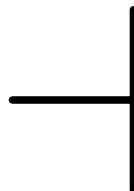

- (1) Start engine (TM 9-2320-365-10).
- (2) Check exhaust manifold for looseness or evidence of exhaust leakage.
- (3) Shut down engine (TM 9-2320-365-10).
- (4) Lower cab (TM 9-2320-365-10).

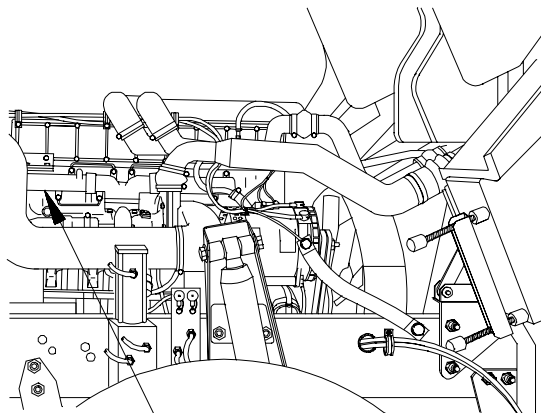

EXHAUST MANIFOLD

4B2C1BA-

c2. EXHAUST FUMES IN CAB
INITIAL SETUP Equipment Conditions Engine shut down (TM 9-2320-365-10).

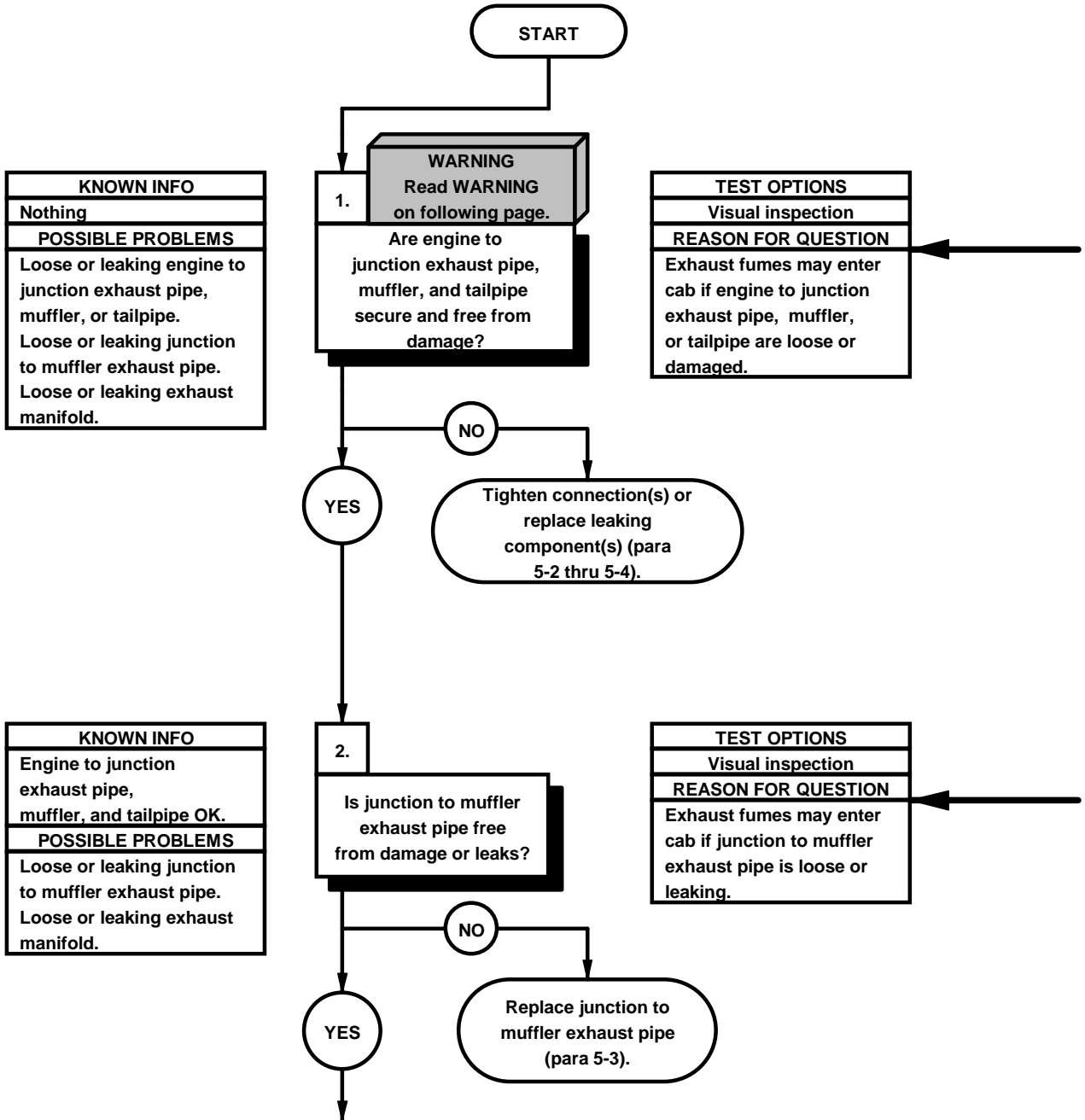

WARNING

Ensure exhaust system is cool before performing maintenance. Failure to comply may result in injury to personnel.

NOTE

Exhaust system component hardware has to be torqued. Refer to para 5-2 thru 5-4.

Check junction to muffler exhaust pipe, muffler, and tailpipe for loose connections and leaks.

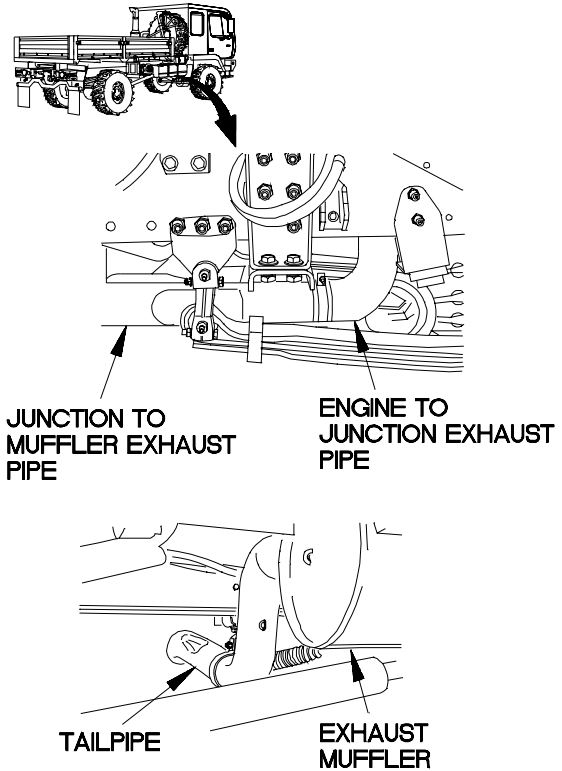

32C0201A

Check engine to junction exhaust pipe for loose connections or leaks.

c2. EXHAUST FUMES IN CAB (WITHOUT EXHAUST RESTRICTOR) (CONT)

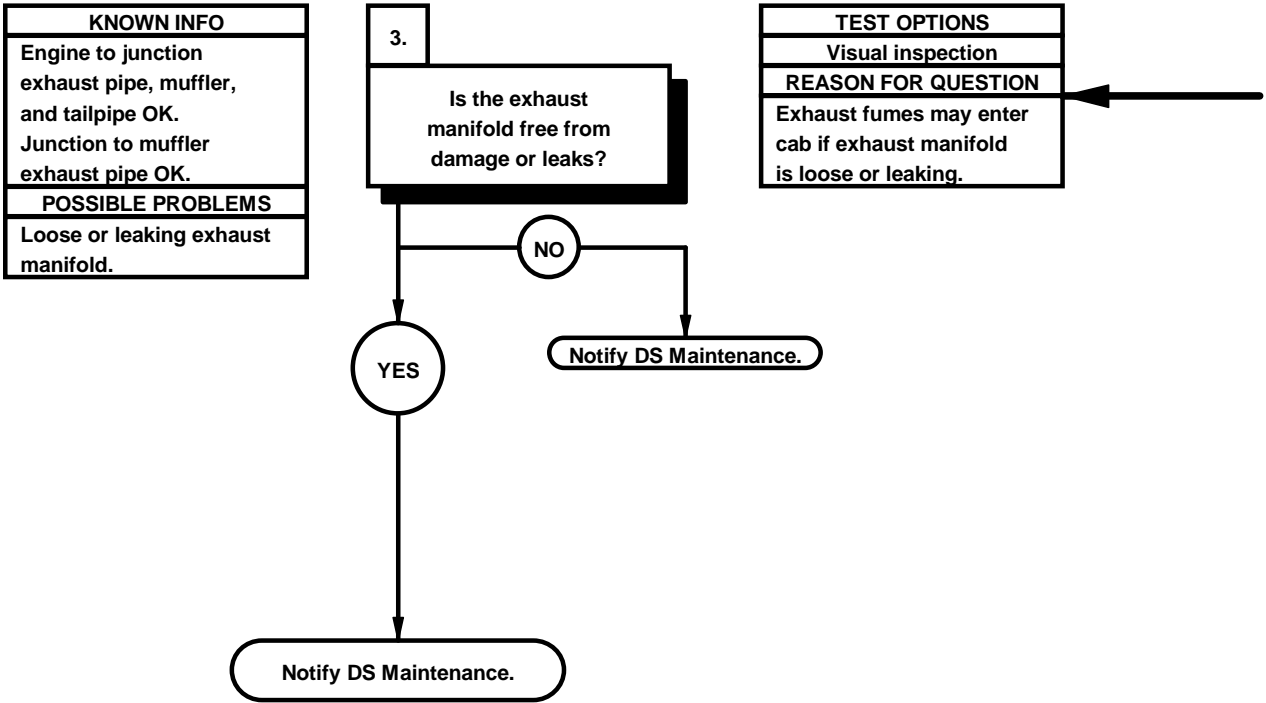

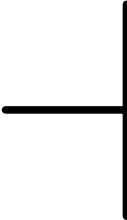
- 
- (1) Raise cab (TM 9-2320-365-10).
 - (2) Start engine (TM 9-2320-365-10).
 - (3) Check exhaust manifold for looseness or leaks.
 - (4) Shut down engine (TM 9-2320-365-10).
 - (5) Lower cab (TM 9-2320-365-10).

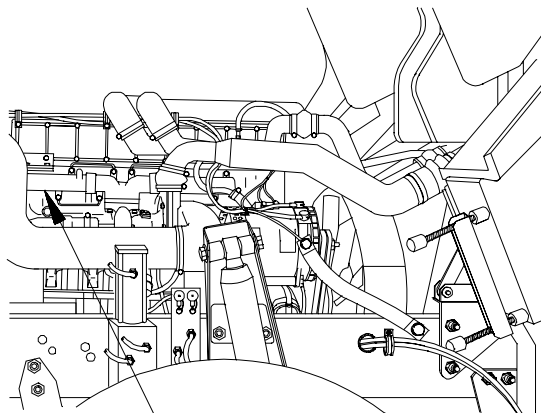

EXHAUST MANIFOLD

4B2C1BA-

2-15. COOLING SYSTEM TROUBLESHOOTING

This paragraph covers Cooling System Troubleshooting. The Cooling System Fault Index, Table 2-6, lists faults for the cooling system of the vehicle.

Table 2-6. Cooling System Fault Index

Fault No.	Description	Page
d1.	Engine Overheats	2-130
d2.	Oil in Cooling System	2-142
d3.	Loss of coolant	2-144

d1. ENGINE OVERHEATS

INITIAL SETUP

Equipment Conditions

Engine shut down (TM 9-2320-365-10).

Personnel Required

(2)

Tools and Special Tools

- Tool Kit, Genl Mech (Item 44, Appendix C)
- Test Kit, Radiator (Item 40.1, Appendix C)
- Pressure Tester, Radiator (Item 26, Appendix C)
- Pan, Drain (Item 24, Appendix C)
- Wrench, Torque, 0-200 lb-in. (Item 58, Appendix C)

NOTE

Perform Engine System Troubleshooting a9. Engine Overheats prior to beginning this task.

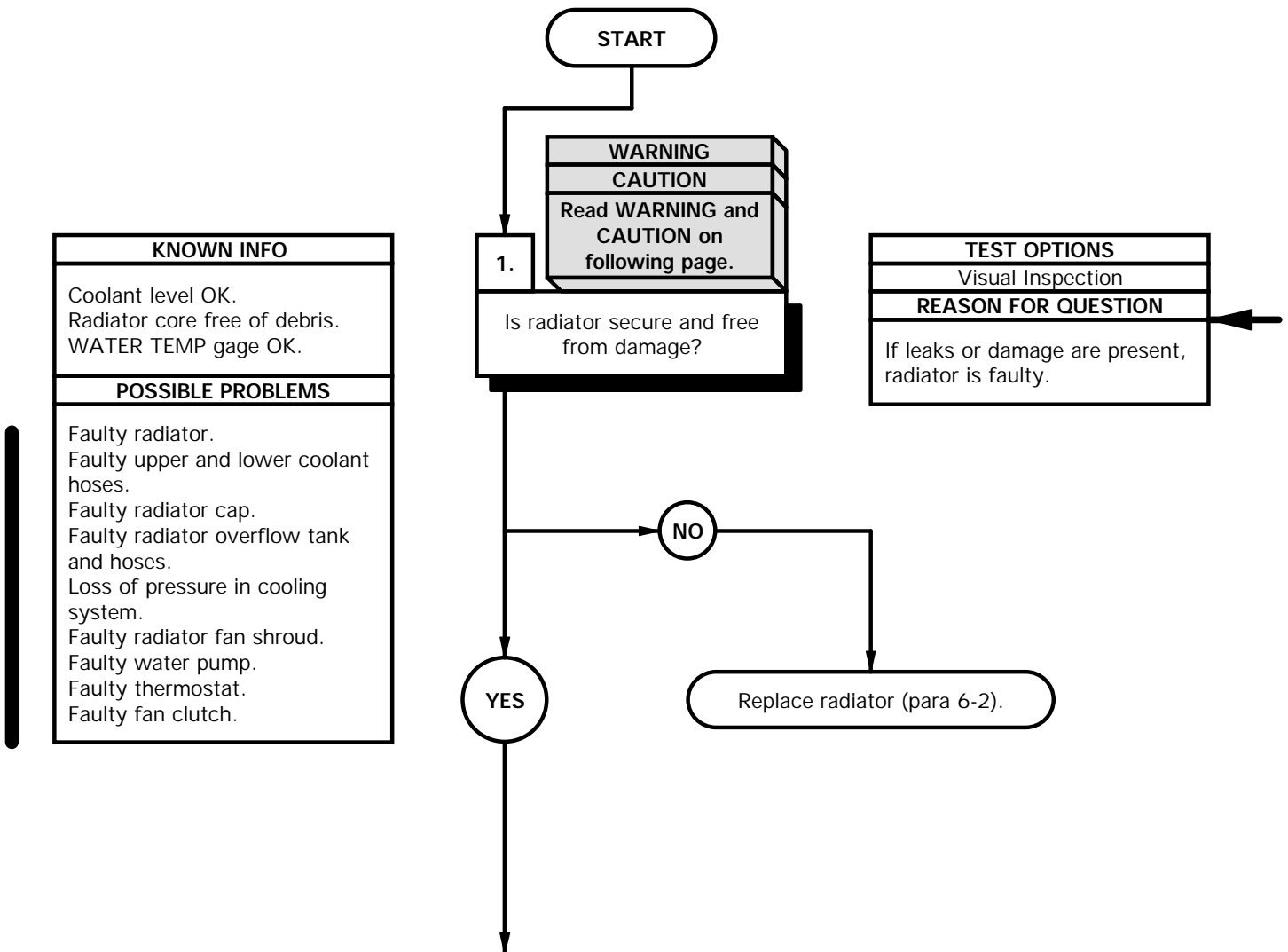

WARNING

Coolant may be very hot and under pressure from engine operation. Ensure engine is cool before performing troubleshooting. Failure to comply may result in injury to personnel.

- (1) Raise cab (TM 9-2320-365-10).
- (2) Check radiator for leaks and damage.
- (3) Remove radiator cap from radiator overflow tank.
- (4) Install test kit on radiator overflow tank.
- (5) Install radiator tester on test kit.

CAUTION

Do not pressurize over 16 psi (110 kPa). Failure to comply may result in damage to cooling system.

- (6) Pressurize radiator overflow tank, using tester, to 15 psi (103 kPa).
- (7) Observe radiator for coolant leaks.

NOTE

Pressure loss without external leaks indicates engine internal coolant leaks.

- (8) Observe radiator tester for loss of pressure.
- (9) If leaks or damage are present, replace radiator (para 6-2).

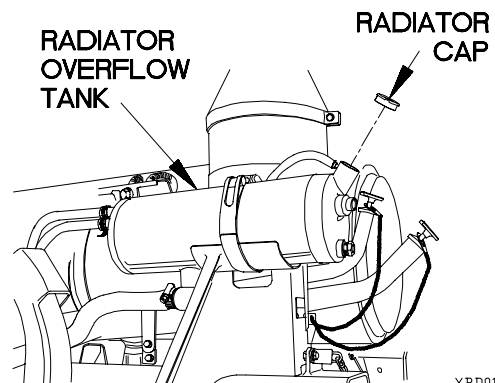
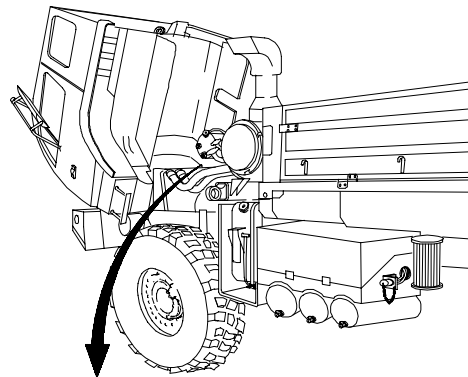

XBD0101B

d1. ENGINE OVERHEATS (CONT)

KNOWN INFO
Coolant level OK. Radiator core free of debris. WATER TEMP gage OK. Radiator OK.
POSSIBLE PROBLEMS
Faulty upper and lower coolant hoses. Faulty radiator cap. Faulty radiator overflow tank and hoses. Loss of pressure in cooling system. Faulty radiator fan shroud. Faulty water pump. Faulty thermostat. Faulty fan clutch.

2.

WARNING
CAUTION
Read WARNING and CAUTION on following page.

Does cooling system maintain pressure?

TEST OPTIONS
Visual Inspection
REASON FOR QUESTION
This question eliminates possible problems and determines where troubleshooting continues.

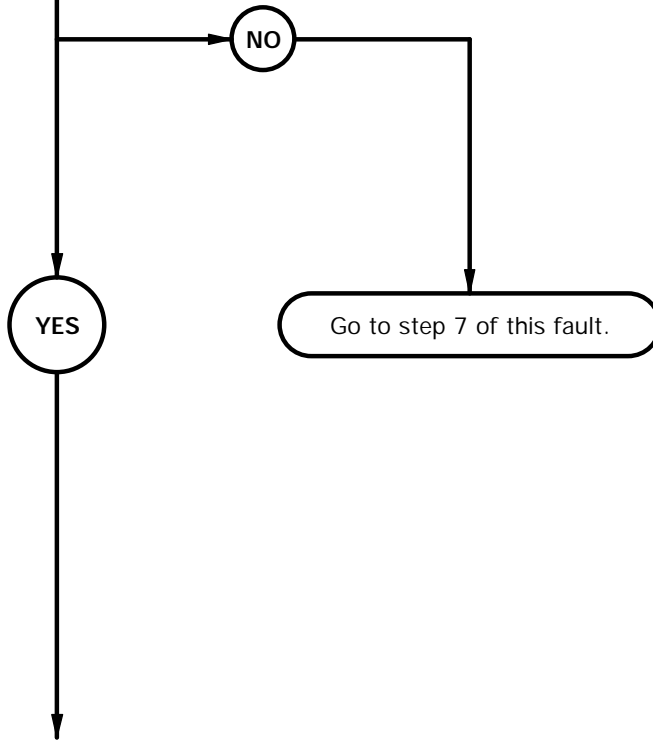

WARNING

Coolant may be very hot and under pressure from engine operation. Ensure engine is cool before performing troubleshooting. Failure to comply may result in injury to personnel.

CAUTION

Do not pressurize over 16 psi (110 kPa). Failure to comply may result in damage to cooling system.

- (1) Pressurize radiator overflow tank, using tester, to 15 psi (103 kPa).
- (2) Observe radiator overflow tank for coolant leaks.

NOTE

Pressure loss without external leaks indicates engine internal coolant leaks.

- (3) Observe radiator tester for loss of pressure.
- (4) If cooling system does not maintain pressure, go to step 7 of this fault.
- (5) Remove tester and test kit from radiator overflow tank.
- (6) Install radiator cap on radiator overflow tank.

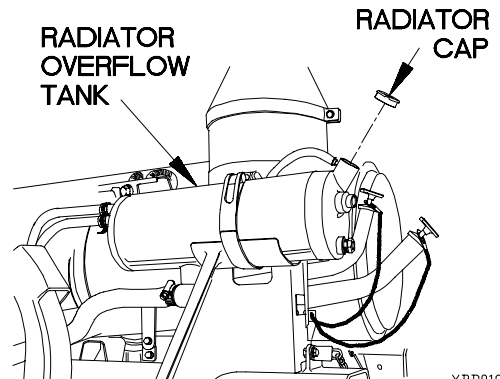
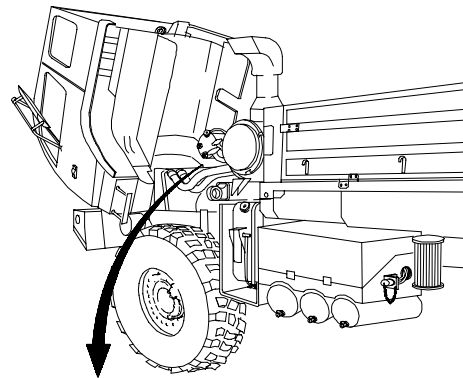

XBD0102B

d1. ENGINE OVERHEATS (CONT)

KNOWN INFO
Coolant level OK. Radiator core free of debris. WATER TEMP gage OK. Radiator OK. Upper and lower coolant hoses OK. Radiator cap OK. Radiator overflow tank and hoses OK. Cooling system pressure OK.
POSSIBLE PROBLEMS
Faulty radiator fan shroud. Faulty water pump. Faulty thermostat. Faulty fan clutch.

3.
Is radiator fan shroud secure and free from damage?

TEST OPTIONS
Visual Inspection
REASON FOR QUESTION
If damage is present, radiator fan shroud is faulty.

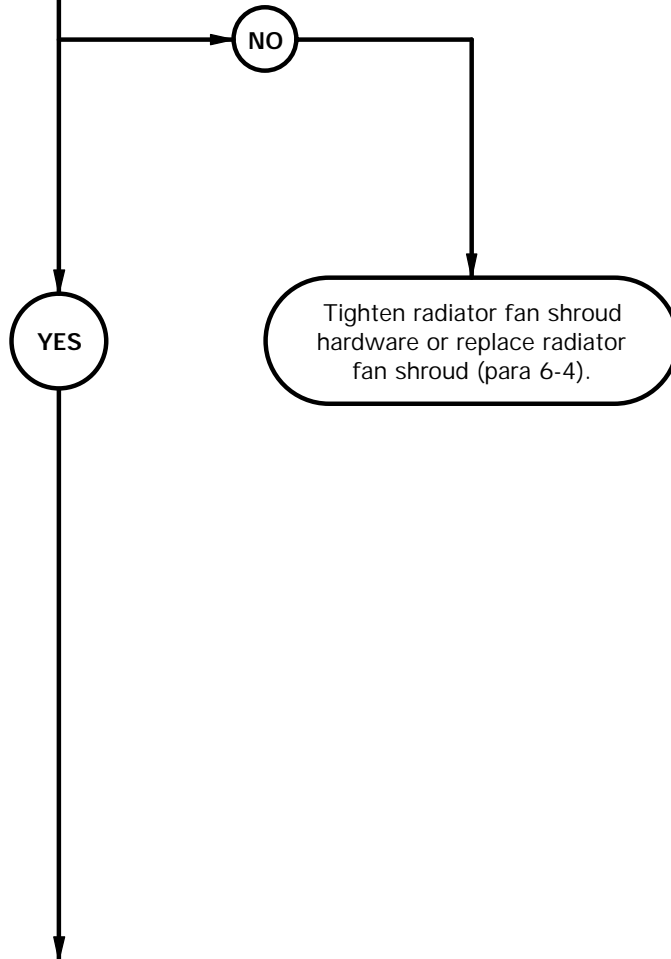

- 
- (1) Check radiator fan shroud for loose hardware and damage.
 - (2) If radiator fan shroud hardware is loose, tighten hardware.
 - (3) If radiator fan shroud is damaged, replace radiator fan shroud (para 6-4).

d1. ENGINE OVERHEATS (CONT)

KNOWN INFO
Coolant level OK. Radiator core free of debris. WATER TEMP gage OK. Radiator OK. Upper and lower coolant hoses OK. Radiator cap OK. Radiator overflow tank and hoses OK. Cooling system pressure OK. Radiator fan shroud OK.
POSSIBLE PROBLEMS
Faulty water pump. Faulty thermostat. Faulty fan clutch.

KNOWN INFO
Coolant level OK. Radiator core free of debris. WATER TEMP gage OK. Radiator OK. Upper and lower coolant hoses OK. Radiator cap OK. Radiator overflow tank and hoses OK. Cooling system pressure OK. Radiator fan shroud OK. Water pump OK.
POSSIBLE PROBLEMS
Faulty thermostat. Faulty fan clutch.

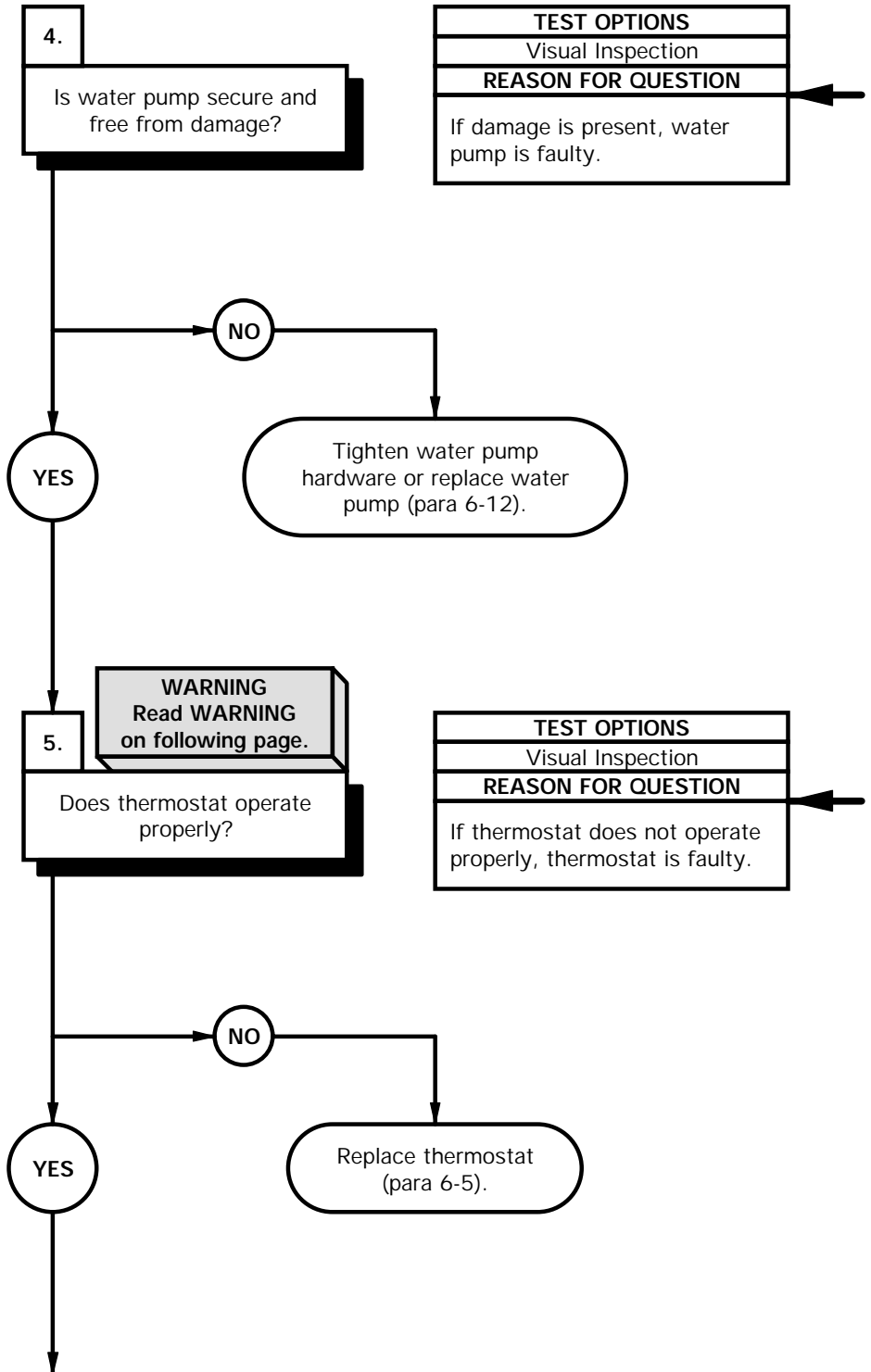

- (1) Check water pump for loose hardware and damage.
- (2) If water pump hardware is loose, tighten hardware.
- (3) If water pump is damaged, replace water pump (para 6-12).

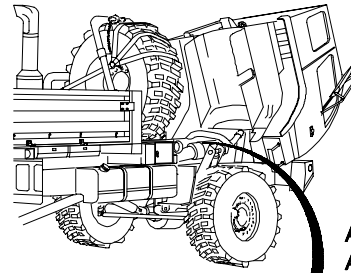

**ALTERNATOR
AND ALTERNATOR
BRACKET
REMOVED
FOR CLARITY**

WATER PUMP

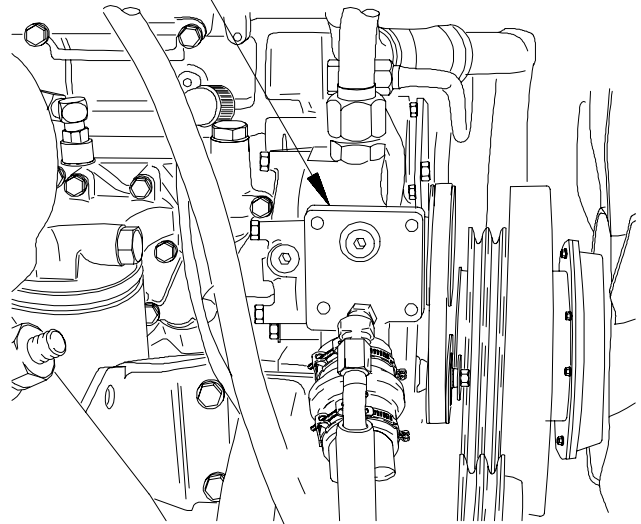

WARNING

Coolant may be very hot and under pressure from engine operation. Ensure engine is cool before performing troubleshooting. Failure to comply may result in injury to personnel.

- (1) Remove coolant hose from overflow tank to radiator (para 6-3).
- (2) Place coolant hose in drain pan.
- (3) Start engine (TM 9-2320-365-10).

WARNING

Use care when opening door with cab raised. Failure to comply may result in injury to personnel or damage to equipment.

NOTE

Coolant flowing constantly through return hose indicates closed thermostat.

- (4) Observe flow of coolant from coolant hose.
- (5) If thermostat does not operate properly, replace thermostat (para 6-5).
- (6) Shut down engine (TM 9-2320-365-10).
- (7) Install coolant hose on overflow tank and radiator (para 6-3).
- (8) Refill overflow tank to proper level (TM 9-2320-365-10).
- (9) Lower cab (TM 9-2320-365-10).

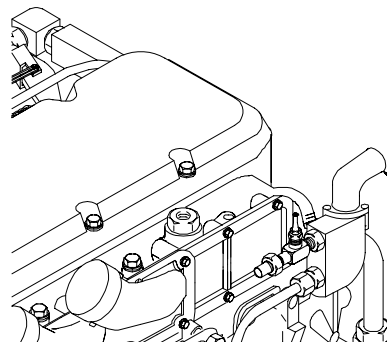
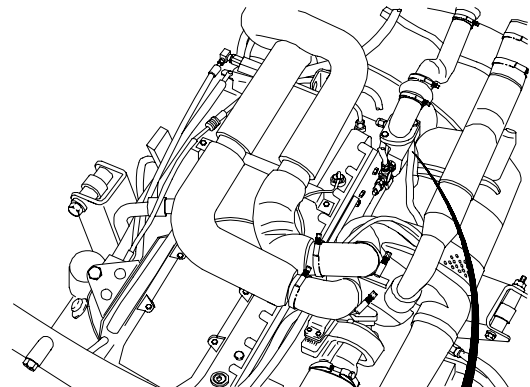

THERMOSTAT

XBD0104B

d1. ENGINE OVERHEATS (CONT)

KNOWN INFO
Coolant level OK. Radiator core free of debris. WATER TEMP gage OK. Radiator OK. Upper and lower coolant hoses OK. Radiator cap OK. Radiator overflow tank and hoses OK. Cooling system pressure OK. Radiator fan shroud OK. Water pump OK. Thermostat OK.
POSSIBLE PROBLEMS
Faulty fan clutch.

6.
Does fan clutch spin freely without air applied?

TEST OPTIONS
Visual Inspection
REASON FOR QUESTION
If fan clutch spins freely without air pressure applied, fan clutch is faulty.

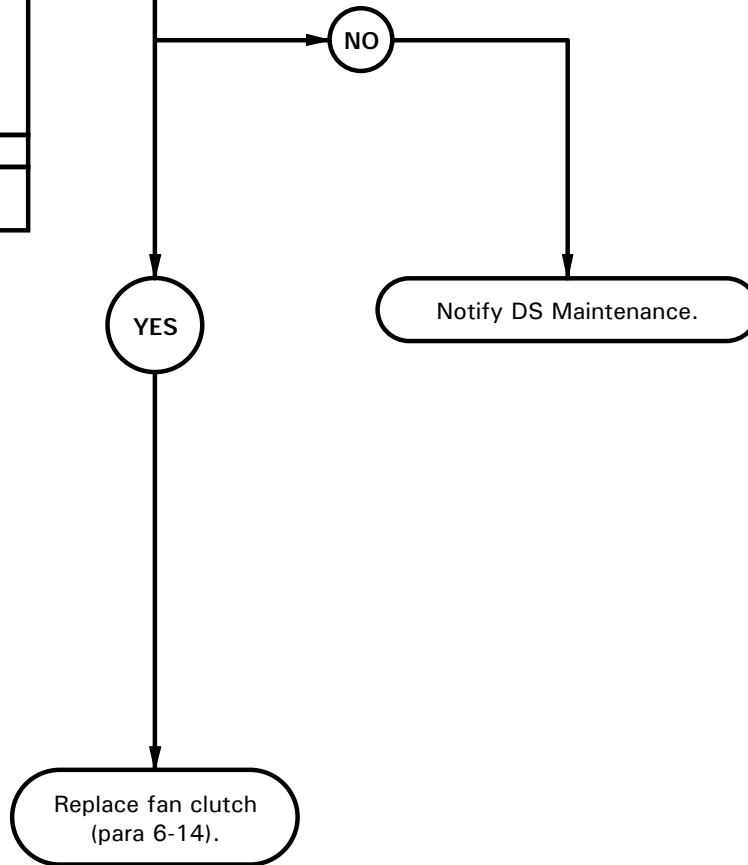

- (1) Remove two screws and washers from front grille.
- (2) Remove screw and washer from front grille.
- (3) Remove front grille from cab.
- (4) Disconnect air hose from fan clutch.
- (5) Check to see if fan clutch turns freely.
- (6) If fan clutch turns freely without air applied, replace fan clutch (para 6-14).
- (7) Connect air hose to fan clutch.
- (8) Position front grille on cab with washer and screw.
- (9) Position two washers and screws in front grille.
- (10) Tighten screw to 48-60 lb-in. (5-7 N·m).
- (11) Tighten two screws to 24 lb-in. (3 N·m).

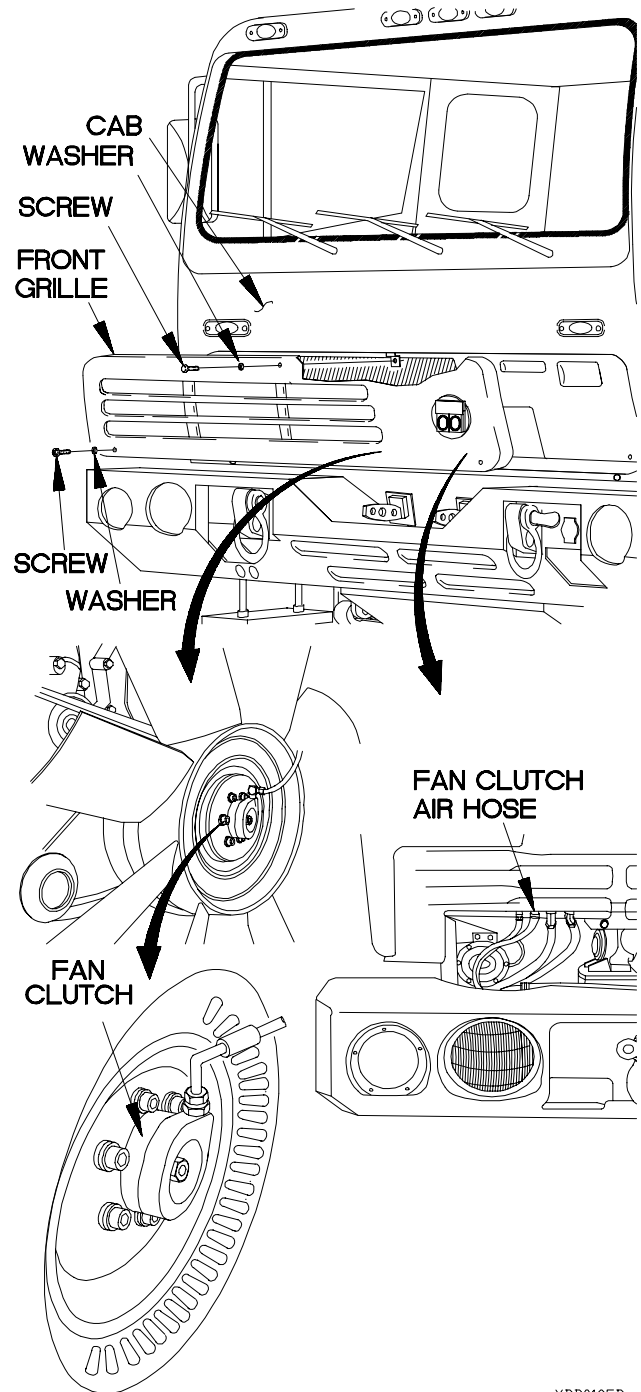

XBD0105B

d1. ENGINE OVERHEATS (CONT)

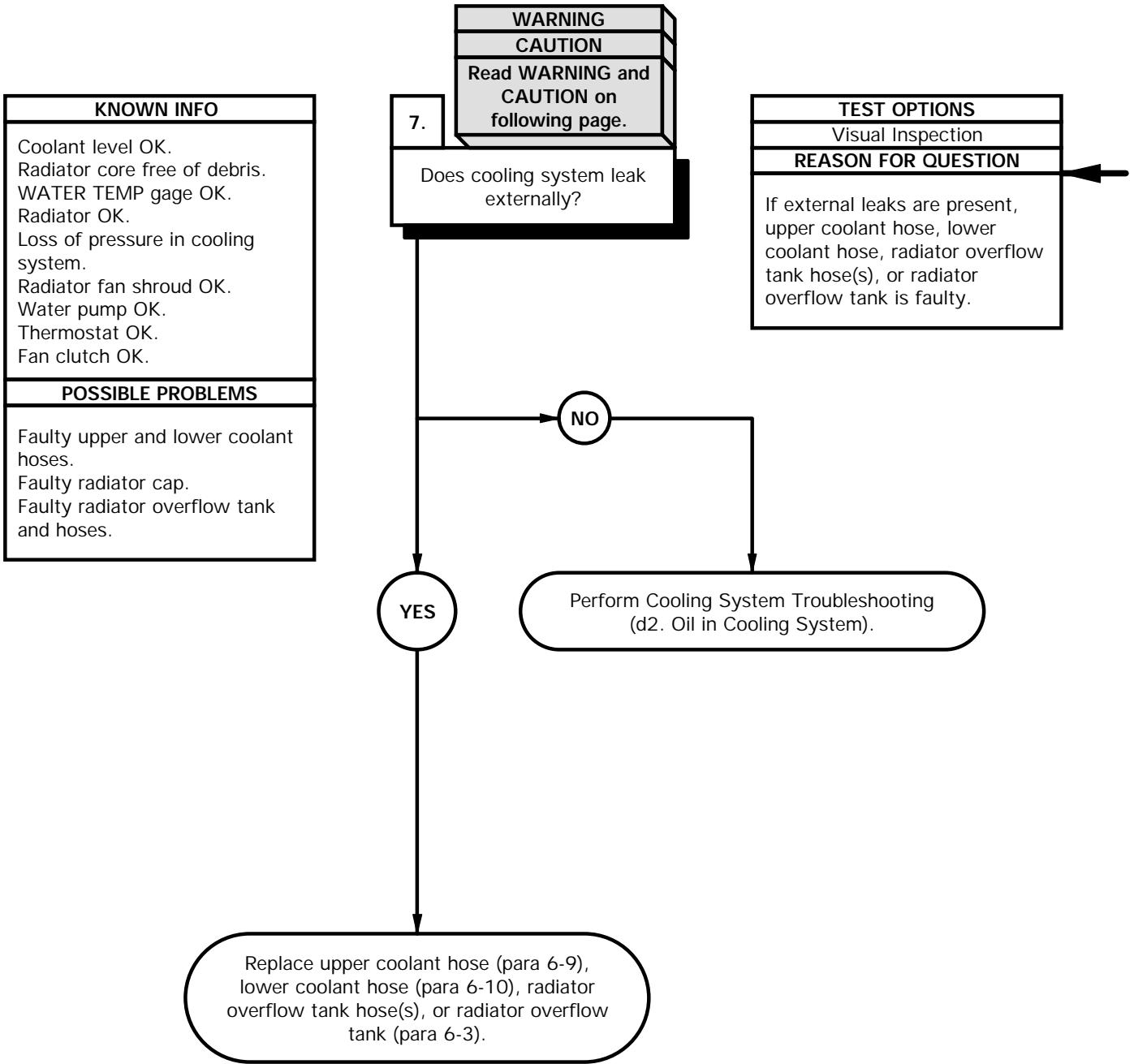

WARNING

Coolant may be very hot and under pressure from engine operation. Ensure engine is cool before performing troubleshooting. Failure to comply may result in injury to personnel.

CAUTION

Do not pressurize over 16 psi (110 kPa). Failure to comply may result in damage to cooling system.

- (1) Pressurize radiator overflow tank, using tester, to 15 psi (103 kPa).
- (2) Observe hoses for coolant leaks.

NOTE

Pressure loss without external leaks indicates engine internal coolant leaks.

- (3) Observe radiator tester for loss of pressure.
- (4) If no external leaks are present, perform Cooling System Troubleshooting (d2. Oil in Cooling System).
- (5) If external leaks are present, replace upper coolant hose (para 6-10), radiator overflow tank hose(s), or radiator overflow tank (para 6-3).
- (6) Remove tester and test kit from radiator overflow tank.
- (7) Install radiator cap on radiator overflow tank.

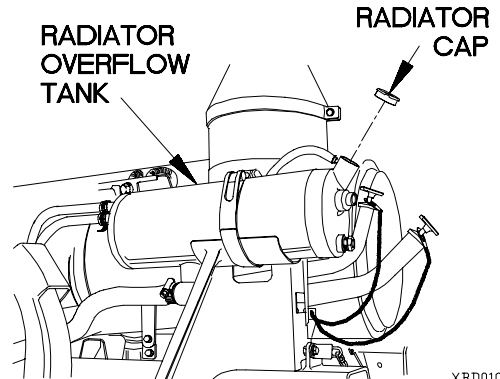
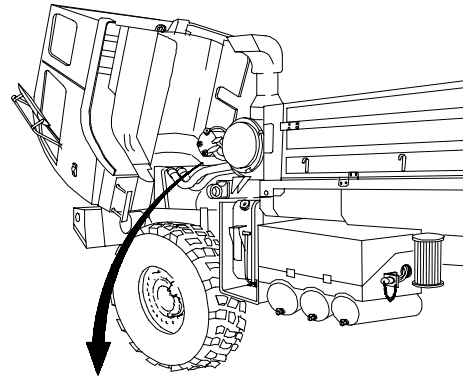

XBD0106B

d2. OIL IN COOLING SYSTEM

INITIAL SETUP

Equipment Conditions

Engine shut down (TM 9-2320-365-10)

Tools and Special Tools

Tool Kit, Genl Mech (Item 44, Appendix C)

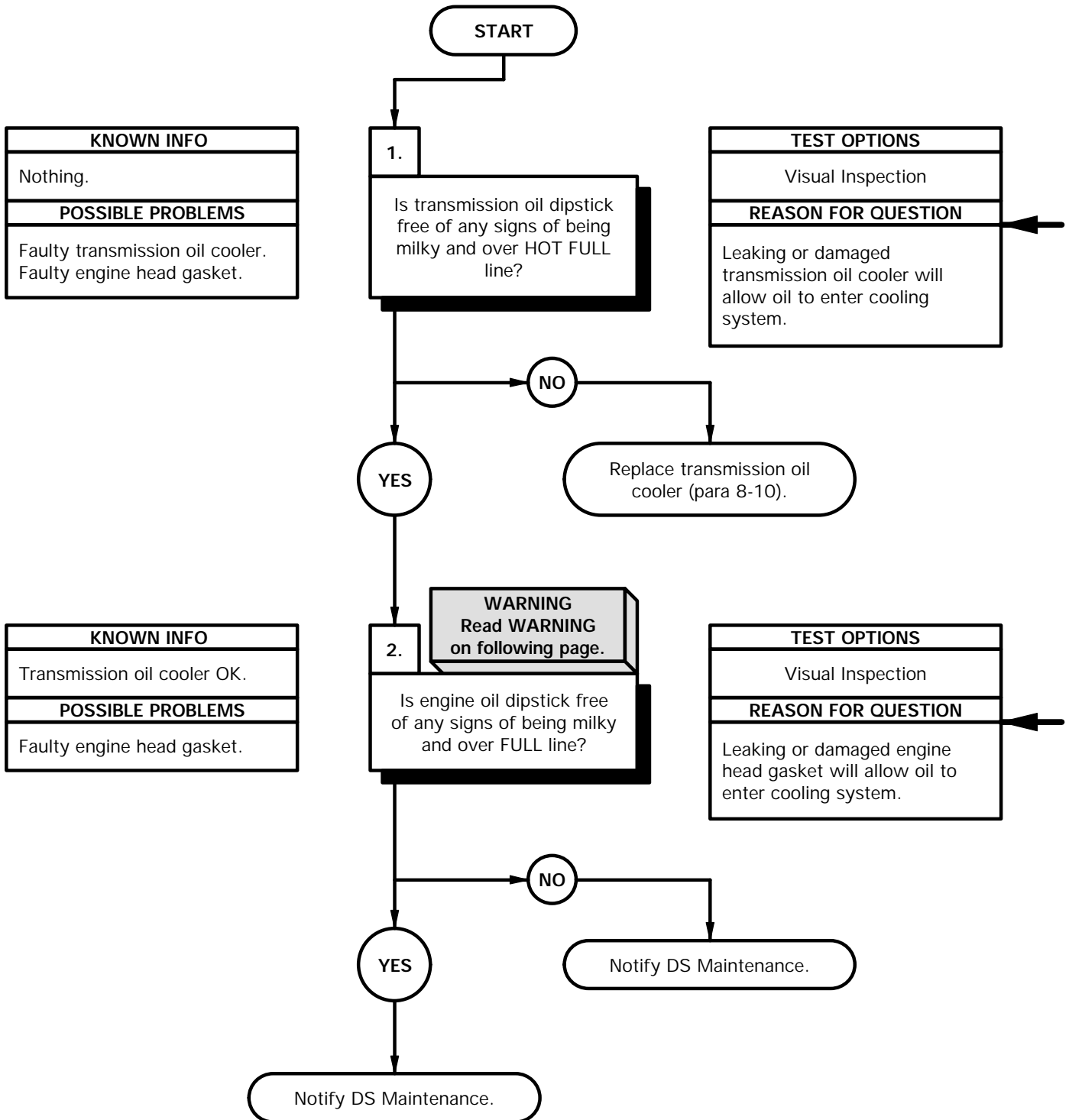

NOTE

Perform transmission oil check when engine is at normal operating temperature (160° F-230° F (71° C-110° C)).

- (1) Start engine (TM 9-2320-365-10).
- (2) Check transmission oil dipstick for signs of oil being milky and over HOT FULL line.
- (3) If transmission oil dipstick shows oil level over HOT FULL line and milky, replace transmission oil cooler (para 8-10).
- (4) Shut down engine (TM 9-2320-365-10).

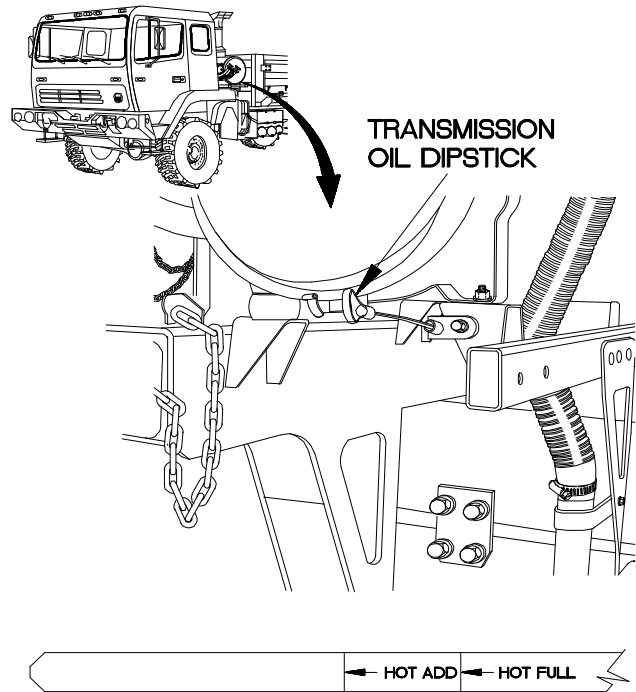

WARNING

Engine oil dipstick is located close to starter solenoid connections which are 24 VDC and high amperage. Use caution removing/installing engine oil dipstick to prevent shorting across starter solenoid connections. Failure to comply may result in serious injury or death to personnel or damage to equipment.

- (1) Raise cab (TM 9-2320-365-10).
- (2) Check engine oil dipstick for signs of being milky and over FULL line.
- (3) If engine oil dipstick shows engine oil to be milky and over FULL line, notify DS Maintenance.
- (4) If engine oil dipstick shows engine oil appears normal and not over FULL line, notify DS Maintenance.
- (5) Lower cab (TM 9-2320-365-10).

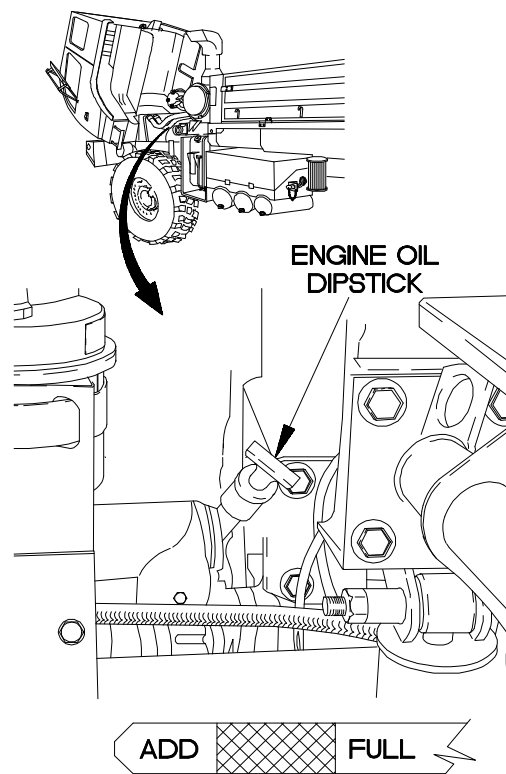

XBD0201B

d3. LOSS OF COOLANT	
INITIAL SETUP	
Equipment Conditions Engine shut down (TM 9-2320-365-10).	Tools and Special Tools Tool Kit, Genl Mech (Item 44, Appendix C) Test Kit, Radiator (P/N 4910-00-728-8227) Pressure Tester, Radiator (Item 26, Appendix C) Goggles, Industrial (Item 15, Appendix C)
Personnel Required (2)	

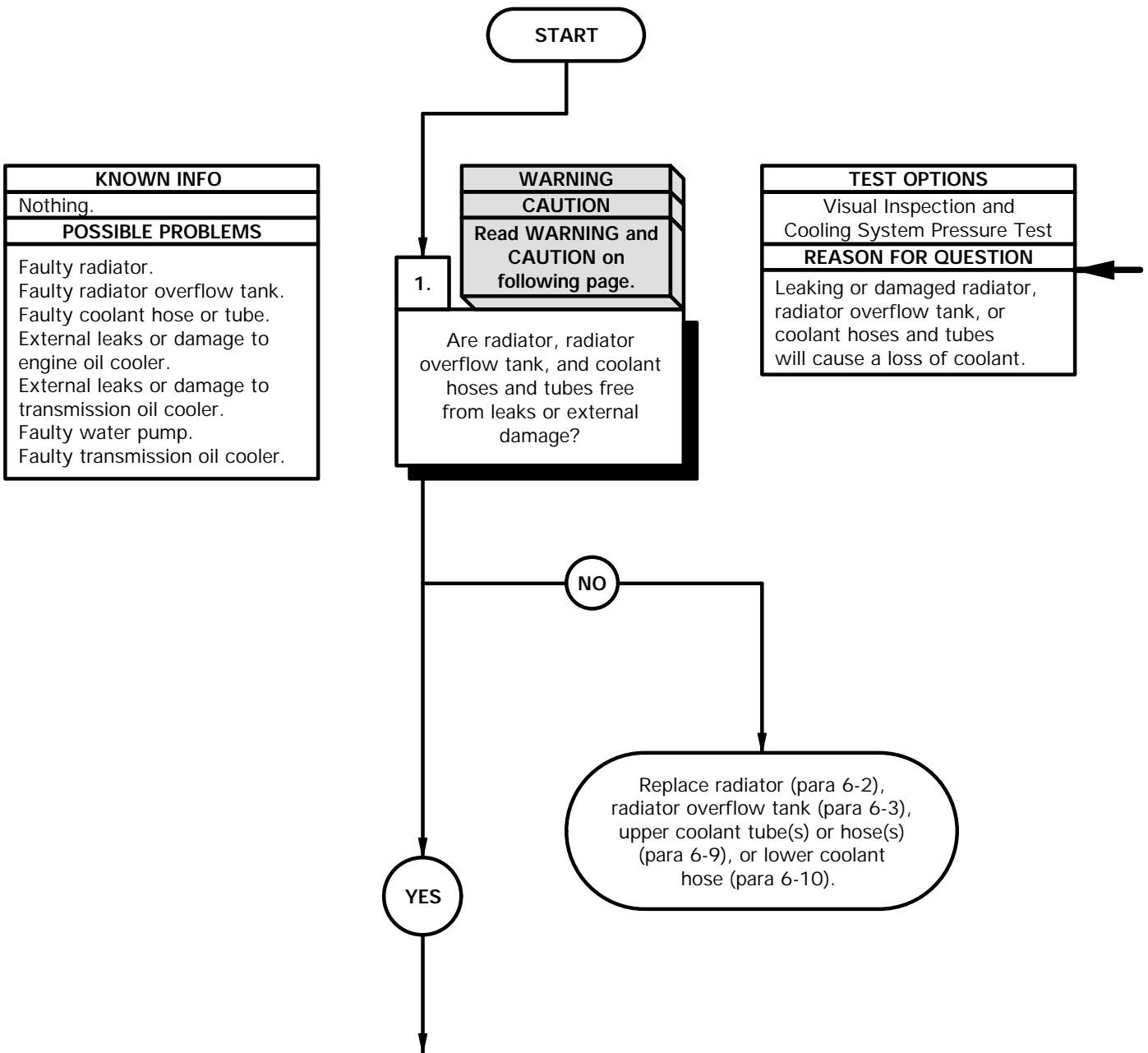

WARNING

Coolant may be very hot and under pressure from engine operation. Ensure engine is cool before performing maintenance. Failure to comply may result in injury to personnel.

- (1) Raise cab (TM 9-2320-365-10).
- (2) Check radiator, radiator overflow tank, and coolant hoses and tubes for leaks and damage.

COOLING SYSTEM PRESSURE TEST

- (1) Remove radiator cap from radiator overflow tank.
- (2) Install test kit on radiator overflow tank.
- (3) Install pressure tester on test kit.

CAUTION

Do not pressurize over 16 psi (110 kPa). Failure to comply may result in damage to cooling system.

- (4) Pressurize radiator overflow tank, using tester, to 15 psi (103 kPa).
- (5) Observe radiator and radiator overflow tank for coolant leaks.

NOTE

Pressure loss without external leaks indicates internal coolant leaks.

- (6) Observe radiator tester for loss of pressure.
- (7) Remove pressure tester and test kit from radiator overflow tank.
- (8) Install radiator cap on radiator overflow tank.

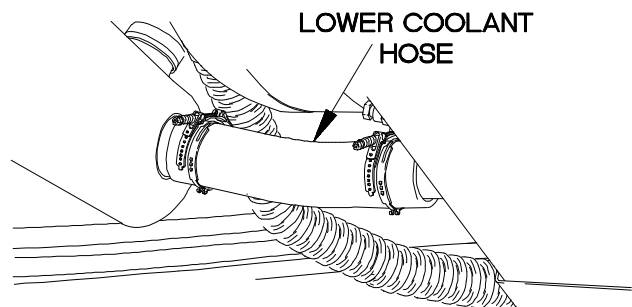
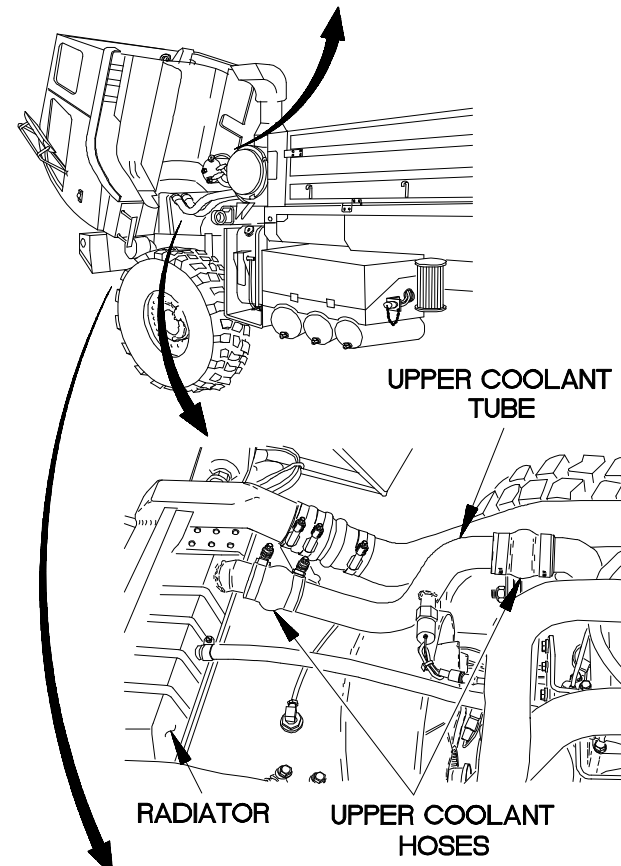
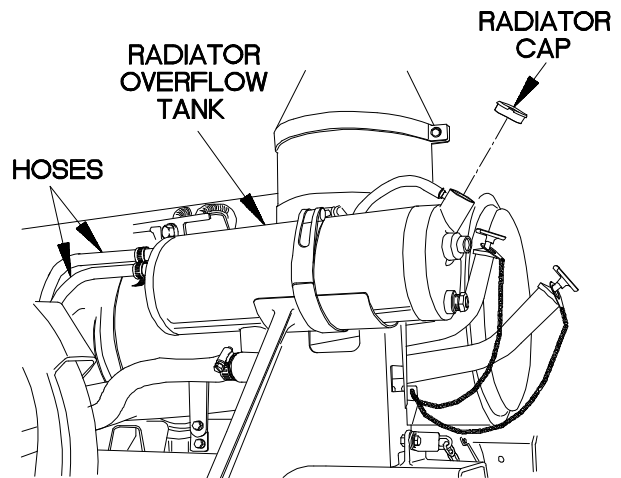

XBD0301B

d3. LOSS OF COOLANT (CONT)

KNOWN INFO
Radiator OK. Radiator overflow tank OK. Air coolant hoses and tubes OK.
POSSIBLE PROBLEMS
External leaks or damage to engine oil cooler. External leaks or damage to transmission oil cooler. Faulty water pump. Faulty transmission oil cooler.

KNOWN INFO
Radiator OK. Radiator overflow tank OK. All coolant hoses and tubes OK. Engine oil cooler free from external leaks or damage.
POSSIBLE PROBLEMS
External leaks or damage to transmission oil cooler. Faulty water pump. Faulty transmission oil cooler.

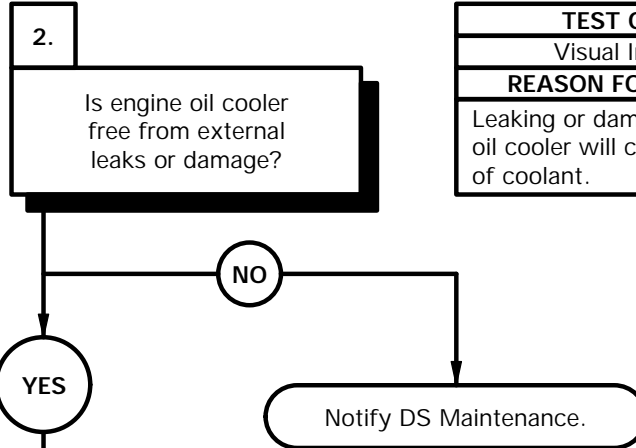

TEST OPTIONS
Visual Inspection
REASON FOR QUESTION
Leaking or damaged engine oil cooler will cause a loss of coolant.

TEST OPTIONS
Visual Inspection
REASON FOR QUESTION
Leaking or damaged transmission oil cooler will cause a loss of coolant.

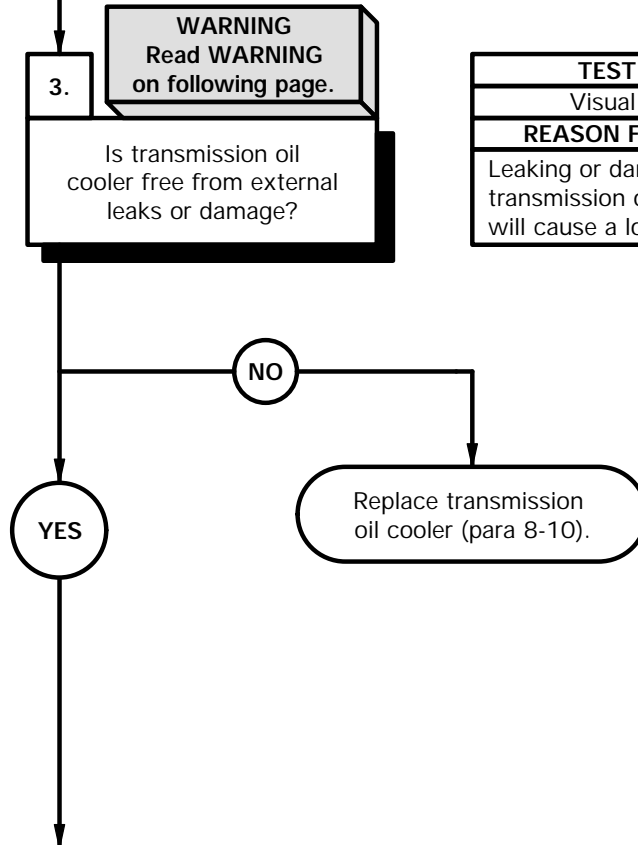

- (1) Check engine oil cooler for leaks and obvious signs of damage.
- (2) If leaks or damage are noted, notify DS Maintenance.

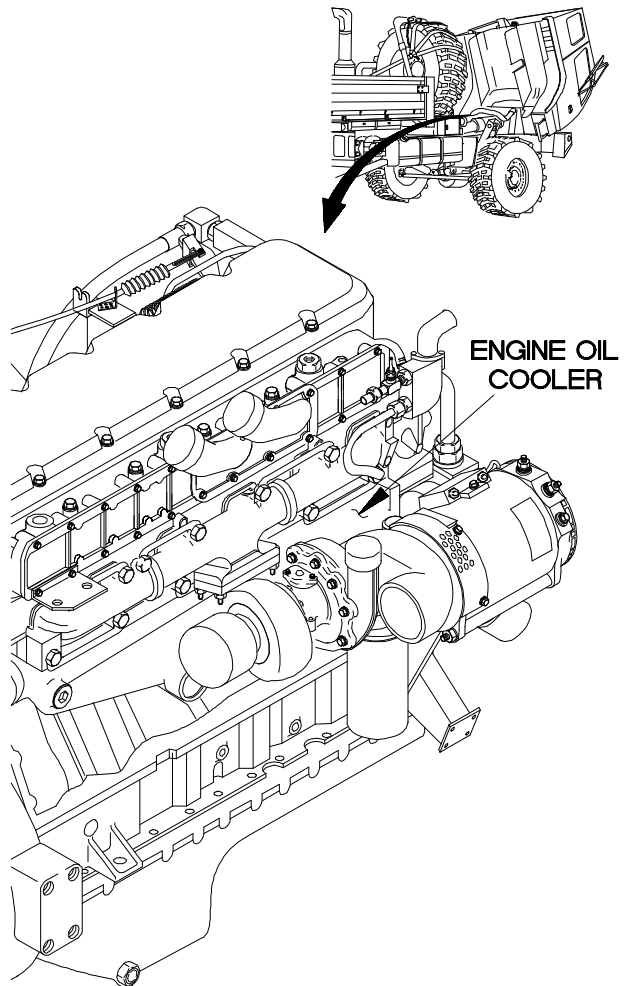

WARNING

Wear appropriate eye protection when working under vehicle due to the possibility of falling debris. Failure to comply may result in injury to personnel.

- (1) Check transmission oil cooler for obvious signs of damage and leakage.
- (2) If leaks or damage are noted, replace transmission oil cooler (para 8-10).
- (3) Lower cab (TM 9-2320-365-10).

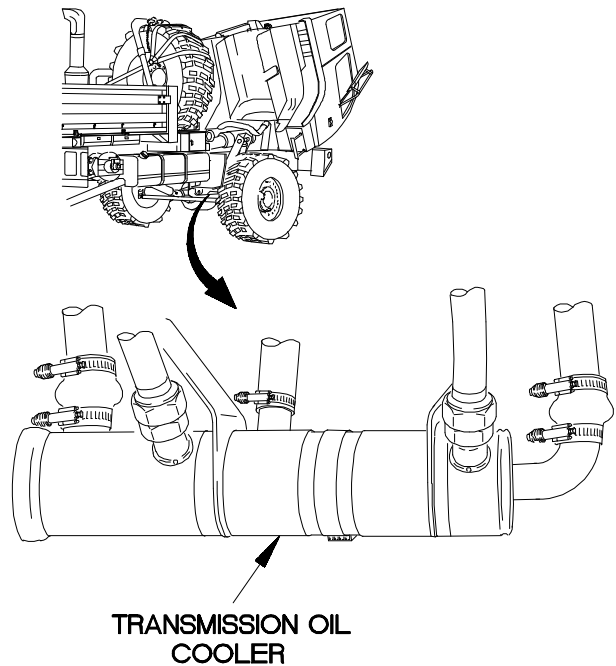

XBD0302B

d3. LOSS OF COOLANT (CONT)

KNOWN INFO
Radiator OK. Radiator overflow tank OK. All coolant hoses and tubes OK. Engine oil cooler free from external leaks or damage. Transmission oil cooler free from external leaks or damage.
POSSIBLE PROBLEMS
Faulty water pump. Faulty transmission oil cooler.

4.
Is water pump free from leaks or damage?

TEST OPTIONS
Visual Inspection
REASON FOR QUESTION
Leaking or damaged water pump will cause a loss of coolant.

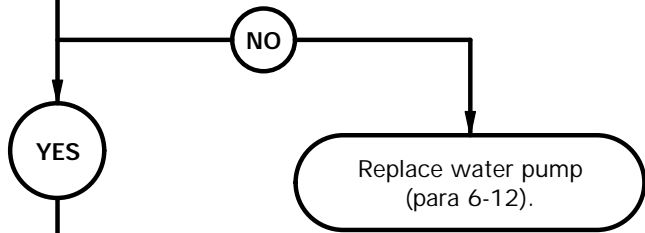

KNOWN INFO
Radiator OK. Radiator overflow tank OK. All coolant hoses and tubes OK. Engine oil cooler free from external leaks or damage. Transmission oil cooler free from external leaks or damage. Water pump OK.
POSSIBLE PROBLEMS
Faulty transmission oil cooler.

5.
Is transmission oil dipstick free of any signs of being over HOT FULL line, discolored, or milky?

TEST OPTIONS
Visual Inspection
REASON FOR QUESTION
Leaking or damaged transmission oil cooler will cause a loss of coolant.

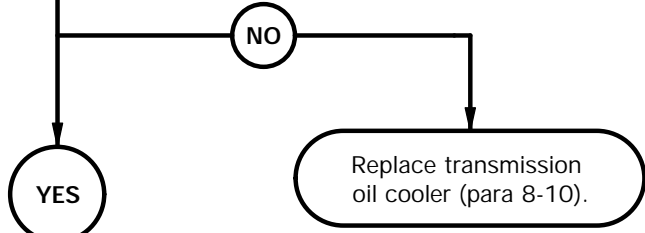

Notify DS Maintenance.

- (1) Start engine (TM 9-2320-365-10).
- (2) Check water pump for obvious signs of damage and leakage.
- (3) If leaks or damage are found, replace water pump (para 6-12).
- (4) Shut down engine (TM 9-2320-365-10).

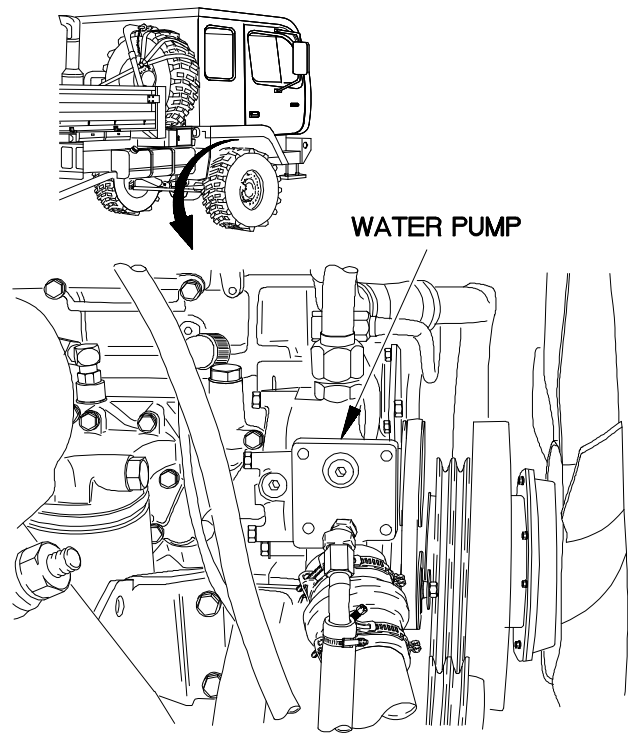

WATER PUMP

NOTE

Perform transmission oil check when engine is at normal operating temperature (160° F-230° F (71° C-110° C)).

- (1) Start engine (TM 9-2320-365-10).
- (2) Check transmission oil dipstick for signs of being over HOT FULL line, discolored, or milky.
- (3) If signs of being over HOT FULL line, discolored, or milky are found, replace transmission oil cooler (para 8-10).
- (4) If no signs of being over HOT FULL line, discolored, or milky are found, notify DS Maintenance.
- (5) Shut down engine (TM 9-2320-365-10).

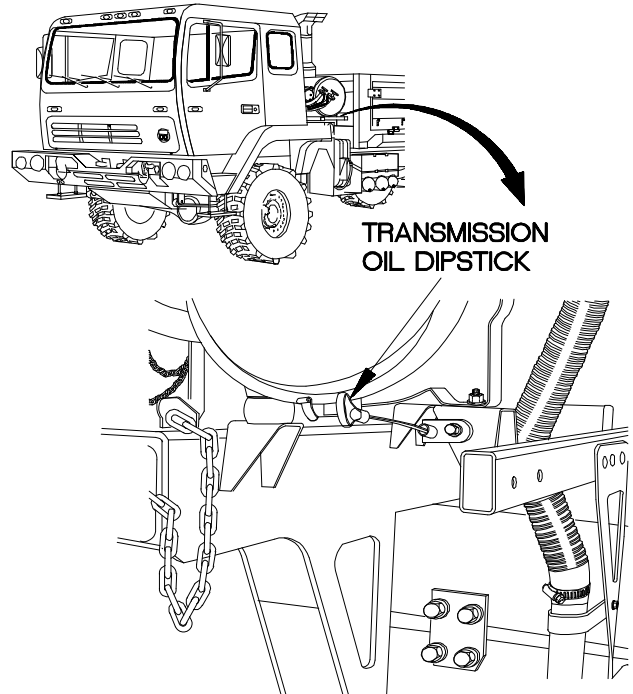

TRANSMISSION OIL DIPSTICK

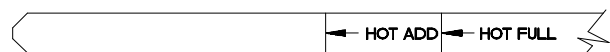

XBD0303B

2-16. ELECTRICAL SYSTEM TROUBLESHOOTING

This paragraph covers Electrical System Troubleshooting. The Electrical System Fault Index, Table 2-7, lists faults for the electrical system of the vehicle.

Table 2-7. Electrical System Fault Index

Fault No.	Description	Page
e1.	Circuit Breaker Does Not Operate	2-150
e2.	Engine Does Not Crank	2-154
e3.	12 VDC and/or 24 VDC Circuits Do Not Operate	2-254
e4.	24 VDC Circuits Do Not Operate	2-258
e5.	Deleted	2-276
e6.	Engine Cranks But Does Not Start	2-300
e7.	FUEL Gage Does Not Operate or Is Inaccurate	2-308
e8.	WATER TEMP Gage Does Not Operate or Is Inaccurate	2-314
e9.	REAR BRAKE AIR Pressure Gage Does Not Operate or Is Inaccurate	2-318
e10.	FRONT BRAKE AIR Pressure Gage Does Not Operate or Is Inaccurate	2-322
e11.	Engine Oil Pressure Gage Does Not Operate or Is Inaccurate	2-326
e12.	Speedometer Does Not Operate or Is Inaccurate	2-332
e13.	VOLTS Gage Does Not Operate or Is Inaccurate	2-346
e14.	Tachometer Does Not Operate or Is Inaccurate	2-348
e15.	Audible Alarm Does Not Operate	2-358
e16.	Troop Transport Audible Alarm Does Not Operate	2-362
e16A.	Master Power Switch Does Not Shut Down Engine	2-370.4
e16B.	Lamp Test Switch Does Not Illuminate	2-370.10
e17.	Radiator Fan Off Switch Does Not Illuminate	2-372
e17A.	Ether Start Switch Does Not Illuminate	2-376
e17B.	Hazard Lights Switch Does Not Illuminate	2-376.4
e17C.	Amber Warning Light Switch Does Not Illuminate	2-376.8
e17D.	Master Power Switch Does Not Illuminate	2-376.12
e18.	REAR BRAKE AIR Gage Does Not Illuminate	2-378
e18A.	FUEL Gage Does Not Illuminate	2-380.2
e18B.	FRONT BRAKE AIR Gage Does Not Illuminate	2-380.6
e18C.	Speedometer Does Not Illuminate	2-380.10
e18D.	VOLTS Gage Does Not Illuminate	2-380.14
e18E.	WATER TEMP Gage Does Not Illuminate	2-380.18
e19.	OIL PRESS Gage Does Not Illuminate	2-382
e20.	Auxiliary Panel, Personnel Heater, and Instrument Panel Do Not Illuminate	2-386
e21.	Tachometer Does Not Illuminate	2-390
e22.	Auxiliary Panel Switch Does Not Illuminate	2-394
e23.	Auxiliary Panel Does Not Illuminate	2-398
e24.	High Engine Temperature Indicator Does Not Operate	2-402
e24A.	High Engine Temperature Indicator Illuminates	2-408.2
e25.	CTIS Overspeed Indicator Does Not Operate	2-410
e26.	Chemical Detector Indicator Does Not Operate	2-424
e27.	Left Turn Signal Indicator Does Not Operate	2-428
e28.	Right Turn Signal Indicator Does Not Operate	2-432
e29.	Turn Signal Indicators and High Beams On Indicator Do Not Operate	2-438
e30.	High Beams On Indicator Does Not Operate	2-440
e31.	Parking Brake Indicator and/or Emergency Brake Indicator Does Not Illuminate	2-444
e32.	PTO Indicator Does Not Operate	2-460
e33.	Fan Off Indicator Does Not Operate	2-472

2-16. ELECTRICAL SYSTEM TROUBLESHOOTING (CONT)

Table 2-7. Electrical System Fault Index (Cont)

Fault No.	Description	Page
e34.	WTEC II Transmission Temperature Indicator Does Not Operate	2-478
e35.	WTEC III Transmission Temperature Indicator Does Not Operate	2-486
e36.	Front Brake Air Indicator Does Not Illuminate When Air Pressure is Below 65 PSI	2-492
e37.	Rear Brake Air Indicator Does Not Illuminate When Air Pressure is Below 65 PSI	2-498
e38.	Engine Oil Pressure Indicator Does Not Operate	2-504
e39.	Master Stop Indicator Does Not Operate	2-510
e40.	One or Both Headlights (High and Low Beams) Do Not Illuminate	2-512
e41.	One or Both Headlight Low Beams Do Not Illuminate	2-520
e42.	One or Both Headlight High Beams Do Not Illuminate	2-526
e43.	Parking Lights Do Not Illuminate	2-534
e44.	LH Door and/or LH Front Marker Lights Do Not Illuminate	2-542
e45.	RH Door and/or RH Front Marker Lights Do Not Illuminate	2-552
e46.	One or More Cab Top Marker Lights Do Not Illuminate	2-562
e47.	Side and/or Rear Marker Lights Do Not Illuminate	2-576
e47A.	All Marker Lights Do Not Illuminate in Normal Mode	2-584.52
e48.	One or Both Composite Taillights Do Not Illuminate	2-586
e49.	One or Both Front Blackout Marker Lights Do Not Illuminate	2-596
e50.	Blackout Drive Light Does Not Illuminate	2-606
e51.	One or Both Rear Blackout Marker Lights Do Not Illuminate	2-616
e52.	Warning Light Does Not Illuminate	2-626
e53.	Backup Light Does Not Illuminate	2-638
e54.	Blackout Marker Lights Do Not Illuminate	2-676
e54A.	Front Hazard Lights Do Not Illuminate	2-678
e55.	Rear Hazard Lights Do Not Illuminate	2-680
e56.	Front and Rear Hazard Lights Do Not Illuminate	2-682
e57.	Front and Rear Turn Signals Do Not Operate	2-690
e58.	Left or Right Front Turn Signals Do Not Operate	2-702
e59.	One or Both Stoplights Do Not Illuminate	2-710
e60.	One or Both Blackout Stoplights Do Not Illuminate	2-728
e61.	Stoplights and Blackout Stoplights Do Not Operate	2-740
e62.	Trailer Marker/Taillights Do Not Illuminate	2-750
e63.	Trailer Right Stop/Turn Light Does Not Illuminate	2-760
e64.	Trailer Left Stop/Turn Light Does Not Illuminate	2-770
e65.	Trailer Blackout Marker Lights Do Not Illuminate	2-780
e66.	Trailer Blackout Stoplights Do Not Illuminate	2-790
e67.	Intervehicle Clearance Lights Do Not Operate	2-800
e68.	Intervehicle Left Turn Signal Does Not Illuminate	2-804
e69.	Intervehicle Right Turn Signal Does Not Illuminate	2-810
e70.	Intervehicle Stoplights Do Not Illuminate	2-816
e71.	Intervehicle Taillights Do Not Operate	2-822
e72.	Personnel Heater Control Illumination Does Not Operate	2-826
e73.	Personnel Heater Fan Does Not Operate	2-832
e74.	Windshield Washer Does Not Operate	2-838
e75.	Windshield Wiper Does Not Operate On Low Speed	2-850
e76.	All Windshield Wiper Speeds Do Not Operate	2-858
e77.	Windshield Wiper Does Not Operate On Intermittent Speed	2-864
e78.	Windshield Wiper Does Not Operate On High Speed	2-874

Table 2-7. Electrical System Fault Index (Cont)

Fault No.	Description	Page
e79.	Horn Does Not Operate	2-880
e80.	Chemical Alarm Does Not Operate	2-892
e81.	Chemical Detector Does Not Operate	2-900
e82.	Central Tire Inflation System (CTIS) Does Not Operate	2-906
e83.	CTIS Does Not Inflate Tires	2-920
e84.	CTIS Does Not Deflate Tires	2-930
e85.	11K Self-Recovery Winch (SRW) Does Not Reel In or Pay Out	2-940
e86.	11K Self-Recovery Winch (SRW) Does Not Reel In	2-946
e87.	11K Self-Recovery Winch (SRW) Does Not Pay Out	2-958
e88.	PTO Does Not Operate	2-970
e89.	Electrical System Does Not Maintain a Charge	2-1010
e90.	WTEC II Transmission ECU Pushbutton Shift Selector (TEPSS) Illumination Does Not Dim	2-1018
e91.	Engine Fan Runs Constantly	2-1028
e92.	Engine Fan Does Not Turn Off Using Radiator Fan Off Switch	2-1036
e93.	Ether Start Does Not Operate	2-1044
e94.	Excessive Condensation in Fuel	2-1060
e95.	Radio Does Not Operate	2-1064
e96.	Start Inhibit Pushbutton Does Not Operate	2-1070
e97.	Air Dryer Does Not Operate	2-1076
e98.	Battery Tester Does Not Operate	2-1082

Volume 2

e99.	M1079 Fan Does Not Operate	2-1088
e100.	All M1079 Van Body Marker Lights Do Not Operate	2-1100
e101.	M1079 Van Body Clearance Marker Light Does Not Illuminate	2-1104
e102.	All M1079 Fluorescent Lights Do Not Operate	2-1108
e103.	M1079 Lighting Fixture(s) DS80 and/or DS81 Do Not Operate	2-1118
e104.	M1079 Lighting Fixture(s) DS82 and/or DS83 Do Not Operate	2-1134
e105.	M1079 110 VAC Outlet J233 Does Not Operate	2-1152
e106.	M1079 110 VAC Outlet J234 Does Not Operate	2-1160
e107.	M1079 110 VAC Outlet J235 Does Not Operate	2-1168
e108.	M1079 110 VAC Outlet J232 Does Not Operate in Normal Mode	2-1176
e109.	M1079 110 VAC Outlet J232 and J233 Do Not Operate in Blackout Override Mode	2-1190
e110.	M1079 110 VAC Outlet J231 Does Not Operate	2-1194
e111.	M1079 110 VAC Outlet J230 Does Not Operate	2-1208
e112.	M1079 Blackout Light(s) Does Not Operate	2-1222
e113.	M1079 Emergency Light(s) Does Not Illuminate	2-1230
e114.	M1079 Field Phone 1 and/or 2 Binding Post Does Not Operate	2-1244
e115.	M1079 Air Conditioner Does Not Operate	2-1264
e116.	M1079 Heater Does Not Operate	2-1276
e117.	M1079 24 VDC Binding Post(s) Does Not Operate	2-1296
e118.	M1079 Van Door Open Light Does Not Illuminate and Audible Alarm Does Not Operate	2-1324
e119.	M1079 110 VAC Power Does Not Operate	2-1338
e120.	M1079 Fluorescent Lights Do Not Operate in Blackout Override Mode	2-1352

e1. CIRCUIT BREAKER DOES NOT OPERATE

INITIAL SETUP

Equipment Conditions

Engine shut down (TM 9-2320-365-10).

Tools and Special Tools

Tool Kit, Genl Mech (Item 44, Appendix C)

STE/ICE-R (Item 39, Appendix C)

Multimeter, Digital (Item 22, Appendix C)

References

TM 9-4910-571-12&P

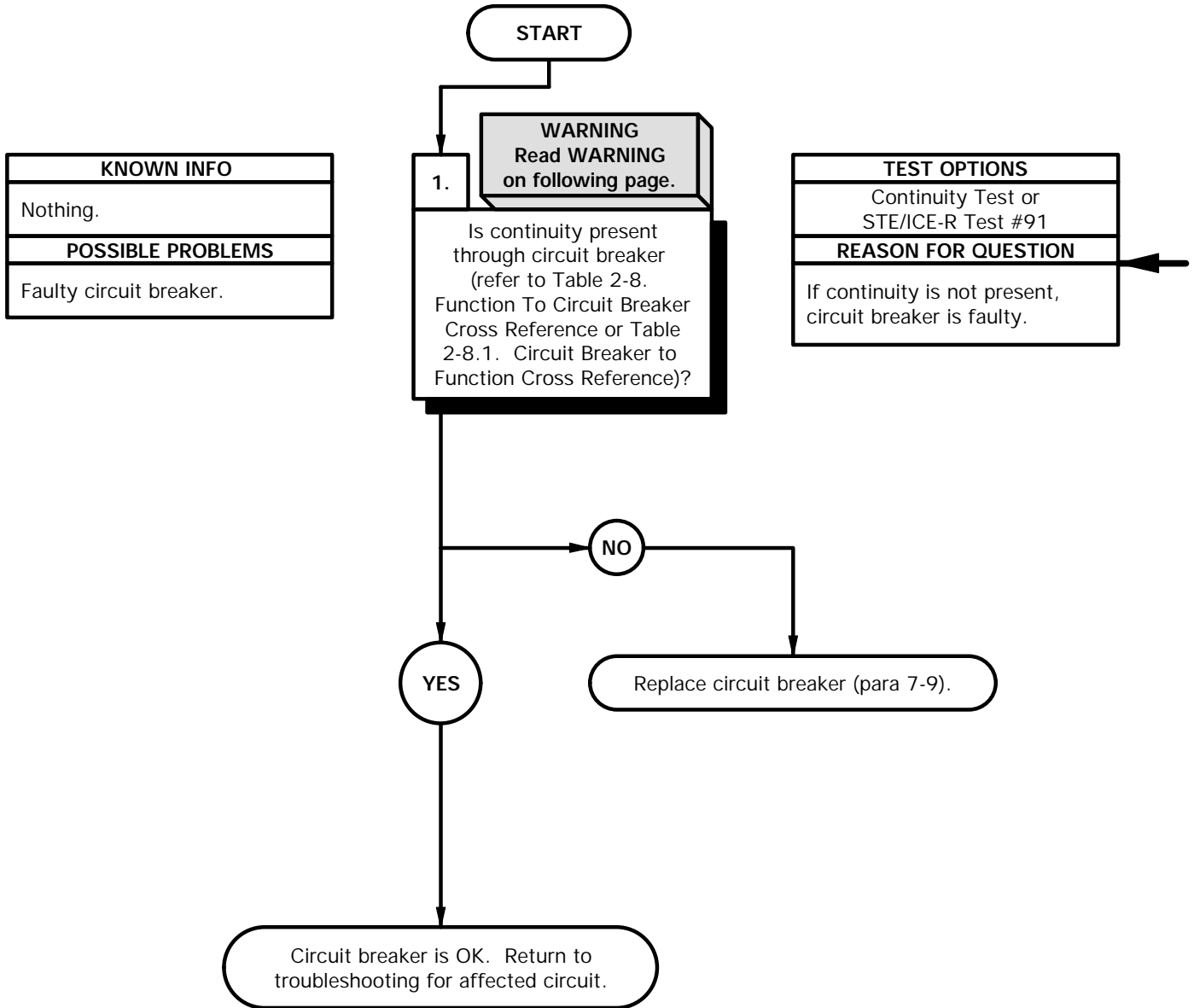

WARNING

Remove rings, bracelets, watches, necklaces, and any other jewelry before working around vehicle. Jewelry can catch on equipment and cause injury or short across electrical circuits and cause severe burns or electrical shock.

- CONTINUITY TEST**
- (1) Remove Power Distribution Panel (PDP) cover (para 16-2).
 - (2) Locate circuit breaker to be tested on PDP (refer to Figure 2-1. Circuit Breaker Locations and Table 2-8. Function to Circuit Breaker Cross Reference or Table 2-8.1. Circuit Breaker to Function Cross Reference).
 - (3) Check reset button on circuit breaker. If button is up (circuit breaker tripped), press button to reset.
 - (4) Remove circuit breaker to be tested from PDP.
 - (5) Set multimeter to ohms.
 - (6) Connect positive (+) probe of multimeter to one circuit breaker terminal.
 - (7) Connect negative (-) probe of multimeter to other circuit breaker terminal and note reading on multimeter.
 - (8) If continuity is not present, replace circuit breaker (para 7-9).
 - (9) If continuity is present, circuit breaker is OK. Return to troubleshooting for affected circuit.
 - (10) Install tested circuit breaker in PDP.
 - (11) Install PDP cover (para 16-2).

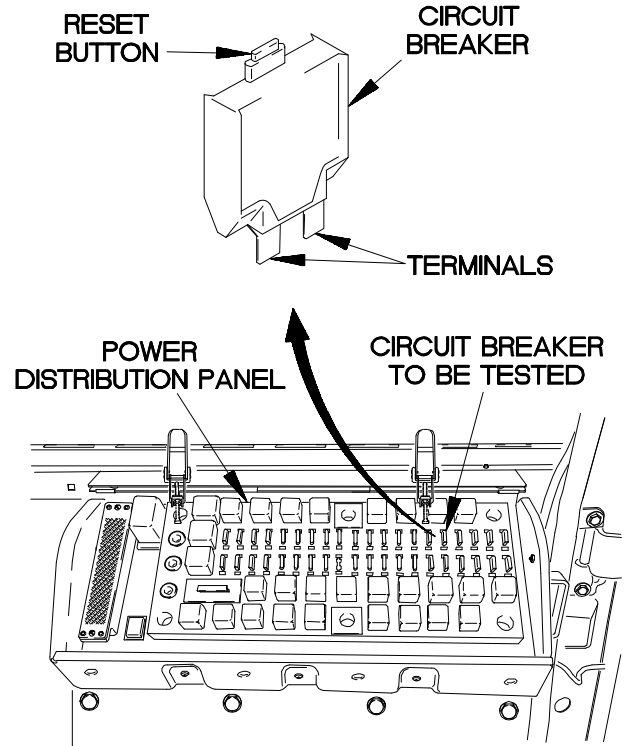

XBE0101B

Figure 2-1. Circuit Breaker Locations

○	D3	K12	K15	K9	K2	○	K32	K13	K19	K24	○
		CB30 CB45	CB20 CB48	CB41 CB42	CB44 CB43	CB50 CB39	CB36 CB23	CB21 CB22	CB79 CB40	CB37 CB49	CB77 CB68
○	D1										
		CB72 CB67	CB53 CB65	CB80 CB54	CB66 CB76	CB70	CB78 CB38	CB35 CB71	CB74 CB73	CB63 CB64	CB61 CB62
○	D2										
○	Storage	K25	K29	K6	K11	K26	K1	K10	K8	K7	
○	K20	K52	K53	K28	K27	○	K30	K31	K34	K37	○

XBE0102B

e1. CIRCUIT BREAKER DOES NOT OPERATE (CONT)

Table 2-8. Function to Circuit Breaker Cross Reference

Function	Circuit Breaker / AMP
10 AMP Fuse WTEC II Transmission ECU Pushbutton Shift Selector (TEPSS)	CB79 / 15
12 VDC Intervehicular Left Turn Signal	CB76 / 15
12 VDC Intervehicular Marker Lights	CB67 / 25
12 VDC Intervehicular Right Turn Signal	CB76 / 15
12 VDC Intervehicular Stoplight	CB76 / 15
12 VDC Intervehicular Taillights	CB80 / 25
24 VDC Intervehicular Auxiliary	CB76 / 15
24 VDC Intervehicular Blackout Clearance	CB42 / 10
24 VDC Intervehicular Blackout Stoplight	CB39 / 10
24 VDC Intervehicular Clearance and Rear Light	CB41 / 15
24 VDC Intervehicular Left and Right Turn Signals and Stoplights (WTEC III)	CB44 / 15
24 VDC Intervehicular Left Blackout Marker	CB42 / 10
24 VDC Intervehicular Left Turn Signal and Stoplight (WTEC II)	CB43 / 15
24 VDC Intervehicular Right Blackout Marker	CB42 / 10
24 VDC Intervehicular Right Turn Signal and Stoplight (WTEC II)	CB44 / 15
Air Dryer	CB21 / 15

Table 2-8. Function to Circuit Breaker Cross Reference (Cont)

Function	Circuit Breaker / AMP
All Marker Lights	CB67 / 25
Audible Alarm	CB77 / 10
Backup Light	CB73 / 8
Blackout Drive Light	CB54 / 8
Blackout Override Switch	CB72 / 15
Blackout Override Switch Light	CB70 / 20
Cab Radio	CB20 / 25
Central Tire Inflation System (CTIS)	CB40 / 10
Central Tire Inflation System (CTIS) Air Pressure Switch	CB40 / 10
Central Tire Inflation System (CTIS) Overspeed Indicator Light	CB40 / 10
Chemical Alarm	CB30 / 10
Chemical Detector	CB30 / 10
Chemical Detector Indicator Light	CB30 / 10
Circuit Breaker CB54	CB70 / 20
Circuit Breaker CB65	CB70 / 20
Circuit Breaker CB66	CB70 / 20
Circuit Breaker CB74	CB70 / 20
Circuit Breaker CB76	CB70 / 20
Dimmer Module	CB70 / 20
Emergency Brake Indicator Light	CB77 / 10
Engine Fan Off Indicator Light	CB77 / 10

Table 2-8. Function to Circuit Breaker Cross Reference (Cont)

Function	Circuit Breaker / AMP
Engine Fan Off Switch (Fan)	CB22 / 10
Engine Fan Off Switch (Indicator Light)	CB77 / 10
Engine Fan Off Switch Light	CB70 / 20
Engine Fan Solenoid	CB22 / 10
Engine Oil Pressure Gage	CB77 / 10
Engine Oil Pressure Gage Light	CB70 / 20
Engine Oil Pressure Indicator Light	CB77 / 10
Engine Oil Pressure Sensor	CB77 / 10
Engine Oil Pressure Switch	CB77 / 10
Ether Sensor	CB22 / 10
Ether Start Solenoid	CB22 / 10
Ether Start Switch	CB22 / 10
Ether Start Switch Light	CB70 / 20
Frequency Divider	CB21 / 15
Front Brake Air Indicator Light	CB77 / 10
Front Brake Air Indicator Light Switch	CB77 / 10
Front Brake Air Pressure Gage	CB77 / 10
Front Brake Air Pressure Gage Light	CB70 / 20
Front Brake Air Pressure Transmitter	CB77 / 10
Front Left Blackout Marker	CB66 / 8
Front Left Parking Light	CB65 / 8
Front Left Turn Signal	CB76 / 15

Table 2-8. Function to Circuit Breaker Cross Reference (Cont)

Function	Circuit Breaker / AMP
Front Right Blackout Marker	CB66 / 8
Front Right Parking Light	CB65 / 8
Front Right Turn Signal	CB76 / 15
Fuel Gage	CB77 / 10
Fuel Gage Light	CB70 / 20
Fuel Level Sensor	CB77 / 10
Fuel Solenoid	CB79 / 15
Fuel Water Solenoid	CB49 / 15
Hazard Warning Switch	CB71 / 15
Hazard Warning Switch	CB76 / 15
Hazard Warning Switch Light	CB70 / 20
Headlight Dimmer Switch	CB70 / 20
Headlight HI Beam Indicator Light	CB78 / 15
Horn	CB36 / 20
Lamp Test Switch Light	CB70 / 20
Left Blackout Stoplight	CB76 / 15
Left Headlight	CB78 / 15
Left Rear Composite Lamp Taillight	CB80 / 25
Left Turn Signal Indicator Light	CB76 / 15
Magnetic Pickup	CB77 / 10
Main Light Switch	CB70 / 20
Master Power Switch	CB70 / 20
Master Power Switch Light	CB70 / 20
Master Stop Indicator Light	CB77 / 10

e1. CIRCUIT BREAKER DOES NOT OPERATE (CONT)

Table 2-8. Function to Circuit Breaker Cross Reference (Cont)

Function	Circuit Breaker / AMP
Parking Brake Indicator Light	CB77 / 10
Parking Brake Switch	CB77 / 10
Personnel Heater	CB23 / 15
Personnel Heater Lights	CB70 / 20
Power Take-Off (PTO) Indicator Light	CB77 / 10
Power Take-Off (PTO) Pressure Switch	CB77 / 10
Power Take-Off (PTO) Solenoid	CB49 / 15
Power Take-Off (PTO) Switch	CB49 / 15
Power Take-Off (PTO) Switch Light	CB70 / 20
Rear Brake Air Indicator Light	CB77 / 10
Rear Brake Air Indicator Light Switch	CB77 / 10
Rear Brake Air Pressure Gage	CB77 / 10
Rear Brake Air Pressure Gage Light	CB70 / 20
Rear Brake Air Pressure Transmitter	CB77 / 10
Rear Left Composite Lamp Turn Signal	CB76 / 15
Rear LH Blackout Marker	CB66 / 8
Rear RH Blackout Marker	CB66 / 8
Rear Right Composite Lamp Turn Signal	CB76 / 15
Right Blackout Stoplight	CB76 / 15

Table 2-8. Function to Circuit Breaker Cross Reference (Cont)

Function	Circuit Breaker / AMP
Right Headlight	CB78 / 15
Right Rear Composite Lamp Taillight	CB80 / 25
Right Turn Signal Indicator Light	CB76 / 15
Rotating Warning Light	CB38 / 20
Rotating Warning Light Switch	CB70 / 20
Rotating Warning Light Switch Light	CB70 / 20
Speedometer	CB77 / 10
Speedometer Light	CB70 / 20
Start Inhibit Pushbutton Switch	CB79 / 15
Starter Pushbutton Switch	CB21 / 15
Stoplight Switches	CB76 / 15
Tachometer	CB77 / 10
Tachometer Light	CB70 / 20
Transmission Temperature Indicator Light	CB77 / 10
Troop Transport Alarm Switch	CB77 / 10
Turn Signal Flasher ECU	CB71 / 15
Turn Signal Flasher ECU	CB74 / 10
Van Door Indicator Light	CB77 / 10
Van Door Switch	CB50 / 15
Voltmeter	CB77 / 10
Voltmeter Light	CB70 / 20

**Table 2-8. Function to Circuit Breaker Cross Reference
(Cont)**

Function	Circuit Breaker / AMP
Water Temperature Gage	CB77 / 10
Water Temperature Gage Light	CB70 / 20
Water Temperature Indicator Light	CB77 / 10
Water Temperature Sensor	CB77 / 10
Water Temperature Switch	CB77 / 10
Water Temperature Switch (Fan)	CB22 / 10
Winch In Solenoid	CB49 / 15
Winch In/Out Switch	CB49 / 15
Winch In/Out Switch Light	CB70 / 20
Winch Out Solenoid	CB49 / 15
Winch Switch	CB49 / 15
Winch Switch Light	CB70 / 20
Windshield Wiper ECU	CB37 / 20
Wiper Motor	CB37 / 20
WTEC II Transmission ECU Pushbutton Shift Selector (TEPSS)	CB35 / 15
WTEC II Vehicle Interface Module (VIM)	CB35 / 15
WTEC II / WTEC III Transmission Pushbutton Shift Selector (TPSS) Dimmer Module	CB66 / 8
WTEC III Transmission ECU	CB43 / 15
WTEC III Transmission ECU	CB79 / 15

e1. CIRCUIT BREAKER DOES NOT OPERATE (CONT)

Table 2-8.1. Circuit Breaker to Function Cross Reference

Circuit Breaker / AMP	Function
CB20 / 25	Cab Radio
CB21 / 15	Air Dryer
CB21 / 15	Frequency Divider
CB21 / 15	Starter Pushbutton Switch
CB22 / 10	Engine Fan Off Switch (Fan)
CB22 / 10	Engine Fan Solenoid
CB22 / 10	Ether Sensor
CB22 / 10	Ether Start Solenoid
CB22 / 10	Ether Start Switch
CB22 / 10	Water Temperature Switch (Fan)
CB23 / 15	Personnel Heater
CB30 / 10	Chemical Alarm
CB30 / 10	Chemical Detector
CB30 / 10	Chemical Detector Indicator Light
CB35 / 15	WTEC II Transmission ECU Pushbutton Shift Selector (TEPSS)
CB35 / 15	WTEC II Vehicle Interface Module (VIM)
CB36 / 20	Horn
CB37 / 20	Windshield Wiper ECU
CB37 / 20	Wiper Motor
CB38 / 20	Rotating Warning Light
CB39 / 10	24 VDC Intervehicular Blackout Stoptlight

Table 2-8.1. Circuit Breaker to Function Cross Reference (Cont)

Circuit Breaker / AMP	Function
CB40 / 10	Central Tire Inflation System (CTIS)
CB40 / 10	Central Tire Inflation System (CTIS) Air Pressure Switch
CB40 / 10	Central Tire Inflation System (CTIS) Overspeed Indicator Light
CB41 / 15	24 VDC Intervehicular Clearance and Rear Light
CB42 / 10	24 VDC Intervehicular Blackout Clearance
CB42 / 10	24 VDC Intervehicular Left Blackout Marker
CB42 / 10	24 VDC Intervehicular Right Blackout Marker
CB43 / 15	24 VDC Intervehicular Left Turn Signal and Stoptlight (WTEC II)
CB43 / 15	WTEC III Transmission ECU
CB44 / 15	24 VDC Intervehicular Left and Right Turn Signals and Stoptlights (WTEC III)
CB44 / 15	24 VDC Intervehicular Right Turn Signal and Stoptlight (WTEC II)
CB49 / 15	Fuel Water Solenoid
CB49 / 15	Power Take-Off (PTO) Solenoid
CB49 / 15	Power Take-Off (PTO) Switch
CB49 / 15	Winch In Solenoid
CB49 / 15	Winch In/Out Switch
CB49 / 15	Winch Out Solenoid

Table 2-8.1. Circuit Breaker to Function Cross Reference (Cont)

Circuit Breaker / AMP	Function
CB49 / 15	Winch Switch
CB50 / 15	Van Door Switch
CB54 / 8	Blackout Drive Light
CB65 / 8	Front Left Parking Light
CB65 / 8	Front Right Parking Light
CB66 / 8	Front Left Blackout Marker
CB66 / 8	Front Right Blackout Marker
CB66 / 8	Rear LH Blackout Marker
CB66 / 8	Rear RH Blackout Marker
CB66 / 8	WTEC II / WTEC III Transmission Pushbutton Shift Selector (TPSS) Dimmer Module
CB67 / 25	12 VDC Intervehicular Marker Lights
CB67 / 25	All Marker Lights
CB70 / 20	Blackout Override Switch Light
CB70 / 20	Circuit Breaker CB54
CB70 / 20	Circuit Breaker CB65
CB70 / 20	Circuit Breaker CB66
CB70 / 20	Circuit Breaker CB74
CB70 / 20	Circuit Breaker CB76
CB70 / 20	Dimmer Module
CB70 / 20	Engine Fan Off Switch Light
CB70 / 20	Engine Oil Pressure Gage Light
CB70 / 20	Ether Start Switch Light
CB70 / 20	Fuel Gage Light

Table 2-8.1. Circuit Breaker to Function Cross Reference (Cont)

Circuit Breaker / AMP	Function
CB70 / 20	Front Brake Air Pressure Gage Light
CB70 / 20	Hazard Warning Switch Light
CB70 / 20	Headlight Dimmer Switch
CB70 / 20	Lamp Test Switch Light
CB70 / 20	Main Light Switch
CB70 / 20	Master Power Switch
CB70 / 20	Master Power Switch Light
CB70 / 20	Personnel Heater Lights
CB70 / 20	Power Take-Off (PTO) Switch Light
CB70 / 20	Rear Brake Air Pressure Gage Light
CB70 / 20	Rotating Warning Light Switch
CB70 / 20	Rotating Warning Light Switch Light
CB70 / 20	Speedometer Light
CB70 / 20	Tachometer Light
CB70 / 20	Voltmeter Light
CB70 / 20	Water Temperature Gage Light
CB70 / 20	Winch In/Out Switch Light
CB70 / 20	Winch Switch Light
CB71 / 15	Hazard Warning Switch
CB71 / 15	Turn Signal Flasher ECU
CB72 / 15	Blackout Override Switch
CB73 / 8	Backup Light
CB74 / 10	Turn Signal Flasher ECU

e1. CIRCUIT BREAKER DOES NOT OPERATE (CONT)

Table 2-8.1. Circuit Breaker to Function Cross Reference (Cont)

Circuit Breaker / AMP	Function
CB76 / 15	12 VDC Intervehicular Left Turn Signal
CB76 / 15	12 VDC Intervehicular Right Turn Signal
CB76 / 15	12 VDC Intervehicular Stoplight
CB76 / 15	24 VDC Intervehicular Auxiliary
CB76 / 15	Front Left Turn Signal
CB76 / 15	Front Right Turn Signal
CB76 / 15	Hazard Warning Switch
CB76 / 15	Left Blackout Stoplight
CB76 / 15	Left Turn Signal Indicator Light
CB76 / 15	Rear Left Composite Lamp Turn Signal
CB76 / 15	Rear Right Composite Lamp Turn Signal
CB76 / 15	Right Blackout Stoplight
CB76 / 15	Right Turn Signal Indicator Light
CB76 / 15	Stoplight Switches
CB77 / 10	Audible Alarm
CB77 / 10	Emergency Brake Indicator Light
CB77 / 10	Engine Fan Off Indicator Light
CB77 / 10	Engine Fan Off Switch (Indicator Light)
CB77 / 10	Engine Oil Pressure Gage
CB77 / 10	Engine Oil Pressure Indicator Light

Table 2-8.1. Circuit Breaker to Function Cross Reference (Cont)

Circuit Breaker / AMP	Function
CB77 / 10	Engine Oil Pressure Sensor
CB77 / 10	Engine Oil Pressure Switch
CB77 / 10	Front Brake Air Indicator Light
CB77 / 10	Front Brake Air Indicator Light Switch
CB77 / 10	Front Brake Air Pressure Gage
CB77 / 10	Front Brake Air Pressure Transmitter
CB77 / 10	Fuel Gage
CB77 / 10	Fuel Level Sensor
CB77 / 10	Magnetic Pickup
CB77 / 10	Master Stop Indicator Light
CB77 / 10	Parking Brake Indicator Light
CB77 / 10	Parking Brake Switch
CB77 / 10	Power Take-Off (PTO) Indicator Light
CB77 / 10	Power Take-Off (PTO) Pressure Switch
CB77 / 10	Rear Brake Air Indicator Light
CB77 / 10	Rear Brake Air Indicator Light Switch
CB77 / 10	Rear Brake Air Pressure Gage
CB77 / 10	Rear Brake Air Pressure Transmitter
CB77 / 10	Speedometer
CB77 / 10	Tachometer

**Table 2-8.1. Circuit Breaker to Function Cross Reference
(Cont)**

Circuit Breaker / AMP	Function
CB77 / 10	Transmission Temperature Indicator Light
CB77 / 10	Troop Transport Alarm Switch
CB77 / 10	Van Door Indicator Switch
CB77 / 10	Voltmeter
CB77 / 10	Water Temperature Gage
CB77 / 10	Water Temperature Indicator Light
CB77 / 10	Water Temperature Sensor
CB77 / 10	Water Temperature Switch
CB78 / 15	Headlight HI Beam Indicator Light
CB78 / 15	Left Headlight
CB78 / 15	Right Headlight
CB79 / 15	10 AMP Fuse WTEC II Transmission ECU Pushbutton Shift Selector (TEPSS)
CB79 / 15	Fuel Solenoid
CB79 / 15	Start Inhibit Pushbutton Switch
CB79 / 15	WTEC III Transmission ECU
CB80 / 25	12 VDC Intervehicular Taillights
CB80 / 25	Left Rear Composite Lamp Taillight
CB80 / 25	Right Rear Composite Lamp Taillight

e2. ENGINE DOES NOT CRANK

INITIAL SETUP

<p>Equipment Conditions Engine shut down (TM 9-2320-365-10). Cab raised (TM 9-2320-365-10).</p> <p>Tools and Special Tools Tool Kit, Genl Mech (Item 44, Appendix C) STE/ICE-R (Item 39, Appendix C) Multimeter, Digital (Item 22, Appendix C) Wire, Elect, 50 ft (Item 77, Appendix D) Wire, Relay Test (Item 9, Appendix E)</p>	<p>Materials/Parts Ties, Cable, Plastic (Item 76, Appendix D) Adhesive (Item 8, Appendix D) Dispenser, Pressure Sensitive Adhesive Tape (Item 21, Appendix D) Seal Ring, Metal (Item 251, Appendix G)</p> <p>Personnel Required (2)</p> <p>References TM 9-4910-571-12&P</p>
--	---

KNOWN INFO
Transmission pushbutton shift selector in neutral (N). Batteries OK. Service drive lights OK. Circuit breakers OK.
POSSIBLE PROBLEMS
Faulty starting motor. Faulty auxiliary starter solenoid. Faulty battery to starter cable assembly. Faulty oil pressure switch. Faulty relay K24. Faulty start and charging cable assembly. Faulty relay K1. Faulty engine control cable assembly. Faulty starter pushbutton switch. Faulty neutral start relay. Faulty WTEC II Vehicle Interface Module (VIM). Faulty WTEC II cab transmission wiring harness. Faulty WTEC II transmission ECU pushbutton shift selector (TEPSS). Faulty relay K26. Faulty dashboard cable assembly. Faulty WTEC III transmission ECU. Faulty WTEC III transmission pushbutton shift selector (TPSS).

NOTE
 Perform Engine System Troubleshooting a1. Engine Does Not Crank and Electrical System Troubleshooting e1. Circuit Breaker Does Not Operate on circuit breakers CB21 and CB77 prior to beginning this task.

Remove and install plastic cable ties as required.

TEST OPTIONS
Visual Inspection
REASON FOR QUESTION
If vehicle is equipped with connector P81, perform Thermal Switch Bypass procedure. If vehicle is not equipped with connector P81, continue with step 2 of this fault.

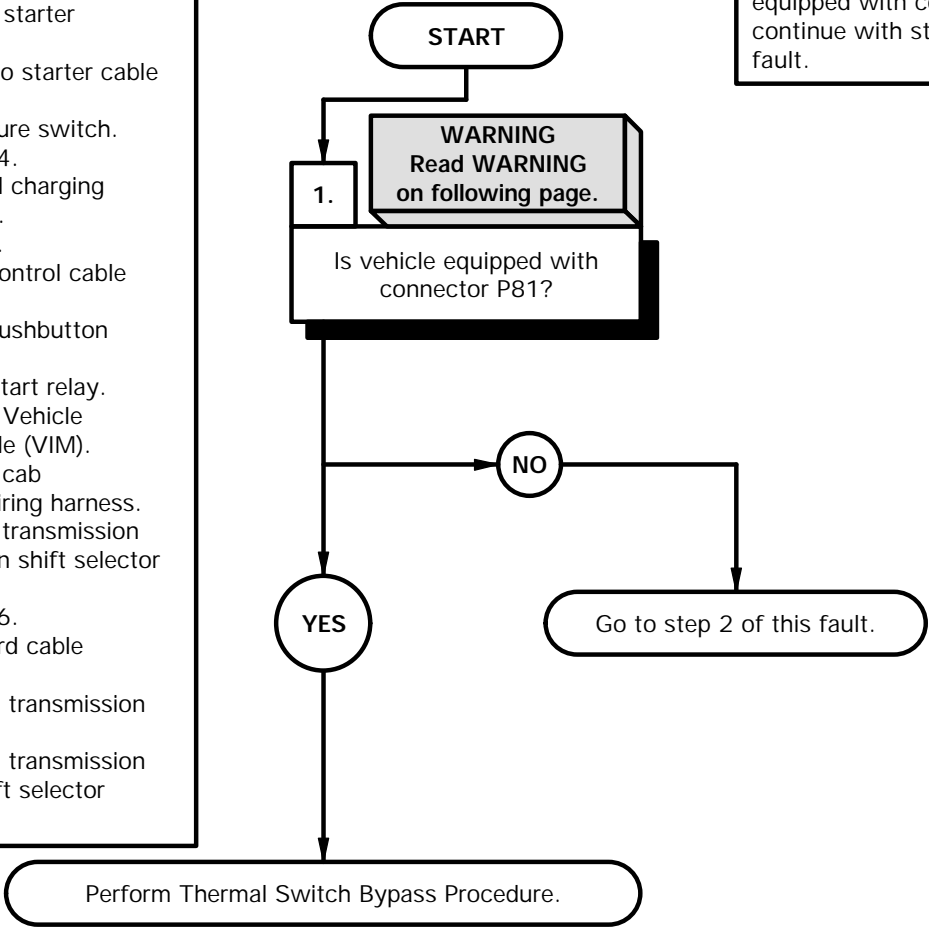

WARNING

Wear appropriate eye protection when working under vehicle due to the possibility of falling debris. Failure to comply may result in injury to personnel.

- (1) If vehicle is not equipped with connector P81 continue with step 2 of this fault.
- (2) If vehicle is equipped with connector P81 perform Thermal Switch Bypass Procedure, see below.
- (3) After performing Thermal Switch Bypass Procedure, attempt to start engine (TM 9-2320-365-10).
- (4) If engine still does not crank, continue with step 2 of this fault.

THERMAL SWITCH BYPASS PROCEDURE

NOTE

The tools and materials are required to perform the thermal switch bypass:
 Heater, Gun type, Electrical (Appendix B, Item 20)
 Tape, Insulation, Electrical (Appendix D, Item 75)
 Splice, Conductor (Item 261, Appendix G)
 Insulation, Sleeving, Electrical (1.5 in. or 3.8 cm) (Item 30.1, Appendix D)

- (1) Disconnect batteries (para 7-48).
- (2) Disconnect connector P81 from thermal switch connector.
- (3) Cut connector P81 from branch of start and charging cable assembly.
- (4) Remove band marker from branch of start and charging cable assembly.

NOTE

Remove electrical tape as required.

- (5) Remove insulation sleeving from convoluted tubing to body of start and charging cable assembly.
- (6) Remove insulation sleeving from two wires to body of start and charging cable assembly.

NOTE

Measure wires from body of start and charging cable assembly.

- (7) Cut one wire 3 in. (7.6 cm).
- (8) Cut other wire 4 in. (10.2 cm).
- (9) Remove 0.38 in. (1 cm) of insulation from two wires.

**THERMAL SWITCH BYPASS PROCEDURE
(Cont)**

- (10) Cut insulation sleeving 1.5 in. (3.8 cm).
- (11) Position insulation sleeving on 4 in. (10.2 cm) wire.
- (12) Install conductor splice on two wires.
- (13) Install insulation sleeving on conductor splice.

NOTE

Install electrical tape as required.

- (14) Install conductor splice in convoluted tubing.
- (15) Lower cab (TM 9-2320-365-10).
- (16) Connect batteries (para 7-48).

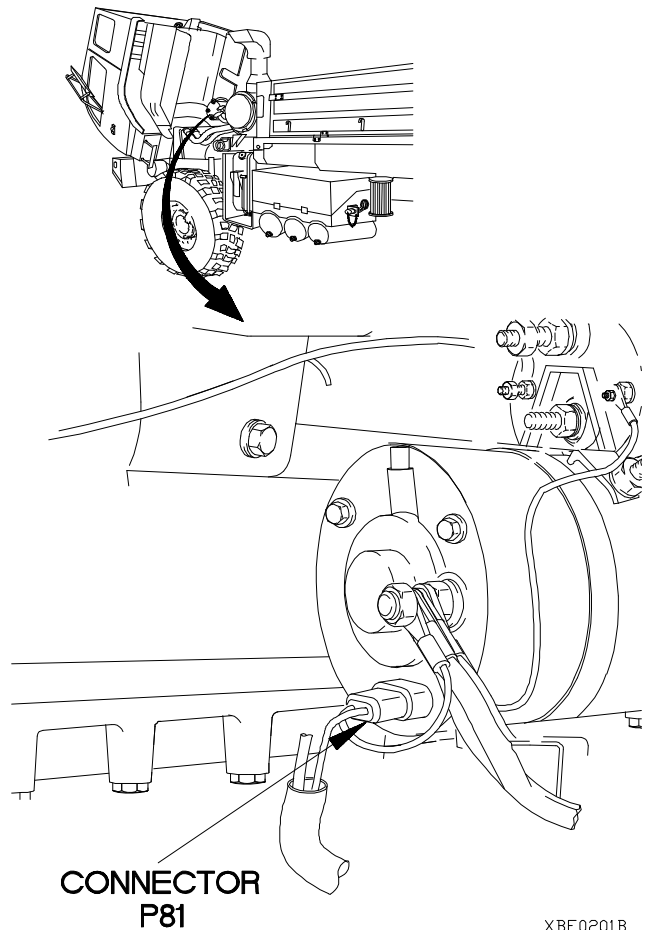

XBE0201B

e2. ENGINE DOES NOT CRANK (CONT)

KNOWN INFO
Transmission pushbutton shift selector in neutral (N). Batteries OK. Service drive lights OK. Circuit breakers OK.
POSSIBLE PROBLEMS
Faulty starting motor. Faulty auxiliary starter solenoid. Faulty battery to starter cable assembly. Faulty oil pressure switch. Faulty relay K24. Faulty start and charging cable assembly. Faulty relay K1. Faulty engine control cable assembly. Faulty starter pushbutton switch. Faulty neutral start relay. Faulty WTEC II vehicle interface module (VIM). Faulty WTEC II cab transmission wiring harness. Faulty WTEC II transmission ECU pushbutton shift selector (TEPSS). Faulty relay K26. Faulty dashboard cable assembly. Faulty WTEC III transmission ECU. Faulty WTEC III transmission pushbutton shift selector (TPSS).

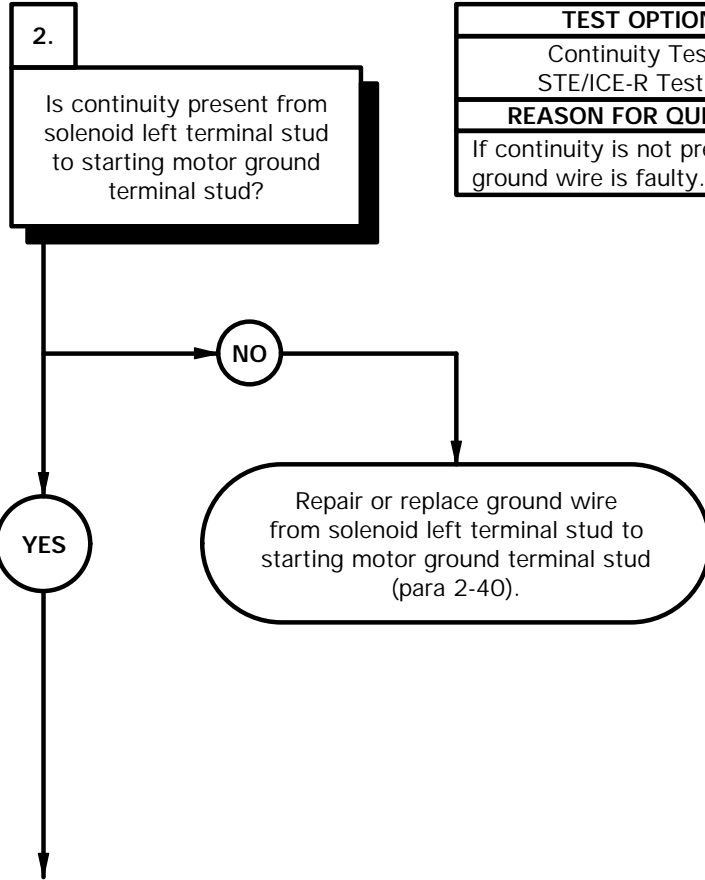

TEST OPTIONS
Continuity Test or STE/ICE-R Test #91
REASON FOR QUESTION
If continuity is not present, ground wire is faulty.

CONTINUITY TEST

- (1) Disconnect batteries (para 7-48).
- (2) Set multimeter to ohms.
- (3) Connect positive (+) probe of multimeter to solenoid left terminal stud.
- (4) Connect negative (-) probe of multimeter to starting motor ground terminal stud and note reading on multimeter.
- (5) If continuity is not present repair or replace ground wire from solenoid left terminal stud to starting motor ground terminal stud (para 2-40).

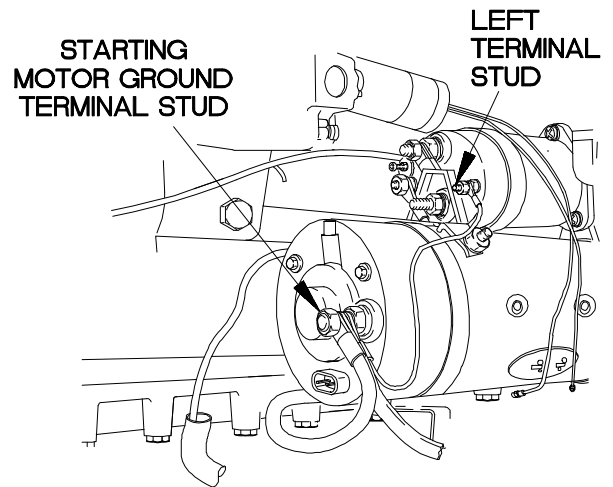

XBE0202B

e2. ENGINE DOES NOT CRANK (CONT)

KNOWN INFO
Transmission pushbutton shift selector in neutral (N). Batteries OK. Service drive lights OK. Circuit breakers OK.
POSSIBLE PROBLEMS
Faulty starting motor. Faulty auxiliary starter solenoid. Faulty battery to starter cable assembly. Faulty oil pressure switch. Faulty relay K24. Faulty start and charging cable assembly. Faulty relay K1. Faulty engine control cable assembly. Faulty starter pushbutton switch. Faulty neutral start relay. Faulty WTEC II vehicle interface module (VIM). Faulty WTEC II cab transmission wiring harness. Faulty WTEC II transmission ECU pushbutton shift selector (TEPSS). Faulty relay K26. Faulty dashboard cable assembly. Faulty WTEC III transmission pushbutton shift selector (TPSS).

3. **WARNING**
Read **WARNING** on following page.

Is 24 VDC present at terminal lug TL26?

TEST OPTIONS
Voltage Test or STE/ICE-R Test #89
REASON FOR QUESTION
If 24 VDC is not present, go to step 4 of this fault. If 24 VDC is present, starting motor is faulty.

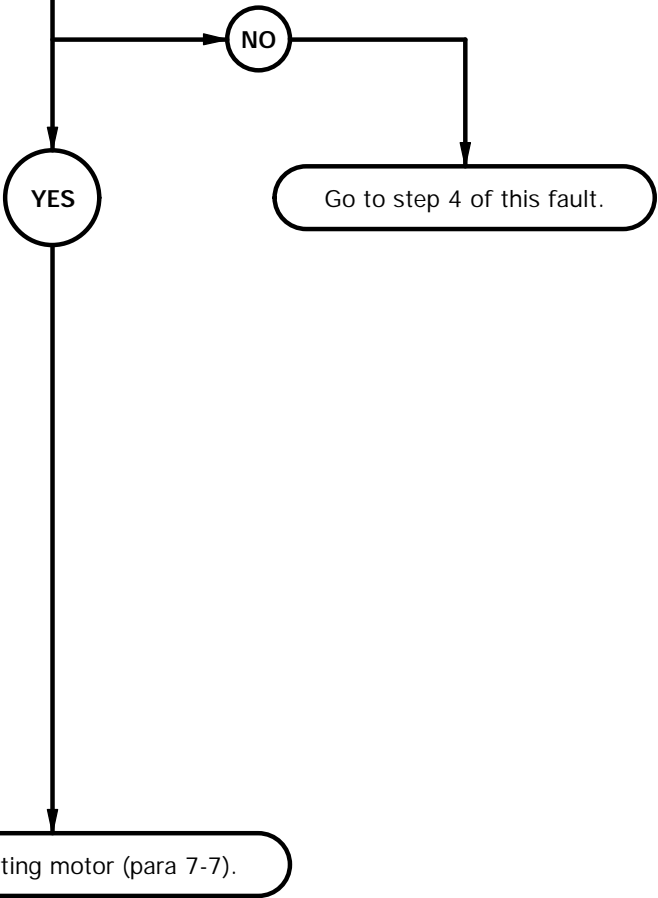

WARNING

Remove rings, bracelets, watches, necklaces, and any other jewelry before working around vehicle. Jewelry can catch on equipment and cause injury or short across electrical circuits and cause severe burns or electrical shock.

VOLTAGE TEST

- (1) Remove adhesive from solenoid right terminal stud.
- (2) Connect batteries (para 7-48).
- (3) Set multimeter to volts DC.
- (4) Connect positive (+) probe of multimeter to terminal lug TL26.
- (5) Connect negative (-) probe of multimeter to ground.
- (6) Lower cab (TM 9-2320-365-10).
- (7) Position master power switch to on (TM 9-2320-365-10).
- (8) Press starter pushbutton (TM 9-2320-365-10) and note reading on multimeter.
- (9) If 24 VDC is not present go to 4 of this fault.
- (10) If 24 VDC is present, replace starting motor (para 7-7).
- (11) Position master power switch to off (TM 9-2320-365-10).

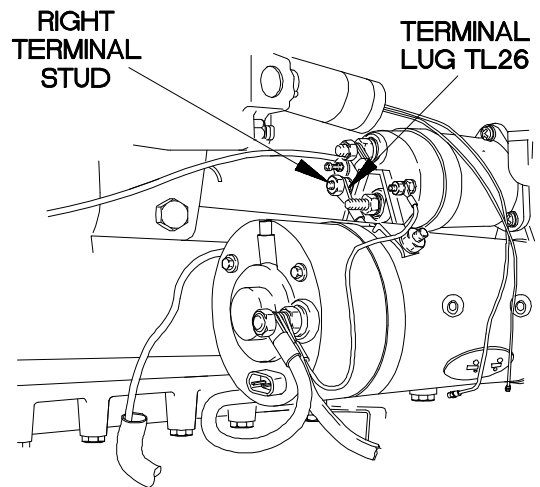

XBE0203B

e2. ENGINE DOES NOT CRANK (CONT)

KNOWN INFO
Transmission pushbutton shift selector in neutral (N). Batteries OK. Service drive lights OK. Circuit breakers OK. Starting motor OK.
POSSIBLE PROBLEMS
Faulty auxiliary starter solenoid. Faulty battery to starter cable assembly. Faulty oil pressure switch. Faulty relay K24. Faulty start and charging cable assembly. Faulty relay K1. Faulty engine control cable assembly. Faulty starter pushbutton switch. Faulty neutral start relay. Faulty WTEC II vehicle interface module (VIM). Faulty WTEC II cab transmission wiring harness. Faulty WTEC II transmission ECU pushbutton shift selector (TEPSS). Faulty relay K26. Faulty dashboard cable assembly. Faulty WTEC III transmission pushbutton shift selector (TPSS).

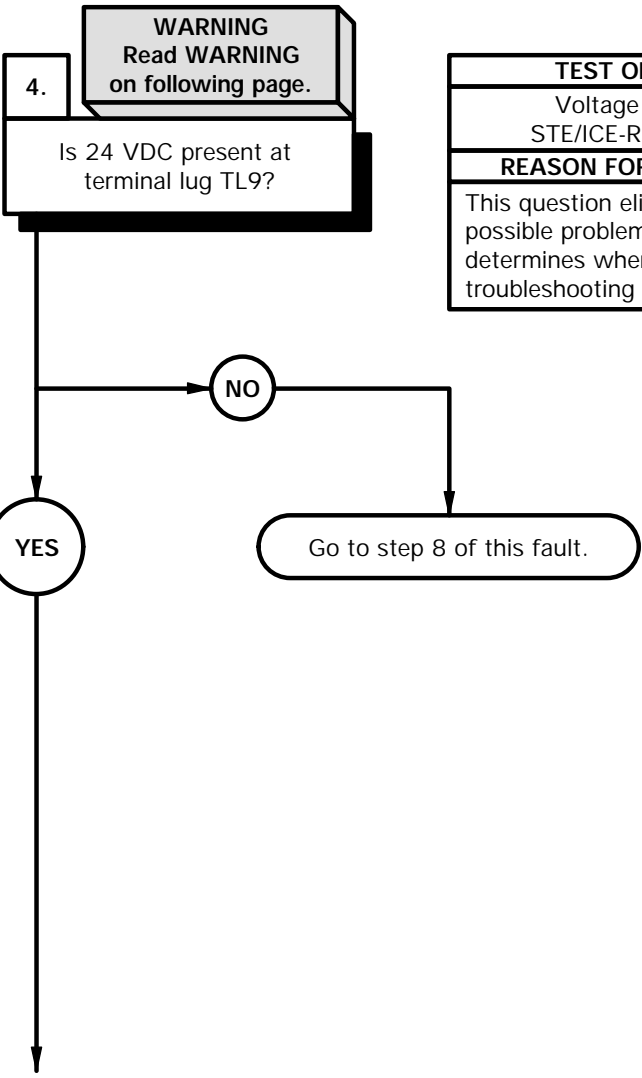

TEST OPTIONS
Voltage Test or STE/ICE-R Test #89
REASON FOR QUESTION
This question eliminates possible problems and determines where troubleshooting continues.

WARNING

Remove rings, bracelets, watches, necklaces, and any other jewelry before working around vehicle. Jewelry can catch on equipment and cause injury or short across electrical circuits and cause severe burns or electrical shock.

VOLTAGE TEST

- (1) Raise cab (TM 9-2320-365-10).
- (2) Disconnect batteries (para 7-48).
- (3) Remove adhesive from auxiliary starter solenoid.
- (4) Connect batteries (para 7-48).
- (5) Set multimeter to volts DC.
- (6) Connect positive (+) probe of multimeter to terminal lug TL9.
- (7) Connect negative (-) probe of multimeter to ground and note reading on multimeter.
- (8) If 24 VDC is not present, go to step 8 of this fault.

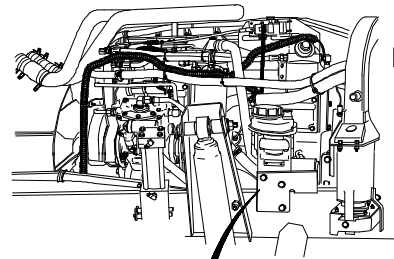

POWER STEERING
PUMP RESERVOIR
REMOVED FOR
CLARITY

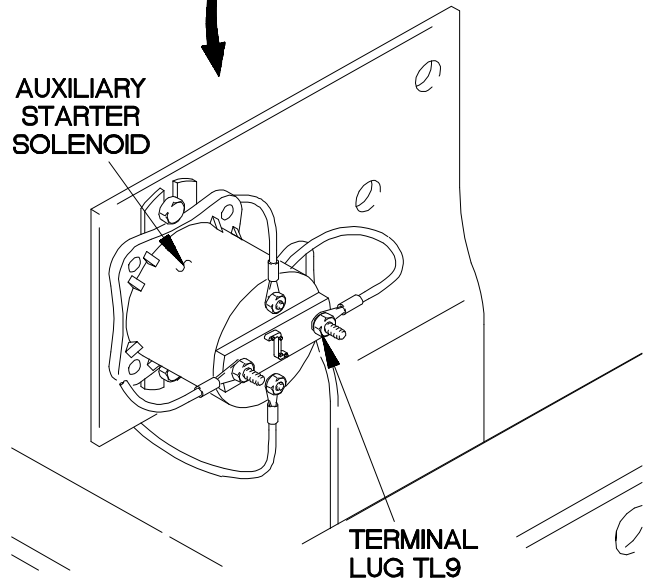

AUXILIARY
STARTER
SOLENOID

TERMINAL
LUG TL9

XBE0204B

e2. ENGINE DOES NOT CRANK (CONT)

KNOWN INFO
Transmission pushbutton shift selector in neutral (N). Batteries OK. Service drive lights OK. Circuit breakers OK. Starting motor OK. Battery to starter cable assembly OK.
POSSIBLE PROBLEMS
Faulty auxiliary starter solenoid. Faulty oil pressure switch. Faulty relay K24. Faulty start and charging cable assembly. Faulty relay K1. Faulty engine control cable assembly. Faulty starter pushbutton switch. Faulty neutral start relay. Faulty WTEC II vehicle interface module (VIM). Faulty WTEC II cab transmission wiring harness. Faulty WTEC II transmission ECU pushbutton shift selector (TEPSS). Faulty relay K26. Faulty dashboard cable assembly. Faulty WTEC III transmission pushbutton shift selector (TPSS).

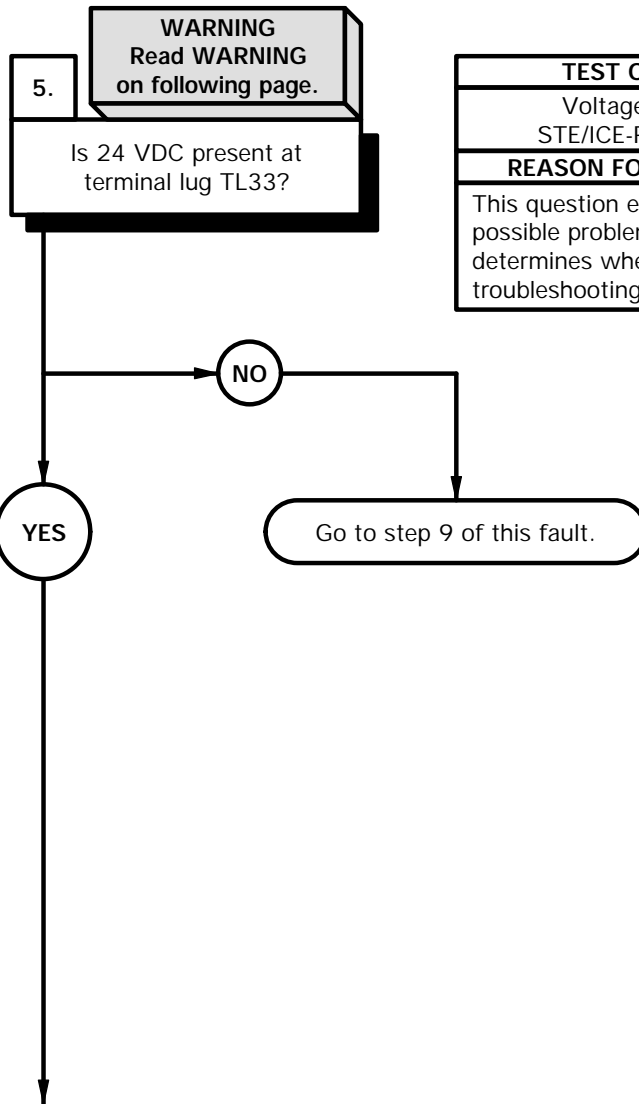

TEST OPTIONS
Voltage Test or STE/ICE-R Test #89
REASON FOR QUESTION
This question eliminates possible problems and determines where troubleshooting continues.

WARNING

Remove rings, bracelets, watches, necklaces, and any other jewelry before working around vehicle. Jewelry can catch on equipment and cause injury or short across electrical circuits and cause severe burns or electrical shock.

VOLTAGE TEST

- (1) Set multimeter to volts DC.
- (2) Connect positive (+) probe of multimeter to terminal lug TL33.
- (3) Connect negative (-) probe of multimeter to ground.
- (4) Lower cab (TM 9-2320-365-10).
- (5) Position master power switch to on (TM 9-2320-365-10).
- (6) Press starter pushbutton (TM 9-2320-365-10) and note reading on multimeter.
- (7) If 24 VDC is not present, go to step 9 of this fault.
- (8) Position master power switch to off (TM 9-2320-365-10).
- (9) Raise cab (TM 9-2320-365-10).

POWER STEERING
PUMP RESERVOIR
REMOVED FOR
CLARITY

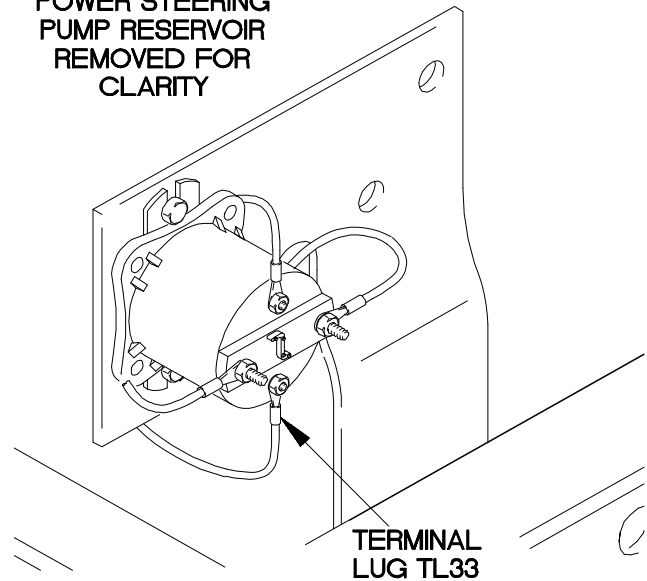

XBE0205B

e2. ENGINE DOES NOT CRANK (CONT)

KNOWN INFO
Transmission pushbutton shift selector in neutral (N). Batteries OK. Service drive lights OK. Circuit breakers OK. Starting motor OK. Battery to starter cable assembly OK. Oil pressure switch OK. Relay K24 OK. Relay K1 OK. Engine control cable assembly OK. Starter pushbutton switch OK. Neutral start relay OK. WTEC II vehicle interface module (VIM) OK. WTEC II cab transmission wiring harness OK. WTEC II transmission ECU pushbutton shift selector (TEPSS) OK. Relay K26 OK. Dashboard cable assembly OK.
POSSIBLE PROBLEMS
Faulty auxiliary starter solenoid. Faulty start and charging cable assembly.

6.
 Is continuity present from terminal lug TL23 to ground?

TEST OPTIONS
Continuity Test or STE/ICE-R Test #91
REASON FOR QUESTION
If continuity is not present, wire 93 is faulty.

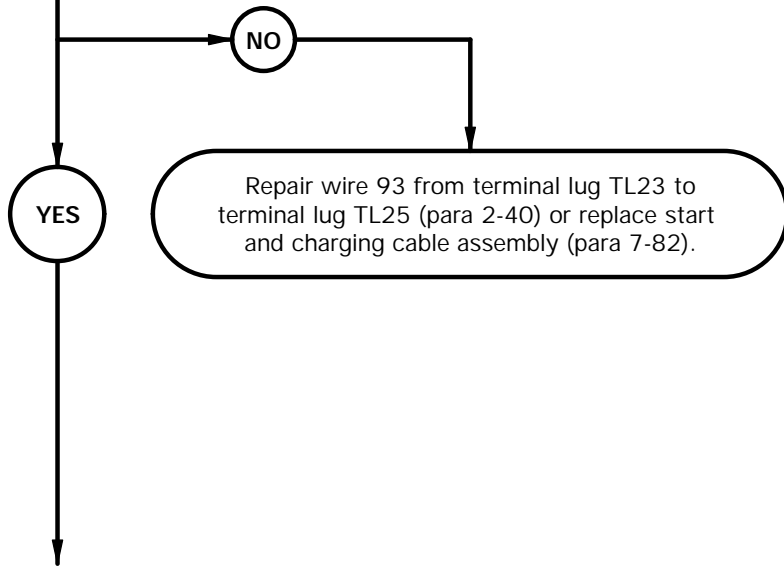

CONTINUITY TEST

- (1) Disconnect batteries (para 7-48).
- (2) Remove nut, lockwasher, and terminal lug TL23 from auxiliary starter solenoid. Discard lockwasher.
- (3) Set multimeter to ohms.
- (4) Connect positive (+) probe of multimeter to terminal lug TL23.
- (5) Connect negative (-) probe of multimeter to ground and note reading on multimeter.
- (6) If continuity is not present, repair wire 93 from terminal lug TL23 to terminal lug TL25 (para 2-40) or replace start and charging cable assembly (para 7-82).
- (7) Install terminal lug TL23 on auxiliary starter solenoid with lockwasher and nut.

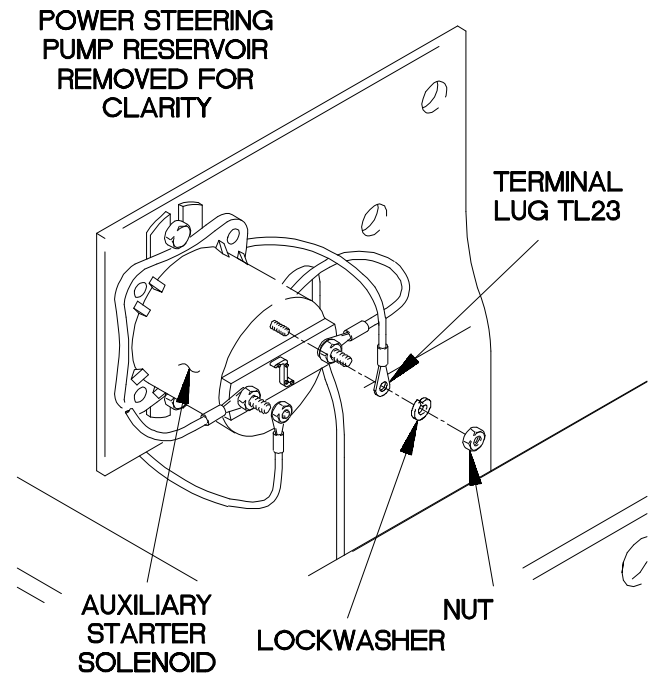

XBE0206B

e2. ENGINE DOES NOT CRANK (CONT)

KNOWN INFO

Transmission pushbutton shift selector in neutral (N).
 Batteries OK.
 Service drive lights OK.
 Circuit breakers OK.
 Starting motor OK.
 Battery to starter cable assembly OK.
 Oil pressure switch OK.
 Relay K24 OK.
 Relay K1 OK.
 Engine control cable assembly OK.
 Starter pushbutton switch OK.
 Neutral start relay OK.
 WTEC II vehicle interface module (VIM) OK.
 WTEC II cab transmission wiring harness OK.
 WTEC II transmission ECU pushbutton shift selector (TEPSS) OK.
 Relay K26 OK.
 Dashboard cable assembly OK.

POSSIBLE PROBLEMS

Faulty auxiliary starter solenoid.
 Faulty start and charging cable assembly.

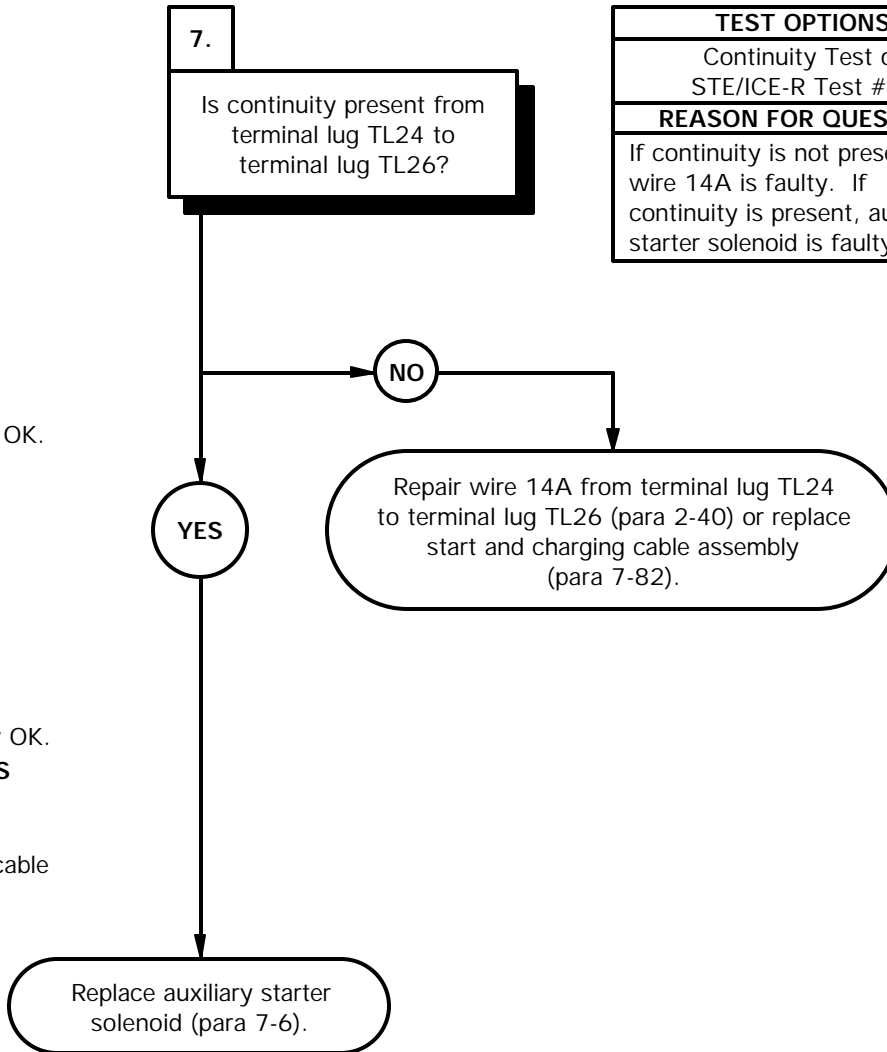

TEST OPTIONS
Continuity Test or STE/ICE-R Test #91
REASON FOR QUESTION
If continuity is not present, wire 14A is faulty. If continuity is present, auxiliary starter solenoid is faulty.

CONTINUITY TEST

- (1) Remove nut, lockwasher, and terminal lug TL24 from auxiliary starter solenoid. Discard lockwasher.
- (2) Set multimeter to ohms.
- (3) Connect positive (+) probe of multimeter to terminal lug TL24.
- (4) Connect negative (-) probe of multimeter to terminal lug TL26 and note reading on multimeter.
- (5) If continuity is not present, repair wire 14A from terminal lug TL24 to terminal lug TL26 (para 2-40) or replace start and charging cable assembly (para 7-82).
- (6) If continuity is present, replace auxiliary starter solenoid (para 7-6).
- (7) Install terminal lug TL24 on auxiliary starter solenoid with lockwasher and nut.
- (8) Apply adhesive to auxiliary starter solenoid.
- (9) Apply adhesive to solenoid right terminal stud.
- (10) Lower cab (TM 9-2320-365-10).
- (11) Connect batteries (para 7-48).

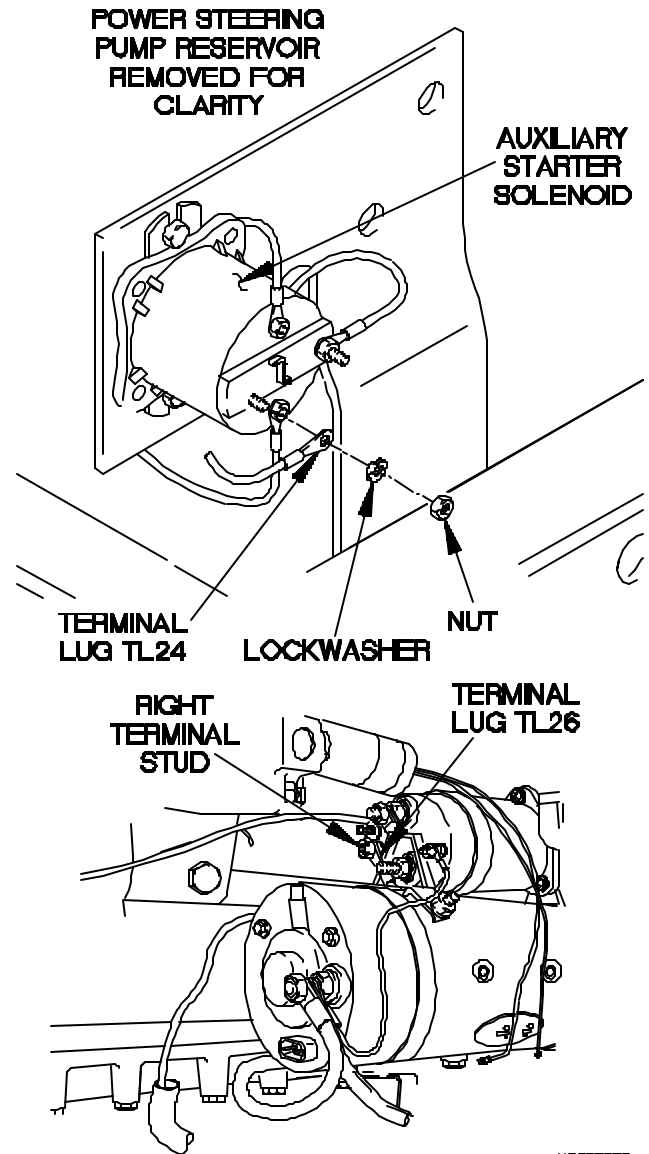

X8CD2078

e2. ENGINE DOES NOT CRANK (CONT)

KNOWN INFO
Transmission pushbutton shift selector in neutral (N). Batteries OK. Service drive lights OK. Circuit breakers OK. Starting motor OK.
POSSIBLE PROBLEMS
Faulty battery to starter cable assembly. Faulty start and charging cable assembly.

8. **WARNING**
Read **WARNING** on following page.

Is 24 VDC present at terminal lug TL12?

TEST OPTIONS
Voltage Test or STE/ICE-R Test #89
REASON FOR QUESTION
If 24 VDC is not present, wire 1602 is faulty. If 24 VDC is present, wire 14 faulty.

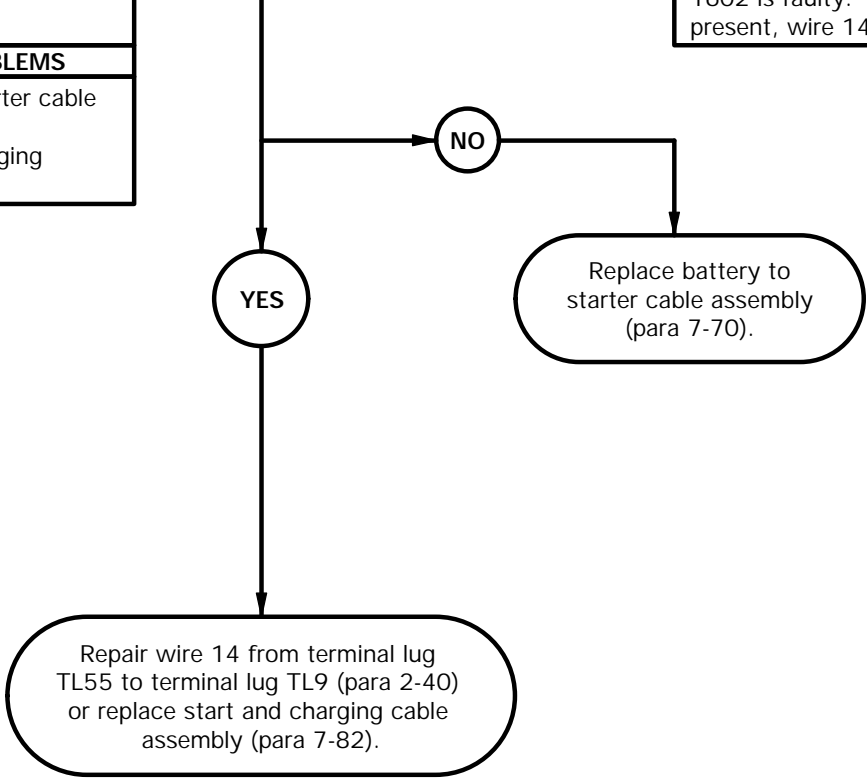

WARNING

Remove rings, bracelets, watches, necklaces, and any other jewelry before working around vehicle. Jewelry can catch on equipment and cause injury or short across electrical circuits and cause severe burns or electrical shock.

VOLTAGE TEST

- (1) Set multimeter to volts DC.
- (2) Connect positive (+) probe of multimeter to terminal lug TL12.
- (3) Connect negative (-) probe of multimeter to ground and note reading on multimeter.
- (4) If 24 VDC is not present, replace battery to starter cable assembly (para 7-70).
- (5) If 24 VDC is present, repair wire 14 from terminal lug TL55 to terminal lug TL9 (para 2-40) or replace start and charging cable assembly (para 7-82).
- (6) Disconnect batteries (para 7-48).
- (7) Apply adhesive to auxiliary starter solenoid.
- (8) Apply adhesive to solenoid right terminal stud.
- (9) Connect batteries (para 7-48).
- (10) Lower cab (TM 9-2320-365-10).

TERMINAL SHOWN
EXPLODED FOR CLARITY

TERMINAL
LUG TL12

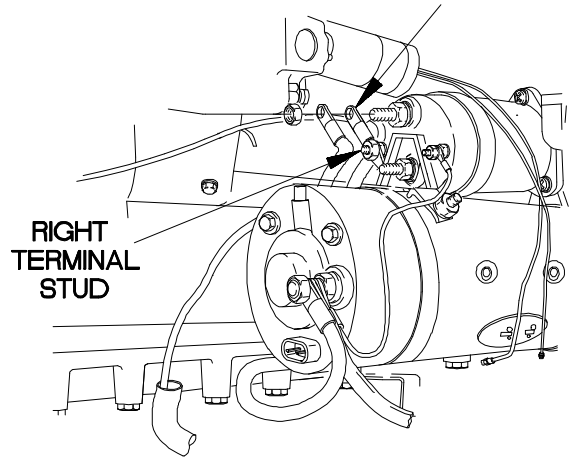

POWER STEERING
PUMP RESERVOIR
REMOVED FOR
CLARITY

AUXILIARY
STARTER
SOLENOID

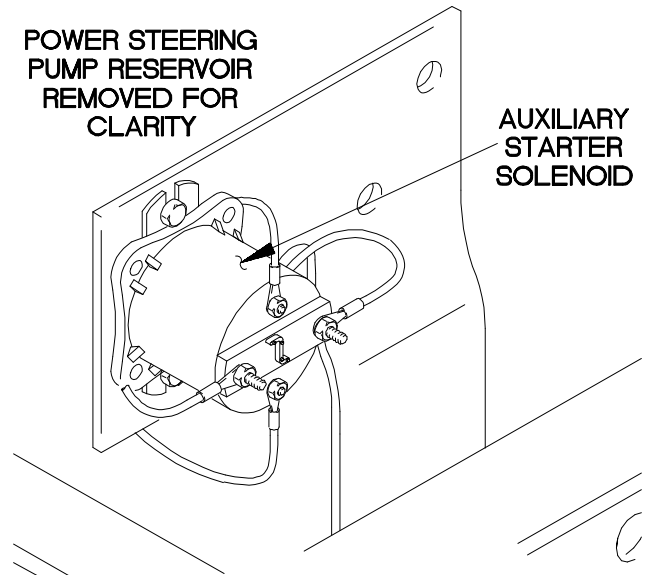

XBE0208B

e2. ENGINE DOES NOT CRANK (CONT)

KNOWN INFO
Transmission pushbutton shift selector in neutral (N). Batteries OK. Service drive lights OK. Circuit breakers OK. Starting motor OK. Battery to starter cable assembly OK.
POSSIBLE PROBLEMS
Faulty oil pressure switch. Faulty relay K24. Faulty start and charging cable assembly. Faulty relay K1. Faulty engine control cable assembly. Faulty starter pushbutton switch. Faulty neutral start relay. Faulty WTEC II vehicle interface module (VIM). Faulty WTEC II cab transmission wiring harness. Faulty WTEC II transmission ECU pushbutton shift selector (TEPSS). Faulty relay K26. Faulty dashboard cable assembly. Faulty WTEC III transmission pushbutton shift selector (TPSS).

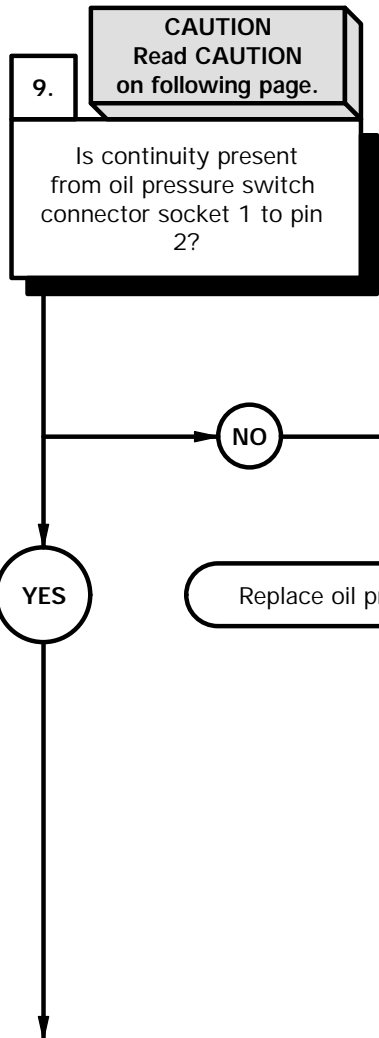

TEST OPTIONS
Continuity Test or STE/ICE-R Test #91
REASON FOR QUESTION
If continuity is not present, oil pressure switch is faulty.



CAUTION

Use care when testing electrical connectors. Do not damage connector pins or sockets with multimeter probes. Failure to comply may result in damage to equipment.

NOTE

Inspect connector pins/sockets for damage, corrosion, and serviceability. Check that connector pins are not pushed back or not capable of making good contact.

CONTINUITY TEST

- (1) Disconnect batteries (para 7-48).
- (2) Apply adhesive to auxiliary starter solenoid.
- (3) Apply adhesive to solenoid right terminal stud.
- (4) Disconnect connector clamp from oil pressure switch connector.
- (5) Disconnect connector P34 from oil pressure switch connector.
- (6) Set multimeter to ohms.
- (7) Connect positive (+) probe of multimeter to oil pressure switch connector socket 1.
- (8) Connect negative (-) probe of multimeter to oil pressure switch connector pin 2 and note reading on multimeter.
- (9) If continuity is not present, replace oil pressure switch (para 7-40).

POWER STEERING
PUMP RESERVOIR
REMOVED FOR
CLARITY

AUXILIARY
STARTER
SOLENOID

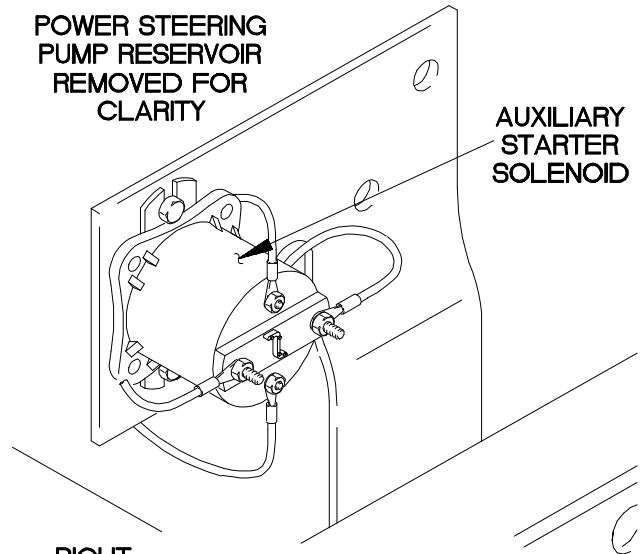

RIGHT
TERMINAL
STUD

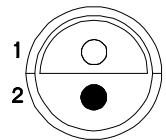
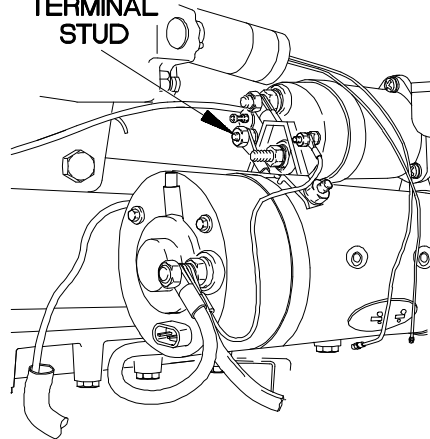

OIL PRESSURE
SWITCH
CONNECTOR

CONNECTOR
P34

CONNECTOR
CLAMP

OIL PRESSURE
SWITCH
CONNECTOR

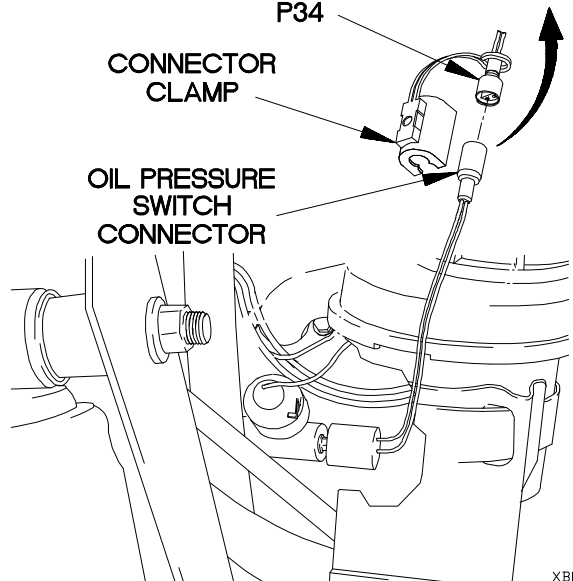

XBE0209B

e2. ENGINE DOES NOT CRANK (CONT)

KNOWN INFO
Transmission pushbutton shift selector in neutral (N). Batteries OK. Service drive lights OK. Circuit breakers OK. Starting motor OK. Battery to starter cable assembly OK. Oil pressure switch OK.
POSSIBLE PROBLEMS
Faulty relay K24. Faulty start and charging cable assembly. Faulty relay K1. Faulty engine control cable assembly. Faulty starter pushbutton switch. Faulty neutral start relay. Faulty WTEC II vehicle interface module (VIM). Faulty WTEC II cab transmission wiring harness. Faulty WTEC II transmission ECU pushbutton shift selector (TEPSS). Faulty relay K26. Faulty dashboard cable assembly. Faulty WTEC III transmission pushbutton shift selector (TPSS).

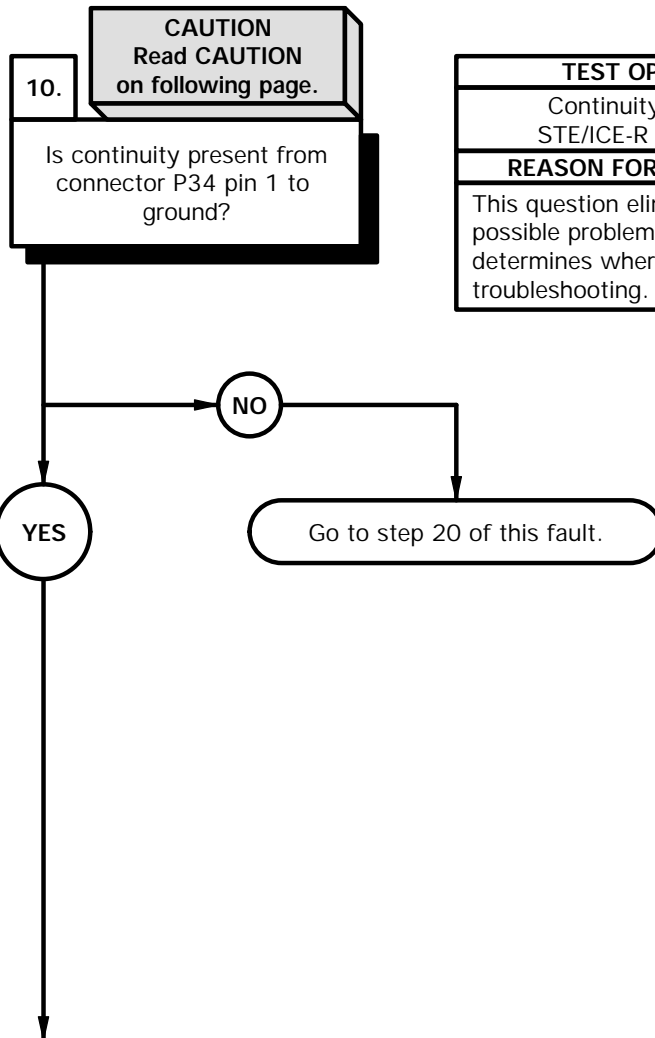

TEST OPTIONS
Continuity Test or STE/ICE-R Test #91
REASON FOR QUESTION
This question eliminates possible problems and determines where to continue troubleshooting.

CAUTION

Use care when testing electrical connectors. Do not damage connector pins or sockets with multimeter probes. Failure to comply may result in damage to equipment.

NOTE

Inspect connector pins/sockets for damage, corrosion, and serviceability. Check that connector pins are not pushed back or not capable of making good contact.

CONTINUITY TEST

- (1) Set multimeter to ohms.
- (2) Connect positive (+) probe of multimeter to connector P34 pin 1.
- (3) Connect negative (-) probe of multimeter to ground and note reading on multimeter.
- (4) If continuity is not present, go to step 20 of this fault.

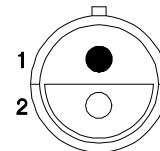
**P34**

XBE0210B

e2. ENGINE DOES NOT CRANK (CONT)

KNOWN INFO
Transmission pushbutton shift selector in neutral (N). Batteries OK. Service drive lights OK. Circuit breakers OK. Starting motor OK. Battery to starter cable assembly OK. Oil pressure switch OK.
POSSIBLE PROBLEMS
Faulty relay K24. Faulty start and charging cable assembly. Faulty relay K1. Faulty engine control cable assembly. Faulty starter pushbutton switch. Faulty neutral start relay. Faulty WTEC II vehicle interface module (VIM). Faulty WTEC II cab transmission wiring harness. Faulty WTEC II transmission ECU pushbutton shift selector (TEPSS). Faulty relay K26. Faulty dashboard cable assembly. Faulty WTEC III transmission pushbutton shift selector (TPSS).

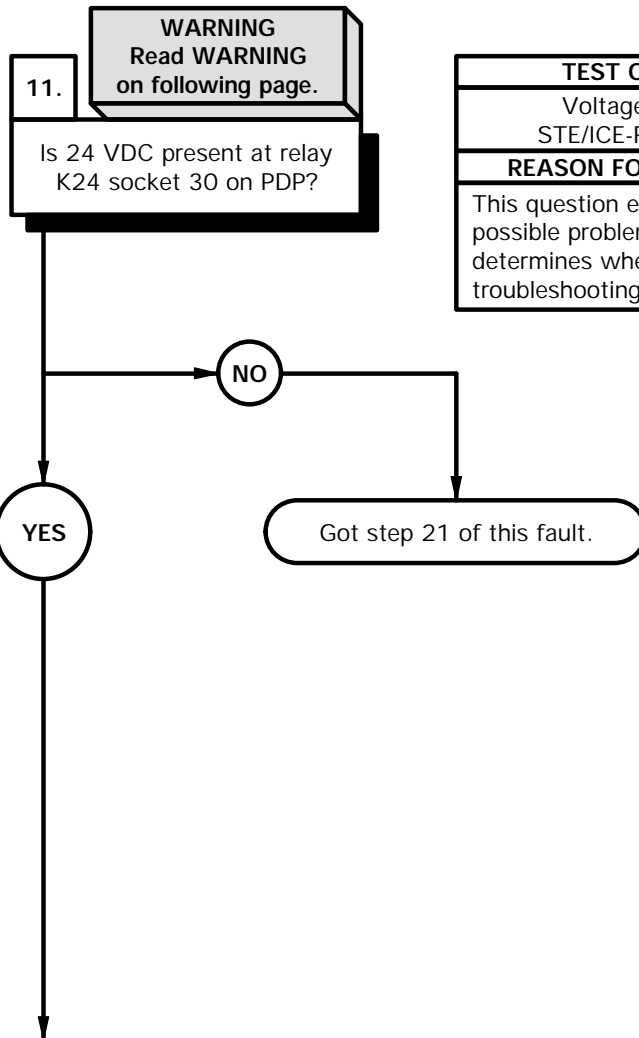

TEST OPTIONS
Voltage Test or STE/ICE-R Test #89
REASON FOR QUESTION
This question eliminates possible problems and determines where to continue troubleshooting.

WARNING

Remove rings, bracelets, watches, necklaces, and any other jewelry before working around vehicle. Jewelry can catch on equipment and cause injury or short across electrical circuits and cause severe burns or electrical shock.

VOLTAGE TEST

- (1) Connect connector P34 to oil pressure switch connector.
- (2) Connect connector clamp to oil pressure switch connector.
- (3) Lower cab (TM 9-2320-365-10).
- (4) Connect batteries (para 7-48).
- (5) Remove power distribution panel (PDP) cover (para 16-2).

NOTE

Tag relays and connection points prior to removal.

- (6) Remove relay K24 from PDP.
- (7) Set multimeter to volts DC.
- (8) Connect positive (+) probe of multimeter to relay K24 socket 30 on PDP.
- (9) Connect negative (-) probe of multimeter to ground.
- (10) Position master power switch to on (TM 9-2320-365-10) and note reading on multimeter.
- (11) If 24 VDC is not present, go to step 21 of this fault.
- (12) Position master power switch to off (TM 9-2320-365-10).

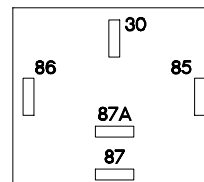
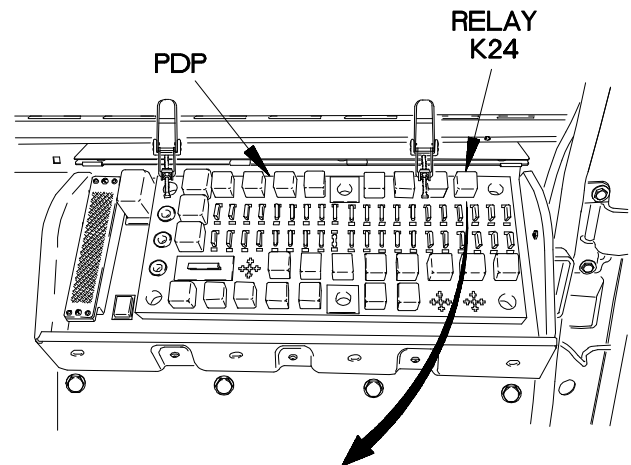
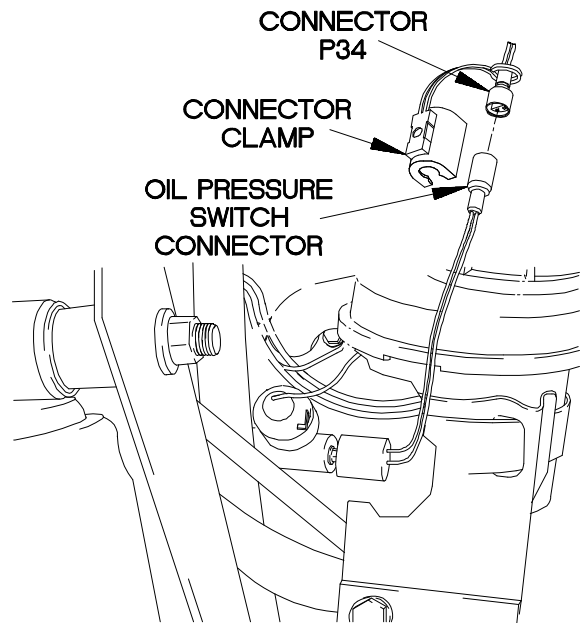

RELAY K24 CAVITY

XBE0211B

e2. ENGINE DOES NOT CRANK (CONT)

KNOWN INFO
Transmission pushbutton shift selector in neutral (N). Batteries OK. Service drive lights OK. Circuit breakers OK. Starting motor OK. Battery to starter cable assembly OK. Oil pressure switch OK. Neutral start relay OK. WTEC II vehicle interface module (VIM) OK. WTEC II cab transmission wiring harness OK. WTEC II transmission ECU pushbutton shift selector (TEPSS) OK. Relay K26 OK. WTEC III transmission pushbutton shift selector (TPSS) OK.
POSSIBLE PROBLEMS
Faulty relay K24. Faulty start and charging cable assembly. Faulty relay K1. Faulty engine control cable assembly. Faulty starter pushbutton switch. Faulty dashboard cable assembly.

WARNING
Read **WARNING** on following page.

12.
Is 24 VDC present at relay K24 socket 86 on PDP?

TEST OPTIONS
Voltage Test or STE/ICE-R Test #89
REASON FOR QUESTION
This question eliminates possible problems and determines where to continue troubleshooting.

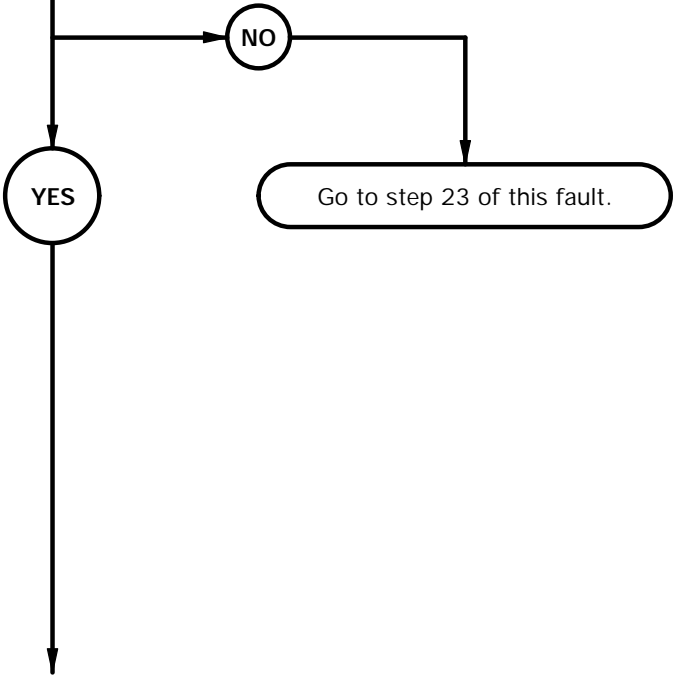

WARNING

Remove rings, bracelets, watches, necklaces, and any other jewelry before working around vehicle. Jewelry can catch on equipment and cause injury or short across electrical circuits and cause severe burns or electrical shock.

VOLTAGE TEST

- (1) Set multimeter to volts DC.
- (2) Connect positive (+) probe of multimeter to relay K24 socket 86 on PDP.
- (3) Connect negative (-) probe of multimeter to ground.
- (4) Position master power switch to on (TM 9-2320-365-10) and note reading on multimeter.
- (5) If 24 VDC is not present, go to step 23 of this fault.
- (6) Position master power switch to off (TM 9-2320-365-10).

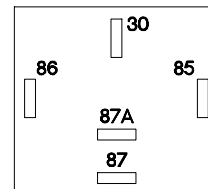
**RELAY K24 CAVITY**

XBE0212B

e2. ENGINE DOES NOT CRANK (CONT)

KNOWN INFO
Transmission pushbutton shift selector in neutral (N). Batteries OK. Service drive lights OK. Circuit breakers OK. Starting motor OK. Battery to starter cable assembly OK. Oil pressure switch OK. Neutral start relay OK. WTEC II vehicle interface module (VIM) OK. WTEC II cab transmission wiring harness OK. WTEC II transmission ECU pushbutton shift selector (TEPSS) OK. Relay K26 OK. WTEC III transmission pushbutton shift selector (TPSS) OK.
POSSIBLE PROBLEMS
Faulty relay K24. Faulty start and charging cable assembly. Faulty relay K1. Faulty engine control cable assembly. Faulty starter pushbutton switch. Faulty dashboard cable assembly.

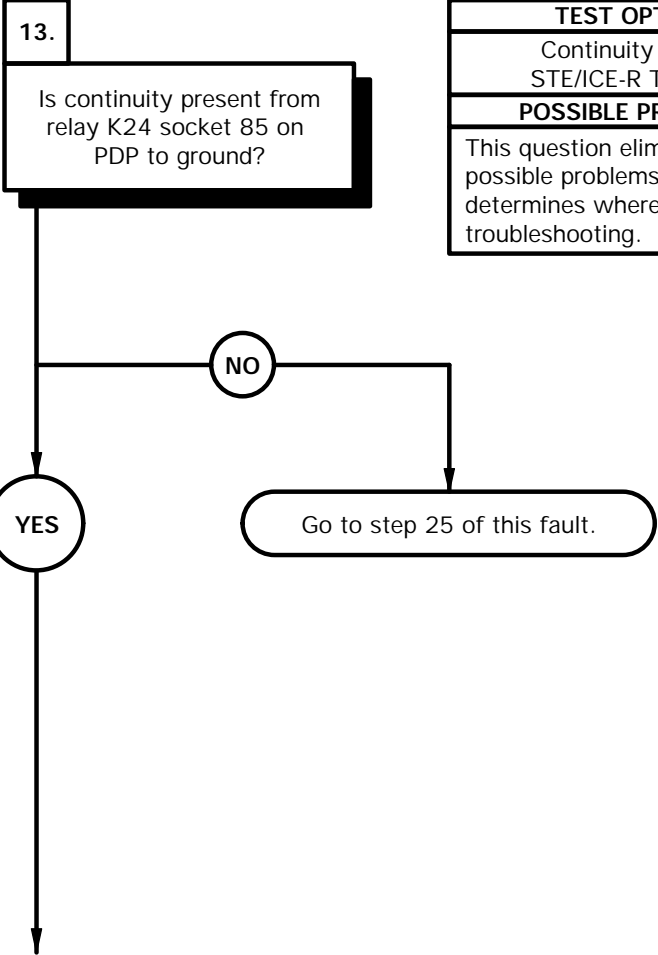

TEST OPTIONS
Continuity Test or STE/ICE-R Test #91
POSSIBLE PROBLEMS
This question eliminates possible problems and determines where to continue troubleshooting.



CONTINUITY TEST

- (1) Disconnect batteries (para 7-48).
- (2) Set multimeter to ohms.
- (3) Connect positive (+) probe of multimeter to relay K24 socket 85 on PDP.
- (4) Connect negative (-) probe of multimeter to ground and note reading on multimeter.
- (5) If continuity is not present, go to step 25 of this fault.

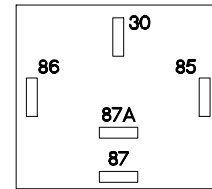
**RELAY K24 CAVITY**

XBE0213B

e2. ENGINE DOES NOT CRANK (CONT)

KNOWN INFO
Transmission pushbutton shift selector in neutral (N). Batteries OK. Service drive lights OK. Circuit breakers OK. Starting motor OK. Battery to starter cable assembly OK. Oil pressure switch OK. Neutral start relay OK. WTEC II vehicle interface module (VIM) OK. WTEC II cab transmission wiring harness OK. WTEC II transmission ECU pushbutton shift selector (TEPSS) OK. Relay K26 OK. WTEC III transmission pushbutton shift selector (TPSS) OK. Engine control cable assembly OK.
POSSIBLE PROBLEMS
Faulty relay K24. Faulty start and charging cable assembly. Faulty relay K1. Faulty starter pushbutton switch. Faulty dashboard cable assembly.

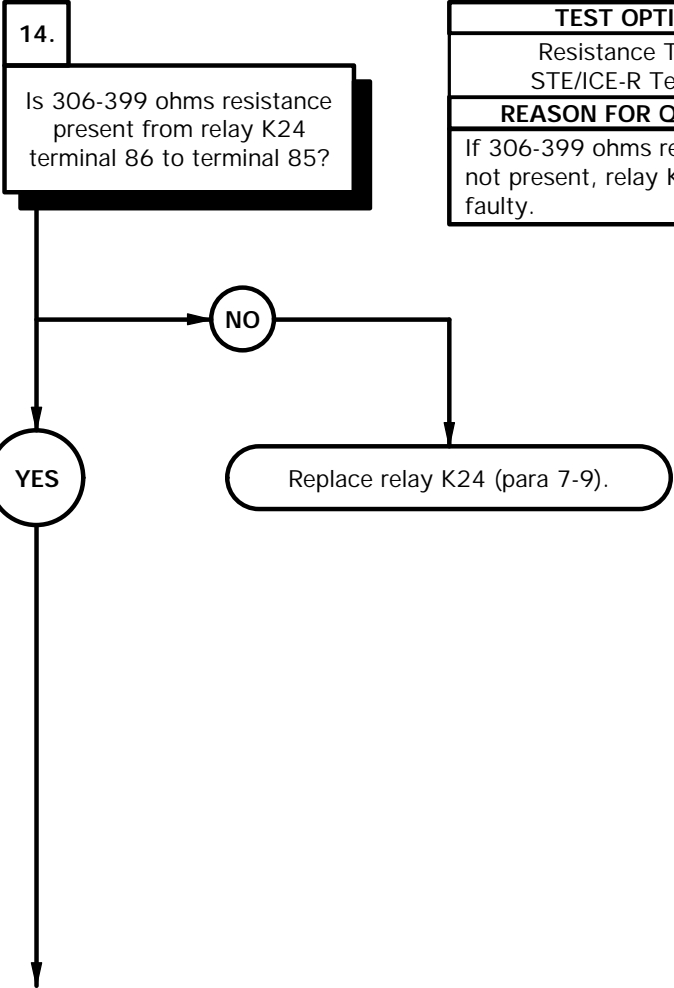

TEST OPTIONS
Resistance Test or STE/ICE-R Test #91
REASON FOR QUESTION
If 306-399 ohms resistance is not present, relay K24 is faulty.



RESISTANCE TEST

- (1) Set multimeter to ohms.
- (2) Connect positive (+) probe of multimeter to relay K24 terminal 86.
- (3) Connect negative (-) probe of multimeter to relay K24 terminal 85 and note reading on multimeter.
- (4) If 306-399 ohms resistance is not present, replace relay K24 (para 7-9).
- (5) Connect batteries (para 7-48).

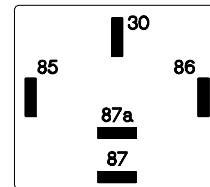
**RELAY K24**

XBE0214B

e2. ENGINE DOES NOT CRANK (CONT)

KNOWN INFO
Transmission pushbutton shift selector in neutral (N). Batteries OK. Service drive lights OK. Circuit breakers OK. Starting motor OK. Battery to starter cable assembly OK. Oil pressure switch OK. Neutral start relay OK. WTEC II vehicle interface module (VIM) OK. WTEC II cab transmission wiring harness OK. WTEC II transmission ECU pushbutton shift selector (TEPSS) OK. Relay K26 OK. WTEC III transmission pushbutton shift selector (TPSS) OK. Engine control cable assembly OK.
POSSIBLE PROBLEMS
Faulty relay K24. Faulty start and charging cable assembly. Faulty relay K1. Faulty starter pushbutton switch. Faulty dashboard cable assembly.

15. **WARNING**
Read **WARNING** on following page.

Is 24 VDC present at PDP relay K24 socket 87?

TEST OPTIONS
Voltage Test or STE/ICE-R Test #89
REASON FOR QUESTION
If 24 VDC is not present, relay K24 is faulty.

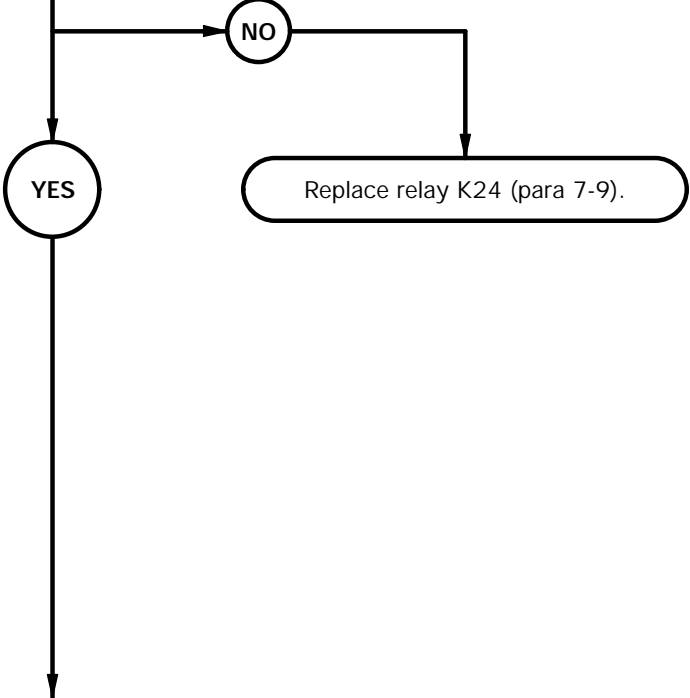

WARNING

Remove rings, bracelets, watches, necklaces, and any other jewelry before working around vehicle. Jewelry can catch on equipment and cause injury or short across electrical circuits and cause severe burns or electrical shock.

VOLTAGE TEST

- (1) Install relay test wire in relay K24 socket 87 on PDP.
- (2) Install relay K24 in PDP.
- (3) Set multimeter to volts DC.
- (4) Connect positive (+) probe of multimeter to relay test wire.
- (5) Connect negative (-) probe of multimeter to ground.
- (6) Position master power switch to on (TM 9-2320-365-10) and note reading on multimeter.
- (7) If 24 VDC is not present, replace relay K24 (para 7-9).
- (8) Position master power switch to off (TM 9-2320-365-10).
- (9) Remove relay K24 from PDP.
- (10) Remove relay test wire from relay K24 socket 87 on PDP.
- (11) Install relay K24 in PDP.

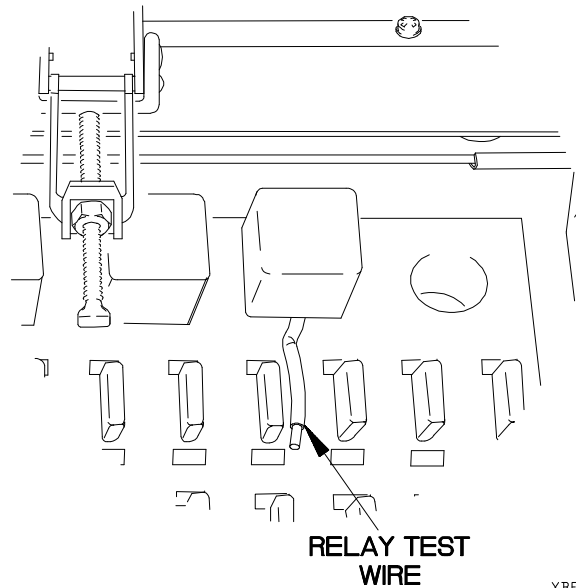
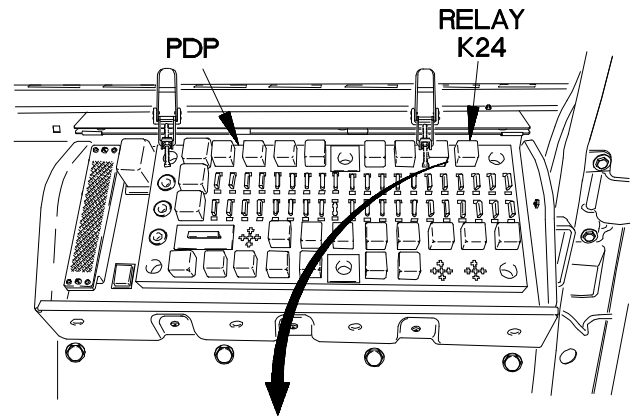

XBE0215B

e2. ENGINE DOES NOT CRANK (CONT)

KNOWN INFO
Transmission pushbutton shift selector in neutral (N). Batteries OK. Service drive lights OK. Circuit breakers OK. Starting motor OK. Battery to starter cable assembly OK. Oil pressure switch OK. Neutral start relay OK. WTEC II vehicle interface module (VIM) OK. WTEC II cab transmission wiring harness OK. WTEC II transmission ECU pushbutton shift selector (TEPSS) OK. Relay K26 OK. WTEC III transmission pushbutton shift selector (TPSS) OK. Engine control cable assembly OK. Relay K24 OK.
POSSIBLE PROBLEMS
Faulty start and charging cable assembly. Faulty relay K1. Faulty starter pushbutton switch. Faulty dashboard cable assembly.

16.

WARNING
Read **WARNING** on following page.

Is 24 VDC present at relay K1 socket 30 on PDP?

TEST OPTIONS
Voltage Test or STE/ICE-R Test #89
REASON FOR QUESTION
If 24 VDC is not present, wire 1602 is faulty.

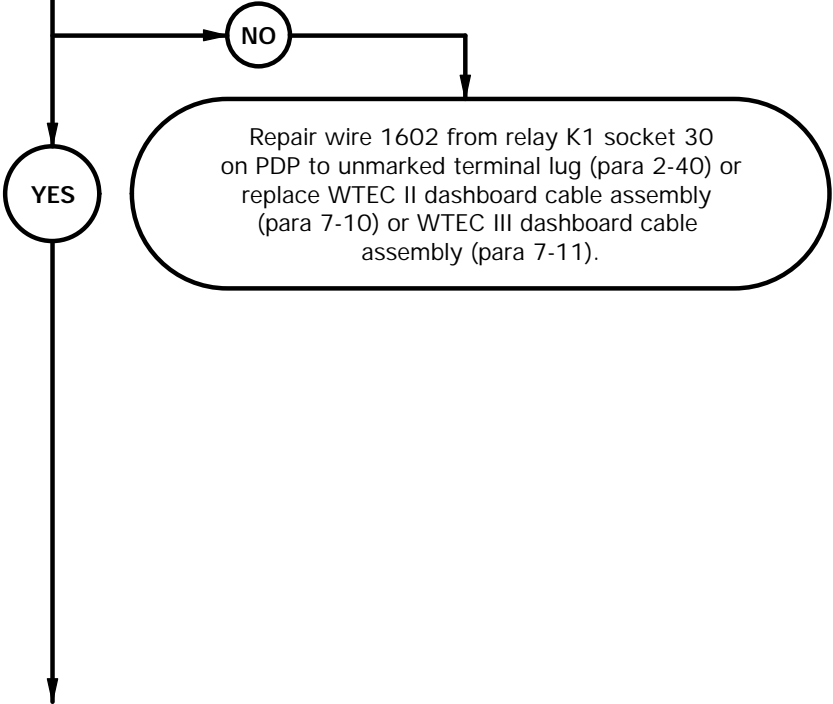

WARNING

Remove rings, bracelets, watches, necklaces, and any other jewelry before working around vehicle. Jewelry can catch on equipment and cause injury or short across electrical circuits and cause severe burns or electrical shock.

VOLTAGE TEST

- (1) Disconnect batteries (para 7-48).
- (2) Remove relay K1 from PDP.
- (3) Connect batteries (para 7-48).
- (4) Set multimeter to volts DC.
- (5) Connect positive (+) probe of multimeter to PDP relay K1 socket 30.
- (6) Connect negative (-) probe of multimeter to ground and note reading on multimeter.
- (7) If 24 VDC is not present, repair wire 1602 from relay K1 socket 30 on PDP to unmarked terminal lug (para 2-40) or replace WTEC II dashboard cable assembly (para 7-10) or WTEC III dashboard cable assembly (para 7-11).

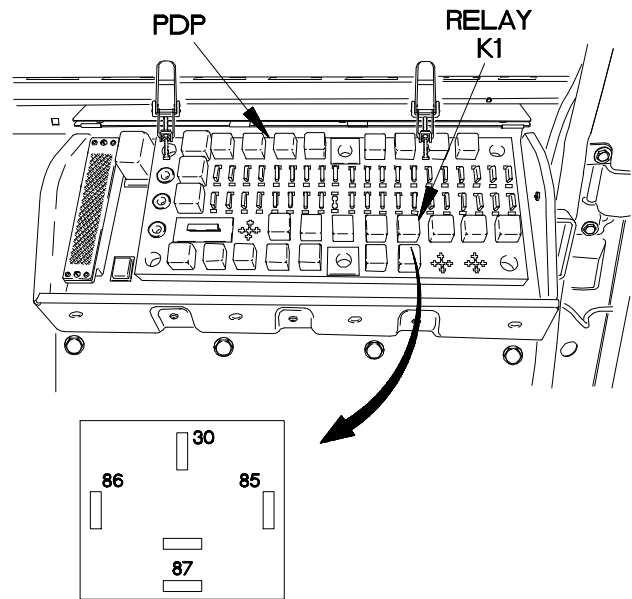

RELAY K1 CAVITY

XBE0216B

e2. ENGINE DOES NOT CRANK (CONT)

KNOWN INFO
Transmission pushbutton shift selector in neutral (N). Batteries OK. Service drive lights OK. Circuit breakers OK. Starting motor OK. Battery to starter cable assembly OK. Oil pressure switch OK. Neutral start relay OK. WTEC II vehicle interface module (VIM) OK. WTEC II cab transmission wiring harness OK. WTEC II transmission ECU pushbutton shift selector (TEPSS) OK. Relay K26 OK. WTEC III transmission pushbutton shift selector (TPSS) OK. Engine control cable assembly OK. Relay K24 OK.
POSSIBLE PROBLEMS
Faulty start and charging cable assembly. Faulty relay K1. Faulty starter pushbutton switch. Faulty dashboard cable assembly.

17. **WARNING**
Read **WARNING** on following page.

Is 24 VDC present at relay K1 socket 87 on PDP?

TEST OPTIONS
Voltage Test or STE/ICE-R Test #89
REASON FOR QUESTION
If 24 VDC is not present, relay K1 is faulty.

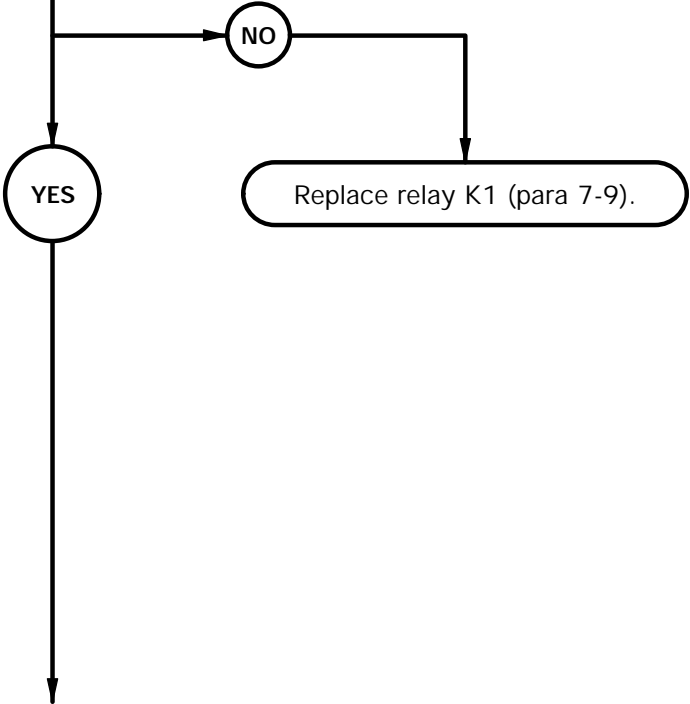

WARNING

Remove rings, bracelets, watches, necklaces, and any other jewelry before working around vehicle. Jewelry can catch on equipment and cause injury or short across electrical circuits and cause severe burns or electrical shock.

VOLTAGE TEST

- (1) Disconnect batteries (para 7-48).
- (2) Install relay test wire in relay K1 socket 87 on PDP.
- (3) Install relay K1 in PDP.
- (4) Connect batteries (para 7-48).
- (5) Set multimeter to volts DC.
- (6) Connect positive (+) probe of multimeter to relay test wire.
- (7) Connect negative (-) probe of multimeter to ground.
- (8) Position master power switch to on (TM 9-2320-365-10).
- (9) Press starter pushbutton (TM 9-2320-365-10) and note reading on multimeter.
- (10) If 24 VDC is not present, replace relay K1 (para 7-9).
- (11) Position master power switch to off (TM 9-2320-365-10).
- (12) Disconnect batteries (para 7-48).
- (13) Remove relay K1 from PDP.
- (14) Remove relay test wire from relay K1 socket 87 on PDP.
- (15) Install relay K1 in PDP.

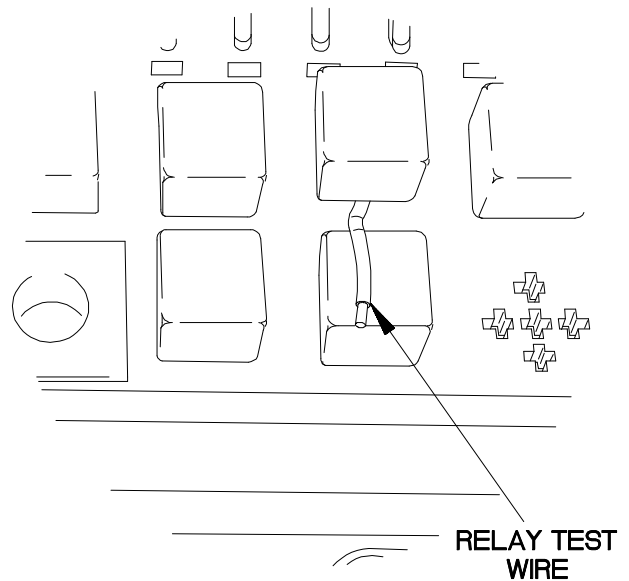
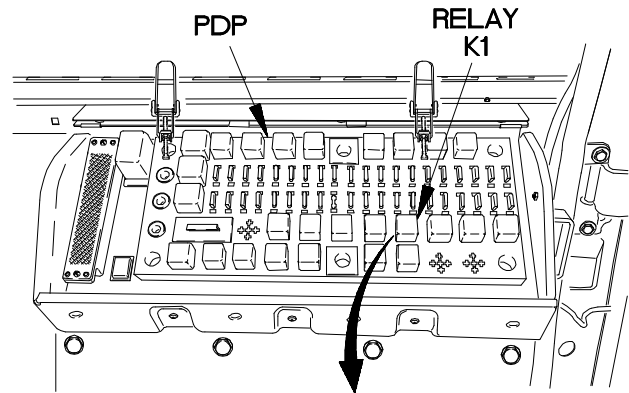

XBE0217B

e2. ENGINE DOES NOT CRANK (CONT)

KNOWN INFO
Transmission pushbutton shift selector in neutral (N). Batteries OK. Service drive lights OK. Circuit breakers OK. Starting motor OK. Battery to starter cable assembly OK. Oil pressure switch OK. Neutral start relay OK. WTEC II vehicle interface module (VIM) OK. WTEC II cab transmission wiring harness OK. WTEC II transmission ECU pushbutton shift selector (TEPSS) OK. Relay K26 OK. WTEC III transmission pushbutton shift selector (TPSS) OK. Engine control cable assembly OK. Relay K24 OK. Relay K1 OK.
POSSIBLE PROBLEMS
Faulty start and charging cable assembly. Faulty starter pushbutton switch. Faulty dashboard cable assembly.

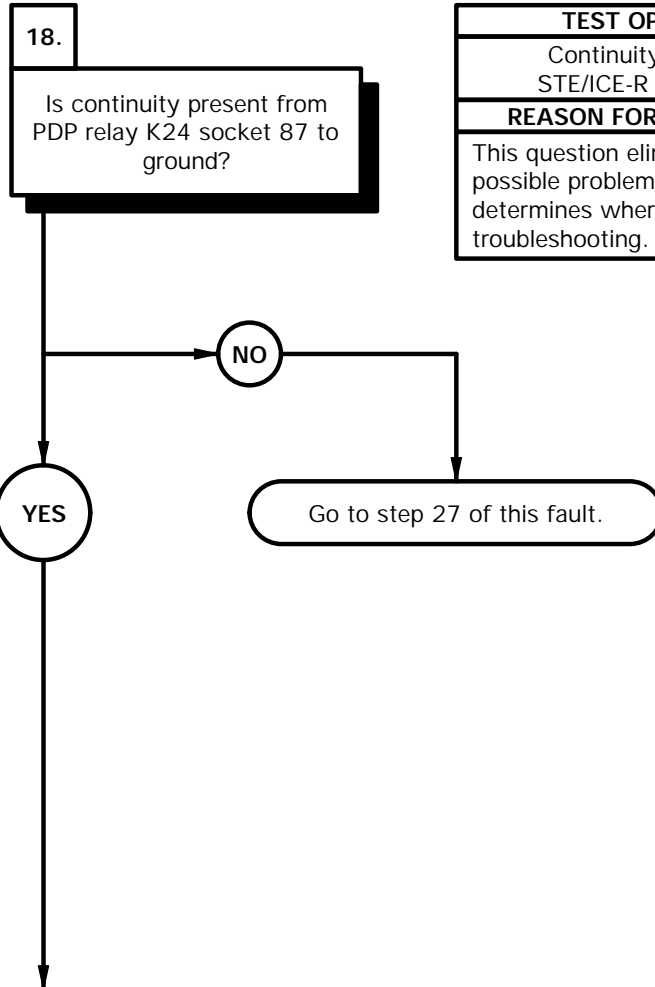

TEST OPTIONS
Continuity Test or STE/ICE-R Test #91
REASON FOR QUESTION
This question eliminates possible problems and determines where to continue troubleshooting.

- CONTINUITY TEST**
- (1) Remove relay K24 from PDP.
 - (2) Set multimeter to ohms.
 - (3) Connect positive (+) probe of multimeter to relay K24 socket 87 on PDP.
 - (4) Connect negative (-) probe of multimeter to ground.
 - (5) Press starter pushbutton (TM 9-2320-365-10) and note reading on multimeter.
 - (6) If continuity is not present, go to step 27 of this fault.

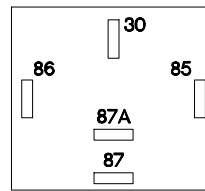
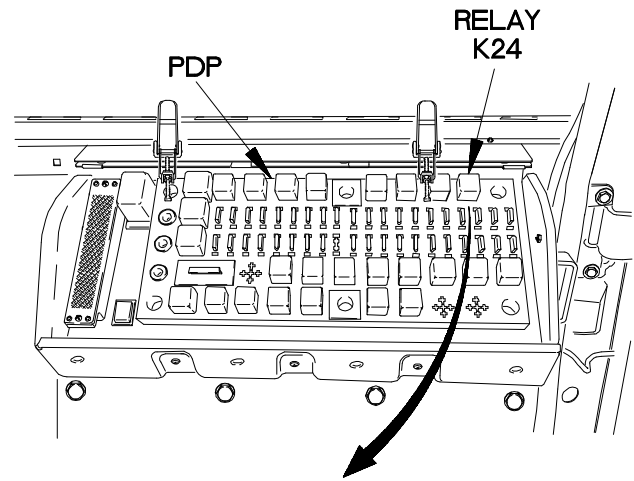

RELAY K24 CAVITY

XBE0218B

e2. ENGINE DOES NOT CRANK (CONT)

KNOWN INFO
Transmission pushbutton shift selector in neutral (N). Batteries OK. Service drive lights OK. Circuit breakers OK. Starting motor OK. Battery to starter cable assembly OK. Oil pressure switch OK. Neutral start relay OK. WTEC II vehicle interface module (VIM) OK. WTEC II cab transmission wiring harness OK. WTEC II transmission ECU pushbutton shift selector (TEPSS) OK. Relay K26 OK. WTEC III transmission pushbutton shift selector (TPSS) OK. Engine control cable assembly OK. Relay K24 OK. Relay K1 OK. Starter pushbutton switch OK.
POSSIBLE PROBLEMS
Faulty start and charging cable assembly. Faulty dashboard cable assembly.

CAUTION
Read CAUTION on following page.

19.
Is continuity present from relay K1 socket 87 on PDP to connector J43 socket 8?

TEST OPTIONS
Continuity Test or STE/ICE-R Test #91
REASON FOR QUESTION
If continuity is not present, wire 74 is faulty. If continuity is present, wire 74 is faulty.

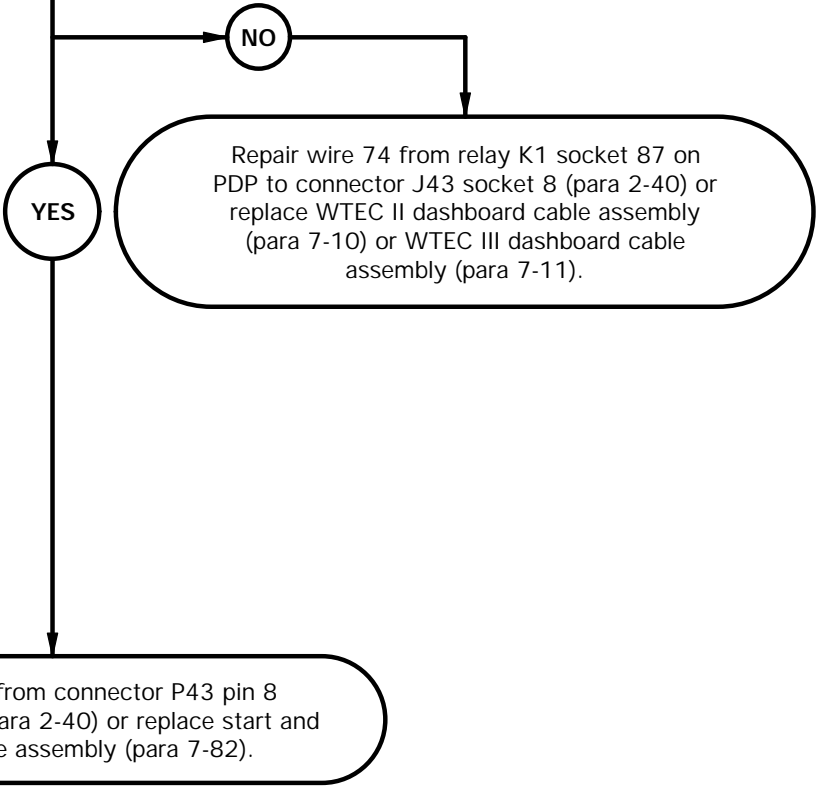

CAUTION

Use care when testing electrical connectors. Do not damage connector pins or sockets with multimeter probes. Failure to comply may result in damage to equipment.

NOTE

Inspect connector pins/sockets for damage, corrosion, and serviceability. Check that connector pins are not pushed back or not capable of making good contact.

CONTINUITY TEST

- (1) Install relay K24 in PDP.
- (2) Remove relay K1 from PDP.
- (3) Remove instrument panel for access (para 7-15).
- (4) Disconnect connector J43 from connector P43.
- (5) Set multimeter to ohms.
- (6) Connect positive (+) probe of multimeter to connector J43 socket 8.
- (7) Connect negative (-) probe of multimeter to relay K1 socket 87 on PDP and note reading on multimeter.
- (8) If continuity is not present, repair wire 74 from relay K1 socket 87 on PDP and connector J43 socket 8 (para 2-40) or replace WTEC II dashboard cable assembly (para 7-10) or WTEC III dashboard cable assembly (para 7-11).
- (9) If continuity is present, repair wire 74 from connector P43 pin 8 to terminal TL33 (para 2-40) or replace start and charging cable assembly (para 7-82).
- (10) Connect connector J43 to connector P43.
- (11) Install instrument panel (para 7-15).
- (12) Install relay K1 in PDP.
- (13) Install power distribution panel (PDP) cover (para 16-2).
- (14) Connect batteries (para 7-48).

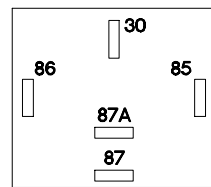
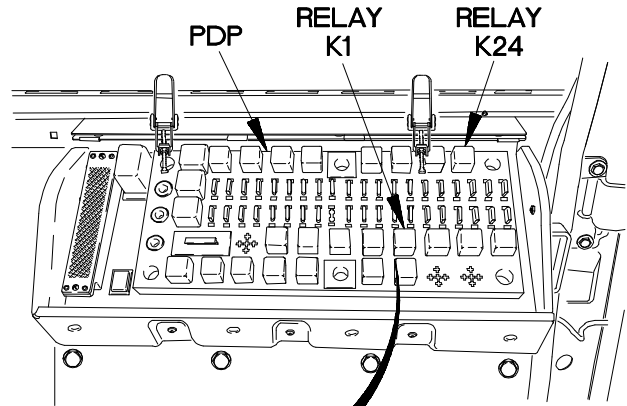

RELAY K1 CAVITY

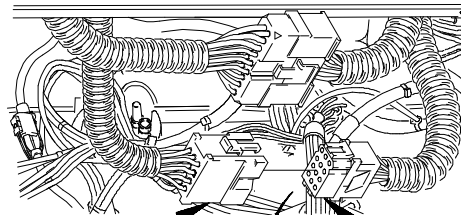

CONNECTOR P43

CONNECTOR J43

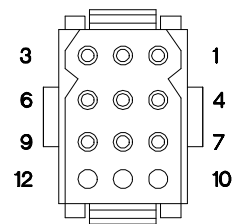

J43

XBE0219B

e2. ENGINE DOES NOT CRANK (CONT)

KNOWN INFO

Transmission pushbutton shift selector in neutral (N).
 Batteries OK.
 Service drive lights OK.
 Circuit breakers OK.
 Starting motor OK.
 Battery to starter cable assembly OK.
 Oil pressure switch OK.

POSSIBLE PROBLEMS

Faulty engine control cable assembly.
 Faulty dashboard cable assembly.

CAUTION
 Read CAUTION on following page.

20.
 Is continuity present from connector P34 pin 1 to connector P31 socket 7?

TEST OPTIONS
 Continuity Test or STE/ICE-R Test #91

REASON FOR QUESTION
 If continuity is not present, wire 3006 is faulty. If continuity is present, wire 3006 is faulty.

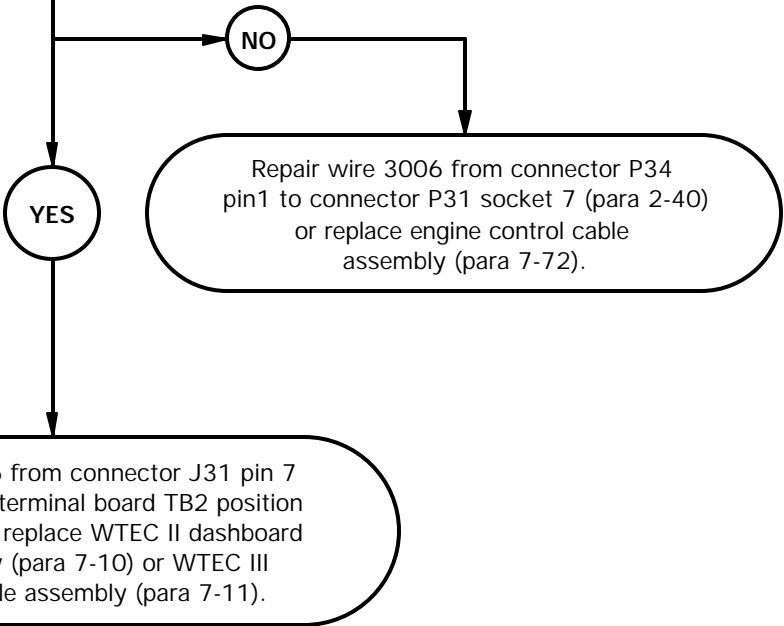

CAUTION

Use care when testing electrical connectors. Do not damage connector pins or sockets with multimeter probes. Failure to comply may result in damage to equipment.

NOTE

Inspect connector pins/sockets for damage, corrosion, and serviceability. Check that connector pins are not pushed back or not capable of making good contact.

CONTINUITY TEST

- (1) Set multimeter to ohms.
- (2) Connect positive (+) probe of multimeter to connector P34 pin 1.
- (3) Lower cab (TM 9-2320-365-10).
- (4) Remove instrument panel for access (para 7-15).
- (5) Disconnect connector J31 from connector P31.
- (6) Connect negative (-) probe of multimeter to connector P31 socket 7 and note reading on multimeter.
- (7) If continuity is not present, repair wire 3006 from connector P34 pin 1 to connector P31 socket 7 (para 2-40) or replace engine control cable assembly (para 7-72).
- (8) If continuity is present, repair wire 3006 from connector J31 pin 7 to terminal lug at terminal board TB2 position 11 (para 2-40) or replace WTEC II dashboard cable assembly (para 7-10) or WTEC III dashboard cable assembly (para 7-11).
- (9) Connect connector P31 to connector J31.
- (10) Install instrument panel (para 7-15).
- (11) Raise cab (TM 9-2320-365-10).
- (12) Connect connector P34 to oil pressure switch connector.
- (13) Connect connector clamp on oil pressure switch connector.
- (14) Connect batteries (para 7-48).
- (15) Lower cab (TM 9-2320-365-10).

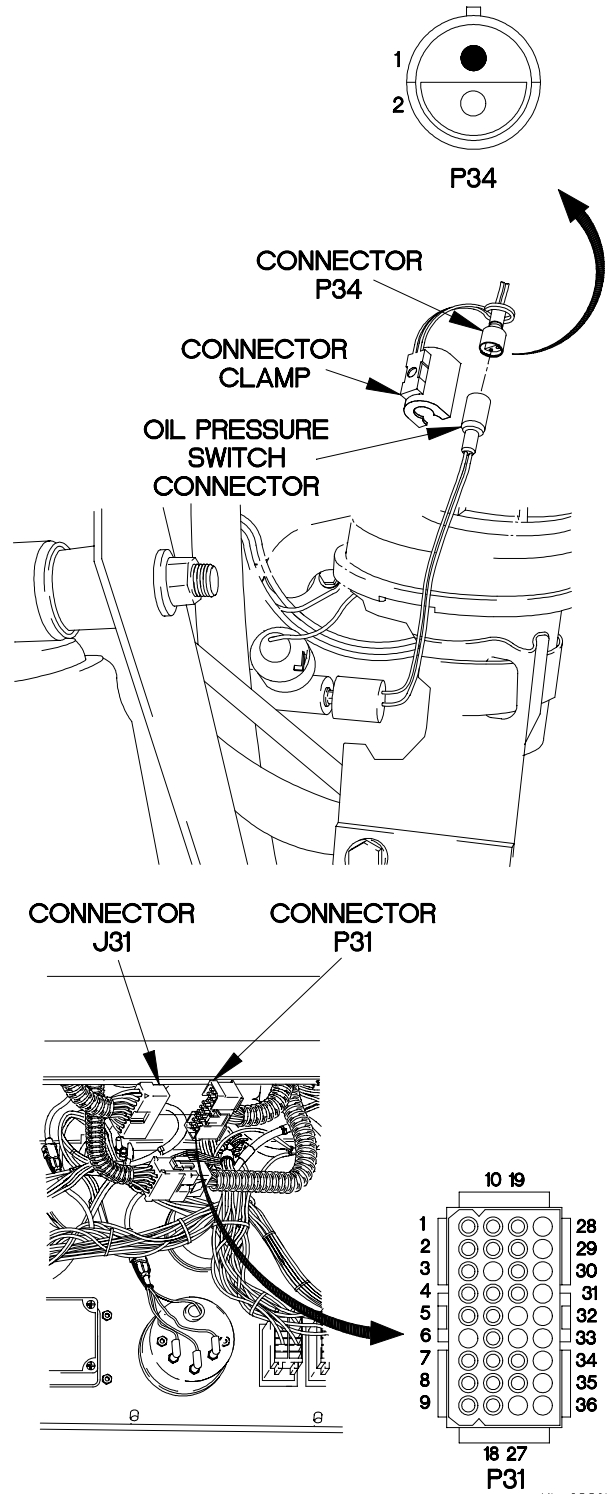

e2. ENGINE DOES NOT CRANK (CONT)

KNOWN INFO
Transmission pushbutton shift selector in neutral (N). Batteries OK. Service drive lights OK. Circuit breakers OK. Starting motor OK. Battery to starter cable assembly OK. Oil pressure switch OK.
POSSIBLE PROBLEMS
Faulty relay K1. Faulty neutral start relay. Faulty WTEC II vehicle interface module (VIM). Faulty WTEC II cab transmission wiring harness. Faulty WTEC II transmission ECU pushbutton shift selector (TEPSS). Faulty relay K26. Faulty dashboard cable assembly. Faulty WTEC III transmission pushbutton shift selector (TPSS).

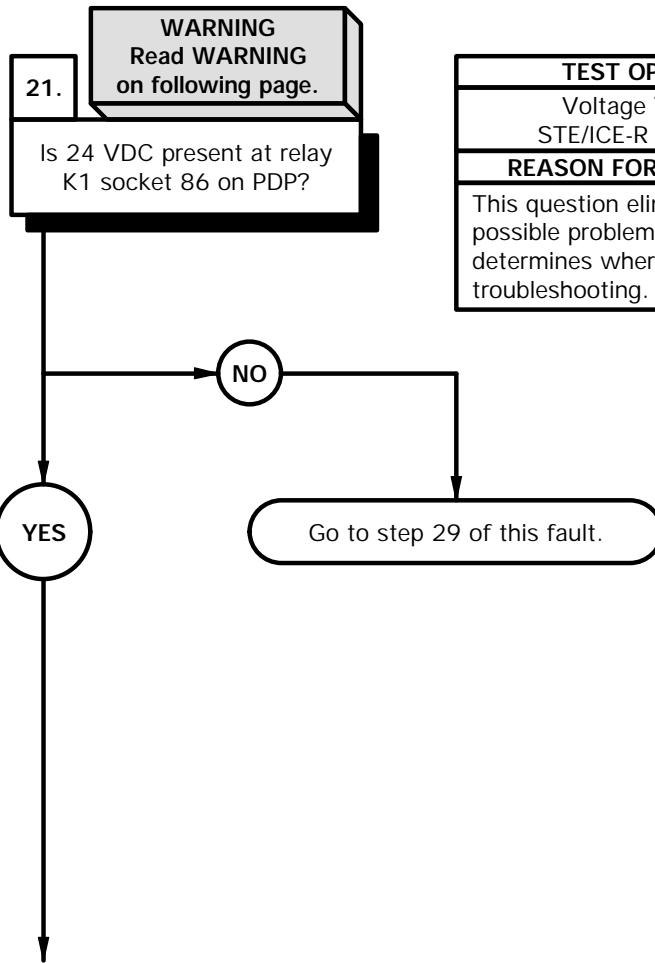

TEST OPTIONS
Voltage Test or STE/ICE-R Test #89
REASON FOR QUESTION
This question eliminates possible problems and determines where to continue troubleshooting.

WARNING

Remove rings, bracelets, watches, necklaces, and any other jewelry before working around vehicle. Jewelry can catch on equipment and cause injury or short across electrical circuits and cause severe burns or electrical shock.

VOLTAGE TEST

- (1) Install relay K24 in PDP.
- (2) Disconnect batteries (para 7-48).
- (3) Remove relay K1 from PDP.
- (4) Connect batteries (para 7-48).
- (5) Set multimeter to volts DC.
- (6) Connect positive (+) probe of multimeter to relay K1 socket 86 on PDP.
- (7) Connect negative (-) probe of multimeter to ground.
- (8) Position master power switch to on (TM 9-2320-365-10) and note reading on multimeter.
- (9) If 24 VDC is not present, go to step 29 of this fault.
- (10) Position master power switch to off (TM 9-2320-365-10).

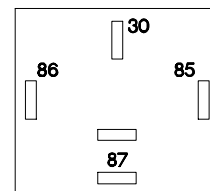
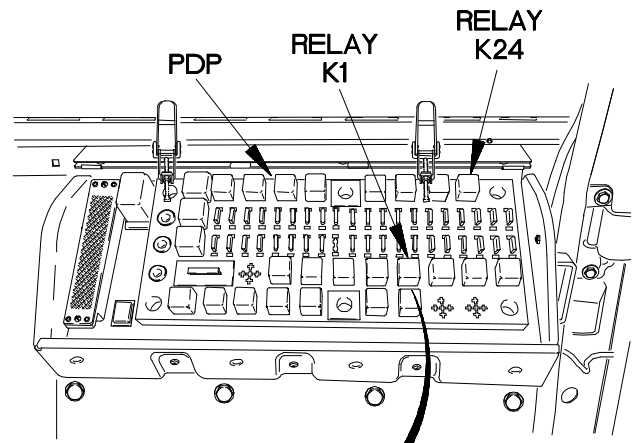

RELAY K1 CAVITY

XBE0221B

e2. ENGINE DOES NOT CRANK (CONT)

KNOWN INFO
Transmission pushbutton shift selector in neutral (N). Batteries OK. Service drive lights OK. Circuit breakers OK. Starting motor OK. Battery to starter cable assembly OK. Oil pressure switch OK. Neutral start relay OK. WTEC II vehicle interface module (VIM) OK. WTEC II cab transmission wiring harness OK. WTEC II transmission ECU pushbutton shift selector (TEPSS) OK. Relay K26 OK. WTEC III transmission pushbutton shift selector (TPSS) OK.
POSSIBLE PROBLEMS
Faulty relay K1. Faulty dashboard cable assembly.

22.
Is 306-399 ohms resistance present from relay K1 terminal 86 to terminal 85?

TEST OPTIONS
Resistance Test or STE/ICE-R Test #91
REASON FOR QUESTION
If 306-399 ohms resistance is not present, relay K1 is faulty. If 306-399 ohms resistance is present, wire 74 is faulty.

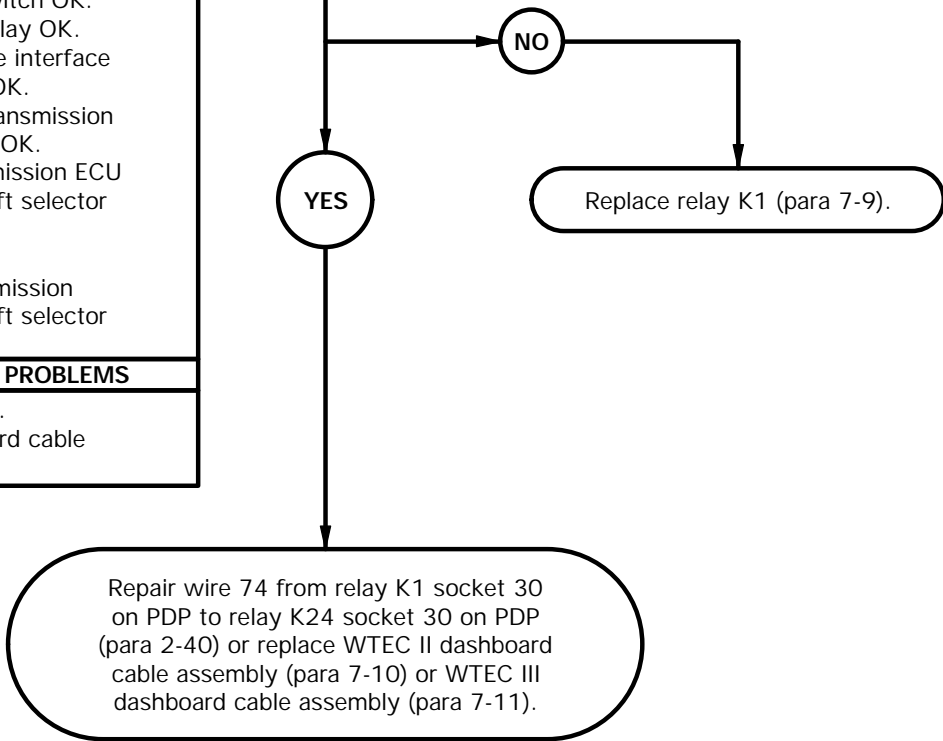

RESISTANCE TEST

- (1) Set multimeter to ohms.
- (2) Connect positive (+) probe of multimeter to relay K1 terminal 86.
- (3) Connect negative (-) probe of multimeter to relay K1 terminal 85 and note reading on multimeter.
- (4) If 306-399 ohms resistance is not present, replace relay K1 (para 7-9).
- (5) If 306-399 ohms resistance is present, repair wire 74 from relay K1 socket 30 on PDP to relay K24 socket 30 on PDP (para 2-40) or replace WTEC II dashboard cable assembly (para 7-10) or WTEC III dashboard cable assembly (para 7-11).
- (6) Disconnect batteries (para 7-48).
- (7) Install relay K1 in PDP.
- (8) Install PDP cover (para 16-2).
- (9) Connect batteries (para 7-48).

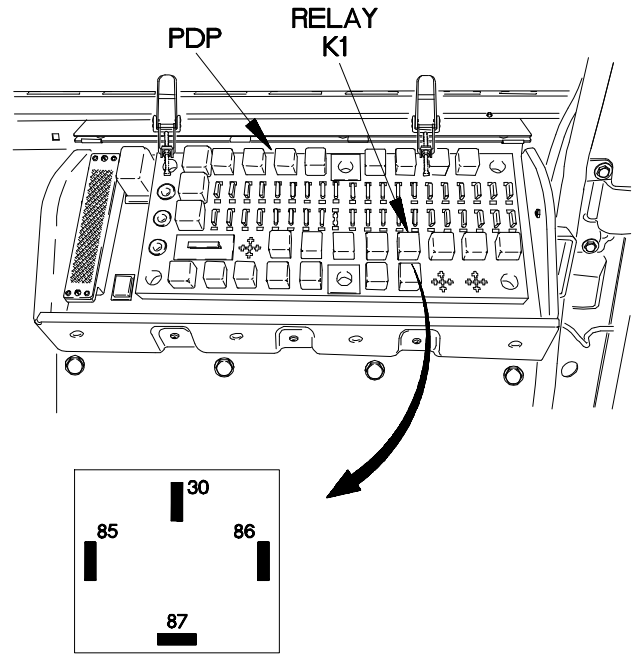

RELAY K1

XBE0222B

e2. ENGINE DOES NOT CRANK (CONT)

KNOWN INFO
Transmission pushbutton shift selector in neutral (N). Batteries OK. Service drive lights OK. Circuit breakers OK. Starting motor OK. Battery to starter cable assembly OK. Oil pressure switch OK. Neutral start relay OK. WTEC II vehicle interface module (VIM) OK. WTEC II cab transmission wiring harness OK. WTEC II transmission ECU pushbutton shift selector (TEPSS) OK. Relay K26 OK. WTEC III transmission pushbutton shift selector (TPSS) OK.
POSSIBLE PROBLEMS
Faulty dashboard cable assembly.

23.
Is continuity present from relay K24 socket 86 on PDP to relay K11 socket 30 on PDP?

TEST OPTIONS
Continuity Test or STE/ICE-R Test #91
REASON FOR QUESTION
If continuity is not present, wire 1658 is faulty.

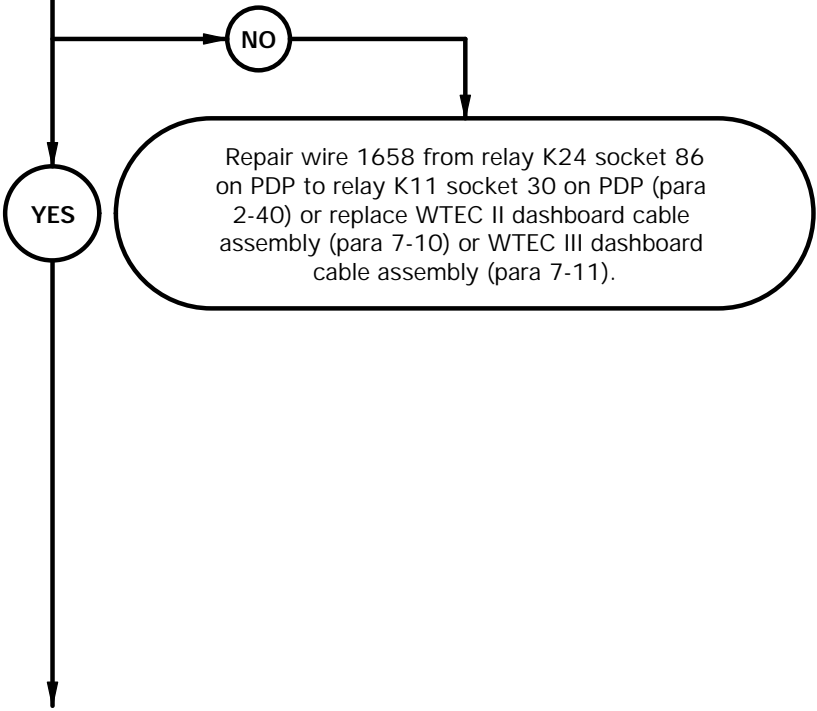

CONTINUITY TEST

- (1) Disconnect batteries (para 7-48).
- (2) Remove relay K11 from PDP.
- (3) Set multimeter to ohms.
- (4) Connect positive (+) probe of multimeter to relay K24 socket 86 on PDP.
- (5) Connect negative (-) probe of multimeter to relay K11 socket 30 and note reading on multimeter.
- (6) If continuity is not present, repair wire 1658 from relay K24 socket 86 on PDP to relay K30 socket 30 on PDP (para 2-40) or replace WTEC II dashboard cable assembly (para 7-10) or WTEC III dashboard cable assembly (para 7-11).
- (7) Install relay K24 in PDP.

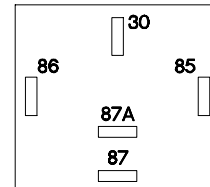
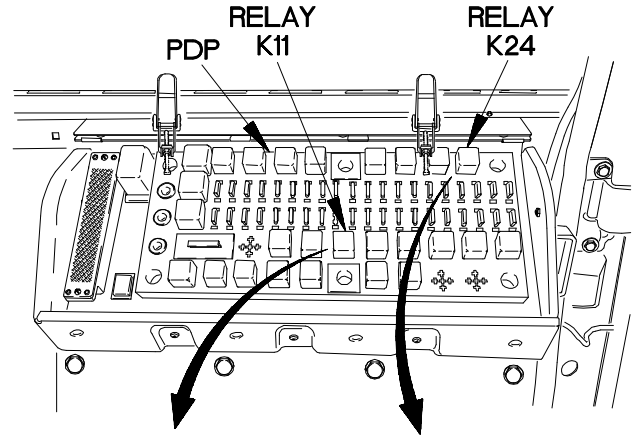

RELAY K11 CAVITY

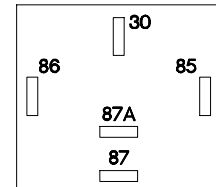

RELAY K24 CAVITY

XBE0223B

e2. ENGINE DOES NOT CRANK (CONT)

KNOWN INFO

Transmission pushbutton shift selector in neutral (N).
 Batteries OK.
 Service drive lights OK.
 Circuit breakers OK.
 Starting motor OK.
 Battery to starter cable assembly OK.
 Oil pressure switch OK.
 Neutral start relay OK.
 WTEC II vehicle interface module (VIM) OK.
 WTEC II cab transmission wiring harness OK.
 WTEC II transmission ECU pushbutton shift selector (TEPSS) OK.
 Relay K26 OK.
 WTEC III transmission pushbutton shift selector (TPSS) OK.

POSSIBLE PROBLEMS

Faulty dashboard cable assembly.

24.
 Is continuity present from relay K11 socket 30 on PDP to terminal board TB1 position 64 on PDP?

TEST OPTIONS
Continuity Test or STE/ICE-R Test #91
REASON FOR QUESTION
If continuity is not present, wire 1658 is faulty. If continuity is present, wire 1929 is faulty.

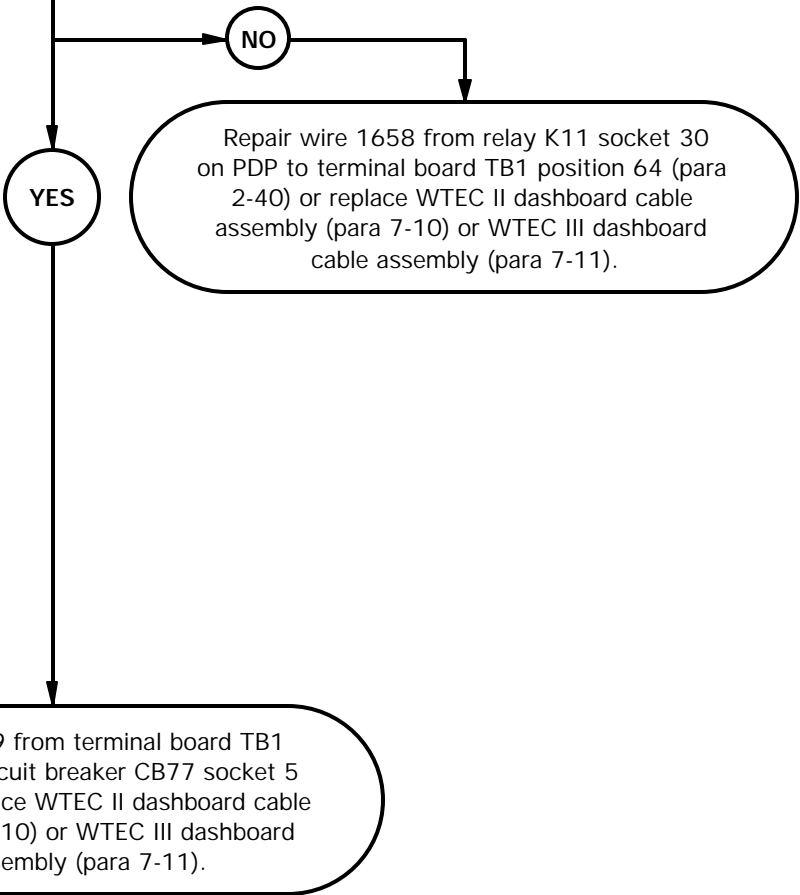

CONTINUITY TEST

- (1) Remove three screws and washers from PDP.
- (2) Remove three screws from PDP.
- (3) Lift PDP outward to gain access.
- (4) Set multimeter to ohms.
- (5) Connect positive (+) probe of multimeter to relay K11 socket 30 on PDP.
- (6) Connect negative (-) probe of multimeter to terminal board TB1 position 64 on PDP and note reading on multimeter.
- (7) If continuity is not present, repair wire 1658 from relay K11 socket 30 on PDP to terminal board TB1 position 64 (para 2-40) or replace WTEC II dashboard cable assembly (para 7-10) or WTEC III dashboard cable assembly (para 7-11).
- (8) If continuity is present, repair wire 1929 from circuit breaker CB77 socket 5 on PDP to terminal board TB1 position 64 (para 2-40) or replace WTEC II dashboard cable assembly (para 7-10) or WTEC III dashboard cable assembly (para 7-11).
- (9) Install PDP on dashboard with three screws.
- (10) Install three washers and screws in PDP.
- (11) Install relay K11 in PDP.
- (12) Install PDP cover (para 16-2).
- (13) Connect batteries (para 7-48).

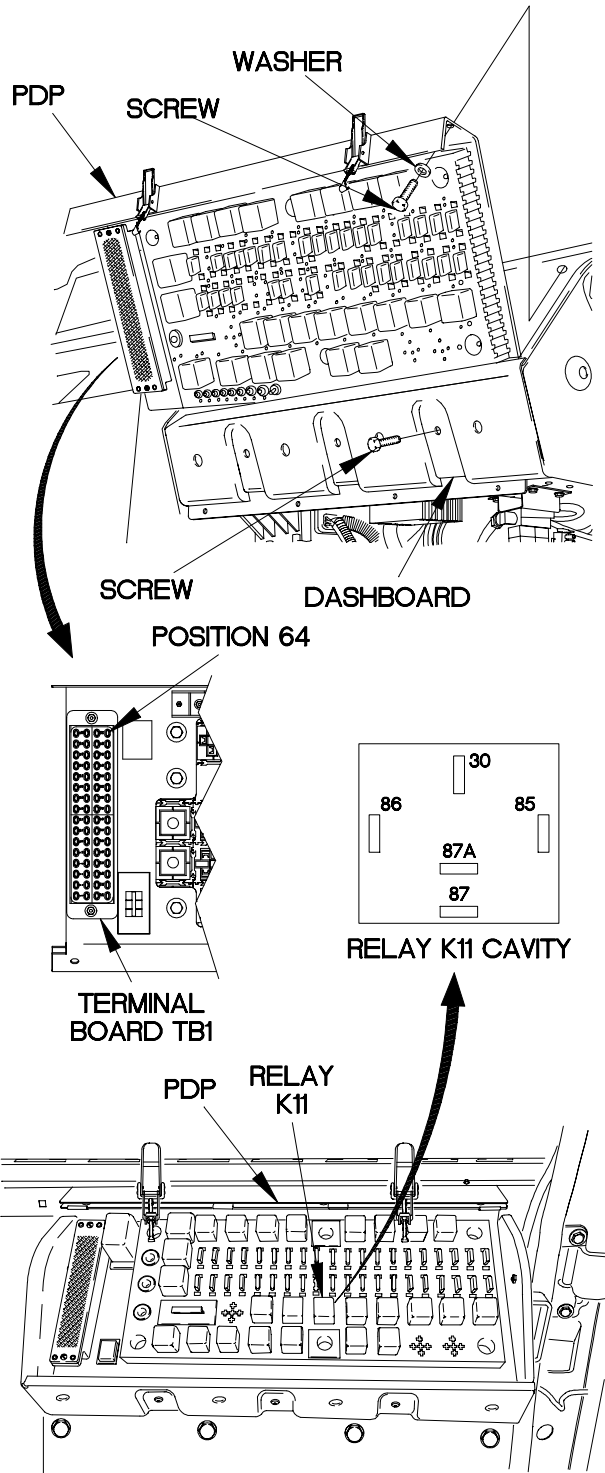

Xbe0224b

e2. ENGINE DOES NOT CRANK (CONT)

KNOWN INFO
Transmission pushbutton shift selector in neutral (N). Batteries OK. Service drive lights OK. Circuit breakers OK. Starting motor OK. Battery to starter cable assembly OK. Oil pressure switch OK. Neutral start relay OK. WTEC II vehicle interface module (VIM) OK. WTEC II cab transmission wiring harness OK. WTEC II transmission ECU pushbutton shift selector (TEPSS) OK. Relay K26 OK. WTEC III transmission pushbutton shift selector (TPSS) OK.
POSSIBLE PROBLEMS
Faulty engine control cable assembly. Faulty dashboard cable assembly.

25.
Is continuity present from relay K24 socket 85 on PDP to relay K11 socket 85 on PDP?

TEST OPTIONS
Continuity Test or STE/ICE-R Test #91
REASON FOR QUESTION
If continuity is not present, wire 34 is faulty.

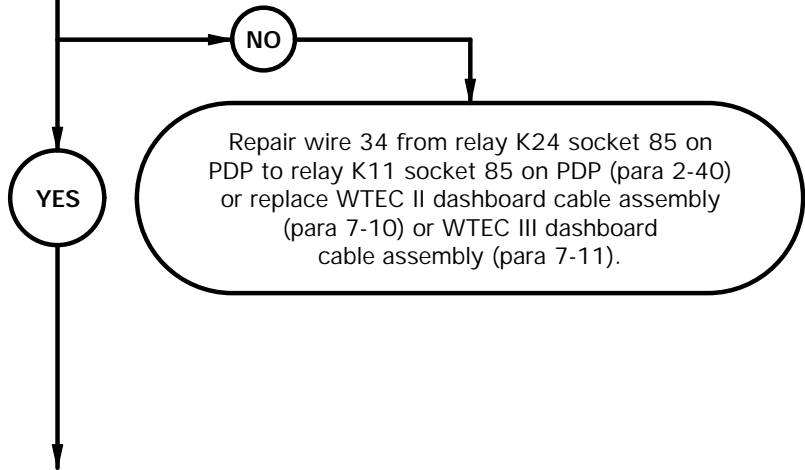

CONTINUITY TEST

- (1) Remove relay K11 from PDP.
- (2) Set multimeter to ohms.
- (3) Connect positive (+) probe of multimeter to relay K24 socket 85 on PDP.
- (4) Connect negative (-) probe of multimeter to relay K11 socket 85 on PDP and note reading on multimeter.
- (5) If continuity is not present, repair wire 34 from relay K24 socket 85 on PDP to relay K11 socket 85 on PDP (para 2-40) or replace WTEC II dashboard cable assembly (para 7-10) or WTEC III dashboard cable assembly (para 7-11).
- (6) Install relay K24 in PDP.

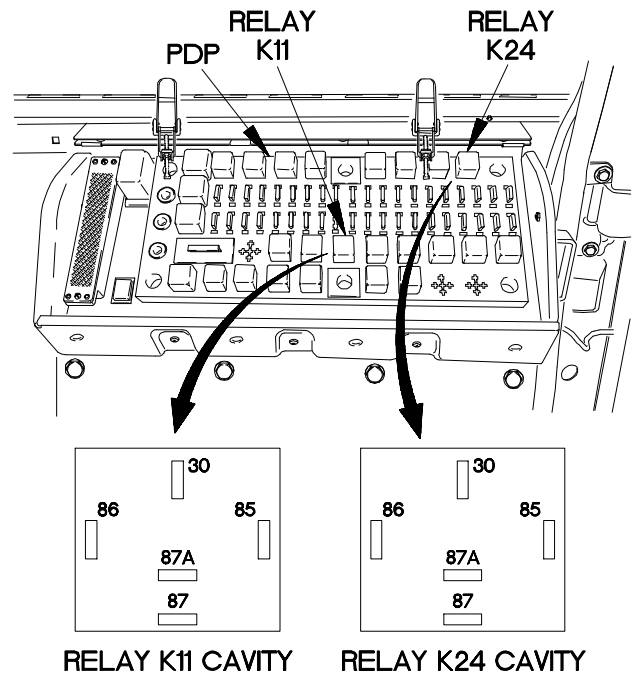

XBE0225B

e2. ENGINE DOES NOT CRANK (CONT)

KNOWN INFO
Transmission pushbutton shift selector in neutral (N). Batteries OK. Service drive lights OK. Circuit breakers OK. Starting motor OK. Battery to starter cable assembly OK. Oil pressure switch OK. Neutral start relay OK. WTEC II vehicle interface module (VIM) OK. WTEC II cab transmission wiring harness OK. WTEC II transmission ECU pushbutton shift selector (TEPSS) OK. Relay K26 OK. WTEC III transmission pushbutton shift selector (TPSS) OK.
POSSIBLE PROBLEMS
Faulty engine control cable assembly. Faulty dashboard cable assembly.

CAUTION
Read CAUTION on following page.

26. Is continuity present from relay K11 socket 85 on PDP to connector J31 pin 21?

TEST OPTIONS
Continuity Test or STE/ICE-R Test #91
REASON FOR QUESTION
If continuity is not present, wire 34 is faulty. If continuity is present wire 34 is faulty.

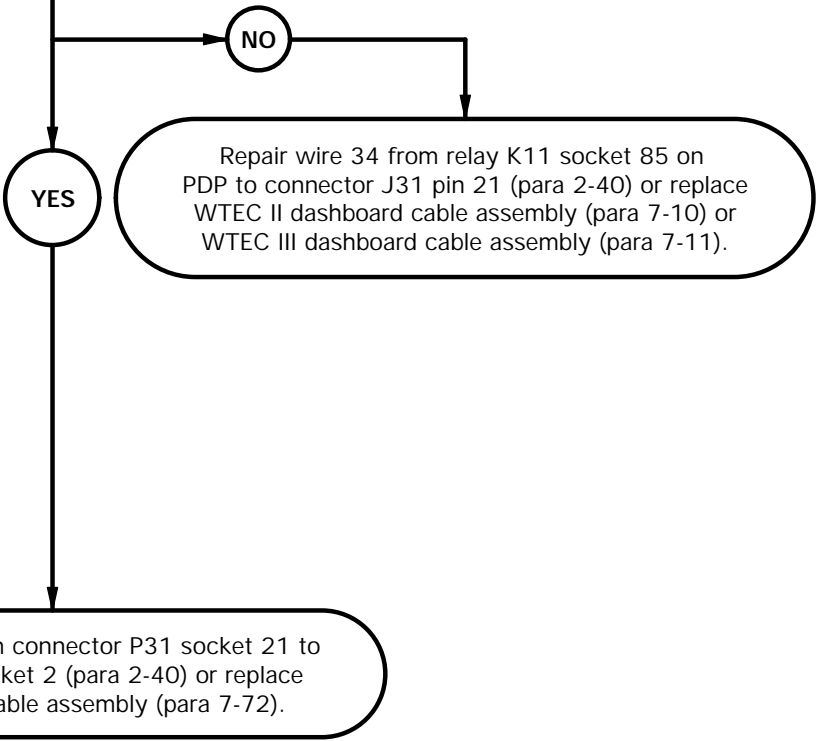

CAUTION

Use care when testing electrical connectors. Do not damage connector pins or sockets with multimeter probes. Failure to comply may result in damage to equipment.

NOTE

Inspect connector pins/sockets for damage, corrosion, and serviceability. Check that connector pins are not pushed back or not capable of making good contact.

CONTINUITY TEST

- (1) Remove instrument panel for access (para 7-15).
- (2) Disconnect connector J31 from connector P31.
- (3) Set multimeter to ohms.
- (4) Connect positive (+) probe of multimeter to connector J31 pin 21.
- (5) Connect negative (-) probe of multimeter to relay K11 socket 85 on PDP and note reading on multimeter.
- (6) If continuity is not present, repair wire 34 from relay K11 socket 85 on PDP to connector J31 pin 21 (para 2-40) or replace WTEC II dashboard cable assembly (para 7-10) or WTEC III dashboard cable assembly (para 7-11).
- (7) If continuity is present, repair wire 34 from connector P31 socket 21 to connector P34 socket 2 (para 2-40) or replace engine control cable assembly (para 7-72).
- (8) Connect connector J31 to connector P31.
- (9) Install instrument panel (para 7-15).
- (10) Install relay K11 in PDP.
- (11) Install power distribution panel (PDP) cover (para 16-2).
- (12) Connect batteries (para 7-48).

CONNECTOR J31 CONNECTOR P31

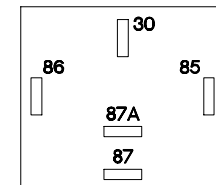
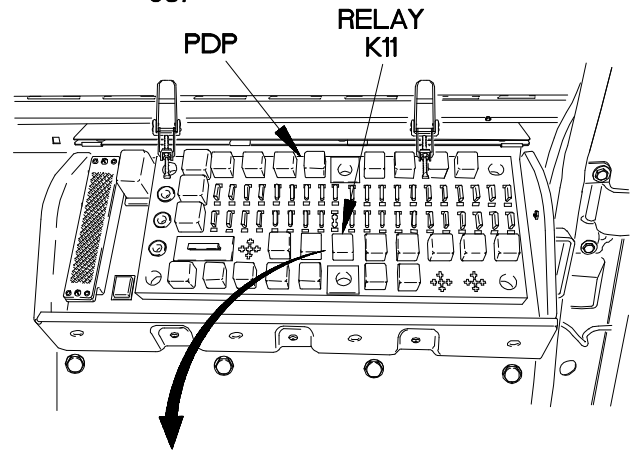
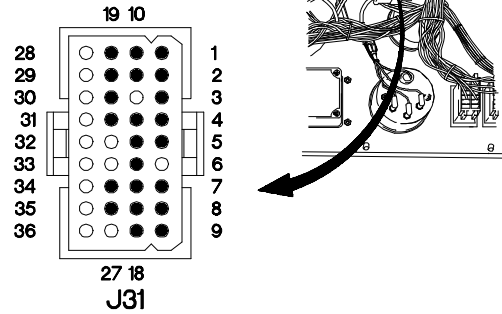

RELAY K11 CAVITY

XBE0226B

e2. ENGINE DOES NOT CRANK (CONT)

KNOWN INFO
Transmission pushbutton shift selector in neutral (N). Batteries OK. Service drive lights OK. Circuit breakers OK. Starting motor OK. Battery to starter cable assembly OK. Oil pressure switch OK. Neutral start relay OK. WTEC II vehicle interface module (VIM) OK. WTEC II cab transmission wiring harness OK. WTEC II transmission ECU pushbutton shift selector (TEPSS) OK. Relay K26 OK. WTEC III transmission pushbutton shift selector (TPSS) OK. Engine control cable assembly OK. Relay K24 OK. Relay K1 OK.
POSSIBLE PROBLEMS
Faulty starter pushbutton switch. Faulty dashboard cable assembly.

27.
 Is continuity present from relay K24 socket 87 on PDP to terminal lug TL162?

TEST OPTIONS
Continuity Test or STE/ICE-R Test #91
REASON FOR QUESTION
If continuity is not present, wire 1405 is faulty.

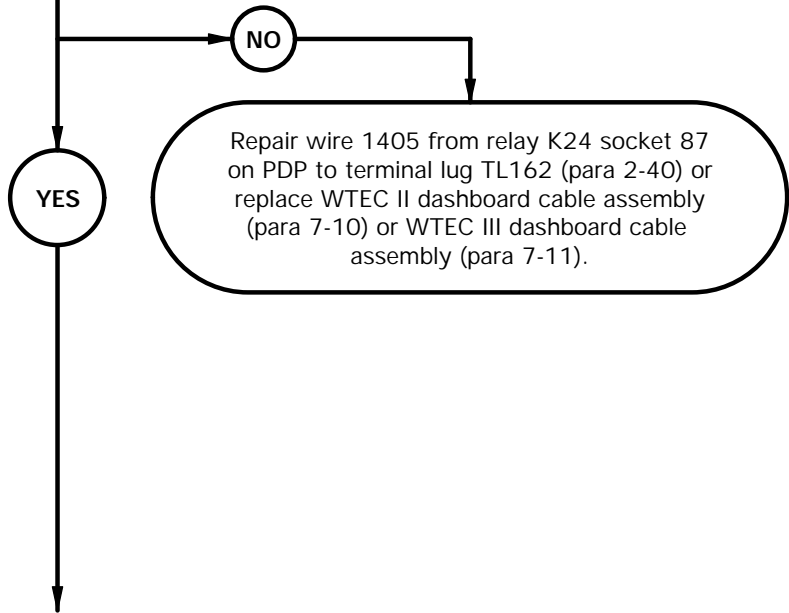

CONTINUITY TEST

- (1) Remove instrument panel for access (para 7-15).
- (2) Disconnect terminal lug TL162 from starter pushbutton switch.
- (3) Set multimeter to ohms.
- (4) Connect positive (+) probe of multimeter to terminal lug TL162.
- (5) Connect negative (-) probe of multimeter to relay K24 socket 87 on PDP and note reading on multimeter.
- (6) If continuity is not present, repair wire 1405 from relay K24 socket 87 on PDP to terminal lug TL162 (para 2-40) or replace WTEC II dashboard cable assembly (para 7-10) or WTEC III dashboard cable assembly (para 7-11).
- (7) Install relay K24 in PDP.
- (8) Connect terminal lug TL162 to starter pushbutton switch.

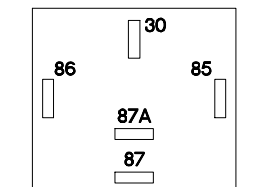
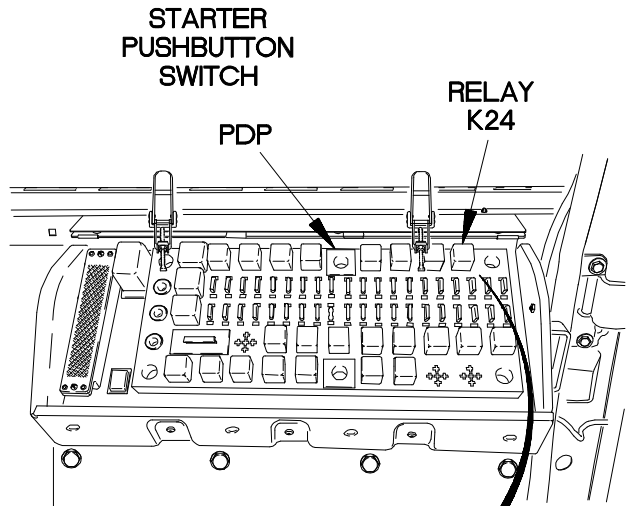
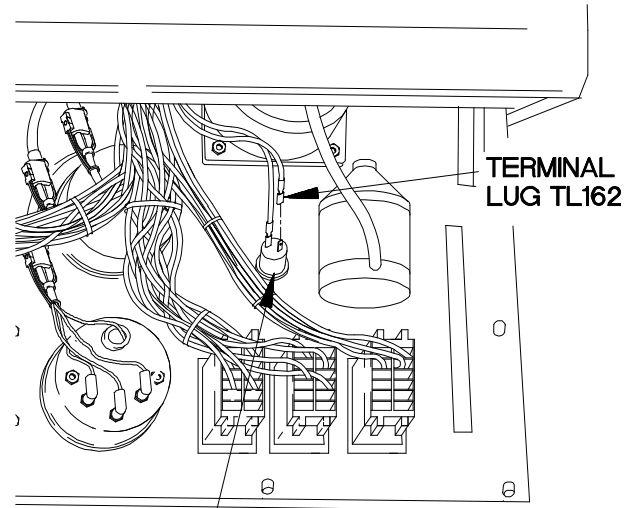

RELAY K24 CAVITY

XBE0227B

e2. ENGINE DOES NOT CRANK (CONT)

KNOWN INFO
Transmission pushbutton shift selector in neutral (N). Batteries OK. Service drive lights OK. Circuit breakers OK. Starting motor OK. Battery to starter cable assembly OK. Oil pressure switch OK. Neutral start relay OK. WTEC II vehicle interface module (VIM) OK. WTEC II cab transmission wiring harness OK. WTEC II transmission ECU pushbutton shift selector (TEPSS) OK. Faulty relay K26. Faulty WTEC III transmission pushbutton shift selector (TPSS). Engine control cable assembly OK. Relay K24 OK. Relay K1 OK.
POSSIBLE PROBLEMS
Faulty starter pushbutton switch. Faulty dashboard cable assembly.

28.
 Is continuity present from terminal lug TL163 to ground?

TEST OPTIONS
Continuity Test or STE/ICE-R Test #91
REASON FOR QUESTION
If continuity is not present, wire 3007 is faulty. If continuity is present, starter pushbutton switch is faulty.

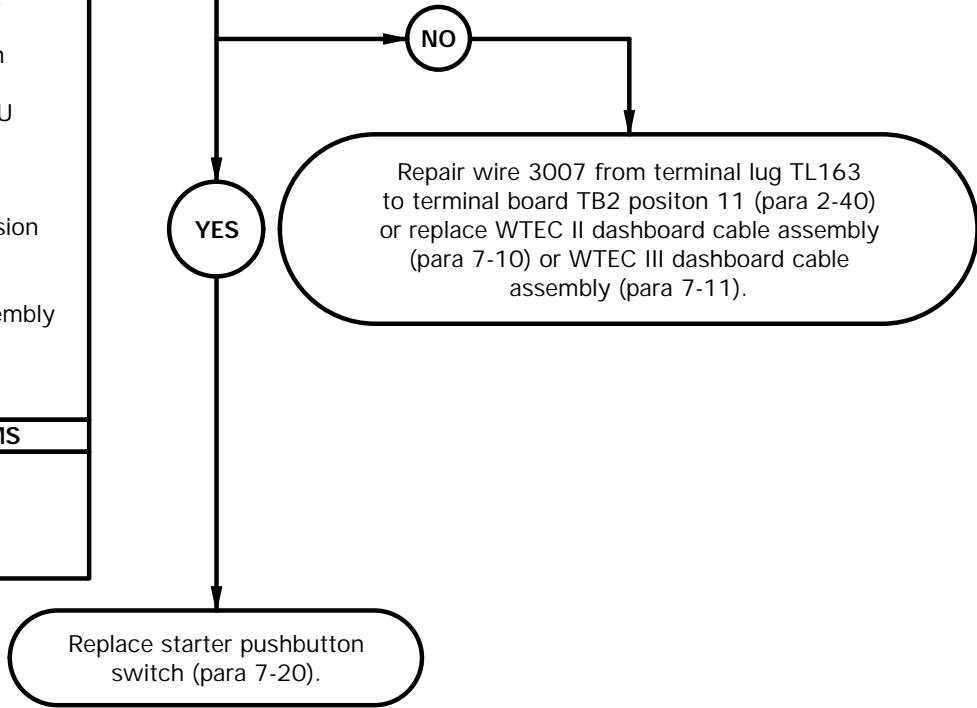

CONTINUITY TEST

- (1) Disconnect terminal lug TL163 from starter pushbutton switch.
- (2) Set multimeter to ohms.
- (3) Connect positive (+) probe of multimeter to terminal lug TL163.
- (4) Connect negative (-) probe of multimeter to ground and note reading on multimeter.
- (5) If continuity is not present, repair wire 3007 from terminal TL163 to terminal board TB2 position 11 (para 2-40) or replace WTEC II dashboard cable assembly (para 7-10) or WTEC III dashboard cable assembly (para 7-11).
- (6) If continuity is present, replace starter pushbutton switch (para 7-20).
- (7) Connect terminal lug TL163 to starter pushbutton.
- (8) Install instrument panel (para 7-15).
- (9) Install power distribution panel (PDP) cover (para 16-2).
- (10) Connect batteries (para 7-48).

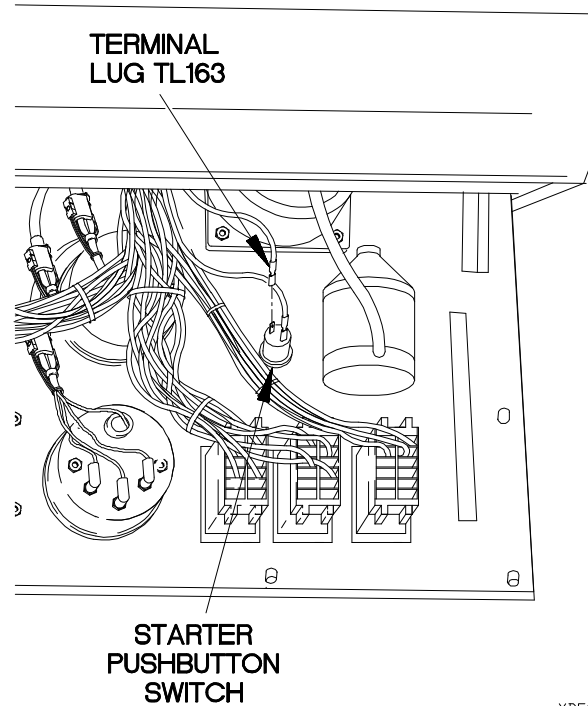

XBE0228B

e2. ENGINE DOES NOT CRANK (CONT)

KNOWN INFO
Transmission pushbutton shift selector in neutral (N). Batteries OK. Service drive lights OK. Circuit breakers OK. Starting motor OK. Battery to starter cable assembly OK. Oil pressure switch OK.
POSSIBLE PROBLEMS
Faulty neutral start relay. Faulty WTEC II vehicle interface module (VIM). Faulty WTEC II cab transmission wiring harness. Faulty WTEC II transmission ECU pushbutton shift selector (TEPSS). Faulty relay K26. Faulty dashboard cable assembly. Faulty WTEC III transmission ECU. Faulty WTEC III transmission pushbutton shift selector (TPSS).

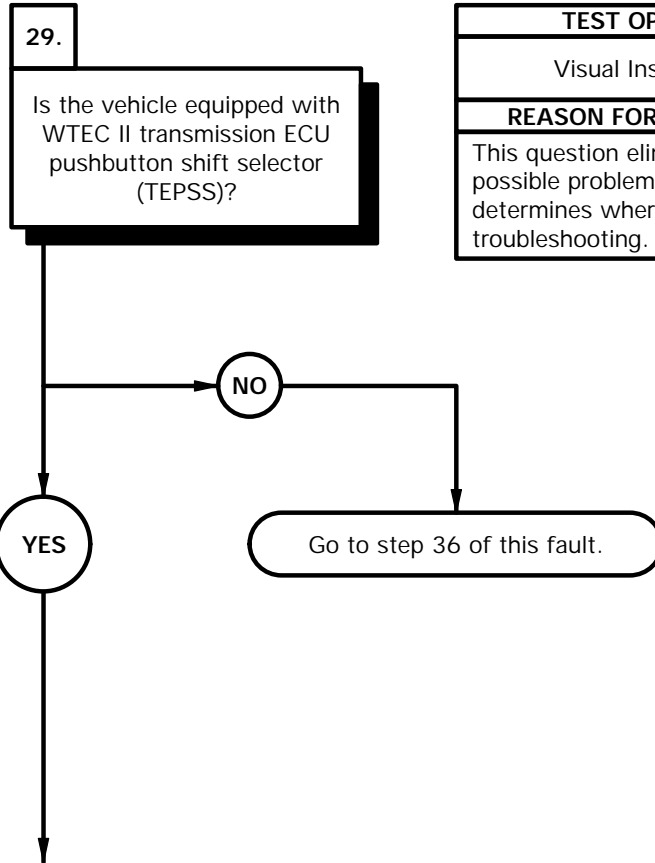

TEST OPTIONS
Visual Inspection
REASON FOR QUESTION
This question eliminates possible problems and determines where to continue troubleshooting.

- (1) Check if vehicle is equipped with WTEC II transmission ECU pushbutton shift selector (TEPSS).
- (2) If TEPSS is not equipped with a filter cover, go to step 36 of this fault.

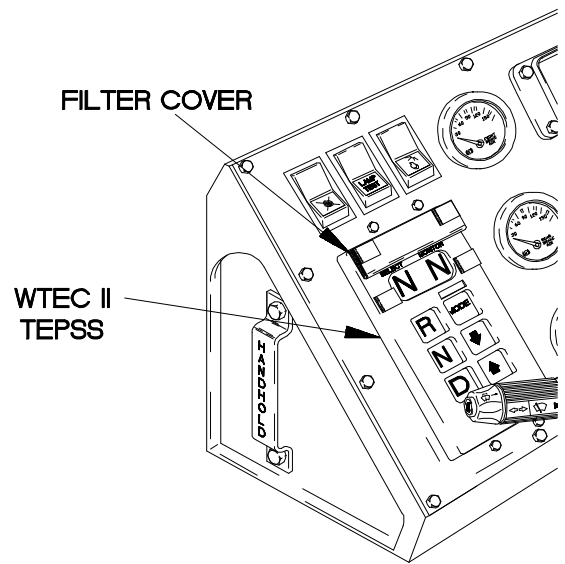
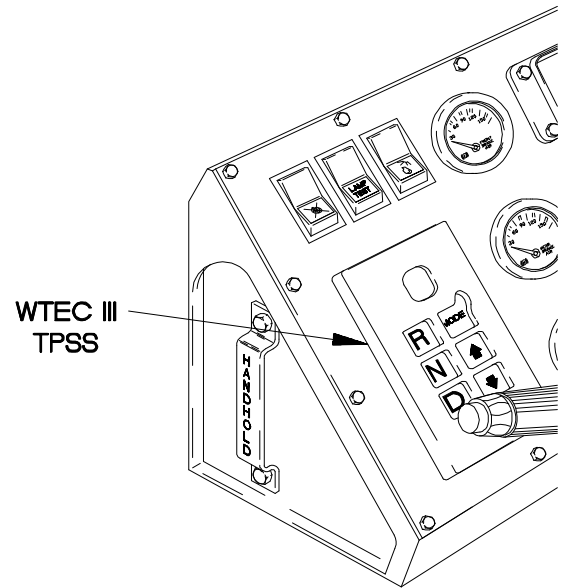

XBE0229B

e2. ENGINE DOES NOT CRANK (CONT)

KNOWN INFO
Transmission pushbutton shift selector in neutral (N). Batteries OK. Service drive lights OK. Circuit breakers OK. Starting motor OK. Battery to starter cable assembly OK. Oil pressure switch OK.
POSSIBLE PROBLEMS
Faulty neutral start relay. Faulty WTEC II vehicle interface module (VIM). Faulty WTEC II cab transmission wiring harness. Faulty WTEC II transmission ECU pushbutton shift selector (TEPSS). Faulty dashboard cable assembly.

30. **WARNING**
Read **WARNING** on following page.

Is 24 VDC present at neutral start relay socket 87 on VIM?

TEST OPTIONS
Voltage Test or STE/ICE-R Test #89
REASON FOR QUESTION
This question eliminates possible problems and determines where to continue troubleshooting.

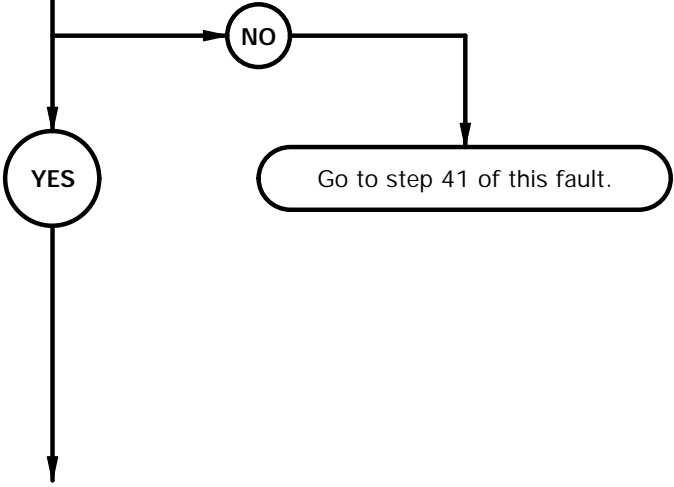

WARNING

Remove rings, bracelets, watches, necklaces, and any other jewelry before working around vehicle. Jewelry can catch on equipment and cause injury or short across electrical circuits and cause severe burns or electrical shock.

VOLTAGE TEST

- (1) Install relay K1 in PDP.
- (2) Remove kick panel (para 16-3).
- (3) Remove circuit breaker CB35 from PDP.
- (4) Remove eight screws, washers, cover, and metal seal ring from VIM. Discard metal seal ring.
- (5) Remove neutral start relay from VIM.
- (6) Set multimeter to volts DC.
- (7) Connect positive (+) probe of multimeter to neutral start relay socket 87 on VIM.
- (8) Connect negative (-) probe of multimeter to ground.
- (9) Install circuit breaker CB35 in PDP and note reading on multimeter.
- (10) If 24 VDC is not present, go to step 41 of this fault.
- (11) Remove circuit breaker CB35 from PDP.

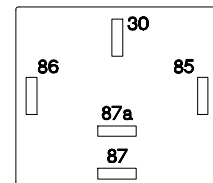
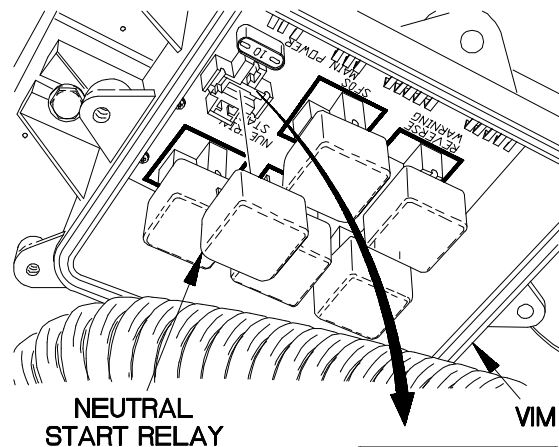
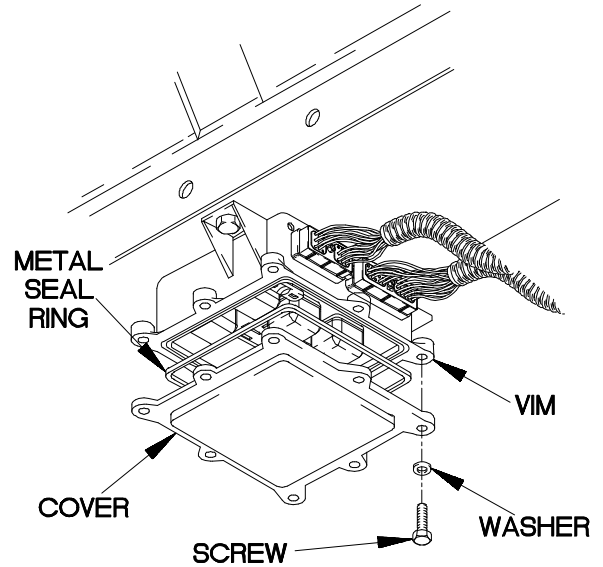
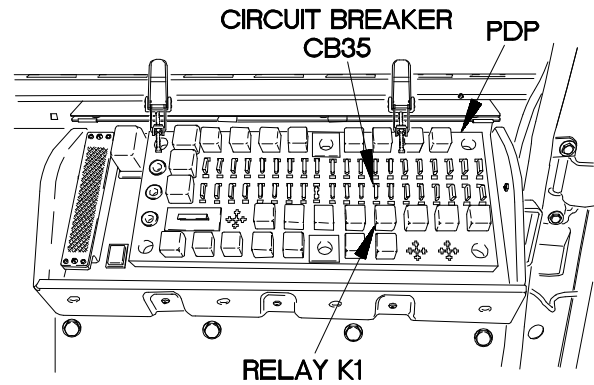

NEUTRAL START RELAY CAVITY

XBE0230B

e2. ENGINE DOES NOT CRANK (CONT)

KNOWN INFO
Transmission pushbutton shift selector in neutral (N). Batteries OK. Service drive lights OK. Circuit breakers OK. Starting motor OK. Battery to starter cable assembly OK. Oil pressure switch OK.
POSSIBLE PROBLEMS
Faulty neutral start relay. Faulty WTEC II vehicle interface module (VIM). Faulty WTEC II cab transmission wiring harness. Faulty WTEC II transmission ECU pushbutton shift selector (TEPSS). Faulty dashboard cable assembly.

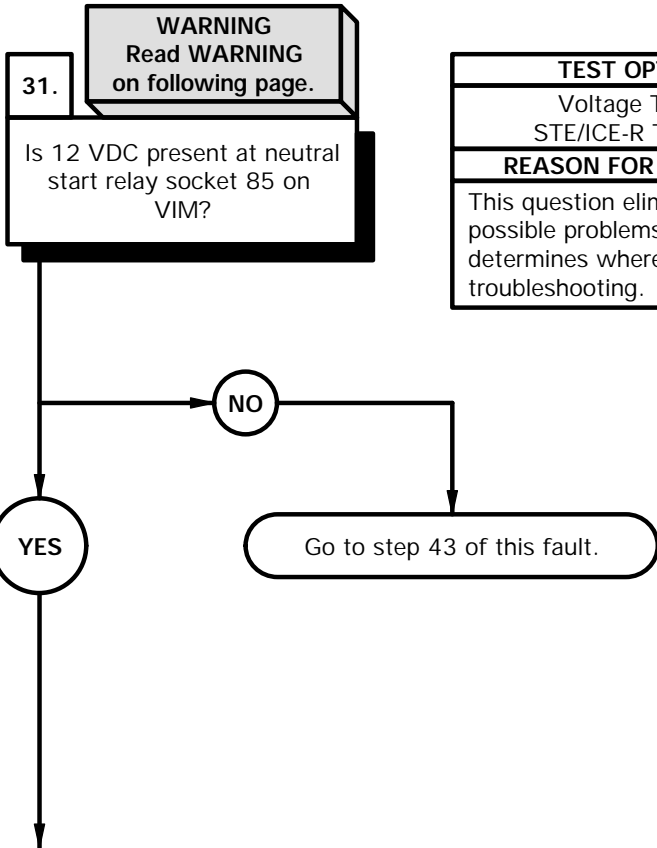

TEST OPTIONS
Voltage Test or STE/ICE-R Test #89
REASON FOR QUESTION
This question eliminates possible problems and determines where to continue troubleshooting.

WARNING

Remove rings, bracelets, watches, necklaces, and any other jewelry before working around vehicle. Jewelry can catch on equipment and cause injury or short across electrical circuits and cause severe burns or electrical shock.

VOLTAGE TEST

- (1) Set multimeter to volts DC.
- (2) Connect positive (+) probe of multimeter to neutral start relay socket 85 on VIM.
- (3) Connect negative (-) probe of multimeter to ground.
- (4) Install circuit breaker CB35 in PDP and note reading on multimeter.
- (5) If 12 VDC is not present, go to step 43 of this fault.
- (6) Remove circuit breaker CB35 from PDP.

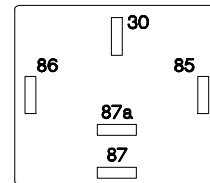
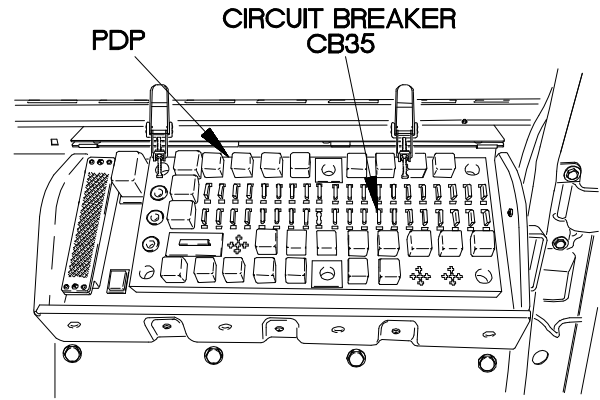

**NEUTRAL
START RELAY
CAVITY**

XBE0231B

e2. ENGINE DOES NOT CRANK (CONT)

KNOWN INFO
Transmission pushbutton shift selector in neutral (N). Batteries OK. Service drive lights OK. Circuit breakers OK. Starting motor OK. Battery to starter cable assembly OK. Oil pressure switch OK. WTEC II cab transmission wiring harness OK. WTEC II transmission ECU pushbutton shift selector (TEPSS) OK.
POSSIBLE PROBLEMS
Faulty neutral start relay. Faulty WTEC II vehicle interface module (VIM). Faulty dashboard cable assembly.

32.
Is continuity present from neutral start relay socket 86 on VIM to ground?

TEST OPTIONS
Continuity Test or STE/ICE-R Test #91
REASON FOR QUESTION
This question eliminates possible problems and determines where to continue troubleshooting.

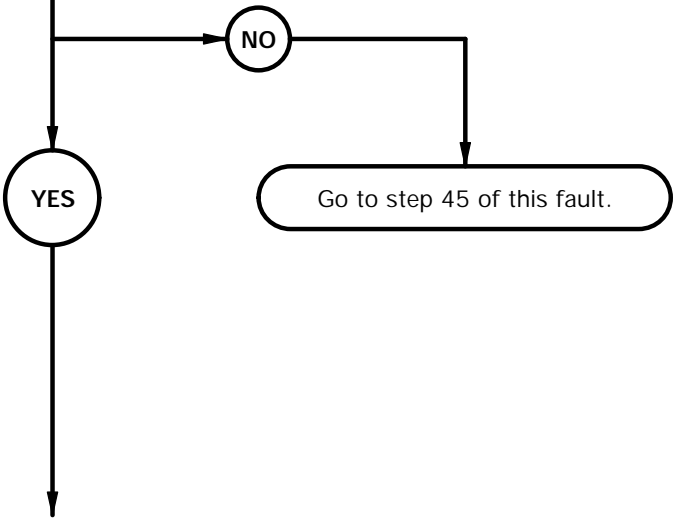

CONTINUITY TEST

- (1) Set multimeter to ohms.
- (2) Connect positive (+) probe of multimeter to neutral start relay socket 86 on VIM.
- (3) Connect negative (-) probe of multimeter to ground and note reading on multimeter.
- (4) If continuity is not present, go to step 45 of this fault.

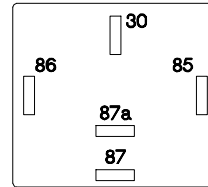

**NEUTRAL
START RELAY
CAVITY**

XBE0232B

e2. ENGINE DOES NOT CRANK (CONT)

KNOWN INFO
Transmission pushbutton shift selector in neutral (N). Batteries OK. Service drive lights OK. Circuit breakers OK. Starting motor OK. Battery to starter cable assembly OK. Oil pressure switch OK. WTEC II cab transmission wiring harness OK. WTEC II transmission ECU pushbutton shift selector (TEPSS) OK.
POSSIBLE PROBLEMS
Faulty neutral start relay. Faulty WTEC II vehicle interface module (VIM). Faulty dashboard cable assembly.

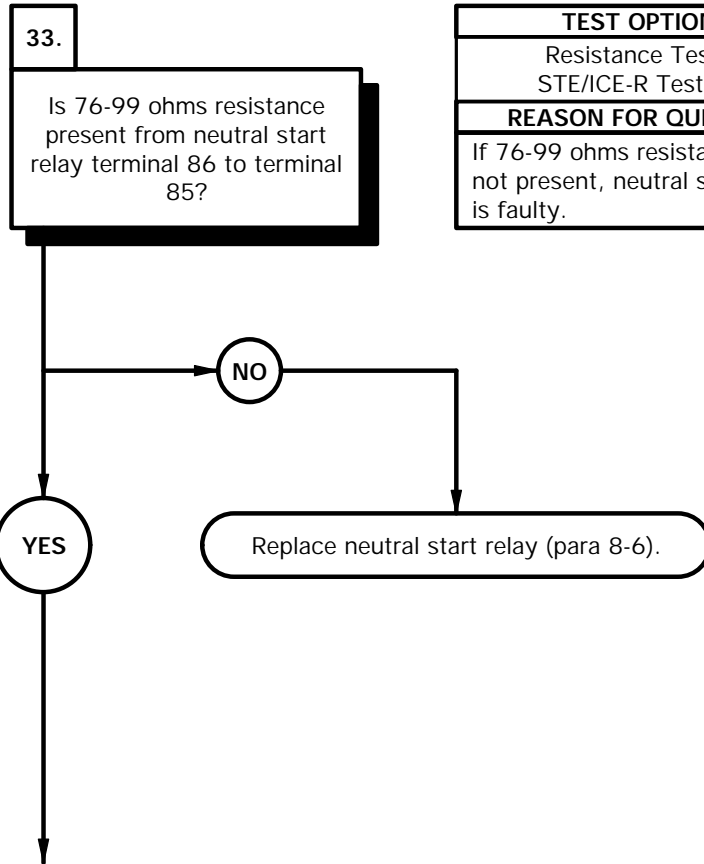

TEST OPTIONS
Resistance Test or STE/ICE-R Test #91
REASON FOR QUESTION
If 76-99 ohms resistance is not present, neutral start relay is faulty.



RESISTANCE TEST

- (1) Set multimeter to ohms.
- (2) Connect positive (+) probe of multimeter to neutral start relay terminal 85.
- (3) Connect negative (-) probe of multimeter to neutral start relay terminal 86 and note reading on multimeter.
- (4) If 76-99 ohms resistance is not present, replace neutral start relay (para 8-6).

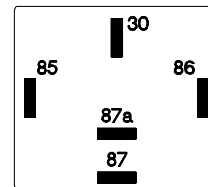
**NEUTRAL
START RELAY**

XBE0233B

e2. ENGINE DOES NOT CRANK (CONT)

KNOWN INFO
Transmission pushbutton shift selector in neutral (N). Batteries OK. Service drive lights OK. Circuit breakers OK. Starting motor OK. Battery to starter cable assembly OK. Oil pressure switch OK. WTEC II cab transmission wiring harness OK. WTEC II transmission ECU pushbutton shift selector (TEPSS) OK.
POSSIBLE PROBLEMS
Faulty neutral start relay. Faulty WTEC II vehicle interface module (VIM). Faulty dashboard cable assembly.

34. **WARNING**
Read **WARNING** on following page.

Is 24 VDC present at VIM neutral start relay socket 30?

TEST OPTIONS
Voltage Test or STE/ICE-R Test #89
REASON FOR QUESTION
If 24 VDC is not present, neutral start relay is faulty.

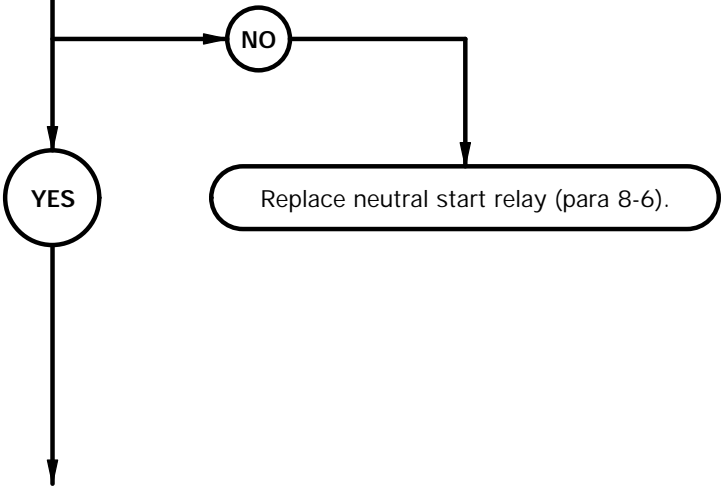

WARNING

Remove rings, bracelets, watches, necklaces, and any other jewelry before working around vehicle. Jewelry can catch on equipment and cause injury or short across electrical circuits and cause severe burns or electrical shock.

VOLTAGE TEST

- (1) Install relay test wire in neutral start relay socket 30 on VIM.
- (2) Install neutral start relay in VIM.
- (3) Install circuit breaker CB35 in PDP.
- (4) Set multimeter to volts DC.
- (5) Connect positive (+) probe of multimeter to relay test wire.
- (6) Connect negative (-) probe of multimeter to ground.
- (7) Position master power switch to on (TM 9-2320-365-10) and note reading on multimeter.
- (8) If 24 VDC is not present, replace neutral start relay (para 8-6).
- (9) Position master power switch to off (TM 9-2320-365-10).
- (10) Remove circuit breaker CB35 from PDP.
- (11) Remove neutral start relay from VIM.
- (12) Remove relay test wire from neutral start relay socket 30 on VIM.

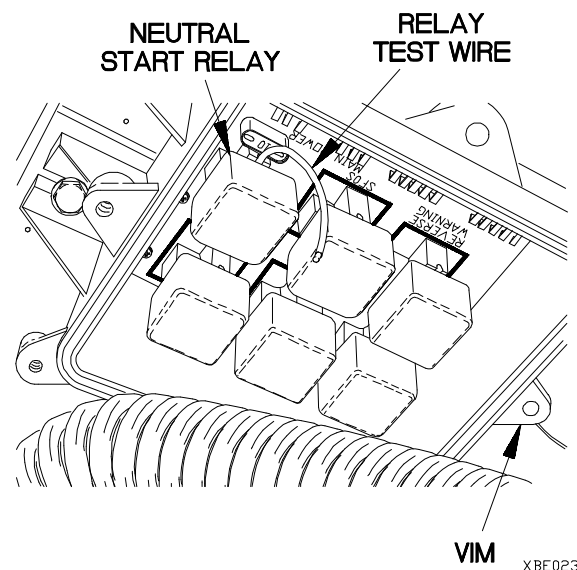
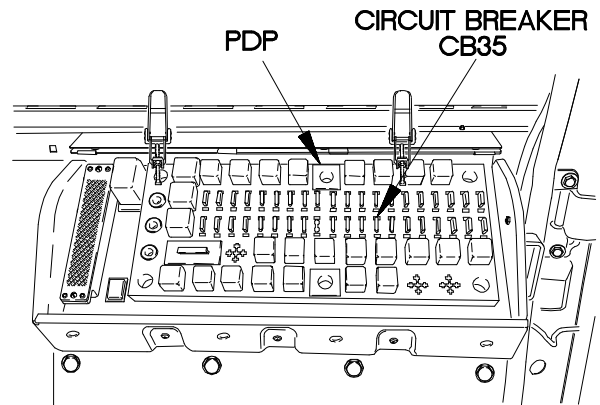

e2. ENGINE DOES NOT CRANK (CONT)

KNOWN INFO
Transmission pushbutton shift selector in neutral (N). Batteries OK. Service drive lights OK. Circuit breakers OK. Starting motor OK. Battery to starter cable assembly OK. Oil pressure switch OK. WTEC II cab transmission wiring harness OK. WTEC II transmission ECU pushbutton shift selector (TEPSS) OK. Neutral start relay OK.
POSSIBLE PROBLEMS
Faulty WTEC II vehicle interface module (VIM). Faulty dashboard cable assembly.

CAUTION
Read CAUTION on following page.

35. Is continuity present from VIM neutral start relay socket 30 to VIM connector pin G1?

TEST OPTIONS
Continuity Test or STE/ICE-R Test #91
REASON FOR QUESTION
If continuity is not present, WTEC II vehicle interface module (VIM) is faulty. If continuity is present, wire 1691 is faulty.

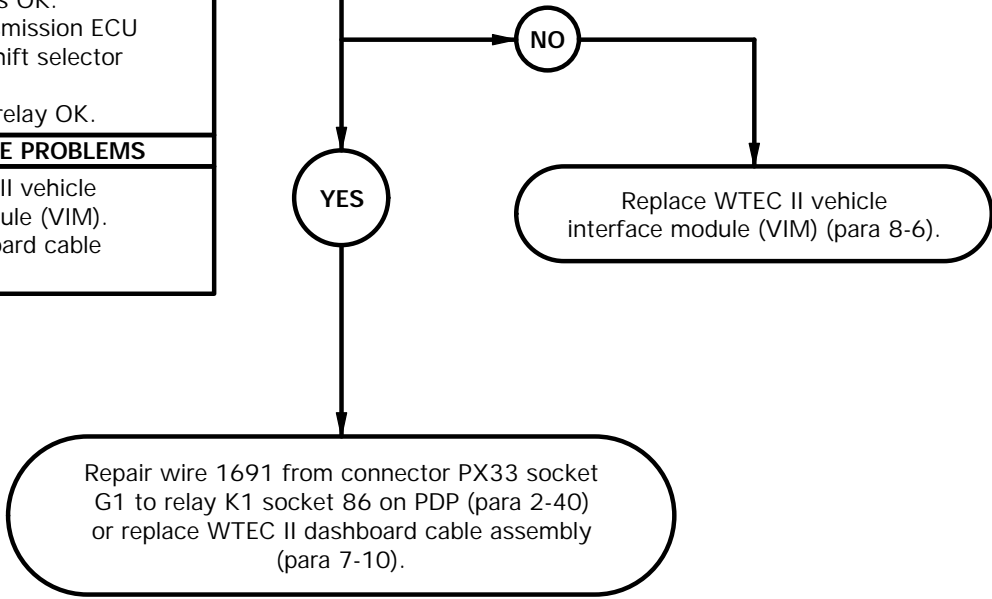

CAUTION

Use care when testing electrical connectors. Do not damage connector pins or sockets with multimeter probes. Failure to comply may result in damage to equipment.

NOTE

Inspect connector pins/sockets for damage, corrosion, and serviceability. Check that connector pins are not pushed back or not capable of making good contact.

CONTINUITY TEST

- (1) Disconnect batteries (para 7-48).
- (2) Loosen screw in connector PX33.
- (3) Disconnect connector PX33 from VIM connector.
- (4) Set multimeter to ohms.
- (5) Connect positive (+) probe of multimeter to neutral start relay socket 30 on VIM.
- (6) Connect negative (-) probe of multimeter to VIM connector pin G1 and note reading on multimeter.
- (7) If continuity is not present, replace WTEC II vehicle interface module (VIM) (para 8-6).
- (8) If continuity is present, repair wire 1691 from connector PX33 socket G1 to relay K1 socket 86 on PDP (para 2-40) or replace WTEC II dashboard cable assembly (para 7-10).
- (9) Connect connector PX33 to VIM connector.
- (10) Tighten screw in connector PX33.
- (11) Install neutral start relay in VIM.
- (12) Install cover on VIM with metal seal ring, eight washers, and screws.
- (13) Install circuit breaker CB35 in PDP.
- (14) Install kick panel (para 16-3).
- (15) Connect batteries (para 7-48).

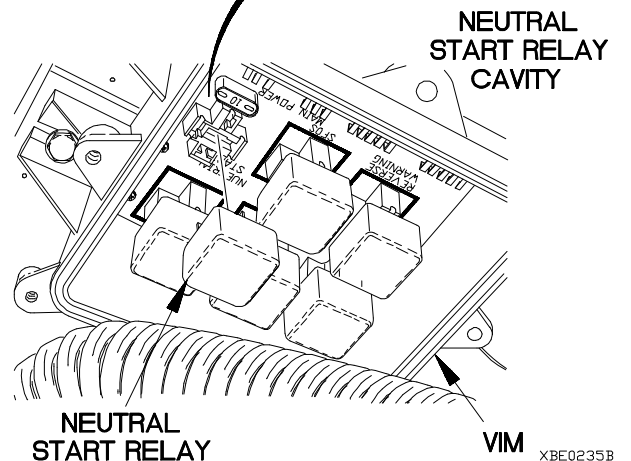
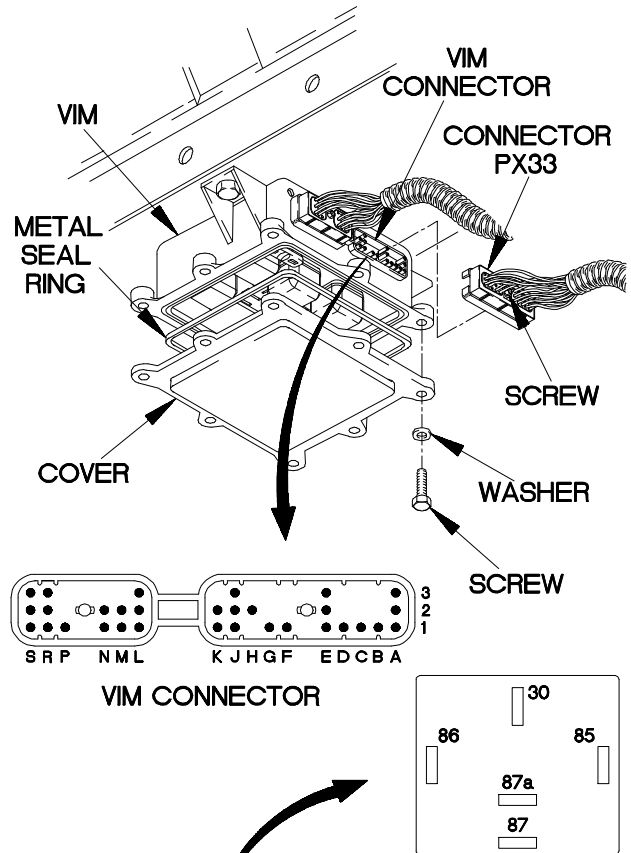
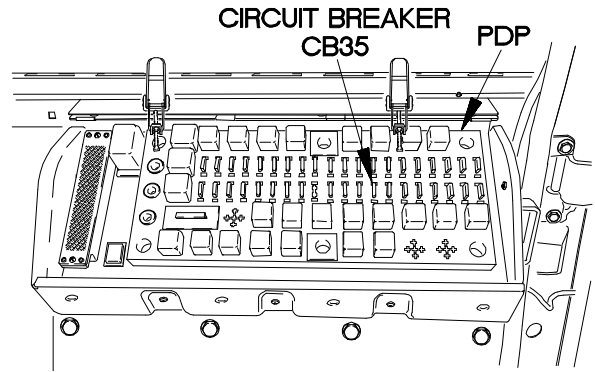

e2. ENGINE DOES NOT CRANK (CONT)

KNOWN INFO
Transmission pushbutton shift selector in neutral (N). Batteries OK. Service drive lights OK. Circuit breakers OK. Starting motor OK. Battery to starter cable assembly OK. Oil pressure switch OK.
POSSIBLE PROBLEMS
Faulty relay K26. Faulty dashboard cable assembly. Faulty WTEC III transmission ECU. Faulty WTEC III transmission pushbutton shift selector (TPSS).

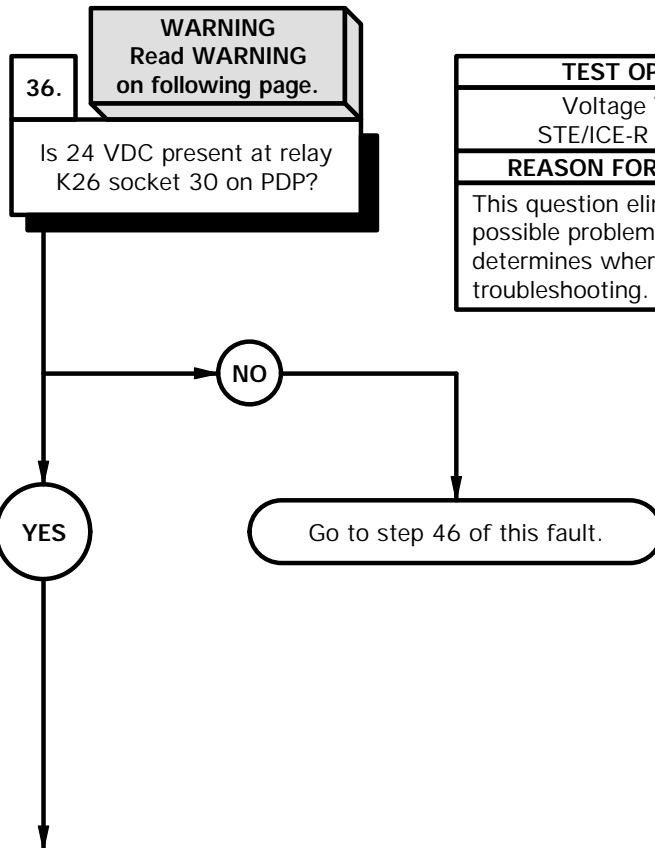

TEST OPTIONS
Voltage Test or STE/ICE-R Test #89
REASON FOR QUESTION
This question eliminates possible problems and determines where to continue troubleshooting.

WARNING

Remove rings, bracelets, watches, necklaces, and any other jewelry before working around vehicle. Jewelry can catch on equipment and cause injury or short across electrical circuits and cause severe burns or electrical shock.

VOLTAGE TEST

- (1) Install relay K1 in PDP.
- (2) Remove relay K26 from PDP.
- (3) Set multimeter to volts DC.
- (4) Connect positive (+) probe of multimeter to relay K26 socket 30 on PDP.
- (5) Connect negative (-) probe of multimeter to ground.
- (6) Position master power switch to on (TM 9-2320-365-10) and note reading on multimeter.
- (7) If 24 VDC is not present, go to step 46 of this fault.
- (8) Position master power switch to off (TM 9-2320-365-10).

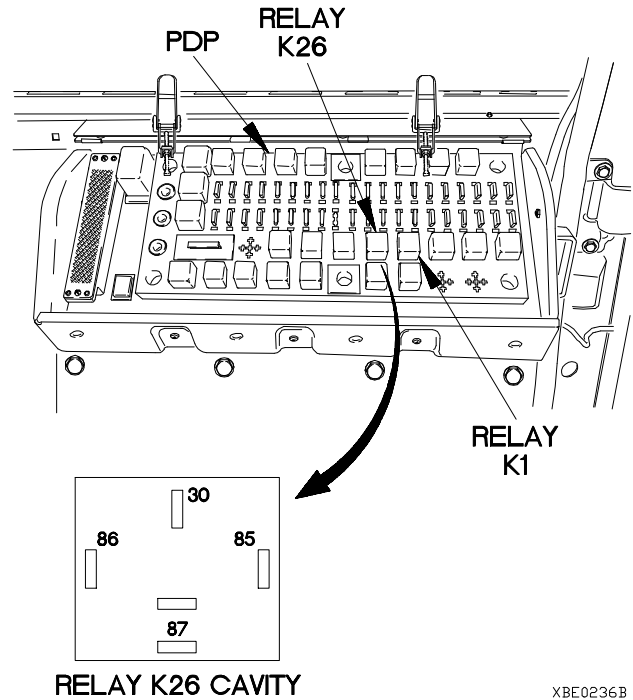

XBE0236B

e2. ENGINE DOES NOT CRANK (CONT)

KNOWN INFO
Transmission pushbutton shift selector in neutral (N). Batteries OK. Service drive lights OK. Circuit breakers OK. Starting motor OK. Battery to starter cable assembly OK. Oil pressure switch OK.
POSSIBLE PROBLEMS
Faulty relay K26. Faulty dashboard cable assembly. Faulty WTEC III transmission ECU. Faulty WTEC III transmission pushbutton shift selector (TPSS).

37. **WARNING**
Read **WARNING** on following page.

Is 24 VDC present at relay K26 socket 86 on PDP?

TEST OPTIONS
Voltage Test or STE/ICE-R Test #89
REASON FOR QUESTION
This question eliminates possible problems and determines where to continue troubleshooting.

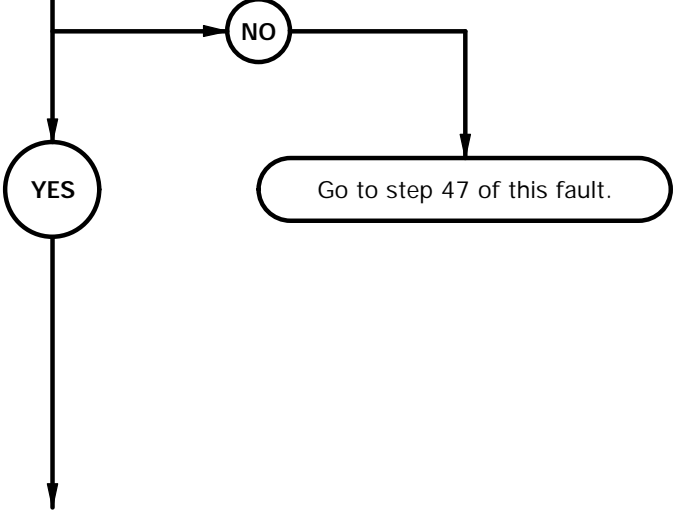

WARNING

Remove rings, bracelets, watches, necklaces, and any other jewelry before working around vehicle. Jewelry can catch on equipment and cause injury or short across electrical circuits and cause severe burns or electrical shock.

VOLTAGE TEST

- (1) Set multimeter to volts DC.
- (2) Connect positive (+) probe of multimeter to relay K26 socket 86 on PDP.
- (3) Connect negative (-) probe of multimeter to ground.
- (4) Position master power switch to on (TM 9-2320-365-10) and note reading on multimeter.
- (5) If 24 VDC is not present, go to step 47 of this fault.
- (6) Position master power switch to off (TM 9-2320-365-10).

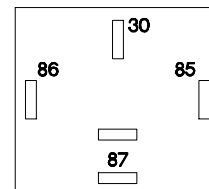
**RELAY K26 CAVITY**

XBE0237B

e2. ENGINE DOES NOT CRANK (CONT)

KNOWN INFO
Transmission pushbutton shift selector in neutral (N). Batteries OK. Service drive lights OK. Circuit breakers OK. Starting motor OK. Battery to starter cable assembly OK. Oil pressure switch OK. WTEC III transmission pushbutton shift selector (TPSS) OK.
POSSIBLE PROBLEMS
Faulty relay K26. Faulty dashboard cable assembly.

38.
Is continuity present from relay K26 socket 85 on PDP to ground?

TEST OPTIONS
Continuity Test or STE/ICE-R Test #91
REASON FOR QUESTION
If continuity is not present, wire 3102 is faulty.

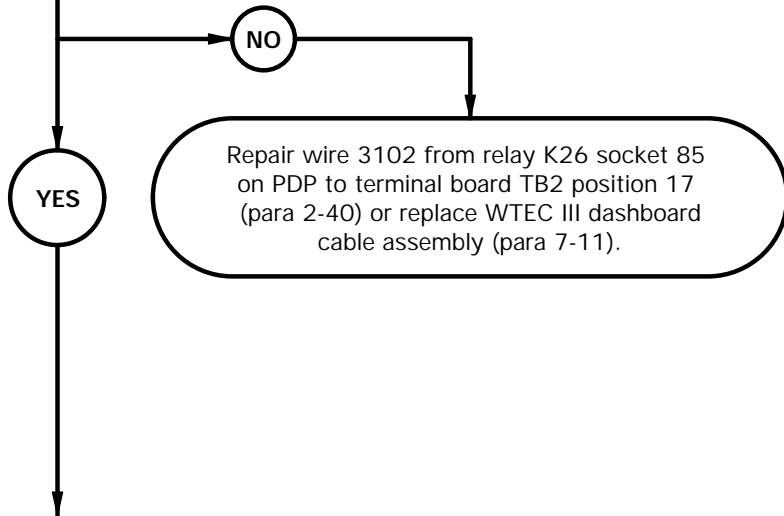

CONTINUITY TEST

- (1) Set multimeter to ohms.
- (2) Connect positive (+) probe of multimeter to relay K26 socket 85 on PDP.
- (3) Connect negative (-) probe of multimeter to ground and note reading on multimeter.
- (4) If continuity is not present, repair wire 3102 from relay K26 socket 85 on PDP to terminal board TB2 position 17 (para 2-40) or replace WTEC III dashboard cable assembly (para 7-11).

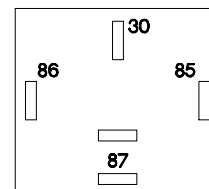
**RELAY K26 CAVITY**

XBE0238B

e2. ENGINE DOES NOT CRANK (CONT)

KNOWN INFO
Transmission pushbutton shift selector in neutral (N). Batteries OK. Service drive lights OK. Circuit breakers OK. Starting motor OK. Battery to starter cable assembly OK. Oil pressure switch OK. WTEC III transmission pushbutton shift selector (TPSS) OK.
POSSIBLE PROBLEMS
Faulty relay K26. Faulty dashboard cable assembly.

39.
Is 306-399 ohms resistance present from relay K26 terminal 85 to terminal 86?

TEST OPTIONS
Resistance Test or STE/ICE-R Test #91
REASON FOR QUESTION
If 306-399 ohms resistance is not present, relay K26 is faulty.

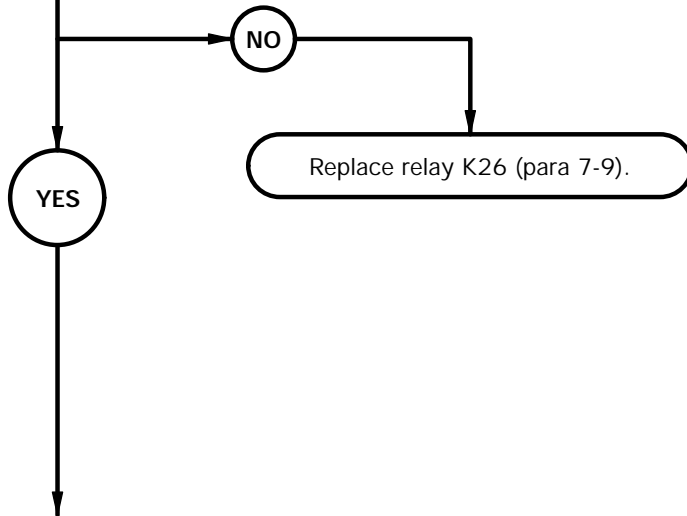

RESISTANCE TEST

- (1) Set multimeter to ohms.
- (2) Connect positive (+) probe of multimeter to relay K26 terminal 85.
- (3) Connect negative (-) probe of multimeter to relay K26 terminal 86 and note reading on multimeter.
- (4) If 306-399 ohms resistance is not present, replace relay K26 (para 7-9).

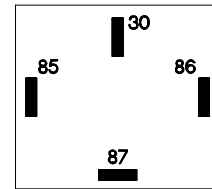
**RELAY K26**

XBE0239B

e2. ENGINE DOES NOT CRANK (CONT)

KNOWN INFO
Transmission pushbutton shift selector in neutral (N). Batteries OK. Service drive lights OK. Circuit breakers OK. Starting motor OK. Battery to starter cable assembly OK. Oil pressure switch OK. WTEC III transmission pushbutton shift selector (TPSS) OK.
POSSIBLE PROBLEMS
Faulty relay K26. Faulty dashboard cable assembly.

WARNING
Read **WARNING** on following page.

40.
Is 24 VDC present at relay K26 socket 87 on PDP?

TEST OPTIONS
Voltage Test or STE/ICE-R Test #89
REASON FOR QUESTION
If 24 VDC is not present, relay K26 is faulty.

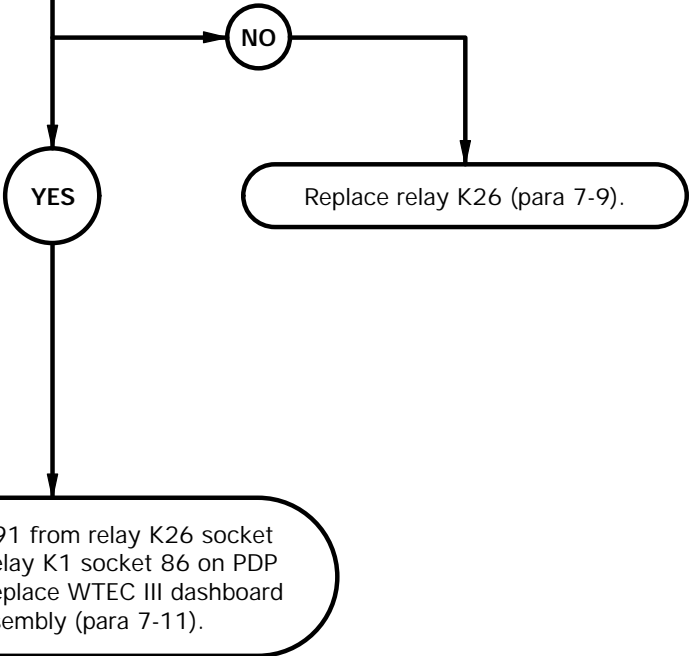

WARNING

Remove rings, bracelets, watches, necklaces, and any other jewelry before working around vehicle. Jewelry can catch on equipment and cause injury or short across electrical circuits, or cause severe burns or electrical shock.

VOLTAGE TEST

- (1) Install relay test wire in relay K26 socket 87 on PDP.
- (2) Install relay K26 in PDP.
- (3) Set multimeter to volts DC.
- (4) Connect positive (+) probe of multimeter to relay test wire.
- (5) Connect negative (-) probe of multimeter to ground.
- (6) Position master power switch to on (TM 9-2320-365-10) and note reading on multimeter.
- (7) If 24 VDC is not present, replace relay K26 (para 7-9).
- (8) If 24 VDC is present, repair wire 1691 from relay 26 socket 87 on PDP to relay K1 socket 86 on PDP (para 2-40) or replace WTEC III dashboard cable assembly (para 7-11).
- (9) Position master power switch to off (TM 9-2320-365-10).
- (10) Remove relay K26 from PDP.
- (11) Remove relay test wire from relay K26 socket 87 on PDP.
- (12) Install relay K26 in PDP.
- (13) Install power distribution panel (PDP) cover (para 16-2).

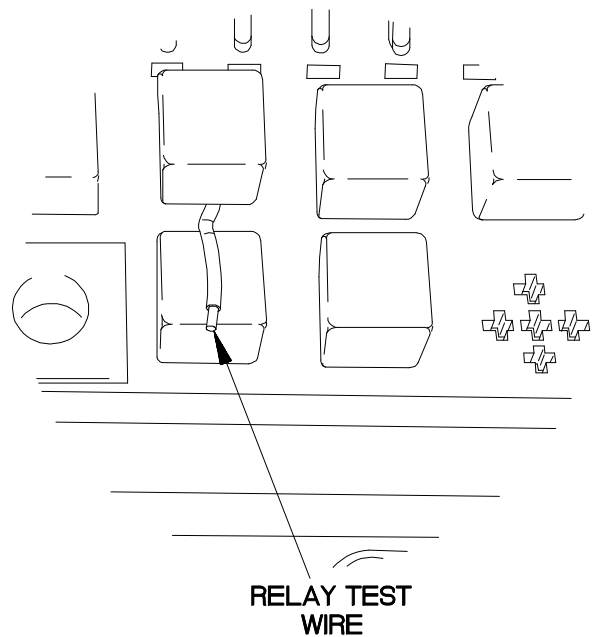
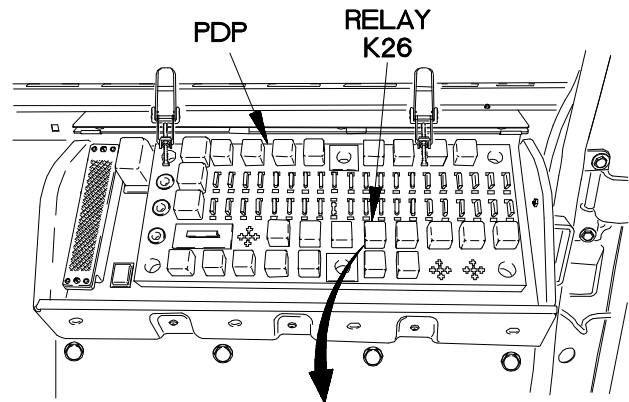

XBE0240B

e2. ENGINE DOES NOT CRANK (CONT)

KNOWN INFO
Transmission pushbutton shift selector in neutral (N). Batteries OK. Service drive lights OK. Circuit breakers OK. Starting motor OK. Battery to starter cable assembly OK. Oil pressure switch OK.
POSSIBLE PROBLEMS
Faulty WTEC II vehicle interface module (VIM). Faulty dashboard cable assembly.

41. **CAUTION**
Read CAUTION on following page.

Is continuity present from VIM connector pin F1 to neutral start relay socket 87 on VIM?

TEST OPTIONS
Continuity Test or STE/ICE-R Test #91
REASON FOR QUESTION
If continuity is not present, WTEC II vehicle interface module is faulty.

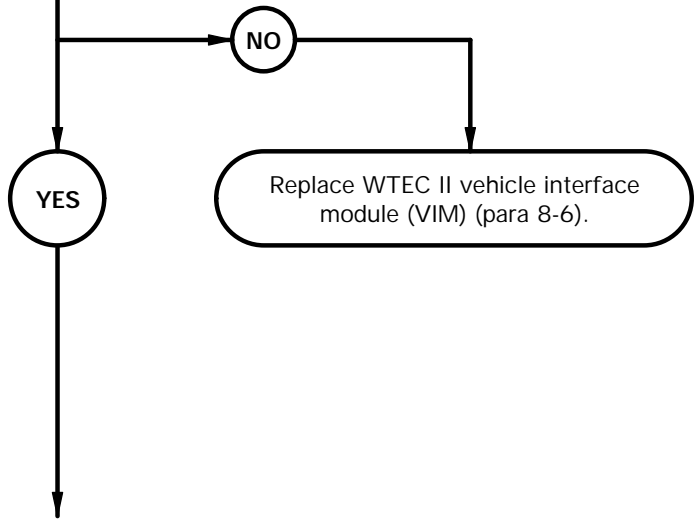

CAUTION

Use care when testing electrical connectors. Do not damage connector pins or sockets with multimeter probes. Failure to comply may result in damage to equipment.

NOTE

Inspect connector pins/sockets for damage, corrosion, and serviceability. Check that connector pins are not pushed back or not capable of making good contact.

CONTINUITY TEST

- (1) Disconnect batteries (para 7-48).
- (2) Loosen screw in connector PX33.
- (3) Disconnect connector PX33 from VIM connector.
- (4) Set multimeter to ohms.
- (5) Connect positive (+) probe of multimeter to neutral start relay socket 87 on VIM.
- (6) Connect negative (-) probe of multimeter to VIM connector PX33 pin F1 and note reading on multimeter.
- (7) If continuity is not present, replace WTEC II vehicle interface module (VIM) (para 8-6).
- (8) Install neutral start relay in VIM.
- (9) Install cover on VIM with metal seal ring, eight washers, and screws.
- (10) Install circuit breaker CB35 in PDP.

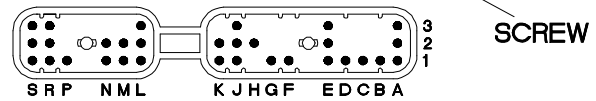
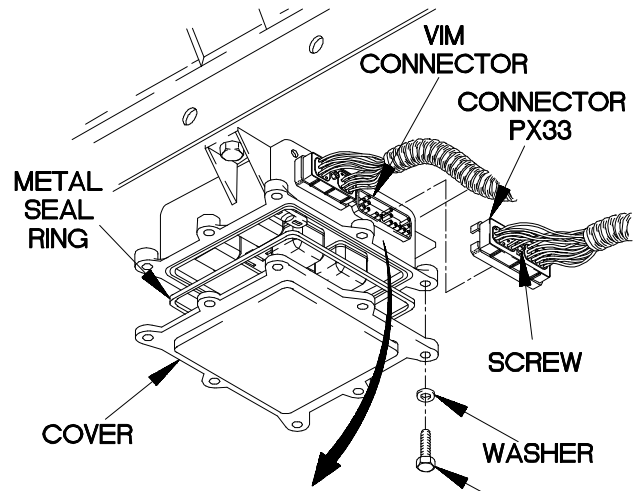

VIM CONNECTOR

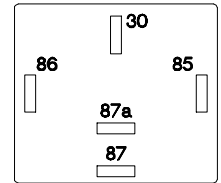

NEUTRAL START RELAY CAVITY

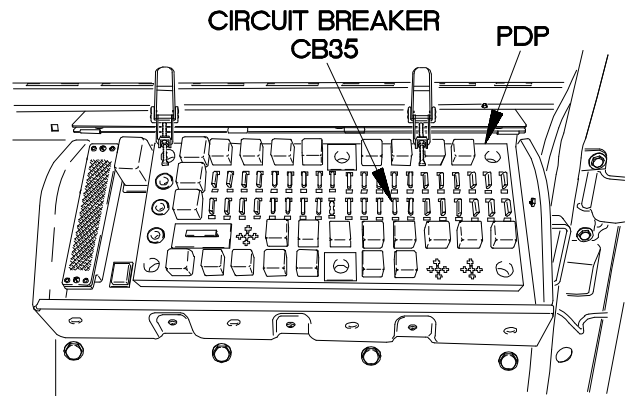
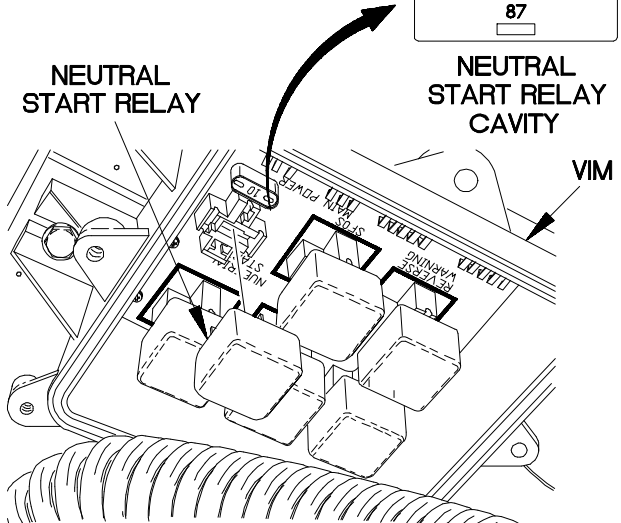

XBE0241B

e2. ENGINE DOES NOT CRANK (CONT)

KNOWN INFO
Transmission pushbutton shift selector in neutral (N). Batteries OK. Service drive lights OK. Circuit breakers OK. Starting motor OK. Battery to starter cable assembly OK. Oil pressure switch OK. WTEC II vehicle interface module (VIM) OK.
POSSIBLE PROBLEMS
Faulty dashboard cable assembly.

CAUTION
Read CAUTION on following page.

42.
Is continuity present from connector PX33 socket F1 to terminal board TB1 position 34?

TEST OPTIONS
Continuity Test or STE/ICE-R Test #91
REASON FOR QUESTION
If continuity is not present, WTEC II vehicle interface module is faulty. If continuity is present, wire 1692 is faulty.

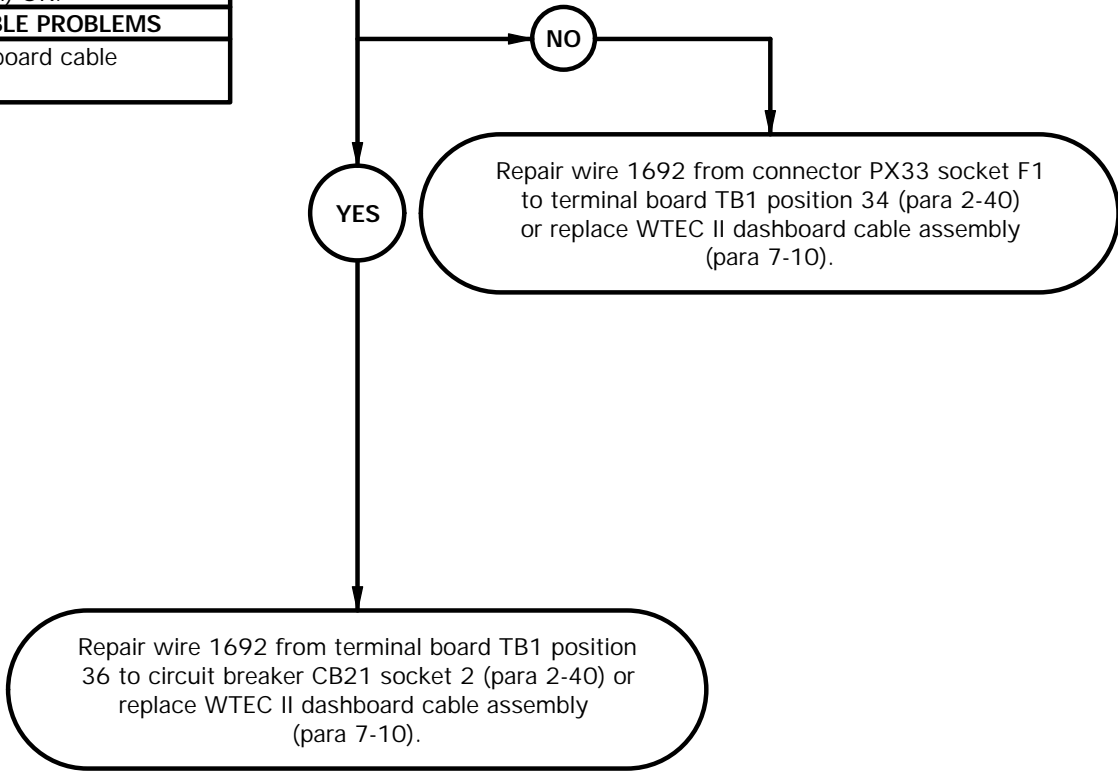

CAUTION

Use care when testing electrical connectors. Do not damage connector pins or sockets with multimeter probes. Failure to comply may result in damage to equipment.

NOTE

Inspect connector pins/sockets for damage, corrosion, and serviceability. Check that connector pins are not pushed back or not capable of making good contact.

CONTINUITY TEST

- (1) Remove three screws and washers from PDP.
- (2) Remove three screws from PDP.
- (3) Lift PDP outward to gain access.
- (4) Set multimeter to ohms.
- (5) Connect positive (+) probe of multimeter to terminal board TB1 position 34.
- (6) Connect negative (-) probe of multimeter connector PX33 socket F1 and note reading on multimeter.
- (7) If continuity is not present, repair wire 1692 from connector PX33 socket F1 to terminal board TB1 position 34 (para 2-40) or replace WTEC II dashboard cable assembly (para 7-10).
- (8) If continuity is present, repair wire 1692 from terminal board TB1 position 36 and circuit breaker CB21 socket 2 (para 2-40) or replace WTEC II dashboard cable assembly (para 7-10).
- (9) Install PDP on dashboard with three screws.
- (10) Install three washers and screws in PDP.
- (11) Connect connector PX33 to VIM connector.
- (12) Tighten screw in connector PX33.
- (13) Install kick panel (para 16-3).
- (14) Connect batteries (para 7-48).

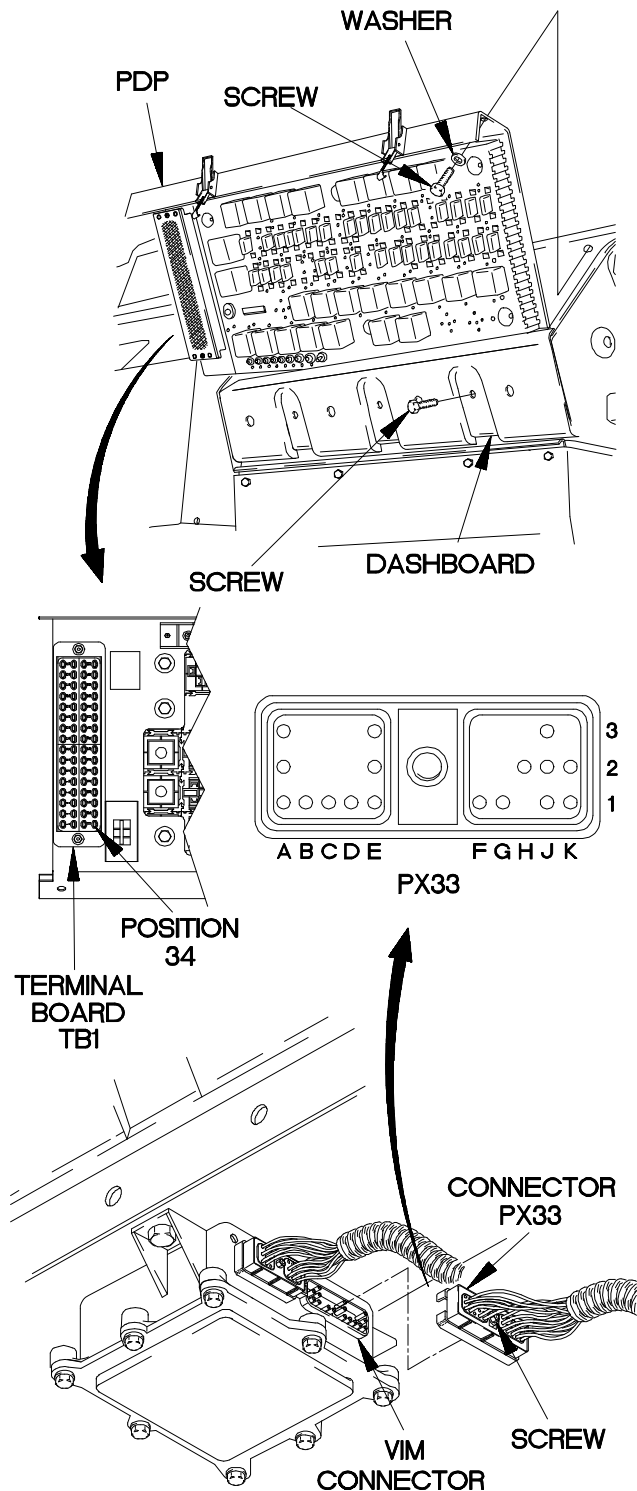

XBE0242B

e2. ENGINE DOES NOT CRANK (CONT)

KNOWN INFO
Transmission pushbutton shift selector in neutral (N). Batteries OK. Service drive lights OK. Circuit breakers OK. Starting motor OK. Battery to starter cable assembly OK. Oil pressure switch OK.
POSSIBLE PROBLEMS
Faulty WTEC II vehicle interface module (VIM). Faulty WTEC II cab transmission wiring harness. Faulty WTEC II transmission ECU pushbutton shift selector (TEPSS).

CAUTION
Read CAUTION on following page.

43.
Is continuity present from neutral start relay socket 85 on VIM to VIM connector pin P1?

TEST OPTIONS
Continuity Test or STE/ICE-R Test #91
REASON FOR QUESTION
If continuity is not present, WTEC II vehicle interface module (VIM) is faulty.

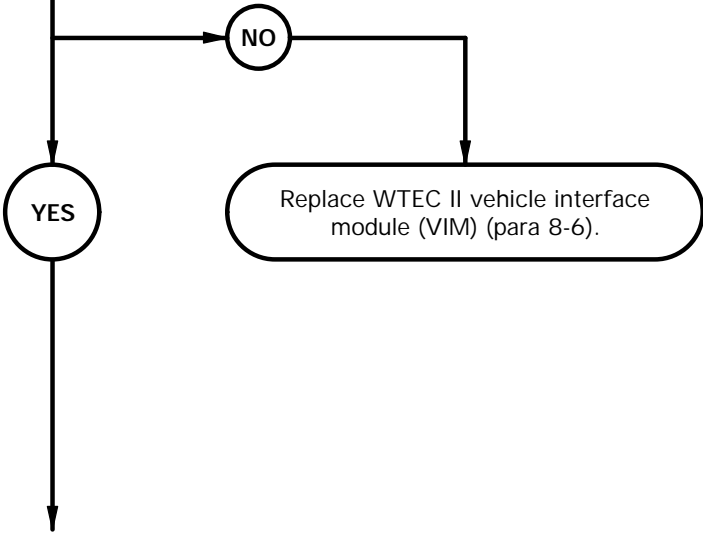

CAUTION

Use care when testing electrical connectors. Do not damage connector pins or sockets with multimeter probes. Failure to comply may result in damage to equipment.

NOTE

Inspect connector pins/sockets for damage, corrosion, and serviceability. Check that connector pins are not pushed back or not capable of making good contact.

CONTINUITY TEST

- (1) Disconnect batteries (para 7-48).
- (2) Loosen screw on connector J116.
- (3) Disconnect connector J116 from VIM connector.
- (4) Set multimeter to ohms.
- (5) Connect positive (+) probe of multimeter to neutral start relay socket 85 on VIM.
- (6) Connect negative (-) probe of multimeter to VIM connector pin P1 and note reading on multimeter.
- (7) If continuity is not present, replace WTEC II vehicle interface module (VIM) (para 8-6).
- (8) Install neutral start relay in VIM.
- (9) Install cover on VIM with metal seal ring, eight washers, and screws.
- (10) Install circuit breaker CB35 in PDP.

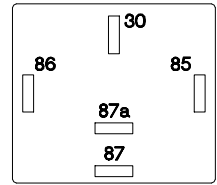
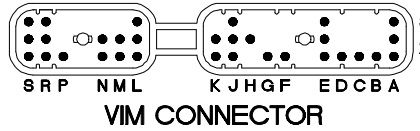
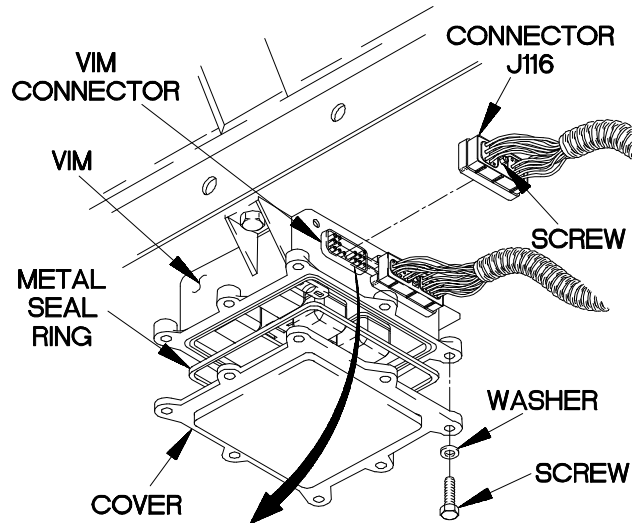

NEUTRAL START RELAY CAVITY

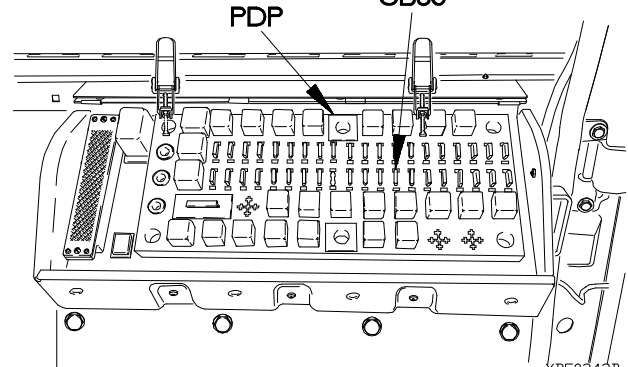
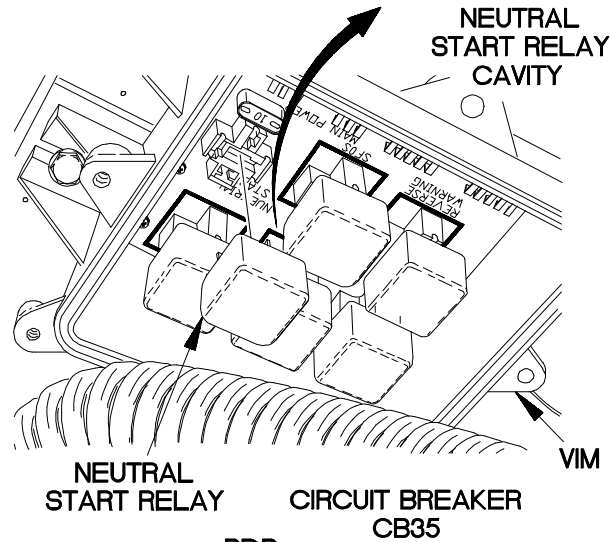

XBE0243B

e2. ENGINE DOES NOT CRANK (CONT)

KNOWN INFO
Transmission pushbutton shift selector in neutral (N). Batteries OK. Service drive lights OK. Circuit breakers OK. Starting motor OK. Battery to starter cable assembly OK. Oil pressure switch OK. WTEC II vehicle interface module (VIM) OK.
POSSIBLE PROBLEMS
Faulty WTEC II cab transmission wiring harness. Faulty WTEC II transmission ECU pushbutton shift selector (TEPSS).

CAUTION
Read CAUTION on following page.

44.
Is continuity present from connector J116 socket D1 to connector J114 socket 23?

TEST OPTIONS
Continuity Test or STE/ICE-R Test #91
REASON FOR QUESTION
If continuity is not present, WTEC II cab transmission wiring harness is faulty. If continuity is present, WTEC II transmission ECU pushbutton shift selector (TEPSS) is faulty.

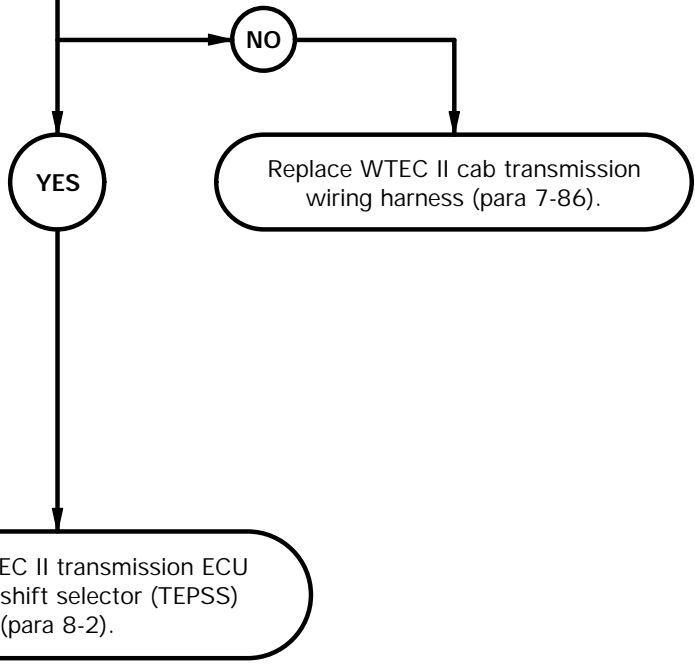

CAUTION

Use care when testing electrical connectors. Do not damage connector pins or sockets with multimeter probes. Failure to comply may result in damage to equipment.

NOTE

Inspect connector pins/sockets for damage, corrosion, and serviceability. Check that connector pins are not pushed back or not capable of making good contact.

CONTINUITY TEST

- (1) Remove instrument panel for access (para 7-15).
- (2) Disconnect connector J114 from WTEC II transmission ECU pushbutton shift selector (TEPSS).
- (3) Set multimeter to ohms.
- (4) Connect positive (+) probe of multimeter to connector J114 socket 23.
- (5) Connect negative (-) probe of multimeter to connector J116 socket D1 and note reading on multimeter.
- (6) If continuity is not present, replace WTEC II cab transmission wiring harness (para 7-86).
- (7) If continuity is present, replace WTEC II transmission ECU pushbutton shift selector (TEPSS) (para 8-2).
- (8) Connect connector J114 to WTEC II transmission ECU pushbutton shift selector (TEPSS).
- (9) Install instrument panel (para 7-15).
- (10) Connect connector J116 to VIM connector.
- (11) Tighten screw on connector J116.
- (12) Install kick panel (para 16-3).
- (13) Connect batteries (para 7-48).

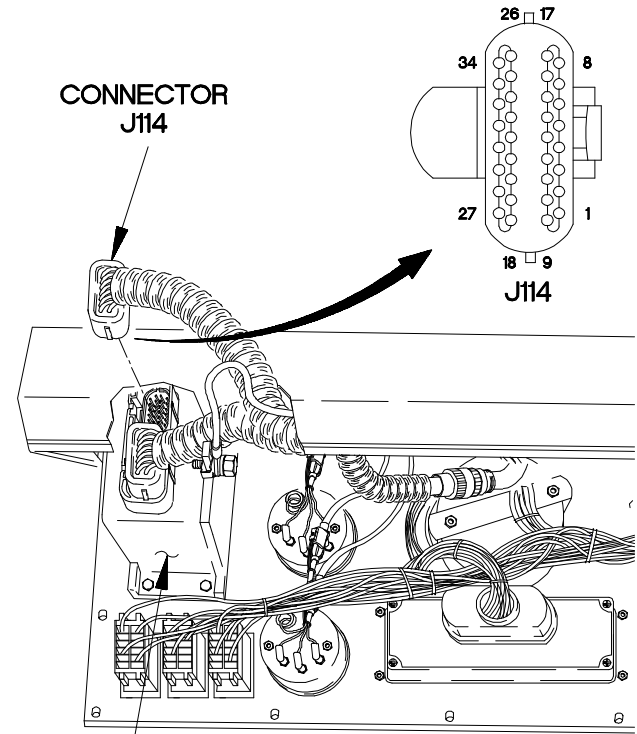

**WTEC II
TRANSMISSION
ECU PUSHBUTTON
SHIFT SELECTOR**

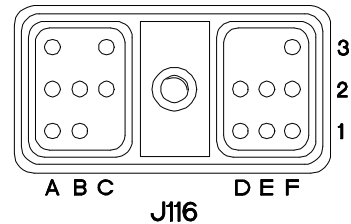
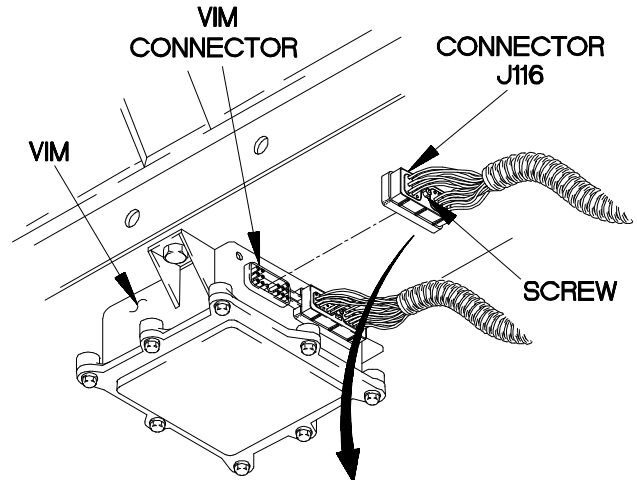

XBE0244B

e2. ENGINE DOES NOT CRANK (CONT)

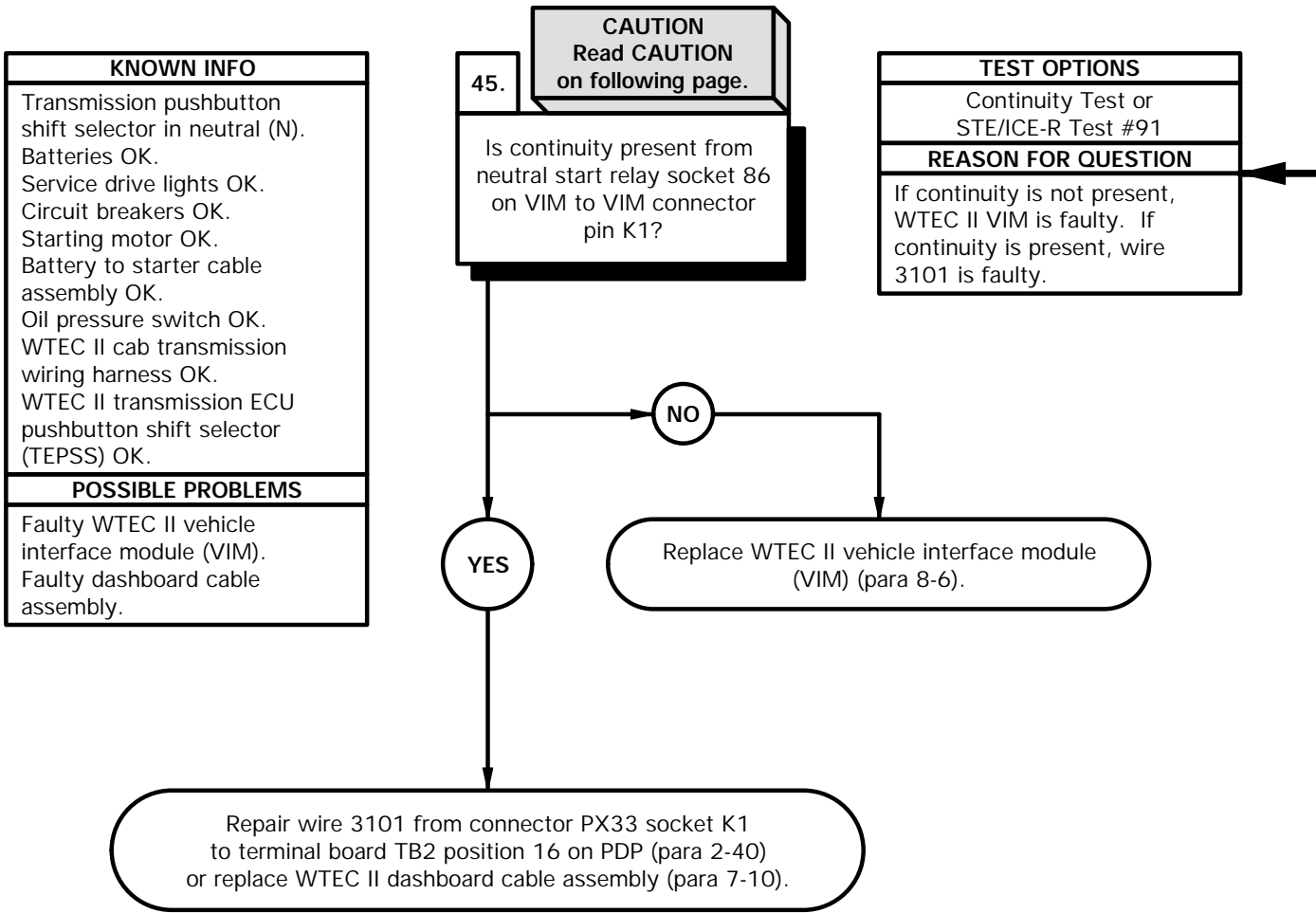

CAUTION

Use care when testing electrical connectors. Do not damage connector pins or sockets with multimeter probes. Failure to comply may result in damage to equipment.

NOTE

Inspect connector pins/sockets for damage, corrosion, and serviceability. Check that connector pins are not pushed back or not capable of making good contact.

CONTINUITY TEST

- (1) Set multimeter to ohms.
- (2) Connect positive (+) probe of multimeter to neutral start relay socket 86 on VIM.
- (3) Connect negative (-) probe of multimeter to VIM connector pin K1 and note reading on multimeter.
- (4) If continuity is not present, replace WTEC II vehicle interface module (VIM) (para 8-6).
- (5) If continuity is present, repair wire 3101 from connector PX33 socket K1 to terminal board TB2 position 16 on PDP (para 2-40) or replace WTEC II dashboard cable assembly (para 7-10).
- (6) Install neutral start relay in VIM.
- (7) Install cover on VIM with metal seal ring, eight washers, and screws.
- (8) Connect connector PX33 to VIM connector.
- (9) Tighten screw in connector PX33.
- (10) Install circuit breaker CB35 in PDP.
- (11) Install kick panel (para 16-3).

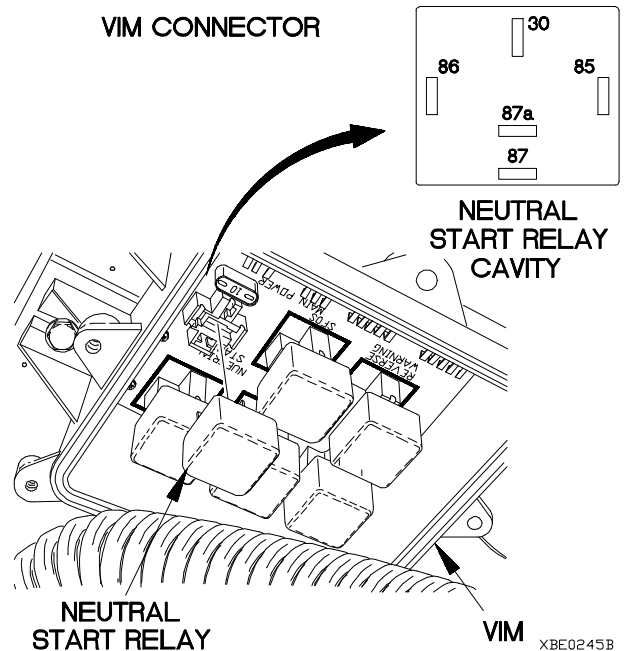
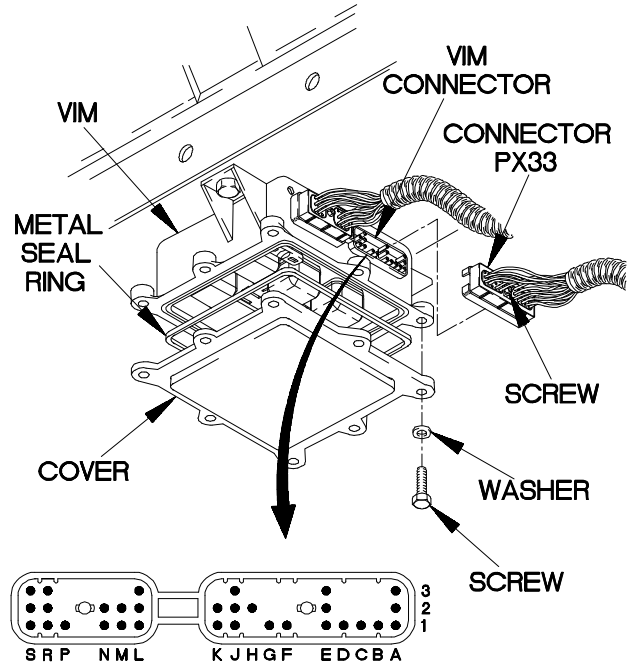
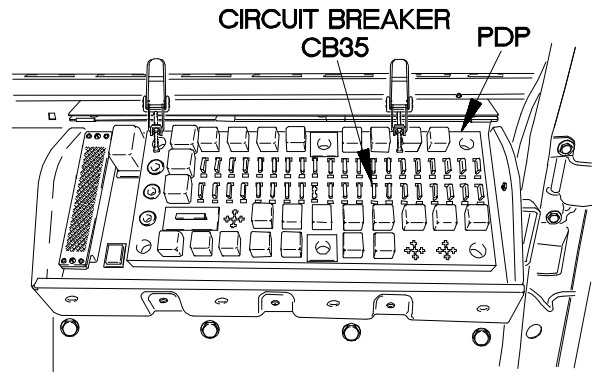

e2. ENGINE DOES NOT CRANK (CONT)

KNOWN INFO
Transmission pushbutton shift selector in neutral (N). Batteries OK. Service drive lights OK. Circuit breakers OK. Starting motor OK. Battery to starter cable assembly OK. Oil pressure switch OK.
POSSIBLE PROBLEMS
Faulty dashboard cable assembly.

WARNING
Read WARNING on following page.

46.
Is 24 VDC present at terminal board TB1 position 36?

TEST OPTIONS
Voltage Test or STE/ICE-R Test #89
REASON FOR QUESTION
Is 24 VDC is not present, wire 1692 is faulty.

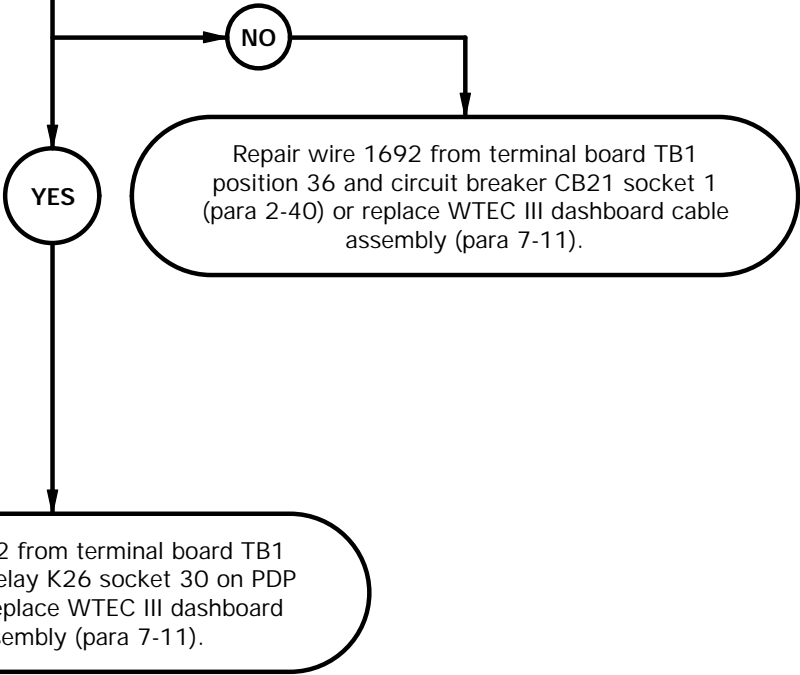

WARNING

Remove rings, bracelets, watches, necklaces, and any other jewelry before working around vehicle. Jewelry can catch on equipment and cause injury or short across electrical circuits and cause severe burns or electrical shock.

VOLTAGE TEST

- (1) Install relay K26 in PDP.
- (2) Remove three screws and washers from PDP.
- (3) Remove three screws from PDP.
- (4) Lift PDP outward to gain access.
- (5) Set multimeter to volts DC.
- (6) Connect positive (+) probe of multimeter to terminal board TB1 position 36.
- (7) Connect negative (-) probe of multimeter to ground.
- (8) Position master power switch to on (TM 9-2320-365-10) and note reading on multimeter.
- (9) If 24 VDC is not present, repair wire 1692 from terminal board TB1 position 36 to circuit breaker CB21 socket 1 (para 2-40) or replace WTEC III dashboard cable assembly (para 7-11).
- (10) If 24 VDC is present, repair wire 1692 from terminal board TB1 position 34 to relay K26 socket 30 on PDP (para 2-40) or replace WTEC III dashboard cable assembly (para 7-11).
- (11) Position master power switch to off (TM 9-2320-365-10).
- (12) Install PDP on dashboard with three screws.
- (13) Install three washers and screws in PDP.
- (14) Install PDP cover (para 16-2).

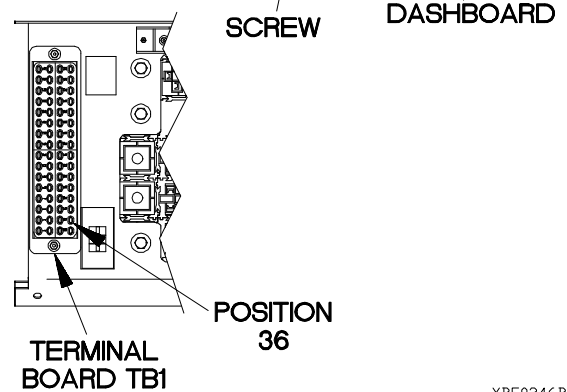
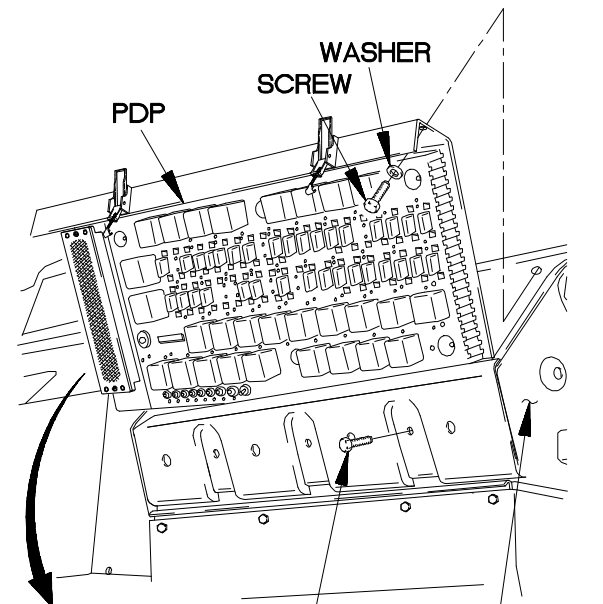
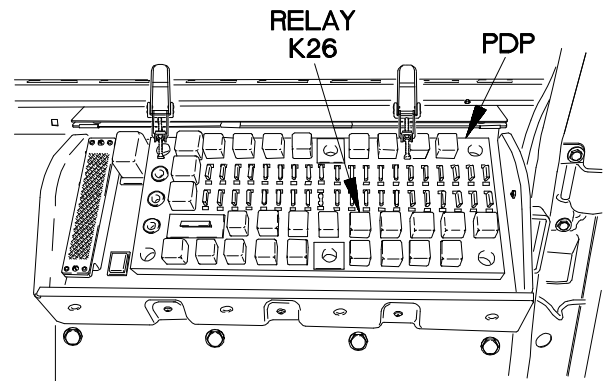

XBE0246B

e2. ENGINE DOES NOT CRANK (CONT)

KNOWN INFO
Transmission pushbutton shift selector in neutral (N). Batteries OK. Service drive lights OK. Circuit breakers OK. Starting motor OK. Battery to starter cable assembly OK. Oil pressure switch OK.
POSSIBLE PROBLEMS
Faulty dashboard cable assembly. Faulty WTEC III transmission ECU. Faulty WTEC III transmission pushbutton shift selector (TPSS).

CAUTION
Read CAUTION on following page.

47. Is continuity present from relay K26 socket 86 on PDP to connector P115 socket 8?

TEST OPTIONS
Continuity Test or STE/ICE-R Test #91
REASON FOR QUESTION
If continuity is not present, wire 123 is faulty.

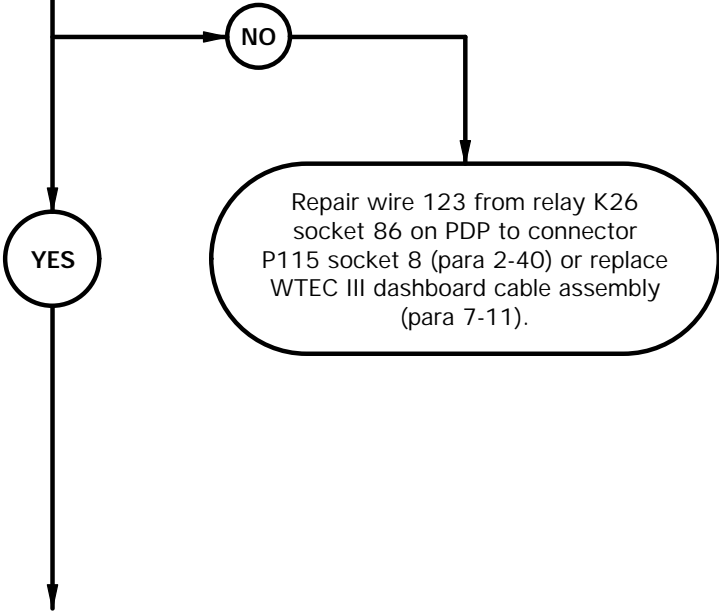

CAUTION

Use care when testing electrical connectors. Do not damage connector pins or sockets with multimeter probes. Failure to comply may result in damage to equipment.

NOTE

Inspect connector pins/sockets for damage, corrosion, and serviceability. Check that connector pins are not pushed back or not capable of making good contact.

CONTINUITY TEST

- (1) Disconnect batteries (para 7-48).
- (2) Remove kick panel (para 16-3).
- (3) Disconnect connector clamp from connector P115.
- (4) Disconnect connector P115 from WTEC III transmission ECU connector.
- (5) Set multimeter to ohms.
- (6) Connect positive (+) probe of multimeter to relay K26 socket 86.
- (7) Connect negative (-) probe of multimeter to connector P115 socket 8 and note reading on multimeter.
- (8) If continuity is not present, repair wire 123 from relay K26 socket 86 to connector P115 socket 8 (para 2-40) or replace WTEC III dashboard cable assembly (para 7-11).
- (9) Connect connector P115 to WTEC III transmission ECU connector.
- (10) Connect connector clamp to connector P115.
- (11) Install relay K26 in PDP.

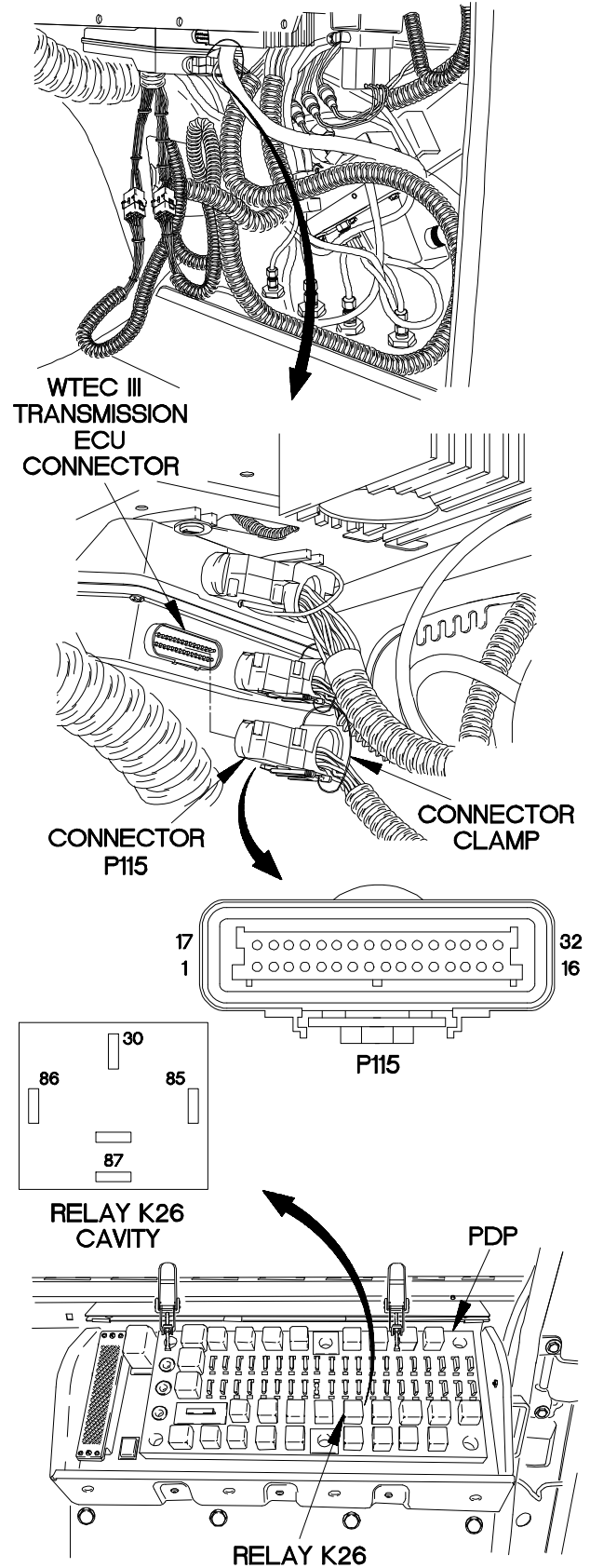

e2. ENGINE DOES NOT CRANK (CONT)

KNOWN INFO
Transmission pushbutton shift selector in neutral (N). Batteries OK. Service drive lights OK. Circuit breakers OK. Starting motor OK. Battery to starter cable assembly OK. Oil pressure switch OK.
POSSIBLE PROBLEMS
Faulty dashboard cable assembly. Faulty WTEC III transmission ECU. Faulty WTEC III transmission pushbutton shift selector (TPSS).

CAUTION
Read CAUTION on following page.

48. Is continuity present from connector PX33 socket (refer to Table 2-8.2. Connector PX33 Ground Continuity Test) to terminal board TB2 position (refer to Table 2-8.2. Connector PX33 Ground Continuity Test)?

TEST OPTIONS
Continuity Test or STE/ICE-R Test #91
REASON FOR QUESTION
If continuity is not present, wire (refer to Table 2-8.2. Connector PX33 Ground Continuity Test) is faulty.

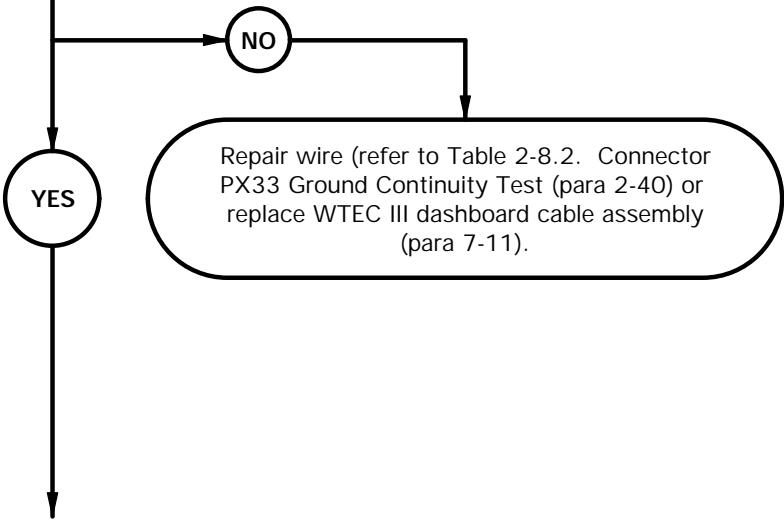

CAUTION

Use care when testing electrical connectors. Do not damage connector pins or sockets with multimeter probes. Failure to comply may result in damage to equipment.

NOTE

Inspect connector pins/sockets for damage, corrosion, and serviceability. Check that connector pins are not pushed back or not capable of making good contact.

CONTINUITY TEST

- (1) Remove instrument panel for access (para 7-15).
- (2) Disconnect connector PX33 from WTEC III TPSS connector.
- (3) Remove three screws and washers from PDP.
- (4) Remove three screws from PDP.
- (5) Lift PDP outward to gain access.
- (6) Set multimeter to ohms.
- (7) For each line of Table 2-8.2. Connector PX33 Ground Continuity Test perform the following:
 - (a) Connect positive (+) probe of multimeter to connector PX33 socket.
 - (b) Connect negative (-) probe of multimeter to terminal board TB2 position and not reading on multimeter.
- (8) If continuity is not present on either wire in Table 2-8.2. Connector PX33 Ground Continuity Test repair wire (para 2-40) or replace WTEC III dashboard cable assembly (para 7-11).
- (9) Install PDP on dashboard with three screws.
- (10) Install three washers and screws in PDP.

Table 2-8.2. Connector PX33 Ground Continuity Test

Connector PX33 Socket	Terminal Board TB2 Position	Wire
T	15	186
V	13	188

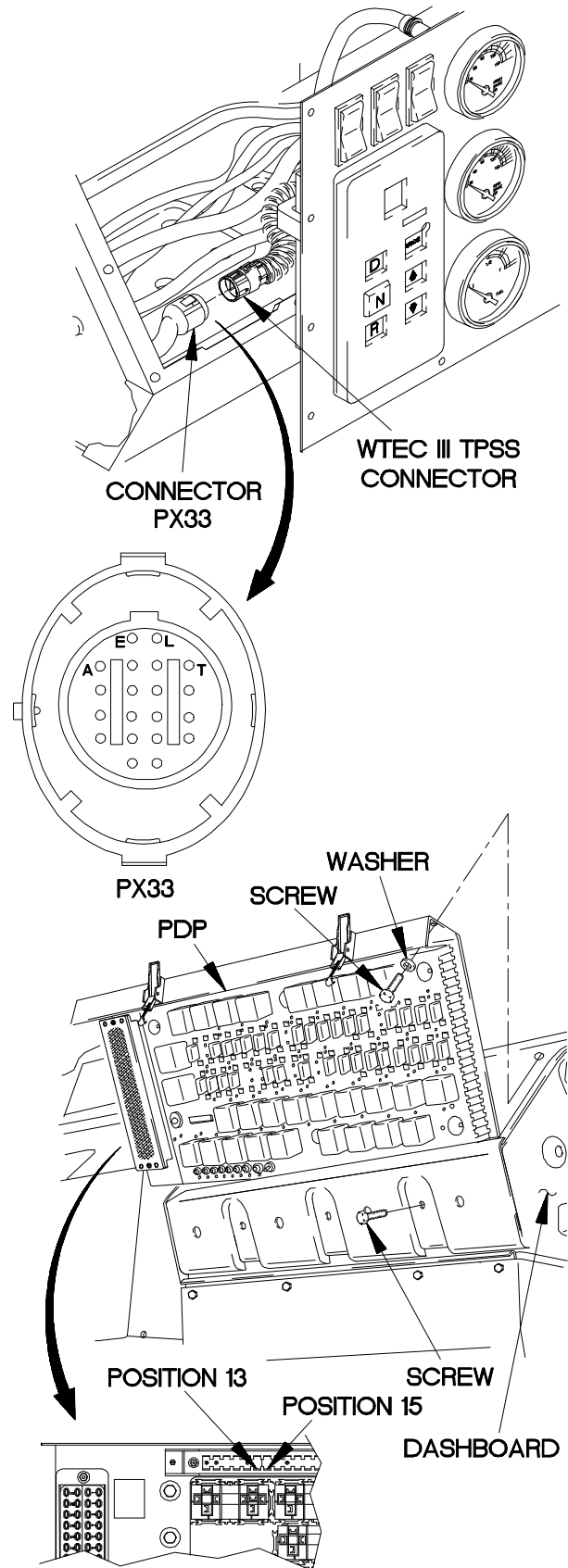

XBE0248B

e2. ENGINE DOES NOT CRANK (CONT)

KNOWN INFO
Transmission pushbutton shift selector in neutral (N). Batteries OK. Service drive lights OK. Circuit breakers OK. Starting motor OK. Battery to starter cable assembly OK. Oil pressure switch OK.
POSSIBLE PROBLEMS
Faulty dashboard cable assembly. Faulty WTEC III transmission ECU. Faulty WTEC III transmission pushbutton shift selector (TPSS).

CAUTION
Read CAUTION on following page.

49. Is continuity present from connector PX33 socket (refer to Table 2-8.3. Connector PX33 Continuity Test) to connector P116 socket (refer to Table 2-8.3. Connector PX33 Continuity Test)?

TEST OPTIONS
Continuity Test or STE/ICE-R Test #91
REASON FOR QUESTION
If continuity is not present, wire (refer to Table 2-8.3. Connector PX33 Continuity Test) is faulty.

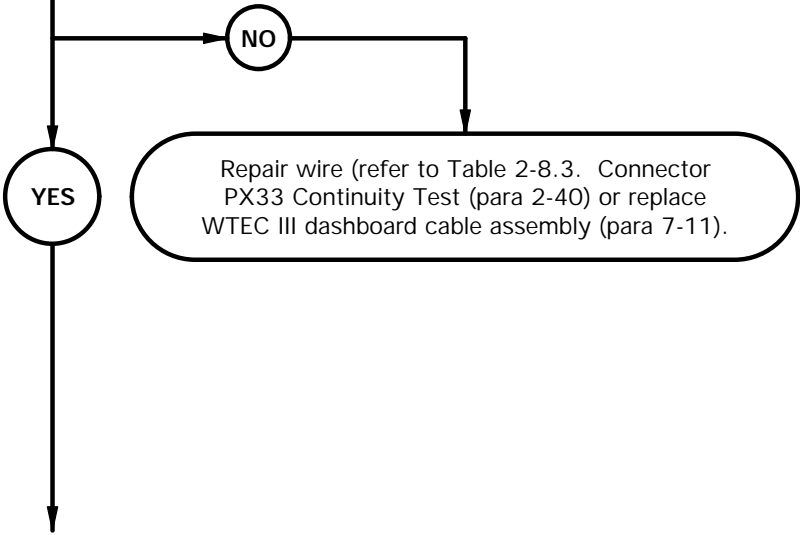

CAUTION

Use care when testing electrical connectors. Do not damage connector pins or sockets with multimeter probes. Failure to comply may result in damage to equipment.

NOTE

Inspect connector pins/sockets for damage, corrosion, and serviceability. Check that connector pins are not pushed back or not capable of making good contact.

CONTINUITY TEST

- (1) Disconnect connector clamp from connector P116.
- (2) Disconnect connector P116 from WTEC III transmission ECU connector.
- (3) Set multimeter to ohms.
- (4) For each line of Table 2-8.3. Connector PX33 Ground Continuity Test perform the following:
 - (a) Connect positive (+) probe of multimeter to connector PX33 socket.
 - (b) Connect negative (-) probe of multimeter to connector P116 position and not reading on multimeter.
- (5) If continuity is not present on either wire in Table 2-8.3. Connector PX33 Continuity Test repair wire (para 2-40) or replace WTEC III dashboard cable assembly (para 7-11).
- (6) Install PDP on dashboard with three screws.
- (7) Connect connector P116 to WTEC III transmission ECU connector.
- (8) Connect connector clamp to connector P116.

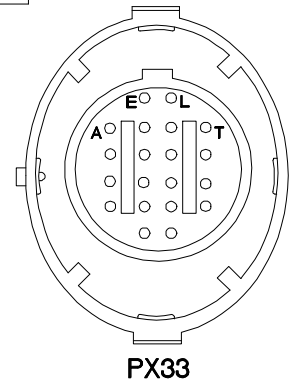
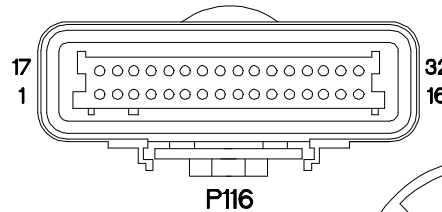
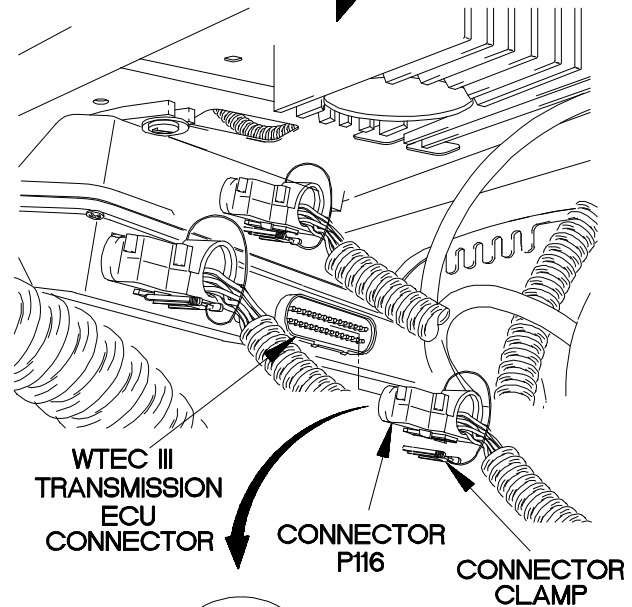
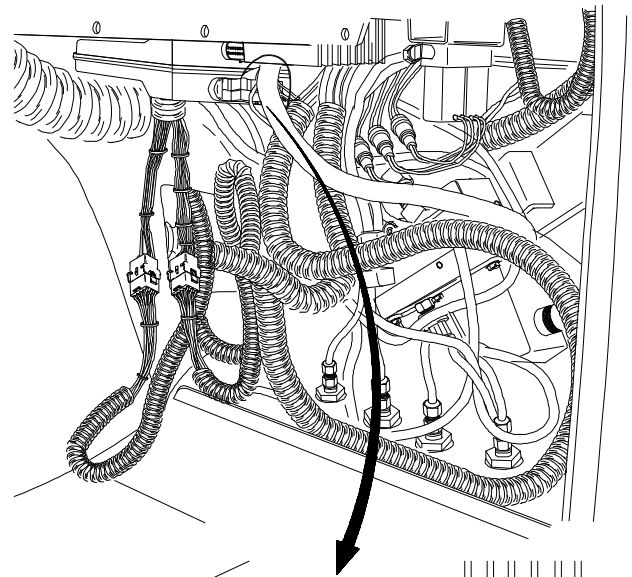

Table 2-8.3. Connector PX33 Continuity Test

Connector PX33 Socket	Connector P116 Socket	Wire
P	32	143
L	15	176
A	5	170
B	6	171
C	7	172
D	8	173
E	9	174
S	14	180
M	10	175
N	3	124
R	16	136

XBE0249B

e2. ENGINE DOES NOT CRANK (CONT)

KNOWN INFO
Transmission pushbutton shift selector in neutral (N). Batteries OK. Service drive lights OK. Circuit breakers OK. Starting motor OK. Battery to starter cable assembly OK. Oil pressure switch OK. Dashboard cable assembly OK.
POSSIBLE PROBLEMS
Faulty WTEC III transmission ECU. Faulty WTEC III transmission pushbutton shift selector (TPSS).

50.
Does engine crank with a known good WTEC III transmission pushbutton shift selector (TPSS)?

TEST OPTIONS
WTEC III Transmission Pushbutton Shift Selector Test
REASON FOR QUESTION
If engine cranks, WTEC III transmission pushbutton shift selector is faulty. If engine does not crank, WTEC III transmission ECU is faulty.

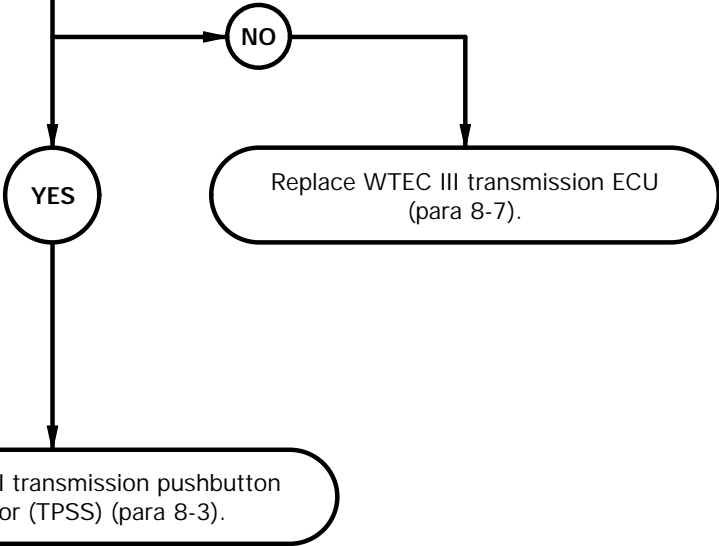

**WTEC III TRANSMISSION PUSHBUTTON SHIFT
SELECTOR TEST (TPSS)**

- (1) Replace WTEC III TPSS (para 8-3).
- (2) Connect batteries (para 7-48).
- (3) Attempt to start engine
(TM 9-2320-365-10).
- (4) If engine does not crank, replace WTEC III
transmission ECU (para 8-7).
- (5) If engine does crank, replace WTEC III
TPSS (para 8-3).
- (6) Install instrument panel (para 7-15).
- (7) Install kick panel (para 16-3).

e3. 12 VDC AND 24 VDC CIRCUITS DO NOT OPERATE

INITIAL SETUP

Equipment Conditions

Engine shut down (TM 9-2320-365-10).

Materials/Parts

- Dispenser, Pressure Sensitive Adhesive Tape (Item 21, Appendix D)
- Lockwasher (Item 66.1, Appendix G)
- Lockwasher (Item 73, Appendix G)
- Lockwasher (Item 76, Appendix G)
- Lockwasher (Item 78, Appendix G)
- Lockwasher (4) (Item 92, Appendix G)
- Lockwasher (2) (Item 65, Appendix G)
- Self-locking Nut (Item 148, Appendix G)
- Ties, Cable, Plastic (Item 76 Appendix D)
- Wire, Elect, 50 ft (Item 77, Appendix D)

Tools and Special Tools

- Tool Kit, Genl Mech (Item 44, Appendix C)
- STE/ICE-R (Item 39, Appendix C)
- Multimeter, Digital (Item 22, Appendix C)
- Apron, Rubber (Item 3, Appendix C)
- Goggles, Industrial (Item 15, Appendix C)
- Gloves, Rubber (Item 13, Appendix C)
- Socket Set, Socket Wrench (Item 35, Appendix C)
- Tester, Antifreeze and Battery (Item 41, Appendix C)
- Wire, Relay Test (Item 9, Appendix E)
- Wrench, Torque, 0-175 lb-ft. (Item 57, Appendix C)
- Wrench, Torque, 0-200 lb-in. (Item 58, Appendix C)

References

- TM 9-6140-200-14
- TM 9-4910-571-12&P

Personnel Required

(2)

KNOWN INFO
Circuit breaker CB70 OK.
POSSIBLE PROBLEMS
Faulty battery(ies). Faulty cab to chassis ground strap. Faulty PDP to cab ground cable. Faulty dashboard cable assembly. Faulty shunt. Faulty starter to shunt 24 VDC cable. Faulty battery to shunt cable assembly. Faulty starter to chassis ground cable. Faulty 100 AMP reverse polarity relay. Faulty battery to 100 AMP reverse polarity relay 12 VDC cable. Faulty 100 AMP reverse polarity relay to PDP 12 VDC cable. Faulty 200 AMP reverse polarity relay. Faulty 200 AMP terminal block. Faulty 200 AMP terminal block to PDP 12 VDC cable. Faulty 200 AMP terminal block to reverse polarity relay 12 VDC load cable. Faulty 200 AMP terminal block to reverse polarity relay 12 VDC battery cable. Faulty battery to 200 AMP terminal block 12 VDC cable assembly.

NOTE

Perform Electrical System Troubleshooting e1. Circuit Breaker Does Not Operate on circuit breaker CB70 prior to beginning this task.

TEST OPTIONS
Battery Specific Gravity Test
REASON FOR QUESTION
If battery(ies) is unserviceable, 12 vdc circuits will not operate.

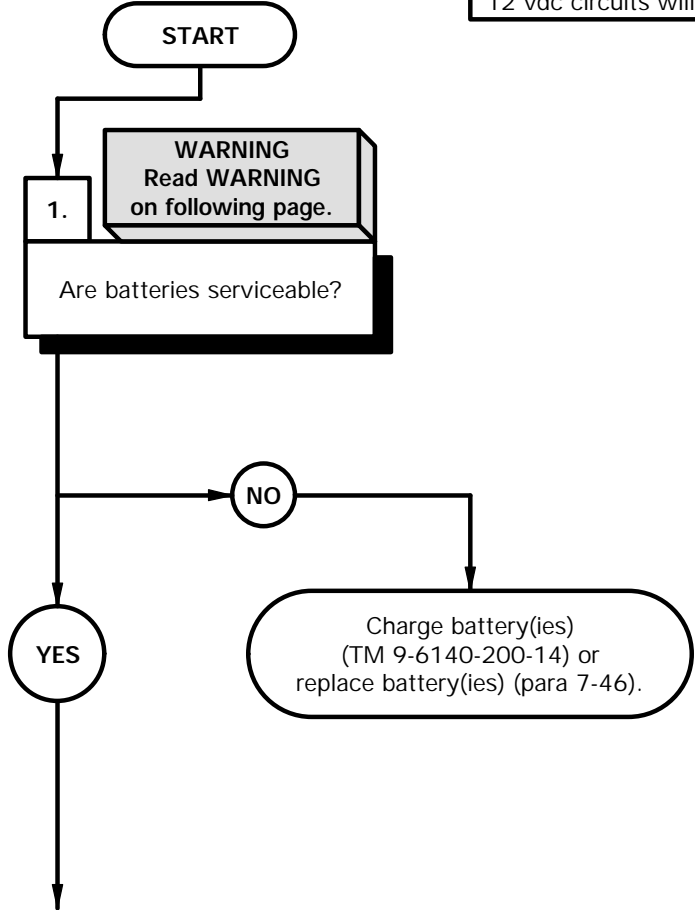

WARNING

Remove rings, bracelets, watches, necklaces, and any other jewelry before working around vehicle. Jewelry can catch on equipment and cause injury or short across electrical circuit and cause severe burns or electrical shock. Batteries can explode from a spark. Battery acid is harmful to skin and eyes. Always wear eye protection and rubber gloves when working with batteries.

Battery Specific Gravity Test

- (1) Remove four batteries from battery box (para 7-46).
- (2) Test batteries for serviceability (TM 9-6140-200-14).
- (3) Replace battery(ies) if unserviceable (TM 9-6140-200-14).
- (4) Install four batteries in battery box (para 7-46).

e3. 12 VDC AND 24 VDC CIRCUITS DO NOT OPERATE (CONT)

KNOWN INFO
Circuit breakers CB70 OK. Battery(ies) OK.
POSSIBLE PROBLEMS
Faulty cab to chassis ground strap. Faulty PDP to cab ground cable. Faulty dashboard cable assembly. Faulty shunt. Faulty starter to shunt 24 VDC cable. Faulty battery to shunt cable assembly. Faulty starter to chassis ground cable. Faulty 100 AMP reverse polarity relay. Faulty battery to 100 AMP reverse polarity relay 12 VDC cable. Faulty 100 AMP reverse polarity relay to PDP 12 VDC cable. Faulty 200 AMP reverse polarity relay. Faulty 200 AMP terminal block. Faulty 200 AMP terminal block to PDP 12 VDC cable. Faulty 200 AMP terminal block to reverse polarity relay 12 VDC load cable. Faulty 200 AMP terminal block to reverse polarity relay 12 VDC battery cable. Faulty battery to 200 AMP terminal block 12 VDC cable assembly.

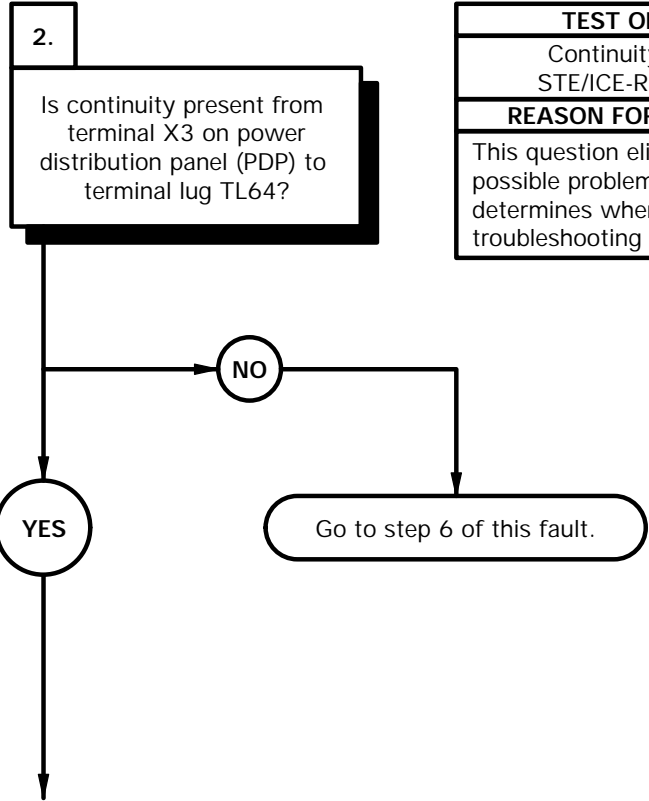

TEST OPTIONS
Continuity Test or STE/ICE-R Test #91
REASON FOR QUESTION
This question eliminates possible problems and determines where troubleshooting continues.



CONTINUITY TEST

- (1) Disconnect batteries (para 7-48).

NOTE

Remove plastic cable ties as required.

- (2) Remove two screws and washers from front grille.
- (3) Remove screw, washer, and front grille from cab.
- (4) Remove power distribution panel (PDP) cover (para 16-2).
- (5) Set multimeter to ohms.
- (6) Connect positive (+) probe of multimeter to terminal X3 on power distribution panel (PDP).
- (7) Connect negative (-) probe of multimeter to terminal lug TL64 and note reading on multimeter.
- (8) If continuity is not present, go to step 6 of this fault.

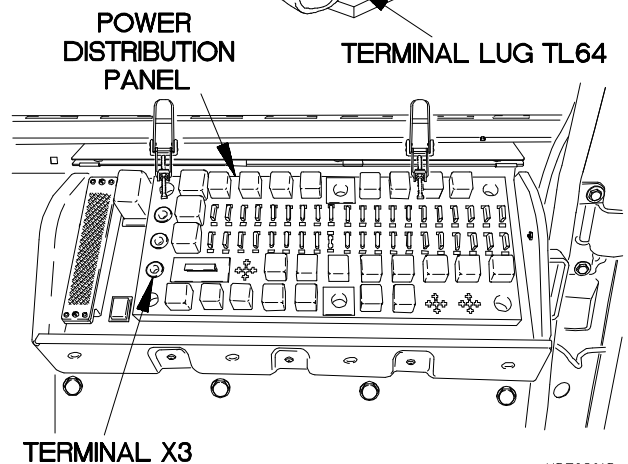
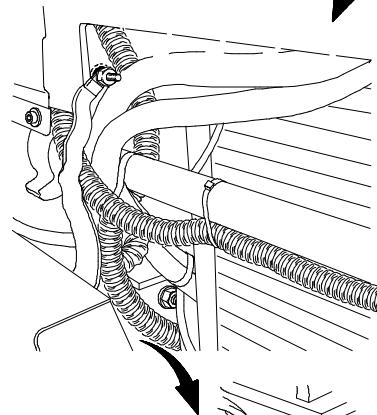
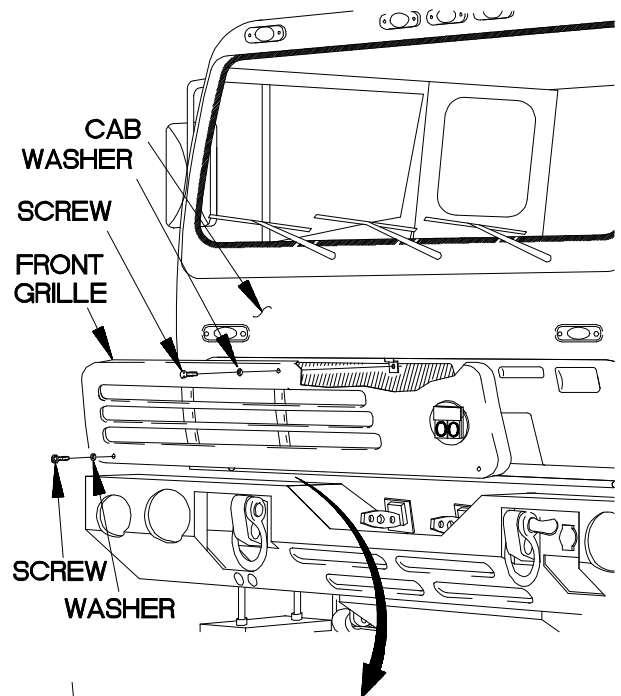

XBE0301B

e3. 12 VDC AND 24 VDC CIRCUITS DO NOT OPERATE (CONT)

KNOWN INFO
Circuit breaker CB70 OK. Battery(ies) OK. Cab to chassis ground strap OK. PDP to cab ground cable OK.
POSSIBLE PROBLEMS
Faulty dashboard cable assembly. Faulty shunt. Faulty starter to shunt 24 VDC cable. Faulty battery to shunt cable assembly. Faulty starter to chassis ground cable. Faulty 100 AMP reverse polarity relay. Faulty battery to 100 AMP reverse polarity relay 12 VDC cable. Faulty 100 AMP reverse polarity relay to PDP 12 VDC cable. Faulty 200 AMP reverse polarity relay. Faulty 200 AMP terminal block. Faulty 200 AMP terminal block to PDP 12 VDC cable. Faulty 200 AMP terminal block to reverse polarity relay 12 VDC load cable. Faulty 200 AMP terminal block to reverse polarity relay 12 VDC battery cable. Faulty battery to 200 AMP terminal block 12 VDC cable assembly.

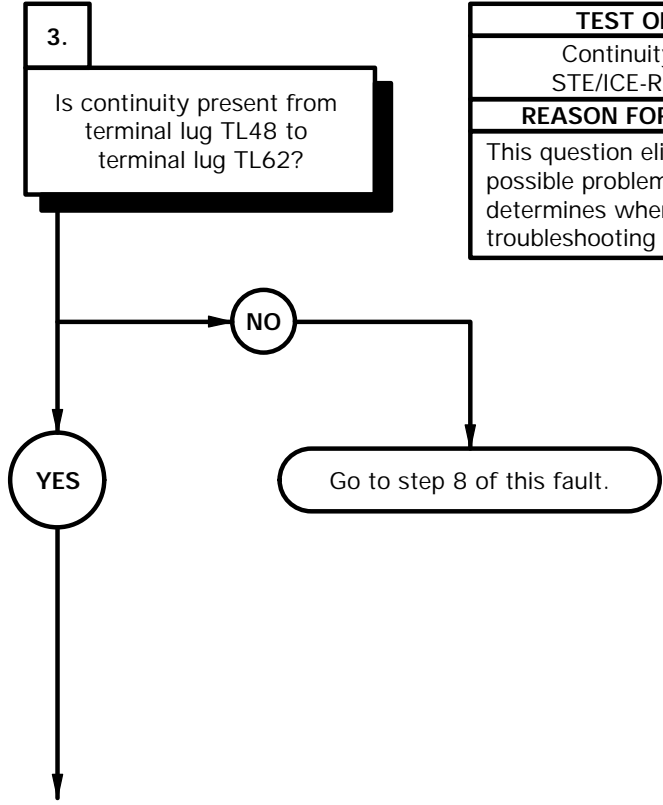

TEST OPTIONS
Continuity Test or STE/ICE-R Test #91
REASON FOR QUESTION
This question eliminates possible problems and determines where troubleshooting continues.

CONTINUITY TEST

NOTE

Install plastic cable ties as required.

- (1) Position front grille on cab with washer and screw.
- (2) Position two washers and screws in front grille.
- (3) Tighten screw to 48-60 lb-in. (5-7 N.m).
- (4) Tighten two screws to 24 lb-in. (3 N.m).
- (5) Set multimeter to ohms.
- (6) Connect positive (+) probe of multimeter to terminal lug TL48.
- (7) Connect negative (-) probe of multimeter to terminal lug TL62 and note reading on multimeter.
- (8) If continuity is not present, go to step 8 of this fault.

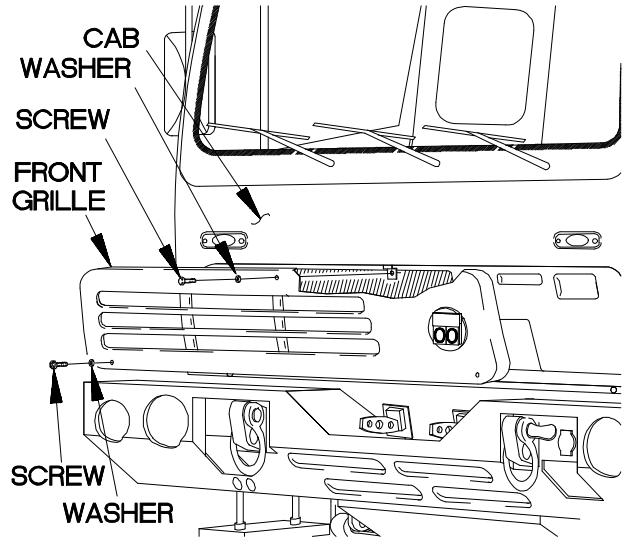

TERMINAL LUG TL48

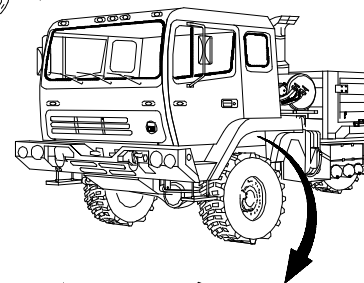
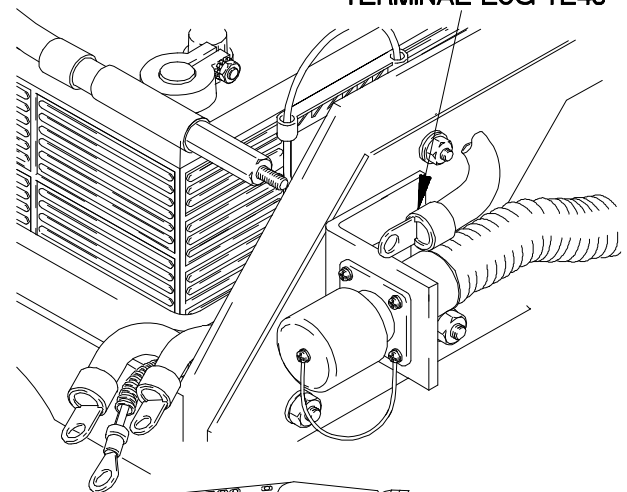

TERMINAL LUG TL62

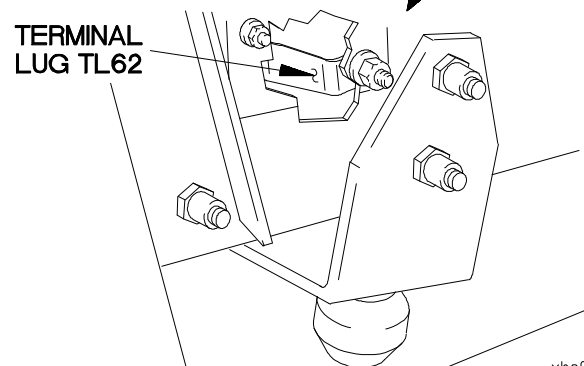

xbe0302b

e3. 12 VDC AND 24 VDC CIRCUITS DO NOT OPERATE (CONT)

KNOWN INFO
Circuit breaker CB70 OK. Battery(ies) OK. Cab to chassis ground strap OK. PDP to cab ground cable OK. Shunt OK. Starter to shunt 24 VDC cable OK. Battery to shunt cable assembly OK. Starter to chassis ground cable OK.
POSSIBLE PROBLEMS
Faulty dashboard cable assembly. Faulty 100 AMP reverse polarity relay. Faulty battery to 100 AMP reverse polarity relay 12 VDC cable. Faulty 100 AMP reverse polarity relay to PDP 12 VDC cable. Faulty 200 AMP reverse polarity relay. Faulty 200 AMP terminal block. Faulty 200 AMP terminal block to PDP 12 VDC cable. Faulty 200 AMP terminal block to reverse polarity relay 12 VDC load cable. Faulty 200 AMP terminal block to reverse polarity relay 12 VDC battery cable. Faulty battery to 200 AMP terminal block 12 VDC cable assembly.

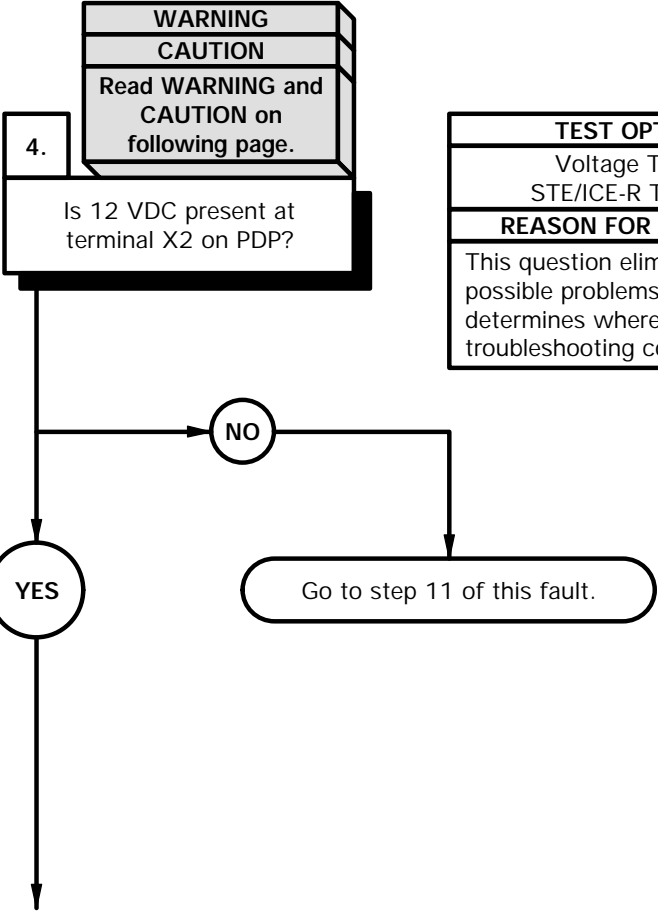

TEST OPTIONS
Voltage Test or STE/ICE-R Test #89
REASON FOR QUESTION
This question eliminates possible problems and determines where troubleshooting continues.



WARNING

Remove rings, bracelets, watches, necklaces, and any other jewelry before working around vehicle. Jewelry can catch on equipment and cause injury or short across electrical circuits and cause severe burns or electrical shock.

VOLTAGE TEST

- (1) Connect batteries (para 7-48).
- (2) Set multimeter to volts DC.

CAUTION

When testing to terminal X2 on PDP, ensure that multimeter probes come in contact with the outside metal ring. Failure to comply may result in false troubleshooting test results.

- (3) Connect positive (+) probe of multimeter to terminal X2 on PDP
- (4) Connect negative (-) probe of multimeter to ground and note reading on multimeter.
- (5) If 12 VDC is not present, go to step 11 of this fault.

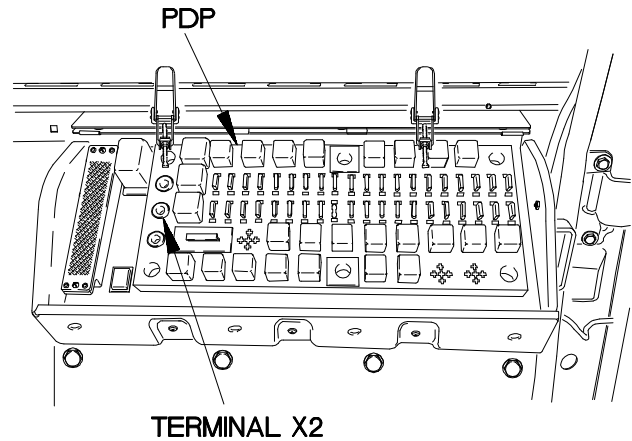

xbe0303b

e3. 12 VDC AND 24 VDC CIRCUITS DO NOT OPERATE (CONT)

KNOWN INFO
Faulty dashboard cable assembly.
POSSIBLE PROBLEMS
<p>Circuit breaker CB70 OK. Battery(ies) OK. Cab to chassis ground strap OK. PDP to cab ground cable OK. Shunt OK. Starter to shunt 24 VDC cable OK. Battery to shunt cable assembly OK. Starter to chassis ground cable OK. 100 AMP reverse polarity relay OK. Battery to 100 AMP reverse polarity relay 12 VDC cable OK. 100 AMP reverse polarity relay to PDP 12 VDC cable OK. 200 AMP reverse polarity relay OK. 200 AMP terminal block OK. 200 AMP terminal block to PDP 12 VDC cable OK. 200 AMP terminal block to reverse polarity relay 12 VDC load cable OK. 200 AMP terminal block to reverse polarity relay 12 VDC battery cable OK. Battery to 200 AMP terminal block 12 VDC cable assembly OK.</p>

WARNING
 Read WARNING on following page.

5. Is 12 VDC present at circuit breaker socket 1, left of circuit breaker CB70 on PDP?

TEST OPTIONS
Voltage Test or STE/ICE-R Test #89
REASON FOR QUESTION
If 12 VDC is not present, wire 1601 is faulty. If 12 VDC is present, bus bar X7 is faulty.

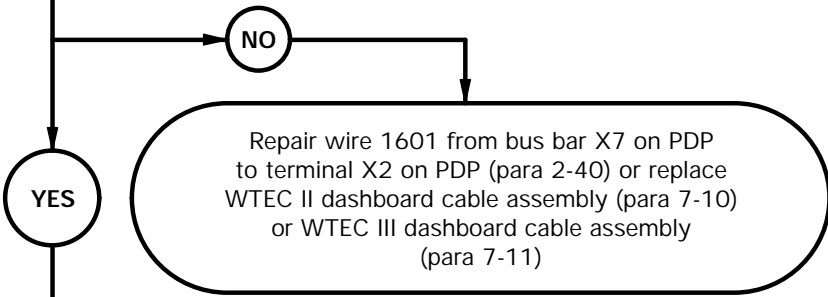

Replace bus bar X7 on PDP or replace WTEC II dashboard cable assembly (para 7-10) or WTEC III dashboard cable assembly(para 7-11)

WARNING

Remove rings, bracelets, watches, necklaces, and any other jewelry before working around vehicle. Jewelry can catch on equipment and cause injury or short across electrical circuits and cause severe burns or electrical shock.

VOLTAGE TEST

- (1) Position master power switch to on (TM 9-2320-365-10).
- (2) Set multimeter to volts DC.
- (3) Connect positive (+) probe of multimeter to circuit breaker socket 1, left of circuit breaker CB70 on PDP.
- (4) Connect negative (-) probe of multimeter to ground and note reading on multimeter.
- (5) If 12 VDC is not present, repair wire 1601 from bus bar X7 on PDP to terminal X2 on PDP (para 2-40) or replace WTEC II dashboard cable assembly (para 7-10) or WTEC III dashboard cable assembly (para 7-11).
- (6) If 12 VDC is present, replace bus bar X7 on PDP or WTEC II dashboard cable assembly (para 7-10) or WTEC III dashboard cable assembly (para 7-11).
- (7) Position master power switch to off (TM 9-2320-365-10).
- (8) Install PDP cover (para 16-2).

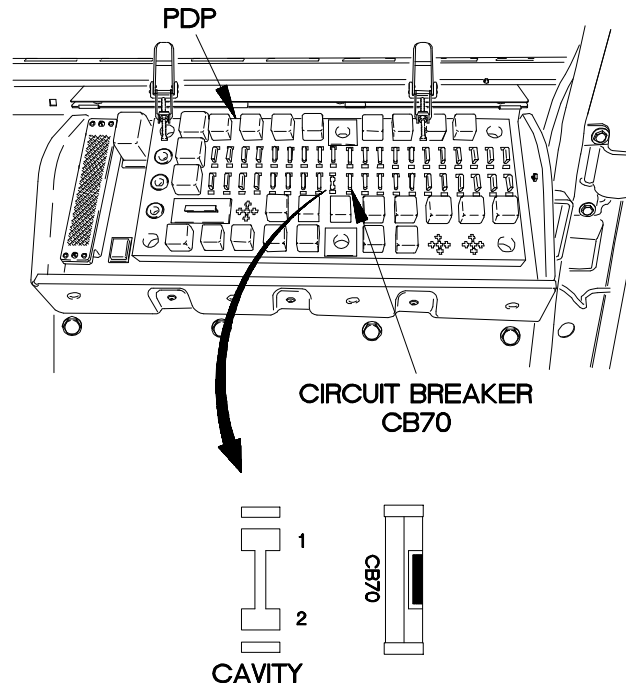

XBE0304B

e3. 12 VDC AND 24 VDC CIRCUITS DO NOT OPERATE (CONT)

KNOWN INFO
Circuit breakers CB70 OK. Battery(ies) OK.
POSSIBLE PROBLEMS
Faulty cab to chassis ground strap. Faulty PDP to cab ground cable. Faulty dashboard cable assembly.

6.
Is continuity present from terminal lug TL65 to terminal lug TL64?

TEST OPTIONS
Continuity Test or STE/ICE-R Test #91
REASON FOR QUESTION
If continuity is not present, cab to chassis ground strap is faulty.

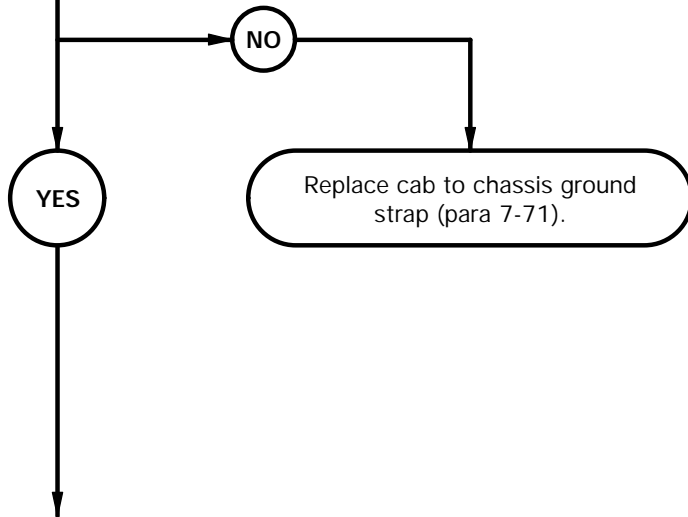

CONTINUITY TEST

- (1) Remove self-locking nut, washer, terminal lug TL65, and lockwasher from stud. Discard self-locking nut and lockwasher.
- (2) Set multimeter to ohms.
- (3) Connect positive (+) probe of multimeter to terminal lug TL65.
- (4) Connect negative (-) probe of multimeter to terminal lug TL64 and note reading on multimeter.
- (5) If continuity is not present, replace cab to chassis ground strap (para 7-71).
- (6) Install lockwasher and terminal lug TL65 on stud with washer and self-locking nut.

NOTE

Install plastic cable ties as required.

- (7) Position front grille on cab with washer and screw.
- (8) Position two washers and screws in front grille.
- (9) Tighten screw to 48-60 lb-in. (5-7 N.m).
- (10) Tighten two screws to 24 lb-in. (3 N.m).

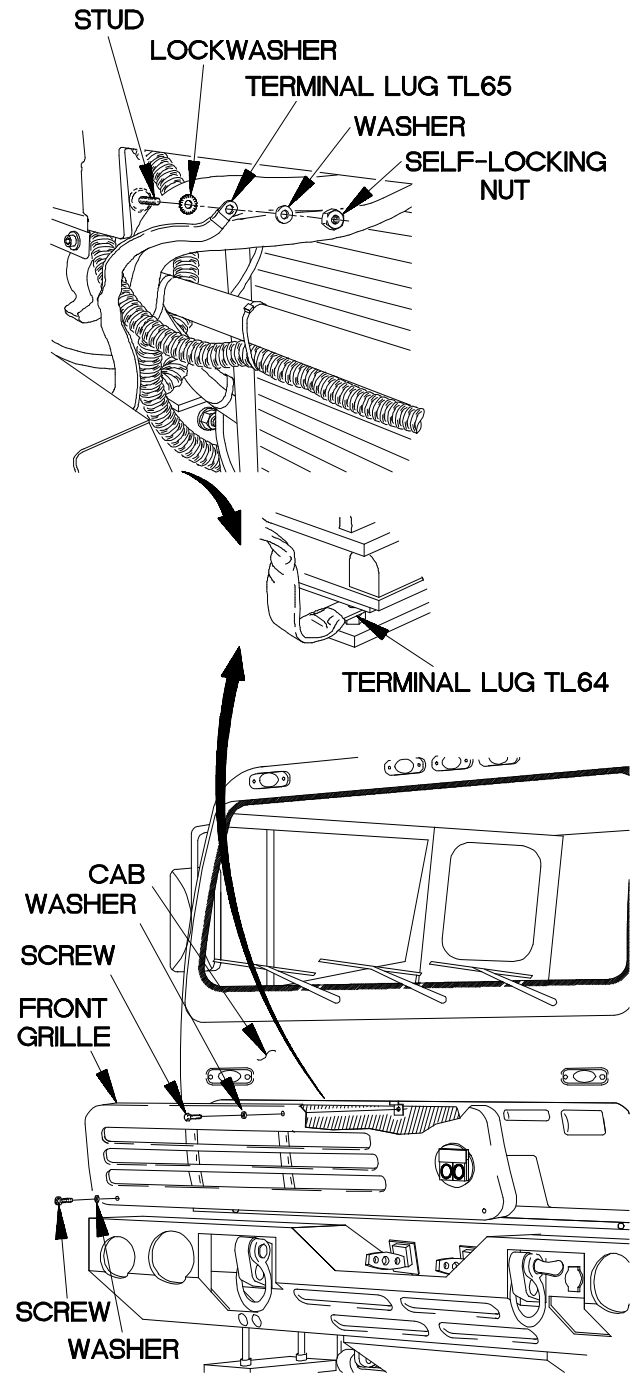

xbe0305b

e3. 12 VDC AND 24 VDC CIRCUITS DO NOT OPERATE (CONT)

KNOWN INFO
Circuit breakers CB70 OK. Battery(ies) OK. Cab to chassis ground strap OK.
POSSIBLE PROBLEMS
Faulty PDP to cab ground cable. Faulty dashboard cable assembly.

7.
Is continuity present from terminal lug TL56 to terminal lug TL57?

TEST OPTIONS
Continuity Test or STE/ICE-R Test #91
REASON FOR QUESTION
If continuity is not present, PDP to cab ground cable is faulty. If continuity is present, wire 1603 is faulty.

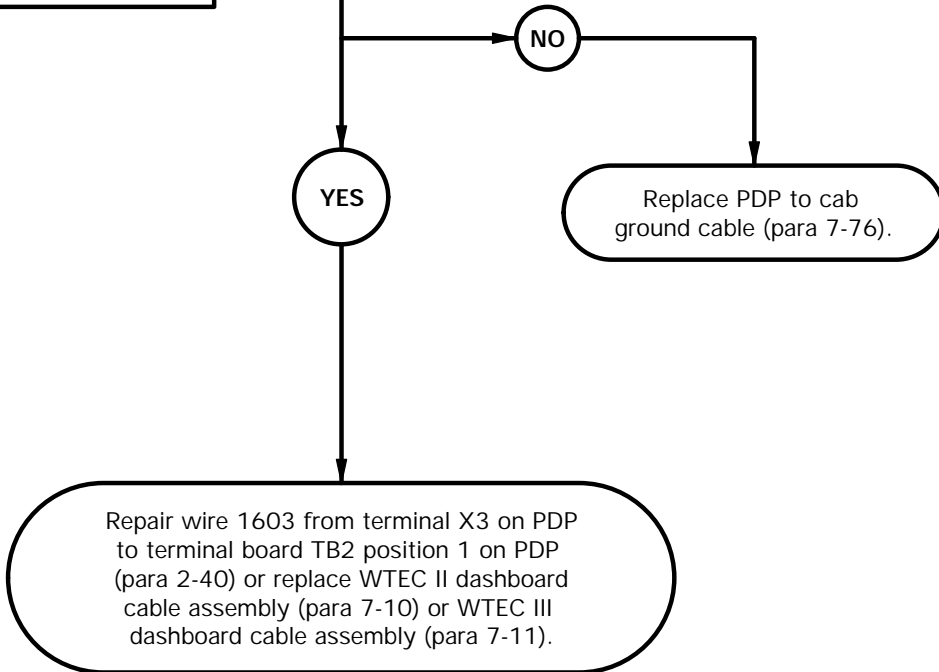

CONTINUITY TEST

- (1) Remove three screws and washers from PDP.
- (2) Remove three screws from PDP.
- (3) Lift outward to gain access.
- (4) Remove nut, lockwasher, terminal lug TL190, and terminal lug TL57 from grounding stud. Discard lockwasher.
- (5) Set multimeter to ohms.
- (6) Connect positive (+) probe of multimeter to terminal lug TL57.
- (7) Connect negative (-) probe of multimeter to terminal lug TL56 and note reading on multimeter.
- (8) If continuity is not present, replace PDP to cab ground cable (para 7-76).
- (9) If continuity is present, repair wire 1603 from terminal X3 on PDP to terminal board TB2 position 1 on PDP (para 2-40) or replace WTEC II dashboard cable assembly (para 7-10) or WTEC III dashboard cable assembly (para 7-11).
- (10) Install terminal lug TL190 and terminal lug TL57 on grounding stud with lockwasher and nut.
- (11) Install PDP on dashboard with three screws.
- (12) Install three washers and screws in PDP.
- (13) Install PDP cover (para 16-2).
- (14) Connect batteries (para 7-48).

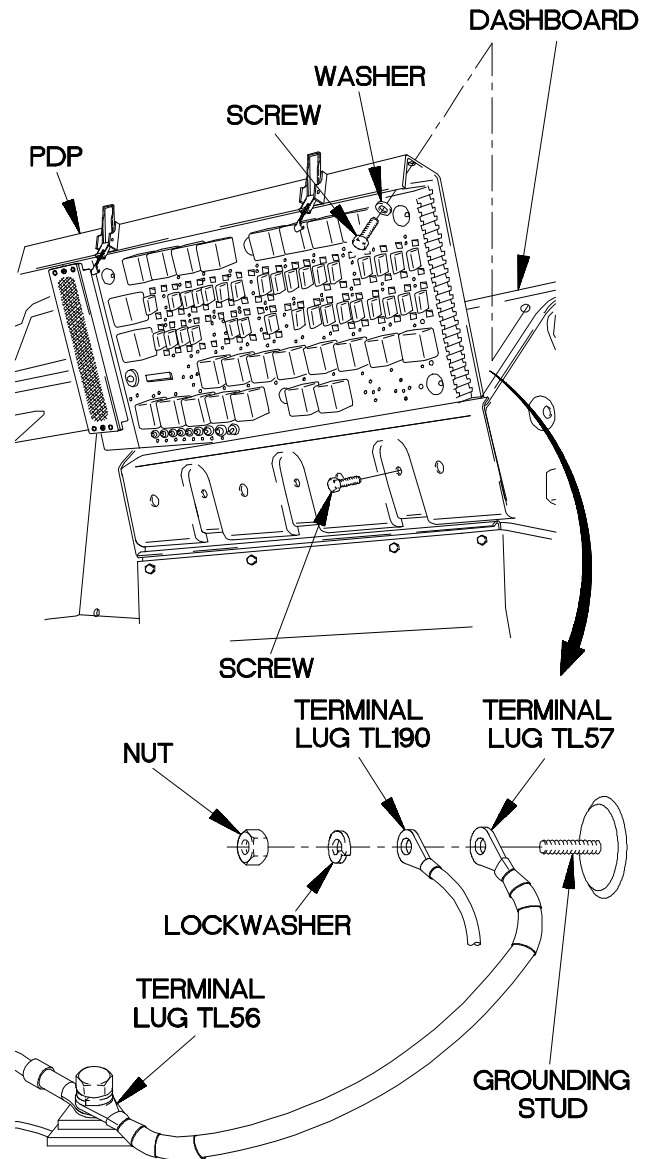

xbe0306b

e3. 12 VDC AND 24 VDC CIRCUITS DO NOT OPERATE (CONT)

KNOWN INFO
Circuit breaker CB70 OK. Battery(ies) OK. Cab to chassis ground strap OK. PDP to cab ground cable OK.
POSSIBLE PROBLEMS
Faulty shunt. Faulty starter to shunt 24 VDC cable. Faulty battery to shunt cable assembly. Faulty starter to chassis ground cable.

8.
Is continuity present from one end of shunt to other end of shunt?

TEST OPTIONS
Continuity Test or STE/ICE-R Test #91
REASON FOR QUESTION
If continuity is not present, shunt is faulty.

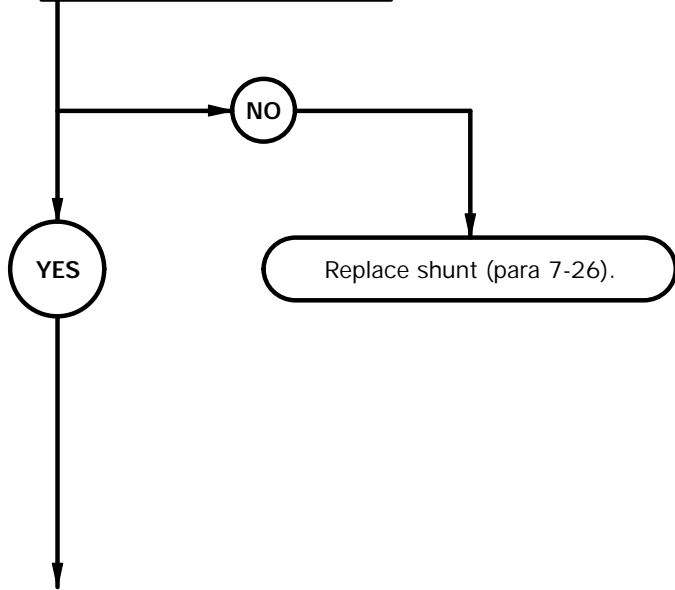

CONTINUITY TEST

- (1) Raise cab (TM 9-2320-365-10).
- (2) Lower spare tire (TM 9-2320-365-10).
- (3) Install PDP cover (para 16-2).
- (4) Loosen clamp on air hose.
- (5) Remove air hose from intake air cleaner boot.

NOTE

Tag wires and connection points prior to disconnecting.

- (6) Remove screw, lockwasher, and terminal lug TL52 from shunt. Discard lockwasher.
- (7) Remove screw, lockwasher, and terminal lug TL45 from shunt. Discard lockwasher.
- (8) Set multimeter to ohms.
- (9) Connect positive (+) probe of multimeter to one end of shunt.
- (10) Connect negative (-) probe of multimeter to other end of shunt and note reading of multimeter.
- (11) If continuity is not present, replace shunt (para 7-26).

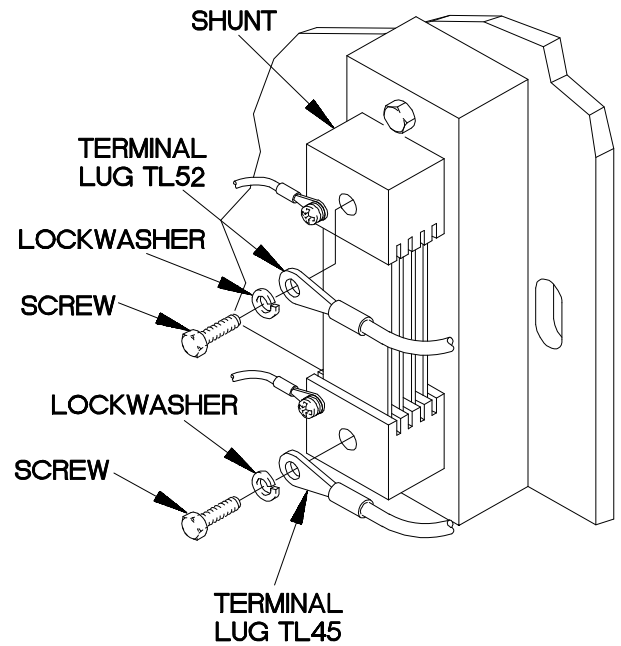
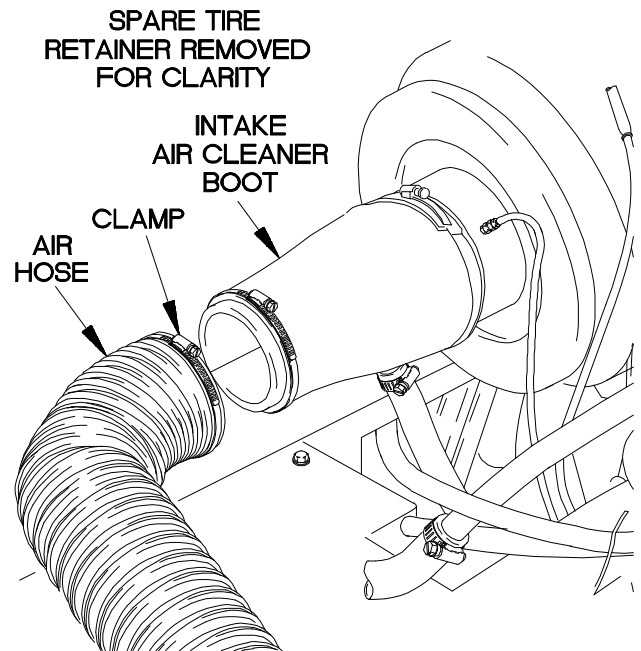

xbe0307b

e3. 12 VDC AND 24 VDC CIRCUITS DO NOT OPERATE (CONT)

KNOWN INFO
Circuit breaker CB70 OK. Battery(ies) OK. Cab to chassis ground strap OK. PDP to cab ground cable OK. Shunt OK.
POSSIBLE PROBLEMS
Faulty starter to shunt 24 VDC cable. Faulty battery to shunt cable assembly. Faulty starter to chassis ground cable.

9.
Is continuity present from starting motor ground terminal stud to terminal lug TL45?

TEST OPTIONS
Continuity Test or STE/ICE-R Test #91
REASON FOR QUESTION
If continuity is not present, starter to shunt 24 VDC cable is faulty.

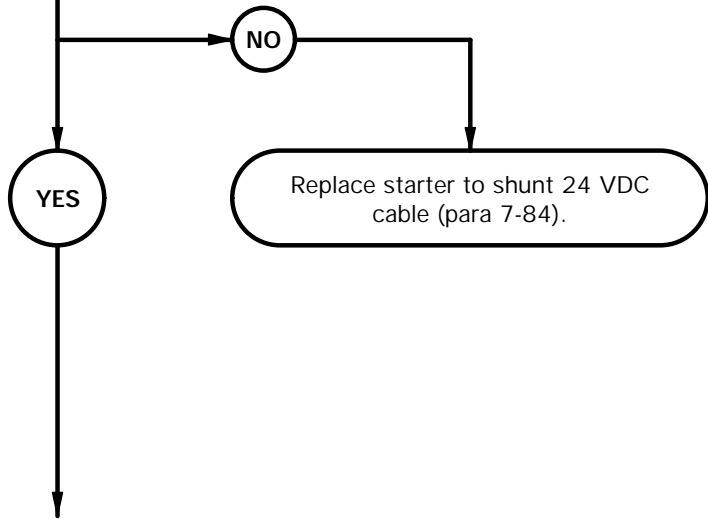

CONTINUITY TEST

- (1) Set multimeter to ohms.
- (2) Connect positive (+) probe of multimeter to starting motor ground terminal stud.
- (3) Connect negative (-) probe of multimeter to terminal lug TL45 and note reading on multimeter.
- (4) If continuity is not present, replace starter to shunt 24 VDC cable (para 7-84).
- (5) Lower cab (TM 9-2320-365-10).
- (6) Install terminal lug TL45 on shunt with lockwasher and screw.

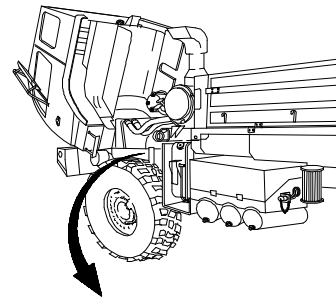

**STARTING
MOTOR GROUND
TERMINAL STUD**

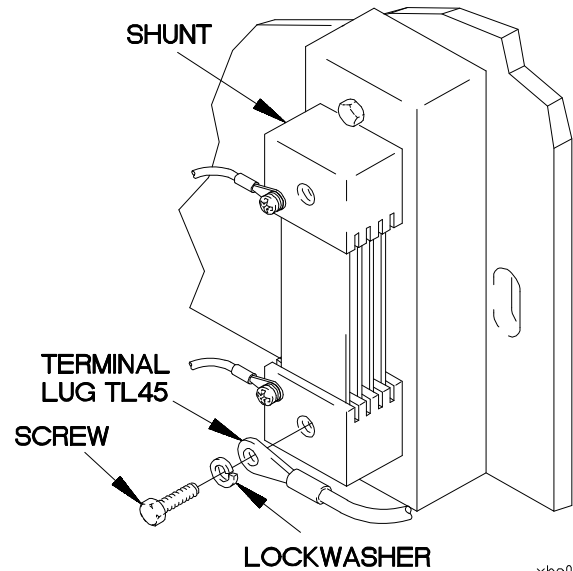
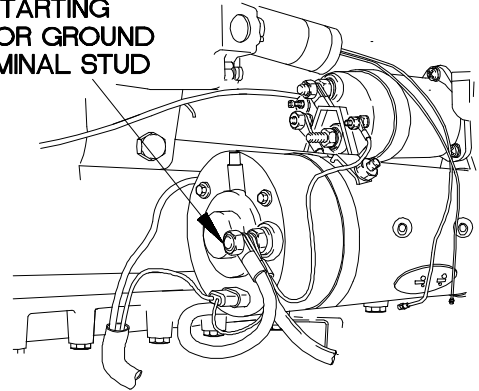

xbe0308b

e3. 12 VDC AND 24 VDC CIRCUITS DO NOT OPERATE (CONT)

KNOWN INFO
Circuit breaker CB70 OK. Battery(ies) OK. Cab to chassis ground strap OK. PDP to cab ground cable OK. Shunt OK. Starter to shunt 24 VDC cable OK.
POSSIBLE PROBLEMS
Faulty battery to shunt cable assembly. Faulty starter to chassis ground cable.

10.
Is continuity present from terminal lug TL52 to terminal lug TL48?

TEST OPTIONS
Continuity Test or STE/ICE-R Test #91
REASON FOR QUESTION
If continuity is not present, battery to shunt cable assembly is faulty. If continuity is present starter to chassis ground cable is faulty.

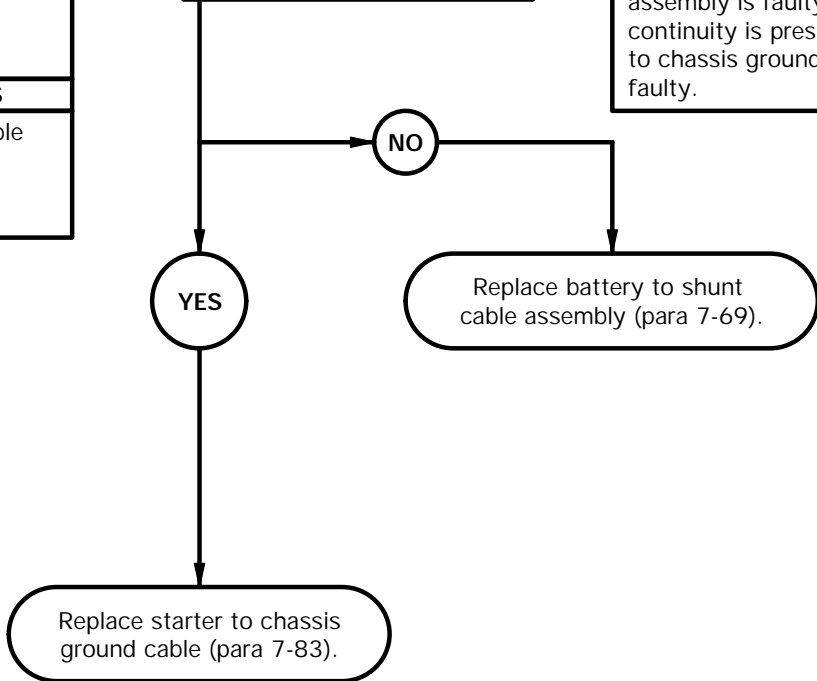

CONTINUITY TEST

- (1) Set multimeter to ohms.
- (2) Connect positive (+) probe of multimeter to terminal lug TL52.
- (3) Connect negative (-) probe of multimeter to terminal lug TL48 and note reading on multimeter.
- (4) If continuity is not present, replace battery to shunt cable assembly (para 7-69).
- (5) If continuity is present, replace starter to chassis ground cable (para 7-83).
- (6) Install terminal lug TL52 on shunt with lockwasher and screw.
- (7) Position air hose on intake air cleaner boot with clamp.
- (8) Tighten clamp to 36-48 lb-in. (4-5 N.m).
- (9) Raise spare tire (TM 9-2320-365-10).
- (10) Connect batteries (para 7-48).

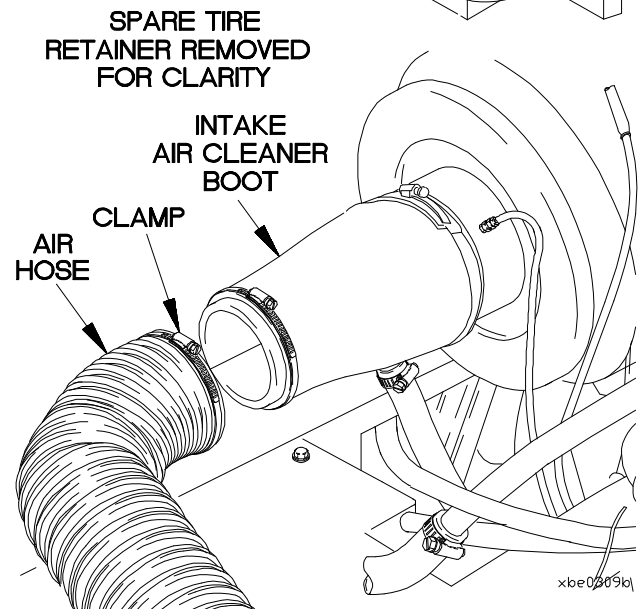
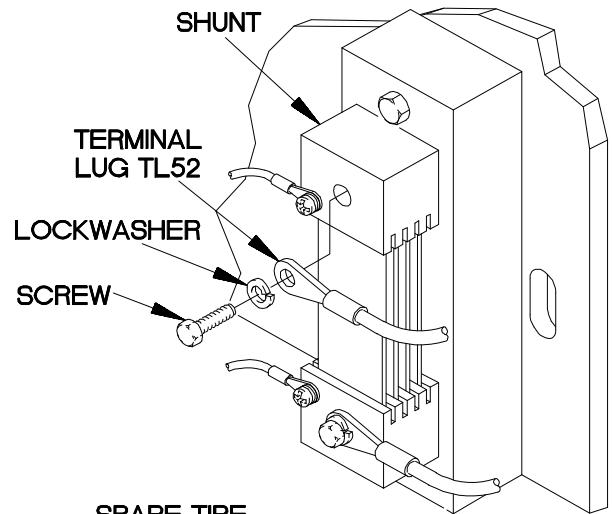
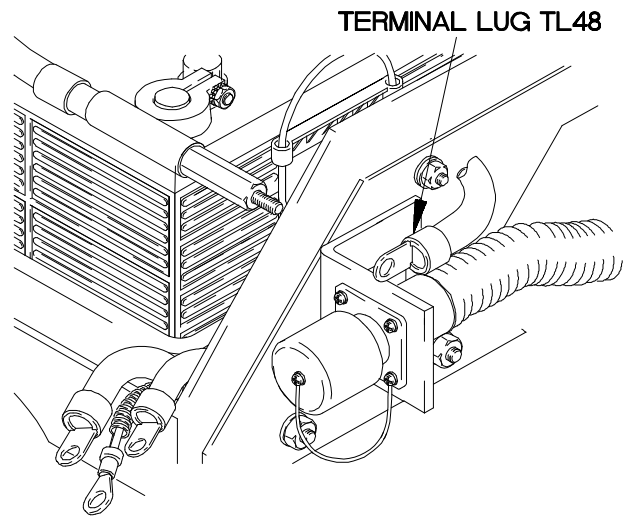

e3. 12 VDC AND 24 VDC CIRCUITS DO NOT OPERATE (CONT)

KNOWN INFO
Circuit breaker CB70 OK. Battery(ies) OK. Cab to chassis ground strap OK. PDP to cab ground cable OK. Shunt OK. Starter to shunt 24 VDC cable OK. Battery to shunt cable assembly OK. Starter to chassis ground cable OK.
POSSIBLE PROBLEMS
Faulty 100 AMP reverse polarity relay. Faulty battery to 100 AMP reverse polarity relay 12 VDC cable. Faulty 100 AMP reverse polarity relay to PDP 12 VDC cable. Faulty 200 AMP reverse polarity relay. Faulty 200 AMP terminal block. Faulty 200 AMP terminal block to PDP 12 VDC cable. Faulty 200 AMP terminal block to reverse polarity relay 12 VDC load cable. Faulty 200 AMP terminal block to reverse polarity relay 12 VDC battery cable. Faulty battery to 200 AMP terminal block 12 VDC cable assembly.

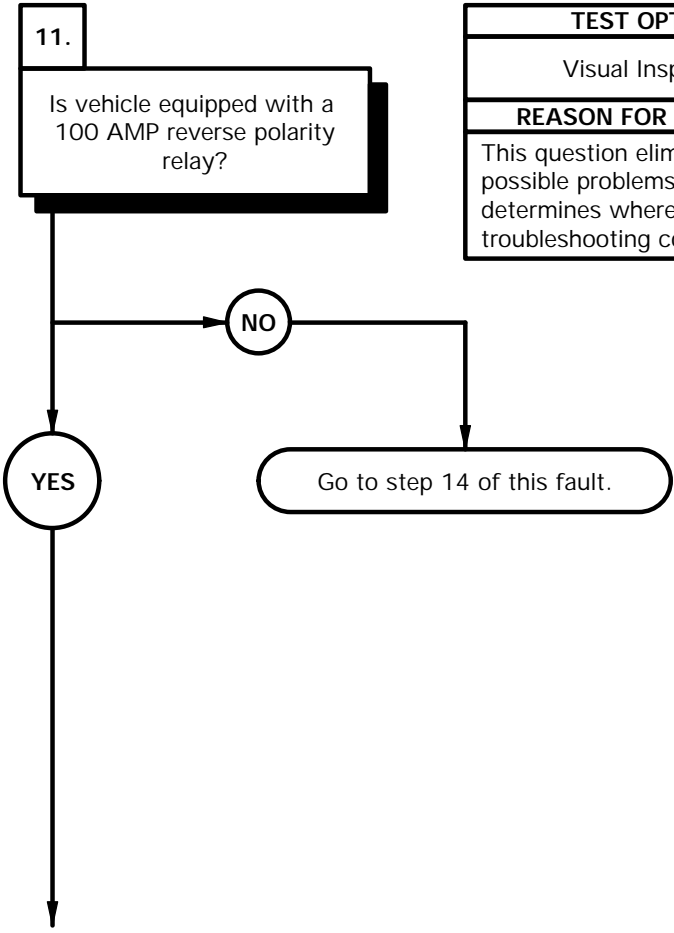

TEST OPTIONS
Visual Inspection
REASON FOR QUESTION
This question eliminates possible problems and determines where troubleshooting continues.



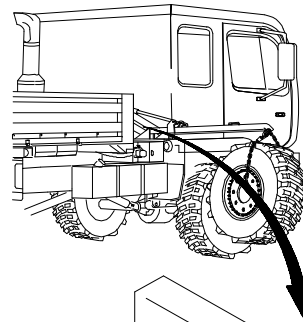

- (1) Lower spare tire (TM 9-2320-365-10).
- (2) Check if vehicle is equipped with 100 AMP reverse polarity relay.
- (3) If vehicle is not equipped with 100 AMP reverse polarity relay, go to step 14 of this fault.

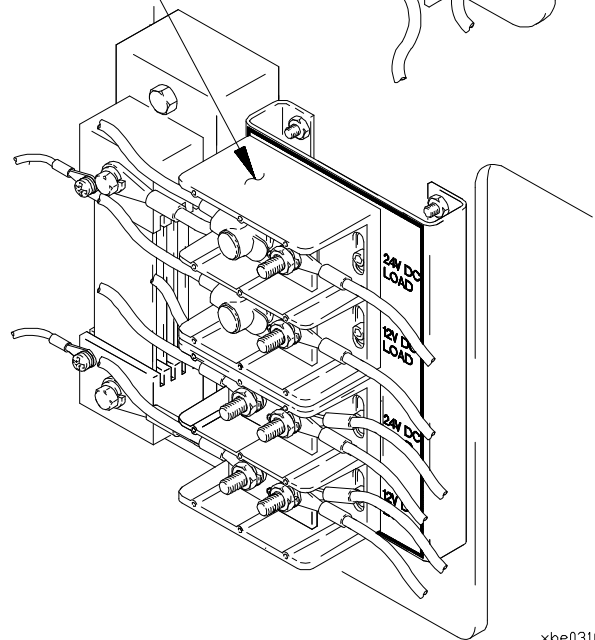
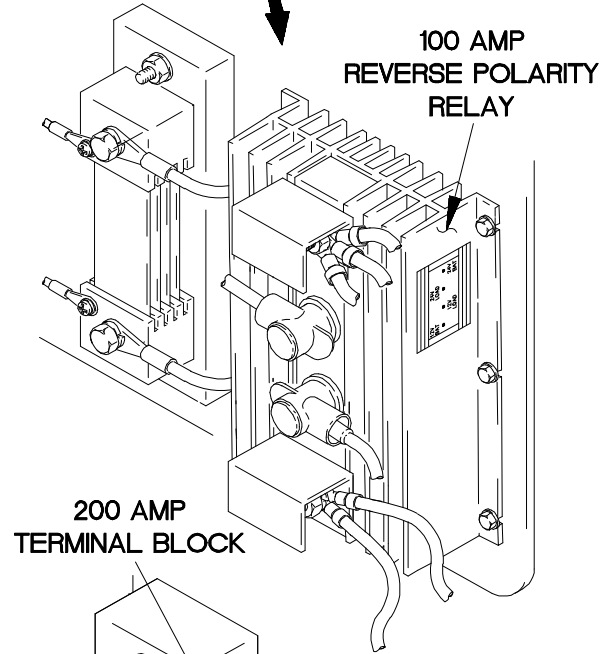

xle0310b

e3. 12 VDC AND 24 VDC CIRCUITS DO NOT OPERATE (CONT)

KNOWN INFO
Circuit breaker CB70 OK. Battery(ies) OK. Cab to chassis ground strap OK. PDP to cab ground cable OK. Shunt OK. Starter to shunt 24 VDC cable OK. Battery to shunt cable assembly OK. Starter to chassis ground cable OK.
POSSIBLE PROBLEMS
Faulty 100 AMP reverse polarity relay. Faulty battery to 100 AMP reverse polarity relay 12 VDC cable. Faulty 100 AMP reverse polarity relay to PDP 12 VDC cable.

12. **CAUTION**
Read CAUTION on following page.

Is continuity present from terminal lug TL80 to terminal X2 on PDP?

TEST OPTIONS
Continuity Test or STE/ICE-R Test #91
REASON FOR QUESTION
If continuity is not present, 100 AMP reverse polarity relay to PDP 12VDC cable is faulty.

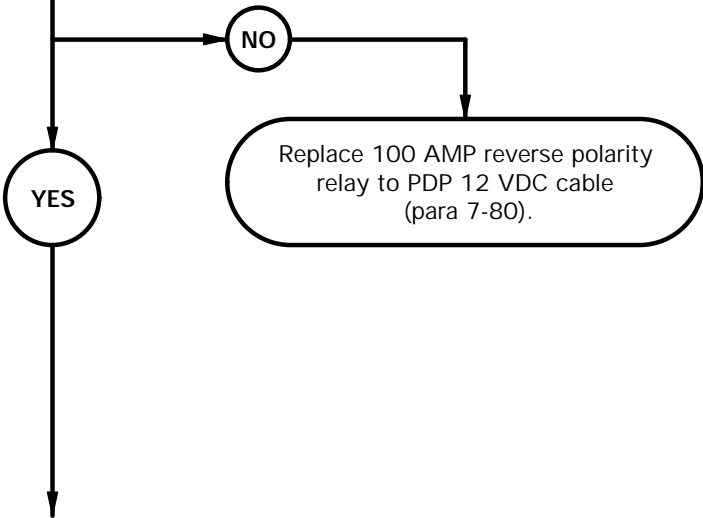

CONTINUITY TEST

- (1) Disconnect batteries (para 7-48).
- (2) Loosen clamp on air hose.
- (3) Remove air hose from intake air cleaner boot.
- (4) Lift dust boot on 12V LOAD terminal stud on 100 AMP reverse polarity relay.

NOTE

Tag all terminal lugs and connection points prior to disconnecting.

- (5) Remove nut, lockwasher, and terminal lug TL80 from 12V LOAD terminal stud on 100 AMP reverse polarity relay.
- (6) Set multimeter to ohms.

CAUTION

When testing to terminal X2 on PDP, ensure that multimeter probes come in contact with the outside metal ring. Failure to comply may result in false troubleshooting test results.

- (7) Connect positive probe (+) of multimeter to terminal X2 on PDP.
- (8) Connect negative probe (-) of multimeter to terminal lug TL80 and note reading on multimeter.
- (9) If continuity is not present, replace 100 AMP reverse polarity relay to PDP 12 VDC cable (para 7-80).
- (10) Position terminal lug TL80 on 12V LOAD terminal stud on 100 AMP reverse polarity relay with lockwasher and nut.
- (11) Tighten nut to 120-144 lb-in. (14-16 N.m).
- (12) Position dust boot on 12V LOAD terminal stud on 100 AMP reverse polarity relay.
- (13) Install PDP cover (para 16-2).

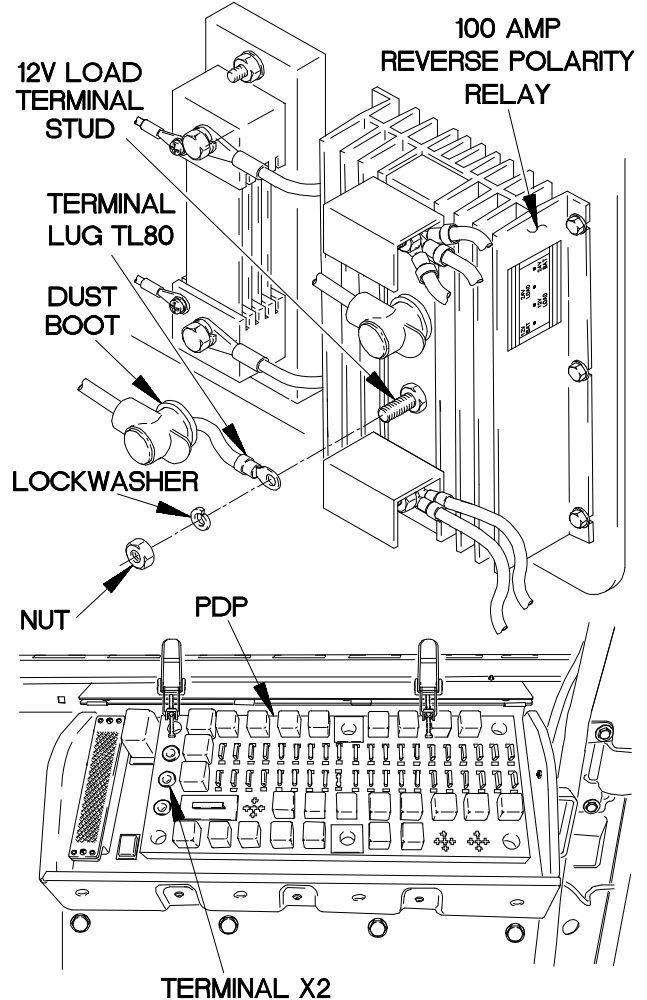
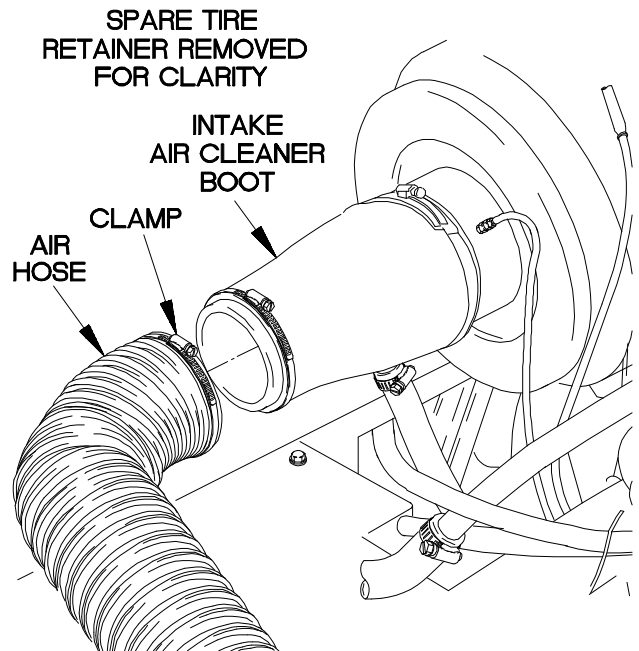

x8e0311b

e3. 12 VDC AND 24 VDC CIRCUITS DO NOT OPERATE (CONT)

KNOWN INFO
Circuit breaker CB70 OK. Battery(ies) OK. Cab to chassis ground strap OK. PDP to cab ground cable OK. Shunt OK. Starter to shunt 24 VDC cable OK. Battery to shunt cable assembly OK. Starter to chassis ground cable OK. 100 AMP reverse polarity relay to PDP 12 VDC cable OK.
POSSIBLE PROBLEMS
Faulty 100 AMP reverse polarity relay. Faulty battery to 100 AMP reverse polarity relay 12 VDC cable.

13.
 Is continuity present from terminal lug TL99 to terminal lug TL47?

TEST OPTIONS
Continuity Test or STE/ICE-R Test #91
REASON FOR QUESTION
If continuity is not present, battery to 100 AMP reverse polarity relay 12 VDC cable is faulty. If continuity is present, 100 AMP reverse polarity relay is faulty.

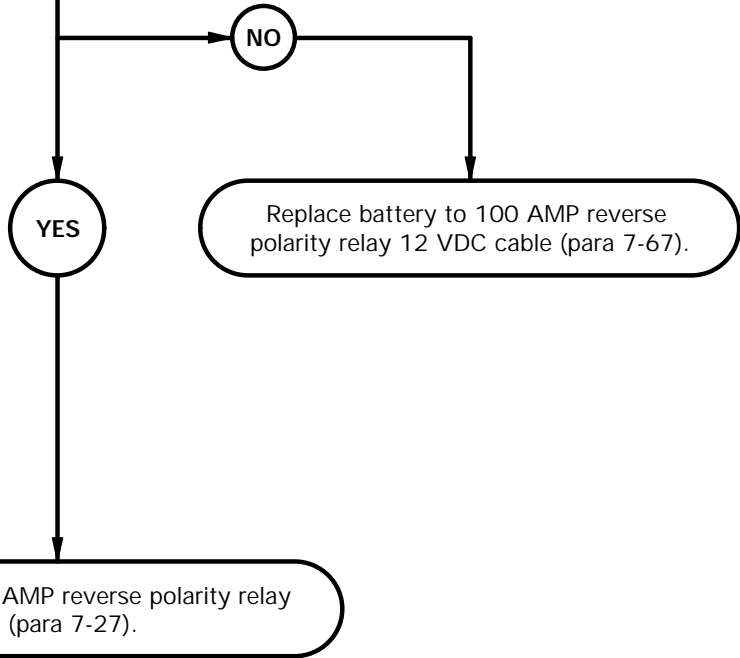

CONTINUITY TEST

- (1) Lift terminal cover on 12V BAT terminal stud on 100 AMP reverse polarity relay.
- (2) Remove nut, lockwasher, terminal lug TL61, and terminal lug TL47 from 12V BAT terminal stud on 100 AMP reverse polarity relay. Discard lockwasher.
- (3) Set multimeter to ohms.
- (4) Connect positive probe (+) of multimeter to terminal lug TL99.
- (5) Connect negative probe (-) of multimeter to terminal lug TL47 and note reading on multimeter.
- (6) If continuity is not present, replace battery to 100 AMP reverse polarity relay 12 VDC cable (para 7-67).
- (7) If continuity is present, replace 100 AMP reverse polarity relay (para 7-27).
- (8) Lift terminal cover on 12V BAT terminal stud on 100 AMP reverse polarity relay.
- (9) Position terminal lugs TL47 and TL61 on 12V BAT terminal stud on 100 AMP reverse polarity relay with lockwasher and nut.
- (10) Tighten nut to 120-144 lb-in. (14-16 N.m).
- (11) Position air hose on intake air cleaner boot with clamp.
- (12) Tighten clamp to 36-48 lb-in. (4-5 N.m).
- (13) Connect batteries (para 7-48).
- (14) Raise spare tire (TM 9-2320-365-10).

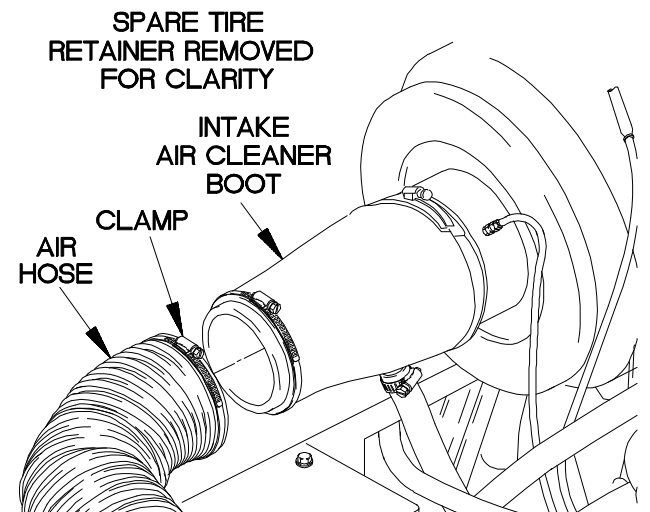
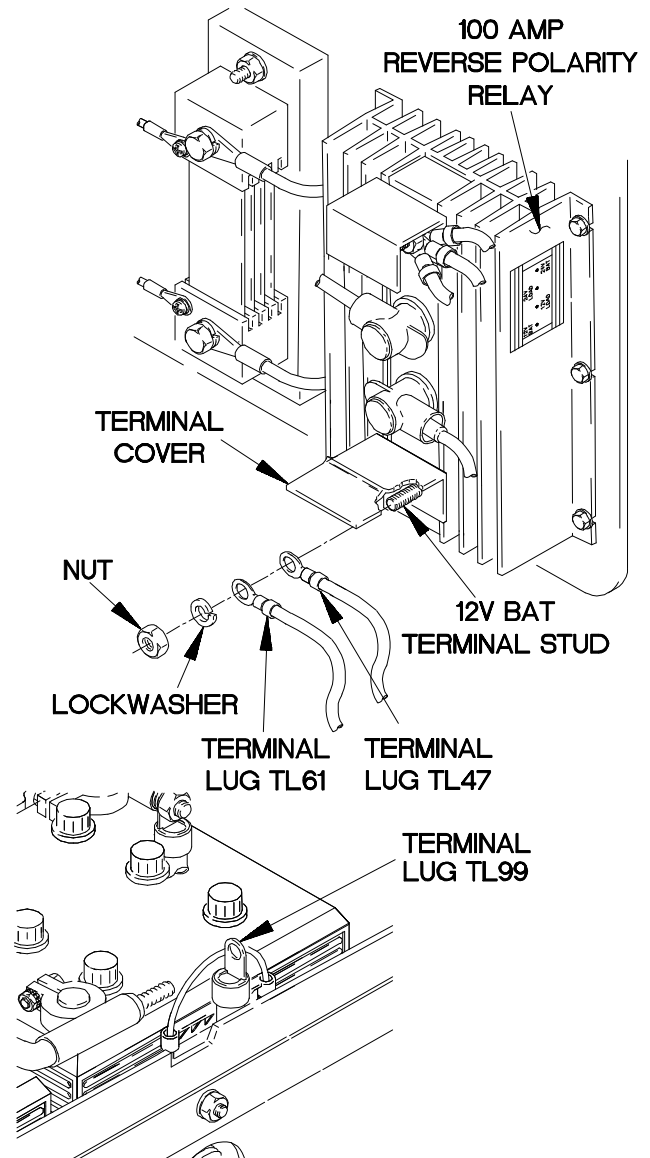

XBE0312B

e3. 12 VDC AND 24 VDC CIRCUITS DO NOT OPERATE (CONT)

KNOWN INFO
Circuit breaker CB70 OK. Battery(ies) OK. Cab to chassis ground strap OK. PDP to cab ground cable OK. Shunt OK. Starter to shunt 24 VDC cable OK. Battery to shunt cable assembly OK. Starter to chassis ground cable OK.
POSSIBLE PROBLEMS
Faulty 200 AMP reverse polarity relay. Faulty 200 AMP terminal block. Faulty 200 AMP terminal block to PDP 12 VDC cable. Faulty 200 AMP terminal block to reverse polarity relay 12 VDC load cable. Faulty 200 AMP terminal block to reverse polarity relay 12 VDC battery cable. Faulty battery to 200 AMP terminal block 12 VDC cable assembly.

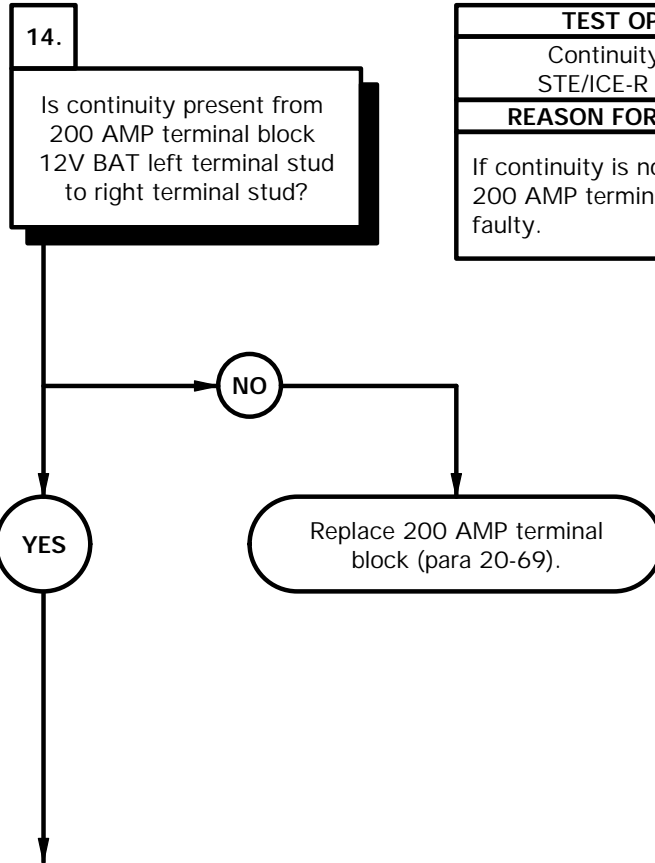

TEST OPTIONS
Continuity Test or STE/ICE-R Test #91
REASON FOR QUESTION
If continuity is not present, 200 AMP terminal block is faulty.

CONTINUITY TEST

- (1) Disconnect batteries (para 7-48).
- (2) Remove nut, lockwasher, washer, and terminal lug TL47 from left 12V BAT terminal stud on 200 AMP terminal block. Discard lockwasher.
- (3) Remove nut, lockwasher, washer, and terminal lugs TL171 and TL61 from right 12V BAT terminal stud on 200 AMP terminal block. Discard lockwasher.
- (4) Set multimeter to ohms.
- (5) Connect positive (+) probe of multimeter to left 12V BAT terminal stud on 200 AMP terminal block.
- (6) Connect negative (-) probe of multimeter to right 12V BAT terminal stud on 200 AMP terminal block and note reading on multimeter.
- (7) If continuity is not present, replace 200 AMP terminal block (para 20-69).
- (8) Position terminal lug TL47 on left 12V BAT terminal stud on 200 AMP terminal block with washer, lockwasher, and nut.
- (9) Tighten nut to 15-19 lb-ft (21-25 N.m).

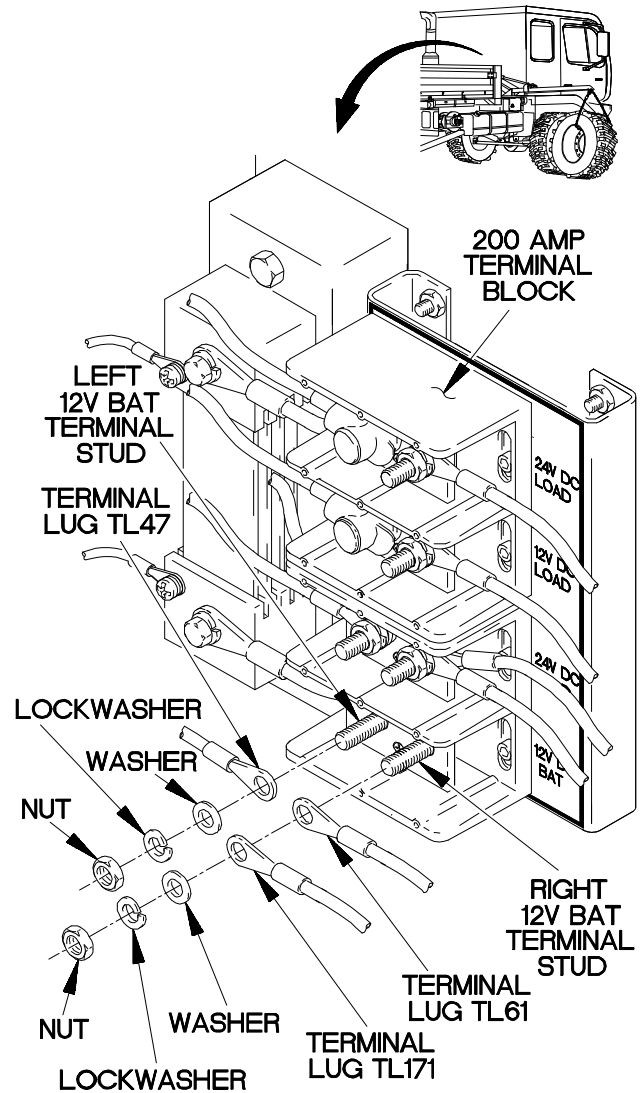

xbe0313b

e3. 12 VDC AND 24 VDC CIRCUITS DO NOT OPERATE (CONT)

KNOWN INFO
Circuit breaker CB70 OK. Battery(ies) OK. Cab to chassis ground strap OK. PDP to cab ground cable OK. Shunt OK. Starter to shunt 24 VDC cable OK. Battery to shunt cable assembly OK. Starter to chassis ground cable OK.
POSSIBLE PROBLEMS
Faulty 200 AMP reverse polarity relay. Faulty 200 AMP terminal block. Faulty 200 AMP terminal block to PDP 12 VDC cable. Faulty 200 AMP terminal block to reverse polarity relay 12 VDC load cable. Faulty 200 AMP terminal block to reverse polarity relay 12 VDC battery cable. Faulty battery to 200 AMP terminal block 12 VDC cable assembly.

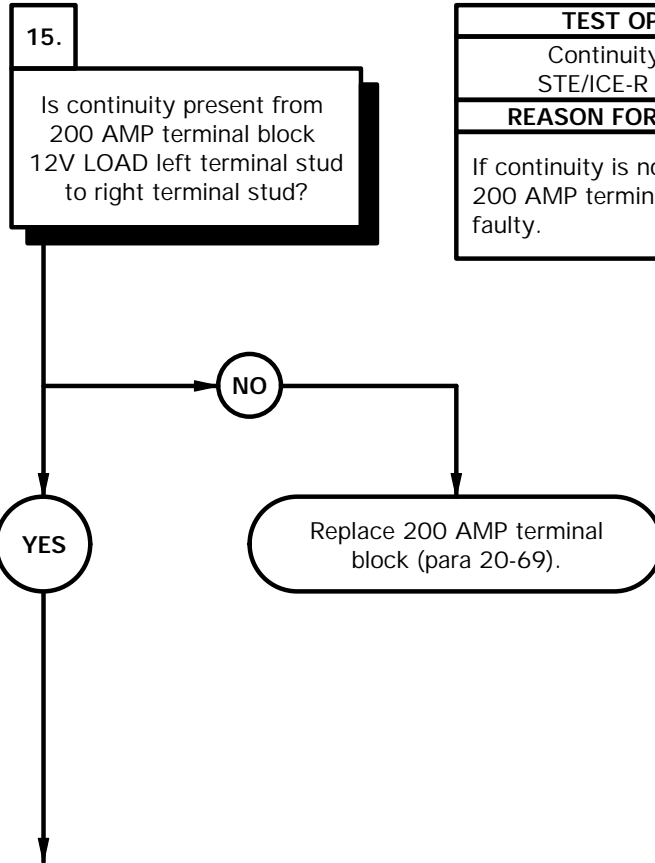

TEST OPTIONS
Continuity Test or STE/ICE-R Test #91
REASON FOR QUESTION
If continuity is not present, 200 AMP terminal block is faulty.

CONTINUITY TEST

- (1) Lift dust boot on left 12V LOAD terminal stud on 200 AMP terminal block.
- (2) Remove nut, lockwasher, washer, and terminal lug TL80 from left 12V LOAD terminal stud on 200 AMP terminal block. Discard lockwasher.
- (3) Remove nut, lockwasher, washer, and terminal lug TL172 from right 12V LOAD terminal stud on 200 AMP terminal block. Discard lockwasher.
- (4) Set multimeter to ohms.
- (5) Connect positive (+) probe of multimeter to left 12V LOAD terminal stud on 200 AMP terminal block.
- (6) Connect negative (-) probe of multimeter to right 12V LOAD terminal stud on 200 AMP terminal block and note reading on multimeter.
- (7) If continuity is not present, replace 200 AMP terminal block (para 20-69).

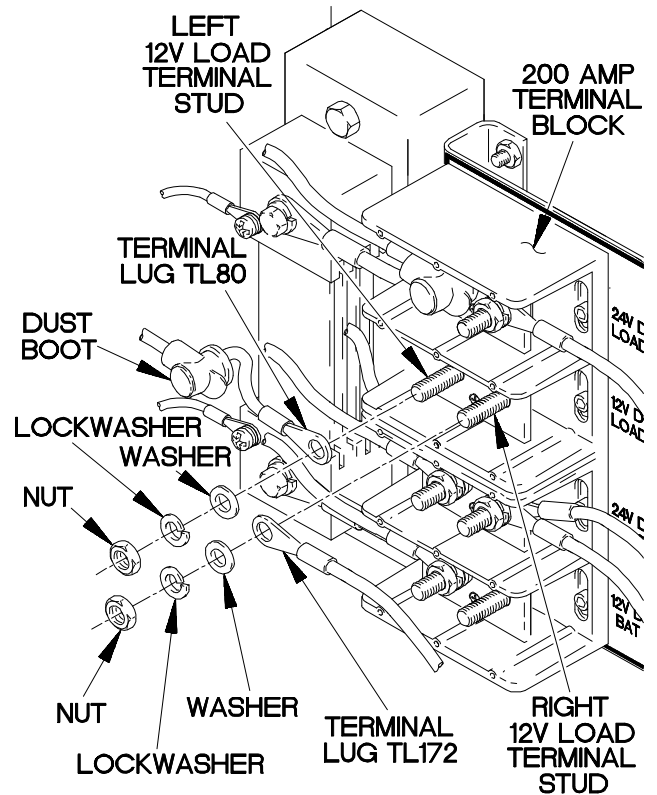

xbe0314B

e3. 12 VDC AND 24 VDC CIRCUITS DO NOT OPERATE (CONT)

KNOWN INFO
Circuit breaker CB70 OK. Battery(ies) OK. Cab to chassis ground strap OK. PDP to cab ground cable OK. Shunt OK. Starter to shunt 24 VDC cable OK. Battery to shunt cable assembly OK. Starter to chassis ground cable OK. 200 AMP terminal block OK.
POSSIBLE PROBLEMS
Faulty 200 AMP reverse polarity relay. Faulty 200 AMP terminal block to PDP 12 VDC cable. Faulty 200 AMP terminal block to reverse polarity relay 12 VDC load cable. Faulty 200 AMP terminal block to reverse polarity relay 12 VDC battery cable. Faulty battery to 200 AMP terminal block 12 VDC cable assembly.

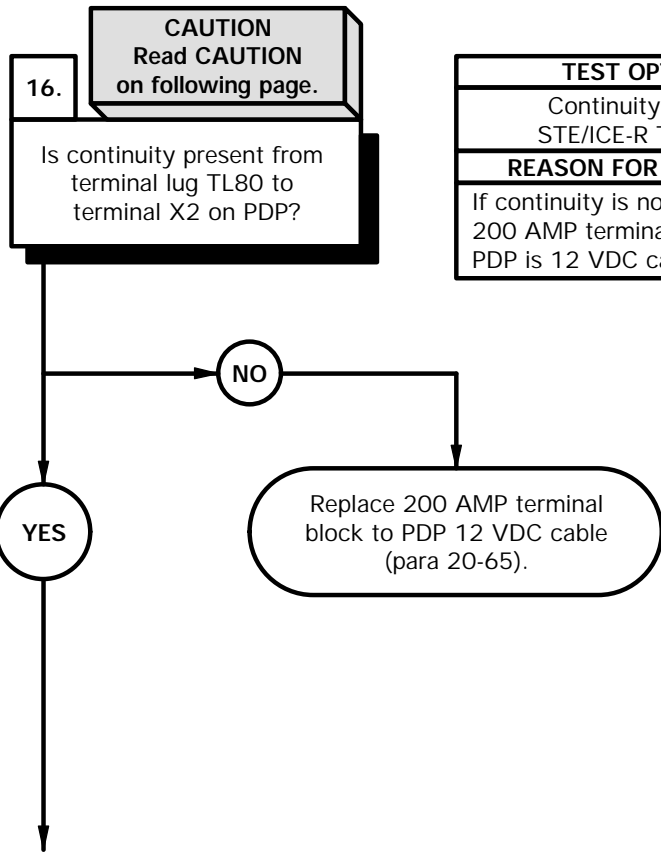

TEST OPTIONS
Continuity Test or STE/ICE-R Test #91
REASON FOR QUESTION
If continuity is not present, 200 AMP terminal block to PDP is 12 VDC cable is faulty.

CONTINUITY TEST

- (1) Set multimeter to ohms.
- (2) Connect positive (+) probe of multimeter to terminal lug TL80.

CAUTION

When testing to terminal X2 on PDP, ensure that multimeter probes come in contact with the outside metal ring. Failure to comply may result in false troubleshooting test results.

- (3) Connect negative (-) probe of multimeter to terminal block X2 on PDP and note reading on multimeter.
- (4) If continuity is not present, replace 200 AMP terminal block to PDP 12 VDC cable (para 20-65).
- (5) Position terminal lug TL80 on left 12V LOAD terminal stud on 200 AMP terminal block with washer, lockwasher, and nut.
- (6) Tighten nut to 15-19 lb-ft (21-25 N.m).
- (7) Position dust boot on left 12V LOAD terminal stud on 200 AMP terminal block.

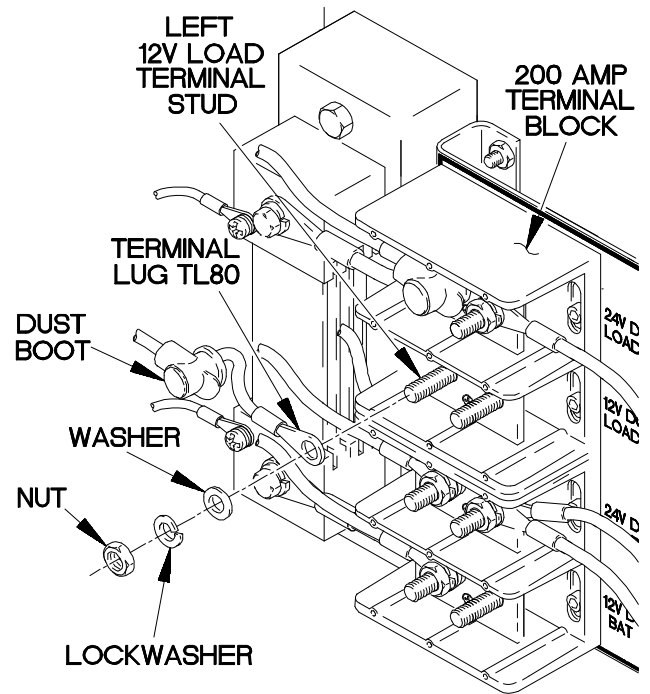
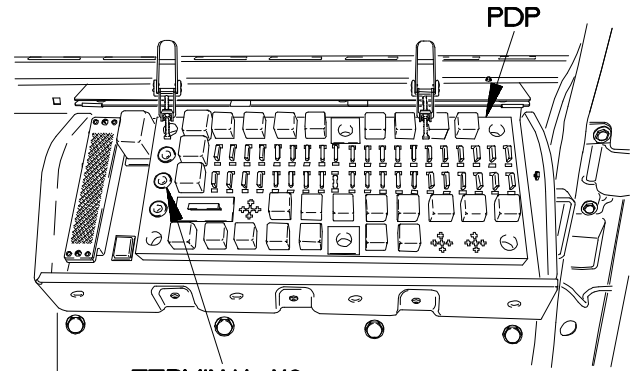

xbe0315B

e3. 12 VDC AND 24 VDC CIRCUITS DO NOT OPERATE (CONT)

KNOWN INFO
Circuit breaker CB70 OK. Battery(ies) OK. Cab to chassis ground strap OK. PDP to cab ground cable OK. Shunt OK. Starter to shunt 24 VDC cable OK. Battery to shunt cable assembly OK. Starter to chassis ground cable OK. 200 AMP terminal block OK. 200 AMP terminal block to PDP 12 VDC cable OK.
POSSIBLE PROBLEMS
Faulty 200 AMP reverse polarity relay. Faulty 200 AMP terminal block to reverse polarity relay 12 VDC load cable. Faulty 200 AMP terminal block to reverse polarity relay 12 VDC battery cable. Faulty battery to 200 AMP terminal block 12 VDC cable assembly.

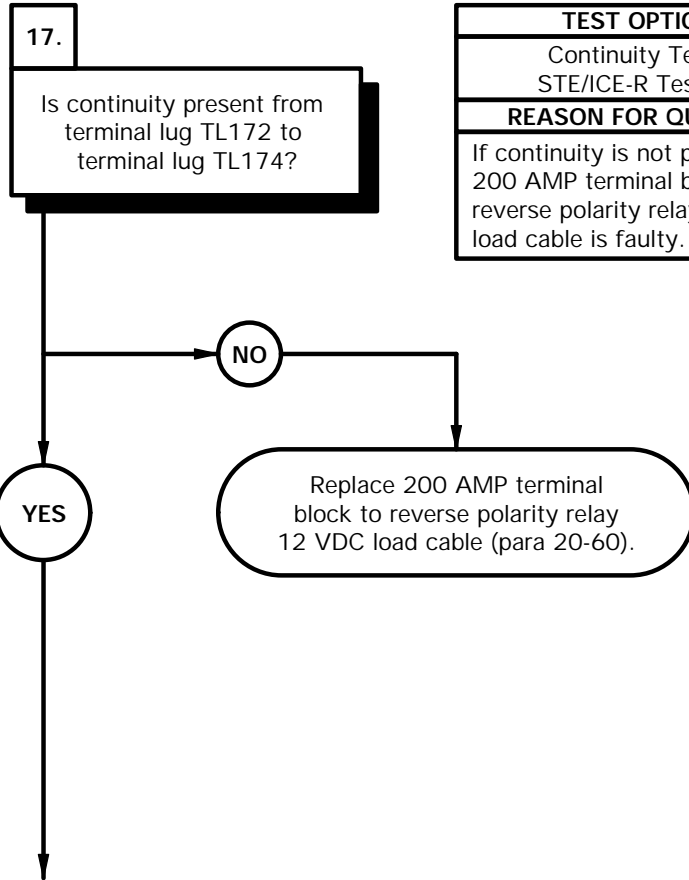

TEST OPTIONS
Continuity Test or STE/ICE-R Test #91
REASON FOR QUESTION
If continuity is not present, 200 AMP terminal block to reverse polarity relay 12 VDC load cable is faulty.

CONTINUITY TEST

- (1) Lift dust boot on 12V LOAD terminal stud on 200 AMP reverse polarity relay.
- (2) Remove nut, lockwasher, and terminal lug TL174 from 12V LOAD terminal stud on 200 AMP reverse polarity relay. Discard lockwasher.
- (3) Set multimeter to ohms.
- (4) Connect positive (+) probe of multimeter to terminal lug TL172.
- (5) Connect negative (-) probe of multimeter to terminal lug TL174 and note reading on multimeter.
- (6) If continuity is not present, replace 200 AMP terminal block to reverse polarity relay 12 VDC load cable (para 20-60).
- (7) Position terminal lug TL172 on right 12V LOAD terminal stud on 200 AMP terminal block with washer, lockwasher, and nut.
- (8) Tighten nut to 15-19 lb-ft (21-25 N.m).
- (9) Position terminal lug TL174 on 12V LOAD terminal stud on 200 AMP reverse polarity relay with lockwasher and nut.
- (10) Tighten nut to 108-132 lb-in. (12-15 N.m).
- (11) Position dust boot on 12V LOAD terminal stud on 200 AMP reverse polarity relay.

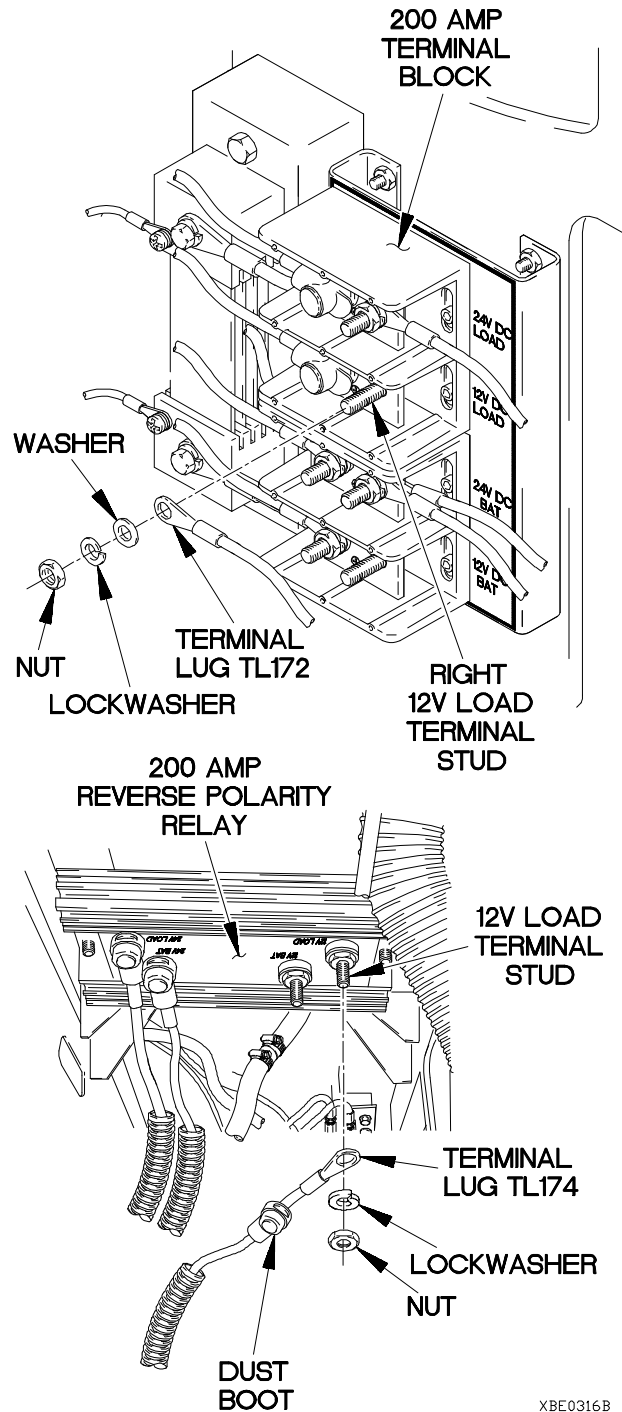

XBE0316B

e3. 12 VDC AND 24 VDC CIRCUITS DO NOT OPERATE (CONT)

KNOWN INFO
Circuit breaker CB70 OK. Battery(ies) OK. Cab to chassis ground strap OK. PDP to cab ground cable OK. Shunt OK. Starter to shunt 24 VDC cable OK. Battery to shunt cable assembly OK. Starter to chassis ground cable OK. 200 AMP terminal block OK. 200 AMP terminal block to PDP 12 VDC cable OK. 200 AMP terminal block to reverse polarity relay 12 VDC load cable OK.
POSSIBLE PROBLEMS
Faulty 200 AMP reverse polarity relay. Faulty 200 AMP terminal block to reverse polarity relay 12 VDC battery cable. Faulty battery to 200 AMP terminal block 12 VDC cable assembly.

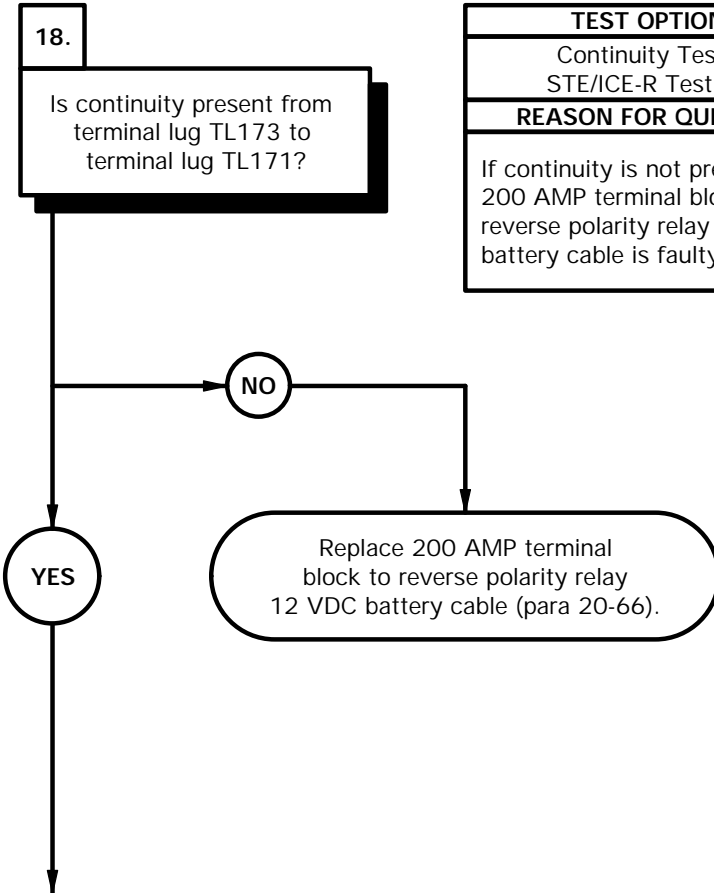

TEST OPTIONS
Continuity Test or STE/ICE-R Test #91
REASON FOR QUESTION
If continuity is not present, 200 AMP terminal block to reverse polarity relay 12 VDC battery cable is faulty.

CONTINUITY TEST

- (1) Lift dust boot on 12V BAT terminal stud on 200 AMP reverse polarity relay.
- (2) Remove nut, lockwasher, and terminal lug TL173 from 12V BAT terminal stud on 200 AMP reverse polarity relay. Discard lockwasher.
- (3) Set multimeter to ohms.
- (4) Connect positive (+) probe of multimeter to terminal lug TL173.
- (5) Connect negative (-) probe of multimeter to terminal lug TL171 and note reading on multimeter.
- (6) If continuity is not present, replace 200 AMP terminal block to reverse polarity relay 12 VDC battery cable (para 20-66).
- (7) Position terminal lugs TL171 and TL61 on right 12V BAT terminal stud on 200 AMP terminal block with washer, lockwasher, and nut.
- (8) Tighten nuts to 15-19 lb-ft (21-25 N.m).
- (9) Position terminal lug TL173 on 12V BAT terminal stud on 200 AMP reverse polarity relay with lockwasher and nut.
- (10) Tighten nut to 108-132 lb-in. (12-15 N.m).
- (11) Position dust boot on 12V BAT terminal stud on 200 AMP reverse polarity relay.

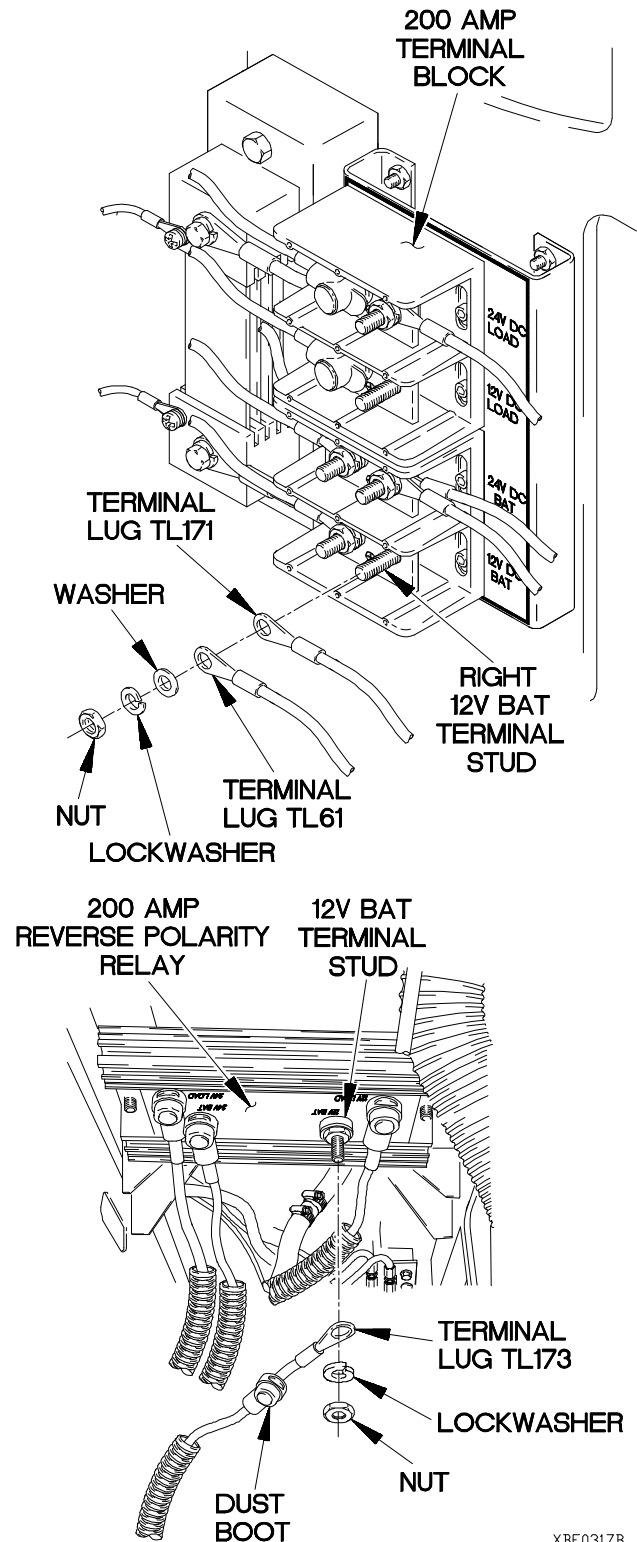

XBE0317B

e3. 12 VDC AND 24 VDC CIRCUITS DO NOT OPERATE (CONT)

KNOWN INFO
Circuit breaker CB70 OK. Battery(ies) OK. Cab to chassis ground strap OK. PDP to cab ground cable OK. Shunt OK. Starter to shunt 24 VDC cable OK. Battery to shunt cable assembly OK. Starter to chassis ground cable OK. 200 AMP terminal block OK. 200 AMP terminal block to PDP 12 VDC cable OK. 200 AMP terminal block to reverse polarity relay 12 VDC load cable OK. 200 AMP terminal block to reverse polarity relay 12 VDC battery cable OK.
POSSIBLE PROBLEMS
Faulty 200 AMP reverse polarity relay. Faulty battery to 200 AMP terminal block 12 VDC cable assembly.

19.
 Is continuity present from terminal lug TL47 to terminal lug TL99?

TEST OPTIONS
Continuity Test or STE/ICE-R Test #91
REASON FOR QUESTION
If continuity is not present, battery to 200 AMP terminal block 12 VDC cable assembly, is faulty. If continuity is present, 200 AMP reverse polarity relay is faulty.

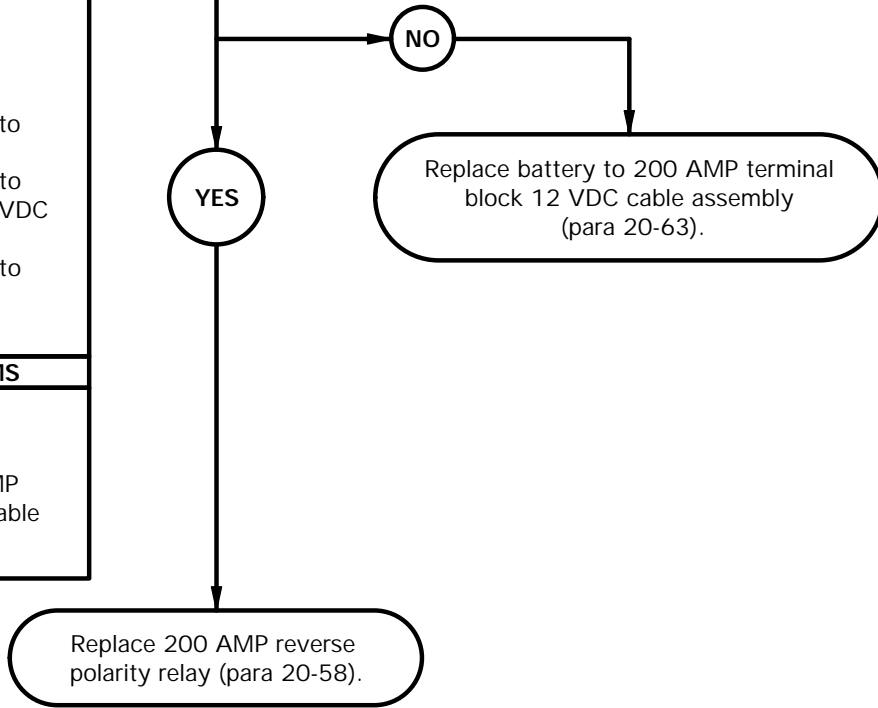

CONTINUITY TEST

- (1) Set multimeter to ohms.
- (2) Connect positive (+) probe of multimeter to terminal lug TL47.
- (3) Connect negative (-) probe of multimeter to terminal lug TL99 and note reading on multimeter.
- (4) If continuity is not present, replace battery to 200 AMP terminal block 12 VDC cable assembly (para 20-63).
- (5) If continuity is present, replace 200 AMP reverse polarity relay (para 20-58).
- (6) Install PDP cover (para 16-2).
- (7) Connect batteries (para 7-48).
- (8) Raise spare tire (TM 9-2320-365-10).

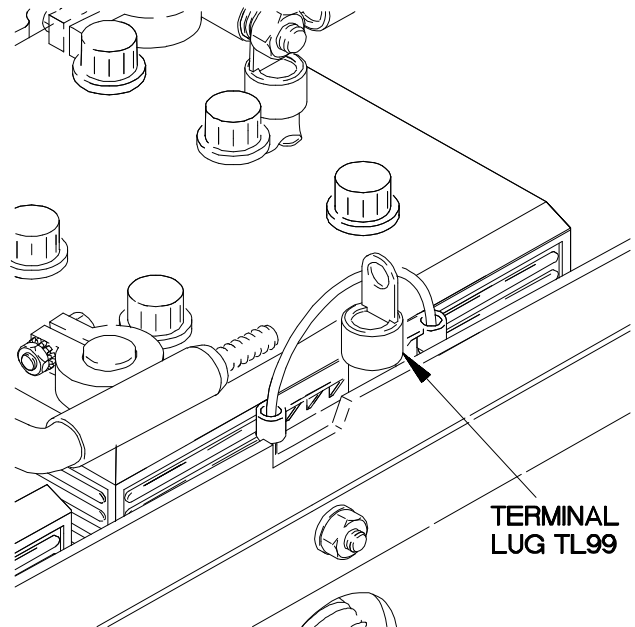
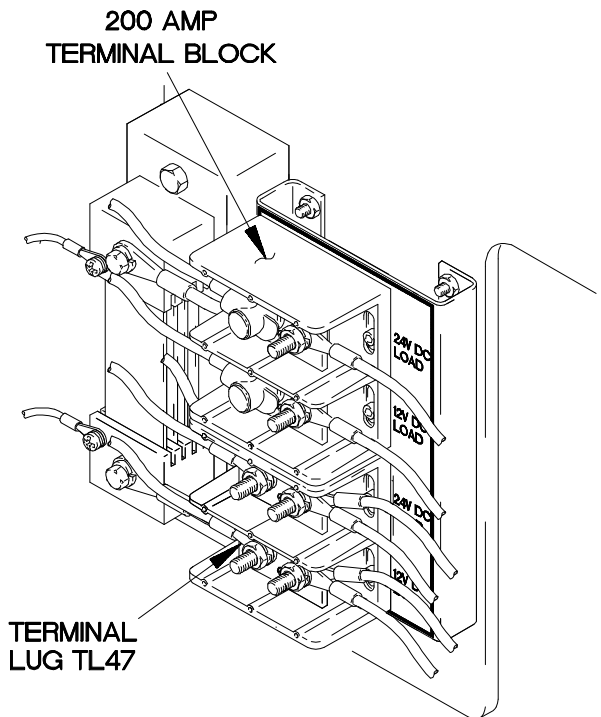

XBE0318B

e4. 24 VDC CIRCUITS DO NOT OPERATE	
INITIAL SETUP	
<p>Equipment Conditions Engine shut down (TM 9-2320-365-10).</p> <p>Tools and Special Tools Tool Kit, Genl Mech (Item 44, Appendix C) STE/ICE-R (Item 39, Appendix C) Multimeter, Digital (Item 22, Appendix C) Tester, Antifreeze and Battery (Item 41, Appendix C) Goggles, Industrial (Item 15, Appendix C) Gloves, Rubber (Item 13, Appendix C) Apron, Rubber (Item 3, Appendix C) Socket Set, Socket Wrench (Item 34, Appendix C) Wrench, Torque, 0-200 lb-in. (Item 58, Appendix C) Wrench, Torque, 0-175 lb-ft (Item 57, Appendix C) Wire, Relay Test (Item 9, Appendix E)</p>	<p>Materials/Parts Ties, Cable, Plastic (Item 76, Appendix D) Dispenser, Pressure Sensitive Tape (Item 21, Appendix D) Wire, Elect, 50 ft (Item 77, Appendix D) Lockwasher (2) (Item 91, Appendix G) (100 AMP) Lockwasher (2) (Item 66, Appendix G) (200 AMP) Lockwasher (4) (Item 92, Appendix G) (200 AMP)</p> <p>Personnel Required (2)</p> <p>References TM 9-6140-200-14 TM 9-4910-571-12&P</p>

NOTE
Perform electrical troubleshooting e1. Circuit Breaker Does Not Operate on circuit breaker CB70 prior to beginning this task.

Remove and install plastic cable ties as required.

TEST OPTIONS
Battery Specific Gravity Test
REASON FOR QUESTION
If battery(ies) is unserviceable, 12 vdc circuits will not operate.

KNOWN INFO
Service drive lights OK. Circuit breaker CB70 OK.
POSSIBLE PROBLEMS
Faulty relay K2. Faulty master power switch. Faulty dashboard cable assembly. Faulty 100 AMP reverse polarity relay. Faulty 100 AMP reverse polarity relay to power distribution panel (PDP) 24 VDC cable. Faulty battery to 100 AMP reverse polarity relay 24 VDC cable. Faulty 200 AMP reverse polarity relay. Faulty 200 AMP terminal block. Faulty battery to 200 AMP terminal block 24 VDC cable assembly. Faulty 200 AMP terminal block to reverse polarity relay 24 VDC battery cable. Faulty 200 AMP terminal block to reverse polarity relay 24 VDC load cable. Faulty 200 AMP terminal block to power distribution panel (PDP) 24 VDC cable.

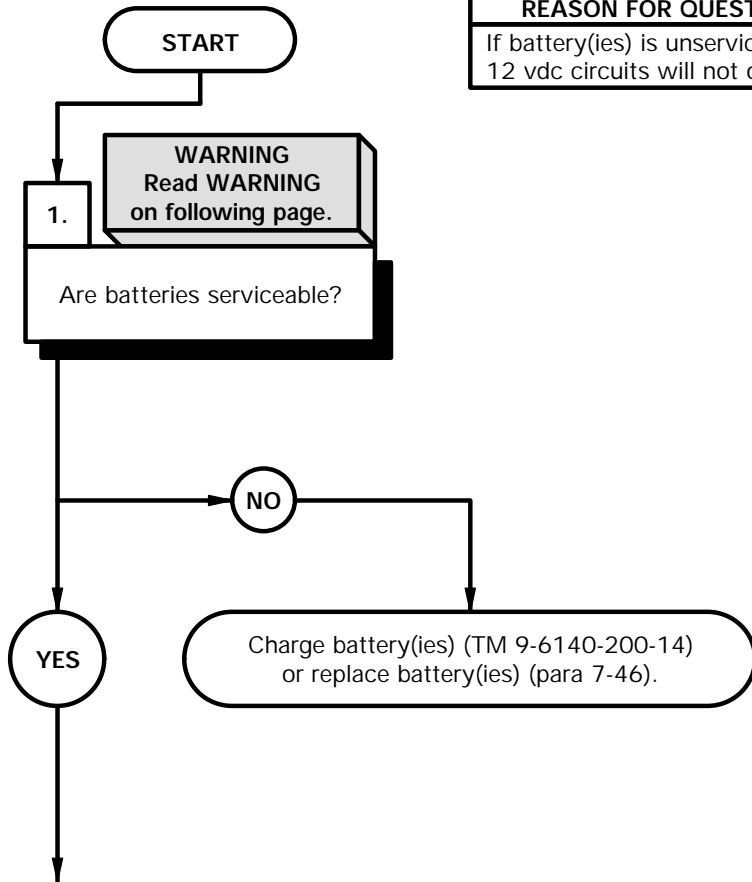

WARNING

Remove rings, bracelets, watches, necklaces, and any other jewelry before working around vehicle. Jewelry can catch on equipment and cause injury or short across electrical circuit and cause severe burns or electrical shock. Batteries can explode from a spark. Battery acid is harmful to skin and eyes. Always wear eye protection and rubber gloves when working with batteries.

BATTERY SPECIFIC GRAVITY TEST

- (1) Remove four batteries from battery box (para 7-46).
- (2) Test batteries for serviceability (TM 9-6140-200-14).
- (3) Charge battery(ies) if discharged but serviceable (TM 9-6140-200-14).
- (4) Replace battery(ies) if unserviceable (para 7-46).
- (5) Install four batteries in battery box (para 7-46).

e4. 24 VDC CIRCUITS DO NOT OPERATE (CONT)

KNOWN INFO
Service drive lights OK. Circuit breaker CB70 OK. Batteries OK.
POSSIBLE PROBLEMS
Faulty relay K2. Faulty master power switch. Faulty dashboard cable assembly. Faulty 100 AMP reverse polarity relay. Faulty 100 AMP reverse polarity relay to power distribution panel (PDP) 24 VDC cable. Faulty battery to 100 AMP reverse polarity relay 24 VDC cable. Faulty 200 AMP reverse polarity relay. Faulty 200 AMP terminal block. Faulty battery to 200 AMP terminal block 24 VDC cable assembly. Faulty 200 AMP terminal block to reverse polarity relay 24 VDC battery cable. Faulty 200 AMP terminal block to reverse polarity relay 24 VDC load cable. Faulty 200 AMP terminal block to power distribution panel (PDP) 24 VDC cable.

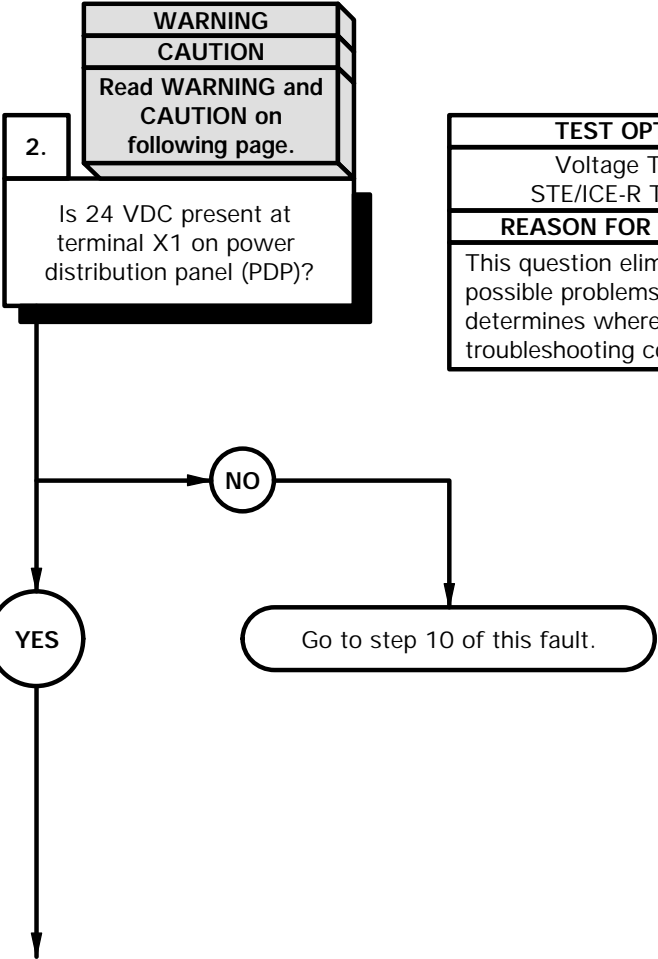

TEST OPTIONS
Voltage Test or STE/ICE-R Test #89
REASON FOR QUESTION
This question eliminates possible problems and determines where troubleshooting continues.

WARNING

Remove rings, bracelets, watches, necklaces, and any other jewelry before working around vehicle. Jewelry can catch on equipment and cause injury or short across electrical circuits and cause severe burns or electrical shock.

VOLTAGE TEST

- (1) Remove power distribution panel (PDP) cover (para 16-2).
- (2) Set multimeter to volts DC.

CAUTION

When testing to terminal X1 on PDP, ensure that multimeter probes come in contact with the outside metal ring. Failure to comply may result in false troubleshooting test results.

- (3) Connect positive (+) probe of multimeter to terminal X1 on power distribution panel (PDP).
- (4) Connect negative (-) probe of multimeter to ground and note reading on multimeter.
- (5) If 24 VDC is not present, go to step 10 of this fault.

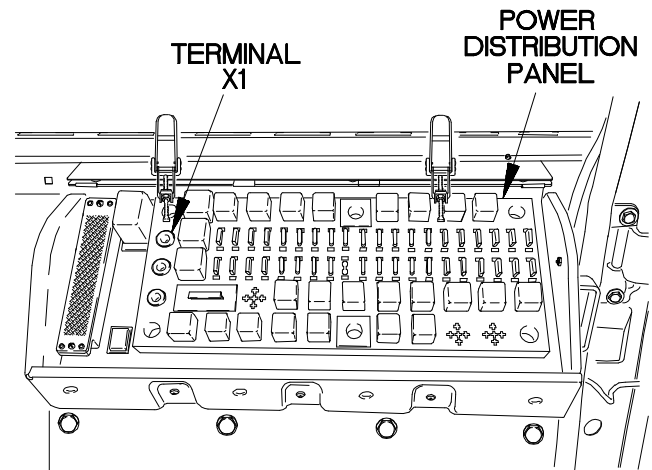

XBE0401B

e4. 24 VDC CIRCUITS DO NOT OPERATE (CONT)

KNOWN INFO
Service drive lights OK. Circuit breaker CB70 OK. Batteries OK. 100 AMP reverse polarity relay OK. 100 AMP reverse polarity relay to power distribution panel (PDP) 24 VDC cable OK. Battery to 100 AMP reverse polarity relay 24 VDC cable OK. 200 AMP reverse polarity relay OK. 200 AMP terminal block OK. Battery to 200 AMP terminal block 24 VDC cable assembly OK. 200 AMP terminal block to reverse polarity relay 24 VDC battery cable OK. 200 AMP terminal block to reverse polarity relay 24 VDC load cable OK. 200 AMP terminal block to power distribution panel (PDP) 24 VDC cable OK.
POSSIBLE PROBLEMS
Faulty relay K2. Faulty master power switch. Faulty dashboard cable assembly.

3.

WARNING
Read WARNING on following page.

Is 24 VDC present at circuit breaker CB39 socket 3 on PDP?

TEST OPTIONS
Voltage Test or STE/ICE-R Test #89
REASON FOR QUESTION
This question eliminates possible problems and determines where troubleshooting continues.

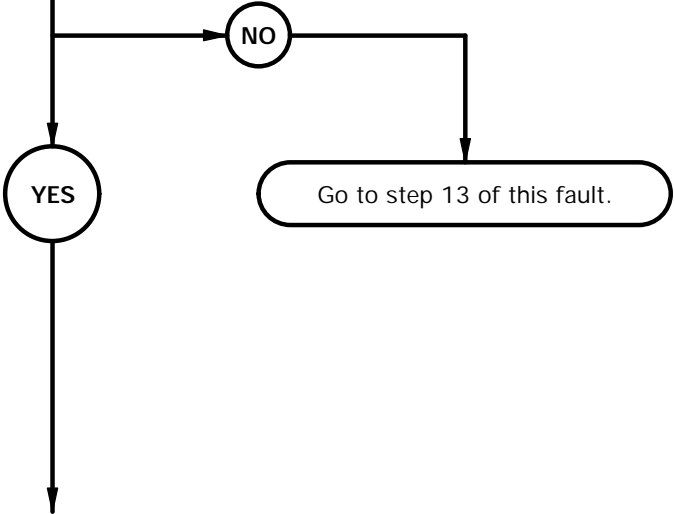

WARNING

Remove rings, bracelets, watches, necklaces, and any other jewelry before working around vehicle. Jewelry can catch on equipment and cause injury or short across electrical circuits and cause severe burns or electrical shock.

VOLTAGE TEST

- (1) Remove circuit breaker CB39 from PDP.
- (2) Set multimeter to volts DC.
- (3) Connect positive (+) probe of multimeter to circuit breaker CB39 socket 3 on PDP.
- (4) Connect negative (-) probe of multimeter to ground and note reading on multimeter.
- (5) If 24 VDC is not present, go to step 13 of this fault.
- (6) Install circuit breaker CB39 in PDP.

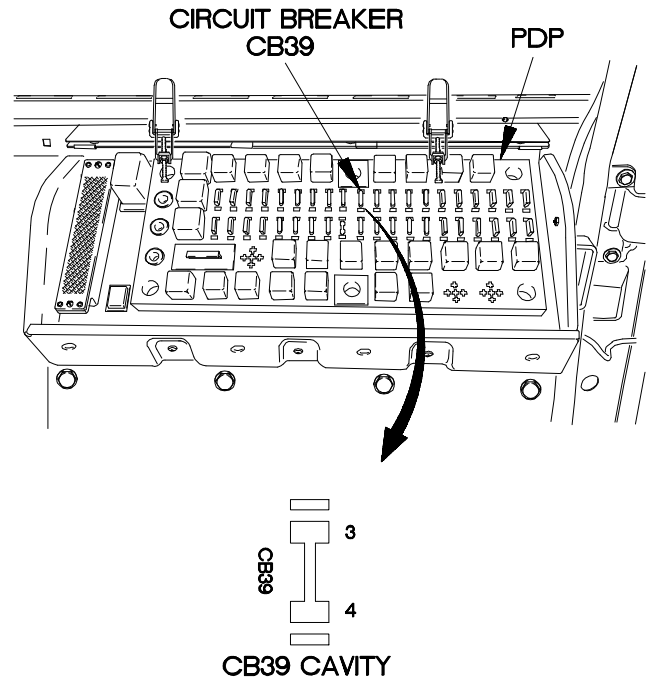

XBE0402B

e4. 24 VDC CIRCUITS DO NOT OPERATE (CONT)

KNOWN INFO
Service drive lights OK. Circuit breaker CB70 OK. Batteries OK. 100 AMP reverse polarity relay OK. 100 AMP reverse polarity relay to power distribution panel (PDP) 24 VDC cable OK. Battery to 100 AMP reverse polarity relay 24 VDC cable OK. 200 AMP reverse polarity relay OK. 200 AMP terminal block OK. Battery to 200 AMP terminal block 24 VDC cable assembly OK. 200 AMP terminal block to reverse polarity relay 24 VDC battery cable OK. 200 AMP terminal block to reverse polarity relay 24 VDC load cable OK. 200 AMP terminal block to power distribution panel (PDP) 24 VDC cable OK.
POSSIBLE PROBLEMS
Faulty relay K2. Faulty master power switch. Faulty dashboard cable assembly.

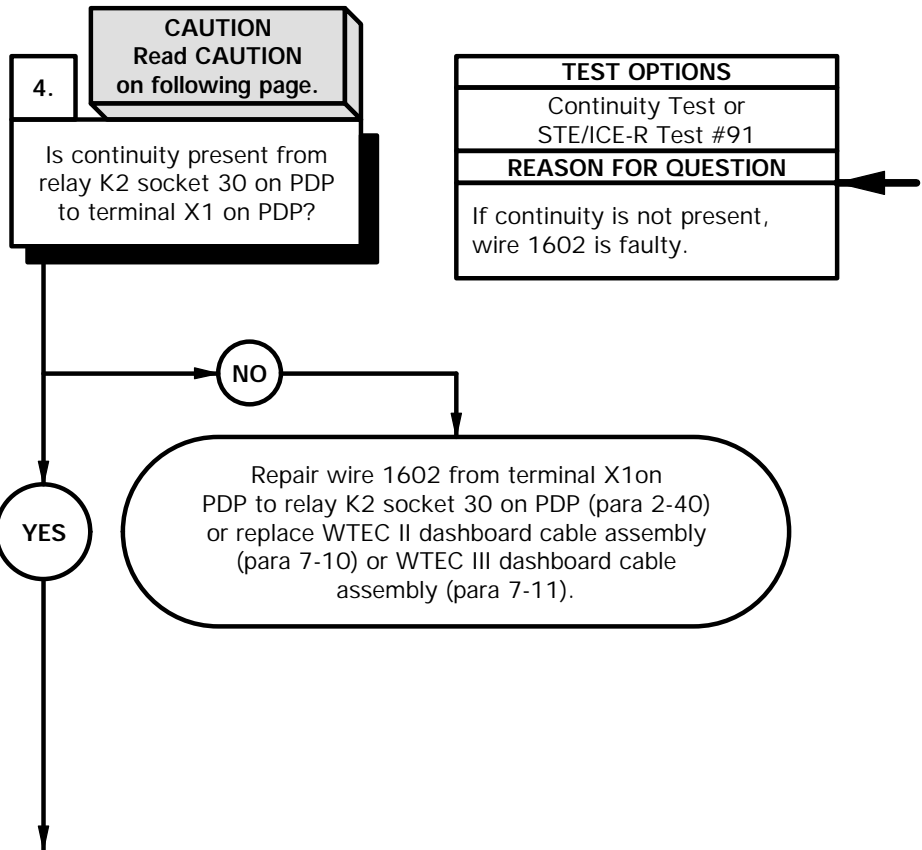

CONTINUITY TEST

- (1) Disconnect batteries (para 7-48)
- (2) Remove relay K2 from PDP.
- (3) Set multimeter to ohms.
- (4) Connect positive (+) probe of multimeter to relay K2 socket 30 on PDP.

CAUTION

When testing to terminal X1 on PDP, ensure that multimeter probes come in contact with the outside metal ring. Failure to comply may result in false troubleshooting test results.

- (5) Connect negative (-) probe of multimeter to terminal X1 on PDP and note reading on multimeter.
- (6) If continuity is not present, repair wire 1602 from terminal X1 on PDP to relay K2 socket 30 on PDP (para 2-40) or replace WTEC II dashboard cable assembly (para 7-10) or WTEC III dashboard cable assembly (para 7-11).

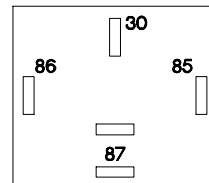
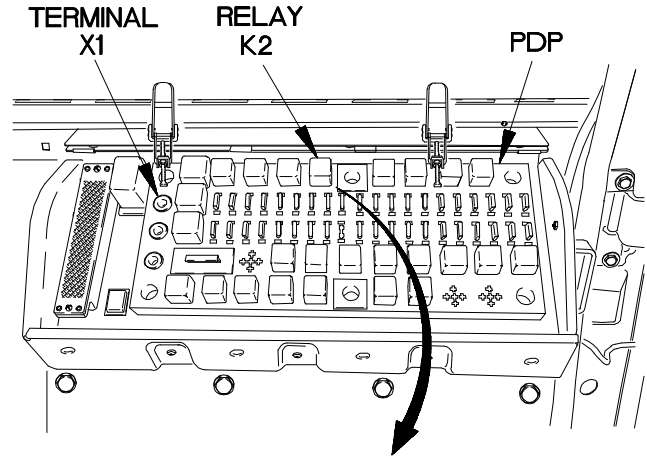

RELAY K2 CAVITY

XBE0403B

e4. 24 VDC CIRCUITS DO NOT OPERATE (CONT)

KNOWN INFO
Service drive lights OK. Circuit breaker CB70 OK. Batteries OK. 100 AMP reverse polarity relay OK. 100 AMP reverse polarity relay to power distribution panel (PDP) 24 VDC cable OK. Battery to 100 AMP reverse polarity relay 24 VDC cable OK. 200 AMP reverse polarity relay OK. 200 AMP terminal block OK. Battery to 200 AMP terminal block 24 VDC cable assembly OK. 200 AMP terminal block to reverse polarity relay 24 VDC battery cable OK. 200 AMP terminal block to reverse polarity relay 24 VDC load cable OK. 200 AMP terminal block to power distribution panel (PDP) 24 VDC cable OK.
POSSIBLE PROBLEMS
Faulty relay K2. Faulty master power switch. Faulty dashboard cable assembly.

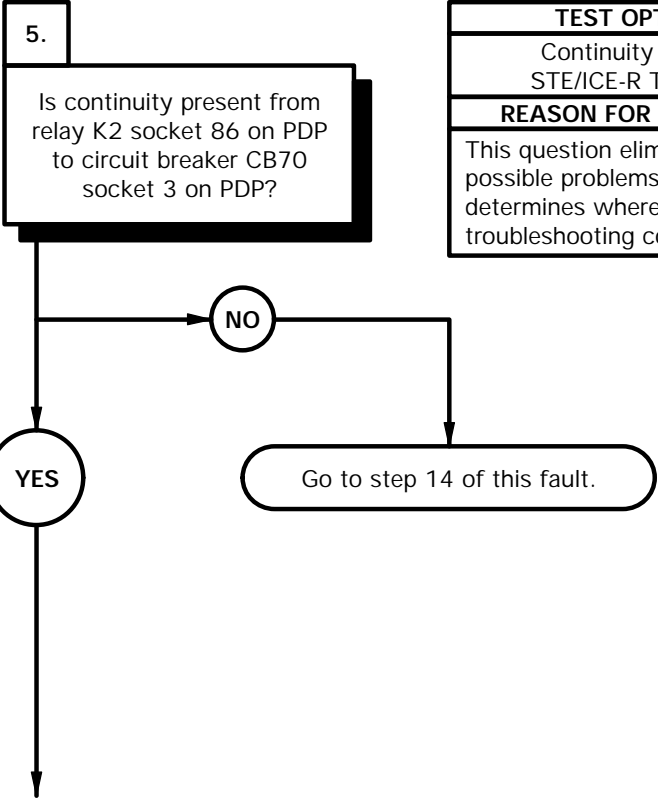

TEST OPTIONS
Continuity Test or STE/ICE-R Test #91
REASON FOR QUESTION
This question eliminates possible problems and determines where troubleshooting continues.



CONTINUITY TEST

- (1) Remove circuit breaker CB70 from PDP.
- (2) Position master power switch to on (TM 9-2320-365-10).
- (3) Set multimeter to ohms.
- (4) Connect positive (+) probe of multimeter to relay K2 socket 86 on PDP.
- (5) Connect negative (-) probe of multimeter to circuit breaker CB70 socket 4 on PDP and note reading on multimeter.
- (6) If continuity is not present, go to step 14 of this fault.
- (7) Position master power switch to off (TM 9-2320-365-10).
- (8) Install circuit breaker CB70 in PDP.

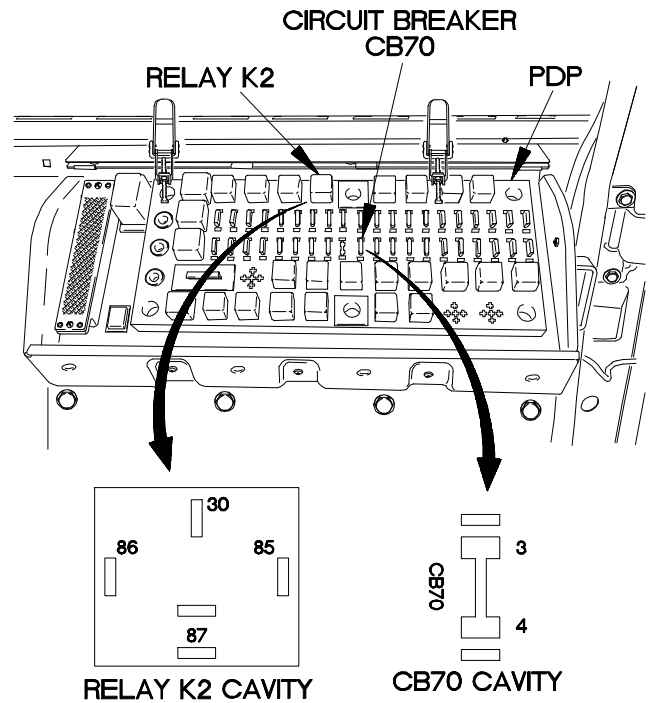

XBE0404B

e4. 24 VDC CIRCUITS DO NOT OPERATE (CONT)

KNOWN INFO
Service drive lights OK. Circuit breaker CB70 OK. Batteries OK. 100 AMP reverse polarity relay OK. 100 AMP reverse polarity relay to power distribution panel (PDP) 24 VDC cable OK. Battery to 100 AMP reverse polarity relay 24 VDC cable OK. 200 AMP reverse polarity relay OK. 200 AMP terminal block OK. Battery to 200 AMP terminal block 24 VDC cable assembly OK. 200 AMP terminal block to reverse polarity relay 24 VDC battery cable OK. 200 AMP terminal block to reverse polarity relay 24 VDC load cable OK. 200 AMP terminal block to power distribution panel (PDP) 24 VDC cable OK. Master power switch OK.
POSSIBLE PROBLEMS
Faulty relay K2. Faulty dashboard cable assembly.

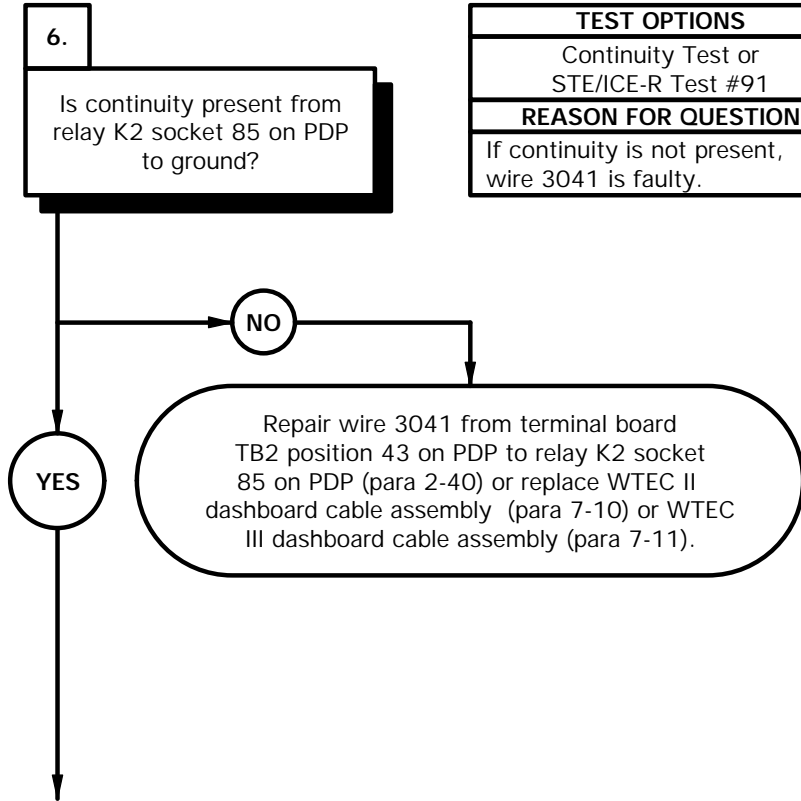

TEST OPTIONS
Continuity Test or STE/ICE-R Test #91
REASON FOR QUESTION
If continuity is not present, wire 3041 is faulty.

CONTINUITY TEST

- (1) Set multimeter to ohms.
- (2) Connect positive (+) probe of multimeter to relay K2 socket 85 on PDP.
- (3) Connect negative (-) probe of multimeter to ground and note reading on multimeter.
- (4) If continuity is not present, repair wire 3041 from terminal board TB2 position 43 on PDP to relay K2 socket 85 on PDP (para 2-40) or replace WTEC II dashboard cable assembly (para 7-10) or WTEC III dashboard cable assembly (para 7-11).

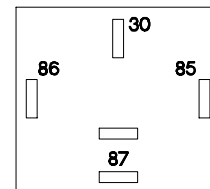
**RELAY K2 CAVITY**

XBE0405B

e4. 24 VDC CIRCUITS DO NOT OPERATE (CONT)

KNOWN INFO
Service drive lights OK. Circuit breaker CB70 OK. Batteries OK. 100 AMP reverse polarity relay OK. 100 AMP reverse polarity relay to power distribution panel (PDP) 24 VDC cable OK. Battery to 100 AMP reverse polarity relay 24 VDC cable OK. 200 AMP reverse polarity relay OK. 200 AMP terminal block OK. Battery to 200 AMP terminal block 24 VDC cable assembly OK. 200 AMP terminal block to reverse polarity relay 24 VDC battery cable OK. 200 AMP terminal block to reverse polarity relay 24 VDC load cable OK. 200 AMP terminal block to power distribution panel (PDP) 24 VDC cable OK. Master power switch OK.
POSSIBLE PROBLEMS
Faulty relay K2. Faulty dashboard cable assembly.

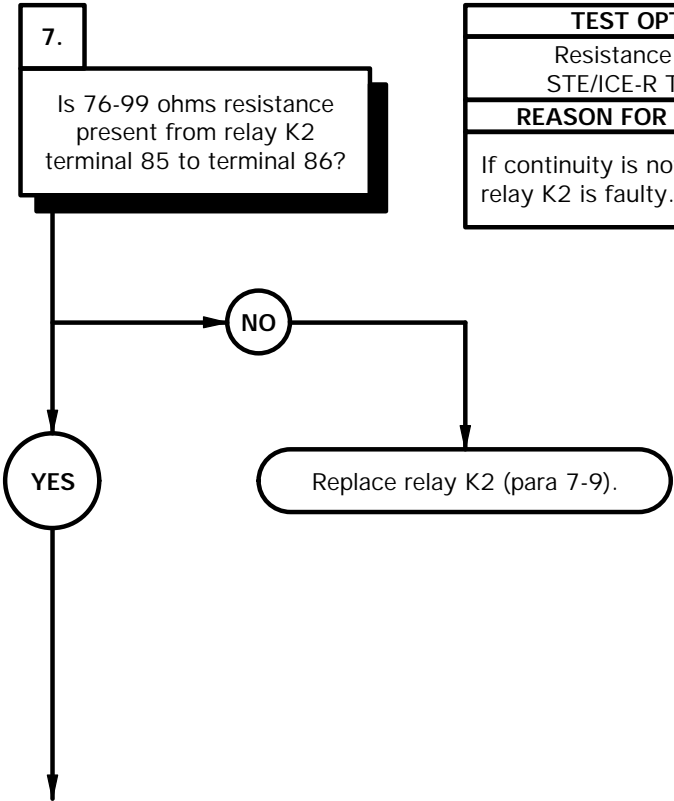

TEST OPTIONS
Resistance Test or STE/ICE-R Test #91
REASON FOR QUESTION
If continuity is not present, relay K2 is faulty.



RESISTANCE TEST

- (1) Set multimeter to ohms.
- (2) Connect positive (+) probe of multimeter to relay K2 terminal 85.
- (3) Connect negative (-) probe of multimeter to relay K2 terminal 86 and note reading on multimeter.
- (4) If 76-99 ohms resistance is not present, replace relay K2 (para 7-9).

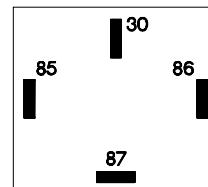
**RELAY K2**

XBE0406B

e4. 24 VDC CIRCUITS DO NOT OPERATE (CONT)

KNOWN INFO
Service drive lights OK. Circuit breaker CB70 OK. Batteries OK. 100 AMP reverse polarity relay OK. 100 AMP reverse polarity relay to power distribution panel (PDP) 24 VDC cable OK. Battery to 100 AMP reverse polarity relay 24 VDC cable OK. 200 AMP reverse polarity relay OK. 200 AMP terminal block OK. Battery to 200 AMP terminal block 24 VDC cable assembly OK. 200 AMP terminal block to reverse polarity relay 24 VDC battery cable OK. 200 AMP terminal block to reverse polarity relay 24 VDC load cable OK. 200 AMP terminal block to power distribution panel (PDP) 24 VDC cable OK. Master power switch OK.
POSSIBLE PROBLEMS
Faulty relay K2. Faulty dashboard cable assembly.

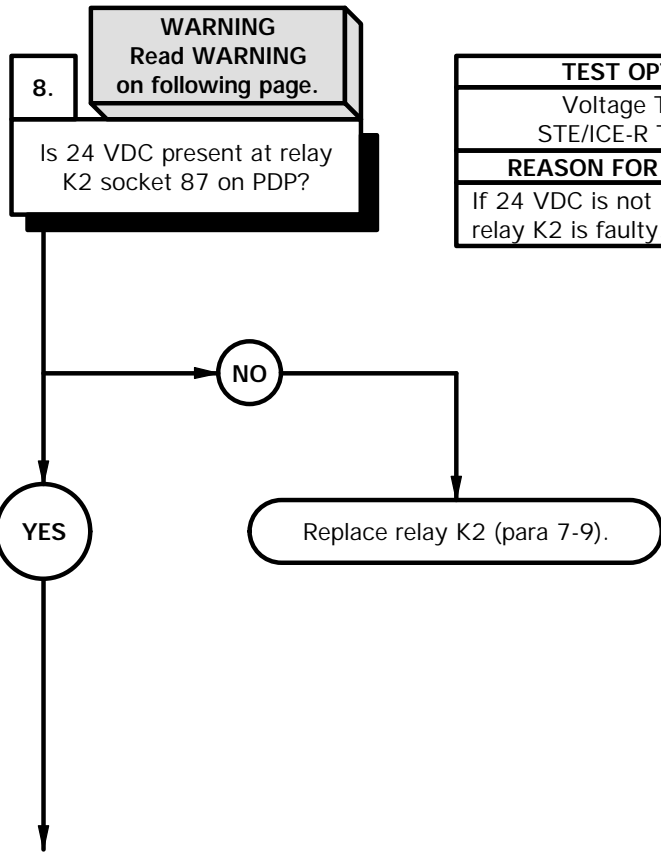

WARNING

Remove rings, bracelets, watches, necklaces, and any other jewelry before working around vehicle. Jewelry can catch on equipment and cause injury or short across electrical circuits and cause severe burns or electrical shock.

VOLTAGE TEST

- (1) Install relay test wire in relay K2 socket 87 on PDP.
- (2) Install relay K2 in PDP.
- (3) Connect batteries (para 7-48).
- (4) Position master power switch to on (TM 9-2320-365-10).
- (5) Set multimeter to volts DC.
- (6) Connect positive (+) probe of multimeter to relay test wire.
- (7) Connect negative (-) probe of multimeter to ground and note reading on multimeter.
- (8) If 24 VDC is not present, replace relay K2 (para 7-9).
- (9) Position master power switch to off (TM 9-2320-365-10).
- (10) Disconnect batteries (para 7-48).
- (11) Remove relay K2 from PDP.
- (12) Remove relay test wire from PDP relay K2 socket 87.

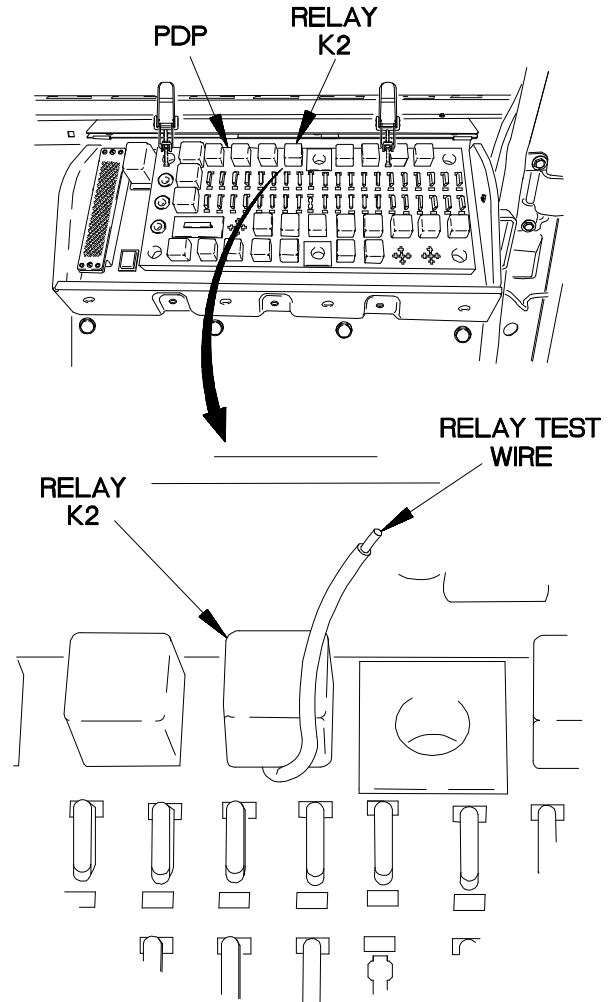

XBE0407B

e4. 24 VDC CIRCUITS DO NOT OPERATE (CONT)

KNOWN INFO
Service drive lights OK. Circuit breaker CB70 OK. Batteries OK. 100 AMP reverse polarity relay OK. 100 AMP reverse polarity relay to power distribution panel (PDP) 24 VDC cable OK. Battery to 100 AMP reverse polarity relay 24 VDC cable OK. 200 AMP reverse polarity relay OK. 200 AMP terminal block OK. Battery to 200 AMP terminal block 24 VDC cable assembly OK. 200 AMP terminal block to reverse polarity relay 24 VDC battery cable OK. 200 AMP terminal block to reverse polarity relay 24 VDC load cable OK. 200 AMP terminal block to power distribution panel (PDP) 24 VDC cable OK. Master power switch OK. Relay K2 OK.
POSSIBLE PROBLEMS
Faulty dashboard cable assembly.

9.
 Is continuity present from relay K2 socket 87 on PDP to circuit breaker CB36 socket 6 on PDP?

TEST OPTIONS
Continuity Test or STE/ICE-R Test #91
REASON FOR QUESTION
If continuity is not present, wire 1604 is faulty. If continuity is present, bus bar X6 is faulty.

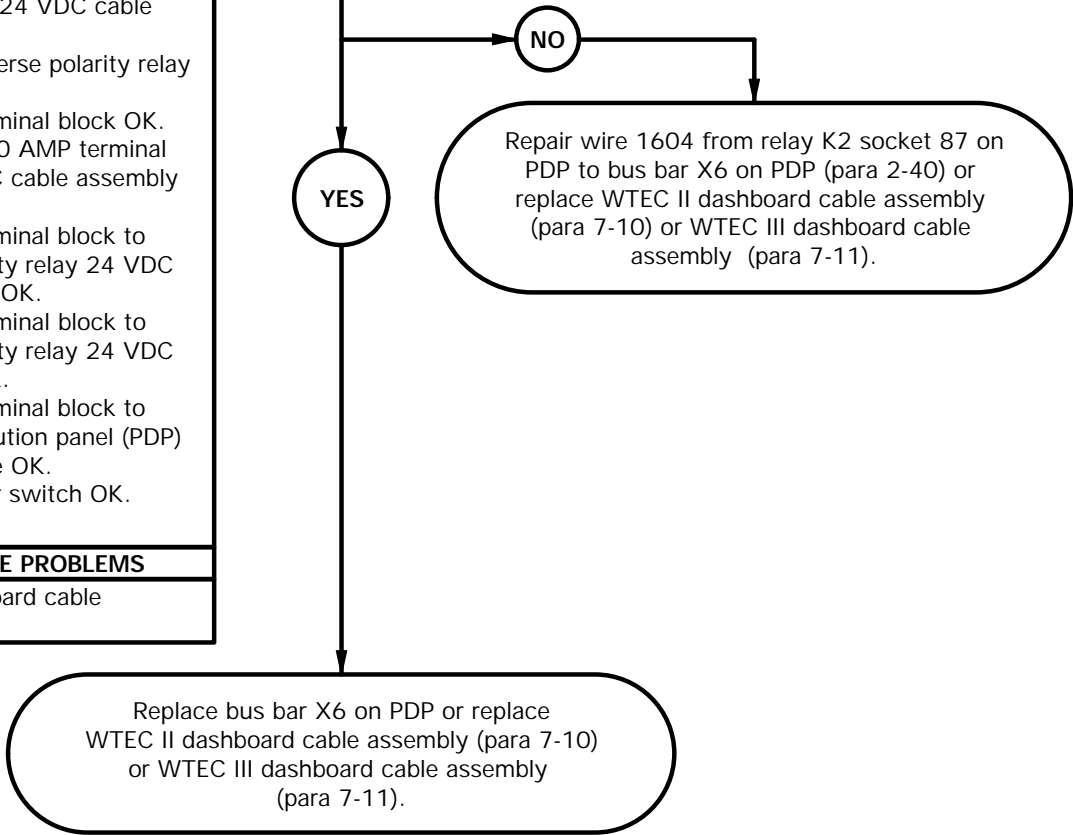

CONTINUITY TEST

- (1) Remove circuit breaker CB36 from PDP.
- (2) Set multimeter to ohms.
- (3) Connect positive (+) probe of multimeter to relay K2 socket 87 on PDP.
- (4) Connect negative (-) probe of multimeter to circuit breaker CB36 socket 6 on PDP and note reading on multimeter.
- (5) If continuity is not present, repair wire 1604 from relay K2 socket 87 on PDP to bus bar X6 on PDP (para 2-40) or replace WTEC II dashboard cable assembly (para 7-10) or WTEC III dashboard cable assembly (para 7-11).
- (6) If continuity is present, replace bus bar X6 on PDP or replace WTEC II dashboard cable assembly (para 7-10) or WTEC III dashboard cable assembly (para 7-11).
- (7) Install circuit breaker CB36 in PDP.
- (8) Install relay K2 in PDP.
- (9) Install power distribution panel (PDP) cover (para 16-2).
- (10) Connect batteries (para 7-48).

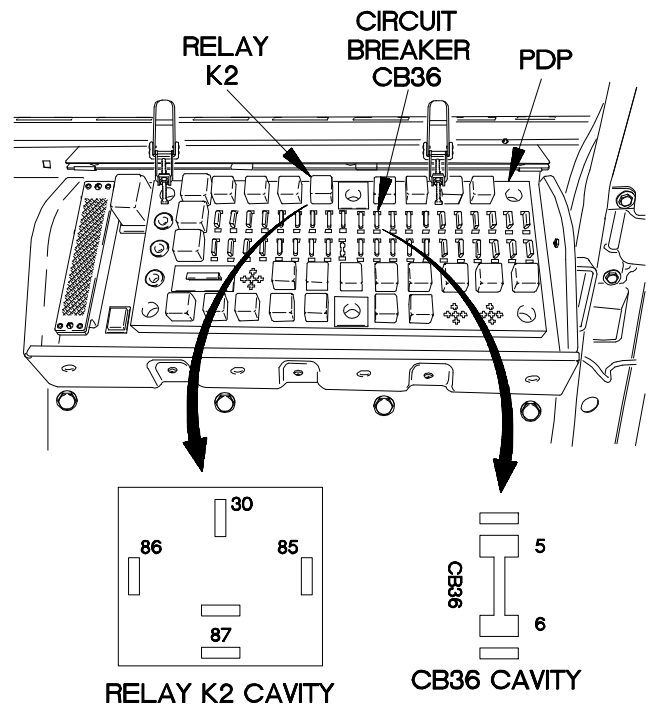

XBE0408B

e4. 24 VDC CIRCUITS DO NOT OPERATE (CONT)

KNOWN INFO
Service drive lights OK. Circuit breaker CB70 OK. Batteries OK.
POSSIBLE PROBLEMS
Faulty 100 AMP reverse polarity relay. Faulty 100 AMP reverse polarity relay to power distribution panel (PDP) 24 VDC cable. Faulty battery to 100 AMP reverse polarity relay 24 VDC cable. Faulty 200 AMP reverse polarity relay. Faulty 200 AMP terminal block. Faulty battery to 200 AMP terminal block 24 VDC cable assembly. Faulty 200 AMP terminal block to reverse polarity relay 24 VDC battery cable. Faulty 200 AMP terminal block to reverse polarity relay 24 VDC load cable. Faulty 200 AMP terminal block to power distribution panel (PDP) 24 VDC cable.

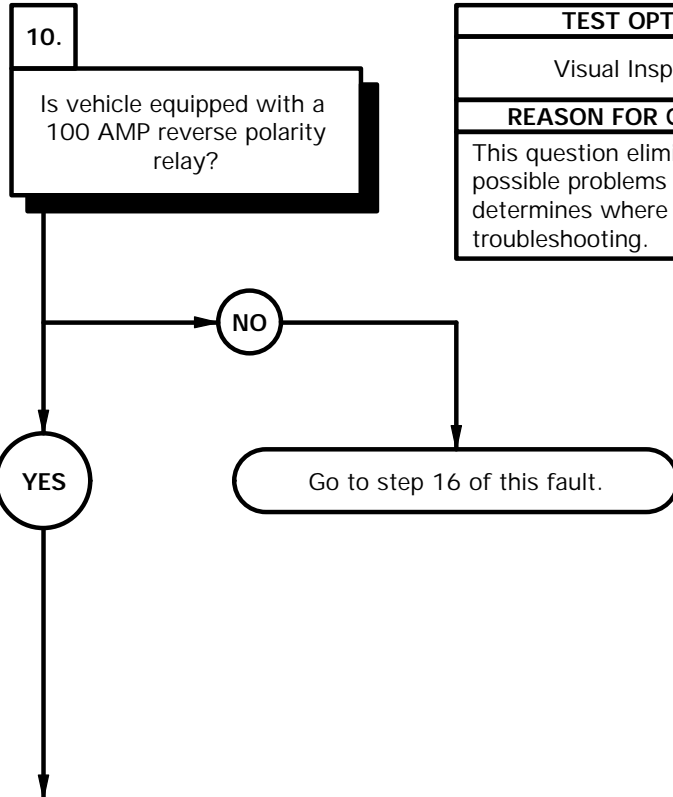

TEST OPTIONS
Visual Inspection
REASON FOR QUESTION
This question eliminates possible problems and determines where to continue troubleshooting.

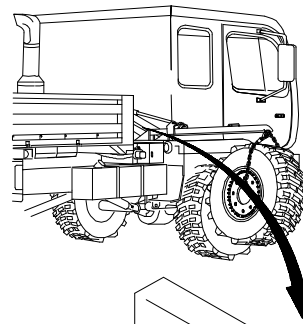

- (1) Lower spare tire (TM 9-2320-365-10).
- (2) Check if vehicle is equipped with 100 AMP reverse polarity relay.
- (3) If vehicle is not equipped with 100 AMP reverse polarity relay, go to step 16 of this fault.

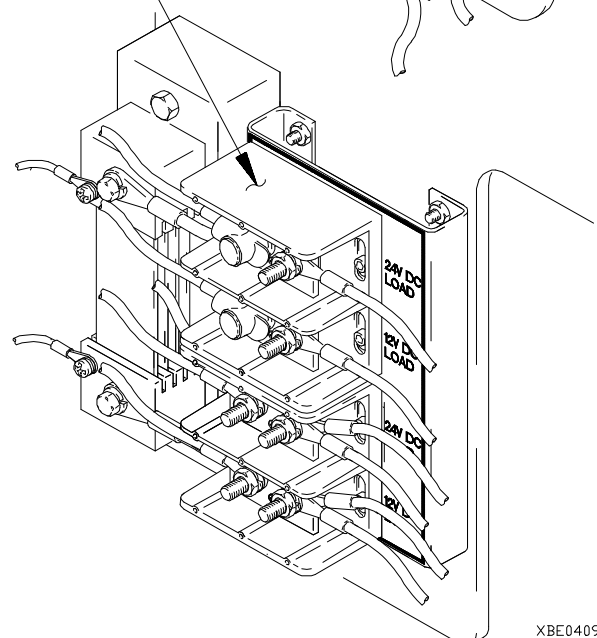
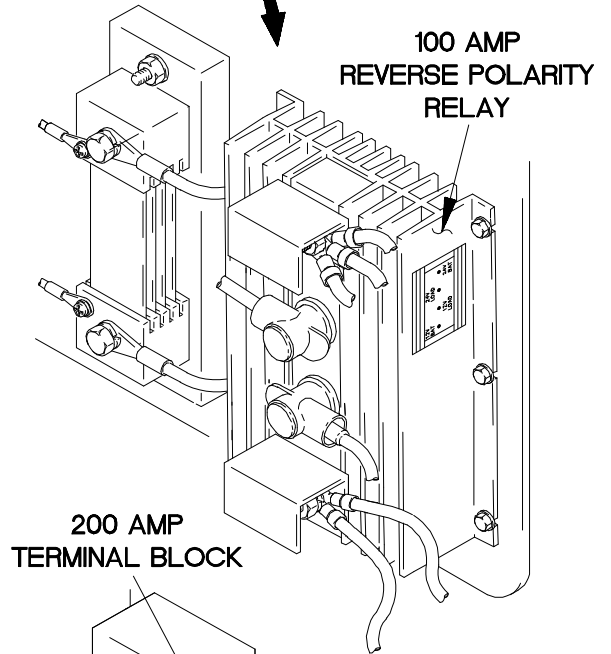

e4. 24 VDC CIRCUITS DO NOT OPERATE (CONT)

KNOWN INFO
Service drive lights OK. Circuit breaker CB70 OK. Batteries OK.
POSSIBLE PROBLEMS
Faulty 100 AMP reverse polarity relay. Faulty 100 AMP reverse polarity relay to power distribution panel (PDP) 24 VDC cable. Faulty battery to 100 AMP reverse polarity relay 24 VDC cable.

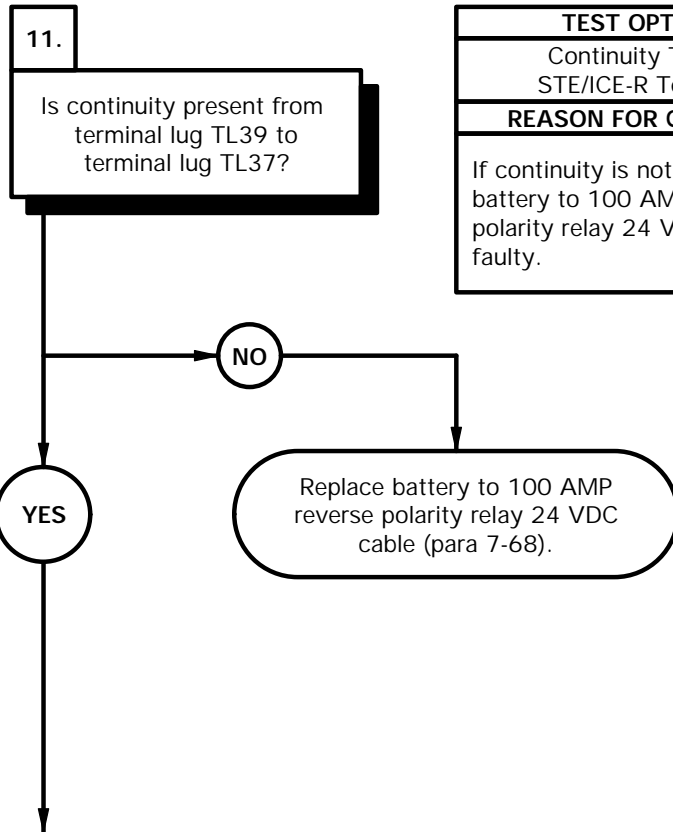

TEST OPTIONS
Continuity Test or STE/ICE-R Test #91
REASON FOR QUESTION
If continuity is not present, battery to 100 AMP reverse polarity relay 24 VDC cable is faulty.

CONTINUITY TEST

- (1) Disconnect batteries (para 7-48)
- (2) Remove nut, terminal lug TL10, and terminal lug TL39 from battery 24 VDC cable.
- (3) Loosen clamp on air hose.
- (4) Remove air hose from intake air cleaner boot.

NOTE

Tag all terminal lug and connection points prior to disconnecting.

- (5) Lift terminal cover on 24V BAT terminal stud on 100 AMP reverse polarity relay.
- (6) Remove nut, lockwasher, and terminal lugs TL1, TL37, and TL36 from 24V BAT terminal stud on 100 AMP reverse polarity relay. Discard lockwasher.
- (7) Set multimeter to ohms.
- (8) Connect positive (+) probe of multimeter to terminal lug TL37.
- (9) Connect negative (-) probe of multimeter to terminal lug TL39 and note reading on multimeter.
- (10) If continuity is not present, replace battery to 100 AMP reverse polarity relay 24 VDC cable (para 7-68).
- (11) Lift terminal cover on 24V BAT terminal stud on 100 AMP reverse polarity relay.
- (12) Position terminal lugs TL36, TL37, and TL1 on 24V BAT terminal stud on 100 AMP reverse polarity relay with lockwasher and nut.
- (13) Tighten nut to 120-144 lb-in. (14-16 N.m).
- (14) Install terminal lug TL39 and terminal lug TL10 on battery 24 VDC cable with nut.

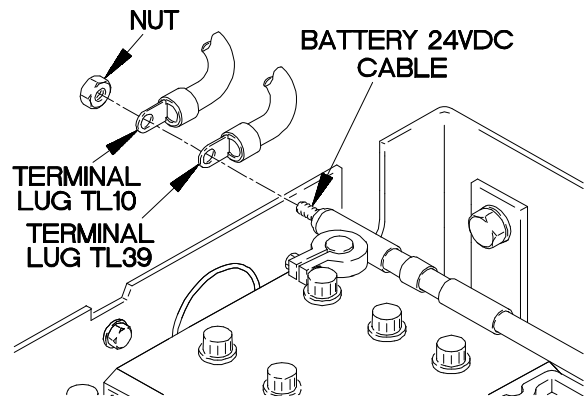
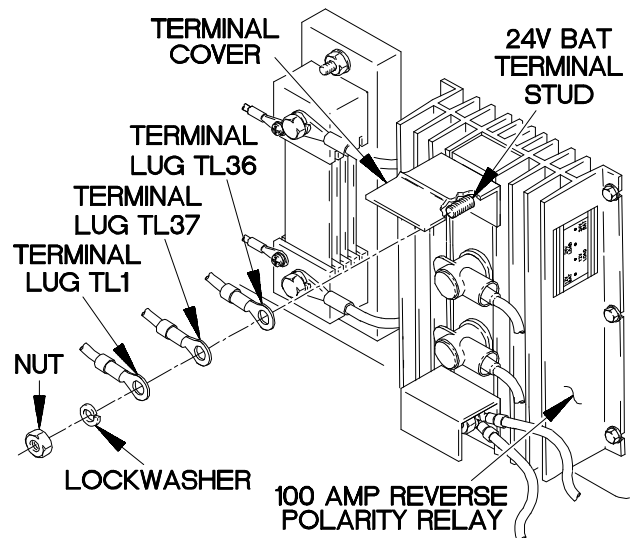
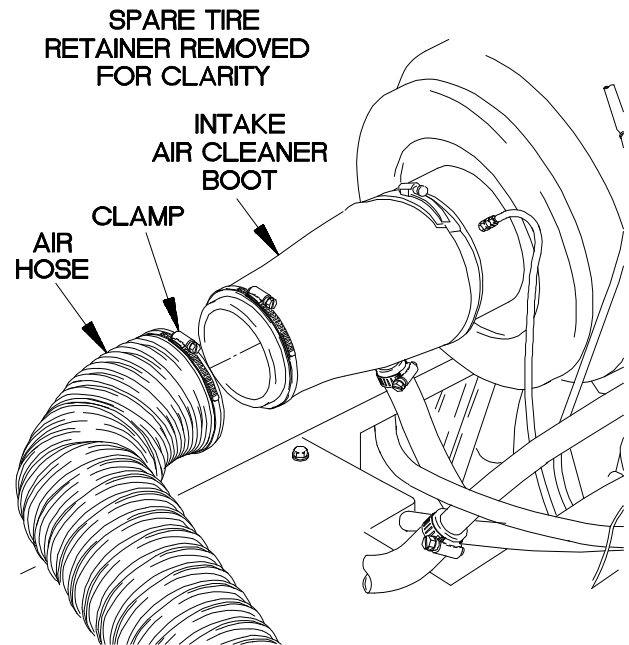

XBE0410B

e4. 24 VDC CIRCUITS DO NOT OPERATE (CONT)

KNOWN INFO
Service drive lights OK. Circuit breaker CB70 OK. Batteries OK. Battery to 100 AMP reverse polarity relay 24 VDC cable OK.
POSSIBLE PROBLEMS
Faulty 100 AMP reverse polarity relay. Faulty 100 AMP reverse polarity relay to power distribution panel (PDP) 24 VDC cable.

CAUTION
Read CAUTION on following page.

12.
Is continuity present from terminal lug TL44 to terminal X1 on PDP?

TEST OPTIONS
Continuity Test or STE/ICE-R Test #91
REASON FOR QUESTION
If continuity is not present, 100 AMP reverse polarity relay to PDP 24 VDC cable is faulty. If continuity is present, 100 AMP reverse polarity relay is faulty.

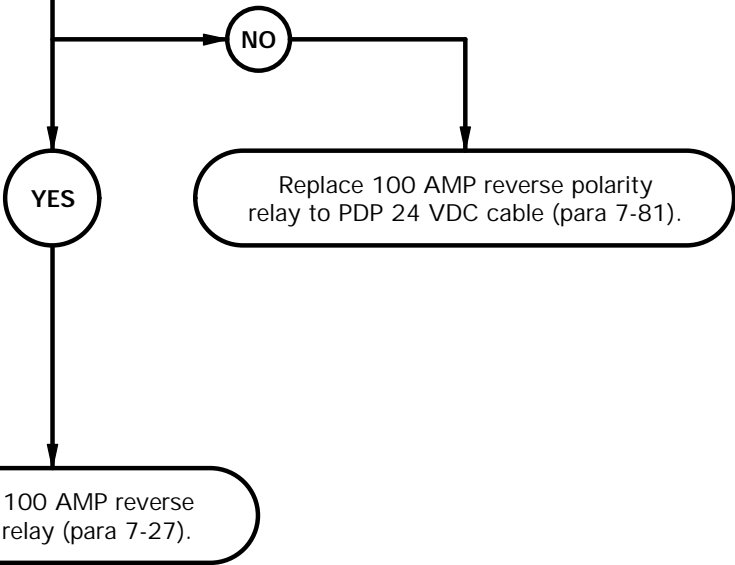

CONTINUITY TEST

- (1) Lift dust boot on 24V LOAD terminal stud on 100 AMP reverse polarity relay.
- (2) Remove nut, lockwasher, and terminal lug TL44 from 24V LOAD terminal stud on 100 AMP reverse polarity relay. Discard lockwasher.
- (3) Set multimeter to ohms.
- (4) Connect positive (+) probe of multimeter to terminal lug TL44.

CAUTION

When testing to terminal X1 on PDP, ensure that multimeter probes come in contact with the outside metal ring. Failure to comply may result in false troubleshooting test results.

- (5) Connect negative (-) probe of multimeter to terminal X1 on PDP and note reading on multimeter.
- (6) If continuity is not present, replace 100 AMP reverse polarity relay to PDP 24 VDC cable (para 7-81).
- (7) If continuity is present, replace 100 AMP reverse polarity relay (para 7-27).
- (8) Install PDP cover (para 16-2).
- (9) Position terminal lug TL44 on 24V LOAD terminal stud on 100 AMP reverse polarity relay with lockwasher and nut.
- (10) Tighten nut to 120-144 lb-in. (14-16 N.m).
- (11) Position dust boot on 24V LOAD terminal stud on 100 AMP reverse polarity relay.
- (12) Position air hose on intake air cleaner boot with clamp.
- (13) Tighten clamp to 36-48 lb-in. (4-5 N.m).
- (14) Connect batteries (para 7-48)
- (15) Raise spare tire (TM 9-2320-365-10).

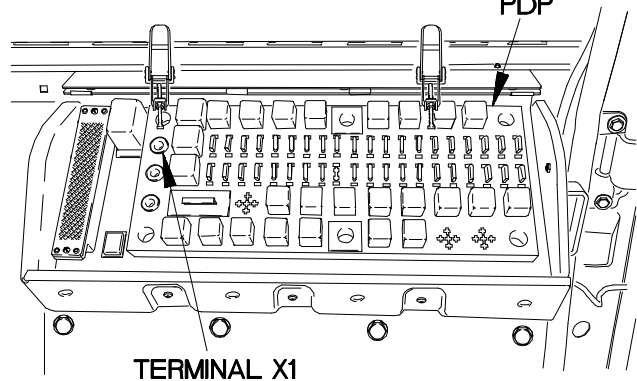
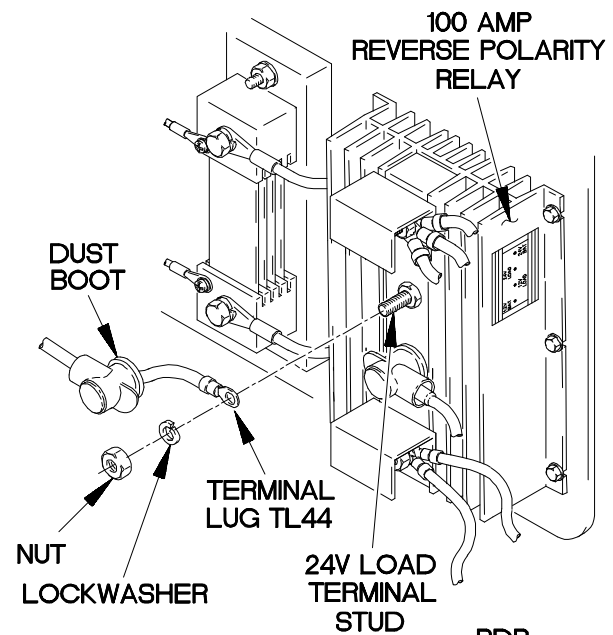
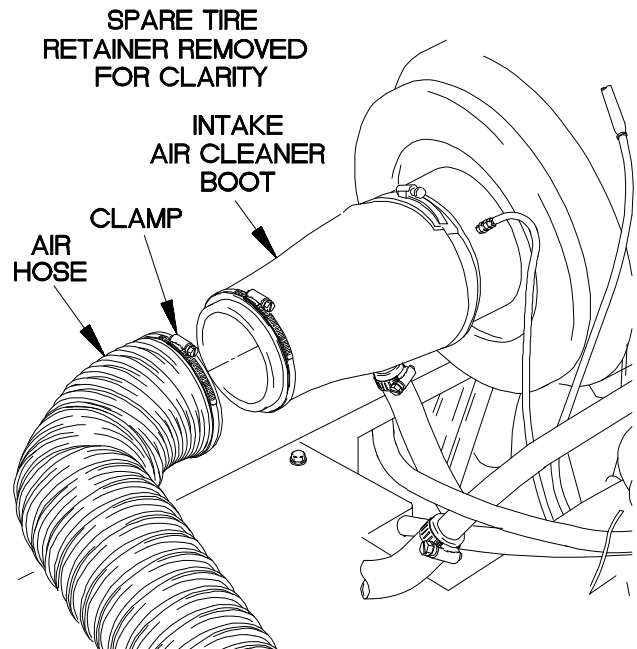

XBE0411B

e4. 24 VDC CIRCUITS DO NOT OPERATE (CONT)

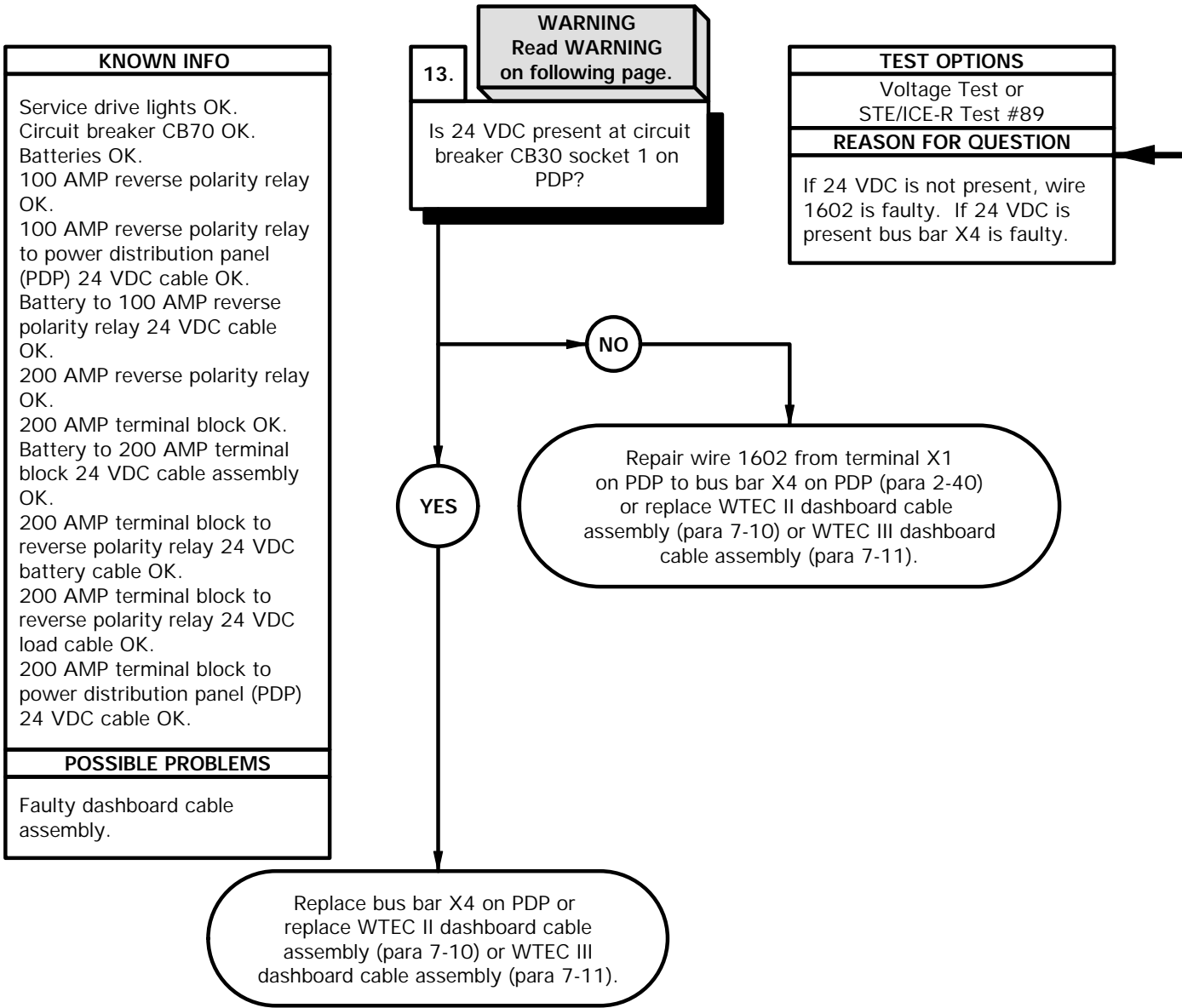

WARNING

Remove rings, bracelets, watches, necklaces, and any other jewelry before working around vehicle. Jewelry can catch on equipment and cause injury or short across electrical circuits and cause severe burns or electrical shock.

VOLTAGE TEST

- (1) Remove circuit breaker CB30 from PDP.
- (2) Set multimeter to volts DC.
- (3) Connect positive (+) probe of multimeter to circuit breaker CB30 socket 1 on PDP.
- (4) Connect negative (-) probe of multimeter to ground and note reading on multimeter.
- (5) If 24 VDC is not present, Repair wire 1602 from terminal X1 on PDP to bus bar X4 on PDP (para 2-40) or replace WTEC II dashboard cable assembly (para 7-10) or WTEC III dashboard cable assembly (para 7-11).
- (6) If 24 VDC is present, replace bus bar X4 on PDP or replace WTEC II dashboard cable assembly (para 7-10) or WTEC III dashboard cable assembly (para 7-11).
- (7) Install circuit breaker CB30 in PDP.
- (8) Install PDP cover (para 16-2).

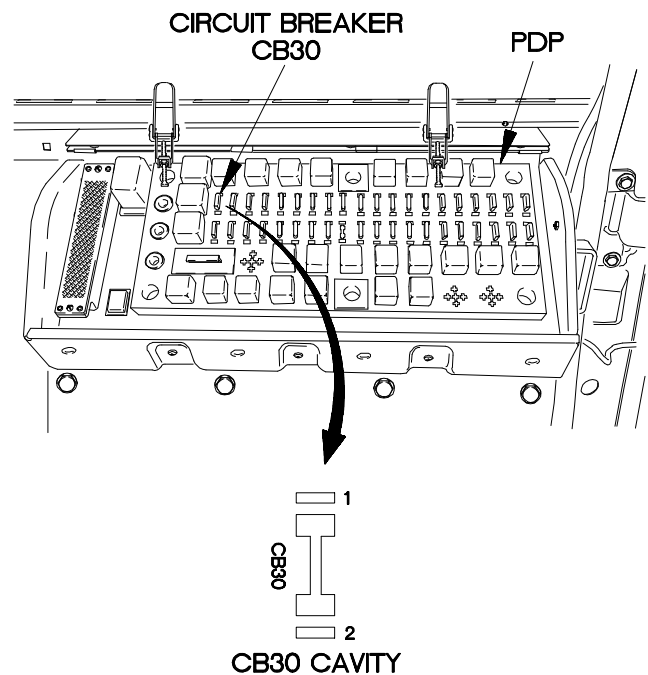

XBE0412B

e4. 24 VDC CIRCUITS DO NOT OPERATE (CONT)

KNOWN INFO
Service drive lights OK. Circuit breaker CB70 OK. Batteries OK. 100 AMP reverse polarity relay OK. 100 AMP reverse polarity relay to power distribution panel (PDP) 24 VDC cable OK. Battery to 100 AMP reverse polarity relay 24 VDC cable OK. 200 AMP reverse polarity relay OK. 200 AMP terminal block OK. Battery to 200 AMP terminal block 24 VDC cable assembly OK. 200 AMP terminal block to reverse polarity relay 24 VDC battery cable OK. 200 AMP terminal block to reverse polarity relay 24 VDC load cable OK. 200 AMP terminal block to power distribution panel (PDP) 24 VDC cable.
POSSIBLE PROBLEMS
Faulty master power switch. Faulty dashboard cable assembly.

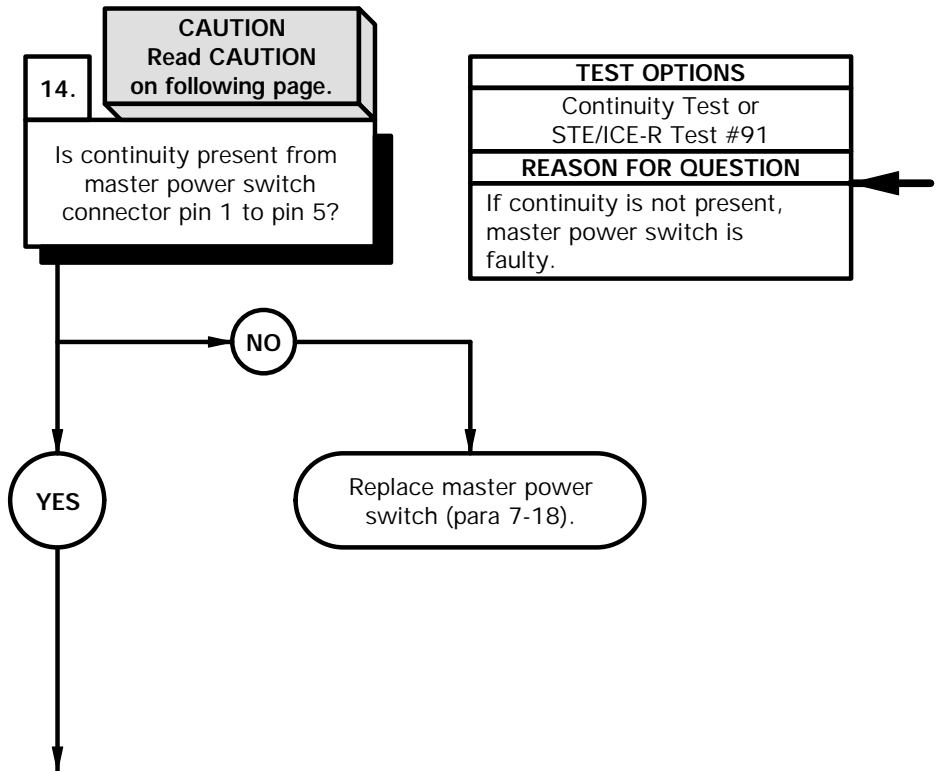

CAUTION

Use care when testing electrical connectors. Do not damage connector pins or sockets with multimeter probes. Failure to comply may result in damage to equipment.

NOTE

Inspect connector pins/sockets for damage, corrosion, and serviceability. Check that connector pins are not pushed back and are capable of making good contact.

CONTINUITY TEST

- (1) Remove instrument panel for access (para 7-15).
- (2) Disconnect connector PX17 from master power switch connector.
- (3) Position master power switch to on.
- (4) Set multimeter to ohms.
- (5) Connect positive (+) probe of multimeter to master power switch connector pin 1.
- (6) Connect negative (-) probe of multimeter to master power switch connector pin 5 and note reading on multimeter.
- (7) If continuity is not present, replace master power switch (para 7-18).
- (8) Position master power switch to off.

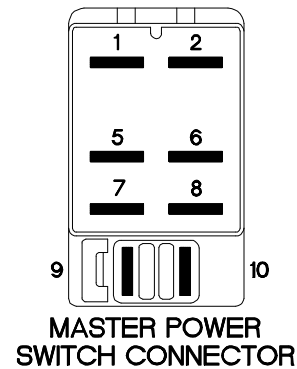
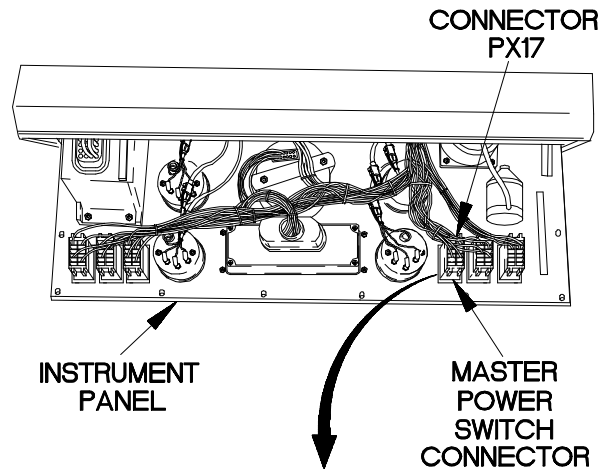

XBE0413B

e4. 24 VDC CIRCUITS DO NOT OPERATE (CONT)

KNOWN INFO
Service drive lights OK. Circuit breaker CB70 OK. Batteries OK. 100 AMP reverse polarity relay OK. 100 AMP reverse polarity relay to power distribution panel (PDP) 24 VDC cable OK. Battery to 100 AMP reverse polarity relay 24 VDC cable OK. 200 AMP reverse polarity relay OK. 200 AMP terminal block OK. Battery to 200 AMP terminal block 24 VDC cable assembly OK. 200 AMP terminal block to reverse polarity relay 24 VDC battery cable OK. 200 AMP terminal block to reverse polarity relay 24 VDC load cable OK. 200 AMP terminal block to power distribution panel (PDP) 24 VDC cable OK. Master power switch OK.
POSSIBLE PROBLEMS
Faulty dashboard cable assembly.

CAUTION
Read CAUTION on following page.

15.
Is continuity present from relay K2 socket 86 on PDP to connector PX17 socket 1?

TEST OPTIONS
Continuity Test or STE/ICE-R Test #91
REASON FOR QUESTION
If continuity is not present, wire 1548 is faulty. If continuity is present wire 1586 is faulty.

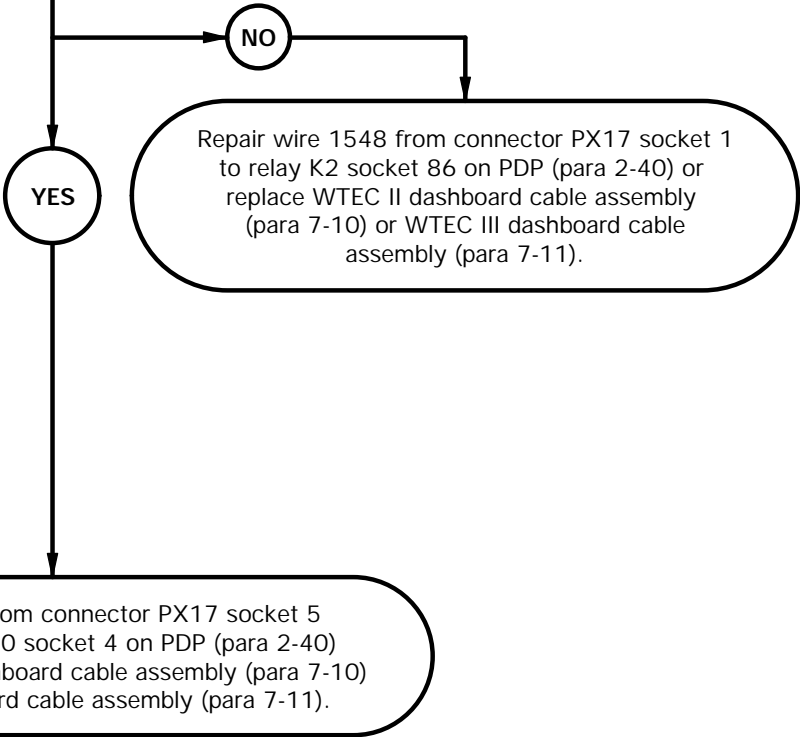

CAUTION

Use care when testing electrical connectors. Do not damage connector pins or sockets with multimeter probes. Failure to comply may result in damage to equipment.

NOTE

Inspect connector pins/sockets for damage, corrosion, and serviceability. Check that connector pins are not pushed back and are capable of making good contact.

CONTINUITY TEST

- (1) Set multimeter to ohms.
- (2) Connect positive (+) probe of multimeter to connector PX17 socket 1.
- (3) Connect negative (-) probe of multimeter to relay K2 socket 86 on PDP and note reading on multimeter.
- (4) If continuity is not present, repair wire 1548 from connector PX17 socket 1 to relay K2 socket 86 on PDP (para 2-40) or replace WTEC II dashboard cable assembly (para 7-10) or WTEC III dashboard cable assembly (para 7-11).
- (5) If continuity is present, repair wire 1586 from connector PX17 socket 5 to circuit breaker CB70 socket 4 on PDP (para 2-40) or replace WTEC II dashboard cable assembly (para 7-10) or WTEC III dashboard cable assembly (para 7-11).
- (6) Connect connector PX17 to master power switch connector.
- (7) Install instrument panel (para 7-15).
- (8) Install relay K2 in PDP.
- (9) Install PDP cover (para 16-2).
- (10) Connect batteries (para 7-48).

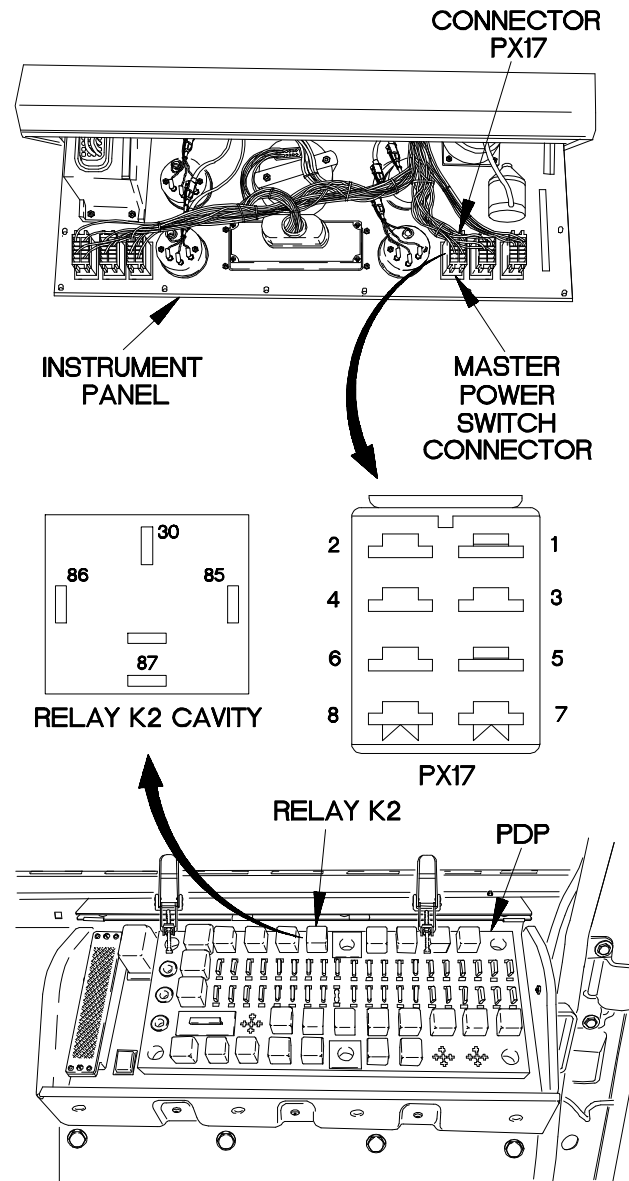

XBE0414B

e4. 24 VDC CIRCUITS DO NOT OPERATE (CONT)

KNOWN INFO
Service drive lights OK. Circuit breaker CB70 OK. Batteries OK.
POSSIBLE PROBLEMS
Faulty 200 AMP reverse polarity relay. Faulty 200 AMP terminal block. Faulty battery to 200 AMP terminal block 24 VDC cable assembly. Faulty 200 AMP terminal block to reverse polarity relay 24 VDC battery cable. Faulty 200 AMP terminal block to reverse polarity relay 24 VDC load cable. Faulty 200 AMP terminal block to power distribution panel (PDP) 24 VDC cable.

16.
Is continuity present from 200 AMP terminal block 24V BATT left terminal stud to right terminal stud?

TEST OPTIONS
Continuity Test or STE/ICE-R Test #91
REASON FOR QUESTION
If continuity is not present, 200 AMP terminal block is faulty.

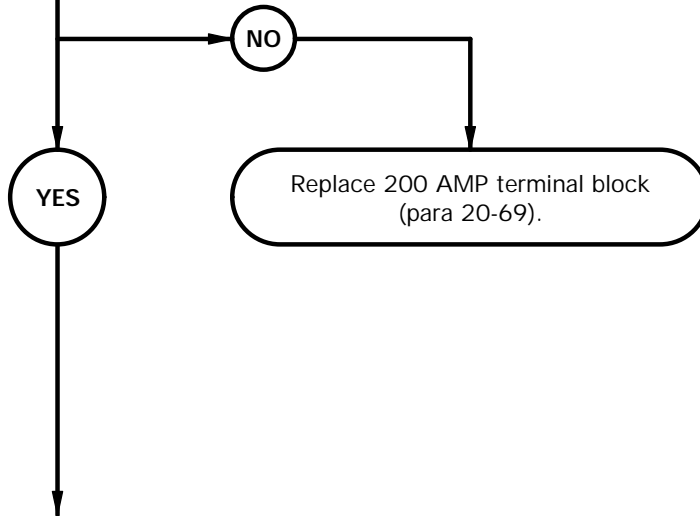

CONTINUITY TEST

NOTE

Tag terminal lugs and connection points prior to disconnecting.

- (1) Disconnect batteries (para 7-48).
- (2) Remove nut, lockwasher, washer, and terminal lugs TL37 and TL36 from left 24V BAT terminal stud on 200 AMP terminal block. Discard lockwasher.
- (3) Remove nut, lockwasher, washer, and terminal lugs TL1 and TL166 from right 24V BAT terminal stud on 200 AMP terminal block. Discard lockwasher.
- (4) Set multimeter to ohms.
- (5) Connect positive (+) probe of multimeter to left 24V BAT terminal stud on 200 AMP terminal block.
- (6) Connect negative (-) probe of multimeter to right 24V BAT terminal stud on 200 AMP terminal block and note reading on multimeter.
- (7) If continuity is not present, replace 200 AMP terminal block (para 20-69).

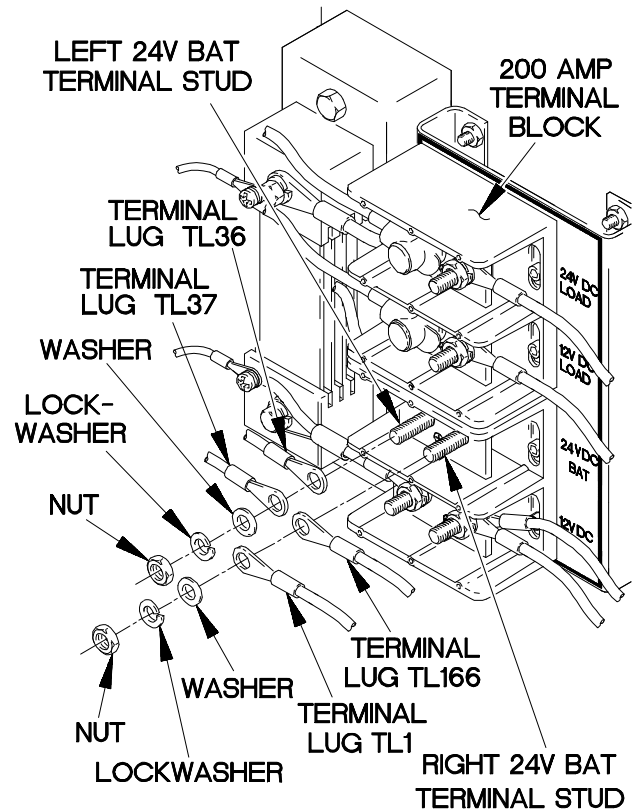

XBE0415B

e4. 24 VDC CIRCUITS DO NOT OPERATE (CONT)

KNOWN INFO
Service drive lights OK. Circuit breaker CB70 OK. Batteries OK.
POSSIBLE PROBLEMS
Faulty 200 AMP reverse polarity relay. Faulty 200 AMP terminal block. Faulty battery to 200 AMP terminal block 24 VDC cable assembly. Faulty 200 AMP terminal block to reverse polarity relay 24 VDC battery cable. Faulty 200 AMP terminal block to reverse polarity relay 24 VDC load cable. Faulty 200 AMP terminal block to power distribution panel (PDP) 24 VDC cable.

17.
Is continuity present from 200 AMP terminal block 24V LOAD left terminal stud to right terminal stud?

TEST OPTIONS
Continuity Test or STE/ICE-R Test #91
REASON FOR QUESTION
If continuity is not present, 200 AMP terminal block is faulty.

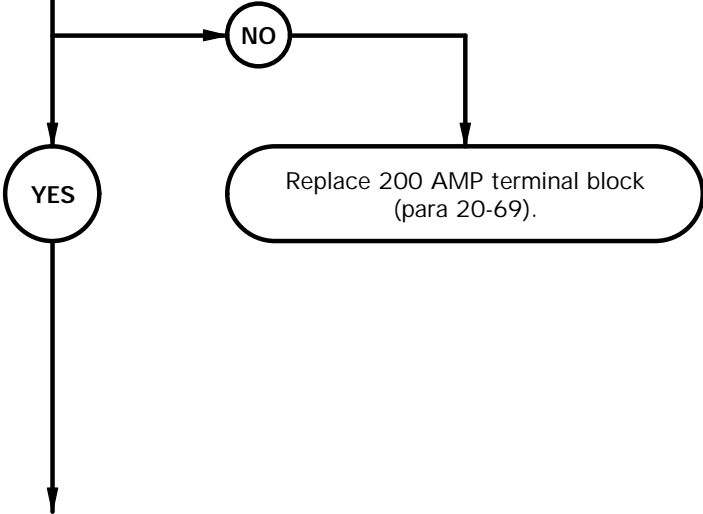

CONTINUITY TEST

- (1) Lift dust boot from left 24V LOAD terminal stud on 200 AMP terminal block.
- (2) Remove nut, lockwasher, washer, and terminal lug TL44 from left 24V LOAD terminal stud on 200 AMP terminal block. Discard lockwasher.
- (3) Remove nut, lockwasher, washer, and terminal lug TL167 from right 24V LOAD terminal stud on 200 AMP terminal block. Discard lockwasher.
- (4) Set multimeter to ohms.
- (5) Connect positive (+) probe of multimeter to left 24V LOAD terminal stud on 200 AMP terminal block.
- (6) Connect negative (-) probe of multimeter to right 24V LOAD terminal stud on 200 AMP terminal block and note reading on multimeter.
- (7) If continuity is not present, replace 200 AMP terminal block (para 20-69).

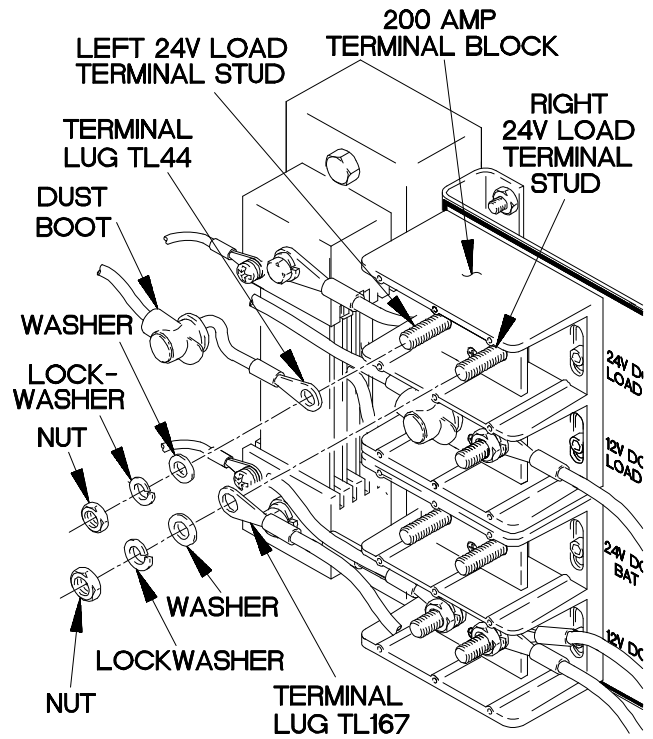

XBE0416B

e4. 24 VDC CIRCUITS DO NOT OPERATE (CONT)

KNOWN INFO
Service drive lights OK. Circuit breaker CB70 OK. Batteries OK. 200 AMP terminal block OK.
POSSIBLE PROBLEMS
Faulty 200 AMP reverse polarity relay OK. Faulty battery to 200 AMP terminal block 24 VDC cable assembly. Faulty 200 AMP terminal block to reverse polarity relay 24 VDC battery cable. Faulty 200 AMP terminal block to reverse polarity relay 24 VDC load cable. Faulty 200 AMP terminal block to power distribution panel (PDP) 24 VDC cable.

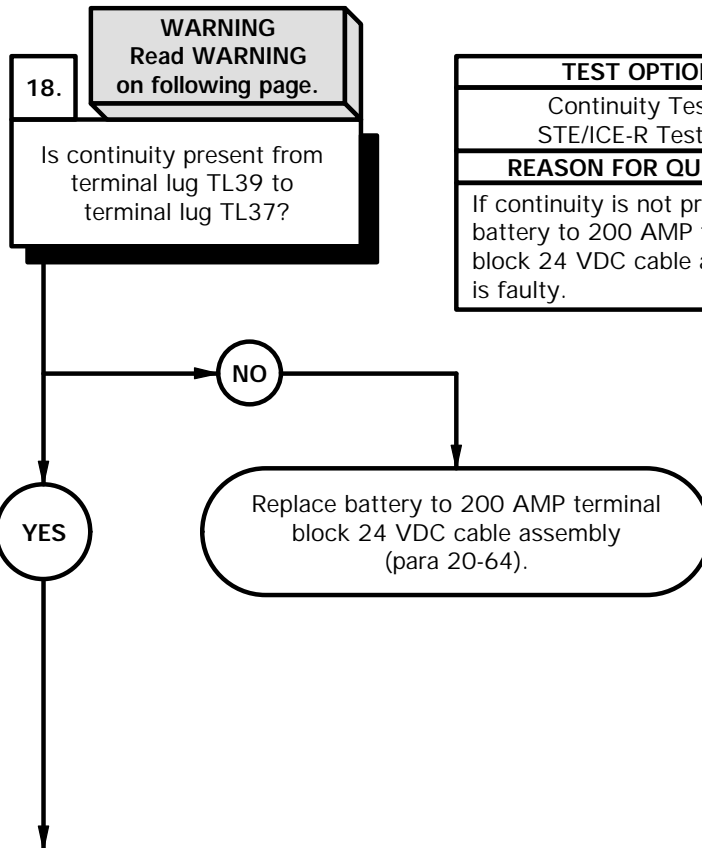

TEST OPTIONS
Continuity Test or STE/ICE-R Test #91
REASON FOR QUESTION
If continuity is not present, battery to 200 AMP terminal block 24 VDC cable assembly is faulty.

WARNING

Remove rings, bracelets, watches, necklaces, and any other jewelry before working around vehicle. Jewelry can catch on equipment and cause injury or short across electrical circuits and cause severe burns or electrical shock.

CONTINUITY TEST

- (1) Remove nut and terminal lugs TL39 and TL10 from battery 24 VDC cable.
- (2) Set multimeter to ohms.
- (3) Connect positive (+) probe of multimeter to terminal lug TL39.
- (4) Connect negative (-) probe of multimeter to terminal lug TL37 and note reading on multimeter.
- (5) If continuity is not present, replace battery to 200 AMP terminal block 24 VDC cable assembly (para 20-64).
- (6) Position terminal lugs TL36 and TL37 on left 24V BAT terminal stud on 200 AMP terminal block with washer, lockwasher, and nut.
- (7) Tighten nut to 15-19 lb-ft (21-25 N.m).
- (8) Install terminal lugs TL10 and TL39 on battery 24 VDC cable with nut.

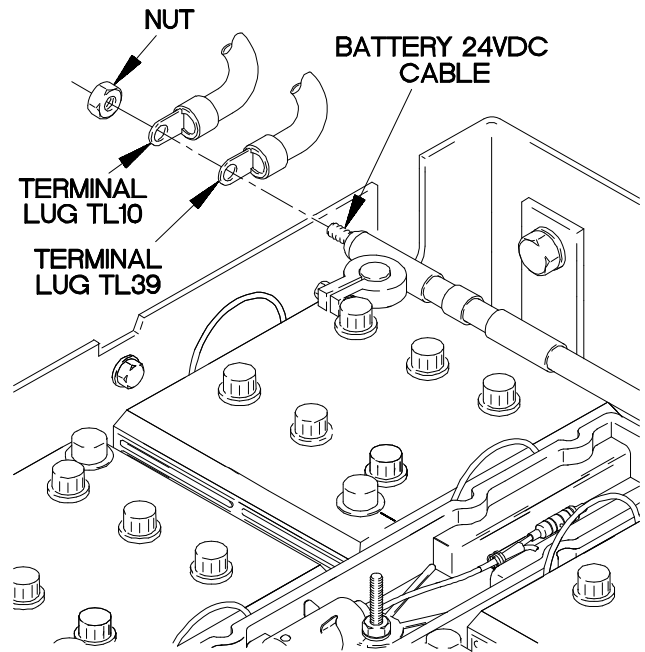

LEFT 24V BAT TERMINAL STUD 200 AMP TERMINAL BLOCK

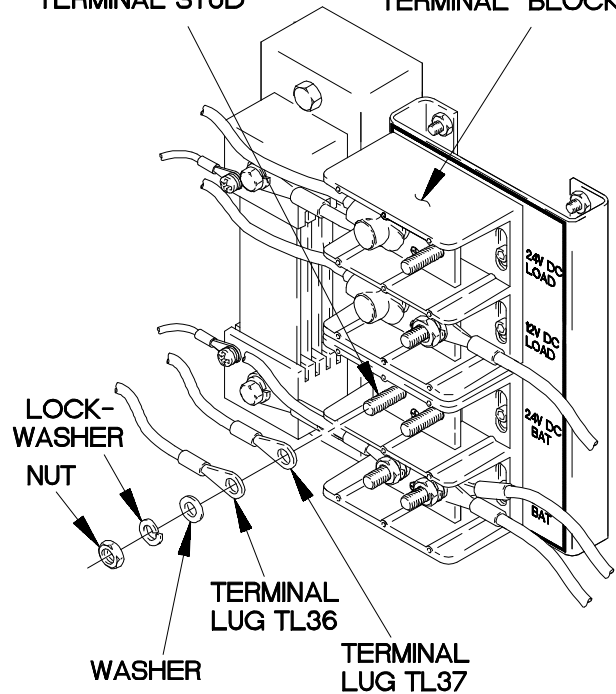

XBE0417B

e4. 24 VDC CIRCUITS DO NOT OPERATE (CONT)

KNOWN INFO
Service drive lights OK. Circuit breaker CB70 OK. Batteries OK. 200 AMP terminal block OK. Battery to 200 AMP terminal block 24 VDC cable assembly OK.
POSSIBLE PROBLEMS
Faulty 200 AMP reverse polarity relay. Faulty 200 AMP terminal block to reverse polarity relay 24 VDC battery cable. Faulty 200 AMP terminal block to reverse polarity relay 24 VDC load cable. Faulty 200 AMP terminal block to power distribution panel (PDP) 24 VDC cable.

19.

Is continuity present from terminal lug TL166 to terminal lug TL168?

TEST OPTIONS
Continuity Test or STE/ICE-R Test #91
REASON FOR QUESTION
If continuity is not present, 200 AMP terminal block to reverse polarity relay 24 VDC battery cable is faulty.

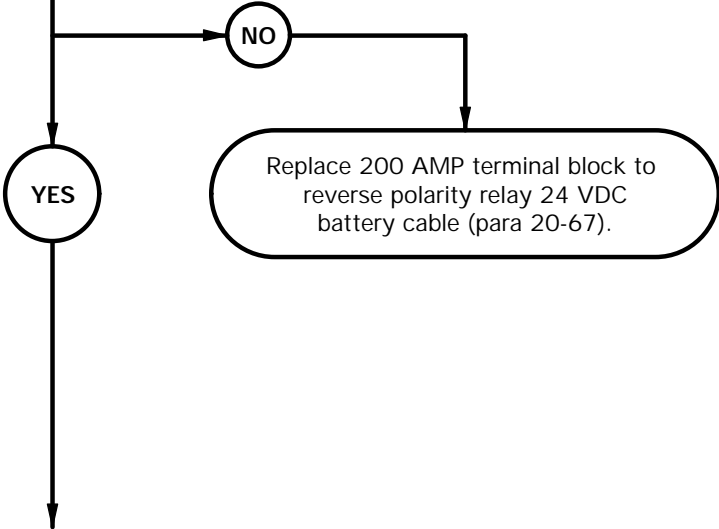

CONTINUITY TEST

- (1) Lift dust boot on 24V BAT terminal stud on 200 AMP reverse polarity relay.
- (2) Remove nut, lockwasher, terminal lug TL168 from 24V BAT terminal stud on 200 AMP reverse polarity relay. Discard lockwasher.
- (3) Set multimeter to ohms.
- (4) Connect positive (+) probe of multimeter to terminal lug TL166.
- (5) Connect negative (-) probe of multimeter to terminal lug TL168 and note reading on multimeter.
- (6) If continuity is not present, replace 200 AMP terminal block to reverse polarity relay 24 VDC battery cable (para 20-67).
- (7) Position terminal lug TL168 on 24V BAT terminal stud on 200 AMP reverse polarity relay with lockwasher and nut.
- (8) Tighten nut to 27-33 lb-ft (37-45 N.m).
- (9) Position dust boot on 24 V BAT terminal stud on 200 AMP reverse polarity relay.
- (10) Position terminal lugs TL166 and TL1 on right 24 VDC BAT terminal stud on 200 AMP terminal block with washer, lockwasher, and nut.
- (11) Tighten nut to 15-19 lb-ft (21-25 N.m).

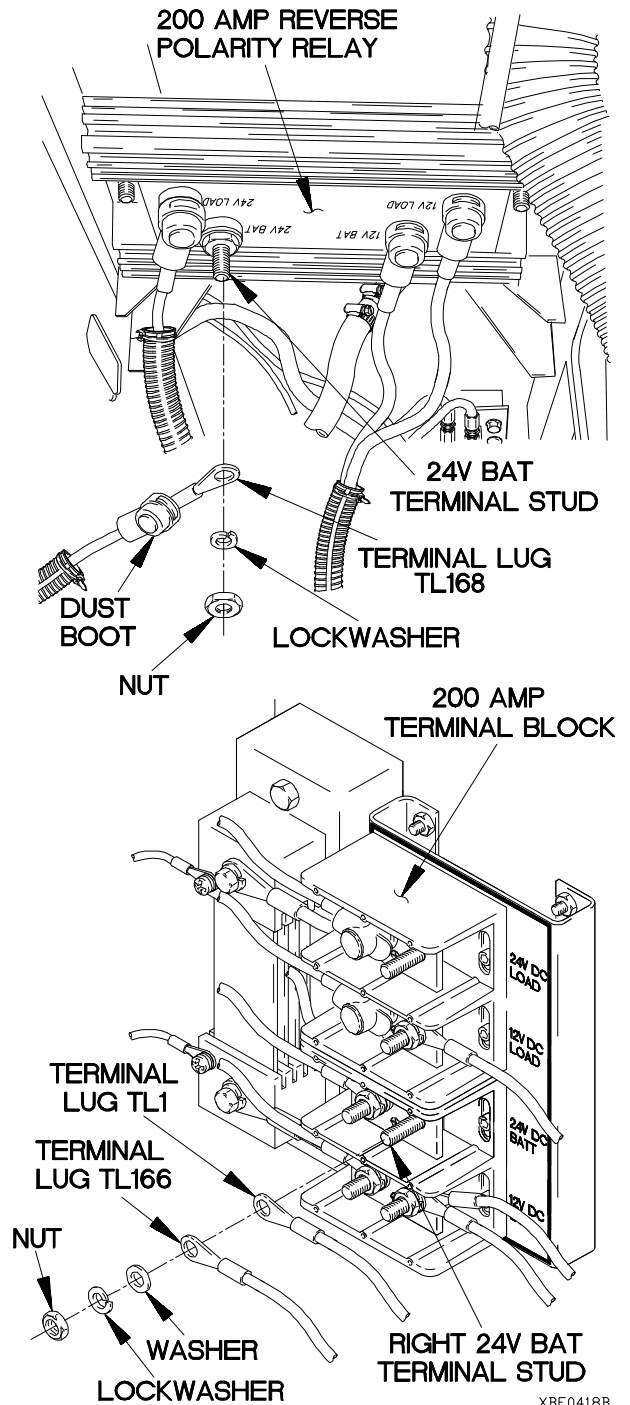

XBE0418B

e4. 24 VDC CIRCUITS DO NOT OPERATE (CONT)

KNOWN INFO
Service drive lights OK. Circuit breaker CB70 OK. Batteries OK. 200 AMP terminal block OK. Battery to 200 AMP terminal block 24 VDC cable assembly OK. 200 AMP terminal block to reverse polarity relay 24 VDC battery cable OK.
POSSIBLE PROBLEMS
Faulty 200 AMP reverse polarity relay. Faulty 200 AMP terminal block to reverse polarity relay 24 VDC load cable. Faulty 200 AMP terminal block to power distribution panel (PDP) 24 VDC cable.

20.
Is continuity present from terminal lug TL169 to terminal lug TL167?

TEST OPTIONS
Continuity Test or STE/ICE-R Test #91
REASON FOR QUESTION
If continuity is not present, 200 AMP terminal block to reverse polarity relay 24 VDC load cable is faulty. If continuity is present, 200 AMP terminal block to PDP 24 VDC cable is faulty.

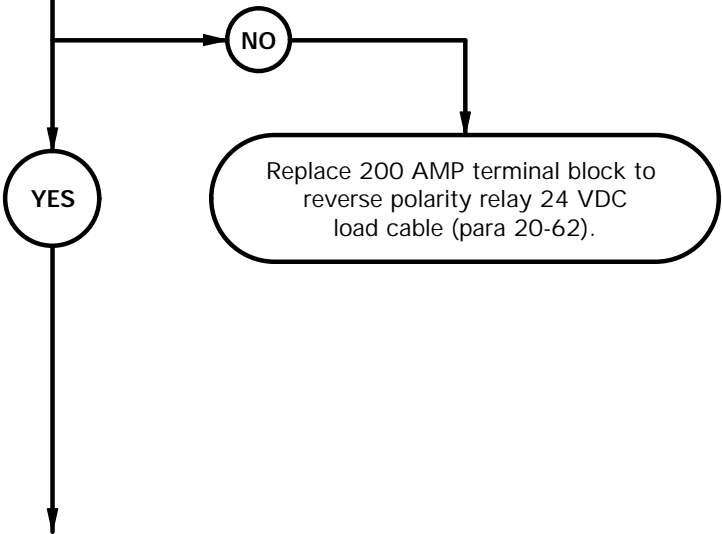

CONTINUITY TEST

- (1) Lift dust boot on 24V LOAD terminal stud on 200 AMP reverse polarity relay.
- (2) Remove nut, lockwasher, and terminal lug TL169 from 24V LOAD terminal stud on 200 AMP reverse polarity relay. Discard lockwasher.
- (3) Set multimeter to ohms.
- (4) Connect positive (+) probe of multimeter to terminal lug TL169.
- (5) Connect negative (-) probe of multimeter to terminal lug TL167 and note reading on multimeter.
- (6) If continuity is not present, replace 200 AMP terminal block to reverse polarity relay 24 VDC load cable (para 20-62).
- (7) If continuity is present, replace 200 AMP terminal block to PDP 24 VDC cable (para 20-62).
- (8) Position terminal lug TL167 on right 24V LOAD terminal stud on 200 AMP terminal block with washer, lockwasher, and nut.
- (9) Tighten nut to 15-19 lb-ft (21-25 N.m).
- (10) Position terminal lug TL169 on 24V LOAD terminal stud on 200 AMP reverse polarity relay with lockwasher and nut.
- (11) Tighten nut to 27-33 lb-ft (37-45 N.m).
- (12) Position dust boot on 24V LOAD terminal stud on 200 AMP reverse polarity relay.

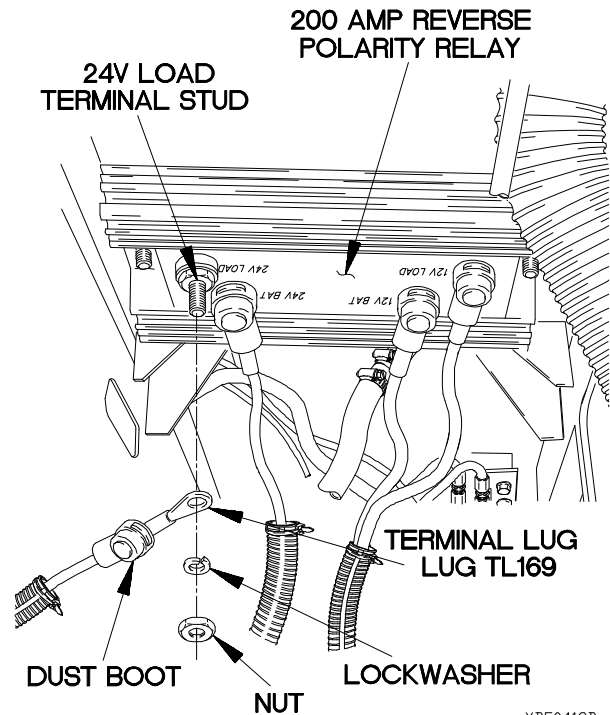
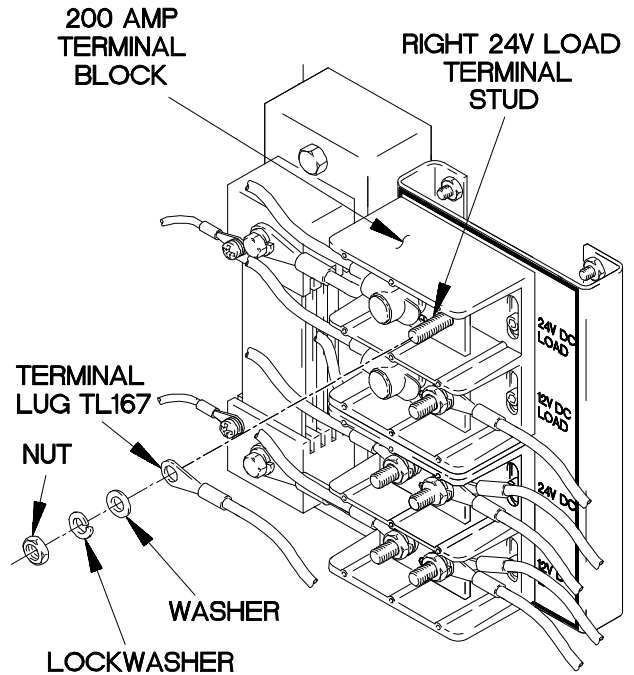

XBE0419B

e4. 24 VDC CIRCUITS DO NOT OPERATE (CONT)

KNOWN INFO
Service drive lights OK. Circuit breaker CB70 OK. Batteries OK. 200 AMP terminal block OK. Battery to 200 AMP terminal block 24 VDC cable assembly OK. 200 AMP terminal block to reverse polarity relay 24 VDC battery cable OK. Faulty 200 AMP terminal block to reverse polarity relay 24 VDC load cable.
POSSIBLE PROBLEMS
Faulty 200 AMP reverse polarity relay. Faulty 200 AMP terminal block to power distribution panel (PDP) 24 VDC cable.

21.
 Is continuity present from terminal X1 on PDP to terminal lug TL44?

TEST OPTIONS
Continuity Test or STE/ICE-R Test #91
REASON FOR QUESTION
If continuity is not present, 200 MAP terminal block to PDP 24 VDC cable is faulty. If continuity is present, 200 AMP reverse polarity relay is faulty.

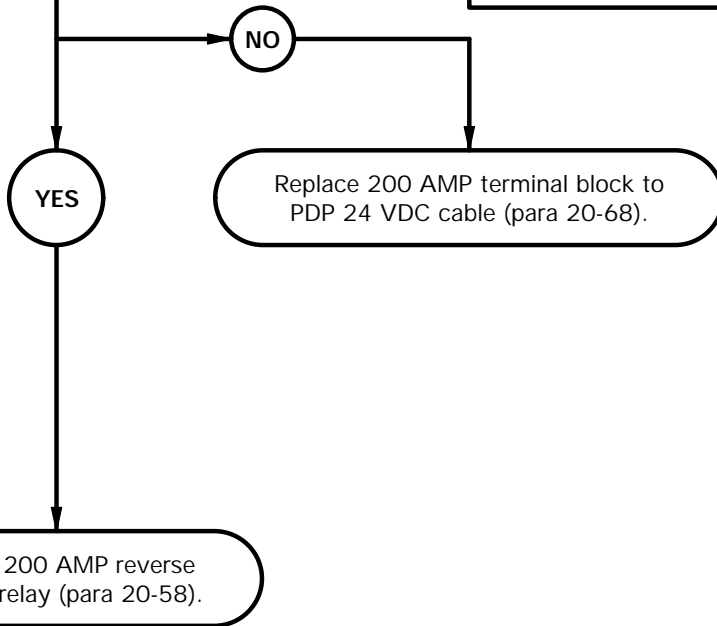

CONTINUITY TEST

(1) Set multimeter to ohms.

CAUTION

When testing to terminal X1 on PDP, ensure that multimeter probes come in contact with the outside metal ring. Failure to comply may result in false troubleshooting test results.

- (2) Connect positive (+) probe of multimeter to terminal X1 on PDP.
- (3) Connect negative (-) probe of multimeter to terminal lug TL44 and note reading on multimeter.
- (4) If continuity is not present, replace 200 AMP terminal block to PDP 24 VDC cable (para 20-68).
- (5) If continuity is present, replace 200 AMP reverse polarity relay (para 20-58).
- (6) Position terminal lug TL44 on left 24V LOAD terminal stud on 200 AMP terminal block with washer, lockwasher, and nut.
- (7) Tighten nut to 15-19 lb-ft (21-25 N.m)
- (8) Position dust boot on left 24V LOAD terminal stud on 200 AMP terminal block.
- (9) Install PDP cover (para 16-2).
- (10) Connect batteries (para 7-48).
- (11) Raise spare tire (TM 9-2320-365-10).

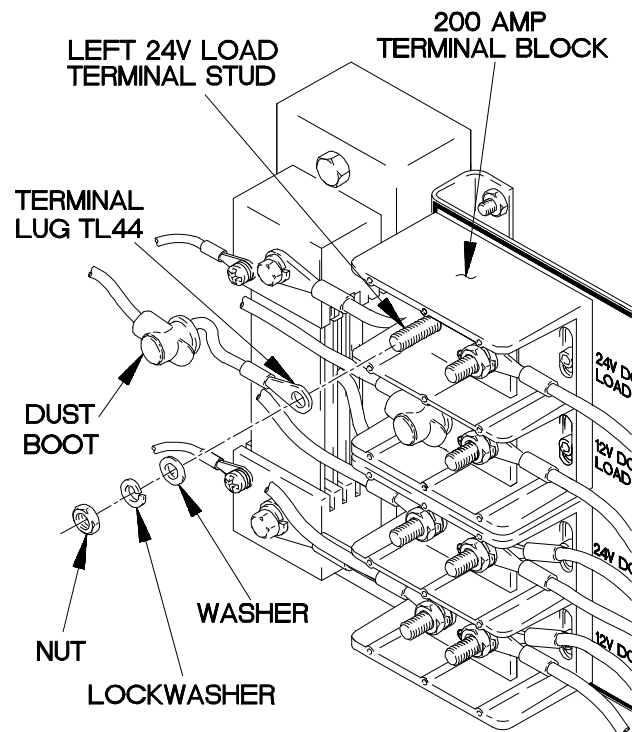
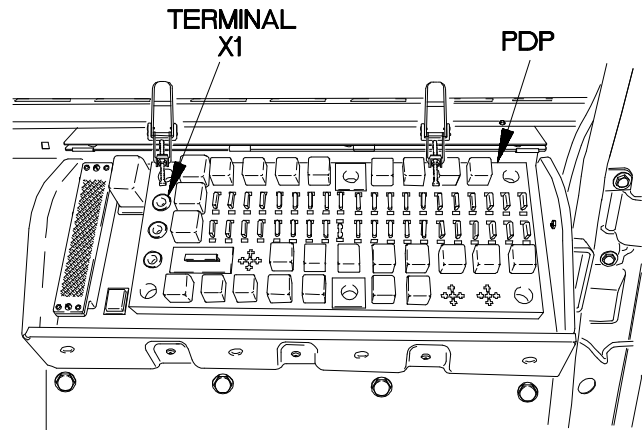

XBE0420B

e6. ENGINE CRANKS BUT DOES NOT START

INITIAL SETUP

Equipment Condition

Engine shut down (TM 9-2320-365-10).
Cab raised (TM 9-2320-365-10).

Tools and Special Tools

Tool Kit, Genl Mech (Item 44, Appendix C)
STE/ICE-R (Item 39, Appendix C)
Multimeter, Digital (Item 22, Appendix C)

Personnel Required
(2)

References

TM 9-4910-571-12&P

Materials/Parts

Wire, Elect, 50 ft (Item 77, Appendix D)

NOTE

Perform Engine System Troubleshooting a2.
Engine Cranks But Does Not Start prior
to beginning this task.

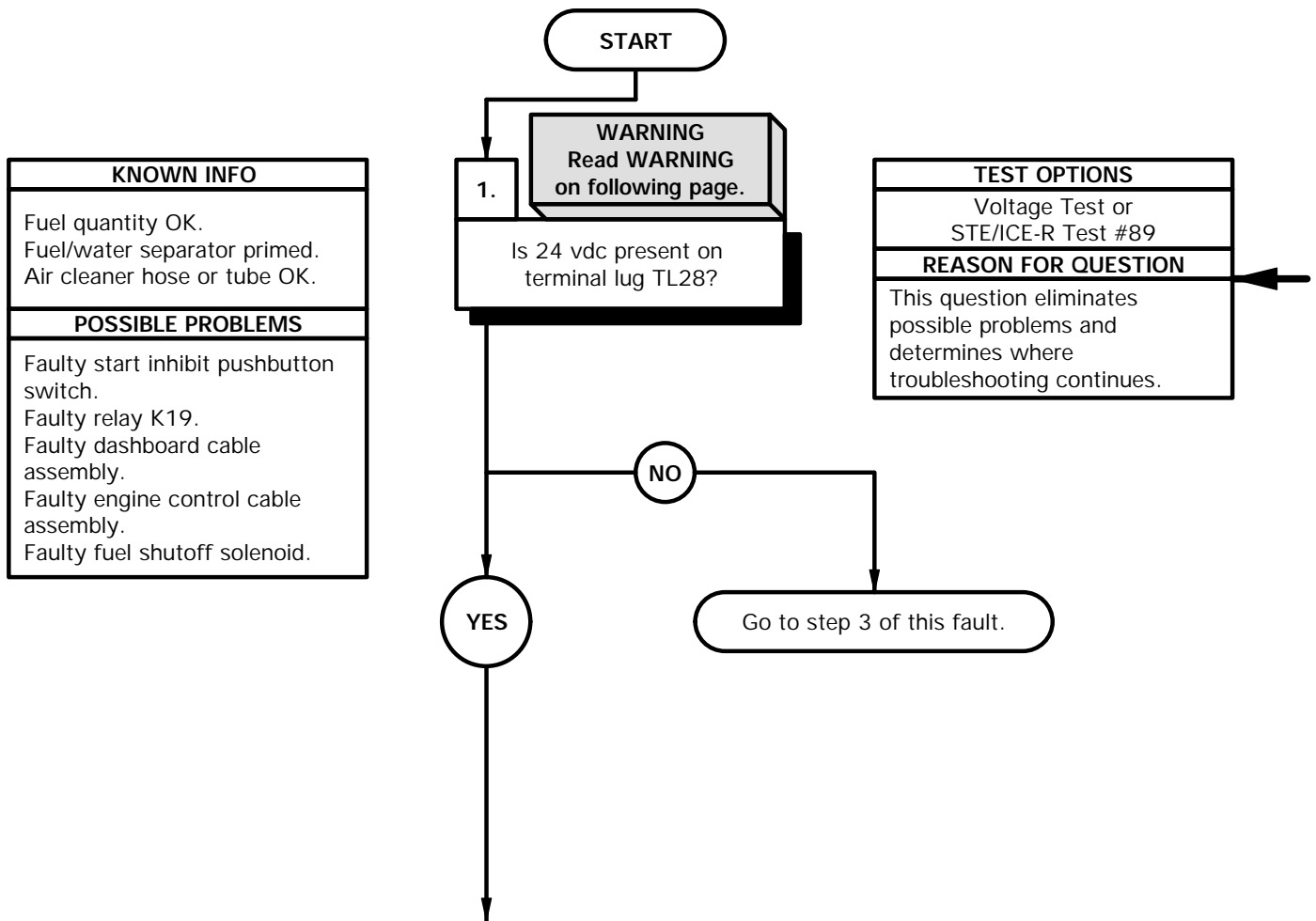

WARNING

Remove rings, bracelets, watches, necklaces, and any other jewelry before working around vehicle. Jewelry can catch on equipment and cause injury or short across electrical circuits and cause severe burns or electrical shock.

VOLTAGE TEST

- (1) Set multimeter to volts dc.
- (2) Connect positive (+) probe of multimeter to terminal lug TL28 on fuel solenoid.
- (3) Connect negative (-) probe of multimeter to ground.
- (4) Position master power switch to on (TM 9-2320-365-10) and note reading on multimeter.
- (5) If 24 vdc is not present, go to step 3 of this fault.
- (6) Position master power switch to off (TM 9-2320-365-10).

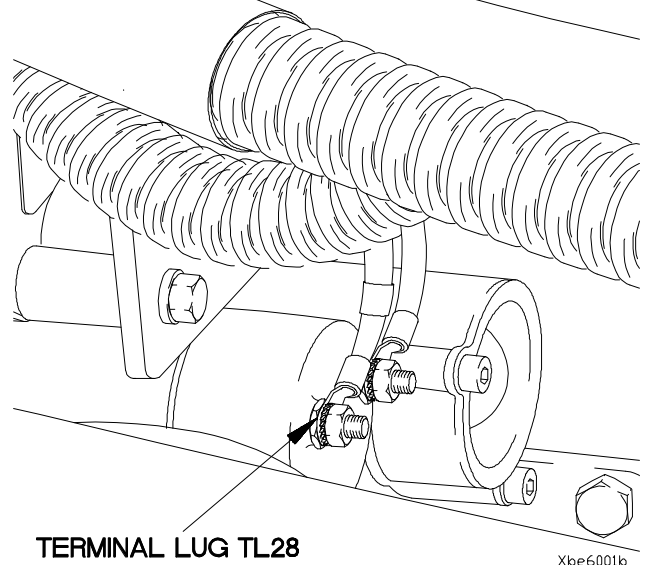
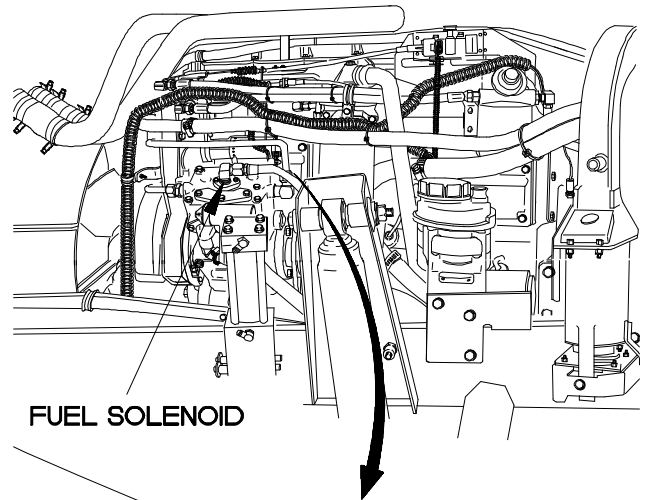
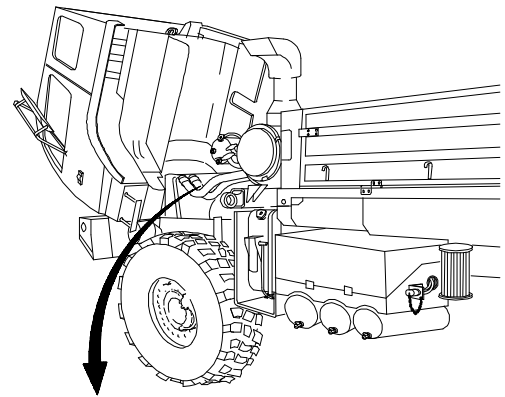

Xbe6001b

e6. ENGINE CRANKS BUT DOES NOT START (CONT)

KNOWN INFO
Fuel quantity OK. Fuel/water separator primed. Air cleaner hose or tube OK. Relay K19 OK. Start inhibit pushbutton switch OK.
POSSIBLE PROBLEMS
Faulty dashboard cable assembly. Faulty engine control cable assembly. Faulty fuel shutoff solenoid.

2.
Is continuity present from terminal lug TL29 to ground?

TEST OPTIONS
Continuity Test or STE/ICE-R Test #91
REASON FOR QUESTION
This question eliminates possible problems and determines where troubleshooting continues.

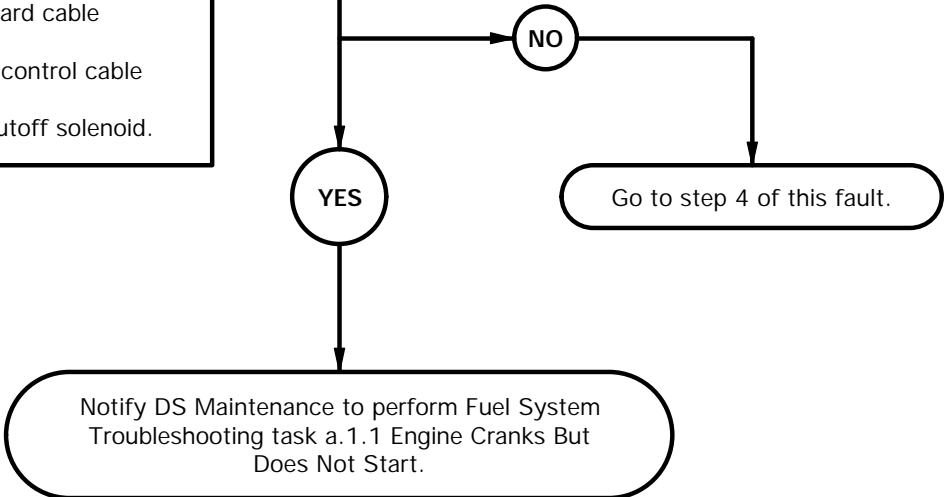

KNOWN INFO
Fuel quantity OK. Fuel/water separator primed. Air cleaner hose or tube OK.
POSSIBLE PROBLEMS
Faulty start inhibit pushbutton switch. Faulty relay K19. Faulty dashboard cable assembly. Faulty engine control cable assembly.

3.
WARNING
Read **WARNING** on following page.
Is 24 VDC present at relay K19 socket 86 on power distribution panel (PDP)?

TEST OPTIONS
Voltage Test or STE/ICE-R Test #89
REASON FOR QUESTION
If 24 VDC is not present, go to step 5 of this fault. If 24 VDC is present, start inhibit pushbutton switch is faulty.

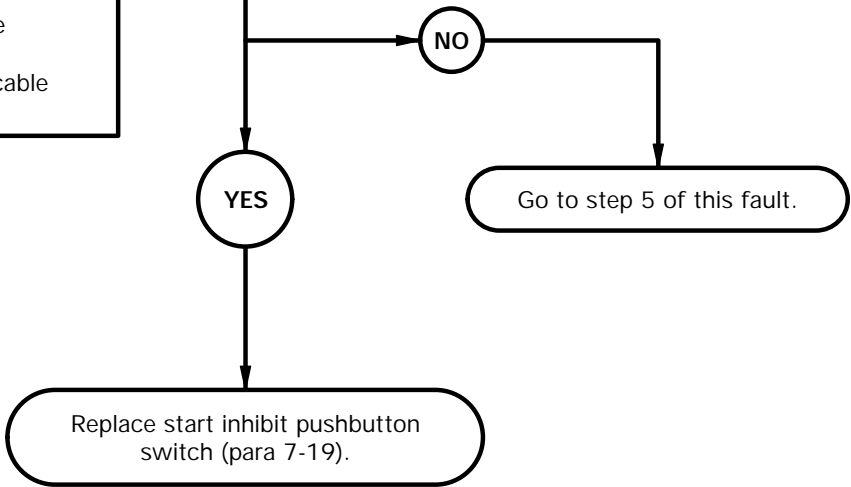

CONTINUITY TEST

- (1) Set multimeter to ohms.
- (2) Connect positive (+) probe of multimeter to terminal lug TL29 on fuel solenoid.
- (3) Connect negative (-) probe of multimeter to ground and note reading on multimeter.
- (4) If continuity is not present, go to step 4 of this fault.
- (5) If continuity is present, fuel solenoid is faulty, notify DS Maintenance.
- (6) Lower cab (TM 9-2320-365-10).

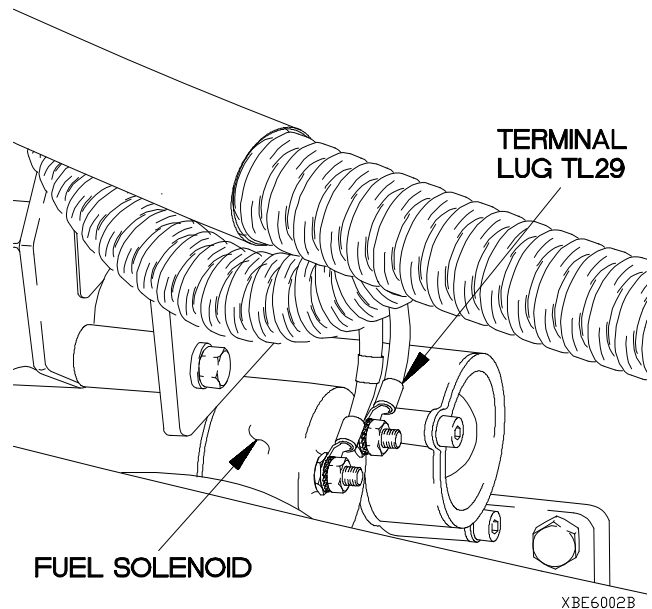

XBE6002B

WARNING

Remove rings, bracelets, watches, necklaces, and any other jewelry before working around vehicle. Jewelry can catch on equipment and cause injury or short across electrical circuits and cause severe burns or electrical shock.

VOLTAGE TEST

- (1) Lower cab (TM 9-2320-365-10).
- (2) Remove power distribution panel (PDP) cover (para 16-2).
- (3) Remove relay K19 from power distribution panel (PDP).
- (4) Set multimeter to volts DC.
- (5) Connect positive (+) probe of multimeter to relay K19 socket 86 on power distribution panel (PDP).
- (6) Connect negative (-) probe of multimeter to ground
- (7) Position master power switch to on (TM 9-2320-365-10) and note reading on multimeter.
- (8) If 24 VDC is not present, go to step 5 of this fault.
- (9) If 24 VDC is present, replace start inhibit pushbutton switch (para 7-19).
- (10) Position master power switch to off (TM 9- 2320-365-10).

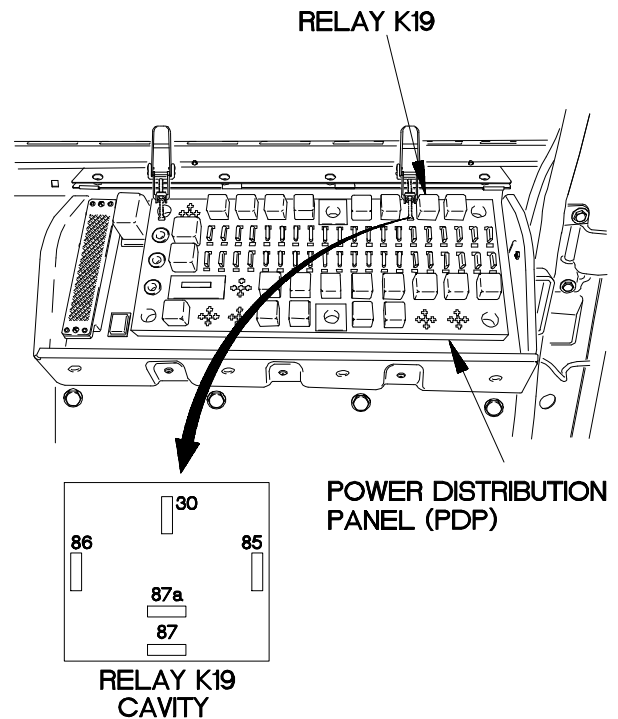

Xbe6003b

e6. ENGINE CRANKS BUT DOES NOT START (CONT)

KNOWN INFO
Fuel quantity OK. Fuel/water separator primed. Air cleaner hose or tube OK. Start inhibit pushbutton switch OK. Relay K19 OK.
POSSIBLE PROBLEMS
Faulty dashboard cable assembly. Faulty engine control cable assembly.

CAUTION
Read CAUTION on following page.

4.
Is continuity present from connector J31 pin 5 to ground?

TEST OPTIONS
Continuity Test or STE/ICE-R Test #91
REASON FOR QUESTION
If continuity is not present, wire 3015 from connector J31 pin 5 to terminal board TB2 position 18 on power distribution panel (PDP) is faulty. If continuity is present, wire 3015 from connector P31 socket 5 to terminal lug TL29 is faulty.

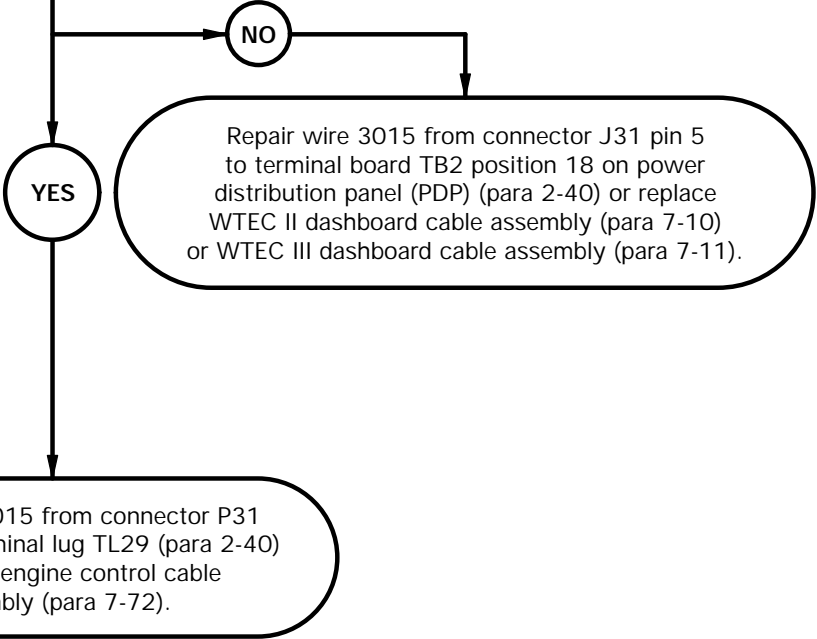

CAUTION

Use care when testing electrical connectors. Do not damage connector pins or sockets with multimeter probes. Failure to comply may result in damage to equipment.

CONTINUITY TEST

- (1) Disconnect batteries (para 7-48).
- (2) Remove instrument panel assembly for access (para 7-15).
- (3) Disconnect connector J31 from connector P31.
- (4) Set multimeter to ohms.
- (5) Connect positive (+) probe of multimeter to connector J31 pin 5.
- (6) Connect negative (-) probe of multimeter to ground and note reading on multimeter.
- (7) If continuity is not present, repair wire 3015 from connector J31 pin 5 to terminal board TB2 position 18 on power distribution PDP (para 2-40) or replace WTEC II dashboard cable assembly (para 7-10) or WTEC III dashboard cable assembly (para 7-11).
- (8) If continuity is present, repair wire 3015 from connector P31 socket 5 to terminal lug TL29 (para 2-40) or replace engine control cable assembly (para 7-72).
- (9) Connect connector J31 to connector P31.
- (10) Install instrument panel assembly (para 7-15).
- (11) Connect batteries (para 7-48).

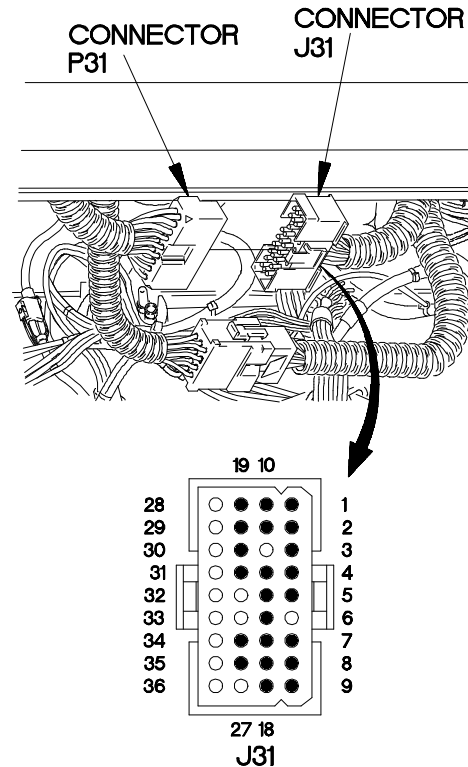

XBE6004B

e6. ENGINE CRANKS BUT DOES NOT START (CONT)

KNOWN INFO
Fuel quantity OK. Fuel/water separator primed. Air cleaner hose or tube OK. Start inhibit pushbutton switch OK.
POSSIBLE PROBLEMS
Faulty relay K19. Faulty dashboard cable assembly. Faulty engine control cable assembly.

KNOWN INFO
Fuel quantity OK. Fuel/water separator primed. Air cleaner hose or tube OK. Start inhibit pushbutton switch OK. Relay K19 OK.
POSSIBLE PROBLEMS
Faulty dashboard cable assembly. Faulty engine control cable assembly.

5.
Is continuity present from relay K19 terminals 30 to 87A?

TEST OPTIONS
Continuity Test or STE/ICE-R Test #91
REASON FOR QUESTION
If continuity is not present, relay K19 is faulty.

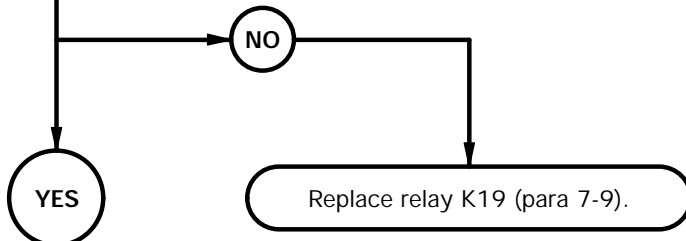

6.
Is 24 VDC present from relay K19 socket 30 on PDP?

TEST OPTIONS
Voltage Test or STE/ICE-R Test #89
REASON FOR QUESTION
This question eliminates possible problems and determines where troubleshooting continues.

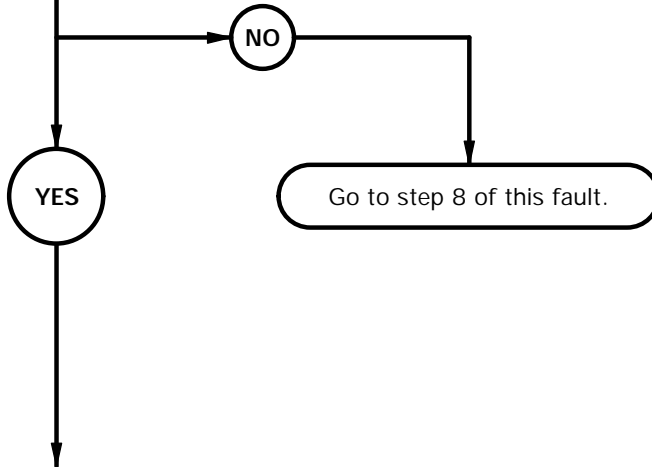

CONTINUITY TEST

- (1) Set multimeter to ohms.
- (2) Connect positive (+) probe of multimeter to relay K19 terminal 87a.
- (3) Connect negative (-) probe of multimeter to relay K19 terminal 30 and note reading on multimeter.
- (4) If continuity is not present, replace relay K19 (para 7-9).

WARNING

Remove rings, bracelets, watches, necklaces, and any other jewelry before working around vehicle. Jewelry can catch on equipment and cause injury or short across electrical circuits and cause severe burns or electrical shock.

VOLTAGE TEST

- (1) Set multimeter to volts DC.
- (2) Connect positive (+) of multimeter to relay K19 socket 30 on PDP.
- (3) Connect negative (-) probe of multimeter to ground.
- (4) Position master power switch to on (TM 9-2320-365-10) and note reading on multimeter.
- (5) If 24 VDC is not present, go to step 8 of this fault.
- (6) Position master power switch to off (TM 9-2320-365-10).

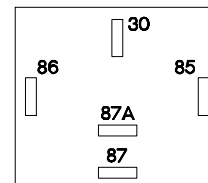

**RELAY K19
CAVITY**

Xbe6006b

e6. ENGINE CRANKS BUT DOES NOT START (CONT)

KNOWN INFO
Fuel quantity OK. Fuel/water separator primed. Air cleaner hose or tube OK. Start inhibit pushbutton switch OK. Relay K19 OK.
POSSIBLE PROBLEMS
Faulty dashboard cable assembly. Faulty engine control cable assembly.

CAUTION
Read CAUTION on following page.

7.
Is continuity present from relay K19 socket 87A to connector J31 pin 14?

TEST OPTIONS
Continuity Test or STE/ICE-R Test #91
REASON FOR QUESTION
If continuity is not present, wire 54 from relay K19 socket 87A on PDP to connector J31 pin 14 is faulty. If continuity is present, wire 54 from connector P31 socket 14 to terminal lug TL28 is faulty.

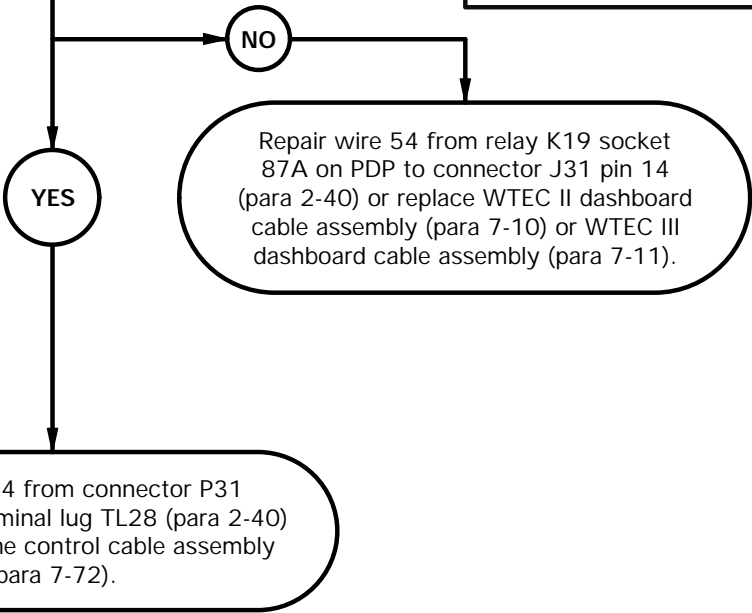

CAUTION

Use care when testing electrical connectors. Do not damage connector pins or sockets with multimeter probes. Failure to comply may result in damage to equipment.

CONTINUITY TEST

- (1) Disconnect batteries (para 7-48).
- (2) Remove instrument panel for access (para 7-15).
- (3) Disconnect connector J31 from connector P31.
- (4) Set multimeter to ohms.
- (5) Connect positive (+) probe of multimeter to relay K19 socket 87A on PDP.
- (6) Connect negative (-) probe of multimeter to connector J31 pin 14 and note reading on multimeter.
- (7) If continuity is not present, repair wire 54 from connector J31 pin 14 to relay K19 socket 87A on PDP (para 2-40) or replace WTEC II dashboard cable assembly (7-10) or WTEC III dashboard cable assembly (para 7-11).
- (8) If continuity is present, repair wire 54 from connector P31 socket 14 to terminal lug TL 28 (para 2-40) or replace engine control cable assembly (para 7-72).
- (9) Connect connector J31 to connector P31.
- (10) Install instrument panel (para 7-15).
- (11) Install relay K19 in PDP.
- (12) Install PDP cover (para 16-2).
- (13) Connect batteries (para 7-48).

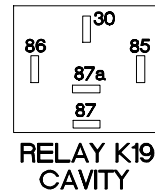
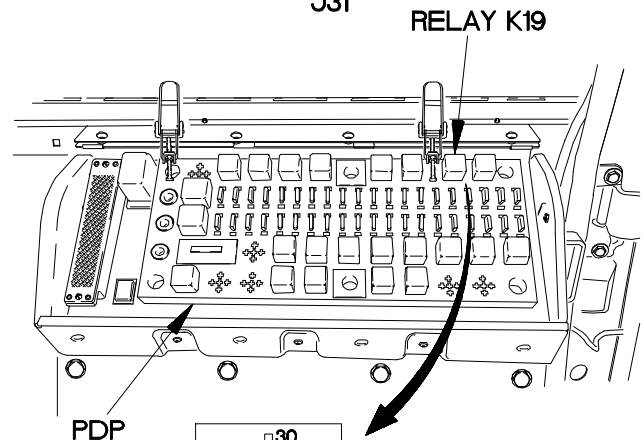
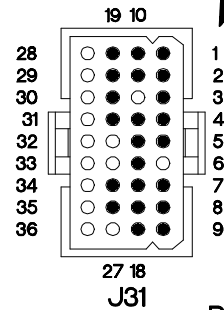
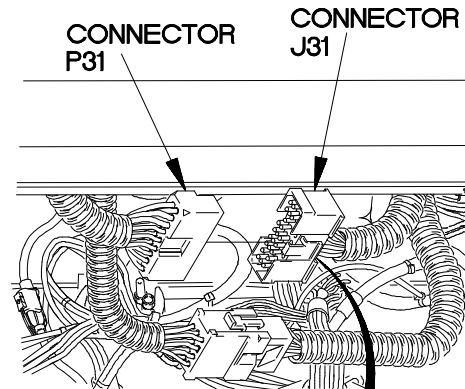

XBE6007B

e6. ENGINE CRANKS BUT DOES NOT START (CONT)

KNOWN INFO
Fuel quantity OK. Fuel/water separator primed. Air cleaner hose or tube OK. Start inhibit pushbutton switch OK. Relay K19 OK.
POSSIBLE PROBLEMS
Faulty dashboard cable assembly. Faulty engine control cable assembly.

8.

WARNING
Read **WARNING** on following page.

Is 24 VDC present at terminal board TB1 position 59?

TEST OPTIONS
Voltage Test or STE/ICE-R Test #89
REASON FOR QUESTION
If 24 VDC is not present, wire 1690 is faulty. If 24 VDC is present, wire 1462 is faulty.

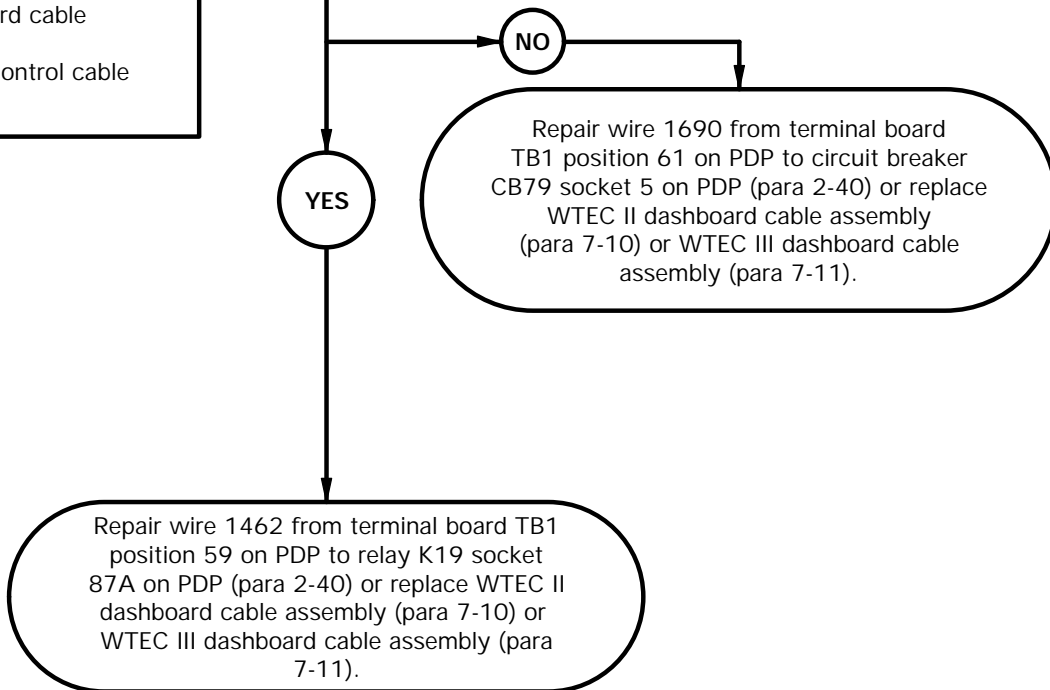

WARNING

Remove rings, bracelets, watches, necklaces, and any other jewelry before working around vehicle. Jewelry can catch on equipment and cause injury or short across electrical circuits and cause severe burns or electrical shock.

VOLTAGE TEST

- (1) Install relay K19 in PDP.
- (2) Remove three screws and washers from PDP.
- (3) Remove three screws from PDP.
- (4) Set multimeter to volts DC.
- (5) Connect positive (+) probe of multimeter to terminal board TB1 position 59 on PDP.
- (6) Connect negative (-) probe of multimeter to ground.
- (7) Position master power switch to on (TM 9-2320-365-10) and note reading on multimeter.
- (8) If 24 VDC is not present, repair wire 1690 from terminal board TB1 position 61 on PDP to circuit breaker CB79 socket 5 on PDP (para 2-40) or replace WTEC II dashboard cable assembly (para 7-10) or WTEC III dashboard cable assembly (para 7-11).
- (9) If 24 VDC is present, repair wire 1462 from terminal board TB1 position 59 on PDP to relay K19 socket 87A on PDP (para 2-40) or replace WTEC II dashboard cable assembly (para 7-10) or WTEC III dashboard cable assembly (para 7-11).
- (10) Install PDP on dashboard with three washers and screws.
- (11) Install three screws in PDP.
- (12) Install PDP cover (para 16-2).

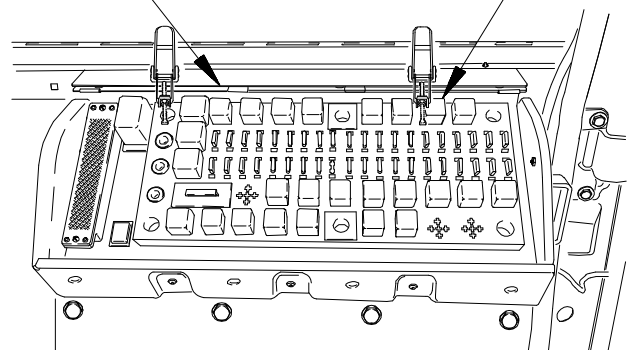
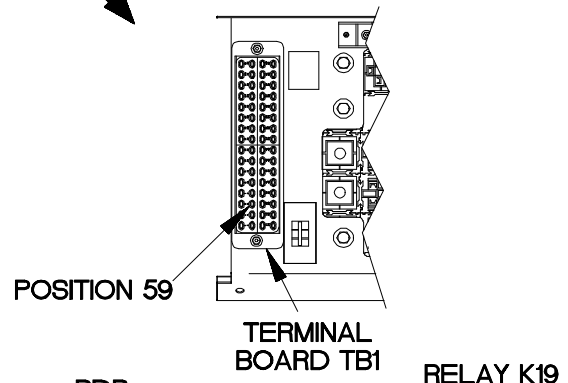
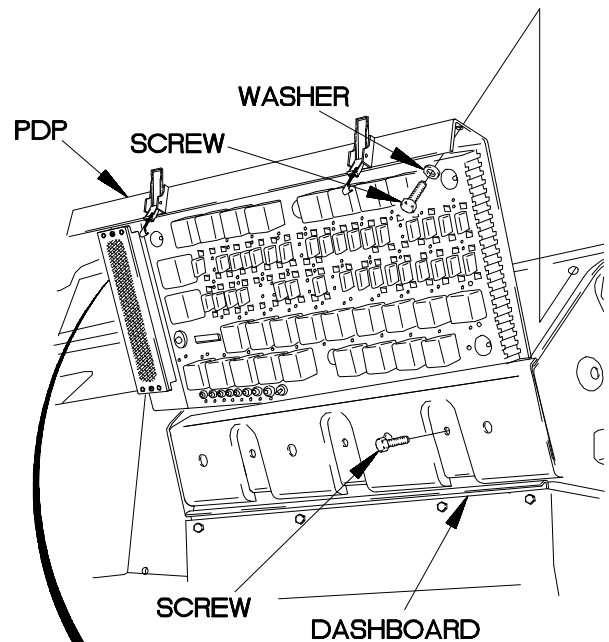

XBE6008B

e7. FUEL GAGE DOES NOT OPERATE OR IS INACCURATE

INITIAL SETUP

Equipment Conditions

Engine shut down (TM 9-2320-365-10).

Personnel Required

(2)

References

TM 9-4910-571-12&P

Tools and Special Tools

Tool Kit, Genl Mech (Item 44, Appendix C)

STE/ICE-R (Item 39, Appendix C)

Multimeter, Digital (Item 22, Appendix C)

Materials/Parts

Wire, Elect, 50 ft (Item 77, Appendix D)

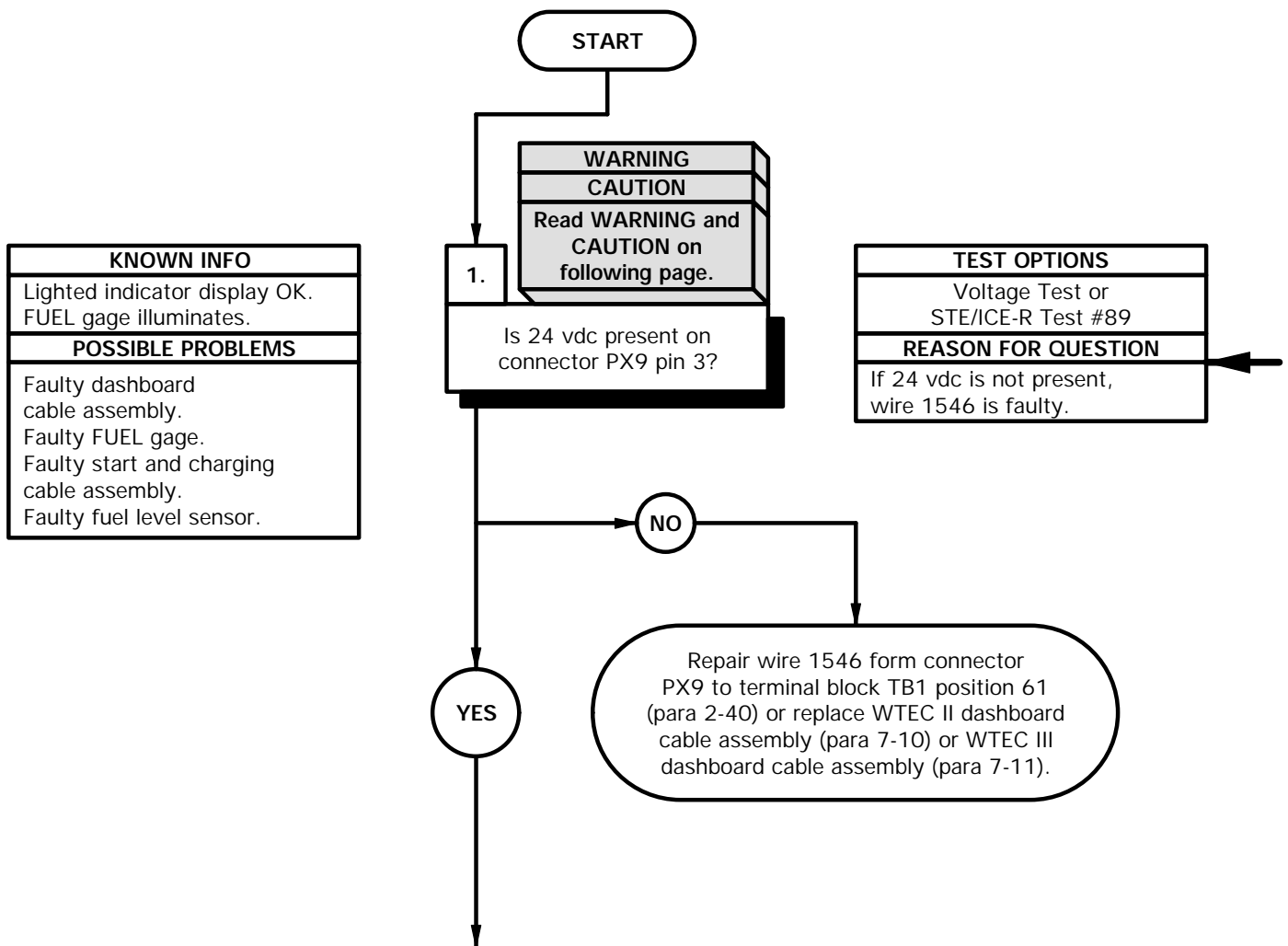

WARNING

Remove rings, bracelets, watches, necklaces, and any other jewelry before working around vehicle. Jewelry can catch on equipment and cause injury or short across electrical circuits and cause severe burns or electrical shock.

CAUTION

Use care when testing electrical connectors. Do not damage connector pins or sockets with multimeter probes. Failure to comply may result in damage to equipment.

NOTE

Inspect connector pins/sockets for damage, corrosion, and serviceability. Check that connector pins are not pushed back and are capable of making good contact.

VOLTAGE TEST

- (1) Remove instrument panel assembly for access (para 7-15).
- (2) Disconnect connector clamp from fuel gage connector.
- (3) Disconnect connector PX9 from fuel gage connector.
- (4) Set multimeter to volts dc.
- (5) Connect positive (+) probe of multimeter to connector PX9-3.
- (6) Connect negative (-) probe of multimeter to a known good ground.
- (7) Position master power switch to on (TM 9-2320-365-10) and note reading on multimeter.
- (8) If 24 vdc is not present, repair wire 1546 from connector PX9 pin 3 to terminal board TB1 position 61 (para 2-40) or replace WTEC II dashboard cable assembly (para 7-10) or WTEC III dashboard cable assembly (para 7-11).
- (9) Position master power switch to off (TM 9-2320-365-10).

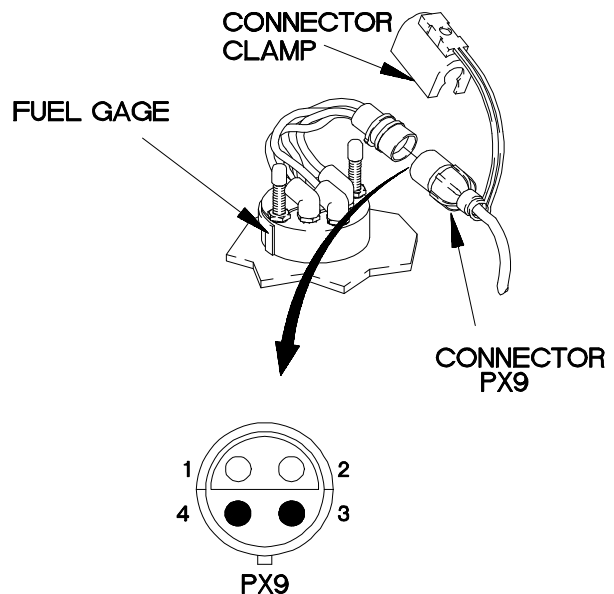

XBE0701B

e7. FUEL GAGE DOES NOT OPERATE OR IS INACCURATE (CONT)

KNOWN INFO
Lighted indicator display OK. FUEL gage illuminates.
POSSIBLE PROBLEMS
Faulty FUEL gage. Faulty dashboard cable assembly. Faulty start and charging cable assembly. Faulty fuel level sensor.

2. **CAUTION**
Read CAUTION on following page.

Is less than 30 ohms present from connector PX9 pin 4 to a known good ground?

TEST OPTIONS
Resistance Test or STE/ICE-R Test #91
REASON FOR QUESTION
If greater than 30 ohms is present, FUEL gage is faulty.

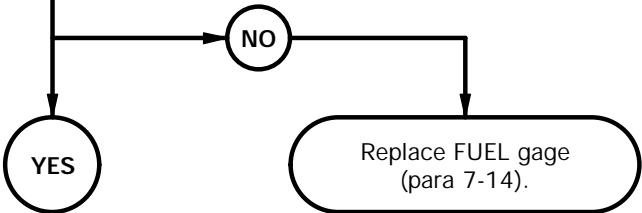

KNOWN INFO
Lighted indicator display OK. FUEL gage illuminates. FUEL gage OK.
POSSIBLE PROBLEMS
Faulty dashboard cable assembly. Faulty start and charging cable assembly. Faulty fuel level sensor.

3. **CAUTION**
Read CAUTION on following page.

Is continuity present from connector PX9 pin 4 to connector P82 pin 1?

TEST OPTIONS
Continuity Test or STE/ICE-R Test #91
REASON FOR QUESTION
If continuity is not present, wire 28 is faulty.

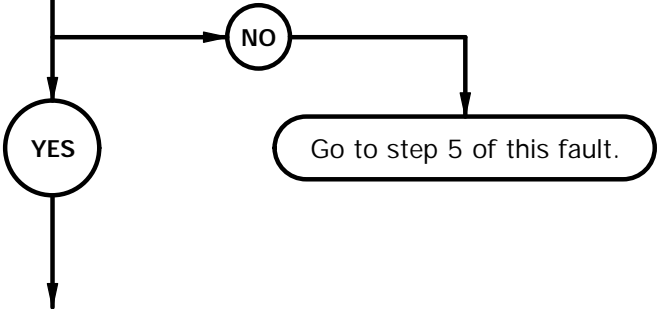

CAUTION

Use care when testing electrical connectors. Do not damage connector pins or sockets with multimeter probes. Failure to comply may result in damage to equipment.

NOTE

Inspect connector pins/sockets for damage, corrosion, and serviceability. Check that connector pins are not pushed back and are capable of making good contact.

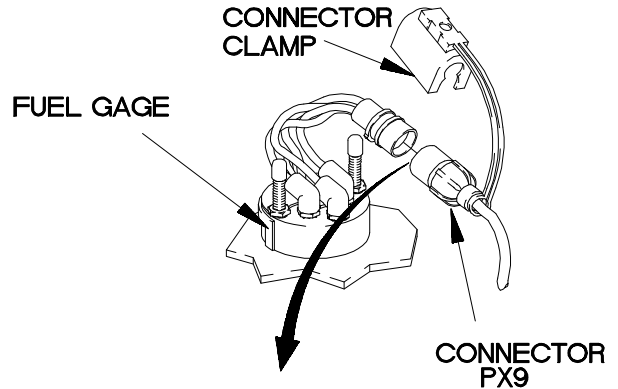

RESISTANCE TEST

- (1) Set multimeter to ohms.
- (2) Connect positive (+) probe of multimeter to connector PX9 pin 2.
- (3) Connect negative (-) probe of multimeter to a known good ground and note reading on multimeter.
- (4) If greater than 30 ohms is present, replace FUEL gage (para 7-14).

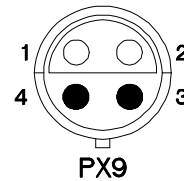

XBE0701B

CONTINUITY TEST

- (1) Disconnect connector clamp from fuel level sensor.
- (2) Disconnect connector P82 from fuel level sensor.
- (3) Set multimeter to ohms.
- (4) Connect positive (+) probe of multimeter to connector PX9 pin 4.
- (5) Connect negative (-) probe of multimeter to connector P82 pin 1 and note reading on multimeter.
- (6) If continuity is not present, go to step 5 of this fault.

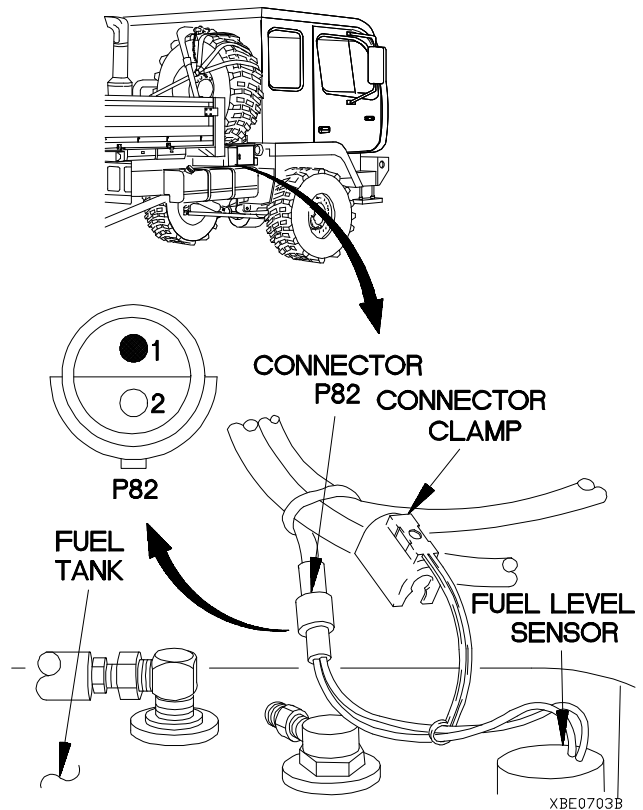

XBE0703B

e7. FUEL GAGE DOES NOT OPERATE OR IS INACCURATE (CONT)

KNOWN INFO
Lighted indicator display OK. FUEL gage illuminates. FUEL gage OK. Dashboard cable assembly OK.
POSSIBLE PROBLEMS
Faulty start and charging cable assembly. Faulty fuel level sensor.

4.

CAUTION
 Read CAUTION on following page.

Is continuity present from connector P82 pin 2 to a known good ground?

TEST OPTIONS
Continuity Test or STE/ICE-R Test #91
REASON FOR QUESTION
If continuity is not present, wire 3001 is faulty. If continuity is present, fuel level sensor is faulty.

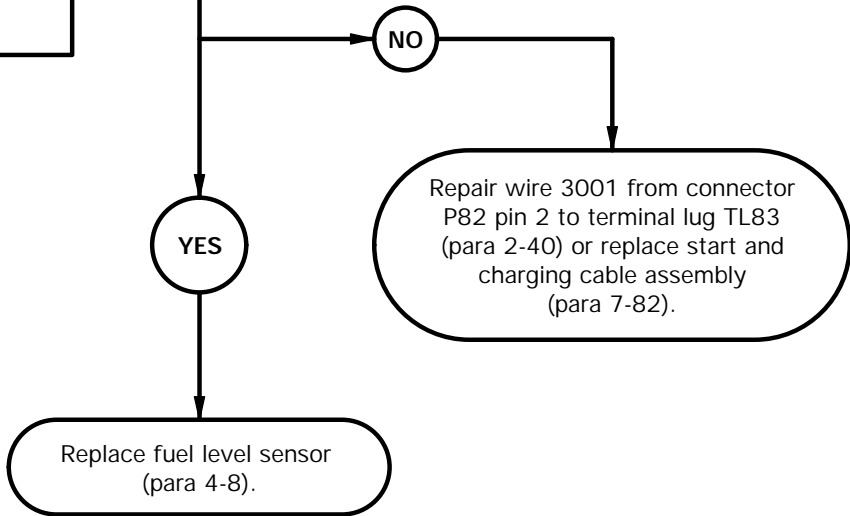

CAUTION

Use care when testing electrical connectors. Do not damage connector pins or sockets with multimeter probes. Failure to comply may result in damage to equipment.

NOTE

Inspect connector pins/sockets for damage, corrosion, and serviceability. Check that connector pins are not pushed back and are capable of making good contact.

CONTINUITY TEST

- (1) Connect connector PX9 to fuel gage connector.
- (2) Connect connector clamp on fuel gage connector.
- (3) Install instrument panel assembly (para 7-15).
- (4) Set multimeter to ohms.
- (5) Connect positive (+) probe of multimeter to connector P82 socket 2.
- (6) Connect negative (-) probe of multimeter to a known good ground and note reading on multimeter.
- (7) If continuity is not present, repair wire 3001 from connector P82 socket 2 to terminal lug TL83 (para 2-40) or replace start and charging cable assembly (para 7-82).
- (8) If continuity is present, replace fuel level sensor (para 4-8).
- (9) Connect connector P82 to fuel level sensor.
- (10) Connect connector clamp on fuel level sensor.

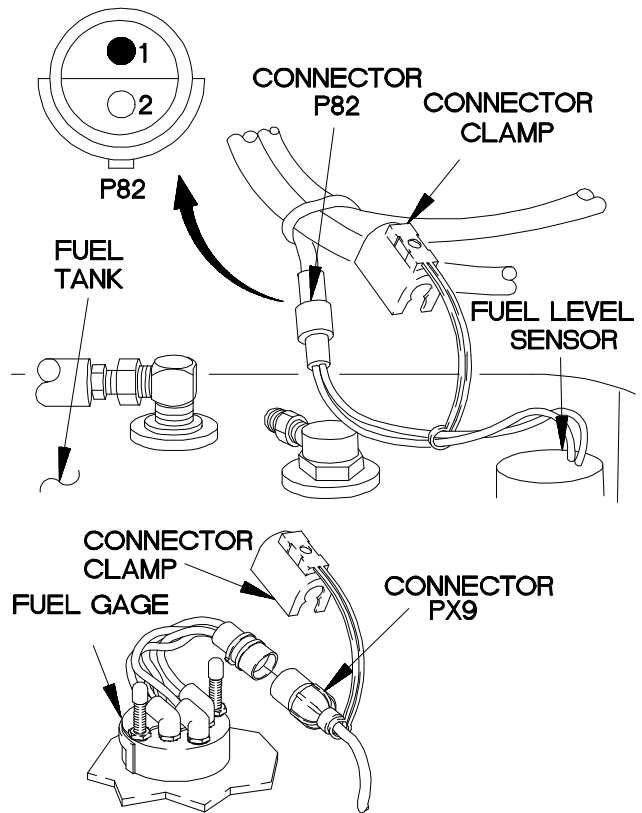

XBE0704B

e7. FUEL GAGE DOES NOT OPERATE OR IS INACCURATE (CONT)

KNOWN INFO
Lighted indicator display OK. FUEL gage illuminates. FUEL gage OK. Fuel level sensor OK.
POSSIBLE PROBLEMS
Faulty dashboard cable assembly. Faulty start and charging cable assembly.

5. **CAUTION**
Read CAUTION on following page.

Is continuity present from connector J43 socket 3 to connector PX9 pin 4?

TEST OPTIONS
Continuity Test or STE/ICE-R Test #91
REASON FOR QUESTION
If continuity is not present, wire 28 in dashboard cable assembly is faulty. If continuity is present, wire 28 in start and charging cable assembly is faulty.

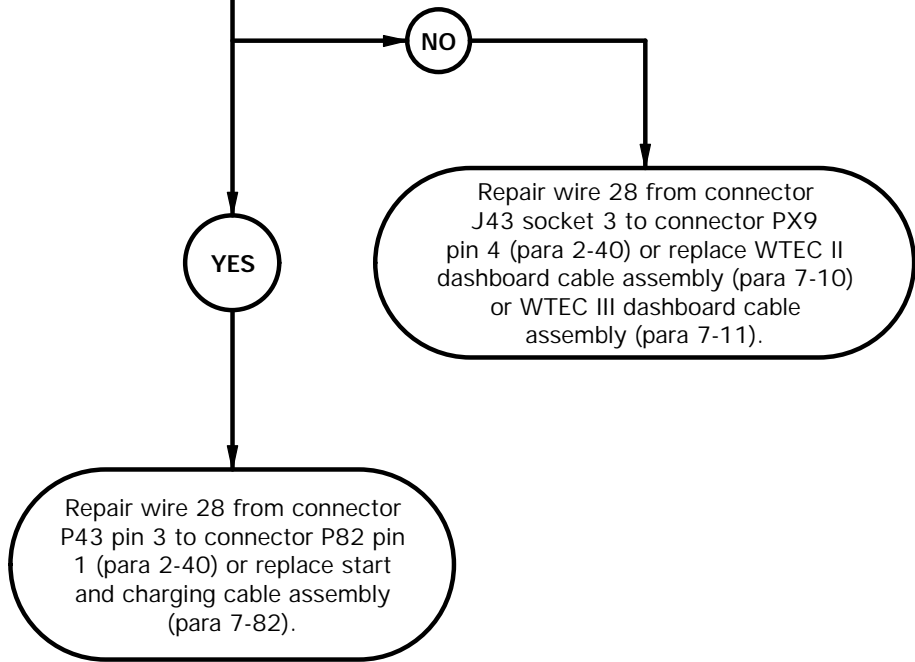

CAUTION

Use care when testing electrical connectors. Do not damage connector pins or sockets with multimeter probes. Failure to comply may result in damage to equipment.

NOTE

Inspect connector pins/sockets for damage, corrosion, and serviceability. Check that connector pins are not pushed back and are capable of making good contact.

CONTINUITY TEST

- (1) Connect connector P82 to fuel level sensor.
- (2) Connect connector clamp on fuel level sensor.
- (3) Disconnect connector J43 from connector P43.
- (4) Set multimeter to ohms.
- (5) Connect positive (+) probe of multimeter to connector J43 socket 3.
- (6) Connect negative (-) probe of multimeter to PX9 pin 4 and note reading on multimeter.
- (7) If continuity is not present, repair wire 28 from connector PX9 pin 4 to connector J43 socket 3 (para 2-40) or replace WTEC II dashboard cable assembly (para 7-10) or WTEC III dashboard cable assembly (para 7-11).
- (8) If continuity is present, repair wire 28 from connector P43 pin 3 to connector P82 pin 1 (para 2-40) or replace start and charging cable assembly (para 7-82).
- (9) Connect connector J43 to connector P43.
- (10) Connect connector PX9 to fuel gage connector.
- (11) Connect connector clamp on fuel gage connector.
- (12) Install instrument panel assembly (para 7-15).

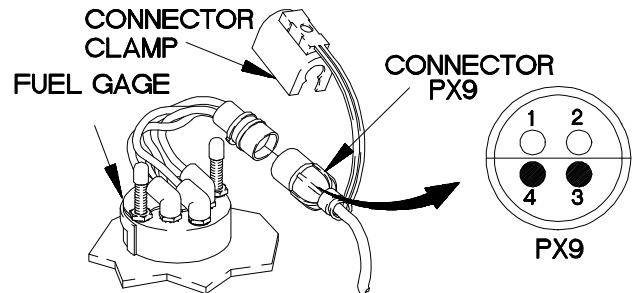
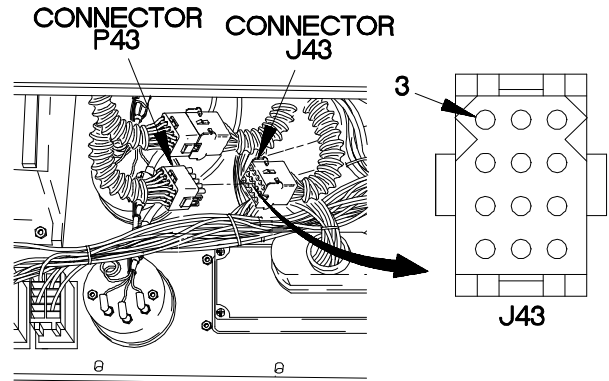
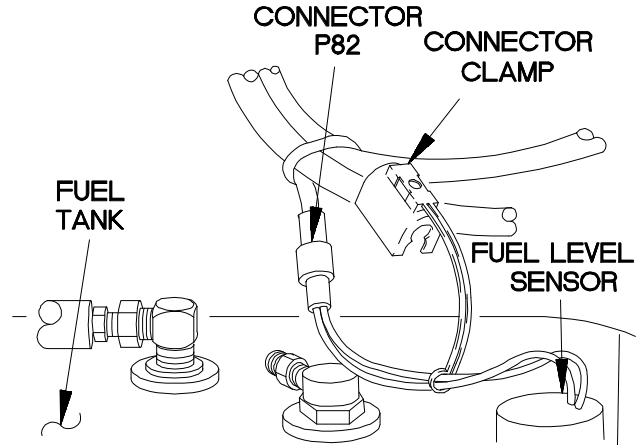

XBE0705B

e8. WATER TEMP GAGE DOES NOT OPERATE OR IS INACCURATE

INITIAL SETUP

Equipment Condition

Engine shut down (TM 9-2320-365-10).

Personnel Required

(2)

References

TM 9-4910-571-12&P

Tools and Special Tools

Tool Kit, Genl Mech (Item 44, Appendix C)

STE/ICE-R (Item 39, Appendix C)

Multimeter, Digital (Item 22, Appendix C)

Materials/Parts

Wire, Elect, 50 ft (Item 77, Appendix D)

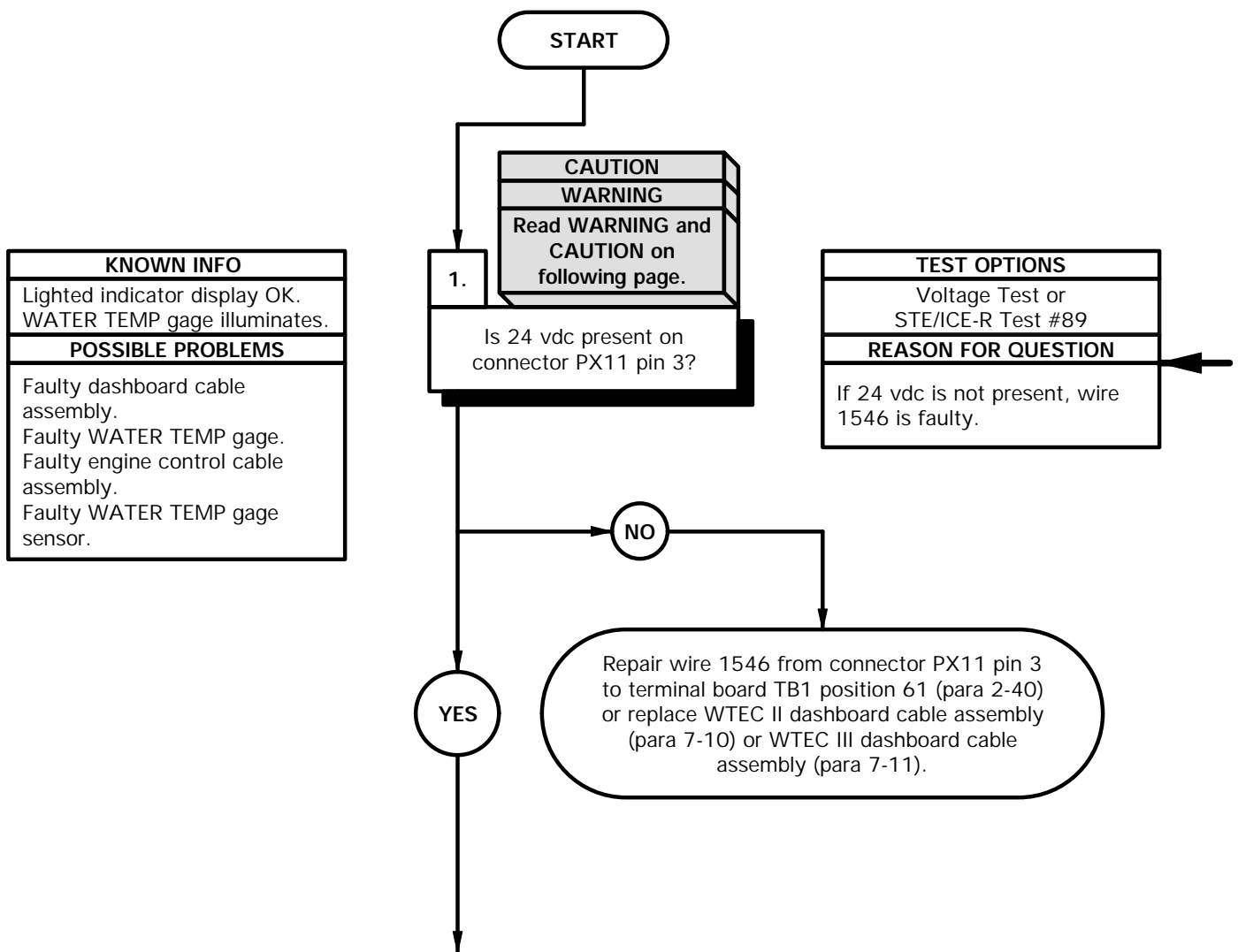

WARNING

Remove rings, bracelets, watches, necklaces, and any other jewelry before working around vehicle. Jewelry can catch on equipment and cause injury or short across electrical circuits and cause severe burns or electrical shock.

CAUTION

Use care when testing electrical connectors. Do not damage connector pins or sockets with multimeter probes. Failure to comply may result in damage to equipment.

NOTE

Inspect connector pins/sockets for damage, corrosion, and serviceability. Check that connector pins are not pushed back and are capable of making good contact.

VOLTAGE TEST

- (1) Remove instrument panel assembly for access (para 7-15).
- (2) Disconnect connector clamp from WATER TEMP gage connector.
- (3) Disconnect connector PX11 from WATER TEMP gage connector.
- (4) Set multimeter to volts dc.
- (5) Connect positive (+) probe of multimeter to connector PX11 pin 3.
- (6) Connect negative (-) probe of multimeter to ground.
- (7) Position master power switch to on (TM 9-2320-365-10) and note reading on multimeter.
- (8) If 24 vdc is not present, repair wire 1546 from connector PX11 pin 3 to terminal board TB1 position 61 (para 2-40) or replace WTEC II dashboard cable assembly (para 7-10) or WTEC III dashboard cable assembly (para 7-11).
- (9) Position master power switch to off (TM 9-2320-365-10).

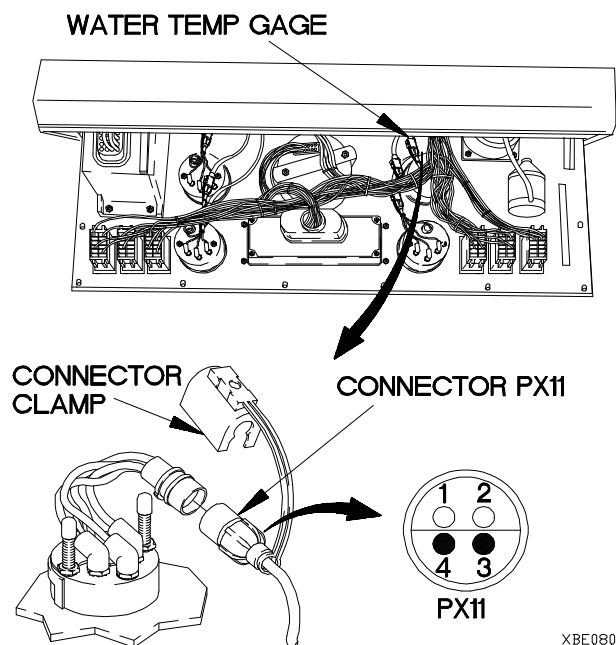

e8. WATER TEMP GAGE DOES NOT OPERATE OR IS INACCURATE (CONT)

KNOWN INFO
Lighted indicator display OK. WATER TEMP gage illuminates.
POSSIBLE PROBLEMS
Faulty WATER TEMP gage. Faulty dashboard cable assembly. Faulty engine control cable assembly. Faulty WATER TEMP gage sensor.

2.

CAUTION
Read CAUTION on following page.

Is less than 750 ohms present from connector PX11 pin 4 to a known good ground?

TEST OPTIONS
Resistance Test or STE/ICE-R Test #91
REASON FOR QUESTION
If less than 750 ohms resistance is present, WATER TEMP gage is faulty.

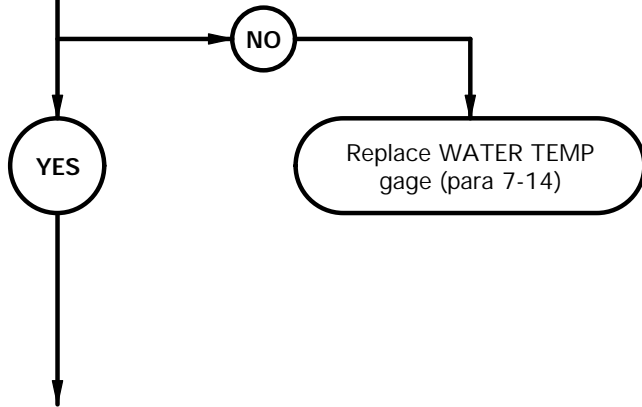

CAUTION

Use care when testing electrical connectors. Do not damage connector pins or sockets with multimeter probes. Failure to comply may result in damage to equipment.

NOTE

Inspect connector pins/sockets for damage, corrosion, and serviceability. Check that connector pins are not pushed back and are capable of making good contact.

RESISTANCE TEST

- (1) Set multimeter to ohms.
- (2) Connect positive (+) probe of multimeter to connector PX11 pin 4.
- (3) Connect negative (-) probe of multimeter to a known good ground and note reading on multimeter.
- (4) If less than 750 ohms is present, go to step 3 of this fault.
- (5) If greater than 750 ohms is present, replace WATER TEMP gage (para 7-14).

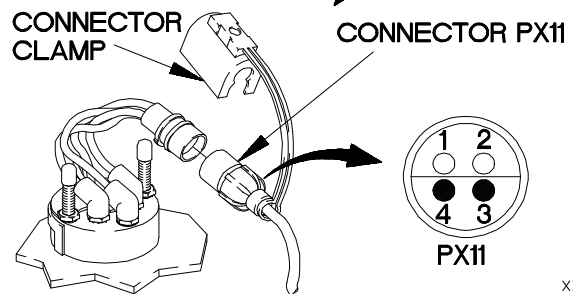
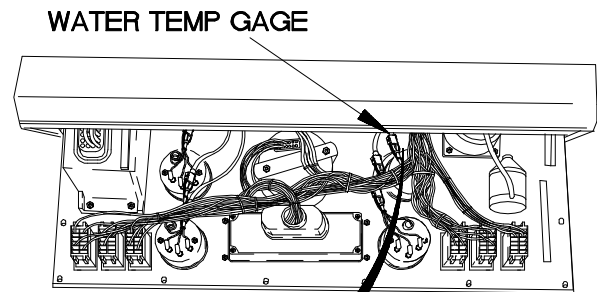

XBE0801B

e8. WATER TEMP GAGE DOES NOT OPERATE OR IS INACCURATE (CONT)

KNOWN INFO
Lighted indicator display OK. WATER TEMP gage illuminates. WATER TEMP gage OK.
POSSIBLE PROBLEMS
Faulty dashboard cable assembly. Faulty engine control cable assembly. Faulty WATER TEMP gage sensor.

3.

CAUTION
Read CAUTION on following page.

Is continuity present from connector PX11 pin 4 to connector P41?

TEST OPTIONS
Continuity Test or STE/ICE-R Test #91
REASON FOR QUESTION
If continuity is present, WATER TEMP gage sensor is faulty.

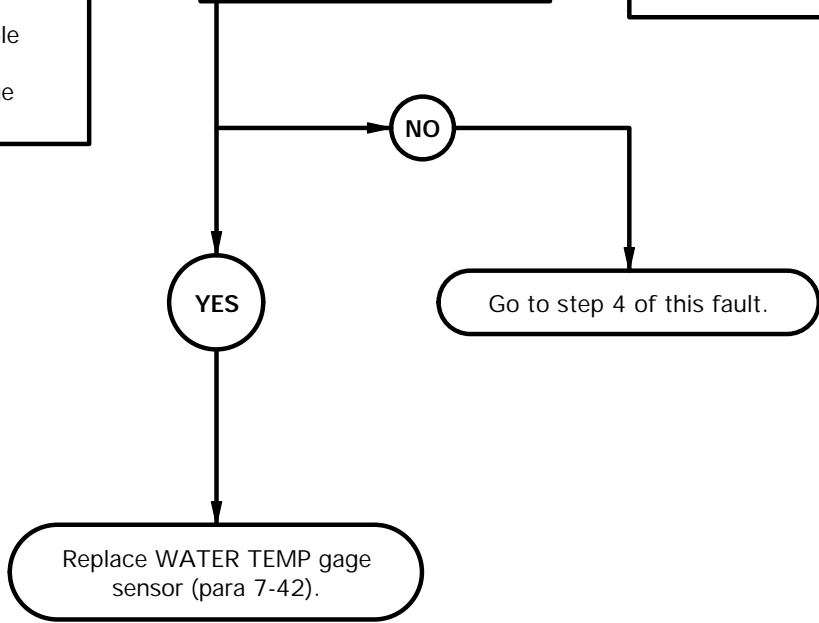

CAUTION

Use care when testing electrical connectors. Do not damage connector pins or sockets with multimeter probes. Failure to comply may result in damage to equipment.

NOTE

Inspect connector pins/sockets for damage, corrosion, and serviceability. Check that connector pins are not pushed back and are capable of making good contact.

CONTINUITY TEST

- (1) Raise cab (TM 9-2320-365-10).
- (2) Disconnect connector clamp from WATER TEMP gage sensor connector, if equipped.
- (3) Disconnect connector P41 from WATER TEMP gage sensor connector.
- (4) Set multimeter to ohms.
- (5) Connect positive (+) probe of multimeter to connector PX11 pin 4.
- (6) Connect negative (-) probe of multimeter to connector P41 and note reading on multimeter.
- (7) If continuity is not present, go to step 4 of this fault.
- (8) If continuity is present, replace WATER TEMP gage sensor (para 7-42).
- (9) Connect connector P41 to WATER TEMP gage sensor connector.
- (10) Connect connector clamp to WATER TEMP gage sensor connector, if equipped.
- (11) Lower cab (TM 9-2320-365-10).

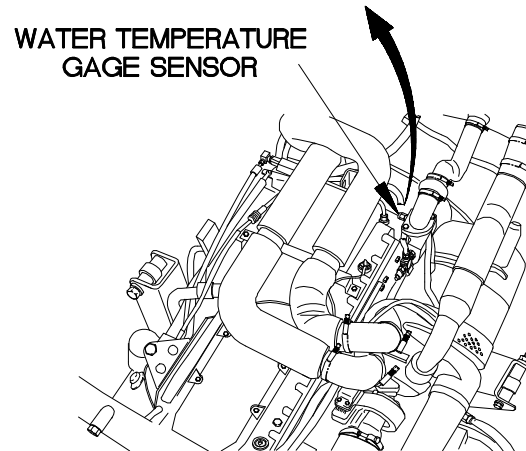
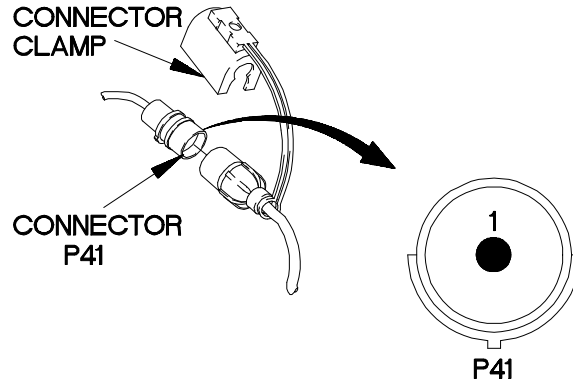

xBe0802B

e8. WATER TEMP GAGE DOES NOT OPERATE OR IS INACCURATE (CONT)

KNOWN INFO
Lighted indicator display OK. WATER TEMP gage illuminates. WATER TEMP gage OK. WATER TEMP gage sensor OK.
POSSIBLE PROBLEMS
Faulty dashboard cable assembly. Faulty engine control cable assembly.

CAUTION
Read CAUTION on following page.

4. Is continuity present from connector PX11 pin 4 to connector J31 pin 20?

TEST OPTIONS
Continuity Test or STE/ICE-R Test #91
REASON FOR QUESTION
If continuity is not present, wire 33 in dashboard cable assembly is faulty. If continuity is present, wire 33 in engine control cable assembly is faulty.

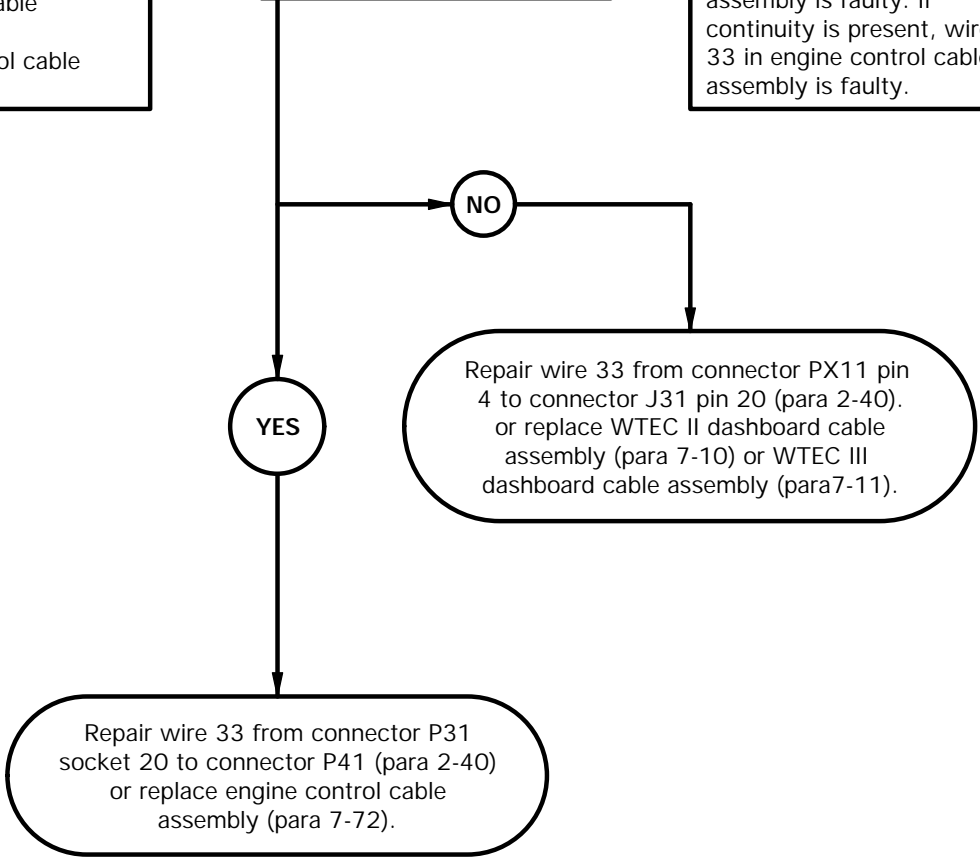

CAUTION

Use care when testing electrical connectors. Do not damage connector pins or sockets with multimeter probes. Failure to comply may result in damage to equipment.

NOTE

Inspect connector pins/sockets for damage, corrosion, and serviceability. Check that connector pins are not pushed back and are capable of making good contact.

- CONTINUITY TEST**
- (1) Disconnect connector J31 from connector P31.
 - (2) Set multimeter to ohms.
 - (3) Connect positive (+) probe of multimeter to connector PX11 pin 4.
 - (4) Connect negative (-) probe of multimeter to connector J31 pin 20 and note reading on multimeter.
 - (5) If continuity is not present, repair wire 33 from connector PX11 pin 4 to connector J31 pin 20 (para 2-40) or replace WTEC II dashboard cable assembly (para 7-10) or WTEC III dashboard cable assembly (para 7-11).
 - (6) If continuity is present, repair wire 33 from connector P31 socket 20 to connector P41 (para 2-40) or replace engine control cable assembly (para 7-72).
 - (7) Connect connector J31 to connector P31.
 - (8) Connect connector PX11 to WATER TEMP gage connector.
 - (9) Connect connector clamp on WATER TEMP gage connector.
 - (10) Install instrument panel assembly (para 7-15).

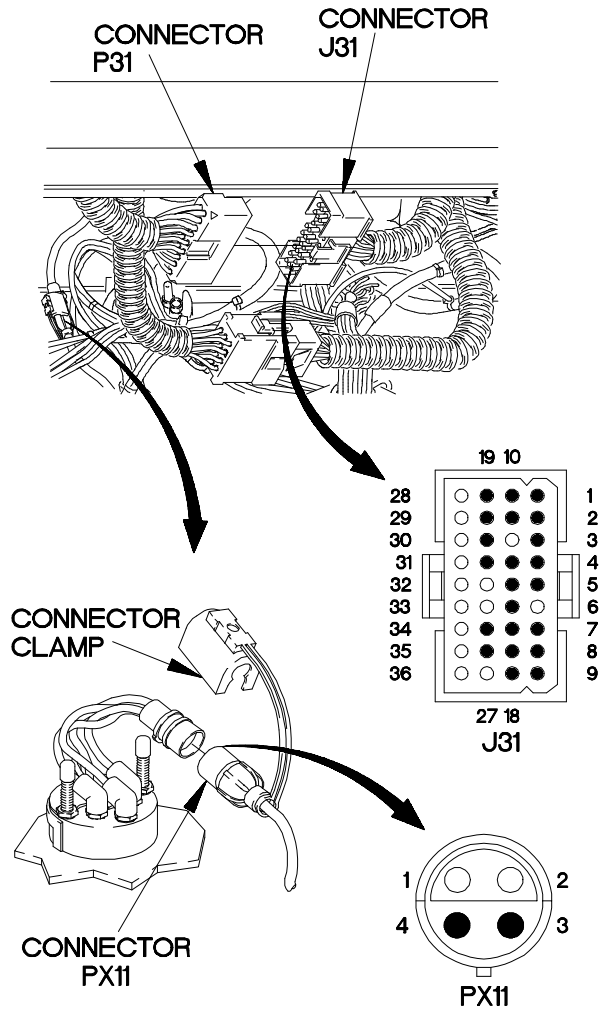

XBE0803B

e9. REAR BRAKE AIR PRESSURE GAGE DOES NOT OPERATE OR IS INACCURATE

INITIAL SETUP

Equipment Condition

Engine shut down (TM 9-2320-365-10).
Air tanks drained (TM9-2320-365-10)

Personnel Required

(2)

Materials/Parts

Nut, Self-Locking (Item 148, Appendix G)
Antiseize Compound (Item 14, Appendix D)
Ties, Cable, Plastic (Item 76, Appendix D)

Tools and Special Tools

Tool Kit, Genl Mech (Item 44, Appendix C)
STE/ICE-R (Item 39, Appendix C)
Multimeter, Digital (Item 22, Appendix C)
Wrench, Torque, 0-300 lb-in. (Item 58.1, Appendix C)

References

TM 9-4910-571-12&P

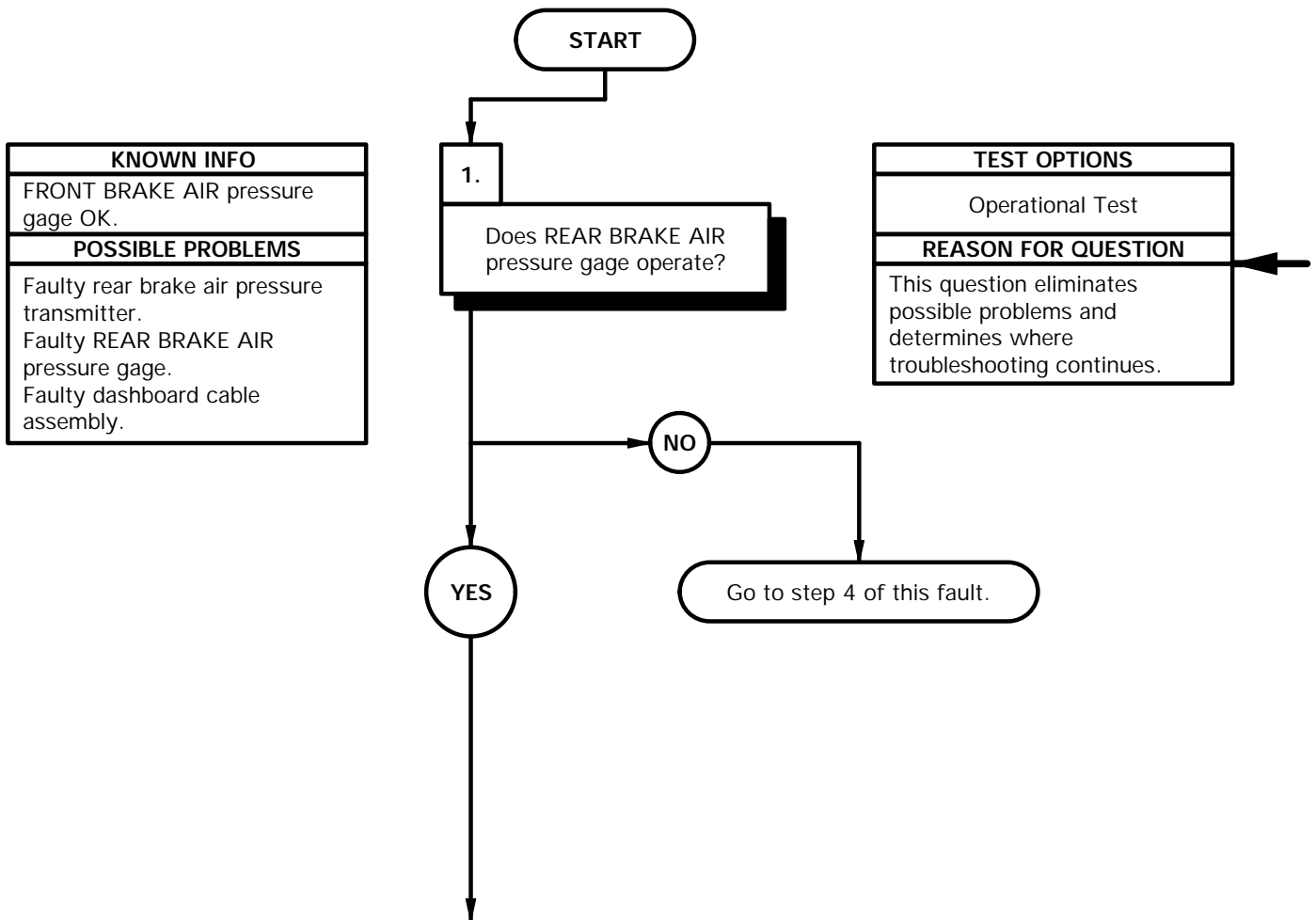

OPERATIONAL TEST

- (1) Start engine (TM 9-2320-365-10).
- (2) Allow vehicle to build air pressure.
- (3) Note reading on REAR BRAKE AIR pressure gage.
- (4) If REAR BRAKE AIR pressure gage reads 0 PSI, go to step 4 of this fault.
- (5) Shut down engine (TM 9-2320-365-10).

**REAR BRAKE
AIR PRESSURE GAGE**

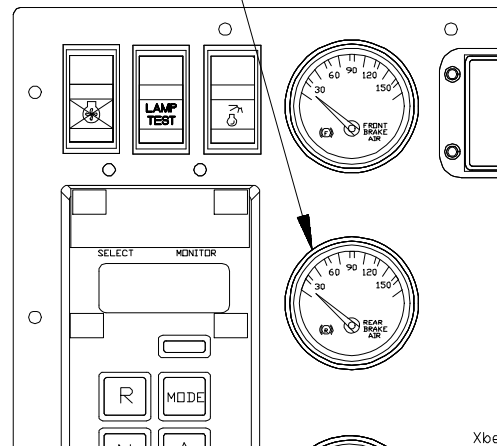

Xbe0901B

e9. REAR BRAKE AIR PRESSURE GAGE DOES NOT OPERATE OR IS INACCURATE (CONT)

KNOWN INFO
FRONT BRAKE AIR pressure gage OK.
POSSIBLE PROBLEMS
Faulty rear brake air pressure transmitter. Faulty REAR BRAKE AIR pressure gage.

2.
Is mounting surface between air pressure transmitters mounting bracket and dashboard free from corrosion and are all fittings and hardware tight?

TEST OPTIONS
Visual Inspection
REASON FOR QUESTION
If mounting surfaces are not free of corrosion or fittings and hardware are not tight the pressure transmitter will give a faulty reading.

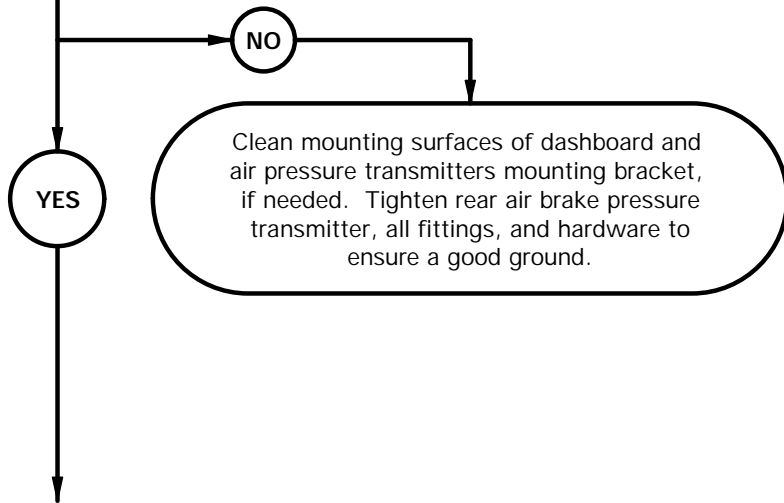

OPERATIONAL TEST

- (1) Remove instrument panel assembly for access (para 7-15).

NOTE

Note orientation of brackets on dashboard prior to removing.

- (2) Remove self-locking nut, air pressure transmitters mounting bracket, screw and bracket from dashboard. Discard self-locking nut.
- (3) Inspect dashboard and air pressure transmitters mounting bracket mounting surfaces for corrosion.
- (4) If mounting surfaces between air pressure transmitters mounting bracket and dashboard are not free of corrosion or all fittings and hardware are not tight, clean mounting surfaces if needed. Tighten rear brake air pressure transmitter, all fittings, and hardware to ensure a good ground.
- (5) Position bracket, screw, air pressure transmitters mounting bracket, and self-locking nut on dashboard.
- (6) Tighten self-locking nut to 168-192 lb-in. (19-21 N.m).
- (7) Install instrument panel assembly (para 7-15).

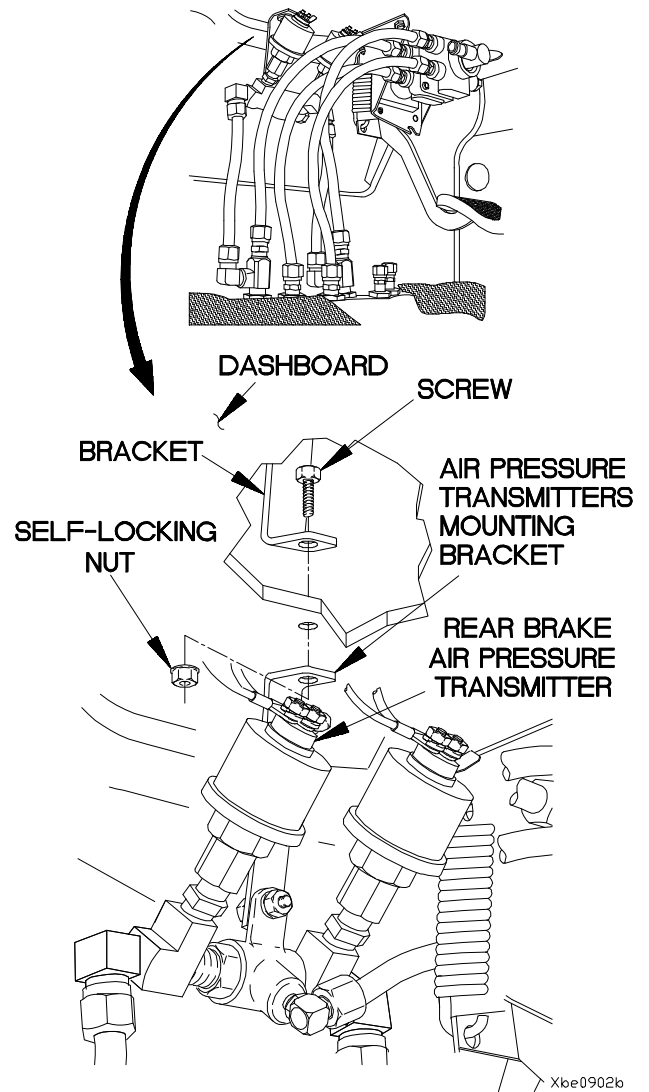

e9. REAR BRAKE AIR PRESSURE GAGE DOES NOT OPERATE OR IS INACCURATE (CONT)

KNOWN INFO
FRONT BRAKE AIR pressure gage OK. Dashboard cable assembly OK.
POSSIBLE PROBLEMS
Faulty REAR BRAKE AIR pressure gage. Faulty rear brake air pressure transmitter.

3.
Does REAR BRAKE AIR pressure gage operate normally with a known good rear brake air pressure transmitter?

TEST OPTIONS
Operational Test
REASON FOR QUESTION
If REAR BRAKE AIR pressure gage does not operate, REAR BRAKE AIR pressure gage is faulty. If REAR BRAKE AIR pressure gage does operate, rear brake air pressure transmitter is faulty.

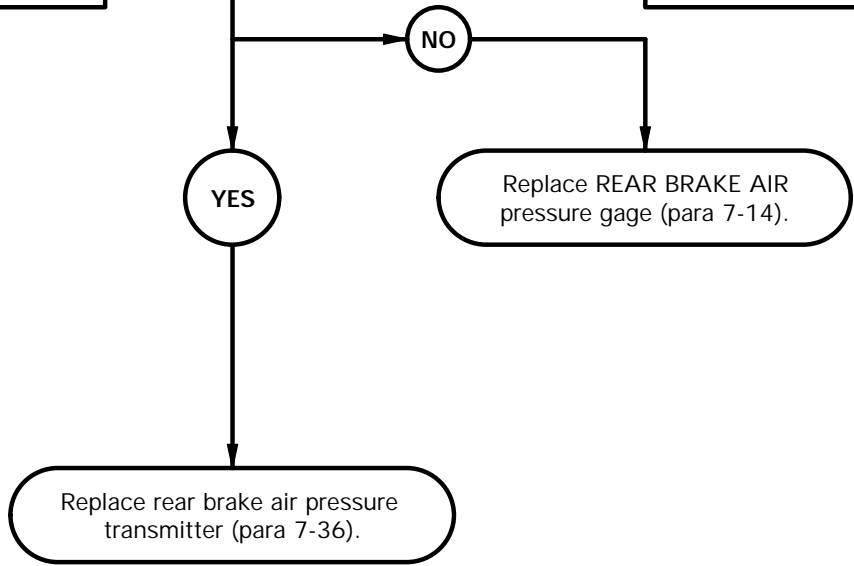

CONTINUITY TEST

- (1) Replace rear brake air pressure transmitter (para 7-36).
- (2) Start engine (TM 9-2320-365-10).
- (3) Observe REAR BRAKE AIR pressure gage and allow vehicle to build air pressure.
- (4) If REAR BRAKE AIR pressure gage does not operate normally, replace REAR BRAKE AIR pressure gage (para 7-14).
- (5) If REAR BRAKE AIR pressure gage does operate normally, replace rear brake air pressure transmitter (para 7-36).
- (6) Shut down engine (TM 9-2320-365-10).

**REAR BRAKE
AIR PRESSURE GAGE**

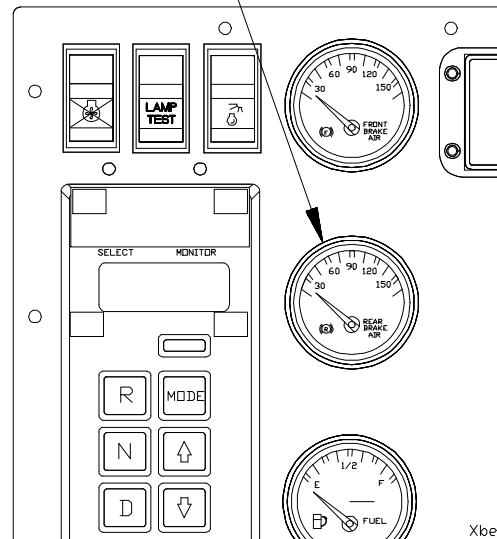

Xbe0903B

e9. REAR BRAKE AIR PRESSURE GAGE DOES NOT OPERATE OR IS INACCURATE (CONT)

KNOWN INFO
FRONT BRAKE AIR pressure gage OK.
POSSIBLE PROBLEMS
Faulty rear brake air pressure transmitter. Faulty REAR BRAKE AIR pressure gage. Faulty dashboard cable assembly.

4.

WARNING
CAUTION
Read WARNING and CAUTION on following page.

Is 24 VDC present at connector PX5 pin 3?

TEST OPTIONS
Voltage Test or STE/ICE-R Test #89
REASON FOR QUESTION
If 24 VDC is not present, wire 1546 is faulty.

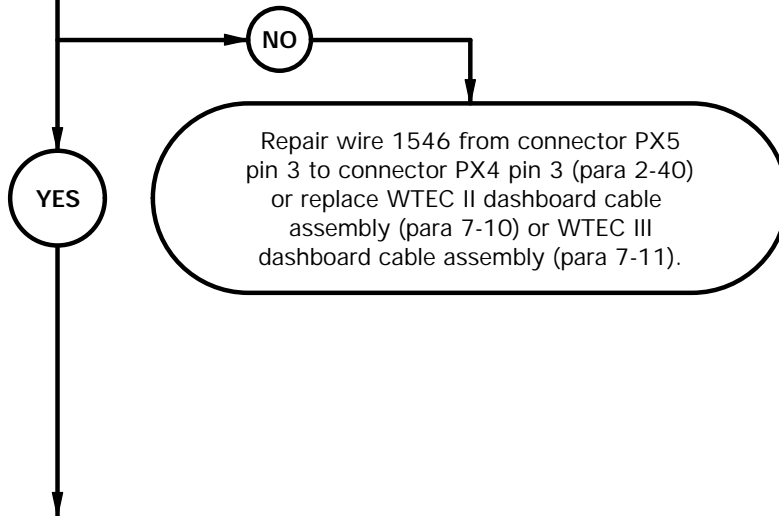

WARNING

Remove rings, bracelets, watches, necklaces, and any other jewelry before working around vehicle. Jewelry can catch on equipment and cause injury or short across electrical circuits and cause severe burns or electrical shock.

CAUTION

Use care when testing electrical connectors. Do not damage connector pins or sockets with multimeter probes. Failure to comply may result in damage to equipment.

NOTE

Inspect connector pins/sockets for damage, corrosion, and serviceability. Check that connector pins are not pushed back or not capable of making good contact.

VOLTAGE TEST

- (1) Remove instrument panel for access (para 7-15).
- (2) Disconnect connector clamp from REAR BRAKE AIR pressure gage connector.
- (3) Disconnect connector PX5 from REAR BRAKE AIR pressure gage connector.
- (4) Set multimeter to volts DC.
- (5) Connect positive (+) probe of multimeter to connector PX5 pin 3.
- (6) Connect negative (-) probe of multimeter to ground.
- (7) Position master power switch to on (TM 9-2320-365-10).
- (8) If 24 VDC is not present, repair wire 1546 from connector PX5 pin 3 to connector PX4 pin 3 (para 2-40) or replace WTEC II dashboard cable assembly (para 7-10) or WTEC III dashboard cable assembly (para 7-11).
- (9) Position master power switch to off (TM 9-2320-365-10).

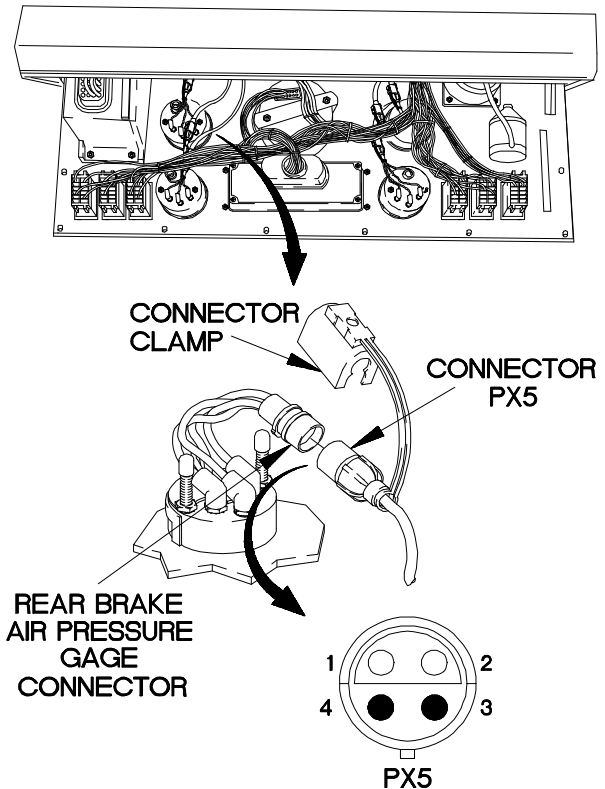

Xbe0904b

e9. REAR BRAKE AIR PRESSURE GAGE DOES NOT OPERATE OR IS INACCURATE (CONT)

KNOWN INFO
FRONT BRAKE AIR pressure gage OK.
POSSIBLE PROBLEMS
Faulty rear brake air pressure transmitter. Faulty REAR BRAKE AIR pressure gage. Faulty dashboard cable assembly.

5.

CAUTION
Read CAUTION on following page.

Is continuity present from connector PX5 pin 4 to terminal lug TL151?

TEST OPTIONS
Continuity Test or STE/ICE-R Test #91
REASON FOR QUESTION
If continuity is not present, wire 1792 is faulty.

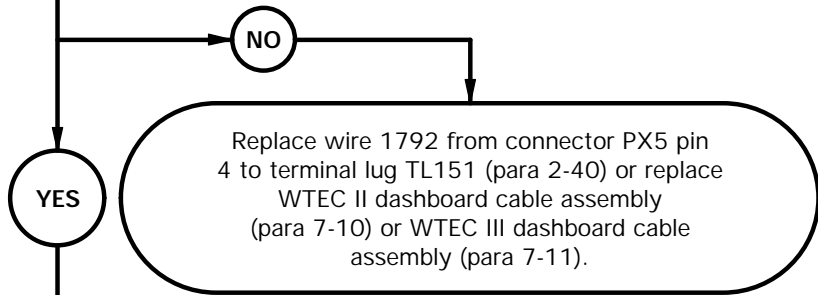

KNOWN INFO
FRONT BRAKE AIR pressure gage OK. Dashboard cable assembly OK.
POSSIBLE PROBLEMS
Faulty REAR BRAKE AIR pressure gage. Faulty rear brake air pressure transmitter.

6.

Is continuity present from rear brake air pressure transmitter housing to ground?

TEST OPTIONS
Continuity Test or STE/ICE-R Test #91
REASON FOR QUESTION
If continuity is not present, ground is faulty.

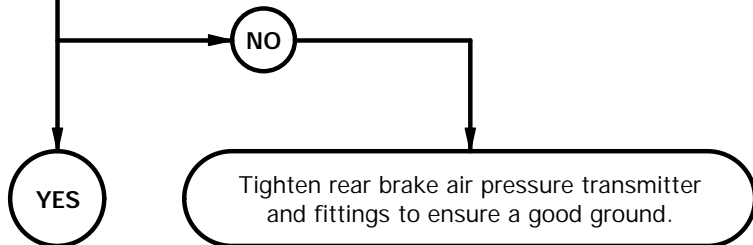

CAUTION

Use care when testing electrical connectors. Do not damage connector pins or sockets with multimeter probes. Failure to comply may result in damage to equipment.

NOTE

Inspect connector pins/sockets for damage, corrosion, and serviceability. Check that connector pins are not pushed back or not capable of making good contact.

CONTINUITY TEST

NOTE

Remove plastic cable ties as required.

- (1) Set multimeter to ohms.
- (2) Connect positive (+) probe of multimeter to connector PX5 pin 4.
- (3) Connect negative (-) probe of multimeter to terminal lug TL151 and note reading on multimeter.
- (4) If continuity is not present, replace wire 1792 from connector PX5 pin 4 to terminal lug TL151 (para 2-40) or replace WTEC II dashboard cable assembly (para 7-10) or WTEC III dashboard cable assembly (para 7-11).

CONTINUITY TEST

- (1) Set multimeter to ohms.
- (2) Connect positive (+) probe of multimeter to rear air brake pressure transmitter housing.
- (3) Connect negative (-) probe of multimeter to ground and note reading on multimeter.
- (4) If continuity is not present, tighten rear brake air pressure transmitter and fittings to ensure a good ground.
- (5) Connect connector PX5 to REAR BRAKE AIR pressure gage connector.
- (6) Connect connector clamp to REAR BRAKE AIR pressure gage connector.

NOTE

Install plastic cable ties as required.

- (7) Install instrument panel assembly (para 7-15).

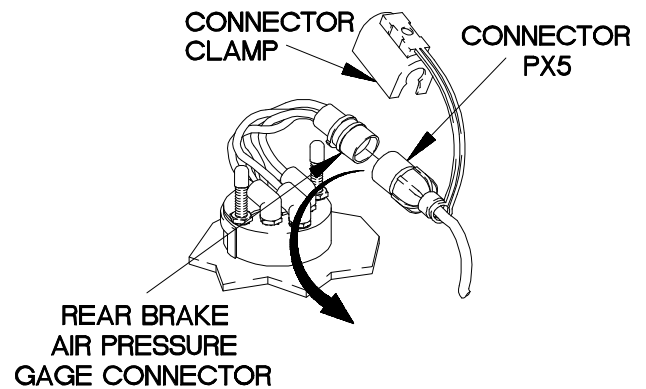
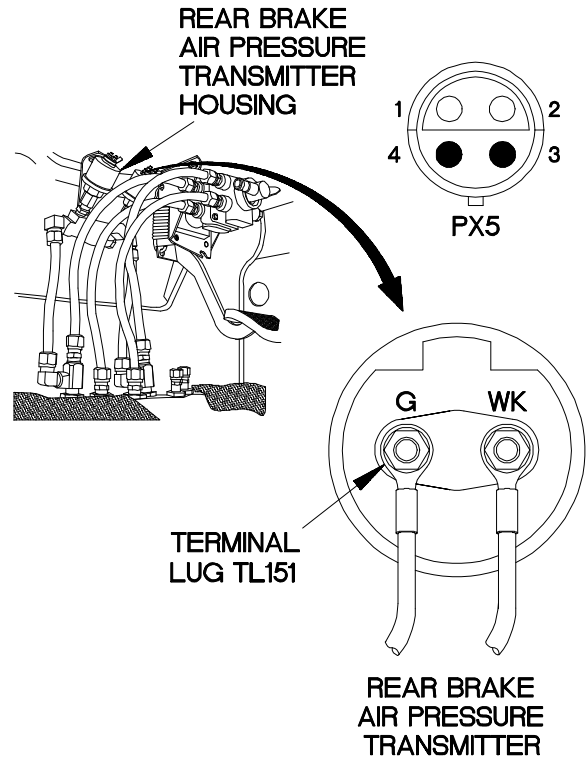

Xbe0905b

e9. REAR BRAKE AIR PRESSURE GAGE DOES NOT OPERATE OR IS INACCURATE (CONT)

KNOWN INFO
FRONT BRAKE AIR pressure gage OK. Dashboard cable assembly OK.
POSSIBLE PROBLEMS
Faulty REAR BRAKE AIR pressure gage. Faulty rear brake air pressure transmitter.

7.
Does REAR BRAKE AIR pressure gage operate with a known good rear air brake pressure transmitter?

TEST OPTIONS
Operational Test
REASON FOR QUESTION
If REAR BRAKE AIR pressure gage does not operate, REAR BRAKE AIR pressure gage is faulty. If REAR BRAKE AIR pressure gage does operate, rear brake air pressure transmitter is faulty.

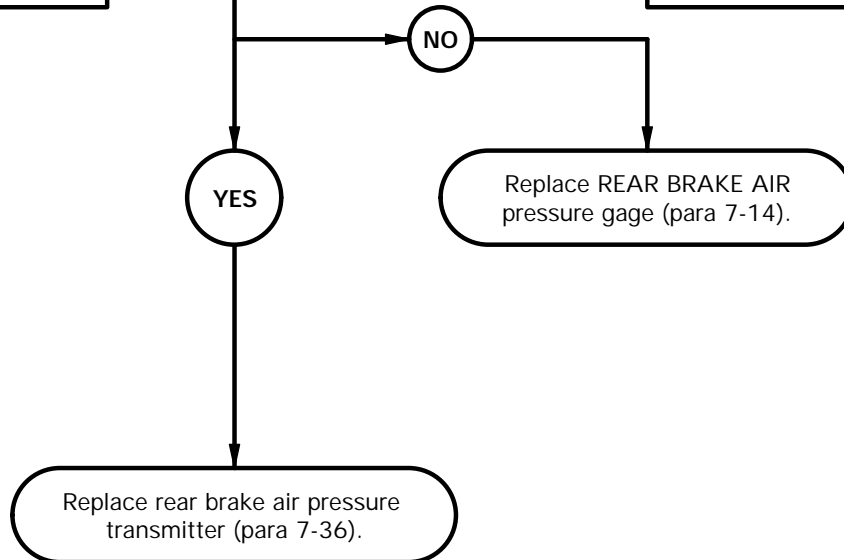

CONTINUITY TEST

- (1) Replace rear brake air pressure transmitter (para 7-36).
- (2) Start engine (TM 9-2320-365-10).
- (3) Allow vehicle to build air pressure.
- (4) Note reading on REAR BRAKE AIR pressure gage.
- (5) If REAR BRAKE AIR pressure gage does not operate, replace REAR BRAKE AIR pressure gage (para 7-14).
- (6) If REAR BRAKE AIR pressure gage does operate, replace rear brake air pressure transmitter (para 7-36).
- (7) Shut down engine (TM 9-2320-365-10).

REAR BRAKE AIR GAGE

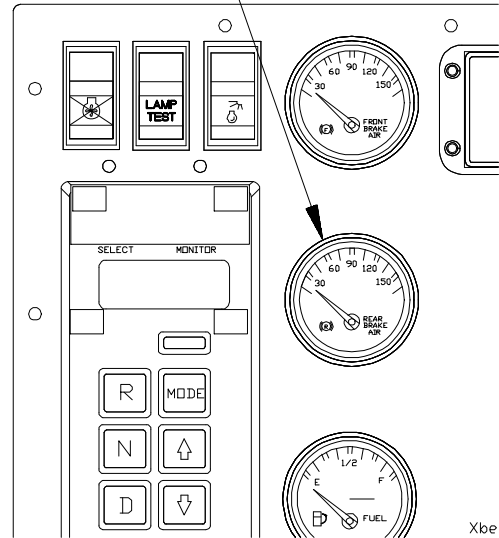

Xbe0903B

e10. FRONT BRAKE AIR PRESSURE GAGE DOES NOT OPERATE OR IS INACCURATE

INITIAL SETUP

Equipment Condition

Engine shut down (TM 9-2320-365-10).
Air tanks drained (TM9-2320-365-10)

Personnel Required

(2)

Materials/Parts

Nut, Self-Locking (Item 148, Appendix G)
Antiseize Compound (Item 14, Appendix D)
Ties, Cable, Plastic (Item 76, Appendix D)

Tools and Special Tools

Tool Kit, Genl Mech (Item 44, Appendix C)
STE/ICE-R (Item 39, Appendix C)
Multimeter, Digital (Item 22, Appendix C)
Wrench, Torque, 0-300 lb-in. (Item 58.1, Appendix C)

References

TM 9-4910-571-12&P

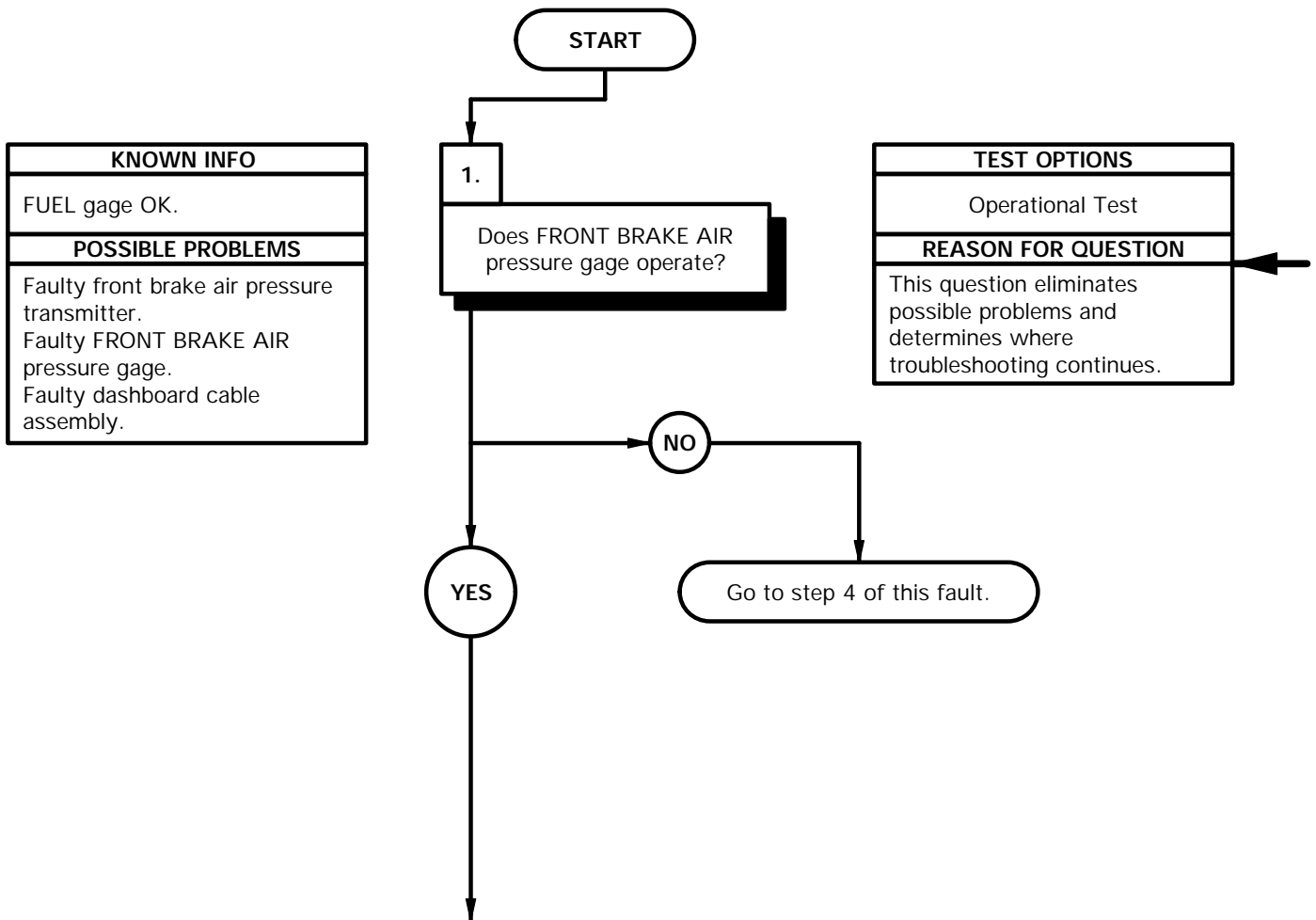

OPERATIONAL TEST

- (1) Start engine (TM 9-2320-365-10).
- (2) Allow vehicle to build air pressure.
- (3) Note reading on FRONT BRAKE AIR pressure gage.
- (4) If FRONT BRAKE AIR pressure gage reads 0 PSI, go to step 4 of this fault.
- (5) Shut down engine (TM 9-2320-365-10).

**FRONT BRAKE
AIR PRESSURE GAGE**

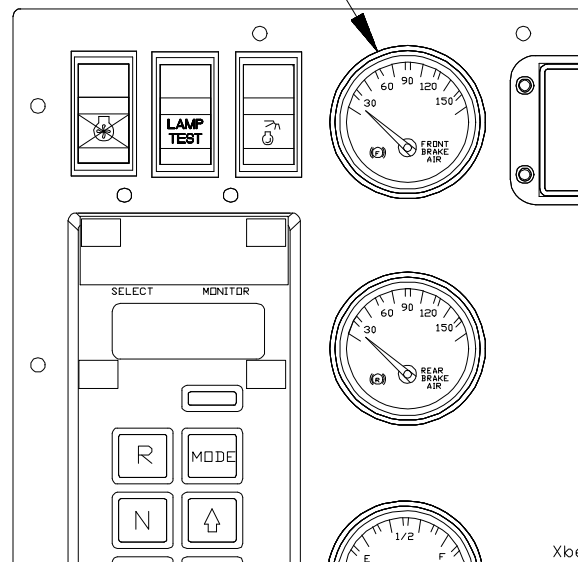

Xloe1001B

e10. FRONT BRAKE AIR PRESSURE GAGE DOES NOT OPERATE OR IS INACCURATE (CONT)

KNOWN INFO
FUEL gage OK.
POSSIBLE PROBLEMS
Faulty front brake air pressure transmitter. Faulty FRONT BRAKE AIR pressure gage.

2.
Is mounting surface between air pressure transmitters mounting bracket and dashboard free from corrosion and are all fittings and hardware tight?

TEST OPTIONS
Visual Inspection
REASON FOR QUESTION
If mounting surfaces are not free of corrosion or fittings and hardware are not tight the pressure transmitter will give a faulty reading.

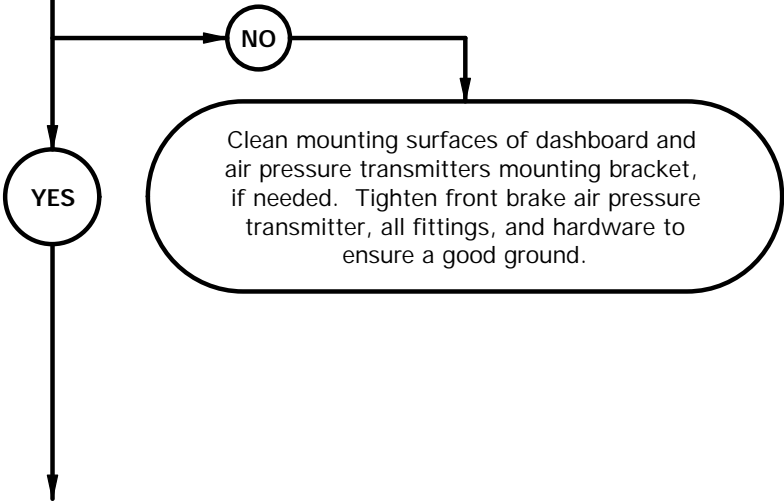

OPERATIONAL TEST

- (1) Remove instrument panel assembly for access (para 7-15).

NOTE

Note orientation of brackets on dashboard prior to removing.

- (2) Remove self-locking nut, air pressure transmitters mounting bracket, screw and bracket from dashboard. Discard self-locking nut.
- (3) Inspect dashboard and air pressure transmitters mounting bracket mounting surfaces for corrosion.
- (4) If mounting surfaces between air pressure transmitters mounting bracket and dashboard are not free of corrosion or all fittings and hardware are not tight, clean mounting surfaces if needed. Tighten front brake air pressure transmitter, all fittings, and hardware to ensure a good ground.
- (5) Position bracket, screw, air pressure transmitters mounting bracket, and self-locking nut on dashboard.
- (6) Tighten self-locking nut to 168-192 lb-in. (19-21 N.m).
- (7) Install instrument panel assembly (para 7-15).

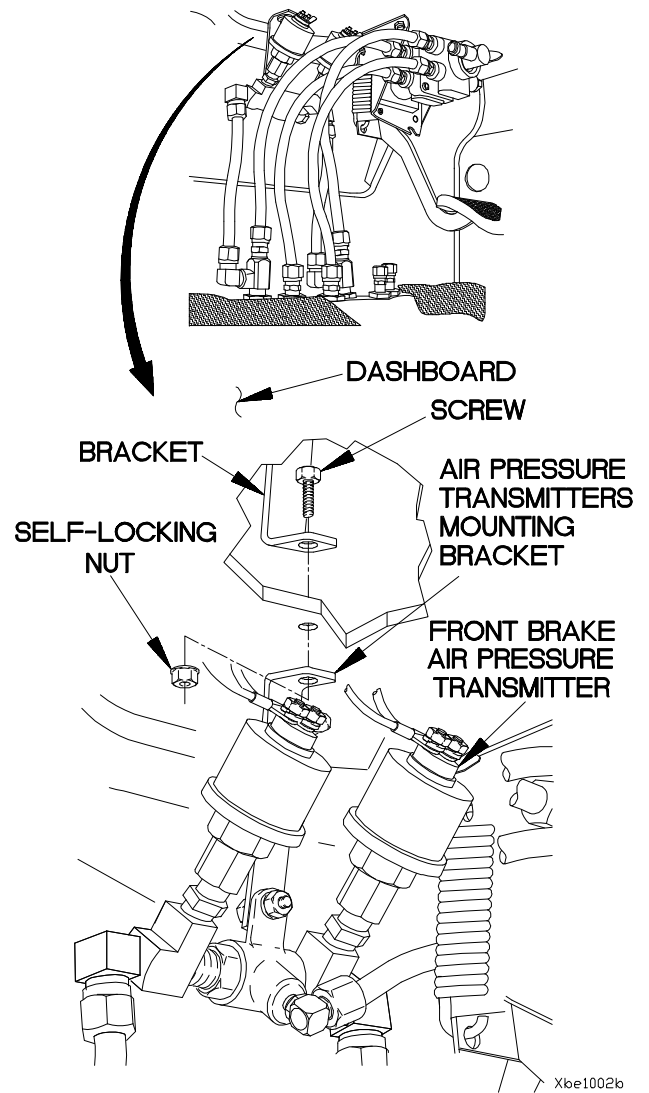

Xbe1002b

e10. FRONT BRAKE AIR PRESSURE GAGE DOES NOT OPERATE OR IS INACCURATE (CONT)

KNOWN INFO
FUEL gage OK. Dashboard cable assembly OK.
POSSIBLE PROBLEMS
Faulty FRONT BRAKE AIR pressure gage. Faulty front brake air pressure transmitter.

3.
Does FRONT BRAKE AIR pressure gage operate normally with a known good rear air pressure transmitter?

TEST OPTIONS
Operational Test
REASON FOR QUESTION
If FRONT BRAKE AIR pressure gage does not operate, FRONT BRAKE AIR pressure gage is faulty. If FRONT BRAKE AIR pressure gage does operate, front brake air pressure transmitter is faulty.

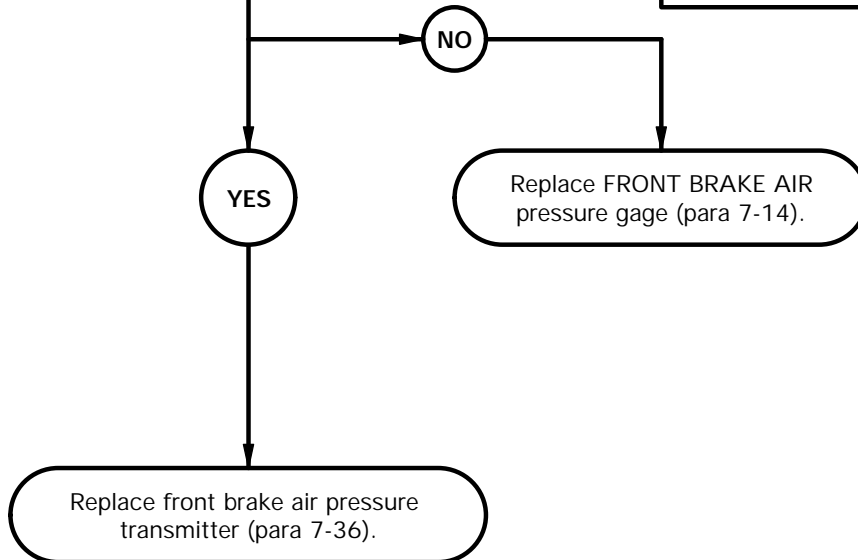

CONTINUITY TEST

- (1) Replace front brake air pressure transmitter (para 7-36).
- (2) Start engine (TM 9-2320-365-10).
- (3) Observe FRONT BRAKE AIR pressure gage and allow vehicle to build air pressure.
- (4) If FRONT BRAKE AIR pressure gage does not operate normally, replace FRONT BRAKE AIR pressure gage (para 7-14).
- (5) If FRONT BRAKE AIR pressure gage does operate normally, replace front brake air pressure transmitter (para 7-36).
- (6) Shut down engine (TM 9-2320-365-10).

**FRONT BRAKE
AIR PRESSURE GAGE**

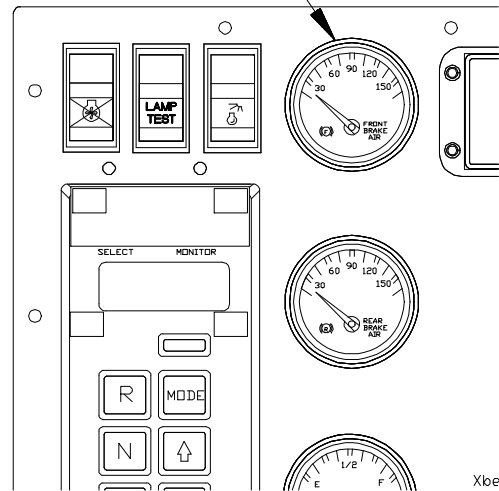

Xloe1003B

e10. FRONT BRAKE AIR PRESSURE GAGE DOES NOT OPERATE OR IS INACCURATE (CONT)

KNOWN INFO
FUEL gage OK.
POSSIBLE PROBLEMS
Faulty front brake air pressure transmitter. Faulty FRONT BRAKE AIR pressure gage. Faulty dashboard cable assembly.

4.

WARNING
CAUTION
Read WARNING and CAUTION on following page.

Is 24 VDC present at connector PX4 pin 3?

TEST OPTIONS
Voltage Test or STE/ICE-R Test #89
REASON FOR QUESTION
If 24 VDC is not present, wire 1546 is faulty.

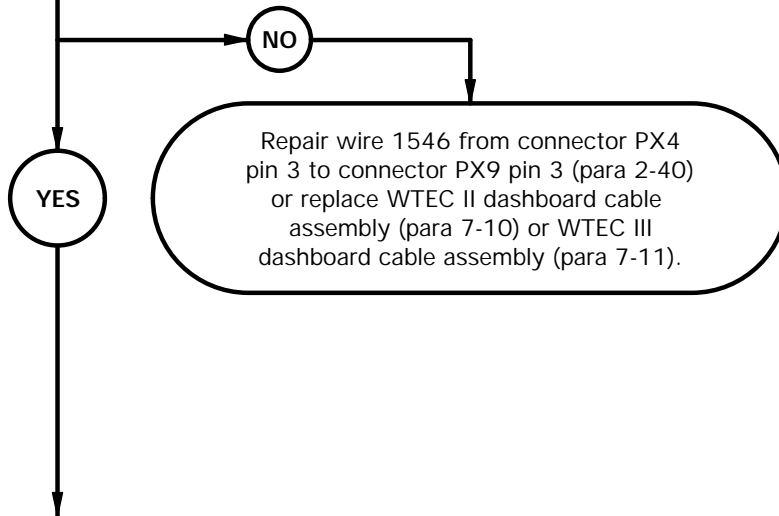

WARNING

Remove rings, bracelets, watches, necklaces, and any other jewelry before working around vehicle. Jewelry can catch on equipment and cause injury or short across electrical circuits and cause severe burns or electrical shock.

CAUTION

Use care when testing electrical connectors. Do not damage connector pins or sockets with multimeter probes. Failure to comply may result in damage to equipment.

NOTE

Inspect connector pins/sockets for damage, corrosion, and serviceability. Check that connector pins are not pushed back or not capable of making good contact.

VOLTAGE TEST

- (1) Remove instrument panel for access (para 7-15).
- (2) Disconnect connector clamp from FRONT BRAKE AIR pressure gage connector.
- (3) Disconnect connector PX4 from FRONT BRAKE AIR pressure gage connector.
- (4) Set multimeter to volts DC.
- (5) Connect positive (+) probe of multimeter to connector PX4 pin 3.
- (6) Connect negative (-) probe of multimeter to ground.
- (7) Position master power switch to on (TM 9-2320-365-10).
- (8) If 24 VDC is not present, repair wire 1546 from connector PX4 pin 3 to connector PX9 pin 3 (para 2-40) or replace WTEC II dashboard cable assembly (para 7-10) or WTEC III dashboard cable assembly (para 7-11).
- (9) Position master power switch to off (TM 9-2320-365-10).

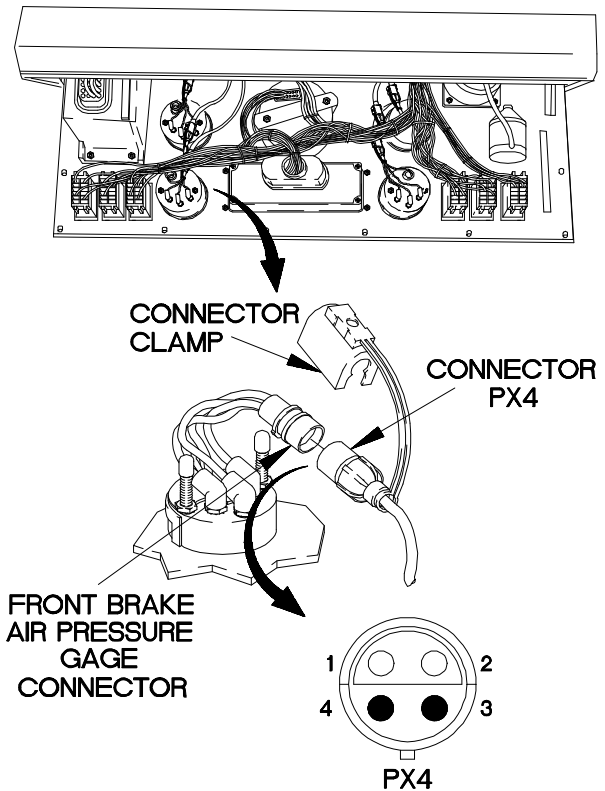

Xbe1004b

e10. FRONT BRAKE AIR PRESSURE GAGE DOES NOT OPERATE OR IS INACCURATE (CONT)

KNOWN INFO
FUEL gage OK.
POSSIBLE PROBLEMS
Faulty front brake air pressure transmitter. Faulty FRONT BRAKE AIR pressure gage. Faulty dashboard cable assembly.

5.

CAUTION
Read CAUTION on following page.

Is continuity present from connector PX4 pin 4 to terminal lug TL150?

TEST OPTIONS
Continuity Test or STE/ICE-R Test #91
REASON FOR QUESTION
If continuity is not present, wire 1792 is faulty.

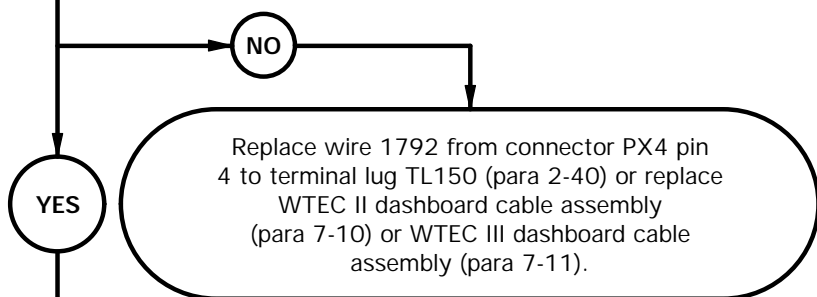

KNOWN INFO
FUEL gage OK. Dashboard cable assembly OK.
POSSIBLE PROBLEMS
Faulty FRONT BRAKE AIR pressure gage. Faulty front brake air pressure transmitter.

6.

Is continuity present from front brake air pressure transmitter housing to ground?

TEST OPTIONS
Continuity Test or STE/ICE-R Test #91
REASON FOR QUESTION
If continuity is not present, ground is faulty.

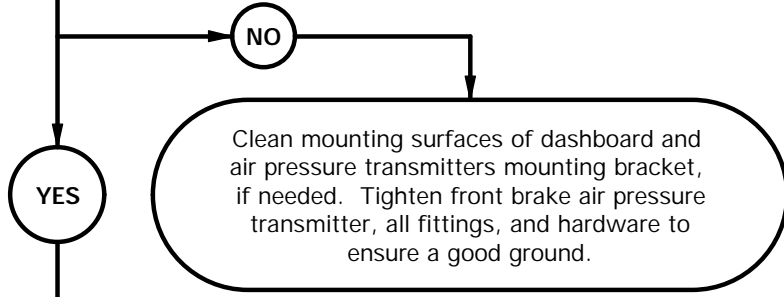

CAUTION

Use care when testing electrical connectors. Do not damage connector pins or sockets with multimeter probes. Failure to comply may result in damage to equipment.

NOTE

Inspect connector pins/sockets for damage, corrosion, and serviceability. Check that connector pins are not pushed back or not capable of making good contact.

CONTINUITY TEST

NOTE

Remove plastic cable ties as required.

- (1) Set multimeter to ohms.
- (2) Connect positive (+) probe of multimeter to connector PX4 pin 4.
- (3) Connect negative (-) probe of multimeter to terminal lug TL150 and note reading on multimeter.
- (4) If continuity is not present, replace wire 1792 from connector PX4 pin 4 to terminal lug TL150 (para 2-40) or replace WTEC II dashboard cable assembly (para 7-10) or WTEC III dashboard cable assembly (para 7-11).

CONTINUITY TEST

- (1) Set multimeter to ohms.
- (2) Connect positive (+) probe of multimeter to front brake air pressure transmitter housing.
- (3) Connect negative (-) probe of multimeter to ground and note reading on multimeter.
- (4) If continuity is not present, perform steps (5) through (12).
- (5) Remove self-locking nut, air pressure transmitters mounting bracket, screw, and bracket from dashboard. Discard self-locking nut.
- (6) Inspect dashboard and air pressure transmitters mounting bracket for corrosion.
- (7) If mounting surface is corroded or fittings and hardware are not tight, clean mounting surface if needed. Tighten front brake air pressure transmitter, all fittings, and hardware to ensure a good ground.
- (8) Position bracket, screw, air pressure transmitters mounting bracket, and self-locking nut on dashboard.
- (9) Tighten self-locking nut to 168-192 lb-in. (19-21 N.m).

CONTINUITY TEST (Cont)

- (10) Connect connector PX4 to FRONT BRAKE AIR pressure gage connector.
- (11) Connect connector clamp to FRONT BRAKE AIR pressure gage.

NOTE

Install plastic cable ties as required

- (12) Install instrument panel assembly (para 7-15).

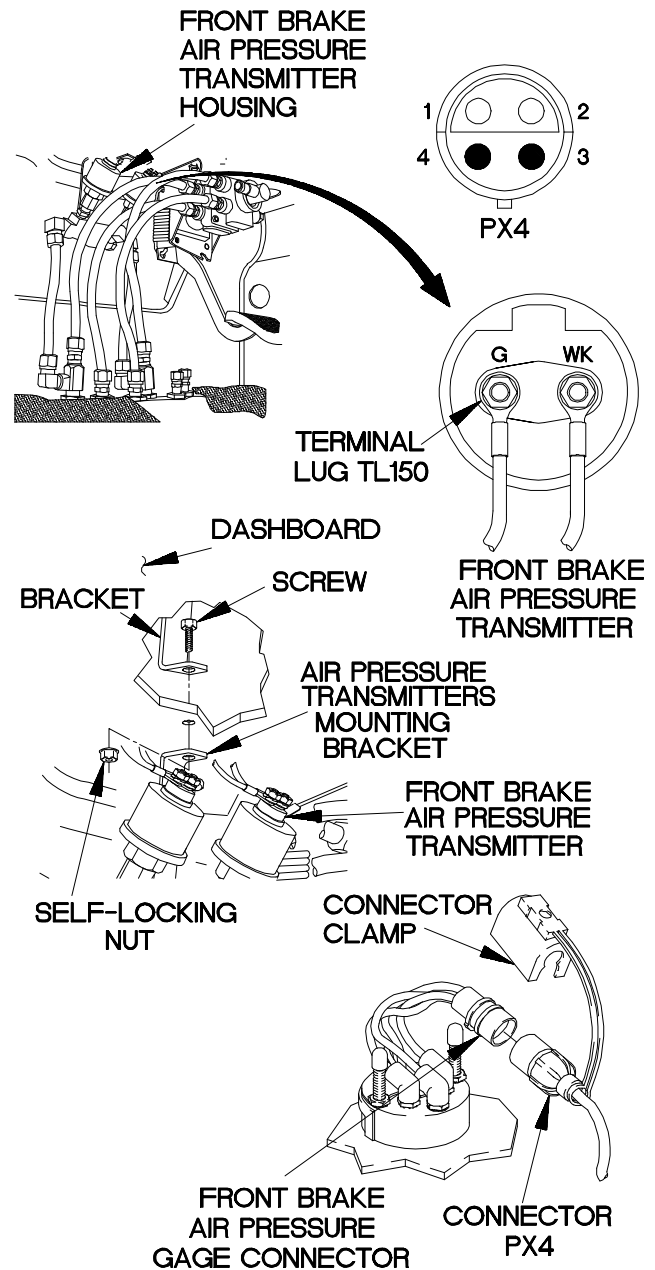

Xb6e1005b

e10. FRONT BRAKE AIR PRESSURE GAGE DOES NOT OPERATE OR IS INACCURATE (CONT)

KNOWN INFO
FUEL gage OK. Dashboard cable assembly OK.
POSSIBLE PROBLEMS
Faulty FRONT BRAKE AIR pressure gage. Faulty rear brake air pressure transmitter.

7.
Does FRONT BRAKE AIR pressure gage operate with a known good front brake air pressure transmitter?

TEST OPTIONS
Operational Test
REASON FOR QUESTION
If FRONT BRAKE AIR pressure gage does not operate, FRONT BRAKE AIR pressure gage is faulty. If REAR BRAKE AIR pressure gage does operate, front brake air pressure transmitter is faulty.

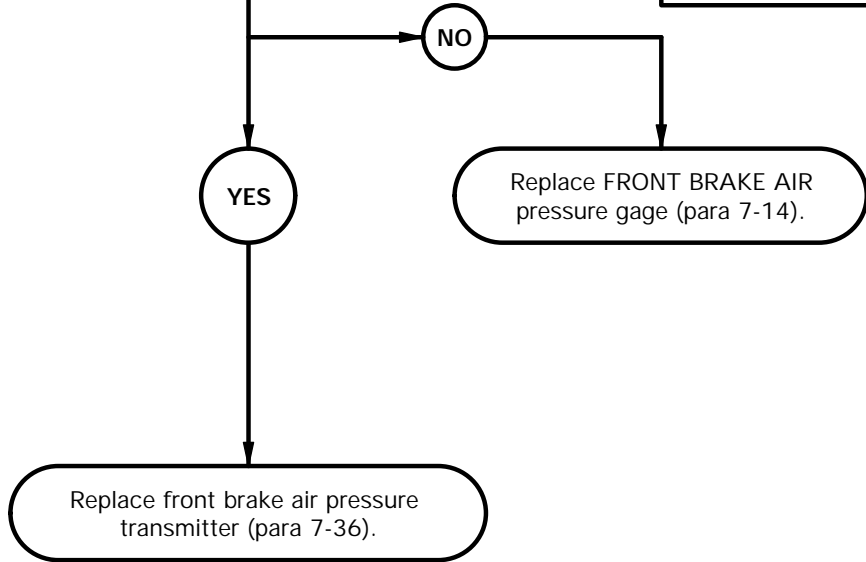

CONTINUITY TEST

- (1) Connect connector PX4 to FRONT BRAKE AIR pressure gage connector.
- (2) Connect connector clamp to FRONT BRAKE AIR pressure gage.
- (3) Install instrument panel assembly (para 7-15).
- (4) Replace front brake air pressure transmitter (para 7-36).
- (5) Start engine (TM 9-2320-365-10).
- (6) Allow vehicle to build air pressure.
- (7) Note reading on FRONT BRAKE AIR pressure gage.
- (8) If FRONT BRAKE AIR pressure gage does not operate, replace FRONT BRAKE AIR pressure gage (para 7-14).
- (9) If FRONT BRAKE AIR pressure gage does operate, replace front brake air pressure transmitter (para 7-36).
- (10) Shut down engine (TM 9-2320-365-10).

FRONT BRAKE AIR PRESSURE GAGE

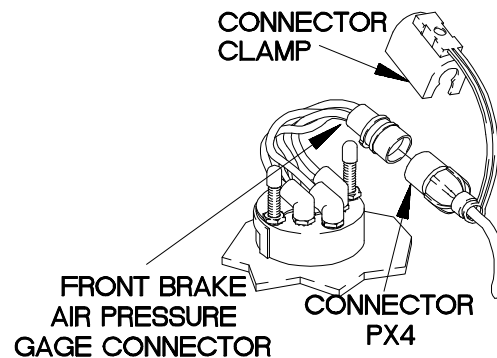
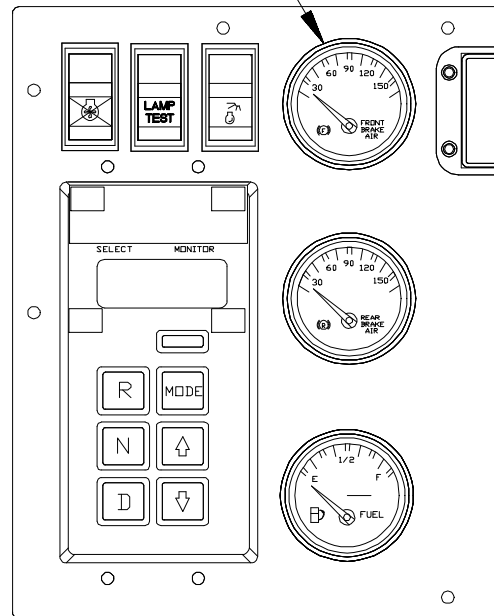

Xbe1006B

e11. ENGINE OIL PRESSURE GAGE DOES NOT OPERATE OR IS INACCURATE

INITIAL SETUP

Equipment Condition

Engine shut down (TM 9-2320-365-10).

Personnel Required

(2)

Tools and Special Tools

Tool Kit, Genl Mech (Item 44, Appendix C)

STE/ICE-R (Item 39, Appendix C)

Multimeter, Digital (Item 22, Appendix C)

References

TM 9-4910-571-12&P

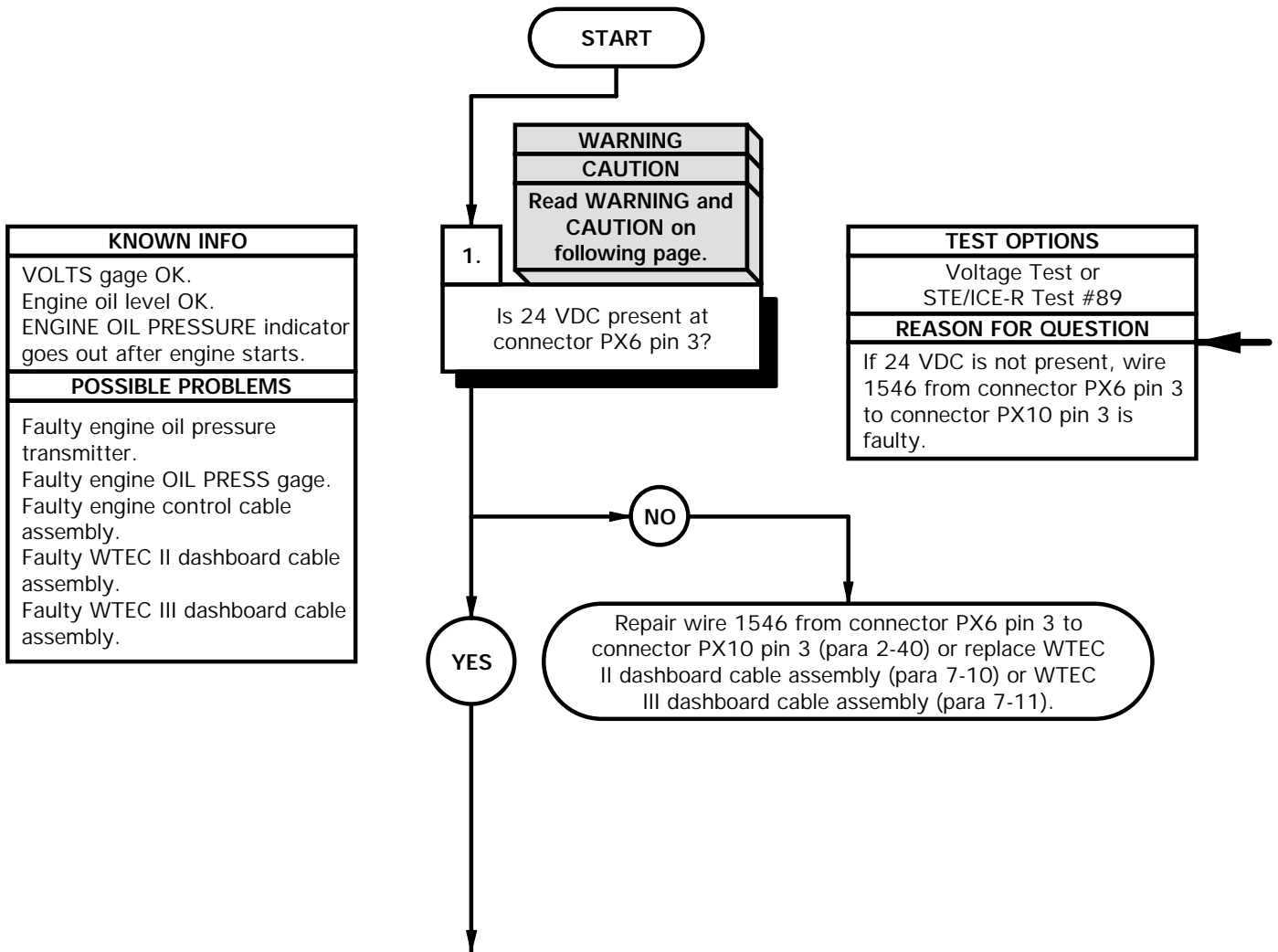

WARNING

Remove rings, bracelets, watches, necklaces, and any other jewelry before working around vehicle. Jewelry can catch on equipment and cause injury or short across electrical circuits and cause severe burns or electrical shock.

CAUTION

Use care when testing electrical connectors. Do not damage connector pins or sockets with multimeter probes. Failure to comply may result in damage to equipment.

NOTE

Inspect connector pins/sockets for damage, corrosion, and serviceability. Check that connector pins are not pushed back and are capable of making good contact.

VOLTAGE TEST

- (1) Remove instrument panel assembly for access (para 7-15).
- (2) Disconnect connector clamp from engine OIL PRESS gage connector.
- (3) Disconnect connector PX6 from engine OIL PRESS gage connector.
- (4) Set multimeter to volts DC.
- (5) Connect positive (+) probe of multimeter to connector PX6 pin 3.
- (6) Connect negative (-) probe of multimeter to known good ground.
- (7) Position master power switch to on (TM 9-2320-365-10) and note reading on multimeter.
- (8) If 24 VDC is not present, repair wire 1546 from connector PX6 pin 3 to connector PX10 pin 3 (para 2-40) or replace WTEC II dashboard cable assembly (para 7-10) or WTEC III dashboard cable assembly (para 7-11).
- (9) Position master power switch to off (TM 9-2320-365-10).

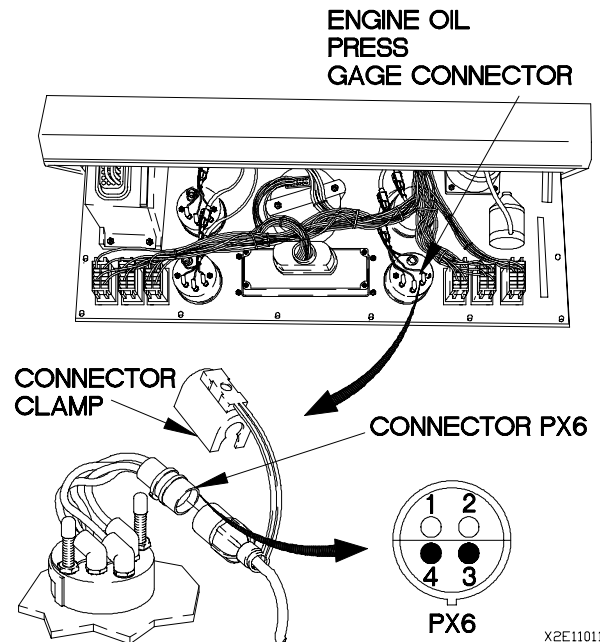

e11. ENGINE OIL PRESSURE GAGE DOES NOT OPERATE OR IS INACCURATE (CONT)

KNOWN INFO
VOLTS gage OK. Engine oil level OK. Engine oil pressure indicator goes out after engine starts.
POSSIBLE PROBLEMS
Faulty engine oil pressure transmitter. Faulty engine OIL PRESS gage. Faulty engine control cable assembly. Faulty WTEC II dashboard cable assembly. Faulty WTEC III dashboard cable assembly.

2.
Is 202-243 ohms resistance present from connector PX6 pin 4 to a known good ground?

TEST OPTIONS
Resistance Test or STE/ICE-R #91
REASON FOR QUESTION
This question eliminates possible problems and determines where troubleshooting continues.

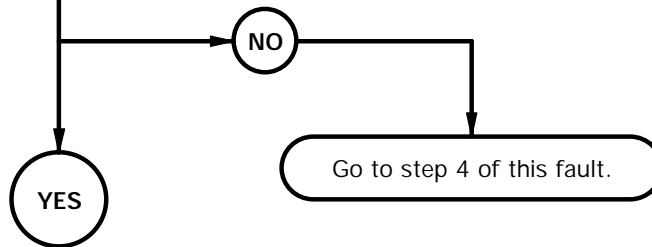

KNOWN INFO
VOLTS gage OK. Engine oil level OK. Engine oil pressure indicator goes out after engine starts. Engine control cable assembly OK. WTEC II dashboard cable assembly OK. WTEC III dashboard cable assembly OK.
POSSIBLE PROBLEMS
Faulty engine oil pressure transmitter. Faulty engine OIL PRESS gage.

3.
Is 90-130 ohms resistance present from connector PX6 pin 4 to a known good ground?

TEST OPTIONS
Resistance Test or STE/ICE-R #91
REASON FOR QUESTION
If 90-130 ohms resistance is not present, engine oil pressure transmitter is faulty. If 90-130 ohms of resistance is present, engine OIL PRESS gage is faulty.

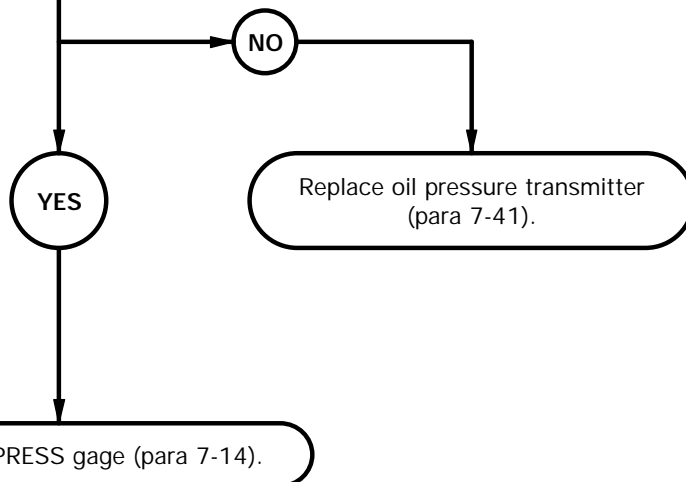

RESISTANCE TEST

- (1) Set multimeter to ohms.
- (2) Connect positive (+) probe of multimeter to connector PX6 pin 4.
- (3) Connect negative (-) probe of multimeter to known good ground and note reading on multimeter.
- (4) If 202-243 ohms resistance is not present, go to step 4 of this fault.

RESISTANCE TEST

- (1) Start engine (TM 9-2320-365-10).
- (2) Set multimeter to ohms.
- (3) Connect positive (+) probe of multimeter to connector PX6 pin 4.
- (4) Connect negative (-) probe of multimeter to known good ground and note reading on multimeter.
- (5) If 90-130 ohms resistance is not present, replace engine oil pressure transmitter (para 7-41).
- (6) If 90-130 ohms resistance is present, replace engine OIL PRESS gage (para 7-14).
- (7) Shut down engine (TM 9-2320-365-10).
- (8) Connect connector PX6 to engine OIL PRESS gage connector.
- (9) Connect connector clamp to engine OIL PRESS gage connector.
- (10) Install instrument panel assembly (para 7-15).

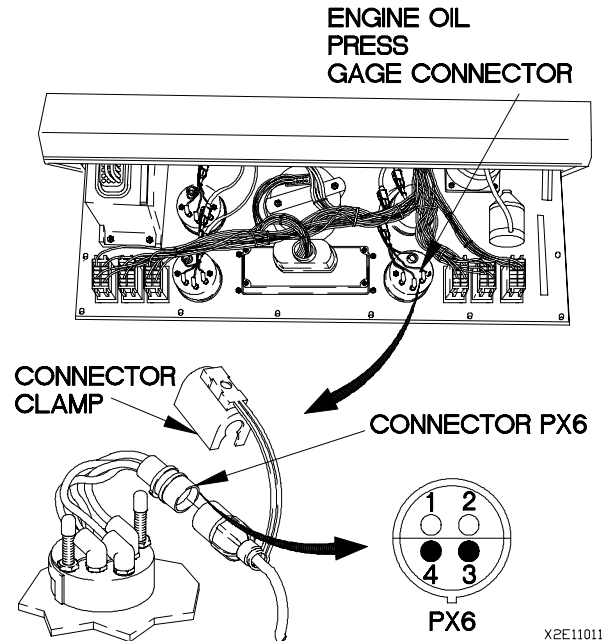

e11. ENGINE OIL PRESSURE GAGE DOES NOT OPERATE OR IS INACCURATE (CONT)

KNOWN INFO
VOLTS gage OK. Engine oil level OK. Engine oil pressure indicator goes out after engine starts.
POSSIBLE PROBLEMS
Faulty engine oil pressure transmitter. Faulty engine control cable assembly. Faulty WTEC II dashboard cable assembly. Faulty WTEC III dashboard cable assembly.

4.
Is 202-243 ohms resistance present from engine oil pressure transmitter connector pin 2 to a known good ground?

TEST OPTIONS
Resistance Test or STE/ICE-R #91
REASON FOR QUESTION
If 202-243 ohms resistance is not present, engine oil pressure transmitter is faulty.

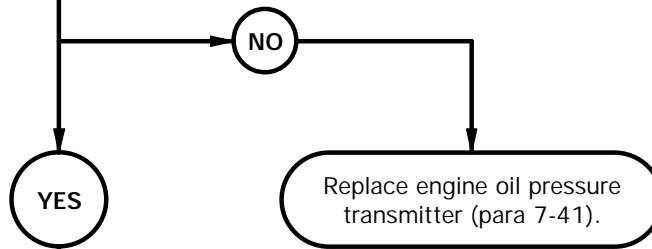

KNOWN INFO
VOLTS gage OK. Engine oil level OK. Engine oil pressure indicator goes out after engine starts. Engine oil pressure transmitter OK.
POSSIBLE PROBLEMS
Faulty engine control cable assembly. Faulty WTEC II dashboard cable assembly. Faulty WTEC III dashboard cable assembly.

5.
Is continuity present from connector J31 pin 11 to connector PX6 pin 4?

TEST OPTIONS
Continuity Test or STE/ICE-R Test #91
REASON FOR QUESTION
If continuity is not present, wire 36 from connector J31 pin 11 to connector PX6 pin 4 is faulty.

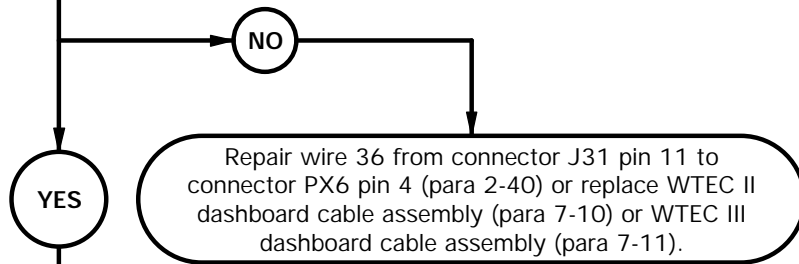

RESISTANCE TEST

- (1) Raise cab (TM 9-2320-365-10)
- (2) Set multimeter to ohms.
- (3) Disconnect connector P32 from engine oil pressure transmitter connector.
- (4) Connect positive (+) probe of multimeter to engine oil pressure transmitter pin 2.
- (5) Connect negative (-) probe of multimeter to known good ground and note reading on multimeter.
- (6) If 202-243 ohms resistance is not present, replace engine oil pressure transmitter (para 7-41).

NOTE

Perform steps (7) through (9) if 202-243 ohms resistance is not present.

- (7) Connect connector PX6 to engine OIL PRESS gage connector.
- (8) Connect connector clamp to engine OIL PRESS gage connector.
- (9) Install instrument panel assembly (para 7-15).

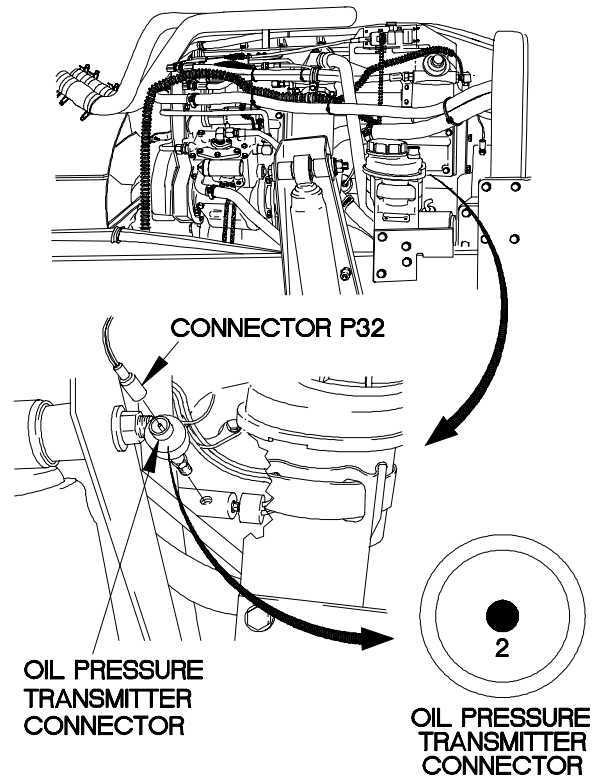

CONTINUITY TEST

- (1) Connect connector P32 to engine oil pressure transmitter connector.
- (2) Lower cab (TM 9-2320-365-10).
- (3) Disconnect connector J31 from connector P31.
- (4) Set multimeter to ohms.
- (5) Connect positive (+) probe of multimeter to connector PX6 pin 4.
- (6) Connect negative (-) probe of multimeter to connector J31 pin 11 and note reading on multimeter.
- (7) If continuity is not present, repair wire 36 from connector PX6 pin 4 to connector J31 pin 11 (para 2-40) or replace WTEC II dashboard cable assembly (para 7-10) or WTEC III dashboard cable assembly (para 7-11).

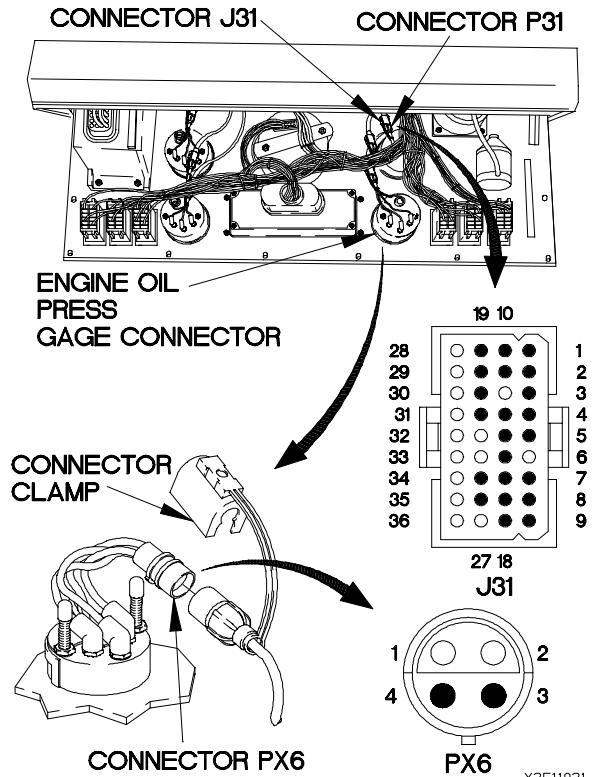

X2E11031

e11. ENGINE OIL PRESSURE GAGE DOES NOT OPERATE OR IS INACCURATE (CONT)

KNOWN INFO
VOLTS gage OK. Engine oil level OK. Engine oil pressure indicator goes out after engine starts. Engine oil pressure transmitter OK.
POSSIBLE PROBLEMS
Faulty engine control cable assembly. Faulty WTEC II dashboard cable assembly. Faulty WTEC III dashboard cable assembly.

6.
Is continuity present from connector PX6 pin 4 to a known good ground?

TEST OPTIONS
Continuity Test or STE/ICE-R Test #91
REASON FOR QUESTION
If continuity is not present, wire 36 from connector P31 socket 11 to connector P32 socket 2 is faulty. If continuity is present, wire 36 from connector J31 pin 11 to connector PX6 pin 4 is faulty.

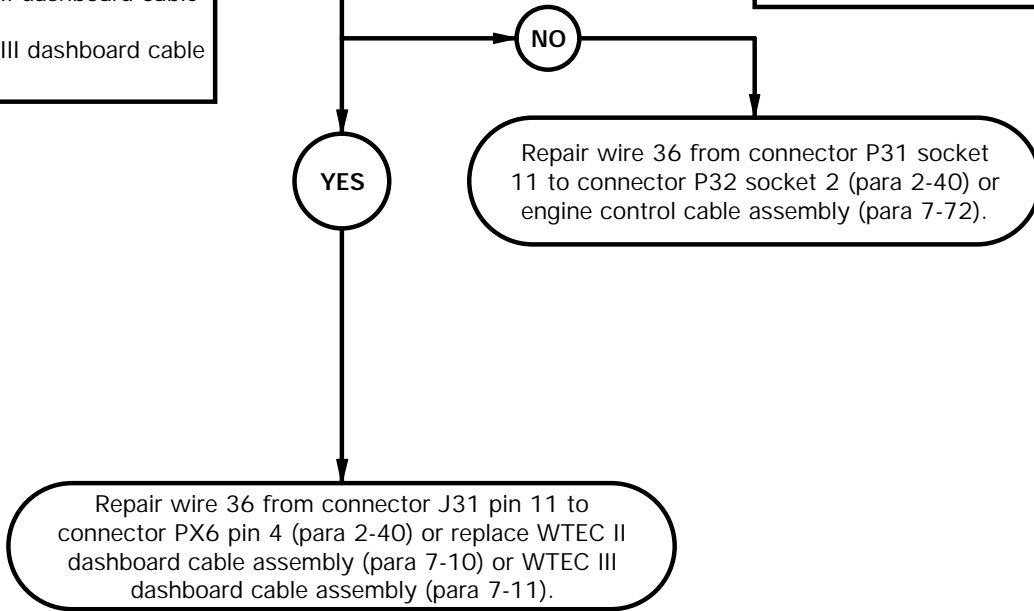

CONTINUITY TEST

- (1) Set multimeter to ohms.
- (2) Connect positive (+) probe of multimeter to connector PX6 pin 4.
- (3) Connect negative (-) probe of multimeter to known good ground and note reading on multimeter.
- (4) If continuity is not present, repair wire 36 from connector P31 socket 11 to connector P32 socket 2 (para 2-40) or engine control cable assembly (para 7-72).
- (5) If continuity is present, repair wire 36 from connector J31 pin 11 to connector PX6 pin 4 (para 2-40) or replace WTEC II dashboard cable assembly (para 7-10) or WTEC III dashboard cable assembly (para 7-11).
- (6) Connect connector J31 to connector P31.
- (7) Connect connector PX6 to engine OIL PRESS gage connector.
- (8) Connect connector clamp to engine OIL PRESS gage connector.
- (9) Install instrument panel assembly (para 7-15).

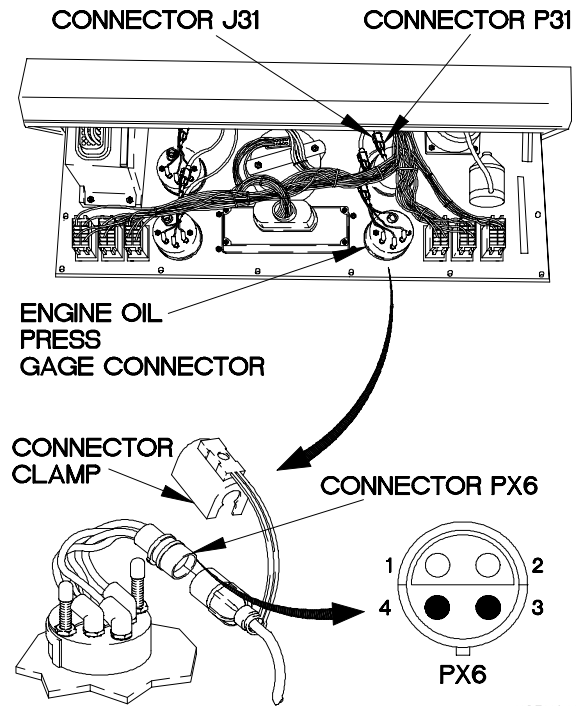

X2E11041

e12. SPEEDOMETER DOES NOT OPERATE OR IS INACCURATE

INITIAL SETUP

Equipment Conditions

Engine shut down (TM 9-2320-365-10).

Materials/Parts

Nut, Self-Locking (2) (Item 125, Appendix G)

Tools and Special Tools

Tool Kit, Genl Mech (Item 44, Appendix C)
 STE/ICE-R (Item 39, Appendix C)
 Multimeter, Digital (Item 22, Appendix C)
 Wrench, Torque, 0-75 lb-in. (Item 86, Appendix B)

Personnel Required

(2)

References

TM 9-4910-571-12&P

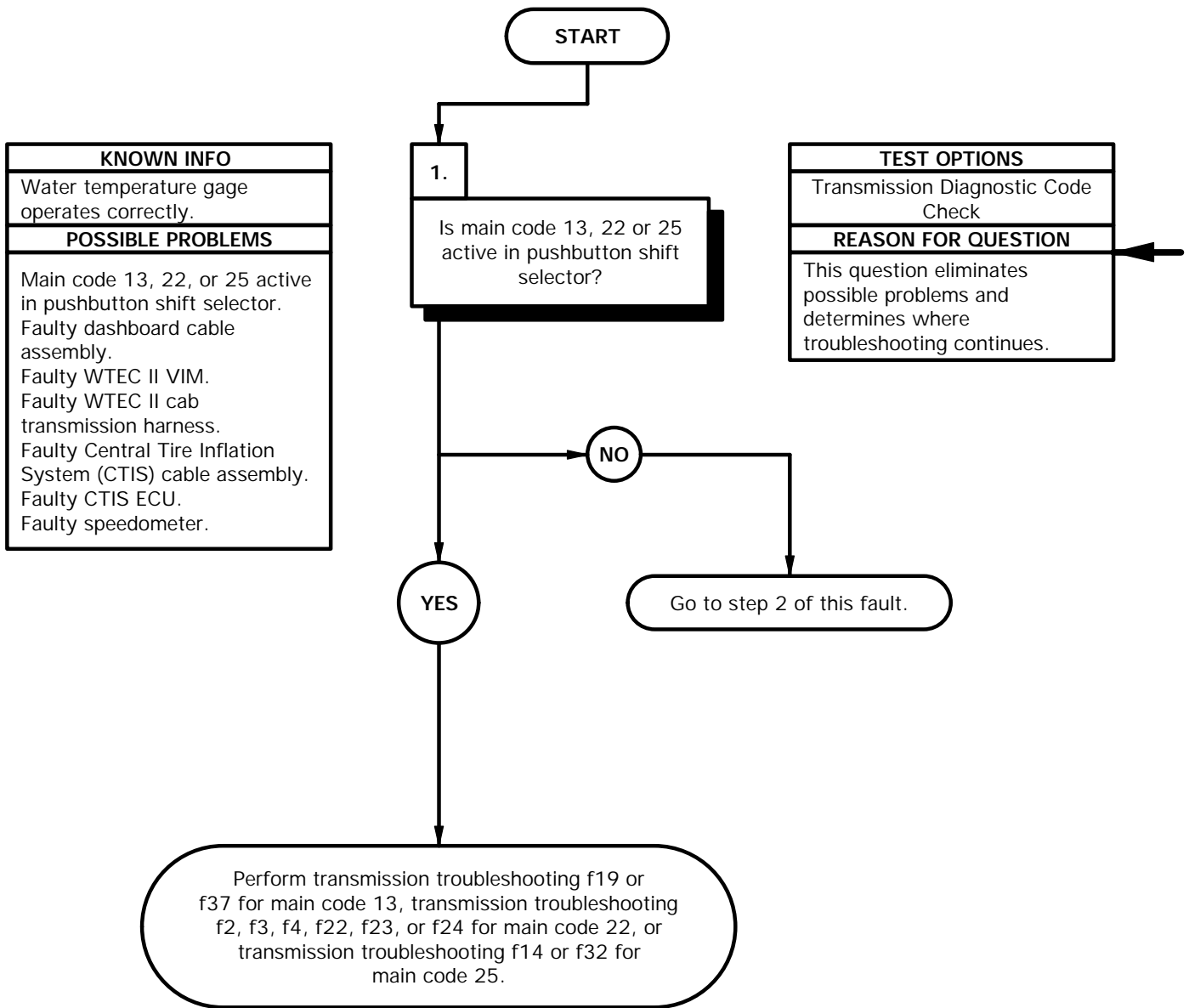

- (1) Check for active transmission diagnostic codes (para 8-4 or 8-5).
- (2) If main code 13 is active in pushbutton shift selector, perform transmission troubleshooting f19 or f37.
- (3) If main code 22 is active in pushbutton shift selector, perform transmission troubleshooting f2, f3, f4, f22, f23, or f24.
- (4) If main code 25 is active in pushbutton shift selector, perform transmission troubleshooting f14 or f32.

e12. SPEEDOMETER DOES NOT OPERATE OR IS INACCURATE (CONT)

KNOWN INFO
Water Temperature gage operates correctly. Main code 13, 22, or 25 not active in pushbutton shift selector.
POSSIBLE PROBLEMS
Faulty dashboard cable assembly. Faulty WTEC II VIM. Faulty WTEC II cab transmission harness. Faulty CTIS cable assembly. Faulty CTIS ECU. Faulty speedometer.

2.

WARNING
CAUTION
Read WARNING and CAUTION on following page.

Is 24 VDC present at connector PX8 pin 3?

TEST OPTIONS
Voltage Test or STE/ICE-R Test #89
REASON FOR QUESTION
If 24 VDC is not present, wire 1546 is faulty.

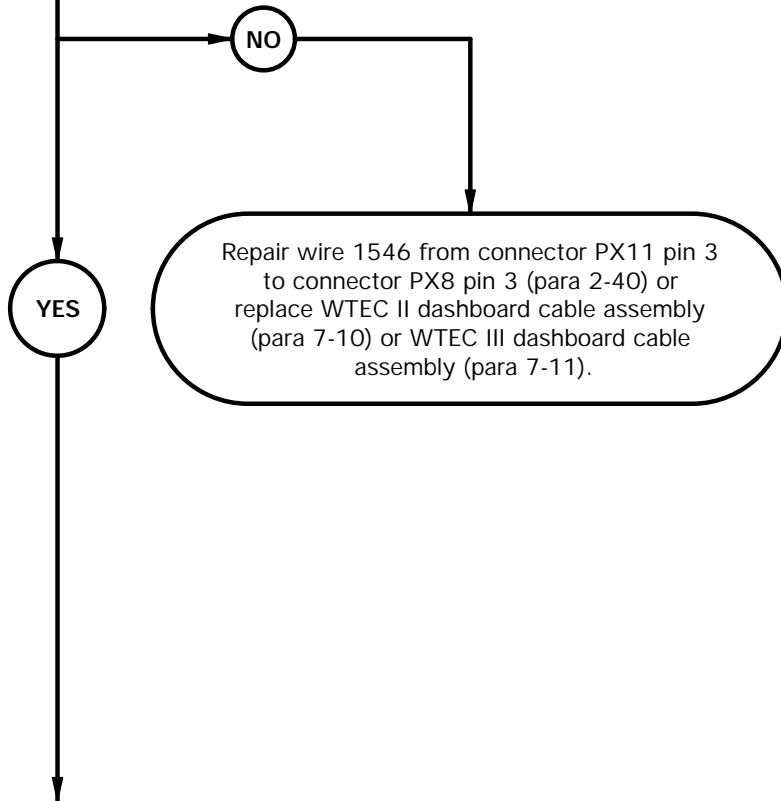

WARNING

Remove rings, bracelets, watches, necklaces, and any other jewelry before working around vehicle. Jewelry can catch on equipment and cause injury or short across electrical circuits and cause severe burns or electrical shock.

CAUTION

Use care when testing electrical connectors. Do not damage connector pins or sockets with multimeter probes. Failure to comply may result in damage to equipment.

NOTE

Inspect connector pins/sockets for damage, corrosion, and serviceability. Check that connector pins are not pushed back or not capable of making good contact.

VOLTAGE TEST

- (1) Remove instrument panel assembly for access (para 7-15).
- (2) Disconnect connector clamp from speedometer connector.
- (3) Disconnect connector PX8 from speedometer connector.
- (4) Set multimeter to volts DC.
- (5) Connect positive (+) probe of multimeter to connector PX8 pin 3.
- (6) Connect negative (-) probe of multimeter to ground.
- (7) Position master power switch to on (TM 9-2320-365-10) and note reading on multimeter.
- (8) If 24 VDC is not present, repair wire 1546 from connector PX11 pin 3 to connector PX8 pin 3 (para 2-40) or replace WTEC II dashboard cable assembly (para 7-10) or WTEC III dashboard cable assembly (para 7-11).
- (9) Position master power switch to off (TM 9-2320-365-10).

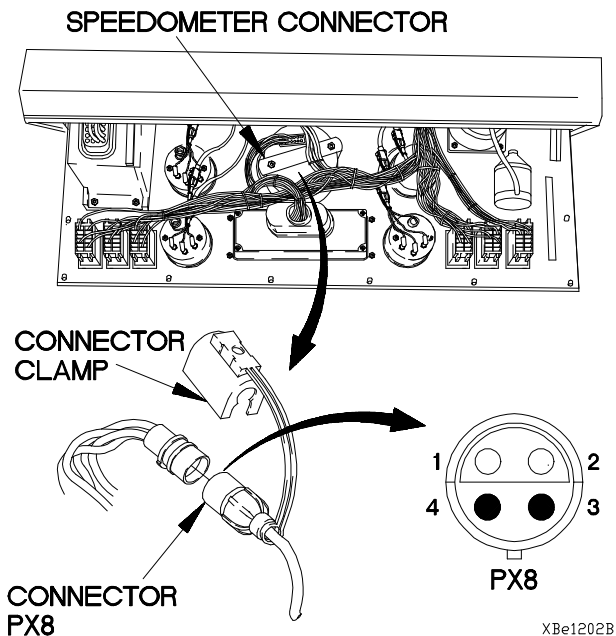

e12. SPEEDOMETER DOES NOT OPERATE OR IS INACCURATE (CONT)

KNOWN INFO
Water temperature gage operates correctly. Main code 13, 22, or 25 not active in pushbutton shift selector.
POSSIBLE PROBLEMS
Faulty dashboard cable assembly. Faulty WTEC II VIM. Faulty WTEC II cab transmission harness. Faulty CTIS cable assembly. Faulty CTIS ECU. Faulty speedometer.

KNOWN INFO
Water temperature gage operates correctly. Main code 13, 22, or 25 not active in pushbutton shift selector. VOLTS gage operates correctly.
POSSIBLE PROBLEMS
Faulty dashboard cable assembly. Faulty WTEC II VIM. Faulty WTEC II cab transmission harness. Faulty CTIS cable assembly. Faulty CTIS ECU. Faulty speedometer.

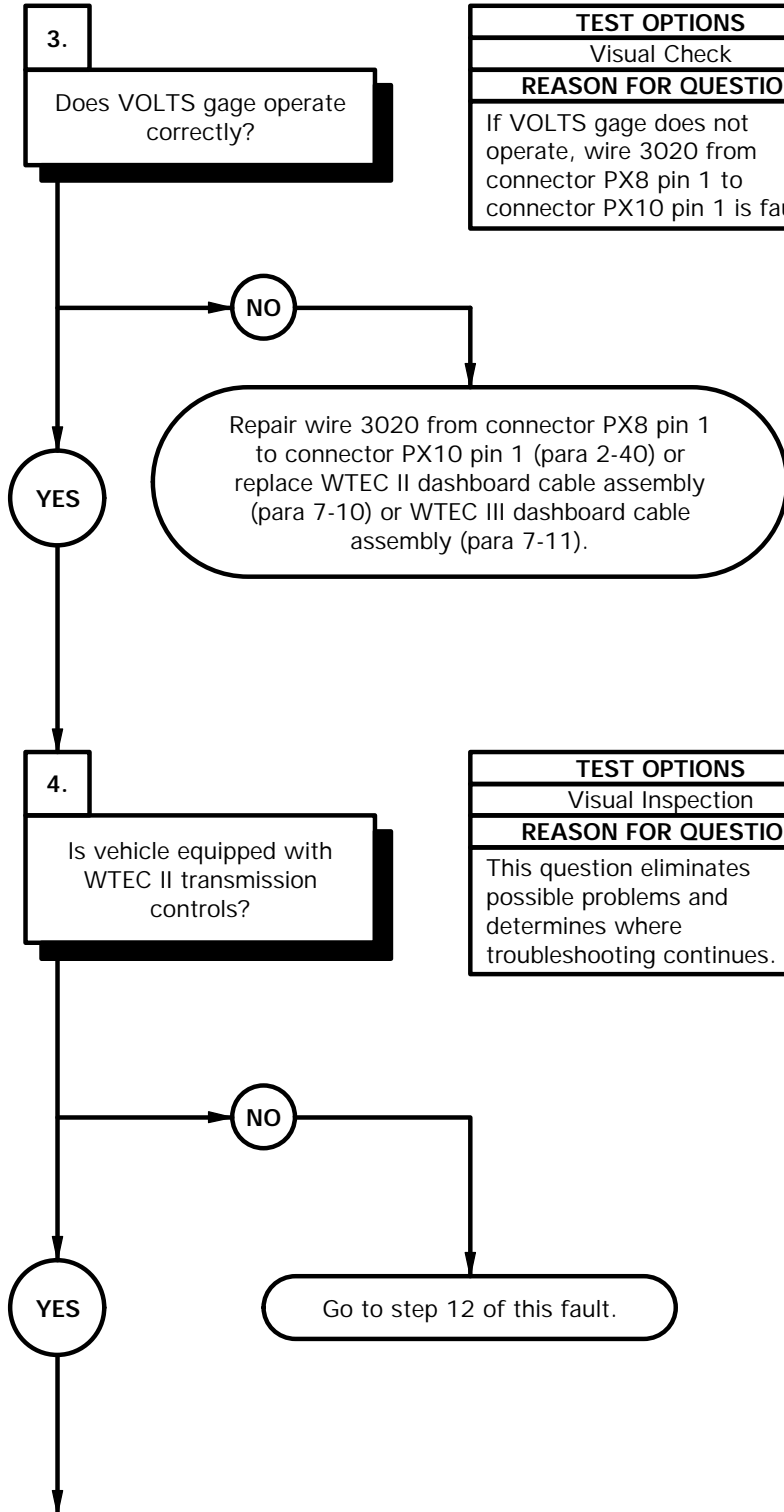

TEST OPTIONS
Visual Check
REASON FOR QUESTION
If VOLTS gage does not operate, wire 3020 from connector PX8 pin 1 to connector PX10 pin 1 is faulty.

TEST OPTIONS
Visual Inspection
REASON FOR QUESTION
This question eliminates possible problems and determines where troubleshooting continues.

- (1) Position master power switch to on (TM 9-2320-365-10).
- (2) Observe if VOLTS gage indicator needle moves (TM 9-2320-365-10).
- (3) If VOLTS gage indicator needle does not move, repair wire 3020 from connector PX8 pin 1 to connector PX10 pin 1 (para 2-40) or replace WTEC II dashboard cable assembly (para 7-10) or WTEC III dashboard cable assembly (para 7-11).
- (4) Position master power switch to off (TM 9-2320-365-10).

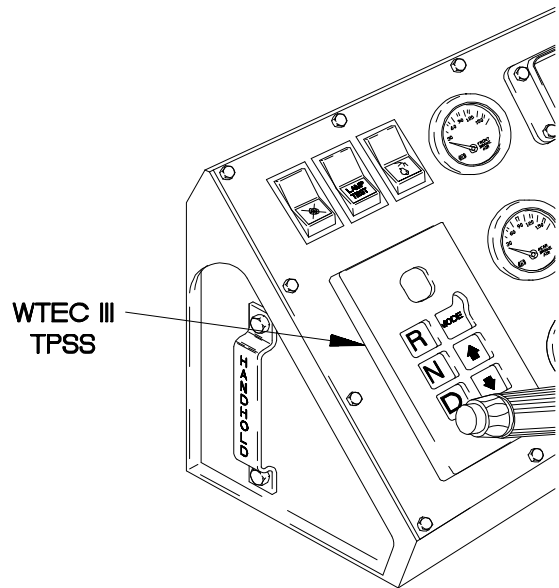

- (1) Check if vehicle is equipped with WTEC II Transmission ECU Pushbutton Shift Selector (TEPSS).
- (2) If pushbutton shift selector is not mounted with four screws and is not equipped with a filter cover, go to step 12 of this fault.

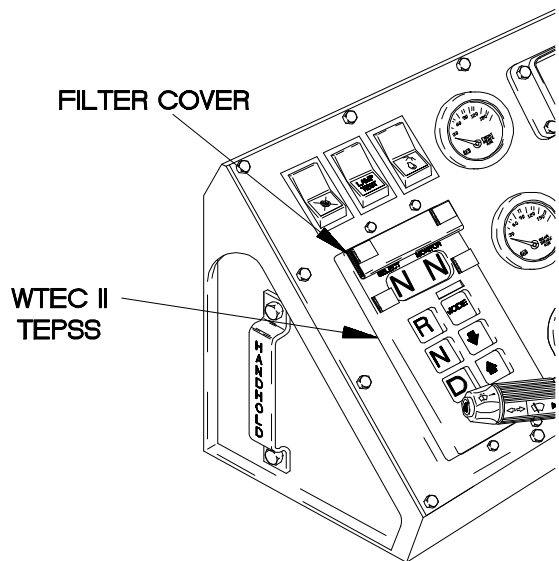

XBe1204B

e12. SPEEDOMETER DOES NOT OPERATE OR IS INACCURATE (CONT)

KNOWN INFO
Water temperature gage operates correctly. Main code 13, 22, or 25 not active in pushbutton shift selector. VOLTS gage operates correctly. Vehicle is equipped with WTEC II transmission controls.
POSSIBLE PROBLEMS
Faulty WTEC II dashboard cable assembly. Faulty WTEC II VIM. Faulty WTEC II cab transmission harness. Faulty CTIS cable assembly. Faulty CTIS ECU. Faulty speedometer.

KNOWN INFO
Water temperature gage operates correctly. Main code 13, 22, or 25 not active in pushbutton shift selector. VOLTS gage operates correctly. Vehicle is equipped with WTEC II transmission controls.
POSSIBLE PROBLEMS
Faulty WTEC II dashboard cable assembly. Faulty WTEC II VIM. Faulty WTEC II cab transmission harness. Faulty CTIS cable assembly. Faulty CTIS ECU. Faulty speedometer.

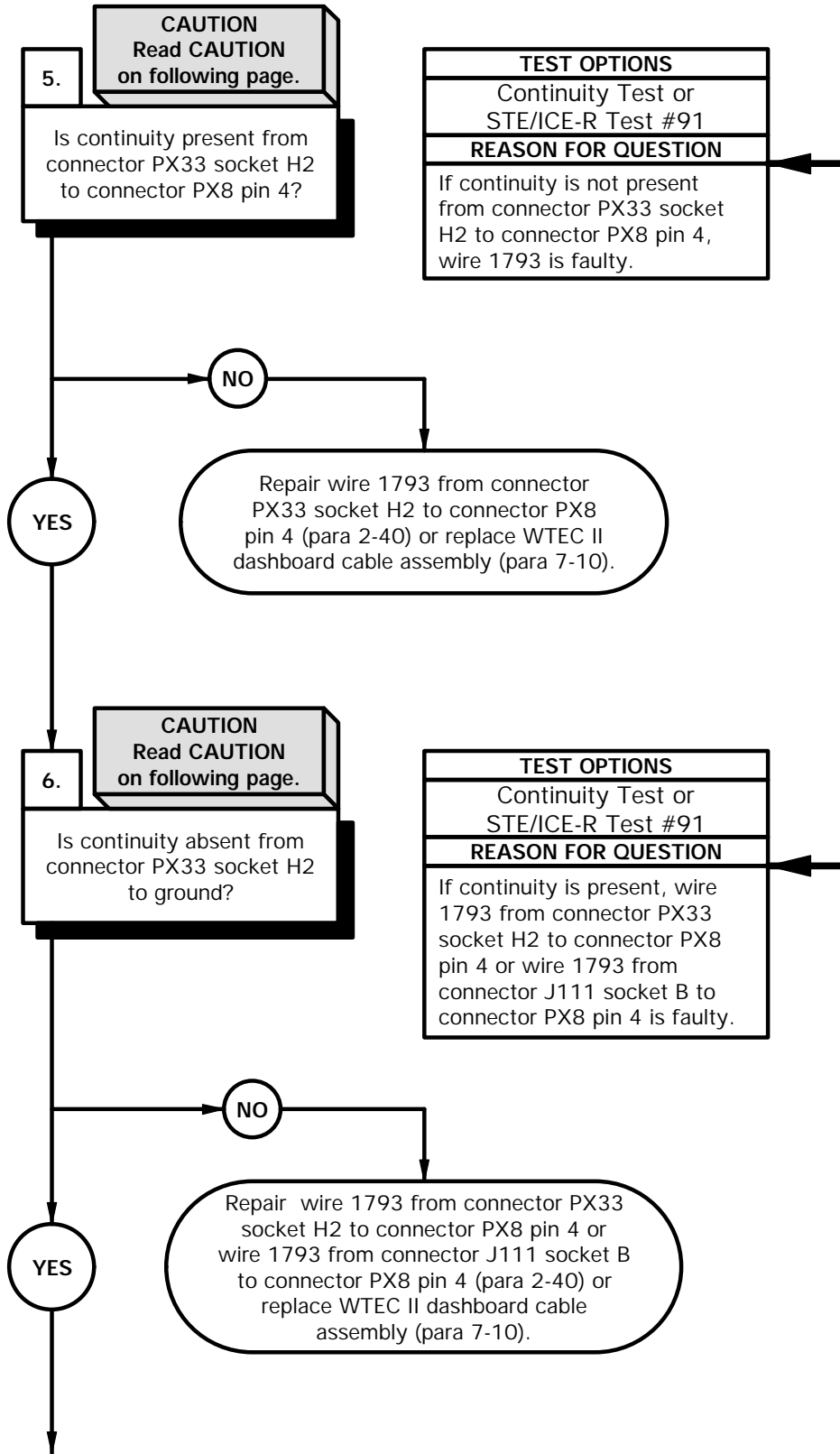

CAUTION

Use care when testing electrical connectors. Do not damage connector pins or sockets with multimeter probes. Failure to comply may result in damage to equipment.

NOTE

Inspect connector pins/sockets for damage, corrosion, and serviceability. Check that connector pins are not pushed back or not capable of making good contact.

CONTINUITY TEST

- (1) Remove kick panel (para 16-3).
- (2) Loosen screw in connector PX33.
- (3) Disconnect connector PX33 from WTEC II VIM.
- (4) Set multimeter to ohms.
- (5) Connect positive (+) probe of multimeter to connector PX33 socket H2.
- (6) Connect negative (-) probe of multimeter to connector PX8 pin 4 and note reading on multimeter.
- (7) If continuity is not present, repair wire 1793 from connector PX33 socket H2 to connector PX8 pin 4 (para 2-40) or replace WTEC II dashboard cable assembly (para 7-10).

CONTINUITY TEST

- (1) Remove PDP cover (TM 9-2320-365-10).
- (2) Remove three screws and washers from PDP.
- (3) Remove three screws from PDP.
- (4) Lift PDP outward to gain access.
- (5) Disconnect connector P111 from connector J111.
- (6) Set multimeter to ohms.
- (7) Connect positive (+) probe of multimeter to connector PX33 socket H2.
- (8) Connect negative (-) probe of multimeter to ground and note reading on multimeter.
- (9) If continuity is present, remove plastic cable ties as required and perform visual inspection of wire 1793 from connector PX33 socket H2 to connector PX8 pin 4 and wire 1793 from connector PX8 pin 4 to connector J111 socket B to determine which wire is faulty. Repair wire 1793 (para 2-40) or replace WTEC II dashboard cable assembly (para 7-10).
- (10) Connect connector PX33 to WTEC II VIM.
- (11) Tighten screw in connector PX33.
- (12) Install kick panel (para 16-3).

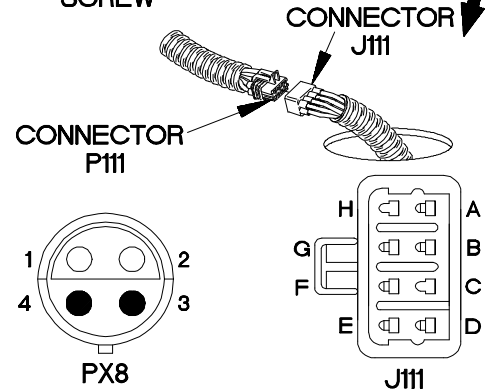
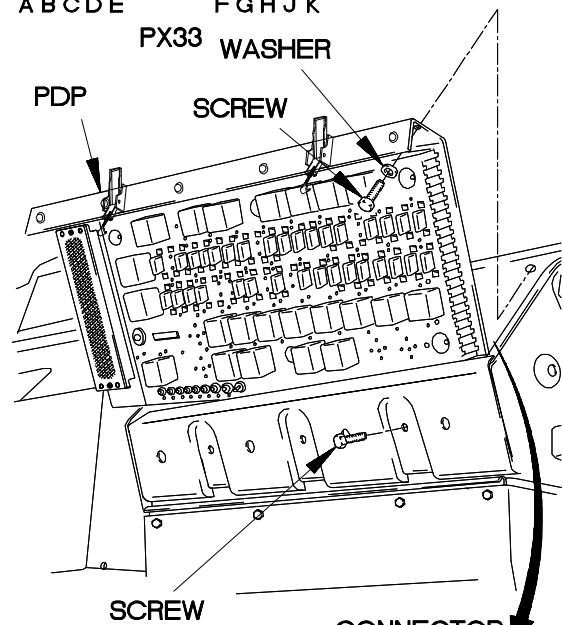
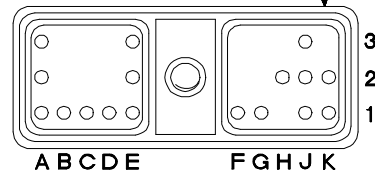
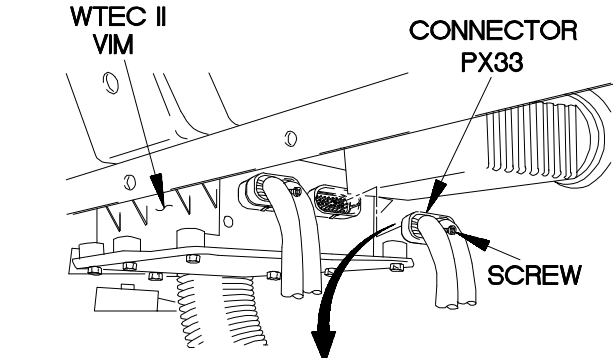

xBe1205B

e12. SPEEDOMETER DOES NOT OPERATE OR IS INACCURATE (CONT)

KNOWN INFO
Water temperature gage operates correctly. Main code 13, 22, or 25 not active in pushbutton shift selector. VOLTS gage operates correctly. Vehicle is equipped with WTEC II transmission controls. WTEC II dashboard cable assembly OK.
POSSIBLE PROBLEMS
Faulty WTEC II VIM. Faulty WTEC II cab transmission harness. Faulty CTIS cable assembly. Faulty CTIS ECU. Faulty speedometer.

7. **CAUTION**
Read CAUTION on following page.

Is continuity present from WTEC II VIM connector pin H2 to WTEC II VIM connector pin M2?

TEST OPTIONS
Continuity Test or STE/ICE-R Test #91
REASON FOR QUESTION
If continuity is not present, WTEC II VIM is faulty.

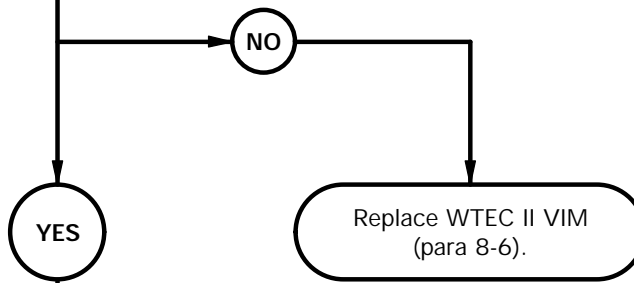

KNOWN INFO
Water temperature gage operates correctly. Main code 13, 22, or 25 not active in pushbutton shift selector. VOLTS gage operates correctly. Vehicle is equipped with WTEC II transmission controls. WTEC II dashboard cable assembly OK. WTEC II VIM OK.
POSSIBLE PROBLEMS
Faulty WTEC II cab transmission harness. Faulty CTIS cable assembly. Faulty CTIS ECU. Faulty speedometer.

8. **CAUTION**
Read CAUTION on following page.

Is continuity present from connector J116 socket B2 to connector J115 socket 23 and continuity absent from connector J116 socket B2 to ground?

TEST OPTIONS
Continuity Test or STE/ICE-R Test #91
REASON FOR QUESTION
If continuity is not present from connector J116 socket B2 to connector J115 socket 23 or continuity is present from connector J116 socket B2 to ground, WTEC II cab transmission harness is faulty.

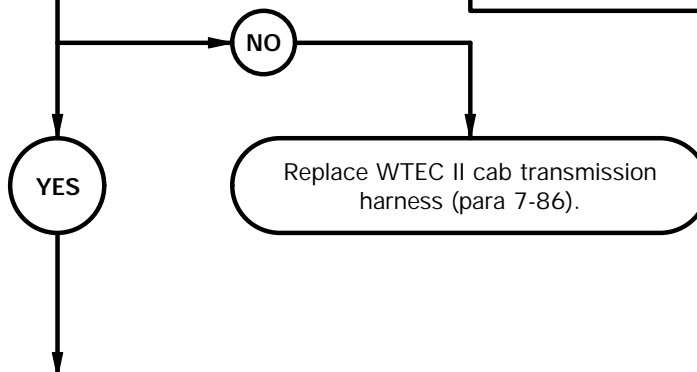

CAUTION

Use care when testing electrical connectors. Do not damage connector pins or sockets with multimeter probes. Failure to comply may result in damage to equipment.

NOTE

Inspect connector pins/sockets for damage, corrosion, and serviceability. Check that connector pins are not pushed back or not capable of making good contact.

- CONTINUITY TEST**
- (1) Loosen screw in connector J116.
 - (2) Disconnect connector J116 from WTEC II VIM.
 - (3) Set multimeter to ohms.
 - (4) Connect positive (+) probe of multimeter to WTEC II VIM connector pin H2.
 - (5) Connect negative (-) probe of multimeter to WTEC II VIM connector pin M2 and note reading on multimeter.
 - (6) If continuity is not present, replace WTEC II VIM (para 8-6).
 - (7) Connect connector PX33 to WTEC II VIM.
 - (8) Tighten screw in connector PX33.

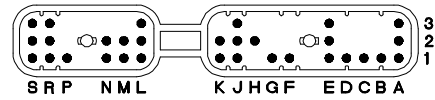

VIM CONNECTOR

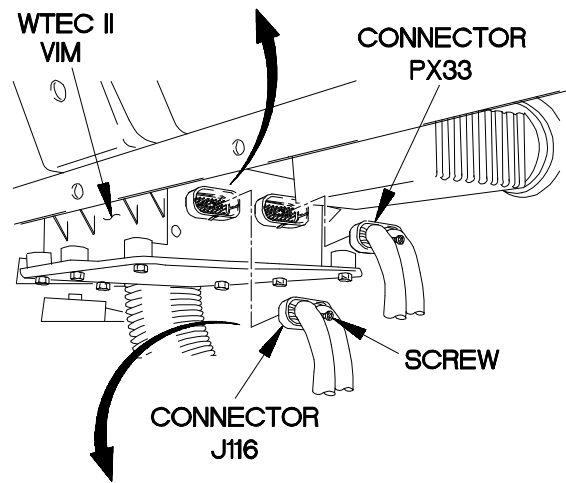

- CONTINUITY TEST**
- (1) Disconnect connector J115 from WTEC II TEPSS.
 - (2) Set multimeter to ohms.
 - (3) Connect positive (+) probe of multimeter to connector J116 socket B2.
 - (4) Connect negative (-) probe of multimeter to connector J115 socket 23 and note reading on multimeter.
 - (5) If continuity is not present, replace WTEC II cab transmission harness (para 7-86).
 - (6) Connect positive (+) probe of multimeter to connector J116 socket B2.
 - (7) Connect negative (-) probe of multimeter to ground and note reading on multimeter.
 - (8) If continuity is present, replace WTEC II cab transmission harness (para 7-86).
 - (9) Connect connector J115 to WTEC II TEPSS.
 - (10) Connect connector J116 to WTEC II VIM.
 - (11) Tighten screw in connector J116.

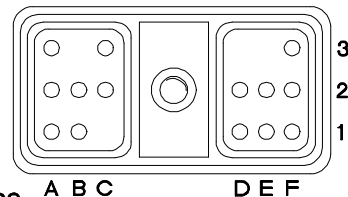

J116

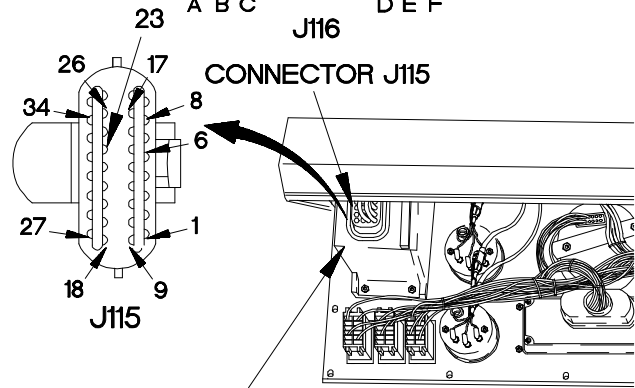

WTEC II TEPSS

XBE1207b

e12. SPEEDOMETER DOES NOT OPERATE OR IS INACCURATE (CONT)

KNOWN INFO
Water temperature gage operates correctly. Main code 13, 22, or 25 not active in pushbutton shift selector. VOLTS gage operates correctly. Vehicle is equipped with WTEC II transmission controls. WTEC II dashboard cable assembly OK. WTEC II VIM OK. WTEC II cab transmission harness OK.
POSSIBLE PROBLEMS
Faulty CTIS cable assembly. Faulty CTIS ECU. Faulty speedometer.

9. **CAUTION**
Read CAUTION on following page.

Is continuity absent from connector P110 socket U to ground?

TEST OPTIONS
Continuity Test or STE/ICE-R Test #91
REASON FOR QUESTION
If continuity is present, wire 1793 in CTIS cable assembly is faulty.

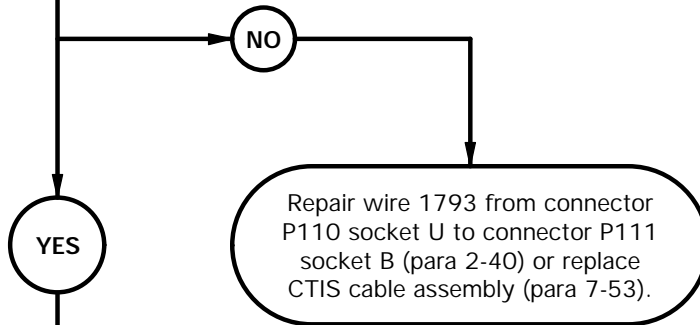

KNOWN INFO
Water temperature gage operates correctly. Main code 13, 22, or 25 not active in pushbutton shift selector. VOLTS gage operates correctly. Vehicle is equipped with WTEC II transmission controls. WTEC II dashboard cable assembly OK. WTEC II VIM OK. WTEC II cab transmission harness OK. CTIS cable assembly OK.
POSSIBLE PROBLEMS
Faulty CTIS ECU. Faulty speedometer.

10. Is continuity absent from CTIS ECU connector pin U to ground?

TEST OPTIONS
Continuity Test or STE/ICE-R Test #91
REASON FOR QUESTION
If continuity is present from CTIS ECU connector pin U to ground, CTIS ECU is faulty.

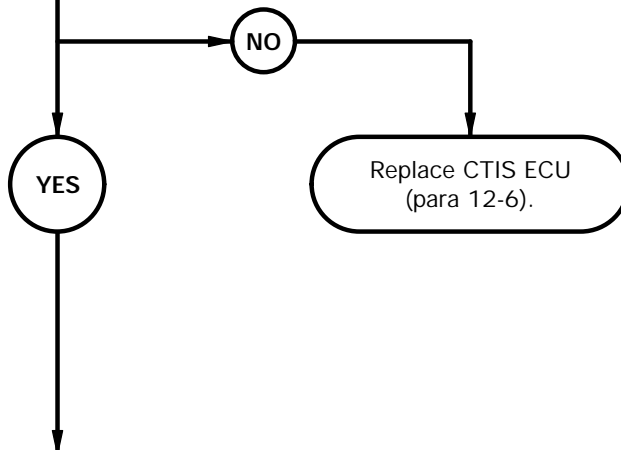

CAUTION

Use care when testing electrical connectors. Do not damage connector pins or sockets with multimeter probes. Failure to comply may result in damage to equipment.

NOTE

Inspect connector pins/sockets for damage, corrosion, and serviceability. Check that connector pins are not pushed back or not capable of making good contact.

- CONTINUITY TEST**
- (1) Disconnect connector P110 from CTIS ECU.
 - (2) Set multimeter to ohms.
 - (3) Connect positive (+) probe of multimeter to connector P110 socket U.
 - (4) Connect negative (-) probe of multimeter to ground and note reading on multimeter.
 - (5) If continuity is present, repair wire 1793 from connector P110 socket U to connector P111 socket B (para 2-40) or replace CTIS cable assembly (para 7-53).

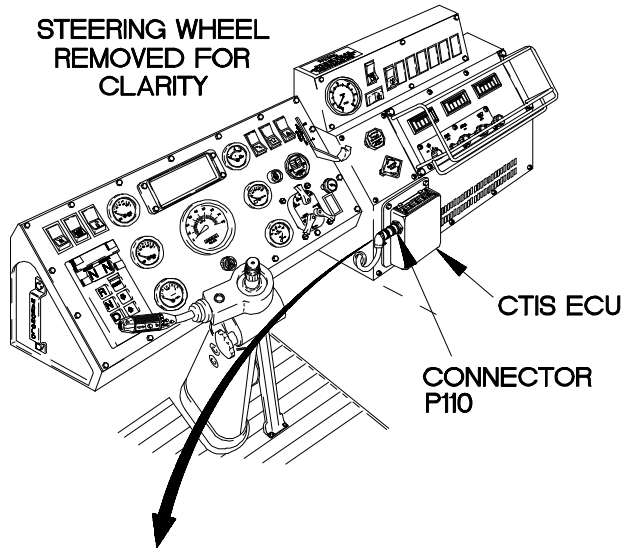

- CONTINUITY TEST**
- (1) Set multimeter to ohms.
 - (2) Connect positive (+) probe of multimeter to CTIS ECU connector pin U.
 - (3) Connect negative (-) probe of multimeter to ground and note reading on multimeter.
 - (4) If continuity is present, replace CTIS ECU (para 12-6).
 - (5) Connect connector P110 to CTIS ECU.

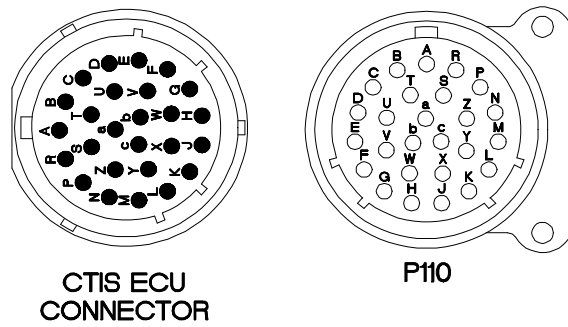

xBe1209b

e12. SPEEDOMETER DOES NOT OPERATE OR IS INACCURATE (CONT)

KNOWN INFO
Water temperature gage operates correctly. Main code 13, 22, or 25 not active in pushbutton shift selector. VOLTS gage operates correctly. Vehicle is equipped with WTEC II transmission controls. WTEC II dashboard cable assembly OK. WTEC II VIM OK. WTEC II cab transmission harness OK. CTIS cable assembly OK. CTIS ECU OK.
POSSIBLE PROBLEMS
Faulty speedometer.

TEST OPTIONS
Visual Inspection
REASON FOR QUESTION
If speedometer dip switch settings are correct and speedometer does not operate or is inaccurate, speedometer is faulty.

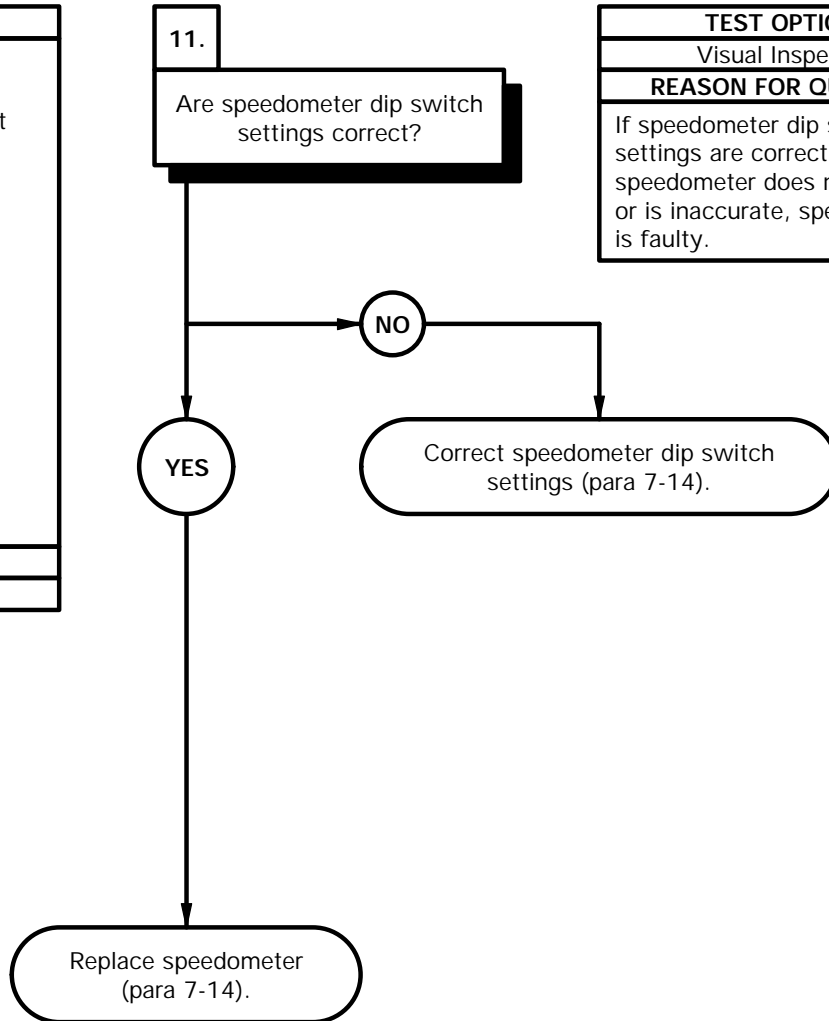

- (1) Remove two protective caps, self-locking nuts, retaining ring, and speedometer from instrument panel assembly. Discard self-locking nuts.
- (2) Note position of speedometer dip switches. Refer to Table 2-8.4. Speedometer Dip Switch Settings.
- (3) If speedometer dip switch setting(s) are incorrect, correct speedometer dip switch setting(s) (para 7-14).
- (4) If speedometer dip switch settings are correct, replace speedometer (para 7-14).
- (5) Position speedometer in instrument panel assembly with retaining ring and two self-locking nuts.
- (6) Tighten two self-locking nuts to 9 lb-in. (1 N·m).
- (7) Install two protective caps on speedometer.
- (8) Connect connector PX8 to speedometer connector.
- (9) Connect connector clamp on speedometer connector.
- (10) Install instrument panel assembly (para 7-10).
- (11) Connect connector P111 to connector J111.
- (12) Install PDP on dashboard with three washers and screws.
- (13) Install three screws in PDP.
- (14) Install PDP cover (TM 9-2320-365-10).

Table 2-8.4. Speedometer Dip Switch Settings

Switch Number	Switch Setting
1	Up
2	Up
3	Down
4	Up
5	Up
6	Down
7	Down
8	Up
9	Down
10	Up

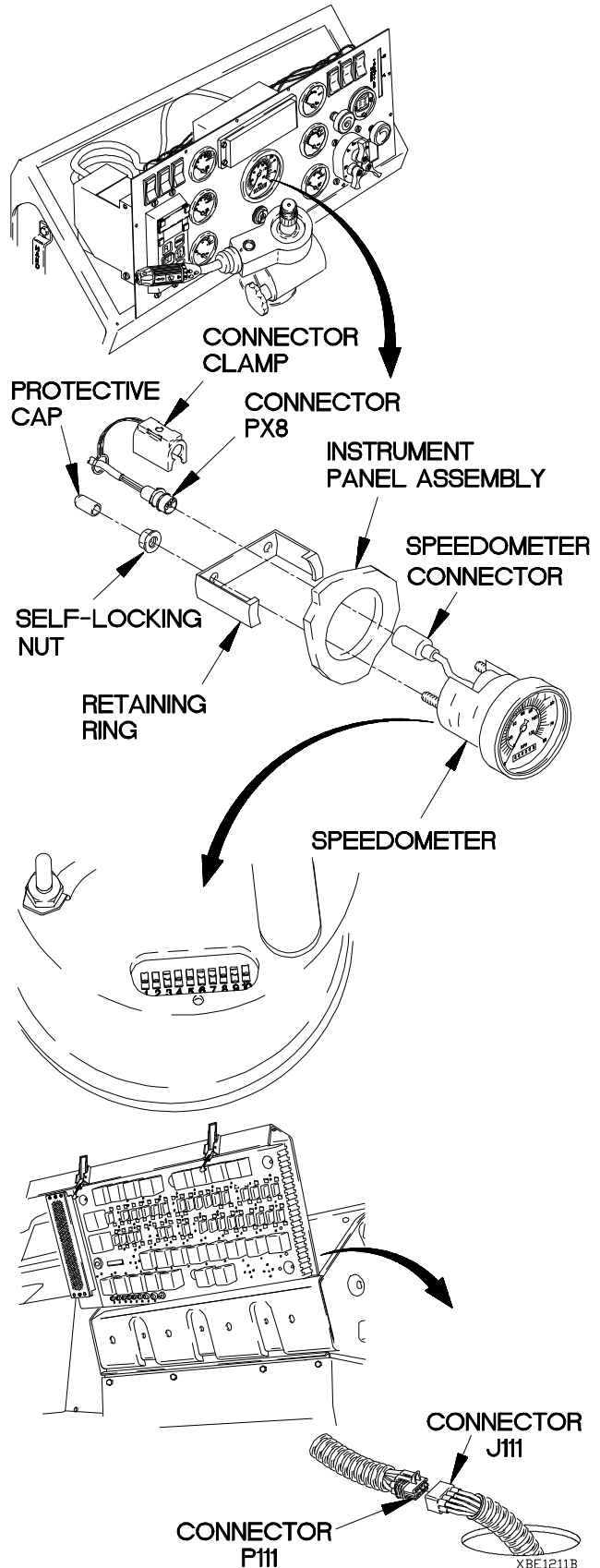

e12. SPEEDOMETER DOES NOT OPERATE OR IS INACCURATE (CONT)

KNOWN INFO
Water temperature gage operates correctly. Main code 13, 22, or 25 not active in pushbutton shift selector. VOLTS gage operates correctly. Vehicle is equipped with WTEC III transmission controls.
POSSIBLE PROBLEMS
Faulty WTEC III dashboard cable assembly. Faulty CTIS cable assembly. Faulty CTIS ECU. Faulty speedometer.

KNOWN INFO
Water temperature gage operates correctly. Main code 13, 22, or 25 not active in pushbutton shift selector. VOLTS gage operates correctly. Vehicle is equipped with WTEC III transmission controls.
POSSIBLE PROBLEMS
Faulty WTEC III dashboard cable assembly. Faulty CTIS cable assembly. Faulty CTIS ECU. Faulty speedometer.

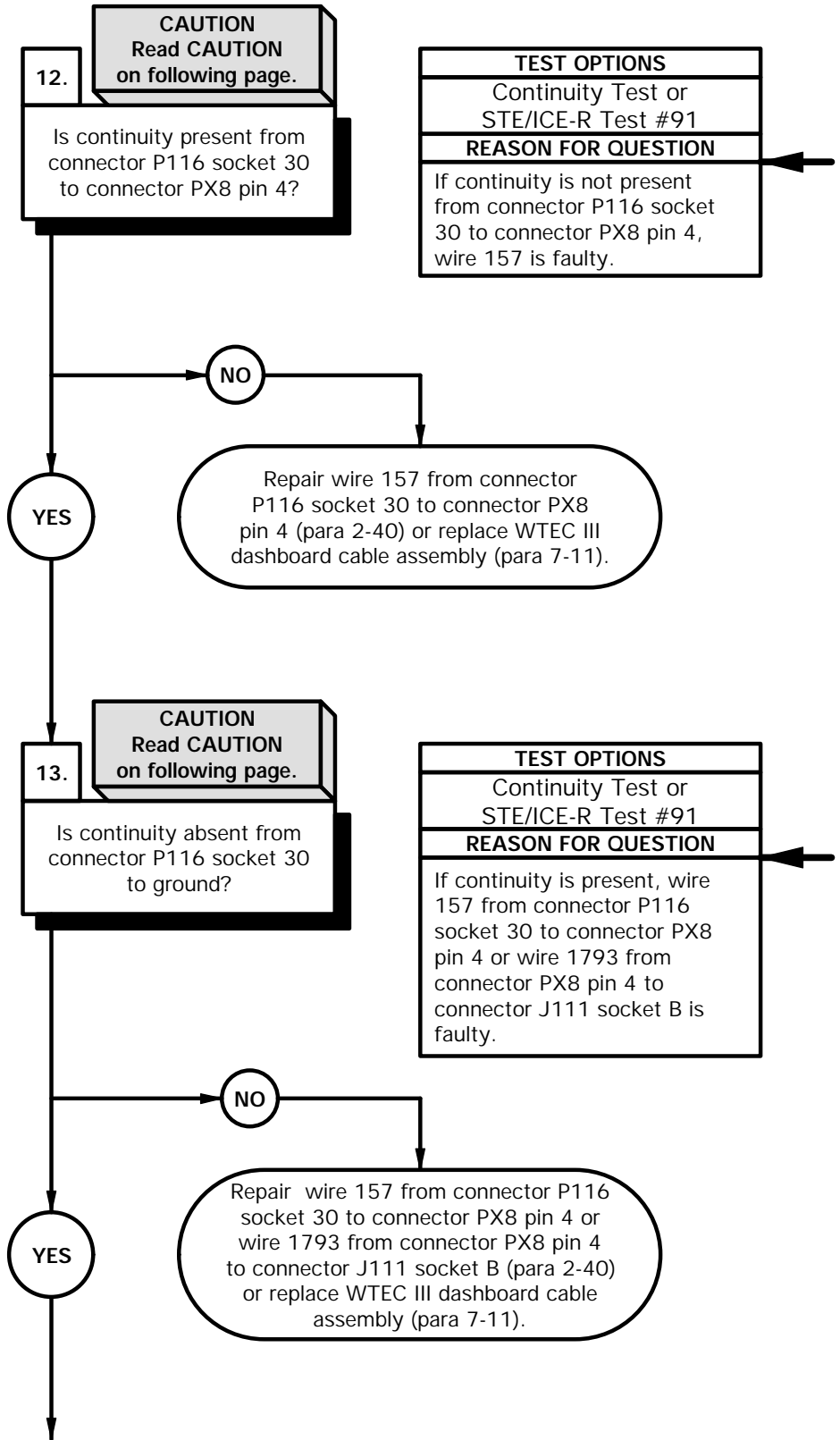

CAUTION

Use care when testing electrical connectors. Do not damage connector pins or sockets with multimeter probes. Failure to comply may result in damage to equipment.

NOTE

Inspect connector pins/sockets for damage, corrosion, and serviceability. Check that connector pins are not pushed back or not capable of making good contact.

CONTINUITY TEST

- (1) Remove kick panel (para 16-3).
- (2) Disconnect connector clamp from connector P116.
- (3) Disconnect connector P116 from WTEC III transmission ECU.
- (4) Set multimeter to ohms.
- (5) Connect positive (+) probe of multimeter to connector P116 socket 30.
- (6) Connect negative (-) probe of multimeter to connector PX8 pin 4 and note reading on multimeter.
- (7) If continuity is not present, repair wire 157 from connector P116 socket 30 to connector PX8 pin 4 (para 2-40) or replace WTEC III dashboard cable assembly (para 7-11).

CONTINUITY TEST

- (1) Remove PDP cover (TM 9-2320-365-10).
- (2) Remove three screws and washers from PDP.
- (3) Remove three screws from PDP.
- (4) Lift PDP outward to gain access.
- (5) Disconnect connector P111 from connector J111.
- (6) Set multimeter to ohms.
- (7) Connect positive (+) probe of multimeter to connector P116 socket 30.
- (8) Connect negative (-) probe of multimeter to ground and note reading on multimeter.
- (9) If continuity is present, remove plastic cable ties as required and perform visual inspection of wire 157 from connector P116 socket 30 to connector PX8 pin 4 and wire 1793 from connector PX8 pin 4 to connector J111 socket B to determine which wire is faulty. Repair wire 157 or 1793 (para 2-40) or replace WTEC III dashboard cable assembly (para 7-11).
- (10) Connect connector P116 to WTEC III transmission ECU.
- (11) Connect connector clamp on connector P116.
- (12) Install kick panel (para 16-3).

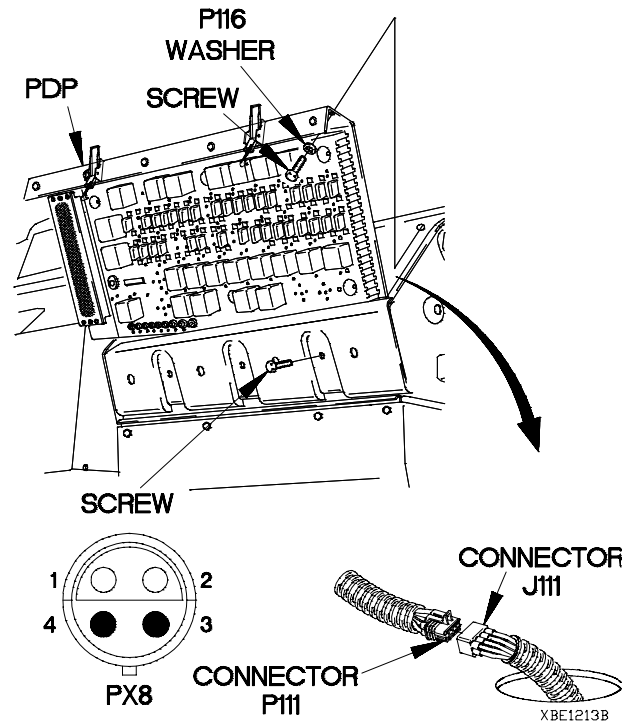
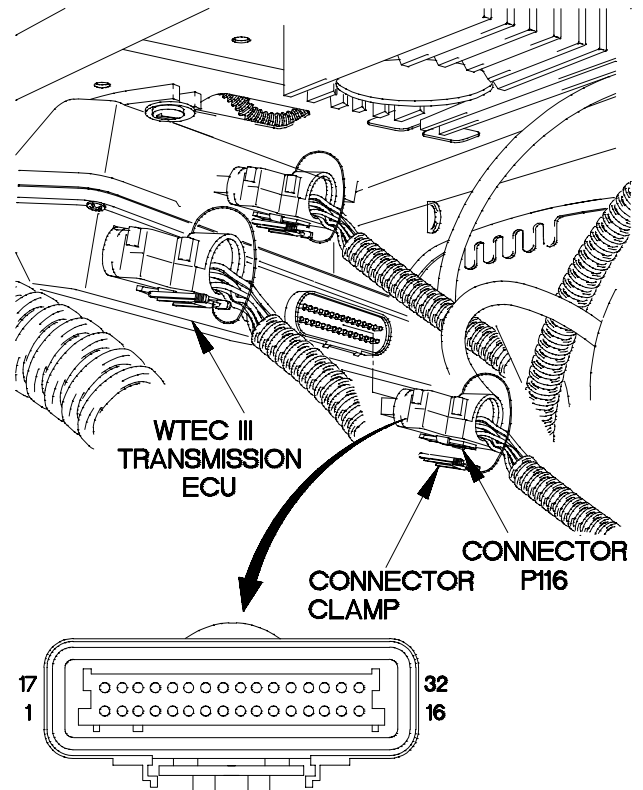

e12. SPEEDOMETER DOES NOT OPERATE OR IS INACCURATE (CONT)

KNOWN INFO
Water temperature gage operates correctly. Main code 13, 22, or 25 not active in pushbutton shift selector. VOLTS gage operates correctly. Vehicle is equipped with WTEC III transmission controls. WTEC III dashboard cable assembly OK.
POSSIBLE PROBLEMS
Faulty CTIS cable assembly. Faulty CTIS ECU. Faulty speedometer.

14.

CAUTION
Read CAUTION on following page.

Is continuity absent from connector P110 socket U to ground?

TEST OPTIONS
Continuity Test or STE/ICE-R Test #91
REASON FOR QUESTION
If continuity is present, wire 1793 in CTIS cable assembly is faulty.

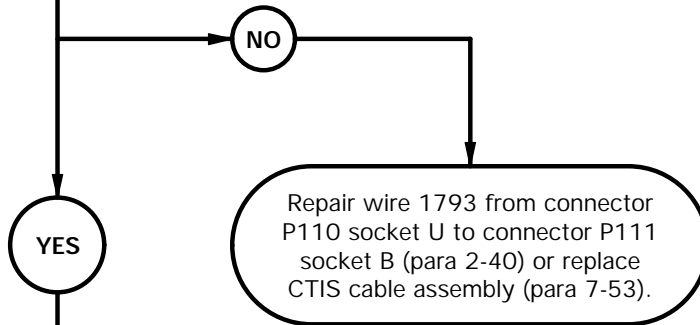

KNOWN INFO
Water temperature gage operates correctly. Main code 13, 22, or 25 not active in pushbutton shift selector. VOLTS gage operates correctly. Vehicle is equipped with WTEC III transmission controls. WTEC III dashboard cable assembly OK. CTIS cable assembly OK.
POSSIBLE PROBLEMS
Faulty CTIS ECU. Faulty speedometer.

15.

Is continuity absent from CTIS ECU connector pin U to ground?

TEST OPTIONS
Continuity Test or STE/ICE-R Test #91
REASON FOR QUESTION
If continuity is present from CTIS ECU connector pin U to ground, CTIS ECU is faulty.

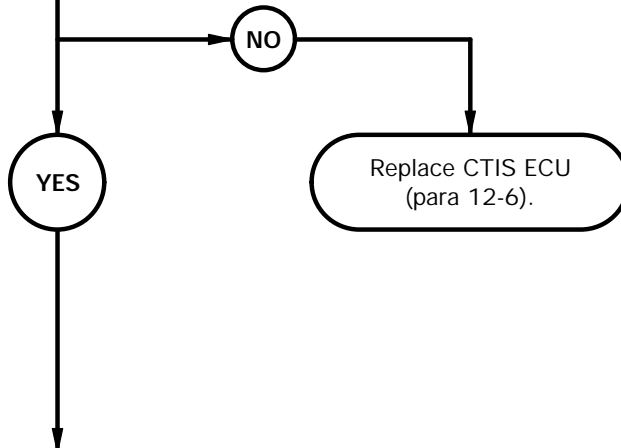

CAUTION

Use care when testing electrical connectors. Do not damage connector pins or sockets with multimeter probes. Failure to comply may result in damage to equipment.

NOTE

Inspect connector pins/sockets for damage, corrosion, and serviceability. Check that connector pins are not pushed back or not capable of making good contact.

CONTINUITY TEST

- (1) Disconnect connector P110 from CTIS ECU.
- (2) Set multimeter to ohms.
- (3) Connect positive (+) probe of multimeter to connector P110 socket U.
- (4) Connect negative (-) probe of multimeter to ground and note reading on multimeter.
- (5) If continuity is present, repair wire 1793 from connector P110 socket U to connector P111 socket B (para 2-40) or replace CTIS cable assembly (para 7-53).

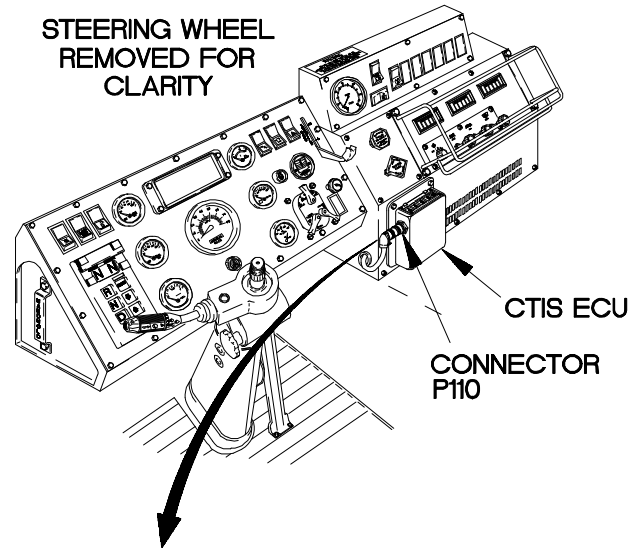

CONTINUITY TEST

- (1) Set multimeter to ohms.
- (2) Connect positive (+) probe of multimeter to CTIS ECU connector pin U.
- (3) Connect negative (-) probe of multimeter to ground and note reading on multimeter.
- (4) If continuity is present, replace CTIS ECU (para 12-6).
- (5) Connect connector P110 to CTIS ECU.

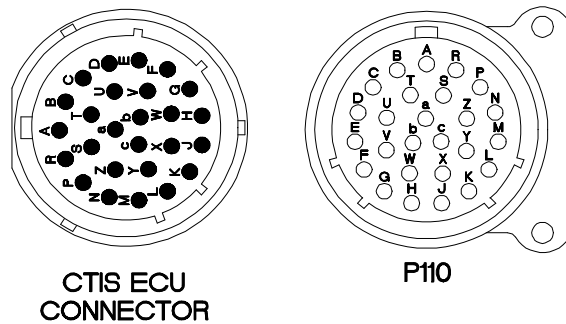

XBE1214B

e12. SPEEDOMETER DOES NOT OPERATE OR IS INACCURATE (CONT)

KNOWN INFO
Water temperature gage operates correctly. Main code 13, 22, or 25 not active in pushbutton shift selector. VOLTS gage operates correctly. Vehicle is equipped with WTEC III transmission controls. WTEC III dashboard cable assembly OK. CTIS cable assembly OK. CTIS ECU OK.
POSSIBLE PROBLEMS
Faulty speedometer.

16.
Are speedometer dip switch settings correct?

TEST OPTIONS
Visual Inspection
REASON FOR QUESTION
If speedometer dip switch settings are correct and speedometer does not operate or is inaccurate, speedometer is faulty.

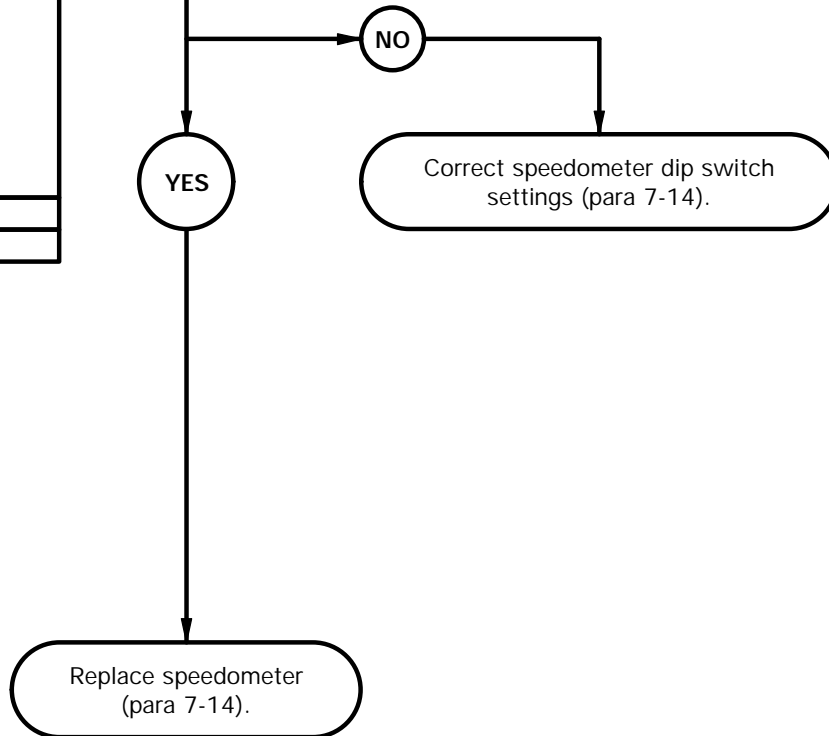

- (1) Remove two protective caps, self-locking nuts, retaining ring, and speedometer from instrument panel assembly. Discard self-locking nuts.
- (2) Note position of speedometer dip switches. Refer to Table 2-8.5. Speedometer Dip Switch Settings.
- (3) If speedometer dip switch setting(s) are incorrect, correct speedometer dip switch setting(s) (para 7-14).
- (4) If speedometer dip switch settings are correct, replace speedometer (para 7-14).
- (5) Position speedometer in instrument panel assembly with retaining ring and two self-locking nuts.
- (6) Tighten two self-locking nuts to 9 lb-in. (1 N·m).
- (7) Install two protective caps on speedometer.
- (8) Connect connector PX8 to speedometer connector.
- (9) Connect connector clamp on speedometer connector.
- (10) Install instrument panel assembly (para 7-10).
- (11) Connect connector P111 to connector J111.
- (12) Install PDP on dashboard with three washers and screws.
- (13) Install three screws in PDP.
- (14) Install PDP cover (TM 9-2320-365-10).

Table 2-8.5. Speedometer Dip Switch Settings

Switch Number	Switch Setting
1	Up
2	Up
3	Down
4	Up
5	Up
6	Down
7	Down
8	Up
9	Down
10	Up

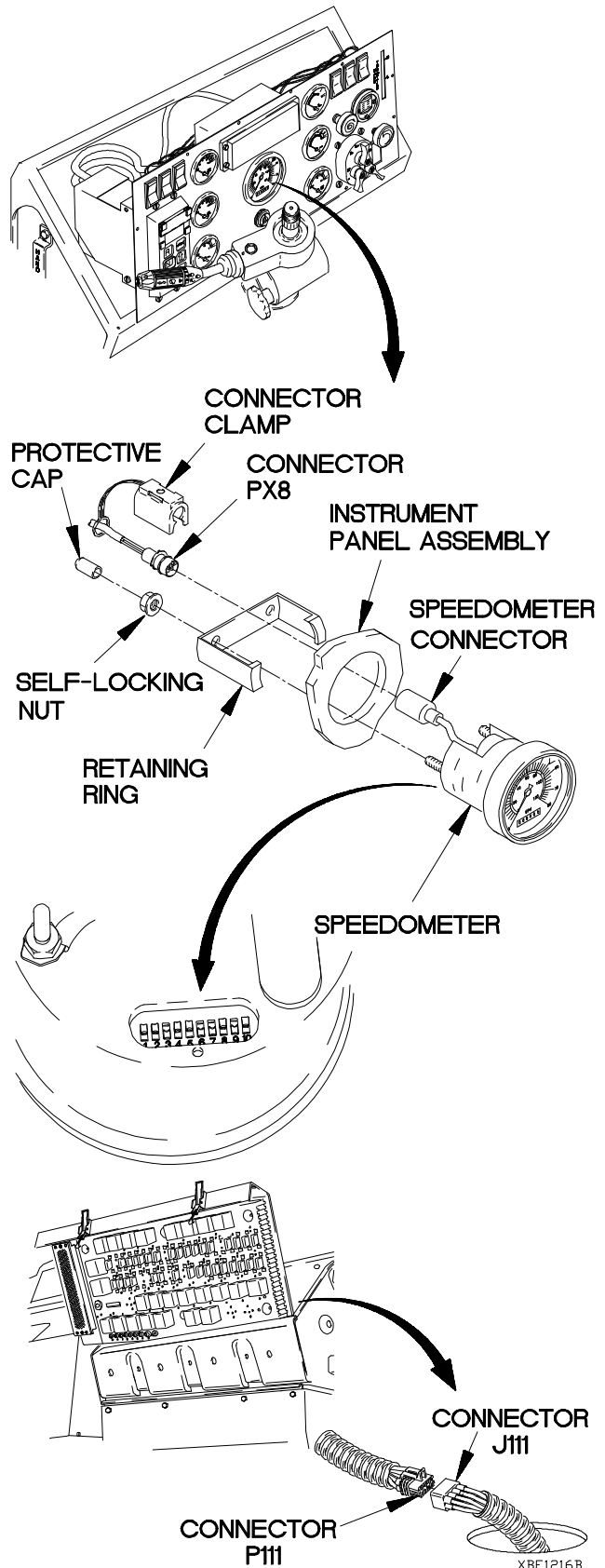

e13. VOLTS GAGE DOES NOT OPERATE OR IS INACCURATE

INITIAL SETUP

Equipment Conditions

Engine shut down (TM 9-2320-365-10).

Personnel Required

(2)

Tools and Special Tools

Tool Kit, Genl Mech (Item 44, Appendix C)
 STE/ICE-R (Item 39, Appendix C)
 Multimeter, Digital (Item 22, Appendix C)

References

TM 9-4910-571-12&P

NOTE

Perform Electrical System Troubleshooting e1. Circuit Breaker Does Not Operate on circuit breaker CB77 prior to beginning this task.

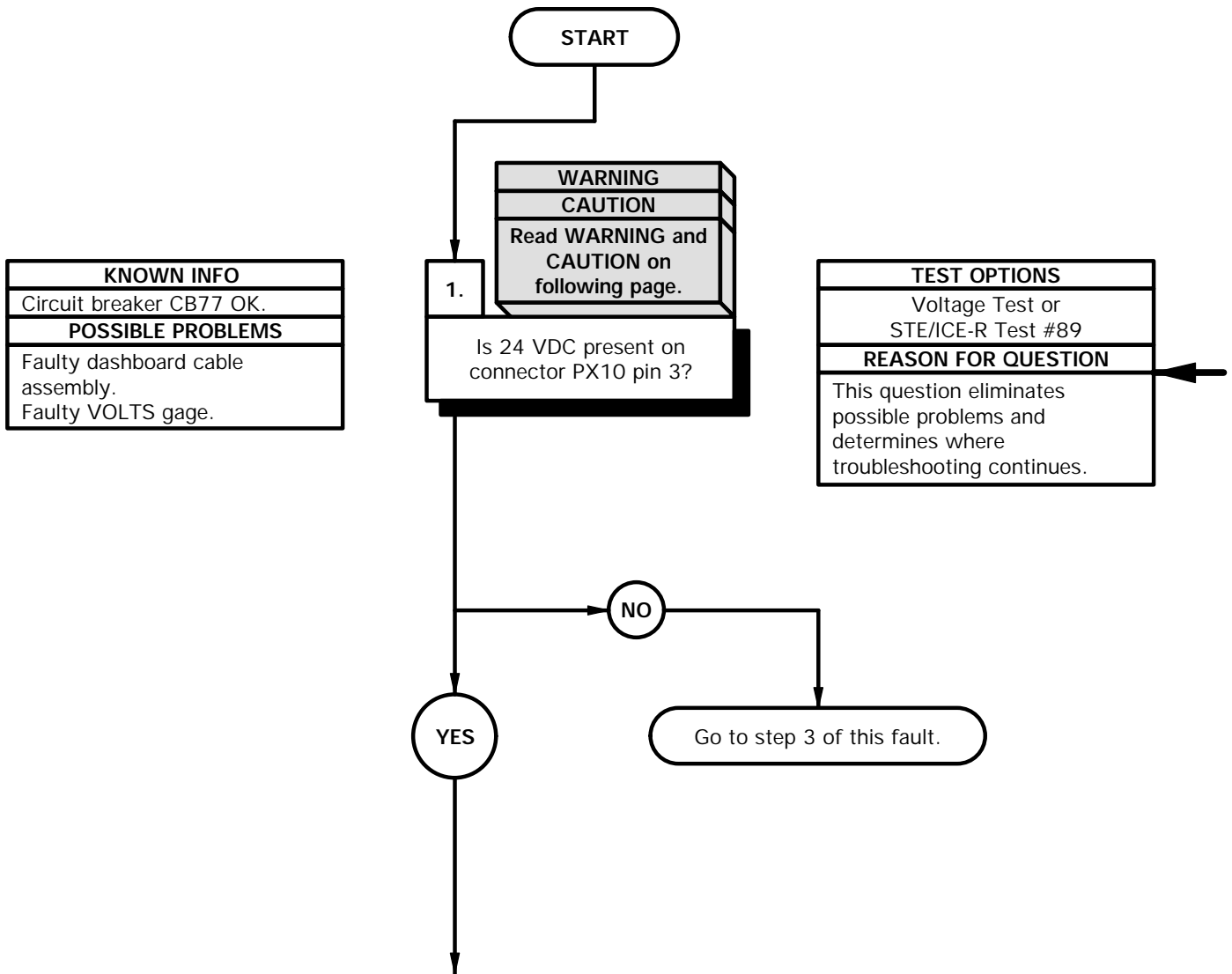

WARNING

Remove rings, bracelets, watches, necklaces, and any other jewelry before working around vehicle. Jewelry can catch on equipment and cause injury or short across electrical circuits and cause severe burns or electrical shock.

CAUTION

Use care when testing electrical connectors. Do not damage connector pins or sockets with multimeter probes. Failure to comply may result in damage to equipment.

NOTE

Inspect connector pins/sockets for damage, corrosion, and serviceability. Check that connector pins are not pushed back and are capable of making good contact.

VOLTAGE TEST

- (1) Remove instrument panel assembly for access (para 7-15).
- (2) Disconnect connector clamp from VOLTS gage connector.
- (3) Disconnect connector PX10 from VOLTS gage connector.
- (4) Set multimeter to volts DC.
- (5) Connect positive (+) probe of multimeter to connector PX10 pin 3.
- (6) Connect negative (-) probe of multimeter to ground.
- (7) Position master power switch to on (TM 9-2320-365-10) and note reading on multimeter.
- (8) If 24 VDC is not present, go to step 3 of this task.
- (9) Position master power switch to off (TM 9-2320-365-10).

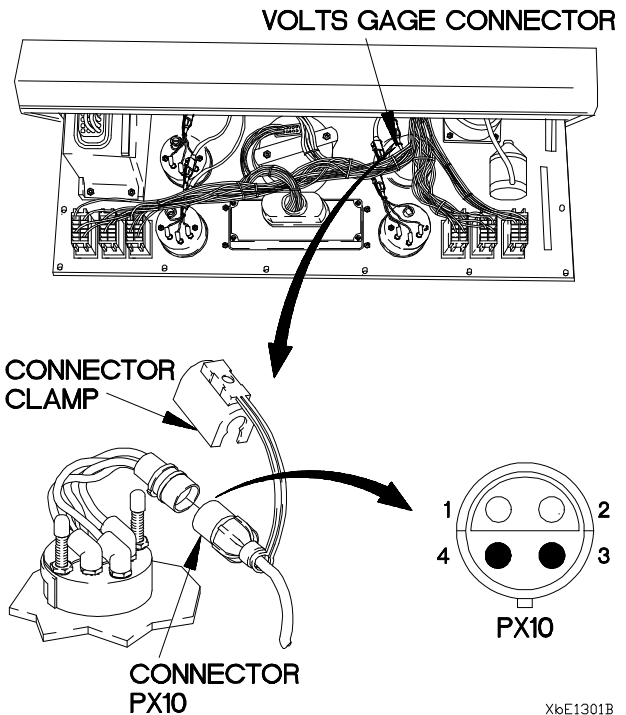

X6E1301B

e13. VOLTS GAGE DOES NOT OPERATE OR IS INACCURATE (CONT)

KNOWN INFO
Circuit breaker CB77 OK.
POSSIBLE PROBLEMS
Faulty dashboard cable assembly. Faulty VOLTS gage.

2.

CAUTION
Read CAUTION on following page.

Is continuity present from connector PX10 socket 1 to a known good ground?

TEST OPTIONS
Continuity Test or STE/ICE-R Test #91
REASON FOR QUESTION
If continuity is not present, wire 3004 from connector PX10 socket 1 to terminal board TB2 position 9 is faulty.

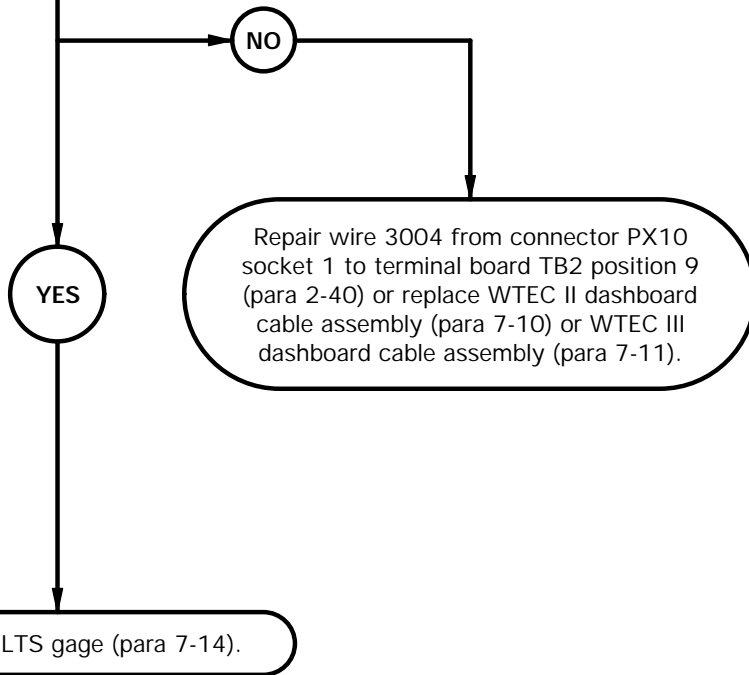

CAUTION

Use care when testing electrical connectors. Do not damage connector pins or sockets with multimeter probes. Failure to comply may result in damage to equipment.

NOTE

Inspect connector pins/sockets for damage, corrosion, and serviceability. Check that connector pins are not pushed back and are capable of making good contact.

CONTINUITY TEST

- (1) Set multimeter to ohms.
- (2) Connect positive (+) probe of multimeter to connector PX10 socket 1.
- (3) Connect negative (-) probe of multimeter to ground and note reading on multimeter.
- (4) If continuity is not present, repair wire 3004 from connector PX10 socket 1 to terminal board TB2 position 9 (para 2-40) or replace WTEC II dashboard cable assembly (para 7-10) or WTEC III dashboard cable assembly (para 7-11).
- (5) If continuity is present, replace VOLTS gage (para 7-14).
- (6) Connect connector PX10 to VOLTS gage connector.
- (7) Connect connector clamp on VOLTS gage connector.
- (8) Install instrument panel assembly (para 7-15).

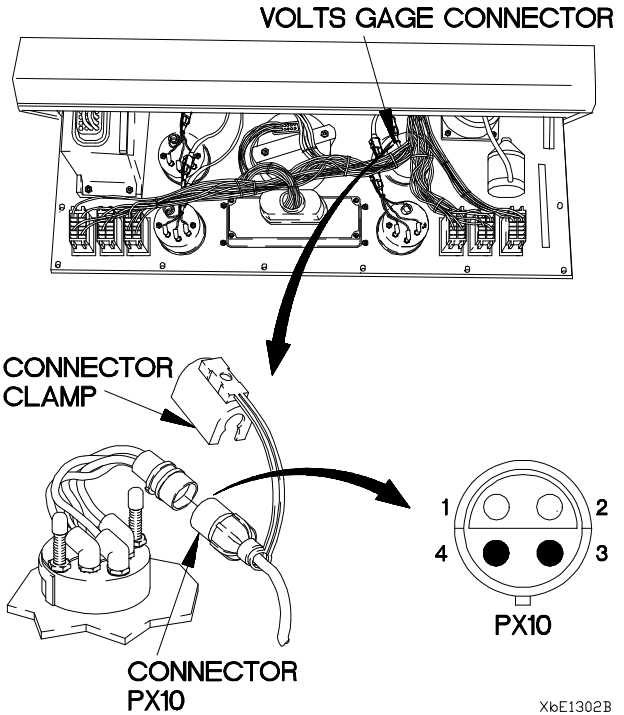

X6E1302B

e13. VOLTS GAGE DOES NOT OPERATE OR IS INACCURATE (CONT)

KNOWN INFO
Circuit breaker CB77 OK. VOLTS gage OK.
POSSIBLE PROBLEMS
Faulty dashboard cable assembly.

3.

WARNING
CAUTION
Read WARNING and CAUTION on following page.

Is 24 VDC present at connector J913 socket 9?

TEST OPTIONS
Voltage Test or STE/ICE-R Test #89
REASON FOR QUESTION
This question eliminates possible problems and determines where troubleshooting continues.

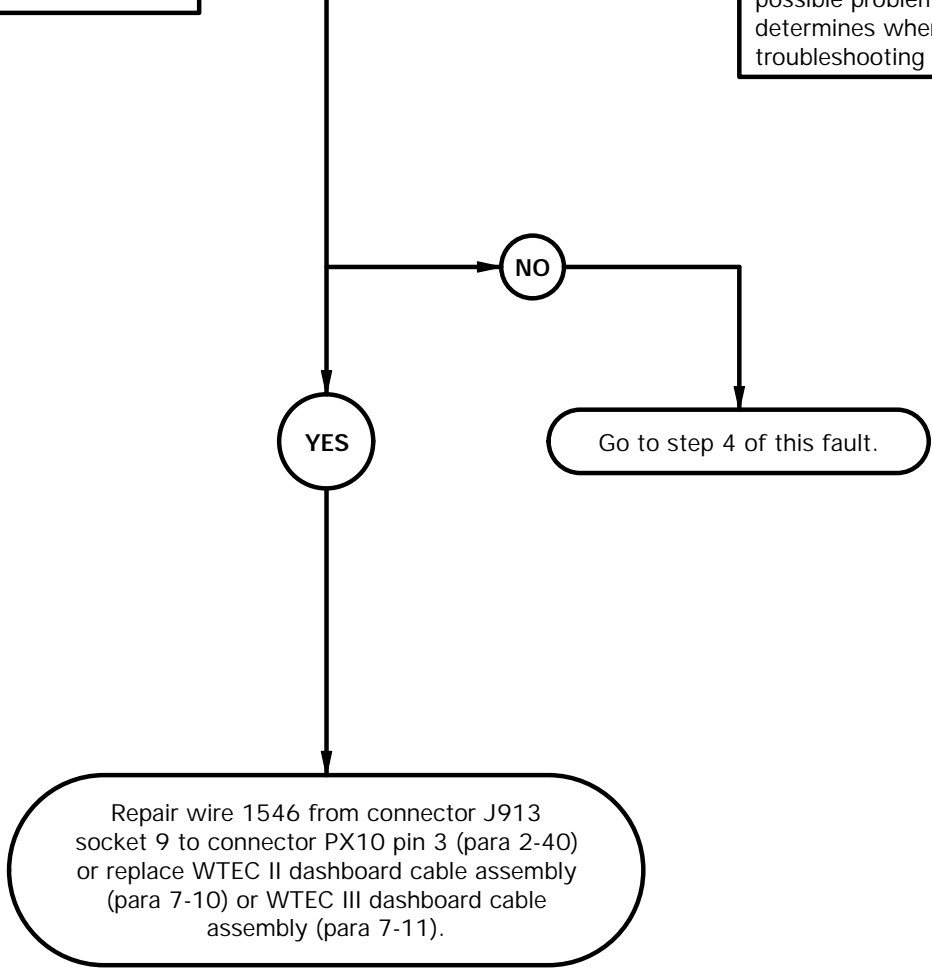

WARNING

Remove rings, bracelets, watches, necklaces, and any other jewelry before working around vehicle. Jewelry can catch on equipment and cause injury or short across electrical circuits and cause severe burns or electrical shock.

CAUTION

Use care when testing electrical connectors. Do not damage connector pins or sockets with multimeter probes. Failure to comply may result in damage to equipment.

NOTE

Inspect connector pins/sockets for damage, corrosion, and serviceability. Check that connector pins are not pushed back and are capable of making good contact.

VOLTAGE TEST

- (1) Remove personnel heater for access (para 18-9).
- (2) Disconnect connector P913 from connector J913, if required.
- (3) Set multimeter to volts DC.
- (4) Connect positive (+) probe of multimeter to connector J913 socket 9.
- (5) Connect negative (-) probe of multimeter to ground.
- (6) Position master power switch to on (TM 9-2320-365-10) and not reading on multimeter.
- (7) If 24 VDC is not present, go to step 4 of this fault.
- (8) If 24 VDC is present, repair wire 1546 from connector J913 socket 9 to connector PX10 pin 3 (para 2-40) or replace WTEC II dashboard cable assembly (para 7-10) or WTEC III dashboard cable assembly (para 7-11).
- (9) Position master power switch to off (TM 9-2320-365-10).
- (10) Connect connector PX10 to VOLTS gage connector.
- (11) Connect connector clamp on VOLTS gage connector.
- (12) Connect connector P913 to connector J913, if required.
- (13) Install personnel heater assembly (para 18-9).
- (14) Install instrument panel assembly (para 7-15).

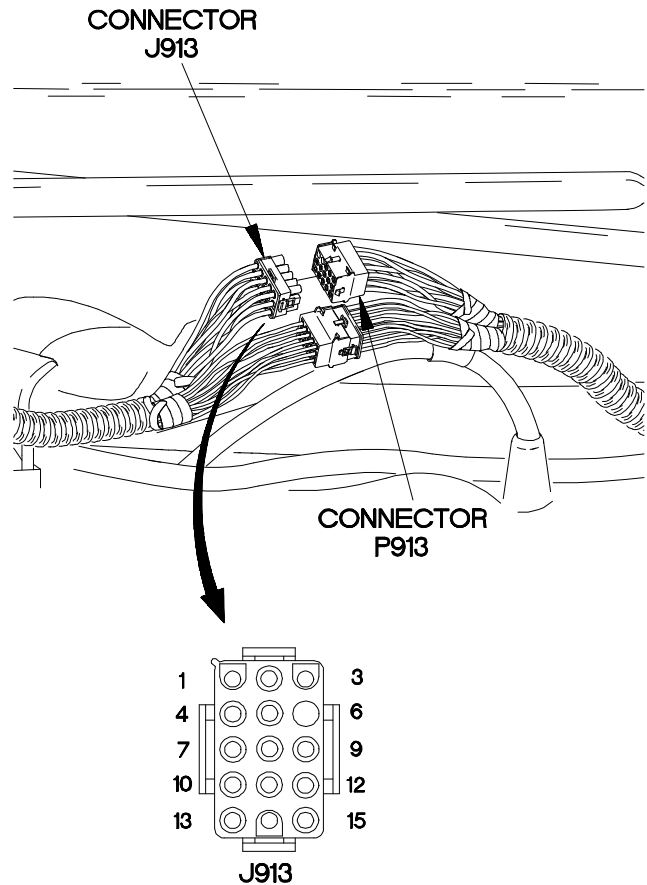

X6E1303B

e13. VOLTS GAGE DOES NOT OPERATE OR IS INACCURATE (CONT)

KNOWN INFO
Circuit breaker CB77 OK. VOLTS gage OK.
POSSIBLE PROBLEMS
Faulty dashboard cable assembly.

4.

WARNING
Read WARNING on following page.

Is 24 VDC present at terminal board TB1 position 64?

TEST OPTIONS
Voltage Test or STE/ICE-R Test #89
REASON FOR QUESTION
If 24 VDC is not present, wire 1929 is faulty. If 24 VDC is present, wire 1546 is faulty.

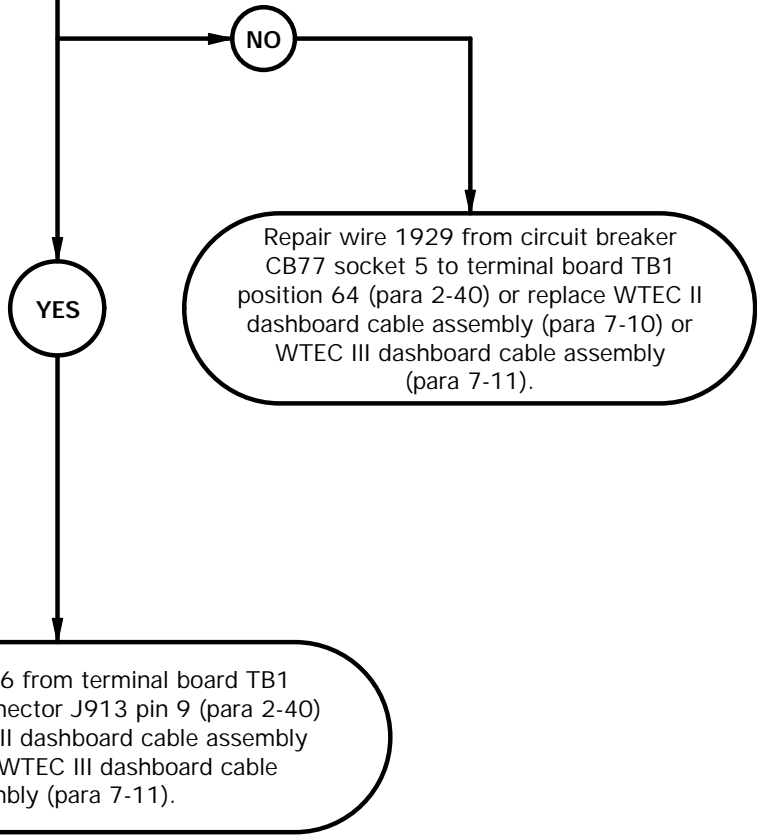

WARNING

Remove rings, bracelets, watches, necklaces, and any other jewelry before working around vehicle. Jewelry can catch on equipment and cause injury or short across electrical circuits and cause severe burns or electrical shock.

VOLTAGE TEST

- (1) Remove PDP cover (TM 9-2320-365-10).
- (2) Remove three screws and washers from PDP.
- (3) Remove three screws from PDP.
- (4) Lift PDP outward to gain access.
- (5) Set multimeter to volts DC.
- (6) Connect positive (+) probe of multimeter to terminal board TB1 position 64.
- (7) Connect negative (-) probe of multimeter to ground.
- (8) Position master power switch to on (TM 9-2320-365-10) and note reading on multimeter.
- (9) If 24 VDC is not present, repair wire 1929 from circuit breaker CB77 socket 5 to terminal board TB1 position 64 (para 2-40) or replace WTEC II dashboard cable assembly (para 7-10) or WTEC III dashboard cable assembly (para 7-11).
- (10) If 24 VDC is present, repair wire 1546 from terminal board TB1 position 61 to connector J913 socket 9 (para 2-40) or replace WTEC II dashboard cable assembly (para 7-10) or WTEC III dashboard cable assembly (para 7-11).
- (12) Position master power switch to off (TM 9-2320-365-10).
- (13) Install PDP on dashboard with three screws.
- (14) Install three washers and screws in PDP.

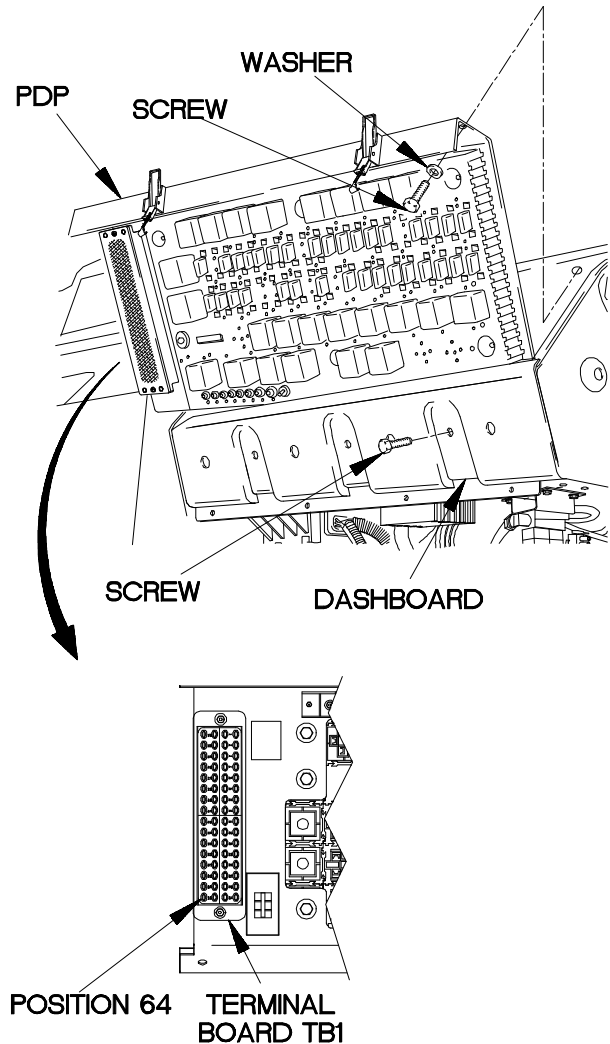

X6E1304B

e14. TACHOMETER DOES NOT OPERATE OR IS INACCURATE

INITIAL SETUP

Equipment Conditions

Engine shut down (TM 9-2320-365-10).

Materials/Parts

Wire, Elect, 50 ft (Item 77, Appendix D)

Tools and Special Tools

Tool Kit, Genl Mech (Item 44, Appendix C)
 STE/ICE-R (Item 39, Appendix C)
 Multimeter, Digital (Item 22, Appendix C)
 Wrench, Torque, 0-75 lb-in. (Item 86, Appendix B)

Personnel Required

(2)

References

TM 9-4910-571-12&P

NOTE

If tachometer does not illuminate, perform Electrical System Troubleshooting e21. Tachometer Does Not Illuminate prior to beginning this task.

KNOWN INFO
Tachometer illuminates. VOLTS gage OK.
POSSIBLE PROBLEMS
Faulty engine speed sensor. Faulty dashboard cable assembly. Faulty auxiliary panel cable assembly. Faulty engine control cable assembly. Faulty tachometer.

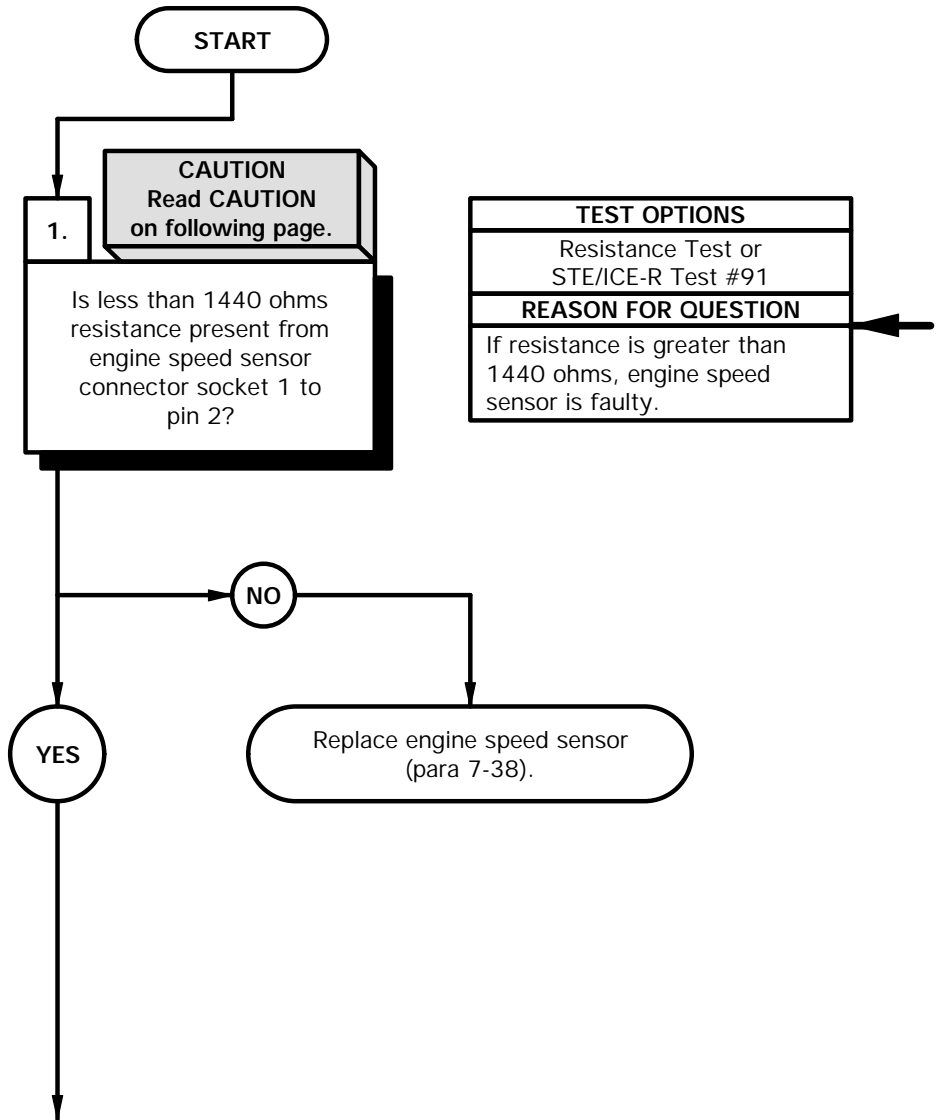

CAUTION

Use care when testing electrical connectors. Do not damage connector pins or sockets with multimeter probes. Failure to comply may result in damage to equipment.

NOTE

Inspect connector pins/sockets for damage, corrosion, and serviceability. Check that connector pins are not pushed back and are capable of making good contact.

CONTINUITY TEST

- (1) Raise cab (TM 9-2320-365-10).
- (2) Disconnect connector clamp from engine speed sensor connector.
- (3) Disconnect connector P38 from engine speed sensor connector.
- (4) Set multimeter to ohms.
- (5) Connect positive (+) probe of multimeter to socket 1 of engine speed sensor connector.
- (6) Connect negative (-) probe of multimeter to pin 2 of engine speed sensor connector and note reading on multimeter.
- (7) If greater than 1440 ohms resistance is present, replace engine speed sensor (para 7-38).

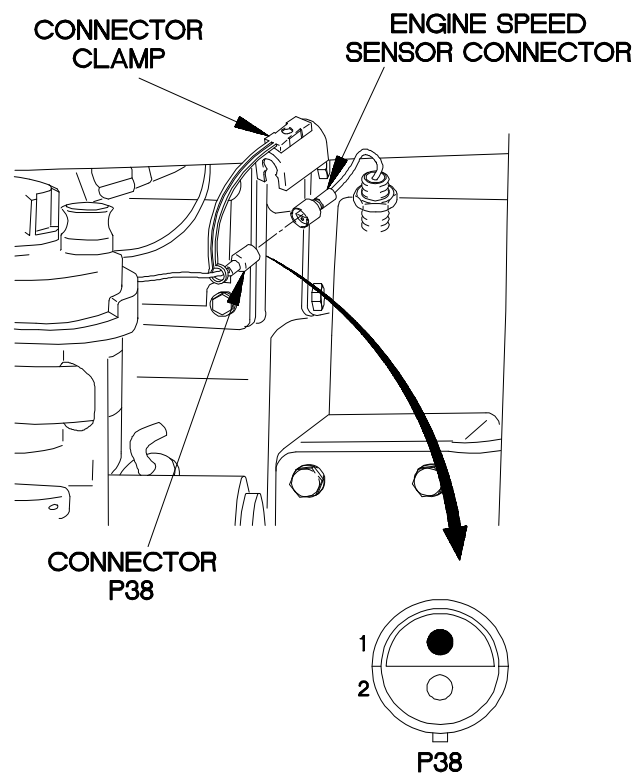
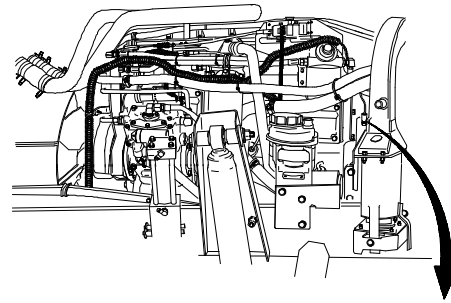

XBE1401B

e14. TACHOMETER DOES NOT OPERATE OR IS INACCURATE (CONT)

KNOWN INFO
Tachometer illuminates. VOLTS gage OK. Engine speed sensor OK electrically.
POSSIBLE PROBLEMS
Faulty engine speed sensor. Faulty dashboard cable assembly. Faulty auxiliary panel cable assembly. Faulty engine control cable assembly. Faulty tachometer.

KNOWN INFO
Tachometer illuminates. VOLTS gage OK. Engine speed sensor OK.
POSSIBLE PROBLEMS
Faulty dashboard cable assembly. Faulty auxiliary panel cable assembly. Faulty engine control cable assembly. Faulty tachometer.

2.
Is engine speed sensor free from damage?

TEST OPTIONS
Visual Inspection
REASON FOR QUESTION
A damaged engine speed sensor will cause tachometer to malfunction.

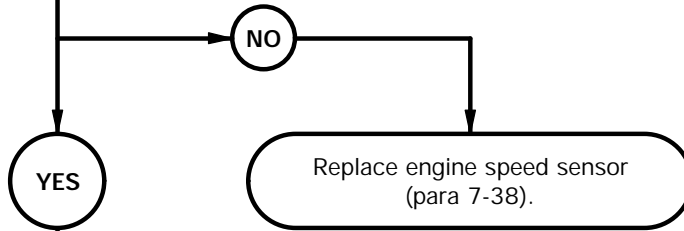

3.
Does tachometer operate correctly after performing step 2?

TEST OPTIONS
STE/ICE-R Test #10
REASON FOR QUESTION
This question eliminates possible problems and determines where troubleshooting continues.

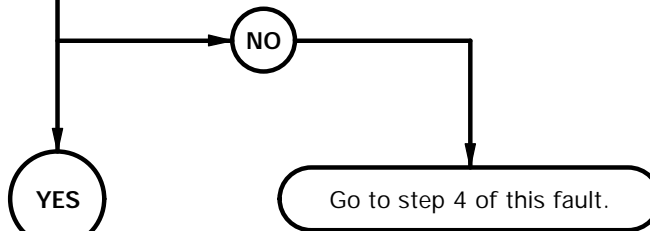

- (1) Remove engine speed sensor (para 7-38).
- (2) Observe lower end of engine speed sensor for damage caused by contact with engine ring gear.
- (3) If engine speed sensor is damaged, replace engine speed sensor (para 7-38).
- (4) Install engine speed sensor (para 7-38).
- (5) Adjust engine speed sensor (para 7-38).

- (1) Perform STE/ICE-R test #10.
- (2) Position PTO switch to on (TM 9-2320-365-10).
- (3) Observe if STE/ICE-R test #10 results and tachometer reading are in agreement.
- (4) Position PTO switch to off (TM 9-2320-365-10).
- (5) Shut down engine (TM 9-2320-365-10).
- (6) If STE/ICE-R test #10 and tachometer reading are not in agreement, go to step 4 of this fault.

e14. TACHOMETER DOES NOT OPERATE OR IS INACCURATE (CONT)

KNOWN INFO
Tachometer illuminates. VOLTS gage OK. Engine speed sensor OK.
POSSIBLE PROBLEMS
Faulty dashboard cable assembly. Faulty auxiliary panel cable assembly. Faulty engine control cable assembly. Faulty tachometer.

4.

WARNING

CAUTION

Read **WARNING** and **CAUTION** on following page.

Is 24 VDC present on connector P901 pin 3?

TEST OPTIONS
Voltage Test or STE/ICE-R Test #89
REASON FOR QUESTION
If 24 VDC is not present, wire 1546 is faulty.

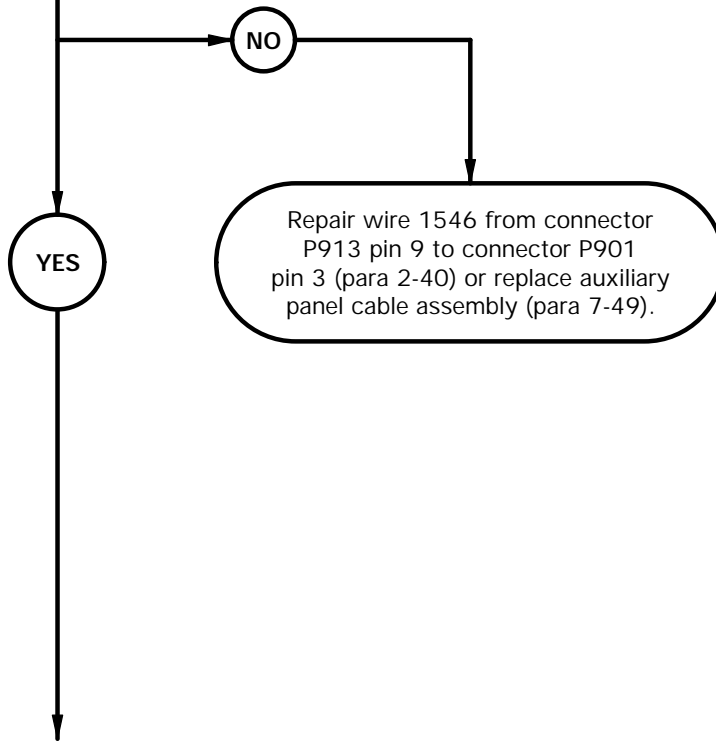

WARNING

Remove rings, bracelets, watches, necklaces, and any other jewelry before working around vehicle. Jewelry can catch on equipment and cause injury or short across electrical circuits and cause severe burns or electrical shock.

CAUTION

Use care when testing electrical connectors. Do not damage connector pins or sockets with multimeter probes. Failure to comply may result in damage to equipment.

NOTE

Inspect connector pins/sockets for damage, corrosion, and serviceability. Check that connector pins are not pushed back and are capable of making good contact.

VOLTAGE TEST

- (1) Remove six screws from auxiliary panel.
- (2) Lift auxiliary panel from auxiliary panel housing to gain access.
- (3) Disconnect connector clamp from tachometer connector.
- (4) Disconnect connector P901 from tachometer connector.
- (5) Set multimeter to VDC.
- (6) Connect positive (+) probe of multimeter to connector P901 pin 3.
- (7) Connect negative (-) probe of multimeter to ground.
- (8) Position master power switch to on (TM 9-2320-365-10) and note reading on multimeter.
- (9) If 24 VDC is not present, repair wire 1546 from connector P913 pin 9 to connector P901 pin 3 (para 2-40) or replace auxiliary panel cable assembly (para 7-49).
- (10) Position master power switch to off (TM 9-2320-365-10).

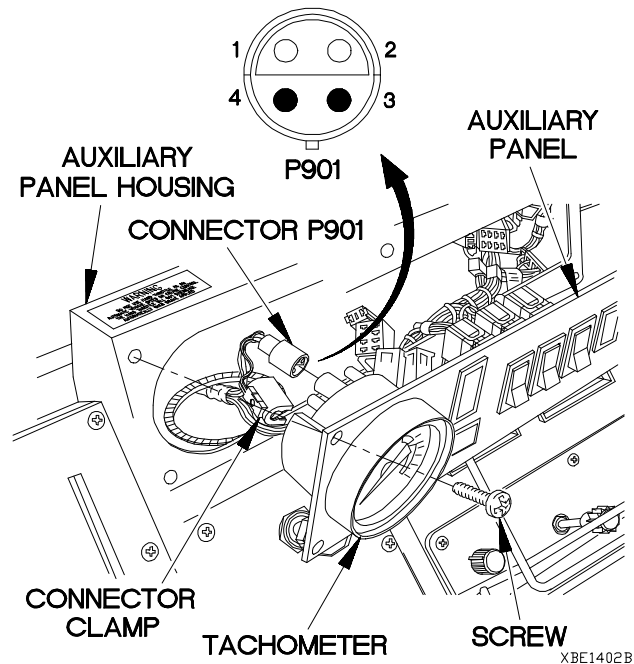

XBE1402B

e14. TACHOMETER DOES NOT OPERATE OR IS INACCURATE (CONT)

KNOWN INFO
Tachometer illuminates. VOLTS gage OK. Engine speed sensor OK.
POSSIBLE PROBLEMS
Faulty dashboard cable assembly. Faulty auxiliary panel cable assembly. Faulty engine control cable assembly. Faulty tachometer.

5. **CAUTION**
Read CAUTION on following page.

Is continuity present from connector P901 pin 4 to connector P38 pin 1?

TEST OPTIONS
Continuity Test or STE/ICE-R Test #91
REASON FOR QUESTION
This question eliminates possible problems and determines where troubleshooting continues.

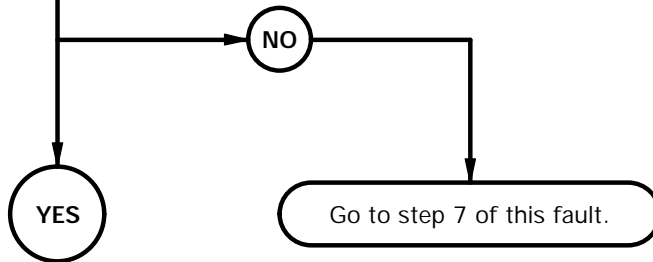

KNOWN INFO
Tachometer illuminates. VOLTS gage OK. Engine speed sensor OK. Auxiliary panel cable assembly OK.
POSSIBLE PROBLEMS
Faulty dashboard cable assembly. Faulty engine control cable assembly. Faulty tachometer.

6. Is continuity present from connector P38 socket 2 to a known good ground?

TEST OPTIONS
Continuity Test or STE/ICE-R Test #91
REASON FOR QUESTION
If continuity is present, tachometer is faulty.

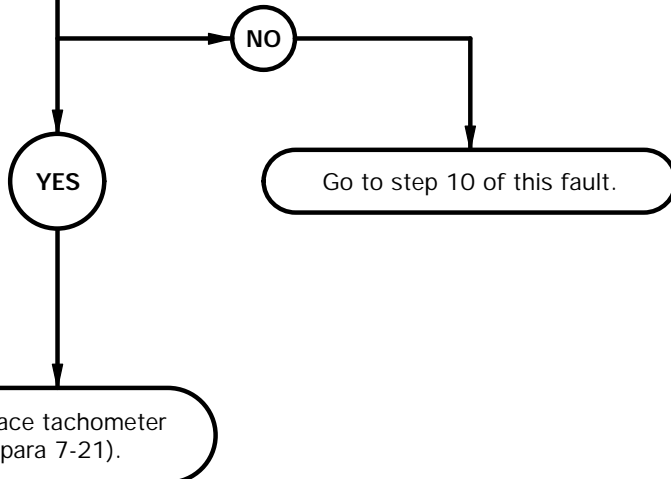

CAUTION

Use care when testing electrical connectors. Do not damage connector pins or sockets with multimeter probes. Failure to comply may result in damage to equipment.

NOTE

Inspect connector pins/sockets for damage, corrosion, and serviceability. Check that connector pins are not pushed back and are capable of making good contact.

CONTINUITY TEST

- (1) Set multimeter to ohms.
- (2) Connect positive (+) probe of multimeter to connector P901 pin 4.
- (3) Raise cab (TM 9-2320-365-10).
- (4) Disconnect connector clamp from engine speed sensor connector.
- (5) Disconnect connector P38 from engine speed sensor connector.
- (7) Connect negative (-) probe of multimeter to connector P38 pin 1 and note reading on multimeter.
- (8) If continuity is not present, go to step 7 of this fault.

CONTINUITY TEST

- (1) Set multimeter to ohms.
- (2) Connect positive (+) probe of multimeter to connector P38 socket 2.
- (3) Connect negative (-) probe of multimeter to ground and note reading on multimeter.
- (4) If continuity is not present, go to step 10 of this fault.
- (5) If continuity is present, replace tachometer (para 7-21).
- (6) Connect connector P38 to engine speed sensor connector.
- (7) Connect connector clamp on engine speed sensor connector.
- (8) Lower cab (TM 9-2320-365-10).
- (9) Connect connector P901 to tachometer connector.
- (10) Connect connector clamp on tachometer connector.
- (11) Position auxiliary panel on auxiliary panel housing with six screws.
- (12) Tighten six screws to 18 lb-in. (2 N·m).

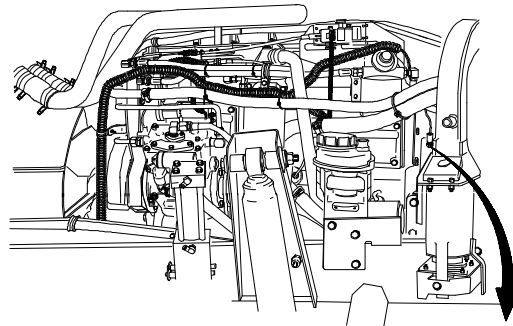

CONNECTOR CLAMP ENGINE SPEED SENSOR CONNECTOR

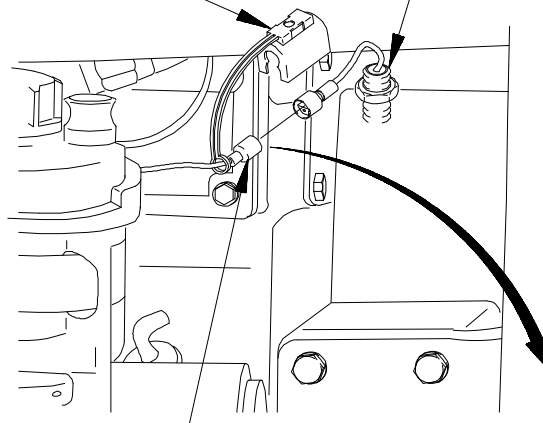

CONNECTOR P38

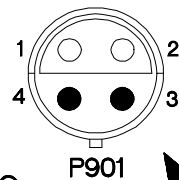
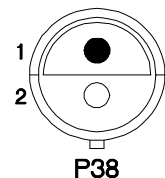

AUXILIARY PANEL

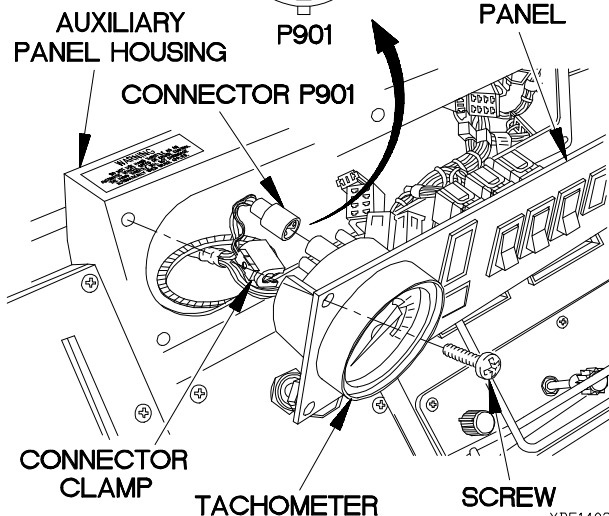

CONNECTOR CLAMP TACHOMETER SCREW

XBE1403B

e14. TACHOMETER DOES NOT OPERATE OR IS INACCURATE (CONT)

KNOWN INFO
Tachometer illuminates. VOLTS gage OK. Engine speed sensor OK.
POSSIBLE PROBLEMS
Faulty dashboard cable assembly. Faulty auxiliary panel cable assembly. Faulty engine control cable assembly.

7.

CAUTION
Read CAUTION on following page.

Is continuity present from connector P901 pin 4 to connector J31 pin 8?

TEST OPTIONS
Continuity Test or STE/ICE-R Test #91
REASON FOR QUESTION
This question eliminates possible problems and determines where troubleshooting continues.

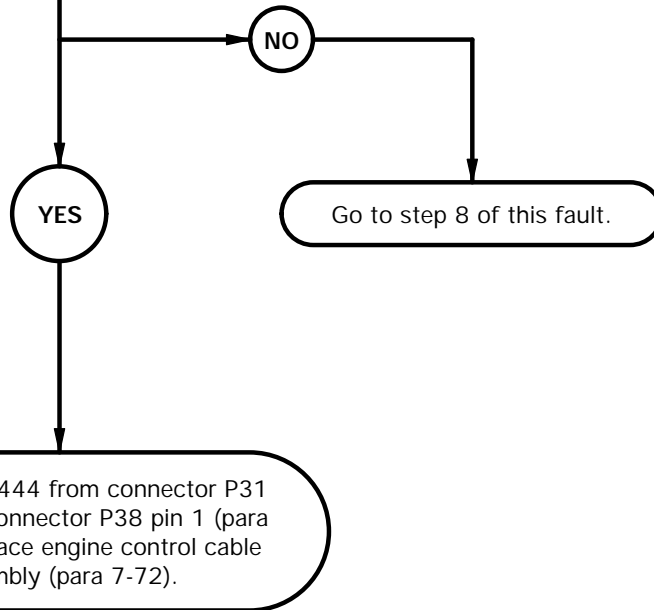

CAUTION

Use care when testing electrical connectors. Do not damage connector pins or sockets with multimeter probes. Failure to comply may result in damage to equipment.

NOTE

Inspect connector pins/sockets for damage, corrosion, and serviceability. Check that connector pins are not pushed back and are capable of making good contact.

CONTINUITY TEST

- (1) Connect connector P38 to engine speed sensor connector.
- (2) Connect connector clamp on engine speed sensor connector.
- (3) Lower cab (TM 9-2320-365-10).
- (4) Remove instrument panel assembly for access (para 7-15).
- (5) Disconnect connector P31 from connector J31.
- (6) Set multimeter to ohms.
- (7) Connect positive (+) probe of multimeter to connector P901 pin 4.
- (8) Connect negative (-) probe of multimeter to connector J31 pin 8 and note reading on multimeter.
- (9) If continuity is not present, go to step 8 of this fault.
- (10) If continuity is present, repair wire 1444 from connector P31 socket 8 to connector P38 pin 1 (para 2-40) or replace engine control cable assembly (para 7-72).
- (11) Connect connector P31 to connector J31.
- (12) Install instrument panel assembly (para 7-15).

NOTE

Perform steps (13) through (16) if continuity is present.

- (13) Connect connector P901 to tachometer connector.
- (14) Connect connector clamp on tachometer connector.
- (15) Position auxiliary panel on auxiliary panel housing with six screws.
- (16) Tighten six screws to 18 lb-in. (2 N·m).

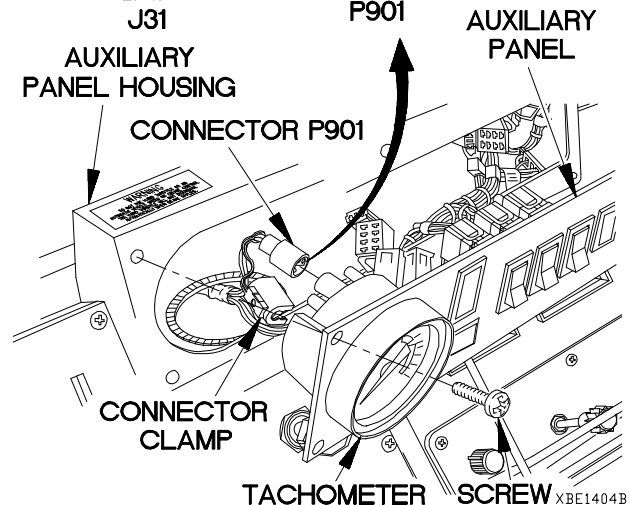
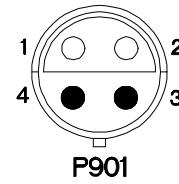
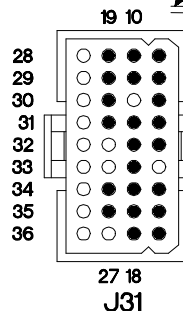
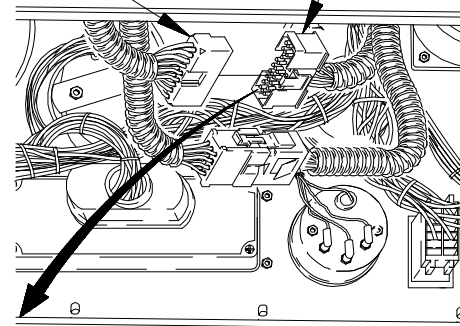
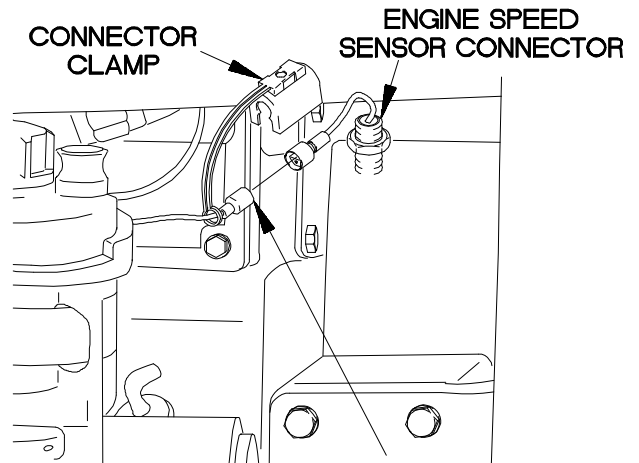

e14. TACHOMETER DOES NOT OPERATE OR IS INACCURATE (CONT)

KNOWN INFO
Tachometer illuminates. VOLTS gage OK. Engine speed sensor OK.
POSSIBLE PROBLEMS
Faulty dashboard cable assembly. Faulty auxiliary panel cable assembly.

8.

CAUTION
Read CAUTION on following page.

Is continuity present from connector P901 pin 4 to connector PX26 socket 1?

TEST OPTIONS
Continuity Test or STE/ICE-R Test #91
REASON FOR QUESTION
This question eliminates possible problems and determines where troubleshooting continues.

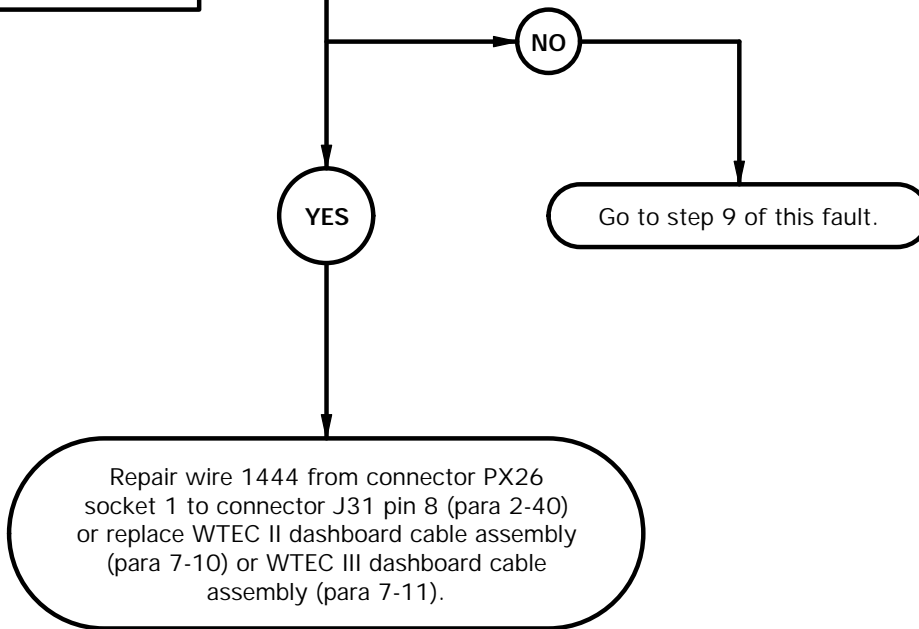

CAUTION

Use care when testing electrical connectors. Do not damage connector pins or sockets with multimeter probes. Failure to comply may result in damage to equipment.

NOTE

Inspect connector pins/sockets for damage, corrosion, and serviceability. Check that connector pins are not pushed back and are capable of making good contact.

CONTINUITY TEST

- (1) Disconnect connector PX26 from frequency ECU connector.
- (2) Set multimeter to ohms.
- (3) Connect positive (+) probe of multimeter to connector P901 pin 4.
- (4) Connect negative (-) probe of multimeter to connector PX26 socket 1 and note reading on multimeter.
- (5) If continuity is not present, go to step 9 of this fault.
- (6) If continuity is present, repair wire 1444 from connector PX26 socket 1 to connector J31 pin 8 (para 2-40) or replace WTEC II dashboard cable assembly (para 7-10) or WTEC III dashboard cable assembly (para 7-11).
- (7) Connect connector PX26 to frequency ECU connector.

NOTE

Perform steps (8) through (11) if continuity is present.

- (8) Connect connector P901 to tachometer connector.
- (9) Connect connector clamp on tachometer connector.
- (10) Position auxiliary panel on auxiliary panel housing with six screws.
- (11) Tighten six screws to 18 lb-in. (2 N·m).

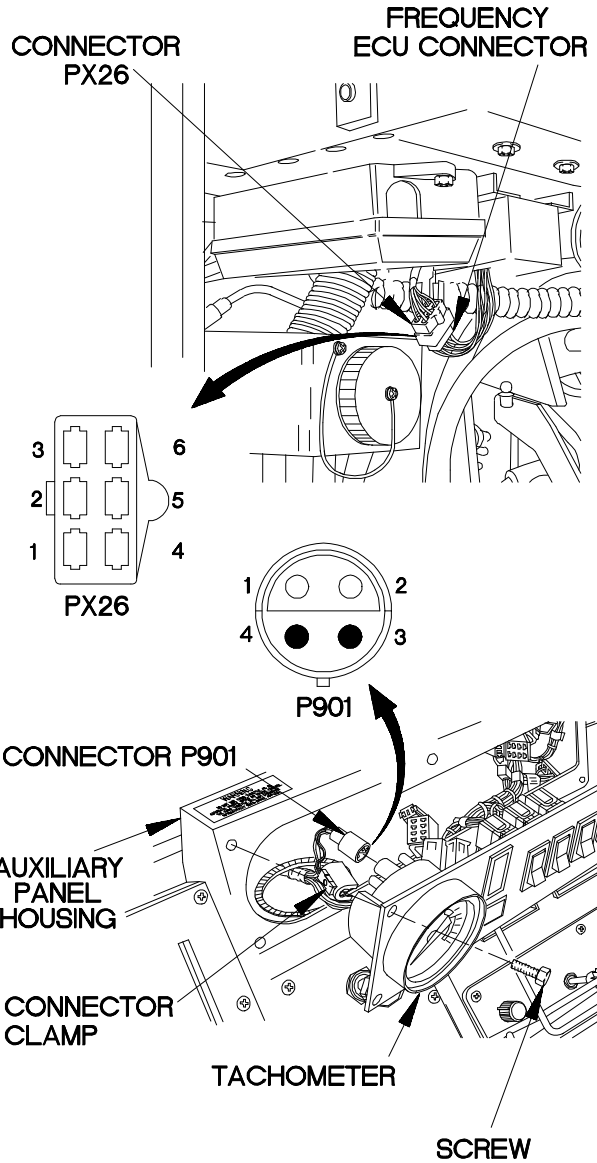

XBE1405B

e14. TACHOMETER DOES NOT OPERATE OR IS INACCURATE (CONT)

KNOWN INFO
Tachometer illuminates. VOLTS gage OK. Engine speed sensor OK.
POSSIBLE PROBLEMS
Faulty dashboard cable assembly. Faulty auxiliary panel cable assembly.

CAUTION
Read CAUTION on following page.

9.
Is continuity present from connector P901 pin 4 to connector P913 pin 12?

TEST OPTIONS
Continuity Test or STE/ICE-R Test #91
REASON FOR QUESTION
If continuity is not present, wire 1550 in auxiliary panel cable assembly is faulty. If continuity is present, wire 1550 in dashboard cable assembly is faulty.

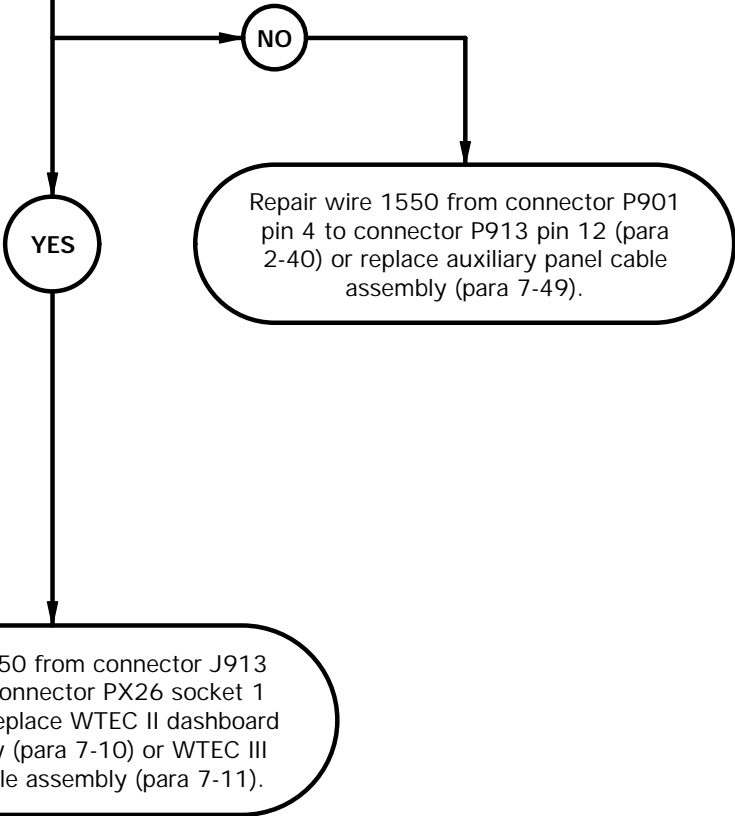

CAUTION

Use care when testing electrical connectors. Do not damage connector pins or sockets with multimeter probes. Failure to comply may result in damage to equipment.

NOTE

Inspect connector pins/sockets for damage, corrosion, and serviceability. Check that connector pins are not pushed back and are capable of making good contact.

CONTINUITY TEST

- (1) Remove personnel heater assembly for access (para 18-9).
- (2) Disconnect connector P913 from connector J913.
- (3) Set multimeter to ohms.
- (4) Connect positive (+) probe of multimeter to connector P901 pin 4.
- (5) Connect negative (-) probe of multimeter to connector P913 pin 12 and note reading on multimeter.
- (6) If continuity is not present, repair wire 1550 from connector P901 pin 4 to connector P913 pin 12 (para 2-40) or replace auxiliary panel cable assembly (para 7-49).
- (7) If continuity is present, repair wire 1550 from connector J913 socket 12 to connector PX26 socket 1 (para 2-40) or replace WTEC II dashboard cable assembly (para 7-10) or WTEC III dashboard cable assembly (para 7-11).
- (8) Connect connector P913 to connector J913.
- (9) Install personnel heater assembly (para 18-9).

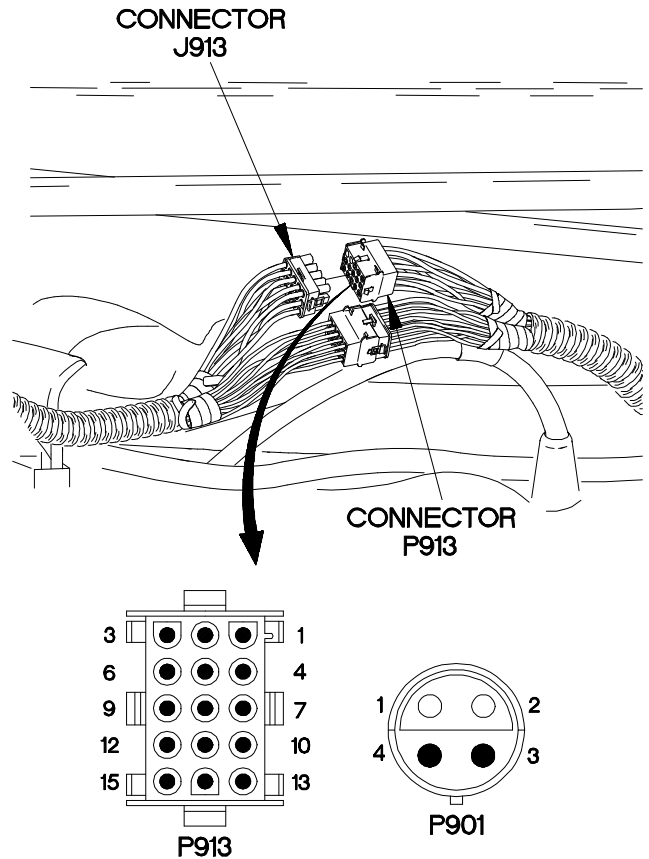

XBE1406B

e14. TACHOMETER DOES NOT OPERATE OR IS INACCURATE (CONT)

KNOWN INFO
Tachometer illuminates. VOLTS gage OK. Engine speed sensor OK.
POSSIBLE PROBLEMS
Faulty dashboard cable assembly. Faulty auxiliary panel cable assembly. Faulty engine control cable assembly.

10. **CAUTION**
Read CAUTION on following page.

Is continuity present from connector J31 pin 16 to a known good ground?

TEST OPTIONS
Continuity Test or STE/ICE-R Test #91
REASON FOR QUESTION
This question eliminates possible problems and determines where troubleshooting continues.

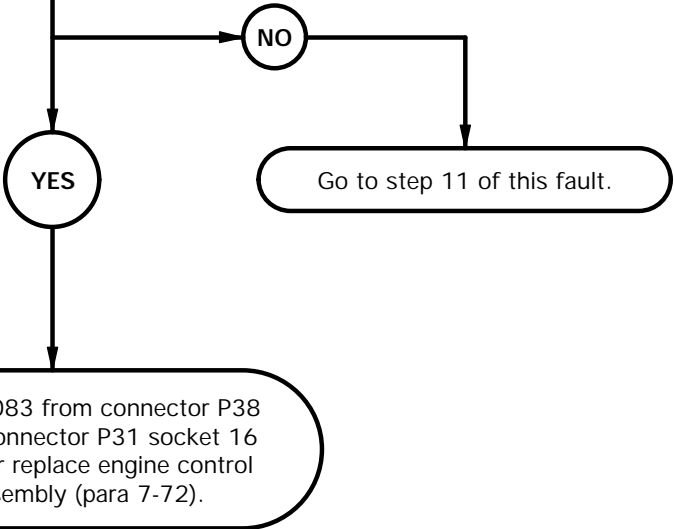

KNOWN INFO
Tachometer illuminates. VOLTS gage OK. Engine speed sensor OK.
POSSIBLE PROBLEMS
Faulty dashboard cable assembly. Faulty auxiliary panel cable assembly.

11. **CAUTION**
Read CAUTION on following page.

Is continuity present from connector PX26 socket 6 to a known good ground?

TEST OPTIONS
Continuity Test or STE/ICE-R Test #91
REASON FOR QUESTION
If continuity is not present, wire 3083 is faulty.

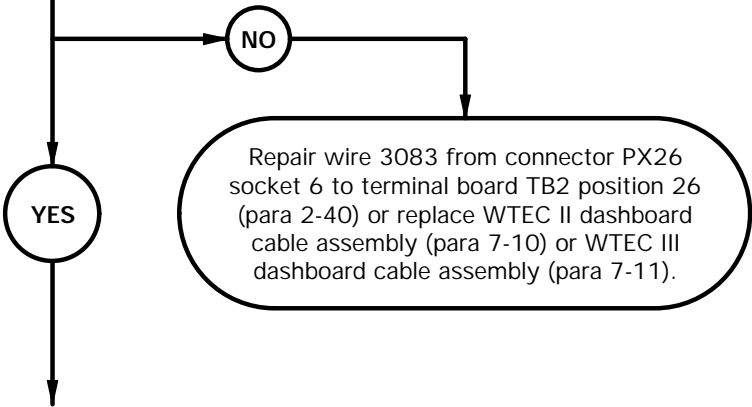

CAUTION

Use care when testing electrical connectors. Do not damage connector pins or sockets with multimeter probes. Failure to comply may result in damage to equipment.

NOTE

Inspect connector pins/sockets for damage, corrosion, and serviceability. Check that connector pins are not pushed back and are capable of making good contact.

CONTINUITY TEST

- (1) Remove instrument panel assembly for access (para 7-15).
- (2) Disconnect connector P31 from connector J31.
- (3) Set multimeter to ohms.
- (4) Connect positive (+) probe of multimeter to connector J31 pin 16.
- (5) Connect negative (-) probe of multimeter to ground and note reading on multimeter.
- (6) If continuity is not present, go to step 11 of this fault.
- (7) If continuity is present, repair wire 3083 from connector P38 socket 2 to connector P31 socket 16 (para 2-40) or replace engine control cable assembly (para 7-72).
- (8) Connect connector P31 to connector J31.
- (9) Install instrument panel assembly (para 7-15).

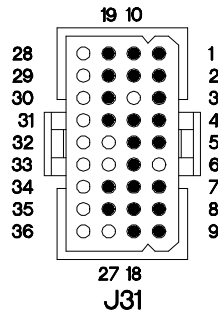
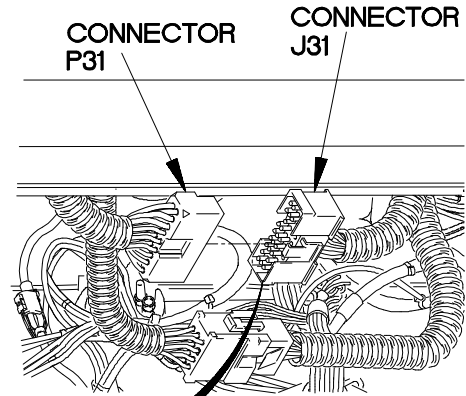

FREQUENCY ECU CONNECTOR

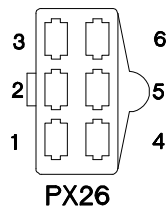
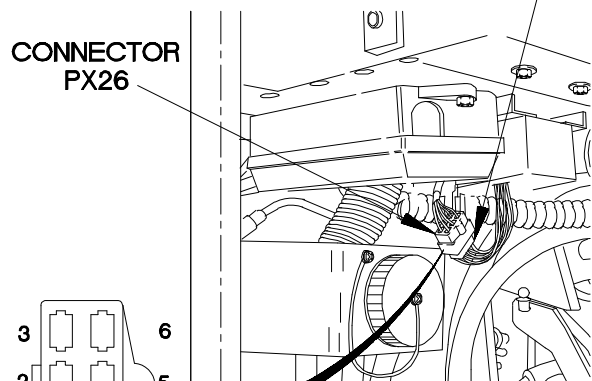

CONTINUITY TEST

- (1) Disconnect connector PX26 from frequency ECU connector.
- (2) Set multimeter to ohms.
- (3) Connect positive (+) probe of multimeter to connector PX26 socket 6.
- (4) Connect negative (-) probe of multimeter to ground and note reading on multimeter.
- (5) If continuity is not present, repair wire 3083 from connector PX26 socket 6 to terminal board TB2 position 26 (para 2-40) or replace WTEC II dashboard cable assembly (para 7-10) or WTEC III dashboard cable assembly (para 7-11).

XBE1407B

e14. TACHOMETER DOES NOT OPERATE OR IS INACCURATE (CONT)

KNOWN INFO
Tachometer illuminates. VOLTS gage OK. Engine speed sensor OK.
POSSIBLE PROBLEMS
Faulty dashboard cable assembly.

12. **CAUTION**
Read CAUTION on following page.

Is continuity present from connector PX26 socket 6 to socket 4?

TEST OPTIONS
Continuity Test or STE/ICE-R Test #91
REASON FOR QUESTION
If continuity is not present, wire 3083 from connector PX26 socket 6 to socket 4 is faulty. If continuity is present, wire 3083 from connector PX26 socket 4 to connector J31 pin 16 is faulty.

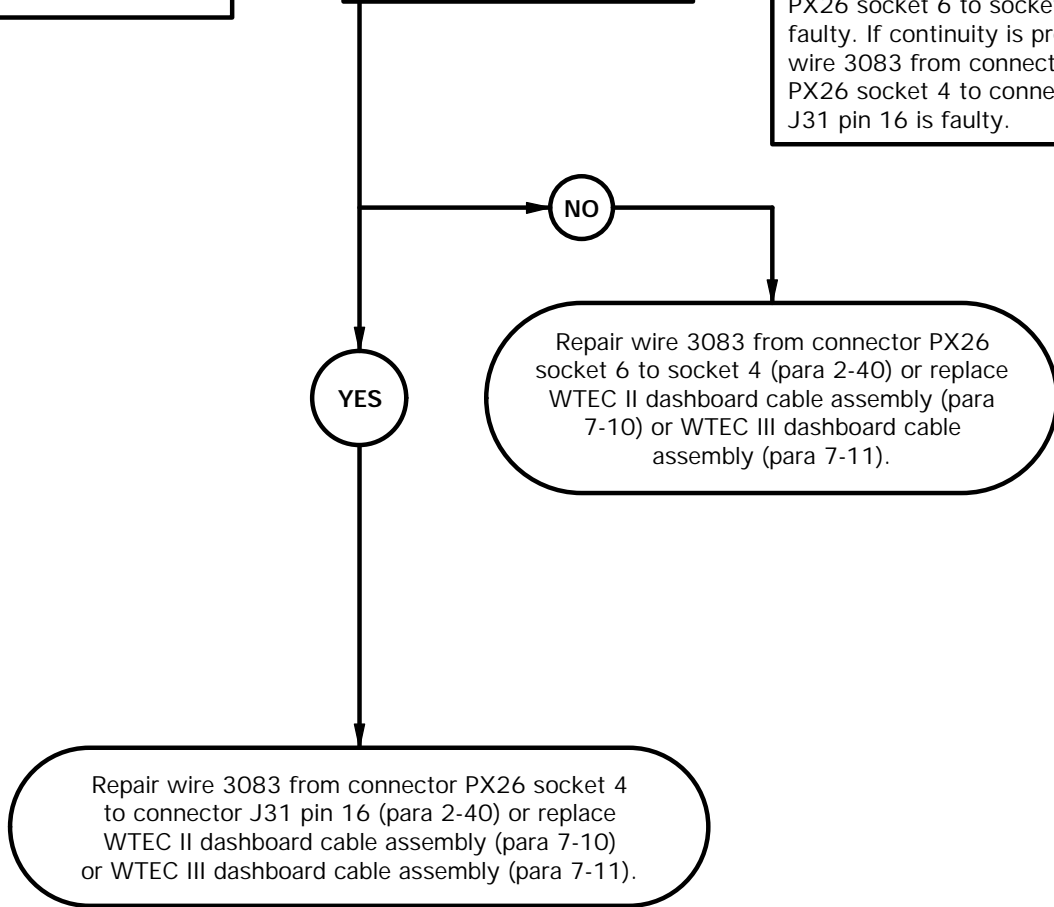

CAUTION

Use care when testing electrical connectors. Do not damage connector pins or sockets with multimeter probes. Failure to comply may result in damage to equipment.

NOTE

Inspect connector pins/sockets for damage, corrosion, and serviceability. Check that connector pins are not pushed back and are capable of making good contact.

CONTINUITY TEST

- (1) Set multimeter to ohms.
- (2) Connect positive (+) probe of multimeter to connector PX26 socket 6.
- (3) Connect negative (-) probe of multimeter to connector PX26 socket 4 and note reading on multimeter.
- (4) If continuity is not present, repair wire 3083 from connector PX26 socket 6 to socket 4 (para 2-40) or replace WTEC II dashboard cable assembly (para 7-10) or WTEC III dashboard cable assembly (para 7-11).
- (5) If continuity is present, repair wire 3083 connector PX26 socket 4 to connector J31 pin 16 (para 2-40) or replace WTEC II dashboard cable assembly (para 7-10) or WTEC III dashboard cable assembly (para 7-11).
- (6) Connect connector PX26 to frequency ECU connector.

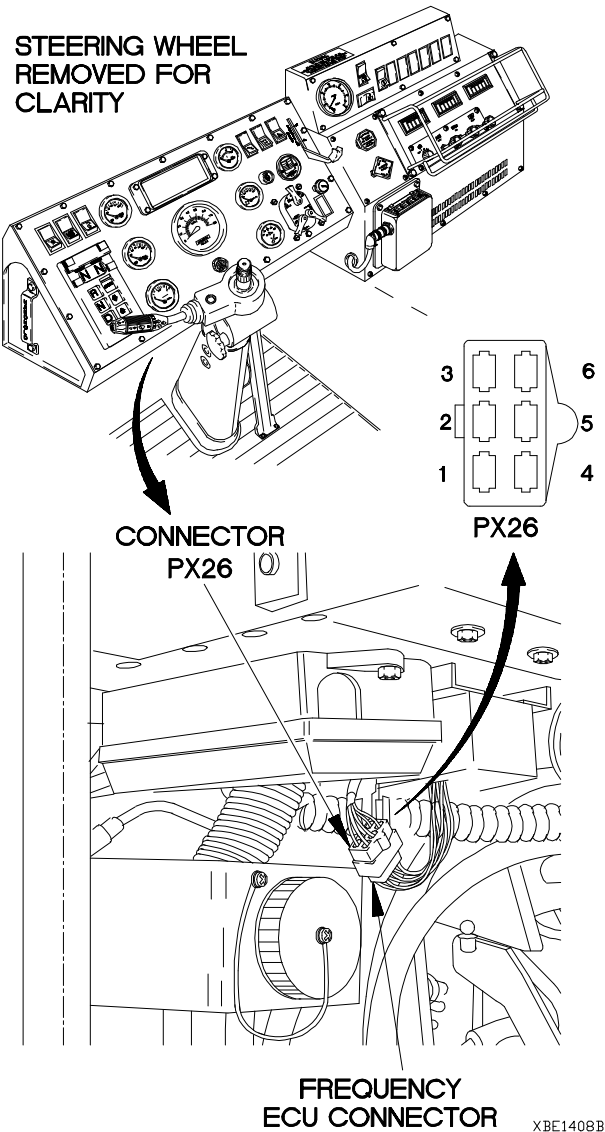

e15. AUDIBLE ALARM DOES NOT OPERATE

INITIAL SETUP

Equipment Conditions

Engine shut down (TM 9-2320-365-10).
Air tanks drained (TM 9-2320-365-10).

Materials/Parts

Wire, Elect, 50 ft (Item 77, Appendix D)

Tools and Special Tools

Tool Kit, Genl Mech (Item 44, Appendix C)
STE/ICE-R (Item 39, Appendix C)
Multimeter, Digital (Item 22, Appendix C)

Personnel Required

(2)

References

TM 9-4910-571-12&P

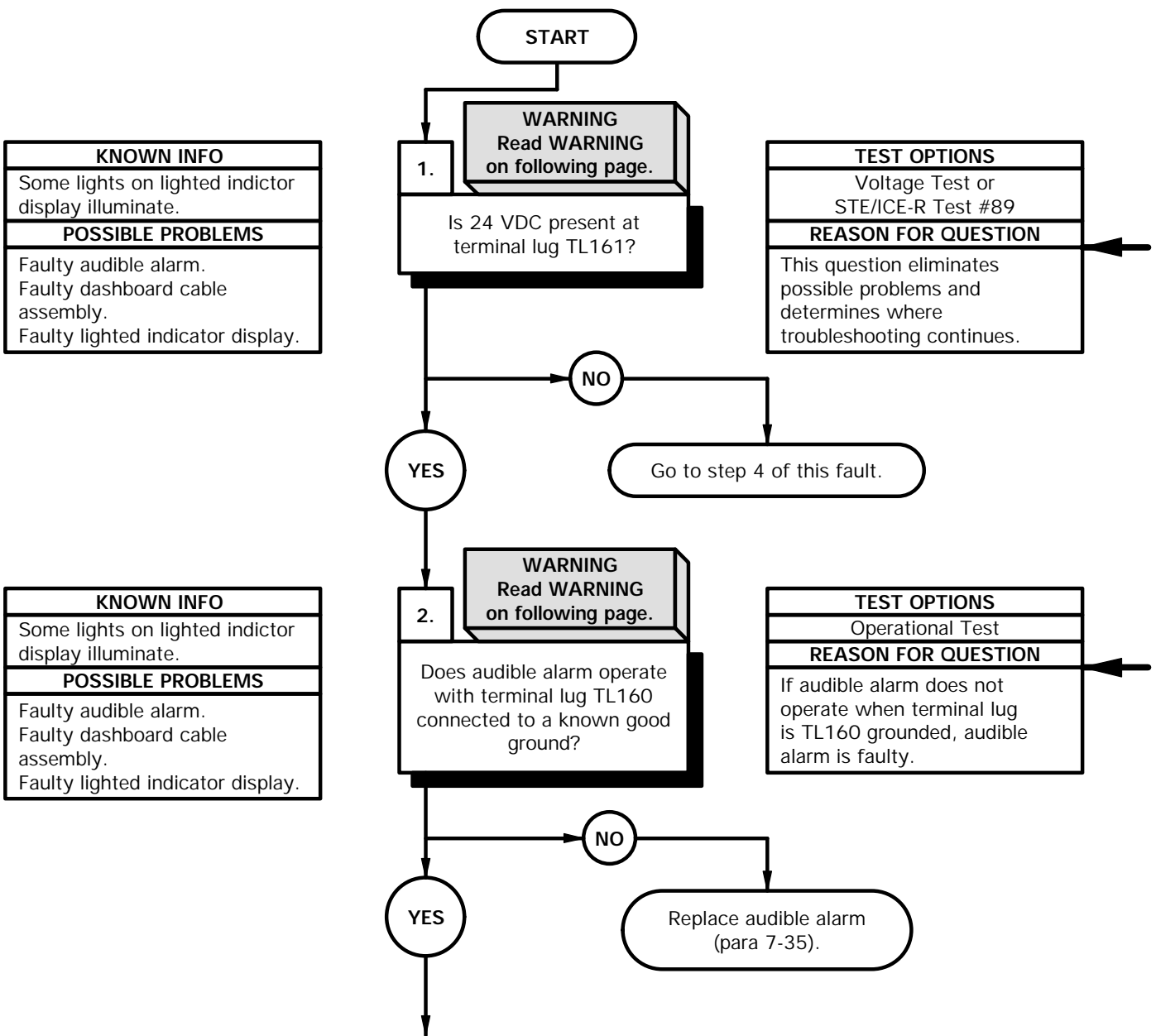

WARNING

Remove rings, bracelets, watches, necklaces, and any other jewelry before working around vehicle. Jewelry can catch on equipment and cause injury or short across electrical circuits and cause severe burns or electrical shock.

VOLTAGE TEST

- (1) Remove instrument panel assembly for access (para 7-15).
- (2) Set multimeter to volts DC.
- (3) Connect positive (+) probe of multimeter to terminal lug TL161.
- (4) Connect negative (-) probe of multimeter to ground.
- (5) Position master power switch to on (TM 9-2320-365-10) and note reading on multimeter.
- (6) If 24 VDC is not present, go to step 4 of this fault.
- (7) Position master power switch to off (TM 9-2320-365-10).

OPERATIONAL TEST

- (1) Connect one end of electrical wire to terminal lug TL160.
- (2) Connect opposite end of electrical wire to ground.
- (3) Position master power switch to on (TM 9-2320-365-10).
- (4) If audible alarm does not operate, replace audible alarm (para 7-35).
- (5) Position master power switch to off (TM 9-2320-365-10).

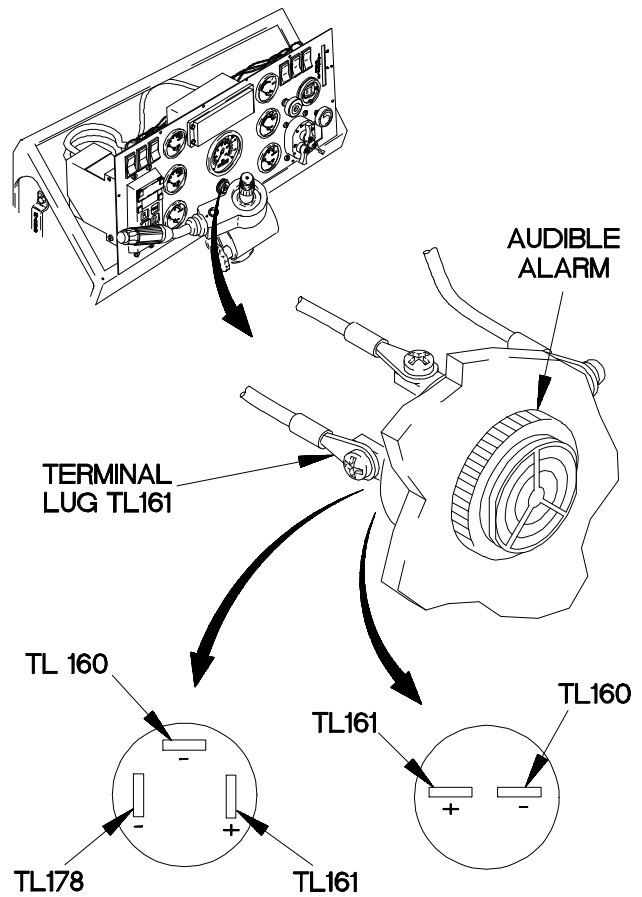

Xbe1501b

e15. AUDIBLE ALARM DOES NOT OPERATE (CONT)

KNOWN INFO
Some lights on lighted indicator display illuminate. Audible alarm OK.
POSSIBLE PROBLEMS
Faulty dashboard cable assembly. Faulty lighted indicator display.

3.

CAUTION
Read CAUTION on following page.

Is continuity present from terminal lug TL160 to connector PX7 pin 19?

TEST OPTIONS
Continuity Test or STE/ICE-R Test #91
REASON FOR QUESTION
If continuity is not present, wire 1536 from terminal lug TL160 to connector PX7 pin 19 is faulty. If continuity is present, lighted indicator display is faulty.

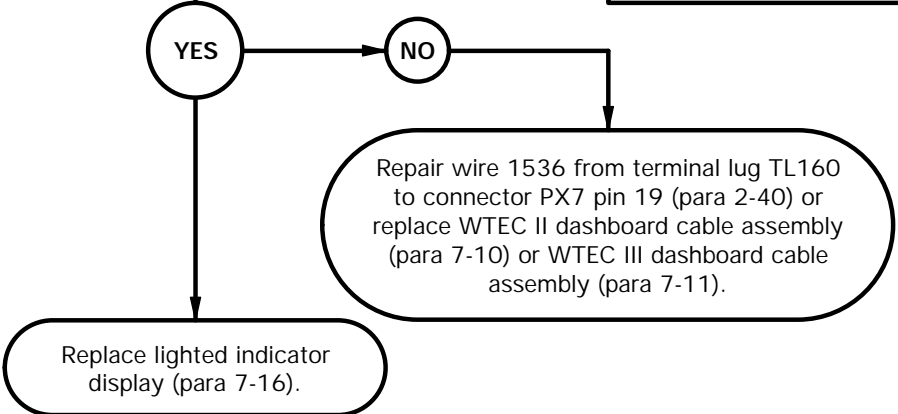

KNOWN INFO
Some lights on lighted indicator display illuminate. Audible alarm OK.
POSSIBLE PROBLEMS
Faulty dashboard cable assembly. Faulty lighted indicator display.

4.

CAUTION
Read CAUTION on following page.

Is continuity present from terminal lug TL161 to connector PX7 pin 16?

TEST OPTIONS
Continuity Test or STE/ICE-R Test #91
REASON FOR QUESTION
If continuity is not present, wire 1532 from terminal lug TL161 to connector PX7 pin 16 is faulty. If continuity is present, lighted indicator display is faulty.

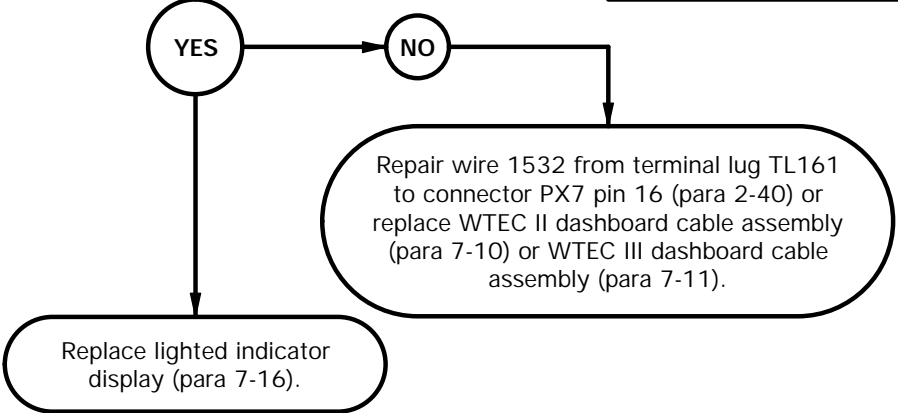

CAUTION

Use care when testing electrical connectors. Do not damage connector pins or sockets with multimeter probes. Failure to comply may result in damage to equipment.

NOTE

Inspect connector pins/sockets for damage, corrosion, and serviceability. Check that connector pins are not pushed back and are capable of making good contact.

CONTINUITY TEST

- (1) Disconnect connector PX7 from lighted indicator display.
- (2) Set multimeter to ohms.
- (3) Connect positive (+) probe of multimeter to terminal lug TL160.
- (4) Connect negative (-) probe of multimeter to connector PX7 pin 19 and note reading on multimeter.
- (5) If continuity is not present, repair wire 1536 from terminal lug TL160 to connector PX7 pin 19 (para 2-40) or replace WTEC II dashboard cable assembly (para 7-10) or WTEC III dashboard cable assembly (para 7-11).
- (6) If continuity is present, replace lighted indicator display (para 7-16).
- (7) Connect connector PX7 to lighted indicator display.
- (8) Install instrument panel assembly (para 7-15).

CONTINUITY TEST

- (1) Disconnect connector PX7 from lighted indicator display.
- (2) Set multimeter to ohms.
- (3) Connect positive (+) probe of multimeter to terminal lug TL161.
- (4) Connect negative (-) probe of multimeter to connector PX7 pin 16 and note reading on multimeter.
- (5) If continuity is not present, repair wire 1532 from terminal lug TL161 to connector PX7 pin 16 (para 2-40) or replace WTEC II dashboard cable assembly (para 7-10) or WTEC III dashboard cable assembly (para 7-11).
- (6) If continuity is present, replace lighted indicator display (para 7-16).
- (7) Connect connector PX7 to lighted indicator display.
- (8) Install instrument panel assembly (para 7-15).

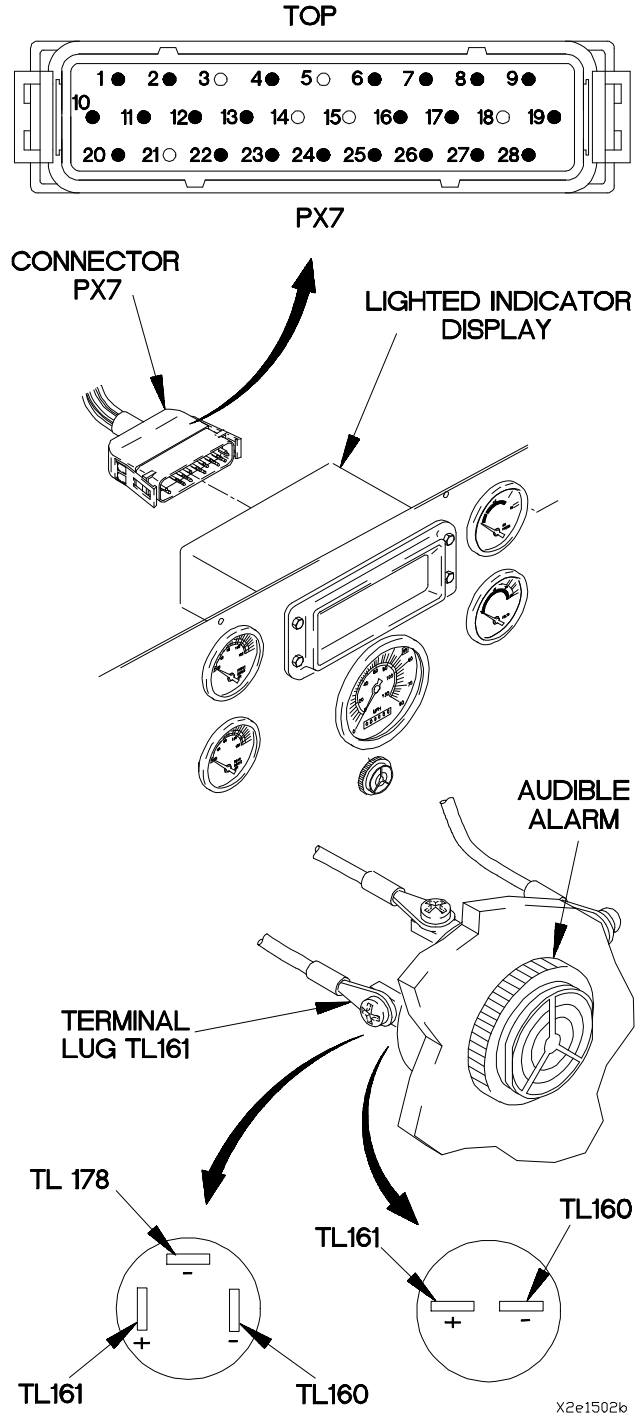

X2e1502b

e16. TROOP TRANSPORT AUDIBLE ALARM DOES NOT OPERATE

INITIAL SETUP

Equipment Conditions

Engine shut down (TM 9-2320-365-10)

Tools and Special Tools

Tool Kit, Genl Mech (Item 44, Appendix C)
 STE/ICE-R (Item 39, Appendix C)
 Multimeter, Digital (Item 22, Appendix C)
 Wrench, Torque, 0-75 lb-in. (Item 86, Appendix B)

Materials/Parts

Lockwasher (2) (Item 72, Appendix G)
 Wire, Elect, 50 ft (Item 77, Appendix D)

Personnel Required

(2)

References

TM 9-4910-571-12&P

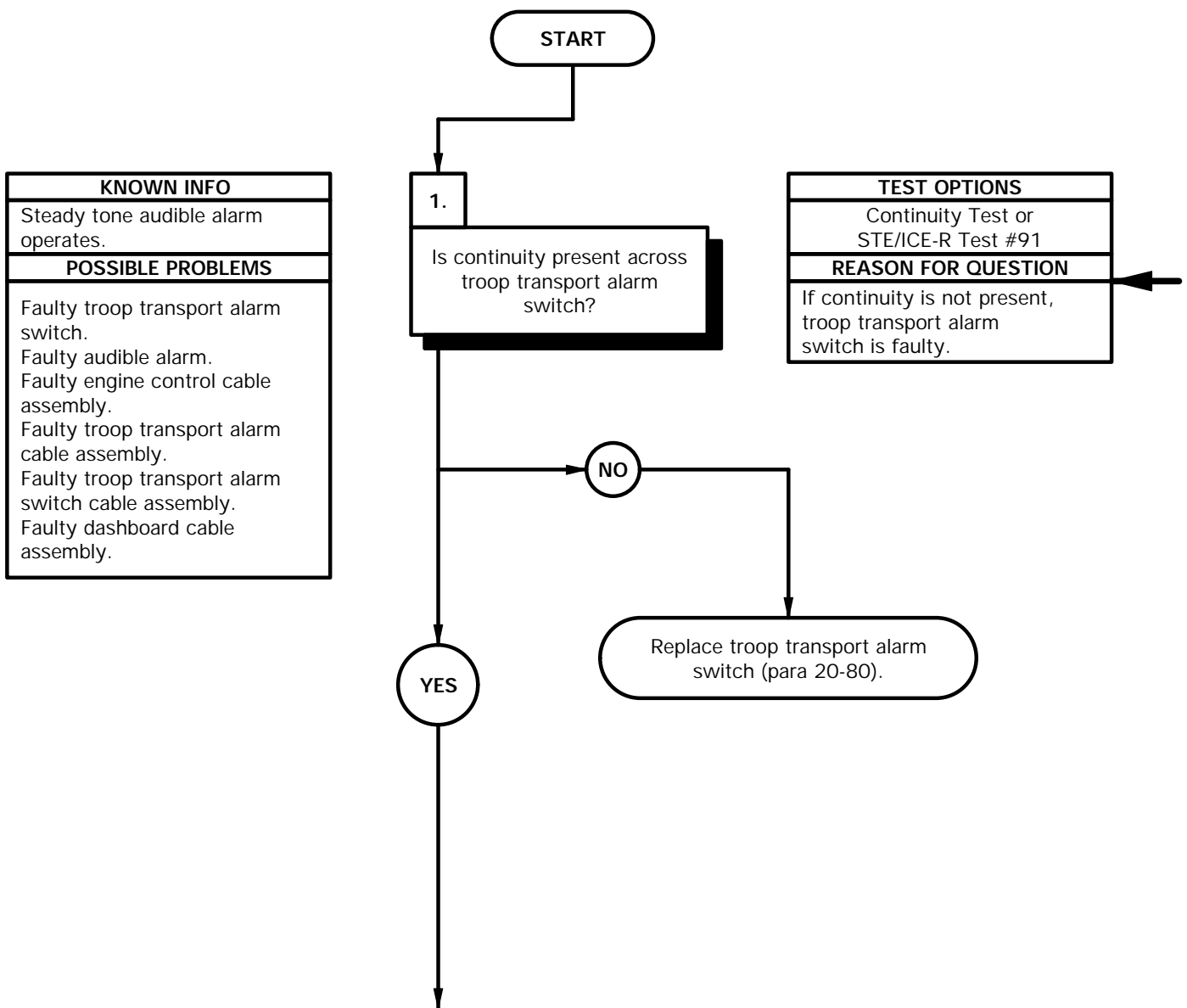

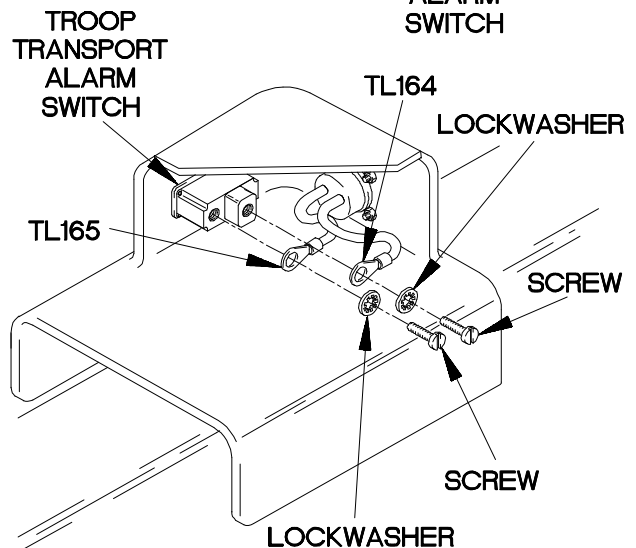
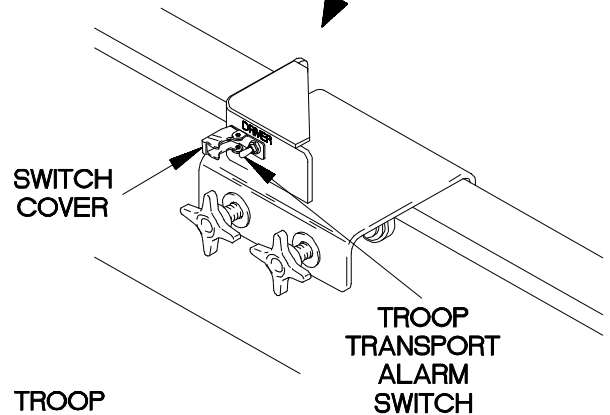
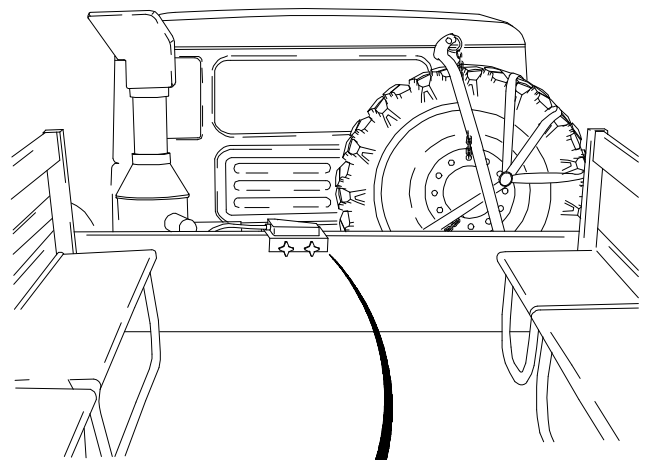

CONTINUITY TEST

- (1) Remove two screws, lockwashers, and terminal lugs TL164 and TL165 from troop transport alarm switch. Discard lockwashers.
- (2) Lift switch cover on troop transport alarm switch.
- (3) Set multimeter to ohms.
- (4) Connect positive (+) probe of multimeter to one terminal of troop transport alarm switch.
- (5) Connect negative (-) probe of multimeter to second terminal of troop transport alarm switch.
- (6) Position troop transport alarm switch to on and note reading on multimeter.
- (7) If continuity is not present, replace troop transport alarm switch (para 20-80).
- (8) Install terminal lugs TL165 and TL164 on troop transport alarm switch with two lockwashers and screws.
- (9) Close switch cover on troop transport alarm switch.

Xke1601b

e16. TROOP TRANSPORT AUDIBLE ALARM DOES NOT OPERATE (CONT)

KNOWN INFO
Steady tone audible alarm operates. Troop transport alarm switch OK.
POSSIBLE PROBLEMS
Faulty audible alarm. Faulty engine control cable assembly. Faulty troop transport alarm cable assembly. Faulty troop transport alarm switch cable assembly. Faulty dashboard cable assembly.

2.

WARNING
Read **WARNING** on following page.

Does troop transport audible alarm operate when connected to a known good ground?

TEST OPTIONS
Voltage Test or STE/ICE-R Test #89
REASON FOR QUESTION
If troop transport audible alarm does not operate when connected to a known good ground, audible alarm is faulty.

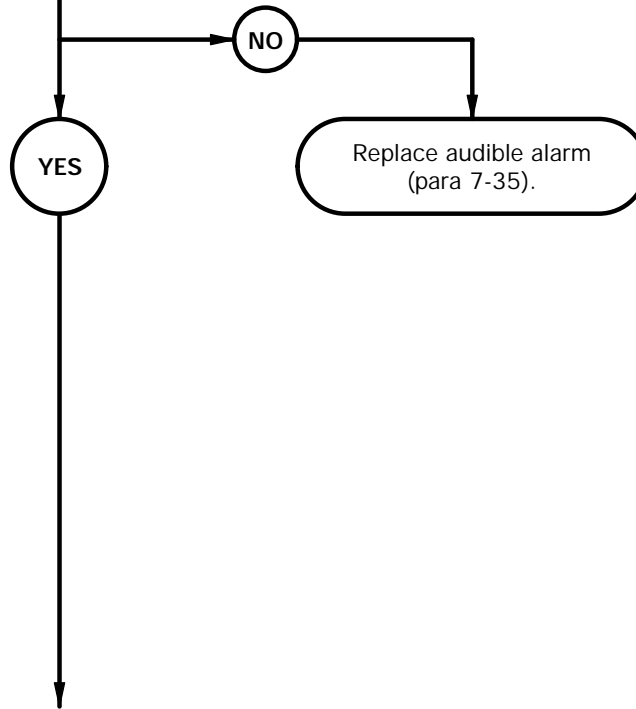

WARNING

Remove rings, bracelets, watches, necklaces, and any other jewelry before working around vehicle. Jewelry can catch on equipment and cause injury or short across electrical circuits and cause severe burns or electrical shock.

VOLTAGE TEST

- (1) Start engine (TM 9-2320-365-10) and allow enough pressure to build in air tanks to cause steady tone audible alarm to cease.
- (2) Shut down engine (TM 9-2320-365-10).
- (3) Remove PDP cover (TM 9-2320-365-10).
- (4) Remove circuit breaker CB77 from PDP (para 7-9).
- (5) Remove instrument panel assembly for access (para 7-15).
- (6) Install circuit breaker CB77 on PDP (para 7-9).
- (7) Connect one end of electrical wire to terminal lug TL178.
- (8) Connect opposite end of electrical wire to ground.
- (9) Position master power switch to on (TM 9-2320-365-10).
- (10) If troop transport audible alarm does not operate, replace audible alarm (para 7-35).
- (11) Position master power switch to off (TM 9-2320-365-10).
- (12) Install PDP cover (TM 9-2320-365-10).

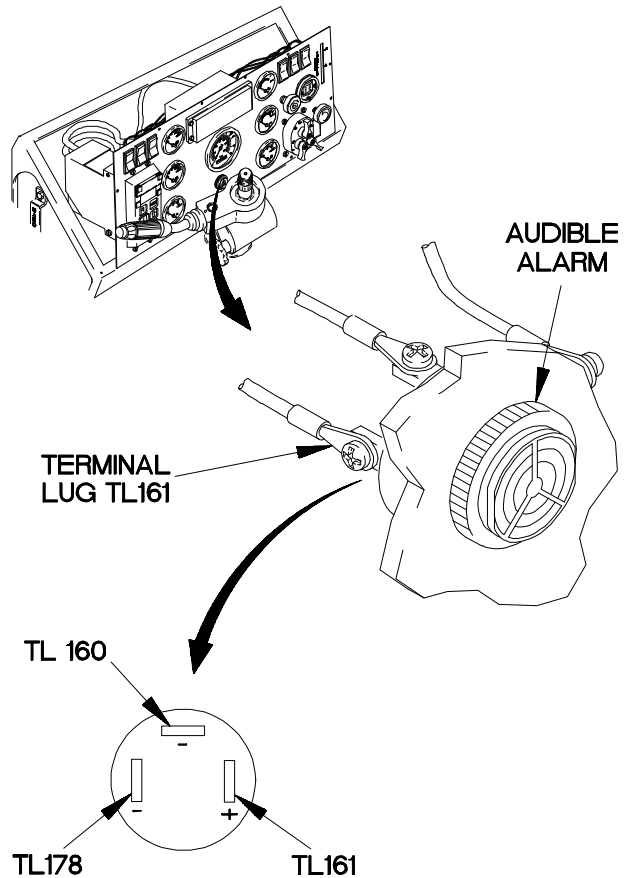

Xbe1602b

e16. TROOP TRANSPORT AUDIBLE ALARM DOES NOT OPERATE (CONT)

KNOWN INFO
Steady tone audible alarm operates. Troop transport alarm switch OK. Audible alarm OK.
POSSIBLE PROBLEMS
Faulty engine control cable assembly. Faulty troop transport alarm cable assembly. Faulty troop transport alarm switch cable assembly. Faulty dashboard cable assembly.

KNOWN INFO
Steady tone audible alarm operates. Troop transport alarm switch OK. Audible alarm OK.
POSSIBLE PROBLEMS
Faulty engine control cable assembly. Faulty troop transport alarm cable assembly. Faulty troop transport alarm switch cable assembly. Faulty dashboard cable assembly.

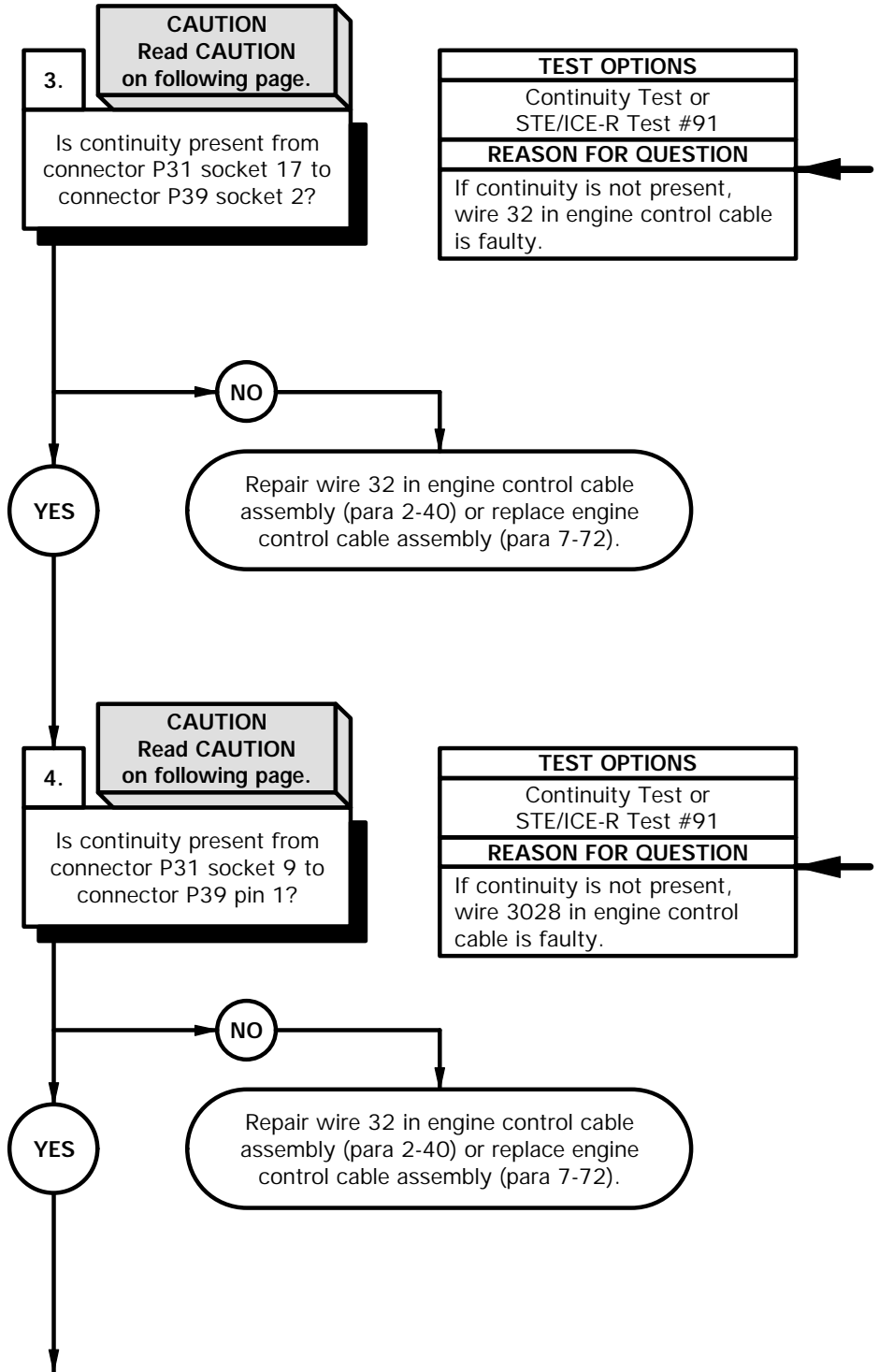

CAUTION

Use care when testing electrical connectors. Do not damage connector pins or sockets with multimeter probes. Failure to comply may result in damage to equipment.

NOTE

Inspect connector pins/sockets for damage, corrosion, and serviceability. Check that connector pins are not pushed back and are capable of making good contact.

CONTINUITY TEST

- (1) Remove instrument panel for access (para 7-15).
- (2) Disconnect connector P31 from connector J31.
- (3) Raise cab (TM 9-2320-365-10).
- (4) Disconnect connector clamp from connector P39.
- (5) Disconnect connector P39 from connector J39.
- (6) Set multimeter to ohms.
- (7) Connect positive (+) probe of multimeter to connector P39 socket 2.
- (8) Connect negative (-) probe of multimeter to connector P31 socket 17 and note reading on multimeter.
- (9) If continuity is not present, repair wire 32 in engine control cable (para 2-40) or replace engine control cable assembly (para 7-72).

CONTINUITY TEST

- (1) Set multimeter to ohms.
- (2) Connect positive (+) probe of multimeter to connector P39 pin 1.
- (3) Connect negative (-) probe of multimeter to connector P31 socket 9 and note reading on multimeter.
- (4) If continuity is not present, repair wire 3028 in engine control cable (para 2-40) or replace engine control cable assembly (para 7-72).

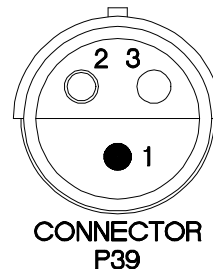
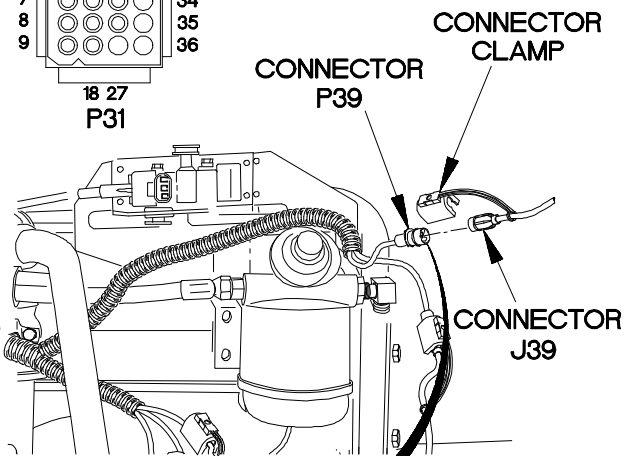
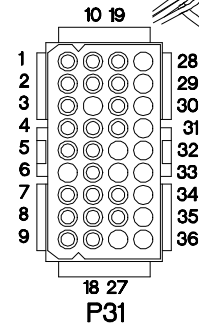
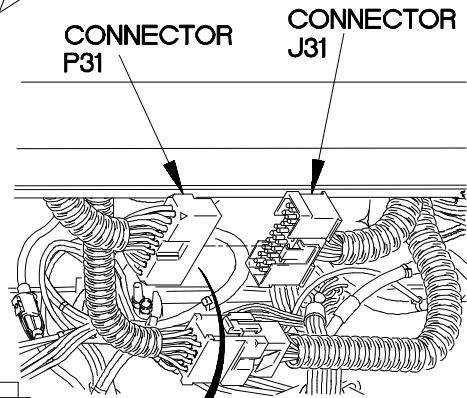
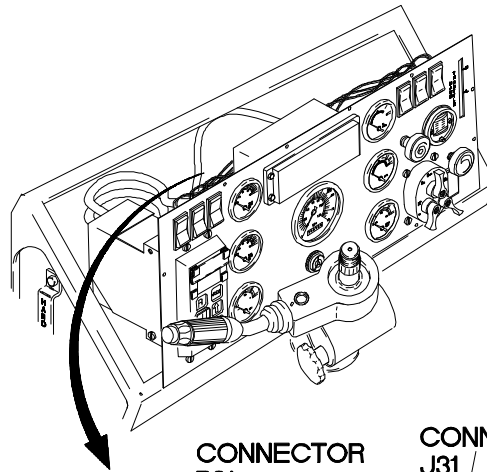

Xbe1603b

e16. TROOP TRANSPORT AUDIBLE ALARM DOES NOT OPERATE (CONT)

KNOWN INFO
Steady tone audible alarm operates. Troop transport alarm switch OK. Audible alarm OK. Engine control cable assembly OK.
POSSIBLE PROBLEMS
Faulty troop transport alarm cable assembly. Faulty troop transport alarm switch cable assembly. Faulty dashboard cable assembly.

KNOWN INFO
Steady tone audible alarm operates. Troop transport alarm switch OK. Audible alarm OK. Engine control cable assembly OK.
POSSIBLE PROBLEMS
Faulty troop transport alarm cable assembly. Faulty troop transport alarm switch cable assembly. Faulty dashboard cable assembly.

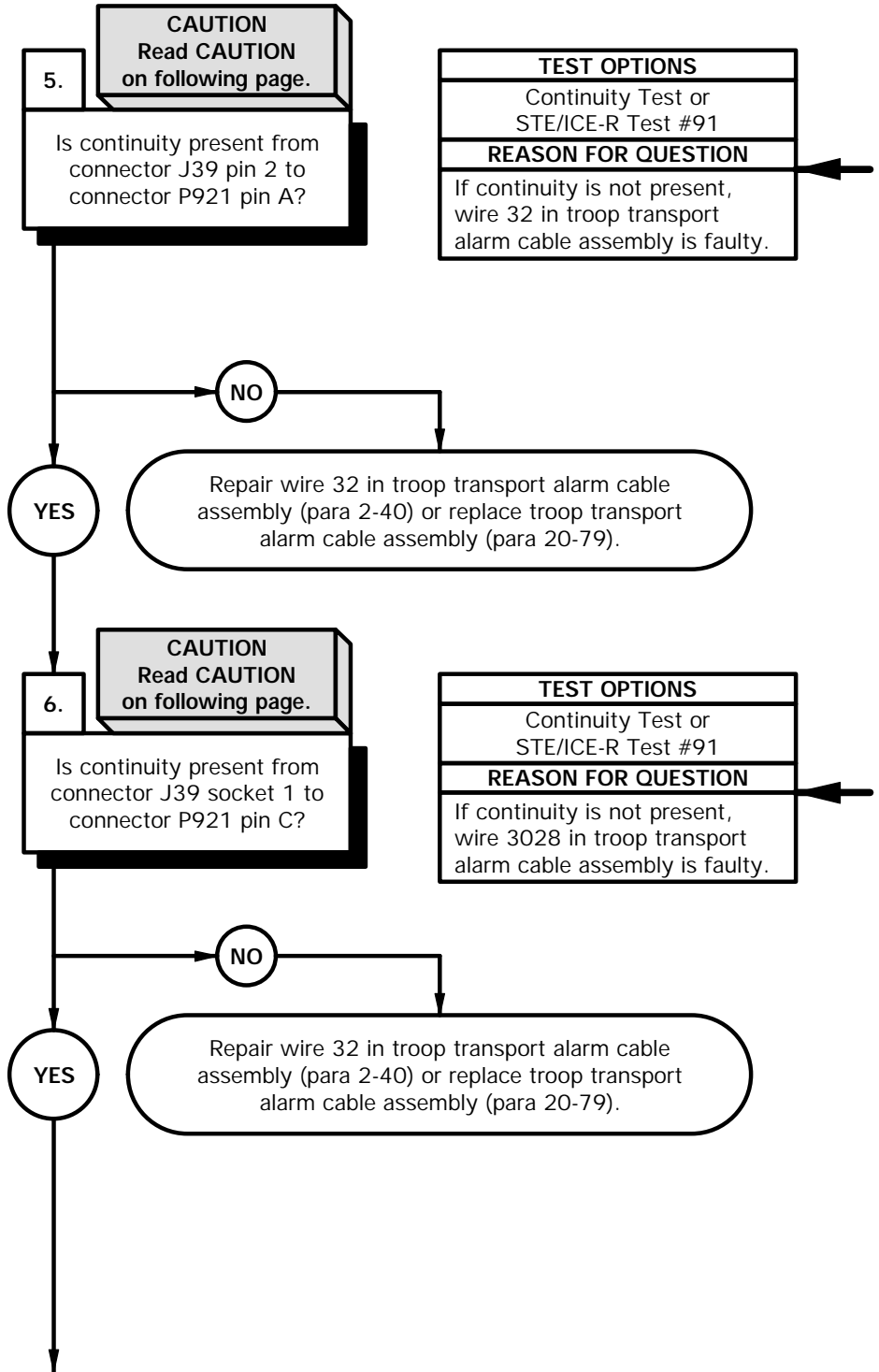

CAUTION

Use care when testing electrical connectors. Do not damage connector pins or sockets with multimeter probes. Failure to comply may result in damage to equipment.

NOTE

Inspect connector pins/sockets for damage, corrosion, and serviceability. Check that connector pins are not pushed back and are capable of making good contact.

CONTINUITY TEST

- (1) Disconnect connector P921 from connector J921.
- (2) Set multimeter to ohms.
- (3) Connect positive (+) probe of multimeter to connector P921 pin A.
- (4) Connect negative (-) probe of multimeter to connector J39 pin 2 and note reading on multimeter.
- (5) If continuity is not present, repair wire 3028 in troop transport alarm cable assembly (para 2-40) or replace troop transport alarm cable assembly (para 20-79).

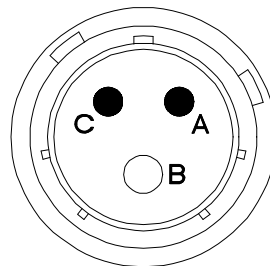
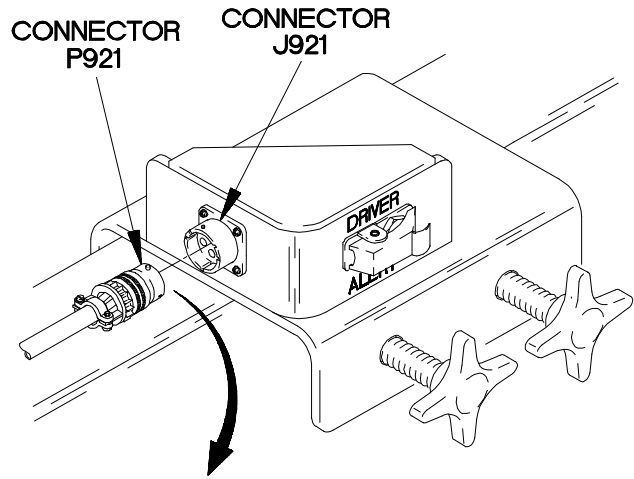

CONNECTOR P921

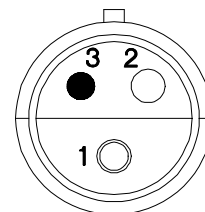
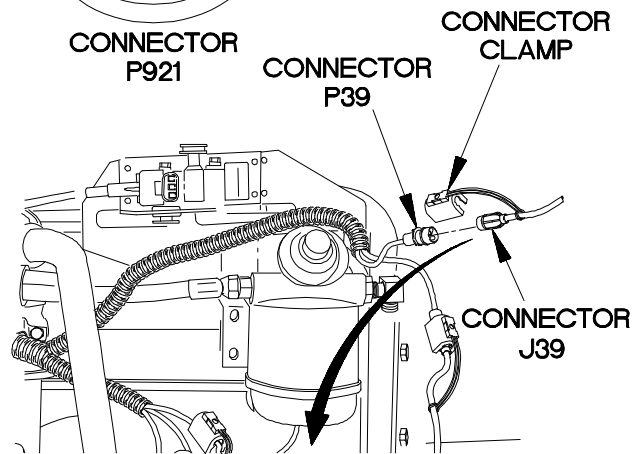

CONNECTOR J39

CONTINUITY TEST

- (1) Set multimeter to ohms.
- (2) Connect positive (+) probe of multimeter to connector J39 socket 1.
- (3) Connect negative (-) probe of multimeter to connector P921 pin C and note reading on multimeter.
- (4) If continuity is not present, repair wire 3028 in troop transport alarm cable assembly (para 2-40) or replace troop transport alarm cable assembly (para 20-79).
- (5) Connect connector P39 to connector J39.
- (6) Connect connector clamp on connector P39.
- (7) Lower cab (TM 9-2320-365-10).

Xbe1605b

e16. TROOP TRANSPORT AUDIBLE ALARM DOES NOT OPERATE (CONT)

KNOWN INFO
Steady tone audible alarm operates. Troop transport alarm switch OK. Audible alarm OK. Engine control cable assembly OK. Troop transport alarm cable assembly OK.
POSSIBLE PROBLEMS
Faulty troop transport alarm switch cable assembly. Faulty dashboard cable assembly.

KNOWN INFO
Steady tone audible alarm operates. Troop transport alarm switch OK. Audible alarm OK. Engine control cable assembly OK. Troop transport alarm cable assembly OK.
POSSIBLE PROBLEMS
Faulty troop transport alarm switch cable assembly. Faulty dashboard cable assembly.

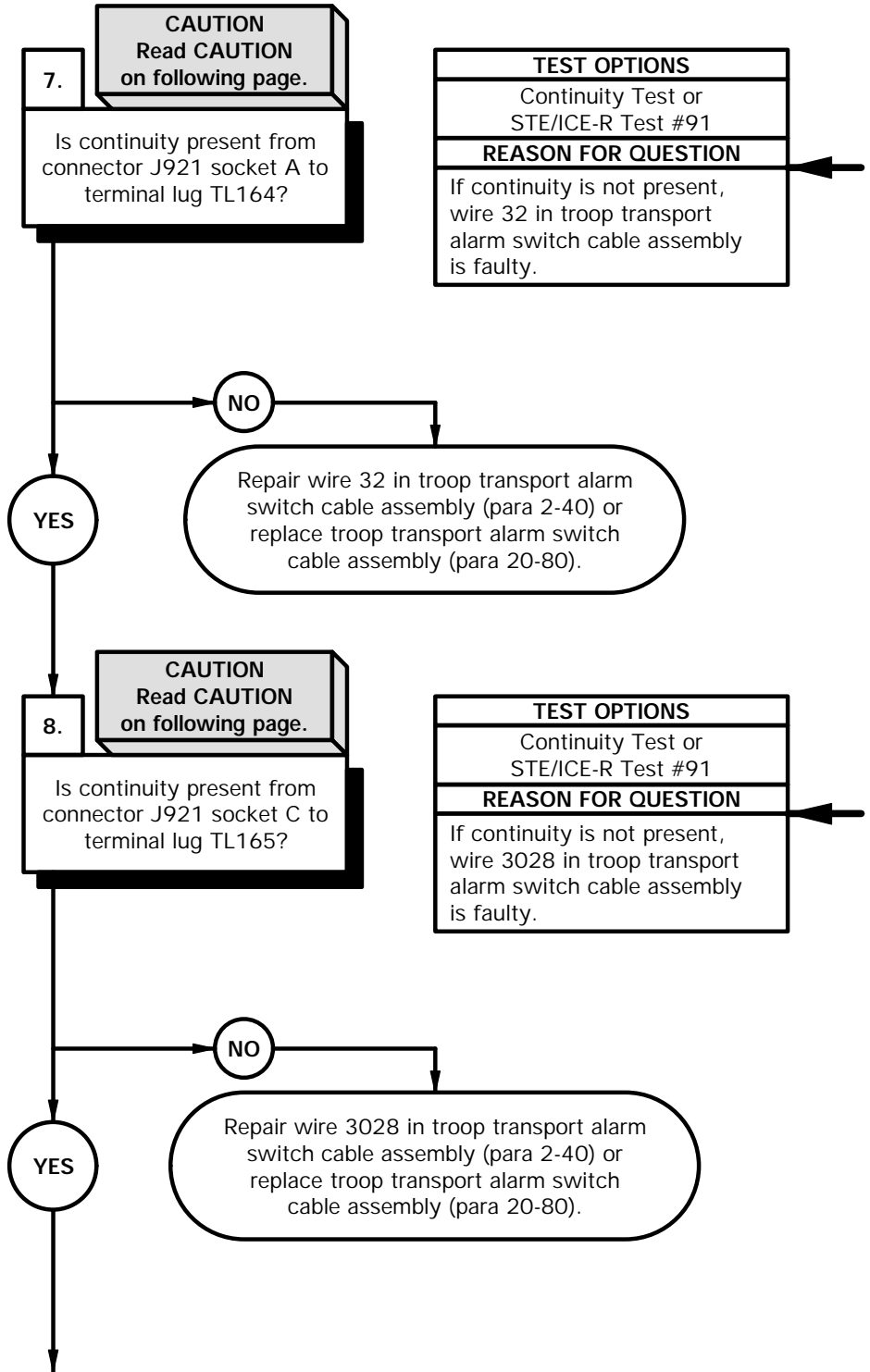

CAUTION

Use care when testing electrical connectors. Do not damage connector pins or sockets with multimeter probes. Failure to comply may result in damage to equipment.

NOTE

Inspect connector pins/sockets for damage, corrosion, and serviceability. Check that connector pins are not pushed back and are capable of making good contact.

CONTINUITY TEST

- (1) Set multimeter to ohms.
- (2) Connect positive (+) probe of multimeter to connector J921 socket A.
- (3) Connect negative (-) probe of multimeter to terminal lug TL164 and note reading on multimeter.
- (4) If continuity is not present, repair wire 32 in troop transport alarm switch cable assembly (para 2-40) or replace troop transport alarm switch cable assembly (para 20-80).

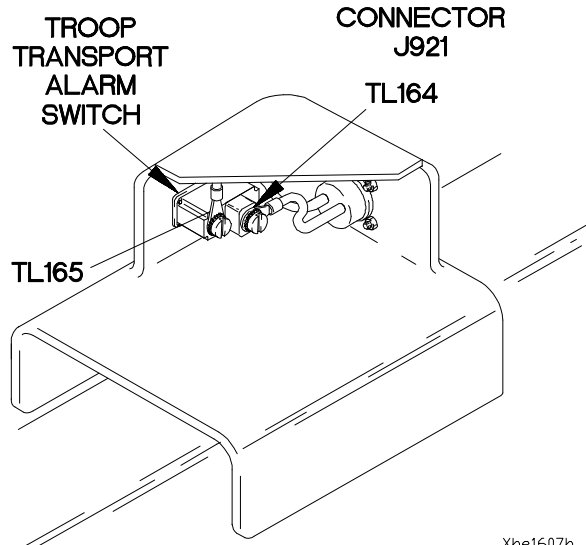
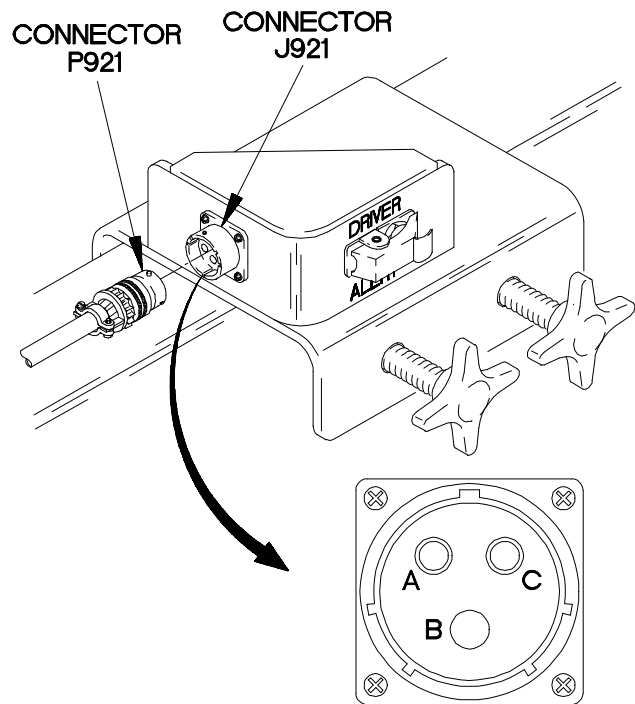

Xbe1607b

CONTINUITY TEST

- (1) Set multimeter to ohms.
- (2) Connect positive (+) probe of multimeter to connector J921 socket C.
- (3) Connect negative (-) probe of multimeter to terminal lug TL165 and note reading on multimeter.
- (4) If continuity is not present, repair wire 3028 in troop transport alarm switch cable assembly (para 2-40) or replace troop transport alarm switch cable assembly (para 20-80).
- (5) Connect connector P921 to connector J921.

e16. TROOP TRANSPORT AUDIBLE ALARM DOES NOT OPERATE (CONT)

KNOWN INFO
Steady tone audible alarm operates. Troop transport alarm switch OK. Audible alarm OK. Engine control cable assembly OK. Troop transport alarm cable assembly OK. Troop transport alarm switch cable assembly OK.
POSSIBLE PROBLEMS
Faulty dashboard cable assembly.

9. **CAUTION**
Read CAUTION on following page.

Is continuity present from connector J31 pin 9 to ground?

TEST OPTIONS
Continuity Test or STE/ICE-R Test #91
REASON FOR QUESTION
If continuity is not present, wire 3028 in dashboard cable assembly is faulty. If continuity is present, wire 32 in dashboard cable assembly is faulty.

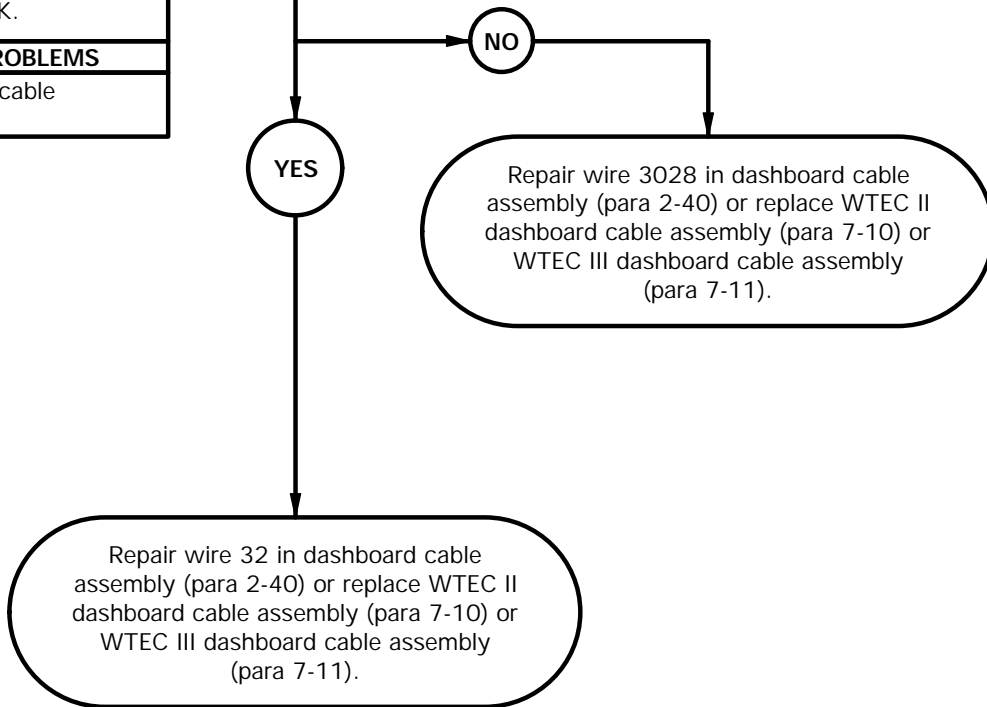

CAUTION

Use care when testing electrical connectors. Do not damage connector pins or sockets with multimeter probes. Failure to comply may result in damage to equipment.

NOTE

Inspect connector pins/sockets for damage, corrosion, and serviceability. Check that connector pins are not pushed back and are capable of making good contact.

CONTINUITY TEST

- (1) Set multimeter to ohms.
- (2) Connect positive (+) probe of multimeter to connector J31 pin 9.
- (3) Connect negative (-) probe of multimeter to ground and note reading on multimeter.
- (4) If continuity is not present, repair wire 3028 in dashboard cable assembly (para 2-40) or replace WTEC II dashboard cable assembly (para 7-10) or WTEC III dashboard cable assembly (para 7-11).
- (5) If continuity is present, repair wire 32 in dashboard cable assembly (para 2-40) or replace WTEC II dashboard cable assembly (para 7-10) or WTEC III dashboard cable assembly (para 7-11).
- (6) Connect connector P31 to connector J31.
- (7) Install instrument panel (para 7-15).

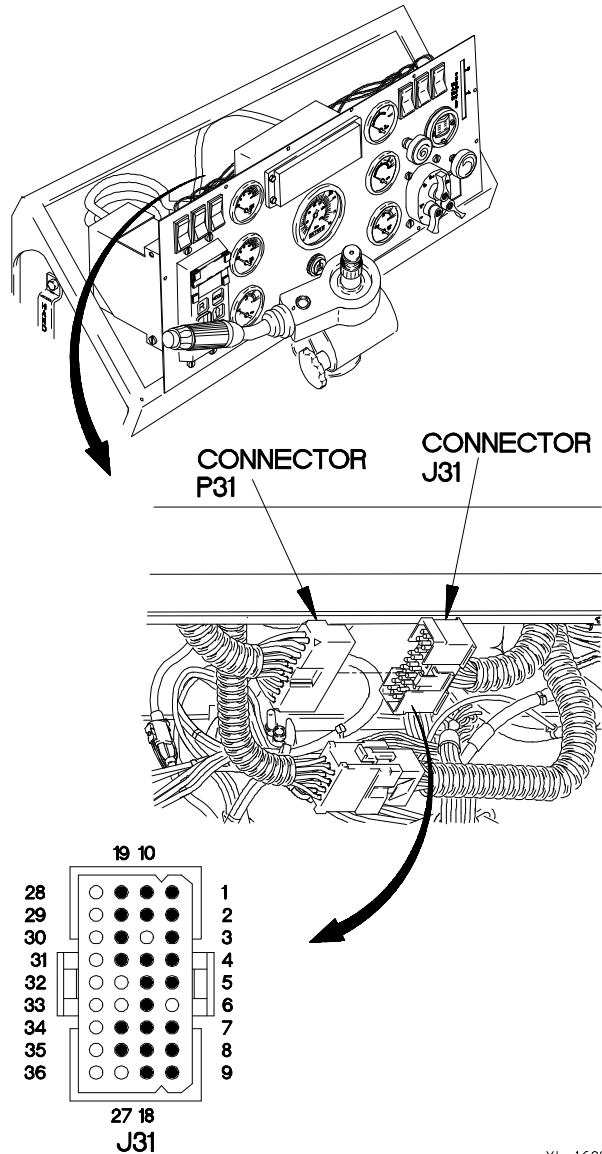

Xbe1609b

e16A. MASTER POWER SWITCH DOES NOT SHUT DOWN ENGINE

INITIAL SETUP

Equipment Conditions

Engine shut down (TM 9-2320-365-10).

Personnel Required

(2)

Tools and Special Tools

Tool Kit, Genl Mech (Item 44, Appendix C)
 STE/ICE-R (Item 39, Appendix C)
 Multimeter, Digital (Item 22, Appendix C)

References

TM 9-4910-571-12&P

KNOWN INFO
Master power switch off.
POSSIBLE PROBLEMS
Faulty master power switch. Faulty relay K2.

TEST OPTIONS
Visual Inspection
REASON FOR QUESTION
If engine shuts down when circuit breaker CB70 is removed, master power switch is faulty. If engine does not shut down when circuit breaker CB70, relay K2 is faulty.

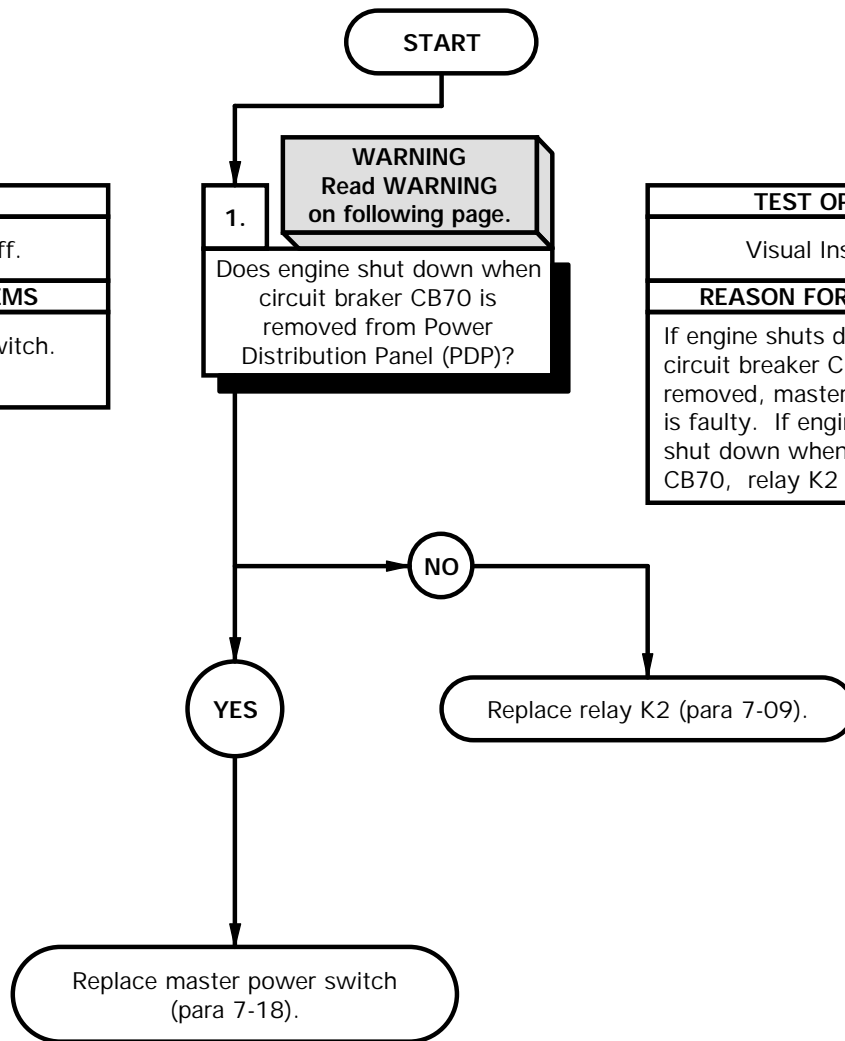

WARNING

Remove rings, bracelets, watches, necklaces, and any other jewelry before working around vehicle. Jewelry can catch on equipment and cause injury or short across electrical circuits and cause severe burns or electrical shock.

VISUAL INSPECTION

- (1) Remove Power Distribution Panel (PDP) cover (para 16-2).
- (2) Remove circuit breaker CB79 from Power Distribution Panel (PDP).
- (3) Install circuit breaker CB79 in Power Distribution Panel (PDP).
- (4) Start engine (TM 9-2320-365-10).
- (5) Position master power switch to off (TM 9-2320-365-10).
- (6) Remove circuit breaker CB70 from Power Distribution Panel (PDP).
- (7) If engine does not shut down when circuit breaker CB70 is removed, replace relay K2 (para 7-9).
- (8) If engine shuts down when circuit breaker CB70, replace master power switch (para 7-18).

NOTE

Perform step (9) if engine does not shut down.

- (9) Press start inhibit switch.
- (10) Install circuit breaker CB70 in Power Distribution Panel (PDP).
- (11) Install Power Distribution Panel (PDP) cover (para 16-2).

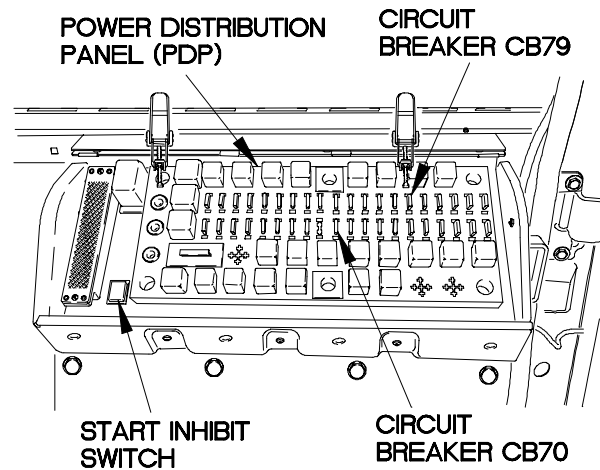

X2e1601

e16B. LAMP TEST SWITCH DOES NOT ILLUMINATE

INITIAL SETUP

Equipment Conditions

Engine shut down (TM 9-2320-365-10).

Personnel Required

(2)

Tools and Special Tools

Tool Kit, Genl Mech (Item 44, Appendix C)
 STE/ICE-R (Item 39, Appendix C)
 Multimeter, Digital (Item 22, Appendix C)

References

TM 9-4910-571-12&P

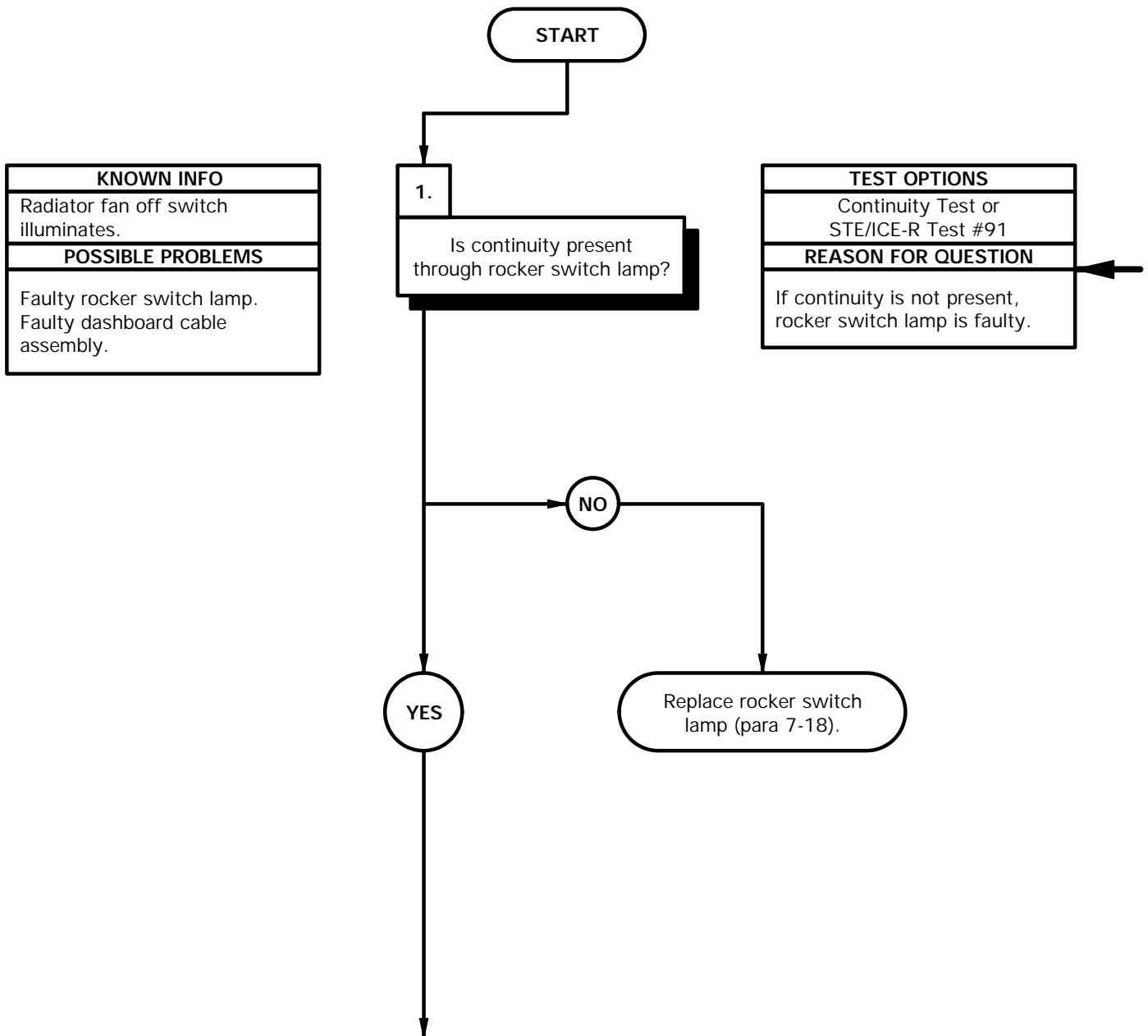

NOTE

Inspect connector pins/sockets for damage, corrosion, and serviceability. Check that connector pins are not pushed back and are capable of making good contact.

CONTINUITY TEST

- (1) Remove instrument panel for access (para 7-15).
- (2) Disconnect connector PX2A from lamp test switch lamp base connector.
- (3) Set multimeter to ohms.
- (4) Connect positive (+) probe of multimeter to one terminal of lamp base connector.
- (5) Connect negative (-) probe of multimeter to second terminal of lamp base connector and note reading on multimeter.
- (6) If continuity is not present, replace rocker switch lamp (para 7-18).

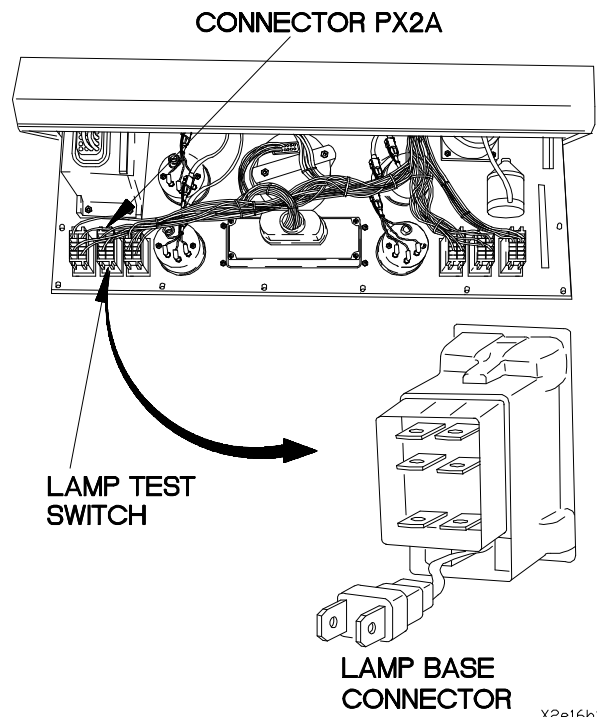

e16B. LAMP TEST SWITCH DOES NOT ILLUMINATE (CONT)

KNOWN INFO
Radiator fan off switch illuminates. Rocker switch lamp OK.
POSSIBLE PROBLEMS
Faulty dashboard cable assembly.

2.

CAUTION
Read CAUTION on following page.

Is continuity present from connector PX2A socket 2 to a known good ground?

TEST OPTIONS
Continuity Test or STE/ICE-R Test #91
REASON FOR QUESTION
If continuity is not present, wire 3020 is faulty. If continuity is present, wire 1908 is faulty.

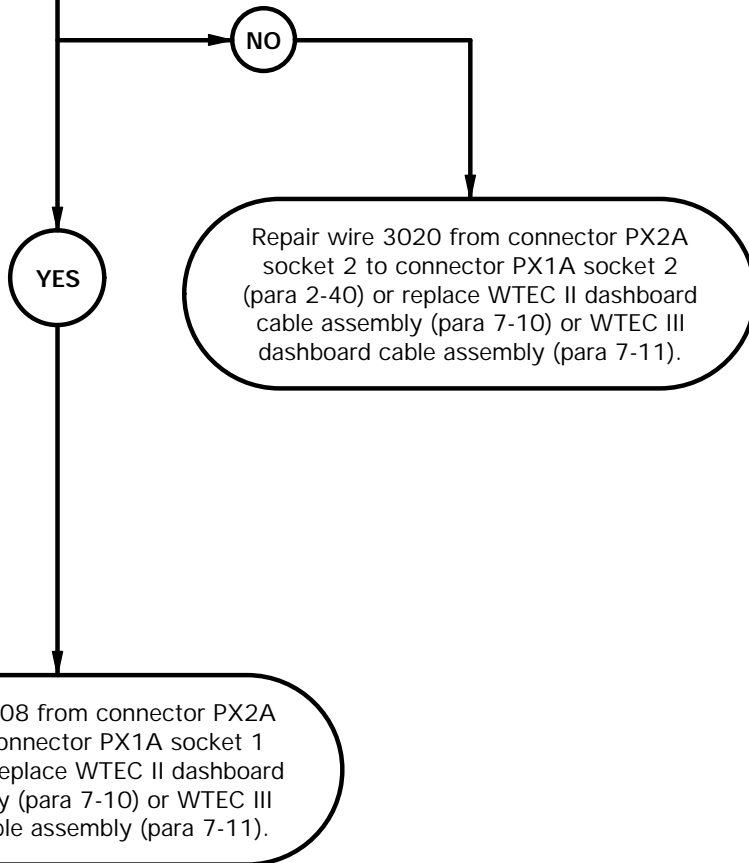

CAUTION

Use care when testing electrical connectors. Do not damage connector pins or sockets with multimeter probes. Failure to comply may result in damage to equipment.

CONTINUITY TEST

- (1) Set multimeter to ohms.
- (2) Connect positive (+) probe of multimeter to connector PX2A socket 2.
- (3) Connect negative (-) probe of multimeter to ground and note reading on multimeter.
- (4) If continuity is not present, repair wire 3020 from connector PX2A socket 2 to connector PX1A socket 2 (para 2-40) or replace WTEC II dashboard cable assembly (para 7-10) or WTEC III dashboard cable assembly (para 7-11).
- (5) If continuity is present, repair wire 1908 from connector PX2A socket 1 to connector PX1A socket 1 (para 2-40) or replace WTEC II dashboard cable assembly (para 7-10) or WTEC III dashboard cable assembly (para 7-11).
- (6) Connect connector PX2A to lamp test switch lamp base connector.
- (7) Install instrument panel assembly (para 7-15).

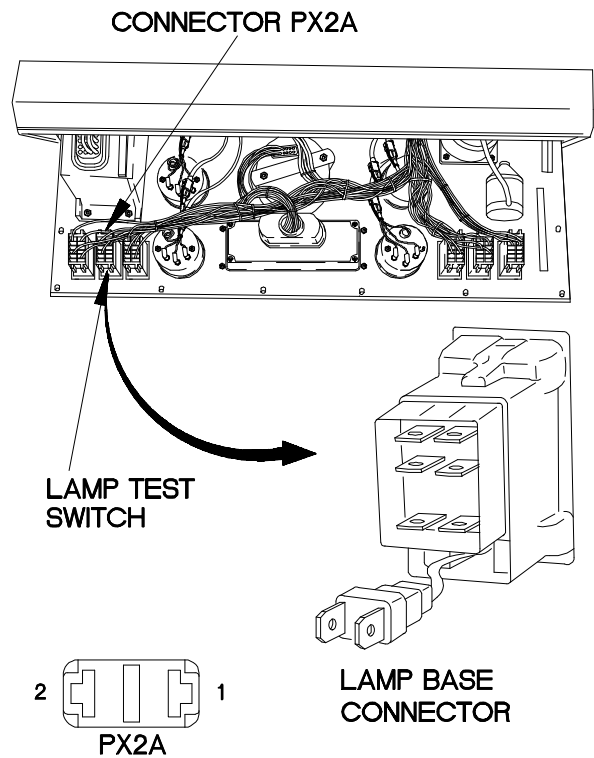

X2e16e2b

e17. RADIATOR FAN OFF SWITCH DOES NOT ILLUMINATE

INITIAL SETUP

Equipment Conditions

Engine shut down (TM 9-2320-365-10).

Personnel Required

(2)

Tools and Special Tools

Tool Kit, Genl Mech (Item 44, Appendix C)

STE/ICE-R (Item 39, Appendix C)

Multimeter, Digital (Item 22, Appendix C)

References

TM 9-4910-571-12&P

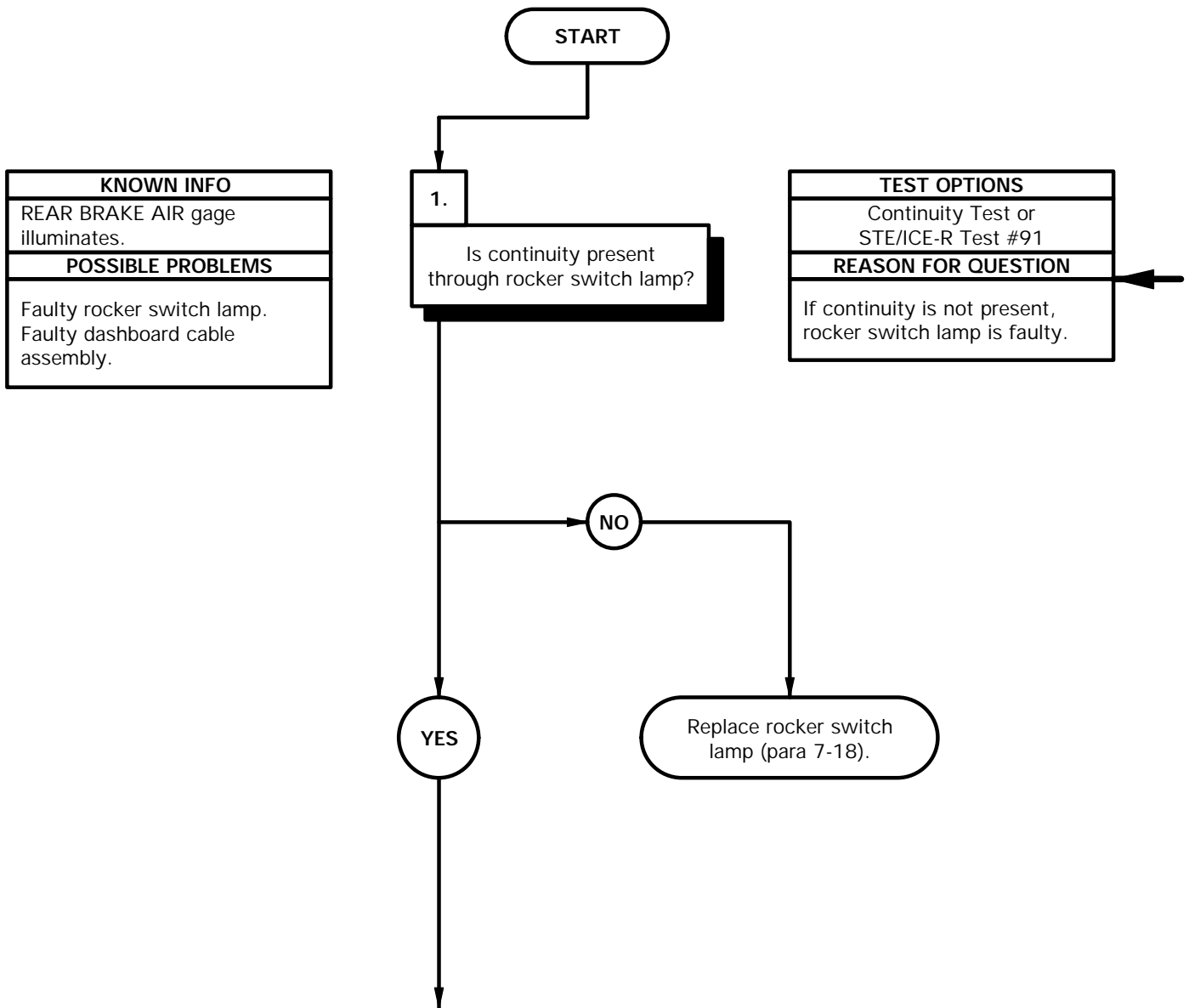

NOTE

Inspect connector pins/sockets for damage, corrosion, and serviceability. Check that connector pins are not pushed back and are capable of making good contact.

CONTINUITY TEST

- (1) Remove instrument panel for access (para 7-15).
- (2) Disconnect connector PX1A from radiator fan off switch lamp base connector.
- (3) Set multimeter to ohms.
- (4) Connect positive (+) probe of multimeter to one terminal of lamp base connector.
- (5) Connect negative (-) probe of multimeter to second terminal of lamp base connector and note reading on multimeter.
- (6) If continuity is not present, replace rocker switch lamp (para 7-18).

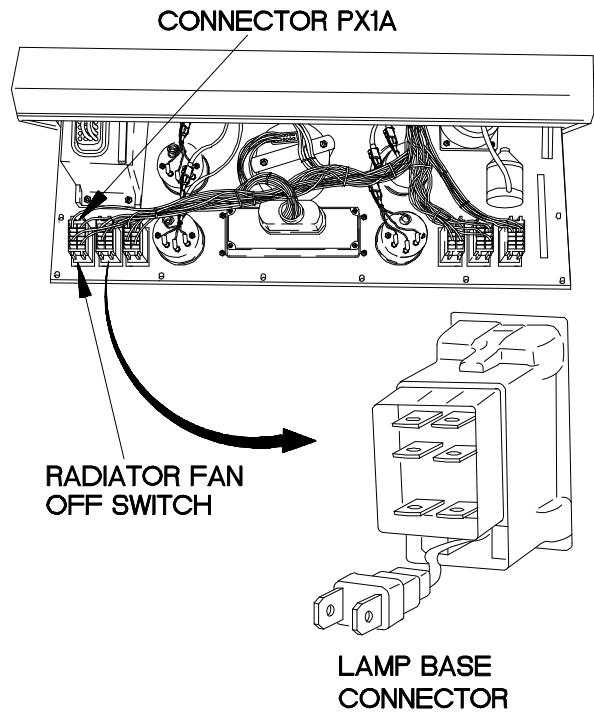

X2e1701B

e17. RADIATOR FAN OFF SWITCH DOES NOT ILLUMINATE (CONT)

KNOWN INFO
REAR BRAKE AIR gage illuminates. Rocker switch lamp OK.
POSSIBLE PROBLEMS
Faulty dashboard cable assembly.

CAUTION
Read CAUTION on following page.

2.
Is continuity present from connector PX1A socket 2 to a known good ground?

TEST OPTIONS
Continuity Test or STE/ICE-R Test #91
REASON FOR QUESTION
If continuity is not present, wire 3020 is faulty. If continuity is present, wire 1908 is faulty.

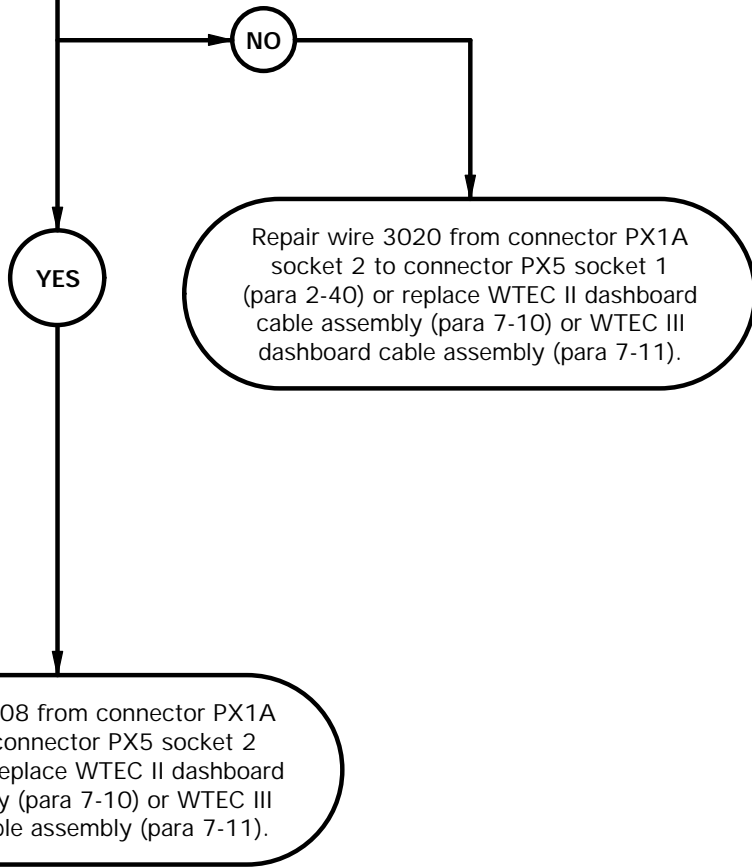

CAUTION

Use care when testing electrical connectors. Do not damage connector pins or sockets with multimeter probes. Failure to comply may result in damage to equipment.

CONTINUITY TEST

- (1) Set multimeter to ohms.
- (2) Connect positive (+) probe of multimeter to connector PX1A socket 2.
- (3) Connect negative (-) probe of multimeter to ground and note reading on multimeter.
- (4) If continuity is not present, repair wire 3020 from connector PX1A socket 2 to connector PX5 socket 1 (para 2-40) or replace WTEC II dashboard cable assembly (para 7-10) or WTEC III dashboard cable assembly (para 7-11).
- (5) If continuity is present, repair wire 1908 from connector PX1A socket 1 to connector PX5 socket 2 (para 2-40) or replace WTEC II dashboard cable assembly (para 7-10) or WTEC III dashboard cable assembly (para 7-11).
- (6) Connect connector PX1A to radiator fan off switch lamp base connector.
- (7) Install instrument panel assembly (para 7-15).

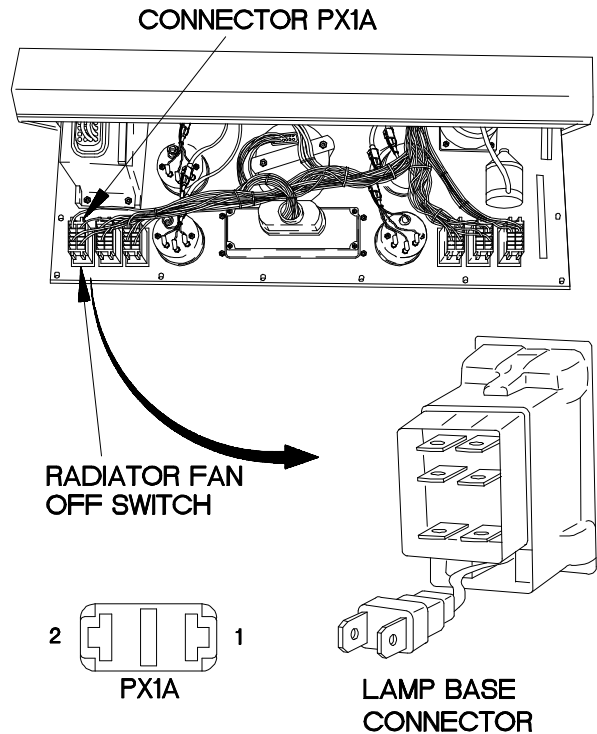

X2e1702B

e17A. ETHER START SWITCH DOES NOT ILLUMINATE

INITIAL SETUP

Equipment Conditions

Engine shut down (TM 9-2320-365-10).

Personnel Required

(2)

Tools and Special Tools

Tool Kit, Genl Mech (Item 44, Appendix C)

STE/ICE-R (Item 39, Appendix C)

Multimeter, Digital (Item 22, Appendix C)

References

TM 9-4910-571-12&P

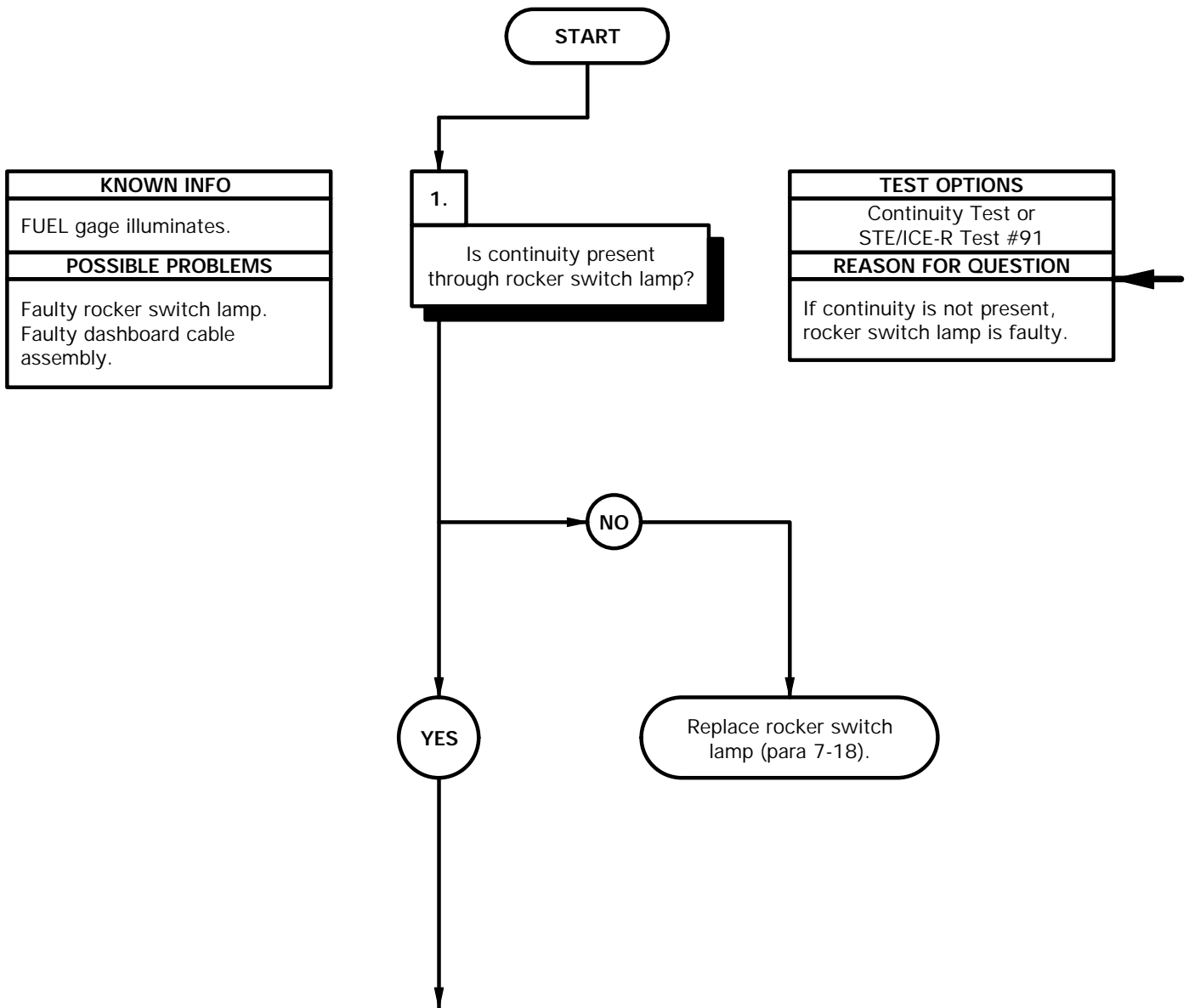

NOTE

Inspect connector pins/sockets for damage, corrosion, and serviceability. Check that connector pins are not pushed back and are capable of making good contact.

CONTINUITY TEST

- (1) Remove instrument panel for access (para 7-15).
- (2) Disconnect connector PX13A from ether start switch lamp base connector.
- (3) Set multimeter to ohms.
- (4) Connect positive (+) probe of multimeter to one terminal of lamp base connector.
- (5) Connect negative (-) probe of multimeter to second terminal of lamp base connector and note reading on multimeter.
- (6) If continuity is not present, replace rocker switch lamp (para 7-18).

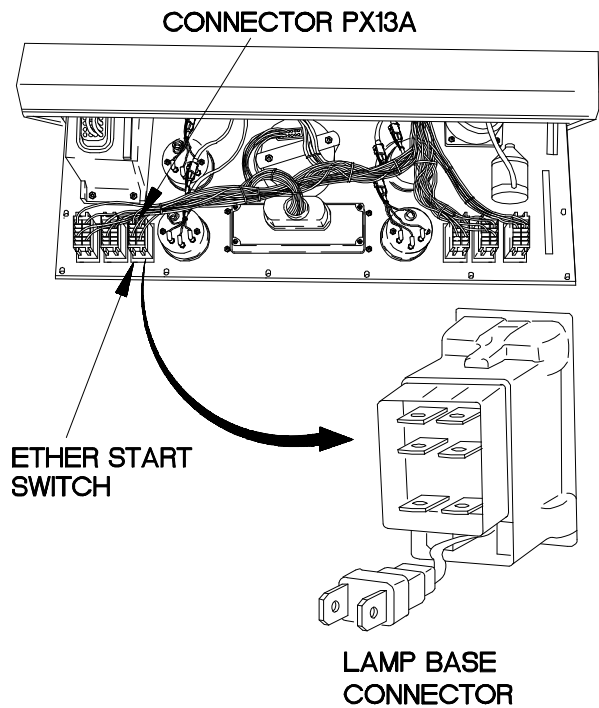

X2e17A1B

e17A. ETHER START SWITCH DOES NOT ILLUMINATE (CONT)

KNOWN INFO
FUEL gage illuminates. Rocker switch lamp OK.
POSSIBLE PROBLEMS
Faulty dashboard cable assembly.

CAUTION
Read CAUTION on following page.

2.
Is continuity present from connector PX13A socket 2 to a known good ground?

TEST OPTIONS
Continuity Test or STE/ICE-R Test #91
REASON FOR QUESTION
If continuity is not present, wire 3020 is faulty. If continuity is present, wire 1908 is faulty.

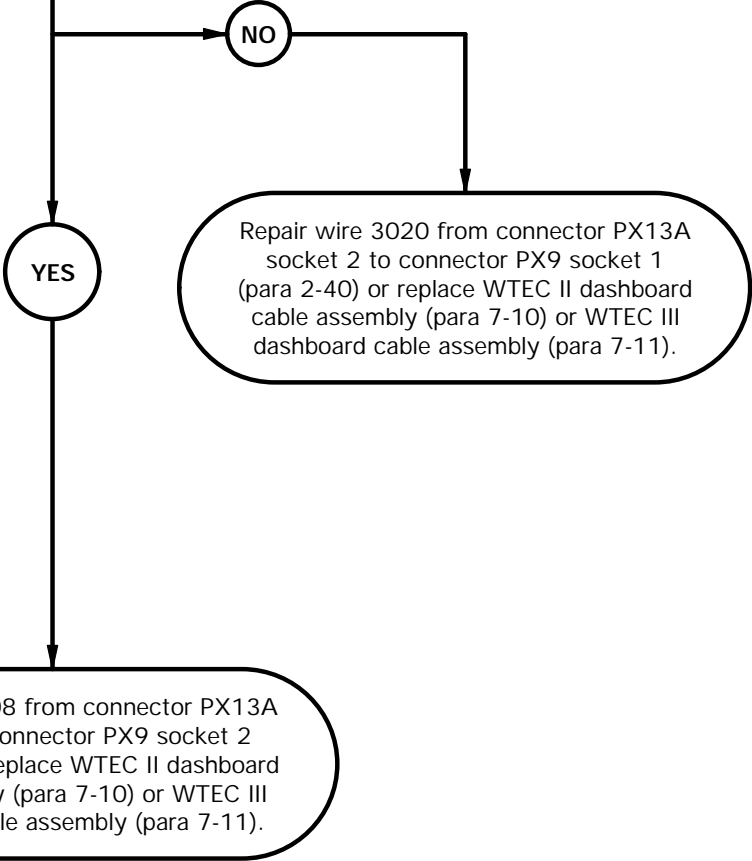

CAUTION

Use care when testing electrical connectors. Do not damage connector pins or sockets with multimeter probes. Failure to comply may result in damage to equipment.

CONTINUITY TEST

- (1) Set multimeter to ohms.
- (2) Connect positive (+) probe of multimeter to connector PX13A socket 2.
- (3) Connect negative (-) probe of multimeter to ground and note reading on multimeter.
- (4) If continuity is not present, repair wire 3020 from connector PX13A socket 2 to connector PX9 socket 1 (para 2-40) or replace WTEC II dashboard cable assembly (para 7-10) or WTEC III dashboard cable assembly (para 7-11).
- (5) If continuity is present, repair wire 1908 from connector PX13A socket 1 to connector PX9 socket 2 (para 2-40) or replace WTEC II dashboard cable assembly (para 7-10) or WTEC III dashboard cable assembly (para 7-11).
- (6) Connect connector PX13A to ether start switch lamp base connector.
- (7) Install instrument panel assembly (para 7-15).

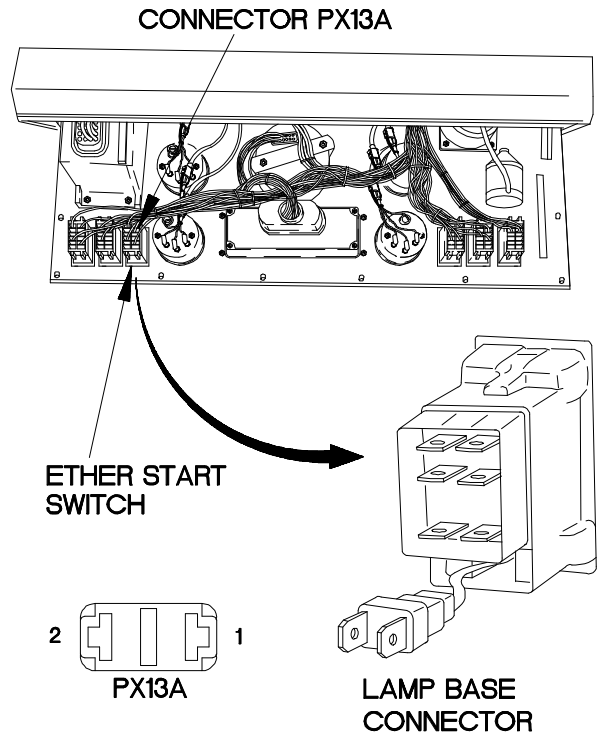

X2e17A2B

e17B. HAZARD LIGHTS SWITCH DOES NOT ILLUMINATE

INITIAL SETUP

Equipment Conditions

Engine shut down (TM 9-2320-365-10).

Personnel Required

(2)

Tools and Special Tools

Tool Kit, Genl Mech (Item 44, Appendix C)

STE/ICE-R (Item 39, Appendix C)

Multimeter, Digital (Item 22, Appendix C)

References

TM 9-4910-571-12&P

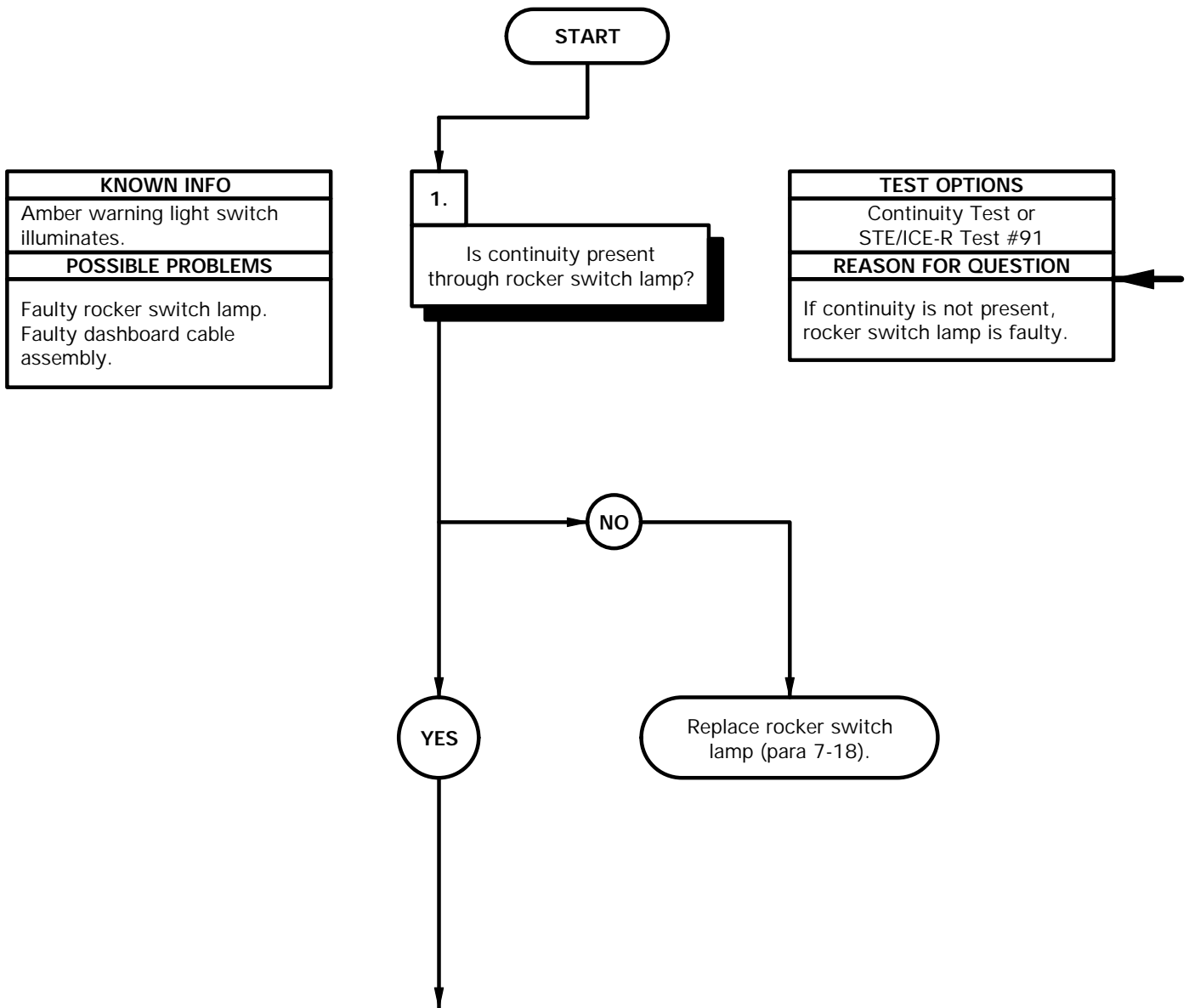

NOTE

Inspect connector pins/sockets for damage, corrosion, and serviceability. Check that connector pins are not pushed back and are capable of making good contact.

CONTINUITY TEST

- (1) Remove instrument panel for access (para 7-15).
- (2) Disconnect connector PX14A from hazard lights switch lamp base connector.
- (3) Set multimeter to ohms.
- (4) Connect positive (+) probe of multimeter to one terminal of lamp base connector.
- (5) Connect negative (-) probe of multimeter to second terminal of lamp base connector and note reading on multimeter.
- (6) If continuity is not present, replace rocker switch lamp (para 7-18).

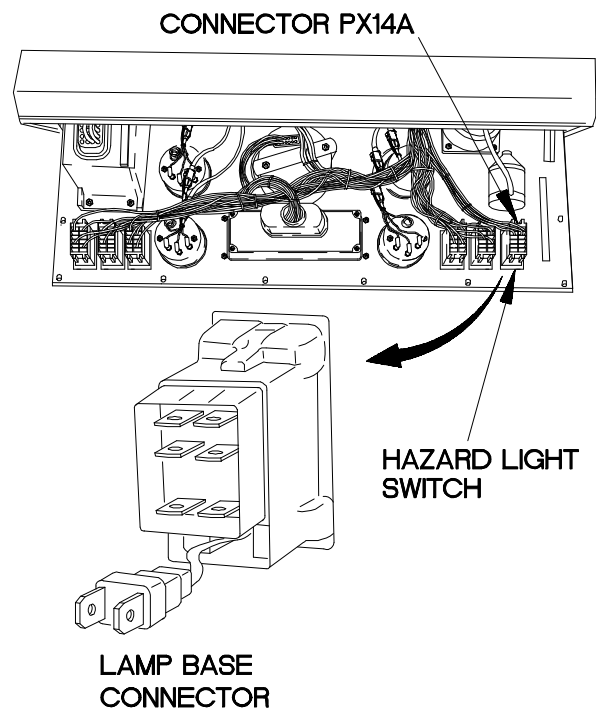

X2e17B1B

e17B. HAZARD LIGHTS SWITCH DOES NOT ILLUMINATE (CONT)

KNOWN INFO
Amber warning light switch illuminates. Rocker switch lamp OK.
POSSIBLE PROBLEMS
Faulty dashboard cable assembly.

2.

CAUTION
Read CAUTION on following page.

Is continuity present from connector PX14A socket 2 to a known good ground?

TEST OPTIONS
Continuity Test or STE/ICE-R Test #91
REASON FOR QUESTION
If continuity is not present, wire 3020 is faulty. If continuity is present, wire 1908 is faulty.

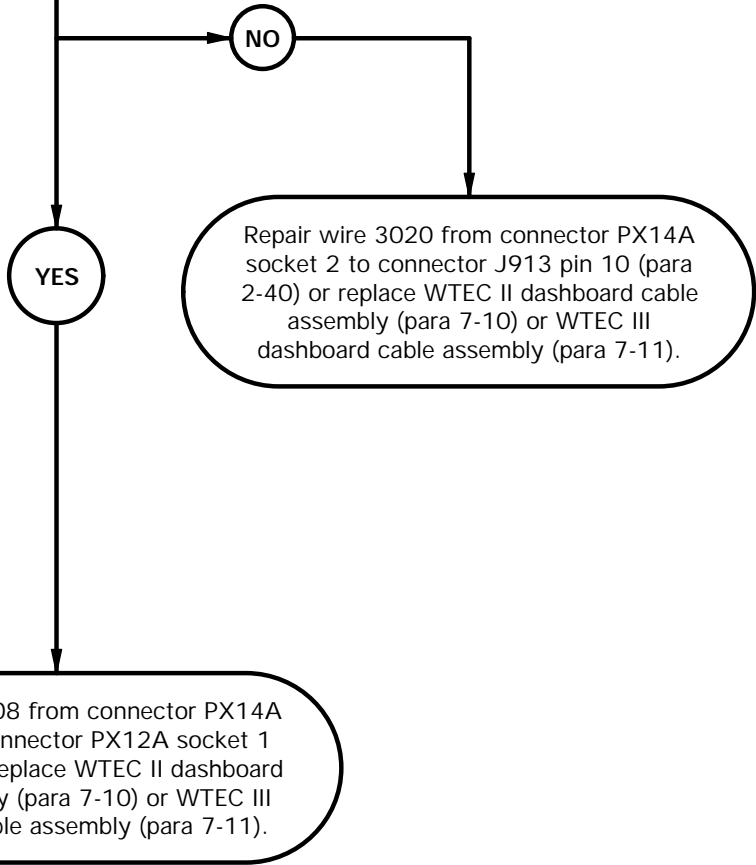

CAUTION

Use care when testing electrical connectors. Do not damage connector pins or sockets with multimeter probes. Failure to comply may result in damage to equipment.

CONTINUITY TEST

- (1) Set multimeter to ohms.
- (2) Connect positive (+) probe of multimeter to connector PX14A socket 2.
- (3) Connect negative (-) probe of multimeter to ground and note reading on multimeter.
- (4) If continuity is not present, repair wire 3020 from connector PX14A socket 2 to connector J913 pin 10 (para 2-40) or replace WTEC II dashboard cable assembly (para 7-10) or WTEC III dashboard cable assembly (para 7-11).
- (5) If continuity is present, repair wire 1908 from connector PX14A socket 1 to connector PX12A socket 1 (para 2-40) or replace WTEC II dashboard cable assembly (para 7-10) or WTEC III dashboard cable assembly (para 7-11).
- (6) Connect connector PX14A to hazard lights switch lamp base connector.
- (7) Install instrument panel assembly (para 7-15).

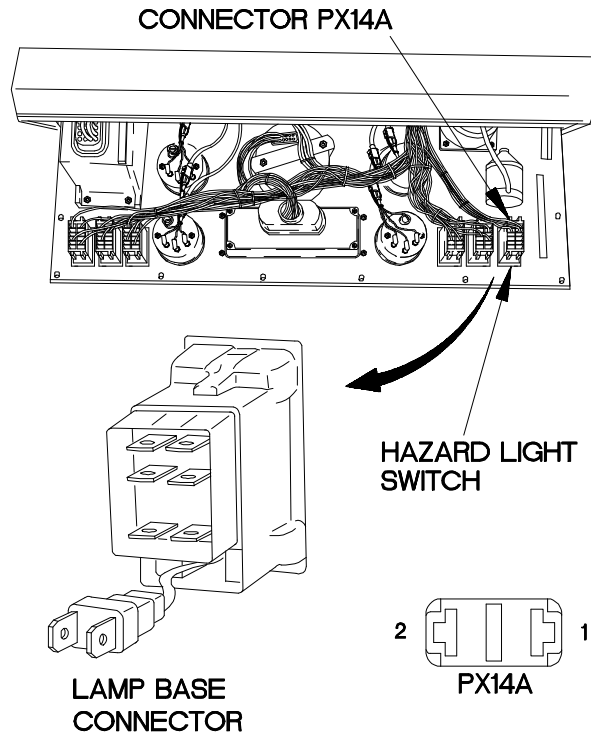

X2e17B2B

e17C. AMBER WARNING LIGHT SWITCH DOES NOT ILLUMINATE

INITIAL SETUP

Equipment Conditions

Engine shut down (TM 9-2320-365-10).

Personnel Required

(2)

Tools and Special Tools

Tool Kit, Genl Mech (Item 44, Appendix C)
 STE/ICE-R (Item 39, Appendix C)
 Multimeter, Digital (Item 22, Appendix C)

References

TM 9-4910-571-12&P

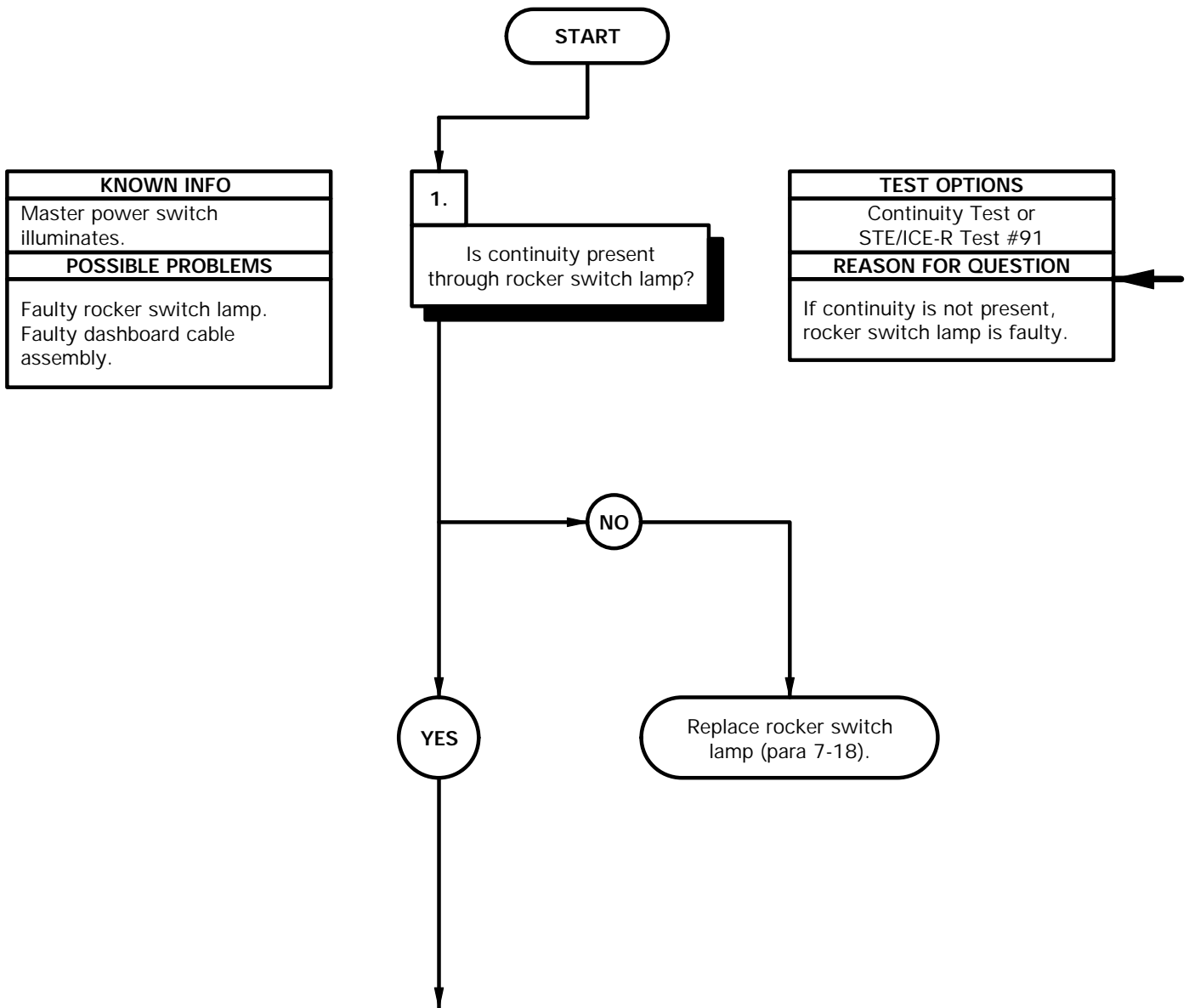

NOTE

Inspect connector pins/sockets for damage, corrosion, and serviceability. Check that connector pins are not pushed back and are capable of making good contact.

CONTINUITY TEST

- (1) Remove instrument panel for access (para 7-15).
- (2) Disconnect connector PX12A from amber warning light switch lamp base connector.
- (3) Set multimeter to ohms.
- (4) Connect positive (+) probe of multimeter to one terminal of lamp base connector.
- (5) Connect negative (-) probe of multimeter to second terminal of lamp base connector and note reading on multimeter.
- (6) If continuity is not present, replace rocker switch lamp (para 7-18).

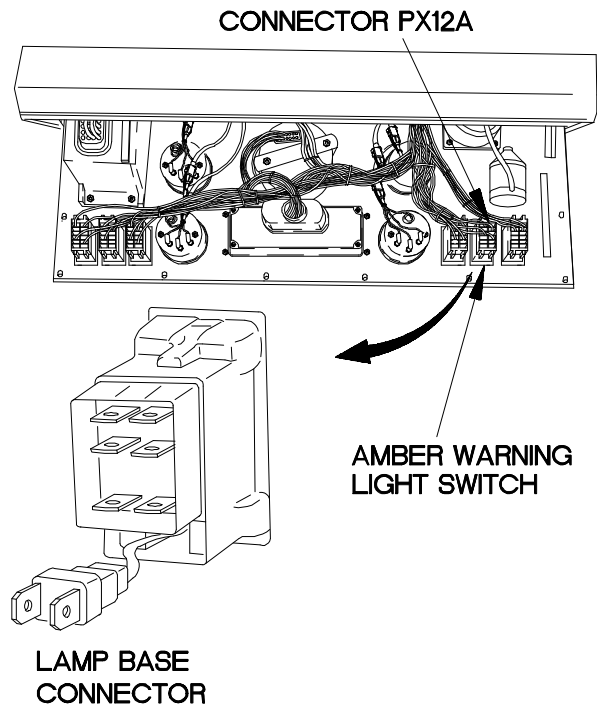

X2e17C1B

e17C. AMBER WARNING LIGHT SWITCH DOES NOT ILLUMINATE (CONT)

KNOWN INFO
Master power switch illuminates. Rocker switch lamp OK.
POSSIBLE PROBLEMS
Faulty dashboard cable assembly.

2.

CAUTION
Read CAUTION on following page.

Is continuity present from connector PX12A socket 2 to a known good ground?

TEST OPTIONS
Continuity Test or STE/ICE-R Test #91
REASON FOR QUESTION
If continuity is not present, wire 3020 is faulty. If continuity is present, wire 1908 is faulty.

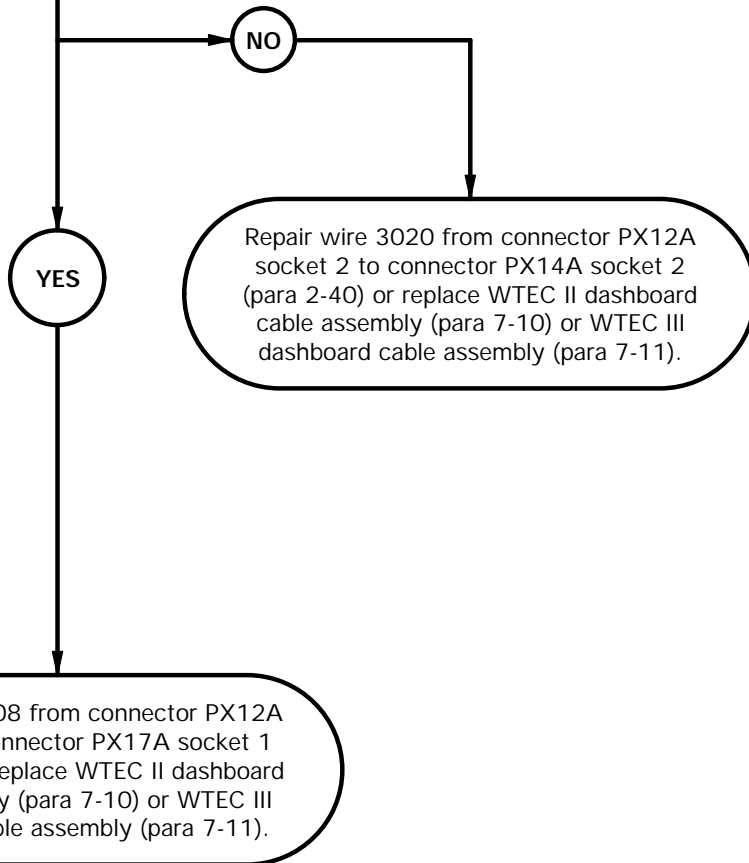

CAUTION

Use care when testing electrical connectors. Do not damage connector pins or sockets with multimeter probes. Failure to comply may result in damage to equipment.

CONTINUITY TEST

- (1) Set multimeter to ohms.
- (2) Connect positive (+) probe of multimeter to connector PX12A socket 2.
- (3) Connect negative (-) probe of multimeter to ground and note reading on multimeter.
- (4) If continuity is not present, repair wire 3020 from connector PX12A socket 2 to connector PX14A socket 2 (para 2-40) or replace WTEC II dashboard cable assembly (para 7-10) or WTEC III dashboard cable assembly (para 7-11).
- (5) If continuity is present, repair wire 1908 from connector PX12A socket 1 to connector PX17A socket 1 (para 2-40) or replace WTEC II dashboard cable assembly (para 7-10) or WTEC III dashboard cable assembly (para 7-11).
- (6) Connect connector PX12A to amber warning light switch lamp base connector.
- (7) Install instrument panel assembly (para 7-15).

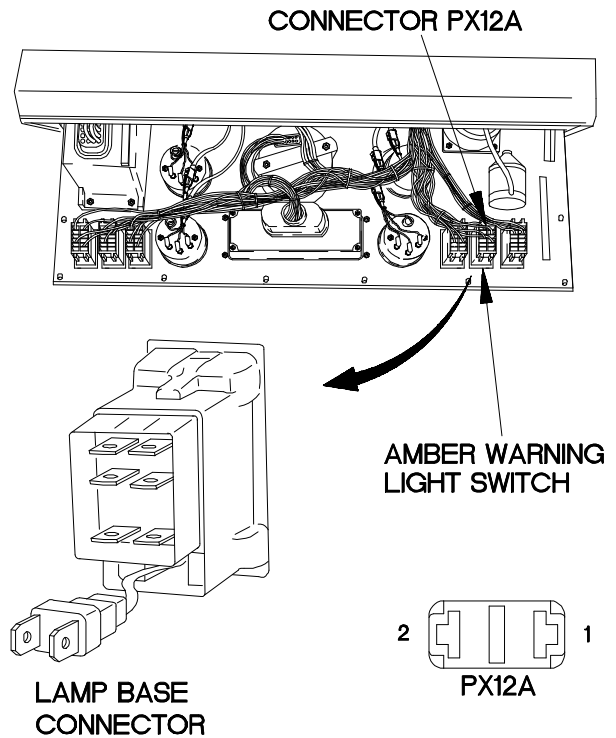

X2e17C2B

e17D. MASTER POWER SWITCH DOES NOT ILLUMINATE

INITIAL SETUP

Equipment Conditions

Engine shut down (TM 9-2320-365-10).

Personnel Required

(2)

Tools and Special Tools

Tool Kit, Genl Mech (Item 44, Appendix C)

STE/ICE-R (Item 39, Appendix C)

Multimeter, Digital (Item 22, Appendix C)

References

TM 9-4910-571-12&P

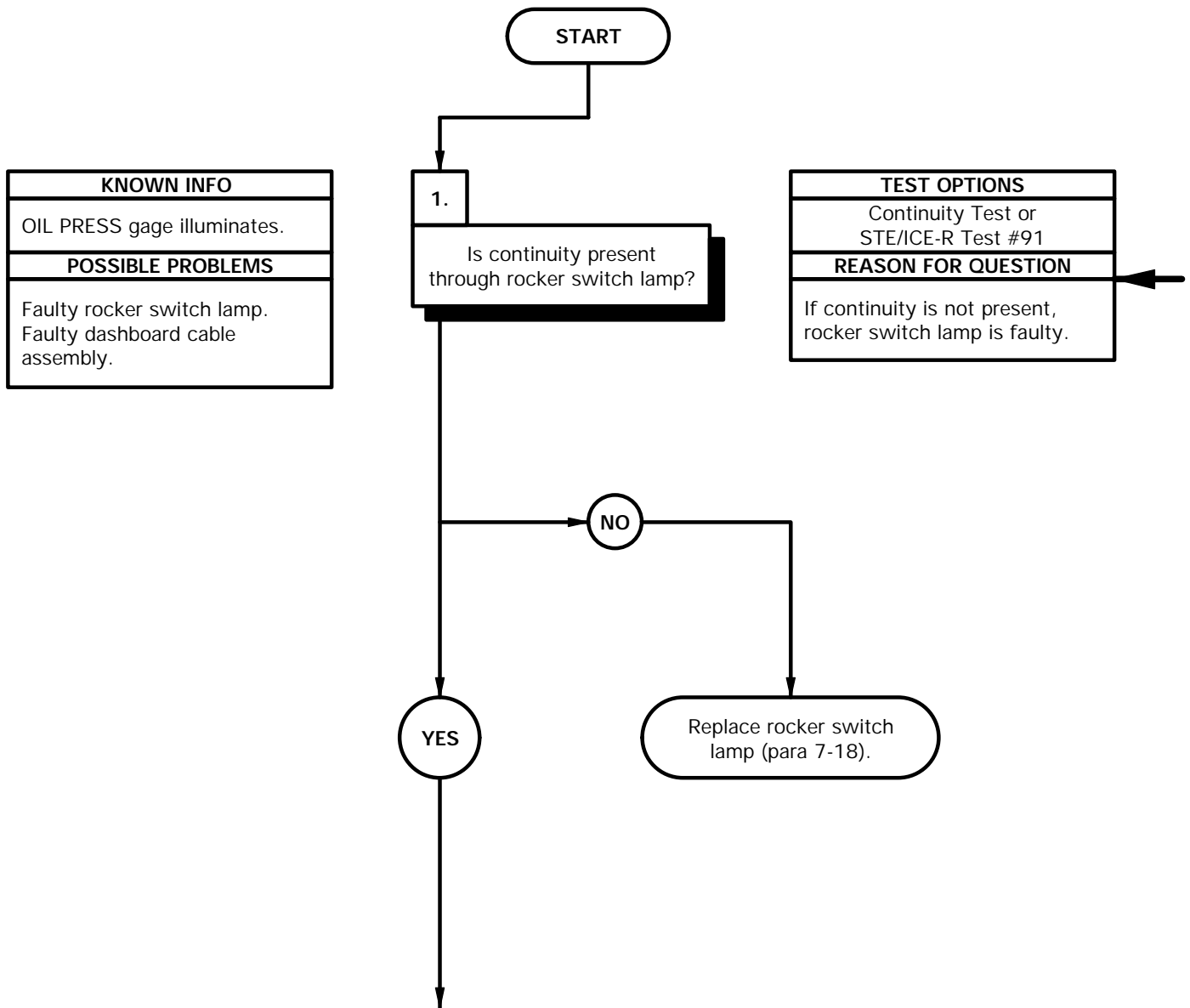

NOTE

Inspect connector pins/sockets for damage, corrosion, and serviceability. Check that connector pins are not pushed back and are capable of making good contact.

CONTINUITY TEST

- (1) Remove instrument panel for access (para 7-15).
- (2) Disconnect connector PX17A from master power switch lamp base connector.
- (3) Set multimeter to ohms.
- (4) Connect positive (+) probe of multimeter to one terminal of lamp base connector.
- (5) Connect negative (-) probe of multimeter to second terminal of lamp base connector and note reading on multimeter.
- (6) If continuity is not present, replace rocker switch lamp (para 7-18).

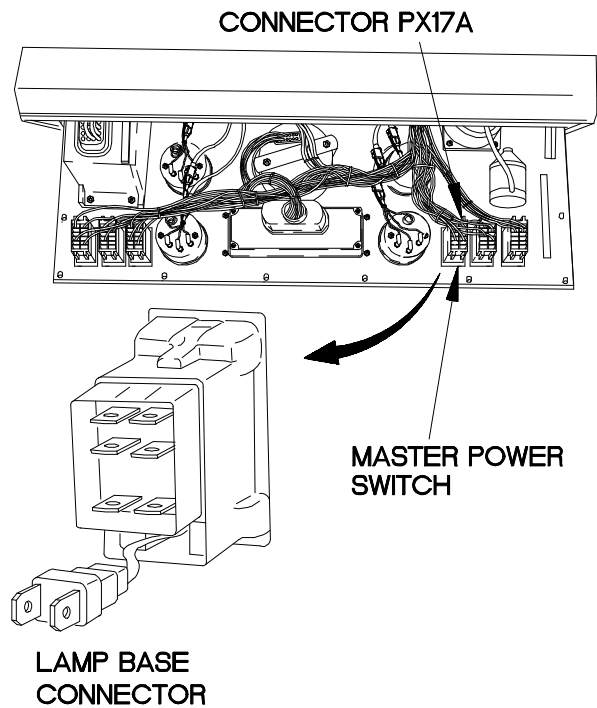

X2e17D1B

e17D. MASTER POWER SWITCH DOES NOT ILLUMINATE (CONT)

KNOWN INFO
OIL PRESS gage illuminates. Rocker switch lamp OK.
POSSIBLE PROBLEMS
Faulty dashboard cable assembly.

CAUTION
Read CAUTION on following page.

2.
Is continuity present from connector PX17A socket 2 to a known good ground?

TEST OPTIONS
Continuity Test or STE/ICE-R Test #91
REASON FOR QUESTION
If continuity is not present, wire 3020 is faulty. If continuity is present, wire 1908 is faulty.

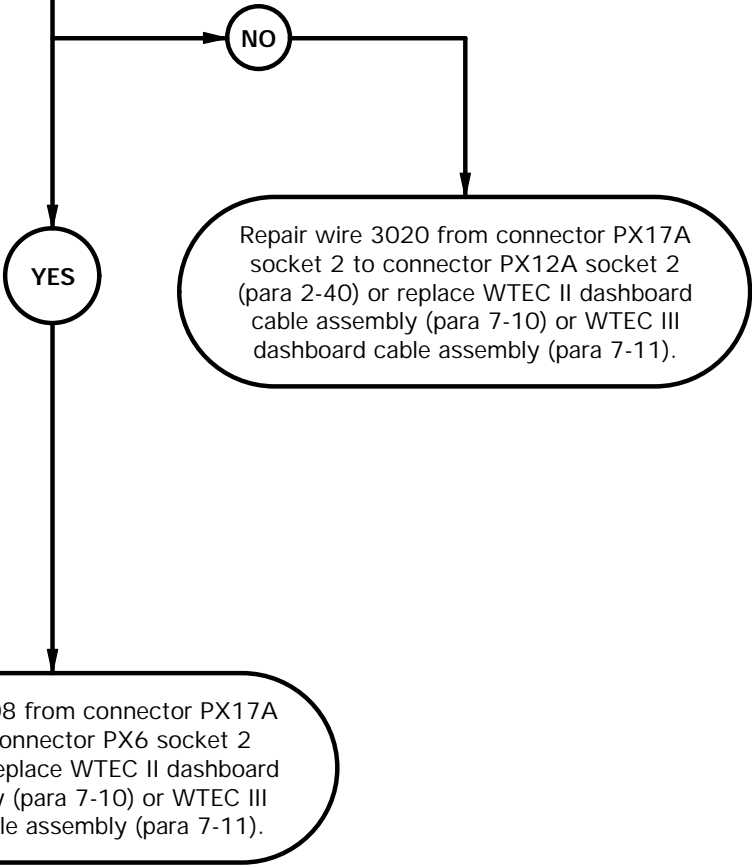

CAUTION

Use care when testing electrical connectors. Do not damage connector pins or sockets with multimeter probes. Failure to comply may result in damage to equipment.

CONTINUITY TEST

- (1) Set multimeter to ohms.
- (2) Connect positive (+) probe of multimeter to connector PX17A socket 2.
- (3) Connect negative (-) probe of multimeter to ground and note reading on multimeter.
- (4) If continuity is not present, repair wire 3020 from connector PX17A socket 2 to connector PX12A socket 2 (para 2-40) or replace WTEC II dashboard cable assembly (para 7-10) or WTEC III dashboard cable assembly (para 7-11).
- (5) If continuity is present, repair wire 1908 from connector PX17A socket 1 to connector PX6 socket 2 (para 2-40) or replace WTEC II dashboard cable assembly (para 7-10) or WTEC III dashboard cable assembly (para 7-11).
- (6) Connect connector PX17A to master power switch lamp base connector.
- (7) Install instrument panel assembly (para 7-15).

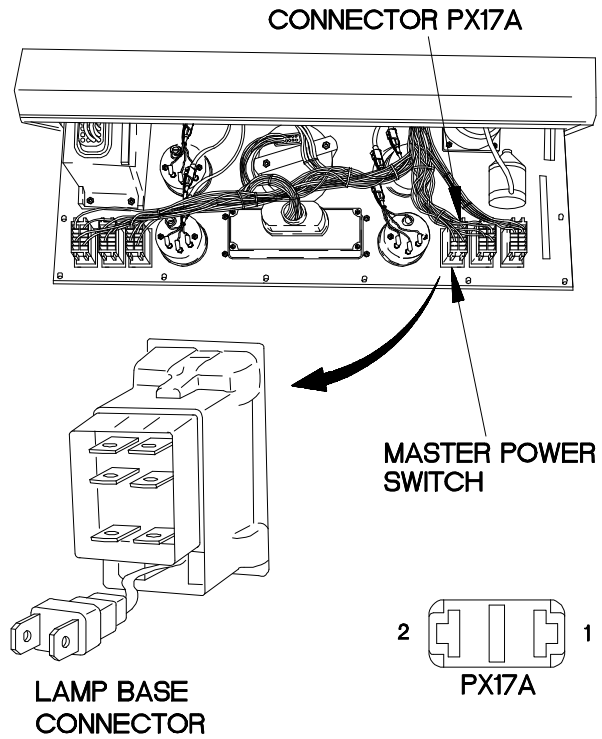

X2e17D2B

e18. REAR BRAKE AIR GAGE DOES NOT ILLUMINATE

INITIAL SETUP

Equipment Conditions

Engine shut down (TM 9-2320-365-10).

Personnel Required

(2)

Tools and Special Tools

Tool Kit, Genl Mech (Item 44, Appendix C)

STE/ICE-R (Item 39, Appendix C)

Multimeter, Digital (Item 22, Appendix C)

References

TM 9-4910-571-12&P

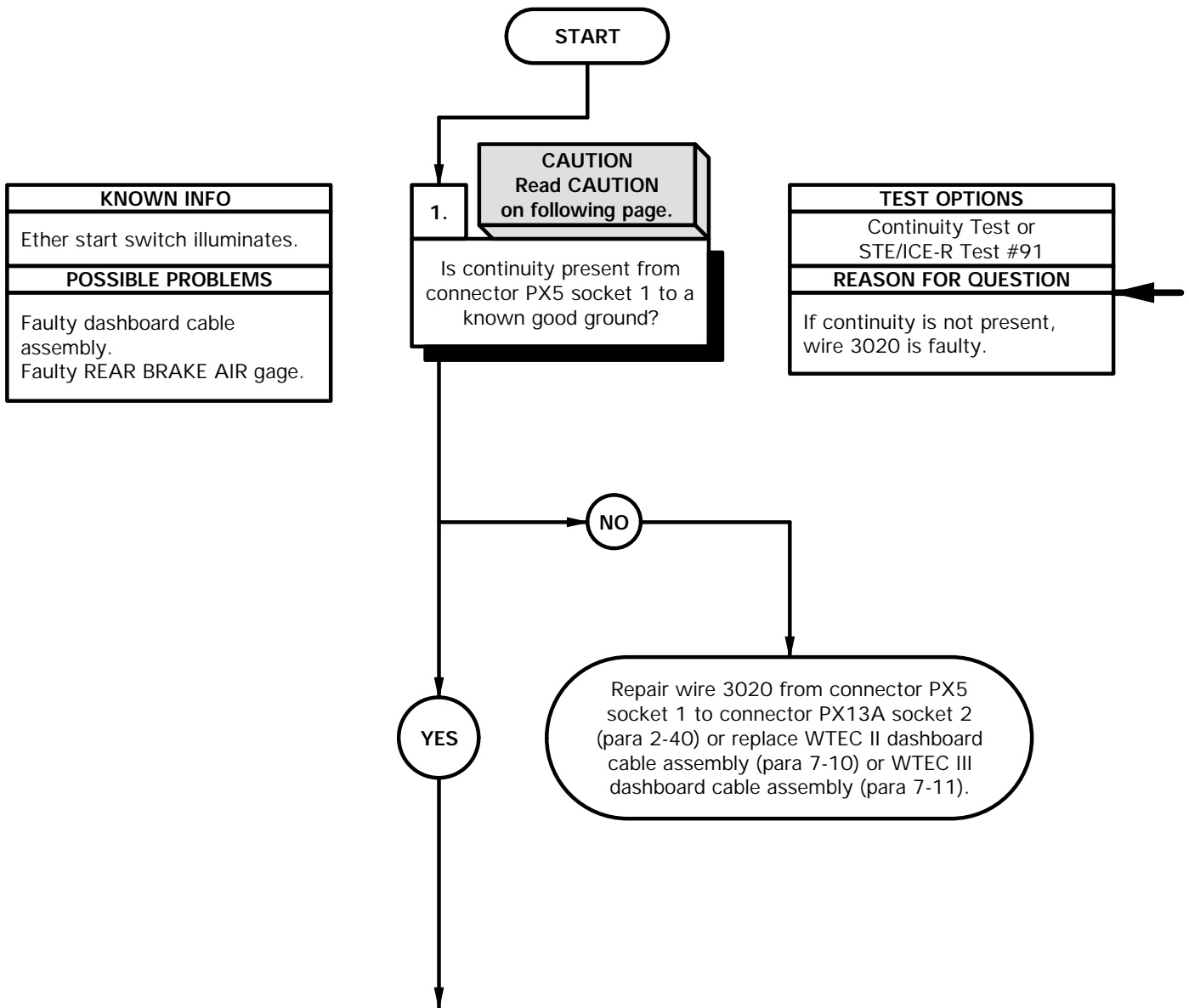

CAUTION

Use care when testing electrical connectors. Do not damage connector pins or sockets with multimeter probes. Failure to comply may result in damage to equipment.

NOTE

Inspect connector pins/sockets for damage, corrosion, and serviceability. Check that connector pins are not pushed back and are capable of making good contact.

CONTINUITY TEST

- (1) Remove instrument panel assembly for access (para 7-15).
- (2) Disconnect connector clamp from REAR BRAKE AIR gage connector.
- (3) Disconnect connector PX5 from REAR BRAKE AIR gage connector.
- (4) Set multimeter to ohms.
- (5) Connect positive (+) probe of multimeter to connector PX5 socket 1.
- (6) Connect negative (-) probe of multimeter to ground and note reading on multimeter.
- (7) If continuity is not present, repair wire 3020 from connector PX5 socket 1 to connector PX13A socket 2 (para 2-40) or replace WTEC II dashboard cable assembly (para 7-10) or WTEC III dashboard cable assembly (para 7-11).

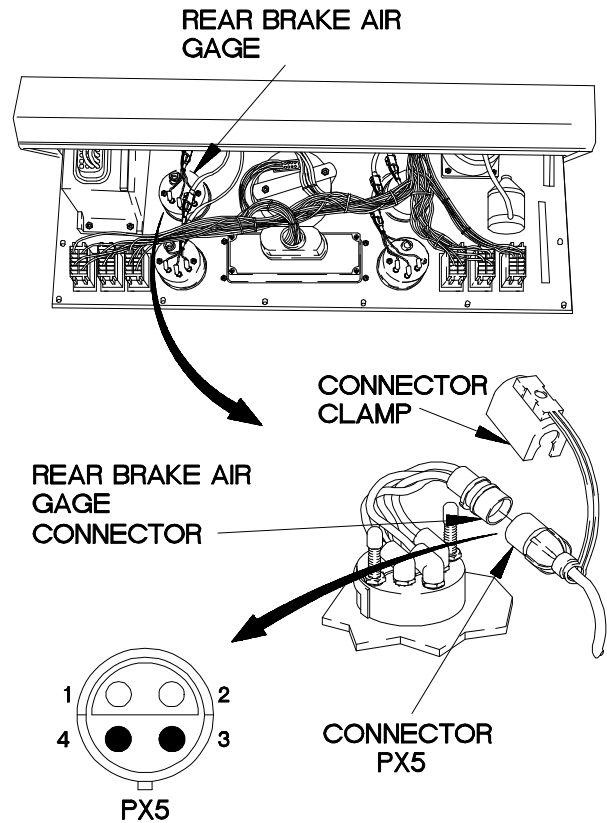

XBE1802B

e18. REAR BRAKE AIR GAGE DOES NOT ILLUMINATE (CONT)

KNOWN INFO
Ether start switch illuminates.
POSSIBLE PROBLEMS
Faulty dashboard cable assembly. Faulty REAR BRAKE AIR gage.

2.

WARNING

CAUTION

Read **WARNING** and **CAUTION** on following page.

Is 12 VDC present at connector PX5 socket 2?

TEST OPTIONS
Voltage Test or STE/ICE-R Test #89
REASON FOR QUESTION
If 12 VDC is not present, wire 1908 is faulty. If 12 VDC is present, REAR BRAKE AIR gage is faulty.

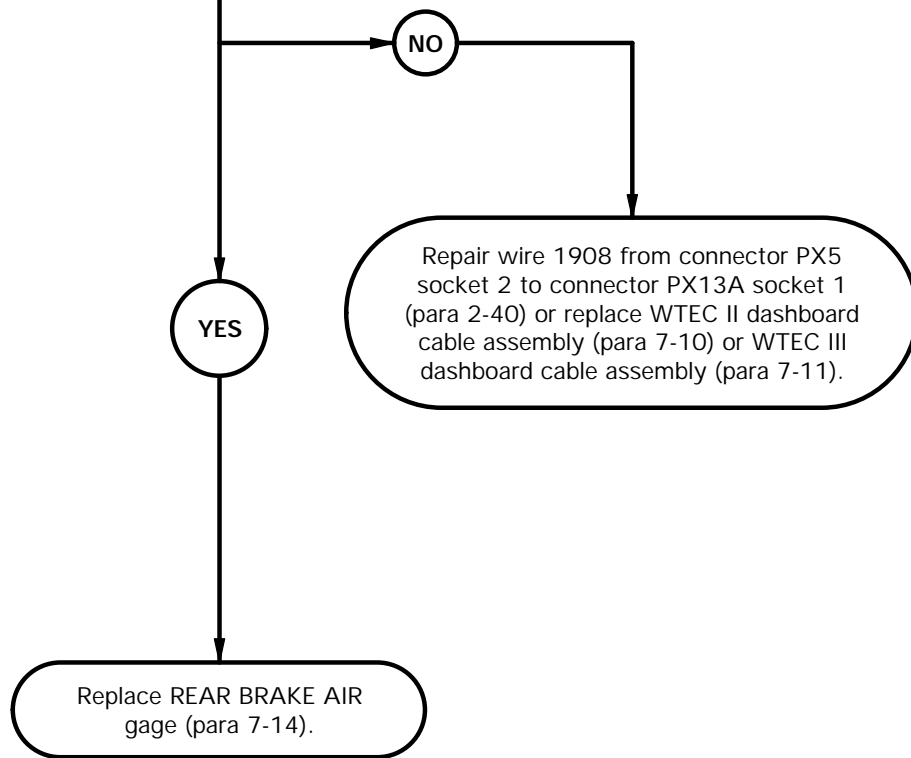

WARNING

Remove rings, bracelets, watches, necklaces, and any other jewelry before working around vehicle. Jewelry can catch on equipment and cause injury or short across electrical circuits and cause severe burns or electrical shock.

CAUTION

Use care when testing electrical connectors. Do not damage connector pins or sockets with multimeter probes. Failure to comply may result in damage to equipment.

VOLTAGE TEST

- (1) Set multimeter to volts DC.
- (2) Connect positive (+) probe of multimeter to connector PX5 socket 2.
- (3) Connect negative (-) probe of multimeter to ground.
- (4) Position main light switch main selector lever to SER DRIVE (TM 9-2320-365-10).
- (5) Position main light switch auxiliary lever to PNL BRT (TM 9-2320-365-10).
- (6) Position dimmer switch for maximum brightness (TM 9-2320-365-10) and note reading on multimeter.
- (7) If 12 VDC is not present, repair wire 1908 from connector PX5 socket 2 to connector PX13A socket 1 (para 2-40) or replace WTEC II dashboard cable assembly (para 7-10) or WTEC III dashboard cable assembly (para 7-11).
- (8) If 12 VDC is present, replace REAR BRAKE AIR gage (para 7-14).
- (9) Position main light switch to auxiliary lever to OFF (TM 9-2320-365-10).
- (10) Position main light switch main selector lever to OFF (TM 9-2320-365-10).
- (11) Connect connector PX5 to REAR BRAKE AIR gage connector.
- (12) Connect connector clamp on REAR BRAKE AIR gage connector.
- (13) Install instrument panel (para 7-15).

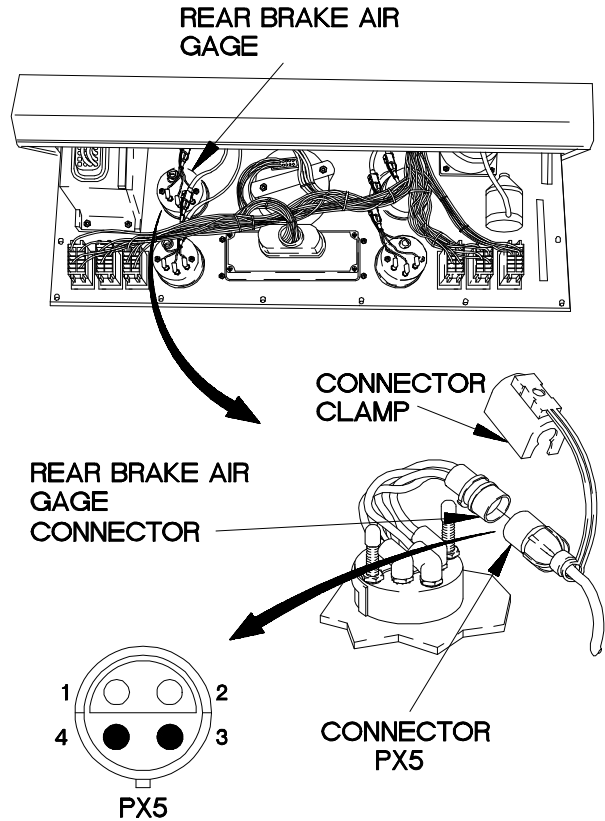

XBE1802B

e18A. FUEL GAGE DOES NOT ILLUMINATE

INITIAL SETUP

Equipment Conditions

Engine shut down (TM 9-2320-365-10).

Personnel Required

(2)

Tools and Special Tools

Tool Kit, Genl Mech (Item 44, Appendix C)
 STE/ICE-R (Item 39, Appendix C)
 Multimeter, Digital (Item 22, Appendix C)

References

TM 9-4910-571-12&P

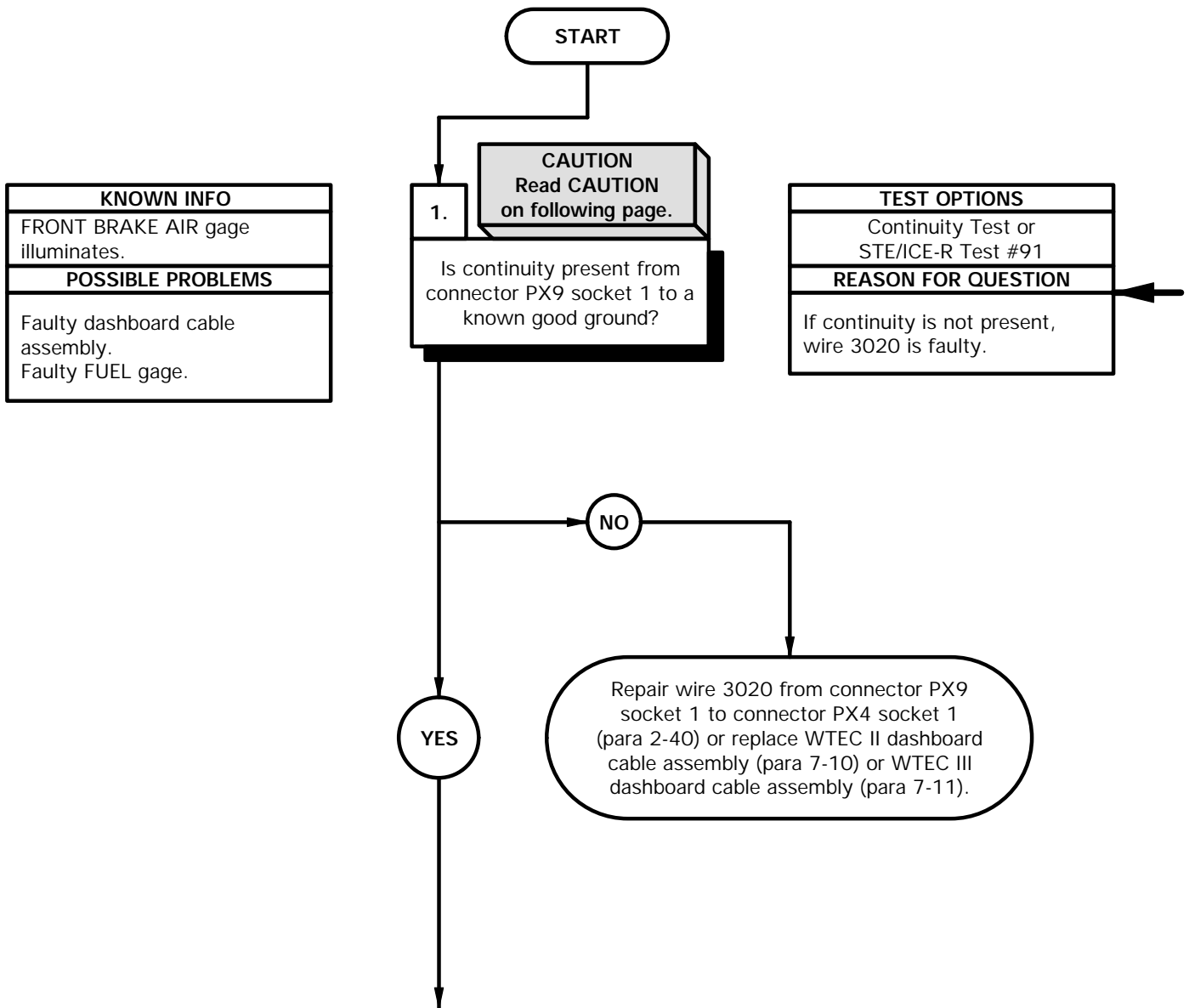

CAUTION

Use care when testing electrical connectors. Do not damage connector pins or sockets with multimeter probes. Failure to comply may result in damage to equipment.

NOTE

Inspect connector pins/sockets for damage, corrosion, and serviceability. Check that connector pins are not pushed back and are capable of making good contact.

CONTINUITY TEST

- (1) Remove instrument panel assembly for access (para 7-15).
- (2) Disconnect connector clamp from FUEL gage connector.
- (3) Disconnect connector PX9 from FUEL gage connector.
- (4) Set multimeter to ohms.
- (5) Connect positive (+) probe of multimeter to connector PX9 socket 1.
- (6) Connect negative (-) probe of multimeter to ground and note reading on multimeter.
- (7) If continuity is not present, repair wire 3020 from connector PX9 socket 1 to connector PX4 socket 1 (para 2-40) or replace WTEC II dashboard cable assembly (para 7-10) or WTEC III dashboard cable assembly (para 7-11).

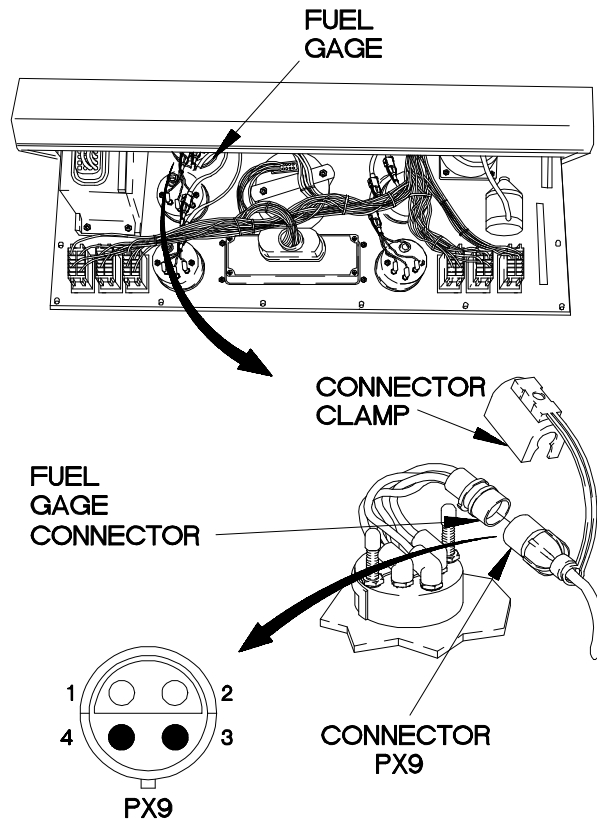

XBE18A02B

e18A. FUEL GAGE DOES NOT ILLUMINATE (CONT)

KNOWN INFO
FRONT BRAKE AIR gage illuminates.
POSSIBLE PROBLEMS
Faulty dashboard cable assembly. Faulty FUEL gage.

2.

WARNING
CAUTION
Read **WARNING** and **CAUTION** on following page.

Is 12 VDC present at connector PX9 socket 2?

TEST OPTIONS
Voltage Test or STE/ICE-R Test #89
REASON FOR QUESTION
If 12 VDC is not present, wire 1908 is faulty. If 12 VDC is present, FUEL gage is faulty.

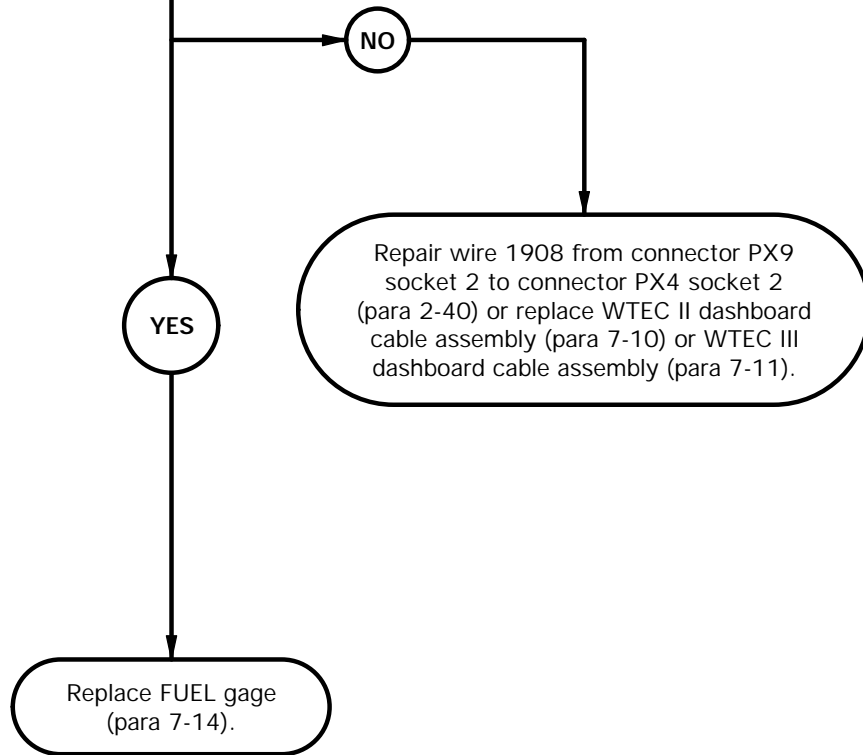

WARNING

Remove rings, bracelets, watches, necklaces, and any other jewelry before working around vehicle. Jewelry can catch on equipment and cause injury or short across electrical circuits and cause severe burns or electrical shock.

CAUTION

Use care when testing electrical connectors. Do not damage connector pins or sockets with multimeter probes. Failure to comply may result in damage to equipment.

VOLTAGE TEST

- (1) Set multimeter to volts DC.
- (2) Connect positive (+) probe of multimeter to connector PX9 socket 2.
- (3) Connect negative (-) probe of multimeter to ground.
- (4) Position main light switch main selector lever to SER DRIVE (TM 9-2320-365-10).
- (5) Position main light switch auxiliary lever to PNL BRT (TM 9-2320-365-10).
- (6) Position dimmer switch for maximum brightness (TM 9-2320-365-10) and note reading on multimeter.
- (7) If 12 VDC is not present, repair wire 1908 from connector PX9 socket 2 to connector PX4 socket 2 (para 2-40) or replace WTEC II dashboard cable assembly (para 7-10) or WTEC III dashboard cable assembly (para 7-11).
- (8) If 12 VDC is present, replace FUEL gage (para 7-14).
- (9) Position main light switch to auxiliary lever to OFF (TM 9-2320-365-10).
- (10) Position main light switch main selector lever to OFF (TM 9-2320-365-10).
- (11) Connect connector PX9 to FUEL gage connector.
- (12) Connect connector clamp on FUEL gage connector.
- (13) Install instrument panel (para 7-15).

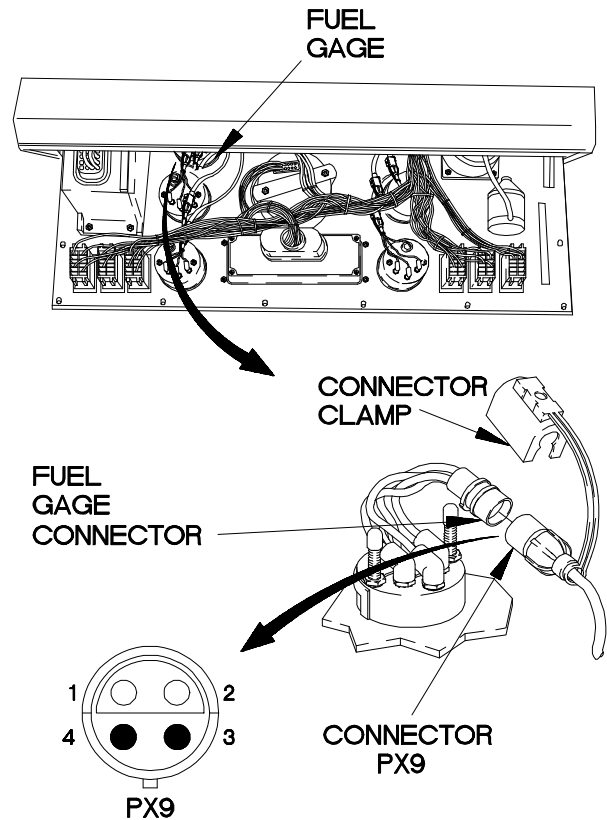

XBE18A02B

e18B. FRONT BRAKE AIR GAGE DOES NOT ILLUMINATE

INITIAL SETUP

Equipment Conditions

Engine shut down (TM 9-2320-365-10).

Personnel Required

(2)

Tools and Special Tools

Tool Kit, Genl Mech (Item 44, Appendix C)
 STE/ICE-R (Item 39, Appendix C)
 Multimeter, Digital (Item 22, Appendix C)

References

TM 9-4910-571-12&P

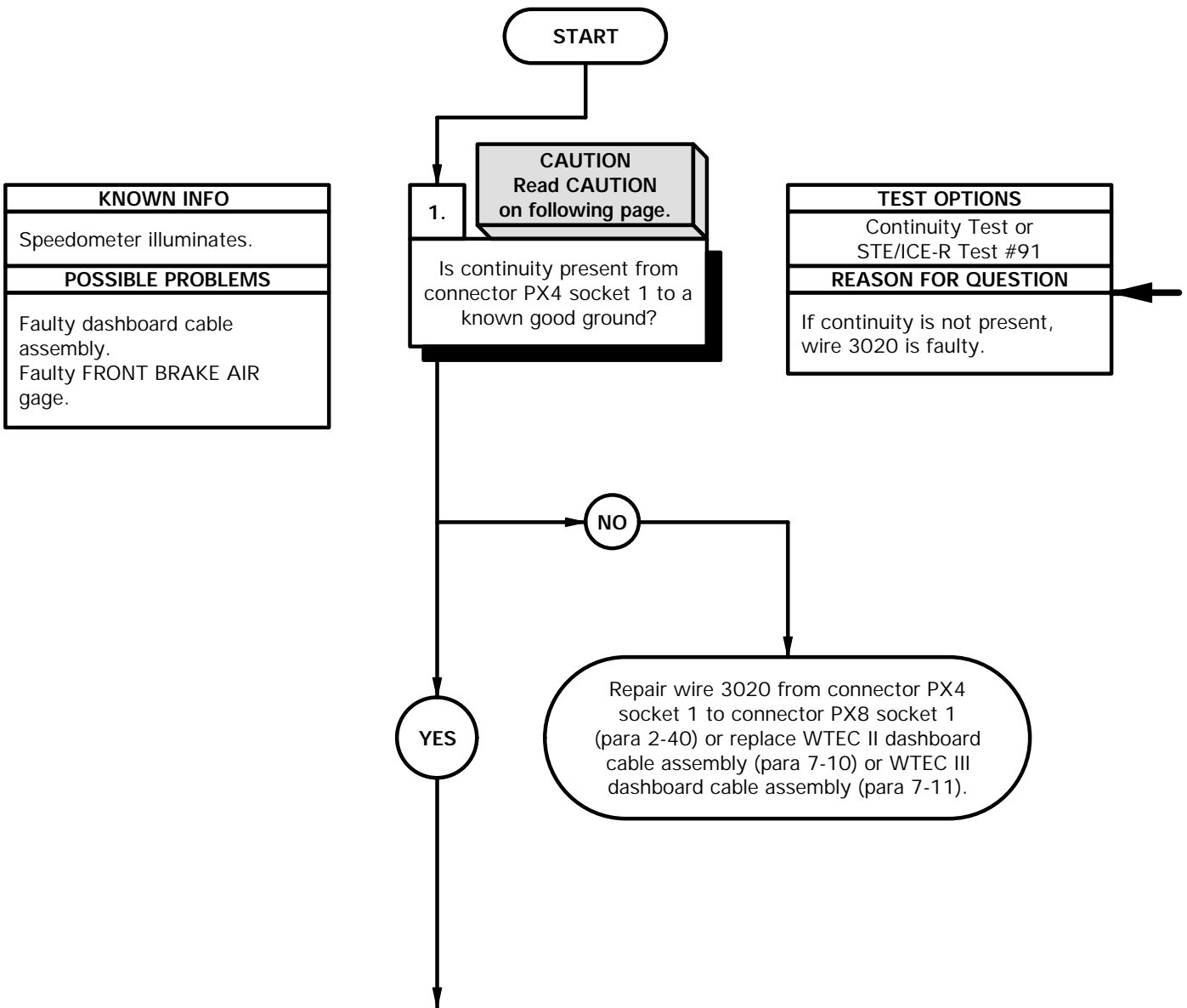

CAUTION

Use care when testing electrical connectors. Do not damage connector pins or sockets with multimeter probes. Failure to comply may result in damage to equipment.

NOTE

Inspect connector pins/sockets for damage, corrosion, and serviceability. Check that connector pins are not pushed back and are capable of making good contact.

CONTINUITY TEST

- (1) Remove instrument panel assembly for access (para 7-15).
- (2) Disconnect connector clamp from FRONT BRAKE AIR gage connector.
- (3) Disconnect connector PX4 from FRONT BRAKE AIR gage connector.
- (4) Set multimeter to ohms.
- (5) Connect positive (+) probe of multimeter to connector PX4 socket 1.
- (6) Connect negative (-) probe of multimeter to ground and note reading on multimeter.
- (7) If continuity is not present, repair wire 3020 from connector PX4 socket 1 to connector PX8 socket 1 (para 2-40) or replace WTEC II dashboard cable assembly (para 7-10) or WTEC III dashboard cable assembly (para 7-11).

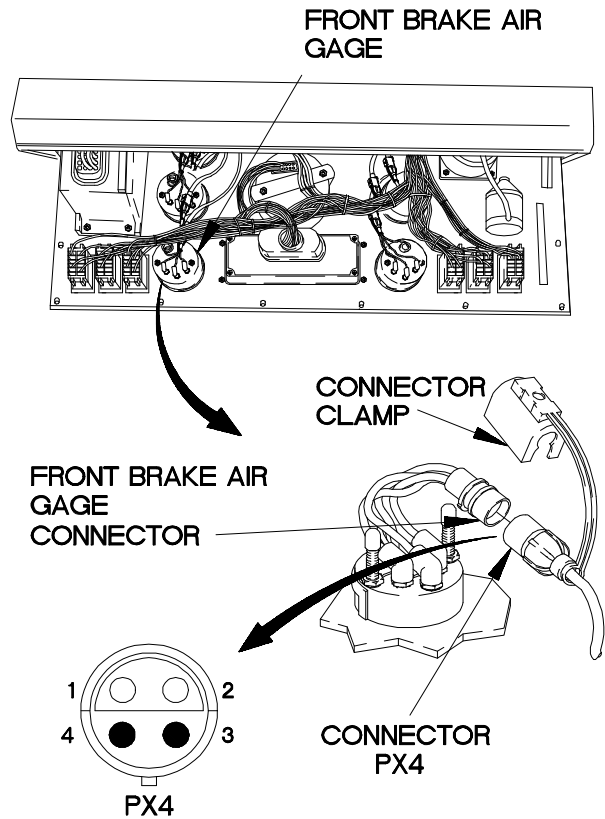

XBE18B02B

e18B. FRONT BRAKE AIR GAGE DOES NOT ILLUMINATE (CONT)

KNOWN INFO
Speedometer illuminates.
POSSIBLE PROBLEMS
Faulty dashboard cable assembly. Faulty FRONT BRAKE AIR gage.

2.

WARNING
CAUTION
Read **WARNING** and **CAUTION** on following page.

Is 12 VDC present at connector PX4 socket 2?

TEST OPTIONS
Voltage Test or STE/ICE-R Test #89
REASON FOR QUESTION
If 12 VDC is not present, wire 1908 is faulty. If 12 VDC is present, FRONT BRAKE AIR gage is faulty.

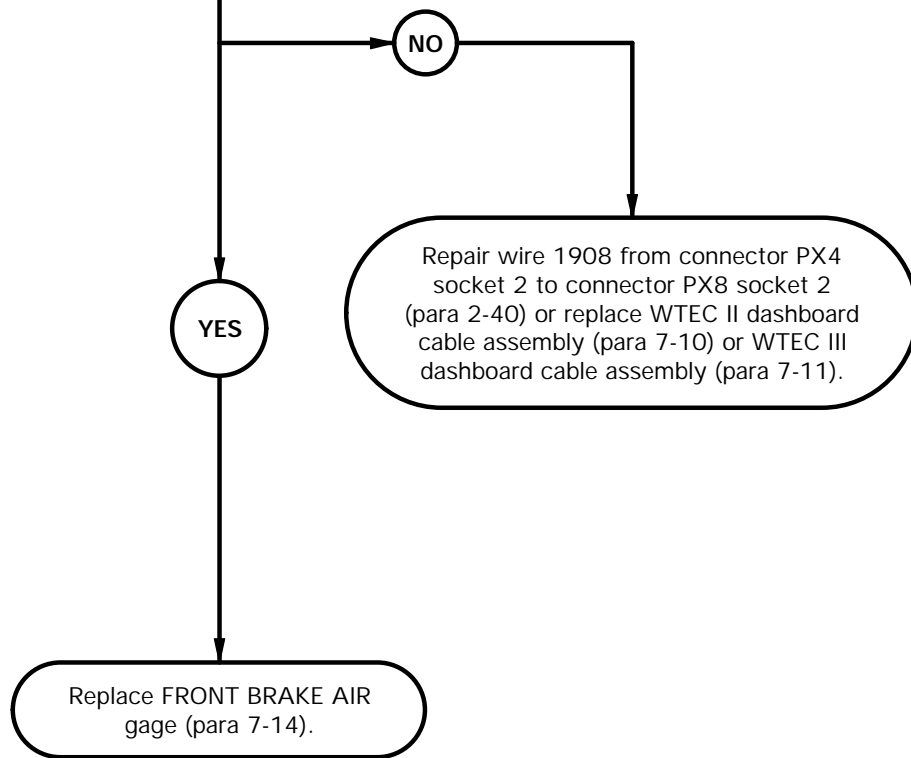

WARNING

Remove rings, bracelets, watches, necklaces, and any other jewelry before working around vehicle. Jewelry can catch on equipment and cause injury or short across electrical circuits and cause severe burns or electrical shock.

CAUTION

Use care when testing electrical connectors. Do not damage connector pins or sockets with multimeter probes. Failure to comply may result in damage to equipment.

VOLTAGE TEST

- (1) Set multimeter to volts DC.
- (2) Connect positive (+) probe of multimeter to connector PX4 socket 2.
- (3) Connect negative (-) probe of multimeter to ground.
- (4) Position main light switch main selector lever to SER DRIVE (TM 9-2320-365-10).
- (5) Position main light switch auxiliary lever to PNL BRT (TM 9-2320-365-10).
- (6) Position dimmer switch for maximum brightness (TM 9-2320-365-10) and note reading on multimeter.
- (7) If 12 VDC is not present, repair wire 1908 from connector PX4 socket 2 to connector PX8 socket 2 (para 2-40) or replace WTEC II dashboard cable assembly (para 7-10) or WTEC III dashboard cable assembly (para 7-11).
- (8) If 12 VDC is present, replace FRONT BRAKE AIR gage (para 7-14).
- (9) Position main light switch to auxiliary lever to OFF (TM 9-2320-365-10).
- (10) Position main light switch main selector lever to OFF (TM 9-2320-365-10).
- (11) Connect connector PX4 to FRONT BRAKE AIR gage connector.
- (12) Connect connector clamp on FRONT BRAKE AIR gage connector.
- (13) Install instrument panel (para 7-15).

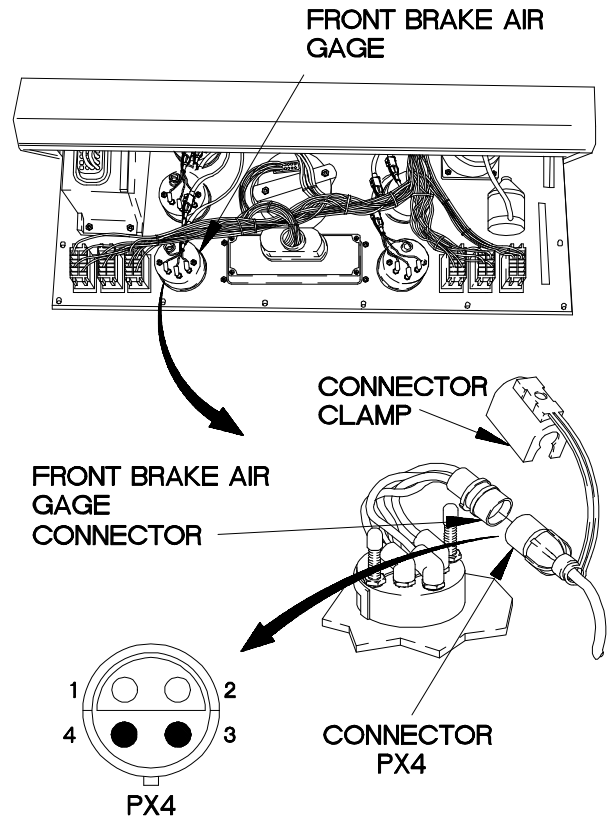

XBE18B02B

e18C. SPEEDOMETER DOES NOT ILLUMINATE

INITIAL SETUP

Equipment Conditions

Engine shut down (TM 9-2320-365-10).

Personnel Required

(2)

Tools and Special Tools

Tool Kit, Genl Mech (Item 44, Appendix C)
 STE/ICE-R (Item 39, Appendix C)
 Multimeter, Digital (Item 22, Appendix C)

References

TM 9-4910-571-12&P

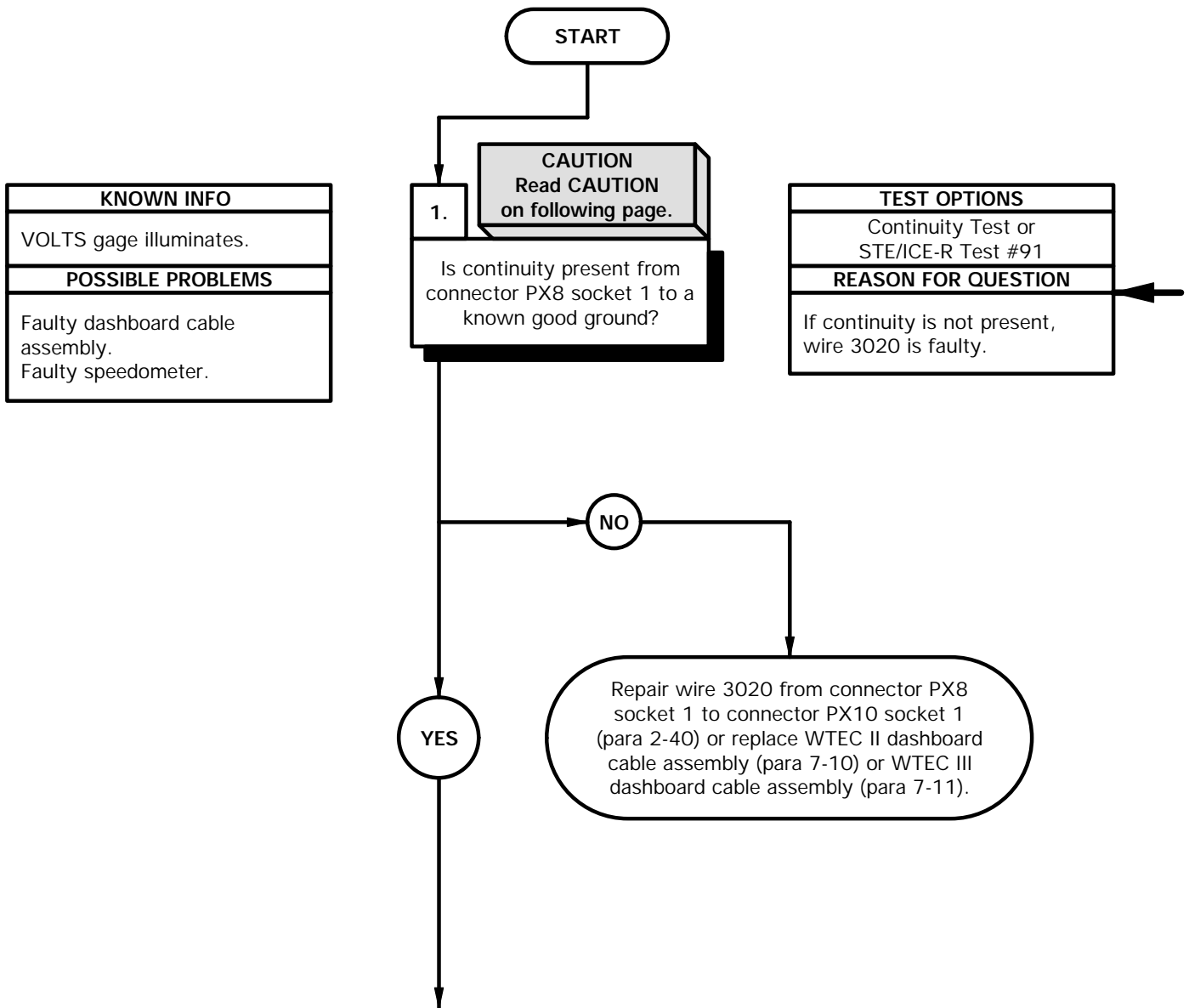

CAUTION

Use care when testing electrical connectors. Do not damage connector pins or sockets with multimeter probes. Failure to comply may result in damage to equipment.

NOTE

Inspect connector pins/sockets for damage, corrosion, and serviceability. Check that connector pins are not pushed back and are capable of making good contact.

CONTINUITY TEST

- (1) Remove instrument panel assembly for access (para 7-15).
- (2) Disconnect connector clamp from speedometer connector.
- (3) Disconnect connector PX8 from speedometer connector.
- (4) Set multimeter to ohms.
- (5) Connect positive (+) probe of multimeter to connector PX8 socket 1.
- (6) Connect negative (-) probe of multimeter to ground and note reading on multimeter.
- (7) If continuity is not present, repair wire 3020 from connector PX8 socket 1 to connector PX10 socket 1 (para 2-40) or replace WTEC II dashboard cable assembly (para 7-10) or WTEC III dashboard cable assembly (para 7-11).

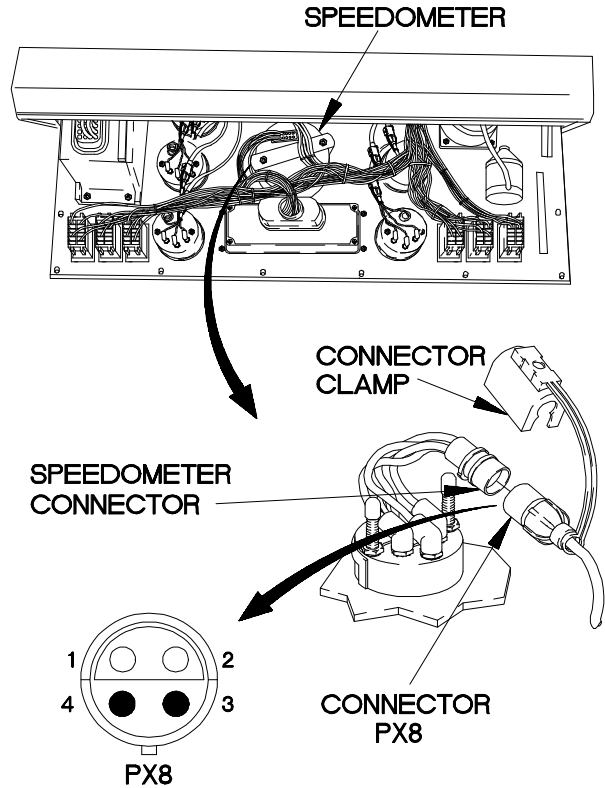

XBE18C02B

e18C. SPEEDOMETER DOES NOT ILLUMINATE (CONT)

KNOWN INFO
VOLTS gage illuminates.
POSSIBLE PROBLEMS
Faulty dashboard cable assembly. Faulty speedometer.

2.

WARNING
CAUTION
Read **WARNING** and **CAUTION** on following page.

Is 12 VDC present at connector PX8 socket 2?

TEST OPTIONS
Voltage Test or STE/ICE-R Test #89
REASON FOR QUESTION
If 12 VDC is not present, wire 1908 is faulty. If 12 VDC is present, speedometer is faulty.

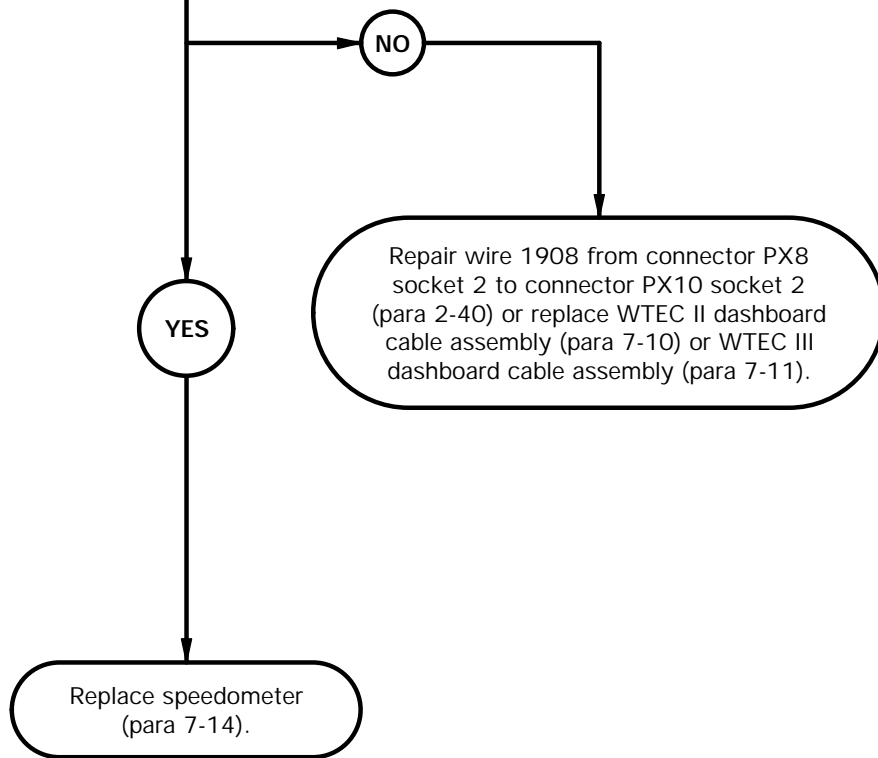

WARNING

Remove rings, bracelets, watches, necklaces, and any other jewelry before working around vehicle. Jewelry can catch on equipment and cause injury or short across electrical circuits and cause severe burns or electrical shock.

CAUTION

Use care when testing electrical connectors. Do not damage connector pins or sockets with multimeter probes. Failure to comply may result in damage to equipment.

VOLTAGE TEST

- (1) Set multimeter to volts DC.
- (2) Connect positive (+) probe of multimeter to connector PX8 socket 2.
- (3) Connect negative (-) probe of multimeter to ground.
- (4) Position main light switch main selector lever to SER DRIVE (TM 9-2320-365-10).
- (5) Position main light switch auxiliary lever to PNL BRT (TM 9-2320-365-10).
- (6) Position dimmer switch for maximum brightness (TM 9-2320-365-10) and note reading on multimeter.
- (7) If 12 VDC is not present, repair wire 1908 from connector PX8 socket 2 to connector PX10 socket 2 (para 2-40) or replace WTEC II dashboard cable assembly (para 7-10) or WTEC III dashboard cable assembly (para 7-11).
- (8) If 12 VDC is present, replace speedometer (para 7-14).
- (9) Position main light switch to auxiliary lever to OFF (TM 9-2320-365-10).
- (10) Position main light switch main selector lever to OFF (TM 9-2320-365-10).
- (11) Connect connector PX8 to speedometer connector.
- (12) Connect connector clamp on speedometer connector.
- (13) Install instrument panel (para 7-15).

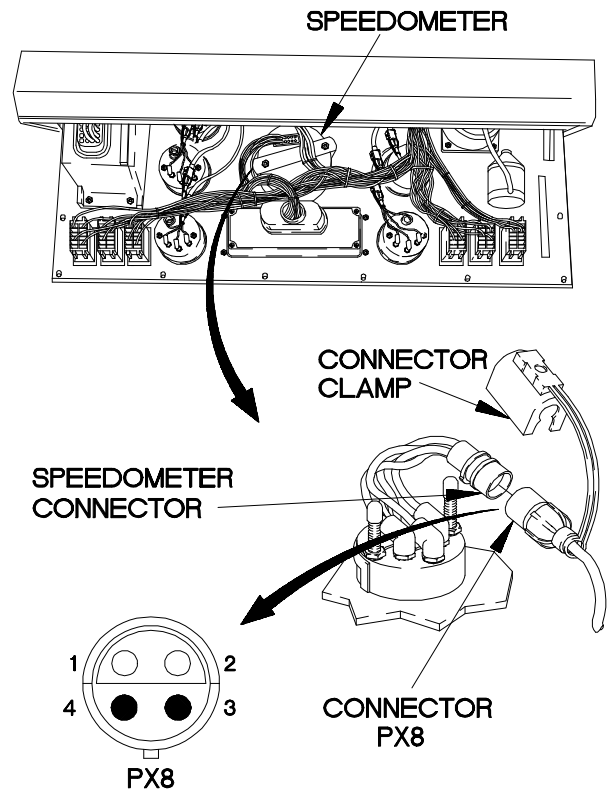

e18D. VOLTS GAGE DOES NOT ILLUMINATE

INITIAL SETUP

Equipment Conditions

Engine shut down (TM 9-2320-365-10).

Personnel Required

(2)

Tools and Special Tools

Tool Kit, Genl Mech (Item 44, Appendix C)
 STE/ICE-R (Item 39, Appendix C)
 Multimeter, Digital (Item 22, Appendix C)

References

TM 9-4910-571-12&P

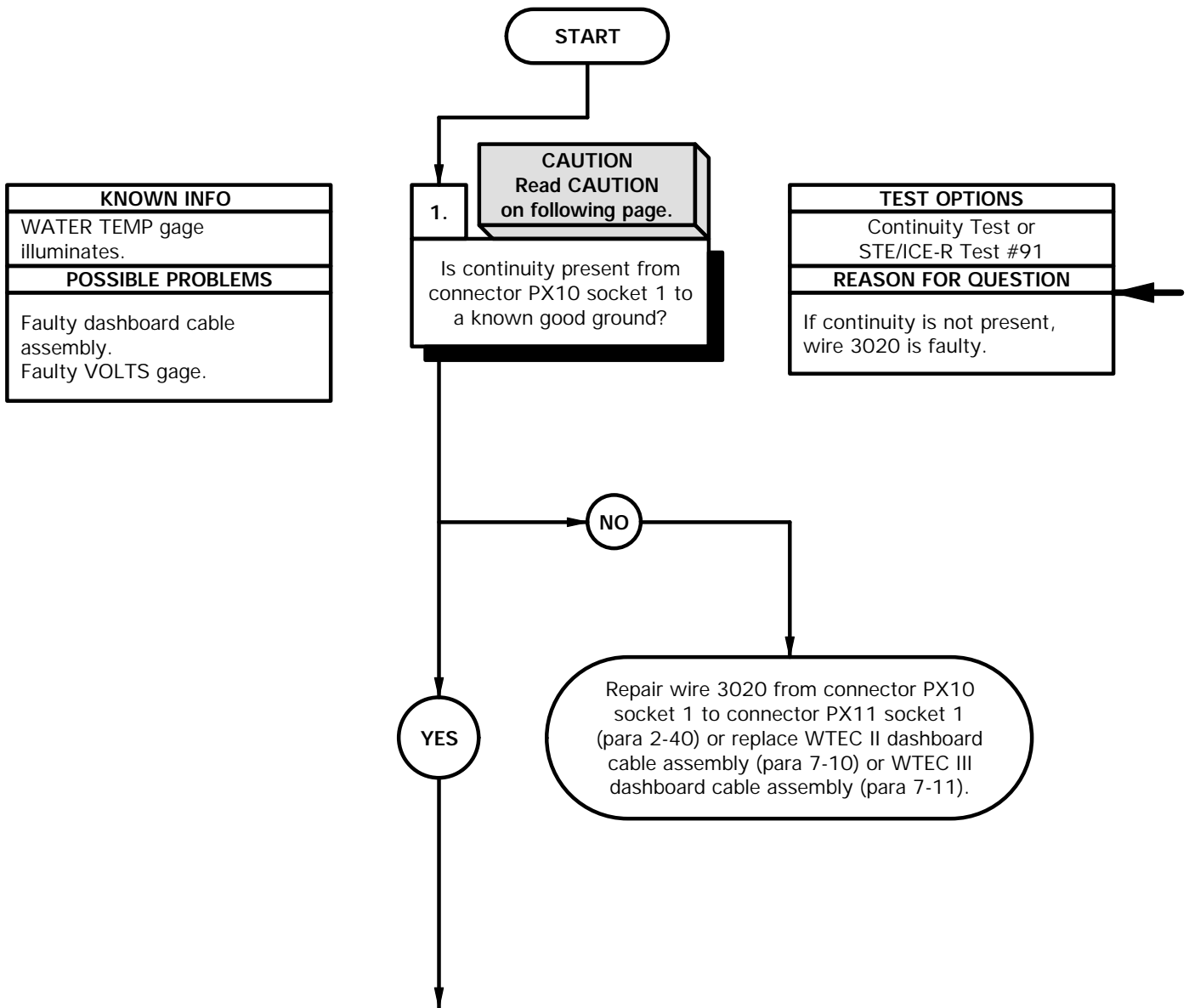

CAUTION

Use care when testing electrical connectors. Do not damage connector pins or sockets with multimeter probes. Failure to comply may result in damage to equipment.

NOTE

Inspect connector pins/sockets for damage, corrosion, and serviceability. Check that connector pins are not pushed back and are capable of making good contact.

CONTINUITY TEST

- (1) Remove instrument panel assembly for access (para 7-15).
- (2) Disconnect connector clamp from VOLTS gage connector.
- (3) Disconnect connector PX10 from VOLTS gage connector.
- (4) Set multimeter to ohms.
- (5) Connect positive (+) probe of multimeter to connector PX10 socket 1.
- (6) Connect negative (-) probe of multimeter to ground and note reading on multimeter.
- (7) If continuity is not present, repair wire 3020 from connector PX10 socket 1 to connector PX11 socket 1 (para 2-40) or replace WTEC II dashboard cable assembly (para 7-10) or WTEC III dashboard cable assembly (para 7-11).

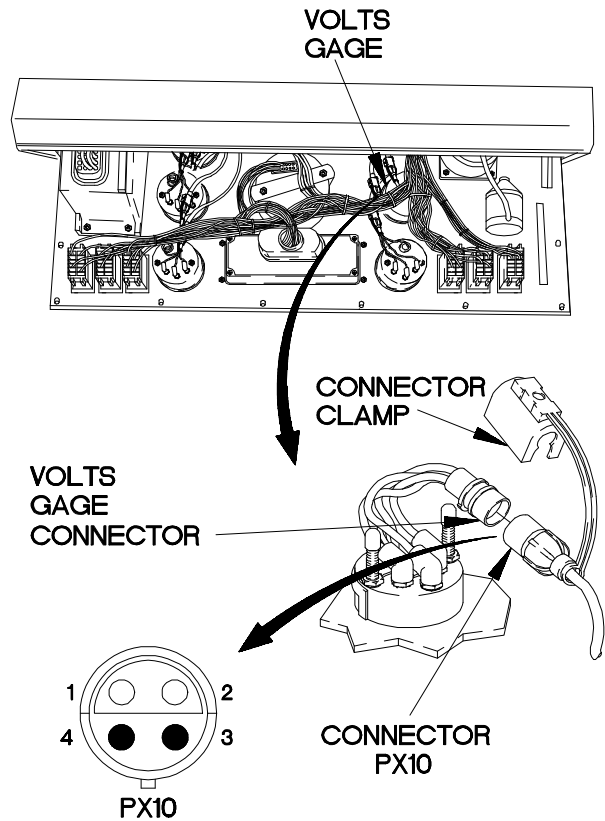

XBE18D02B

e18D. VOLTS GAGE DOES NOT ILLUMINATE (CONT)

KNOWN INFO
WATER TEMP gage illuminates.
POSSIBLE PROBLEMS
Faulty dashboard cable assembly. Faulty VOLTS gage.

2.

WARNING
CAUTION
Read WARNING and CAUTION on following page.

Is 12 VDC present at connector PX10 socket 2?

TEST OPTIONS
Voltage Test or STE/ICE-R Test #89
REASON FOR QUESTION
If 12 VDC is not present, wire 1908 is faulty. If 12 VDC is present, VOLTS gage is faulty.

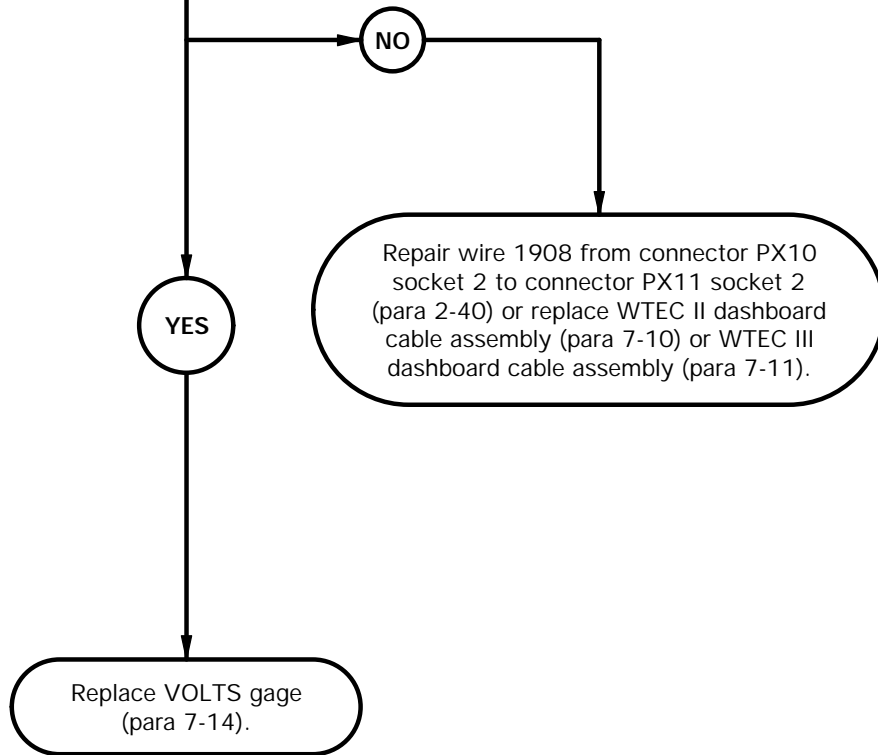

WARNING

Remove rings, bracelets, watches, necklaces, and any other jewelry before working around vehicle. Jewelry can catch on equipment and cause injury or short across electrical circuits and cause severe burns or electrical shock.

CAUTION

Use care when testing electrical connectors. Do not damage connector pins or sockets with multimeter probes. Failure to comply may result in damage to equipment.

VOLTAGE TEST

- (1) Set multimeter to volts DC.
- (2) Connect positive (+) probe of multimeter to connector PX10 socket 2.
- (3) Connect negative (-) probe of multimeter to ground.
- (4) Position main light switch main selector lever to SER DRIVE (TM 9-2320-365-10).
- (5) Position main light switch auxiliary lever to PNL BRT (TM 9-2320-365-10).
- (6) Position dimmer switch for maximum brightness (TM 9-2320-365-10) and note reading on multimeter.
- (7) If 12 VDC is not present, repair wire 1908 from connector PX10 socket 2 to connector PX11 socket 2 (para 2-40) or replace WTEC II dashboard cable assembly (para 7-10) or WTEC III dashboard cable assembly (para 7-11).
- (8) If 12 VDC is present, replace VOLTS gage (para 7-14).
- (9) Position main light switch to auxiliary lever to OFF (TM 9-2320-365-10).
- (10) Position main light switch main selector lever to OFF (TM 9-2320-365-10).
- (11) Connect connector PX10 to VOLTS gage connector.
- (12) Connect connector clamp on VOLTS gage connector.
- (13) Install instrument panel (para 7-15).

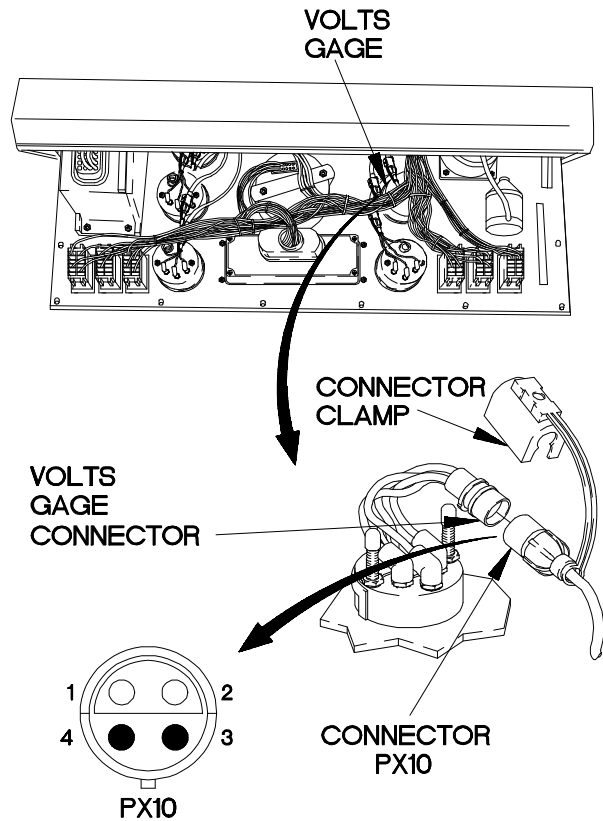

XBE18D02B

e18E. WATER TEMP GAGE DOES NOT ILLUMINATE

INITIAL SETUP

Equipment Conditions

Engine shut down (TM 9-2320-365-10).

Materials/Parts

Dimmer Switch Test Wire (Item 20, Appendix E)

Tools and Special Tools

Tool Kit, Genl Mech (Item 44, Appendix C)
 STE/ICE-R (Item 39, Appendix C)
 Multimeter, Digital (Item 22, Appendix C)

Personnel Required

(2)

References

TM 9-4910-571-12&P

NOTE

Perform Electrical System Troubleshooting
 e1. Circuit Breaker Does Not Operate on
 circuit breaker CB70 prior to beginning this task.

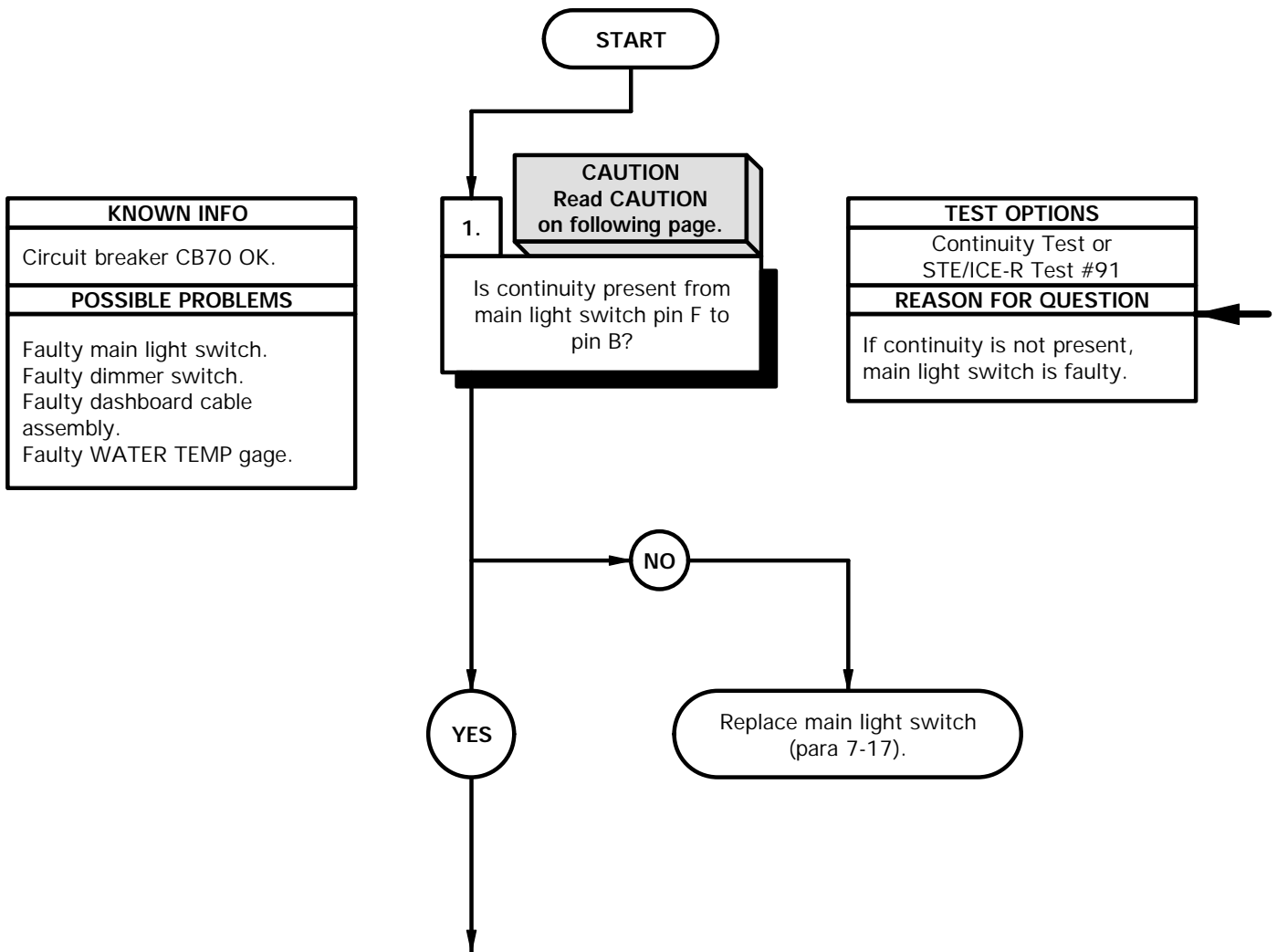

CAUTION

Use care when testing electrical connectors. Do not damage connector pins or sockets with multimeter probes. Failure to comply may result in damage to equipment.

NOTE

Inspect connector pins/sockets for damage, corrosion, and serviceability. Check that connector pins are not pushed back and are capable of making good contact.

CONTINUITY TEST

- (1) Remove PDP cover (TM 9-2320-365-10).
- (2) Remove circuit breaker CB70 from PDP.
- (3) Remove instrument panel assembly for access (para 7-15).
- (4) Disconnect connector PX15 from main light switch connector.
- (5) Position main light switch main selector lever to SER DRIVE (TM 9-2320-365-10).
- (6) Position main light switch auxiliary selector lever to PNL BRT (TM 9-2320-365-10).
- (7) Set multimeter to ohms.
- (8) Connect positive (+) probe of multimeter to main light switch connector pin F.
- (9) Connect negative (-) probe of multimeter to main light switch connector pin B and note reading on multimeter.
- (10) If continuity is not present, replace main light switch (para 7-17).
- (11) Position main light switch auxiliary lever to OFF (TM 9-2320-365-10).
- (12) Position main light switch main selector lever to OFF (TM 9-2320-365-10).

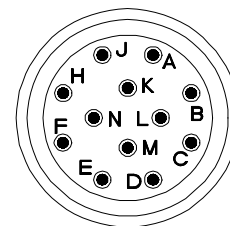
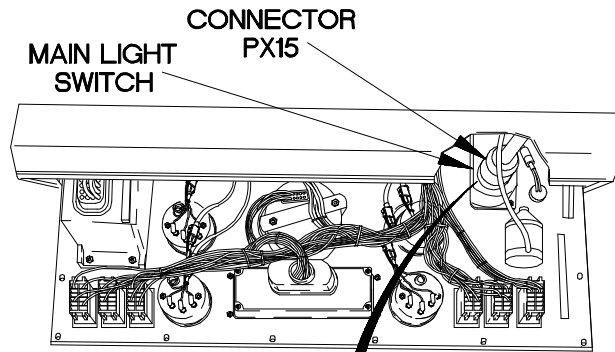
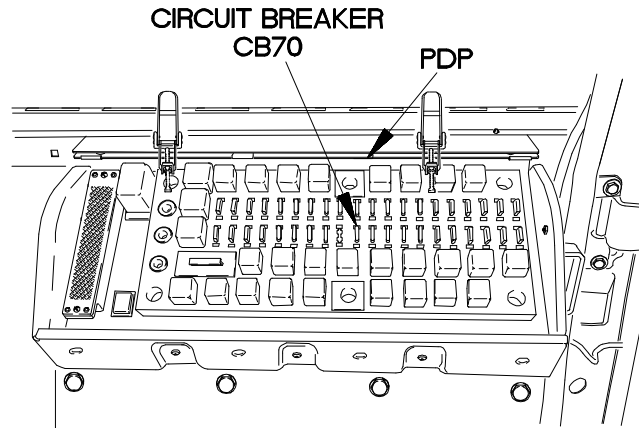

MAIN LIGHT SWITCH CONNECTOR

XBE18E01B

e18E. WATER TEMP GAGE DOES NOT ILLUMINATE (CONT)

KNOWN INFO
Circuit breaker CB70 OK. Main light switch OK.
POSSIBLE PROBLEMS
Faulty dashboard cable assembly. Faulty dimmer switch. Faulty WATER TEMP gage.

2.

WARNING
CAUTION
Read WARNING and CAUTION on following page.

Is 12 VDC present at connector PX15 socket F?

TEST OPTIONS
Voltage Test or STE/ICE-R Test #89
REASON FOR QUESTION
If 12 VDC is not present, wire 1586 is faulty.

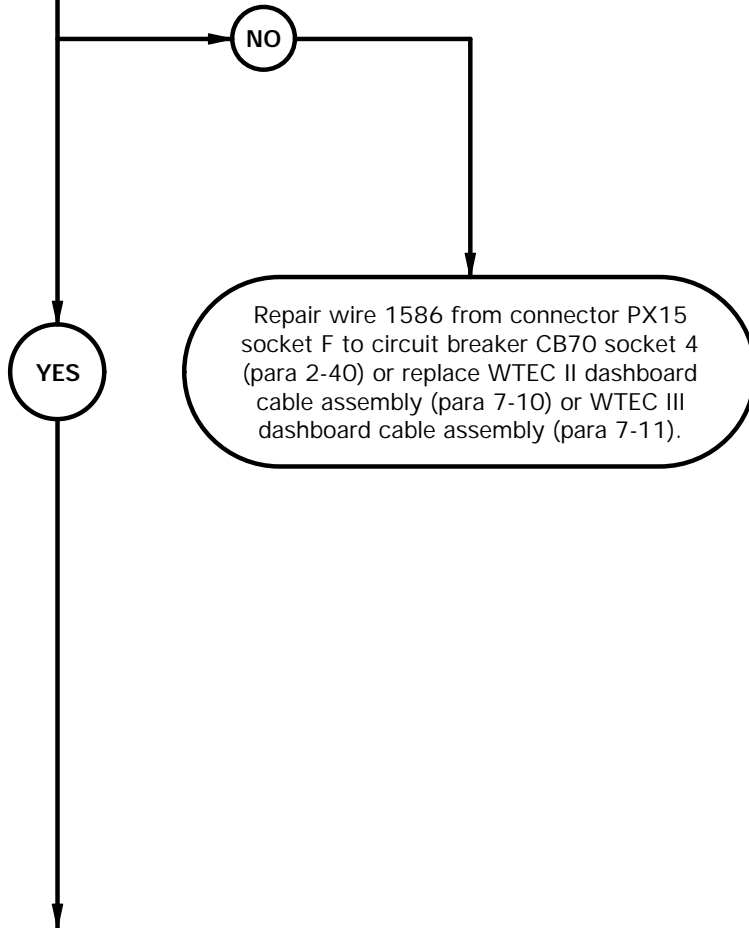

WARNING

Remove rings, bracelets, watches, necklaces, and any other jewelry before working around vehicle. Jewelry can catch on equipment and cause injury or short across electrical circuits and cause severe burns or electrical shock.

CAUTION

Use care when testing electrical connectors. Do not damage connector pins or sockets with multimeter probes. Failure to comply may result in damage to equipment.

VOLTAGE TEST

- (1) Install circuit breaker CB70 on PDP.
- (2) Set multimeter to volts DC.
- (3) Connect positive (+) probe of multimeter to connector PX15 socket F.
- (4) Connect negative (-) probe of multimeter to ground and note reading on multimeter.
- (5) If 12 VDC is not present, repair wire 1586 from connector PX15 socket F to circuit breaker CB70 socket 4 (para 2-40) or replace WTEC II dashboard cable assembly (para 7-10) or WTEC III dashboard cable assembly (para 7-11).

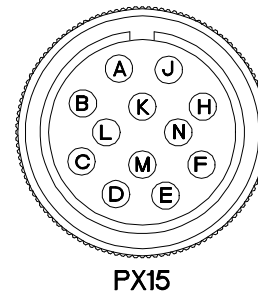
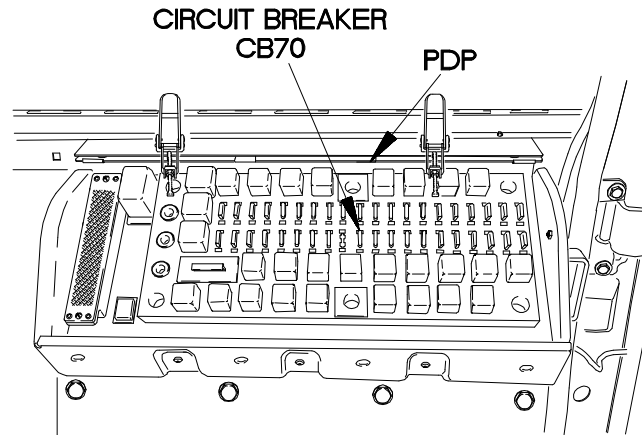

XBE18E02B

e18E. WATER TEMP GAGE DOES NOT ILLUMINATE (CONT)

KNOWN INFO
Circuit breaker CB70 OK. Main light switch OK.
POSSIBLE PROBLEMS
Faulty dashboard cable assembly. Faulty dimmer switch. Faulty WATER TEMP gage.

3.

WARNING

CAUTION

Read **WARNING** and **CAUTION** on following page.

Is 12 VDC present at connector PX24 socket 1?

TEST OPTIONS
Voltage Test or STE/ICE-R Test #89
REASON FOR QUESTION
If 12 VDC is not present, wire 1542 is faulty.

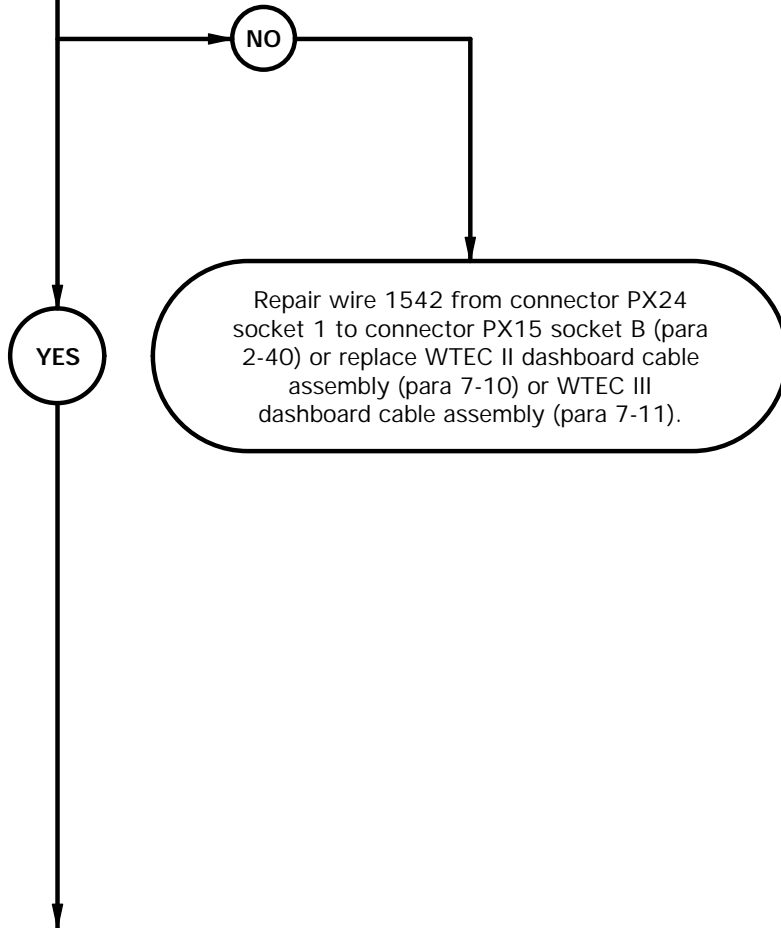

WARNING

Remove rings, bracelets, watches, necklaces, and any other jewelry before working around vehicle. Jewelry can catch on equipment and cause injury or short across electrical circuits and cause severe burns or electrical shock.

CAUTION

Use care when testing electrical connectors. Do not damage connector pins or sockets with multimeter probes. Failure to comply may result in damage to equipment.

VOLTAGE TEST

- (1) Remove circuit breaker CB70 from PDP.
- (2) Connect connector PX15 to main light switch connector.
- (3) Install circuit breaker CB70 on PDP.
- (4) Disconnect connector clamp from dimmer switch connector.
- (5) Disconnect connector PX24 from dimmer switch connector.
- (6) Set multimeter to volts DC.
- (7) Connect positive (+) probe of multimeter to connector PX24 socket 1.
- (8) Connect negative (-) probe of multimeter to ground.
- (9) Position main light switch main selector lever to SER DRIVE (TM 9-2320-365-10).
- (10) Position main light switch auxiliary lever to PNL BRT (TM 9-2320-365-10) and note reading on multimeter.
- (11) If 12 VDC is not present, repair wire 1542 from connector PX24 pin 1 to connector PX15 socket B (para 2-40) or replace WTEC II dashboard cable assembly (para 7-10) or WTEC III dashboard cable assembly (para 7-11).
- (12) Position main light switch auxiliary lever to OFF (TM 9-2320-365-10).
- (13) Position main light switch main selector lever to OFF (TM 9-2320-365-10).
- (14) Install PDP cover (TM 9-2320-365-10).

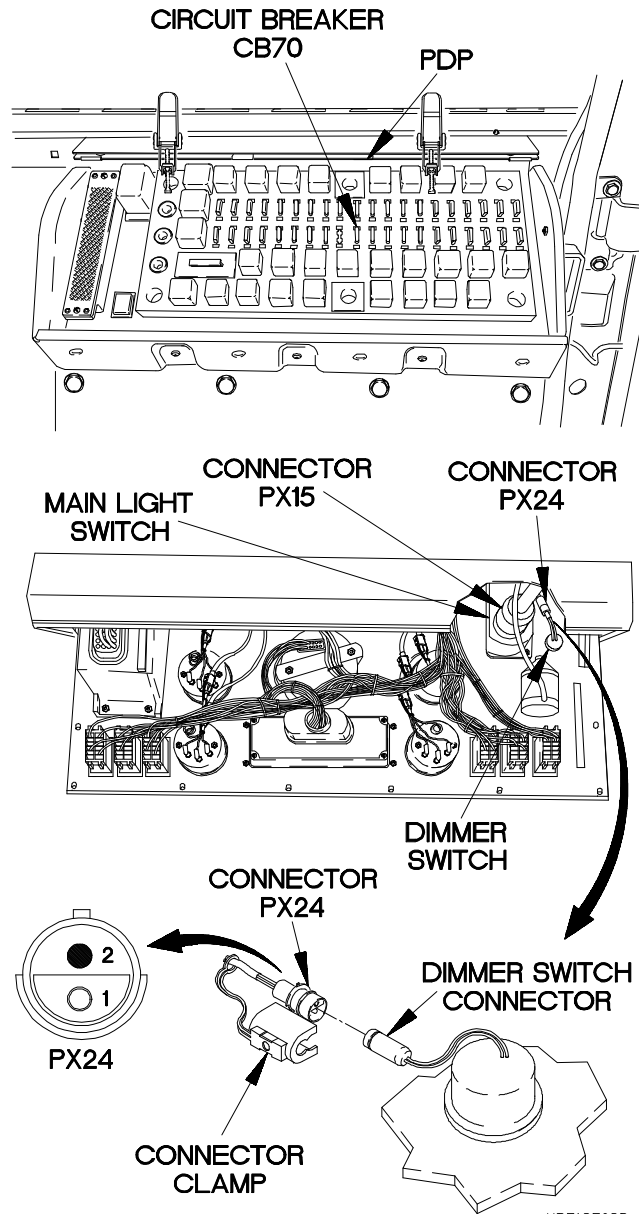

XBE18E03B

e18E. WATER TEMP GAGE DOES NOT ILLUMINATE (CONT)

KNOWN INFO
Circuit breaker CB70 OK. Main light switch OK.
POSSIBLE PROBLEMS
Faulty dimmer switch. Faulty dashboard cable assembly. Faulty WATER TEMP gage.

4.

WARNING
CAUTION
Read WARNING and CAUTION on following page.

Is 12 VDC present at dimmer switch connector socket 2?

TEST OPTIONS
Voltage Test or STE/ICE-R Test #89
REASON FOR QUESTION
If 12 VDC is not present, dimmer switch is faulty.

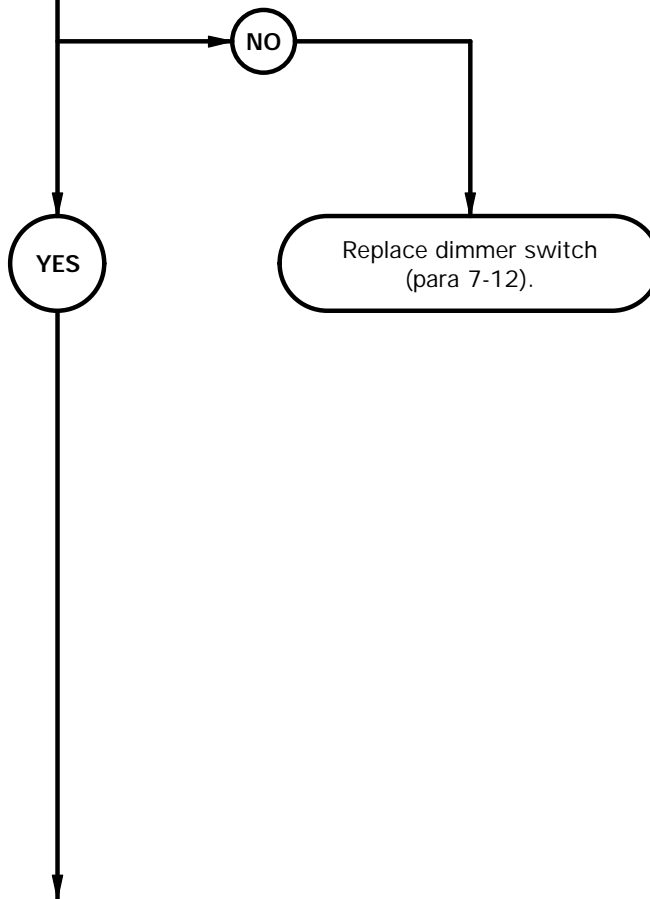

WARNING

Remove rings, bracelets, watches, necklaces, and any other jewelry before working around vehicle. Jewelry can catch on equipment and cause injury or short across electrical circuits and cause severe burns or electrical shock.

CAUTION

Use care when testing electrical connectors. Do not damage connector pins or sockets with multimeter probes. Failure to comply may result in damage to equipment.

NOTE

Inspect connector pins/sockets for damage, corrosion, and serviceability. Check that connector pins are not pushed back and are capable of making good contact.

CONTINUITY TEST

- (1) Position dimmer switch for maximum brightness (TM 9-2320-365-10).
- (2) Install dimmer switch test wire pin in connector PX24 socket 1.
- (3) Install dimmer switch test wire socket on dimmer switch connector pin 1.
- (4) Set multimeter to volts DC.
- (5) Connect positive (+) probe of multimeter to dimmer switch connector socket 2.
- (6) Connect negative (-) probe of multimeter to ground.
- (7) Position main light switch main selector lever to SER DRIVE (TM 9-2320-365-10).
- (8) Position main light switch auxiliary lever to PNL BRT (TM 9-2320-365-10) and note reading on multimeter.
- (9) If 12 VDC is not present, replace dimmer switch (para 7-12).
- (10) Position main light switch auxiliary lever to OFF (TM 9-2320-365-10).
- (11) Position main light switch main selector lever to OFF (TM 9-2320-365-10).
- (12) Disconnect dimmer switch test wire from dimmer switch connector.
- (13) Disconnect dimmer switch test wire from connector PX24.

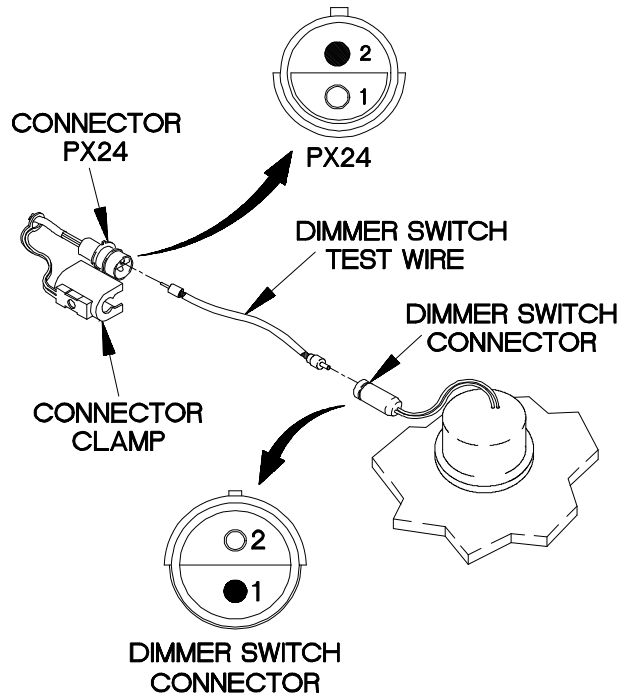

XBE18E04B

e18E. WATER TEMP GAGE DOES NOT ILLUMINATE (CONT)

KNOWN INFO
Circuit breaker CB70 OK. Main light switch OK. Dimmer switch OK.
POSSIBLE PROBLEMS
Faulty dashboard cable assembly. Faulty WATER TEMP gage.

5. **CAUTION**
Read CAUTION on following page.

Is continuity present from connector PX11 socket 2 to connector PX24 pin 2?

TEST OPTIONS
Continuity Test or STE/ICE-R Test #91
REASON FOR QUESTION
If continuity is not present, wire 1908 is faulty.

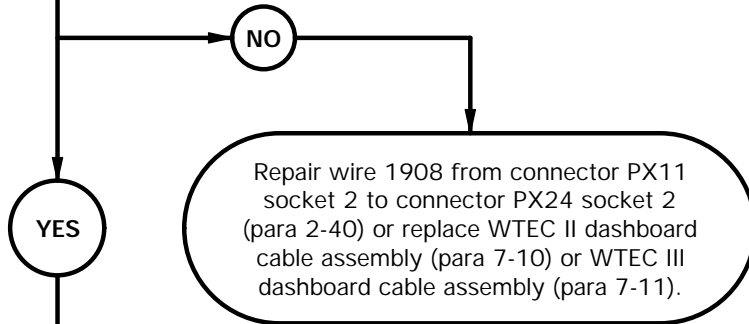

KNOWN INFO
Circuit breaker CB70 OK. Main light switch OK. Dimmer switch OK.
POSSIBLE PROBLEMS
Faulty dashboard cable assembly. Faulty WATER TEMP gage.

6. **CAUTION**
Read CAUTION on following page.

Is continuity present from connector PX11 socket 1 to a known good ground?

TEST OPTIONS
Continuity Test or STE/ICE-R Test #91
REASON FOR QUESTION
If continuity is not present, wire 3020 is faulty. If continuity is present, WATER TEMP gage is faulty.

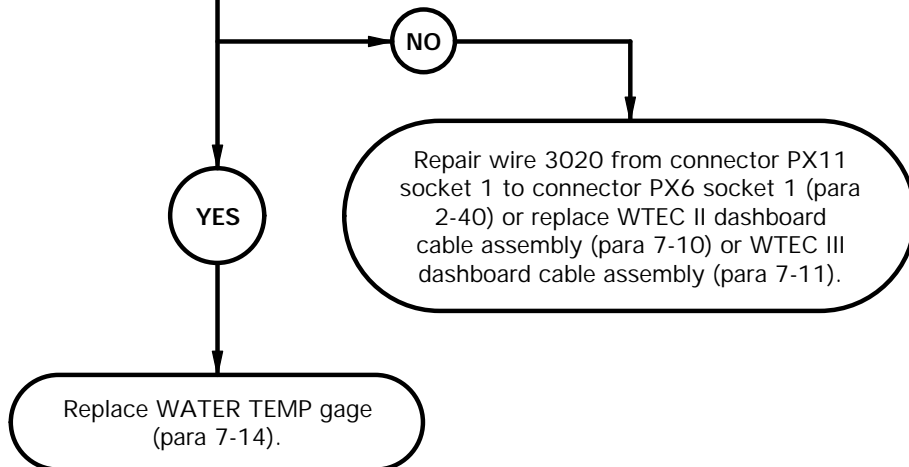

CAUTION

Use care when testing electrical connectors. Do not damage connector pins or sockets with multimeter probes. Failure to comply may result in damage to equipment.

CONTINUITY TEST

- (1) Disconnect connector clamp from WATER TEMP gage connector.
- (2) Disconnect connector PX11 from WATER TEMP gage connector.
- (3) Set multimeter to ohms.
- (4) Connect positive (+) probe of multimeter to connector PX11 socket 2.
- (5) Connect negative (-) probe of multimeter to connector PX24 pin 2 and note reading on multimeter.
- (6) If continuity is not present, repair wire 1908 from connector PX11 socket 2 to connector PX24 socket 2 (para 2-40) or replace WTEC II dashboard cable assembly (para 7-10) or WTEC III dashboard cable assembly (para 7-11).

CONTINUITY TEST

- (1) Set multimeter to ohms.
- (2) Connect positive (+) probe of multimeter to connector PX11 socket 1.
- (3) Connect negative (-) probe of multimeter to ground and note reading on multimeter.
- (4) If continuity is not present, repair wire 3020 from connector PX11 socket 1 to connector PX6 socket 1 (para 2-40) or replace WTEC II dashboard cable assembly (para 7-10) or WTEC III dashboard cable assembly (para 7-11).
- (5) If continuity is present, replace WATER TEMP gage (para 7-14).
- (6) Connect connector PX24 to dimmer switch connector.
- (7) Connect connector clamp on dimmer switch connector.
- (8) Connect connector PX11 to WATER TEMP gage connector.
- (9) Connect connector clamp on WATER TEMP gage connector.
- (10) Install instrument panel assembly (para 7-15).

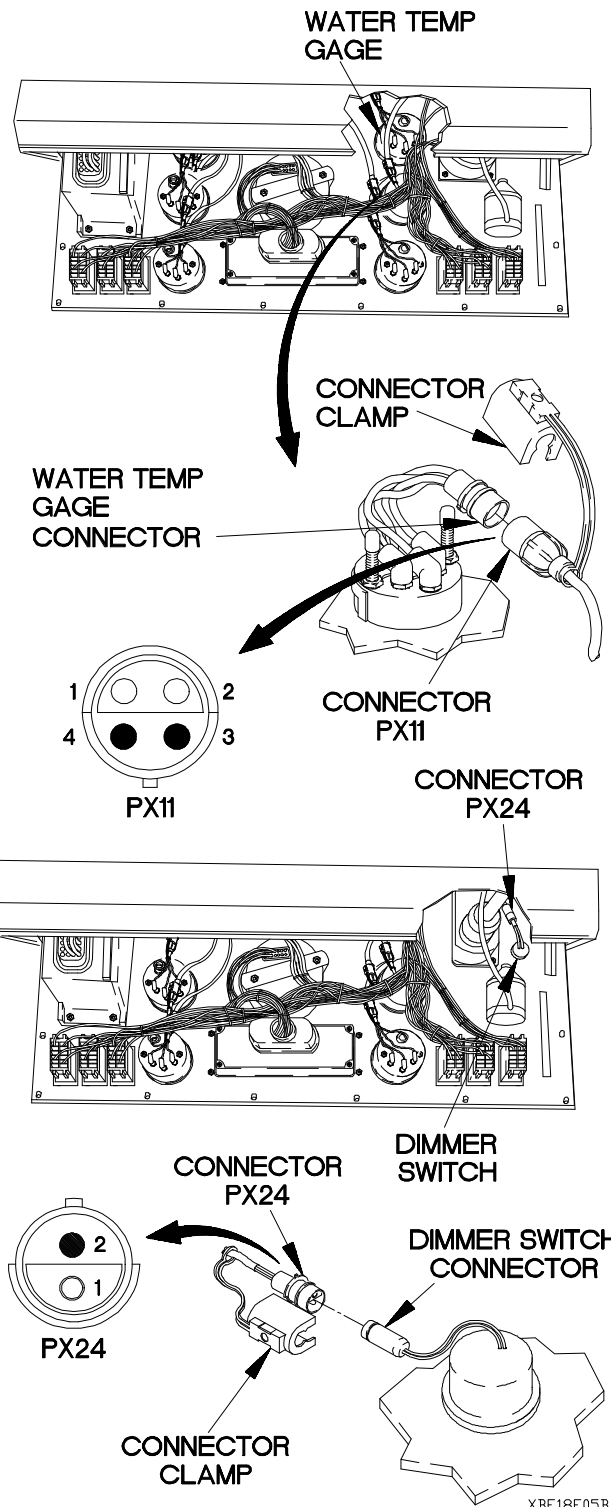

e19. OIL PRESS GAGE DOES NOT ILLUMINATE

INITIAL SETUP

Equipment Conditions

Engine shut down (TM 9-2320-365-10).

Materials/Parts

Dimmer Switch Test Wire (Item 20, Appendix E)

Tools and Special Tools

Tool Kit, Genl Mech (Item 44, Appendix C)
 STE/ICE-R (Item 39, Appendix C)
 Multimeter, Digital (Item 22, Appendix C)

Personnel Required

(2)

References

TM 9-4910-571-12&P

NOTE

Perform Electrical System Troubleshooting e1. Circuit Breaker Does Not Operate on circuit breaker CB70 prior to beginning this task.

KNOWN INFO
Circuit breaker CB70 OK.
POSSIBLE PROBLEMS
Faulty main light switch. Faulty dimmer switch. Faulty dashboard cable assembly. Faulty OIL PRESS gage.

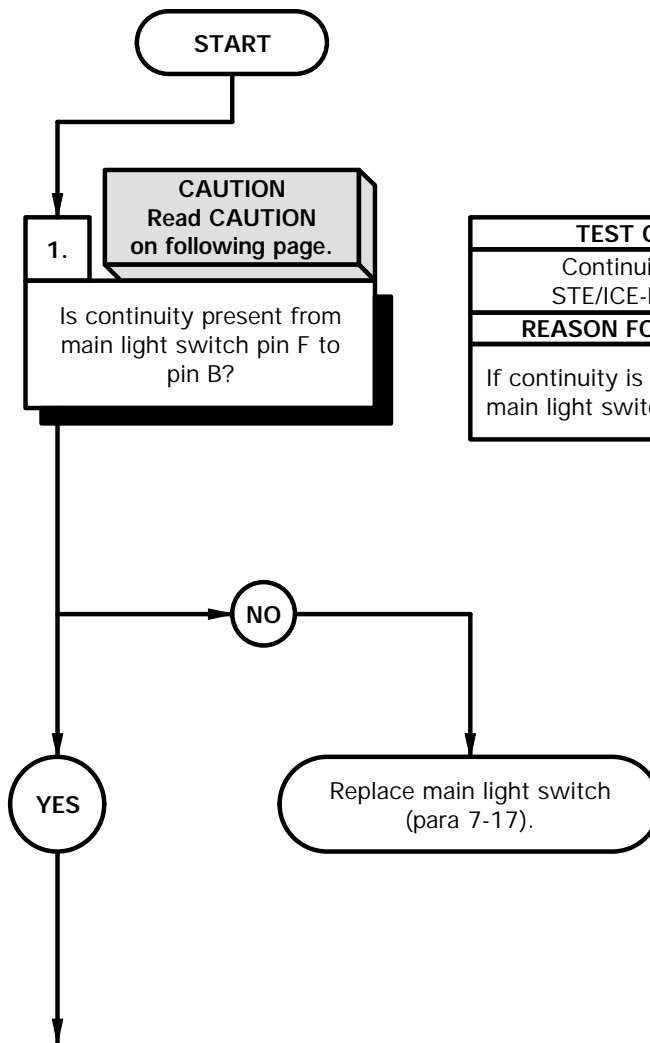

TEST OPTIONS
Continuity Test or STE/ICE-R Test #91
REASON FOR QUESTION
If continuity is not present, main light switch is faulty.

CAUTION

Use care when testing electrical connectors. Do not damage connector pins or sockets with multimeter probes. Failure to comply may result in damage to equipment.

NOTE

Inspect connector pins/sockets for damage, corrosion, and serviceability. Check that connector pins are not pushed back and are capable of making good contact.

CONTINUITY TEST

- (1) Remove PDP cover (TM 9-2320-365-10).
- (2) Remove circuit breaker CB70 from PDP.
- (3) Remove instrument panel assembly for access (para 7-15).
- (4) Disconnect connector PX15 from main light switch connector.
- (5) Position main light switch main selector lever to SER DRIVE (TM 9-2320-365-10).
- (6) Position main light switch auxiliary selector lever to PNL BRT (TM 9-2320-365-10).
- (7) Set multimeter to ohms.
- (8) Connect positive (+) probe of multimeter to main light switch connector pin F.
- (9) Connect negative (-) probe of multimeter to main light switch connector pin B and note reading on multimeter.
- (10) If continuity is not present, replace main light switch (para 7-17).
- (11) Position main light switch auxiliary lever to OFF (TM 9-2320-365-10).
- (12) Position main light switch main selector lever to OFF (TM 9-2320-365-10).

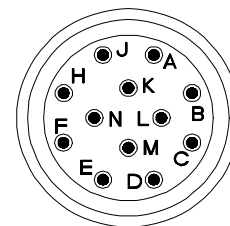
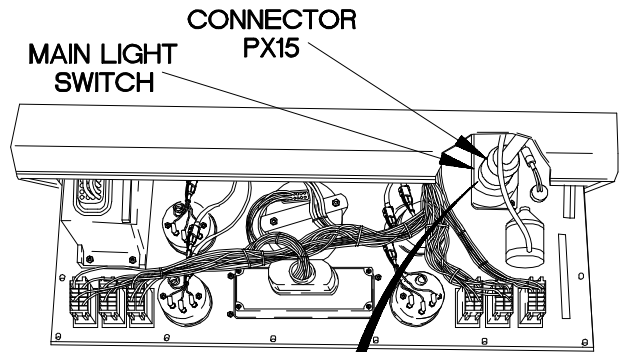
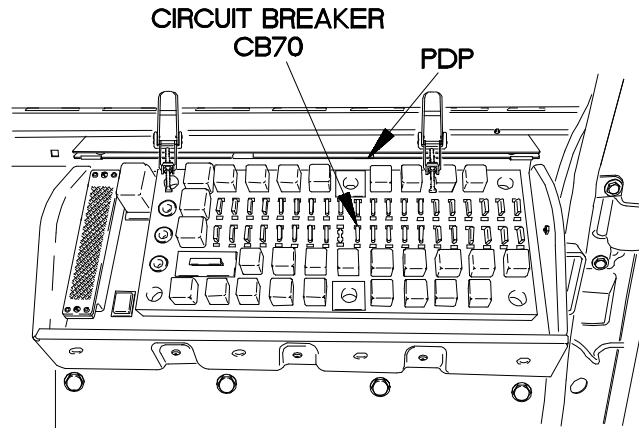

MAIN LIGHT SWITCH CONNECTOR

XBE1901B

e19. OIL PRESS GAGE DOES NOT ILLUMINATE (CONT)

KNOWN INFO
Circuit breaker CB70 OK. Main light switch OK.
POSSIBLE PROBLEMS
Faulty dashboard cable assembly. Faulty dimmer switch. Faulty OIL PRESS gage.

2.

WARNING
CAUTION
Read WARNING and CAUTION on following page.

Is 12 VDC present at connector PX15 socket F?

TEST OPTIONS
Voltage Test or STE/ICE-R Test #89
REASON FOR QUESTION
If 12 VDC is not present, wire 1586 is faulty.

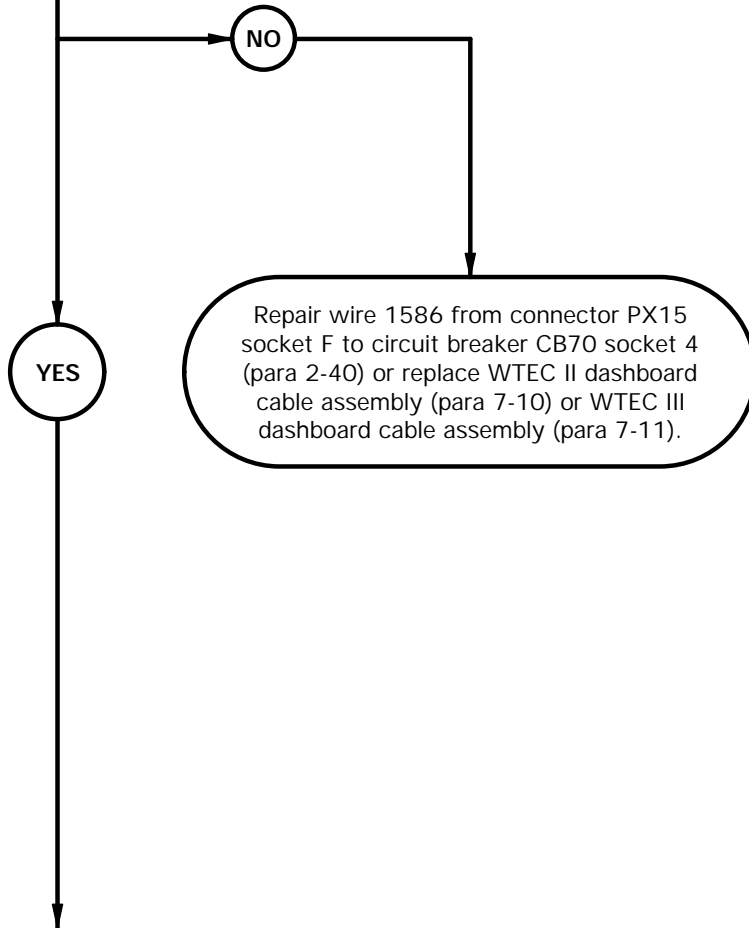

WARNING

Remove rings, bracelets, watches, necklaces, and any other jewelry before working around vehicle. Jewelry can catch on equipment and cause injury or short across electrical circuits and cause severe burns or electrical shock.

CAUTION

Use care when testing electrical connectors. Do not damage connector pins or sockets with multimeter probes. Failure to comply may result in damage to equipment.

VOLTAGE TEST

- (1) Install circuit breaker CB70 on PDP.
- (2) Set multimeter to volts DC.
- (3) Connect positive (+) probe of multimeter to connector PX15 socket F.
- (4) Connect negative (-) probe of multimeter to ground and note reading on multimeter.
- (5) If 12 VDC is not present, repair wire 1586 from connector PX15 socket F to circuit breaker CB70 socket 4 (para 2-40) or replace WTEC II dashboard cable assembly (para 7-10) or WTEC III dashboard cable assembly (para 7-11).

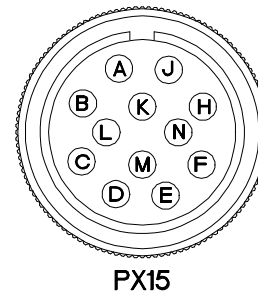
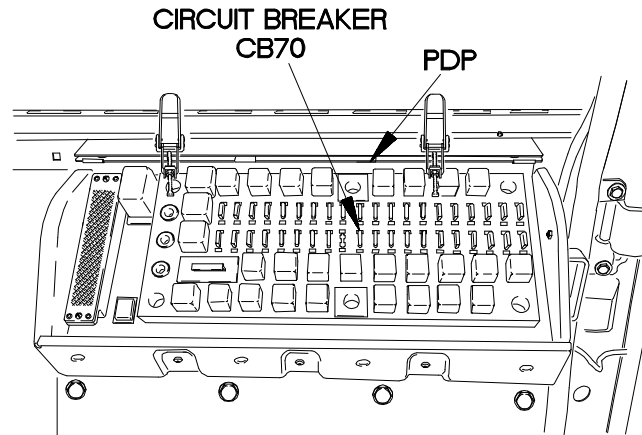

XBE1902B

e19. OIL PRESS GAGE DOES NOT ILLUMINATE (CONT)

KNOWN INFO
Circuit breaker CB70 OK. Main light switch OK.
POSSIBLE PROBLEMS
Faulty dashboard cable assembly. Faulty dimmer switch. Faulty OIL PRESS gage.

3.

WARNING

CAUTION

Read **WARNING** and **CAUTION** on following page.

Is 12 VDC present at connector PX24 socket 1?

TEST OPTIONS
Voltage Test or STE/ICE-R Test #89
REASON FOR QUESTION
If 12 VDC is not present, wire 1542 is faulty.

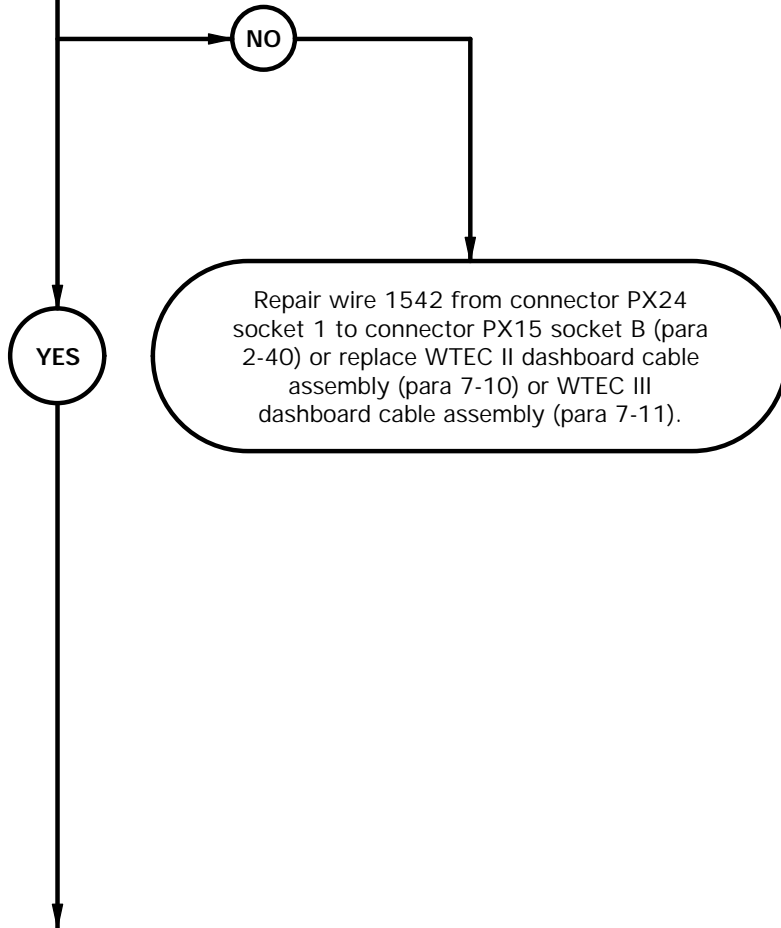

WARNING

Remove rings, bracelets, watches, necklaces, and any other jewelry before working around vehicle. Jewelry can catch on equipment and cause injury or short across electrical circuits and cause severe burns or electrical shock.

CAUTION

Use care when testing electrical connectors. Do not damage connector pins or sockets with multimeter probes. Failure to comply may result in damage to equipment.

VOLTAGE TEST

- (1) Remove circuit breaker CB70 from PDP.
- (2) Connect connector PX15 to main light switch connector.
- (3) Install circuit breaker CB70 on PDP.
- (4) Disconnect connector clamp from dimmer switch connector.
- (5) Disconnect connector PX24 from dimmer switch connector.
- (6) Set multimeter to volts DC.
- (7) Connect positive (+) probe of multimeter to connector PX24 socket 1.
- (8) Connect negative (-) probe of multimeter to ground.
- (9) Position main light switch main selector lever to SER DRIVE (TM 9-2320-365-10).
- (10) Position main light switch auxiliary lever to PNL BRT (TM 9-2320-365-10) and note reading on multimeter.
- (11) If 12 VDC is not present, repair wire 1542 from connector PX24 pin 1 to connector PX15 socket B (para 2-40) or replace WTEC II dashboard cable assembly (para 7-10) or WTEC III dashboard cable assembly (para 7-11).
- (12) Position main light switch auxiliary lever to OFF (TM 9-2320-365-10).
- (13) Position main light switch main selector lever to OFF (TM 9-2320-365-10).
- (14) Install PDP cover (TM 9-2320-365-10).

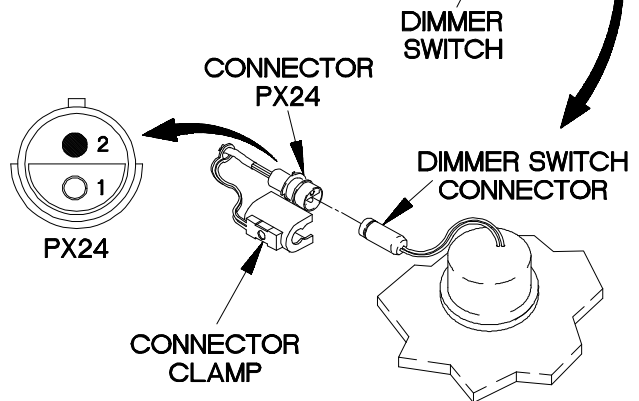
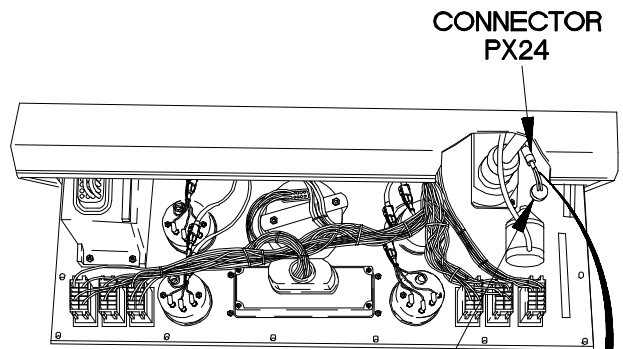
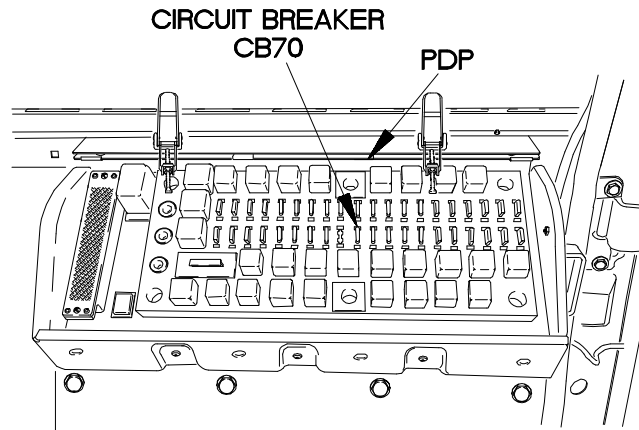

XBE1903B

e19. OIL PRESS GAGE DOES NOT ILLUMINATE (CONT)

KNOWN INFO
Circuit breaker CB70 OK. Main light switch OK.
POSSIBLE PROBLEMS
Faulty dimmer switch. Faulty dashboard cable assembly. Faulty OIL PRESS gage.

4.

WARNING
CAUTION
Read WARNING and CAUTION on following page.

Is 12 VDC present at dimmer switch connector socket 2?

TEST OPTIONS
Voltage Test or STE/ICE-R Test #89
REASON FOR QUESTION
If 12 VDC is not present, dimmer switch is faulty.

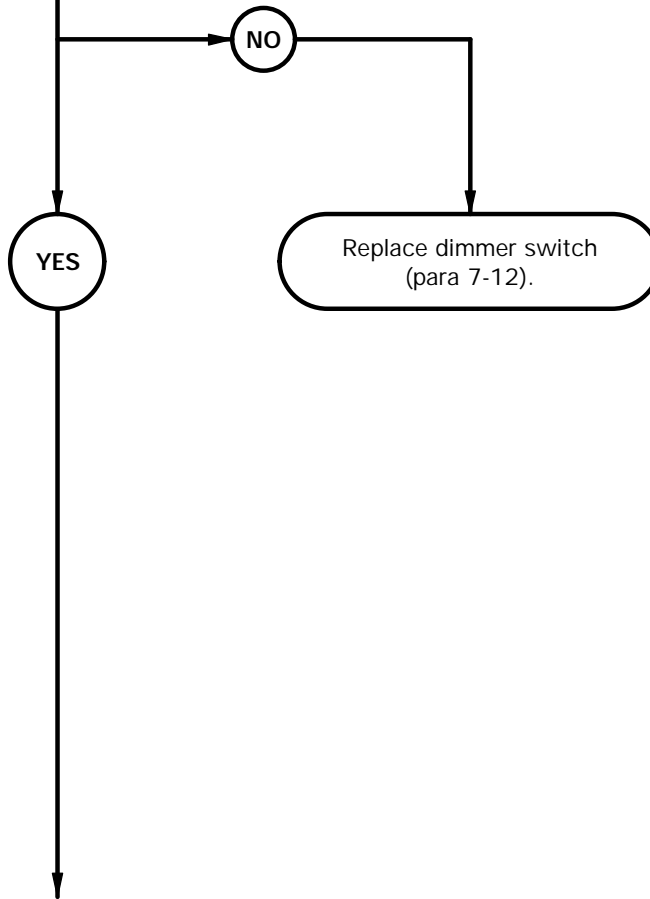

WARNING

Remove rings, bracelets, watches, necklaces, and any other jewelry before working around vehicle. Jewelry can catch on equipment and cause injury or short across electrical circuits and cause severe burns or electrical shock.

CAUTION

Use care when testing electrical connectors. Do not damage connector pins or sockets with multimeter probes. Failure to comply may result in damage to equipment.

NOTE

Inspect connector pins/sockets for damage, corrosion, and serviceability. Check that connector pins are not pushed back and are capable of making good contact.

CONTINUITY TEST

- (1) Position dimmer switch for maximum brightness (TM 9-2320-365-10).
- (2) Install dimmer switch test wire pin in connector PX24 socket 1.
- (3) Install dimmer switch test wire socket on dimmer switch connector pin 1.
- (4) Set multimeter to volts DC.
- (5) Connect positive (+) probe of multimeter to dimmer switch connector socket 2.
- (6) Connect negative (-) probe of multimeter to ground.
- (7) Position main light switch main selector lever to SER DRIVE (TM 9-2320-365-10).
- (8) Position main light switch auxiliary lever to PNL BRT (TM 9-2320-365-10) and note reading on multimeter.
- (9) If 12 VDC is not present, replace dimmer switch (para 7-12).
- (10) Position main light switch auxiliary lever to OFF (TM 9-2320-365-10).
- (11) Position main light switch main selector lever to OFF (TM 9-2320-365-10).
- (12) Disconnect dimmer switch test wire from dimmer switch connector.
- (13) Disconnect dimmer switch test wire from connector PX24.

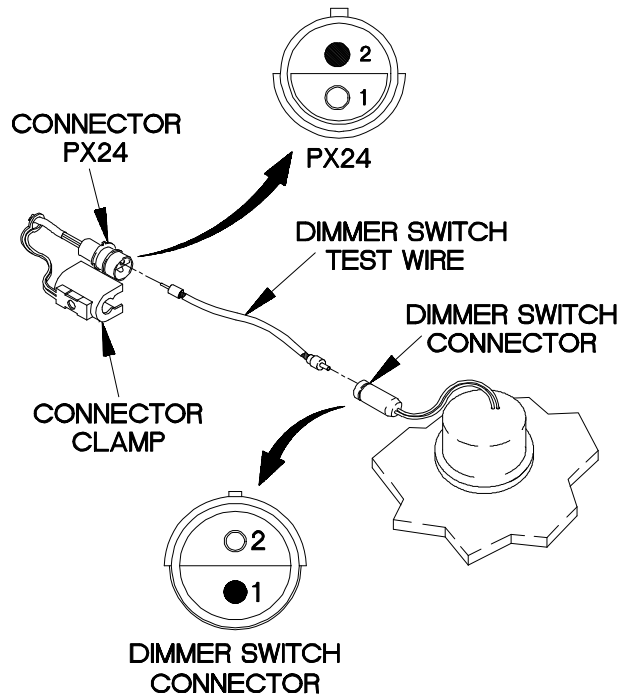

XBE1904B

e19. OIL PRESS GAGE DOES NOT ILLUMINATE (CONT)

KNOWN INFO
Circuit breaker CB70 OK. Main light switch OK. Dimmer switch OK.
POSSIBLE PROBLEMS
Faulty dashboard cable assembly. Faulty OIL PRESS gage.

5. **CAUTION**
Read CAUTION on following page.

Is continuity present from connector PX6 socket 2 to connector PX24 pin 2?

TEST OPTIONS
Continuity Test or STE/ICE-R Test #91
REASON FOR QUESTION
If continuity is not present, wire 1908 is faulty.

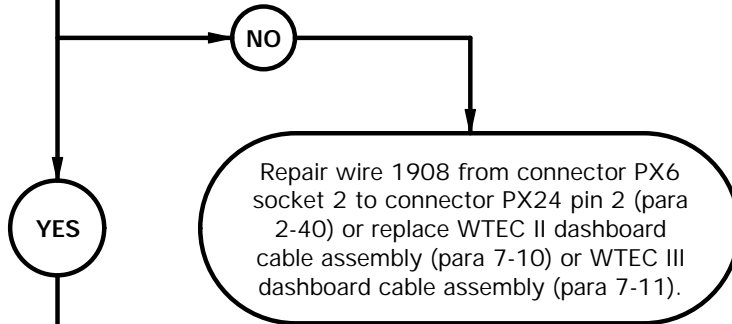

KNOWN INFO
Circuit breaker CB70 OK. Main light switch OK. Dimmer switch OK.
POSSIBLE PROBLEMS
Faulty dashboard cable assembly. Faulty OIL PRESS gage.

6. **CAUTION**
Read CAUTION on following page.

Is continuity present from connector PX6 socket 1 to a known good ground?

TEST OPTIONS
Continuity Test or STE/ICE-R Test #91
REASON FOR QUESTION
If continuity is not present, wire 3020 is faulty. If continuity is present, OIL PRESS gage is faulty.

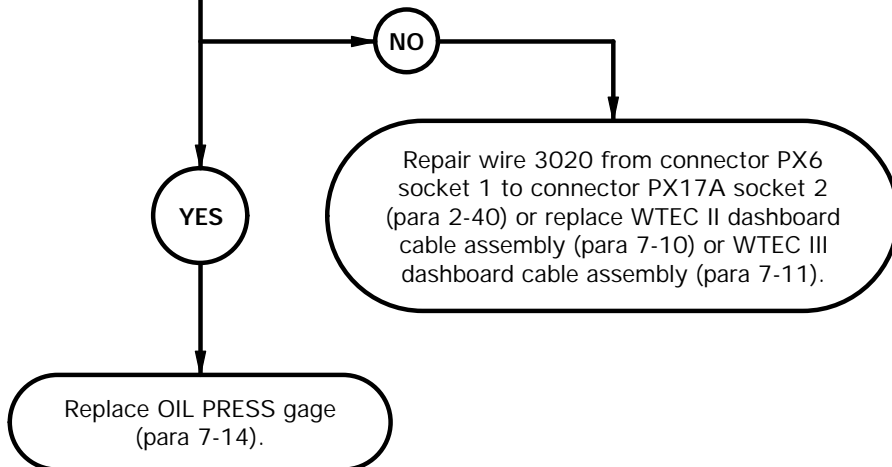

CAUTION

Use care when testing electrical connectors. Do not damage connector pins or sockets with multimeter probes. Failure to comply may result in damage to equipment.

CONTINUITY TEST

- (1) Disconnect connector clamp from OIL PRESS gage connector.
- (2) Disconnect connector PX6 from OIL PRESS gage connector.
- (3) Set multimeter to ohms.
- (4) Connect positive (+) probe of multimeter to connector PX6 socket 2.
- (5) Connect negative (-) probe of multimeter to connector PX24 pin 2 and note reading on multimeter.
- (6) If continuity is not present, repair wire 1908 from connector PX6 socket 2 to connector PX24 socket 2 (para 2-40) or replace WTEC II dashboard cable assembly (para 7-10) or WTEC III dashboard cable assembly (para 7-11).

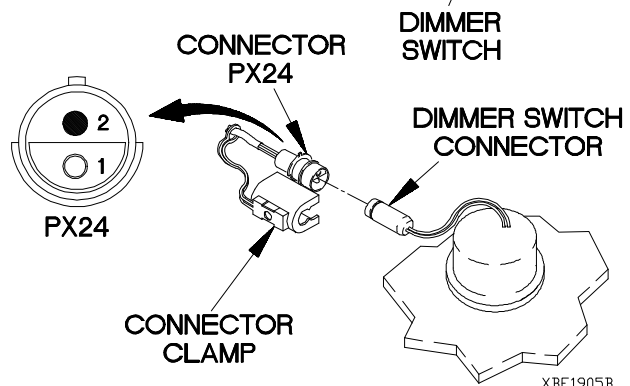
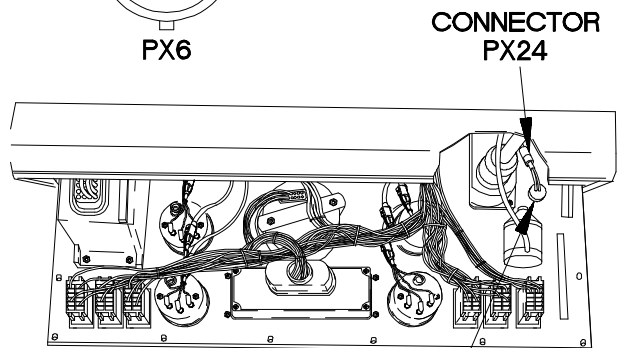
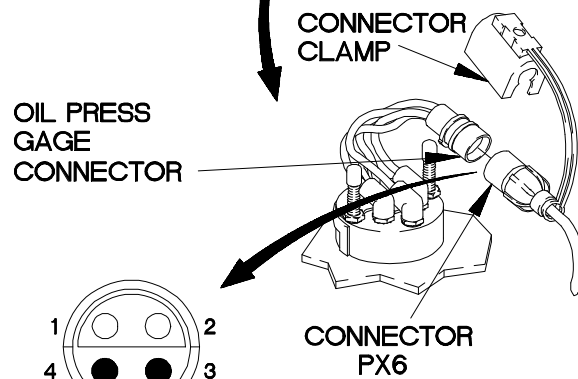
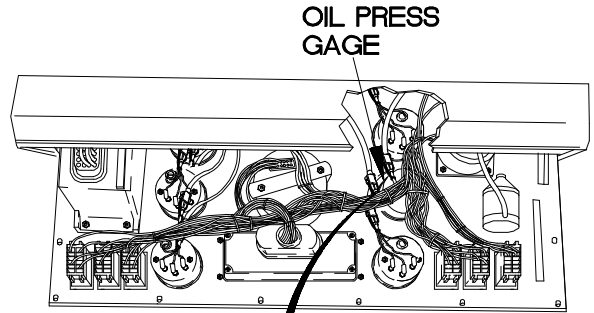

XBE1905B

CONTINUITY TEST

- (1) Set multimeter to ohms.
- (2) Connect positive (+) probe of multimeter to connector PX6 socket 1.
- (3) Connect negative (-) probe of multimeter to ground and note reading on multimeter.
- (4) If continuity is not present, repair wire 3020 from connector PX6 socket 1 to connector PX17A socket 2 (para 2-40) or replace WTEC II dashboard cable assembly (para 7-10) or WTEC III dashboard cable assembly (para 7-11).
- (5) If continuity is present, replace OIL PRESS gage (para 7-14).
- (6) Connect connector PX24 to dimmer switch connector.
- (7) Connect connector clamp on dimmer switch connector.
- (8) Connect connector PX6 to OIL PRESS gage connector.
- (9) Connect connector clamp on OIL PRESS gage connector.
- (10) Install instrument panel assembly (para 7-15).

e20. AUXILIARY PANEL, PERSONNEL HEATER, AND INSTRUMENT PANEL DO NOT ILLUMINATE	
INITIAL SETUP	
Equipment Condition Engine shut down (TM 9-2320-365-10).	Tools and Special Tools Tool Kit, Genl Mech (Item 44, Appendix C) STE/ICE-R (Item 39, Appendix C) Multimeter, Digital (Item 22, Appendix C)
Personnel Required (2)	References TM 9-4910-571-12&P

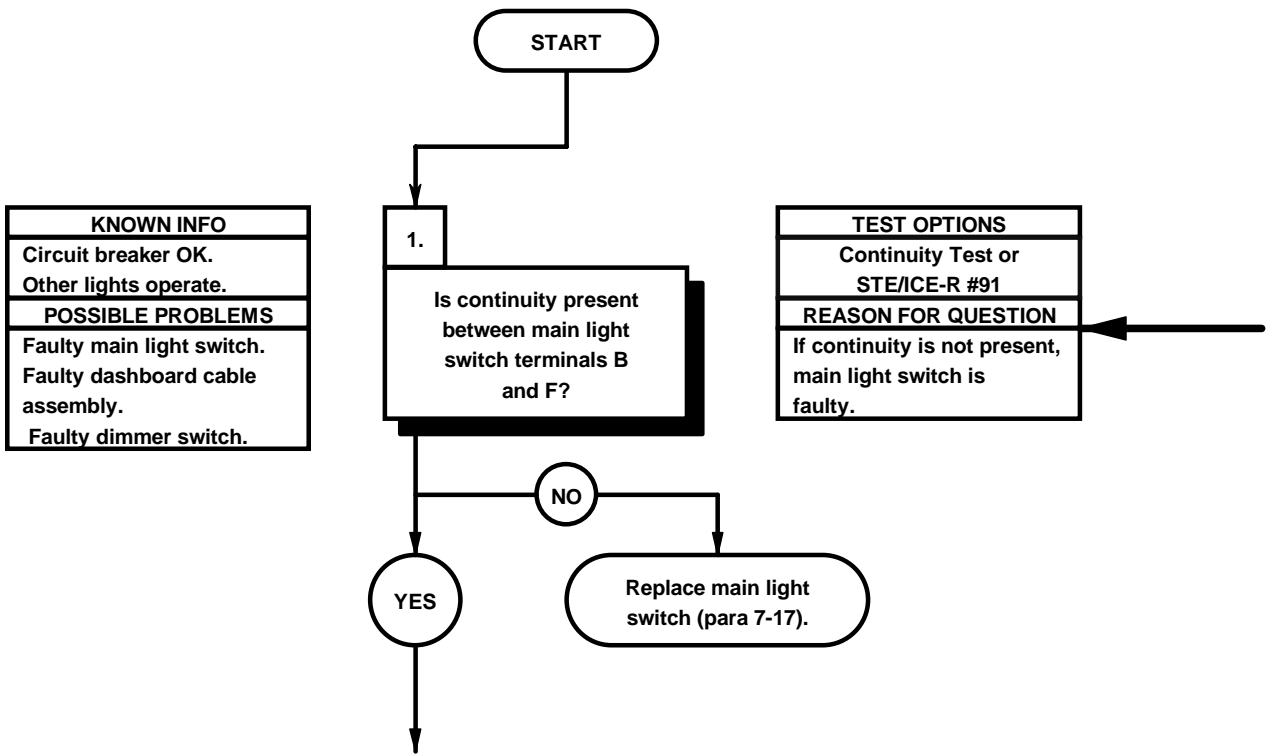

CONTINUITY TEST

- (1) Remove instrument panel assembly for access (para 7-15).
- (2) Disconnect connector PX15 from main light switch.
- (3) Set multimeter to ohms.
- (4) Position main light switch to SER DRIVE (TM 9-2320-365-10).
- (5) Position main light switch auxiliary lever to PANEL BRT (TM 9-2320-365-10).
- (6) Connect positive (+) probe of multimeter to main light switch terminal F.
- (7) Connect negative (-) probe of multimeter to main light switch terminal B and note reading on multimeter.
- (8) If continuity is not present, replace main light switch (para 7-17).
- (9) Position main light switch to OFF (TM 9-2320-365-10).

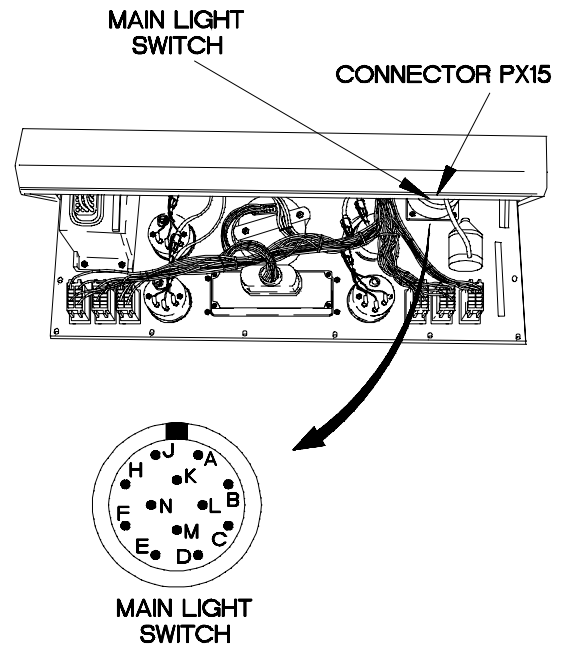

X2e20011

20. AUXILIARY PANEL, PERSONNEL HEATER, AND INSTRUMENT PANEL DO NOT ILLUMINATE (CONT)

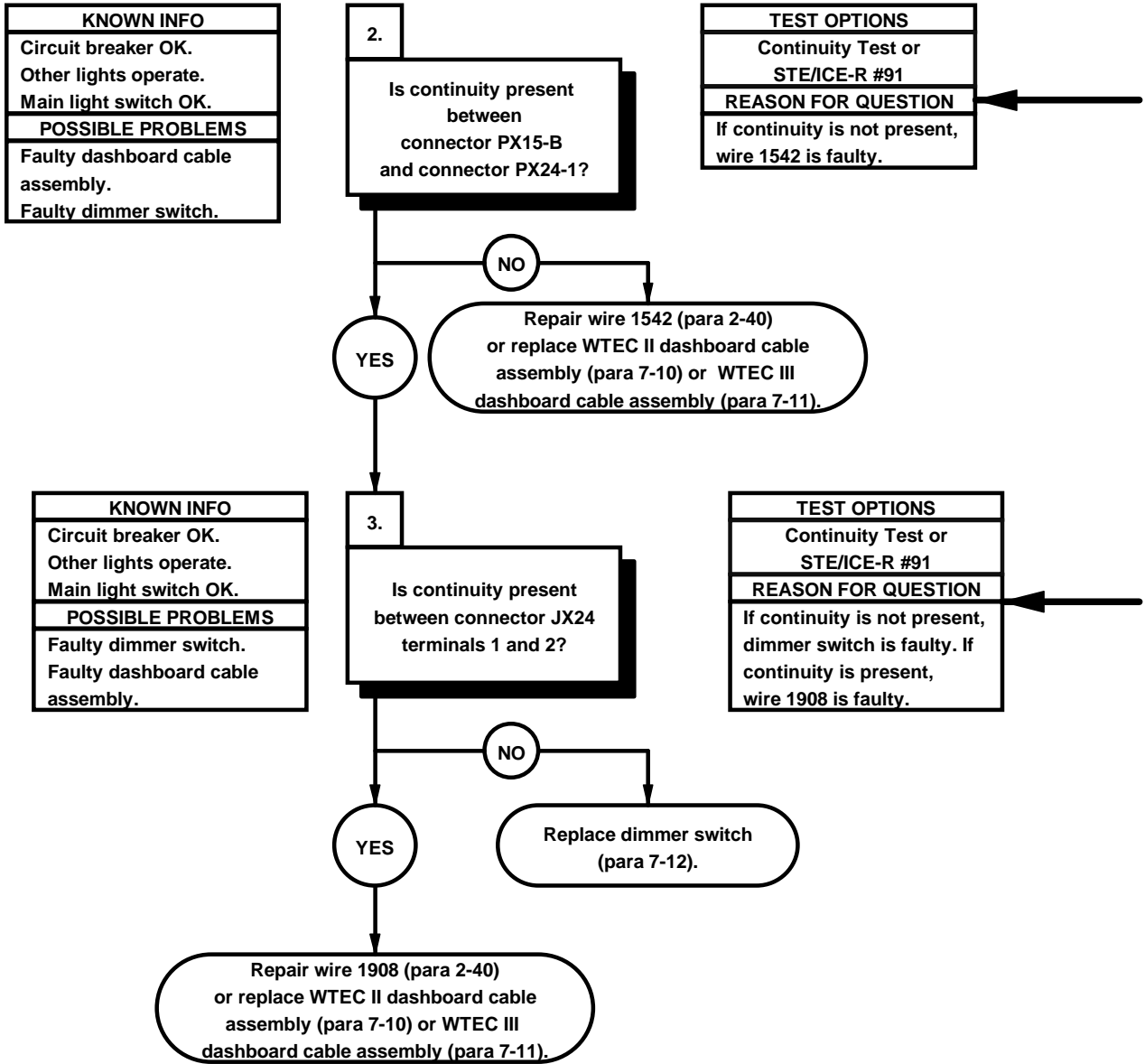

CONTINUITY TEST

- (1) Disconnect connector PX24 from dimmer switch.
- (2) Set multimeter to ohms.
- (3) Connect positive (+) probe of multimeter to connector PX15-B.
- (4) Connect negative (-) probe of multimeter to connector PX24-1 and note reading on multimeter.
- (5) If continuity is not present, repair wire 1542 (para 2-40) or replace WTEC II dashboard cable assembly (para 7-10) or WTEC III dashboard cable assembly (para 7-11).
- (6) Connect connector PX15 to main light switch.

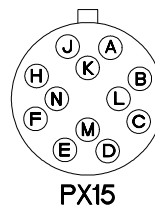
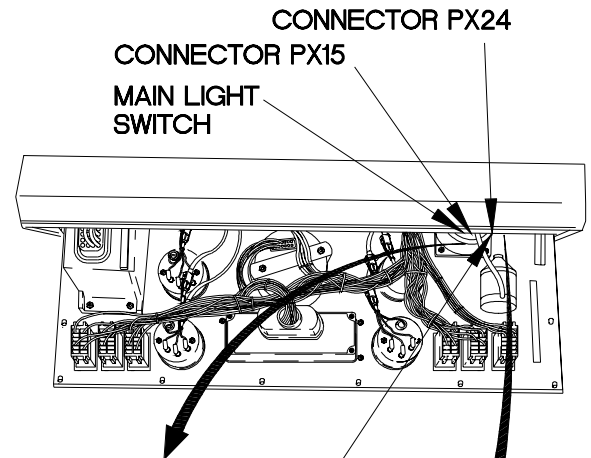

DIMMER SWITCH

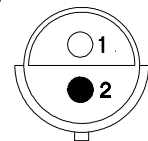

PX24

DIMMER SWITCH CONNECTOR

CONTINUITY TEST

- (1) Position dimmer switch to maximum illumination (TM 9-2320-365-10).
- (2) Set multimeter to ohms.
- (3) Connect positive (+) probe of multimeter to dimmer switch connector terminal 1.
- (4) Connect negative (-) probe of multimeter to dimmer switch connector terminal 2 and note reading on multimeter.
- (5) If continuity is not present, replace dimmer switch (para 7-12).
- (6) If continuity is present, repair wire 1908 (para 2-40) or replace WTEC II dashboard cable assembly (para 7-10) or WTEC III dashboard cable assembly (para 7-11).
- (7) Connect connector PX24 to dimmer switch.
- (8) Install instrument panel assembly (para 7-15).

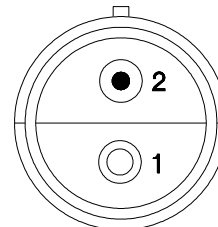
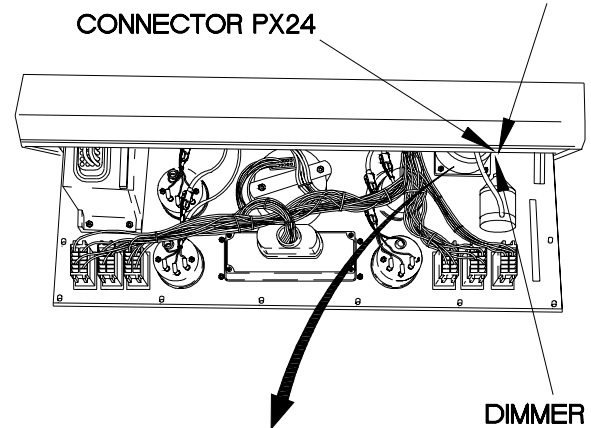

DIMMER SWITCH CONNECTOR

X2e2203A

e21. TACHOMETER DOES NOT ILLUMINATE

INITIAL SETUP

Equipment Conditions

Engine shut down (TM 9-2320-365-10).

Personnel Required

(2)

Tools and Special Tools

Tool Kit, Genl Mech (Item 44, Appendix C)
 STE/ICE-R (Item 39, Appendix C)
 Multimeter, Digital (Item 22, Appendix C)
 Wrench, Torque, 0-200 lb-in. (Item 58, Appendix C)

References

TM 9-4910-571-12&P

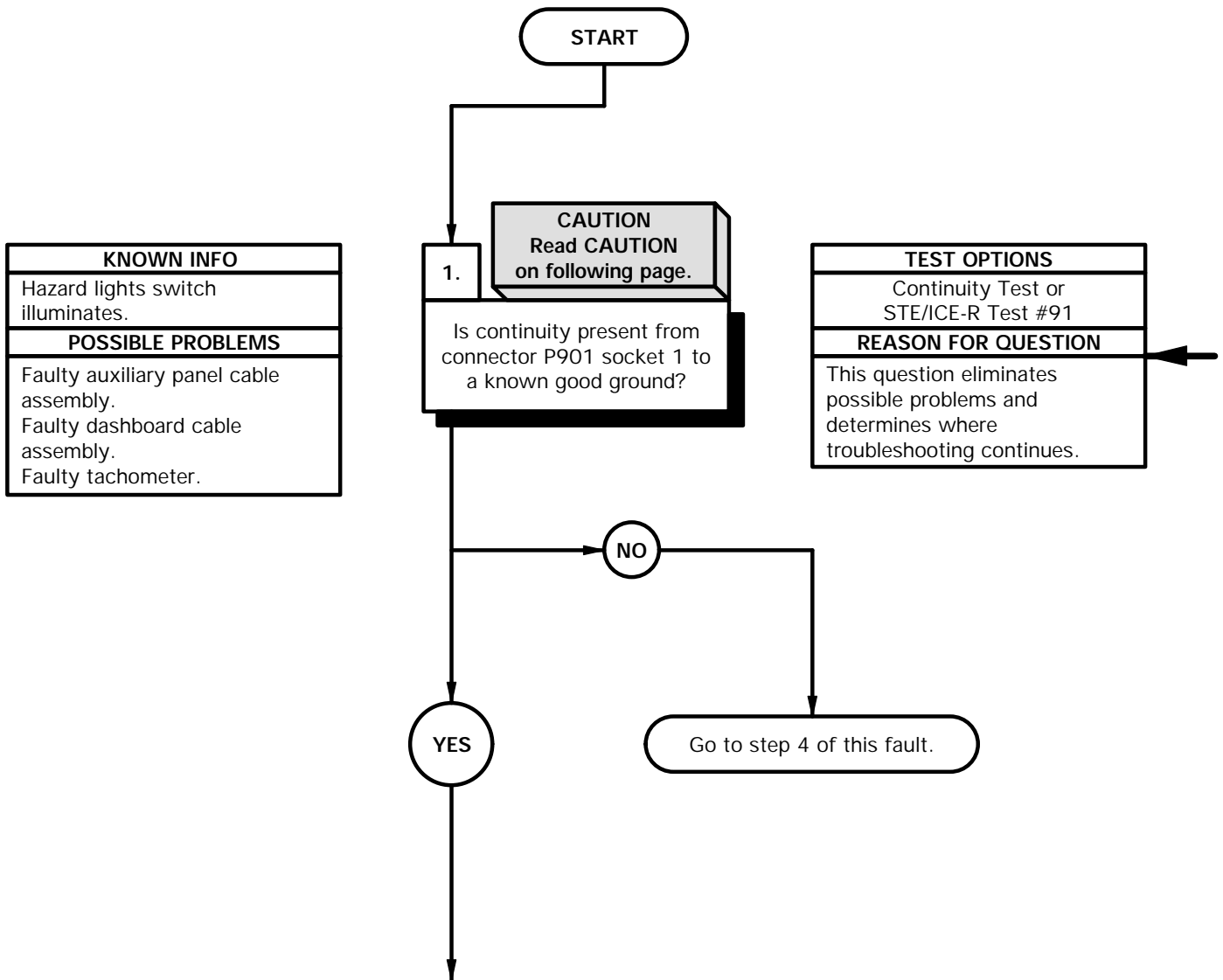

CAUTION

Use care when testing electrical connectors. Do not damage connector pins or sockets with multimeter probes. Failure to comply may result in damage to equipment.

NOTE

Inspect connector pins/sockets for damage, corrosion, and serviceability. Check that connector pins are not pushed back and are capable of making good contact.

CONTINUITY TEST

- (1) Remove six screws from auxiliary panel.
- (2) Lift auxiliary panel from auxiliary panel housing to gain access.
- (3) Disconnect connector clamp from tachometer connector.
- (4) Disconnect connector P901 from tachometer connector.
- (5) Set multimeter to ohms.
- (6) Connect positive (+) probe of multimeter to connector P901 socket 1.
- (7) Connect negative (-) probe of multimeter to ground and note reading on multimeter.
- (8) If continuity is not present, go to step 4 of this fault.

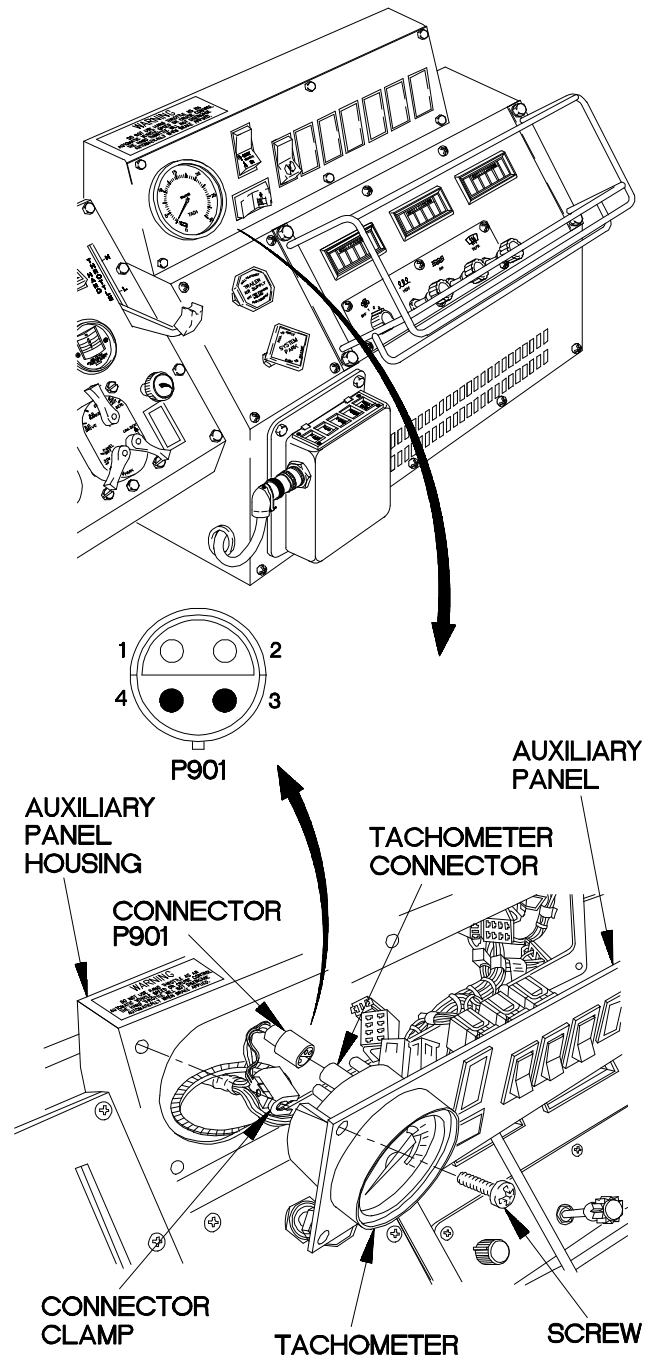

XBE2101B

e21. TACHOMETER DOES NOT ILLUMINATE (CONT)

KNOWN INFO
Hazard lights switch illuminates.
POSSIBLE PROBLEMS
Faulty auxiliary panel cable assembly. Faulty dashboard cable assembly. Faulty tachometer.

2.

WARNING
CAUTION
Read WARNING and CAUTION on following page.

Is 12 VDC present at connector P901 socket 2?

TEST OPTIONS
Voltage Test or STE/ICE-R Test #89
REASON FOR QUESTION
If 12 VDC is present, tachometer is faulty.

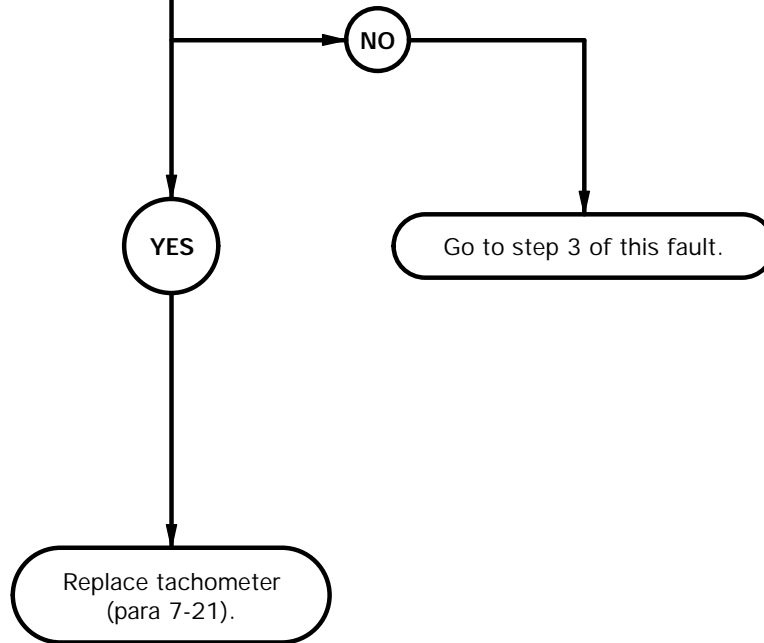

WARNING

Remove rings, bracelets, watches, necklaces, and any other jewelry before working around vehicle. Jewelry can catch on equipment and cause injury or short across electrical circuits and cause severe burns or electrical shock.

CAUTION

Use care when testing electrical connectors. Do not damage connector pins or sockets with multimeter probes. Failure to comply may result in damage to equipment.

VOLTAGE TEST

- (1) Set multimeter to volts DC.
- (2) Connect positive (+) probe of multimeter to connector P901 socket 2.
- (3) Connect negative (-) probe of multimeter to ground.
- (4) Position main light switch main selector lever to SER DRIVE (TM 9-2320-365-10).
- (5) Position main light switch auxiliary lever to PNL BRT (TM 9-2320-365-10) and note reading on multimeter.
- (6) If 12 VDC is not present, go to step 3 of this fault.
- (7) If 12 VDC is present, replace tachometer (para 7-21).
- (8) Position main light switch auxiliary lever to OFF (TM 9-2320-365-10).
- (9) Position main light switch main selector lever to OFF (TM 9-2320-365-10).

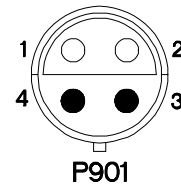

XBE2102B

e21. TACHOMETER DOES NOT ILLUMINATE (CONT)

KNOWN INFO
Hazard lights switch illuminates. Tachometer OK.
POSSIBLE PROBLEMS
Faulty auxiliary panel cable assembly. Faulty dashboard cable assembly.

3.

WARNING
CAUTION
Read **WARNING** and **CAUTION** on following page.

Is 12 VDC present at connector J913 socket 11?

TEST OPTIONS
Voltage Test or STE/ICE-R Test #89
REASON FOR QUESTION
If 12 VDC is not present, wire 1908 in dashboard cable assembly is faulty. If 12 VDC is present, wire 1908 in auxiliary panel cable is faulty.

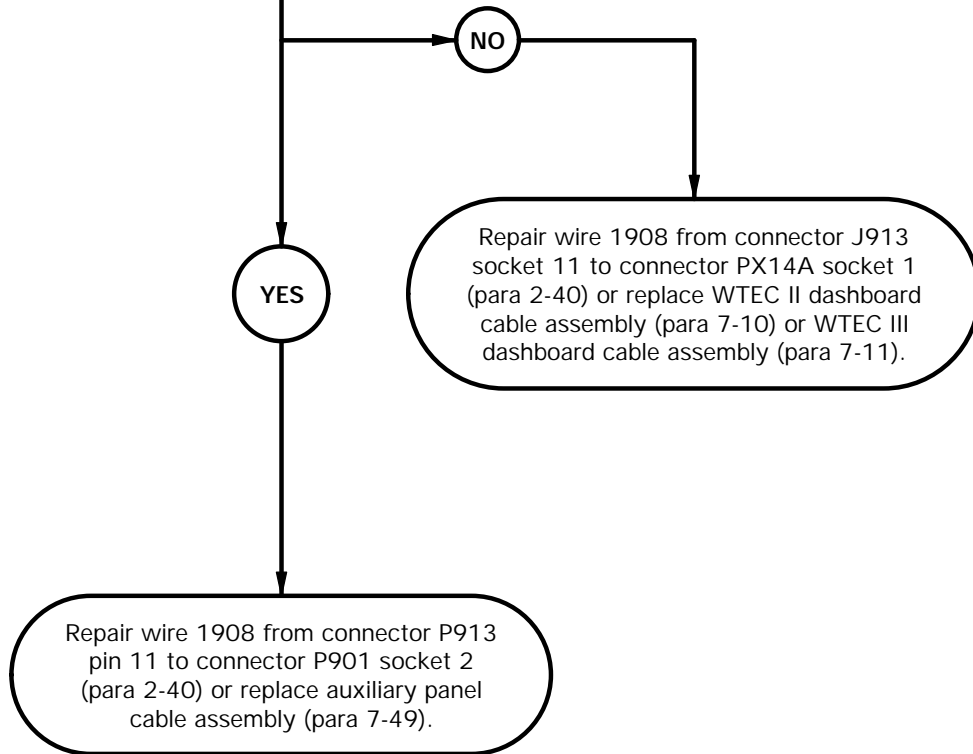

WARNING

Remove rings, bracelets, watches, necklaces, and any other jewelry before working around vehicle. Jewelry can catch on equipment and cause injury or short across electrical circuits and cause severe burns or electrical shock.

CAUTION

Use care when testing electrical connectors. Do not damage connector pins or sockets with multimeter probes. Failure to comply may result in damage to equipment.

VOLTAGE TEST

- (1) Remove personnel heater for access (para 18-9).
- (2) Set multimeter to volts DC.
- (3) Connect positive (+) probe of multimeter to connector J913 socket 11.
- (4) Connect negative (-) probe of multimeter to ground.
- (5) Position main light switch main selector lever to SER DRIVE (TM 9-2320-365-10).
- (6) Position main light switch auxiliary lever to PNL BRT (TM 9-2320-365-10) and note reading on multimeter.
- (7) If 12 VDC is not present, repair wire 1908 from connector J913 socket 11 to connector PX14A socket 1 (para 2-40) or replace WTEC II dashboard cable assembly (para 7-10) or WTEC III dashboard cable assembly (para 7-11).
- (8) If 12 VDC is present, repair wire 1908 from connector P913 pin 11 to connector P901 socket 2 (para 2-40) or replace auxiliary panel cable assembly (para 7-49).
- (9) Position main light switch auxiliary lever to OFF (TM 9-2320-365-10).
- (10) Position main light switch main selector lever to OFF (TM 9-2320-365-10).
- (11) Install personnel heater assembly (para 18-9).

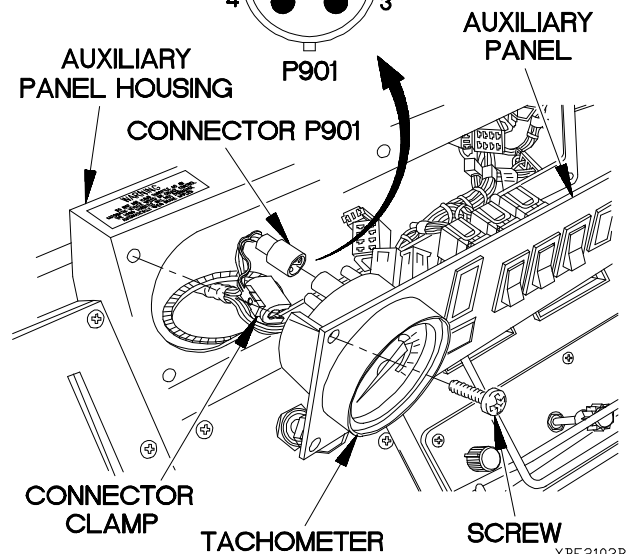
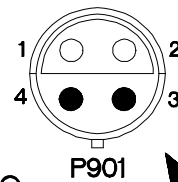
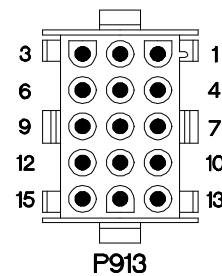
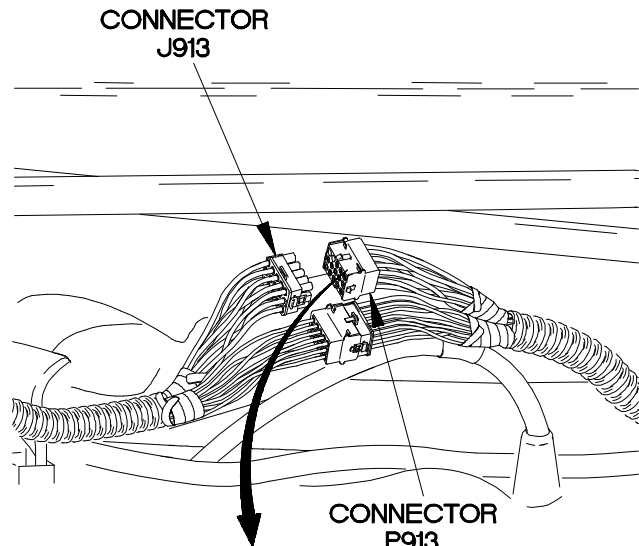

e21. TACHOMETER DOES NOT ILLUMINATE (CONT)

KNOWN INFO
Hazard lights switch illuminates. Tachometer OK.
POSSIBLE PROBLEMS
Faulty auxiliary panel cable assembly. Faulty dashboard cable assembly.

4.

CAUTION
Read CAUTION on following page.

Is continuity present from connector P901 socket 1 to connector P913 pin 10?

TEST OPTIONS
Continuity Test or STE/ICE-R Test #91
REASON FOR QUESTION
If continuity is not present, auxiliary panel cable assembly is faulty.

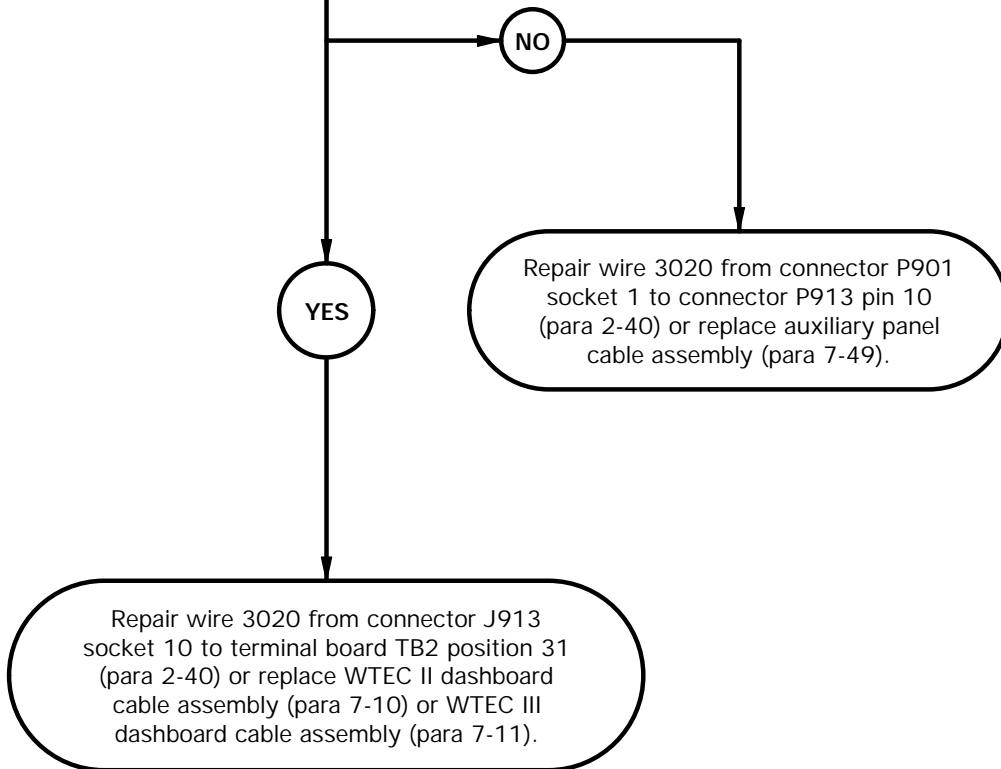

CAUTION

Use care when testing electrical connectors. Do not damage connector pins or sockets with multimeter probes. Failure to comply may result in damage to equipment.

NOTE

Inspect connector pins/sockets for damage, corrosion, and serviceability. Check that connector pins are not pushed back and are capable of making good contact.

CONTINUITY TEST

- (1) Remove personnel heater assembly for access (para 18-9).
- (2) Disconnect connector P913 from connector J913.
- (3) Set multimeter to ohms.
- (4) Connect positive (+) probe of multimeter to connector P901 socket 1.
- (5) Connect negative (-) probe of multimeter to connector P913 pin 10 and note reading on multimeter.
- (6) If continuity is not present, repair wire 3020 from connector P901 socket 1 to connector P913 pin 10 (para 2-40) or replace auxiliary panel cable assembly (para 7-49).
- (7) If continuity is present, repair wire 3020 from connector J913 socket 10 to terminal board TB2 position 31 (para 2-40) or replace WTEC II dashboard cable assembly (para 7-10) or WTEC III dashboard cable assembly (para 7-11).
- (8) Install personnel heater assembly (para 18-9).

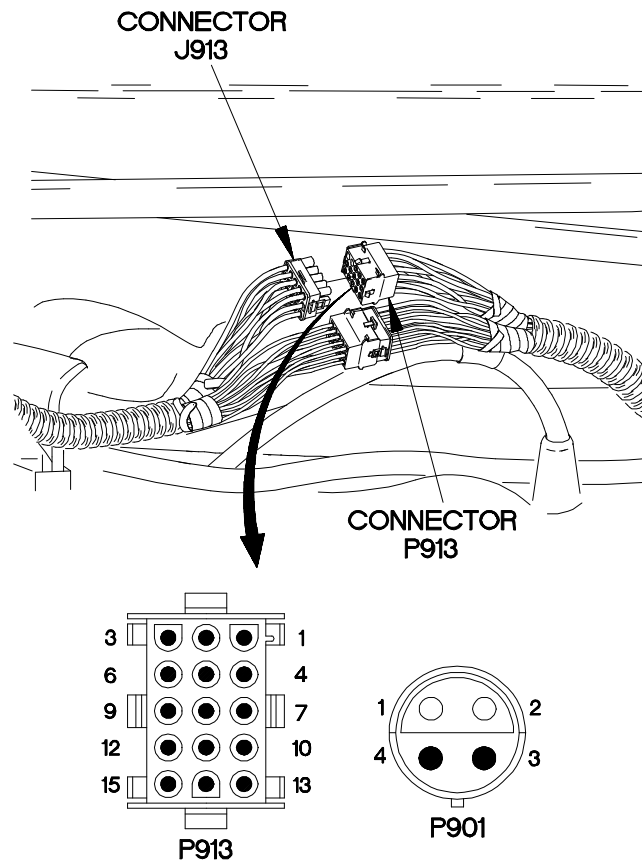

XBE2104B

e22. AUXILIARY PANEL SWITCH DOES NOT ILLUMINATE	
INITIAL SETUP	
Equipment Condition Engine shut down (TM 9-2320-365-10).	Tools and Special Tools Tool Kit, Genl Mech (Item 44, Appendix C) STE/ICE-R (Item 39, Appendix C) Multimeter, Digital (Item 22, Appendix C) Wrench, Torque, 0-200 lb-in. (Item 58, Appendix C)
Personnel Required (2)	
References TM 9-4910-571-12&P	

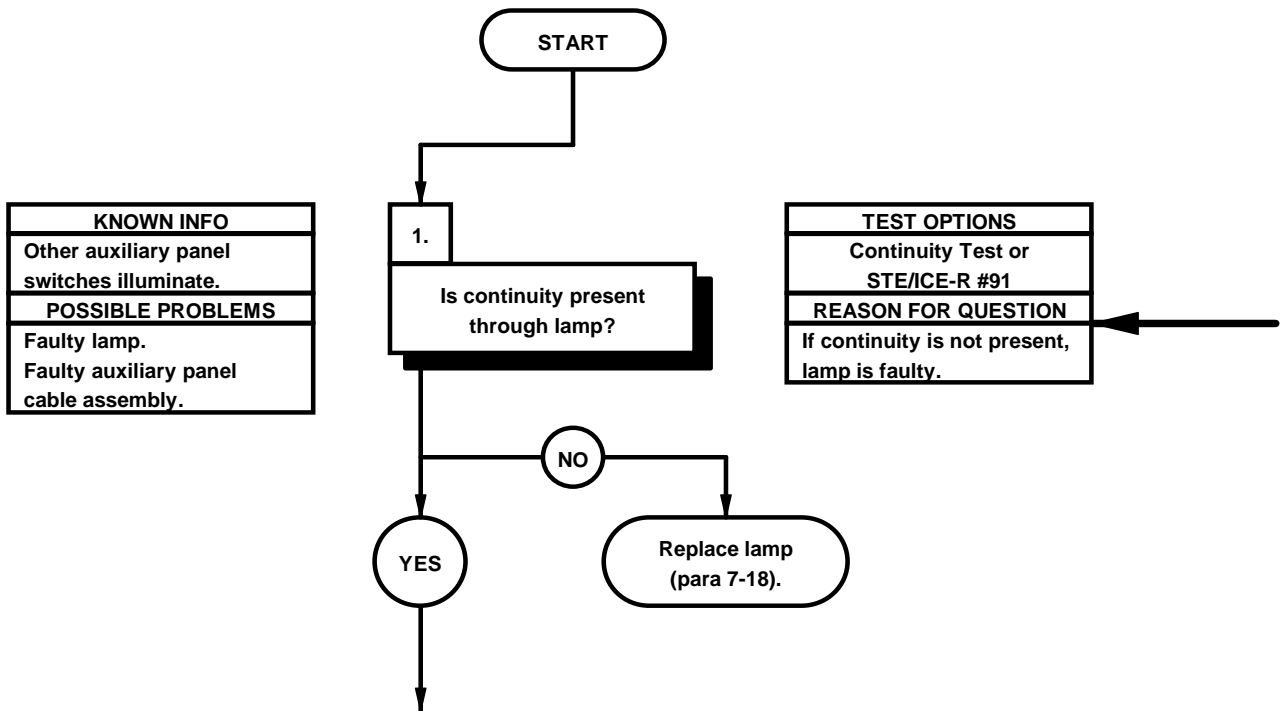

NOTE
 All auxiliary panel switch illumination faults are traced the same way. Power Take-Off (PTO) switch shown.

CONTINUITY TEST

- (1) Remove six screws from auxiliary panel.
- (2) Lift auxiliary panel from auxiliary panel housing to gain access.

NOTE

Main connector and "A" connector will come off as a unit.

- (3) Disconnect PTO switch connector from PTO switch.
- (4) Set multimeter to ohms.
- (5) Connect positive (+) probe of multimeter to PTO switch lamp terminal 1.
- (6) Connect negative (-) probe of multimeter to PTO switch lamp terminal 2 and note reading on multimeter.
- (7) If continuity is not present, replace lamp (para 7-18).

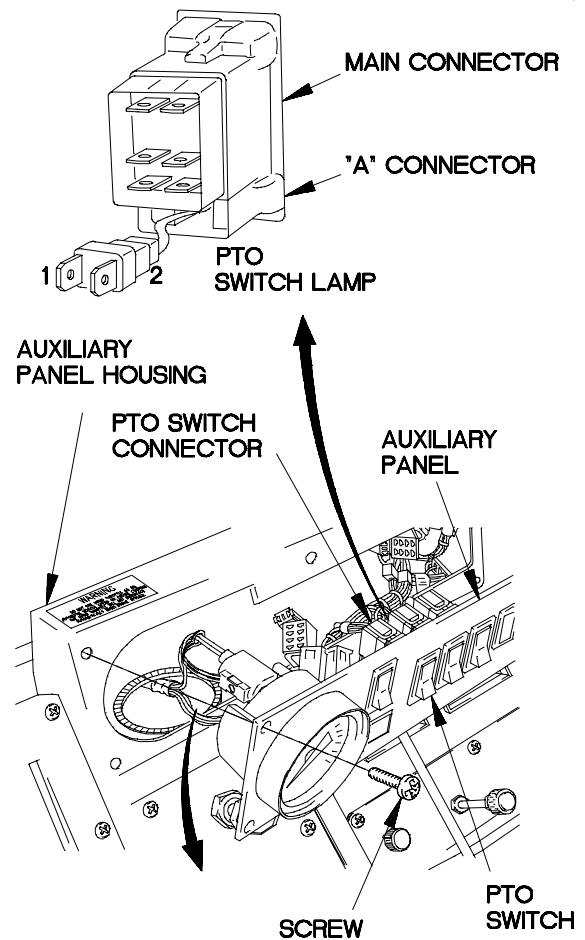

X2e22011

e22. AUXILIARY PANEL SWITCH DOES NOT ILLUMINATE (CONT)

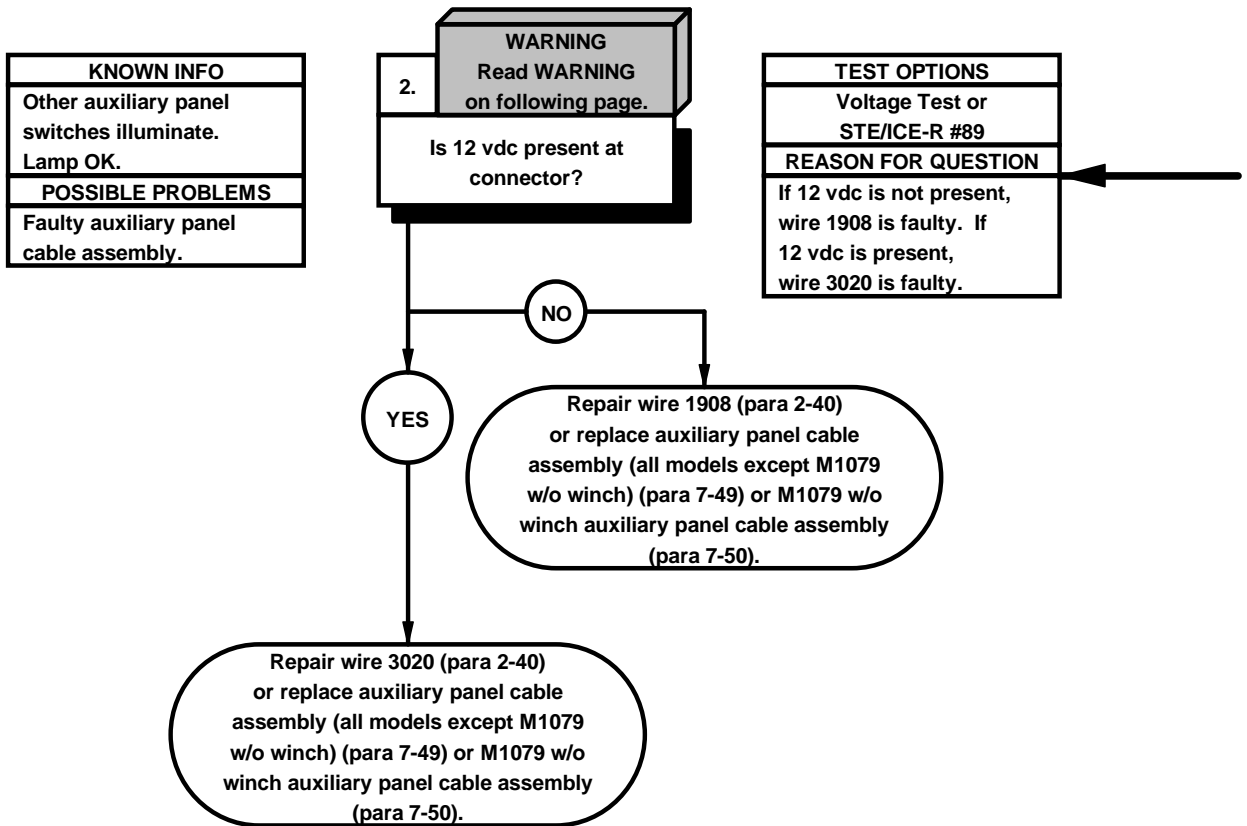

WARNING

Remove rings, bracelets, watches, necklaces, and any other jewelry before working around vehicle. Jewelry can catch on equipment and cause injury or short across electrical circuit and cause severe burns or electrical shock.

VOLTAGE TEST

- (1) Set multimeter to volts dc.
- (2) Connect positive (+) probe of multimeter to "A" switch connector terminal 1.
- (3) Connect negative (-) probe of multimeter to ground.
- (4) Position main light switch auxiliary lever to PANEL BRT (TM 9-2320-365-10).
- (5) Position dimmer switch to maximum brightness (TM 9-2320-365-10).
- (6) Position main light switch to SER DRIVE (TM 9-2320-365-10) and note reading on multimeter.
- (7) If 12 vdc is not present, repair wire 1908 (para 2-40) or replace auxiliary panel cable assembly (all models except M1079 w/o winch) (para 7-49) or M1079 w/o winch auxiliary panel cable assembly (para 7-50).
- (8) If 12 vdc is present, repair wire 3020 (para 2-40) or replace auxiliary panel cable assembly (all models except M1079 w/o winch) (para 7-49) or M1079 w/o winch auxiliary panel cable assembly (para 7-50).
- (9) Position main light switch to OFF (TM 9-2320-365-10).
- (10) Connect PTO switch connector to PTO switch.
- (11) Position auxiliary panel on auxiliary panel housing with six screws.
- (12) Tighten six screws to 24 lb-in. (3 N-m).

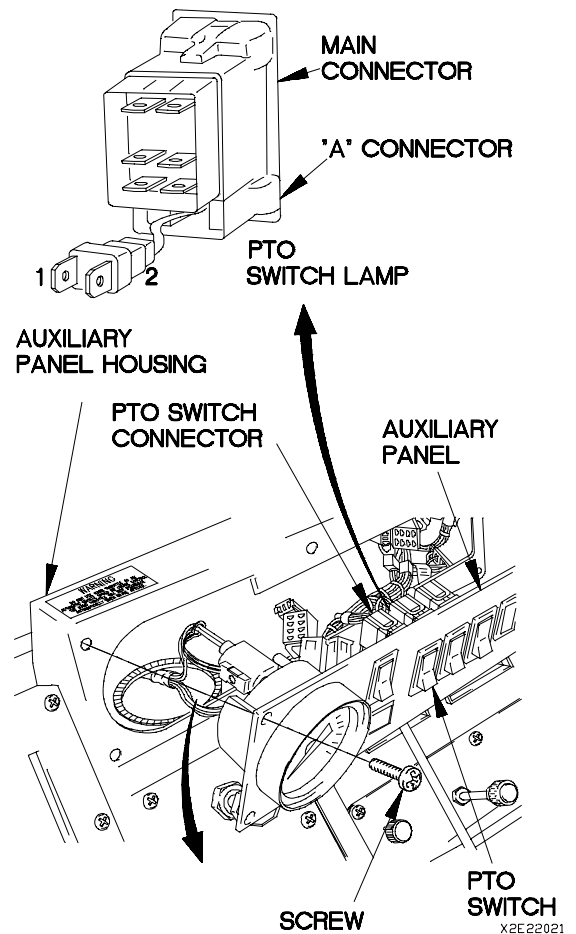

e23. AUXILIARY PANEL DOES NOT ILLUMINATE	
INITIAL SETUP	
Equipment Condition Engine shut down (TM 9-2320-365-10).	Tools and Special Tools Tool Kit, Genl Mech (Item 44, Appendix C) STE/ICE-R (Item 39, Appendix C) Multimeter, Digital (Item 22, Appendix C) Wrench, Torque, 0-200 lb-in. (Item 58, Appendix C)
Personnel Required (2)	
References TM 9-4910-571-12&P	

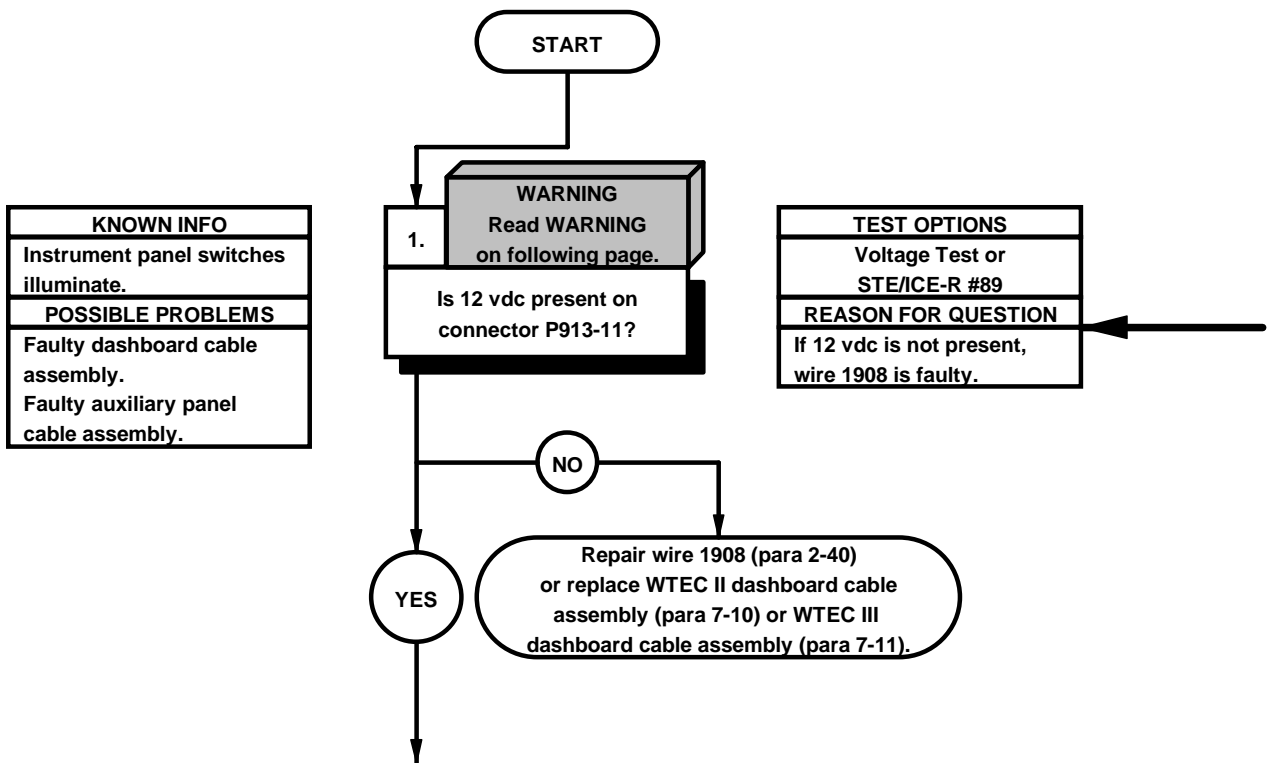

WARNING

Remove rings, bracelets, watches, necklaces, and any other jewelry before working around vehicle. Jewelry can catch on equipment and cause injury or short across electrical circuit and cause severe burns or electrical shock.

VOLTAGE TEST

- (1) Remove personnel heater for access (para 18-9).
- (2) Disconnect connector J913 from connector P913.
- (3) Set multimeter to volts dc.
- (4) Connect positive (+) probe of multimeter to connector P913-11.
- (5) Connect negative (-) probe of multimeter to ground.
- (6) Position main light switch to STOP LIGHT and PANEL BRIGHT (TM 9-2320-365-10) and note reading on multimeter.
- (7) If 12 vdc is not present, repair wire 1908 (para 2-40) or replace WTEC II dashboard cable assembly (para 7-10) or WTEC III dashboard cable assembly (para 7-11).
- (8) Position main light switch to OFF (TM 9-2320-365-10).

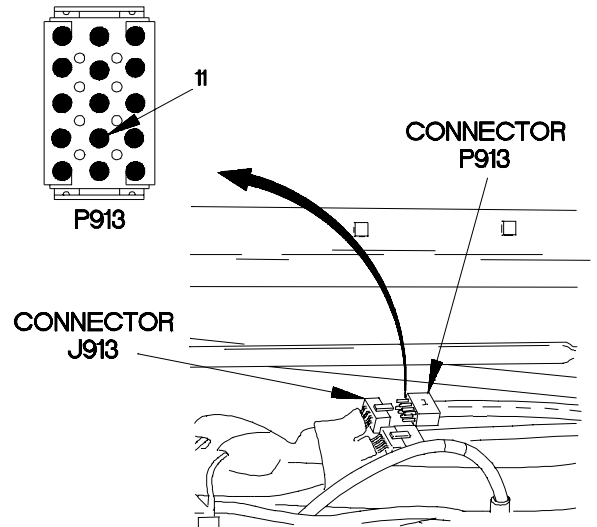

X2E2501A

ø23. AUXILIARY PANEL DOES NOT ILLUMINATE (CONT)

KNOWN INFO
Instrument panel switches illuminate. Dashboard cable assembly OK.
POSSIBLE PROBLEMS
Faulty auxiliary panel cable assembly.

2.
Is continuity present between connector J913-10 and connector P914A-2?

TEST OPTIONS
Continuity Test STE/ICE-R #91
REASON FOR QUESTION
If continuity is not present, wire 3020 is faulty.

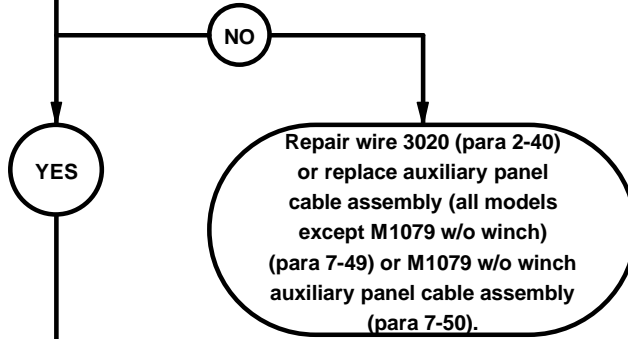

KNOWN INFO
Instrument panel switches illuminate. Dashboard cable assembly OK.
POSSIBLE PROBLEMS
Faulty auxiliary panel cable assembly.

3.
Is continuity present between connector P913-11 and connector P914A-1?

TEST OPTIONS
Continuity Test STE/ICE-R #91
REASON FOR QUESTION
If continuity is not present, wire 1908 is faulty.

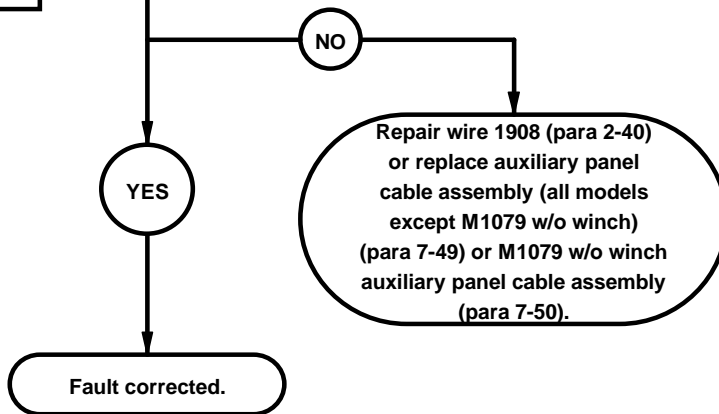

CONTINUITY TEST

- (1) Remove six screws from auxiliary panel.
- (2) Lift auxiliary panel from auxiliary panel housing to gain access.
- (3) Disconnect connector P914A from fuel preheat switch, if equipped.
- (4) Set multimeter to ohms.
- (5) Connect positive (+) probe of multimeter to connector J913-10.
- (6) Connect negative (-) probe of multimeter to connector P914A-2 and note reading on multimeter.
- (7) If continuity is not present, repair wire 3020 (para 2-40) or replace auxiliary panel cable assembly (all models except M1079 w/o winch) (para 7-49) or M1079 w/o winch auxiliary panel cable assembly (para 7-50).

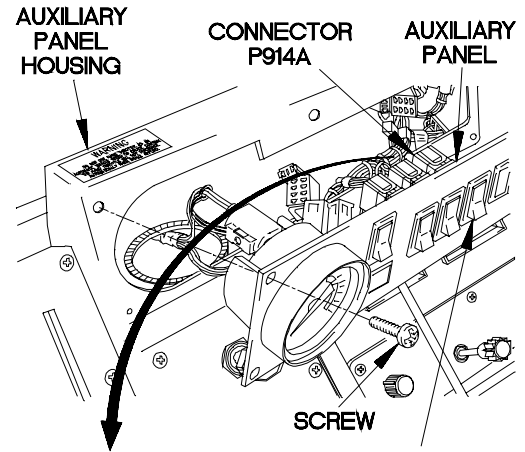

CONTINUITY TEST

- (1) Set multimeter to ohms.
- (2) Connect positive (+) probe of multimeter to connector P913-11.
- (3) Connect negative (-) probe of multimeter to connector P914A-1 and note reading on multimeter.
- (4) If continuity is not present, repair wire 1908 (para 2-40) or replace auxiliary panel cable assembly (all models except M1079 w/o winch) (para 7-49) or M1079 w/o winch auxiliary panel cable assembly (para 7-50).
- (5) Connect connector P914A to fuel preheat switch, if equipped.
- (6) Position auxiliary panel housing on auxiliary panel with six screws.
- (7) Tighten six screws to 24 lb-in. (3 N-m).
- (8) Connect connector P913 to connector J913.
- (9) Install personnel heater (para 18-9).

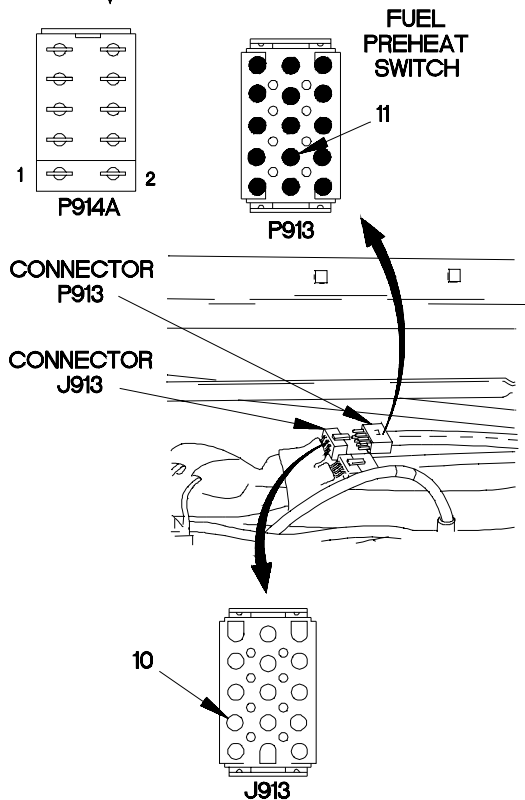

X2E2502A

e24. HIGH ENGINE TEMPERATURE INDICATOR DOES NOT OPERATE	
INITIAL SETUP	
Equipment Condition Engine shut down (TM 9-2320-365-10). Batteries disconnected (para 7-48).	Tools and Special Tools Tool Kit, Genl Mech (Item 44, Appendix C) STE/ICE-R (Item 39, Appendix C) Multimeter, Digital (Item 22, Appendix C) Wrench, Torque, 0-75 lb-in. (Item 86, Appendix B)
Personnel Required (2)	References TM 9-4910-571-12&P

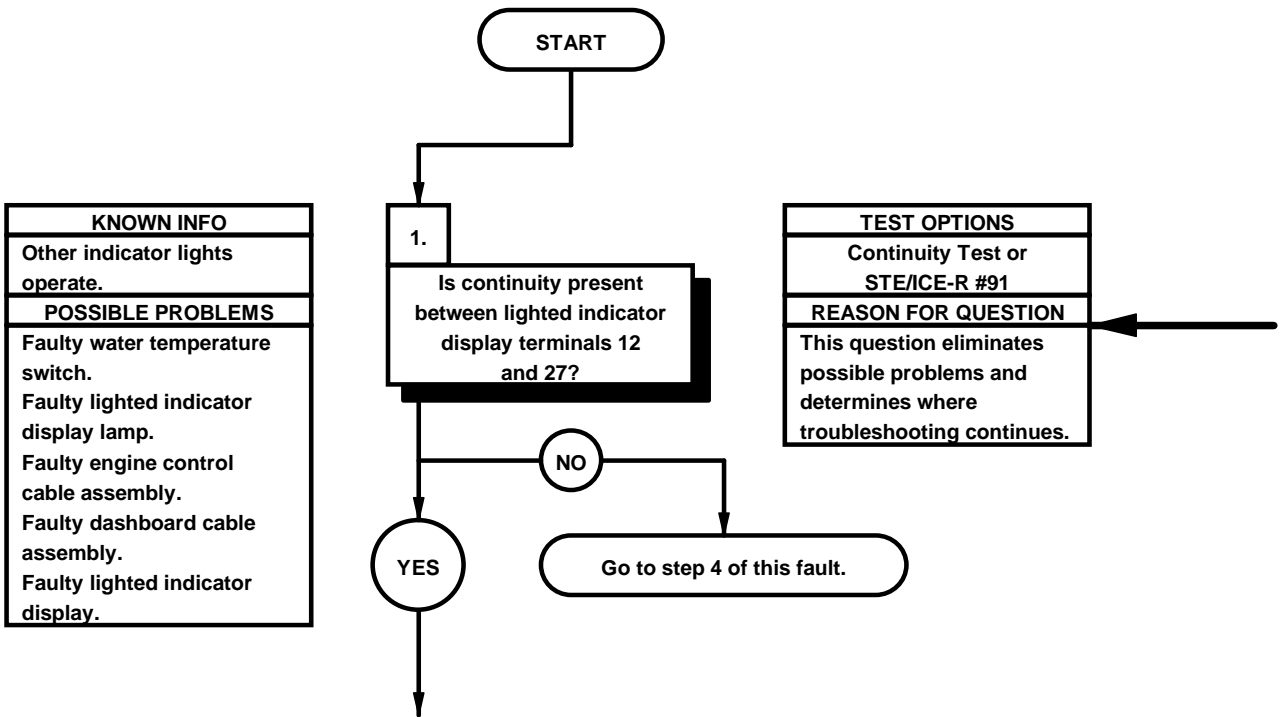

- | CONTINUITY TEST | |
|-----------------|---|
| (1) | Remove four screws from lighted indicator display. |
| (2) | Remove lighted indicator display from instrument panel assembly. |
| (3) | Disconnect connector PX7 from lighted indicator display. |
| (4) | Set multimeter to ohms. |
| (5) | Connect positive (+) probe of multimeter to lighted indicator display terminal 27. |
| (6) | Connect negative (-) probe of multimeter to lighted indicator display terminal 12 and note reading on multimeter. |
| (7) | If continuity is not present, go to step 4 of this fault. |

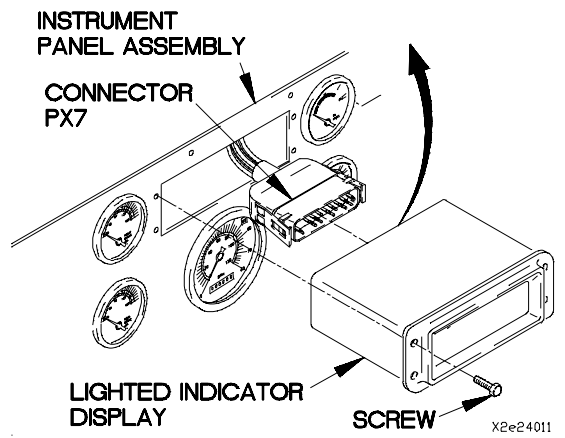
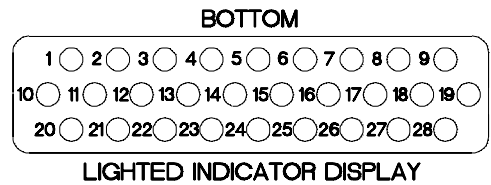
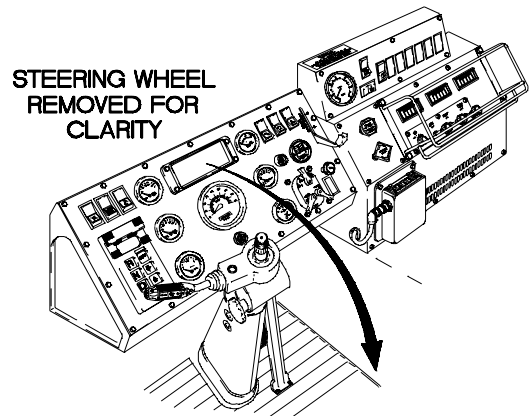

ø24. HIGH ENGINE TEMPERATURE INDICATOR DOES NOT OPERATE (CONT)

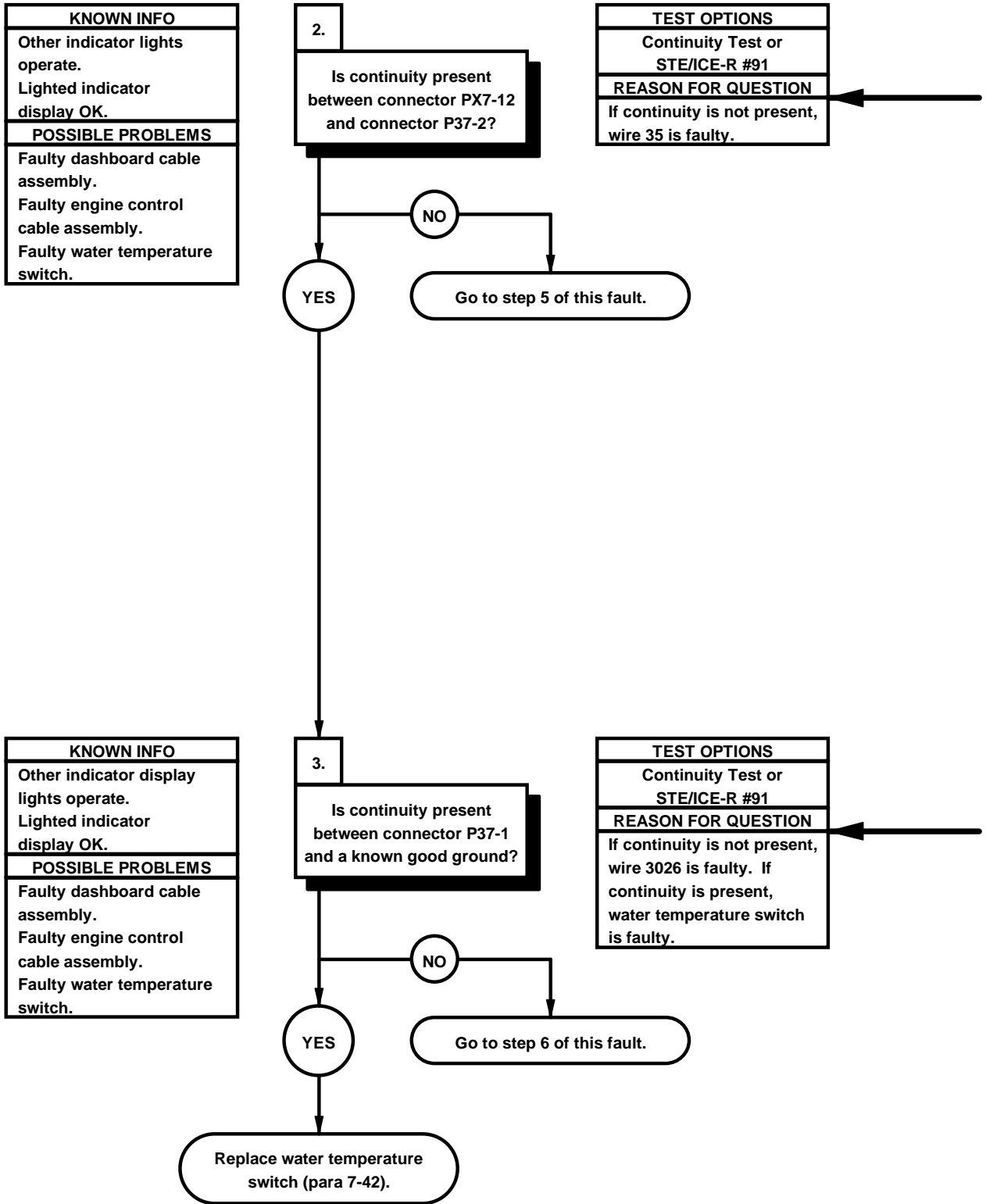

- CONTINUITY TEST**
- (1) Raise cab (TM 9-2320-365-10).
 - (2) Set multimeter to ohms.
 - (3) Disconnect connector clamp from connector J37.
 - (4) Disconnect connector P37 from connector J37.
 - (5) Connect positive (+) probe of multimeter to connector P37-2.
 - (6) Connect negative (-) probe of multimeter to connector PX7-12 and note reading on multimeter.
 - (7) If continuity is not present, go to step 5 of this fault.

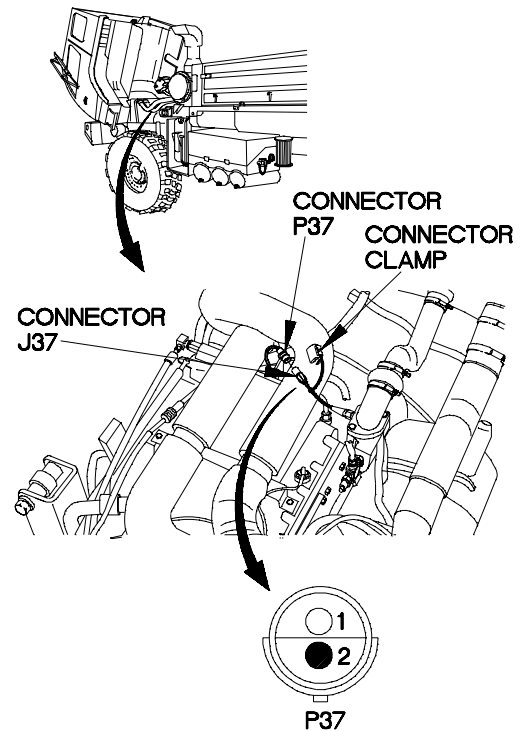

- CONTINUITY TEST**
- (1) Set multimeter to ohms.
 - (2) Connect positive (+) probe of multimeter to connector P37-1.
 - (3) Connect negative (-) probe of multimeter to ground and note reading on multimeter.
 - (4) If continuity is not present, go to step 6 of this fault.
 - (5) If continuity is present, replace water temperature switch (para 7-42).
 - (6) Connect connector P37 to connector J37.
 - (7) Connect connector clamp on connector J37.
 - (8) Lower cab (TM 9-2320-365-10).

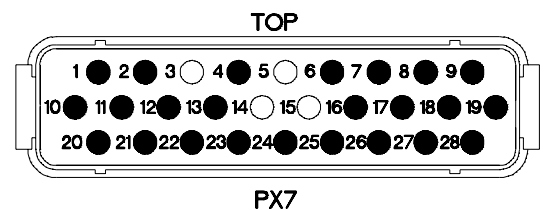

X2e24021

ø24. HIGH ENGINE TEMPERATURE INDICATOR DOES NOT OPERATE (CONT)

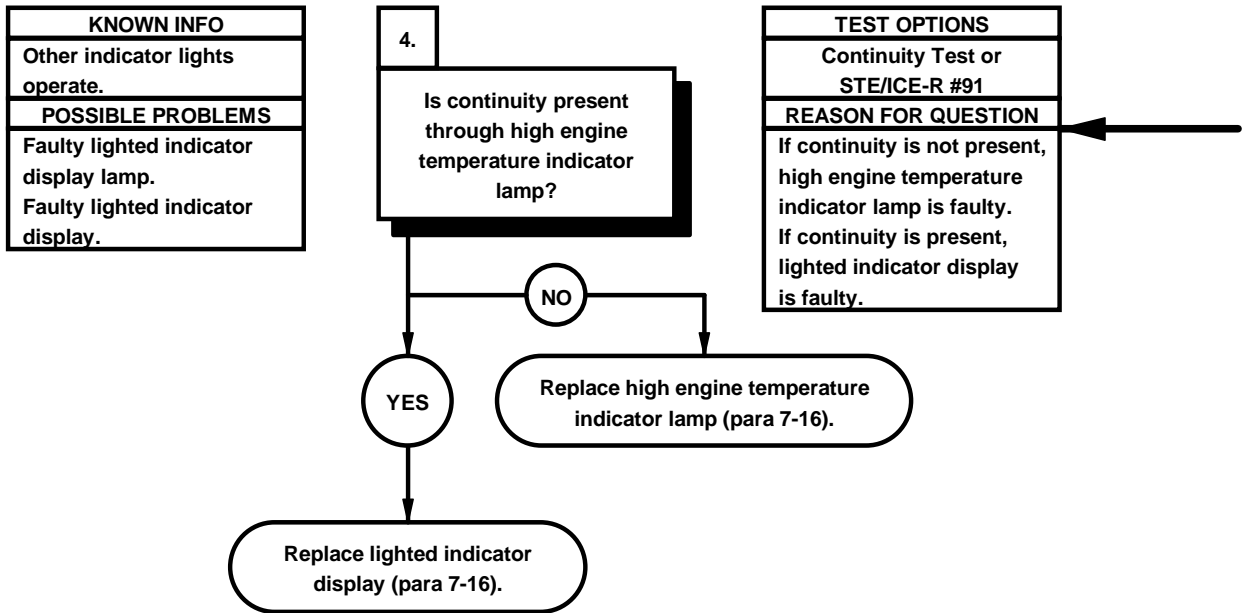

CONTINUITY TEST

- (1) Loosen four captive screws in lamp mounting panel.
- (2) Remove lamp mounting panel from lighted indicator display housing.
- (3) Remove high engine temperature lamps from printed circuit board.
- (4) Set multimeter to ohms.
- (5) Check continuity through each high engine temperature indicator lamp and note reading on multimeter.
- (6) If continuity is not present, replace lamp (para 7-16).
- (7) If continuity is present, replace lighted indicator display (para 7-16).
- (8) Install high engine temperature lamps in printed circuit board.
- (9) Install lamp mounting panel in lighted indicator display housing.
- (10) Tighten four captive screws in lamp mounting panel.
- (11) Connect lighted indicator display to connector PX7.
- (12) Position lighted indicator display in instrument panel assembly with four screws.
- (13) Tighten four screws to 6-10 lb-in. (1 N-m).
- (14) Connect batteries (para 7-48).

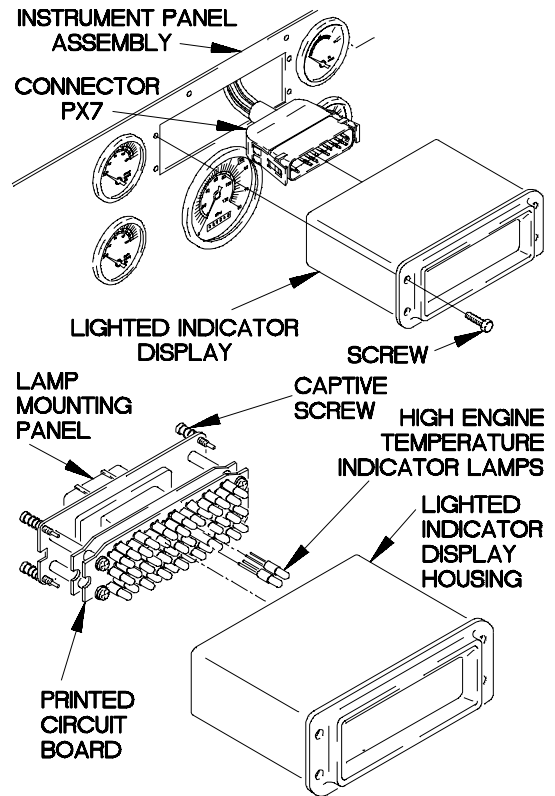
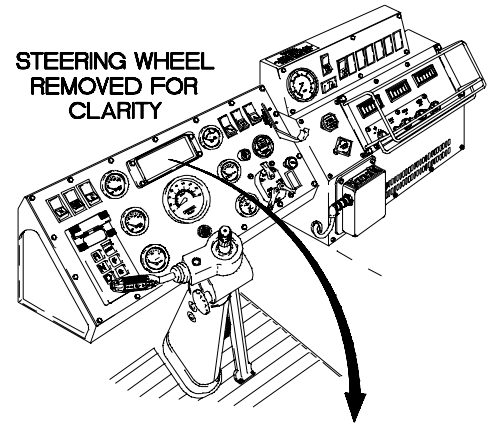

X2e24031

ø24. HIGH ENGINE TEMPERATURE INDICATOR DOES NOT OPERATE (CONT)

KNOWN INFO
Other indicator lights operate. Lighted indicator display OK. Water temperature switch OK.
POSSIBLE PROBLEMS
Faulty dashboard cable assembly. Faulty engine control cable assembly.

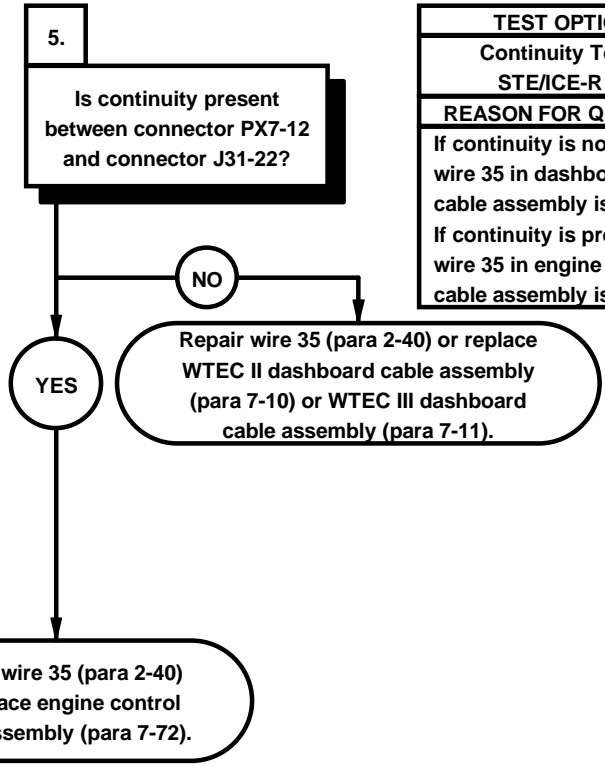

TEST OPTIONS
Continuity Test or STE/ICE-R #91
REASON FOR QUESTION
If continuity is not present, wire 35 in dashboard cable assembly is faulty. If continuity is present, wire 35 in engine control cable assembly is faulty.

KNOWN INFO
Other indicator display lights operate. Lighted indicator display OK. Water temperature switch OK.
POSSIBLE PROBLEMS
Faulty dashboard cable assembly. Faulty engine control cable assembly.

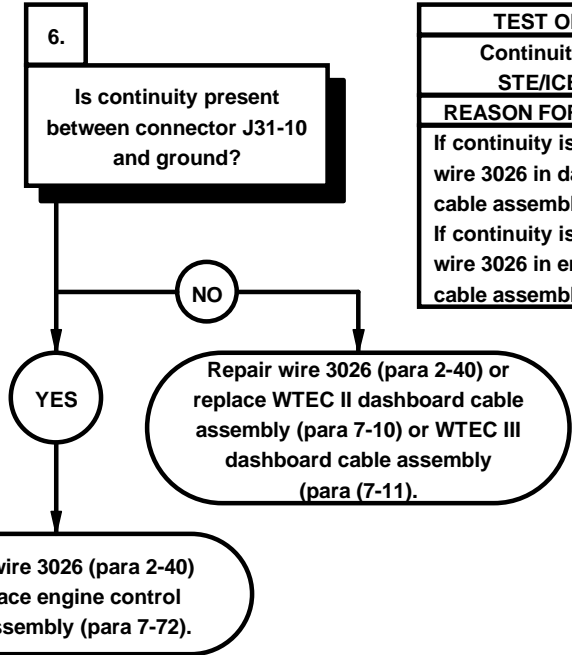

TEST OPTIONS
Continuity Test or STE/ICE-R #91
REASON FOR QUESTION
If continuity is not present, wire 3026 in dashboard cable assembly is faulty. If continuity is present, wire 3026 in engine control cable assembly is faulty.

CONTINUITY TEST

- (1) Remove instrument panel assembly for access (para 7-15).
- (2) Set multimeter to ohms.
- (3) Disconnect connector J31 from connector P31.
- (4) Connect positive (+) probe of multimeter to connector PX7-12.
- (5) Connect negative (-) probe of multimeter to connector J31-22 and note reading on multimeter.
- (6) If continuity is not present, repair wire 35 (para 2-40) or replace WTEC II dashboard cable assembly (para 7-10) or WTEC III dashboard cable assembly (para (7-11).
- (7) If continuity is present, repair wire 35 (para 2-40) or replace engine control cable assembly (para 7-72).
- (8) Connect connector J31 to connector P31.
- (9) Install instrument panel assembly (para 7-15).
- (10) Connect lighted indicator display to connector PX7.
- (11) Position lighted indicator display in instrument panel assembly with four screws.
- (12) Tighten four screws to 6-10 lb-in. (1 N·m).
- (13) Connect batteries (para 7-48).

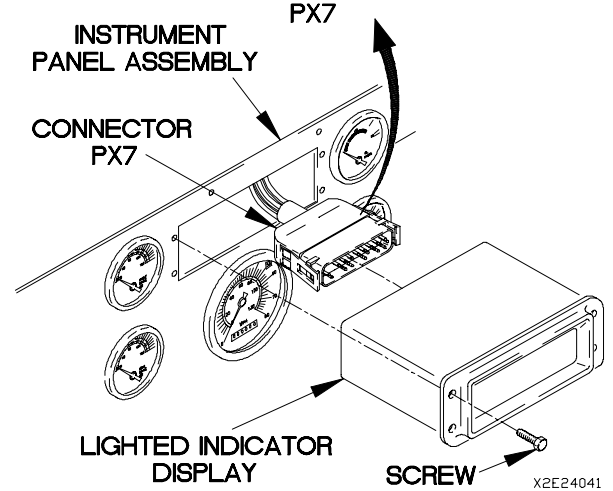
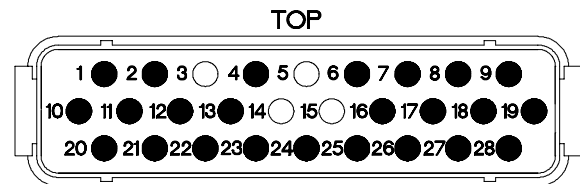
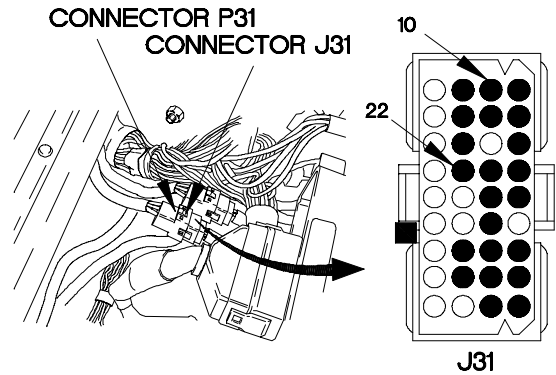

CONTINUITY TEST

- (1) Remove instrument panel assembly for access (para 7-15).
- (2) Set multimeter to ohms.
- (3) Disconnect connector J31 from connector P31.
- (4) Connect positive (+) probe of multimeter to connector J31-10.
- (5) Connect negative (-) probe of multimeter to ground and note reading on multimeter.
- (6) If continuity is not present, repair wire 3026 (para 2-40) or replace WTEC II dashboard cable assembly (para 7-10) or WTEC III dashboard cable assembly (para 7-11).
- (7) If continuity is present, repair wire 3026 (para 2-40) or replace engine control cable assembly (para 7-72).
- (8) Connect connector J31 to connector P31.
- (9) Install instrument panel assembly (para 7-15).
- (10) Connect lighted indicator display to connector PX7.
- (11) Position lighted indicator display in instrument panel assembly with four screws.
- (12) Tighten four screws to 6-10 lb-in. (1 N·m).
- (13) Connect batteries (para 7-48).

e24A. HIGH ENGINE TEMPERATURE INDICATOR ILLUMINATES

INITIAL SETUP

Equipment Conditions

Engine shut down (TM 9-2320-365-10).

Personnel Required

(2)

Tools and Special Tools

Tool Kit, Genl Mech (Item 44, Appendix C)

STE/ICE-R (Item 39, Appendix C)

Multimeter, Digital (Item 22, Appendix C)

References

TM 9-4910-571-12&P

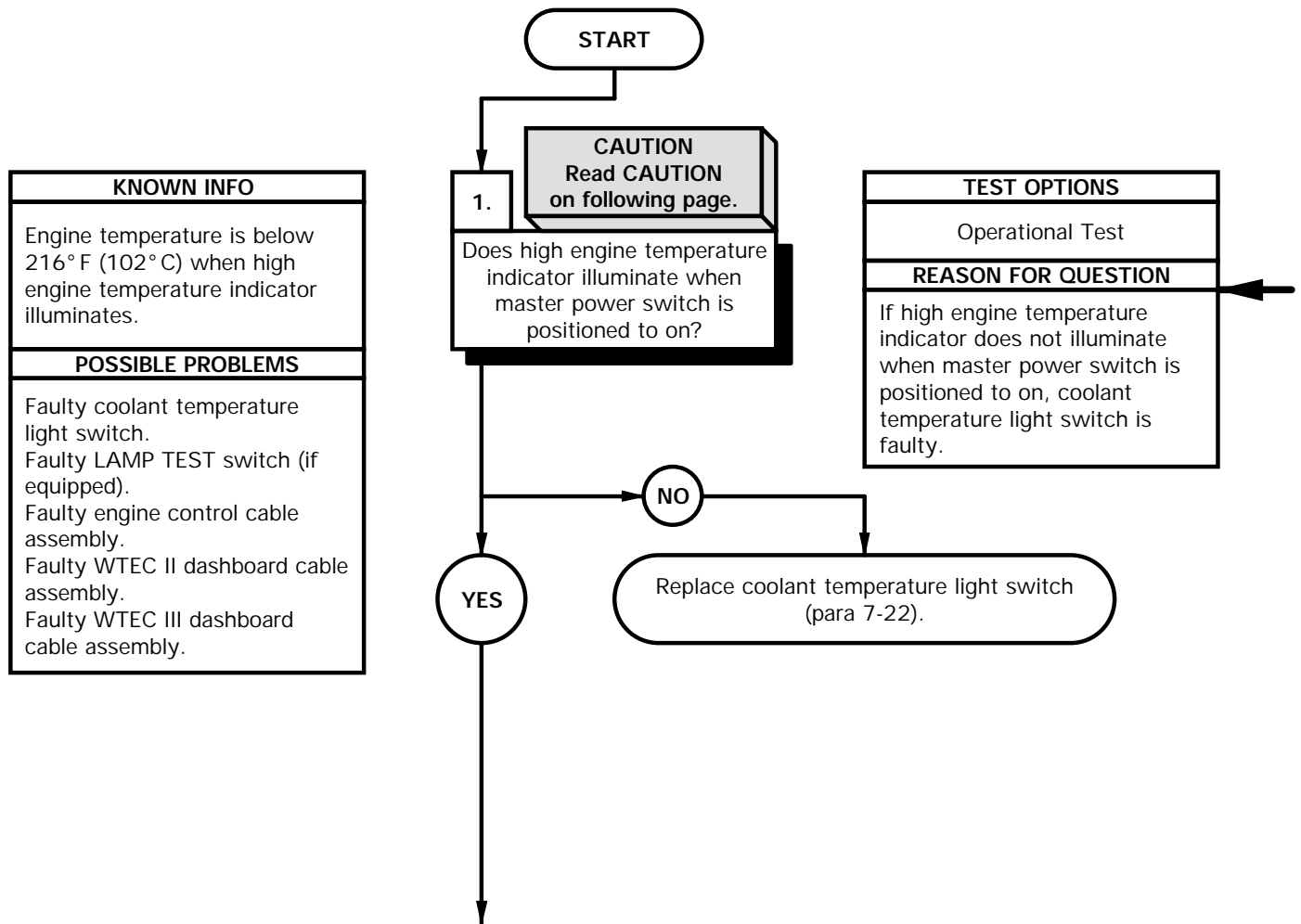

CAUTION

Ensure engine has cooled before performing this troubleshooting task. Failure to comply may result in incorrect test results.

OPERATIONAL TEST

- (1) Position master power switch to on (TM 9-2320-365-10).
- (2) Check to see if high engine temperature indicator illuminates (TM 9-2320-365-10).
- (3) If high engine temperature indicator illuminates, replace coolant temperature light switch (para 7-22).
- (4) Position master power switch to off (TM 9-2320-365-10).

e24A. HIGH ENGINE TEMPERATURE INDICATOR ILLUMINATES (CONT)

KNOWN INFO
Engine temperature is below 216°F (102°C) when high engine temperature indicator illuminates. High engine temperature indicator illuminates when master power switch is positioned to on.
POSSIBLE PROBLEMS
Faulty coolant temperature light switch. Faulty LAMP TEST switch (if equipped). Faulty engine control cable assembly. Faulty WTEC II dashboard cable assembly. Faulty WTEC III dashboard cable assembly.

2.

CAUTION
 Read CAUTION on following page.

Is continuity present from coolant temperature light switch connector socket 2 to known good ground?

TEST OPTIONS
Continuity Test or STE/ICE-R Test #91
REASON FOR QUESTION
If continuity is present, coolant temperature light switch is faulty.

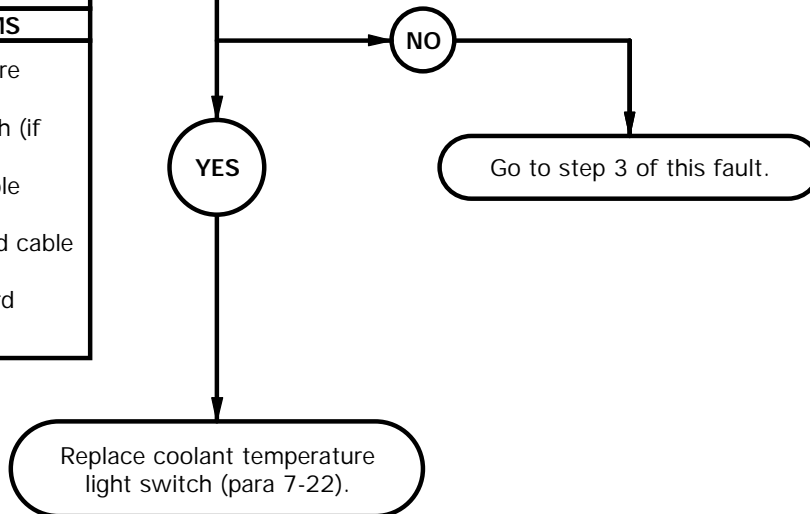

CAUTION

Use care when testing electrical connectors. Do not damage connector pins or sockets with multimeter probes. Failure to comply may result in damage to equipment.

NOTE

Inspect connector pins/sockets for damage, corrosion, and serviceability. Check that connector pins are not pushed back and are capable of making good contact.

CONTINUITY TEST

- (1) Raise cab (TM 9-2320-365-10).
- (2) Disconnect connector clamp from coolant temperature light switch connector,
- (3) Disconnect connector P37 from coolant temperature light switch.
- (4) Set multimeter to ohms.
- (5) Connect positive (+) probe of multimeter to coolant temperature light switch connector socket 2.
- (6) Connect negative (-) probe of multimeter to known good ground and note reading on multimeter.
- (7) If continuity is not present, go to step 3 of this Fault.
- (8) If continuity is present, replace coolant temperature light switch (para 7-22).
- (9) Connect connector P37 to coolant temperature light switch.
- (10) Connect connector clamp to coolant temperature light switch connector.
- (11) Lower cab (TM 9-2320-365-10).

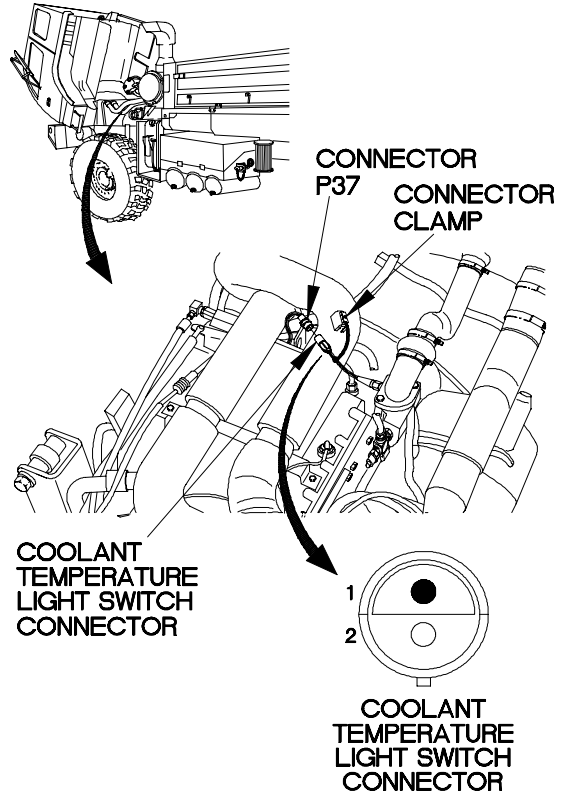

X2E24A021

e24A. HIGH ENGINE TEMPERATURE INDICATOR ILLUMINATES (CONT)

KNOWN INFO
<p>Engine temperature is below 216° F (102° C) when high engine temperature indicator illuminates. High engine temperature indicator illuminates when master power switch is positioned to on. Coolant temperature light switch OK.</p>
POSSIBLE PROBLEMS
<p>Faulty LAMP TEST switch (if equipped). Faulty engine control cable assembly. Faulty WTEC II dashboard cable assembly. Faulty WTEC III dashboard cable assembly.</p>

KNOWN INFO
<p>Engine temperature is below 216° F (102° C) when high engine temperature indicator illuminates. High engine temperature indicator illuminates when master power switch is positioned to on. Coolant temperature light switch OK.</p>
POSSIBLE PROBLEMS
<p>Faulty LAMP TEST switch. Faulty engine control cable assembly. Faulty WTEC II dashboard cable assembly. Faulty WTEC III dashboard cable assembly.</p>

TEST OPTIONS
Visual Inspection
REASON FOR QUESTION
<p>This question eliminates possible problems and determines where troubleshooting continues.</p>

TEST OPTIONS
Operational Test
REASON FOR QUESTION
<p>If TRANS OIL TEMP indicator illuminates with high engine temperature indicator, LAMP TEST switch is faulty.</p>

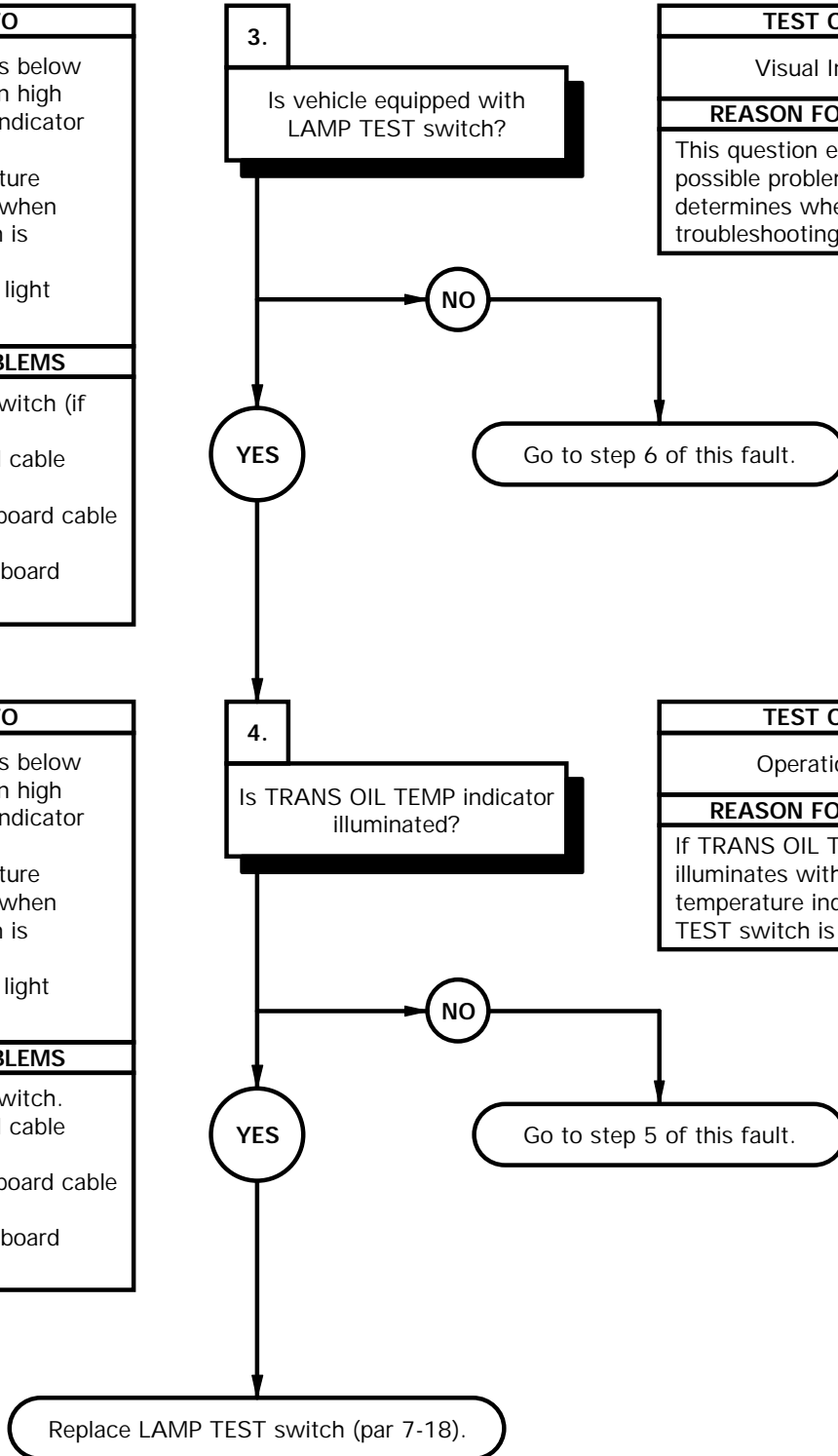

- (1) Check to see if vehicle is equipped with LAMP TEST switch (TM 9-2320-365-10).
- (2) If vehicle is not equipped with LAMP TEST switch go to step 6 of this fault.

OPERATIONAL TEST

- (1) Position master power switch to on (TM 9-2320-365-10).
- (2) Check to see if TRANS OIL TEMP indicator illuminates (TM 9-2320-365-10).
- (3) If TRANS OIL TEMP indicator does not illuminate, go to step 5 of this fault.
- (4) If TRANS OIL TEMP indicator illuminates, replace LAMP TEST switch (para 7-18).
- (5) Position master power switch to off (TM 9-2320-365-10).

e24A. HIGH ENGINE TEMPERATURE INDICATOR ILLUMINATES (CONT)

KNOWN INFO
Engine temperature is below 216° F (102° C) when high engine temperature indicator illuminates. High engine temperature indicator illuminates when master power switch is positioned to on. Coolant temperature light switch OK.
POSSIBLE PROBLEMS
Faulty LAMP TEST switch. Faulty engine control cable assembly. Faulty WTEC II dashboard cable assembly. Faulty WTEC III dashboard cable assembly.

5.
 Does high engine temperature indicator illuminate when connector PX2 is disconnected?

TEST OPTIONS
Operational Test
REASON FOR QUESTION
If high engine temperature indicator does not illuminate when connector PX2 is disconnected, LAMP TEST switch is faulty. If high engine temperature indicator illuminates when connector PX2 is disconnected, go to step 7 of this fault.

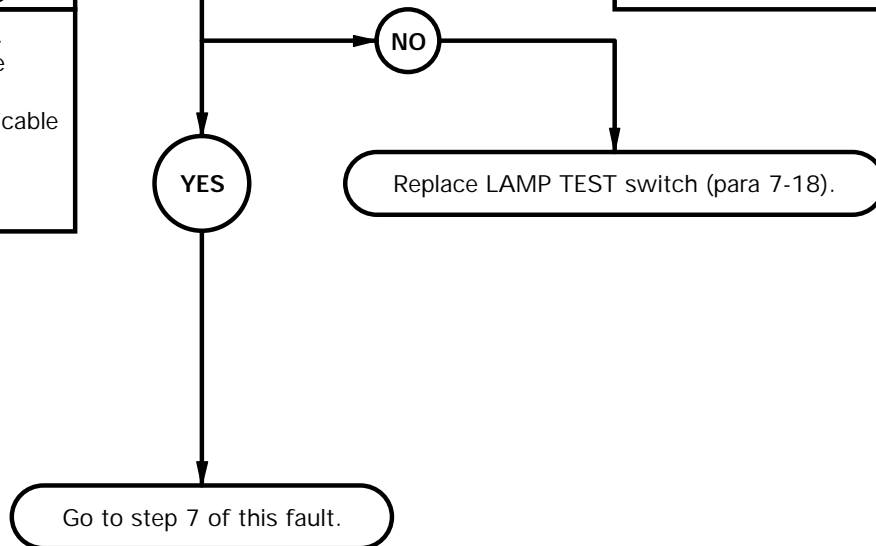

OPERATIONAL TEST

- (1) Remove instrument panel for access (para 7-15).
- (2) Disconnect connector PX2 from LAMP TEST switch connector.
- (3) Position master power switch to on (TM 9-2320-365-10).
- (4) Check to see if high engine temperature indicator illuminates (TM 9-2320-365-10).
- (5) If high engine temperature indicator does not illuminate, replace LAMP TEST switch (para 7-18).
- (6) If high engine temperature indicator illuminates, go to step 7 of this fault.

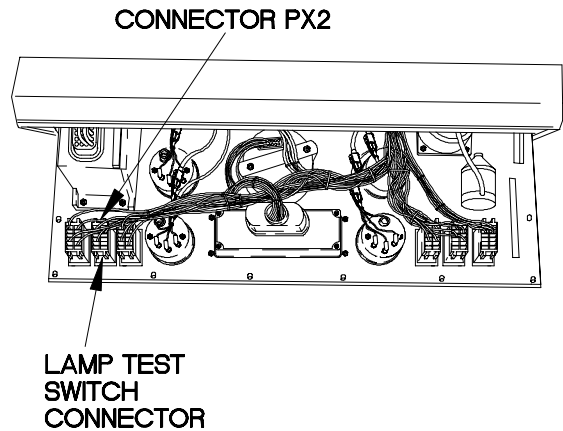

X2E24A051

e24A. HIGH ENGINE TEMPERATURE INDICATOR ILLUMINATES (CONT)

KNOWN INFO
Engine temperature is below 216° F (102° C) when high engine temperature indicator illuminates. High engine temperature indicator illuminates when master power switch is positioned to on. Coolant temperature light switch OK.
POSSIBLE PROBLEMS
Faulty engine control cable assembly. Faulty WTEC II dashboard cable assembly. Faulty WTEC III dashboard cable assembly.

KNOWN INFO
Engine temperature is below 216° F (102° C) when high engine temperature indicator illuminates. High engine temperature indicator illuminates when master power switch is positioned to on. Coolant temperature light switch OK. LAMP TEST switch OK (if equipped).
POSSIBLE PROBLEMS
Faulty engine control cable assembly. Faulty WTEC II dashboard cable assembly. Faulty WTEC III dashboard cable assembly.

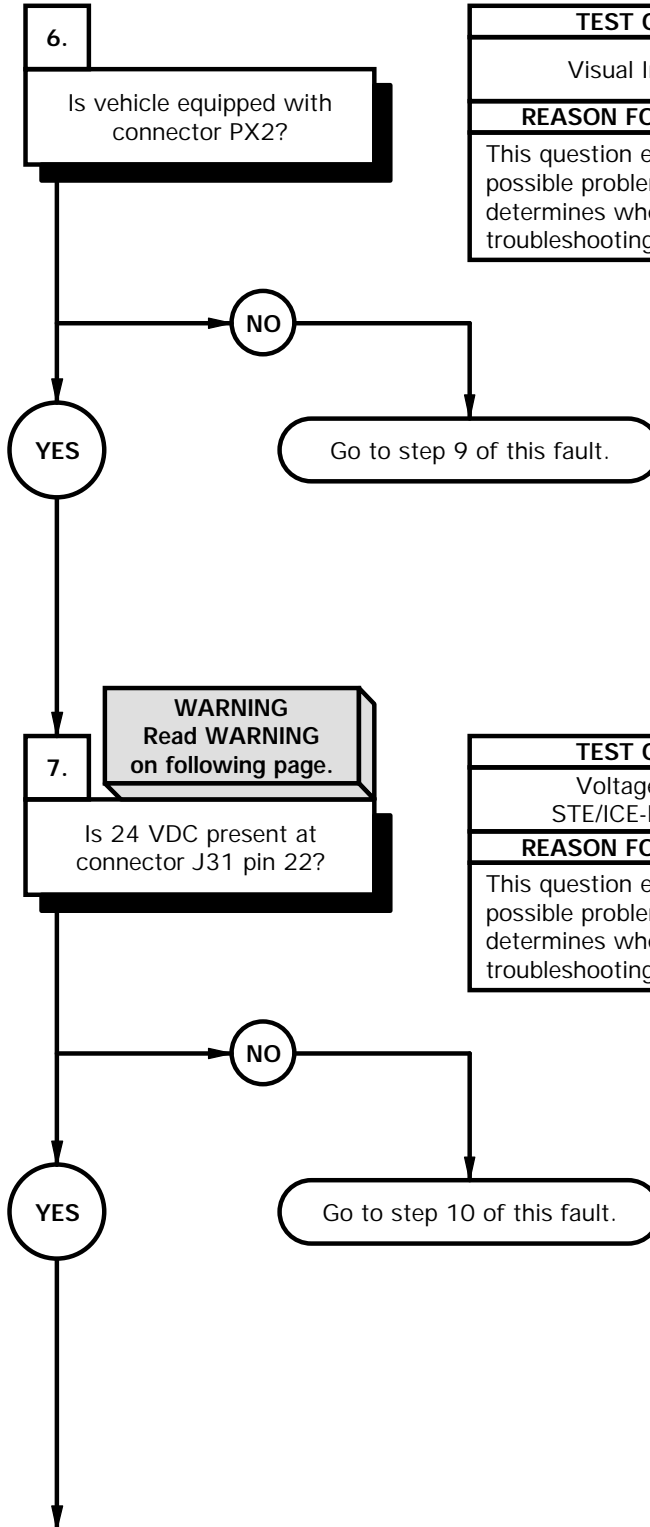

TEST OPTIONS
Visual Inspection
REASON FOR QUESTION
This question eliminates possible problems and determines where troubleshooting continues.

TEST OPTIONS
Voltage Test or STE/ICE-R Test #89
REASON FOR QUESTION
This question eliminates possible problems and determines where troubleshooting continues.

- (1) Remove instrument panel assembly for access (para 7-15).
- (2) Check to see if connector PX2 is in dashboard.
- (3) If vehicle is not equipped with connector PX2, go step 9 of this fault.

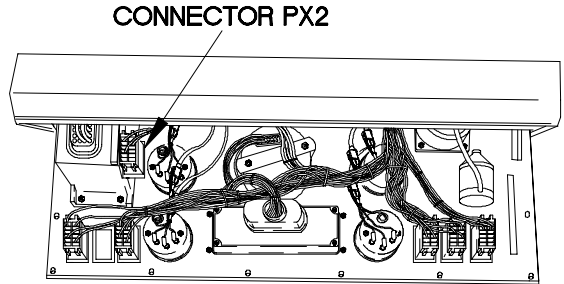

X2E24A061

WARNING

Remove rings, bracelets, watches, necklaces, and any other jewelry before working around vehicle. Jewelry can catch on equipment and cause injury or short across electrical circuits and cause severe burns or electrical shock.

VOLTAGE TEST

- (1) Disconnect batteries (para 7-48).
- (2) Disconnect connector J31 from connector P31.
- (3) Connect batteries (para 7-48)
- (4) Set multimeter to volts DC.
- (5) Connect positive (+) probe of multimeter to connector J31 pin 22.
- (6) Connect negative probe of multimeter to known good ground.
- (7) Position master power switch to on (TM 9-2320-365-10) and note reading on multimeter.
- (8) If 24 VDC is not present, go to step 10 of this fault.
- (9) Position master power switch to off (TM 9-2320-365-10).

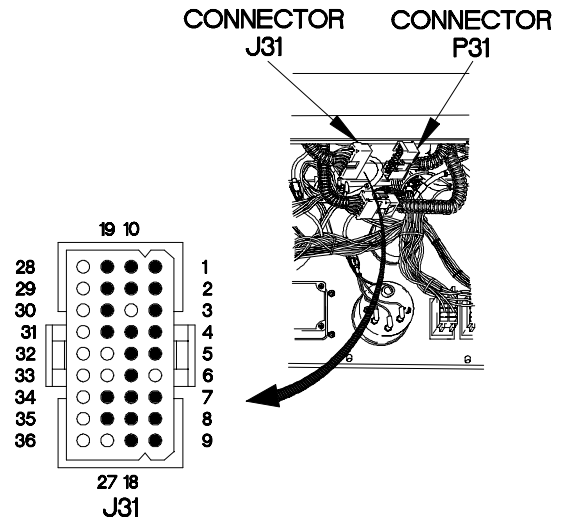

X2E24A071

e24A. HIGH ENGINE TEMPERATURE INDICATOR ILLUMINATES (CONT)

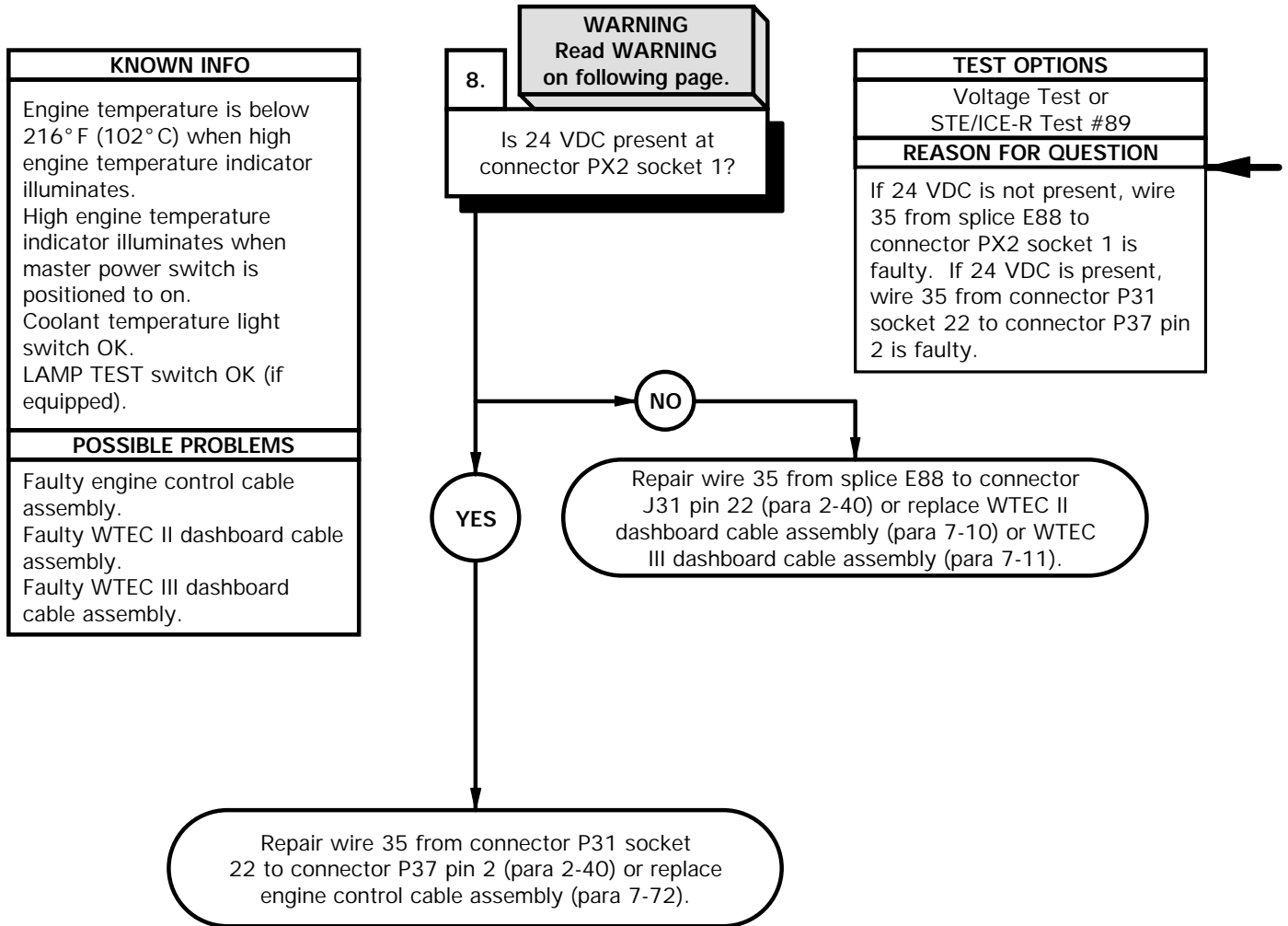

WARNING

Remove rings, bracelets, watches, necklaces, and any other jewelry before working around vehicle. Jewelry can catch on equipment and cause injury or short across electrical circuits and cause severe burns or electrical shock.

VOLTAGE TEST

- (1) Set multimeter to volts DC.
- (2) Connect positive (+) probe of multimeter to connector PX2 socket 1.
- (3) Connect negative (-) probe of multimeter to known good ground.
- (4) Position master power switch to on (TM 9-2320-365-10) and note reading on multimeter.
- (5) If 24 VDC is not present, repair wire 35 from splice E88 to connector J31 pin 22 (para 2-40) or replace WTEC II dashboard cable assembly (para 7-10) or WTEC III dashboard cable assembly (para 7-11).
- (6) If 24 VDC is present, repair wire 35 from connector P31 socket 22 to connector P37 pin 2 (para 2-40) or replace engine control cable assembly (para 7-72).
- (7) Position master power switch to off (TM 9-2320-365-10).
- (8) Disconnect batteries (para 7-48)
- (9) Connect connector P31 to connector J31.

NOTE

Perform step (10) if vehicle is equipped with LAMP TEST switch.

- (10) Connect connector PX2 to LAMP TEST switch connector.
- (11) Install instrument panel assembly (para 7-15).
- (12) Connect batteries (para 7-48).

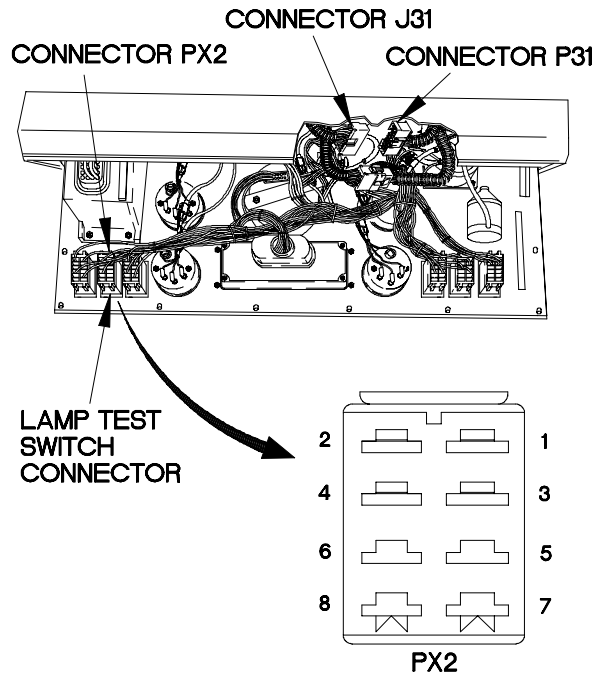

X2E24A081

e24A. HIGH ENGINE TEMPERATURE INDICATOR ILLUMINATES (CONT)

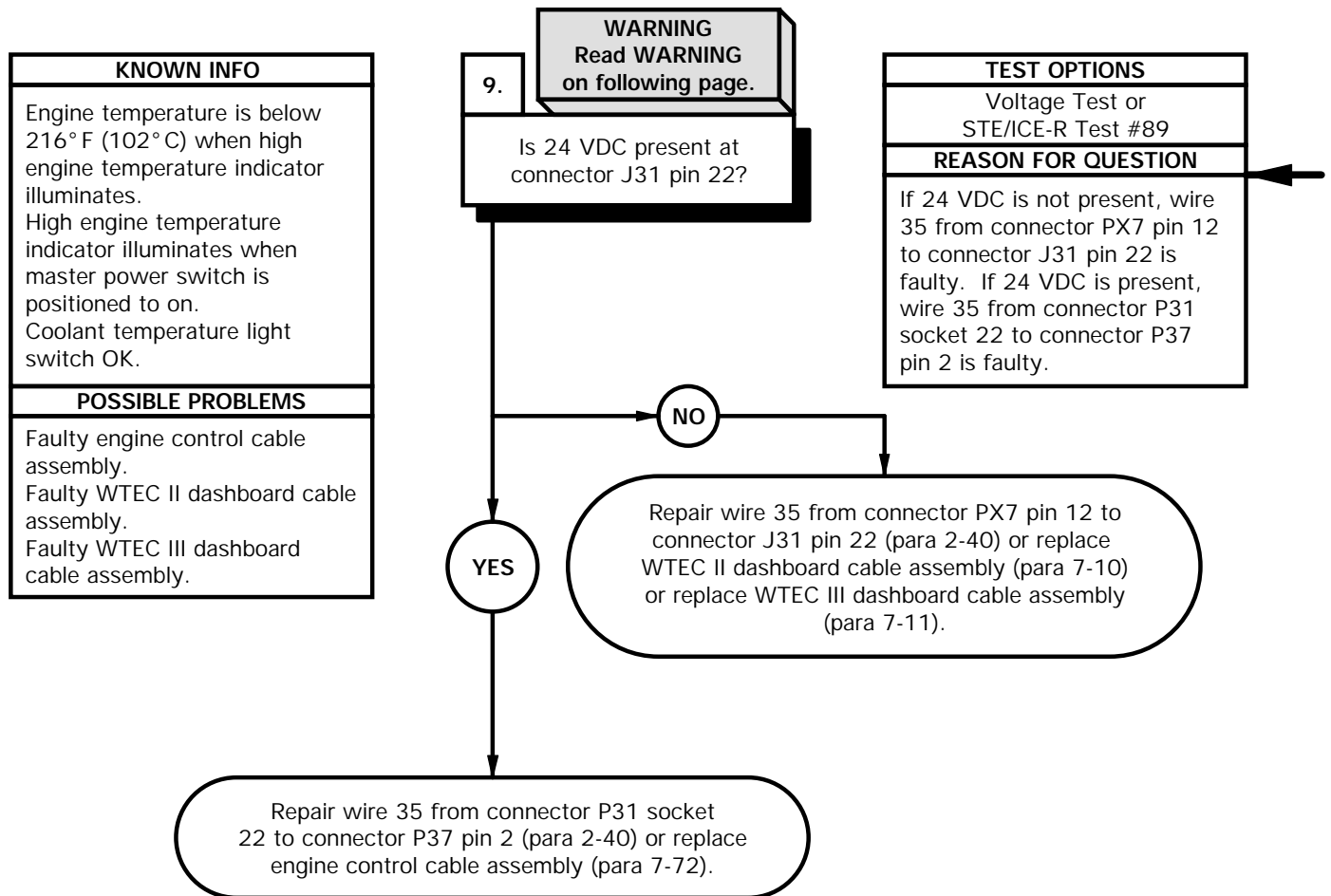

WARNING

Remove rings, bracelets, watches, necklaces, and any other jewelry before working around vehicle. Jewelry can catch on equipment and cause injury or short across electrical circuits and cause severe burns or electrical shock.

VOLTAGE TEST

- (1) Disconnect batteries (para 7-48).
- (2) Disconnect connector J31 from connector P31.
- (3) Connect batteries (para 7-48).
- (4) Set multimeter to volts DC.
- (5) Connect positive (+) probe of multimeter to connector J31 pin 22.
- (6) Connect negative (-) probe of multimeter to known good ground.
- (7) Position master power switch to on and note reading on multimeter.
- (8) If 24 VDC is not present, repair wire 35 from connector PX7 pin 12 to connector J31 pin 22 (para 2-40) or replace WTEC II dashboard cable assembly (para 7-10) or replace WTEC III dashboard cable assembly (para 7-11).
- (9) If 24 VDC is present, repair wire 35 from connector P31 socket 22 to connector P37 pin 2 (para 2-40) or replace engine control cable assembly (para 7-72).
- (10) Position master power switch to off (TM 9-2320-365-10).
- (11) Disconnect batteries (para 7-48).
- (12) Connect connect P31 to connector J31.
- (13) Install instrument panel assembly (para 7-15).
- (14) Connect batteries (para 7-48).

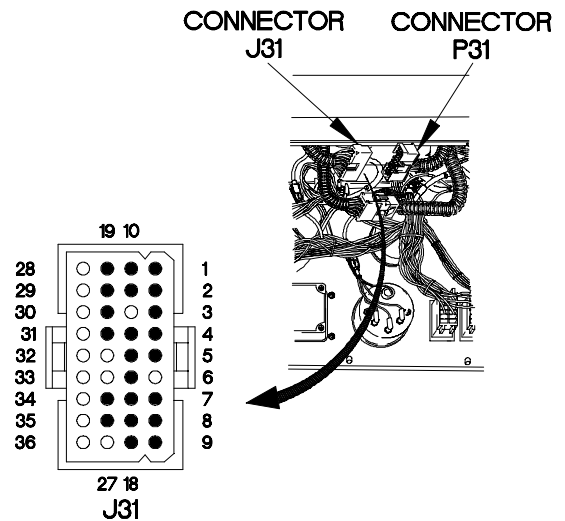

X2E24A091

e24A. HIGH ENGINE TEMPERATURE INDICATOR ILLUMINATES (CONT)

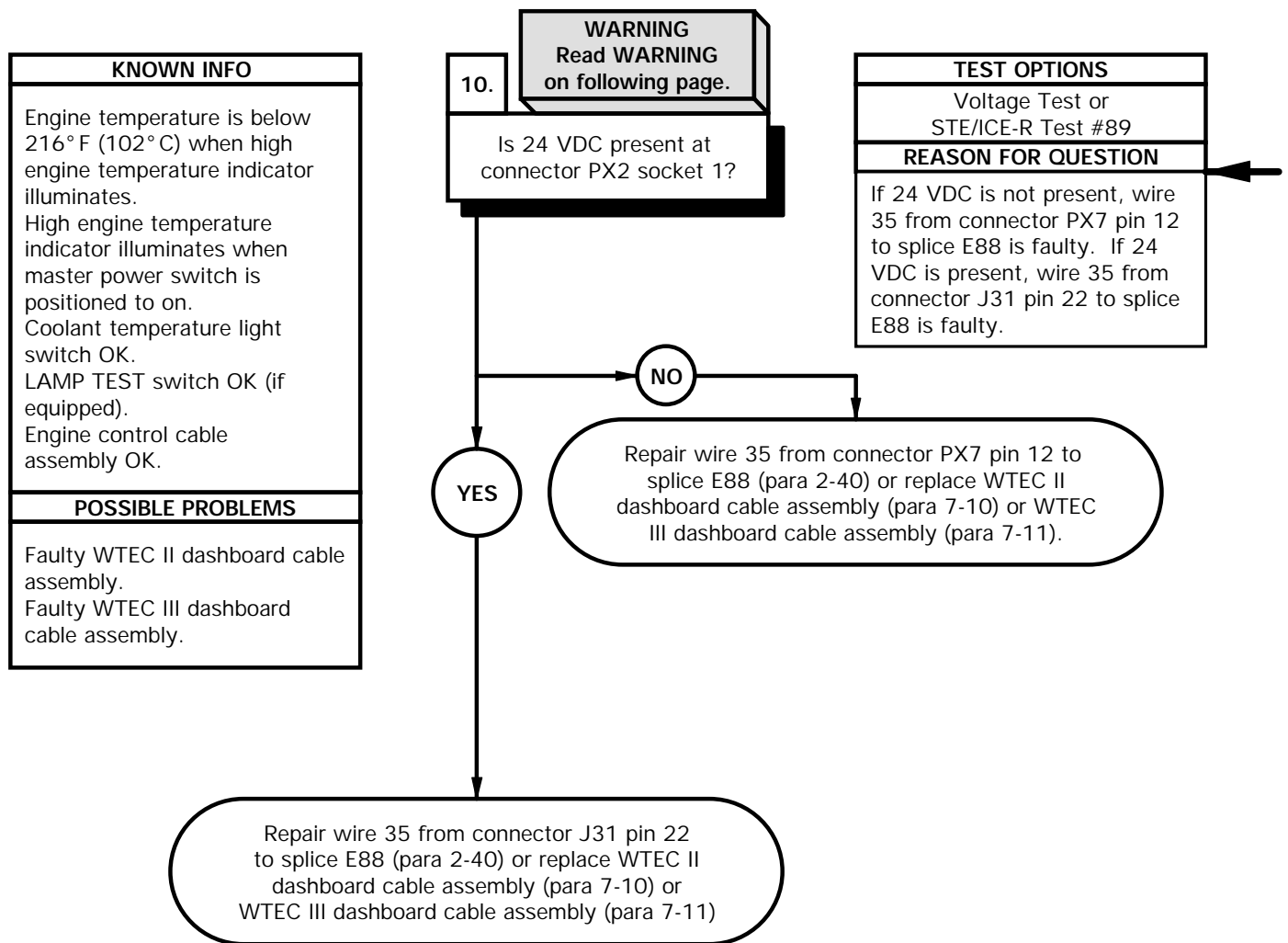

WARNING

Remove rings, bracelets, watches, necklaces, and any other jewelry before working around vehicle. Jewelry can catch on equipment and cause injury or short across electrical circuits and cause severe burns or electrical shock.

VOLTAGE TEST

- (1) Set multimeter to volts DC.
- (2) Connect positive (+) probe of multimeter to connector PX2 socket 1.
- (3) Connect negative (-) probe of multimeter to known good ground and note reading on multimeter.
- (4) Position master power switch to on (TM 9-2320-365-10) and note reading on multimeter.
- (5) If 24 VDC is not present, repair wire 35 from connector PX7 pin 12 to splice E88 (para 2-40) or replace WTEC II dashboard cable assembly (para 7-10) or WTEC III dashboard cable assembly (para 7-11).
- (6) If 24 VDC is present, repair wire 35 from connector J31 pin 22 to splice E88 (para 2-40) or replace WTEC II dashboard cable assembly (para 7-10) or WTEC III dashboard cable assembly (para 7-11).
- (7) Position master power switch to off (TM 9-2320-365-10).
- (8) Disconnect batteries (para 7-48)
- (9) Connect connector P31 to connector J31.

NOTE

Perform step (10) if vehicle is equipped with LAMP TEST switch.

- (10) Connect connector PX2 to LAMP TEST switch connector.
- (11) Install instrument panel assembly (para 7-15).
- (12) Connect batteries (para 7-48).

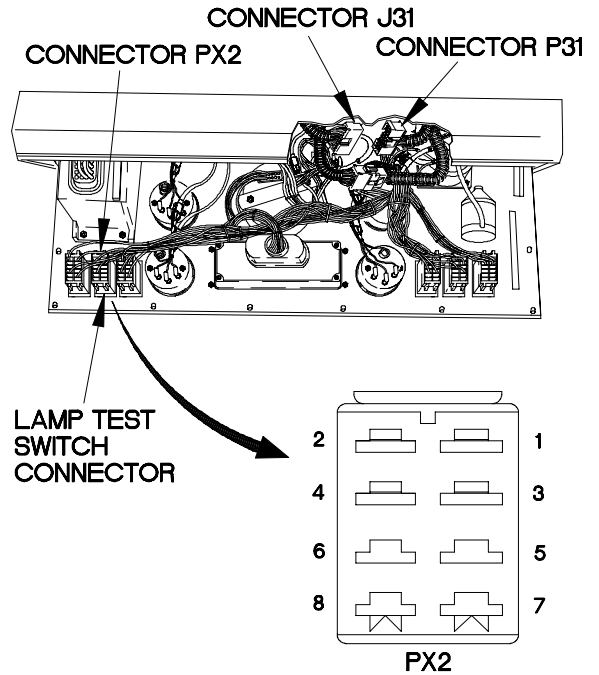

X2E24A101

e25. CTIS OVERSPEED INDICATOR DOES NOT OPERATE	
INITIAL SETUP	
Equipment Condition Engine shut down (TM 9-2320-365-10). Batteries disconnected (para 7-48).	Tools and Special Tools Tool Kit, Genl Mech (Item 44, Appendix C) STE/ICE-R (Item 39, Appendix C) Multimeter, Digital (Item 22, Appendix C) Wrench, Torque, 0-75 lb-in. (Item 86, Appendix B)
Personnel Required (2)	References TM 9-4910-571-12&P

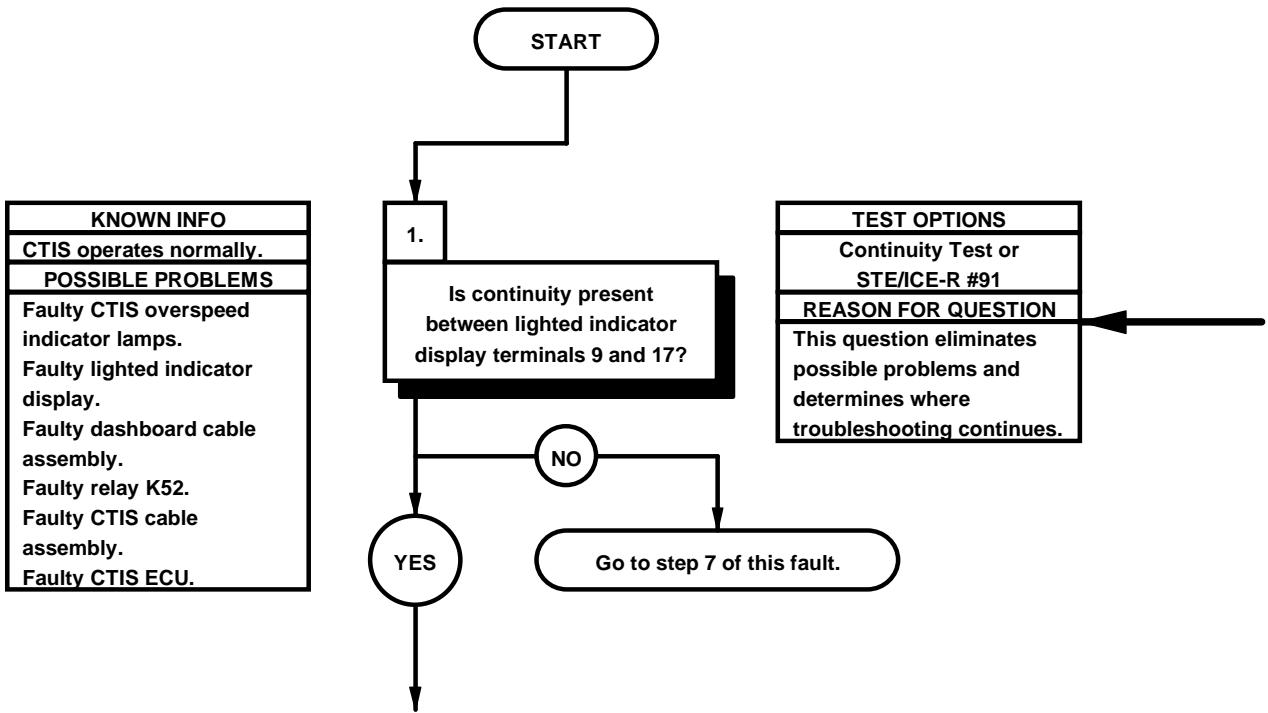

- | CONTINUITY TEST | |
|-----------------|---|
| (1) | Remove four screws from lighted indicator display. |
| (2) | Remove lighted indicator display from instrument panel assembly. |
| (3) | Disconnect connector PX7 from lighted indicator display. |
| (4) | Set multimeter to ohms. |
| (5) | Connect positive (+) probe of multimeter to lighted indicator display terminal 9. |
| (6) | Connect negative (-) probe of multimeter to lighted indicator display terminal 17 and note reading on multimeter. |
| (7) | If continuity is not present, go to step 7 of this fault. |

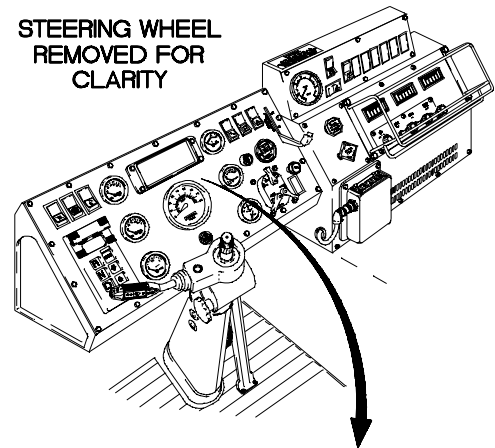

BOTTOM

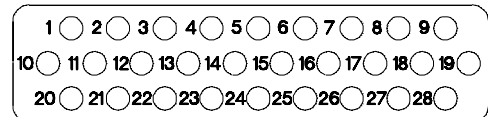

LIGHTED INDICATOR DISPLAY

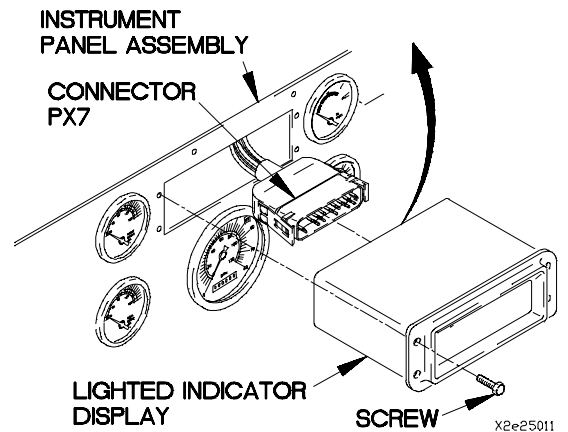

e25. CTIS OVERSPEED INDICATOR DOES NOT OPERATE (CONT)

KNOWN INFO
CTIS operates normally. Lighted indicator display OK.
POSSIBLE PROBLEMS
Faulty dashboard cable assembly. Faulty relay K52. Faulty CTIS ECU. Faulty CTIS cable assembly.

2.
Is continuity present between connector PX7-17 and a known good ground?

TEST OPTIONS
Continuity Test or STE/ICE-R #91
REASON FOR QUESTION
If continuity is not present, wire 3030 is faulty.

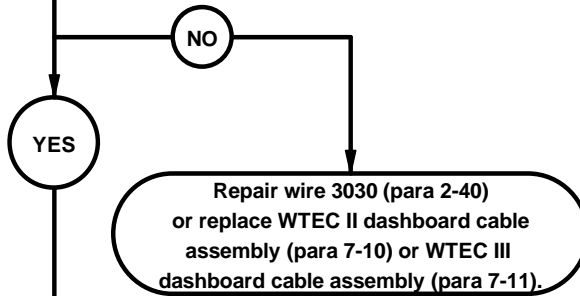

KNOWN INFO
CTIS operates normally. Lighted indicator display OK.
POSSIBLE PROBLEMS
Faulty relay K52. Faulty dashboard cable assembly. Faulty CTIS ECU. Faulty CTIS cable assembly.

3.
Is continuity present between relay K52 terminals 30 and 87A?

TEST OPTIONS
Continuity Test or STE/ICE-R #91
REASON FOR QUESTION
If continuity is not present, relay K52 is faulty.

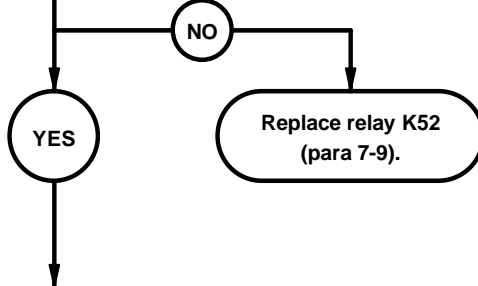

- CONTINUITY TEST**
- (1) Set multimeter to ohms.
 - (2) Connect positive (+) probe of multimeter to connector PX7-17.
 - (3) Connect negative (-) probe of multimeter to ground and note reading on multimeter.
 - (4) If continuity is not present, repair wire 3030 (para 2-40) or replace WTEC II dashboard cable assembly (para 7-10) or WTEC III dashboard cable assembly (para 7-11).

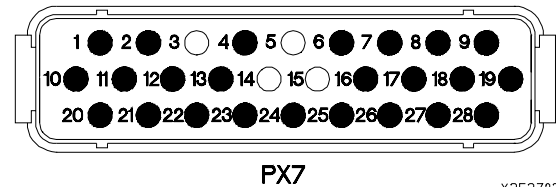
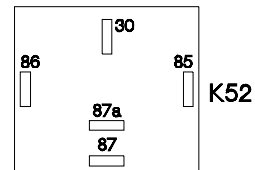
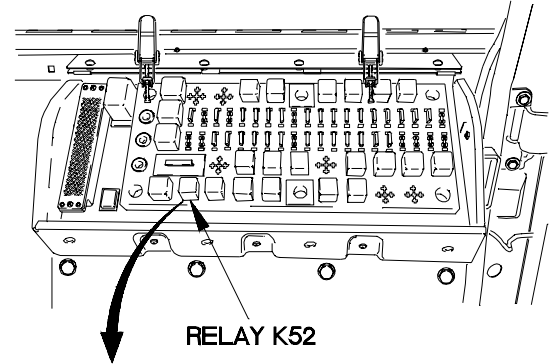

X2E2702A

- CONTINUITY TEST**
- (1) Remove PDP cover (para 16-2).
 - (2) Remove relay K52 from PDP.
 - (3) Set multimeter to ohms.
 - (4) Connect positive (+) probe of multimeter to relay K52 terminal 30.
 - (5) Connect negative (-) probe of multimeter to relay K52 terminal 87A and note reading on multimeter.
 - (6) If continuity is not present, replace relay K52 (para 7-9).

e25. CTIS OVERSPEED INDICATOR DOES NOT OPERATE (CONT)

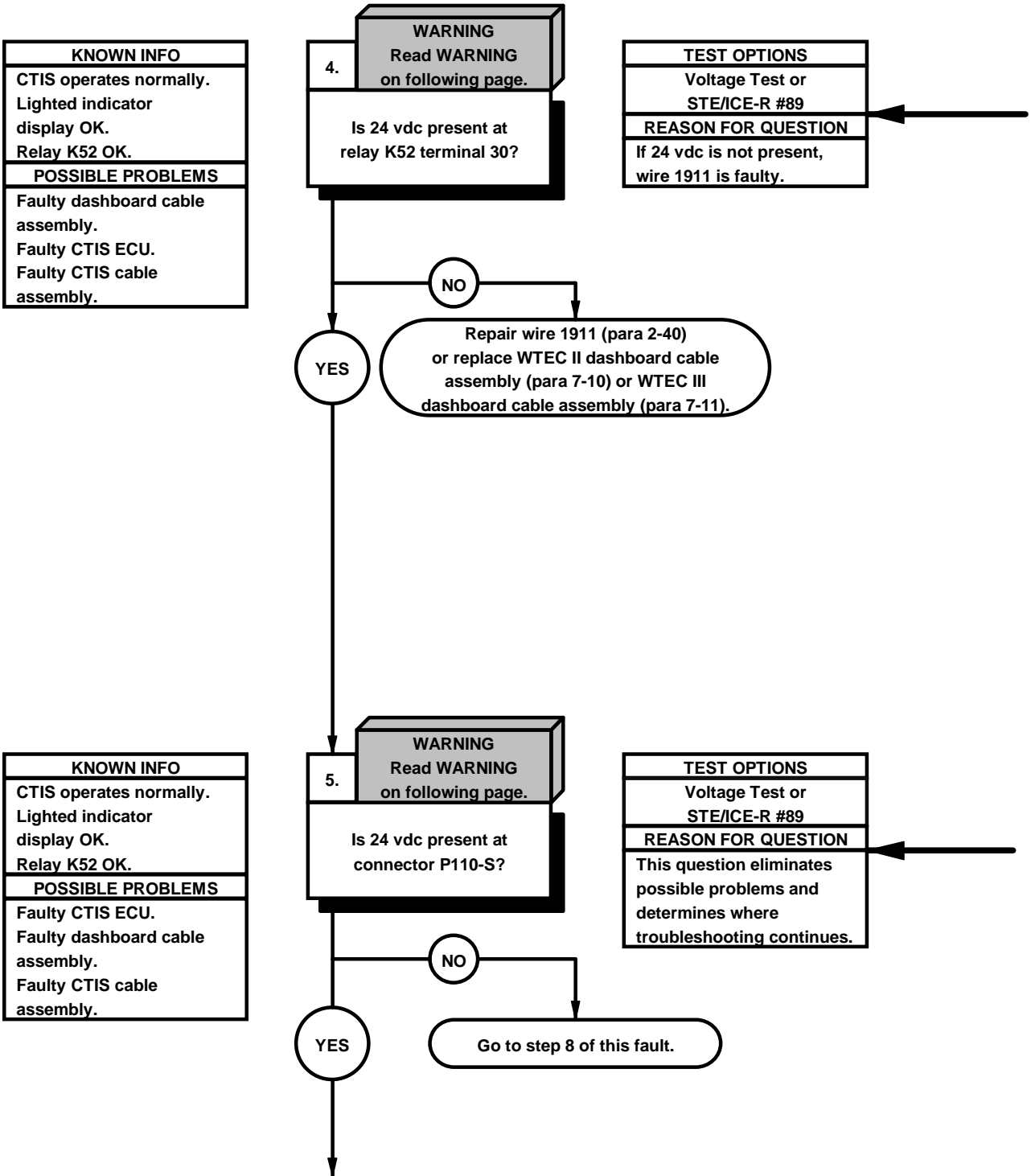

WARNING

Remove rings, bracelets, watches, necklaces, and any other jewelry before working around vehicle. Jewelry can catch on equipment and cause injury or short across electrical circuit and cause severe burns or electrical shock.

VOLTAGE TEST

- (1) Connect batteries (para 7-48).
- (2) Set multimeter to volts dc.
- (3) Connect positive (+) probe of multimeter to PDP, terminal 30, where relay K52 was removed.
- (4) Connect negative (-) probe of multimeter to ground.
- (5) Position master power switch to on (TM 9-2320-365-10) and note reading on multimeter.
- (6) If 24 vdc is not present, repair wire 1911 (para 2-40) or replace WTEC II dashboard cable assembly (para 7-10) or WTEC III dashboard cable assembly (para 7-11).
- (7) Position master power switch to off (TM 9-2320-365-10).
- (8) Install relay K52 in PDP.
- (9) Install PDP cover (para 16-2).

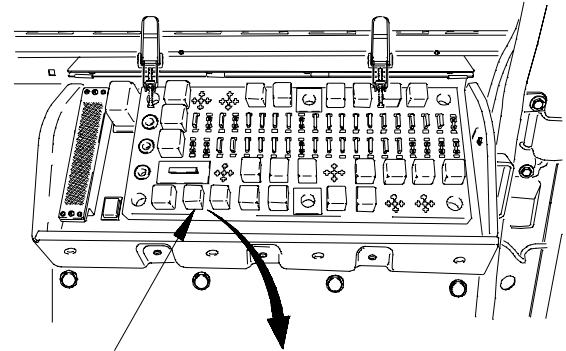

RELAY K52 CAVITY

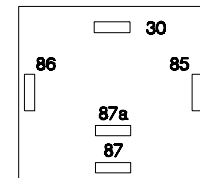

RELAY K52 CAVITY

X2e25031

WARNING

Remove rings, bracelets, watches, necklaces, and any other jewelry before working around vehicle. Jewelry can catch on equipment and cause injury or short across electrical circuit and cause severe burns or electrical shock.

VOLTAGE TEST

- (1) Disconnect connector P110 from CTIS ECU.
- (2) Set multimeter to volts dc.
- (3) Connect positive (+) probe of multimeter to connector P110-S.
- (4) Connect negative (-) probe of multimeter to ground.
- (5) Position master power switch to on (TM 9-2320-365-10) and note reading on multimeter.
- (6) If 24 vdc is not present, go to step 8 of this fault.
- (7) Position master power switch to off (TM 9-2320-365-10).

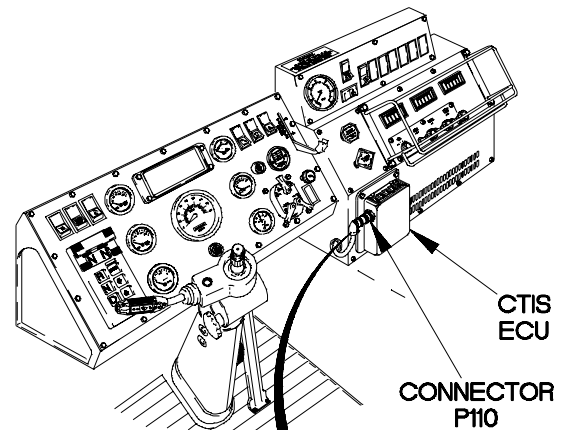

CTIS ECU

CONNECTOR P110

STEERING WHEEL REMOVED FOR CLARITY

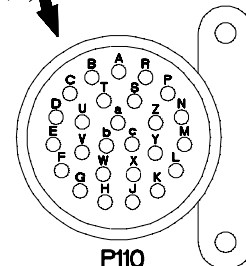

P110

X2e25041

e25. CTIS OVERSPEED INDICATOR DOES NOT OPERATE (CONT)

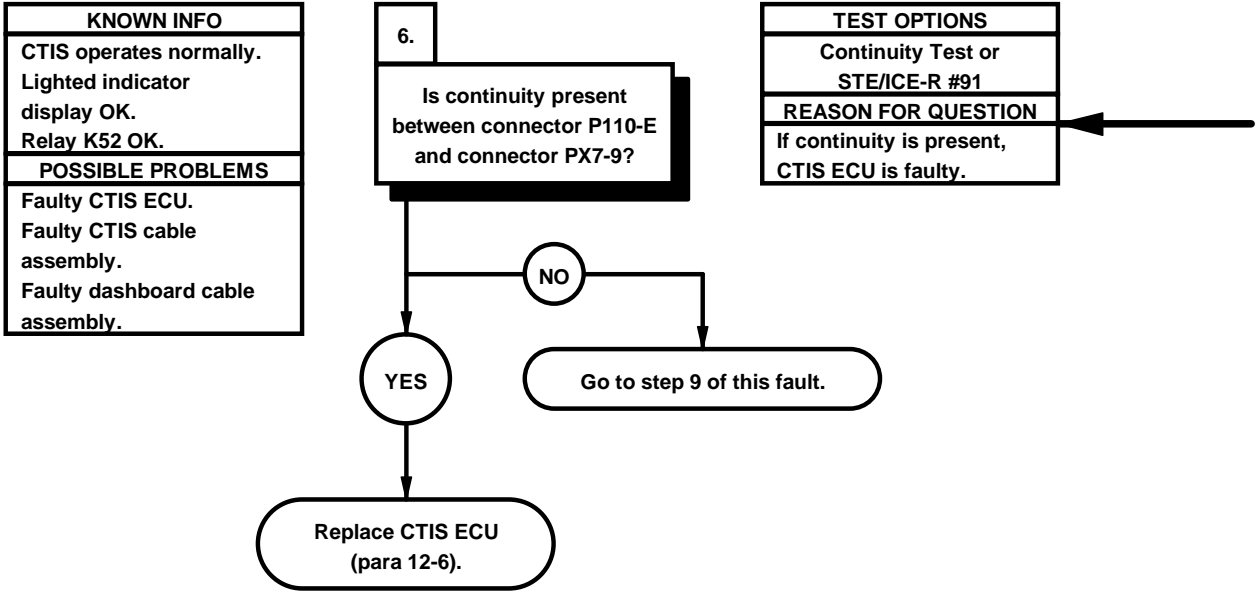

CONTINUITY TEST

- (1) Set multimeter to ohms.
- (2) Connect positive (+) probe of multimeter to connector P110-E.
- (3) Connect negative (-) probe of multimeter to connector PX7-9 and note reading on multimeter.
- (4) If continuity is not present, go to step 9 of this fault.
- (5) If continuity is present, replace CTIS ECU (para 12-6).
- (6) Connect lighted indicator display to connector PX7.
- (7) Position lighted indicator display in instrument panel assembly with four screws.
- (8) Tighten four screws to 6-10 lb-in. (1 N-m).
- (9) Connect batteries (para 7-48).

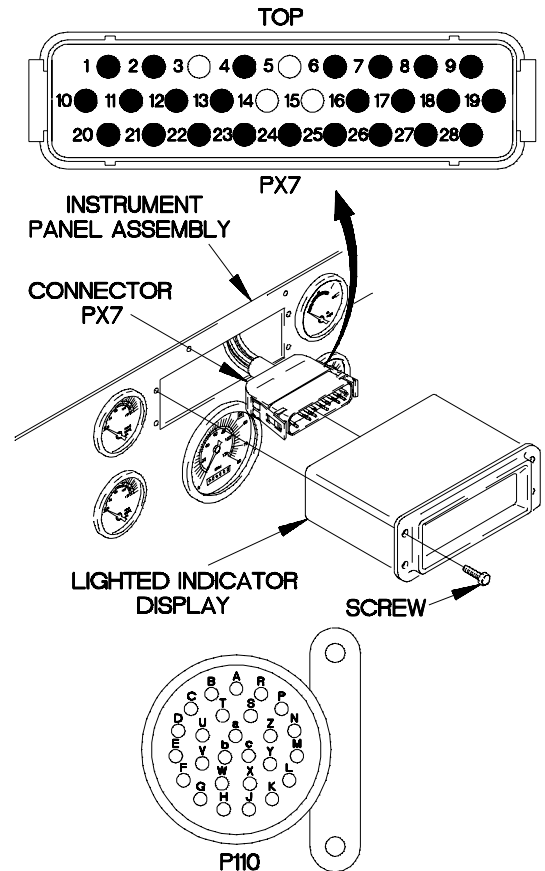
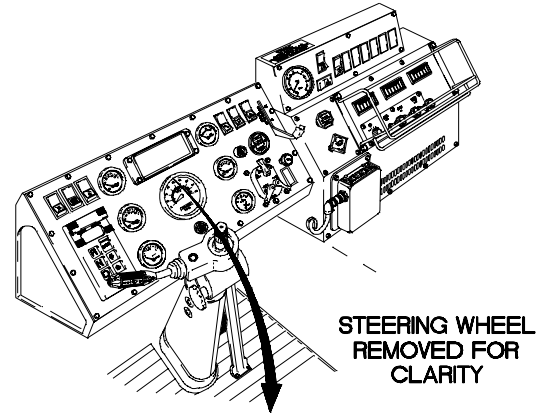

X2e25051

e25. CTIS OVERSPEED INDICATOR DOES NOT OPERATE (CONT)

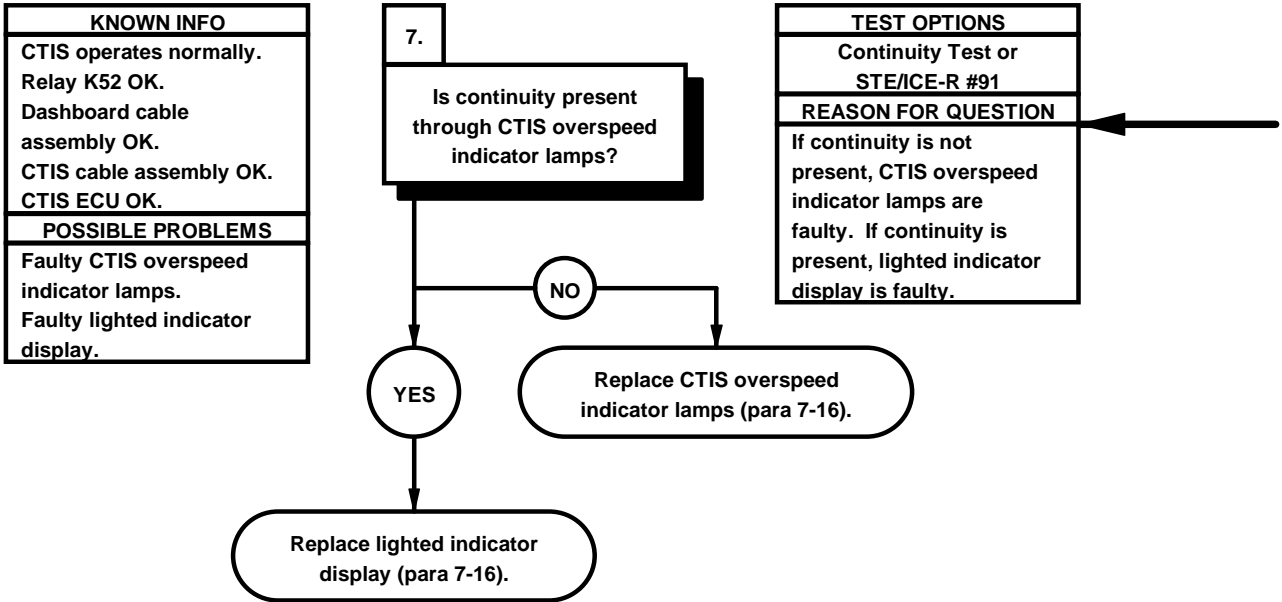

CONTINUITY TEST

- (1) Loosen four captive screws in lamp mounting panel.
- (2) Remove lamp mounting panel from lighted indicator display housing.
- (3) Remove CTIS overspeed indicator lamps from printed circuit board.
- (4) Set multimeter to ohms.
- (5) Check continuity through each CTIS overspeed indicator lamp and note reading on multimeter.
- (6) If continuity is not present, replace lamps (para 7-16).
- (7) If continuity is present, replace lighted indicator display (para 7-16).
- (8) Install CTIS overspeed indicator lamps in printed circuit board.
- (9) Install lamp mounting panel in lighted indicator display housing.
- (10) Tighten four captive screws in lamp mounting panel.
- (11) Connect lighted indicator display to connector PX7.
- (12) Position lighted indicator display in instrument panel assembly with four screws.
- (13) Tighten four screws to 6-10 lb-in. (1 N-m).
- (14) Connect batteries (para 7-48).

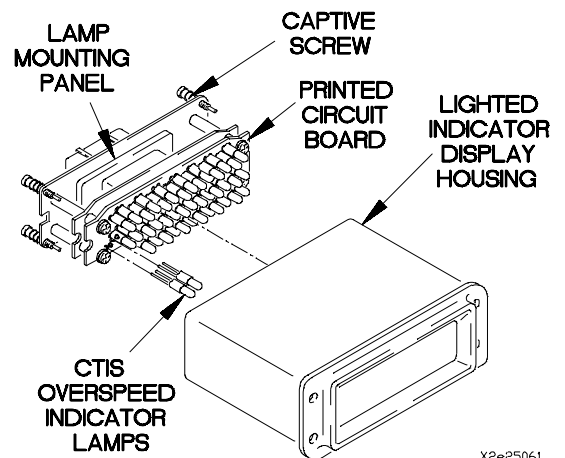
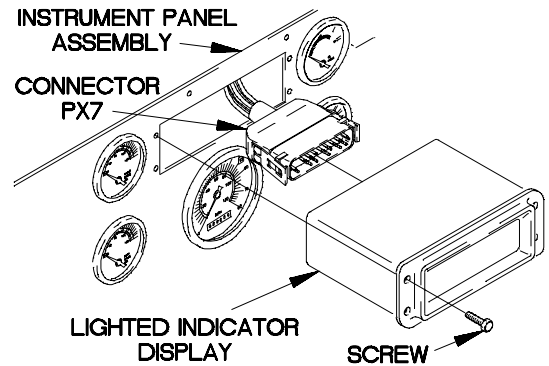
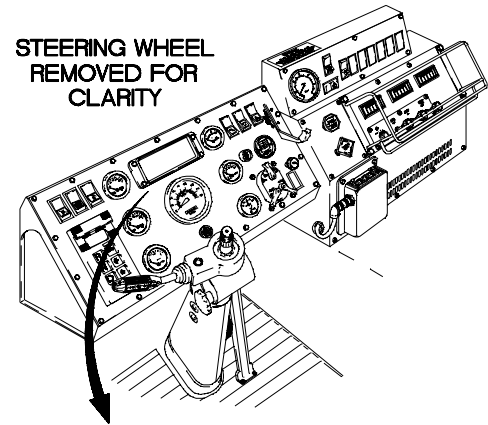

X2e25061

e25. CTIS OVERSPEED INDICATOR DOES NOT OPERATE (CONT)

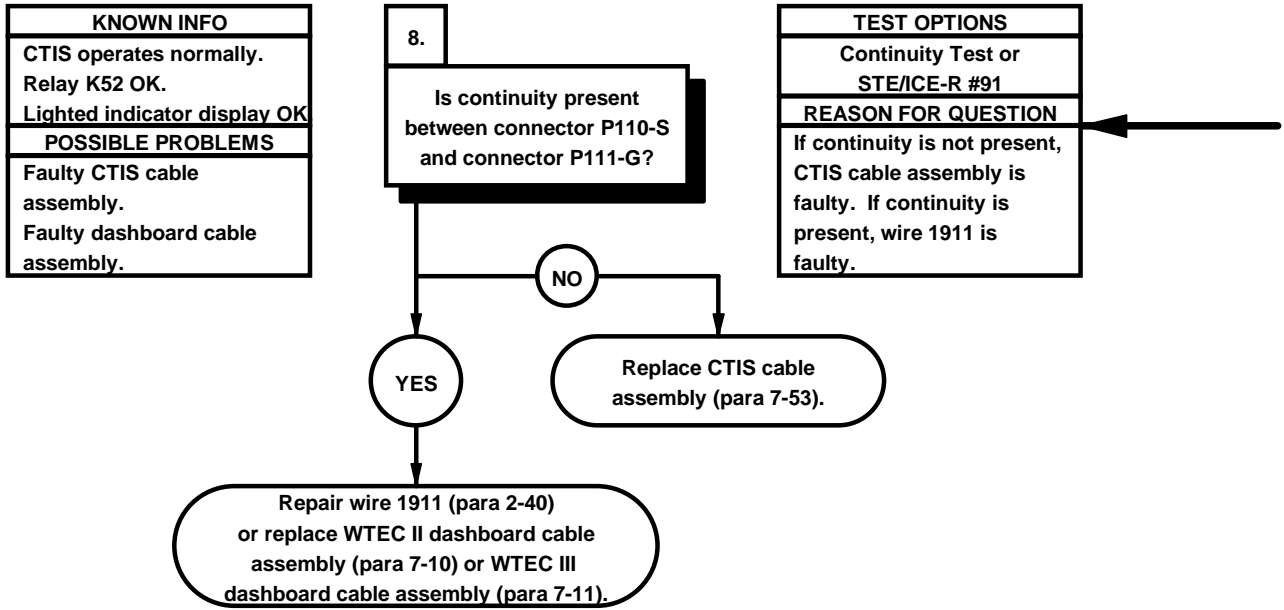

CONTINUITY TEST

- (1) Remove PDP cover (para 16-2).
- (2) Remove three screws and washers from PDP.
- (3) Remove three screws from PDP.
- (4) Lift PDP outward to gain access.
- (5) Disconnect connector P111 from connector J111.
- (6) Set multimeter to ohms.
- (7) Connect positive (+) probe of multimeter to connector P110-S.
- (8) Connect negative (-) probe of multimeter to connector P111-G and note reading on multimeter.
- (9) If continuity is not present, replace CTIS cable assembly (para 7-53).
- (10) If continuity is present, repair wire 1911 (para 2-40) or replace WTEC II dashboard cable assembly (para 7-10) or WTEC III dashboard cable assembly (para 7-11).
- (11) Connect connector P111 to connector J111.
- (12) Install PDP on dashboard with three screws.
- (13) Install three washers and screws in PDP.
- (14) Install PDP cover (para 16-2).
- (15) Connect lighted indicator display to connector PX7.
- (16) Position lighted indicator display in instrument panel assembly with four screws.
- (17) Tighten four screws to 6-10 lb-in. (1 N·m).

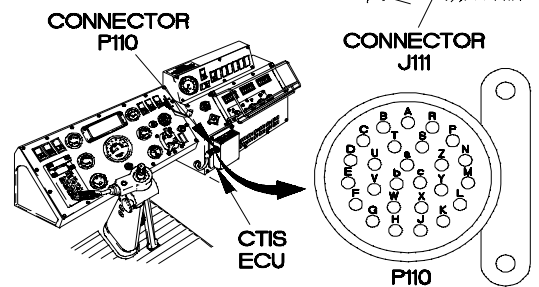
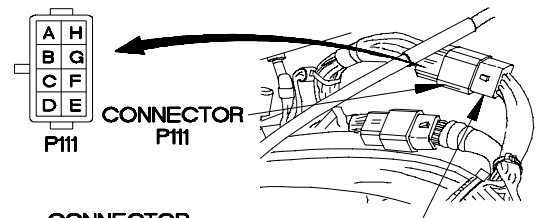
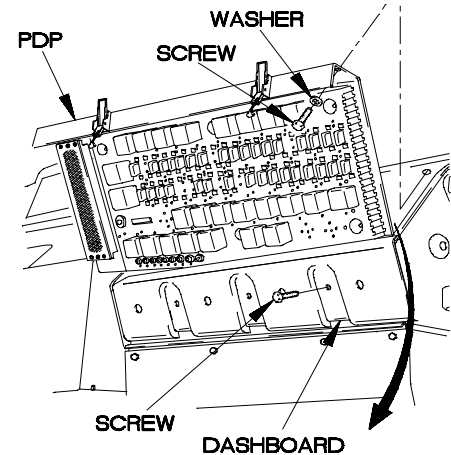
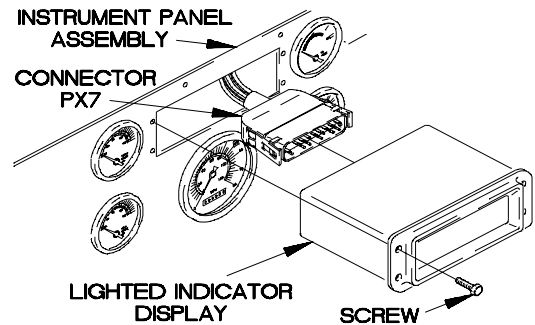

X2e25071

e25. CTIS OVERSPEED INDICATOR DOES NOT OPERATE (CONT)

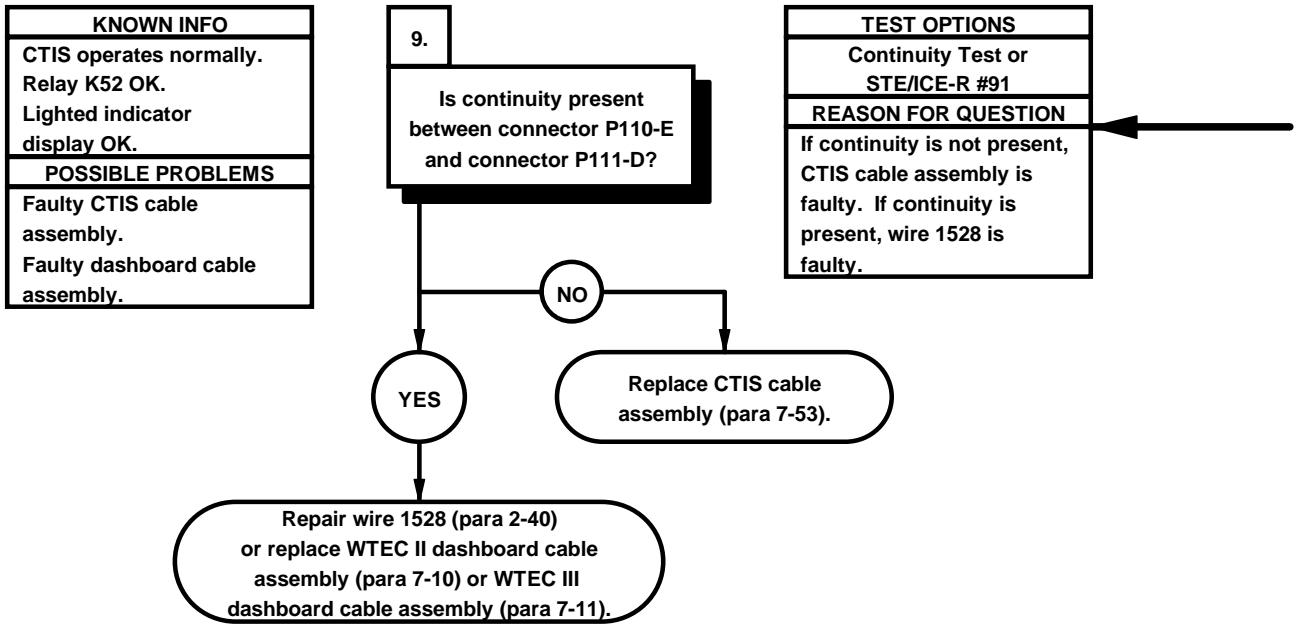

CONTINUITY TEST

- (1) Remove PDP cover (para 16-2).
- (2) Remove three screws and washers from PDP.
- (3) Remove three screws from PDP.
- (4) Lift PDP outward to gain access.
- (5) Disconnect connector P111 from connector J111.
- (6) Set multimeter to ohms.
- (7) Connect positive (+) probe of multimeter to connector P110-E.
- (8) Connect negative (-) probe of multimeter to connector P111-D and note reading on multimeter.
- (9) If continuity is not present, replace CTIS cable assembly (para 7-53).
- (10) If continuity is present, repair wire 1528 (para 2-40) or replace WTEC II dashboard cable assembly (para 7-10) or WTEC III dashboard cable assembly (para 7-11).
- (11) Connect connector P111 to connector J111.
- (12) Install PDP on dashboard with three screws.
- (13) Install three washers and screws in PDP.
- (14) Install PDP cover (para 16-2).
- (15) Connect connector P110 to CTIS ECU.

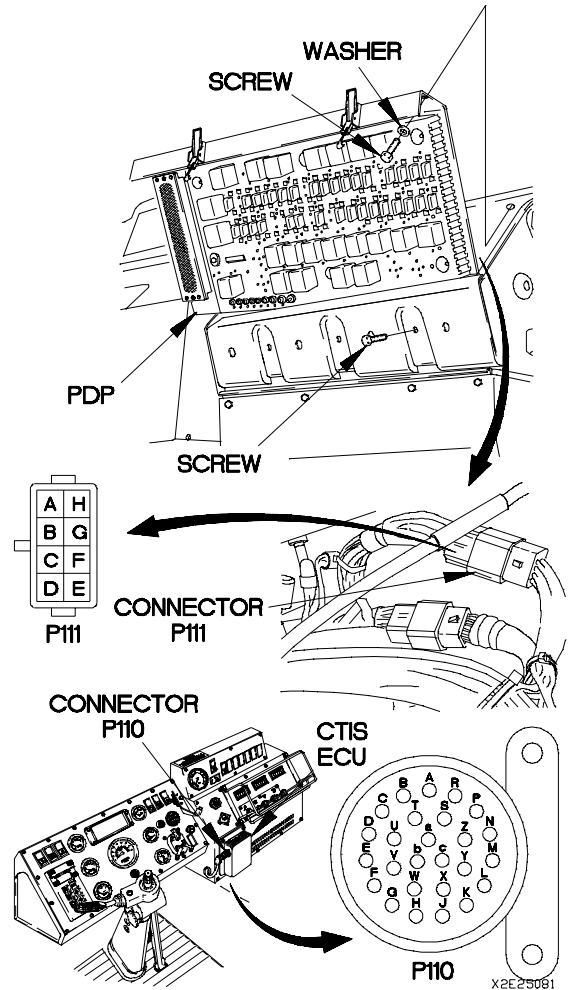

e26. CHEMICAL DETECTOR INDICATOR DOES NOT OPERATE	
INITIAL SETUP	
Equipment Condition Engine shut down (TM 9-2320-365-10). Batteries disconnected (para 7-48).	Tools and Special Tools Tool Kit, Genl Mech (Item 44, Appendix C) STE/ICE-R (Item 39, Appendix C) Multimeter, Digital (Item 22, Appendix C) Wrench, Torque, 0-75 lb-in. (Item 86, Appendix B)
Personnel Required (2)	References TM 9-4910-571-12&P

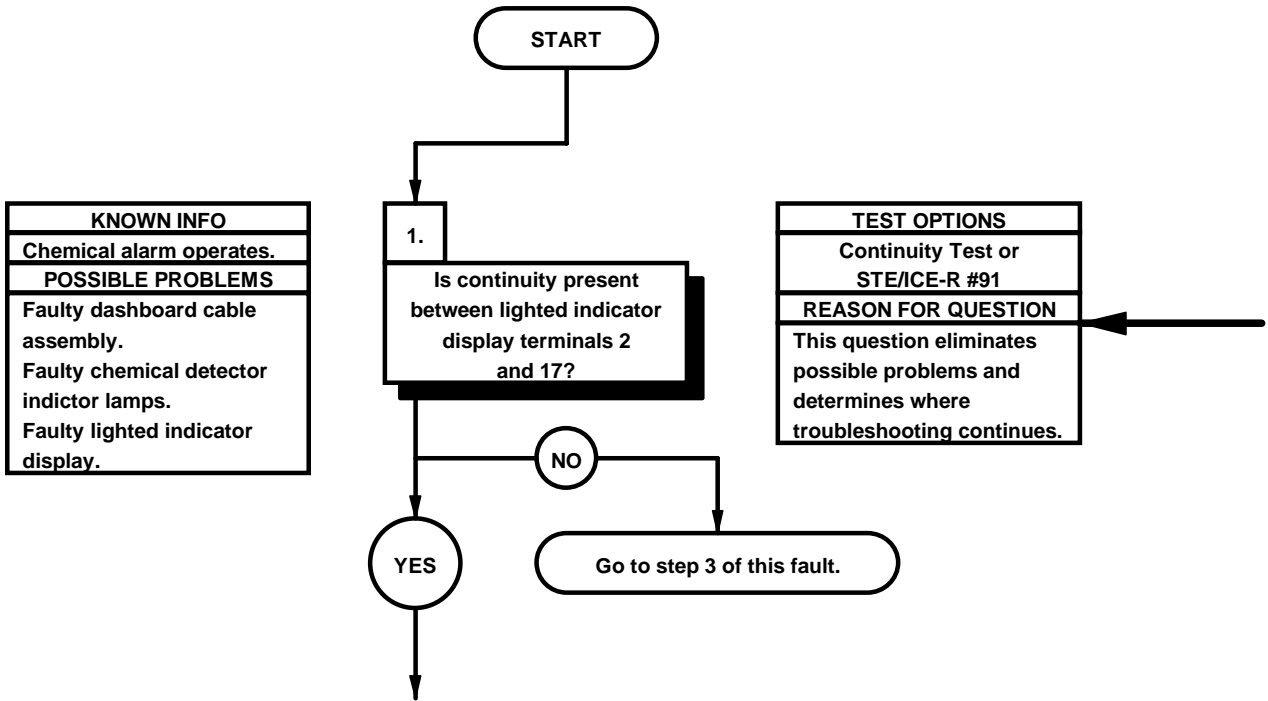

CONTINUITY TEST

- (1) Remove four screws from lighted indicator display.
- (2) Remove lighted indicator display from instrument panel assembly.
- (3) Disconnect connector PX7 from lighted indicator display.
- (4) Set multimeter to ohms.
- (5) Connect positive (+) probe of multimeter to lighted indicator display terminal 2.
- (6) Connect negative (-) probe of multimeter to lighted indicator display terminal 17 and note reading on multimeter.
- (7) If continuity is not present, go to step 3 of this fault.

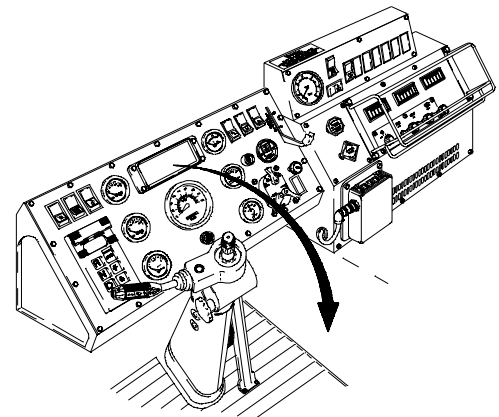

BOTTOM

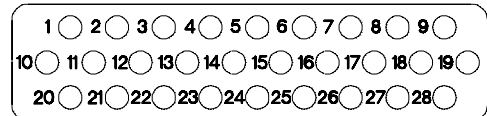

LIGHTED INDICATOR DISPLAY

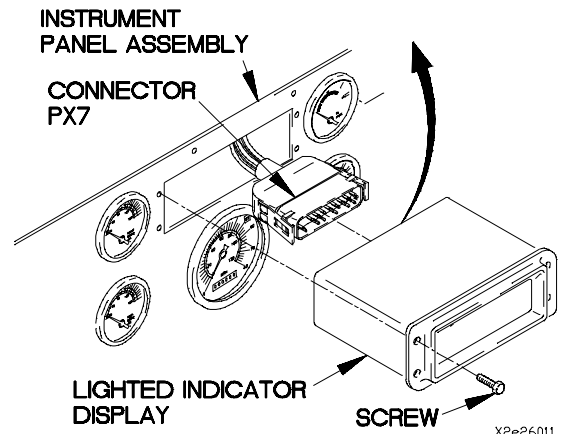

ø26. CHEMICAL DETECTOR INDICATOR DOES NOT OPERATE (CONT)

KNOWN INFO
Chemical alarm operates. Lighted indicator display OK
POSSIBLE PROBLEMS
Faulty dashboard cable assembly.

2.
Is continuity present between connector PX7-17 and a known good ground?

TEST OPTIONS
Continuity Test or STE/ICE-R #91
REASON FOR QUESTION
If continuity is not present, wire 3030 is faulty. If continuity is present, wire 1803 is faulty.

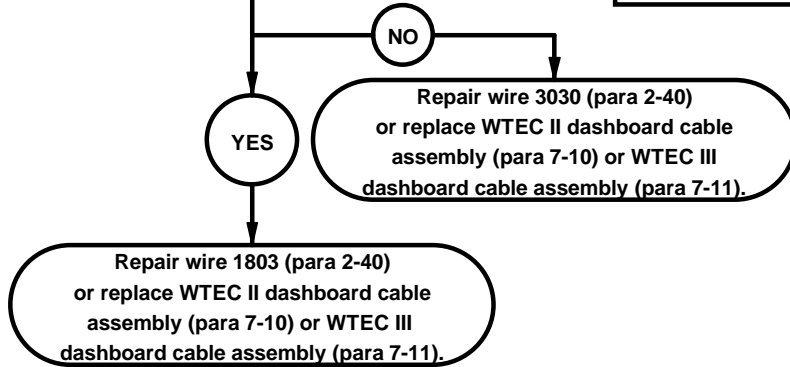

KNOWN INFO
Chemical alarm operates. Dashboard cable assembly OK.
POSSIBLE PROBLEMS
Faulty chemical detector indicator lamps. Faulty lighted indicator display.

3.
Is continuity present through chemical detector indicator lamps?

TEST OPTIONS
Continuity Test or STE/ICE-R #91
REASON FOR QUESTION
If continuity is not present, chemical detector indicator lamps are faulty. If continuity is present, lighted indicator display is faulty.

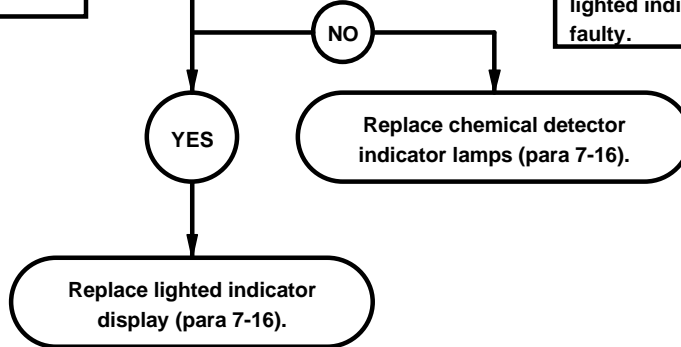

CONTINUITY TEST

- (1) Set multimeter to ohms.
- (2) Connect positive (+) probe of multimeter to connector PX7-17.
- (3) Connect negative (-) probe of multimeter to ground and note reading on multimeter.
- (4) If continuity is not present, repair wire 3030 (para 2-40) or replace WTEC II dashboard cable assembly (para 7-10) or WTEC III dashboard cable assembly (para 7-11).
- (5) If continuity is present, repair wire 1803 (para 2-40) or replace WTEC II dashboard cable assembly (para 7-10) or WTEC III dashboard cable assembly (para 7-11).
- (6) Connect lighted indicator display to connector PX7.
- (7) Position lighted indicator display in instrument panel assembly with four screws.
- (8) Tighten four screws to 6-10 lb-in. (1 N-m).
- (9) Connect batteries (para 7-48).

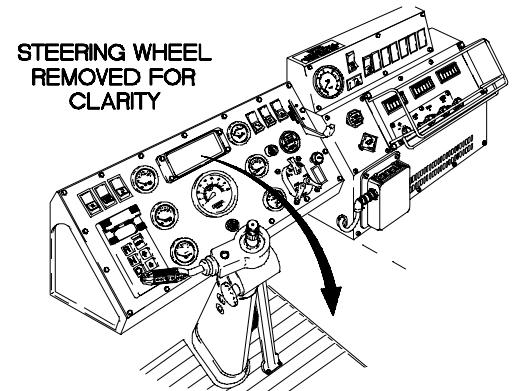

TOP

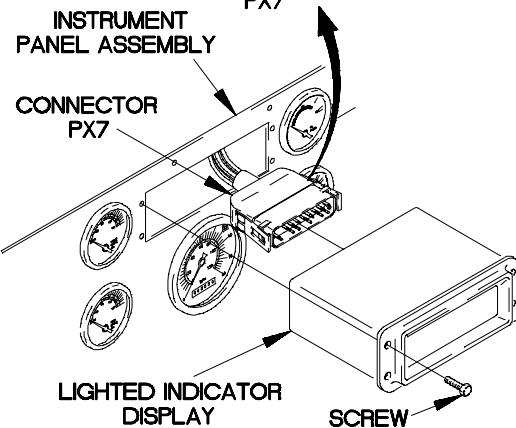
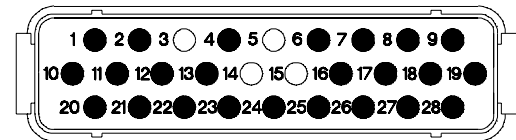

CONTINUITY TEST

- (1) Loosen four captive screws in lamp mounting panel.
- (2) Remove lamp mounting panel from lighted indicator display housing.
- (3) Remove chemical detector indicator lamps from printed circuit board.
- (4) Set multimeter to ohms.
- (5) Check continuity through each chemical detector indicator lamp and note reading on multimeter.
- (6) If continuity is not present, replace lamps (para 7-16).
- (7) If continuity is present, replace lighted indicator display (para 7-16).
- (8) Install chemical detector indicator lamps in printed circuit board.
- (9) Install lamp mounting panel in lighted indicator display housing.
- (10) Tighten four captive screws in lamp mounting panel.
- (11) Connect lighted indicator display to connector PX7.
- (12) Position lighted indicator display in instrument panel assembly with four screws.
- (13) Tighten four screws to 6-10 lb-in. (1 N-m).
- (14) Connect batteries (para 7-48).

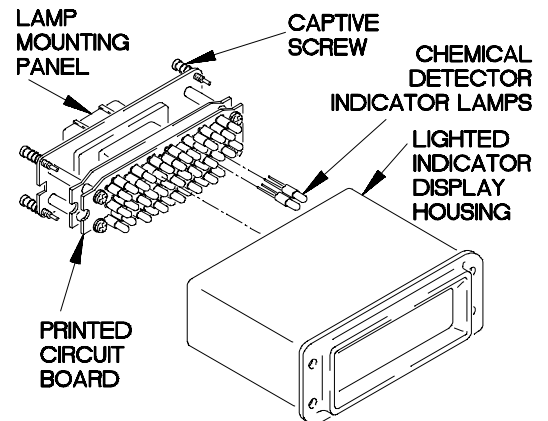

X2e26021

e27. LEFT TURN SIGNAL INDICATOR DOES NOT OPERATE	
INITIAL SETUP	
Equipment Condition Engine shut down (TM 9-2320-365-10). Batteries disconnected (para 7-48).	Tools and Special Tools Tool Kit, Genl Mech (Item 44, Appendix C) STE/ICE-R (Item 39, Appendix C) Multimeter, Digital (Item 22, Appendix C) Wrench, Torque, 0-75 lb-in. (Item 86, Appendix B)
Personnel Required (2)	References TM 9-4910-571-12&P

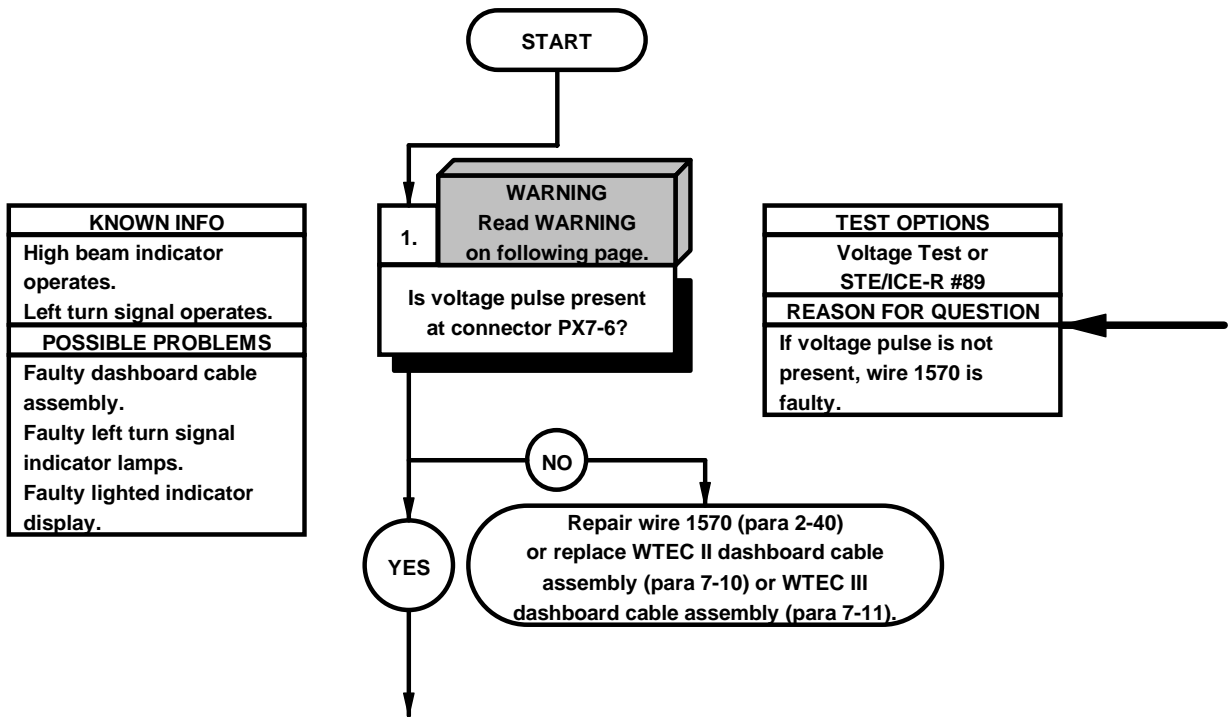

WARNING

Remove rings, bracelets, watches, necklaces, and any other jewelry before working around vehicle. Jewelry can catch on equipment and cause injury or short across electrical circuit and cause severe burns or electrical shock.

VOLTAGE TEST

- (1) Remove four screws from lighted indicator display.
- (2) Remove lighted indicator display from instrument panel assembly.
- (3) Disconnect connector PX7 from lighted indicator display.
- (4) Connect batteries (para 7-48).
- (5) Set multimeter to volts dc.
- (6) Connect positive (+) probe of multimeter to connector PX7-6.
- (7) Connect negative (-) probe of multimeter to ground.
- (8) Position master power switch to on (TM 9-2320-365-10).
- (9) Position main light switch to SER DRIVE (TM 9-2320-365-10).
- (10) Position turn signal to left turn signal position (TM 9-2320-365-10) and note reading on multimeter.
- (11) If voltage pulse is not present, repair wire 1570 (para 2-40) or replace WTEC II dashboard cable assembly (para 7-10) or WTEC III dashboard cable assembly (para 7-11).
- (12) Position master power switch to off (TM 9-2320-365-10).
- (13) Position main light switch to OFF (TM 9-2320-365-10).
- (14) Position turn signal switch to middle position (TM 9-2320-365-10).

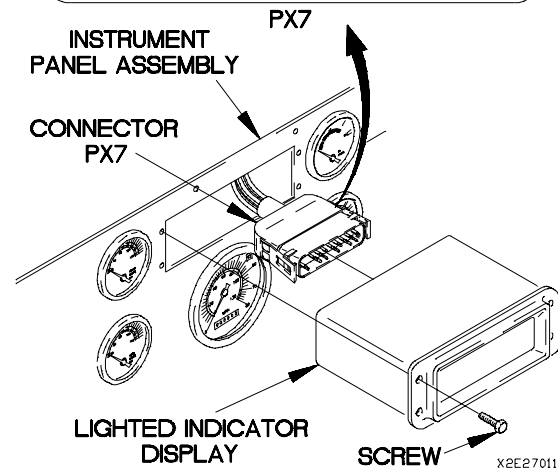
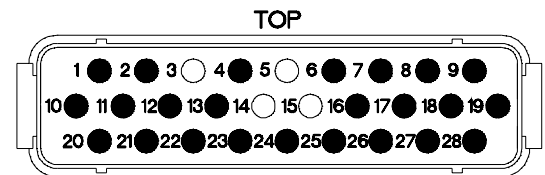
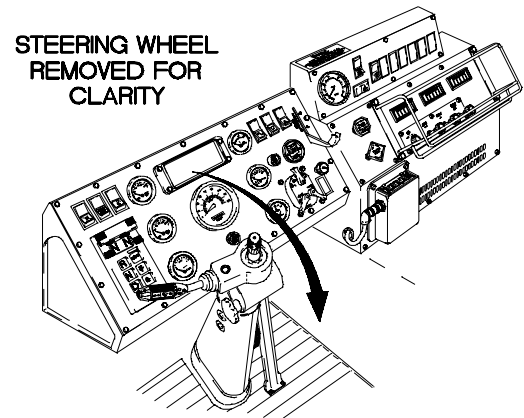

ø27. LEFT TURN SIGNAL INDICATOR DOES NOT OPERATE (CONT)

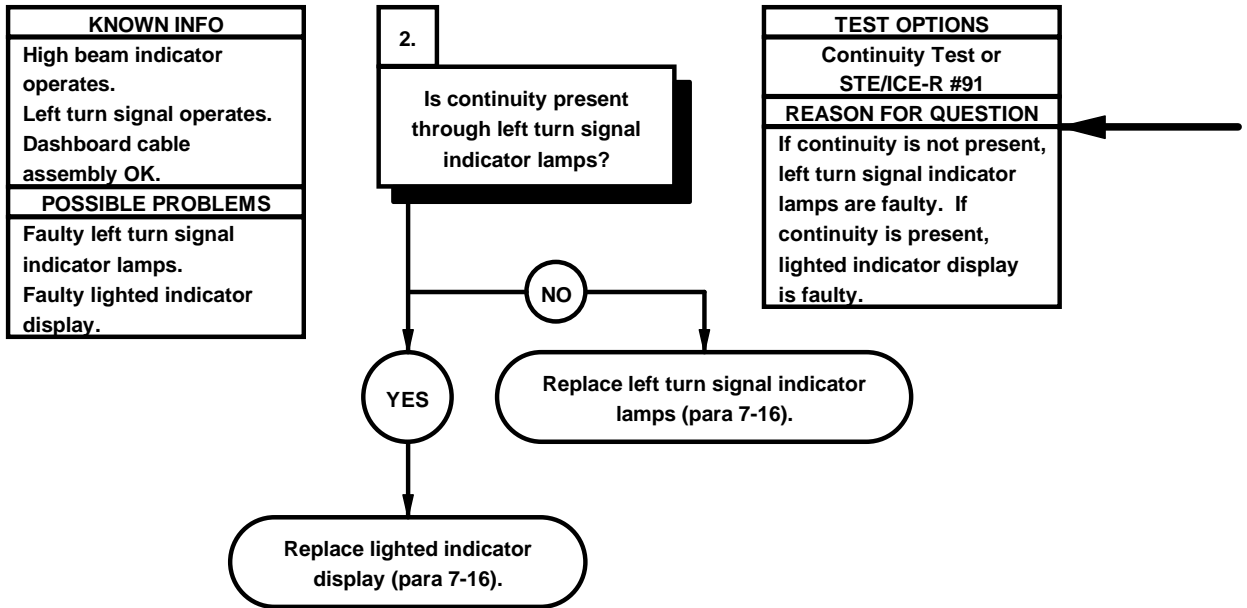

CONTINUITY TEST

- (1) Loosen four captive screws in lamp mounting panel.
- (2) Remove lamp mounting panel from lighted indicator display housing.
- (3) Remove left turn signal indicator lamps from printed circuit board.
- (4) Set multimeter to ohms.
- (5) Check continuity through each left turn signal indicator lamp and note reading on multimeter.
- (6) If continuity is not present, replace lamps (para 7-16).
- (7) If continuity is present, replace lighted indicator display (para 7-16).
- (8) Install left turn signal indicator lamps in printed circuit board.
- (9) Install lamp mounting panel in lighted indicator display housing.
- (10) Tighten four captive screws in lamp mounting panel.
- (11) Disconnect batteries (para 7-48).
- (12) Connect lighted indicator display to connector PX7.
- (13) Position lighted indicator display in instrument panel assembly with four screws.
- (14) Tighten four screws to 6-10 lb-in. (1 N-m).

STEERING WHEEL
REMOVED FOR
CLARITY

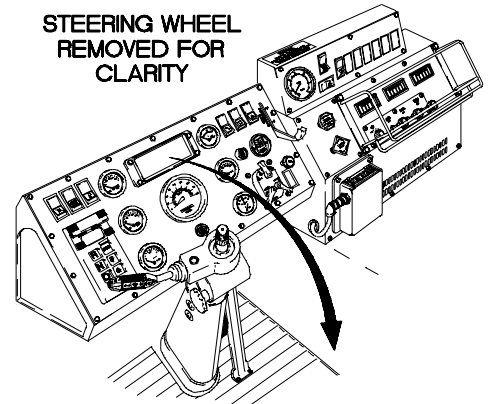

INSTRUMENT PANEL
ASSEMBLY

CONNECTOR
PX7

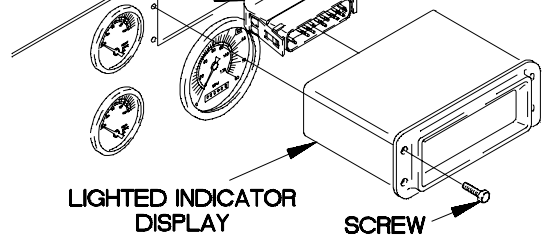

LIGHTED INDICATOR
DISPLAY

SCREW

LAMP
MOUNTING
PANEL

CAPTIVE
SCREW

PRINTED
CIRCUIT
BOARD

LIGHTED
INDICATOR
DISPLAY
HOUSING

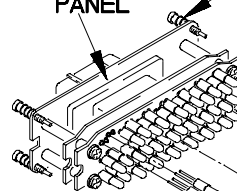

LEFT TURN
SIGNAL
INDICATOR
LAMPS

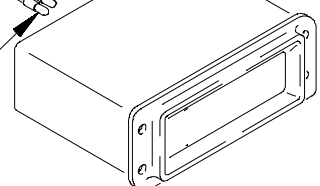

X2E27021

e28. RIGHT TURN SIGNAL INDICATOR DOES NOT OPERATE	
INITIAL SETUP	
Equipment Condition Engine shut down (TM 9-2320-365-10). Batteries disconnected (para 7-48).	Tools and Special Tools Tool Kit, Genl Mech (Item 44, Appendix C) STE/ICE-R (Item 39, Appendix C) Multimeter, Digital (Item 22, Appendix C) Wrench, Torque, 0-75 lb-in. (Item 86, Appendix B)
Personnel Required (2)	References TM 9-4910-571-12&P

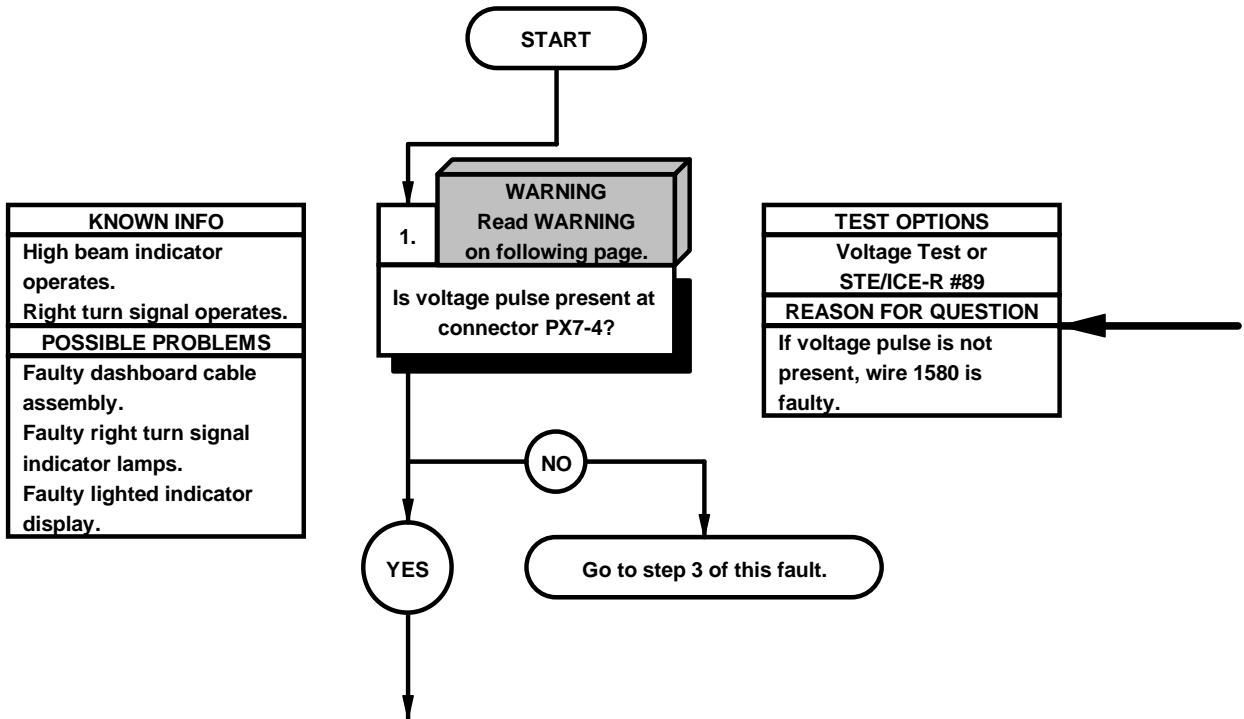

WARNING

Remove rings, bracelets, watches, necklaces, and any other jewelry before working around vehicle. Jewelry can catch on equipment and cause injury or short across electrical circuit and cause severe burns or electrical shock.

VOLTAGE TEST

- (1) Remove four screws from lighted indicator display.
- (2) Remove lighted indicator display from instrument panel assembly.
- (3) Disconnect connector PX7 from lighted indicator display.
- (4) Connect batteries (para 7-48).
- (5) Set multimeter to volts dc.
- (6) Connect positive (+) probe of multimeter to connector PX7-4.
- (7) Connect negative (-) probe of multimeter to ground.
- (8) Position master power switch to on (TM 9-2320-365-10).
- (9) Position main light switch to SER DRIVE (TM 9-2320-365-10).
- (10) Position right signal to right turn signal position (TM 9-2320-365-10) and note reading on multimeter.
- (11) If voltage pulse is not present, go to step 3 of this fault.
- (12) Position master power switch to off (TM 9-2320-365-10).
- (13) Position main light switch to OFF (TM 9-2320-365-10).
- (14) Position turn signal control to middle position (TM 9-2320-365-10).

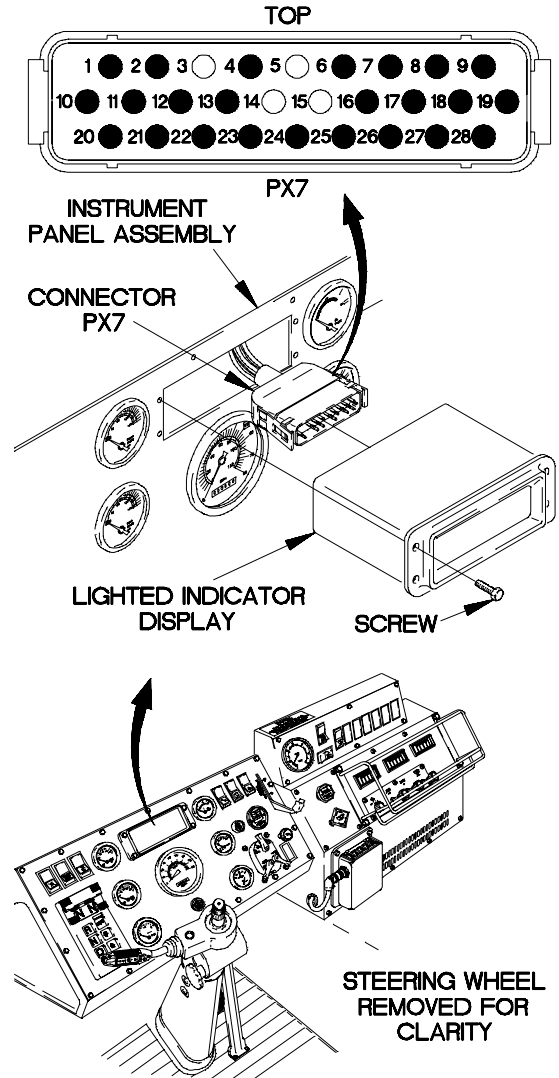

X2E28011

ø28. RIGHT TURN SIGNAL INDICATOR DOES NOT OPERATE (CONT)

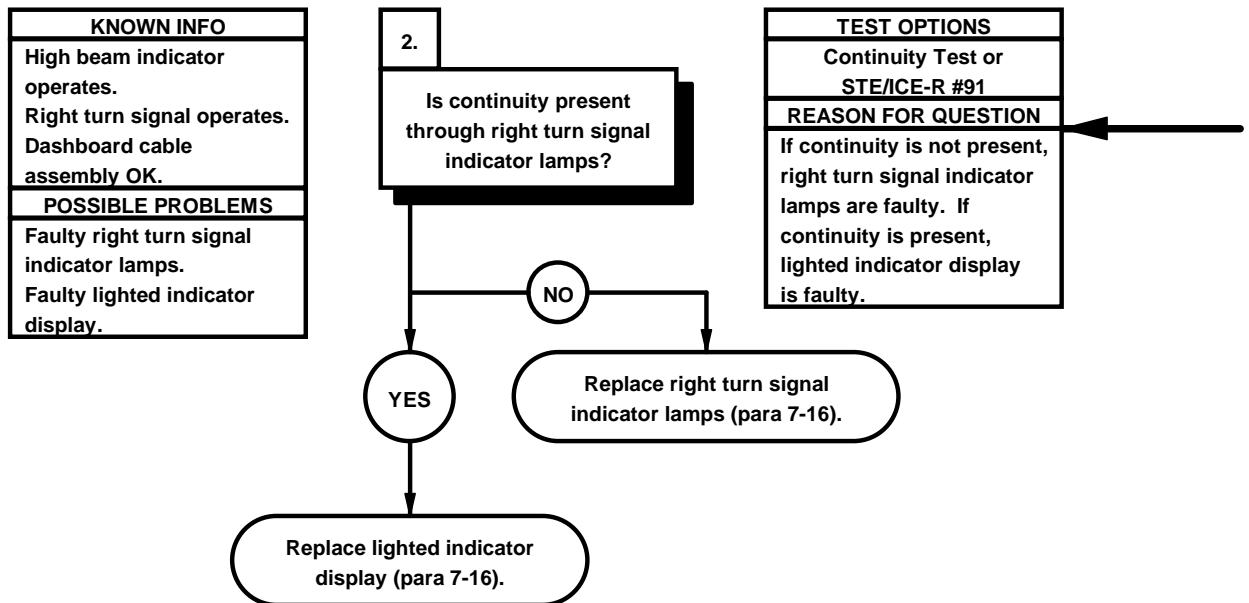

CONTINUITY TEST

- (1) Loosen four captive screws in lamp mounting panel.
- (2) Remove lamp mounting panel from lighted indicator display housing.
- (3) Remove right turn signal indicator lamps from printed circuit board.
- (4) Set multimeter to ohms.
- (5) Check continuity through each right turn signal indicator lamp and note reading on multimeter.
- (6) If continuity is not present, replace lamps (para 7-16).
- (7) If continuity is present, replace lighted indicator display (para 7-16).
- (8) Install right turn signal indicator lamps in printed circuit board.
- (9) Install lamp mounting panel in lighted indicator display housing.
- (10) Tighten four captive screws in lamp mounting panel.
- (11) Disconnect batteries (para 7-48).
- (12) Connect lighted indicator display to connector PX7.
- (13) Position lighted indicator display in instrument panel assembly with four screws.
- (14) Tighten four screws to 6-10 lb-in. (1 N-m).
- (15) Connect batteries (para 7-48).

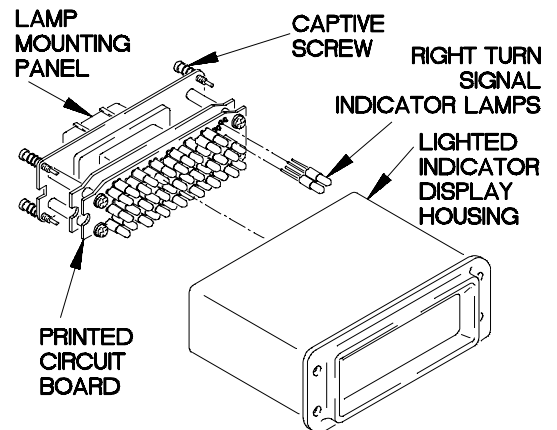
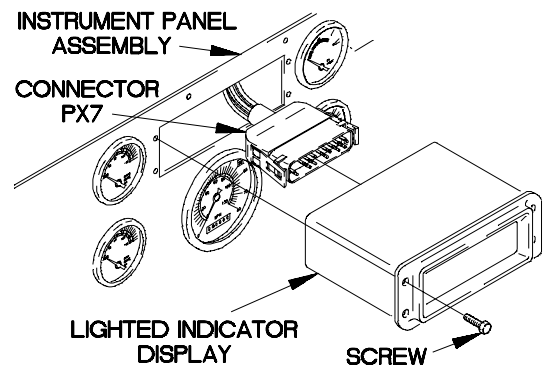
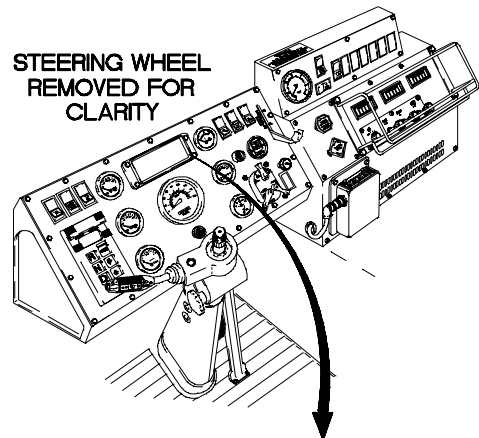

X2E28021

28. RIGHT TURN SIGNAL INDICATOR DOES NOT OPERATE (CONT)

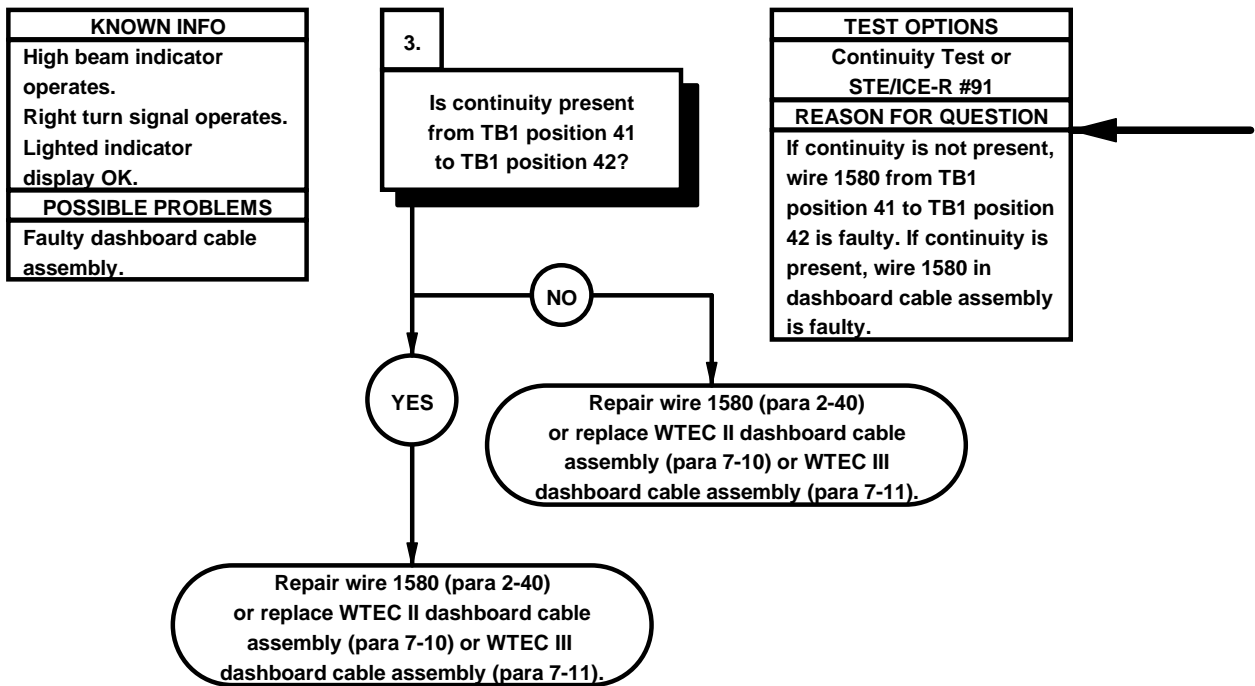

CONTINUITY TEST

- (1) Disconnect batteries (para 7-48).
- (2) Remove PDP cover (para 16-2).
- (3) Remove three screws and washers from PDP.
- (4) Remove three screws from PDP.
- (5) Lift PDP outward to gain access.
- (6) Connect positive (+) probe of multimeter to TB1 position 41.
- (7) Connect negative (-) probe of multimeter to TB1 position 42 and note reading on multimeter.
- (8) If continuity is not present, repair wire 1580 from TB1 position 41 to TB1 position 42 (para 2-40) or replace WTEC II dashboard cable assembly (para 7-10) or WTEC III dashboard cable assembly (para 7-11).
- (9) If continuity is present, repair wire 1580 in dashboard cable assembly (para 2-40) or replace WTEC II dashboard cable assembly (para 7-10) or WTEC III dashboard cable assembly (para 7-11).
- (10) Install PDP on dashboard with three screws.
- (11) Install three washers and screws in PDP.
- (12) Install PDP cover (para 16-2).
- (13) Connect lighted indicator display to connector PX7.
- (14) Position lighted indicator display in instrument panel assembly with four screws.
- (15) Tighten four screws to 6-10 lb-in. (1 N-m).
- (16) Connect batteries (para 7-48).

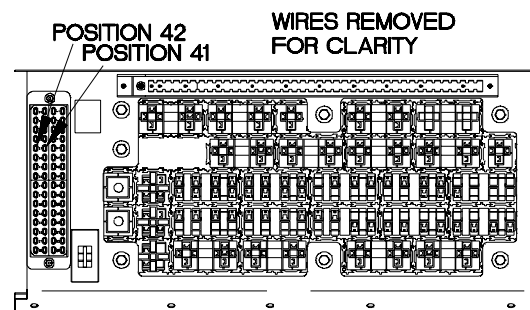
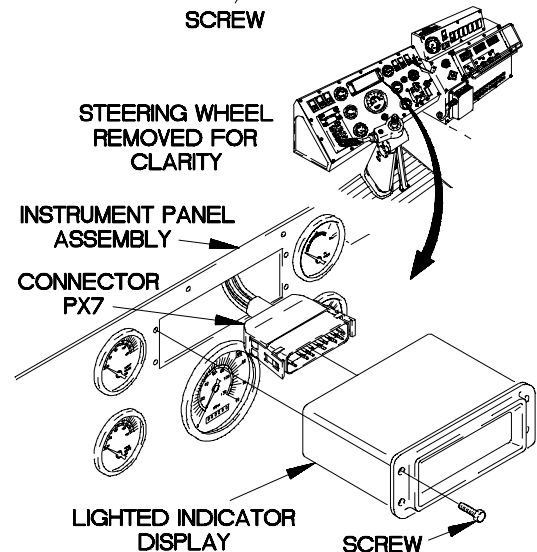
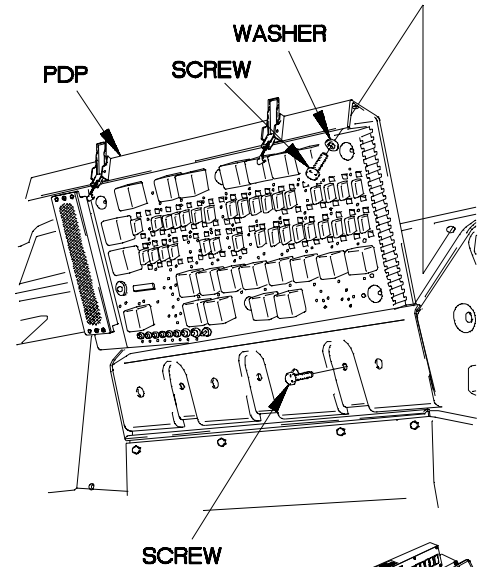

X2E28031

e29. TURN SIGNAL INDICATORS AND HIGH BEAMS ON INDICATOR DO NOT OPERATE	
INITIAL SETUP	
Equipment Condition Engine shut down (TM 9-2320-365-10). Batteries disconnected (para 7-48).	Tools and Special Tools Tool Kit, Genl Mech (Item 44, Appendix C) STE/ICE-R (Item 39, Appendix C) Multimeter, Digital (Item 22, Appendix C) Wrench, Torque, 0-75 lb-in. (Item 86, Appendix B)
Personnel Required (2)	References TM 9-4910-571-12&P

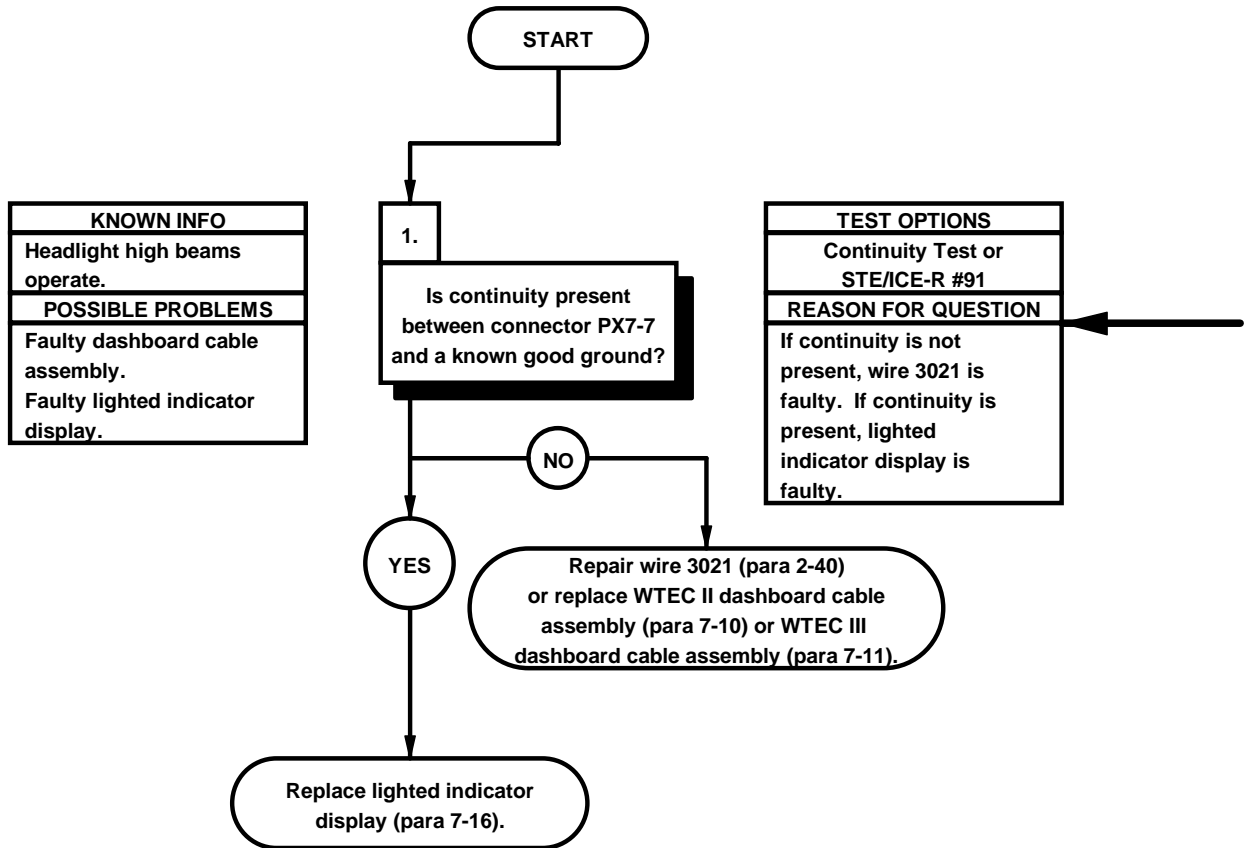

CONTINUITY TEST

- (1) Remove four screws from lighted indicator display.
- (2) Remove lighted indicator display from instrument panel assembly.
- (3) Disconnect connector PX7 from lighted indicator display.
- (4) Set multimeter to ohms.
- (5) Connect positive (+) probe of multimeter to connector PX7-7.
- (6) Connect negative (-) probe of multimeter to ground and note reading on multimeter.
- (7) If continuity is not present, repair wire 3021 (para 2-40) or replace WTEC II dashboard cable assembly (para 7-10) or WTEC III dashboard cable assembly (para 7-11).
- (8) If continuity is present, replace lighted indicator display (para 7-16).
- (9) Connect lighted indicator display to connector PX7.
- (10) Position lighted indicator display in instrument panel assembly with four screws.
- (11) Tighten four screws to 6-10 lb-in. (1 N-m).
- (12) Connect batteries (para 7-48).

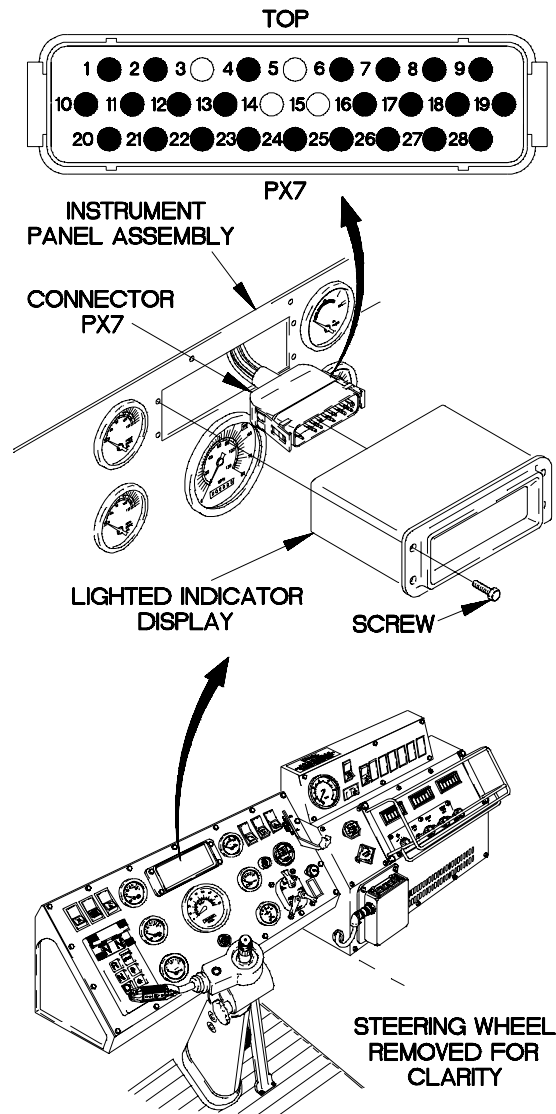

X2E29011

e30. HIGH BEAMS ON INDICATOR DOES NOT OPERATE	
INITIAL SETUP	
Equipment Condition Engine shut down (TM 9-2320-365-10). Batteries disconnected (para 7-48).	Tools and Special Tools Tool Kit, Genl Mech (Item 44, Appendix C) STE/ICE-R (Item 39, Appendix C) Multimeter, Digital (Item 22, Appendix C) Wrench, Torque, 0-75 lb-in. (Item 86, Appendix B)
Personnel Required (2)	References TM 9-4910-571-12&P

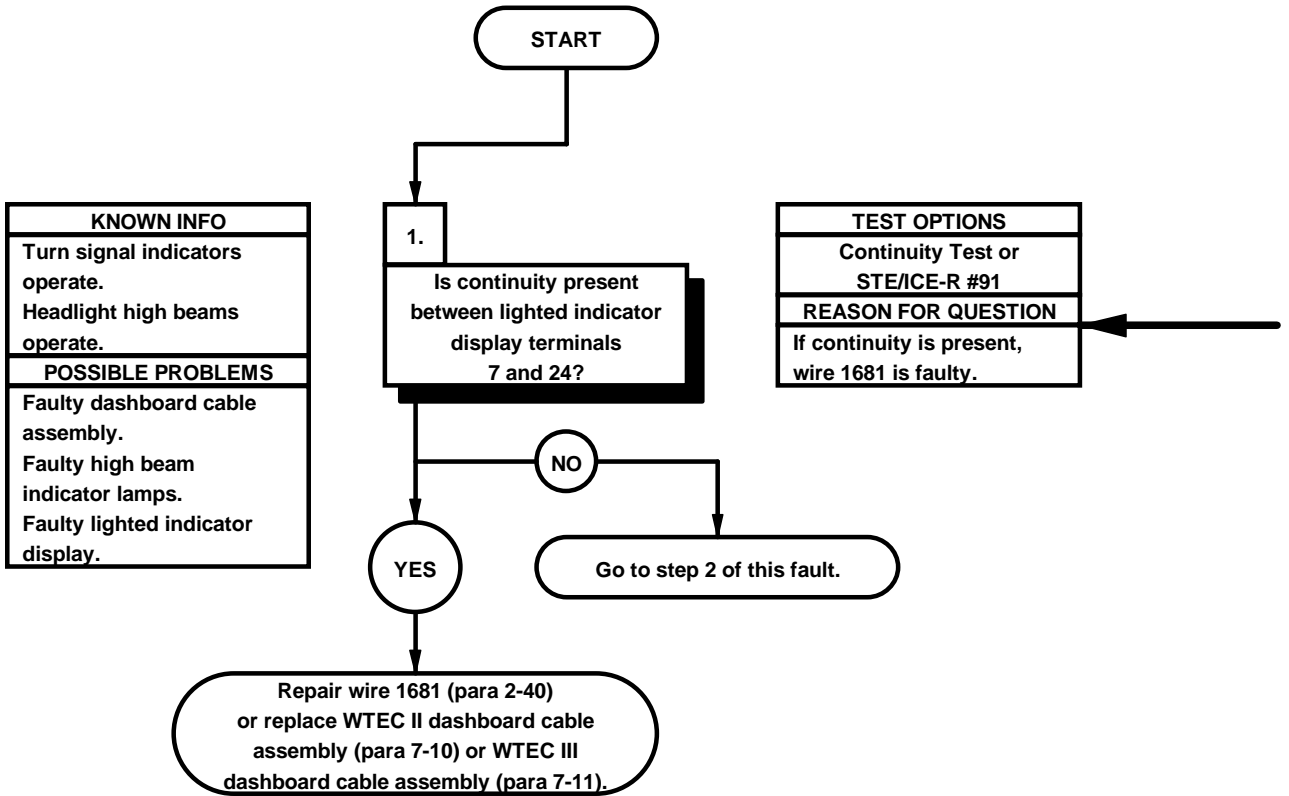

CONTINUITY TEST

- (1) Remove four screws from lighted indicator display.
- (2) Remove lighted indicator display from instrument panel assembly.
- (3) Disconnect connector PX7 from lighted indicator display.
- (4) Set multimeter to ohms.
- (5) Connect positive (+) probe of multimeter to lighted indicator display terminal 7.
- (6) Connect negative (-) probe of multimeter to lighted indicator display terminal 24 and note reading on multimeter.
- (7) If continuity is present, repair wire 1681 (para 2-40) or replace WTEC II dashboard cable assembly (para 7-10) or WTEC III dashboard cable assembly (para 7-11).

STEERING WHEEL
REMOVED FOR
CLARITY

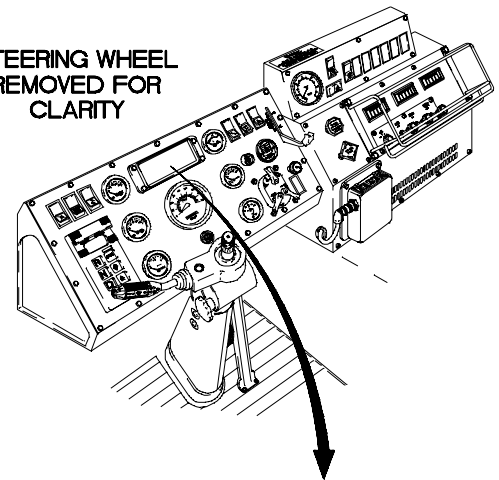

BOTTOM

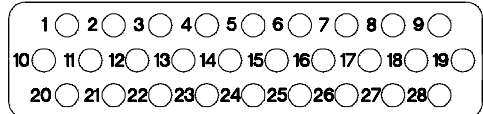

LIGHTED INDICATOR DISPLAY

**INSTRUMENT
PANEL ASSEMBLY**

**CONNECTOR
PX7**

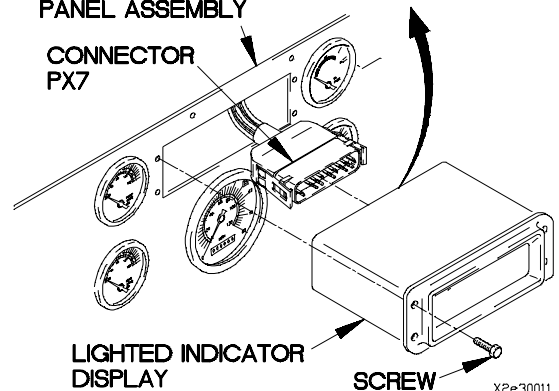

ø30. HIGH BEAMS ON INDICATOR DOES NOT OPERATE (CONT)

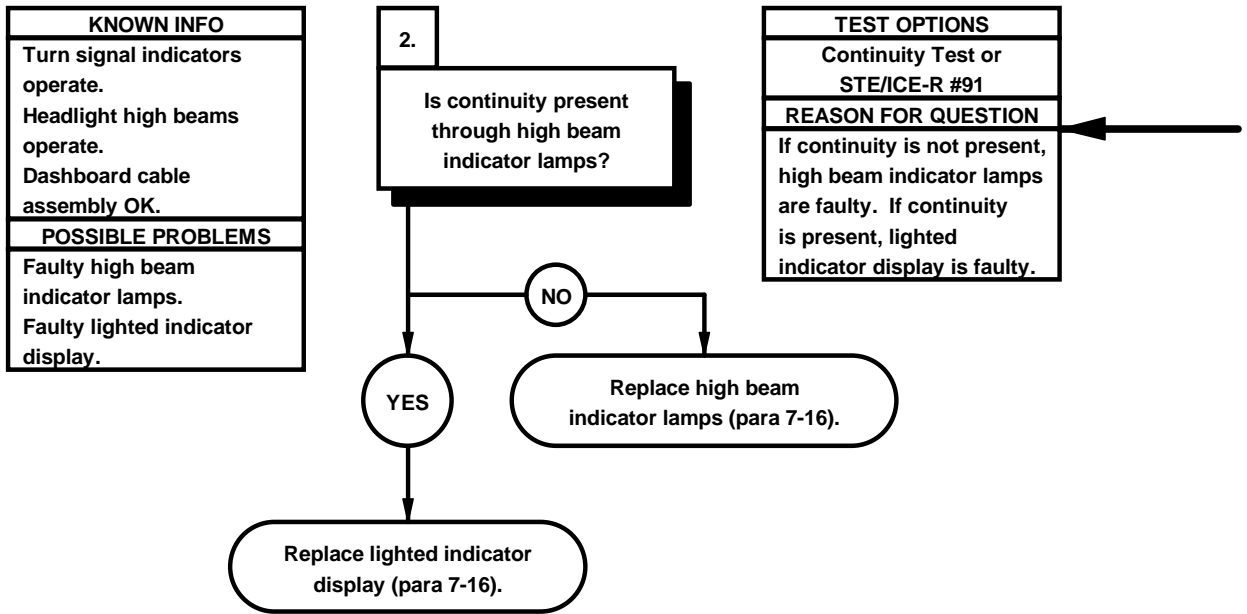

CONTINUITY TEST

- (1) Loosen four captive screws in lamp mounting panel.
- (2) Remove lamp mounting panel from lighted indicator display housing.
- (3) Remove high beam indicator lamps from printed circuit board.
- (4) Set multimeter to ohms.
- (5) Check continuity through each high beam indicator lamp and note reading on multimeter.
- (6) If continuity is not present, replace lamps (para 7-16).
- (7) If continuity is present, replace lighted indicator display (para 7-16).
- (8) Install high beam indicator lamps in printed circuit board.
- (9) Install lamp mounting panel in lighted indicator display housing.
- (10) Tighten four captive screws in lamp mounting panel.
- (11) Connect lighted indicator display to connector PX7.
- (12) Position lighted indicator display in instrument panel assembly with four screws.
- (13) Tighten four screws to 6-10 lb-in. (1 N·m).
- (14) Connect batteries (para 7-48).

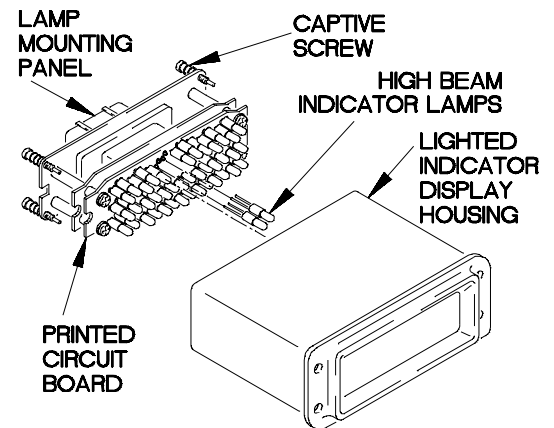
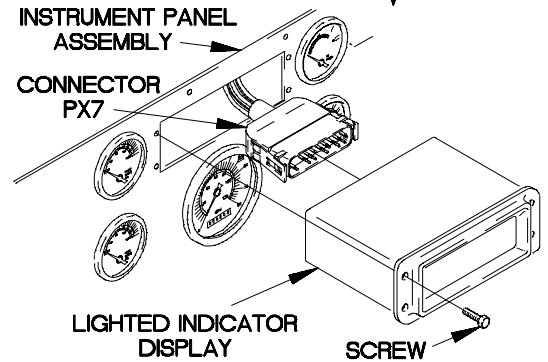
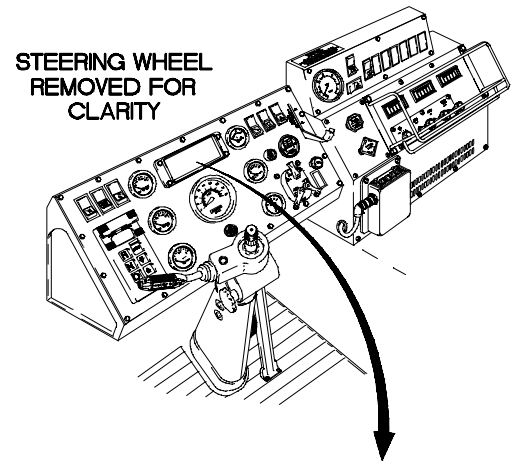

X2E30021

e31. PARKING BRAKE INDICATOR AND/OR EMERGENCY BRAKE INDICATOR DOES NOT ILLUMINATE

INITIAL SETUP

Equipment Conditions

Engine shut down (TM 9-2320-365-10).

Materials/Parts

Wire, Elect., 50 ft (Item 77, Appendix D)

Tools and Special Tools

Tool Kit, Genl Mech (Item 44, Appendix C)
 STE/ICR-R (Item 39, Appendix C)
 Multimeter, Digital (Item 22, Appendix C)
 Wrench, Torque, 0-200 lb-in. (Item 58, Appendix C)
 Wrench, Torque, 0-75 lb-in. (Item 86, Appendix B)

Personnel Required

(2)

References

TM 9-4910-571-12&P

NOTE

Perform Electrical System Troubleshooting e1. Circuit Breaker Does Not Operate on circuit breaker CB77 prior to beginning this task.

KNOWN INFO
Parking brake operates. Circuit breaker CB77 OK.
POSSIBLE PROBLEMS
Faulty front light cable assembly. Faulty low pressure transmitter. Faulty emergency brake indicator lamps. Faulty dashboard cable assembly. Faulty parking brake indicator lamps. Faulty lighted indicator display.

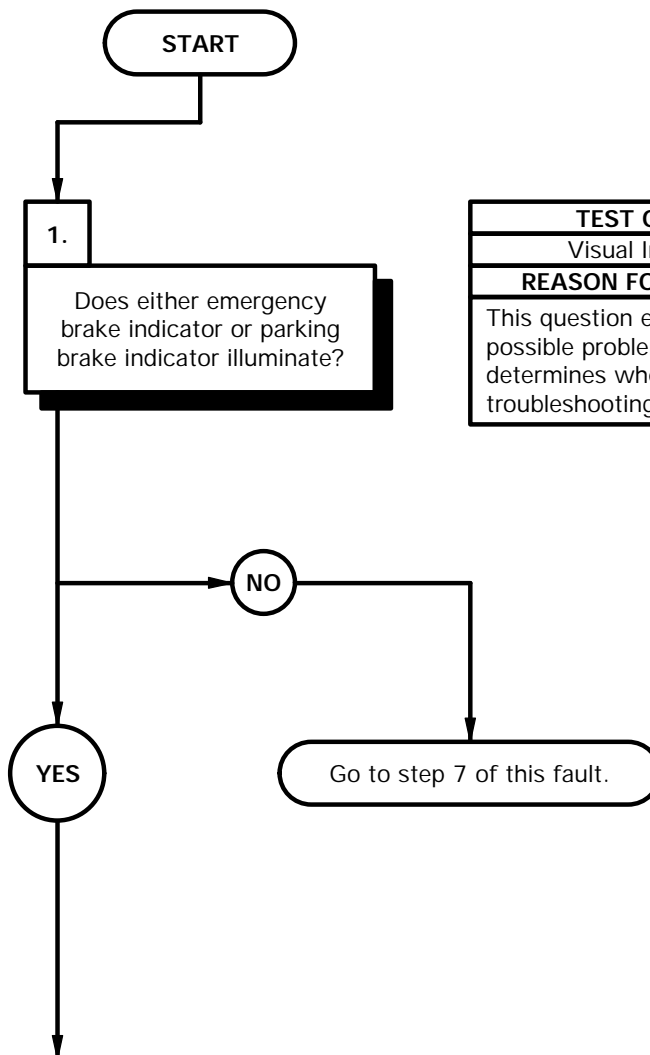

TEST OPTIONS
Visual Inspection
REASON FOR QUESTION
This question eliminates possible problems and determines where troubleshooting continues.

- (1) Start engine (TM 9-2320-365-10).
- (2) Visually check lighted indicator display.
- (3) If emergency brake and parking brake indicator lights both do not illuminate, go to step 7 of this fault.

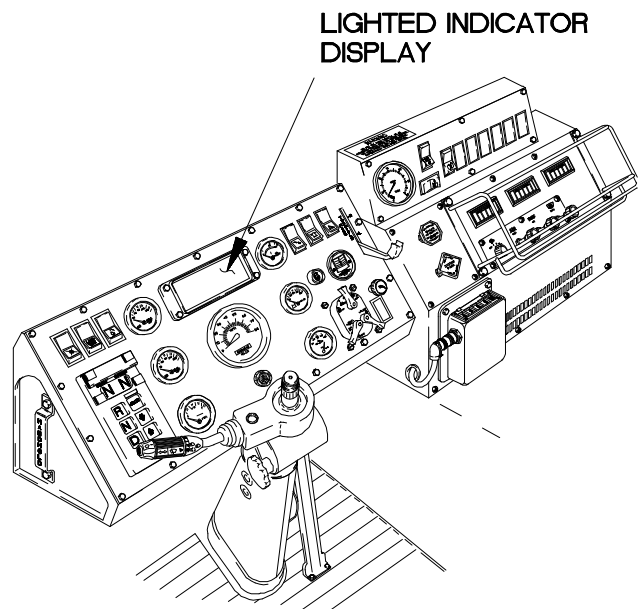

STEERING WHEEL
REMOVED FOR
CLARITY

XBE3101B

e31. PARKING BRAKE INDICATOR AND/OR EMERGENCY BRAKE INDICATOR DOES NOT ILLUMINATE (CONT)

KNOWN INFO
Parking brake operates. Circuit breaker CB77 OK. Front lights cable assembly OK. Low pressure transmitter OK.
POSSIBLE PROBLEMS
Faulty emergency brake indicator lamps. Faulty dashboard cable assembly. Faulty parking brake indicator lamps. Faulty lighted indicator display.

TEST OPTIONS
Visual Inspection
REASON FOR QUESTION
This question eliminates possible problems and determines where troubleshooting continues.

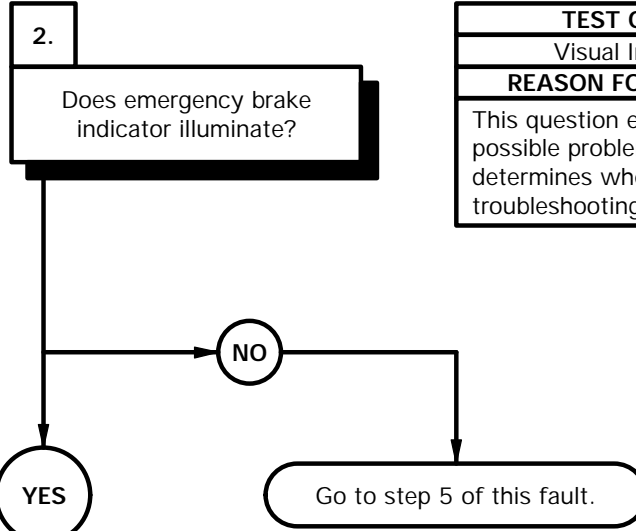

KNOWN INFO
Parking brake operates. Circuit breaker CB77 OK. Front lights cable assembly OK. Low pressure transmitter OK. Emergency brake indicator lamps OK.
POSSIBLE PROBLEMS
Faulty dashboard cable assembly. Faulty parking brake indicator lamps. Faulty lighted indicator display.

CAUTION
Read CAUTION on following page.

TEST OPTIONS
Continuity Test or STE/ICE-R Test #91
REASON FOR QUESTION
If continuity is present, wire 1616 is faulty.

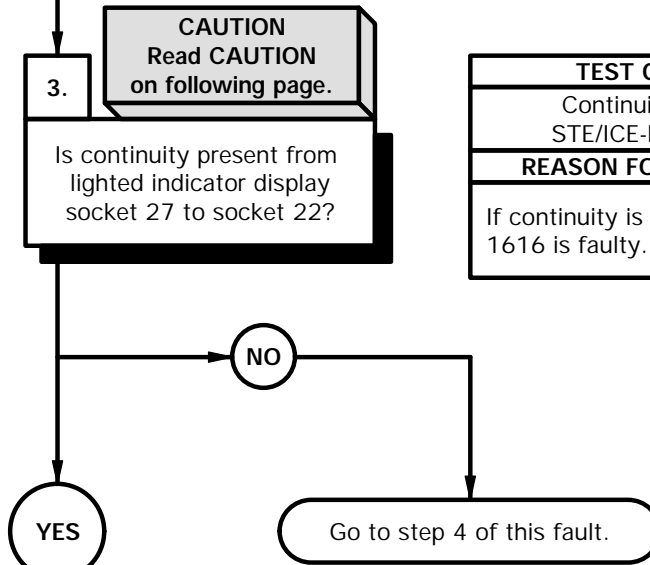

Repair wire 1616 from connector PX7 pin 22 to splice E2 (para 2-40) or replace WTEC II dashboard cable assembly (para 7-10) or WTEC III dashboard cable assembly (para 7-11).

- (1) Visually check lighted indicator display.
- (2) If emergency brake indicator does not illuminate, go to step 5 of this fault.
- (3) Shut down engine (TM 9-2320-365-10).

CAUTION

Use care when testing electrical connectors. Do not damage connector pins or sockets with multimeter probes. Failure to comply may result in damage to equipment.

NOTE

Inspect connector pins/sockets for damage, corrosion, and serviceability. Check that connector pins are not pushed back and are capable of making good contact.

CONTINUITY TEST

- (1) Disconnect batteries (para 7-48).
- (2) Remove four screws from lighted indicator display.
- (3) Remove lighted indicator display from instrument panel assembly.
- (4) Disconnect connector PX7 from lighted indicator display.
- (5) Set multimeter to ohms.
- (6) Connect positive (+) probe of multimeter to lighted indicator display socket 27.
- (7) Connect negative (-) probe of multimeter to lighted indicator display socket 22 and note reading on multimeter.
- (8) If continuity is not present, go to step 4 of this fault.
- (9) If continuity is present, repair wire 1616 from connector PX7 pin 22 to splice E2 (para 2-40) or replace WTEC II dashboard cable assembly (para 7-10) or WTEC III dashboard cable assembly (para 7-11).

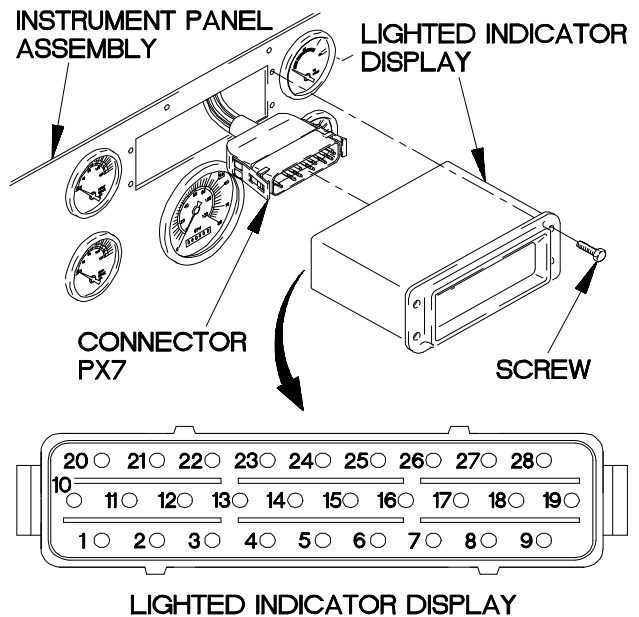
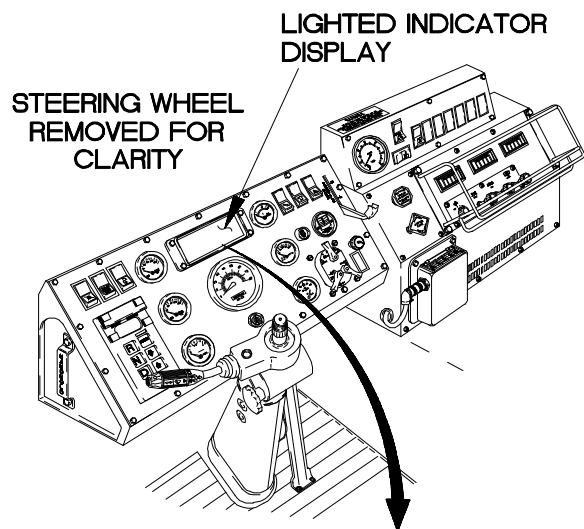

XBE3102B

e31. PARKING BRAKE INDICATOR AND/OR EMERGENCY BRAKE INDICATOR DOES NOT ILLUMINATE (CONT)

KNOWN INFO
Parking brake operates. Circuit breaker CB77 OK. Front lights cable assembly OK. Low pressure transmitter OK. Emergency brake indicator lamps OK. Dashboard cable assembly OK.
POSSIBLE PROBLEMS
Faulty parking brake indicator lamps. Faulty lighted indicator display.

4.
Is continuity present through both parking brake indicator lamps?

TEST OPTIONS
Continuity Test or STE/ICE-R Test #91
REASON FOR QUESTION
If continuity is not present, parking brake indicator lamps are faulty. If continuity is present, lighted indicator display is faulty.

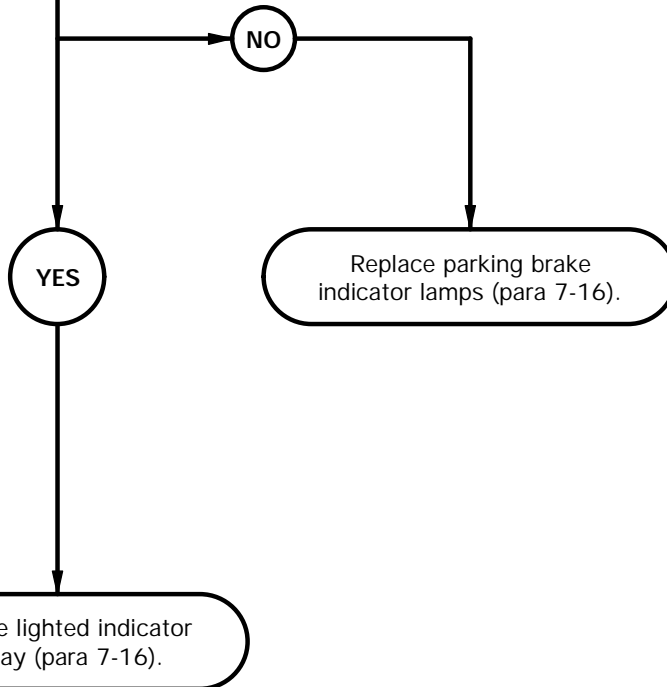

CONTINUITY TEST

- (1) Loosen four captive screws in lamp mounting panel.
- (2) Remove lamp mounting panel from lighted indicator display housing.
- (3) Remove parking brake indicator lamps from printed circuit board.
- (4) Set multimeter to ohms.
- (5) Check continuity through each parking brake indicator lamp and note reading on multimeter.
- (6) If continuity is not present in both lamps, replace lamps (para 7-16).
- (7) If continuity is present in either lamp, replace lighted indicator display (para 7-16).
- (8) Install parking brake indicator lamps in printed circuit board.
- (9) Install lamp mounting panel in lighted indicator display housing.
- (10) Tighten four captive screws in lamp mounting panel.
- (11) Connect lighted indicator display to connector PX7.
- (12) Position lighted indicator display in instrument panel assembly with four screws.
- (13) Tighten four screws to 6-10 lb-in. (1 N·m).
- (14) Connect batteries (para 7-48).

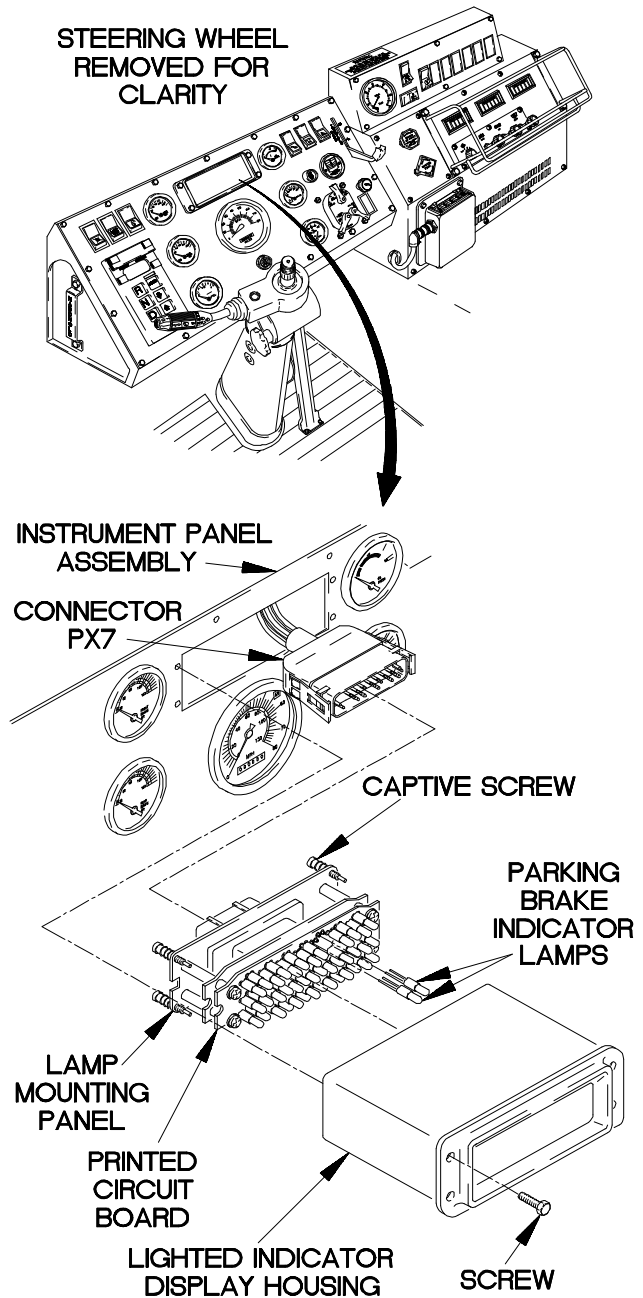

XBE3103B

e31. PARKING BRAKE INDICATOR AND/OR EMERGENCY BRAKE INDICATOR DOES NOT ILLUMINATE (CONT)

KNOWN INFO
Parking brake operates. Circuit breaker CB77 OK. Front lights cable assembly OK. Low pressure transmitter OK. Parking brake indicator lamps OK.
POSSIBLE PROBLEMS
Faulty dashboard cable assembly. Faulty emergency brake indicator lamps. Faulty lighted indicator display.

5. **CAUTION**
Read CAUTION on following page.

Is continuity present from lighted indicator display socket 27 to socket 11?

TEST OPTIONS
Continuity Test or STE/ICE-R Test #91
REASON FOR QUESTION
If continuity is present, wire 1616 is faulty.

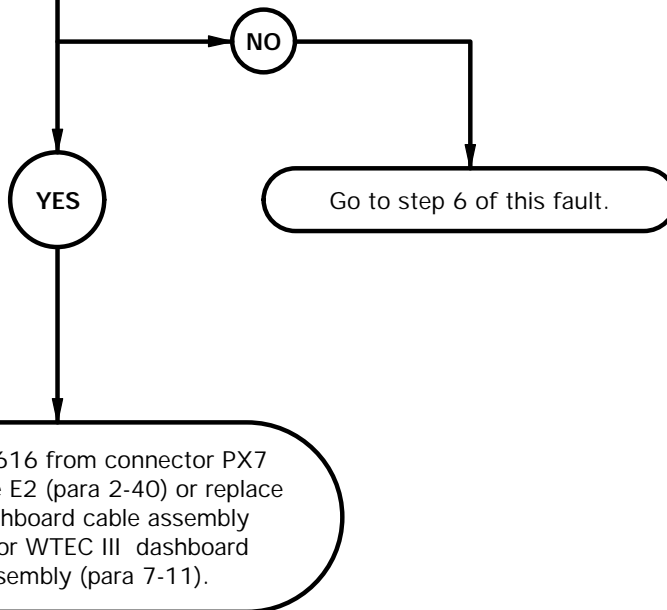

CAUTION

Use care when testing electrical connectors. Do not damage connector pins or sockets with multimeter probes. Failure to comply may result in damage to equipment.

NOTE

Inspect connector pins/sockets for damage, corrosion, and serviceability. Check that connector pins are not pushed back and are capable of making good contact.

CONTINUITY TEST

- (1) Disconnect batteries (para 7-48).
- (2) Remove four screws from lighted indicator display.
- (3) Remove lighted indicator display from instrument panel assembly.
- (4) Disconnect connector PX7 from lighted indicator display.
- (5) Set multimeter to ohms.
- (6) Connect positive (+) probe of multimeter to lighted indicator display socket 27.
- (7) Connect negative (-) probe of multimeter to lighted indicator display socket 11 and note reading on multimeter.
- (8) If continuity is not present, go to step 6 of this fault.
- (9) If continuity is present, repair wire 1616 from connector PX7 pin 11 to splice E2 (para 2-40) or replace WTEC II dashboard cable assembly (para 7-10) or WTEC III dashboard cable assembly (para 7-11).

STEERING WHEEL
REMOVED FOR
CLARITY

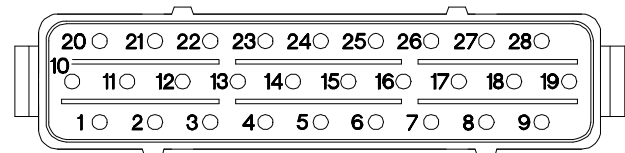
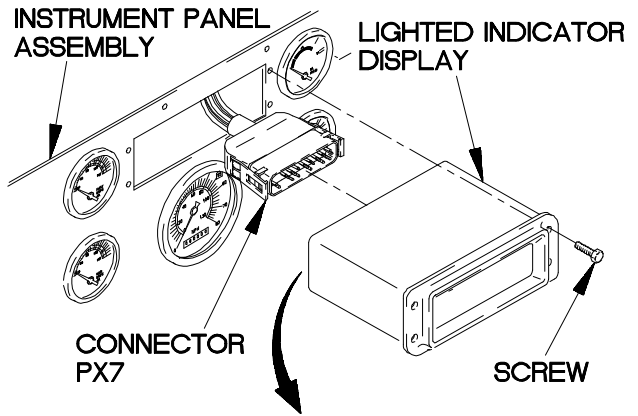
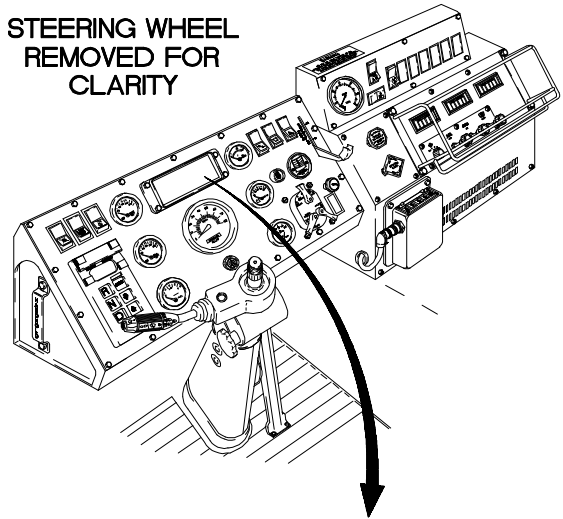

LIGHTED INDICATOR DISPLAY

XBE3104B

e31. PARKING BRAKE INDICATOR AND/OR EMERGENCY BRAKE INDICATOR DOES NOT ILLUMINATE (CONT)

KNOWN INFO
Parking brake operates. Circuit breaker CB77 OK. Front lights cable assembly OK. Low pressure transmitter OK. Parking brake indicator lamps OK. Dashboard cable assembly OK.
POSSIBLE PROBLEMS
Faulty emergency brake indicator lamps. Faulty lighted indicator display.

6.
Is continuity present through both emergency brake indicator lamps?

TEST OPTIONS
Continuity Test or STE/ICE-R Test #91
REASON FOR QUESTION
If continuity is not present, emergency brake indicator lamps are faulty. If continuity is present, lighted indicator display is faulty.

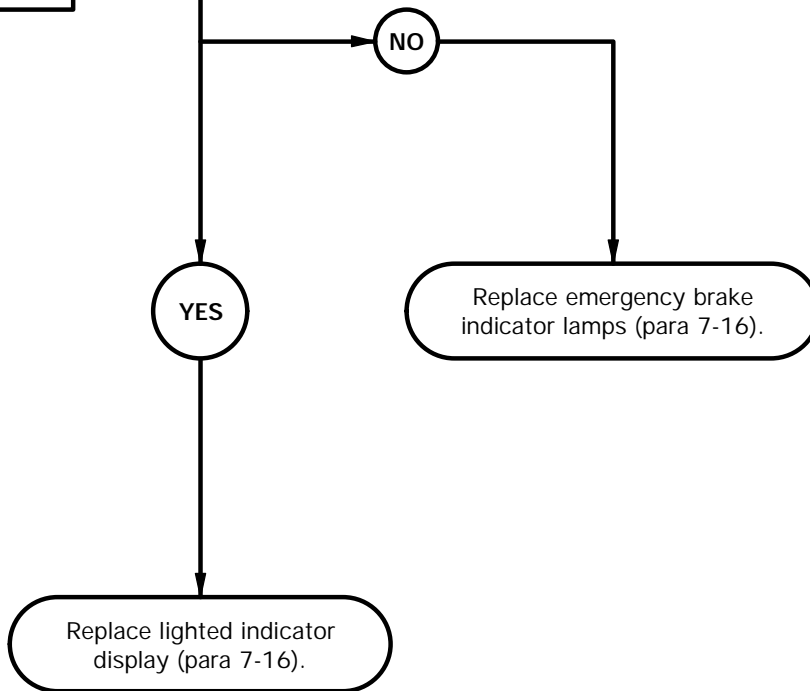

CONTINUITY TEST

- (1) Loosen four captive screws in lamp mounting panel.
- (2) Remove lamp mounting panel from lighted indicator display housing.
- (3) Remove emergency brake indicator lamps from printed circuit board.
- (4) Set multimeter to ohms.
- (5) Check continuity through each emergency brake indicator lamp and note reading on multimeter.
- (6) If continuity is not present in both lamps, replace lamps (para 7-16).
- (7) If continuity is present in either lamp, replace lighted indicator display (para 7-16).
- (8) Install emergency brake indicator lamps in printed circuit board.
- (9) Install lamp mounting panel in lighted indicator display housing.
- (10) Tighten four captive screws in lamp mounting panel.
- (11) Connect lighted indicator display to connector PX7.
- (12) Position lighted indicator display in instrument panel assembly with four screws.
- (13) Tighten four screws to 6-10 lb-in. (1 N·m).
- (14) Connect batteries (para 7-48).

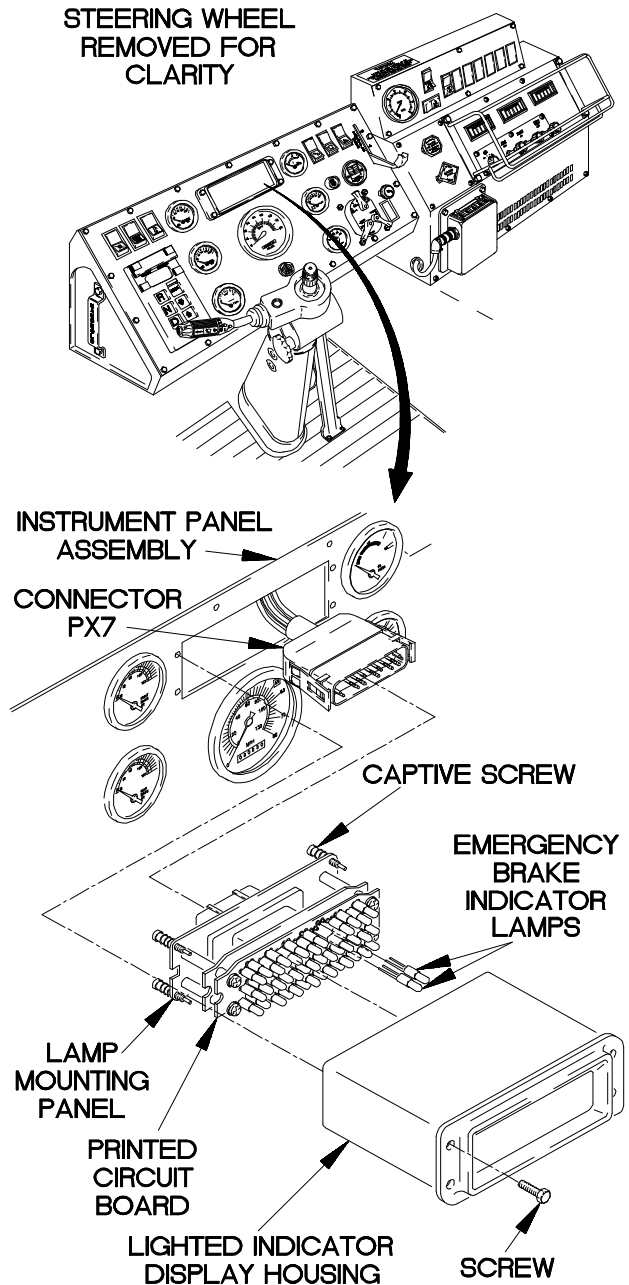

XBE3105B

e31. PARKING BRAKE INDICATOR AND/OR EMERGENCY BRAKE INDICATOR DOES NOT ILLUMINATE (CONT)

KNOWN INFO
Parking brake operates. Circuit breaker CB77 OK. Parking brake indicator lamps OK. Emergency brake indicator lamps OK.
POSSIBLE PROBLEMS
Faulty lighted indicator display. Faulty dashboard cable assembly. Faulty front lights cable assembly. Faulty low pressure transmitter.

7. **CAUTION**
Read CAUTION on following page.

Is continuity present from lighted indicator display socket 27 to socket 22?

TEST OPTIONS
Continuity Test or STE/ICE-R Test #91
REASON FOR QUESTION
If continuity is not present, lighted indicator display is faulty.

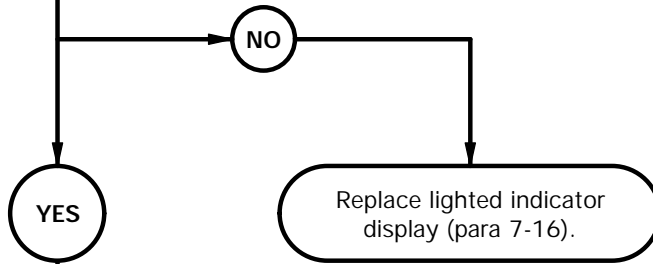

KNOWN INFO
Parking brake operates. Circuit breaker CB77 OK. Parking brake indicator lamps OK. Emergency brake indicator lamps OK. Lighted indicator display OK.
POSSIBLE PROBLEMS
Faulty dashboard cable assembly. Faulty front lights cable assembly. Faulty low pressure transmitter.

8. **CAUTION**
Read CAUTION on following page.

Is continuity present from connector PX7 pin 22 to connector J27 socket 16?

TEST OPTIONS
Continuity Test or STE/ICE-R Test #91
REASON FOR QUESTION
If continuity is not present, wire 1616 is faulty.

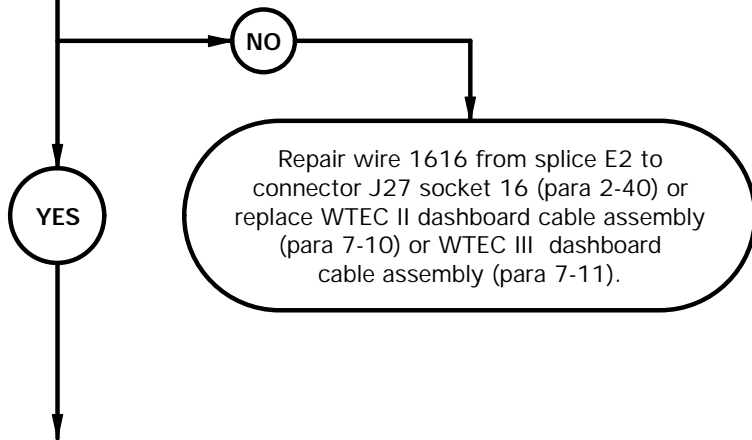

CAUTION

Use care when testing electrical connectors. Do not damage connector pins or sockets with multimeter probes. Failure to comply may result in damage to equipment.

NOTE

Inspect connector pins/sockets for damage, corrosion, and serviceability. Check that connector pins are not pushed back and are capable of making good contact.

CONTINUITY TEST

- (1) Disconnect batteries (para 7-48).
- (2) Remove four screws from lighted indicator display.
- (3) Remove lighted indicator display from instrument panel assembly.
- (4) Disconnect connector PX7 from lighted indicator display.
- (5) Set multimeter to ohms.
- (6) Connect positive (+) probe of multimeter to lighted indicator display socket 27.
- (7) Connect negative (-) probe of multimeter to lighted indicator display socket 22 and note reading on multimeter.
- (8) If continuity is not present, go to step 4 of this faulty.
- (9) If continuity is not present, replace lighted indicator display (para 7-16).

CONTINUITY TEST

- (1) Remove PDP cover (para 16-2).
- (2) Remove three screws and washers from PDP.
- (3) Remove three screws from PDP.
- (4) Lift PDP outward to gain access.
- (5) Disconnect connector J27 from connector P27.
- (6) Set multimeter to ohms.
- (7) Connect positive (+) probe of multimeter to connector PX7 pin 22.
- (8) Connect negative (-) probe of multimeter to connector J27 socket 16 and note reading on multimeter.
- (9) If continuity is not present, repair wire 1616 from splice E2 to connector J27 socket 16 (para 2-40) or replace WTEC II dashboard cable assembly (para 7-10) or WTEC III dashboard cable assembly (para 7-11).

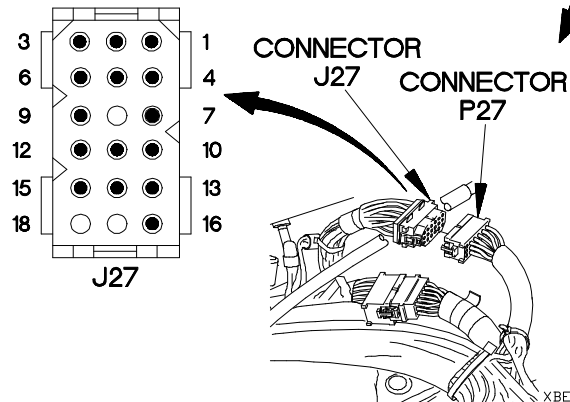
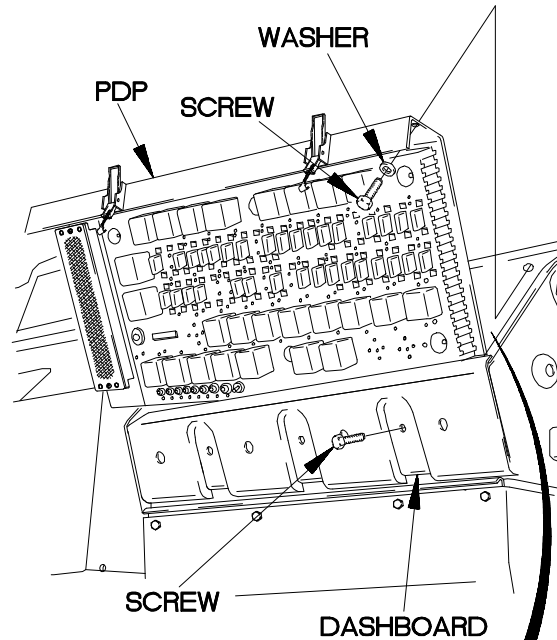
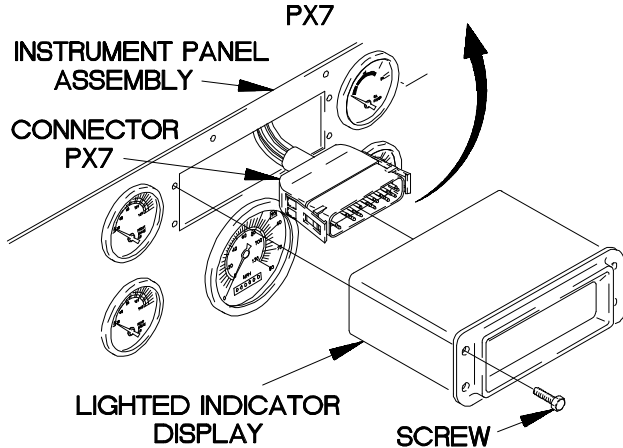
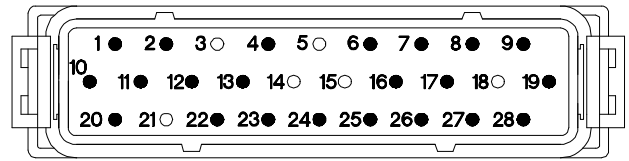

XBE3106B

e31. PARKING BRAKE INDICATOR AND/OR EMERGENCY BRAKE INDICATOR DOES NOT ILLUMINATE (CONT)

KNOWN INFO
Parking brake operates. Circuit breaker CB77 OK. Parking brake indicator lamps OK. Emergency brake indicator lamps OK. Lighted indicator display OK. Dashboard cable assembly OK.
POSSIBLE PROBLEMS
Faulty front lights cable assembly. Faulty low pressure transmitter.

9. **CAUTION**
Read CAUTION on following page.

Is continuity present from connector P27 pin 16 to terminal lug TL202?

TEST OPTIONS
Continuity Test or STE/ICE-R Test #91
REASON FOR QUESTION
If continuity is not present, wire 1616 is faulty.

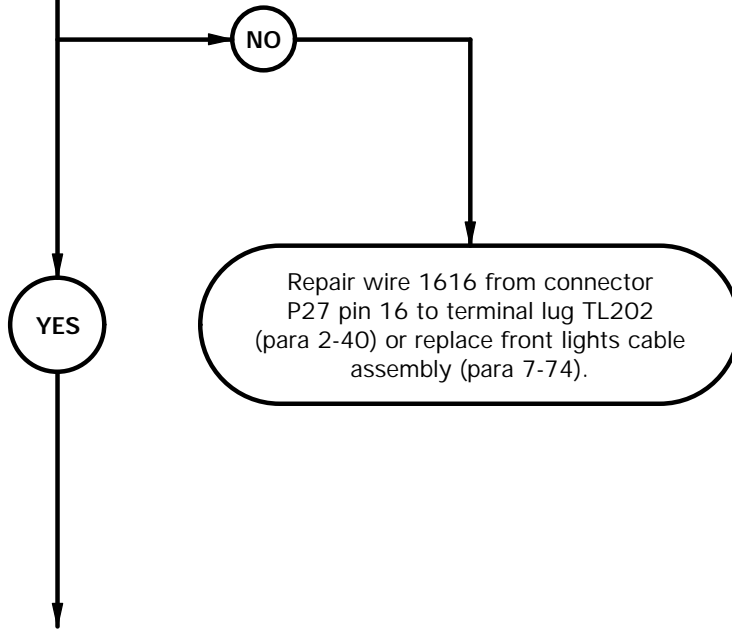

CAUTION

Use care when testing electrical connectors. Do not damage connector pins or sockets with multimeter probes. Failure to comply may result in damage to equipment.

NOTE

Inspect connector pins/sockets for damage, corrosion, and serviceability. Check that connector pins are not pushed back and are capable of making good contact.

CONTINUITY TEST

- (1) Remove two screws and washers from front grille.
- (2) Remove screw and washer from front grille.
- (3) Remove front grille from cab.
- (4) Set multimeter to ohms.
- (5) Connect positive (+) probe of multimeter to connector P27 pin 16.
- (6) Connect negative (-) probe of multimeter to terminal lug TL202 and note reading on multimeter.
- (7) If continuity is not present, repair wire 1616 from connector P27 pin 16 to terminal lug TL202 (para 2-40) or replace front lights cable assembly (para 7-74).
- (8) Connect connector P27 to connector J27.
- (9) Connect lighted indicator display to connector PX7.
- (10) Position lighted indicator display in instrument panel assembly with four screws.
- (11) Tighten four screws to 6-10 lb-in. (1 N·m).
- (12) Connect batteries (para 7-48).

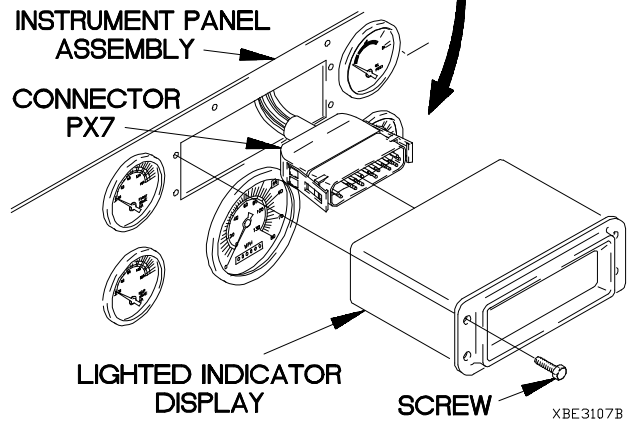
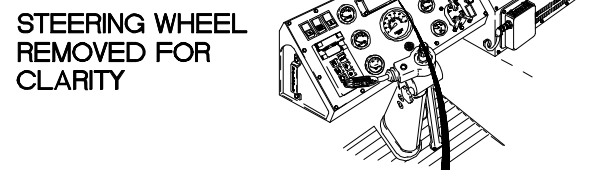
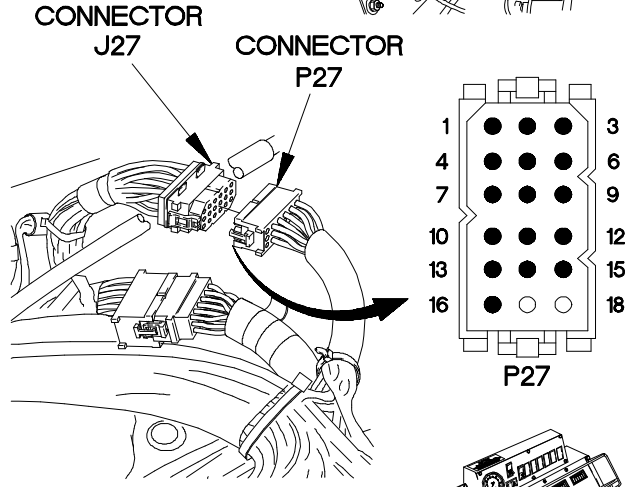
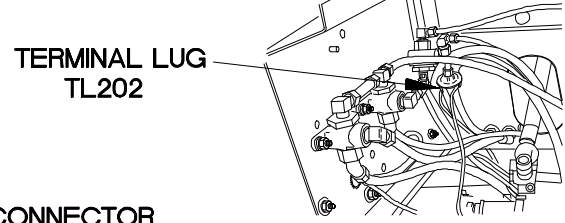
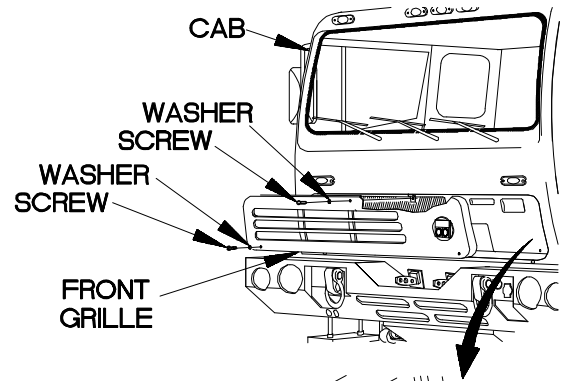

e31. PARKING BRAKE INDICATOR AND/OR EMERGENCY BRAKE INDICATOR DOES NOT ILLUMINATE (CONT)

KNOWN INFO
Parking brake operates. Circuit breaker CB77 OK. Parking brake indicator lamps OK. Emergency brake indicator lamps OK. Lighted indicator display OK. Dashboard cable assembly OK.
POSSIBLE PROBLEMS
Faulty front lights cable assembly. Faulty low pressure transmitter.

10.
 Is continuity present from terminal lug TL201 to a known good ground?

TEST OPTIONS
Continuity Test or STE/ICE-R Test #91
REASON FOR QUESTION
If continuity is not present, wire 3024 is faulty. If continuity is present, low pressure transmitter is faulty.

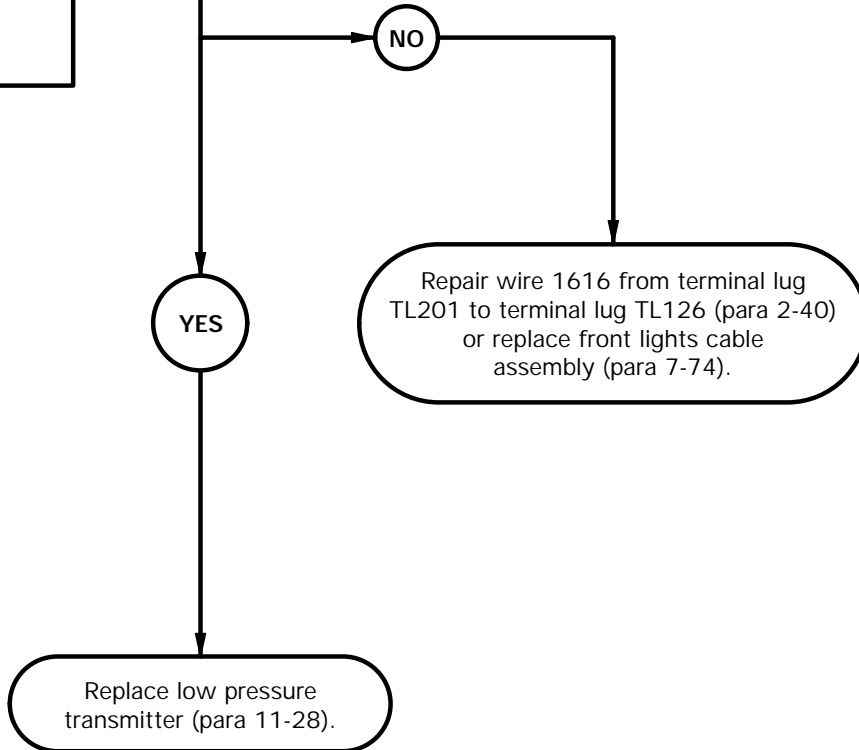

CONTINUITY TEST

- (1) Set multimeter to ohms.
- (2) Connect positive (+) probe of multimeter to terminal lug TL201.
- (3) Connect negative (-) probe of multimeter to ground and note reading on multimeter.
- (4) If continuity is not present, repair wire 3024 from terminal lug TL201 to terminal lug TL126 (para 2-40) or replace front lights cable assembly (para 7-74).
- (5) If continuity is present, replace low pressure transmitter (para 11-28).
- (6) Position front grille on cab with washer and screw.
- (7) Position two washers and screws in front grille.
- (8) Tighten screw to 48-60 lb-in. (5-7 N·m).
- (9) Tighten two screws to 24 lb-in. (3 N·m).
- (10) Install PDP in dashboard with three screws.
- (11) Install three washers and screws in PDP.
- (12) Install PDP cover (para 16-2).

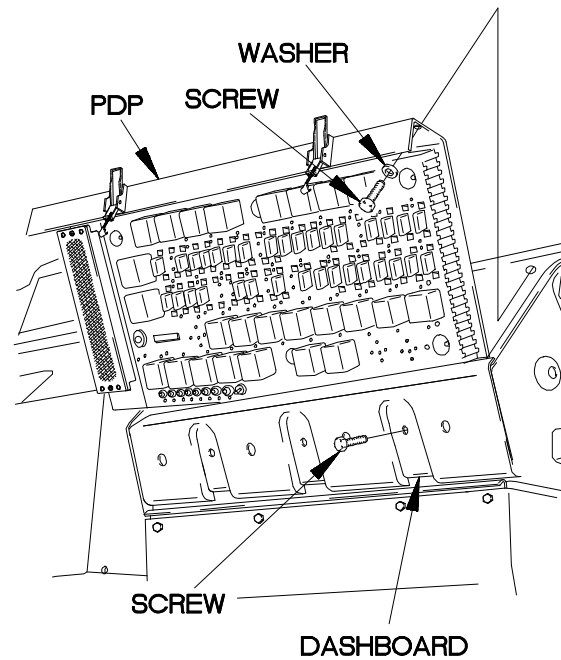
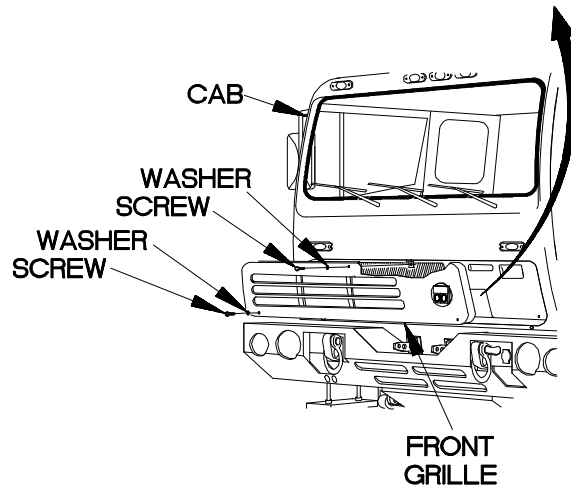
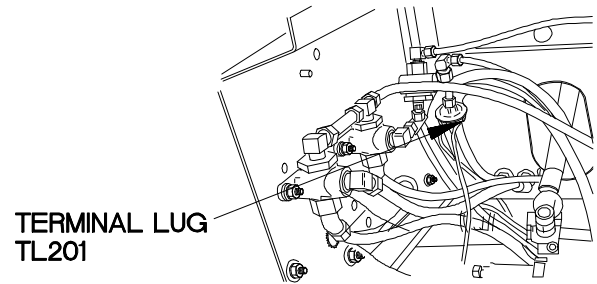

XBE3108B

e32. PTO INDICATOR DOES NOT OPERATE	
INITIAL SETUP	
Equipment Condition Engine shut down (TM 9-2320-365-10). Batteries disconnected (para 7-48).	Tools and Special Tools Tool Kit, Genl Mech (Item 44, Appendix C) STE/ICE-R (Item 39, Appendix C) Multimeter, Digital (Item 22, Appendix C) Wrench, Torque, 0-75 lb-in. (Item 86, Appendix B)
Personnel Required (2)	
References TM 9-4910-571-12&P	

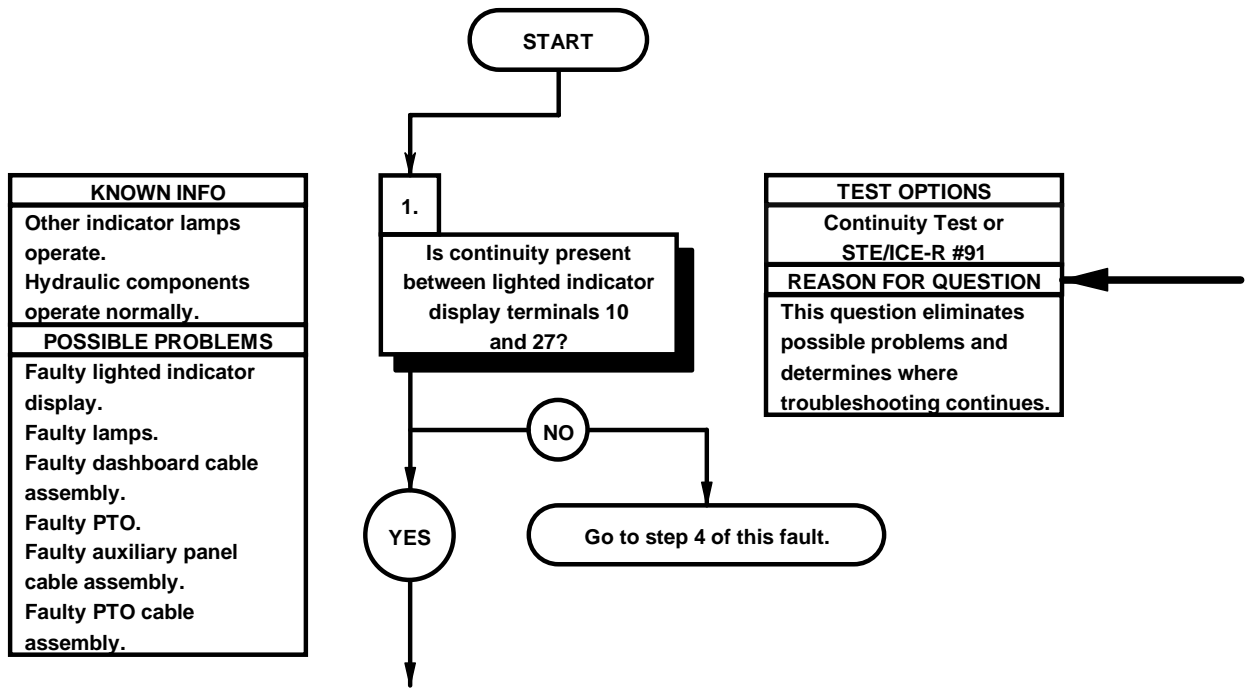

- | CONTINUITY TEST | |
|-----------------|---|
| | (1) Remove four screws from lighted indicator display. |
| | (2) Remove lighted indicator display from instrument panel assembly. |
| | (3) Disconnect connector PX7 from lighted indicator display. |
| | (4) Set multimeter to ohms. |
| | (5) Connect positive (+) probe of multimeter to lighted indicator display terminal 27. |
| | (6) Connect negative (-) probe of multimeter to lighted indicator display terminal 10 and note reading on multimeter. |
| | (7) If continuity is not present, go to step 4 of this fault. |

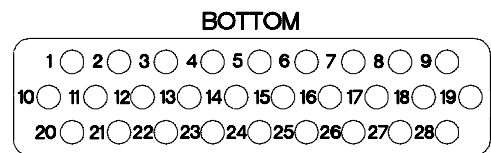
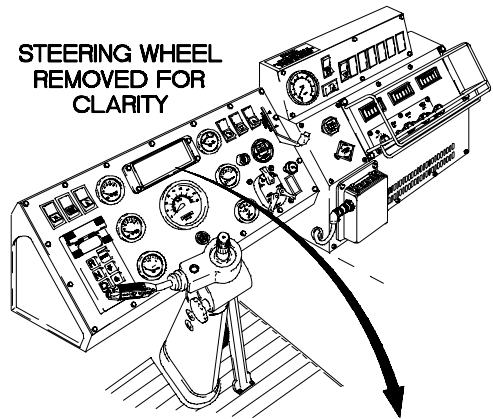

LIGHTED INDICATOR DISPLAY

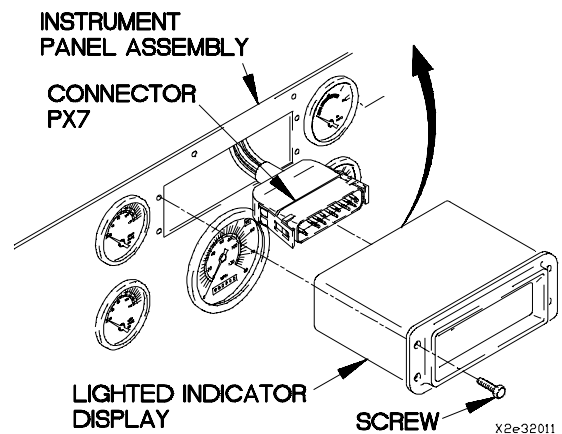

ø32. PTO INDICATOR DOES NOT OPERATE (CONT)

KNOWN INFO
Other indicator lights operate. Hydraulic components operate normally. Lighted indicator display OK. Lamps OK.
POSSIBLE PROBLEMS
Faulty dashboard cable assembly. Faulty PTO. Faulty auxiliary panel cable assembly. Faulty PTO cable assembly.

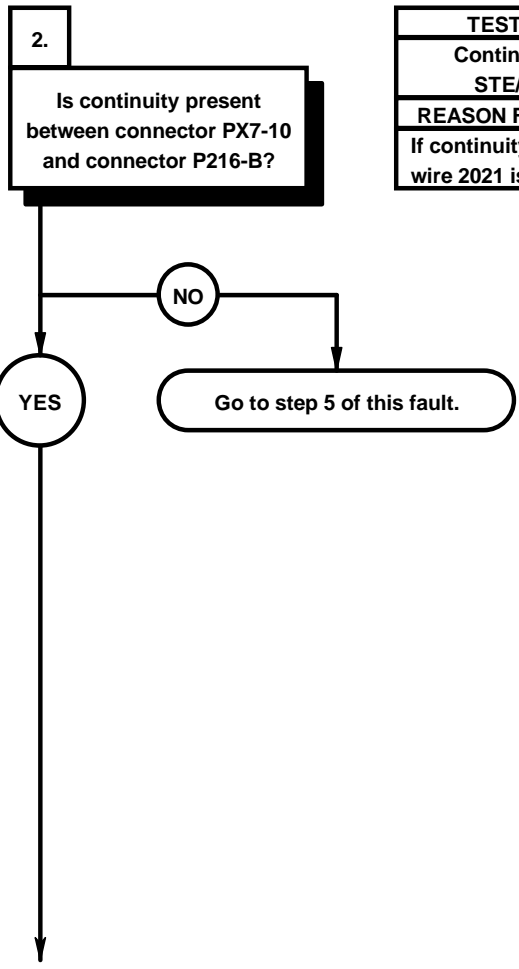

TEST OPTIONS
Continuity Test or STE/ICE-R#91
REASON FOR QUESTION
If continuity is not present, wire 2021 is faulty.

CONTINUITY TEST

- (1) Disconnect connector P216 from connector J216.
- (2) Set multimeter to ohms.
- (3) Connect positive (+) probe of multimeter to connector PX7-10.
- (4) Connect negative (-) probe of multimeter to connector P216-B and note reading on multimeter.
- (5) If continuity is not present, go to step 5 of this fault.

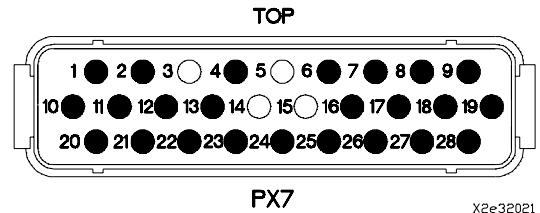
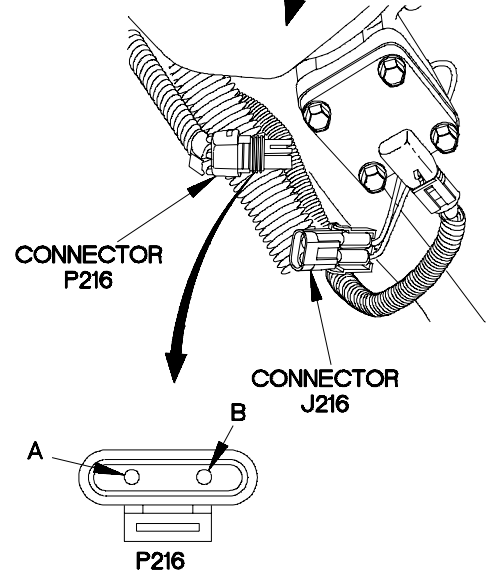
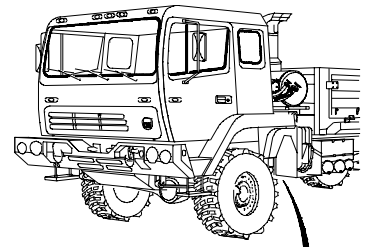

X2e32021

ø32. PTO INDICATOR DOES NOT OPERATE (CONT)

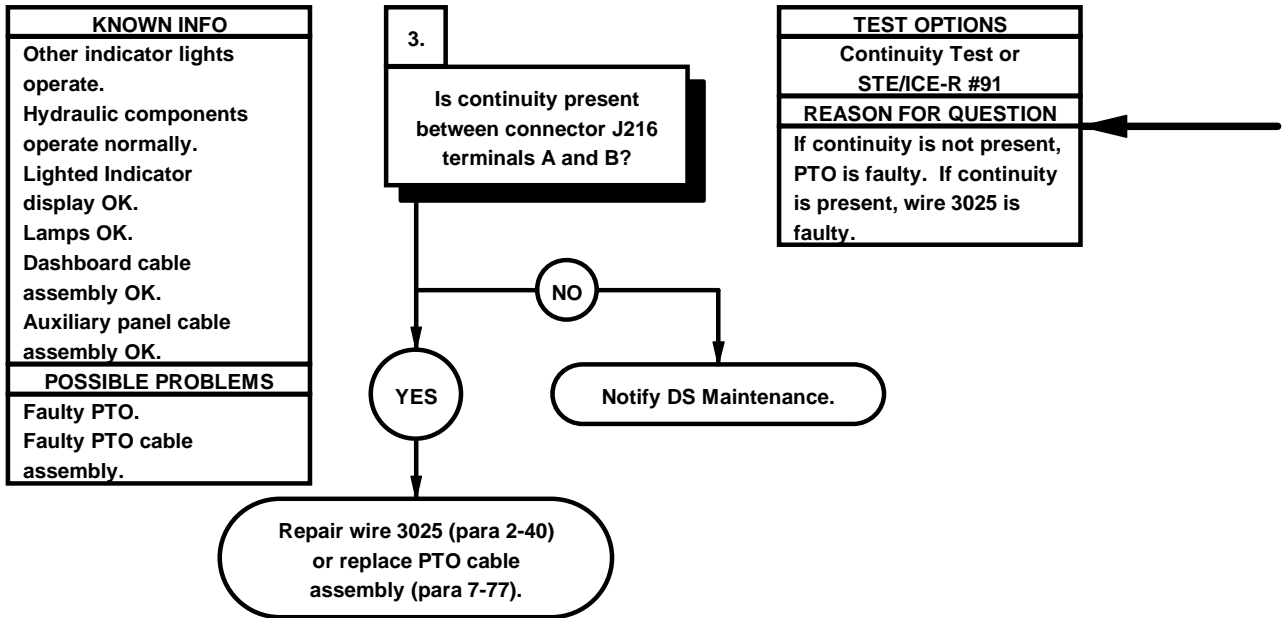

CONTINUITY TEST

- (1) Connect lighted indicator display to connector PX7.
- (2) Position lighted indicator display in instrument panel assembly with four screws.
- (3) Tighten four screws to 6-10 lb-in. (1 N-m).
- (4) Connect batteries (para 7-48).
- (5) Set multimeter to ohms.
- (6) Connect positive (+) probe of multimeter to connector J216-B.
- (7) Connect negative (-) probe of multimeter to connector J216-A.
- (8) Start engine (TM 9-2320-365-10).
- (9) Position PTO switch to on (TM 9-2320-365-10) and note reading on multimeter.
- (10) If continuity is not present, notify DS Maintenance.
- (11) If continuity is present, repair wire 3025 (para 2-40) or replace PTO cable assembly (para 7-77).
- (12) Position PTO switch to off (TM 9-2320-365-10).
- (13) Shut down engine (TM 9-2320-365-10).
- (14) Connect connector P216 to connector J216.

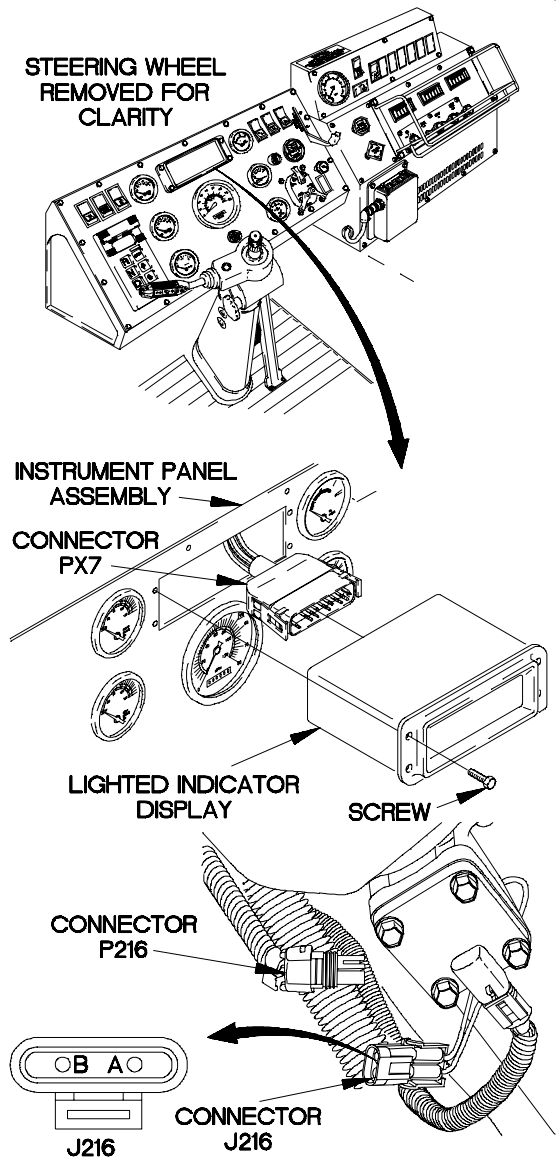

X2e32031

ø32. PTO INDICATOR DOES NOT OPERATE (CONT)

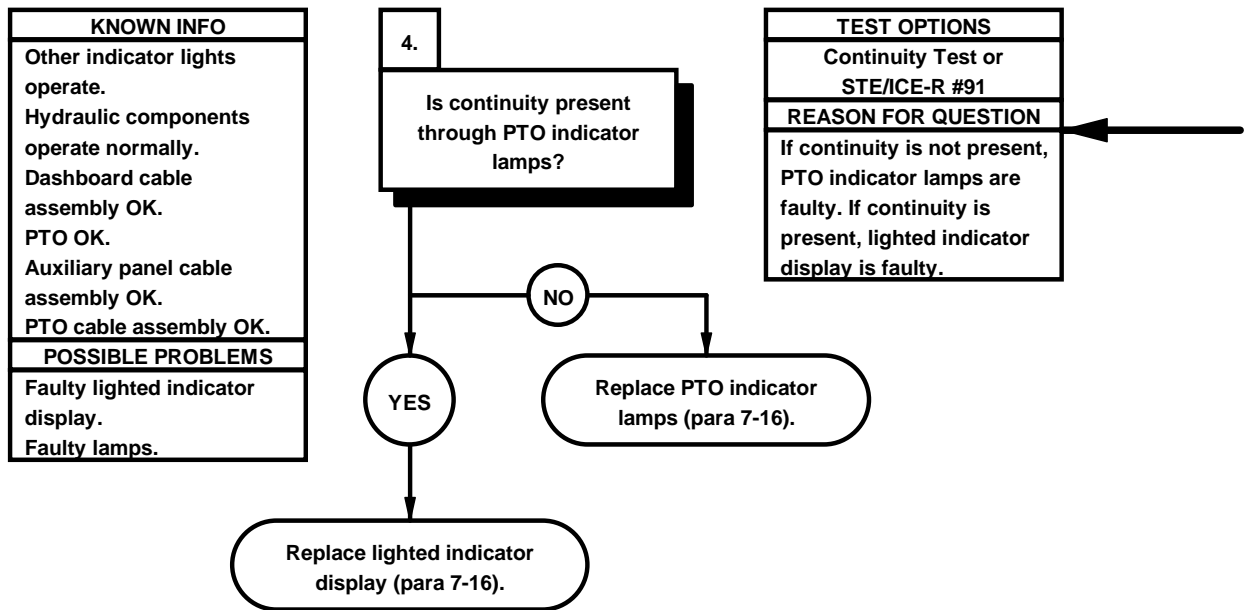

CONTINUITY TEST

- (1) Loosen four captive screws in lamp mounting panel.
- (2) Remove lamp mounting panel from lighted indicator display housing.
- (3) Remove PTO indicator lamps from printed circuit board.
- (4) Set multimeter to ohms.
- (5) Check continuity through each indicator lamp and note reading on multimeter.
- (6) If continuity is not present, replace PTO indicator lamps (para 7-16).
- (7) If continuity is present, replace lighted indicator display (para 7-16).
- (8) Install PTO indicator lamps in printed circuit board.
- (9) Install lamp mounting panel in lighted indicator display housing.
- (10) Tighten four captive screws in lamp mounting panel.
- (11) Connect lighted indicator display to connector PX7.
- (12) Position lighted indicator display in instrument panel assembly with four screws.
- (13) Tighten four screws to 6-10 lb-in. (1 N-m).
- (14) Connect batteries (para 7-48).

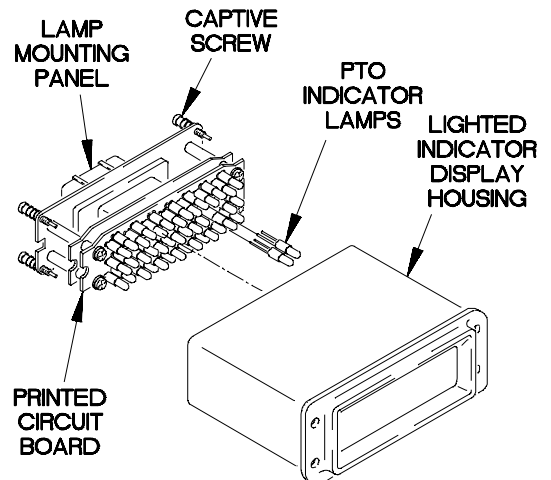
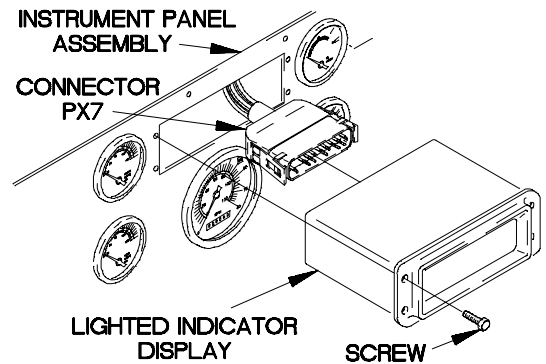
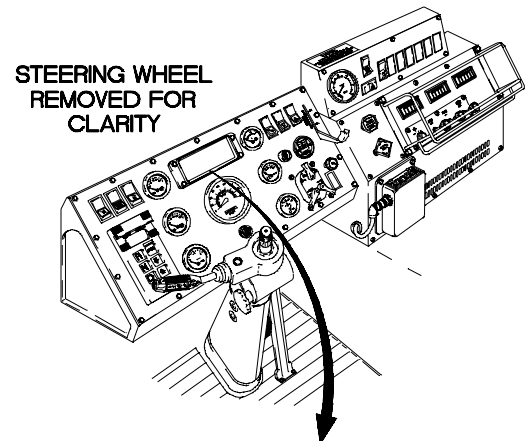

X2e32041

ø32. PTO INDICATOR DOES NOT OPERATE (CONT)

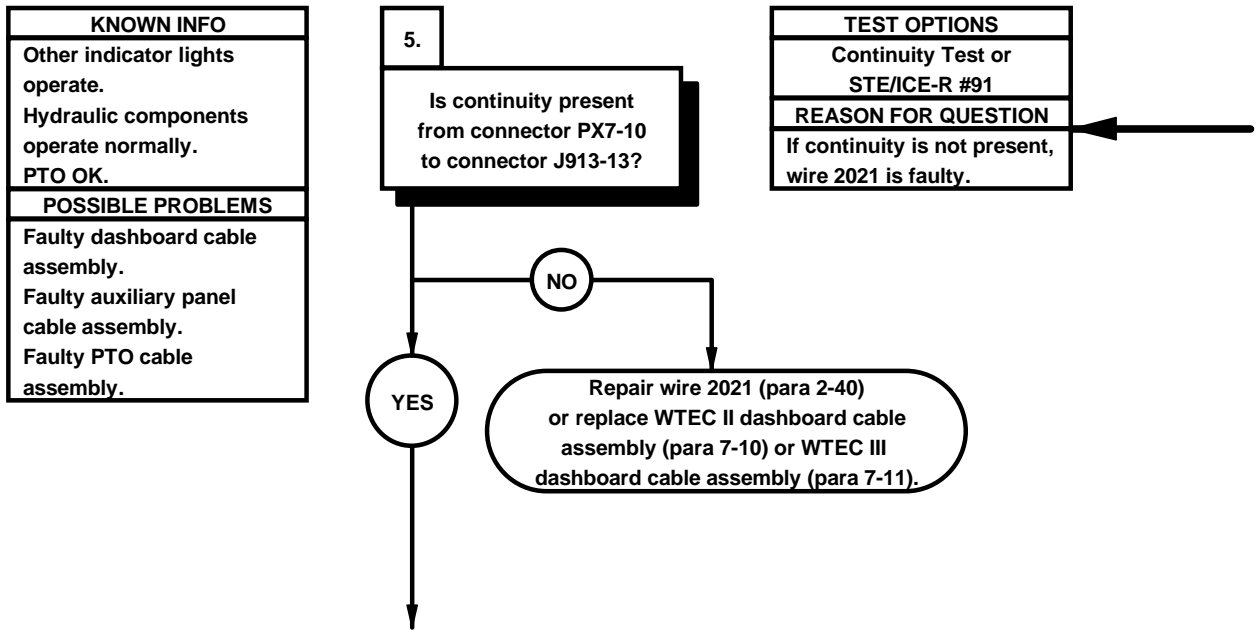

CONTINUITY TEST

- (1) Remove personnel heater for access (para 18-9).
- (2) Disconnect connector P913 from connector J913.
- (3) Set multimeter to ohms.
- (4) Connect positive (+) probe of multimeter to PX7-10.
- (5) Connect negative (-) probe of multimeter to J913-13 and note reading on multimeter.
- (6) If continuity is not present, repair wire 2021 (para 2-40) or replace WTEC II dashboard cable assembly (para 7-10) or WTEC III dashboard cable assembly (para 7-11).
- (7) Connect lighted indicator display to connector PX7.
- (8) Position lighted indicator display in instrument panel assembly with four screws.
- (9) Tighten four screws to 6-10 lb-in. (1 N-m).
- (10) Connect batteries (para 7-48).

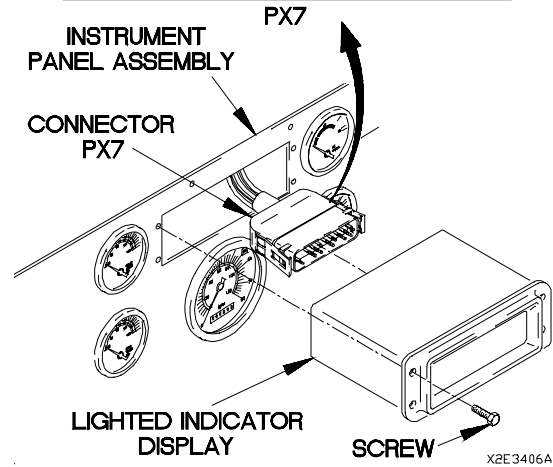
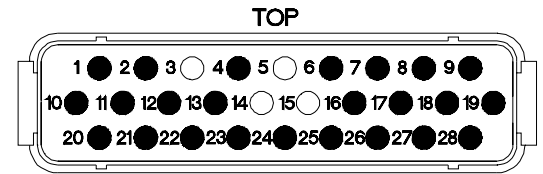
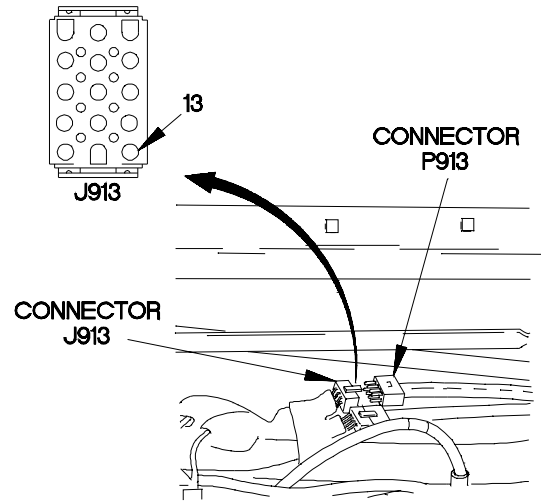

ø32. PTO INDICATOR DOES NOT OPERATE (CONT)

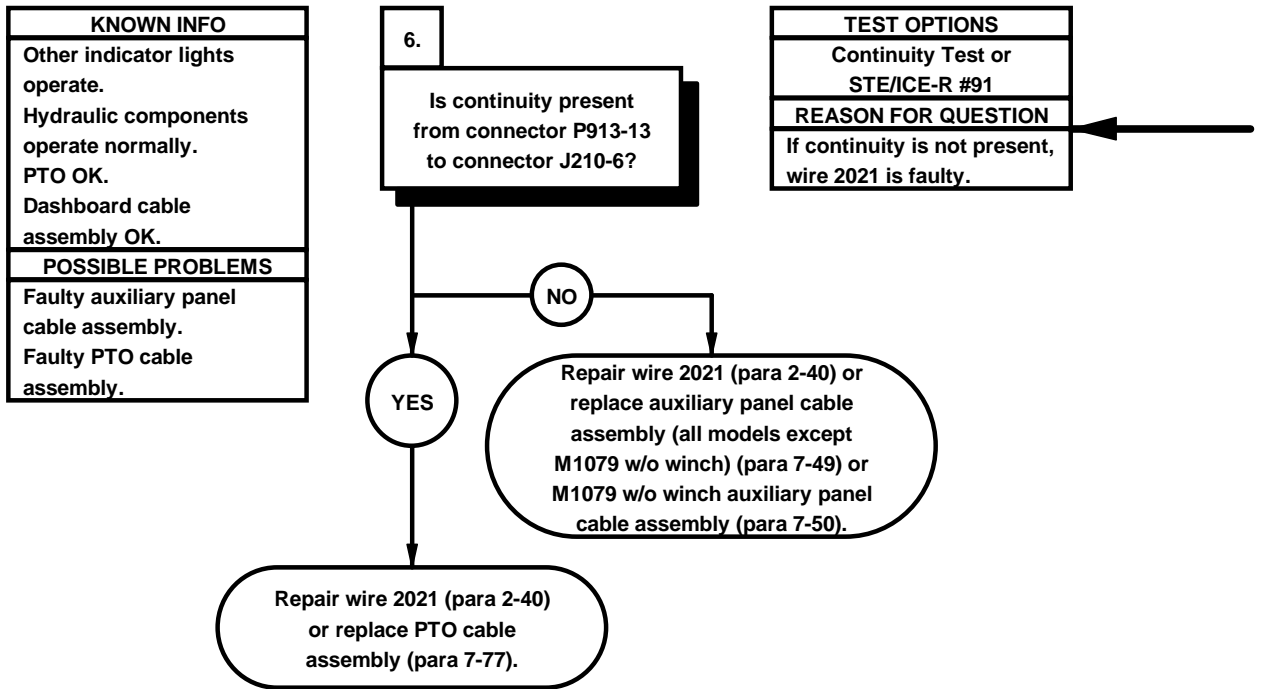

CONTINUITY TEST

- (1) Disconnect connector P210 from connector J210.
- (2) Set multimeter to ohms.
- (3) Connect positive (+) probe of multimeter to J210-6.
- (4) Connect negative (-) probe of multimeter to P913-13 and note reading on multimeter.
- (5) If continuity is not present, repair wire 2021 (para 2-40) or replace auxiliary panel cable assembly (all models except M1079 w/o winch) (para 7-49) or M1079 w/o winch auxiliary panel cable assembly (para 7-50).
- (6) If continuity is present, repair wire 2021 (para 2-40) or replace PTO cable assembly (para 7-77).
- (7) Connect connector J210 to connector P210.
- (8) Connect connector P913 to connector J913.
- (9) Install personnel heater (para 18-9).

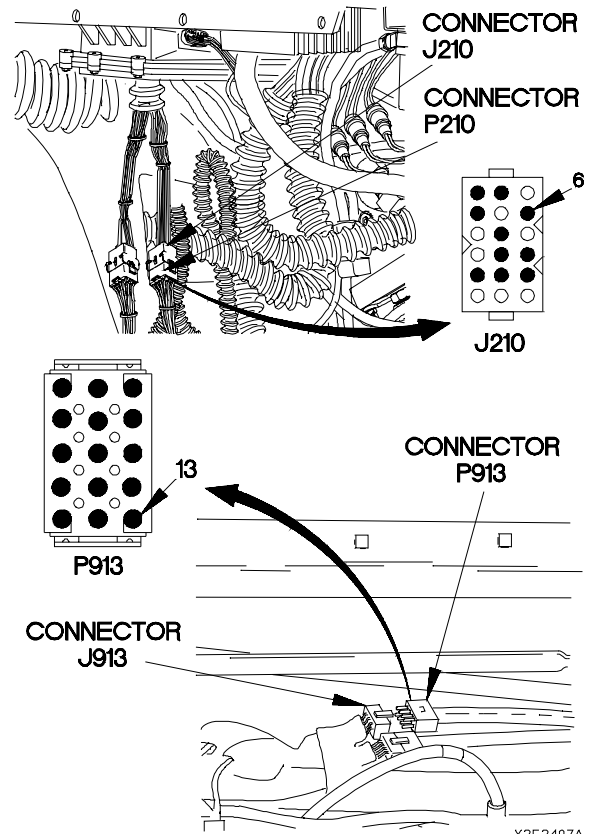

e33. FAN OFF INDICATOR DOES NOT OPERATE	
INITIAL SETUP	
Equipment Condition Engine shut down (TM 9-2320-365-10). Batteries disconnected (para 7-48).	Tools and Special Tools Tool Kit, Genl Mech (Item 44, Appendix C) STE/ICE-R (Item 39, Appendix C) Multimeter, Digital (Item 22, Appendix C) Wrench, Torque, 0-75 lb-in. (Item 86, Appendix B)
Personnel Required (2)	References TM 9-4910-571-12&P

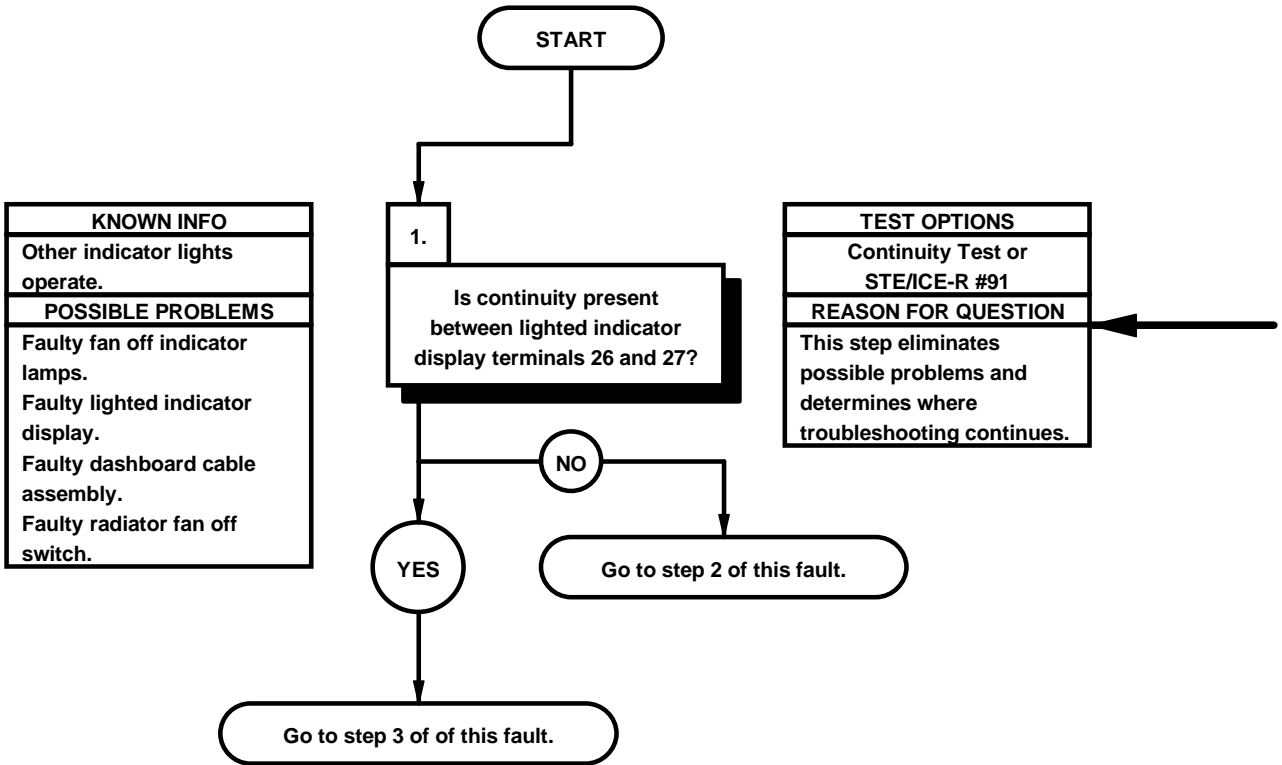

CONTINUITY TEST

- (1) Remove four screws from lighted indicator display.
- (2) Remove lighted indicator display from instrument panel assembly.
- (3) Disconnect connector PX7 from lighted indicator display.
- (4) Set multimeter to ohms.
- (5) Connect positive (+) probe of multimeter to lighted indicator display terminal 27.
- (6) Connect negative (-) probe of multimeter to lighted indicator display terminal 26 and note reading on multimeter.
- (7) If continuity is not present, go to step 2 of this fault.
- (8) If continuity is present, go to step 3 of this fault.

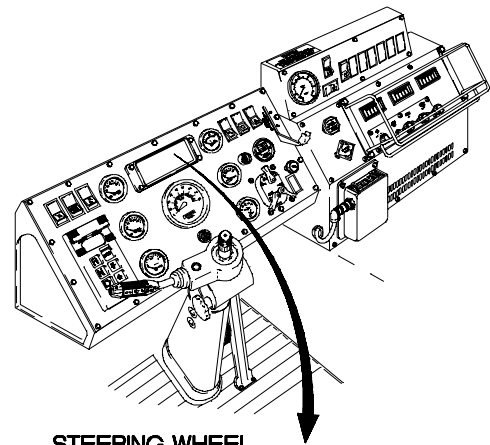

STEERING WHEEL
REMOVED FOR
CLARITY

BOTTOM

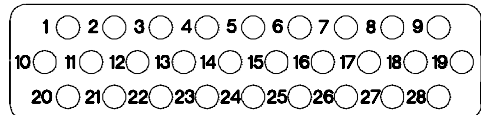

LIGHTED INDICATOR DISPLAY

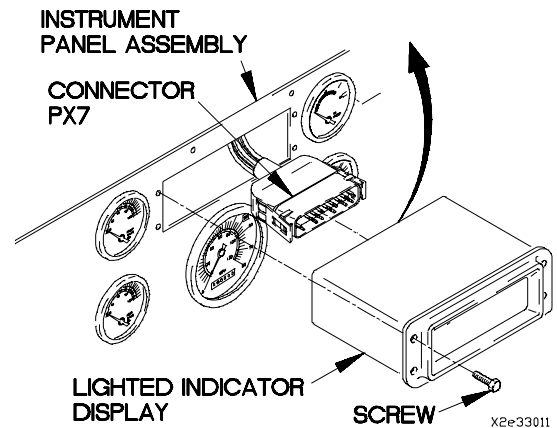

X2e33011

33. FAN OFF INDICATOR DOES NOT OPERATE (CONT)

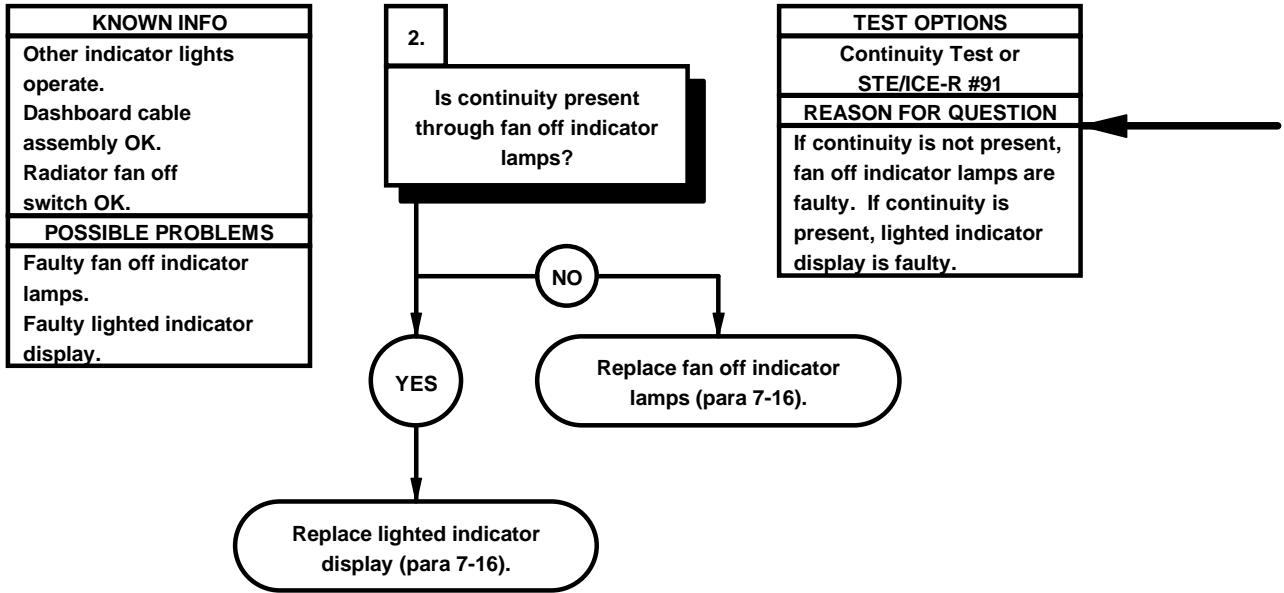

CONTINUITY TEST

- (1) Loosen four captive screws in lamp mounting panel.
- (2) Remove lamp mounting panel from lighted indicator display housing.
- (3) Remove fan off indicator lamps from printed circuit board.
- (4) Set multimeter to ohms.
- (5) Check continuity through each fan off indicator lamp and note reading on multimeter.
- (6) If continuity is not present, replace fan off indicator lamps (para 7-16).
- (7) If continuity is present, replace lighted indicator display (para 7-16).
- (8) Install fan off indicator lamps in printed circuit board.
- (9) Install lamp mounting panel in lighted indicator display housing.
- (10) Tighten four captive screws in lamp mounting panel.
- (11) Connect lighted indicator display to connector PX7.
- (12) Position lighted indicator display in instrument panel assembly with four screws.
- (13) Tighten four screws to 6-10 lb-in. (1 N-m).
- (14) Connect batteries (para 7-48).

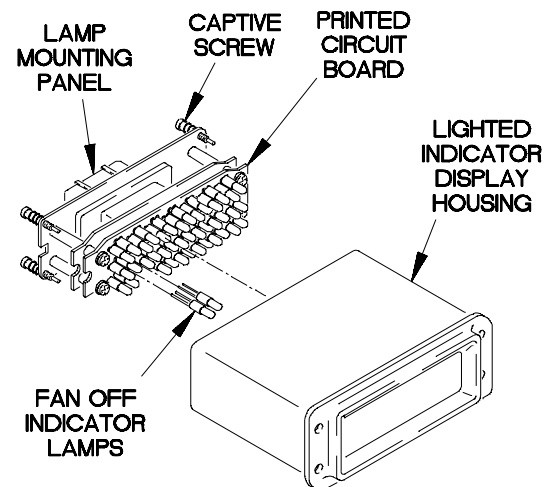
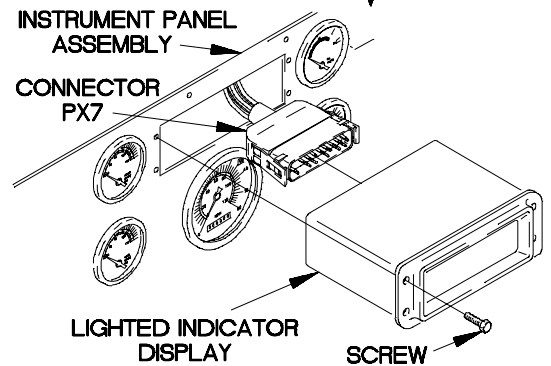
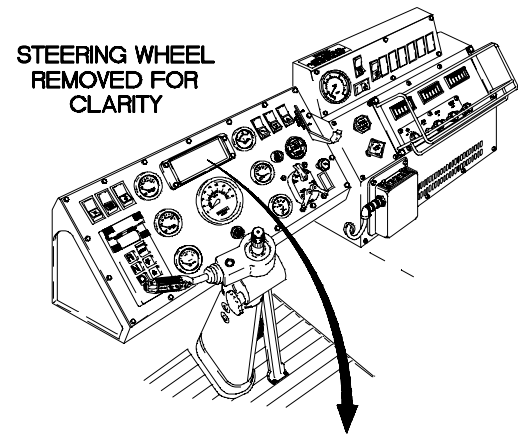

X2e33021

33. FAN OFF INDICATOR DOES NOT OPERATE (CONT)

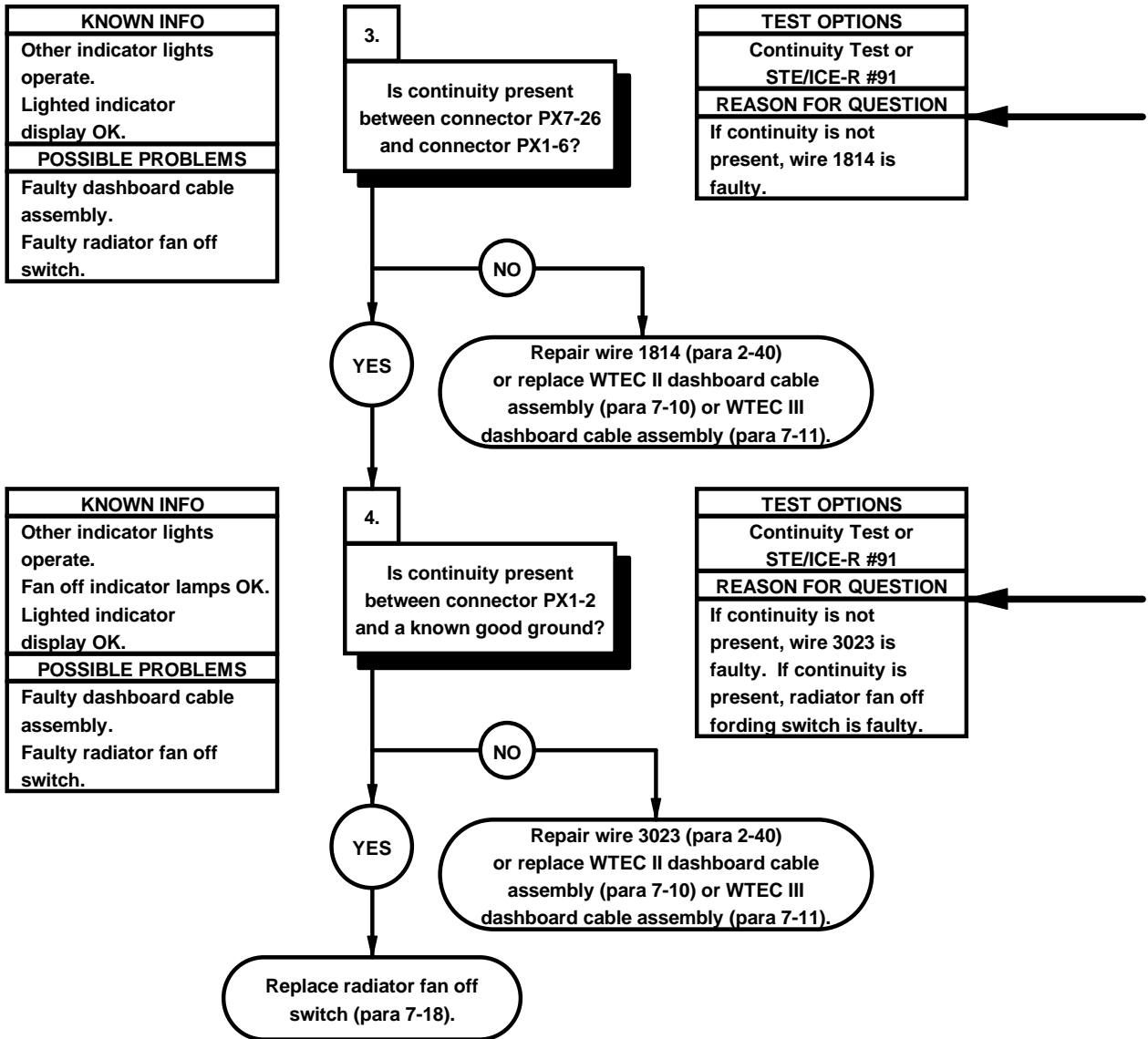

- CONTINUITY TEST**
- (1) Remove instrument panel assembly for access (para 7-15).
 - (2) Disconnect connector PX1 from radiator fan off switch.
 - (3) Set multimeter to ohms.
 - (4) Connect positive (+) probe of multimeter to connector PX7-26.
 - (5) Connect negative (-) probe of multimeter to connector PX1-6 and note reading on multimeter.
 - (6) If continuity is not present, repair wire 1814 (para 2-40) or replace WTEC II dashboard cable assembly (para 7-10) or WTEC III dashboard cable assembly (para 7-11).

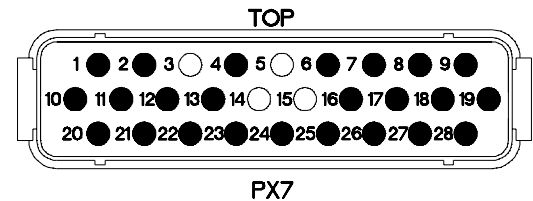
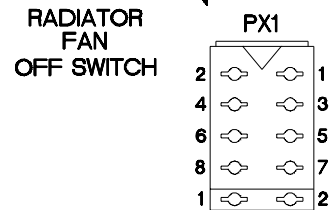
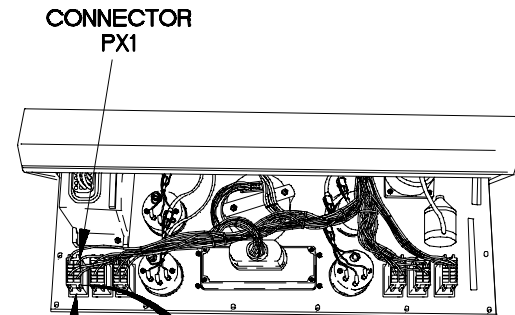

- CONTINUITY TEST**
- (1) Set multimeter to ohms.
 - (2) Connect positive (+) probe of multimeter to connector PX1-2.
 - (3) Connect negative (-) probe of multimeter to ground and note reading on multimeter.
 - (4) If continuity is not present, repair wire 3023 (para 2-40) or replace WTEC II dashboard cable assembly (para 7-10) or WTEC III dashboard cable assembly (para 7-11).
 - (5) If continuity is present, replace radiator fan off switch (para 7-18).
 - (6) Connect connector PX1 to radiator fan off switch.
 - (7) Install instrument panel assembly (para 7-15).
 - (8) Connect lighted indicator display to connector PX7.
 - (9) Position lighted indicator display in instrument panel assembly with four screws.
 - (10) Tighten four screws to 6-10 lb-in. (1 N-m).
 - (11) Connect batteries (para 7-48).

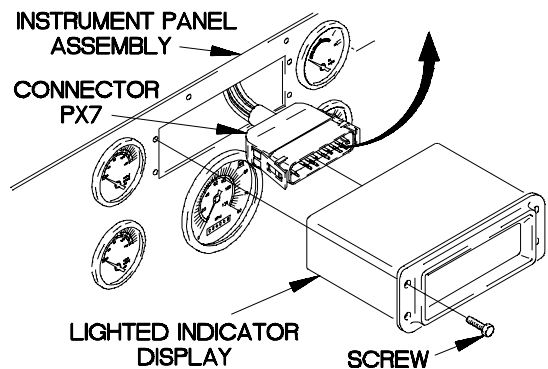

X2e33031

e34. WTEC II TRANSMISSION TEMPERATURE INDICATOR DOES NOT OPERATE	
INITIAL SETUP	
Equipment Condition Engine shut down (TM 9-2320-365-10). Batteries disconnected (para 7-48).	Tools and Special Tools Tool Kit, Genl Mech (Item 44, Appendix C) STE/ICE-R (Item 39, Appendix C) Multimeter, Digital (Item 22, Appendix C) Wrench, Torque, 0-75 lb-in. (Item 86, Appendix B)
Personnel Required (2)	References TM 9-4910-571-12&P
Materials/Parts Wire, Elect, 50 ft (Item 77, Appendix D)	

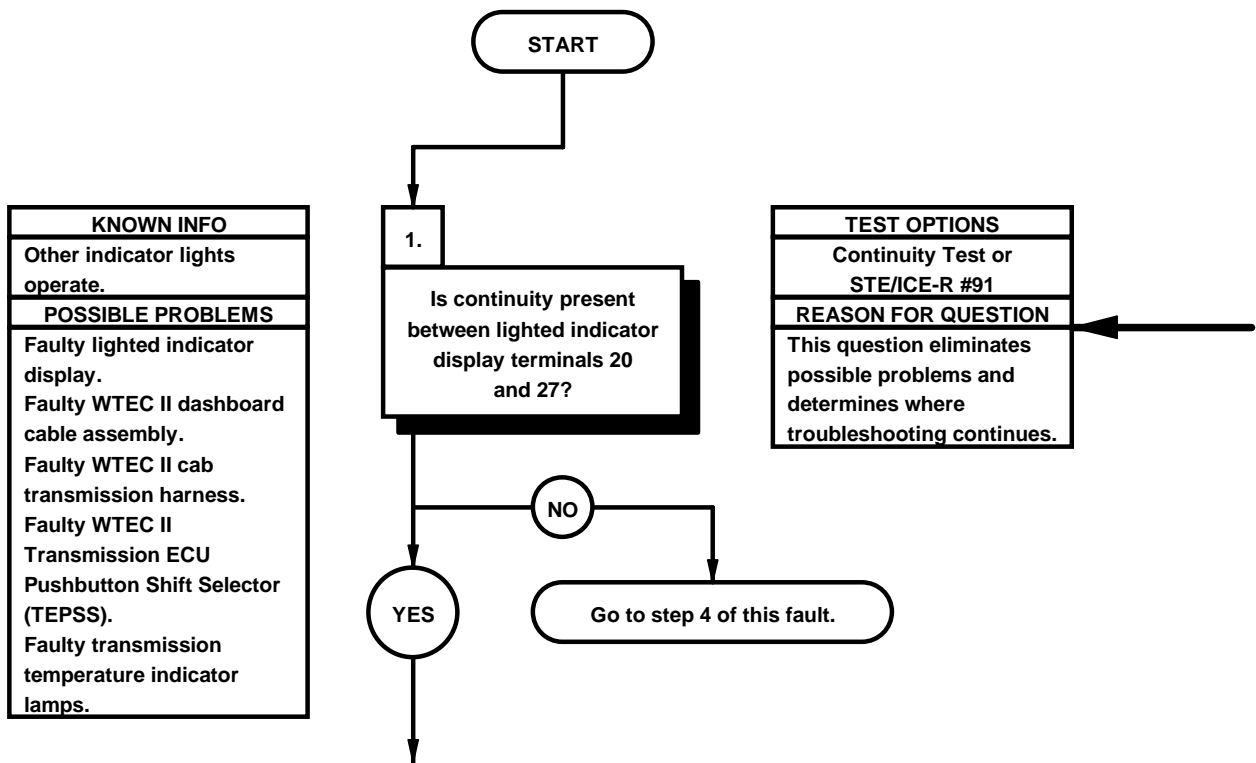

- | CONTINUITY TEST | |
|-----------------|---|
| | (1) Remove four screws from lighted indicator display. |
| | (2) Remove lighted indicator display from instrument panel assembly. |
| | (3) Disconnect connector PX7 from lighted indicator display. |
| | (4) Set multimeter to ohms. |
| | (5) Connect positive (+) probe of multimeter to lighted indicator display terminal 27. |
| | (6) Connect negative (-) probe of multimeter to lighted indicator display terminal 20 and note reading on multimeter. |
| | (7) If continuity is not present, go to step 4 of this fault. |

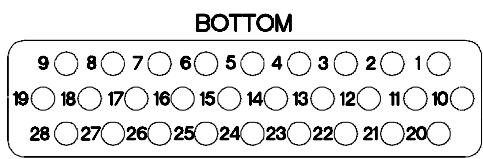
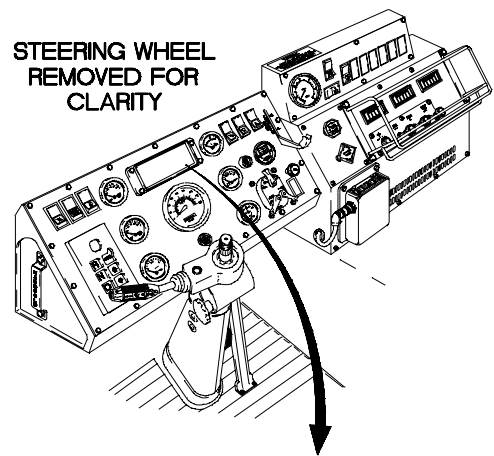

LIGHTED INDICATOR DISPLAY

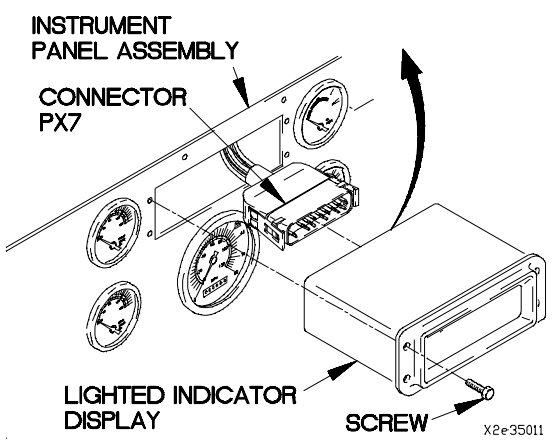

e34. WTEC II TRANSMISSION TEMPERATURE INDICATOR DOES NOT OPERATE (CONT)

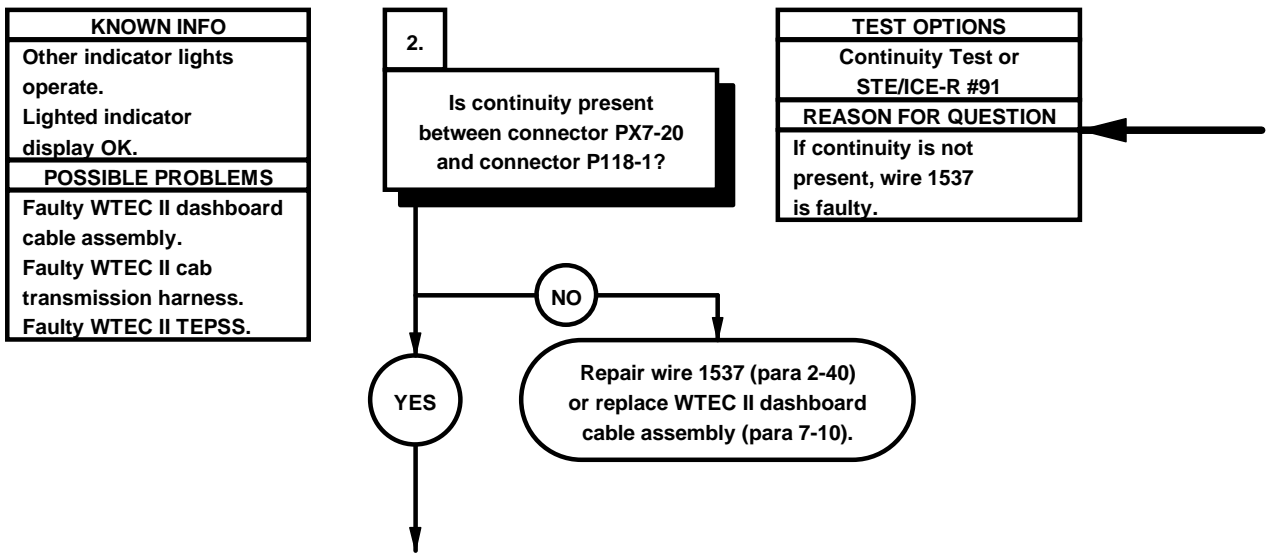

CONTINUITY TEST

- (1) Remove instrument panel assembly for access (para 7-15).
- (2) Disconnect connector PX17 from master power switch.
- (3) Disconnect connector J118 from connector P118.
- (4) Set multimeter to ohms.
- (5) Connect positive (+) probe of multimeter to connector PX7-20.
- (6) Connect negative (-) probe of multimeter to connector P118-1 and note reading on multimeter.
- (7) If continuity is not present, repair wire 1537 (para 2-40) or replace WTEC II dashboard cable assembly (para 7-10).

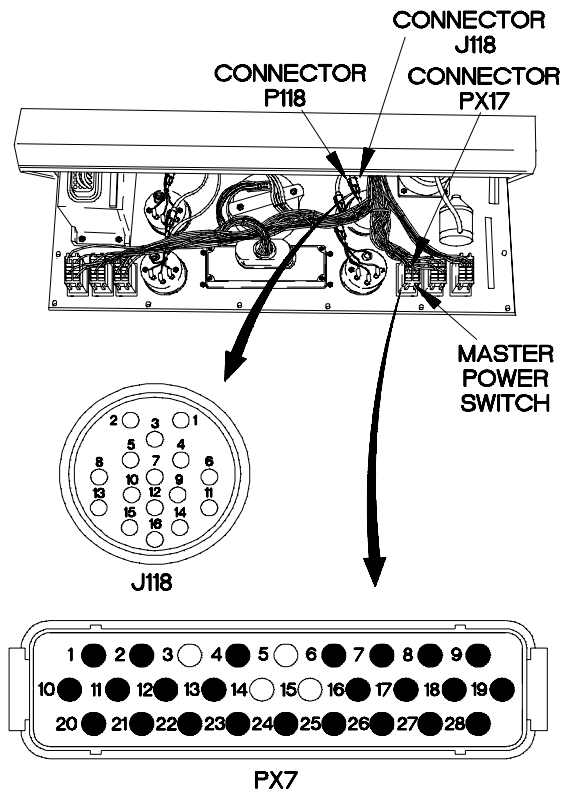

X2e35021

e34. WTEC II TRANSMISSION TEMPERATURE INDICATOR DOES NOT OPERATE (CONT)

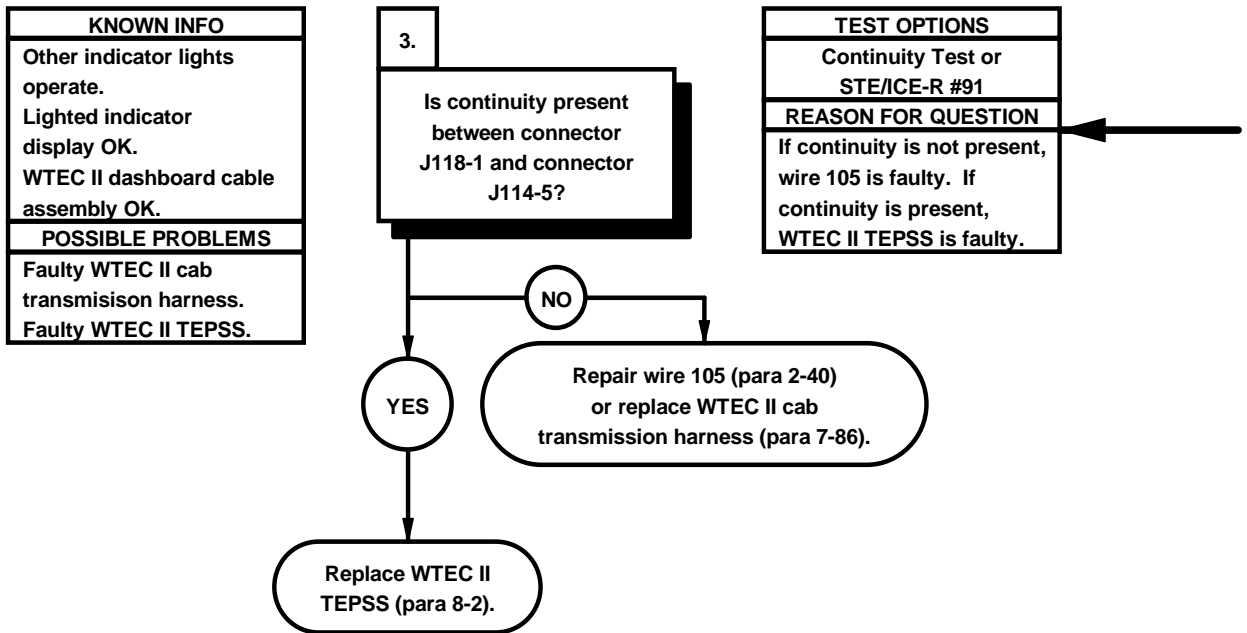

CONTINUITY TEST

- (1) Disconnect connector J114 (bottom connector) from WTEC II TEPSS.
- (2) Set multimeter to ohms.
- (3) Connect positive (+) probe of multimeter to connector J114-5.
- (4) Connect negative (-) probe of multimeter to connector J118-1 and note reading on multimeter.
- (5) If continuity is not present, repair wire 105 (para 2-40) or replace WTEC II cab transmission harness (para 7-86).
- (6) If continuity is present, replace WTEC II TEPSS (para 8-2).
- (7) Connect connector J114 to WTEC II TEPSS.
- (8) Connect connector J118 to connector P118.
- (9) Install instrument panel assembly (para 7-15).
- (10) Connect lighted indicator display to connector PX7.
- (11) Position lighted indicator display in instrument panel assembly with four screws.
- (12) Tighten four screws to 6-10 lb-in. (1 N·m).
- (13) Connect batteries (para 7-48).

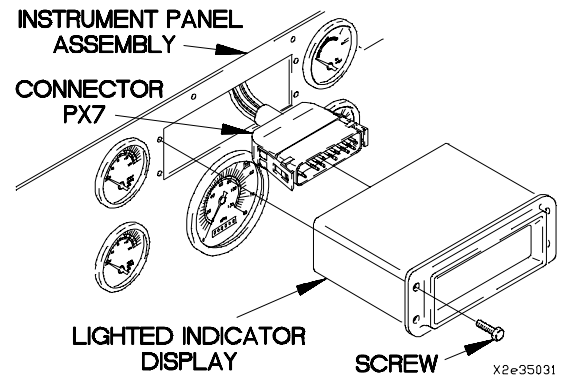
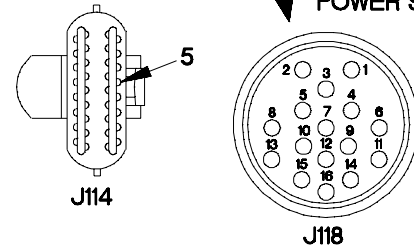
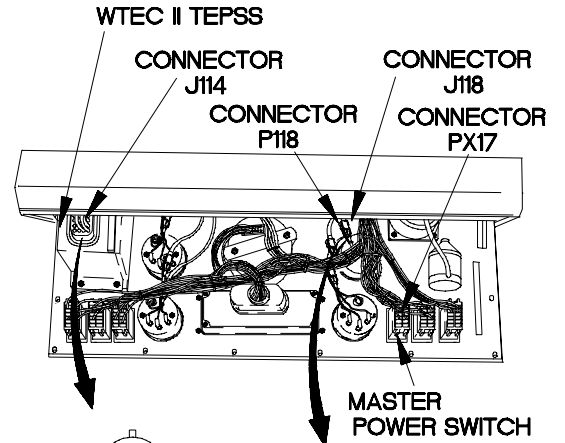

e34. WTEC II TRANSMISSION TEMPERATURE INDICATOR DOES NOT OPERATE (CONT)

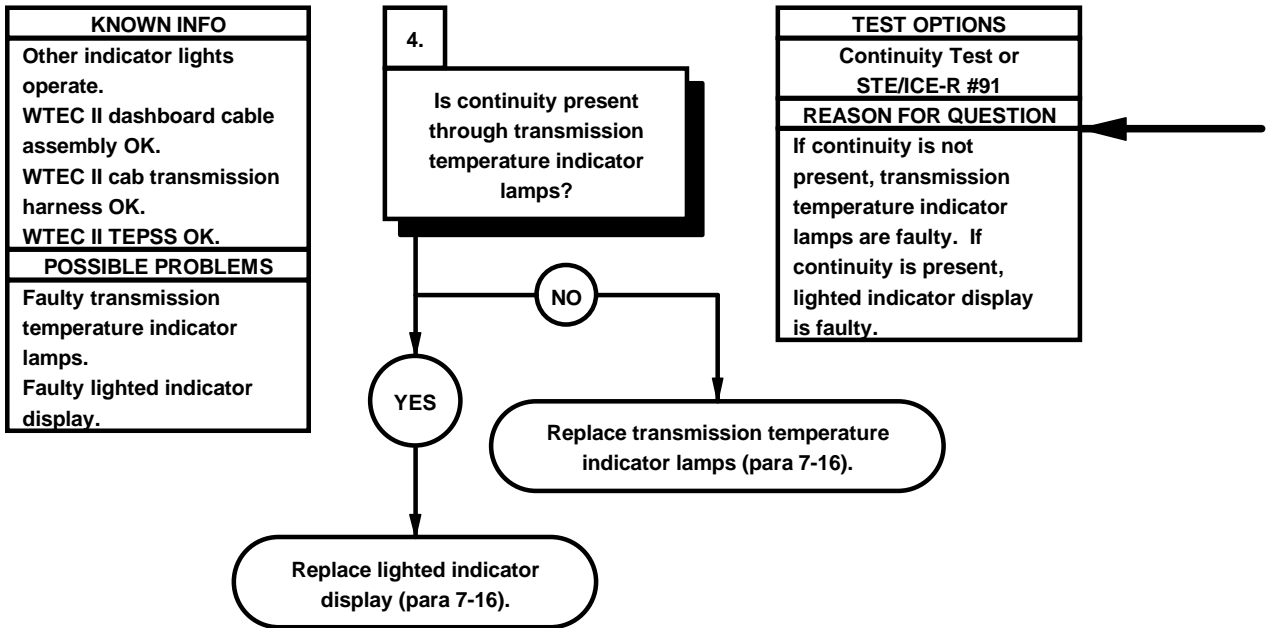

CONTINUITY TEST

- (1) Loosen four captive screws in lamp mounting panel.
- (2) Remove lamp mounting panel from lighted indicator display housing.
- (3) Remove transmission temperature indicator lamps from printed circuit board.
- (4) Set multimeter to ohms.
- (5) Check continuity through each transmission temperature indicator lamp and note reading on multimeter.
- (6) If continuity is not present, replace transmission temperature indicator lamps (para 7-16).
- (7) If continuity is present, replace lighted indicator display (para 7-16).
- (8) Install transmission temperature indicator lamps in printed circuit board.
- (9) Install lamp mounting panel in lighted indicator display housing.
- (10) Tighten four captive screws in lamp mounting panel.
- (11) Connect lighted indicator display to connector PX7.
- (12) Position lighted indicator display in instrument panel assembly with four screws.
- (13) Tighten four screws to 6-10 lb-in. (1 N-m).
- (14) Connect batteries (para 7-48).

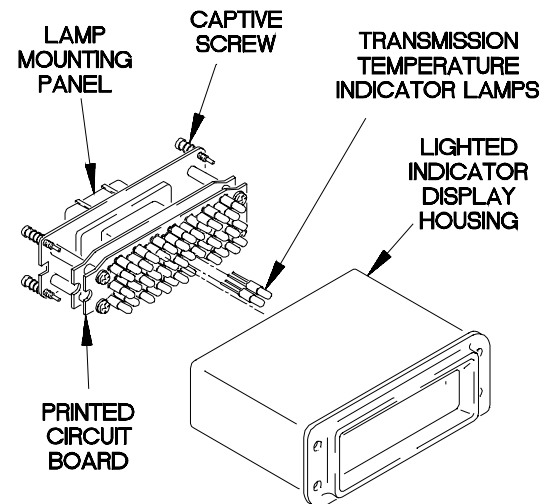
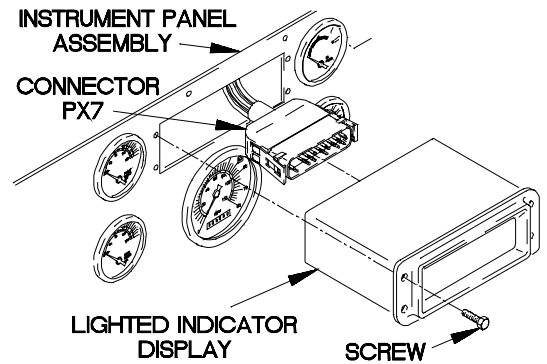
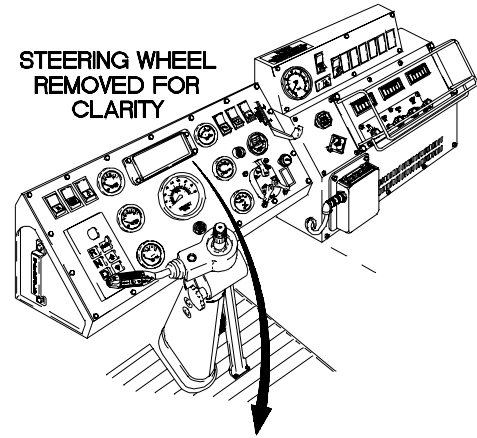

X2E3704A

e35. WTEC III TRANSMISSION TEMPERATURE INDICATOR DOES NOT OPERATE	
INITIAL SETUP	
Equipment Condition Engine shut down (TM 9-2320-365-10). Batteries disconnected (para 7-48).	Tools and Special Tools Tool Kit, Genl Mech (Item 44, Appendix C) STE/ICE-R (Item 39, Appendix C) Multimeter, Digital (Item 22, Appendix C) Wrench, Torque, 0-75 lb-in. (Item 86, Appendix B)
Personnel Required (2)	References TM 9-4910-571-12&P
Materials/Parts Wire, Elect, 50 ft (Item 77, Appendix D)	

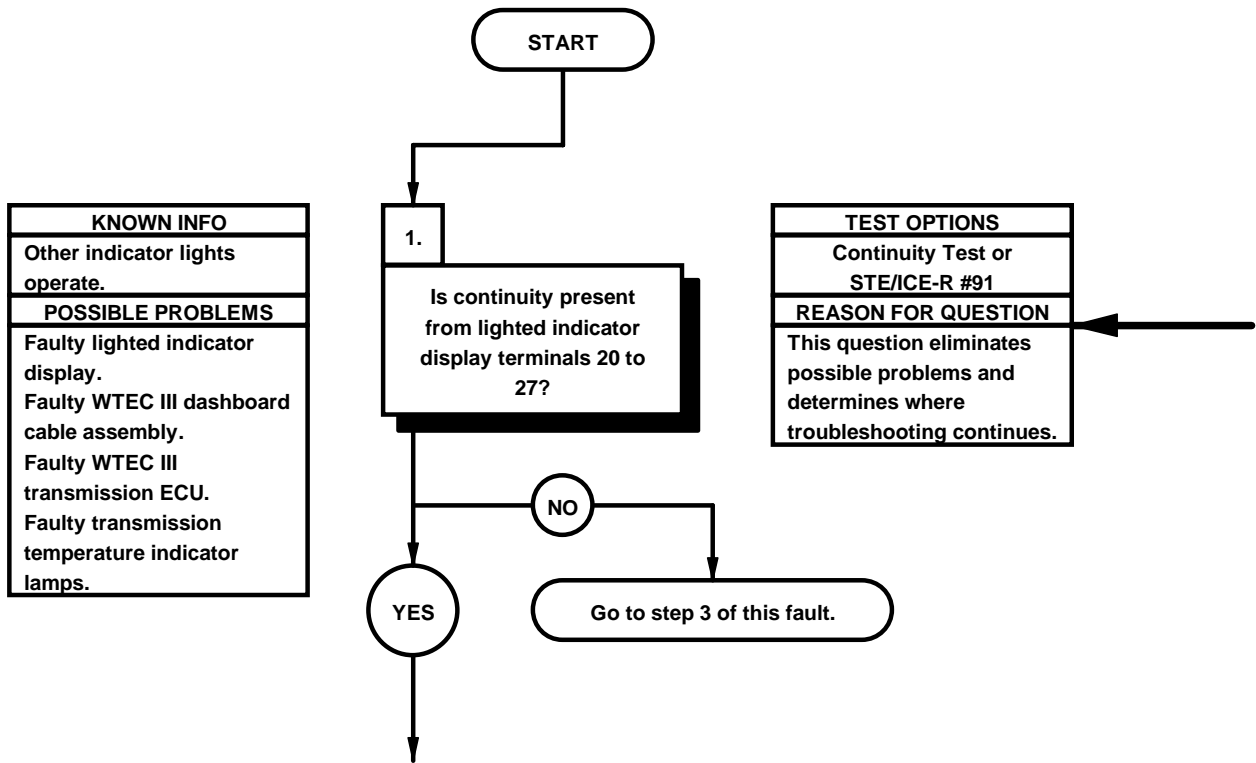

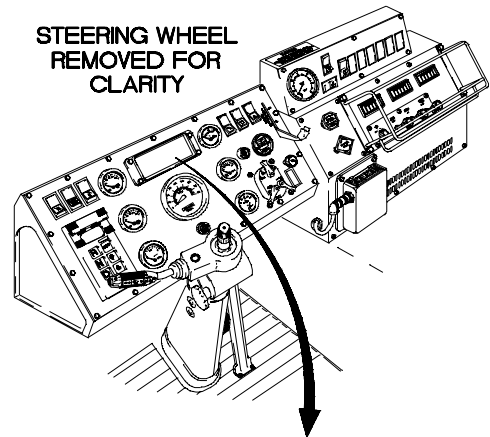

- | CONTINUITY TEST | |
|-----------------|---|
| (1) | Remove four screws from lighted indicator display. |
| (2) | Remove lighted indicator display from instrument panel assembly. |
| (3) | Disconnect connector PX7 from lighted indicator display. |
| (4) | Set multimeter to ohms. |
| (5) | Connect positive (+) probe of multimeter to lighted indicator display terminal 27. |
| (6) | Connect negative (-) probe of multimeter to lighted indicator display terminal 20 and note reading on multimeter. |
| (7) | If continuity is not present, go to step 3 of this fault. |

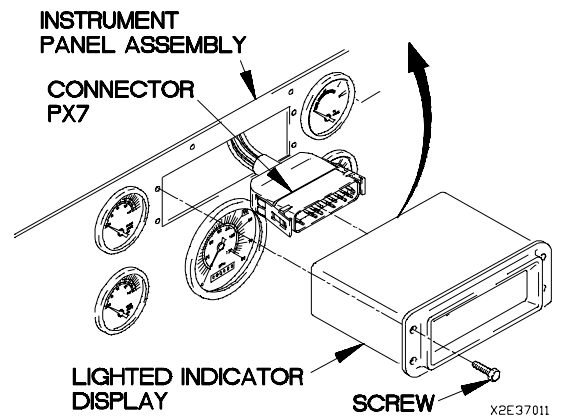
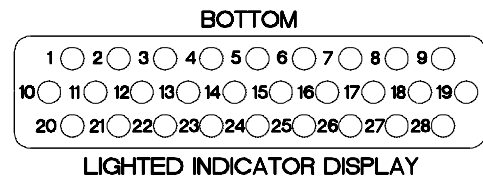

35. WTEC III TRANSMISSION TEMPERATURE INDICATOR DOES NOT OPERATE (CONT)

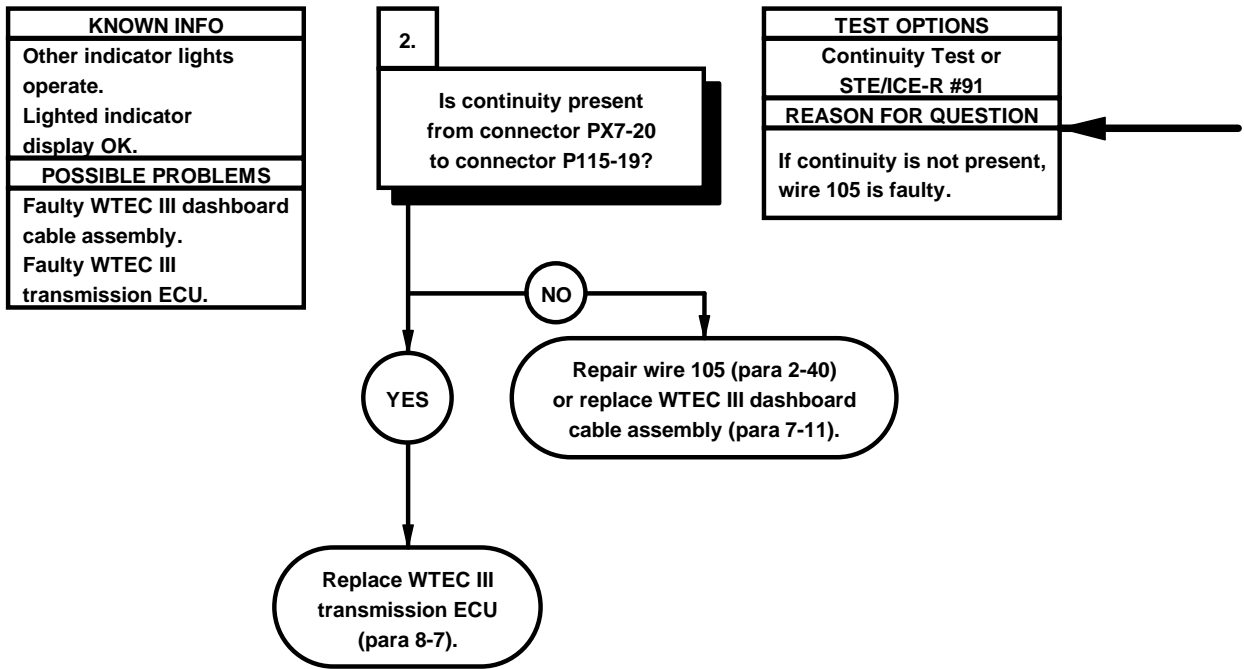

- CONTINUITY TEST**
- (1) Remove kick panel (para 16-3).
 - (2) Disconnect connector clamp from connector P115.
 - (3) Disconnect connector P115 from WTEC III transmission ECU.
 - (4) Set multimeter to ohms.
 - (5) Connect positive (+) probe of multimeter to connector PX7-20.
 - (6) Connect negative (-) probe of multimeter to connector P115-19 and note reading on multimeter.
 - (7) If continuity is not present, repair wire 105 (para 2-40) or replace WTEC III dashboard cable assembly (para 7-11).
 - (8) If continuity is present, replace WTEC III transmission ECU (para 8-7).
 - (9) Connect connector P115 to WTEC III transmission ECU.
 - (10) Connect connector clamp to connector P115.
 - (11) Install kick panel (para 16-3).
 - (12) Connect lighted indicator display to connector PX7.
 - (13) Position lighted indicator display in instrument panel assembly with four screws.
 - (14) Tighten four screws to 6-10 lb-in. (1 N-m).
 - (15) Connect batteries (para 7-48).

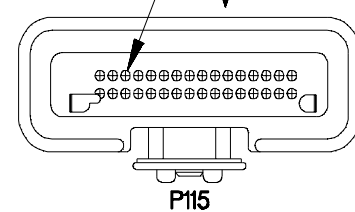
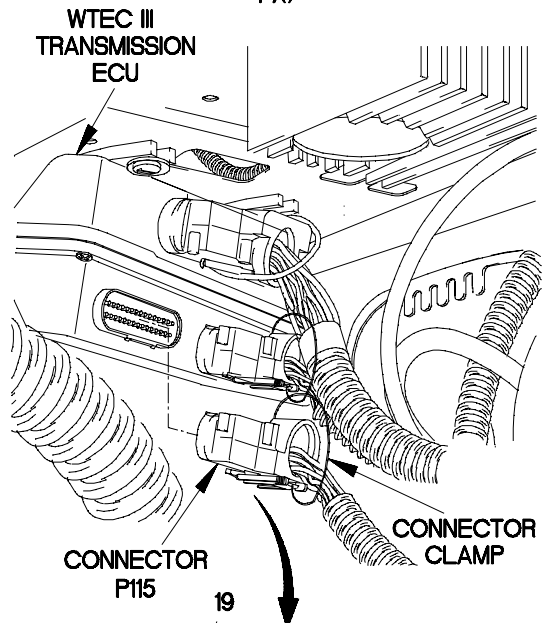
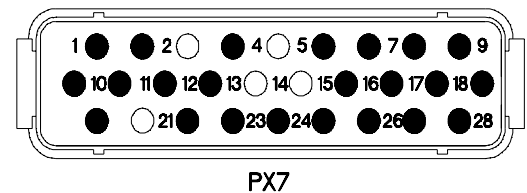
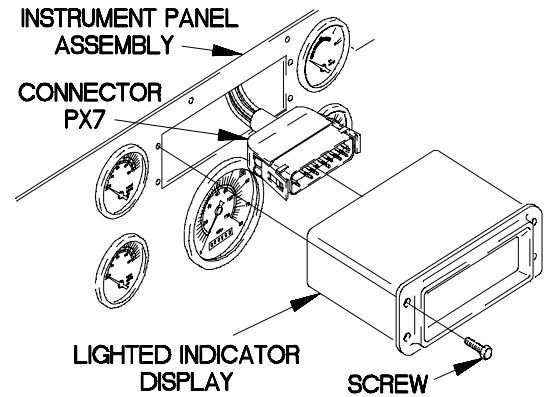

X2E36021

35. WTEC III TRANSMISSION TEMPERATURE INDICATOR DOES NOT OPERATE (CONT)

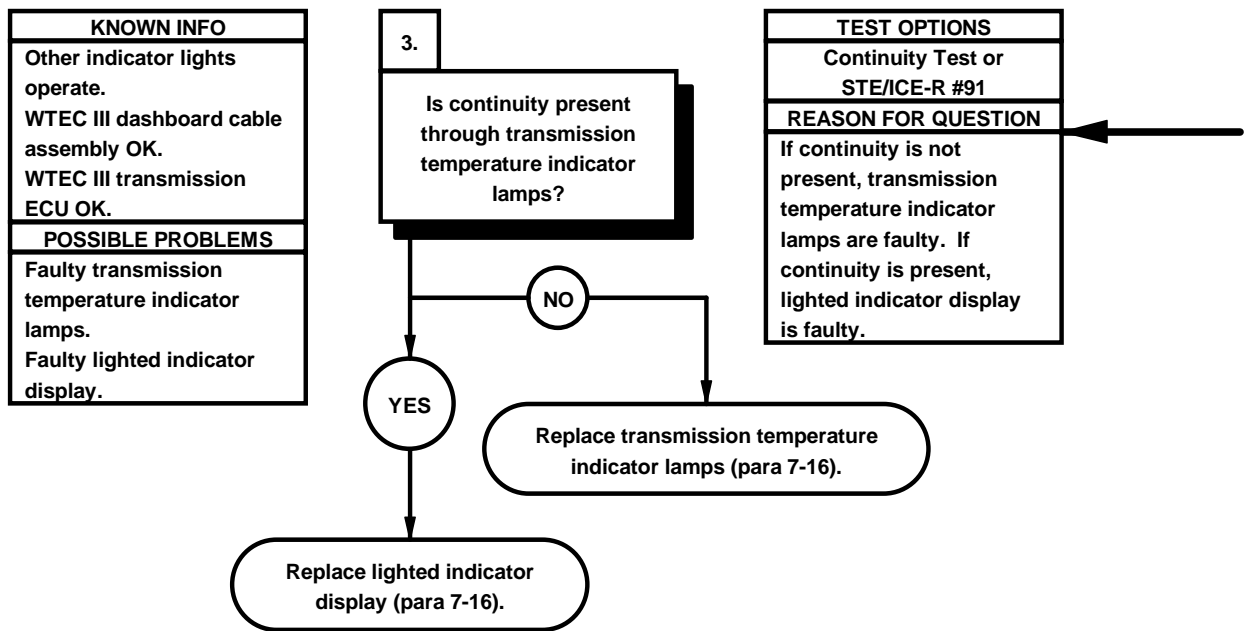

- | CONTINUITY TEST | |
|-----------------|---|
| | (1) Remove four screws from lighted indicator display. |
| | (2) Remove lighted indicator display from instrument panel assembly. |
| | (3) Disconnect connector PX7 from lighted indicator display. |
| | (4) Loosen four captive screws in lamp mounting panel. |
| | (5) Remove lamp mounting panel from lighted indicator display housing. |
| | (6) Remove transmission temperature indicator lamps from printed circuit board. |
| | (7) Set multimeter to ohms. |
| | (8) Check continuity through each transmission temperature indicator lamp and note reading on multimeter. |
| | (9) If continuity is not present, replace transmission temperature indicator lamps (para 7-16). |
| | (10) If continuity is present, replace lighted indicator display (para 7-16). |
| | (11) Install transmission temperature indicator lamps in printed circuit board. |
| | (12) Install lamp mounting panel in lighted indicator display housing. |
| | (13) Tighten four captive screws in lamp mounting panel. |
| | (14) Connect lighted indicator display to connector PX7. |
| | (15) Position lighted indicator display in instrument panel assembly with four screws. |
| | (16) Tighten four screws to 6-10 lb-in. (1 N-m). |
| | (17) Connect batteries (para 7-48). |

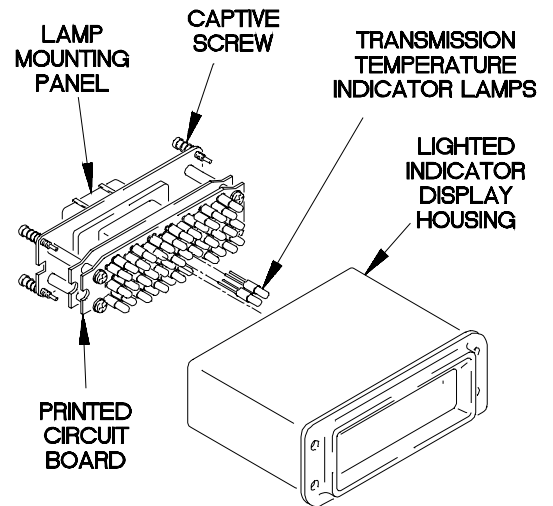
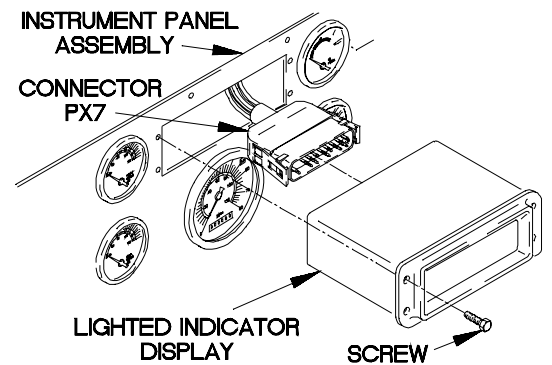
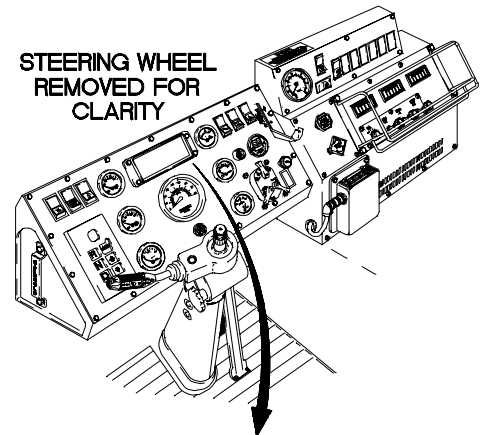

X2E3704A

e36. FRONT BRAKE AIR INDICATOR DOES NOT ILLUMINATE WHEN AIR PRESSURE IS BELOW 65 PSI

INITIAL SETUP

Equipment Condition

Engine shut down (TM 9-2320-365-10).
 Batteries disconnected (para 7-48).
 Air tanks drained (TM 9-2320-365-10).

Personnel Required

(2)

Tools and Special Tools

Tool Kit, Genl Mech (Item 44, Appendix C)
 STE/ICE-R (Item 39, Appendix C)
 Multimeter, Digital (Item 22, Appendix C)
 Wrench, Torque, 0-75 lb-in. (Item 86, Appendix B)

References

TM 9-4910-571-12&P

KNOWN INFO
Other indicator lights illuminate. FRONT BRAKE AIR pressure gage operates.
POSSIBLE PROBLEMS
Faulty front brake air indicator lamps. Faulty front air pressure transmitter. Faulty lighted indicator display. Faulty dashboard cable assembly.

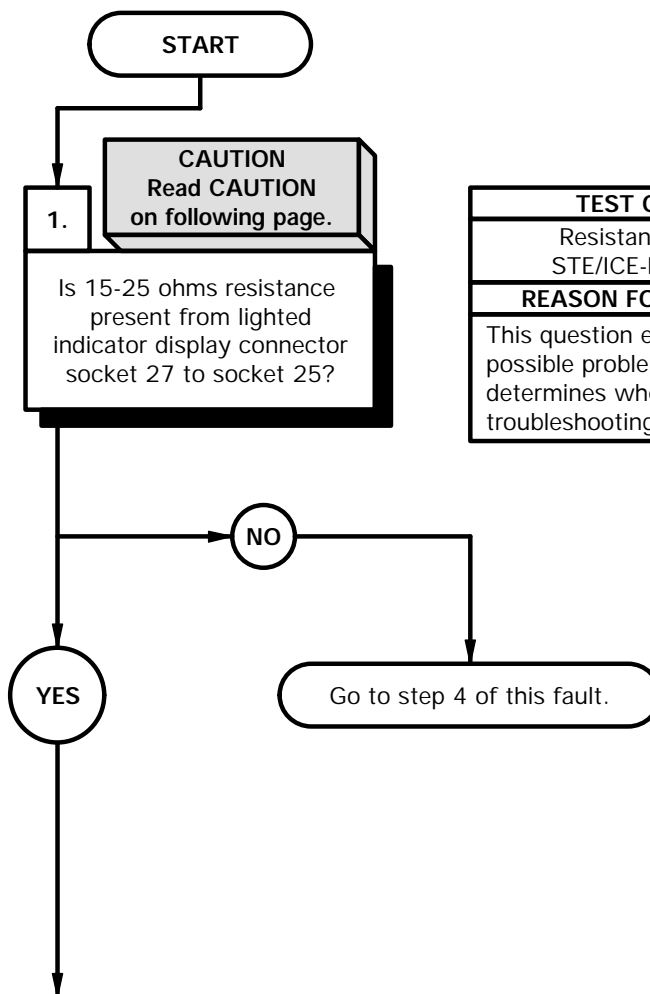

TEST OPTIONS
Resistance Test or STE/ICE-R Test #91
REASON FOR QUESTION
This question eliminates possible problems and determines where troubleshooting continues.

CAUTION

Use care when testing electrical connectors. Do not damage connector pins or sockets with multimeter probes. Failure to comply may result in damage to equipment.

NOTE

Inspect connector pins/sockets for damage, corrosion, and serviceability. Check that connector pins are not pushed back or not capable of making good contact.

RESISTANCE TEST

- (1) Remove four screws from lighted indicator display.
- (2) Remove lighted indicator display from instrument panel assembly.
- (3) Disconnect connector PX7 from lighted indicator display connector.
- (4) Set multimeter to ohms.
- (5) Connect positive (+) probe of multimeter to lighted indicator display connector socket 27.
- (6) Connect negative (-) probe of multimeter to lighted indicator display connector socket 25 and note reading on multimeter.
- (7) If 15-25 ohms resistance is not present, go to step 4 of this fault.

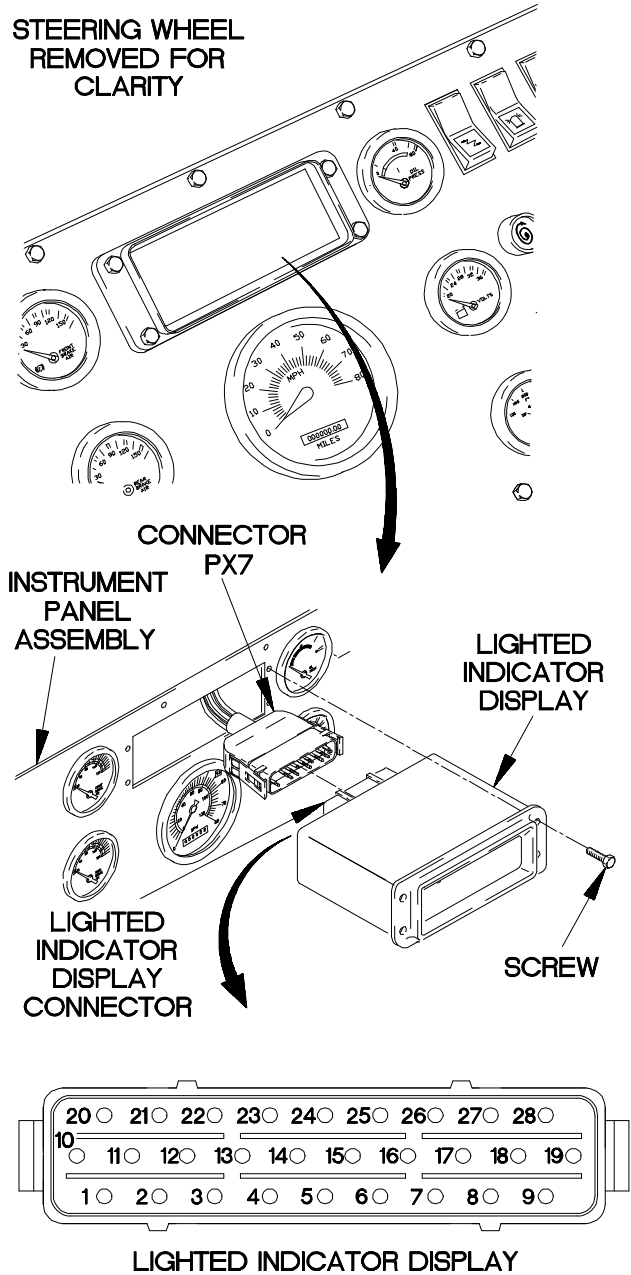

XBE3701B

e36. FRONT BRAKE AIR INDICATOR DOES NOT ILLUMINATE WHEN AIR PRESSURE IS BELOW 65 PSI (CONT)

KNOWN INFO
Other indicator lights illuminate. FRONT BRAKE AIR pressure gage operates. Front brake air indicator lamps OK. Lighted indicator display OK.
POSSIBLE PROBLEMS
Faulty front air pressure transmitter. Faulty dashboard cable assembly.

2.

CAUTION
Read CAUTION on following page.

Is continuity present from connector PX7 pin 25 to terminal lug TL156?

TEST OPTIONS
Continuity Test or STE/ICE-R Test #91
REASON FOR QUESTION
If continuity is not present, wire 1530 is faulty.

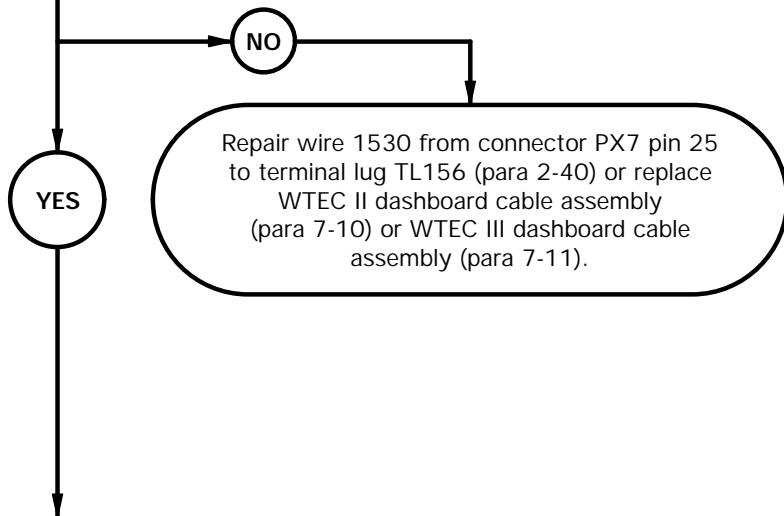

CAUTION

Use care when testing electrical connectors. Do not damage connector pins or sockets with multimeter probes. Failure to comply may result in damage to equipment.

NOTE

Inspect connector pins/sockets for damage, corrosion, and serviceability. Check that connector pins are not pushed back or not capable of making good contact.

CONTINUITY TEST

- (1) Set multimeter to ohms.
- (2) Connect positive (+) probe of multimeter to connector PX7 pin 25.
- (3) Connect negative (-) probe of multimeter to terminal lug TL156 and note reading on multimeter.
- (4) If continuity is not present, repair wire 1530 from connector PX7 pin 25 to terminal lug TL156 (para 2-40) or replace WTEC II dashboard cable assembly (para 7-10) or WTEC III dashboard cable assembly (para 7-11).

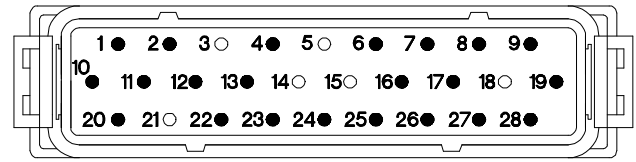

PX7

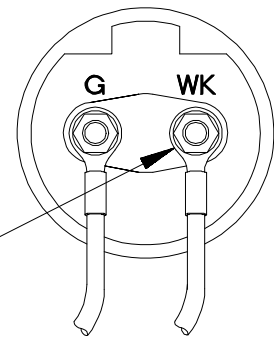
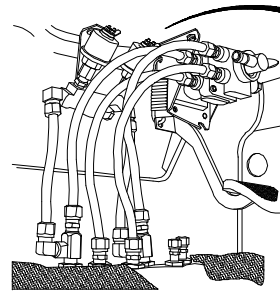

FRONT BRAKE
AIR PRESSURE
TRANSMITTER

XBE3702B

e36. FRONT BRAKE AIR INDICATOR DOES NOT ILLUMINATE WHEN AIR PRESSURE IS BELOW 65 PSI (CONT)

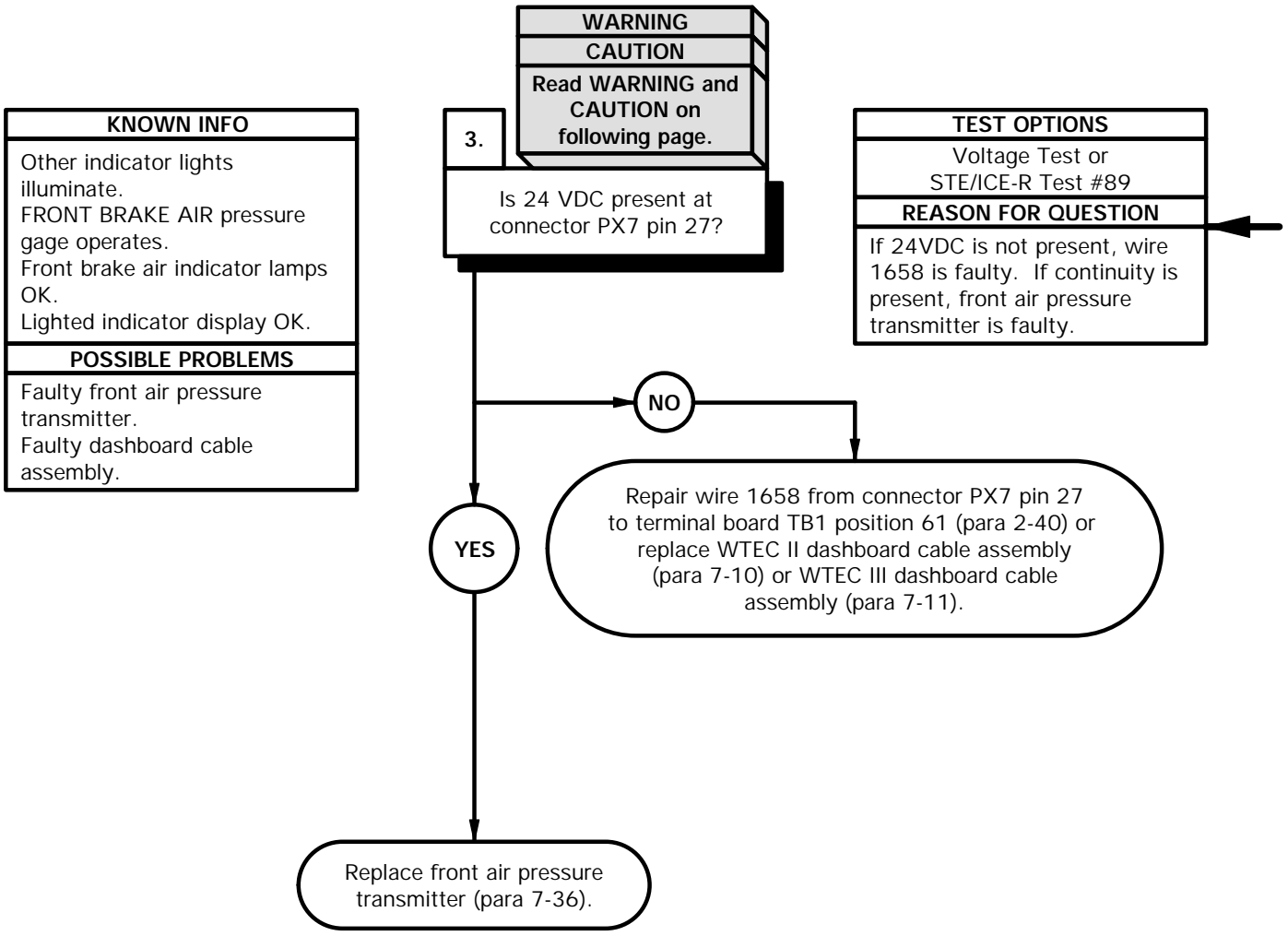

WARNING

Remove rings, bracelets, watches, necklaces, and any other jewelry before working around vehicle. Jewelry can catch on equipment and cause injury or short across electrical circuits and cause severe burns or electrical shock.

CAUTION

Use care when testing electrical connectors. Do not damage connector pins or sockets with multimeter probes. Failure to comply may result in damage to equipment.

NOTE

Inspect connector pins/sockets for damage, corrosion, and serviceability. Check that connector pins are not pushed back or not capable of making good contact.

VOLTAGE TEST

- (1) Set multimeter to volts DC.
- (2) Connect positive (+) probe of multimeter to connector PX7 pin 27.
- (3) Connect negative (-) probe of multimeter to ground.
- (4) Connect batteries (para 7-48).
- (5) Position master power switch to on (TM 9-2320-365-10) and note reading on multimeter.
- (6) Position master power switch to off (TM 9-2320-365-10).
- (7) Disconnect batteries (para 7-48).
- (8) If 24 VDC is not present, repair wire 1658 from connector PX7 pin 27 to terminal board TB1 position 61 (para 2-40) or replace WTEC II dashboard cable assembly (para 7-10) or WTEC III dashboard cable assembly (para 7-11).
- (9) If continuity is present, replace front air pressure transmitter (para 7-36).
- (10) Connect lighted indicator display connector to connector PX7.
- (11) Position lighted indicator display in instrument panel assembly with four screws.
- (12) Tighten four screws to 6-10 lb-in. (1 N·m).
- (13) Connect batteries (para 7-48).

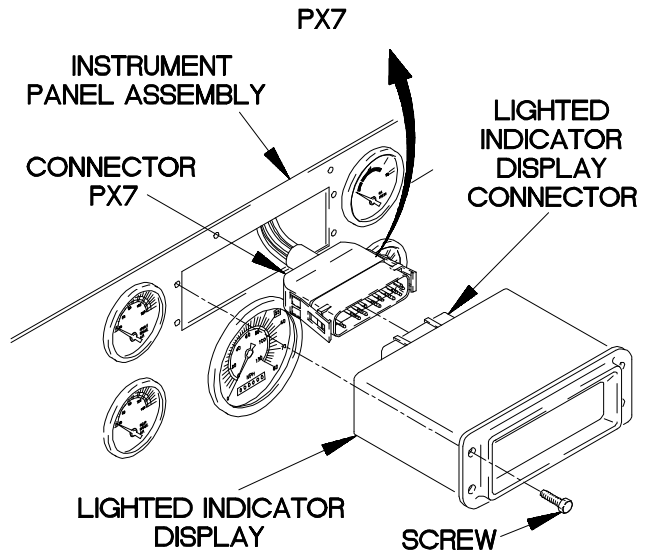
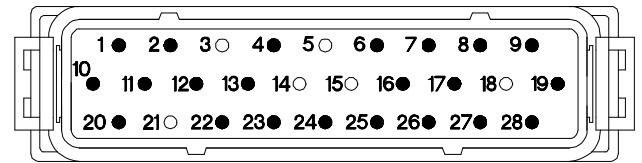

XBE3703B

e36. FRONT BRAKE AIR INDICATOR DOES NOT ILLUMINATE WHEN AIR PRESSURE IS BELOW 65 PSI (CONT)

KNOWN INFO
Other indicator lights illuminate. FRONT BRAKE AIR pressure gage operates.
POSSIBLE PROBLEMS
Faulty front brake air indicator lamps. Faulty lighted indicator display.

4.
Is continuity present through front brake air indicator lamps?

TEST OPTIONS
Continuity Test or STE/ICE-R Test #91
REASON FOR QUESTION
If continuity is not present, front brake air indicator lamps are faulty. If continuity is present, lighted indicator display is faulty.

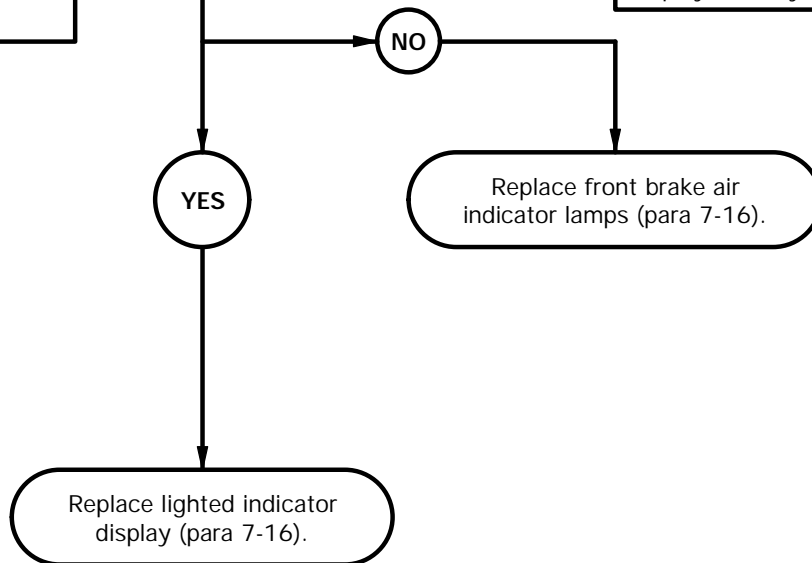

CONTINUITY TEST

- (1) Loosen four captive screws in lamp mounting panel.
- (2) Remove lamp mounting panel from lighted indicator display.
- (3) Remove two front brake air indicator lamps from printed circuit board.
- (4) Set multimeter to ohms.
- (5) Check continuity through each front brake air indicator lamp and note reading on multimeter.
- (6) If continuity is not present, replace front brake air indicator lamps (para 7-16).
- (7) If continuity is present, replace lighted indicator display (para 7-16).
- (8) Install two front brake air indicator lamps in printed circuit board.
- (9) Install lamp mounting panel in lighted indicator display.
- (10) Tighten four captive screws in lamp mounting panel.
- (11) Connect lighted indicator display connector to connector PX7.
- (12) Position lighted indicator display in instrument panel assembly with four screws.
- (13) Tighten four screws to 6-10 lb-in. (1 N·m).
- (14) Connect batteries (para 7-48).

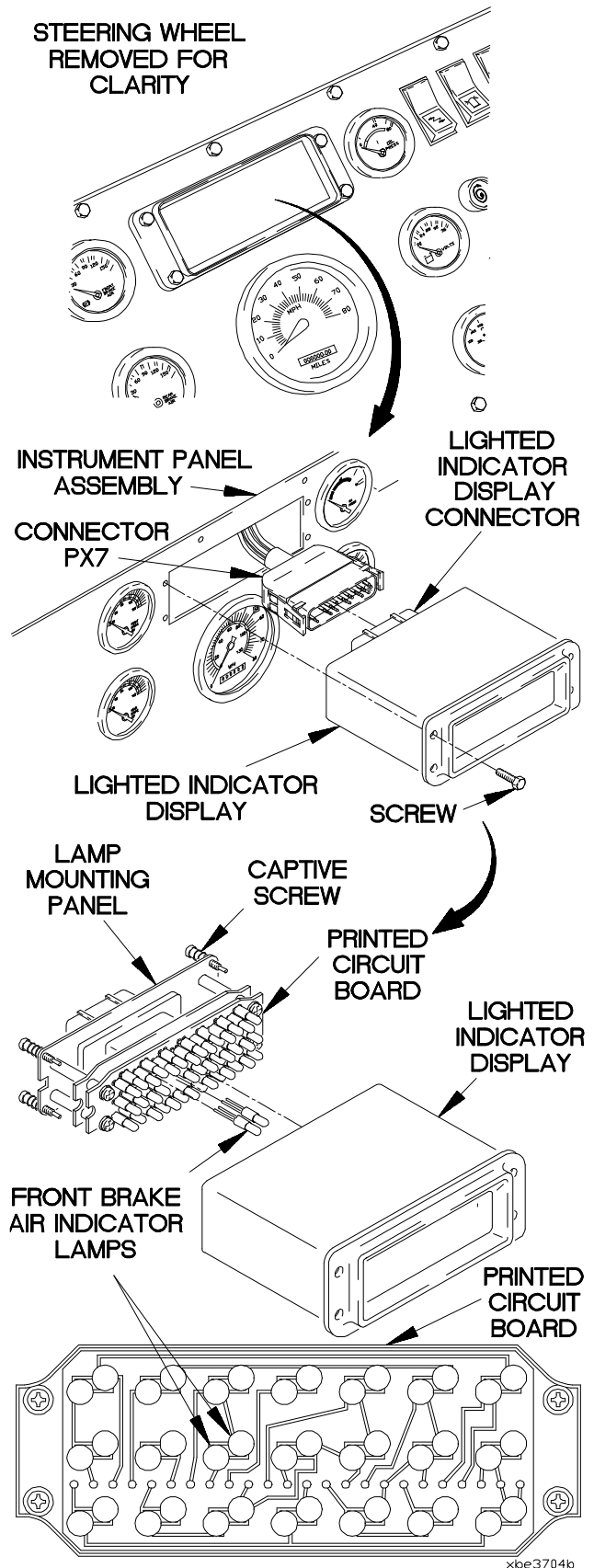

xbe3704b

e37. REAR BRAKE AIR INDICATOR DOES NOT ILLUMINATE WHEN AIR PRESSURE IS BELOW 65 PSI

INITIAL SETUP

Equipment Condition

Engine shut down (TM 9-2320-365-10).
 Batteries disconnected (para 7-48).
 Air tanks drained (TM 9-2320-365-10).

Tools and Special Tools

Tool Kit, Genl Mech (Item 44, Appendix C)
 STE/ICE-R (Item 39, Appendix C)
 Multimeter, Digital (Item 22, Appendix C)
 Wrench, Torque, 0-75 lb-in. (Item 86, Appendix B)

Personnel Required

(2)

References

TM 9-4910-571-12&P

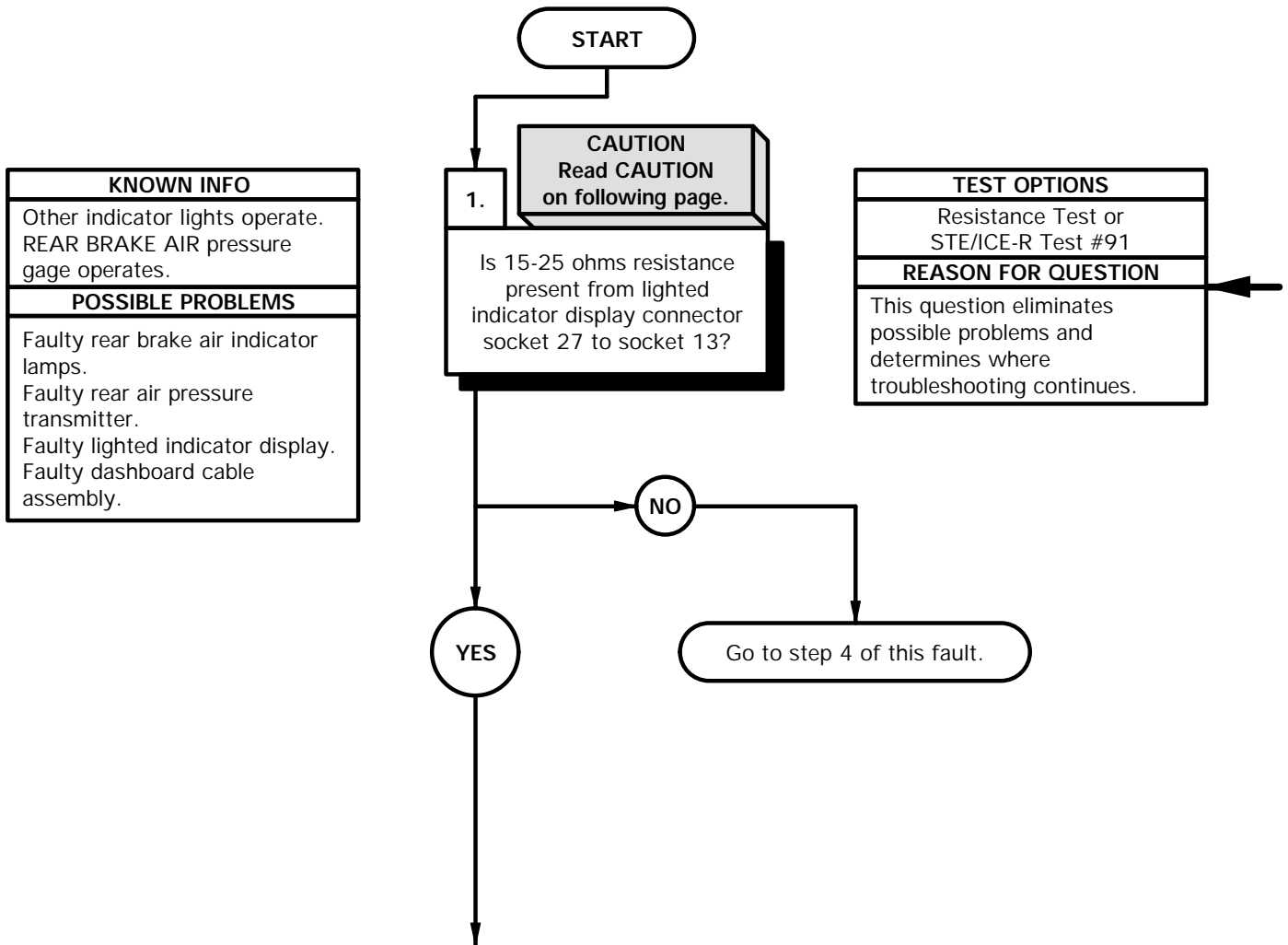

CAUTION

Use care when testing electrical connectors. Do not damage connector pins or sockets with multimeter probes. Failure to comply may result in damage to equipment.

NOTE

Inspect connector pins/sockets for damage, corrosion, and serviceability. Check that connector pins are not pushed back or not capable of making good contact.

RESISTANCE TEST

- (1) Remove four screws from lighted indicator display.
- (2) Remove lighted indicator display from instrument panel assembly.
- (3) Disconnect connector PX7 from lighted indicator display connector.
- (4) Set multimeter to ohms.
- (5) Connect positive (+) probe of multimeter to lighted indicator display connector socket 27.
- (6) Connect negative (-) probe of multimeter to lighted indicator display connector socket 13 and note reading on multimeter.
- (7) If 15-25 ohms resistance is not present, go to step 4 of this fault.

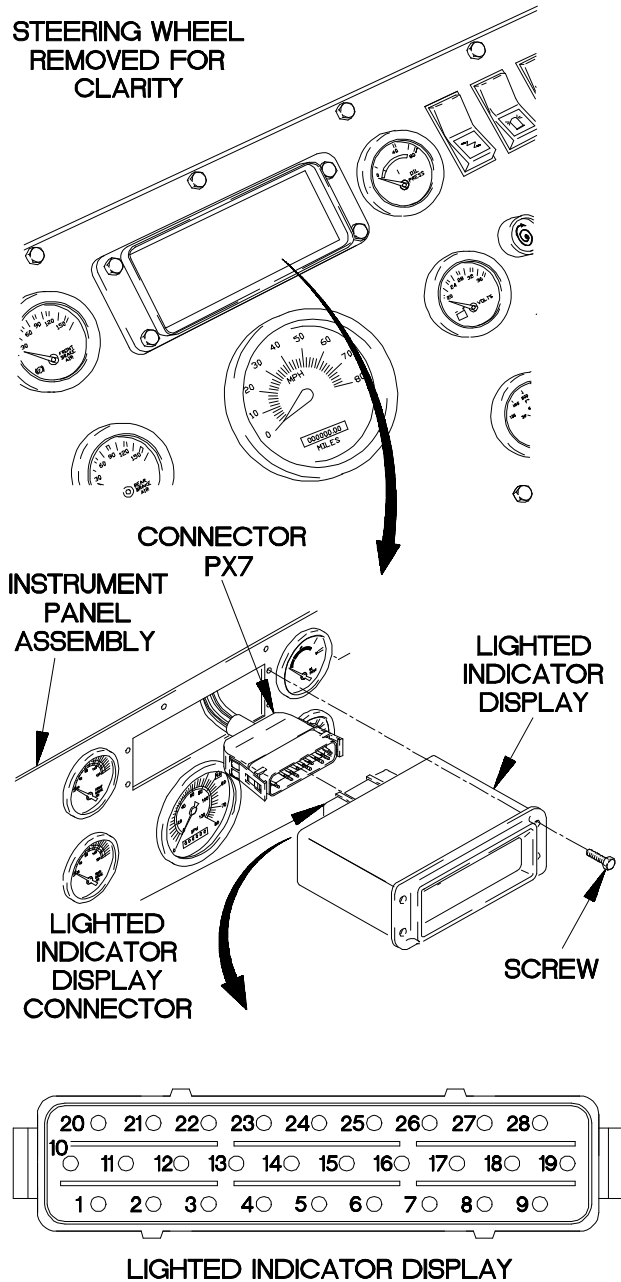

X6E3801b

e37. REAR BRAKE AIR INDICATOR DOES NOT ILLUMINATE WHEN AIR PRESSURE IS BELOW 65 PSI (CONT)

KNOWN INFO
Other indicator lights operate. REAR BRAKE AIR pressure gage operates. Rear brake air indicator lamps OK. Lighted indicator display OK.
POSSIBLE PROBLEMS
Faulty rear air pressure transmitter. Faulty dashboard cable assembly.

2.

CAUTION
Read CAUTION on following page.

Is continuity present from connector PX7 pin 13 to terminal lug TL157?

TEST OPTIONS
Continuity Test or STE/ICE-R Test #91
REASON FOR QUESTION
If continuity is not present, wire 1525 is faulty.

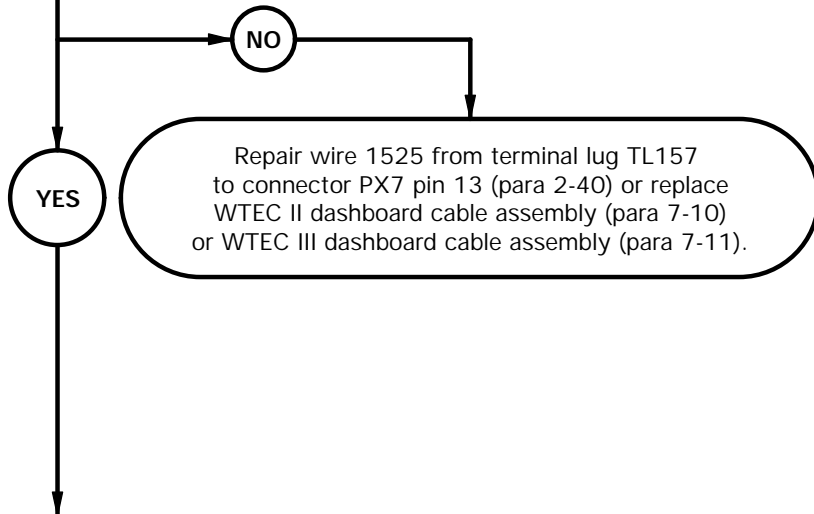

CAUTION

Use care when testing electrical connectors. Do not damage connector pins or sockets with multimeter probes. Failure to comply may result in damage to equipment.

NOTE

Inspect connector pins/sockets for damage, corrosion, and serviceability. Check that connector pins are not pushed back or not capable of making good contact.

CONTINUITY TEST

- (1) Set multimeter to ohms.
- (2) Connect positive (+) probe of multimeter to connector PX7 pin 13.
- (3) Connect negative (-) probe of multimeter to terminal lug TL157 and note reading on multimeter.
- (4) If continuity is not present, repair wire 1525 from terminal lug TL157 to connector PX7 pin 13 (para 2-40) or replace WTEC II dashboard cable assembly (para 7-10) or WTEC III dashboard cable assembly (para 7-11).

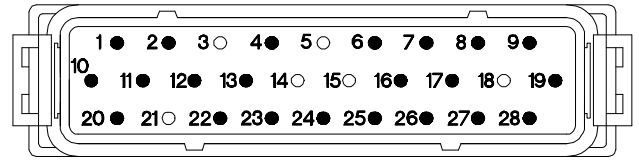

PX7

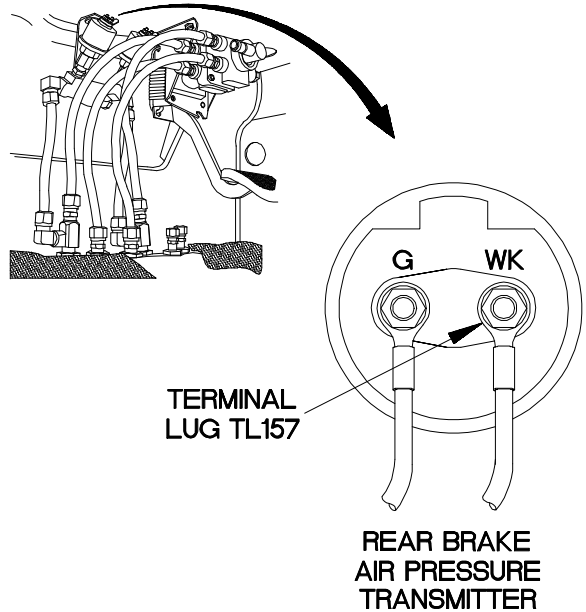

X6E3802b

e37. REAR BRAKE AIR INDICATOR DOES NOT ILLUMINATE WHEN AIR PRESSURE IS BELOW 65 PSI (CONT)

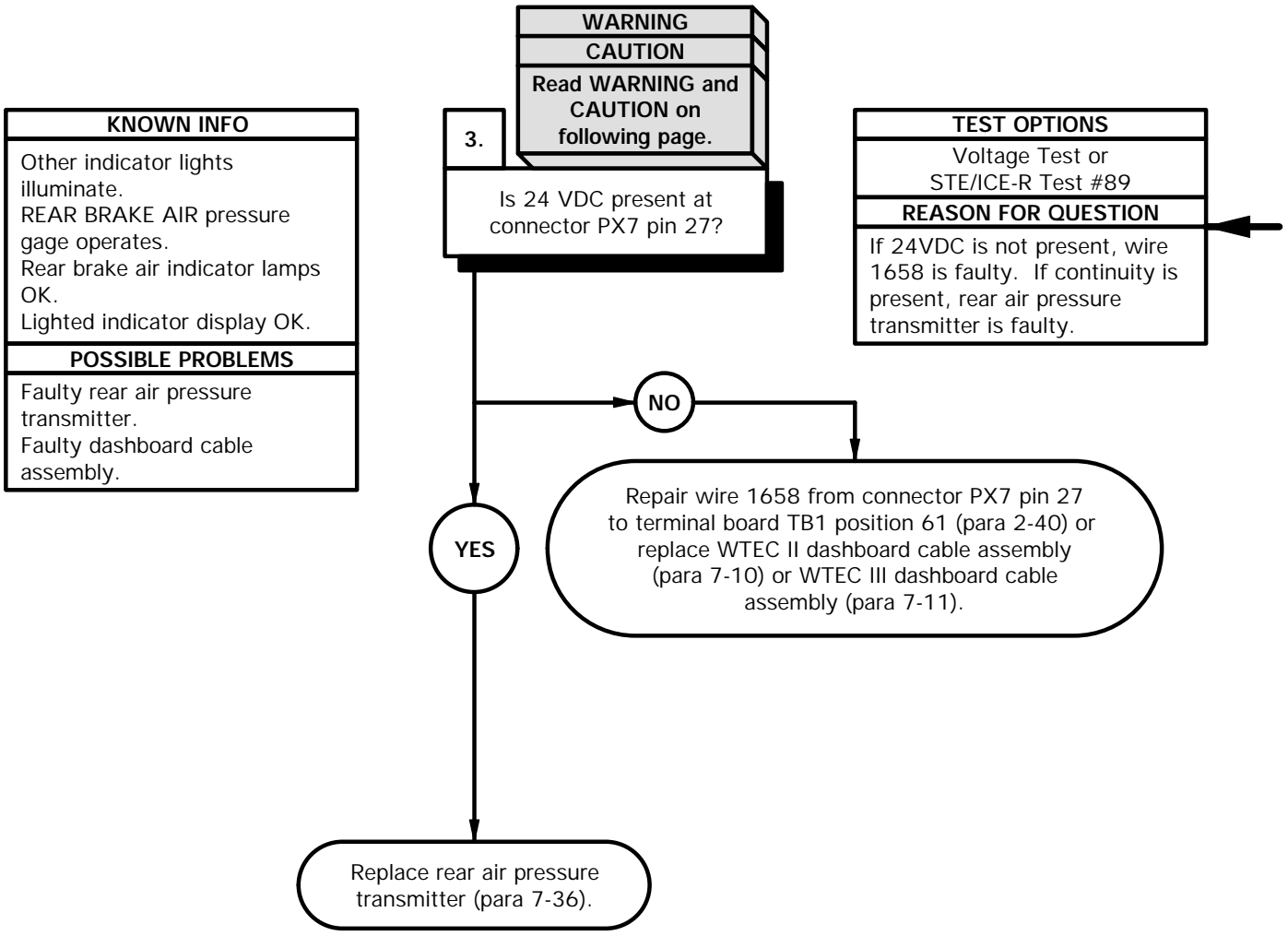

WARNING

Remove rings, bracelets, watches, necklaces, and any other jewelry before working around vehicle. Jewelry can catch on equipment and cause injury or short across electrical circuits and cause severe burns or electrical shock.

CAUTION

Use care when testing electrical connectors. Do not damage connector pins or sockets with multimeter probes. Failure to comply may result in damage to equipment.

NOTE

Inspect connector pins/sockets for damage, corrosion, and serviceability. Check that connector pins are not pushed back or not capable of making good contact.

VOLTAGE TEST

- (1) Set multimeter to volts DC.
- (2) Connect positive (+) probe of multimeter to connector PX7 pin 27.
- (3) Connect negative (-) probe of multimeter to ground.
- (4) Connect batteries (para 7-48).
- (5) Position master power switch to on (TM 9-2320-365-10) and note reading on multimeter.
- (6) Position master power switch to off (TM 9-2320-365-10).
- (7) Disconnect batteries (para 7-48).
- (8) If 24 VDC is not present, repair wire 1658 from connector PX7 pin 27 to terminal board TB1 position 61 (para 2-40) or replace WTEC II dashboard cable assembly (para 7-10) or WTEC III dashboard cable assembly (para 7-11).
- (9) If continuity is present, replace rear air pressure transmitter (para 7-36).
- (10) Connect lighted indicator display connector to connector PX7.
- (11) Position lighted indicator display in instrument panel assembly with four screws.
- (12) Tighten four screws to 6-10 lb-in. (1 N·m).
- (13) Connect batteries (para 7-48).

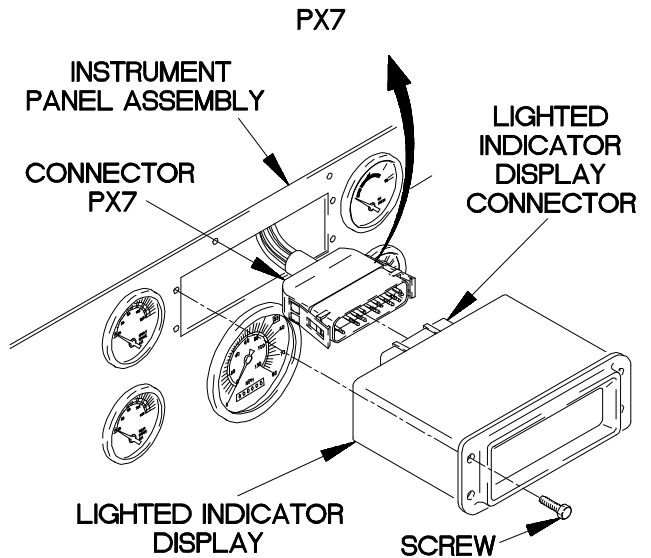
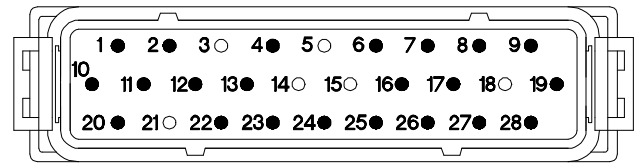

XBE3803B

e37. REAR BRAKE AIR INDICATOR DOES NOT ILLUMINATE WHEN AIR PRESSURE IS BELOW 65 PSI (CONT)

KNOWN INFO
Other indicator lights illuminate. REAR BRAKE AIR pressure gage operates.
POSSIBLE PROBLEMS
Faulty rear brake air indicator lamps. Faulty lighted indicator display.

4.
Is continuity present through rear brake air indicator lamps?

TEST OPTIONS
Continuity Test or STE/ICE-R Test #91
REASON FOR QUESTION
If continuity is not present, rear brake air indicator lamps are faulty. If continuity is present, lighted indicator display is faulty.

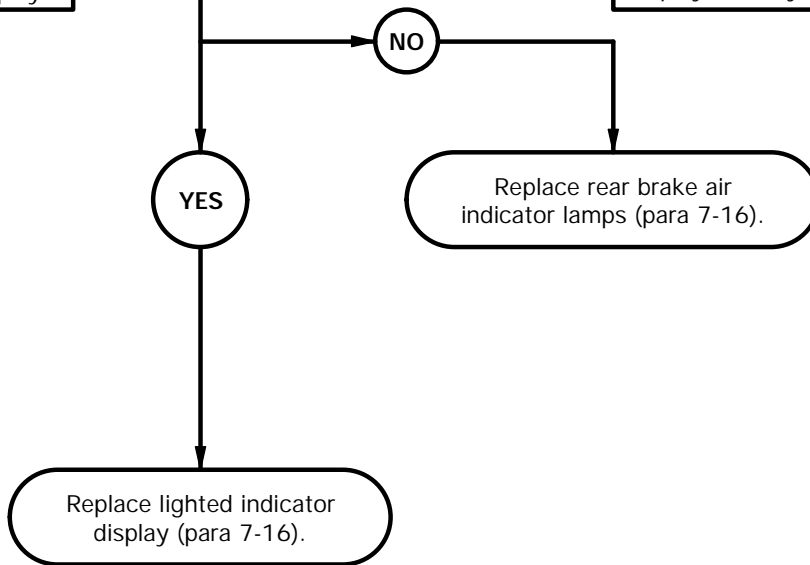

CONTINUITY TEST

- (1) Loosen four captive screws in lamp mounting panel.
- (2) Remove lamp mounting panel from lighted indicator display housing.
- (3) Remove two rear brake air indicator lamps from printed circuit board.
- (4) Set multimeter to ohms.
- (5) Check continuity through each rear brake air indicator lamp and note reading on multimeter.
- (6) If continuity is not present, replace rear brake air indicator lamps (para 7-16).
- (7) If continuity is present, replace lighted indicator display (para 7-16).
- (8) Install two rear brake air indicator lamps in printed circuit board.
- (9) Install lamp mounting panel in lighted indicator display housing.
- (10) Tighten four captive screws in lamp mounting panel.
- (11) Connect lighted indicator display connector to connector PX7.
- (12) Position lighted indicator display in instrument panel assembly with four screws.
- (13) Tighten four screws to 6-10 lb-in. (1 N·m).
- (14) Connect batteries (para 7-48).

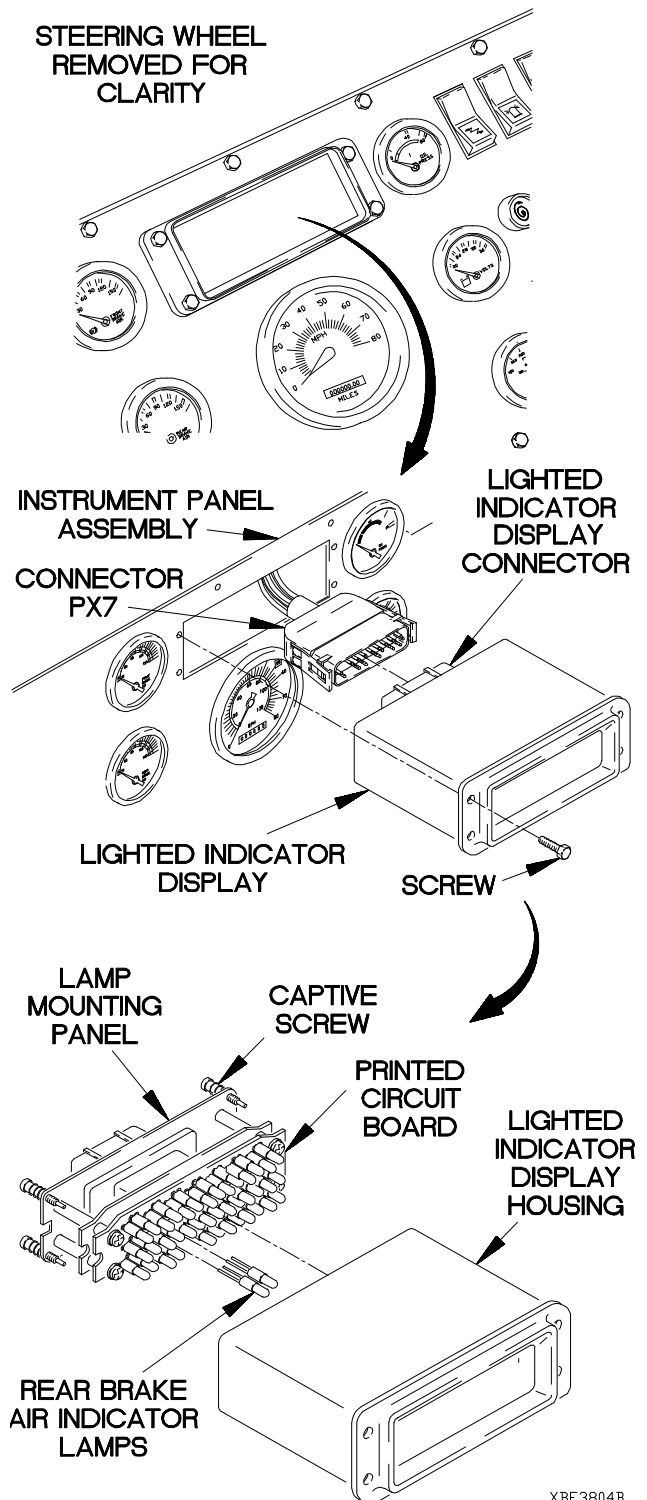

e38. ENGINE OIL PRESSURE INDICATOR DOES NOT OPERATE	
INITIAL SETUP	
Equipment Condition Engine shut down (TM 9-2320-365-10). Batteries disconnected (para 7-48).	Tools and Special Tools Tool Kit, Genl Mech (Item 44, Appendix C) STE/ICE-R (Item 39, Appendix C) Multimeter, Digital (Item 22, Appendix C) Wrench, Torque, 0-75 lb-in. (Item 86, Appendix B)
Personnel Required (2)	References TM 9-4910-571-12&P

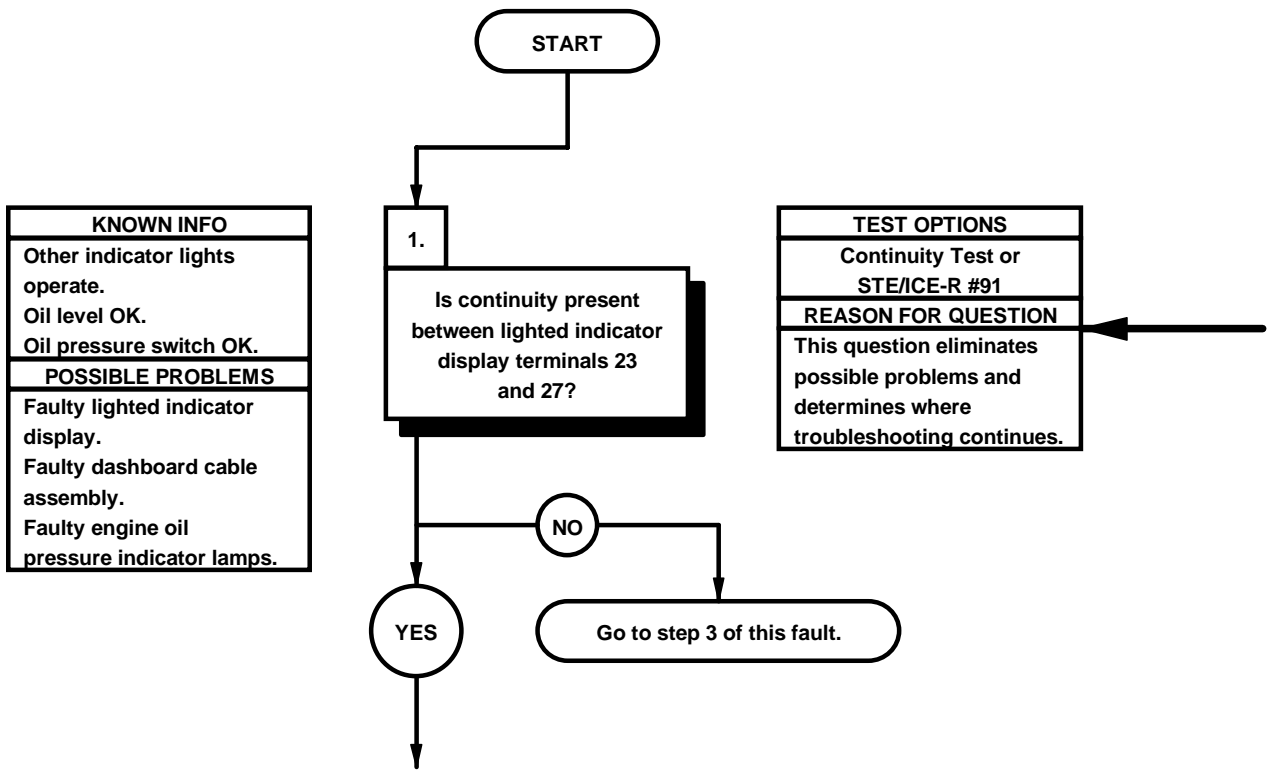

- | CONTINUITY TEST | |
|-----------------|---|
| (1) | Remove four screws from lighted indicator display. |
| (2) | Remove lighted indicator display from instrument panel assembly. |
| (3) | Disconnect connector PX7 from lighted indicator display. |
| (4) | Set multimeter to ohms. |
| (5) | Connect positive (+) probe of multimeter to lighted indicator display terminal 27. |
| (6) | Connect negative (-) probe of multimeter to lighted indicator display terminal 23 and note reading on multimeter. |
| (7) | If continuity is not present, go to step 3 of this fault. |

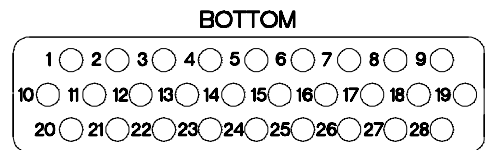
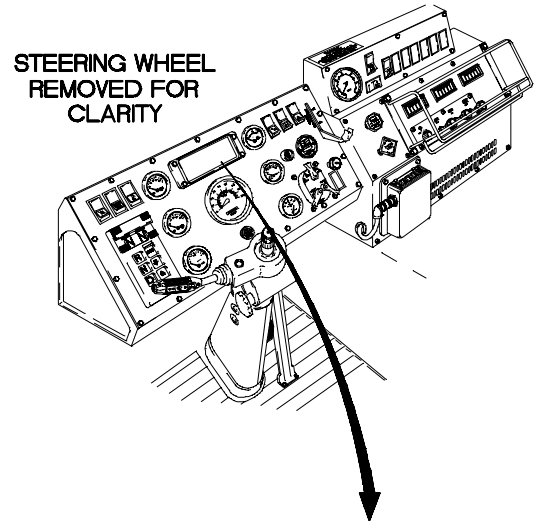

LIGHTED INDICATOR DISPLAY

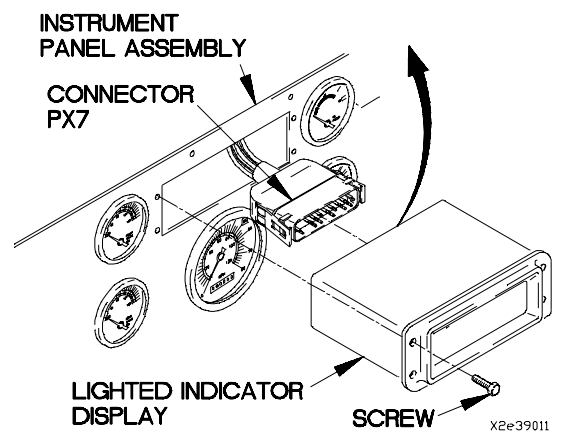

e38. ENGINE OIL PRESSURE INDICATOR DOES NOT OPERATE (CONT)

KNOWN INFO
Other indicator lights operate. Oil level OK. Oil pressure switch OK. Lighted indicator display OK.
POSSIBLE PROBLEMS
Faulty dashboard cable assembly.

2.
Is continuity present between relay K11 terminal 85 and PX7-23?

TEST OPTIONS
Continuity Test or STE/ICE-R #91
REASON FOR QUESTION
If continuity is not present, wire 34A is faulty.

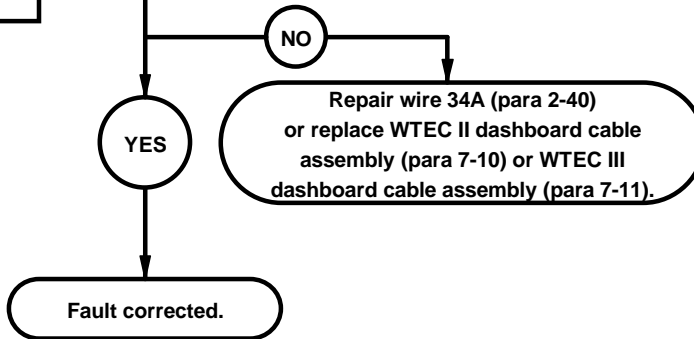

CONTINUITY TEST

- (1) Remove PDP cover (para 16-2).
- (2) Remove relay K11 from PDP.
- (3) Set multimeter to ohms.
- (4) Connect positive (+) probe of multimeter to PDP, terminal 85, where relay K11 was removed.
- (5) Connect negative (-) probe of multimeter to PX7-23 and note reading on multimeter.
- (6) If continuity is not present, repair wire 34A (para 2-40) or replace WTEC II dashboard cable assembly (para 7-10) or WTEC III dashboard cable assembly (para 7-11).
- (7) Install relay K11 in PDP.
- (8) Install PDP cover (para 16-2).
- (9) Connect lighted indicator display to connector PX7.
- (10) Position lighted indicator display in instrument panel assembly with four screws.
- (11) Tighten four screws to 6-10 lb-in. (1 N-m).
- (12) Connect batteries (para 7-48).

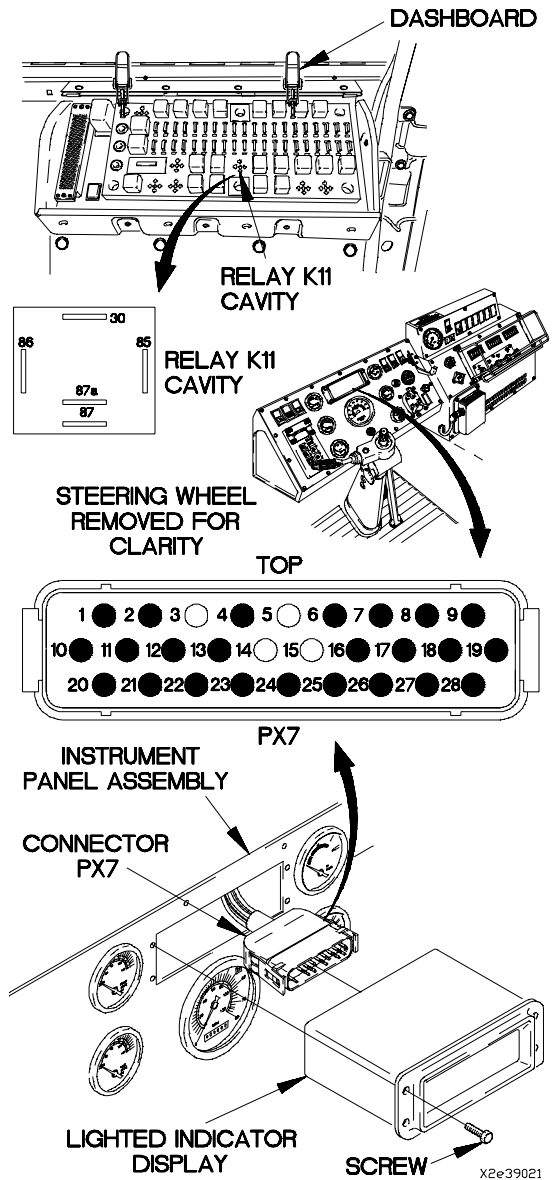

ø38. ENGINE OIL PRESSURE INDICATOR DOES NOT OPERATE (CONT)

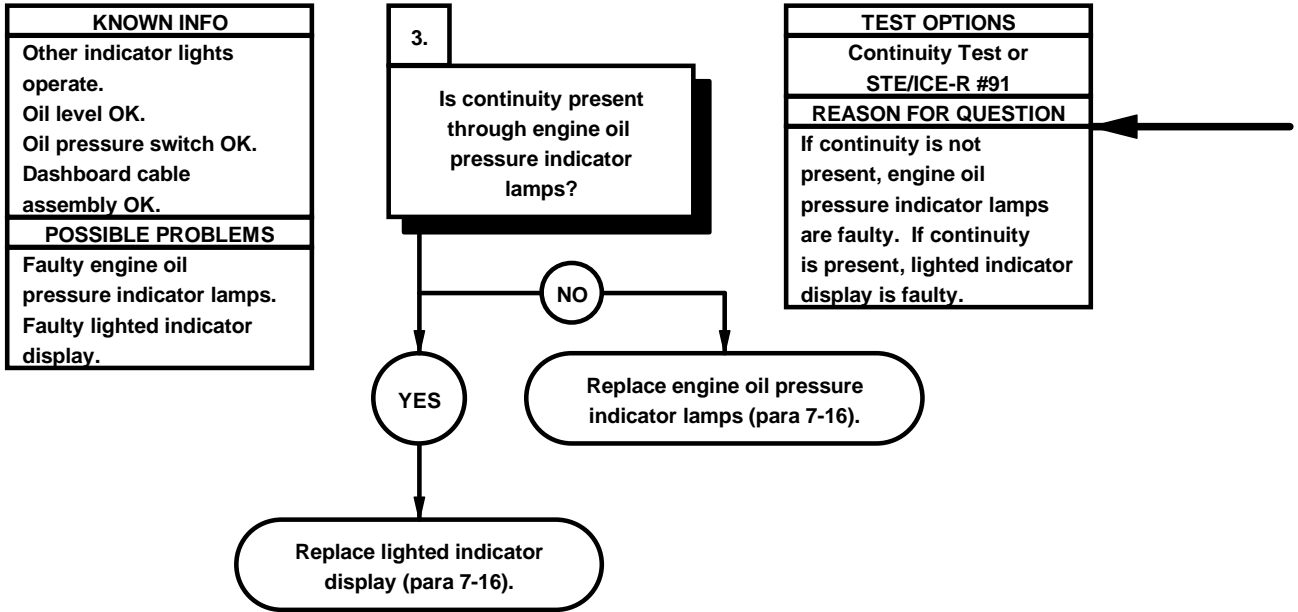

CONTINUITY TEST

- (1) Loosen four captive screws in lamp mounting panel.
- (2) Remove lamp mounting panel from lighted indicator display housing.
- (3) Remove engine oil pressure indicator lamps from printed circuit board.
- (4) Set multimeter to ohms.
- (5) Check continuity through each engine oil pressure indicator lamp and note reading on multimeter.
- (6) If continuity is not present, replace engine oil pressure indicator lamps (para 7-16).
- (7) If continuity is present, replace lighted indicator display (para 7-16).
- (8) Install engine oil pressure indicator lamps in printed circuit board.
- (9) Install lamp mounting panel in lighted indicator display housing.
- (10) Tighten four captive screws in lamp mounting panel.
- (11) Connect lighted indicator display to connector PX7.
- (12) Position lighted indicator display in instrument panel assembly with four screws.
- (13) Tighten four screws to 6-10 lb-in. (1 N-m).
- (14) Connect batteries (para 7-48).

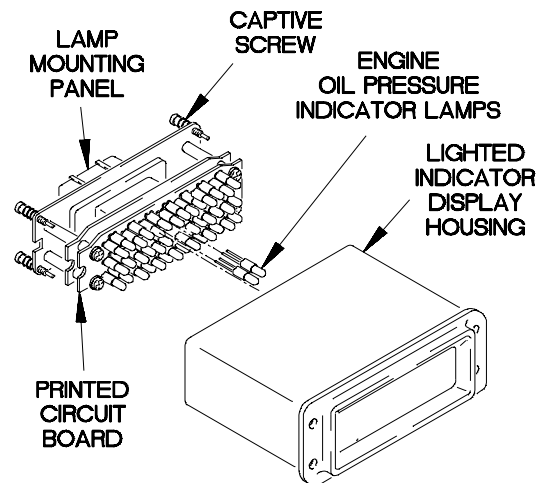
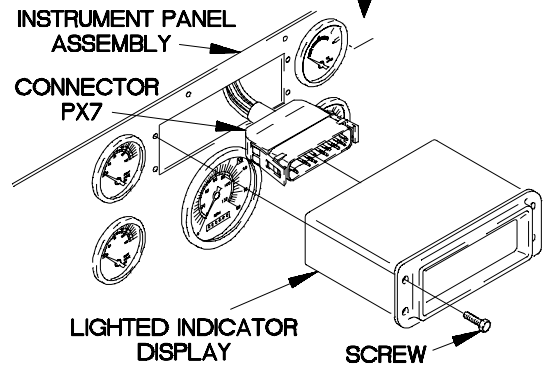
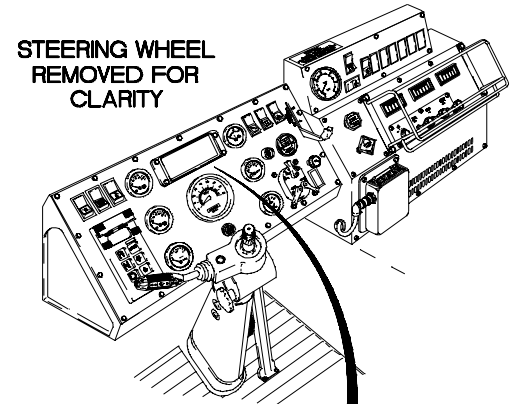

X2e-39031

e39. MASTER STOP INDICATOR DOES NOT OPERATE	
INITIAL SETUP	
Equipment Condition Engine shut down (TM 9-2320-365-10). Batteries disconnected (para 7-48).	Tools and Special Tools Tool Kit, Genl Mech (Item 44, Appendix C) STE/ICE-R (Item 39, Appendix C) Multimeter, Digital (Item 22, Appendix C) Wrench, Torque, 0-75 lb-in. (Item 86, Appendix B)
Personnel Required (2)	References TM 9-4910-571-12&P

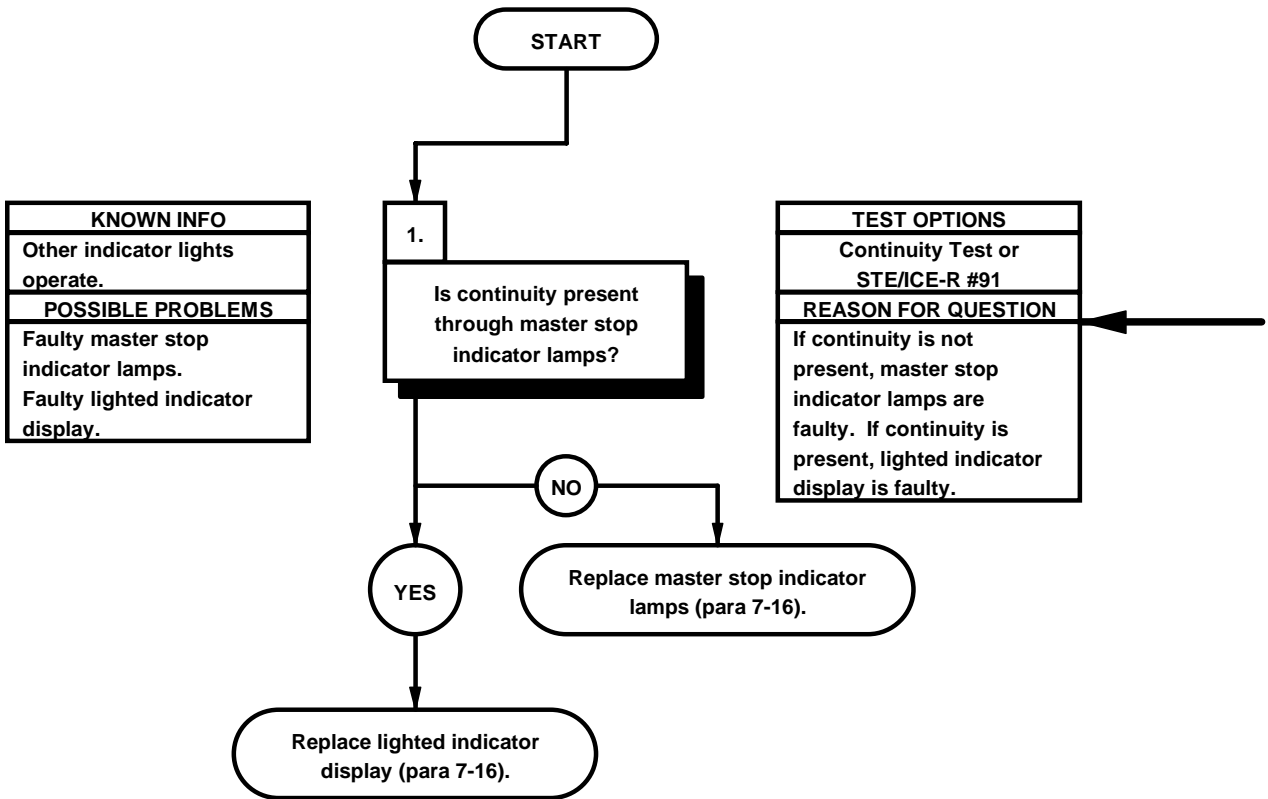

CONTINUITY TEST

- (1) Remove four screws from lighted indicator display.
- (2) Remove lighted indicator display from instrument panel assembly.
- (3) Disconnect connector PX7 from lighted indicator display.
- (4) Loosen four captive screws in lamp mounting panel.
- (5) Remove lamp mounting panel from lighted indicator display housing.
- (6) Remove master stop indicator lamps from printed circuit board.
- (7) Set multimeter to ohms.
- (8) Check continuity through each master stop indicator lamp and note reading on multimeter.
- (9) If continuity is not present, replace master stop indicator lamps (para 7-16).
- (10) If continuity is present, replace lighted indicator display (para 7-16).
- (11) Install master stop indicator lamps in printed circuit board.
- (12) Install lamp mounting panel in lighted indicator display housing.
- (13) Tighten four captive screws in lamp mounting panel.
- (14) Connect lighted indicator display to connector PX7.
- (15) Position lighted indicator display in instrument panel assembly with four screws.
- (16) Tighten four screws to 6-10 lb-in. (1 N·m).
- (17) Connect batteries (para 7-48).

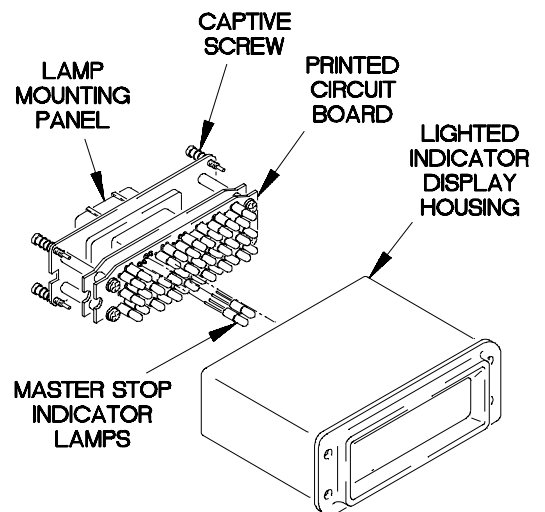
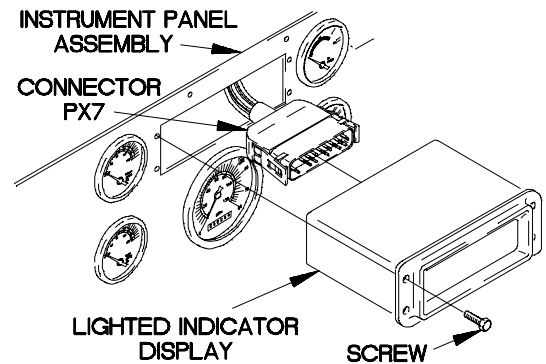
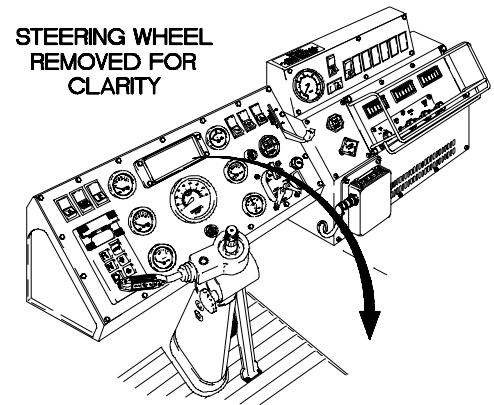

X2e-40011

e40. ONE OR BOTH HEADLIGHTS (HIGH AND LOW BEAM) DO NOT ILLUMINATE

INITIAL SETUP

Equipment Condition
 Engine shut down (TM 9-2320-365-10).

Personnel Required
 (2)

Tools and Special Tools
 Tool Kit, Genl Mech (Item 44, Appendix C)
 STE/ICE-R (Item 39, Appendix C)
 Multimeter, Digital (Item 22, Appendix C)

References
 TM 9-4910-571-12&P

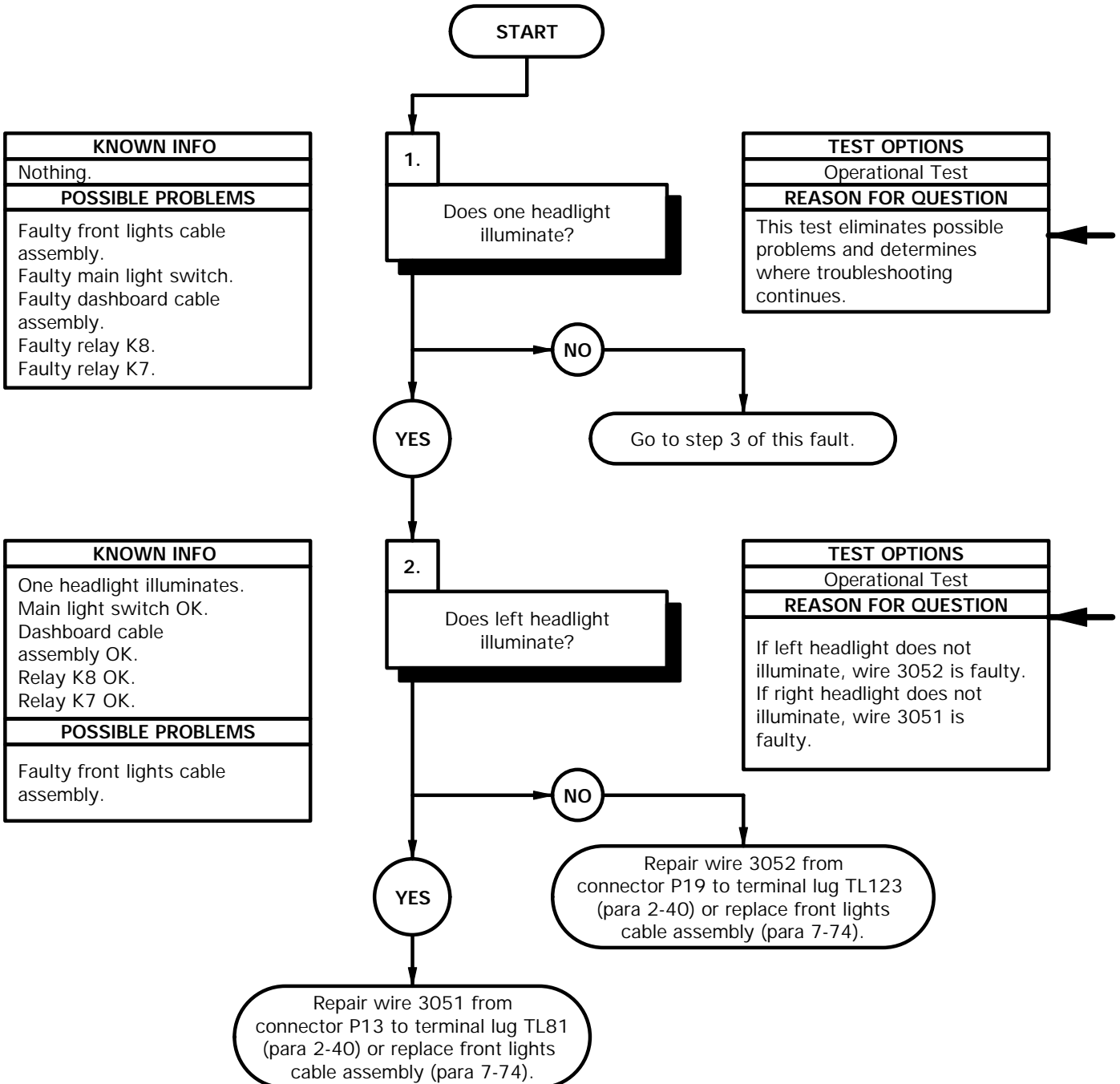

OPERATIONAL TEST

- (1) Position main light switch to SER DRIVE (TM 9-2320-365-10).
- (2) If both headlights do not operate, go to step 3 of this fault.
- (3) Position main light switch to OFF (TM 9-2320-365-10).

OPERATIONAL TEST

- (1) Position main light switch to SER DRIVE (TM 9-2320-365-10).
- (2) Observe which headlight illuminates.
- (3) If left headlight illuminates, repair wire 3051 from connector P13 to terminal lug TL81 (para 2-40) or replace front lights cable assembly (para 7-74).
- (4) If RH headlight illuminates, repair wire 3052 from connector P19 to terminal lug TL123 (para 2-40) or replace front lights cable assembly (para 7-74).
- (5) Position main light switch to OFF (TM 9-2320-365-10).

e40. ONE OR BOTH HEADLIGHTS (HIGH AND LOW BEAM) DO NOT ILLUMINATE (CONT)

KNOWN INFO
Front lights cable assembly OK.
POSSIBLE PROBLEMS
Faulty main light switch. Faulty dashboard cable assembly. Faulty relay K8. Faulty relay K7.

KNOWN INFO
Front lights cable assembly OK. Main light switch OK.
POSSIBLE PROBLEMS
Faulty dashboard cable assembly. Faulty relay K8. Faulty relay K7.

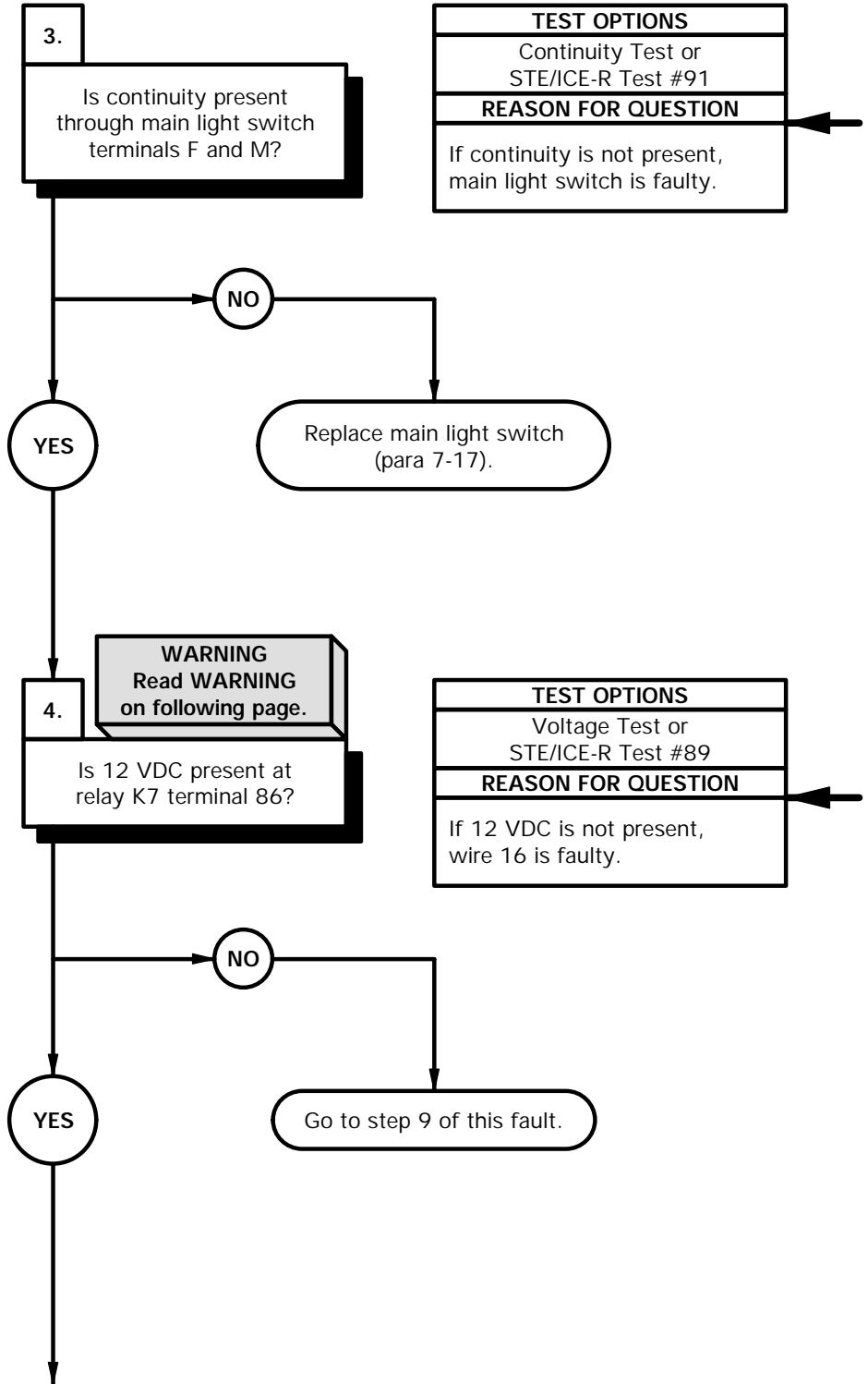

NOTE

Inspect connector pins/sockets for damage, corrosion, and serviceability. Check that connector pins are not pushed back and are capable of making good contact.

CONTINUITY TEST

- (1) Remove main light switch (para 7-17).
- (2) Position main light switch to SER DRIVE (TM 9-2320-365-10).
- (3) Set multimeter to ohms.
- (4) Connect positive (+) probe of multimeter to main light switch terminal M.
- (5) Connect negative (-) probe of multimeter to main light switch terminal F and note reading on multimeter.
- (6) If continuity is not present replace main light switch (para 7-17).
- (7) Position main light switch to OFF (TM 9-2320-365-10).
- (8) Install main light switch (para 7-17).

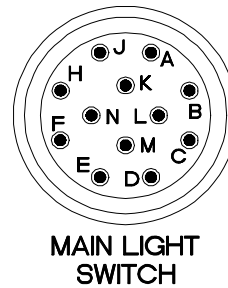

X2e4101B

WARNING

Remove rings, bracelets, watches, necklaces, and any other jewelry before working around vehicle. Jewelry can catch on equipment and cause injury or short across electrical circuits and cause severe burns or electrical shock.

VOLTAGE TEST

- (1) Remove PDP cover (para 16-2).
- (2) Remove relay K7 from PDP.
- (3) Set multimeter to volts DC.
- (4) Connect positive (+) probe of multimeter to PDP terminal 86, where relay K7 was removed.
- (5) Connect negative (-) probe of multimeter to ground.
- (6) Position main light switch to SER DRIVE (TM 9-2320-365-10) and note reading on multimeter.
- (7) If 12 VDC is not present, go to step 9 of this fault.
- (8) Position main light switch to OFF (TM 9-2320-365-10).

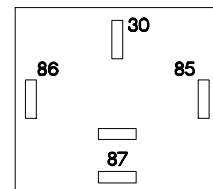
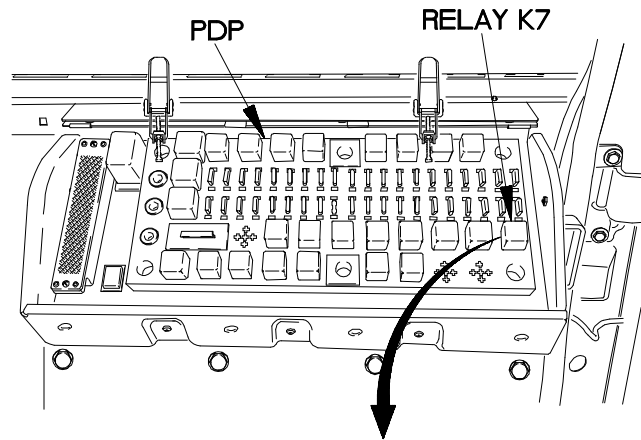

RELAY K7 CAVITY

X2e4102B

e40. ONE OR BOTH HEADLIGHTS (HIGH AND LOW BEAM) DO NOT ILLUMINATE (CONT)

KNOWN INFO
Front lights cable assembly OK. Main light switch OK.
POSSIBLE PROBLEMS
Faulty dashboard cable assembly. Faulty relay K8. Faulty relay K7.

KNOWN INFO
Front lights cable assembly OK. Main light switch OK.
POSSIBLE PROBLEMS
Faulty dashboard cable assembly. Faulty relay K8. Faulty relay K7.

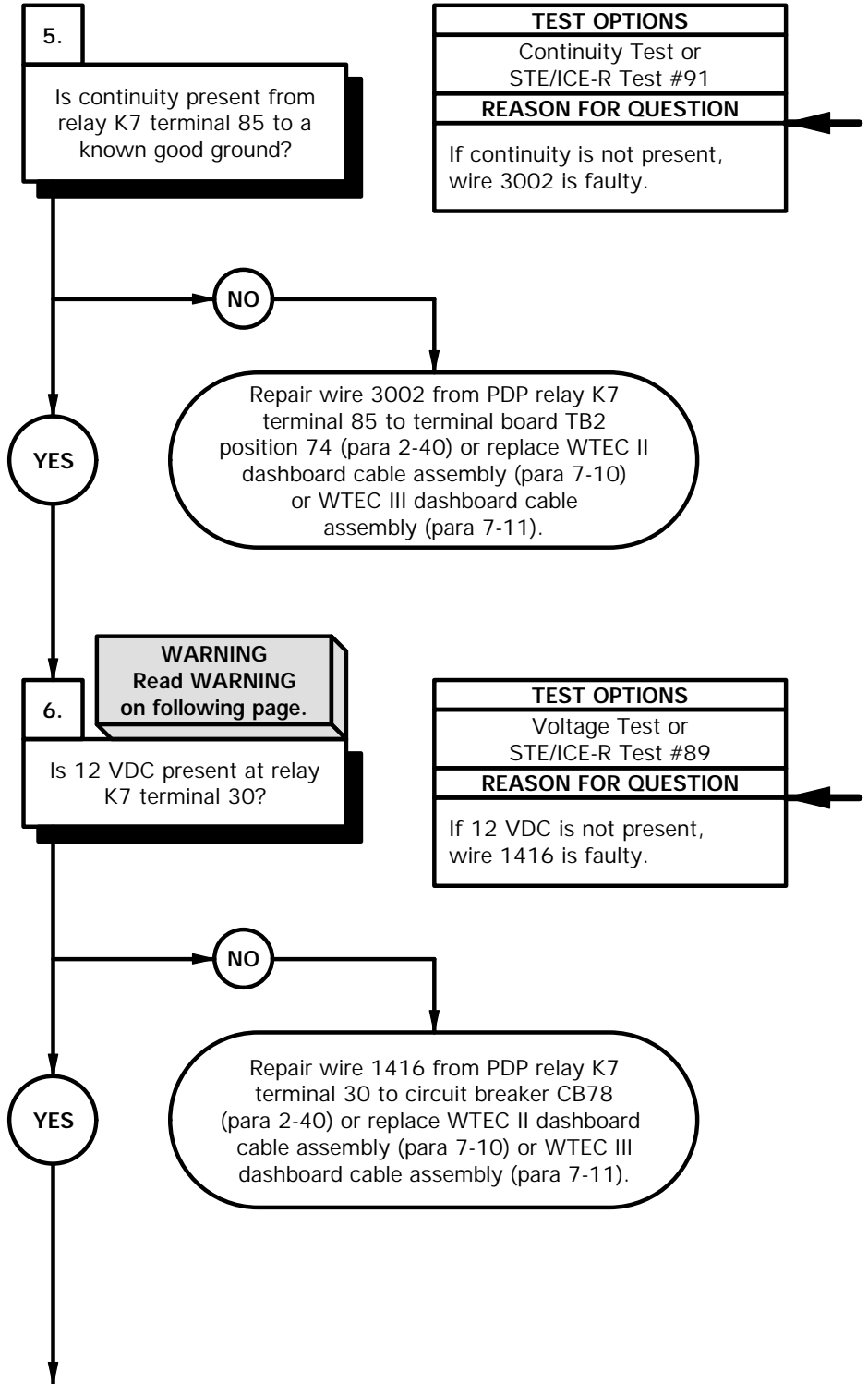

CONTINUITY TEST

- (1) Set multimeter to ohms.
- (2) Connect positive (+) probe of multimeter to PDP terminal 85, where relay K7 was removed.
- (3) Connect negative (-) probe of multimeter to ground and note reading on multimeter.
- (4) If continuity is not present, repair wire 3002 from PDP relay K7 terminal 85 to terminal board TB2 position 74 (para 2-40) or replace WTEC II dashboard cable assembly (para 7-10) or WTEC III dashboard cable assembly (para 7-11).

WARNING

Remove rings, bracelets, watches, necklaces, and any other jewelry before working around vehicle. Jewelry can catch on equipment and cause injury or short across electrical circuits and cause severe burns or electrical shock.

VOLTAGE TEST

- (1) Set multimeter to volts DC.
- (2) Connect positive (+) probe of multimeter to PDP terminal 30, where relay K7 was removed.
- (3) Connect negative (-) probe of multimeter to ground.
- (4) Position main light switch to SER DRIVE (TM 9-2320-365-10) and note reading on multimeter.
- (5) If 12 VDC is not present, Repair wire 1416 from PDP relay K7 terminal 30 to circuit breaker CB78 (para 2-40) or replace WTEC II dashboard cable assembly (para 7-10) or WTEC III dashboard cable assembly (para 7-11).
- (6) Position main light switch to OFF (TM 9-2320-365-10).

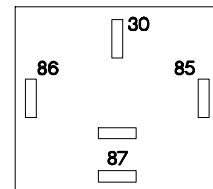
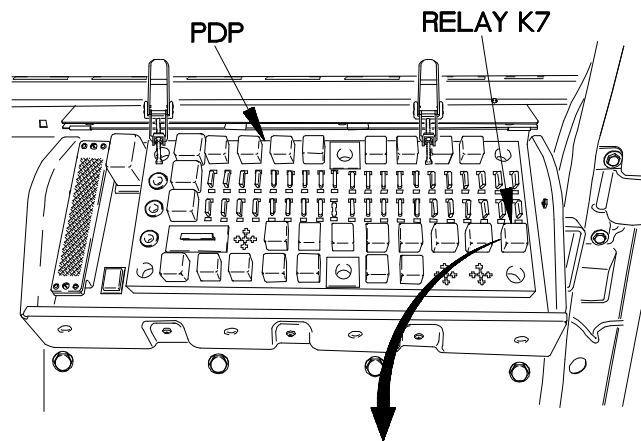

RELAY K7 CAVITY

X2e4102B

e40. ONE OR BOTH HEADLIGHTS (HIGH AND LOW BEAM) DO NOT ILLUMINATE (CONT)

KNOWN INFO
Front lights cable assembly OK. Main light switch OK.
POSSIBLE PROBLEMS
Faulty dashboard cable assembly. Faulty relay K8. Faulty relay K7.

TEST OPTIONS
Continuity Test or STE/ICE-R Test #91
REASON FOR QUESTION
If continuity is not present, wire 1417 is faulty.

7.
Is continuity present from relay K7 terminal 87 to relay K8 terminal 30?

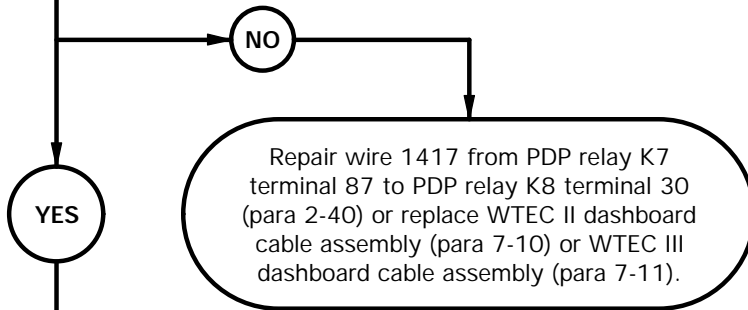

KNOWN INFO
Front lights cable assembly OK. Main light switch OK. Dashboard cable assembly OK.
POSSIBLE PROBLEMS
Faulty relay K8. Faulty relay K7.

TEST OPTIONS
Continuity Test or STE/ICE-R Test #91
REASON FOR QUESTION
If continuity is not present, relay K8 is faulty. If continuity is present, relay K7 is faulty.

8.
Is continuity present from relay K8 terminal 30 to terminal 87A?

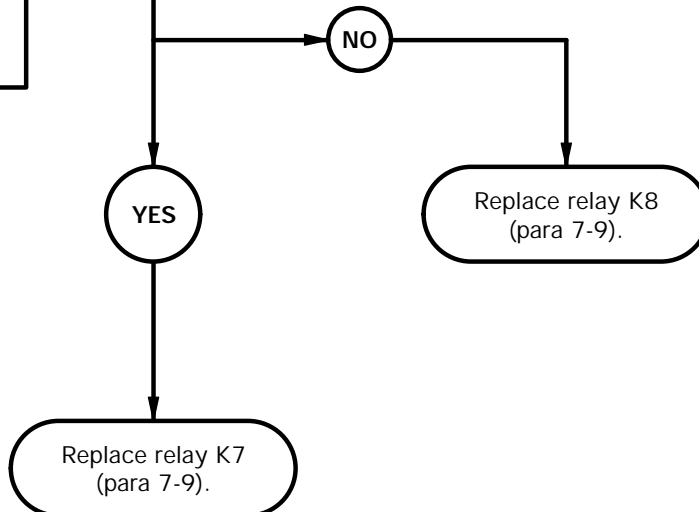

CONTINUITY TEST

- (1) Remove relay K8 from PDP.
- (2) Set multimeter to ohms.
- (3) Connect positive (+) probe of multimeter to PDP terminal 87, where relay K7 was removed.
- (4) Connect negative (-) probe of multimeter to PDP terminal 30, where relay K8 was removed and note reading on multimeter.
- (5) If continuity is not present, repair wire 1417 from PDP relay K7 terminal 87 to PDP relay K8 terminal 30 (para 2-40) or replace WTEC II dashboard cable assembly (para 7-10) or WTEC III dashboard cable assembly (para 7-11).
- (6) Install relay K7 in PDP.

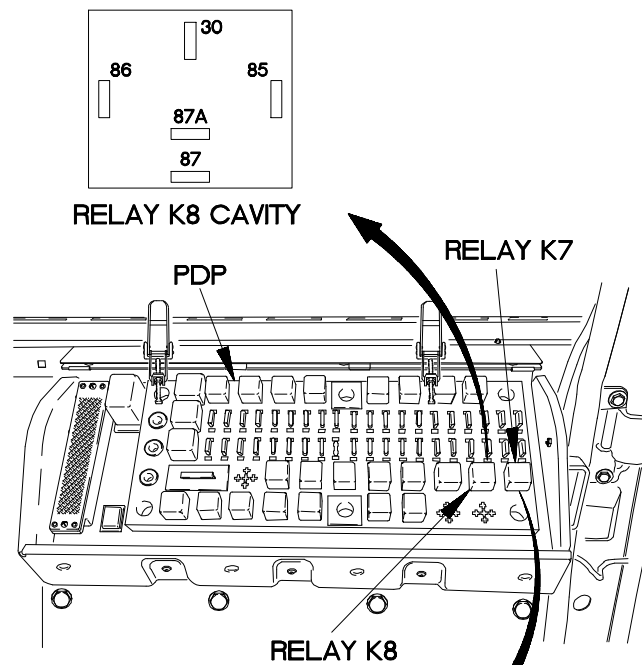

CONTINUITY TEST

- (1) Set multimeter to ohms.
- (2) Connect positive (+) probe of multimeter to relay K8 terminal 87A.
- (3) Connect negative (-) probe of multimeter to relay K8 terminal 30 and note reading on multimeter.
- (4) If continuity is not present, replace relay K8 (para 7-9).
- (5) If continuity is present, replace relay K7 (para 7-9).
- (6) Install relay K8 in PDP.
- (7) Install PDP cover (para 16-2).

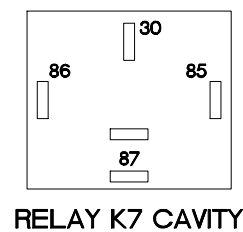

X2e4104B

e40. ONE OR BOTH HEADLIGHTS (HIGH AND LOW BEAM) DO NOT ILLUMINATE (CONT)

KNOWN INFO
Front lights cable assembly OK. Main light switch OK. Relay K8 OK. Relay K7 OK.
POSSIBLE PROBLEMS
Faulty dashboard cable assembly.

CAUTION
Read CAUTION on following page.

9. Is continuity present from relay K7 terminal 86 to connector P18 pin 3?

TEST OPTIONS
Continuity Test or STE/ICE-R Test #91
REASON FOR QUESTION
This test determines which section of wire 16 is faulty.

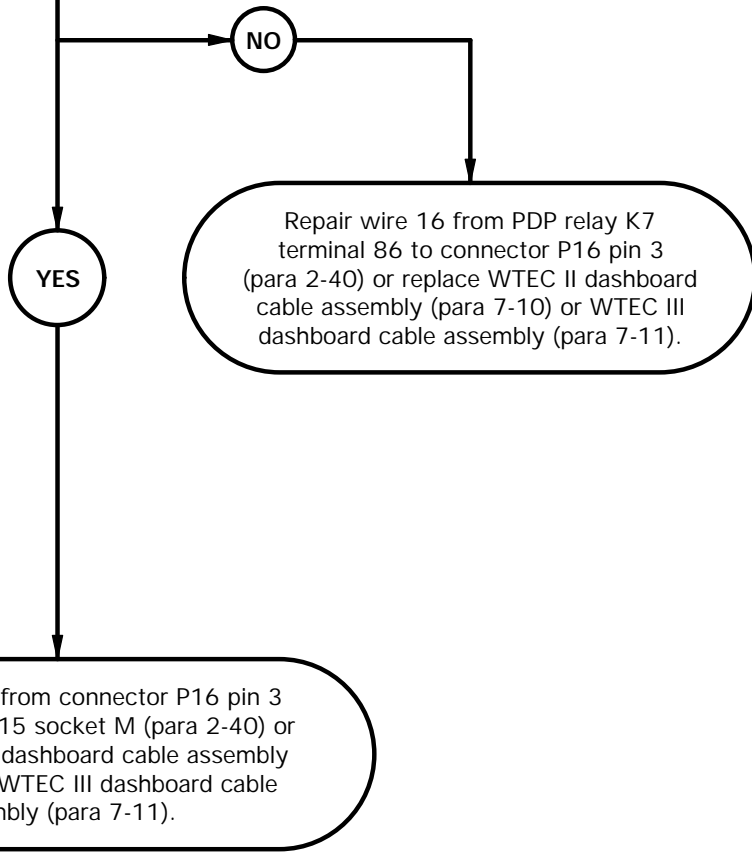

CAUTION

Use care when testing electrical connectors. Do not damage connector pins or sockets with multimeter probes. Failure to comply may result in damage to equipment.

NOTE

Inspect connector pins/sockets for damage, corrosion, and serviceability. Check that connector pins are not pushed back and are capable of making good contact.

CONTINUITY TEST

- (1) Remove instrument panel assembly for access (para 7-15).
- (2) Disconnect connector P18 from connector J18.
- (3) Set multimeter to ohms.
- (4) Connect positive (+) probe of multimeter to PDP terminal 86, where relay K7 was removed.
- (5) Connect negative (-) probe of multimeter to connector P18 pin 3 and note reading on multimeter.
- (6) If continuity is not present, repair wire 16 from PDP relay K7 terminal 86 to connector P18 pin 3 (para 2-40) or replace WTEC II dashboard cable assembly (para 7-10) or WTEC III dashboard cable assembly (para 7-11).
- (7) If continuity is present, repair wire 16 from connector P16 pin 3 to connector PX15 socket M (para 2-40) or replace WTEC II dashboard cable assembly (para 7-10) or WTEC III dashboard cable assembly (para 7-11).
- (8) Install relay K7 in PDP.
- (9) Install PDP cover (para 16-2).
- (10) Connect connector P18 to connector J18.
- (11) Install instrument panel assembly (para 7-15).

CONNECTOR P18

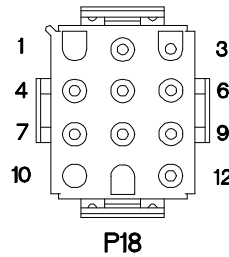
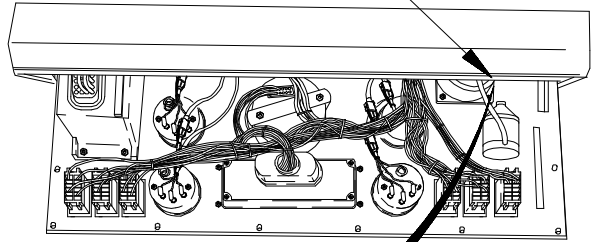

X2e4106B

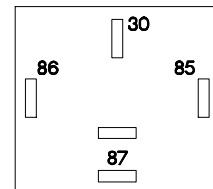
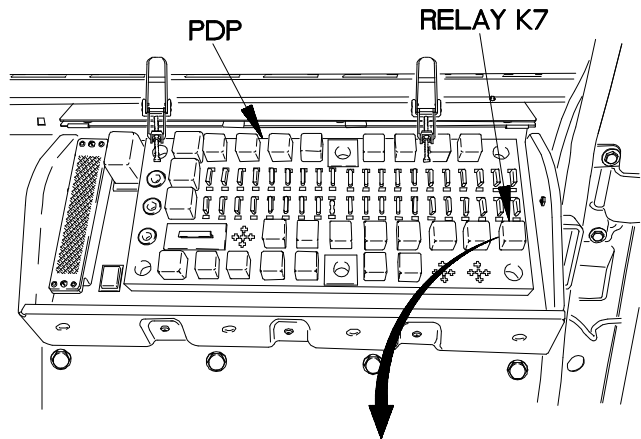

RELAY K7 CAVITY

X2e4102B

e41. ONE OR BOTH HEADLIGHT LOW BEAMS DO NOT ILLUMINATE	
INITIAL SETUP	
Equipment Condition Engine shut down (TM 9-2320-365-10).	Tools and Special Tools Tool Kit, Genl Mech (Item 44, Appendix C) STE/ICE-R (Item 39, Appendix C) Multimeter, Digital (Item 22, Appendix C)
Personnel Required (2)	References TM 9-4910-571-12&P

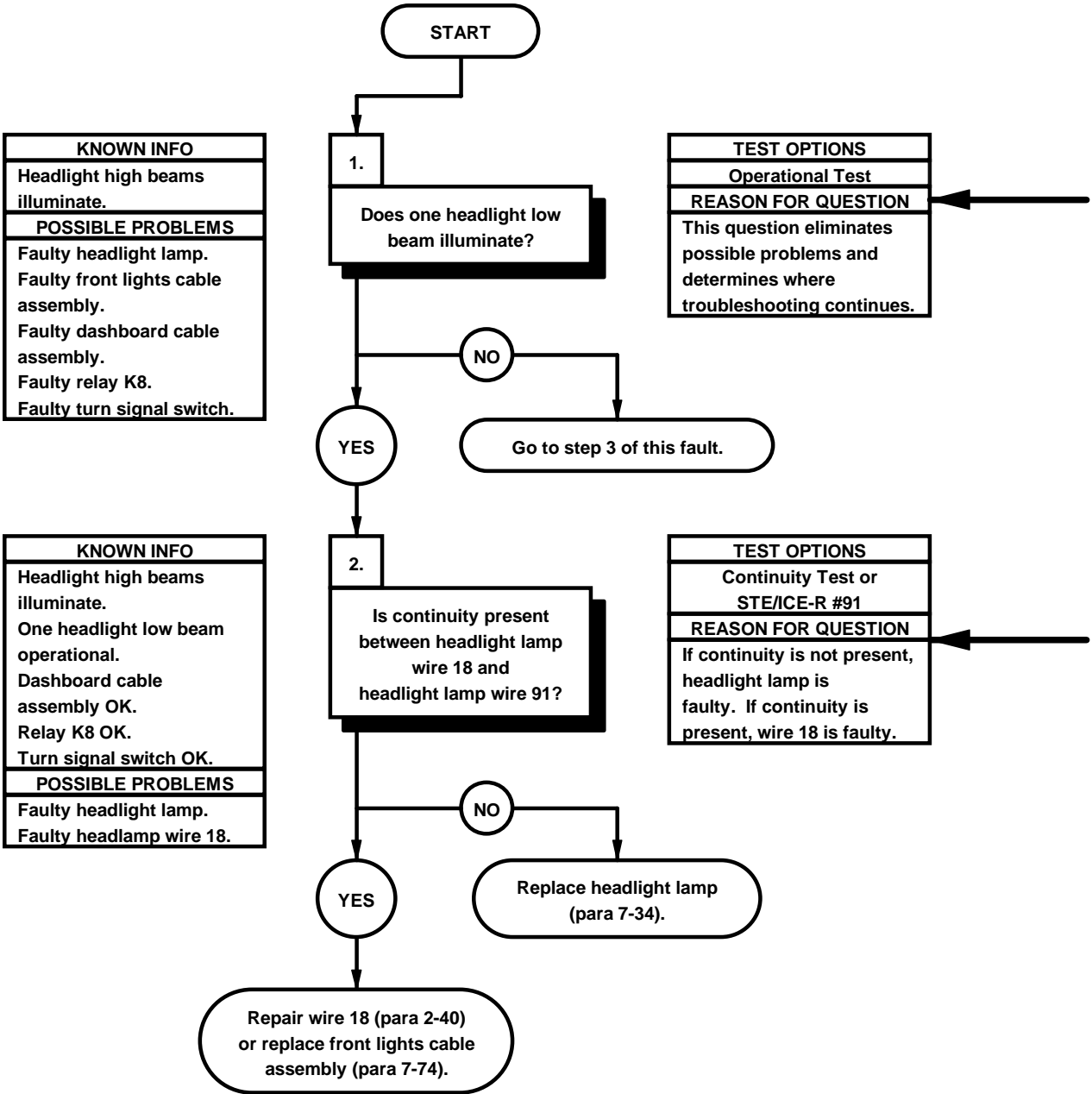

- | OPERATIONAL TEST | |
|------------------|--|
| | (1) Position main light switch to SER DRIVE (TM 9-2320-365-10). |
| | (2) Position headlight low beams to on (TM 9-2320-365-10). |
| | (3) If both headlight low beams do not illuminate, go to step 3 of this fault. |
| | (4) Position main light switch to OFF (TM 9-2320-365-10). |

- | CONTINUITY TEST | |
|-----------------|--|
| | (1) Remove three screws and retaining ring from housing. |
| | (2) Remove lamp from housing. |
| | (3) Disconnect headlight lamp wire 18 from housing. |
| | (4) Disconnect headlight lamp wire 91 from housing. |
| | (5) Set multimeter to ohms. |
| | (6) Connect positive (+) probe of multimeter to headlight lamp wire 18. |
| | (7) Connect negative (-) probe of multimeter to headlight lamp wire 91 and note reading on multimeter. |
| | (8) If continuity is not present, replace headlight lamp (para 7-34). |
| | (9) If continuity is present, repair wire 18 (para 2-40) or replace front lights cable assembly (para 7-74). |
| | (10) Connect headlight lamp wire 18 to housing. |
| | (11) Connect headlight lamp wire 91 to housing. |
| | (12) Install lamp in housing. |
| | (13) Install retaining ring on housing with three screws. |

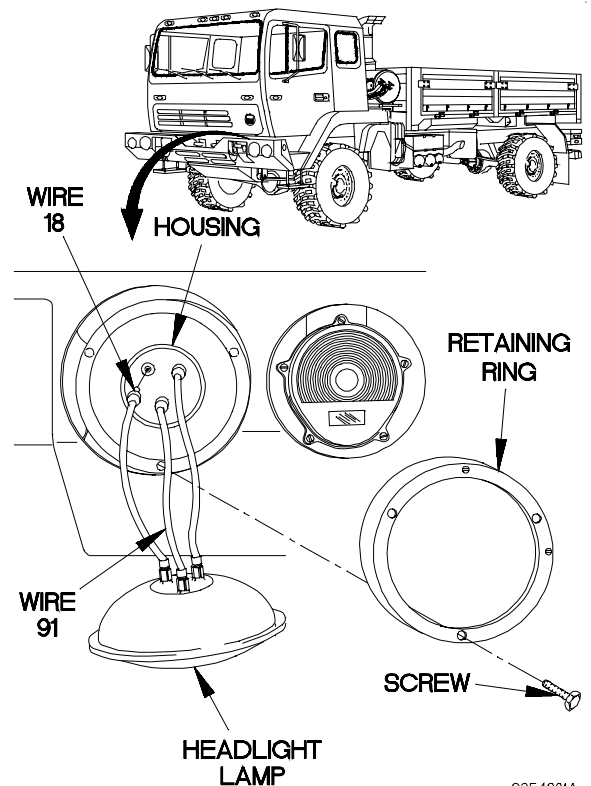

32E4301A

ø41. ONE OR BOTH HEADLIGHT LOW BEAMS DO NOT ILLUMINATE (CONT)

KNOWN INFO
Headlight high beams illuminate. Headlight lamp OK.
POSSIBLE PROBLEMS
Faulty front lights cable assembly. Faulty dashboard cable assembly. Faulty relay K8. Faulty turn signal switch.

3.
Is continuity present between connector P12 (RH) or connector P4 (LH) headlight terminal and relay K8 terminal 87A?

TEST OPTIONS
Continuity Test or STE/ICE-R #91
REASON FOR QUESTION
If continuity is not present, wire 18 is faulty.

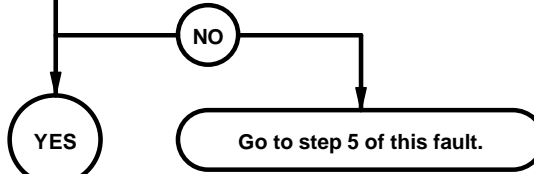

KNOWN INFO
Headlight high beams illuminate. Headlight lamp OK. Front lights cable assembly OK. Dashboard cable assembly OK.
POSSIBLE PROBLEMS
Faulty relay K8. Faulty turn signal switch.

4.
Is continuity present between relay K8 terminal 87A and relay K8 terminal 30?

TEST OPTIONS
Continuity Test or STE/ICE-R#91
REASON FOR QUESTION
If continuity is not present, relay K8 is faulty. If continuity is present, turn signal switch is faulty.

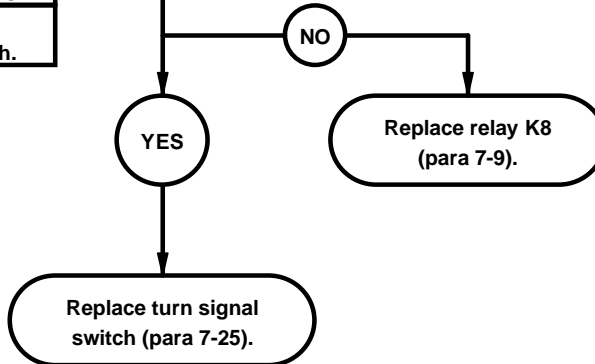

- CONTINUITY TEST**
- (1) Remove PDP cover (para 16-2).
 - (2) Remove relay K8 from PDP.
 - (3) Disconnect connector P12 (RH) or connector P4 (LH) from housing.
 - (4) Set multimeter to ohms.
 - (5) Connect positive (+) probe of multimeter to connector P12 (RH) or connector P4 (LH).
 - (6) Connect negative (-) probe of multimeter to PDP, terminal 87A, where relay K8 was removed and note reading on multimeter.
 - (7) If continuity is not present, go to step 5 of this fault.
 - (8) Connect connector P12 (RH) or connector P5 (LH) to housing.

- CONTINUITY TEST**
- (1) Set multimeter to ohms
 - (2) Connect positive (+) probe of multimeter to relay K8 terminal 87A.
 - (3) Connect negative (-) probe of multimeter to relay K8 terminal 30 and note reading on multimeter.
 - (4) If continuity is not present, replace relay K8 (para 7-9).
 - (5) If continuity is present, replace turn signal switch (para 7-25).
 - (6) Install relay K8 in PDP.
 - (7) Install PDP cover (para 16-2).

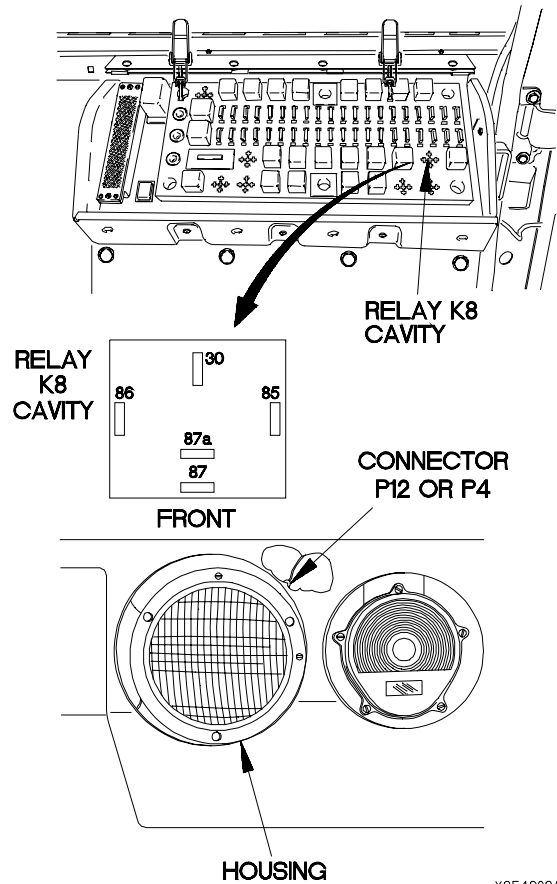

X2E4302A

e41. ONE OR BOTH HEADLIGHT LOW BEAMS DO NOT ILLUMINATE (CONT)

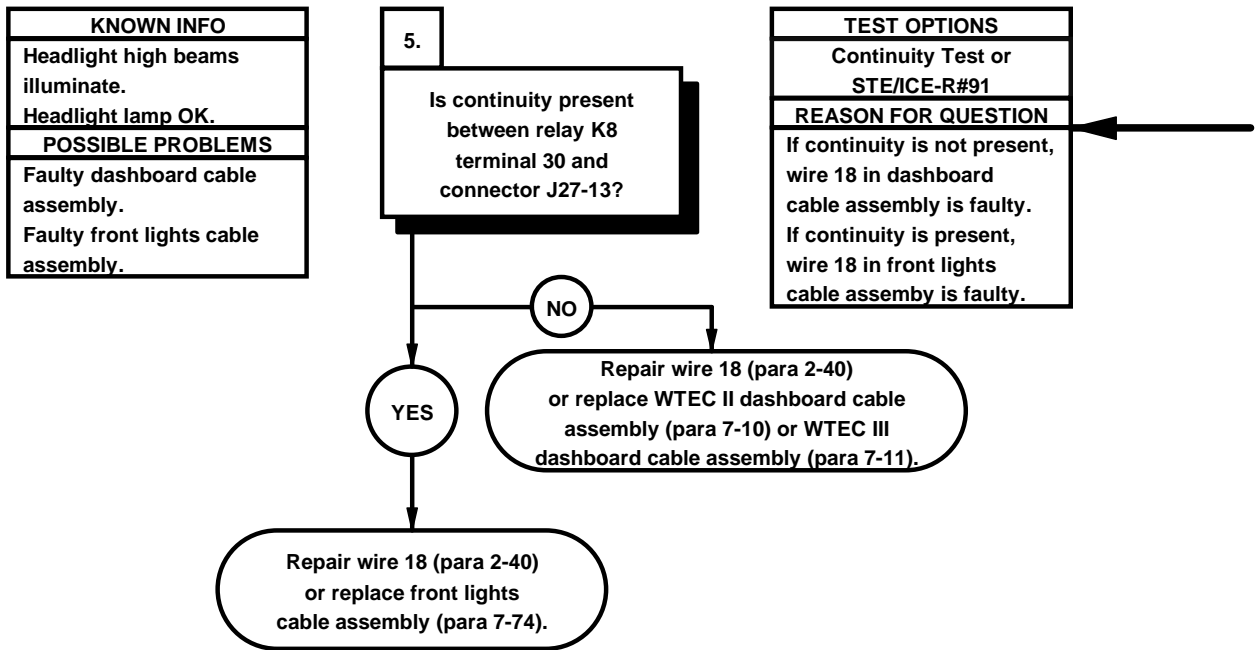

- CONTINUITY TEST**
- (1) Remove three screws and washers from PDP.
 - (2) Remove three screws from PDP.
 - (3) Lift PDP outward to gain access.
 - (4) Disconnect connector J27 from connector P27.
 - (5) Set multimeter to ohms
 - (6) Connect positive (+) probe of multimeter to PDP, relay K8 terminal 87A, where relay K8 was removed.
 - (7) Connect negative (-) probe of multimeter to connector J27-13 and note reading on multimeter.
 - (8) If continuity is not present, repair wire 18 (para 2-40) or replace WTEC II dashboard cable assembly (para 7-10) or WTEC III dashboard cable assembly (para 7-11).
 - (9) If continuity is present, repair wire 18 (para 2-40) or replace front lights cable assembly (para 7-74).
 - (10) Connect connector P27 to connector J27.
 - (11) Install PDP in dashboard with three screws.
 - (12) Install three washers and screws in PDP.
 - (13) Install relay K8 in PDP.
 - (14) Install PDP cover (para 16-2).

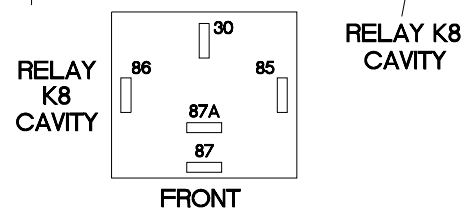
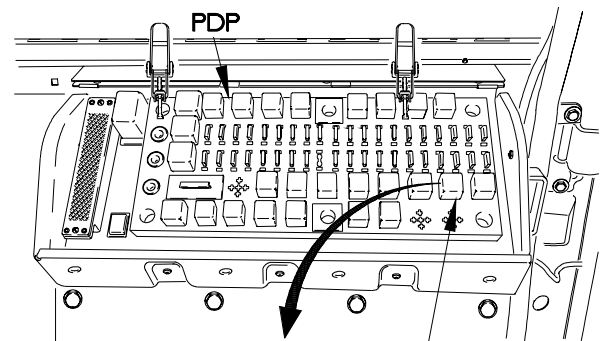
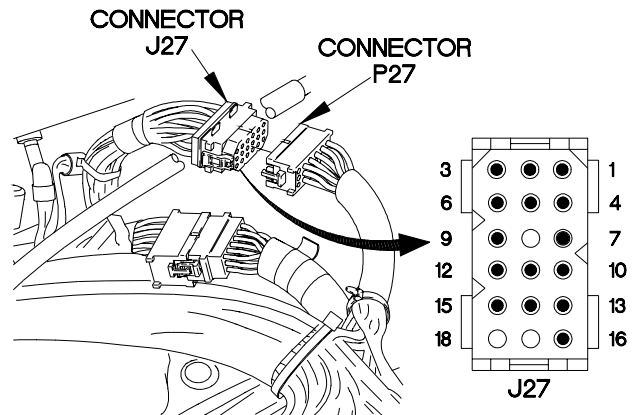
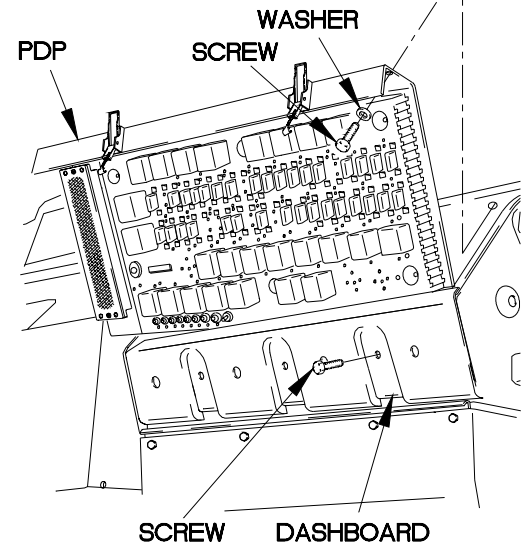

X2E4203R

e42. ONE OR BOTH HEADLIGHT HIGH BEAMS DO NOT ILLUMINATE	
INITIAL SETUP	
Equipment Condition Engine shut down (TM 9-2320-365-10).	Tools and Special Tools Tool Kit, Genl Mech (Item 44, Appendix C) STE/ICE-R (Item 39, Appendix C) Multimeter, Digital (Item 22, Appendix C)
Personnel Required (2)	References TM 9-4910-571-12&P

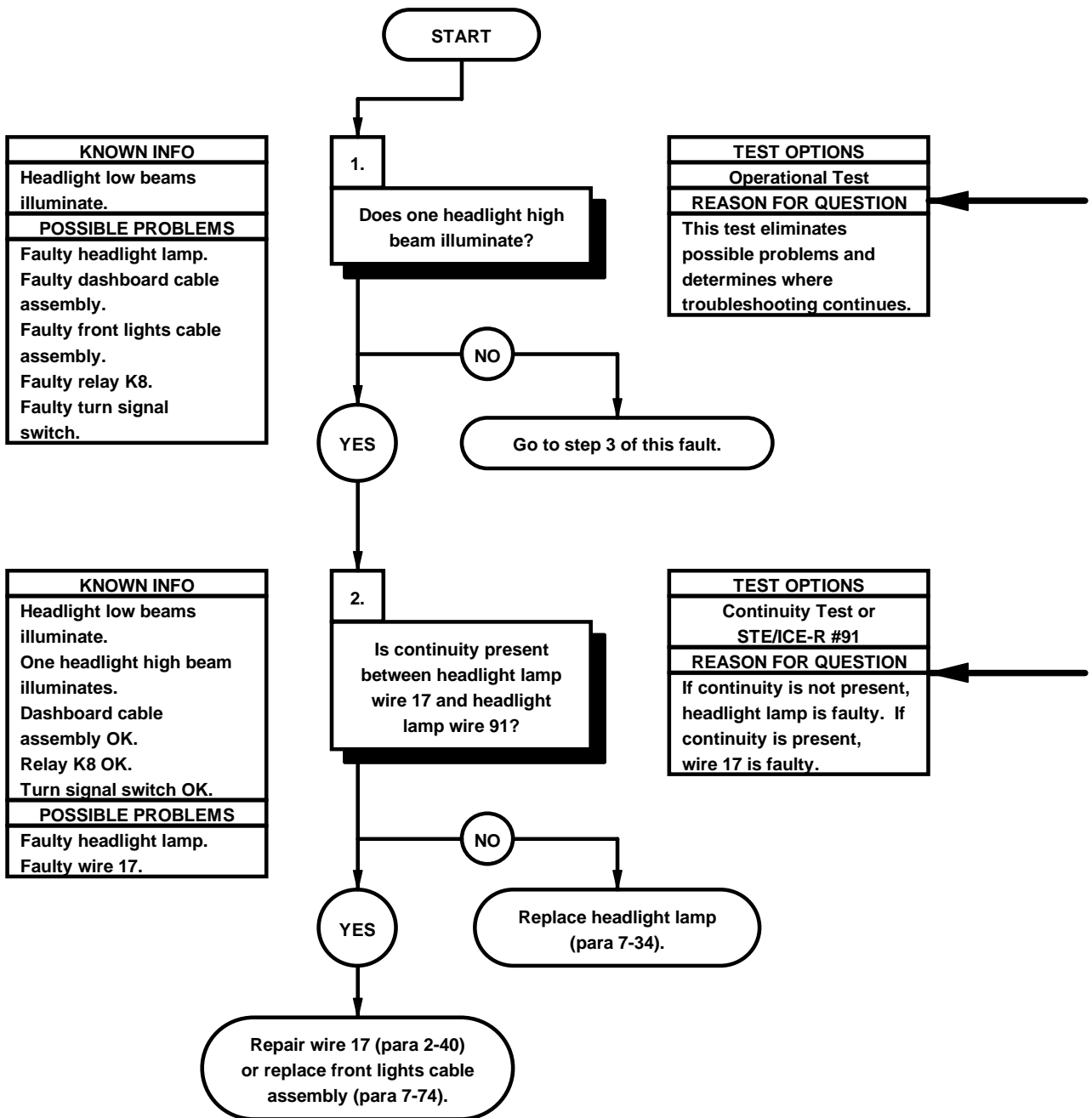

- | OPERATIONAL TEST | |
|------------------|--|
| | (1) Position main light switch to SER DRIVE (TM 9-2320-365-10). |
| | (2) Position headlight high beams on (TM 9-2320-365-10). |
| | (3) If both headlights high beams do not illuminate, and go to step 3 of this fault. |
| | (4) Position main light switch to OFF (TM 9-2320-365-10). |

- | CONTINUITY TEST | |
|-----------------|--|
| | (1) Remove three screws and retaining ring from housing. |
| | (2) Remove headlight lamp from housing. |
| | (3) Disconnect headlight lamp wire 17 from housing. |
| | (4) Disconnect headlight lamp wire 91 from housing. |
| | (5) Set multimeter to ohms. |
| | (6) Connect positive (+) probe of multimeter to headlight lamp wire 17. |
| | (7) Connect negative (-) probe of multimeter to headlight lamp wire 91 and note reading on multimeter. |
| | (8) If continuity is not present, replace headlight lamp (para 7-34). |
| | (9) If continuity is present, repair wire 17 (para 2-40) or replace front lights cable assembly (para 7-74). |
| | (10) Connect headlight lamp wire 17 to housing. |
| | (11) Connect headlight lamp wire 91 to housing. |
| | (12) Install headlight lamp in housing. |
| | (13) Install retaining ring on housing with three screws. |

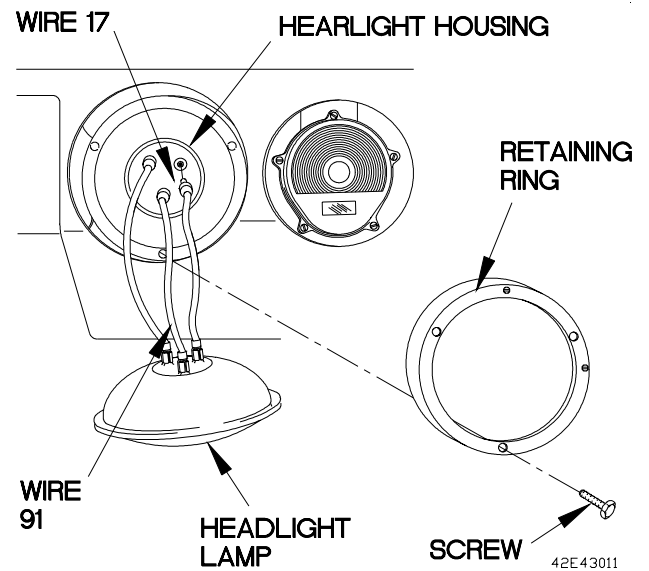

ø42. ONE OR BOTH HEADLIGHT HIGH BEAMS DO NOT ILLUMINATE (CONT)

KNOWN INFO
Headlight low beams illuminate. Headlight lamp OK.
POSSIBLE PROBLEMS
Faulty front lights cable assembly. Faulty dashboard cable assembly. Faulty relay K8. Faulty turn signal switch.

3.

Is continuity present between connector P14 (RH) or connector P20 (LH) and relay K8 terminal 87?

TEST OPTIONS
Continuity Test or STE/ICE-R #91
REASON FOR QUESTION
If continuity is not present, wire 17 is faulty.

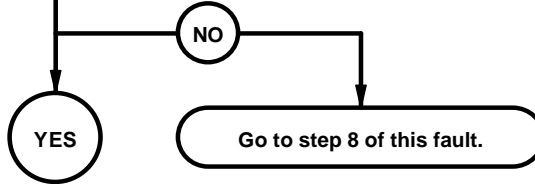

KNOWN INFO
Headlight low beams illuminate. Headlight lamp OK. Front lights cable assembly OK.
POSSIBLE PROBLEMS
Faulty relay K8. Faulty dashboard cable assembly. Faulty turn signal switch.

4.

WARNING
Read WARNING on following page.

Is 12 vdc present at relay K8 terminal 86?

TEST OPTIONS
Voltage Test or STE/ICE-R #89
REASON FOR QUESTION
This test eliminates possible problems and determines where troubleshooting continues.

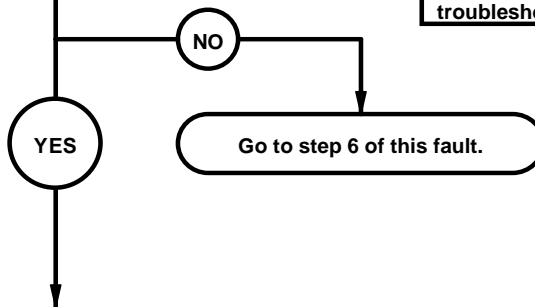

CONTINUITY TEST

- (1) Remove PDP cover (para para 16-2).
- (2) Remove relay K8 from PDP.
- (3) Disconnect connector P14 (RH) or connector P20 (LH) from housing.
- (4) Set multimeter to ohms.
- (5) Connect positive (+) probe of multimeter to PDP, terminal 87A, where relay K8 was removed.
- (6) Connect negative (-) probe of multimeter to connector P14 (RH) or connector P20 (LH) and note reading on multimeter.
- (7) If continuity is not present, go to step 8 of this fault.
- (8) Connect connector P14 (RH) or connector P20 (LH) to housing.

WARNING

Remove rings, bracelets, watches, necklaces, and any other jewelry before working around vehicle. Jewelry can catch on equipment and cause injury or short across electrical circuit and cause severe burns or electrical shock.

VOLTAGE TEST

- (1) Set multimeter to volts dc.
- (2) Connect positive (+) probe of multimeter to PDP, terminal 86, where relay K8 was removed.
- (3) Connect negative (-) probe of multimeter to ground.
- (4) Position main light switch to SER DRIVE (TM 9-2320-365-10).
- (5) Position headlight high beams to on (TM 9-2320-365-10) and note reading on multimeter.
- (6) If 12 vdc is not present, go to step 6 of this fault.
- (7) Position main light switch to OFF (TM 9-2320-365-10).

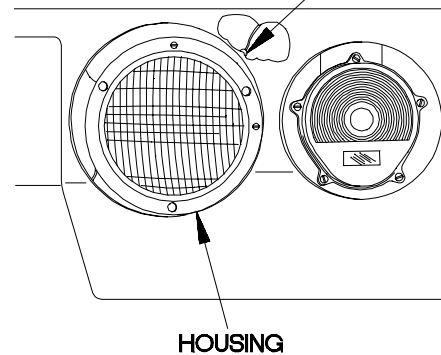
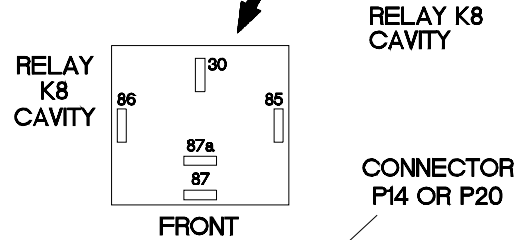
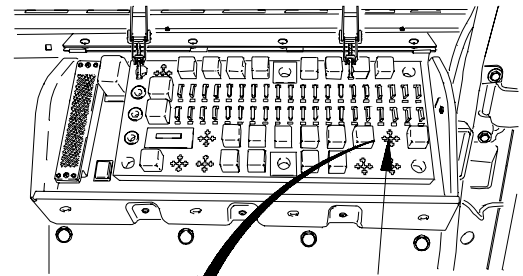

X2E4402A

¶42. ONE OR BOTH HEADLIGHT HIGH BEAMS DO NOT ILLUMINATE (CONT)

KNOWN INFO
Headlight low beams illuminate.
Headlight lamp OK.
Front lights cable assembly OK.
Turn signal switch OK.
POSSIBLE PROBLEMS
Faulty dashboard cable assembly.
Faulty relay K8.

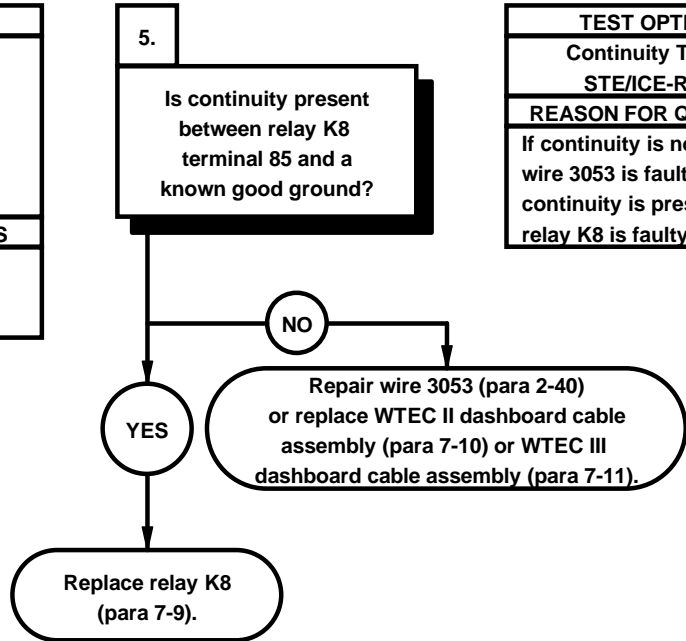

TEST OPTIONS
Continuity Test or STE/ICE-R #91
REASON FOR QUESTION
If continuity is not present, wire 3053 is faulty. If continuity is present, relay K8 is faulty.

KNOWN INFO
Headlight low beams illuminate.
Headlight lamp OK.
Front lights cable assembly OK.
POSSIBLE PROBLEMS
Faulty turn signal switch.
Faulty dashboard cable assembly.

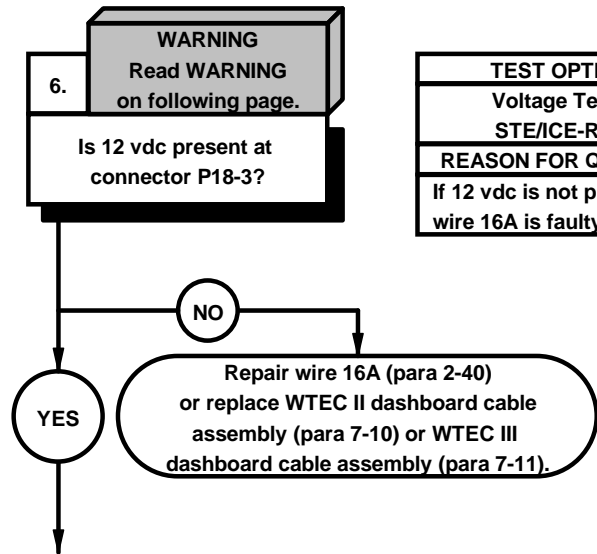

TEST OPTIONS
Voltage Test or STE/ICE-R #89
REASON FOR QUESTION
If 12 vdc is not present, wire 16A is faulty.

CONTINUITY TEST

- (1) Set multimeter to ohms.
- (2) Connect positive (+) probe of multimeter to PDP, terminal 85, where relay K8 was removed.
- (3) Connect negative (-) probe of multimeter to ground and note reading on multimeter.
- (4) If continuity is not present, repair wire 3053 (para 2-40) or replace WTEC II dashboard cable assembly (para 7-10) or WTEC III dashboard cable assembly (para 7-11).
- (5) If continuity is present, replace relay K8 (para 7-9).
- (6) Install relay K8 in PDP.
- (7) Install PDP cover (para 16-2).

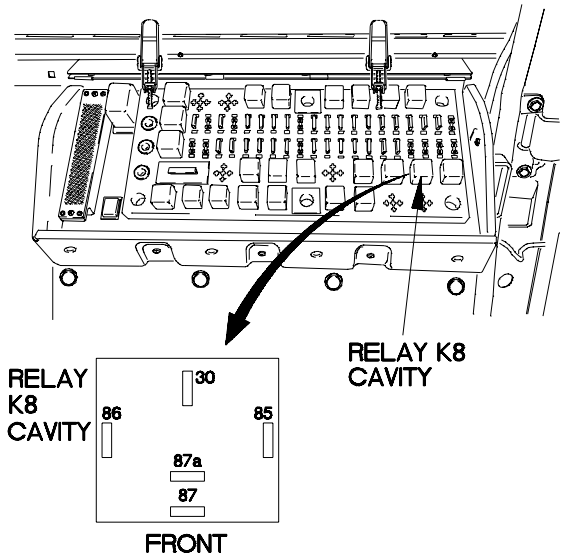

X2e43031

WARNING

Remove rings, bracelets, watches, necklaces, and any other jewelry before working around vehicle. Jewelry can catch on equipment and cause injury or short across electrical circuit and cause severe burns or electrical shock.

VOLTAGE TEST

- (1) Remove instrument panel assembly for access (para 7-15).
- (2) Disconnect connector P18 from connector J18.
- (3) Set multimeter to volts dc.
- (4) Connect positive (+) probe of multimeter to connector P18-3.
- (5) Connect negative (-) probe of multimeter to ground.
- (6) Position main light switch to SER DRIVE (TM 9-2320-365-10) and note reading on multimeter.
- (7) If 12 vdc is not present, repair wire 16A (para 2-40) or replace WTEC II dashboard cable assembly (para 7-10) or WTEC III dashboard cable assembly (para 7-11).
- (8) Position main light switch to OFF (TM 9-2320-365-10).

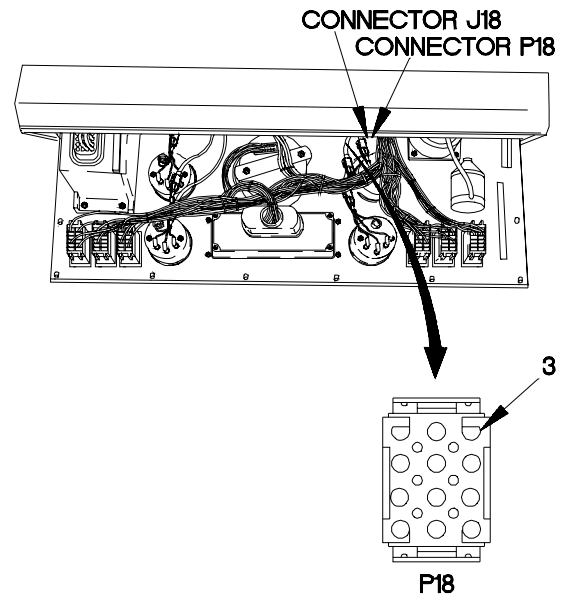

X2E4404A

¶42. ONE OR BOTH HEADLIGHT HIGH BEAMS DO NOT ILLUMINATE (CONT)

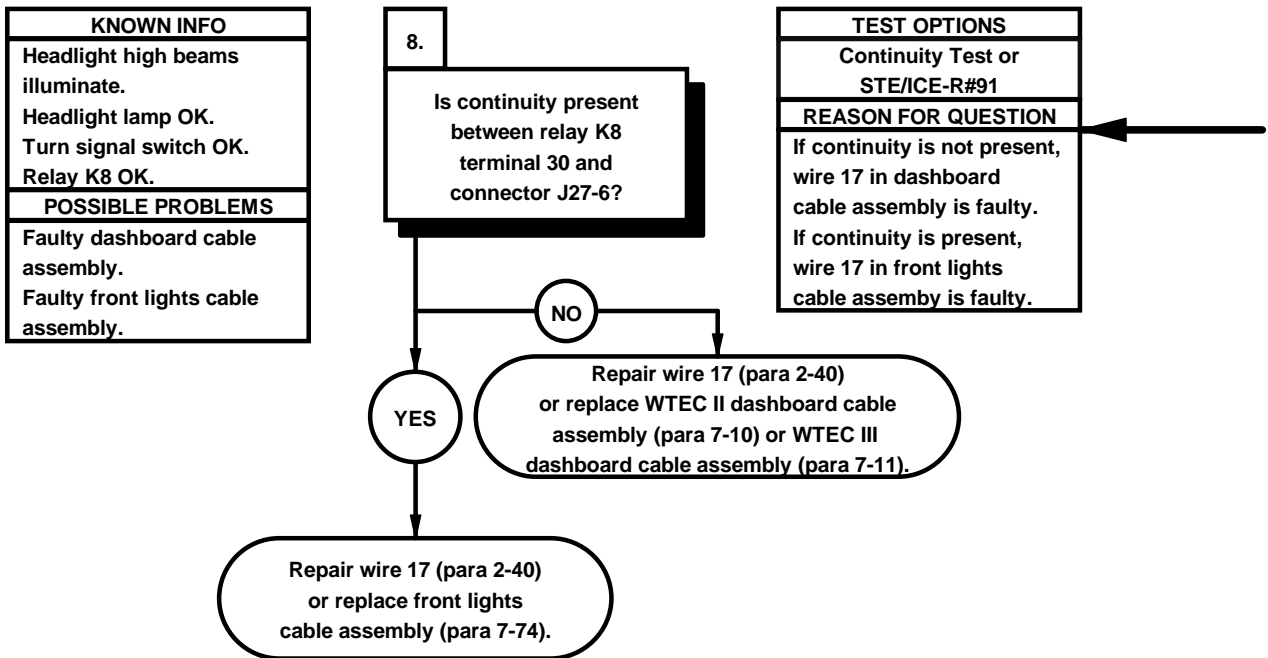
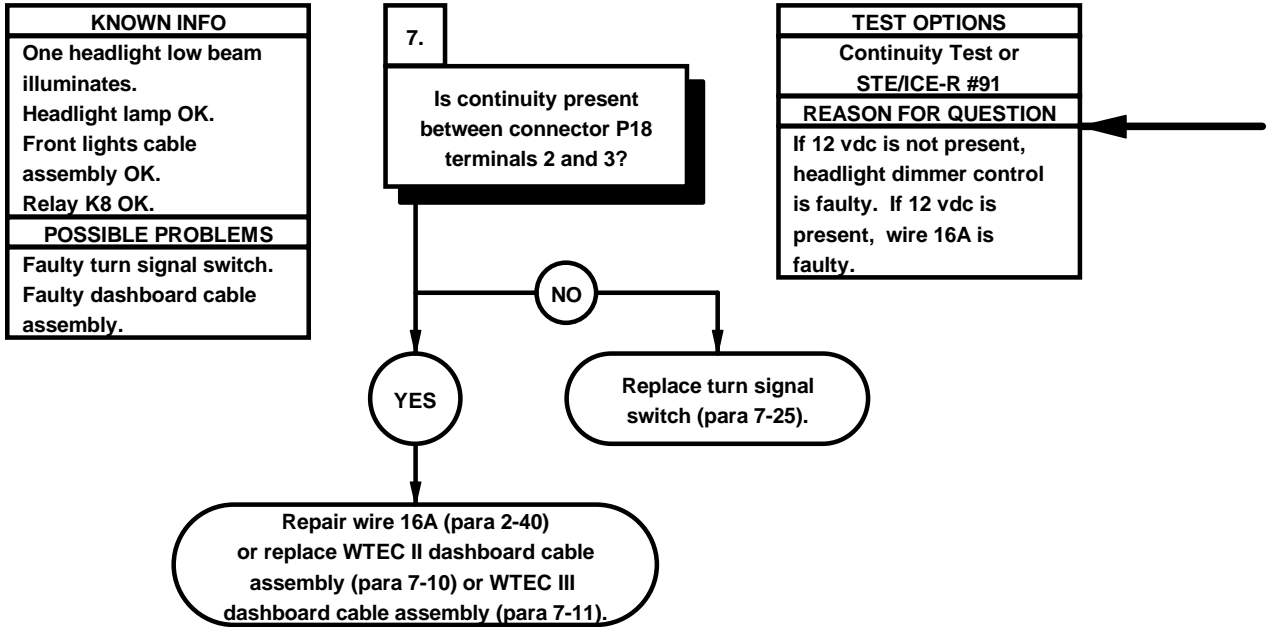

- CONTINUITY TEST**
- (1) Set multimeter to ohms.
 - (2) Connect positive (+) probe of multimeter to connector P18-3.
 - (3) Connect negative (-) probe of multimeter to connector P18-2.
 - (4) If continuity is not present, replace turn signal switch (para 7-25).
 - (5) If continuity is present, repair wire 16A (para 2-40) or replace WETC II dashboard cable assembly (para 7-10) or WTEC III dashboard cable assembly (para 7-11).
 - (6) Connect connector P18 to connector J18.
 - (7) Install instrument panel assembly (para 7-15).
 - (8) Install relay K8 in PDP.
 - (9) Install PDP cover (para 16-2).

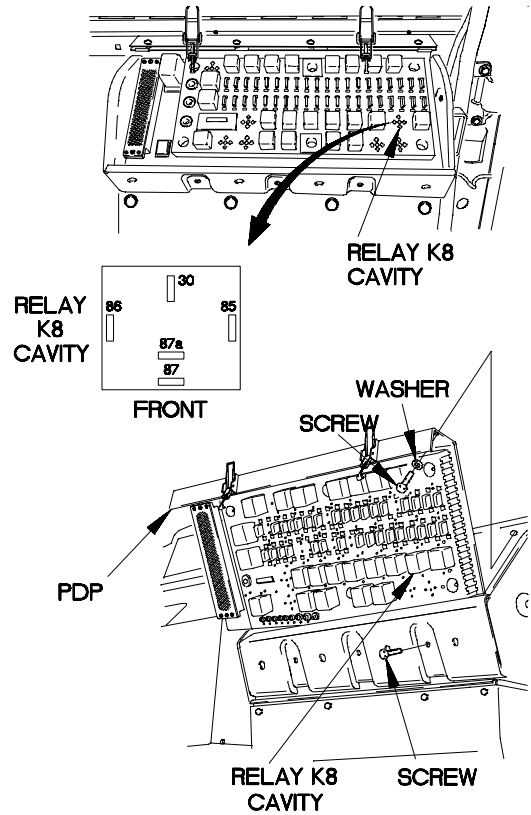

- CONTINUITY TEST**
- (1) Remove three screws and washers from PDP.
 - (2) Remove three screws from PDP.
 - (3) Lift PDP outward to gain access.
 - (4) Disconnect connector J27 from connector P27.
 - (5) Set multimeter to ohms.
 - (6) Connect positive (+) probe of multimeter to PDP, relay K8 terminal 30, where relay K8 was removed.
 - (7) Connect negative (-) probe of multimeter to connector J27-6 and note reading on multimeter.
 - (8) If continuity is not present, repair wire 17 (para 2-40) or replace WTEC II dashboard cable assembly (para 7-10) or WTEC III dashboard cable assembly (para 7-11).
 - (9) If continuity is present, repair wire 17 (para 2-40) or replace front lights cable assembly (para 7-74).
 - (10) Connect connector P27 to connector J27.
 - (11) Install PDP in dashboard with three screws.
 - (12) Install three washers and screws in PDP.
 - (13) Install relay K8 in PDP.
 - (14) Install PDP cover (para 16-2).

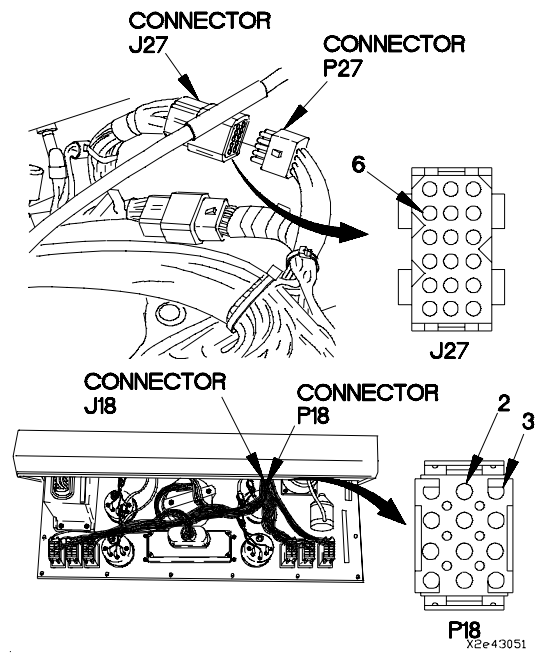

e43. PARKING LIGHTS DO NOT ILLUMINATE	
INITIAL SETUP	
Equipment Condition Engine shut down (TM 9-2320-365-10).	Tools and Special Tools Tool Kit, Genl Mech (Item 44, Appendix C) STE/ICE-R (Item 39, Appendix C) Multimeter, Digital (Item 22, Appendix C)
Personnel Required (2)	References TM 9-4910-571-12&P
Materials/Parts Packing, Preformed (Item 170, Appendix G)	

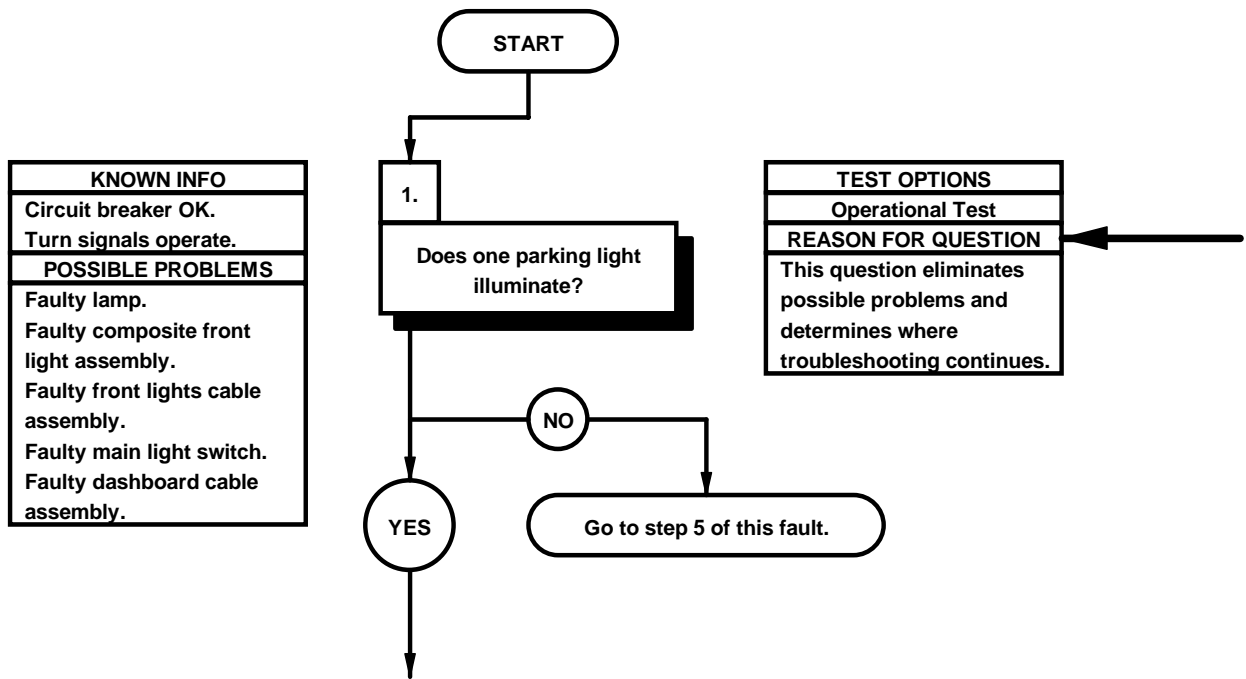

OPERATIONAL TEST

- (1) Position main light switch to SER DRIVE (TM 9-2320-365-10).
- (2) Position main light switch auxiliary lever to PARK (TM 9-2320-365-10).
- (3) If no parking lights illuminate, go to step 5 of this fault.
- (4) Position main light switch to OFF (TM 9-2320-365-10).

e43. PARKING LIGHTS DO NOT ILLUMINATE (CONT)

KNOWN INFO
Circuit breaker OK. Turn signals operate. Other parking light illuminates. Main light switch OK.
POSSIBLE PROBLEMS
Faulty lamp. Faulty composite front light assembly. Faulty front lights cable assembly. Faulty dashboard cable assembly.

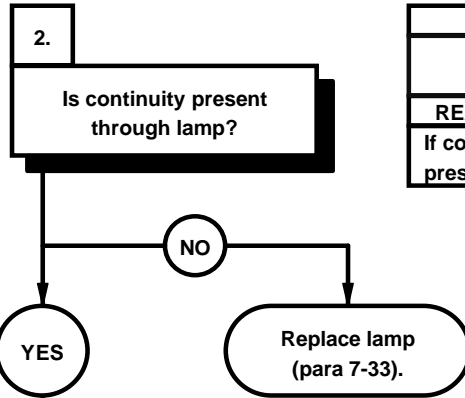

TEST OPTIONS
Continuity Test or STE/ICE-R#91
REASON FOR QUESTION
If continuity is not present, lamp is faulty.

KNOWN INFO
Circuit breaker OK. Turn signals operate. Other parking light illuminates. Main light switch OK. Lamp OK.
POSSIBLE PROBLEMS
Faulty composite front light assembly. Faulty front lights cable assembly. Faulty dashboard cable assembly.

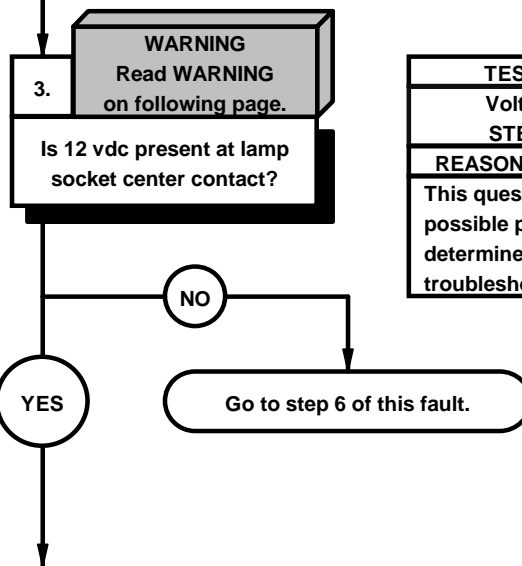

TEST OPTIONS
Voltage Test or STE/ICE-R #89
REASON FOR QUESTION
This question eliminates possible problems and determines where troubleshooting continues.

CONTINUITY TEST
<ol style="list-style-type: none"> (1) Loosen five screws on cover. (2) Remove cover and preformed packing from housing. Discard preformed packing. (3) Remove lamp from socket. (4) Set multimeter to ohms. (5) Check continuity through lamp and note reading on multimeter. (6) If continuity is not present, replace lamp (para 7-33).

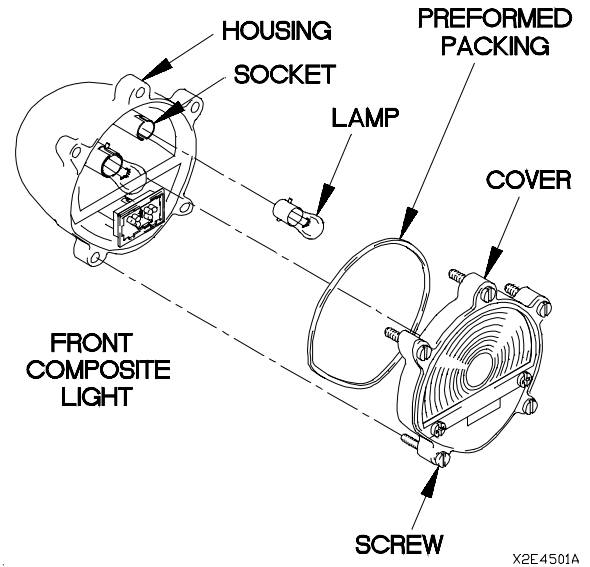

WARNING

Remove rings, bracelets, watches, necklaces, and any other jewelry before working around vehicle. Jewelry can catch on equipment and cause injury or short across electrical circuit and cause severe burns or electrical shock.

VOLTAGE TEST
<ol style="list-style-type: none"> (1) Set multimeter to volts dc. (2) Connect positive (+) probe of multimeter to center contact of lamp socket. (3) Connect negative (-) probe of multimeter to ground. (4) Position main light switch to SER DRIVE (TM 9-2320-365-10). (5) Position main light switch auxiliary lever to PARK (TM 9-2320-365-10) and note reading on multimeter. (6) If 12 vdc is not present, go to step 6 of this fault. (7) Position main light switch to OFF (TM 9-2320-365-10).

e43. PARKING LIGHTS DO NOT ILLUMINATE (CONT)

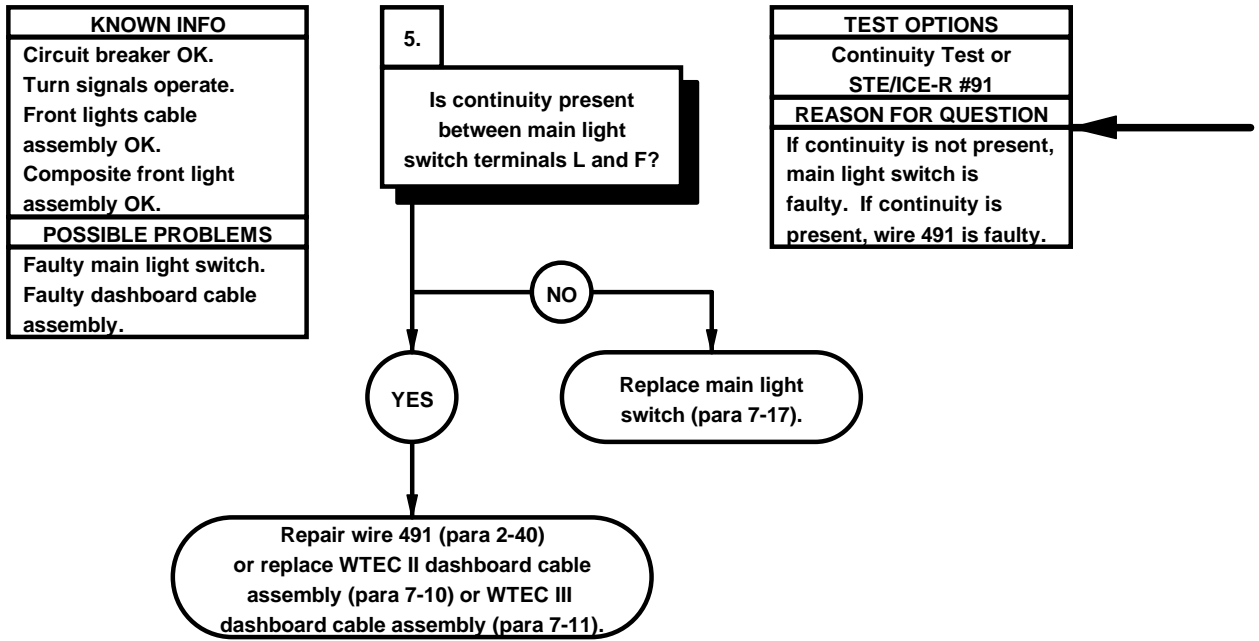
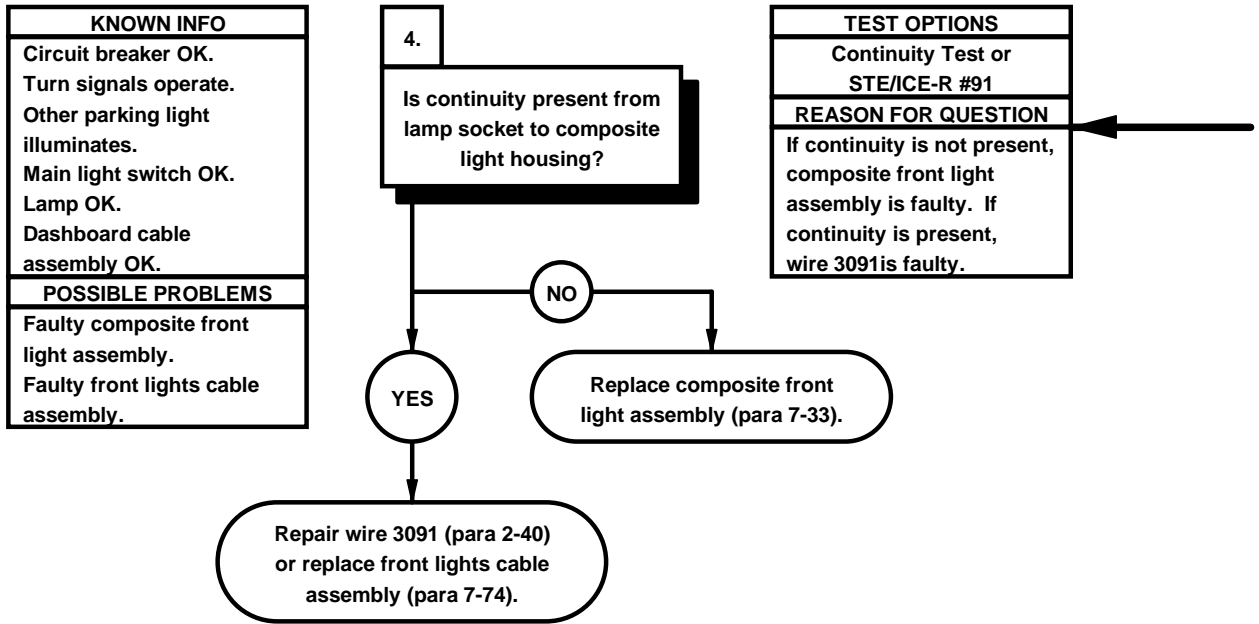

- | CONTINUITY TEST |
|--|
| (1) Set multimeter to ohms. |
| (2) Connect positive (+) probe of multimeter to lamp socket. |
| (3) Connect negative (-) probe of multimeter to composite front light housing and note reading on multimeter. |
| (4) If continuity is not present, replace composite front light assembly (para 7-33). |
| (5) If continuity is present, repair wire 3091 (para 2-40) or replace front lights cable assembly (para 7-74). |
| (6) Install lamp in socket. |
| (7) Install preformed packing and cover on housing with five screws. |

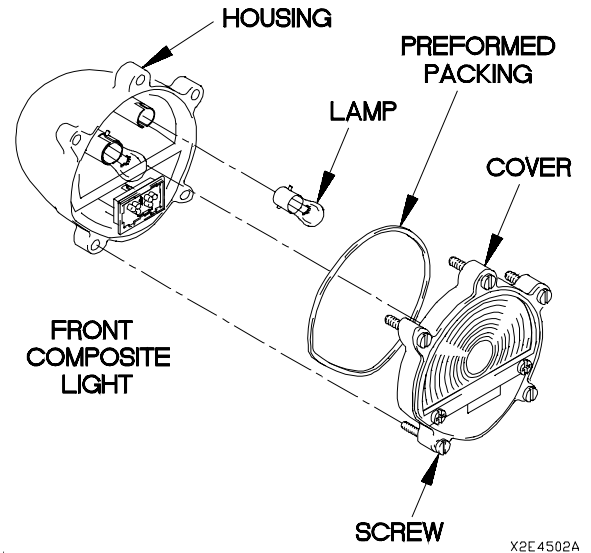

- | CONTINUITY TEST |
|---|
| (1) Remove instrument panel assembly for access (para 7-15). |
| (2) Disconnect connector PX15 from main light switch. |
| (3) Set multimeter to ohms. |
| (4) Connect positive (+) probe of multimeter to main light switch terminal L. |
| (5) Connect negative (-) probe of multimeter to main light switch terminal F. |
| (6) Position main light switch auxiliary lever to PARK (TM 9-2320-365-10) and note reading on multimeter. |
| (7) If continuity is not present, replace main light switch (para 7-17). |
| (8) If continuity is present, repair wire 491 (para 2-40) or replace WTEC II dashboard cable assembly (para 7-10) or WTEC III dashboard cable assembly (para 7-11). |
| (9) Connect connector PX15 to main light switch. |
| (10) Install instrument panel assembly (para 7-15). |

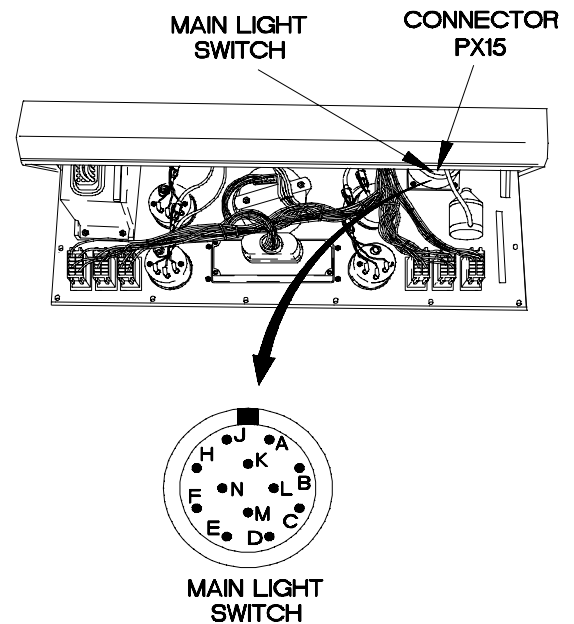

e43. PARKING LIGHTS DO NOT ILLUMINATE (CONT)

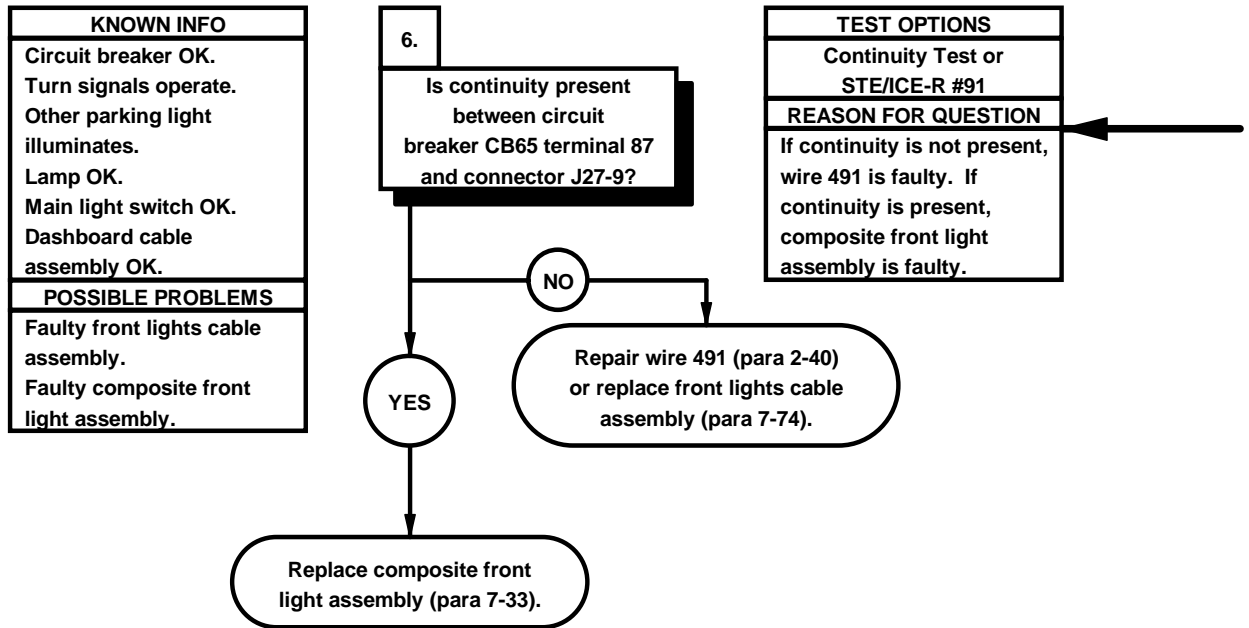

CONTINUITY TEST

- (1) Remove PDP cover (para 16-2).
- (2) Remove three screws and washers from PDP.
- (3) Remove three screws from PDP.
- (4) Lift PDP outward to gain access.
- (5) Disconnect connector J27 from connector P27.
- (6) Remove circuit breaker CB65 from PDP.
- (7) Set multimeter to ohms.
- (8) Connect positive (+) probe of multimeter to PDP, terminal 8, where CB65 was removed.
- (9) Connect negative (-) probe of multimeter to connector J27-9 and note reading on multimeter.
- (10) If continuity is not present, repair wire 491 (para 2-40) or replace front lights cable assembly (para 7-74).
- (11) If continuity is present, replace composite front light assembly (para 7-33).
- (12) Install lamp in socket.
- (13) Install preformed packing and cover on housing with five screws.
- (14) Connect connector J27 to connector P27.
- (15) Install PDP on dashboard with three screws.
- (16) Install three washers and screws in PDP.
- (17) Install circuit breaker CB65 in PDP.
- (18) Install PDP cover (para 16-2).

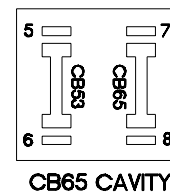
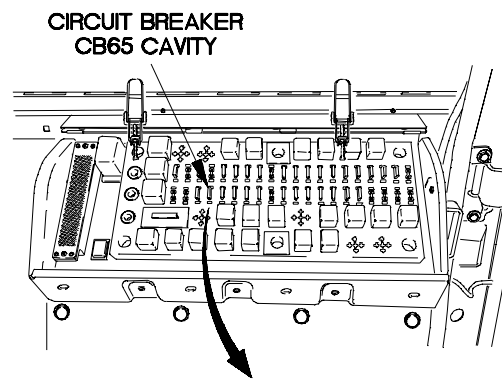
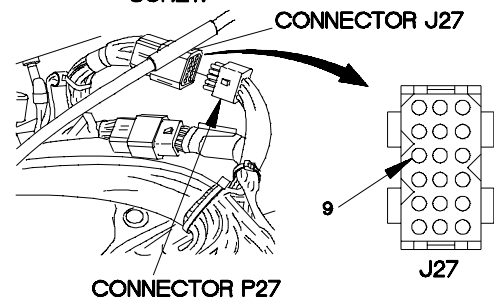
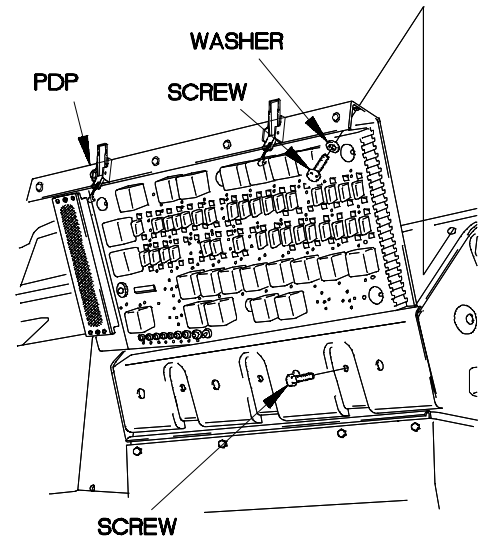

X2e44041

e44. LH DOOR AND/OR LH FRONT MARKER LIGHTS DO NOT ILLUMINATE

INITIAL SETUP

Equipment Conditions

Engine shut down (TM 9-2320-365-10).

Tools and Special Tools

Tool Kit, Genl Mech (Item 44, Appendix C)
 STE/ICE-R (Item 39, Appendix C)
 Multimeter, Digital (Item 22, Appendix C)

Materials/Parts

Lockwasher (4) (Item 71, Appendix G)
 Gasket (2) (Item 28, Appendix G)

Personnel Required

(2)

References

TM 9-4910-571-12&P

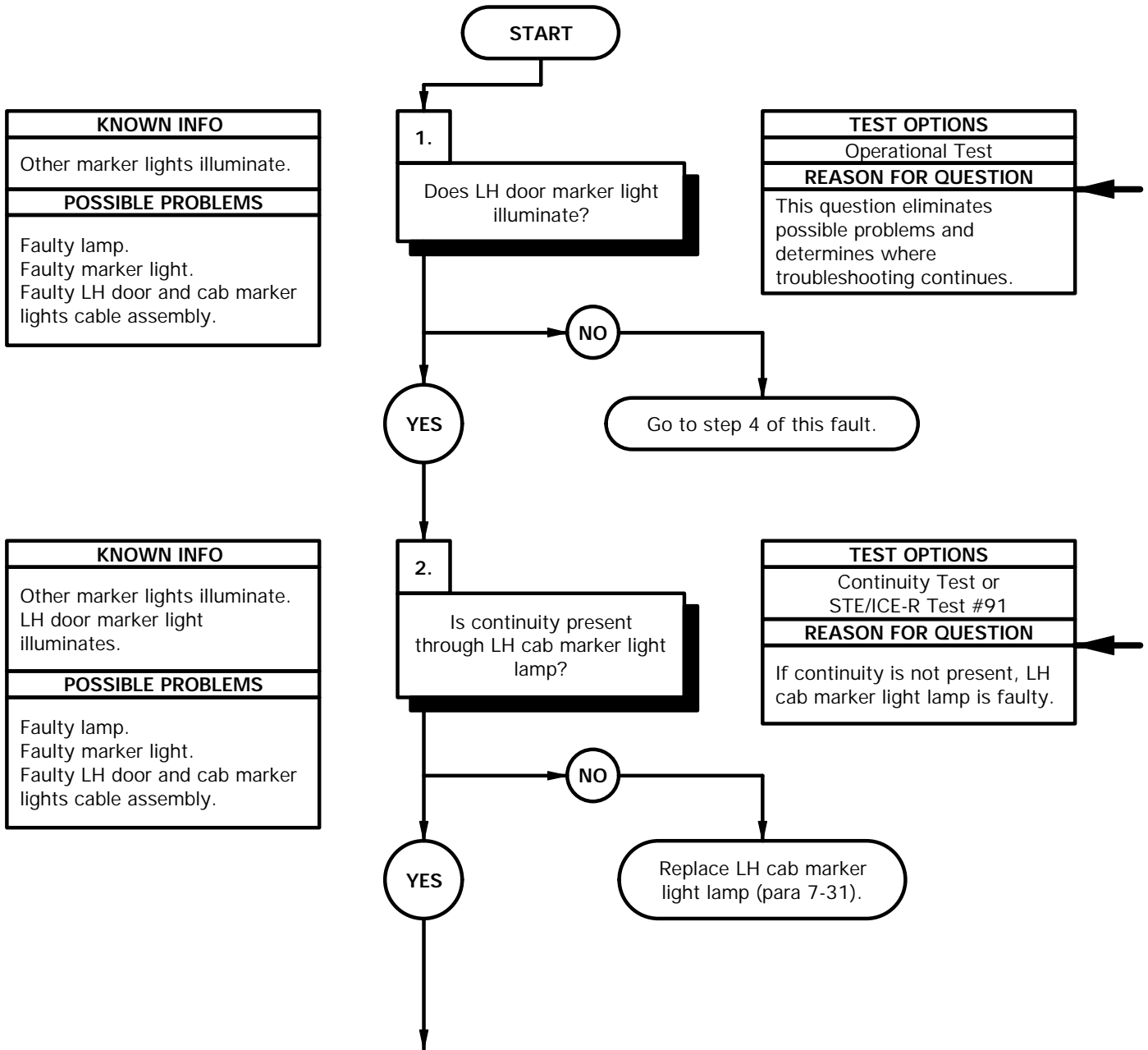

- (1) Position main light switch to SER DRIVE (TM 9-2320-365-10).
- (2) If LH door marker light lamp does not illuminate, go to step 4 of this fault.
- (3) Position main light switch to OFF (TM 9-2320-365-10).

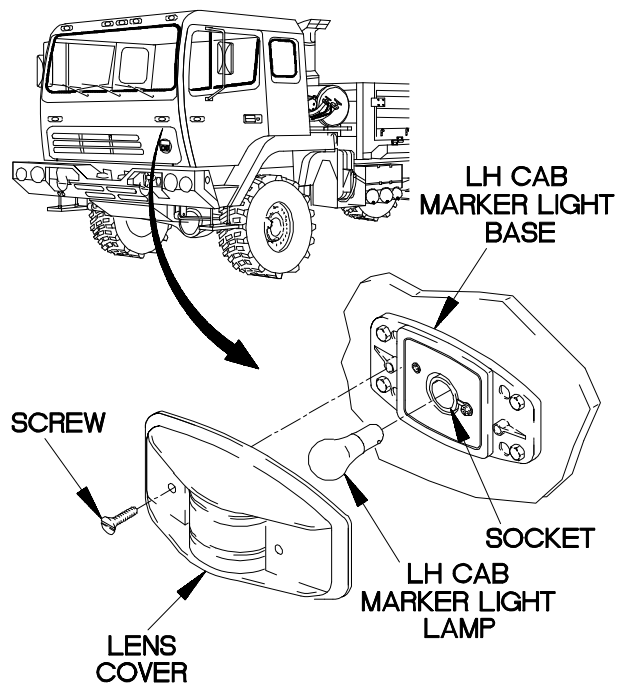

CONTINUITY TEST

- (1) Remove two screws and lens cover from LH cab marker light base.
- (2) Remove LH marker light lamp from socket.
- (3) Set multimeter to ohms.
- (4) Check continuity through LH marker light lamp and note reading on multimeter.
- (5) If continuity is not present, replace LH marker light lamp (para 7-31).

XBE4501B

e44. LH DOOR AND/OR LH FRONT MARKER LIGHTS DO NOT ILLUMINATE (CONT)

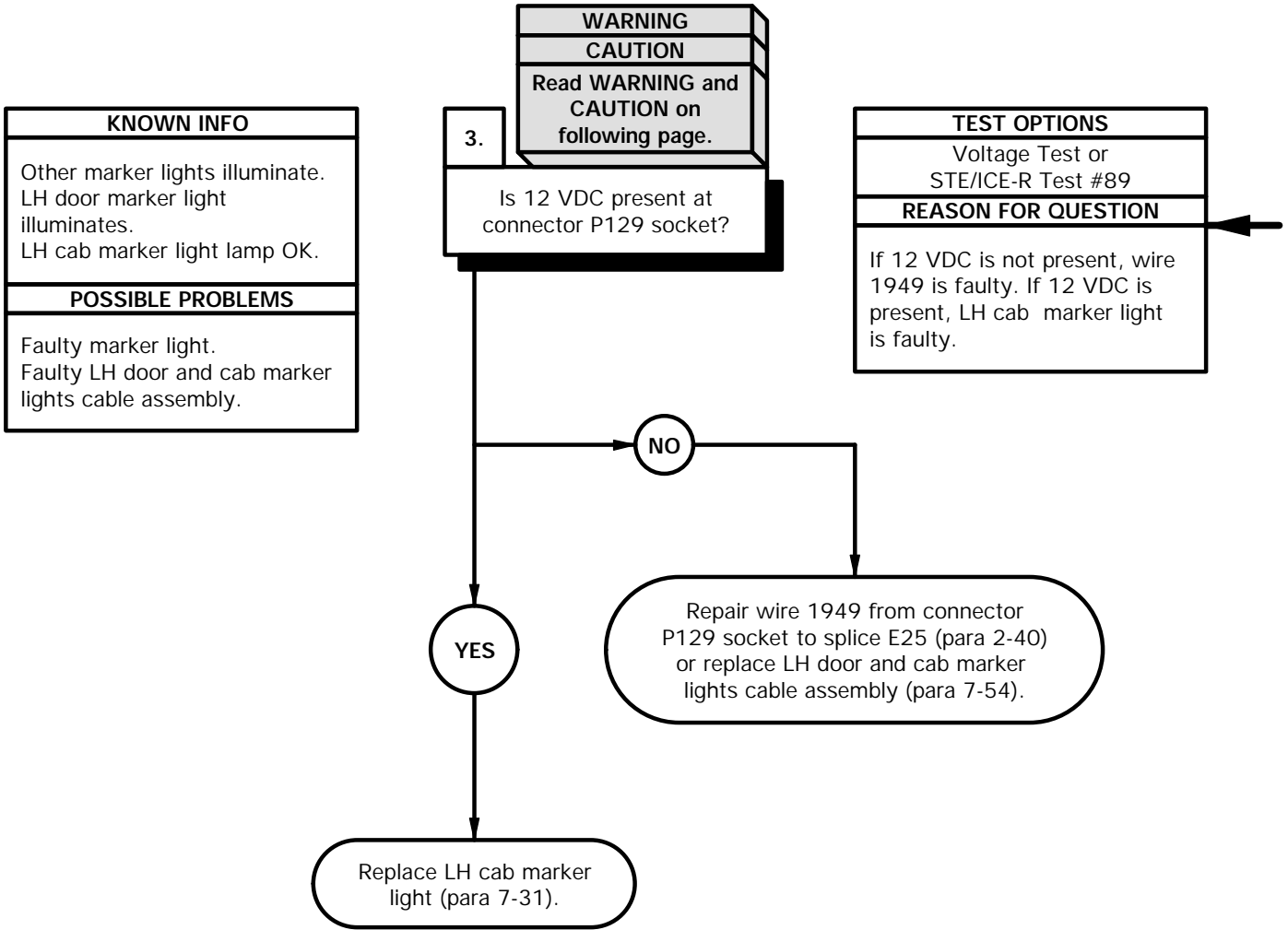

WARNING

Remove rings, bracelets, watches, necklaces, and any other jewelry before working around vehicle. Jewelry can catch on equipment and cause injury or short across electrical circuits and cause severe burns or electrical shock.

CAUTION

Use care when testing electrical connectors. Do not damage connector pins or sockets with multimeter probes. Failure to comply may result in damage to equipment.

NOTE

Inspect connector pins/sockets for damage, corrosion, and serviceability. Check that connector pins are not pushed back and are capable of making good contact.

VOLTAGE TEST (Cont)

- (14) Install lockwasher, terminal lug TL133, lockwasher, and nut on back of LH cab marker light base.
- (15) Install LH cab marker light base on vehicle with four screws.
- (16) Install LH cab marker light lamp in socket.
- (17) Install lens cover on base with two screws.

VOLTAGE TEST

- (1) Remove four screws from LH cab marker light base.

NOTE

Do not let wires slip through hole into cab structure. If wires slip into cab structure, vehicle will need further disassembly to retrieve wires.

- (2) Remove nut, lockwasher, terminal lug TL133, and lockwasher from LH cab marker light base. Discard lockwashers.
- (3) Extend base and disconnect connector P129 from marker light connector.
- (4) Remove gasket from LH door marker light base. Discard gasket.
- (5) Set multimeter to volts DC.
- (6) Connect positive (+) probe of multimeter to connector P129 socket.
- (7) Connect negative (-) probe of multimeter to ground.
- (8) Position main light switch to SER DRIVE (TM 9-2320-365-10) and note reading on multimeter.
- (9) If 12 VDC is not present, repair wire 1949 from connector P129 socket to splice E25 (para 2-40) or replace LH door and cab marker lights cable assembly (para 7-54).
- (10) If 12 VDC is present, replace LH cab marker light (para 7-31).
- (11) Position main light switch to OFF (TM 9-2320-365-10).
- (12) Install gasket on LH cab marker light base.
- (13) Connect marker light connector to connector P129.

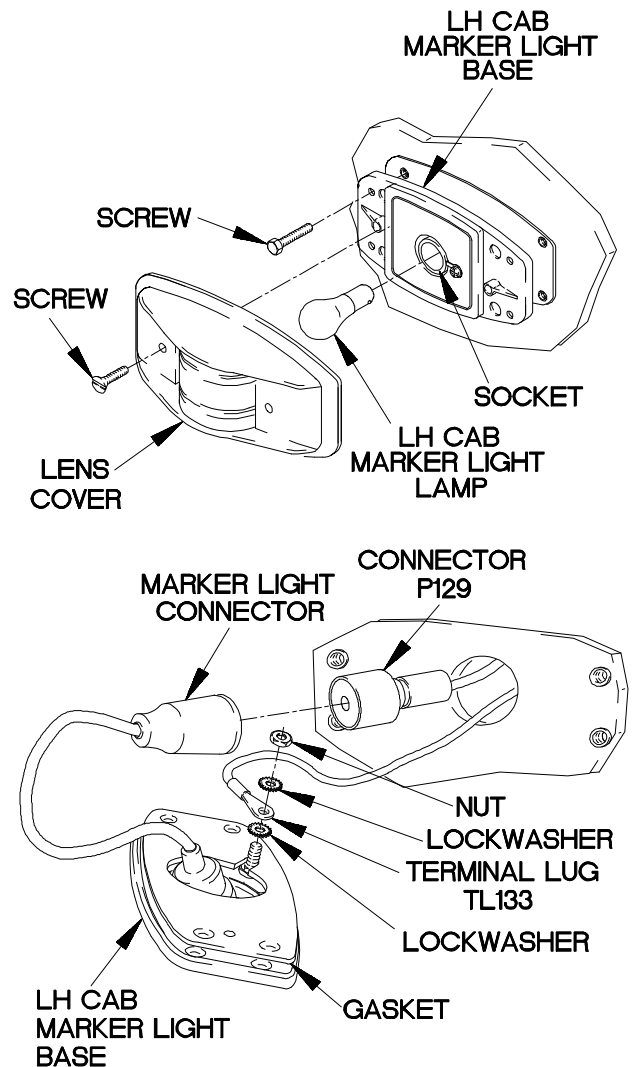

XBe4503B

e44. LH DOOR AND/OR LH FRONT MARKER LIGHTS DO NOT ILLUMINATE (CONT)

KNOWN INFO
Other marker lights illuminate.
POSSIBLE PROBLEMS
Faulty lamp. Faulty marker light. Faulty LH door and cab marker lights cable assembly.

4.
Is continuity present through LH door marker light lamp?

TEST OPTIONS
Continuity Test or STE/ICE-R Test #91
REASON FOR QUESTION
If continuity is not present, LH door marker light lamp is faulty.

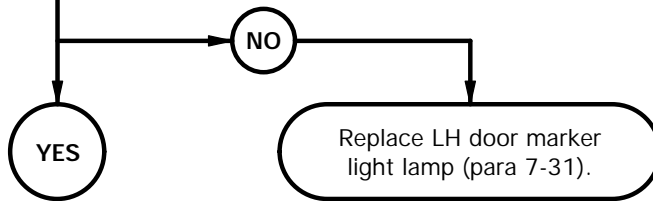

KNOWN INFO
Other marker lights illuminate. LH door marker light lamp OK.
POSSIBLE PROBLEMS
Faulty lamp. Faulty marker light. Faulty LH door and cab marker lights cable assembly.

5.
Does LH cab marker light illuminate?

TEST OPTIONS
Operational Test
REASON FOR QUESTION
This question eliminates possible problems and determines where troubleshooting continues.

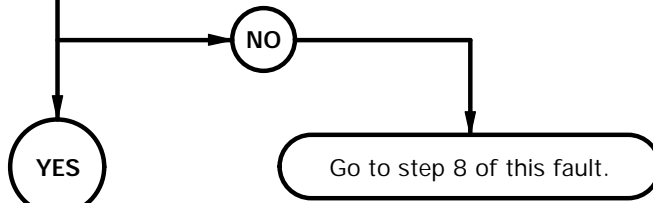

CONTINUITY TEST

- (1) Remove two screws and lens cover from LH door marker light base.
- (2) Remove LH door marker light lamp from socket.
- (3) Set multimeter to ohms.
- (4) Check continuity through LH door marker light lamp and note reading on multimeter.
- (5) If continuity is not present, replace LH door marker light lamp (para 7-31).

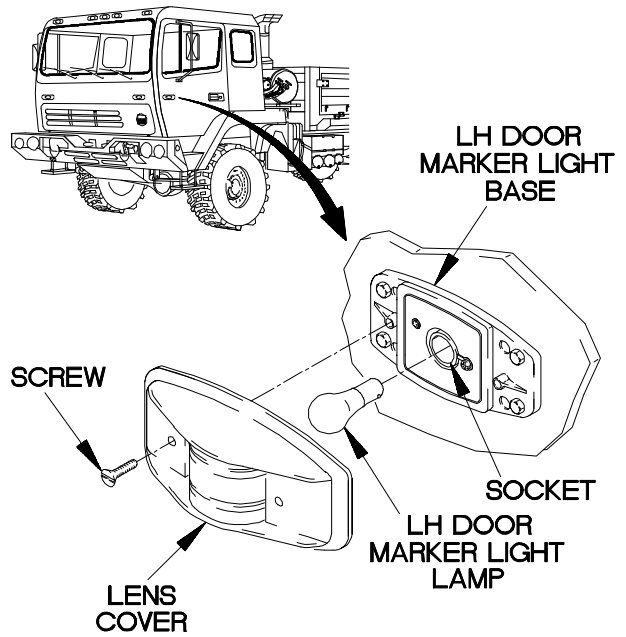

XBe4504B

- (1) Position main light switch to SER DRIVE (TM 9-2320-365-10).
- (2) If LH cab marker light lamp does not illuminate, go to step 8 of this fault.
- (3) Position main light switch to OFF (TM 9-2320-365-10).

e44. LH DOOR AND/OR LH FRONT MARKER LIGHTS DO NOT ILLUMINATE (CONT)

KNOWN INFO
Other marker lights illuminate. LH door marker light lamp OK. LH cab marker light illuminates.
POSSIBLE PROBLEMS
Faulty marker light. Faulty LH door and cab marker lights cable assembly.

6.

WARNING
CAUTION
Read WARNING and CAUTION on following page.

Is 12 VDC present at connector P130 socket?

TEST OPTIONS
Voltage Test or STE/ICE-R Test #89
REASON FOR QUESTION
If 12 VDC is not present, wire 1949 is faulty.

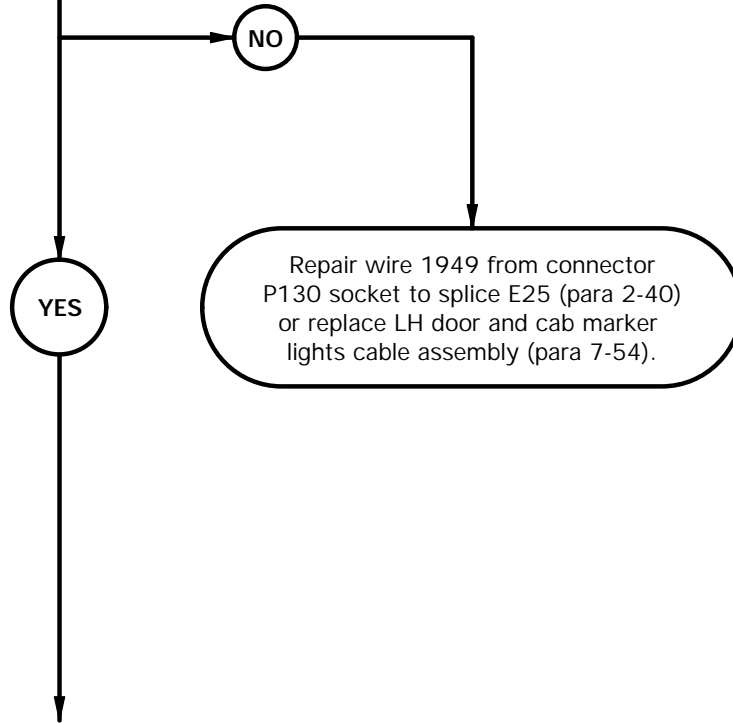

WARNING

Remove rings, bracelets, watches, necklaces, and any other jewelry before working around vehicle. Jewelry can catch on equipment and cause injury or short across electrical circuits and cause severe burns or electrical shock.

CAUTION

Use care when testing electrical connectors. Do not damage connector pins or sockets with multimeter probes. Failure to comply may result in damage to equipment.

NOTE

Inspect connector pins/sockets for damage, corrosion, and serviceability. Check that connector pins are not pushed back and are capable of making good contact.

VOLTAGE TEST

- (1) Remove four screws from LH door marker light base.

NOTE

Do not let wires slip through hole into cab structure. If wires slip into cab structure, vehicle will need further disassembly to retrieve wires.

- (2) Remove nut, lockwasher, terminal lug TL130, and lockwasher from LH door marker light base. Discard lockwashers.
- (3) Extend base and disconnect connector P130 from marker light connector.
- (4) Remove gasket from LH door marker light base. Discard gasket.
- (5) Set multimeter to volts DC.
- (6) Connect positive (+) probe of multimeter to connector P130 socket.
- (7) Connect negative (-) probe of multimeter to ground.
- (8) Position main light switch to SER DRIVE (TM 9-2320-365-10) and note reading on multimeter.
- (9) If 12 VDC is not present, repair wire 1949 from connector P130 socket to splice E25 (para 2-40) or replace LH door and cab marker lights cable assembly (para 7-54).
- (10) Position main light switch to OFF (TM 9-2320-365-10).

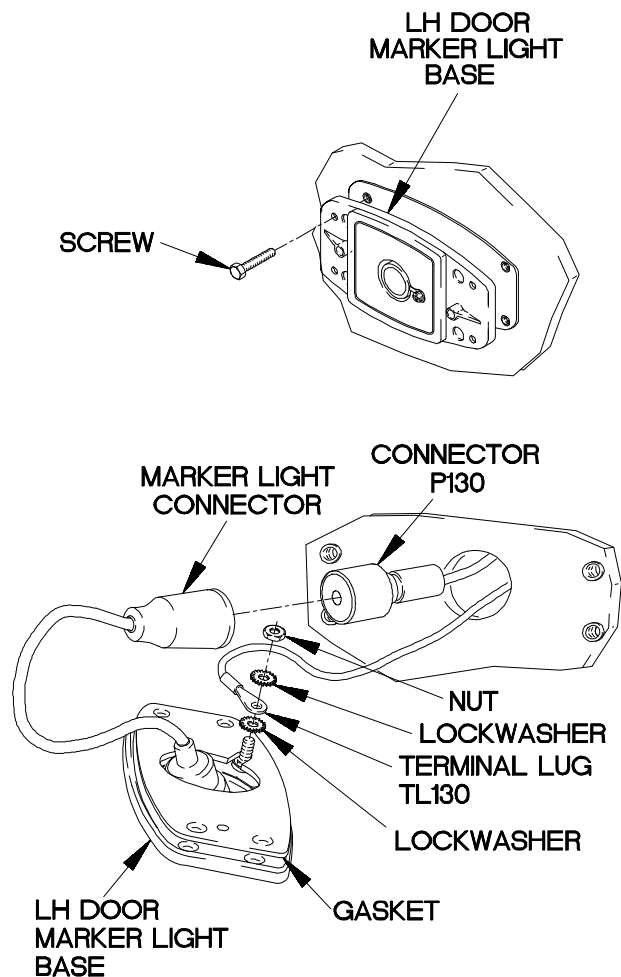

XBe4505B

e44. LH DOOR AND/OR LH FRONT MARKER LIGHTS DO NOT ILLUMINATE (CONT)

KNOWN INFO
Other marker lights illuminate. LH door marker light lamp OK. LH cab marker light illuminates.
POSSIBLE PROBLEMS
Faulty marker light. Faulty LH door and cab marker lights cable assembly.

7.
Is continuity present from terminal lug TL130 to terminal lug TL133?

TEST OPTIONS
Continuity Test or STE/ICE-R Test #91
REASON FOR QUESTION
If continuity is not present, wire 3098 is faulty. If continuity is present, LH door marker light is faulty.

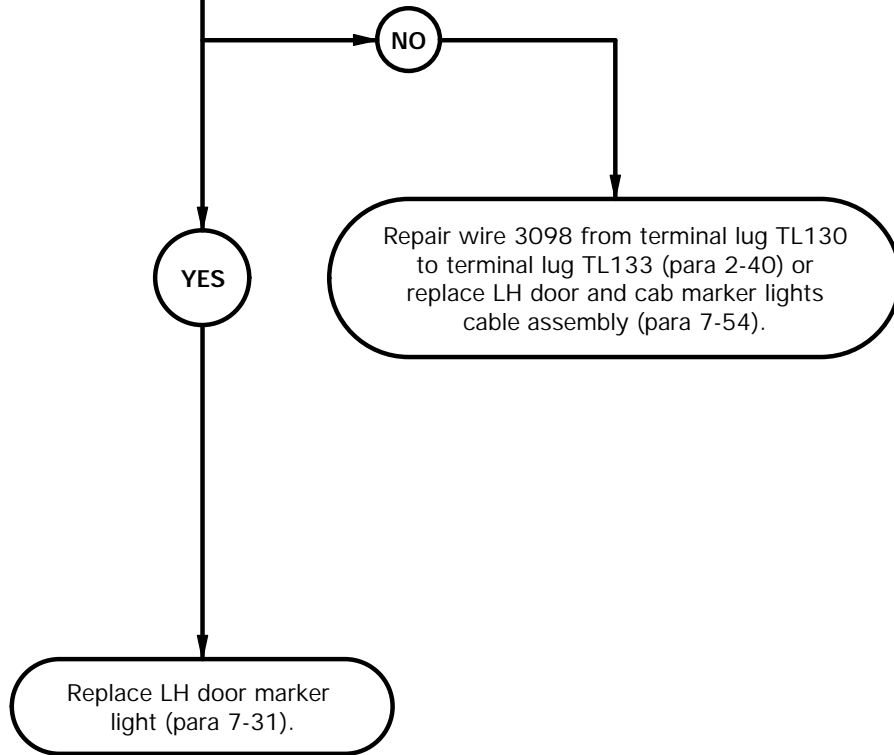

CONTINUITY TEST

- (1) Remove two screws and lens cover from LH cab marker light base.
- (2) Remove LH cab marker light lamp from socket.
- (3) Remove four screws from LH cab marker light base.

NOTE

Do not let wires slip through hole into cab structure. If wires slip into cab structure, vehicle will need further disassembly to retrieve wires.

- (4) Remove nut, lockwasher, terminal lug TL133, and lockwasher from LH cab marker light base. Discard lockwashers.
- (5) Extend base and disconnect connector P129 from marker light connector.
- (6) Remove gasket from LH cab marker light base. Discard gasket.
- (7) Set multimeter to ohms.
- (8) Connect positive (+) probe of multimeter to terminal lug TL130.
- (9) Connect negative (-) probe of multimeter to terminal lug TL133 and note reading on multimeter.
- (10) If continuity is not present, repair wire 3098 from terminal lug TL130 to terminal lug TL133 (para 2-40) or replace LH door and cab marker lights cable assembly (para 7-54).
- (11) If continuity is present, replace LH door marker light (para 7-31).
- (12) Install gasket on LH cab marker light base.
- (13) Connect marker light connector to connector P129.
- (14) Install lockwasher, terminal lug TL133, lockwasher, and nut on back of LH cab marker light base.
- (15) Install LH cab marker light base on vehicle with four screws.
- (16) Install LH cab marker light lamp in socket.
- (17) Install lens cover on base with two screws.
- (18) Install gasket on LH door marker light base.
- (19) Connect marker light connector to connector P130.
- (20) Install lockwasher, terminal lug TL130, lockwasher, and nut on back of base.
- (21) Install LH door marker light base on vehicle with four screws.
- (22) Install LH door marker light lamp in socket.
- (23) Install lens cover on base with two screws.

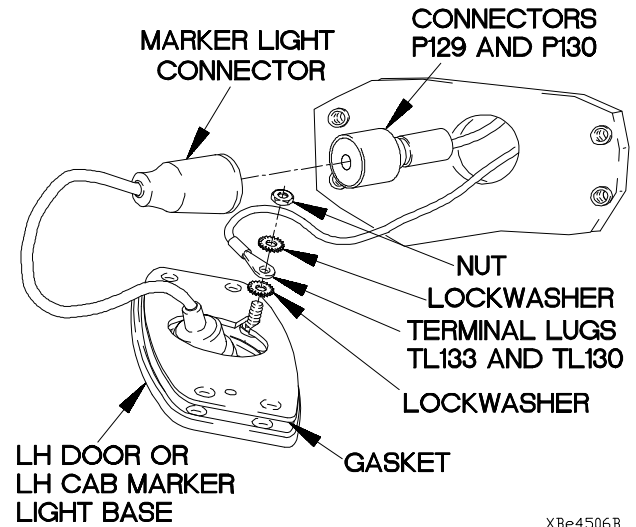
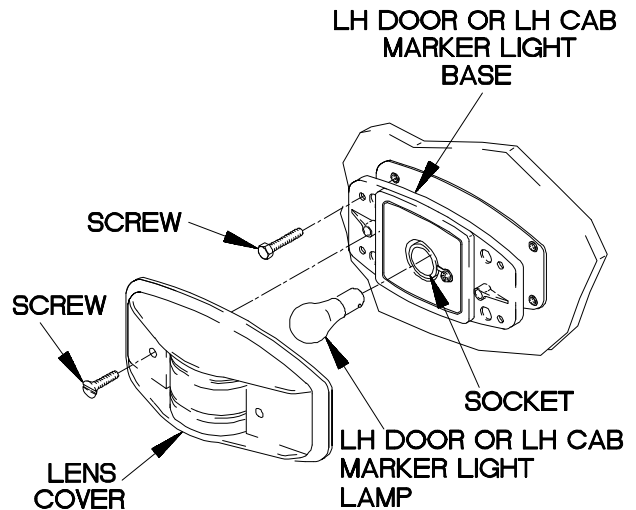

XBe4506B

e44. LH DOOR AND/OR LH FRONT MARKER LIGHTS DO NOT ILLUMINATE (CONT)

KNOWN INFO
Other marker lights illuminate. LH door marker light lamp OK.
POSSIBLE PROBLEMS
Faulty lamp. Faulty marker light. Faulty LH door and cab marker lights cable assembly.

TEST OPTIONS
Continuity Test or STE/ICE-R Test #91
REASON FOR QUESTION
If continuity is not present, LH cab marker light lamp is faulty.

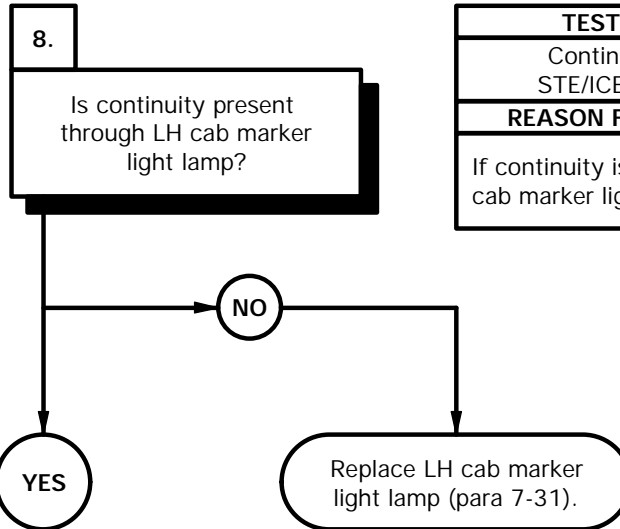

KNOWN INFO
Other marker lights illuminate. LH door marker light Lamp OK. LH cab marker light lamp OK.
POSSIBLE PROBLEMS
Faulty marker light. Faulty LH door and cab marker lights cable assembly.

TEST OPTIONS
Continuity Test or STE/ICE-R Test #91
REASON FOR QUESTION
This question eliminates possible problems and determines where troubleshooting continues.

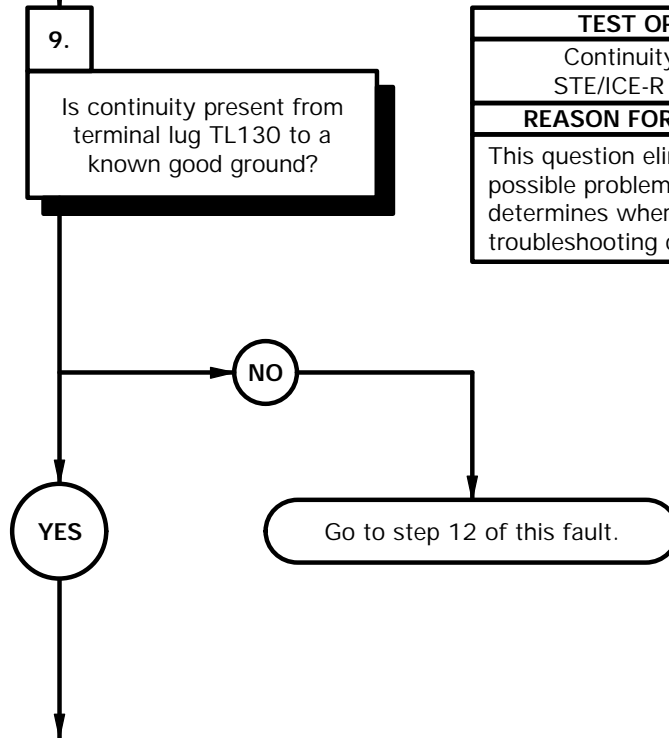

CONTINUITY TEST

- (1) Remove two screws and lens cover from LH cab marker light base.
- (2) Remove LH cab marker light lamp from socket.
- (3) Set multimeter to ohms.
- (4) Check continuity through LH cab marker light lamp and note reading on multimeter.
- (5) If continuity is not present, replace LH cab marker light lamp (para 7-31).

CONTINUITY TEST

- (1) Remove two screws and lens cover from LH door marker light base.
- (2) Remove LH door marker light lamp from socket.
- (3) Remove four screws from LH door marker light.

NOTE

Do not let wires slip through hole into cab structure. If wires slip into cab structure, vehicle will need further disassembly to retrieve wires.

- (4) Remove nut, lockwasher, terminal lug TL130, and lockwasher from LH door marker light base. Discard lockwashers.
- (5) Extend base and disconnect connector P130 from marker light connector.
- (6) Remove gasket from LH door marker light base. Discard gasket.
- (7) Set multimeter to ohms.
- (8) Connect positive (+) probe of multimeter to terminal lug TL130.
- (9) Connect negative (-) probe of multimeter to ground and note reading on multimeter.
- (10) If continuity is not present, go to step 12 of this fault.

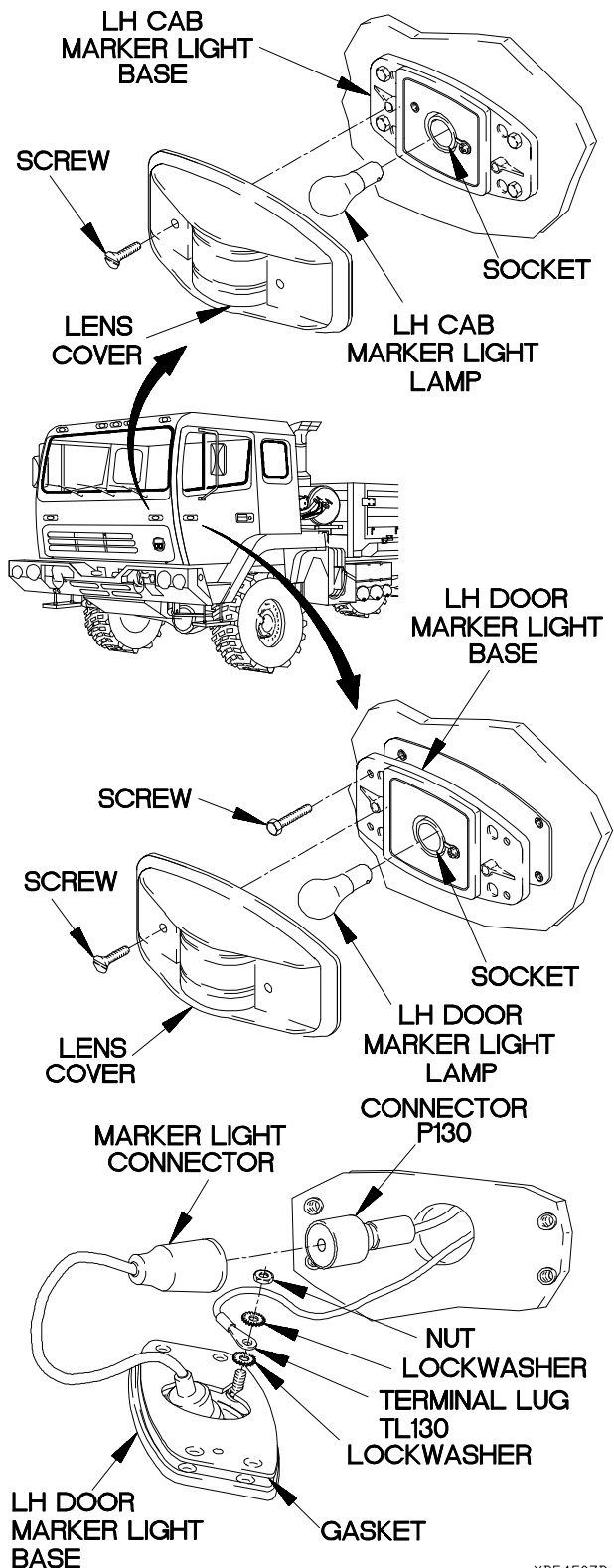

XBE4507B

e44. LH DOOR AND/OR LH FRONT MARKER LIGHTS DO NOT ILLUMINATE (CONT)

KNOWN INFO
Other marker lights illuminate. LH door marker light illuminates. LH cab marker light lamp OK.
POSSIBLE PROBLEMS
Faulty marker light. Faulty LH door and cab marker lights cable assembly.

10.

WARNING
CAUTION
Read WARNING and CAUTION on following page.

Is 12 VDC present at connector P129 socket?

TEST OPTIONS
Voltage Test or STE/ICE-R Test #89
REASON FOR QUESTION
This question eliminates possible problems and determines where troubleshooting continues.

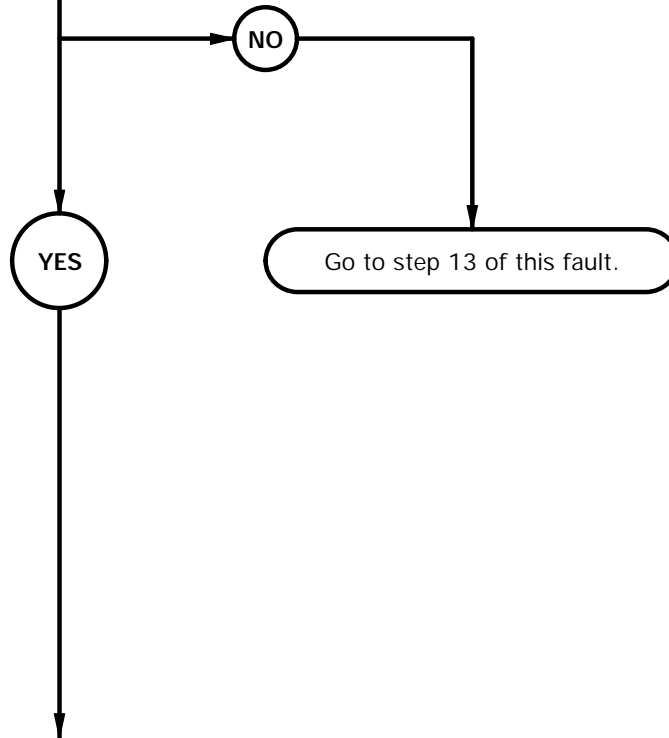

WARNING

Remove rings, bracelets, watches, necklaces, and any other jewelry before working around vehicle. Jewelry can catch on equipment and cause injury or short across electrical circuits and cause severe burns or electrical shock.

CAUTION

Use care when testing electrical connectors. Do not damage connector pins or sockets with multimeter probes. Failure to comply may result in damage to equipment.

NOTE

Inspect connector pins/sockets for damage, corrosion, and serviceability. Check that connector pins are not pushed back and are capable of making good contact.

VOLTAGE TEST

- (1) Remove four screws from LH cab marker light base.

NOTE

Do not let wires slip through hole into cab structure. If wires slip into cab structure, vehicle will need further disassembly to retrieve wires.

- (2) Remove nut, lockwasher, terminal lug TL133, and lockwasher from LH cab marker light base. Discard lockwashers.
- (3) Extend base and disconnect connector P129 from marker light connector.
- (4) Remove gasket from LH cab marker light base. Discard gasket.
- (5) Set multimeter to volts DC.
- (6) Connect positive (+) probe of multimeter to connector P129 socket.
- (7) Connect negative (-) probe of multimeter to ground.
- (8) Position main light switch to SER DRIVE (TM 9-2320-365-10) and note reading on multimeter.
- (9) If 12 VDC is not present, go to step 13 of this fault.
- (10) Position main light switch to OFF (TM 9-2320-365-10).
- (11) Install gasket on LH cab marker light base.
- (12) Connect marker light connector to connector P129.
- (13) Install lockwasher, terminal lug TL133, lockwasher, and nut on back of LH cab marker light base.

VOLTAGE TEST (Cont)

- (14) Install LH cab marker light base on vehicle with four screws.
- (15) Install LH cab marker light lamp in socket.
- (16) Install lens cover on base with two screws.

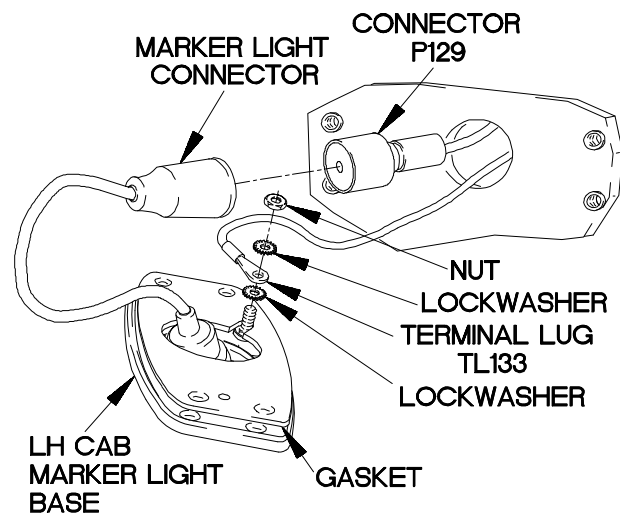
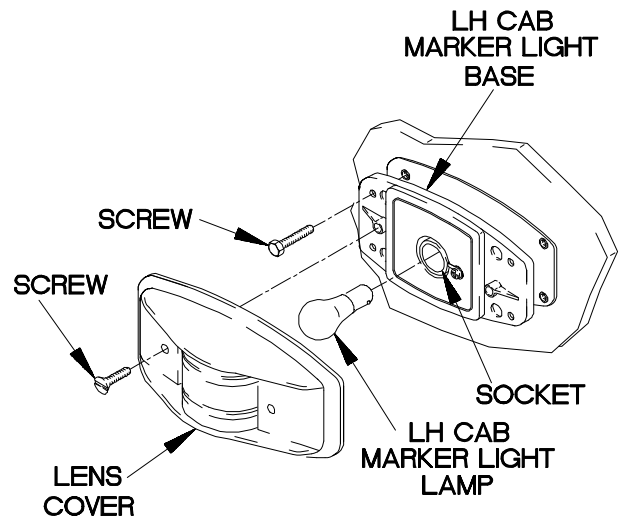

XBe4509B

e44. LH DOOR AND/OR LH FRONT MARKER LIGHTS DO NOT ILLUMINATE (CONT)

KNOWN INFO
Other marker lights illuminate. LH door marker light lamp OK. LH cab marker light illuminates.
POSSIBLE PROBLEMS
Faulty marker light. Faulty LH door and cab marker lights cable assembly.

11.

WARNING

CAUTION

Read **WARNING** and **CAUTION** on following page.

Is 12 VDC present at connector P130 socket?

TEST OPTIONS
Voltage Test or STE/ICE-R Test #89
REASON FOR QUESTION
If 12 VDC is not present, wire 1949 is faulty.

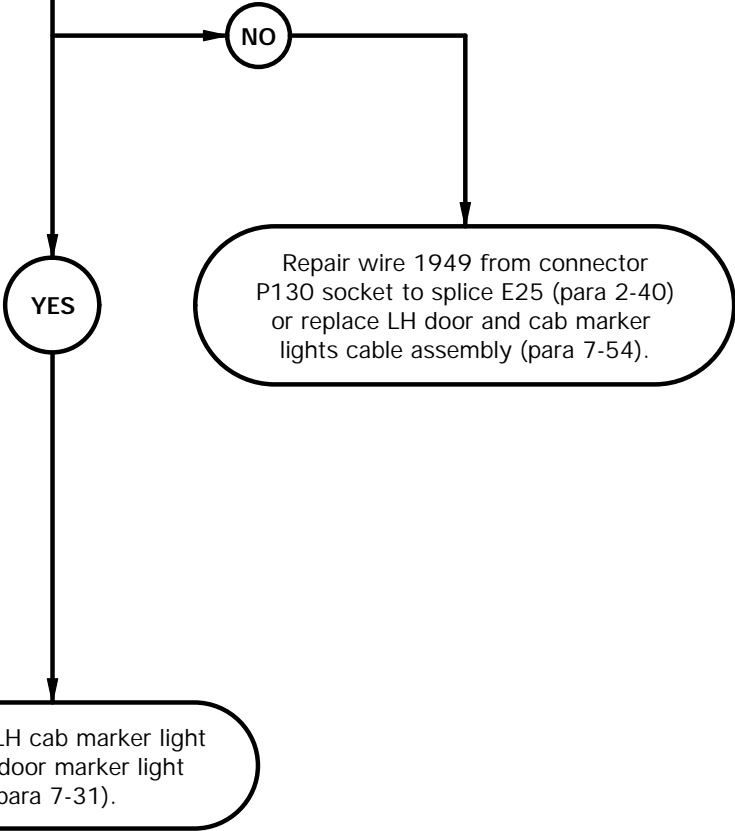

WARNING

Remove rings, bracelets, watches, necklaces, and any other jewelry before working around vehicle. Jewelry can catch on equipment and cause injury or short across electrical circuits and cause severe burns or electrical shock.

CAUTION

Use care when testing electrical connectors. Do not damage connector pins or sockets with multimeter probes. Failure to comply may result in damage to equipment.

NOTE

Inspect connector pins/sockets for damage, corrosion, and serviceability. Check that connector pins are not pushed back and are capable of making good contact.

VOLTAGE TEST

- (1) Set multimeter to volts DC.
- (2) Connect positive (+) probe of multimeter to connector P130 socket.
- (3) Connect negative (-) probe of multimeter to ground.
- (4) Position main light switch to SER DRIVE (TM 9-2320-365-10) and note reading on multimeter.
- (5) If 12 VDC is not present, repair wire 1949 from connector P130 socket to splice E25 (para 2-40) or replace LH door and cab marker lights cable assembly (para 7-54).
- (6) If 12 VDC is present, replace LH cab marker light and LH door marker light (para 7-31).
- (7) Position main light switch to OFF (TM 9-2320-365-10).
- (8) Install gasket on LH door marker light base.
- (9) Connect marker light connector to connector P130.
- (10) Install lockwasher, terminal lug TL130, lockwasher, and nut on back of LH door marker light base.
- (11) Install LH door marker light base on vehicle with four screws.
- (12) Install LH door marker light lamp in socket.
- (13) Install lens cover on base with two screws.

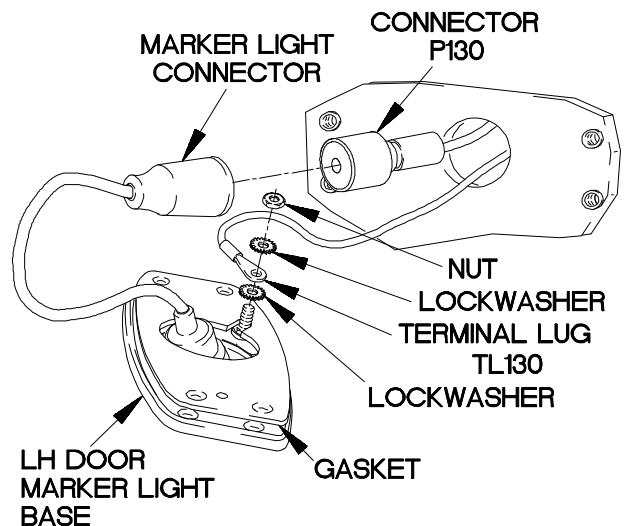
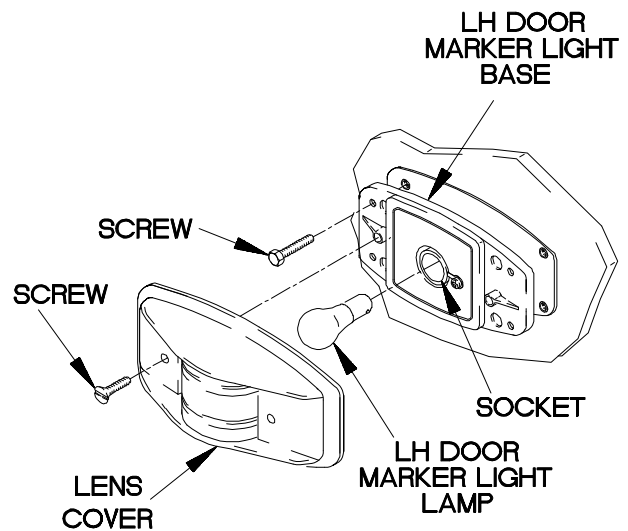

XBe4510B

e44. LH DOOR AND/OR LH FRONT MARKER LIGHTS DO NOT ILLUMINATE (CONT)

KNOWN INFO
Other marker lights illuminate. LH door marker light lamp OK. LH cab marker light illuminates.
POSSIBLE PROBLEMS
Faulty marker light. Faulty LH door and cab marker lights cable assembly.

12.
Is continuity present from terminal lug TL130 to terminal lug TL133?

TEST OPTIONS
Continuity Test or STE/ICE-R Test #91
REASON FOR QUESTION
If continuity is not present, wire 3098 is faulty. If continuity is present, LH door marker light is faulty.

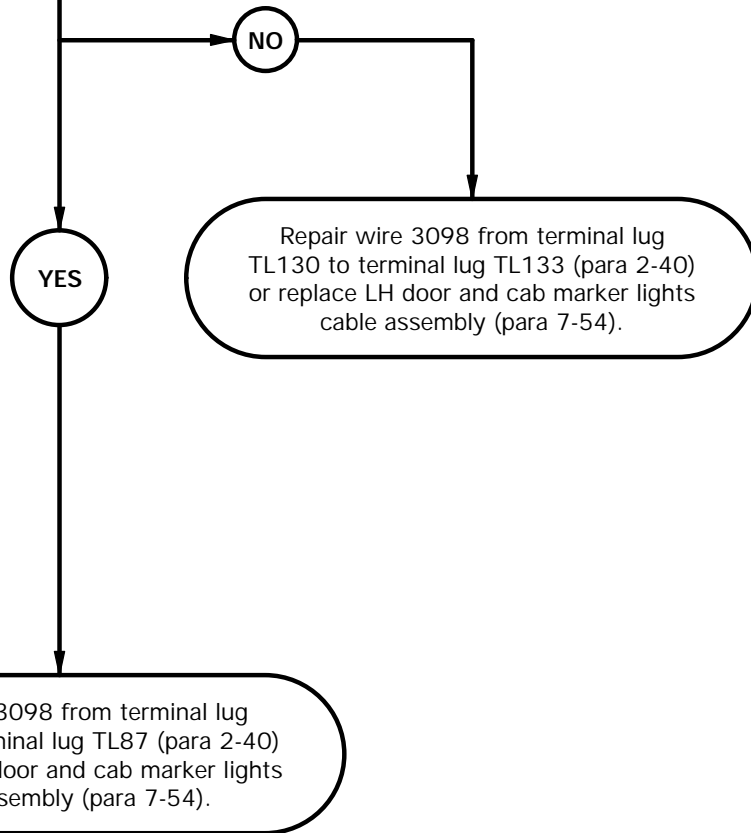

CONTINUITY TEST

- (1) Remove four screws from LH cab marker light base.

NOTE

Do not let wires slip through hole into cab structure. If wires slip into cab structure, vehicle will need further disassembly to retrieve wires.

- (2) Remove nut, lockwasher, terminal lug TL133, and lockwasher from LH cab marker light base. Discard lockwashers.
- (3) Extend base and disconnect connector P129 from marker light connector.
- (4) Remove gasket from LH cab marker light base. Discard gasket.
- (5) Set multimeter to ohms.
- (6) Connect positive (+) probe of multimeter to terminal lug TL130.
- (7) Connect negative (-) probe of multimeter to terminal lug TL133 and note reading on multimeter.
- (8) If continuity is not present, repair wire 3098 from terminal lug TL130 to terminal lug TL133 (para 2-40) or replace LH door and cab marker lights cable assembly (para 7-54).
- (9) If continuity is present, replace LH door marker light (para 7-31).
- (10) Install gasket on LH cab marker light base.
- (11) Connect marker light connector to connector P129.
- (12) Install lockwasher, terminal lug TL133, lockwasher, and nut on back of LH cab marker light base.
- (13) Install LH cab marker light base on vehicle with four screws.
- (14) Install LH cab marker light lamp in socket.
- (15) Install lens cover on base with two screws.
- (16) Install gasket on LH door marker light base.
- (17) Connect marker light connector to connector P130.
- (18) Install lockwasher, terminal lug TL130, lockwasher, and nut on back of LH door marker light base.
- (19) Install LH door marker light base on vehicle with four screws.
- (20) Install LH door marker light lamp in socket.
- (21) Install lens cover on base with two screws.

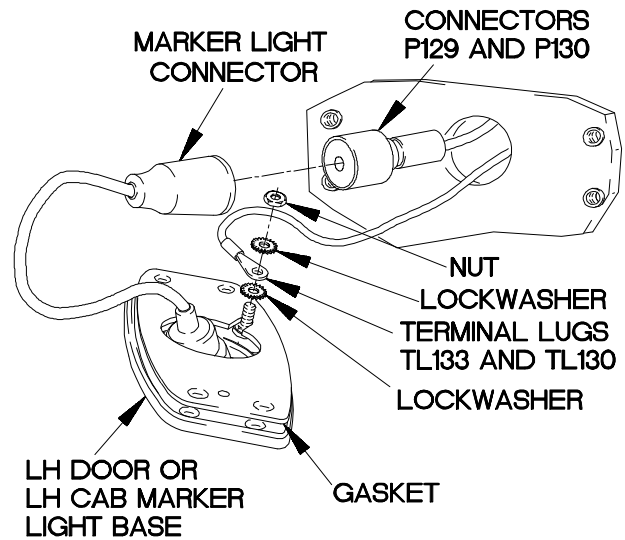
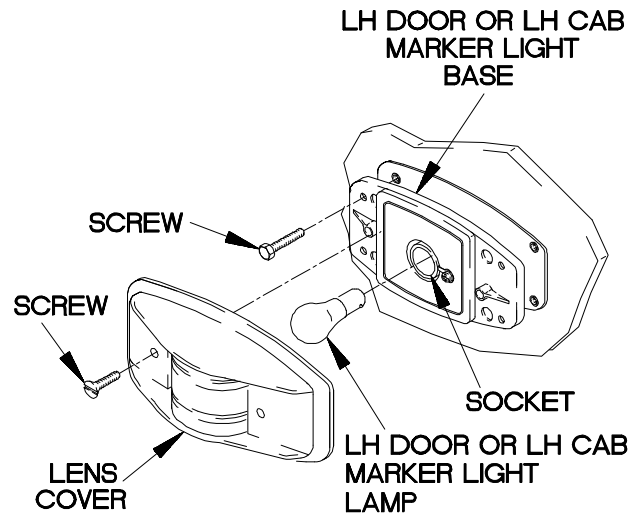

XBe4511B

e44. LH DOOR AND/OR LH FRONT MARKER LIGHTS DO NOT ILLUMINATE (CONT)

KNOWN INFO
Other marker lights illuminate. LH door marker light lamp OK. LH cab marker light illuminates.
POSSIBLE PROBLEMS
Faulty marker light. Faulty LH door and cab marker lights cable assembly.

13.

WARNING
CAUTION
Read **WARNING** and **CAUTION** on following page.

Is 12 VDC present at connector P130 socket?

TEST OPTIONS
Voltage Test or STE/ICE-R Test #89
REASON FOR QUESTION
If 12 VDC is not present, wire 1949 is faulty. If 12 VDC is present, LH door and cab marker light cable assembly is faulty.

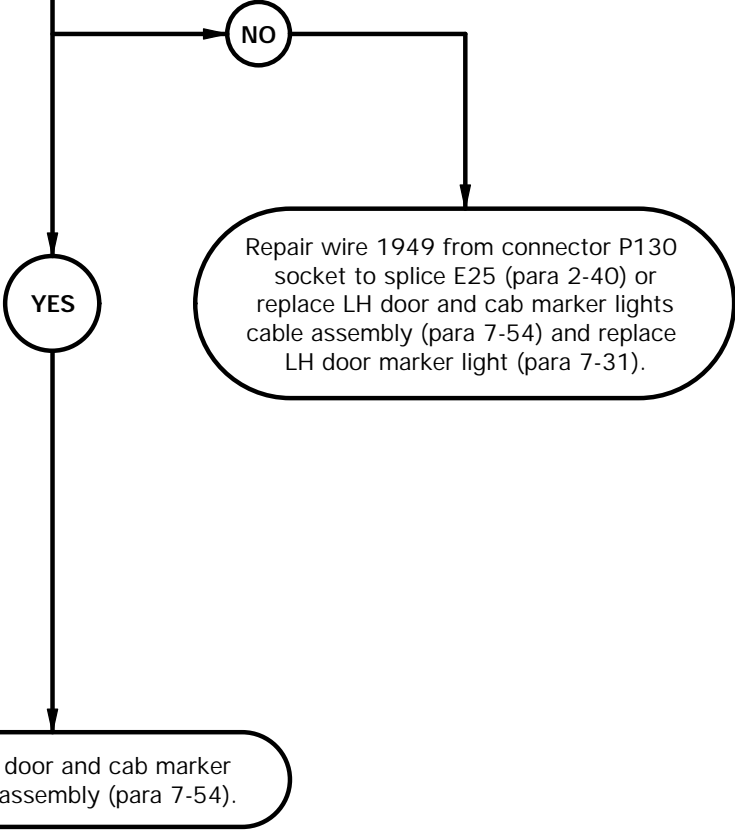

WARNING

Remove rings, bracelets, watches, necklaces, and any other jewelry before working around vehicle. Jewelry can catch on equipment and cause injury or short across electrical circuits and cause severe burns or electrical shock.

CAUTION

Use care when testing electrical connectors. Do not damage connector pins or sockets with multimeter probes. Failure to comply may result in damage to equipment.

NOTE

Inspect connector pins/sockets for damage, corrosion, and serviceability. Check that connector pins are not pushed back and are capable of making good contact.

VOLTAGE TEST

- (1) Set multimeter to volts DC.
- (2) Connect positive (+) probe of multimeter to connector P130 socket.
- (3) Connect negative (-) probe of multimeter to ground.
- (4) Position main light switch to SER DRIVE (TM 9-2320-365-10) and note reading on multimeter.
- (5) If 12 VDC is not present, repair wire 1949 from connector P130 socket to splice E25 (para 2-40) or replace LH door and cab marker lights cable assembly (para 7-54) and replace LH door marker light (para 7-31).
- (6) If 12 VDC is present, replace LH door and cab marker light cable assembly (para 7-54).
- (7) Position main light switch to OFF (TM 9-2320-365-10).
- (8) Install gasket on LH door marker light base.
- (9) Connect marker light connector to connector P130.
- (10) Install lockwasher, terminal lug TL130, lockwasher, and nut on back of LH door marker light base.
- (11) Install LH door marker light base on vehicle with four screws.
- (12) Install LH door marker light lamp in socket.
- (13) Install lens cover on base with two screws.

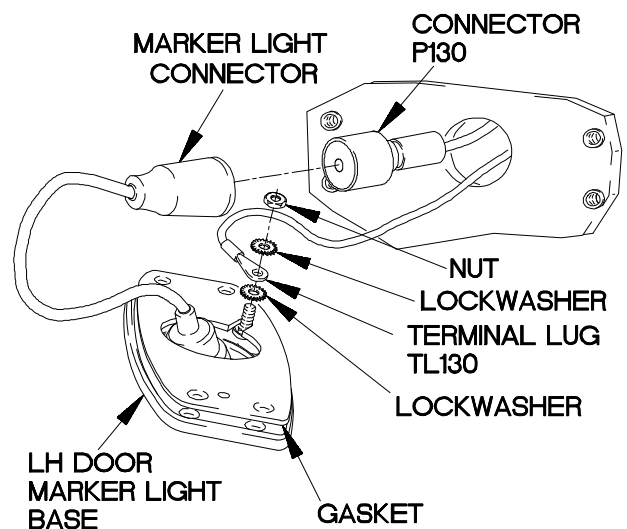
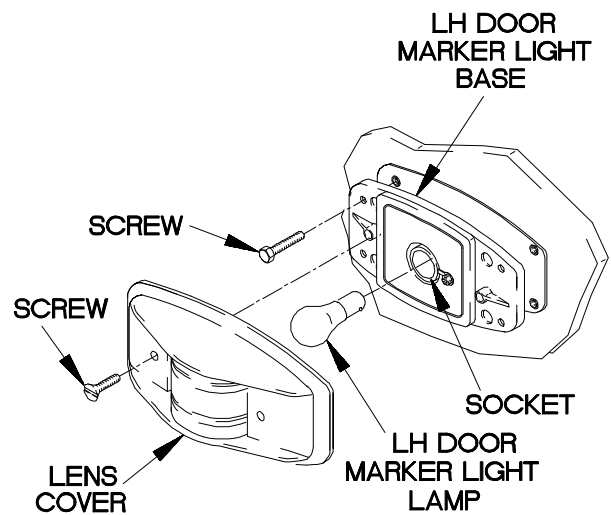

XBe4512B

e45. RH DOOR AND/OR RH FRONT MARKER LIGHTS DO NOT ILLUMINATE	
INITIAL SETUP	
<p>Equipment Conditions Engine shut down (TM 9-23230-365-10).</p> <p>Personnel Required (2)</p> <p>Materials/Parts Lockwasher (4) (Item 70, Appendix G) Gasket (2) (Item 23, Appendix G)</p>	<p>Tools and Special Tools Tool Kit, Genl Mech (Item 44, Appendix C) STE/ICR-R (Item 39, Appendix C) Multimeter, Digital (Item 22, Appendix C)</p> <p>References TM 9-4910-571-12&P</p>

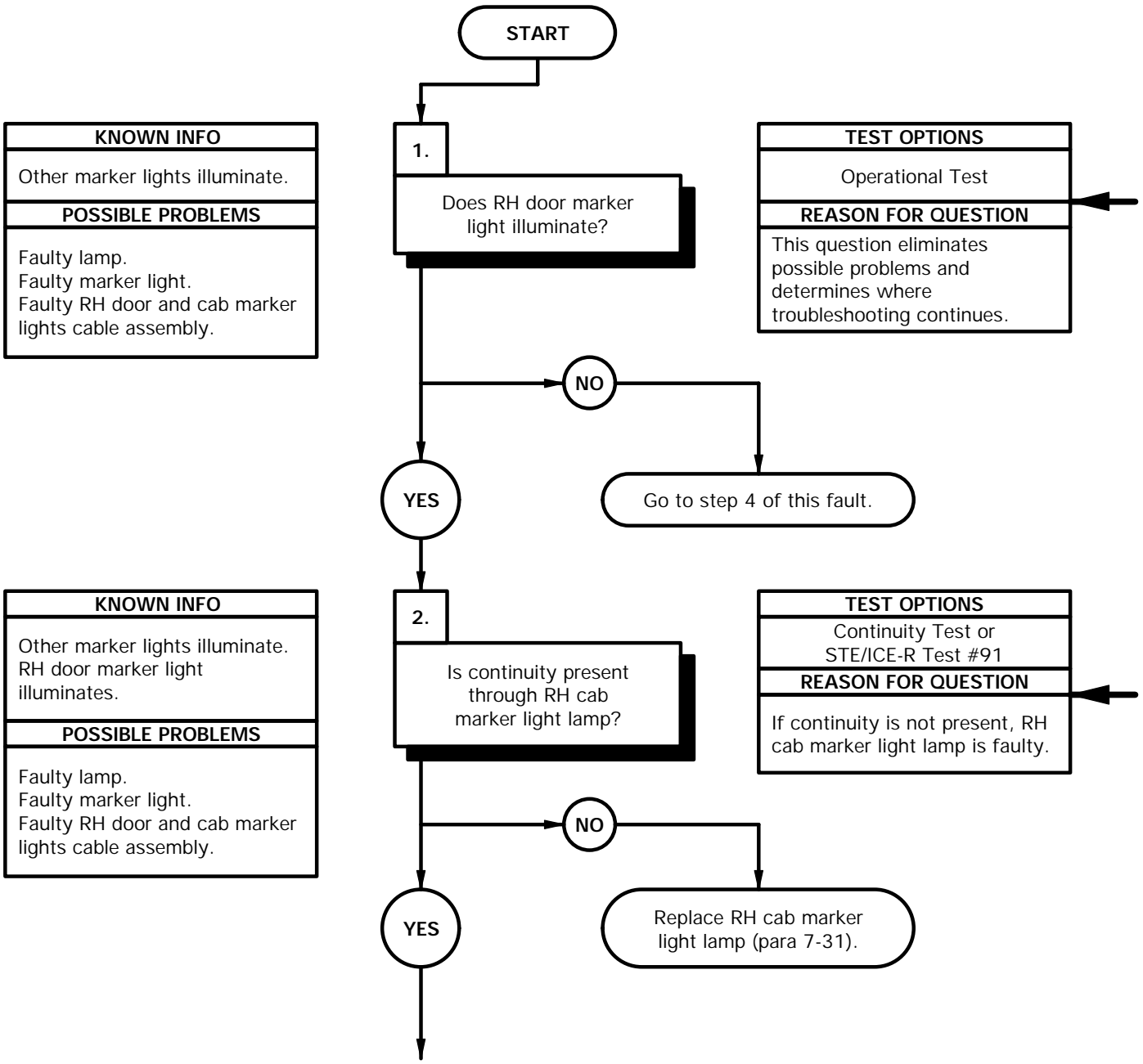

- (1) Position main light switch to SER DRIVE (TM 9-2320-365-10).
- (2) If RH door marker light lamp does not illuminate, go to step 4 of this fault.
- (3) Position main light switch to OFF (TM 9-2320-365-10).

CONTINUITY TEST

- (1) Remove two screws and lens cover from RH cab marker light base.
- (2) Remove RH cab marker light lamp from socket.
- (3) Set multimeter to ohms.
- (4) Check continuity through RH marker light lamp and note reading on multimeter.
- (5) If continuity is not present, replace RH cab marker light lamp (para 7-31).

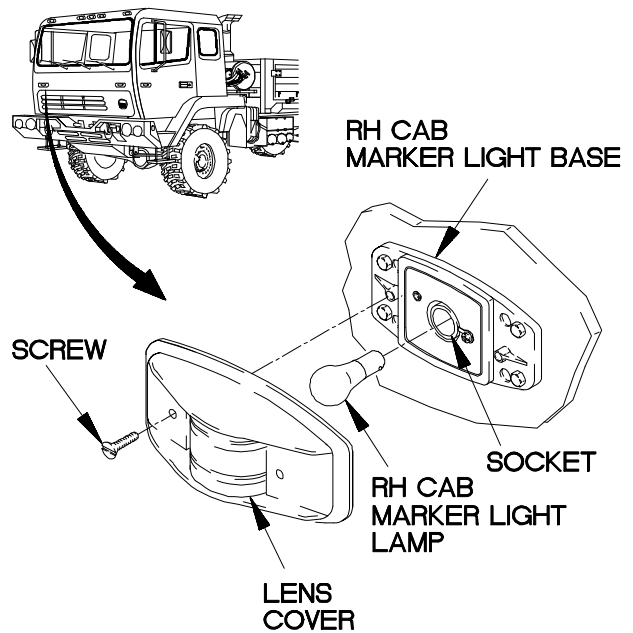

XBE4601B

e45. RH DOOR AND/OR RH FRONT MARKER LIGHTS DO NOT ILLUMINATE (CONT)

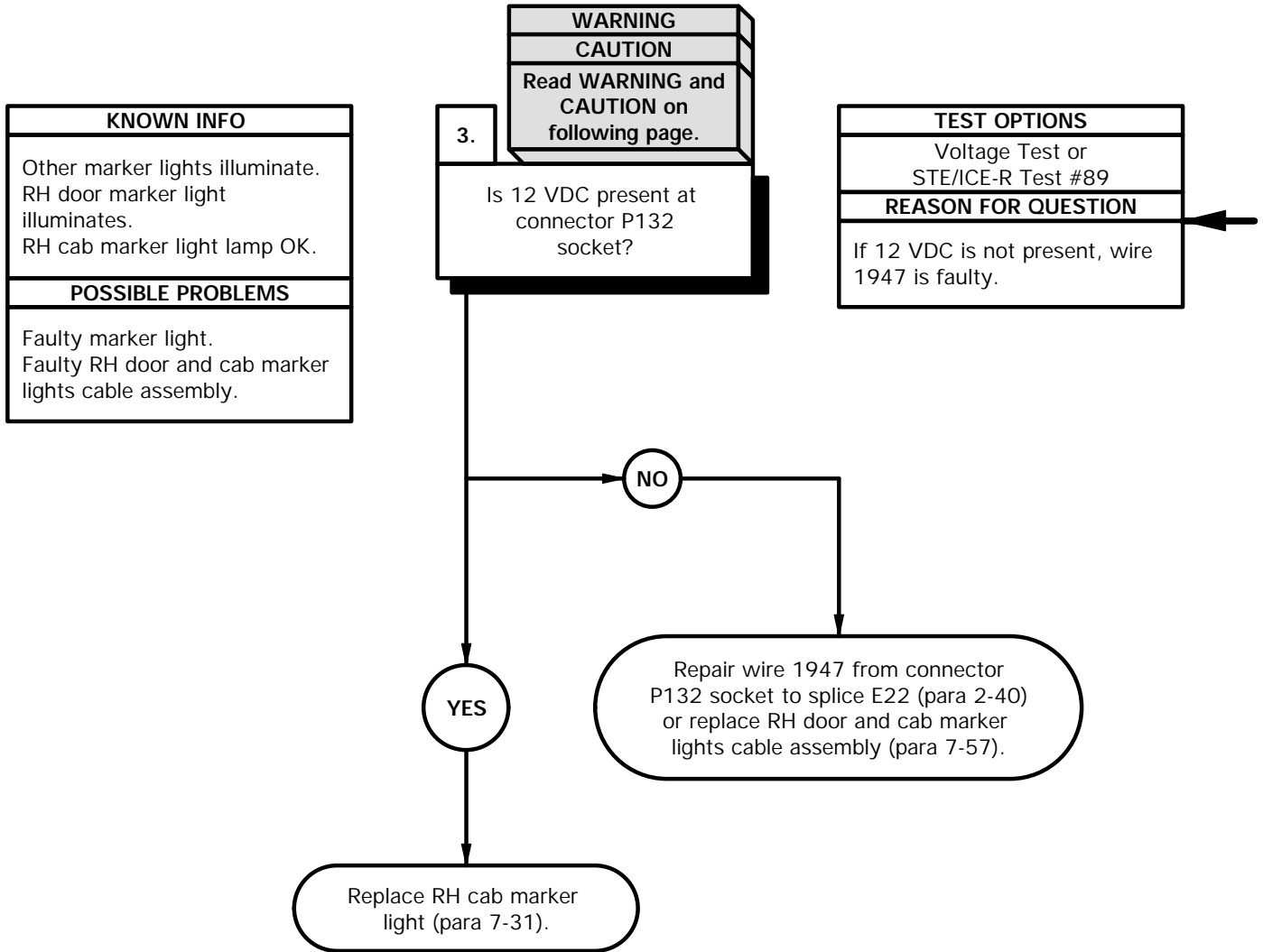

WARNING

Remove rings, bracelets, watches, necklaces, and any other jewelry before working around vehicle. Jewelry can catch on equipment and cause injury or short across electrical circuits and cause severe burns or electrical shock.

CAUTION

Use care when testing electrical connectors. Do not damage connector pins or sockets with multimeter probes. Failure to comply may result in damage to equipment.

NOTE

Inspect connector pins/sockets for damage, corrosion, and serviceability. Check that connector pins are not pushed back and are capable of making good contact.

VOLTAGE TEST

- (1) Remove four screws from RH cab marker light base.

NOTE

Do not let wires slip through hole into cab structure. If wires slip into cab structure, vehicle will need further disassembly to retrieve wires.

- (2) Remove nut, lockwasher, terminal lug TL134, and lockwasher from RH cab marker light base. Discard lockwashers.
- (3) Extend base and disconnect connector P132 from marker light connector.
- (4) Remove gasket from RH cab marker light base. Discard gasket.
- (5) Set multimeter to volts DC.
- (6) Connect positive (+) probe of multimeter to connector P132 socket.
- (7) Connect negative (-) probe of multimeter to ground.
- (8) Position main light switch to SER DRIVE (TM 9-2320-365-10) and note reading on multimeter.
- (9) If 12 VDC is not present, repair wire 1947 from connector P132 socket to splice E22 (para 2-40) or replace RH door and cab marker lights cable assembly (para 7-57).
- (10) If 12 VDC is present, replace RH cab marker light (para 7-31).
- (11) Position main light switch to OFF (TM 9-2320-365-10).
- (12) Install gasket on RH cab marker light base.
- (13) Connect marker light connector to connector P132.

VOLTAGE TEST (Cont)

- (14) Install lockwasher, terminal lug TL134, lockwasher, and nut on back of RH cab marker light base.
- (15) Install RH cab marker light base on vehicle with four screws.
- (16) Install RH cab marker light lamp in socket.
- (17) Install lens cover on base with two screws.

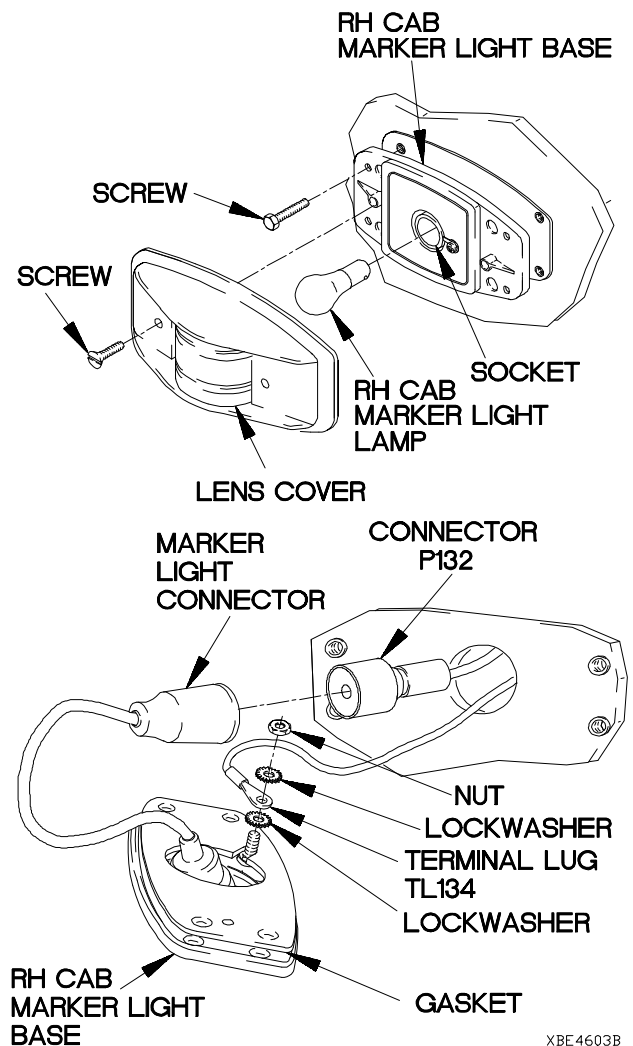

XBE4603B

e45. RH DOOR AND/OR RH FRONT MARKER LIGHTS DO NOT ILLUMINATE (CONT)

KNOWN INFO
Other marker lights illuminate.
POSSIBLE PROBLEMS
Faulty lamp. Faulty marker light. Faulty RH door and cab marker lights cable assembly.

TEST OPTIONS
Continuity Test or STE/ICE-R Test #91
REASON FOR QUESTION
If continuity is not present, RH door marker light lamp is faulty.

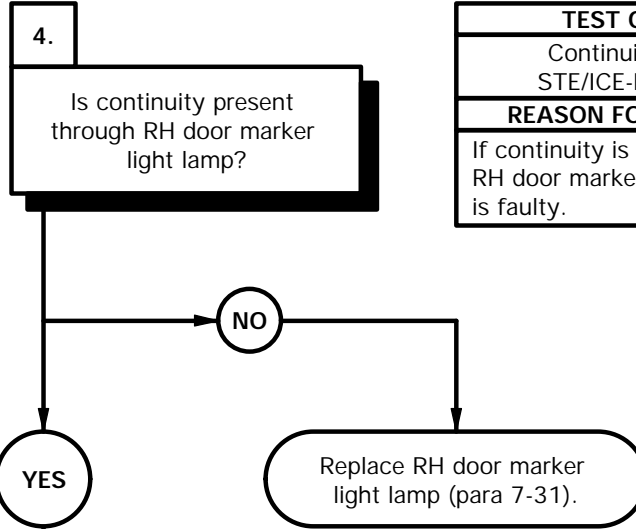

KNOWN INFO
Other marker lights illuminate. RH door marker light lamp OK.
POSSIBLE PROBLEMS
Faulty lamp. Faulty marker light. Faulty RH door and cab marker lights cable assembly.

TEST OPTIONS
Operational Test
REASON FOR QUESTION
This question eliminates possible problems and determines where troubleshooting continues.

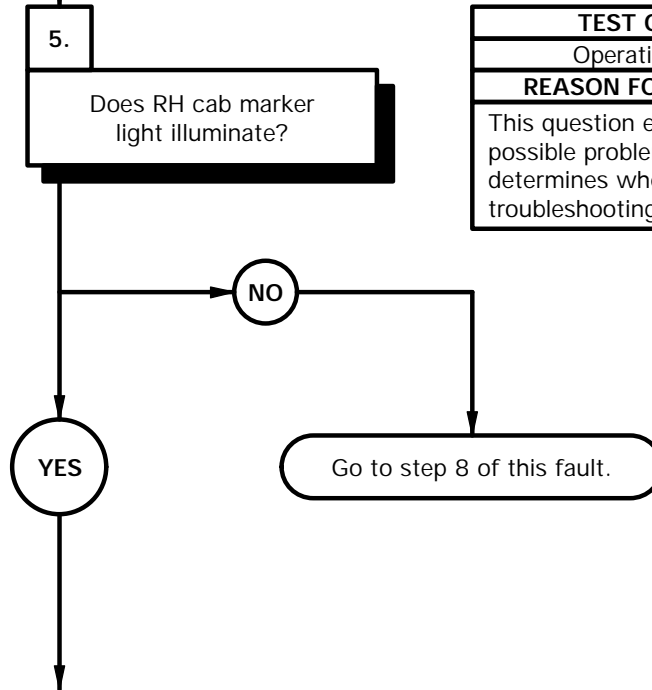

CONTINUITY TEST

- (1) Remove two screws and lens cover from RH door marker light base.
- (2) Remove RH door marker light lamp from socket.
- (3) Set multimeter to ohms.
- (4) Check continuity through RH door marker light lamp and note reading on multimeter.
- (5) If continuity is present, replace RH door marker light lamp (para 7-31).

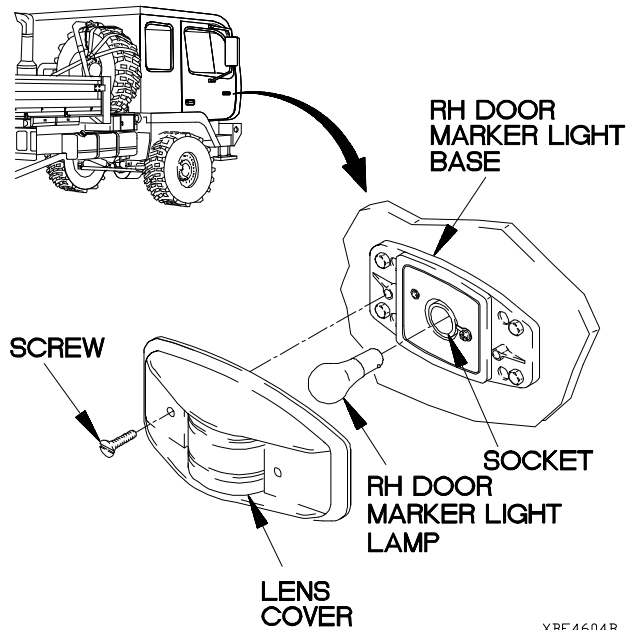

XBE4604B

- (1) Position main light switch to SER DRIVE (TM 9-2320-365-10).
- (2) If RH cab marker light lamp does not illuminate, go to step 8 of fault.
- (3) Position main light switch to OFF (TM 9-2320-365-10).

e45. RH DOOR AND/OR RH FRONT MARKER LIGHTS DO NOT ILLUMINATE (CONT)

KNOWN INFO
Other marker lights illuminate. RH door marker light illuminates. RH cab marker light lamp OK.
POSSIBLE PROBLEMS
Faulty marker light. Faulty RH door and cab marker lights cable assembly.

6.

WARNING

CAUTION

Read **WARNING** and **CAUTION** on following page.

Is 12 VDC present at connector P131 socket?

TEST OPTIONS
Voltage Test or STE/ICE-R Test #89
REASON FOR QUESTION
If 12 VDC is not present, wire 1947 is faulty.

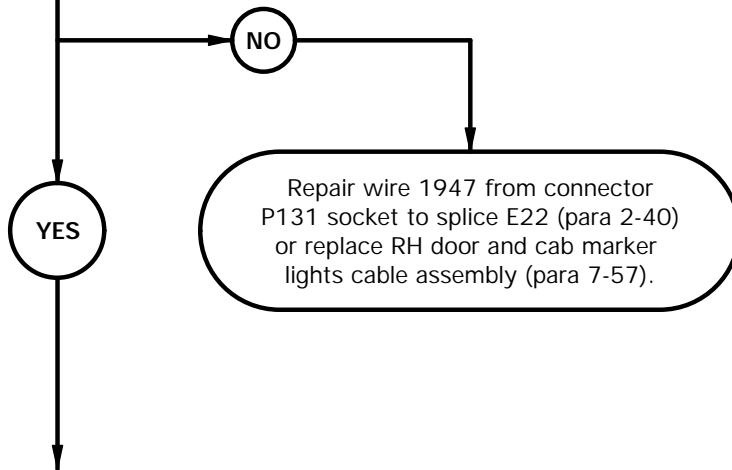

WARNING

Remove rings, bracelets, watches, necklaces, and any other jewelry before working around vehicle. Jewelry can catch on equipment and cause injury or short across electrical circuits and cause severe burns or electrical shock.

CAUTION

Use care when testing electrical connectors. Do not damage connector pins or sockets with multimeter probes. Failure to comply may result in damage to equipment.

NOTE

Inspect connector pins/sockets for damage, corrosion, and serviceability. Check that connector pins are not pushed back and are capable of making good contact.

VOLTAGE TEST

- (1) Remove four screws from RH door marker light base.

NOTE

Do not let wires slip through hole into cab structure. If wires slip into cab structure, vehicle will need further disassembly to retrieve wires.

- (2) Remove nut, lockwasher, terminal lug TL131, and lockwasher from RH door marker light base. Discard lockwashers.
- (3) Extend base and disconnect connector P131 from marker light connector.
- (4) Remove gasket from RH door marker light base. Discard gasket.
- (5) Set multimeter to volts DC.
- (6) Connect positive (+) probe of multimeter to connector P131 socket.
- (7) Connect negative (-) probe of multimeter to ground.
- (8) Position main light switch to SER DRIVE (TM 9-2320-365-10) and note reading on multimeter.
- (9) If 12 VDC is not present, repair wire 1947 from connector P131 socket to splice E22 (para 2-40) or replace RH door and cab marker lights cable assembly (para 7-57).
- (10) Position main light switch to OFF (TM 9-2320-365-10).

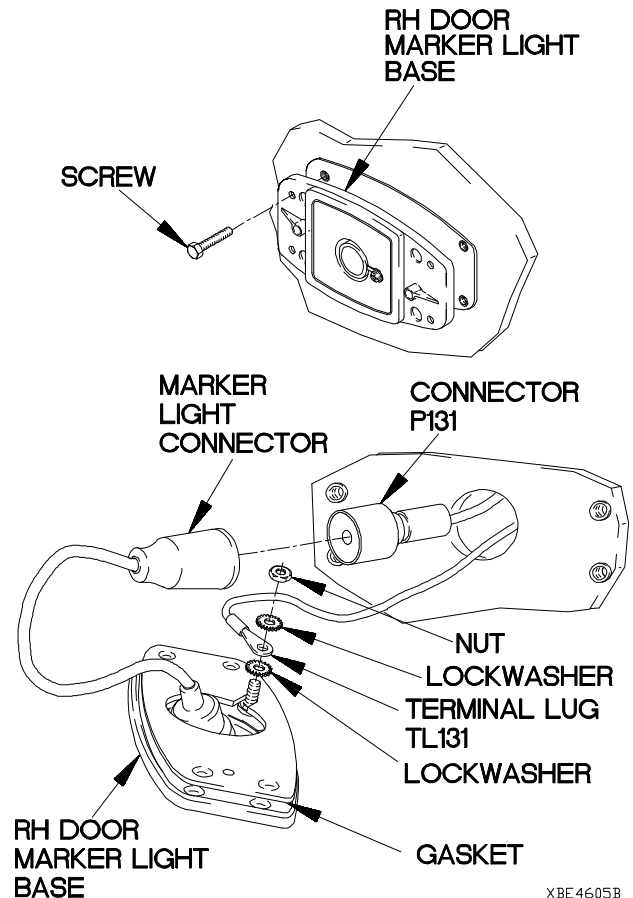

XBE4605B

e45. RH DOOR AND/OR RH FRONT MARKER LIGHTS DO NOT ILLUMINATE (CONT)

KNOWN INFO
Other marker lights illuminate. RH door marker light lamp OK. RH cab marker light illuminates.
POSSIBLE PROBLEMS
Faulty marker light. Faulty RH door and cab marker lights cable assembly.

7.
Is continuity present from terminal lug TL134 to terminal lug TL131?

TEST OPTIONS
Continuity Test or STE/ICE-R Test #91
REASON FOR QUESTION
If continuity is not present, wire 3096 is faulty. If continuity is present, RH door marker light is faulty.

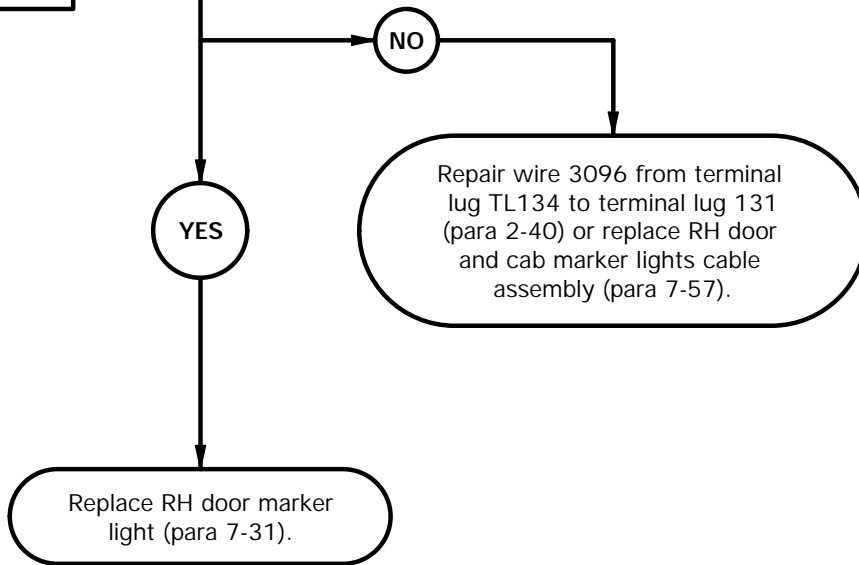

CONTINUITY TEST

- (1) Remove two screws and lens cover from RH cab marker light base.
- (2) Remove RH cab marker light lamp from socket.
- (3) Remove four screws from RH cab marker light base.

NOTE

Do not let wires slip through hole into cab structure. If wires slip into cab structure, vehicle will need further disassembly to retrieve wires.

- (4) Remove nut, lockwasher, terminal lug TL134, and lockwasher from RH cab marker light base. Discard lockwashers.
- (5) Extend base and disconnect connector P132 from marker light connector.
- (6) Remove gasket from RH cab marker light base. Discard gasket.
- (7) Set multimeter to ohms.
- (8) Connect positive (+) probe of multimeter to terminal lug TL131.
- (9) Connect negative (-) probe of multimeter to terminal lug TL134 and note reading on multimeter.
- (10) If continuity is not present, repair wire 3096 from terminal lug TL131 to terminal lug TL134 (para 2-40) or replace RH door and cab marker lights cable assembly (para 7-57).
- (11) If continuity is present, replace RH door marker light (para 7-31).
- (12) Install gasket on RH cab marker light base.
- (13) Connect marker light connector to connector P132.
- (14) Install lockwasher, terminal lug TL134, lockwasher, and nut on back of RH cab marker light base.
- (15) Install RH cab marker light base on vehicle with four screws.
- (16) Install RH cab marker light lamp in socket.
- (17) Install lens cover on base with two screws.
- (18) Install gasket on RH cab marker light base.
- (19) Connect marker light connector to connector P131.
- (20) Install lockwasher, terminal lug TL131, lockwasher, and nut on back of base.
- (21) Install RH door marker light base on vehicle with four screws.
- (22) Install RH door marker light lamp in socket.
- (23) Install lens cover on base with two screws.

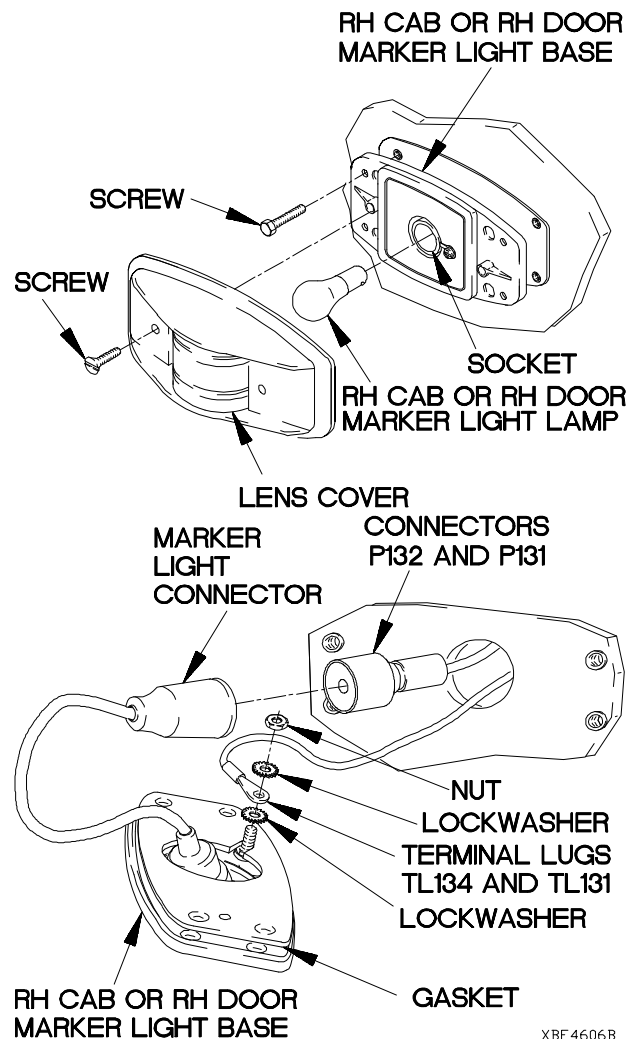

XBE4606B

e45. RH DOOR AND/OR RH FRONT MARKER LIGHTS DO NOT ILLUMINATE (CONT)

KNOWN INFO
Other marker lights illuminate. RH door marker light lamp OK.
POSSIBLE PROBLEMS
Faulty lamp. Faulty marker light. Faulty RH door and cab marker lights cable assembly.

TEST OPTIONS
Continuity Test or STE/ICE-R Test #91
REASON FOR QUESTION
If continuity is not present, RH cab marker light lamp is faulty.

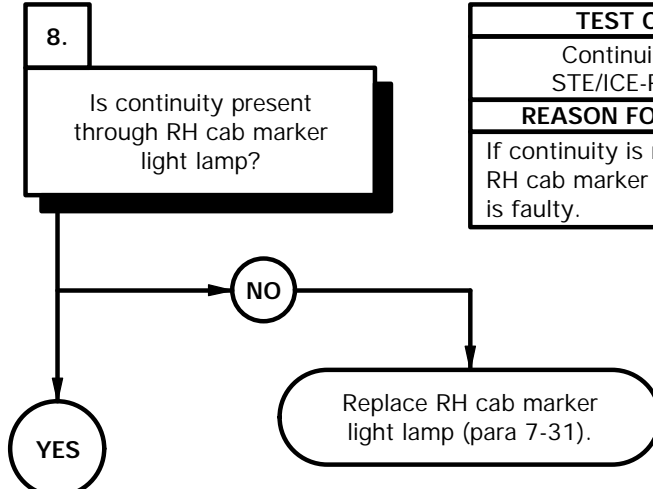

KNOWN INFO
Other marker lights illuminate. RH door marker light lamp OK. RH cab marker light lamp OK.
POSSIBLE PROBLEMS
Faulty marker light. Faulty RH door and cab marker lights cable assembly.

TEST OPTIONS
Continuity Test or STE/ICE-R Test #91
REASON FOR QUESTION
This question eliminates possible problems and determines where troubleshooting continues.

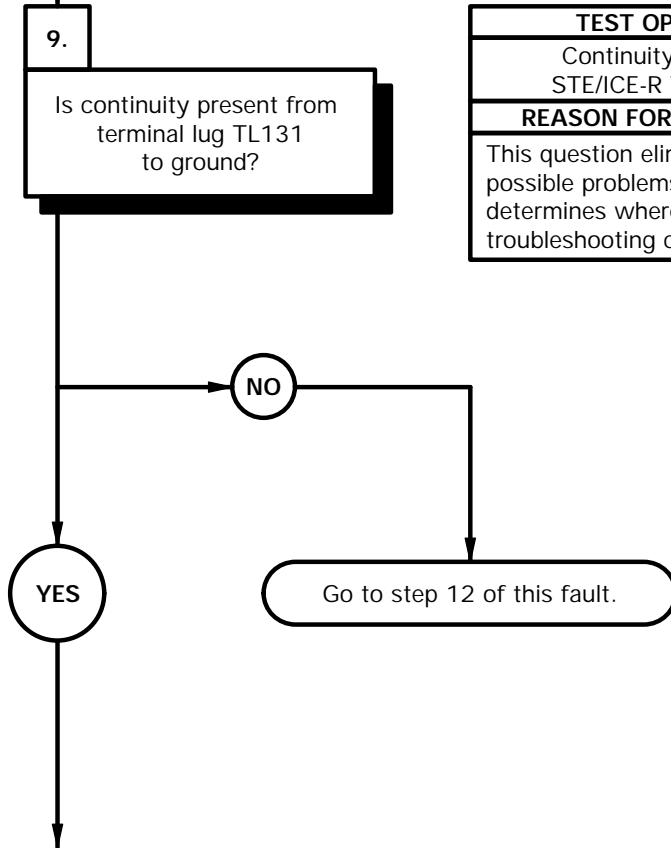

CONTINUITY TEST

- (1) Remove two screws and lens cover from RH cab marker light base.
- (2) Remove RH cab marker light lamp from socket.
- (3) Set multimeter to ohms.
- (4) Check continuity through RH cab marker light lamp and note reading on multimeter.
- (5) If continuity is not present, replace RH cab marker light lamp (para 7-31).

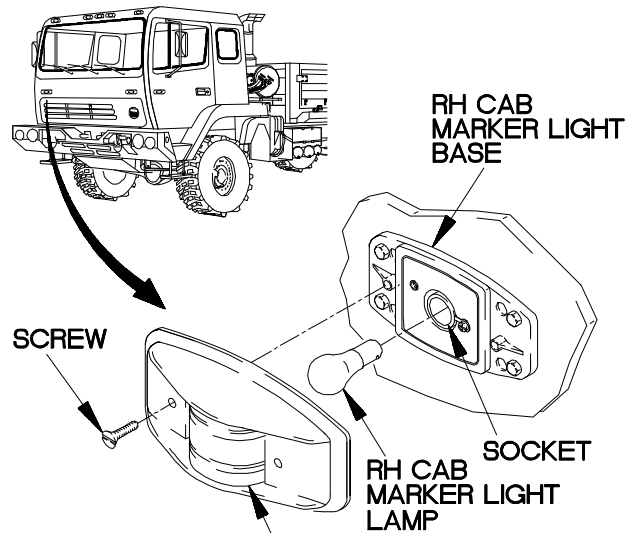

CONTINUITY TEST

- (1) Remove two screws and lens cover from RH door marker light base.
- (2) Remove RH door marker light lamp from socket.
- (3) Remove four screws from RH door marker light.

NOTE

Do not let wires slip through hole into cab structure. If wires slip into cab structure, vehicle will need further disassembly to retrieve wires.

- (4) Remove nut, lockwasher, terminal lug TL131, and lockwasher from RH door marker light base. Discard lockwashers.
- (5) Extend base and disconnect connector P131 from marker light connector.
- (6) Remove gasket from RH door marker light base. Discard gasket.
- (7) Set multimeter to ohms.
- (8) Connect positive (+) probe of multimeter to terminal lug TL131.
- (9) Connect negative (-) probe of multimeter to ground and note reading on multimeter.
- (10) If continuity is not present from terminal lug TL131 to ground, go to step 12 of this fault.

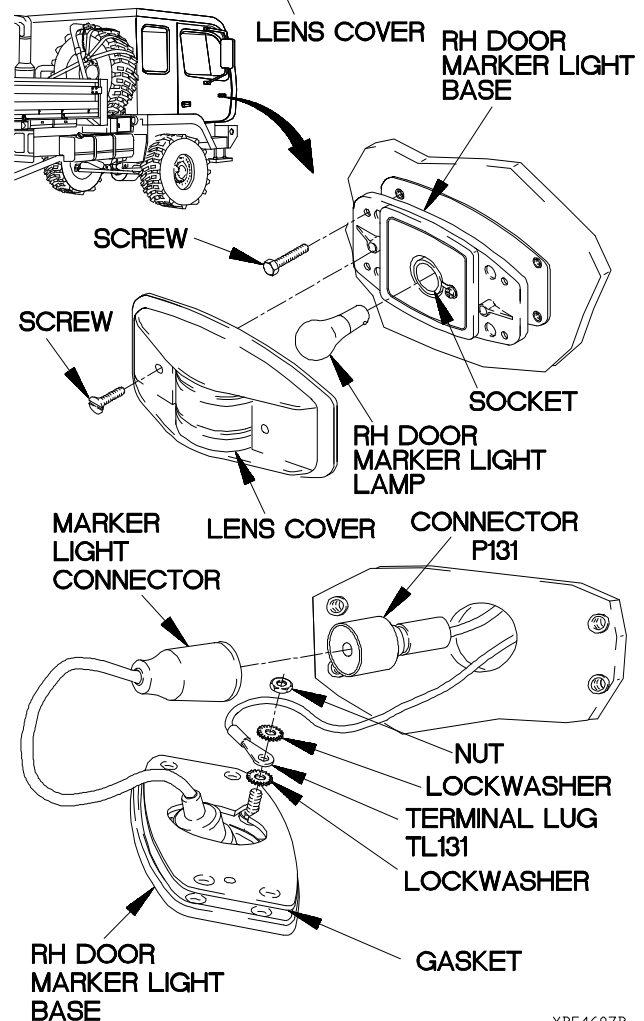

XBE4607B

e45. RH DOOR AND/OR RH FRONT MARKER LIGHTS DO NOT ILLUMINATE (CONT)

KNOWN INFO
Other marker lights illuminate. RH door marker light illuminates. RH cab marker light lamp OK.
POSSIBLE PROBLEMS
Faulty marker light. Faulty RH door and cab marker lights cable assembly.

WARNING

CAUTION

Read **WARNING** and **CAUTION** on following page.

10. Is 12 VDC present at connector P132 socket?

TEST OPTIONS
Voltage Test or STE/ICE-R Test #89
REASON FOR QUESTION
This question eliminates possible problems and determines where troubleshooting continues.

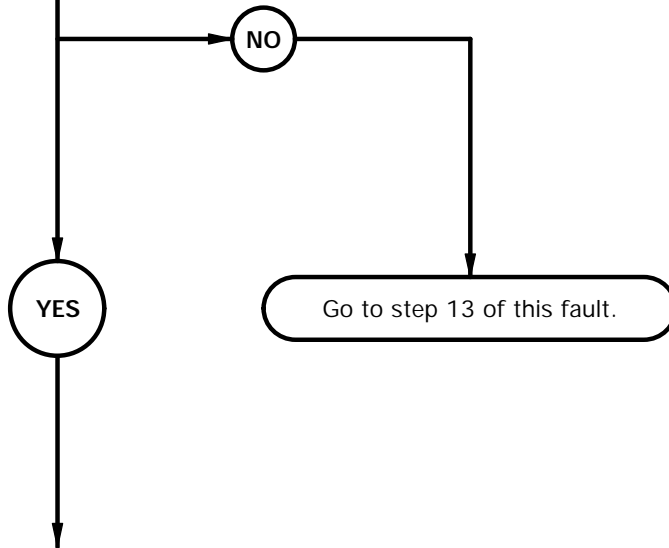

WARNING

Remove rings, bracelets, watches, necklaces, and any other jewelry before working around vehicle. Jewelry can catch on equipment and cause injury or short across electrical circuits and cause severe burns or electrical shock.

CAUTION

Use care when testing electrical connectors. Do not damage connector pins or sockets with multimeter probes. Failure to comply may result in damage to equipment.

NOTE

Inspect connector pins/sockets for damage, corrosion, and serviceability. Check that connector pins are not pushed back and are capable of making good contact.

VOLTAGE TEST (Cont)

- (14) Install RH cab marker light base on vehicle with four screws.
- (15) Install RH cab marker light lamp in socket.
- (16) Install lens cover on base with two screws.

VOLTAGE TEST

- (1) Remove four screws from RH cab marker light base.

NOTE

Do not let wires slip through hole into cab structure. If wires slip into cab structure, vehicle will need further disassembly to retrieve wires.

- (2) Remove nut, lockwasher, terminal lug TL134, and lockwasher from RH cab marker light base. Discard lockwashers.
- (3) Extend base and disconnect connector P132 from marker light connector.
- (4) Remove gasket from RH cab marker light base. Discard gasket.
- (5) Set multimeter to volts DC.
- (6) Connect positive (+) probe of multimeter to connector P132 socket.
- (7) Connect negative (-) probe of multimeter to ground.
- (8) Position main light switch to SER DRIVE (TM 9-2320-365-10) and note reading on multimeter.
- (9) If 12 VDC is not present, go to step 13 of this fault.
- (10) Position main light switch to OFF (TM 9-2320-365-10).
- (11) Install gasket on RH cab marker light base.
- (12) Connect marker light connector to connector P132.
- (13) Install lockwasher, terminal lug TL134, lockwasher, and nut on back of RH cab marker light base.

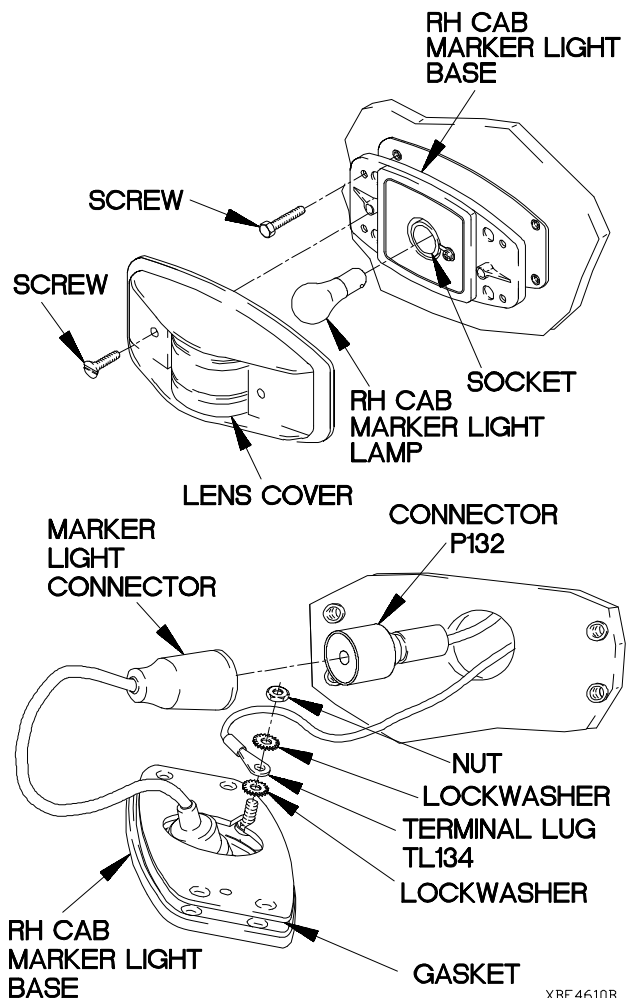

XBE4610B

e45. RH DOOR AND/OR RH FRONT MARKER LIGHTS DO NOT ILLUMINATE (CONT)

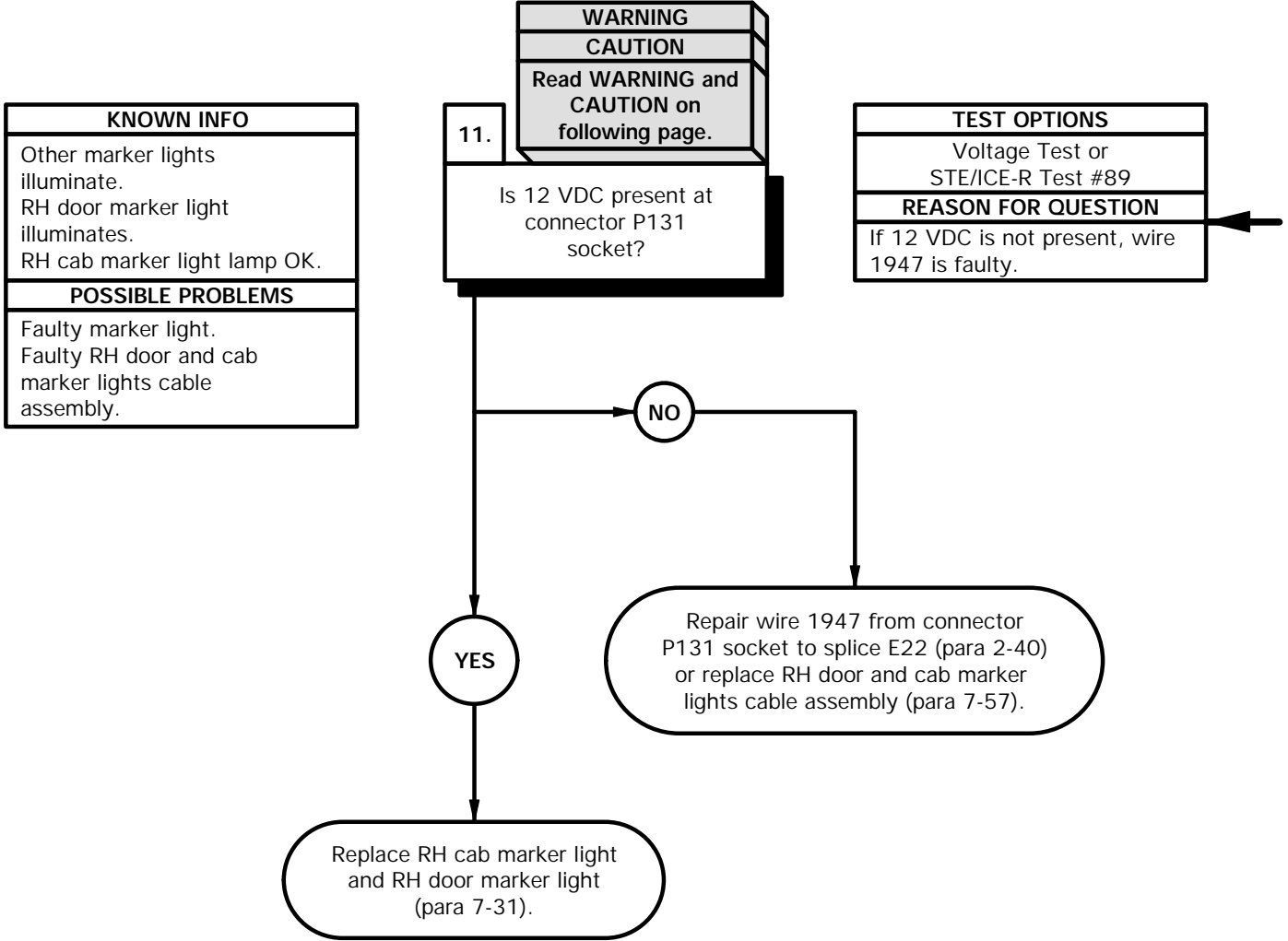

WARNING

Remove rings, bracelets, watches, necklaces, and any other jewelry before working around vehicle. Jewelry can catch on equipment and cause injury or short across electrical circuits and cause severe burns or electrical shock.

CAUTION

Use care when testing electrical connectors. Do not damage connector pins or sockets with multimeter probes. Failure to comply may result in damage to equipment.

NOTE

Inspect connector pins/sockets for damage, corrosion, and serviceability. Check that connector pins are not pushed back and are capable of making good contact.

VOLTAGE TEST

- (1) Set multimeter to volts DC.
- (2) Connect positive (+) probe of multimeter to connector P132 socket.
- (3) Connect negative (-) probe of multimeter to ground.
- (4) Position main light switch to SER DRIVE (TM 9-2320-365-10) and note reading on multimeter.
- (5) If 12 VDC is not present, repair wire 1947 from connector P132 socket to splice E22 (para 2-40) or replace RH door and cab marker lights cable assembly (para 7-57).
- (6) If 12 VDC is present, replace RH cab marker light and RH door marker light (para 7-31).
- (7) Position main light switch to OFF (TM 9-2320-365-10).
- (8) Install gasket on RH door marker light base.
- (9) Connect marker light connector to connector P132.
- (10) Install lockwasher, terminal lug TL134, lockwasher, and nut on back of RH door marker light base.
- (11) Install RH door marker light base on vehicle with four screws.
- (12) Install RH door marker light lamp in socket.
- (13) Install lens cover on base with two screws.

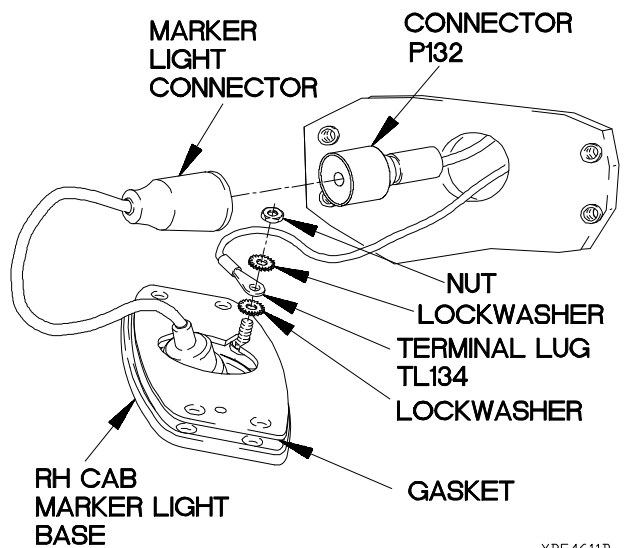
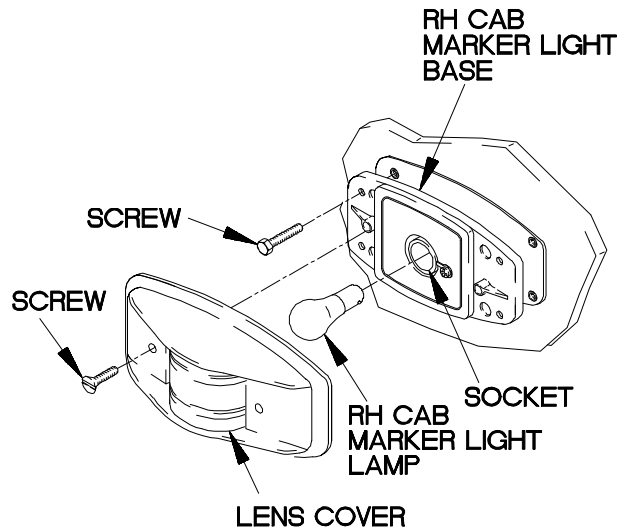

XBE4611B

e45. RH DOOR AND/OR RH FRONT MARKER LIGHTS DO NOT ILLUMINATE (CONT)

KNOWN INFO
Other marker lights illuminate. RH door marker light lamp OK. RH cab marker light illuminates.
POSSIBLE PROBLEMS
Faulty marker light. Faulty RH door and cab marker lights cable assembly.

12.
Is continuity present from terminal lug TL134 to terminal lug TL131?

TEST OPTIONS
Continuity Test or STE/ICE-R Test #91
REASON FOR QUESTION
If continuity is not present, wire 3096 is faulty. If continuity is present, RH door marker light is faulty.

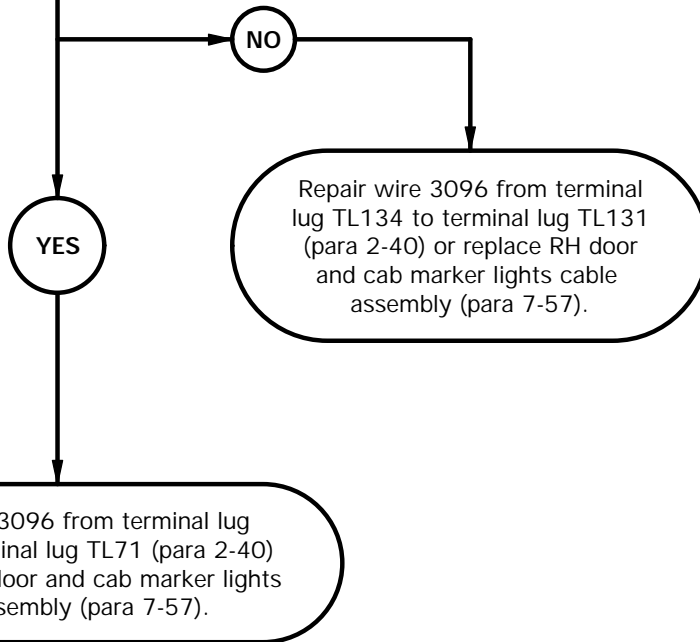

CONTINUITY TEST

- (1) Remove four screws from RH cab marker light base.

NOTE

Do not let wires slip through hole into cab structure. If wires slip into cab structure, vehicle will need further disassembly to retrieve wires.

- (2) Remove nut, lockwasher, terminal lug TL134, and lockwasher from RH cab marker light base. Discard lockwashers.
- (3) Extend base and disconnect connector P132 from marker light connector.
- (4) Remove gasket from RH cab marker light base. Discard gasket.
- (5) Set multimeter to ohms.
- (6) Connect positive (+) probe of multimeter to terminal lug TL131.
- (7) Connect negative (-) probe of multimeter to terminal lug TL134 and note reading on multimeter.
- (8) If continuity is not present, repair wire 3096 from terminal lug TL134 to terminal lug TL131 (para 2-40) or replace RH door and cab marker lights cable assembly (para 7-57).
- (9) If continuity is present, replace RH door marker light (para 7-31).
- (10) Install gasket on RH cab marker light base.
- (11) Connect marker light connector to connector P132.
- (12) Install lockwasher, terminal lug TL134, lockwasher, and nut on back of RH cab marker light base.
- (13) Install RH cab marker light base on vehicle with four screws.
- (14) Install RH cab marker light lamp in socket.
- (15) Install lens cover on base with two screws.
- (16) Install gasket on RH door marker light base.
- (17) Connect marker light connector to connector P131.
- (18) Install lockwasher, terminal lug TL131, lockwasher, and nut on back of RH door marker light base.
- (19) Install RH door marker light base on vehicle with four screws.
- (20) Install RH door marker light lamp in socket.
- (21) Install lens cover on base with two screws.

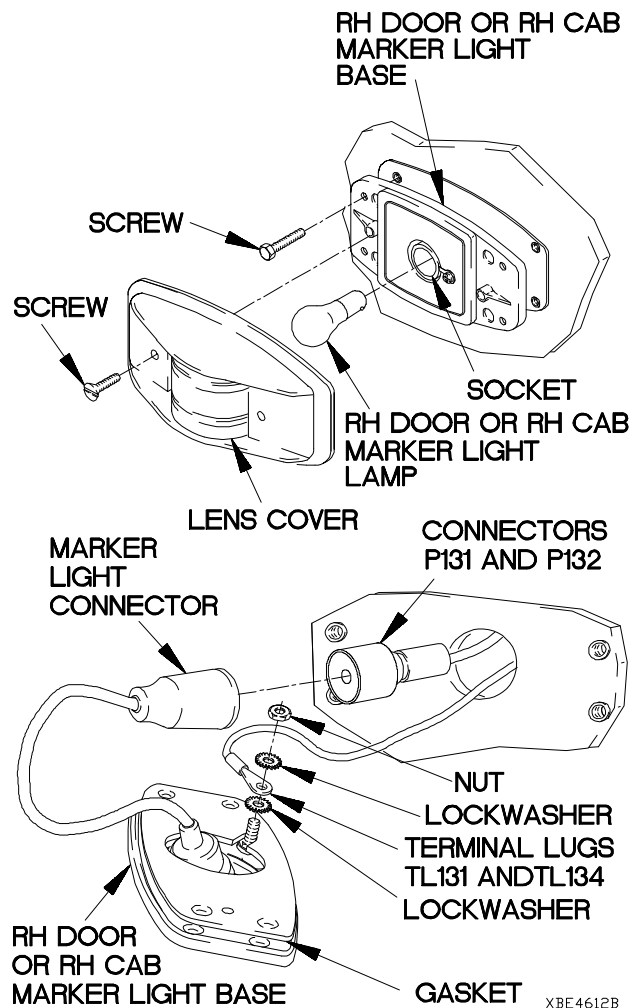

e45. RH DOOR AND/OR RH FRONT MARKER LIGHTS DO NOT ILLUMINATE (CONT)

KNOWN INFO
Other marker lights illuminate. RH door marker light lamp OK. RH cab marker light illuminates.
POSSIBLE PROBLEMS
Faulty marker light. Faulty RH door and cab marker lights cable assembly.

13.

WARNING

CAUTION

Read **WARNING** and **CAUTION** on following page.

Is 12 VDC present at connector P131 socket?

TEST OPTIONS
Voltage Test or STE/ICE-R Test #89
REASON FOR QUESTION
If 12 VDC is not present, wire 1947 is faulty. If 12 VDC is present, RH door and cab marker light cable assembly is faulty.

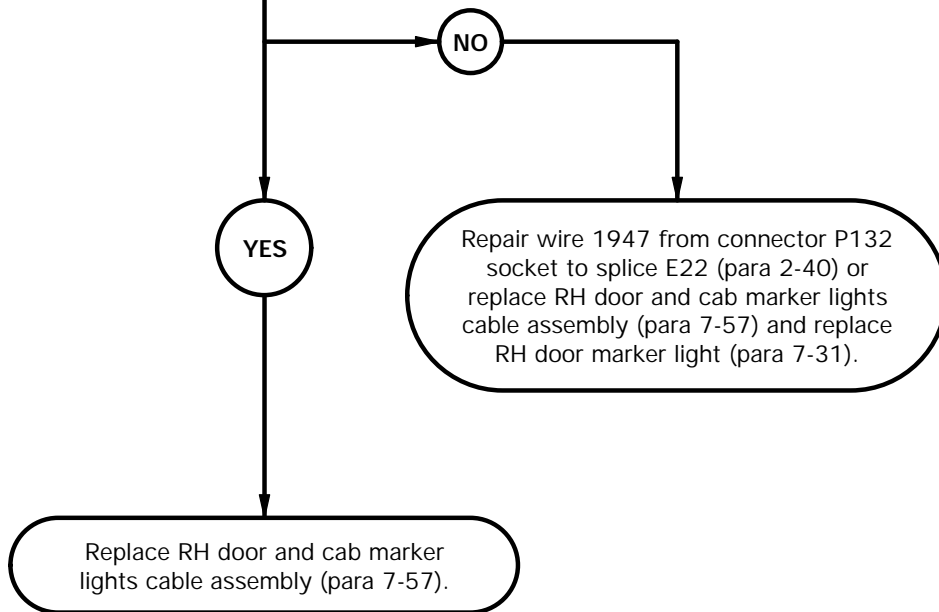

WARNING

Remove rings, bracelets, watches, necklaces, and any other jewelry before working around vehicle. Jewelry can catch on equipment and cause injury or short across electrical circuits and cause severe burns or electrical shock.

CAUTION

Use care when testing electrical connectors. Do not damage connector pins or sockets with multimeter probes. Failure to comply may result in damage to equipment.

NOTE

Inspect connector pins/sockets for damage, corrosion, and serviceability. Check that connector pins are not pushed back and are capable of making good contact.

VOLTAGE TEST

- (1) Set multimeter to volts DC.
- (2) Connect positive (+) probe of multimeter to connector P131 socket.
- (3) Connect negative (-) probe of multimeter to ground.
- (4) Position main light switch to SER DRIVE (TM 9-2320-365-10) and note reading on multimeter.
- (5) If 12 VDC is not present, repair wire 1947 from connector P131 socket to splice E22 (para 2-40) or replace RH door and cab marker lights cable assembly (para 7-57).
- (6) If 12 VDC is present, replace RH door and cab marker light cable assembly (para 7-57).
- (7) Position main light switch to OFF (TM 9-2320-365-10).
- (8) Install gasket on RH door marker light base.
- (9) Connect marker light connector to connector P131.
- (10) Install lockwasher, terminal lug TL131, lockwasher, and nut on back of RH door marker light base.
- (11) Install RH door marker light base on vehicle with four screws.
- (12) Install RH door marker light lamp in socket.
- (13) Install lens cover on base with two screws.

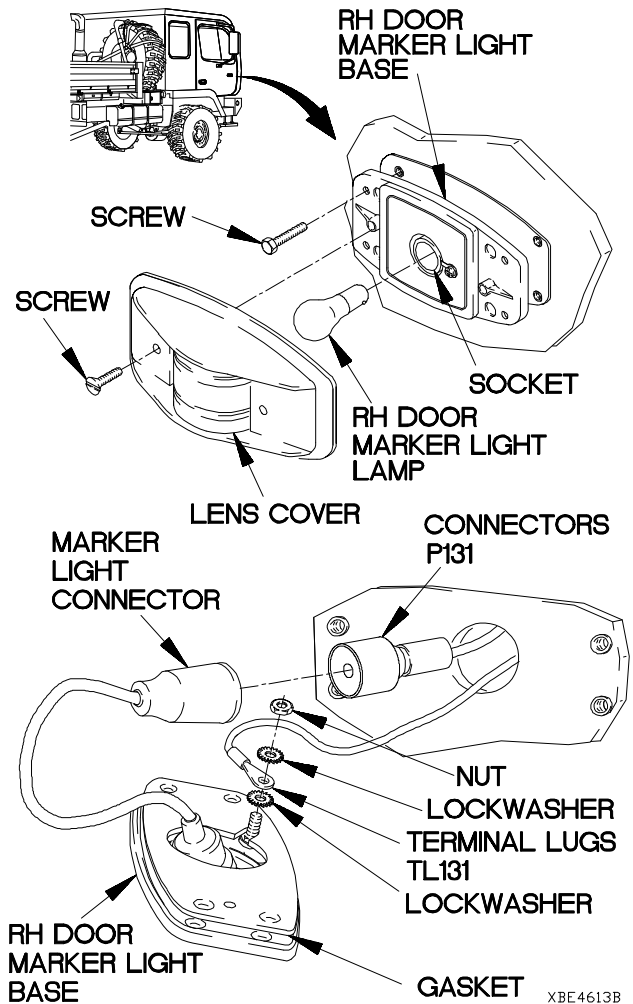

e46. ONE OR MORE CAB TOP MARKER LIGHTS DO NOT ILLUMINATE	
INITIAL SETUP	
Equipment Conditions Engine shut down (TM 9-23230-365-10).	Tools and Special Tools Tool Kit, Genl Mech (Item 44, Appendix C) STE/ICR-R (Item 39, Appendix C) Multimeter, Digital (Item 22, Appendix C)
Personnel Required (2)	References TM 9-4910-571-12&P
Materials/Parts Lockwasher (4) (Item 71, Appendix G) Gasket (2) (Item 28, Appendix G) Wire, Elec, 50 ft (Item 77, Appendix D)	

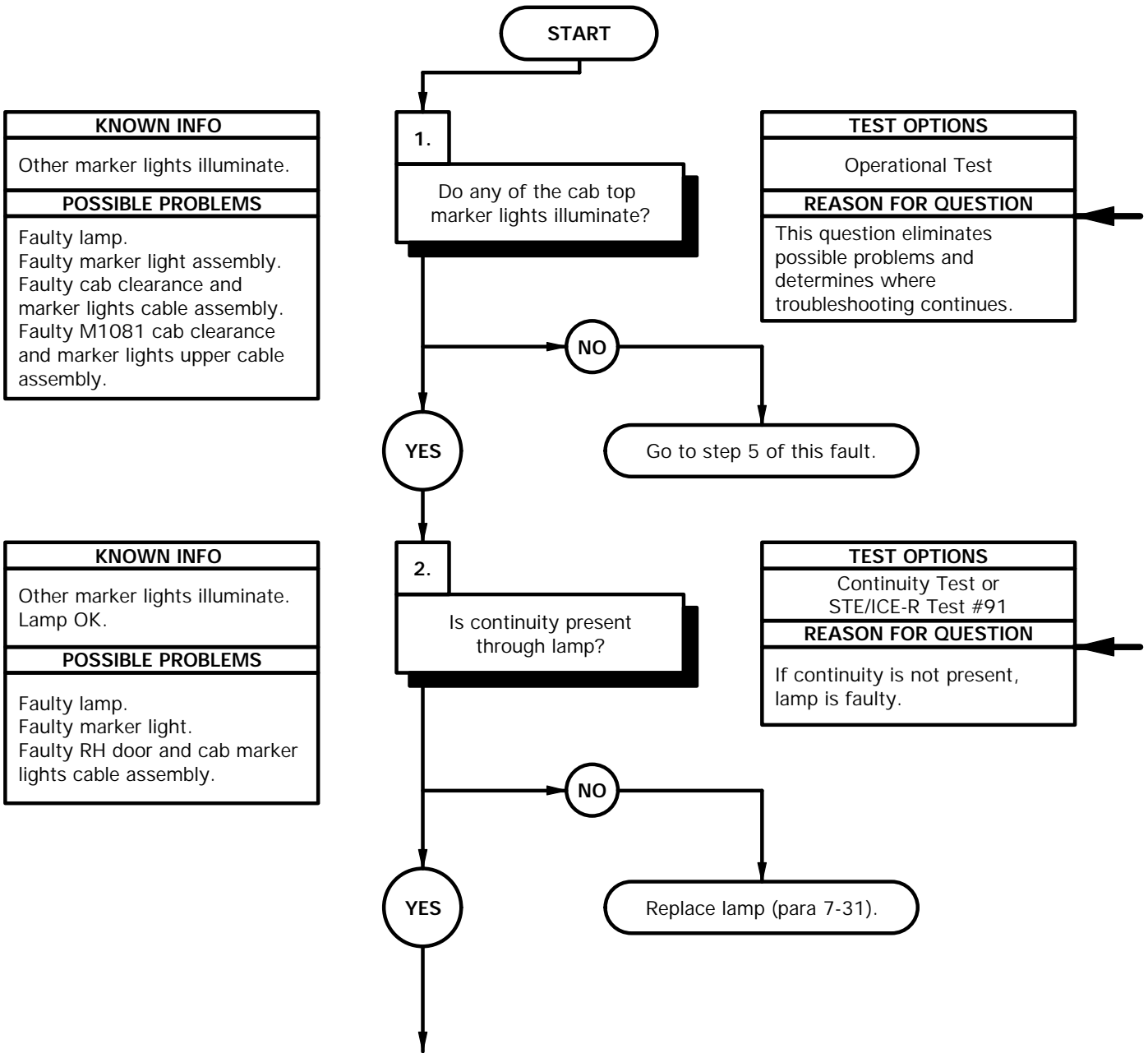

- (1) Position main light switch to SER DRIVE (TM 9-2320-365-10).
- (2) If no cab top marker lights illuminate, go to step 5 of this fault.
- (3) Position main light switch to OFF (TM 9-2320-365-10).

CONTINUITY TEST

- (1) Remove two screws and lens cover from marker light base.
- (2) Remove marker light lamp from socket.
- (3) Set multimeter to ohms.
- (4) Check continuity through marker light lamp and note reading on multimeter.
- (5) If continuity is not present, replace marker light lamp (para 7-31).

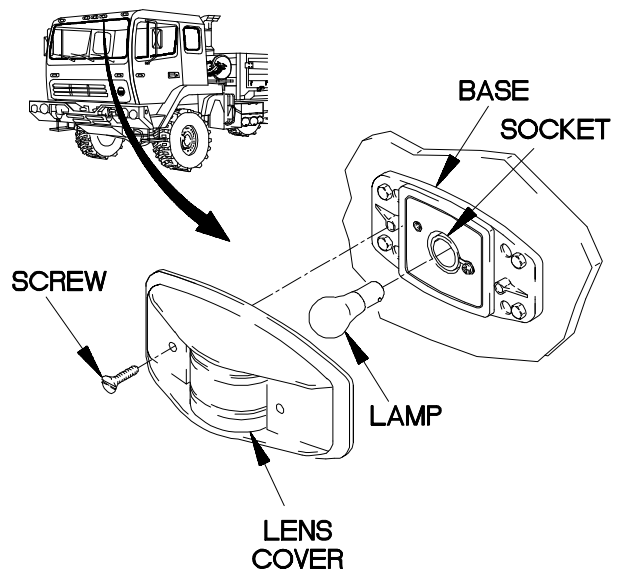

XBE4701B

e46. ONE OR MORE CAB TOP MARKER LIGHTS DO NOT ILLUMINATE (CONT)

KNOWN INFO
Other marker lights illuminate. Lamp OK.
POSSIBLE PROBLEMS
Faulty marker light assembly. Faulty cab clearance and marker lights cable assembly. Faulty M1081 cab clearance and marker lights upper cable assembly.

3.

WARNING
CAUTION
Read WARNING and CAUTION on following page.

Is 12 VDC present at connector (refer to Table 2-11.1. Cab Clearance and Marker Light Connectors) Socket 1?

TEST OPTIONS
Voltage Test or STE/ICE-R Test #89
REASON FOR QUESTION
If 12 VDC is not present, wire 1951 is faulty.

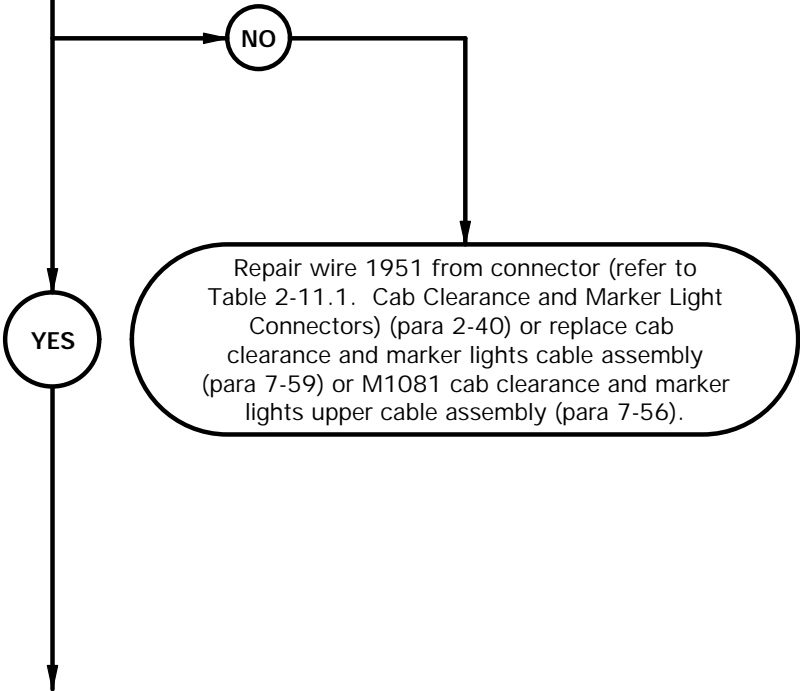

WARNING

Remove rings, bracelets, watches, necklaces, and any other jewelry before working around vehicle. Jewelry can catch on equipment and cause injury or short across electrical circuits and cause severe burns or electrical shock.

CAUTION

Use care when testing electrical connectors. Do not damage connector pins or sockets with multimeter probes. Failure to comply may result in damage to equipment.

NOTE

Inspect connector pins/sockets for damage, corrosion, and serviceability. Check that connector pins are not pushed back and are capable of making good contact.

VOLTAGE TEST

- (1) Remove four screws from marker light base.

NOTE

Do not let wires slip through hole into cab structure. If wires slip into cab structure, vehicle will need further disassembly to retrieve wires.

- (2) Remove nut, lockwasher, terminal lug and lockwasher from marker light base. Discard lockwashers.

- (3) Extend base and disconnect connector (refer to Table 2-11.1. Cab Clearance and Marker Light Connectors) from marker light connector.

- (4) Remove gasket from marker light base. Discard gasket.

- (5) Set multimeter to volts DC.

- (6) Connect positive (+) probe of multimeter to connector (refer to Table 2-11.1. Cab Clearance and Marker Light Connectors).

- (7) Connect negative (-) probe of multimeter to ground.

- (8) Position main light switch to SER DRIVE (TM 9-2320-365-10) and note reading on multimeter.

- (9) If 12 VDC is not present, repair wire 1951b from connector (refer to Table 2-11.1. Cab Clearance and Marker Light Connectors) d (para 2-40) or replace cab clearance and or marker lights cable assembly (para 7-59) or M1081 cab clearance and marker lights upper cable assembly (para 7-56).

- (10) Position main light switch to OFF (TM 9-2320-365-10).

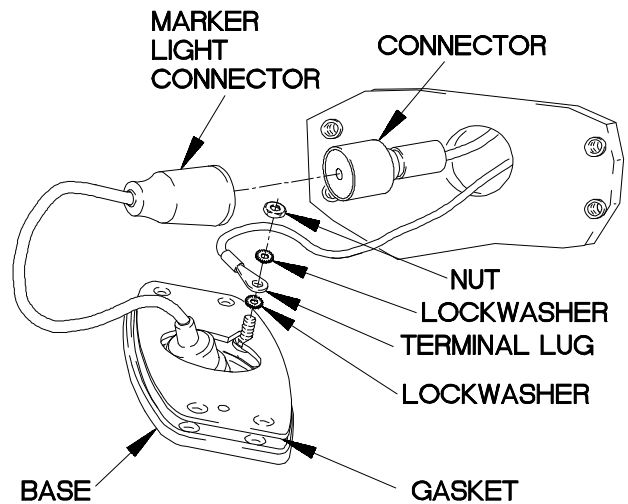
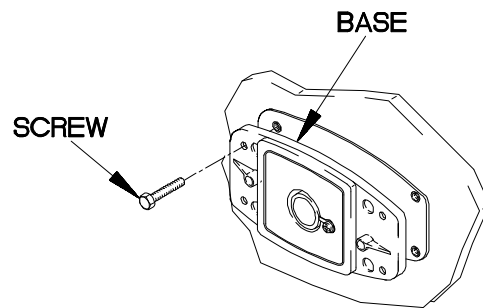

XBE4702B

Table 2-11.1. Cab Clearance and Marker Light Connectors

Marker/ID Light	Connector	Wire Segment
RH Cab Top Marker Light	P55	P55 to splice E23
RH Cab Top ID Light	P59	P59 to splice E23
Middle Cab Top ID Light	P60	P60 to splice E23
LH Cab Top ID Light	P57	P57 to splice E23
LH Cab Top Marker Light	P50	P50 to splice E23

e46. ONE OR MORE TOP CAB MARKER LIGHTS DO NOT ILLUMINATE (CONT)

KNOWN INFO
Other marker lights illuminate. Lamp OK.
POSSIBLE PROBLEMS
Faulty marker light assembly. Faulty cab clearance and marker lights cable assembly. Faulty M1081 cab clearance and marker lights upper cable assembly.

4.
Is continuity present from terminal lug (refer to Table 2-11.2. Cab Clearance and Marker Light Terminal Lugs) to ground?

TEST OPTIONS
Continuity Test or STE/ICE-R Test #91
REASON FOR QUESTION
If continuity is not present, wire 3097 is faulty. If continuity is present, marker light is faulty.

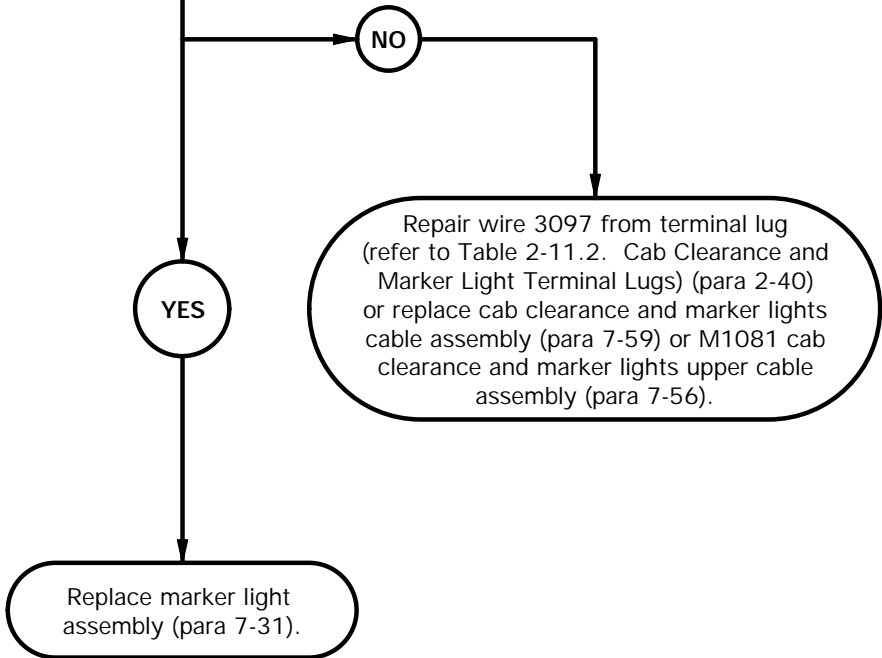

- CONTINUITY TEST**
- (1) Set multimeter to ohms.
 - (2) Connect positive (+) probe of multimeter to terminal lug (refer to Table 2-11.2. Cab Clearance and Marker Light Terminal Lugs).
 - (3) Connect negative (-) probe of multimeter to to ground and note reading on multimeter.
 - (4) If continuity is not present, repair wire 3097 (para 2-40) or replace cab clearance and marker lights cable assembly (para 7-59) or M1081 cab clearance and marker lights upper cable assembly (para 7-56).
 - (5) If continuity is present, replace marker light assembly (para 7-31).
 - (6) Install gasket on marker light base.
 - (7) Connect connector (refer to Table 2-11.2. Cab Clearance and Marker Light Connectors) to marker light connector.
 - (8) Install lockwasher, terminal lug (refer to Table 2-11.2. Cab Clearance and Marker Light Terminal Lugs), lockwasher, and nut on back of base.
 - (9) Install marker light base on vehicle with four screws.
 - (10) Install marker light lamp in socket.
 - (11) Install lens cover on base with two screws.

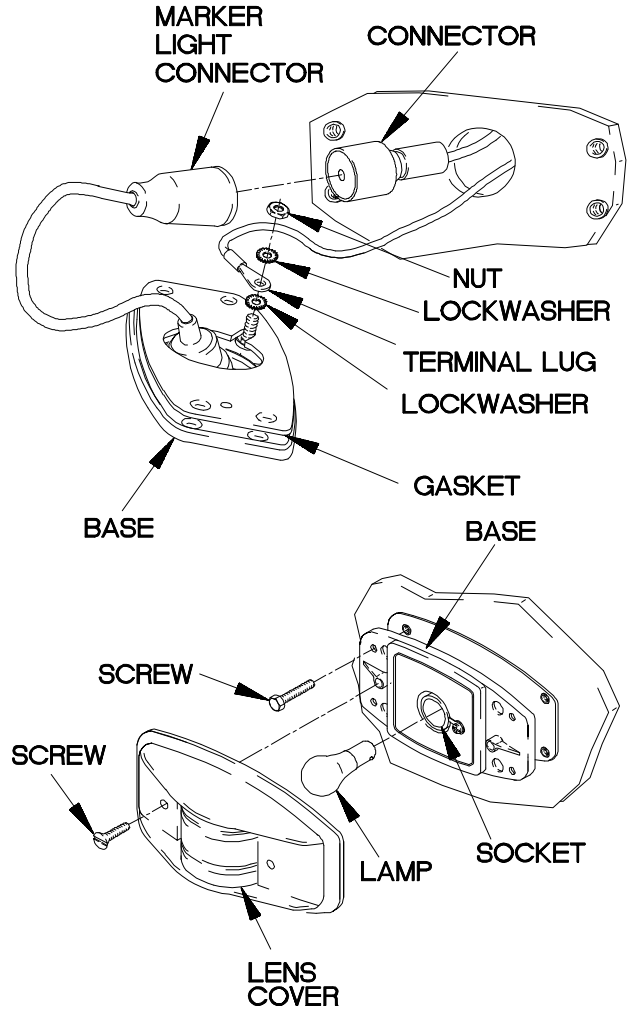

XBE4703B

Table 2-11.2. Cab Clearance and Marker Light Terminal Lugs

Light	Terminal Lug	Wire Segment
RH Cab Top Marker Light	TL3	TL3 to splice E24
RH Cab Top ID Light	TL4	TL4 to splice E24
Middle Cab Top ID Light	TL8	TL8 to splice E24
LH Cab Top ID Light	TL22	TL22 to splice E24
LH Cab Top Marker Light	TL27	TL27 to splice E24

e46. ONE OR MORE TOP CAB MARKER LIGHTS DO NOT ILLUMINATE (CONT)

KNOWN INFO
No cab top marker lights illuminate.
POSSIBLE PROBLEMS
Faulty cab clearance and marker lights cable assembly. Faulty M1081 cab clearance and marker lights lower cable assembly. Faulty M1081 cab clearance and marker lights upper cable assembly.

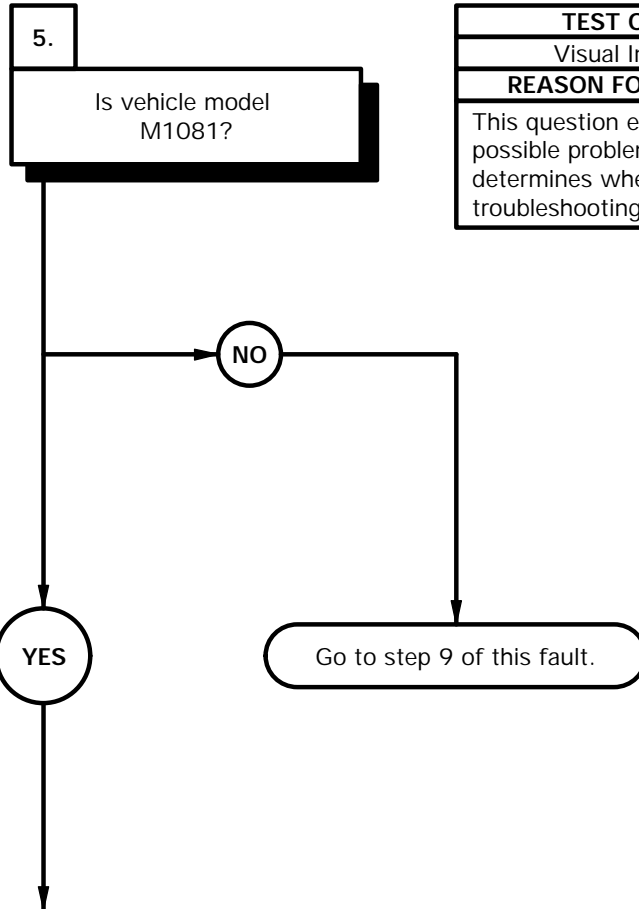

TEST OPTIONS
Visual Inspection
REASON FOR QUESTION
This question eliminates possible problems and determines where troubleshooting continues.





- (1) Is vehicle model M1081? If vehicle is not model M1081, go to step 9 of this fault.



e46. ONE OR MORE CAB TOP MARKER LIGHTS DO NOT ILLUMINATE (CONT)

KNOWN INFO
No cab top marker lights illuminate.
POSSIBLE PROBLEMS
Faulty M1081 cab clearance and marker lights lower cable assembly. Faulty M1081 cab clearance and marker lights upper cable assembly.

6.

WARNING
CAUTION
Read **WARNING** and **CAUTION** on following page.

Is 12 VDC present at connector P3 socket 1?

TEST OPTIONS
Voltage Test or STE/ICE-R Test #89
REASON FOR QUESTION
If 12 VDC is not present, wire 1951 is faulty.

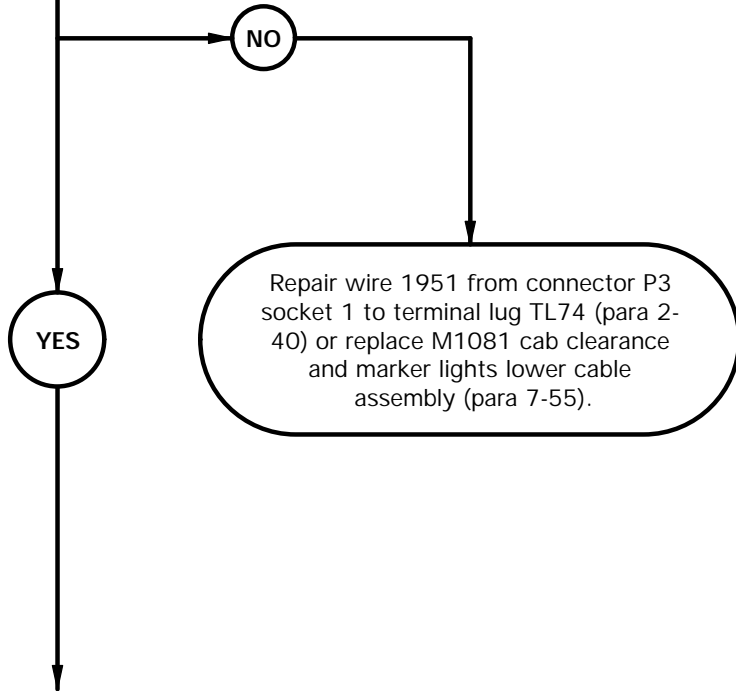

WARNING

Remove rings, bracelets, watches, necklaces, and any other jewelry before working around vehicle. Jewelry can catch on equipment and cause injury or short across electrical circuits and cause severe burns or electrical shock.

CAUTION

Use care when testing electrical connectors. Do not damage connector pins or sockets with multimeter probes. Failure to comply may result in damage to equipment.

NOTE

Inspect connector pins/sockets for damage, corrosion, and serviceability. Check that connector pins are not pushed back and are capable of making good contact.

VOLTAGE TEST

- (1) Disconnect connector P3 from connector J3.
- (2) Set multimeter to volts DC.
- (3) Connect positive (+) probe of multimeter to connector P3 socket 1.
- (4) Connect negative (-) probe of multimeter to ground.
- (5) Position main light switch to SER DRIVE (TM 9-2320-365-10) and note reading on multimeter.
- (6) If 12 VDC is not present, repair wire 1951 (para 2-40) from connector P3 socket 1 to terminal lug TL74 or replace M1081cab clearance and marker lights lower cable assembly (para 7-55).
- (7) Position main light switch to OFF (TM 9-2320-365-10).

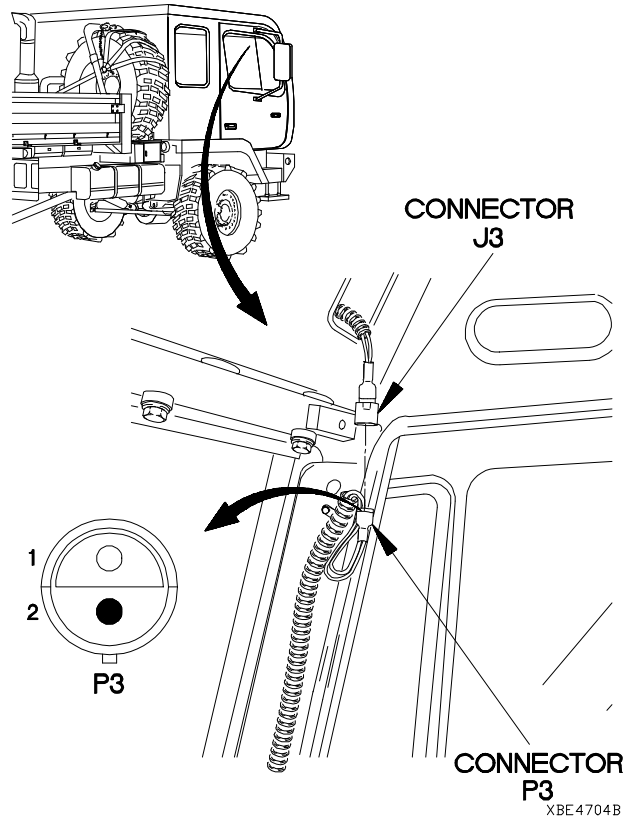

e46. ONE OR MORE CAB TOP MARKER LIGHTS DO NOT ILLUMINATE (CONT)

KNOWN INFO
No cab top marker lights illuminate.
POSSIBLE PROBLEMS
Faulty M1081 cab clearance and marker lights lower cable assembly. Faulty M1081 cab clearance and marker lights upper cable assembly.

7. **CAUTION**
Read CAUTION on following page.

Is continuity present from connector P3 pin 2 to ground?

TEST OPTIONS
Continuity Test or STE/ICE-R Test #91
REASON FOR QUESTION
If continuity is not present, wire 3097 is faulty.

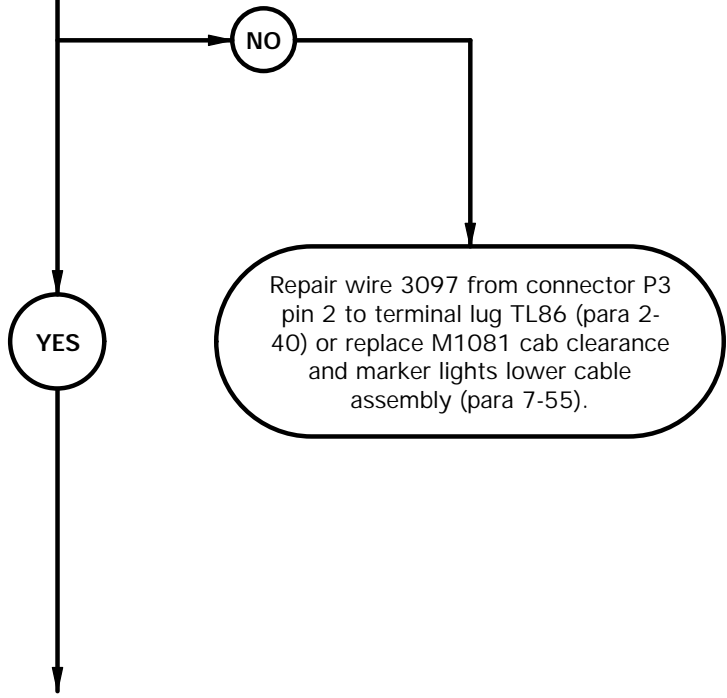

CAUTION

Use care when testing electrical connectors. Do not damage connector pins or sockets with multimeter probes. Failure to comply may result in damage to equipment.

NOTE

Inspect connector pins/sockets for damage, corrosion, and serviceability. Check that connector pins are not pushed back and are capable of making good contact.

CONTINUITY TEST

- (1) Set multimeter to ohms.
- (2) Connect positive (+) probe of multimeter to connector P3 pin 2.
- (3) Connect negative (-) probe of multimeter to ground and note reading on multimeter.
- (4) If continuity is not present, repair wire 3097 (para 2-40) from connector P3 pin 2 to terminal lug TL86 or replace M1081 cab clearance and marker lights lower cable assembly (para 7-55).

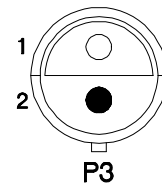

XBE4705B

e46. ONE OR MORE CAB TOP MARKER LIGHTS DO NOT ILLUMINATE (CONT)

KNOWN INFO
No cab top marker lights illuminate. M1081 cab clearance and marker lights lower cable assembly OK.
POSSIBLE PROBLEMS
Faulty M1081 cab clearance and marker lights upper cable assembly.

8. **CAUTION**
Read CAUTION on following page.

Is continuity present from connector J3 socket 2 to terminal lug TL27?

TEST OPTIONS
Continuity Test or STE/ICE-R Test #91
REASON FOR QUESTION
If continuity is not present, wire 3097 is faulty. If continuity is present, wire 1951 is faulty.

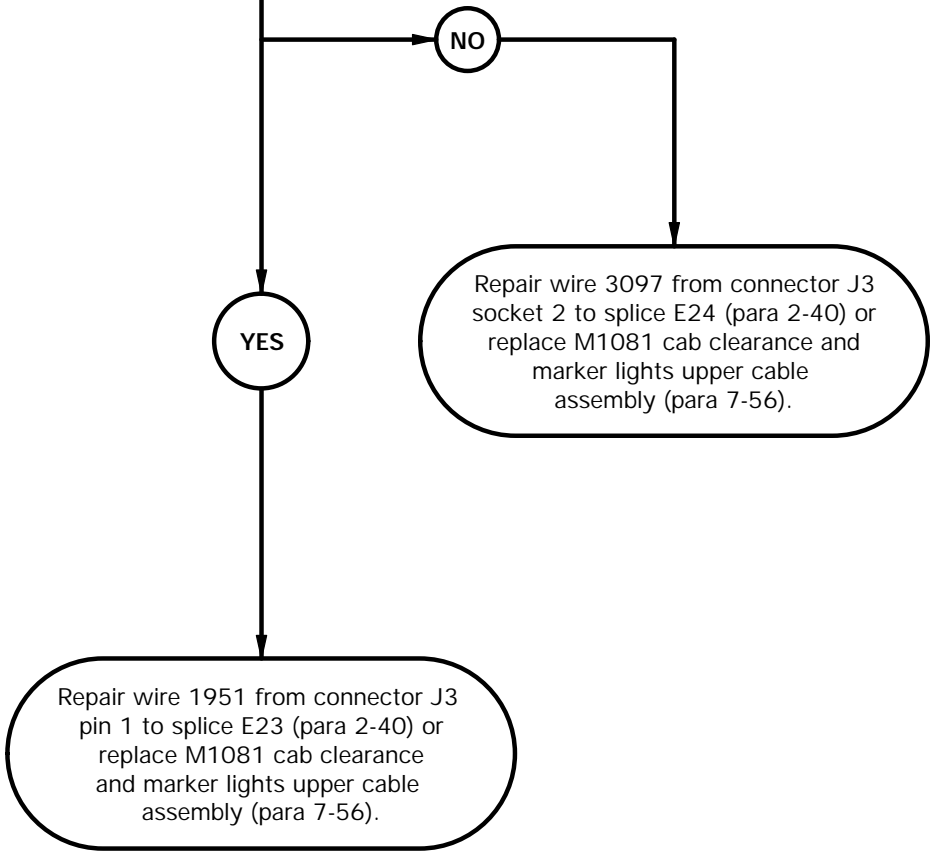

CAUTION

Use care when testing electrical connectors. Do not damage connector pins or sockets with multimeter probes. Failure to comply may result in damage to equipment.

NOTE

Inspect connector pins/sockets for damage, corrosion, and serviceability. Check that connector pins are not pushed back and are capable of making good contact.

CONTINUITY TEST

- (1) Remove two screws and lens cover from LH cab top marker light base.
- (2) Remove LH cab top marker light lamp from socket.
- (3) Remove four screws from LH cab top marker light base.

NOTE

Do not let wires slip through hole into cab structure. If wires slip into cab structure, vehicle will need further disassembly to retrieve wires.

- (4) Remove nut, lockwasher, terminal lug TL27, and lockwasher from LH cab top marker light base. Discard lockwashers.
- (5) Extend base and disconnect marker light connector from connector P50.
- (6) Remove gasket from LH cab top marker light base. Discard gasket.
- (7) Set multimeter to ohms.
- (8) Connect positive (+) probe of multimeter to connector J3 socket 2.
- (9) Connect negative (-) probe of multimeter to terminal lug TL27 and note reading on multimeter.
- (10) If continuity is not present, repair wire 3097 from connector J3 socket 2 to splice E24 (para 2-40) or replace M1081 cab clearance and marker lights upper cable assembly (para 7-56).
- (11) If continuity is present, repair wire 1951 from connector J3 pin 1 to splice E23 (para 2-40) or replace M1081 cab clearance and marker lights upper cable assembly (para 7-56).
- (12) Install gasket on LH cab top marker light base.
- (13) Connect marker light connector to connector P50.
- (14) Install lockwasher, terminal lug TL27, lockwasher, and nut on back of LH cab top marker light base.

CONTINUITY TEST (Cont)

- (15) Install LH cab top marker light base on vehicle with four screws.
- (16) Install LH cab top marker light lamp in socket.
- (17) Install lens cover on base with two screws.
- (18) Connect connector P3 to connector J3.

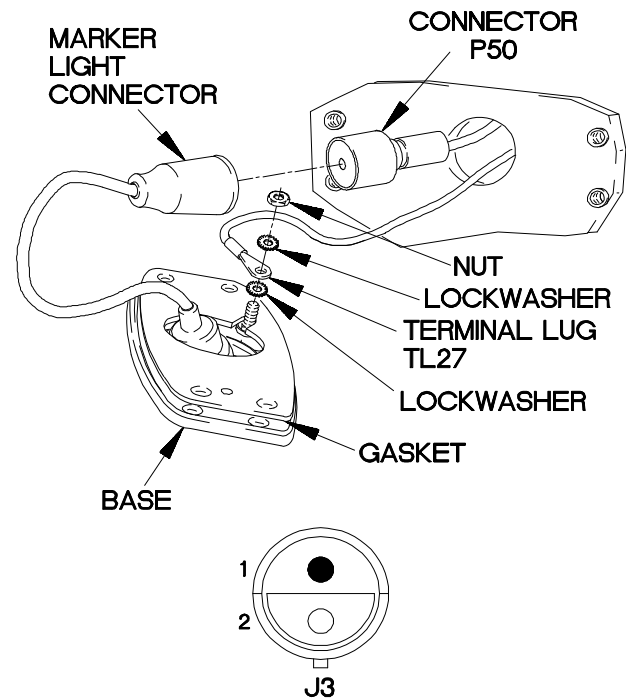
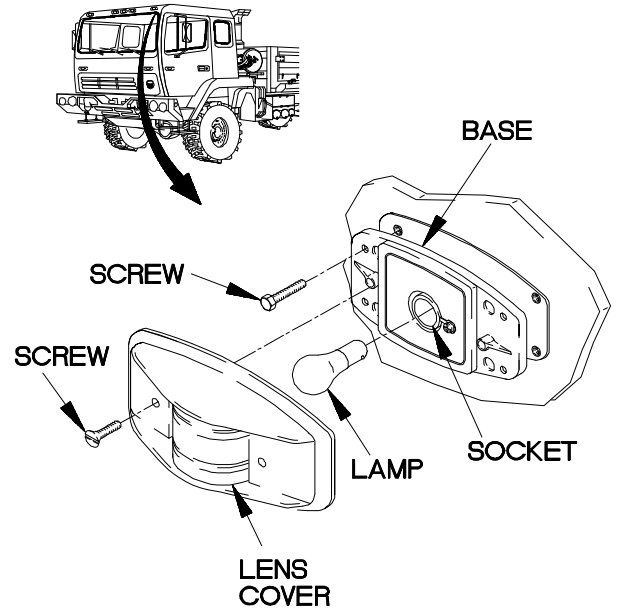

Xbe4707b

e46. ONE OR MORE CAB TOP MARKER LIGHTS DO NOT ILLUMINATE (CONT)

KNOWN INFO
No cab top marker lights illuminate.
POSSIBLE PROBLEMS
Faulty cab clearance and marker lights cable assembly.

9.
Is continuity present from terminal lug TL3 to ground?

TEST OPTIONS
Continuity Test or STE/ICE-R Test #91
REASON FOR QUESTION
If continuity is not present, wire 3097 is faulty. If continuity is present, wire 1951 is faulty.

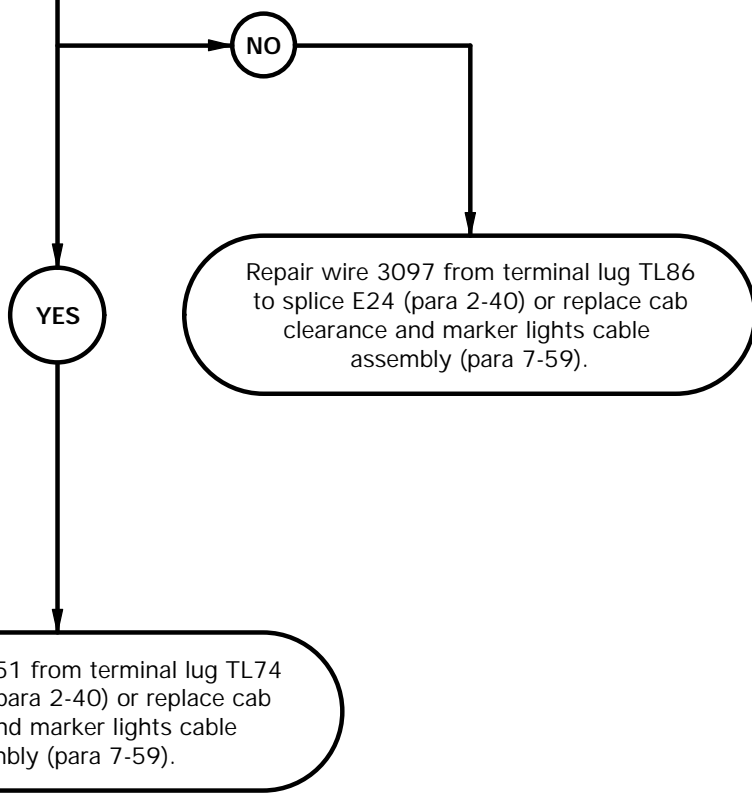

CONTINUITY TEST

- (1) Remove two screws and lens cover from RH cab top marker light base.
- (2) Remove RH cab top marker lamp from socket.
- (3) Remove four screws from RH cab top marker light base.

NOTE

Do not let wires slip through hole into cab structure. If wires slip into cab structure, vehicle will need further disassembly to retrieve wires.

- (4) Remove nut, lockwasher, terminal lug TL3, and lockwasher from RH cab top marker light base. Discard lockwashers.
- (5) Extend base and disconnect marker light connector from connector P55.
- (6) Remove gasket from RH cab top marker light base. Discard gasket.
- (7) Set multimeter to ohms.
- (8) Connect positive (+) probe of multimeter to terminal lug TL3.
- (9) Connect negative (-) probe of multimeter to ground and note reading on multimeter.
- (10) If continuity is not present, repair wire 3097 from terminal lug TL86 to splice E24 (para 2-40) or replace cab clearance and marker lights cable assembly (para 7-59).
- (11) If continuity is present, repair wire 1951 from terminal lug TL74 to splice E23 (para 2-40) or replace cab clearance and marker lights cable assembly (para 7-59).
- (12) Install gasket on RH cab top marker light base.
- (13) Connect connector P55 to marker light connector.
- (14) Install lockwasher, terminal lug TL3, lockwasher, and nut on back of RH cab top marker light base.
- (15) Install RH cab top marker light base on vehicle with four screws.
- (16) Install RH cab top marker light lamp in socket.
- (17) Install lens cover on RH cab top marker light light base with two screws.

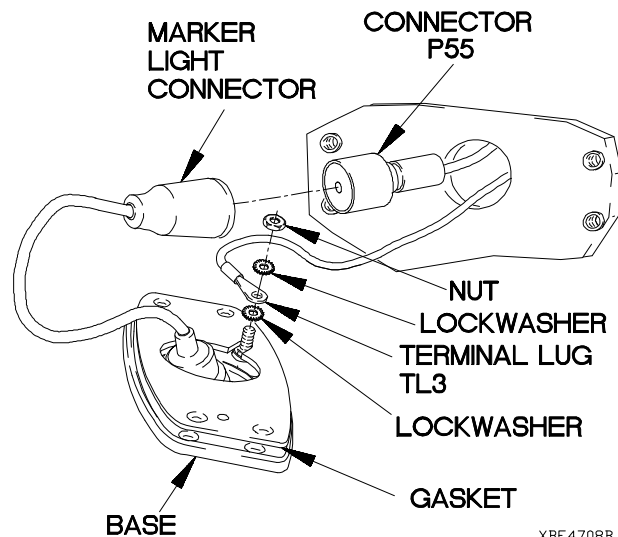
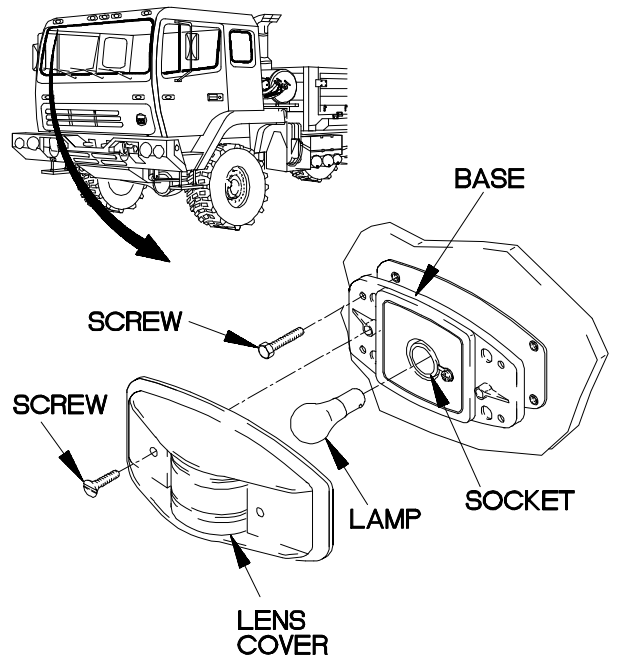

XBE4708B

e47. SIDE AND/OR REAR MARKER LIGHT(S) DO NOT ILLUMINATE	
INITIAL SETUP	
<p>Equipment Conditions Engine shut down (TM 9-2320-365-10).</p> <p>Personnel Required (2)</p> <p>Materials/Parts Lockwasher (6) (Item 71, Appendix G) Ties, Cable, Plastic (Item 76, Appendix D)</p>	<p>Tools and Special Tools Tool Kit, Genl Mech (Item 44, Appendix C) STE/ICR-R (Item 39, Appendix C) Multimeter, Digital (Item 22, Appendix C)</p> <p>References TM 9-4910-571-12&P</p>

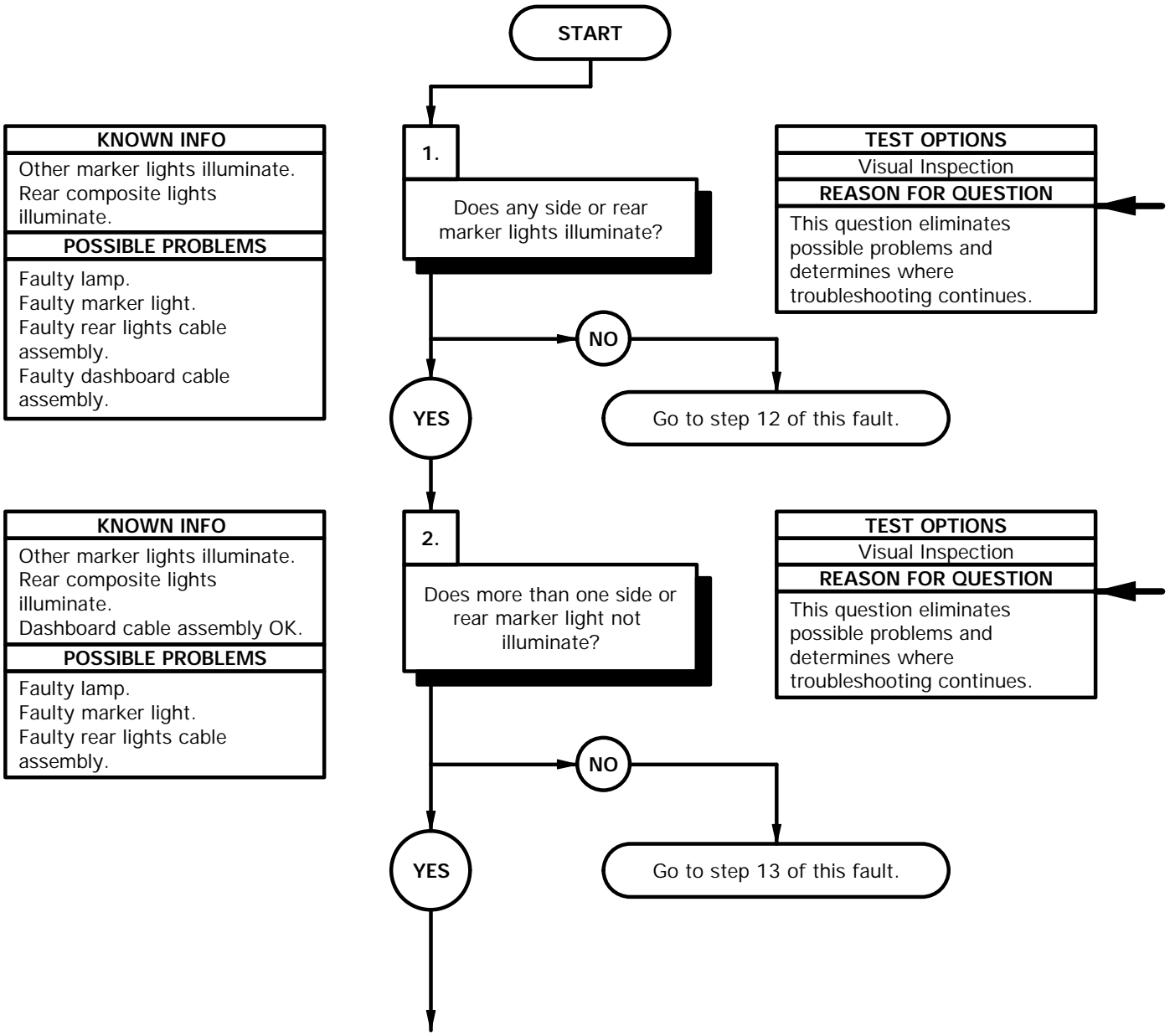

- (1) Position main light switch to SER DRIVE (TM 9-2320-365-10).
- (2) Note side and/or rear marker light(s) that do not illuminate.
- (3) If all side and/or rear marker lights do not illuminate, go to step 12 of this fault.
- (4) Position main light switch to OFF (TM 9-2320-365-10).

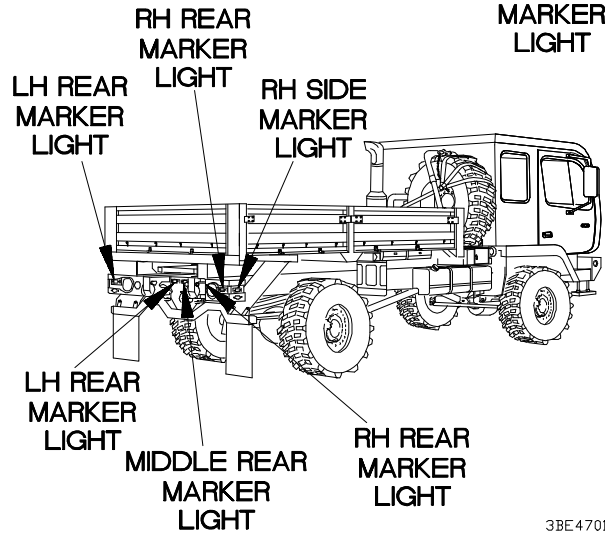
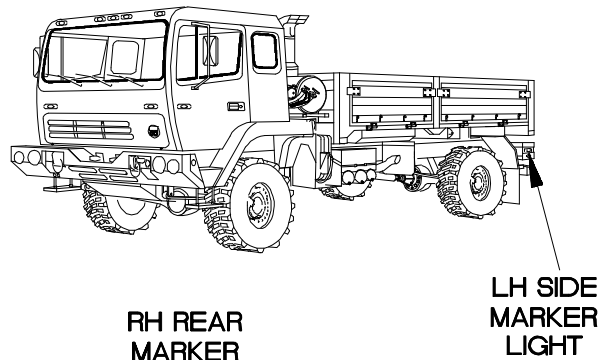

3BE4701B

If only one side and/or rear marker light does not illuminate, go to step 13 of this fault.

e47. SIDE AND/OR REAR MARKER LIGHT(S) DO NOT ILLUMINATE (CONT)

KNOWN INFO
Other marker lights illuminate. Rear composite lights illuminate. Dashboard cable assembly OK.
POSSIBLE PROBLEMS
Faulty lamp. Faulty marker light. Faulty rear lights cable assembly.

TEST OPTIONS
Visual Inspection
REASON FOR QUESTION
This question eliminates possible problems and determines where troubleshooting continues.

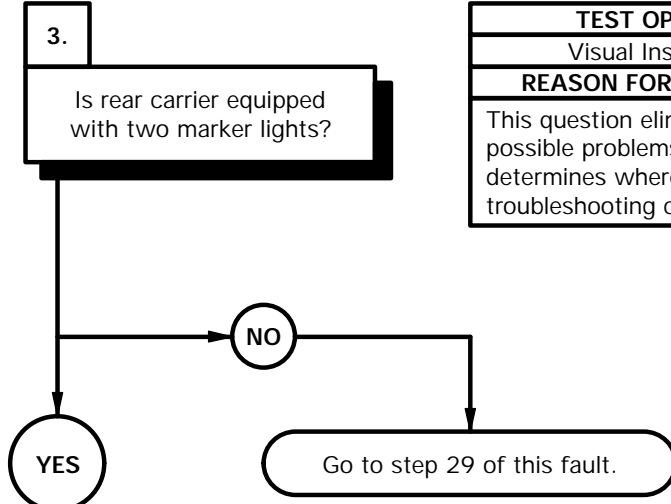

KNOWN INFO
Other marker lights illuminate. Rear composite lights illuminate. Dashboard cable assembly OK.
POSSIBLE PROBLEMS
Faulty lamp. Faulty marker lamp. Faulty rear lights cable assembly.

TEST OPTIONS
Visual Inspection
REASON FOR QUESTION
This question eliminates possible problems and determines where troubleshooting continues.

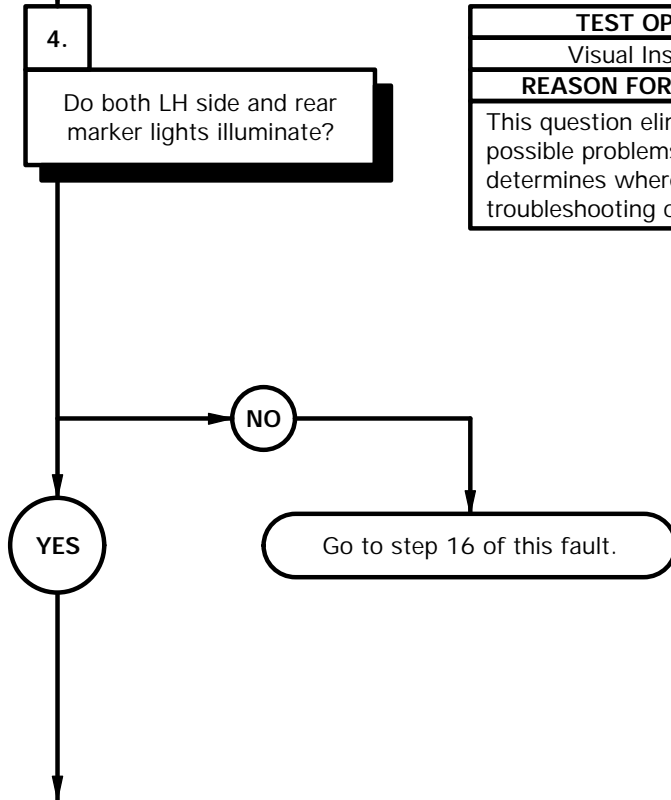

┆ If rear carrier is equipped with one marker light, go to step 29 of this fault.

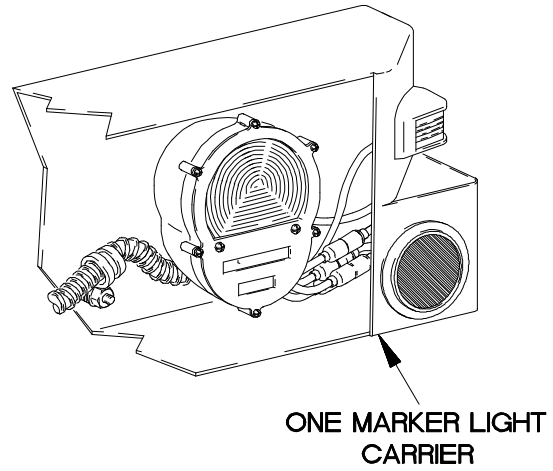

┆ If both LH side and rear marker lights do not illuminate, go to step 16 of this fault.

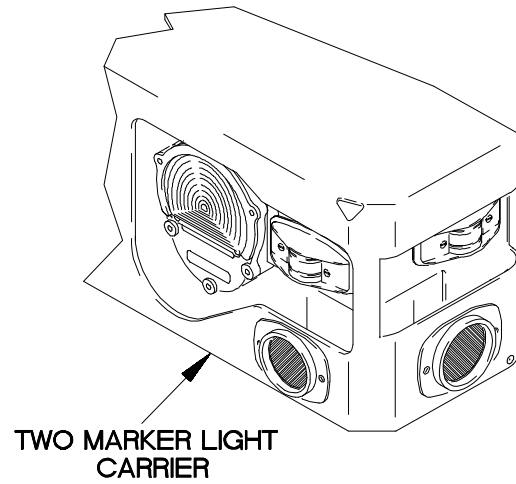

3BE4704B

e47. SIDE AND/OR REAR MARKER LIGHT(S) DO NOT ILLUMINATE (CONT)

KNOWN INFO
Other marker lights illuminate. Rear composite lights illuminate. Dashboard cable assembly OK.
POSSIBLE PROBLEMS
Faulty lamp. Faulty marker light. Faulty rear lights cable assembly.

TEST OPTIONS
Visual Inspection
REASON FOR QUESTION
This question eliminates possible problems and determines where troubleshooting continues.

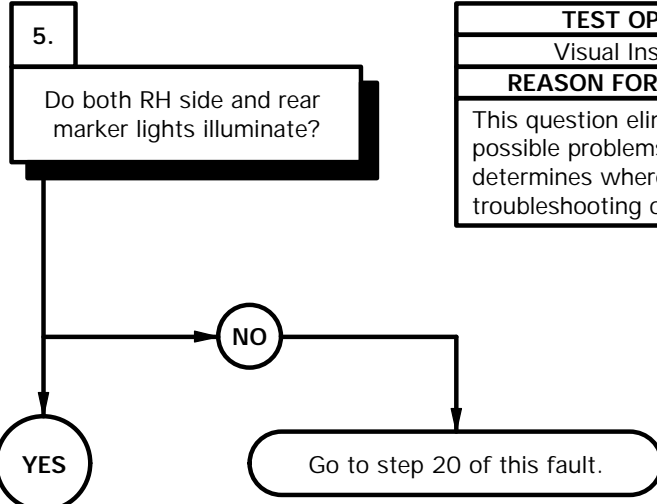

KNOWN INFO
Other marker lights illuminate. Rear composite lights illuminate. Dashboard cable assembly OK.
POSSIBLE PROBLEMS
Faulty lamp. Faulty marker lamp. Faulty rear lights cable assembly.

TEST OPTIONS
Visual Inspection
REASON FOR QUESTION
This question eliminates possible problems and determines where troubleshooting continues.

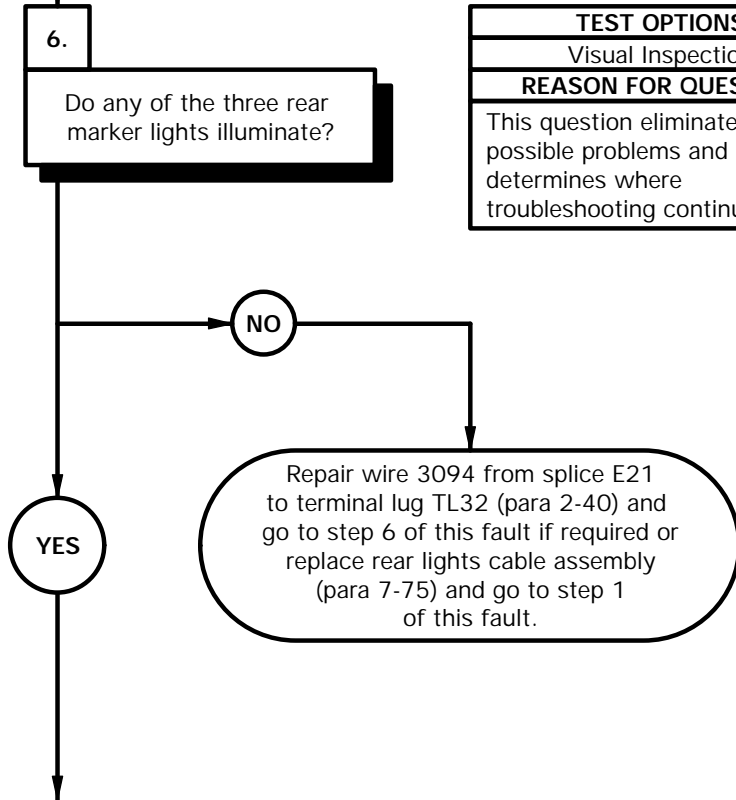

┆ If both RH side and rear marker lights do not illuminate, go to step 20 of this fault.

┆ If all three marker lights do not illuminate, repair wire 3094 from splice E21 to terminal lug TL32 (para 2-40) and go to step 6 of this fault if required or replace rear lights cable assembly (para 7-75) and go to step 1 of this fault.

e47. SIDE AND/OR REAR MARKER LIGHT(S) DO NOT ILLUMINATE (CONT)

KNOWN INFO
Other marker lights illuminate. Rear composite lights illuminate. Dashboard cable assembly OK.
POSSIBLE PROBLEMS
Faulty lamp. Faulty marker light. Faulty rear lights cable assembly.

TEST OPTIONS
Visual Inspection
REASON FOR QUESTION
This question eliminates possible problems and determines where troubleshooting continues.

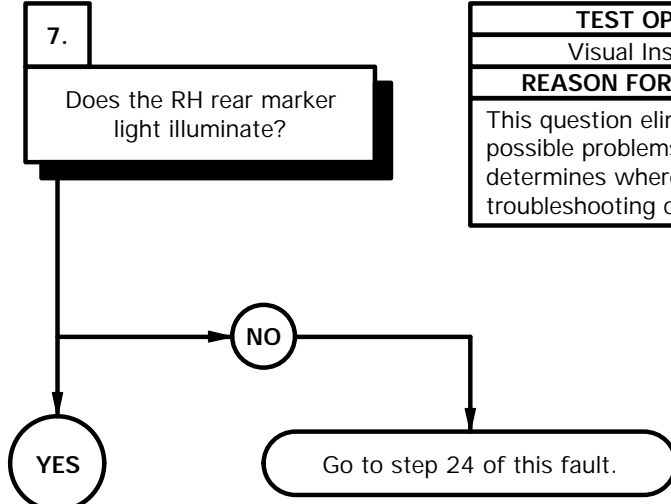

KNOWN INFO
Other marker lights illuminate. Rear composite lights illuminate. Dashboard cable assembly OK.
POSSIBLE PROBLEMS
Faulty lamp. Faulty marker light. Faulty rear lights cable assembly.

TEST OPTIONS
Visual Inspection
REASON FOR QUESTION
This question eliminates possible problems and determines where troubleshooting continues.

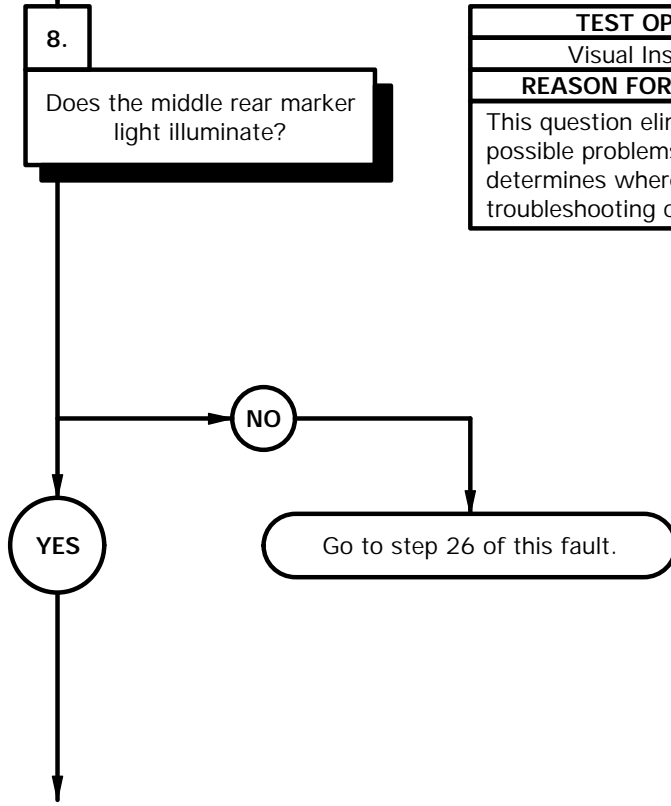

┆ If the RH rear marker light does not illuminate,
go to step 24 of this fault.



┆ If the middle rear marker light does not illuminate,
go to step 26 of this fault.



e47. SIDE AND/OR REAR MARKER LIGHT(S) DO NOT ILLUMINATE (CONT)

KNOWN INFO
Other marker lights illuminate. Rear composite lights illuminate. Dashboard cable assembly OK.
POSSIBLE PROBLEMS
Faulty lamp. Faulty marker light. Faulty rear lights cable assembly.

9.
Is continuity present through LH rear marker light lamp?

TEST OPTIONS
Continuity Test or STE/ICE-R Test #91
REASON FOR QUESTION
If continuity is not present, LH rear marker light lamp is faulty.

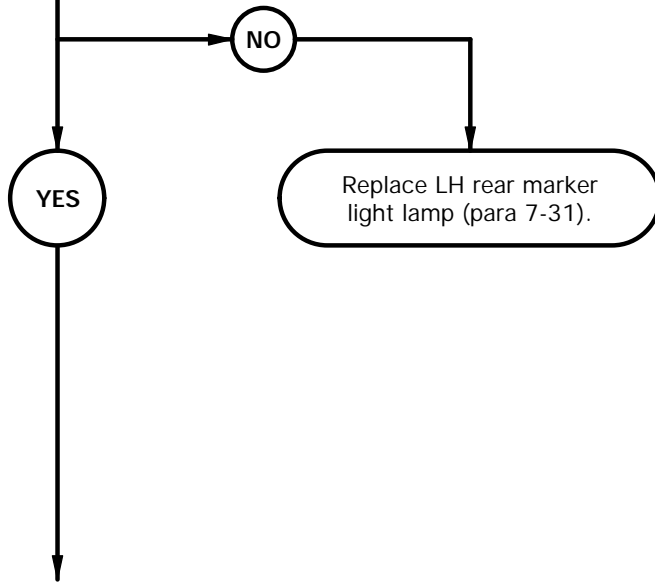

CONTINUITY TEST

- (1) Remove two screws and lens cover from LH rear marker light base.
- (2) Remove LH rear marker light lamp from socket.
- (3) Set multimeter to ohms.
- (4) Check continuity through LH rear marker light lamp and note reading on multimeter.
- (5) If continuity is not present, replace LH rear marker light lamp (para 7-31).
- (6) Install LH rear marker light lamp in socket.
- (7) Install lens cover on LH rear marker light base with two screws.

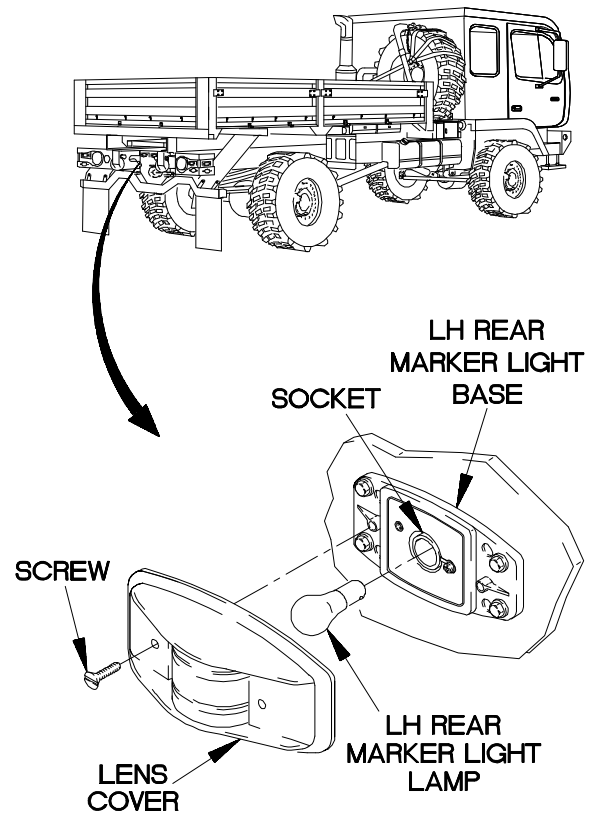

3BE4709B

e47. SIDE AND/OR REAR MARKER LIGHT(S) DO NOT ILLUMINATE (CONT)

KNOWN INFO
Other marker lights illuminate. Rear composite lights illuminate. Dashboard cable assembly OK.
POSSIBLE PROBLEMS
Faulty lamp. Faulty marker light. Faulty rear lights cable assembly.

10.

WARNING
CAUTION
Read WARNING and CAUTION on following page.

Is 12 VDC present at connector P54?

TEST OPTIONS
Voltage Test or STE/ICE-R Test #89
REASON FOR QUESTION
If 12 VDC is not present, wire 489 is faulty.

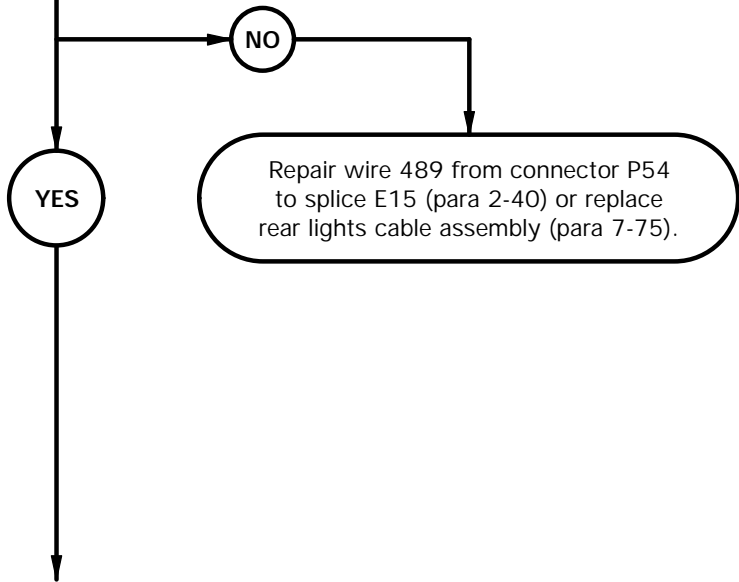

WARNING

Remove rings, bracelets, watches, necklaces, and any other jewelry before working around vehicle. Jewelry can catch on equipment and cause injury or short across electrical circuits and cause severe burns or electrical shock.

CAUTION

Use care when testing electrical connectors. Do not damage connector pins or sockets with multimeter probes. Failure to comply may result in damage to equipment.

NOTE

Inspect connector pins/sockets for damage, corrosion, and serviceability. Check that connector pins are not pushed back and are capable of making good contact.

VOLTAGE TEST

- (1) Disconnect connector P54 from LH rear marker light connector.
- (2) Set multimeter to volts DC.
- (3) Connect positive (+) probe of multimeter to connector P54.
- (4) Connect negative (-) probe of multimeter to ground.
- (5) Position main light switch to SER DRIVE (TM 9-2320-365-10) and note reading on multimeter.
- (6) If 12 VDC is not present, repair wire 489 from connector P54 to splice E15 (para 2-40) or replace rear lights cable assembly (para 7-75).
- (7) Position main light switch to OFF (TM 9-2320-365-10).
- (8) Connect LH rear marker light connector to connector P54.

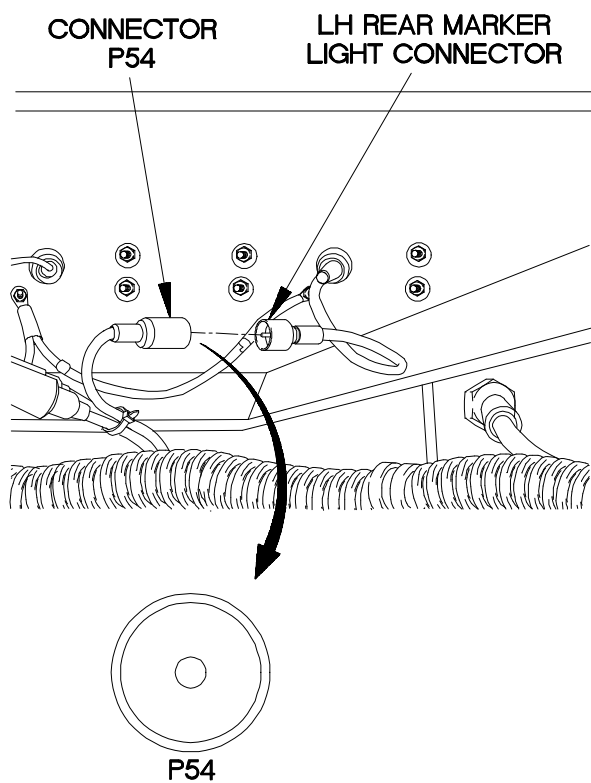

XBE4810B

e47. SIDE AND/OR REAR MARKER LIGHT(S) DO NOT ILLUMINATE (CONT)

KNOWN INFO
Other marker lights illuminate. Rear composite lights illuminate. Dashboard cable assembly OK.
POSSIBLE PROBLEMS
Faulty lamp. Faulty marker light. Faulty rear lights cable assembly.

11.
Is continuity present from terminal lug TL30 to terminal lug TL31?

TEST OPTIONS
Continuity Test or STE/ICE-R Test #91
REASON FOR QUESTION
If continuity is not present, wire 3094 is faulty. If continuity is present, LH rear marker light is faulty.

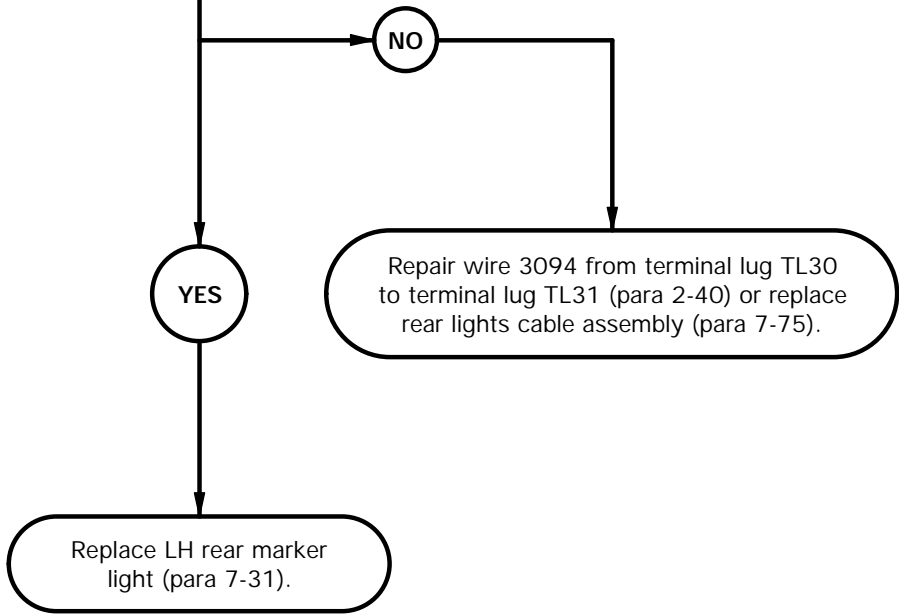

CONTINUITY TEST

- (1) Remove nut, lockwasher, terminal lug TL30, and lockwasher from LH rear marker light screw. Discard lockwashers.
- (2) Remove nut, lockwasher, terminal lug TL31, and lockwasher from middle rear marker light screw. Discard lockwashers.
- (3) Set multimeter to ohms.
- (4) Connect positive (+) probe of multimeter to terminal lug TL30.
- (5) Connect negative (-) probe of multimeter to terminal lug TL31 and note reading on multimeter.
- (6) If continuity is not present, repair wire 3094 from terminal lug TL30 to terminal lug TL31 (para 2-40) or replace rear lights cable assembly (para 7-75).
- (7) If continuity is present, replace LH rear marker light (para 7-31).
- (8) Install lockwasher, terminal lug TL31, lockwasher, and nut on middle rear marker light screw.
- (9) Install lockwasher, terminal lug TL30, lockwasher, and nut on LH rear marker light screw.
- (10) Install LH rear marker light lamp in socket.
- (11) Install lens cover on LH rear marker light base with two screws.

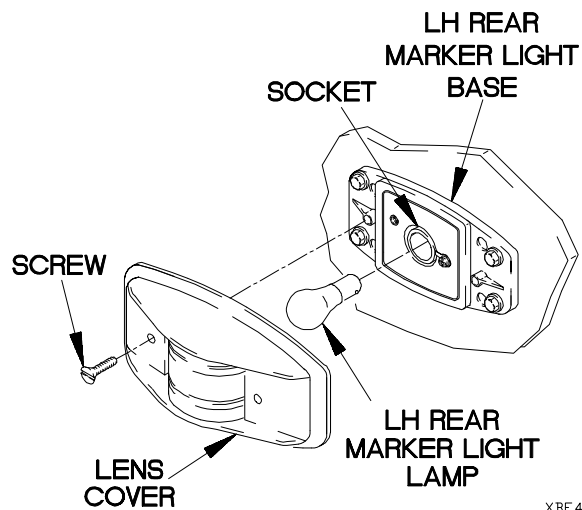
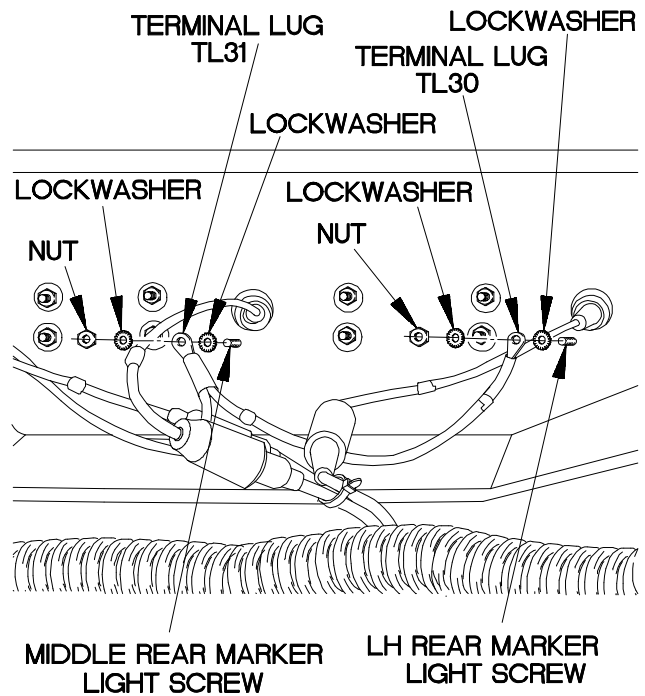

XBE4811B

e47. SIDE AND/OR REAR MARKER LIGHT(S) DO NOT ILLUMINATE (CONT)

KNOWN INFO
Other marker lights illuminate. Rear composite lights illuminate.
POSSIBLE PROBLEMS
Faulty rear lights cable assembly. Faulty dashboard cable assembly.

12. **CAUTION**
Read CAUTION on following page.

Is continuity present from connector J51 pin 7 to terminal board TB1 position 11?

TEST OPTIONS
Continuity Test or STE/ICE-R Test #91
REASON FOR QUESTION
If continuity is not present, wire 489 is faulty.

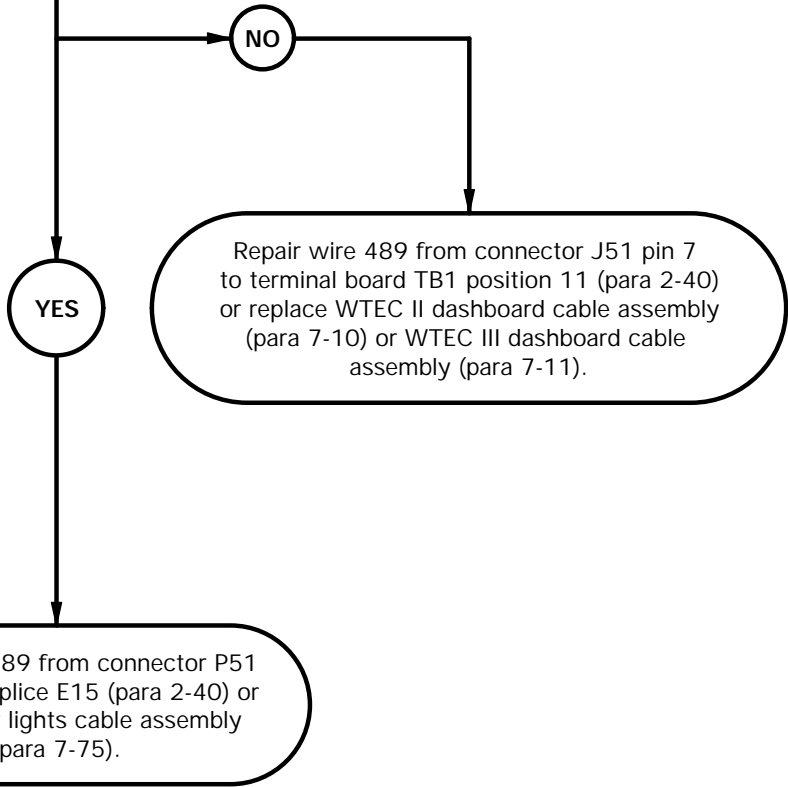

CAUTION

Use care when testing electrical connectors. Do not damage connector pins or sockets with multimeter probes. Failure to comply may result in damage to equipment.

NOTE

Use care when testing electrical connectors. Do not damage connector pins or sockets with multimeter probes. Failure to comply may result in damage to equipment.

CONTINUITY TEST

- (1) Disconnect batteries (para 7-48).
- (2) Remove PDP cover (para 16-2).
- (3) Remove three screws and washers from PDP.
- (4) Remove three screws from PDP.
- (5) Lift PDP outward to gain access.
- (6) Disconnect connector P51 from connector J51.
- (7) Set multimeter to ohms.
- (8) Connect positive (+) probe of multimeter to connector J51 pin 7.
- (9) Connect negative (-) probe of multimeter to terminal board TB1 position 11 and note reading on multimeter.
- (10) If continuity is not present, repair wire 489 from connector J51 pin 7 to terminal board TB1 position 11 (para 2-40) or replace WTEC II dashboard cable assembly (para 7-10) or WTEC III dashboard cable assembly (para 7-11).
- (11) If continuity is present, repair wire 489 from connector P51 socket 7 to splice E15 (para 2-40) or replace rear lights cable assembly (para 7-75).
- (12) Connect connector J51 to connector P51.
- (13) Install PDP on dashboard with three screws.
- (14) Install three washers and screws in PDP.
- (15) Install PDP cover (para 16-2).
- (16) Connect batteries (para 7-48).

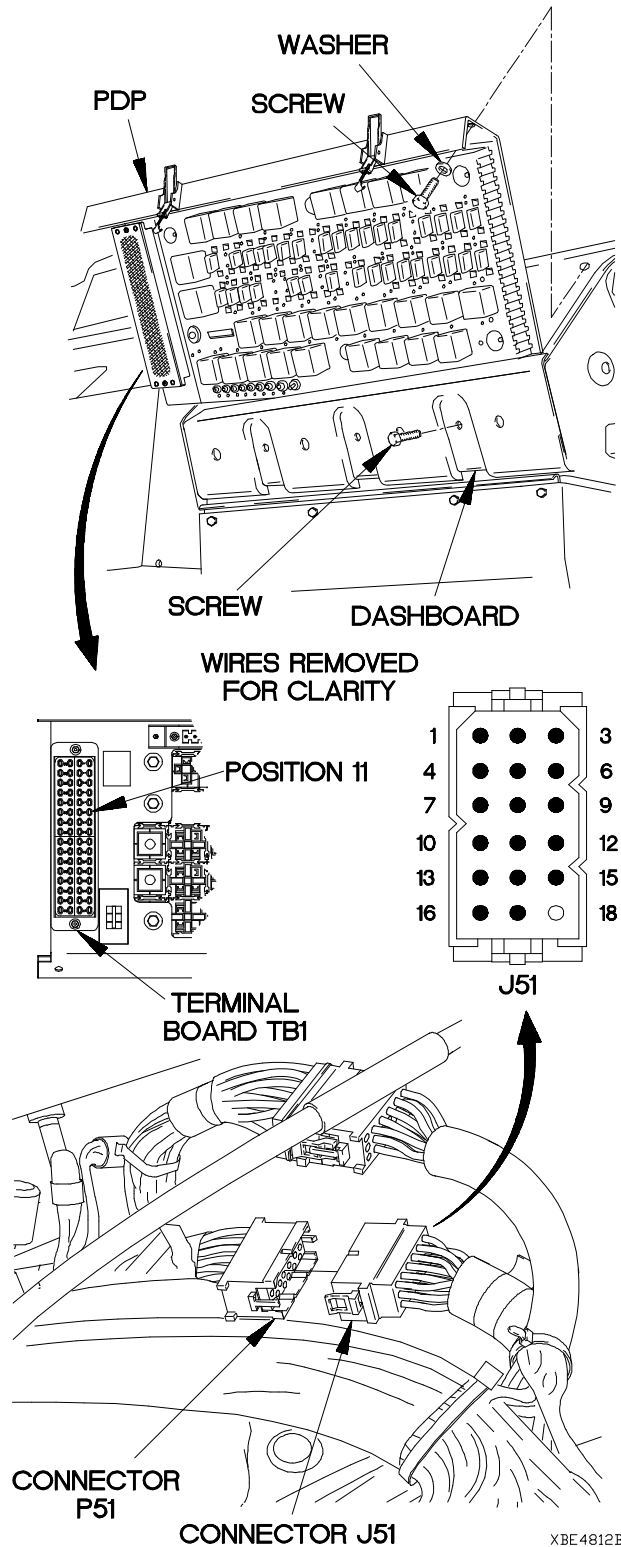

XBE4812B

e47. SIDE AND/OR REAR MARKER LIGHT(S) DO NOT ILLUMINATE (CONT)

KNOWN INFO
Other marker lights illuminate. Rear composite lights illuminate. Dashboard cable assembly OK.
POSSIBLE PROBLEMS
Faulty lamp. Faulty marker light. Faulty rear lights cable assembly.

13.
Is continuity present through marker light lamp?

TEST OPTIONS
Continuity Test or STE/ICE-R Test #91
REASON FOR QUESTION
If continuity is not present, marker light lamp is faulty.

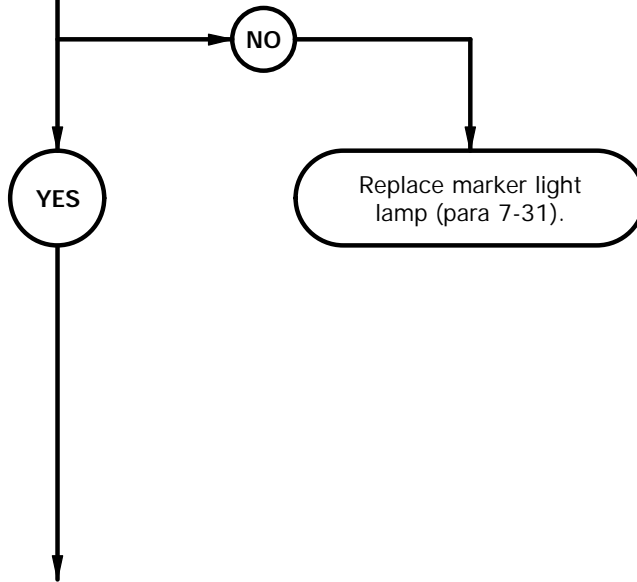

CONTINUITY TEST

- (1) Remove two screws and lens cover from marker light base.
- (2) Remove marker light lamp from socket.
- (3) Set multimeter to ohms.
- (4) Check continuity through marker light lamp and note reading on multimeter.
- (5) If continuity is not present, replace marker light lamp (para 7-31).
- (6) Install marker light lamp in socket.
- (7) Install lens cover on marker light base with two screws.

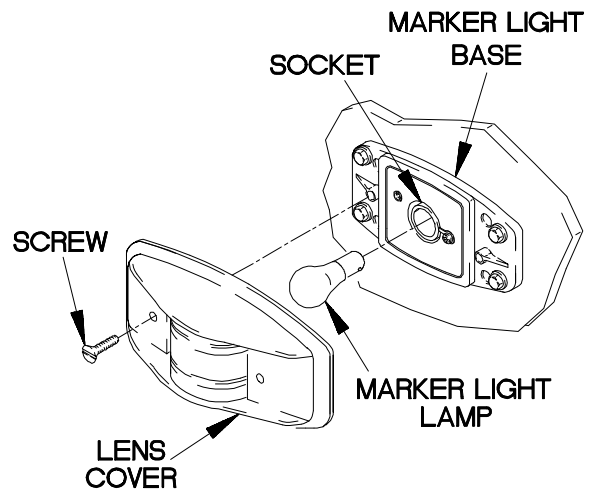

XBE4813B

e47. SIDE AND/OR REAR MARKER LIGHT(S) DO NOT ILLUMINATE (CONT)

KNOWN INFO
Other marker lights illuminate. Rear composite lights illuminate. Dashboard cable assembly OK. Lamp OK.
POSSIBLE PROBLEMS
Faulty marker light. Faulty rear lights cable assembly.

14.

WARNING
CAUTION
Read WARNING and CAUTION on following page.

Is 12 VDC present at connector?

TEST OPTIONS
Voltage Test or STE/ICE-R Test #89
REASON FOR QUESTION
If 12 VDC is not present, wire 489 is faulty.

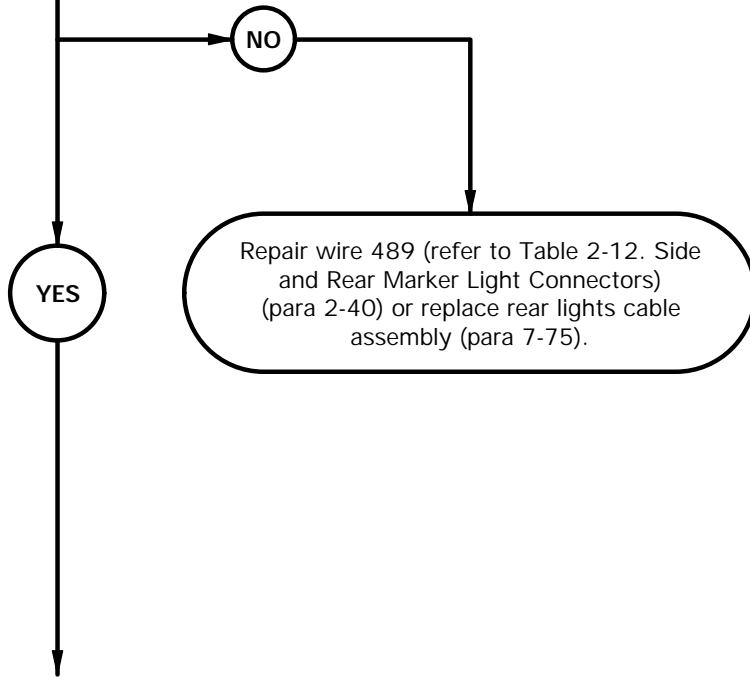

WARNING

Remove rings, bracelets, watches, necklaces, and any other jewelry before working around vehicle. Jewelry can catch on equipment and cause injury or short across electrical circuits and cause severe burns or electrical shock.

CAUTION

Use care when testing electrical connectors. Do not damage connector pins or sockets with multimeter probes. Failure to comply may result in damage to equipment.

NOTE

Use care when testing electrical connectors. Do not damage connector pins or sockets with multimeter probes. Failure to comply may result in damage to equipment.

VOLTAGE TEST

- (1) Disconnect marker light connector from connector (refer to Table 2-12. Side and Rear Marker Light Connectors).
- (2) Set multimeter to volts DC.
- (3) Connect positive (+) probe of multimeter to connector (refer to Table 2-12. Side and Rear Marker Light Connectors).
- (4) Connect negative (-) probe of multimeter to ground.
- (5) Position main light switch to SER DRIVE (TM 9-2320-365-10) and note reading on multimeter.
- (6) Position main light switch to OFF (TM 9-2320-365-10).
- (7) If 12 VDC is not present, repair wire 489 (refer to Table 2-12. Side and Rear Marker Light Connectors) (para 2-40) or replace rear lights cable assembly (para 7-75).

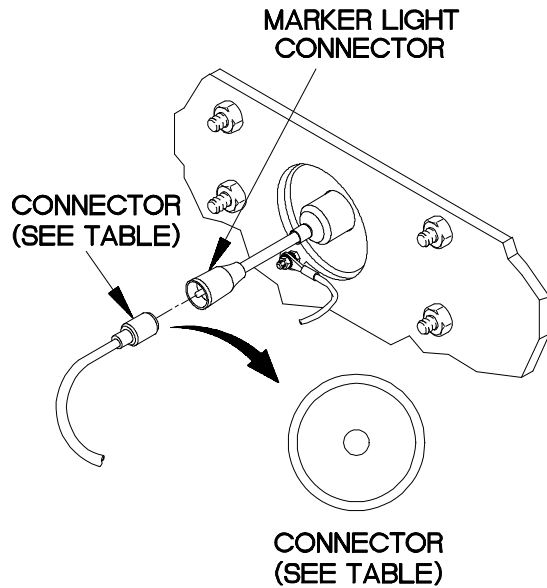

XBE4814B

Table 2-12. Side and Rear Marker Light Connectors

Marker Light	Connector	Wire 489 Segment
LH Side	P85	Connector P85 to Splice E16
LH Rear	P86	Connector P86 to Splice E15
Left Rear	P54	Connector P54 to Splice E15
Middle Rear	P56	Connector P56 to Splice E15
Right Rear	P58	Connector P58 to Splice E15
RH Rear	P89	Connector P89 to Splice E17
RH Side	P88	Connector P88 to Splice E17

e47. SIDE AND/OR REAR MARKER LIGHT(S) DO NOT ILLUMINATE (CONT)

KNOWN INFO
Other marker lights illuminate. Rear composite lights illuminate. Dashboard cable assembly OK. Lamp OK.
POSSIBLE PROBLEMS
Faulty marker light. Faulty rear lights cable assembly.

15.
Is continuity present from terminal lug to ground?

TEST OPTIONS
Continuity Test or STE/ICE-R Test #91
REASON FOR QUESTION
If continuity is not present, wire (refer to Table 2-12.1. Side and Rear Marker Light Terminal Lugs) is faulty.

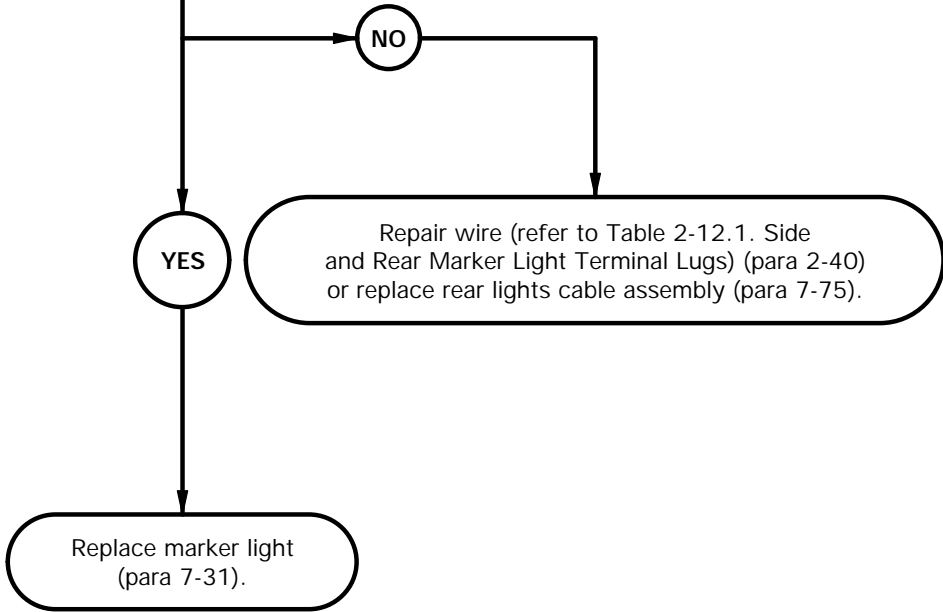

CONTINUITY TEST	
(1)	Remove nut, lockwasher, terminal lug, and lockwasher from marker light screw. Discard lockwashers.
(2)	Set multimeter to ohms.
(3)	Connect positive (+) probe of multimeter to terminal lug (refer to Table 2-12.1 Side and Rear Marker Light Terminal Lugs).
(4)	Connect negative (-) probe of multimeter to ground and note reading on multimeter.
(5)	If continuity is not present, repair wire (refer to Table 2-12.1 Side and Rear Marker Light Terminal Lugs) (para 2-40) or replace rear lights cable assembly (para 7-75).
(6)	If continuity is present, replace marker light (para 7-31).
(7)	Install lockwasher, terminal lug, lockwasher, and nut on marker light screw.
(8)	Connect marker light connector to connector (refer to Table 2-12.1. Side and Rear Marker Light Connectors).

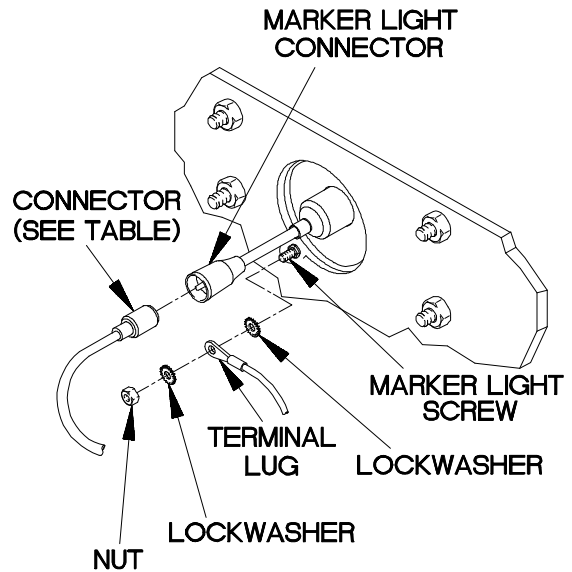

Table 2-12.1. Side and Rear Marker Light Terminal Lugs

Marker Light	Connector	Wire Segment
LH Side	TL15	Wire 3094 from Terminal Lug TL15 to Terminal Lug TL16
LH Rear	TL16	Replace Marker Light (para 7-38)
Left Rear	TL30	Wire 3094 from Terminal Lug TL31 to Terminal Lug TL30
Middle Rear	TL31	Replace Marker Light (para 7-38)
Right Rear	TL32	Replace Marker Light (para 7-38)
RH Rear	TL20	Replace Marker Light (para 7-38)
RH Side	TL19	Wire 3095 from Terminal Lug TL19 to Terminal Lug TL20

XBE4815B

e47. SIDE AND/OR REAR MARKER LIGHT(S) DO NOT ILLUMINATE (CONT)

KNOWN INFO
Other marker lights illuminate. Rear composite lights illuminate. Dashboard cable assembly OK.
POSSIBLE PROBLEMS
Faulty lamp. Faulty marker light. Faulty rear lights cable assembly.

TEST OPTIONS
Visual Inspection
REASON FOR QUESTION
This question eliminates possible problems and determines where troubleshooting continues.

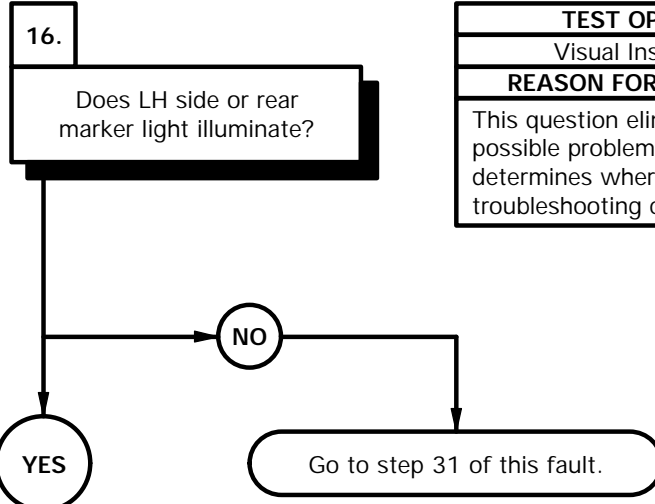

KNOWN INFO
Other marker lights illuminate. Rear composite lights illuminate. Dashboard cable assembly OK.
POSSIBLE PROBLEMS
Faulty lamp. Faulty marker light. Faulty rear lights cable assembly.

TEST OPTIONS
Visual Inspection
REASON FOR QUESTION
This question eliminates possible problems and determines where troubleshooting continues.

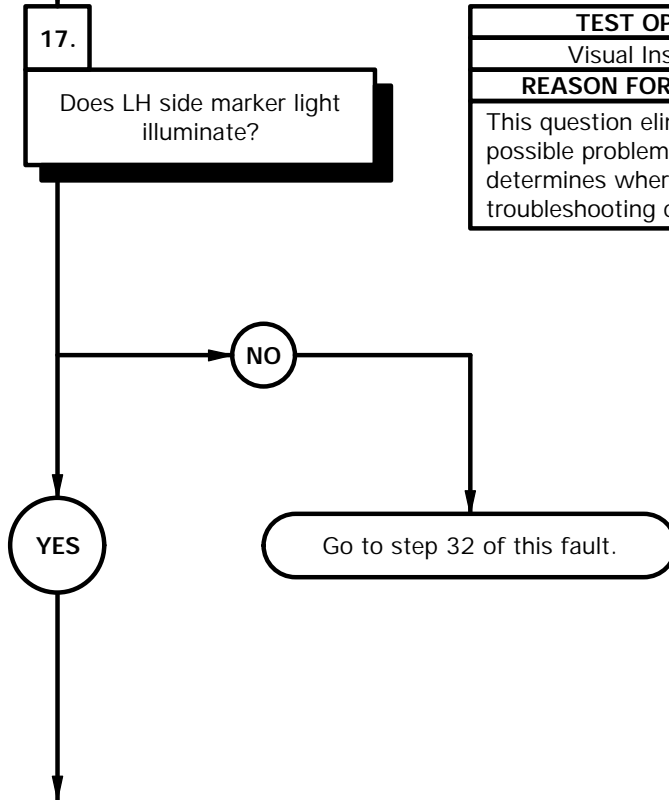

└ If LH side and rear marker lights do not illuminate, go to step 31 of this fault.



└ If LH side marker light does not illuminate, go to step 32 of this fault.



e47. SIDE AND/OR REAR MARKER LIGHT(S) DO NOT ILLUMINATE (CONT)

KNOWN INFO
Other marker lights illuminate. Rear composite lights illuminate. Dashboard cable assembly OK.
POSSIBLE PROBLEMS
Faulty lamp. Faulty marker light. Faulty rear lights cable assembly.

18.
Is continuity present through LH rear marker light lamp?

TEST OPTIONS
Continuity Test or STE/ICE-R Test #91
REASON FOR QUESTION
If continuity is not present, LH rear marker light lamp is faulty.

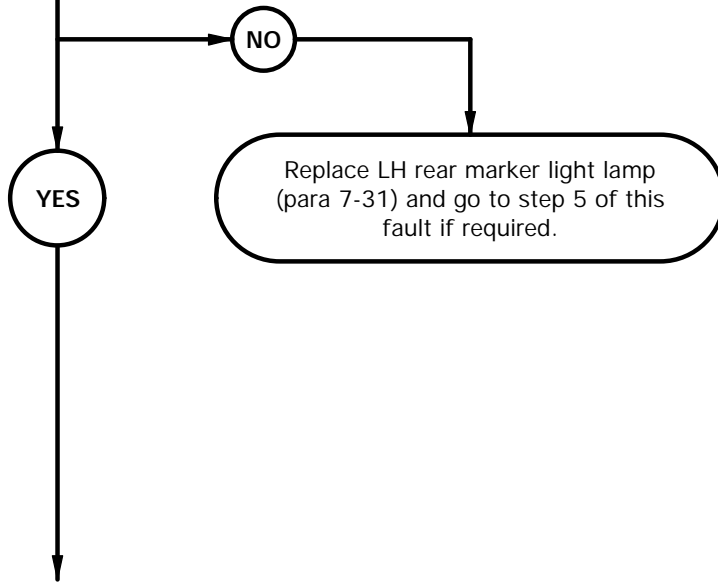

CONTINUITY TEST

- (1) Remove two screws and lens cover from LH rear marker light base.
- (2) Remove LH rear marker light lamp from socket.
- (3) Set multimeter to ohms.
- (4) Check continuity through LH rear marker light lamp and note reading on multimeter.
- (5) If continuity is not present, replace LH rear marker light lamp (para 7-31) and go to step 5 of this fault if required.
- (6) Install LH rear marker light lamp in socket.
- (7) Install lens cover on LH rear marker light base with two screws.

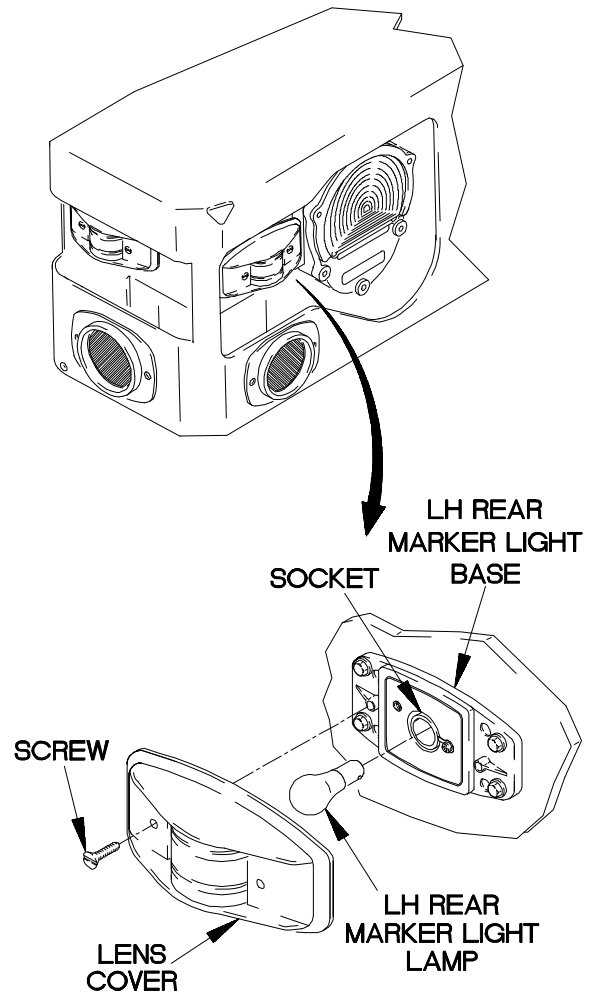

XBE4819B

e47. SIDE AND/OR REAR MARKER LIGHT(S) DO NOT ILLUMINATE (CONT)

KNOWN INFO
Other marker lights illuminate. Rear composite lights illuminate. Dashboard cable assembly OK.
POSSIBLE PROBLEMS
Faulty lamp. Faulty marker light. Faulty rear lights cable assembly.

19.

WARNING

CAUTION

Read **WARNING** and **CAUTION** on following page.

Is 12 VDC present at connector P86?

TEST OPTIONS
Voltage Test or STE/ICE-R Test #89
REASON FOR QUESTION
If 12 VDC is not present, wire 489 is faulty. If 12 VDC is present, LH rear marker light is faulty.

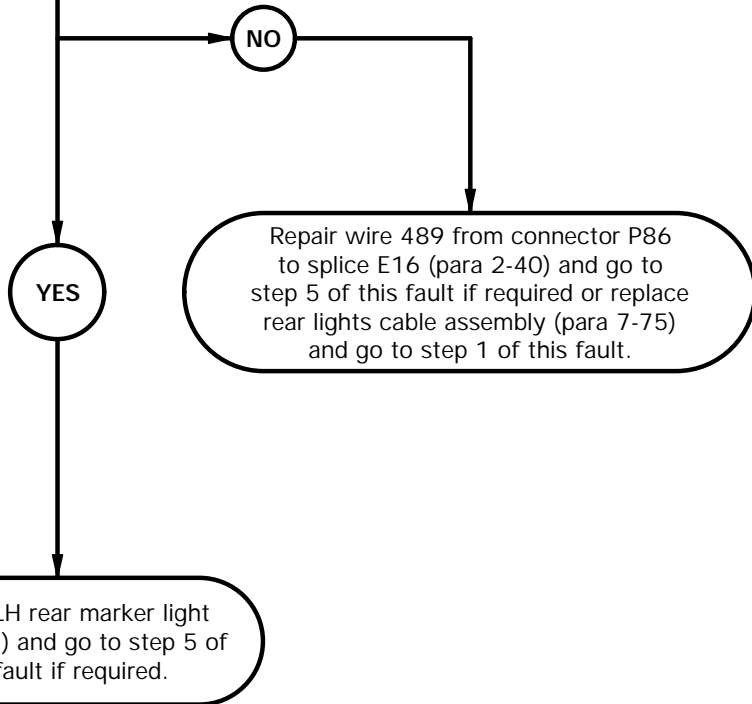

WARNING

Remove rings, bracelets, watches, necklaces, and any other jewelry before working around vehicle. Jewelry can catch on equipment and cause injury or short across electrical circuits and cause severe burns or electrical shock.

CAUTION

Use care when testing electrical connectors. Do not damage connector pins or sockets with multimeter probes. Failure to comply may result in damage to equipment.

NOTE

Inspect connector pins/sockets for damage, corrosion, and serviceability. Check that connector pins are not pushed back and are capable of making good contact.

VOLTAGE TEST

- (1) Disconnect connector P86 from LH rear marker light connector.
- (2) Set multimeter to volts DC.
- (3) Connect positive (+) probe of multimeter to connector P86.
- (4) Connect negative (-) probe of multimeter to ground.
- (5) Position main light switch to SER DRIVE (TM 9-2320-365-10) and note reading on multimeter.
- (6) If 12 VDC is not present, repair wire 489 from connector P86 to splice E16 (para 2-40) and go to step 5 of this fault if required or replace rear lights cable assembly (para 7-75) and go to step 1 of this fault.
- (7) If 12 VDC is present, replace LH rear marker light (para 7-31) and go to step 5 of this fault if required.
- (8) Position main light switch to OFF (TM 9-2320-365-10).
- (9) Connect LH rear marker light connector to connector P86.

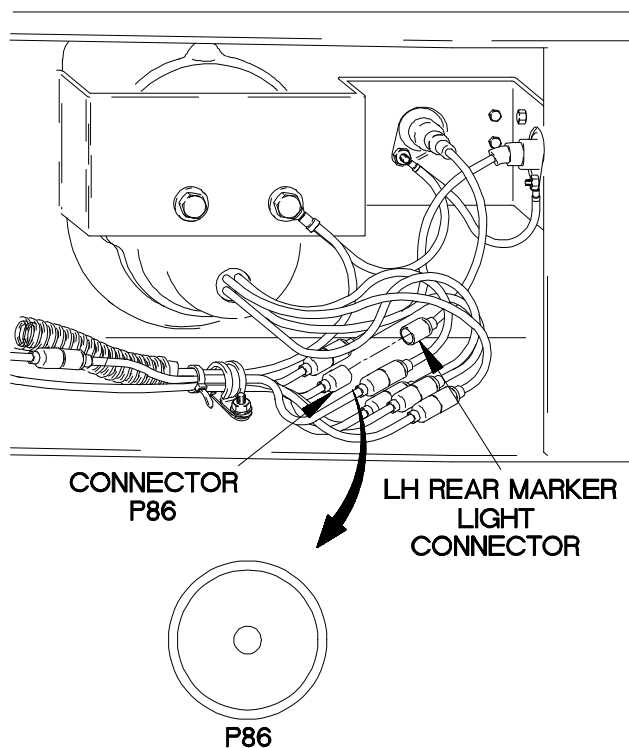

Xbe4820b

e47. SIDE AND/OR REAR MARKER LIGHT(S) DO NOT ILLUMINATE (CONT)

KNOWN INFO
Other marker lights illuminate. Rear composite lights illuminate. Dashboard cable assembly OK.
POSSIBLE PROBLEMS
Faulty lamp. Faulty marker light. Faulty rear lights cable assembly.

TEST OPTIONS
Visual Inspection
REASON FOR QUESTION
This question eliminates possible problems and determines where troubleshooting continues.

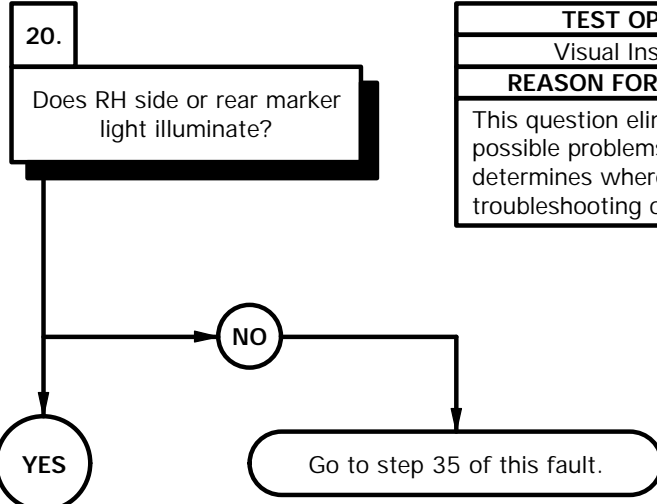

KNOWN INFO
Other marker lights illuminate. Rear composite lights illuminate. Dashboard cable assembly OK.
POSSIBLE PROBLEMS
Faulty lamp. Faulty marker light. Faulty rear lights cable assembly.

TEST OPTIONS
Visual Inspection
REASON FOR QUESTION
This question eliminates possible problems and determines where troubleshooting continues.

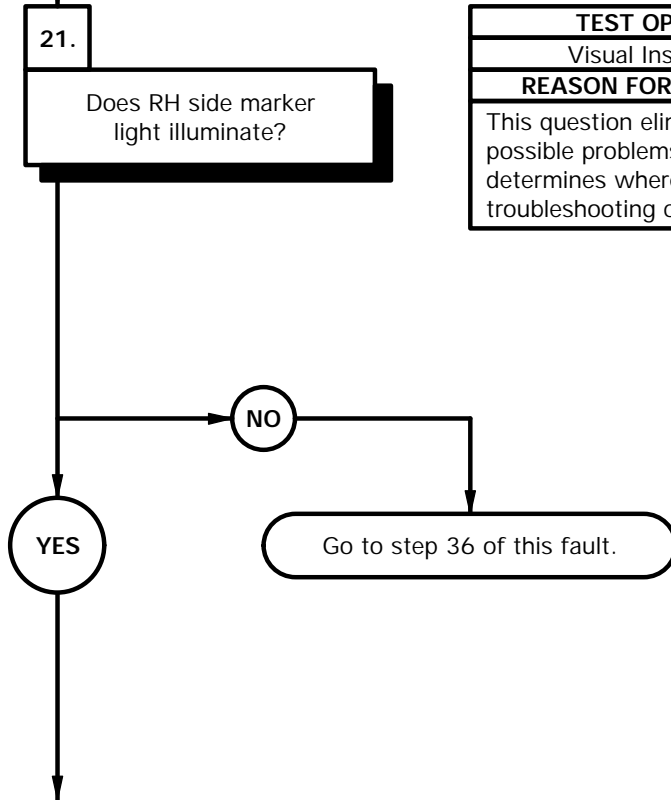

┆ If RH side or rear marker light does not illuminate,
go to step 35 of this fault.



┆ If RH side marker light does not illuminate,
go to step 36 of this fault.



e47. SIDE AND/OR REAR MARKER LIGHT(S) DO NOT ILLUMINATE (CONT)

KNOWN INFO
Other marker lights illuminate. Rear composite lights illuminate. Dashboard cable assembly OK.
POSSIBLE PROBLEMS
Faulty lamp. Faulty marker light. Faulty rear lights cable assembly.

22.
Is continuity present through RH rear marker light lamp?

TEST OPTIONS
Continuity Test or STE/ICE-R Test #91
REASON FOR QUESTION
If continuity is not present, RH rear marker light lamp is faulty.

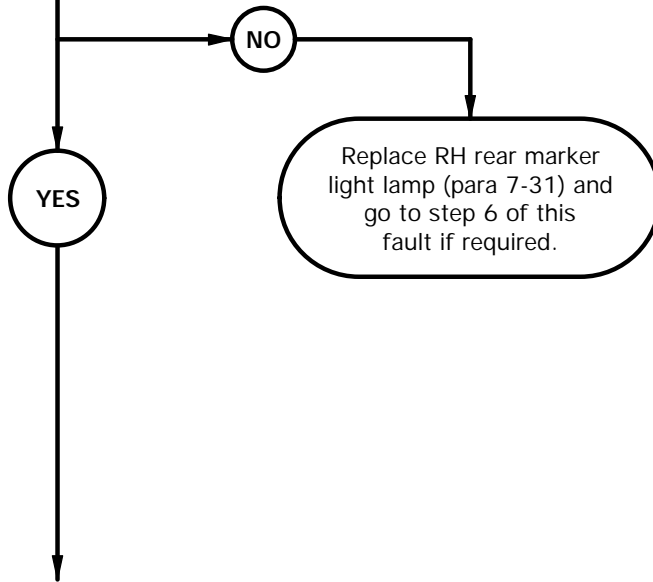

CONTINUITY TEST

- (1) Remove two screws and lens cover from RH rear marker light base.
- (2) Remove RH rear marker light lamp from socket.
- (3) Set multimeter to ohms.
- (4) Check continuity through RH rear marker light lamp and note reading on multimeter.
- (5) If continuity is not present, replace RH rear marker light lamp (para 7-31) and go to step 6 of this fault if required.
- (6) Install RH rear marker light lamp in socket.
- (7) Install lens cover on RH rear marker light base with two screws.

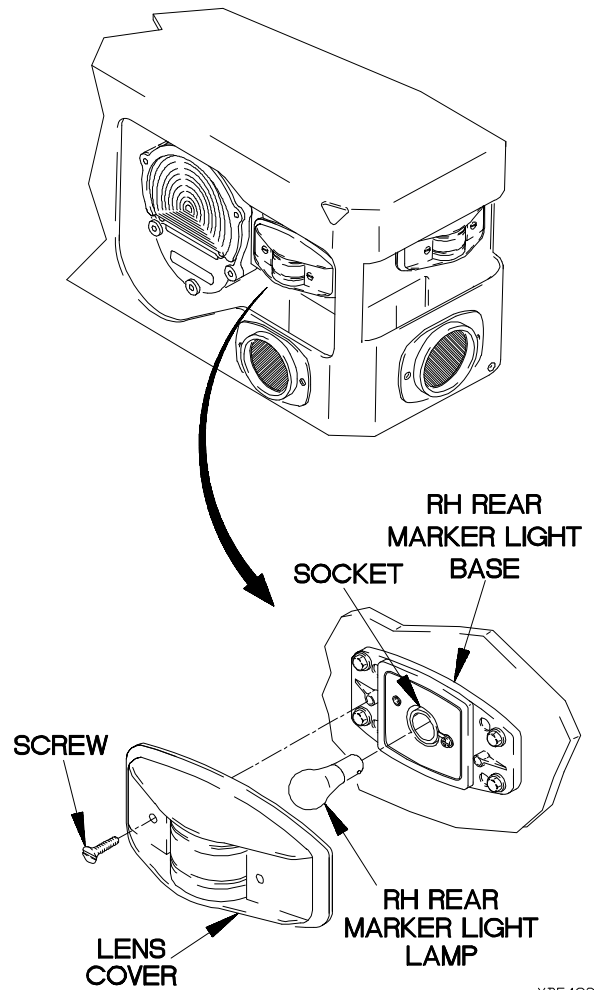

XBE4823B

e47. SIDE AND/OR REAR MARKER LIGHT(S) DO NOT ILLUMINATE (CONT)

KNOWN INFO
Other marker lights illuminate. Rear composite lights illuminate. Dashboard cable assembly OK.
POSSIBLE PROBLEMS
Faulty lamp. Faulty marker light. Faulty rear lights cable assembly.

23.

WARNING

CAUTION

Read **WARNING** and **CAUTION** on following page.

Is 12 VDC present at connector P89?

TEST OPTIONS
Voltage Test or STE/ICE-R Test #89
REASON FOR QUESTION
If 12 VDC is not present, wire 489 is faulty. If 12 VDC is present RH rear marker light is faulty.

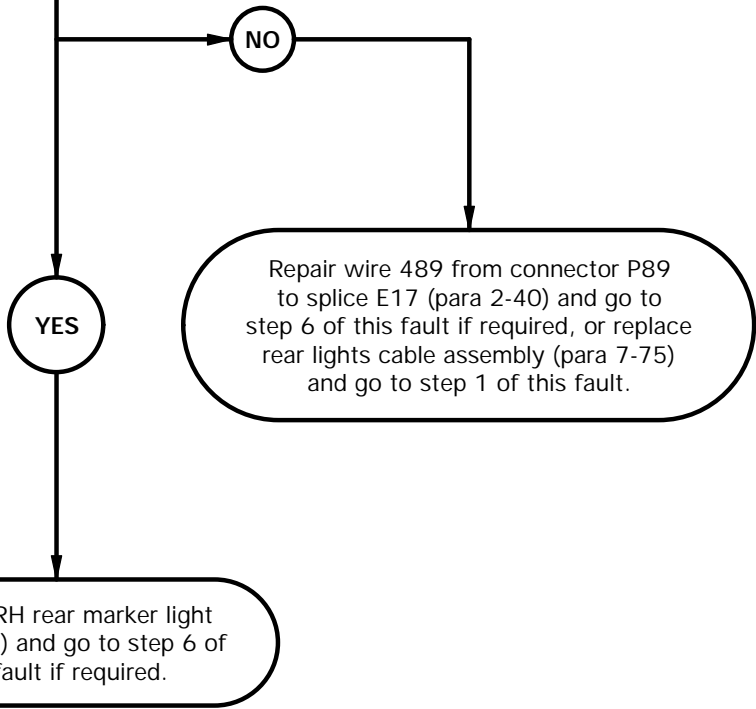

WARNING

Remove rings, bracelets, watches, necklaces, and any other jewelry before working around vehicle. Jewelry can catch on equipment and cause injury or short across electrical circuits and cause severe burns or electrical shock.

CAUTION

Use care when testing electrical connectors. Do not damage connector pins or sockets with multimeter probes. Failure to comply may result in damage to equipment.

NOTE

Inspect connector pins/sockets for damage, corrosion, and serviceability. Check that connector pins are not pushed back and are capable of making good contact.

VOLTAGE TEST

- (1) Disconnect connector P89 from RH rear marker light connector.
- (2) Set multimeter to volts DC.
- (3) Connect positive (+) probe of multimeter to connector P89.
- (4) Connect negative (-) probe of multimeter to ground.
- (5) Position main light switch to SER DRIVE (TM 9-2320-365-10) and note reading on multimeter.
- (6) If 12 VDC is not present, repair wire 489 from connector P89 to splice E17 (para 2-40) and go to step 6 of this fault if required or replace rear lights cable assembly (para 7-75) and go to step 1 of this fault.
- (7) If 12 VDC is present, replace RH rear marker light (para 7-31) and go to step 6 of this fault.
- (8) Position main light switch to OFF (TM 9-2320-365-10).
- (9) Connect RH rear marker light connector to connector P89.

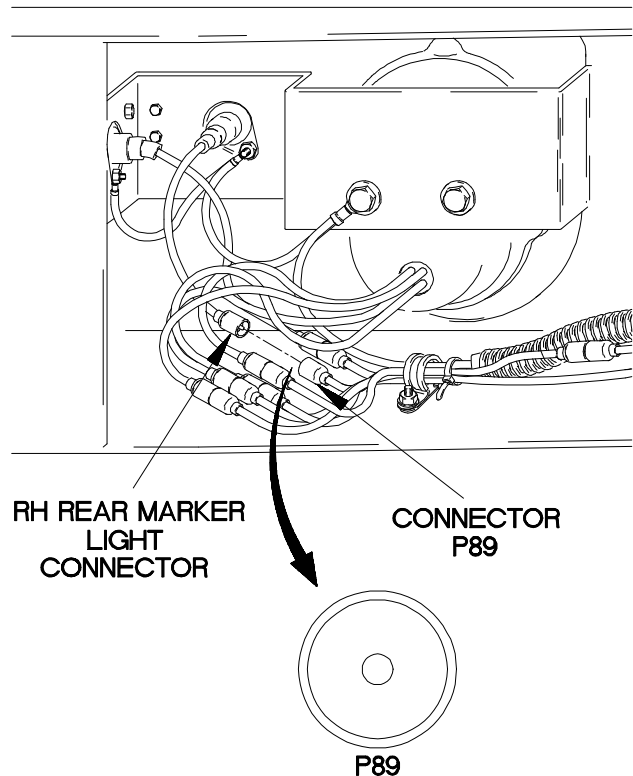

XBE4824B

e47. SIDE AND/OR REAR MARKER LIGHT(S) DO NOT ILLUMINATE (CONT)

KNOWN INFO
Other marker lights illuminate. Rear composite lights illuminate. Dashboard cable assembly OK.
POSSIBLE PROBLEMS
Faulty lamp. Faulty marker light. Faulty rear lights cable assembly.

24.
Is continuity present through RH rear marker light lamp?

TEST OPTIONS
Continuity Test or STE/ICE-R Test #91
REASON FOR QUESTION
If continuity is not present, RH rear marker light lamp is faulty.

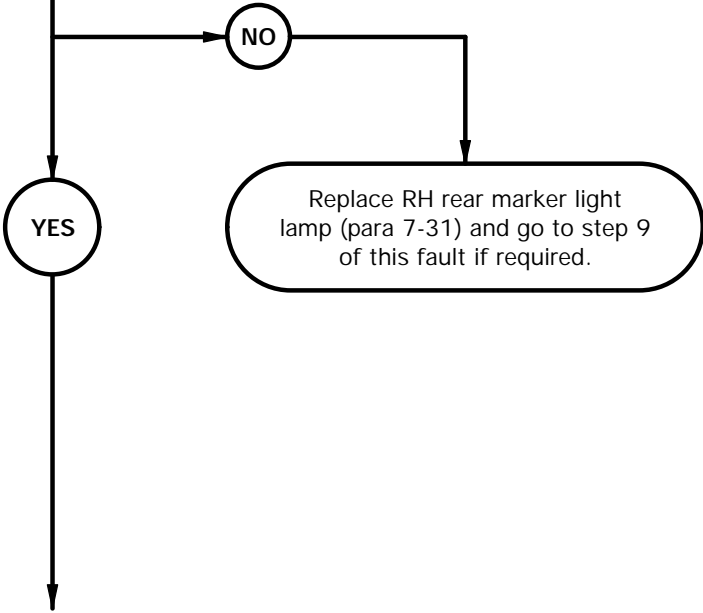

CONTINUITY TEST

- (1) Remove two screws and lens cover from RH rear marker light base.
- (2) Remove RH rear marker light lamp from socket.
- (3) Set multimeter to ohms.
- (4) Check continuity through RH rear marker light lamp and note reading on multimeter.
- (5) If continuity is not present, replace RH rear marker light lamp (para 7-31) and go to step 9 of this fault if required.
- (6) Install RH rear marker light lamp in socket.
- (7) Install lens cover on RH rear marker light base with two screws.

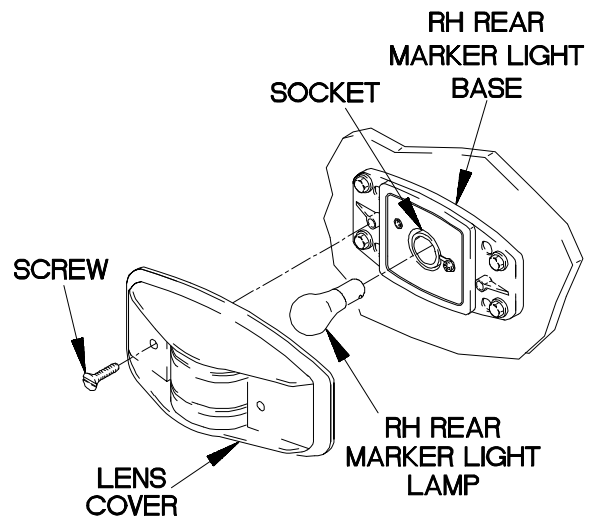

XBE4825B

e47. SIDE AND/OR REAR MARKER LIGHT(S) DO NOT ILLUMINATE (CONT)

KNOWN INFO
Other marker lights illuminate. Rear composite lights illuminate. Dashboard cable assembly OK.
POSSIBLE PROBLEMS
Faulty lamp. Faulty marker light. Faulty rear lights cable assembly.

25.

WARNING

CAUTION

Read **WARNING** and **CAUTION** on following page.

Is 12 VDC present at connector P58?

TEST OPTIONS
Voltage Test or STE/ICE-R Test #89
REASON FOR QUESTION
If 12 VDC is not present, wire 489 is faulty. If 12 VDC is present, RH rear marker light is faulty.

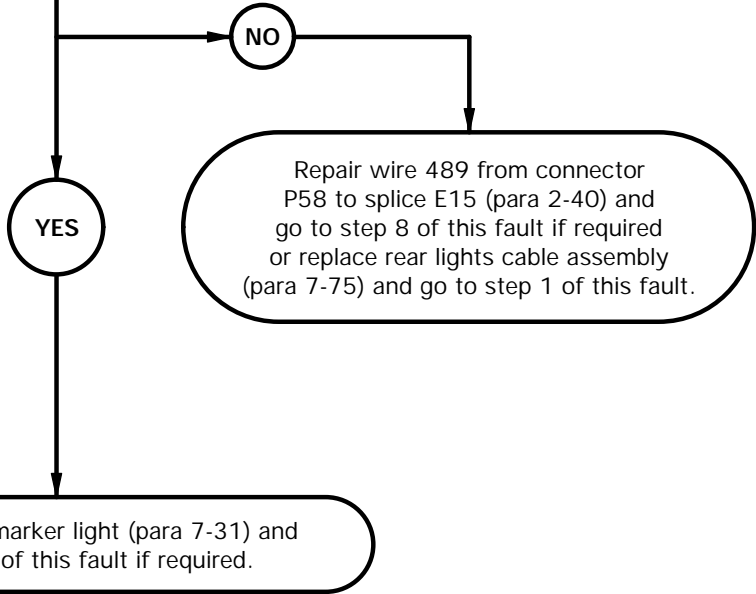

WARNING

Remove rings, bracelets, watches, necklaces, and any other jewelry before working around vehicle. Jewelry can catch on equipment and cause injury or short across electrical circuits and cause severe burns or electrical shock.

CAUTION

Use care when testing electrical connectors. Do not damage connector pins or sockets with multimeter probes. Failure to comply may result in damage to equipment.

NOTE

Inspect connector pins/sockets for damage, corrosion, and serviceability. Check that connector pins are not pushed back and are capable of making good contact.

VOLTAGE TEST

- (1) Disconnect connector P58 from RH rear marker light connector.
- (2) Set multimeter to volts DC.
- (3) Connect positive (+) probe of multimeter to connector P58.
- (4) Connect negative (-) probe of multimeter to ground.
- (5) Position main light switch to SER DRIVE (TM 9-2320-365-10) and note reading on multimeter.
- (6) If 12 VDC is not present, repair wire 489 from connector P58 to splice E15 (para 2-40) and go to step 8 of this fault if required or replace rear lights cable assembly (para 7-75) and go to step 1 of this fault.
- (7) If 12 VDC is present, replace RH rear marker light (para 7-31) and go to step 8 of this fault if required.
- (8) Position main light switch to OFF (TM 9-2320-365-10).
- (9) Connect RH rear marker light connector to connector P58.

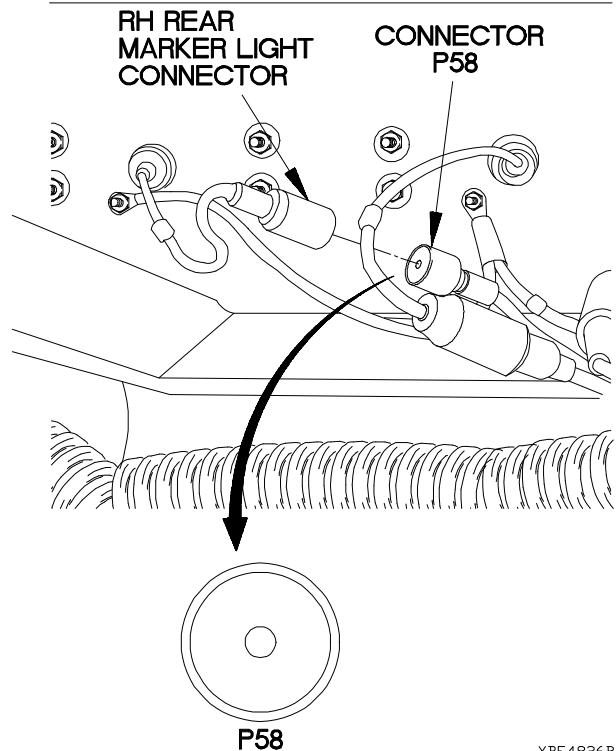

XBE4826B

e47. SIDE AND/OR REAR MARKER LIGHT(S) DO NOT ILLUMINATE (CONT)

KNOWN INFO
Other marker lights illuminate. Rear composite lights illuminate. Dashboard cable assembly OK.
POSSIBLE PROBLEMS
Faulty lamp. Faulty marker light. Faulty rear lights cable assembly.

26.
Is continuity present through middle rear marker light lamp?

TEST OPTIONS
Continuity Test or STE/ICE-R Test #91
REASON FOR QUESTION
If continuity is not present, middle rear marker light lamp is faulty.

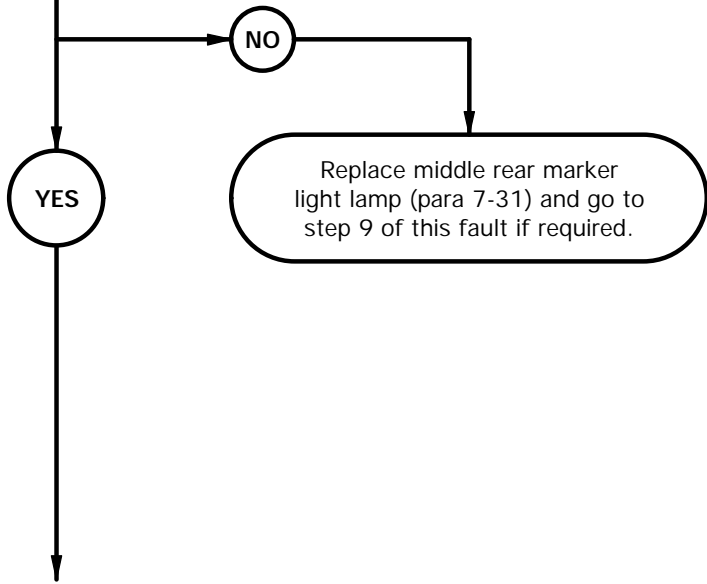

CONTINUITY TEST

- (1) Remove two screws and lens cover from middle rear marker light base.
- (2) Remove middle rear marker light lamp from socket.
- (3) Set multimeter to ohms.
- (4) Check continuity through middle rear marker light lamp and note reading on multimeter.
- (5) If continuity is not present, replace middle rear marker light lamp (para 7-31) and go to step 9 of this fault if required.
- (6) Install middle rear marker light lamp in socket.
- (7) Install lens cover on middle rear marker light base with two screws.

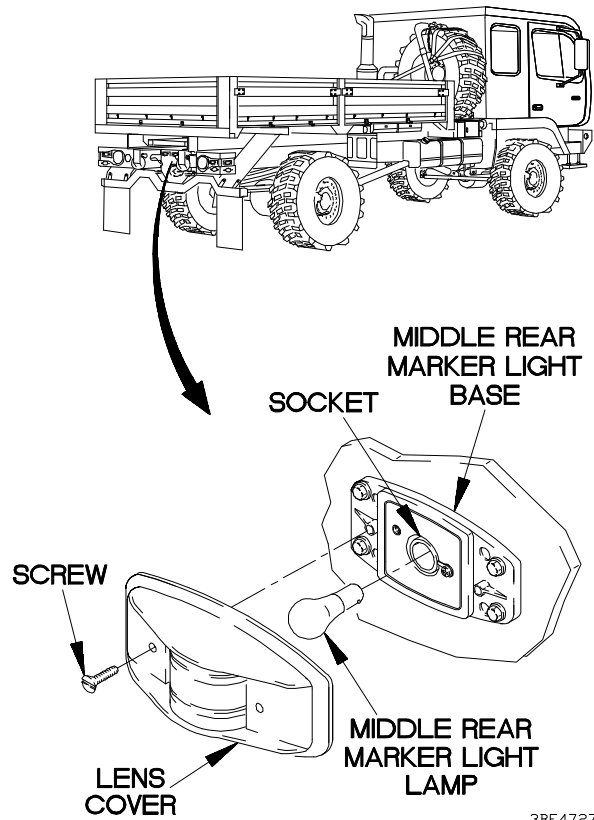

3BE4727B

e47. SIDE AND/OR REAR MARKER LIGHT(S) DO NOT ILLUMINATE (CONT)

KNOWN INFO
Other marker lights illuminate. Rear composite lights illuminate. Dashboard cable assembly OK.
POSSIBLE PROBLEMS
Faulty lamp. Faulty marker light. Faulty rear lights cable assembly.

27.

WARNING

CAUTION

Read **WARNING** and **CAUTION** on following page.

Is 12 VDC present at connector P56?

TEST OPTIONS
Voltage Test or STE/ICE-R Test #89
REASON FOR QUESTION
If 12 VDC is not present, wire 489 is faulty.

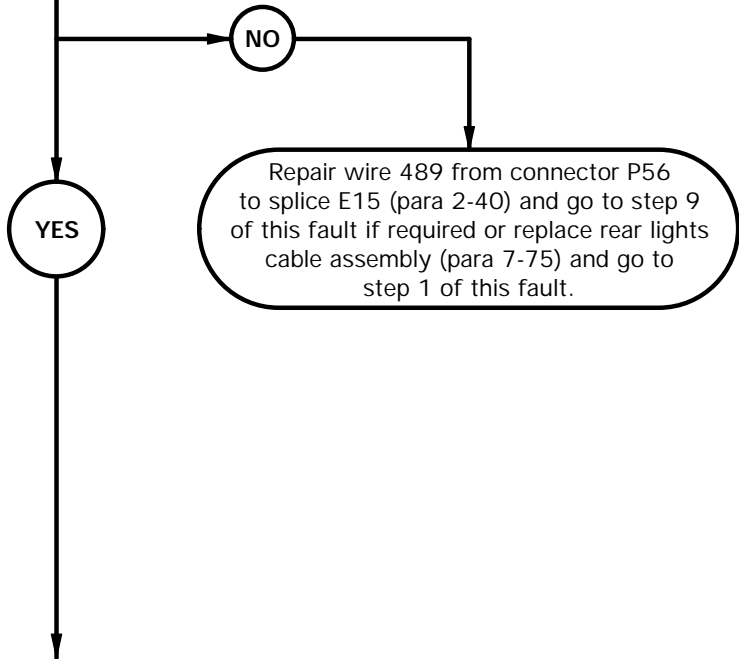

WARNING

Remove rings, bracelets, watches, necklaces, and any other jewelry before working around vehicle. Jewelry can catch on equipment and cause injury or short across electrical circuits and cause severe burns or electrical shock.

CAUTION

Use care when testing electrical connectors. Do not damage connector pins or sockets with multimeter probes. Failure to comply may result in damage to equipment.

NOTE

Inspect connector pins/sockets for damage, corrosion, and serviceability. Check that connector pins are not pushed back and are capable of making good contact.

VOLTAGE TEST

- (1) Disconnect connector P56 from middle rear marker light connector.
- (2) Set multimeter to volts DC.
- (3) Connect positive (+) probe of multimeter to connector P56.
- (4) Connect negative (-) probe of multimeter to ground.
- (5) Position main light switch to SER DRIVE (TM 9-2320-365-10) and note reading on multimeter.
- (6) If 12 VDC is not present, repair wire 489 from connector P56 to splice E15 (para 2-40) and go to step 9 of this fault if required or replace rear lights cable assembly (para 7-75) and go to step 1 of this fault.
- (7) Position main light switch to OFF (TM 9-2320-365-10).
- (8) Connect middle rear marker light connector to connector P56.

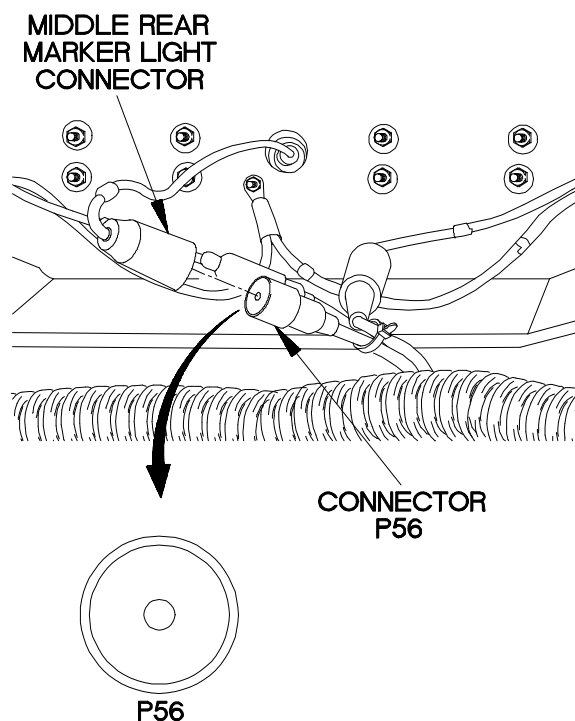

XBE4828B

e47. SIDE AND/OR REAR MARKER LIGHT(S) DO NOT ILLUMINATE (CONT)

KNOWN INFO
Other marker lights illuminate. Rear composite lights illuminate. Dashboard cable assembly OK.
POSSIBLE PROBLEMS
Faulty lamp. Faulty marker light. Faulty rear lights cable assembly.

28.
Is continuity present from terminal lug TL31 to terminal lug TL32?

TEST OPTIONS
Continuity Test or STE/ICE-R Test #91
REASON FOR QUESTION
If continuity is not present, wire 3094 is faulty. If continuity is present, middle rear marker light is faulty.

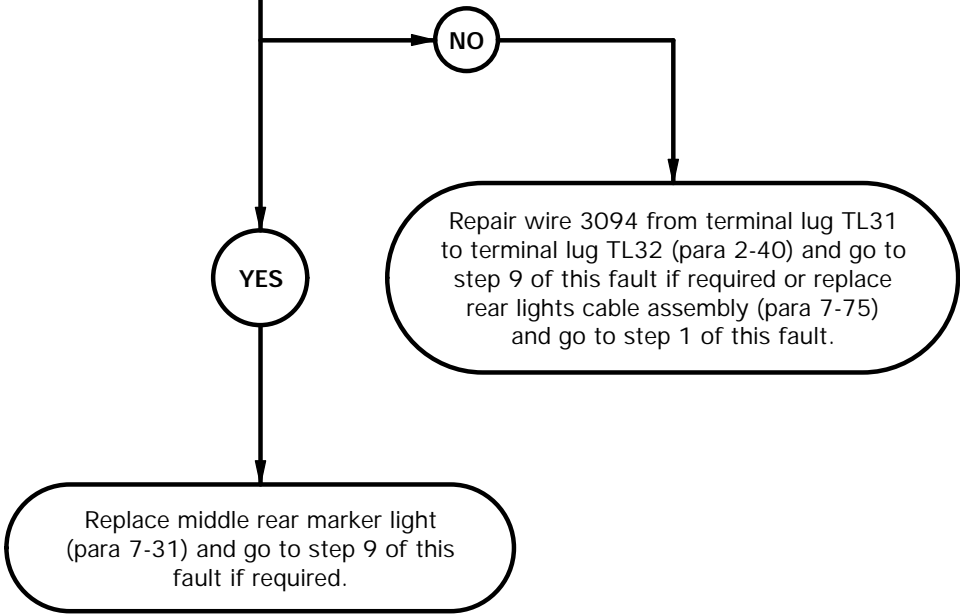

CONTINUITY TEST

- (1) Remove nut, lockwasher, terminal lug TL31, and lockwasher from middle rear marker light screw. Discard lockwashers.
- (2) Remove nut, lockwasher, terminal lug TL32, and lockwasher from RH rear marker light screw. Discard lockwashers.
- (3) Set multimeter to ohms.
- (4) Connect positive (+) probe of multimeter to terminal lug TL31.
- (5) Connect negative (-) probe of multimeter to terminal lug TL32 and note reading on multimeter.
- (6) If continuity is not present, repair wire 3094 from terminal lug TL31 to terminal lug TL32 (para 2-40) and go to step 9 of this fault if required or replace rear lights cable assembly (para 7-75) and go to step 1 of this fault.
- (7) If continuity is present, replace middle rear marker light (para 7-31) and go to step 9 of this fault if required.
- (8) Install lockwasher, terminal lug TL32, lockwasher, and nut on RH rear marker light screw.
- (9) Install lockwasher, terminal lug TL31, lockwasher, and nut on middle rear marker light screw.

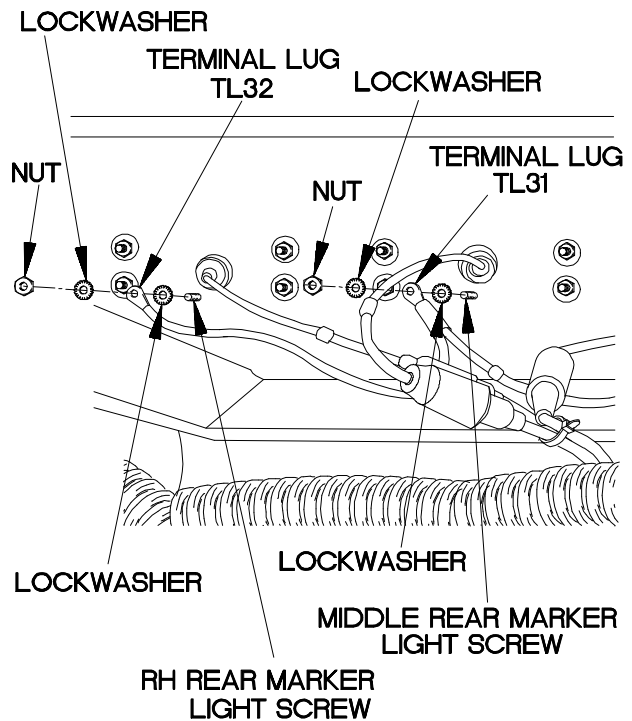

XBE4829B

e47. SIDE AND/OR REAR MARKER LIGHT(S) DO NOT ILLUMINATE (CONT)

KNOWN INFO
Other marker lights illuminate. Rear composite lights illuminate. Dashboard cable assembly OK.
POSSIBLE PROBLEMS
Faulty lamp. Faulty marker light. Faulty rear lights cable assembly.

TEST OPTIONS
Visual Inspection
REASON FOR QUESTION
This question eliminates possible problems and determines where troubleshooting continues.

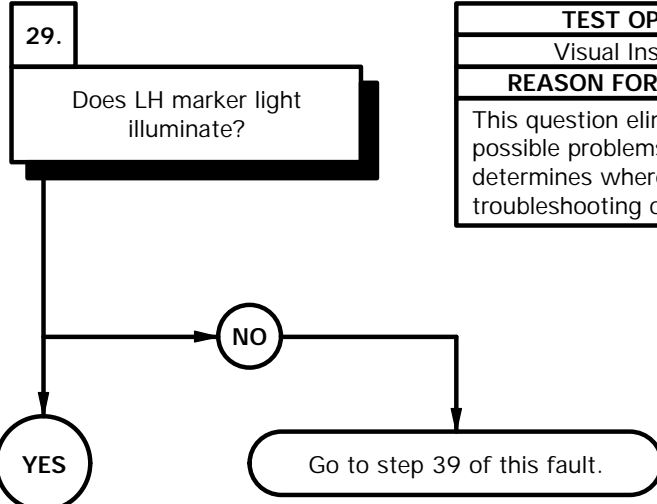

KNOWN INFO
Other marker lights illuminate. Rear composite lights illuminate. Dashboard cable assembly OK.
POSSIBLE PROBLEMS
Faulty lamp. Faulty marker light. Faulty rear lights cable assembly.

TEST OPTIONS
Visual Inspection
REASON FOR QUESTION
This question eliminates possible problems and determines where troubleshooting continues.

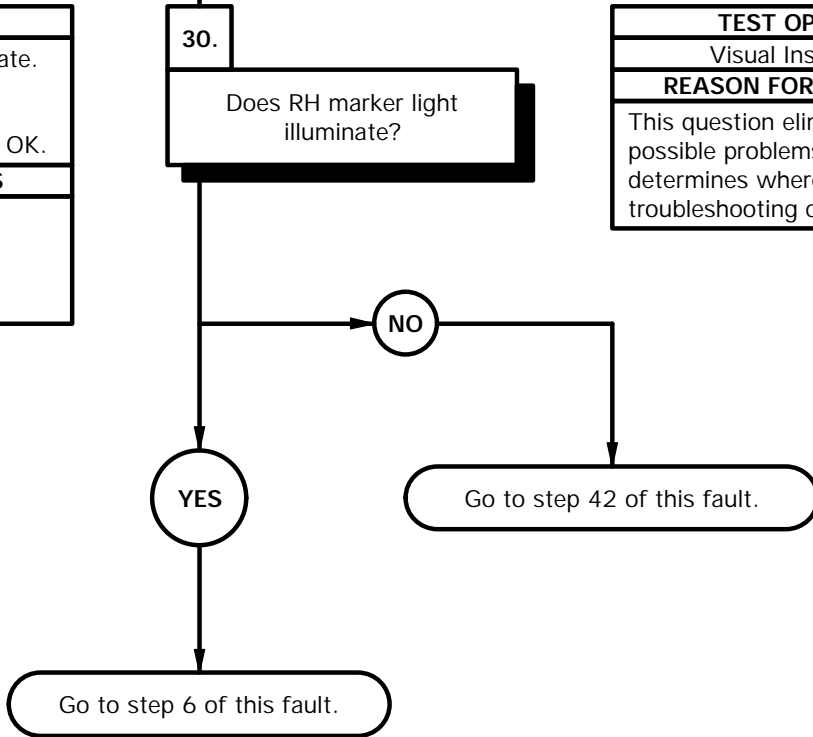

┆ If LH marker light does not illuminate, go to step 39 of this fault.



┆ If RH marker light does not illuminate, go to step 42 of this fault.



e47. SIDE AND/OR REAR MARKER LIGHT(S) DO NOT ILLUMINATE (CONT)

KNOWN INFO
Other marker lights illuminate. Rear composite lights illuminate. Dashboard cable assembly OK.
POSSIBLE PROBLEMS
Faulty rear lights cable assembly.

31.
Is continuity present from terminal lug TL16 to ground?

TEST OPTIONS
Continuity Test or STE/ICE-R Test #91
REASON FOR QUESTION
If continuity is not present, wire 3094 is faulty. If continuity is present, wire 489 is faulty.

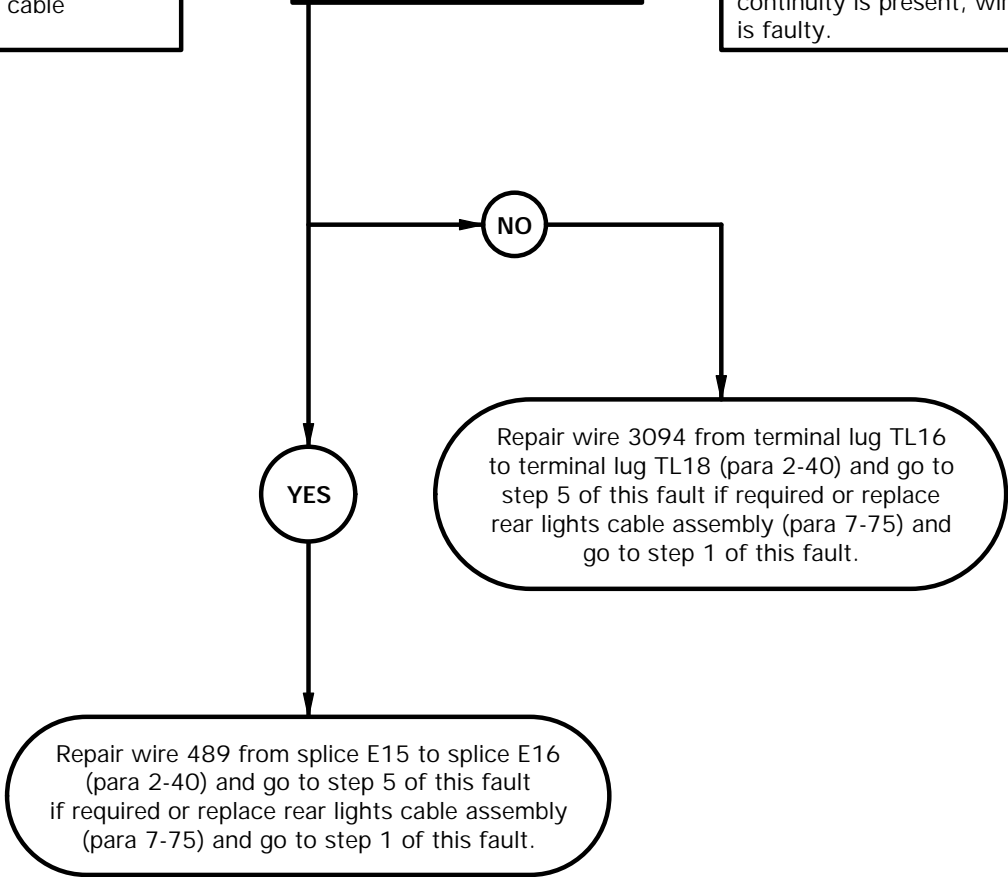

CONTINUITY TEST

- (1) Remove nut, lockwasher, terminal lug TL16 and lockwasher from LH rear marker light screw. Discard lockwashers.
- (2) Set multimeter to ohms.
- (3) Connect positive (+) probe of multimeter to terminal lug TL16.
- (4) Connect negative (-) probe of multimeter to ground and note reading on multimeter.
- (5) If continuity is not present, repair wire 3094 from terminal lug TL16 to ground (para 2-40) and go to step 5 of this fault if required or replace rear lights cable assembly (para 7-75) and go to step 1 of this fault.
- (6) If continuity is present, repair wire 489 from splice E15 to splice E16 (para 2-40) and go to step 5 of this fault if required or replace rear lights cable assembly (para 7-75) and go to step 1 of this fault.
- (7) Install lockwasher, terminal lug TL16, lockwasher, and nut on LH rear marker light screw.

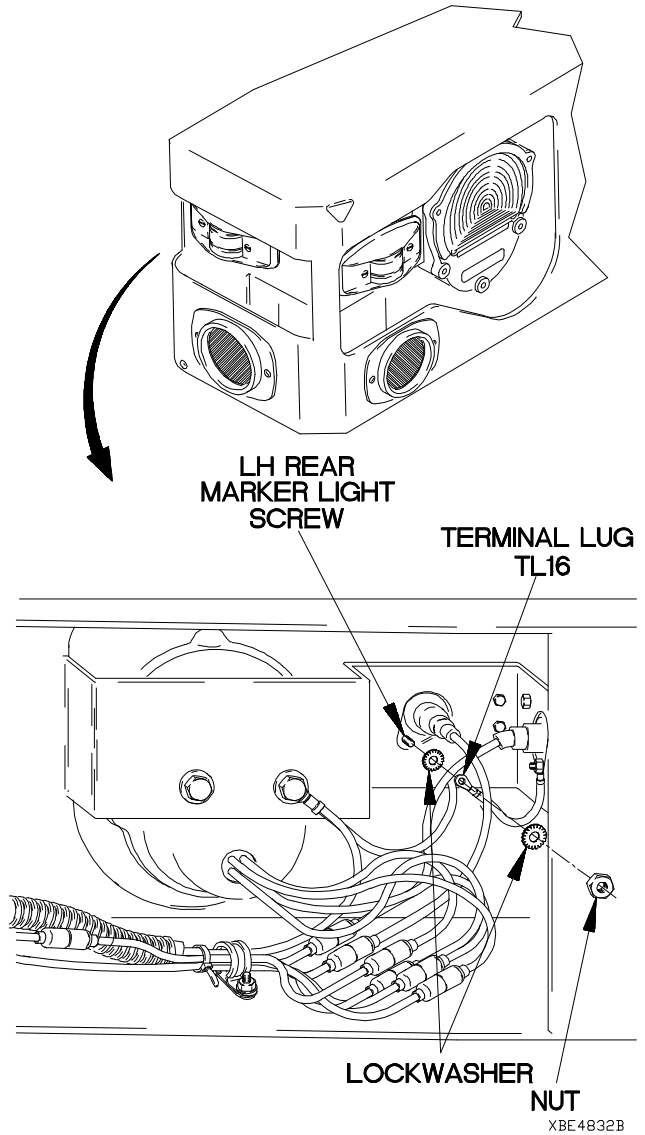

e47. SIDE AND/OR REAR MARKER LIGHT(S) DO NOT ILLUMINATE (CONT)

KNOWN INFO
Other marker lights illuminate. Rear composite lights illuminate. Dashboard cable assembly OK.
POSSIBLE PROBLEMS
Faulty lamp. Faulty marker light. Faulty rear lights cable assembly.

32.
Is continuity present through LH side marker light lamp?

TEST OPTIONS
Continuity Test or STE/ICE-R Test #91
REASON FOR QUESTION
If continuity is not present, LH side marker light lamp is faulty.

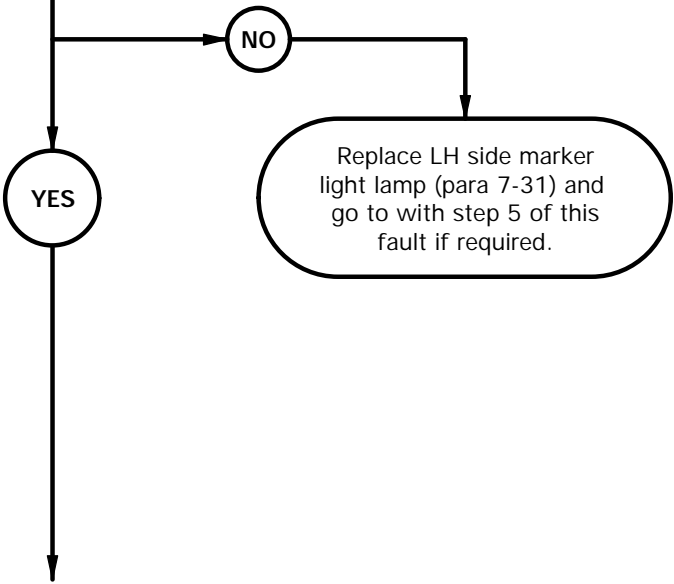

CONTINUITY TEST

- (1) Remove two screws and lens cover from LH side marker light base.
- (2) Remove LH side marker light lamp from socket.
- (3) Set multimeter to ohms.
- (4) Check continuity through LH side marker light lamp and note reading on multimeter.
- (5) If continuity is not present, replace LH side marker light lamp (para 7-31) and go to step 5 of this fault if required.
- (6) Install LH side marker lamp in socket.
- (7) Install lens cover on LH side marker light base with two screws.

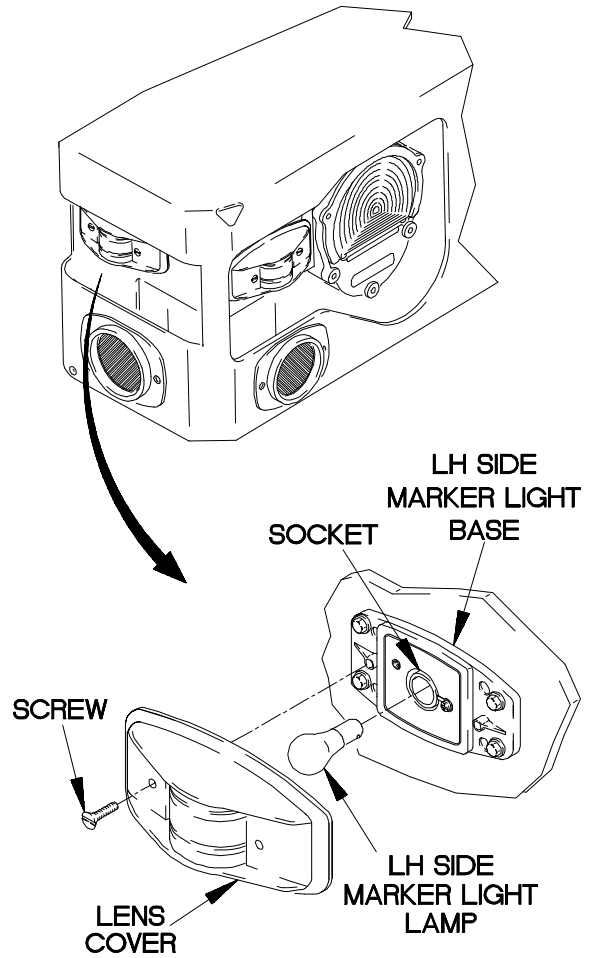

XBE4833B

e47. SIDE AND/OR REAR MARKER LIGHT(S) DO NOT ILLUMINATE (CONT)

KNOWN INFO
Other marker lights illuminate. Rear composite lights illuminate. Dashboard cable assembly OK. Lamp OK.
POSSIBLE PROBLEMS
Faulty marker light. Faulty rear lights cable assembly.

33.

WARNING
CAUTION
Read WARNING and CAUTION on following page.

Is 12 VDC present at connector P85?

TEST OPTIONS
Voltage Test or STE/ICE-R Test #89
REASON FOR QUESTION
If 12 VDC is not present, wire 489 is faulty.

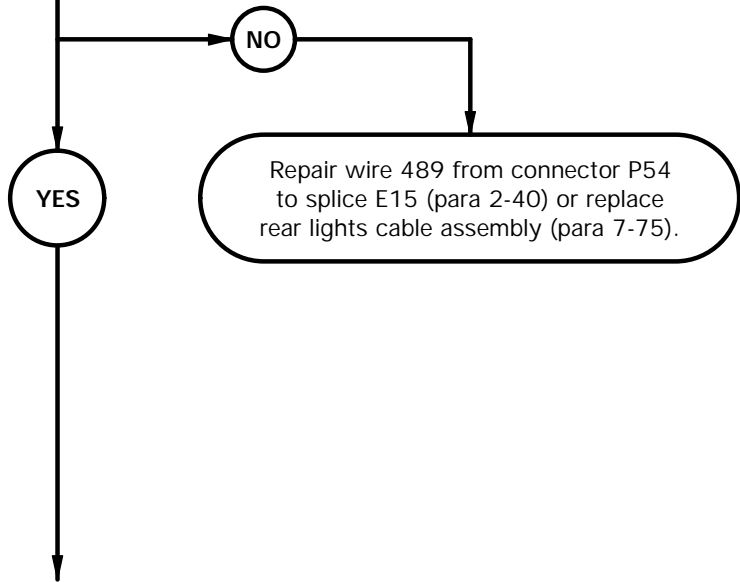

WARNING

Remove rings, bracelets, watches, necklaces, and any other jewelry before working around vehicle. Jewelry can catch on equipment and cause injury or short across electrical circuits and cause severe burns or electrical shock.

CAUTION

Use care when testing electrical connectors. Do not damage connector pins or sockets with multimeter probes. Failure to comply may result in damage to equipment.

NOTE

Inspect connector pins/sockets for damage, corrosion, and serviceability. Check that connector pins are not pushed back and are capable of making good contact.

VOLTAGE TEST

- (1) Disconnect connector P85 from LH side marker light connector.
- (2) Set multimeter to volts DC.
- (3) Connect positive (+) probe of multimeter to connector P85.
- (4) Connect negative (-) probe of multimeter to ground.
- (5) Position main light switch to SER DRIVE (TM 9-2320-365-10) and note reading on multimeter.
- (6) If 12 VDC is not present, repair wire 489 from connector P85 to splice E16 (para 2-40) or replace rear lights cable assembly (para 7-75).
- (7) Position main light switch to OFF (TM 9-2320-365-10).

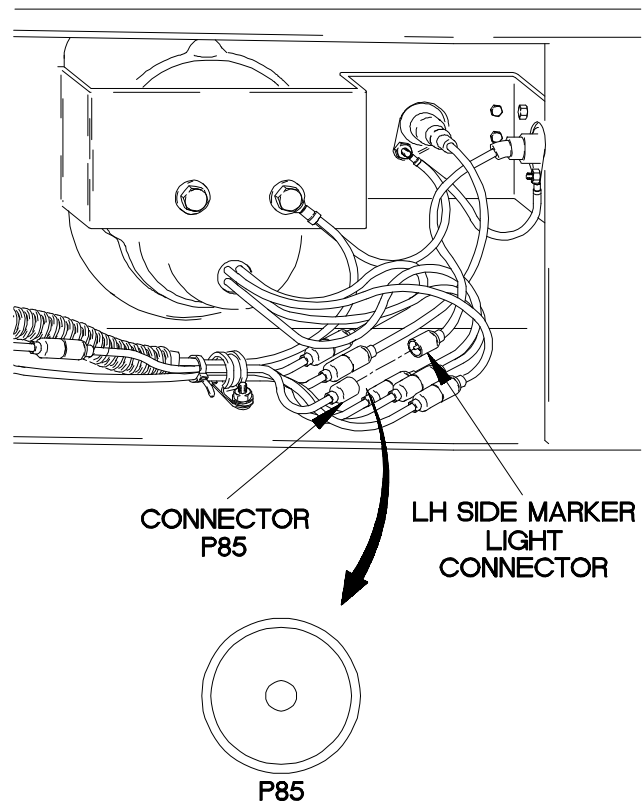

XBE4834B

e47. SIDE AND/OR REAR MARKER LIGHT(S) DO NOT ILLUMINATE (CONT)

KNOWN INFO
Other marker lights illuminate. Rear composite lights illuminate. Dashboard cable assembly OK. Lamp OK.
POSSIBLE PROBLEMS
Faulty marker light. Faulty rear lights cable assembly.

34.
Is continuity present from terminal lug TL15 to ground?

TEST OPTIONS
Continuity Test or STE/ICE-R Test #91
REASON FOR QUESTION
If continuity is not present, wire 3094 is faulty. If continuity is present, LH side marker light is faulty.

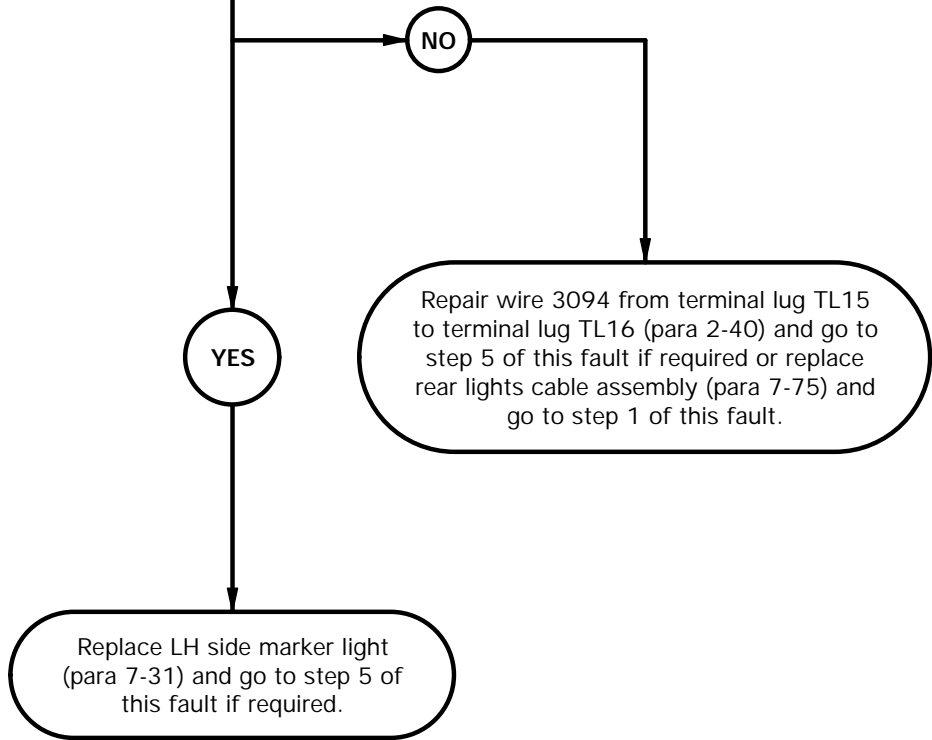

CONTINUITY TEST

- (1) Remove nut, lockwasher, terminal lug TL15, and lockwasher from LH side marker light screw. Discard lockwashers.
- (2) Set multimeter to ohms.
- (3) Connect positive (+) probe of multimeter to terminal lug TL15.
- (4) Connect negative (-) probe of multimeter to ground and note reading on multimeter.
- (5) If continuity is not present, repair wire 3094 from terminal lug TL15 to terminal lug TL16 (para 2-40) and go to step 5 of this fault if required or replace rear lights cable assembly (para 7-75) and go to step 1 of this fault.
- (6) If continuity is present, replace LH side marker light (para 7-31) and go to step 5 of this fault if required.
- (7) Install lockwasher, terminal lug TL15, lockwasher, and nut on LH side marker light screw.
- (8) Connect LH side marker light connector to connector P85.

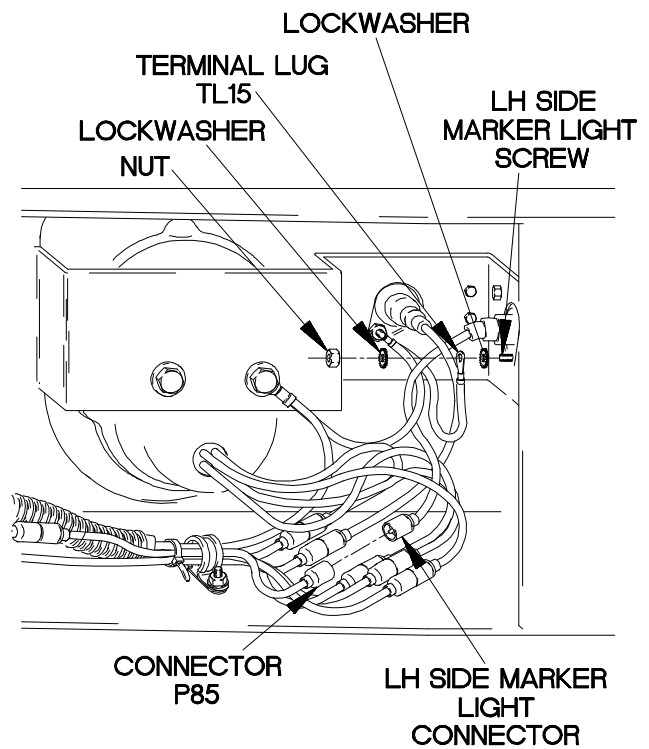

XBE4835B

e47. SIDE AND/OR REAR MARKER LIGHT(S) DO NOT ILLUMINATE (CONT)

KNOWN INFO
Other marker lights illuminate. Rear composite lights illuminate. Dashboard cable assembly OK. Lamp OK.
POSSIBLE PROBLEMS
Faulty rear lights cable assembly.

35.
Is continuity present from terminal lug TL20 to ground?

TEST OPTIONS
Continuity Test or STE/ICE-R Test #91
REASON FOR QUESTION
If continuity is not present, wire 3095 is faulty. If continuity is present, wire 489 is faulty.

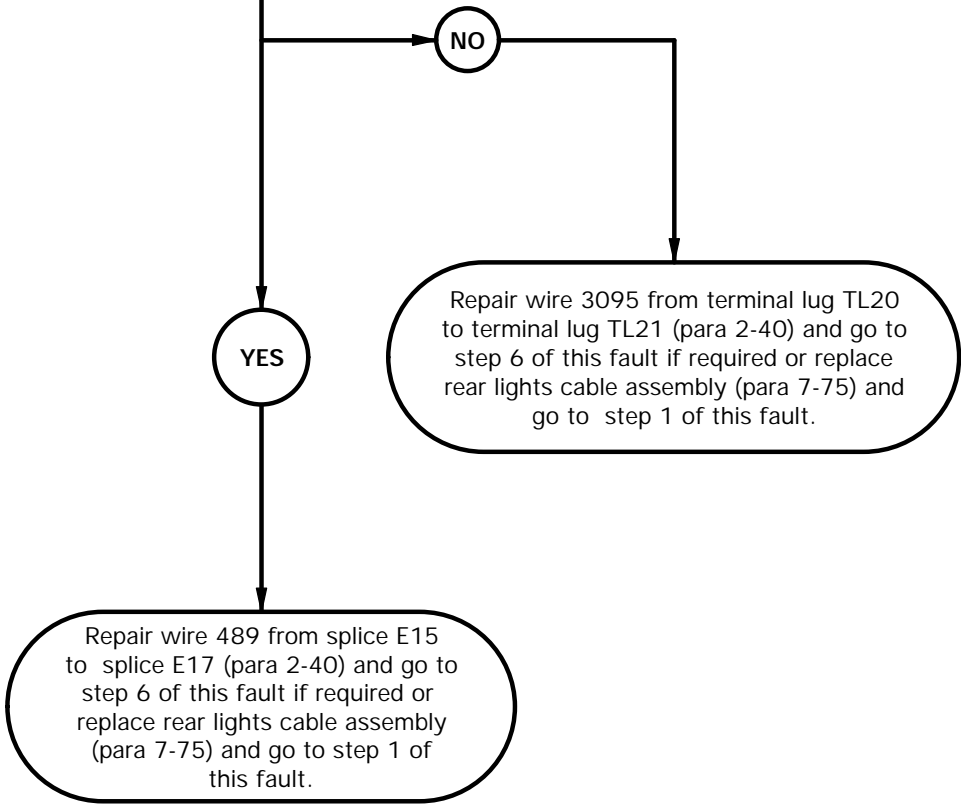

CONTINUITY TEST

- (1) Remove nut, lockwasher, terminal lug TL20 and lockwasher from RH rear marker light screw. Discard lockwashers.
- (2) Set multimeter to ohms.
- (3) Connect positive (+) probe of multimeter to terminal lug TL20.
- (4) Connect negative (-) probe of multimeter to ground and note reading on multimeter.
- (5) If continuity is not present, repair wire 3095 from terminal lug TL20 to terminal lug TL21 (para 2-40) and go to step 6 of this fault if required or replace rear lights cable assembly (para 7-75) and go to step 1 of this fault.
- (6) If continuity is present, repair wire 489 from splice E15 to splice E17 (para 2-40) and go to step 6 of this fault if required or replace rear lights cable assembly (para 7-75) and go to step 1 of this fault.
- (7) Install lockwasher, terminal lug TL20, lockwasher, and nut on RH rear marker light screw.

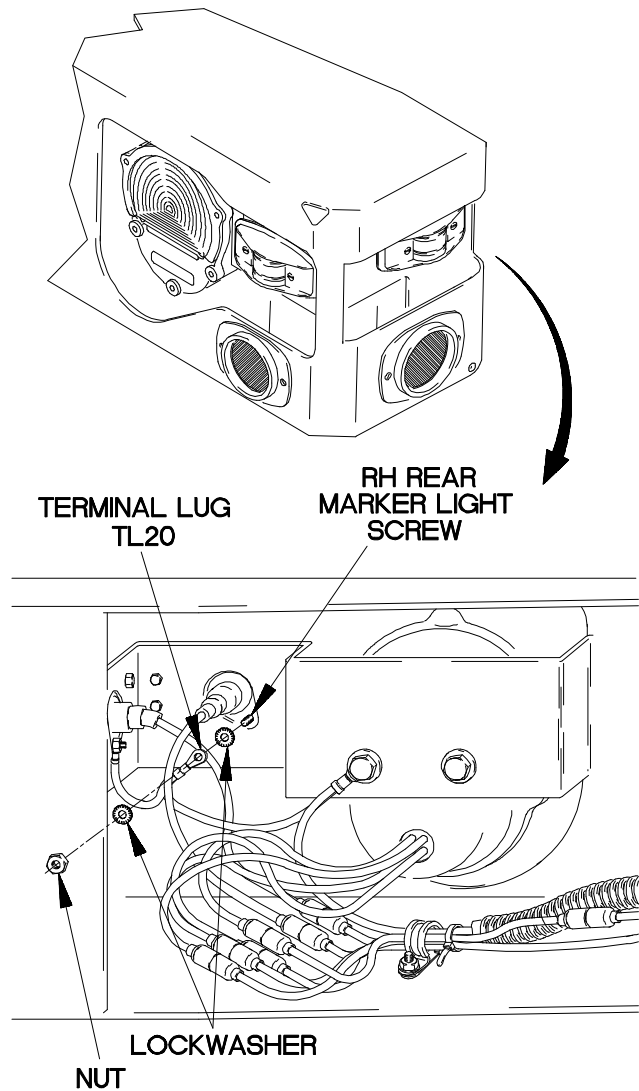

XBE4836B

e47. SIDE AND/OR REAR MARKER LIGHT(S) DO NOT ILLUMINATE (CONT)

KNOWN INFO
Other marker lights illuminate. Rear composite lights illuminate. Dashboard cable assembly OK.
POSSIBLE PROBLEMS
Faulty lamp. Faulty marker light. Faulty rear lights cable assembly.

36.
Is continuity present through RH side marker light lamp?

TEST OPTIONS
Continuity Test or STE/ICE-R Test #91
REASON FOR QUESTION
If continuity is not present, RH side marker light lamp is faulty.

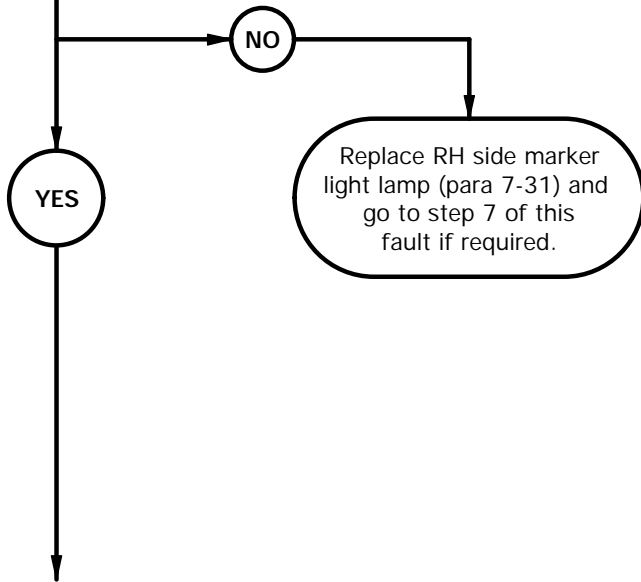

CONTINUITY TEST

- (1) Remove two screws and lens cover from RH side marker light base.
- (2) Remove RH side marker light lamp from socket.
- (3) Set multimeter to ohms.
- (4) Check continuity through RH side marker light lamp and note reading on multimeter.
- (5) If continuity is not present, replace RH side marker light lamp (para 7-31) and go to step 7 of this fault if required.
- (6) Install RH side marker light lamp in socket.
- (7) Install lens cover on RH side marker light base with two screws.

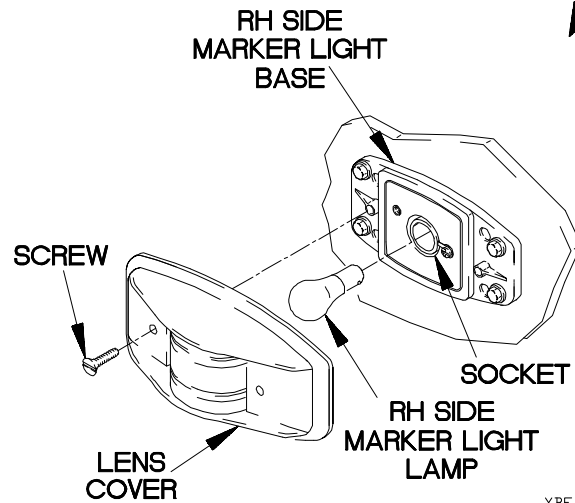
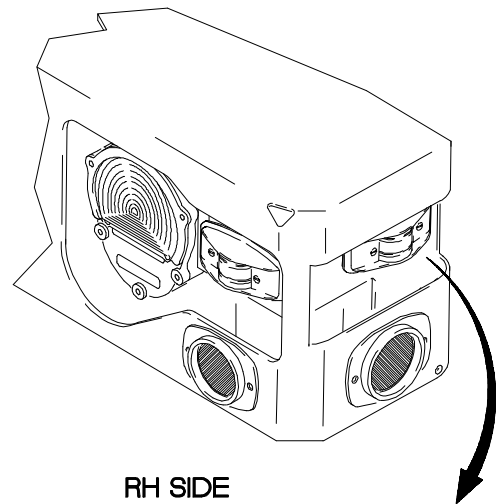

XBE4837B

e47. SIDE AND/OR REAR MARKER LIGHT(S) DO NOT ILLUMINATE (CONT)

KNOWN INFO
Other marker lights illuminate. Rear composite lights illuminate. Dashboard cable assembly OK. Lamp OK.
POSSIBLE PROBLEMS
Faulty marker light. Faulty rear lights cable assembly.

37.

WARNING
CAUTION
Read WARNING and CAUTION on following page.

Is 12 VDC present at connector P88?

TEST OPTIONS
Voltage Test or STE/ICE-R Test #89
REASON FOR QUESTION
If 12 VDC is not present, wire 489 is faulty.

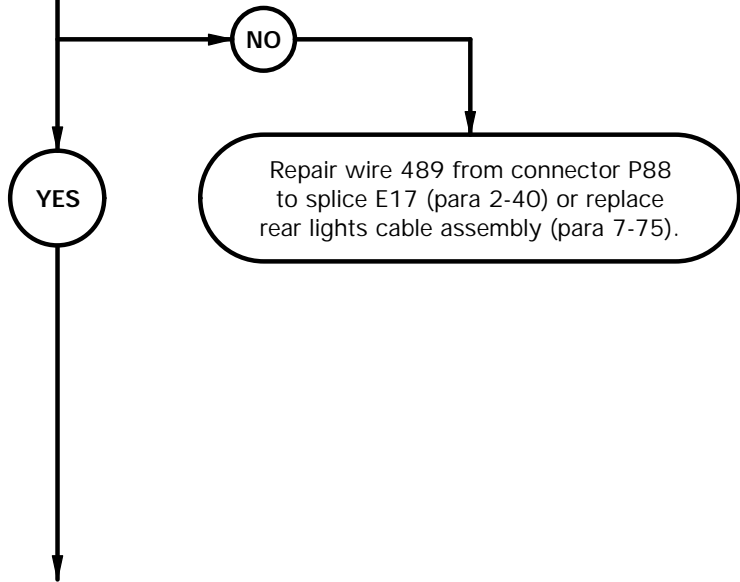

WARNING

Remove rings, bracelets, watches, necklaces, and any other jewelry before working around vehicle. Jewelry can catch on equipment and cause injury or short across electrical circuits and cause severe burns or electrical shock.

CAUTION

Use care when testing electrical connectors. Do not damage connector pins or sockets with multimeter probes. Failure to comply may result in damage to equipment.

NOTE

Inspect connector pins/sockets for damage, corrosion, and serviceability. Check that connector pins are not pushed back and are capable of making good contact.

VOLTAGE TEST

- (1) Disconnect connector P88 from RH side marker light connector.
- (2) Set multimeter to volts DC.
- (3) Connect positive (+) probe of multimeter to connector P88.
- (4) Connect negative (-) probe of multimeter to ground.
- (5) Position main light switch to SER DRIVE (TM 9-2320-365-10) and note reading on multimeter.
- (6) If 12 VDC is not present, repair wire 489 from connector P88 to splice E17 (para 2-40) or replace rear lights cable assembly (para 7-75).
- (7) Position main light switch to OFF (TM 9-2320-365-10).

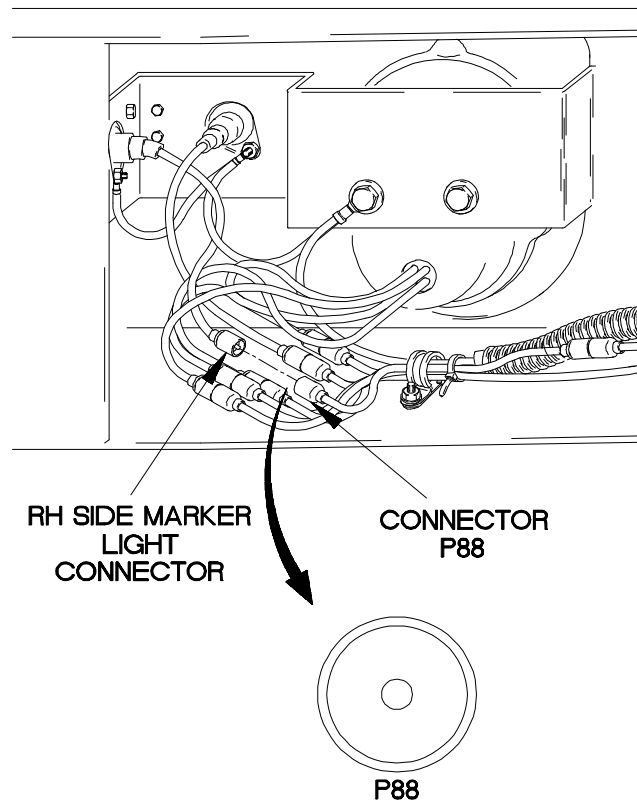

XBE4838B

e47. SIDE AND/OR REAR MARKER LIGHT(S) DO NOT ILLUMINATE (CONT)

KNOWN INFO
Other marker lights illuminate. Rear composite lights illuminate. Dashboard cable assembly OK. Lamp OK.
POSSIBLE PROBLEMS
Faulty marker light. Faulty rear lights cable assembly.

38.
Is continuity present from terminal lug TL19 to ground?

TEST OPTIONS
Continuity Test or STE/ICE-R Test #91
REASON FOR QUESTION
If continuity is not present, wire 3095 is faulty. If continuity is present, RH side marker light is faulty.

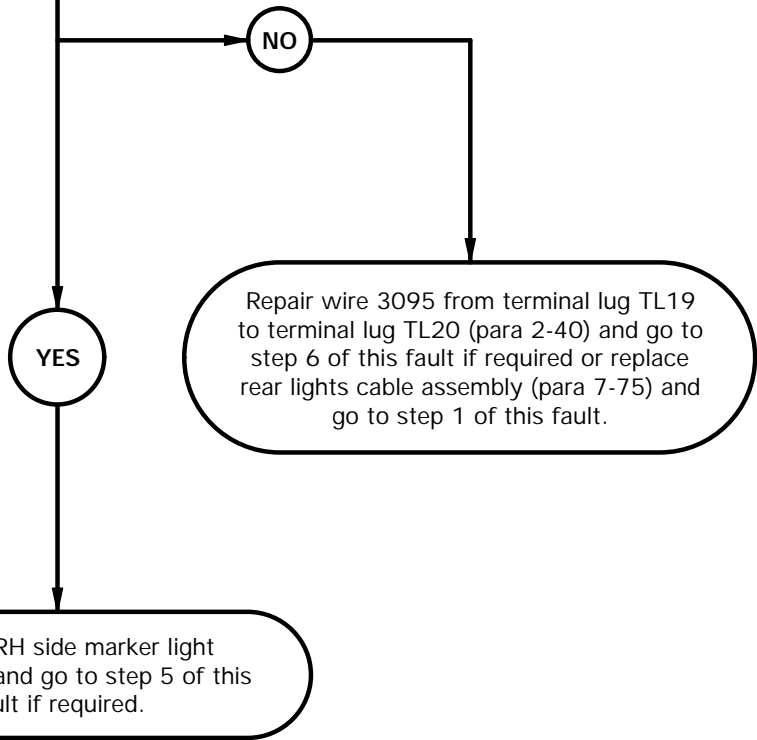

CONTINUITY TEST

- (1) Remove nut, lockwasher, terminal lug TL19, and lockwasher from RH side marker light screw. Discard lockwashers.
- (2) Set multimeter to ohms.
- (3) Connect positive (+) probe of multimeter to terminal lug TL19.
- (4) Connect negative (-) probe of multimeter to ground and note reading on multimeter.
- (5) If continuity is not present, repair wire 3095 from terminal lug TL19 to terminal lug TL20 (para 2-40) and go to step 6 of this fault if required or replace rear lights cable assembly (para 7-75) and go to step 1 of this fault.
- (6) If continuity is present, replace RH side marker light (para 7-31) and go to step 5 of this fault if required.
- (7) Install lockwasher, terminal lug TL19, lockwasher, and nut on RH side marker light screw.
- (8) Connect RH side marker light connector to connector P88.

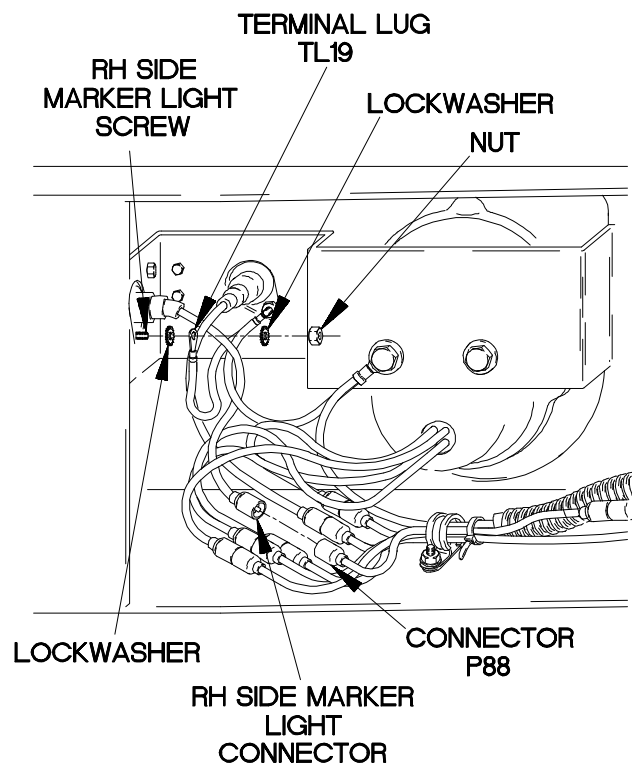

XBE4839B

e47. SIDE AND/OR REAR MARKER LIGHT(S) DO NOT ILLUMINATE (CONT)

KNOWN INFO
Other marker lights illuminate. Rear composite lights illuminate. Dashboard cable assembly OK.
POSSIBLE PROBLEMS
Faulty lamp. Faulty marker light. Faulty rear lights cable assembly.

KNOWN INFO
Other marker lights illuminate. Rear composite lights illuminate. Dashboard cable assembly OK. Lamp OK.
POSSIBLE PROBLEMS
Faulty marker light. Faulty rear lights cable assembly.

39.
Is continuity present through LH marker light lamp?

TEST OPTIONS
Continuity Test or STE/ICE-R Test #91
REASON FOR QUESTION
If continuity is not present, LH marker light lamp is faulty.

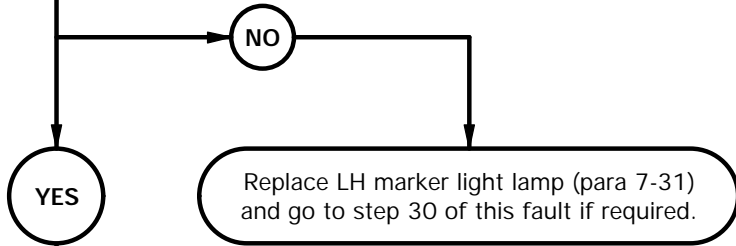

WARNING
CAUTION
Read **WARNING** and **CAUTION** on following page.

40.
Is 12 VDC present at connector P86?

TEST OPTIONS
Voltage Test or STE/ICE-R Test #89
REASON FOR QUESTION
This question eliminates possible problems and determines where troubleshooting continues.

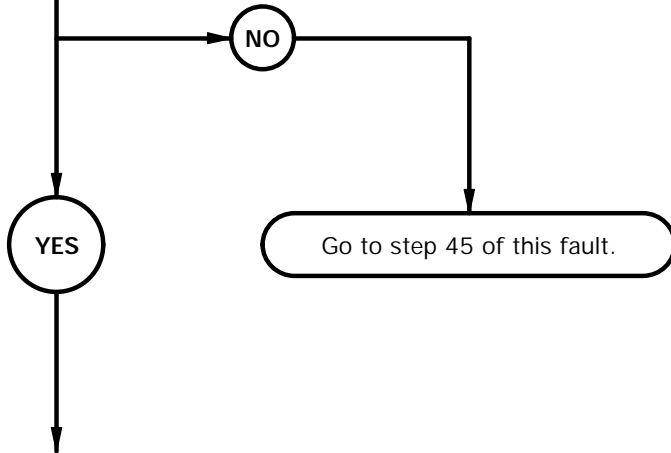

CONTINUITY TEST

- (1) Remove two screws and lens cover from LH marker light base.
- (2) Remove LH marker light lamp from socket.
- (3) Set multimeter to ohms.
- (4) Check continuity through LH marker light lamp and note reading on multimeter.
- (5) If continuity is not present, replace LH marker light lamp (para 7-31) and go to step 30 of this fault if required.
- (6) Install LH marker light lamp in socket.
- (7) Install lens cover on LH marker light base with two screws.

WARNING

Remove rings, bracelets, watches, necklaces, and any other jewelry before working around vehicle. Jewelry can catch on equipment and cause injury or short across electrical circuits and cause severe burns or electrical shock.

CAUTION

Use care when testing electrical connectors. Do not damage connector pins or sockets with multimeter probes. Failure to comply may result in damage to equipment.

NOTE

Inspect connector pins/sockets for damage, corrosion, and serviceability. Check that connector pins are not pushed back and are capable of making good contact.

VOLTAGE TEST

- (1) Disconnect LH marker light connector from connector P86.
- (2) Set multimeter to volts DC.
- (3) Connect positive (+) probe of multimeter to connector P86.
- (4) Connect negative (-) probe of multimeter to ground.
- (5) Position main light switch to SER DRIVE (TM 9-2320-365-10) and note reading on multimeter.
- (6) Position main light switch to OFF (TM 9-2320-365-10).
- (7) If 12 VDC is not present, go to step 45 of this fault.

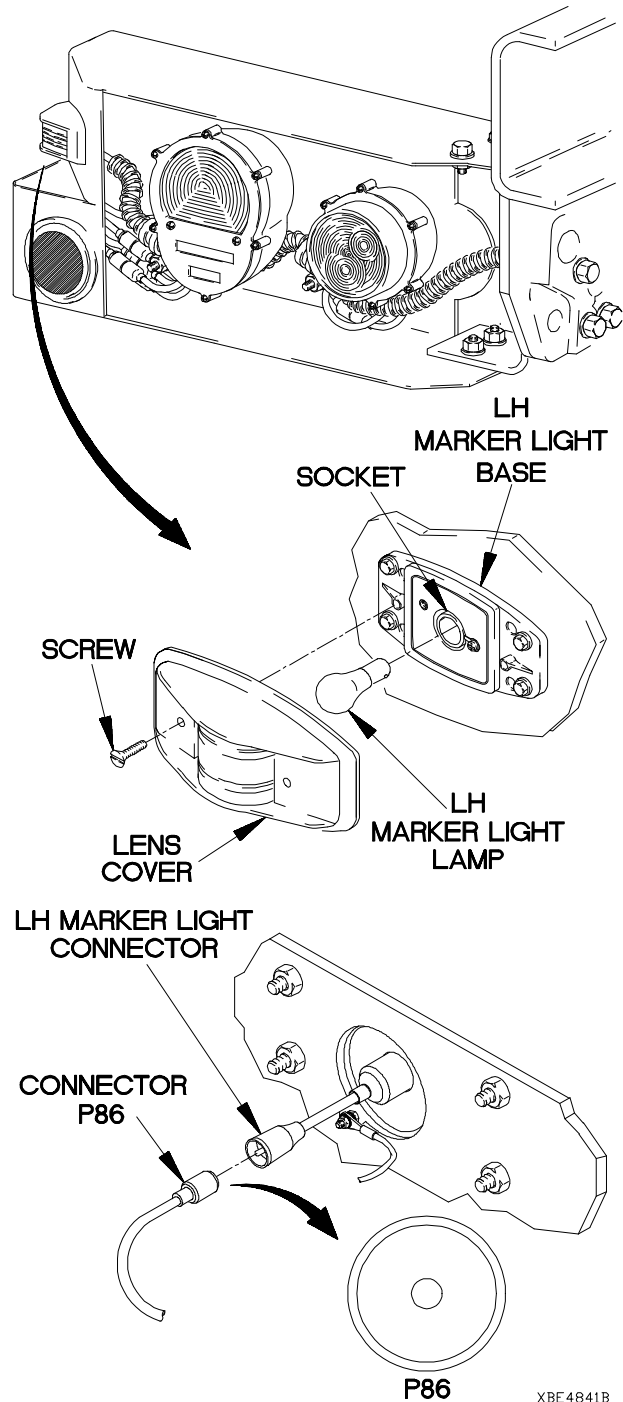

e47. SIDE AND/OR REAR MARKER LIGHT(S) DO NOT ILLUMINATE (CONT)

KNOWN INFO
Other marker lights illuminate. Rear composite lights illuminate. Dashboard cable assembly OK. Lamp OK.
POSSIBLE PROBLEMS
Faulty marker lights. Faulty rear lights cable assembly.

41.
Is continuity present from terminal lug TL16 to ground?

TEST OPTIONS
Continuity Test or STE/ICE-R Test #91
REASON FOR QUESTION
If continuity is not present, wire 3094 is faulty. If continuity is present, LH marker light is faulty.

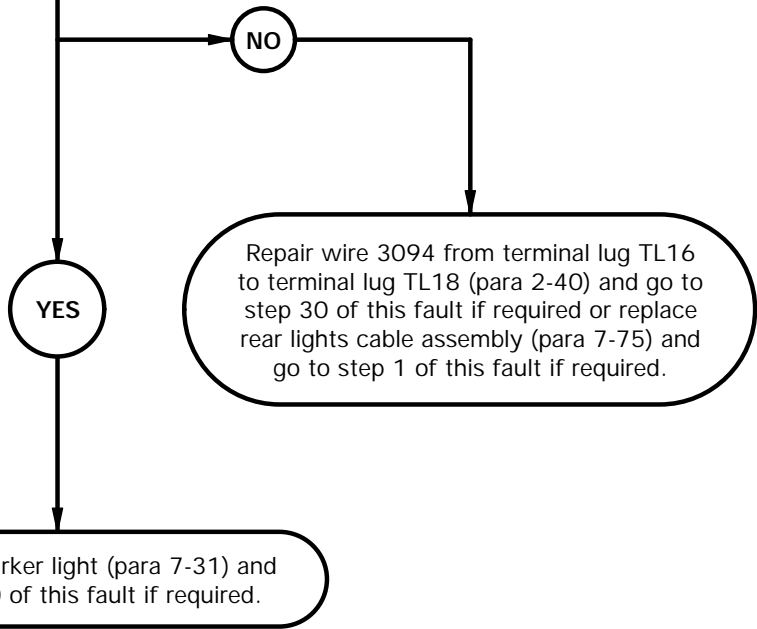

CONTINUITY TEST

- (1) Remove nut, lockwasher, terminal lug TL16, and lockwasher from LH marker light screw. Discard lockwashers.
- (2) Connect positive (+) probe of multimeter to terminal lug TL16.
- (3) Connect negative (-) probe of multimeter to ground and note reading on multimeter.
- (4) If continuity is not present, repair wire 3094 from terminal lug TL16 to terminal lug TL18 (para 2-40) and go to step 30 of this fault if required or replace rear lights cable assembly (para 7-75) and go to step 1 of this fault.
- (5) If continuity is present, replace LH marker light (para 7-38) and go to step 30 of this fault if required.
- (6) Install lockwasher, terminal lug TL16, lockwasher, and nut on LH marker light screw.
- (7) Connect LH marker light connector to connector P86.

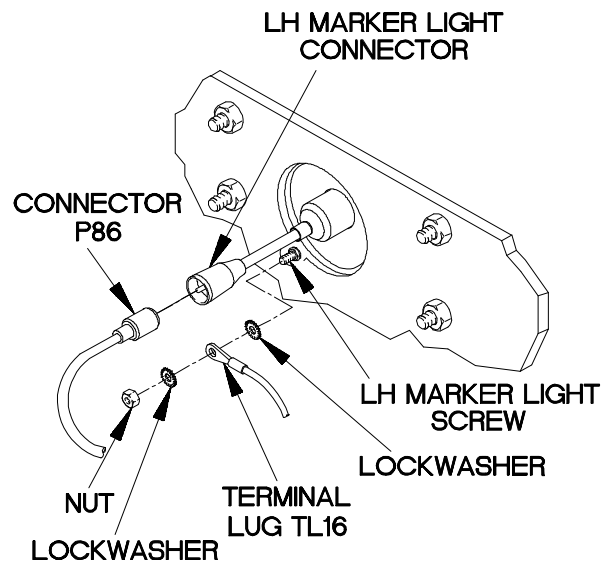

XBE4842B

e47. SIDE AND/OR REAR MARKER LIGHT(S) DO NOT ILLUMINATE (CONT)

KNOWN INFO
Other marker lights illuminate. Rear composite lights illuminate. Dashboard cable assembly OK.
POSSIBLE PROBLEMS
Faulty lamp. Faulty marker light. Faulty rear lights cable assembly.

KNOWN INFO
Other marker lights illuminate. Rear composite lights illuminate. Dashboard cable assembly OK. Lamp OK.
POSSIBLE PROBLEMS
Faulty marker light. Faulty rear lights cable assembly.

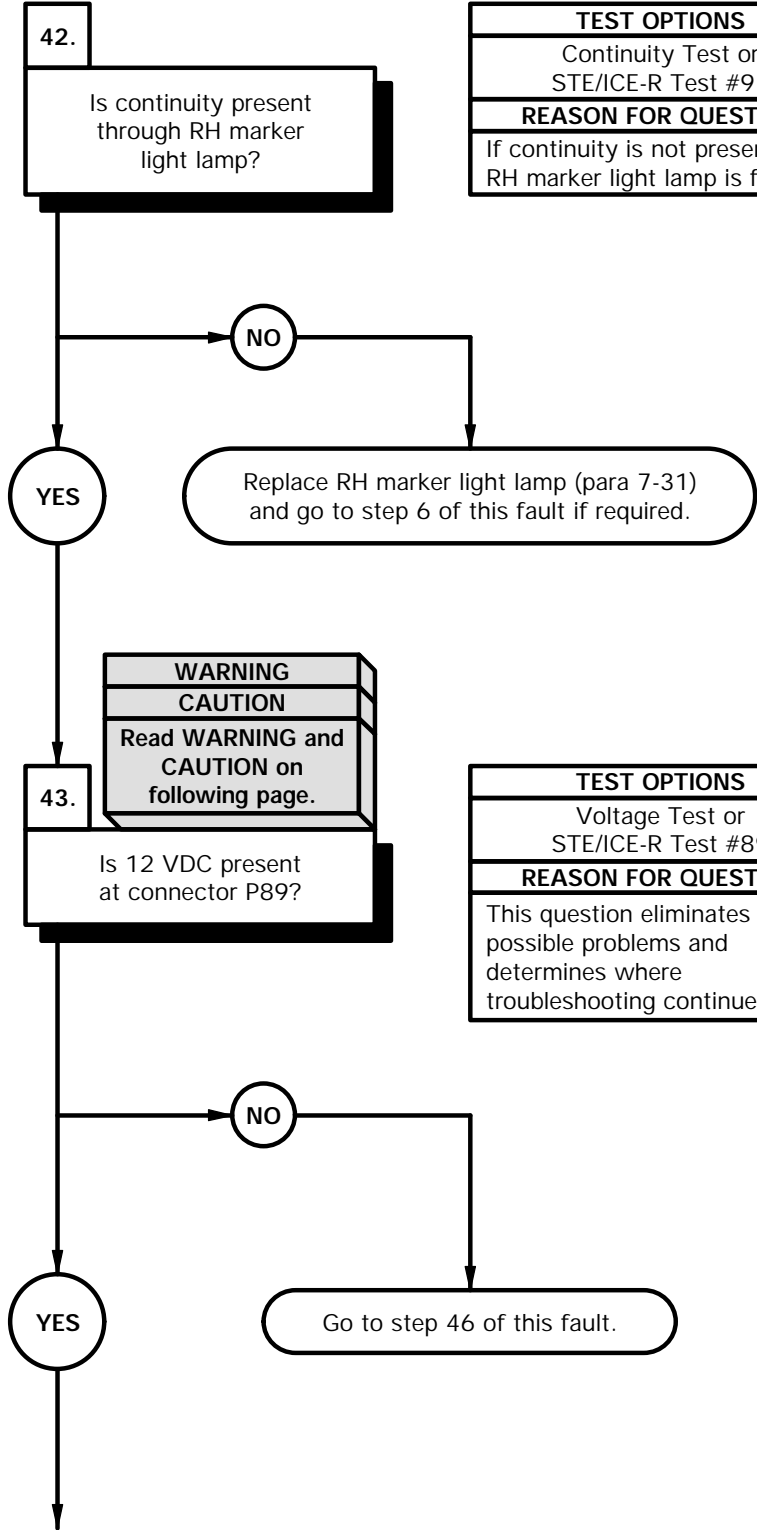

TEST OPTIONS
Continuity Test or STE/ICE-R Test #91
REASON FOR QUESTION
If continuity is not present, RH marker light lamp is faulty.

TEST OPTIONS
Voltage Test or STE/ICE-R Test #89
REASON FOR QUESTION
This question eliminates possible problems and determines where troubleshooting continues.

CONTINUITY TEST

- (1) Remove two screws and lens cover from RH marker light base.
- (2) Remove RH marker light lamp from socket.
- (3) Set multimeter to ohms.
- (4) Check continuity through RH marker light lamp and note reading on multimeter.
- (5) If continuity is not present, replace RH marker light lamp (para 7-31) and go to step 6 of this fault if required.
- (6) Install RH marker light lamp in socket.
- (7) Install lens cover on RH marker light base with two screws.

WARNING

Remove rings, bracelets, watches, necklaces, and any other jewelry before working around vehicle. Jewelry can catch on equipment and cause injury or short across electrical circuits and cause severe burns or electrical shock.

CAUTION

Use care when testing electrical connectors. Do not damage connector pins or sockets with multimeter probes. Failure to comply may result in damage to equipment.

NOTE

Inspect connector pins/sockets for damage, corrosion, and serviceability. Check that connector pins are not pushed back and are capable of making good contact.

VOLTAGE TEST

- (1) Disconnect RH marker lamp connector from connector P89.
- (2) Set multimeter to volts DC.
- (3) Connect positive (+) probe of multimeter to connector P89.
- (4) Connect negative (-) probe of multimeter to ground.
- (5) Position main light switch to SER DRIVE (TM 9-2320-365-10) and note reading on multimeter.
- (6) Position main light switch to OFF (TM 9-2320-365-10).
- (7) If 12 VDC is not present, go to step 46 of this fault.

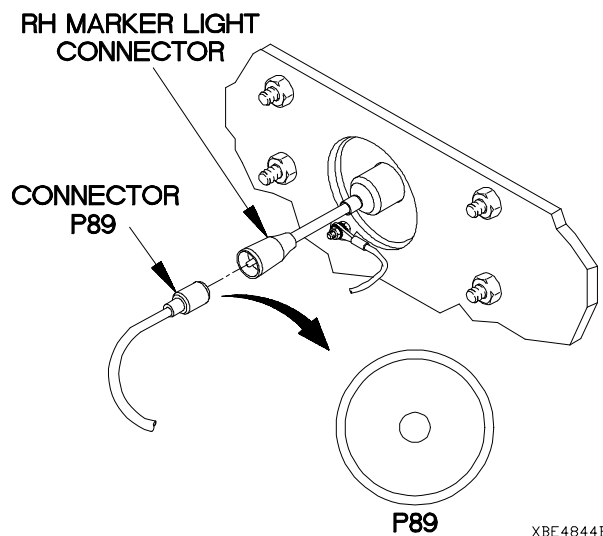
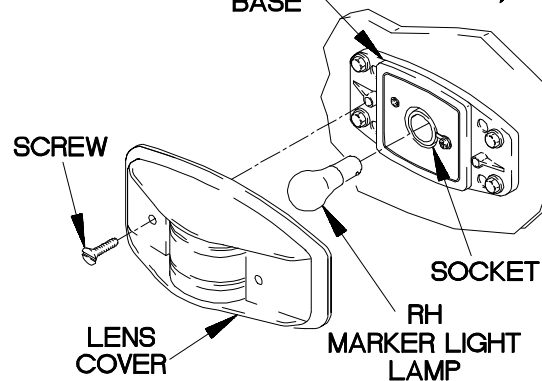
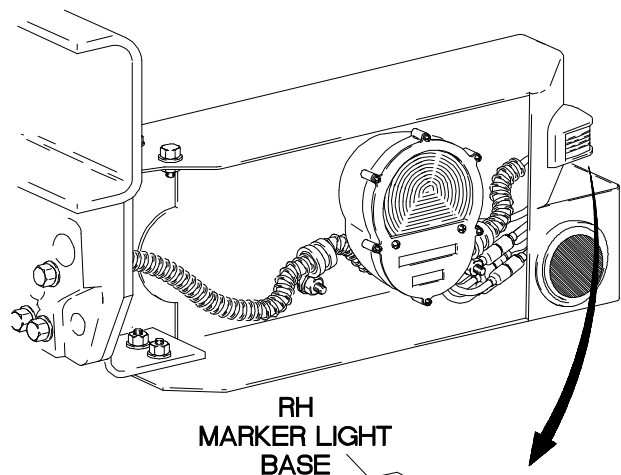

XBE4844B

e47. SIDE AND/OR REAR MARKER LIGHT(S) DO NOT ILLUMINATE (CONT)

KNOWN INFO
Other marker lights illuminate. Rear composite lights illuminate. Dashboard cable assembly OK. Lamp OK.
POSSIBLE PROBLEMS
Faulty marker lights. Faulty rear lights cable assembly.

44.
Is continuity present from terminal lug TL20 to ground?

TEST OPTIONS
Continuity Test or STE/ICE-R Test #91
REASON FOR QUESTION
If continuity is not present, wire 3095 is faulty. If continuity is present, RH marker light is faulty.

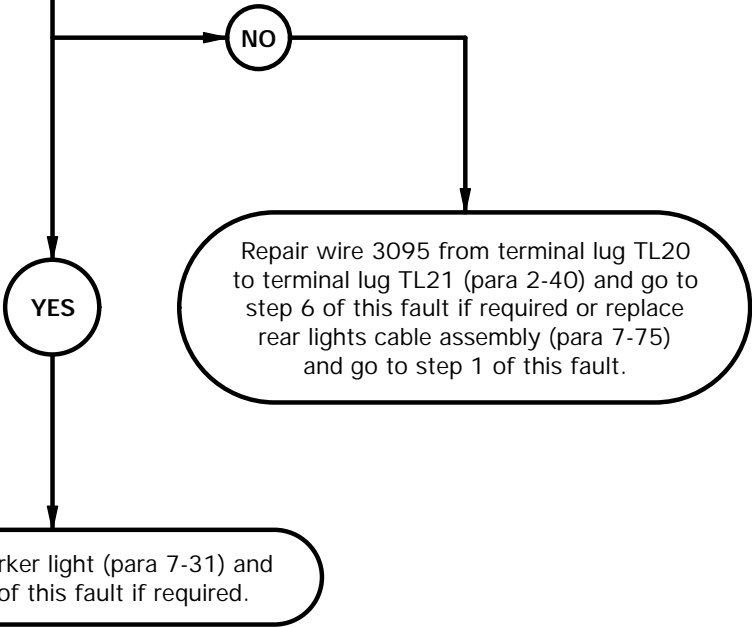

CONTINUITY TEST

- (1) Remove nut, lockwasher, terminal lug TL20, and lockwasher from RH marker light screw. Discard lockwashers.
- (2) Connect positive (+) probe of multimeter to terminal lug TL20.
- (3) Connect negative (-) probe of multimeter to ground and note reading on multimeter.
- (4) If continuity is not present, repair wire 3095 from terminal lug TL20 to terminal lug TL21 (para 2-40) and go to step 6 of this fault if required or replace rear lights cable assembly (para 7-75) and go to step 1 of this fault.
- (5) If continuity is present, replace RH marker light and go to step 6 of this fault if required.
- (6) Install lockwasher, terminal lug TL20, lockwasher, and nut on RH marker light screw.
- (7) Connect RH marker light connector to connector P89.

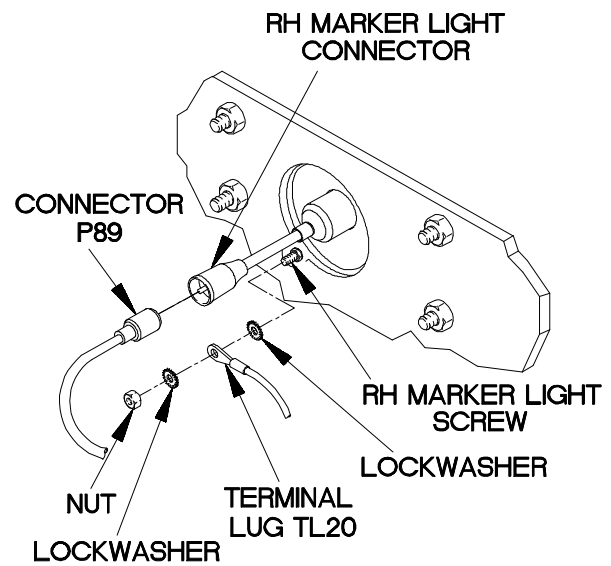

XBE4845B

e47. SIDE AND/OR REAR MARKER LIGHT(S) DO NOT ILLUMINATE (CONT)

KNOWN INFO
Other marker lights illuminate. Rear composite lights illuminate. Dashboard cable assembly OK. Lamp OK. Marker light OK.
POSSIBLE PROBLEMS
Faulty rear lights cable assembly.

45.

WARNING

CAUTION

Read **WARNING** and **CAUTION** on following page.

Is 12 VDC present at connector P85?

TEST OPTIONS
Voltage Test or STE/ICE-R Test #89
REASON FOR QUESTION
If 12 VDC is not present, wire 489 is faulty. If 12 VDC is present, wire 489 is faulty.

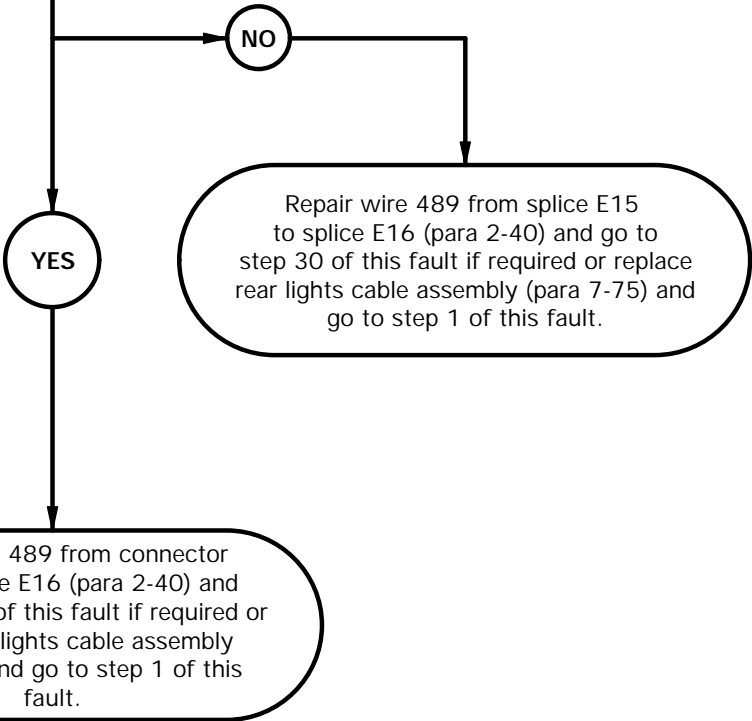

WARNING

Remove rings, bracelets, watches, necklaces, and any other jewelry before working around vehicle. Jewelry can catch on equipment and cause injury or short across electrical circuits and cause severe burns or electrical shock.

CAUTION

Use care when testing electrical connectors. Do not damage connector pins or sockets with multimeter probes. Failure to comply may result in damage to equipment.

NOTE

Inspect connector pins/sockets for damage, corrosion, and serviceability. Check that connector pins are not pushed back and are capable of making good contact.

VOLTAGE TEST

NOTE

Remove plastic cable ties as required.

- (1) Disconnect connector P85 from LH rear side marker light connector.
- (2) Set multimeter to volts DC.
- (3) Connect positive (+) probe of multimeter to connector P85.
- (4) Connect negative (-) probe of multimeter to ground.
- (5) Position main light switch to SER DRIVE (TM 9-2320-365-10) and note reading on multimeter.
- (6) If 12 VDC is not present, repair wire 489 from connector P85 to splice E16 (para 2-40) and go to step 30 of this fault if required or replace rear lights cable assembly (para 7-75) and go to step 1 of this fault.
- (7) If 12 VDC is present, repair wire 489 from connector P85 to splice E16 (para 2-40) and go to step 30 of this fault if required or replace rear lights cable assembly (para 7-75) and go to step 1 of this fault.
- (8) Position main light switch to OFF (TM 9-2320-365-10).

NOTE

Install plastic cable ties as required.

- (9) Connect connector P85 to LH rear side marker light connector.

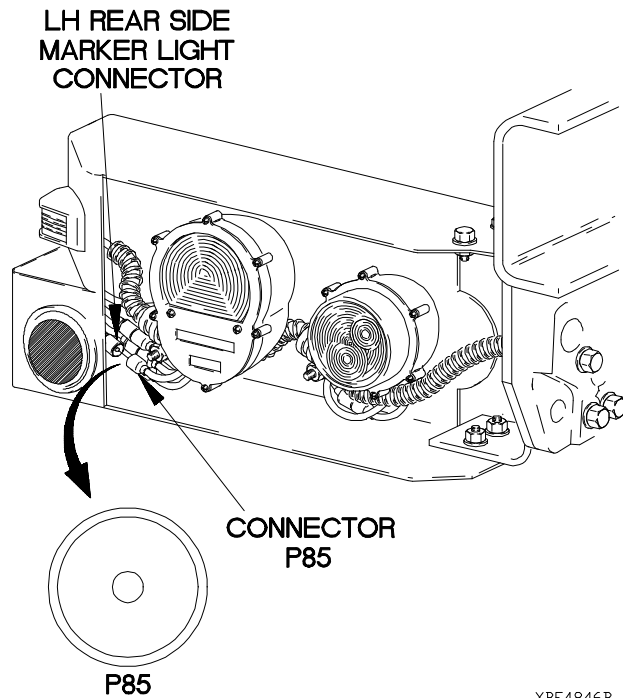

e47. SIDE AND/OR REAR MARKER LIGHT(S) DO NOT ILLUMINATE (CONT)

KNOWN INFO
Other marker lights illuminate. Rear composite lights illuminate. Dashboard cable assembly OK. Lamp OK. Marker light OK.
POSSIBLE PROBLEMS
Faulty rear lights cable assembly.

46.

WARNING

CAUTION

Read **WARNING** and **CAUTION** on following page.

Is 12 VDC present at connector P88?

TEST OPTIONS
Voltage Test or STE/ICE-R Test #89
REASON FOR QUESTION
If 12 VDC is not present, wire 489 is faulty. If 12 VDC is present, wire 489 is faulty.

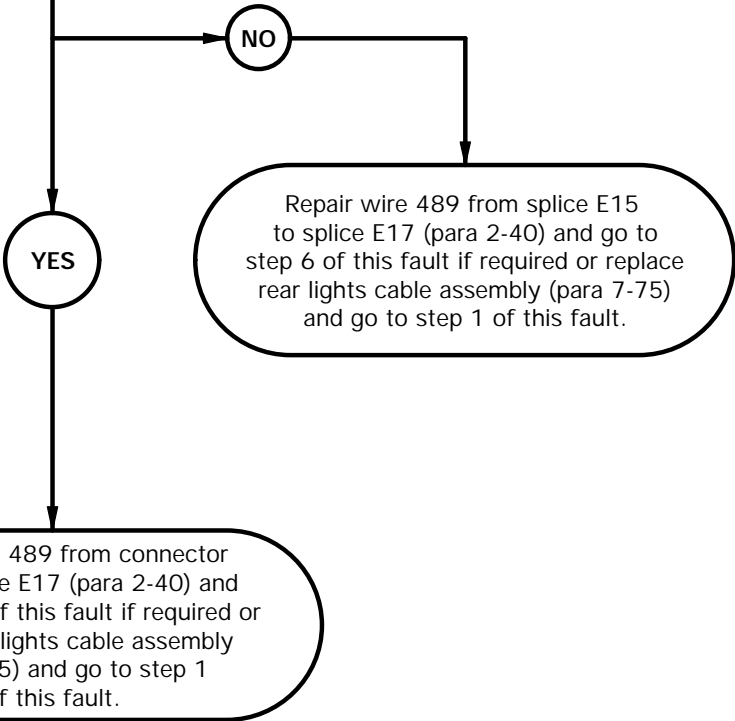

WARNING

Remove rings, bracelets, watches, necklaces, and any other jewelry before working around vehicle. Jewelry can catch on equipment and cause injury or short across electrical circuits and cause severe burns or electrical shock.

CAUTION

Use care when testing electrical connectors. Do not damage connector pins or sockets with multimeter probes. Failure to comply may result in damage to equipment.

NOTE

Inspect connector pins/sockets for damage, corrosion, and serviceability. Check that connector pins are not pushed back and are capable of making good contact.

VOLTAGE TEST

NOTE

Remove plastic cable ties as required.

- (1) Disconnect connector P88 from RH rear side marker light connector.
- (2) Set multimeter to volts DC.
- (3) Connect positive (+) probe of multimeter to connector P88.
- (4) Connect negative (-) probe of multimeter to ground.
- (5) Position main light switch to SER DRIVE (TM 9-2320-365-10) and note reading on multimeter.
- (6) If 12 VDC is not present, repair wire 489 from connector P88 to splice E17 (para 2-40) and go to step 6 of this fault if required or replace rear lights cable assembly (para 7-75) and go to step 1 of this fault.
- (7) If 12 VDC is present, repair wire 489 from connector P88 to splice E17 (para 2-40) and go to step 6 of this fault if required or replace rear lights cable assembly (para 7-75) and go to step 1 of this fault.
- (8) Position main light switch to OFF (TM 9-2320-365-10).

NOTE

Install plastic cable ties as required.

- (9) Connect connector P88 to RH rear side marker light connector.

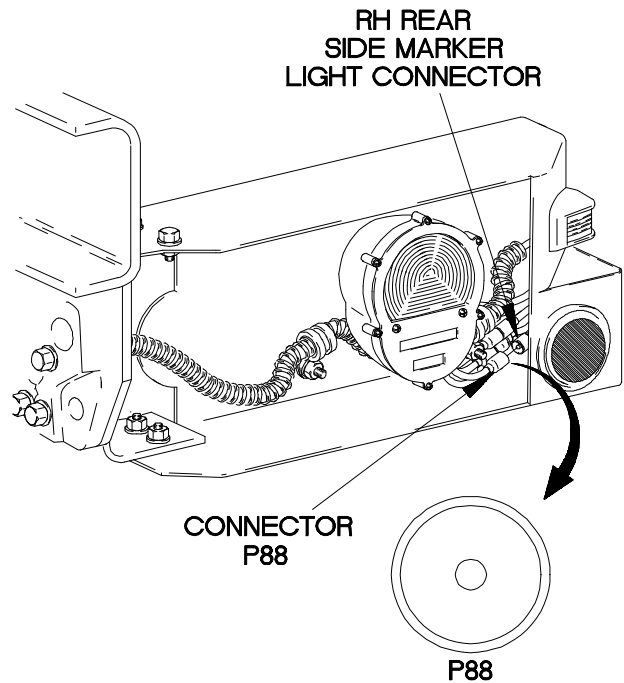

XBE4847B

e47A. ALL MARKER LIGHTS DO NOT ILLUMINATE IN NORMAL MODE	
INITIAL SETUP	
Equipment Conditions Engine shut down (TM 9-2320-365-10).	Tools and Special Tools Tool Kit, Genl Mech (Item 44, Appendix C) STE/ICR-R (Item 39, Appendix C) Multimeter, Digital (Item 22, Appendix C)
Personnel Required (2)	References TM 9-4910-571-12&P

NOTE

Perform Electrical System Troubleshooting e1. Circuit Breaker Does Not Operate on circuit breaker CB67 prior to beginning this task.

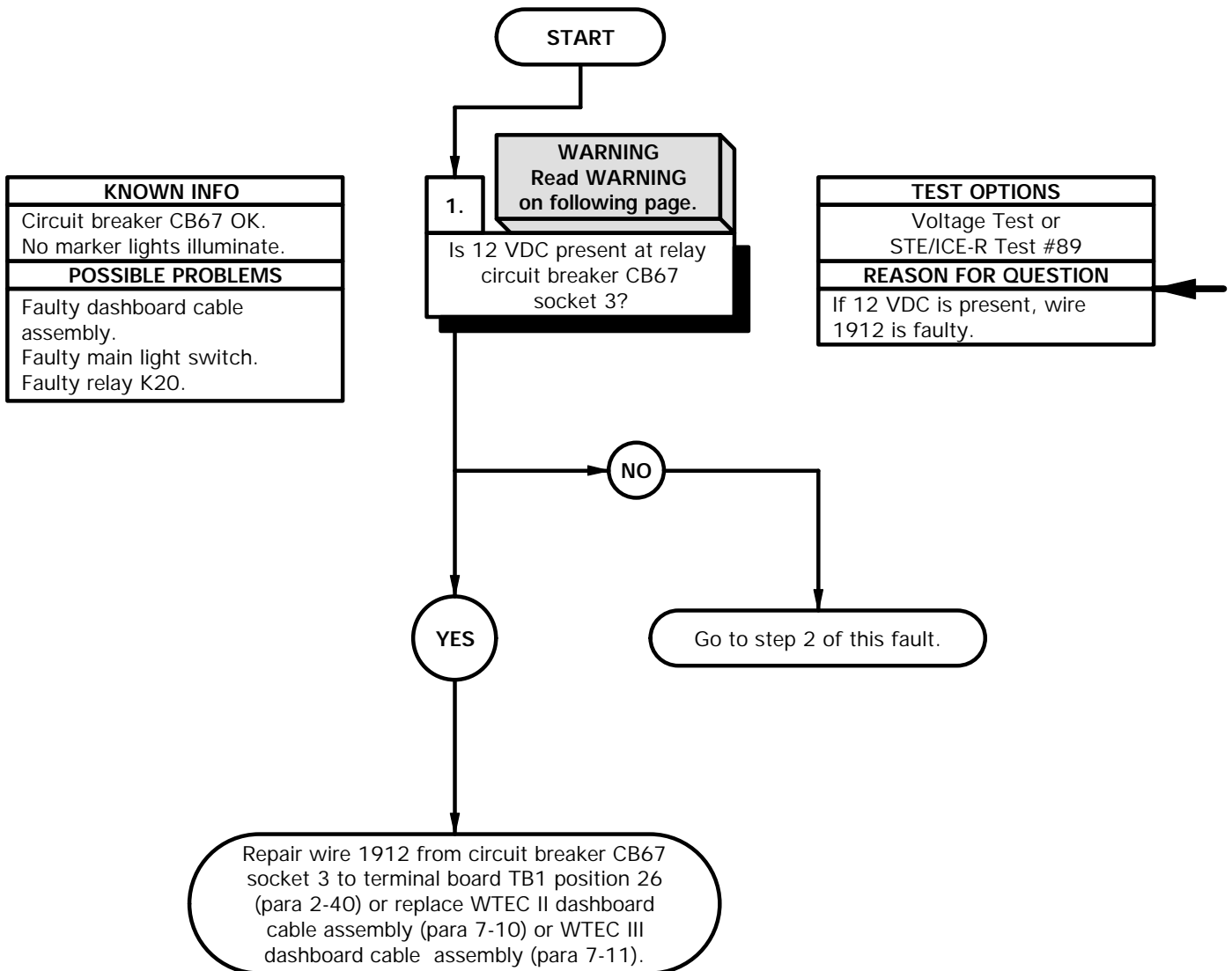

WARNING

Remove rings, bracelets, watches, necklaces, and any other jewelry before working around vehicle. Jewelry can catch on equipment and cause injury or short across electrical circuits and cause severe burns or electrical shock.

VOLTAGE TEST

- (1) Remove PDP cover (para 16-2).
- (2) Remove circuit breaker CB67 from PDP.
- (3) Set multimeter to volts DC.
- (4) Connect positive (+) probe of multimeter to circuit breaker CB67 socket 3 on PDP.
- (5) Connect negative (-) probe of multimeter to ground.
- (6) Position main light switch to SER DRIVE (TM 9-2320-365-10) and note reading on multimeter.
- (7) If 12 VDC is not present, go to step 2 of this fault.
- (8) If 12 VDC is present, repair wire 1912 from circuit breaker CB67 socket 3 to terminal board TB1 position 26 (para 2-40) or replace WTEC II dashboard cable assembly (para 7-10) or WTEC III dashboard cable assembly (para 7-11).
- (9) Position main light switch to OFF (TM 9-2320-365-10).

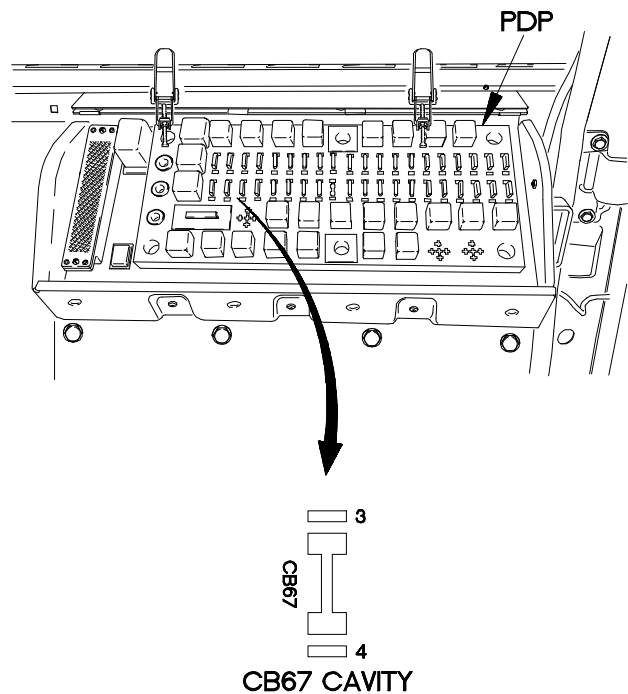

X6E48A1B

e47A. ALL MARKER LIGHTS DO NOT ILLUMINATE IN NORMAL MODE (CONT)

KNOWN INFO
Circuit breaker CB67 OK. No marker lights illuminate.
POSSIBLE PROBLEMS
Faulty dashboard cable assembly. Faulty main light switch. Faulty relay K20.

2.
Is continuity present from circuit breaker CB67 socket 3 to relay K20 terminal 87 on PDP?

TEST OPTIONS
Continuity Test or STE/ICE-R Test #91
REASON FOR QUESTION
If continuity is not present, wire 1914 is faulty.

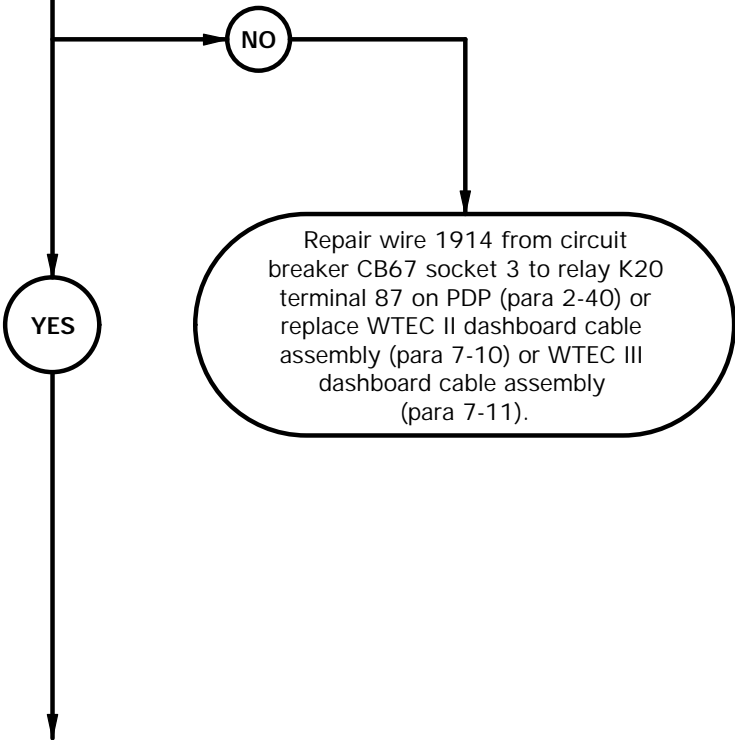

CONTINUITY TEST

- (1) Disconnect batteries (para 7-48).
- (2) Remove relay K20 from PDP.
- (3) Set multimeter to ohms.
- (4) Connect positive (+) probe of multimeter to circuit breaker CB67 socket 3 on PDP.
- (5) Connect negative (-) probe of multimeter to relay K20 terminal 87 on PDP and note reading on multimeter.
- (6) If 12 VDC is not present, repair wire 1914 from circuit breaker CB67 socket 3 to relay K20 terminal 87 on PDP (para 2-40) or replace WTEC II dashboard cable assembly (para 7-10) or WTEC III dashboard cable assembly (para 7-11).
- (7) Install circuit breaker CB67 in PDP.
- (8) Connect batteries (para 7-48).

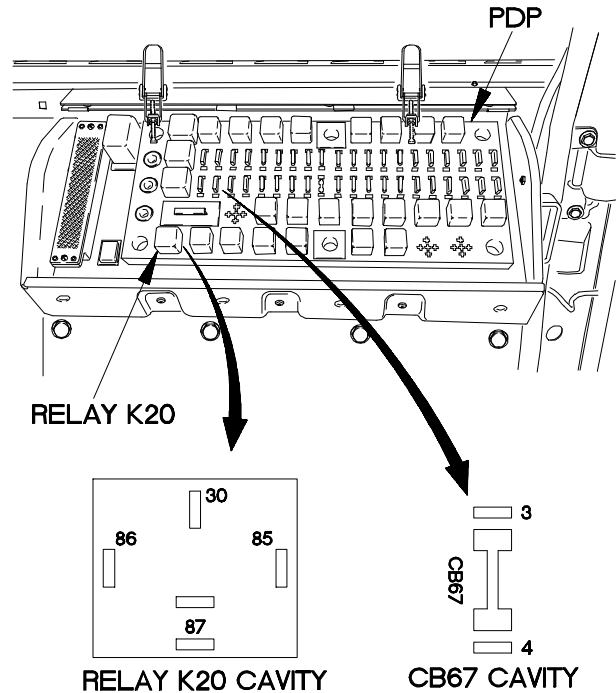

X6E48A2B

e47A. ALL MARKER LIGHTS DO NOT ILLUMINATE IN NORMAL MODE (CONT)

KNOWN INFO
Circuit breaker CB67 OK. No marker lights illuminate.
POSSIBLE PROBLEMS
Faulty dashboard cable assembly. Faulty main light switch. Faulty relay K20.

3. **WARNING**
Read **WARNING** on following page.

Is 12 VDC present at relay K20 terminal 30 on PDP?

TEST OPTIONS
Voltage Test or STE/ICE-R Test #89
REASON FOR QUESTION
If 12 VDC is not present, wire 1501 is faulty.

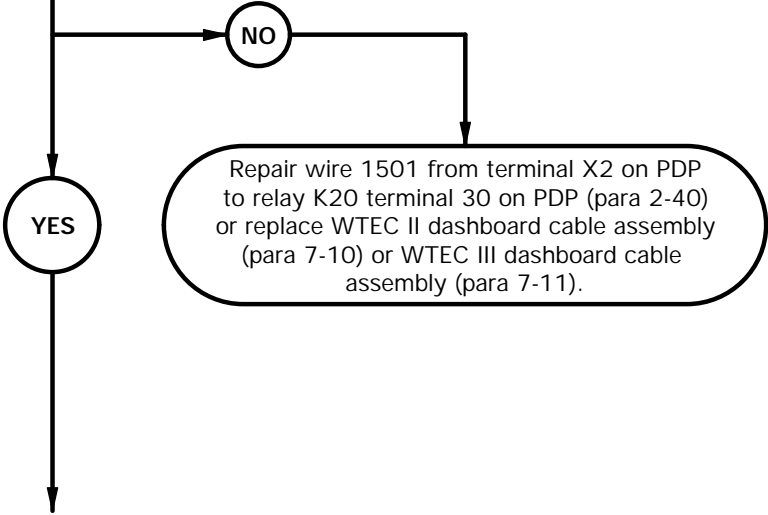

WARNING

Remove rings, bracelets, watches, necklaces, and any other jewelry before working around vehicle. Jewelry can catch on equipment and cause injury or short across electrical circuits and cause severe burns or electrical shock.

VOLTAGE TEST

- (1) Set multimeter to volts DC.
- (2) Connect positive (+) probe of multimeter to relay K20 terminal 30 on PDP.
- (3) Connect negative (-) probe of multimeter to ground and note reading on multimeter.
- (4) If 12 VDC is not present, repair wire 1501 from terminal X2 on PDP to relay K20 terminal 30 on PDP (para 2-40) or replace WTEC II dashboard cable assembly (para 7-10) or WTEC III dashboard cable assembly (para 7-11).

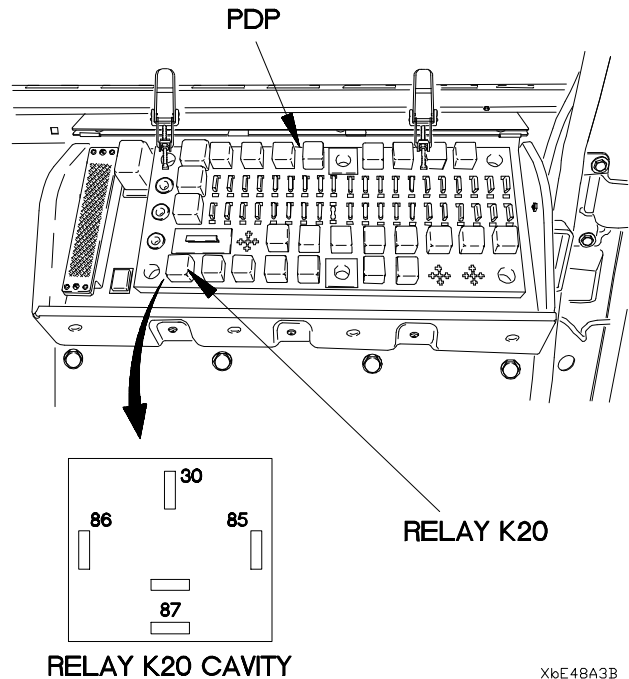

X6E48A3B

e47A. ALL MARKER LIGHTS DO NOT ILLUMINATE IN NORMAL MODE (CONT)

KNOWN INFO
Circuit breaker CB67 OK. No marker lights illuminate.
POSSIBLE PROBLEMS
Faulty dashboard cable assembly. Faulty main light switch. Faulty relay K20.

4. **WARNING**
Read **WARNING**
on following page.

Is 12 VDC present at relay K20 terminal 86 on PDP?

TEST OPTIONS
Voltage Test or STE/ICE-R Test #89
REASON FOR QUESTION
This question eliminates possible problems and determines where troubleshooting continues.

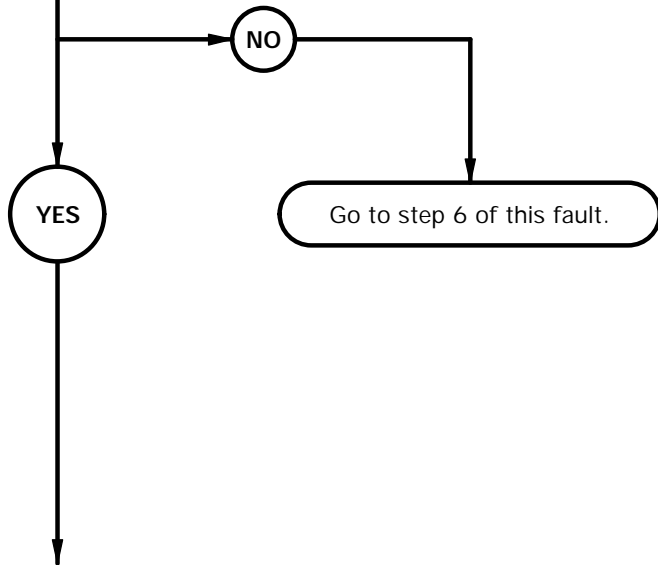

WARNING

Remove rings, bracelets, watches, necklaces, and any other jewelry before working around vehicle. Jewelry can catch on equipment and cause injury or short across electrical circuits and cause severe burns or electrical shock.

VOLTAGE TEST

- (1) Set multimeter to volts DC.
- (2) Connect positive (+) probe of multimeter to relay K20 terminal 86 on PDP.
- (3) Connect negative (-) probe of multimeter to ground.
- (4) Position main light switch to SER DRIVE (TM 9-2320-365-10) and note reading on multimeter.
- (5) If 12 VDC is not present, go to step 6 of this fault.
- (6) Position main light switch to OFF (TM 9-2320-365-10).

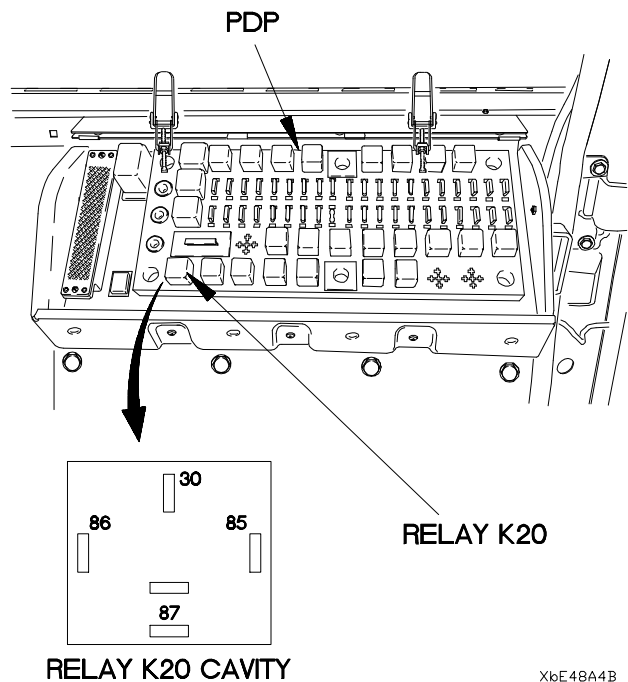

X6E48A4B

e47A. ALL MARKER LIGHTS DO NOT ILLUMINATE IN NORMAL MODE (CONT)

KNOWN INFO
Circuit breaker CB67 OK. No marker lights illuminate. Main light switch OK.
POSSIBLE PROBLEMS
Faulty dashboard cable assembly. Faulty relay K20.

5.
Is continuity present from relay K20 terminal 85 on PDP to ground?

TEST OPTIONS
Continuity Test or STE/ICE-R Test #91
REASON FOR QUESTION
If continuity is not present, wire 3054 is faulty.

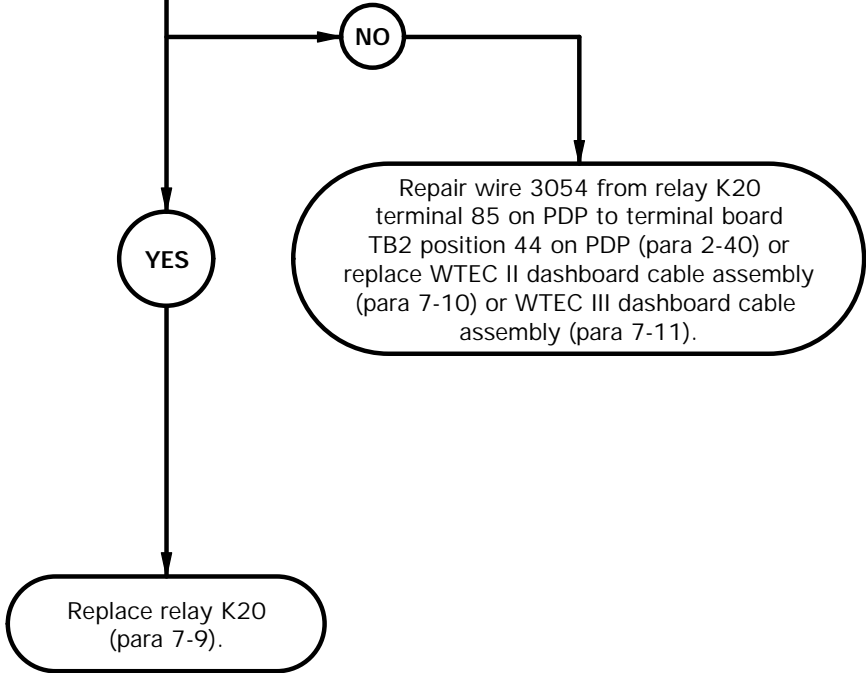

CONTINUITY TEST

- (1) Disconnect batteries (para 7-48).
- (2) Set multimeter to ohms.
- (3) Connect positive (+) probe of multimeter to relay K20 terminal 85 on PDP.
- (4) Connect negative (-) probe of multimeter to ground and note reading on multimeter.
- (5) If continuity is not present, repair wire 3054 from relay K20 terminal 85 on PDP to terminal board TB2 position 44 on PDP (para 2-40) or replace WTEC II dashboard cable assembly (para 7-10) or WTEC III dashboard cable assembly (para 7-11).
- (6) If continuity is present, replace relay K20 (para 7-9).
- (7) Install relay K20 in PDP.
- (8) Install PDP cover (para 16-2).

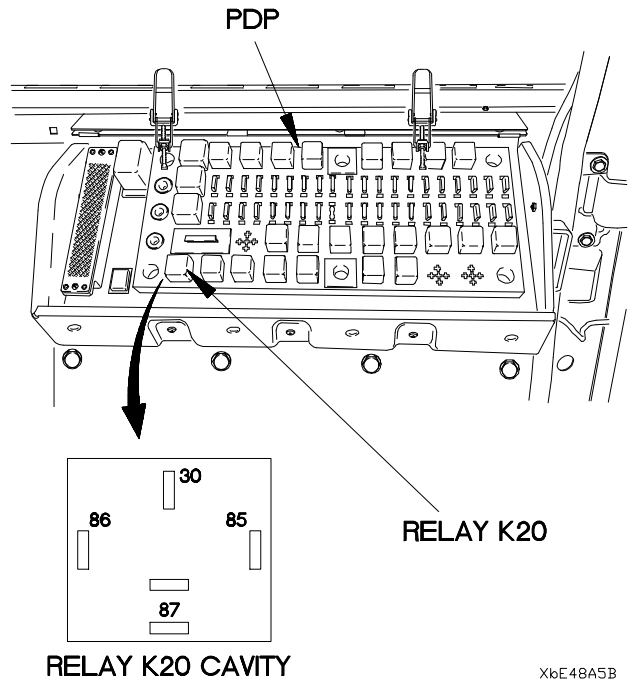

X6E48A5B

e47A. ALL MARKER LIGHTS DO NOT ILLUMINATE IN NORMAL MODE (CONT)

KNOWN INFO
Circuit breaker CB67 OK. No marker lights illuminate. Relay K20 OK.
POSSIBLE PROBLEMS
Faulty dashboard cable assembly. Faulty main light switch.

6.

CAUTION
Read CAUTION on following page.

Is continuity present from relay K20 terminal 86 to connector PX12 pin 5?

TEST OPTIONS
Continuity Test or STE/ICE-R Test #91
REASON FOR QUESTION
If continuity is not present, wire 1575 is faulty.

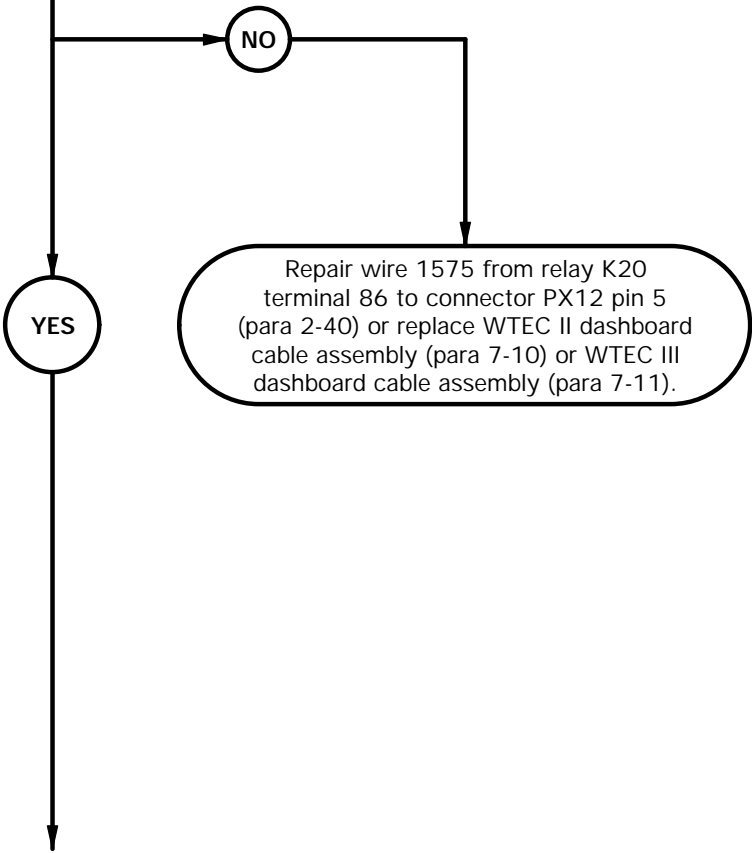

CAUTION

Use care when testing electrical connectors. Do not damage connector pins or sockets with multimeter probes. Failure to comply may result in damage to equipment.

NOTE

Inspect connector pins/sockets for damage, corrosion, and serviceability. Check that connector pins are not pushed back and are capable of making good contact.

CONTINUITY TEST

- (1) Disconnect batteries (para 7-48).
- (2) Remove instrument panel assembly for access (para 7-15).
- (3) Disconnect connector PX12 from warning light switch.
- (4) Set multimeter to ohms.
- (5) Connect positive (+) probe of multimeter to connector PX12 pin 5.
- (6) Connect negative (-) probe of multimeter to relay K20 terminal 86 on PDP and note reading on multimeter.
- (7) If continuity is not present, repair wire 1575 from relay K20 terminal 86 to connector PX12 pin 5 (para 2-40) or replace WTEC II dashboard cable assembly (para 7-10) or WTEC III dashboard cable assembly (para 7-11).
- (8) Install relay K20 in PDP.
- (9) Install PDP cover (para 16-2).

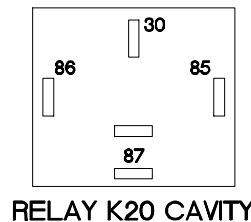
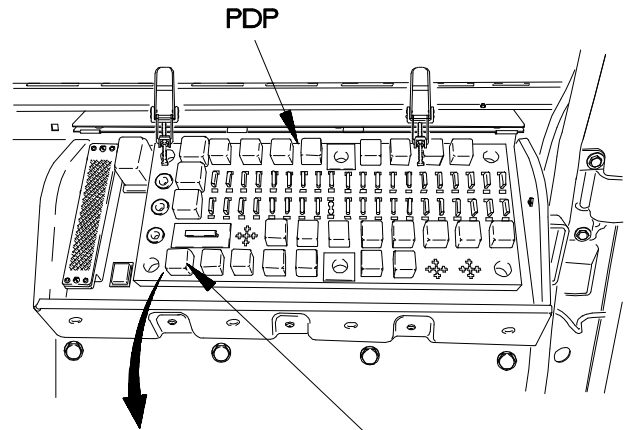
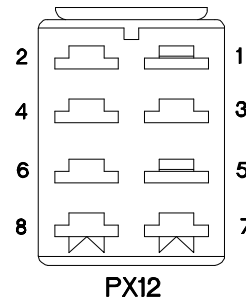
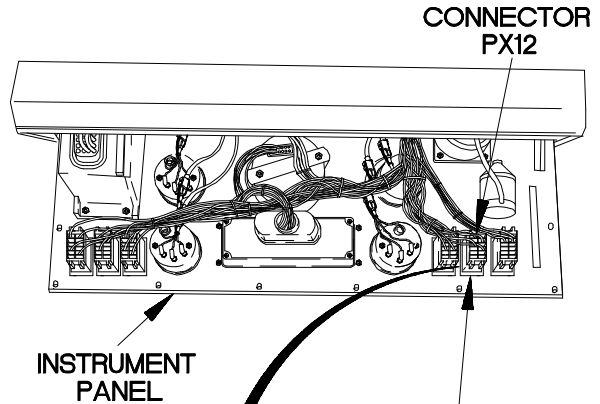

X6E48A6B

e47A. ALL MARKER LIGHTS DO NOT ILLUMINATE IN NORMAL MODE (CONT)

KNOWN INFO
Circuit breaker CB67 OK. No marker lights illuminate. Relay K20 OK.
POSSIBLE PROBLEMS
Faulty dashboard cable assembly. Faulty main light switch.

WARNING
Read **WARNING**
on following page.

7.
Is continuity present from connector PX12 pin 5 to connector PX15 socket H?

TEST OPTIONS
Continuity Test or STE/ICE-R Test #91
REASON FOR QUESTION
If continuity is not present, wire 1575 is faulty. If continuity is present, main light switch is faulty.

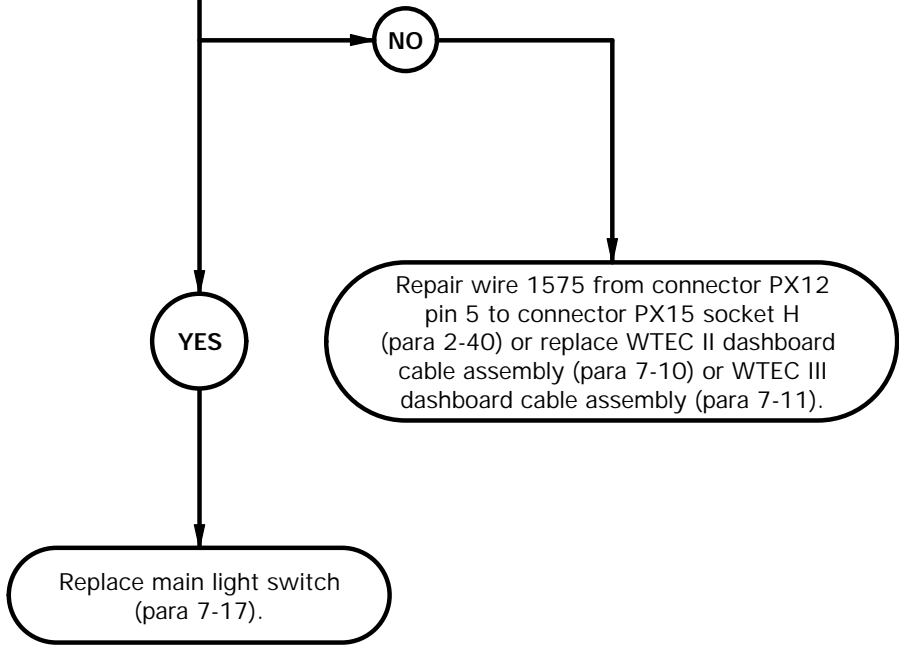

CAUTION

Use care when testing electrical connectors. Do not damage connector pins or sockets with multimeter probes. Failure to comply may result in damage to equipment.

NOTE

Inspect connector pins/sockets for damage, corrosion, and serviceability. Check that connector pins are not pushed back and are capable of making good contact.

CONTINUITY TEST

- (1) Disconnect connector PX15 from main light switch.
- (2) Set multimeter to ohms.
- (3) Connect positive (+) probe of multimeter to connector PX12 pin 5.
- (4) Connect negative (-) probe of multimeter to connector PX15 socket H and note reading on multimeter.
- (5) If continuity is not present, repair wire 1575 from connector PX12 pin 5 to connector PX15 socket H (para 2-40) or replace WTEC II dashboard cable assembly (para 7-10) or WTEC III dashboard cable assembly (para 7-11).
- (6) If continuity is present, replace main light switch (para 7-17).
- (7) Connect connector PX15 to main light switch.
- (8) Connect connector PX12 to warning light switch.
- (9) Install instrument panel assembly (para 7-15).
- (10) Connect batteries (para 7-48).

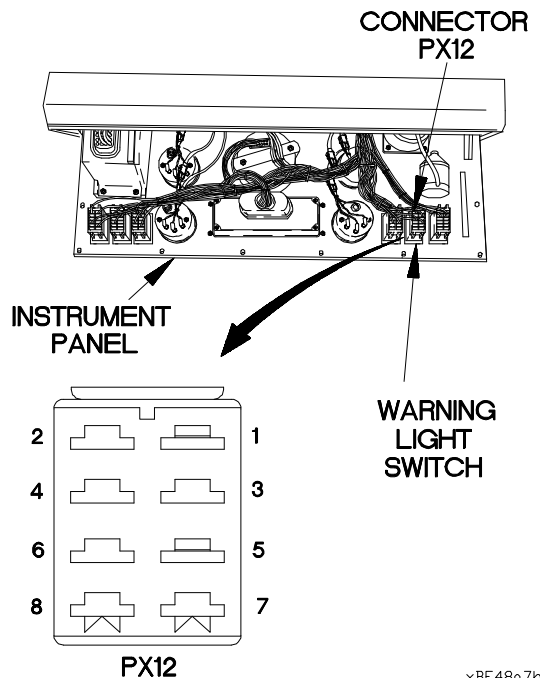
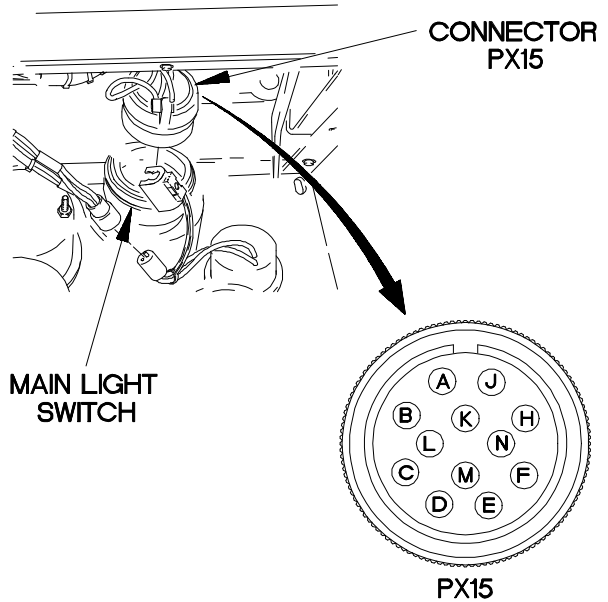

xBE48a 7b

e48. ONE OR BOTH COMPOSITE TAILLIGHTS DO NOT ILLUMINATE

INITIAL SETUP

Equipment Condition

Engine shut down (TM 9-2320-365-10).

Personnel Required

(2)

Material/Parts

Packing, Preformed (Item 172, Appendix G)
 Lockwasher (2) (Item 92, Appendix G)

Tools and Special Tools

Tool Kit, Genl Mech (Item 44, Appendix C)
 STE/ICE-R (Item 39, Appendix C)
 Multimeter, Digital (Item 22, Appendix C)



References

TM 9-4910-571-12&P

NOTE

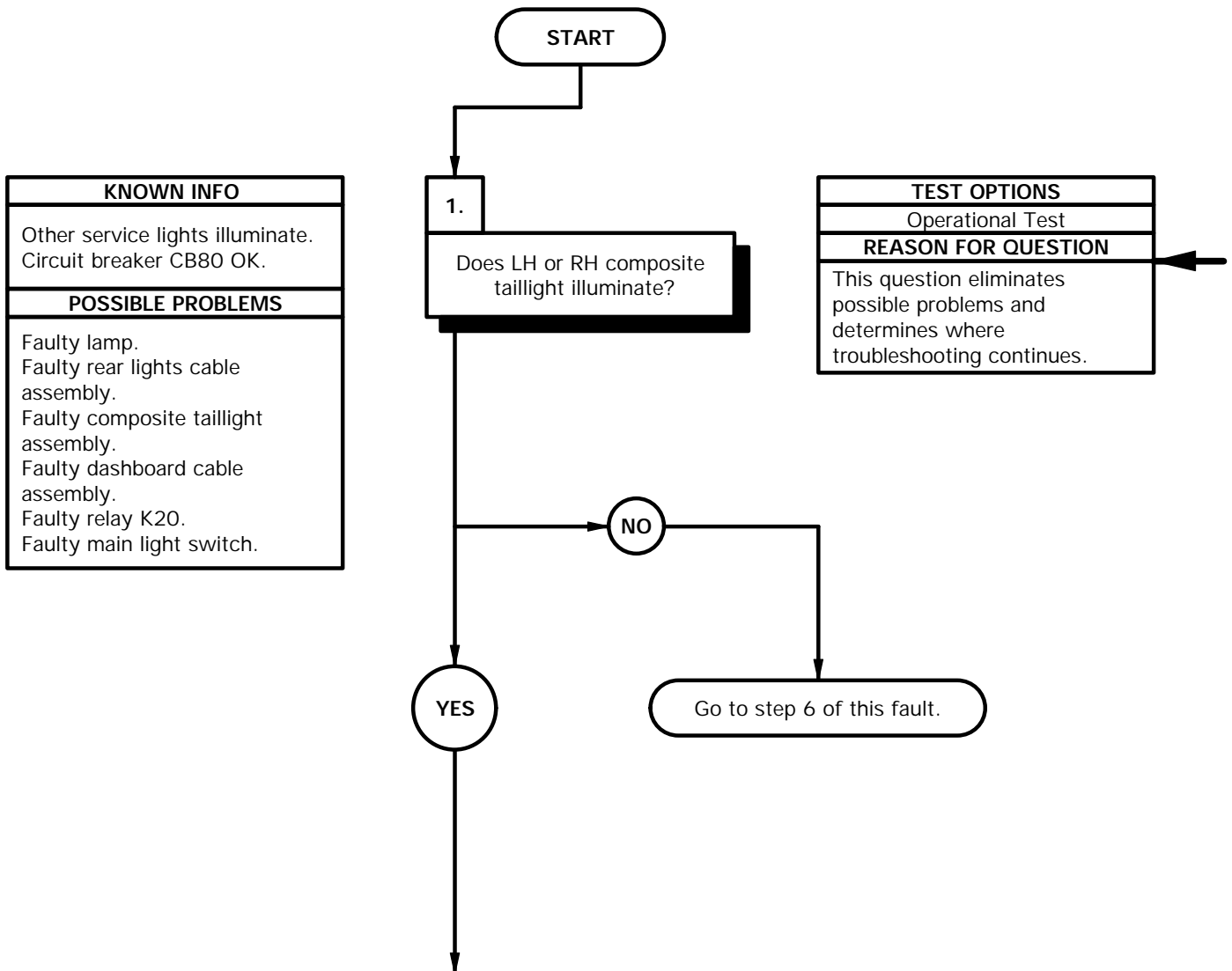
Perform Electrical System Troubleshooting e1. Circuit Breaker Does Not Operate on circuit breaker CB80 prior to beginning this task.



- 
- (1) Position main light switch to SER DRIVE (TM 9-2320-365-10).
 - (2) If neither composite taillight illuminates, go to step 6 of this fault.
 - (3) Position main light switch to OFF (TM 9-2320-365-10).
- 

e48. ONE OR BOTH COMPOSITE TAILLIGHTS DO NOT ILLUMINATE (CONT)

KNOWN INFO
Other service light illuminates. Circuit breaker CB80 OK. One composite taillight illuminate. Dashboard cable assembly OK.
POSSIBLE PROBLEMS
Faulty rear lights cable assembly. Faulty composite taillight assembly. Faulty lamp.

TEST OPTIONS
Visual Inspection
REASON FOR QUESTION
This question illuminates possible problems and determines where troubleshooting continues.

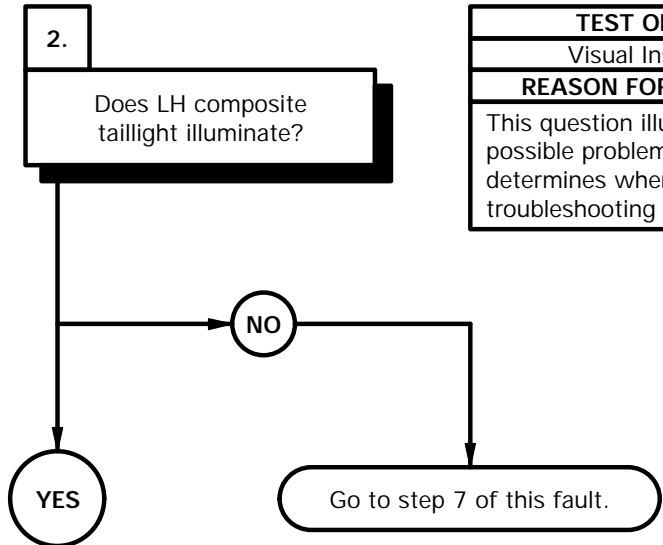

KNOWN INFO
Other service light illuminates. Circuit breaker CB80 OK. One composite taillight illuminates. Dashboard cable assembly OK.
POSSIBLE PROBLEMS
Faulty rear lights cable assembly. Faulty composite taillight assembly. Faulty lamp.

TEST OPTIONS
Continuity Test or STE/ICE-R Test #91
REASON FOR QUESTION
If continuity is not present, RH composite taillight lamp is faulty.

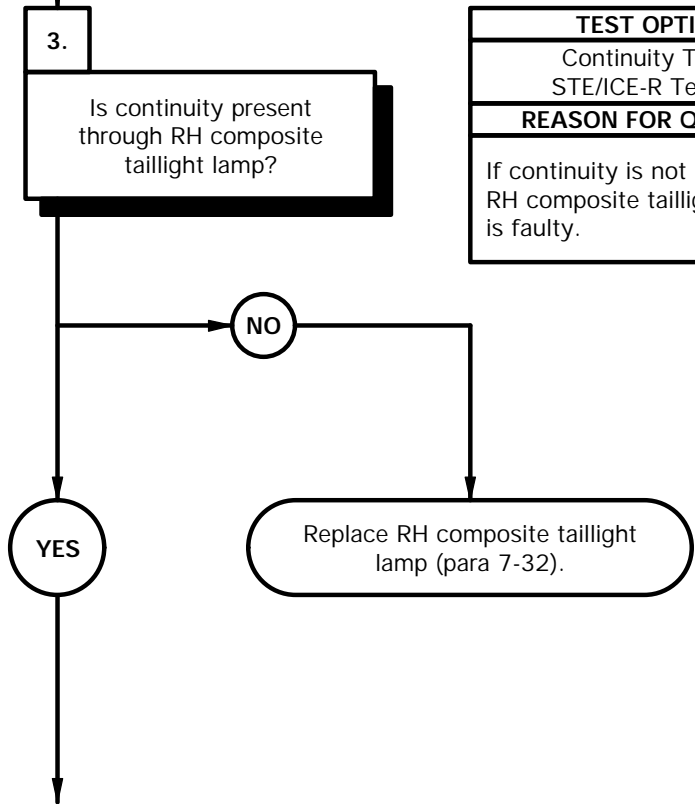

If LH taillight does not illuminate, go to step 7 of this fault.

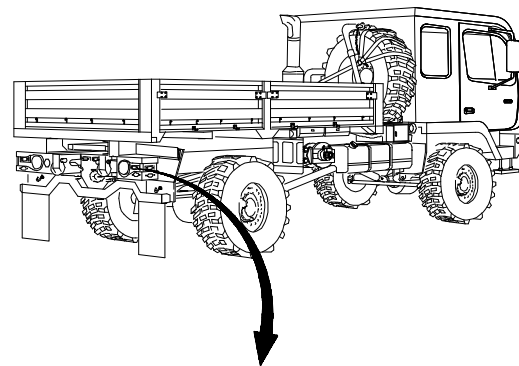

- | CONTINUITY TEST | |
|-----------------|--|
| (1) | Loosen six screws and remove cover and preformed packing from RH composite taillight. Discard preformed packing. |
| (2) | Remove RH composite taillight lamp from socket. |
| (3) | Set multimeter to ohms. |
| (4) | Check continuity through RH composite taillight lamp and note reading on multimeter. |
| (5) | If continuity is not present, replace RH composite taillight lamp (para 7-32). |

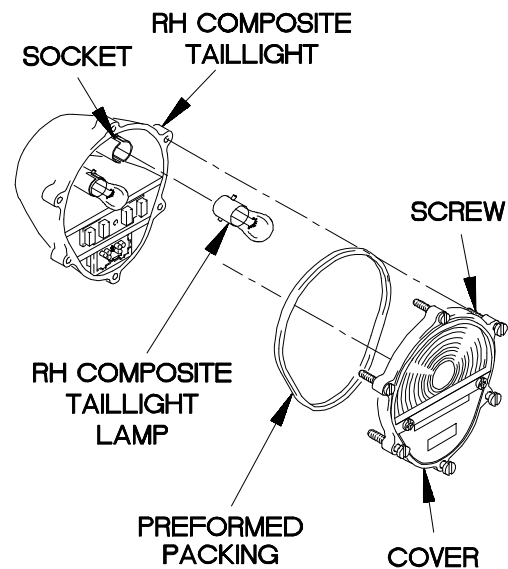

3BE4803B

e48. ONE OR BOTH COMPOSITE TAILLIGHTS DO NOT ILLUMINATE (CONT)

KNOWN INFO
Other service light illuminates. Circuit breaker CB80 OK. One composite taillight illuminates. Dashboard cable assembly OK. Lamp OK.
POSSIBLE PROBLEMS
Faulty rear lights cable assembly. Faulty composite taillight assembly.

4.

WARNING
CAUTION
Read WARNING and CAUTION on following page.

Is 12 VDC present at connector P64?

TEST OPTIONS
Voltage Test or STE/ICE-R Test #89
REASON FOR QUESTION
If 12 VDC is not present, wire 21 is faulty.

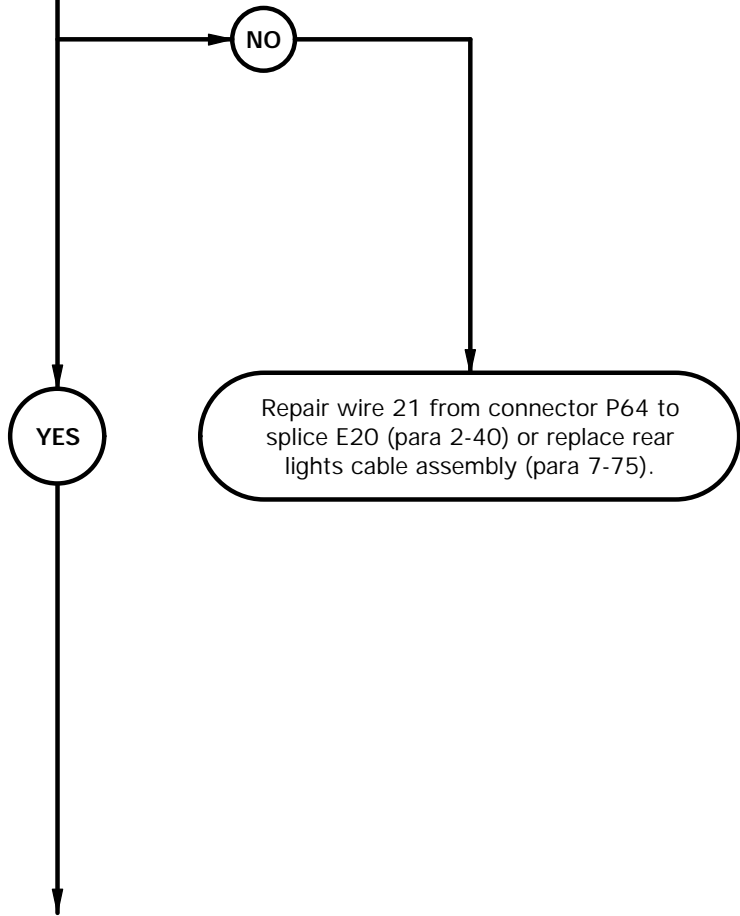

WARNING

Remove rings, bracelets, watches, necklaces, and any other jewelry before working around vehicle. Jewelry can catch on equipment and cause injury or short across electrical circuits, and cause severe burns or electrical shock.

CAUTION

Use care when testing electrical connectors. Do not damage connector pins or sockets with multimeter probes. Failure to comply may result in damage to equipment.

NOTE

Inspect connector pins/sockets for damage, corrosion, and serviceability. Check that connector pins are not pushed back and are capable of making good contact.

VOLTAGE TEST

- (1) Disconnect connector P64 from RH composite taillight assembly.
- (2) Set multimeter to volts DC.
- (3) Connect positive (+) probe of multimeter to connector P64.
- (4) Connect negative (-) probe of multimeter to ground.
- (5) Position main light switch to SER DRIVE (TM 9-2320-365-10) and note reading on multimeter.
- (6) If 12 VDC is not present, repair wire 21 from connector P64 to splice E20 (para 2-40) or replace rear lights cable assembly (para 7-75).
- (7) Position main light switch to OFF (TM 9-2320-365-10).

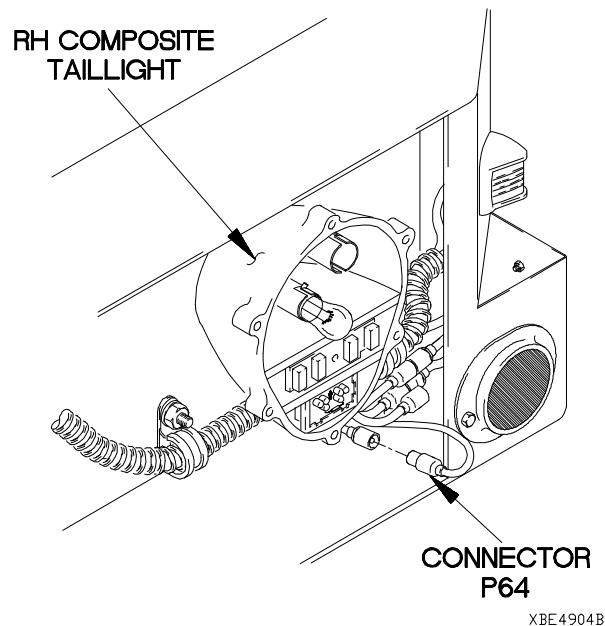

e48. ONE OR BOTH COMPOSITE TAILLIGHTS DO NOT ILLUMINATE (CONT)

KNOWN INFO
Other service light illuminates. Circuit breaker CB80 OK. One composite taillight illuminates. Dashboard cable assembly OK. Lamp OK. Rear lights cable assembly OK.
POSSIBLE PROBLEMS
Faulty composite taillight assembly.

5.
Is continuity present from terminal lug TL21 to ground?

TEST OPTIONS
Continuity Test or STE/ICE-R Test #91
REASON FOR QUESTION
If continuity is not present, wire 3095 from terminal lug TL21 to terminal lug TL92 is faulty. If continuity is present, RH composite taillight assembly is faulty.

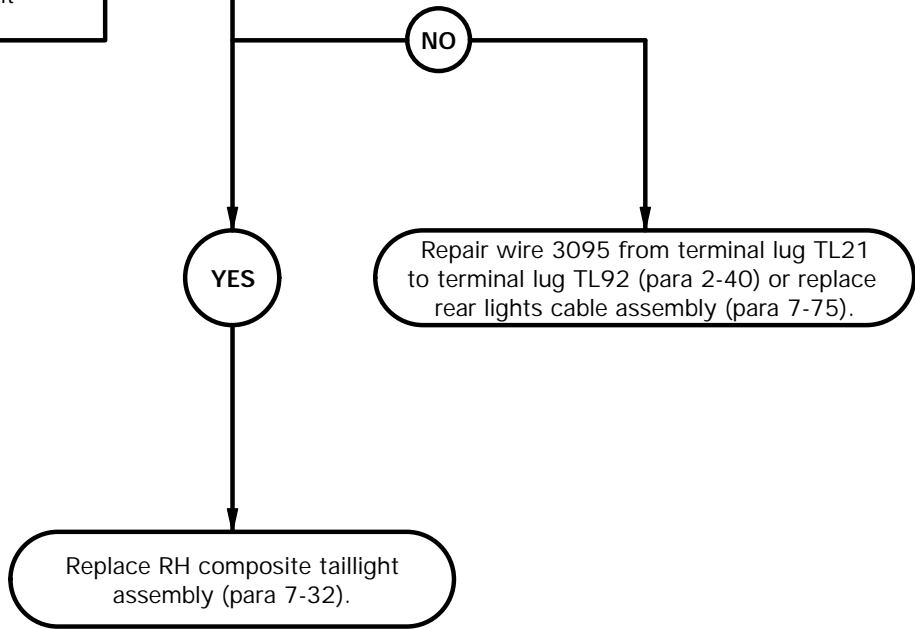

CONTINUITY TEST

- (1) Remove two screws, lockwashers, RH composite taillight assembly, and terminal lug TL21 from right taillight carrier. Discard lockwashers.
- (2) Set multimeter to ohms.
- (3) Connect positive (+) probe of multimeter to terminal lug TL21.
- (4) Connect negative (-) probe of multimeter to ground and note reading on multimeter.
- (5) If continuity is not present, repair wire 3095 from terminal lug TL21 to terminal lug TL92 (para 2-40) or replace rear lights cable assembly (para 7-75).
- (6) If continuity is present, replace RH composite taillight assembly (para 7-32).
- (7) Install terminal lug TL21, and RH composite taillight assembly on right taillight carrier with two lockwashers and screws.
- (8) Connect connector P64 to RH composite taillight assembly.
- (9) Install RH composite taillight lamp in socket.
- (10) Install preformed packing and cover on RH composite taillight assembly with six screws.

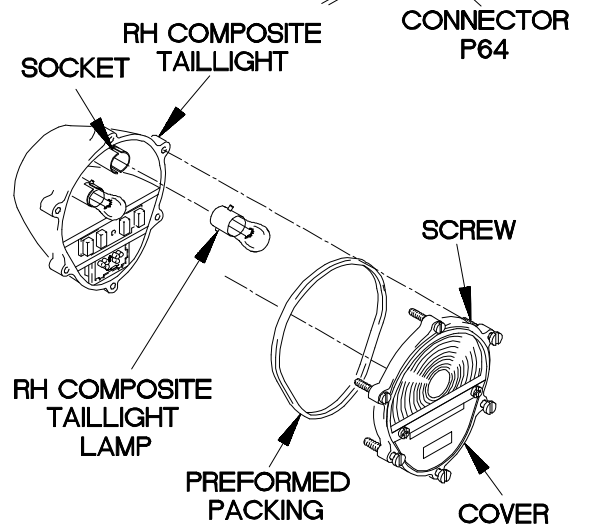
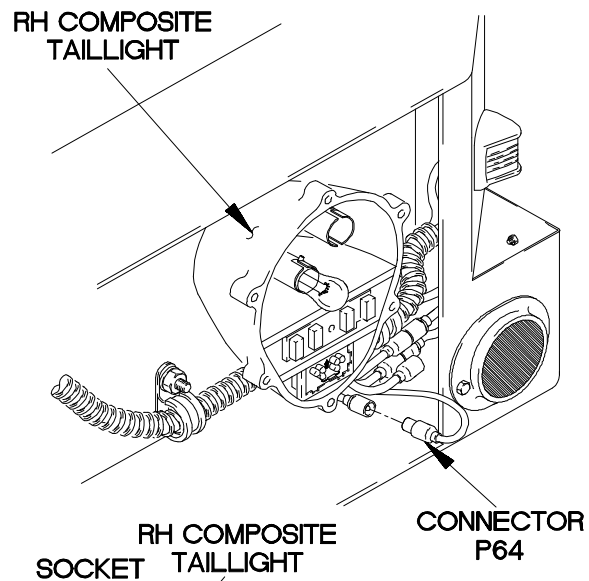
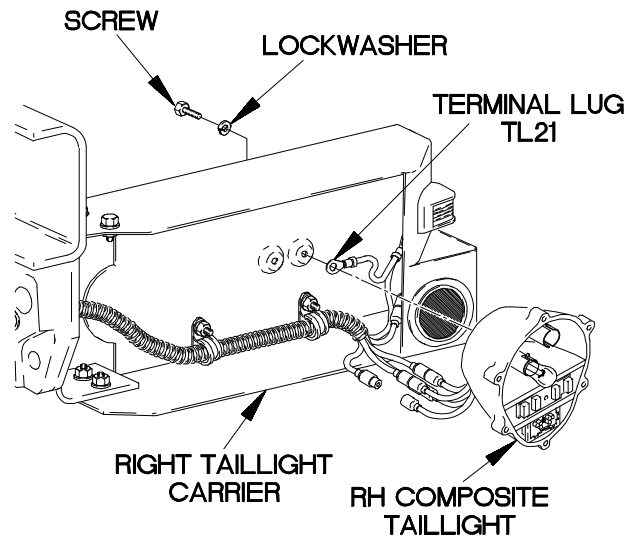

Xloe4905B

e48. ONE OR BOTH COMPOSITE TAILLIGHTS DO NOT ILLUMINATE (CONT)

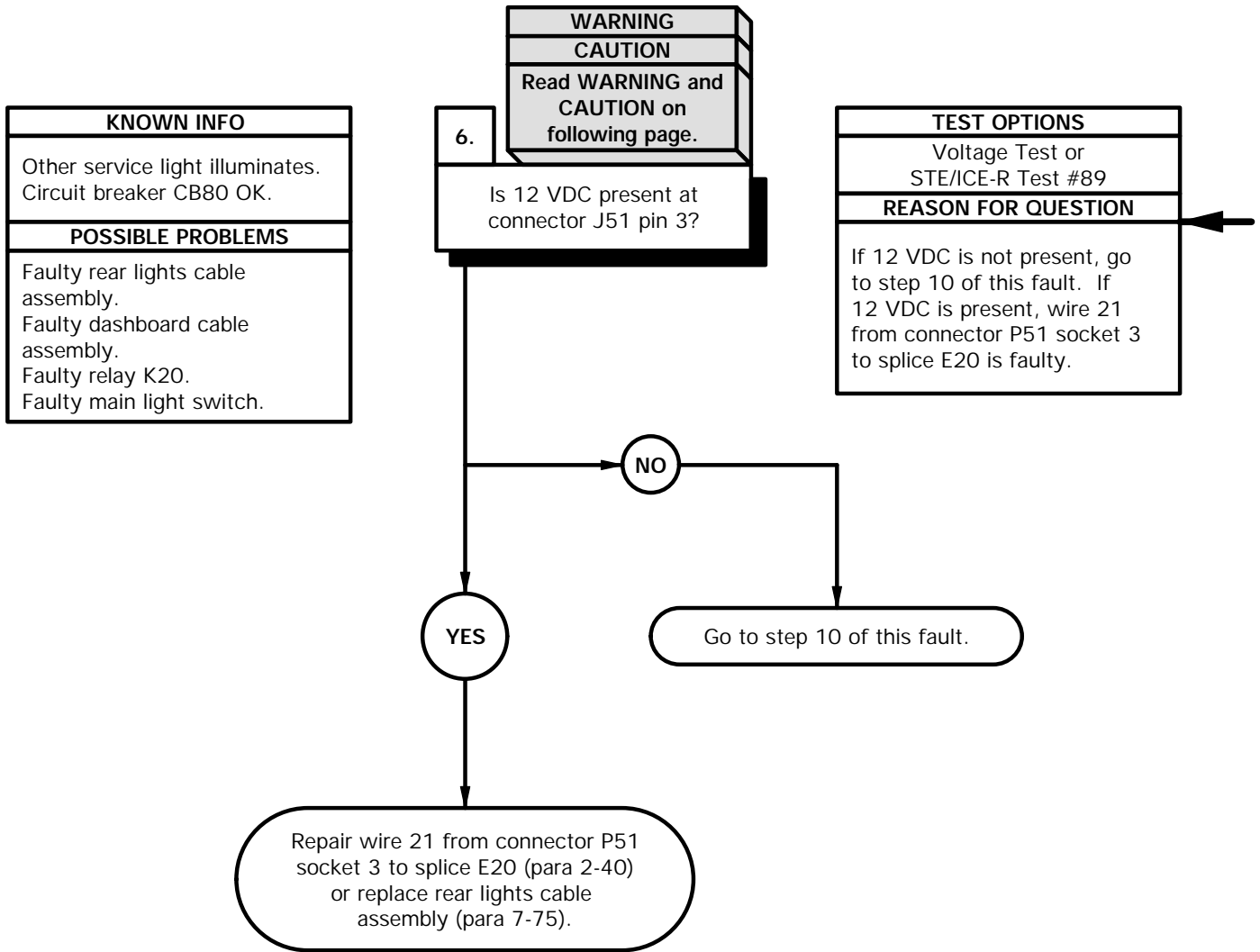

WARNING

Remove rings, bracelets, watches, necklaces, and any other jewelry before working around vehicle. Jewelry can catch on equipment and cause injury or short across electrical circuits and cause severe burns or electrical shock.

CAUTION

Use care when testing electrical connectors. Do not damage connector pins or sockets with multimeter probes. Failure to comply may result in damage to equipment.

NOTE

Inspect connector pins/sockets for damage, corrosion, and serviceability. Check that connector pins are not pushed back and are capable of making good contact.

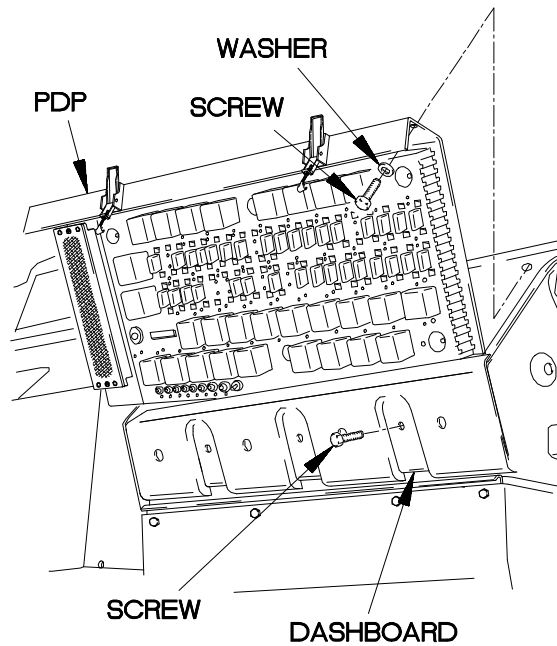

VOLTAGE TEST

- (1) Remove PDP cover (para 16-2).
- (2) Remove three screws and washers from PDP.
- (3) Remove three screws from PDP.
- (4) Lift PDP outward to gain access.
- (5) Disconnect connector P51 from connector J51.
- (6) Set multimeter to volts DC.
- (7) Connect positive (+) probe of multimeter to connector J51 pin 3.
- (8) Connect negative (-) probe of multimeter to ground.
- (9) Position main light switch to SER DRIVE (TM 9-2320-365-10) and note reading on multimeter.
- (10) If 12 VDC is not present, go to step 10 of this fault.
- (11) If 12 VDC is present, repair wire 21 from connector P51 socket 3 to splice E20 (para 2-40) or replace rear lights cable assembly (para 7-75).
- (12) Position main light switch to OFF (TM 9-2320-365-10).
- (13) Connect connector J51 to connector P51.
- (14) Install PDP on dashboard with three screws.
- (15) Install three washers and screws in PDP.

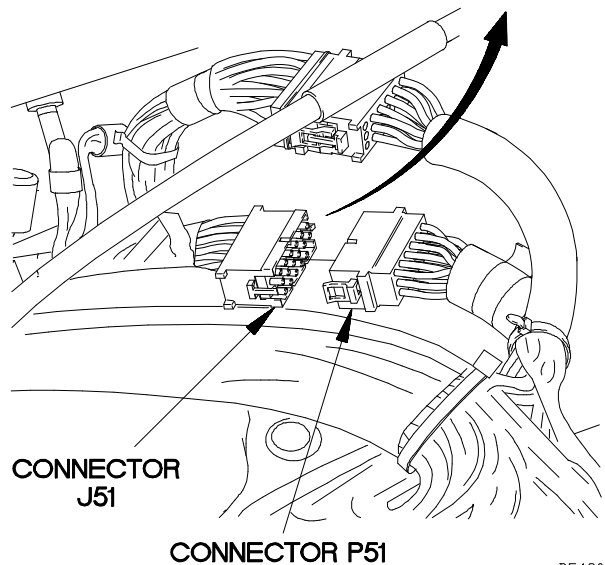
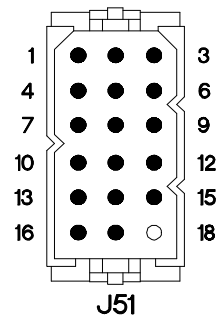

xBE49066

e48. ONE OR BOTH COMPOSITE TAILLIGHTS DO NOT ILLUMINATE (CONT)

KNOWN INFO
Other service light illuminates. Circuit breaker CB80 OK. One composite taillight illuminates. Dashboard cable assembly OK.
POSSIBLE PROBLEMS
Faulty rear lights cable assembly. Faulty composite taillight assembly. Faulty lamp.

7.
Is continuity present through LH composite taillight lamp?

TEST OPTIONS
Continuity Test or STE/ICE-R Test #91
REASON FOR QUESTION
If continuity is not present, LH composite taillight lamp is faulty.

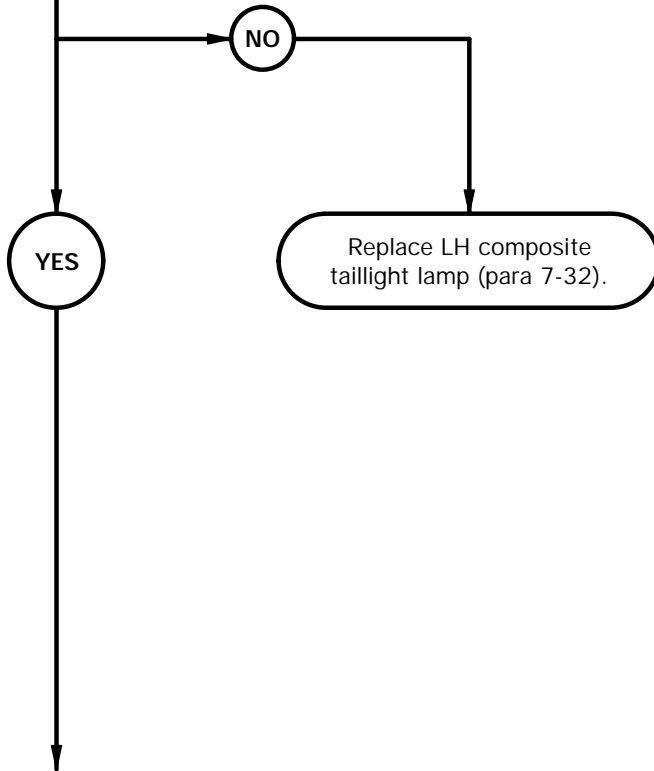

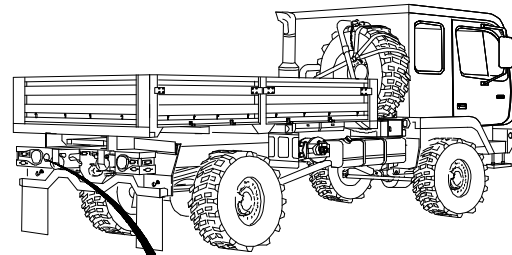

- CONTINUITY TEST**
- (1) Loosen six screws and remove cover and preformed packing from LH composite taillight lamp. Discard preformed packing.
 - (2) Remove LH composite taillight lamp from socket.
 - (3) Set multimeter to ohms.
 - (4) Check continuity through LH composite taillight lamp and note reading on multimeter.
 - (5) If continuity is not present, replace LH composite taillight lamp (para 7-32).

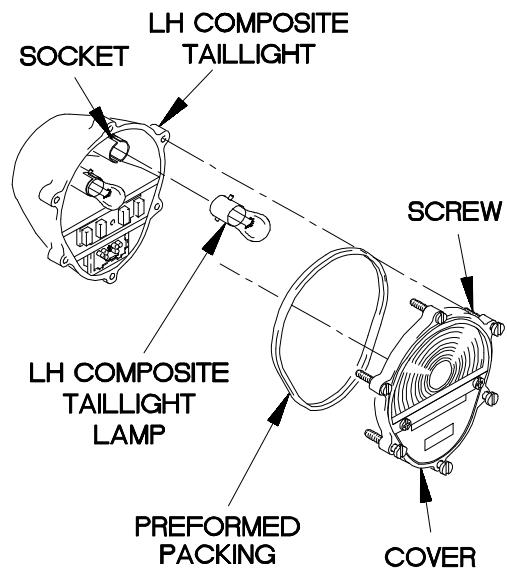

3BE4807B

e48. ONE OR BOTH COMPOSITE TAILLIGHTS DO NOT ILLUMINATE (CONT)

KNOWN INFO
Other service light illuminates. Circuit breaker CB80 OK. One composite taillight illuminates. Dashboard cable assembly OK. Lamp OK.
POSSIBLE PROBLEMS
Faulty rear lights cable assembly. Faulty composite taillight assembly.

8.

WARNING

CAUTION

Read **WARNING** and **CAUTION** on following page.

Is 12 VDC present at connector P78?

TEST OPTIONS
Voltage Test or STE/ICE-R Test #89
REASON FOR QUESTION
If 12 VDC is not present, wire 21 from connector P78 to splice E20 is faulty.

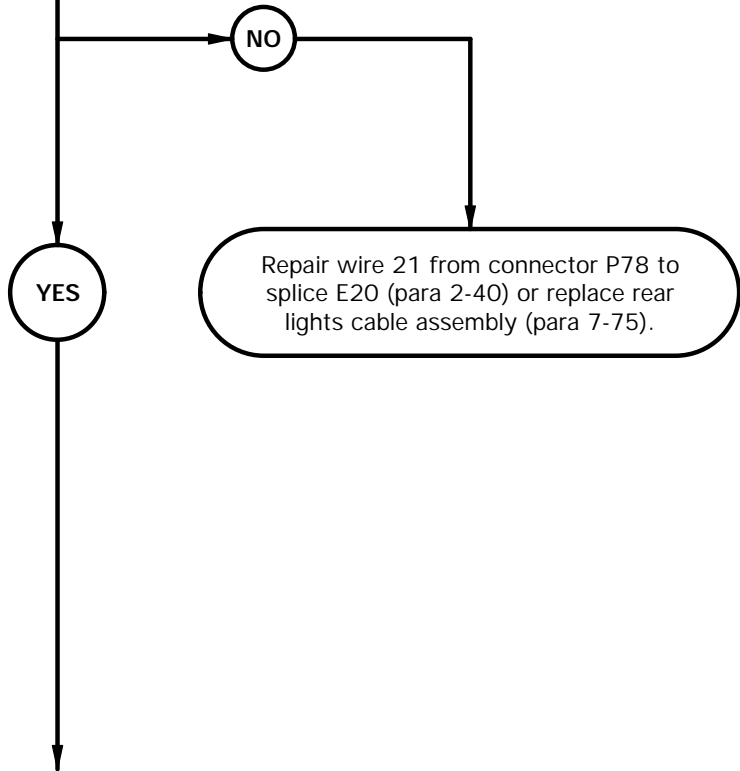

WARNING

Remove rings, bracelets, watches, necklaces, and any other jewelry before working around vehicle. Jewelry can catch on equipment and cause injury or short across electrical circuits, or cause severe burns or electrical shock.

CAUTION

Use care when testing electrical connectors. Do not damage connector pins or sockets with multimeter probes. Failure to comply may result in damage to equipment.

NOTE

Inspect connector pins/sockets for damage, corrosion, and serviceability. Check that connector pins are not pushed back and are capable of making good contact.

VOLTAGE TEST

- (1) Disconnect connector P78 from LH composite taillight assembly.
- (2) Set multimeter to volts DC.
- (3) Connect positive (+) probe of multimeter to connector P78.
- (4) Connect negative (-) probe of multimeter to ground.
- (5) Position main light switch to SER DRIVE (TM 9-2320-365-10) and note reading on multimeter.
- (6) If 12 VDC is not present, repair wire 21 from connector P78 to splice E20 (para 2-40) or replace rear lights cable assembly (para 7-75).
- (7) Position main light switch to OFF (TM 9-2320-365-10).

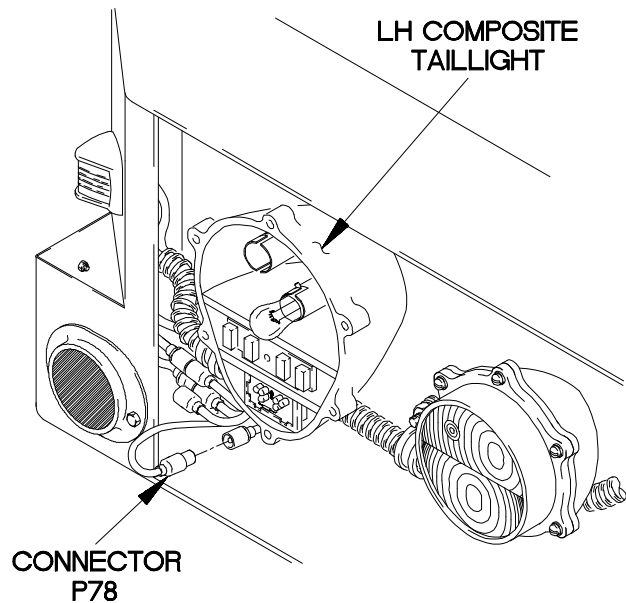

XBE4910B

e48. ONE OR BOTH COMPOSITE TAILLIGHTS DO NOT ILLUMINATE (CONT)

KNOWN INFO
Other service light illuminates. Circuit breaker CB80 OK. One composite taillight illuminates. Dashboard cable assembly OK. Lamp OK.
POSSIBLE PROBLEMS
Faulty composite taillight assembly. Faulty rear lights cable assembly.

9.
Is continuity present from terminal lug TL18 to ground?

TEST OPTIONS
Continuity Test or STE/ICE-R Test #91
REASON FOR QUESTION
If continuity is not present, wire 3094 from terminal lug TL18 to splice E21 is faulty. If continuity is present, LH composite taillight assembly is faulty.

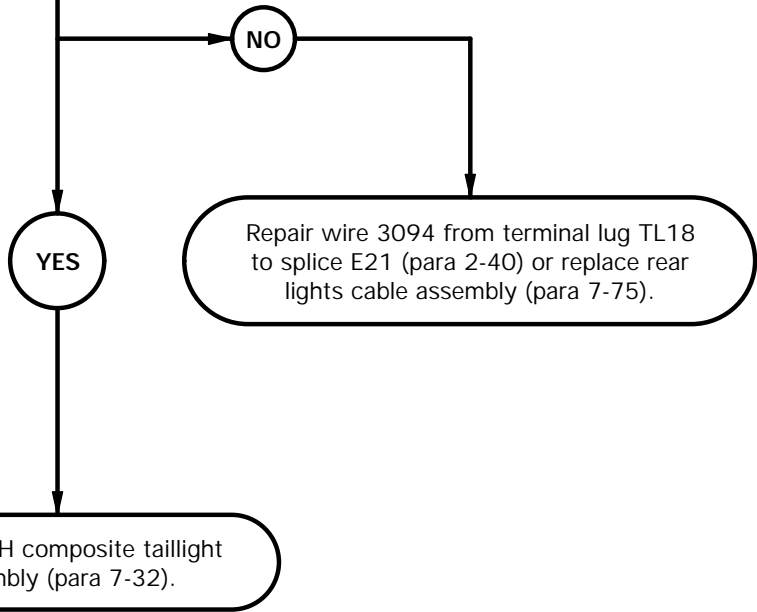

CONTINUITY TEST

- (1) Remove two screws, lockwashers, LH composite taillight assembly, and terminal lug TL18 from right taillight carrier. Discard lockwashers.
- (2) Set multimeter to ohms.
- (3) Connect positive (+) probe of multimeter to terminal lug TL18.
- (4) Connect negative (-) probe of multimeter to ground and note reading on multimeter.
- (5) If continuity is not present, repair wire 3094 from terminal lug TL18 to splice E21 (para 2-40).
- (6) If continuity is present, replace LH composite taillight assembly (para 7-32).
- (7) Install terminal lug TL18, and LH composite taillight assembly on left taillight carrier with two lockwashers and screws.
- (8) Connect connector P78 to LH composite taillight assembly.
- (9) Install LH composite taillight lamp in socket.
- (10) Install preformed packing and cover on LH composite taillight assembly with six screws.

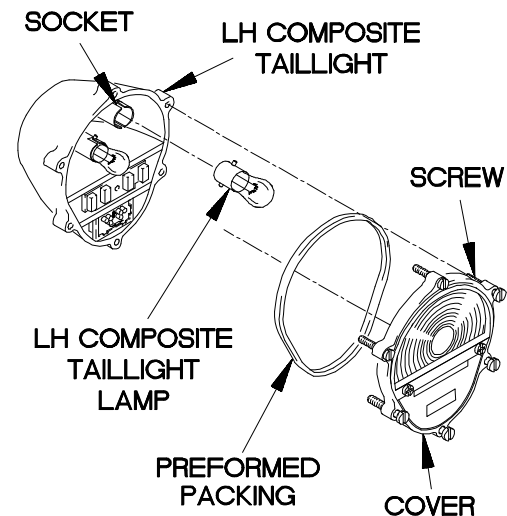
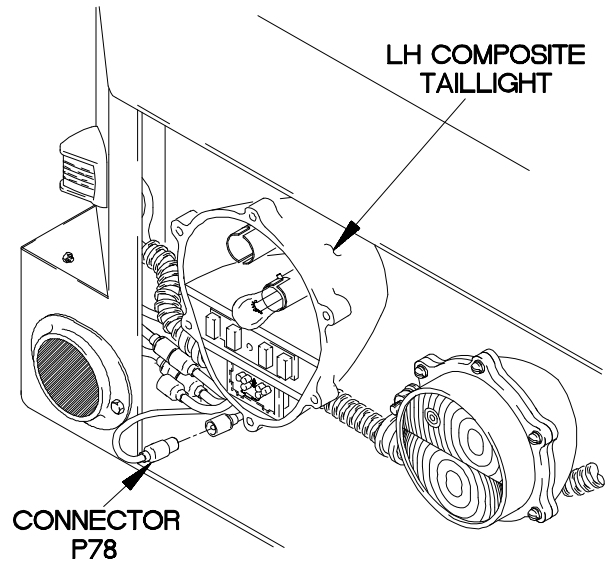
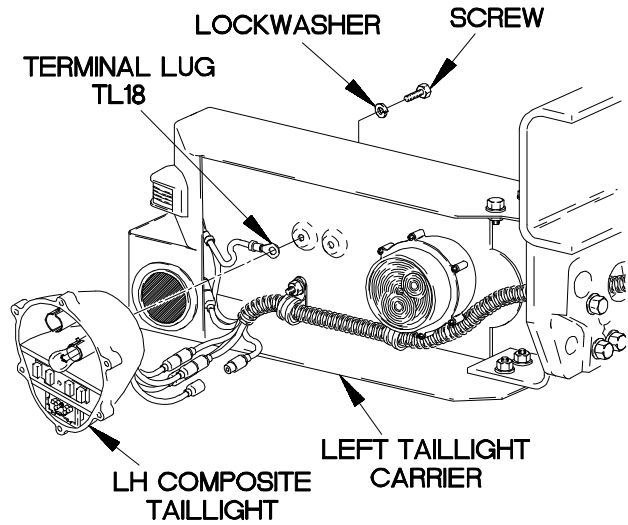

XBE4911B

e48. ONE OR BOTH COMPOSITE TAILLIGHTS DO NOT ILLUMINATE (CONT)

KNOWN INFO
Other service light illuminates. Circuit breaker CB80 OK. Rear lights cable assembly OK.
POSSIBLE PROBLEMS
Faulty main light switch. Faulty dashboard cable assembly. Faulty relay K20.

10.

WARNING
Read WARNING on following page.

Is 12 VDC present at circuit breaker CB80 socket 1?

TEST OPTIONS
Voltage Test or STE/ICE-R Test #89
REASON FOR QUESTION
If 12 VDC is present, wire 21 is faulty.

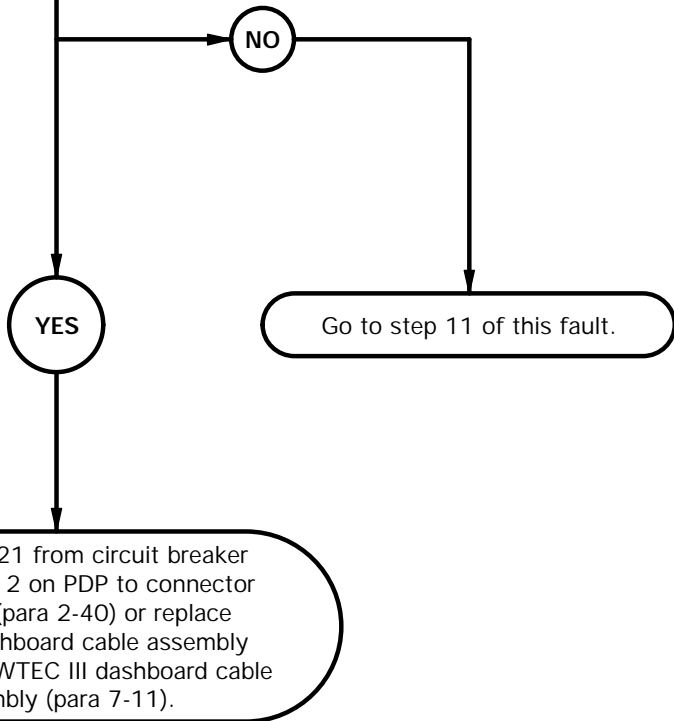

WARNING

Remove rings, bracelets, watches, necklaces, and any other jewelry before working around vehicle. Jewelry can catch on equipment and cause injury or short across electrical circuits and cause severe burns or electrical shock.

VOLTAGE TEST

- (1) Remove PDP cover (para 16-2).
- (2) Remove circuit breaker CB80 from PDP.
- (3) Set multimeter to volts DC.
- (4) Connect positive (+) probe of multimeter to circuit breaker CB80 socket 1.
- (5) Connect negative (-) probe of multimeter to ground.
- (6) Position main light switch to SER DRIVE (TM 9-2320-365-10) and note reading on multimeter.
- (7) If 12 VDC is not present, go to 11 of this fault.
- (8) If 12 VDC is present, repair wire 21 from circuit breaker CB80 socket 2 on PDP to connector J51 pin 3 (para 2-40) or replace WTEC II dashboard cable assembly (para 7-10) or WTEC III dashboard cable assembly (para 7-11).
- (9) Position main light switch to OFF (TM 9-2320-365-10).

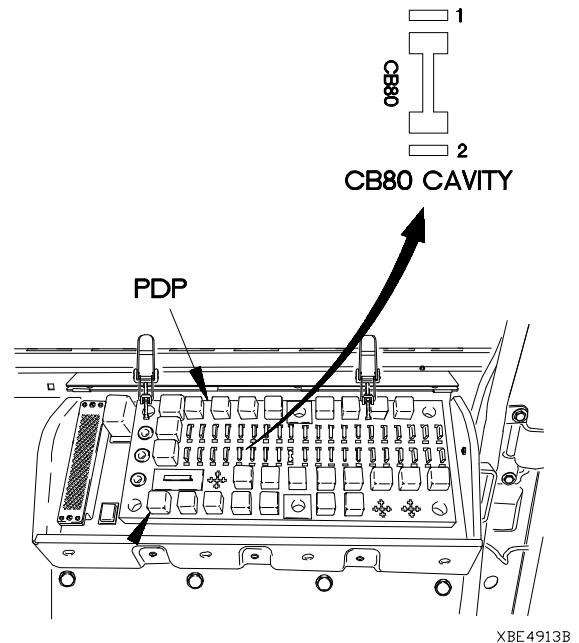

XBE4913B

e48. ONE OR BOTH COMPOSITE TAILLIGHTS DO NOT ILLUMINATE (CONT)

KNOWN INFO
Other service light illuminates. Circuit breaker CB80 OK. Rear lights cable assembly OK.
POSSIBLE PROBLEMS
Faulty main light switch. Faulty dashboard cable assembly. Faulty relay K20.

CAUTION
Read CAUTION on following page.

11.
Is continuity present from circuit breaker to CB80 socket 1 to relay K20 terminal 87 on PDP?

TEST OPTIONS
Continuity Test or STE/ICE-R Test #91
REASON FOR QUESTION
If continuity is not present, wire 1914 from relay K20 terminal 87 on PDP to circuit breaker CB80 socket 1 on PDP is faulty.

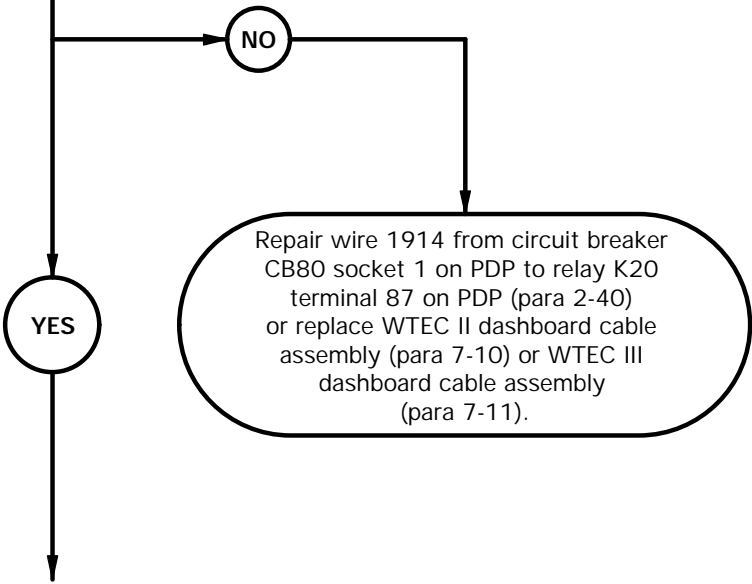

CAUTION

Use care when testing electrical connectors. Do not damage connector pins or sockets with multimeter probes. Failure to comply may result in damage to equipment.

NOTE

Inspect connector pins/sockets for damage, corrosion, and serviceability. Check that connector pins are not pushed back and are capable of making good contact.

CONTINUITY TEST

- (1) Disconnect batteries (para 7-48).
- (2) Remove relay K20 from PDP.
- (3) Set multimeter to ohms.
- (4) Connect positive (+) probe of multimeter to circuit breaker CB80 socket 1 on PDP.
- (5) Connect negative (-) probe of multimeter to relay K20 terminal 87 on PDP and note reading on multimeter.
- (6) If 12 VDC is not present, repair wire 1914 from circuit breaker CB80 socket 1 on PDP to relay K20 terminal 87 on PDP (para 2-40) or replace WTEC II dashboard cable assembly (para 7-10) or WTEC III dashboard cable assembly (para 7-11).
- (7) Install circuit breaker CB80 in PDP.
- (8) Connect batteries (para 7-48).

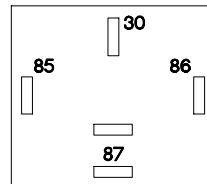

RELAY K20 CAVITY

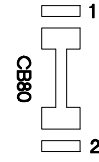

CB80 CAVITY

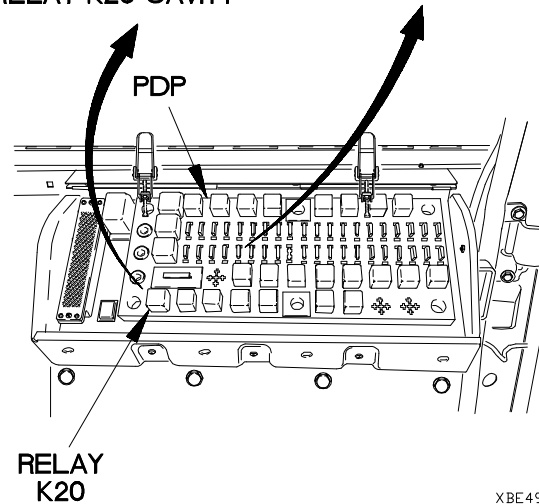

XBE4914B

e48. ONE OR BOTH COMPOSITE TAILLIGHTS DO NOT ILLUMINATE (CONT)

KNOWN INFO
Other service light illuminates. Circuit breaker CB80 OK. Rear lights cable assembly OK.
POSSIBLE PROBLEMS
Faulty dashboard cable assembly. Faulty relay K20. Faulty main light switch.

12.

WARNING
Read **WARNING** on following page.

Is 12 VDC present at relay K20 terminal 30 on PDP?

TEST OPTIONS
Voltage Test or STE/ICE-R Test #89
REASON FOR QUESTION
If 12 VDC is not present, wire 1501 from terminal X2 to relay K20 terminal 30 on PDP is faulty.

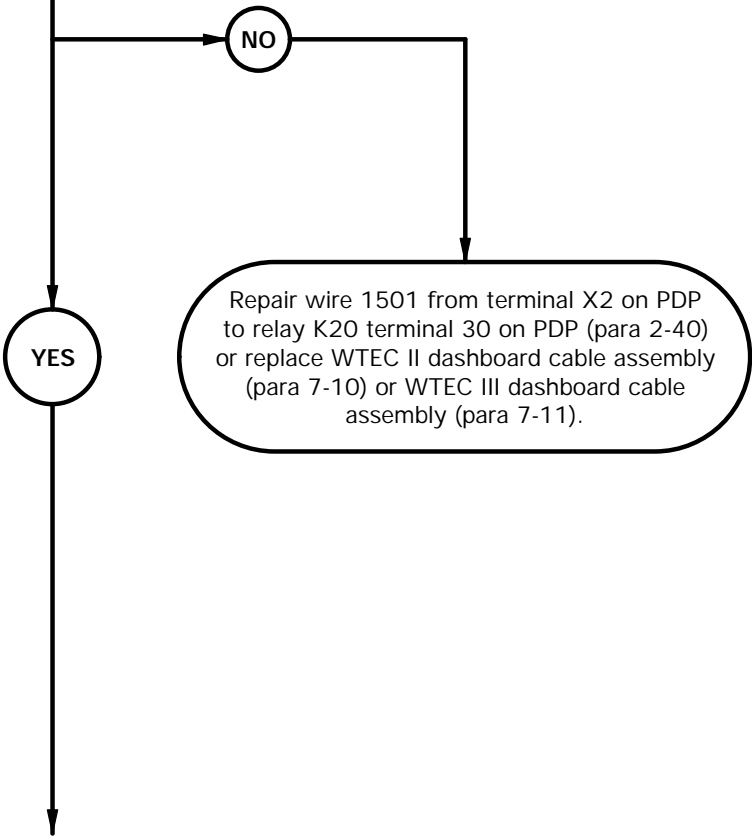

WARNING

Remove rings, bracelets, watches, necklaces, and any other jewelry before working around vehicle. Jewelry can catch on equipment and cause injury or short across electrical circuits and cause severe burns or electrical shock.

VOLTAGE TEST

- (1) Set multimeter to volts DC.
- (2) Connect positive (+) probe of multimeter to relay K20 terminal 30 on PDP.
- (3) Connect negative (-) probe of multimeter to ground.
- (4) Position main light switch to SER DRIVE (TM 9-2320-365-10) and note reading on multimeter.
- (5) If 12 VDC is not present, repair wire 1501 from terminal X2 on PDP to relay K20 terminal 30 on PDP (para 2-40) or replace WTEC II dashboard cable assembly (para 7-10) or WTEC III dashboard cable assembly (para 7-11).
- (6) Position main light switch to OFF (TM 9-2320-365-10).

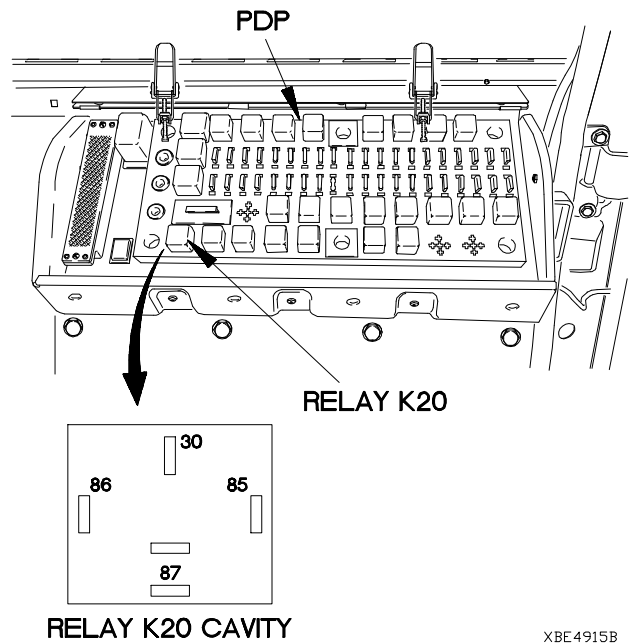

XBE4915B

e48. ONE OR BOTH COMPOSITE TAILLIGHTS DO NOT ILLUMINATE (CONT)

KNOWN INFO
Other service light illuminates. Circuit breaker CB80 OK. Rear lights cable assembly OK.
POSSIBLE PROBLEMS
Faulty dashboard cable assembly. Faulty relay K20. Faulty main light switch.

13. **WARNING**
Read **WARNING** on following page.

Is 12 VDC present at relay K20 terminal 86 on PDP?

TEST OPTIONS
Voltage Test or STE/ICE-R Test #89
REASON FOR QUESTION
This question eliminates possible problems and determines where troubleshooting continues.

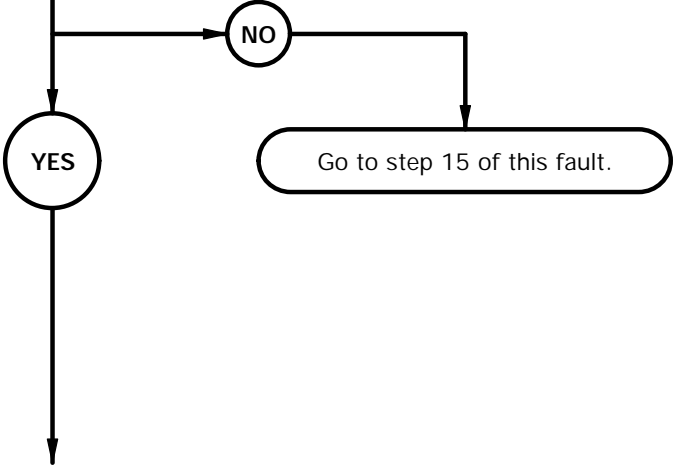

WARNING

Remove rings, bracelets, watches, necklaces, and any other jewelry before working around vehicle. Jewelry can catch on equipment and cause injury or short across electrical circuits and cause severe burns or electrical shock.

VOLTAGE TEST

- (1) Set multimeter to volts DC.
- (2) Connect positive (+) probe of multimeter to relay K20 terminal 86 on PDP.
- (3) Connect negative (-) probe of multimeter to ground and note reading on multimeter.
- (4) If 12 VDC is not present, go to step 15 of this fault.

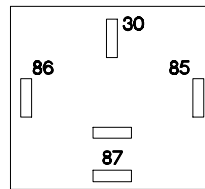
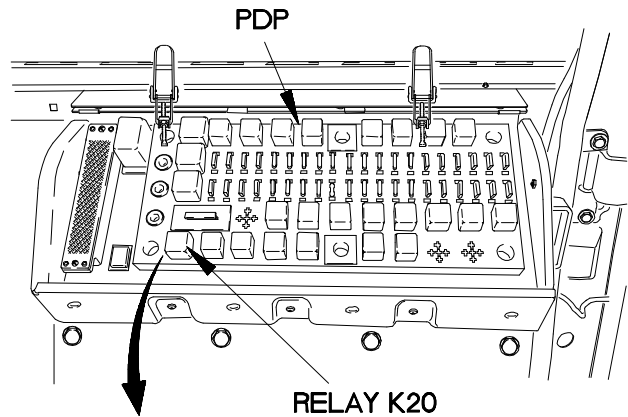

RELAY K20 CAVITY

XBE4916B

e48. ONE OR BOTH COMPOSITE TAILLIGHTS DO NOT ILLUMINATE (CONT)

KNOWN INFO
Other service light illuminates. Circuit breaker CB80 OK. Rear lights cable assembly OK.
POSSIBLE PROBLEMS
Faulty dashboard cable assembly. Faulty relay K20.

14.
Is continuity present from relay K20 terminal 85 on PDP to ground?

TEST OPTIONS
Continuity Test or STE/ICE-R Test #91
REASON FOR QUESTION
If continuity is not present, wire 3054 is faulty. If continuity is present, relay K20 is faulty.

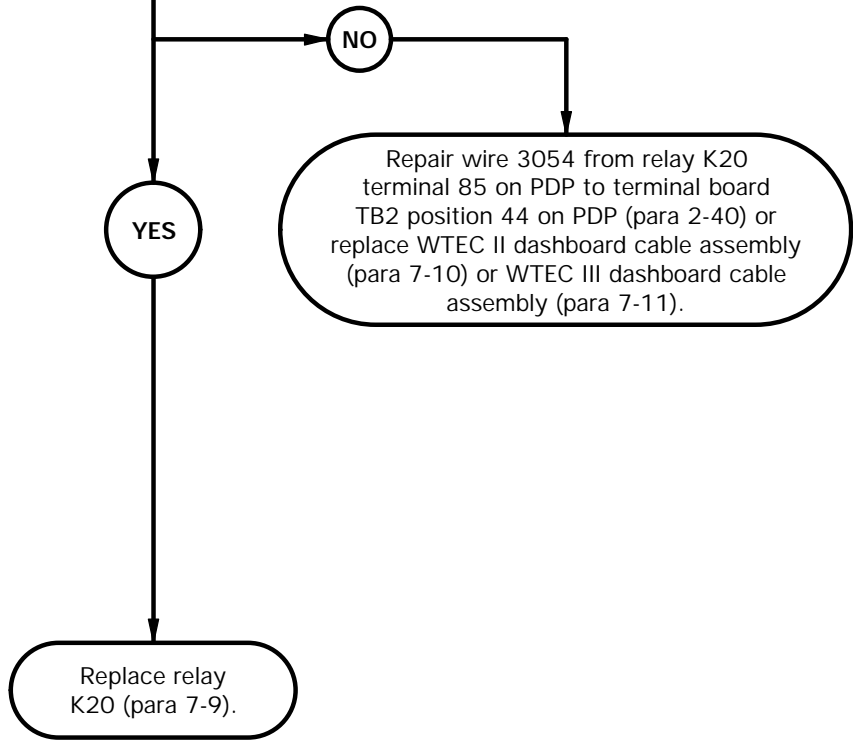

CONTINUITY TEST

- (1) Set multimeter to ohms.
- (2) Connect positive (+) probe of multimeter to relay K20 terminal 85 on PDP.
- (3) Connect negative (-) probe of multimeter to ground and note reading on multimeter.
- (4) If continuity is not present, repair wire 3054 from relay K20 terminal 85 on PDP to terminal board TB2 position 44 on PDP (para 2-40) or replace WTEC II dashboard cable assembly (para 7-10) or WTEC III dashboard cable assembly (para 7-11).
- (5) If continuity is present, replace relay K20 (para 7-9).
- (6) Install relay K20 in PDP.
- (7) Install PDP cover (para 16-2).

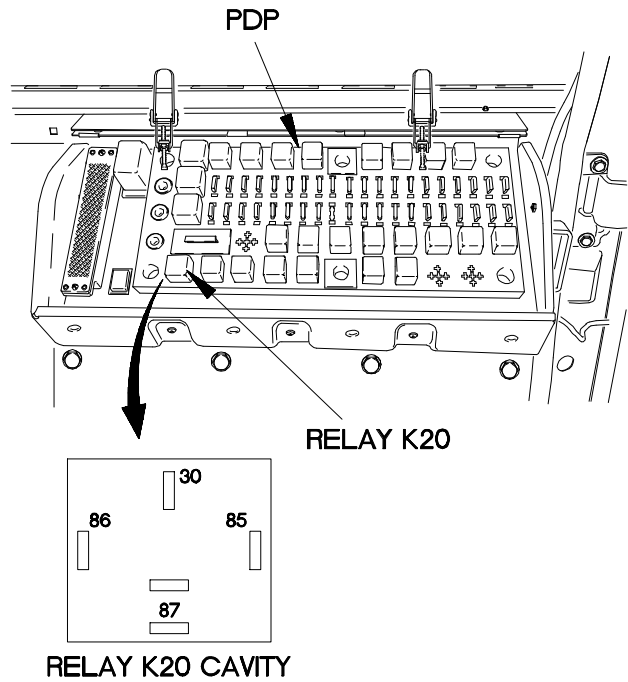

XBE4917B

e48. ONE OR BOTH COMPOSITE TAILLIGHTS DO NOT ILLUMINATE (CONT)

KNOWN INFO
Other service light illuminates. Circuit breaker CB80 OK. Lamp OK. Relay K20 OK. Rear lights cable assembly OK.
POSSIBLE PROBLEMS
Faulty dashboard cable assembly. Faulty main light switch.

CAUTION
Read CAUTION on following page.

15.
Is continuity present from connector PX15 socket H to relay K20 terminal 86 on PDP?

TEST OPTIONS
Continuity Test or STE/ICE-R Test #91
REASON FOR QUESTION
If continuity is present, main light switch is faulty.

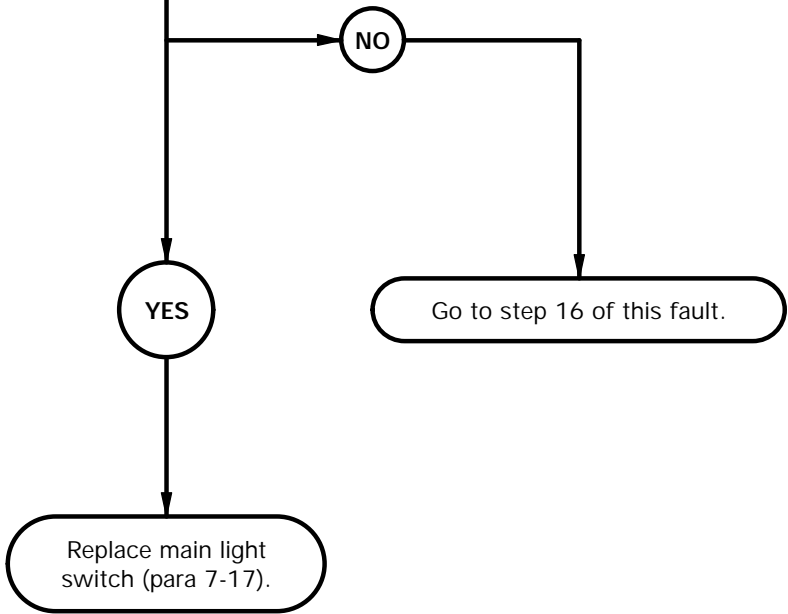

CAUTION

Use care when testing electrical connectors. Do not damage connector pins or sockets with multimeter probes. Failure to comply may result in damage to equipment.

NOTE

Inspect connector pins/sockets for damage, corrosion, and serviceability. Check that connector pins are not pushed back and are capable of making good contact.

CONTINUITY TEST

- (1) Remove circuit breaker CB70 from PDP.
- (2) Remove instrument panel assembly for access (para 7-15).
- (3) Disconnect connector PX15 from main light switch.
- (4) Install circuit breaker CB70 in PDP.
- (5) Set multimeter to ohms.
- (6) Connect positive (+) probe of multimeter to connector PX15 socket H.
- (7) Connect negative (-) probe of multimeter to relay K20 terminal 86 on PDP and note reading on multimeter.
- (8) If continuity is not present, go to step 16 of this fault.
- (9) If continuity is present, replace main light switch (para 7-17).

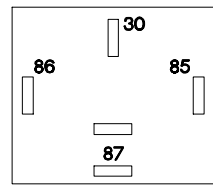
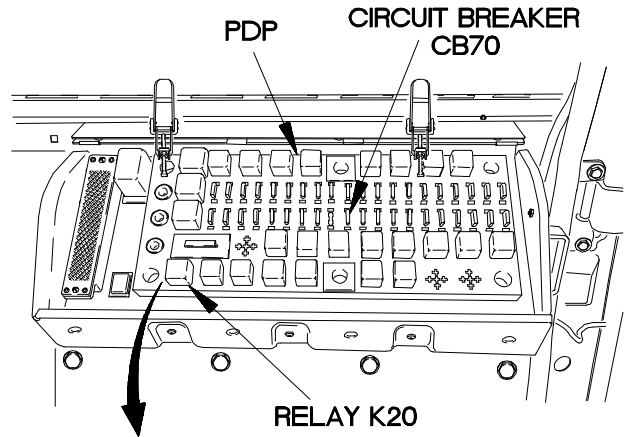

RELAY K20 CAVITY

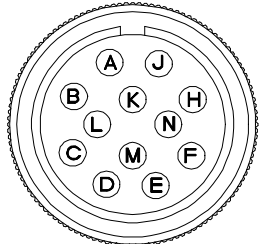

PX15

CONNECTOR PX15

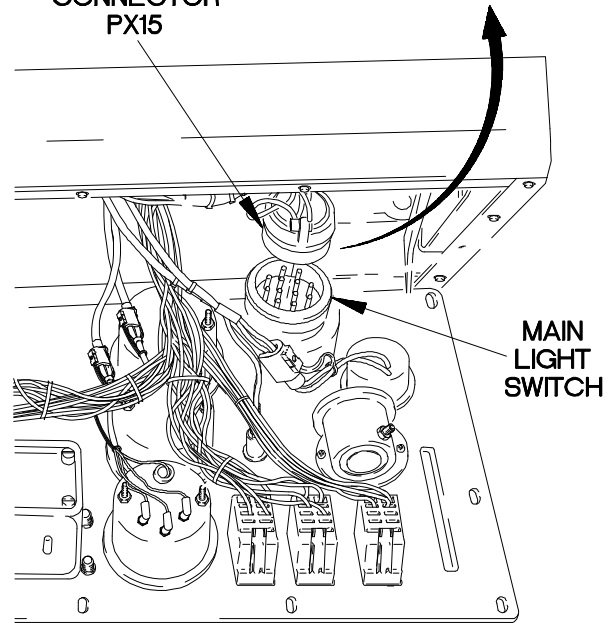

XBE4919B

e48. ONE OR BOTH COMPOSITE TAILLIGHTS DO NOT ILLUMINATE (CONT)

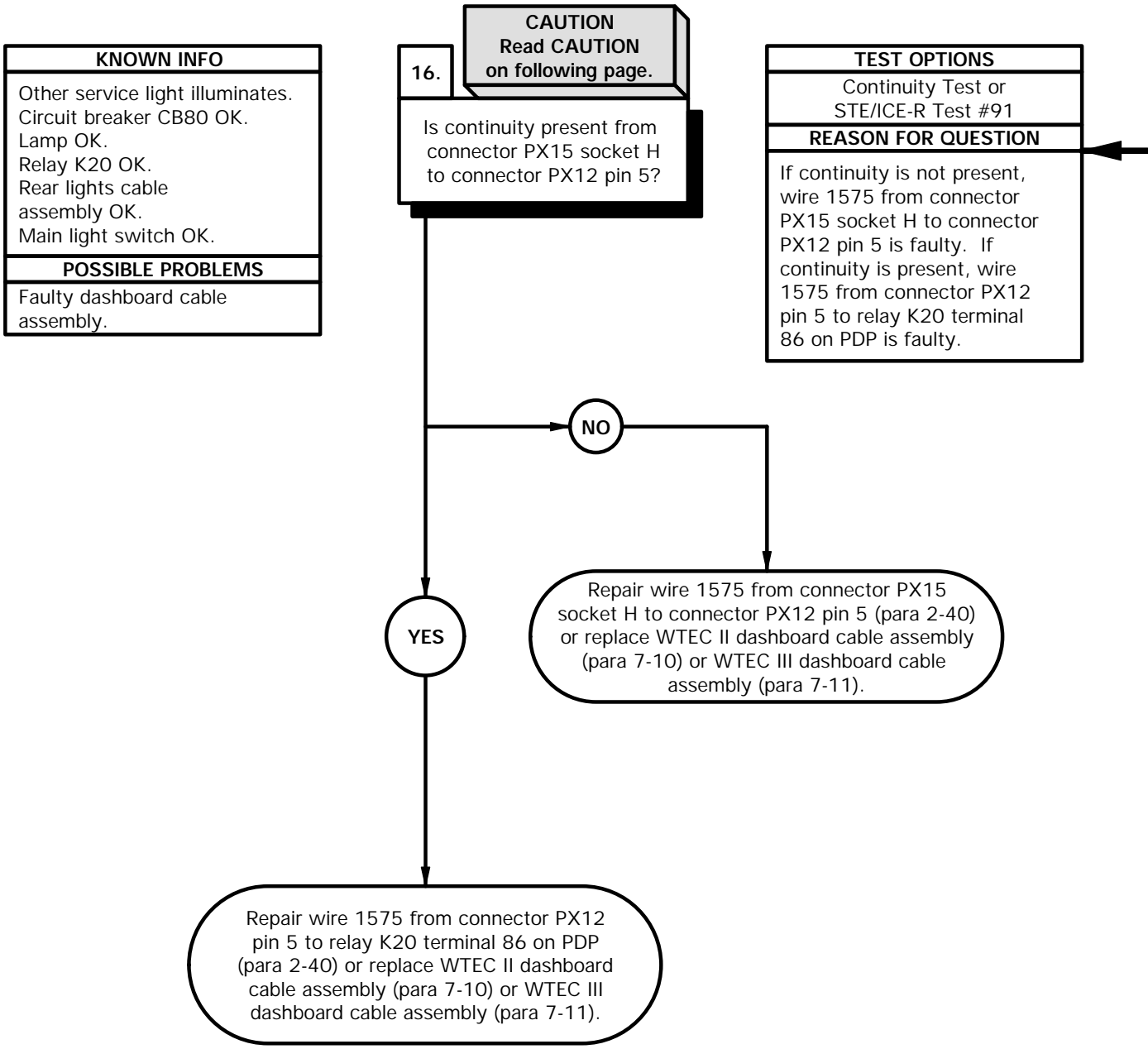

CAUTION

Use care when testing electrical connectors. Do not damage connector pins or sockets with multimeter probes. Failure to comply may result in damage to equipment.

NOTE

Inspect connector pins/sockets for damage, corrosion, and serviceability. Check that connector pins are not pushed back and are capable of making good contact.

CONTINUITY TEST

- (1) Remove circuit breaker CB70 from PDP.
- (2) Disconnect connector PX12 from warning light switch.
- (3) Install circuit breaker CB70 in PDP.
- (4) Set multimeter to ohms.
- (5) Connect positive (+) probe of multimeter to connector PX15 socket H.
- (6) Connect negative (-) probe of multimeter to connector PX12 pin 5 and note reading on multimeter.
- (7) If continuity is not present, repair wire 1575 from connector PX15 socket H (para 2-40) or replace WTEC II dashboard cable assembly (para 7-10) or WTEC III dashboard cable assembly (para 7-11).
- (8) If continuity is present, repair wire 1575 from connector PX12 pin 5 to relay K20 terminal 86 on PDP (para 2-40) or replace WTEC II dashboard cable assembly (para 7-10) or WTEC III dashboard cable assembly (para 7-11).
- (9) Remove circuit breaker CB70 from PDP.
- (10) Connect connector PX12 to warning light switch.
- (11) Connect connector PX15 to main light switch.
- (12) Install circuit breaker CB70 in PDP.
- (13) Install relay K20 in PDP.
- (14) Install PDP cover (16-2).
- (15) Install instrument panel assembly (para 7-15).

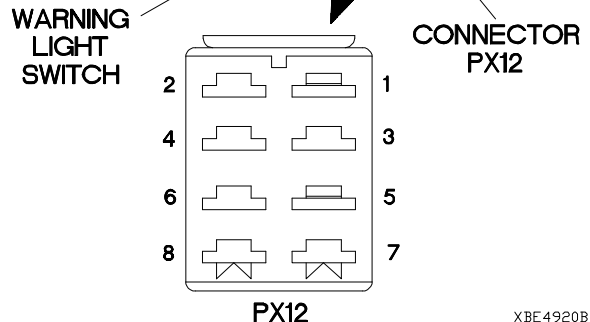
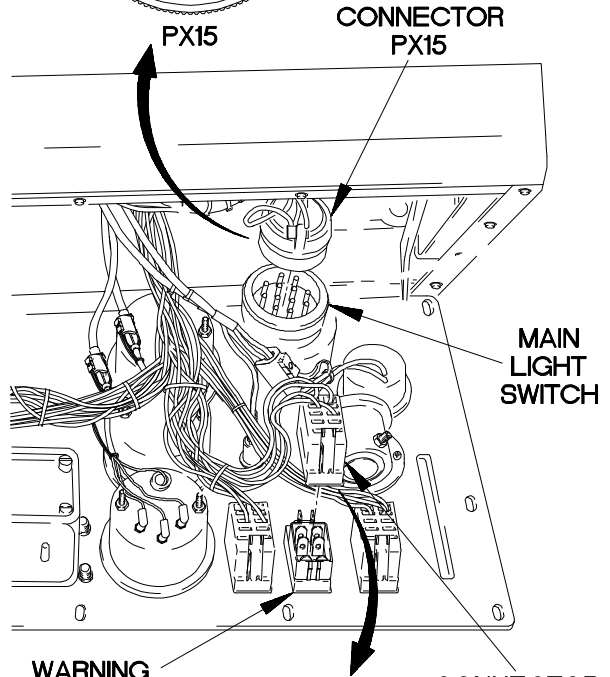
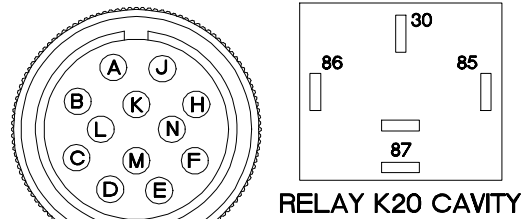
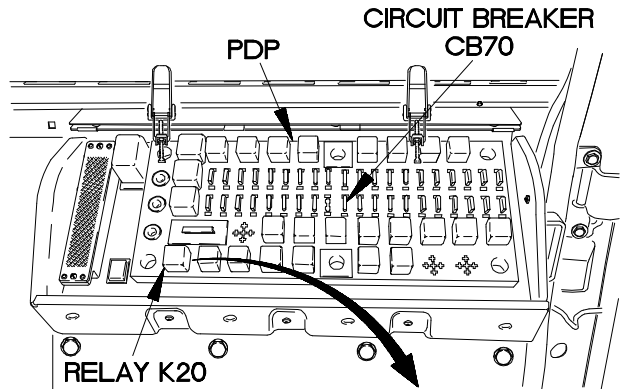

XBE4920B

e49. ONE OR BOTH FRONT BLACKOUT MARKER LIGHTS DO NOT ILLUMINATE	
INITIAL SETUP	
Equipment Condition Engine shut down (TM 9-2320-365-10).	Tools and Special Tools Tool Kit, Genl Mech (Item 44, Appendix C) STE/ICE-R (Item 39, Appendix C) Multimeter, Digital (Item 22, Appendix C)
Personnel Required (2)	References TM 9-4910-571-12&P
Materials/Parts Packing, Preformed (Item 172, Appendix G)	

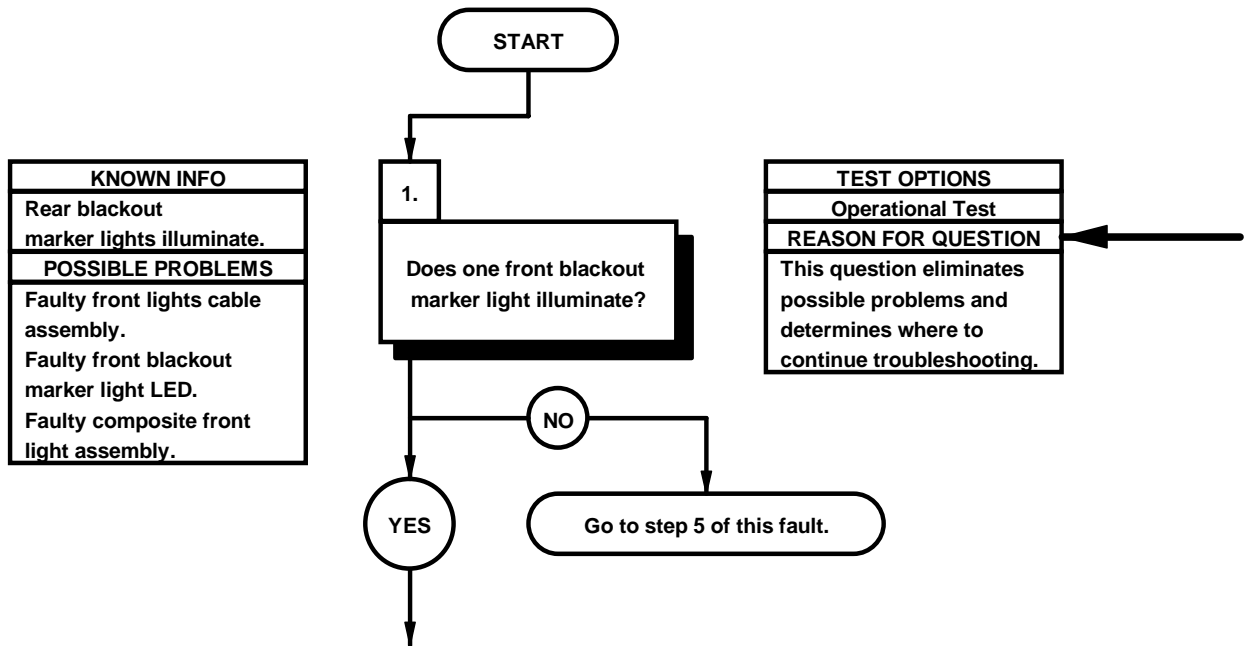

OPERATIONAL TEST
<p>(1) Position main light switch to BO MARKER (TM 9-2320-365-10).</p> <p>(2) Observe front blackout marker lights and determine how many lights do not illuminate.</p> <p>(3) If both marker lights do not illuminate, go to step 5 of this fault.</p> <p>(4) Position main light switch to OFF (TM 9-2320-365-10).</p>

e49. ONE OR BOTH FRONT BLACKOUT MARKER LIGHTS DO NOT ILLUMINATE (CONT)

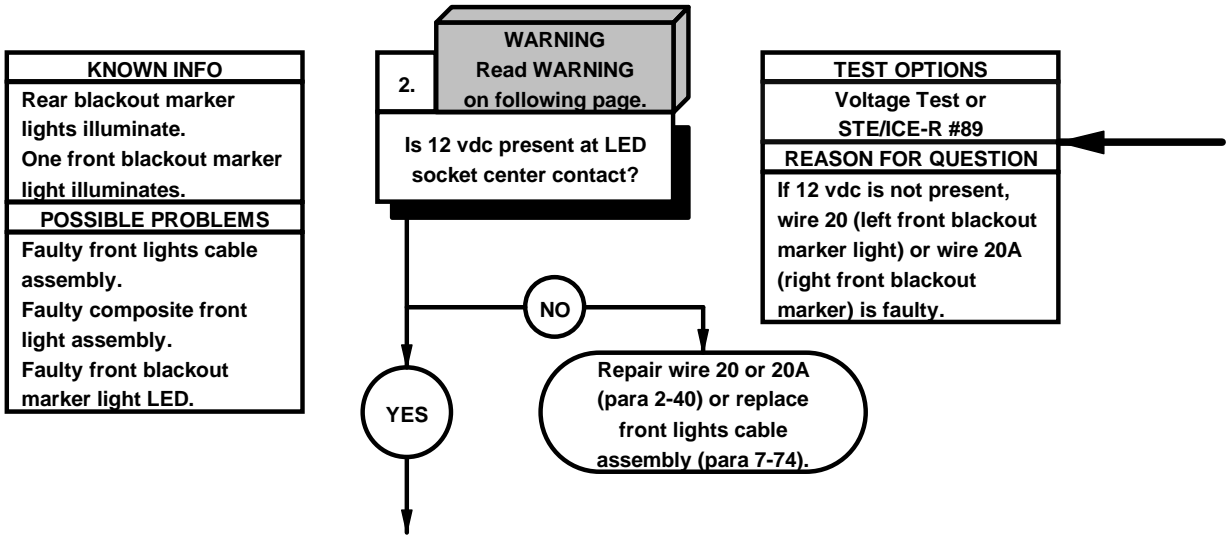

WARNING

Remove rings, bracelets, watches, necklaces, and any other jewelry before working around vehicle. Jewelry can catch on equipment and cause injury or short across electrical circuit and cause severe burns or electrical shock.

VOLTAGE TEST

- (1) Loosen five screws on cover.
- (2) Remove cover and preformed packing from housing. Discard preformed packing.
- (3) Open blackout marker lamp.
- (4) Remove blackout marker lamp from socket.
- (5) Set multimeter to volts dc.
- (6) Connect positive (+) probe of multimeter to LED socket center contact.
- (7) Connect negative (-) probe of multimeter to ground.
- (8) Position main light switch BO MARKER (TM 9-2320-365-10) and note reading on multimeter.
- (9) If 12 vdc is not present, repair wire 20 (left front blackout marker) or wire 20A (right front blackout marker) (para 2-40) or replace front lights cable assembly (para 7-74).
- (10) Position main light switch to OFF (TM 9-2320-365-10).

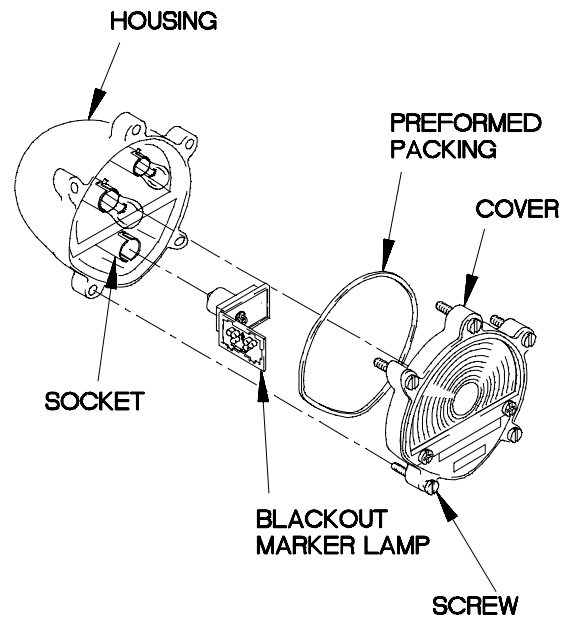

x2E50011

e49. ONE OR BOTH FRONT BLACKOUT MARKER LIGHTS DO NOT ILLUMINATE (CONT)

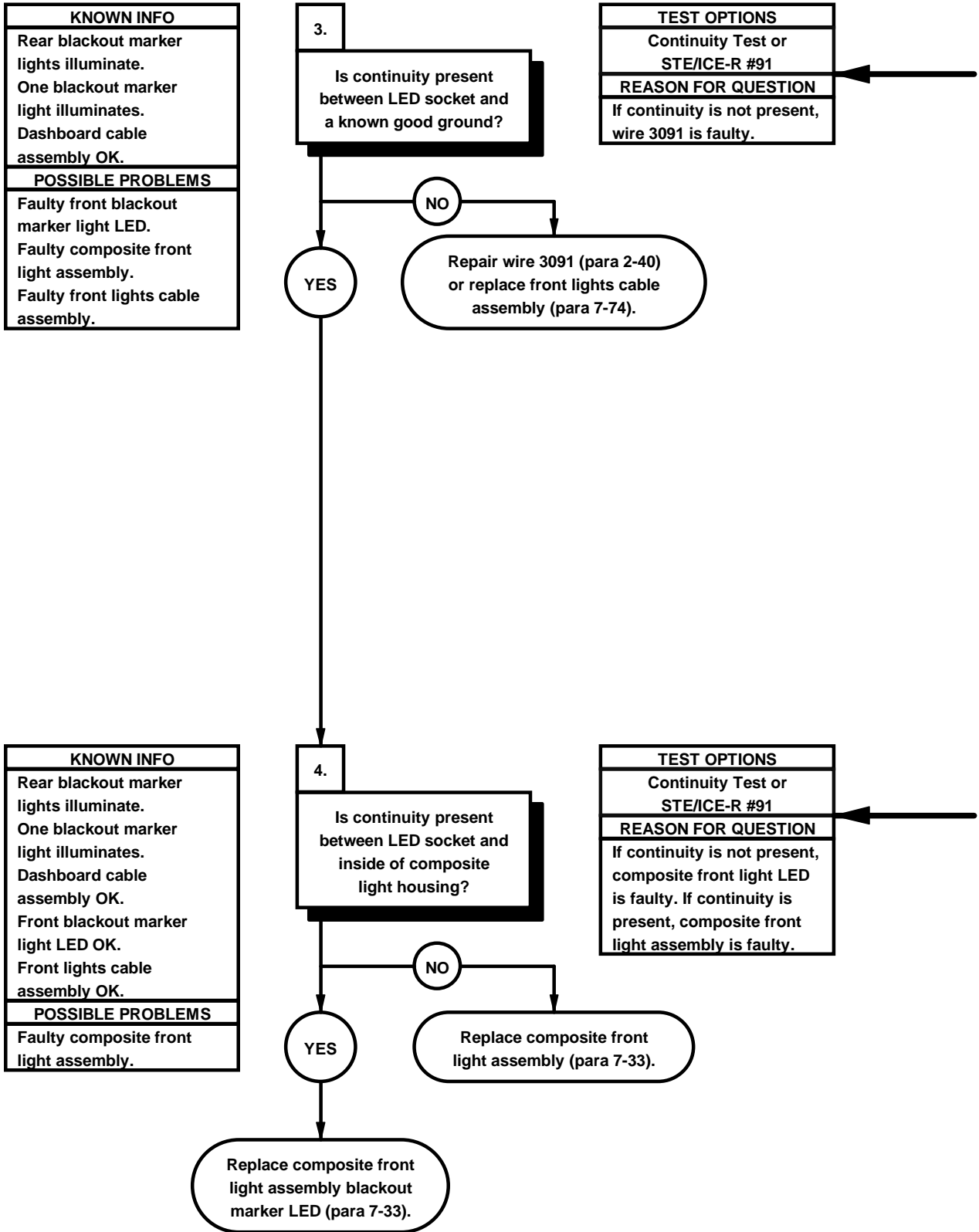

CONTINUITY TEST	
	(1) Set multimeter to ohms.
	(2) Connect positive (+) probe of multimeter to LED socket.
	(3) Connect negative (-) probe of multimeter to ground and note reading on multimeter.
	(4) If continuity is not present, repair wire 3091 (para 2-40) or replace front lights cable assembly (para 7-74).

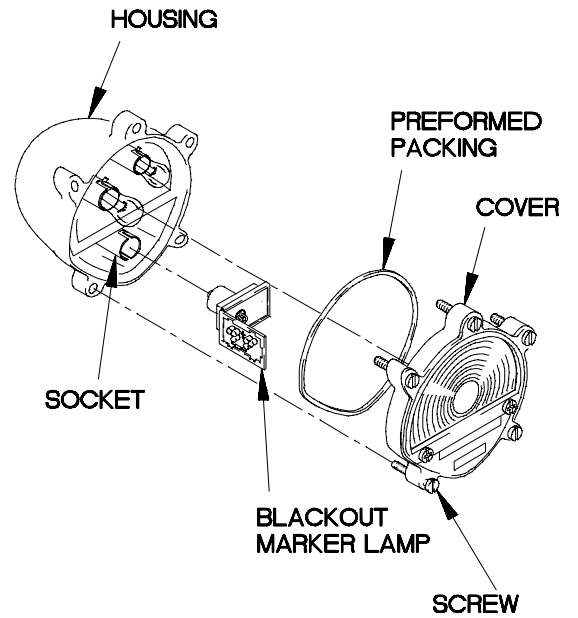

CONTINUITY TEST	
	(1) Set multimeter to ohms.
	(2) Connect positive (+) probe of multimeter to inside of housing.
	(3) Connect negative (-) probe of multimeter to socket and note reading on multimeter.
	(4) If continuity is present, replace composite front light assembly blackout marker LED (para 7-33).
	(5) If continuity is not present, replace composite front light assembly (para 7-33).
	(6) Open blackout marker lamp.
	(7) Install blackout marker lamp in socket.
	(8) Install preformed packing and cover on housing with five screws.

X2E50021

e49. ONE OR BOTH FRONT BLACKOUT MARKER LIGHTS DO NOT ILLUMINATE (CONT)

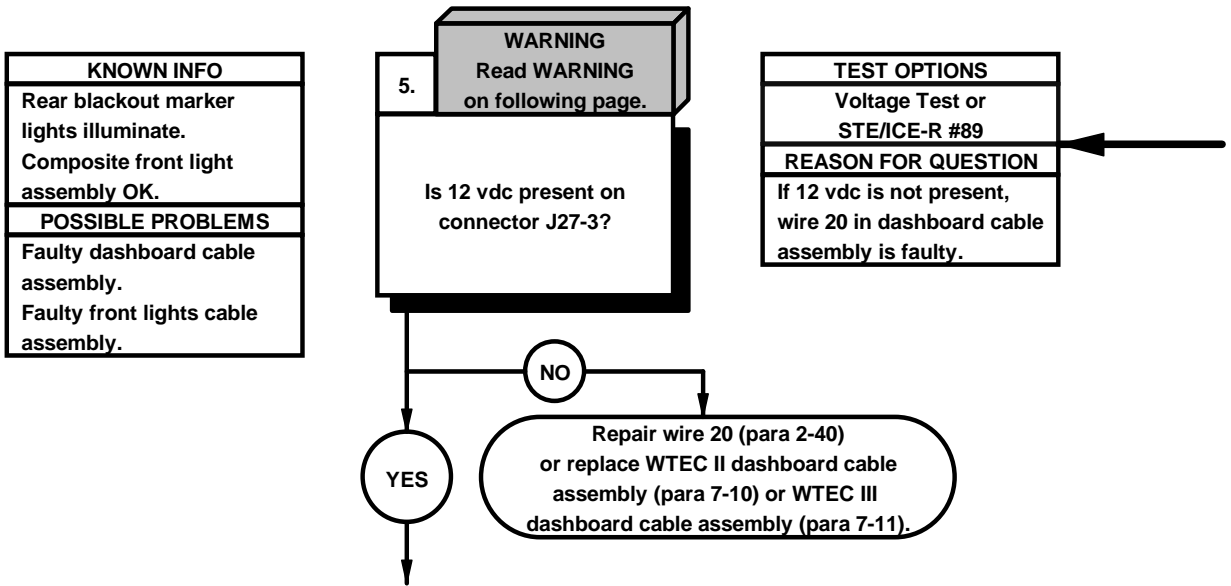

WARNING

Remove rings, bracelets, watches, necklaces, and any other jewelry before working around vehicle. Jewelry can catch on equipment and cause injury or short across electrical circuit and cause severe burns or electrical shock.

VOLTAGE TEST

- (1) Remove PDP cover (para 16-2).
- (2) Remove three screws and washers from PDP.
- (3) Remove three screws from PDP.
- (4) Lift PDP outward to gain access.
- (5) Disconnect connector J27 from connector P27.
- (6) Set multimeter to ohms.
- (7) Connect positive (+) probe of multimeter to J27-3.
- (8) Connect negative (-) probe of multimeter to ground.
- (9) Position main light switch to SER DRIVE (TM 9-2320-365-10) and note reading on multimeter.
- (10) If 12 vdc is not present, repair wire 20 (para 2-40) or replace WTEC II dashboard cable assembly (para 7-10) or WTEC III dashboard cable assembly (para 7-11).
- (11) Position main light switch to OFF (TM 9-2320-365-10).
- (12) Connect connector J27 to connector P27.
- (13) Install PDP on dashboard with three screws.
- (14) Install three washers and screws in PDP.
- (15) Install PDP cover (para 16-2).

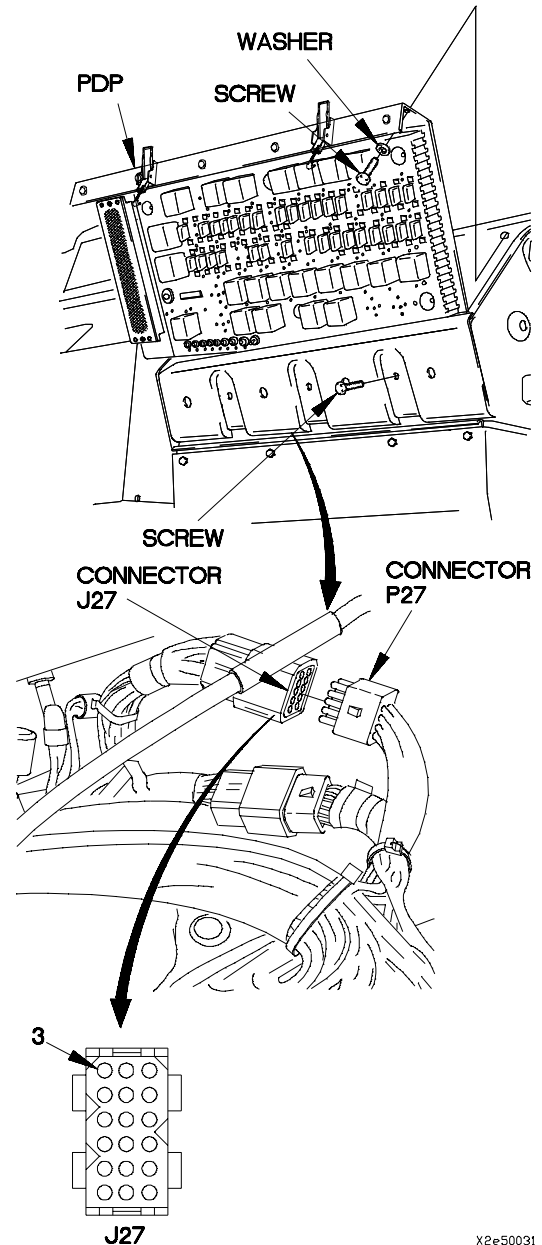

X2e50031

e49. ONE OR BOTH FRONT BLACKOUT MARKER LIGHTS DO NOT ILLUMINATE (CONT)

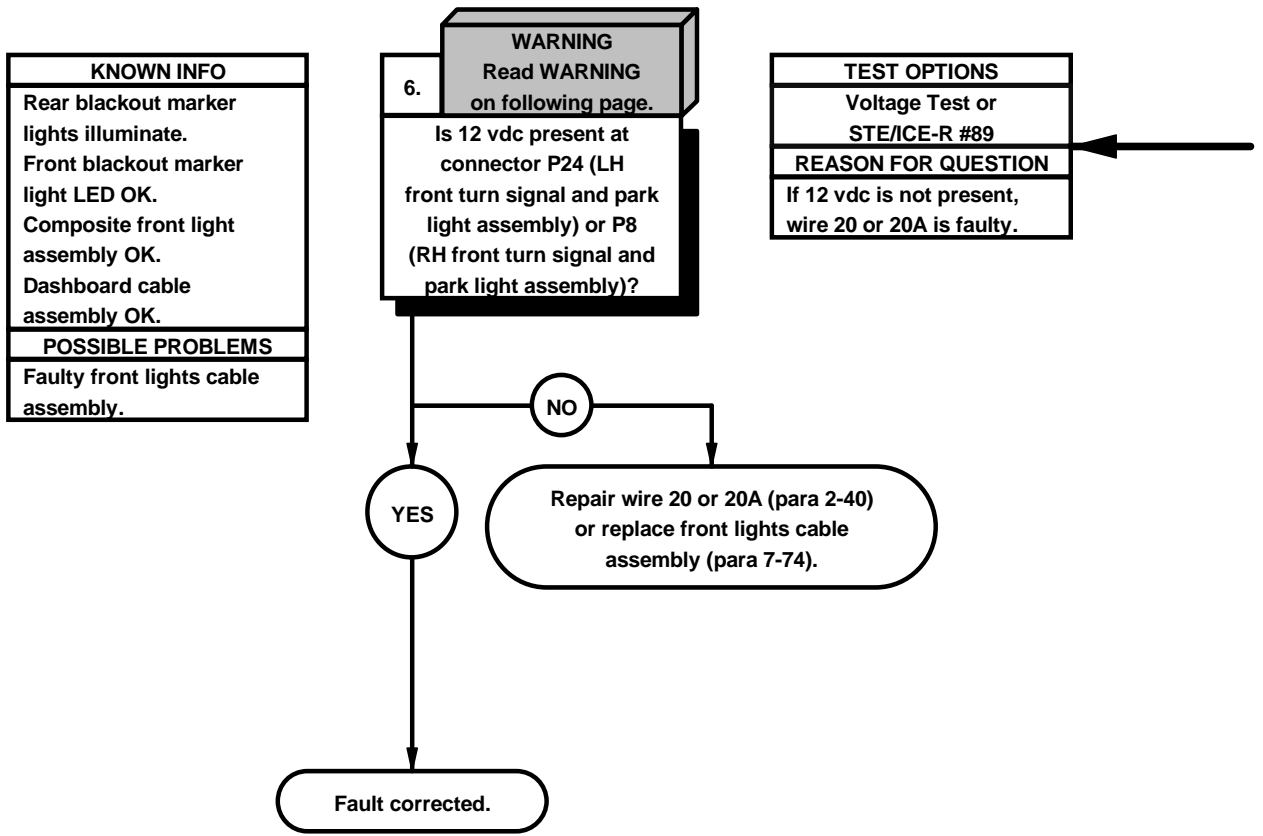

WARNING

Remove rings, bracelets, watches, necklaces, and any other jewelry before working around vehicle. Jewelry can catch on equipment and cause injury or short across electrical circuit and cause severe burns or electrical shock.

VOLTAGE TEST

- (1) Disconnect connector P24 (LH composite front light assembly) or connector P8 (RH composite front assembly) from composite front assembly connector.
- (2) Set multimeter to ohms.
- (3) Connect positive (+) probe of multimeter to connector P24 or connector P8.
- (4) Connect negative (-) probe of multimeter to ground.
- (5) Position main light switch to BO MARKER (TM 9-2320-365-10) and note reading on multimeter.
- (6) If 12 vdc is not present, repair wire 20 or 20A (para 2-40) or replace front lights cable assembly (para 7-74).
- (7) Position main light switch to OFF (TM 9-2320-365-10).
- (8) Connect connector P24 or connector P8 to composite front light assembly connector.

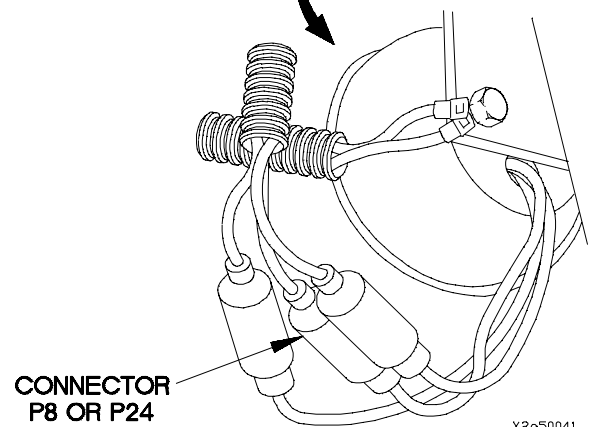
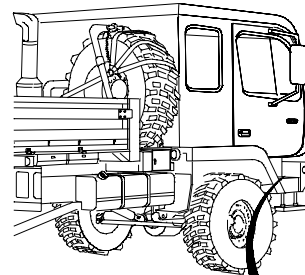

X2e50041

e50. BLACKOUT DRIVE LIGHT DOES NOT ILLUMINATE	
INITIAL SETUP	
Equipment Condition Engine shut down (TM 9-2320-365-10).	Tools and Special Tools Tool Kit, Genl Mech (Item 44, Appendix C) STE/ICE-R (Item 39, Appendix C) Multimeter, Digital (Item 22, Appendix C)
Personnel Required (2)	References TM 9-4910-571-12&P
Materials/Parts Packing, Preformed (Item 168, Appendix G)	

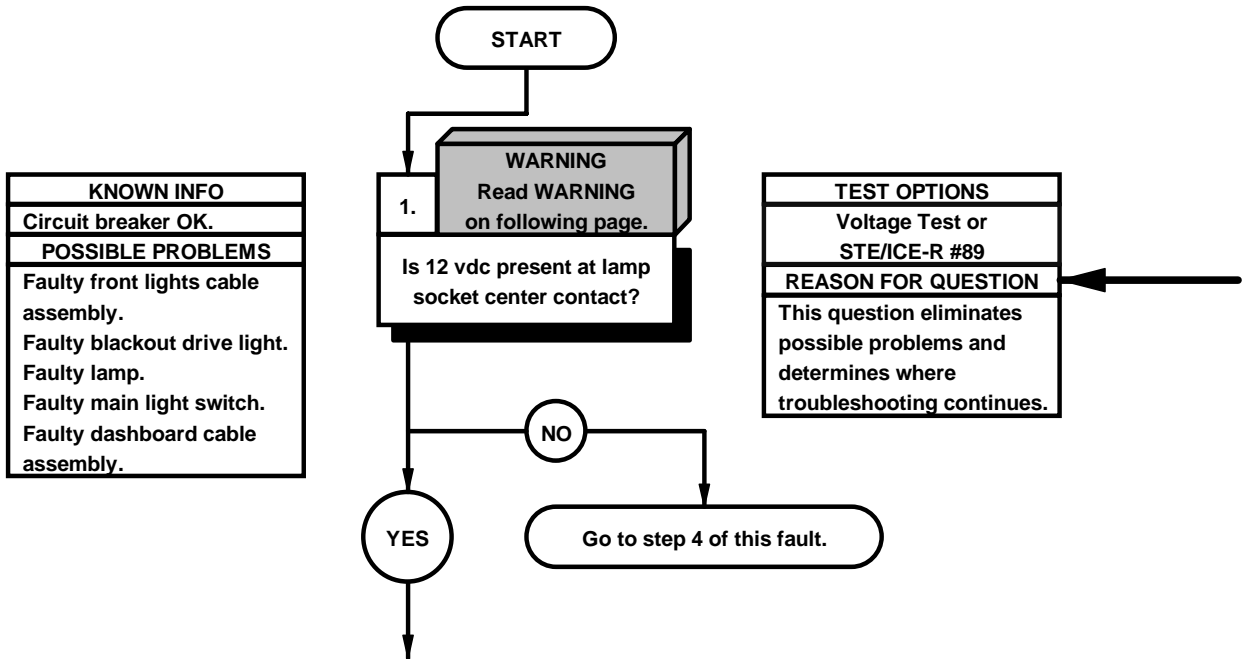

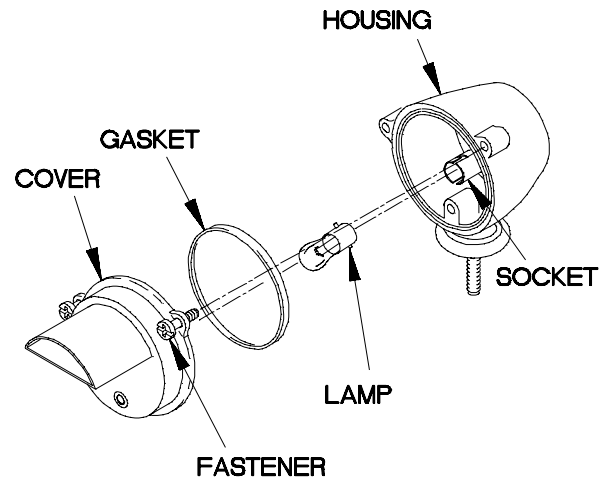

WARNING

Remove rings, bracelets, watches, necklaces, and any other jewelry before working around vehicle. Jewelry can catch on equipment and cause injury or short across electrical circuit and cause severe burns or electrical shock.

X2E51011

VOLTAGE TEST

- (1) Loosen three screws on cover.
- (2) Remove cover and gasket from housing.
Discard gasket.
- (3) Remove lamp from socket.
- (4) Set multimeter to volts dc.
- (5) Connect positive (+) probe of multimeter to lamp socket center contact.
- (6) Connect negative (-) probe of multimeter to ground.
- (7) Position main light switch to BO DRIVE (TM 9-2320-365-10) and note reading on multimeter.
- (8) If 12 vdc is not present, go to step 4 of this fault.
- (9) Position main light switch to OFF (TM 9-2320-365-10).

e50. BLACKOUT DRIVE LIGHT DOES NOT ILLUMINATE (CONT)

KNOWN INFO
Circuit breaker OK. Main light switch OK. Dashboard cable assembly OK.
POSSIBLE PROBLEMS
Faulty front lights cable assembly. Faulty blackout drive light. Faulty lamp.

2.
Is continuity present between lamp socket and a known good ground?

TEST OPTIONS
Continuity Test or STE/ICE-R #91
REASON FOR QUESTION
If continuity is not present, wire 3091 is faulty.

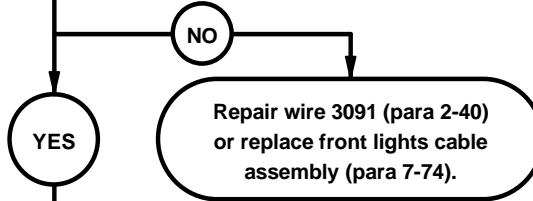

KNOWN INFO
Circuit breaker OK. Main light switch OK. Dashboard cable assembly OK. Front lights cable assembly OK.
POSSIBLE PROBLEMS
Faulty blackout drive light. Faulty lamp.

3.
Is continuity present between lamp socket and inside of blackout drive light housing?

TEST OPTIONS
Continuity Test or STE/ICE-R #91
REASON FOR QUESTION
If continuity is not present, blackout drive light is faulty. If continuity is present, lamp is faulty.

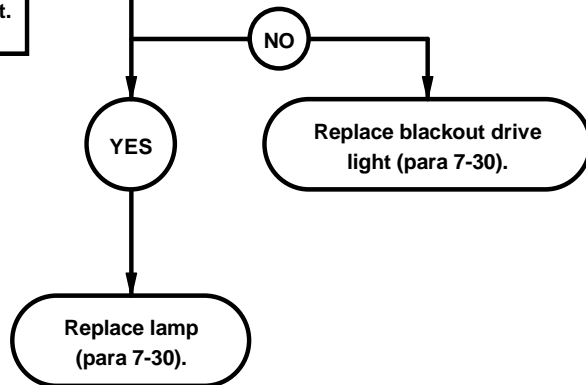

- | CONTINUITY TEST | |
|-----------------|--|
| | (1) Set multimeter to ohms. |
| | (2) Connect positive (+) probe of multimeter to lamp socket. |
| | (3) Connect negative (-) probe of multimeter to ground and note reading on multimeter. |
| | (4) If continuity is not present, repair wire 3091 (para 2-40) or replace front lights cable assembly (para 7-74). |

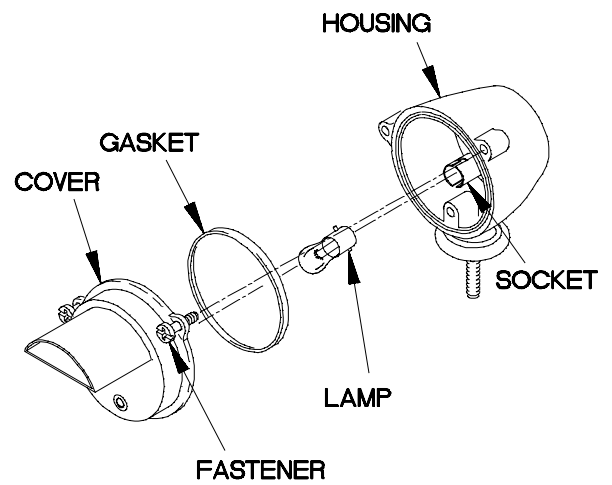

- | CONTINUITY TEST | |
|-----------------|---|
| | (1) Set multimeter to ohms. |
| | (2) Connect positive (+) probe of multimeter to inside of blackout drive light housing. |
| | (3) Connect negative (-) probe of multimeter to lamp socket and note reading on multimeter. |
| | (4) If continuity is not present, replace blackout drive light (para 7-30). |
| | (5) If continuity is present, replace lamp (para 7-30). |
| | (6) Install lamp in socket. |
| | (7) Install gasket and cover on housing with three screws. |

X2E51021

e50. BLACKOUT DRIVE LIGHT DOES NOT ILLUMINATE (CONT)

KNOWN INFO
Circuit breaker OK. Lamp OK. Blackout drive light OK.
POSSIBLE PROBLEMS
Faulty main light switch. Faulty dashboard cable assembly. Faulty front lights cable assembly.

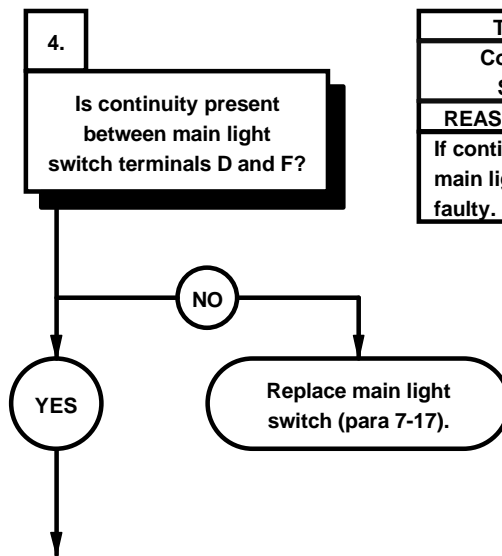

TEST OPTIONS
Continuity Test or STE/ICE-R #91
REASON FOR QUESTION
If continuity is not present, main light switch is faulty.



CONTINUITY TEST

- (1) Remove main light switch (para 7-17).
- (2) Set multimeter to ohms.
- (3) Connect positive (+) probe of multimeter to main light switch terminal F.
- (4) Connect negative (-) probe of multimeter to main light switch terminal D.
- (5) Position main light switch to BO DRIVE (TM 9-2320-365-10) and note reading on multimeter.
- (6) If continuity is not present, replace main light switch (para 7-17).
- (7) Position main light switch to OFF (TM 9-2320-365-10).
- (8) Install main light switch (para 7-17).

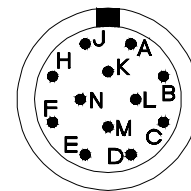

**MAIN
LIGHT
SWITCH**

X2E5203A

e50. BLACKOUT DRIVE LIGHT DOES NOT ILLUMINATE (CONT)

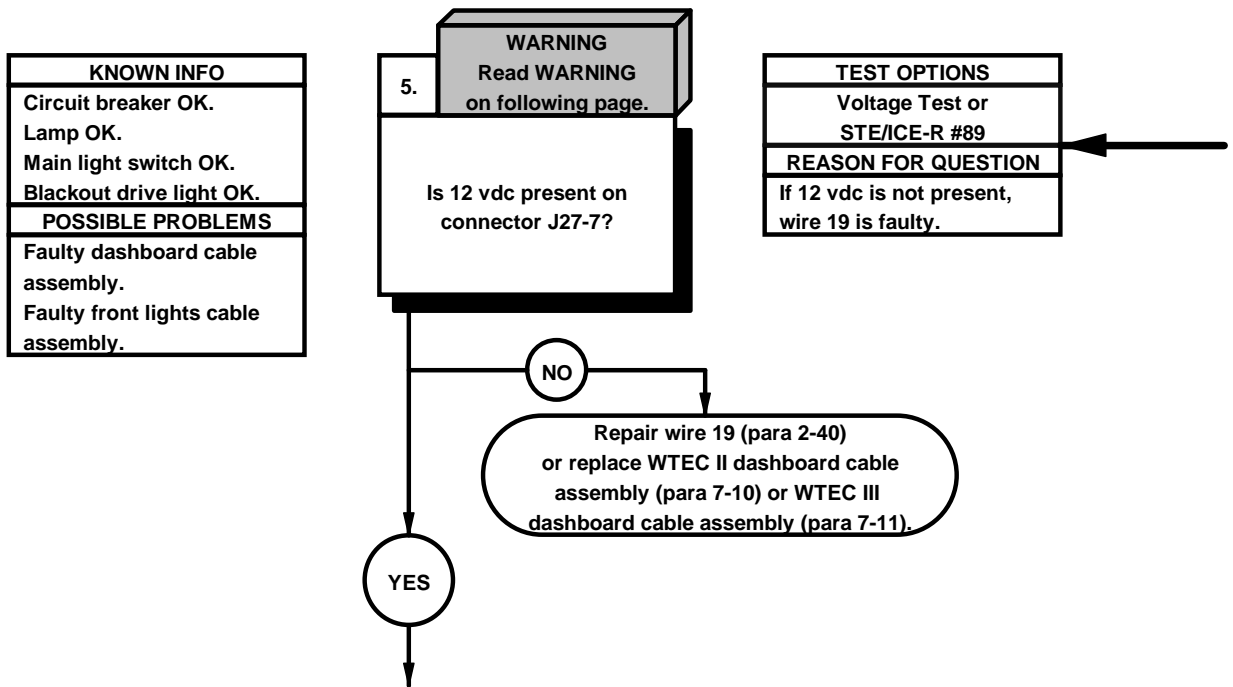

WARNING

Remove rings, bracelets, watches, necklaces, and any other jewelry before working around vehicle. Jewelry can catch on equipment and cause injury or short across electrical circuit and cause severe burns or electrical shock.

VOLTAGE TEST

- (1) Remove PDP cover (para 16-2).
- (2) Remove three screws and washers from PDP.
- (3) Remove three screws from PDP.
- (4) Lift PDP outward to gain access.
- (5) Disconnect connector J27 from connector P27.
- (6) Set multimeter to volts dc.
- (7) Connect positive (+) probe of multimeter to J27-7.
- (8) Connect negative (-) probe of multimeter to ground.
- (9) Position main light switch to BO DRIVE (TM 9-2320-365-10) and note reading on multimeter.
- (10) If 12 vdc is not present, repair wire 19 (para 2-40) or replace WTEC II dashboard cable assembly (para 7-10) or WTEC III dashboard cable assembly (para 7-11).
- (11) Position main light switch to OFF (TM 9-2320-365-10).
- (12) Connect connector J27 to connector P27.
- (13) Install PDP on dashboard with three screws.
- (14) Install three washers and screws in PDP.
- (15) Install PDP cover (para 16-2).

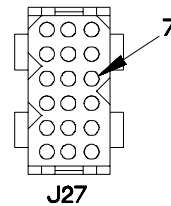
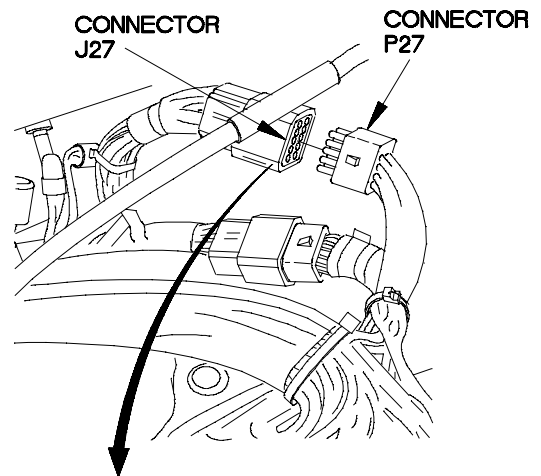
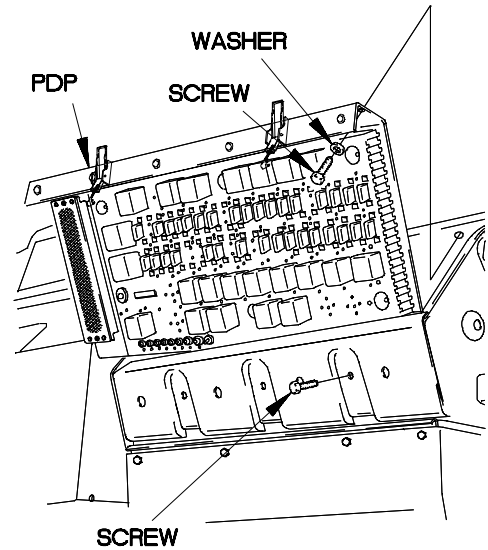

X2e51041

e50. BLACKOUT DRIVE LIGHT DOES NOT ILLUMINATE (CONT)

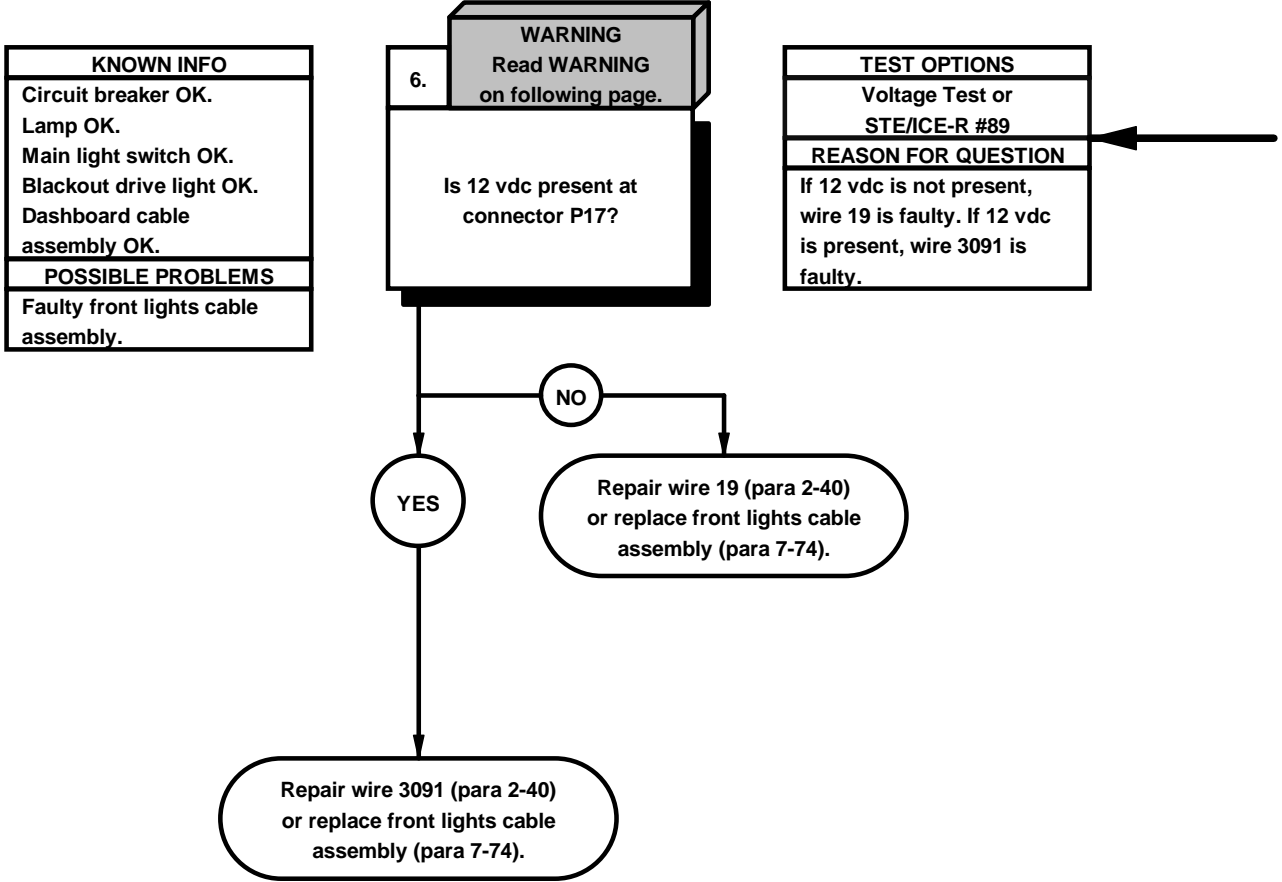

WARNING

Remove rings, bracelets, watches, necklaces, and any other jewelry before working around vehicle. Jewelry can catch on equipment and cause injury or short across electrical circuit and cause severe burns or electrical shock.

VOLTAGE TEST

- (1) Disconnect connector P17 from blackout drive light connector.
- (2) Set multimeter to volts dc.
- (3) Connect positive (+) probe of multimeter to connector P17.
- (4) Connect negative (-) probe of multimeter to ground.
- (5) Position main light switch to BO DRIVE (TM 9-2320-365-10) and note reading on multimeter.
- (6) If 12 vdc is not present, repair wire 19 (para 2-40) or replace front lights cable assembly (para 7-74).
- (7) If 12 vdc is present, repair wire 3091 (para 2-40) or replace front lights cable assembly (para 7-74).
- (8) Position main light switch to OFF (TM 9-2320-365-10).
- (9) Connect connector P17 to blackout drive light connector.

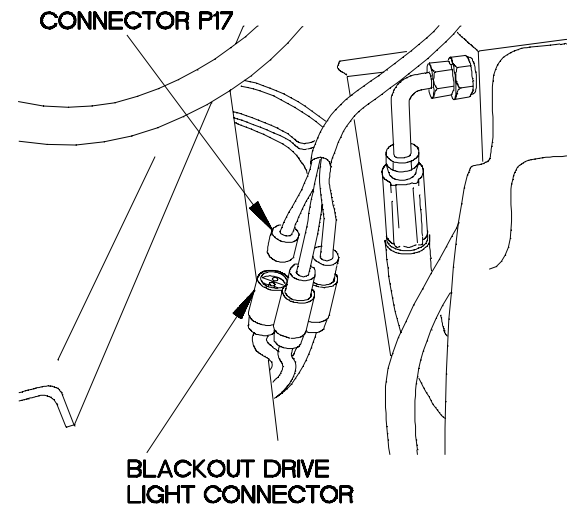
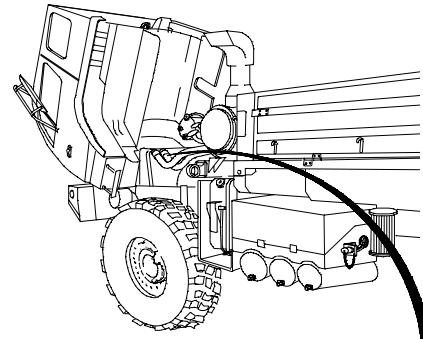

X2e51051

e51. ONE OR BOTH REAR BLACKOUT MARKER LIGHTS DO NOT ILLUMINATE

INITIAL SETUP

Equipment Condition

Engine shut down (TM 9-2320-365-10).

Personnel Required

(2)

Material/Parts

Packing, Preformed (Item 172, Appendix G)
Nut, Self-Locking (Item 137, Appendix G)



Tools and Special Tools

Tool Kit, Genl Mech (Item 44, Appendix C)
STE/ICE-R (Item 39, Appendix C)
Multimeter, Digital (Item 22, Appendix C)

References

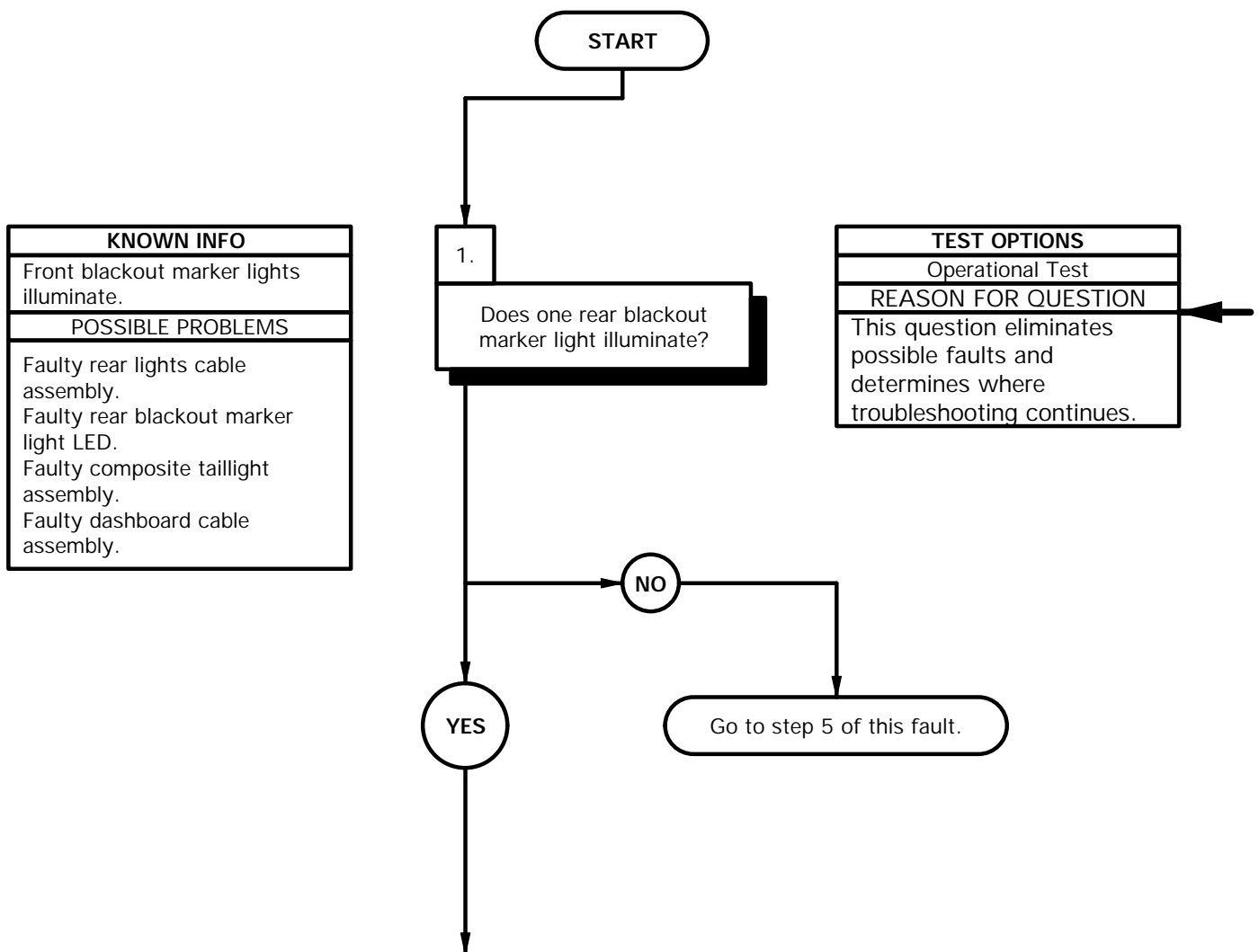
TM 9-4910-571-12&P



- 
- (1) Position main light switch to BO MARKER (TM 9-2320-365-10).
 - (2) Observe operation of rear blackout marker lights.
 - (3) If neither rear blackout marker light illuminates, go to step 5 of this fault.
 - (4) Position main light switch to OFF (TM 9-2320-365-10).
- 

e51. ONE OR BOTH REAR BLACKOUT MARKER LIGHTS DO NOT ILLUMINATE (CONT)

KNOWN INFO
Front blackout marker lights illuminate. One rear blackout marker light illuminates. Dashboard cable assembly OK.
POSSIBLE PROBLEMS
Faulty rear lights cable assembly. Faulty composite taillight assembly. Faulty rear blackout marker light LED.

2.

WARNING
Read **WARNING** on following page.

Is 12 VDC present at LED socket center contact?

TEST OPTIONS
Voltage Test or STE/ICE-R Test #89
REASON FOR QUESTION
If 12 VDC is not present, wire 24 is faulty.

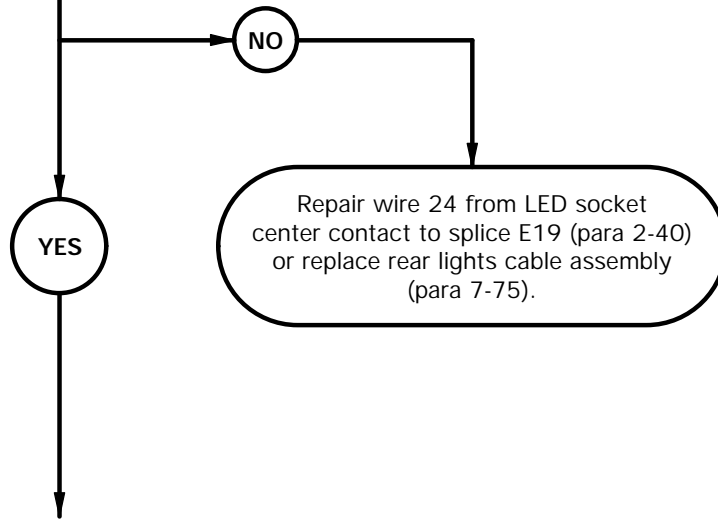

WARNING

Remove rings, bracelets, watches, necklaces, and any other jewelry before working around vehicle. Jewelry can catch on equipment and cause injury or short across electrical circuits and cause severe burns or electrical shock.

VOLTAGE TEST

- (1) Loosen six screws and remove cover and preformed packing from housing. Discard preformed packing.
- (2) Open blackout marker lamp.
- (3) Remove blackout marker lamp from socket.
- (4) Set multimeter to volts DC.
- (5) Connect positive (+) probe of multimeter to LED socket center contact.
- (6) Connect negative (-) probe of multimeter to ground.
- (7) Position main light switch to BO MARKER (TM 9-2320-365-10) and note reading on multimeter.
- (8) If 12 VDC is not present, repair wire 24 from LED socket center contact to splice E19 (para 2-40) or replace rear lights cable assembly (para 7-75).
- (9) Position main light switch to OFF (TM 9-2320-365-10).

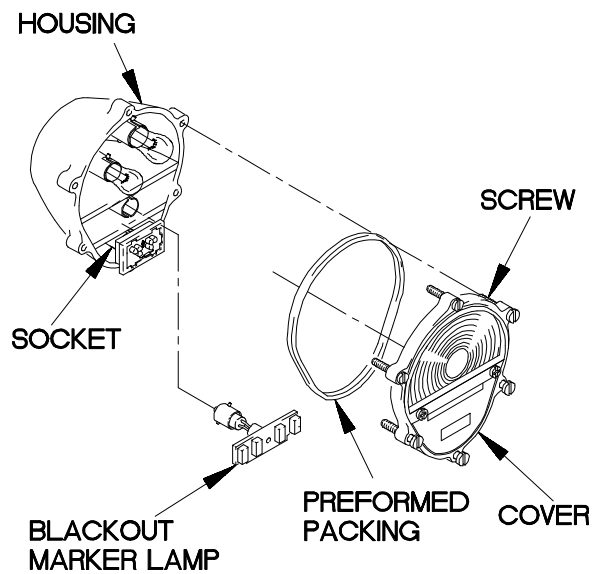

XBE5201B

e51. ONE OR BOTH REAR BLACKOUT MARKER LIGHTS DO NOT ILLUMINATE (CONT)

KNOWN INFO
Front blackout marker lights illuminate. One rear blackout marker light illuminates. Dashboard cable assembly OK.
POSSIBLE PROBLEMS
Faulty rear lights cable assembly. Faulty rear blackout marker light LED. Faulty composite taillight assembly.

KNOWN INFO
Front blackout marker lights illuminate. One rear blackout marker light illuminates. Dashboard cable assembly OK. Rear lights cable assembly OK.
POSSIBLE PROBLEMS
Faulty rear blackout marker light LED. Faulty composite taillight assembly.

3.
Is continuity present from LED socket to ground?

TEST OPTIONS
Continuity Test or STE/ICE-R Test #91
REASON FOR QUESTION
If continuity is not present, wire 3094 (LH rear blackout marker light) or wire 3095 (RH rear blackout marker light) is faulty.

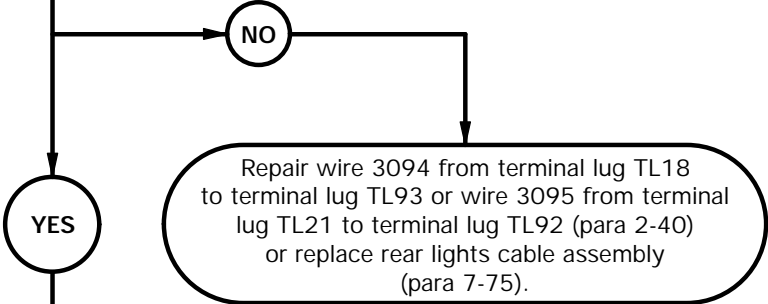

4.
Is continuity present from LED socket and inside of rear taillight housing?

TEST OPTIONS
Continuity Test or STE/ICE-R Test #91
REASON FOR QUESTION
If continuity is not present, composite taillight assembly is faulty. If continuity is present, rear blackout marker light LED is faulty.

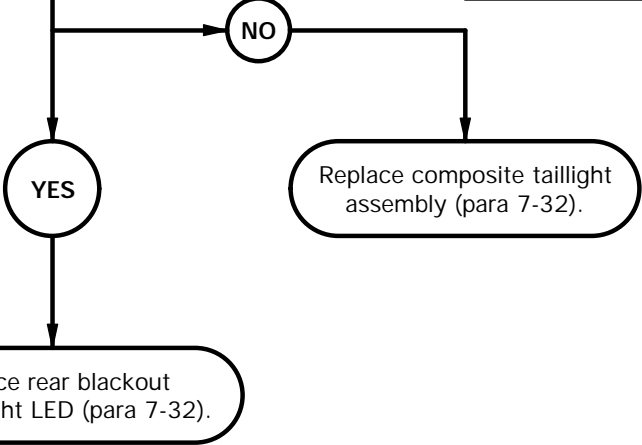

CONTINUITY TEST

- (1) Set multimeter to ohms.
- (2) Connect positive (+) probe of multimeter to LED socket.
- (3) Connect negative (-) probe of multimeter to ground and note reading on multimeter.
- (4) If continuity is not present, repair wire 3094 from terminal lug TL18 to terminal lug TL93 (LH rear blackout marker light) or wire 3095 from terminal lug TL21 to terminal lug TL92 (RH rear blackout marker light) (para 2-40) or replace rear lights cable assembly (para 7-75).

CONTINUITY TEST

- (1) Set multimeter to ohms.
- (2) Connect positive (+) probe of multimeter to inside of housing.
- (3) Connect negative (-) probe of multimeter to LED socket and note reading on multimeter.
- (4) If continuity is not present, replace composite taillight assembly (para 7-32).
- (5) If continuity is present, replace rear blackout marker light LED (para 7-32).
- (6) Open blackout marker lamp.
- (7) Install blackout marker lamp in socket.
- (8) Install preformed packing and cover on housing with six screws.

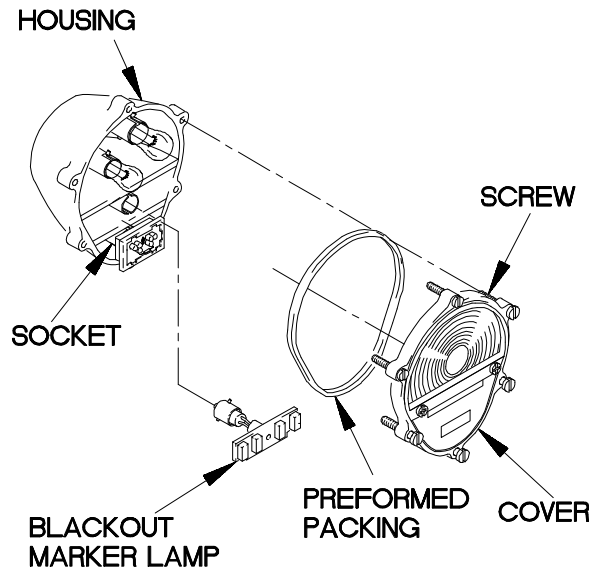

XBE5202B

e51. ONE OR BOTH REAR BLACKOUT MARKER LIGHTS DO NOT ILLUMINATE (CONT)

KNOWN INFO
Front blackout marker lights illuminate. Rear blackout marker light LED OK. Composite taillight assembly OK.
POSSIBLE PROBLEMS
Faulty rear lights cable assembly. Faulty dashboard cable assembly.

5.

WARNING

CAUTION

Read **WARNING** and **CAUTION** on following page.

Is 12 VDC present at connector J51 pin 17?

TEST OPTIONS
Voltage Test or STE/ICE-R Test #89
REASON FOR QUESTION
If 12 VDC is not present, wire 24 is faulty.

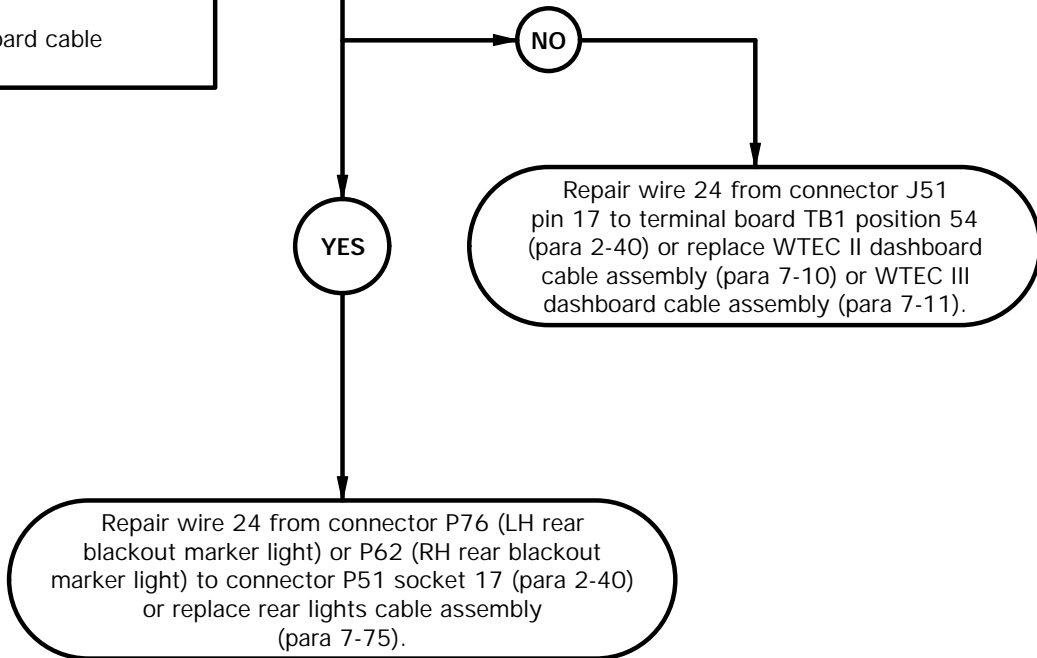

WARNING

Remove rings, bracelets, watches, necklaces, and any other jewelry before working around vehicle. Jewelry can catch on equipment and cause injury or short across electrical circuits and cause severe burns or electrical shock.

CAUTION

Use care when testing electrical connectors. Do not damage connector pins or sockets with multimeter probes. Failure to comply may result in damage to equipment.

NOTE

Inspect connector pins/sockets for damage, corrosion, and serviceability. Check that connector pins are not pushed back and are capable of making good contact.

VOLTAGE TEST

- (1) Remove PDP cover (para 16-2).
- (2) Remove three screws and washers from PDP.
- (3) Remove three screws from PDP.
- (4) Lift PDP outward to gain access.
- (5) Disconnect connector J51 from connector P51.
- (6) Set multimeter to volts DC.
- (7) Connect positive (+) probe of multimeter to connector J51 pin 17.
- (8) Connect negative (-) probe of multimeter to ground.
- (9) Position main light switch to BO MARKER (TM 9-2320-365-10) and note reading on multimeter.
- (10) If 12 VDC is not present, repair wire 24 from connector J51 pin 17 to terminal board TB1 position 54 (para 2-40) or replace WTEC II dashboard cable assembly (para 7-10) or WTEC III dashboard cable assembly (para 7-11).
- (11) If 12 VDC is present, repair wire 24 from connector P76 (LH rear blackout marker light) or P62 (RH rear blackout marker light) to connector P51 socket 17 (para 2-40) or replace rear lights cable assembly (para 7-75).
- (12) Position main light switch to OFF (TM 9-2320-365-10).
- (13) Connect connector J51 to connector P51.
- (14) Install PDP on dashboard with three screws.
- (15) Install three washers and screws in PDP.
- (16) Install PDP cover (para 16-2).

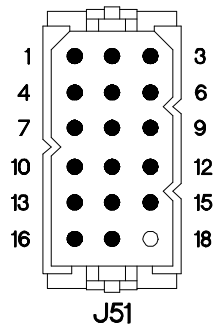
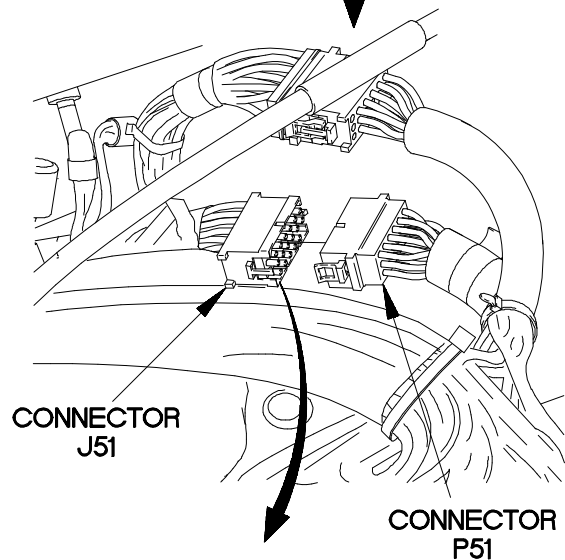
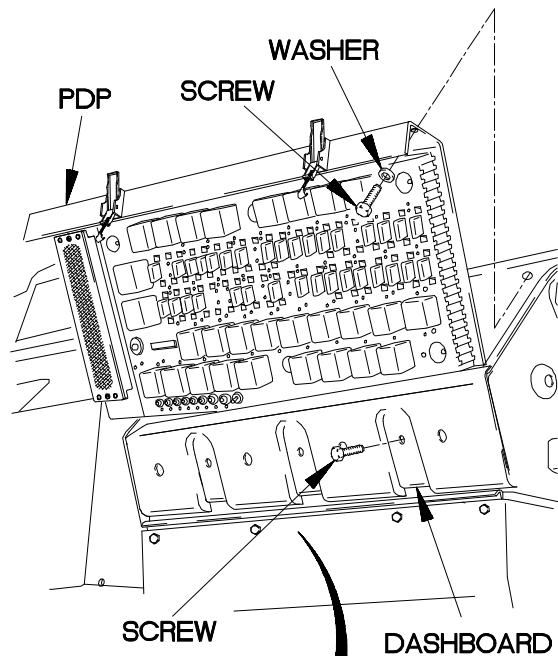

XBE5203B

e52. WARNING LIGHT DOES NOT ILLUMINATE	
INITIAL SETUP	
Equipment Condition Engine shut down (TM 9-2320-365-10).	Tools and Special Tools Tool Kit, Genl Mech (Item 44, Appendix C) STE/ICE-R (Item 39, Appendix C) Multimeter, Digital (Item 22, Appendix C)
Personnel Required (2)	References TM 9-4910-571-12&P

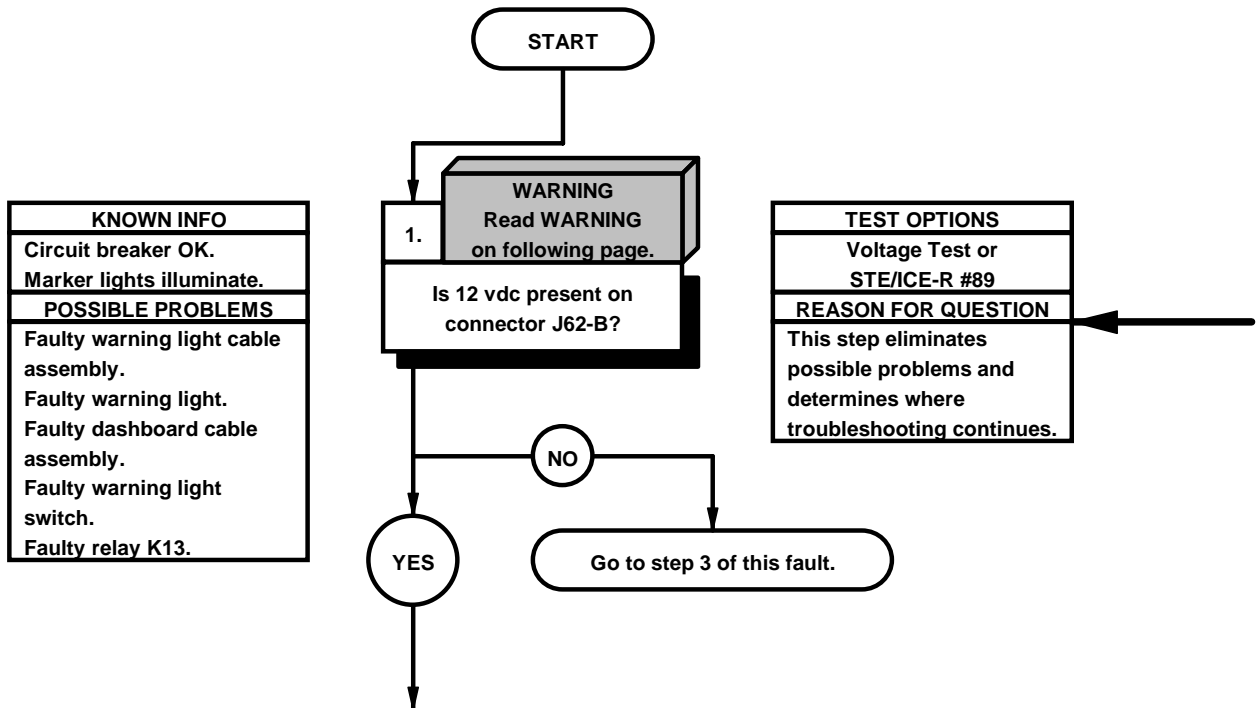

WARNING

Remove rings, bracelets, watches, necklaces, and any other jewelry before working around vehicle. Jewelry can catch on equipment and cause injury or short across electrical circuit and cause severe burns or electrical shock.

VOLTAGE TEST

- (1) Disconnect warning light connector from connector J62.
- (2) Set multimeter to volts dc.
- (3) Connect positive (+) probe of multimeter to connector J62-B.
- (4) Connect negative (-) probe of multimeter to ground.
- (5) Position main light switch to SER DRIVE (TM 9-2320-365-10).
- (6) Position warning light switch to on (TM 9-2320-365-10) and note reading on multimeter.
- (7) If 12 vdc is not present, go to step 3 of this fault.
- (8) Position warning light switch to off (TM 9-2320-365-10).
- (9) Position main light switch to OFF (TM 9-2320-365-10).

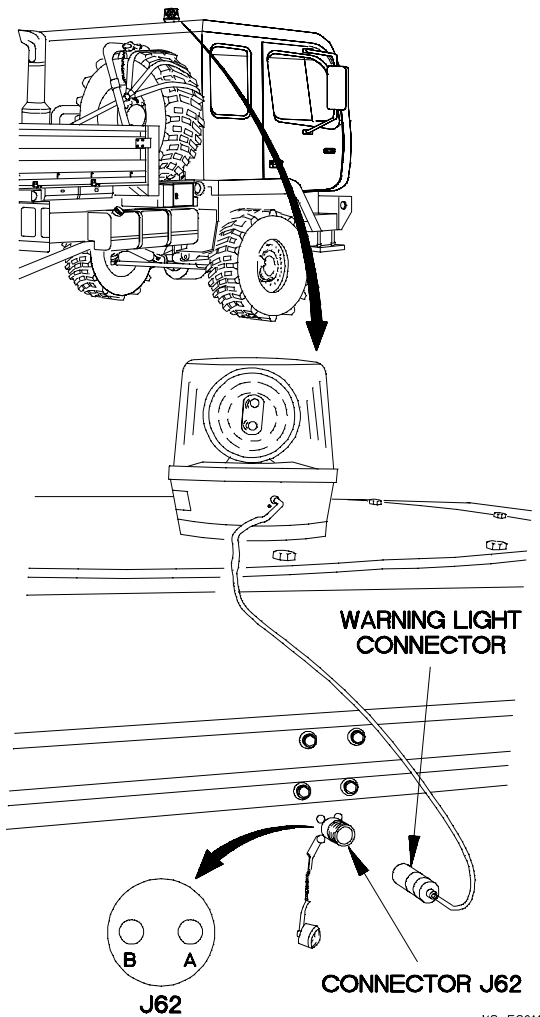

X2e53011

e52. WARNING LIGHT DOES NOT ILLUMINATE (CONT)

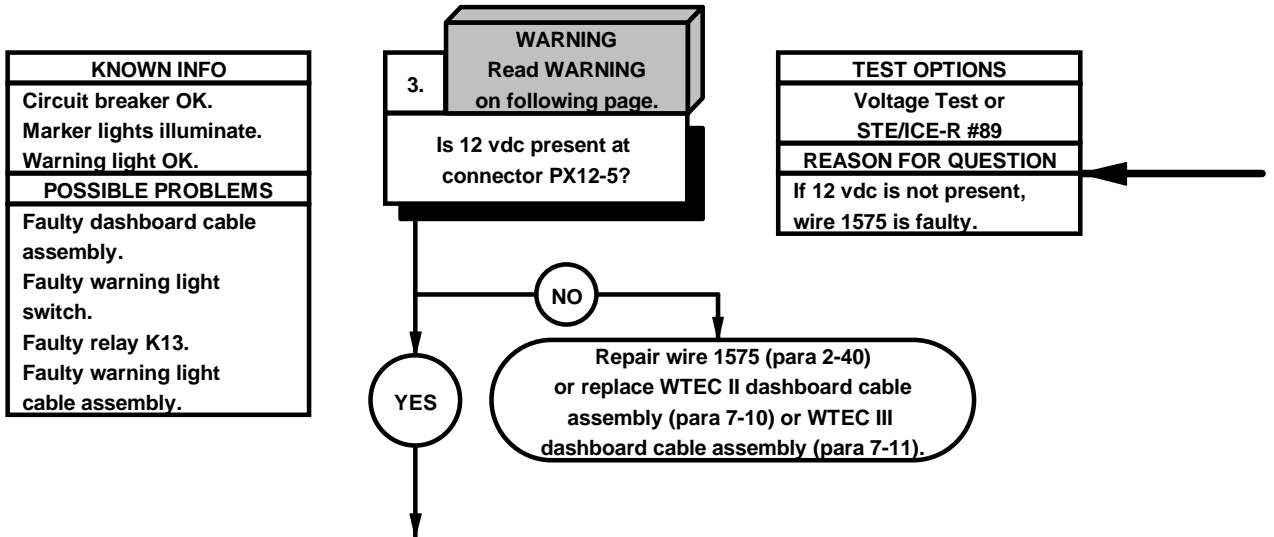
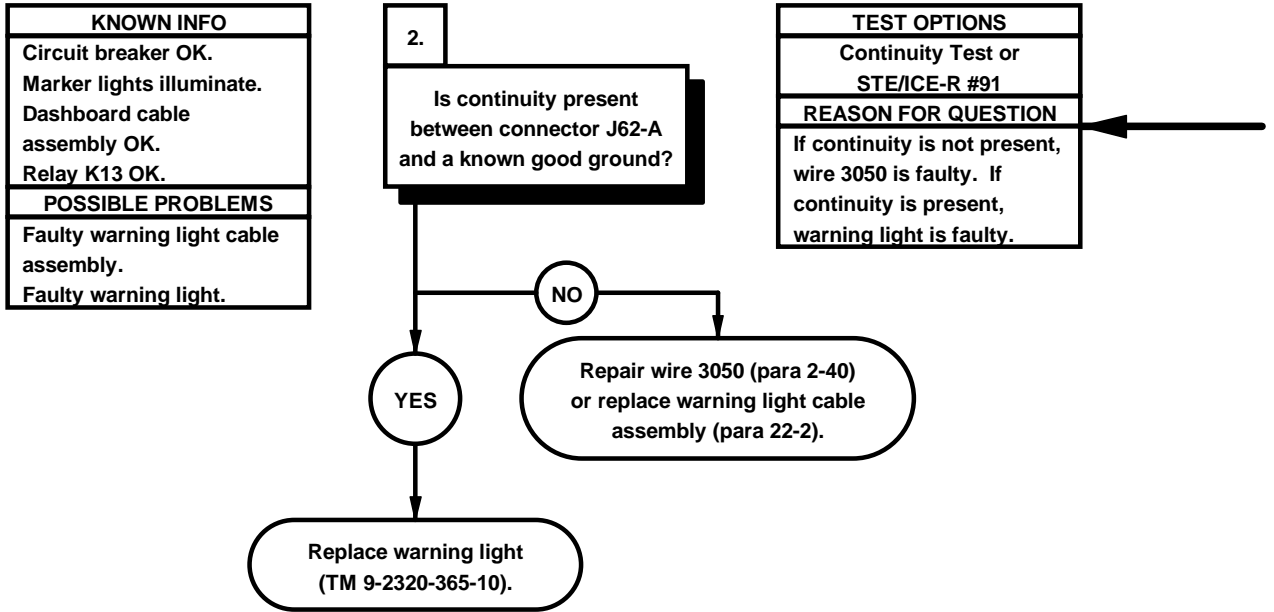

CONTINUITY TEST

- (1) Set multimeter to ohms.
- (2) Connect positive (+) probe of multimeter to connector J62-A.
- (3) Connect negative (-) probe of multimeter to ground and note reading on multimeter.
- (4) If continuity is not present, repair wire 3050 (para 2-40) or replace warning light cable assembly (para 22-2).
- (5) If continuity is present, replace warning light (TM 9-2320-365-10).

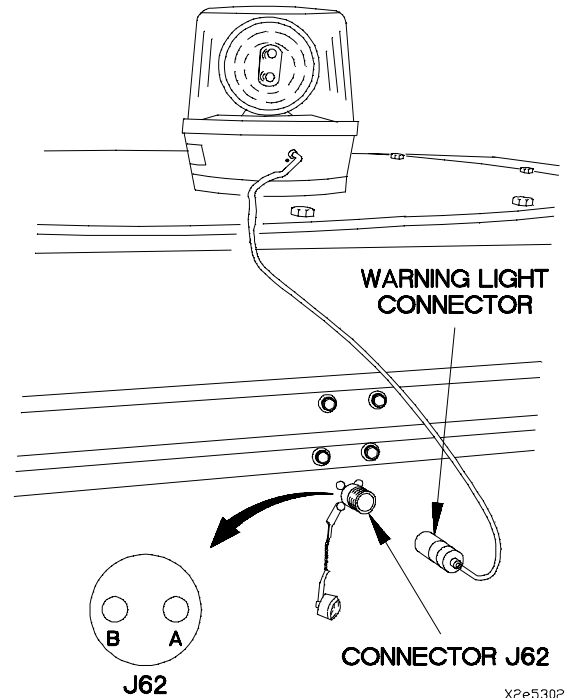

X2e53021

WARNING

Remove rings, bracelets, watches, necklaces, and any other jewelry before working around vehicle. Jewelry can catch on equipment and cause injury or short across electrical circuit and cause severe burns or electrical shock.

VOLTAGE TEST

- (1) Remove instrument panel assembly for access (para 7-15).
- (2) Set multimeter to volts dc.
- (3) Disconnect connector PX12 from warning light switch.
- (4) Position main light switch to SER DRIVE (TM 9-2320-365-10).
- (5) Connect positive (+) probe of multimeter to connector PX12-5.
- (6) Connect negative (-) probe of multimeter to ground.
- (7) If 12 vdc is not present, repair wire 1575 (para 2-40) or replace WTEC II dashboard cable assembly (para 7-10) or WTEC III dashboard cable assembly (para 7-11).
- (8) Position main light switch to OFF (TM 9-2320-365-10).

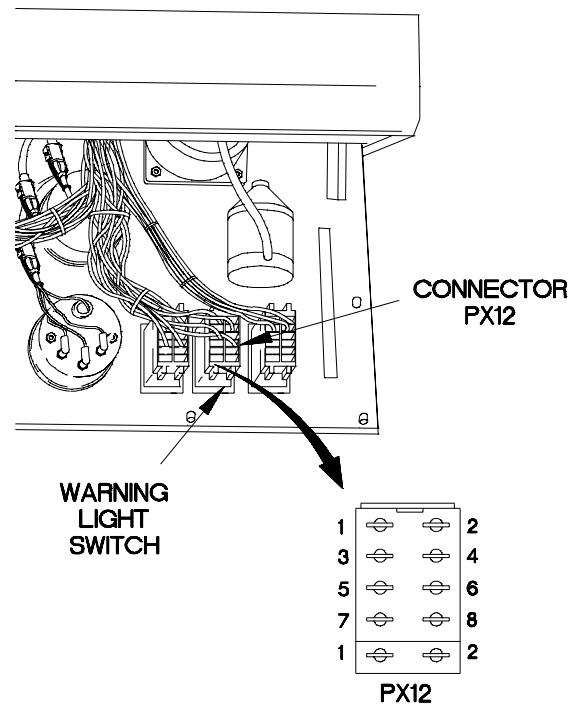

X2e53031

e52. WARNING LIGHT DOES NOT ILLUMINATE (CONT)

KNOWN INFO
Circuit breaker OK. Marker lights illuminate. Warning light OK.
POSSIBLE PROBLEMS
Faulty warning light switch. Faulty dashboard cable assembly. Faulty relay K13. Faulty warning light cable assembly.

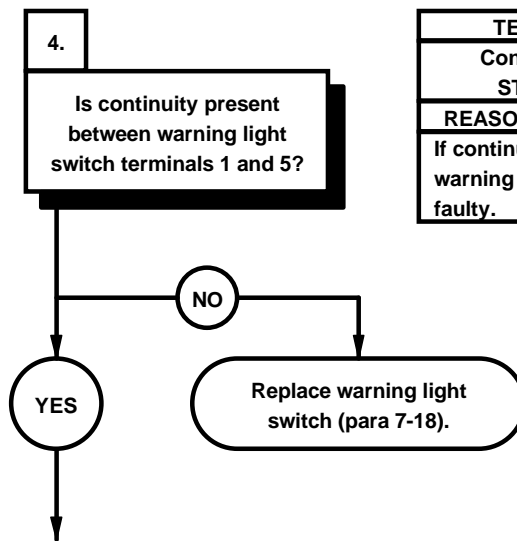

TEST OPTIONS
Continuity Test or STE/ICE-R #91
REASON FOR QUESTION
If continuity is not present, warning light switch is faulty.



CONTINUITY TEST

- (1) Set multimeter to ohms.
- (2) Connect positive (+) probe of multimeter to warning light switch terminal 1.
- (3) Connect negative (-) probe of multimeter to warning light switch terminal 5.
- (4) Position warning light switch to on (TM 9-2320-365-10) and note reading on multimeter.
- (5) If continuity is not present, replace warning light switch (para 7-18).

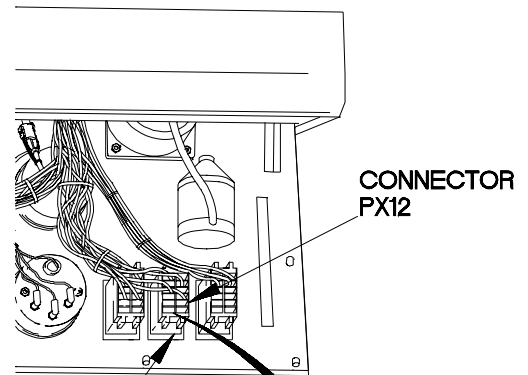

WARNING
LIGHT
SWITCH

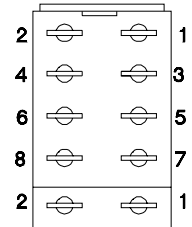

WARNING LIGHT SWITCH

X2E5404A

e52. WARNING LIGHT DOES NOT ILLUMINATE (CONT)

KNOWN INFO
Circuit breaker OK. Marker lights illuminate. Warning light switch OK.
POSSIBLE PROBLEMS
Faulty dashboard cable assembly. Faulty relay K13. Faulty warning light cable assembly.

5.
Is continuity present between connector PX12-1 and relay K13 terminal 86?

TEST OPTIONS
Continuity Test or STE/ICE-R#91
REASON FOR QUESTION
If continuity is not present, wire 1559 is faulty.

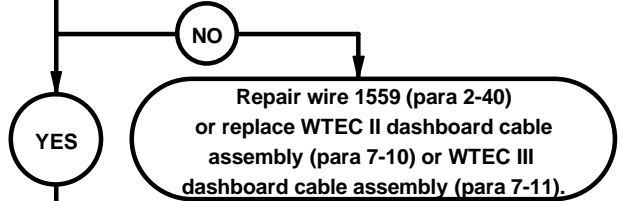

KNOWN INFO
Circuit breaker OK. Marker lights illuminate. Warning light switch OK.
POSSIBLE PROBLEMS
Faulty dashboard cable assembly. Faulty relay K13. Faulty warning light cable assembly.

6.
Is continuity present between relay K13 terminal 85 and a known good ground?

TEST OPTIONS
Continuity Test or STE/ICE-R #91
REASON FOR QUESTION
If continuity is not present, wire 3054 is faulty.

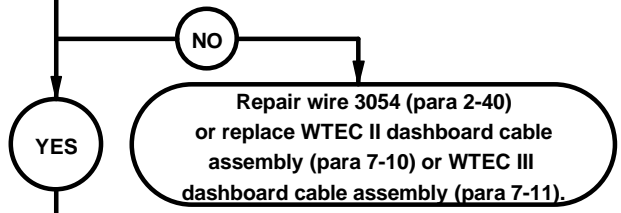

- | CONTINUITY TEST | |
|-----------------|--|
| (1) | Remove PDP cover (para 16-2). |
| (2) | Remove relay K13 from PDP. |
| (3) | Set multimeter to ohms. |
| (4) | Connect positive (+) probe of multimeter to PDP, socket 86, where relay K13 was removed. |
| (5) | Connect negative (-) probe of multimeter to connector PX12-1 and note reading on multimeter. |
| (6) | If continuity is not present, repair wire 1559 (para 2-40) or replace WTEC II dashboard cable assembly (para 7-10) or WTEC III dashboard cable assembly (para 7-11). |
| (7) | Connect connector PX12 to warning light switch. |
| (8) | Install instrument panel assembly (para 7-15). |

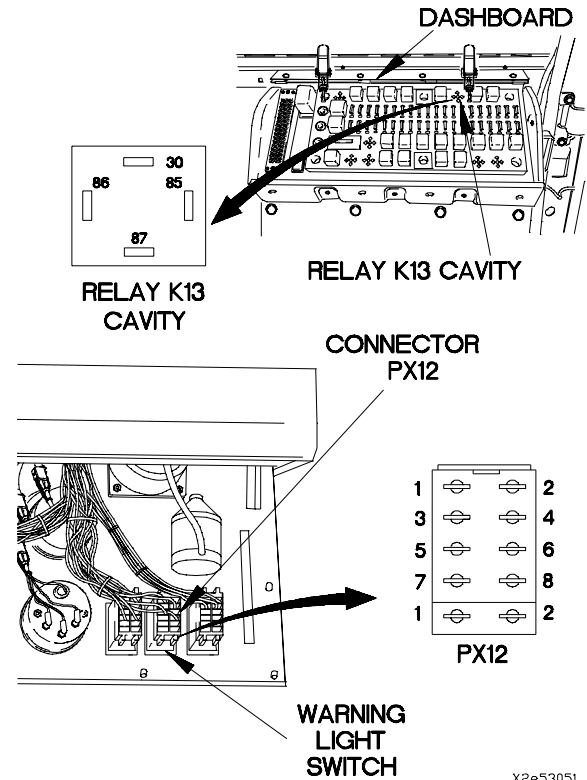

x2e53051

- | CONTINUITY TEST | |
|-----------------|--|
| (1) | Set multimeter to ohms. |
| (2) | Connect positive (+) probe of multimeter to PDP, socket 85, where relay K13 was removed. |
| (3) | Connect negative (-) probe of multimeter to ground and note reading on multimeter. |
| (4) | If continuity is not present, repair wire 3054 (para 2-40) or replace WTEC II dashboard cable assembly (para 7-10) or WTEC III dashboard cable assembly (para 7-11). |

e52. WARNING LIGHT DOES NOT ILLUMINATE (CONT)

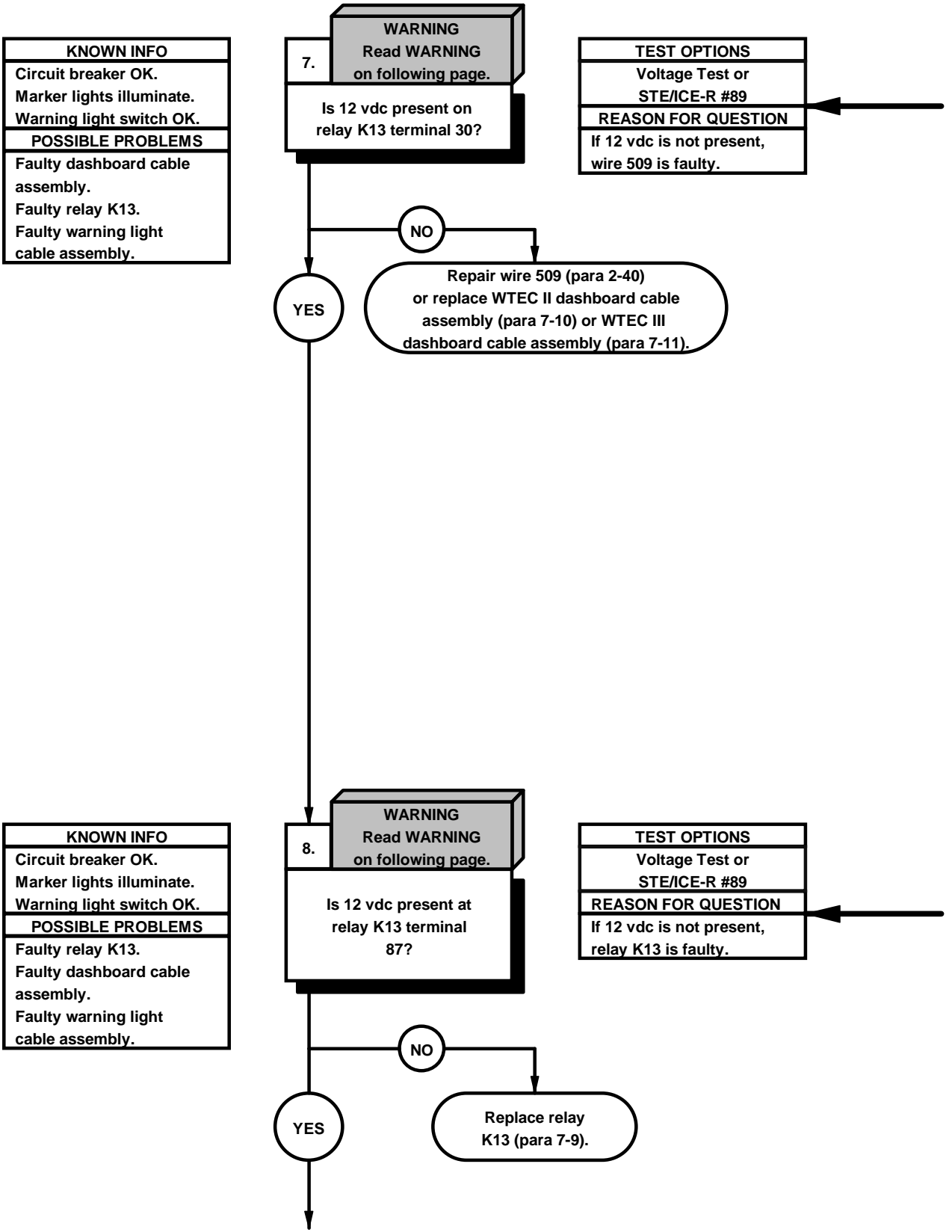

WARNING

Remove rings, bracelets, watches, necklaces, and any other jewelry before working around vehicle. Jewelry can catch on equipment and cause injury or short across electrical circuit and cause severe burns or electrical shock.

VOLTAGE TEST

- (1) Set multimeter to volts dc.
- (2) Connect positive (+) probe of multimeter to PDP, socket 30, where relay K13 was removed.
- (3) Connect negative (-) probe of multimeter to ground.
- (4) Position main light switch to SER DRIVE (TM 9-2320-365-10).
- (5) Position warning light switch to on (TM 9-2320-365-10).
- (6) If 12 vdc is not present, repair wire 509 (para 2-40) or replace WTEC II dashboard cable assembly (para 7-10) or WTEC III dashboard cable assembly (para 7-11).
- (7) Position warning light switch to off (TM 9-2320-365-10).
- (8) Position main light switch to OFF (TM 9-2320-365-10).

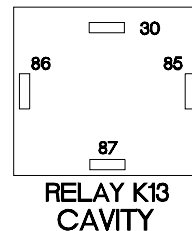
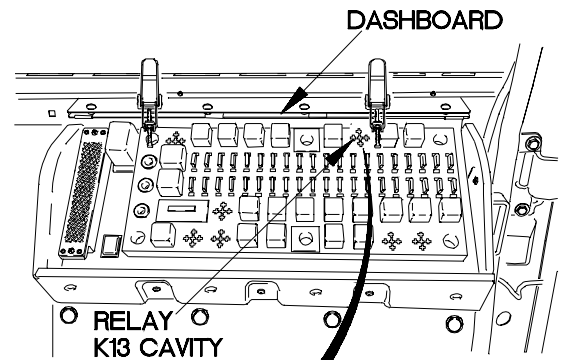

X2E5406A

VOLTAGE TEST

- (1) Install relay K13 in PDP.
- (2) Set multimeter to volts dc.
- (3) Connect positive (+) probe of multimeter to relay K13 terminal 87.
- (4) Connect negative (-) probe of multimeter to ground.
- (5) Position main light switch to SER DRIVE (TM 9-2320-365-10).
- (6) Position warning light switch to on (TM 9-2320-365-10) and note reading on multimeter.
- (7) If 12 vdc is not present, replace relay K13 (para 7-9).
- (8) Position warning light switch to off (TM 9-2320-365-10).
- (9) Position main light switch to OFF (TM 9-2320-365-10).

e52. WARNING LIGHT DOES NOT ILLUMINATE (CONT)

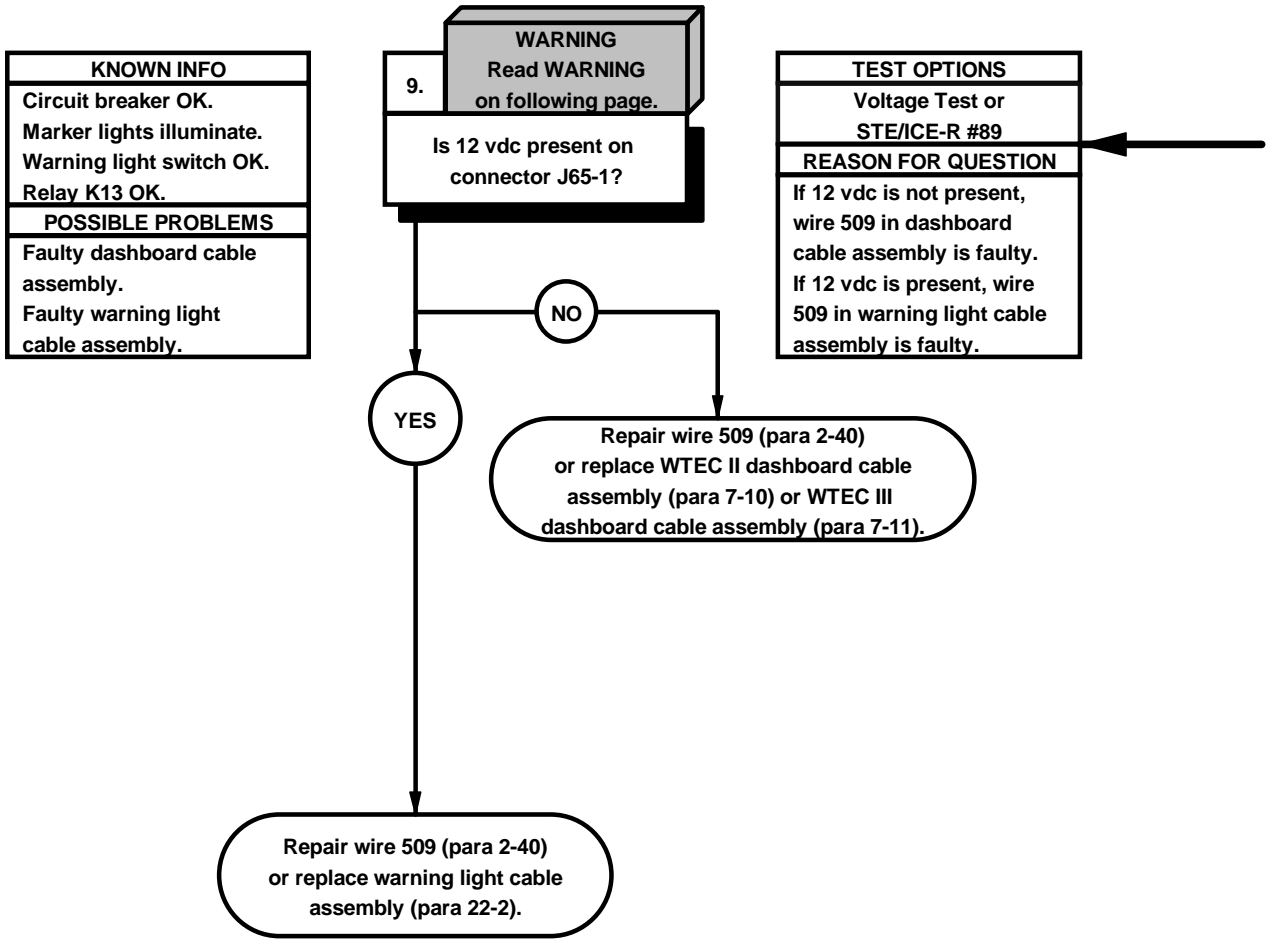

WARNING

Remove rings, bracelets, watches, necklaces, and any other jewelry before working around vehicle. Jewelry can catch on equipment and cause injury or short across electrical circuit and cause severe burns or electrical shock.

VOLTAGE TEST

- (1) Remove seven screws and washers from kick panel.
- (2) Remove kick panel and stiffener from dashboard.
- (3) Disconnect connector P65 from connector J65.
- (4) Set multimeter to volts dc.
- (5) Connect positive (+) probe of multimeter to connector J65-1.
- (6) Connect negative (-) probe of multimeter to ground.
- (7) Position main light switch to SER DRIVE (TM 9-2320-365-10).
- (8) Position warning light switch to on (TM 9-2320-365-10).
- (9) If 12 vdc is not present, repair wire 509 (para 2-40) or replace WTEC II dashboard cable assembly (para 7-10) or WTEC III dashboard cable assembly (para 7-11).
- (10) If 12 vdc is present, repair wire 509 (para 2-40) or replace warning light cable assembly (para 22-2).
- (11) Position warning light switch to off (TM 9-2320-365-10).
- (12) Position main light switch to OFF (TM 9-2320-365-10).
- (13) Connect connector P65 to connector J65.
- (14) Install kick panel (para 16-3).

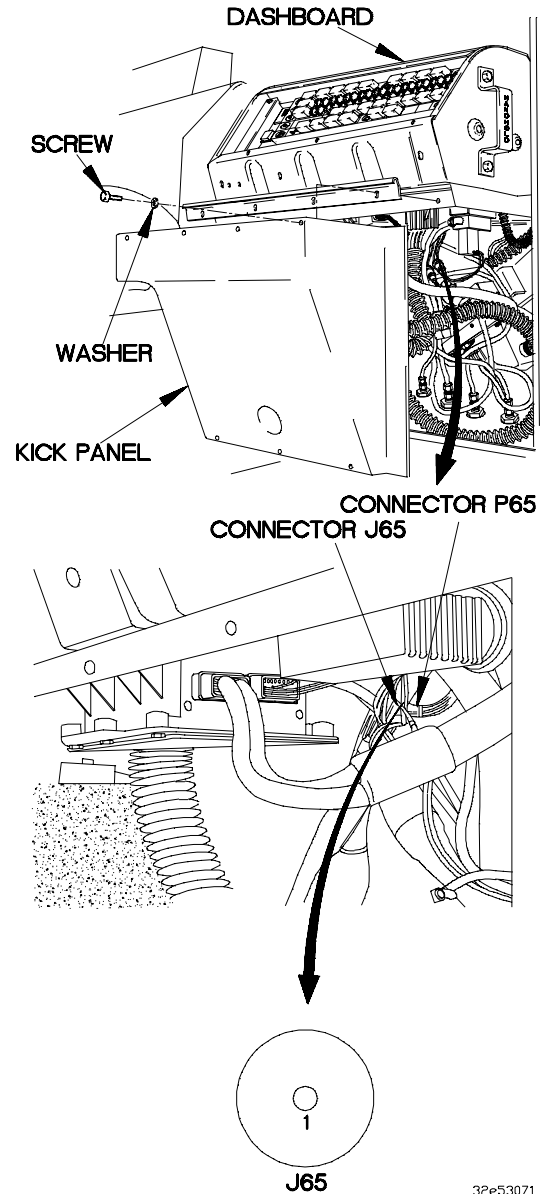

32e53071

e53. BACKUP LIGHT DOES NOT ILLUMINATE	
INITIAL SETUP	
<p>Equipment Conditions Engine shut down (TM 9-2320-365-10). Batteries disconnected (para 7-48).</p> <p>Personnel Required (2)</p> <p>Materials/Parts Packing, Preformed (Item 192, Appendix G) Wire, Electrical, 50 ft (Item 77, Appendix D)</p>	<p>Tools and Special Tools Tool Kit, Genl Mech (Item 44, Appendix C) STE/ICE-R (Item 39, Appendix C) Multimeter, Digital (Item 22, Appendix C)</p> <p>References TM 9-4910-571-12&P</p>

NOTE

Perform Electrical System Troubleshooting e1. Circuit Breaker Does Not Operate on circuit breakers CB70 and CB73 prior to beginning this task.

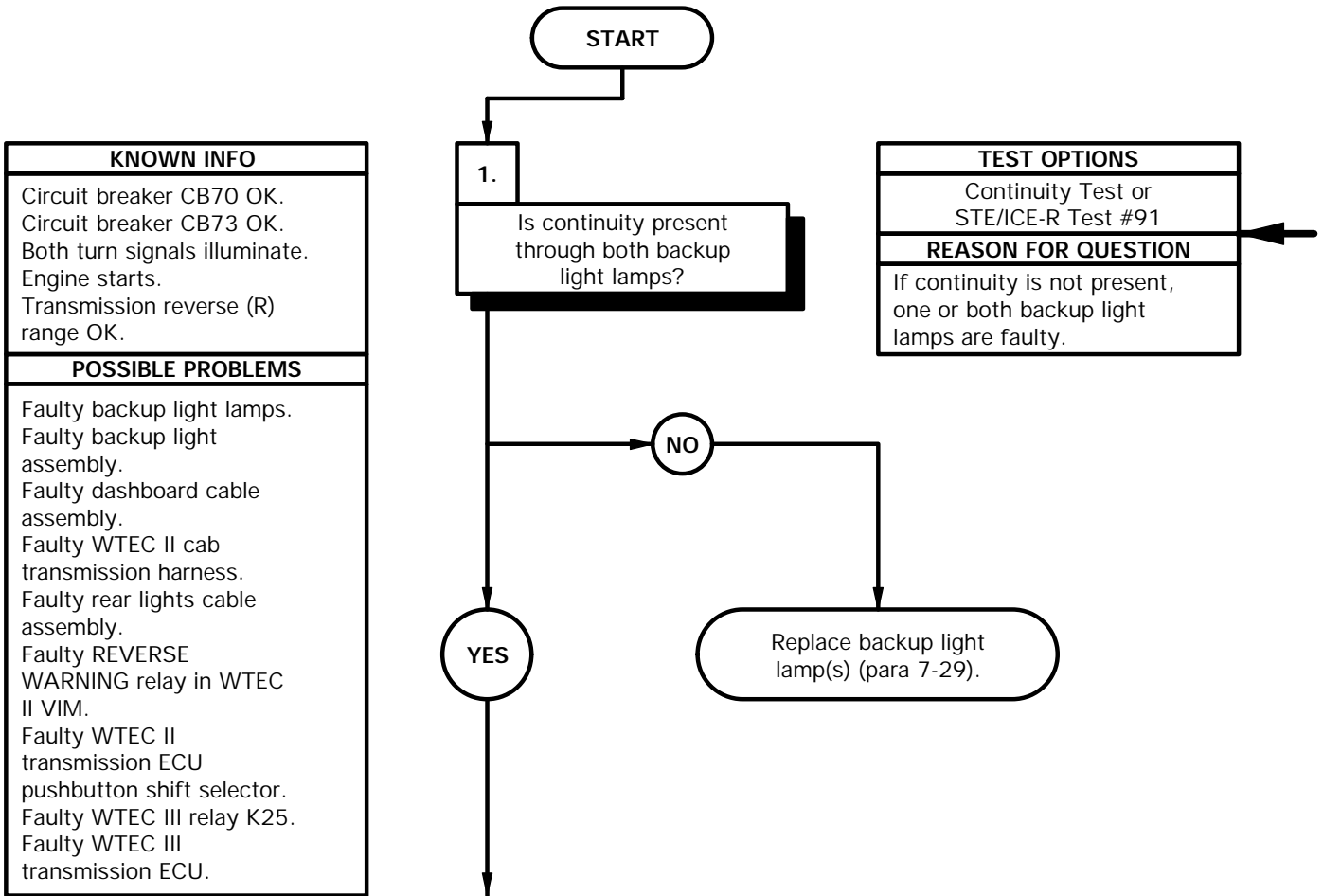

CONTINUITY TEST

- (1) Loosen six captive screws on lens.
- (2) Remove lens from housing.
- (3) Remove preformed packing from housing. Discard preformed packing.
- (4) Remove two lamps from sockets.
- (5) Set multimeter to ohms.
- (6) Connect positive (+) probe of multimeter to center contact of lamp.
- (7) Connect negative (-) probe of multimeter to lamp base and note reading on multimeter.
- (8) If continuity is not present, replace one or both lamps (para 7-29).
- (9) Install two lamps in sockets.
- (10) Install preformed packing and lens on housing with six captive screws.
- (11) Connect batteries (para 7-48).

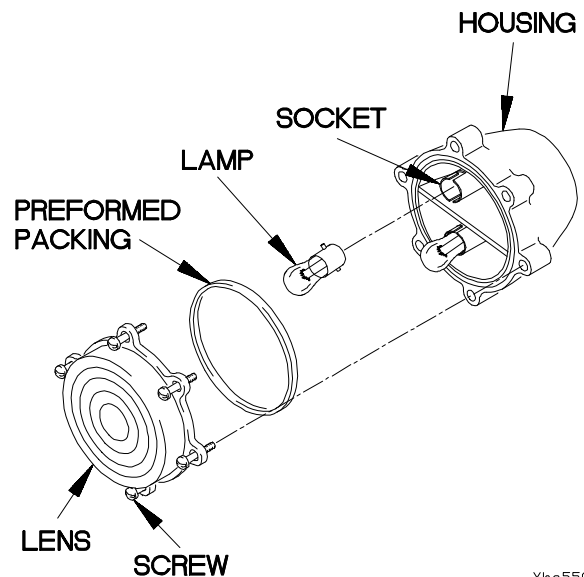

Xbe5501b

e53. BACKUP LIGHT DOES NOT ILLUMINATE (CONT)

<p>KNOWN INFO</p> <p>Circuit breaker CB70 OK. Circuit breaker CB73 OK. Both turn signals illuminate. Engine starts. Transmission reverse (R) range OK. Backup light lamps OK.</p>
<p>POSSIBLE PROBLEMS</p> <p>Faulty backup light assembly. Faulty dashboard cable assembly. Faulty WTEC II cab transmission harness. Faulty rear lights cable assembly. Faulty REVERSE WARNING relay in WTEC II VIM. Faulty WTEC II transmission ECU pushbutton shift selector. Faulty WTEC III relay K25. Faulty WTEC III transmission ECU.</p>

2.

WARNING

CAUTION

Read **WARNING** and **CAUTION** on following page.

Is 12 VDC present at connector P87?

<p>TEST OPTIONS</p> <p>Voltage Test or STE/ICE-R Test #89</p>
<p>REASON FOR QUESTION</p> <p>If 12 VDC is present, backup light assembly is faulty.</p>

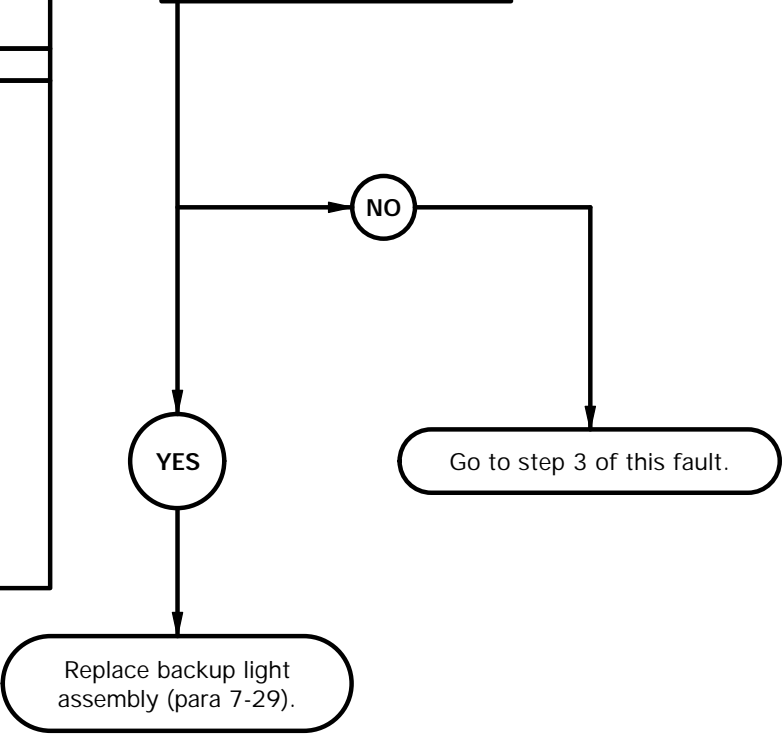

WARNING

Remove rings, bracelets, watches, necklaces, and any other jewelry before working around vehicle. Jewelry can catch on equipment and cause injury or short across electrical circuits and cause severe burns or electrical shock.

CAUTION

Use care when testing electrical connectors. Do not damage connector pins or sockets with multimeter probes. Failure to comply may result in damage to equipment.

NOTE

Inspect connector pins/sockets for damage, corrosion, and serviceability. Check that connector pins are not pushed back and are capable of making good contact.

VOLTAGE TEST

- (1) Disconnect connector P87 from backup light connector.
- (2) Set multimeter to volts DC.
- (3) Connect positive (+) probe of multimeter to connector P87.
- (4) Connect negative (-) probe of multimeter to ground.
- (5) Start engine (TM 9-2320-365-10).
- (6) Position main light switch to SER DRIVE (TM 9-2320-365-10).
- (7) Select R (reverse) on pushbutton shift selector (TM 9-2320-365-10) and note reading on multimeter.
- (8) If 12 VDC is not present, go to step 3 of this faulty. If 12 VDC is present, replace backup light assembly (para 7-29).
- (9) Select N (neutral) on pushbutton shift selector (TM 9-2320-365-10).
- (10) Position main light switch to OFF (TM 9-2320-365-10).
- (11) Shut down engine (TM 9-2320-365-10).
- (12) Connect connector P87 to backup light connector.

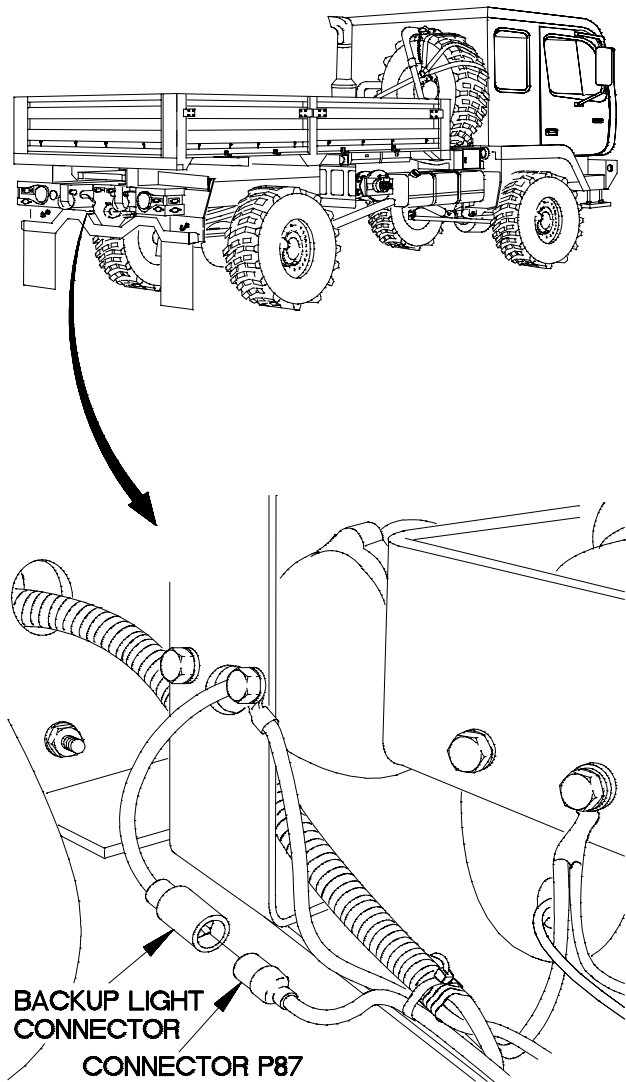

36e5302b

e53. BACKUP LIGHT DOES NOT ILLUMINATE (CONT)

KNOWN INFO
Circuit breaker CB70 OK. Circuit breaker CB73 OK. Both turn signals illuminate. Engine starts. Transmission reverse (R) range OK. Backup light lamps OK. Backup light assembly OK.
POSSIBLE PROBLEMS
Faulty dashboard cable assembly. Faulty WTEC II cab transmission harness. Faulty rear lights cable assembly. Faulty REVERSE WARNING relay in WTEC II VIM. Faulty WTEC II transmission ECU pushbutton shift selector. Faulty WTEC III relay K25. Faulty WTEC III transmission ECU.

3.

WARNING
 Read WARNING on following page.

Is 12 VDC present at circuit breaker CB73 terminal 7?

TEST OPTIONS
Voltage Test or STE/ICE-R Test #89
REASON FOR QUESTION
If 12 VDC is not present, wire 1577 is faulty.

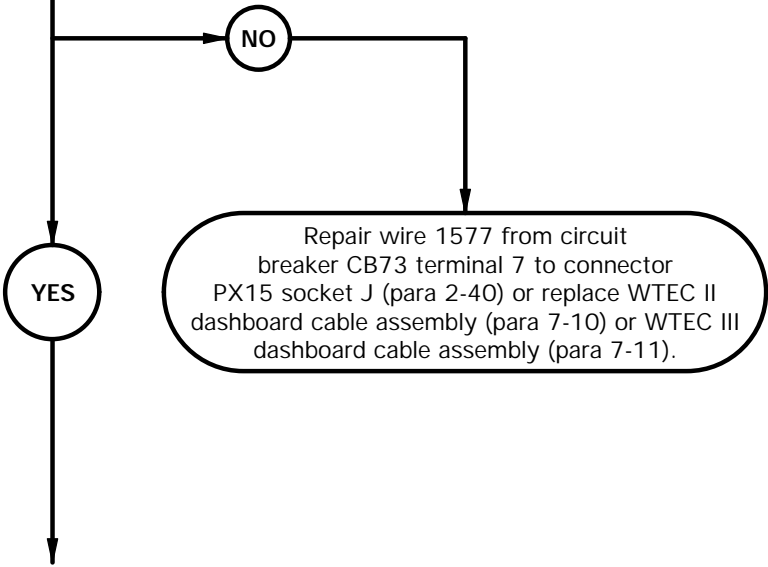

WARNING

Remove rings, bracelets, watches, necklaces, and any other jewelry before working around vehicle. Jewelry can catch on equipment and cause injury or short across electrical circuits and cause severe burns or electrical shock.

VOLTAGE TEST

- (1) Remove PDP cover (para 16-2).
- (2) Remove circuit breaker CB73 from PDP.
- (3) Set multimeter to volts DC.
- (4) Connect positive (+) probe of multimeter to PDP, terminal 7, where circuit breaker CB73 was removed.
- (5) Connect negative (-) probe of multimeter to ground.
- (6) Position main light switch to SER DRIVE (TM 9-2320-365-10) and note reading on multimeter.
- (7) If 12 VDC is not present, repair wire 1577 from circuit breaker CB73 terminal 7 to connector PX15 socket J (para 2-40) or replace WTEC II dashboard cable assembly (para 7-10) or WTEC III dashboard cable assembly (para 7-11).
- (8) Position main light switch to OFF (TM 9-2320-365-10).

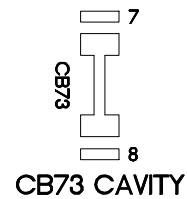
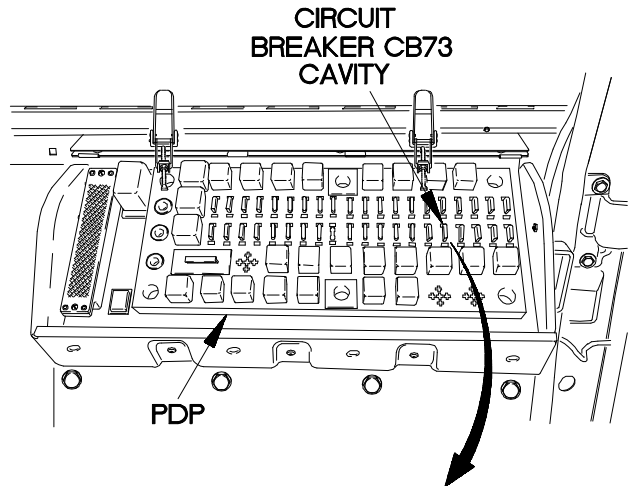

Xbe5503b

e53. BACKUP LIGHT DOES NOT ILLUMINATE (CONT)

KNOWN INFO
Circuit breaker CB70 OK. Circuit breaker CB73 OK. Both turn signals illuminate. Engine starts. Transmission reverse (R) range OK. Backup light lamps OK. Backup light assembly OK.
POSSIBLE PROBLEMS
Faulty dashboard cable assembly. Faulty WTEC II cab transmission harness. Faulty rear lights cable assembly. Faulty REVERSE WARNING relay in WTEC II VIM. Faulty WTEC II transmission ECU pushbutton shift selector. Faulty WTEC III relay K25. Faulty WTEC III transmission ECU.

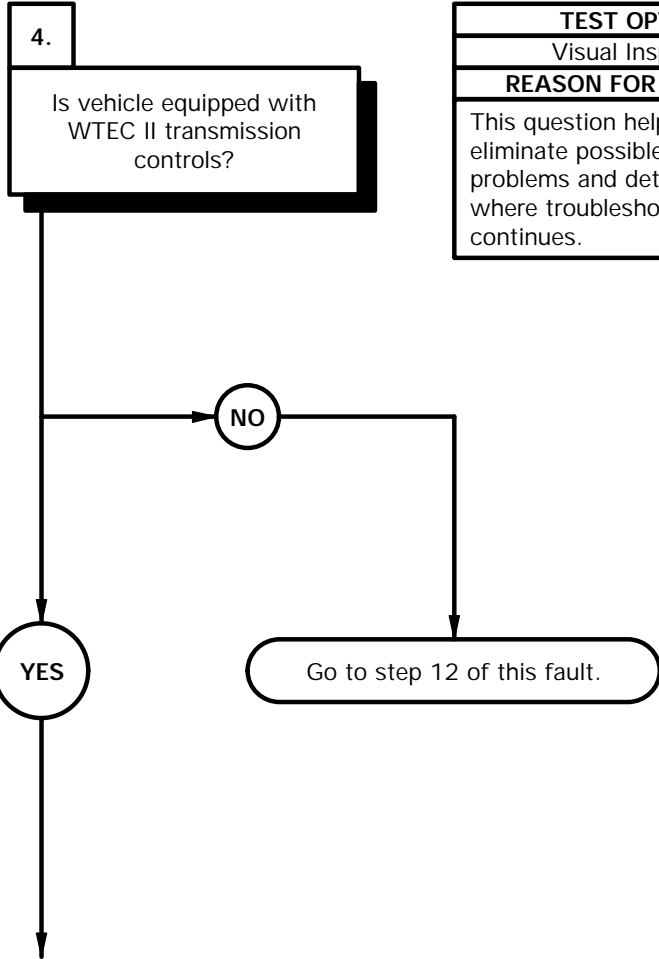

TEST OPTIONS
Visual Inspection
REASON FOR QUESTION
This question helps eliminate possible problems and determines where troubleshooting continues.



- (1) Check if vehicle is equipped with WTEC II TEPSS.
- (2) If transmission pushbutton shift selector is not mounted with four screws and does not have a filter cover, go to step 13 of this fault.

WTEC II
TRANSMISSION
ECU PUSHBUTTON
SHIFT SELECTOR

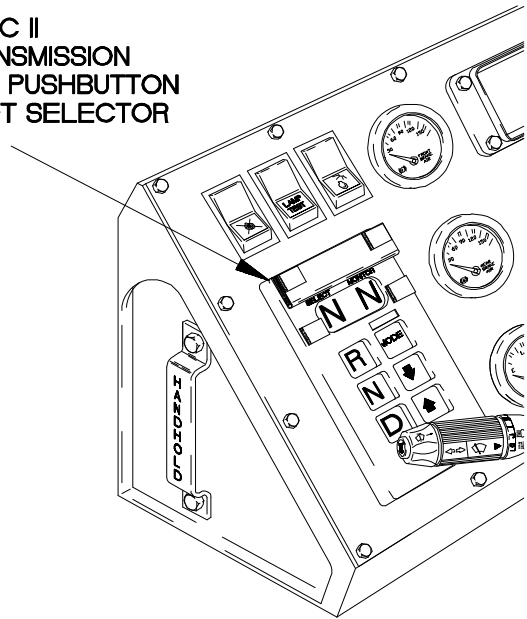

WTEC III
TRANSMISSION
PUSHBUTTON
SHIFT SELECTOR

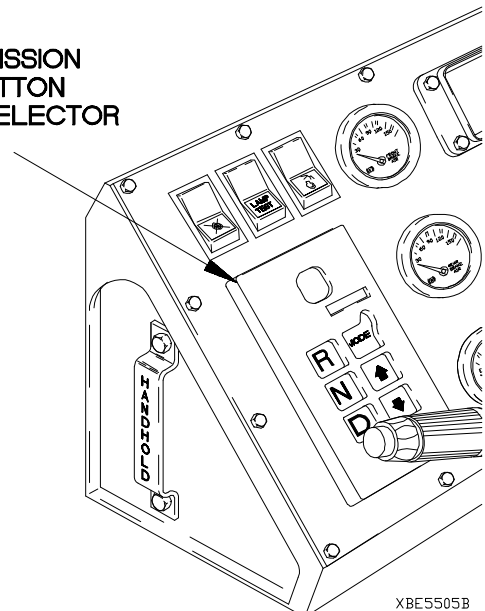

XBE5505B

e53. BACKUP LIGHT DOES NOT ILLUMINATE (CONT)

KNOWN INFO
Circuit breaker CB70 OK. Circuit breaker CB73 OK. Both turn signals illuminate. Engine starts. Transmission reverse (R) range OK. Backup light lamps OK. Backup light assembly OK. WTEC II transmission controls.
POSSIBLE PROBLEMS
Faulty dashboard cable assembly. Faulty WTEC II cab transmission harness. Faulty rear lights cable assembly. Faulty REVERSE WARNING relay in WTEC II VIM. Faulty WTEC II transmission ECU pushbutton shift selector.

5.
 Is continuity present from REVERSE WARNING relay terminal 86 to terminal 85?

TEST OPTIONS
Continuity Test or STE/ICE-R Test #91
REASON FOR QUESTION
If continuity is not present, REVERSE WARNING relay is faulty.

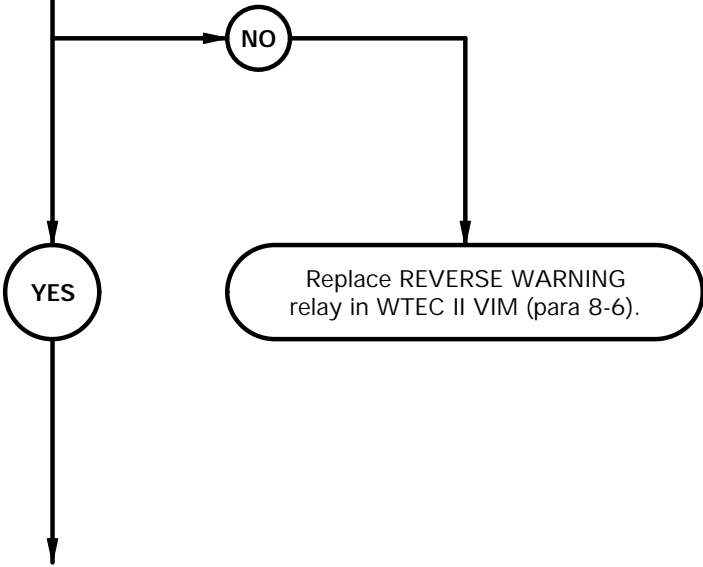

CONTINUITY TEST

- (1) Remove kick panel (para 16-3).
- (2) Remove seven screws and washers from cover.
- (3) Remove screw, washer, cover, and nut from WTEC II VIM.
- (4) Remove REVERSE WARNING relay from WTEC II VIM.
- (5) Set multimeter to ohms.
- (6) Connect positive (+) probe of multimeter to REVERSE WARNING relay terminal 86.
- (7) Connect negative (-) probe of multimeter to REVERSE WARNING relay terminal 85 and note reading on multimeter.
- (8) If continuity is not present, replace REVERSE WARNING relay in WTEC II VIM (para 8-6).
- (9) Install REVERSE WARNING relay in WTEC II VIM.
- (10) Install cover on WTEC II VIM with nut, washer, and screw.
- (11) Install seven washers and screws in cover.

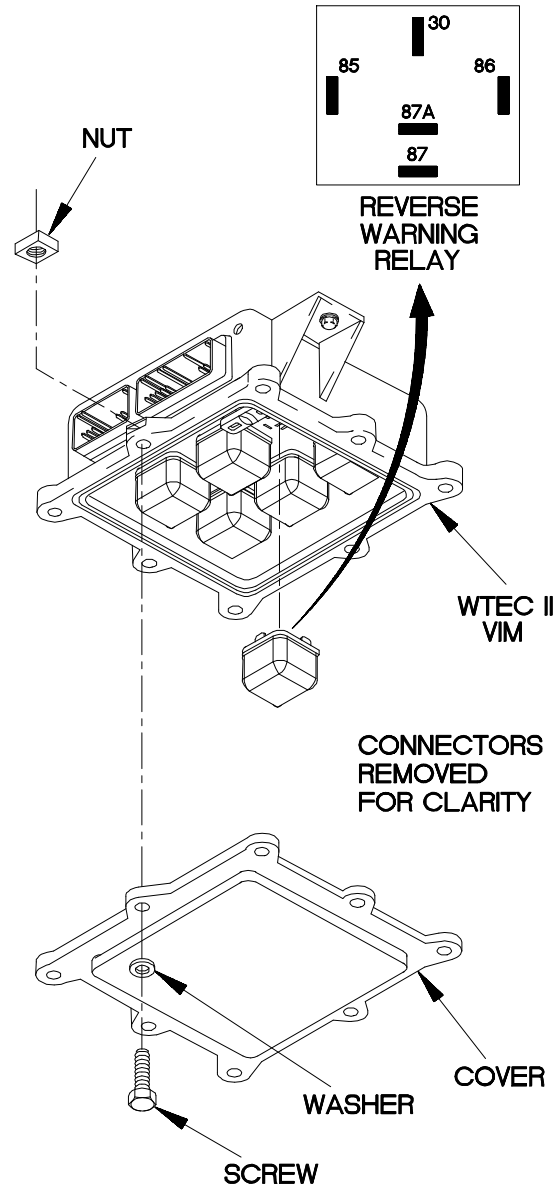

XBE5506B

e53. BACKUP LIGHT DOES NOT ILLUMINATE (CONT)

KNOWN INFO
Circuit breaker CB70 OK. Circuit breaker CB73 OK. Both turn signals illuminate. Engine starts. Transmission reverse (R) range OK. Backup light lamps OK. Backup light assembly OK. WTEC II transmission controls.
POSSIBLE PROBLEMS
Faulty dashboard cable assembly. Faulty WTEC II cab transmission harness. Faulty rear lights cable assembly. Faulty REVERSE WARNING relay in WTEC II VIM. Faulty WTEC II transmission ECU pushbutton shift selector.

WARNING

CAUTION

Read **WARNING** and **CAUTION** on following page.

6. Is 12 VDC present at connector PX33 socket B1?

TEST OPTIONS
Voltage Test or STE/ICE-R Test #89
REASON FOR QUESTION
If 12 VDC is not present, wire 1903 is faulty.

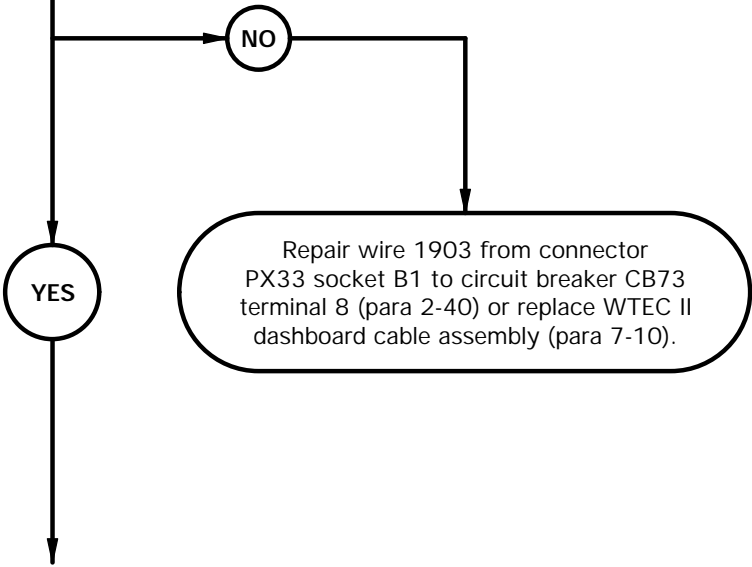

WARNING

Remove rings, bracelets, watches, necklaces, and any other jewelry before working around vehicle. Jewelry can catch on equipment and cause injury or short across electrical circuits and cause severe burns or electrical shock.

CAUTION

Use care when testing electrical connectors. Do not damage connector pins or sockets with multimeter probes. Failure to comply may result in damage to equipment.

NOTE

Inspect connector pins/sockets for damage, corrosion, and serviceability. Check that connector pins are not pushed back and are capable of making good contact.

VOLTAGE TEST

- (1) Loosen screw in connector PX33.
- (2) Disconnect connector PX33 from WTEC II VIM.
- (3) Set multimeter to volts DC.
- (4) Connect positive (+) probe of multimeter to connector PX33 socket B1.
- (5) Connect negative (-) probe of multimeter to ground.
- (6) Position main light switch to SER DRIVE (TM 9-2320-365-10) and note reading on multimeter.
- (7) If 12 VDC is not present, repair wire 1903 from connector PX33 socket B1 to circuit breaker CB73 terminal 8 (para 2-40) or replace WTEC II dashboard cable assembly (para 7-10).
- (8) Position main light switch to OFF (TM 9-2320-365-10).

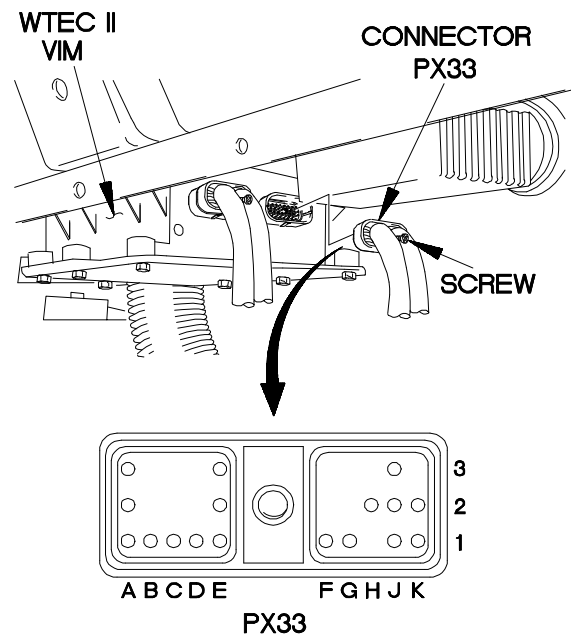

XBE5507B

e53. BACKUP LIGHT DOES NOT ILLUMINATE (CONT)

KNOWN INFO
Circuit breaker CB70 OK. Circuit breaker CB73 OK. Both turn signals illuminate. Engine starts. Transmission reverse (R) range OK. Backup light lamps OK. Backup light assembly OK. WTEC II transmission controls.
POSSIBLE PROBLEMS
Faulty dashboard cable assembly. Faulty WTEC II cab transmission harness. Faulty rear lights cable assembly. Faulty REVERSE WARNING relay in WTEC II VIM. Faulty WTEC II transmission ECU pushbutton shift selector.

WARNING

CAUTION

Read WARNING and CAUTION on following page.

7. Is 12 VDC present at connector PX33 socket C1?

TEST OPTIONS
Voltage Test or STE/ICE-R Test #89
REASON FOR QUESTION
If 12 VDC is not present, wire 1460 is faulty.

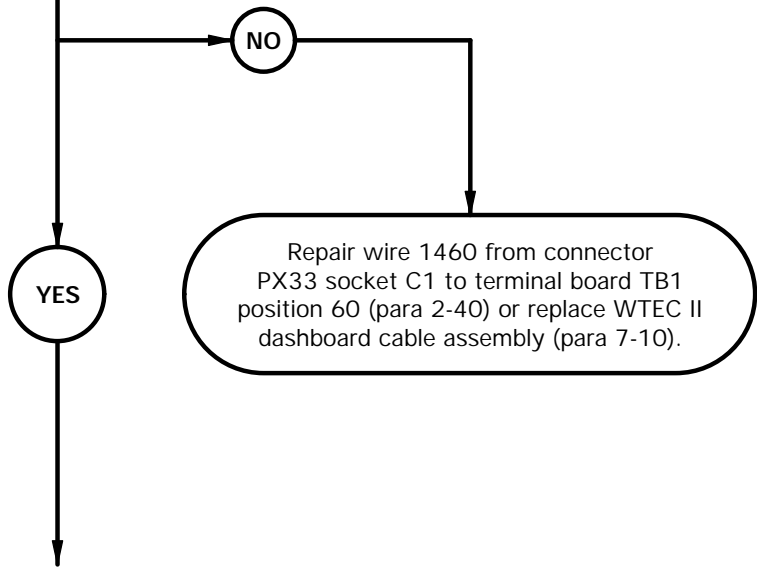

WARNING

Remove rings, bracelets, watches, necklaces, and any other jewelry before working around vehicle. Jewelry can catch on equipment and cause injury or short across electrical circuits and cause severe burns or electrical shock.

CAUTION

Use care when testing electrical connectors. Do not damage connector pins or sockets with multimeter probes. Failure to comply may result in damage to equipment.

NOTE

Inspect connector pins/sockets for damage, corrosion, and serviceability. Check that connector pins are not pushed back and are capable of making good contact.

VOLTAGE TEST

- (1) Set multimeter to volts DC.
- (2) Connect positive (+) probe of multimeter to connector PX33 socket C1.
- (3) Connect negative (-) probe of multimeter to ground.
- (4) Position main light switch to SER DRIVE (TM 9-2320-365-10) and note reading on multimeter.
- (5) If 12 VDC is not present, repair wire 1460 from connector PX33 socket C1 to terminal board TB1 position 60 (para 2-40) or replace WTEC II dashboard cable assembly (para 7-10).
- (6) Position main light switch to OFF (TM 9-2320-365-10).

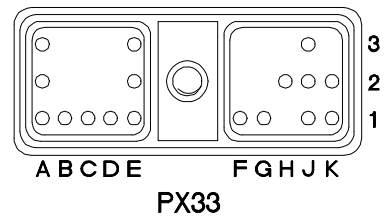

Xbe5508B

e53. BACKUP LIGHT DOES NOT ILLUMINATE (CONT)

KNOWN INFO
Circuit breaker CB70 OK. Circuit breaker CB73 OK. Both turn signals illuminate. Engine starts. Transmission reverse (R) range OK. Backup light lamps OK. Backup light assembly OK. WTEC II transmission controls.
POSSIBLE PROBLEMS
Faulty WTEC II cab transmission harness. Faulty dashboard cable assembly. Faulty rear lights cable assembly. Faulty REVERSE WARNING relay in WTEC II VIM. Faulty WTEC II transmission ECU pushbutton shift selector.

8.

CAUTION
Read CAUTION on following page.

Is continuity present from connector J116 socket F2 to connector J114 socket 13?

TEST OPTIONS
Continuity Test or STE/ICE-R Test #91
REASON FOR QUESTION
If continuity is not present, WTEC II cab transmission harness is faulty.

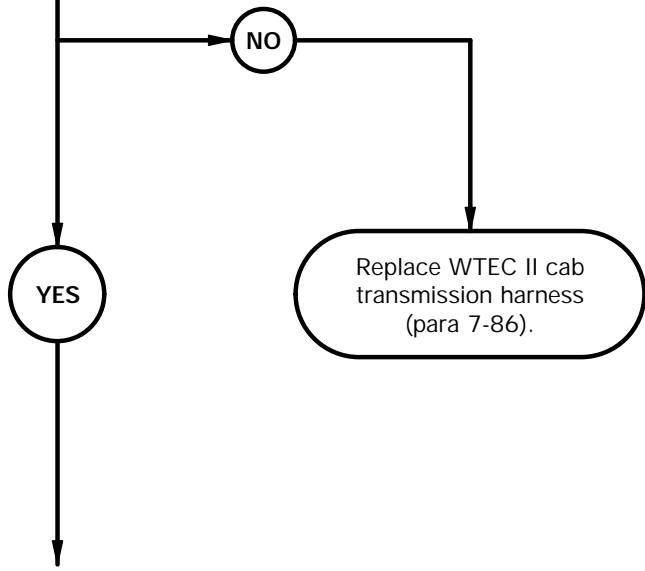

CAUTION

Use care when testing electrical connectors. Do not damage connector pins or sockets with multimeter probes. Failure to comply may result in damage to equipment.

NOTE

Inspect connector pins/sockets for damage, corrosion, and serviceability. Check that connector pins are not pushed back and are capable of making good contact.

CONTINUITY TEST

- (1) Remove instrument panel assembly for access (para 7-15).
- (2) Disconnect connector J114 from WTEC II TEPSS.
- (3) Loosen screw in connector J116.
- (4) Disconnect connector J116 from WTEC II VIM.
- (5) Connect positive (+) probe of multimeter to connector J116 socket F2.
- (6) Connect negative (-) probe of multimeter to connector J114 socket 13 and note reading on multimeter.
- (7) If continuity is not present, replace WTEC II cab transmission harness (para 7-86).
- (8) Connect connector J114 to WTEC II TEPSS.
- (9) Install instrument panel assembly (para 7-15).
- (10) Connect connector J116 to WTEC II VIM.
- (11) Tighten screw in connector J116.

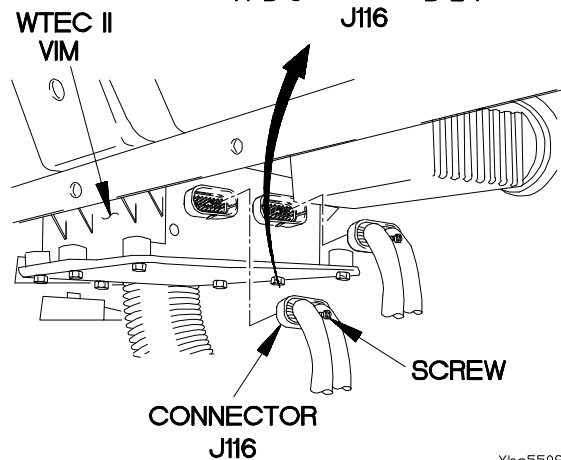
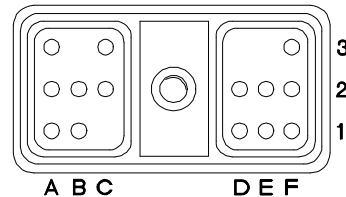
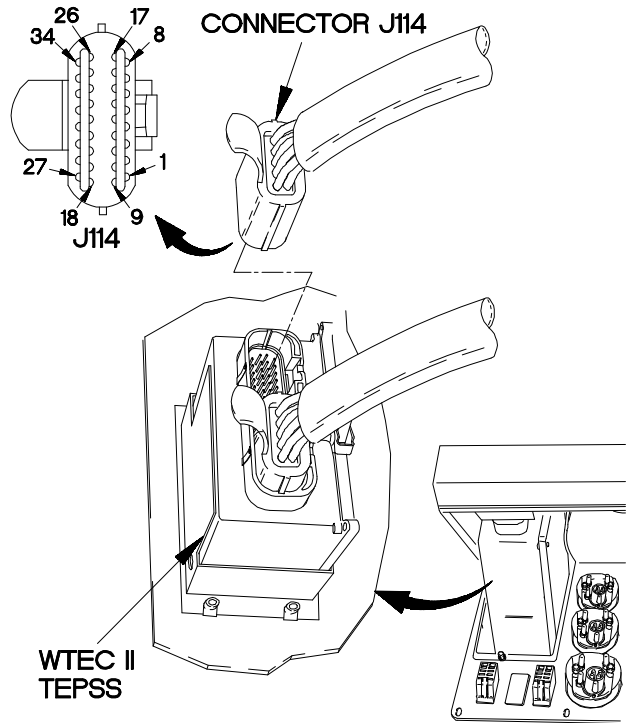

Xbe5509B

e53. BACKUP LIGHT DOES NOT ILLUMINATE (CONT)

KNOWN INFO
Circuit breaker CB70 OK. Circuit breaker CB73 OK. Both turn signals illuminate. Engine starts. Transmission reverse (R) range OK. Backup light lamps OK. Backup light assembly OK. WTEC II transmission controls. WTEC II cab transmission harness OK.
POSSIBLE PROBLEMS
Faulty dashboard cable assembly. Faulty rear lights cable assembly. Faulty REVERSE WARNING relay in WTEC II VIM. Faulty WTEC II transmission ECU pushbutton shift selector.

9.

CAUTION
 Read CAUTION on following page.

Is continuity present from connector PX33 socket A1 to connector J51 pin 2?

TEST OPTIONS
Continuity Test or STE/ICE-R Test #91
REASON FOR QUESTION
If continuity is not present, wire 490 in WTEC II dashboard cable assembly is faulty.

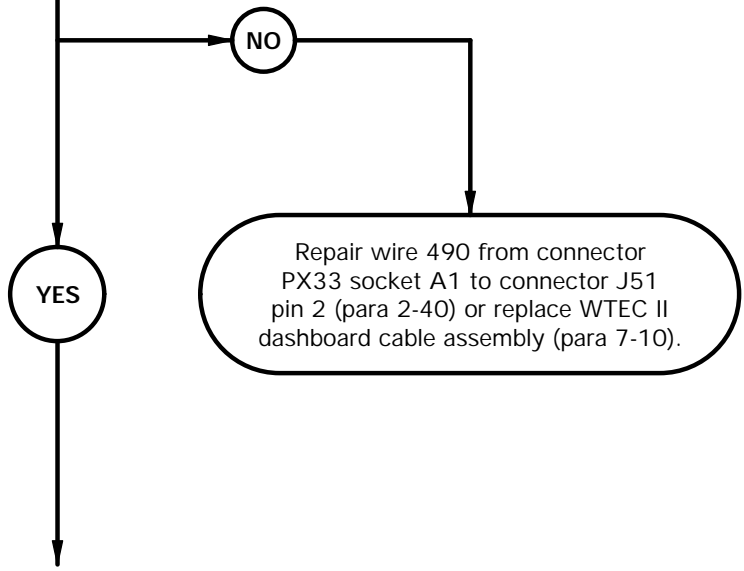

CAUTION

Remove rings, bracelets, watches, necklaces, and any other jewelry before working around vehicle. Jewelry can catch on equipment and cause injury or short across electrical circuits and cause severe burns or electrical shock.

NOTE

Inspect connector pins/sockets for damage, corrosion, and serviceability. Check that connector pins are not pushed back and are capable of making good contact.

CONTINUITY TEST

- (1) Remove three screws from PDP.
- (2) Remove three screws and washers from PDP.
- (3) Lift PDP outward to gain access.
- (4) Disconnect connector P51 from connector J51.
- (5) Set multimeter to ohms.
- (6) Connect positive (+) probe of multimeter to connector PX33 socket A1.
- (7) Connect negative (-) probe of multimeter to connector J51 pin 2 and note reading on multimeter.
- (8) If continuity is not present, repair wire 490 from connector PX33 socket A1 to connector J51 pin 2 (para 2-40) or replace WTEC II dashboard cable assembly (para 7-10).
- (9) Connect connector PX33 to WTEC II VIM.
- (10) Tighten screw in connector PX33.
- (11) Install kick panel (para 16-3).

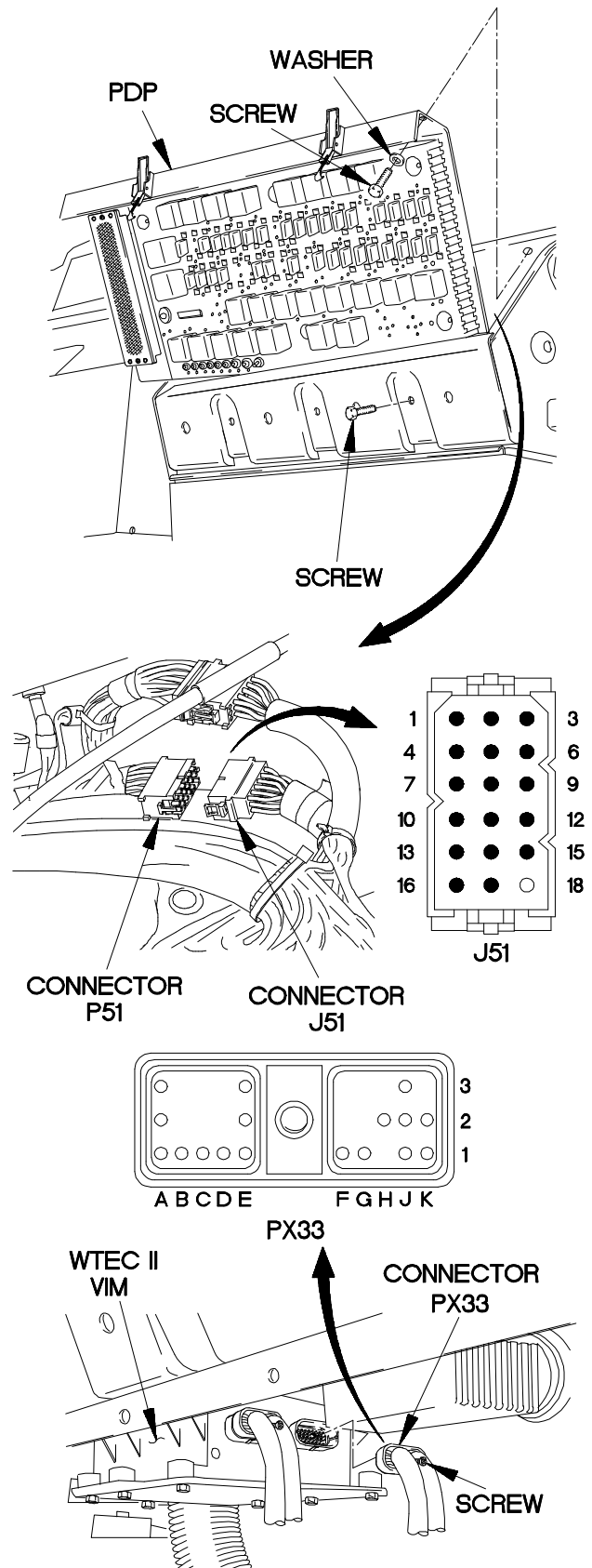

Xoe5510B

e53. BACKUP LIGHT DOES NOT ILLUMINATE (CONT)

KNOWN INFO
Circuit breaker CB70 OK. Circuit breaker CB73 OK. Both turn signals illuminate. Engine starts. Transmission reverse (R) range OK. Backup light lamps OK. Backup light assembly OK. WTEC II transmission controls. WTEC II cab transmission harness OK. WTEC II dashboard cable assembly OK.
POSSIBLE PROBLEMS
Faulty rear lights cable assembly. Faulty REVERSE WARNING relay in WTEC II VIM. Faulty WTEC II transmission ECU pushbutton shift selector.

10. **CAUTION**
Read CAUTION on following page.

Is continuity present from connector P51 socket 2 to connector P87?

TEST OPTIONS
Continuity Test or STE/ICE-R Test #91
REASON FOR QUESTION
If continuity is not present, wire 490 in rear lights cable assembly is faulty.

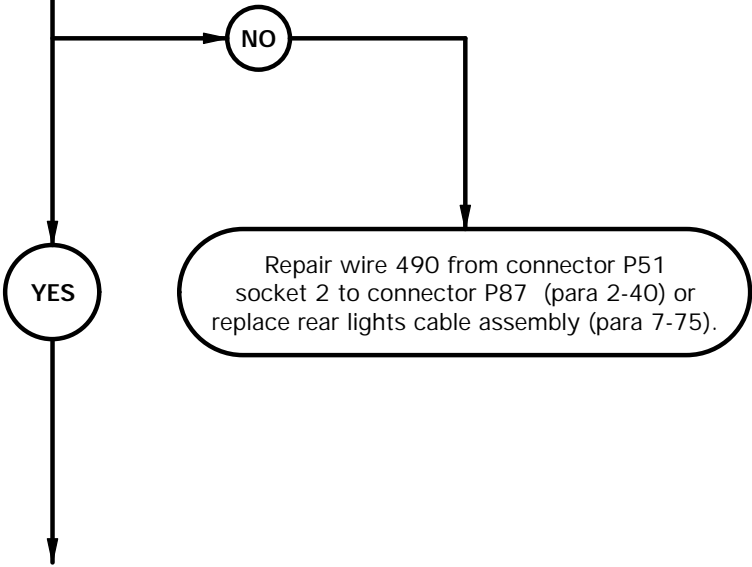

CAUTION

Use care when testing electrical connectors. Do not damage connector pins or sockets with multimeter probes. Failure to comply may result in damage to equipment.

NOTE

Inspect connector pins/sockets for damage, corrosion, and serviceability. Check that connector pins are not pushed back and are capable of making good contact.

CONTINUITY TEST

- (1) Disconnect connector P87 from backup light connector.
- (2) Set multimeter to ohms.
- (3) Connect positive (+) probe of multimeter to connector P51 socket 2.
- (4) Connect negative (-) probe of multimeter to connector P87 and note reading on multimeter.
- (5) If continuity is not present, repair wire 490 from connector P51 socket 2 to connector P87 (para 2-40) or replace rear lights cable assembly (para 7-75).
- (6) Connect connector P87 to backup light connector.
- (7) Connect connector P51 to connector J51.
- (8) Install PDP on dashboard with three screws.
- (9) Install three washers and screws in PDP.

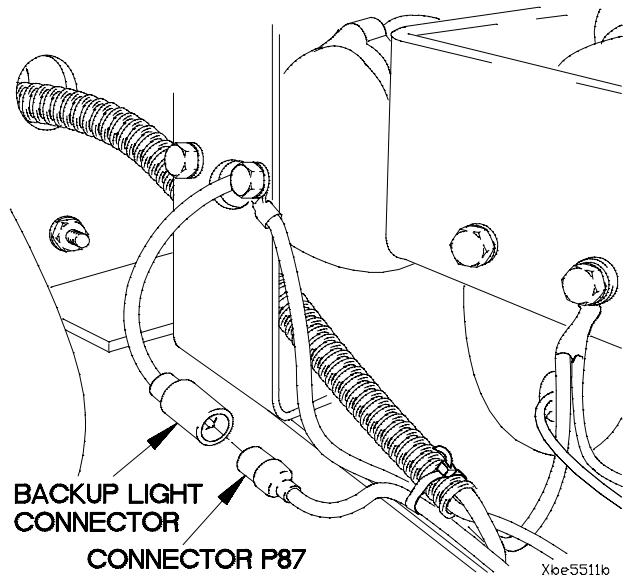
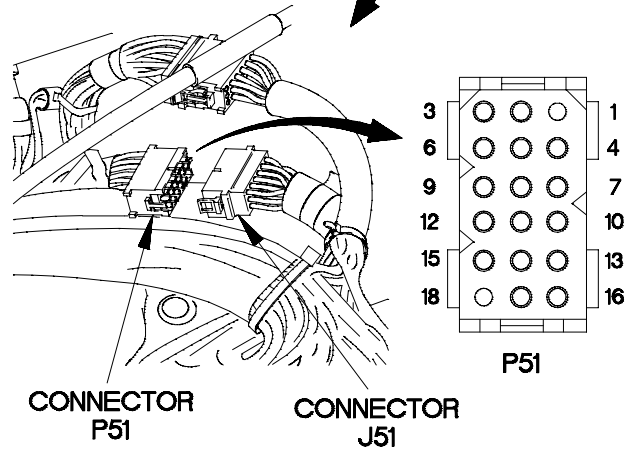
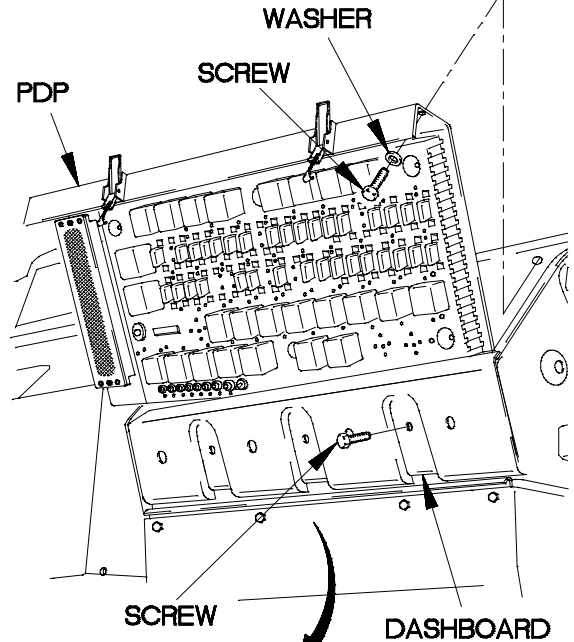

X6e5511b

e53. BACKUP LIGHT DOES NOT ILLUMINATE (CONT)

KNOWN INFO
Circuit breaker CB70 OK. Circuit breaker CB73 OK. Both turn signals illuminate. Engine starts. Transmission reverse (R) range OK. Backup light lamps OK. Backup light assembly OK. WTEC II transmission controls. WTEC II cab transmission harness OK. WTEC II dashboard cable assembly OK. Rear lights cable assembly OK.
POSSIBLE PROBLEMS
Faulty REVERSE WARNING relay in WTEC II VIM. Faulty WTEC II transmission ECU pushbutton shift selector.

11.
 Do backup lights operate with new REVERSE WARNING relay installed in WTEC II VIM?

TEST OPTIONS
REVERSE WARNING Relay Replacement Test
REASON FOR QUESTION
If backup lights operate with new REVERSE WARNING relay installed, REVERSE WARNING relay is faulty. If backup lights do not operate with new REVERSE WARNING relay installed, WTEC II TEPSS is faulty.

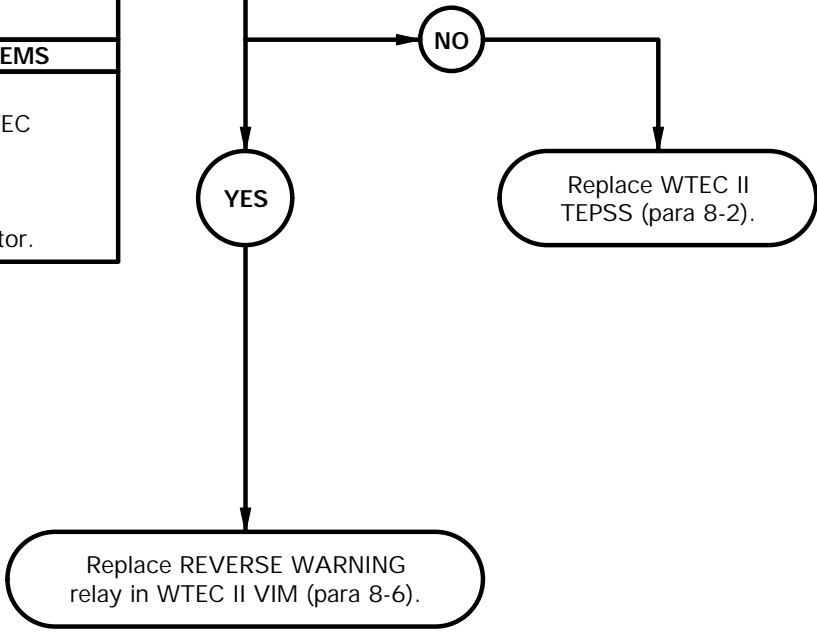

- (1) Replace REVERSE WARNING relay in WTEC II VIM (para 8-6).
- (2) Start engine (TM 9-2320-365-10).
- (3) Position main light switch to SER DRIVE (TM 9-2320-365-10).
- (4) Select R (reverse) on WTEC II TEPSS (TM 9-2320-365-10).
- (5) Check to see if backup lights operate.
- (6) Select N (neutral) on WTEC II TEPSS (TM 9-2320-365-10).
- (7) Position main light switch to OFF (TM 9-2320-365-10).
- (8) Shut down engine (TM 9-2320-365-10).
- (9) If backup lights do not operate, install old REVERSE WARNING relay WTEC II VIM (para 8-6) and replace WTEC II TEPSS (para 8-2).

e53. BACKUP LIGHT DOES NOT ILLUMINATE (CONT)

KNOWN INFO
Circuit breaker CB70 OK. Circuit breaker CB73 OK. Both turn signals illuminate. Engine starts. Transmission reverse (R) range OK. Backup light lamps OK. Backup light assembly OK. WTEC III transmission controls.
POSSIBLE PROBLEMS
Faulty WTEC III relay K25. Faulty WTEC III dashboard cable assembly. Faulty rear lights cable assembly. Faulty WTEC III transmission ECU.

12.
Is continuity present from WTEC III relay K25 terminal 86 to terminal 85?

TEST OPTIONS
Continuity Test or STE/ICE-R Test #91
REASON FOR QUESTION
If continuity is not present, WTEC III relay K25 if faulty.

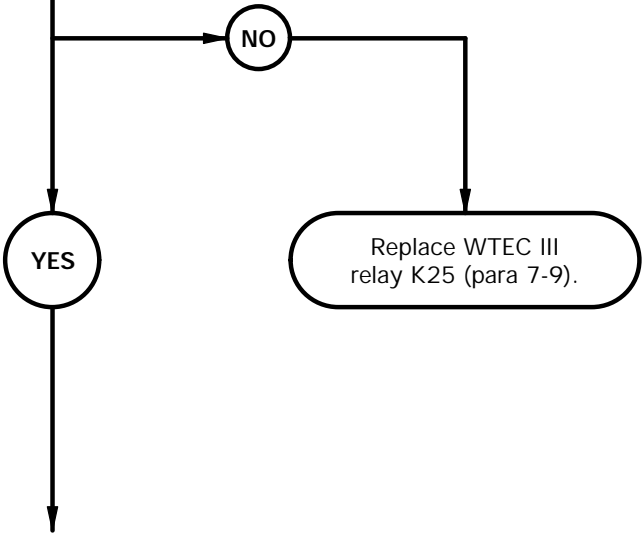

CONTINUITY TEST

- (1) Remove WTEC III relay K25 from PDP.
- (2) Set multimeter to ohms.
- (3) Connect positive (+) probe of multimeter to WTEC III relay K25 terminal 86.
- (4) Connect negative (-) probe of multimeter to WTEC III relay K25 terminal 85 and note reading on multimeter.
- (5) If continuity is not present, replace WTEC III relay K25 (para 7-9).

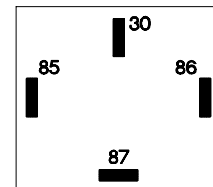
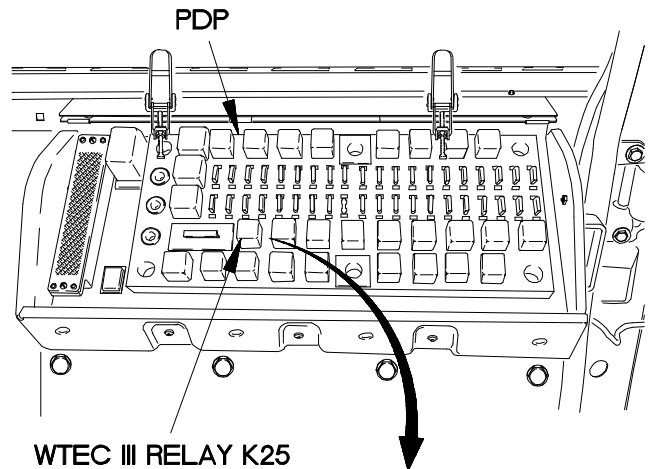

**WTEC III
RELAY K25**

Xbe5513B

e53. BACKUP LIGHT DOES NOT ILLUMINATE (CONT)

KNOWN INFO
Circuit breaker CB70 OK. Circuit breaker CB73 OK. Both turn signals illuminate. Engine starts. Transmission reverse (R) range OK. Backup light lamps OK. Backup light assembly OK. WTEC III transmission controls.
POSSIBLE PROBLEMS
Faulty WTEC III relay K25. Faulty WTEC III dashboard cable assembly. Faulty rear lights cable assembly. Faulty WTEC III transmission ECU.

13. **WARNING**
Read **WARNING** on following page.

Is 12 VDC present at WTEC III relay K25 terminal 30?

TEST OPTIONS
Voltage Test or STE/ICE-R Test #89
REASON FOR QUESTION
If 12 VDC is not present, wire 1903 is faulty.

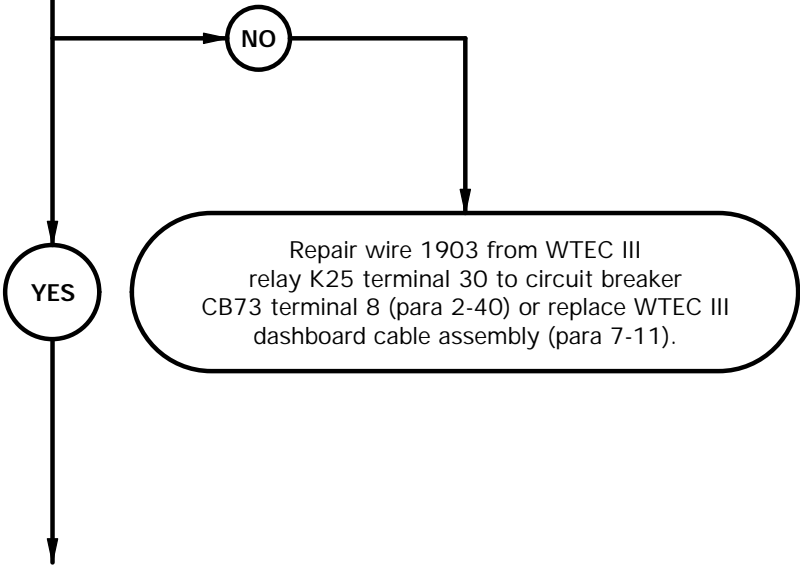

WARNING

Remove rings, bracelets, watches, necklaces, and any other jewelry before working around vehicle. Jewelry can catch on equipment and cause injury or short across electrical circuits and cause severe burns or electrical shock.

VOLTAGE TEST

- (1) Set multimeter to volts DC.
- (2) Connect positive (+) probe of multimeter to PDP, where WTEC III relay K25 terminal 30 was removed.
- (5) Connect negative (-) probe of multimeter to ground.
- (6) Position main light switch to SER DRIVE (TM 9-2320-365-10) and note reading on multimeter.
- (7) If 12 VDC is not present, repair wire 1903 from WTEC III relay K25 terminal 30 to circuit breaker CB73 terminal 8 (para 2-40) or replace WTEC III dashboard cable assembly (para 7-11).
- (8) Position main light switch to OFF (TM 9-2320-365-10).

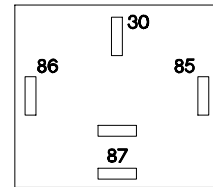
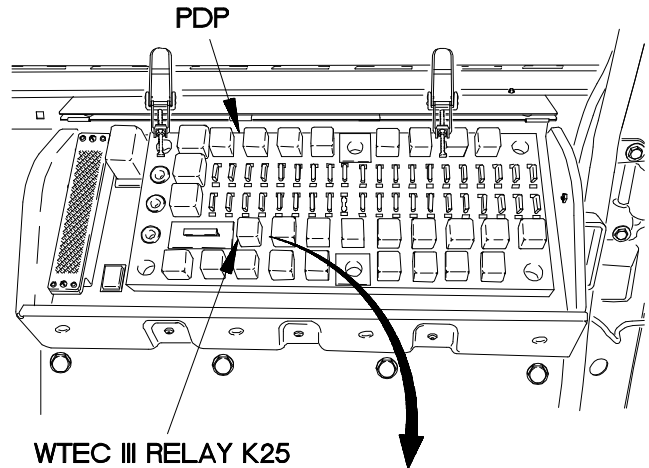

**WTEC III
RELAY K25
CAVITY**

Xbe5514B

e53. BACKUP LIGHT DOES NOT ILLUMINATE (CONT)

KNOWN INFO
Circuit breaker CB70 OK. Circuit breaker CB73 OK. Both turn signals illuminate. Engine starts. Transmission reverse (R) range OK. Backup light lamps OK. Backup light assembly OK. WTEC III transmission controls.
POSSIBLE PROBLEMS
Faulty WTEC III relay K25. Faulty WTEC III dashboard cable assembly. Faulty rear lights cable assembly. Faulty WTEC III transmission ECU.

14.
 Is continuity present from WTEC III relay K34 terminal 86 to WTEC III relay K25 terminal 86?

TEST OPTIONS
Continuity Test or STE/ICE-R Test #91
REASON FOR QUESTION
If continuity is not present, wire 146 is faulty.

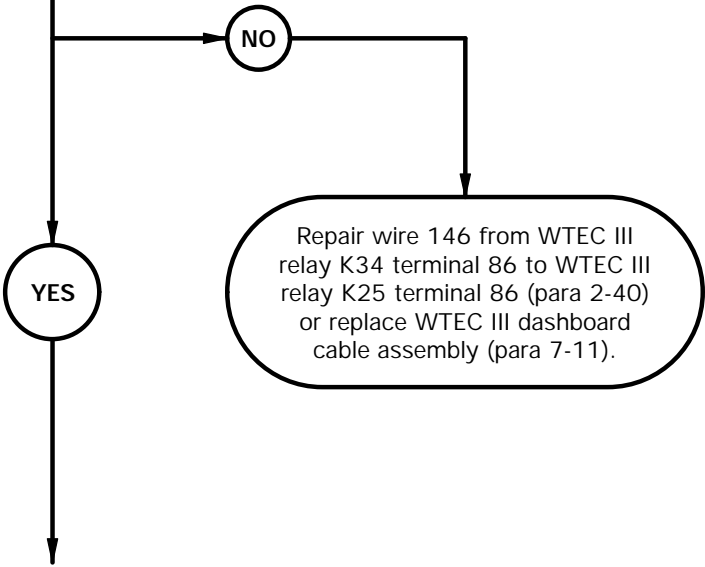

CONTINUITY TEST

- (1) Remove WTEC III relay K34 from PDP.
- (2) Set multimeter to ohms.
- (3) Connect positive (+) probe of multimeter to PDP, where WTEC III relay K34 terminal 86 was removed.
- (4) Connect negative (-) probe of multimeter to PDP, where WTEC III relay K25 terminal 86 was removed, and note reading on multimeter.
- (5) If continuity is not present, repair wire 146 from WTEC III relay K34 terminal 86 to WTEC III relay K25 terminal 86 (para 2-40) or replace WTEC III dashboard cable assembly (para 7-11).
- (6) Install WTEC III relay K34 on PDP.

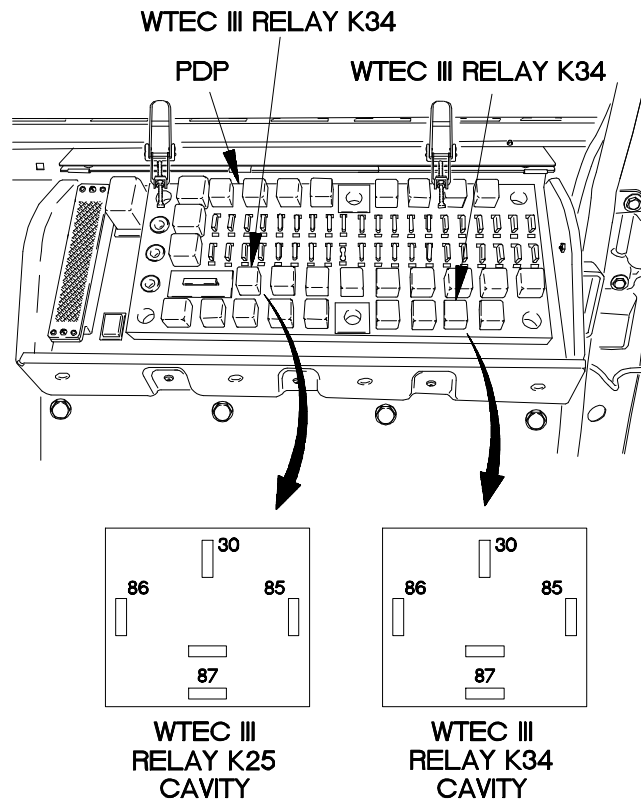

Xbe5515B

e53. BACKUP LIGHT DOES NOT ILLUMINATE (CONT)

KNOWN INFO
Circuit breaker CB70 OK. Circuit breaker CB73 OK. Both turn signals illuminate. Engine starts. Transmission reverse (R) range OK. Backup light lamps OK. Backup light assembly OK. WTEC III transmission controls.
POSSIBLE PROBLEMS
Faulty WTEC III relay K25. Faulty WTEC III dashboard cable assembly. Faulty rear lights cable assembly. Faulty WTEC III transmission ECU.

15. **CAUTION**
Read CAUTION on following page.

Is continuity present from WTEC III relay K25 terminal 85 to connector P115 socket 4?

TEST OPTIONS
Continuity Test or STE/ICE-R Test #91
REASON FOR QUESTION
If continuity is not present, wire 113 is faulty.

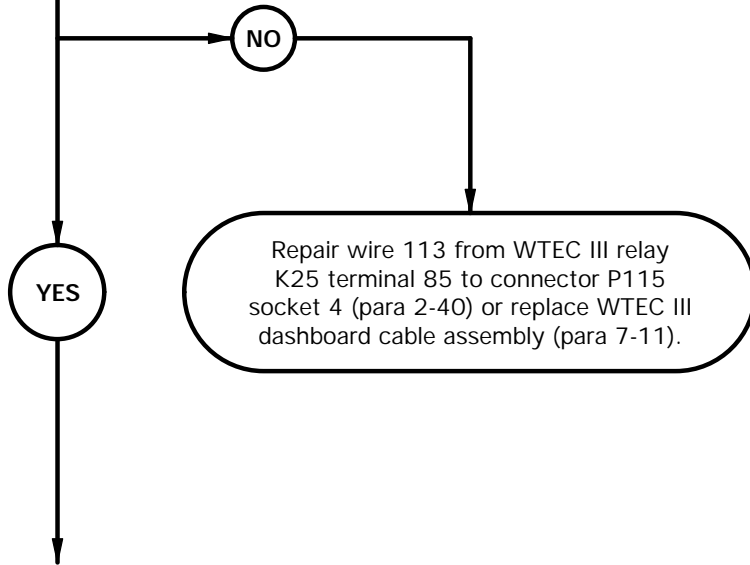

CAUTION

Use care when testing electrical connectors. Do not damage connector pins or sockets with multimeter probes. Failure to comply may result in damage to equipment.

NOTE

Inspect connector pins/sockets for damage, corrosion, and serviceability. Check that connector pins are not pushed back and are capable of making good contact.

CONTINUITY TEST

- (1) Remove kick panel (para 16-3).
- (2) Disconnect connector clamp from connector P115.
- (3) Disconnect connector P115 from WTEC III transmission ECU.
- (4) Set multimeter to ohms.
- (5) Connect positive (+) probe of multimeter to PDP, where WTEC III relay K25 terminal 85 was removed.
- (6) Connect negative (-) probe of multimeter to connector P115 socket 4 and note reading on multimeter.
- (7) If continuity is not present, repair wire 113 from WTEC III relay K25 terminal 85 to connector P115 socket 4 (para 2-40) or replace WTEC III dashboard cable assembly (para 7-11).
- (8) Connect connector P115 to WTEC III transmission ECU.
- (9) Connect connector clamp to connector P115.

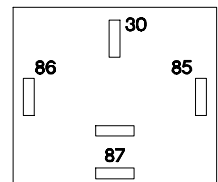
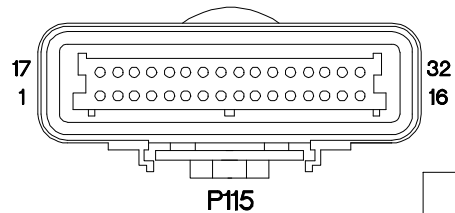
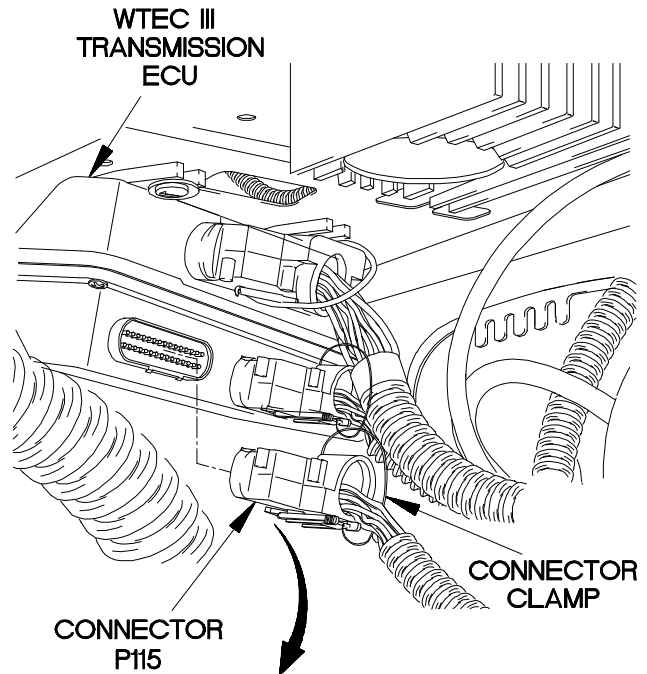

**WTEC III RELAY
K25 CAVITY**

Xbe5516b

e53. BACKUP LIGHT DOES NOT ILLUMINATE (CONT)

KNOWN INFO
Circuit breaker CB70 OK. Circuit breaker CB73 OK. Both turn signals illuminate. Engine starts. Transmission reverse (R) range OK. Backup light lamps OK. Backup light assembly OK. WTEC III transmission controls.
POSSIBLE PROBLEMS
Faulty WTEC III relay K25. Faulty WTEC III dashboard cable assembly. Faulty rear lights cable assembly. Faulty WTEC III transmission ECU.

16. **CAUTION**
Read CAUTION on following page.

Is continuity present from WTEC III relay K25 terminal 87 to connector J51 pin 2?

TEST OPTIONS
Continuity Test or STE/ICE-R Test #91
REASON FOR QUESTION
If continuity is not present, wire 490 is faulty.

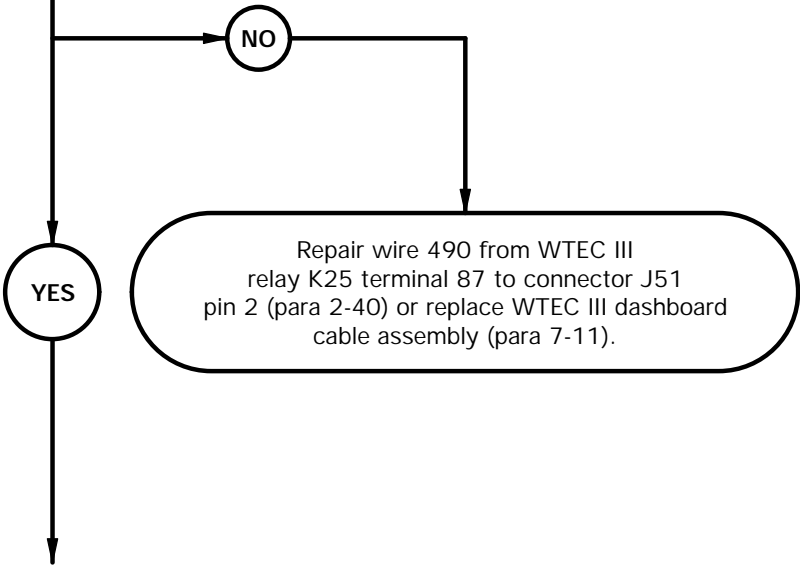

CAUTION

Use care when testing electrical connectors. Do not damage connector pins or sockets with multimeter probes. Failure to comply may result in damage to equipment.

NOTE

Inspect connector pins/sockets for damage, corrosion, and serviceability. Check that connector pins are not pushed back and are capable of making good contact.

CONTINUITY TEST

- (1) Remove three screws from PDP.
- (2) Remove three screws and washers from PDP.
- (3) Lift PDP outward to gain access.
- (4) Disconnect connector P51 from connector J51.
- (5) Set multimeter to ohms.
- (6) Connect positive (+) probe of multimeter to PDP, where WTEC III relay K25 terminal 87 was removed.
- (7) Connect negative (-) probe of multimeter to connector J51 pin 2 and note reading on multimeter.
- (8) If continuity is not present, repair wire 490 from WTEC III relay K25 terminal 87 to connector J51 pin 2 (para 2-40) or replace WTEC III dashboard cable assembly (para 7-11).

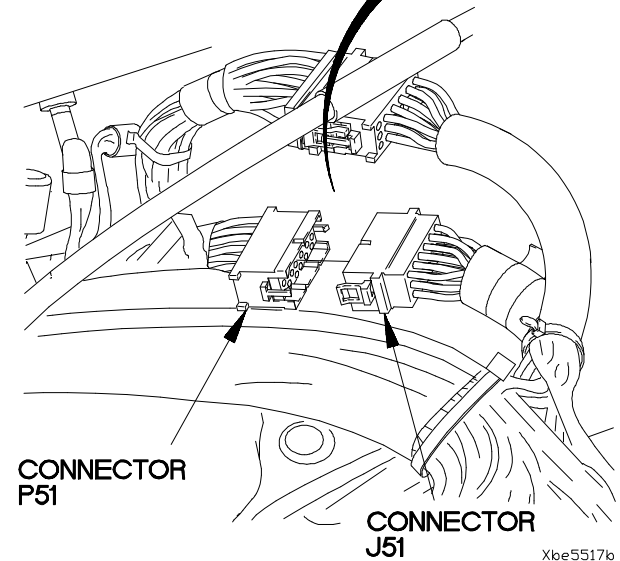
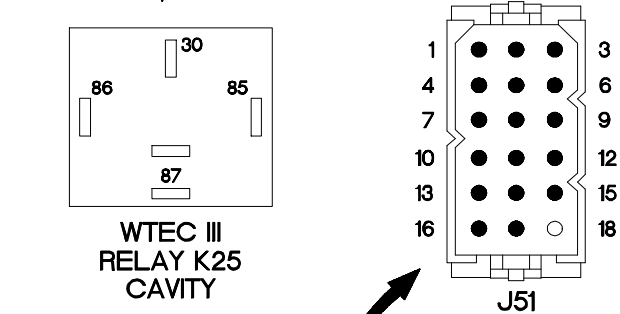
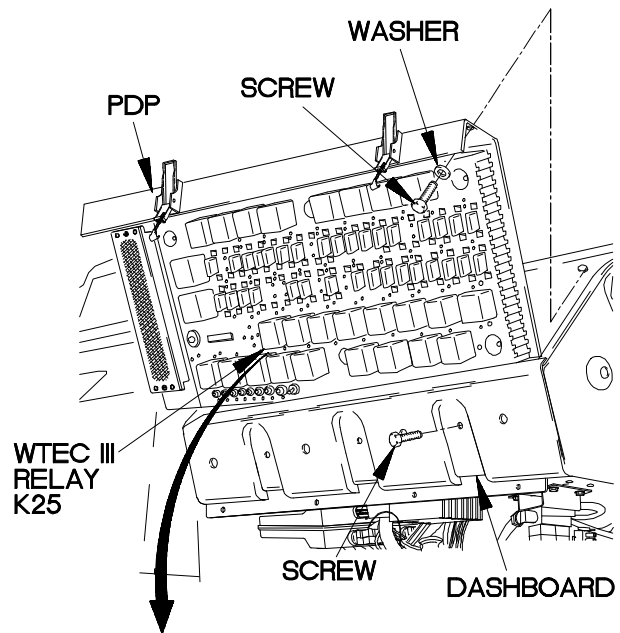

Xbe5517b

e53. BACKUP LIGHT DOES NOT ILLUMINATE (CONT)

KNOWN INFO
Circuit breaker CB70 OK. Circuit breaker CB73 OK. Both turn signals illuminate. Engine starts. Transmission reverse (R) range OK. Backup light lamps OK. Backup light assembly OK. WTEC III transmission controls. WTEC III dashboard cable assembly OK.
POSSIBLE PROBLEMS
Faulty rear lights cable assembly. Faulty WTEC III relay K25. Faulty WTEC III transmission ECU.

17. **CAUTION**
Read CAUTION on following page.

Is continuity present from connector P51 socket 2 to connector P87?

TEST OPTIONS
Continuity Test or STE/ICE-R Test #91
REASON FOR QUESTION
If continuity is not present, wire 490 is faulty.

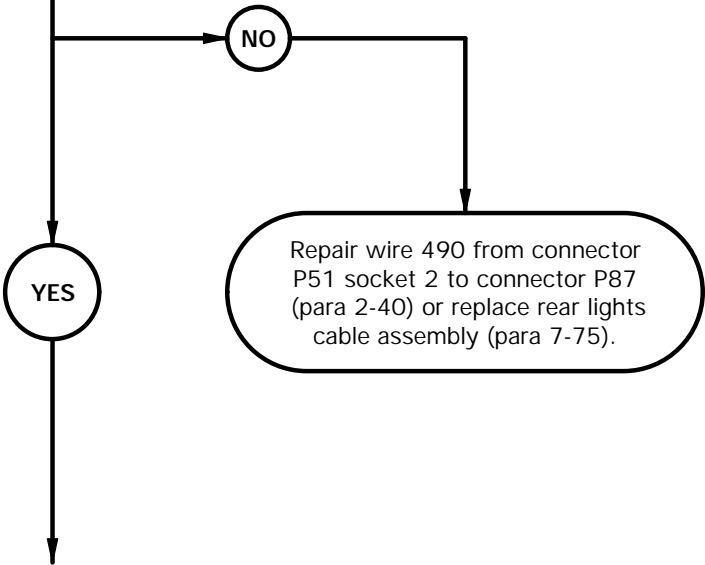

CAUTION

Use care when testing electrical connectors. Do not damage connector pins or sockets with multimeter probes. Failure to comply may result in damage to equipment.

NOTE

Inspect connector pins/sockets for damage, corrosion, and serviceability. Check that connector pins are not pushed back and are capable of making good contact.

CONTINUITY TEST

- (1) Disconnect connector P87 from backup light connector.
- (2) Set multimeter to ohms.
- (3) Connect positive (+) probe of multimeter to connector P51 socket 2.
- (4) Connect negative (-) probe of multimeter to connector P87 and note reading on multimeter.
- (5) If continuity is not present, repair wire 490 from connector P51 socket 2 to connector P87 (para 2-40) or replace rear lights cable assembly (para 7-75).
- (6) Connect connector P87 to backup light connector.
- (7) Connect connector P51 to connector J51.
- (8) Install PDP on dashboard with three screws.
- (9) Install three washers and screws in PDP.

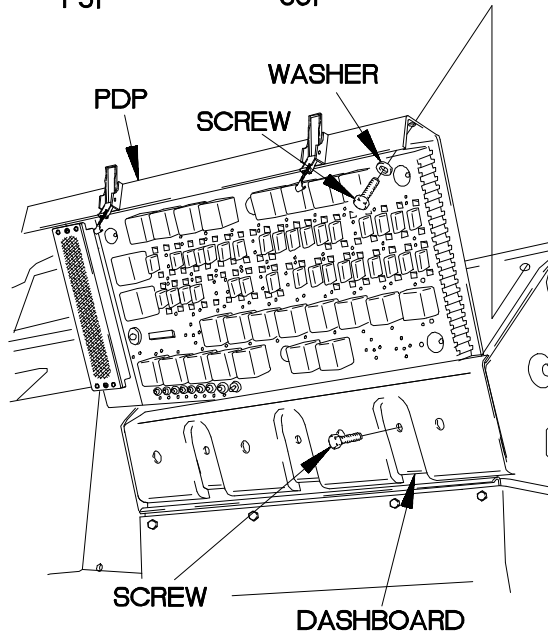
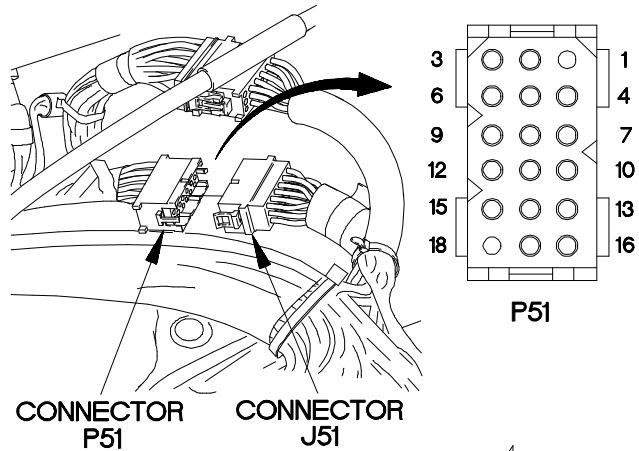
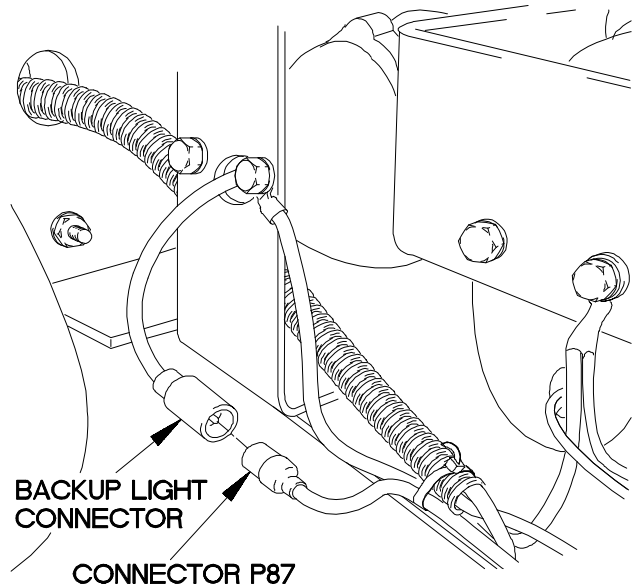

Xbe55186

e53. BACKUP LIGHT DOES NOT ILLUMINATE (CONT)

KNOWN INFO
Circuit breaker CB70 OK. Circuit breaker CB73 OK. Both turn signals illuminate. Engine starts. Transmission reverse (R) range OK. Backup light lamps OK. Backup light assembly OK. WTEC III transmission controls. WTEC III dashboard cable assembly OK. Rear lights cable assembly OK.
POSSIBLE PROBLEMS
Faulty WTEC III relay K25. Faulty WTEC III transmission ECU.

18.
 Do backup lights operate with new WTEC III relay K25 installed?

TEST OPTIONS
WTEC III Relay K25 Replacement Test
REASON FOR QUESTION
If backup lights operate with new WTEC III relay K25 installed, WTEC III relay K25 is faulty. If backup lights do not operate with new WTEC III relay K25 installed, WTEC III transmission ECU is faulty.

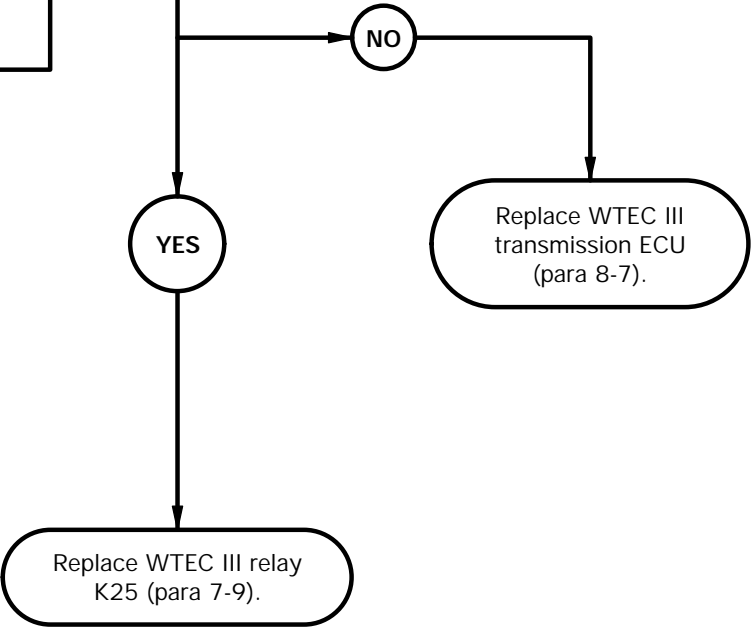

- (1) Install new WTEC III relay K25 on PDP.
- (2) Start engine (TM 9-2320-365-10).
- (3) Position main light switch to SER DRIVE (TM 9-2320-365-10).
- (4) Select R (reverse) on WTEC III TPSS (TM 9-2320-365-10).
- (5) Check to see if backup lights operate.
- (6) Select N (neutral) on WTEC III TPSS (TM 9-2320-365-10).
- (7) Position main light switch to OFF (TM 9-2320-365-10).
- (8) Shut down engine (TM 9-2320-365-10).
- (9) Remove new WTEC III relay K25 from PDP.
- (10) Install old WTEC III relay K25 on PDP.
- (11) If backup lights operate, replace WTEC III relay K25 (para 7-9).
- (12) If backup lights do not operate, replace WTEC III transmission ECU (para 8-7).
- (13) Install kick panel (para 16-3).

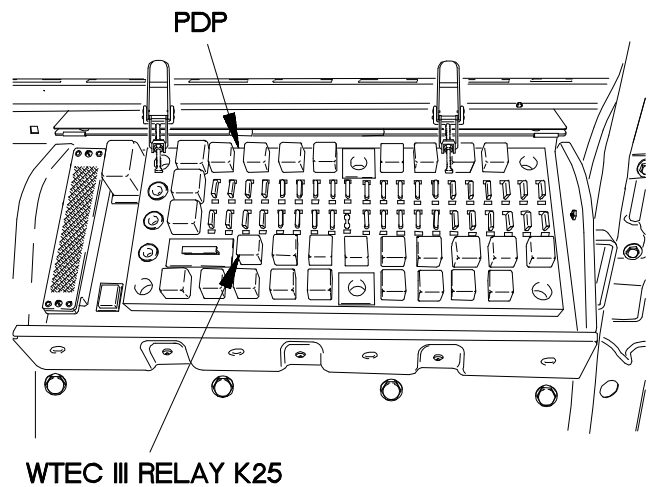

Xbe5519b

e54. BLACKOUT MARKER LIGHTS DO NOT ILLUMINATE	
INITIAL SETUP	
Equipment Conditions Engine shut down (TM 9-2320-365-10).	Tools and Special Tools Tool Kit, Genl Mech (Item 44, Appendix C) STE/ICE-R (Item 39, Appendix C) Multimeter, Digital (Item 22, Appendix C)
Personnel Required (2)	References TM 9-4910-571-12&P

NOTE

Perform Electrical System Troubleshooting e1. Circuit Breaker Does Not Operate on circuit breaker CB66 prior to beginning this task.

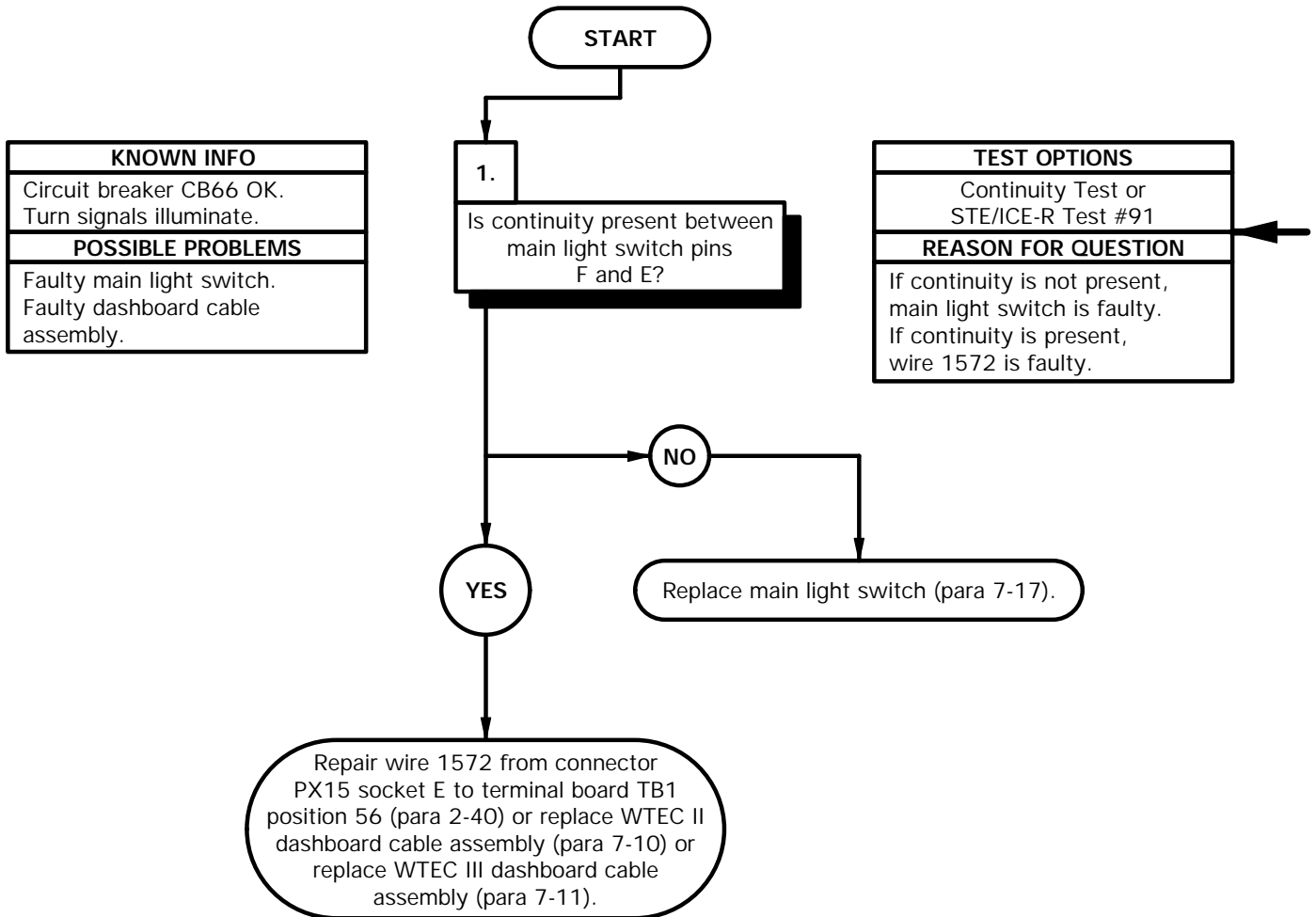

NOTE

Inspect connector pins/sockets for damage, corrosion, and serviceability. Check that connector pins are not pushed back and are capable of making good contact.

CONTINUITY TEST

- (1) Remove instrument panel assembly for access(para 7-15).
- (2) Disconnect connector PX15 from main light switch.
- (3) Set multimeter to ohms.
- (4) Connect positive (+) probe of multimeter to main light switch pin F.
- (5) Connect negative (-) probe of multimeter to main light switch pin E.
- (6) Position main light switch to BO MARKER (TM 9-2320-365-10) and note reading on multimeter.
- (7) If continuity is not present, replace main light switch connector (para 7-17).
- (8) If continuity is present, repair wire 1572 from connector PX15 socket E to terminal board TB1 position 56 (para 2-40) or replace WTEC II dashboard cable assembly (para 7-10) or replace WTEC III dashboard cable assembly (para 7-11).
- (9) Position main light switch to OFF (TM 9-2320-365-10).
- (10) Connect connector PX15 to main light switch.
- (11) Install instrument panel assembly (para 7-15).

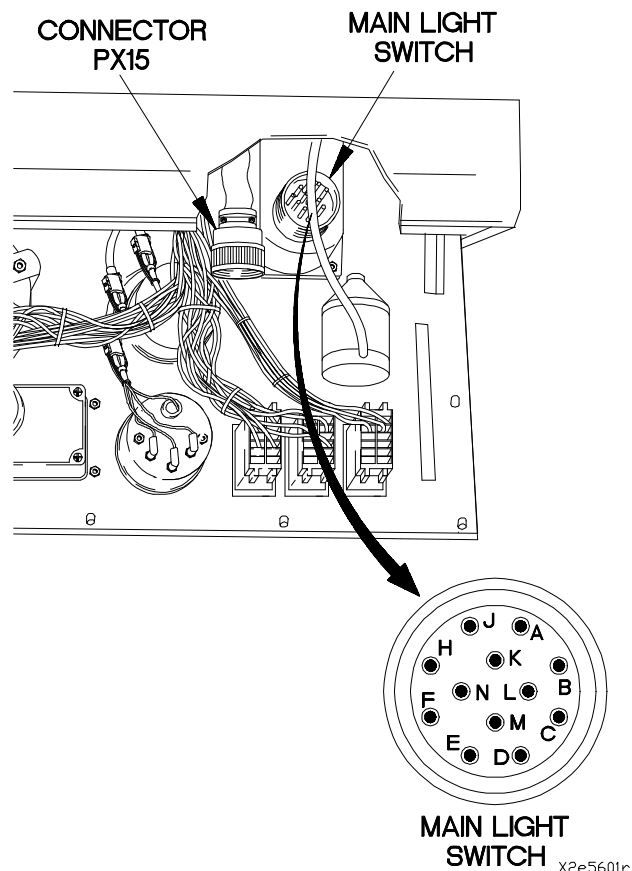

e54A. FRONT HAZARD LIGHTS DO NOT ILLUMINATE

INITIAL SETUP

Equipment Conditions

Engine shut down (TM 9-2320-365-10).

Personnel Required

(2)

Tools and Special Tools

Tool Kit, Genl Mech (Item 44, Appendix C)
 STE/ICE-R (Item 39, Appendix C)
 Multimeter, Digital (Item 22, Appendix C)

References

TM 9-4910-571-12&P

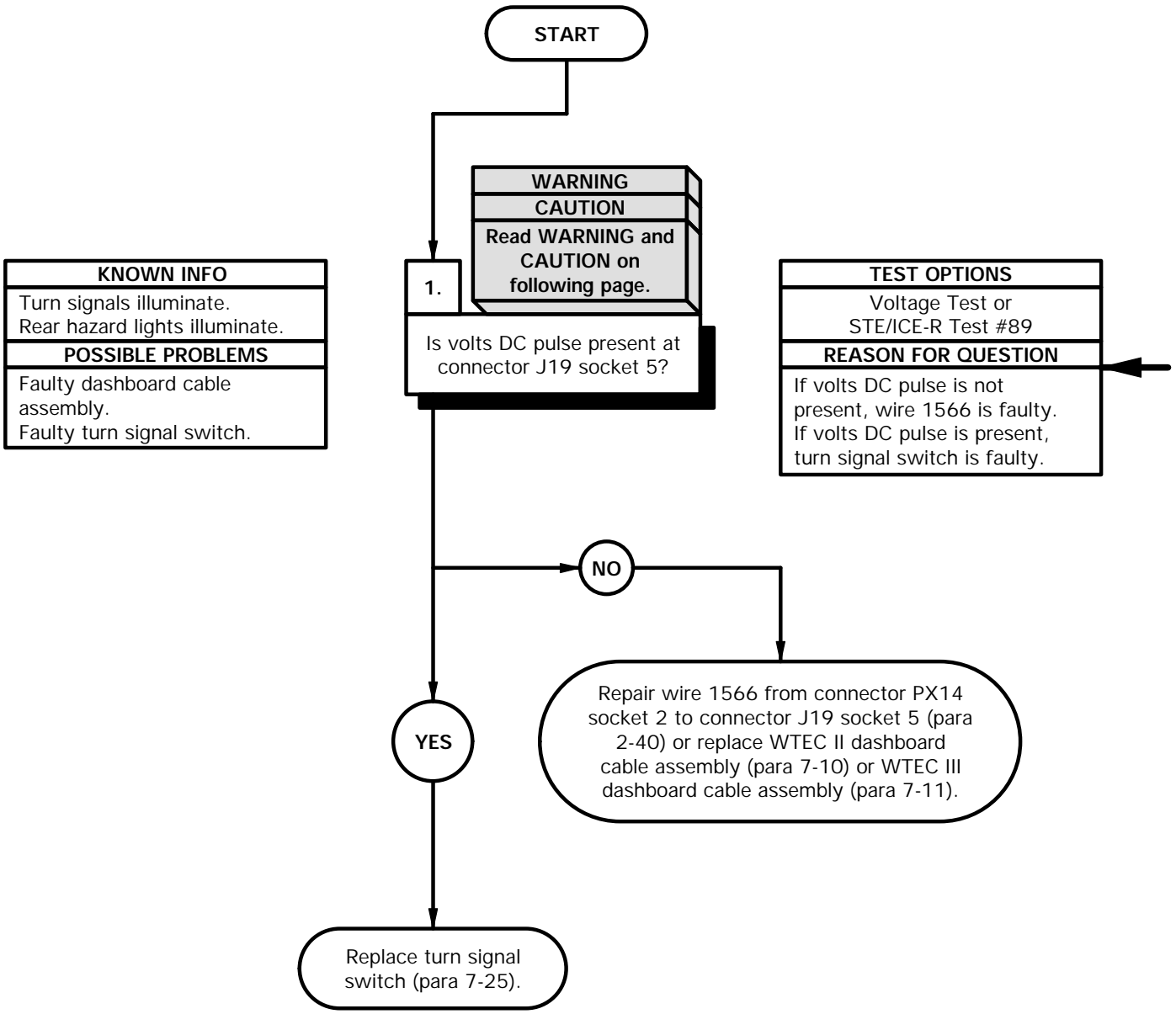

WARNING

Remove rings, bracelets, watches, necklaces, and any other jewelry before working around vehicle. Jewelry can catch on equipment and cause injury or short across electrical circuits and cause severe burns or electrical shock.

CAUTION

Use care when testing electrical connectors. Do not damage connector pins or sockets with multimeter probes. Failure to comply may result in damage to equipment.

NOTE

Inspect connector pins/sockets for damage, corrosion, and serviceability. Check that connector pins are not pushed back and are capable of making good contact.

VOLTAGE TEST

- (1) Remove instrument panel assembly for access (para 7-15).
- (2) Disconnect connector J19 from turn signal switch connector.
- (3) Set multimeter to volts DC.
- (4) Connect positive (+) probe of multimeter to connector J19 socket 5.
- (5) Connect negative (-) probe of multimeter to ground.
- (6) Position main light switch to SER DRIVE (TM 9-2320-365-10).
- (7) Position hazard lights switch to on (TM 9-2320-365-10) and note reading on multimeter.
- (8) If volts DC pulse is not present, Repair wire 1566 from connector PX14 socket 2 to connector J19 socket 5 (para 2-40) or replace WTEC II dashboard cable assembly (para 7-10) or WTEC III dashboard cable assembly (para 7-11).
- (9) If volts DC is present, replace turn signal switch (para 7-25).
- (10) Position hazard lights switch to off (TM 9-2320-365-10).
- (11) Position main light switch to OFF (TM 9-2320-365-10).

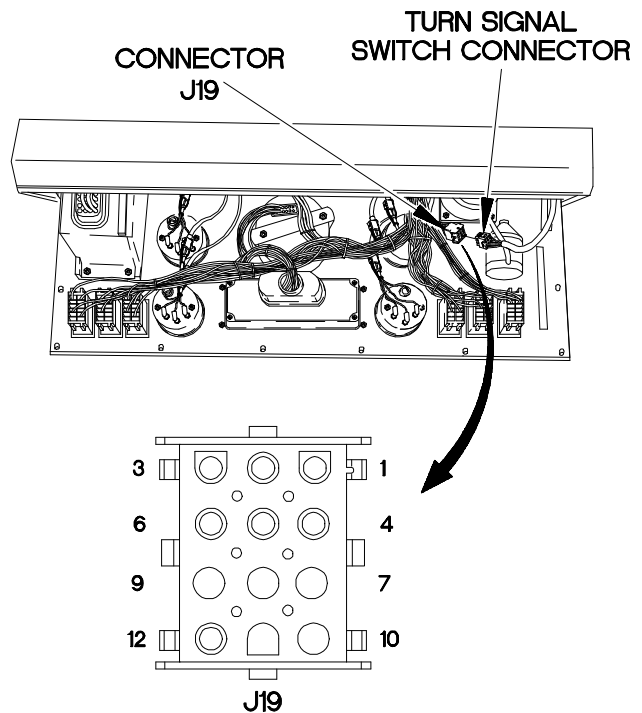

XBE56A01B

e55. REAR HAZARD LIGHTS DO NOT ILLUMINATE

INITIAL SETUP

Equipment Conditions

Engine shut down (TM 9-2320-365-10).

Personnel Required

(2)

Tools and Special Tools

Tool Kit, Genl Mech (Item 44, Appendix C)
 STE/ICE-R (Item 39, Appendix C)
 Multimeter, Digital (Item 22, Appendix C)

References

TM 9-4910-571-12&P

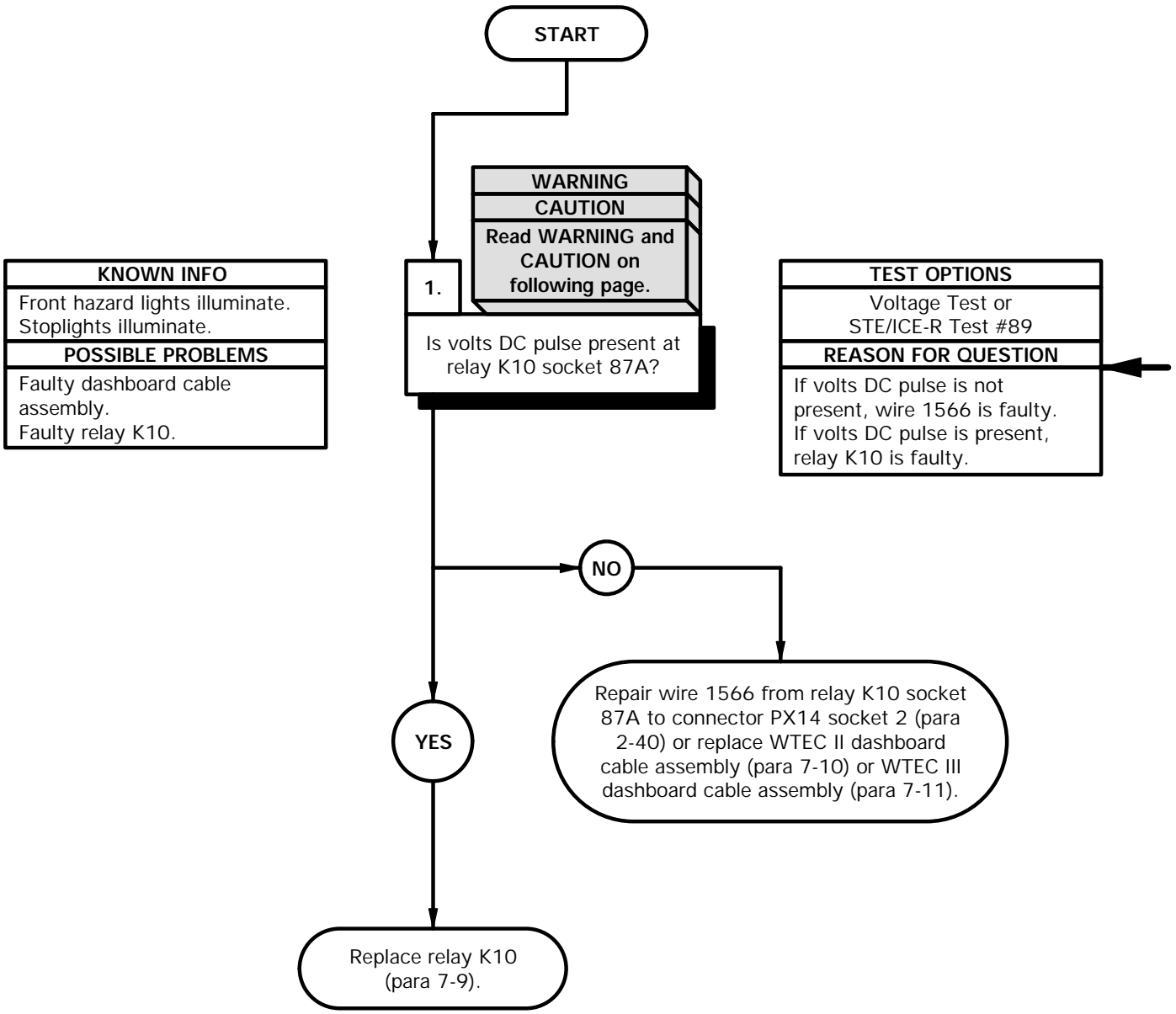

WARNING

Remove rings, bracelets, watches, necklaces, and any other jewelry before working around vehicle. Jewelry can catch on equipment and cause injury or short across electrical circuits and cause severe burns or electrical shock.

CAUTION

Use care when testing electrical connectors. Do not damage connector pins or sockets with multimeter probes. Failure to comply may result in damage to equipment.

NOTE

Inspect connector pins/sockets for damage, corrosion, and serviceability. Check that connector pins are not pushed back and are capable of making good contact.

VOLTAGE TEST

- (1) Remove PDP cover (para 16-2).
- (2) Remove relay K10 from PDP.
- (3) Set multimeter to volts DC.
- (4) Connect positive (+) probe of multimeter to PDP, socket 87A, where relay K10 was removed.
- (5) Connect negative (-) probe of multimeter to ground.
- (6) Position main light switch to SER DRIVE (TM 9-2320-365-10).
- (7) Position hazard lights switch to on (TM 9-2320-365-10) and note reading on multimeter.
- (8) If volts DC pulse is not present, Repair wire 1566 from relay K10 socket 87A to connector PX14 socket 2 (para 2-40) or replace WTEC II dashboard cable assembly (para 7-10) or WTEC III dashboard cable assembly (para 7-11).
- (9) If volts DC is present, replace relay K10 (para 7-9).
- (10) Position hazard lights switch to off (TM 9-2320-366-10-1).
- (11) Position main light switch to OFF (TM 9-2320-366-10-1).
- (12) Install relay K10 in PDP.
- (13) Install PDP cover (para 16-2).

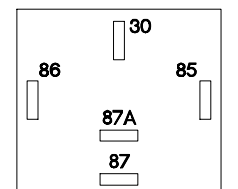
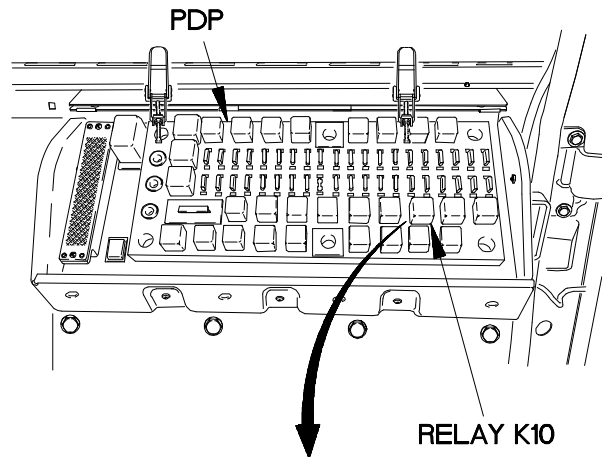

RELAY K10 CAVITY

X2E5701B

e56. FRONT AND REAR HAZARD LIGHTS DO NOT ILLUMINATE

INITIAL SETUP

Equipment Conditions

Engine shut down (TM 9-2320-365-10).

Personnel Required

(2)

Tools and Special Tools

Tool Kit, Genl Mech (Item 44, Appendix C)
 STE/ICE-R (Item 39, Appendix C)
 Multimeter, Digital (Item 22, Appendix C)

References

TM 9-4910-571-12&P

NOTE

Perform Electrical System Troubleshooting e1. Circuit Breaker Does Not Operate on circuit breaker CB71 prior to beginning this task.

KNOWN INFO
Circuit breaker CB71 OK. Turn signals illuminate.
POSSIBLE PROBLEMS
Faulty hazard lights switch. Faulty dashboard cable assembly. Faulty relay K9.

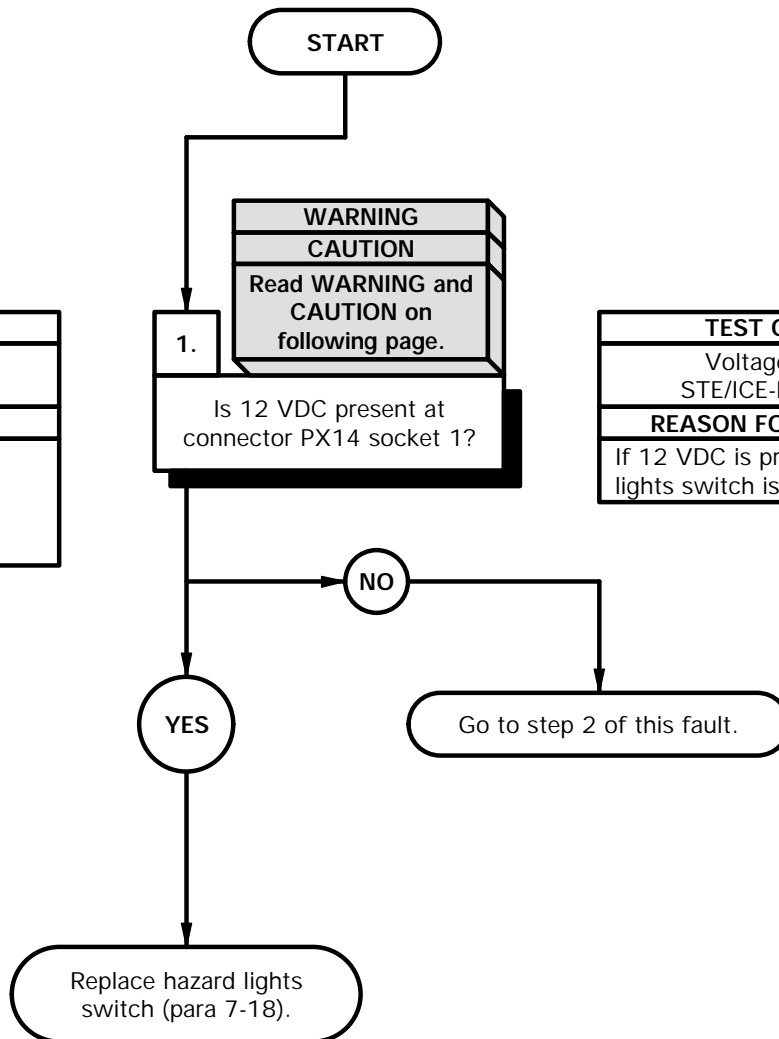

TEST OPTIONS
Voltage Test or STE/ICE-R Test #89
REASON FOR QUESTION
If 12 VDC is present, hazard lights switch is faulty.

WARNING

Remove rings, bracelets, watches, necklaces, and any other jewelry before working around vehicle. Jewelry can catch on equipment and cause injury or short across electrical circuits and cause severe burns or electrical shock.

CAUTION

Use care when testing electrical connectors. Do not damage connector pins or sockets with multimeter probes. Failure to comply may result in damage to equipment.

NOTE

Inspect connector pins/sockets for damage, corrosion, and serviceability. Check that connector pins are not pushed back and are capable of making good contact.

VOLTAGE TEST

- (1) Remove instrument panel assembly for access (para 7-15).
- (2) Disconnect connector PX14 from hazard lights switch.
- (3) Set multimeter to volts DC.
- (4) Connect positive (+) probe of multimeter to connector PX14 socket 1.
- (5) Connect negative (-) probe of multimeter to ground.
- (6) Position main light switch to SER DRIVE (TM 9-2320-365-10) and note reading on multimeter.
- (7) If 12 VDC is not present, go to step 2 of this fault.
- (8) If 12 VDC is present, replace hazard lights switch (para 7-18).
- (9) Position main light switch to OFF (TM 9-2320-365-10).

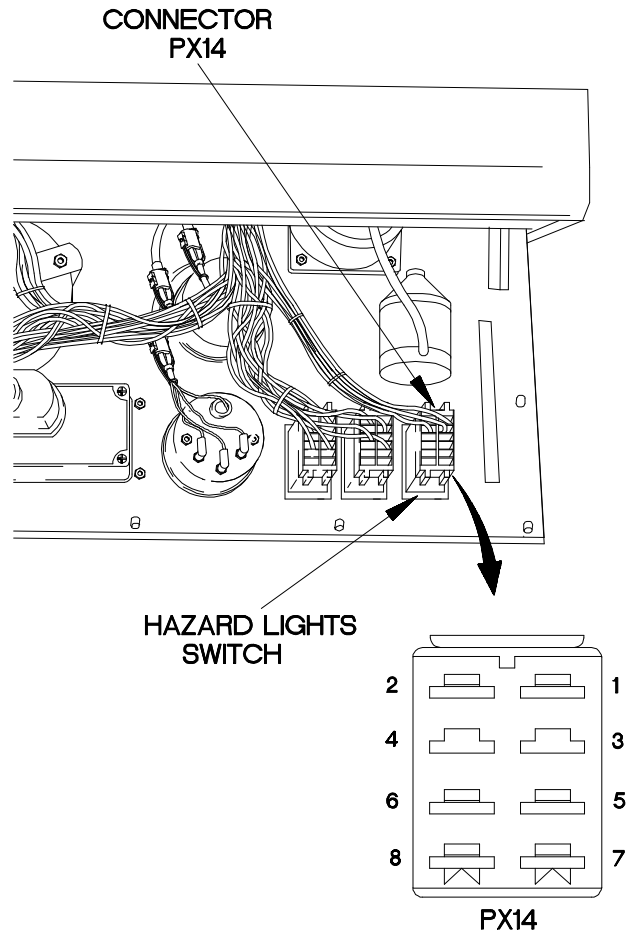

XBE5801B

e56. FRONT AND REAR HAZARD LIGHTS DO NOT ILLUMINATE (CONT)

KNOWN INFO
Circuit breaker CB71 OK. Turn signals illuminate. Hazard lights switch OK.
POSSIBLE PROBLEMS
Faulty dashboard cable assembly. Faulty relay K9.

2. **WARNING**
Read **WARNING** on following page.

Is 12 VDC present at relay K9 terminal 30?

TEST OPTIONS
Voltage Test or STE/ICE-R Test #89
REASON FOR QUESTION
If 12 VDC is not present, wire 1566 is faulty.

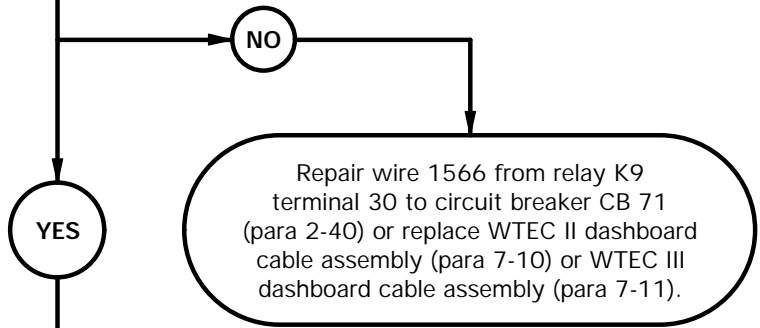

KNOWN INFO
Circuit breaker CB71 OK. Turn signals illuminate. Hazard lights switch OK.
POSSIBLE PROBLEMS
Faulty dashboard cable assembly. Faulty relay K9.

3. **WARNING**
Read **WARNING** on following page.

Is 12 VDC present at relay K9 terminal 86?

TEST OPTIONS
Voltage Test or STE/ICE-R Test #89
REASON FOR QUESTION
If 12 VDC is not present, wire 1514 is faulty.

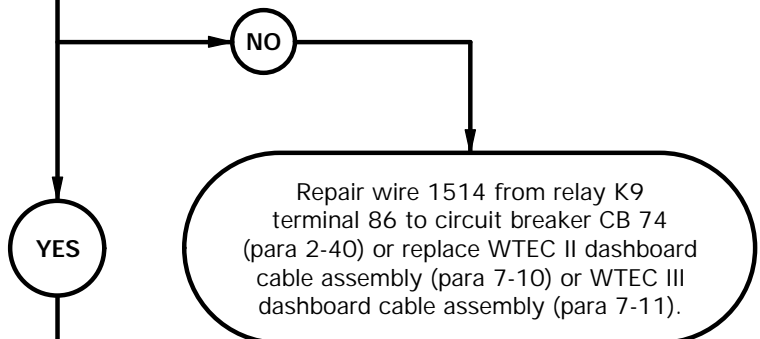

WARNING

Remove rings, bracelets, watches, necklaces, and any other jewelry before working around vehicle. Jewelry can catch on equipment and cause injury or short across electrical circuits and cause severe burns or electrical shock.

VOLTAGE TEST

- (1) Remove PDP cover (para 16-2).
- (2) Remove circuit breaker CB71 from PDP.
- (3) Remove relay K9 from PDP.
- (4) Set multimeter to volts DC.
- (5) Connect positive (+) probe of multimeter to PDP, terminal 30, where relay K9 was removed.
- (6) Connect negative (-) probe of multimeter to ground.
- (7) Install circuit breaker CB71 in PDP and note reading on multimeter.
- (8) If 12 VDC is not present, repair wire 1566 from relay K9 terminal 30 to circuit breaker CB 71 (para 2-40) or replace WTEC II dashboard cable assembly (para 7-10) or WTEC III dashboard cable assembly (para 7-11).

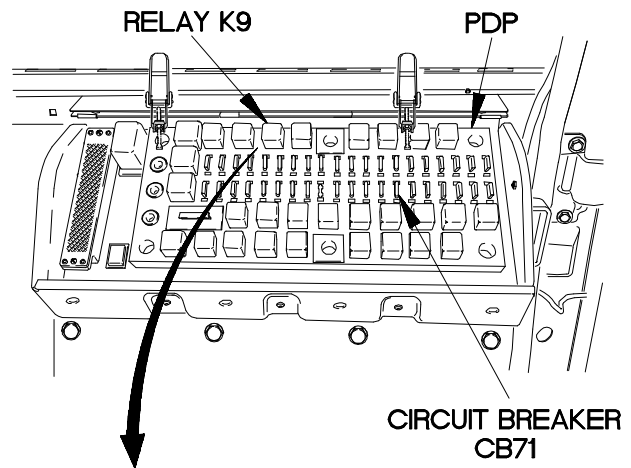

VOLTAGE TEST

- (1) Set multimeter to volts DC.
- (2) Connect positive (+) probe of multimeter to PDP, terminal 86, where relay K9 was removed.
- (3) Connect negative (-) probe of multimeter to ground.
- (4) Position main light switch to SER DRIVE (TM 9-2320-365-10) and not reading on multimeter.
- (5) If 12 VDC is not present, repair wire 1514 from relay K9 terminal 86 to circuit breaker CB74 (para 2-40) or replace WTEC II dashboard cable assembly (para 7-10) or WTEC III dashboard cable assembly (para 7-11).
- (6) Position main light switch to OFF (TM 9-2320-365-10).

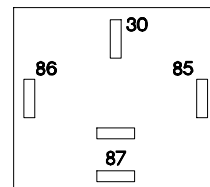

RELAY K9 CAVITY

XBE5802B

e56. FRONT AND REAR HAZARD LIGHTS DO NOT ILLUMINATE (CONT)

KNOWN INFO
Circuit breaker CB71 OK. Turn signals illuminate. Hazard lights switch OK.
POSSIBLE PROBLEMS
Faulty dashboard cable assembly. Faulty relay K9.

KNOWN INFO
Circuit breaker CB71 OK. Turn signals illuminate. Hazard lights switch OK.
POSSIBLE PROBLEMS
Faulty dashboard cable assembly. Faulty relay K9.

4.
Is continuity present between relay K9 terminal 85 and a known good ground?

TEST OPTIONS
Continuity Test or STE/ICE-R Test #91
REASON FOR QUESTION
If continuity is not present, wire 3039 is faulty.

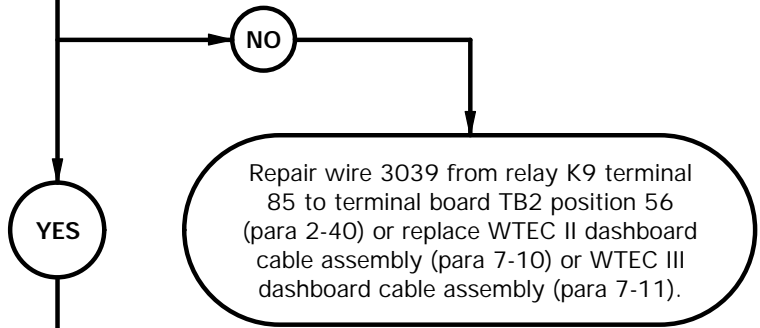

5.
Is continuity present between relay K9 terminal 87 and connector PX14 socket 2?

TEST OPTIONS
Continuity Test or STE/ICE-R Test #91
REASON FOR QUESTION
If continuity is not present, wire 1565 is faulty. If continuity is present, relay K9 is faulty.

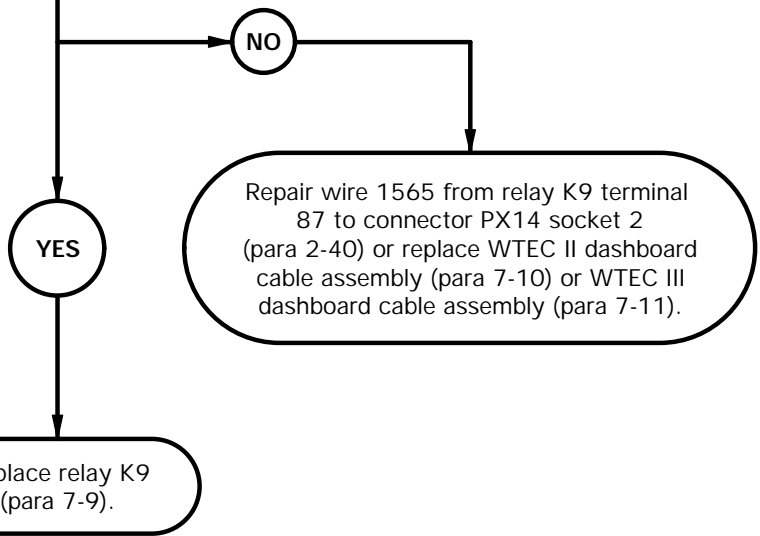

CAUTION
Read CAUTION on following page.

CONTINUITY TEST

- (1) Set multimeter to ohms.
- (2) Connect positive (+) probe of multimeter to PDP, terminal 85, where relay K9 was removed.
- (3) Connect negative (-) probe of multimeter to ground and note reading on multimeter.
- (4) If continuity is not present, repair wire 1565 from relay K9 terminal 85 to terminal board TB2 position 56 (para 2-40) or replace WTEC II dashboard cable assembly (para 7-10) or WTEC III dashboard cable assembly (para 7-11).

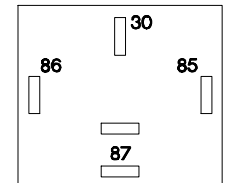
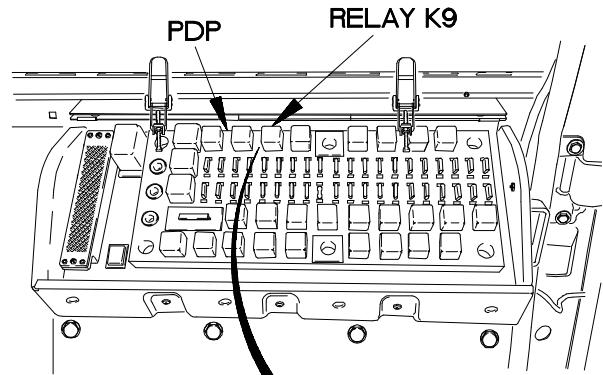

RELAY K9 CAVITY

CAUTION

Use care when testing electrical connectors. Do not damage connector pins or sockets with multimeter probes. Failure to comply may result in damage to equipment.

CONTINUITY TEST

- (1) Set multimeter to ohms.
- (2) Connect positive (+) probe of multimeter to PDP, terminal 87, where relay K9 was removed.
- (3) Connect negative (-) probe of multimeter to connector PX14 socket 2.
- (4) If continuity is not present, repair wire 1565 from relay K9 terminal 87 to connector PX14 socket 2 (para 2-40) or replace WTEC II dashboard cable assembly (para 7-10) or WTEC III dashboard cable assembly (para 7-11).
- (5) If continuity is present, replace relay K9 (para 7-9).
- (6) Connect connector PX14 to hazard lights switch.
- (7) Install relay K9 in PDP.
- (8) Install PDP cover (para 16-2).
- (9) Install instrument panel assembly (para 7-15).

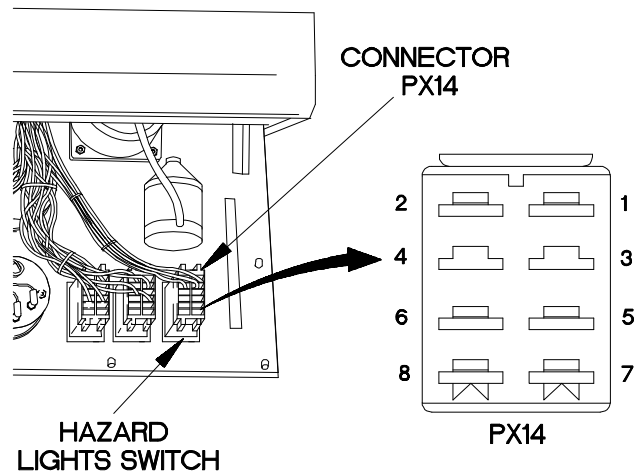

CONNECTOR PX14

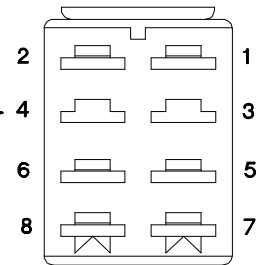

HAZARD LIGHTS SWITCH

XBE5803B

e57. FRONT AND REAR TURN SIGNALS DO NOT OPERATE	
INITIAL SETUP	
Equipment Condition Engine shut down (TM 9-2320-365-10).	Tools and Special Tools Tool Kit, Genl Mech (Item 44, Appendix C) STE/ICE-R (Item 39, Appendix C) Multimeter, Digital (Item 22, Appendix C)
Personnel Required (2)	References TM 9-4910-571-12&P

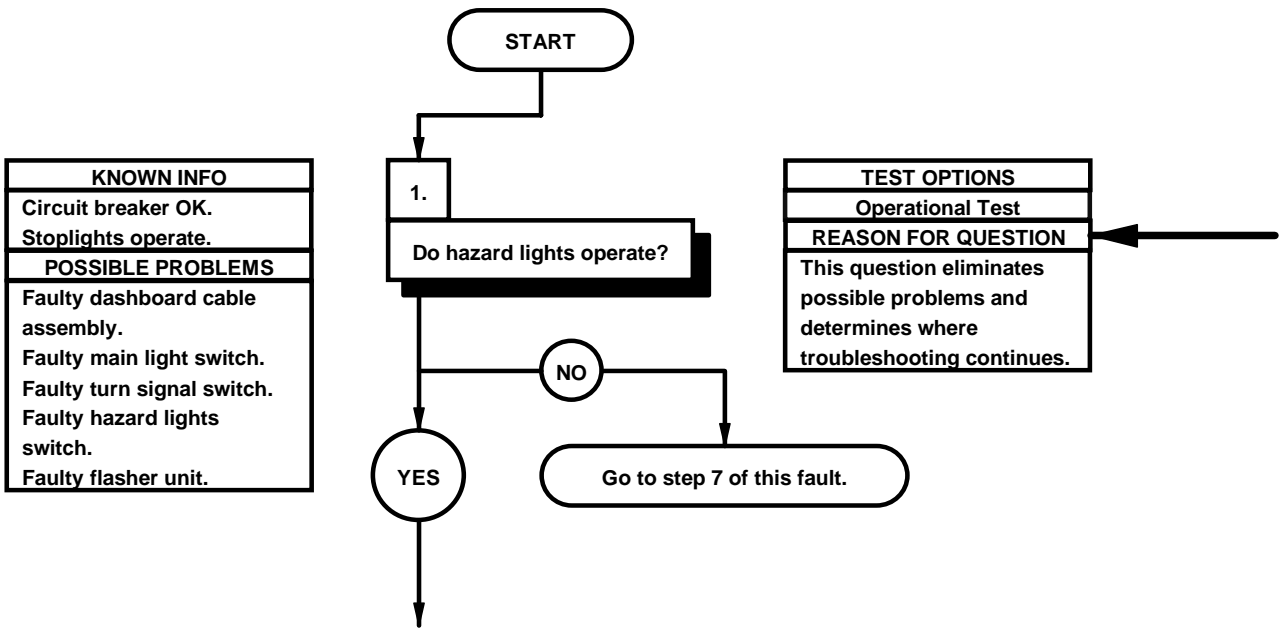

OPERATIONAL TEST

- (1) Position main light switch to STOPLIGHT
(TM 9-2320-365-10).
- (2) Position hazard lights switch to on
(TM 9-2320-365-10).
- (3) Observe hazard lights.
- (4) If hazard lights do not operate, go to step 7
of this fault.
- (5) Position hazard lights switch to off
(TM 9-2320-365-10).
- (6) Position main light switch to OFF
(TM 9-2320-365-10).

e57. FRONT AND REAR TURN SIGNALS DO NOT OPERATE (CONT)

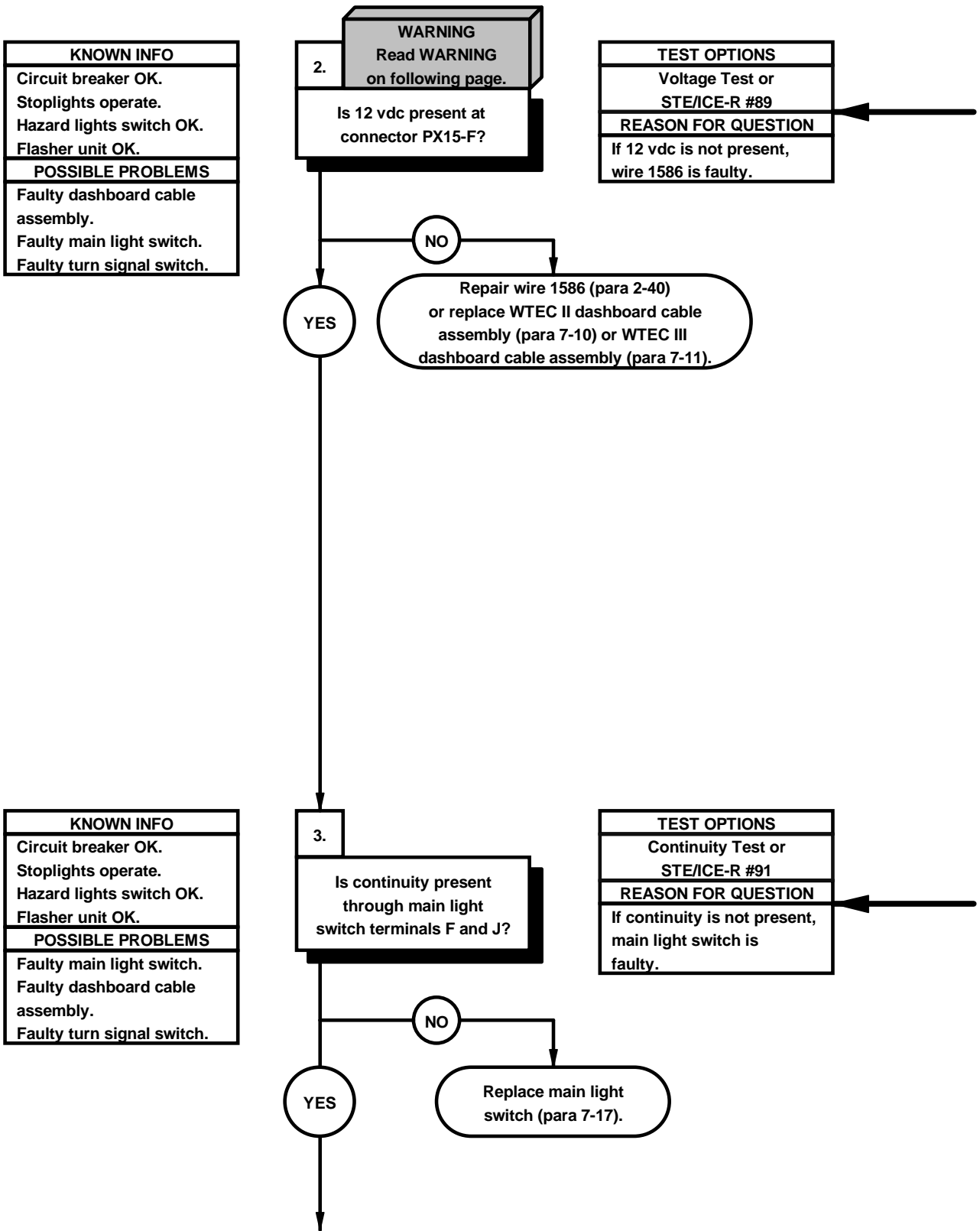

WARNING

Remove rings, bracelets, watches, necklaces, and any other jewelry before working around vehicle. Jewelry can catch on equipment and cause injury or short across electrical circuit and cause severe burns or electrical shock.

VOLTAGE TEST

- (1) Remove instrument panel assembly for access (para 7-15).
- (2) Disconnect connector PX15 from main light switch.
- (3) Set multimeter to volts dc.
- (4) Connect positive (+) probe of multimeter to connector PX15-F.
- (5) Connect negative (-) probe of multimeter to ground and note reading on multimeter.
- (6) If 12 vdc is not present, repair wire 1586 (para 2-40) or replace WTEC II dashboard cable assembly (para 7-10) or WTEC III dashboard cable assembly (para 7-11).

CONNECTOR PX15 MAIN LIGHT SWITCH

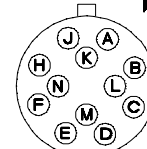
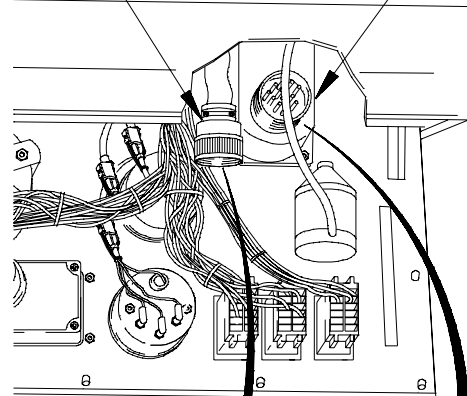

PX15

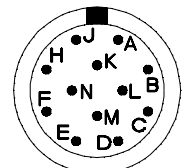

MAIN LIGHT SWITCH

X2E5901A

CONTINUITY TEST

- (1) Remove main light switch (para 7-17).
- (2) Set multimeter to ohms.
- (3) Position main light switch to STOPLIGHT (TM 9-2320-365-10).
- (4) Connect positive (+) probe of multimeter to main light switch terminal F.
- (5) Connect negative (-) probe of multimeter to main light switch terminal J and note reading on multimeter.
- (6) If continuity is not present, replace main light switch (para 7-17).
- (7) Install main light switch (para 7-17).

e57. FRONT AND REAR TURN SIGNALS DO NOT OPERATE (CONT)

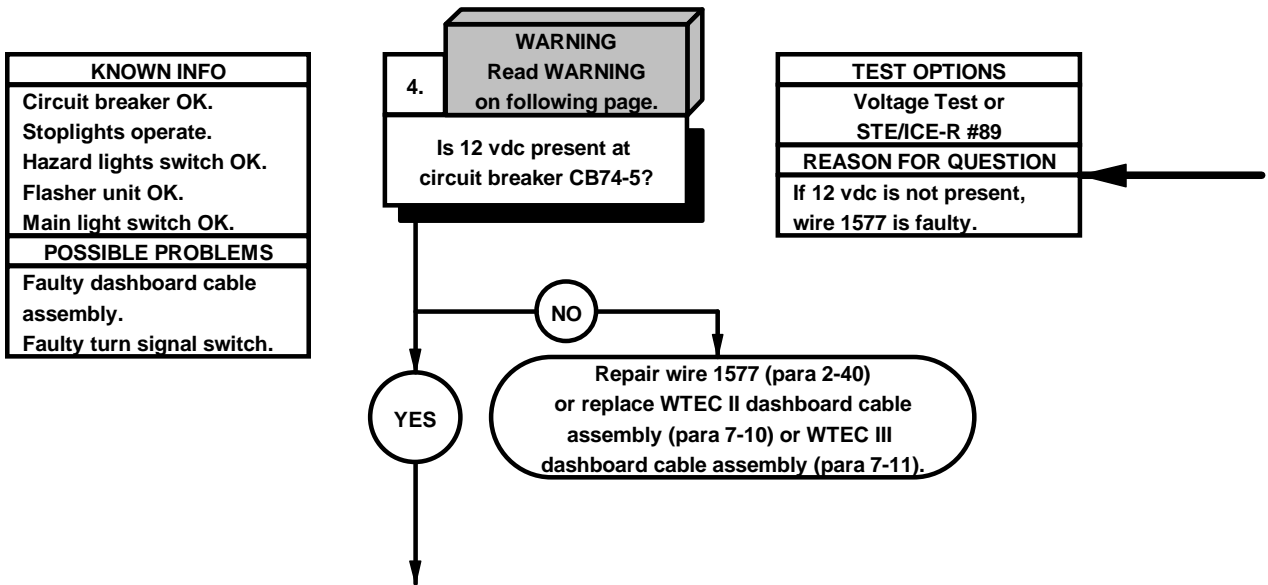

WARNING

Remove rings, bracelets, watches, necklaces, and any other jewelry before working around vehicle. Jewelry can catch on equipment and cause injury or short across electrical circuit and cause severe burns or electrical shock.

VOLTAGE TEST

- (1) Remove PDP cover (para 16-2).
- (2) Remove circuit breaker CB74 from PDP.
- (3) Set multimeter to volts dc.
- (4) Connect positive (+) probe of multimeter to PDP, terminal 5, where circuit breaker CB74 was removed.
- (5) Connect negative (-) probe of multimeter to ground.
- (6) Position main light switch to STOPLIGHT (TM 9-2320-365-10) and note reading on multimeter.
- (7) If 12 vdc is not present, repair wire 1577 (para 2-40) or replace WTEC II dashboard cable assembly (para 7-10) or WTEC III dashboard cable assembly (para 7-11).
- (8) Position main light switch to OFF (TM 9-2320-365-10).
- (9) Install circuit breaker CB74 in PDP.
- (10) Install PDP cover (para 16-2).

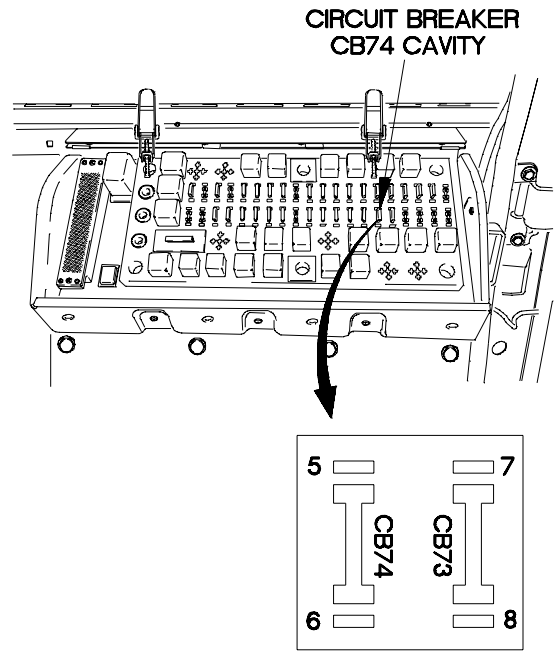

CB74 CAVITY Pdp002-X2E5902A

e57. FRONT AND REAR TURN SIGNALS DO NOT OPERATE (CONT)

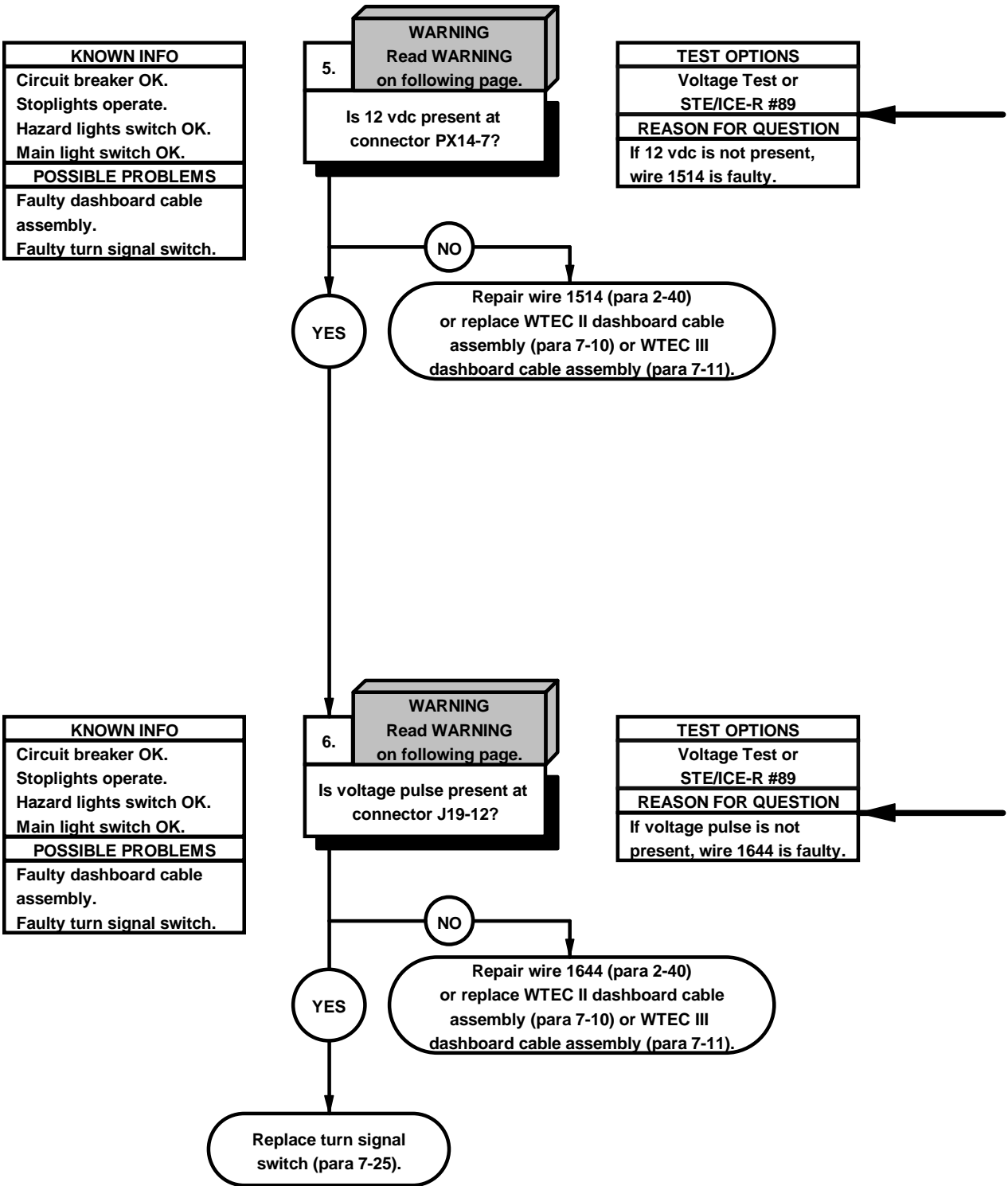

WARNING

Remove rings, bracelets, watches, necklaces, and any other jewelry before working around vehicle. Jewelry can catch on equipment and cause injury or short across electrical circuit and cause severe burns or electrical shock.

VOLTAGE TEST

- (1) Disconnect connector PX14 from hazard lights switch.
- (2) Set multimeter to volts dc.
- (3) Connect positive (+) probe of multimeter to connector PX14-7.
- (4) Connect negative (-) probe of multimeter to ground.
- (5) Position main light switch to STOPLIGHT (TM 9-2320-365-10) and note reading on multimeter.
- (6) If 12 vdc is not present, repair wire 1514 (para 2-40) or replace WTEC II dashboard cable assembly (para 7-10) or WTEC III dashboard cable assembly (para 7-11).
- (7) Position main light switch to OFF (TM 9-2320-365-10).
- (8) Connect connector PX14 to hazard light switch.

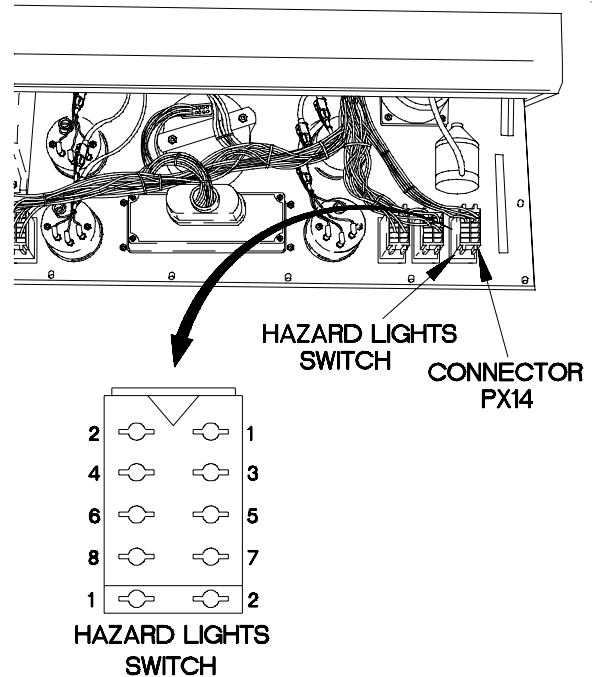

X2E5903A

WARNING

Remove rings, bracelets, watches, necklaces, and any other jewelry before working around vehicle. Jewelry can catch on equipment and cause injury or short across electrical circuit and cause severe burns or electrical shock.

VOLTAGE TEST

- (1) Disconnect connector P19 from connector J19.
- (2) Set multimeter to volts dc.
- (3) Connect positive (+) probe of multimeter to connector J19-12.
- (4) Connect negative (-) probe of multimeter to ground.
- (5) Position main light switch to STOPLIGHT (TM 9-2320-365-10) and note reading on multimeter.
- (6) If voltage pulse is not present, repair wire 1644 (para 2-40) or replace WTEC II dashboard cable assembly (para 7-10) or WTEC III dashboard cable assembly (para 7-11).
- (7) If voltage pulse is present, replace turn signal switch (para 7-25).
- (8) Position main light switch to OFF (TM 9-2320-365-10).
- (9) Connect connector P19 to connector J19.
- (10) Install instrument panel assembly (para 7-15).

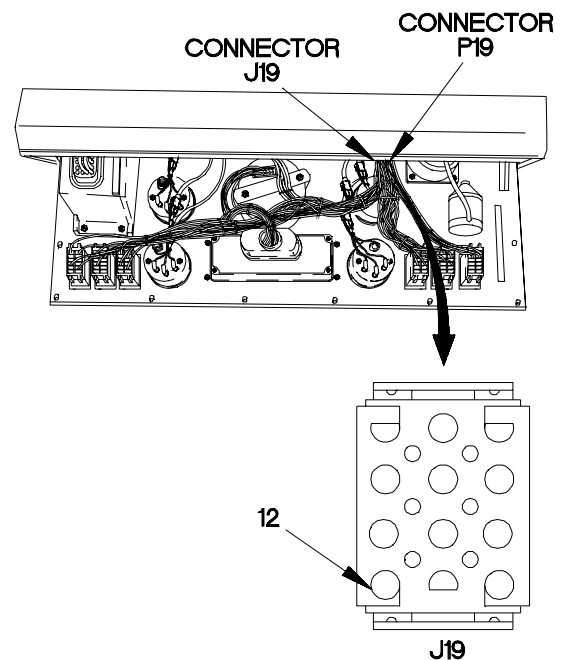

X2E5904A

e57. FRONT AND REAR TURN SIGNALS DO NOT OPERATE (CONT)

KNOWN INFO
Circuit breaker OK. Stoplights operate. Main light switch OK. Turn signal switch OK.
POSSIBLE PROBLEMS
Faulty hazard lights switch. Faulty dashboard cable assembly. Faulty flasher unit.

7.
Is continuity present between hazard lights switch terminals 7 and 5?

TEST OPTIONS
Continuity Test or STE/ICE-R #91
REASON FOR QUESTION
If continuity is not present, hazard lights switch is faulty.

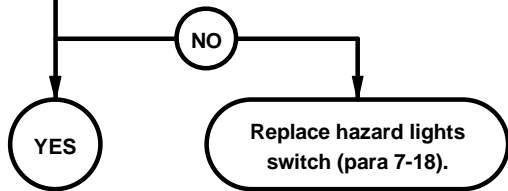

KNOWN INFO
Circuit breaker OK. Stoplights operate. Main light switch OK. Turn signal switch OK. Hazard lights switch OK.
POSSIBLE PROBLEMS
Faulty dashboard cable assembly. Faulty flasher unit.

8.
WARNING
Read WARNING on following page.
Is 12 vdc present at connector PX20-B?

TEST OPTIONS
Voltage Test or STE/ICE-R #89
REASON FOR QUESTION
If 12 vdc is not present, wire 1567 is faulty.

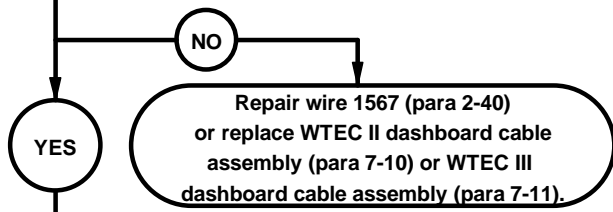

CONTINUITY TEST

- (1) Remove instrument panel assembly for access (para 7-15).
- (2) Disconnect connector PX14 from hazard lights switch.
- (3) Set multimeter to volts dc.
- (4) Position hazard lights switch to on (TM 9-2320-365-10).
- (5) Connect positive (+) probe of multimeter to hazard lights switch terminal 7.
- (6) Connect negative (-) probe of multimeter to hazard lights switch terminal 5 and note reading on multimeter.
- (7) If continuity is not present, replace hazard lights switch (para 7-18).
- (8) Connect connector PX14 to hazard lights switch.

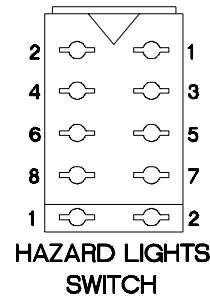
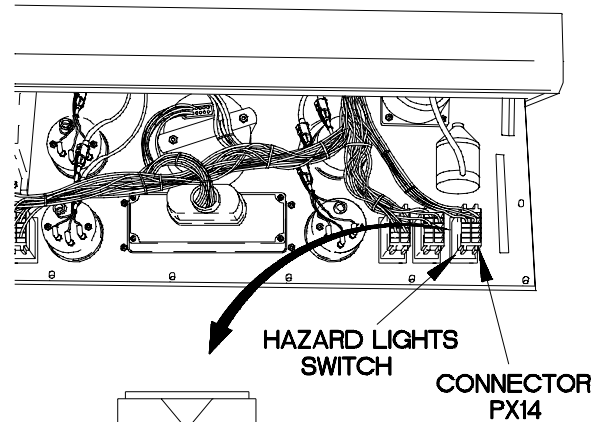

X2E5905A

WARNING

Remove rings, bracelets, watches, necklaces, and any other jewelry before working around vehicle. Jewelry can catch on equipment and cause injury or short across electrical circuit and cause severe burns or electrical shock.

VOLTAGE TEST

- (1) Remove kick panel (para 16-3).
- (2) Remove two screws, washers, and flasher unit from dashboard.
- (3) Disconnect connector PX20 from flasher unit.
- (4) Position hazard light switch to off (TM 9-2320-365-10).
- (5) Set multimeter to volts dc.
- (6) Connect positive (+) probe of multimeter to connector PX20-B.
- (7) Connect negative (-) probe of multimeter to ground.
- (8) Position main light switch to STOPLIGHT (TM 9-2320-365-10) and note reading on multimeter.
- (9) If 12 vdc is not present, repair wire 1567 (para 2-40) or replace WTEC II dashboard cable assembly (para 7-10) or WTEC III dashboard cable assembly (para 7-11).
- (10) Position main light switch to OFF (TM 9-2320-365-10).

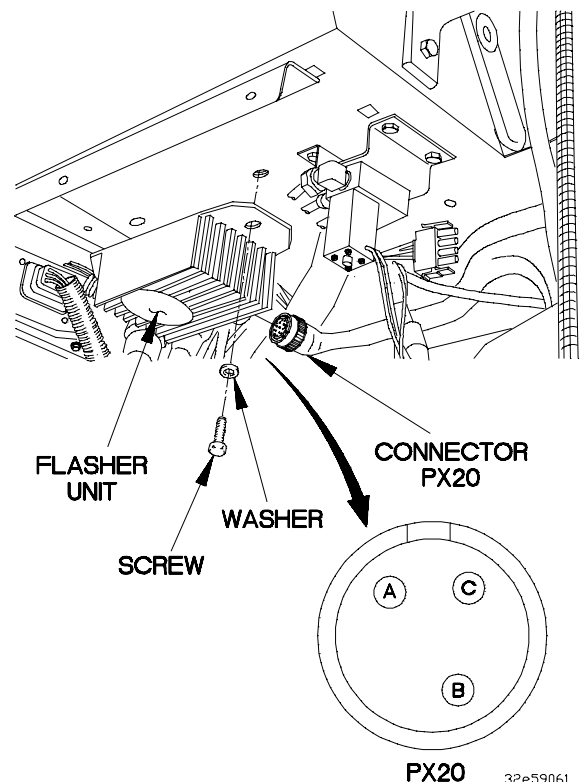

32e59061

e57. FRONT AND REAR TURN SIGNALS DO NOT OPERATE (CONT)

KNOWN INFO
Circuit breaker OK. Stoplights operate. Main light switch OK. Turn signal switch OK. Hazard lights switch OK.
POSSIBLE PROBLEMS
Faulty dashboard cable assembly. Faulty flasher unit.

9.
Is continuity present between connector PX20-A and connector PX14-6?

TEST OPTIONS
Continuity Test or STE/ICE-R #91
REASON FOR QUESTION
If continuity is not present, wire 1568 is faulty.

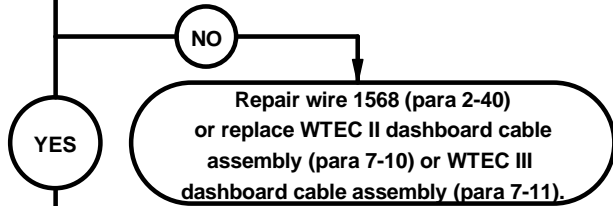

KNOWN INFO
Circuit breaker OK. Stoplights operate. Main light switch OK. Turn signal switch OK. Hazard lights switch OK.
POSSIBLE PROBLEMS
Faulty dashboard cable assembly. Faulty flasher unit.

10.
Is continuity present between connector PX20-C and a known good ground?

TEST OPTIONS
Continuity Test or STE/ICE-R #91
REASON FOR QUESTION
If continuity is not present, wire 3049 is faulty. If continuity is present, flasher unit is faulty.

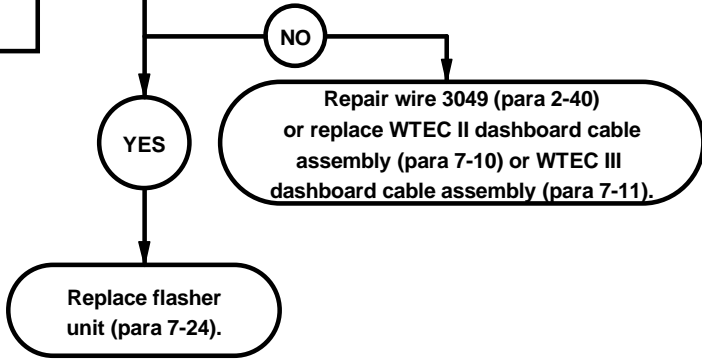

CONTINUITY TEST

- (1) Disconnect connector PX14 from hazard lights switch.
- (2) Set multimeter to ohms.
- (3) Connect positive (+) probe of multimeter to connector PX20-A.
- (4) Connect negative (-) probe of multimeter to connector PX14-6 and note reading on multimeter.
- (5) If continuity is not present, repair wire 1568 (para 2-40) or replace WTEC II dashboard cable assembly (para 7-10) or WTEC III dashboard cable assembly (para 7-11).
- (6) Connect connector PX14 to hazard lights switch.
- (7) Install instrument panel assembly (para 7-15).

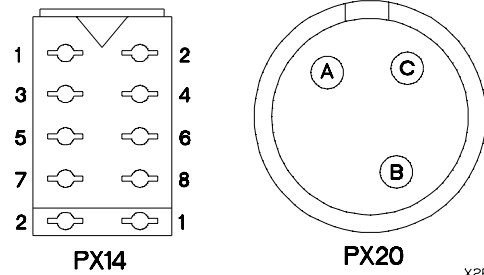
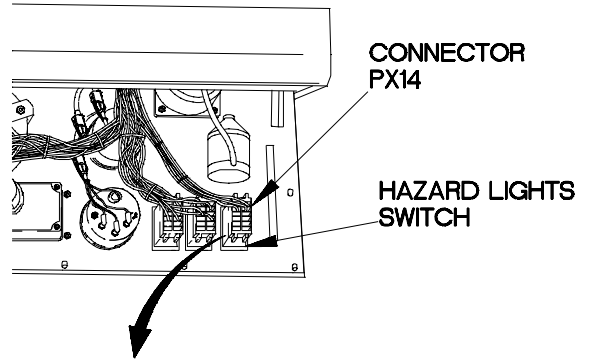

X2E5907A

CONTINUITY TEST

- (1) Set multimeter to ohms.
- (2) Connect positive (+) probe of multimeter to connector PX20-C.
- (3) Connect negative (-) probe of multimeter to ground and note reading on multimeter.
- (4) If continuity is not present, repair wire 3049 (para 2-40) or replace WTEC II dashboard cable assembly (para 7-10) or WTEC III dashboard cable assembly (para 7-11).
- (5) If continuity is present, replace flasher unit (para 7-24).
- (6) Connect connector PX20 to flasher unit.
- (7) Install flasher unit on dashboard with two washers and screws.
- (8) Install kick panel (para 16-3).

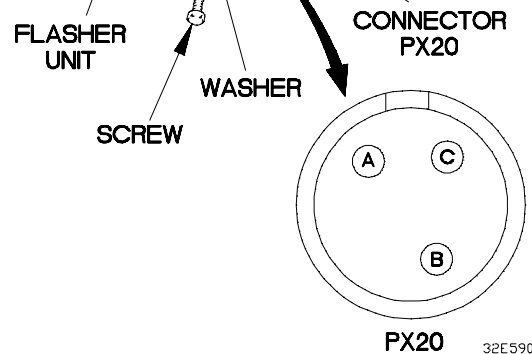
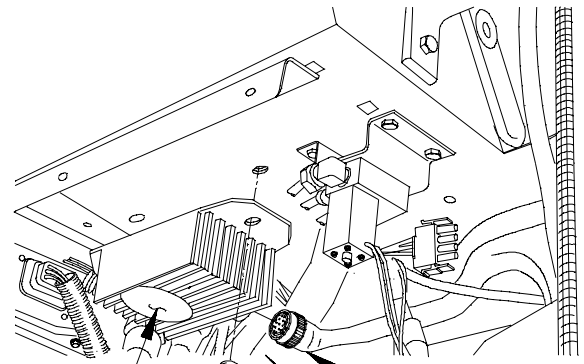

32E59081

e58. LEFT OR RIGHT FRONT TURN SIGNAL DOES NOT OPERATE	
INITIAL SETUP	
Equipment Condition Engine shut down (TM 9-2320-365-10).	Tools and Special Tools Tool Kit, Genl Mech (Item 44, Appendix C) STE/ICE-R (Item 39, Appendix C) Multimeter, Digital (Item 22, Appendix C)
Personnel Required (2)	References TM 9-4910-571-12&P
Materials/Parts Packing, Preformed (Item 170, Appendix G) Lockwasher (Item 92, Appendix G)	

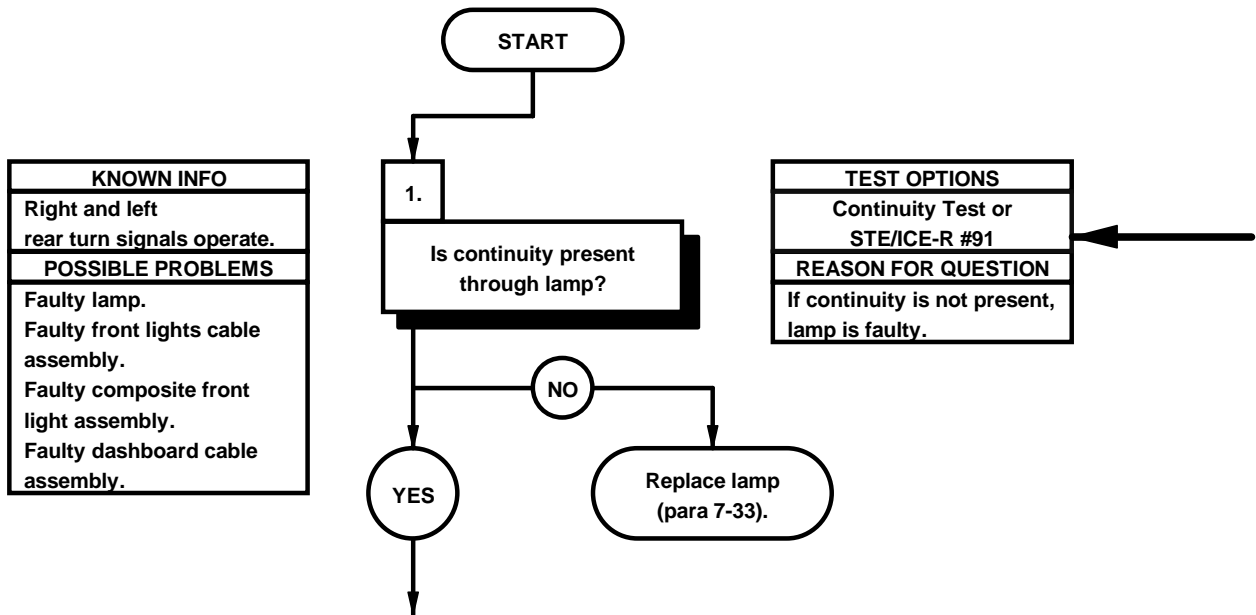

- | CONTINUITY TEST | |
|-----------------|---|
| | (1) Loosen five screws on cover. |
| | (2) Remove cover and preformed packing from housing. Discard preformed packing. |
| | (3) Remove lamp from socket. |
| | (4) Set multimeter to ohms. |
| | (5) Check continuity through lamp and note reading on multimeter. |
| | (6) If continuity is not present, replace lamp (para 7-33). |
| | (7) Install turn signal lamp in socket. |
| | (8) Install preformed packing and cover on housing with five screws. |

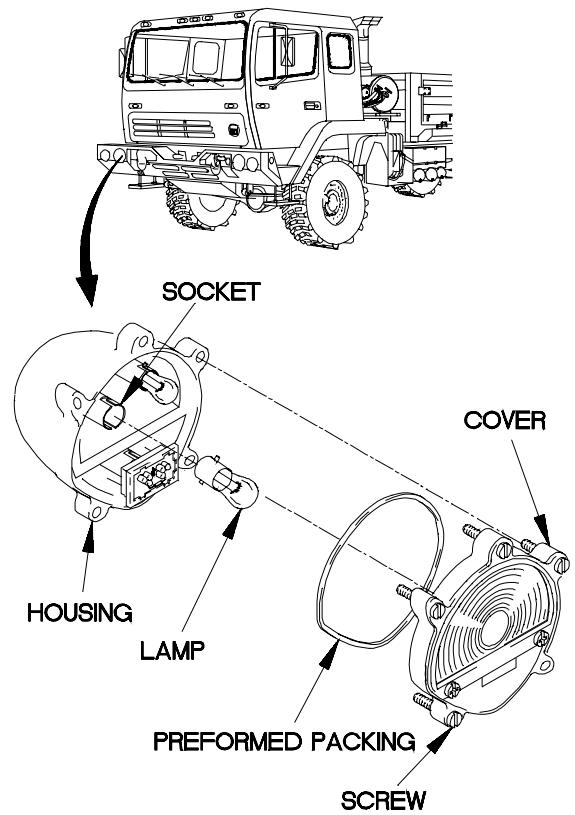

X2E6001A

e58. LEFT OR RIGHT FRONT TURN SIGNAL DOES NOT OPERATE (CONT)

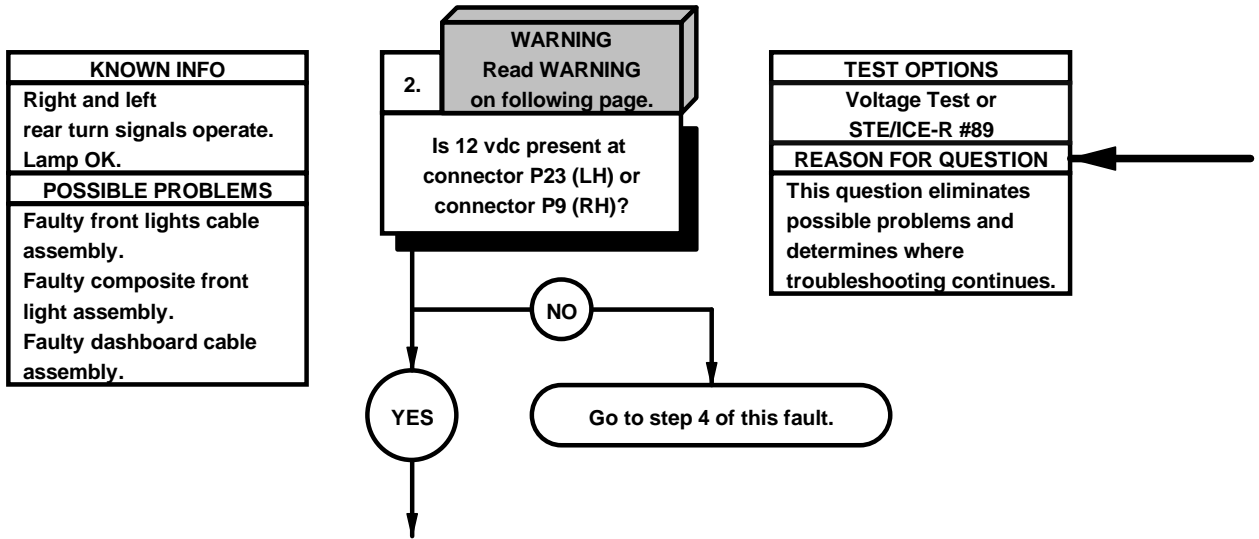

WARNING

Remove rings, bracelets, watches, necklaces, and any other jewelry before working around vehicle. Jewelry can catch on equipment and cause injury or short across electrical circuit and cause severe burns or electrical shock.

VOLTAGE TEST

- (1) Raise cab (TM 9-2320-365-10).
- (2) Disconnect connector P23 (LH composite front light assembly) or P9 (RH composite front light assembly) from composite front light assembly connector.
- (3) Lower cab (TM 9-2320-365-10).
- (4) Connect positive (+) probe of multimeter to connector P23 (LH composite front light assembly) or P9 (RH composite front light assembly).
- (5) Connect negative (-) probe of multimeter to ground.
- (6) Position main light switch to STOPLIGHT (TM 9-2320-365-10).
- (7) Position turn signal switch to left turn or right turn position (TM 9-2320-365-10) and note reading on multimeter.
- (8) If 12 vdc is not present, go to step 4 of this fault.
- (9) Position turn signal switch to off (TM 9-2320-365-10).
- (10) Position main light switch to OFF (TM 9-2320-365-10).
- (11) Raise cab (TM 9-2320-365-10).
- (12) Connect connector P23 (LH composite front light assembly) or P9 (RH composite front light assembly) to composite front light assembly connector.

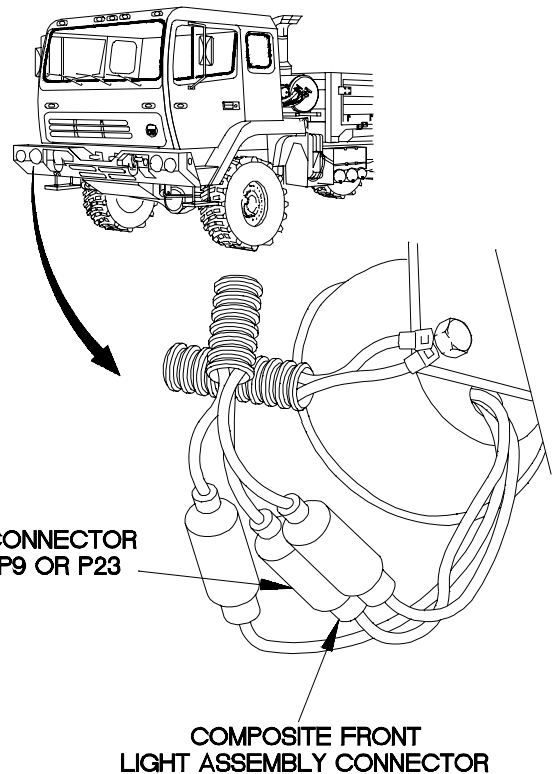

X2E6002A

e58. LEFT OR RIGHT FRONT TURN SIGNAL DOES NOT OPERATE (CONT)

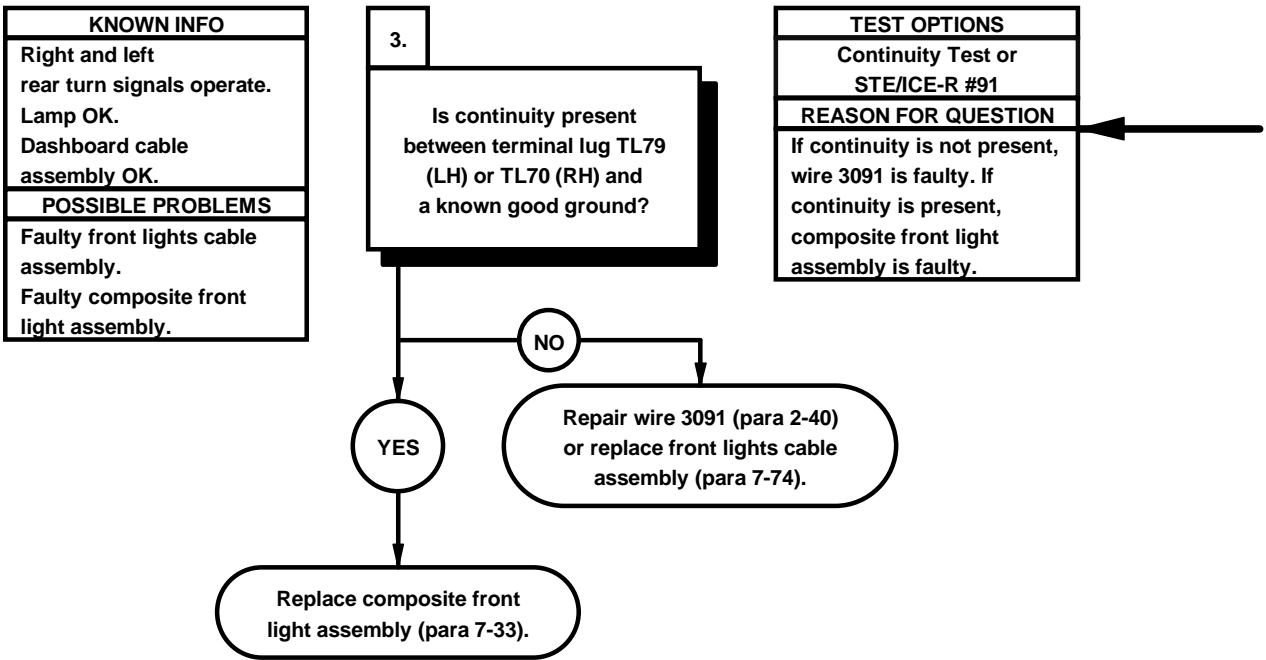

CONTINUITY TEST

- (1) Remove screw, lockwasher, and terminal lug TL79 (LH) or TL70 (RH) from composite front light light assembly. Discard lockwasher.
- (2) Set multimeter to ohms.
- (3) Connect positive (+) probe of multimeter to terminal lug TL79 (LH) or TL90 (RH).
- (4) Connect negative (-) probe of multimeter to ground and note reading on multimeter.
- (5) If continuity is not present, repair wire 3091 (para 2-40) or replace front lights cable assembly (para 7-74).
- (6) If continuity is present, replace composite front light assembly (para 7-33).
- (7) Install terminal lug TL79 (LH) or TL90 (RH), lockwasher, and screw on composite front light assembly.

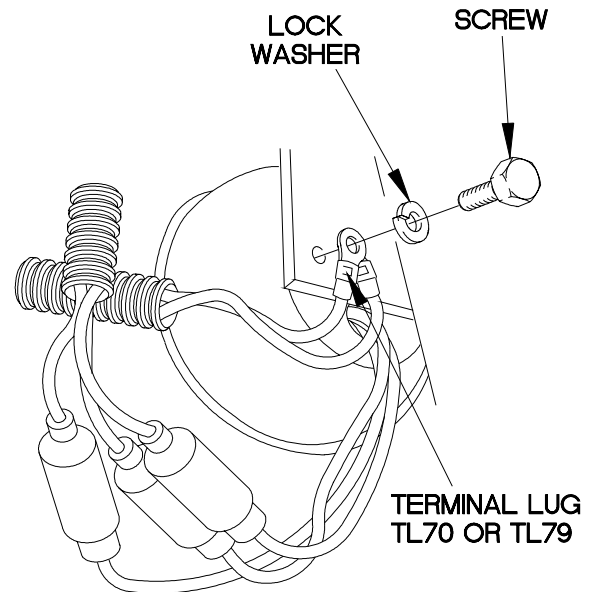

X2E6003A

e58. LEFT OR RIGHT FRONT TURN SIGNAL DOES NOT OPERATE (CONT)

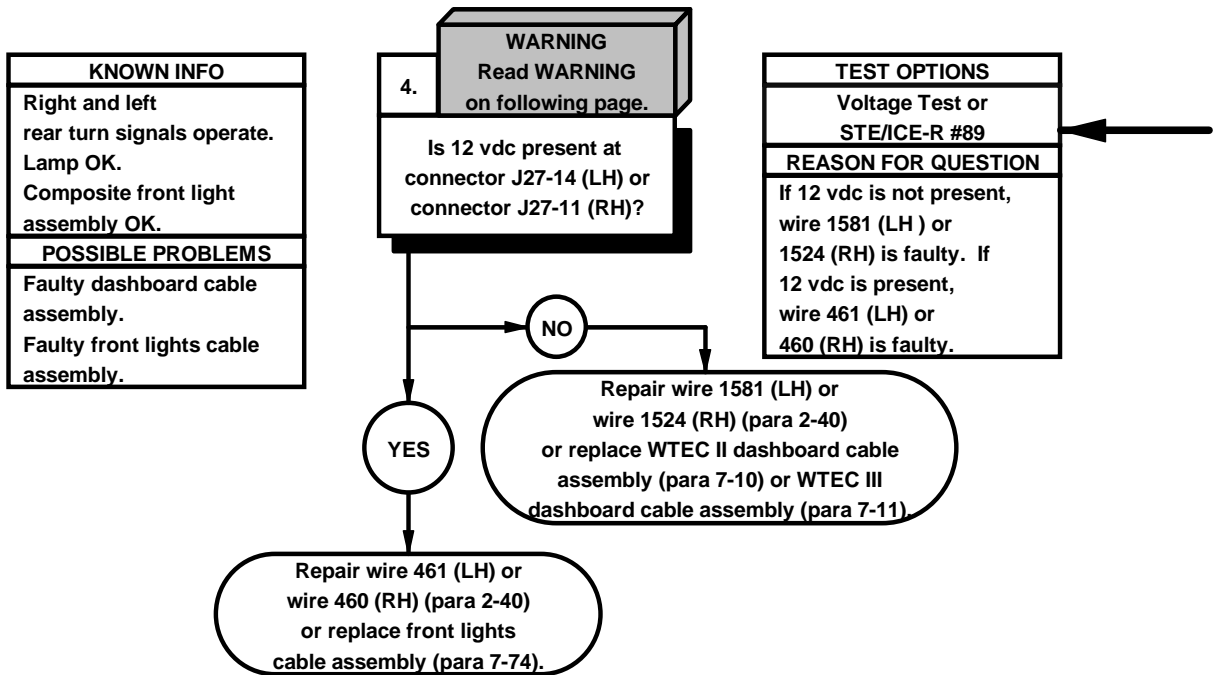

WARNING

Remove rings, bracelets, watches, necklaces, and any other jewelry before working around vehicle. Jewelry can catch on equipment and cause injury or short across electrical circuit and cause severe burns or electrical shock.

VOLTAGE TEST

- (1) Remove PDP cover (para 16-2).
- (2) Remove three screws and washers from PDP.
- (3) Remove three screws from PDP.
- (4) Lift PDP outward to gain access.
- (5) Disconnect connector J27 from connector P27.
- (6) Set multimeter to volts dc.
- (7) Connect positive (+) probe of multimeter to connector J27-14 (LH) or J27-11 (RH).
- (8) Connect negative (-) probe of multimeter to ground.
- (9) Position main light switch to STOPLIGHT (TM 9-2320-365-10).
- (10) Position turn signal switch to up for right turn signal operation or down for left turn signal operation (TM 9-2320-365-10).
- (11) If 12 vdc is not present, repair wire 1581 (LH) or wire 1524 (RH) (para 2-40) or replace WTEC II dashboard cable assembly (para 7-10) or WTEC III dashboard cable assembly (para 7-11).
- (12) If 12 vdc is present, repair wire 461 (LH) or wire 460 (RH) (para 2-40) or replace front lights cable assembly (para 7-74).
- (13) Position main light switch to OFF (TM 9-2320-365-10).
- (14) Position turn signal switch to middle (off) (TM 9-2320-365-10).
- (15) Connect connector P27 to connector J27.
- (16) Install PDP on dashboard with three screws.
- (17) Install three washers and screws in PDP.
- (18) Install PDP cover (para 16-2).

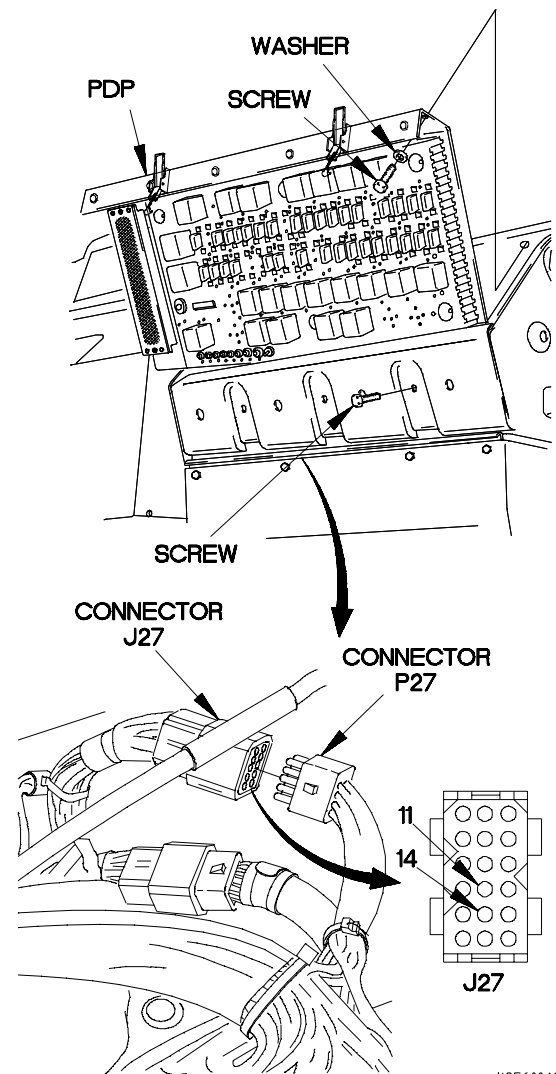

X2E60041

e59. ONE OR BOTH STOPLIGHTS DO NOT ILLUMINATE

INITIAL SETUP

Equipment Condition

Engine shut down (TM 9-2320-365-10).

Personnel Required

(2)

Material/Parts

Packing, Preformed (Item 170, Appendix G)

Tools and Special Tools

Tool Kit, Genl Mech (Item 44, Appendix C)
 STE/ICE-R (Item 39, Appendix C)
 Multimeter, Digital (Item 22, Appendix C)

References

TM 9-4910-571-12&P

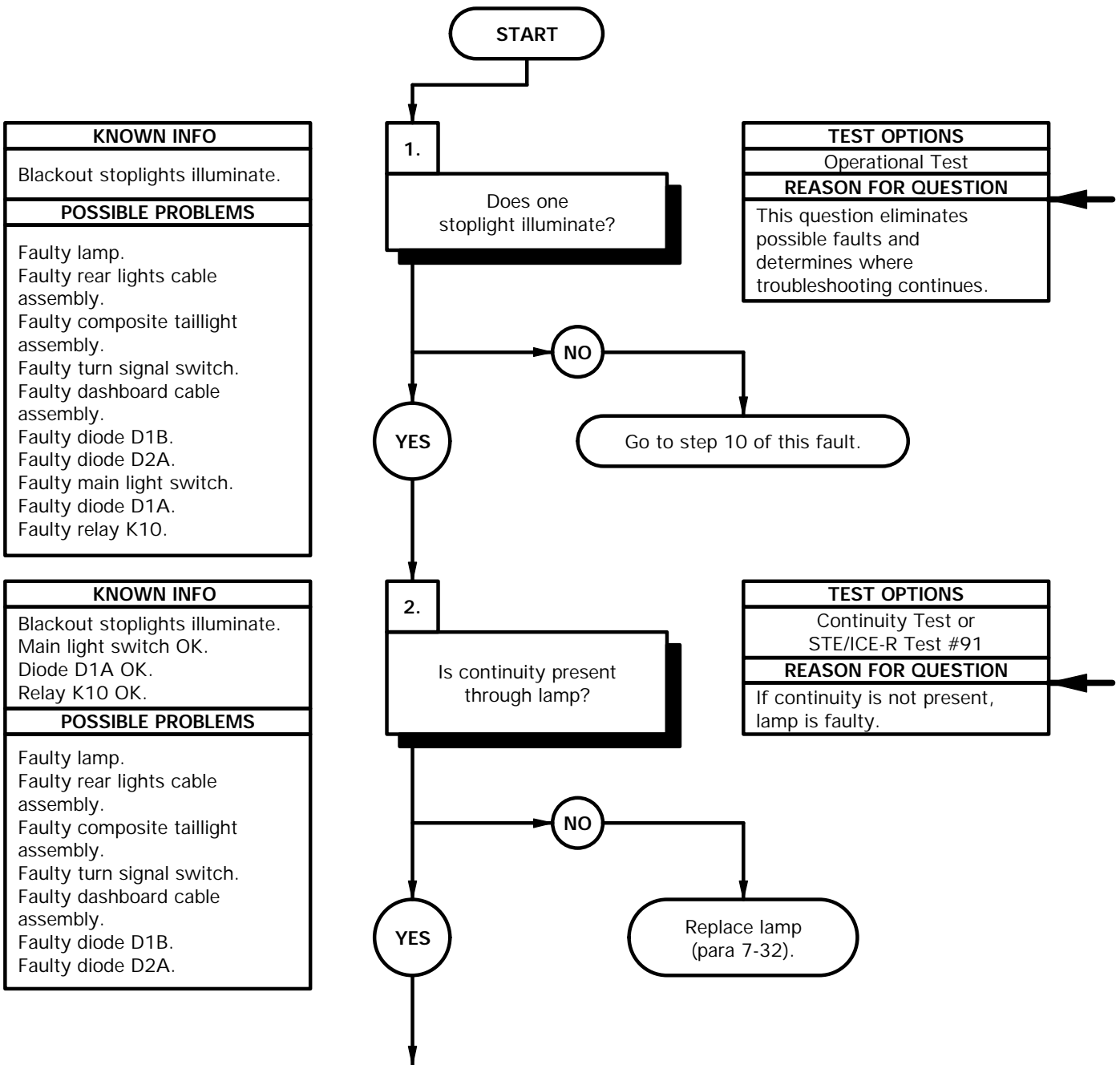

- (1) Position master power switch to on (TM 9-2320-365-10).
- (2) Position main light switch to STOPLIGHT (TM 9-2320-365-10).
- (3) Apply brakes and observe stoplights.
- (4) If both stoplights do not illuminate, go to step 5 of this fault.
- (5) Position main light switch to OFF (TM 9-2320-365-10).
- (6) Position master power switch to off (TM 9-2320-365-10).

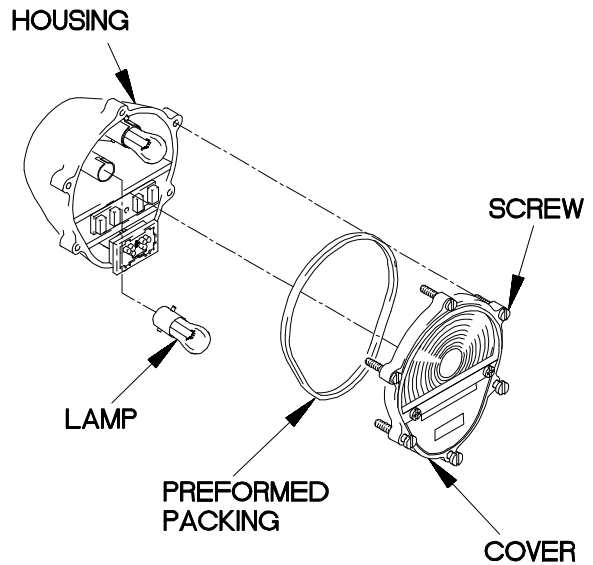

Xbo6101b

CONTINUITY TEST

- (1) Loosen six screws on composite taillight assembly cover.
- (2) Remove cover and preformed packing from housing. Discard preformed packing.
- (3) Remove lamp from socket.
- (4) Set multimeter to ohms.
- (5) Check continuity through lamp.
- (6) If continuity is not present, replace lamp (para 7-32).

e59. ONE OR BOTH STOPLIGHTS DO NOT ILLUMINATE (CONT)

KNOWN INFO
Blackout stoplights illuminate. Main light switch OK. Diode D1A OK. Relay K10 OK. Lamp OK.
POSSIBLE PROBLEMS
Faulty rear lights cable assembly. Faulty composite taillight assembly. Faulty turn signal switch. Faulty dashboard cable assembly. Faulty diode D1B. Faulty diode D2A.

3.

WARNING
Read **WARNING** on following page.

Is 12 VDC present at stoplight lamp socket center contact?

TEST OPTIONS
Voltage Test or STE/ICE-R Test #89
REASON FOR QUESTION
This question eliminates possible problems and determines where troubleshooting continues.

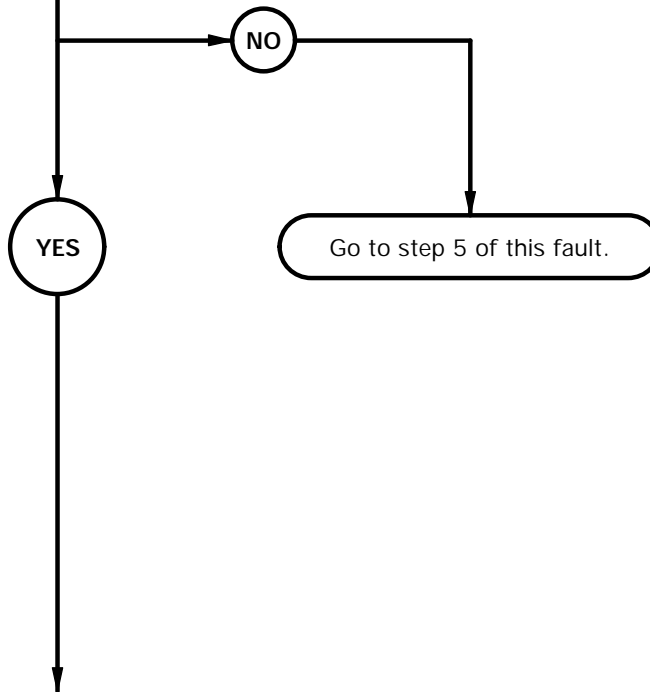

WARNING

Remove rings, bracelets, watches, necklaces, and any other jewelry before working around vehicle. Jewelry can catch on equipment and cause injury or short across electrical circuits and cause severe burns or electrical shock.

VOLTAGE TEST

- (1) Set multimeter to volts DC.
- (2) Connect positive (+) probe of multimeter to stoplight lamp socket center contact.
- (3) Connect negative (-) probe of multimeter to ground.
- (4) Position master power switch to on (TM 9-2320-365-10).
- (5) Position main light switch to STOPLIGHT (TM 9-2320-365-10).
- (6) Apply brakes and note reading on multimeter.
- (7) If 12 VDC is not present, go to step 5 of this fault.
- (8) Position master power switch to off (TM 9-2320-365-10).
- (9) Position main light switch to OFF (TM 9-2320-365-10).
- (10) Install lamp in socket.
- (11) Install preformed packing and cover on housing with six screws.

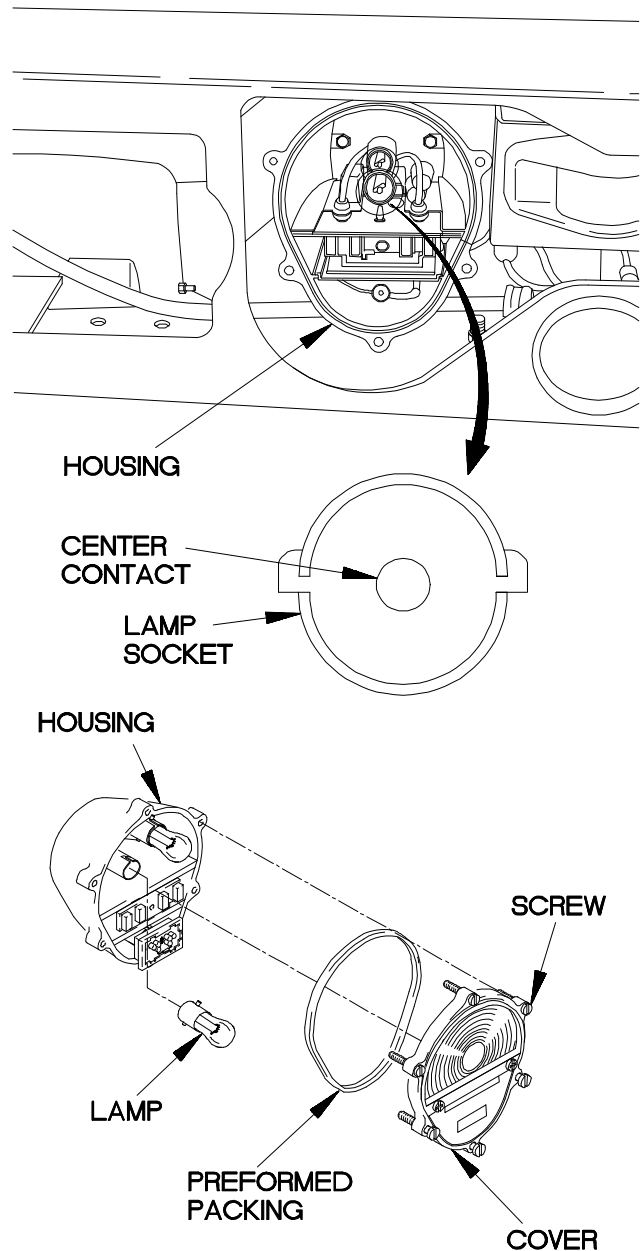

Xbe6102b

e59. ONE OR BOTH STOPLIGHTS DO NOT ILLUMINATE (CONT)

KNOWN INFO
Blackout stoplights illuminate. Main light switch OK. Diode D1A OK. Relay K10 OK. Lamp OK.
POSSIBLE PROBLEMS
Faulty rear lights cable assembly. Faulty composite taillight assembly. Faulty turn signal switch. Faulty dashboard cable assembly. Faulty diode D1B. Faulty diode D2A.

4.

Does taillight illuminate?

TEST OPTIONS
Operational Test
REASON FOR QUESTION
If taillight does not illuminate, wire 3094 (LH) or wire 3095 (RH) is faulty. If taillight illuminates, composite taillight assembly is faulty.

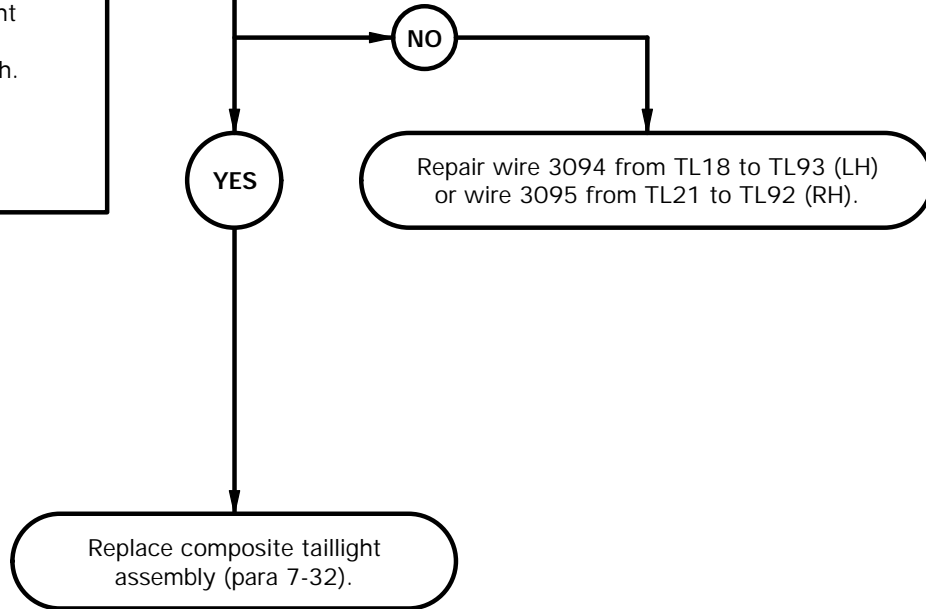

- (1) Position main light switch to SER DRIVE (TM 9-2320-365-10).
- (2) Observe taillight in housing with non-illuminating stoplight.
- (3) If taillight does not illuminate, repair wire 3094 from TL18 to TL93 (LH) or wire 3095 from TL21 to TL92 (RH).
- (4) If taillight illuminates, replace composite taillight assembly (para 7-32).
- (5) Position main light switch to OFF (TM 9-2320-365-10).

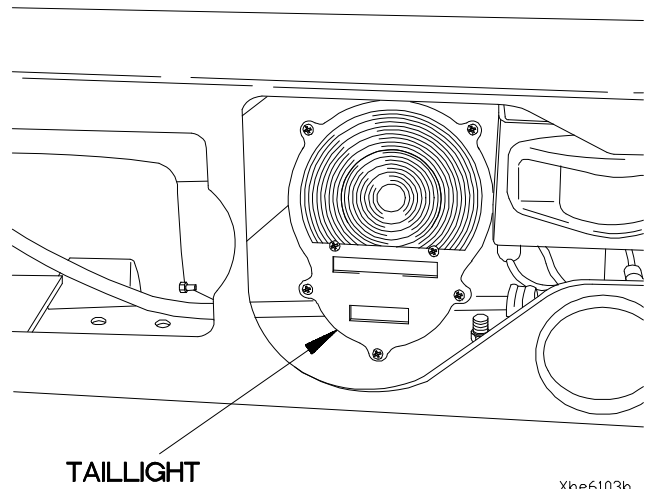

e59. ONE OR BOTH STOPLIGHTS DO NOT ILLUMINATE (CONT)

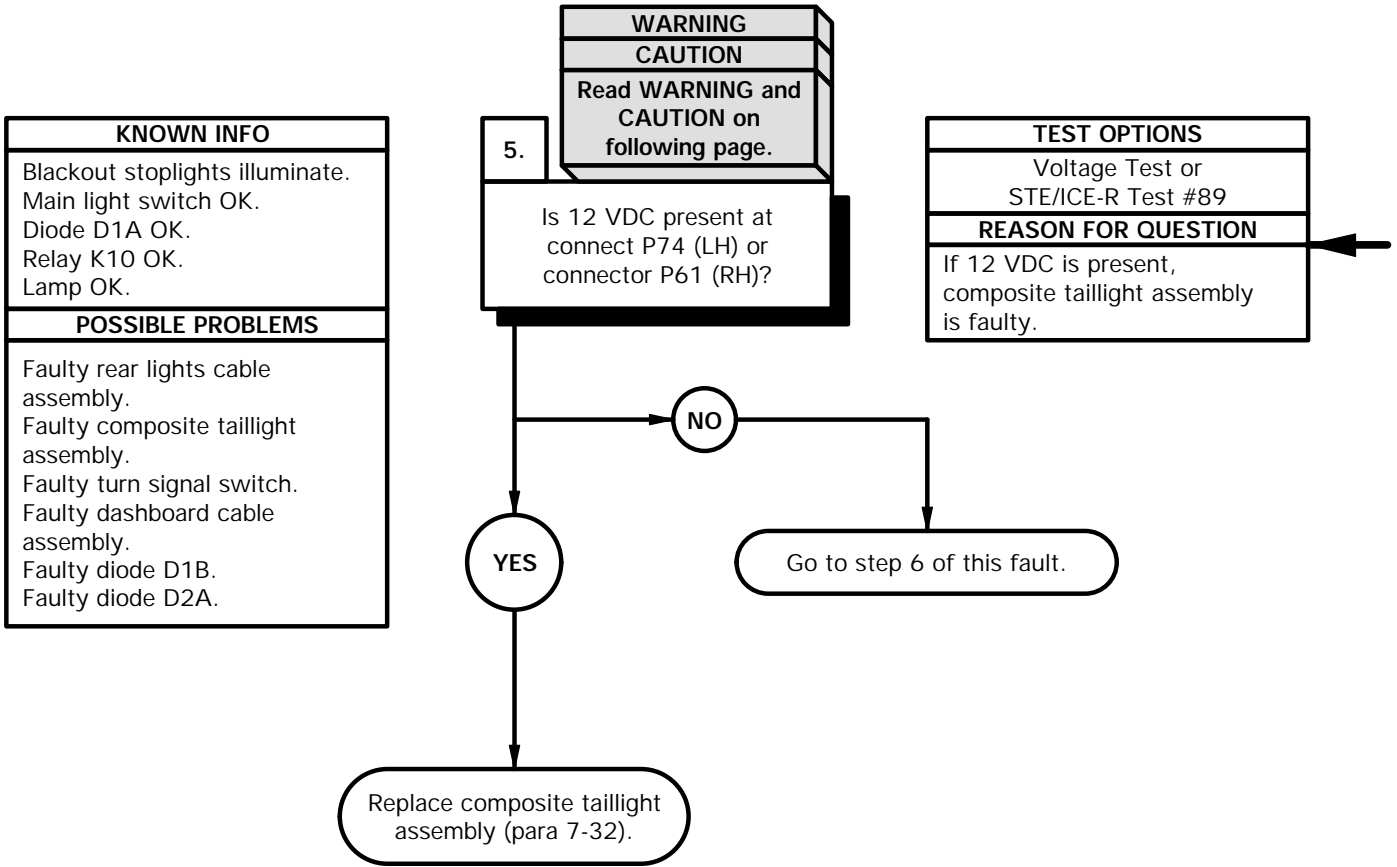

WARNING

Remove rings, bracelets, watches, necklaces, and any other jewelry before working around vehicle. Jewelry can catch on equipment and cause injury or short across electrical circuits and cause severe burns or electrical shock.

CAUTION

Use care when testing electrical connectors. Do not damage connector pins or sockets with multimeter probes. Failure to comply may result in damage to equipment.

NOTE

Inspect connector pins/sockets for damage, corrosion, and serviceability. Check that connector pins are not pushed back and are capable of making good contact.

VOLTAGE TEST

- (1) Disconnect connector P74 (LH) or connector P61 (RH) from stoplight connector.
- (2) Set multimeter to volts DC.
- (3) Connect positive (+) probe of multimeter to connector P74 or connector P61.
- (4) Connect negative (-) probe of multimeter to ground.
- (5) Position master power switch to on (TM 9-2320-365-10).
- (6) Position main light switch to STOPLIGHT (TM 9-2320-365-10).
- (7) Apply brakes and note reading on multimeter.
- (8) If 12 VDC is not present, go to step 6 of this fault.
- (9) If 12 VDC is present, replace composite taillight assembly (para 7-32).
- (10) Position master power switch to off (TM 9-2320-365-10).
- (11) Position main light switch to OFF (TM 9-2320-365-10).
- (12) Connect connector P74 or connector P61 to stoplight connector.

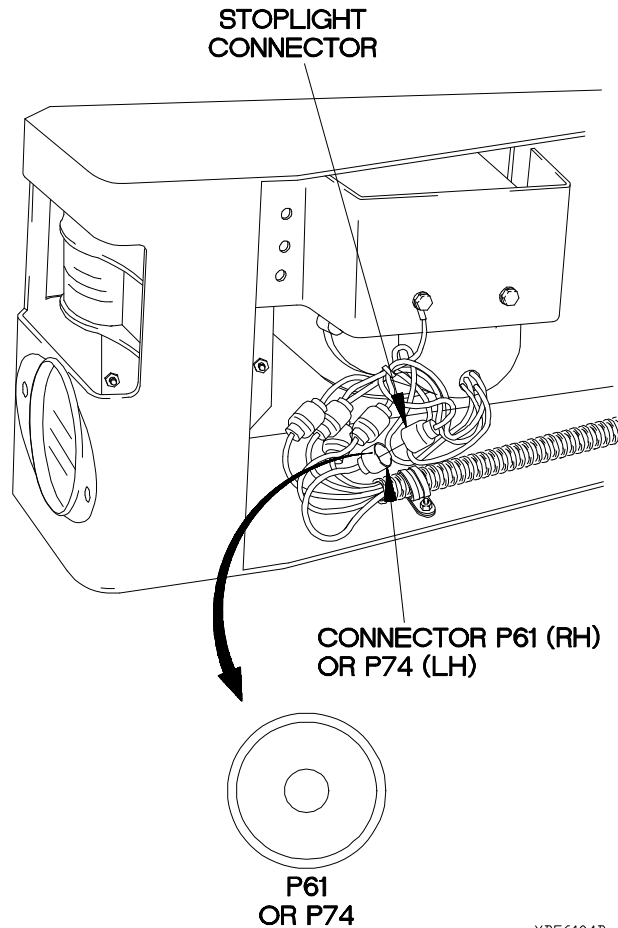

XBE6104B

e59. ONE OR BOTH STOPLIGHTS DO NOT ILLUMINATE (CONT)

KNOWN INFO
Blackout stoplights illuminate. Main light switch OK. Diode D1A OK. Relay K10 OK. Lamp OK. Composite taillight assembly OK.
POSSIBLE PROBLEMS
Faulty rear lights cable assembly. Faulty turn signal switch. Faulty dashboard cable assembly. Faulty diode D1B. Faulty diode D2A.

6.

CAUTION
Read CAUTION on following page.

Is continuity present from turn signal switch connector socket 2 (LH) or socket 3 (RH) to socket 6?

TEST OPTIONS
Continuity Test or STE/ICE-R Test #91
REASON FOR QUESTION
If continuity is not present, turn signal switch is faulty.

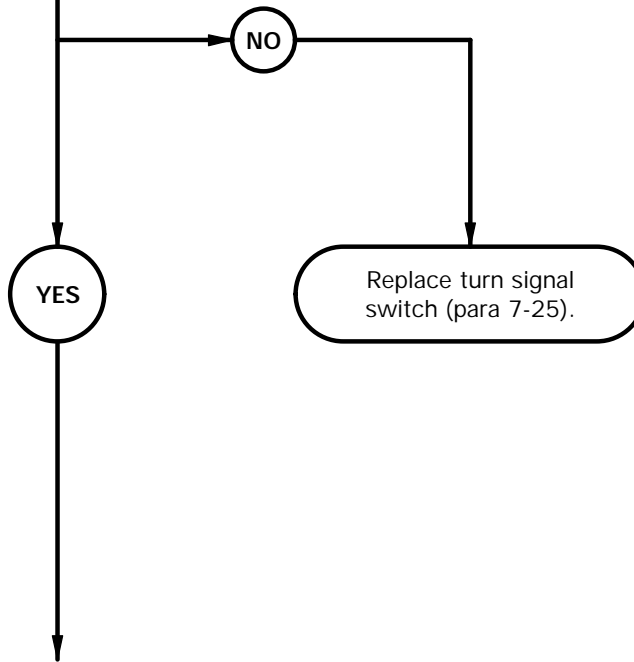

CAUTION

Use care when testing electrical connectors. Do not damage connector pins or sockets with multimeter probes. Failure to comply with multimeter probes. Failure to comply may result in damage to equipment.

NOTE

Inspect connector pins/sockets for damage, corrosion, and serviceability. Check that connector pins are not pushed back and are capable of making good contact.

CONTINUITY TEST

- (1) Remove instrument panel assembly for access (para 7-15).
- (2) Disconnect turn signal switch connector from connector J19.
- (3) Position turn signal switch to center position (TM 9-2320-365-10).
- (4) Set multimeter to ohms.
- (5) Connect positive (+) probe of multimeter to turn signal switch connector socket 6.
- (6) Connect negative (-) probe of multimeter to turn signal switch connector socket 2 (LH) or socket 3 (RH) and note reading on multimeter.
- (7) If continuity is not present, replace turn signal switch (para 7-25).
- (8) Connect connector J19 to turn signal switch connector.
- (9) Install instrument panel assembly (para 7-15).

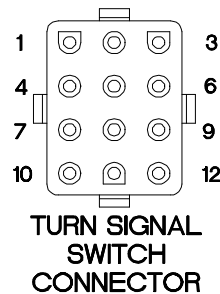
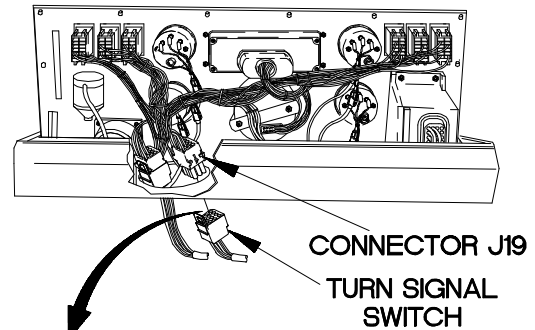

XBE6105B

e59. ONE OR BOTH STOPLIGHTS DO NOT ILLUMINATE (CONT)

KNOWN INFO
Blackout stoplights illuminate. Main light switch OK. Diode D1A OK. Relay K10 OK. Lamp OK. Composite taillight assembly OK. Turn signal switch OK.
POSSIBLE PROBLEMS
Faulty rear lights cable assembly. Faulty dashboard cable assembly. Faulty diode D1B. Faulty diode D2A.

7.

WARNING
Read **WARNING** on following page.

Is 12 VDC present at diode D1B-4 (LH) or diode D2A-2 (RH)?

TEST OPTIONS
Voltage Test or STE/ICE-R Test #89
REASON FOR QUESTION
If 12 VDC is not present wire 461B (LH) or wire 460B (RH) is faulty.

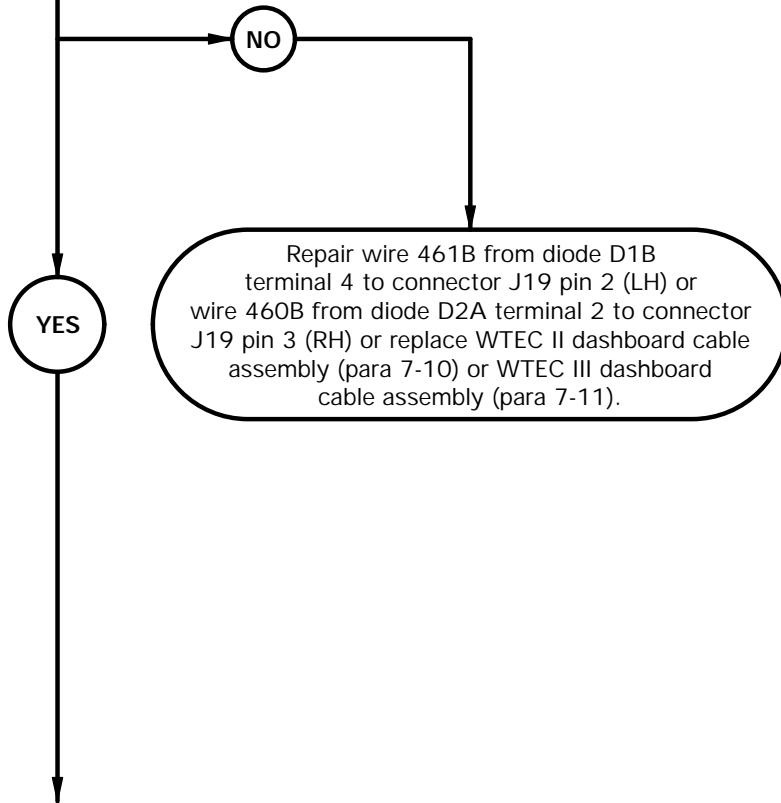

WARNING

Remove rings, bracelets, watches, necklaces, and any other jewelry before working around vehicle. Jewelry can catch on equipment and cause injury or short across electrical circuits and cause severe burns or electrical shock.

- VOLTAGE TEST**
- (1) Remove PDP cover (para 16-2).
 - (2) Remove diode D1B (LH) or diode D2A (RH) from PDP.
 - (3) Set multimeter to volts DC.
 - (4) Connect positive (+) probe of multimeter to PDP, terminal 4 (LH) or terminal 2 (RH) where diode D1B (LH) or diode D2A (RH) was removed.
 - (5) Connect negative (-) probe of multimeter to ground.
 - (6) Position master power switch to on (TM 9-2320-365-10).
 - (7) Position main light switch to STOPLIGHT (TM 9-2320-365-10).
 - (8) Apply brakes and note reading on multimeter.
 - (9) If 12 VDC is not present, repair wire 461B from diode D1B terminal 4 to connector J19 pin 2 (LH) or wire 460B from diode D2A terminal 2 to connector J19 pin 3 (RH) or replace WTEC II dashboard cable assembly (para 7-10) or WTEC III dashboard cable assembly (para 7-11).
 - (10) Position master power switch to off (TM 9-2320-365-10).
 - (11) Position main light switch to OFF (TM 9-2320-365-10).

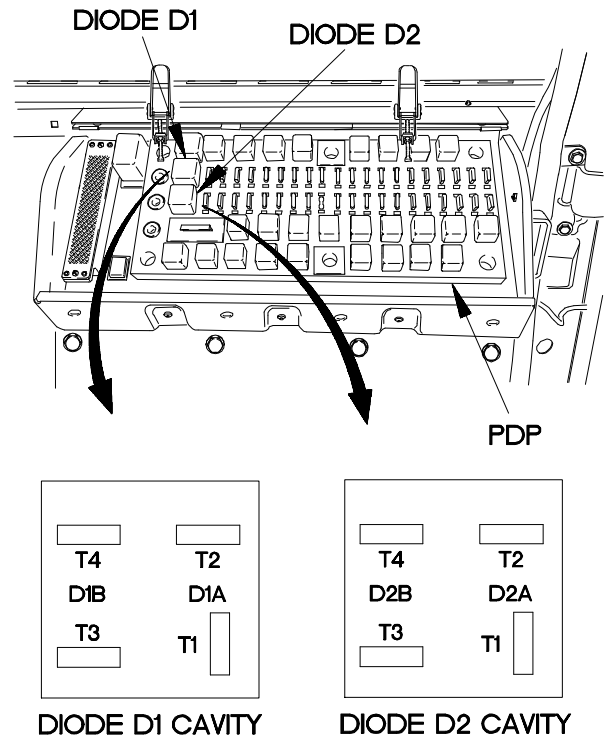

XBE6106B

e59. ONE OR BOTH STOPLIGHTS DO NOT ILLUMINATE (CONT)

KNOWN INFO
Blackout stoplights illuminate. Main light switch OK. Diode D1A OK. Relay K10 OK. Lamp OK. Composite taillight assembly OK. Turn signal switch OK.
POSSIBLE PROBLEMS
Faulty rear lights cable assembly. Faulty dashboard cable assembly. Faulty diode D1B. Faulty diode D2A.

8.

WARNING
CAUTION
Read **WARNING** and **CAUTION** on following page.

Is 12 VDC present at connector J51 pin 5 (LH) or connector J51 pin 4 (RH)?

TEST OPTIONS
Voltage Test or STE/ICE-R Test #89
REASON FOR QUESTION
If 12 VDC is present wire 461B (LH) or wire 460B (RH) is faulty.

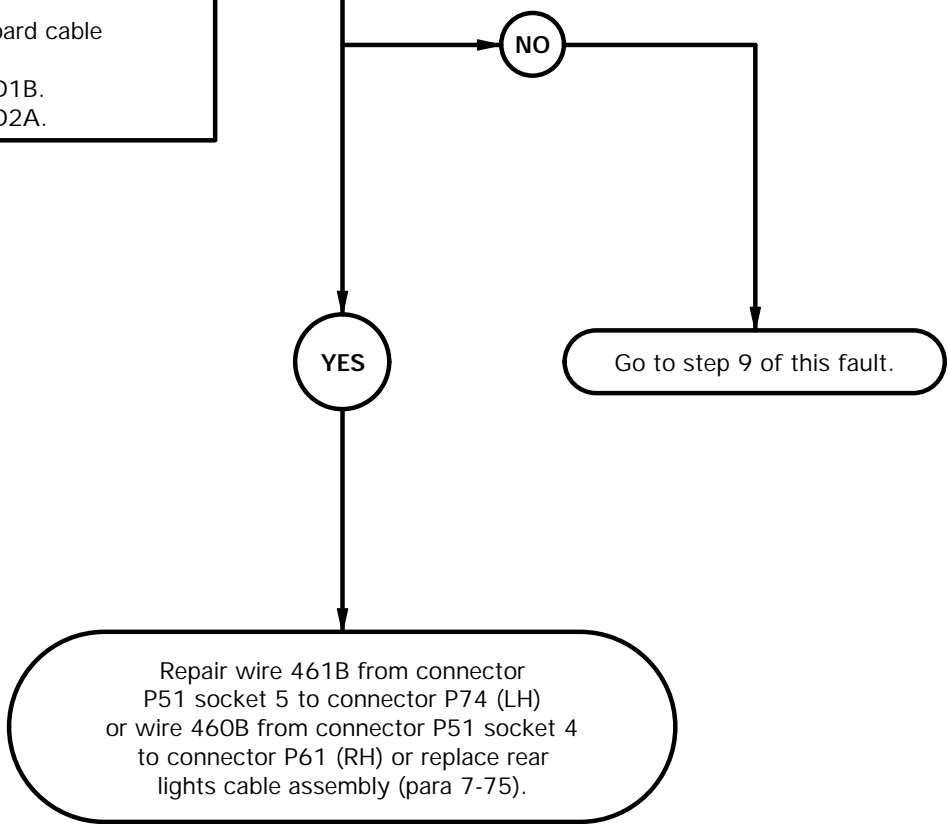

WARNING

Remove rings, bracelets, watches, necklaces, and any other jewelry before working around vehicle. Jewelry can catch on equipment and cause injury or short across electrical circuits and cause severe burns or electrical shock.

CAUTION

Use care when testing electrical connectors. Do not damage connector pins or sockets with multimeter probes. Failure to comply may result in damage to equipment.

NOTE

Inspect connector pins/sockets for damage, corrosion, and serviceability. Check that connector pins are not pushed back and are capable of making good contact.

VOLTAGE TEST

- (1) Remove three screws and washers from PDP.
- (2) Remove three screws from PDP.
- (3) Lift PDP outward to gain access.
- (4) Disconnect connector J51 from connector P51.
- (5) Set multimeter to volts DC.
- (6) Connect positive (+) probe of multimeter to connector J51 pin 5 (LH) or pin 4 (RH).
- (7) Connect negative (-) probe of multimeter to ground.
- (8) Position master power switch to on (TM 9-2320-365-10).
- (9) Position main light switch to STOPLIGHT (TM 9-2320-365-10).
- (10) Apply brakes and note reading on multimeter.
- (11) If 12 VDC is not present, got to step 9 of this faulty.
- (12) If 12 VDC is present, repair wire 461B from connector P51 socket 5 to connector P74 (LH) or wire 460B from connector P51 socket 4 to connector P61 (RH) or replace rear lights cable assembly (para 7-75).
- (13) Position main light switch to OFF (TM 9-2320-365-10).
- (14) Position master power switch to off (TM 9-2320-365-10).

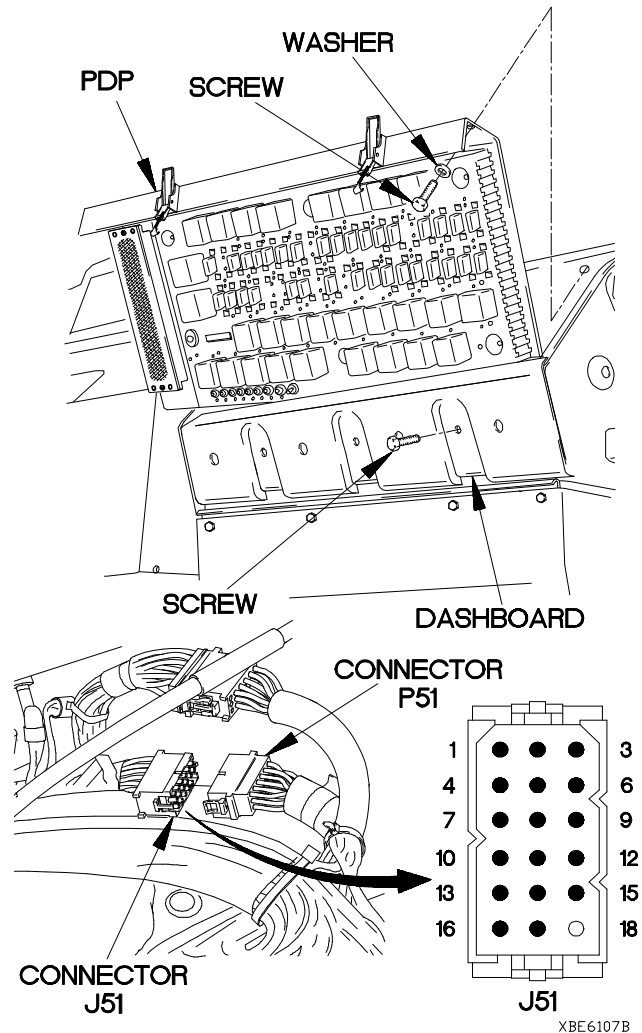

e59. ONE OR BOTH STOPLIGHTS DO NOT ILLUMINATE (CONT)

KNOWN INFO
Blackout stoplights illuminate. Main light switch OK. Diode D1A OK. Relay K10 OK. Lamp OK. Composite taillight assembly OK. Turn signal switch OK. Rear lights cable assembly OK.
POSSIBLE PROBLEMS
Faulty dashboard cable assembly. Faulty diode D1B. Faulty diode D2A.

WARNING
CAUTION
Read **WARNING** and **CAUTION** on following page.

9. Is continuity present from diode D1B terminal 3 to connector J51 pin 5 (LH) or diode D2A terminal 1 to connector J51 pin 4 (RH)?

TEST OPTIONS
Voltage Test or STE/ICE-R Test #89
REASON FOR QUESTION
If 12 continuity is not present wire 461B (LH) or wire 460B (RH) is faulty. If continuity is present, diode D1B (LH) or diode D2A (RH) is faulty.

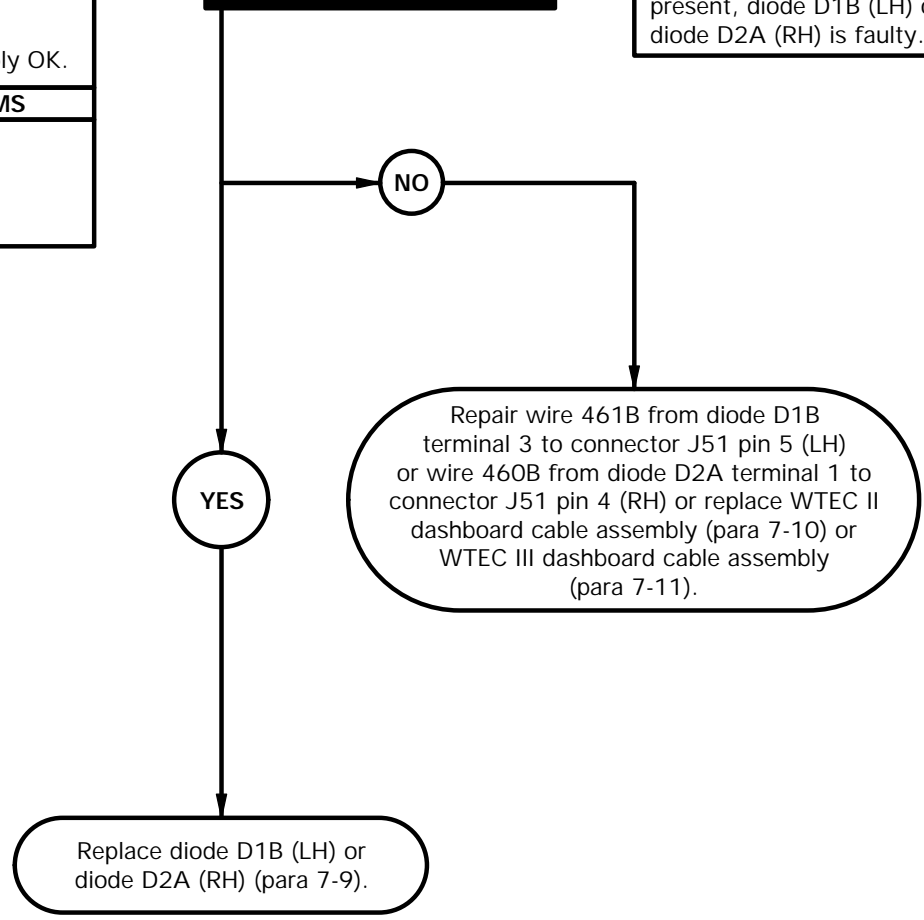

CAUTION

Use care when testing electrical connectors. Do not damage connector pins or sockets with multimeter probes. Failure to comply may result in damage to equipment.

NOTE

Inspect connector pins/sockets for damage, corrosion, and serviceability. Check that connector pins are not pushed back and are capable of making good contact.

CONTINUITY TEST

- (1) Set multimeter to volts ohms.
- (2) Connect positive (+) probe of multimeter to diode D1B terminal 3 (LH) or diode D2A terminal 1 (RH).
- (3) Connect negative (-) probe of multimeter to connector J51 pin 5 (LH) or pin 4 (RH) and note reading on multimeter.
- (4) If continuity is not present, repair wire 461B from connector J51 pin 5 to diode D1B terminal 3 (LH) or wire 460B from connector J51 pin 4 to diode D2A terminal 1 (RH) or replace WTEC II dashboard cable assembly (para 7-10) or WTEC III dashboard cable assembly (para 7-11).
- (5) Connect connector J51 to connector P51.
- (6) Install PDP on dashboard with three screws.
- (7) Install three washers and screws in PDP.
- (8) Install diode D1B (LH) or diode D2A (RH) in PDP.
- (9) Install PDP cover (para 16-2).

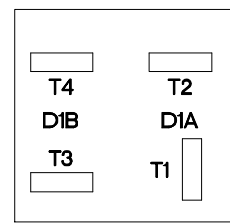
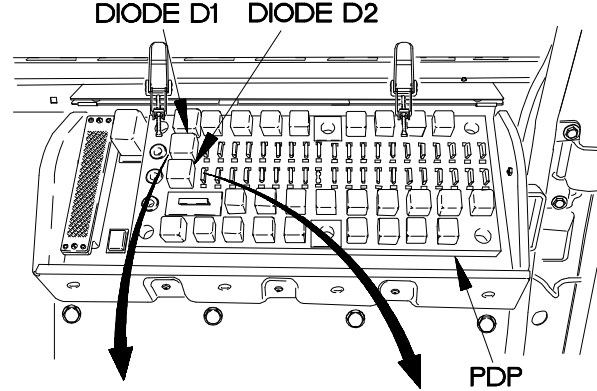
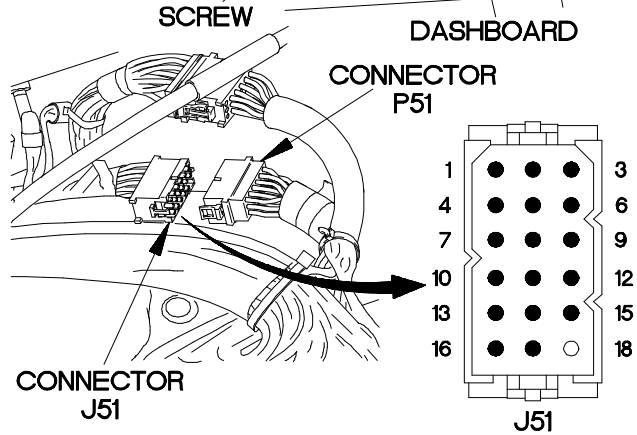
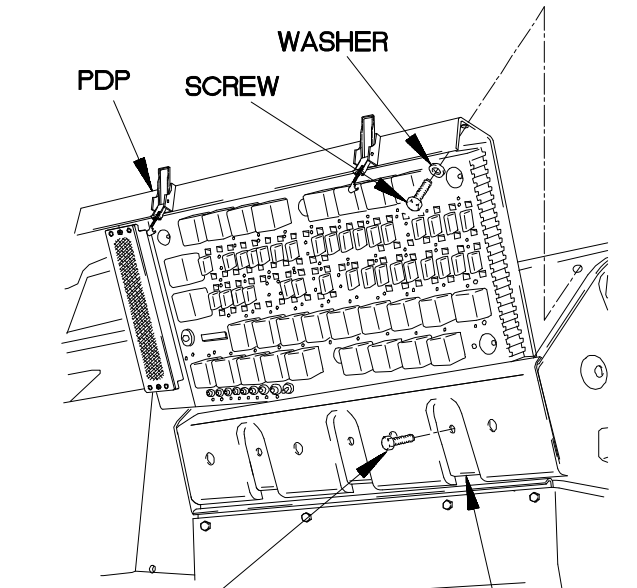

DIODE D1 CAVITY

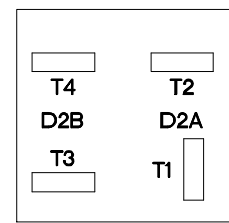

DIODE D2 CAVITY

XBE6108B

e59. ONE OR BOTH STOPLIGHTS DO NOT ILLUMINATE (CONT)

KNOWN INFO
Blackout stoplights illuminate. Lamp OK. Rear lights cable assembly OK. Composite taillight assembly OK. Turn signal switch OK. Diode D1B OK. Diode D2A OK.
POSSIBLE PROBLEMS
Faulty dashboard cable assembly. Faulty main light switch. Faulty diode D1A. Faulty relay K10.

KNOWN INFO
Blackout stoplights illuminate. Lamp OK. Rear lights cable assembly OK. Composite taillight assembly OK. Turn signal switch OK. Diode D1B OK. Diode D2A OK. Main light switch OK.
POSSIBLE PROBLEMS
Faulty dashboard cable assembly. Faulty diode D1A. Faulty relay K10.

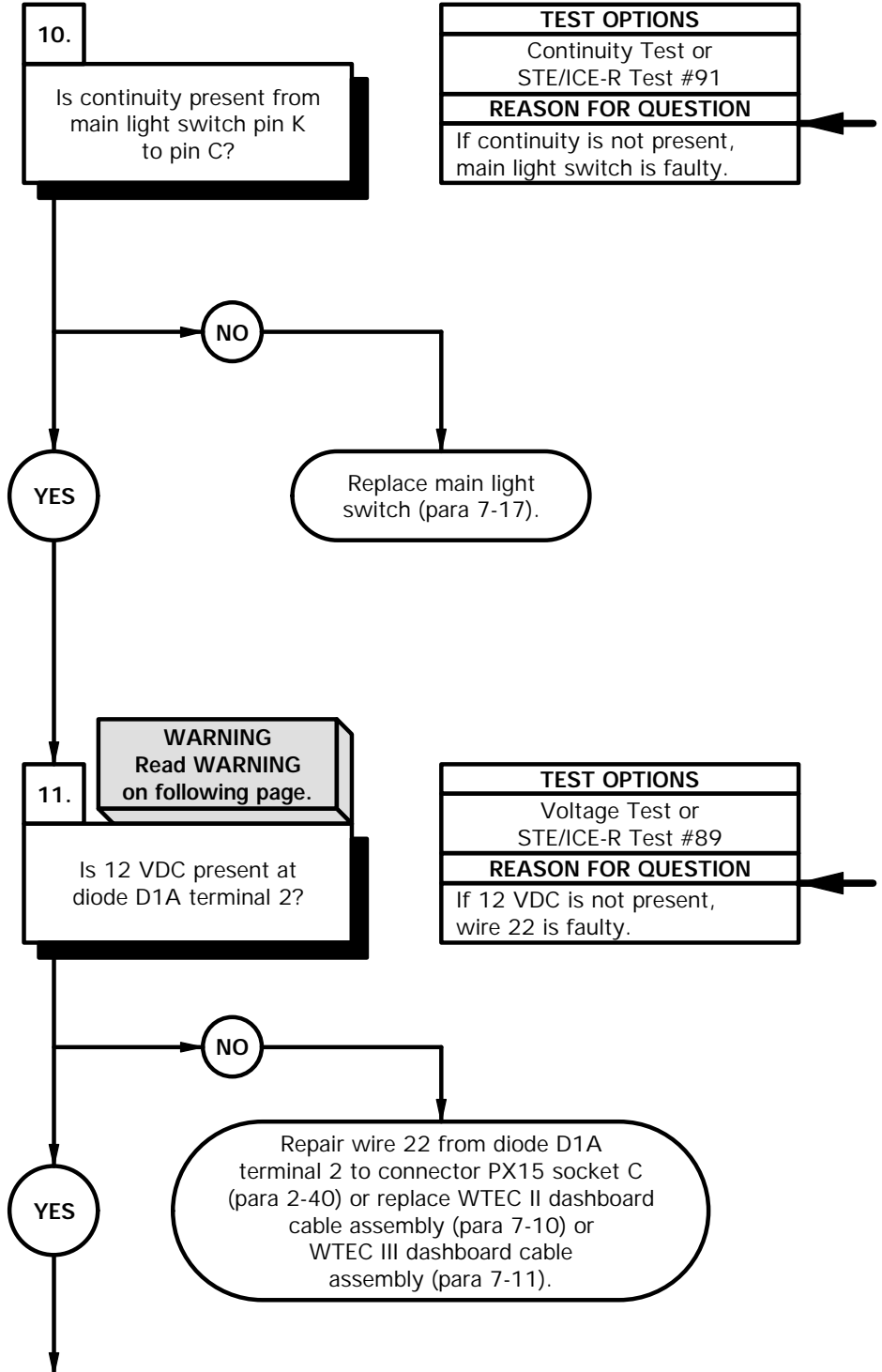

CONTINUITY TEST

- (1) Remove instrument panel assembly for access (para 7-15).
- (2) Disconnect connector PX15 from main light switch.
- (3) Set multimeter to ohms.
- (4) Connect positive (+) probe of multimeter to main light switch pin K.
- (5) Connect negative (-) probe of multimeter to main light switch pin C.
- (6) Position main light switch to STOPLIGHT (TM 9-2320-365-10) and note reading on multimeter.
- (7) If continuity is not present, replace main light switch (para 7-17).
- (8) Position main light switch to OFF (TM 9-2320-365-10).
- (9) Connect connector PX15 to main light switch.

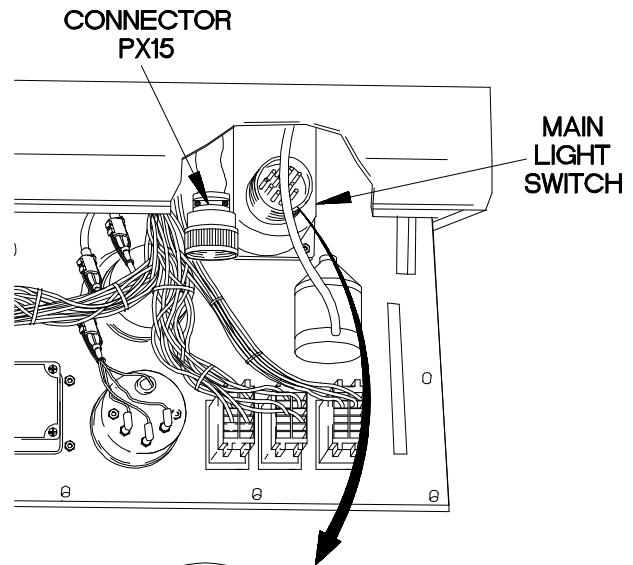

WARNING

Remove rings, bracelets, watches, necklaces, and any other jewelry before working around vehicle. Jewelry can catch on equipment and cause injury or short across electrical circuits and cause severe burns or electrical shock.

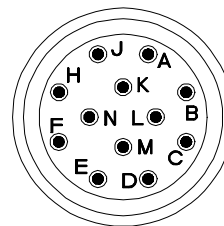

MAIN LIGHT SWITCH CONNECTOR

VOLTAGE TEST

- (1) Remove PDP cover (para 16-2).
- (2) Remove diode D1A from PDP.
- (3) Set multimeter to volts DC.
- (4) Connect positive (+) probe of multimeter to PDP, terminal 2, where diode D1A was removed.
- (5) Connect negative (-) probe of multimeter to ground.
- (6) Position master power switch to on (TM 9-2320-365-10).
- (7) Position main light switch to STOPLIGHT (TM 9-2320-365-10).
- (8) Apply brakes and note reading on multimeter.
- (9) If 12 VDC is not present, repair wire 22 from diode D1A terminal 2 to connector PX15 socket C (para 2-40) or replace WTEC II dashboard cable assembly (para 7-10) or WTEC III dashboard cable assembly (para 7-11).
- (10) Position main light switch to OFF (TM 9-2320-365-10).
- (11) Position master power switch to off (TM 9-2320-365-10).

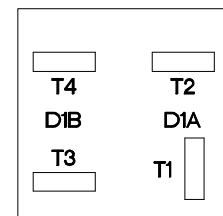
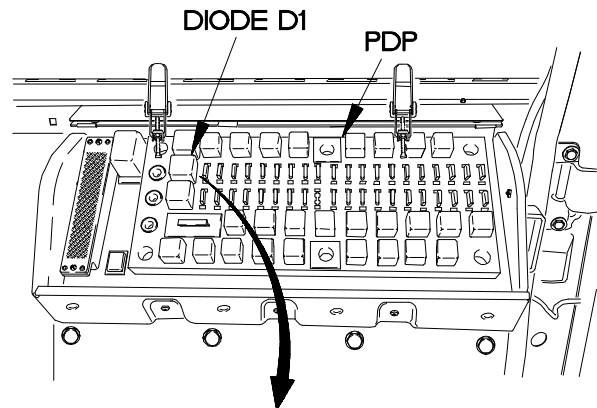

DIODE D1 CAVITY

XBE6109B

e59. ONE OR BOTH STOPLIGHTS DO NOT ILLUMINATE (CONT)

KNOWN INFO
Blackout stoplights illuminate. Lamp OK. Rear lights cable assembly OK. Composite taillight assembly OK. Turn signal switch OK. Diode D1B OK. Diode D2A OK. Main light switch OK.
POSSIBLE PROBLEMS
Faulty dashboard cable assembly. Faulty diode D1A. Faulty relay K10.

12. **WARNING**
Read **WARNING** on following page.

Is 12 VDC present at terminal block TB1 position 27?

TEST OPTIONS
Voltage Test or STE/ICE-R Test #89
REASON FOR QUESTION
This question eliminates possible faults and determines where troubleshooting continues.

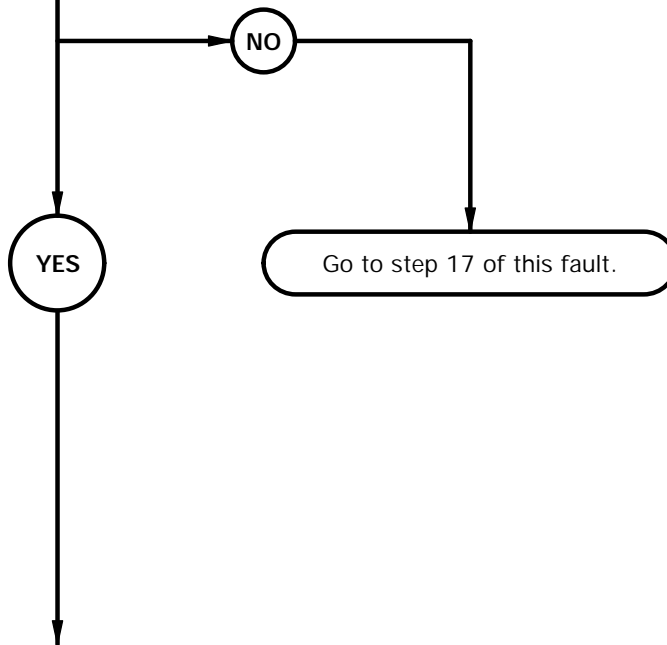

WARNING

Remove rings, bracelets, watches, necklaces, and any other jewelry before working around vehicle. Jewelry can catch on equipment and cause injury or short across electrical circuits and cause severe burns or electrical shock.

VOLTAGE TEST

- (1) Remove three screws and washers from PDP.
- (2) Remove three screws from PDP.
- (3) Lift PDP outward to gain access.
- (4) Set multimeter to volts DC.
- (5) Connect positive (+) probe of multimeter to terminal block TB1 position 27.
- (6) Connect negative (-) probe of multimeter to ground.
- (7) Position master power switch to on (TM 9-2320-365-10).
- (8) Position main light switch to STOPLIGHT (TM 9-2320-365-10).
- (9) Apply brakes and note reading on multimeter.
- (10) If 12 VDC is not present, go to step 17 of this fault.
- (11) Position main light switch to OFF (TM 9-2320-365-10).
- (12) Position master power switch to off (TM 9-2320-365-10).
- (13) Install PDP on dashboard with three screws.
- (14) Install three washers and screws in PDP.
- (15) Install diode D1A in PDP.

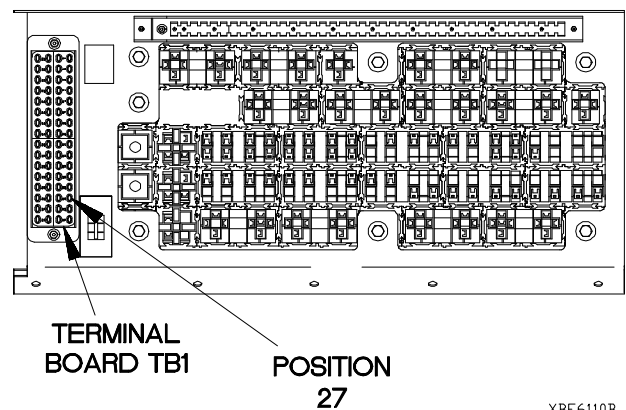
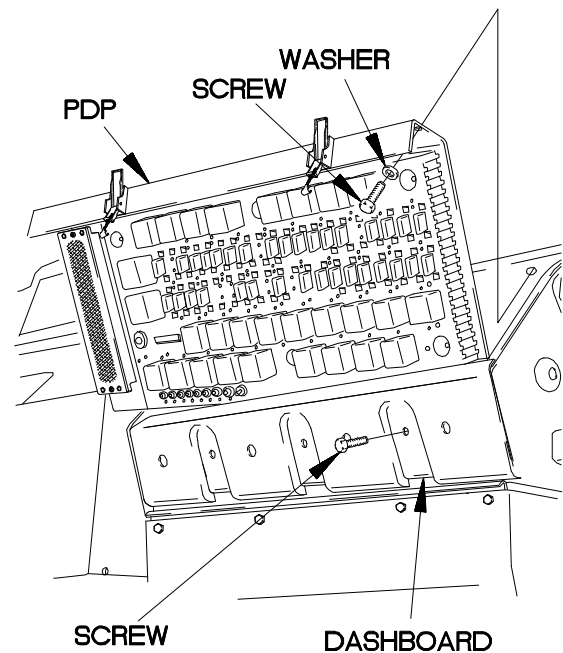
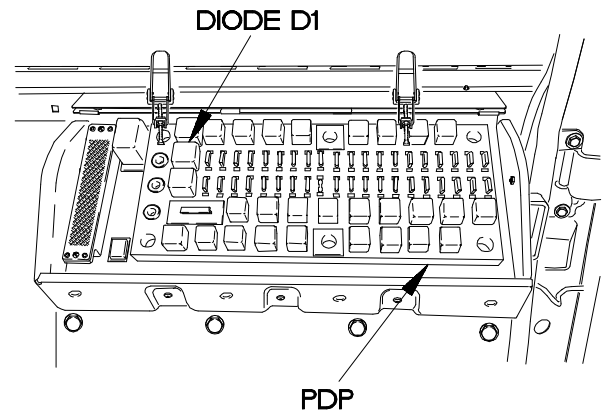

XBE6110B

e59. ONE OR BOTH STOPLIGHTS DO NOT ILLUMINATE (CONT)

KNOWN INFO
Blackout stoplights illuminate. Lamp OK. Rear lights cable assembly OK. Composite taillight assembly OK. Turn signal switch OK. Diode D1B OK. Diode D2A OK. Main light switch OK. Diode D1A OK.
POSSIBLE PROBLEMS
Faulty dashboard cable assembly. Faulty relay K10.

13. **WARNING**
Read **WARNING** on following page.

Is 12 VDC present at relay K10 terminal 86?

TEST OPTIONS
Voltage Test or STE/ICE-R Test #89
REASON FOR QUESTION
If 12 VDC is not present, wire 1940 is faulty.

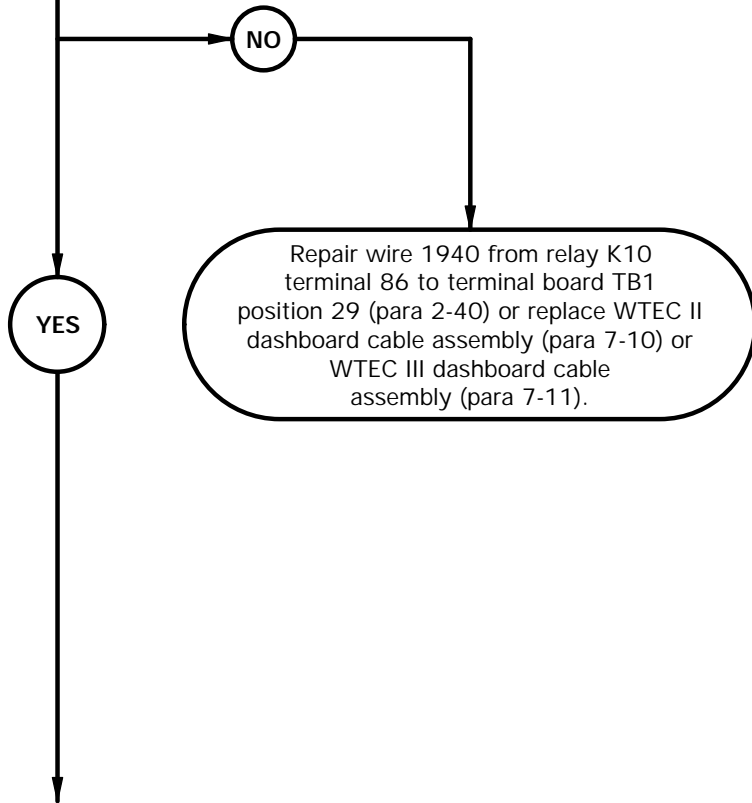

WARNING

Remove rings, bracelets, watches, necklaces, and any other jewelry before working around vehicle. Jewelry can catch on equipment and cause injury or short across electrical circuits and cause severe burns or electrical shock.

VOLTAGE TEST

- (1) Remove relay K10 from PDP.
- (2) Set multimeter to volts DC.
- (3) Connect positive (+) probe of multimeter to PDP, terminal 86, where relay K10 was removed.
- (4) Connect negative (-) probe of multimeter to ground.
- (5) Position master power switch to on (TM 9-2320-365-10).
- (6) Position main light switch to STOPLIGHT (TM 9-2320-365-10).
- (7) Apply brakes and note reading on multimeter.
- (8) If 12 VDC is not present, repair wire 1940 from relay K10 terminal 86 to terminal board TB1 position 29 (para 2-40) or replace WTEC II dashboard cable assembly (para 7-10) or WTEC III dashboard cable assembly (para 7-11).
- (9) Position main light switch to OFF (TM 9-2320-365-10).
- (10) Position master power switch to off (TM 9-2320-365-10).

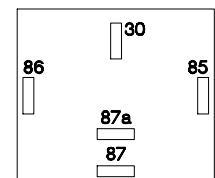
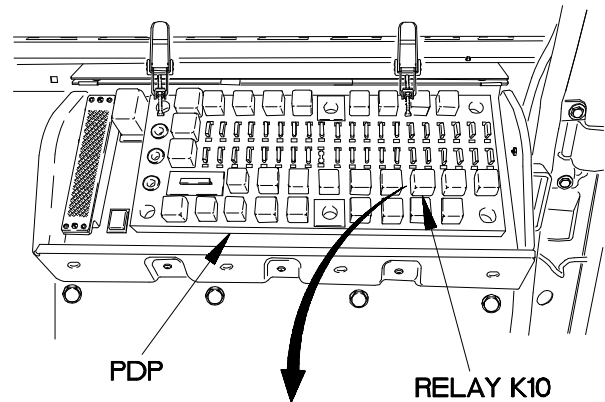

RELAY K10 CAVITY

XBe6111B

e59. ONE OR BOTH STOPLIGHTS DO NOT ILLUMINATE (CONT)

KNOWN INFO
Blackout stoplights illuminate. Lamp OK. Rear lights cable assembly OK. Composite taillight assembly OK. Turn signal switch OK. Diode D1B OK. Diode D2A OK. Main light switch OK. Diode D1A OK.
POSSIBLE PROBLEMS
Faulty dashboard cable assembly. Faulty relay K10.

KNOWN INFO
Blackout stoplights illuminate. Lamp OK. Rear lights cable assembly OK. Composite taillight assembly OK. Turn signal switch OK. Diode D1B OK. Diode D2A OK. Main light switch OK. Diode D1A OK.
POSSIBLE PROBLEMS
Faulty dashboard cable assembly. Faulty relay K10.

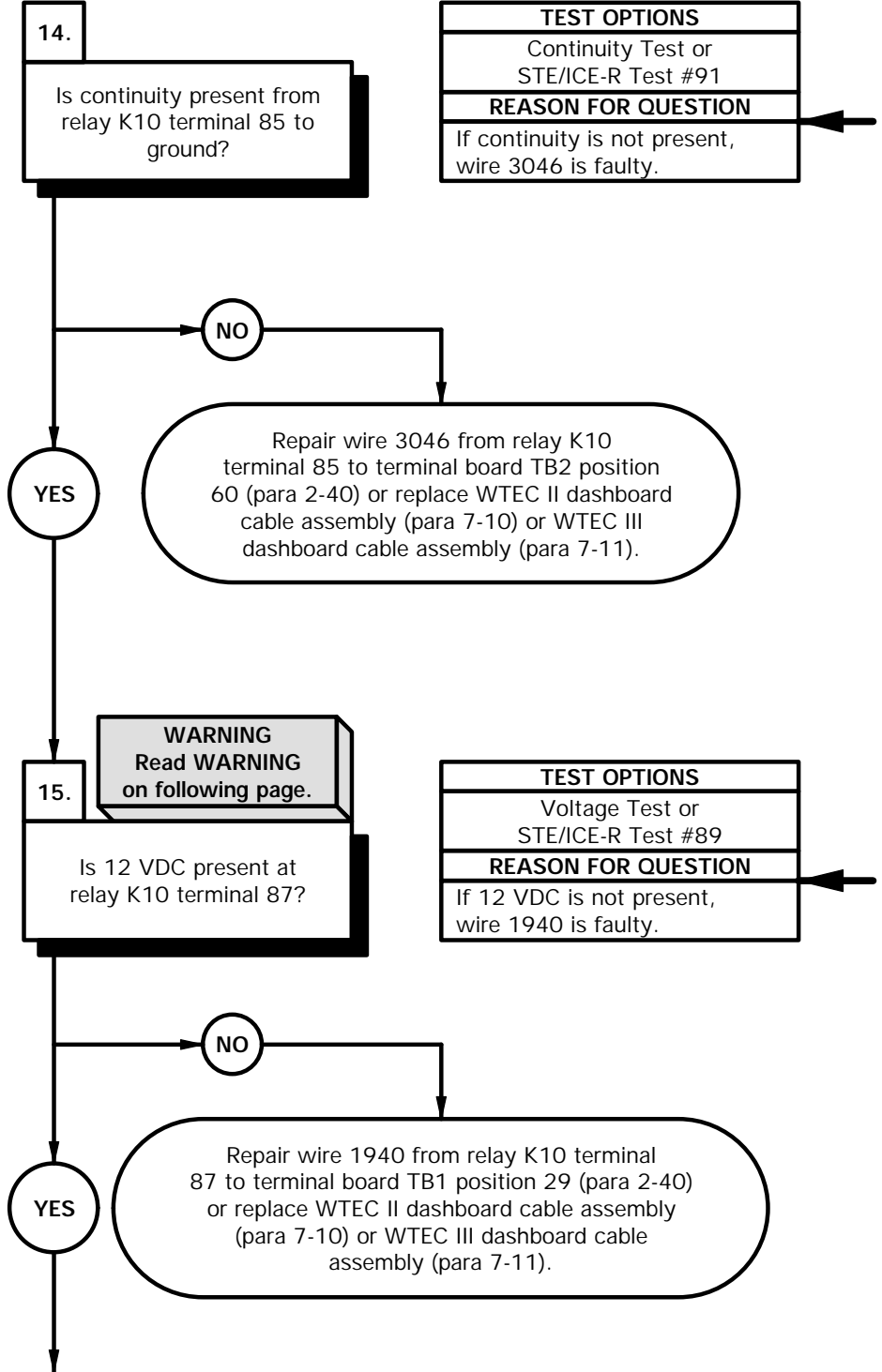

CONTINUITY TEST

- (1) Set multimeter to ohms.
- (2) Connect positive (+) probe of multimeter to PDP, terminal 85, where relay K10 was removed.
- (3) Connect negative (-) probe of multimeter to ground and note reading on multimeter.
- (4) If continuity is not present, repair wire 3046 from relay K10 terminal 85 to terminal board TB2 position 60 (para 2-40) or replace WTEC II dashboard cable assembly (para 7-10) or WTEC III dashboard cable assembly (para 7-11).

WARNING

Remove rings, bracelets, watches, necklaces, and any other jewelry before working around vehicle. Jewelry can catch on equipment and cause injury or short across electrical circuits and cause severe burns or electrical shock.

VOLTAGE TEST

- (1) Set multimeter to volts DC.
- (2) Connect positive (+) probe of multimeter to PDP, terminal 87, where relay K10 was removed.
- (3) Connect negative (-) probe of multimeter to ground.
- (4) Position master power switch to on (TM 9-2320-365-10).
- (5) Position main light switch to STOPLIGHT (TM 9-2320-365-10).
- (6) Apply brakes and note reading on multimeter.
- (7) If 12 VDC is not present, repair wire 1940 from relay K10 terminal 87 to terminal board TB1 position 29 (para 2-40) or replace WTEC II dashboard cable assembly (para 7-10) or WTEC III dashboard cable assembly (para 7-11).
- (8) Position main light switch to OFF (TM 9-2320-365-10).
- (9) Position master power switch to off (TM 9-2320-365-10).

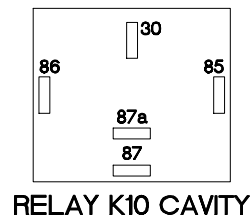
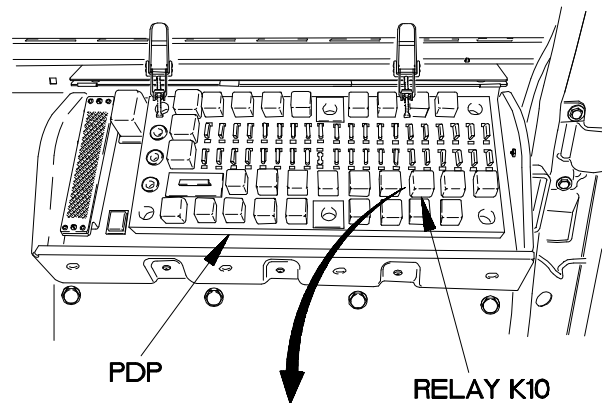

XBe6112B

e59. ONE OR BOTH STOPLIGHTS DO NOT ILLUMINATE (CONT)

KNOWN INFO
Blackout stoplights illuminate. Lamp OK. Rear lights cable assembly OK. Composite taillight assembly OK. Turn signal switch OK. Diode D1B OK. Diode D2A OK. Main light switch OK. Diode D1A OK.
POSSIBLE PROBLEMS
Faulty dashboard cable assembly. Faulty relay K10.

16. **CAUTION**
Read CAUTION on following page.

Is continuity present from relay K10 terminal 30 to connector J19 socket 6?

TEST OPTIONS
Continuity Test or STE/ICE-R Test #91
REASON FOR QUESTION
If continuity is not present, wire 1594 is faulty. If continuity is present, relay K10 is faulty.

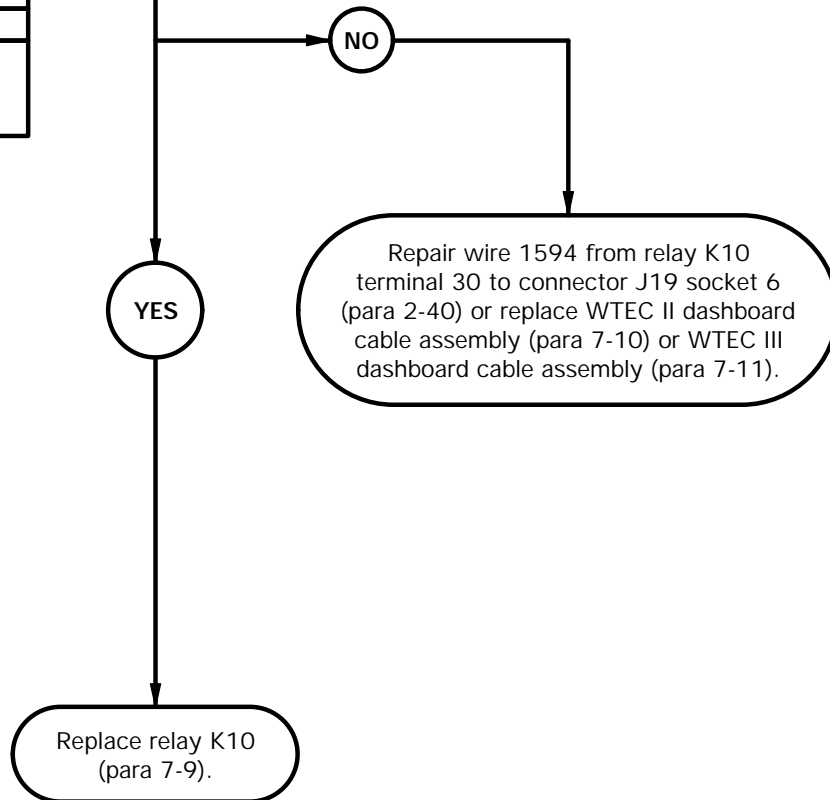

CAUTION

Use care when testing electrical connectors. Do not damage connector pins or sockets with multimeter probes. Failure to comply may result in damage to equipment.

NOTE

Inspect connector pins/sockets for damage, corrosion, and serviceability. Check that connector pins are not pushed back and are capable of making good contact.

CONTINUITY TEST

- (1) Disconnect turn signal switch connector from connector J19.
- (2) Set multimeter to ohms.
- (3) Connect positive (+) probe of multimeter to PDP, terminal 30, where relay K10 was removed.
- (4) Connect negative (-) probe of multimeter to connector J19 socket 6.
- (5) If continuity is not present, repair wire 1594 from relay K10 terminal 30 to connector J19 socket 6 (para 2-40) or replace WTEC II dashboard cable assembly (para 7-10) or WTEC III dashboard cable assembly (para 7-11).
- (6) If continuity is present, replace relay K10 (para 7-9).
- (7) Connect connector J19 to turn signal switch connector.
- (8) Install instrument panel assembly (para 7-15).
- (9) Install relay K10 in PDP.
- (10) Install PDP cover (para 16-2).

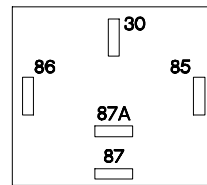
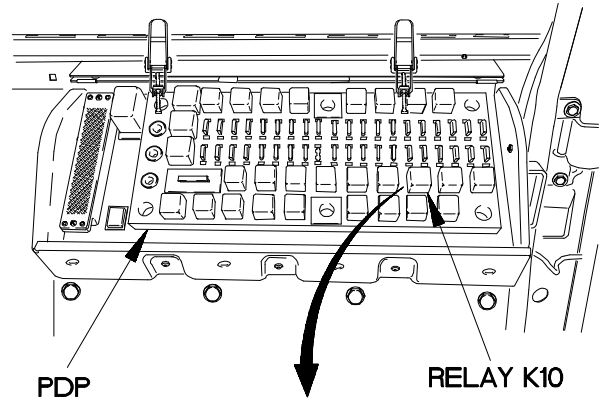

RELAY K10 CAVITY

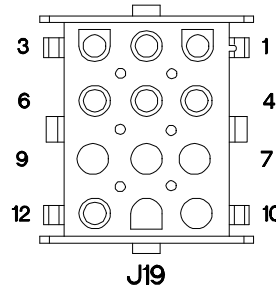
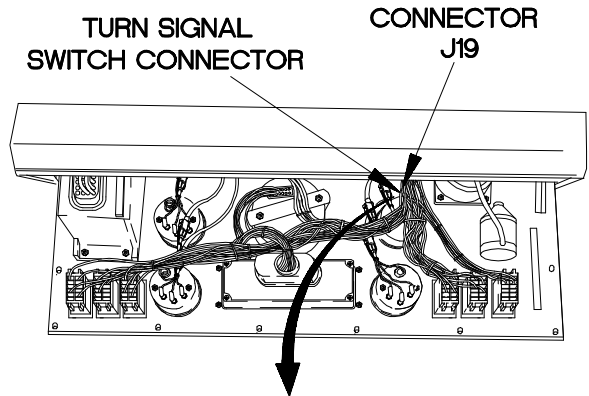

XBE6113B

e59. ONE OR BOTH STOPLIGHTS DO NOT ILLUMINATE (CONT)

KNOWN INFO
Blackout stoplights illuminate. Lamp OK. Rear lights cable assembly OK. Composite taillight assembly OK. Turn signal switch OK. Diode D1B OK. Diode D2A OK. Main light switch OK. Relay K10 OK.
POSSIBLE PROBLEMS
Faulty dashboard cable assembly. Faulty diode D1A.

17.
Is continuity present from terminal board TB1 position 27 to diode D1A terminal 1?

TEST OPTIONS
Continuity Test or STE/ICE-R Test #91
REASON FOR QUESTION
If continuity is not present, wire 22 is faulty.

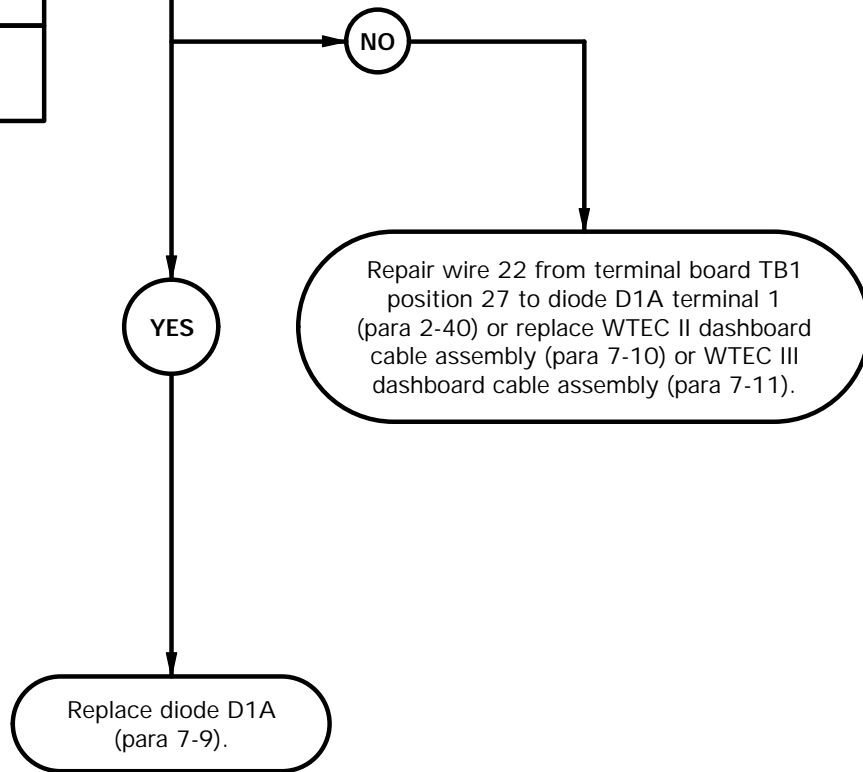

CONTINUITY TEST

- (1) Remove three screws and washers from PDP.
- (2) Remove three screws from PDP.
- (3) Lift PDP outward to gain access.
- (4) Set multimeter to ohms.
- (5) Connect positive (+) probe of multimeter to terminal board TB1 position 27.
- (6) Connect negative (-) probe of multimeter to diode D1A terminal 1 and note reading on multimeter.
- (7) If continuity is not present, repair wire 22 from terminal board TB1 position 27 to diode D1A terminal 1 (para 2-40) 1 or replace WTEC II dashboard cable assembly (para 7-10) or WTEC III dashboard cable assembly (para 7-11).
- (8) If continuity is present, replace diode D1A (para 7-9).
- (9) Install PDP on dashboard with three screws.
- (10) Install three washers and screws in PDP.
- (11) Install diode D1A in PDP.
- (12) Install PDP cover (para 16-2).

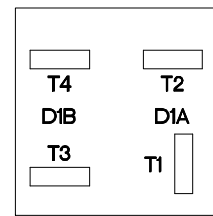
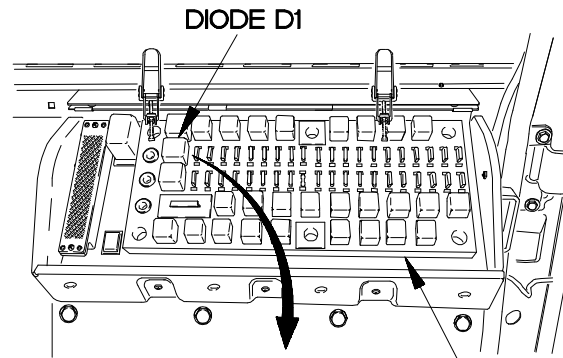

DIODE D1 CAVITY

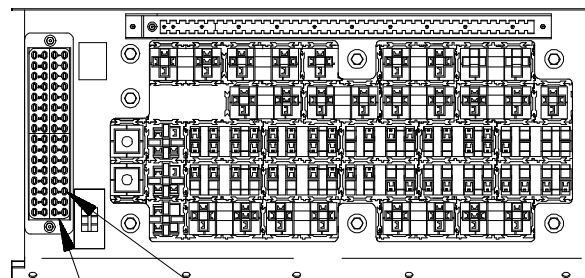
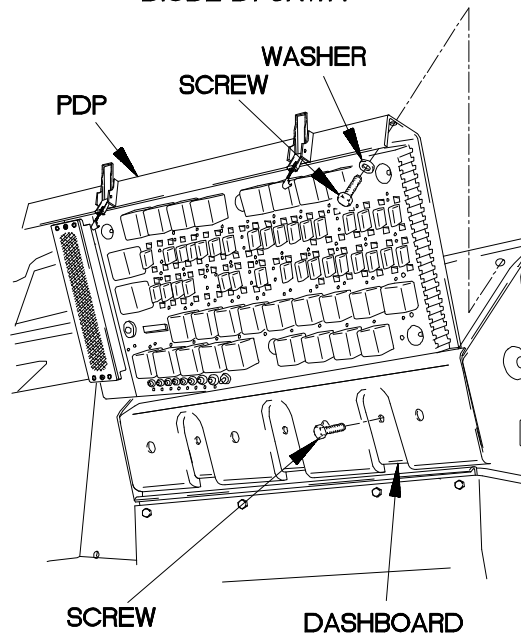

TERMINAL BOARD TB1
POSITION 27

XBE6114B

e60. ONE OR BOTH BLACKOUT STOPLIGHTS DO NOT ILLUMINATE

INITIAL SETUP

Equipment Conditions

Engine shut down (TM 9-2320-365-10).

Material/Parts

Packing, Preformed (Item 170, Appendix G)

Tools and Special Tools

Tool Kit, Genl Mech (Item 44, Appendix C)
 STE/ICE-R (Item 39, Appendix C)
 Multimeter, Digital (Item 22, Appendix C)



Personnel Required

(2)

References

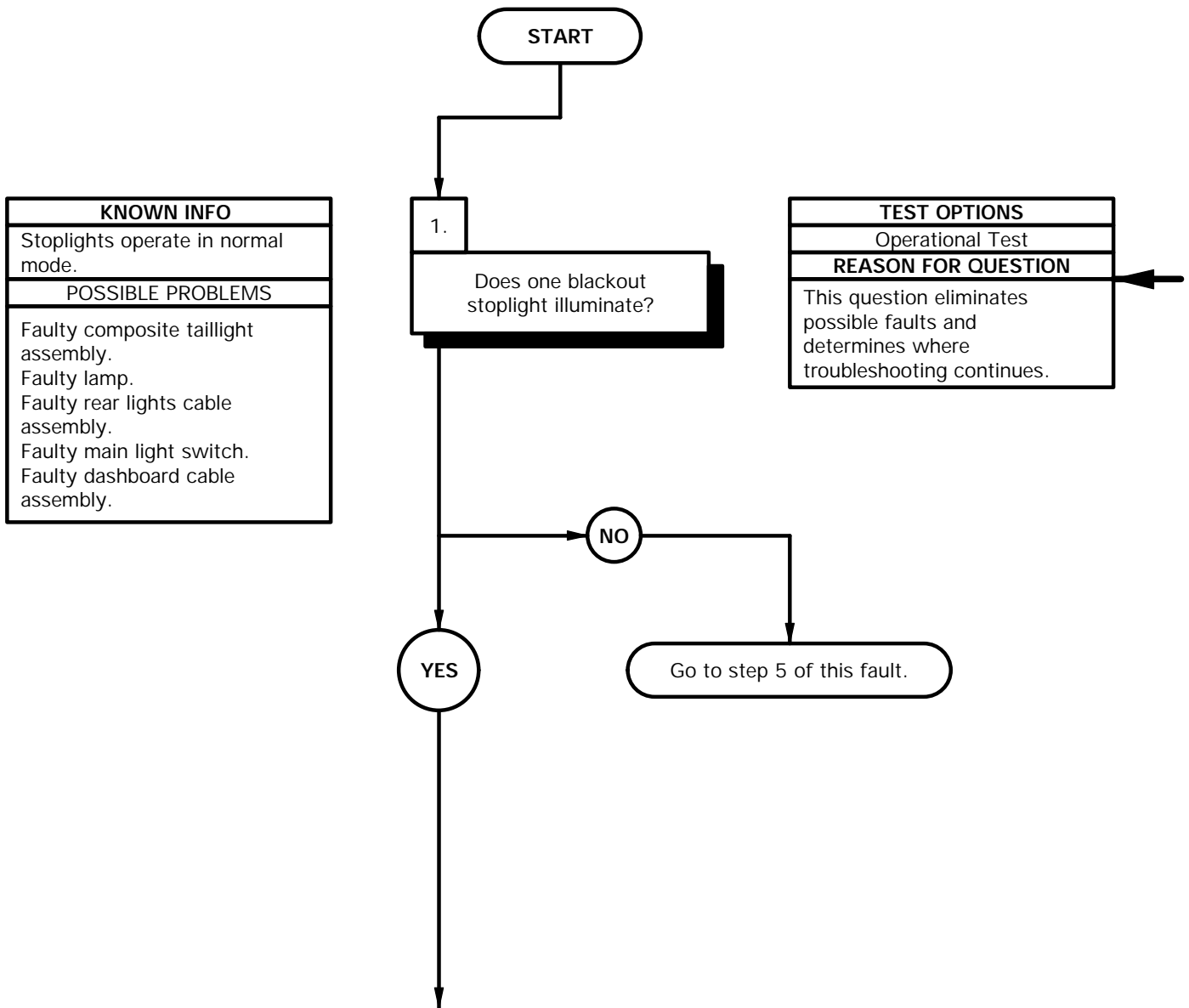
TM 9-4910-571-12&P



- 
- 
- (1) Position master power switch to on (TM 9-2320-365-10).
 - (2) Position main light switch to BO DRIVE (TM 9-2320-365-10).
 - (3) Apply brakes and observe blackout stoplights.
 - (4) If both blackout stoplights do not illuminate, go to step 5 of this fault.
 - (5) Position main light switch to OFF (TM 9-2320-365-10).
 - (6) Position master power switch to off (TM 9-2320-365-10).

e60. ONE OR BOTH BLACKOUT STOPLIGHTS DO NOT ILLUMINATE (CONT)

KNOWN INFO
Stoplights illuminate in normal mode. Dashboard cable assembly OK. Main light switch OK.
POSSIBLE PROBLEMS
Faulty rear lights cable assembly. Faulty composite taillight assembly. Faulty lamp.

2.

WARNING
Read **WARNING** on following page.

Is 12 VDC present at blackout stoplight lamp socket center contact?

TEST OPTIONS
Voltage Test or STE/ICE-R Test #89
REASON FOR QUESTION
This question eliminates possible faults and determines where troubleshooting continues.

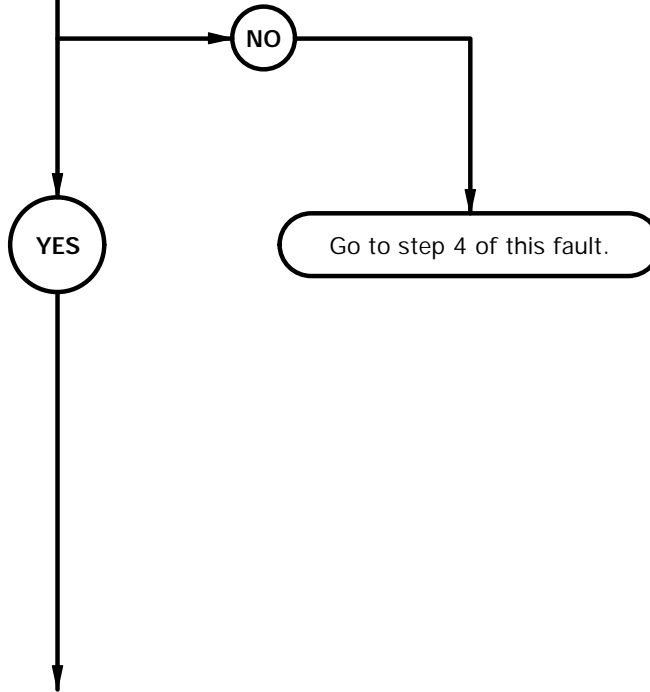

WARNING

Remove rings, bracelets, watches, necklaces, and any other jewelry before working around vehicle. Jewelry can catch on equipment and cause injury or short across electrical circuits and cause severe burns or electrical shock.

VOLTAGE TEST

- (1) Loosen six screws and remove cover and preformed packing from composite taillight assembly housing. Discard preformed packing.
- (2) Remove lamp from socket.
- (3) Set multimeter to volts DC.
- (4) Connect positive (+) probe of multimeter to blackout stoplight lamp socket center contact.
- (5) Connect negative (-) probe of multimeter to ground.
- (6) Position master power switch to on (TM 9-2320-365-10).
- (7) Position main light switch to BO DRIVE (TM 9-2320-365-10).
- (8) Apply brakes and note reading on multimeter.
- (9) If 12 VDC is not present, go to step 4 of this fault.
- (10) Position master power switch to off (TM 9-2320-365-10).
- (11) Position main light switch to OFF (TM 9-2320-365-10).

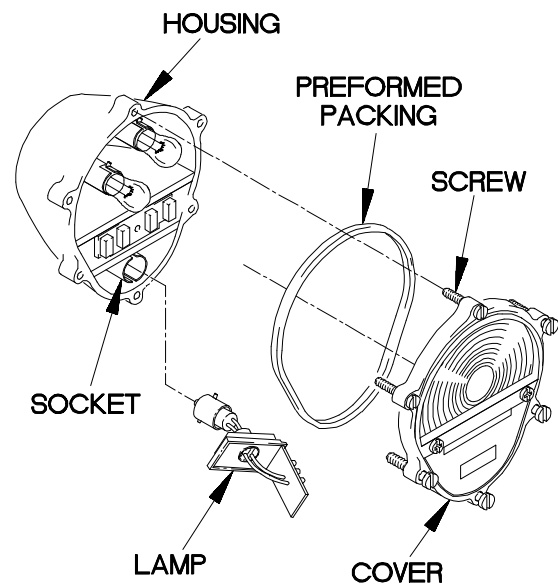

Xbe6201b

e60. ONE OR BOTH BLACKOUT STOPLIGHTS DO NOT ILLUMINATE (CONT)

KNOWN INFO
Stoplights illuminate in normal mode. Dashboard cable assembly OK. Main light switch OK. Rear lights cable assembly OK.
POSSIBLE PROBLEMS
Faulty composite taillight assembly. Faulty lamp.

3.
 Is continuity present from terminal lug TL18 (LH) or TL21 (RH) to blackout stoplight lamp socket?

TEST OPTIONS
Continuity Test or STE/ICE-R Test #91
REASON FOR QUESTION
If continuity is not present, composite taillight assembly is faulty. If continuity is present, lamp is faulty.

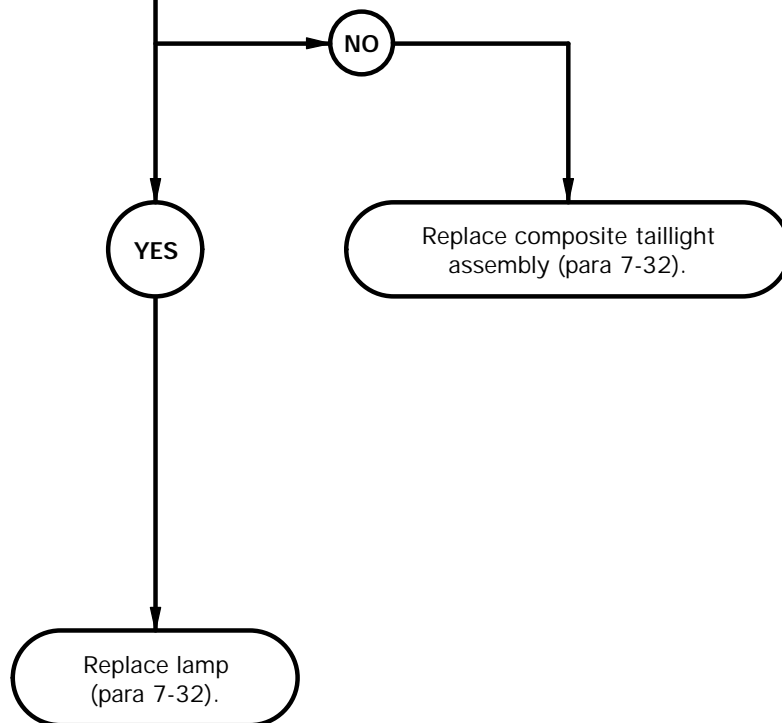

CONTINUITY TEST

- (1) Set multimeter to ohms.
- (2) Connect positive (+) probe of multimeter to terminal lug TL18 (LH) or TL21 (RH).
- (3) Connect negative (-) probe of multimeter to blackout stoplight lamp socket and note reading on multimeter.
- (4) If continuity is not present, replace composite taillight assembly (para 7-32).
- (5) If continuity is present, replace lamp (para 7-32).
- (6) Install lamp in socket.
- (7) Install preformed packing and cover on housing with six screws.

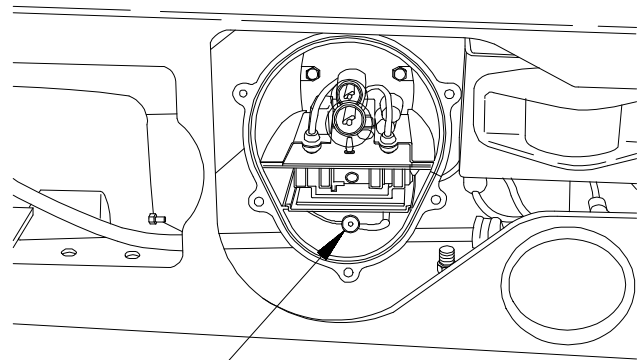

SOCKET

TERMINAL LUG
TL18 (LH) OR TL21 (RH)

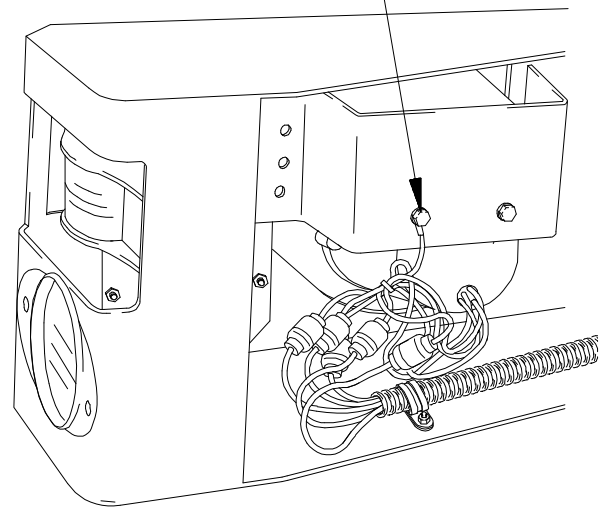

HOUSING

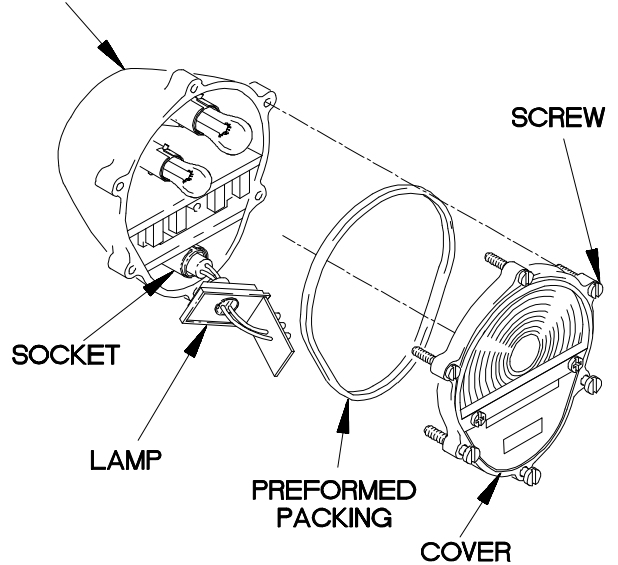

XBE6202B

e60. ONE OR BOTH BLACKOUT STOPLIGHTS DO NOT ILLUMINATE (CONT)

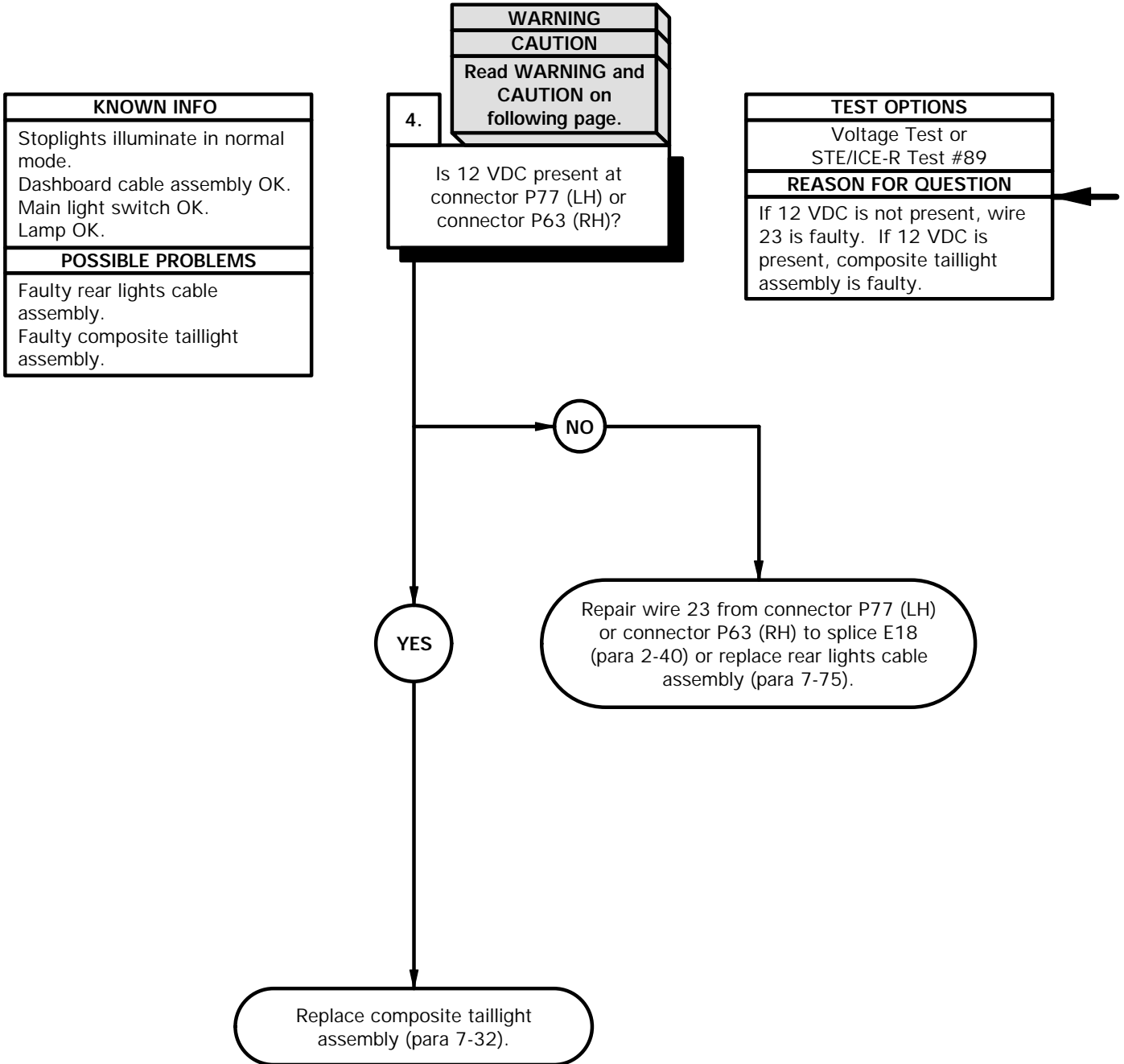

WARNING

Remove rings, bracelets, watches, necklaces, and any other jewelry before working around vehicle. Jewelry can catch on equipment and cause injury or short across electrical circuits and cause severe burns or electrical shock.

CAUTION

Use care when testing electrical connectors. Do not damage connector pins or sockets with multimeter probes. Failure to comply may result in damage to equipment.

NOTE

Inspect connector pins/sockets for damage, corrosion, and serviceability. Check that connector pins are not pushed back and are capable of making good contact.

VOLTAGE TEST

- (1) Set multimeter to volts DC.
- (2) Disconnect connector P77 (LH) or connector P63 (RH) from blackout stoplight connector.
- (3) Connect positive (+) probe of multimeter to connector P77 or connector P63.
- (4) Connect negative (-) probe of multimeter to ground.
- (5) Position master power switch to on (TM 9-2320-365-10).
- (6) Position main light switch to BO DRIVE (TM 9-2320-365-10).
- (7) Apply brakes and note reading on multimeter.
- (8) If 12 VDC is not present, repair wire 23 from connector P77 (LH) or connector P63 (RH) to splice E18 (para 2-40) or replace rear lights cable assembly (para 7-75).
- (9) If 12 VDC is present, replace composite taillight assembly (para 7-32).
- (10) Position master power switch to off (TM 9-2320-365-10).
- (11) Position main light switch to OFF (TM 9-2320-365-10).
- (12) Install lamp in socket.
- (13) Install preformed packing and cover on housing with six screws.

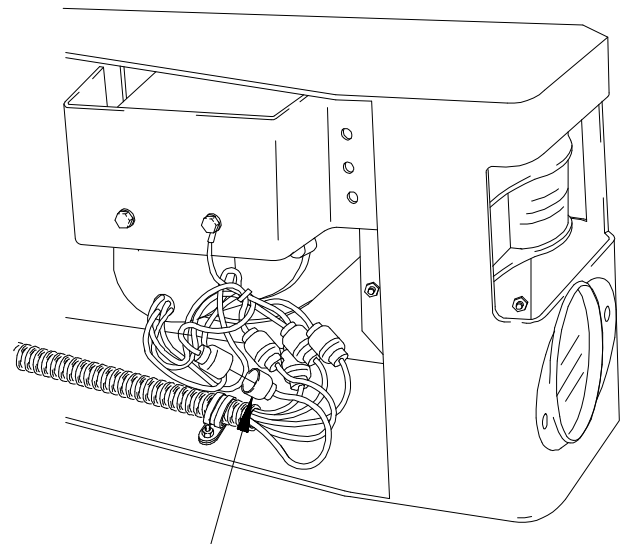

CONNECTOR P77 (LH) OR P63 (RH)

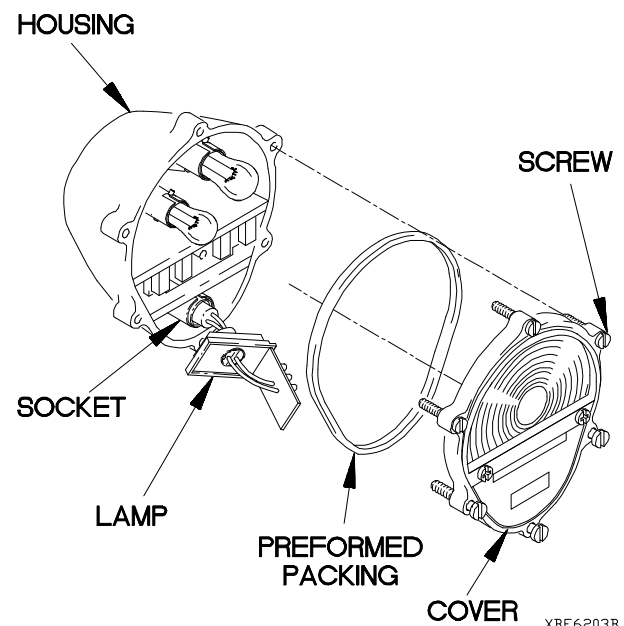

XBE6203B

e60. ONE OR BOTH BLACKOUT STOPLIGHTS DO NOT ILLUMINATE (CONT)

KNOWN INFO
Stoptlights illuminate in normal mode. Composite taillight assembly OK. Lamp OK.
POSSIBLE PROBLEMS
Faulty main light switch. Faulty dashboard cable assembly. Faulty rear lights cable assembly.

5.
Is continuity present from main light switch pin K to pin N?

TEST OPTIONS
Continuity Test or STE/ICE-R Test #91
REASON FOR QUESTION
If continuity is not present, main light switch is faulty.

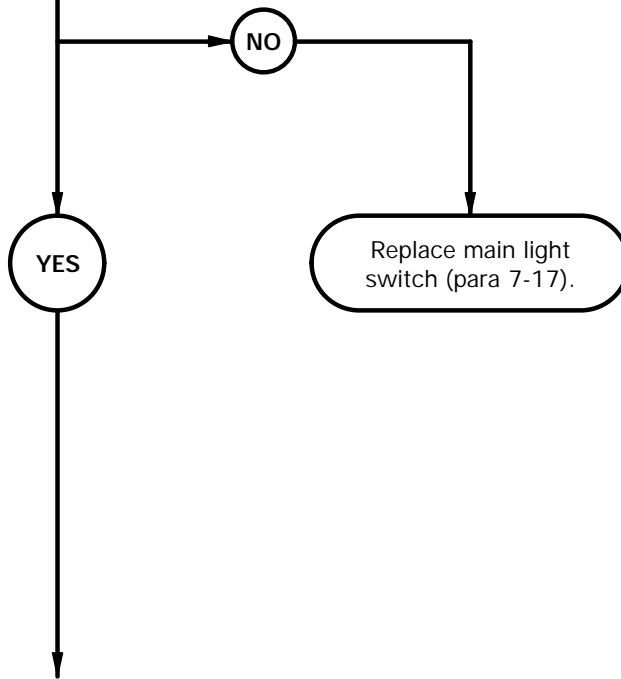

CONTINUITY TEST

- (1) Remove instrument panel assembly for access (para 7-15).
- (2) Disconnect connector PX15 from main light switch.
- (3) Set multimeter to ohms.
- (4) Connect positive (+) probe of multimeter to main light switch pin K.
- (5) Connect negative (-) probe of multimeter to main light switch pin N.
- (6) Position main light switch to BO DRIVE (TM 9-2320-365-10) and note reading on multimeter.
- (7) If continuity is not present, replace main light switch (para 7-17).
- (8) Position main light switch to OFF (TM 9-2320-365-10).

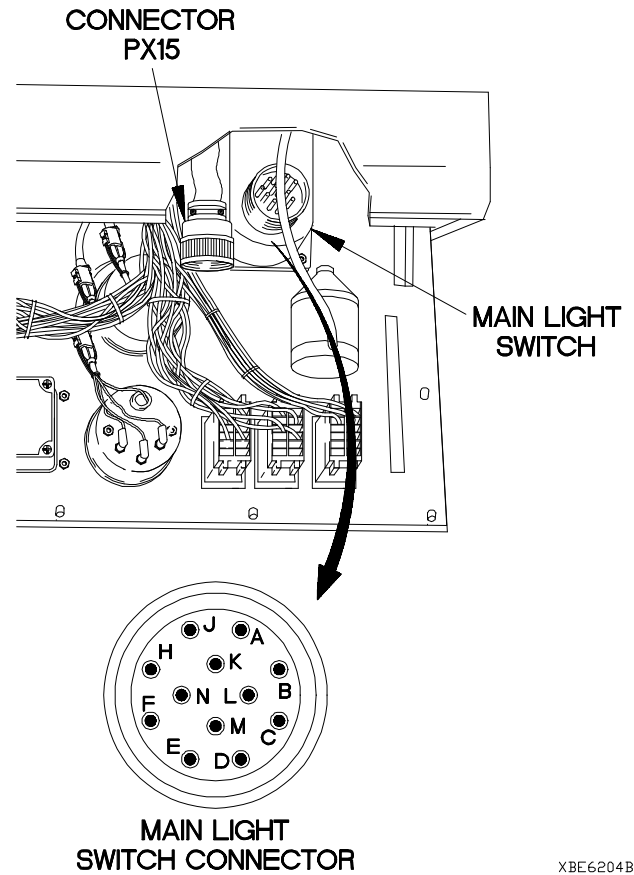

XBE6204B

e60. ONE OR BOTH BLACKOUT STOPLIGHTS DO NOT ILLUMINATE (CONT)

KNOWN INFO
Stoptlights illuminate in normal mode. Composite taillight assembly OK. Lamp OK. Main light switch OK.
POSSIBLE PROBLEMS
Faulty dashboard cable assembly. Faulty rear lights cable assembly.

6. **CAUTION**
Read CAUTION on following page.

Is continuity present from connector PX15 socket N to connector J51 pin 6?

TEST OPTIONS
Continuity Test or STE/ICE-R Test #91
REASON FOR QUESTION
If continuity is not present, wire 23 in dashboard cable assembly is faulty. If continuity is present, wire 23 in rear lights cable assembly is faulty.

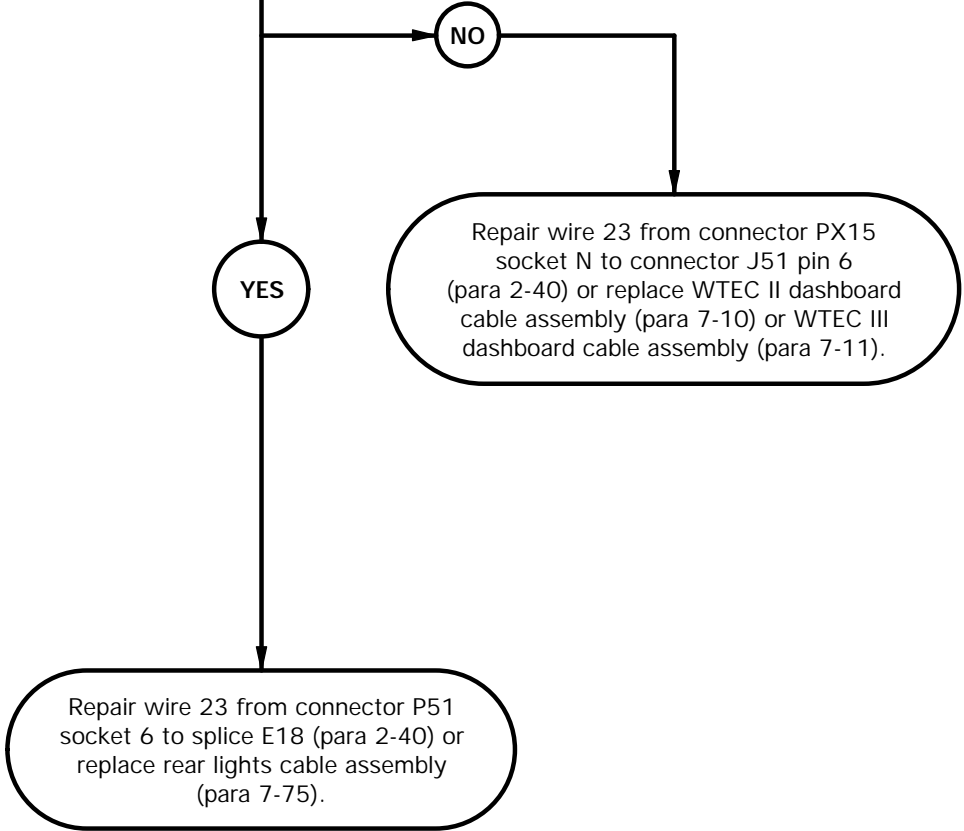

CAUTION

Use care when testing electrical connectors. Do not damage connector pins or sockets with multimeter probes. Failure to comply may result in damage to equipment.

NOTE

Inspect connector pins/sockets for damage, corrosion, and serviceability. Check that connector pins are not pushed back and are capable of making good contact.

CONTINUITY TEST

- (1) Remove PDP cover (para 16-2).
- (2) Remove three screws and washers from PDP.
- (3) Remove three screws from PDP.
- (4) Lift PDP outward to gain access.
- (5) Disconnect connector J51 from connector P51.
- (6) Set multimeter to ohms.
- (7) Connect positive (+) probe of multimeter to connector PX15 socket N.
- (8) Connect negative (-) probe of multimeter to connector J51 pin 6 and note reading on multimeter.
- (9) If continuity is not present, repair wire 23 from connector PX15 socket N to connector J51 pin 6 (para 2-40) or replace WTEC II dashboard cable assembly (para 7-10) or WTEC III dashboard cable assembly (para 7-11).
- (10) If continuity is present, repair wire 23 from connector P51 socket 6 to splice E18 (para 2-40) or replace rear lights cable assembly (para 7-75).
- (11) Connect connector PX15 to main light switch.
- (12) Install instrument panel assembly (para 7-15).
- (13) Connect connector J51 to connector P51.
- (14) Install PDP on dashboard with three screws.
- (15) Install three washers and screws in PDP.
- (16) Install PDP cover (para 16-2).

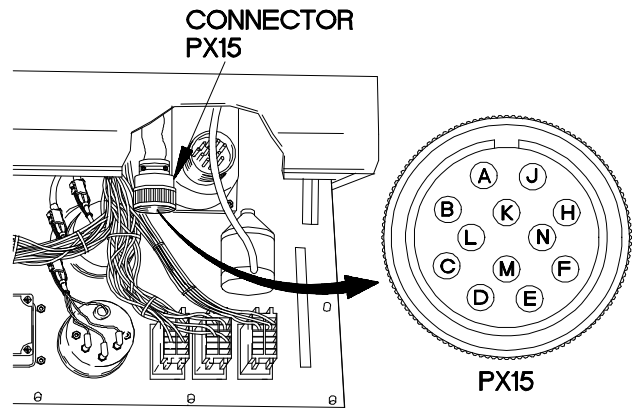
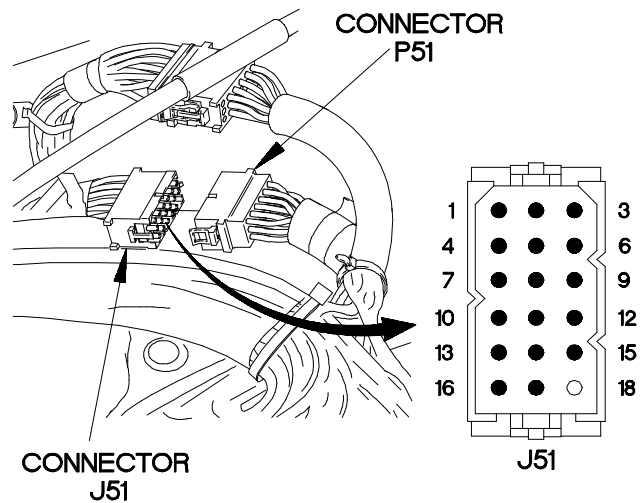
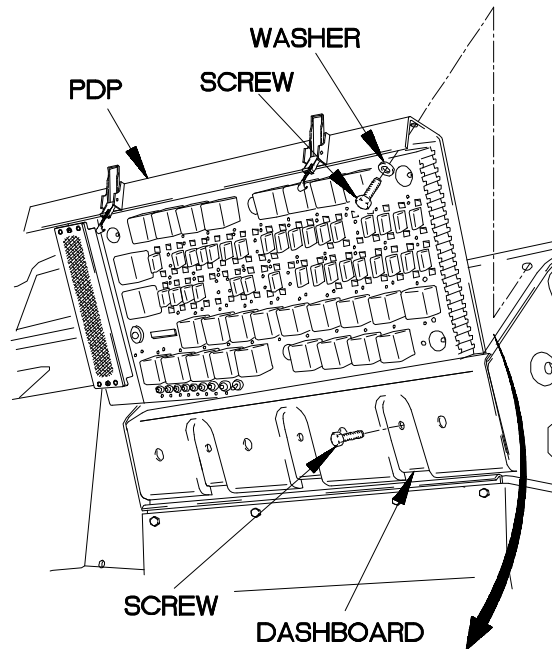

XBE6205B

e61. STOPLIGHTS AND BLACKOUT STOPLIGHTS DO NOT OPERATE	
INITIAL SETUP	
<p>Equipment Condition Engine shut down (TM 9-2320-365-10).</p> <p>Personnel Required (2)</p>	<p>Tools and Special Tools Tool Kit, Genl Mech (Item 44, Appendix C) STE/ICE-R (Item 39, Appendix C) Multimeter, Digital (Item 22, Appendix C)</p> <p>References TM 9-4910-571-12&P</p>

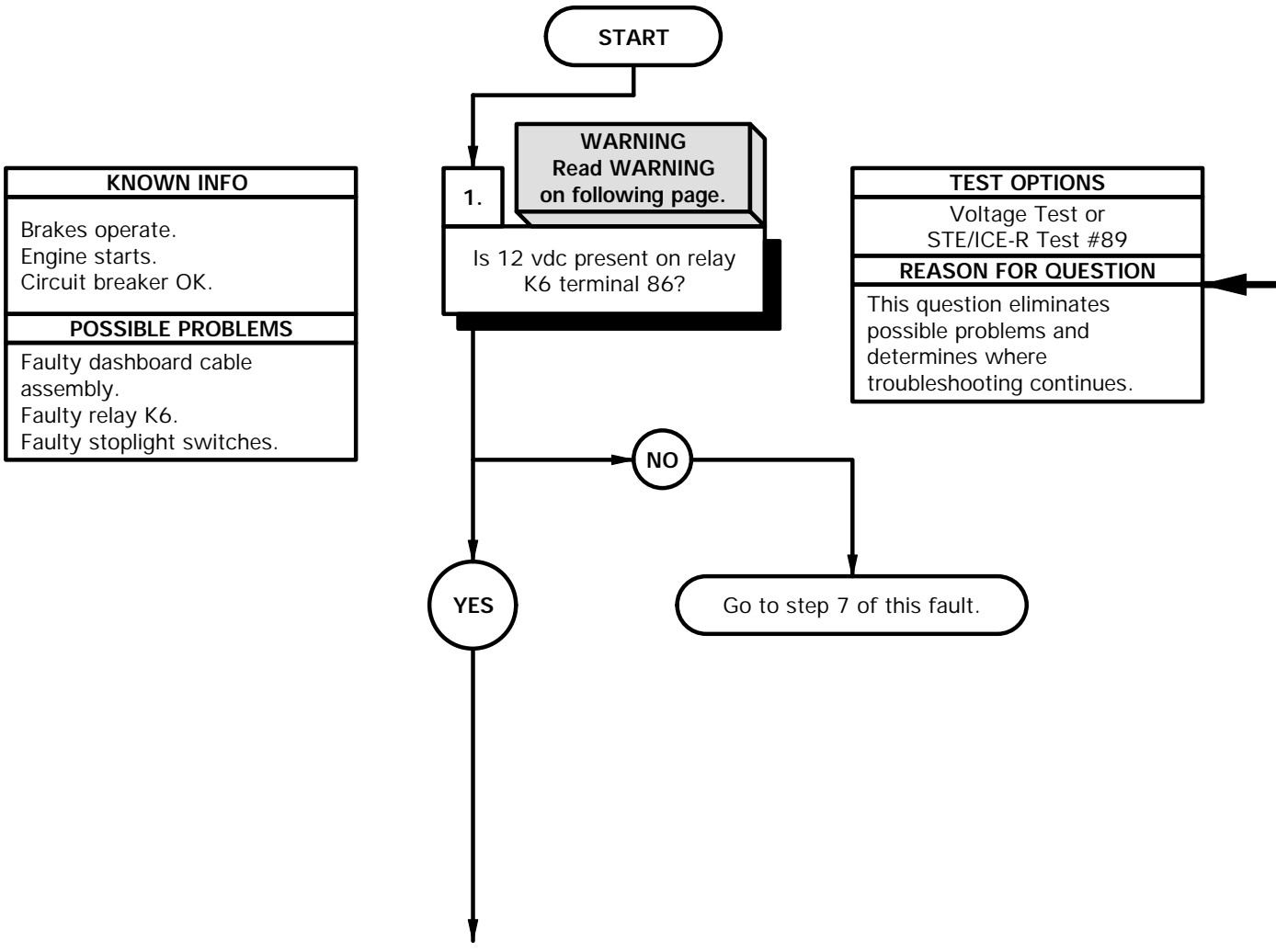

WARNING

Remove rings, bracelets, watches, necklaces, and any other jewelry before working around vehicle. Jewelry can catch on equipment and cause injury or short across electrical circuit and cause severe burns or electrical shock.

VOLTAGE TEST

- (1) Remove PDP cover (para 16-2).
- (2) Remove relay K6 from PDP.
- (3) Set multimeter to volts dc.
- (4) Connect positive (+) probe of multimeter to PDP, terminal 86, where relay K6 was removed.
- (5) Connect negative (-) probe of multimeter to ground.
- (6) Position master power switch to on (TM 9-2320-365-10) and note reading on multimeter.
- (7) If 12 vdc is not present, go to step 7 of this fault.
- (8) Position master power switch to off (TM 9-2320-365-10).

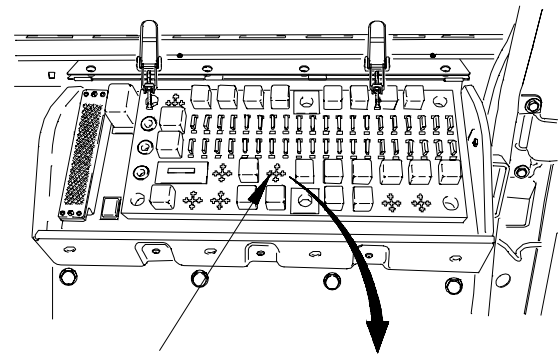

RELAY K6 CAVITY

RELAY K6 CAVITY

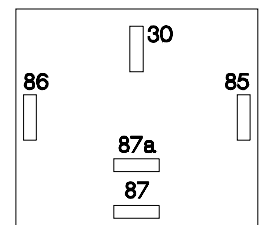

FRONT

X2E6301A

¶61. STOPLIGHTS AND BLACKOUT STOPLIGHTS DO NOT OPERATE (CONT)

KNOWN INFO
Brakes operate. Engine starts. Circuit breaker OK.
POSSIBLE PROBLEMS
Faulty dashboard cable assembly. Faulty relay K6. Faulty stoplight switches.

2.
Is continuity present between relay K6 terminal 85 and a known good ground while depressing brake pedal?

TEST OPTIONS
Continuity Test or STE/ICE-R #91
REASON FOR QUESTION
This question eliminates possible problems and determines where troubleshooting continues.

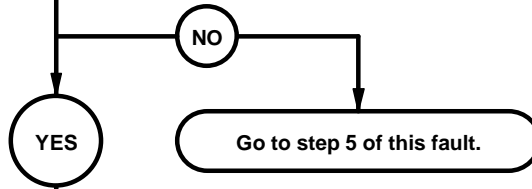

KNOWN INFO
Brakes operate. Engine starts. Circuit breaker OK. Stoplight switches OK.
POSSIBLE PROBLEMS
Faulty dashboard cable assembly. Faulty relay K6.

3.
Is 12 vdc present at relay K6 terminal 30?

TEST OPTIONS
Voltage Test or STE/ICE-R #89
REASON FOR QUESTION
If 12 vdc is not present, wire 1641 is faulty.

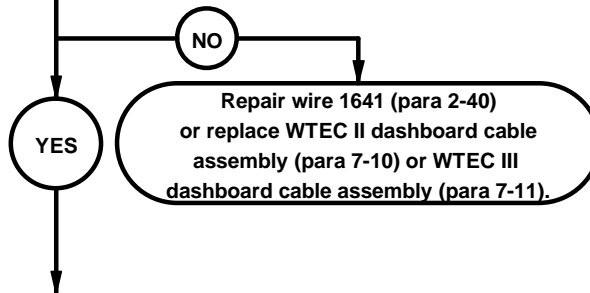

CONTINUITY TEST

- (1) Set multimeter to ohms.
- (2) Connect positive (+) probe of multimeter to PDP, terminal 85, where relay K6 was removed.
- (3) Connect negative (-) probe of multimeter to ground.

NOTE

Full system air pressure is required to actuate stoplights.

- (4) Apply brakes (TM 9-2320-365-10) and note reading on multimeter.
- (5) If continuity is not present, go to step 5 of this fault.

WARNING

Remove rings, bracelets, watches, necklaces, and any other jewelry before working around vehicle. Jewelry can catch on equipment and cause injury or short across electrical circuit and cause severe burns or electrical shock.

VOLTAGE TEST

- (1) Set multimeter to volts dc.
- (2) Connect positive (+) probe of multimeter to PDP, terminal 30, where relay K6 was removed.
- (3) Connect negative (-) probe of multimeter to ground.
- (4) Position master power switch to on (TM 9-2320-365-10) and note reading on multimeter.
- (5) If 12 vdc is not present, repair wire 1641 (para 2-40) or replace WTEC II dashboard cable assembly (para 7-10) or WTEC III dashboard cable assembly (para 7-11).
- (6) Position master power switch to off (TM 9-2320-365-10).

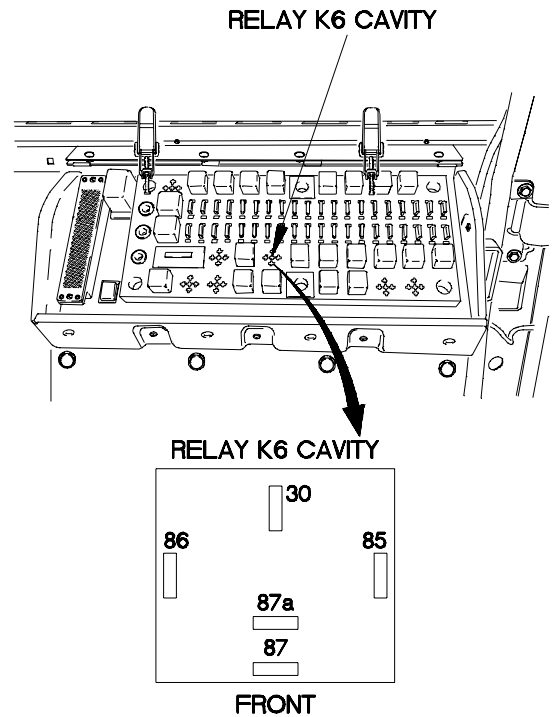

X2E6302A.dwg

ø61. STOPLIGHTS AND BLACKOUT STOPLIGHTS DO NOT OPERATE (CONT)

KNOWN INFO
Brakes operate. Engine starts. Circuit breaker OK. Stoplight switches OK.
POSSIBLE PROBLEMS
Faulty dashboard cable assembly. Faulty relay K6.

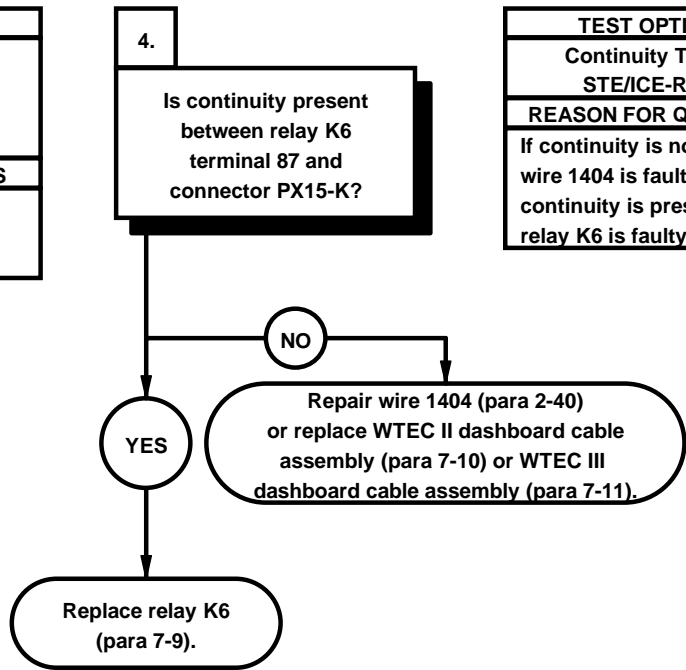

TEST OPTIONS
Continuity Test or STE/ICE-R #91
REASON FOR QUESTION
If continuity is not present, wire 1404 is faulty. If continuity is present, relay K6 is faulty.



- CONTINUITY TEST**
- (1) Remove instrument panel assembly for access (para 7-15).
 - (2) Disconnect connector PX15 from main light switch.
 - (3) Connect positive (+) probe of multimeter to connector PX15-K.
 - (4) Connect negative (-) probe of multimeter to PDP, terminal 87, where relay K6 was removed, and note reading on multimeter.
 - (5) If continuity is not present, repair wire 1404 (para 2-40) or replace WTEC II dashboard cable assembly (para 7-10) or WTEC III dashboard cable assembly (para 7-11).
 - (6) If continuity is present, replace relay K6 (para 7-9).
 - (7) Install relay K6 in PDP.
 - (8) Install PDP cover (para 16-2).
 - (9) Connect connector PX15 to main light switch.
 - (10) Install instrument panel assembly (para 7-15).

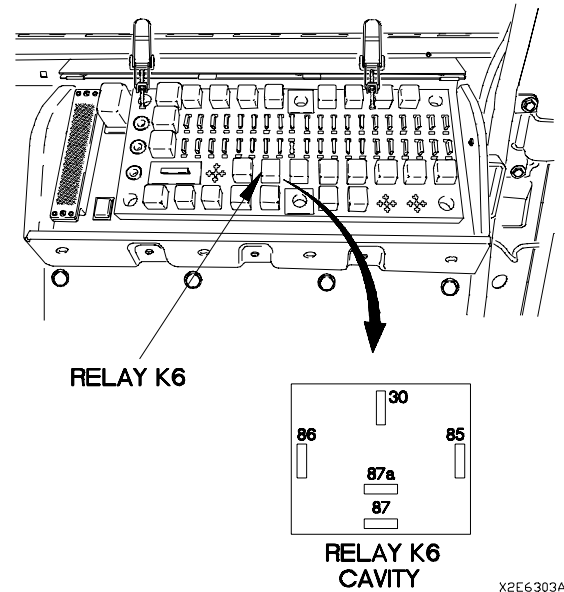
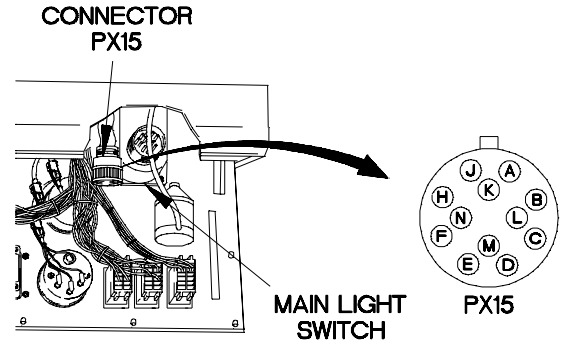

ø61. STOPLIGHTS AND BLACKOUT STOPLIGHTS DO NOT OPERATE (CONT)

KNOWN INFO
Brakes operate. Engine starts. Circuit breaker OK. Relay K6 OK.
POSSIBLE PROBLEMS
Faulty dashboard cable assembly. Faulty stoplight switches.

5.
Is continuity present between relay K6 terminal 85 and terminal lug TL154?

TEST OPTIONS
Continuity Test or STE/ICE-R #91
REASON FOR QUESTION
If continuity is not present, wire 1594 is faulty.

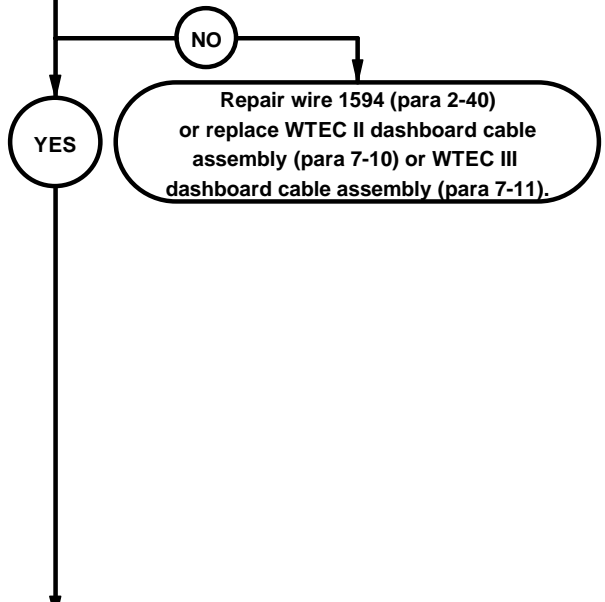

KNOWN INFO
Brakes operate. Engine starts. Circuit breaker OK. Relay K6 OK.
POSSIBLE PROBLEMS
Faulty dashboard cable assembly. Faulty stoplight switches.

6.
Is continuity present between terminal lug TL155 and a known good ground?

TEST OPTIONS
Continuity Test or STE/ICE-R #91
REASON FOR QUESTION
If continuity is not present, wire 3043 is faulty. If continuity is present, stoplight switches are faulty.

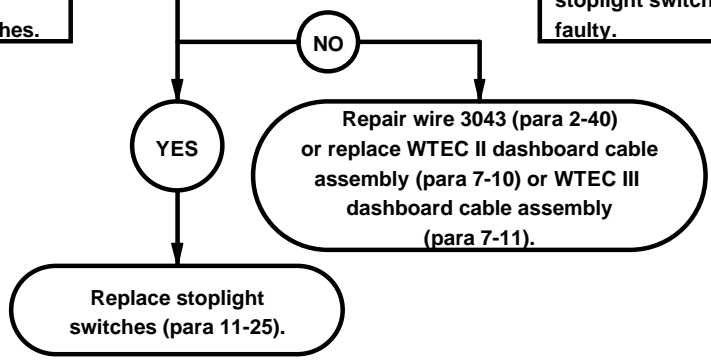

CONTINUITY TEST

- (1) Set multimeter to ohms.
- (2) Connect positive (+) probe of multimeter to terminal lug TL154.
- (3) Connect negative (-) probe of multimeter to PDP, terminal 85, where relay K6 was removed, and note reading on multimeter.
- (4) If continuity is not present, repair wire 1594 (para 2-40) or replace WTEC II dashboard cable assembly (para 7-10) or WTEC III dashboard cable assembly (para 7-11).
- (5) Install relay K6 in PDP.
- (6) Install PDP cover (para 16-2).

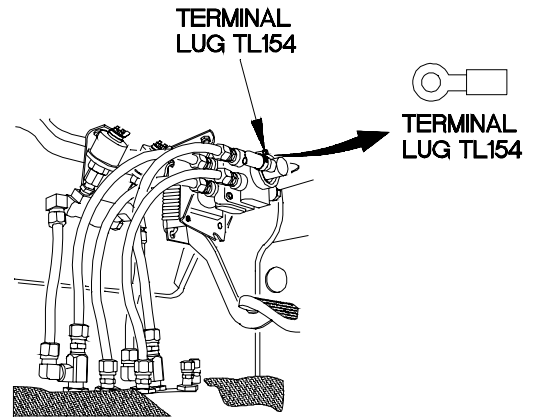

RELAY K6 CAVITY

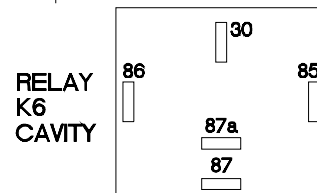
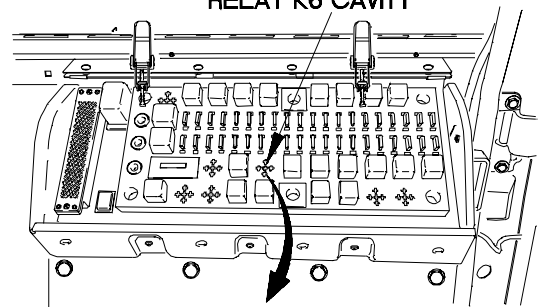

X2E6304A

CONTINUITY TEST

- (1) Set multimeter to ohms.
- (2) Connect positive (+) probe of multimeter to terminal lug TL155.
- (3) Connect negative (-) probe of multimeter to ground and note reading on multimeter.
- (4) If continuity is not present, repair wire 3043 (para 2-40) or replace WTEC II dashboard cable assembly (para 7-10) or WTEC III dashboard cable assembly (para 7-11).
- (5) If continuity is present, replace both stoplight switches (para 11-25).

TERMINAL LUG TL155

TERMINAL LUG TL155

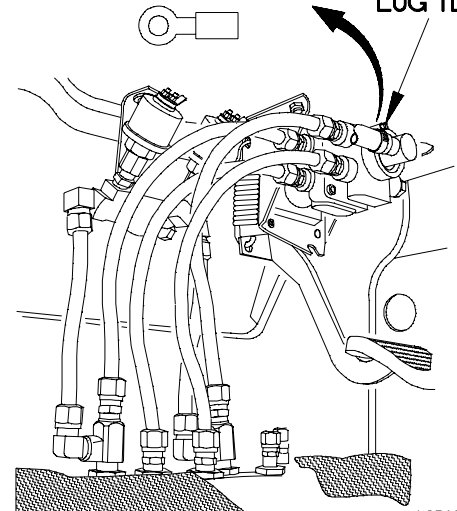

X2E6305A.dwg

ø61. STOPLIGHTS AND BLACKOUT STOPLIGHTS DO NOT OPERATE (CONT)

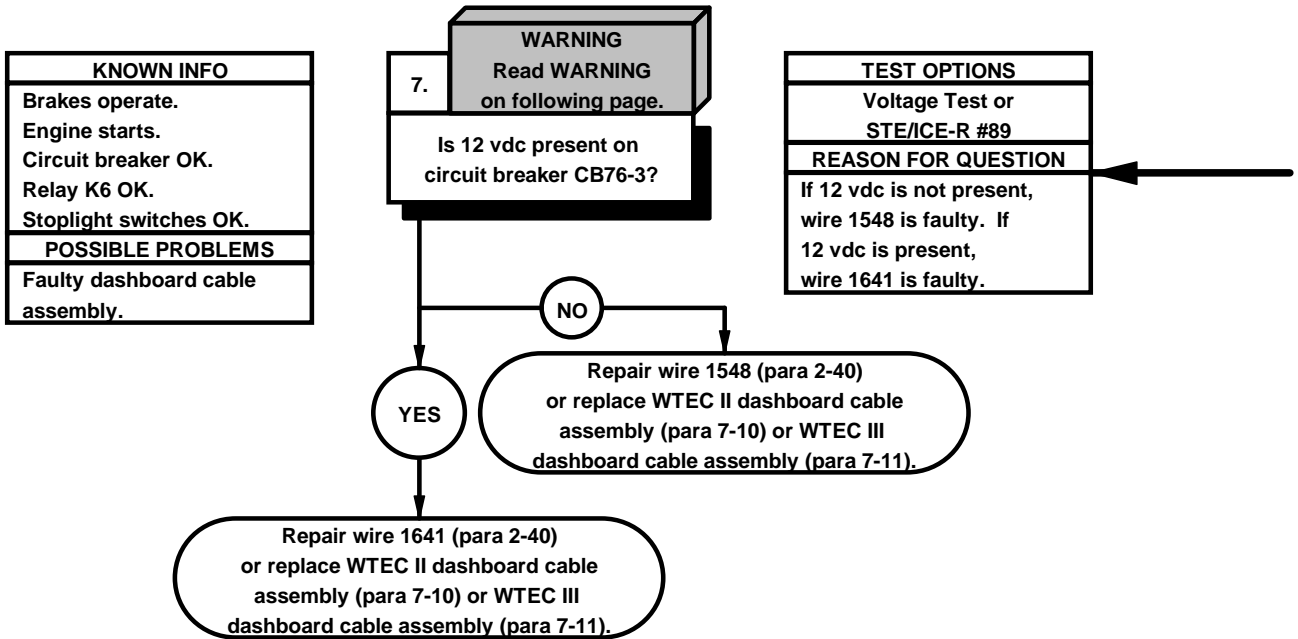

WARNING

Remove rings, bracelets, watches, necklaces, and any other jewelry before working around vehicle. Jewelry can catch on equipment and cause injury or short across electrical circuits and cause severe burns or electrical shock.

VOLTAGE TEST

- (1) Remove circuit breaker CB76 from PDP.
- (2) Set multimeter to volts dc.
- (3) Connect positive (+) probe of multimeter to PDP, terminal 3, where circuit breaker CB76 was removed.
- (4) Connect negative (-) probe of multimeter to ground.
- (5) Position master power switch to on (TM 9-2320-365-10) and note reading on multimeter.
- (6) If 12 vdc is not present, repair wire 1548 (para 2-40) or replace WTEC II dashboard cable assembly (para 7-10) or WTEC III dashboard cable assembly (para 7-11).
- (7) If 12 vdc is present, repair wire 1641 (para 2-40) or replace WTEC II dashboard cable assembly (para 7-10) or WTEC III dashboard cable assembly (para 7-11).
- (8) Position master power switch to off (TM 9-2320-365-10).
- (9) Install circuit breaker CB76 in PDP.
- (10) Install relay K6 in PDP.
- (11) Install PDP cover (para 16-2).

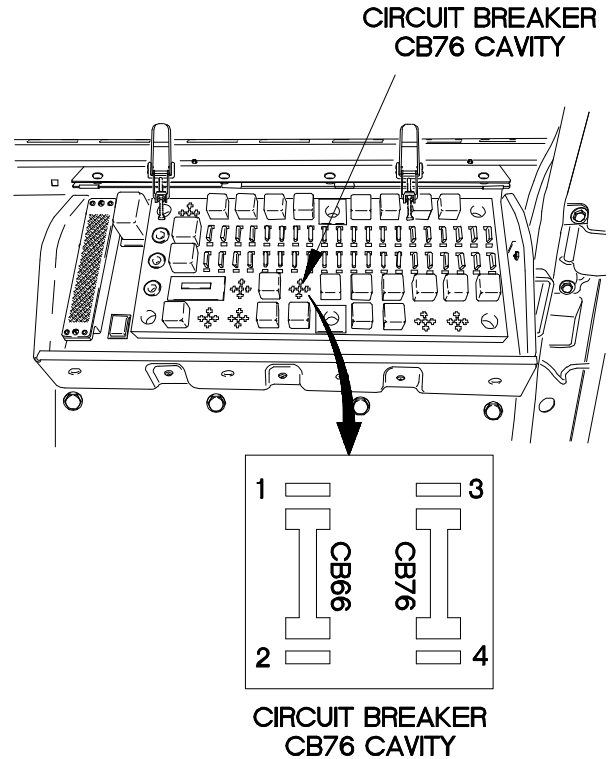

X2e6306a

e62. TRAILER MARKER/TAILLIGHTS DO NOT ILLUMINATE

INITIAL SETUP

Equipment Conditions

Engine shut down (TM 9-2320-365-10).

Material/Parts

Wire, Elect, 50 ft (Item 77, Appendix D)

Tools and Special Tools

Tool Kit, Genl Mech (Item 44, Appendix C)
 STE/ICE-R (Item 39, Appendix C)
 Multimeter, Digital (Item 22, Appendix C)

Personnel Required

(2)

References

TM 9-4910-571-12&P

NOTE

Perform Electrical System Troubleshooting e1. Circuit Breaker Does Not Operate on circuit breaker CB41 prior to beginning this task.

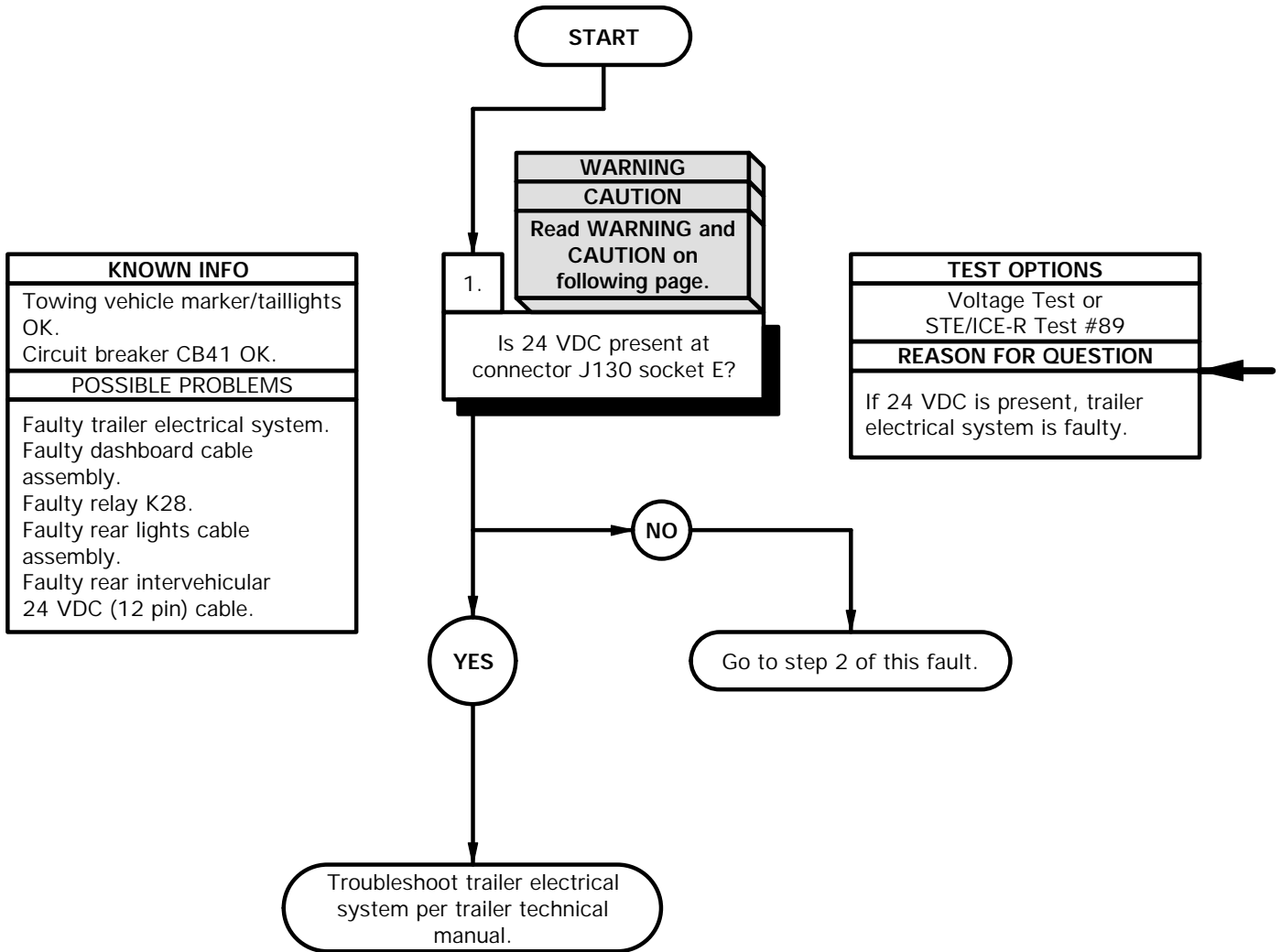

WARNING

Remove rings, bracelets, watches, necklaces, and any other jewelry before working around vehicle. Jewelry can catch on equipment and cause injury or short across electrical circuits and cause severe burns or electrical shock.

CAUTION

Use care when testing electrical connectors. Do not damage connector pins or sockets with multimeter probes. Failure to comply may result in damage to equipment.

NOTE

Inspect connector pins/sockets for damage, corrosion, and serviceability. Check that connector pins are not pushed back and are capable of making good contact.

VOLTAGE TEST

- (1) Lift cover on connector J130 intervehicular 24 VDC connector.
- (2) Set multimeter to volts DC.
- (3) Connect positive (+) probe of multimeter to connector J130 socket E.
- (4) Connect negative (-) probe of multimeter to ground.
- (5) Position main light switch to SER DRIVE (TM 9-2320-365-10) and note reading on multimeter.
- (6) If 24 VDC is not present, go to step 2 of this fault.
- (7) If 24 VDC is present, troubleshoot trailer electrical system per trailer technical manual.
- (8) Position main light switch to OFF (TM 9-2320-365-10).

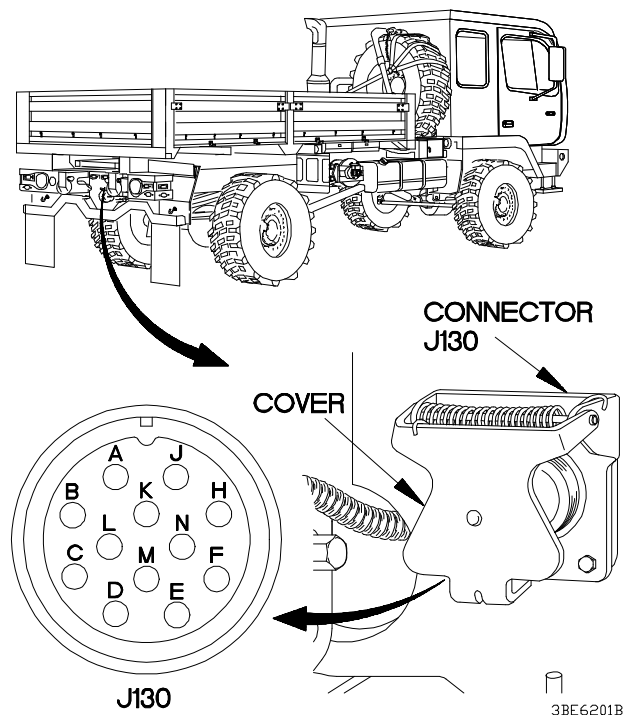

e62. TRAILER MARKER/TAILLIGHTS DO NOT ILLUMINATE (CONT)

KNOWN INFO
Towing vehicle marker/taillights OK. Circuit breaker CB41 OK. Trailer electrical system OK.
POSSIBLE PROBLEMS
Faulty dashboard cable assembly. Faulty relay K28. Faulty rear lights cable assembly. Faulty rear intervehicular 24 VDC (12 pin) cable.

2. **CAUTION**
Read CAUTION on following page.

Is continuity present from connector J130 socket E to relay K28 terminal 87?

TEST OPTIONS
Continuity Test or STE/ICE-R Test #91
REASON FOR QUESTION
This question eliminates possible problems and determines where troubleshooting continues.

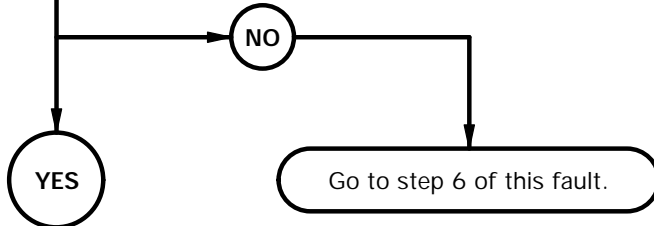

KNOWN INFO
Towing vehicle marker/taillights OK. Circuit breaker CB41 OK. Trailer electrical system OK. Rear lights cable assembly OK. Rear intervehicular 24 VDC (12 pin) cable OK.
POSSIBLE PROBLEMS
Faulty dashboard cable assembly. Faulty relay K28.

3. **WARNING**
Read WARNING on following page.

Is 24 VDC present at relay K28 terminal 30 on PDP?

TEST OPTIONS
Voltage Test or STE/ICE-R Test #89
REASON FOR QUESTION
If 24 VDC is not present, wire 1957 is faulty.

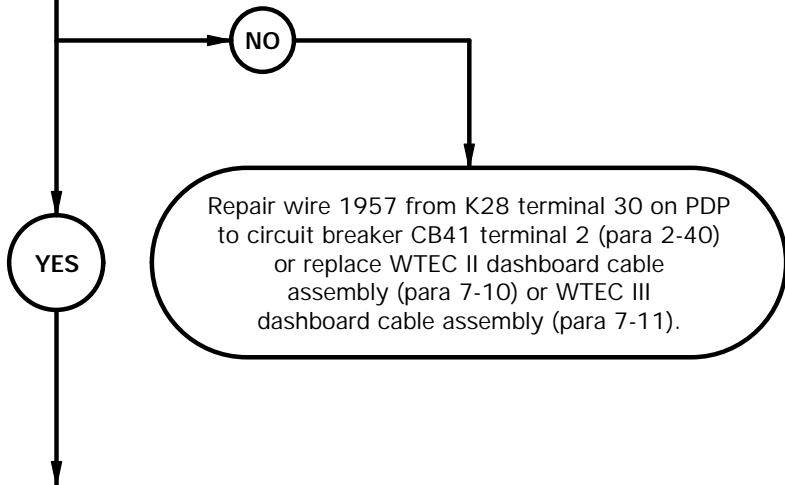

CAUTION

Use care when testing electrical connectors. Do not damage connector pins or sockets with multimeter probes. Failure to comply may result in damage to equipment.

NOTE

Inspect connector pins/sockets for damage, corrosion, and serviceability. Check that connector pins are not pushed back and are capable of making good contact.

CONTINUITY TEST

- (1) Remove PDP cover (para 16-2).
- (2) Remove relay K28 from PDP.
- (3) Set multimeter to ohms.
- (4) Connect positive (+) probe of multimeter to connector J130 socket E.
- (5) Connect negative (-) probe of multimeter to relay K28 terminal 87 on PDP and note reading on multimeter.
- (6) If continuity is not present, go to step 6 of this fault.

WARNING

Remove rings, bracelets, watches, necklaces, and any other jewelry before working around vehicle. Jewelry can catch on equipment and cause injury or short across electrical circuits and cause severe burns or electrical shock.

VOLTAGE TEST

- (1) Set multimeter to volts DC.
- (2) Connect positive (+) probe of multimeter to relay K28 terminal 30 on PDP.
- (3) Connect negative (-) probe of multimeter to ground.
- (4) Position main light switch to SER DRIVE (TM 9-2320-365-10) and note reading on multimeter.
- (5) If 24 VDC is not present, repair wire 1957 from K28 terminal 30 on PDP to circuit breaker CB41 terminal 2 (para 2-40) or replace WTEC II dashboard cable assembly (para 7-10) or WTEC III dashboard cable assembly (para 7-11).
- (6) Position main light switch to OFF (TM 9-2320-365-10).

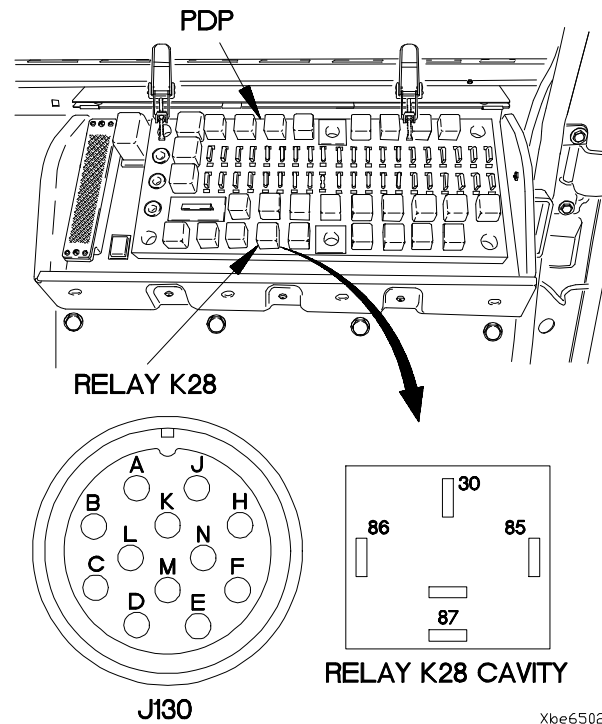

Xbe6502b

e62. TRAILER MARKER/TAILLIGHTS DO NOT ILLUMINATE (CONT)

KNOWN INFO
Towing vehicle marker/taillights OK. Circuit breaker CB41 OK. Trailer electrical system OK. Rear lights cable assembly OK. Rear intervehicular 24 VDC (12 pin) cable OK.
POSSIBLE PROBLEMS
Faulty dashboard cable assembly. Faulty relay K28.

KNOWN INFO
Towing vehicle marker/taillights OK. Circuit breaker CB41 OK. Trailer electrical system OK. Rear lights cable assembly OK. Rear intervehicular 24 VDC (12 pin) cable OK.
POSSIBLE PROBLEMS
Faulty dashboard cable assembly. Faulty relay K28.

4.

WARNING
Read **WARNING** on following page.

Is 12 VDC present at relay K28 terminal 86 on PDP?

TEST OPTIONS
Voltage Test or STE/ICE-R Test #89
REASON FOR QUESTION
If 12 VDC is not present, wire 1955 is faulty.

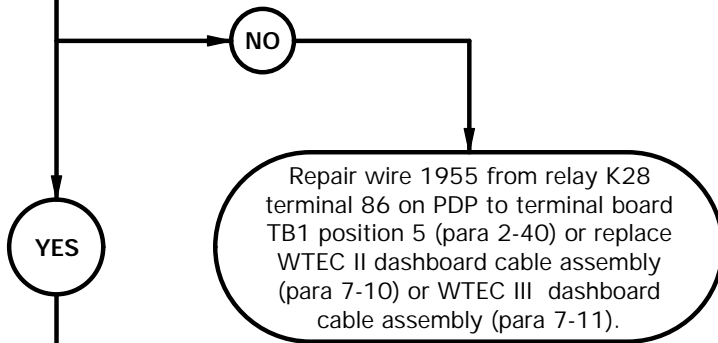

5.

Is continuity present from relay K28 terminal 85 on PDP to ground?

TEST OPTIONS
Continuity Test or STE/ICE-R Test #91
REASON FOR QUESTION
If continuity is not present, wire 3056 is faulty.

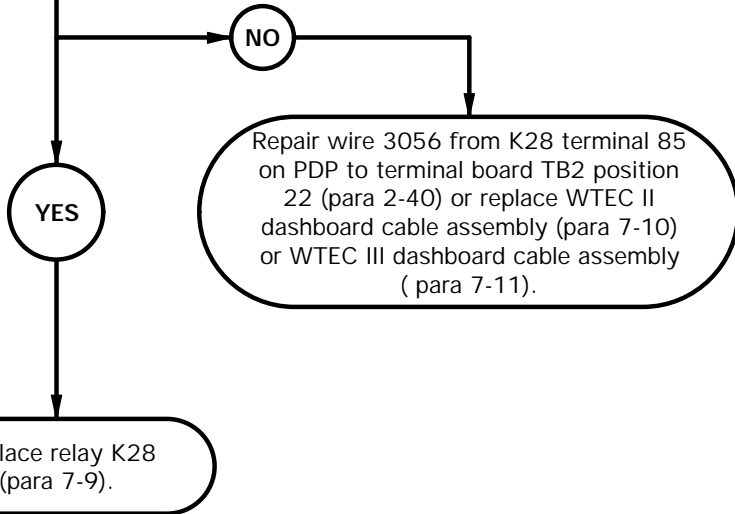

WARNING

Remove rings, bracelets, watches, necklaces, and any other jewelry before working around vehicle. Jewelry can catch on equipment and cause injury or short across electrical circuits and cause severe burns or electrical shock.

VOLTAGE TEST

- (1) Set multimeter to volts DC.
- (2) Connect positive (+) probe of multimeter to relay K28 terminal 86 on PDP.
- (3) Connect negative (-) probe of multimeter to ground.
- (4) Position main light switch to SER DRIVE (TM 9-2320-365-10) and note reading on multimeter.
- (5) If 12 VDC is not present, repair wire 1955 from relay K28 terminal 86 on PDP to terminal board TB1 position 5 (para 2-40) or replace WTEC II dashboard cable assembly (para 7-10) or WTEC III dashboard cable assembly (para 7-11).
- (6) Position main light switch to OFF (TM 9-2320-365-10).

CONTINUITY TEST

- (1) Set multimeter to ohms.
- (2) Connect positive (+) probe of multimeter to relay K28 terminal 85 on PDP.
- (3) Connect negative (-) probe of multimeter to ground and note reading on multimeter.
- (4) If continuity is not present, repair wire 3056 from K28 terminal 85 on PDP to terminal board TB2 position 22 (para 2-40) or replace WTEC II dashboard assembly (para 7-10) or WTEC III dashboard cable assembly (para 7-11).
- (5) If continuity is present, replace relay K28 (para 7-9).
- (6) Install relay K28 in PDP.
- (7) Install PDP cover (para 16-2).

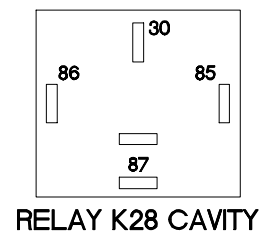
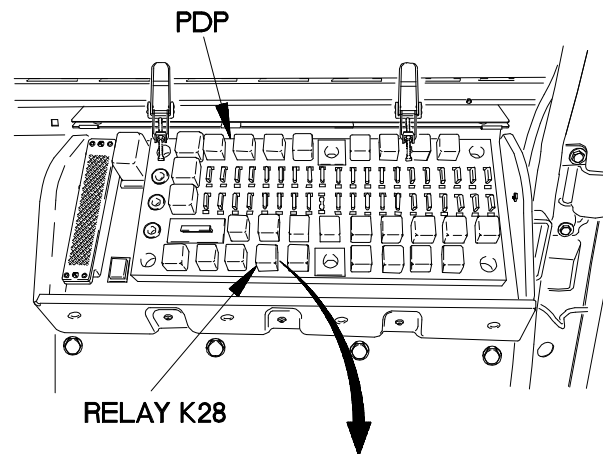

Xbe6503b

e62. TRAILER MARKER/TAILLIGHTS DO NOT ILLUMINATE (CONT)

KNOWN INFO
Towing vehicle marker/taillights OK. Circuit breaker CB41 OK. Trailer electrical system OK. Relay K28 OK.
POSSIBLE PROBLEMS
Faulty dashboard cable assembly. Faulty rear lights cable assembly. Faulty rear intervehicular 24 VDC (12 pin) cable.

6.

CAUTION
Read CAUTION on following page.

Is continuity present from relay K28 terminal 87 on PDP to connector J51 pin 9?

TEST OPTIONS
Continuity Test or STE/ICE-R Test #91
REASON FOR QUESTION
If continuity is not present, wire 489T is faulty.

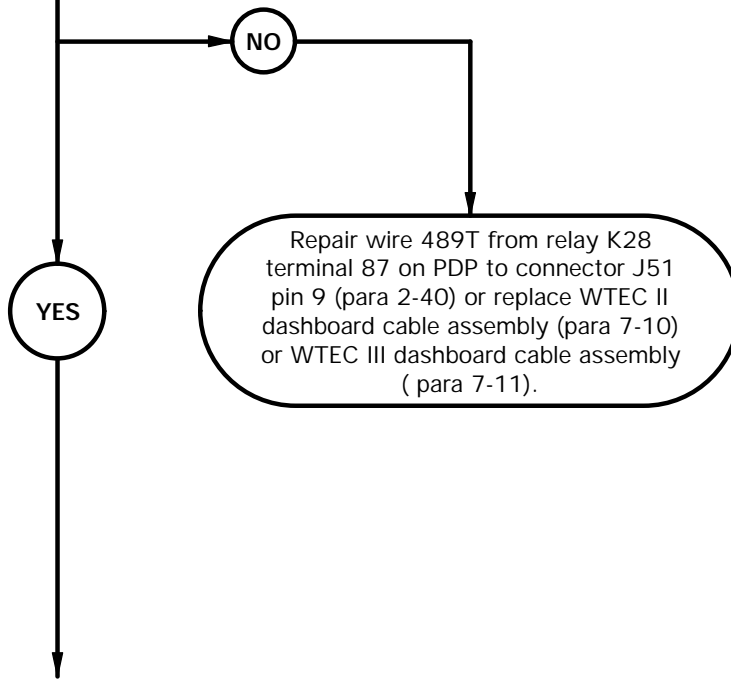

CAUTION

Use care when testing electrical connectors. Do not damage connector pins or sockets with multimeter probes. Failure to comply may result in damage to equipment.

NOTE

Inspect connector pins/sockets for damage, corrosion, and serviceability. Check that connector pins are not pushed back and are capable of making good contact.

CONTINUITY TEST

- (1) Remove three screws and washers from PDP.
- (2) Remove three screws from PDP.
- (3) Lift PDP outward to gain access.
- (4) Disconnect connector J51 from connector P51.
- (5) Set multimeter to ohms.
- (6) Connect positive (+) probe of multimeter to relay K28 terminal 87 on PDP.
- (7) Connect negative (-) probe of multimeter to connector J51 pin 9 and note reading on multimeter.
- (8) If continuity is not present, repair wire 489T from relay K28 terminal 87 on PDP to connector J51 pin 9 (para 2-40) or replace WTEC II dashboard assembly (para 7-10) or WTEC III dashboard cable assembly (para 7-11).
- (9) Install relay K28 in PDP.

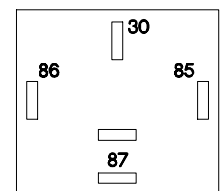
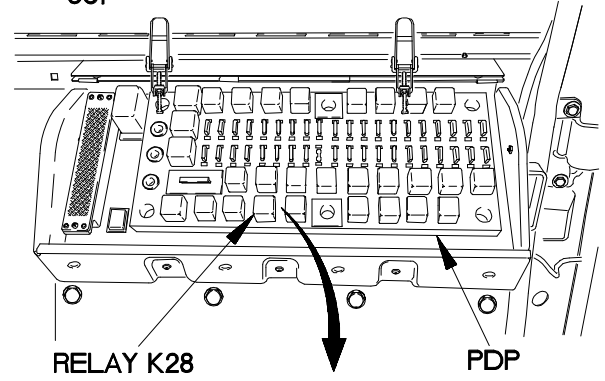
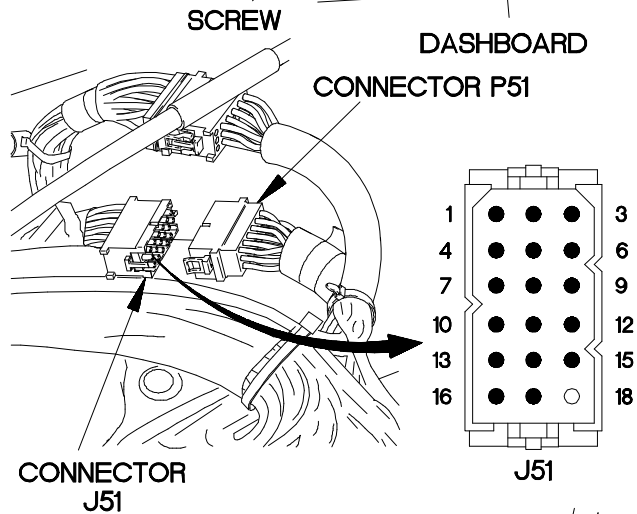
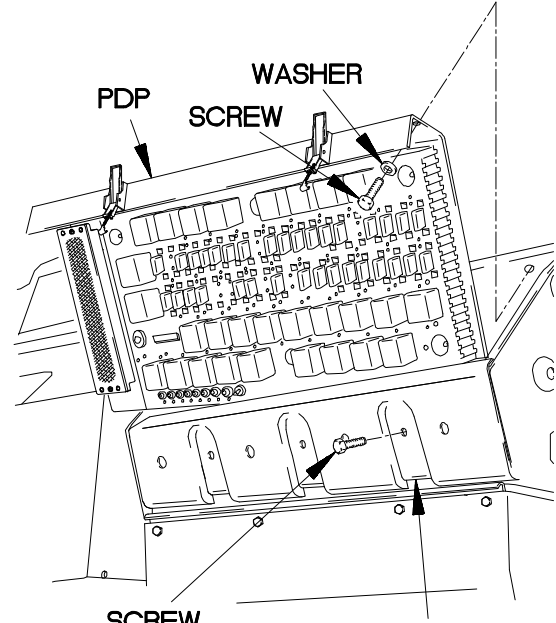

RELAY K28 CAVITY

Xbo6504b

e62. TRAILER MARKER/TAILLIGHTS DO NOT ILLUMINATE (CONT)

KNOWN INFO
Towing vehicle marker/taillights OK. Circuit breaker CB41 OK. Trailer electrical system OK. Dashboard cable assembly OK. Relay K28 OK.
POSSIBLE PROBLEMS
Faulty rear lights cable assembly. Faulty rear intervehicular 24 VDC (12 pin) cable.

7.

CAUTION
 Read CAUTION on following page.

Is continuity present from connector P51 socket 9 to connector P53R pin 2?

TEST OPTIONS
Continuity Test or STE/ICE-R Test #91
REASON FOR QUESTION
If continuity is not present, wire 489T is faulty. If continuity is present, intervehicular 24 VDC (12 pin) cable is faulty.

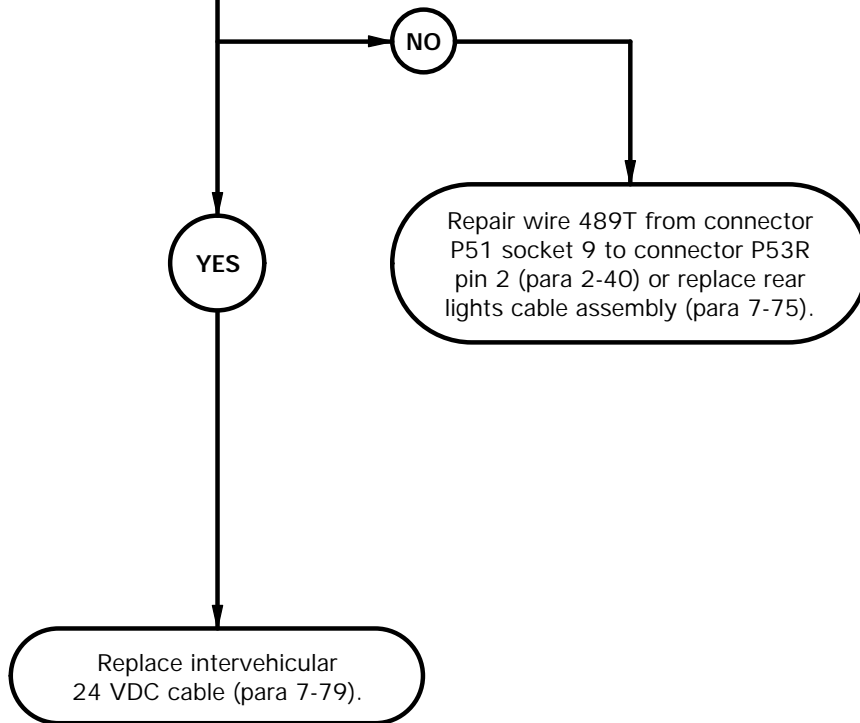

CAUTION

Use care when testing electrical connectors. Do not damage connector pins or sockets with multimeter probes. Failure to comply may result in damage to equipment.

NOTE

Inspect connector pins/sockets for damage, corrosion, and serviceability. Check that connector pins are not pushed back and are capable of making good contact.

CONTINUITY TEST

- (1) Disconnect connector P53R from connector J53R.
- (2) Set multimeter to ohms.
- (3) Connect positive (+) probe of multimeter to connector P51 socket 9.
- (4) Connect negative (-) probe of multimeter to connector P53R pin 2 and note reading on multimeter.
- (5) If continuity is not present, repair wire 489T from connector P51 socket 9 to connector P53R pin 2 (para 2-40) or replace rear lights cable assembly (para 7-75).
- (6) If continuity is present, replace intervehicular 24 VDC (12 pin) cable (para 7-79).
- (7) Connect connector P53R to connector J53R.
- (8) Connect connector P51 to connector J51.
- (9) Install PDP on dashboard with three screws.
- (10) Install three washers and screws in PDP.
- (11) Install PDP cover (para 16-2).

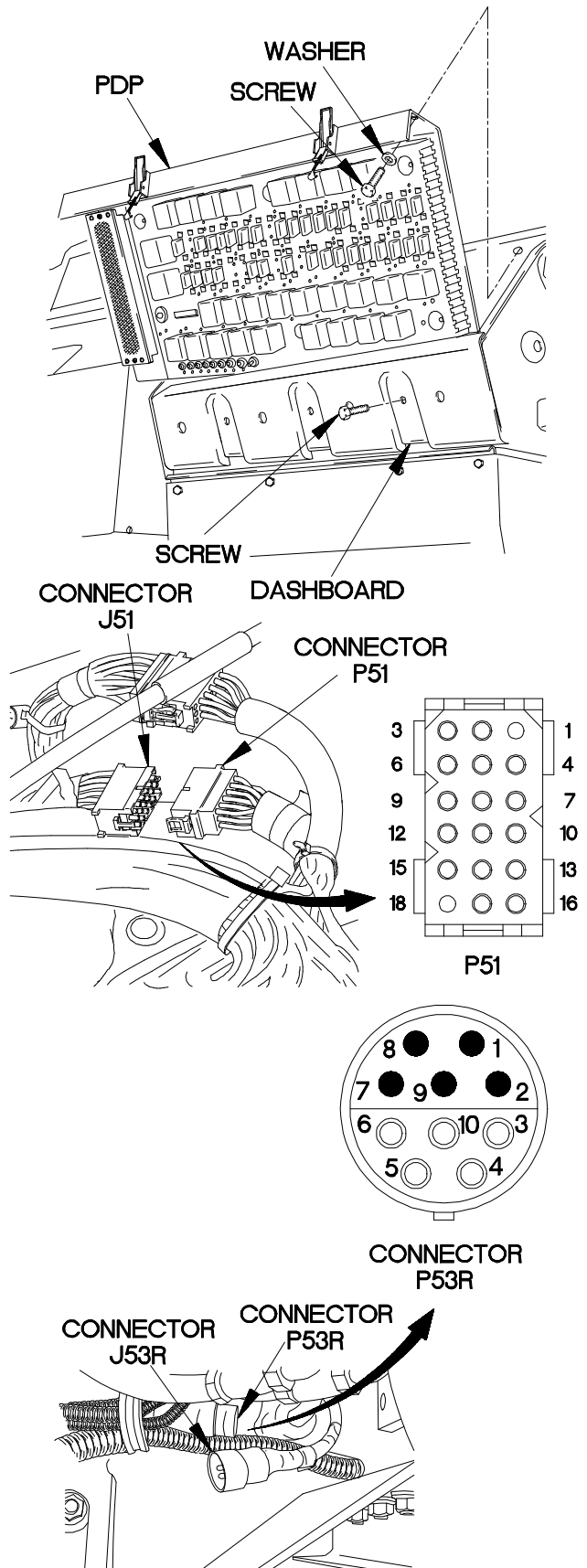

Xbo6506b

e63. TRAILER RIGHT STOP/TURN LIGHT DOES NOT ILLUMINATE

INITIAL SETUP

Equipment Condition

Engine shut down (TM 9-2320-365-10).

Material/Parts

Wire, Elect, 50 ft (Item 77, Appendix D)

Tools and Special Tools

Tool Kit, Genl Mech (Item 44, Appendix C)
 STE/ICE-R (Item 39, Appendix C)
 Multimeter, Digital (Item 22, Appendix C)

Personnel Required
(2)

References

TM 9-4910-571-12&P

NOTE

Perform Electrical System Troubleshooting e1. Circuit Breaker Does Not Operate on circuit breaker CB44 prior to beginning this task.

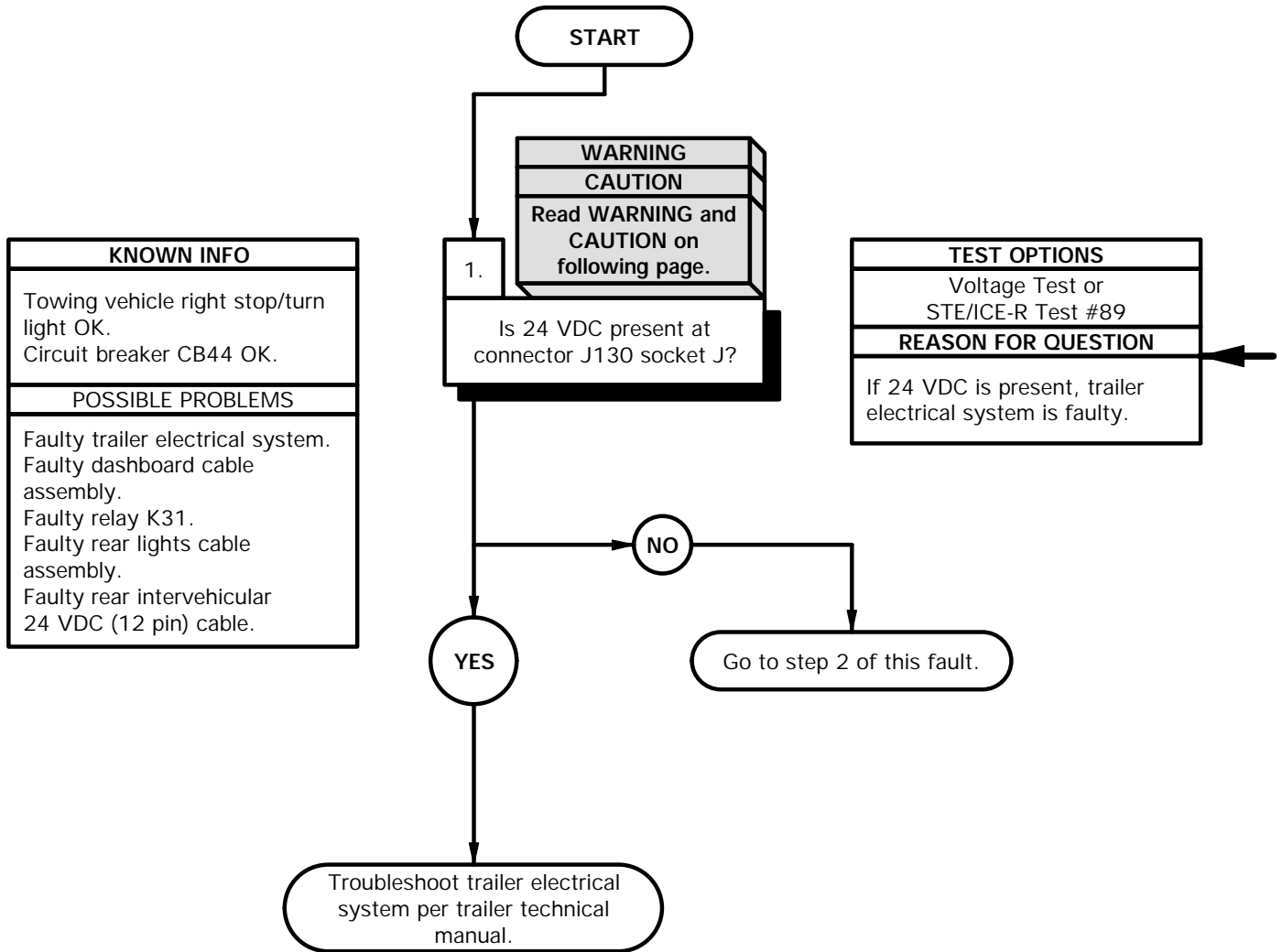

WARNING

Remove rings, bracelets, watches, necklaces, and any other jewelry before working around vehicle. Jewelry can catch on equipment and cause injury or short across electrical circuits and cause severe burns or electrical shock.

CAUTION

Use care when testing electrical connectors. Do not damage connector pins or sockets with multimeter probes. Failure to comply may result in damage to equipment.

NOTE

Inspect connector pins/sockets for damage, corrosion, and serviceability. Check that connector pins are not pushed back and are capable of making good contact.

VOLTAGE TEST

- (1) Lift cover on connector J130 intervehicular 24 VDC connector.
- (2) Set multimeter to volts DC.
- (3) Connect positive (+) probe of multimeter to connector J130 socket J.
- (4) Connect negative (-) probe of multimeter to ground.
- (5) Position master power switch to on (TM 9-2320-365-10).
- (6) Position main light switch to SER DRIVE (TM 9-2320-365-10).
- (7) Apply brakes and note reading on multimeter.
- (8) If 24 VDC is not present, go to step 2 of this fault.
- (9) If 24 VDC is present, troubleshoot trailer electrical system per trailer technical manual.
- (10) Position main light switch to OFF (TM 9-2320-365-10).
- (11) Position master power switch to off (TM 9-2320-365-10).

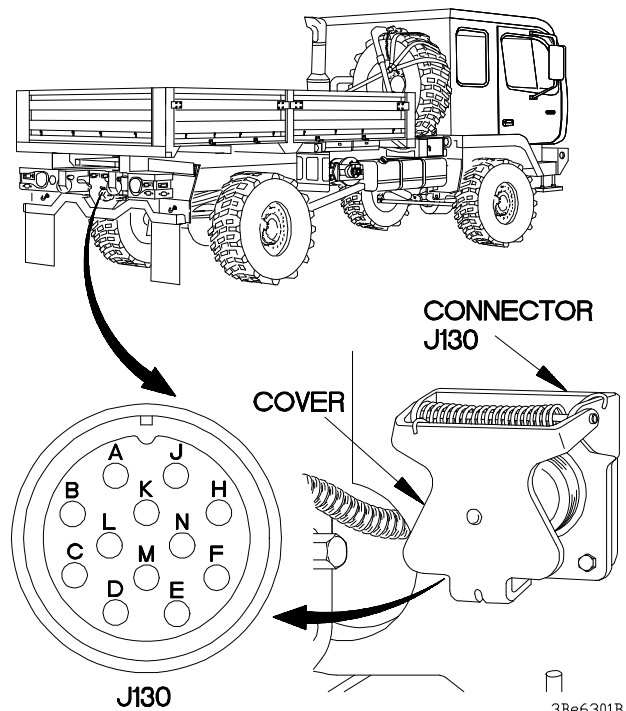

e63. TRAILER RIGHT STOP/TURN LIGHT DOES NOT ILLUMINATE (CONT)

KNOWN INFO
Towing vehicle right stop/turn light OK. Circuit breaker CB44 OK. Trailer electrical system OK.
POSSIBLE PROBLEMS
Faulty dashboard cable assembly. Faulty relay K31. Faulty rear lights cable assembly. Faulty rear intervehicular 24 VDC (12 pin) cable.

2. **CAUTION**
Read CAUTION on following page.

Is continuity present from connector J130 socket J to relay K31 terminal 87?

TEST OPTIONS
Continuity Test or STE/ICE-R Test #91
REASON FOR QUESTION
This question eliminates possible problems and determines where troubleshooting continues.

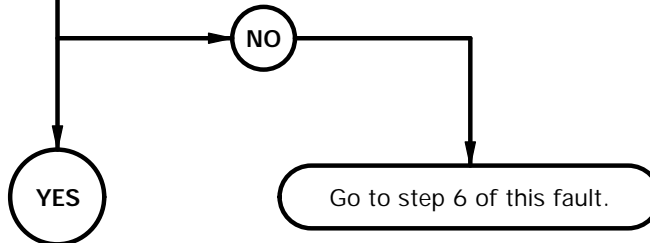

KNOWN INFO
Towing vehicle right stop/turn light OK. Circuit breaker CB44 OK. Trailer electrical system OK. Rear lights cable assembly OK. Rear intervehicular 24 VDC (12 pin) cable OK.
POSSIBLE PROBLEMS
Faulty dashboard cable assembly. Faulty relay K31.

3. **WARNING**
Read WARNING on following page.

Is 24 VDC present at relay K31 terminal 30 on PDP?

TEST OPTIONS
Voltage Test or STE/ICE-R Test #89
REASON FOR QUESTION
If 24 VDC is not present, wire 1956 is faulty.

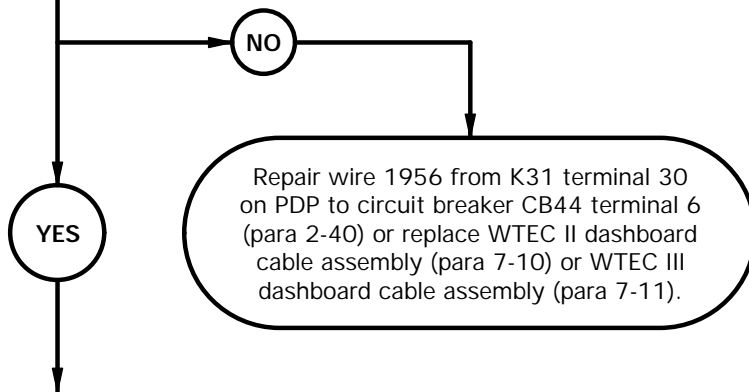

CAUTION

Use care when testing electrical connectors. Do not damage connector pins or sockets with multimeter probes. Failure to comply may result in damage to equipment.

NOTE

Inspect connector pins/sockets for damage, corrosion, and serviceability. Check that connector pins are not pushed back and are capable of making good contact.

CONTINUITY TEST

- (1) Remove PDP cover (para 16-2).
- (2) Remove relay K31 from PDP.
- (3) Set multimeter to ohms.
- (4) Connect positive (+) probe of multimeter to connector J130 socket J.
- (5) Connect negative (-) probe of multimeter to relay K31 terminal 87 on PDP and note reading on multimeter.
- (6) If continuity is not present, go to step 6 of this fault.

WARNING

Remove rings, bracelets, watches, necklaces, and any other jewelry before working around vehicle. Jewelry can catch on equipment and cause injury or short across electrical circuits and cause severe burns or electrical shock.

VOLTAGE TEST

- (1) Set multimeter to volts DC.
- (2) Connect positive (+) probe of multimeter to relay K31 terminal 30 on PDP.
- (3) Connect negative (-) probe of multimeter to ground.
- (4) Position main light switch to SER DRIVE (TM 9-2320-365-10) and note reading on multimeter.
- (5) If 24 VDC is not present, repair wire 1956 from K31 terminal 30 on PDP to circuit breaker CB44 terminal 6 (para 2-40) or replace WTEC II dashboard cable assembly (para 7-10) or WTEC III dashboard cable assembly (para 7-11).
- (6) Position main light switch to OFF (TM 9-2320-365-10).

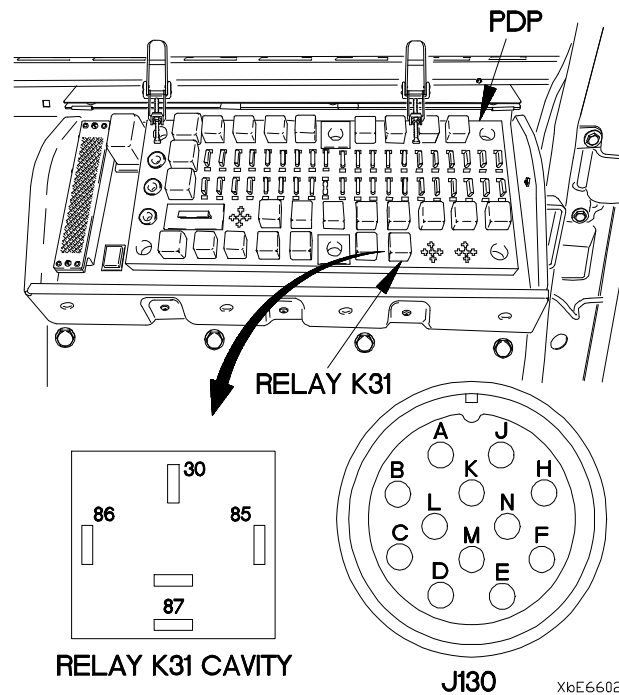

X6E6602B

e63. TRAILER RIGHT STOP/TURN LIGHT DOES NOT ILLUMINATE (CONT)

KNOWN INFO
Towing vehicle right stop/turn light OK. Circuit breaker CB44 OK. Trailer electrical system OK. Rear lights cable assembly OK. Rear intervehicular 24 VDC (12 pin) cable OK.
POSSIBLE PROBLEMS
Faulty dashboard cable assembly. Faulty relay K31.

KNOWN INFO
Towing vehicle right stop/turn light OK. Circuit breaker CB44 OK. Trailer electrical system OK. Rear lights cable assembly OK. Rear intervehicular 24 VDC (12 pin) cable OK.
POSSIBLE PROBLEMS
Faulty dashboard cable assembly. Faulty relay K31.

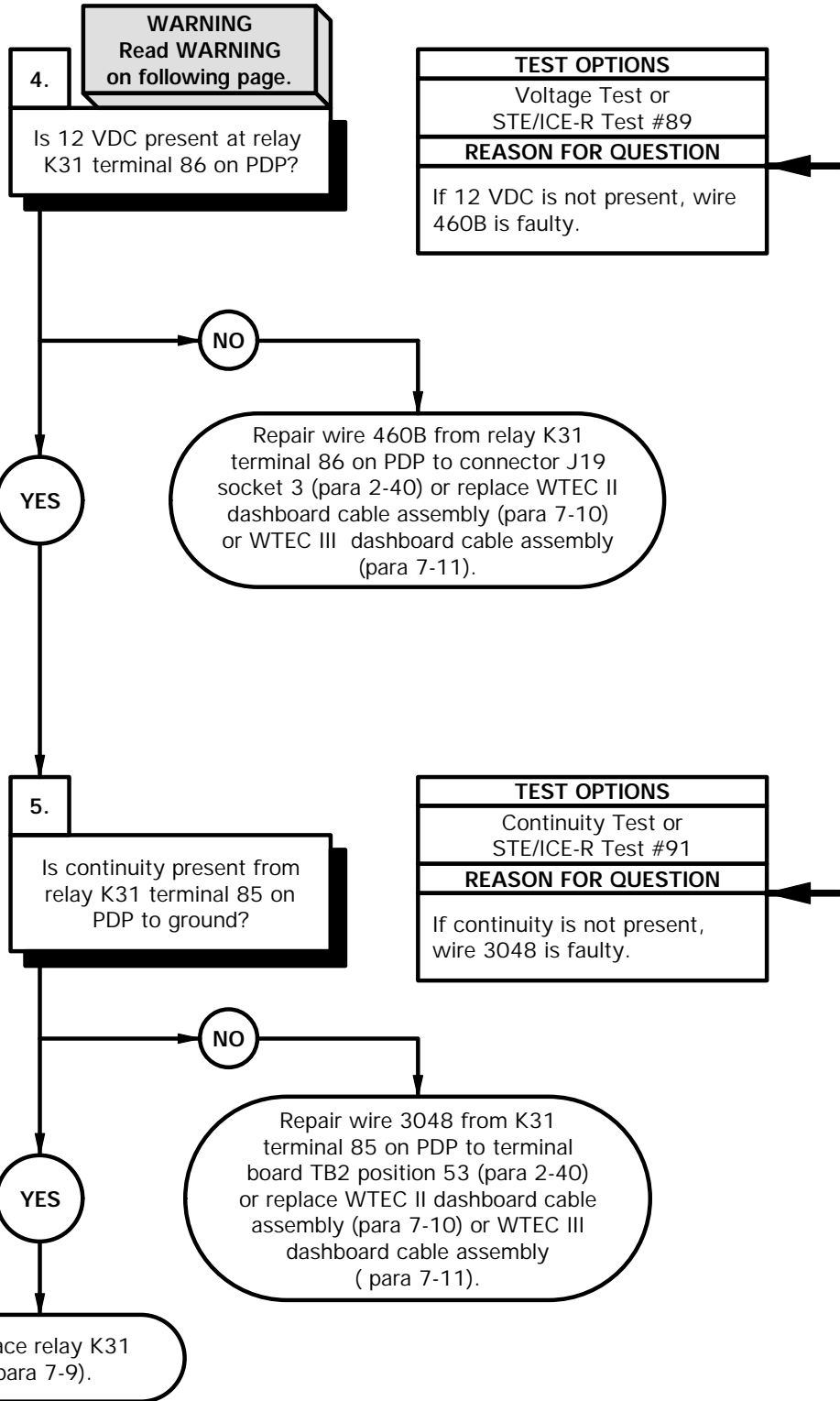

WARNING

Remove rings, bracelets, watches, necklaces, and any other jewelry before working around vehicle. Jewelry can catch on equipment and cause injury or short across electrical circuits and cause severe burns or electrical shock.

VOLTAGE TEST

- (1) Set multimeter to volts DC.
- (2) Connect positive (+) probe of multimeter to relay K31 terminal 86 on PDP.
- (3) Connect negative (-) probe of multimeter to ground.
- (4) Position master power switch to on (TM 9-2320-365-10).
- (5) Position main light switch to SER DRIVE (TM 9-2320-365-10).
- (6) Apply brakes and note reading on multimeter.
- (7) If 12 VDC is not present, repair wire 460B from relay K31 terminal 86 on PDP to connector J19 socket 3 (para 2-40) or replace WTEC II dashboard cable assembly (para 7-10) or WTEC III dashboard cable assembly (para 7-11).
- (8) Position main light switch to OFF (TM 9-2320-365-10).
- (9) Position master power switch to off (TM 9-2320-365-10).

CONTINUITY TEST

- (1) Set multimeter to ohms.
- (2) Connect positive (+) probe of multimeter to relay K31 terminal 85 on PDP.
- (3) Connect negative (-) probe of multimeter to ground and note reading on multimeter.
- (4) If continuity is not present, repair wire 3048 from K31 terminal 85 on PDP to terminal board TB2 position 53 (para 2-40) or replace WTEC II dashboard assembly (para 7-10) or WTEC III dashboard cable assembly (para 7-11).
- (5) If continuity is present, replace relay K31 (para 7-9).
- (6) Install relay K31 in PDP.
- (7) Install PDP cover (para 16-2).

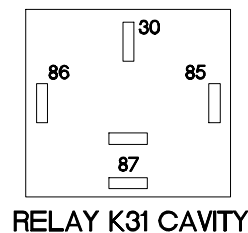
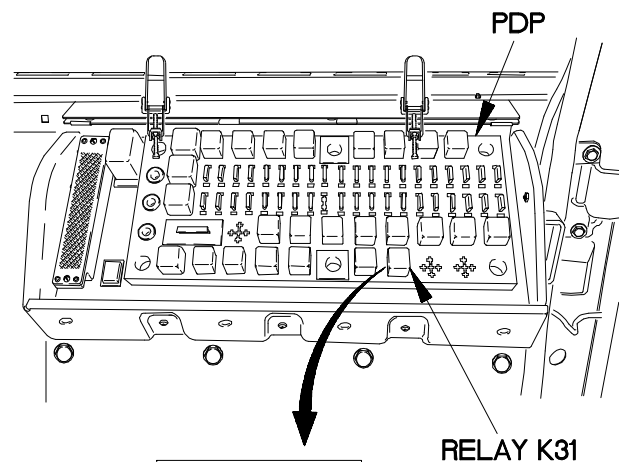

XbE6603B

e63. TRAILER RIGHT STOP/TURN LIGHT DOES NOT ILLUMINATE (CONT)

KNOWN INFO
Towing vehicle right stop/turn light OK. Circuit breaker CB44 OK. Trailer electrical system OK. Relay K31 OK.
POSSIBLE PROBLEMS
Faulty dashboard cable assembly. Faulty rear lights cable assembly. Faulty rear intervehicular 24 VDC (12 pin) cable.

6.

CAUTION
Read CAUTION on following page.

Is continuity present from relay K31 terminal 87 on PDP to connector J51 pin 16?

TEST OPTIONS
Continuity Test or STE/ICE-R Test #91
REASON FOR QUESTION
If continuity is not present, wire 460T is faulty.

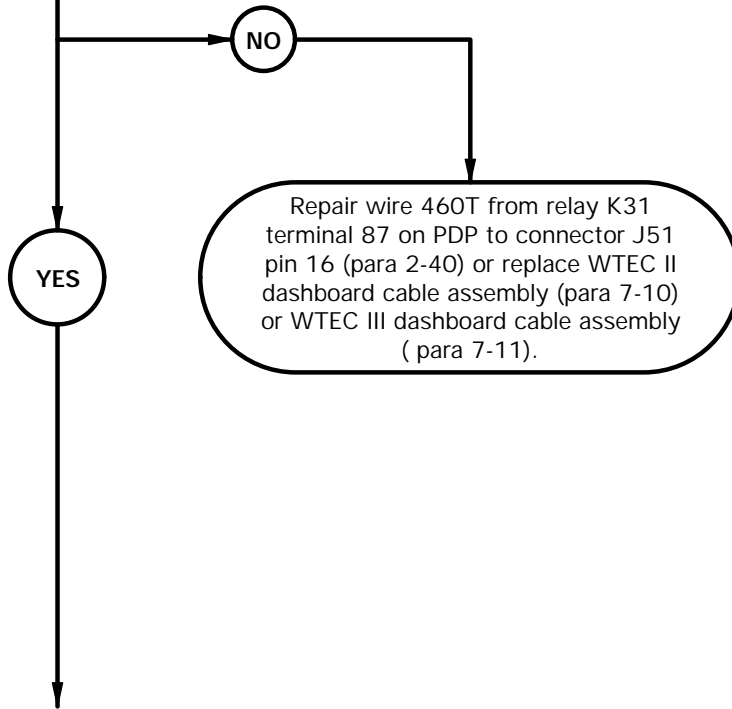

CAUTION

Use care when testing electrical connectors. Do not damage connector pins or sockets with multimeter probes. Failure to comply may result in damage to equipment.

NOTE

Inspect connector pins/sockets for damage, corrosion, and serviceability. Check that connector pins are not pushed back and are capable of making good contact.

CONTINUITY TEST

- (1) Remove three screws and washers from PDP.
- (2) Remove three screws from PDP.
- (3) Lift PDP outward to gain access.
- (4) Disconnect connector J51 from connector P51.
- (5) Set multimeter to ohms.
- (6) Connect positive (+) probe of multimeter to relay K31 terminal 87 on PDP.
- (7) Connect negative (-) probe of multimeter to connector J51 pin 16 and note reading on multimeter.
- (8) If continuity is not present, repair wire 460T from relay K31 terminal 87 on PDP to connector J51 pin 16 (para 2-40) or replace WTEC II dashboard assembly (para 7-10) or WTEC III dashboard cable assembly (para 7-11).
- (9) Install relay K31 in PDP.

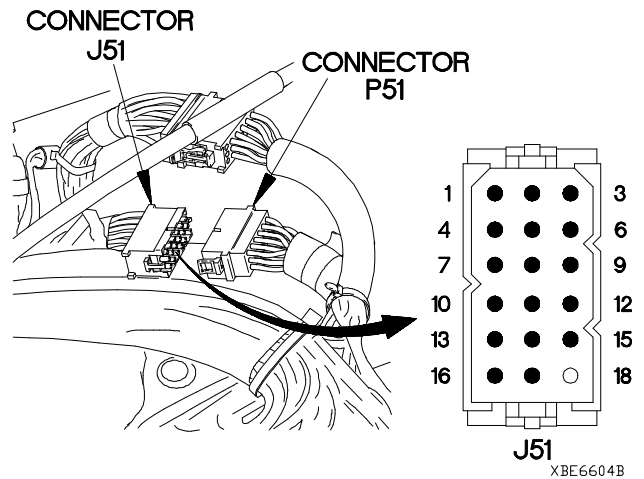
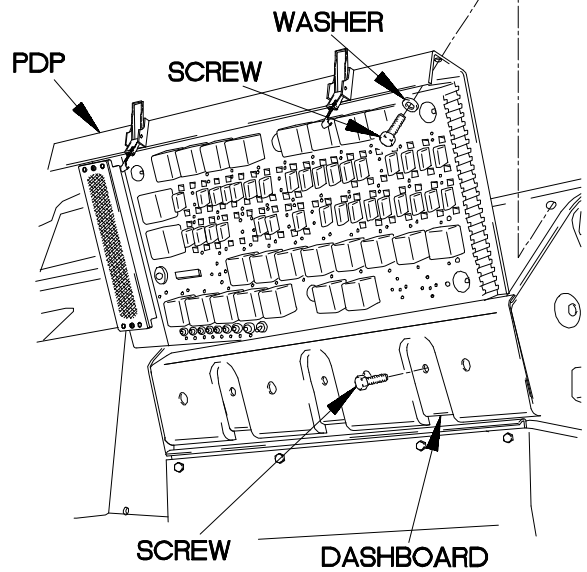
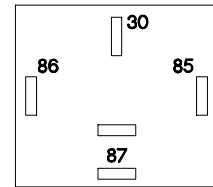
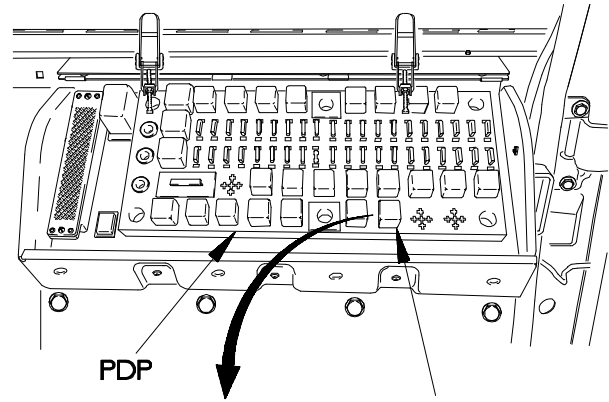

e63. TRAILER RIGHT STOP/TURN LIGHT DOES NOT ILLUMINATE (CONT)

KNOWN INFO
Towing vehicle right stop/turn light OK. Circuit breaker CB44 OK. Trailer electrical system OK. Dashboard cable assembly OK. Relay K31 OK.
POSSIBLE PROBLEMS
Faulty rear lights cable assembly. Faulty rear intervehicular 24 VDC (12 pin) cable.

7.

CAUTION
Read CAUTION on following page.

Is continuity present from connector P51 socket 16 to connector P53R socket 5?

TEST OPTIONS
Continuity Test or STE/ICE-R Test #91
REASON FOR QUESTION
If continuity is not present, wire 460T is faulty. If continuity is present, intervehicular 24 VDC (12 pin) cable is faulty.

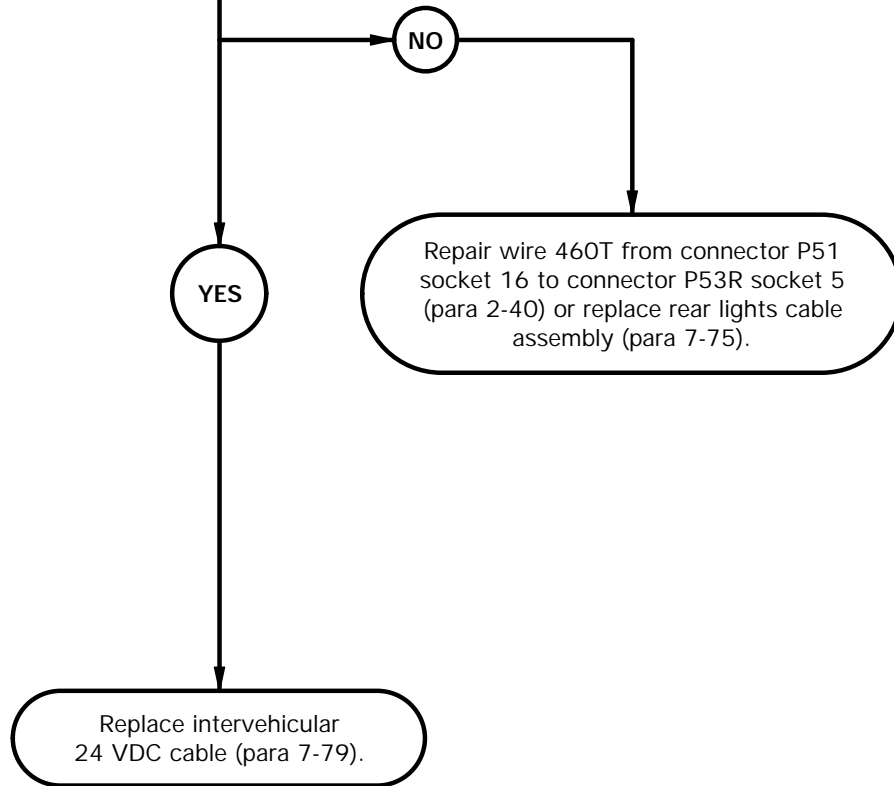

CAUTION

Use care when testing electrical connectors. Do not damage connector pins or sockets with multimeter probes. Failure to comply may result in damage to equipment.

NOTE

Inspect connector pins/sockets for damage, corrosion, and serviceability. Check that connector pins are not pushed back and are capable of making good contact.

CONTINUITY TEST

- (1) Disconnect connector P53R from connector J53R.
- (2) Set multimeter to ohms.
- (3) Connect positive (+) probe of multimeter to connector P51 socket 16.
- (4) Connect negative (-) probe of multimeter to connector P53R socket 5 and note reading on multimeter.
- (5) If continuity is not present, repair wire 460T from connector P51 socket 16 to connector P53R socket 5 (para 2-40) or replace rear lights cable assembly (para 7-75).
- (6) If continuity is present, replace intervehicular 24 VDC (12 pin) cable (para 7-79).
- (7) Connect connector P53R to connector J53R.
- (8) Connect connector P51 to connector J51.
- (9) Install PDP on dashboard with three screws.
- (10) Install three washers and screws in PDP.
- (11) Install PDP cover (para 16-2).

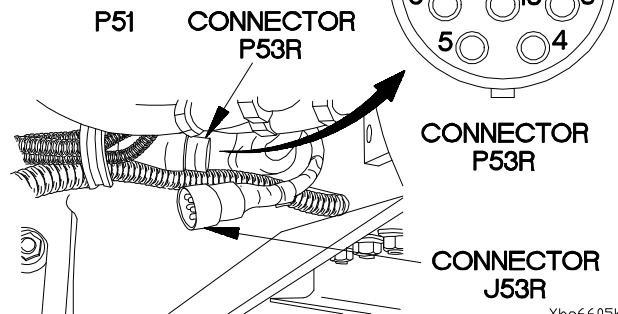
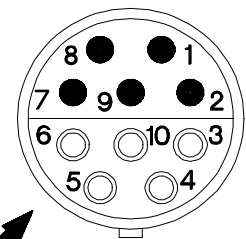
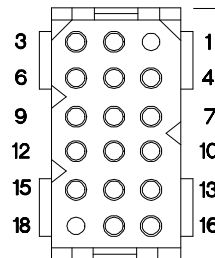
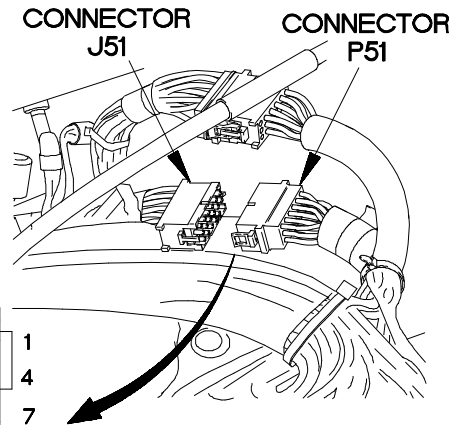
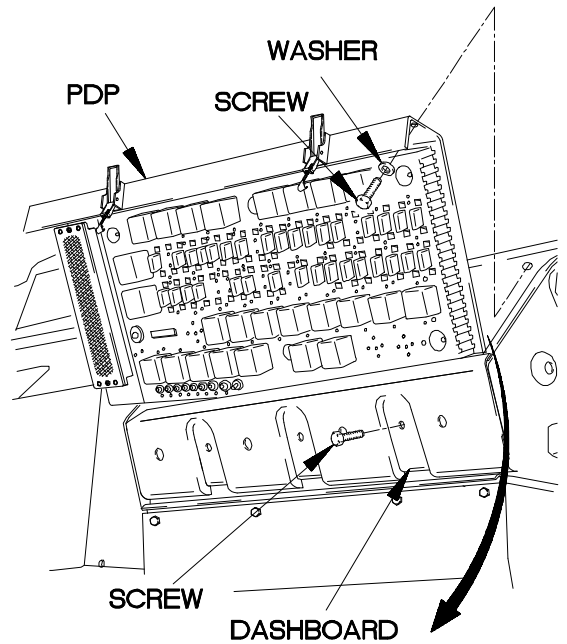

Xk66605b

e64. TRAILER LEFT STOP/TURN LIGHT DOES NOT ILLUMINATE

INITIAL SETUP

Equipment Condition

Engine shut down (TM 9-2320-365-10).

Personnel Required

(2)

Material/Parts

Wire, Elect, 50 ft (Item 77, Appendix D)

Tools and Special Tools

Tool Kit, Genl Mech (Item 44, Appendix C)
 STE/ICE-R (Item 39, Appendix C)
 Multimeter, Digital (Item 22, Appendix C)

References

TM 9-4910-571-12&P

NOTE

Perform Electrical System Troubleshooting e1. Circuit Breaker Does Not Operate on circuit breaker CB43 prior to beginning this task.

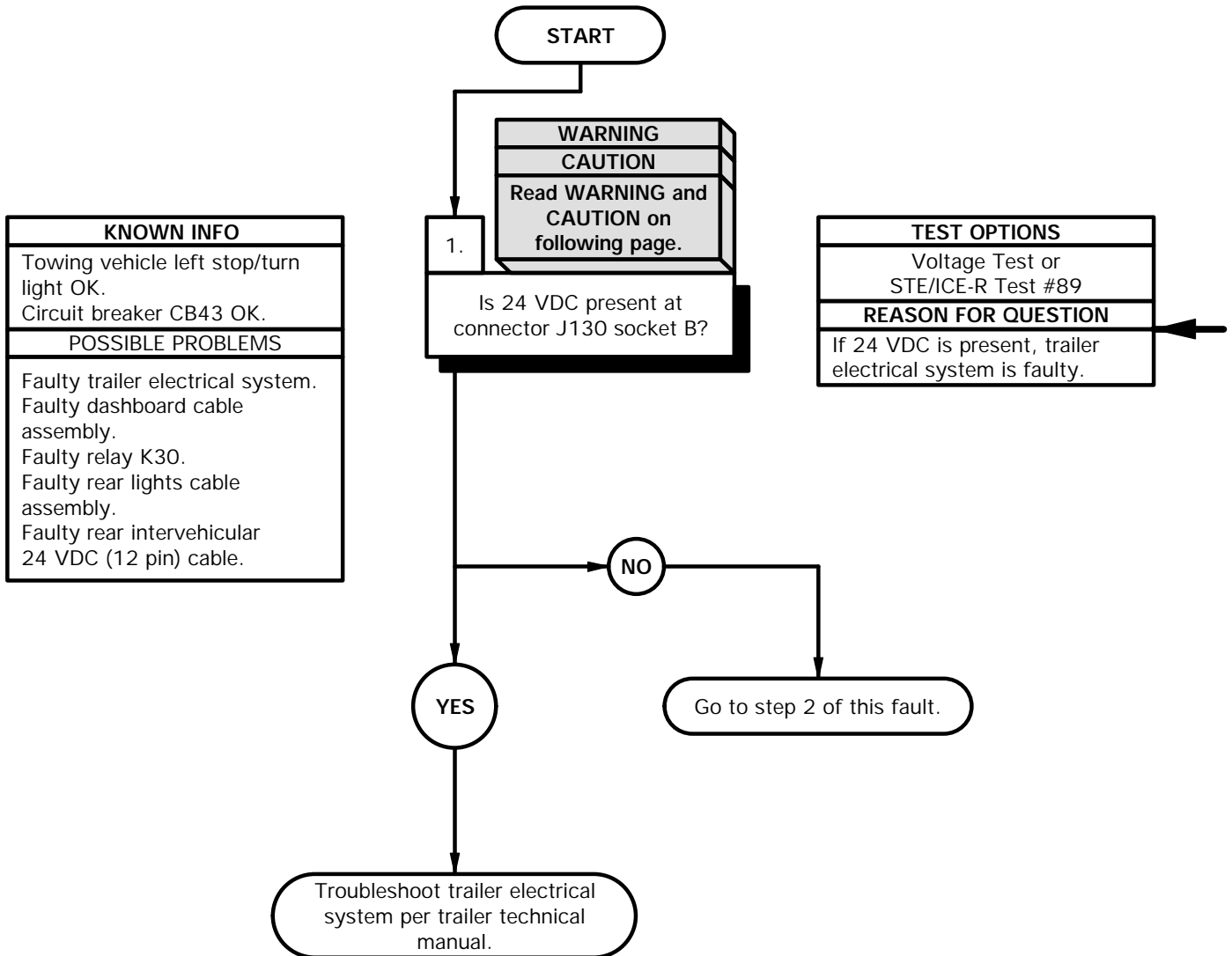

WARNING

Remove rings, bracelets, watches, necklaces, and any other jewelry before working around vehicle. Jewelry can catch on equipment and cause injury or short across electrical circuits and cause severe burns or electrical shock.

CAUTION

Use care when testing electrical connectors. Do not damage connector pins or sockets with multimeter probes. Failure to comply may result in damage to equipment.

NOTE

Inspect connector pins/sockets for damage, corrosion, and serviceability. Check that connector pins are not pushed back and are capable of making good contact.

VOLTAGE TEST

- (1) Lift cover on connector J130 intervehicular 24 VDC connector.
- (2) Set multimeter to volts DC.
- (3) Connect positive (+) probe of multimeter to connector J130 socket B.
- (4) Connect negative (-) probe of multimeter to ground.
- (5) Position master power switch to on (TM 9-2320-365-10).
- (6) Position main light switch to SER DRIVE (TM 9-2320-365-10).
- (7) Apply brakes and note reading on multimeter.
- (8) If 24 VDC is not present, go to step 2 of this fault.
- (9) If 24 VDC is present, troubleshoot trailer electrical system per trailer technical manual.
- (10) Position main light switch to OFF (TM 9-2320-365-10).
- (11) Position master power switch to off (TM 9-2320-365-10).

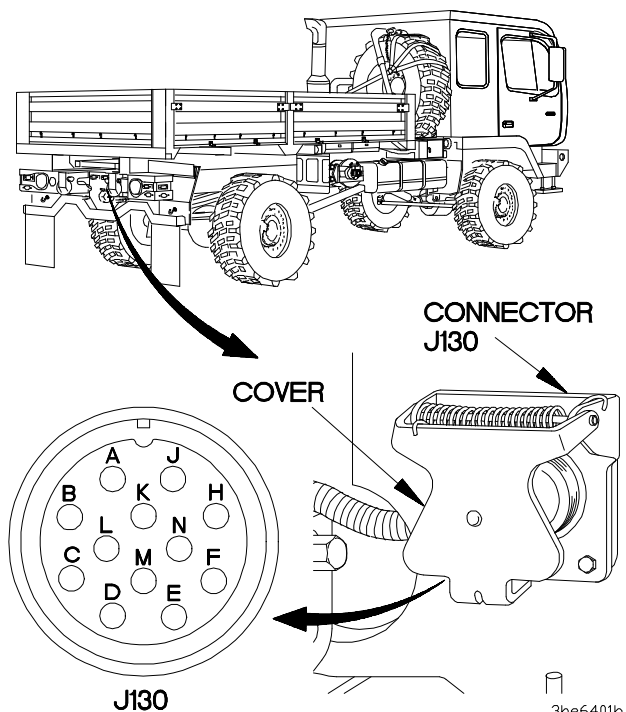

3be6401b

e64. TRAILER LEFT STOP/TURN LIGHT DOES NOT ILLUMINATE (CONT)

KNOWN INFO
Towing vehicle left stop/turn light OK. Circuit breaker CB43 OK. Trailer electrical system OK.
POSSIBLE PROBLEMS
Faulty dashboard cable assembly. Faulty relay K30. Faulty rear lights cable assembly. Faulty rear intervehicular 24 VDC (12 pin) cable.

2. **CAUTION**
Read CAUTION on following page.

Is continuity present from connector J130 socket B to relay K30 terminal 87?

TEST OPTIONS
Continuity Test or STE/ICE-R Test #91
REASON FOR QUESTION
This question eliminates possible problems and determines where troubleshooting continues.

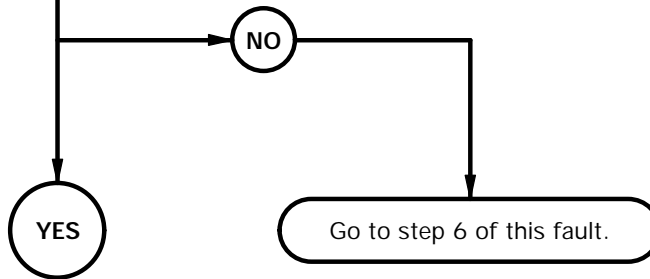

KNOWN INFO
Towing vehicle left stop/turn light OK. Circuit breaker CB43 OK. Trailer electrical system OK. Rear lights cable assembly OK. Rear intervehicular 24 VDC (12 pin) cable OK.
POSSIBLE PROBLEMS
Faulty dashboard cable assembly. Faulty relay K30.

3. **WARNING**
Read WARNING on following page.

Is 24 VDC present at relay K30 terminal 30 on PDP?

TEST OPTIONS
Voltage Test or STE/ICE-R Test #89
REASON FOR QUESTION
If 24 VDC is not present, wire 1922 is faulty.

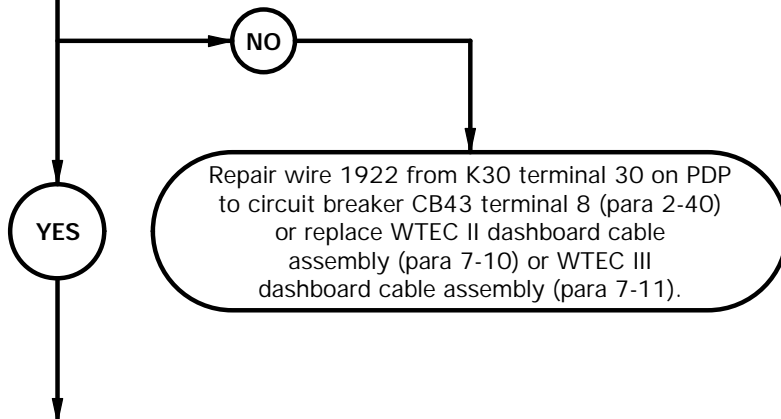

CAUTION

Use care when testing electrical connectors. Do not damage connector pins or sockets with multimeter probes. Failure to comply may result in damage to equipment.

NOTE

Inspect connector pins/sockets for damage, corrosion, and serviceability. Check that connector pins are not pushed back and are capable of making good contact.

CONTINUITY TEST

- (1) Remove PDP cover (para 16-2).
- (2) Remove relay K30 from PDP.
- (3) Set multimeter to ohms.
- (4) Connect positive (+) probe of multimeter to connector J130 socket B.
- (5) Connect negative (-) probe of multimeter to relay K30 terminal 87 on PDP and note reading on multimeter.
- (6) If continuity is not present, go to step 6 of this fault.

WARNING

Remove rings, bracelets, watches, necklaces, and any other jewelry before working around vehicle. Jewelry can catch on equipment and cause injury or short across electrical circuits and cause severe burns or electrical shock.

VOLTAGE TEST

- (1) Set multimeter to volts DC.
- (2) Connect positive (+) probe of multimeter to relay K30 terminal 30 on PDP.
- (3) Connect negative (-) probe of multimeter to ground.
- (4) Position main light switch to SER DRIVE (TM 9-2320-365-10) and note reading on multimeter.
- (5) If 24 VDC is not present, repair wire 1922 from K30 terminal 30 on PDP to circuit breaker CB43 terminal 8 (para 2-40) or replace WTEC II dashboard cable assembly (para 7-10) or WTEC III dashboard cable assembly (para 7-11).
- (6) Position main light switch to OFF (TM 9-2320-365-10).

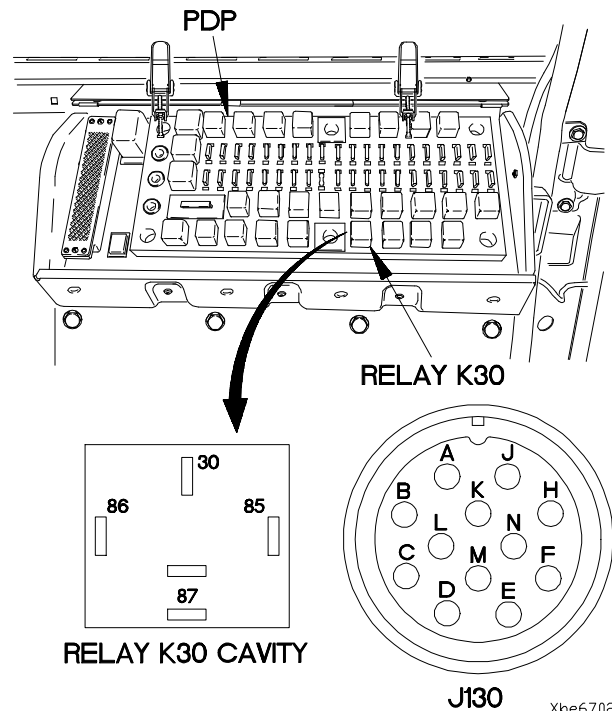

Xlae6702b

e64. TRAILER LEFT STOP/TURN LIGHT DOES NOT ILLUMINATE (CONT)

KNOWN INFO
Towing vehicle left stop/turn light OK. Circuit breaker CB43 OK. Trailer electrical system OK. Rear lights cable assembly OK. Rear intervehicular 24 VDC (12 pin) cable OK.
POSSIBLE PROBLEMS
Faulty dashboard cable assembly. Faulty relay K30.

KNOWN INFO
Towing vehicle left stop/turn light OK. Circuit breaker CB43 OK. Trailer electrical system OK. Rear lights cable assembly OK. Rear intervehicular 24 VDC (12 pin) cable OK.
POSSIBLE PROBLEMS
Faulty dashboard cable assembly. Faulty relay K30.

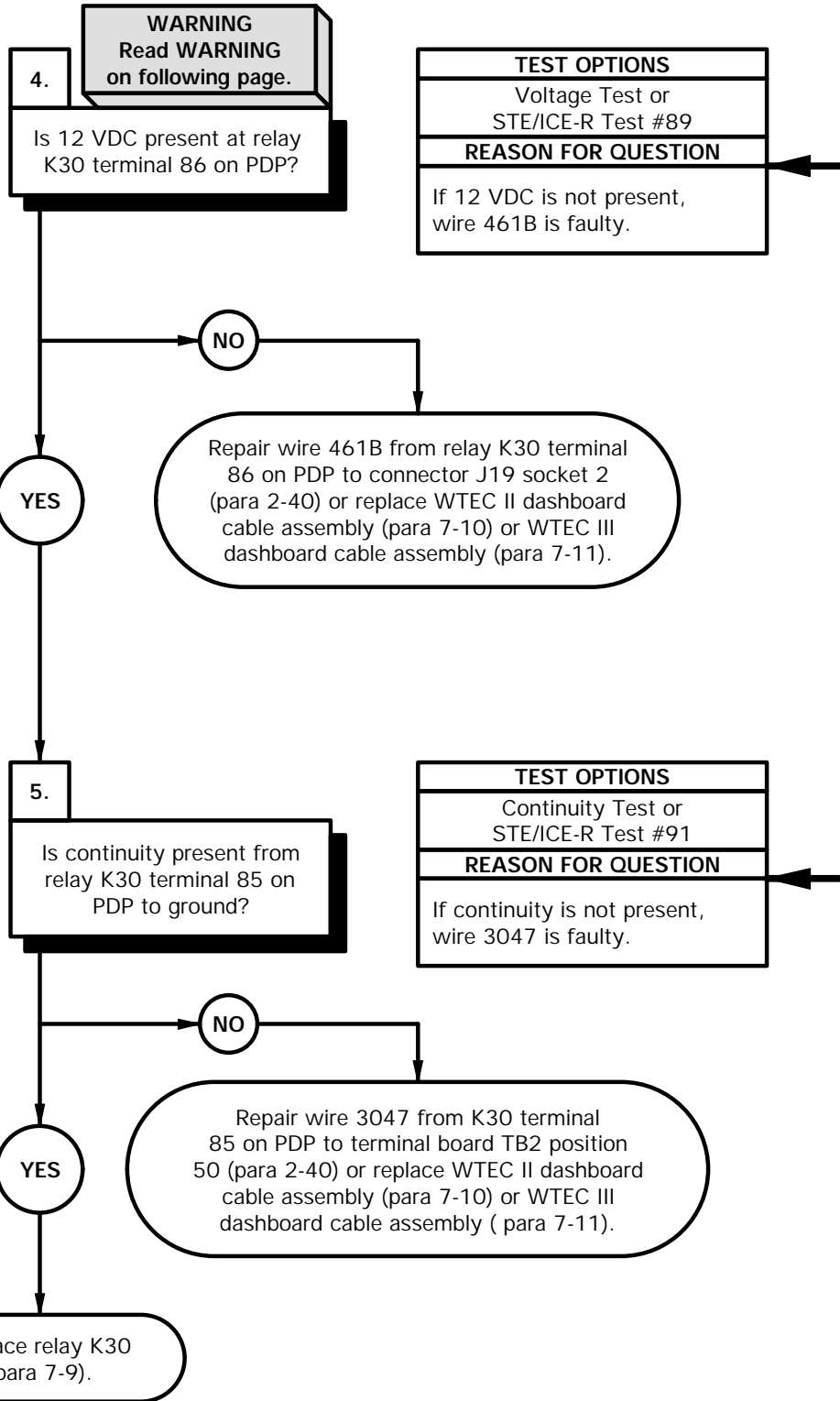

WARNING

Remove rings, bracelets, watches, necklaces, and any other jewelry before working around vehicle. Jewelry can catch on equipment and cause injury or short across electrical circuits and cause severe burns or electrical shock.

VOLTAGE TEST

- (1) Set multimeter to volts DC.
- (2) Connect positive (+) probe of multimeter to relay K30 terminal 86 on PDP.
- (3) Connect negative (-) probe of multimeter to ground.
- (4) Position master power switch to on (TM 9-2320-365-10).
- (5) Position main light switch to SER DRIVE (TM 9-2320-365-10).
- (6) Apply brakes and note reading on multimeter.
- (7) If 12 VDC is not present, repair wire 461B from relay K30 terminal 86 on PDP to connector J19 socket 2 (para 2-40) or replace WTEC II dashboard cable assembly (para 7-10) or WTEC III dashboard cable assembly (para 7-11).
- (8) Position main light switch to OFF (TM 9-2320-365-10).
- (9) Position master power switch to off (TM 9-2320-365-10).

CONTINUITY TEST

- (1) Set multimeter to ohms.
- (2) Connect positive (+) probe of multimeter to relay K30 terminal 85 on PDP.
- (3) Connect negative (-) probe of multimeter to ground and note reading on multimeter.
- (4) If continuity is not present, repair wire 3047 from K30 terminal 85 on PDP to terminal board TB2 position 50 (para 2-40) or replace WTEC II dashboard assembly (para 7-10) or WTEC III dashboard cable assembly (para 7-11).
- (5) If continuity is present, replace relay K30 (para 7-9).
- (6) Install relay K30 in PDP.
- (7) Install PDP cover (para 16-2).

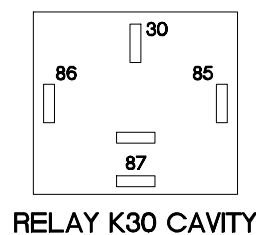
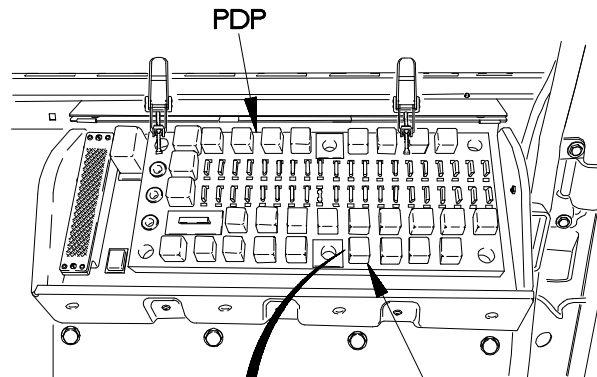

Xbe6703b

e64. TRAILER LEFT STOP/TURN LIGHT DOES NOT ILLUMINATE (CONT)

KNOWN INFO
Towing vehicle left stop/turn light OK. Circuit breaker CB43 OK. Trailer electrical system OK. Relay K30 OK.
POSSIBLE PROBLEMS
Faulty dashboard cable assembly. Faulty rear lights cable assembly. Faulty rear intervehicular 24 VDC (12 pin) cable.

6.

CAUTION
Read CAUTION on following page.

Is continuity present from relay K30 terminal 87 on PDP to connector J51 pin 15?

TEST OPTIONS
Continuity Test or STE/ICE-R Test #91
REASON FOR QUESTION
If continuity is not present, wire 461T is faulty.

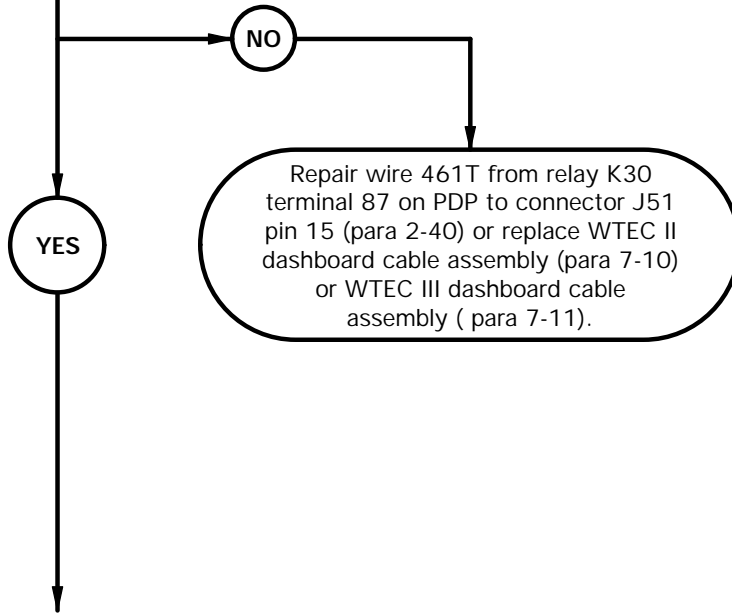

CAUTION

Use care when testing electrical connectors. Do not damage connector pins or sockets with multimeter probes. Failure to comply may result in damage to equipment.

NOTE

Inspect connector pins/sockets for damage, corrosion, and serviceability. Check that connector pins are not pushed back and are capable of making good contact.

CONTINUITY TEST

- (1) Remove three screws and washers from PDP.
- (2) Remove three screws from PDP.
- (3) Lift PDP outward to gain access.
- (4) Disconnect connector J51 from connector P51.
- (5) Set multimeter to ohms.
- (6) Connect positive (+) probe of multimeter to relay K30 terminal 87 on PDP.
- (7) Connect negative (-) probe of multimeter to connector J51 pin 15 and note reading on multimeter.
- (8) If continuity is not present, repair wire 461T from relay K30 terminal 87 on PDP to connector J51 pin 15 (para 2-40) or replace WTEC II dashboard assembly (para 7-10) or WTEC III dashboard cable assembly (para 7-11).
- (9) Install relay K30 in PDP.

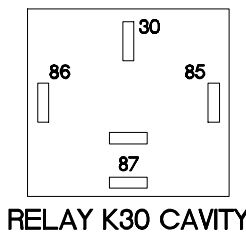
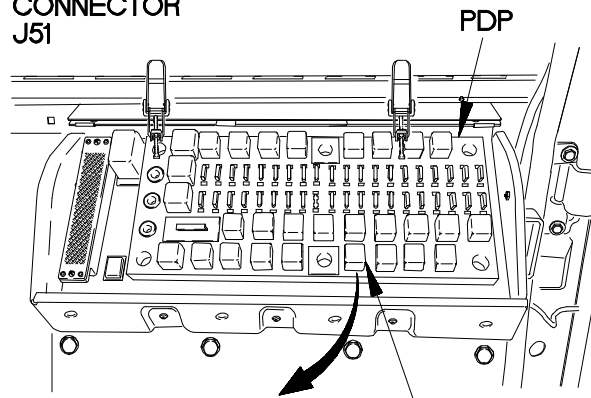
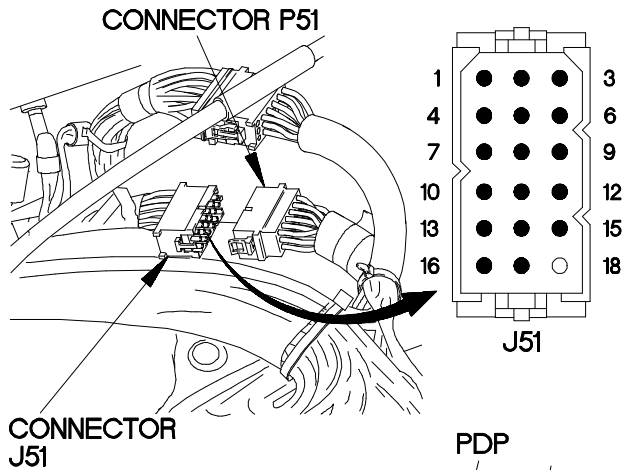
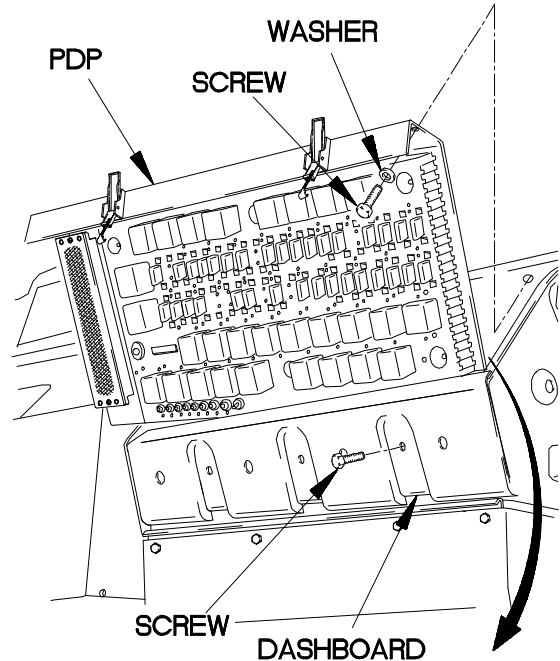

Xloe6704b

e64. TRAILER LEFT STOP/TURN LIGHT DOES NOT ILLUMINATE (CONT)

KNOWN INFO
Towing vehicle left stop/turn light OK. Circuit breaker CB43 OK. Trailer electrical system OK. Dashboard cable assembly OK. Relay K30 OK.
POSSIBLE PROBLEMS
Faulty rear lights cable assembly. Faulty rear intervehicular 24 VDC (12 pin) cable.

7.

CAUTION
Read CAUTION on following page.

Is continuity present from connector P51 socket 15 to connector P53R pin 8?

TEST OPTIONS
Continuity Test or STE/ICE-R Test #91
REASON FOR QUESTION
If continuity is not present, wire 461T is faulty. If continuity is present, intervehicular 24 VDC (12 pin) cable is faulty.

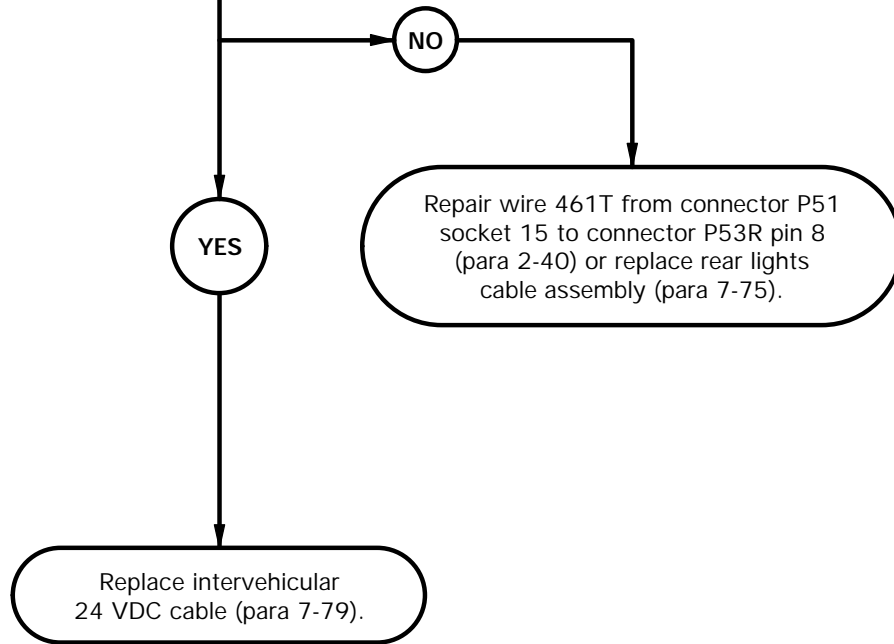

CAUTION

Use care when testing electrical connectors. Do not damage connector pins or sockets with multimeter probes. Failure to comply may result in damage to equipment.

NOTE

Inspect connector pins/sockets for damage, corrosion, and serviceability. Check that connector pins are not pushed back and are capable of making good contact.

CONTINUITY TEST

- (1) Disconnect connector P53R from connector J53R.
- (2) Set multimeter to ohms.
- (3) Connect positive (+) probe of multimeter to connector P51 socket 15.
- (4) Connect negative (-) probe of multimeter to connector P53R pin 8 and note reading on multimeter.
- (5) If continuity is not present, repair wire 461T from connector P51 socket 15 to connector P53R pin 8 (para 2-40) or replace rear lights cable assembly (para 7-75).
- (6) If continuity is present, replace intervehicular 24 VDC (12 pin) cable (para 7-79).
- (7) Connect connector P53R to connector J53R.
- (8) Connect connector P51 to connector J51.
- (9) Install PDP on dashboard with three screws.
- (10) Install three washers and screws in PDP.
- (11) Install PDP cover (para 16-2).

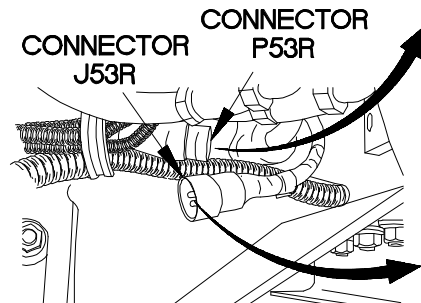
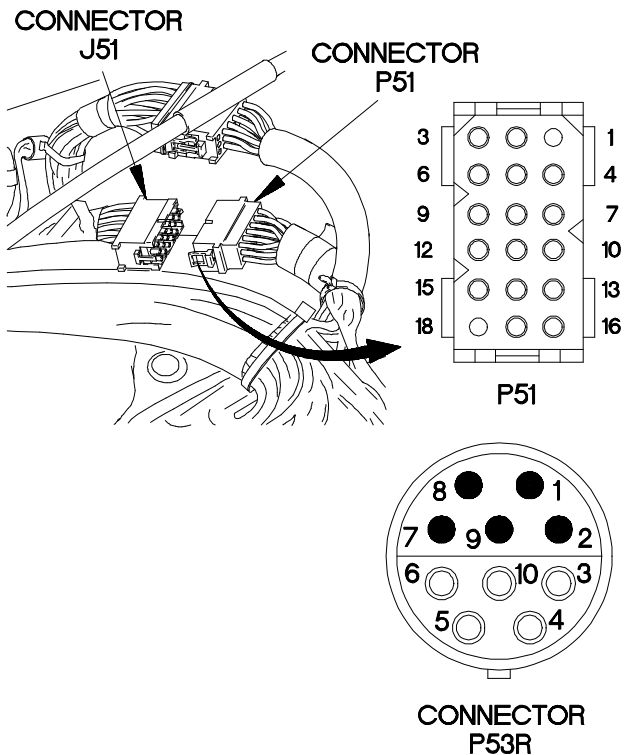
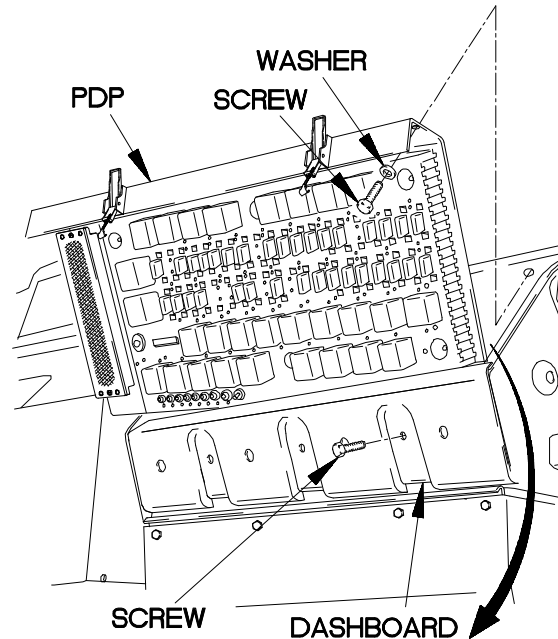

Xloe6705b

e65. TRAILER BLACKOUT MARKER LIGHTS DO NOT ILLUMINATE

INITIAL SETUP

Equipment Condition

Engine shut down (TM 9-2320-365-10).

Personnel Required

(2)

Material/Parts

Wire, Elect, 50 ft (Item 77, Appendix D)

Tools and Special Tools

Tool Kit, Genl Mech (Item 44, Appendix C)

STE/ICE-R (Item 39, Appendix C)

Multimeter, Digital (Item 22, Appendix C)

References

TM 9-4910-571-12&P

NOTE

Perform Electrical System Troubleshooting e1. Circuit Breaker Does Not Operate on circuit breaker CB42 prior to beginning this task.

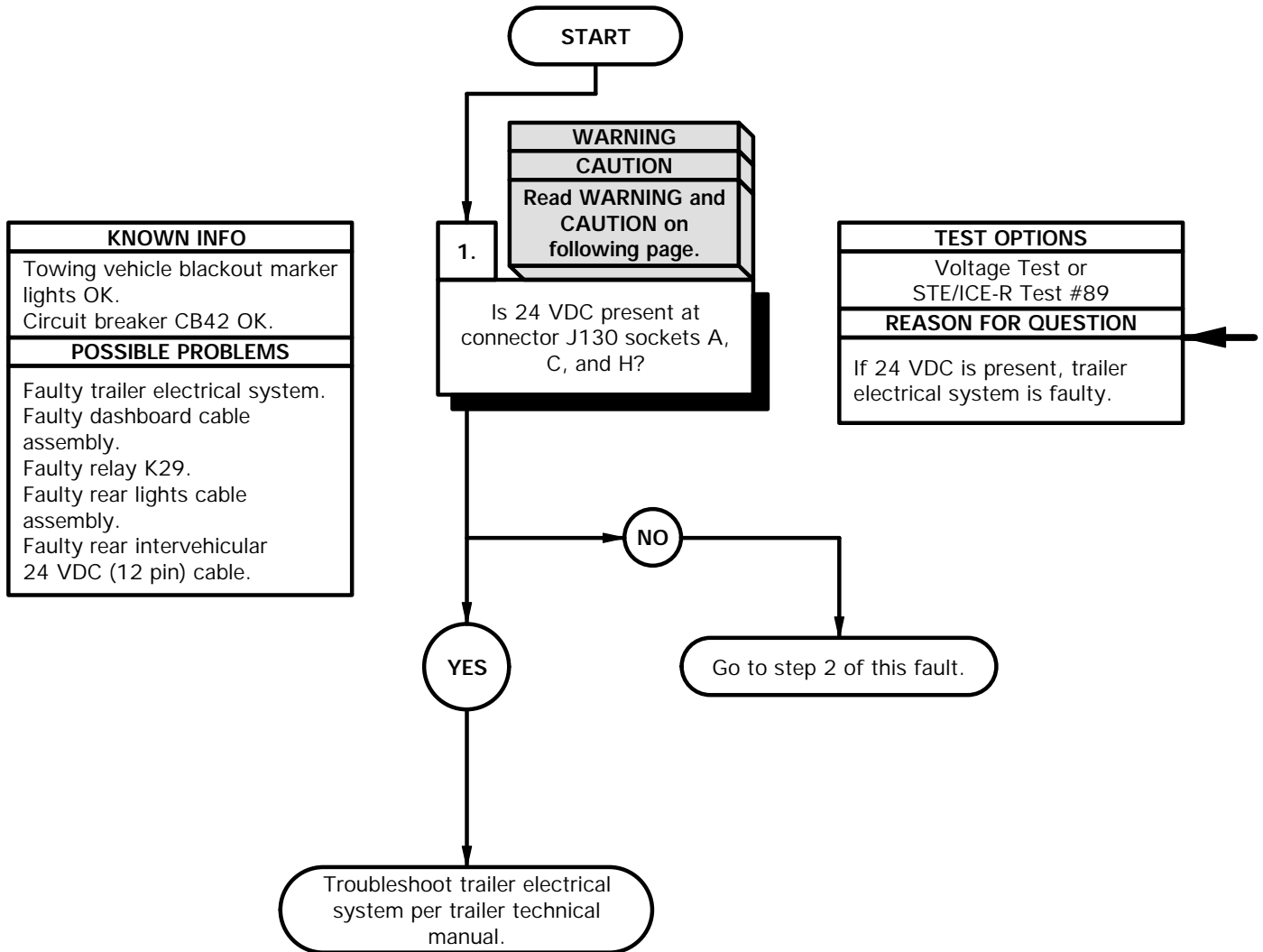

WARNING

Remove rings, bracelets, watches, necklaces, and any other jewelry before working around vehicle. Jewelry can catch on equipment and cause injury or short across electrical circuits and cause severe burns or electrical shock.

CAUTION

Use care when testing electrical connectors. Do not damage connector pins or sockets with multimeter probes. Failure to comply may result in damage to equipment.

NOTE

Inspect connector pins/sockets for damage, corrosion, and serviceability. Check that connector pins are not pushed back and are capable of making good contact.

VOLTAGE TEST

- (1) Lift cover on connector J130 intervehicular 24 VDC connector.
- (2) Set multimeter to volts DC.
- (3) Connect positive (+) probe of multimeter to connector J130 socket A.
- (4) Connect negative (-) probe of multimeter to ground.
- (5) Position main light switch to BO DRIVE (TM 9-2320-365-10) and note reading on multimeter.
- (7) Connect positive (+) probe of multimeter to connector J130 socket C.
- (8) Connect negative (-) probe of multimeter to ground and note reading on multimeter.
- (9) Connect positive (+) probe of multimeter to connector J130 socket H.
- (10) Connect negative (-) probe of multimeter to ground and note reading on multimeter.
- (11) If 24 VDC is not present, go to step 2 of this fault.
- (12) If 24 VDC is present, troubleshoot trailer electrical system per trailer technical manual.
- (13) Position main light switch to OFF (TM 9-2320-365-10).

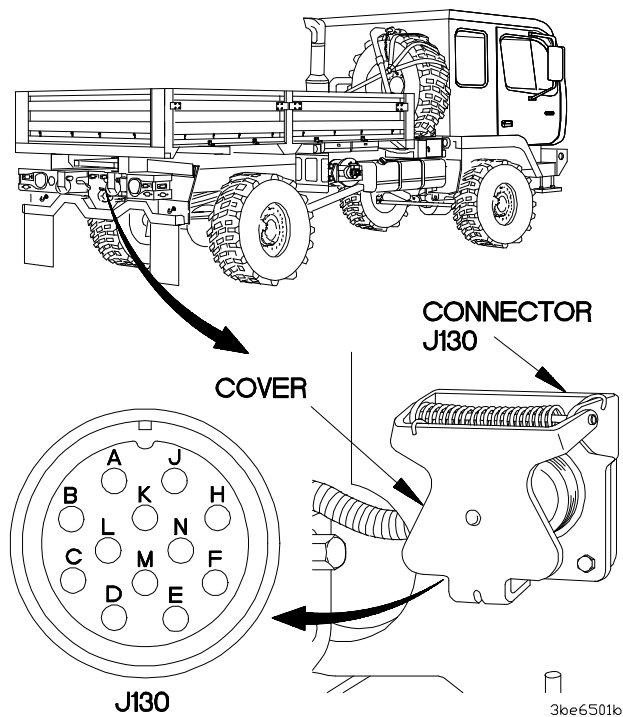

e65. TRAILER BLACKOUT MARKER LIGHTS DO NOT ILLUMINATE (CONT)

KNOWN INFO
Towing vehicle blackout marker lights OK. Circuit breaker CB42 OK. Trailer electrical system OK.
POSSIBLE PROBLEMS
Faulty dashboard cable assembly. Faulty relay K29. Faulty rear lights cable assembly. Faulty rear intervehicular 24 VDC (12 pin) cable.

2. **CAUTION**
Read CAUTION on following page.

Is continuity present from connector J130 sockets A, C, and H to relay K29 terminal 87?

TEST OPTIONS
Continuity Test or STE/ICE-R Test #91
REASON FOR QUESTION
This question eliminates possible problems and determines where troubleshooting continues.

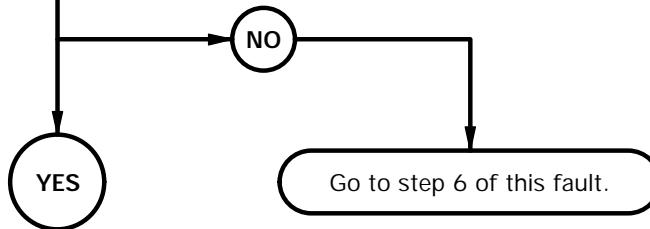

KNOWN INFO
Towing vehicle blackout marker lights OK. Circuit breaker CB42 OK. Trailer electrical system OK. Rear lights cable assembly OK. Rear intervehicular 24 VDC (12 pin) cable OK.
POSSIBLE PROBLEMS
Faulty dashboard cable assembly. Faulty relay K29.

3. **WARNING**
Read WARNING on following page.

Is 24 VDC present at relay K29 terminal 30 on PDP?

TEST OPTIONS
Voltage Test or STE/ICE-R Test #89
REASON FOR QUESTION
If 24 VDC is not present, wire 1958 is faulty.

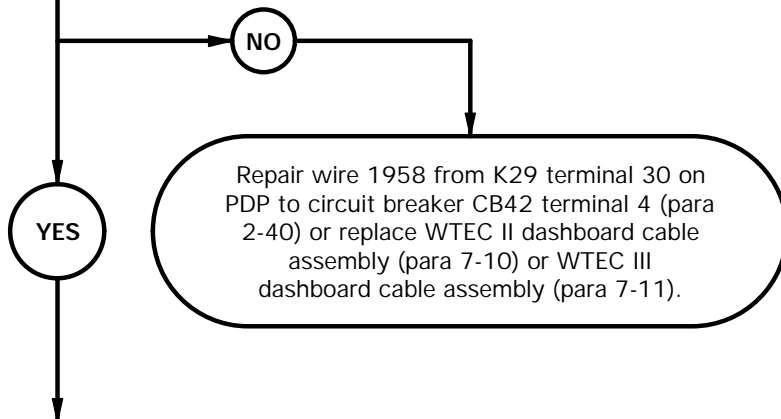

CAUTION

Use care when testing electrical connectors. Do not damage connector pins or sockets with multimeter probes. Failure to comply may result in damage to equipment.

NOTE

Inspect connector pins/sockets for damage, corrosion, and serviceability. Check that connector pins are not pushed back and are capable of making good contact.

CONTINUITY TEST

- (1) Remove PDP cover (para 16-2).
- (2) Remove relay K29 from PDP.
- (3) Set multimeter to ohms.
- (4) Connect positive (+) probe of multimeter to connector J130 sockets A, C, and H, one at a time.
- (5) Connect negative (-) probe of multimeter to relay K29 terminal 87 on PDP and note reading on multimeter.
- (6) If continuity is not present, go to step 6 of this fault.

WARNING

Remove rings, bracelets, watches, necklaces, and any other jewelry before working around vehicle. Jewelry can catch on equipment and cause injury or short across electrical circuits and cause severe burns or electrical shock.

VOLTAGE TEST

- (1) Set multimeter to volts DC.
- (2) Connect positive (+) probe of multimeter to relay K29 terminal 30 on PDP.
- (3) Connect negative (-) probe of multimeter to ground.
- (4) Position main light switch to BO DRIVE (TM 9-2320-365-10) and note reading on multimeter.
- (5) If 24 VDC is not present, repair wire 1958 from K29 terminal 30 on PDP to circuit breaker CB42 terminal 4 (para 2-40) or replace WTEC II dashboard cable assembly (para 7-10) or WTEC III dashboard cable assembly (para 7-11).
- (6) Position main light switch to OFF (TM 9-2320-365-10).

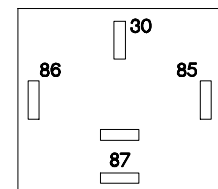
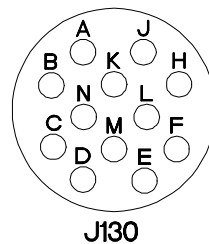
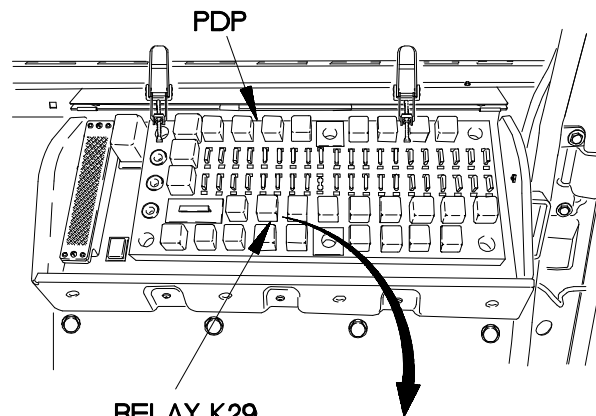

Xbe6802b

e65. TRAILER BLACKOUT MARKER LIGHTS DO NOT ILLUMINATE (CONT)

KNOWN INFO
Towing vehicle blackout marker lights OK. Circuit breaker CB42 OK. Trailer electrical system OK. Rear lights cable assembly OK. Rear intervehicular 24 VDC (12 pin) cable OK.
POSSIBLE PROBLEMS
Faulty dashboard cable assembly. Faulty relay K29.

KNOWN INFO
Towing vehicle blackout marker lights OK. Circuit breaker CB42 OK. Trailer electrical system OK. Rear lights cable assembly OK. Rear intervehicular 24 VDC (12 pin) cable OK.
POSSIBLE PROBLEMS
Faulty dashboard cable assembly. Faulty relay K29.

4.

WARNING
Read **WARNING** on following page.

Is 12 VDC present at relay K29 terminal 86 on PDP?

TEST OPTIONS
Voltage Test or STE/ICE-R Test #89
REASON FOR QUESTION
If 12 VDC is not present, wire 1408 is faulty.

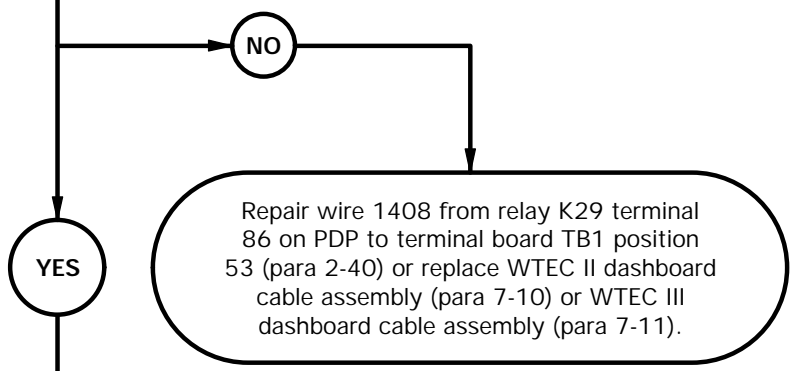

5.

Is continuity present from relay K29 terminal 85 on PDP to ground?

TEST OPTIONS
Continuity Test or STE/ICE-R Test #91
REASON FOR QUESTION
If continuity is not present, wire 3040 is faulty.

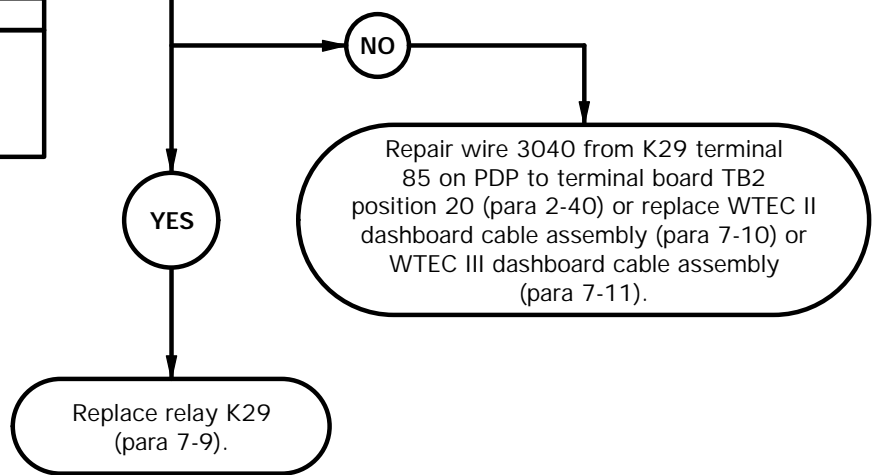

WARNING

Remove rings, bracelets, watches, necklaces, and any other jewelry before working around vehicle. Jewelry can catch on equipment and cause injury or short across electrical circuits and cause severe burns or electrical shock.

VOLTAGE TEST

- (1) Set multimeter to volts DC.
- (2) Connect positive (+) probe of multimeter to relay K29 terminal 86 on PDP.
- (3) Connect negative (-) probe of multimeter to ground.
- (4) Position main light switch to BO DRIVE (TM 9-2320-365-10) and note reading on multimeter.
- (5) If 12 VDC is not present, repair wire 1408 from relay K29 terminal 86 on PDP to terminal board TB1 position 53 (para 2-40) or replace WTEC II dashboard cable assembly (para 7-10) or WTEC III dashboard cable assembly (para 7-11).
- (6) Position main light switch to OFF (TM 9-2320-365-10).

CONTINUITY TEST

- (1) Set multimeter to ohms.
- (2) Connect positive (+) probe of multimeter to relay K29 terminal 85 on PDP.
- (3) Connect negative (-) probe of multimeter to ground and note reading on multimeter.
- (4) If continuity is not present, repair wire 3040 from K29 terminal 85 on PDP to terminal board TB2 position 20 (para 2-40) or replace WTEC II dashboard assembly (para 7-10) or WTEC III dashboard cable assembly (para 7-11).
- (5) If continuity is present, replace relay K29 (para 7-9).
- (6) Install relay K29 in PDP.
- (7) Install PDP cover (para 16-2).

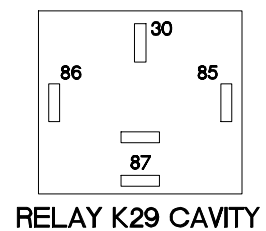
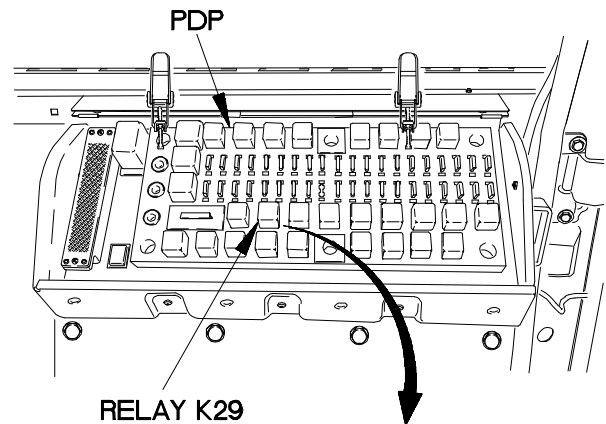

Xbe6803b

e65. TRAILER BLACKOUT MARKER LIGHTS DO NOT ILLUMINATE (CONT)

KNOWN INFO
Towing vehicle blackout marker lights OK. Circuit breaker CB42 OK. Trailer electrical system OK. Relay K29 OK.
POSSIBLE PROBLEMS
Faulty dashboard cable assembly. Faulty rear lights cable assembly. Faulty rear intervehicular 24 VDC (12 pin) cable.

6.

CAUTION
Read CAUTION on following page.

Is continuity present from relay K29 terminal 87 on PDP to connector J51 pin 10?

TEST OPTIONS
Continuity Test or STE/ICE-R Test #91
REASON FOR QUESTION
If continuity is not present, wire 484T is faulty.

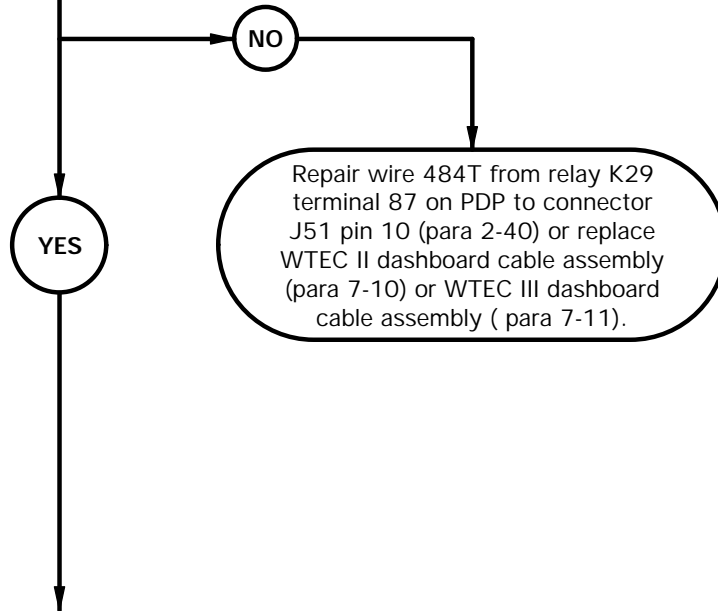

CAUTION

Use care when testing electrical connectors. Do not damage connector pins or sockets with multimeter probes. Failure to comply may result in damage to equipment.

NOTE

Inspect connector pins/sockets for damage, corrosion, and serviceability. Check that connector pins are not pushed back and are capable of making good contact.

CONTINUITY TEST

- (1) Remove three screws and washers from PDP.
- (2) Remove three screws from PDP.
- (3) Lift PDP outward to gain access.
- (4) Disconnect connector J51 from connector P51.
- (5) Set multimeter to ohms.
- (6) Connect positive (+) probe of multimeter to relay K29 terminal 87 on PDP.
- (7) Connect negative (-) probe of multimeter to connector J51 pin 10 and note reading on multimeter.
- (8) If continuity is not present, repair wire 484T from relay K29 terminal 87 on PDP to connector J51 pin 10 (para 2-40) or replace WTEC II dashboard assembly (para 7-10) or WTEC III dashboard cable assembly (para 7-11).
- (9) Install relay K29 in PDP.

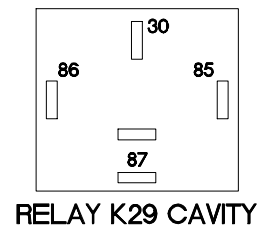
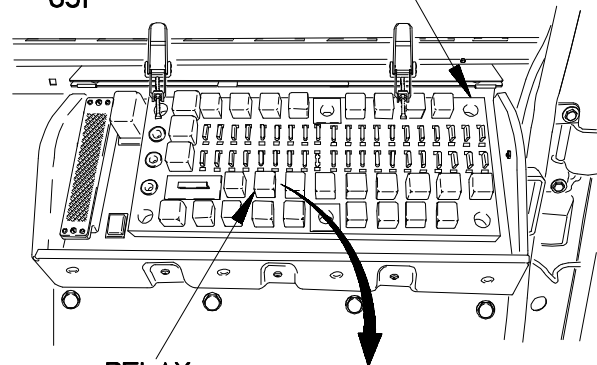
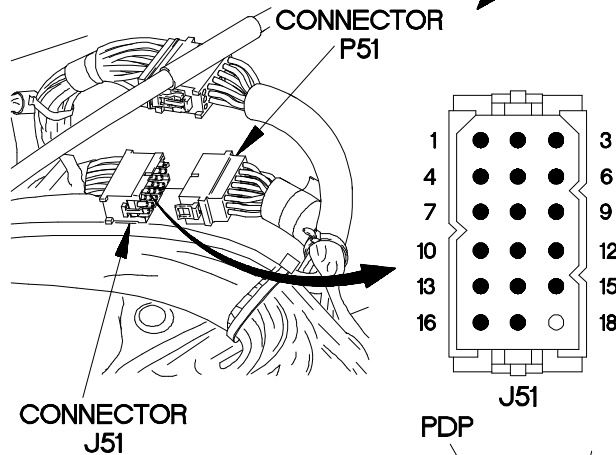
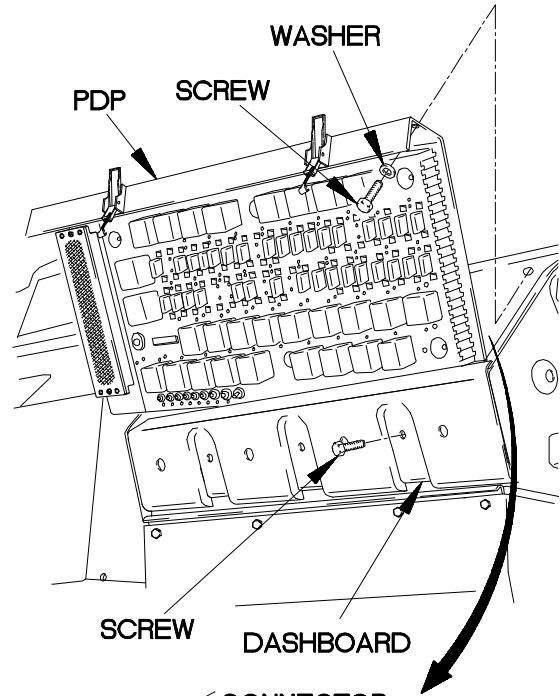

e65. TRAILER BLACKOUT MARKER LIGHTS DO NOT ILLUMINATE (CONT)

KNOWN INFO
Towing vehicle blackout marker lights OK. Circuit breaker CB42 OK. Trailer electrical system OK. Dashboard cable assembly OK. Relay K29 OK.
POSSIBLE PROBLEMS
Faulty rear lights cable assembly. Faulty rear intervehicular 24 VDC (12 pin) cable.

7.

CAUTION
 Read CAUTION on following page.

Is continuity present from connector P51 socket 10 to connector P53R sockets 7 and 9 and pin 10?

TEST OPTIONS
Continuity Test or STE/ICE-R Test #91
REASON FOR QUESTION
If continuity is not present, wire 484T is faulty. If continuity is present, intervehicular 24 VDC (12 pin) cable is faulty.

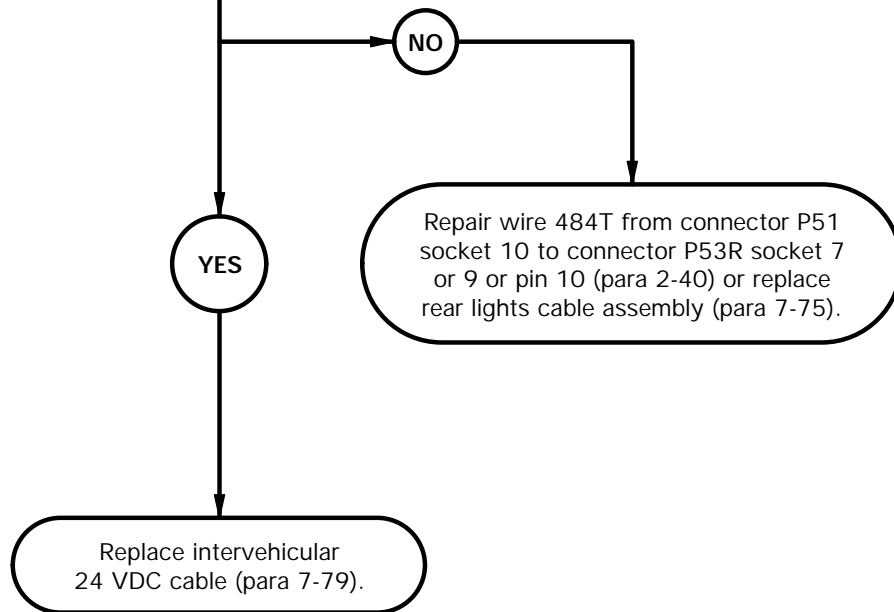

CAUTION

Use care when testing electrical connectors. Do not damage connector pins or sockets with multimeter probes. Failure to comply may result in damage to equipment.

NOTE

Inspect connector pins/sockets for damage, corrosion, and serviceability. Check that connector pins are not pushed back and are capable of making good contact.

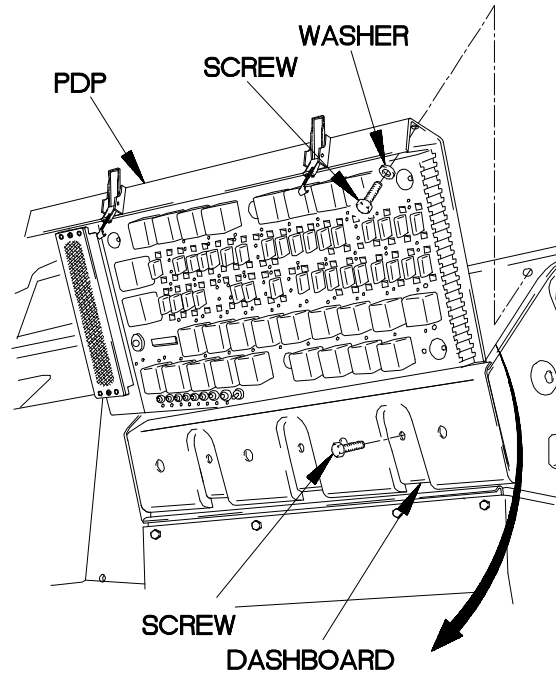

CONTINUITY TEST

- (1) Disconnect connector P53R from connector J53R.
- (2) Set multimeter to ohms.
- (3) Connect positive (+) probe of multimeter to connector P51 socket 10.
- (4) Connect negative (-) probe of multimeter to connector P53R sockets 7 and 9 and pin 10, one at a time, and note reading on multimeter.
- (5) If continuity is not present, repair wire 484T from connector P51 socket 10 to connector P53R socket 7 or 9 or pin 10 (para 2-40) or replace rear lights cable assembly (para 7-75).
- (6) If continuity is present, replace intervehicular 24 VDC (12 pin) cable (para 7-79).
- (7) Connect connector P53R to connector J53R.
- (8) Connect connector P51 to connector J51.
- (9) Install PDP on dashboard with three screws.
- (10) Install three washers and screws in PDP.
- (11) Install PDP cover (para 16-2).

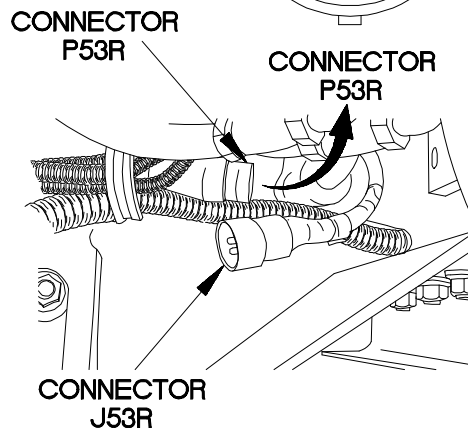
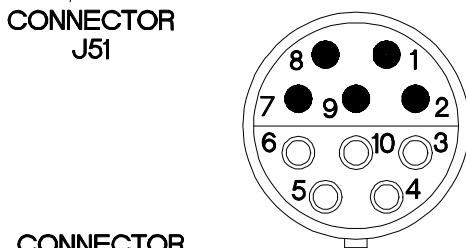
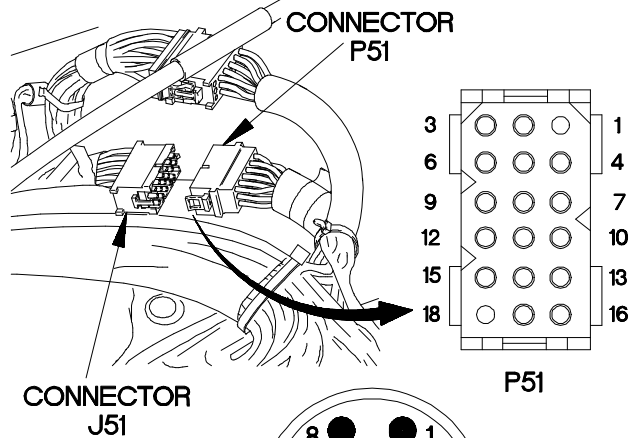

Xbo6805b

e66. TRAILER BLACKOUT STOPLIGHTS DO NOT ILLUMINATE

INITIAL SETUP

Equipment Condition

Engine shut down (TM 9-2320-365-10).

Personnel Required

(2)

Material/Parts

Wire, Elect, 50 ft (Item 77, Appendix D)

Tools and Special Tools

Tool Kit, Genl Mech (Item 44, Appendix C)
 STE/ICE-R (Item 39, Appendix C)
 Multimeter, Digital (Item 22, Appendix C)

References

TM 9-4910-571-12&P

NOTE

Perform Electrical System Troubleshooting e1. Circuit Breaker Does Not Operate on circuit breaker CB39 prior to beginning this task.

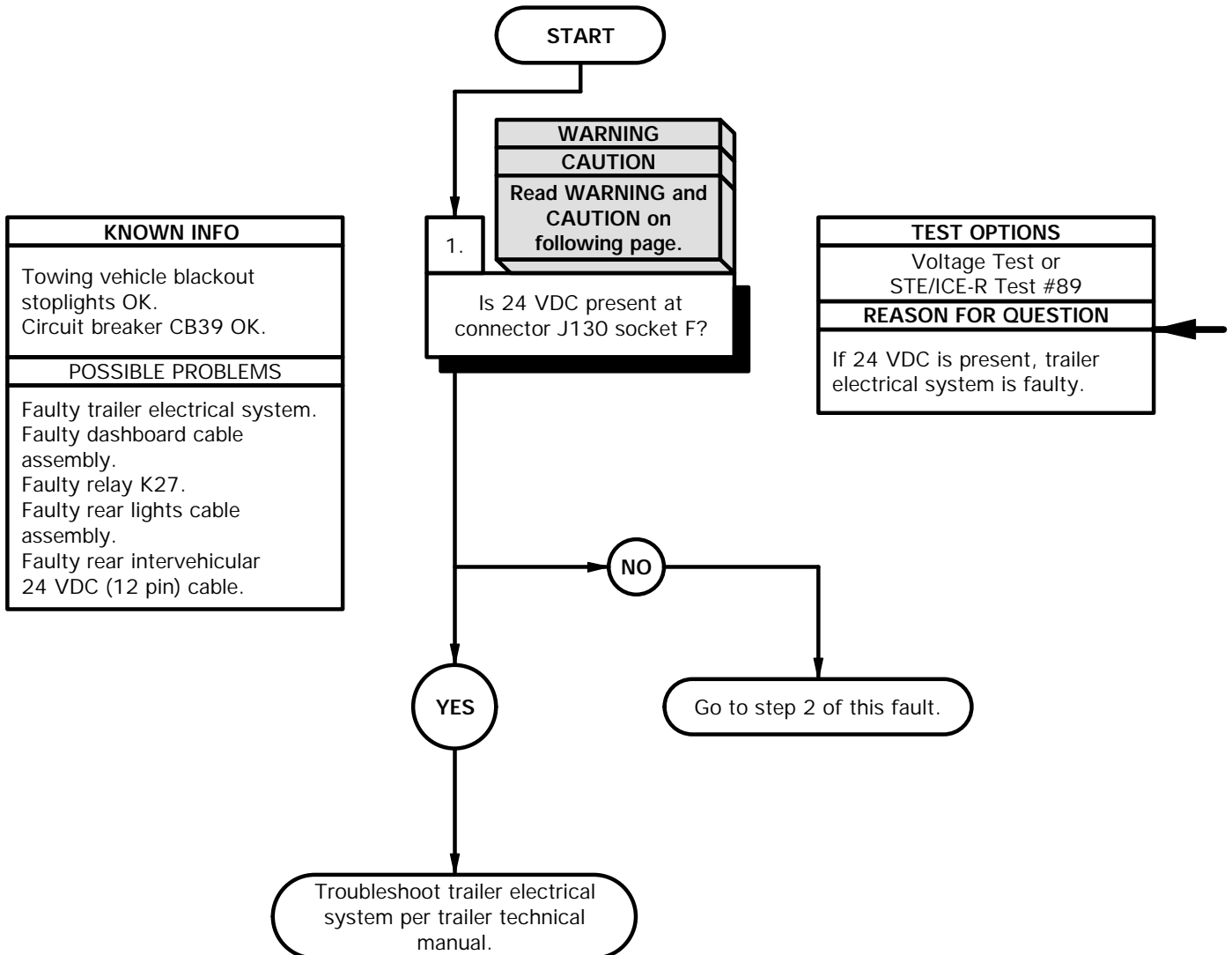

WARNING

Remove rings, bracelets, watches, necklaces, and any other jewelry before working around vehicle. Jewelry can catch on equipment and cause injury or short across electrical circuits and cause severe burns or electrical shock.

CAUTION

Use care when testing electrical connectors. Do not damage connector pins or sockets with multimeter probes. Failure to comply may result in damage to equipment.

NOTE

Inspect connector pins/sockets for damage, corrosion, and serviceability. Check that connector pins are not pushed back and are capable of making good contact.

VOLTAGE TEST

- (1) Lift cover on connector J130 intervehicular 24 VDC connector.
- (2) Set multimeter to volts DC.
- (3) Connect positive (+) probe of multimeter to connector J130 socket F.
- (4) Connect negative (-) probe of multimeter to ground.
- (5) Position master power switch to on (TM 9-2320-365-10).
- (6) Position main light switch to BO DRIVE (TM 9-2320-365-10).
- (7) Apply brakes and note reading on multimeter.
- (8) If 24 VDC is not present, go to step 2 of this fault.
- (9) If 24 VDC is present, troubleshoot trailer electrical system per trailer technical manual.
- (10) Position main light switch to OFF (TM 9-2320-365-10).
- (11) Position master power switch to off (TM 9-2320-365-10).

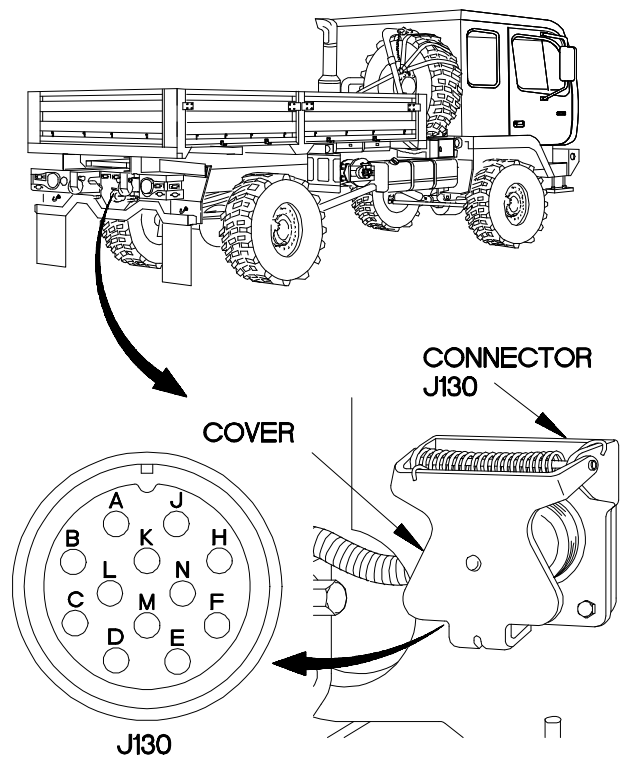

3be6601b

e66. TRAILER BLACKOUT STOPLIGHTS DO NOT ILLUMINATE (CONT)

KNOWN INFO
Towing vehicle blackout stoplights OK. Circuit breaker CB39 OK. Trailer electrical system OK.
POSSIBLE PROBLEMS
Faulty dashboard cable assembly. Faulty relay K27. Faulty rear lights cable assembly. Faulty rear intervehicular 24 VDC (12 pin) cable.

KNOWN INFO
Towing vehicle blackout stoplights OK. Circuit breaker CB39 OK. Trailer electrical system OK. Rear lights cable assembly OK. Rear intervehicular 24 VDC (12 pin) cable OK.
POSSIBLE PROBLEMS
Faulty dashboard cable assembly. Faulty relay K27.

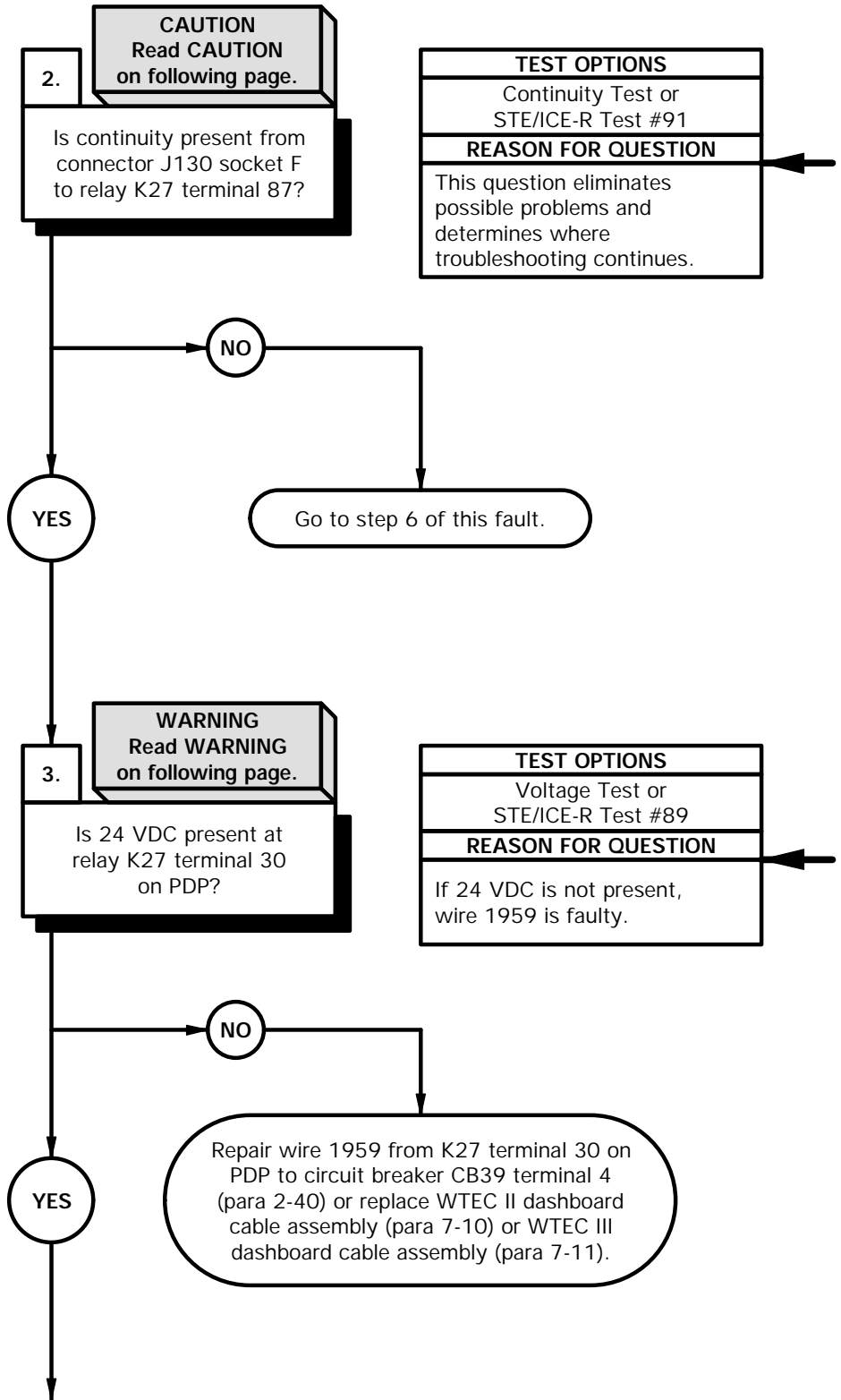

CAUTION

Use care when testing electrical connectors. Do not damage connector pins or sockets with multimeter probes. Failure to comply may result in damage to equipment.

NOTE

Inspect connector pins/sockets for damage, corrosion, and serviceability. Check that connector pins are not pushed back and are capable of making good contact.

CONTINUITY TEST

- (1) Remove PDP cover (para 16-2).
- (2) Remove relay K27 from PDP.
- (3) Set multimeter to ohms.
- (4) Connect positive (+) probe of multimeter to connector J130 socket F.
- (5) Connect negative (-) probe of multimeter to relay K27 terminal 87 on PDP and note reading on multimeter.
- (6) If continuity is not present, go to step 6 of this fault.

WARNING

Remove rings, bracelets, watches, necklaces, and any other jewelry before working around vehicle. Jewelry can catch on equipment and cause injury or short across electrical circuits and cause severe burns or electrical shock.

VOLTAGE TEST

- (1) Set multimeter to volts DC.
- (2) Connect positive (+) probe of multimeter to relay K27 terminal 30 on PDP.
- (3) Connect negative (-) probe of multimeter to ground.
- (4) Position main light switch to BO DRIVE (TM 9-2320-365-10) and note reading on multimeter.
- (5) If 24 VDC is not present, repair wire 1959 from K27 terminal 30 on PDP to circuit breaker CB39 terminal 4 (para 2-40) or replace WTEC II dashboard cable assembly (para 7-10) or WTEC III dashboard cable assembly (para 7-11).
- (6) Position main light switch to OFF (TM 9-2320-365-10).

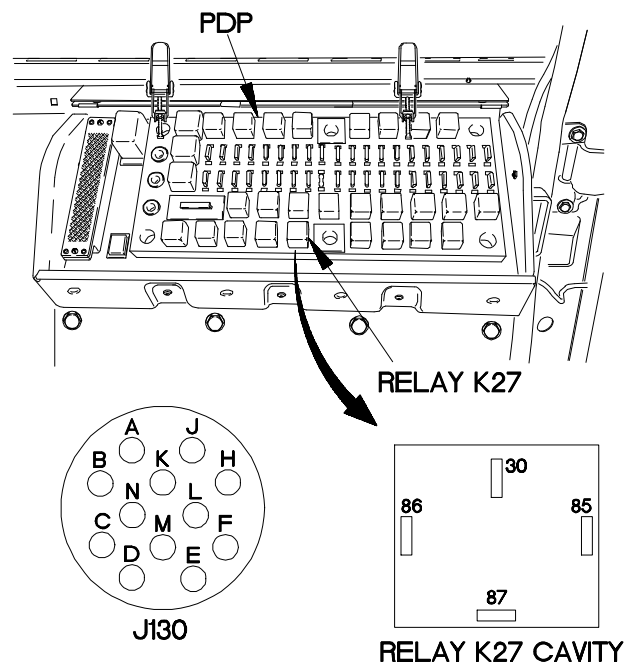

Xbe6902b

e66. TRAILER BLACKOUT STOPLIGHTS DO NOT ILLUMINATE (CONT)

KNOWN INFO
Towing vehicle blackout stoplights OK. Circuit breaker CB39 OK. Trailer electrical system OK. Rear lights cable assembly OK. Rear intervehicular 24 VDC (12 pin) cable OK.
POSSIBLE PROBLEMS
Faulty dashboard cable assembly. Faulty relay K27.

KNOWN INFO
Towing vehicle blackout stoplights OK. Circuit breaker CB39 OK. Trailer electrical system OK. Rear lights cable assembly OK. Rear intervehicular 24 VDC (12 pin) cable OK.
POSSIBLE PROBLEMS
Faulty dashboard cable assembly. Faulty relay K27.

4.

WARNING
Read **WARNING** on following page.

Is 12 VDC present at relay K27 terminal 86 on PDP?

TEST OPTIONS
Voltage Test or STE/ICE-R Test #89
REASON FOR QUESTION
If 12 VDC is not present, wire 23 is faulty.

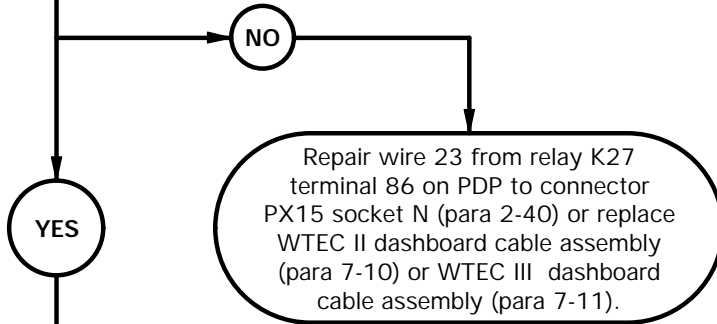

5.

Is continuity present from relay K27 terminal 85 on PDP to ground?

TEST OPTIONS
Continuity Test or STE/ICE-R Test #91
REASON FOR QUESTION
If continuity is not present, wire 3044 is faulty.

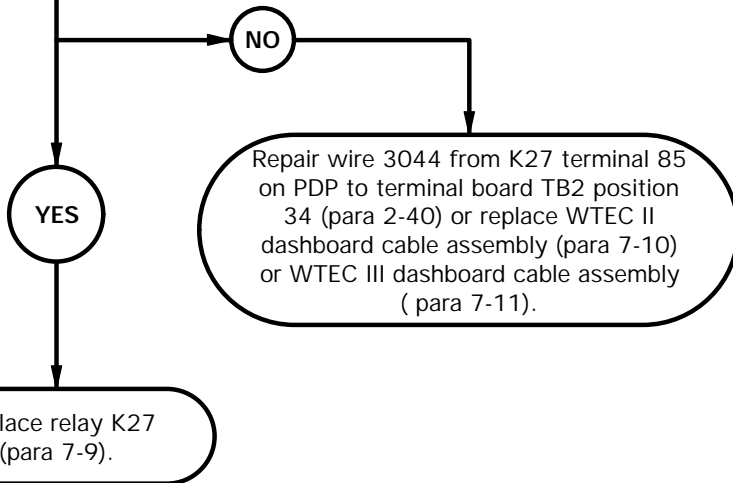

WARNING

Remove rings, bracelets, watches, necklaces, and any other jewelry before working around vehicle. Jewelry can catch on equipment and cause injury or short across electrical circuits and cause severe burns or electrical shock.

VOLTAGE TEST

- (1) Set multimeter to volts DC.
- (2) Connect positive (+) probe of multimeter to relay K27 terminal 86 on PDP.
- (3) Connect negative (-) probe of multimeter to ground.
- (4) Position master power switch to on (TM 9-2320-365-10).
- (5) Position main light switch to BO DRIVE (TM 9-2320-365-10).
- (6) Apply brakes and note reading on multimeter.
- (7) If 12 VDC is not present, repair wire 23 from relay K27 terminal 86 on PDP to connector PX15 socket N (para 2-40) or replace WTEC II dashboard cable assembly (para 7-10) or WTEC III dashboard cable assembly (para 7-11).
- (8) Position main light switch to OFF (TM 9-2320-365-10).
- (9) Position master power switch to off (TM 9-2320-365-10).

CONTINUITY TEST

- (1) Set multimeter to ohms.
- (2) Connect positive (+) probe of multimeter to relay K27 terminal 85 on PDP.
- (3) Connect negative (-) probe of multimeter to ground and note reading on multimeter.
- (4) If continuity is not present, repair wire 3044 from K27 terminal 85 on PDP to terminal board TB2 position 34 (para 2-40) or replace WTEC II dashboard assembly (para 7-10) or WTEC III dashboard cable assembly (para 7-11).
- (5) If continuity is present, replace relay K27 (para 7-9).
- (6) Install relay K27 in PDP.
- (7) Install PDP cover (para 16-2).

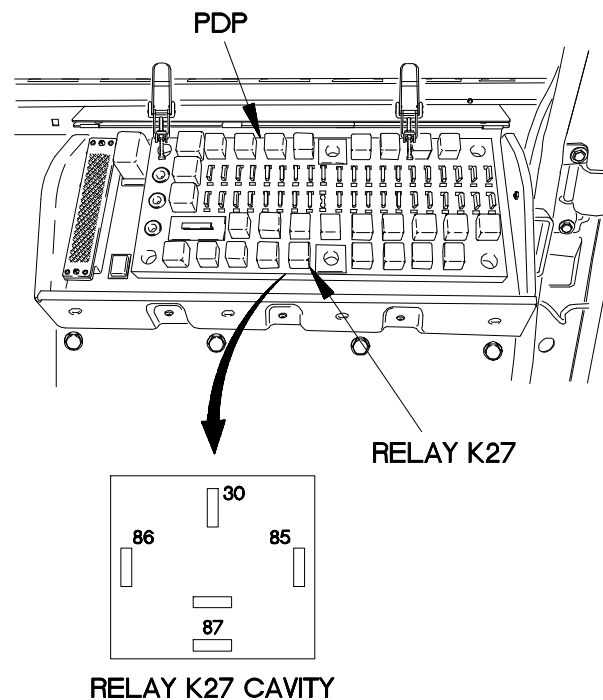

Xbe6903b

e66. TRAILER BLACKOUT STOPLIGHTS DO NOT ILLUMINATE (CONT)

KNOWN INFO
Towing vehicle blackout stoplights OK. Circuit breaker CB39 OK. Trailer electrical system OK. Relay K27 OK.
POSSIBLE PROBLEMS
Faulty dashboard cable assembly. Faulty rear lights cable assembly. Faulty rear intervehicular 24 VDC (12 pin) cable.

6.

CAUTION
Read CAUTION on following page.

Is continuity present from relay K27 terminal 87 on PDP to connector J51 pin 8?

TEST OPTIONS
Continuity Test or STE/ICE-R Test #91
REASON FOR QUESTION
If continuity is not present, wire 23T is faulty.

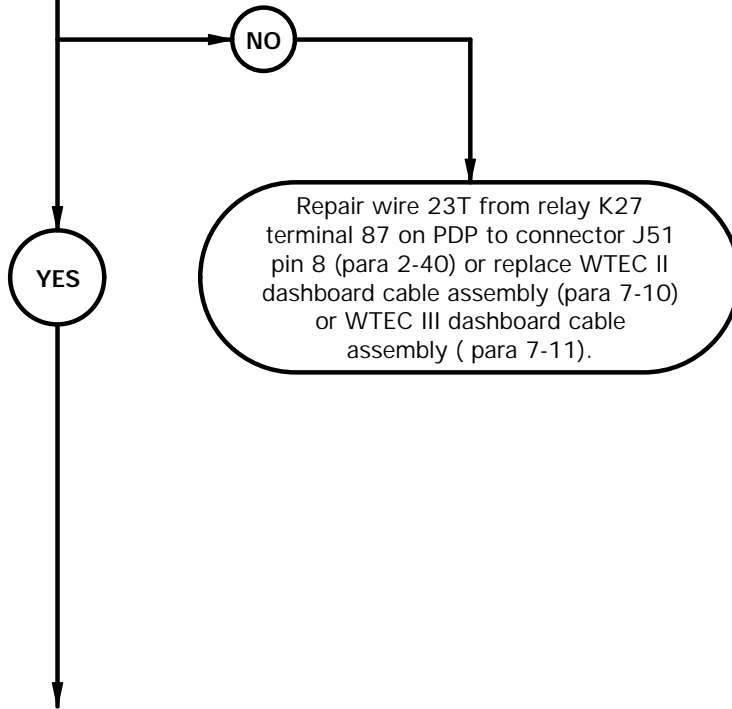

CAUTION

Use care when testing electrical connectors. Do not damage connector pins or sockets with multimeter probes. Failure to comply may result in damage to equipment.

NOTE

Inspect connector pins/sockets for damage, corrosion, and serviceability. Check that connector pins are not pushed back and are capable of making good contact.

CONTINUITY TEST

- (1) Remove three screws and washers from PDP.
- (2) Remove three screws from PDP.
- (3) Lift PDP outward to gain access.
- (4) Disconnect connector J51 from connector P51.
- (5) Set multimeter to ohms.
- (6) Connect positive (+) probe of multimeter to relay K27 terminal 87 on PDP.
- (7) Connect negative (-) probe of multimeter to connector J51 pin 8 and note reading on multimeter.
- (8) If continuity is not present, repair wire 23T from relay K27 terminal 87 on PDP to connector J51 pin 8 (para 2-40) or replace WTEC II dashboard assembly (para 7-10) or WTEC III dashboard cable assembly (para 7-11).
- (9) Install relay K27 in PDP.

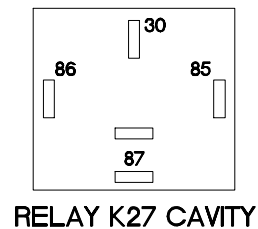
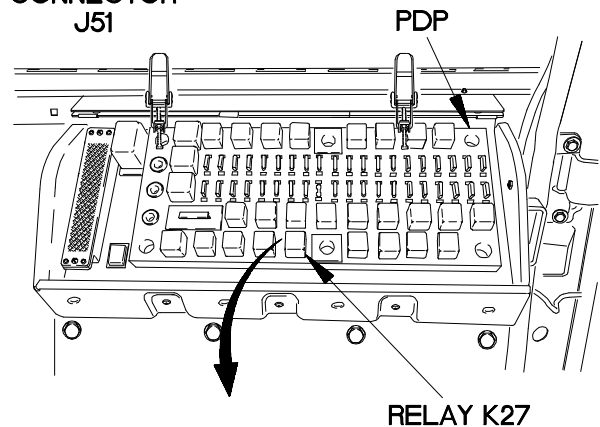
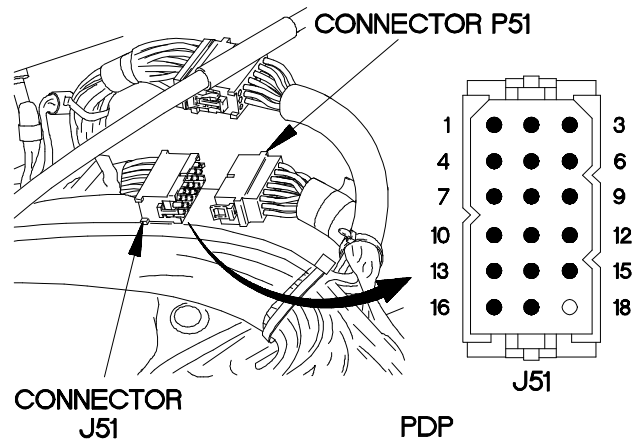
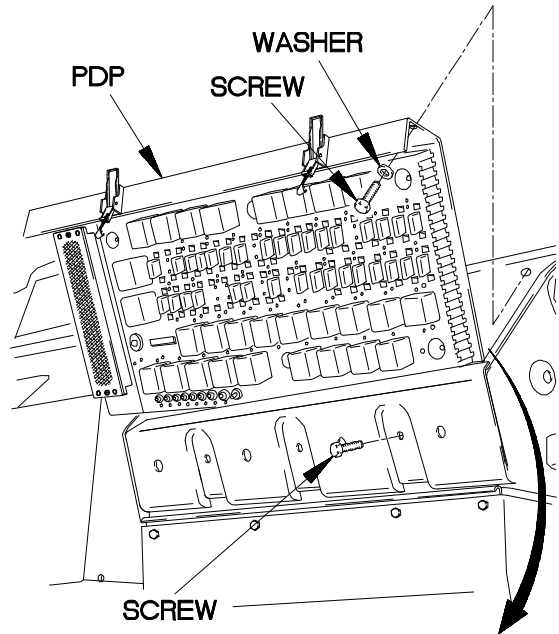

RELAY K27 CAVITY

Xbo6904b

e66. TRAILER BLACKOUT STOPLIGHTS DO NOT ILLUMINATE (CONT)

KNOWN INFO
Towing vehicle blackout stoplights OK. Circuit breaker CB39 OK. Trailer electrical system OK. Dashboard cable assembly OK. Relay K27 OK.
POSSIBLE PROBLEMS
Faulty rear lights cable assembly. Faulty rear intervehicular 24 VDC (12 pin) cable.

7.

CAUTION
 Read CAUTION on following page.

Is continuity present from connector P51 socket 8 to connector P53R socket 6?

TEST OPTIONS
Continuity Test or STE/ICE-R Test #91
REASON FOR QUESTION
If continuity is not present, wire 23T is faulty. If continuity is present, intervehicular 24 VDC (12 pin) cable is faulty.

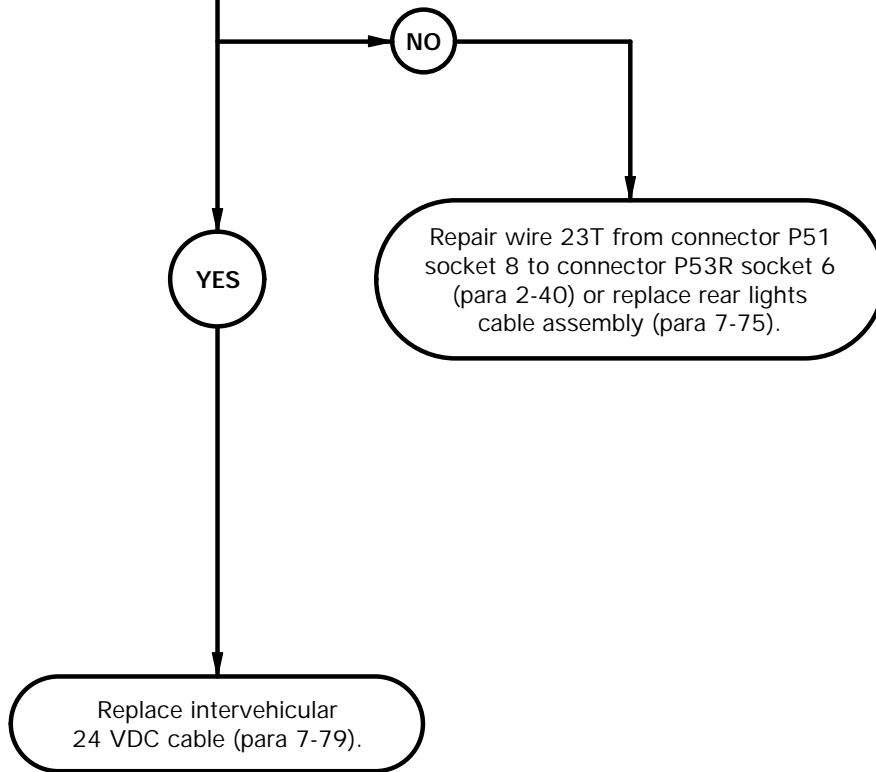

CAUTION

Use care when testing electrical connectors. Do not damage connector pins or sockets with multimeter probes. Failure to comply may result in damage to equipment.

NOTE

Inspect connector pins/sockets for damage, corrosion, and serviceability. Check that connector pins are not pushed back and are capable of making good contact.

CONTINUITY TEST

- (1) Disconnect connector P53R from connector J53R.
- (2) Set multimeter to ohms.
- (3) Connect positive (+) probe of multimeter to connector P51 socket 8.
- (4) Connect negative (-) probe of multimeter to connector P53R socket 6 and note reading on multimeter.
- (5) If continuity is not present, repair wire 23T from connector P51 socket 8 to connector P53R socket 6 (para 2-40) or replace rear lights cable assembly (para 7-75).
- (6) If continuity is present, replace intervehicular 24 VDC (12 pin) cable (para 7-79).
- (7) Connect connector P53R to connector J53R.
- (8) Connect connector P51 to connector J51.
- (9) Install PDP on dashboard with three screws.
- (10) Install three washers and screws in PDP.
- (11) Install PDP cover (para 16-2).

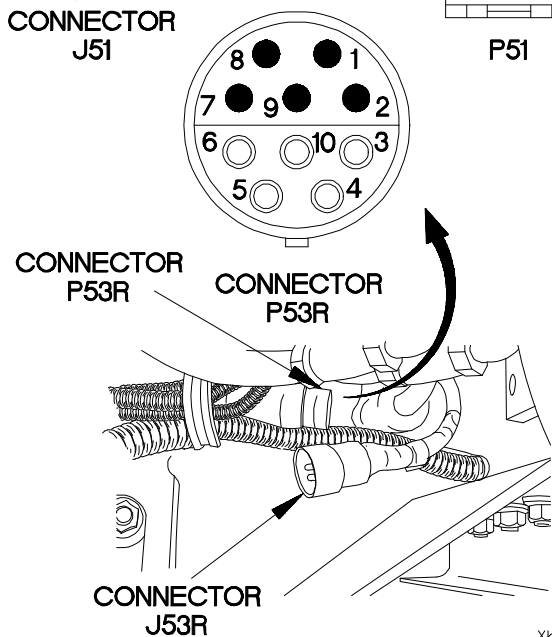
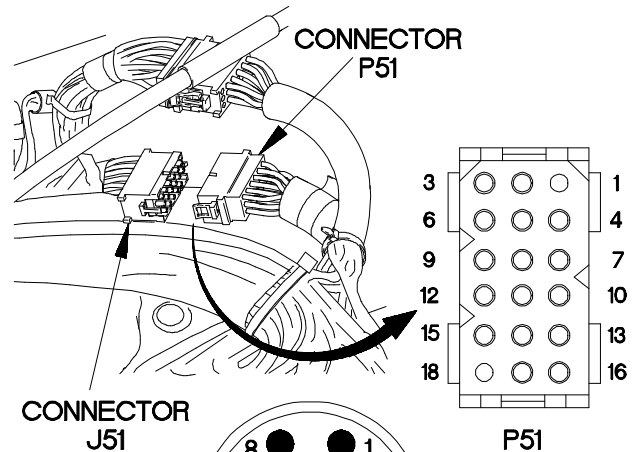
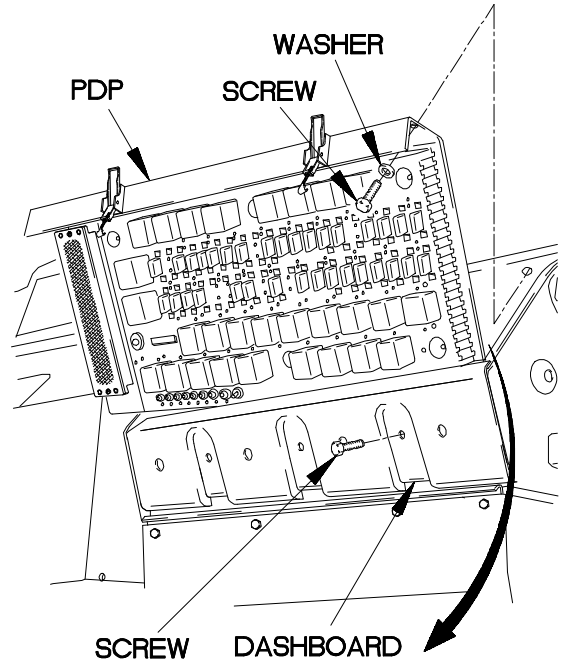

Xbo6906B

e67. INTERVEHICLE CLEARANCE LIGHTS DO NOT OPERATE

INITIAL SETUP

Equipment Condition

Engine shut down (TM 9-2320-365-10).

Personnel Required

(2)

References

TM 9-4910-571-12&P

Tools and Special Tools

Tool Kit, Genl Mech (Item 44, Appendix C)

STE/ICE-R (Item 39, Appendix C)

Multimeter, Digital (Item 22, Appendix C)

Materials/Parts

Ties, Cable, Plastic (Item 76, Appendix D)

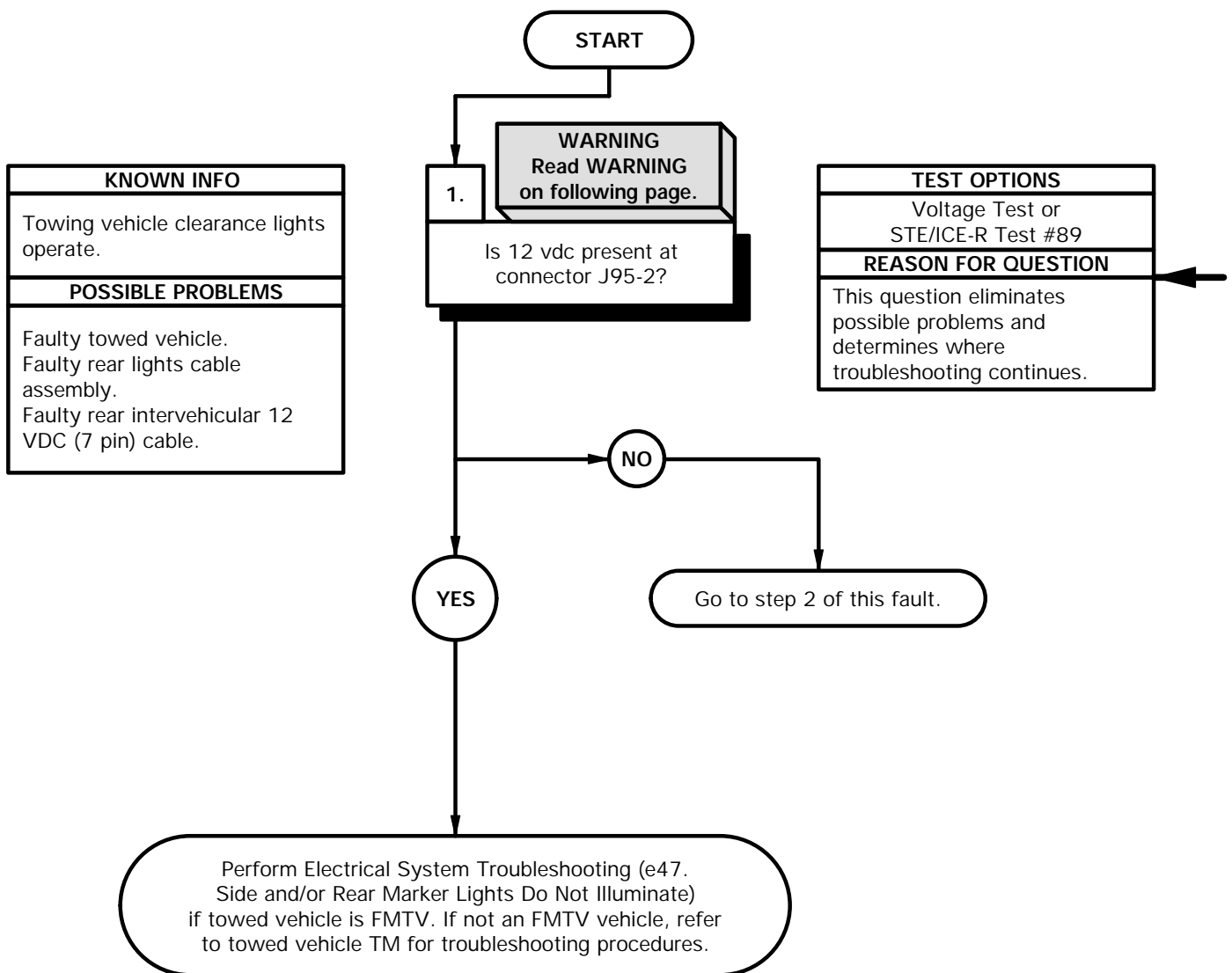

WARNING

Remove rings, bracelets, watches, necklaces, and any other jewelry before working around vehicle. Jewelry can catch on equipment and cause injury or short across electrical circuit and cause severe burns or electrical shock.

VOLTAGE TEST

- (1) Raise cover on connector J95 intervehicular 12 vdc connector.
- (2) Set multimeter to volts dc.
- (3) Connect positive (+) probe of multimeter to connector J95-2.
- (4) Connect negative (-) probe of multimeter to ground.
- (5) Position main light switch to SER DRIVE (TM 9-2320-365-10) and note reading on multimeter.
- (6) If 12 vdc is not present, go to step 2 of this fault.
- (7) If 12 vdc is present, perform Electrical System Troubleshooting (e47. Side and/or Rear Marker Lights Do Not Illuminate) if towed vehicle is FMTV. If towed vehicle is not an FMTV, refer to towed vehicle TM for troubleshooting procedures.
- (8) Position main light switch to OFF (TM 9-2320-365-10).

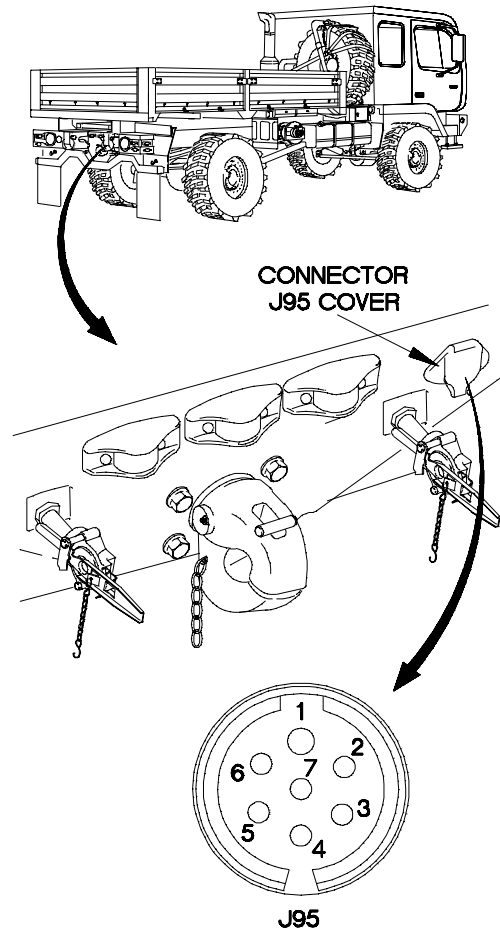

32e 70011

67. INTERVEHICLE CLEARANCE LIGHTS DO NOT OPERATE (CONT)

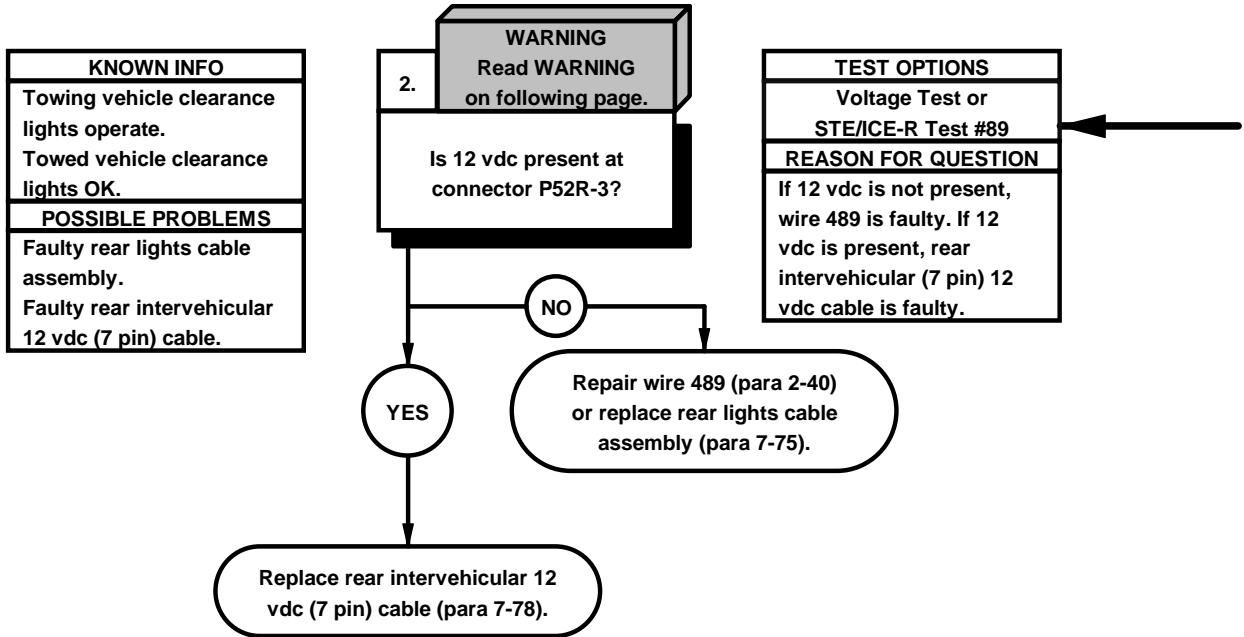

WARNING

Remove rings, bracelets, watches, necklaces, and any other jewelry before working around vehicle. Jewelry can catch on equipment and cause injury or short across electrical circuits and cause severe burns or electrical shock.

VOLTAGE TEST

NOTE

Remove plastic cable ties as required.

- (1) Disconnect connector P52R from connector J52.
- (2) Set multimeter to volts dc.
- (3) Connect positive (+) probe of multimeter to connector P52R-3.
- (4) Connect negative (-) probe of multimeter to ground.
- (5) Position main light switch to SER DRIVE (TM 9-2320-365-10) and note reading on multimeter.
- (6) If 12 vdc is not present, repair wire 489 (para 2-40) or replace rear lights cable assembly (para 7-75).
- (7) If 12 vdc is present, replace rear intervehicular 12 VDC (7 pin) cable (para 7-78).
- (8) Position main light switch to OFF (TM 9-2320-365-10).

NOTE

Install plastic cable ties as required.

- (9) Connect connector P52R to connector J52.

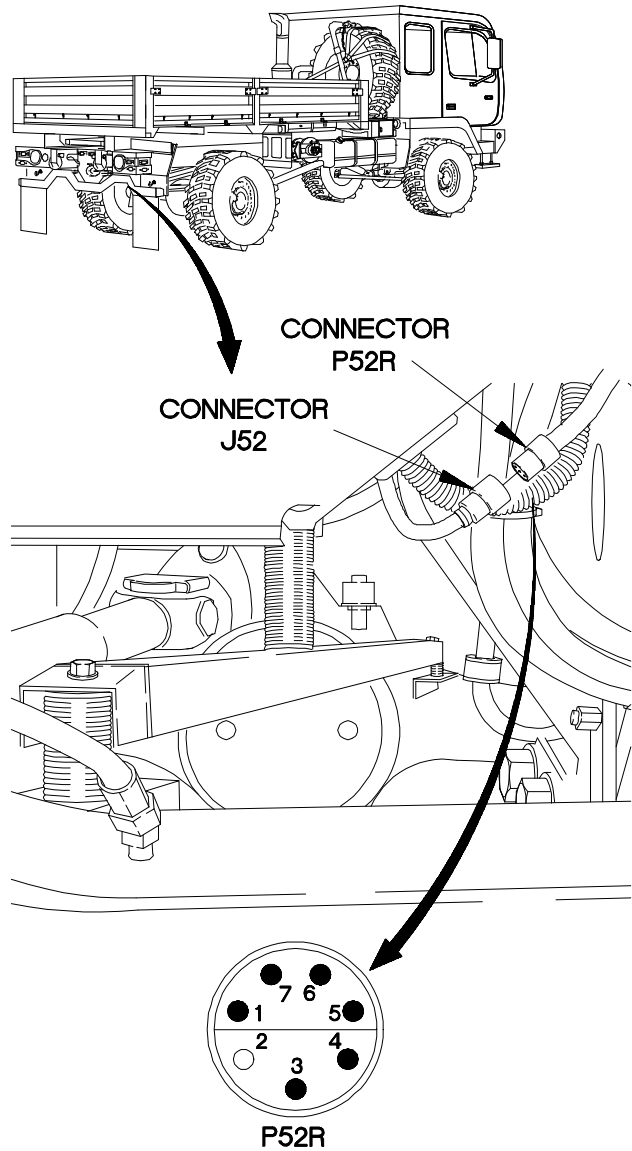

32E71031

e68. INTERVEHICLE LEFT TURN SIGNAL DOES NOT ILLUMINATE

INITIAL SETUP

Equipment Condition

Engine shut down (TM 9-2320-365-10).

Material/Parts

Ties, Cable, Plastic (Item 76, Appendix D)

Tools and Special Tools

Tool Kit, Genl Mech (Item 44, Appendix C)
 STE/ICE-R (Item 39, Appendix C)
 Multimeter, Digital (Item 22, Appendix C)

Personnel Required

(2)

References

TM 9-4910-571-12&P

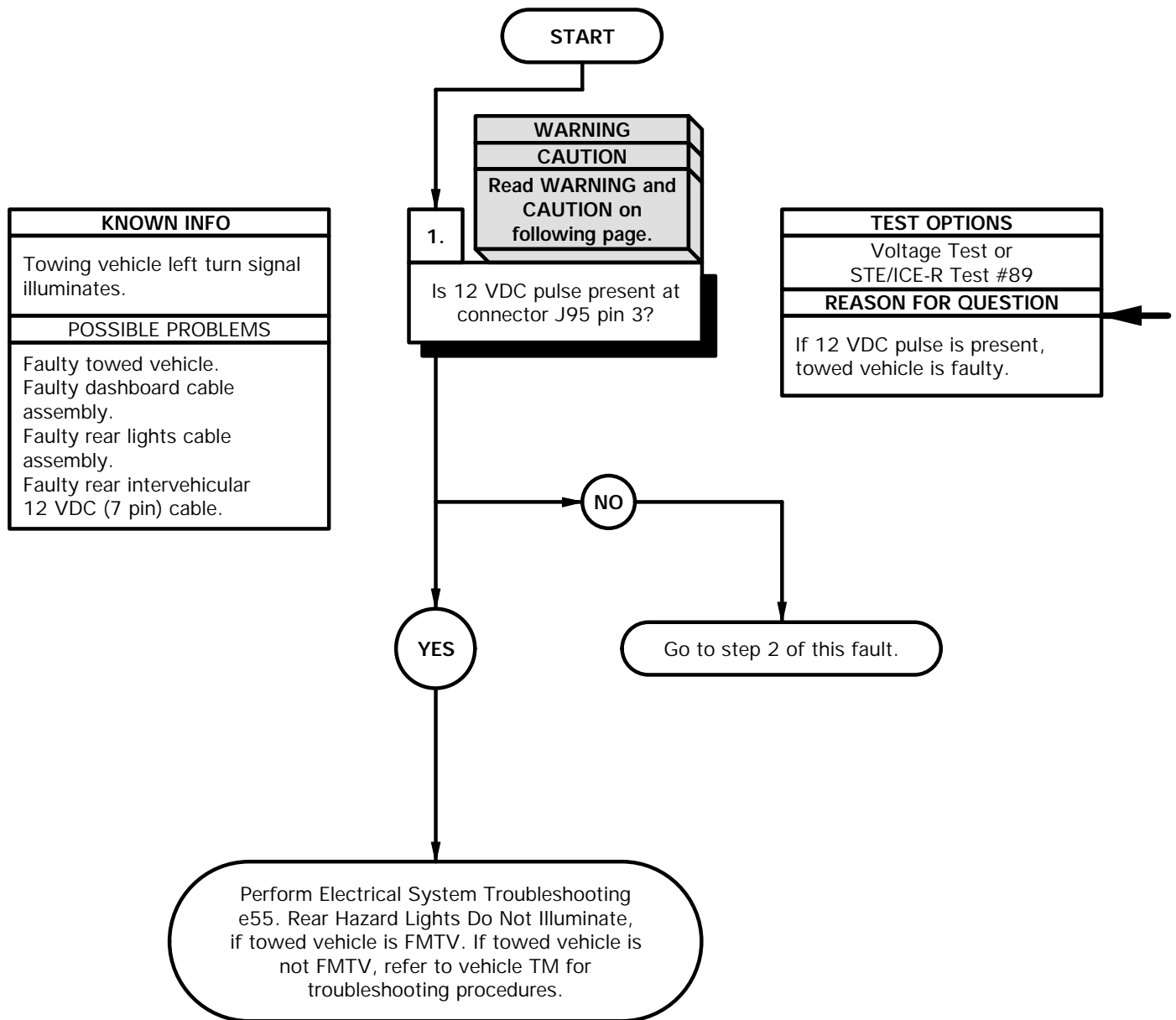

WARNING

Remove rings, bracelets, watches, necklaces, and any other jewelry before working around vehicle. Jewelry can catch on equipment and cause injury or short across electrical circuits and cause severe burns or electrical shock.

CAUTION

Use care when testing electrical connectors. Do not damage connector pins or sockets with multimeter probes. Failure to comply may result in damage to equipment.

NOTE

Inspect connector pins/sockets for damage, corrosion, and serviceability. Check that connector pins are not pushed back and are capable of making good contact.

VOLTAGE TEST

- (1) Lift cover on connector J95 intervehicular 12 VDC connector.
- (2) Set multimeter to volts DC.
- (3) Connect positive (+) probe of multimeter to connector J95 pin 3.
- (4) Connect negative (-) probe of multimeter to ground.
- (5) Position main light switch to SER DRIVE (TM 9-2320-365-10).
- (6) Position turn signal switch to left turn (TM 9-2320-365-10) and note reading on multimeter.
- (7) If 12 VDC pulse is not present, go to step 2 of this fault.
- (8) If 24 VDC pulse is present, perform Electrical System Troubleshooting e55. Rear Hazard Lights Do Not Illuminate, if towed vehicle is FMTV. If towed vehicle is not FMTV, refer to towed vehicle TM for troubleshooting procedures.
- (9) Position turn signal switch to off (TM 9-2320-365-10).
- (10) Position main light switch to OFF (TM 9-2320-365-10).

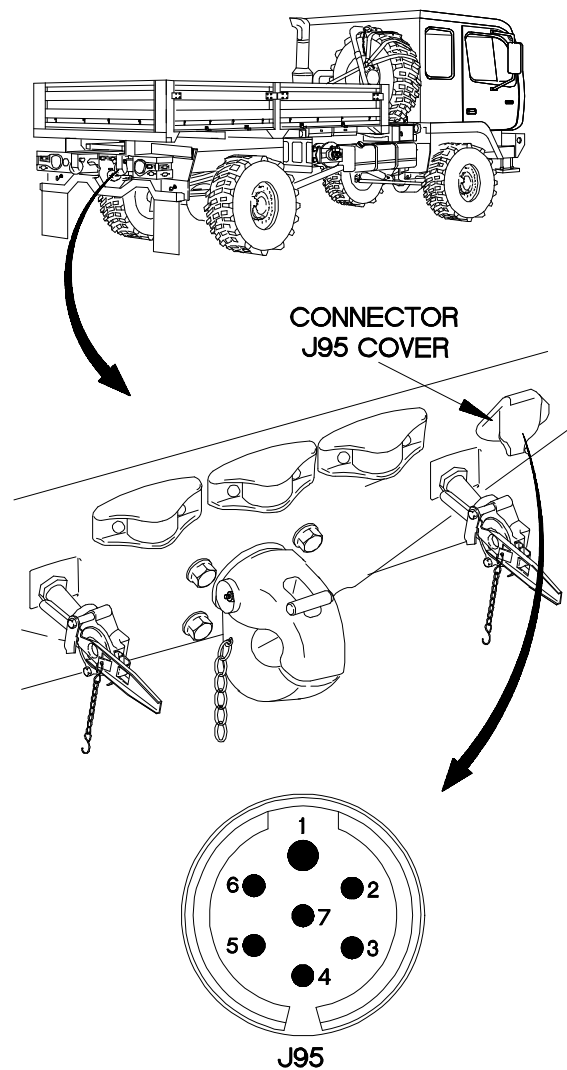

3Be6801b

e68. INTERVEHICLE LEFT TURN SIGNAL DOES NOT ILLUMINATE (CONT)

KNOWN INFO
Towing vehicle left turn signal illuminates. Towed vehicle left turn signal OK.
POSSIBLE PROBLEMS
Faulty dashboard cable assembly. Faulty rear lights cable assembly. Faulty rear intervehicular 12 VDC (7 pin) cable.

2.

WARNING
CAUTION
Read WARNING and CAUTION on following page.

Is 12 VDC pulse present at connector J51 pin 12?

TEST OPTIONS
Voltage Test or STE/ICE-R Test #89
REASON FOR QUESTION
If 12 VDC pulse is not present, wire 461B is faulty.

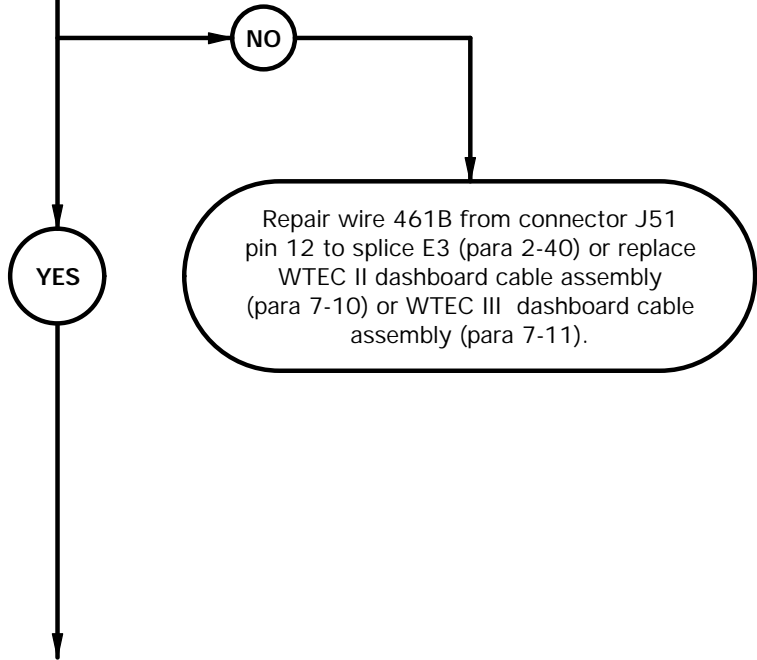

WARNING

Remove rings, bracelets, watches, necklaces, and any other jewelry before working around vehicle. Jewelry can catch on equipment and cause injury or short across electrical circuits and cause severe burns or electrical shock.

CAUTION

Use care when testing electrical connectors. Do not damage connector pins or sockets with multimeter probes. Failure to comply may result in damage to equipment.

NOTE

Inspect connector pins/sockets for damage, corrosion, and serviceability. Check that connector pins are not pushed back and are capable of making good contact.

VOLTAGE TEST

- (1) Remove PDP cover (para 16-2).
- (2) Remove three screws and washers from PDP.
- (3) Remove three screws from PDP.
- (4) Lift PDP outward to gain access.
- (5) Disconnect connector J51 from connector P51.
- (6) Set multimeter to volts DC.
- (7) Connect positive (+) probe of multimeter to connector J51 pin 12.
- (8) Connect negative (-) probe of multimeter to ground.
- (9) Position main light switch to SER DRIVE (TM 9-2320-365-10).
- (10) Position turn signal switch to left turn (TM 9-2320-365-10) and note reading on multimeter.
- (11) If 12 VDC pulse is not present, repair wire 461B from connector J51 pin 12 to splice E3.
- (12) Position main light switch to OFF (TM 9-2320-365-10).
- (13) Position turn signal switch to off (TM 9-2320-365-10).
- (14) Connect connector J51 to connector P51.
- (15) Install PDP on dashboard with three screws.
- (16) Install three washers and screws in PDP.
- (17) Install PDP cover (para 16-2).

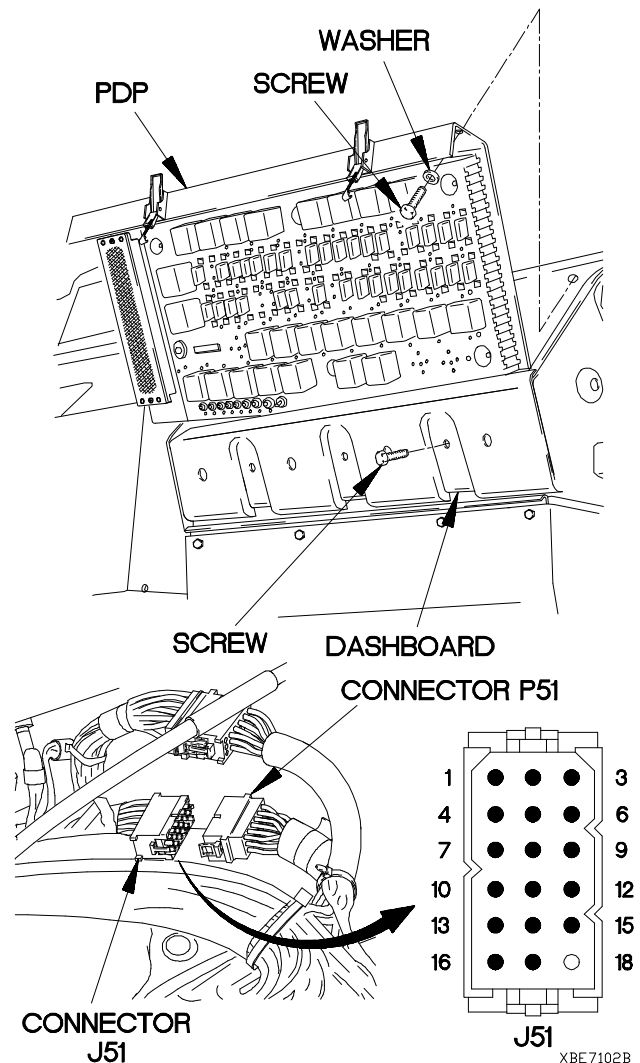

e68. INTERVEHICLE LEFT TURN SIGNAL DOES NOT ILLUMINATE (CONT)

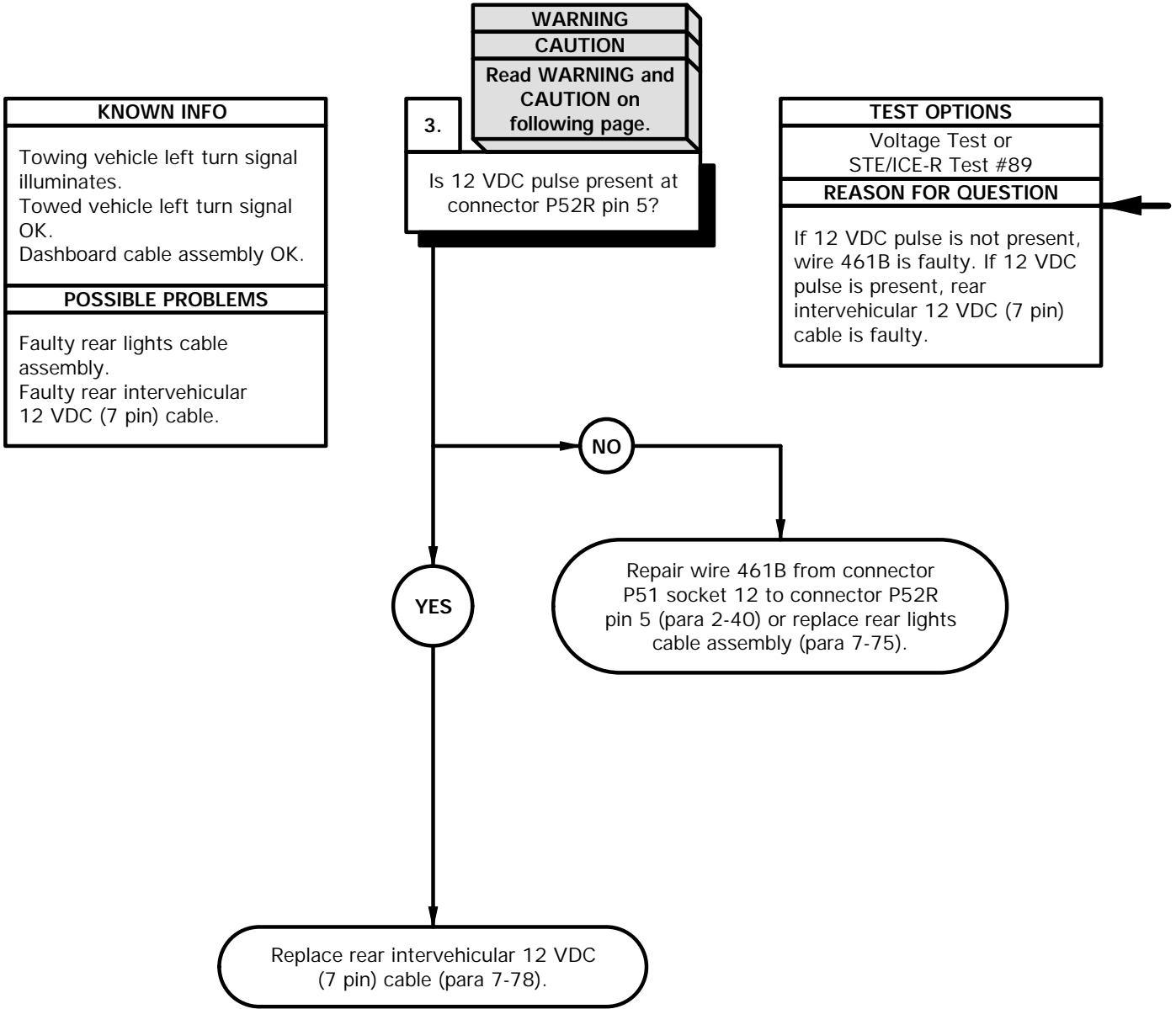

WARNING

Remove rings, bracelets, watches, necklaces, and any other jewelry before working around vehicle. Jewelry can catch on equipment and cause injury or short across electrical circuits and cause severe burns or electrical shock.

CAUTION

Use care when testing electrical connectors. Do not damage connector pins or sockets with multimeter probes. Failure to comply may result in damage to equipment.

NOTE

Inspect connector pins/sockets for damage, corrosion, and serviceability. Check that connector pins are not pushed back and are capable of making good contact.

VOLTAGE TEST

NOTE

Remove plastic cable ties as required.

- (1) Disconnect connector P52R from connector J52.
- (2) Set multimeter to volts DC.
- (3) Connect positive (+) probe of multimeter to connector P52R pin 5.
- (4) Connect negative (-) probe of multimeter to ground.
- (5) Position main light switch to SER DRIVE (TM 9-2320-365-10).
- (6) Position turn signal switch to left turn (TM 9-2320-365-10).
- (7) If 12 VDC pulse is not present, repair wire 461B from connector P51 socket 12 to connector P52R pin 5 (para 2-40) or replace rear lights cable assembly (para 7-75).
- (8) If 12 VDC pulse is present, replace rear intervehicular 12 VDC (7 pin) cable (para 7-78).
- (9) Position turn signal switch to off (TM 9-2320-365-10).

VOLTAGE TEST (Cont)

- (10) Position main light switch to OFF (TM 9-2320-365-10).

NOTE

Install plastic cable ties as required.

- (11) Connect connector P52R to connector J52.

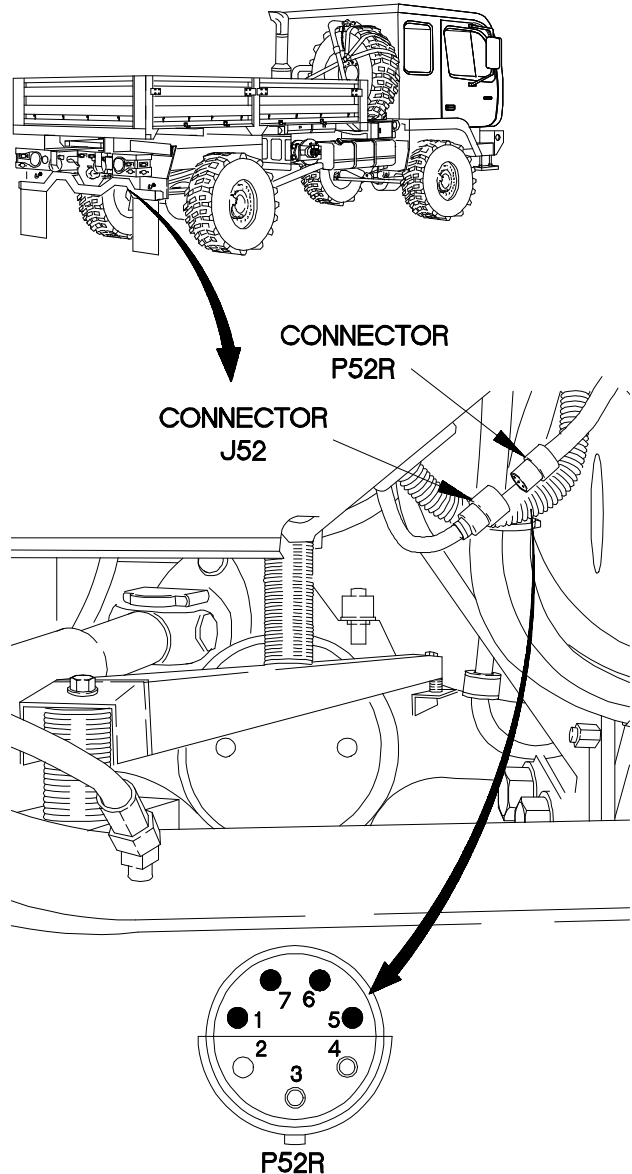

3BE6803B

e69. INTERVEHICLE RIGHT TURN SIGNAL DOES NOT ILLUMINATE

INITIAL SETUP

Equipment Condition

Engine shut down (TM 9-2320-365-10).

Material/Parts

Ties, Cable, Plastic (Item 76, Appendix D)

Tools and Special Tools

Tool Kit, Genl Mech (Item 44, Appendix C)

STE/ICE-R (Item 39, Appendix C)

Multimeter, Digital (Item 22, Appendix C)

Personnel Required

(2)

References

TM 9-4910-571-12&P

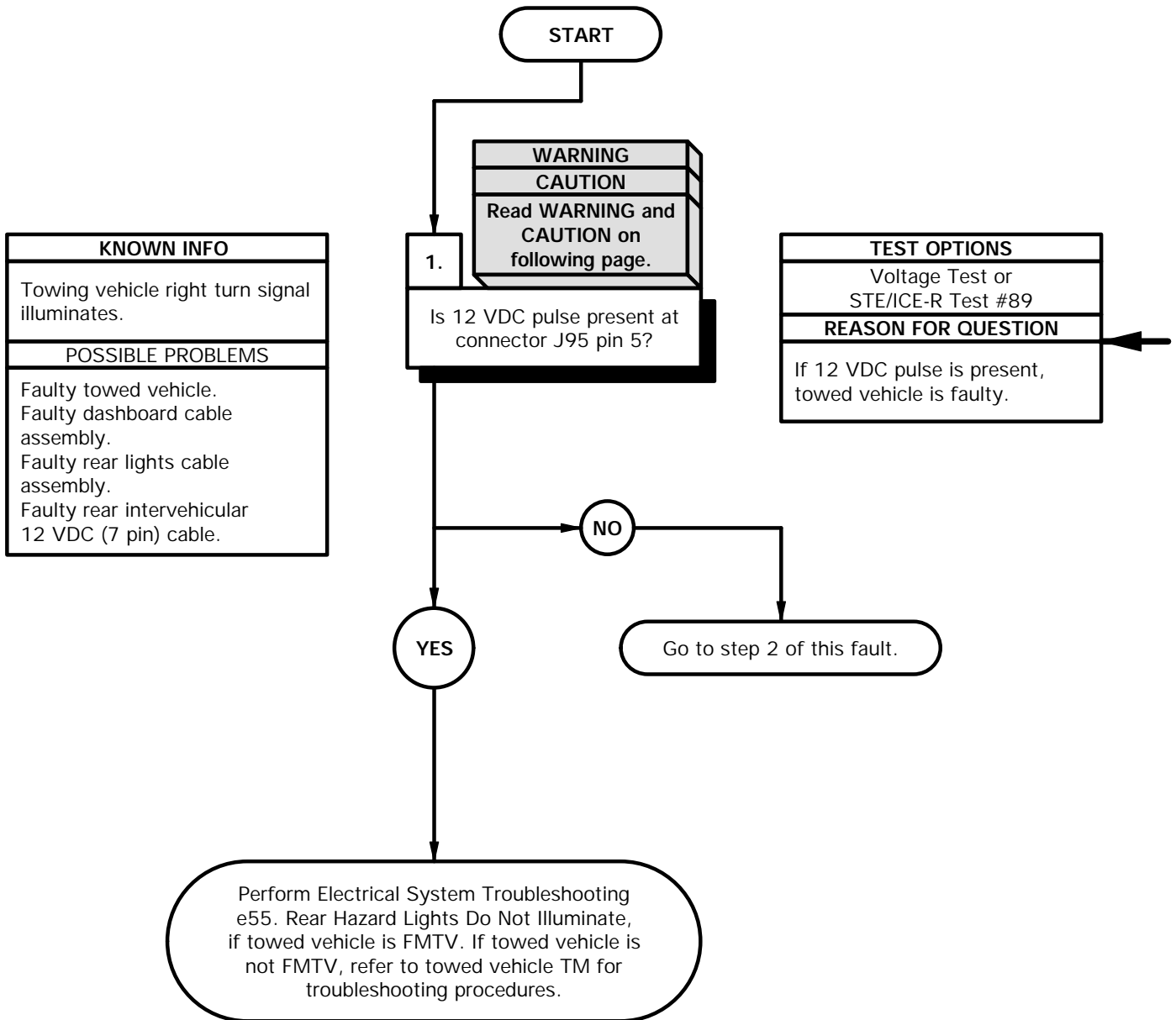

WARNING

Remove rings, bracelets, watches, necklaces, and any other jewelry before working around vehicle. Jewelry can catch on equipment and cause injury or short across electrical circuits and cause severe burns or electrical shock.

CAUTION

Use care when testing electrical connectors. Do not damage connector pins or sockets with multimeter probes. Failure to comply may result in damage to equipment.

NOTE

Inspect connector pins/sockets for damage, corrosion, and serviceability. Check that connector pins are not pushed back and are capable of making good contact.

VOLTAGE TEST

- (1) Lift cover on connector J95 intervehicular 12 VDC connector.
- (2) Set multimeter to volts DC.
- (3) Connect positive (+) probe of multimeter to connector J95 pin 5.
- (4) Connect negative (-) probe of multimeter to ground.
- (5) Position main light switch to SER DRIVE (TM 9-2320-365-10).
- (6) Position turn signal switch to right turn (TM 9-2320-365-10) and note reading on multimeter.
- (7) If 12 VDC pulse is not present, go to step 2 of this fault.
- (8) If 24 VDC pulse is present, perform Electrical System Troubleshooting e55. Rear Hazard Lights Do Not Illuminate, if towed vehicle is FMTV. If towed vehicle is not FMTV, refer to towed vehicle TM for troubleshooting procedures.
- (9) Position turn signal switch to off (TM 9-2320-365-10).
- (10) Position main light switch to OFF (TM 9-2320-365-10).

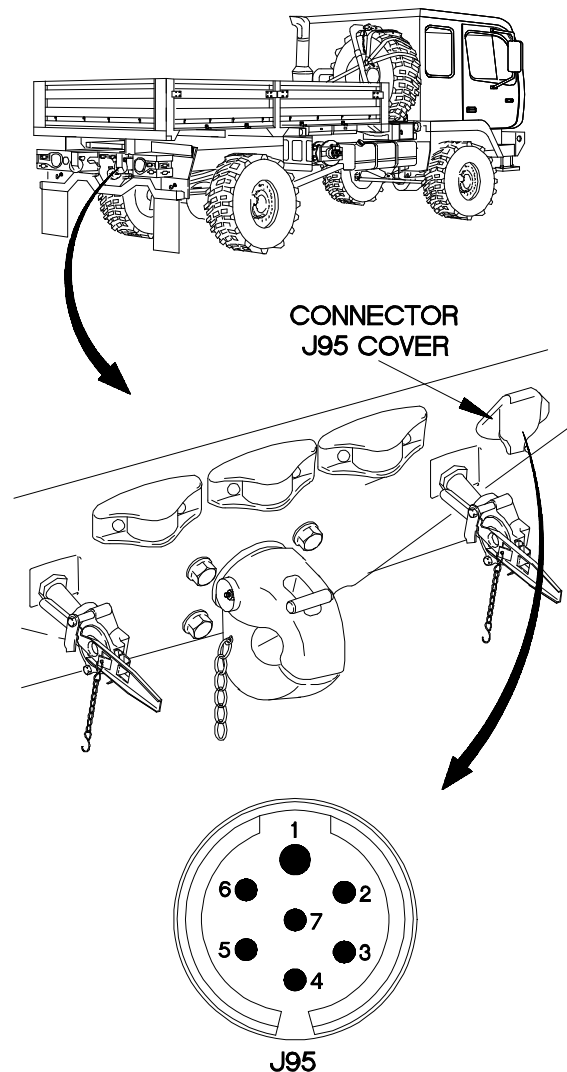

3Be6901b

e69. INTERVEHICLE RIGHT TURN SIGNAL DOES NOT ILLUMINATE (CONT)

KNOWN INFO
Towing vehicle right turn signal illuminates. Towed vehicle right turn signal OK.
POSSIBLE PROBLEMS
Faulty dashboard cable assembly. Faulty rear lights cable assembly. Faulty rear intervehicular 12 VDC (7 pin) cable.

2.

WARNING
CAUTION
Read WARNING and CAUTION on following page.

Is 12 VDC pulse present at connector J51 pin 11?

TEST OPTIONS
Voltage Test or STE/ICE-R Test #89
REASON FOR QUESTION
If 12 VDC pulse is not present, wire 460B is faulty.

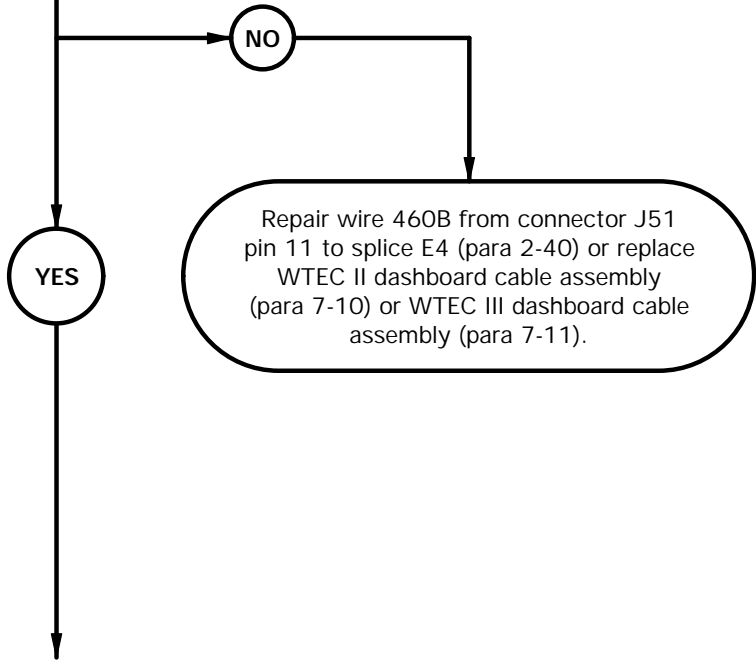

WARNING

Remove rings, bracelets, watches, necklaces, and any other jewelry before working around vehicle. Jewelry can catch on equipment and cause injury or short across electrical circuits and cause severe burns or electrical shock.

CAUTION

Use care when testing electrical connectors. Do not damage connector pins or sockets with multimeter probes. Failure to comply may result in damage to equipment.

NOTE

Inspect connector pins/sockets for damage, corrosion, and serviceability. Check that connector pins are not pushed back and are capable of making good contact.

VOLTAGE TEST

- (1) Remove PDP cover (para 16-2).
- (2) Remove three screws and washers from PDP.
- (3) Remove three screws from PDP.
- (4) Lift PDP outward to gain access.
- (5) Disconnect connector J51 from connector P51.
- (6) Set multimeter to volts DC.
- (7) Connect positive (+) probe of multimeter to connector J51 pin 11.
- (8) Connect negative (-) probe of multimeter to ground.
- (9) Position main light switch to SER DRIVE (TM 9-2320-365-10).
- (10) Position turn signal switch to right turn (TM 9-2320-365-10) and note reading on multimeter.
- (11) If 12 VDC pulse is not present, repair wire 460B from connector J51 pin 11 to splice E4.
- (12) Position main light switch to OFF (TM 9-2320-365-10).
- (13) Position turn signal switch to off (TM 9-2320-365-10).
- (14) Connect connector J51 to connector P51.
- (15) Install PDP on dashboard with three screws.
- (16) Install three washers and screws in PDP.
- (17) Install PDP cover (para 16-2).

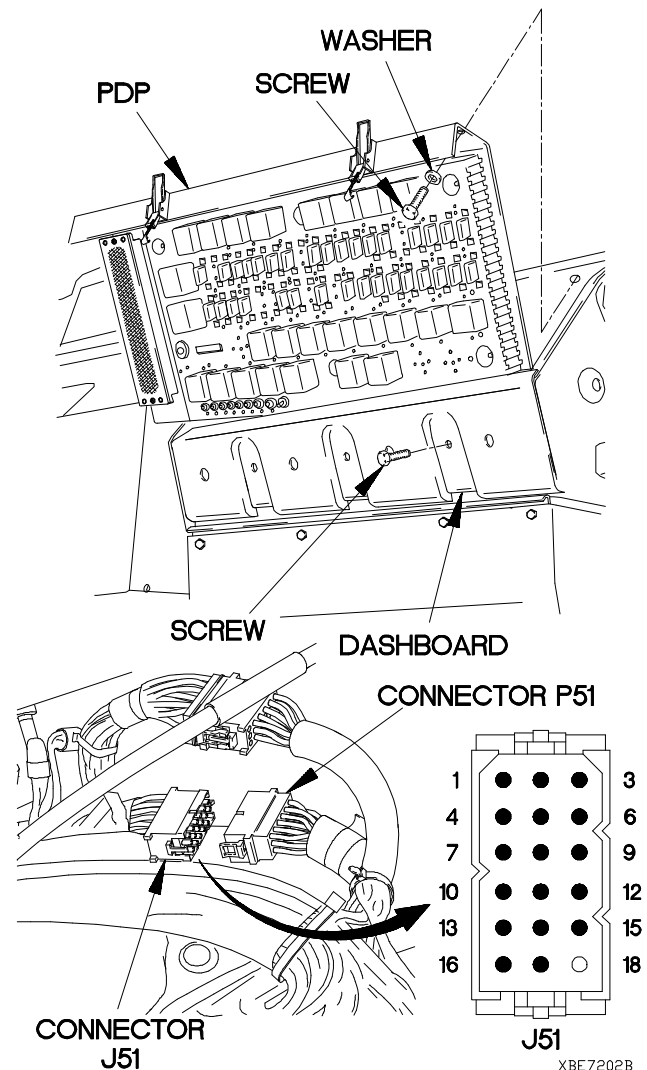

e69. INTERVEHICLE RIGHT TURN SIGNAL DOES NOT ILLUMINATE (CONT)

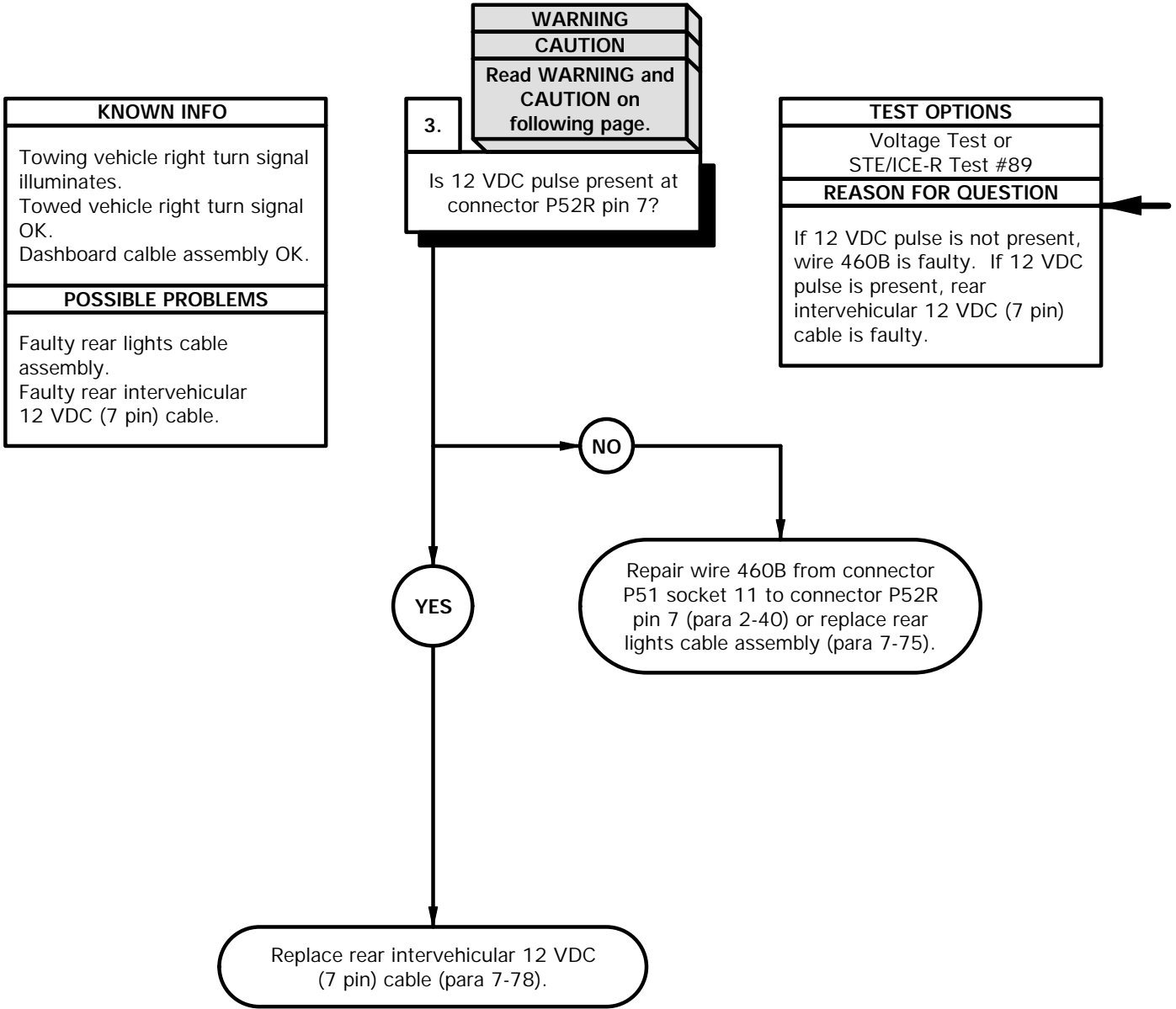

WARNING

Remove rings, bracelets, watches, necklaces, and any other jewelry before working around vehicle. Jewelry can catch on equipment and cause injury or short across electrical circuits and cause severe burns or electrical shock.

CAUTION

Use care when testing electrical connectors. Do not damage connector pins or sockets with multimeter probes. Failure to comply may result in damage to equipment.

NOTE

Inspect connector pins/sockets for damage, corrosion, and serviceability. Check that connector pins are not pushed back and are capable of making good contact.

VOLTAGE TEST

NOTE

Remove plastic cable ties as required.

- (1) Disconnect connector P52R from connector J52.
- (2) Set multimeter to volts DC.
- (3) Connect positive (+) probe of multimeter to connector P52R pin 7.
- (4) Connect negative (-) probe of multimeter to ground.
- (5) Position main light switch to SER DRIVE (TM 9-2320-365-10).
- (6) Position turn signal switch to right turn (TM 9-2320-365-10).
- (7) If 12 VDC pulse is not present, repair wire 460B from connector P51 socket 11 to connector P52R pin 7 (para 2-40) or replace rear lights cable assembly (para 7-75).
- (8) If 12 VDC pulse is present, replace rear intervehicular 12 VDC (7 pin) cable (para 7-78).
- (9) Position turn signal switch to off (TM 9-2320-365-10).

VOLTAGE TEST (Cont)

- (10) Position main light switch to OFF (TM 9-2320-365-10).

NOTE

Install plastic cable ties as required.

- (11) Connect connector P52R to connector J52.

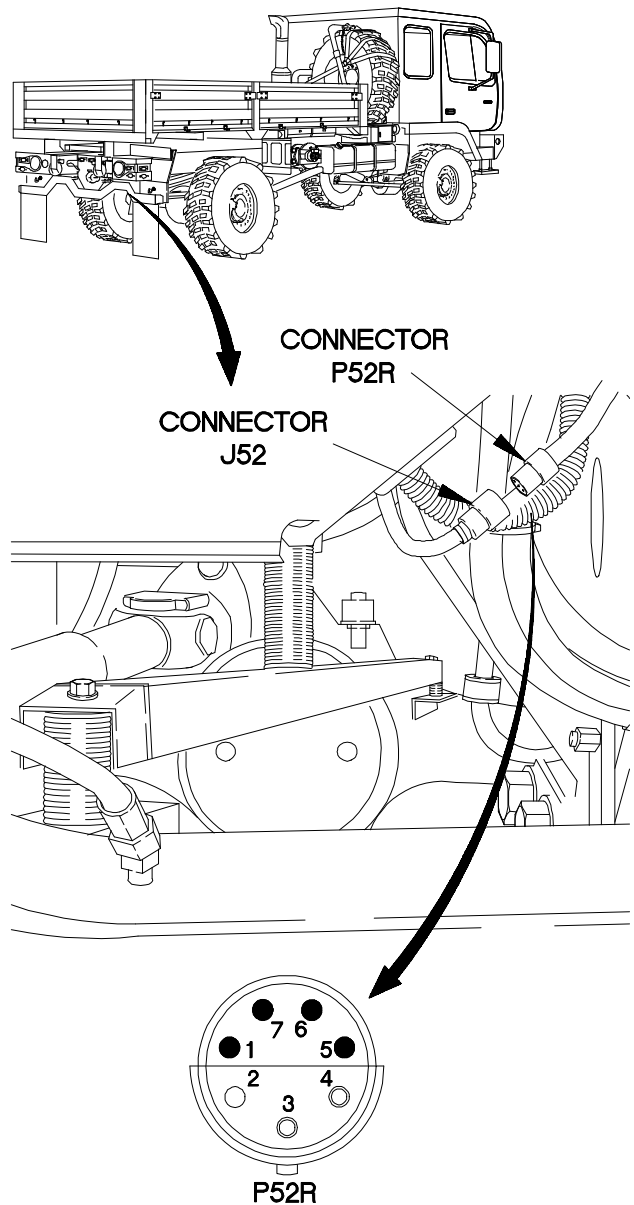

3BE6903B

e70. INTERVEHICLE STOPLIGHTS DO NOT ILLUMINATE

INITIAL SETUP

Equipment Condition

Engine shut down (TM 9-2320-365-10).

Material/Parts

Ties, Cable, Plastic (Item 69, Appendix D)

Tools and Special Tools

Tool Kit, Genl Mech (Item 46, Appendix C)
 STE/ICE-R (Item 41, Appendix C)
 Multimeter, Digital (Item 22, Appendix C)

Personnel Required

(2)

References

TM 9-4910-571-12&P

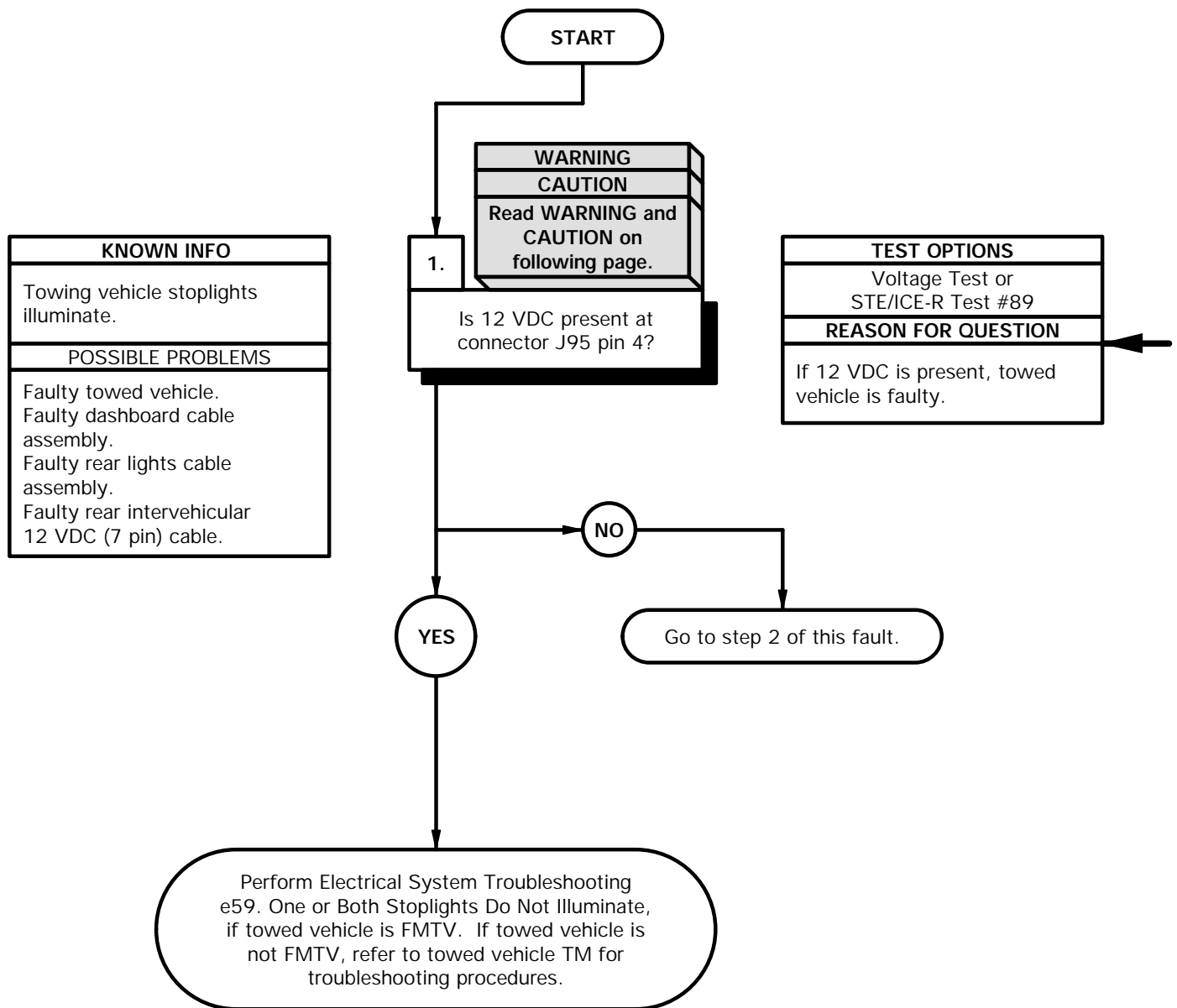

WARNING

Remove rings, bracelets, watches, necklaces, and any other jewelry before working around vehicle. Jewelry can catch on equipment and cause injury or short across electrical circuits and cause severe burns or electrical shock.

CAUTION

Use care when testing electrical connectors. Do not damage connector pins or sockets with multimeter probes. Failure to comply may result in damage to equipment.

NOTE

Inspect connector pins/sockets for damage, corrosion, and serviceability. Check that connector pins are not pushed back and are capable of making good contact.

VOLTAGE TEST

- (1) Lift cover on connector J95 intervehicular 12 VDC connector.
- (2) Set multimeter to volts DC.
- (3) Connect positive (+) probe of multimeter to connector J95 pin 4.
- (4) Connect negative (-) probe of multimeter to ground.
- (5) Position master power switch to on (TM 9-2320-365-10).
- (6) Position main light switch to SER DRIVE (TM 9-2320-365-10).
- (7) Apply brakes and note reading on multimeter.
- (8) If 12 VDC is not present, go to step 2 of this fault.
- (9) If 24 VDC is present, perform Electrical System Troubleshooting e59. One or Both Stoplights Do Not Illuminate, if towed vehicle is FMTV. If towed vehicle is not FMTV, refer to towed vehicle TM for troubleshooting procedures.
- (10) Position main light switch to OFF (TM 9-2320-365-10).
- (11) Position master power switch to off (TM 9-2320-365-10).

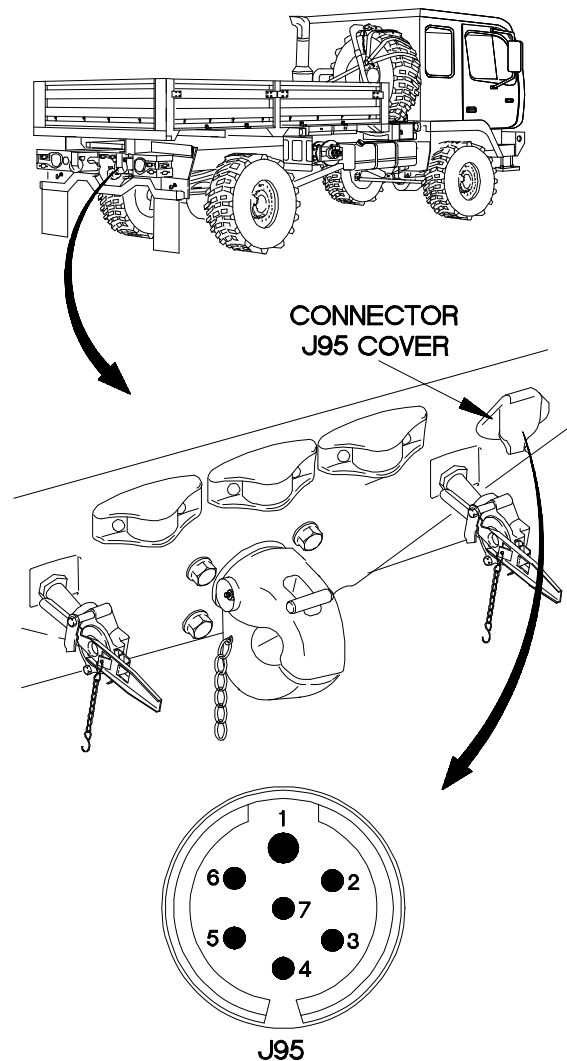

3Be7001b

e70. INTERVEHICLE STOPLIGHTS DO NOT ILLUMINATE (CONT)

KNOWN INFO
Towing vehicle stoplights illuminate. Towed vehicle stoplights OK.
POSSIBLE PROBLEMS
Faulty dashboard cable assembly. Faulty rear lights cable assembly. Faulty rear intervehicular 12 VDC (7 pin) cable.

WARNING

CAUTION

Read **WARNING** and **CAUTION** on following page.

2.

Is 12 VDC present at connector J51 pin 13?

TEST OPTIONS
Voltage Test or STE/ICE-R Test #89
REASON FOR QUESTION
If 12 VDC is not present, wire 22C is faulty.

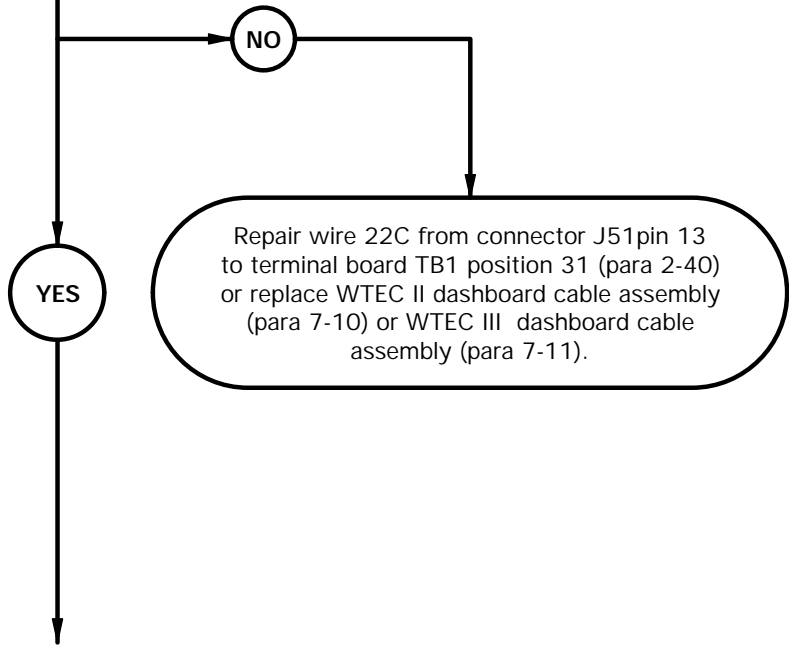

WARNING

Remove rings, bracelets, watches, necklaces, and any other jewelry before working around vehicle. Jewelry can catch on equipment and cause injury or short across electrical circuits and cause severe burns or electrical shock.

CAUTION

Use care when testing electrical connectors. Do not damage connector pins or sockets with multimeter probes. Failure to comply may result in damage to equipment.

NOTE

Inspect connector pins/sockets for damage, corrosion, and serviceability. Check that connector pins are not pushed back and are capable of making good contact.

VOLTAGE TEST

- (1) Remove PDP cover (para 16-2).
- (2) Remove three screws and washers from PDP.
- (3) Remove three screws from PDP.
- (4) Lift PDP outward to gain access.
- (5) Disconnect connector J51 from connector P51.
- (6) Set multimeter to volts DC.
- (7) Connect positive (+) probe of multimeter to connector J51 pin 13.
- (8) Connect negative (-) probe of multimeter to ground.
- (9) Position master power switch to on (TM 9-2320-365-10).
- (10) Position main light switch to SER DRIVE (TM 9-2320-365-10).
- (11) Apply brakes and note reading on multimeter.
- (12) If 12 VDC is not present, repair wire 22C from connector J51 pin 13 to terminal board TB1 position 31.
- (13) Position main light switch to OFF (TM 9-2320-365-10).
- (14) Position master power switch to off (TM 9-2320-365-10).
- (15) Connect connector J51 to connector P51.
- (16) Install PDP on dashboard with three screws.
- (17) Install three washers and screws in PDP.
- (18) Install PDP cover (para 16-2).

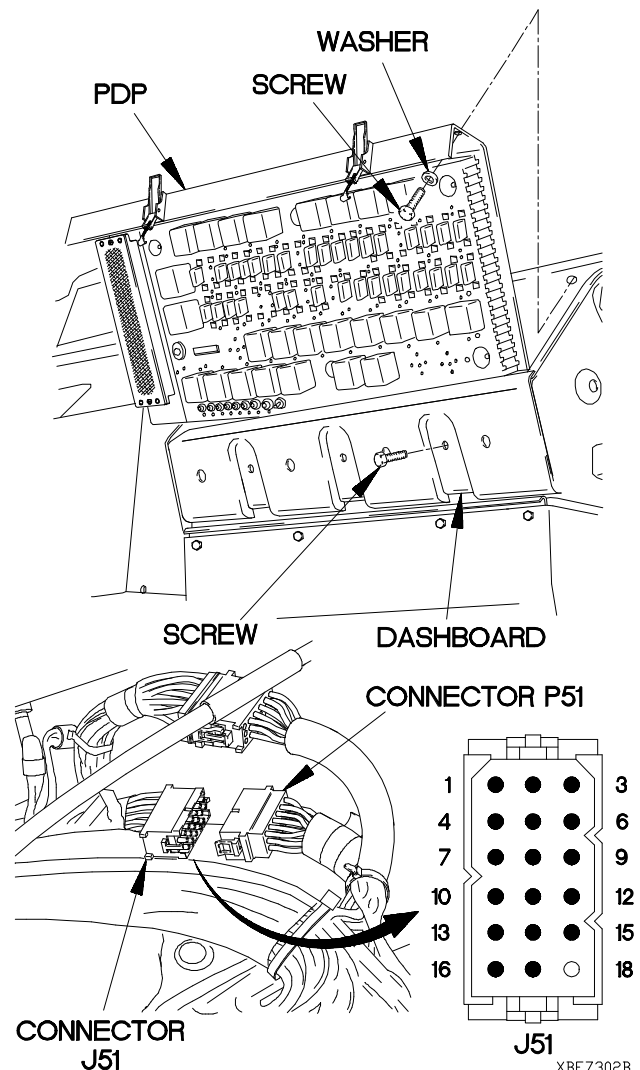

e70. INTERVEHICLE STOPLIGHTS DO NOT ILLUMINATE (CONT)

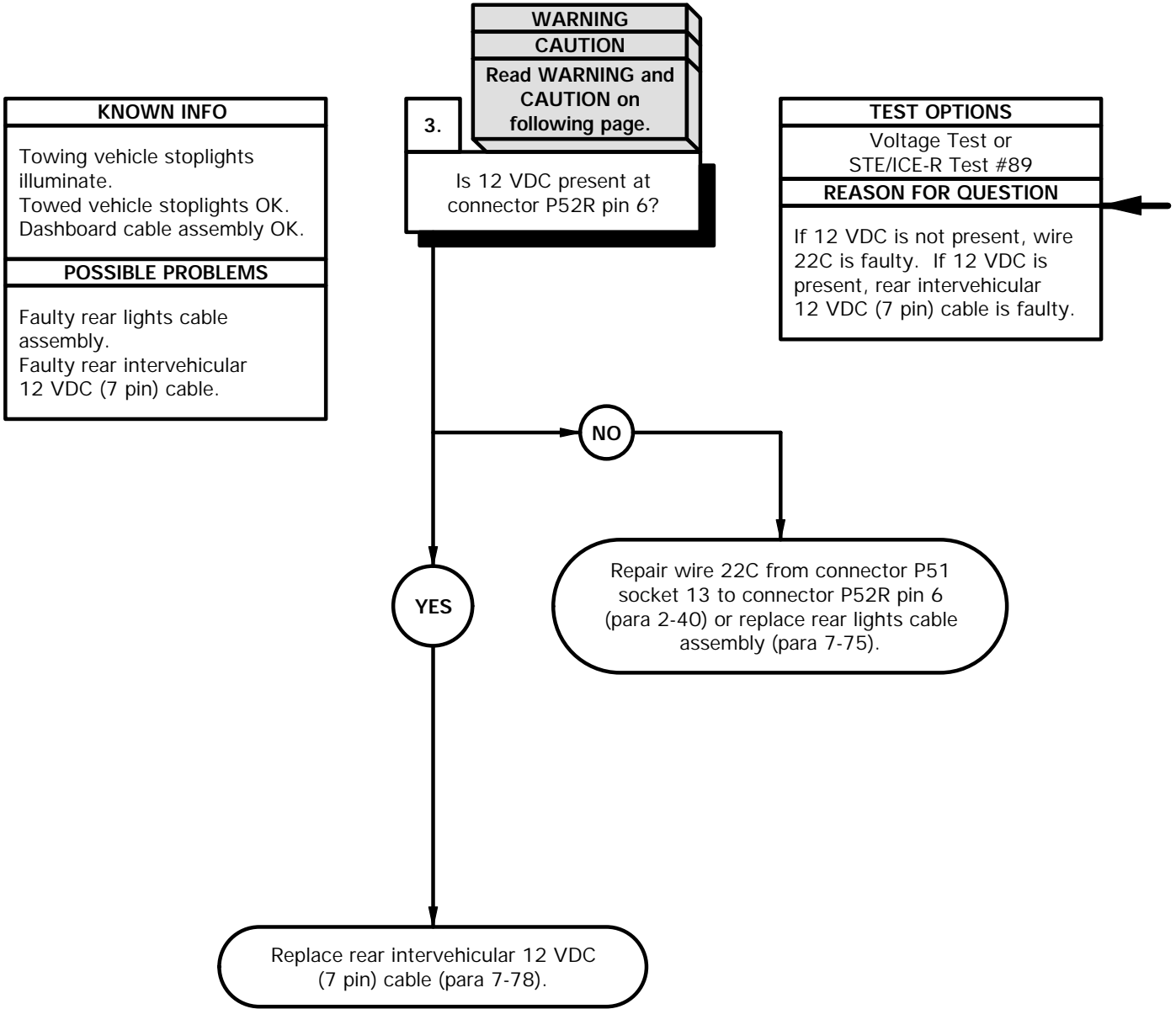

WARNING

Remove rings, bracelets, watches, necklaces, and any other jewelry before working around vehicle. Jewelry can catch on equipment and cause injury or short across electrical circuits and cause severe burns or electrical shock.

CAUTION

Use care when testing electrical connectors. Do not damage connector pins or sockets with multimeter probes. Failure to comply may result in damage to equipment.

NOTE

Inspect connector pins/sockets for damage, corrosion, and serviceability. Check that connector pins are not pushed back and are capable of making good contact.

VOLTAGE TEST

NOTE

Remove plastic cable ties as required.

- (1) Disconnect connector P52R from connector J52.
- (2) Set multimeter to volts DC.
- (3) Connect positive (+) probe of multimeter to connector P52R pin 6.
- (4) Connect negative (-) probe of multimeter to ground.
- (5) Position master power switch to on (TM 9-2320-365-10).
- (6) Position main light switch to SER DRIVE (TM 9-2320-365-10).
- (7) Apply brakes and note reading on multimeter.
- (8) If 12 VDC is not present, repair wire 22C from connector P51 socket 13 to connector P52R pin 6 (para 2-40) or replace rear lights cable assembly (para 7-75).
- (9) If 12 VDC is present, replace rear intervehicular 12 VDC (7 pin) cable (para 7-78).
- (10) Position main light switch to OFF (TM 9-2320-365-10).

VOLTAGE TEST (Cont)

- (11) Position master power switch to off (TM 9-2320-365-10).

NOTE

Install plastic cable ties as required.

- (12) Connect connector P52R to connector J52.

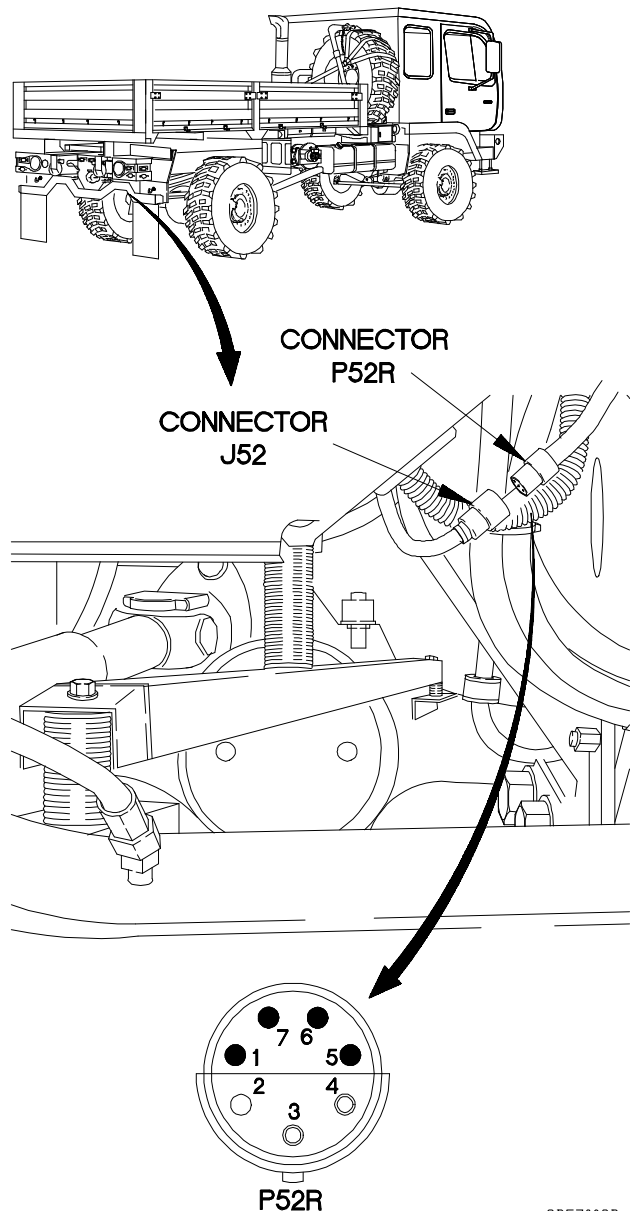

3BE7003B

e71. INTERVEHICLE TAILLIGHTS DO NOT OPERATE

INITIAL SETUP

Equipment Condition

Engine shut down (TM 9-2320-365-10).

Personnel Required

(2)

References

TM 9-4910-571-12&P

Tools and Special Tools

Tool Kit, Genl Mech (Item 44, Appendix C)

STE/ICE-R (Item 39, Appendix C)

Multimeter, Digital (Item 22, Appendix C)

Materials/Parts

Ties, Cable, Plastic (Item 76, Appendix D)

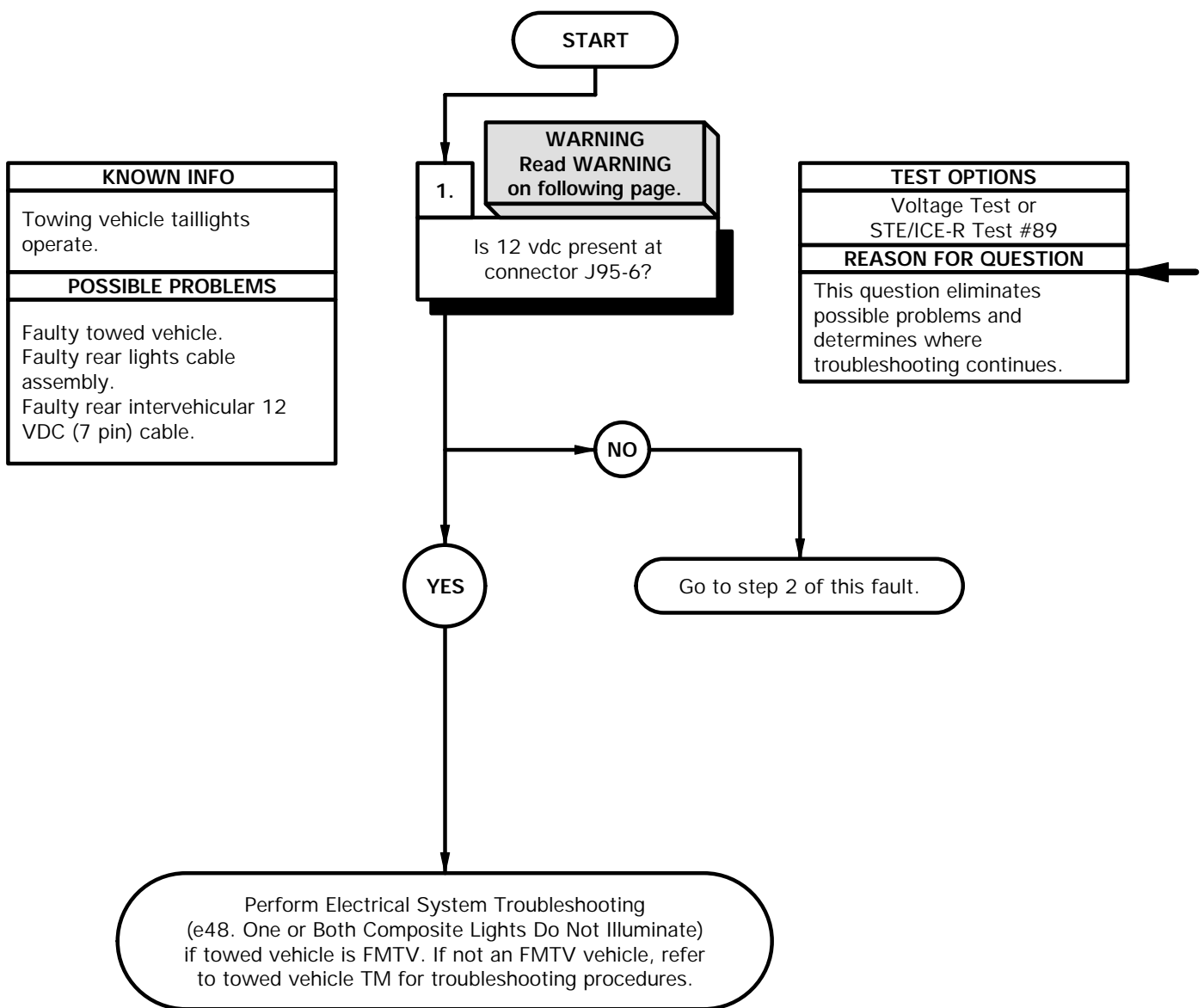

WARNING

Remove rings, bracelets, watches, necklaces, and any other jewelry before working around vehicle. Jewelry can catch on equipment and cause injury or short across electrical circuit and cause severe burns or electrical shock.

VOLTAGE TEST

- (1) Raise cover on connector J95 intervehicular 12 vdc connector.
- (2) Set multimeter to volts dc.
- (3) Connect positive (+) probe of multimeter to connector J95-6.
- (4) Connect negative (-) probe of multimeter to ground.
- (5) Position main light switch to SER DRIVE (TM 9-2320-365-10) and note reading on multimeter.
- (6) If 12 vdc is not present, go to step 2 of this fault.
- (7) If 12 vdc is present, perform Electrical System Troubleshooting (e48. One or Both Composite Lights Do Not Illuminate) if towed vehicle is FMTV. If towed vehicle is not an FMTV, refer to towed vehicle TM for troubleshooting procedures.
- (8) Position main light switch to OFF (TM 9-2320-365-10).

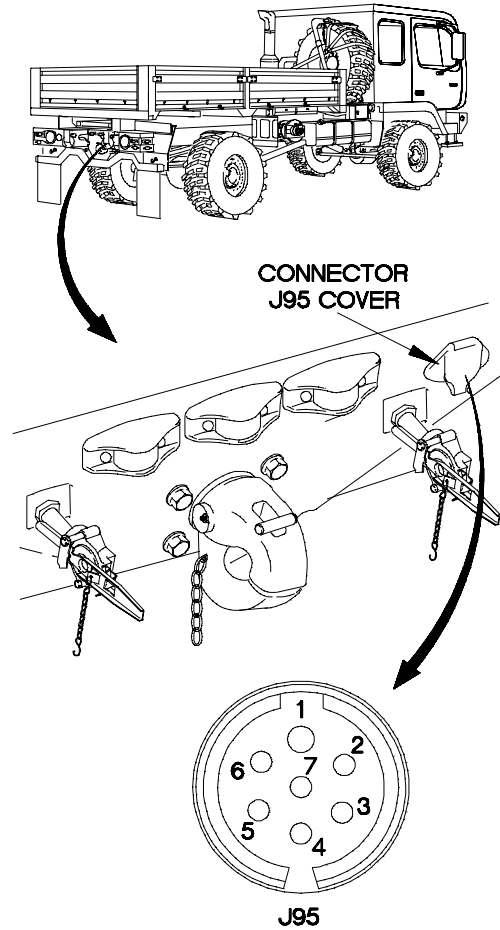

32E74011

e71. INTERVEHICLE TAILLIGHTS DO NOT OPERATE (CONT)

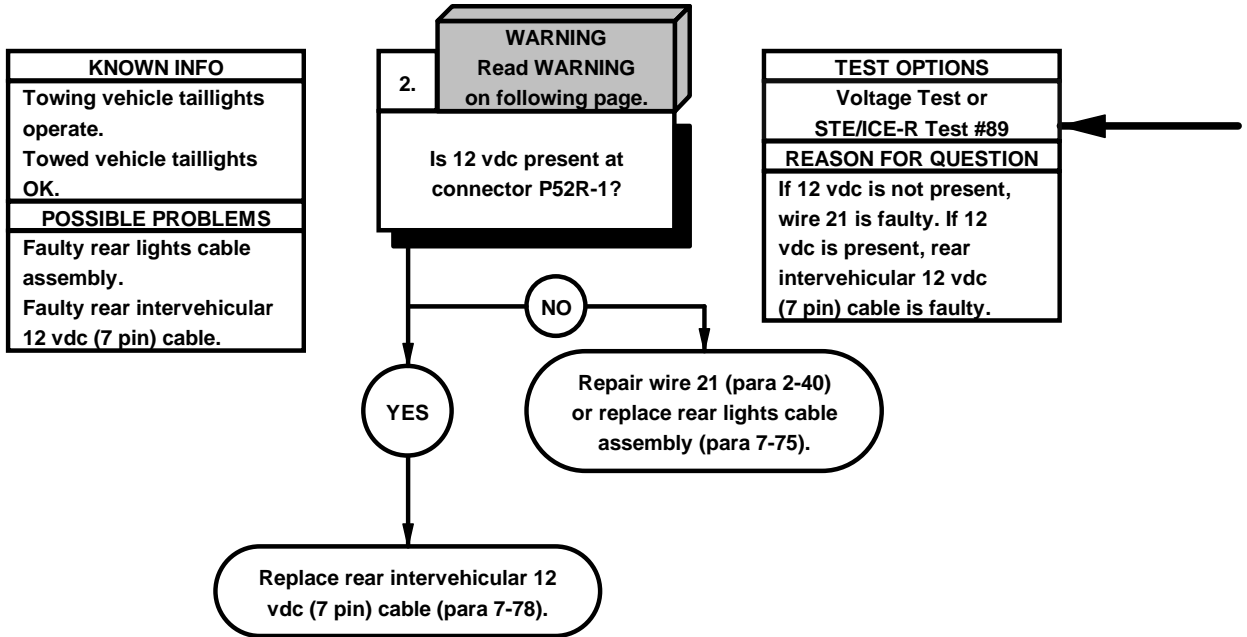

WARNING

Remove rings, bracelets, watches, necklaces, and any other jewelry before working around vehicle. Jewelry can catch on equipment and cause injury or short across electrical circuit and cause severe burns or electrical shock.

VOLTAGE TEST

NOTE

Remove plastic cable ties as required.

- (1) Disconnect connector P52R from connector J52.
- (2) Set multimeter to volts dc.
- (3) Connect positive (+) probe of multimeter to connector P52R-1.
- (4) Connect negative (-) probe of multimeter to ground.
- (5) Position main light switch to SER DRIVE (TM 9-2320-365-10) and note reading on multimeter.
- (6) If 12 vdc is not present, repair wire 21 (para 2-40) or replace rear lights cable assembly (para 7-75).
- (7) If 12 vdc is present, replace rear intervehicular 12 vdc (7 pin) cable (para 7-78).
- (8) Position main light switch to OFF (TM 9-2320-365-10).

NOTE

Install plastic cable ties as required.

- (9) Connect connector P52R to connector J52.

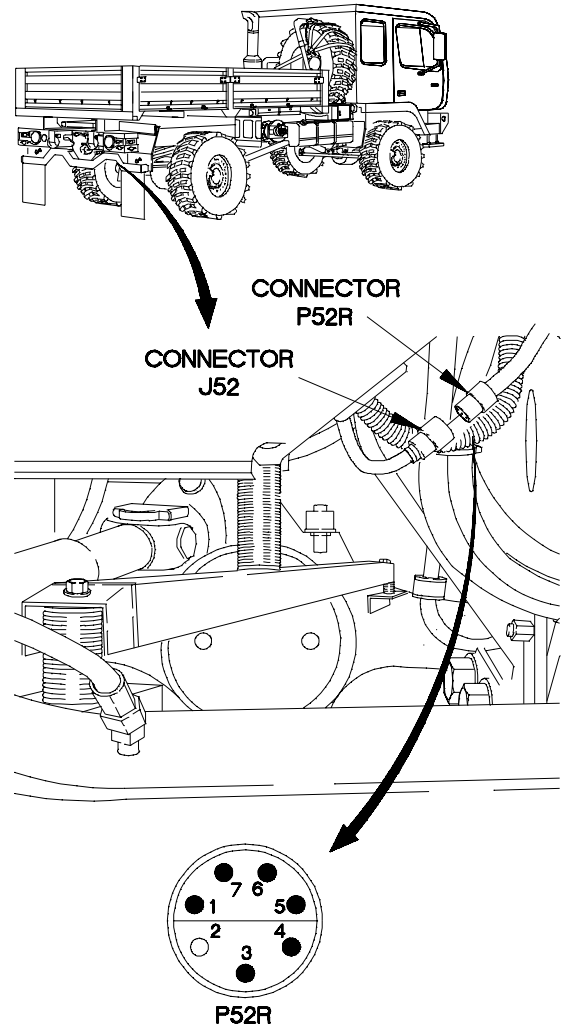

32E74021

e72. PERSONNEL HEATER CONTROL ILLUMINATION DOES NOT OPERATE	
INITIAL SETUP	
Equipment Condition Engine shut down (TM 9-2320-365-10).	Tools and Special Tools Tool Kit, Genl Mech (Item 44, Appendix C) STE/ICE-R (Item 39, Appendix C) Multimeter, Digital (Item 22, Appendix C)
Personnel Required (2)	
References TM 9-4910-571-12&P	

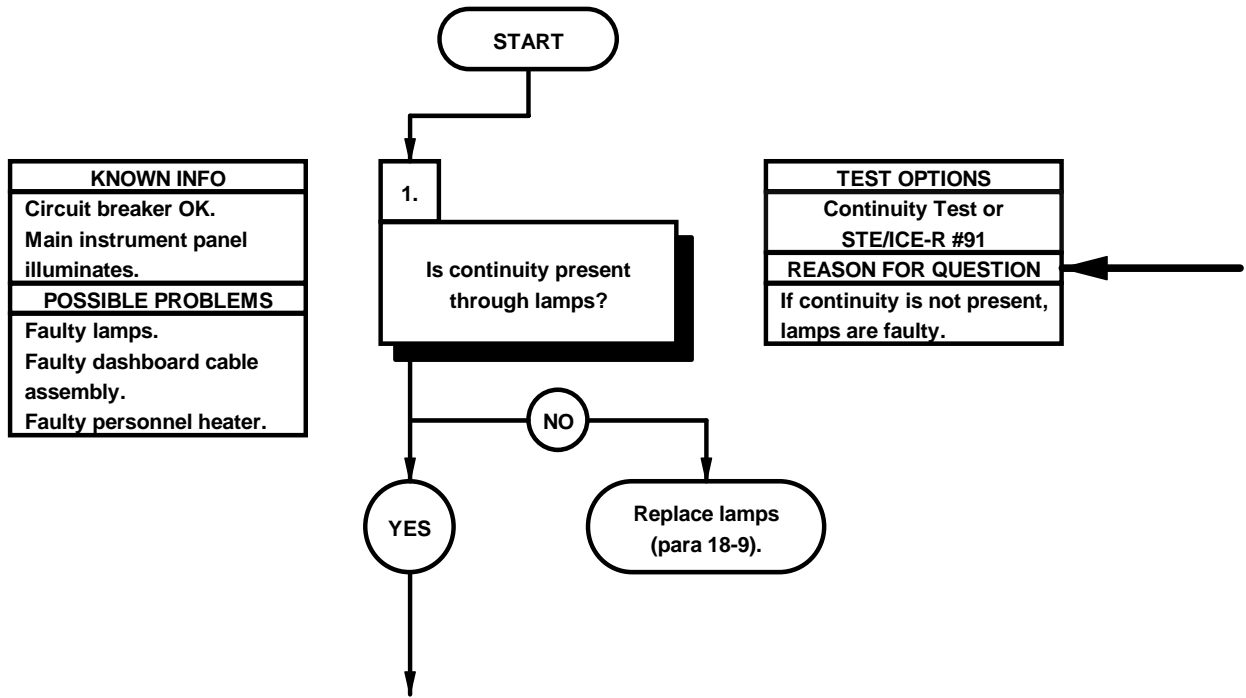

CONTINUITY TEST

- (1) Remove lamps from heater (para 18-9).
- (2) Set multimeter to ohms.
- (3) Check continuity through each lamp.
- (4) If continuity is not present, replace lamp(s) (para 18-9).

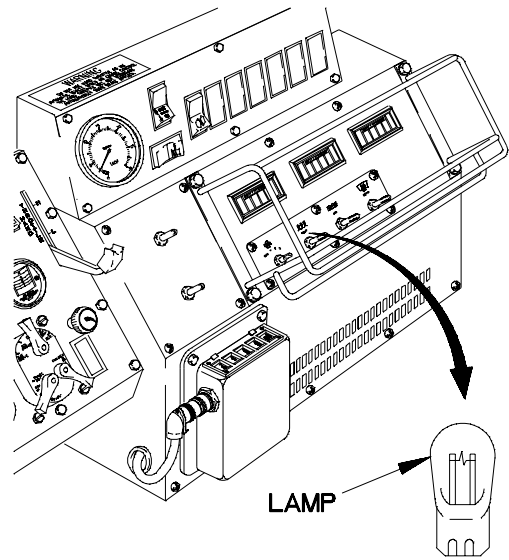

X2E7501A

ø72. PERSONNEL HEATER ILLUMINATION DOES NOT OPERATE (CONT)

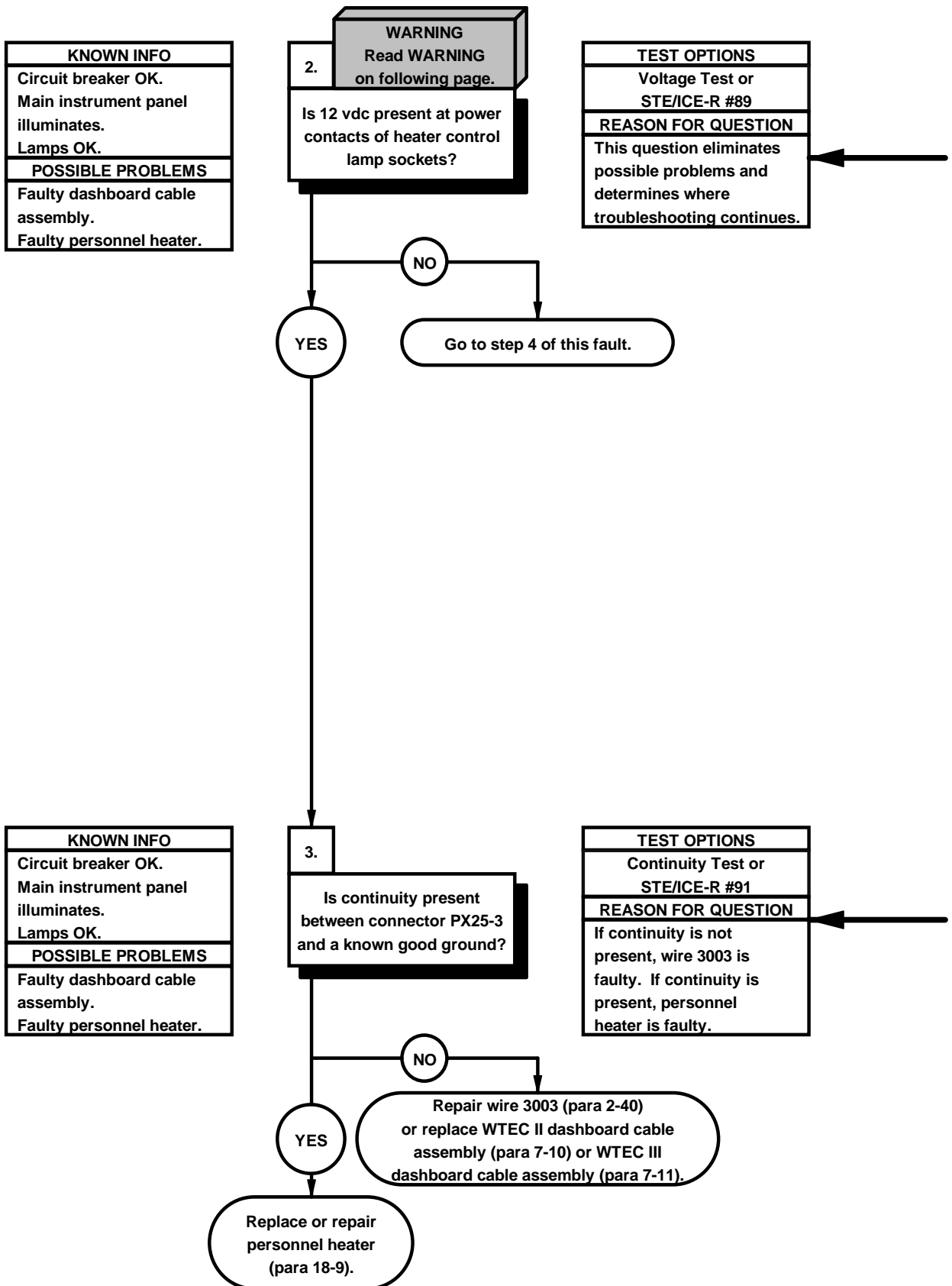

WARNING

Remove rings, bracelets, watches, necklaces, and any other jewelry before working around vehicle. Jewelry can catch on equipment and cause injury or short across electrical circuit and cause severe burns or electrical shock.

VOLTAGE TEST

- (1) Set multimeter to volts dc.
- (2) Connect positive (+) probe of multimeter to power contact of each heater control lamp socket.
- (3) Connect negative (-) probe of multimeter to ground.
- (4) Position main light switch to SER DRIVE (TM 9-2320-365-10).
- (5) Position main light switch auxiliary lever to PANEL BRT (TM 9-2320-365-10).
- (6) Position dimmer switch to maximum brightness (TM 9-2320-365-10) and note reading on multimeter.
- (7) If 12 vdc is not present, go to step 4 of this fault.
- (8) Position main light switch to OFF (TM 9-2320-365-10).
- (9) Position main light switch auxiliary lever to OFF (TM 9-2320-365-10).
- (10) Install lamps in heater (para 18-9).

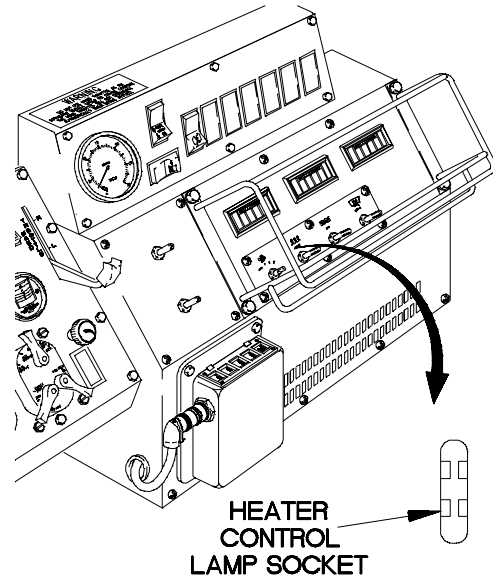

X2E7502A

CONTINUITY TEST

- (1) Remove personnel heater for access (para 18-9).
- (2) Disconnect connector PX25 from personnel heater connector.
- (3) Set multimeter to ohms.
- (4) Connect positive (+) probe of multimeter to connector PX25-3.
- (5) Connect negative (-) probe of multimeter to ground and note reading on multimeter.
- (6) If continuity is not present, repair wire 3003 (para 2-40) or replace WTEC II dashboard cable assembly (para 7-10) or WTEC III dashboard cable assembly (para 7-11).
- (7) If continuity is present, replace or repair personnel heater (para 18-9).
- (8) Connect connector PX25 to personnel heater connector.
- (9) Install personnel heater (para 18-9).

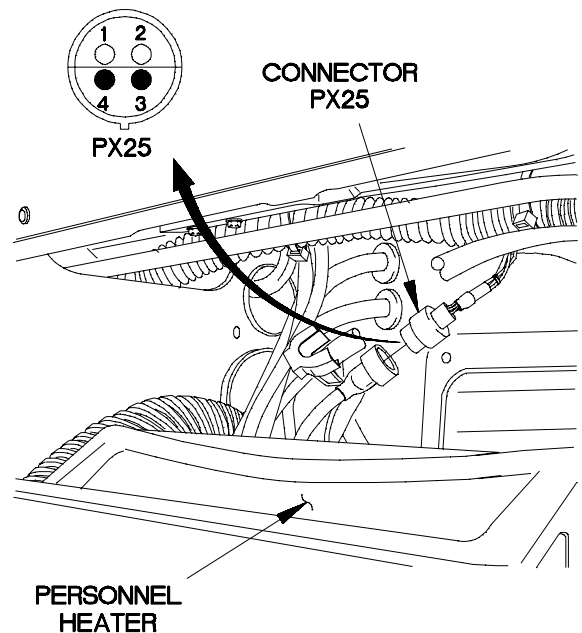

X2E75031

ø72. PERSONNEL HEATER ILLUMINATION DOES NOT OPERATE (CONT)

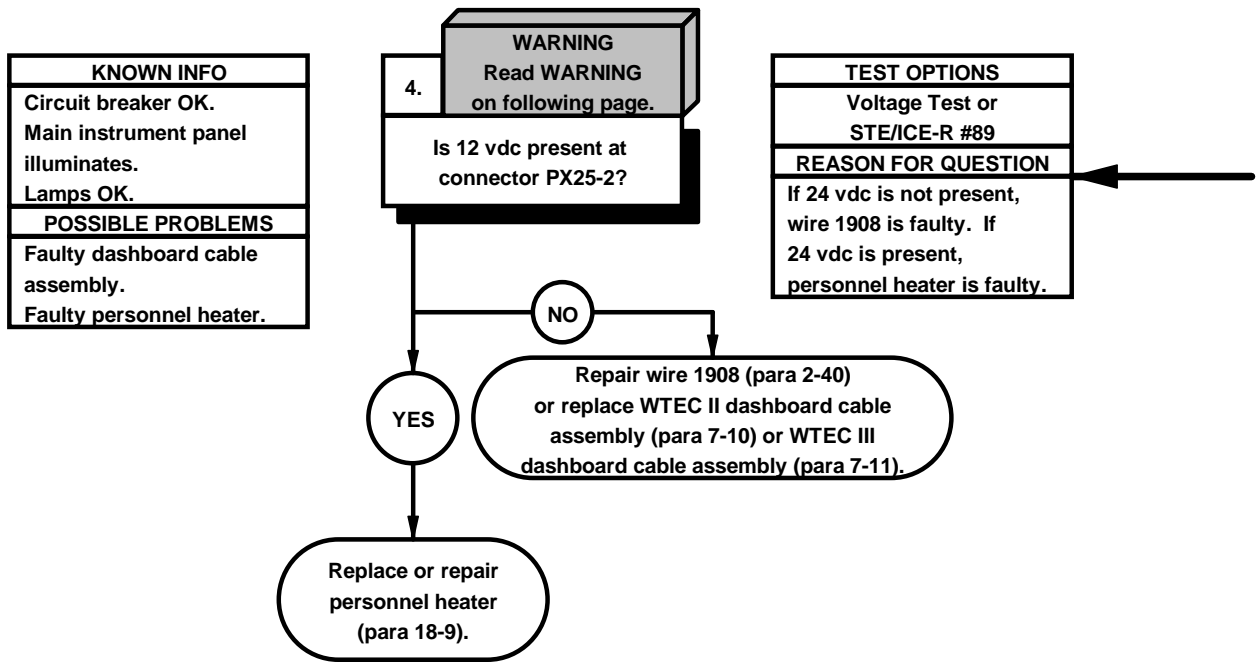

WARNING

Remove rings, bracelets, watches, necklaces, and any other jewelry before working around vehicle. Jewelry can catch on equipment and cause injury or short across electrical circuit and cause severe burns or electrical shock.

VOLTAGE TEST

- (1) Remove personnel heater for access (para 18-9).
- (2) Disconnect connector PX25 from personnel heater connector.
- (3) Set multimeter to volts dc.
- (4) Connect positive (+) probe of multimeter to connector PX25-1.
- (5) Connect negative (-) probe of multimeter to ground.
- (6) Position master power switch to on (TM 9-2320-365-10).
- (7) Position main light switch auxiliary lever to PNL BRT (TM 9-2320-365-10).
- (8) Position dimmer switch to maximum brightness (TM 9-2320-365-10) and note reading on multimeter.
- (9) If 12 vdc is not present, repair wire 1908 (para 2-40) or replace WTEC II dashboard cable assembly (para 7-10) or WTEC III dashboard cable assembly (para 7-11).
- (10) If 12 vdc is present, replace or repair personnel heater (para 18-9).
- (11) Position master power switch to off (TM 9-2320-365-10).
- (12) Position main light switch auxiliary lever to OFF (TM 9-2320-365-10).
- (13) Connect connector PX25 to personnel heater connector.
- (14) Install personnel heater (para 18-9).

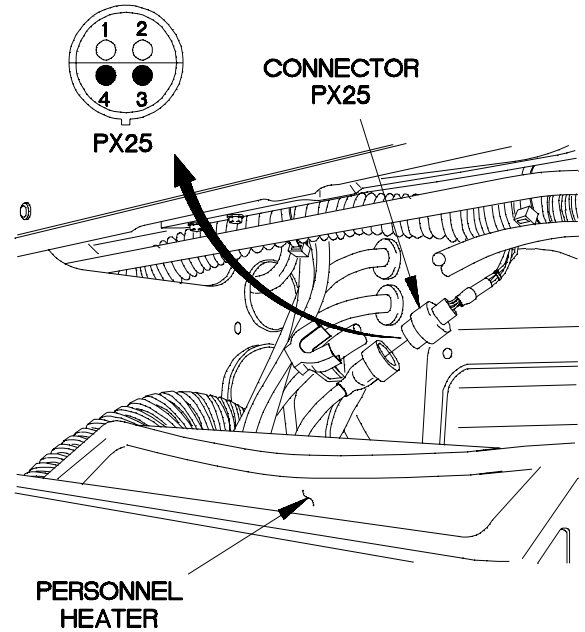

X2E7504A

e73. PERSONNEL HEATER FAN DOES NOT OPERATE	
INITIAL SETUP	
Equipment Condition Engine shut down (TM 9-2320-365-10).	Tools and Special Tools Tool Kit, Genl Mech (Item 44, Appendix C) STE/ICE-R (Item 39, Appendix C) Multimeter, Digital (Item 22, Appendix C)
Personnel Required (2)	
References TM 9-4910-571-12&P	

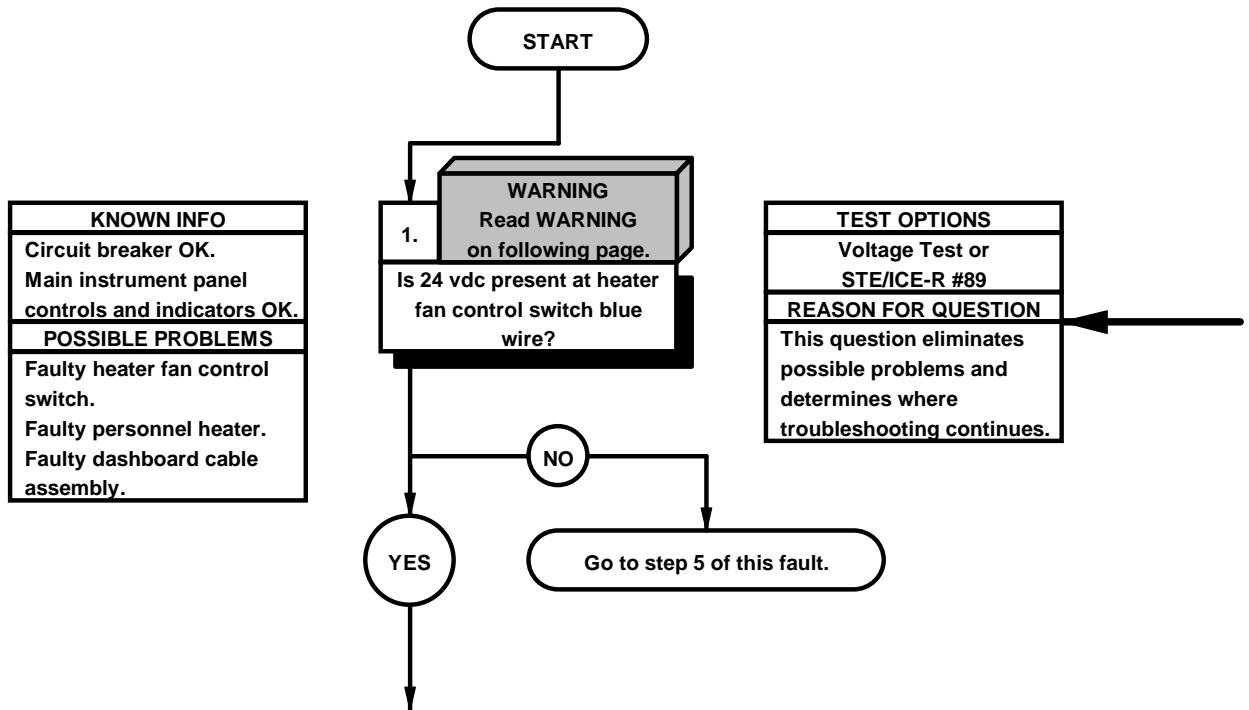

WARNING

Remove rings, bracelets, watches, necklaces, and any other jewelry before working around vehicle. Jewelry can catch on equipment and cause injury or short across electrical circuit and cause severe burns or electrical shock.

VOLTAGE TEST

- (1) Remove heater fan control switch (para 18-10).
- (2) Set multimeter to volts dc.
- (3) Connect positive (+) probe of multimeter to personnel heater fan control switch blue wire.
- (4) Connect negative (-) probe of multimeter to ground.
- (5) Position master power switch to on (TM 9-2320-365-10) and note reading on multimeter.
- (6) If 24 vdc is not present, go to step 5 of this fault.
- (7) Position master power switch to off (TM 9-2320-365-10).

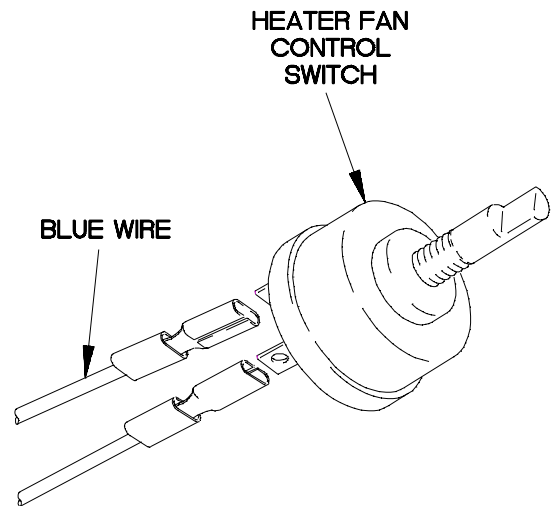

X2E7601A.dwg

73. PERSONNEL HEATER FAN DOES NOT OPERATE (CONT)

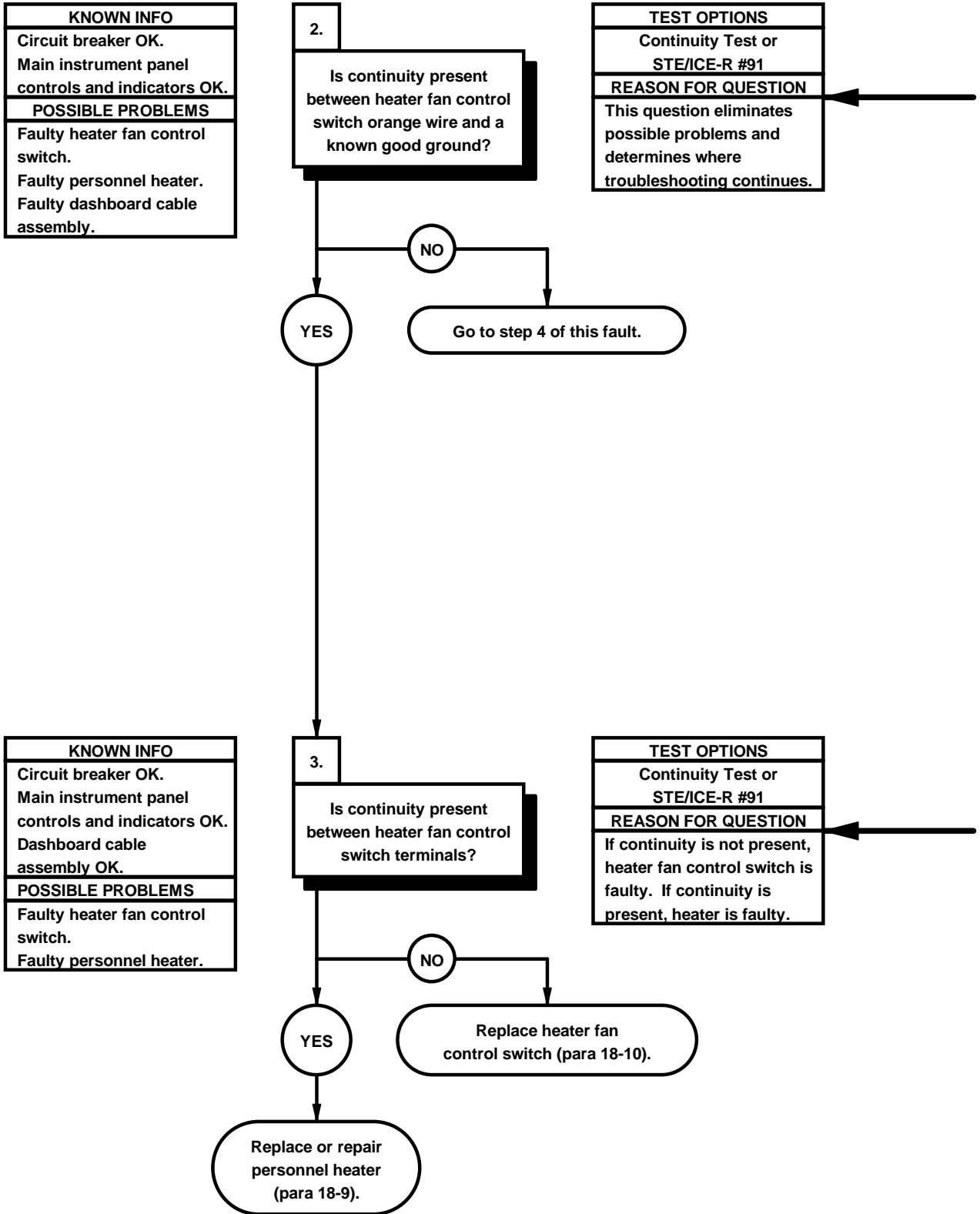

CONTINUITY TEST	
	(1) Set multimeter to ohms.
	(2) Connect positive (+) probe of multimeter to heater fan control switch orange wire.
	(3) Connect negative (-) probe of multimeter to ground and note reading on multimeter.
	(4) If continuity is not present, go to step 4 of this fault.

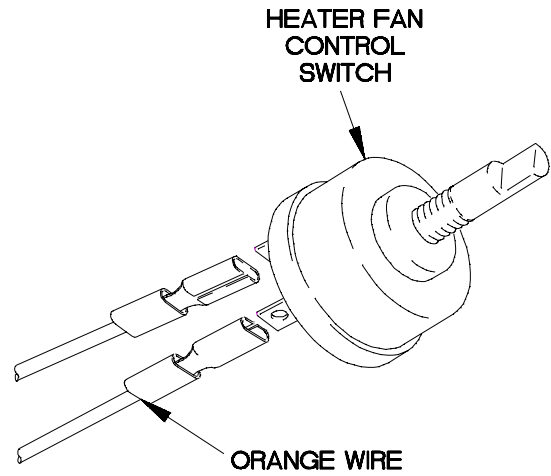

X2E76021.dwg

CONTINUITY TEST	
	(1) Set multimeter to ohms.
	(2) Position heater fan control switch to high speed.
	(3) Connect positive (+) probe of multimeter to one heater fan control switch terminal.
	(4) Connect negative (-) probe of multimeter to other heater fan control switch terminal and note reading on multimeter.
	(5) If continuity is not present, replace heater fan control switch (para 18-10).
	(6) If continuity is present, replace or repair personnel heater (para 18-9).
	(7) Install heater fan control switch (para 18-10).

73. PERSONNEL HEATER FAN DOES NOT OPERATE (CONT)

KNOWN INFO
Circuit breaker OK. Main instrument panel controls and indicators OK. Heater fan control switch OK.
POSSIBLE PROBLEMS
Faulty dashboard cable assembly. Faulty personnel heater.

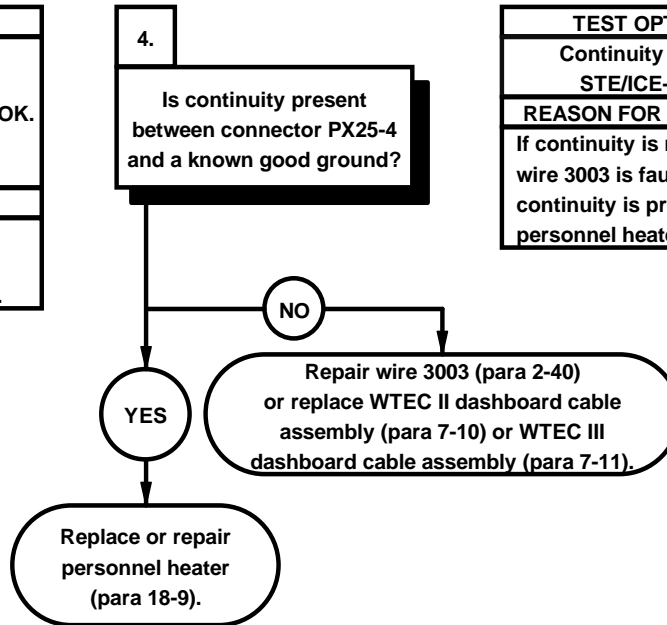

TEST OPTIONS
Continuity Test or STE/ICE-R#91
REASON FOR QUESTION
If continuity is not present, wire 3003 is faulty. If continuity is present, personnel heater is faulty.

KNOWN INFO
Circuit breaker OK. Main instrument panel controls and indicators OK. Heater fan control switch OK.
POSSIBLE PROBLEMS
Faulty dashboard cable assembly. Faulty personnel heater.

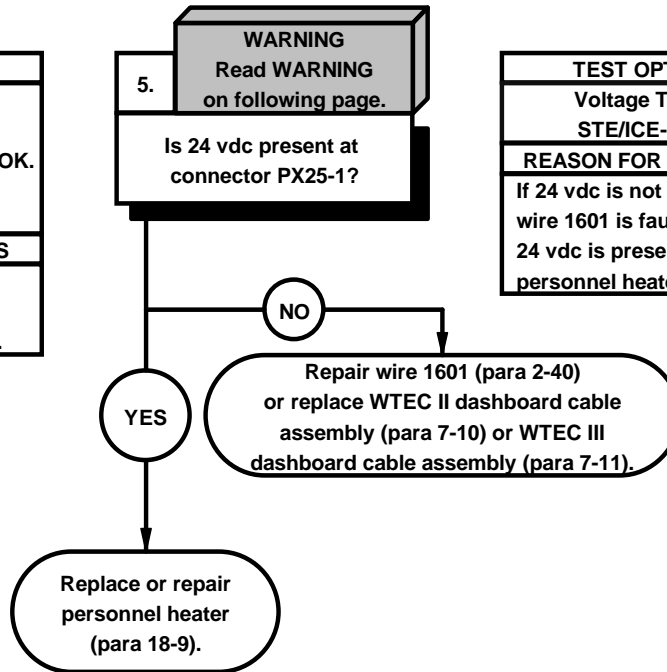

TEST OPTIONS
Voltage Test or STE/ICE-R #89
REASON FOR QUESTION
If 24 vdc is not present, wire 1601 is faulty. If 24 vdc is present, personnel heater is faulty.

CONTINUITY TEST

- (1) Remove personnel heater for access (para 18-9).
- (2) Disconnect connector PX25 from personnel heater connector.
- (3) Set multimeter to ohms.
- (4) Connect positive (+) probe of multimeter to connector PX25-4.
- (5) Connect negative (-) probe of multimeter to ground and note reading on multimeter.
- (6) If continuity is not present, repair wire 3003 (para 2-40) or replace WTEC II dashboard cable assembly (para 7-10) or WTEC III dashboard cable assembly (para 7-11).
- (7) If continuity is present, replace or repair personnel heater (para 18-9).
- (8) Install personnel heater (para 18-9).
- (9) Install heater fan control switch (para 18-10).

WARNING

Remove rings, bracelets, watches, necklaces, and any other jewelry before working around vehicle. Jewelry can catch on equipment and cause injury or short across electrical circuit and cause severe burns or electrical shock.

VOLTAGE TEST

- (1) Remove personnel heater for access (para 18-9).
- (2) Disconnect connector PX25 from personnel heater connector.
- (3) Set multimeter to volts dc.
- (4) Connect positive (+) probe of multimeter to connector PX25-2.
- (5) Connect negative (-) probe of multimeter to ground.
- (6) Position master power switch to on (TM 9-2320-365-10) and note reading on multimeter.
- (7) If 24 vdc is not present, repair wire 1601 (para 2-40) or replace WTEC II dashboard cable assembly (para 7-10) or WTEC III dashboard cable assembly (para 7-11).
- (8) If 24 vdc is present, replace or repair personnel heater (para 18-9).
- (9) Position master power switch to off (TM 9-2320-365-10).
- (10) Install personnel heater (para 18-9).
- (11) Install heater fan control switch (para 18-10).

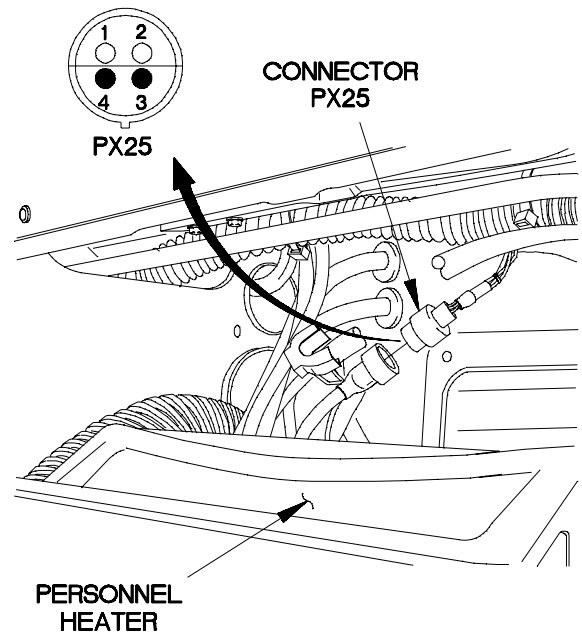

X2E 7603A

e74. WINDSHIELD WASHER DOES NOT OPERATE	
INITIAL SETUP	
Equipment Condition Engine shut down (TM 9-2320-365-10).	Tools and Special Tools Tool Kit, Genl Mech (Item 44, Appendix C) STE/ICE-R (Item 39, Appendix C) Multimeter, Digital (Item 22, Appendix C)
Personnel Required (2)	References TM 9-4910-571-12&P

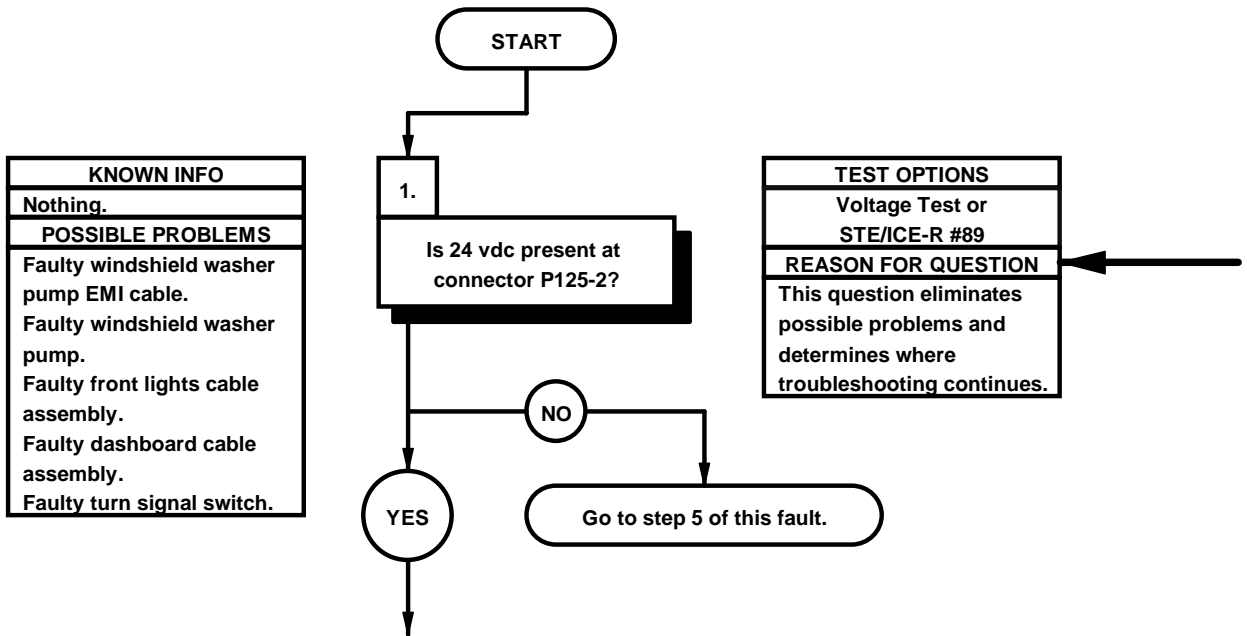

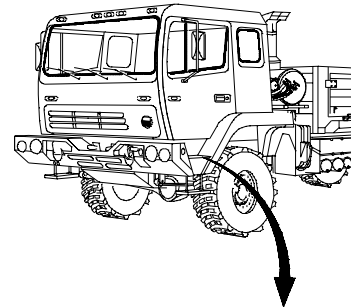

- | VOLTAGE TEST | |
|--------------|--|
| (1) | Open left cab step tread (TM 9-2320-365-10). |
| (2) | Disconnect connector P125 from windshield washer pump connector. |
| (3) | Set multimeter to volts dc. |
| (4) | Connect positive (+) probe of multimeter to connector P125-2. |
| (5) | Connect negative (-) probe of multimeter to ground. |
| (6) | Operate windshield washer (TM 9-2320-365-10). |
| (7) | If 24 vdc is not present, go to step 5 of this fault. |
| (8) | Position master power switch to off (TM 9-2320-365-10). |
| (9) | Connect connector P125 to windshield washer pump connector. |

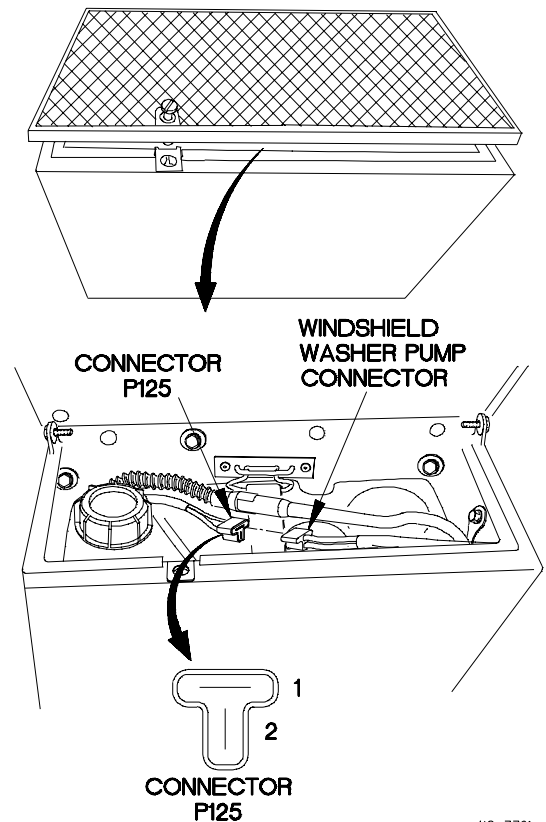

X2e7701a

e74. WINDSHIELD WASHER DOES NOT OPERATE (CONT)

KNOWN INFO
Dash-board cable assembly OK. Turn signal switch OK.
POSSIBLE PROBLEMS
Faulty front lights cable assembly. Faulty windshield washer pump. Faulty windshield washer pump EMI cable.

2.
Is continuity present between connector P25-1 and terminal TL94?

TEST OPTIONS
Continuity Test or STE/ICE-R #91
REASON FOR QUESTION
If continuity is not present, wire 3038 is faulty.

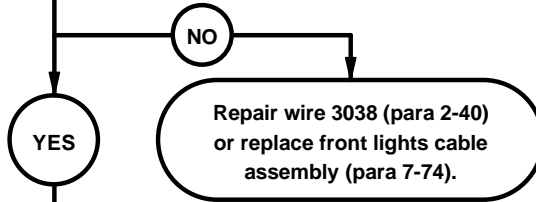

KNOWN INFO
Dash-board cable assembly OK. Turn signal switch OK. Front lights cable assembly OK.
POSSIBLE PROBLEMS
Faulty windshield washer pump. Faulty windshield washer pump EMI cable.

3.
Is continuity present between two terminals on windshield washer pump?

TEST OPTIONS
Continuity Test or STE/ICE-R #91
REASON FOR QUESTION
If continuity is not present, windshield washer pump is faulty.

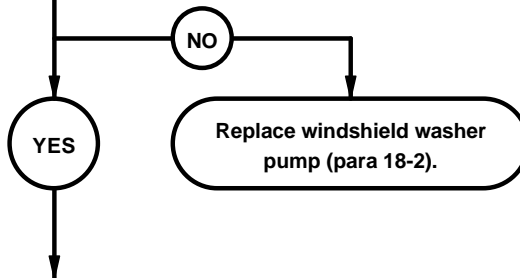

- | CONTINUITY TEST | |
|-----------------|--|
| (1) | Disconnect connector P25 from connector J25. |
| (2) | Set multimeter to ohms. |
| (3) | Connect positive (+) probe of multimeter to connector J25-1. |
| (4) | Connect negative (-) probe of multimeter to terminal TL94. |
| (5) | If continuity is not present, repair wire 3038 (para 2-40) or replace front lights cable assembly (para 7-74). |
| (6) | Connect connector P25 to connector J25. |

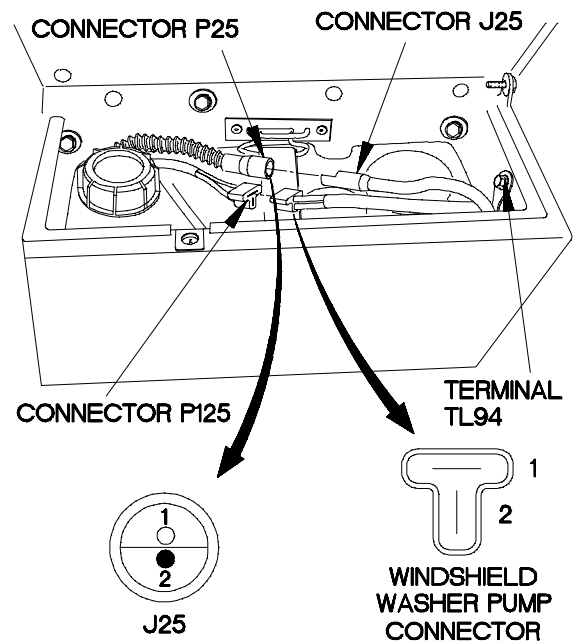

X2e7702a

- | CONTINUITY TEST | |
|-----------------|---|
| (1) | Disconnect connector P125 from windshield washer pump connector. |
| (2) | Set multimeter to ohms. |
| (3) | Connect positive (+) probe of multimeter to terminal 1 of windshield washer pump connector. |
| (4) | Connect negative (-) probe of multimeter to terminal 2 of windshield washer pump connector. |
| (5) | If continuity is not present, replace windshield washer motorpump (para 18-2). |
| (6) | Connect connector P125 to windshield washer pump connector. |

e74. WINDSHIELD WASHER DOES NOT OPERATE (CONT)

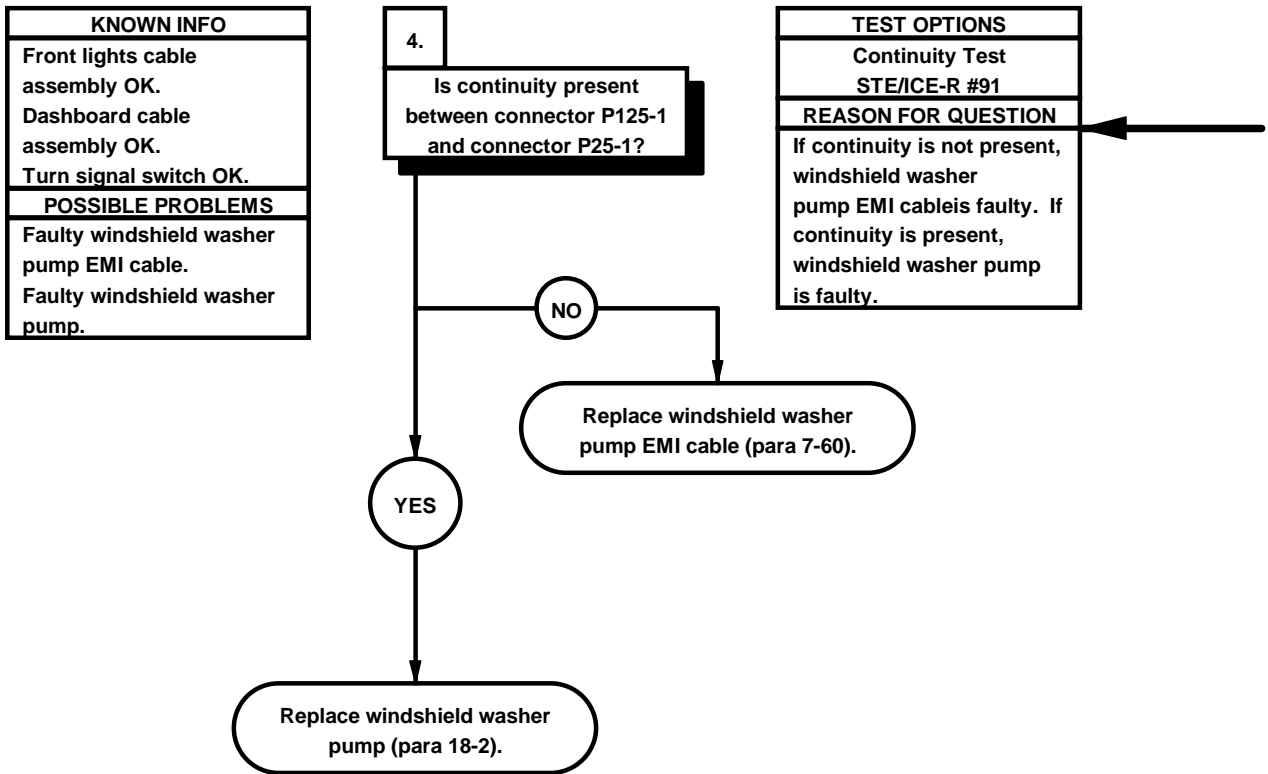

CONTINUITY TEST

- (1) Disconnect connector P25 from connector J25.
- (2) Disconnect connector P125 from windshield washer pump connector.
- (3) Set multimeter to ohms.
- (4) Connect positive (+) probe of multimeter to connector P25-1.
- (5) Connect negative (-) probe of multimeter to connector P125-1 and note reading on multimeter.
- (6) If continuity is not present, replace windshield washer pump EMI cable (para 7-60).
- (7) If continuity is present, replace windshield washer pump (para 18-2).
- (8) Connect connector P25 to connector J25.
- (9) Connect connector P125 to windshield washer pump.
- (10) Close left cab step tread (TM 9-2320-365-10).

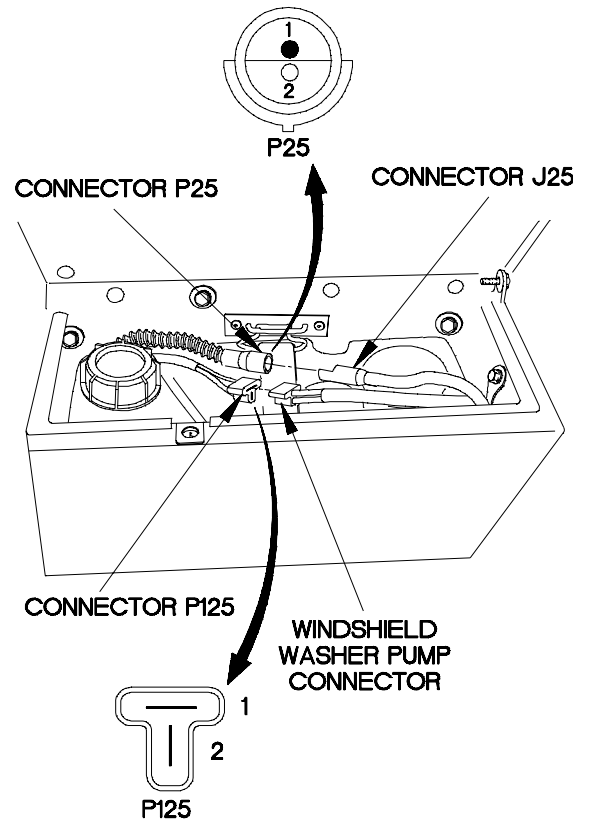

X2E7703A

e74. WINDSHIELD WASHER DOES NOT OPERATE (CONT)

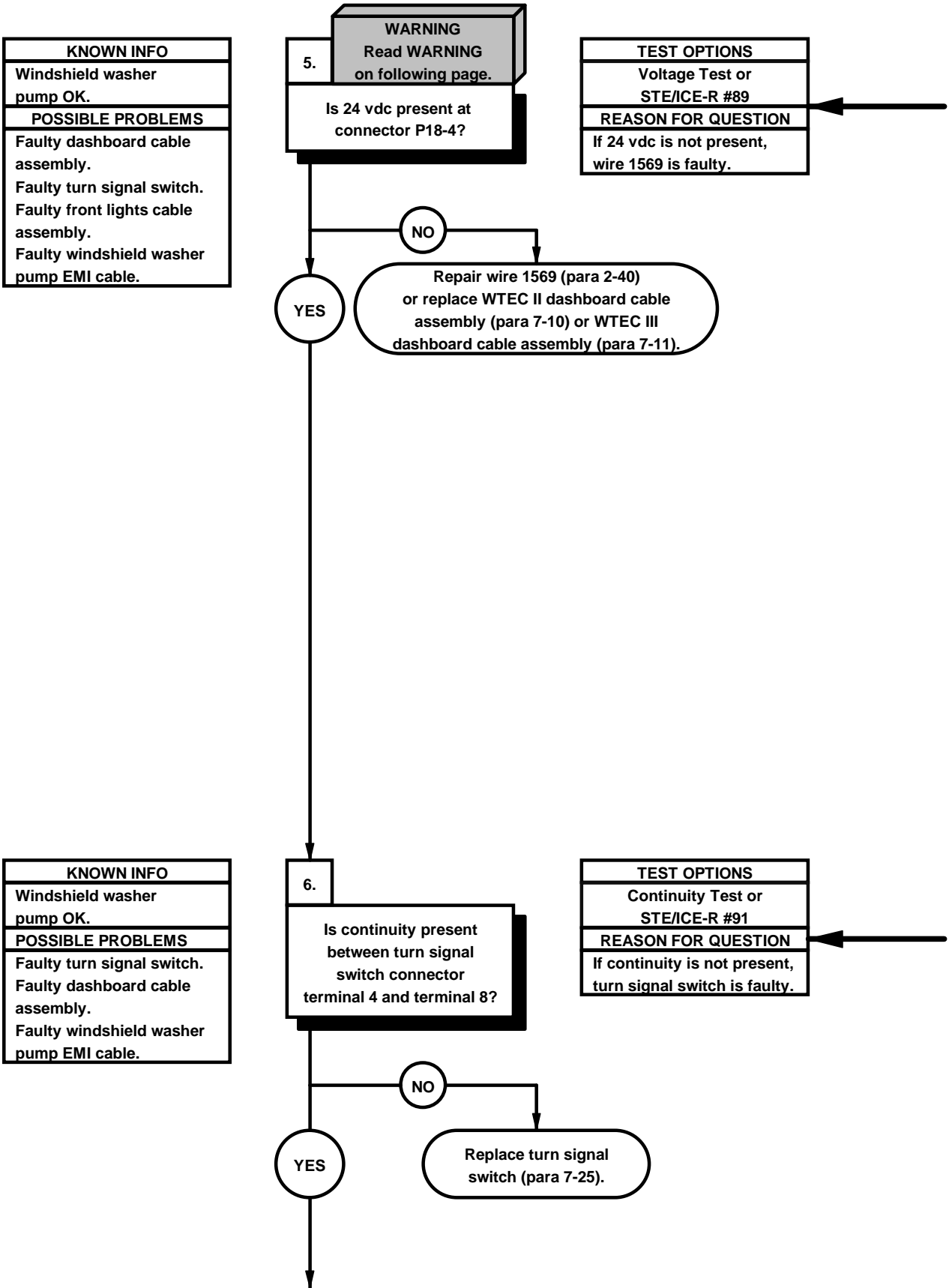

WARNING

Remove rings, bracelets, watches, necklaces, and any other jewelry before working around vehicle. Jewelry can catch on equipment and cause injury or short across electrical circuit and cause severe burns or electrical shock.

VOLTAGE TEST

- (1) Remove instrument panel assembly for access (para 7-15).
- (2) Disconnect connector P18 from turn signal switch connector.
- (3) Set multimeter to volts dc.
- (4) Connect positive (+) probe of multimeter to connector P18-4.
- (5) Connect negative (-) probe of multimeter to ground.
- (6) Position master power switch to on (TM 9-2320-365-10).
- (7) Press windshield washer switch (TM 9-2320-365-10) and note reading on multimeter.
- (8) If 24 vdc is not present, repair wire 1569 (para 2-40) or replace WTEC II dashboard cable assembly (para 7-10) or WTEC III dashboard cable assembly (para 7-11).
- (9) Position master power switch to off (TM 9-2320-365-10).

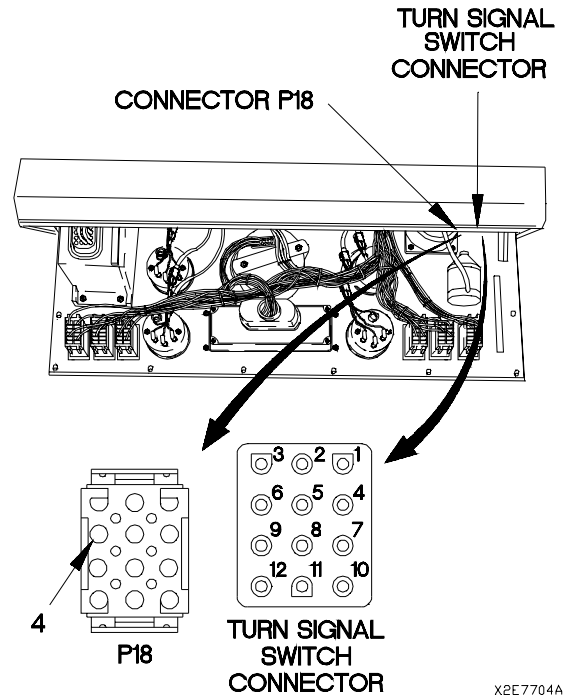

X2E7704A

CONTINUITY TEST

- (1) Set multimeter to ohms.
- (2) Connect positive (+) probe of multimeter to turn signal switch connector terminal 4.
- (3) Connect negative (-) probe of multimeter to turn signal switch connector terminal 8.
- (4) Press windshield washer switch (TM 9-2320-365-10) and note reading on multimeter.
- (5) If continuity is not present, replace turn signal switch (para 7-25).
- (6) Connect connector P18 to turn signal switch connector.
- (7) Install instrument panel assembly (para 7-15).

e74. WINDSHIELD WASHER DOES NOT OPERATE (CONT)

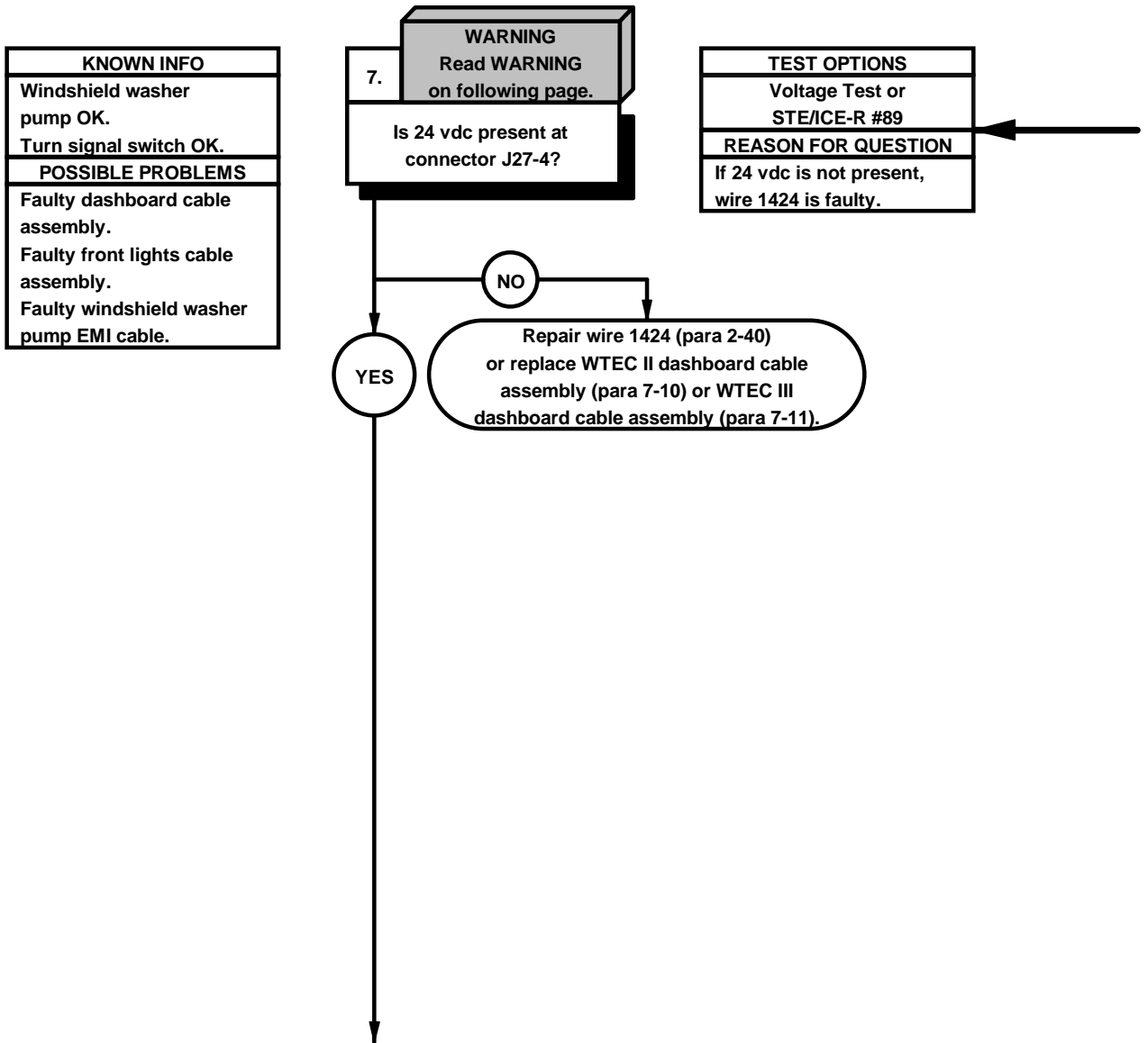

WARNING

Remove rings, bracelets, watches, necklaces, and any other jewelry before working around vehicle. Jewelry can catch on equipment and cause injury or short across electrical circuit and cause severe burns or electrical shock.

VOLTAGE TEST

- (1) Remove PDP cover (para 16-2).
- (2) Remove three screws and washers from PDP.
- (3) Remove three screws from PDP.
- (4) Lift PDP outward to gain access.
- (5) Disconnect connector J27 from connector P27.
- (6) Set multimeter to volts dc.
- (7) Connect positive (+) probe of multimeter to connector J27-4.
- (8) Connect negative (-) probe of multimeter to ground.
- (9) Position master power switch to on (TM 9-2320-365-10).
- (10) Press windshield washer switch (TM 9-2320-365-10) and note reading on multimeter.
- (11) If 24 vdc is not present, repair wire 1424 (para 2-40) or replace WTEC II dashboard cable assembly (para 7-10) or WTEC III dashboard cable assembly (para 7-11).
- (12) Position master power switch to off (TM 9-2320-365-10).
- (13) Connect connector J27 to connector P27.
- (14) Install PDP on dashboard with three screws.
- (15) Install three washers and screws in PDP.
- (16) Install PDP cover (para 16-2).

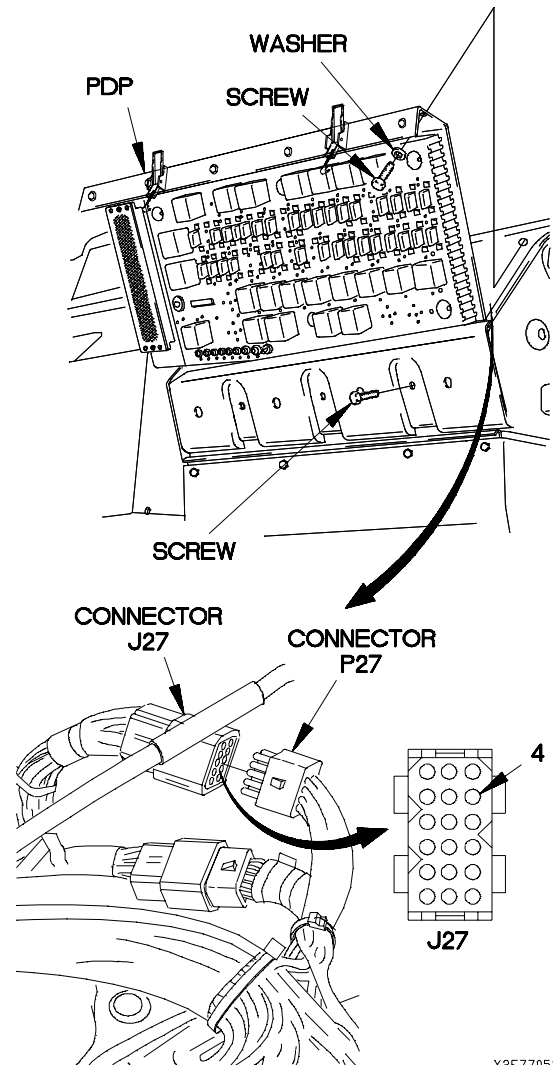

X2E77051

e74. WINDSHIELD WASHER DOES NOT OPERATE (CONT)

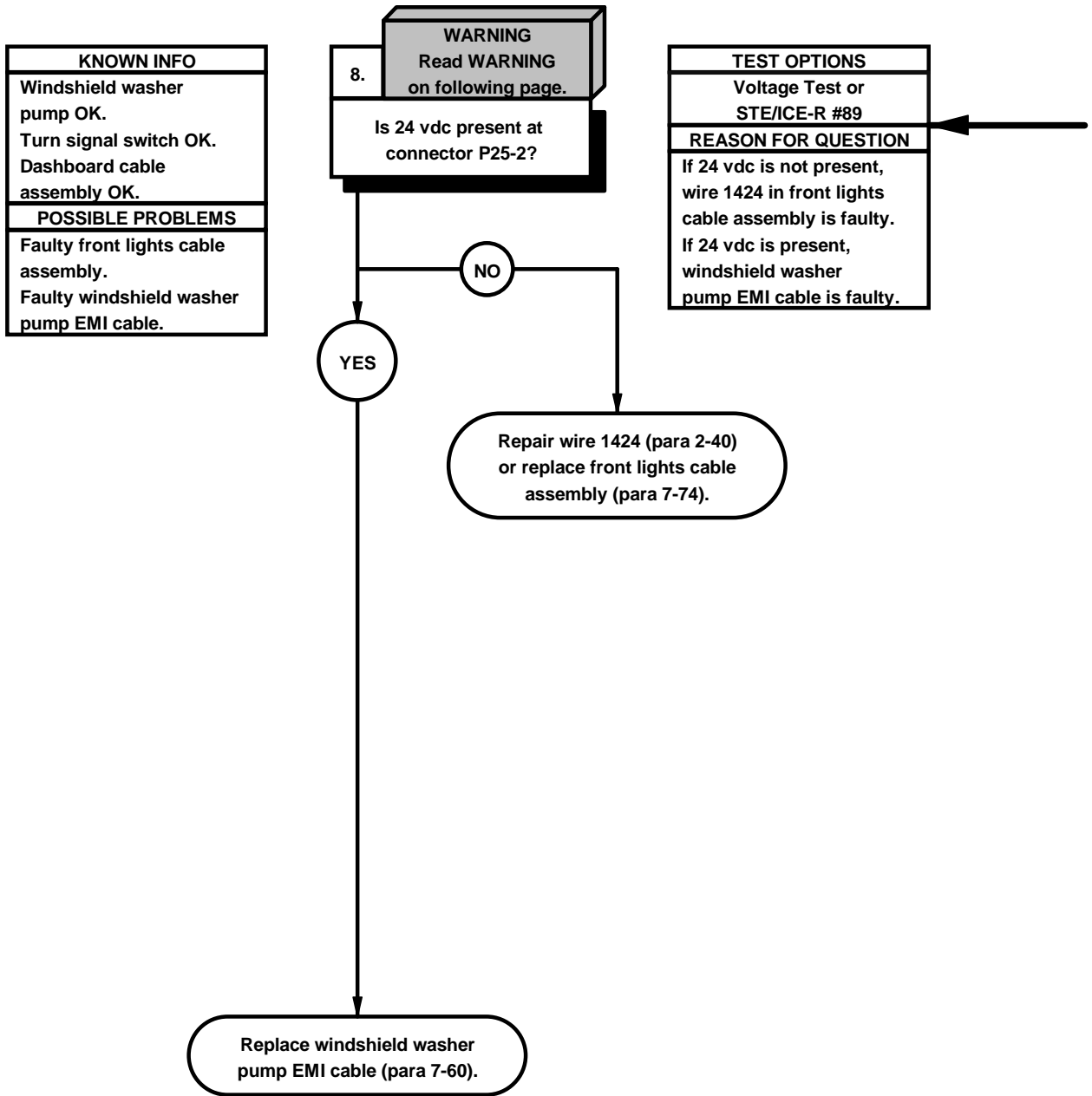

WARNING

Remove rings, bracelets, watches, necklaces, and any other jewelry before working around vehicle. Jewelry can catch on equipment and cause injury or short across electrical circuit and cause severe burns or electrical shock.

VOLTAGE TEST

- (1) Disconnect connector P25 from connector J25.
- (2) Set multimeter to volts dc.
- (3) Connect positive (+) probe of multimeter to connector P25-2.
- (4) Connect negative (-) probe of multimeter to ground.
- (5) Position master power switch to on (TM 9-2320-365-10).
- (6) Press windshield washer switch (TM 9-2320-365-10) and note reading on multimeter.
- (7) If 24 vdc is not present, repair wire 1424 (para 2-40) or replace front lights cable assembly (para 7-74).
- (8) If 24 vdc is present, replace windshield washer pump EMI cable (para 7-60).
- (9) Position master power switch to off (TM 9-2320-365-10).
- (10) Connect connector P25 to connector J25.
- (11) Close left cab step tread (TM 9-2320-365-10).

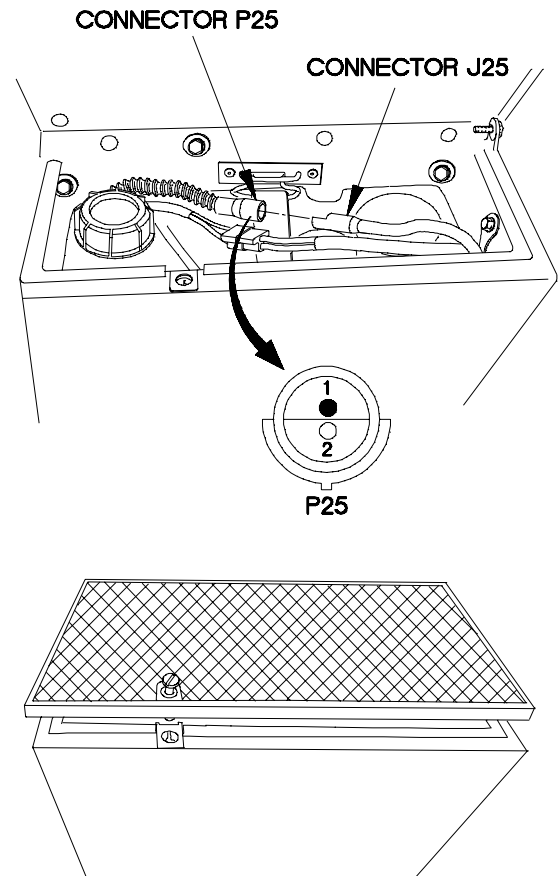

X2E7706A

e75. WINDSHIELD WIPER DOES NOT OPERATE ON LOW SPEED	
INITIAL SETUP	
Equipment Condition Engine shut down (TM 9-2320-365-10).	Tools and Special Tools Tool Kit, Genl Mech (Item 44, Appendix C) STE/ICE-R (Item 39, Appendix C) Multimeter, Digital (Item 22, Appendix C)
Personnel Required (2)	References TM 9-4910-571-12&P

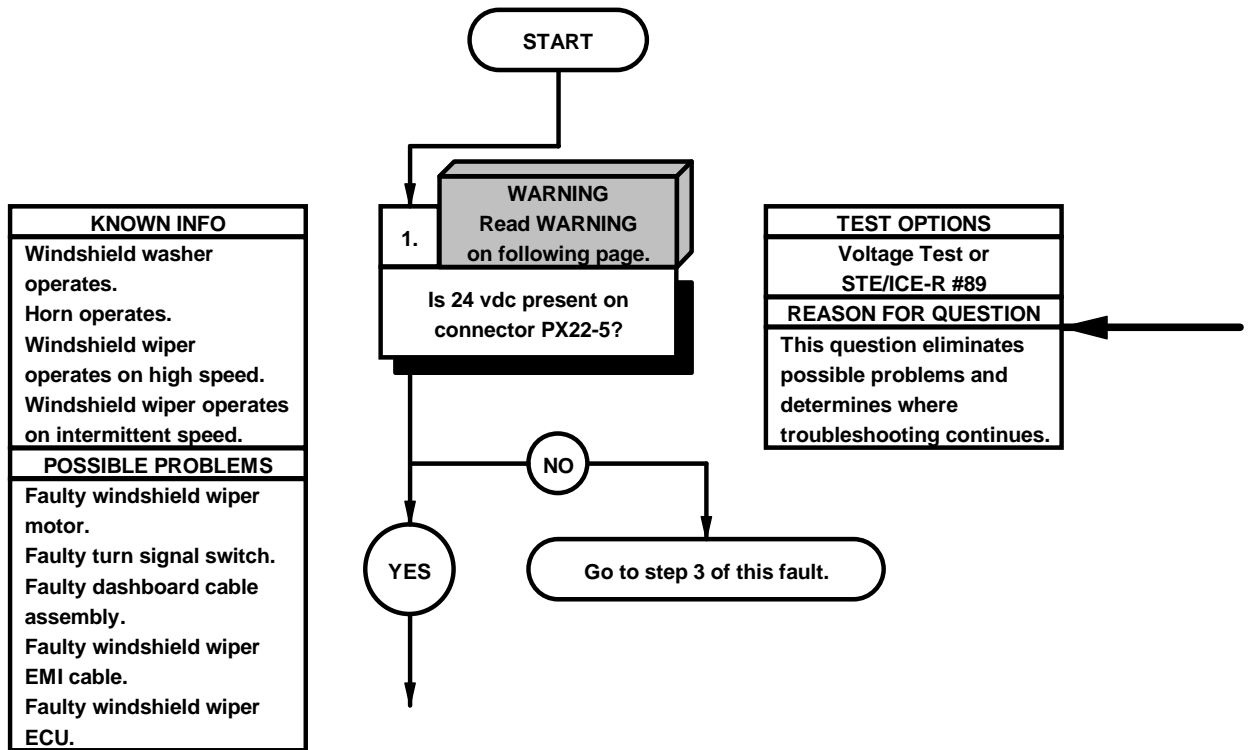

WARNING

Remove rings, bracelets, watches, necklaces, and any other jewelry before working around vehicle. Jewelry can catch on equipment and cause injury or short across electrical circuit and cause severe burns or electrical shock.

VOLTAGE TEST

- (1) Remove PDP cover (para 16-2).
- (2) Remove three screws and washers from PDP.
- (3) Remove three screws from PDP.
- (4) Lift PDP outward to gain access.
- (5) Disconnect connector PX22 from windshield wiper motor.
- (6) Set multimeter to volts dc.
- (7) Connect positive (+) probe of multimeter to connector PX22-5.
- (8) Connect negative (-) probe of multimeter to ground.
- (9) Position master power switch to on (TM 9-2320-365-10).
- (10) Position windshield wiper switch to low (TM 9-2320-365-10) and note reading on multimeter.
- (11) If 24 vdc is not present, go to step 3 of this fault.
- (12) Position windshield wiper switch to off (TM 9-2320-365-10).
- (13) Position master power switch to off (TM 9-2320-365-10).

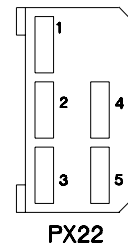
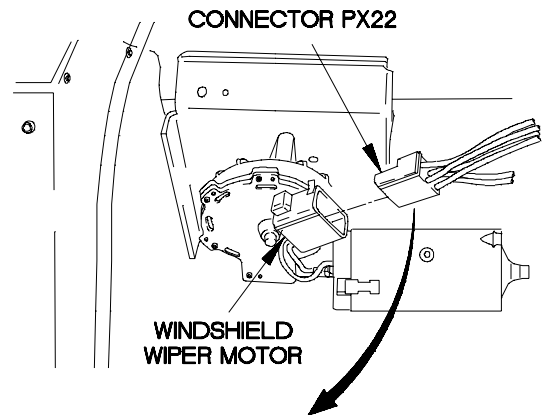
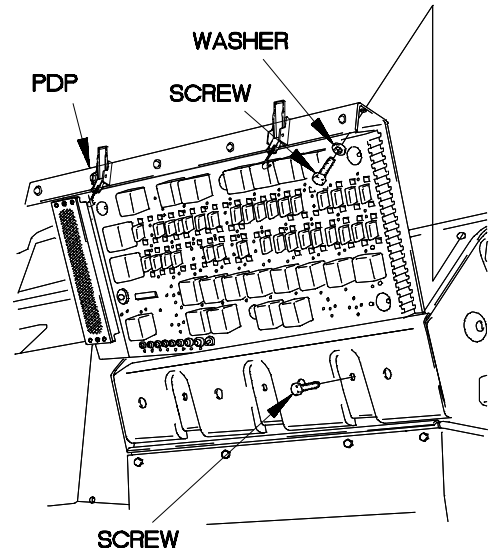

X2E78011

ø75. WINDSHIELD WIPER DOES NOT OPERATE ON LOW SPEED (CONT)

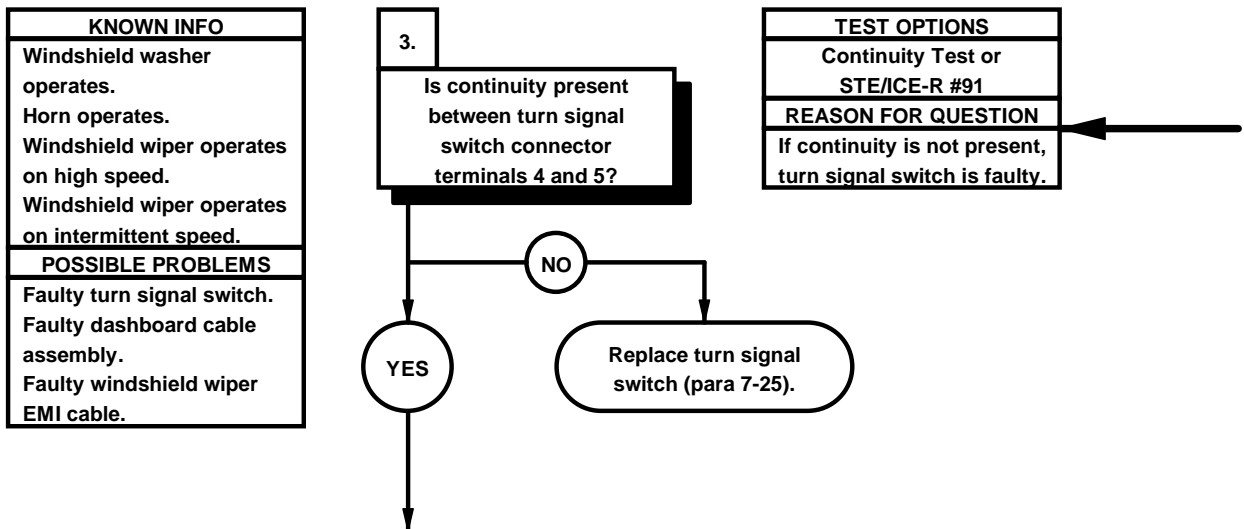
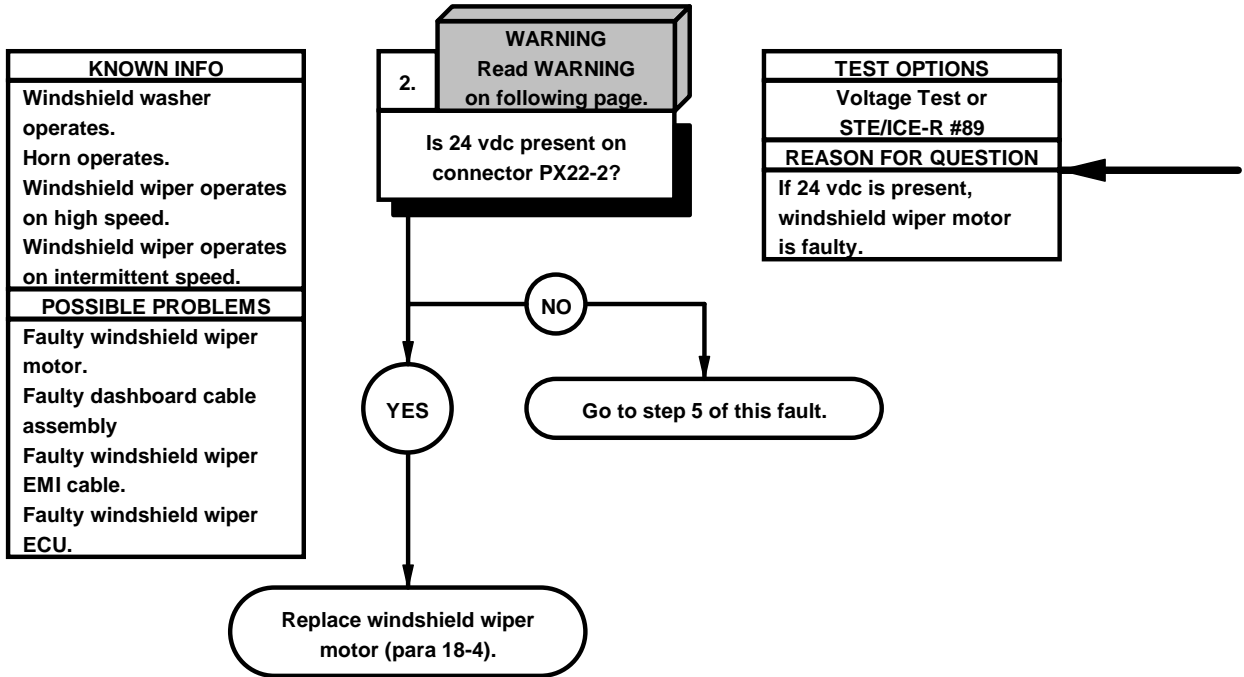

WARNING

Remove rings, bracelets, watches, necklaces, and any other jewelry before working around vehicle. Jewelry can catch on equipment and cause injury or short across electrical circuit and cause severe burns or electrical shock.

VOLTAGE TEST

- (1) Set multimeter to volts dc.
- (2) Connect positive (+) probe of multimeter to connector PX22-2.
- (3) Connect negative (-) probe of multimeter to ground.
- (4) Position master power switch to on (TM 9-2320-365-10).

NOTE

24 vdc is indicated for approximately 1 (one) second.

- (5) Position windshield wiper switch to low (TM 9-2320-365-10) and note reading on multimeter.
- (6) If 24 vdc is not present, go to step 5 of this fault.
- (7) Position windshield wiper switch to off (TM 9-2320-365-10).
- (8) Position master power switch to off (TM 9-2320-365-10).

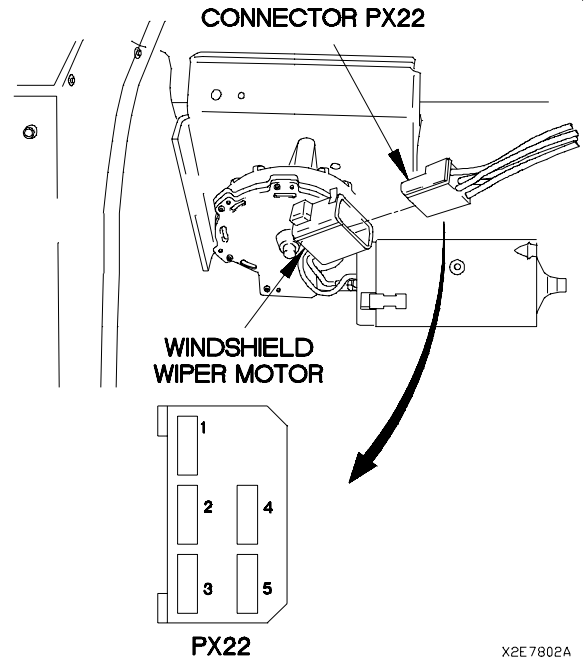

X2E 7802A

CONTINUITY TEST

- (1) Remove instrument panel assembly for access (para 7-15).
- (2) Disconnect turn signal switch connector from connector P18.
- (3) Set multimeter to ohms.
- (4) Connect positive (+) probe of multimeter to turn signal switch connector terminal 4.
- (5) Connect negative (-) probe of multimeter to turn signal switch connector terminal 5.
- (6) Position windshield wiper switch to low position (TM 9-2320-365-10) and note reading on multimeter.
- (7) If continuity is not present, replace turn signal switch (para 7-25).
- (8) Position windshield wiper switch to off (TM 9-2320-365-10).
- (9) Connect turn signal switch connector to connector P18.
- (10) Install instrument panel assembly (para 7-15).

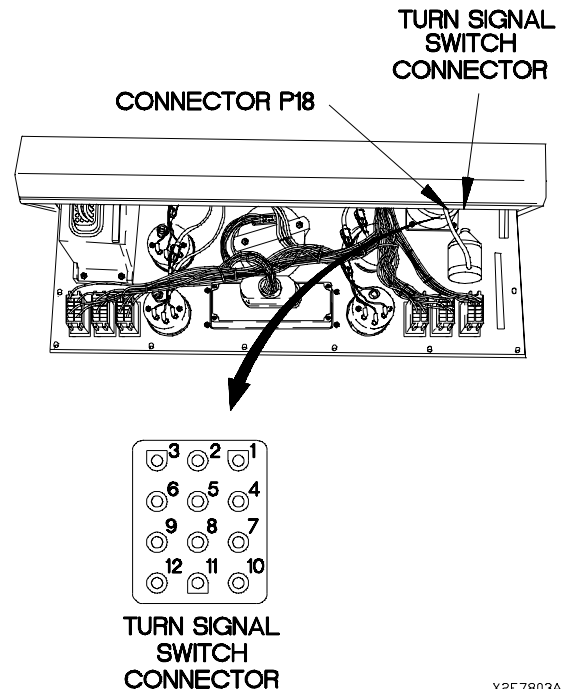

X2E 7803A

ø75. WINDSHIELD WIPER DOES NOT OPERATE ON LOW SPEED (CONT)

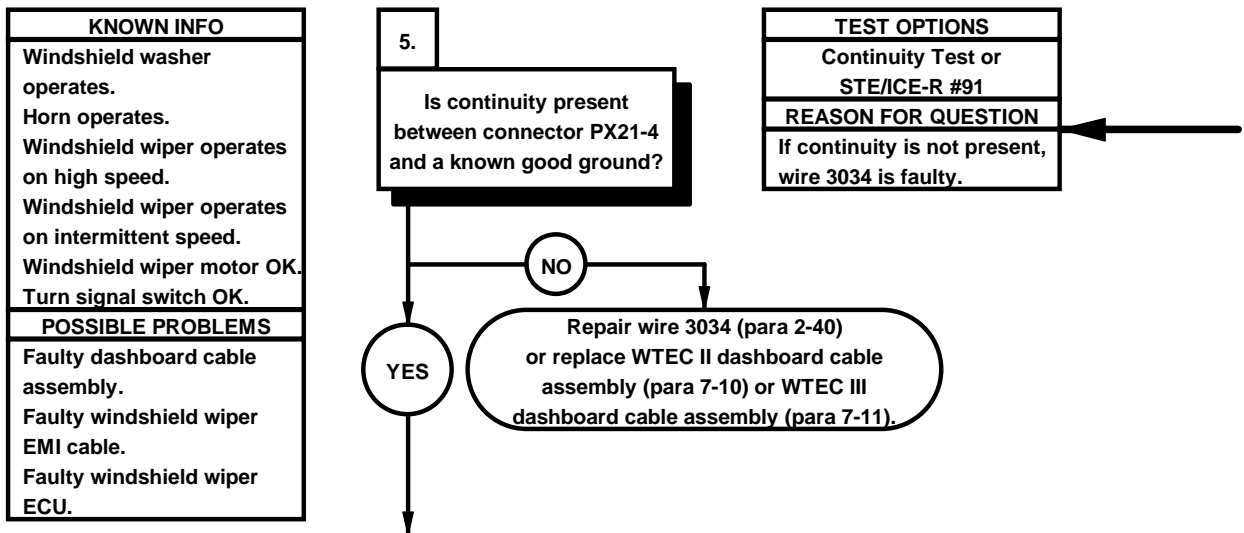
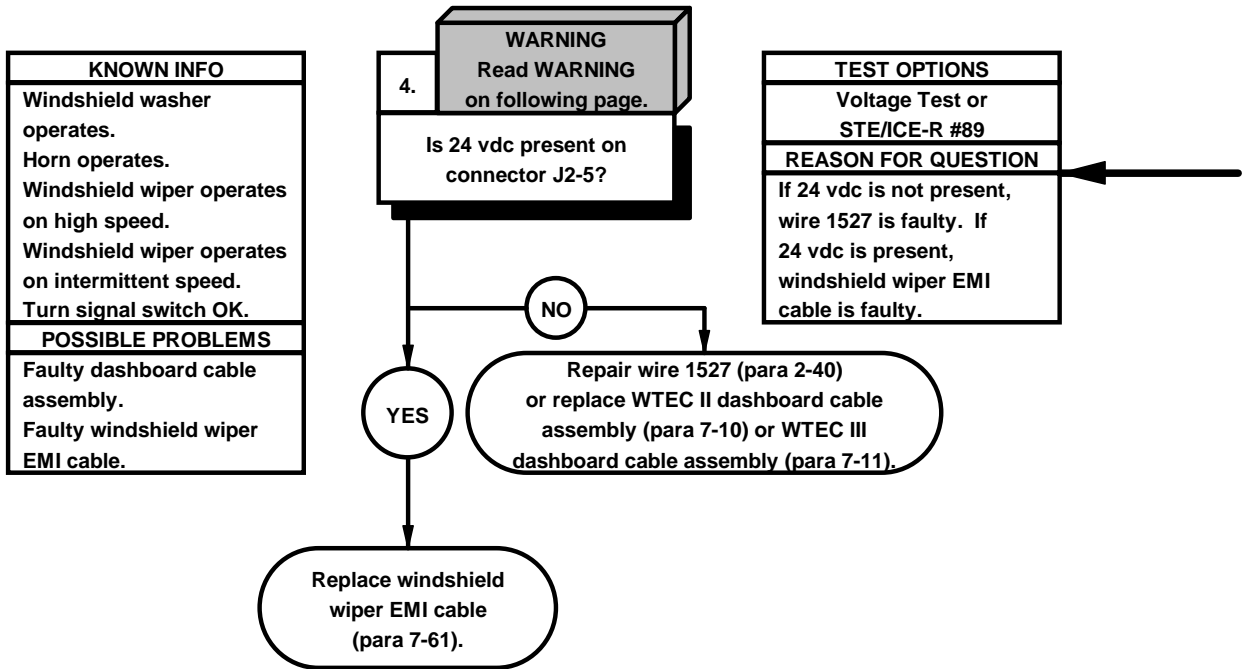

WARNING

Remove rings, bracelets, watches, necklaces, and any other jewelry before working around vehicle. Jewelry can catch on equipment and cause injury or short across electrical circuit and cause severe burns or electrical shock.

VOLTAGE TEST

- (1) Disconnect connector J2 from connector P2.
- (2) Set multimeter to volts dc.
- (3) Connect positive (+) probe of multimeter to connector J2-5.
- (4) Connect negative (-) probe of multimeter to ground.
- (5) Position master power switch to on (TM 9-2320-365-10).
- (6) Position windshield wiper switch to low (TM 9-2320-365-10) and note reading on multimeter.
- (7) If 24 vdc is not present, repair wire 1527 (para 2-40) or replace WTEC II dashboard cable assembly (para 7-10) or WTEC III dashboard cable assembly (para 7-11).
- (8) If 24 vdc is present, replace windshield wiper EMI cable (para 7-61).
- (9) Position windshield wiper switch to off (TM 9-2320-365-10).
- (10) Position master power switch to off (TM 9-2320-365-10).
- (11) Connect connector J2 to connector P2.
- (12) Install PDP on dashboard with three screws.
- (13) Install three washers and screws in PDP.
- (14) Install PDP cover (para 16-2).

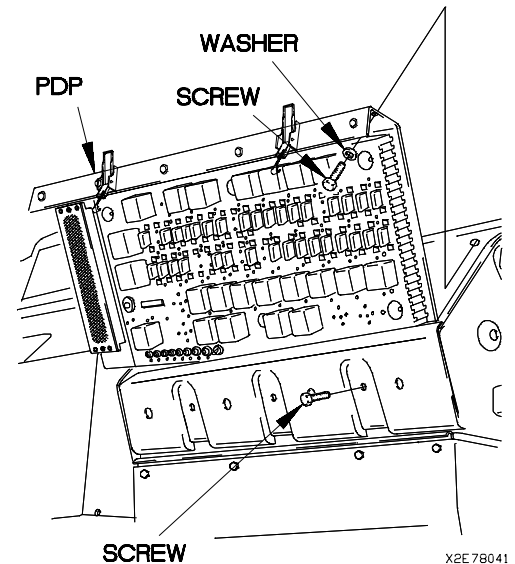
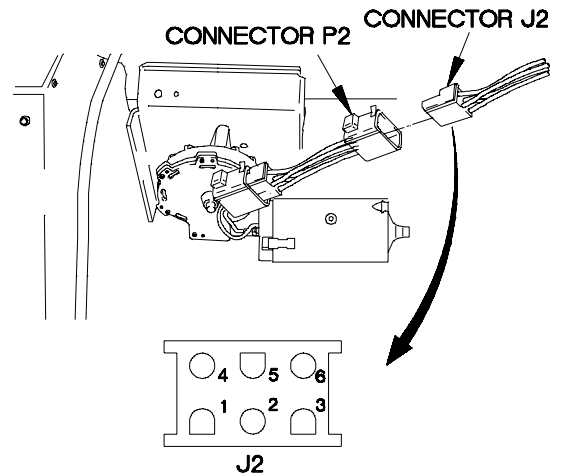

CONTINUITY TEST

- (1) Disconnect windshield wiper ECU from connector PX21.
- (2) Set multimeter to ohms.
- (3) Connect positive (+) probe of multimeter to connector PX21-4.
- (4) Connect negative (-) probe of multimeter to ground and note reading on multimeter.
- (5) If continuity is not present, repair wire 3034 (para 2-40) or replace WTEC II dashboard cable assembly (para 7-10) or WTEC III dashboard cable assembly (para 7-11).

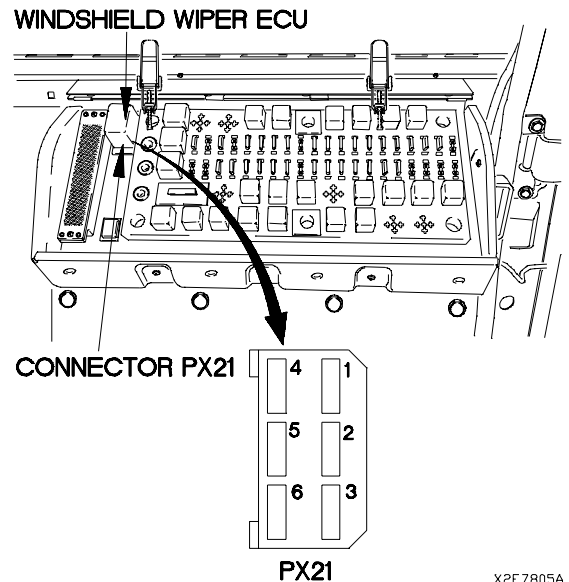

ø75. WINDSHIELD WIPER DOES NOT OPERATE ON LOW SPEED (CONT)

KNOWN INFO
Windshield washer operates. Horn operates. Windshield wiper operates on high speed. Windshield wiper operates on intermittent speed. Windshield wiper motor OK. Turn signal switch OK.
POSSIBLE PROBLEMS
Faulty dashboard cable assembly. Faulty windshield wiper EMI cable. Faulty windshield wiper ECU.

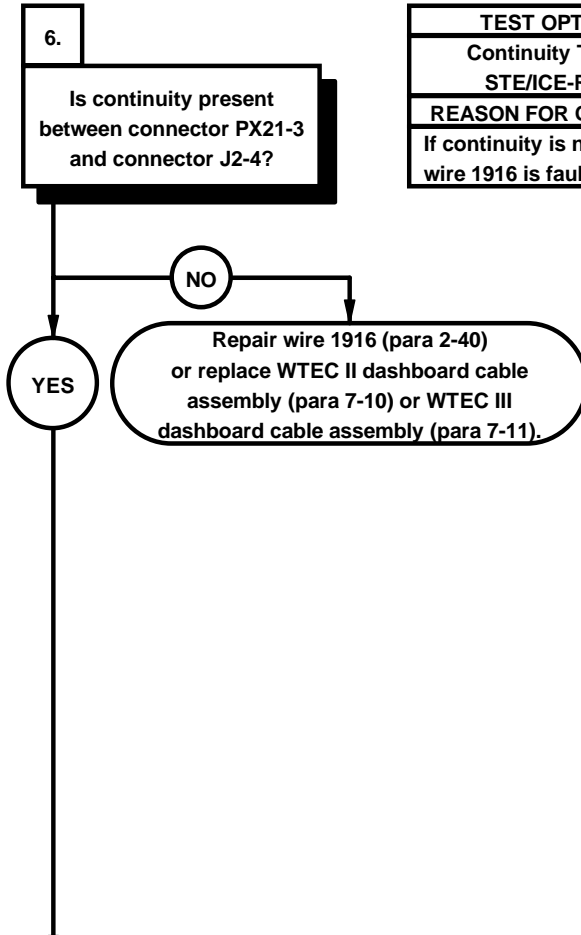

TEST OPTIONS
Continuity Test or STE/ICE-R #91
REASON FOR QUESTION
If continuity is not present, wire 1916 is faulty.

KNOWN INFO
Windshield washer operates. Horn operates. Windshield wiper operates on high speed. Windshield wiper operates on intermittent speed. Windshield wiper motor OK. Turn signal switch OK. Dashboard cable assembly OK.
POSSIBLE PROBLEMS
Faulty windshield wiper EMI cable. Faulty windshield wiper ECU.

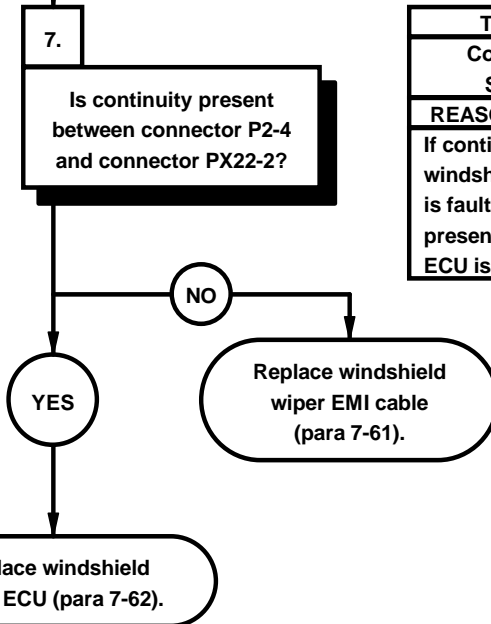

TEST OPTIONS
Continuity Test or STE/ICE-R #91
REASON FOR QUESTION
If continuity is not present, windshield wiper EMI cable is faulty. If continuity is present, windshield wiper ECU is faulty.

CONTINUITY TEST

- (1) Disconnect connector J2 from connector P2.
- (2) Set multimeter to ohms.
- (3) Connect positive (+) probe of multimeter to connector J2-4.
- (4) Connect negative (-) probe of multimeter to connector PX21-3 and note reading on multimeter.
- (5) If continuity is not present, repair wire 1916 (para 2-40) or replace WTEC II dashboard cable assembly (para 7-10) or WTEC III dashboard cable assembly (para 7-11).
- (6) Connect windshield wiper ECU to connector PX21.

WINDSHIELD WIPER ECU

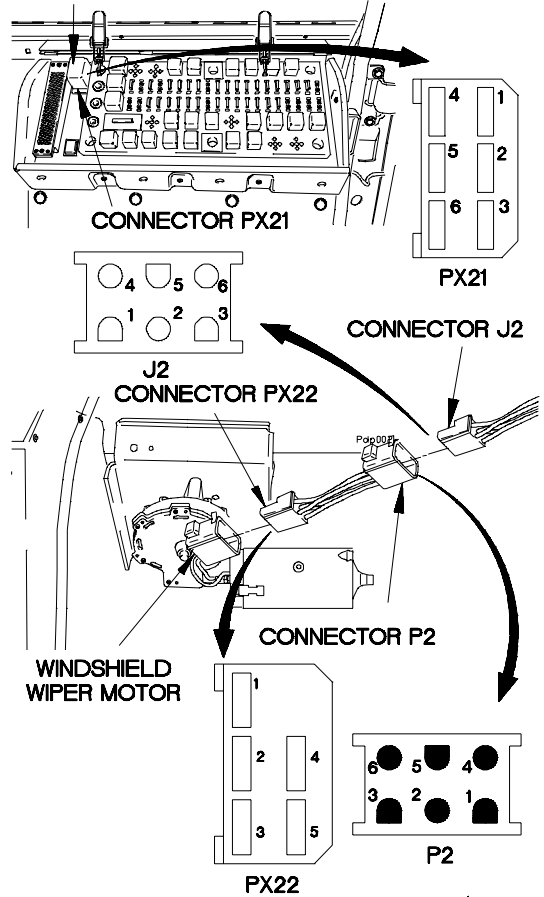

CONTINUITY TEST

- (1) Set multimeter to ohms.
- (2) Connect positive (+) probe of multimeter to connector P2-4.
- (3) Connect negative (-) probe of multimeter to connector PX22-2 and note reading on multimeter.
- (4) If continuity is not present, replace windshield wiper EMI cable (para 7-61).
- (5) If continuity is present, replace windshield wiper ECU (para 7-62).
- (6) Connect connector P2 to connector J2.
- (7) Connect connector PX22 to windshield wiper motor.
- (8) Install PDP on dashboard with three screws.
- (9) Install three washers and screws in PDP.
- (10) Install PDP cover (para 16-2).

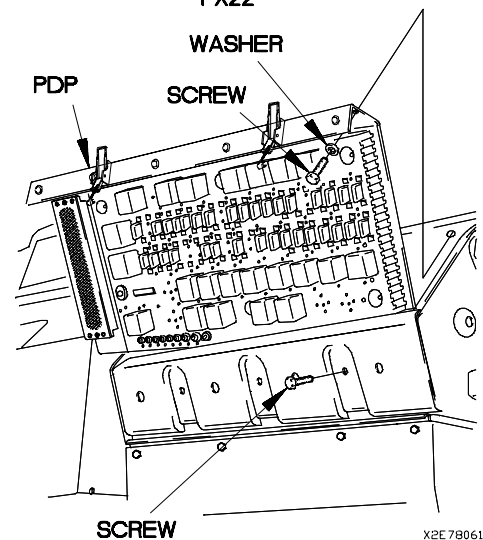

X2E78061

e76. ALL WINDSHIELD WIPER SPEEDS DO NOT OPERATE	
INITIAL SETUP	
Equipment Condition Engine shut down (TM 9-2320-365-10).	Tools and Special Tools Tool Kit, Genl Mech (Item 44, Appendix C) STE/ICE-R (Item 39, Appendix C) Multimeter, Digital (Item 22, Appendix C)
Personnel Required (2)	References TM 9-4910-571-12&P

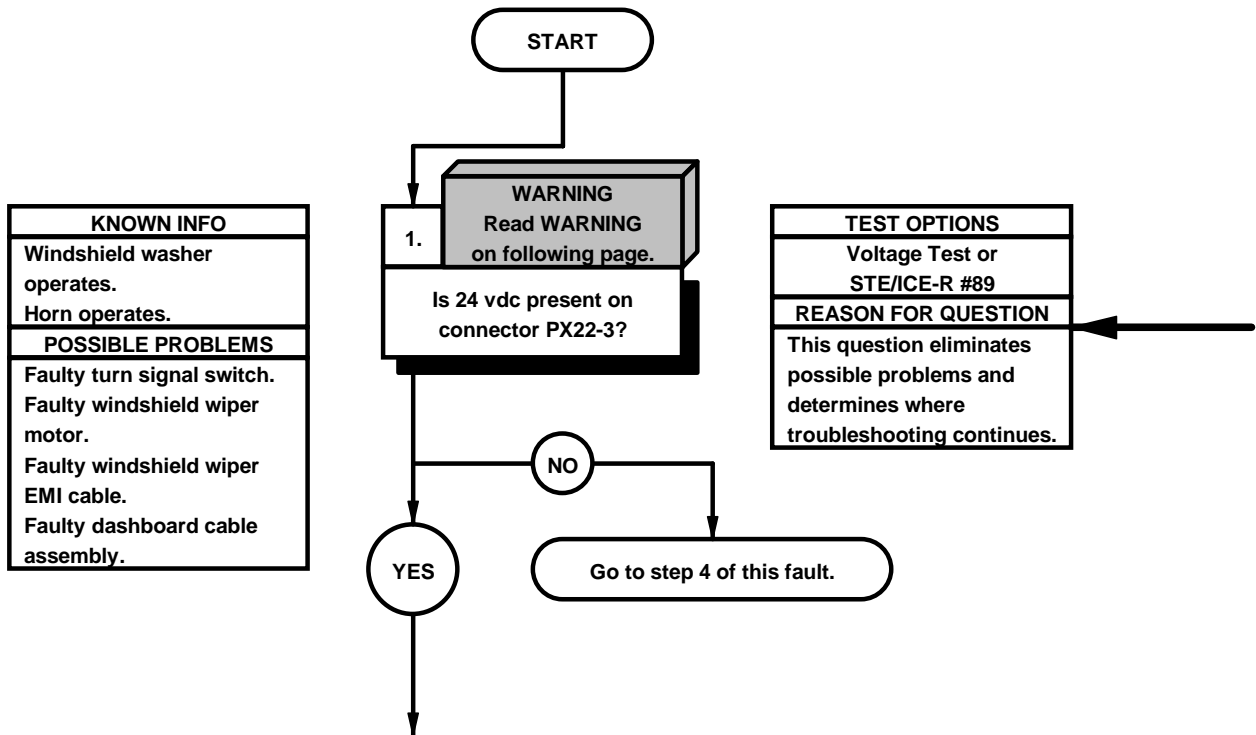

WARNING

Remove rings, bracelets, watches, necklaces, and any other jewelry before working around vehicle. Jewelry can catch on equipment and cause injury or short across electrical circuit and cause severe burns or electrical shock.

VOLTAGE TEST

- (1) Remove PDP cover (para 16-2).
- (2) Remove three screws and washers from PDP.
- (3) Remove three screws from PDP.
- (4) Lift PDP outward to gain access.
- (5) Disconnect connector PX22 from windshield wiper motor.
- (6) Set multimeter to volts dc.
- (7) Connect positive (+) probe of multimeter to connector PX22-3.
- (8) Connect negative (-) probe of multimeter to ground.
- (9) Position master power switch to on (TM 9-2320-365-10) and note reading on multimeter.
- (10) If 24 vdc is not present, go to step 4 of this fault.
- (11) Position master power switch to off (TM 9-2320-365-10).

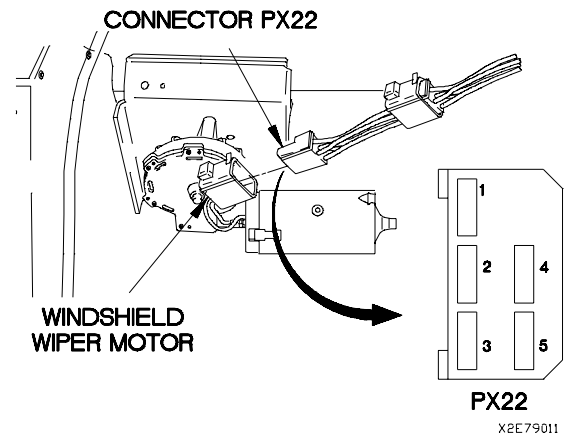
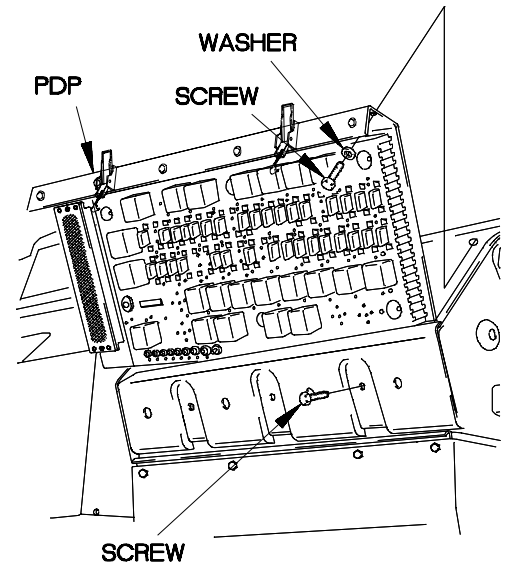

e76. ALL WINDSHIELD WIPER SPEEDS DO NOT OPERATE (CONT)

KNOWN INFO
Windshield washer operates. Horn operates.
POSSIBLE PROBLEMS
Faulty turn signal switch. Faulty windshield wiper motor. Faulty dashboard cable assembly. Faulty windshield wiper EMI cable.

2.
Is continuity present between connector PX22-1 and a known good ground?

TEST OPTIONS
Continuity Test or STE/ICE-R #91
REASON FOR QUESTION
This question eliminates possible problems and determines where troubleshooting continues.

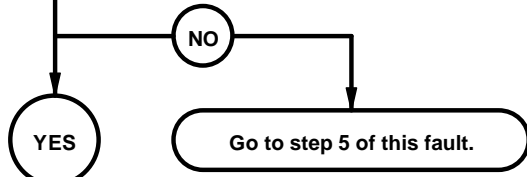

KNOWN INFO
Windshield washer operates. Horn operates. Dashboard cable assembly OK. Windshield wiper EMI cable OK.
POSSIBLE PROBLEMS
Faulty turn signal switch. Faulty windshield wiper motor.

3.
Is continuity present between turn signal switch connector terminals 4 and 6?

TEST OPTIONS
Continuity Test or STE/ICE-R #91
REASON FOR QUESTION
If continuity is not present, turn signal switch is faulty. If continuity is present, windshield wiper motor is faulty.

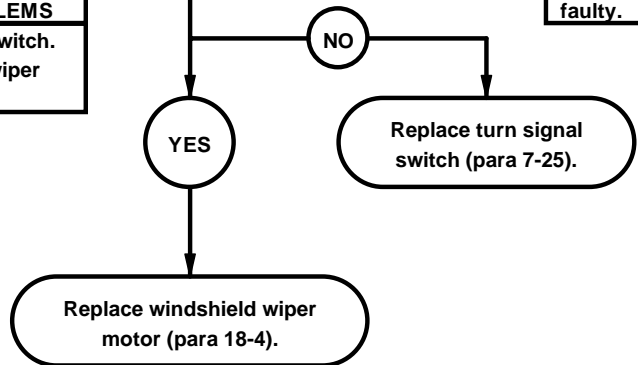

- CONTINUITY TEST**
- (1) Set multimeter to ohms.
 - (2) Connect positive (+) probe of multimeter to connector PX22-1.
 - (3) Connect negative (-) probe of multimeter to ground and note reading on multimeter.
 - (4) If continuity is not present, go to step 5 of this fault.
 - (5) Connect connector PX22 to windshield wiper motor.

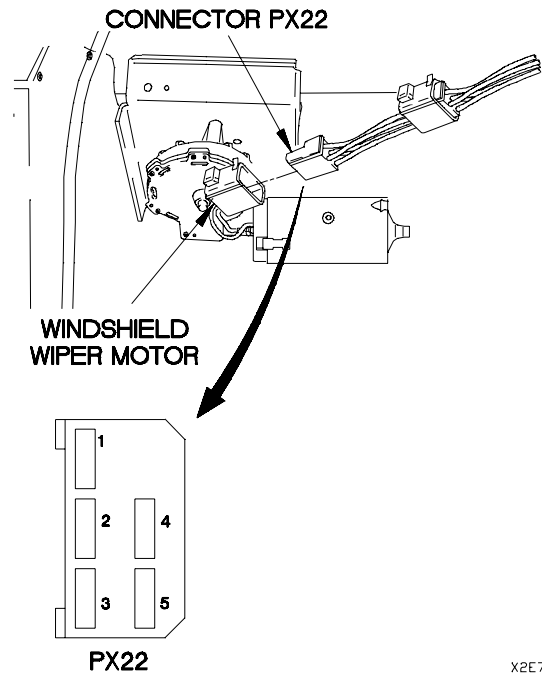

X2E7902A

- CONTINUITY TEST**
- (1) Remove instrument panel assembly for access (para 7-15).
 - (2) Disconnect turn signal switch connector from connector P18.
 - (3) Set multimeter to ohms.
 - (4) Connect positive (+) probe of multimeter to turn signal switch connector terminal 6.
 - (5) Connect negative (-) probe of multimeter to turn signal switch connector terminal 4.
 - (6) Position windshield wiper switch to high (TM 9-2320-365-10) and note reading on multimeter.
 - (7) If continuity is not present, replace turn signal switch (para 7-25).
 - (8) If continuity is present, replace windshield wiper motor (para 18-4).
 - (9) Position windshield wiper switch to off (TM 9-2320-365-10).
 - (10) Connect turn signal switch connector to connector P18.
 - (11) Install instrument panel assembly (para 7-15).
 - (12) Install PDP on dashboard with three screws.
 - (13) Install three washers and screws in PDP.
 - (14) Install PDP cover (para 16-2).

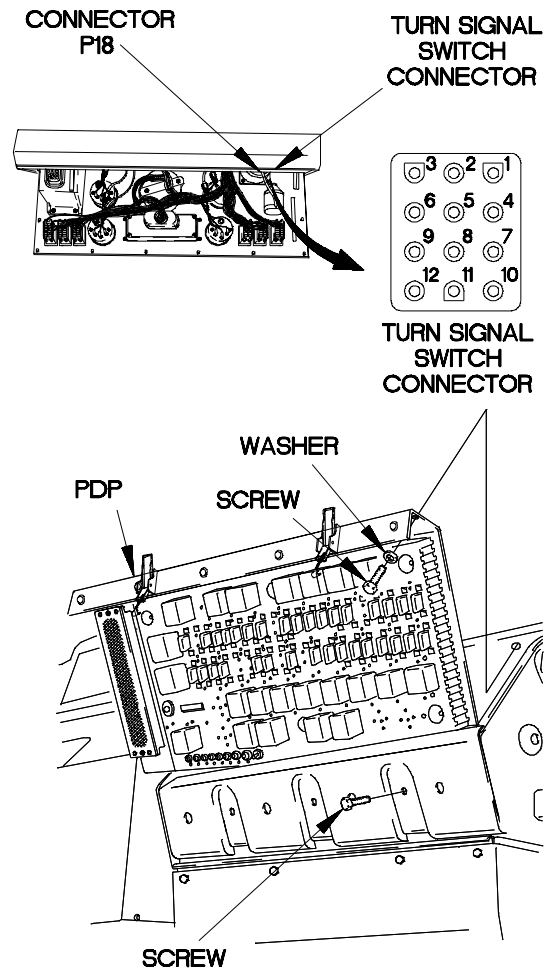

X2E79031

e76. ALL WINDSHIELD WIPER SPEEDS DO NOT OPERATE (CONT)

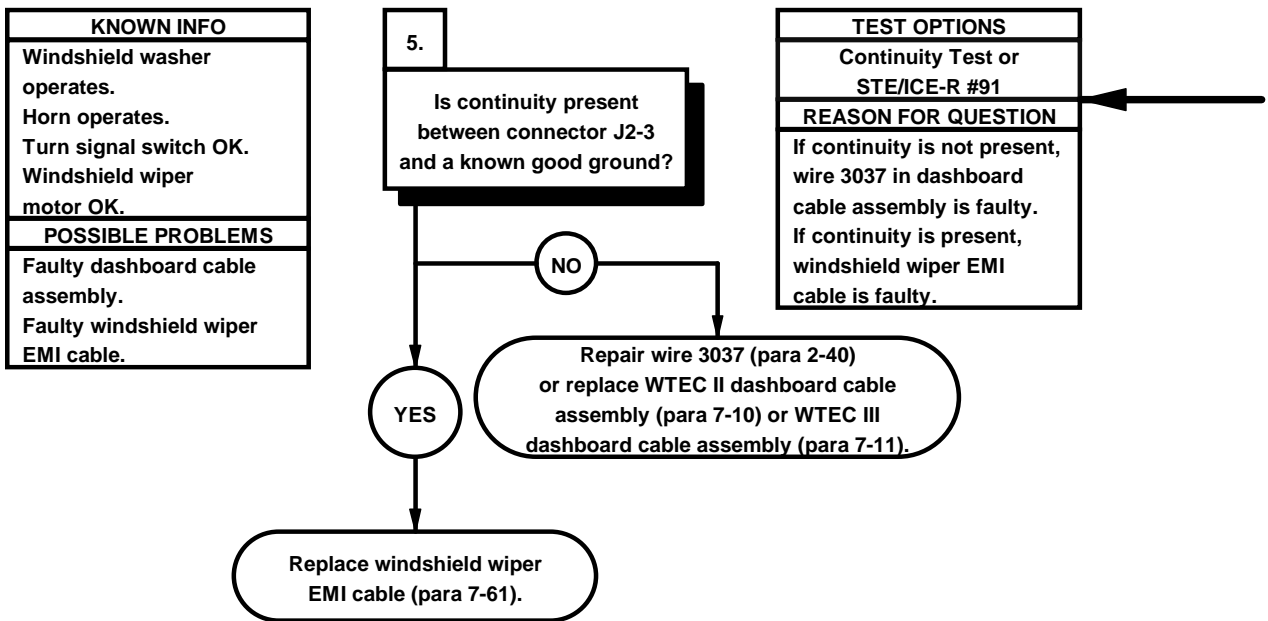
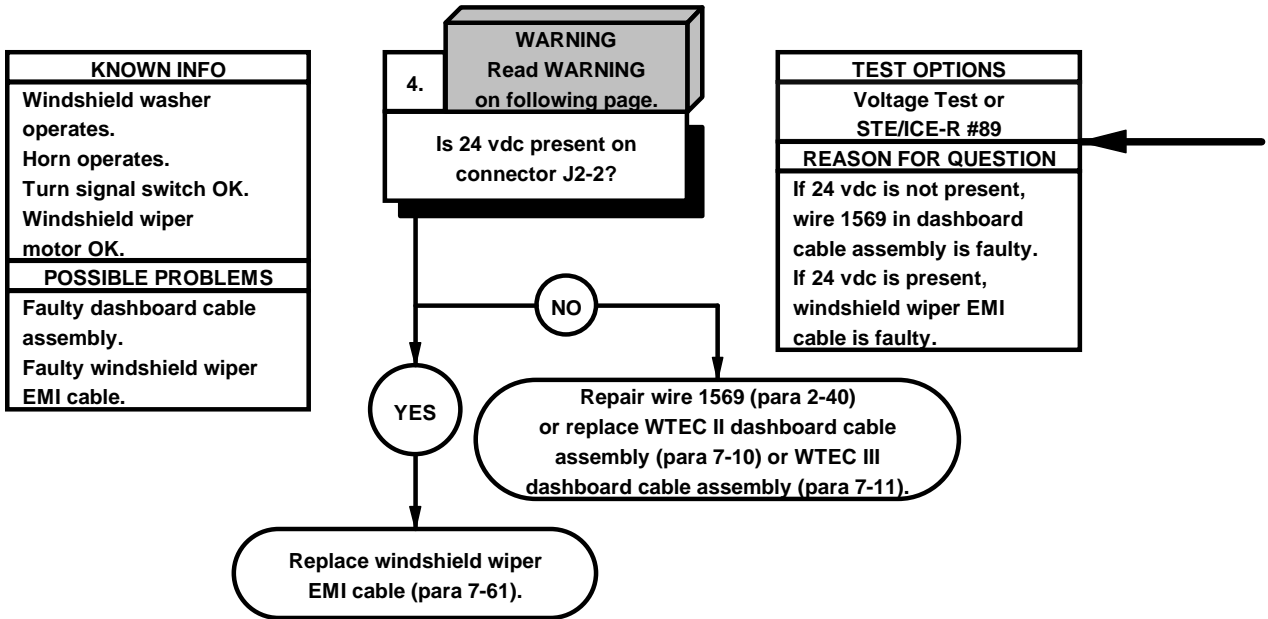

WARNING

Remove rings, bracelets, watches, necklaces, and any other jewelry before working around vehicle. Jewelry can catch on equipment and cause injury or short across electrical circuit and cause severe burns or electrical shock.

VOLTAGE TEST

- (1) Disconnect connector J2 from connector P2.
- (2) Set multimeter to volts dc.
- (3) Connect positive (+) probe of multimeter to connector J2-2.
- (4) Connect negative (-) probe of multimeter to ground.
- (5) Position master power switch to on (TM 9-2320-365-10) and note reading on multimeter.
- (6) If 24 vdc is not present, repair wire 1569 (para 2-40) or replace WTEC II dashboard cable assembly (para 7-10) or WTEC III dashboard cable assembly (para 7-11).
- (7) If 24 vdc is present, replace windshield wiper EMI cable (para 7-61).
- (8) Position master power switch to off (TM 9-2320-365-10).
- (9) Connect connector P2 to connector J2.
- (10) Install PDP on dashboard with three screws.
- (11) Install three washers and screws in PDP.
- (12) Install PDP cover (para 16-2).

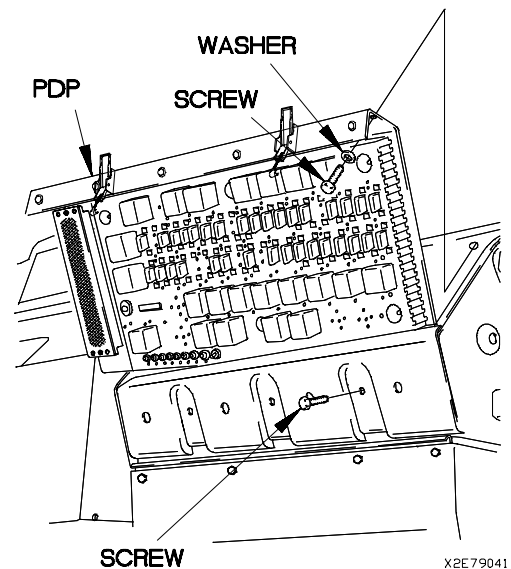
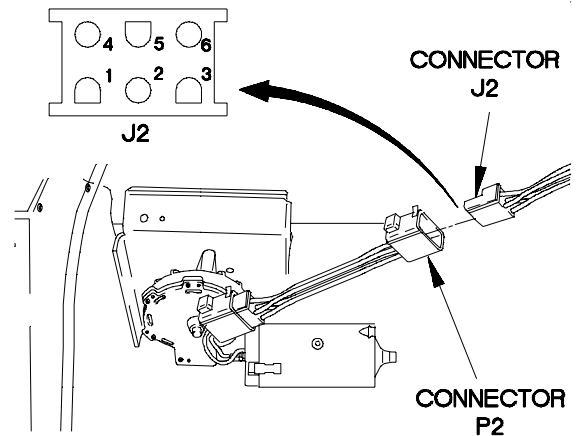

X2E79041

CONTINUITY TEST

- (1) Disconnect connector J2 from connector P2.
- (2) Set multimeter to ohms.
- (3) Connect positive (+) probe of multimeter to connector J2-3.
- (4) Connect negative (-) probe of multimeter to ground and note reading on multimeter.
- (5) If continuity is not present, repair wire 3037 (para 2-40) or replace WTEC II dashboard cable assembly (para 7-10) or WTEC III dashboard cable assembly (para 7-11).
- (6) If continuity is present, replace windshield wiper EMI cable (para 7-61).
- (7) Connect connector P2 to connector J2.
- (8) Install PDP on dashboard with three screws.
- (9) Install three washers and screws in PDP.
- (10) Install PDP cover (para 16-2).

e77. WINDSHIELD WIPER DOES NOT OPERATE ON INTERMITTENT SPEED	
INITIAL SETUP	
Equipment Condition Engine shut down (TM 9-2320-365-10).	Tools and Special Tools Tool Kit, Genl Mech (Item 44, Appendix C) STE/ICE-R (Item 39, Appendix C) Multimeter, Digital (Item 22, Appendix C)
Personnel Required (2)	References TM 9-4910-571-12&P

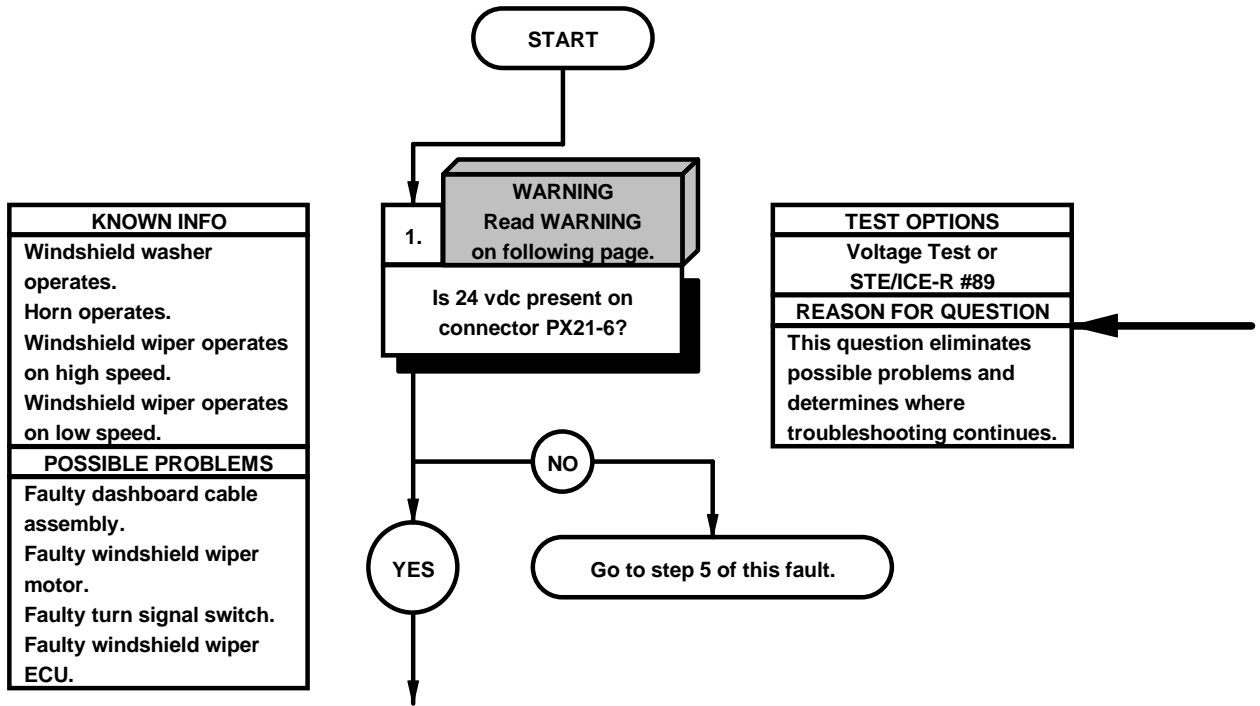

WARNING

Remove rings, bracelets, watches, necklaces, and any other jewelry before working around vehicle. Jewelry can catch on equipment and cause injury or short across electrical circuit and cause severe burns or electrical shock.

VOLTAGE TEST

- (1) Remove PDP cover (para 16-2).
- (2) Disconnect windshield wiper ECU from connector PX21.
- (3) Set multimeter to volts dc.
- (4) Connect positive (+) probe of multimeter to connector PX21-6.
- (5) Connect negative (-) probe of multimeter to ground.
- (6) Position master power switch to on (TM 9-2320-365-10).
- (7) Position windshield wiper switch to intermittent (TM 9-2320-365-10) and note reading on multimeter.
- (8) If 24 vdc is not present, go to step 5 of this fault.
- (9) Position windshield wiper switch to off (TM 9-2320-365-10).
- (10) Position master power switch to off (TM 9-2320-365-10).

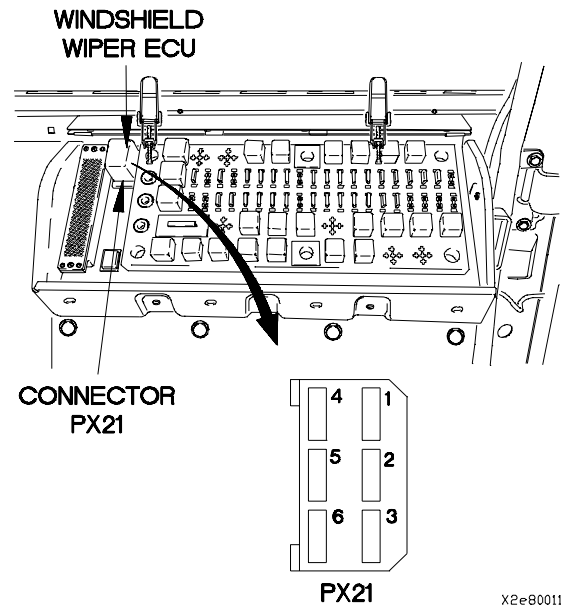

e77. WINDSHIELD WIPER DOES NOT OPERATE ON INTERMITTENT SPEED (CONT)

KNOWN INFO
Windshield washer operates. Horn operates. Windshield wiper operates on high speed. Windshield wiper operates on low speed.
POSSIBLE PROBLEMS
Faulty dashboard cable assembly. Faulty windshield wiper motor. Faulty turn signal switch. Faulty windshield wiper ECU.

2.
Is continuity present between connector PX21-4 and a known good ground?

TEST OPTIONS
Continuity Test or STE/ICE-R #91
REASON FOR QUESTION
If continuity is not present, wire 3034 is faulty.

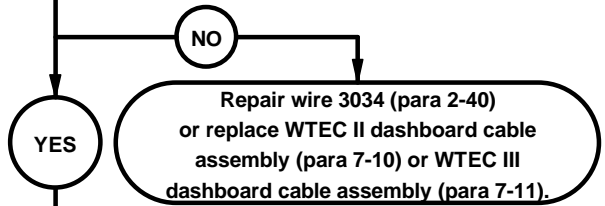

KNOWN INFO
Windshield washer operates. Horn operates. Windshield wiper operates on high speed. Windshield wiper operates on low speed.
POSSIBLE PROBLEMS
Faulty windshield wiper motor. Faulty dashboard cable assembly. Faulty turn signal switch. Faulty windshield wiper ECU.

3.
WARNING
Read WARNING on following page.
Is 24 vdc present on connector PX22-5?

TEST OPTIONS
Voltage Test or STE/ICE-R #89
REASON FOR QUESTION
This question eliminates possible problems and determines where troubleshooting continues.

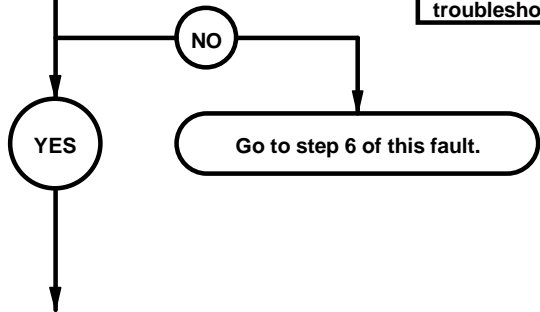

CONTINUITY TEST

- (1) Set multimeter to ohms.
- (2) Connect positive (+) probe of multimeter to connector PX21-4.
- (3) Connect negative (-) probe of multimeter to ground and note reading on multimeter.
- (4) If continuity is not present, repair wire 3034 (para 2-40) or replace WTEC II dashboard cable assembly (para 7-10) or WTEC III dashboard cable assembly (para 7-11).
- (5) Connect windshield wiper ECU to connector PX21.

WARNING

Remove rings, bracelets, watches, necklaces, and any other jewelry before working around vehicle. Jewelry can catch on equipment and cause injury or short across electrical circuit and cause severe burns or electrical shock.

VOLTAGE TEST

- (1) Remove three screws from PDP.
- (2) Remove three screws and washers from PDP.
- (3) Lift PDP outward to gain access.
- (4) Disconnect connector PX22 from windshield wiper motor.
- (5) Set multimeter to volts dc.
- (6) Connect positive (+) probe of multimeter to connector PX22-5.
- (7) Connect negative (-) probe of multimeter to ground.
- (8) Position master power switch to on (TM 9-2320-365-10).
- (9) Position windshield wiper switch to intermittent (TM 9-2320-365-10) and note reading on multimeter.
- (10) If 24 vdc is not present, go to step 6 of this fault.
- (11) Position windshield wiper switch to off (TM 9-2320-365-10).
- (12) Position master power switch to off (TM 9-2320-365-10).

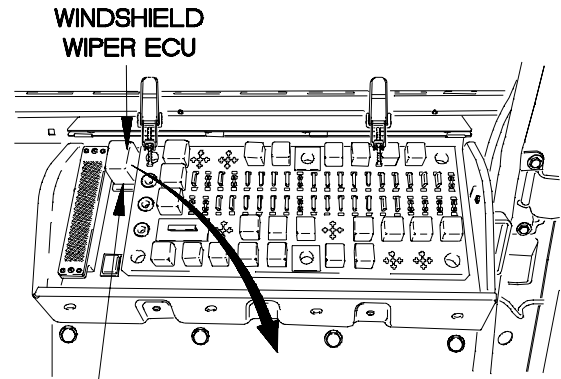

CONNECTOR PX21

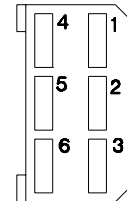

PX21

X2E80021

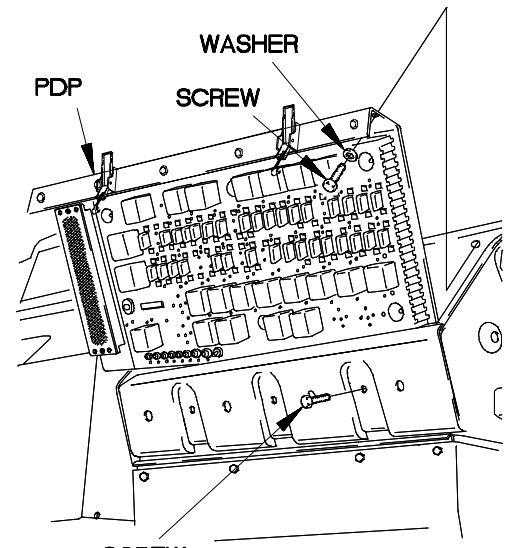

SCREW

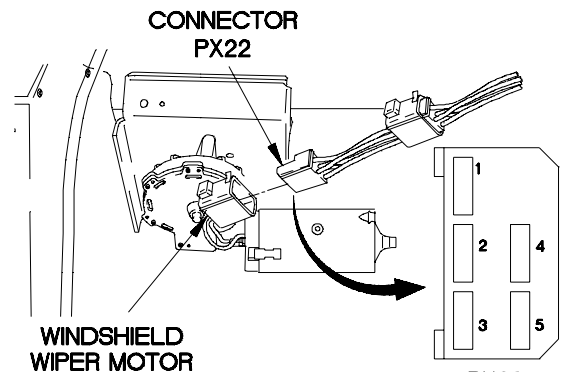

PX22

X2E8003A

e77. WINDSHIELD WIPER DOES NOT OPERATE ON INTERMITTENT SPEED (CONT)

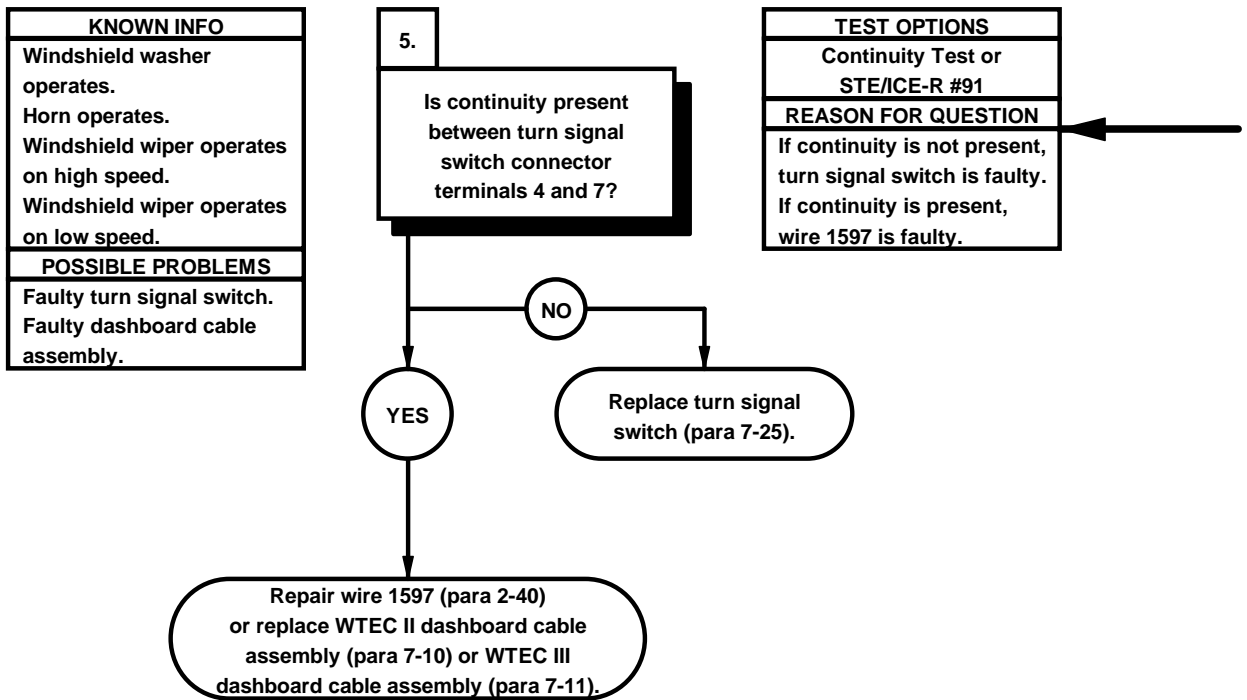
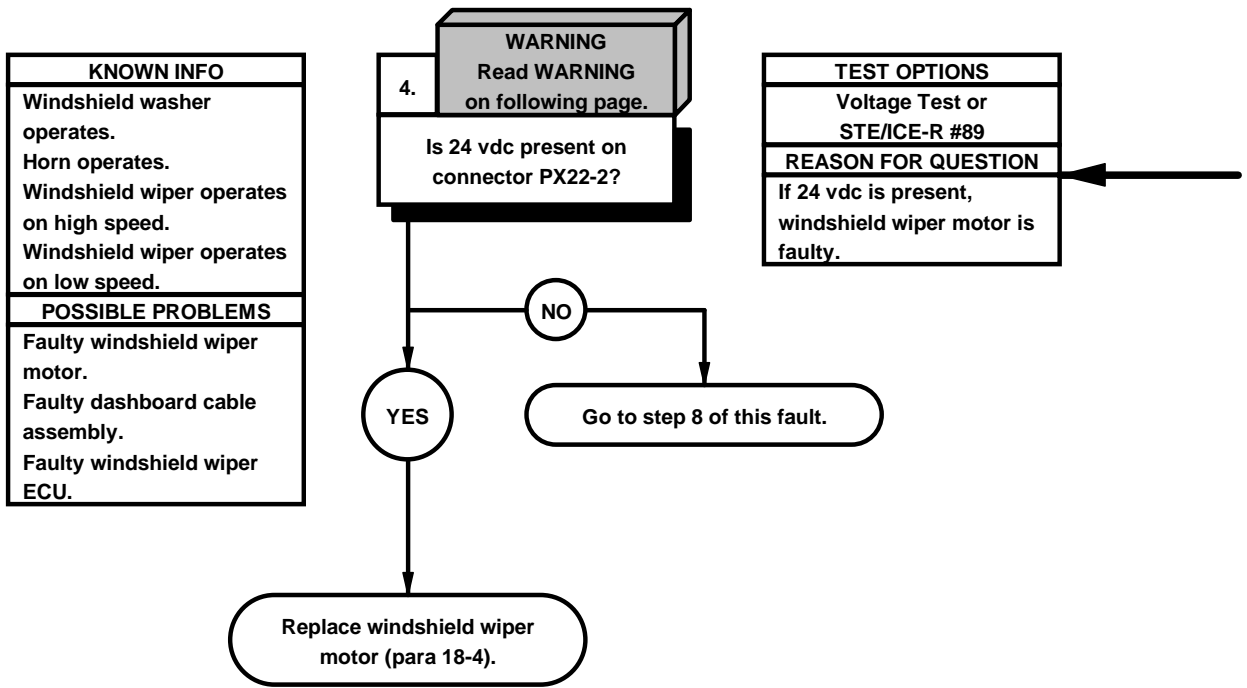

WARNING

Remove rings, bracelets, watches, necklaces, and any other jewelry before working around vehicle. Jewelry can catch on equipment and cause injury or short across electrical circuit and cause severe burns or electrical shock.

VOLTAGE TEST

- (1) Set multimeter to volts dc.
- (2) Connect positive (+) probe of multimeter to connector PX22-2.
- (3) Connect negative (-) probe of multimeter to ground.
- (4) Position master power switch to on (TM 9-2320-365-10).
- (5) Position windshield wiper switch to intermittent (TM 9-2320-365-10) and note reading on multimeter.
- (6) If 24 vdc is not present, go to step 8 of this fault.
- (7) If 24 vdc is present, replace windshield wiper motor (para 18-4).
- (8) Position windshield wiper switch to off (TM 9-2320-365-10).
- (9) Position master power switch to off (TM 9-2320-365-10).
- (10) Connect connector PX22 to windshield wiper motor.

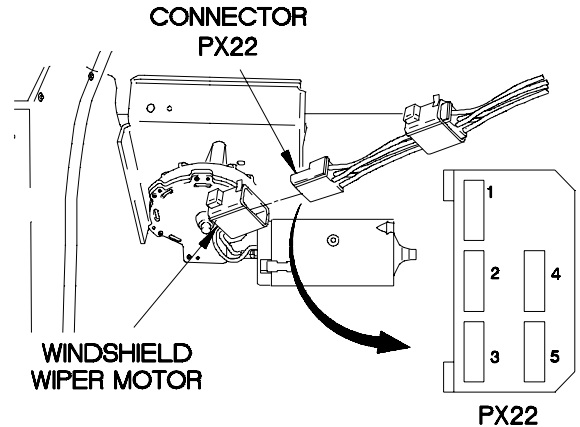

X2E8004A

CONTINUITY TEST

- (1) Remove instrument panel assembly for access (para 7-15).
- (2) Disconnect turn signal switch connector from connector P18.
- (3) Set multimeter to ohms.
- (4) Connect positive (+) probe of multimeter to turn signal switch connector terminal 4.
- (5) Connect negative (-) probe of multimeter to turn signal switch connector terminal 7.
- (6) Position windshield wiper switch to intermittent (TM 9-2320-365-10) and note reading on multimeter.
- (7) If continuity is not present, replace turn signal switch (para 7-25).
- (8) If continuity is present, repair wire 1597 (para 2-40) or replace WTEC II dashboard cable assembly (para 7-10) or WTEC III dashboard cable assembly (para 7-11).
- (9) Position windshield wiper switch to off (TM 9-2320-365-10).
- (10) Connect turn signal switch connector to connector P18.
- (11) Install instrument panel assembly (para 7-15).
- (12) Connect windshield wiper ECU to connector PX21.
- (13) Install PDP cover (para 16-2).

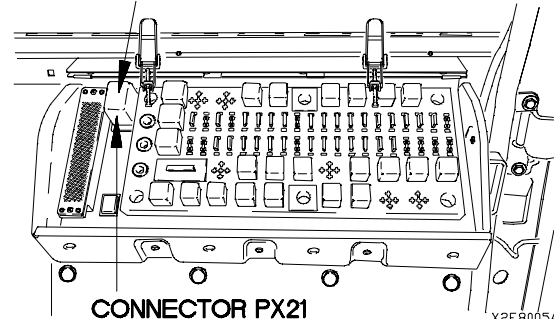
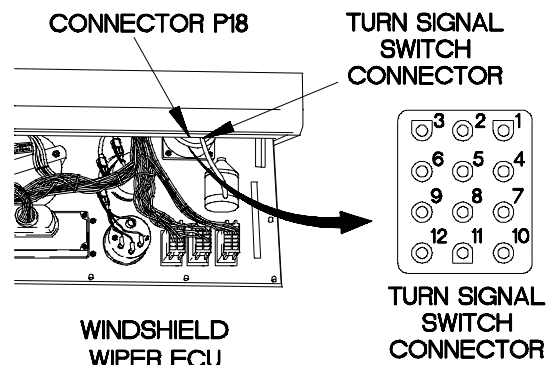

X2E8005A

e77. WINDSHIELD WIPER DOES NOT OPERATE ON INTERMITTENT SPEED (CONT)

KNOWN INFO
Windshield washer operates. Horn operates. Windshield wiper operates on high speed. Windshield wiper operates on low speed.
POSSIBLE PROBLEMS
Faulty dashboard cable assembly. Faulty turn signal switch. Faulty windshield wiper ECU.

KNOWN INFO
Windshield washer operates. Horn operates. Windshield wiper operates on high speed. Windshield wiper operates on low speed.
POSSIBLE PROBLEMS
Faulty turn signal switch. Faulty dashboard cable assembly. Faulty windshield wiper ECU.

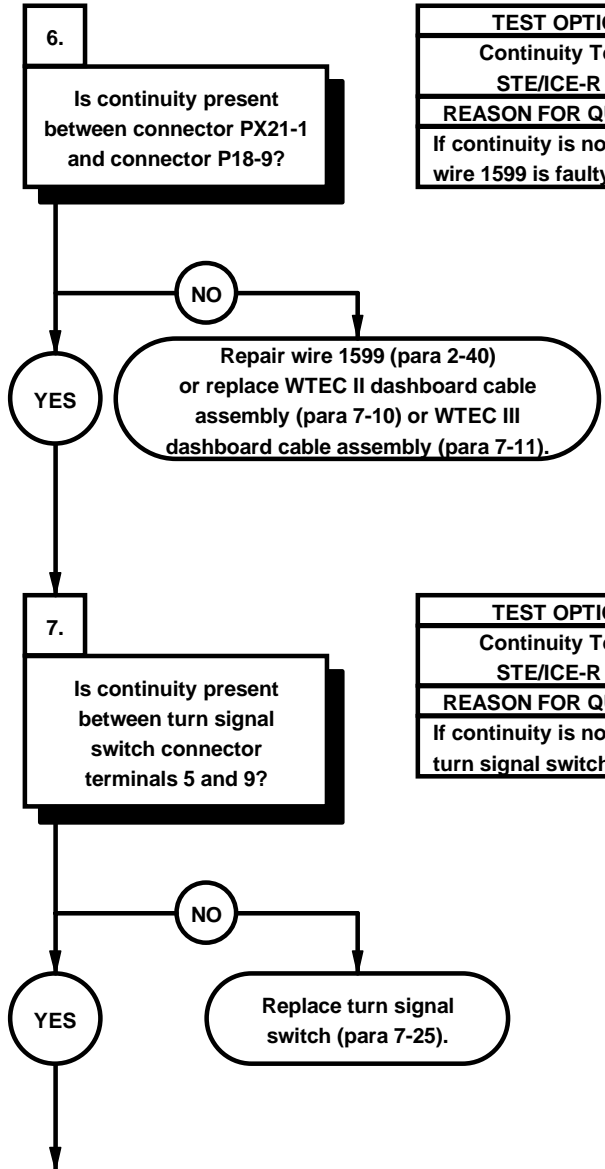

TEST OPTIONS
Continuity Test or STE/ICE-R #91
REASON FOR QUESTION
If continuity is not present, wire 1599 is faulty.

TEST OPTIONS
Continuity Test or STE/ICE-R #91
REASON FOR QUESTION
If continuity is not present, turn signal switch is faulty.

CONTINUITY TEST

- (1) Remove instrument panel assembly for access (para 7-15).
- (2) Disconnect windshield wiper ECU from connector PX21.
- (3) Disconnect connector P18 from turn signal switch connector.
- (4) Set multimeter to ohms.
- (5) Connect positive (+) probe of multimeter to connector PX21-1.
- (6) Connect negative (-) probe of multimeter to connector P18-9 and note reading on multimeter.
- (7) If continuity is not present, repair wire 1599 (para 2-40) or replace WTEC II dashboard cable assembly (para 7-10) or WTEC III dashboard cable assembly (para 7-11).

CONTINUITY TEST

- (1) Set multimeter to ohms.
- (2) Connect positive (+) probe of multimeter to turn signal switch connector terminal 9.
- (3) Connect negative (-) probe of multimeter to turn signal switch connector terminal 5.
- (4) Position windshield wiper switch to intermittent (TM 9-2320-365-10) and note reading on multimeter.
- (5) If continuity is not present, replace turn signal switch (para 7-25).
- (6) Position windshield wiper switch to off (TM 9-2320-365-10).
- (7) Connect windshield wiper ECU to connector PX21.
- (8) Connect connector P18 to turn signal switch connector.
- (9) Install instrument panel assembly (para 7-15).
- (10) Install PDP on dashboard with three screws.
- (11) Install three washers and screws in PDP.
- (12) Install PDP cover (para 16-2).

WINDSHIELD WIPER ECU

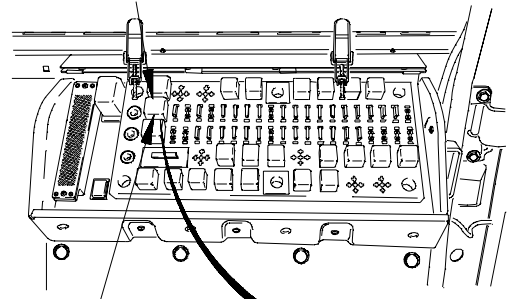

CONNECTOR PX21

CONNECTOR P18

TURN SIGNAL SWITCH CONNECTOR

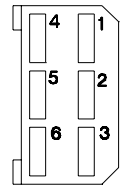

PX21

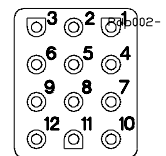
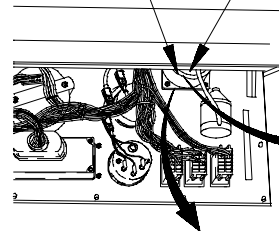

TURN SIGNAL SWITCH CONNECTOR

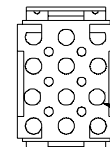

P18

PDP

WASHER

SCREW

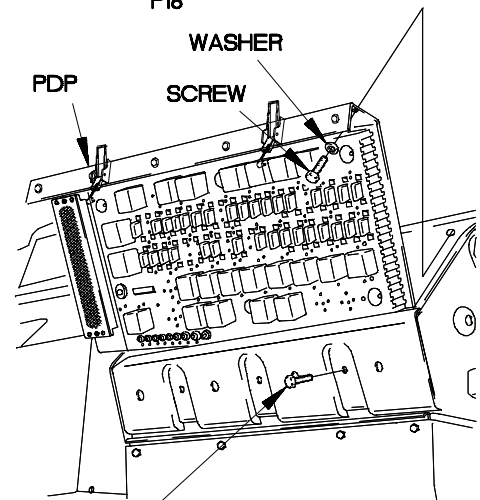

SCREW

X2E80061

e77. WINDSHIELD WIPER DOES NOT OPERATE ON INTERMITTENT SPEED (CONT)

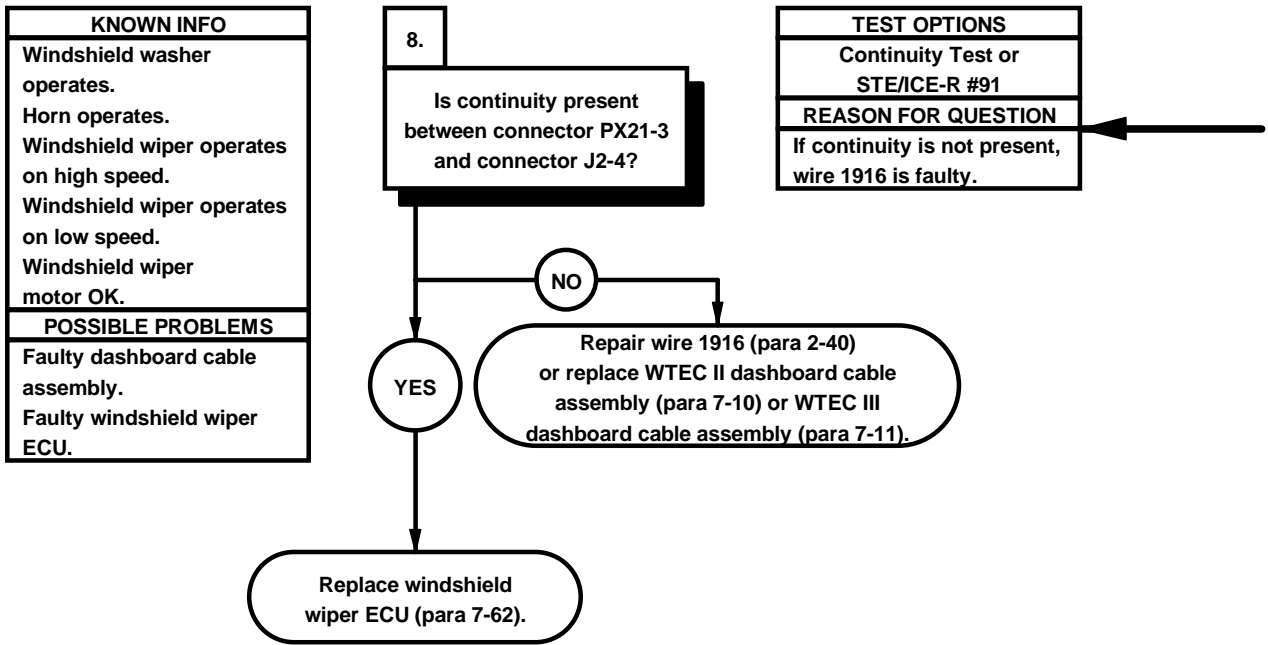

CONTINUITY TEST

- (1) Disconnect connector J2 from connector P2.
- (2) Disconnect windshield wiper ECU from connector PX21.
- (3) Set multimeter to ohms.
- (4) Connect positive (+) probe of multimeter to connector PX21-3.
- (5) Connect negative (-) probe of multimeter to connector J2-4 and note reading on multimeter.
- (6) If continuity is not present, repair wire 1916 (para 2-40) or replace WTEC II dashboard cable assembly (para 7-10) or WTEC III dashboard cable assembly (para 7-11).
- (7) If continuity is present, replace windshield wiper ECU (para 7-62).
- (8) Connect windshield wiper ECU to connector PX21.
- (9) Connect connector P2 to connector J2.
- (10) Install PDP on dashboard with three screws.
- (11) Install three washers and screws in PDP.
- (12) Install PDP cover (para 16-2).

WINDSHIELD WIPER ECU

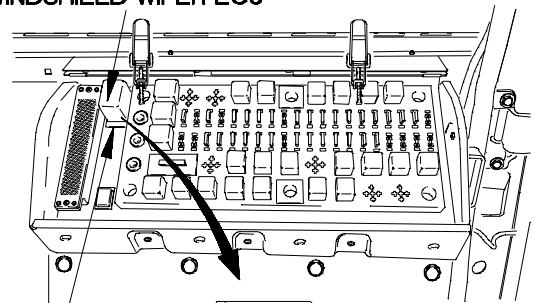

CONNECTOR PX21

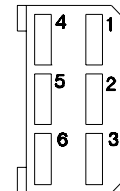

PX21

CONNECTOR J2

CONNECTOR P2

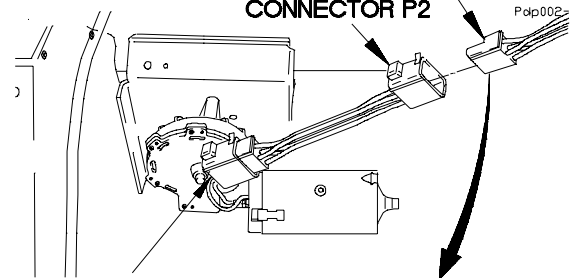

WINDSHIELD WIPER MOTOR

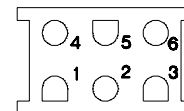

J2

X2E80071

e78. WINDSHIELD WIPER DOES NOT OPERATE ON HIGH SPEED	
INITIAL SETUP	
Equipment Condition Engine shut down (TM 9-2320-365-10).	Tools and Special Tools Tool Kit, Genl Mech (Item 44, Appendix C) STE/ICE-R (Item 39, Appendix C) Multimeter, Digital (Item 22, Appendix C)
Personnel Required (2)	References TM 9-4910-571-12&P

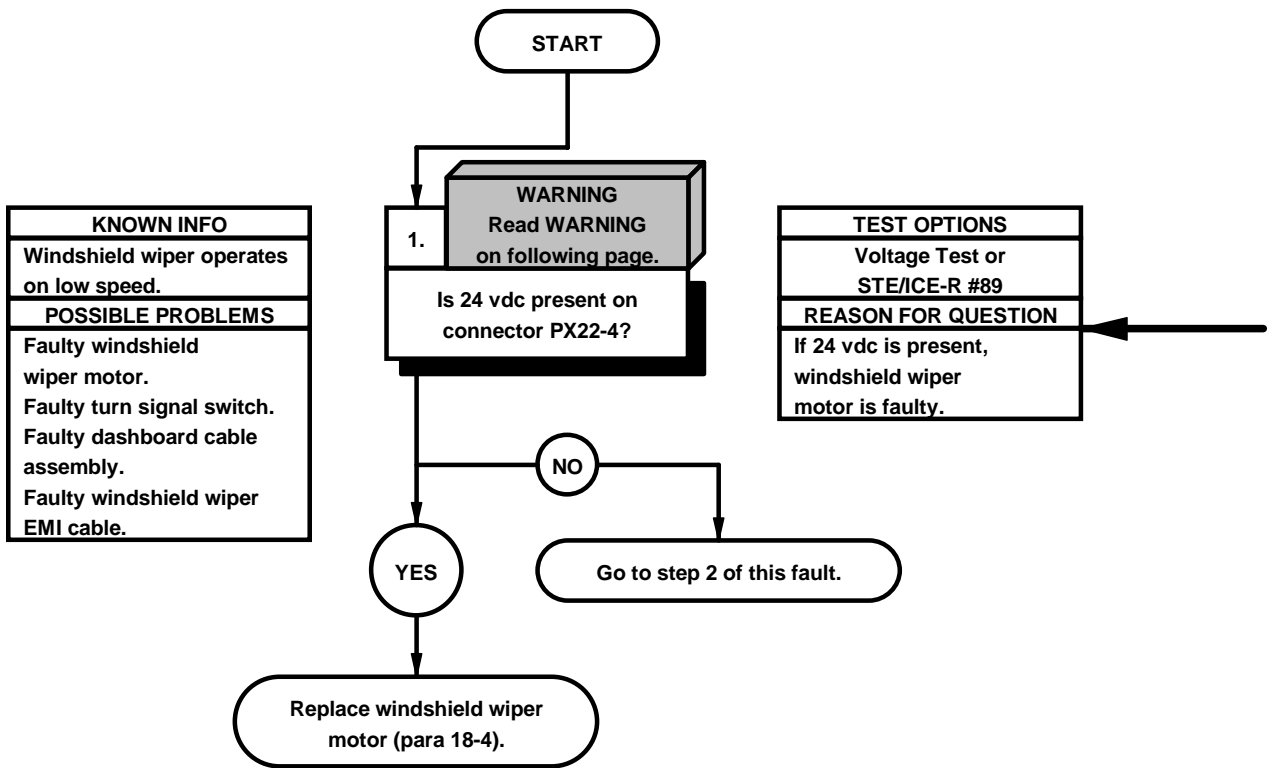

WARNING

Remove rings, bracelets, watches, necklaces, and any other jewelry before working around vehicle. Jewelry can catch on equipment and cause injury or short across electrical circuit and cause severe burns or electrical shock.

VOLTAGE TEST

- (1) Remove PDP cover (para 16-2).
- (2) Remove three screws and washers from PDP.
- (3) Remove three screws from PDP.
- (4) Lift PDP outward to gain access.
- (5) Disconnect connector PX22 from windshield wiper motor.
- (6) Set multimeter to volts dc.
- (7) Connect positive (+) probe of multimeter to connector PX22-4.
- (8) Connect negative (-) probe of multimeter to ground.
- (9) Position master power switch to on (TM 9-2320-365-10).
- (10) Position windshield wiper switch to high (TM 9-2320-365-10) and note reading on multimeter.
- (11) If 24 vdc is not present, go to step 2 of this fault.
- (12) If 24 vdc is present, replace windshield wiper motor (para 18-4).
- (13) Position windshield wiper switch to off (TM 9-2320-365-10).
- (14) Position master power switch to off (TM 9-2320-365-10).
- (15) Connect connector PX22 to windshield wiper motor.

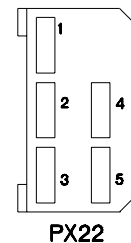
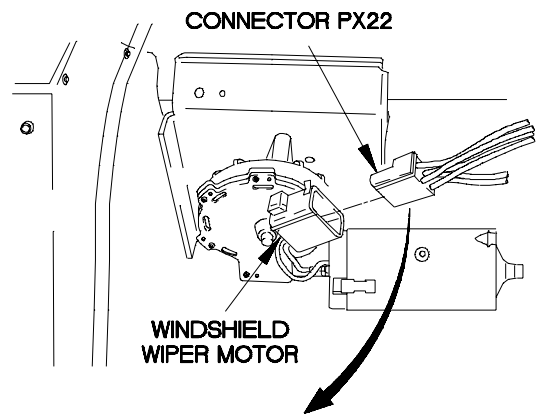
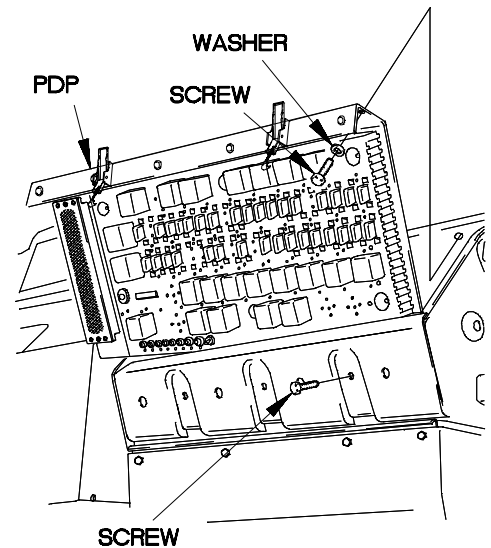

X2E81011

e78. WINDSHIELD WIPER DOES NOT OPERATE ON HIGH SPEED (CONT)

KNOWN INFO
Windshield wiper operates on low speed. Windshield wiper motor OK.
POSSIBLE PROBLEMS
Faulty turn signal switch. Faulty dashboard cable assembly. Faulty windshield wiper EMI cable.

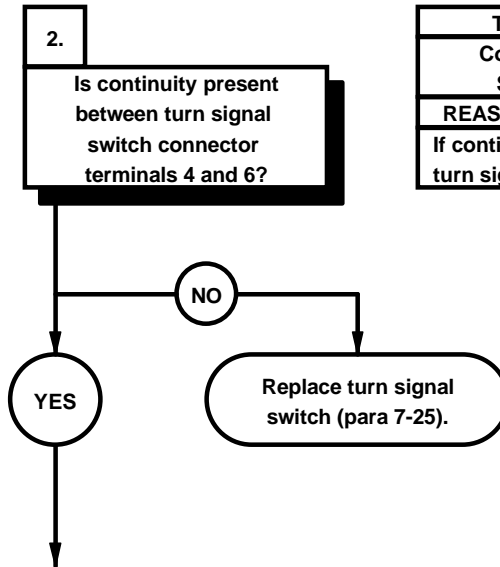

TEST OPTIONS
Continuity Test or STE/ICE-R #91
REASON FOR QUESTION
If continuity is not present, turn signal switch is faulty.



CONTINUITY TEST

- (1) Remove instrument panel assembly for access (para 7-15).
- (2) Disconnect turn signal switch connector from connector P18.
- (3) Set multimeter to ohms.
- (4) Connect positive (+) probe of multimeter to turn signal switch connector terminal 4.
- (5) Connect negative (-) probe of multimeter to turn signal switch connector terminal 6.
- (6) Position windshield wiper switch to high (TM 9-2320-365-10) and note reading on multimeter.
- (7) If continuity is not present, replace turn signal switch (para 7-25).
- (8) Position windshield wiper switch to off (TM 9-2320-365-10).
- (9) Connect turn signal switch connector to connector P18.
- (10) Install instrument panel assembly (para 7-15).

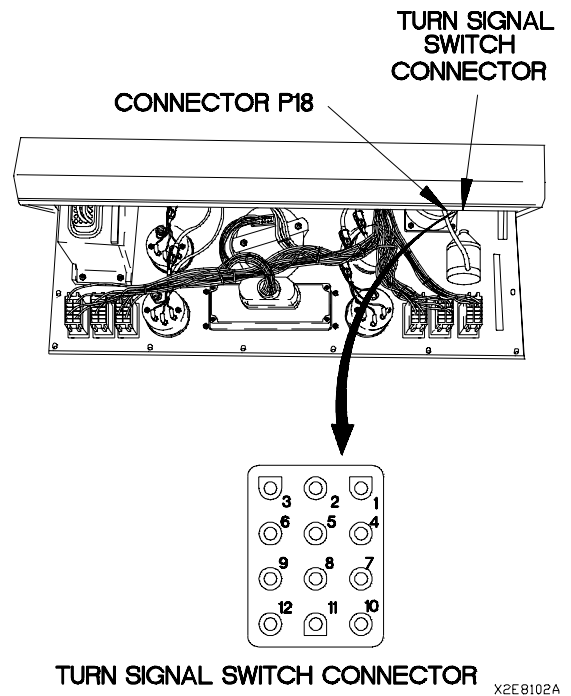

X2E9102A

e78. WINDSHIELD WIPER DOES NOT OPERATE ON HIGH SPEED (CONT)

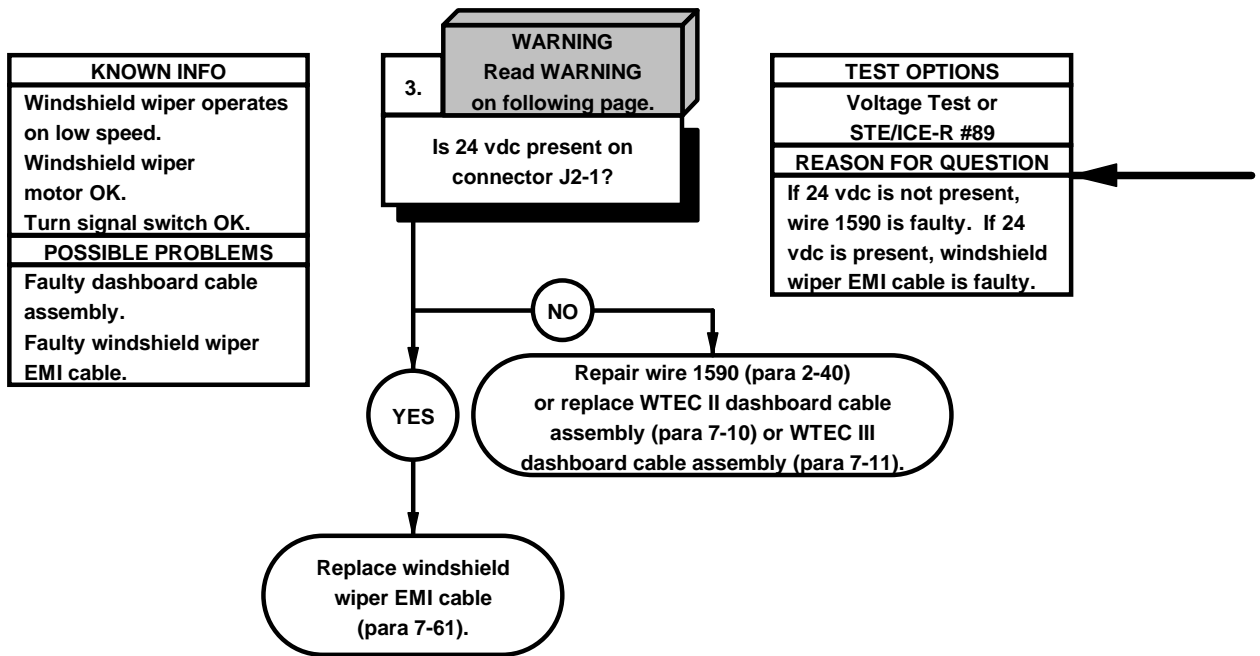

WARNING

Remove rings, bracelets, watches, necklaces, and any other jewelry before working around vehicle. Jewelry can catch on equipment and cause injury or short across electrical circuit and cause severe burns or electrical shock.

VOLTAGE TEST

- (1) Disconnect connector J2 from connector P2.
- (2) Set multimeter to volts dc.
- (3) Connect positive (+) probe of multimeter to connector J2-1.
- (4) Connect negative (-) probe of multimeter to ground.
- (5) Position master power switch to on (TM 9-2320-365-10).
- (6) Position windshield wiper switch to high (TM 9-2320-365-10) and note reading on multimeter.
- (7) If 24 vdc is not present, repair wire 1590 (para 2-40) or replace WTEC II dashboard cable assembly (para 7-10) or WTEC III dashboard cable assembly (para 7-11).
- (8) If 24 vdc is present, replace windshield wiper EMI cable (para 7-61).
- (9) Position windshield wiper switch to off (TM 9-2320-365-10).
- (10) Position master power switch to off (TM 9-2320-365-10).
- (11) Connect connector J2 to connector P2.
- (12) Install PDP on dashboard with three screws.
- (13) Install three washers and screws in PDP.
- (14) Install PDP cover (para 16-2).

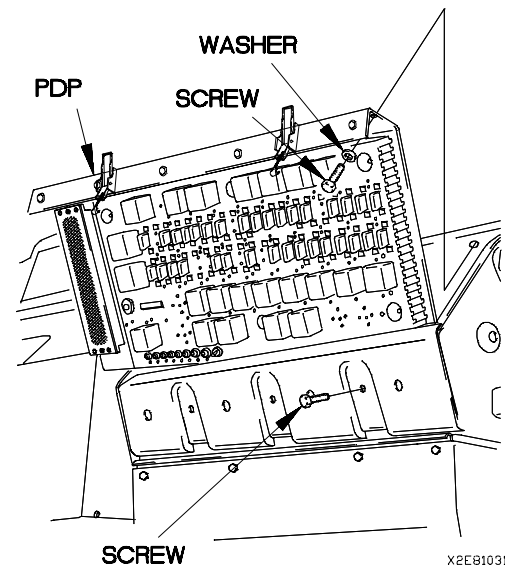
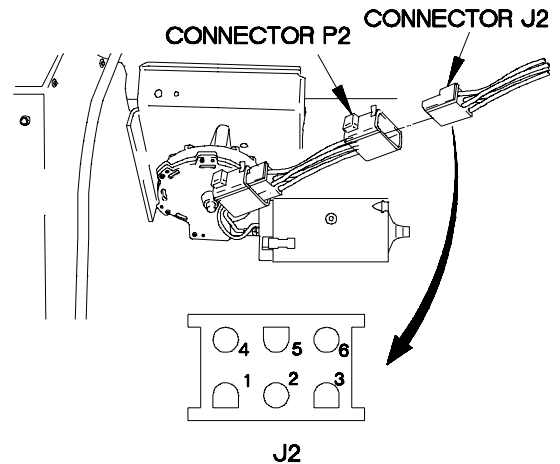

X2E81031

e79. HORN DOES NOT OPERATE	
INITIAL SETUP	
Equipment Condition Engine shut down (TM 9-2320-365-10).	Tools and Special Tools Tool Kit, Genl Mech (Item 44, Appendix C) STE/ICE-R (Item 39, Appendix C) Multimeter, Digital (Item 22, Appendix C) Wrench, Torque, 0-200 lb-in. (Item 58, Appendix C)
Personnel Required (2)	References TM 9-4910-571-12&P

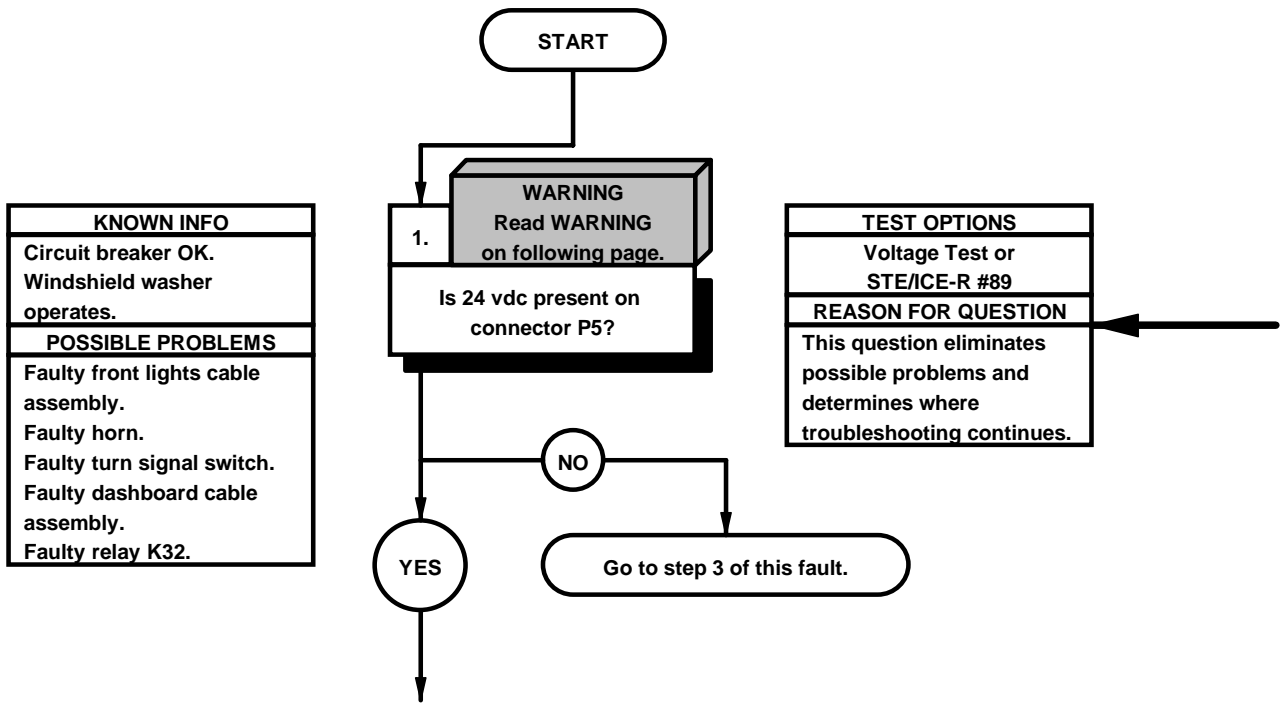

WARNING

Remove rings, bracelets, watches, necklaces, and any other jewelry before working around vehicle. Jewelry can catch on equipment and cause injury or short across electrical circuit and cause severe burns or electrical shock.

VOLTAGE TEST

- (1) Remove two screws and washers from front grille.
- (2) Remove screw and washer from front grille.
- (3) Remove front grille from cab.
- (4) Disconnect connector P5 from horn.
- (5) Set multimeter to volts dc.
- (6) Connect positive (+) probe of multimeter to connector P5.
- (7) Connect negative (-) probe of multimeter to ground.
- (8) Position master power switch to on (TM 9-2320-365-10).
- (9) Press horn button (TM 9-2320-365-10) and note reading of multimeter.
- (10) If 24 vdc is not present, go to step 3 of this fault.
- (11) Position master power switch to off (TM 9-2320-365-10).
- (12) Connect connector P5 to horn.

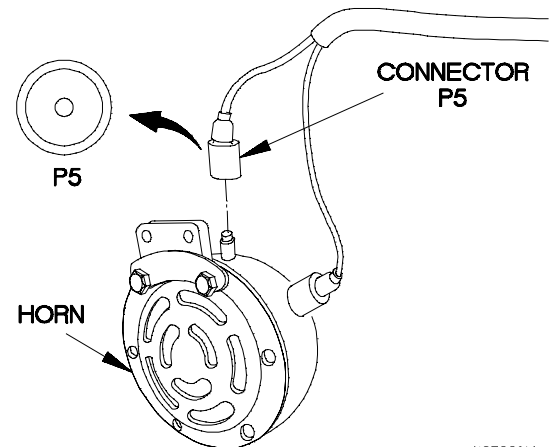
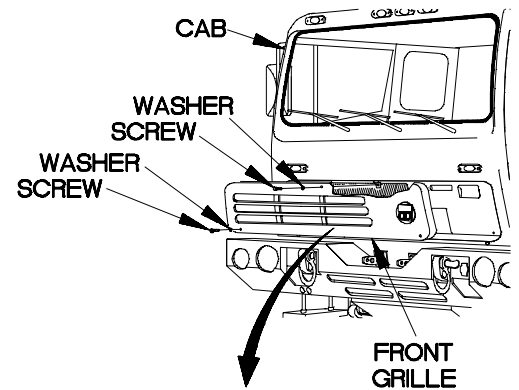

X2E8201A

679. HORN DOES NOT OPERATE (CONT)

KNOWN INFO
Circuit breaker OK. Windshield washer operates. Turn signal switch OK. Dashboard cable assembly OK. Relay K32 OK.
POSSIBLE PROBLEMS
Faulty front lights cable assembly. Faulty horn.

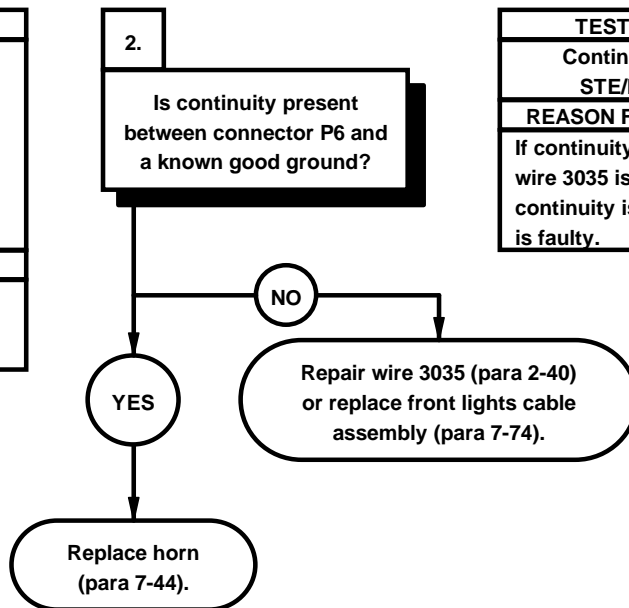

TEST OPTIONS
Continuity Test or STE/ICE-R #91
REASON FOR QUESTION
If continuity is not present, wire 3035 is faulty. If continuity is present, horn is faulty.



CONTINUITY TEST

- (1) Disconnect connector P6 from horn.
- (2) Set multimeter to ohms.
- (3) Connect positive (+) probe of multimeter to connector P6.
- (4) Connect negative (-) probe of multimeter to ground and note reading on multimeter.
- (5) If continuity is not present, repair wire 3035 (para 2-40) or replace front lights cable assembly (para 7-74).
- (6) If continuity is present, replace horn (para 7-44).
- (7) Connect connector P6 to horn.
- (8) Position front grille on cab with washer and screw.
- (9) Position two washers and screws in front grille.
- (10) Tighten screw to 48-60 lb-in. (5-7 N-m).
- (11) Tighten two screws to 24 lb-in. (3 N-m).

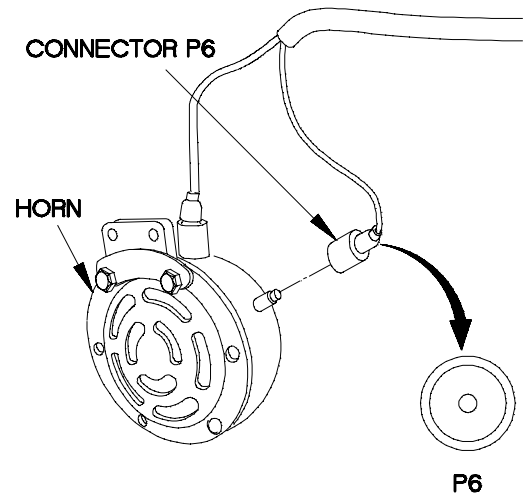
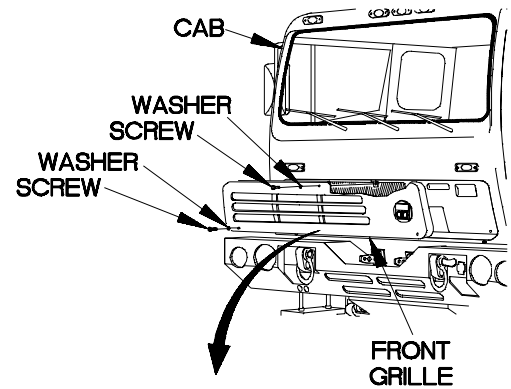

X2E8202A

679. HORN DOES NOT OPERATE (CONT)

KNOWN INFO
Circuit breaker OK. Windshield washer operates. Horn OK.
POSSIBLE PROBLEMS
Faulty turn signal switch. Faulty dashboard cable assembly. Faulty front lights cable assembly. Faulty relay K32.

3.
Is continuity present between turn signal switch connector terminal 4 and terminal 12?

TEST OPTIONS
Continuity Test or STE/ICE-R #91
REASON FOR QUESTION
If continuity is not present, turn signal switch is faulty.

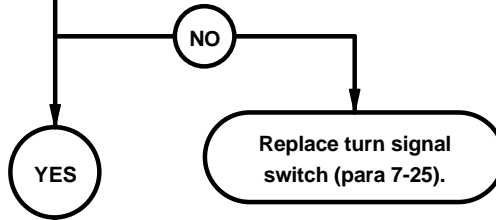

KNOWN INFO
Circuit breaker OK. Windshield washer operates. Horn OK.
POSSIBLE PROBLEMS
Faulty dashboard cable assembly. Faulty front lights cable assembly. Faulty relay K32.

4. **WARNING**
Read WARNING on following page.
Is 24 vdc present on relay K32 terminal 86?

TEST OPTIONS
Voltage Test or STE/ICE-R #89
REASON FOR QUESTION
If 24 vdc is not present, wire 25 is faulty.

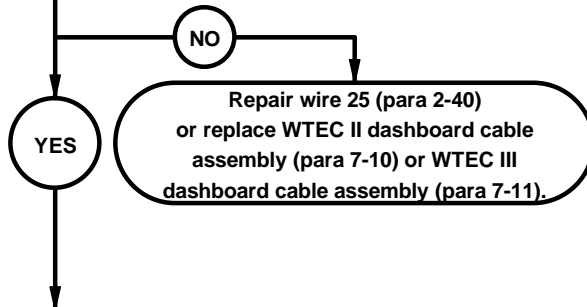

CONTINUITY TEST

- (1) Remove instrument panel assembly for access (para 7-15).
- (2) Disconnect connector P18 from turn signal switch connector.
- (3) Set multimeter to ohms.
- (4) Connect positive (+) probe of multimeter to turn signal switch connector terminal 4.
- (5) Connect negative (-) probe of multimeter to turn signal switch connector terminal 12.
- (6) Press horn button (TM 9-2320-365-10) and note reading on multimeter.
- (7) If continuity is not present, replace turn signal switch (para 7-25).
- (8) Connect connector P18 to turn signal switch connector.
- (9) Install instrument panel assembly (para 7-15).

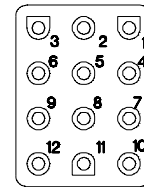
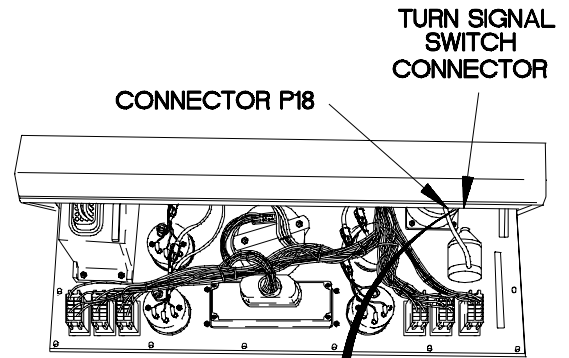

TURN SIGNAL SWITCH CONNECTOR

X2E8203A

WARNING

Remove rings, bracelets, watches, necklaces, and any other jewelry before working around vehicle. Jewelry can catch on equipment and cause injury or short across electrical circuit and cause severe burns or electrical shock.

VOLTAGE TEST

- (1) Remove PDP cover (para 16-2).
- (2) Remove relay K32 from PDP.
- (3) Set multimeter to volts dc.
- (4) Connect positive (+) probe of multimeter to PDP, terminal 86, where relay K32 was removed.
- (5) Connect negative (-) probe of multimeter to ground.
- (6) Position master power switch to on (TM 9-2320-365-10).
- (7) Press horn button (TM 9-2320-365-10) and note reading on multimeter.
- (8) If 24 vdc is not present, repair wire 25 (para 2-40) or WTEC II dashboard cable assembly (para 7-10) or WTEC III dashboard cable assembly (para 7-11).
- (9) Position master power switch to off (TM 9-2320-365-10).

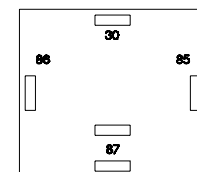
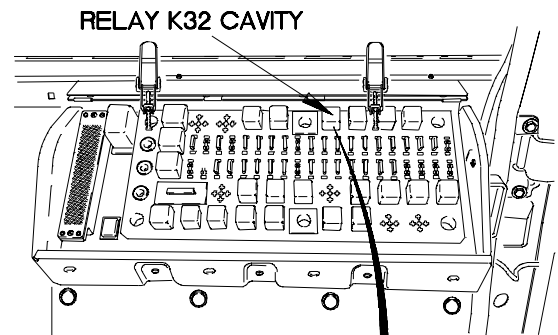

RELAY K32 CAVITY

X2E8204A

679. HORN DOES NOT OPERATE (CONT)

KNOWN INFO
Circuit breaker OK. Windshield washer operates. Horn OK. Turn signal switch OK.
POSSIBLE PROBLEMS
Faulty dashboard cable assembly. Faulty relay K32. Faulty front lights cable assembly.

KNOWN INFO
Circuit breaker OK. Windshield washer operates. Horn OK. Turn signal switch OK.
POSSIBLE PROBLEMS
Faulty dashboard cable assembly. Faulty relay K32. Faulty front lights cable assembly.

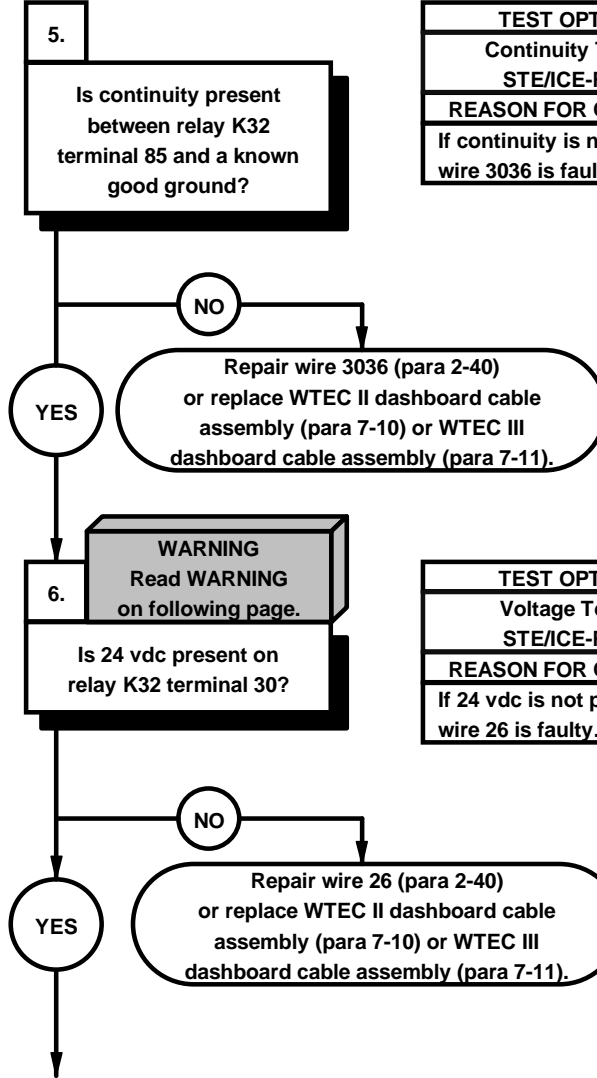

TEST OPTIONS
Continuity Test or STE/CE-R #91
REASON FOR QUESTION
If continuity is not present, wire 3036 is faulty.

TEST OPTIONS
Voltage Test or STE/CE-R #89
REASON FOR QUESTION
If 24 vdc is not present, wire 26 is faulty.

CONTINUITY TEST

- (1) Set multimeter to ohms.
- (2) Connect positive (+) probe of multimeter to PDP, terminal 85, where relay K32 was removed.
- (3) Connect negative (-) probe of multimeter to ground and note reading on multimeter.
- (4) If continuity is not present, repair wire 3036 (para 2-40) or replace WTEC II dashboard cable assembly (para 7-10) or WTEC III dashboard cable assembly (para 7-11).

WARNING

Remove rings, bracelets, watches, necklaces, and any other jewelry before working around vehicle. Jewelry can catch on equipment and cause injury or short across electrical circuit and cause severe burns or electrical shock.

VOLTAGE TEST

- (1) Set multimeter to volts dc.
- (2) Connect positive (+) probe of multimeter to PDP, terminal 30, where relay K32 was removed.
- (3) Connect negative (-) probe of multimeter to ground.
- (4) Position master power switch to on (TM 9-2320-365-10) and note reading on multimeter.
- (5) If 24 vdc is not present, repair wire 26 (para 2-40) or replace WTEC II dashboard cable assembly (para 7-10) or WTEC III dashboard cable assembly (para 7-11).
- (6) Position master power switch to off (TM 9-2320-365-10).

RELAY K32 CAVITY

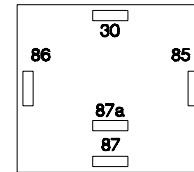
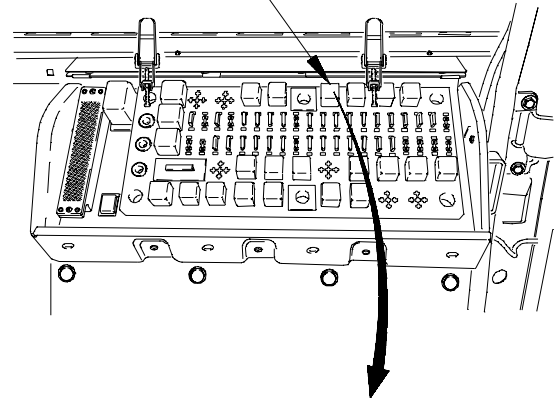

RELAY K32 CAVITY

X2E8205A

679. HORN DOES NOT OPERATE (CONT)

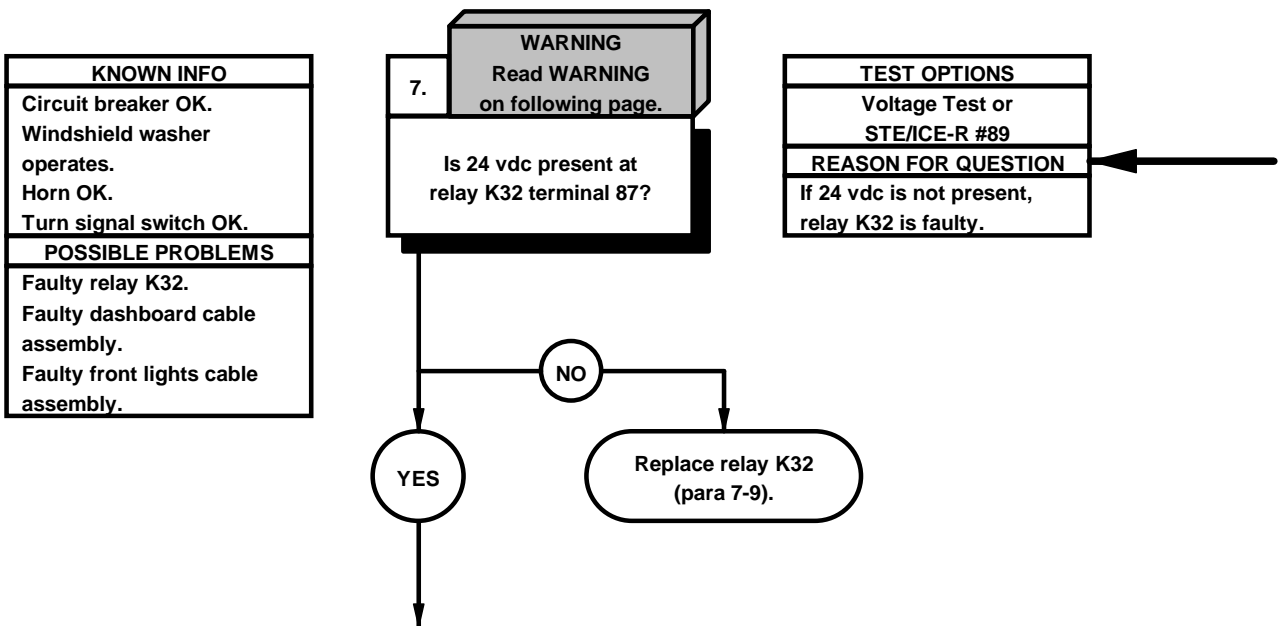

WARNING

Remove rings, bracelets, watches, necklaces, and any other jewelry before working around vehicle. Jewelry can catch on equipment and cause injury or short across electrical circuit and cause severe burns or electrical shock.

VOLTAGE TEST

- (1) Remove three screws and washers from PDP.
- (2) Remove three screws from PDP.
- (3) Lift PDP outward to gain access.
- (4) Install relay K32 in PDP.
- (5) Set multimeter to volts dc.
- (6) Connect positive (+) probe of multimeter to terminal 87 on relay K32.
- (7) Connect negative (-) probe of multimeter to ground.
- (8) Position master power switch to on (TM 9-2320-365-10).
- (9) Press horn button (TM 9-2320-365-10) and note reading on multimeter.
- (10) If 24 vdc is not present, replace relay K32 (para 7-9).
- (11) Position master power switch to off (TM 9-2320-365-10).

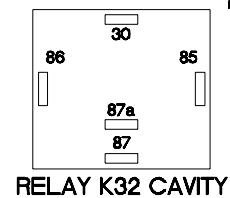
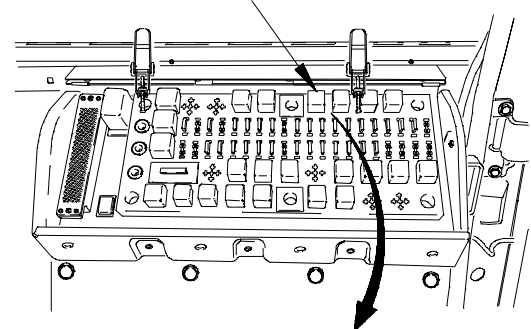
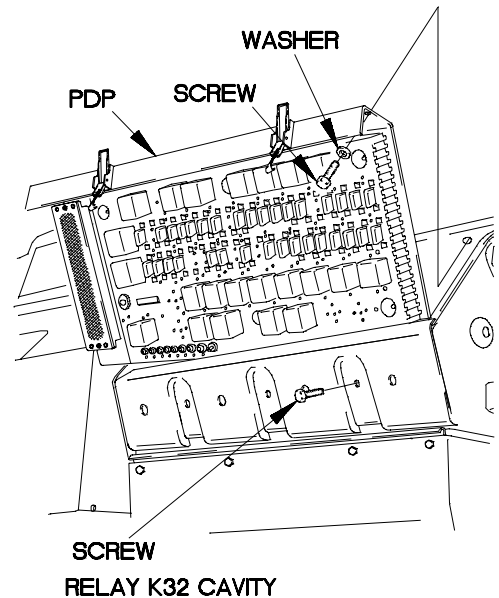

X2E82061

679. HORN DOES NOT OPERATE (CONT)

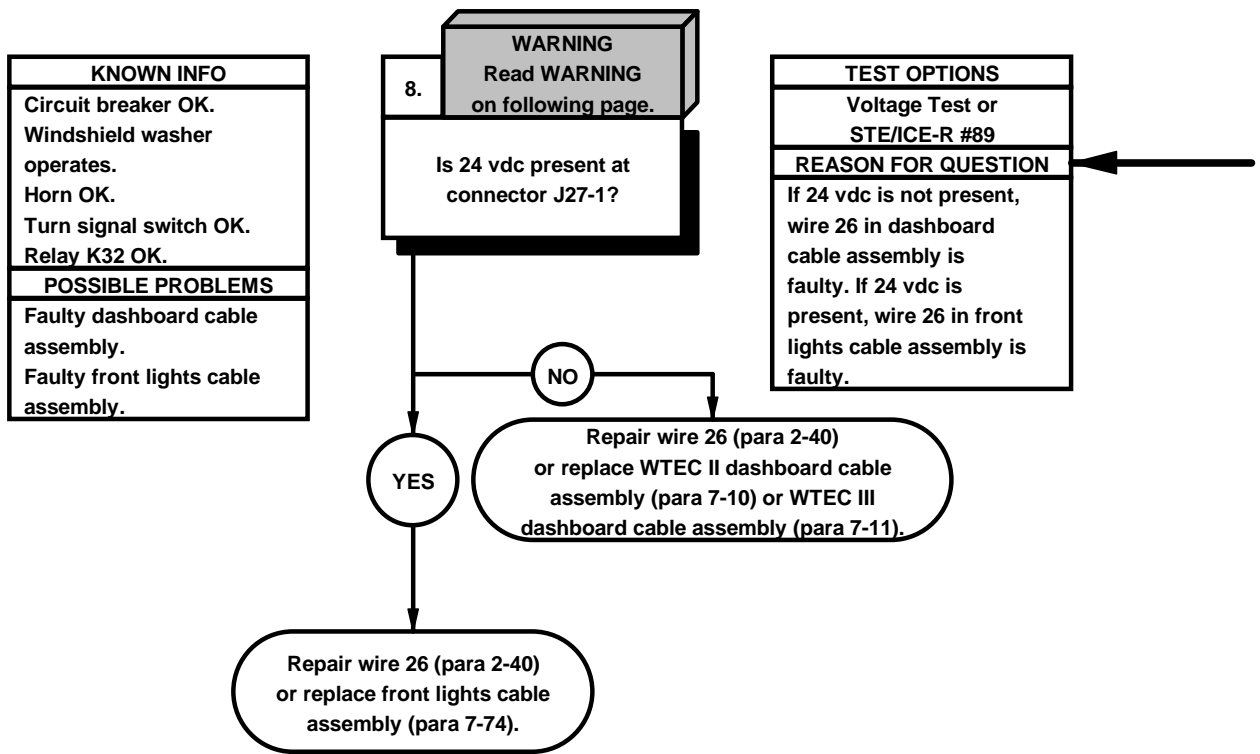

WARNING

Remove rings, bracelets, watches, necklaces, and any other jewelry before working around vehicle. Jewelry can catch on equipment and cause injury or short across electrical circuit and cause severe burns or electrical shock.

VOLTAGE TEST

- (1) Disconnect connector J27 from connector P27.
- (2) Set multimeter to volts dc.
- (3) Connect positive (+) probe of multimeter to connector J27-1.
- (4) Connect negative (-) probe of multimeter to ground.
- (5) Position master power switch to on (TM 9-2320-365-10).
- (6) Press horn button (TM 9-2320-365-10) and note reading on multimeter.
- (7) If 24 vdc is not present, repair wire 26 (para 2-40) or replace WTEC II dashboard cable assembly (para 7-10) or WTEC III dashboard cable assembly (para 7-11).
- (8) If 24 vdc present, repair wire 26 (para 2-40) or replace front lights cable assembly (para 7-74).
- (9) Position master power switch to off (TM 9-2320-365-10).
- (10) Connect connector J27 to connector P27.
- (11) Install PDP on dashboard with three screws.
- (12) Install three washers and screws in PDP.
- (13) Install PDP cover (para 16-2).

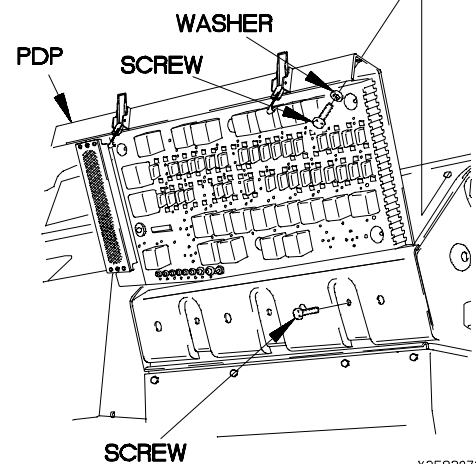
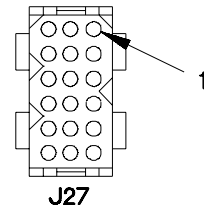
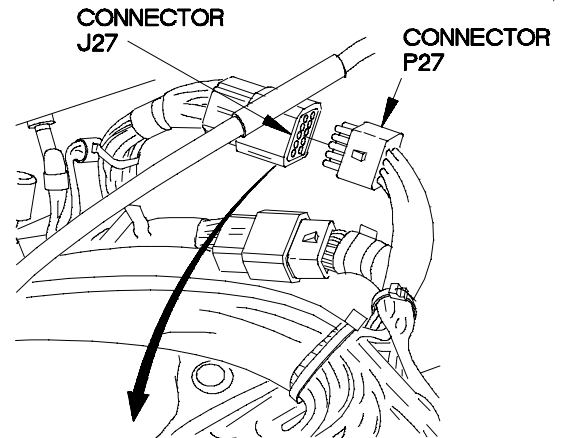

X2E82071

e80. CHEMICAL ALARM DOES NOT OPERATE	
INITIAL SETUP	
Equipment Condition Engine shut down (TM 9-2320-365-10).	Tools and Special Tools Tool Kit, Genl Mech (Item 44, Appendix C) STE/ICE-R (Item 39, Appendix C) Multimeter, Digital (Item 22, Appendix C)
Personnel Required (2)	References TM 9-4910-571-12&P

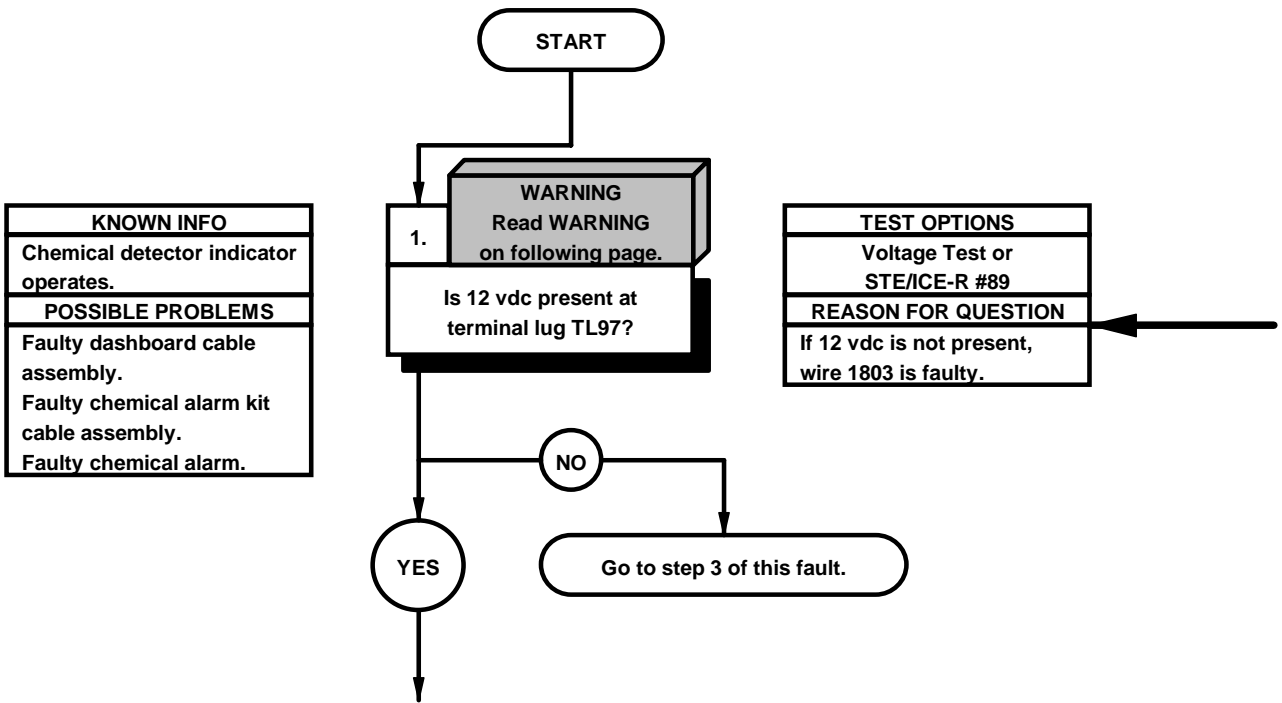

WARNING

Remove rings, bracelets, watches, necklaces, and any other jewelry before working around vehicle. Jewelry can catch on equipment and cause injury or short across electrical circuit and cause severe burns or electrical shock.

VOLTAGE TEST

- (1) Set multimeter to volts dc.
- (2) Connect positive (+) probe of multimeter to terminal lug TL97.
- (3) Connect negative (-) probe of multimeter to ground.
- (4) Position master power switch to on (TM 9-2320-365-10) and note reading on multimeter.
- (5) If 12 vdc is not present, go to step 3 of this fault.
- (6) Position master power switch to off (TM 9-2320-365-10).

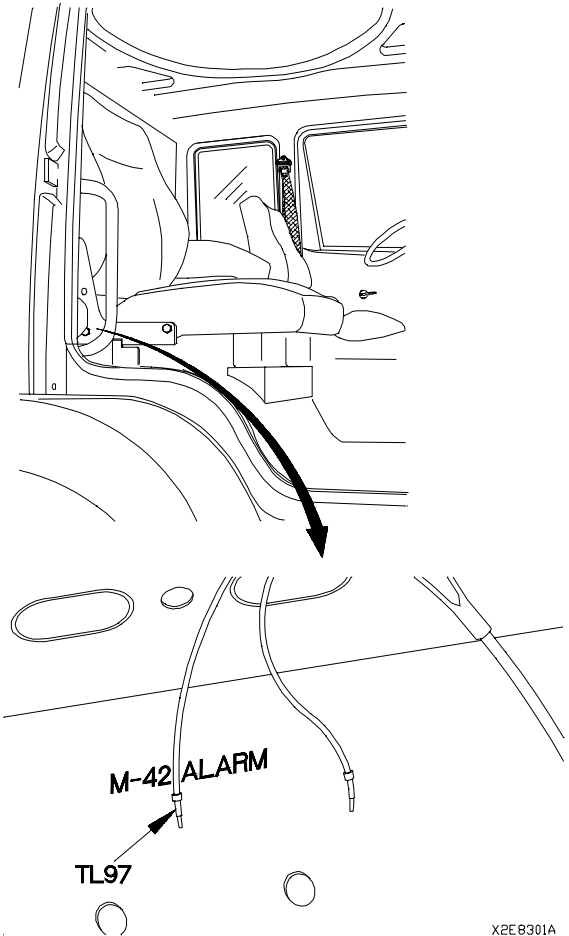

X2E8301A

ø80. CHEMICAL ALARM DOES NOT OPERATE (CONT)

KNOWN INFO
Chemical detector indicator operates.
POSSIBLE PROBLEMS
Faulty dashboard cable assembly.
Faulty chemical alarm kit cable assembly.
Faulty chemical alarm.

2.
Is continuity present between terminal lug TL98 and a known good ground?

TEST OPTIONS
Continuity Test STE/ICE-R #91
REASON FOR QUESTION
If continuity is not present, wire 1804 is faulty. If continuity is present, chemical alarm is faulty.

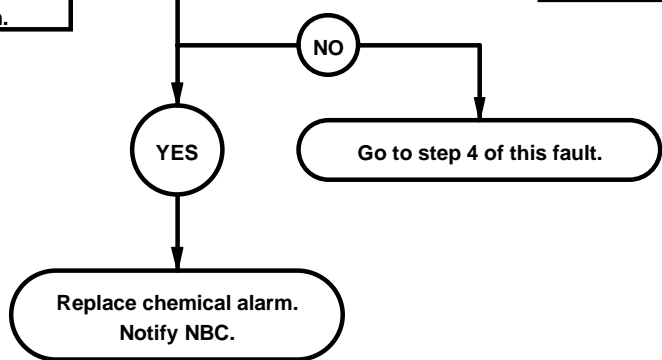

CONTINUITY TEST

- (1) Set multimeter to ohms.
- (2) Connect positive (+) probe of multimeter to terminal lug TL98.
- (3) Connect negative (-) probe of multimeter to ground and note reading on multimeter.
- (4) If continuity is not present, go to step 4 of this fault.
- (5) If continuity is present, replace chemical alarm (notify NBC).

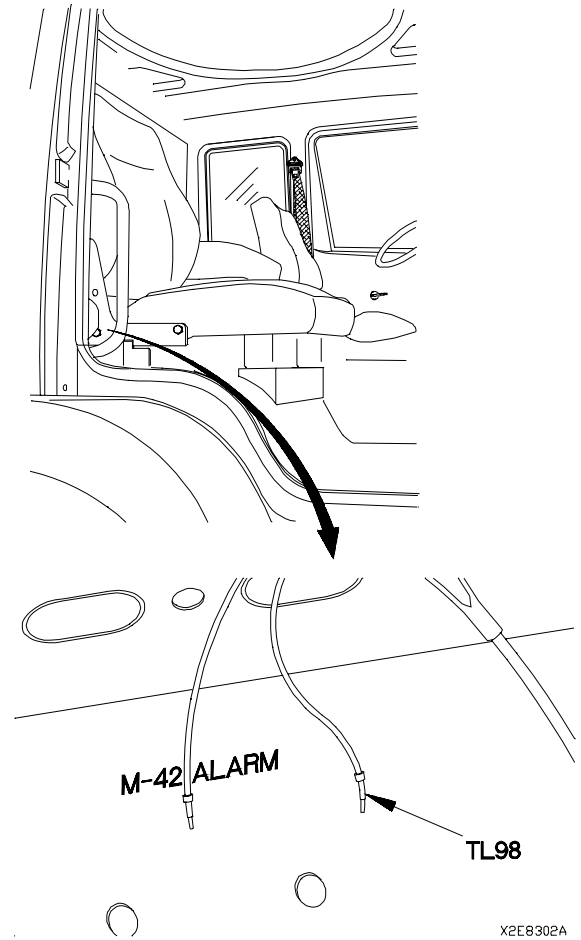

X2E8302A

ø80. CHEMICAL ALARM DOES NOT OPERATE (CONT)

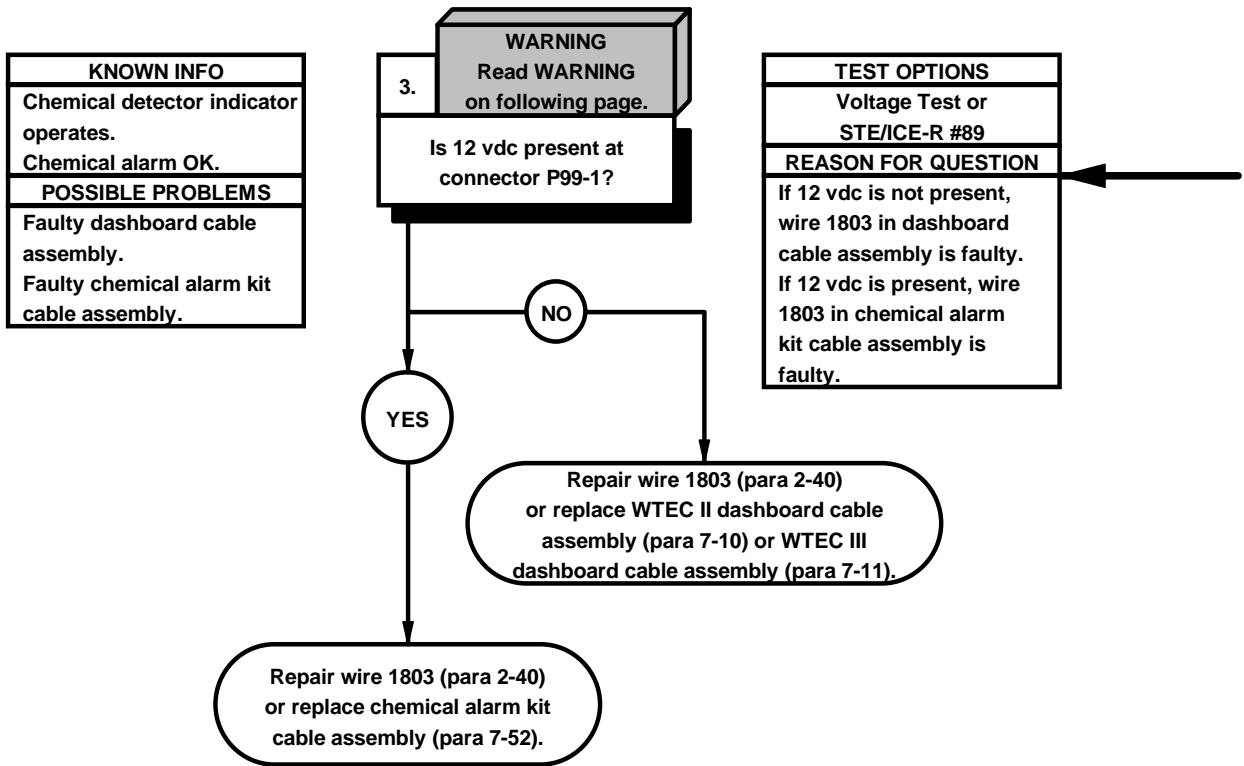

WARNING

Remove rings, bracelets, watches, necklaces, and any other jewelry before working around vehicle. Jewelry can catch on equipment and cause injury or short across electrical circuit and cause severe burns or electrical shock.

VOLTAGE TEST

- (1) Remove kick panel (para 16-3).
- (2) Disconnect connector P99 from connector J99.
- (3) Set multimeter to volts dc.
- (4) Connect positive (+) probe of multimeter to connector P99-1.
- (5) Connect negative (-) probe of multimeter to ground.
- (6) Position master power switch to on (TM 9-2320-365-10) and note reading on multimeter.
- (7) If 24 vdc is not present, repair wire 1803 (para 2-40) or replace WTEC II dashboard cable assembly (para 7-10) or WTEC III dashboard cable assembly (para 7-11).
- (8) If 24 vdc is present, repair wire 1803 (para 2-40) or replace chemical alarm kit cable assembly (para 7-52).
- (9) Position master power switch to off (TM 9-2320-365-10).
- (10) Connect connector P99 to connector J99.
- (11) Install kick panel (para 16-3).

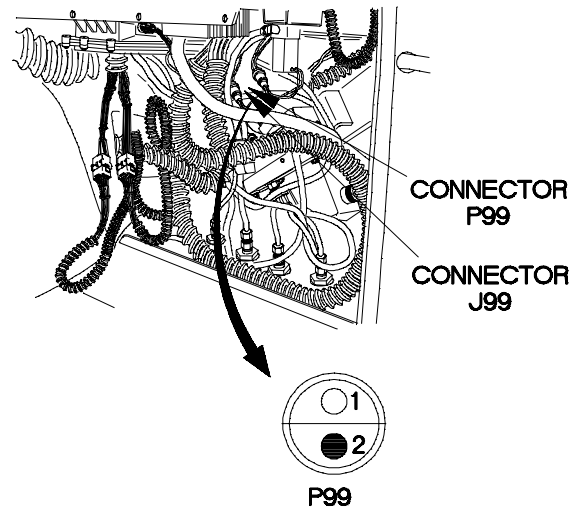

32E83031

ø80. CHEMICAL ALARM DOES NOT OPERATE (CONT)

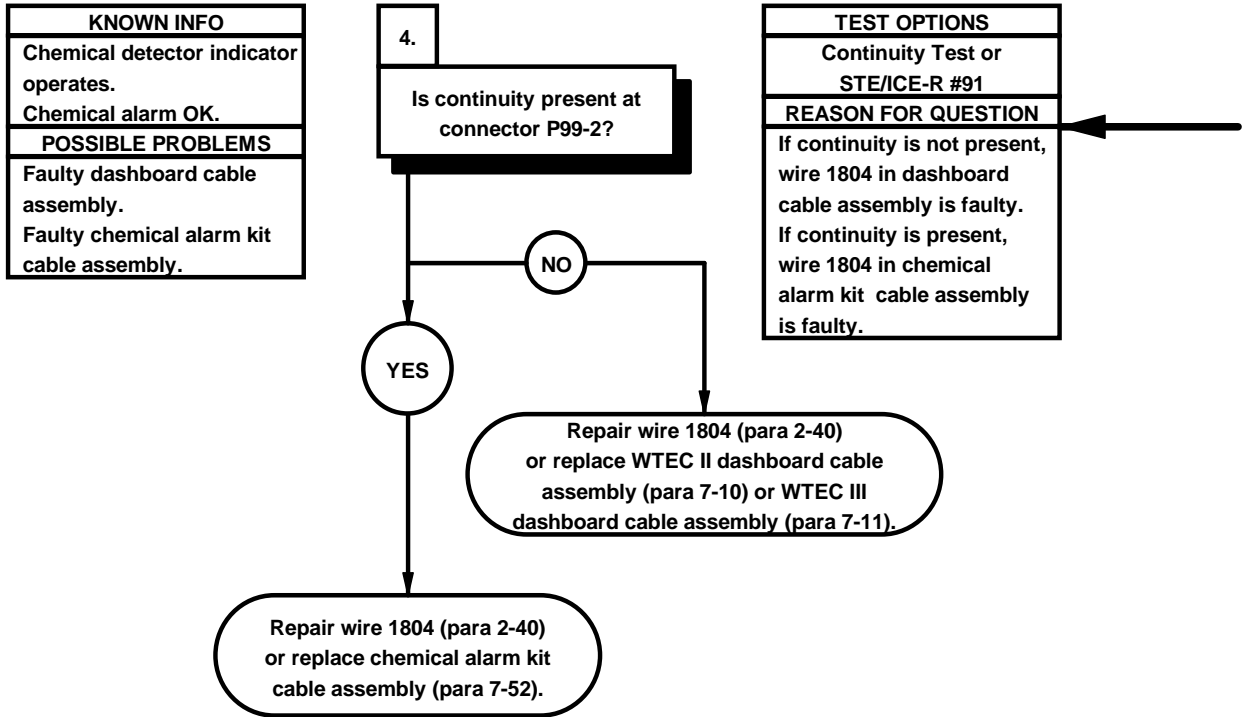

CONTINUITY TEST

- (1) Remove kick panel (para 16-3).
- (2) Disconnect connector P99 from connector J99.
- (3) Set multimeter to ohms.
- (4) Connect positive (+) probe of multimeter to connector P99-2.
- (5) Connect negative (-) probe of multimeter to ground and note reading on multimeter.
- (6) If continuity is not present, repair wire 1804 (para 2-40) or replace WTEC II dashboard cable assembly (para 7-10) or WTEC III dashboard cable assembly (para 7-11).
- (7) If continuity is present, repair wire 1804 (para 2-40) or replace chemical alarm kit cable assembly (para 7-52).
- (8) Connect connector P99 to connector J99.
- (9) Install kick panel (para 16-3).

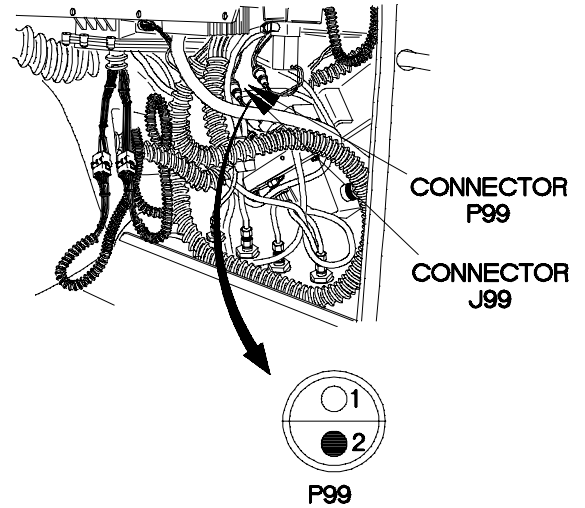

32E83041

e81. CHEMICAL DETECTOR DOES NOT OPERATE	
INITIAL SETUP	
Equipment Condition Engine shut down (TM 9-2320-365-10).	Tools and Special Tools Tool Kit, Genl Mech (Item 44, Appendix C) STE/ICE-R (Item 39, Appendix C) Multimeter, Digital (Item 22, Appendix C) Wrench, Torque, 0-75 lb-in. (Item 86, Appendix B)
Personnel Required (2)	References TM 9-4910-571-12&P

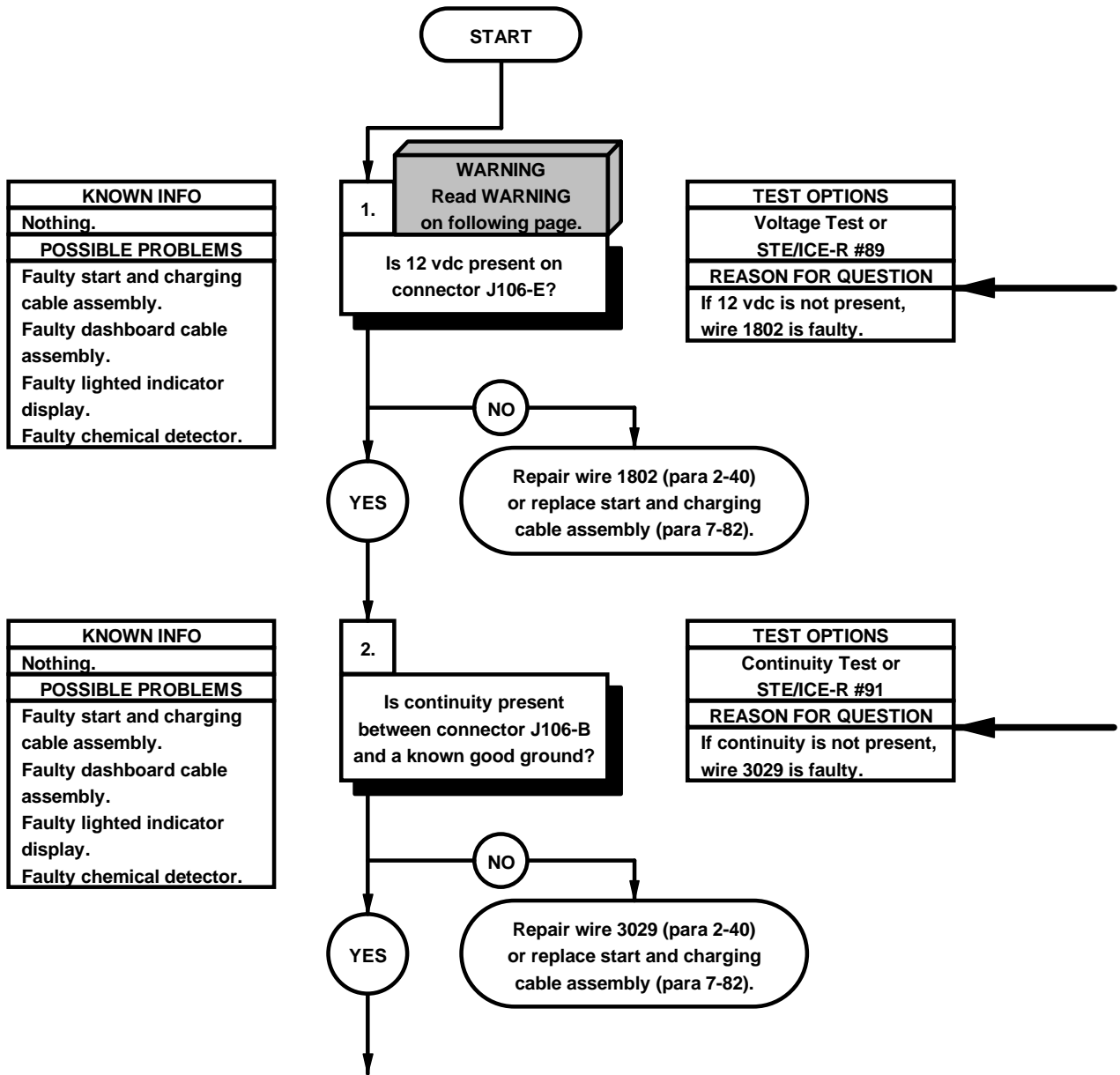

WARNING

Remove rings, bracelets, watches, necklaces, and any other jewelry before working around vehicle. Jewelry can catch on equipment and cause injury or short across electrical circuit and cause severe burns or electrical shock.

VOLTAGE TEST

- (1) Set multimeter to volts dc.
- (2) Connect positive (+) probe of multimeter to connector J106-E.
- (3) Connect negative (-) probe of multimeter to ground.
- (4) Position master power switch to on (TM 9-2320-365-10) and note reading on multimeter.
- (5) If 12 vdc is not present, repair wire 1802 (para 2-40) or replace start and charging cable assembly (para 7-82).
- (6) Position master power switch to off (TM 9-2320-365-10).

CONTINUITY TEST

- (1) Set multimeter to ohms.
- (2) Connect positive (+) probe of multimeter to connector J106-B.
- (3) Connect negative (-) probe of multimeter to ground and note reading on multimeter.
- (4) If continuity is not present, repair wire 3029 (para 2-40) or replace start and charging cable assembly (para 7-82).

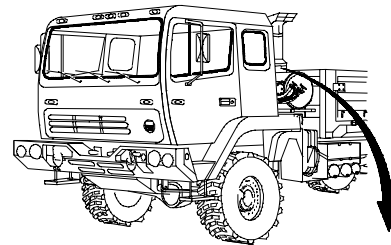

CONNECTOR J106

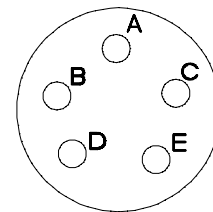
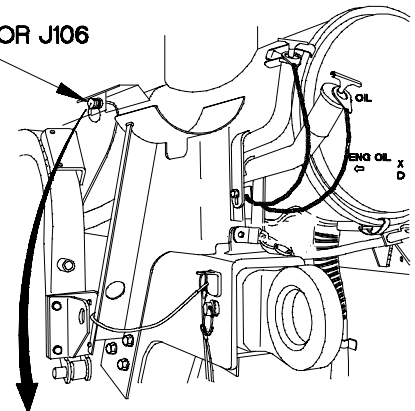

J106

X2E8401A

ø81. CHEMICAL DETECTOR DOES NOT OPERATE (CONT)

KNOWN INFO
Start and charging cable assembly OK.
POSSIBLE PROBLEMS
Faulty dashboard cable assembly.
Faulty lighted indicator display.
Faulty chemical detector.

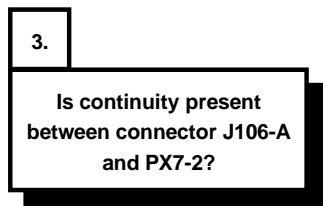

TEST OPTIONS
Continuity Test or STE/ICE-R #91
REASON FOR QUESTION
If continuity is not present, wire 1803 is faulty.

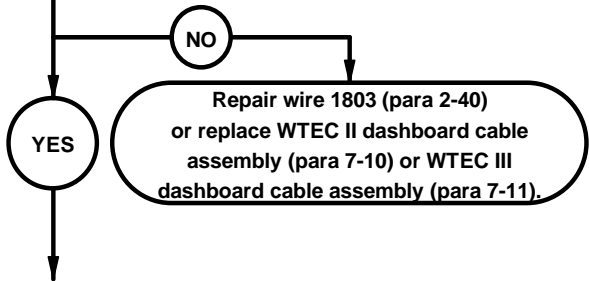

- | CONTINUITY TEST | |
|-----------------|--|
| (1) | Disconnect batteries (para 7-48). |
| (2) | Remove four screws from lighted indicator display. |
| (3) | Remove lighted indicator display from instrument panel assembly. |
| (4) | Disconnect connector PX7 from lighted indicator display. |
| (5) | Set multimeter to ohms. |
| (6) | Connect positive (+) probe of multimeter to connector J106-A. |
| (7) | Connect negative (-) probe of multimeter to connector PX7-2 and note reading on multimeter. |
| (8) | If continuity is not present, repair wire 1803 (para 2-40) or replace WTEC II dashboard cable assembly (para 7-10) or WTEC III dashboard cable assembly (para 7-11). |
| (9) | Connect connector J106 to connector P106. |

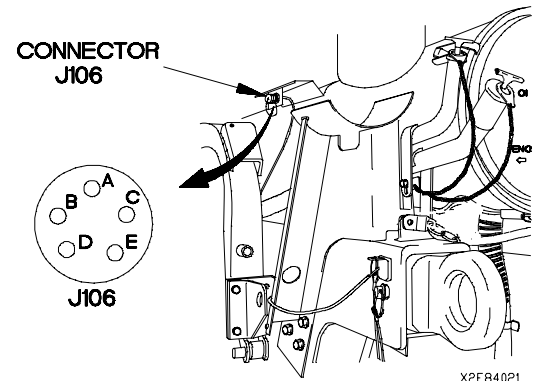
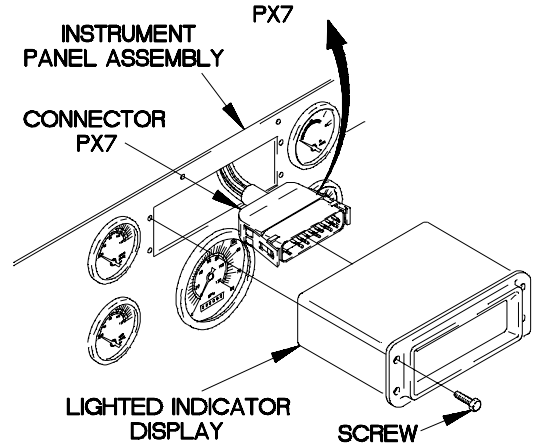
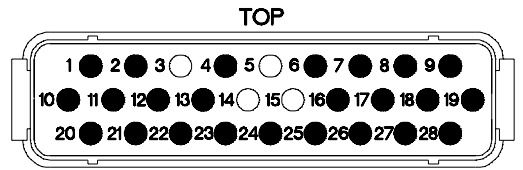
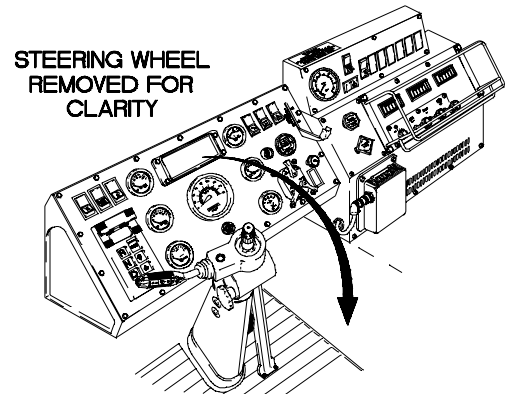

e81. CHEMICAL DETECTOR DOES NOT OPERATE (CONT)

KNOWN INFO
Start and charging cable assembly OK.
POSSIBLE PROBLEMS
Faulty dashboard cable assembly. Faulty lighted indicator display. Faulty chemical detector.

4.
Is continuity present between connector PX7-17 and a known good ground?

TEST OPTIONS
Continuity Test or STE/ICE-R #91
REASON FOR QUESTION
If continuity is not present, wire 3030 is faulty.

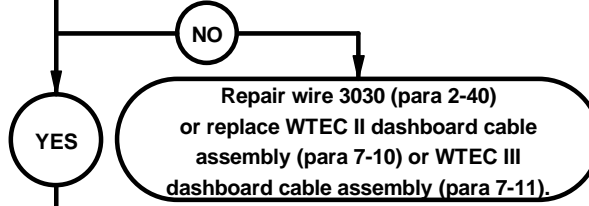

KNOWN INFO
Start and charging cable assembly OK. Dashboard cable assembly OK.
POSSIBLE PROBLEMS
Faulty lighted indicator display. Faulty chemical detector.

5.
Is continuity present between connector PX7-2 and connector PX7-17?

TEST OPTIONS
Continuity Test or STE/ICE-R #91
REASON FOR QUESTION
If continuity is not present, lighted indicator display is faulty. If continuity is present, chemical detector is faulty.

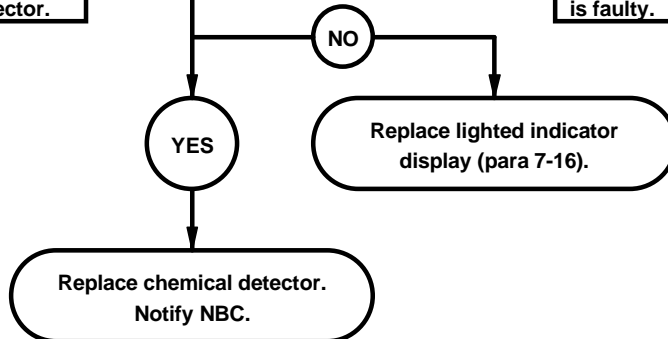

CONTINUITY TEST

- (1) Set multimeter to ohms.
- (2) Connect positive (+) probe of multimeter to connector PX7-17.
- (3) Connect negative (-) probe of multimeter to ground and note reading on multimeter.
- (4) If continuity is not present, repair wire 3030 (para 2-40) or replace WTEC II dashboard cable assembly (para 7-10) or WTEC III dashboard cable assembly (para 7-11).

STEERING WHEEL
REMOVED FOR
CLARITY

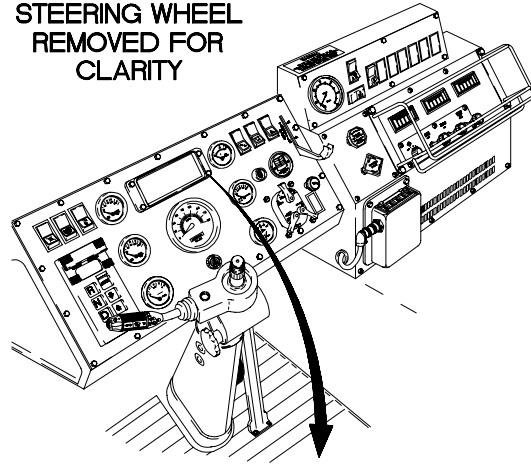

TOP

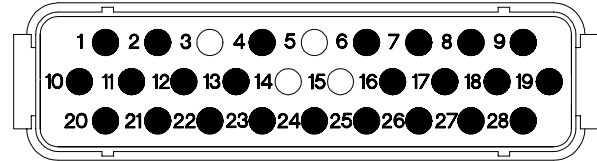

PX7

INSTRUMENT
PANEL ASSEMBLY

CONNECTOR
PX7

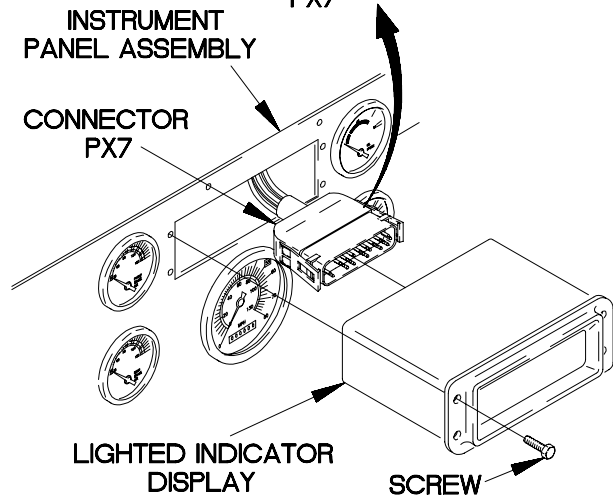

LIGHTED INDICATOR
DISPLAY

SCREW

X2E84031

CONTINUITY TEST

- (1) Set multimeter to ohms.
- (2) Connect positive (+) probe of multimeter to connector PX7-2.
- (3) Connect negative (-) probe of multimeter to connector PX7-17 and note reading on multimeter.
- (4) If continuity is not present, replace lighted indicator display (para 7-16).
- (5) If continuity is present, replace chemical detector (notify NBC).
- (6) Connect lighted indicator display to connector PX7.
- (7) Position lighted indicator display in instrument panel assembly with four screws.
- (8) Tighten four screws to 6-10 lb-in. (1 N·m).
- (9) Connect batteries (para 7-48).

e82. CENTRAL TIRE INFLATION SYSTEM (CTIS) DOES NOT OPERATE

INITIAL SETUP

Equipment Conditions

Engine shut down (TM 9-2320-365-10).

Materials/Parts

Wire, Elect, 50 ft (Item 77, Appendix D)

Tools and Special Tools

Tool Kit, Genl Mech (Item 44, Appendix C)
 STE/ICE-R (Item 39, Appendix C)
 Multimeter, Digital (Item 22, Appendix C)

Personnel Required

(2)

References

TM 9-4910-571-12&P

NOTE

Perform Electrical System Troubleshooting e1. Circuit Breaker Does Not Operate on circuit breaker CB40 prior to beginning this task.

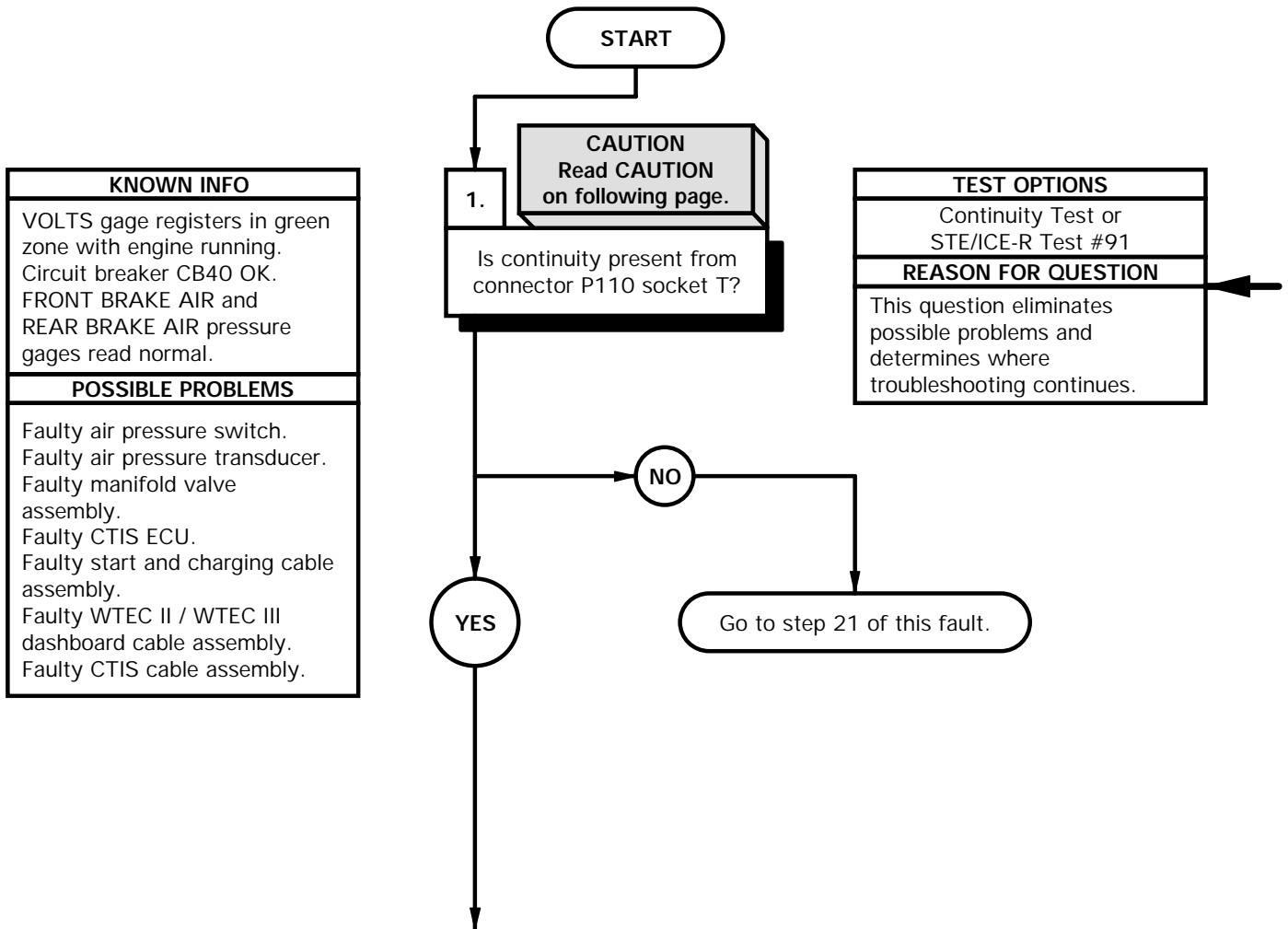

CAUTION

Use care when testing electrical connectors. Do not damage connector pins or sockets with multimeter probes. Failure to comply may result in damage to equipment.

NOTE

Inspect connector pins/sockets for damage, corrosion, and serviceability. Check that connector pins are not pushed back and are capable of making good contact.

CONTINUITY TEST

- (1) Start engine (TM 9-2320-365-10).
- (2) Allow air pressure to build until FRONT BRAKE AIR and REAR BRAKE AIR pressure gages read approximately 120 PSI.
- (3) Shut down engine (TM 9-2320-365-10).
- (4) Disconnect connector P110 from CTIS ECU.
- (5) Set multimeter to ohms.
- (6) Connect positive (+) probe of multimeter to connector P110 socket T.
- (7) Connect negative (-) probe of multimeter to known good ground and note reading on multimeter.
- (8) If continuity is not present, go to step 21 of this fault.

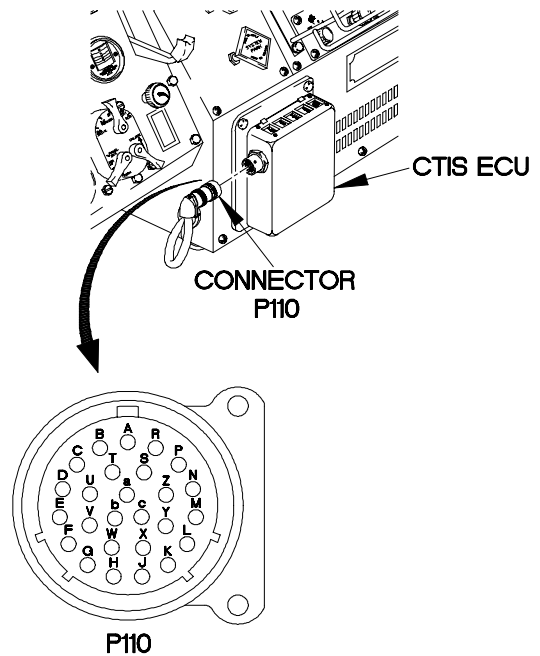

XBE82011

e82. CENTRAL TIRE INFLATION SYSTEM (CTIS) DOES NOT OPERATE (CONT)

KNOWN INFO
VOLTS gage registers in green zone with engine running. Circuit breaker CB40 OK. FRONT BRAKE AIR and REAR BRAKE AIR pressure gages read normal. Air pressure switch OK. Start and charging cable assembly OK.
POSSIBLE PROBLEMS
Faulty air pressure transducer. Faulty manifold valve assembly. Faulty CTIS ECU. Faulty WTEC II / WTEC III dashboard cable assembly. Faulty CTIS cable assembly.

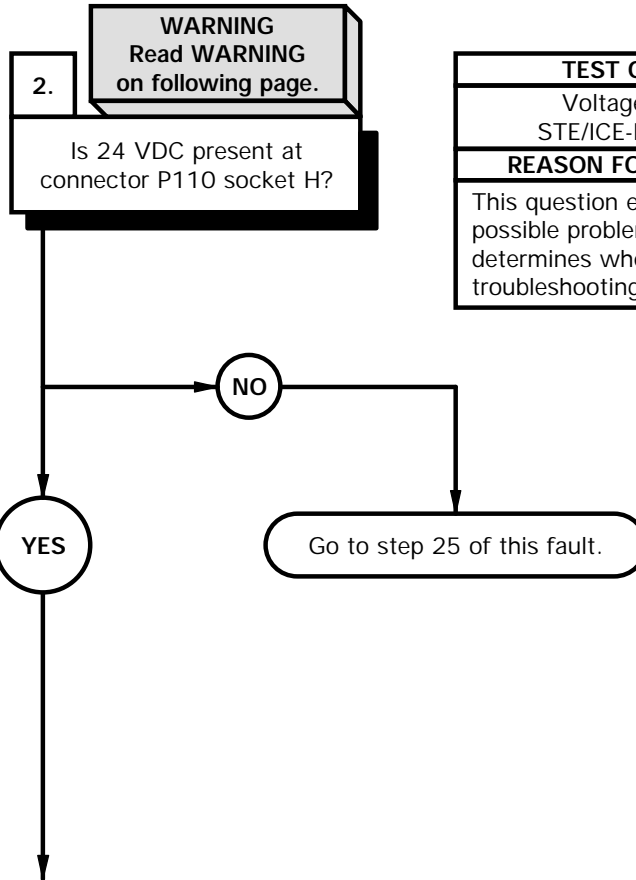

TEST OPTIONS
Voltage Test or STE/ICE-R Test #89
REASON FOR QUESTION
This question eliminates possible problems and determines where troubleshooting continues.

WARNING

Remove rings, bracelets, watches, necklaces, and any other jewelry before working around vehicle. Jewelry can catch on equipment and cause injury or short across electrical circuits and cause severe burns or electrical shock.

VOLTAGE TEST

- (1) Position master power switch to on (TM 9-2320-365-10).
- (2) Set multimeter to volts DC.
- (3) Connect positive (+) probe of multimeter to connector P110 socket H.
- (4) Connect negative (-) probe of multimeter to known good ground and note reading on multimeter.
- (5) If 24 VDC is not present, go to step 25 of this fault.
- (6) Position master power switch to off (TM 9-2320-365-10).

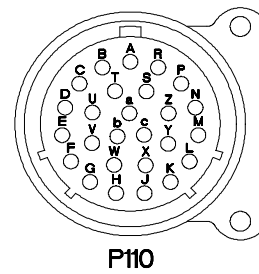

XBE82021

e82. CENTRAL TIRE INFLATION SYSTEM (CTIS) DOES NOT OPERATE (CONT)

KNOWN INFO
VOLTS gage registers in green zone with engine running. Circuit breaker CB40 OK. FRONT BRAKE AIR and REAR BRAKE AIR pressure gages read normal. Air pressure switch OK. Start and charging cable assembly OK.
POSSIBLE PROBLEMS
Faulty air pressure transducer. Faulty manifold valve assembly. Faulty CTIS ECU. Faulty WTEC II / WTEC III dashboard cable assembly. Faulty CTIS cable assembly.

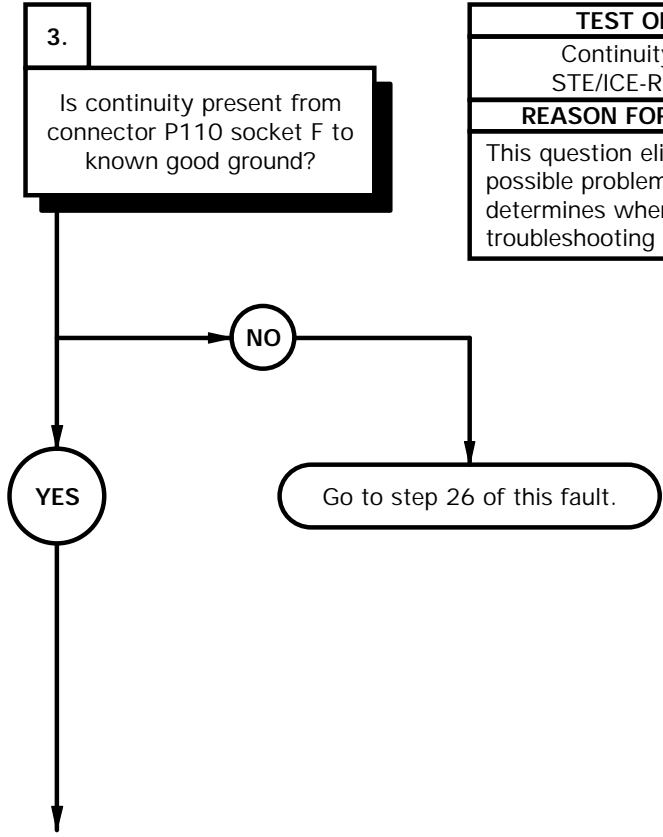

TEST OPTIONS
Continuity Test or STE/ICE-R Test #91
REASON FOR QUESTION
This question eliminates possible problems and determines where troubleshooting continues.

CONTINUITY TEST

- (1) Set multimeter to ohms.
- (2) Connect positive (+) probe of multimeter to connector P110 socket F.
- (3) Connect negative (-) probe of multimeter to known good ground and note reading on multimeter.
- (4) If continuity is not present, go to step 26 of this fault.

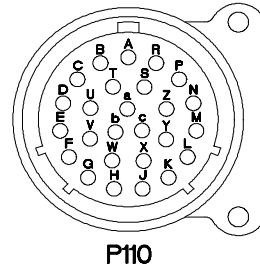

XBE82031

e82. CENTRAL TIRE INFLATION SYSTEM (CTIS) DOES NOT OPERATE (CONT)

KNOWN INFO
VOLTS gage registers in green zone with engine running. Circuit breaker CB40 OK. FRONT BRAKE AIR and REAR BRAKE AIR pressure gages read normal. Air pressure switch OK. Start and charging cable assembly OK. WTEC II / WTEC III dashboard cable assembly OK.
POSSIBLE PROBLEMS
Faulty air pressure transducer. Faulty manifold valve assembly. Faulty CTIS ECU. Faulty CTIS cable assembly.

KNOWN INFO
VOLTS gage registers in green zone with engine running. Circuit breaker CB40 OK. FRONT BRAKE AIR and REAR BRAKE AIR pressure gages read normal. Air pressure switch OK. Start and charging cable assembly OK. WTEC II / WTEC III dashboard cable assembly OK.
POSSIBLE PROBLEMS
Faulty air pressure transducer. Faulty manifold valve assembly. Faulty CTIS ECU. Faulty CTIS cable assembly.

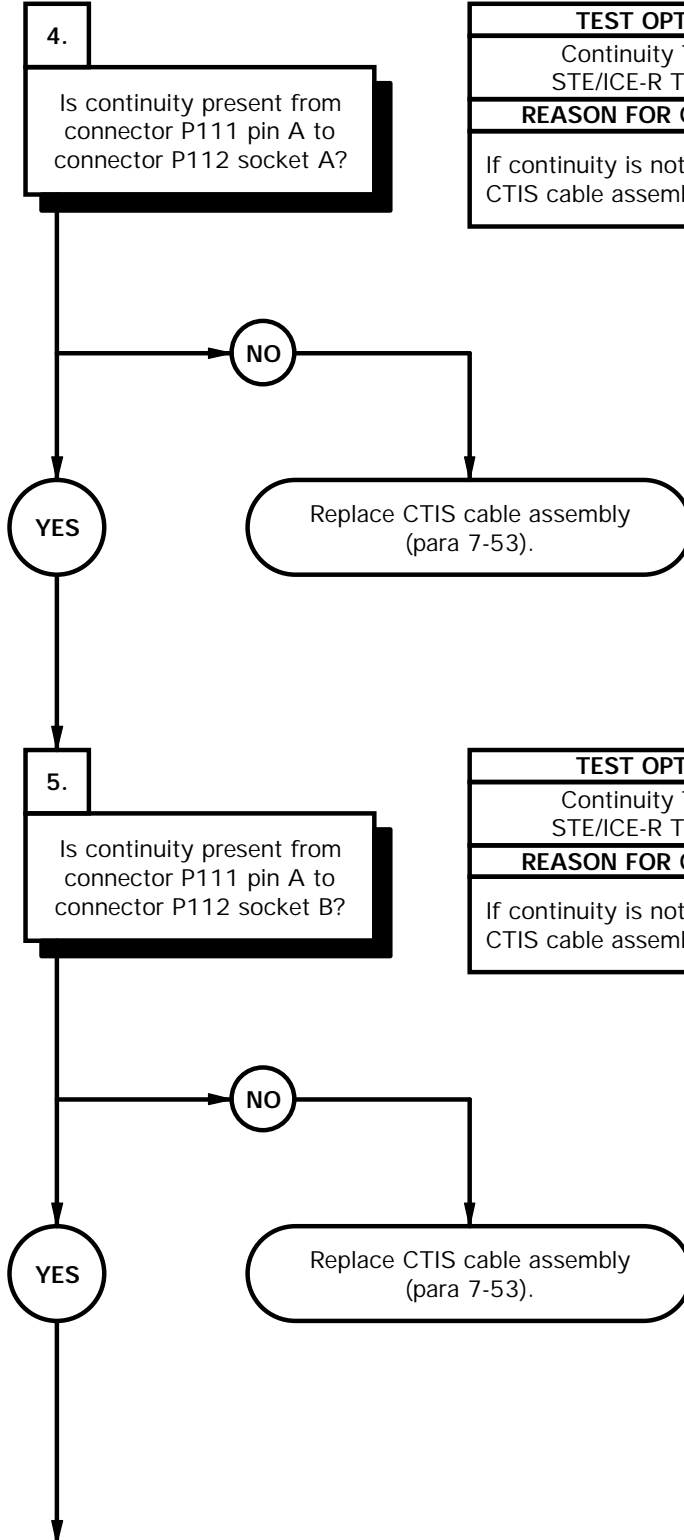

TEST OPTIONS
Continuity Test or STE/ICE-R Test #91
REASON FOR QUESTION
If continuity is not present, CTIS cable assembly is faulty.

TEST OPTIONS
Continuity Test or STE/ICE-R Test #91
REASON FOR QUESTION
If continuity is not present, CTIS cable assembly is faulty.

CONTINUITY TEST

- (1) Remove kick panel (para 16-3).
- (2) Disconnect connector P112 from pneumatic controller connector.
- (3) Disconnect connector J111 from connector P111.
- (4) Set multimeter to ohms.
- (5) Connect positive (+) probe of multimeter to connector P111 pin A.
- (6) Connect negative (-) probe of multimeter to connector P112 socket A and note reading on multimeter.
- (7) If continuity is not present, replace CTIS cable assembly (para 7-53).

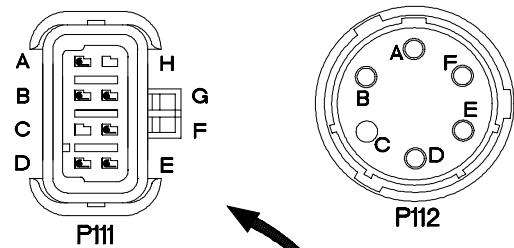
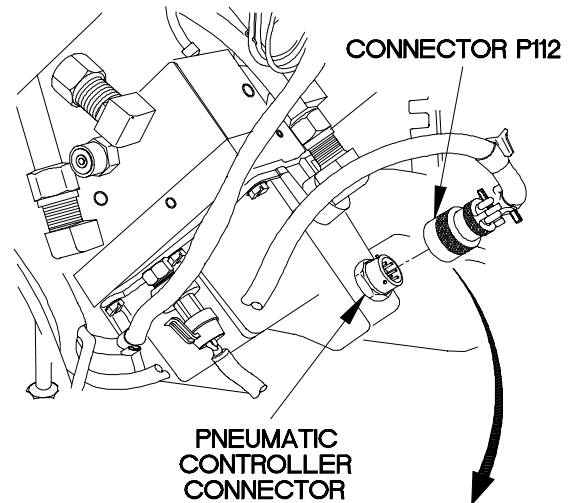

CONTINUITY TEST

- (1) Set multimeter to ohms.
- (2) Connect positive (+) probe of multimeter to connector P111 pin A.
- (3) Connect negative (-) probe of multimeter to connector P112 socket B and note reading on multimeter.
- (4) If continuity is not present, replace CTIS cable assembly (para 7-53).
- (5) Connect connector J111 from connector P111.

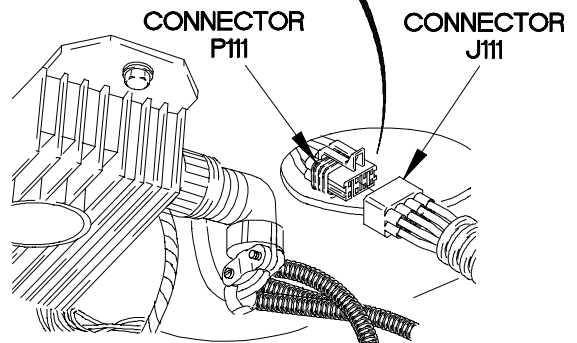

XBE82041

e82. CENTRAL TIRE INFLATION SYSTEM (CTIS) DOES NOT OPERATE (CONT)

KNOWN INFO
VOLTS gage registers in green zone with engine running. Circuit breaker CB40 OK. FRONT BRAKE AIR and REAR BRAKE AIR pressure gages read normal. Air pressure switch OK. Start and charging cable assembly OK. WTEC II / WTEC III dashboard cable assembly OK.
POSSIBLE PROBLEMS
Faulty air pressure transducer. Faulty manifold valve assembly. Faulty CTIS ECU. Faulty CTIS cable assembly.

KNOWN INFO
VOLTS gage registers in green zone with engine running. Circuit breaker CB40 OK. FRONT BRAKE AIR and REAR BRAKE AIR pressure gages read normal. Air pressure switch OK. Start and charging cable assembly OK. WTEC II / WTEC III dashboard cable assembly OK.
POSSIBLE PROBLEMS
Faulty air pressure transducer. Faulty manifold valve assembly. Faulty CTIS ECU. Faulty CTIS cable assembly.

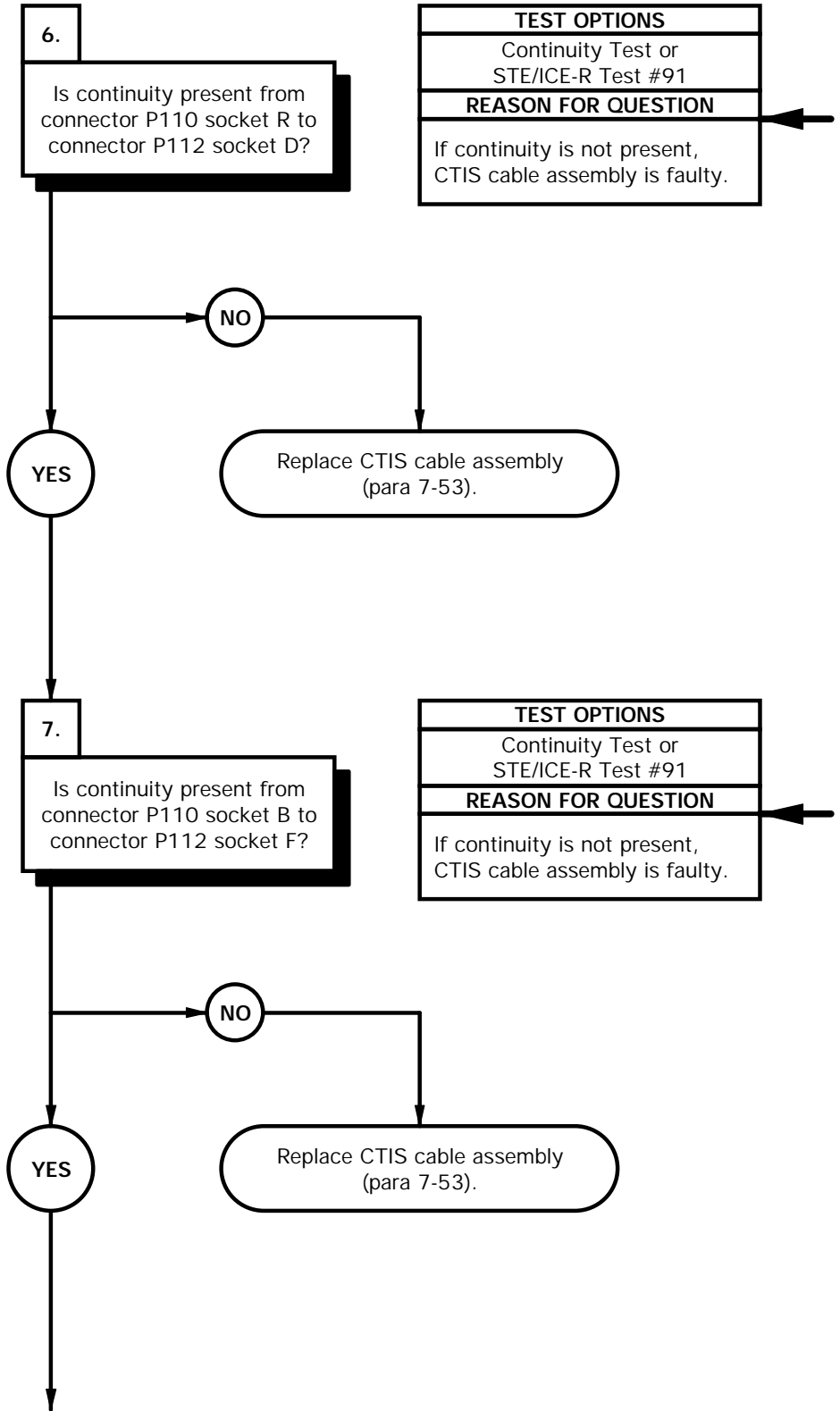

TEST OPTIONS
Continuity Test or STE/ICE-R Test #91
REASON FOR QUESTION
If continuity is not present, CTIS cable assembly is faulty.

TEST OPTIONS
Continuity Test or STE/ICE-R Test #91
REASON FOR QUESTION
If continuity is not present, CTIS cable assembly is faulty.

CONTINUITY TEST

- (1) Set multimeter to ohms.
- (2) Connect positive (+) probe of multimeter to connector P110 socket R.
- (3) Connect negative (-) probe of multimeter to connector P112 socket D and note reading on multimeter.
- (4) If continuity is not present, replace CTIS cable assembly (para 7-53).

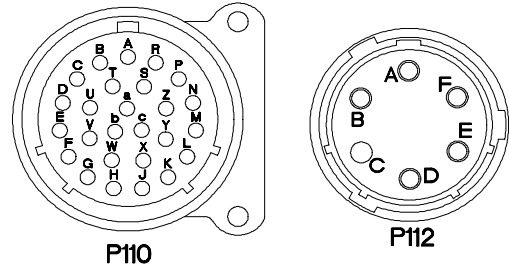

XBE82051

CONTINUITY TEST

- (1) Set multimeter to ohms.
- (2) Connect positive (+) probe of multimeter to connector P110 socket B.
- (3) Connect negative (-) probe of multimeter to connector P112 socket F and note reading on multimeter.
- (4) If continuity is not present, replace CTIS cable assembly (para 7-53).

e82. CENTRAL TIRE INFLATION SYSTEM (CTIS) DOES NOT OPERATE (CONT)

KNOWN INFO
VOLTS gage registers in green zone with engine running. Circuit breaker CB40 OK. FRONT BRAKE AIR and REAR BRAKE AIR pressure gages read normal. Air pressure switch OK. Start and charging cable assembly OK. WTEC II / WTEC III dashboard cable assembly OK.
POSSIBLE PROBLEMS
Faulty air pressure transducer. Faulty manifold valve assembly. Faulty CTIS ECU. Faulty CTIS cable assembly.

KNOWN INFO
VOLTS gage registers in green zone with engine running. Circuit breaker CB40 OK. FRONT BRAKE AIR and REAR BRAKE AIR pressure gages read normal. Air pressure switch OK. Start and charging cable assembly OK. WTEC II / WTEC III dashboard cable assembly OK.
POSSIBLE PROBLEMS
Faulty air pressure transducer. Faulty manifold valve assembly. Faulty CTIS ECU. Faulty CTIS cable assembly.

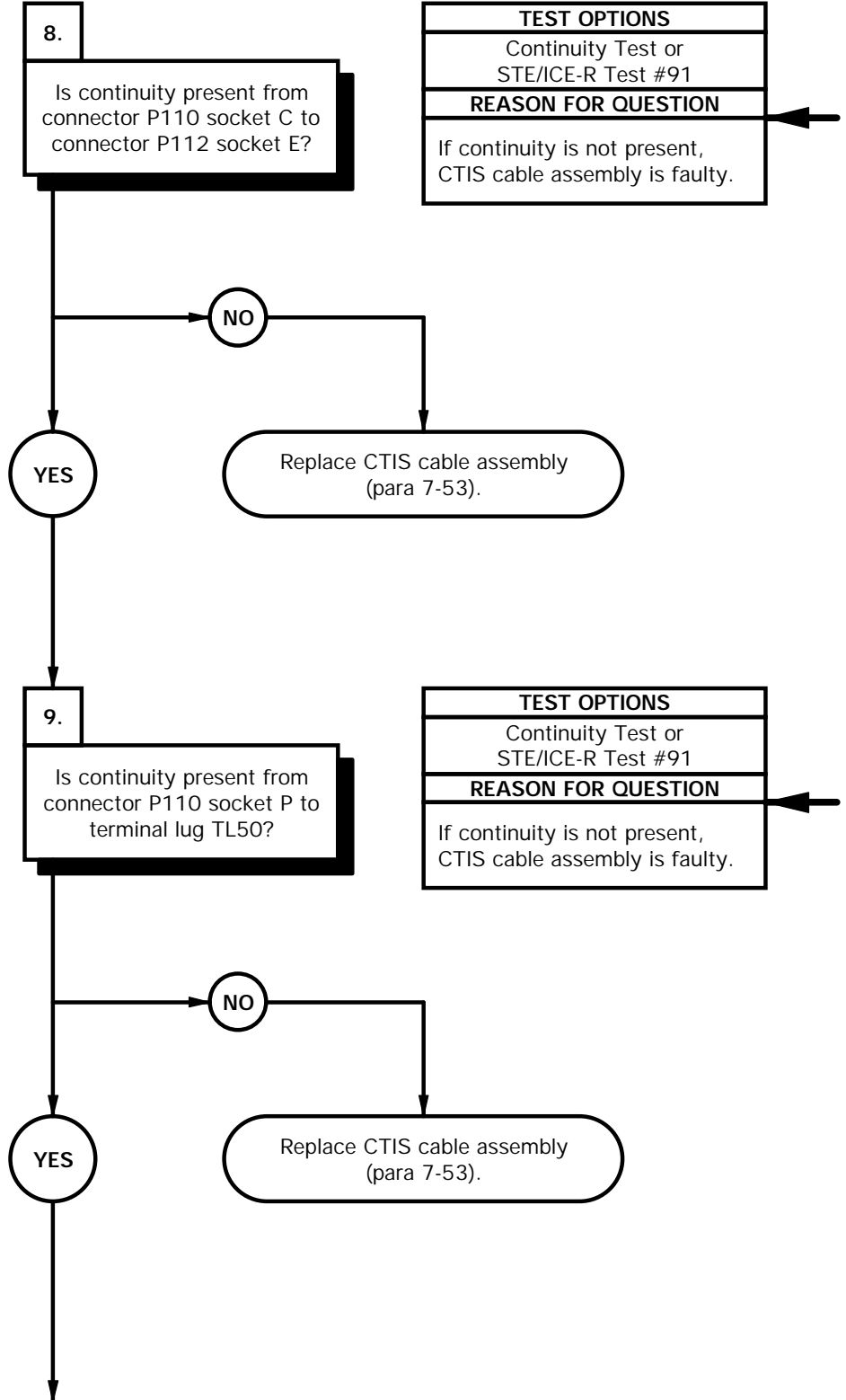

CONTINUITY TEST

- (1) Set multimeter to ohms.
- (2) Connect positive (+) probe of multimeter to connector P110 socket C.
- (3) Connect negative (-) probe of multimeter to connector P112 socket E and note reading on multimeter.
- (4) If continuity is not present, replace CTIS cable assembly (para 7-53).

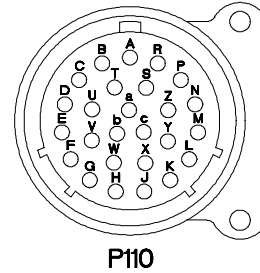

P110

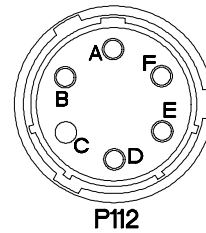

P112

CONTINUITY TEST

- (1) Set multimeter to ohms.
- (2) Connect positive (+) probe of multimeter to connector P110 socket P.
- (3) Connect negative (-) probe of multimeter to terminal lug TL50 and note reading on multimeter.
- (4) If continuity is not present, replace CTIS cable assembly (para 7-53).
- (5) Connect connector P110 to CTIS ECU.

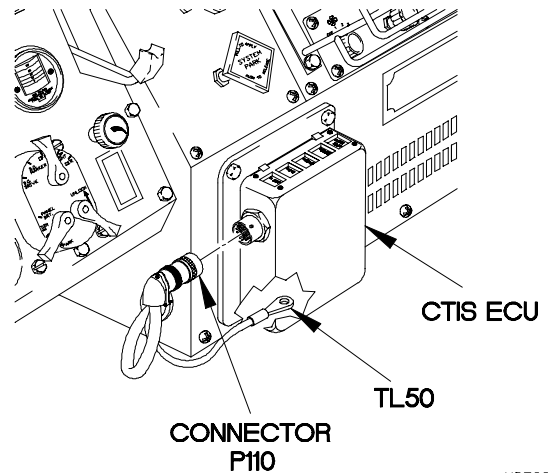

XBE8206A

e82. CENTRAL TIRE INFLATION SYSTEM (CTIS) DOES NOT OPERATE (CONT)

KNOWN INFO
VOLTS gage registers in green zone with engine running. Circuit breaker CB40 OK. FRONT BRAKE AIR and REAR BRAKE AIR pressure gages read normal. Air pressure switch OK. Start and charging cable assembly OK. WTEC II / WTEC III dashboard cable assembly OK.
POSSIBLE PROBLEMS
Faulty air pressure transducer. Faulty manifold valve assembly. Faulty CTIS ECU. Faulty CTIS cable assembly.

KNOWN INFO
VOLTS gage registers in green zone with engine running. Circuit breaker CB40 OK. FRONT BRAKE AIR and REAR BRAKE AIR pressure gages read normal. Air pressure switch OK. Start and charging cable assembly OK. WTEC II / WTEC III dashboard cable assembly OK.
POSSIBLE PROBLEMS
Faulty air pressure transducer. Faulty manifold valve assembly. Faulty CTIS ECU. Faulty CTIS cable assembly.

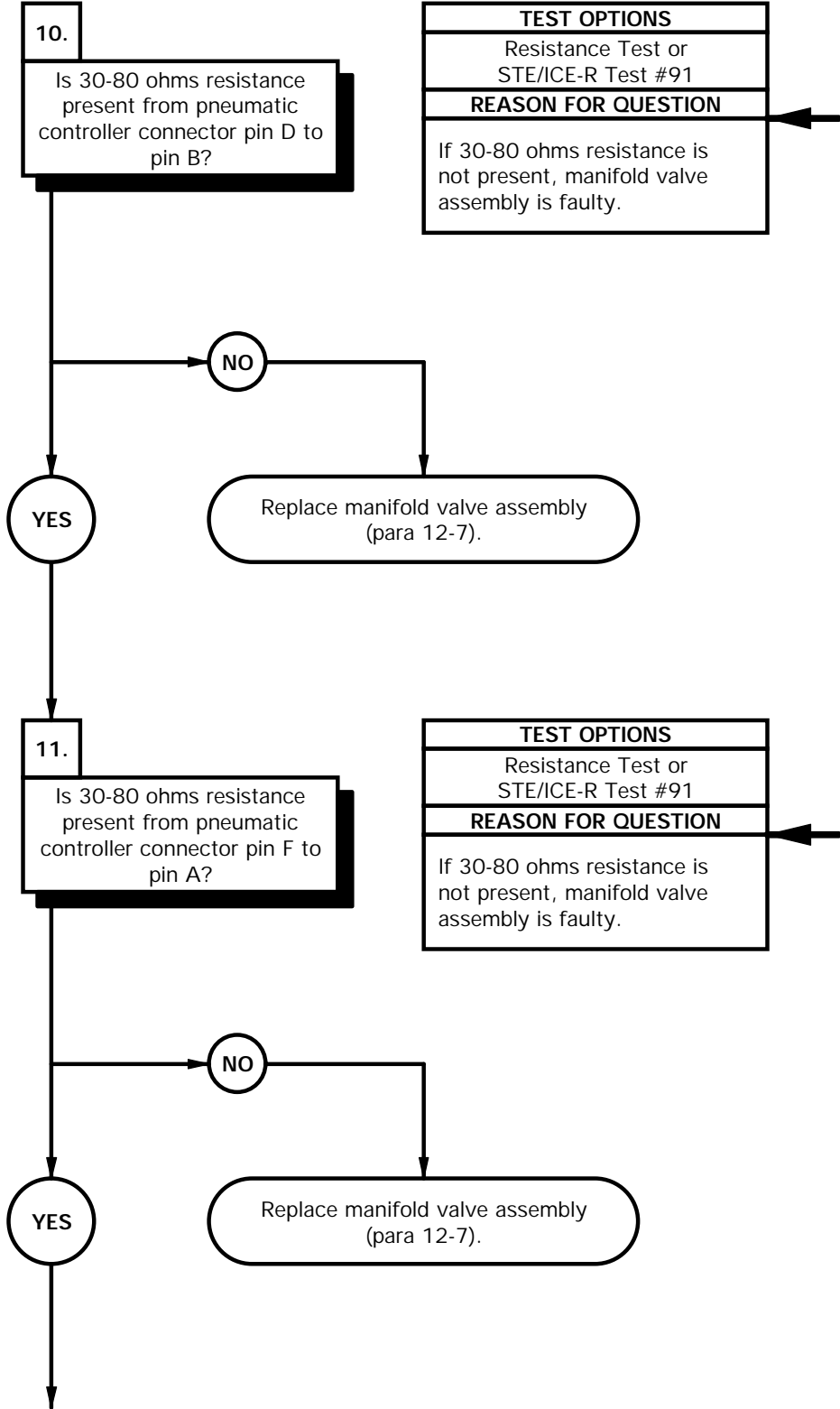

TEST OPTIONS
Resistance Test or STE/ICE-R Test #91
REASON FOR QUESTION
If 30-80 ohms resistance is not present, manifold valve assembly is faulty.

TEST OPTIONS
Resistance Test or STE/ICE-R Test #91
REASON FOR QUESTION
If 30-80 ohms resistance is not present, manifold valve assembly is faulty.

RESISTANCE TEST

- (1) Set multimeter to ohms.
- (2) Connect positive (+) probe of multimeter to pneumatic controller connector pin D.
- (3) Connect negative (-) probe of multimeter to pneumatic controller connector pin B and note reading on multimeter.
- (4) If 30-80 ohms resistance is not present, replace manifold valve assembly (para 12-7).

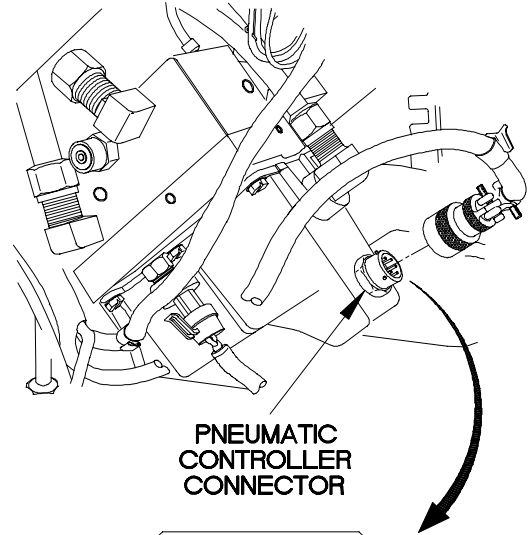

**PNEUMATIC
CONTROLLER
CONNECTOR**

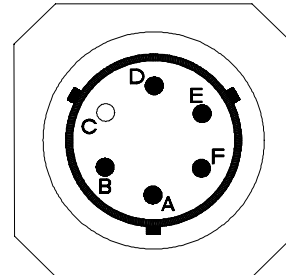

**PNEUMATIC
CONTROLLER
CONNECTOR**

RESISTANCE TEST

- (1) Set multimeter to ohms.
- (2) Connect positive (+) probe of multimeter to pneumatic controller connector pin F.
- (3) Connect negative (-) probe of multimeter to pneumatic controller connector pin A and note reading on multimeter.
- (4) If 30-80 ohms resistance is not present, replace manifold valve assembly (para 12-7).

XBE8207A

e82. CENTRAL TIRE INFLATION SYSTEM (CTIS) DOES NOT OPERATE (CONT)

KNOWN INFO
VOLTS gage registers in green zone with engine running. Circuit breaker CB40 OK. FRONT BRAKE AIR and REAR BRAKE AIR pressure gages read normal. Air pressure switch OK. Start and charging cable assembly OK. WTEC II / WTEC III dashboard cable assembly OK.
POSSIBLE PROBLEMS
Faulty air pressure transducer. Faulty manifold valve assembly. Faulty CTIS ECU. Faulty CTIS cable assembly.

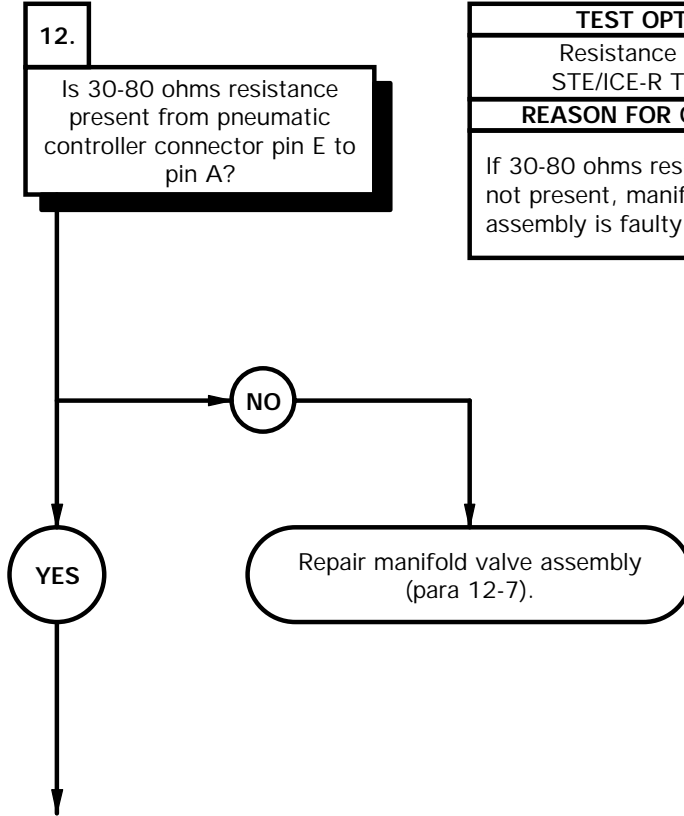

TEST OPTIONS
Resistance Test or STE/ICE-R Test #91
REASON FOR QUESTION
If 30-80 ohms resistance is not present, manifold valve assembly is faulty.

RESISTANCE TEST

- (1) Set multimeter to ohms.
- (2) Connect positive (+) probe of multimeter to pneumatic controller connector pin E.
- (3) Connect negative (-) probe of multimeter to pneumatic controller connector pin A and note reading on multimeter.
- (4) If 30-80 ohms resistance is not present, repair manifold valve assembly (para 12-7).
- (5) Connect connector P112 to pneumatic controller connector.

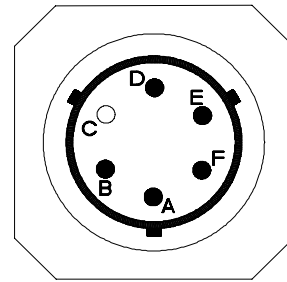

**PNEUMATIC
CONTROLLER
CONNECTOR**

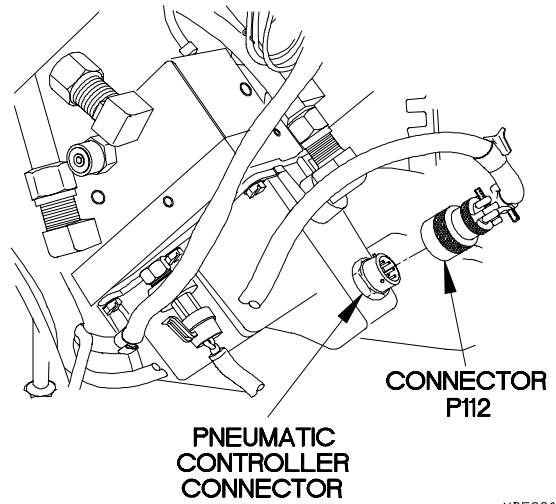

XBE82081

e82. CENTRAL TIRE INFLATION SYSTEM (CTIS) DOES NOT OPERATE (CONT)

KNOWN INFO
VOLTS gage registers in green zone with engine running. Circuit breaker CB40 OK. FRONT BRAKE AIR and REAR BRAKE AIR pressure gages read normal. Air pressure switch OK. Start and charging cable assembly OK. WTEC II / WTEC III dashboard cable assembly OK. Manifold valve assembly OK.
POSSIBLE PROBLEMS
Faulty air pressure transducer. Faulty CTIS ECU. Faulty CTIS cable assembly.

13.

Is 1-50 ohms resistance present from pressure transducer connector pin A to pin B?

TEST OPTIONS
Resistance Test or STE/ICE-R Test #91
REASON FOR QUESTION
If 1-50 ohms resistance is not present, pressure transducer is faulty.

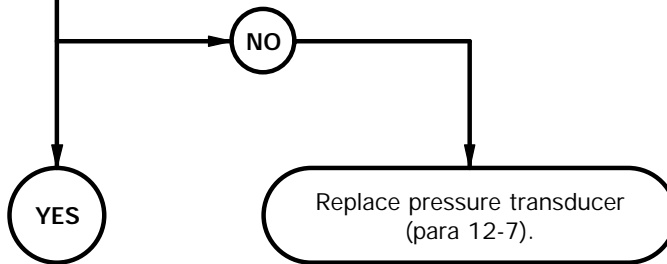

KNOWN INFO
VOLTS gage registers in green zone with engine running. Circuit breaker CB40 OK. FRONT BRAKE AIR and REAR BRAKE AIR pressure gages read normal. Air pressure switch OK. Start and charging cable assembly OK. WTEC II / WTEC III dashboard cable assembly OK. Manifold valve assembly OK.
POSSIBLE PROBLEMS
Faulty air pressure transducer. Faulty CTIS ECU. Faulty CTIS cable assembly.

14.

Is 1-50 ohms resistance present from pressure transducer connector pin B to pin C?

TEST OPTIONS
Resistance Test or STE/ICE-R Test #91
REASON FOR QUESTION
If 1-50 ohms resistance is not present, pressure transducer is faulty.

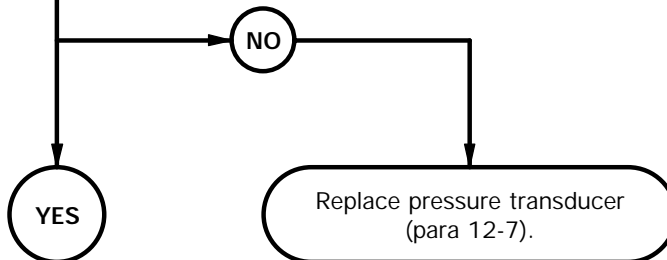

RESISTANCE TEST

- (1) Disconnect connector P113 from pressure transducer connector.
- (2) Set multimeter to ohms.
- (3) Connect positive (+) probe of multimeter to pressure transducer connector pin A.
- (4) Connect negative (-) probe of multimeter to pressure transducer connector pin B and note reading on multimeter.
- (5) If 1-50 ohms resistance is not present, replace pressure transducer (para 12-7).

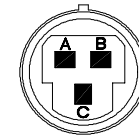

**PRESSURE
TRANSDUCER
CONNECTOR**

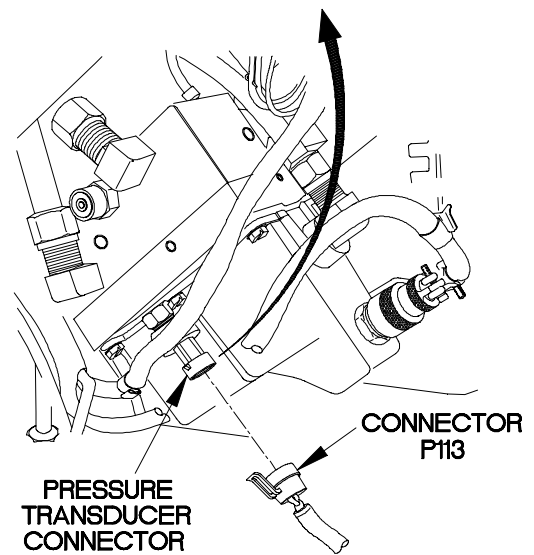

RESISTANCE TEST

- (1) Set multimeter to ohms.
- (2) Connect positive (+) probe of multimeter to pressure transducer connector pin B.
- (3) Connect negative (-) probe of multimeter to pressure transducer connector pin C and note reading on multimeter.
- (4) If 1-50 ohms resistance is not present, replace pressure transducer (para 12-7).

xbe82091

e82. CENTRAL TIRE INFLATION SYSTEM (CTIS) DOES NOT OPERATE (CONT)

KNOWN INFO
VOLTS gage registers in green zone with engine running. Circuit breaker CB40 OK. FRONT BRAKE AIR and REAR BRAKE AIR pressure gages read normal. Air pressure switch OK. Start and charging cable assembly OK. WTEC II / WTEC III dashboard cable assembly OK. Manifold valve assembly OK.
POSSIBLE PROBLEMS
Faulty air pressure transducer. Faulty CTIS ECU. Faulty CTIS cable assembly.

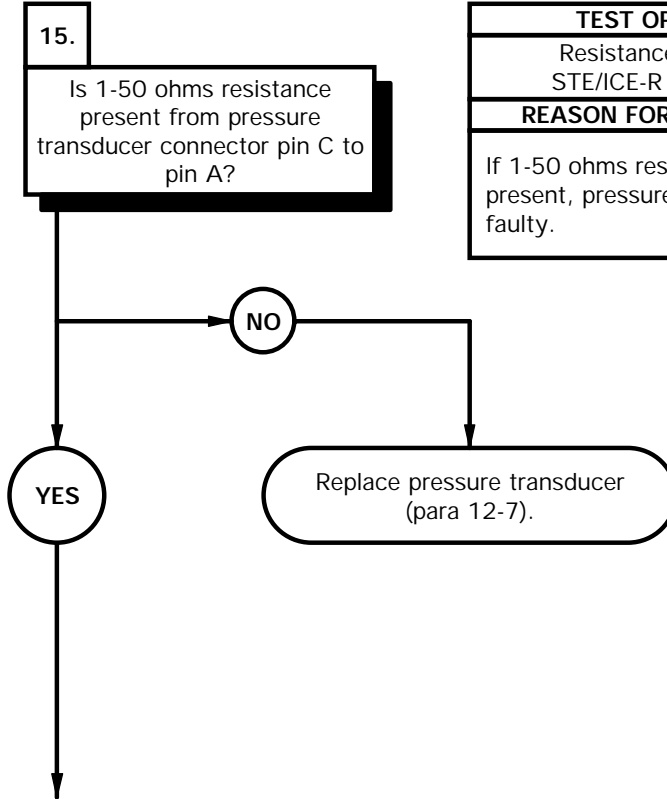

TEST OPTIONS
Resistance Test or STE/ICE-R Test #91
REASON FOR QUESTION
If 1-50 ohms resistance is not present, pressure transducer is faulty.

RESISTANCE TEST

- (1) Set multimeter to ohms.
- (2) Connect positive (+) probe of multimeter to pressure transducer connector pin C.
- (3) Connect negative (-) probe of multimeter to pressure transducer connector pin A and note reading on multimeter.
- (4) If 1-50 ohms resistance is not present, replace pressure transducer (para 12-7).

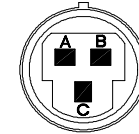

**PRESSURE
TRANSDUCER
CONNECTOR**

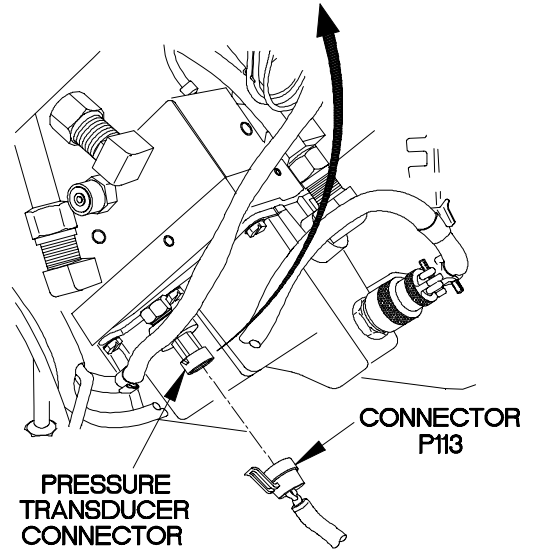

xbe82101

e82. CENTRAL TIRE INFLATION SYSTEM (CTIS) DOES NOT OPERATE (CONT)

KNOWN INFO
VOLTS gage registers in green zone with engine running. Circuit breaker CB40 OK. FRONT BRAKE AIR and REAR BRAKE AIR pressure gages read normal. Air pressure switch OK. Start and charging cable assembly OK. WTEC II / WTEC III dashboard cable assembly OK. Manifold valve assembly OK. Air pressure transducer OK.
POSSIBLE PROBLEMS
Faulty air pressure transducer. Faulty CTIS ECU. Faulty CTIS cable assembly.

KNOWN INFO
VOLTS gage registers in green zone with engine running. Circuit breaker CB40 OK. FRONT BRAKE AIR and REAR BRAKE AIR pressure gages read normal. Air pressure switch OK. Start and charging cable assembly OK. WTEC II / WTEC III dashboard cable assembly OK. Manifold valve assembly OK. Air pressure transducer OK.
POSSIBLE PROBLEMS
Faulty air pressure transducer. Faulty CTIS ECU. Faulty CTIS cable assembly.

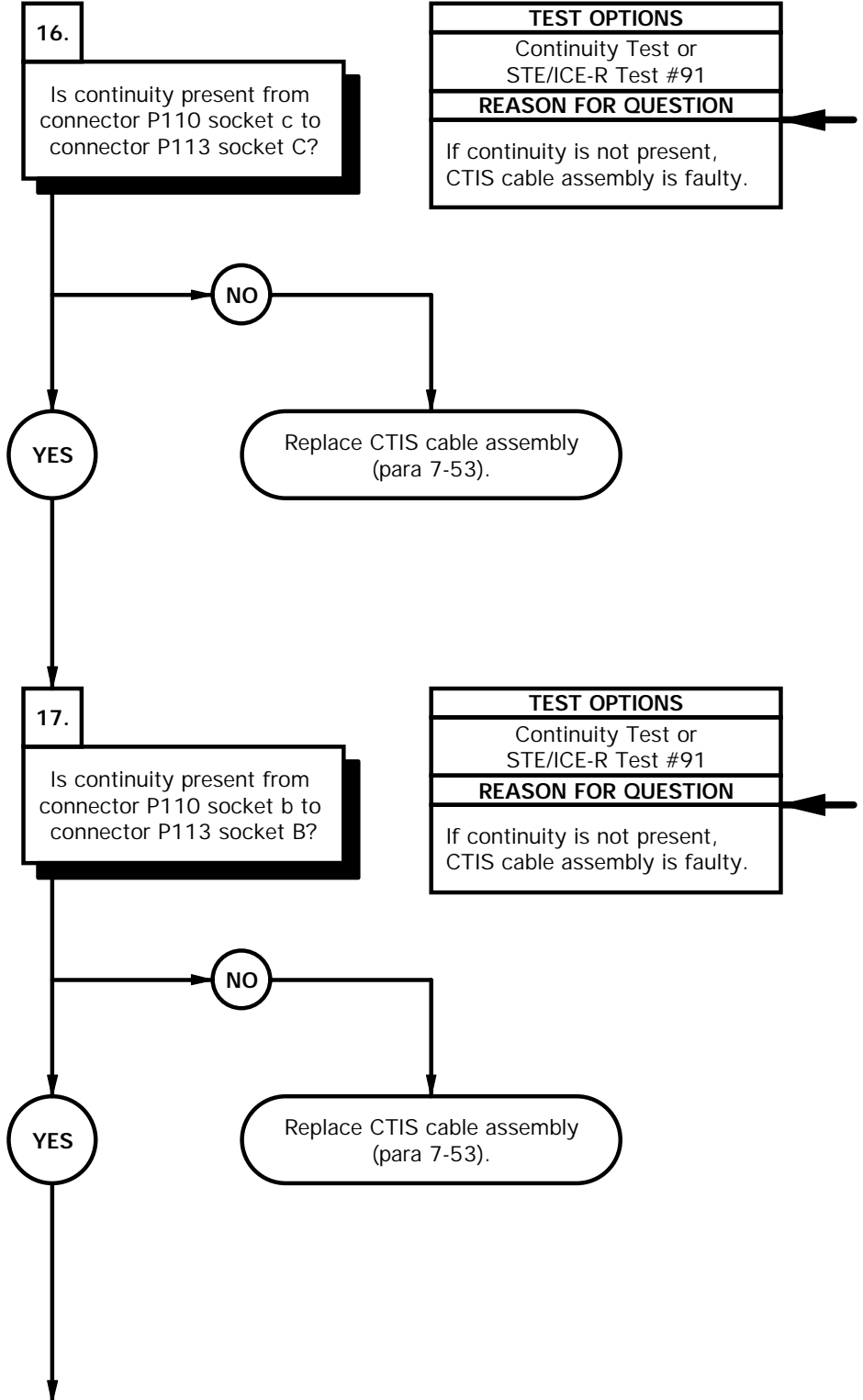

TEST OPTIONS
Continuity Test or STE/ICE-R Test #91
REASON FOR QUESTION
If continuity is not present, CTIS cable assembly is faulty.

TEST OPTIONS
Continuity Test or STE/ICE-R Test #91
REASON FOR QUESTION
If continuity is not present, CTIS cable assembly is faulty.

CONTINUITY TEST

- (1) Disconnect connector P110 from CTIS ECU.
- (2) Set multimeter to ohms.
- (3) Connect positive (+) probe of multimeter to connector P110 socket c.
- (4) Connect negative (-) probe of multimeter to connector P113 socket C and note reading on multimeter.
- (5) If continuity is not present, replace CTIS cable assembly (para 7-53).

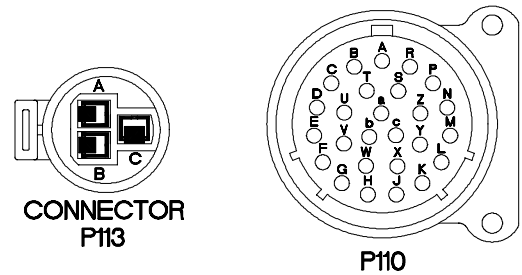
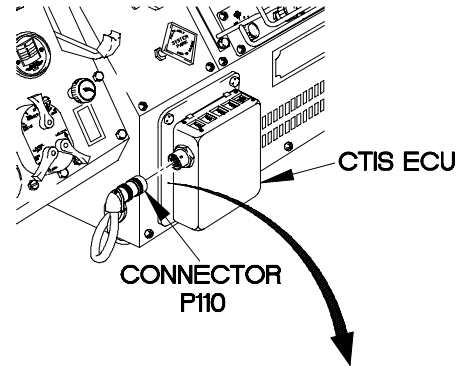

XBE82111

CONTINUITY TEST

- (1) Set multimeter to ohms.
- (2) Connect positive (+) probe of multimeter to connector P110 socket b.
- (3) Connect negative (-) probe of multimeter to connector P113 socket B and note reading on multimeter.
- (4) If continuity is not present, replace CTIS cable assembly (para 7-53).

e82. CENTRAL TIRE INFLATION SYSTEM (CTIS) DOES NOT OPERATE (CONT)

KNOWN INFO
VOLTS gage registers in green zone with engine running. Circuit breaker CB40 OK. FRONT BRAKE AIR and REAR BRAKE AIR pressure gages read normal. Air pressure switch OK. Start and charging cable assembly OK. WTEC II / WTEC III dashboard cable assembly OK. Manifold valve assembly OK.
POSSIBLE PROBLEMS
Faulty air pressure transducer. Faulty CTIS ECU. Faulty CTIS cable assembly.

18.

Is continuity present from connector P110 socket j to connector P113 socket A?

TEST OPTIONS
Continuity Test or STE/ICE-R Test #91
REASON FOR QUESTION
If continuity is not present, CTIS cable assembly is faulty.

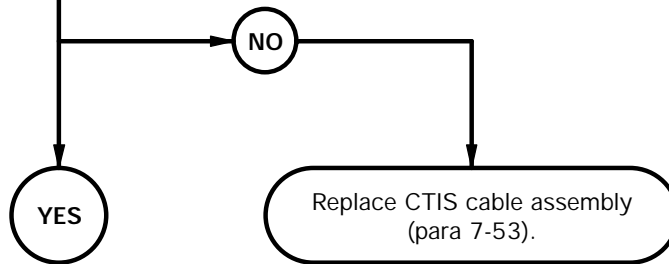

KNOWN INFO
VOLTS gage registers in green zone with engine running. Circuit breaker CB40 OK. FRONT BRAKE AIR and REAR BRAKE AIR pressure gages read normal. Air pressure switch OK. Start and charging cable assembly OK. WTEC II / WTEC III dashboard cable assembly OK. Manifold valve assembly OK.
POSSIBLE PROBLEMS
Faulty air pressure transducer. Faulty CTIS ECU. Faulty CTIS cable assembly.

19.

Is connector P113 socket A, socket B, or socket C short circuited?

TEST OPTIONS
Continuity Test or STE/ICE-R Test #91
REASON FOR QUESTION
If connector P113 is short circuited, CTIS cable assembly is faulty.

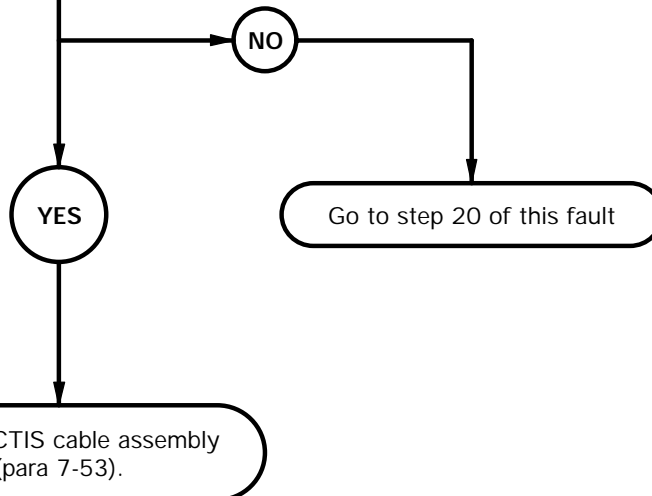

CONTINUITY TEST

- (1) Set multimeter to ohms.
- (2) Connect positive (+) probe of multimeter to connector P110 socket j.
- (3) Connect negative (-) probe of multimeter to connector P113 socket A and note reading on multimeter.
- (4) If continuity is not present, replace CTIS cable assembly (para 7-53).

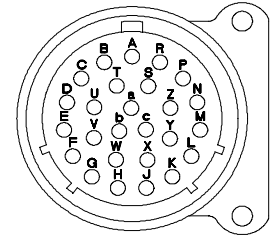
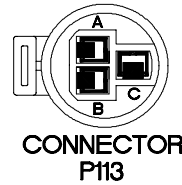

P110

CONTINUITY TEST

- (1) Set multimeter to ohms.
- (2) Connect positive (+) probe of multimeter to connector P113 socket A.
- (3) Connect negative (-) probe of multimeter to known good ground and note reading on multimeter.
- (4) Connect negative (-) probe of multimeter to all other sockets on connector P113 and note reading on multimeter.
- (5) Connect positive (+) probe of multimeter to connector P113 socket B.
- (6) Connect negative (-) probe of multimeter to known good ground and note reading on multimeter.
- (7) Connect negative (-) probe of multimeter to all other sockets on connector P113 and note reading on multimeter.
- (8) Connect positive (+) probe of multimeter to connector P113 socket C.
- (9) Connect negative (-) probe of multimeter to known good ground and note reading on multimeter.
- (10) Connect negative (-) probe of multimeter to all other sockets on connector P113 and note reading on multimeter.
- (11) If continuity not present is steps 3, 4, 6, 7, 9, and 10, go to step 20 of this fault.
- (12) If continuity present is steps 3, 4, 6, 7, 9, or 10, replace CTIS cable assembly (para 7-53).

XBE82121

e82. CENTRAL TIRE INFLATION SYSTEM (CTIS) DOES NOT OPERATE (CONT)

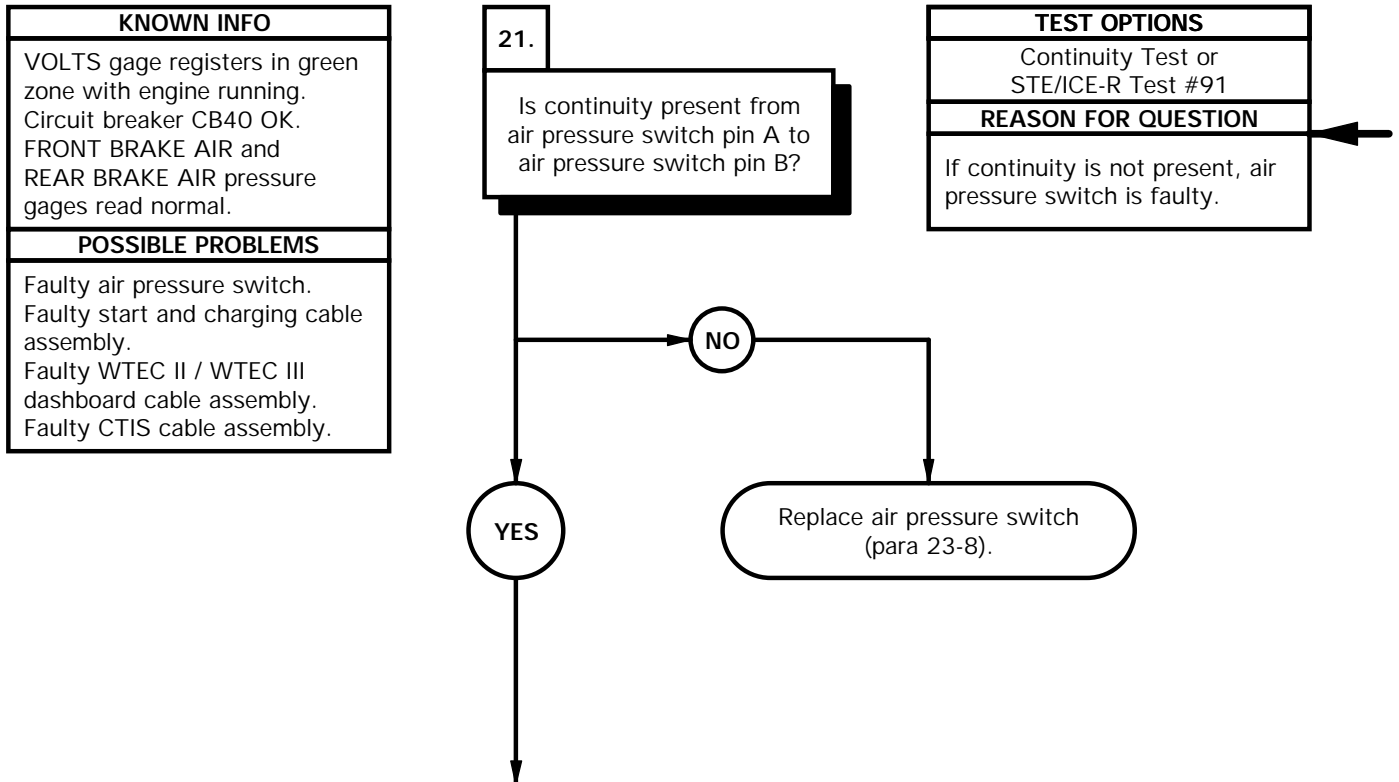
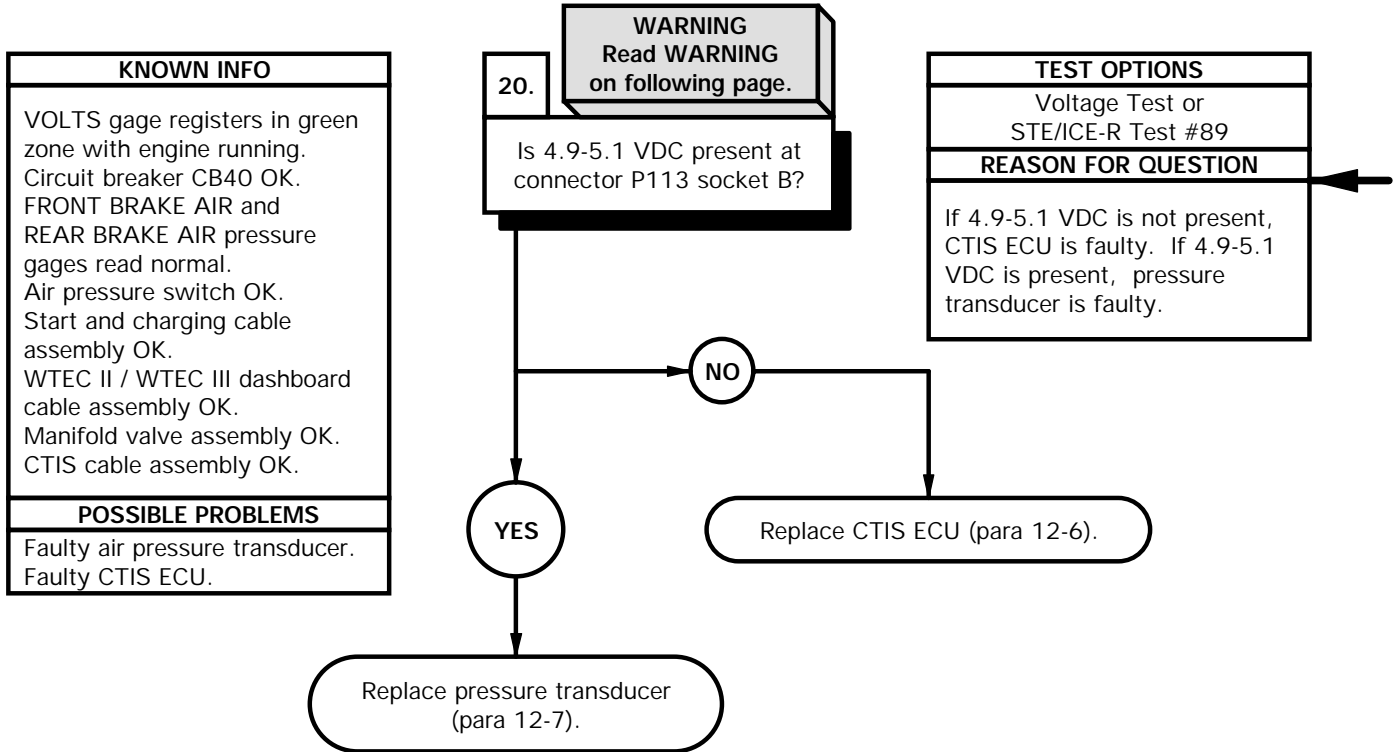

WARNING

Remove rings, bracelets, watches, necklaces, and any other jewelry before working around vehicle. Jewelry can catch on equipment and cause injury or short across electrical circuits and cause severe burns or electrical shock.

VOLTAGE TEST

- (1) Connect connector P110 from CTIS ECU.
- (2) Position master power switch to on (TM 9-2320-365-10).
- (3) Set multimeter to volts DC.
- (4) Connect positive (+) probe of multimeter to connector P113 socket B.
- (5) Connect negative (-) probe of multimeter to known good ground and note reading on multimeter.
- (6) Position master power switch to off (TM 9-2320-365-10).
- (7) If 4.9-5.1 VDC is not present, replace CTIS ECU (para 12-6).
- (8) If 4.9-5.1 VDC is present, replace air pressure transducer (para 12-7).

NOTE

Perform steps (9) and (10) if 4.9-5.1 VDC is not present.

- (9) Connect connector P113 to air pressure transducer connector.
- (10) Install kick panel (para 16-3).

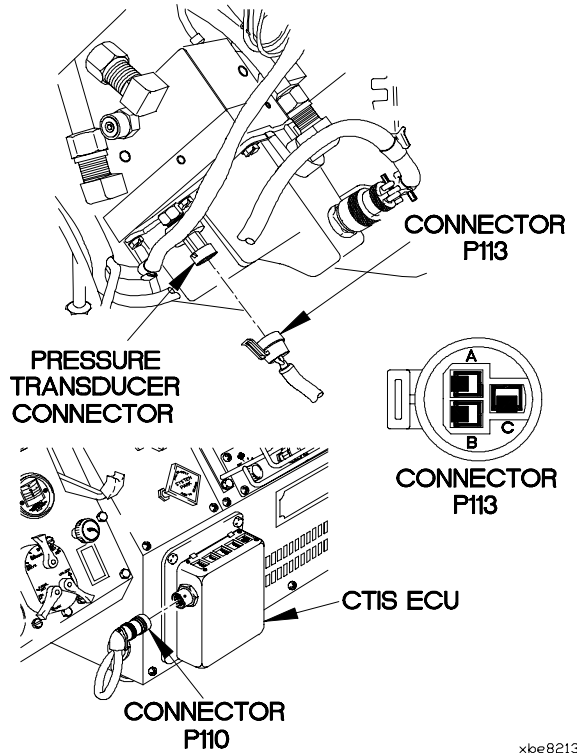

xbe82131

CONTINUITY TEST

- (1) Connect connector P110 to CTIS ECU.
- (2) Disconnect connector P84 from air pressure switch.
- (3) Set multimeter to ohms.
- (4) Connect positive (+) probe of multimeter to air pressure switch pin A.
- (5) Connect negative (-) probe of multimeter to air pressure switch pin B and note reading on multimeter.
- (6) If continuity is not present, replace air pressure switch (para 23-8).

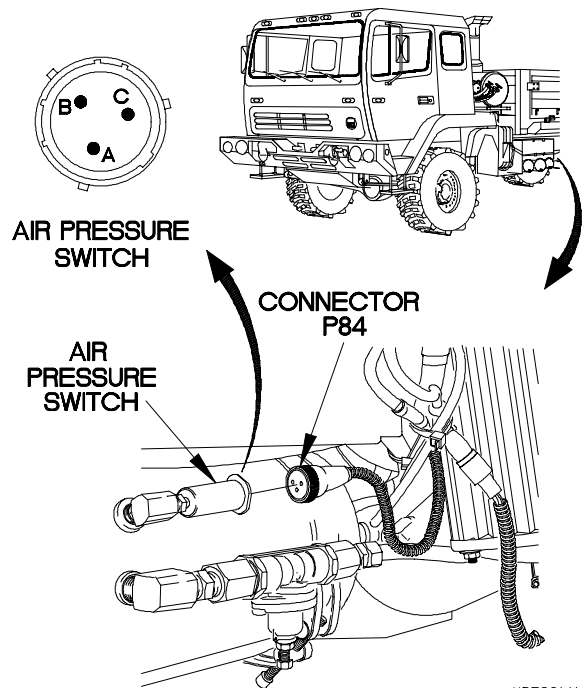

XBE82141

e82. CENTRAL TIRE INFLATION SYSTEM (CTIS) DOES NOT OPERATE (CONT)

KNOWN INFO
VOLTS gage registers in green zone with engine running. Circuit breaker CB40 OK. FRONT BRAKE AIR and REAR BRAKE AIR pressure gages read normal. Air pressure switch OK.
POSSIBLE PROBLEMS
Faulty start and charging cable assembly. Faulty WTEC II / WTEC III dashboard cable assembly. Faulty CTIS cable assembly.

22.
Is continuity present from connector P84 socket A to ground?

TEST OPTIONS
Continuity Test or STE/ICE-R Test #91
REASON FOR QUESTION
If continuity is not present, wire 3032 in start and charging cable assembly is faulty.

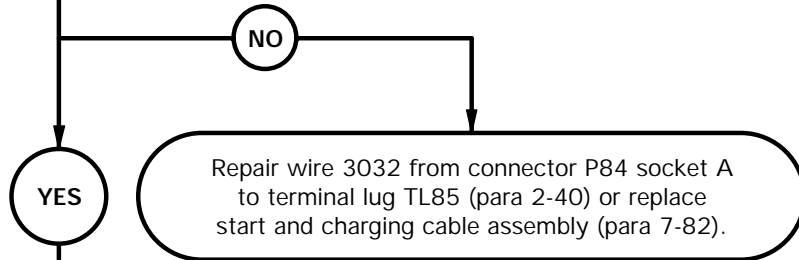

KNOWN INFO
VOLTS gage registers in green zone with engine running. Circuit breaker CB40 OK. FRONT BRAKE AIR and REAR BRAKE AIR pressure gages read normal. Air pressure switch OK.
POSSIBLE PROBLEMS
Faulty start and charging cable assembly. Faulty WTEC II / WTEC III dashboard cable assembly. Faulty CTIS cable assembly.

23.
Is continuity present from connector P111 pin F to connector P110 socket T?

TEST OPTIONS
Continuity Test or STE/ICE-R Test #91
REASON FOR QUESTION
If continuity is not present, CTIS cable assembly is faulty.

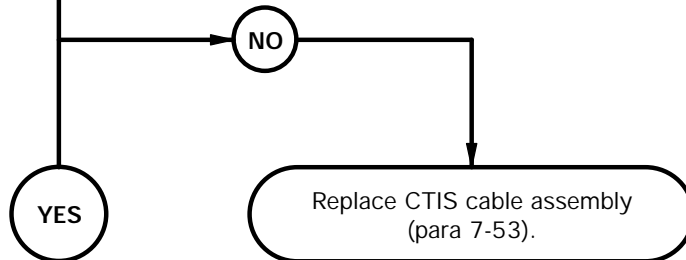

CONTINUITY TEST

- (1) Set multimeter to ohms.
- (2) Connect positive (+) probe of multimeter to connector P84 socket A.
- (3) Connect negative (-) probe of multimeter to ground and note reading on multimeter.
- (4) If continuity is not present, repair wire 3032 from connector P84 socket A to terminal lug TL85 (para 2-40) or replace start and charging cable assembly (para 7-82).
- (5) Connect connector P84 to air pressure switch.

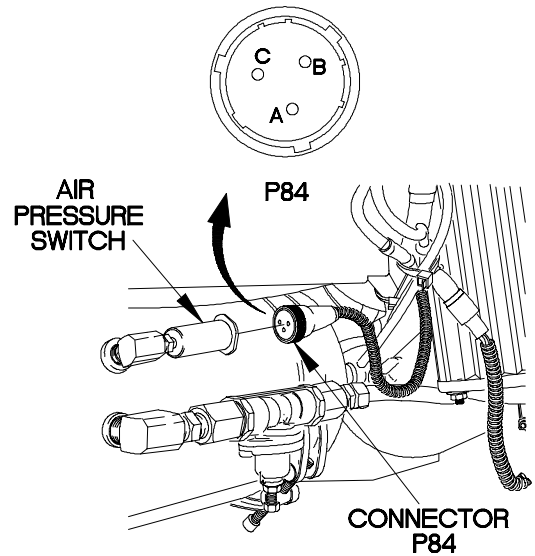

xbe82151

CONTINUITY TEST

- (1) Disconnect connector P110 from CTIS ECU.
- (2) Remove kick panel (para 16-3).
- (3) Disconnect connector P111 from connector J111.
- (4) Set multimeter to ohms.
- (5) Connect positive (+) probe of multimeter to connector P111 pin F.
- (6) Connect negative (-) probe of multimeter to connector P110 socket T and note reading on multimeter.
- (7) If continuity is not present, replace CTIS cable assembly (para 7-53).

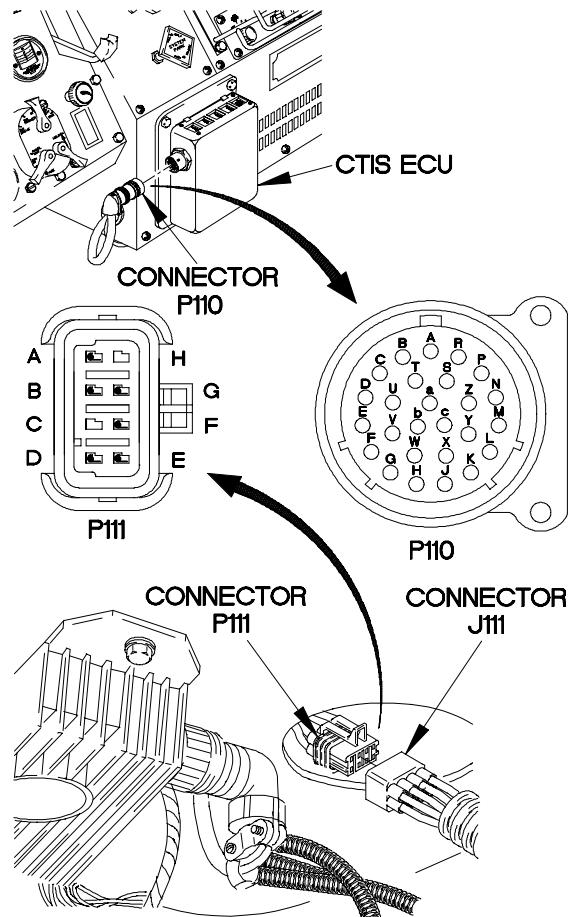

XBE82161

e82. CENTRAL TIRE INFLATION SYSTEM (CTIS) DOES NOT OPERATE (CONT)

KNOWN INFO
VOLTS gage registers in green zone with engine running. Circuit breaker CB40 OK. FRONT BRAKE AIR and REAR BRAKE AIR pressure gages read normal. Air pressure switch OK. CTIS cable assembly OK.
POSSIBLE PROBLEMS
Faulty start and charging cable assembly. Faulty WTEC II / WTEC III dashboard cable assembly.

24.
Is continuity present from connector J43 socket 2 to connector J111 socket F?

TEST OPTIONS
Continuity Test or STE/ICE-R Test #91
REASON FOR QUESTION
If continuity is not present, wire 1790 from connect J43 socket 2 to connector J111 socket F is faulty. If continuity is present, wire 1790 from connector P43 pin 2 to connector P84 socket B is faulty.

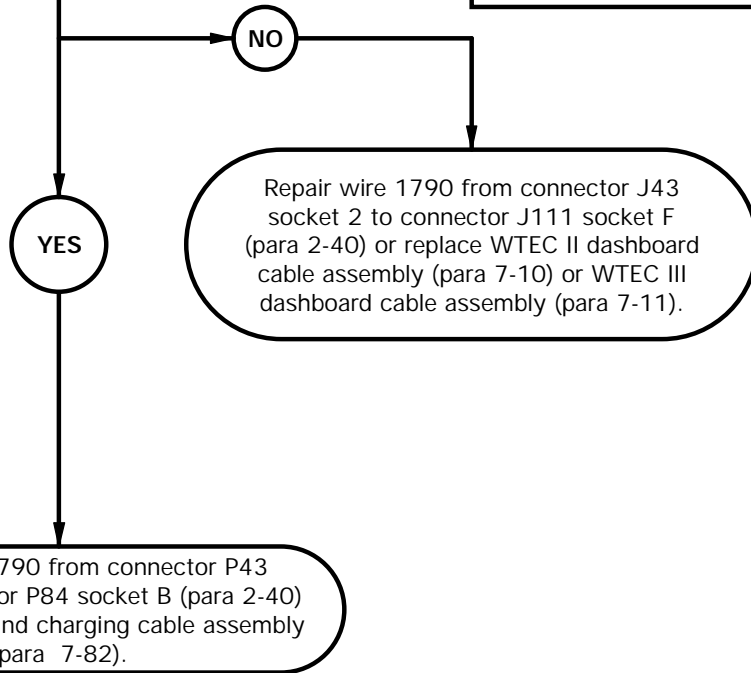

CONTINUITY TEST

- (1) Connect connector P110 to CTIS ECU.
- (2) Remove instrument panel assembly for access (para 7-15).
- (3) Disconnect connector J43 from connector P43.
- (4) Set multimeter to ohms.
- (5) Connect positive (+) probe of multimeter to connector J43 socket 2.
- (6) Connect negative (-) probe of multimeter to connector J111 socket F and note reading on multimeter.
- (7) If continuity is not present, repair wire 1790 from connector J43 socket 2 to connector J111 socket F (para 2-40) or replace WTEC II dashboard cable assembly (para 7-10) or WTEC III dashboard cable assembly (para 7-11).
- (8) If continuity is present, repair wire 1790 from connector P43 pin 2 to connector P84 socket B (para 2-40) or replace start and charging cable assembly (para 7-82).
- (9) Connect connector P43 to connector J43.
- (10) Install instrument panel assembly (para 7-15).
- (11) Connect connector J111 to connector P111.
- (12) Install kick panel (para 16-3).

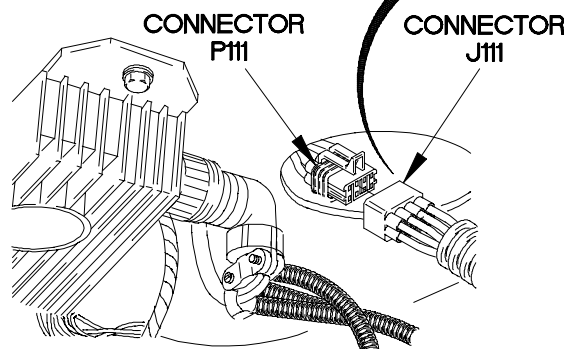
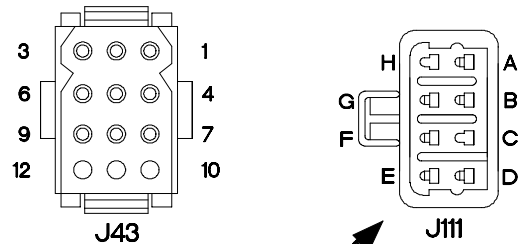
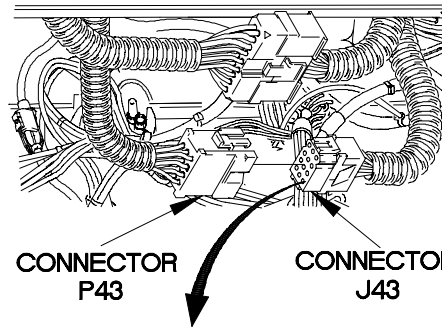
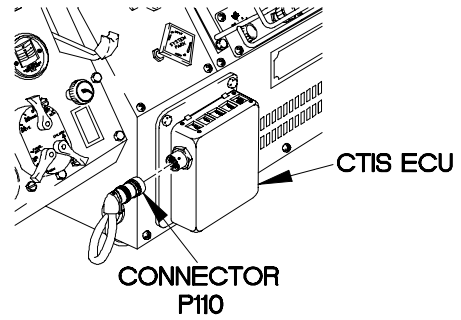

XBE82171

e82. CENTRAL TIRE INFLATION SYSTEM (CTIS) DOES NOT OPERATE (CONT)

KNOWN INFO
VOLTS gage registers in green zone with engine running. Circuit breaker CB40 OK. FRONT BRAKE AIR and REAR BRAKE AIR pressure gages read normal. Air pressure switch OK. Start and charging cable assembly OK.
POSSIBLE PROBLEMS
Faulty WTEC II / WTEC III dashboard cable assembly. Faulty CTIS cable assembly.

25.
Is continuity present from connector J111 socket E to circuit breaker CB40 socket 7?

TEST OPTIONS
Continuity Test or STE/ICE-R Test #91
REASON FOR QUESTION
If continuity is not present, wire 1911 from connector J111 socket E to circuit breaker CB40 socket 7 is faulty. If continuity is present, CTIS cable assembly is faulty.

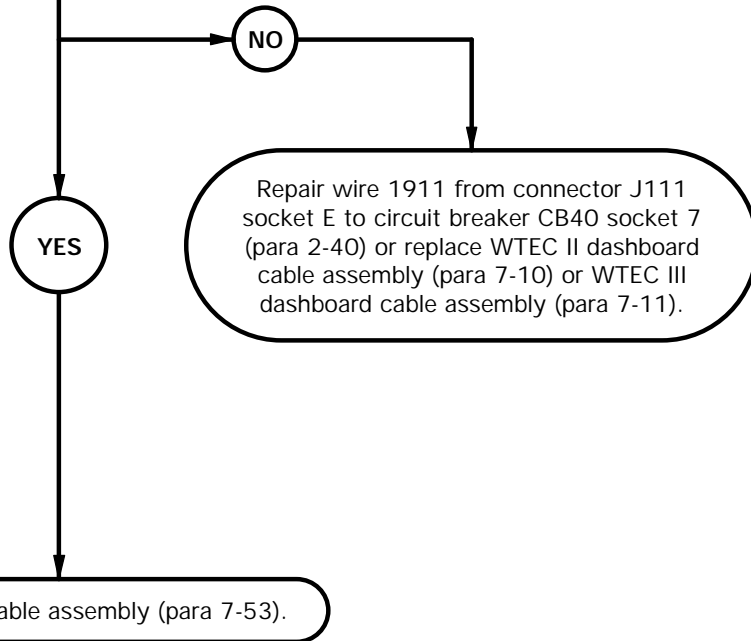

CONTINUITY TEST

- (1) Connect connector P110 to CTIS ECU.
- (2) Remove kick panel (para 16-3).
- (3) Remove circuit breaker CB40 from PDP.
- (4) Disconnect connector P111 from connector J111.
- (5) Set multimeter to ohms.
- (6) Connect positive (+) probe of multimeter to connector J111 socket E.
- (7) Connect negative (-) probe of multimeter to circuit breaker CB40 socket 7 and note reading on multimeter.
- (8) If continuity is not present, repair wire 1911 from connector J111 socket E to circuit breaker CB40 socket 7 (para 2-40) or replace WTEC II dashboard cable assembly (para 7-10) or WTEC III dashboard cable assembly (para 7-11).
- (9) If continuity is present, replace CTIS cable assembly (para 7-53).
- (10) Install circuit breaker CB40 on PDP.
- (11) Connect connector J111 to connector P111.
- (12) Install kick panel (para 16-3).

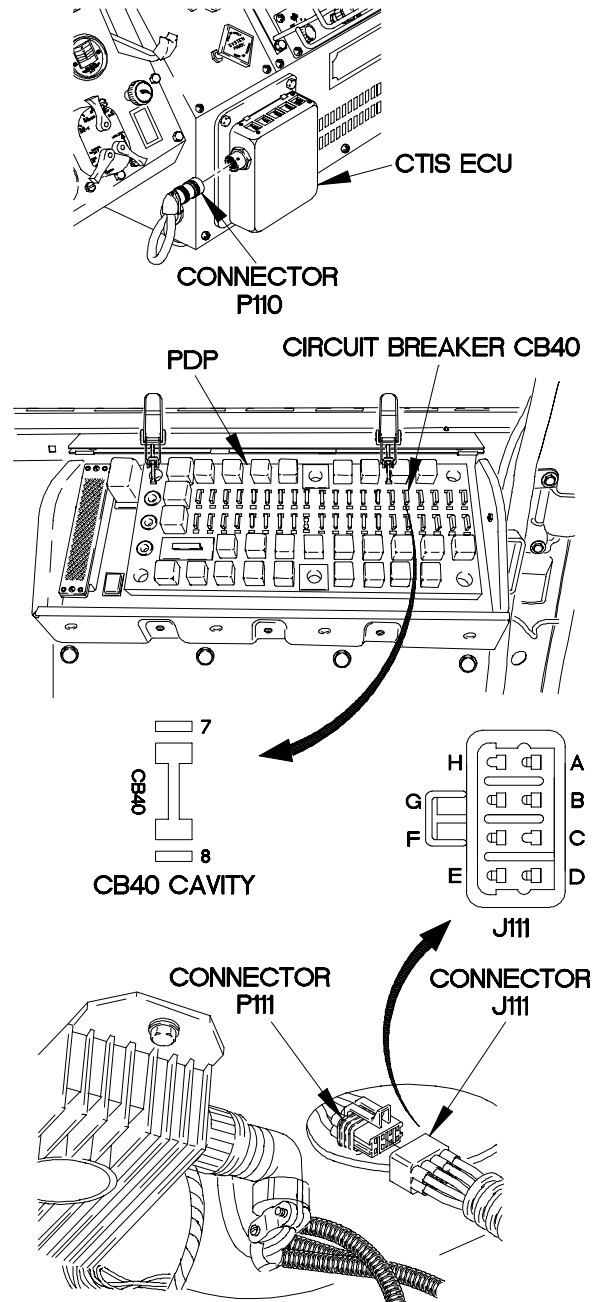

XBE82181

e82. CENTRAL TIRE INFLATION SYSTEM (CTIS) DOES NOT OPERATE (CONT)

KNOWN INFO
VOLTS gage registers in green zone with engine running. Circuit breaker CB40 OK. FRONT BRAKE AIR and REAR BRAKE AIR pressure gages read normal. Air pressure switch OK. Start and charging cable assembly OK.
POSSIBLE PROBLEMS
Faulty WTEC II / WTEC III dashboard cable assembly. Faulty CTIS cable assembly.

26.
Is continuity present from connector P111 pin A to connector P110 socket F?

TEST OPTIONS
Continuity Test or STE/ICE-R Test #91
REASON FOR QUESTION
If continuity is not present, CTIS cable assembly is faulty. If continuity is present, wire 3031 from connector J111 socket A to terminal board TB2 position 35 is faulty.

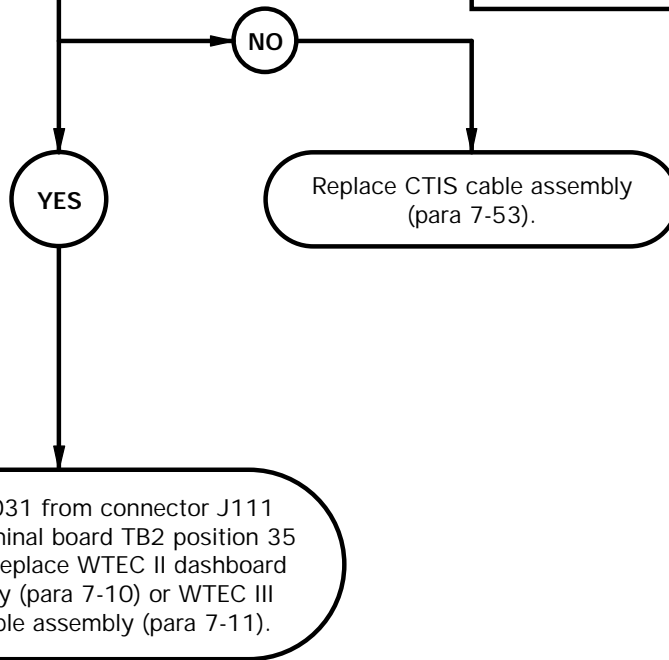

- CONTINUITY TEST**
- (1) Remove kick panel (para 16-3).
 - (2) Disconnect connector J111 from connector P111.
 - (3) Set multimeter to ohms.
 - (4) Connect positive (+) probe of multimeter to connector P110 socket F.
 - (5) Connect negative (-) probe of multimeter to connector P111 pin A and note reading on multimeter.
 - (6) If continuity is not present replace CTIS cable assembly (para 7-53).
 - (7) If continuity is present, repair wire 3031 from connector J111 socket A to terminal board TB2 position 35 (para 2-40) or replace WTEC II dashboard cable assembly (para 7-10) or WTEC III dashboard cable assembly (para 7-11).
 - (8) Connect connector J111 to connector P111.
 - (9) Install kick panel (para 16-3).
 - (10) Connect connector P110 to CTIS ECU.

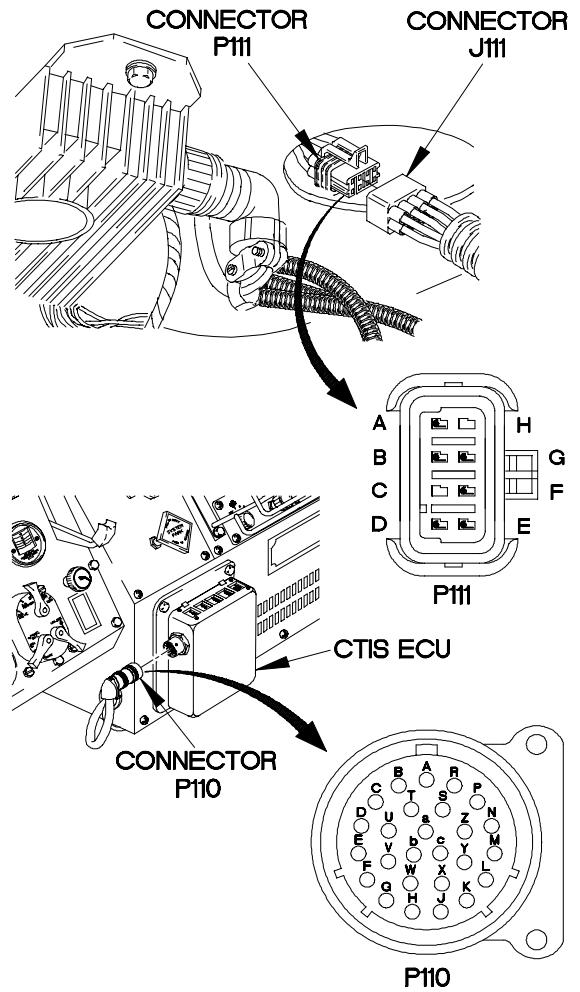

XBE82191

e83. CTIS DOES NOT INFLATE TIRES

INITIAL SETUP

Equipment Condition

Engine shut down (TM 9-2320-365-10).

Personnel Required

(2)

References

TM 9-4910-571-12&P

Tools and Special Tools

Tool Kit, Genl Mech (Item 44, Appendix C)

STE/ICE-R (Item 39, Appendix C)

Multimeter, Digital (Item 22, Appendix C)

Materials/Parts

Wire, Elect, 50 ft (Item 77, Appendix D)

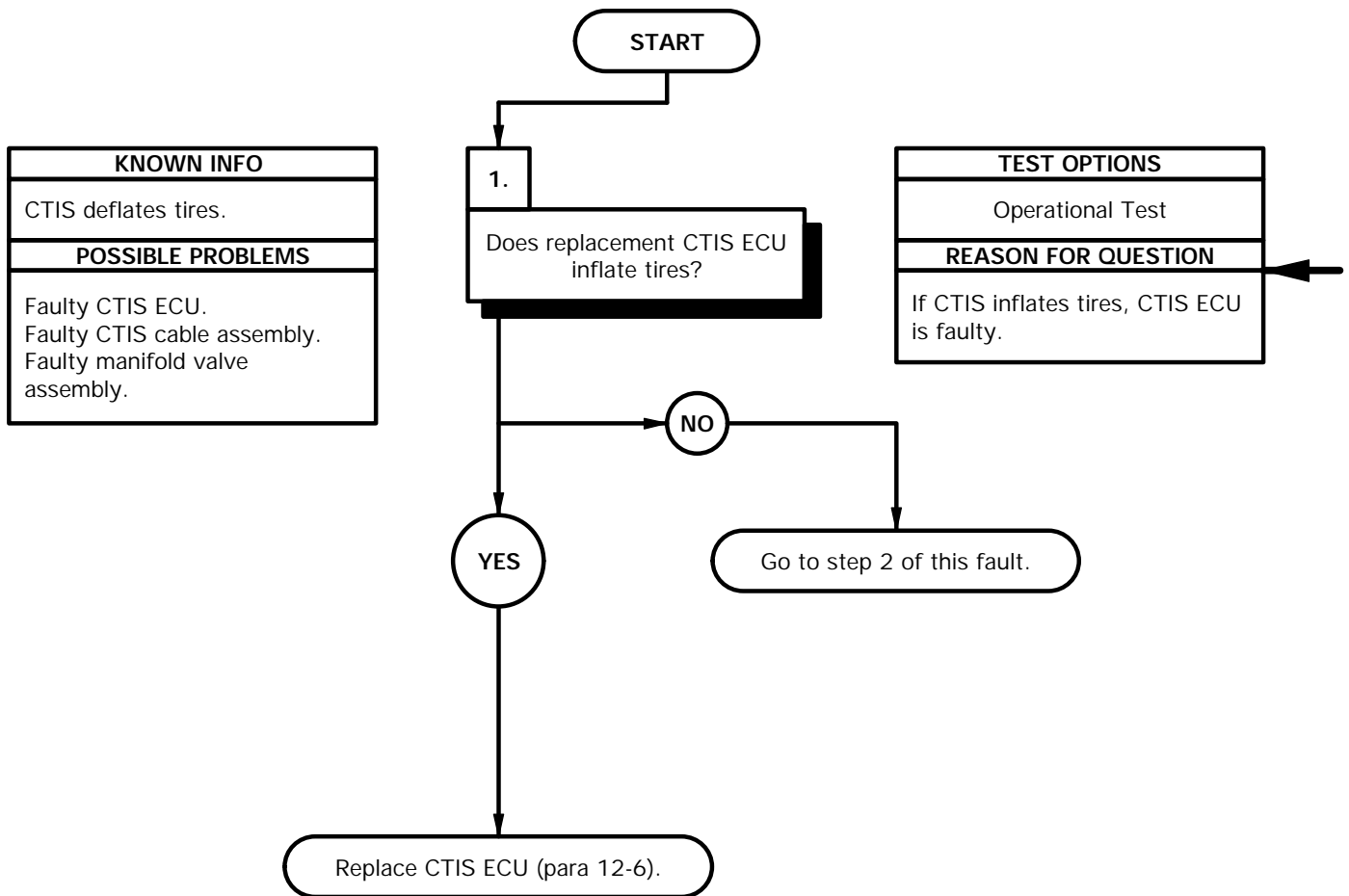

OPERATIONAL TEST

- (1) Disconnect connector P110 from CTIS ECU.
- (2) Connect connector P110 to a known-good CTIS ECU.
- (3) Start vehicle (TM 9-2320-365-10).
- (4) Allow air pressure to reach 85 psi.
- (5) Deflate tires (TM 9-2320-365-10).
- (6) If tires do not inflate, go to step 2 of this fault.
- (7) If tires inflate, replace CTIS ECU (para 12-6).
- (8) Shut down vehicle (TM 9-2320-365-10).
- (9) Disconnect connector P110 from known-good CTIS ECU.

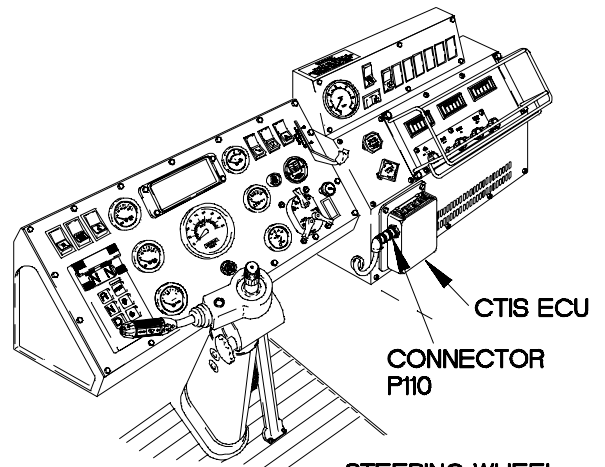

STEERING WHEEL
REMOVED FOR
CLARITY

X2E8601A

ø83. CTIS DOES NOT INFLATE TIRES (CONT)

KNOWN INFO
CTIS deflates tires. CTIS ECU OK.
POSSIBLE PROBLEMS
Faulty CTIS cable assembly. Faulty manifold valve assembly.

2.
Is continuity present between connector P110-B and connector P112-F?

TEST OPTIONS
Continuity Test or STE/ICE-R #91
REASON FOR QUESTION
If continuity is not present, CTIS cable assembly is faulty.

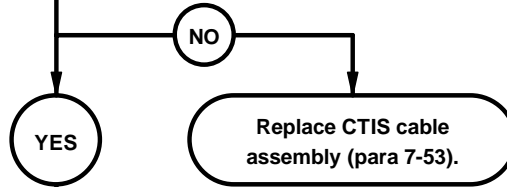

KNOWN INFO
CTIS deflates tires. CTIS ECU OK.
POSSIBLE PROBLEMS
Faulty CTIS cable assembly. Faulty manifold valve assembly.

3.
Is continuity present between connector P110-F and connector P112-A?

TEST OPTIONS
Continuity Test or STE/ICE-R #91
REASON FOR QUESTION
If continuity is not present, CTIS cable assembly is faulty.

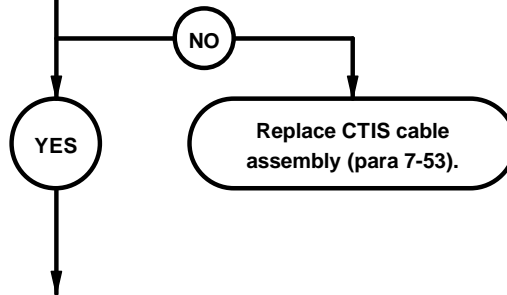

- | CONTINUITY TEST | |
|-----------------|--|
| (1) | Remove kick panel (para 16-3). |
| (2) | Disconnect connector P112 from manifold valve assembly. |
| (3) | Set multimeter to ohms. |
| (4) | Connect positive (+) probe of multimeter to connector P110-B. |
| (5) | Connect negative (-) probe of multimeter to connector P112-F and note reading on multimeter. |
| (6) | If continuity is not present, replace CTIS cable assembly (para 7-53). |

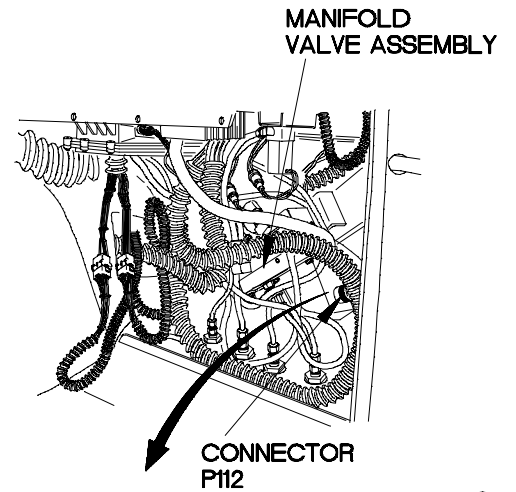

- | CONTINUITY TEST | |
|-----------------|--|
| (1) | Set multimeter to ohms. |
| (2) | Connect positive (+) probe of multimeter to connector P110-F. |
| (3) | Connect negative (-) probe of multimeter to connector P112-A and note reading on multimeter. |
| (4) | If continuity is not present, replace CTIS cable assembly (para 7-53). |

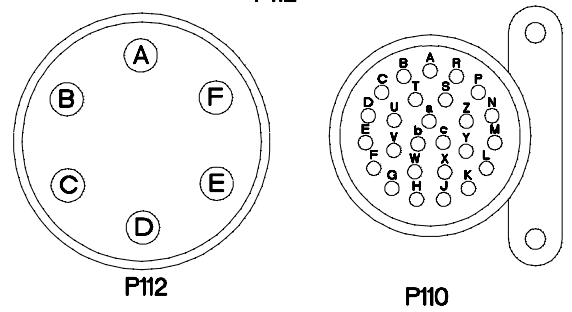

32E8602A

ø83. CTIS DOES NOT INFLATE TIRES (CONT)

KNOWN INFO
CTIS deflates tires. CTIS ECU OK.
POSSIBLE PROBLEMS
Faulty CTIS cable assembly. Faulty manifold valve assembly.

4.
Is continuity present between connector P110-R and connector P112-D?

TEST OPTIONS
Continuity Test or STE/ICE-R #91
REASON FOR QUESTION
If continuity is not present, CTIS cable assembly is faulty.

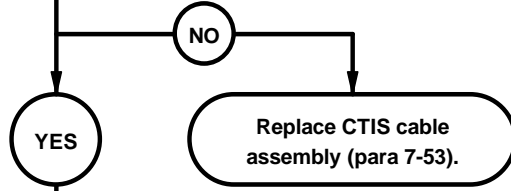

KNOWN INFO
CTIS deflates tires. CTIS ECU OK.
POSSIBLE PROBLEMS
Faulty CTIS cable assembly. Faulty manifold valve assembly.

5.
Is continuity present between connector P110-F and connector P112-B?

TEST OPTIONS
Continuity Test or STE/ICE-R #91
REASON FOR QUESTION
If continuity is not present, CTIS cable assembly is faulty.

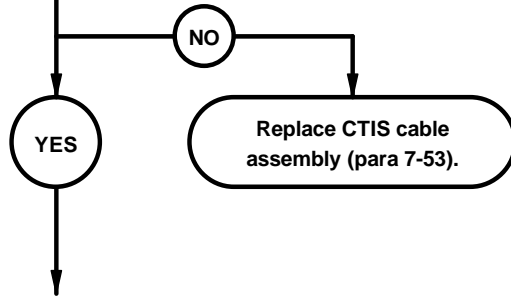

CONTINUITY TEST	
	(1) Set multimeter to ohms.
	(2) Connect positive (+) probe of multimeter to connector P110-R.
	(3) Connect negative (-) probe of multimeter to connector P112-D and note reading on multimeter.
	(4) If continuity is not present, replace CTIS cable assembly (para 7-53).

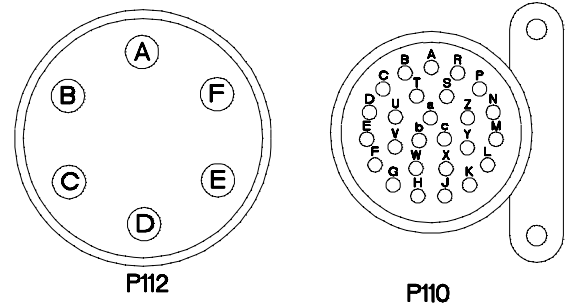
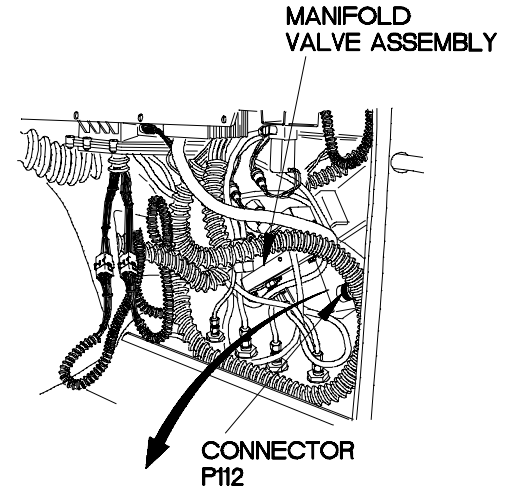

32E8603A

CONTINUITY TEST	
	(1) Set multimeter to ohms.
	(2) Connect positive (+) probe of multimeter to connector P110-F.
	(3) Connect negative (-) probe of multimeter to connector P112-B and note reading on multimeter.
	(4) If continuity is not present, replace CTIS cable assembly (para 7-53).
	(5) Connect connector P112 to manifold valve assembly.

ø83. CTIS DOES NOT INFLATE TIRES (CONT)

KNOWN INFO
CTIS deflates tires. CTIS ECU OK.
POSSIBLE PROBLEMS
Faulty CTIS cable assembly. Faulty manifold valve assembly.

6.
Is continuity present between connector P110-b and connector P113-B?

TEST OPTIONS
Continuity Test or STE/ICE-R #91
REASON FOR QUESTION
If continuity is not present, CTIS cable assembly is faulty.

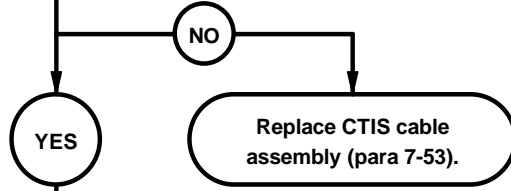

KNOWN INFO
CTIS deflates tires. CTIS ECU OK.
POSSIBLE PROBLEMS
Faulty CTIS cable assembly. Faulty manifold valve assembly.

7.
Is continuity present between connector P110-c and connector P113-C?

TEST OPTIONS
Continuity Test or STE/ICE-R #91
REASON FOR QUESTION
If continuity is not present, CTIS cable assembly is faulty.

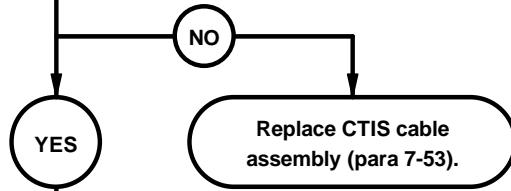

- | CONTINUITY TEST | |
|-----------------|--|
| | (1) Disconnect connector P113 from manifold valve assembly. |
| | (2) Set multimeter to ohms. |
| | (3) Connect positive (+) probe of multimeter to connector P110-b. |
| | (4) Connect negative (-) probe of multimeter to connector P113-B and note reading on multimeter. |
| | (5) If continuity is not present, replace CTIS cable assembly (para 7-53). |

MANIFOLD VALVE ASSEMBLY

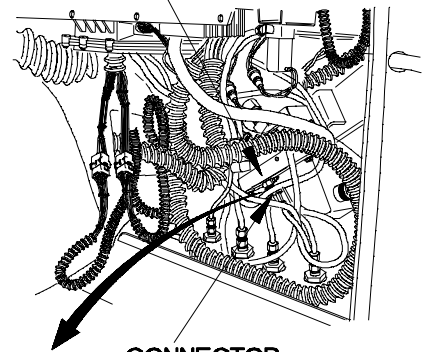

CONNECTOR P113

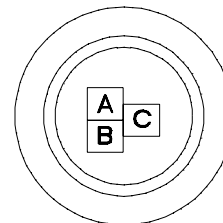

P113

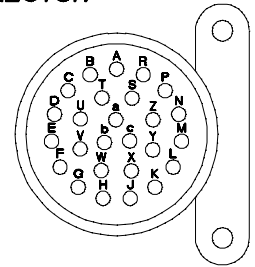

P110

32E8604A

- | CONTINUITY TEST | |
|-----------------|--|
| | (1) Set multimeter to ohms. |
| | (2) Connect positive (+) probe of multimeter to connector P110-c. |
| | (3) Connect negative (-) probe of multimeter to connector P113-C and note reading on multimeter. |
| | (4) If continuity is not present, replace CTIS cable assembly (para 7-53). |

ø83. CTIS DOES NOT INFLATE TIRES (CONT)

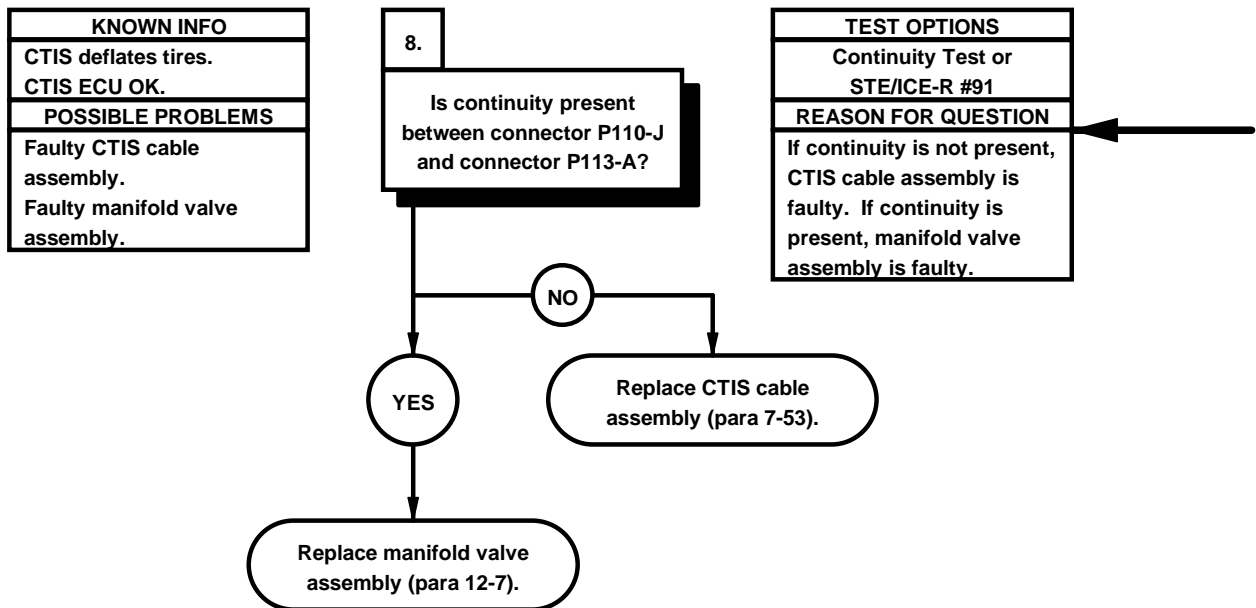

CONTINUITY TEST

- (1) Set multimeter to ohms.
- (2) Connect positive (+) probe of multimeter to connector P110-J.
- (3) Connect negative (-) probe of multimeter to connector P113-A and note reading on multimeter.
- (4) If continuity is not present, replace CTIS cable assembly (para 7-53).
- (5) If continuity is present, replace manifold valve assembly (para 12-7).
- (6) Connect connector P113 to manifold valve assembly.
- (7) Install kick panel (para 16-3).
- (8) Connect connector P110 to CTIS ECU.

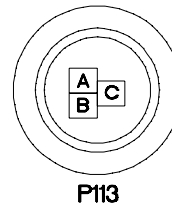
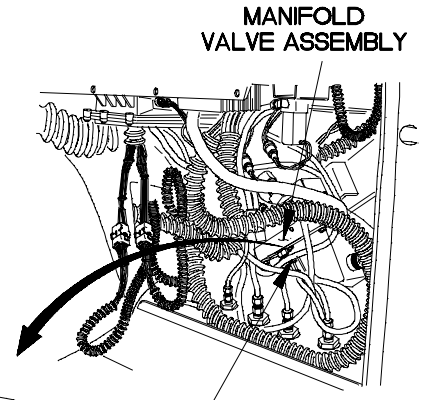

CONNECTOR P113

STEERING WHEEL REMOVED FOR CLARITY

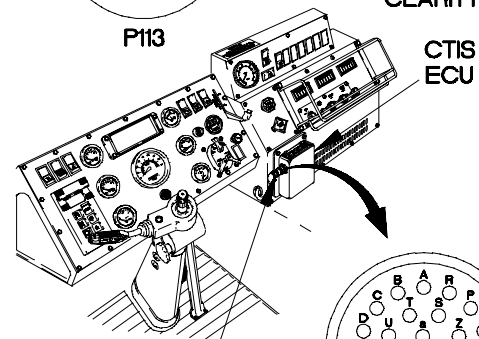

CONNECTOR P110

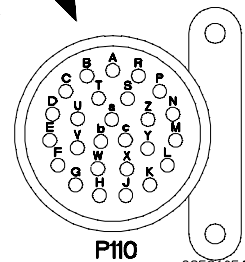

32E8605A

e84. CTIS DOES NOT DEFLATE TIRES	
INITIAL SETUP	
Equipment Condition Engine shut down (TM 9-2320-365-10).	Tools and Special Tools Tool Kit, Genl Mech (Item 44, Appendix C) STE/ICE-R (Item 39, Appendix C) Multimeter, Digital (Item 22, Appendix C)
Personnel Required (2)	Materials/Parts Wire, Elect, 50 ft (Item 77, Appendix D)
References TM 9-4910-571-12&P	

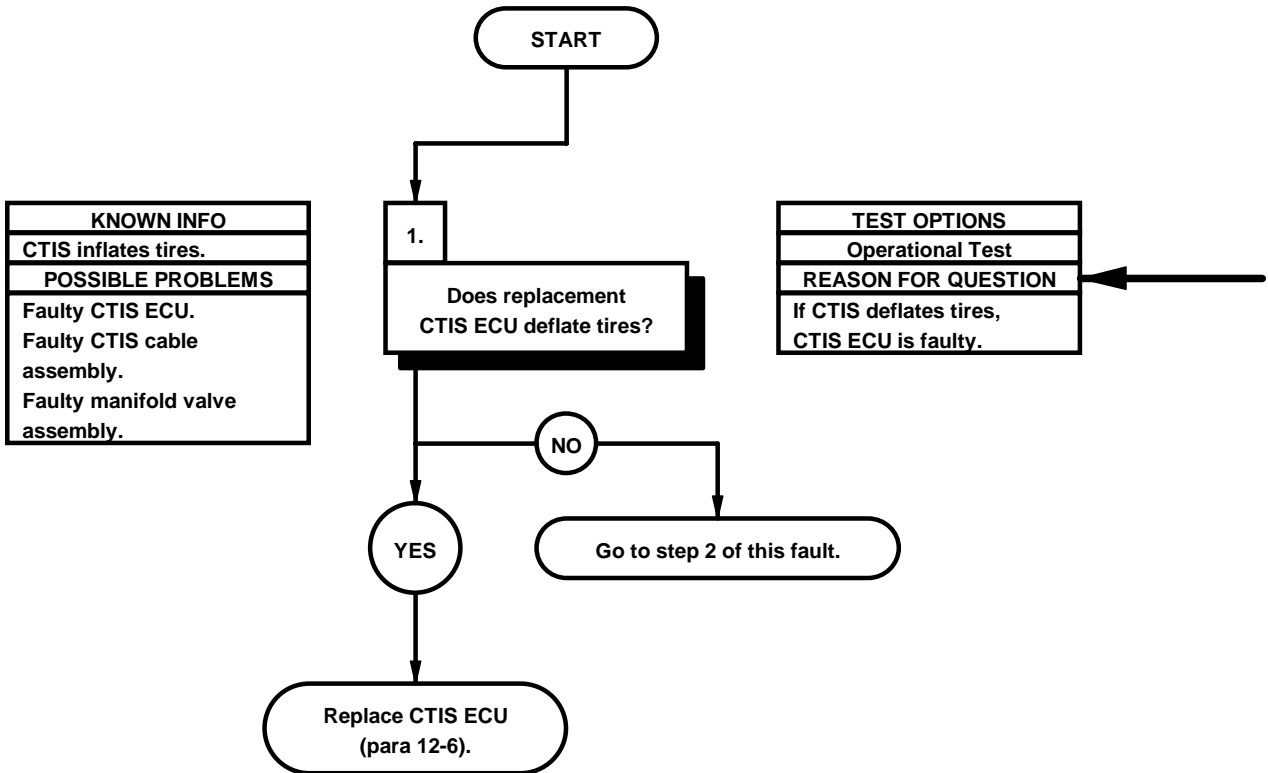

OPERATIONAL TEST

- (1) Disconnect connector P110 from CTIS ECU.
- (2) Connect connector P110 to a known-good CTIS ECU.
- (3) Start vehicle (TM 9-2320-365-10).
- (4) Allow air pressure to reach 85 psi.
- (5) Deflate tires (TM 9-2320-365-10).
- (6) If tires do not deflate, go to step 2 of this fault.
- (7) If tires deflate, replace CTIS ECU (para 12-6).
- (8) Shut down vehicle (TM 9-2320-365-10).
- (9) Disconnect connector P110 from known-good CTIS ECU.

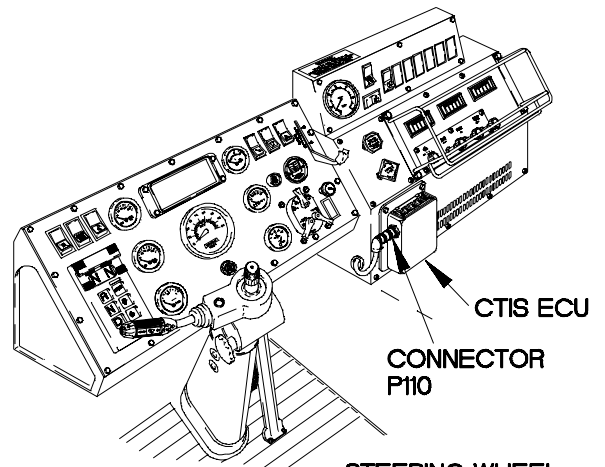

STEERING WHEEL
REMOVED FOR
CLARITY

X2E8701A

84. CTIS DOES NOT DEFLATE TIRES (CONT)

KNOWN INFO
CTIS inflates tires. CTIS ECU OK.
POSSIBLE PROBLEMS
Faulty CTIS cable assembly. Faulty manifold valve assembly.

2.
Is continuity present between connector P110-C and connector P112-E?

TEST OPTIONS
Continuity Test or STE/ICE-R #91
REASON FOR QUESTION
If continuity is not present, CTIS cable assembly is faulty.

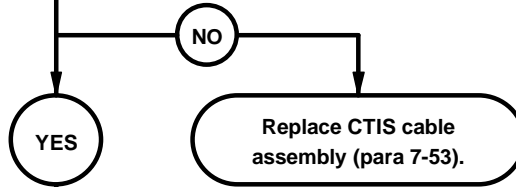

KNOWN INFO
CTIS inflates tires. CTIS ECU OK.
POSSIBLE PROBLEMS
Faulty CTIS cable assembly. Faulty manifold valve assembly.

3.
Is continuity present between connector P110-F and connector P112-A?

TEST OPTIONS
Continuity Test or STE/ICE-R #91
REASON FOR QUESTION
If continuity is not present, CTIS cable assembly is faulty.

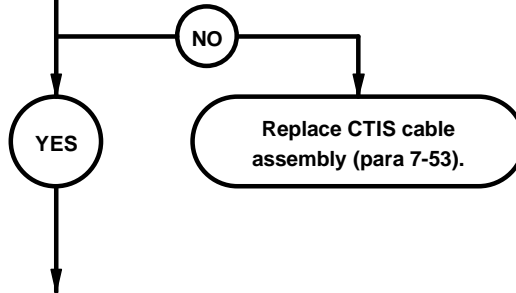

CONTINUITY TEST

- (1) Remove kick panel (para 16-3).
- (2) Disconnect connector P112 from manifold valve assembly.
- (3) Set multimeter to ohms.
- (4) Connect positive (+) probe of multimeter to connector P110-C.
- (5) Connect negative (-) probe of multimeter to connector P112-E and note reading on multimeter.
- (6) If continuity is not present, replace CTIS cable assembly (para 7-53).

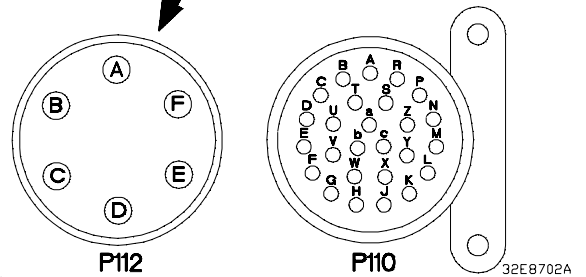
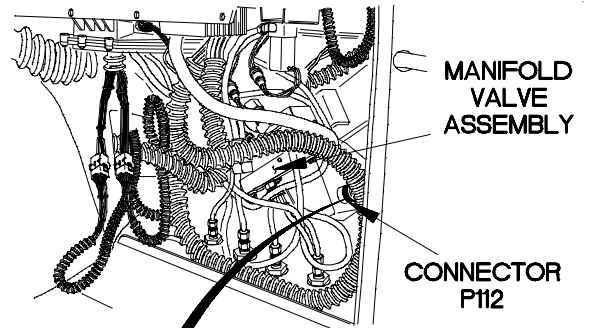

CONTINUITY TEST

- (1) Set multimeter to ohms.
- (2) Connect positive (+) probe of multimeter to connector P110-F.
- (3) Connect negative (-) probe of multimeter to connector P112-A and note reading on multimeter.
- (4) If continuity is not present, replace CTIS cable assembly (para 7-53).

84. CTIS DOES NOT DEFLATE TIRES (CONT)

KNOWN INFO
CTIS inflates tires. CTIS ECU OK.
POSSIBLE PROBLEMS
Faulty CTIS cable assembly. Faulty manifold valve assembly.

4.
Is continuity present between connector P110-R and connector P112-D?

TEST OPTIONS
Continuity Test or STE/ICE-R #91
REASON FOR QUESTION
If continuity is not present, CTIS cable assembly is faulty.

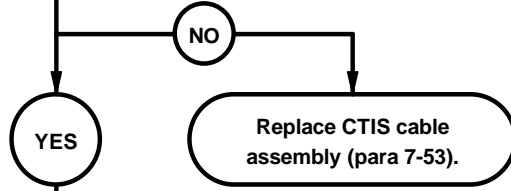

KNOWN INFO
CTIS inflates tires. CTIS ECU OK.
POSSIBLE PROBLEMS
Faulty CTIS cable assembly. Faulty manifold valve assembly.

5.
Is continuity present between connector P110-F and connector P112-B?

TEST OPTIONS
Continuity Test or STE/ICE-R #91
REASON FOR QUESTION
If continuity is not present, CTIS cable assembly is faulty.

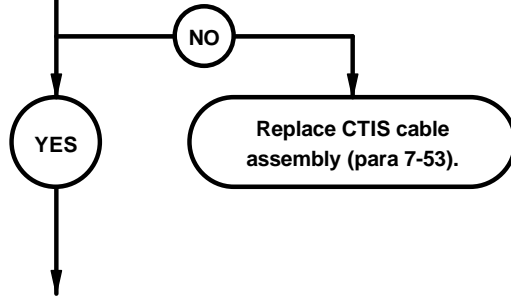

- | CONTINUITY TEST | |
|-----------------|--|
| | (1) Set multimeter to ohms. |
| | (2) Connect positive (+) probe of multimeter to connector P110-R. |
| | (3) Connect negative (-) probe of multimeter to connector P112-D and note reading on multimeter. |
| | (4) If continuity is not present, replace CTIS cable assembly (para 7-53). |

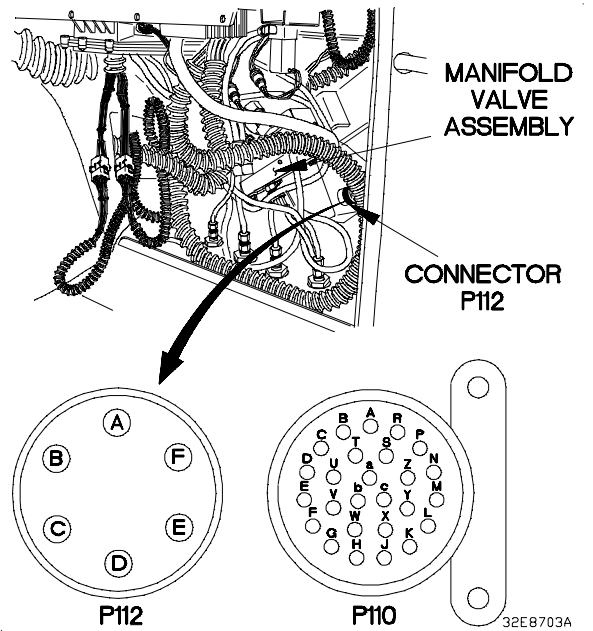

- | CONTINUITY TEST | |
|-----------------|--|
| | (1) Set multimeter to ohms. |
| | (2) Connect positive (+) probe of multimeter to connector P110-F. |
| | (3) Connect negative (-) probe of multimeter to connector P112-B and note reading on multimeter. |
| | (4) If continuity is not present, replace CTIS cable assembly (para 7-53). |
| | (5) Connect connector P112 to manifold valve assembly. |

84. CTIS DOES NOT DEFLATE TIRES (CONT)

KNOWN INFO
CTIS inflates tires. CTIS ECU OK.
POSSIBLE PROBLEMS
Faulty CTIS cable assembly. Faulty manifold valve assembly.

6.
Is continuity present between connector P110-b and connector P113-B?

TEST OPTIONS
Continuity Test or STE/ICE-R #91
REASON FOR QUESTION
If continuity is not present, CTIS cable assembly is faulty.

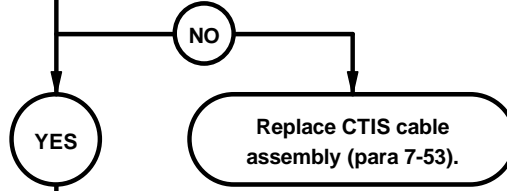

KNOWN INFO
CTIS inflates tires. CTIS ECU OK.
POSSIBLE PROBLEMS
Faulty CTIS cable assembly. Faulty manifold valve assembly.

7.
Is continuity present between connector P110-c and connector P113-C?

TEST OPTIONS
Continuity Test or STE/ICE-R #91
REASON FOR QUESTION
If continuity is not present, CTIS cable assembly is faulty.

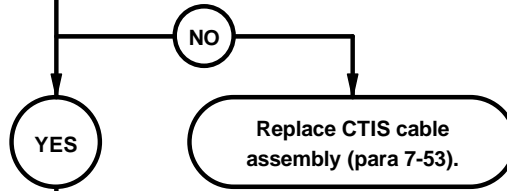

- | CONTINUITY TEST | |
|-----------------|--|
| | (1) Disconnect connector P113 from manifold valve assembly. |
| | (2) Set multimeter to ohms. |
| | (3) Connect positive (+) probe of multimeter to connector P110-b. |
| | (4) Connect negative (-) probe of multimeter to connector P113-B and note reading on multimeter. |
| | (5) If continuity is not present, replace CTIS cable assembly (para 7-53). |

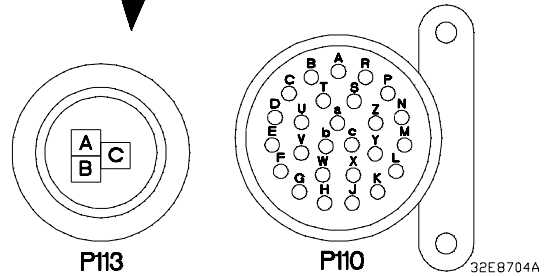
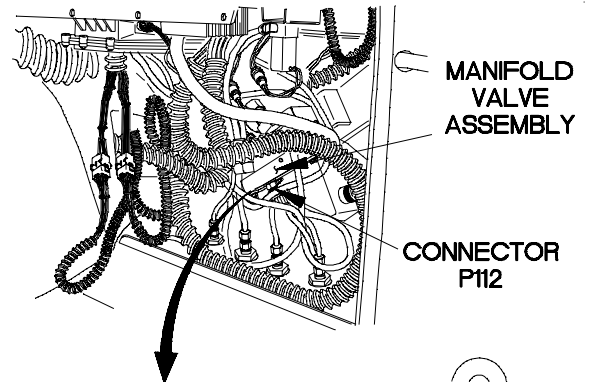

- | CONTINUITY TEST | |
|-----------------|--|
| | (1) Set multimeter to ohms. |
| | (2) Connect positive (+) probe of multimeter to connector P110-c. |
| | (3) Connect negative (-) probe of multimeter to connector P113-C and note reading on multimeter. |
| | (4) If continuity is not present, replace CTIS cable assembly (para 7-53). |

e84. CTIS DOES NOT DEFLATE TIRES (CONT)

KNOWN INFO
CTIS inflates tires. CTIS ECU OK.
POSSIBLE PROBLEMS
Faulty CTIS cable assembly. Faulty manifold valve assembly.

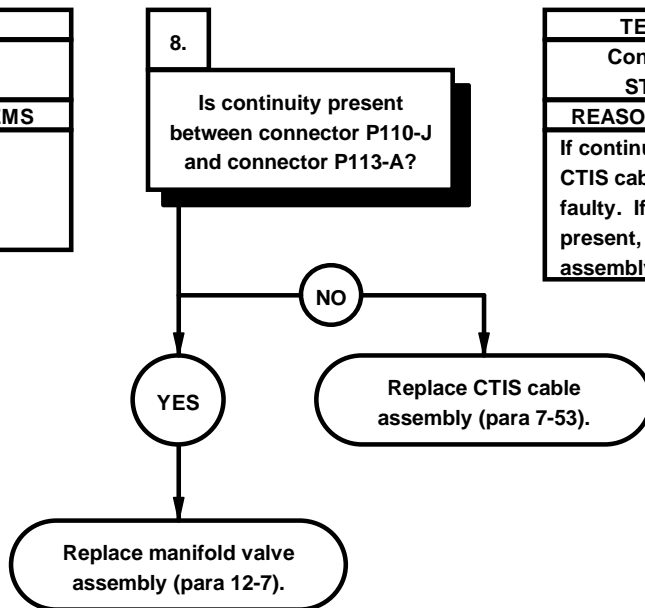

TEST OPTIONS
Continuity Test or STE/ICE-R #91
REASON FOR QUESTION
If continuity is not present, CTIS cable assembly is faulty. If continuity is present, manifold valve assembly is faulty.



- | CONTINUITY TEST | |
|-----------------|--|
| | (1) Set multimeter to ohms. |
| | (2) Connect positive (+) probe of multimeter to connector P110-J. |
| | (3) Connect negative (-) probe of multimeter to connector P113-A and note reading on multimeter. |
| | (4) If continuity is not present, replace CTIS cable assembly (para 7-53). |
| | (5) If continuity is present, replace manifold valve assembly (para 12-7). |
| | (6) Connect connector P113 to manifold valve assembly. |
| | (7) Install kick panel (para 16-3). |
| | (8) Connect connector P110 to CTIS ECU. |

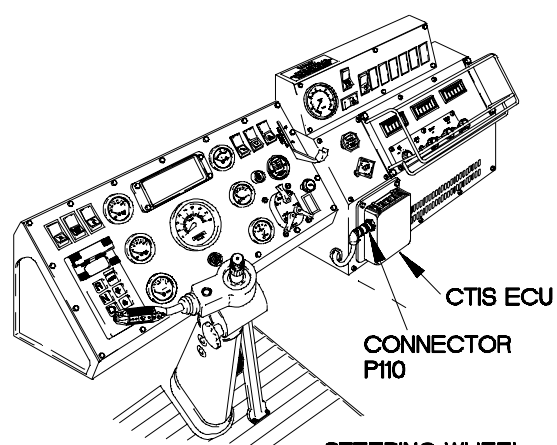
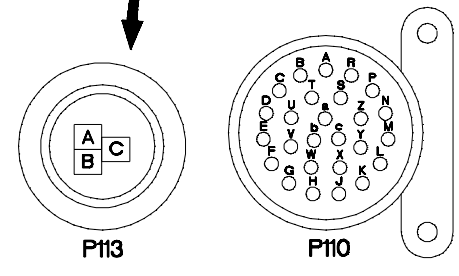
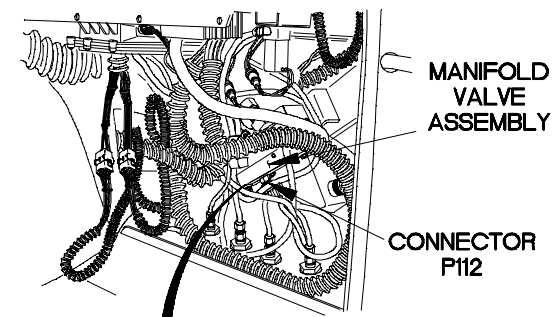

STEERING WHEEL REMOVED FOR CLARITY

32E8705A

e85. 11K SELF-RECOVERY WINCH DOES NOT REEL IN OR PAY OUT	
INITIAL SETUP	
Equipment Condition Engine shut down (TM 9-2320-365-10).	Tools and Special Tools Tool Kit, Genl Mech (Item 44, Appendix C) STE/ICE-R (Item 39, Appendix C) Multimeter, Digital (Item 22, Appendix C)
Personnel Required (2)	References TM 9-4910-571-12&P
Materials/Parts Wire, Elect, 50 ft (Item 77, Appendix D)	

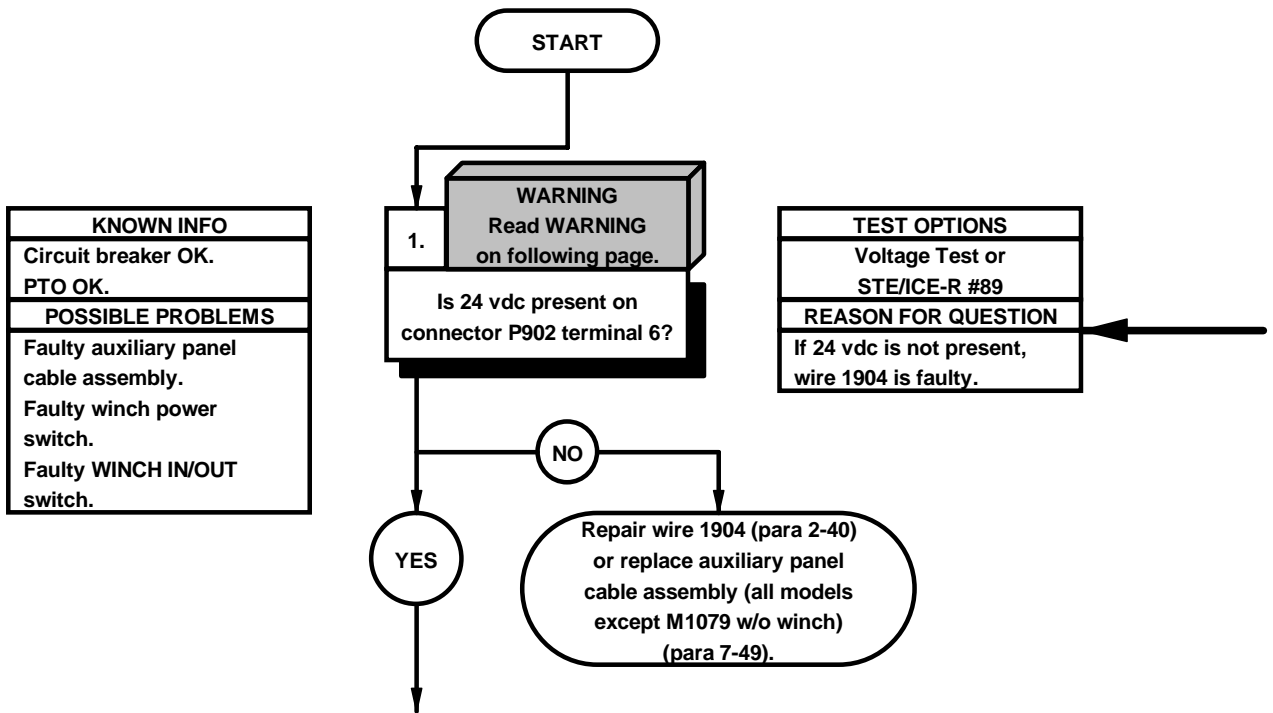

WARNING

Remove rings, bracelets, watches, necklaces, and any other jewelry before working around vehicle. Jewelry can catch on equipment and cause injury or short across electrical circuit and cause severe burns or electrical shock.

VOLTAGE TEST

- (1) Remove auxiliary panel and tilt back. Do not disconnect connectors (para 7-8).
- (2) Disconnect connector P902 from winch power switch.
- (3) Set multimeter to volts dc.
- (4) Connect positive (+) probe of multimeter to connector P902 terminal 6.
- (5) Connect negative (-) probe of multimeter to ground.
- (6) Position master power switch to on (TM 9-2320-365-10).
- (7) Position PTO switch to on (TM 9-2320-365-10) and note reading on multimeter.
- (8) If 24 vdc is not present, repair wire 1904 (para 2-40) or replace auxiliary panel cable assembly (all models except M1079 w/o winch) (para 7-49).
- (9) Position PTO switch to off (TM 9-2320-365-10).
- (10) Position master power switch to off (TM 9-2320-365-10).

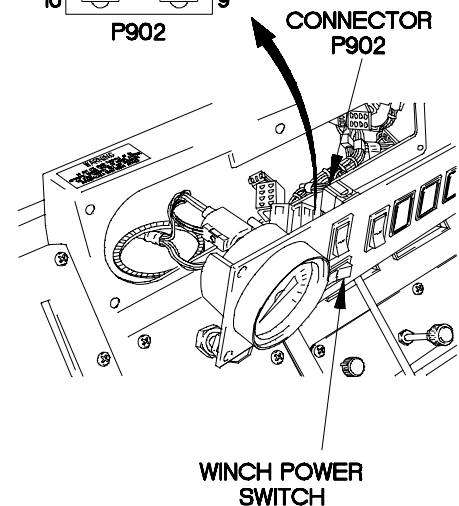
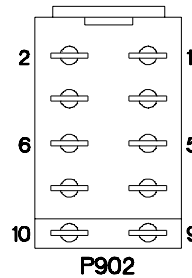
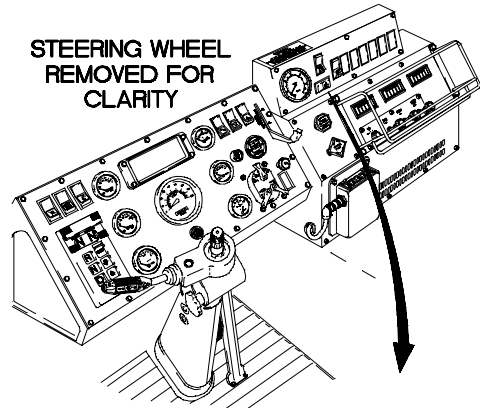

X2E8801A

ø85. 11K SELF-RECOVERY WINCH DOES NOT REEL IN OR PAY OUT (CONT)

KNOWN INFO
Circuit breaker OK. PTO OK.
POSSIBLE PROBLEMS
Faulty winch power switch. Faulty auxiliary panel cable assembly. Faulty WINCH IN/OUT switch.

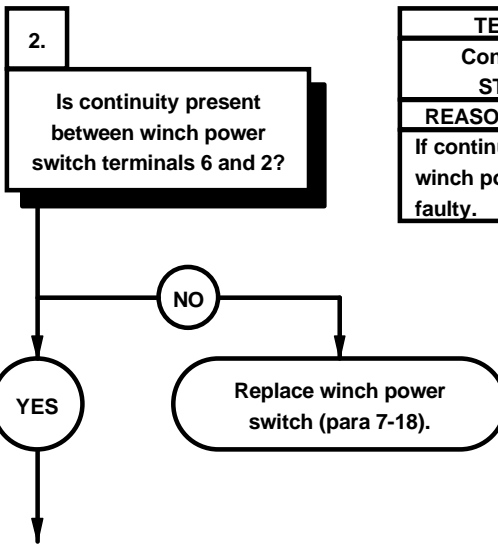

TEST OPTIONS
Continuity Test or STE/ICE-R #91
REASON FOR QUESTION
If continuity is not present, winch power switch is faulty.



CONTINUITY TEST

- (1) Remove kick panel (para 16-3).
- (2) Disconnect connector P112 from manifold valve assembly.
- (3) Set multimeter to ohms.
- (4) Connect positive (+) probe of multimeter to connector P110-C.
- (5) Connect negative (-) probe of multimeter to connector P112-E and note reading on multimeter.
- (6) If continuity is not present, replace CTIS cable assembly (para 7-53).

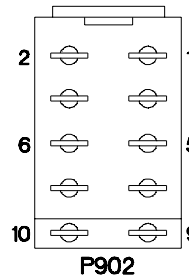
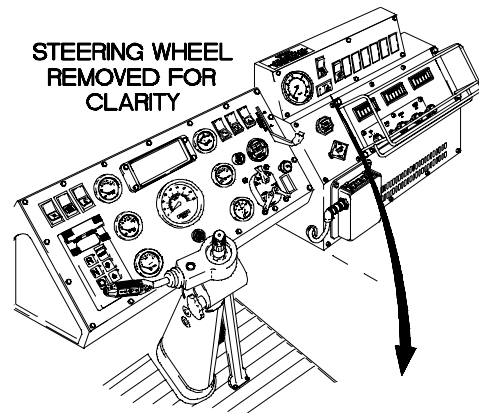

CONNECTOR
P902

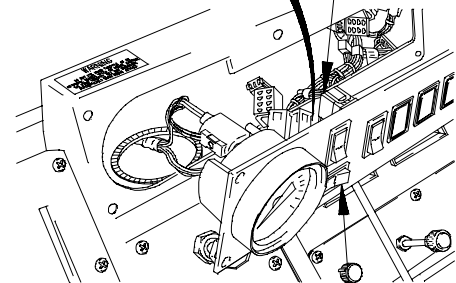

WINCH POWER
SWITCH

CONTINUITY TEST

- (1) Set multimeter to ohms.
- (2) Connect positive (+) probe of multimeter to connector P110-F.
- (3) Connect negative (-) probe of multimeter to connector P112-A and note reading on multimeter.
- (4) If continuity is not present, replace CTIS cable assembly (para 7-53).

X2E8802A

ø85. 11K SELF-RECOVERY WINCH DOES NOT REEL IN OR PAY OUT (CONT)

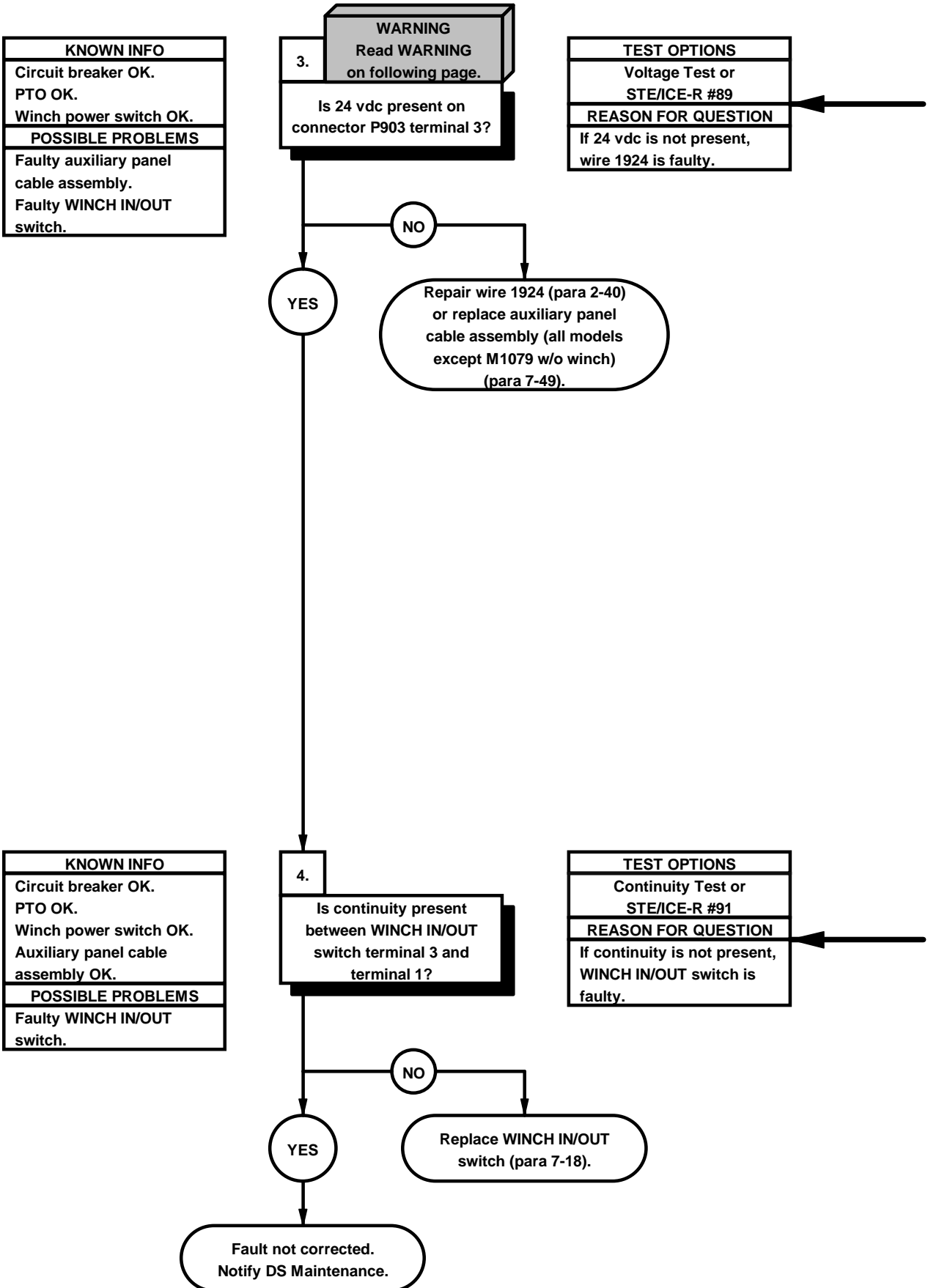

WARNING

Remove rings, bracelets, watches, necklaces, and any other jewelry before working around vehicle. Jewelry can catch on equipment and cause injury or short across electrical circuit and cause severe burns or electrical shock.

VOLTAGE TEST

- (1) Disconnect connector P903 from WINCH IN/OUT switch.
- (2) Set multimeter to volts dc.
- (3) Connect positive (+) probe of multimeter to connector P903 terminal 3.
- (4) Connect negative (-) probe of multimeter to ground.
- (5) Position master power switch to on (TM 9-2320-365-10).
- (6) Position PTO switch to on (TM 9-2320-365-10).
- (7) Position winch power switch to on (TM 9-2320-365-10) and note reading on multimeter.
- (8) If 24 vdc is not present, repair wire 1924 (para 2-40) or replace auxiliary panel cable assembly (all models except M1079 w/o winch) (para 7-49).
- (9) Position winch power switch to off (TM 9-2320-365-10).
- (10) Position PTO switch to off (TM 9-2320-365-10).
- (11) Position master power switch to off (TM 9-2320-365-10).

STEERING WHEEL
REMOVED FOR
CLARITY

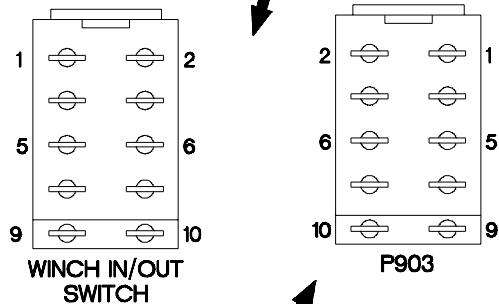
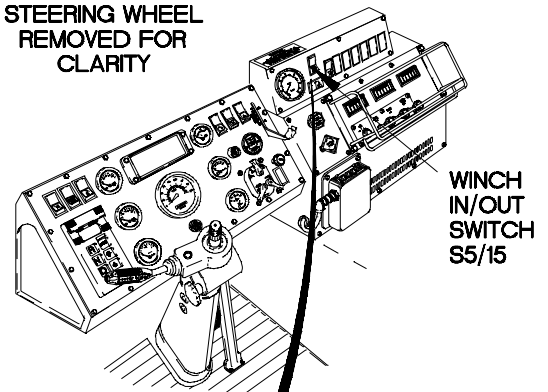

CONTINUITY TEST

- (1) Set multimeter to ohms.
- (2) Connect positive (+) probe of multimeter to WINCH IN/OUT switch terminal 3.
- (3) Connect negative (-) probe of multimeter to WINCH IN/OUT switch terminal 1.
- (4) Position WINCH IN/OUT switch to in (TM 9-2320-365-10) and note reading on multimeter.
- (5) If continuity is not present, replace WINCH IN/OUT switch (para 7-18).
- (6) If continuity is present, fault not corrected. Notify DS Maintenance.
- (7) Connect connector P903 to WINCH IN/OUT switch.
- (8) Install auxiliary panel (para 7-8).

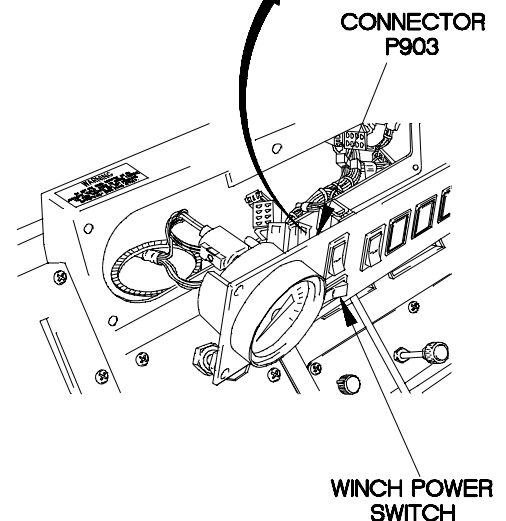

X2E8803A

e86. 11K SELF-RECOVERY WINCH DOES NOT REEL IN

INITIAL SETUP

Equipment Condition

Engine shut down (TM 9-2320-365-10).

Personnel Required

(2)

References

TM 9-4910-571-12&P

Tools and Special Tools

Tool Kit, Genl Mech (Item 44, Appendix C)

STE/ICE-R (Item 39, Appendix C)

Multimeter, Digital (Item 22, Appendix C)

Wrench, Torque, 0-200 lb-in. (Item 58, Appendix C)

Materials/Parts

Wire, Elect, 50 ft (Item 77, Appendix D)

KNOWN INFO
Circuit breaker OK. 11K self-recovery winch pays out.
POSSIBLE PROBLEMS
Faulty winch control valve cable assembly. Faulty winch control valve assembly. Faulty WINCH IN/OUT switch. Faulty PTO cable assembly. Faulty auxiliary panel cable assembly.

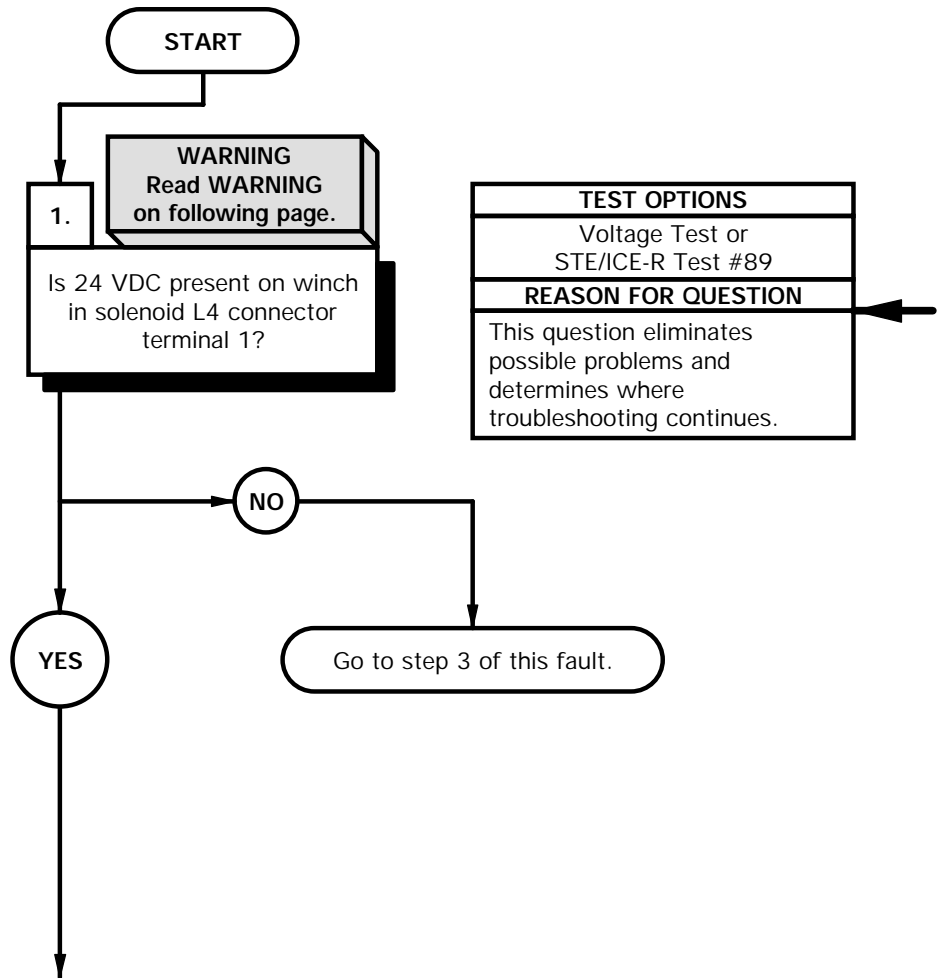

WARNING

Remove rings, bracelets, watches, necklaces, and any other jewelry before working around vehicle. Jewelry can catch on equipment and cause injury or short across electrical circuits and cause severe burns or electrical shock.

VOLTAGE TEST

- (1) Remove four nuts, washers, solenoid bracket, washers, and screws.
- (2) Loosen screw and disconnect winch in solenoid L4 connector from solenoid L4.
- (3) Set multimeter to volts DC.
- (4) Connect positive (+) probe of multimeter to winch in solenoid L4 connector terminal 1.
- (5) Connect negative (-) probe of multimeter to ground.
- (6) Position master power switch to on (TM 9-2320-365-10).
- (7) Position PTO switch to on (TM 9-2320-365-10).
- (8) Position winch power switch to on (TM 9-2320-365-10).
- (9) Position WINCH IN/OUT switch to IN (TM 9-2320-365-10) and note reading on multimeter.
- (10) If 24 VDC is not present, go to step 3 of this fault.
- (11) Position winch power switch to off (TM 9-2320-365-10).
- (12) Position PTO switch to off (TM 9-2320-365-10).
- (13) Position master power switch to off (TM 9-2320-365-10).

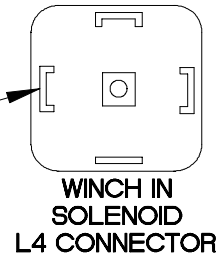
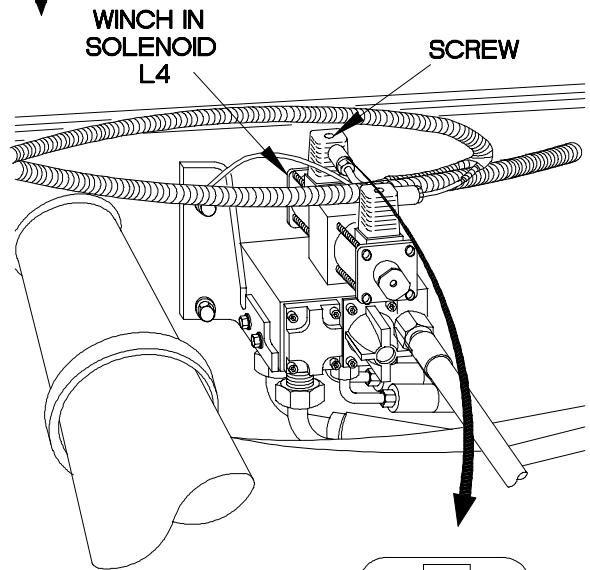
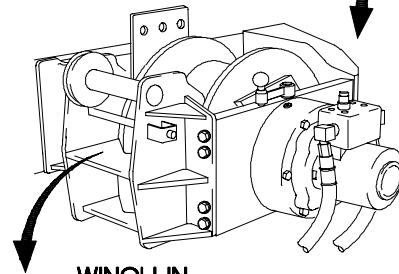
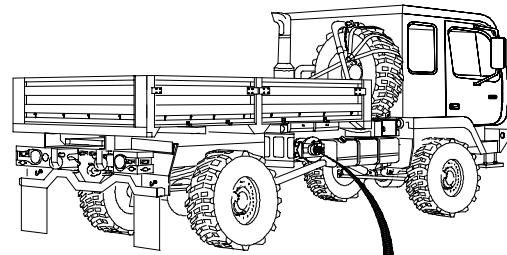

32E8901A

e86. 11K SELF-RECOVERY WINCH DOES NOT REEL IN (CONT)

KNOWN INFO
Circuit breaker OK. 11K self-recovery winch pays out. WINCH IN/OUT switch OK. Auxiliary panel cable assembly OK. PTO cable assembly OK.
POSSIBLE PROBLEMS
Faulty winch control valve cable assembly. Faulty winch control valve assembly.

2.
Is continuity present between winch in solenoid L4 connector terminal 2 and a known good ground?

TEST OPTIONS
Continuity Test or STE/ICE-R Test #91
REASON FOR QUESTION
If continuity is not present, wire 3069 is faulty. If continuity is present, winch control valve assembly is faulty.

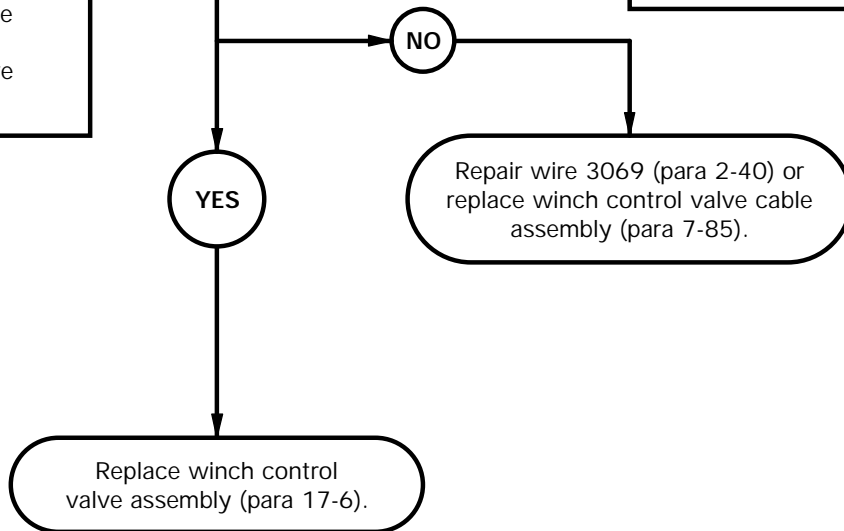

CONTINUITY TEST

- (1) Set multimeter to ohms.
- (2) Connect positive (+) probe of multimeter to winch in solenoid L4 terminal 2.
- (3) Connect negative (-) probe of multimeter to ground and note reading on multimeter.
- (4) If continuity is not present, repair wire 3069 (para 2-40) or replace winch control valve cable assembly (para 7-85).
- (5) If continuity is present, replace winch control valve assembly (para 17-6).
- (6) Connect winch in solenoid L4 connector on solenoid L4 and tighten screw.

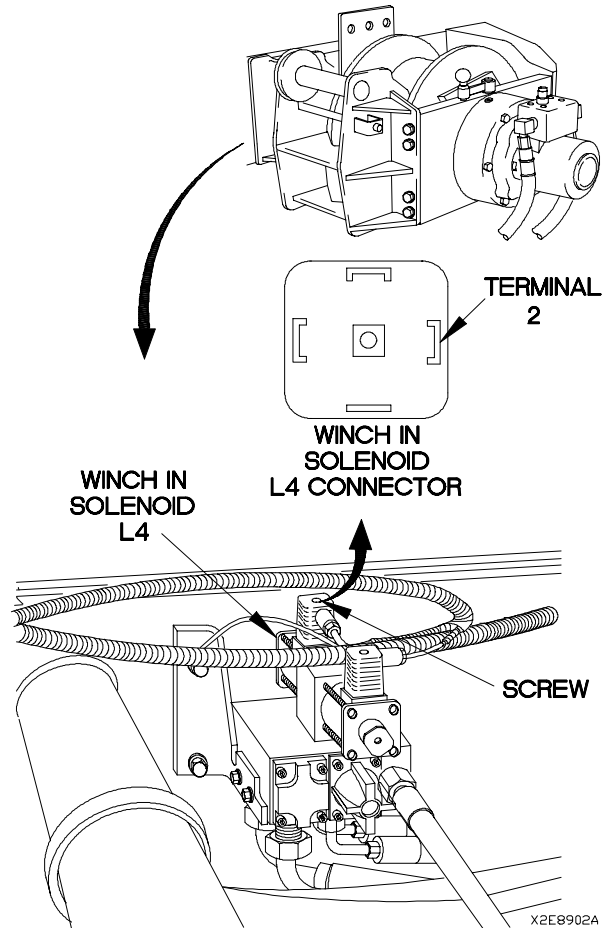

e86. 11K SELF-RECOVERY WINCH DOES NOT REEL IN (CONT)

KNOWN INFO
Circuit breaker OK. 11K self-recovery winch pays out. Winch control valve assembly OK.
POSSIBLE PROBLEMS
Faulty winch in/out switch. Faulty winch control valve cable assembly. Faulty PTO cable assembly. Faulty auxiliary panel cable assembly.

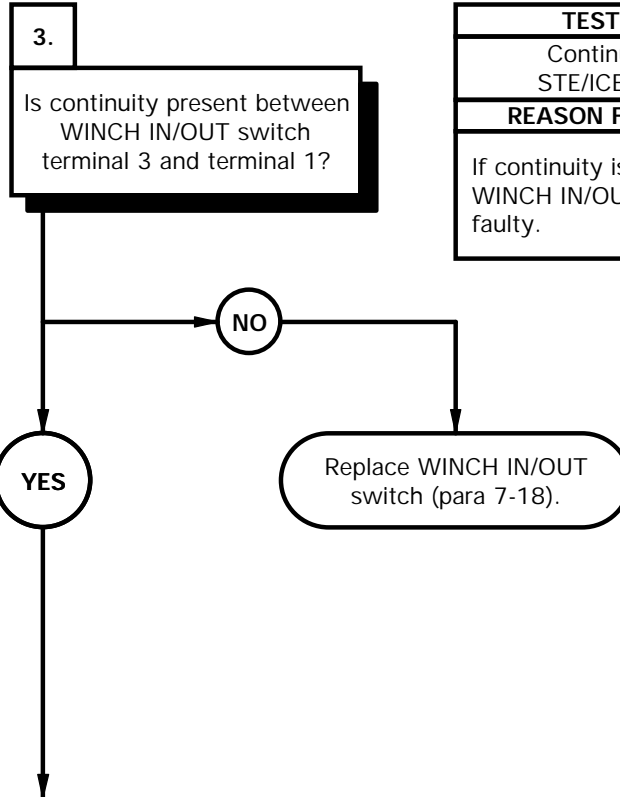

TEST OPTIONS
Continuity Test or STE/ICE-R Test #91
REASON FOR QUESTION
If continuity is not present, WINCH IN/OUT switch is faulty.

CONTINUITY TEST

- (1) Remove six screws from auxiliary panel.
- (2) Lift auxiliary panel from auxiliary panel housing to gain access.
- (3) Disconnect connector P903 from WINCH IN/OUT switch.
- (4) Set multimeter to ohms.
- (5) Connect positive (+) probe of multimeter to WINCH IN/OUT switch terminal 3.
- (6) Connect negative (-) probe of multimeter to WINCH IN/OUT switch terminal 1.
- (7) Position WINCH IN/OUT switch to in (TM 9-2320-365-10) and note reading on multimeter.
- (8) If continuity is not present, replace WINCH IN/OUT switch (para 7-18).

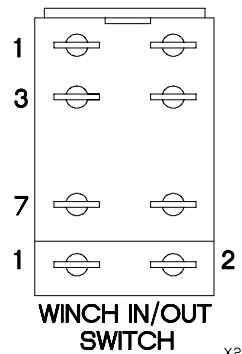
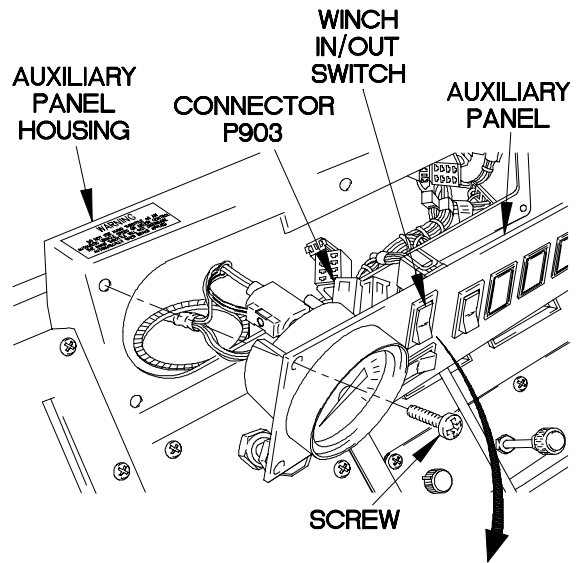

X2E8903A

e86. 11K SELF-RECOVERY WINCH DOES NOT REEL IN (CONT)

KNOWN INFO
Circuit breaker OK. 11K self-recovery winch pays out. Winch control valve assembly OK. WINCH IN/OUT switch OK.
POSSIBLE PROBLEMS
Faulty winch control valve cable assembly. Faulty PTO cable assembly. Faulty auxiliary panel cable assembly.

4.
Is continuity present between connector P903-1 and connector P210-14?

TEST OPTIONS
Continuity Test or STE/ICE-R Test #91
REASON FOR QUESTION
If continuity is not present, wire 2005 is faulty.

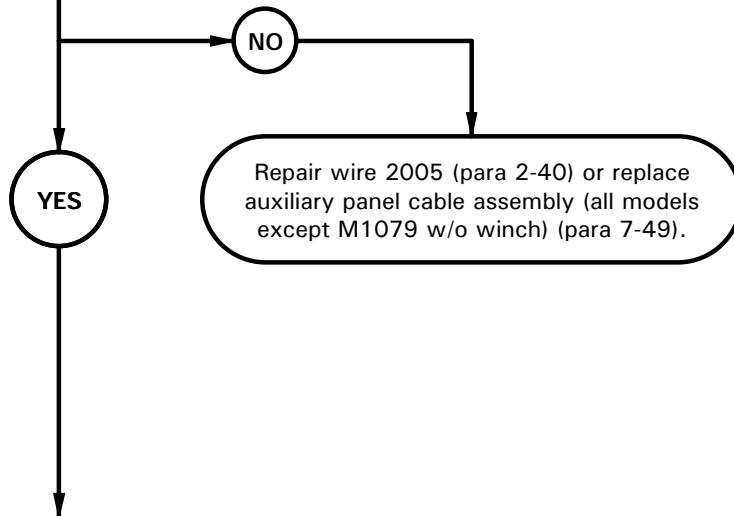

CONTINUITY TEST

- (1) Remove kick panel (para 16-3).
- (2) Disconnect connector P210 from connector J210.
- (3) Set multimeter to ohms.
- (4) Connect positive (+) probe of multimeter to connector P903-1.
- (5) Connect negative (-) probe of multimeter to connector P210-14 and note reading on multimeter.
- (6) If continuity is not present, repair wire 2005 (para 2-40) or replace auxiliary panel cable assembly (all models except M1079 w/o winch (para 7-49).
- (7) Connect connector P903 to WINCH IN/OUT switch.
- (8) Position auxiliary panel on auxiliary panel housing with six screws.
- (9) Tighten six screws to 24 lb-in. (3 N·m).

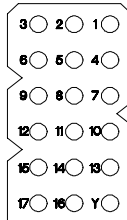
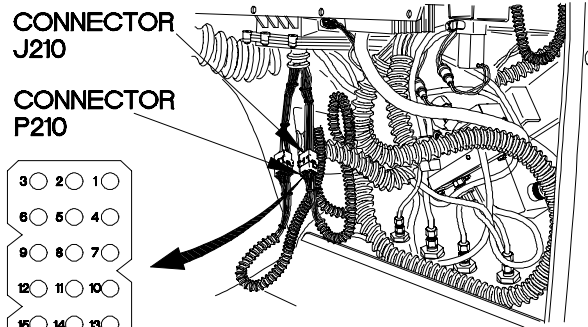

P210

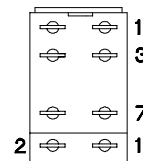

P903

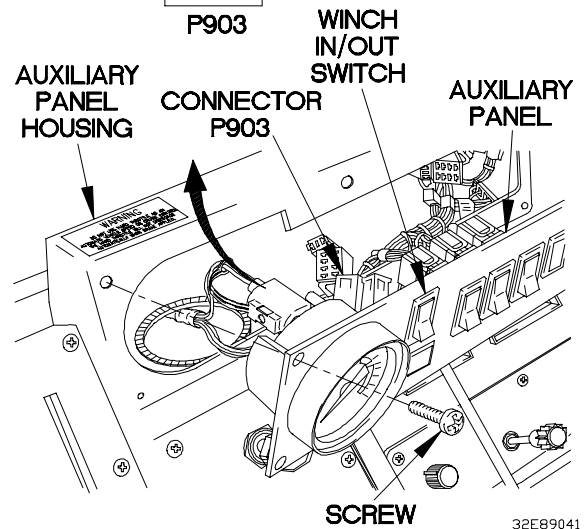

32E89041

e86. 11K SELF-RECOVERY WINCH DOES NOT REEL IN (CONT)

KNOWN INFO
Circuit breaker OK. 11K self-recovery winch pay out. Winch control valve assembly OK. WINCH IN/OUT switch OK. Auxiliary panel cable assembly OK.
POSSIBLE PROBLEMS
Faulty winch control valve cable assembly. Faulty PTO cable assembly.

5.
Is continuity present between connector J210-14 and connector P215-2?

TEST OPTIONS
Continuity Test or STE/ICE-R Test #91
REASON FOR QUESTION
If continuity is not present, wire 2005 is faulty.

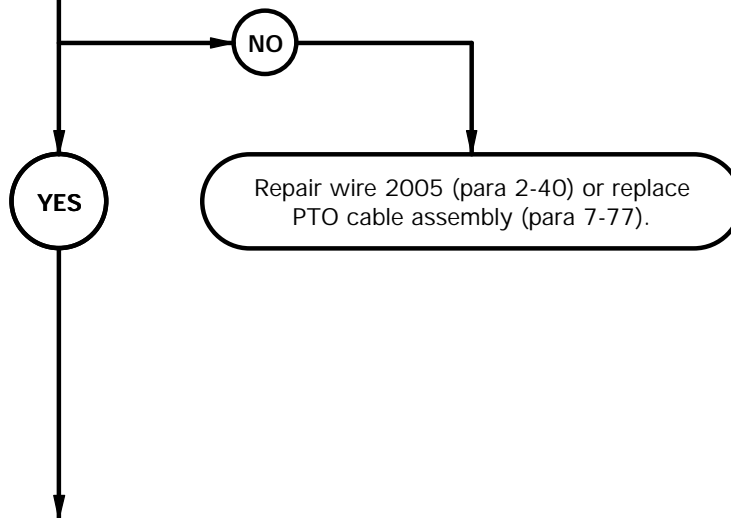

CONTINUITY TEST

- (1) Disconnect connector P215 from connector J215.
- (2) Set multimeter to ohms.
- (3) Connect positive (+) probe of multimeter to connector J210-14.
- (4) Connect negative (-) probe of multimeter to connector P215-2 and note reading on multimeter.
- (5) If continuity is not present, repair wire 2005 (para 2-40) or replace PTO cable assembly (para 7-77).
- (6) Connect connector P210 to connector J210.
- (7) Install kick panel (para 16-3).

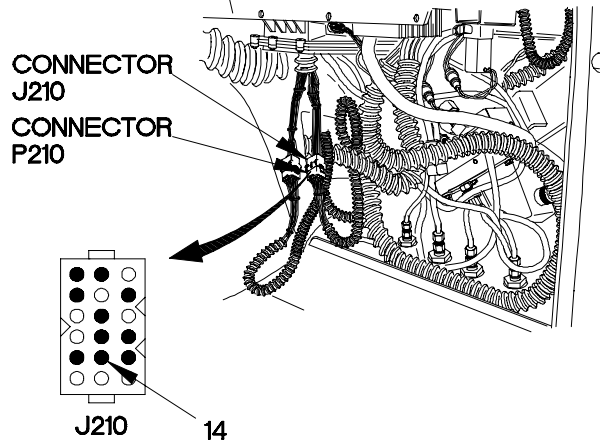
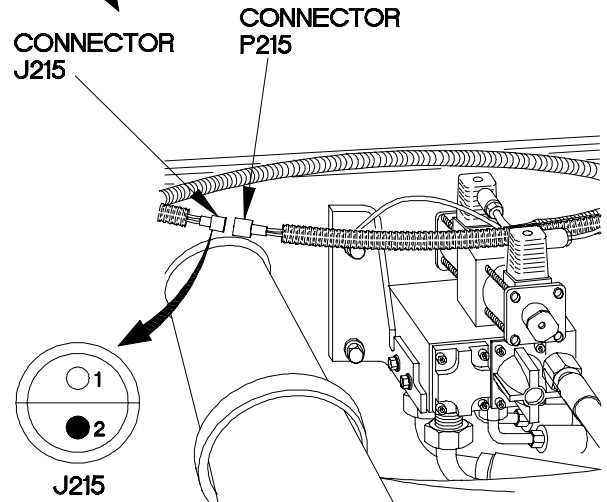
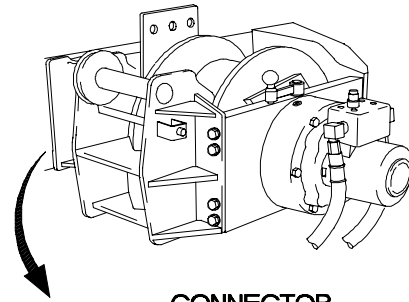
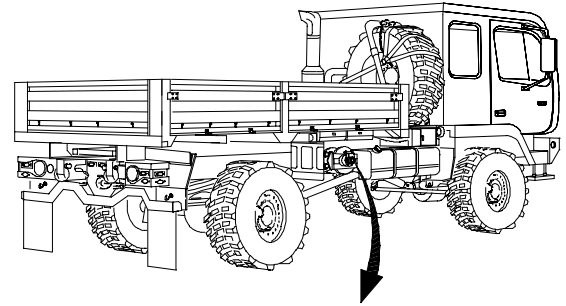

32E8906A

e86. 11K SELF-RECOVERY WINCH DOES NOT REEL IN (CONT)

KNOWN INFO
Circuit breaker OK. 11K self-recovery winch pays out. Winch control valve assembly OK. WINCH IN/OUT switch OK. Auxiliary panel cable assembly OK. PTO cable assembly OK.
POSSIBLE PROBLEMS
Faulty winch control valve cable assembly.

6.
Is continuity present between connector J215-2 and connector L4-1?

TEST OPTIONS
Continuity Test or STE/ICE-R Test #91
REASON FOR QUESTION
If continuity is not present, wire 2005 is faulty. If continuity is present, notify DS Maintenance.

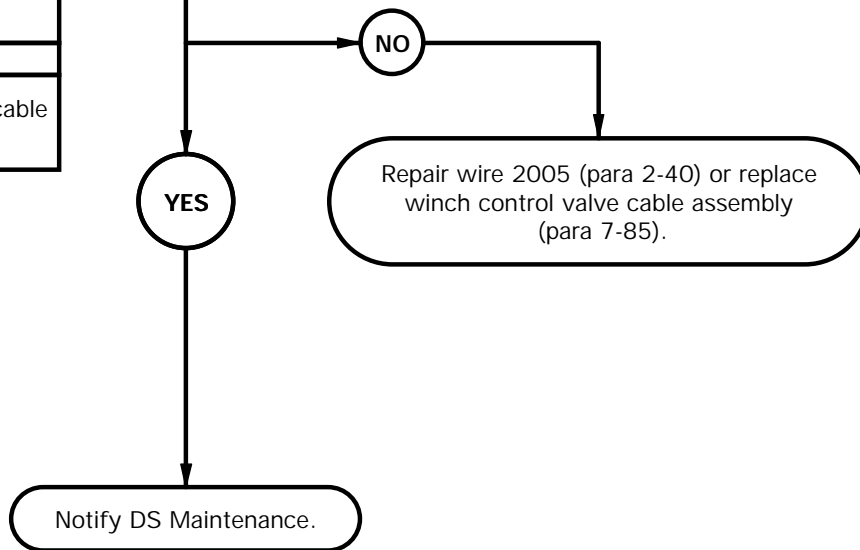

CONTINUITY TEST

- (1) Set multimeter to ohms.
- (2) Connect positive (+) probe of multimeter to connector J215-2.
- (3) Connect negative (-) probe of multimeter to winch in solenoid L4 and note reading on multimeter.
- (4) If continuity is not present, repair wire 2005 (para 2-40) or replace winch control valve cable assembly (para 7-85).
- (5) If continuity is present, notify DS Maintenance.
- (6) Connect connector P215 to connector J215.
- (7) Connect winch in solenoid L4 connector to solenoid L4 and tighten screw.

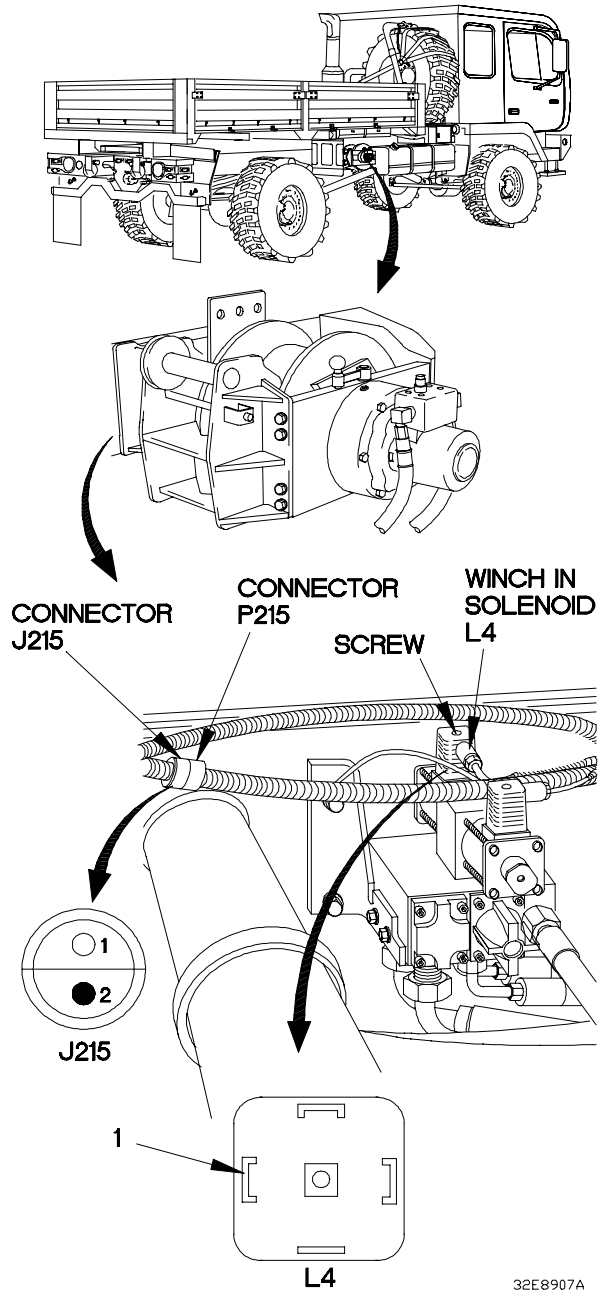

32E8907A

e87. 11K SELF-RECOVERY WINCH DOES NOT PAY OUT

INITIAL SETUP

Equipment Condition

Engine shut down (TM 9-2320-365-10).

Personnel Required

(2)

References

TM 9-4910-571-12&P

Tools and Special Tools

Tool Kit, Genl Mech (Item 44, Appendix C)

STE/ICE-R (Item 39, Appendix C)

Multimeter, Digital (Item 22, Appendix C)

Wrench, Torque, 0-200 lb-in. (Item 58, Appendix C)

Materials/Parts

Wire, Elect, 50 ft (Item 77, Appendix D)

KNOWN INFO
Circuit breaker OK. 11K self-recovery winch reels in OK.
POSSIBLE PROBLEMS
Faulty winch control valve cable assembly. Faulty winch control valve assembly. Faulty WINCH IN/OUT switch. Faulty PTO cable assembly. Faulty auxiliary panel cable assembly.

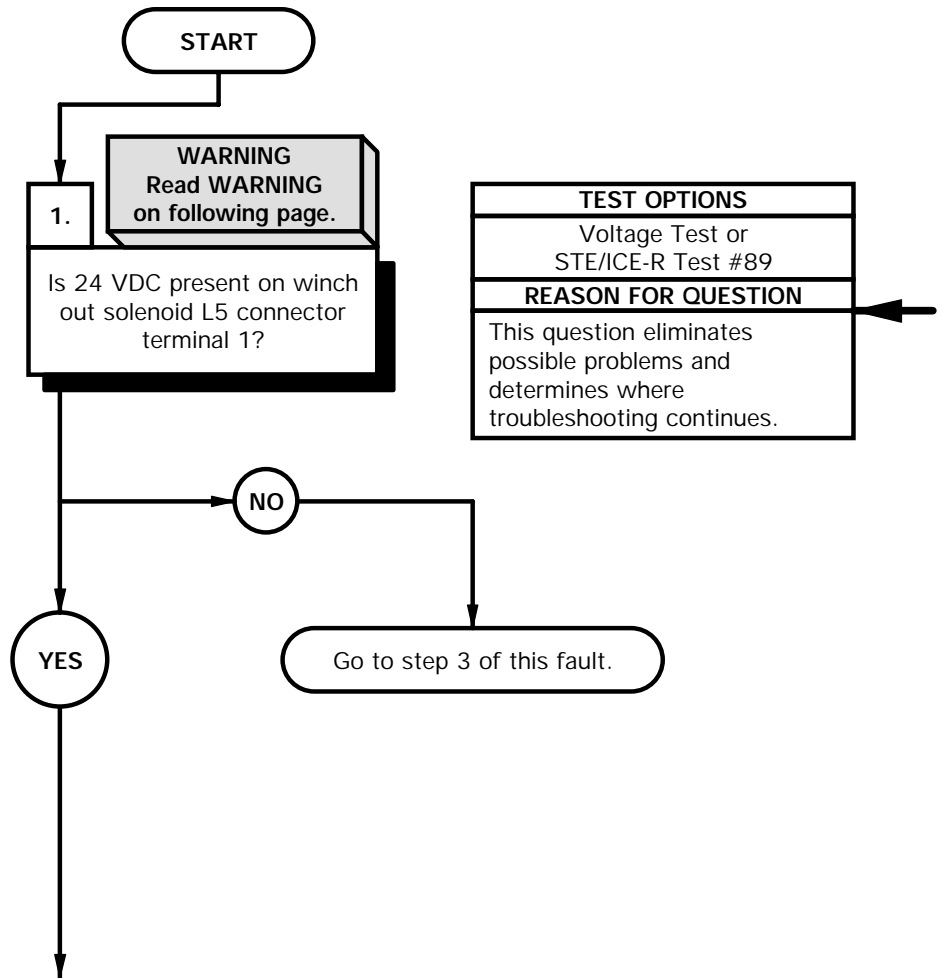

WARNING

Remove rings, bracelets, watches, necklaces, and any other jewelry before working around vehicle. Jewelry can catch on equipment and cause injury or short across electrical circuits and cause severe burns or electrical shock.

VOLTAGE TEST

- (1) Remove four nuts, washers, solenoid bracket, washers, and screws.
- (2) Loosen screw and disconnect winch out solenoid L5 connector from solenoid L5.
- (3) Set multimeter to volts DC.
- (4) Connect positive (+) probe of multimeter to winch out solenoid L5 connector terminal 1.
- (5) Connect negative (-) probe of multimeter to ground.
- (6) Position master power switch to on (TM 9-2320-365-10).
- (7) Position PTO switch to on (TM 9-2320-365-10).
- (8) Position winch power switch to on (TM 9-2320-365-10).
- (9) Position WINCH IN/OUT switch to OUT (TM 9-2320-365-10) and note reading on multimeter.
- (10) If 24 VDC is not present, go to step 3 of this fault.
- (11) Position winch power switch to off (TM 9-2320-365-10).
- (12) Position PTO switch to off (TM 9-2320-365-10).
- (13) Position master power switch to off (TM 9-2320-365-10).

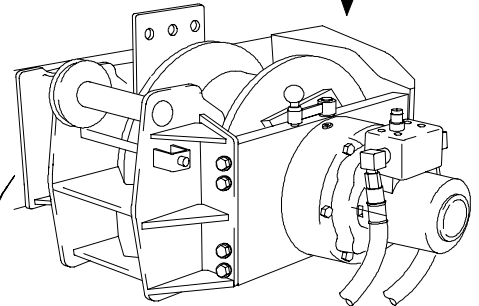
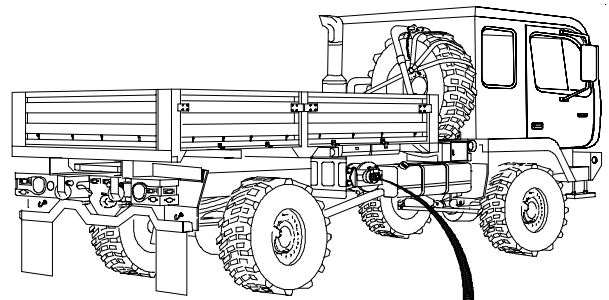

1

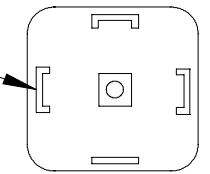

WINCH OUT SOLENOID L5 CONNECTOR

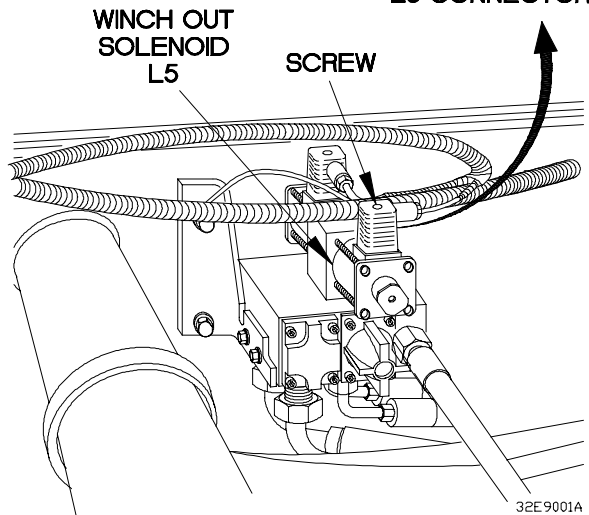

32E9001A

e87. 11K SELF-RECOVERY WINCH DOES NOT PAY OUT (CONT)

KNOWN INFO
Circuit breaker OK. 11K self-recovery winch reels in OK. WINCH IN/OUT switch OK. Auxiliary panel cable assembly OK. PTO cable assembly OK.
POSSIBLE PROBLEMS
Faulty winch control valve cable assembly. Faulty winch control valve assembly.

2.
Is continuity present between winch out solenoid L5 connector terminal 2 and a known good ground?

TEST OPTIONS
Continuity Test or STE/ICE-R Test #91
REASON FOR QUESTION
If continuity is not present, wire 3070 is faulty. If continuity is present, winch control valve assembly is faulty.

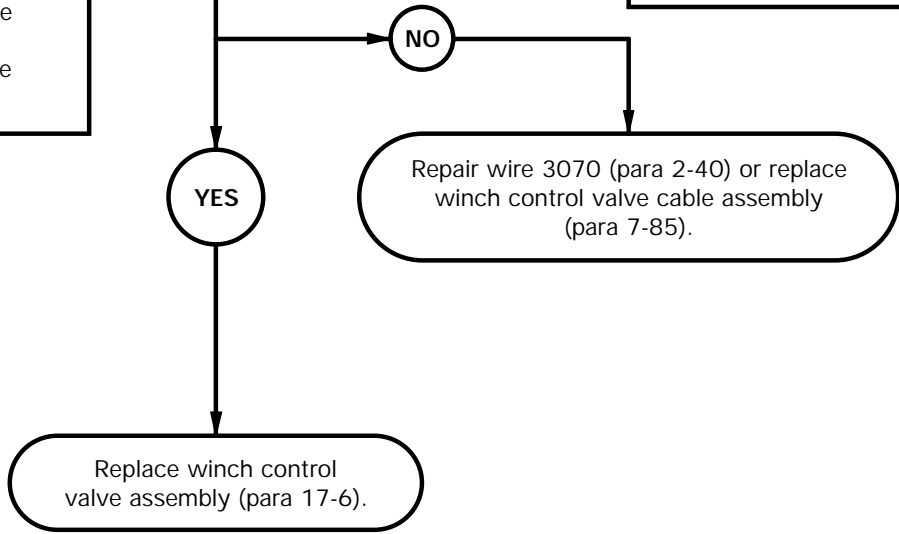

CONTINUITY TEST

- (1) Set multimeter to ohms.
- (2) Connect positive (+) probe of multimeter to winch out solenoid L5 terminal 2.
- (3) Connect negative (-) probe of multimeter to ground and note reading on multimeter.
- (4) If continuity is not present, repair wire 3070 (para 2-40) or replace winch control valve cable cable assembly (para 7-85).
- (5) If continuity is present, replace winch control valve assembly (para 17-6).
- (6) Connect winch out solenoid L5 connector on solenoid L5 and tighten screw.

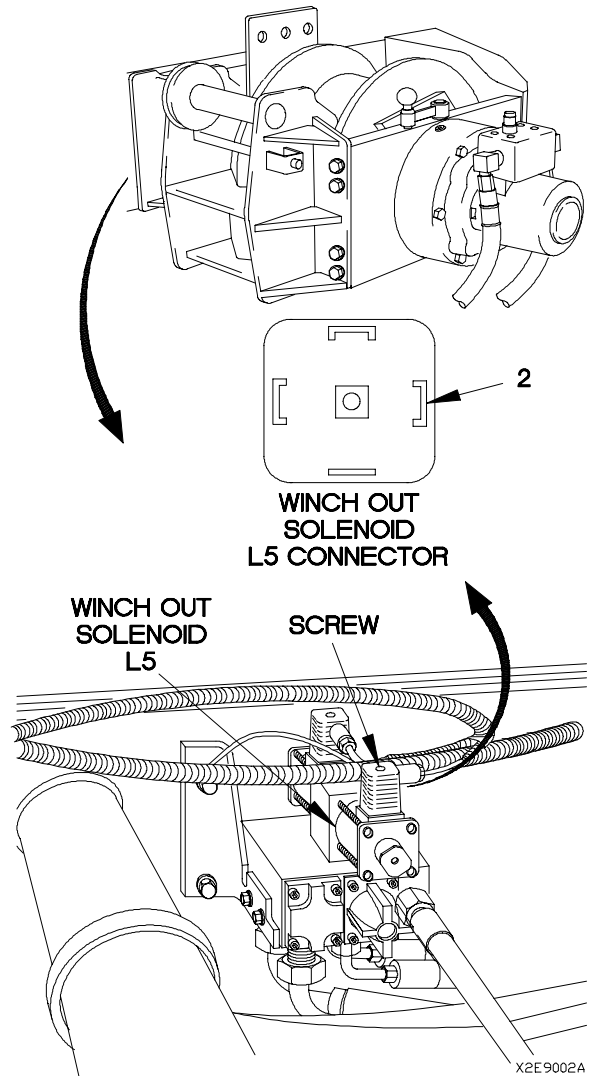

e87. 11K SELF-RECOVERY WINCH DOES NOT PAY OUT (CONT)

KNOWN INFO
Circuit breaker OK. 11K self-recovery winch reels in OK. Winch control valve assembly OK.
POSSIBLE PROBLEMS
Faulty WINCH IN/OUT switch. Faulty winch control valve cable assembly. Faulty PTO cable assembly. Faulty auxiliary panel cable assembly.

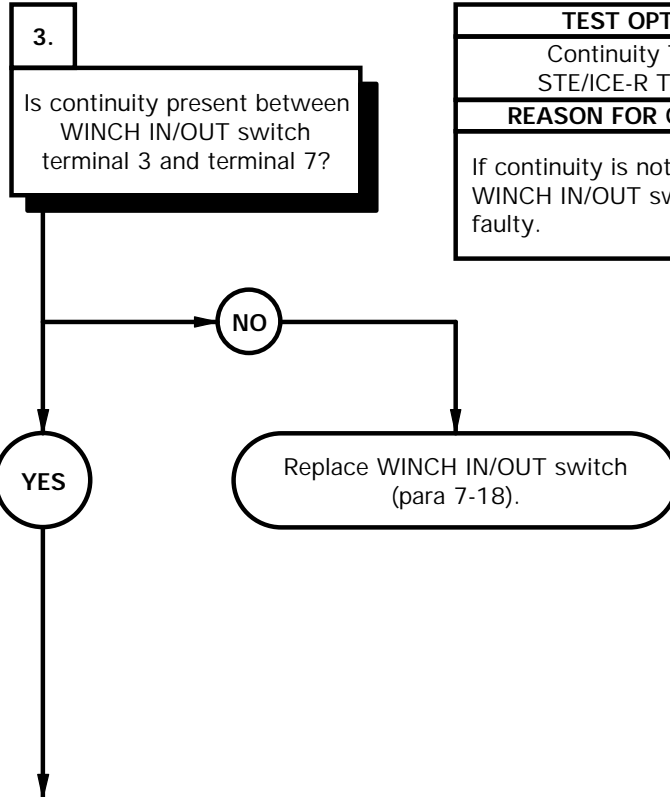

TEST OPTIONS
Continuity Test or STE/ICE-R Test #91
REASON FOR QUESTION
If continuity is not present, WINCH IN/OUT switch is faulty.

CONTINUITY TEST

- (1) Remove six screws from auxiliary panel.
- (2) Lift auxiliary panel from auxiliary panel housing to gain access.
- (3) Disconnect connector P903 from WINCH IN/OUT switch.
- (4) Set multimeter to ohms.
- (5) Connect positive (+) probe of multimeter to WINCH IN/OUT switch terminal 3.
- (6) Connect negative (-) probe of multimeter to WINCH IN/OUT switch terminal 7.
- (7) Position WINCH IN/OUT switch to out (TM 9-2320-365-10) and note reading on multimeter.
- (8) If continuity is not present, replace WINCH IN/OUT switch (para 7-18).

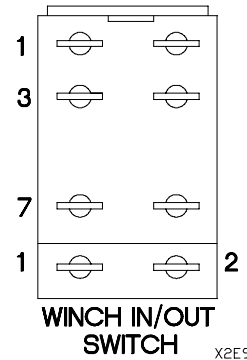
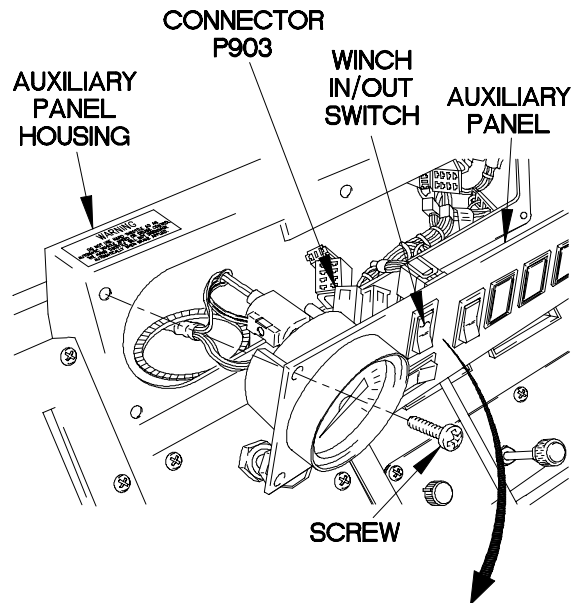

e87. 11K SELF-RECOVERY WINCH DOES NOT PAY OUT (CONT)

KNOWN INFO
Circuit breaker OK. 11K self-recovery winch reels in OK. Winch control valve assembly OK. WINCH IN/OUT switch OK.
POSSIBLE PROBLEMS
Faulty winch control valve cable assembly. Faulty PTO cable assembly. Faulty auxiliary panel cable assembly.

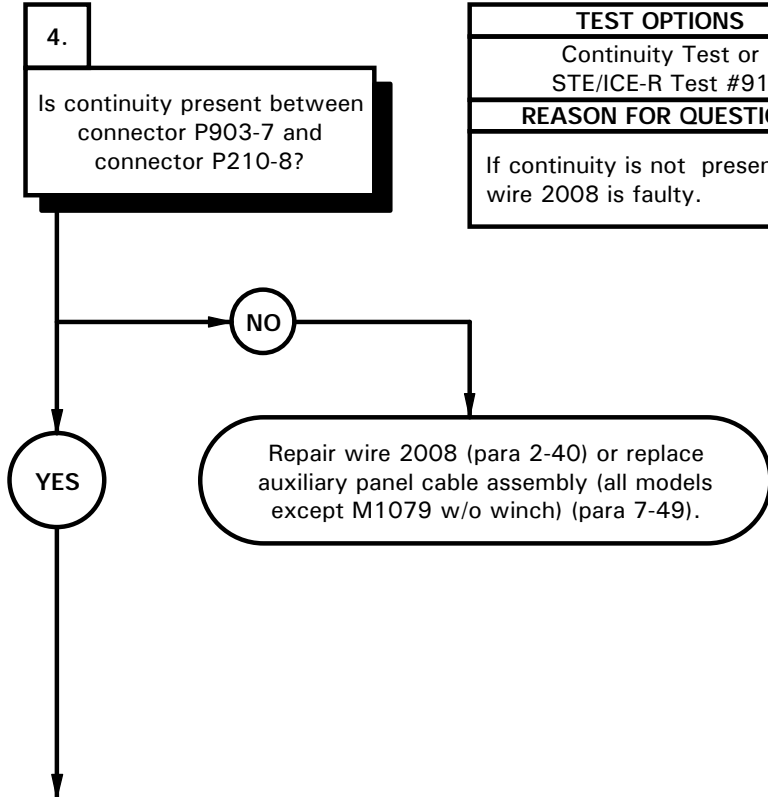

TEST OPTIONS
Continuity Test or STE/ICE-R Test #91
REASON FOR QUESTION
If continuity is not present, wire 2008 is faulty.

CONTINUITY TEST

- (1) Remove kick panel (para 16-3).
- (2) Disconnect connector P210 from connector J210.
- (3) Set multimeter to ohms.
- (4) Connect positive (+) probe of multimeter to connector P903-7.
- (5) Connect negative (-) probe of multimeter to connector P210-8 and note reading on multimeter.
- (6) If continuity is not present, repair wire 2008 (para 2-40) or replace auxiliary panel cable assembly (all models except M1079 w/o winch (para 7-49).
- (7) Connect connector P903 to WINCH IN/OUT switch.
- (8) Position auxiliary panel on auxiliary panel housing with six screws.
- (9) Tighten six screws to 24 lb-in. (3 N·m).

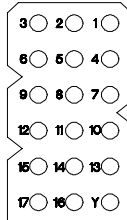
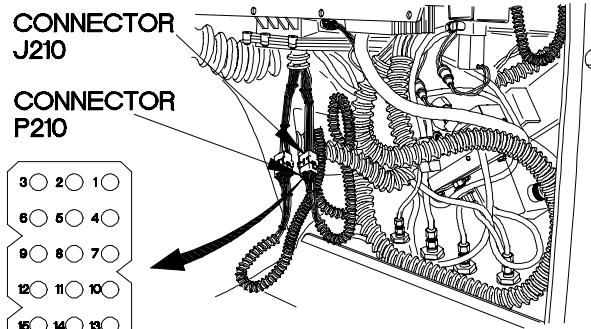

P210

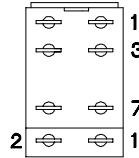

P903

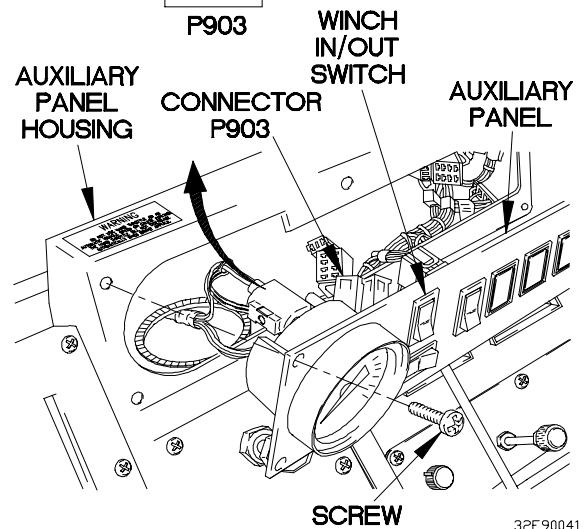

32E90041

e87. 11K SELF-RECOVERY WINCH DOES NOT PAY OUT (CONT)

KNOWN INFO
Circuit breaker OK. 11K self-recovery winch reels in OK. Winch control valve assembly OK. WINCH IN/OUT switch OK. Auxiliary panel cable assembly OK.
POSSIBLE PROBLEMS
Faulty winch control valve cable assembly. Faulty PTO cable assembly.

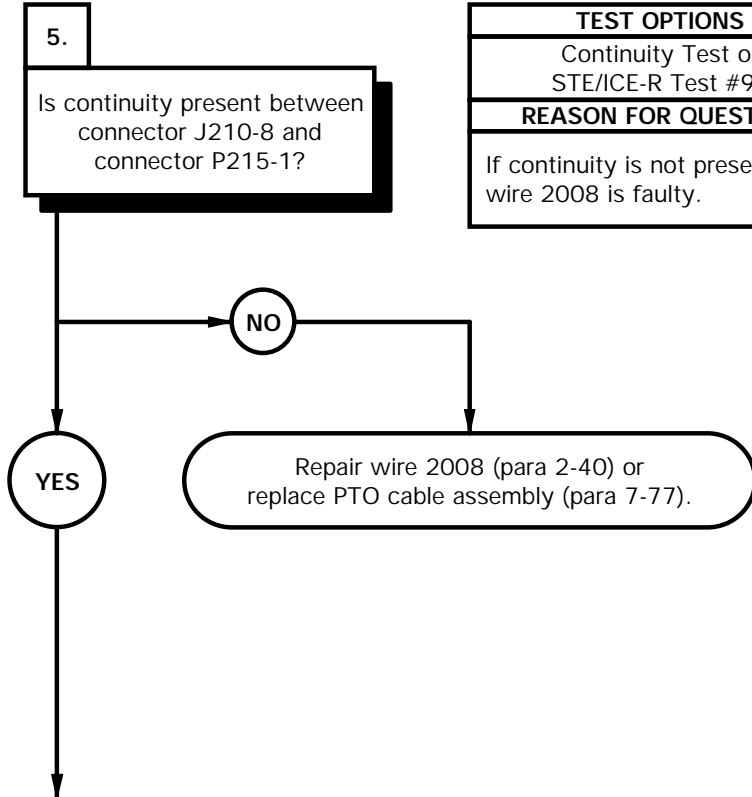

TEST OPTIONS
Continuity Test or STE/ICE-R Test #91
REASON FOR QUESTION
If continuity is not present, wire 2008 is faulty.

CONTINUITY TEST

- (1) Disconnect connector P215 from connector J215.
- (2) Set multimeter to ohms.
- (3) Connect positive (+) probe of multimeter to connector J210-8.
- (4) Connect negative (-) probe of multimeter to connector P215-1 and note reading on multimeter.
- (5) If continuity is not present, repair wire 2008 (para 2-40) or replace PTO cable assembly (para 7-77).
- (6) Connect connector P210 to connector J210.
- (7) Install kick panel (para 16-3).

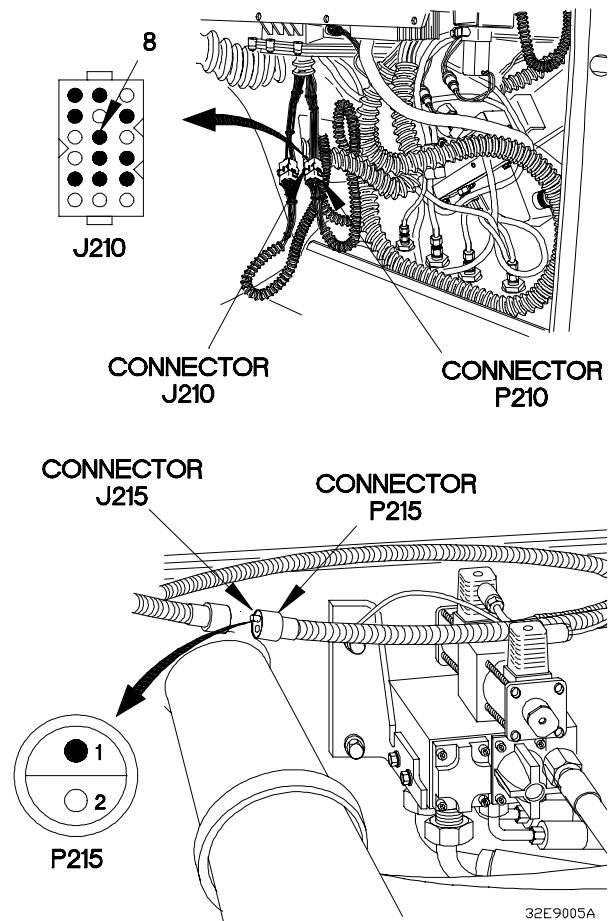

32E9005A

e87. 11K SELF-RECOVERY WINCH DOES NOT PAY OUT (CONT)

KNOWN INFO
Circuit breaker OK. 11K self-recovery winch reels in OK. Winch control valve assembly OK. WINCH IN/OUT switch OK. Auxiliary panel cable assembly OK. PTO cable assembly OK.
POSSIBLE PROBLEMS
Faulty winch control valve cable assembly.

6.
 Is continuity present between connector J215-1 and winch out solenoid L5 connector terminal 1.

TEST OPTIONS
Continuity Test or STE/ICE-R Test #91
REASON FOR QUESTION
If continuity is not present, wire 2008 is faulty. If continuity is present, notify DS Maintenance.

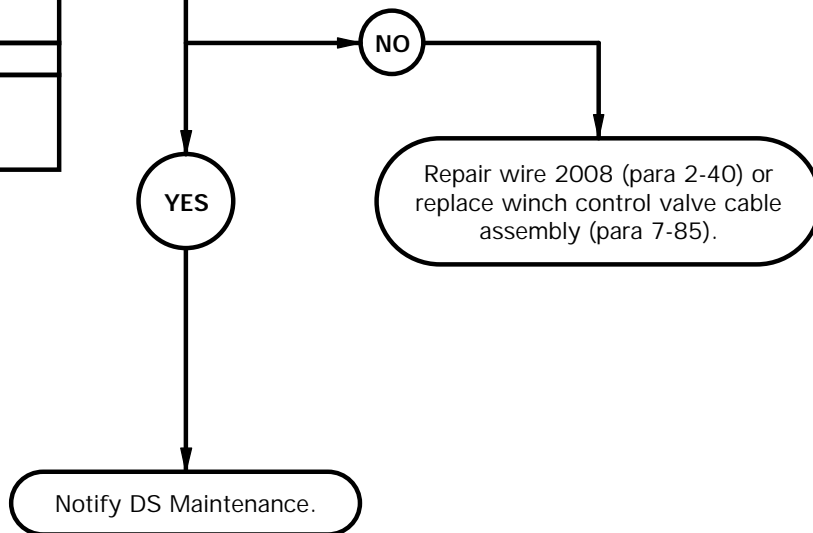

CONTINUITY TEST

- (1) Set multimeter to ohms.
- (2) Connect positive (+) probe of multimeter to connector J215-1.
- (3) Connect negative (-) probe of multimeter to winch out solenoid L5 connector terminal 1 and note reading on multimeter.
- (4) If continuity is not present, repair wire 2008 (para 2-40) or replace winch control valve cable assembly (para 7-85).
- (5) If continuity is present, notify DS Maintenance.
- (6) Connect connector P215 to connector J215.
- (7) Connect winch out solenoid L5 connector to solenoid L5 and tighten screw.

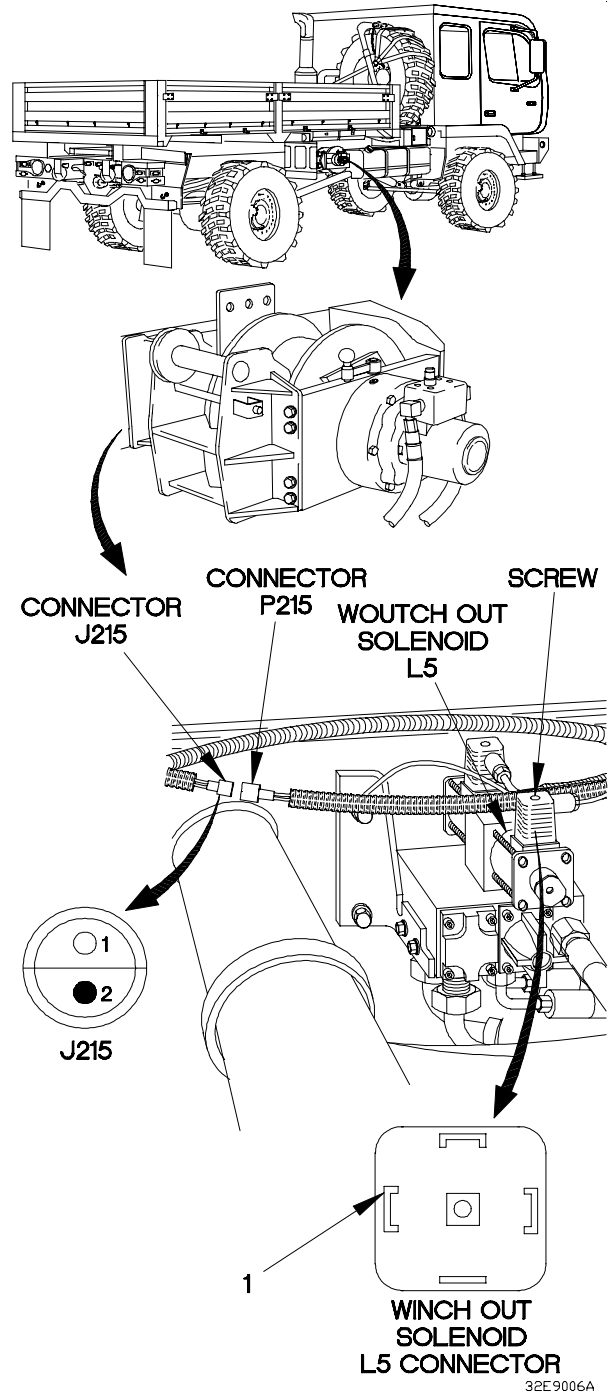

e88. PTO DOES NOT OPERATE

INITIAL SETUP

Equipment Condition

Engine shut down (TM 9-2320-365-10).

Personnel Required

(2)

References

TM 9-4910-571-12&P

Tools and Special Tools

Tool Kit, Genl Mech (Item 44, Appendix C)
 STE/ICE-R (Item 39, Appendix C)
 Multimeter, Digital (Item 22, Appendix C)
 Wrench, Torque, 0-200 lb-in. (Item 78, Appendix C)

Materials/Parts

Wire, Elect, 50 ft (Item 77, Appendix D)
 Wire, Relay Test (Item E-9, Appendix E)

KNOWN INFO
Circuit breaker OK. Vehicle starts.
POSSIBLE PROBLEMS
Faulty PTO cable assembly. Faulty PTO. Faulty dashboard cable assembly. Faulty auxiliary panel cable assembly. Faulty PTO switch. Faulty WTEC II VIM. Faulty WTEC II relay SF02. Faulty WTEC III relay K37. Faulty WTEC III transmission ECU.

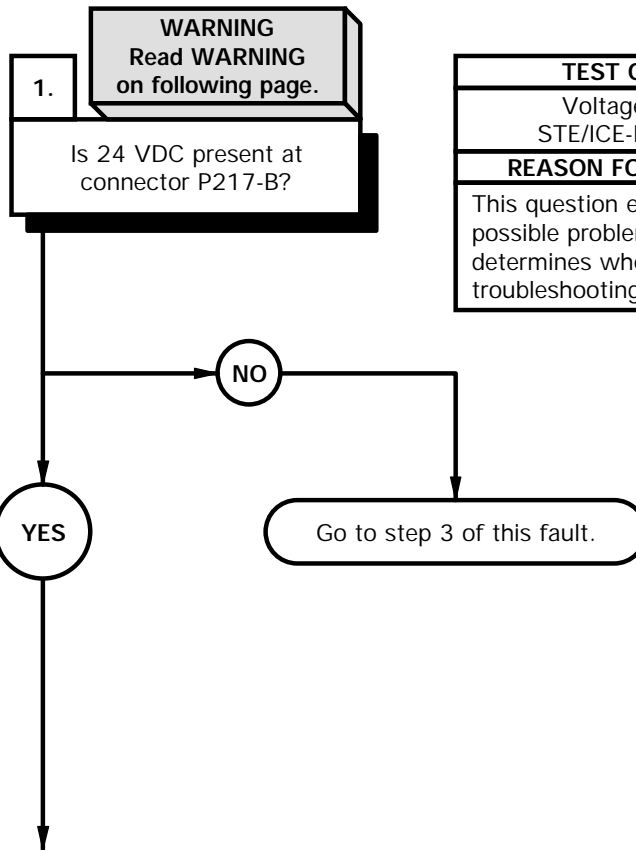

TEST OPTIONS
Voltage Test or STE/ICE-R Test #89
REASON FOR QUESTION
This question eliminates possible problems and determines where troubleshooting continues.

WARNING

Remove rings, bracelets, watches, necklaces, and any other jewelry before working around vehicle. Jewelry can catch on equipment and cause injury or short across electrical circuits and cause severe burns or electrical shock.

VOLTAGE TEST

- (1) Disconnect connector P217 from PTO.
- (2) Set multimeter to volts DC.
- (3) Connect positive (+) probe of multimeter to connector P217-B.
- (4) Connect negative (-) probe of multimeter to ground.
- (5) Start engine (TM 9-2320-365-10).
- (6) Position PTO switch to on (TM 9-2320-365-10) and note reading on multimeter.
- (7) If 24 VDC is not present, go to step 3 of this fault.
- (8) Position PTO switch to off (TM 9-2320-365-10).
- (9) Shut down engine (TM 9-2320-365-10).

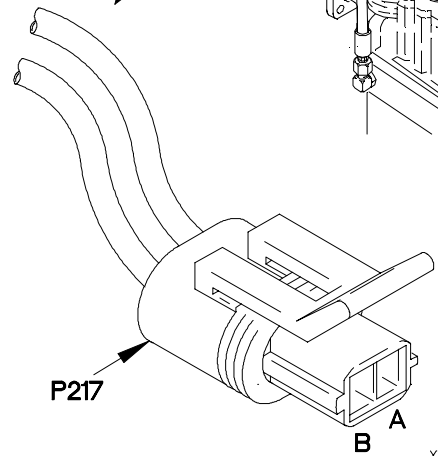
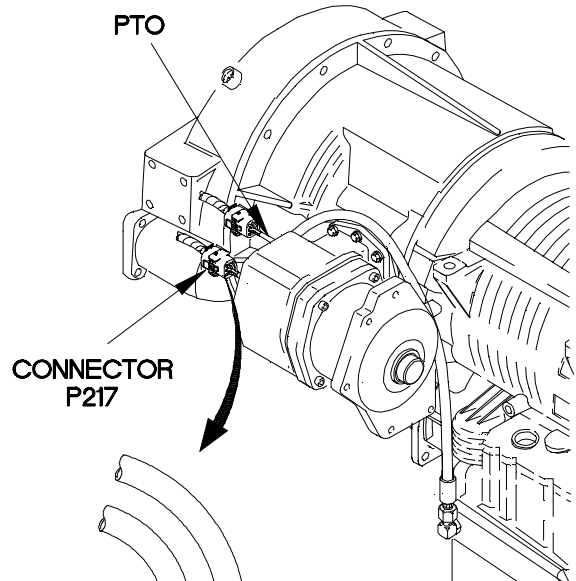
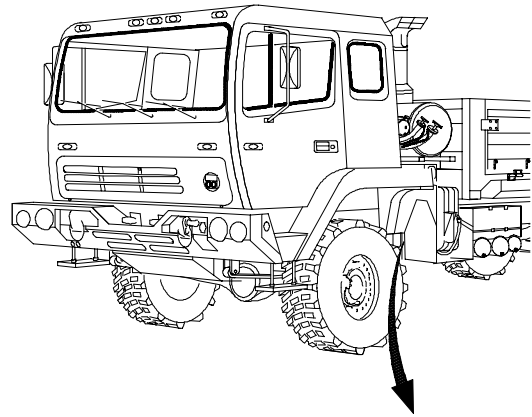

X2E91011

e88. PTO DOES NOT OPERATE (CONT)

KNOWN INFO
Circuit breaker OK. Vehicle starts. Dashboard cable assembly OK. Auxiliary panel cable assembly OK. PTO switch OK. WTEC II VIM OK. WTEC III relay K37 OK. WTEC III transmission ECU OK.
POSSIBLE PROBLEMS
Faulty PTO cable assembly. Faulty PTO.

2.
Is continuity present at connector P217-A?

TEST OPTIONS
Continuity Test or STE/ICE-R Test #91
REASON FOR QUESTION
If continuity is not present, wire 3068 is faulty. If continuity is present, PTO is faulty.

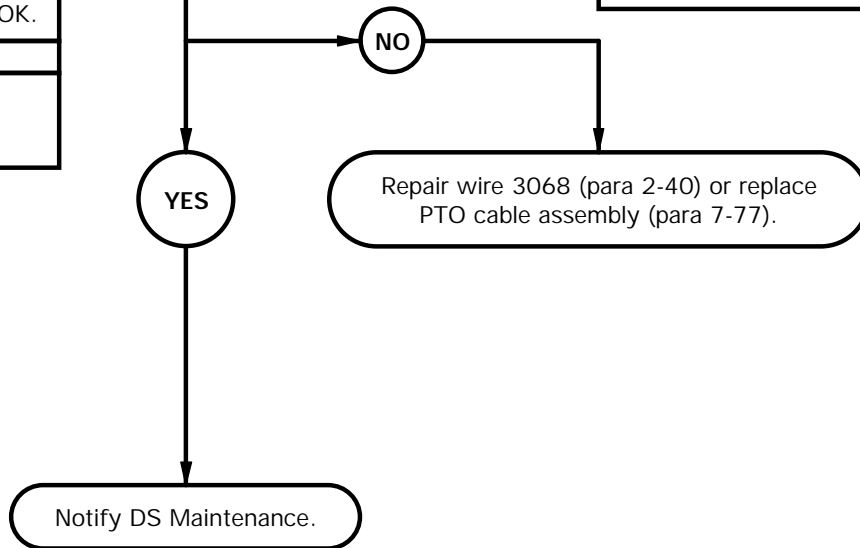

CONTINUITY TEST

- (1) Set multimeter to ohms.
- (2) Connect positive (+) probe of multimeter to connector P217-A.
- (3) Connect negative (-) probe of multimeter to ground and note reading on multimeter.
- (4) If continuity is not present, repair wire 3068 (para 2-40) or replace PTO cable assembly (para 7-77).
- (5) If continuity is present, notify DS Maintenance.
- (6) Connect connector P217 to PTO.

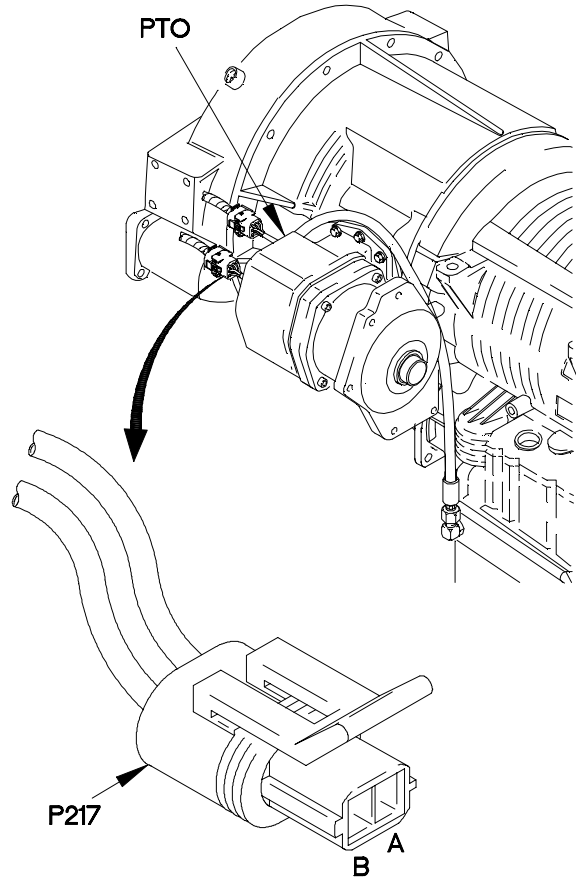

X2E91021

e88. PTO DOES NOT OPERATE (CONT)

KNOWN INFO
Circuit breaker OK. Vehicle starts. PTO OK.
POSSIBLE PROBLEMS
Faulty auxiliary panel cable assembly. Faulty PTO switch. Faulty dashboard cable assembly. Faulty PTO cable assembly. Faulty WTEC II VIM. Faulty WTEC II relay SF02. Faulty WTEC III relay K37. Faulty WTEC III transmission ECU.

3. **WARNING**
Read **WARNING** on following page.

Is 24 VDC present at connector P904-5?

TEST OPTIONS
Voltage Test or STE/ICE-R Test #89
REASON FOR QUESTION
If 24 VDC is not present, wire 1925 is faulty.

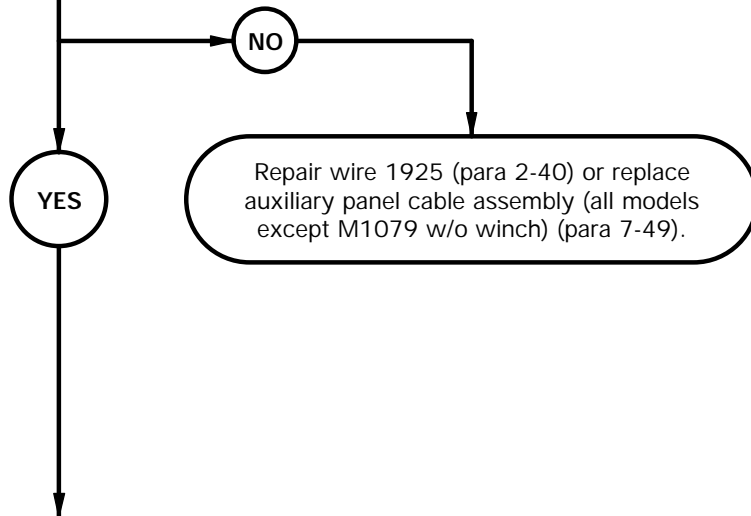

WARNING

Remove rings, bracelets, watches, necklaces, and any other jewelry before working around vehicle. Jewelry can catch on equipment and cause injury or short across electrical circuits and cause severe burns or electrical shock.

VOLTAGE TEST

- (1) Remove six screws from auxiliary panel.
- (2) Lift auxiliary panel from auxiliary panel housing to gain access.
- (3) Disconnect connector P904 from PTO switch.
- (4) Set multimeter to volts DC.
- (5) Connect positive (+) probe of multimeter to connector P904-5.
- (6) Connect negative (-) probe of multimeter to ground.
- (7) Position master power switch to on (TM 9-2320-365-10) and note reading on multimeter.
- (8) If 24 VDC is not present, repair wire 1925 (para 2-40) or replace auxiliary panel cable assembly (all models except M1079 w/o winch) (para 7-49).
- (9) Position master power switch to off (TM 9-2320-365-10).

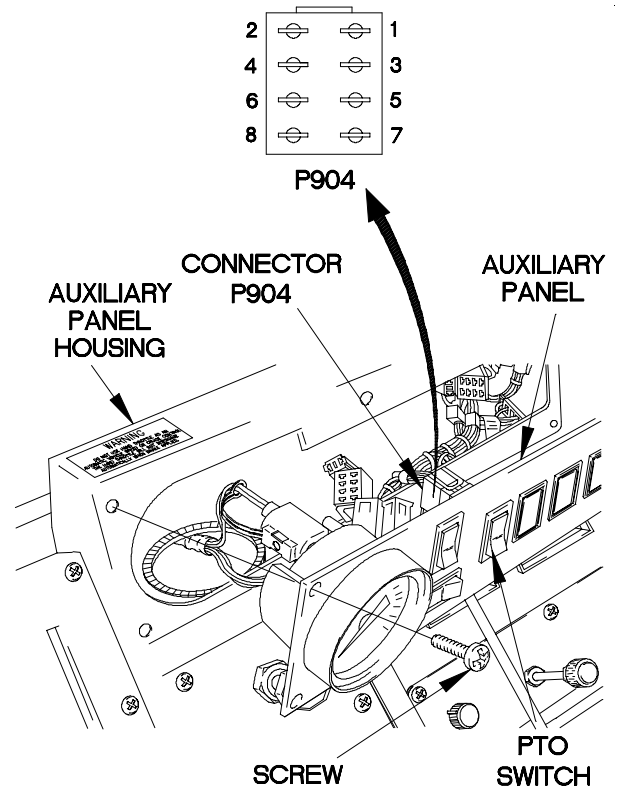

X2E91031

e88. PTO DOES NOT OPERATE (CONT)

KNOWN INFO
Circuit breaker OK. Vehicle starts. PTO OK.
POSSIBLE PROBLEMS
Faulty PTO switch. Faulty auxiliary panel cable assembly. Faulty dashboard cable assembly. Faulty PTO cable assembly. Faulty WTEC II VIM. Faulty WTEC II relay SF02. Faulty WTEC III relay K37. Faulty WTEC III transmission ECU.

4.
Is continuity present from PTO switch terminal 5 to terminal 1?

TEST OPTIONS
Continuity Test or STE/ICE-R Test #91
REASON FOR QUESTION
If continuity is not present, PTO switch is faulty.

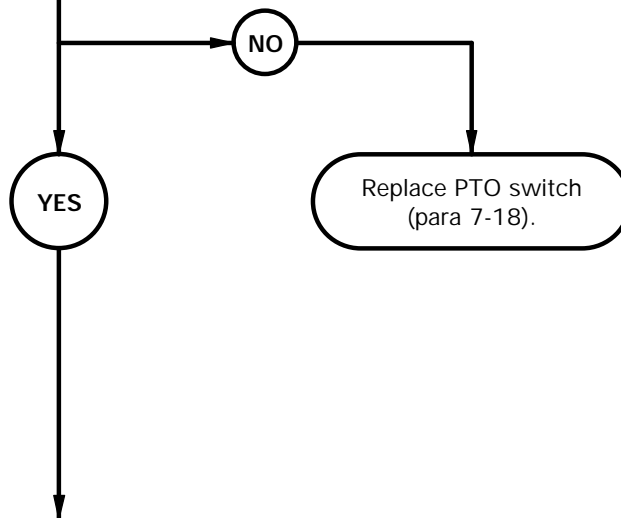

CONTINUITY TEST

- (1) Set multimeter to ohms.
- (2) Connect positive (+) probe of multimeter to PTO switch terminal 5.
- (3) Connect negative (-) probe of multimeter to PTO switch terminal 1.
- (4) Position PTO switch to on (TM 9-2320-365-10) and note reading on multimeter.
- (5) If continuity is not present, replace PTO switch (para 7-18).
- (6) Position PTO switch to off (TM 9-2320-365-10).

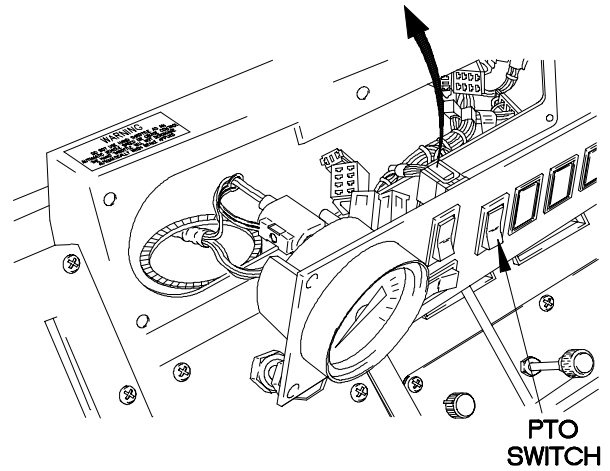
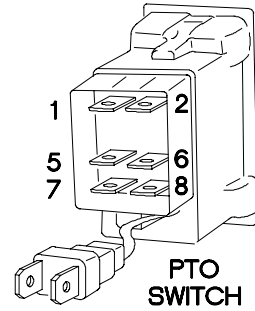

X2E91041

e88. PTO DOES NOT OPERATE (CONT)

KNOWN INFO
Circuit breaker OK. Vehicle starts. PTO OK. PTO switch OK.
POSSIBLE PROBLEMS
Faulty PTO cable assembly. Faulty WTEC II VIM. Faulty dashboard cable assembly. Faulty auxiliary panel cable assembly. Faulty WTEC II relay SF02. Faulty WTEC III relay K37. Faulty WTEC III transmission ECU.

5.
Is continuity present from connector P210-4 to connector P217-B?

TEST OPTIONS
Continuity Test or STE/ICE-R Test #91
REASON FOR QUESTION
If continuity is not present, wire 2019 is faulty.

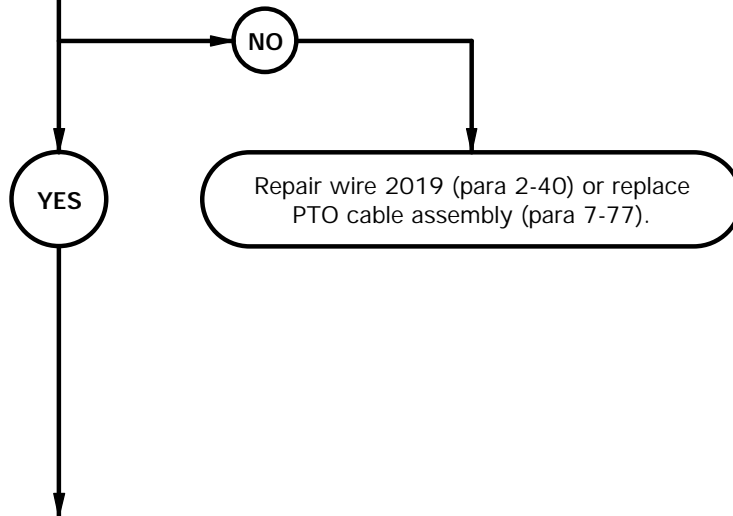

CONTINUITY TEST

- (1) Remove kick panel (para 16-3).
- (2) Disconnect connector P210 from connector J210.
- (3) Set multimeter to ohms.
- (4) Connect positive (+) probe of multimeter to connector P210-4.
- (5) Disconnect connector P217 from PTO.
- (6) Connect negative (-) probe of multimeter to connector P217-B and note reading on multimeter.
- (7) If continuity is not present, repair wire 2019 (para 2-40) or replace PTO cable assembly (para 7-77).
- (8) Connect connector P217 to PTO.
- (9) Connect connector P210 to connector J210.

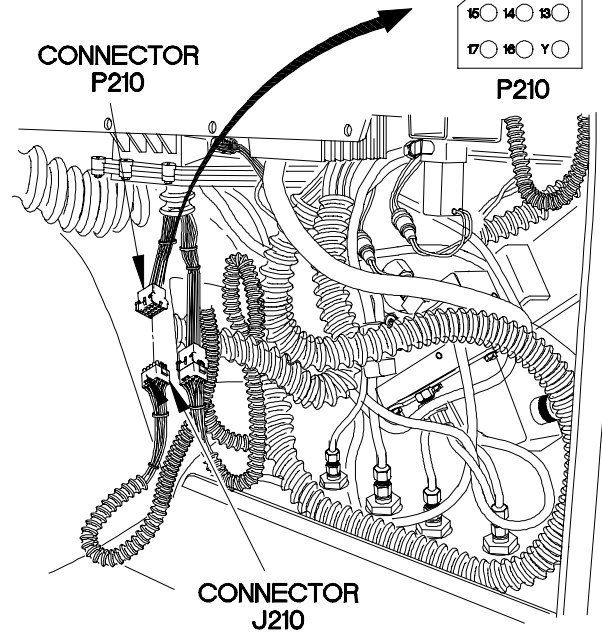
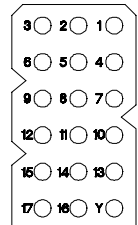
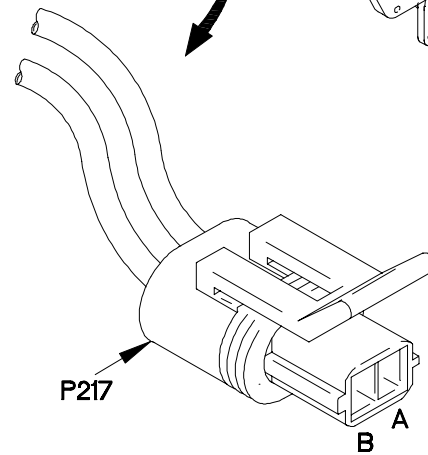
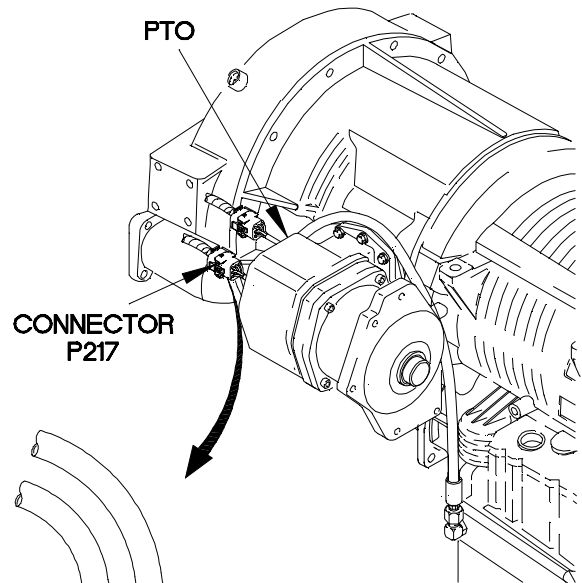

32E91051

e88. PTO DOES NOT OPERATE (CONT)

KNOWN INFO
Circuit breaker OK. Vehicle starts. PTO OK. PTO switch OK. PTO cable assembly OK.
POSSIBLE PROBLEMS
Faulty WTEC II VIM. Faulty dashboard cable assembly. Faulty auxiliary panel cable assembly. Faulty WTEC II relay SF02. Faulty WTEC III relay K37. Faulty WTEC III cab transmission harness. Faulty WTEC III transmission ECU.

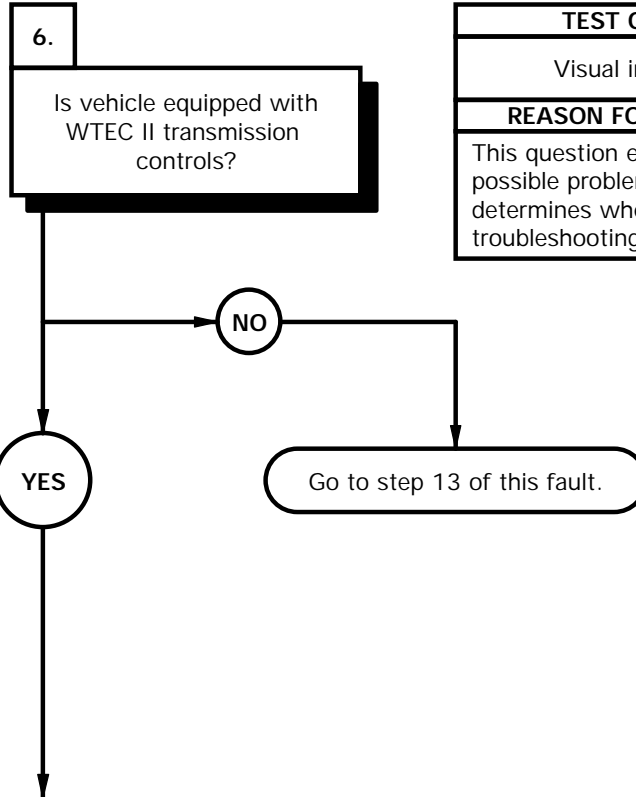

TEST OPTIONS
Visual inspection
REASON FOR QUESTION
This question eliminates possible problems and determines where troubleshooting continues.

- (1) Check if vehicle is equipped with WTEC II transmission ECU pushbutton shift selector.
- (2) If transmission pushbutton shift selector is not mounted with four screws and does not have a filter cover, go to step 13.

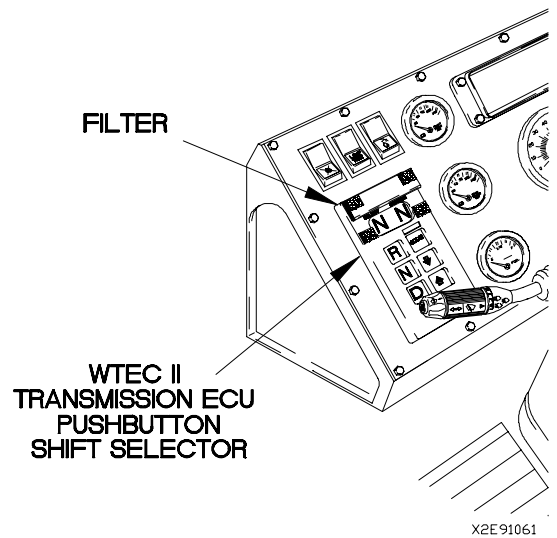
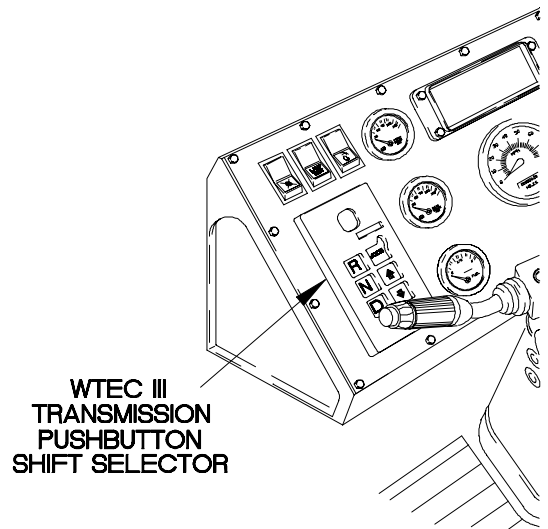

e88. PTO DOES NOT OPERATE (CONT)

KNOWN INFO
Circuit breaker OK. Vehicle starts. PTO OK. PTO switch OK. PTO cable assembly OK.
POSSIBLE PROBLEMS
Faulty WTEC II VIM. Faulty WTEC II dashboard cable assembly. Faulty auxiliary panel cable assembly. Faulty WTEC II relay SF02.

7.
Does PTO operate after replacing WTEC II relay SF02?

TEST OPTIONS
Operational Test
REASON FOR QUESTION
If PTO operates after replacing WTEC II relay SF02, WTEC II relay SF02 is faulty. If PTO does not operate after replacing WTEC II relay SF02, WTEC II VIM is faulty.

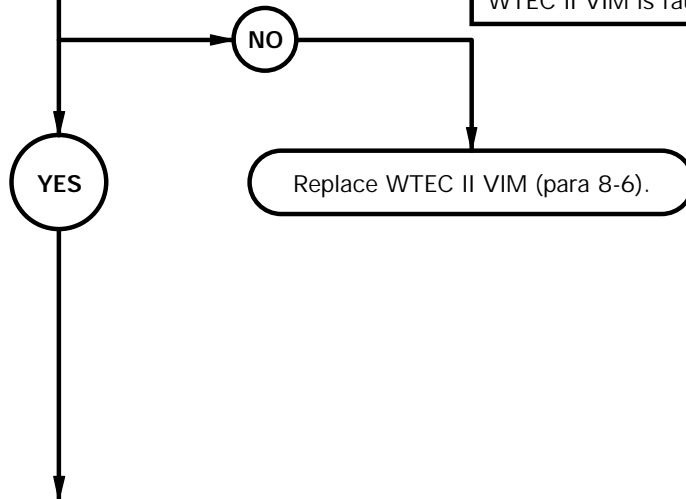

OPERATIONAL TEST

- (1) Remove WTEC II relay SF02 (para 8-6).
- (2) Install new WTEC II relay SF02 (para 8-6).
- (3) Start engine (TM 9-2320-365-10).
- (4) Position PTO switch to on
(TM 9-2320-365-10-1).
- (5) If PTO operates, replace WTEC II relay SF02
(para 8-6).
- (6) If PTO does not operate, replace WTEC II
VIM (para 8-6).

e88. PTO DOES NOT OPERATE (CONT)

KNOWN INFO
Circuit breaker OK. Vehicle starts. PTO OK. PTO switch OK. PTO cable assembly OK. WTEC II VIM OK.
POSSIBLE PROBLEMS
Faulty WTEC II dashboard cable assembly. Faulty auxiliary panel cable assembly. Faulty WTEC II relay SF02.

8. **WARNING**
Read **WARNING**
on following page.

Is 24 VDC present at connector J913-5?

TEST OPTIONS
Voltage Test or STE/ICE-R Test #89
REASON FOR QUESTION
If 24 VDC is not present, wire 1925 is faulty.

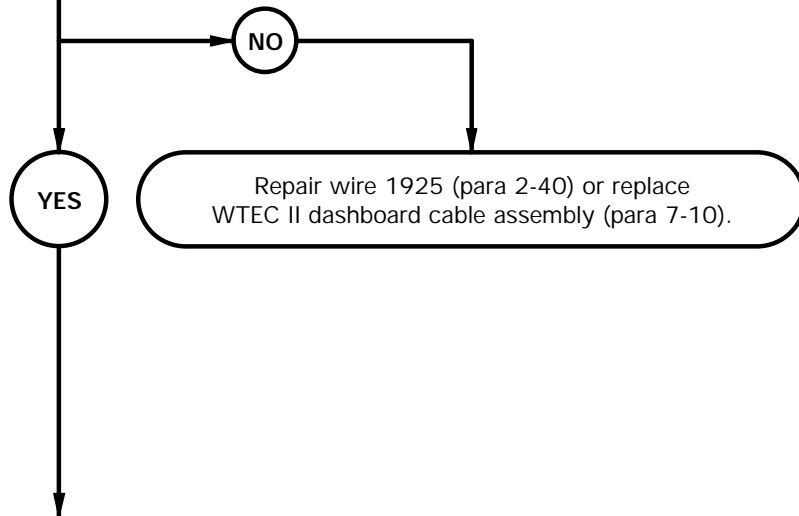

WARNING

Remove rings, bracelets, watches, necklaces, and any other jewelry before working around vehicle. Jewelry can catch on equipment and cause injury or short across electrical circuits and cause severe burns or electrical shock.

VOLTAGE TEST

- (1) Remove personnel heater for access (para 18-9).
- (2) Disconnect connector J913 from connector P913.
- (3) Set multimeter to volts DC.
- (4) Connect positive (+) probe of multimeter to connector J913-5.
- (5) Connect negative (-) probe of multimeter to ground.
- (6) Position master power switch to on (TM 9-2320-365-10) and note reading on multimeter.
- (7) If 24 VDC is not present, repair wire 1925 (para 2-40) or replace WTEC II dashboard cable assembly (para 7-10).
- (8) Position master power switch to off (TM 9-2320-365-10).

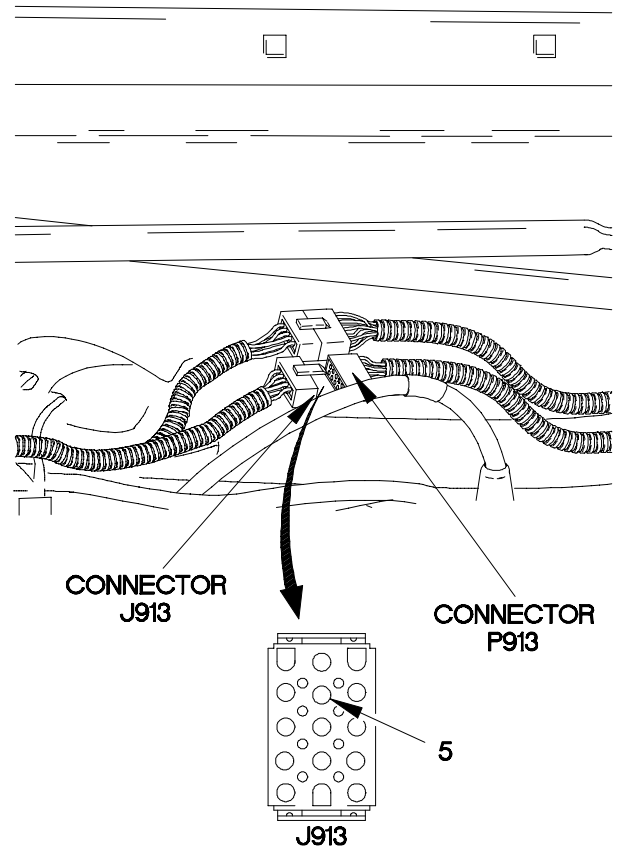

X2E91071

e88. PTO DOES NOT OPERATE (CONT)

KNOWN INFO
Circuit breaker OK. Vehicle starts. PTO OK. PTO switch OK. PTO cable assembly OK. WTEC II VIM OK.
POSSIBLE PROBLEMS
Faulty auxiliary panel cable assembly. Faulty WTEC II dashboard cable assembly. Faulty WTEC II relay SF02.

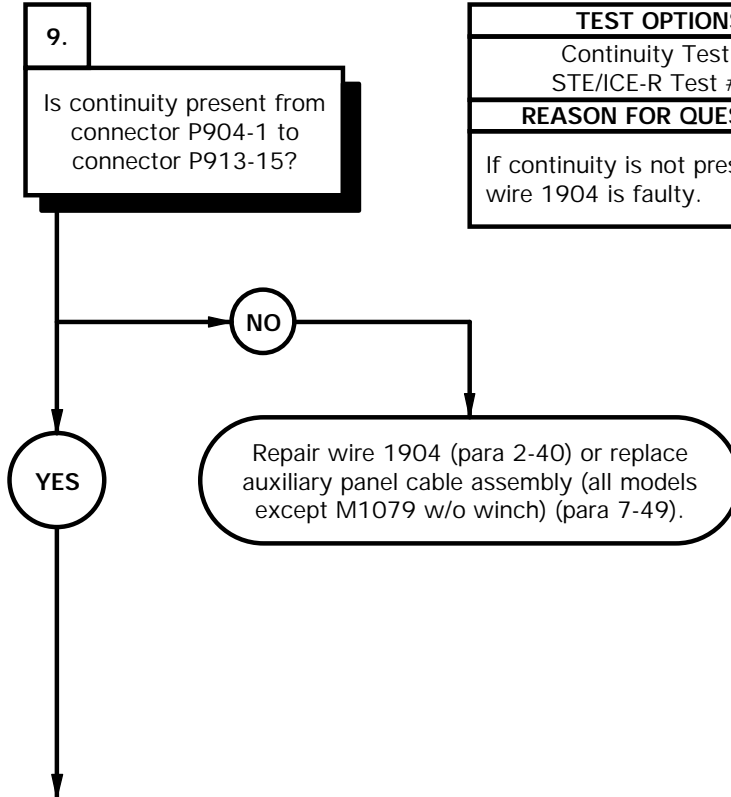

TEST OPTIONS
Continuity Test or STE/ICE-R Test #91
REASON FOR QUESTION
If continuity is not present, wire 1904 is faulty.

CONTINUITY TEST

- (1) Set multimeter to ohms.
- (2) Connect positive (+) probe of multimeter to connector P904-1.
- (3) Connect negative (-) probe of multimeter to connector P913-15 and note reading on multimeter.
- (4) If continuity is not present, repair wire 1904 (para 2-40) or replace auxiliary panel cable assembly (all models except M1079 w/o winch (para 7-49).

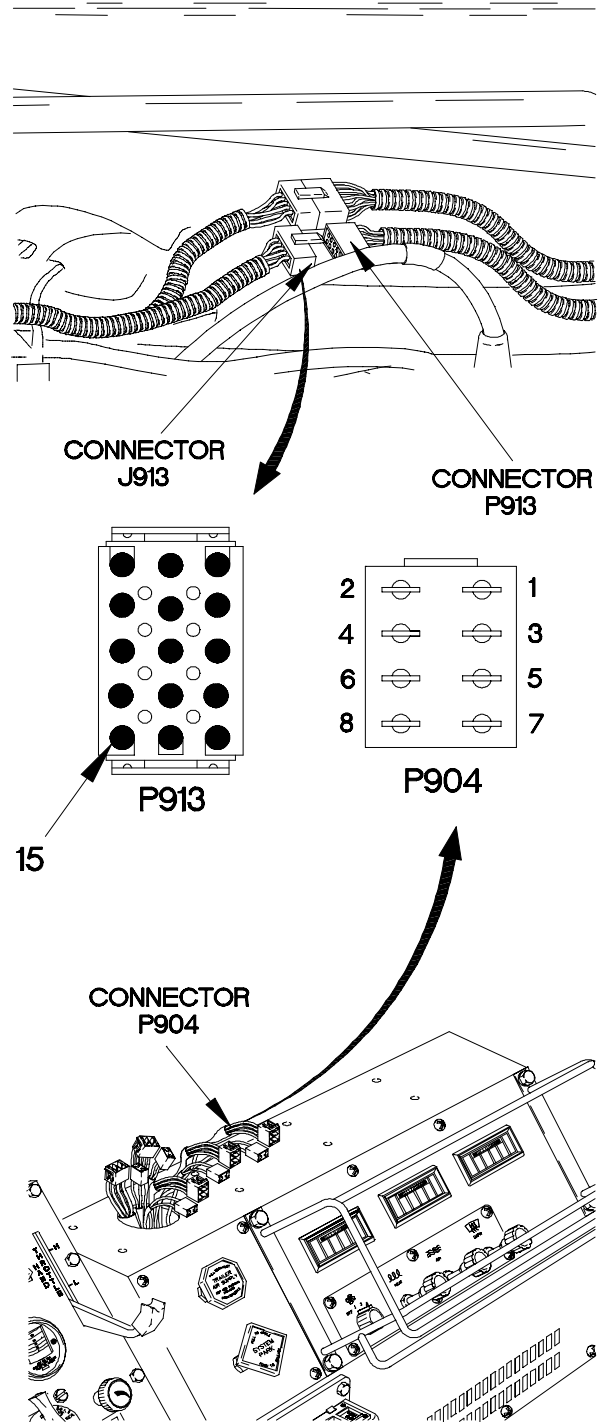

X2E91081

e88. PTO DOES NOT OPERATE (CONT)

KNOWN INFO
Circuit breaker OK. Vehicle starts. PTO OK. PTO switch OK. PTO cable assembly OK. WTEC II VIM OK.
POSSIBLE PROBLEMS
Faulty WTEC II dashboard cable assembly. Faulty auxiliary panel cable assembly. Faulty WTEC II relay SF02.

KNOWN INFO
Circuit breaker OK. Vehicle starts. PTO OK. PTO switch OK. PTO cable assembly OK. WTEC II VIM OK.
POSSIBLE PROBLEMS
Faulty WTEC II dashboard cable assembly. Faulty auxiliary panel cable assembly. Faulty WTEC II relay SF02.

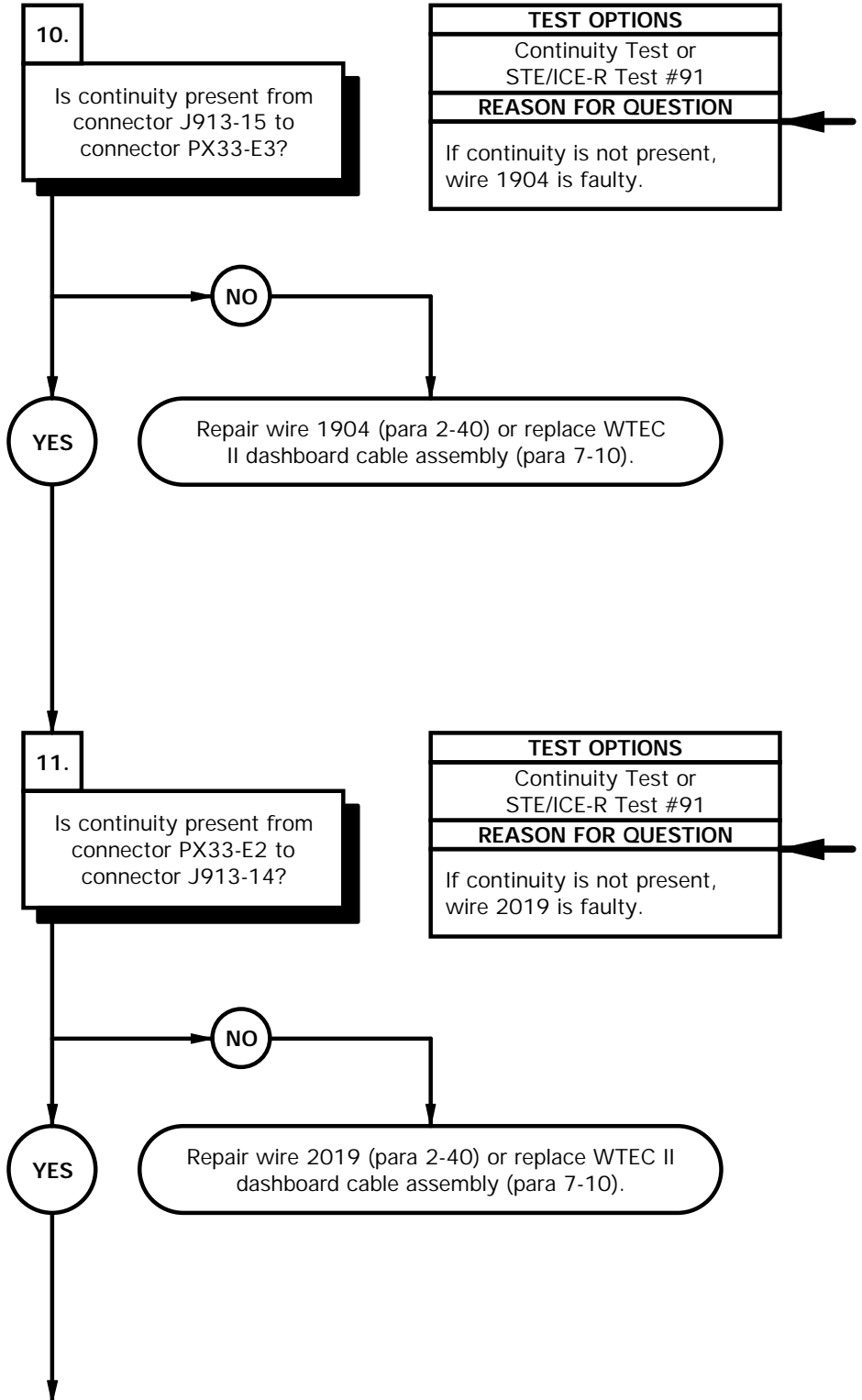

TEST OPTIONS
Continuity Test or STE/ICE-R Test #91
REASON FOR QUESTION
If continuity is not present, wire 1904 is faulty.

TEST OPTIONS
Continuity Test or STE/ICE-R Test #91
REASON FOR QUESTION
If continuity is not present, wire 2019 is faulty.

CONTINUITY TEST
<ol style="list-style-type: none"> (1) Loosen screw in connector PX33. (2) Disconnect connector PX33 from WTEC II VIM. (3) Set multimeter to ohms. (4) Connect positive (+) probe of multimeter to connector J913-15. (5) Connect negative (-) probe of multimeter to connector PX33-E3 and note reading on multimeter. (6) If continuity is not present, repair wire 1904 (para 2-40) or replace WTEC II dashboard cable assembly (para 7-10).

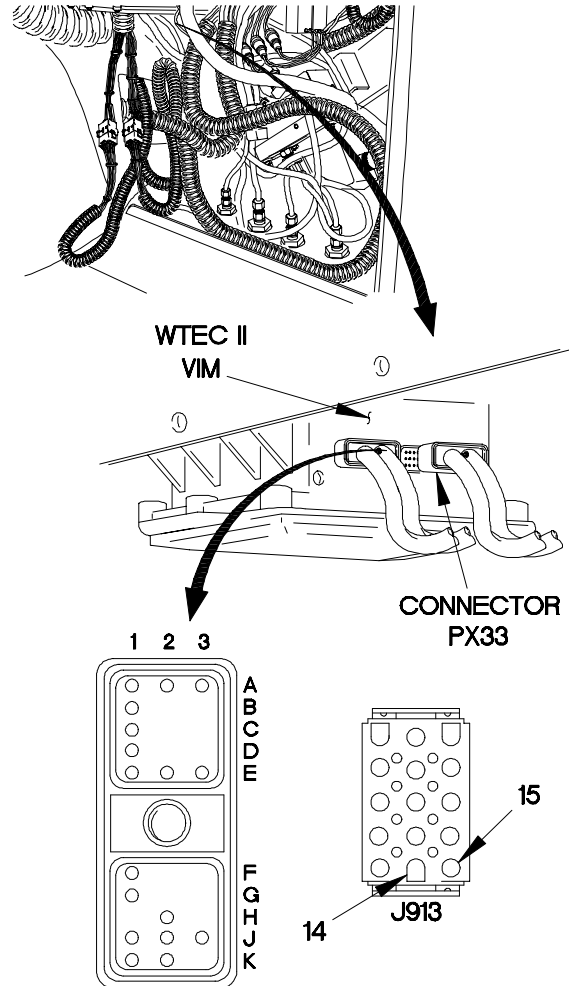

CONTINUITY TEST
<ol style="list-style-type: none"> (1) Set multimeter to ohms. (2) Connect positive (+) probe of multimeter to connector PX33-E2. (3) Connect negative (-) probe of multimeter to connector J913-14 and note reading on multimeter. (4) If continuity is not present, repair wire 2019 (para 2-40) or replace WTEC II dashboard cable assembly (para 7-10). (5) Connect connector PX33 to WTEC II VIM. (6) Tighten screw in connector PX33.

42E91091

e88. PTO DOES NOT OPERATE (CONT)

KNOWN INFO
Circuit breaker OK. Vehicle starts. PTO OK. PTO switch OK. PTO cable assembly OK. WTEC II VIM OK. WTEC II dashboard cable assembly OK.
POSSIBLE PROBLEMS
Faulty auxiliary panel cable assembly. Faulty WTEC II relay SF02.

12.
Is continuity present from connector P913-14 to connector J210-4?

TEST OPTIONS
Continuity Test or STE/ICE-R Test #91
REASON FOR QUESTION
If continuity is not present, wire 2019 is faulty.

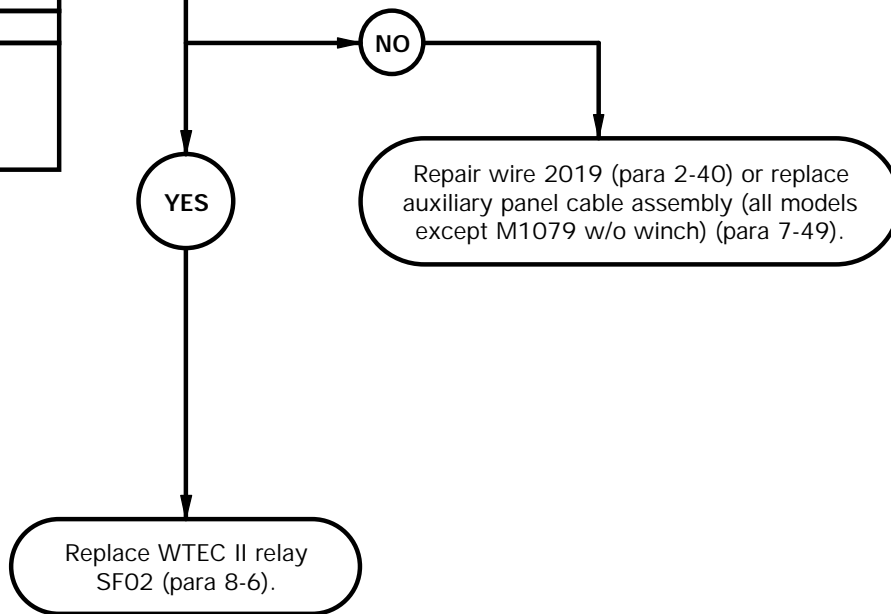

CONTINUITY TEST

- (1) Disconnect connector P210 from connector J210.
- (2) Set multimeter to ohms.
- (3) Connect positive (+) probe of multimeter to connector P913-14.
- (4) Connect negative (-) probe of multimeter to connector J210-4 and note reading on multimeter.
- (5) If continuity is not present, repair wire 2019 (para 2-40) or replace auxiliary panel cable assembly (all models except M1079 w/o winch) (para 7-49).
- (6) If continuity is present, replace WTEC II relay SF02 (para 8-6).
- (7) Connect connector P913 to connector J913.
- (8) Connect connector J210 to connector P210.
- (9) Install personnel heater (para 18-9).

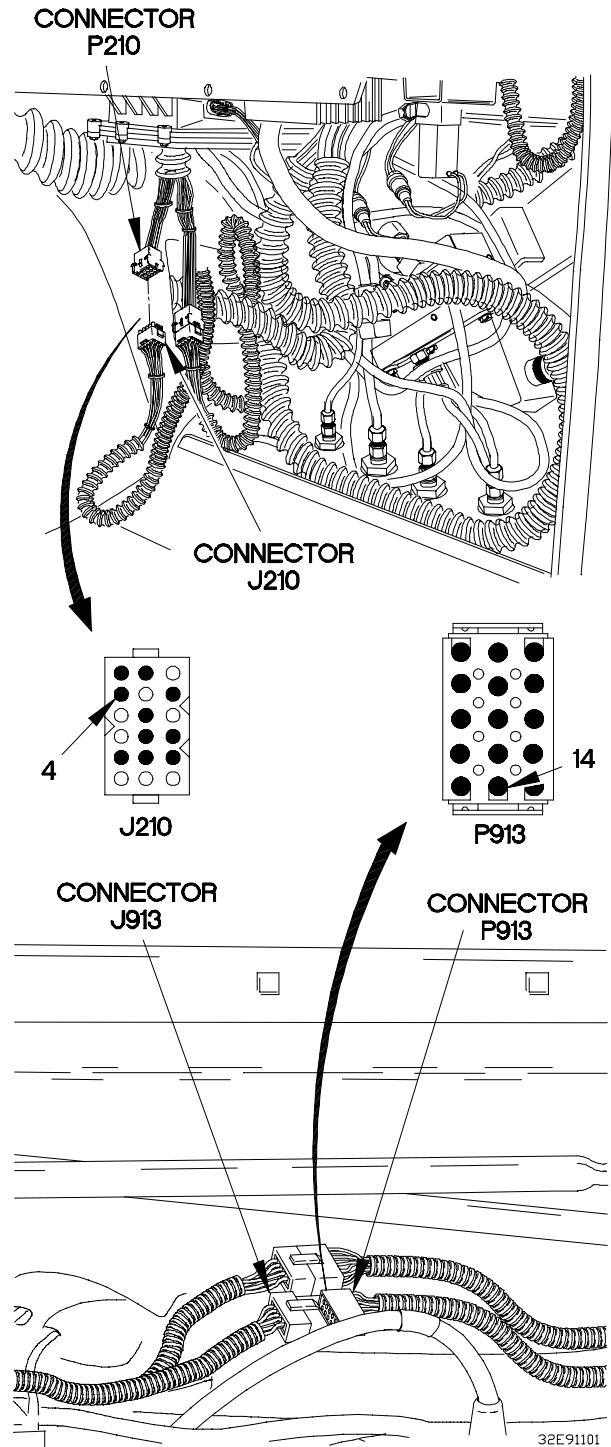

e88. PTO DOES NOT OPERATE (CONT)

KNOWN INFO
Circuit breaker OK. Vehicle starts. PTO OK. PTO switch OK. PTO cable assembly OK.
POSSIBLE PROBLEMS
Faulty WTEC III dashboard cable assembly. Faulty auxiliary panel cable assembly. Faulty WTEC III relay K37. Faulty WTEC III transmission ECU.

13. **WARNING**
 Read **WARNING** on following page.

Is 24 VDC present at connector J913-5?

TEST OPTIONS
Voltage Test or STE/ICE-R Test #89
REASON FOR QUESTION
If 24 VDC is not present, wire 1925 is faulty.

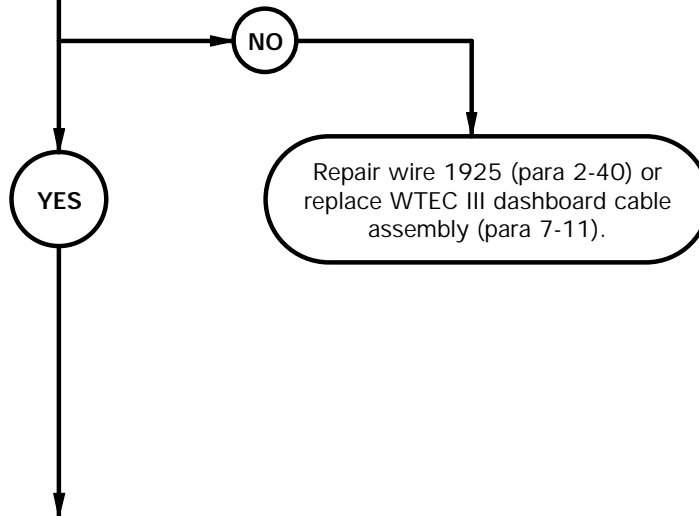

WARNING

Remove rings, bracelets, watches, necklaces, and any other jewelry before working around vehicle. Jewelry can catch on equipment and cause injury or short across electrical circuits and cause severe burns or electrical shock.

VOLTAGE TEST

- (1) Remove personnel heater for access (para 18-9).
- (2) Disconnect connector J913 from connector P913.
- (3) Set multimeter to volts DC.
- (4) Connect positive (+) probe of multimeter to connector J913-5.
- (5) Connect negative (-) probe of multimeter to ground.
- (6) Position master power switch to on (TM 9-2320-365-10) and note reading on multimeter.
- (7) If 24 VDC is not present, repair wire 1925 (para 2-40) or replace WTEC III dashboard cable assembly (para 7-11).
- (8) Position master power switch to off (TM 9-2320-365-10).

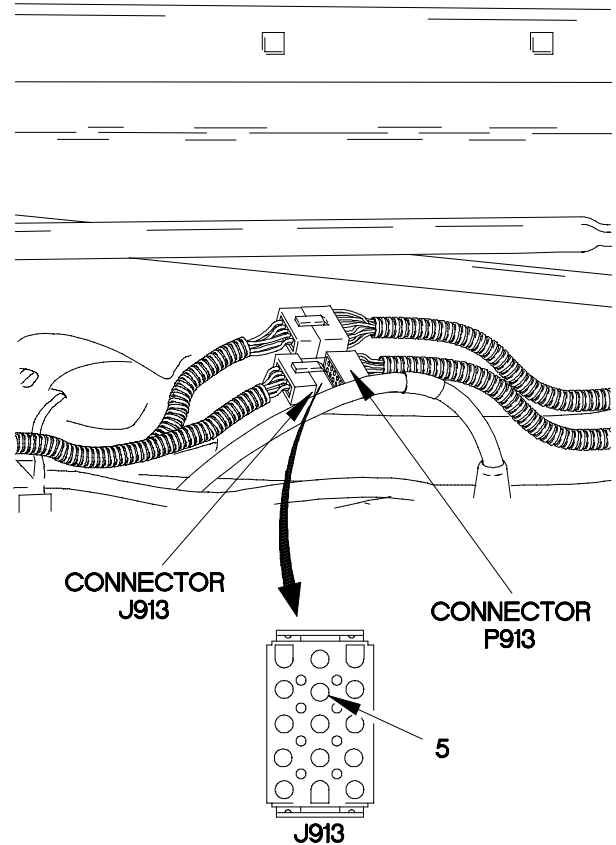

X2E91111

e88. PTO DOES NOT OPERATE (CONT)

KNOWN INFO
Circuit breaker OK. Vehicle starts. PTO OK. PTO switch OK. PTO cable assembly OK.
POSSIBLE PROBLEMS
Faulty auxiliary panel cable assembly. Faulty WTEC III dashboard cable assembly. Faulty WTEC III relay K37. Faulty WTEC III transmission ECU.

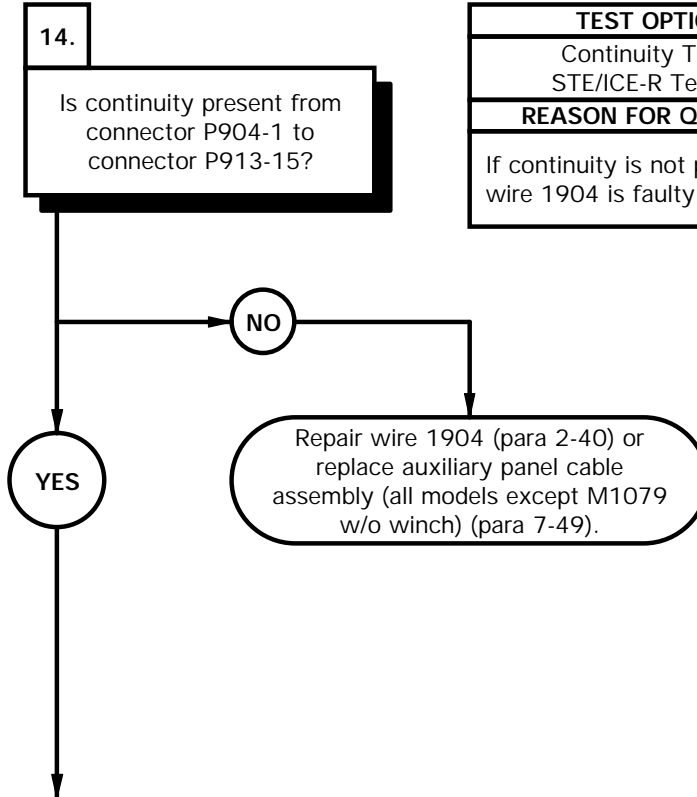

TEST OPTIONS
Continuity Test or STE/ICE-R Test #91
REASON FOR QUESTION
If continuity is not present, wire 1904 is faulty.

CONTINUITY TEST

- (1) Set multimeter to ohms.
- (2) Connect positive (+) probe of multimeter to connector P904-1.
- (3) Connect negative (-) probe of multimeter to connector P913-15 and note reading on multimeter.
- (4) If continuity is not present, repair wire 1904 (para 2-40) or replace auxiliary panel cable assembly (all models except M1079 w/o winch) (para 7-49).

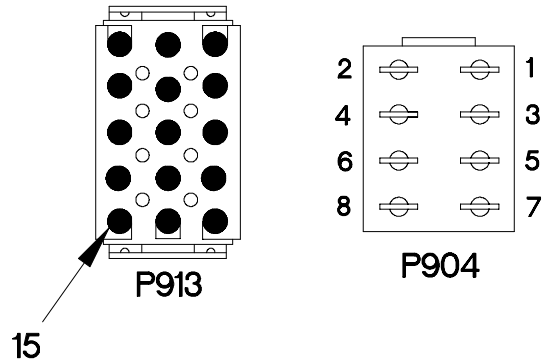

X2E91121

e88. PTO DOES NOT OPERATE (CONT)

KNOWN INFO
Circuit breaker OK. Vehicle starts. PTO OK. PTO switch OK. PTO cable assembly OK.
POSSIBLE PROBLEMS
Faulty WTEC III dashboard cable assembly. Faulty auxiliary panel cable assembly. Faulty WTEC III relay K37. Faulty WTEC III transmission ECU.

15.
Is continuity present from connector J913-15 to WTEC III relay K37 terminal 30?

TEST OPTIONS
Continuity Test or STE/ICE-R Test #91
REASON FOR QUESTION
If continuity is not present, wire 1904 is faulty.

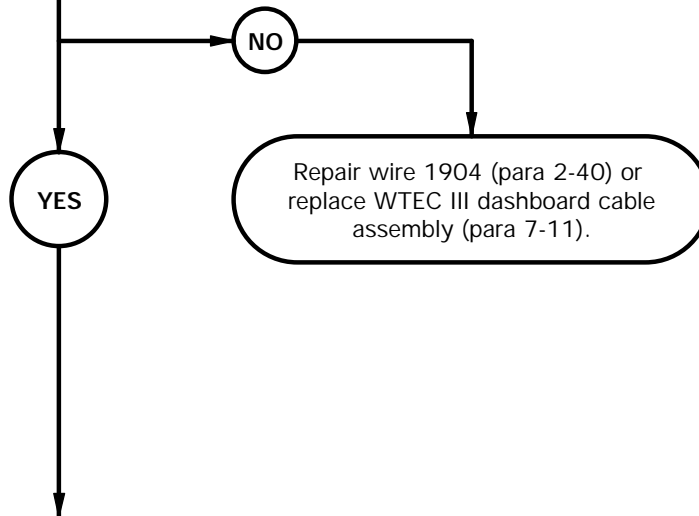

CONTINUITY TEST

- (1) Remove WTEC III relay K37 from PDP.
- (2) Set multimeter to ohms.
- (3) Connect positive (+) probe of multimeter to connector J913-15.
- (4) Connect negative (-) probe of multimeter to PDP, terminal 30, where WTEC III relay K37 was removed, and note reading on multimeter.
- (5) If continuity is not present, repair wire 1904 (para 2-40) or replace WTEC III dashboard cable assembly (para 7-11).
- (6) Install WTEC III relay K37 in PDP.

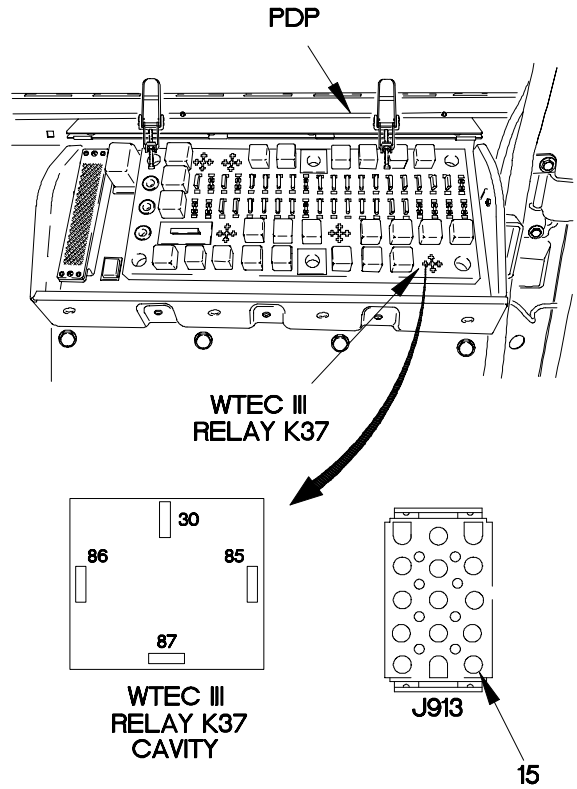

X2E91131

e88. PTO DOES NOT OPERATE (CONT)

KNOWN INFO
Circuit breaker OK. Vehicle starts. PTO OK. PTO switch OK. PTO cable assembly OK.
POSSIBLE PROBLEMS
Faulty WTEC III dashboard cable assembly. Faulty auxiliary panel cable assembly. Faulty WTEC III relay K37. Faulty WTEC III transmission ECU.

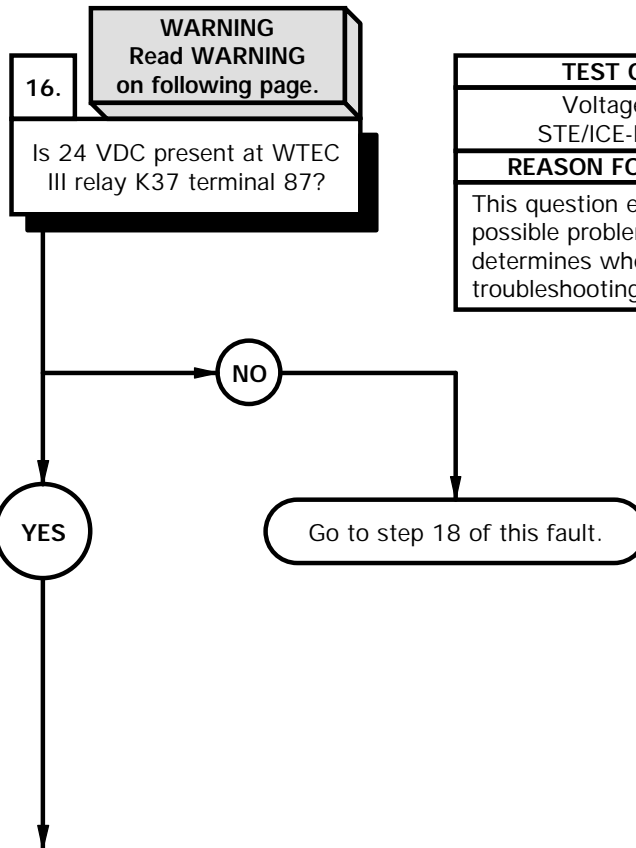

TEST OPTIONS
Voltage Test or STE/ICE-R Test #89
REASON FOR QUESTION
This question eliminates possible problems and determines where troubleshooting continues.

WARNING

Remove rings, bracelets, watches, necklaces, and any other jewelry before working around vehicle. Jewelry can catch on equipment and cause injury or short across electrical circuits and cause severe burns or electrical shock.

VOLTAGE TEST

- (1) Install personnel heater hoses (para 18-9).
- (2) Remove PTO switch from auxiliary panel.
- (3) Install PTO switch on connector P904.
- (4) Remove WTEC III relay K37 from PDP.
- (5) Insert relay test wire in PDP, terminal 87, where WTEC III relay K37 was removed.
- (6) Install WTEC III relay K37 in PDP.
- (7) Set multimeter to volts dc.
- (8) Connect positive (+) probe of multimeter to relay test wire.
- (9) Connect negative (-) probe of multimeter to ground.
- (10) Start engine (TM 9-2320-365-10).
- (11) Position PTO switch to on (TM 9-2320-365-10) and note reading on multimeter.
- (12) If 24 vdc is not present, go to step 18 of this faulty.
- (13) Position PTO switch to off (TM 9-2320-365-10).
- (14) Shut down engine (TM 9-2320-365-10).
- (15) Remove WTEC III relay relay K37 from PDP.
- (16) Remove relay test wire from PDP.
- (17) Install WTEC III relay K37 in PDP.

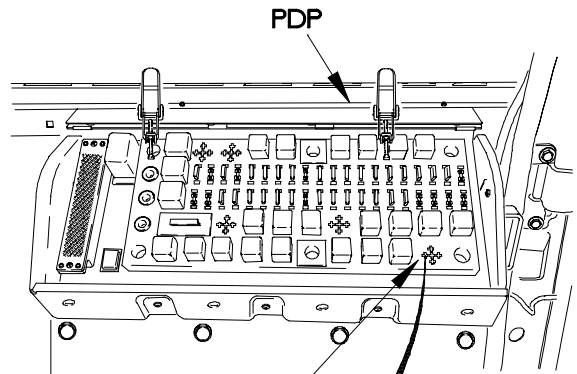

WTEC III RELAY K37

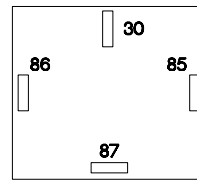

WTEC III RELAY K37 CAVITY

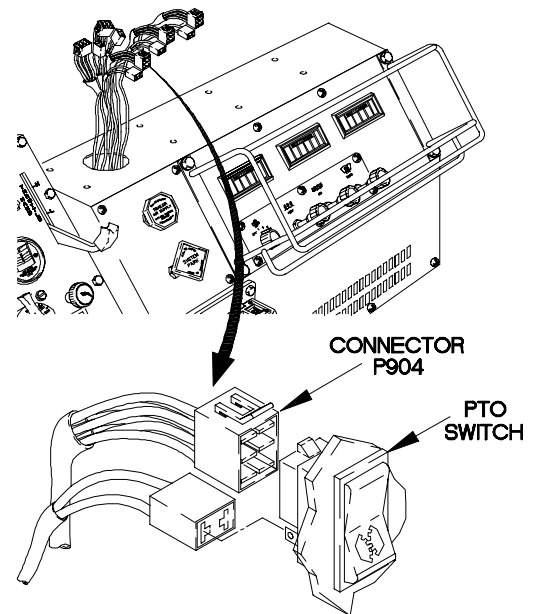

X2E91141

e88. PTO DOES NOT OPERATE (CONT)

KNOWN INFO
Circuit breaker OK. Vehicle starts. PTO OK. PTO switch OK. PTO cable assembly OK. WTEC III relay K37 OK. WTEC III transmission ECU OK.
POSSIBLE PROBLEMS
Faulty auxiliary panel cable assembly. Faulty WTEC III dashboard cable assembly.

17.
Is continuity present from connector P913-14 to connector J210-4?

TEST OPTIONS
Continuity Test or STE/ICE-R Test #91
REASON FOR QUESTION
If continuity is not present, wire 2019 is faulty.

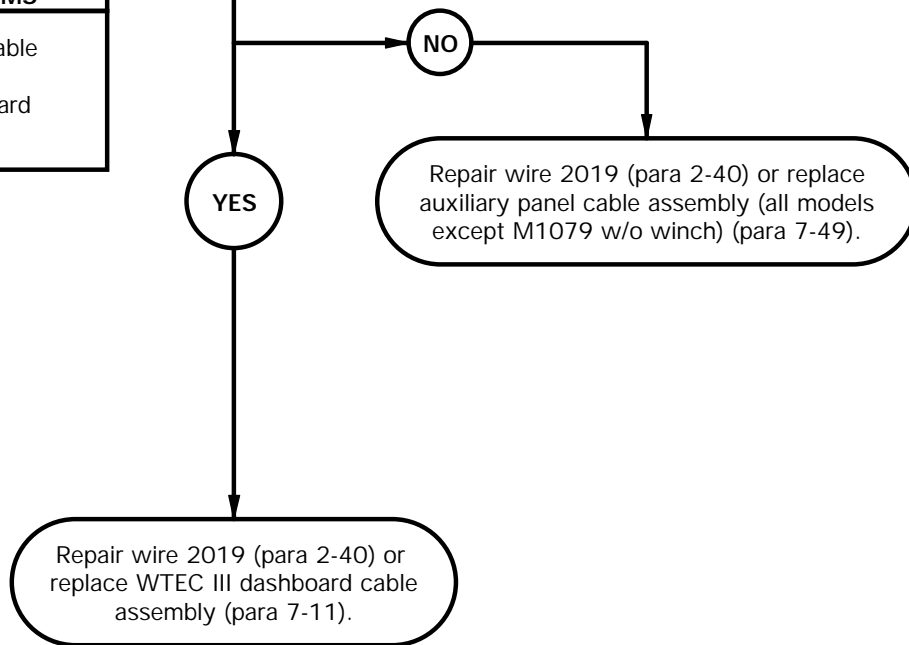

CONTINUITY TEST

- (1) Disconnect connector P210 from connector J210.
- (2) Set multimeter to ohms.
- (3) Connect positive (+) probe of multimeter to connector P913-14.
- (4) Connect negative (-) probe of multimeter to connector J210-4 and note reading on multimeter.
- (5) If continuity is not present, repair wire 2019 (para 2-40) or replace auxiliary panel cable assembly (all models except M1079 w/o winch) (para 7-49).
- (6) If continuity is present, repair wire 2019 (para 2-40) or replace WTEC III dashboard cable assembly (para 7-11).
- (7) Connect connector P913 to connector J913.
- (8) Remove PTO switch from connector P904.
- (9) Install personnel heater (para 18-9).

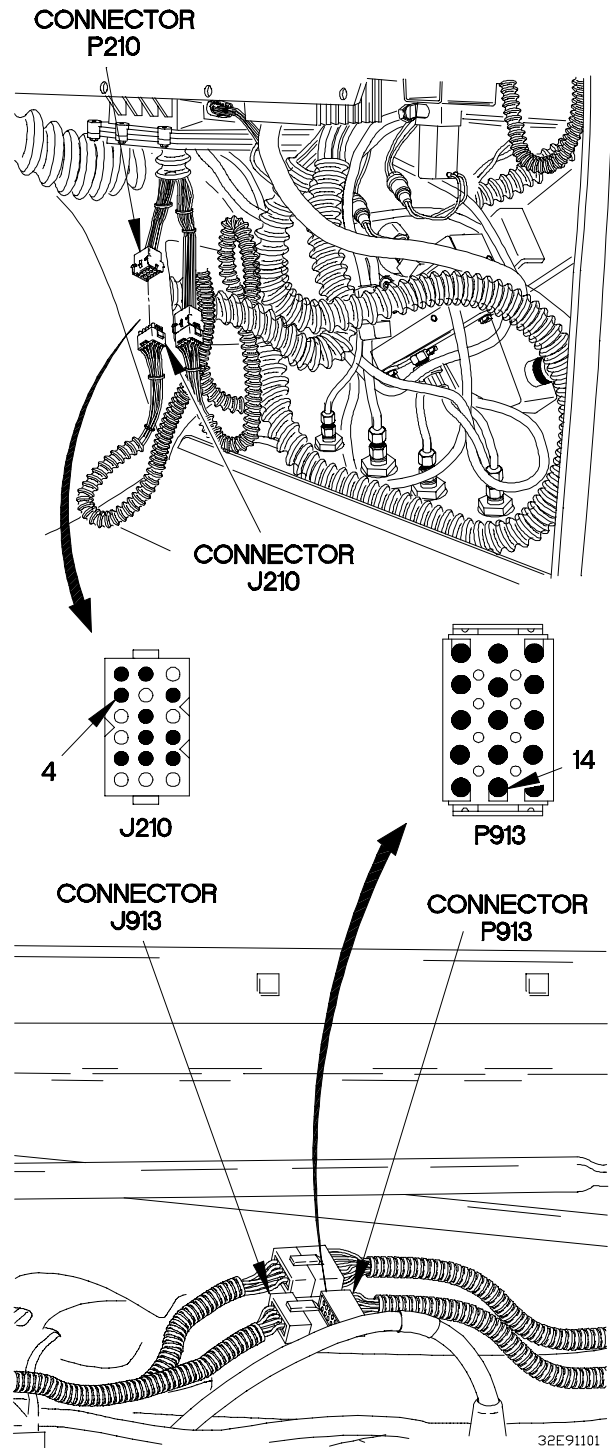

32E91101

e88. PTO DOES NOT OPERATE (CONT)

KNOWN INFO
Circuit breaker OK. Vehicle starts. PTO OK. PTO switch OK. PTO cable assembly OK.
POSSIBLE PROBLEMS
Faulty WTEC III dashboard cable assembly. Faulty WTEC III relay K37. Faulty WTEC III transmission ECU.

18.
Is continuity present from WTEC III relay K37 terminal 85 to ground?

TEST OPTIONS
Continuity Test or STE/ICE-R Test #91
REASON FOR QUESTION
If continuity is not present, wire 3101 faulty.

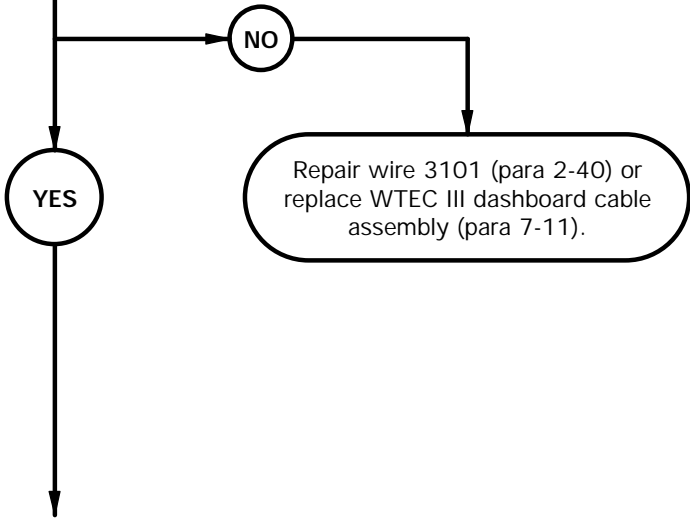

CONTINUITY TEST

- (1) Remove WTEC III relay K37 from PDP.
- (2) Set multimeter to ohms.
- (3) Connect positive (+) probe of multimeter to PDP, terminal 85, where WTEC III relay K37 was removed.
- (4) Connect negative (-) probe of multimeter to ground and note reading on multimeter.
- (5) If continuity is not present, repair wire 3101 (para 2-40) or replace WTEC III dashboard cable assembly (para 7-11).

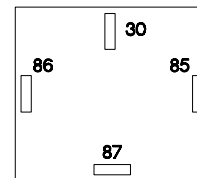
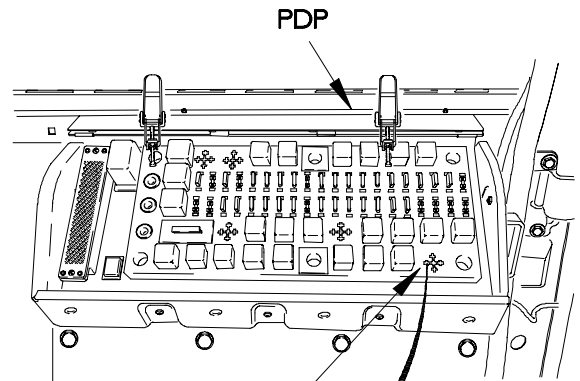

**WTEC III
RELAY K37**

X2E91161

e88. PTO DOES NOT OPERATE (CONT)

KNOWN INFO
Circuit breaker OK. Vehicle starts. PTO OK. PTO cable assembly OK. Auxiliary panel cable assembly OK. PTO switch OK.
POSSIBLE PROBLEMS
Faulty WTEC III dashboard cable assembly. Faulty WTEC III relay K37. Faulty WTEC III transmission ECU.

19. **WARNING**
Read **WARNING** on following page.

Is 24 VDC present on connector P115-13?

TEST OPTIONS
Voltage Test or STE/ICE-R Test #89
REASON FOR QUESTION
If 24 VDC is not present, wire 118 is faulty.

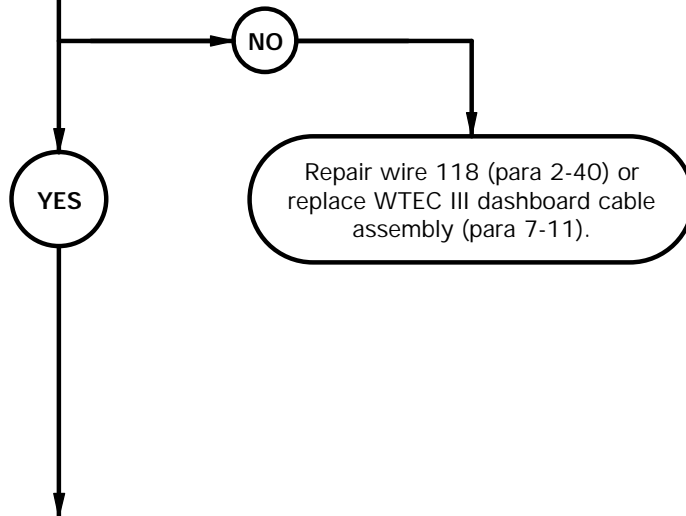

WARNING

Remove rings, bracelets, watches, necklaces, and any other jewelry before working around vehicle. Jewelry can catch on equipment and cause injury or short across electrical circuits and cause severe burns or electrical shock.

VOLTAGE TEST

- (1) Disconnect connector clamp from connector P115.
- (2) Disconnect connector P115 from WTEC III transmission ECU.
- (3) Set multimeter to volts DC.
- (4) Connect positive (+) probe of multimeter to connector P115-13.
- (5) Connect negative (-) probe of multimeter to ground.
- (6) Position master power switch to on (TM 9-2320-365-10).
- (7) Position PTO switch to on (TM 9-2320-365-10) and note reading on multimeter.
- (8) If 24 VDC is not present, repair wire 118 (para 2-40) or replace WTEC III dashboard cable assembly (para 7-11).
- (9) Position PTO switch to off (TM 9-2320-365-10).
- (10) Position master power switch to off (TM 9-2320-365-10).

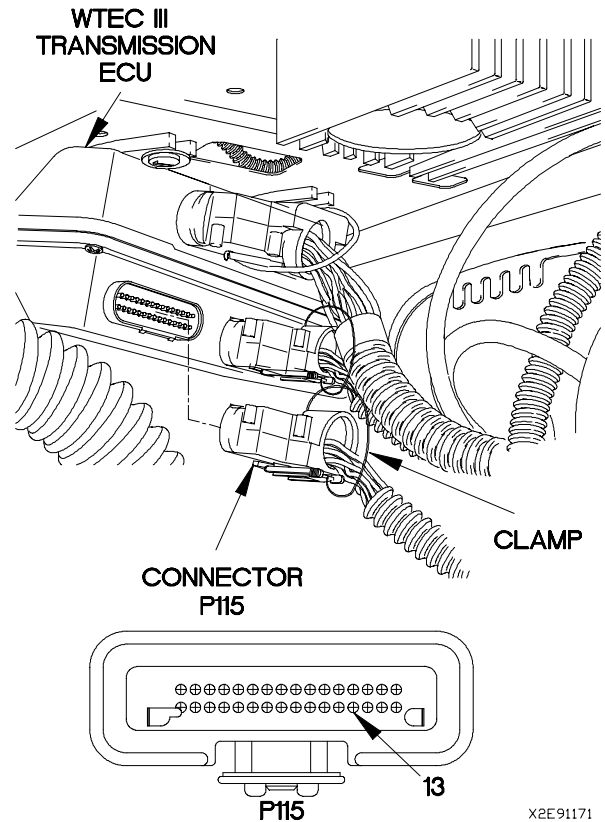

X2E91171

e88. PTO DOES NOT OPERATE (CONT)

KNOWN INFO
Circuit breaker OK. Vehicle starts. PTO OK. PTO cable assembly OK. Auxiliary panel cable assembly OK. PTO switch OK.
POSSIBLE PROBLEMS
Faulty WTEC III dashboard cable assembly. Faulty WTEC III relay K37. Faulty WTEC III transmission ECU.

20.
Is continuity present from connector P115-22 to WTEC III relay K37 terminal 86?

TEST OPTIONS
Continuity Test or STE/ICE-R Test #91
REASON FOR QUESTION
If continuity is not present, wire 112 is faulty.

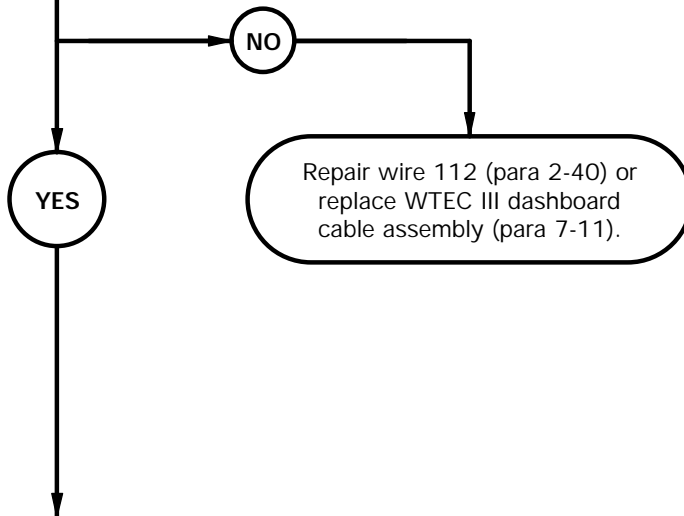

CONTINUITY TEST

- (1) Set multimeter to ohms.
- (2) Connect positive (+) probe of multimeter to connector P115-22.
- (3) Connect negative (-) probe of multimeter to PDP, terminal 86, where WTEC III relay K37 was removed, and note reading on multimeter.
- (4) If continuity is not present, repair wire 112 (para 2-40) or replace WTEC III dashboard cable assembly (para 7-11).
- (5) Connect connector P115 to WTEC III transmission ECU.
- (6) Connect connector clamp on connector P115.

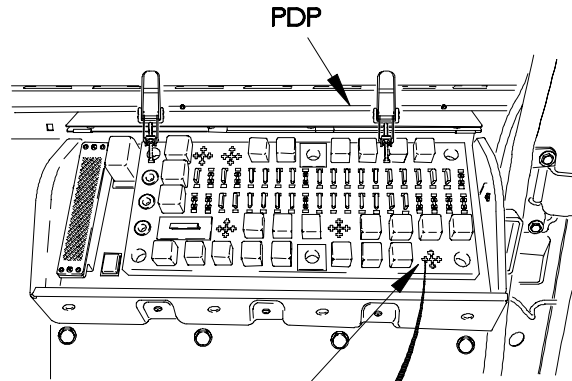

**WTEC III
RELAY K37**

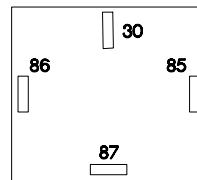

**WTEC III
RELAY K37
CAVITY**

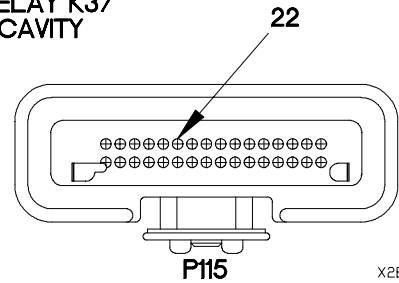

P115

X2E91181

e88. PTO DOES NOT OPERATE (CONT)

KNOWN INFO
Circuit breaker OK. Vehicle starts. PTO OK. PTO cable assembly OK. Auxiliary panel cable assembly OK. PTO switch OK. WTEC III dashboard cable assembly OK.
POSSIBLE PROBLEMS
Faulty WTEC III relay K37. Faulty WTEC III transmission ECU.

21.

WARNING
Read **WARNING** on following page.

Is 24 VDC present on WTEC III relay K37 terminal 86?

TEST OPTIONS
Voltage Test or STE/ICE-R Test #89
REASON FOR QUESTION
If 24 VDC is not present, WTEC III transmission ECU is faulty. If 24 VDC is present, WTEC III relay K37 is faulty.

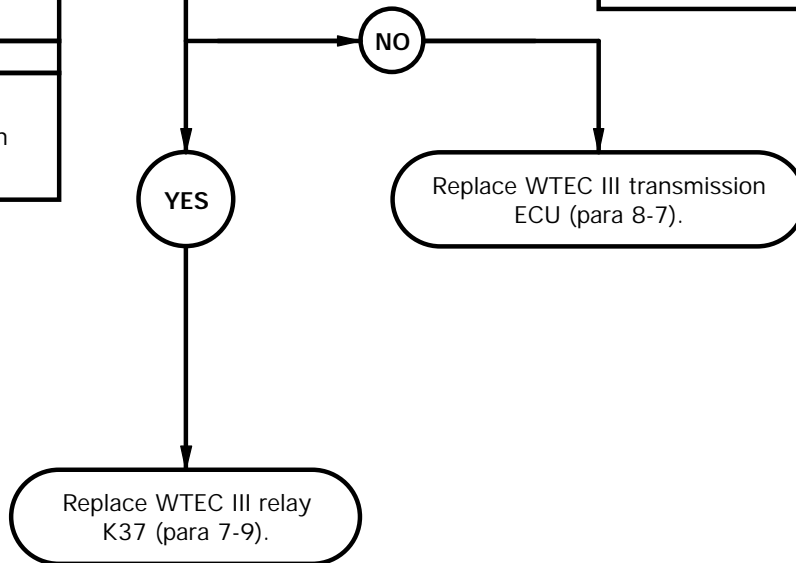

WARNING

Remove rings, bracelets, watches, necklaces, and any other jewelry before working around vehicle. Jewelry can catch on equipment and cause injury or short across electrical circuits and cause severe burns or electrical shock.

VOLTAGE TEST

- (1) Set multimeter to volts DC.
- (2) Connect positive (+) probe of multimeter to PDP, terminal 86, where WTEC III relay K37 was removed.
- (3) Connect negative (-) probe of multimeter to ground and note reading on multimeter.
- (4) If 24 VDC is not present, replace WTEC III transmission ECU (para 8-7).
- (5) If 24 VDC is present, replace WTEC III relay K37 (para 7-9).
- (6) Install WTEC III relay K37 on PDP.
- (7) Remove PTO switch from connector P904.
- (8) Install personnel heater (para 18-9).

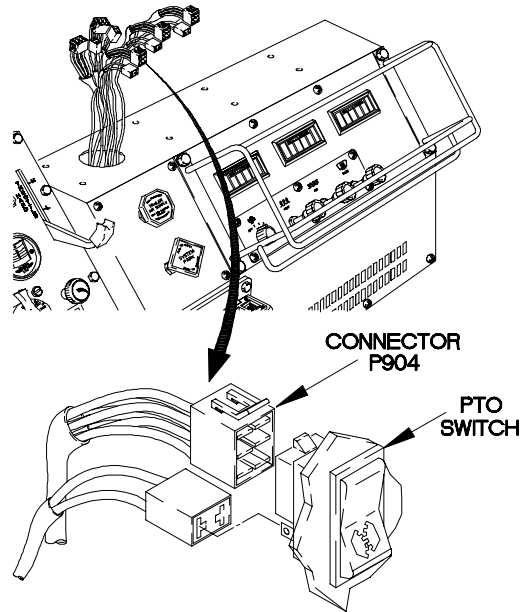
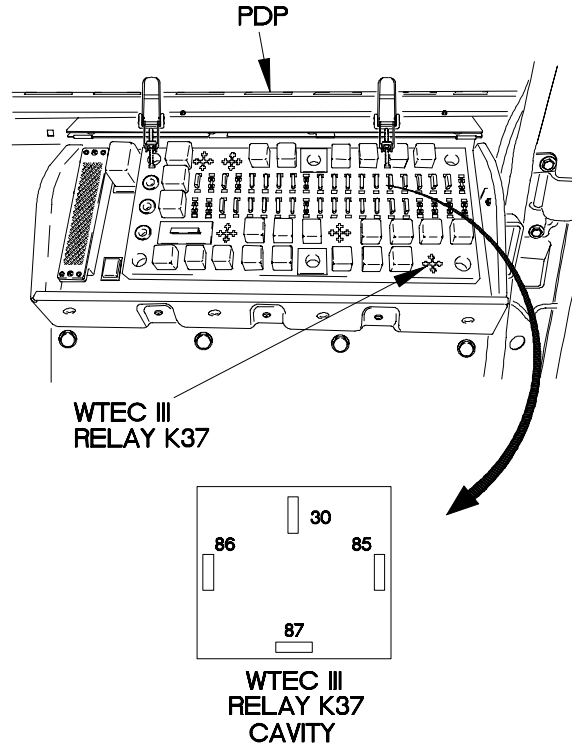

X2E91191

e89. ELECTRICAL SYSTEM DOES NOT MAINTAIN A CHARGE	
INITIAL SETUP	
<p>Equipment Conditions Engine shut down (TM 9-2320-365-10).</p> <p>Materials/Parts Wire, Elect, 50 ft (Item 77, Appendix D) Wire, Relay Test (Item 9, Appendix E) Nut, Self-Locking (Item 131.1, Appendix G) (100 AMP) Nut, Self-Locking (Item 130.1, Appendix G) (200 AMP)</p> <p>References TM 9-6140-200-14 TM 9-4910-571-12&P</p>	<p>Tools and Special Tools Tool Kit, Genl Mech (Item 44, Appendix C) STE/ICE-R (Item 39, Appendix C) Multimeter, Digital (Item 22, Appendix C) Apron, Rubber (Item 3, Appendix C) Gloves, Rubber (Item 13, Appendix C) Goggles, Industrial (Item 15, Appendix C) Tester, Antifreeze and Battery (Item 41, Appendix C) Wrench, Torque, 0-200 lb-in. (Item 58, Appendix C)</p> <p>Personnel Required (2)</p>

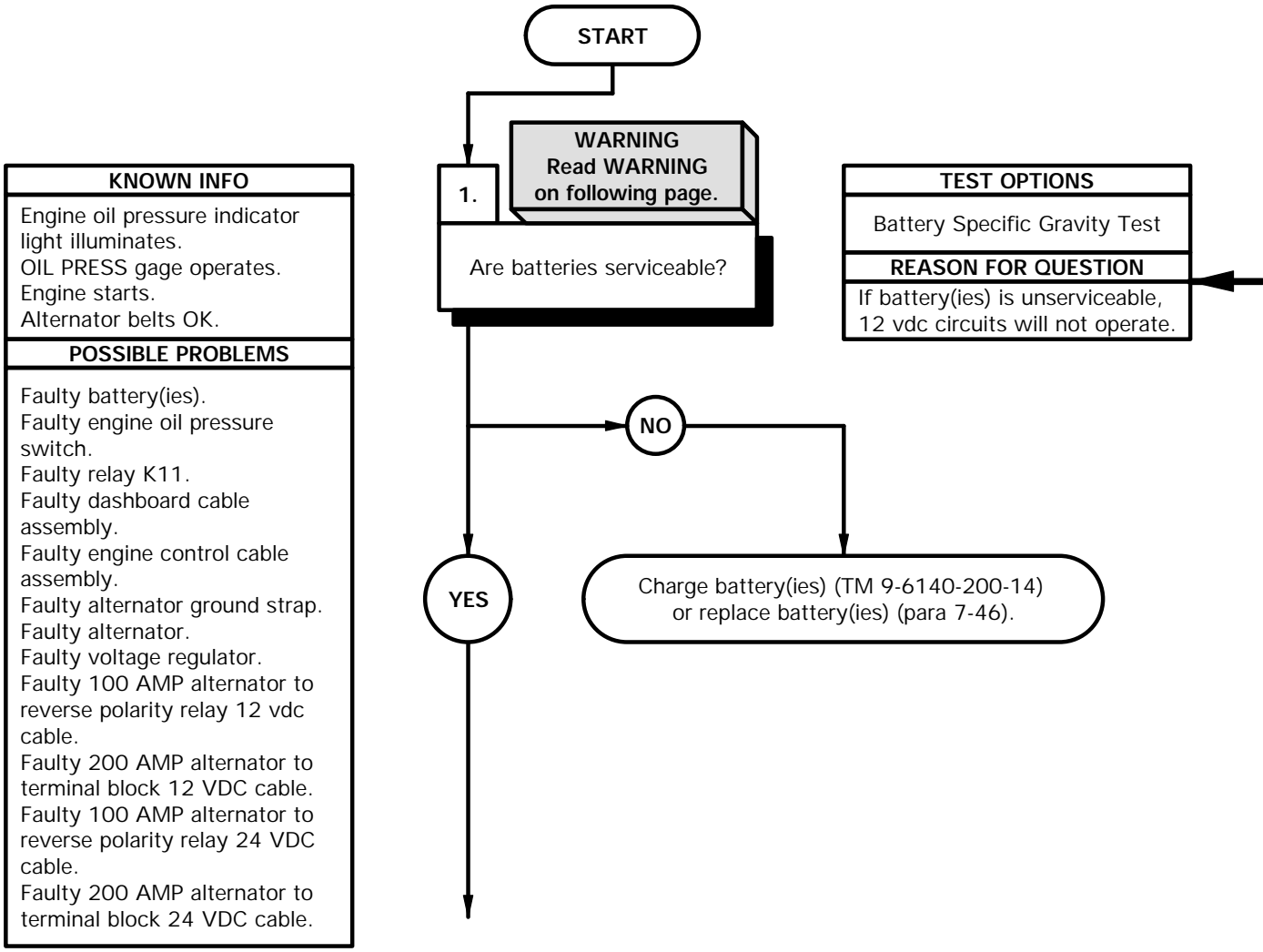

WARNING

Remove rings, bracelets, watches, necklaces, and any other jewelry before working around vehicle. Jewelry can catch on equipment and cause injury or short across electrical circuit and cause severe burns or electrical shock. Batteries can explode from a spark. Battery acid is harmful to skin and eyes. Always wear eye protection and rubber gloves when working with batteries.

BATTERY SPECIFIC GRAVITY TEST

- (1) Remove battery box cover from battery box (TM 9-2320-365-10).
- (2) Remove four batteries from battery box (para 7-46).
- (3) Test batteries for serviceability (TM 9-6140-200-14).
- (4) Replace battery(ies) if unserviceable (TM 9-6140-200-14).
- (5) Install four batteries in battery box (para 7-46).
- (6) Install battery box cover on battery box (TM 9-2320-365-10).

e89. ELECTRICAL SYSTEM DOES NOT MAINTAIN A CHARGE (CONT)

KNOWN INFO
Engine oil pressure indicator light illuminates. OIL PRESS gage operates. Engine starts. Alternator belts OK. Battery(ies) OK.
POSSIBLE PROBLEMS
Faulty engine oil pressure switch. Faulty relay K11. Faulty dashboard cable assembly. Faulty engine control cable assembly. Faulty alternator ground strap. Faulty alternator. Faulty voltage regulator. Faulty 100 AMP alternator to reverse polarity relay 12 vdc cable. Faulty 200 AMP alternator to terminal block 12 VDC cable. Faulty 100 AMP alternator to reverse polarity relay 24 VDC cable. Faulty 200 AMP alternator to terminal block 24 VDC cable.

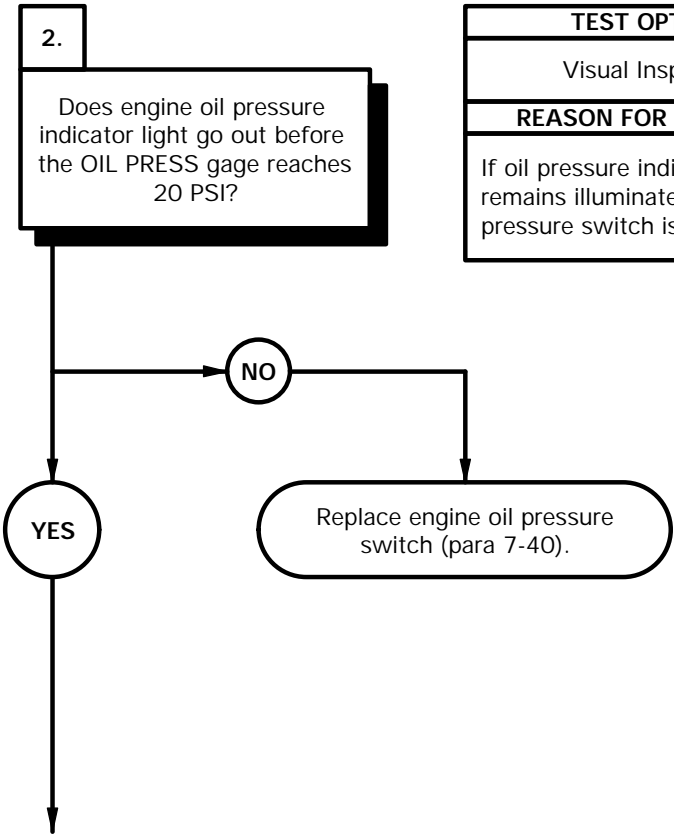

TEST OPTIONS
Visual Inspection
REASON FOR QUESTION
If oil pressure indicator light remains illuminated, oil pressure switch is faulty.



STEERING WHEEL
REMOVED FOR
CLARITY

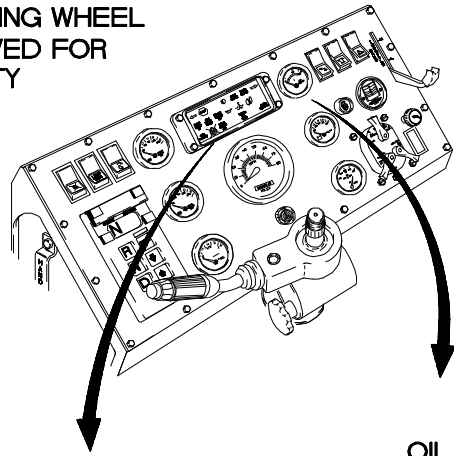

- (1) Start engine (TM 9-2320-365-10).
- (2) If engine oil pressure indicator light remains on after OIL PRESS gage reaches 20 PSI, replace engine oil pressure switch (para 7-40).
- (3) Shut down engine (TM 9-2320-365-10).

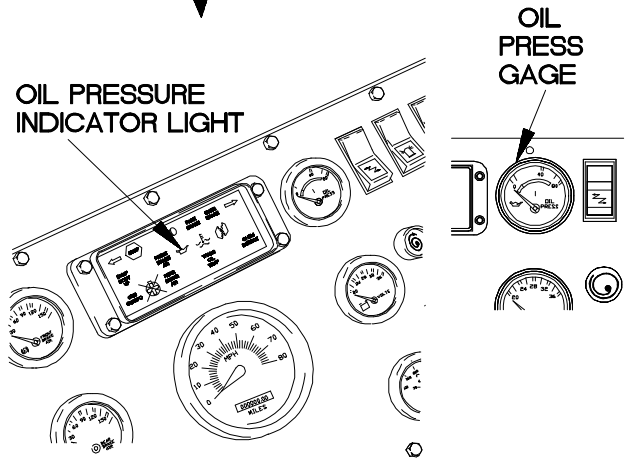

XBE9201B

e89. ELECTRICAL SYSTEM DOES NOT MAINTAIN A CHARGE (CONT)

KNOWN INFO
Engine oil pressure indicator light illuminates. OIL PRESS gage operates. Engine starts. Alternator belts OK. Battery(ies) OK. Engine oil pressure switch OK.
POSSIBLE PROBLEMS
Faulty relay K11. Faulty dashboard cable assembly. Faulty engine control cable assembly. Faulty alternator ground strap. Faulty alternator. Faulty voltage regulator. Faulty 100 AMP alternator to reverse polarity relay 12 vdc cable. Faulty 200 AMP alternator to terminal block 12 VDC cable. Faulty 100 AMP alternator to reverse polarity relay 24 VDC cable. Faulty 200 AMP alternator to terminal block 24 VDC cable.

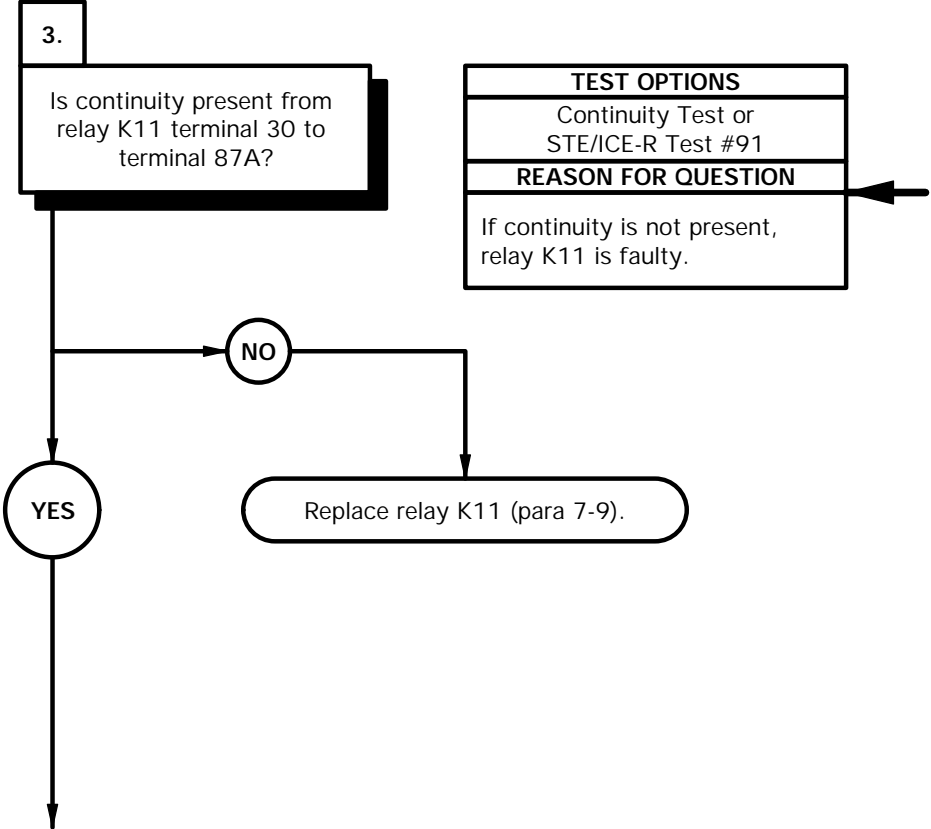

CONTINUITY TEST

- (1) Disconnect batteries (para 7-48).
- (2) Remove power distribution panel (PDP) cover (para 16-2).
- (3) Remove relay K11 from power distribution panel (PDP).
- (4) Set multimeter to ohms.
- (5) Connect positive (+) probe of multimeter to relay K11 terminal 30.
- (6) Connect negative (-) probe of multimeter to relay K11 terminal 87A and note reading on multimeter.
- (7) If continuity is not present, replace relay K11 (para 7-9).

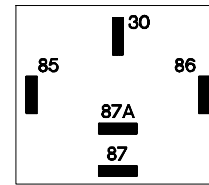
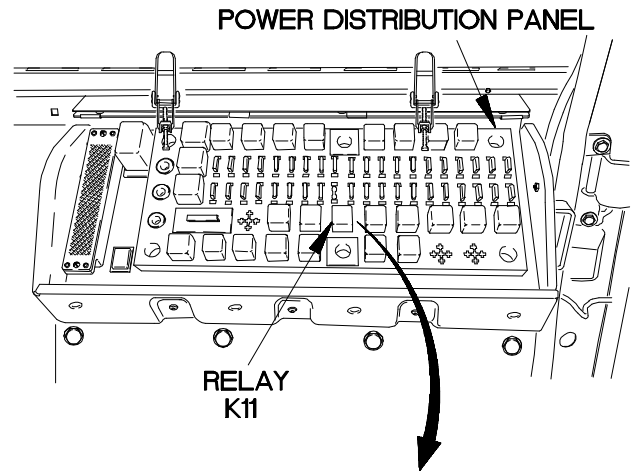

RELAY K11

XBE9202B

e89. ELECTRICAL SYSTEM DOES NOT MAINTAIN A CHARGE (CONT)

KNOWN INFO
Engine oil pressure indicator light illuminates. OIL PRESS gage operates. Engine starts. Alternator belts OK. Battery(ies) OK. Engine oil pressure switch OK. Relay K11 OK.
POSSIBLE PROBLEMS
Faulty dashboard cable assembly. Faulty engine control cable assembly. Faulty alternator ground strap. Faulty alternator. Faulty voltage regulator. Faulty 100 AMP alternator to reverse polarity relay 12 vdc cable. Faulty 200 AMP alternator to terminal block 12 VDC cable. Faulty 100 AMP alternator to reverse polarity relay 24 VDC cable. Faulty 200 AMP alternator to terminal block 24 VDC cable.

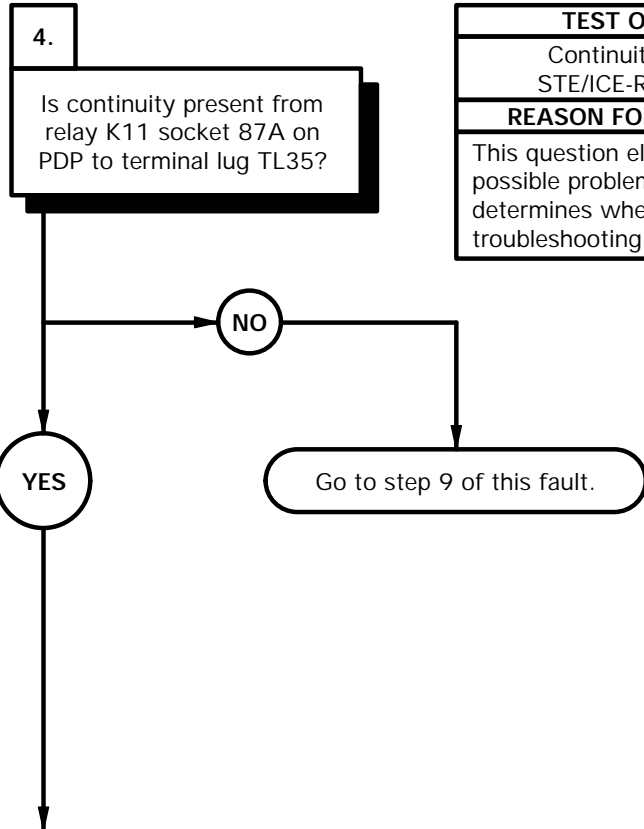

TEST OPTIONS
Continuity Test or STE/ICE-R Test #91
REASON FOR QUESTION
This question eliminates possible problems and determines where troubleshooting continues.

CONTINUITY TEST

- (1) Set multimeter to ohms.
- (2) Connect positive (+) probe of multimeter to relay K11 socket 87A on PDP.
- (3) Raise cab (TM 9-2320-365-10).
- (4) Lift dust boot on terminal lug TL35.
- (5) Remove self-locking nut, washer, and terminal lug TL35 from voltage regulator.
- (6) Connect negative (-) probe of multimeter to terminal lug TL35 and note reading on multimeter.
- (7) If continuity is not present, go to step 9 of this fault.
- (8) Position terminal lug TL35 on voltage regulator with washer and self-locking nut.
- (9) Tighten self-locking nut to 23-27 lb-in. (3 N.m).
- (10) Position dust boot on terminal lug TL35.

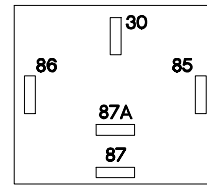

**RELAY K11
CAVITY**

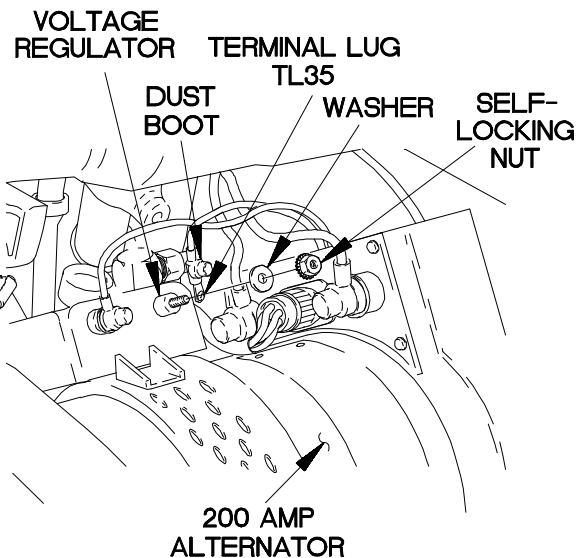
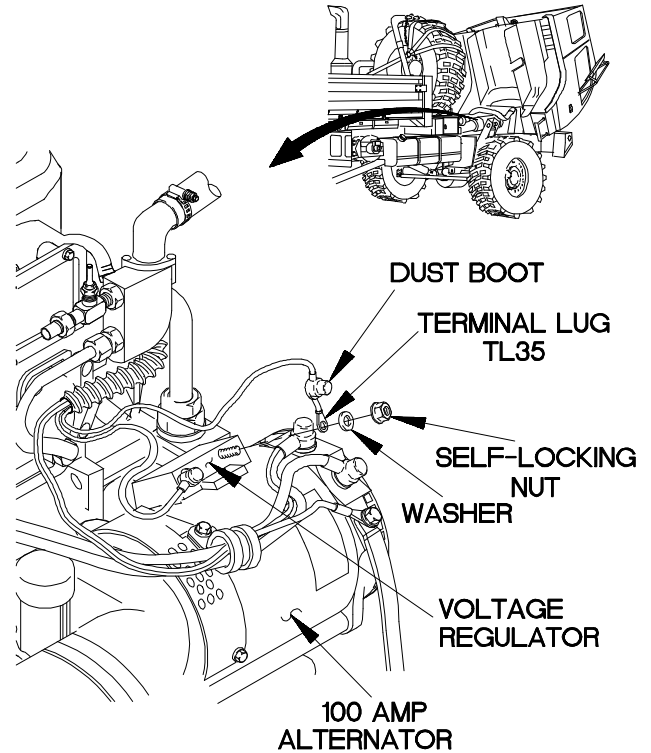

XBE9203B

e89. ELECTRICAL SYSTEM DOES NOT MAINTAIN A CHARGE (CONT)

KNOWN INFO
Engine oil pressure indicator light illuminates. OIL PRESS gage operates. Engine starts. Alternator belts OK. Battery(ies) OK. Engine oil pressure switch OK. Relay K11 OK. Dashboard cable assembly OK. Engine control cable assembly OK.
POSSIBLE PROBLEMS
Faulty alternator ground strap. Faulty alternator. Faulty voltage regulator. Faulty 100 AMP alternator to reverse polarity relay 12 vdc cable. Faulty 200 AMP alternator to terminal block 12 VDC cable. Faulty 100 AMP alternator to reverse polarity relay 24 VDC cable. Faulty 200 AMP alternator to terminal block 24 VDC cable.

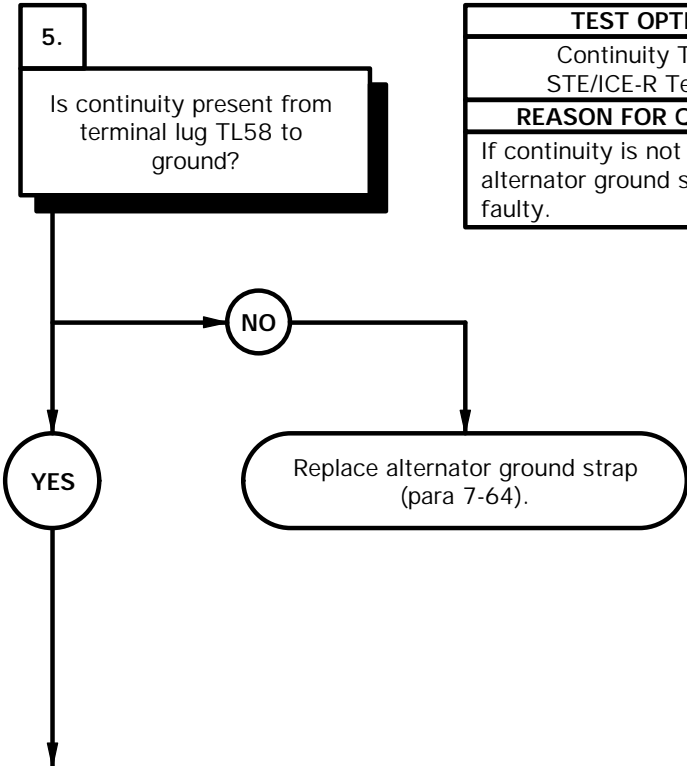

TEST OPTIONS
Continuity Test or STE/ICE-R Test #91
REASON FOR QUESTION
If continuity is not present, alternator ground strap is faulty.

CONTINUITY TEST

- (1) Set multimeter to ohms.
- (2) Connect positive (+) probe of multimeter to terminal lug TL58.
- (3) Connect negative (-) probe of multimeter to ground and note reading on multimeter.
- (4) If continuity is not present, replace alternator ground strap (para 7-64).
- (5) Connect batteries (para 7-48).

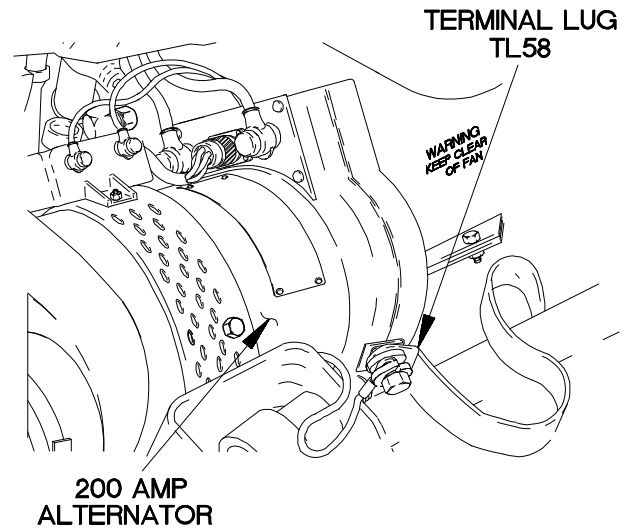
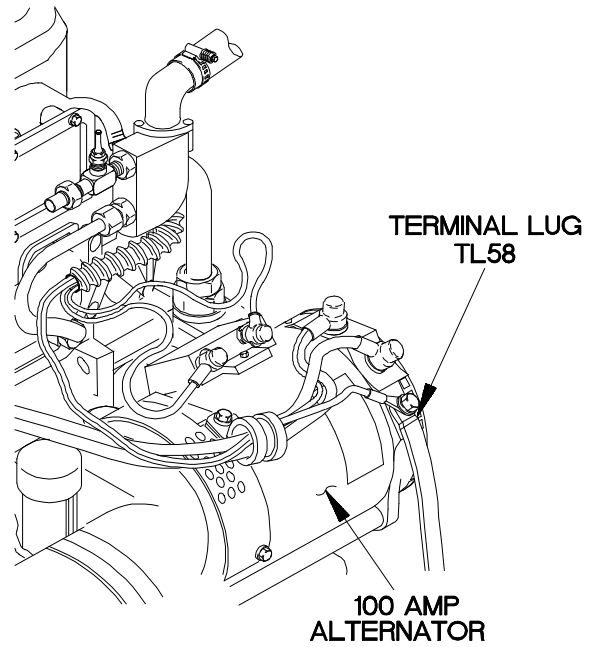

Xbe9204b

e89. ELECTRICAL SYSTEM DOES NOT MAINTAIN A CHARGE (CONT)

KNOWN INFO
Engine oil pressure indicator light illuminates. OIL PRESS gage operates. Engine starts. Alternator belts OK. Battery(ies) OK. Engine oil pressure switch OK. Relay K11 OK. Dashboard cable assembly OK. Engine control cable assembly OK. Alternator ground strap OK.
POSSIBLE PROBLEMS
Faulty alternator. Faulty voltage regulator. Faulty 100 AMP alternator to reverse polarity relay 12 vdc cable. Faulty 200 AMP alternator to terminal block 12 VDC cable. Faulty 100 AMP alternator to reverse polarity relay 24 VDC cable. Faulty 200 AMP alternator to terminal block 24 VDC cable.

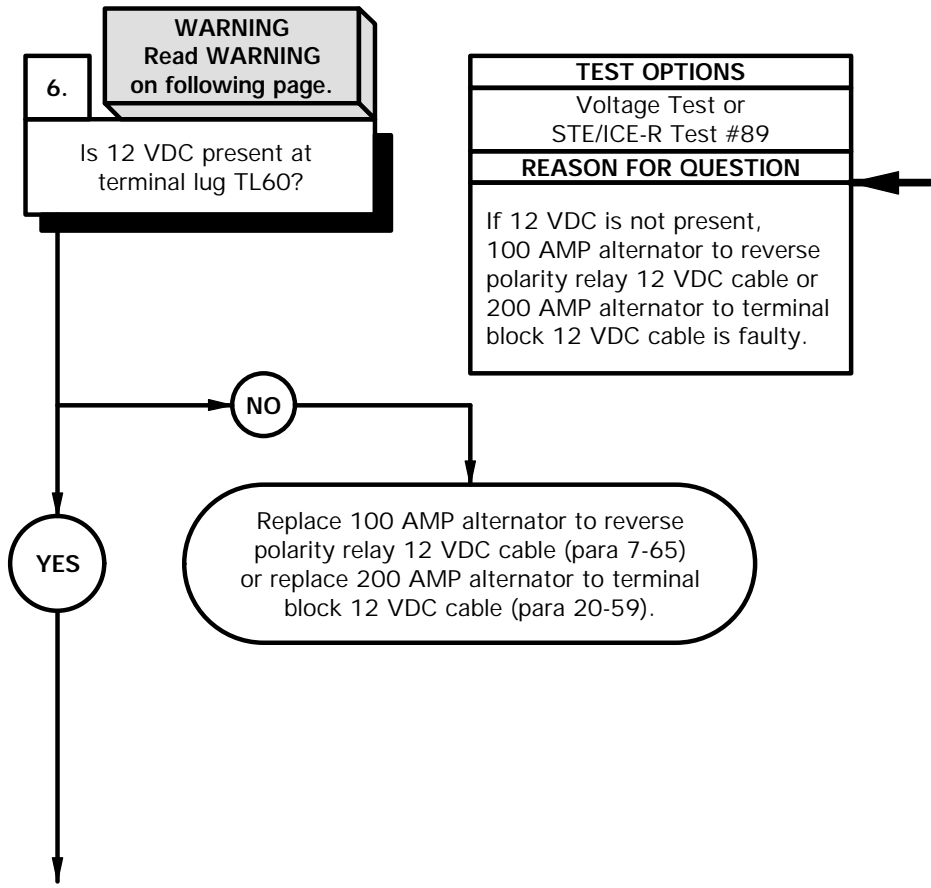

WARNING

Remove rings, bracelets, watches, necklaces, and any other jewelry before working around vehicle. Jewelry can catch on equipment and cause injury or short across electrical circuits and cause severe burns or electrical shock.

VOLTAGE TEST

- (1) Raise cab (TM 9-2320-365-10).
- (2) Lift dust boot from terminal lug TL60.
- (3) Set multimeter to volts DC.
- (4) Connect positive (+) probe of multimeter to terminal lug TL60.
- (5) Connect negative (-) probe of multimeter to ground and note reading on multimeter.
- (6) If 12 VDC is not present, replace 100 AMP alternator to reverse polarity relay 12 VDC cable (para 7-65) or replace 200 AMP alternator to terminal block 12 VDC cable (para 20-59).
- (7) Position dust boot on terminal lug TL60.

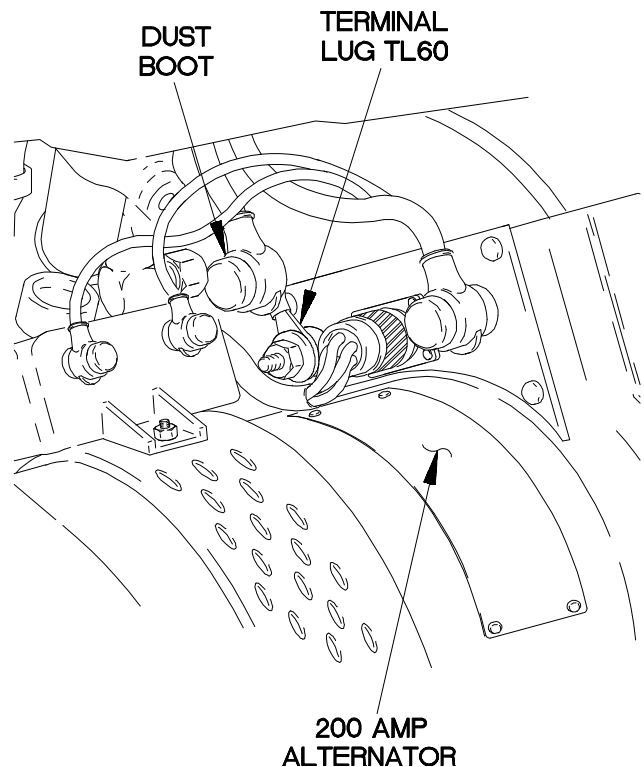
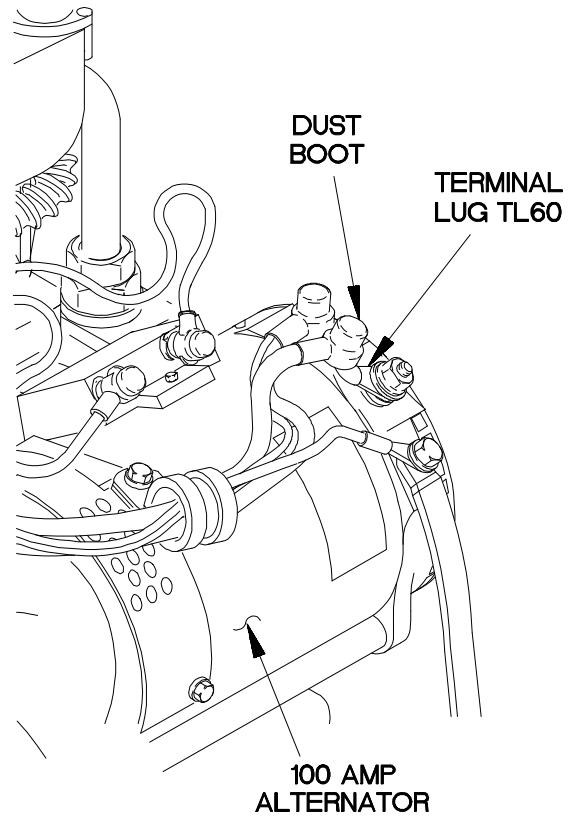

XBE9205B

e89. ELECTRICAL SYSTEM DOES NOT MAINTAIN A CHARGE (CONT)

KNOWN INFO
Engine oil pressure indicator light illuminates. OIL PRESS gage operates. Engine starts. Alternator belts OK. Battery(ies) OK. Engine oil pressure switch OK. Relay K11 OK. Dashboard cable assembly OK. Engine control cable assembly OK. Alternator ground strap OK. 100 AMP alternator to reverse polarity relay 12 vdc cable OK. 200 AMP alternator to terminal block 12 VDC cable OK.
POSSIBLE PROBLEMS
Faulty alternator. Faulty voltage regulator. Faulty 100 AMP alternator to reverse polarity relay 24 VDC cable. Faulty 200 AMP alternator to terminal block 24 VDC cable.

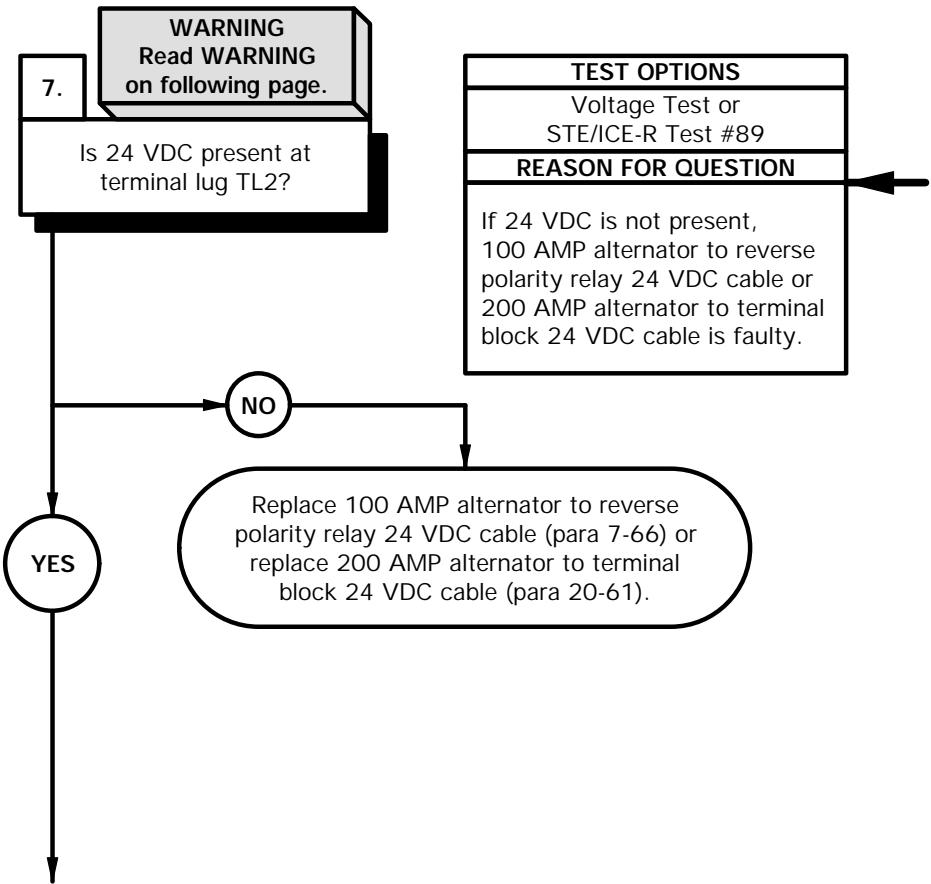

WARNING

Remove rings, bracelets, watches, necklaces, and any other jewelry before working around vehicle. Jewelry can catch on equipment and cause injury or short across electrical circuits and cause severe burns or electrical shock.

VOLTAGE TEST

- (1) Lift dust boot from terminal lug TL2.
- (2) Set multimeter to volts DC.
- (3) Connect positive (+) probe of multimeter to terminal lug TL2.
- (4) Connect negative (-) probe of multimeter to ground and note reading on multimeter.
- (5) If 24 VDC is not present, replace 100 AMP alternator to reverse polarity relay 24 VDC cable (para 7-66) or replace 200 AMP alternator to terminal block 12 VDC cable (para 20-61).
- (6) Position dust boot on terminal lug TL2.
- (7) Disconnect batteries (para 7-48).
- (8) Lower cab (TM9-2320-365-10).
- (9) Install relay K11 in PDP.
- (10) Install PDP cover (para 16-2).
- (11) Connect batteries (para 7-48).

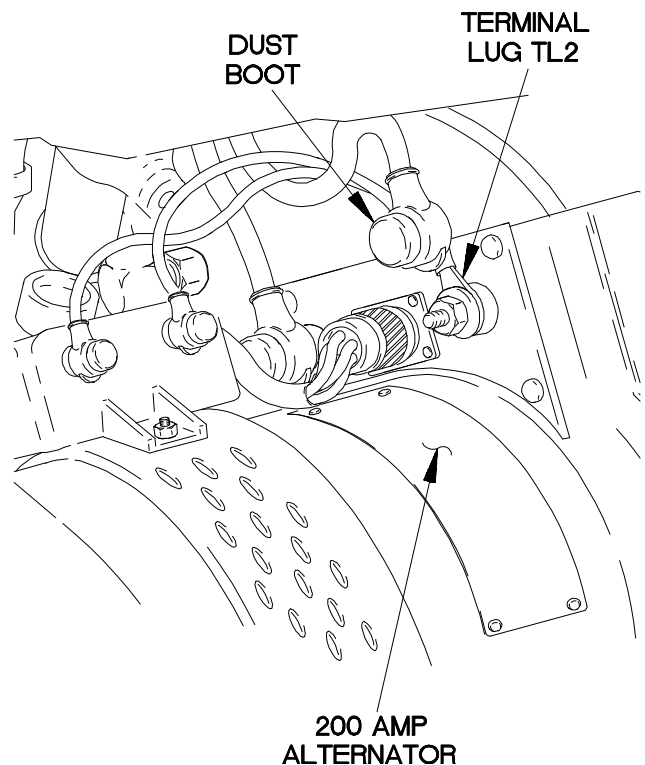
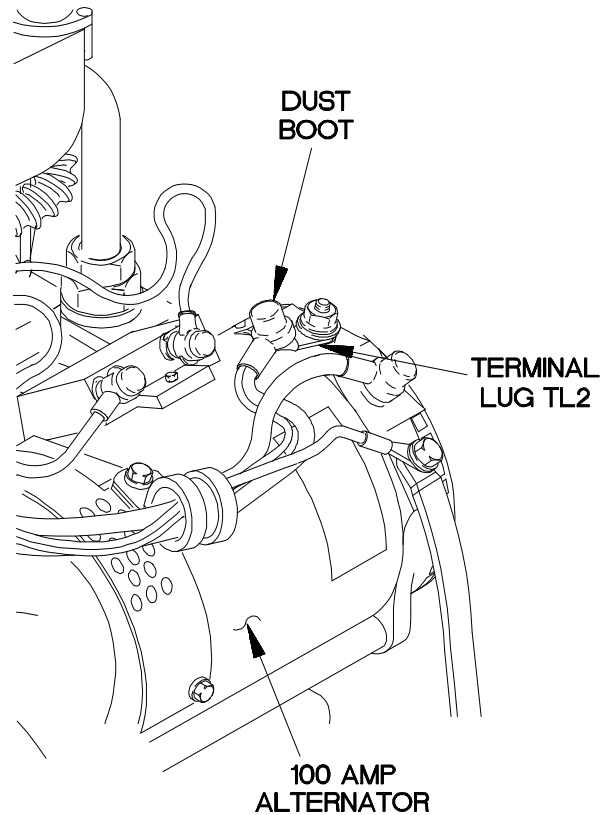

xbe9206b

e89. ELECTRICAL SYSTEM DOES NOT MAINTAIN A CHARGE (CONT)

KNOWN INFO
Engine oil pressure indicator light illuminates. OIL PRESS gage operates. Engine starts. Alternator belts OK. Battery(ies) OK. Engine oil pressure switch OK. Relay K11 OK. Dashboard cable assembly OK. Engine control cable assembly OK. Alternator ground strap OK. 100 AMP alternator to reverse polarity relay 12 vdc cable OK. 200 AMP alternator to terminal block 12 VDC cable OK. 100 AMP alternator to reverse polarity relay 24 VDC cable OK. 200 AMP alternator to terminal block 24 VDC cable OK.
POSSIBLE PROBLEMS
Faulty alternator. Faulty voltage regulator.

WARNING
Read WARNING on following page.

8. Is the alternator output within normal voltage range for both 12 VDC and 24 VDC terminal studs with a known good voltage regulator?

TEST OPTIONS
Voltage Test or STE/ICE-R Test #89
REASON FOR QUESTION
With a known good voltage regulator installed; if the voltage regulator output is not within normal range, the alternator is faulty. If the voltage regulator output is within normal range, the previous voltage regulator is faulty.

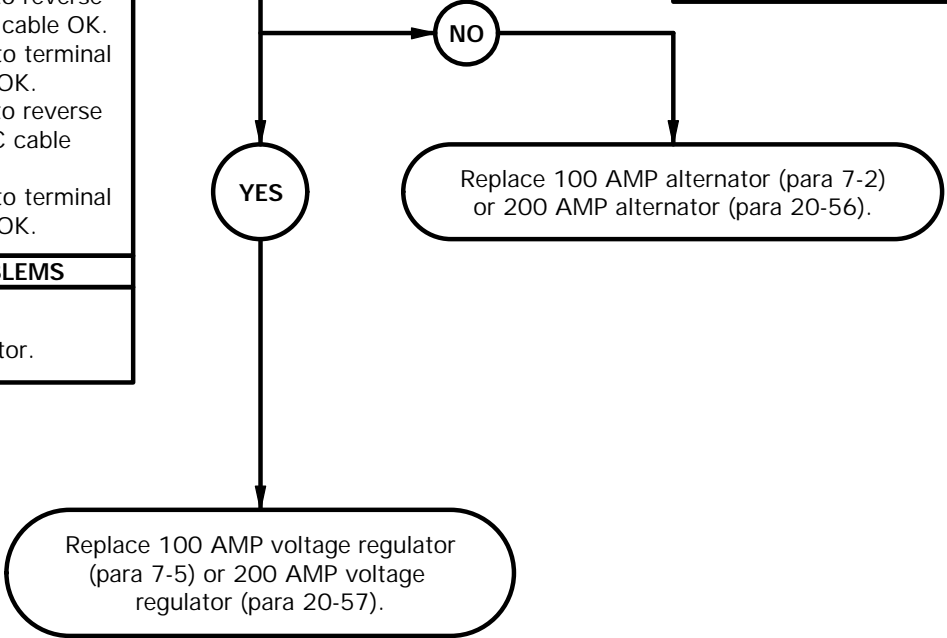

WARNING

Remove rings, bracelets, watches, necklaces, and any other jewelry before working around vehicle. Jewelry can catch on equipment and cause injury or short across electrical circuits and cause severe burns or electrical shock.

VOLTAGE TEST

- (1) Replace 100 AMP voltage regulator (para 7-5) or 200 AMP voltage regulator (para 20-57) with a known good voltage regulator.
- (2) Start engine (TM 9-2320-365-10).
- (3) Raise cab (TM 9-2320-365-10).
- (4) Lift dust boot from alternator 12 VDC terminal stud.
- (5) Set multimeter to volts DC.
- (6) Connect positive (+) probe of multimeter to alternator 12 VDC terminal stud.
- (7) Connect negative (-) probe of multimeter to ground and note reading on multimeter.
- (8) If 13.25 -14.75V is not present, replace 100 AMP alternator (para 7-2) or 200 AMP alternator (para 20-56).
- (9) If 13.25-14.75V is present, replace 100 AMP voltage regulator (para 7-5) or 200 AMP voltage regulator (para 20-57).
- (10) Position dust boot on alternator 12 VDC terminal stud.
- (11) Lift dust boot from alternator 24 VDC terminal stud.
- (12) Connect positive (+) probe of multimeter to alternator 24 VDC terminal stud.
- (13) Connect negative (-) probe of multimeter to ground and note reading on multimeter.
- (14) If 27.25 -28.75V is not present, replace 100 AMP alternator (para 7-2) or 200 AMP alternator (para 20-56).
- (15) If 27.25-28.75V is present, replace 100 AMP voltage regulator (para 7-5) or 200 AMP voltage regulator (para 20-57).
- (16) Position dust boot on alternator 24 VDC terminal stud.
- (17) Lower cab (TM 9-2320-365-10).
- (18) Shut down engine (TM 9-2320-365-10).

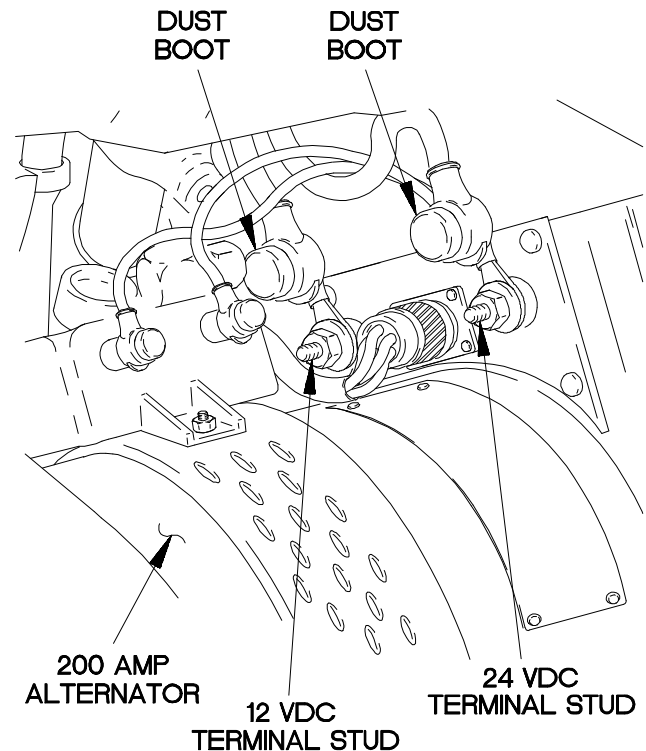
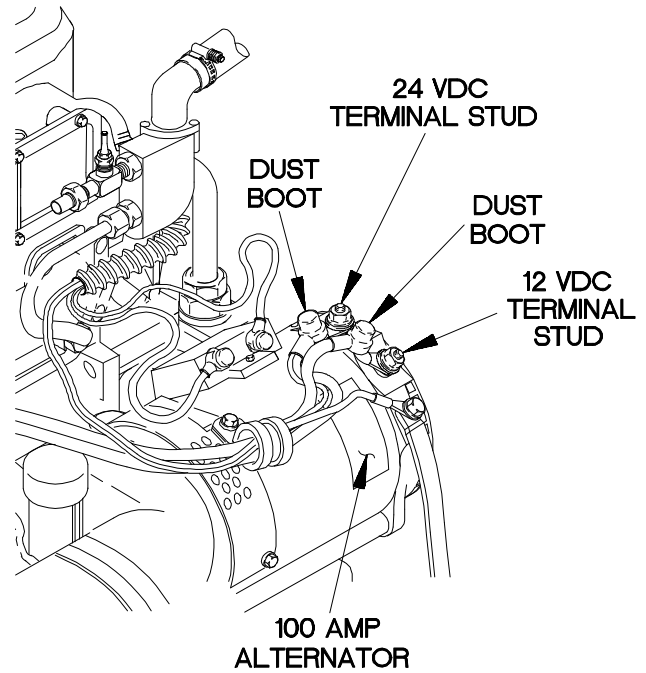

XBe9207B

e89. ELECTRICAL SYSTEM DOES NOT MAINTAIN A CHARGE (CONT)

KNOWN INFO
Engine oil pressure indicator light illuminates. OIL PRESS gage operates. Engine starts. Alternator belts OK. Battery(ies) OK. Engine oil pressure switch OK. Relay K11 OK.
POSSIBLE PROBLEMS
Faulty dashboard cable assembly. Faulty engine control cable assembly.

9. **CAUTION**
Read CAUTION on following page.

Is continuity present from relay K11 terminal 87A on PDP to connector J31 pin 1?

TEST OPTIONS
Continuity Test or STE/ICE-R Test #91
REASON FOR QUESTION
If continuity is not present, wire 568A from connector J31 pin 1 to relay K11 terminal 87A on PDP is faulty. If continuity is present, wire 568A from connector P31 socket 1 to terminal lug TL35 is faulty.

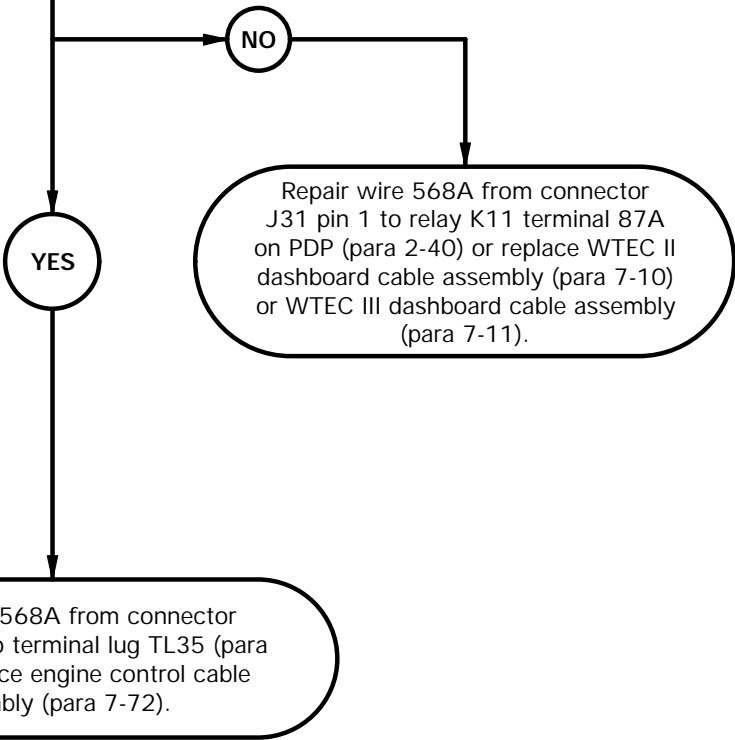

CAUTION

Use care when testing electrical connectors. Do not damage connector pins or sockets with multimeter probes. Failure to comply may result in damage to equipment.

NOTE

Inspect connector pins/sockets for damage, corrosion, and serviceability. Check that connector pins are not pushed back and are capable of making good contact.

CONTINUITY TEST

- (1) Lower cab (TM 9-2320-365-10).
- (2) Remove instrument panel for access (para 7-15).
- (3) Disconnect connector J31 from connector P31.
- (4) Set multimeter to ohms.
- (5) Connect positive (+) probe of multimeter to relay K11 terminal 87A on PDP.
- (6) Connect negative (-) probe of multimeter to connector J31 pin 1 and note reading on multimeter.
- (7) If continuity is not present, repair wire 568A from connector J31 pin 1 to relay K11 terminal 87A (para 2-40) on PDP or replace WTEC II dashboard cable assembly (para 7-10) or WTEC III dashboard cable assembly (para 7-11).
- (8) If continuity is present, repair wire 568A from connector P31 socket 1 to terminal lug TL35 (para 2-40) or replace engine control cable assembly (para 7-72).
- (9) Connect connector J31 to connector P31.
- (10) Install instrument panel (para 7-15).
- (11) Install relay K11 in PDP.
- (12) Install PDP cover (para 16-2).
- (13) Connect batteries (para 7-48).

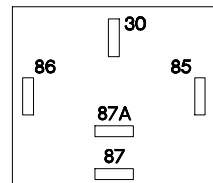
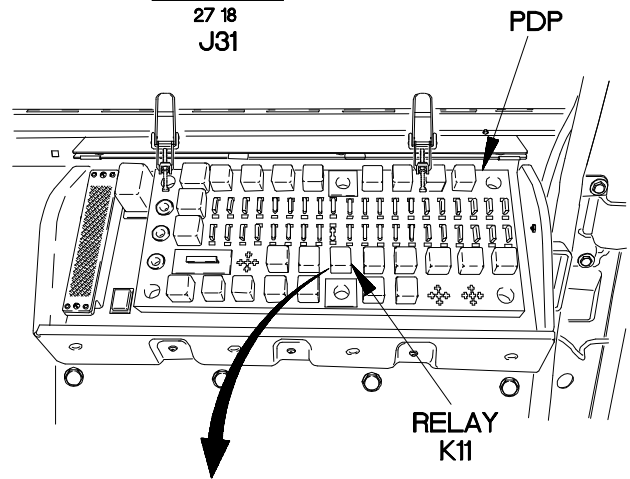
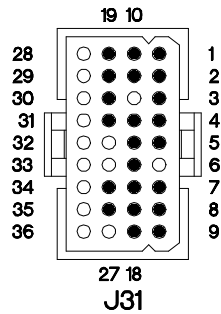
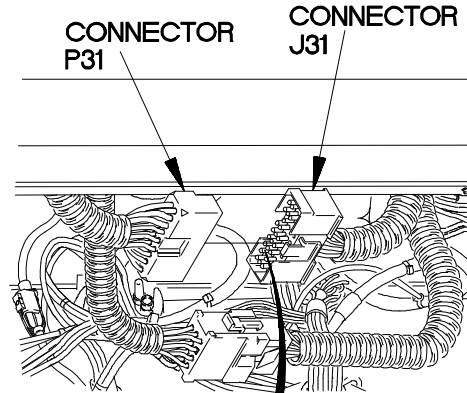

RELAY K11 CAVITY

XBE9208B

e90. WTEC II TRANSMISSION ECU PUSHBUTTON SHIFT SELECTOR (TEPSS) ILLUMINATION DOES NOT DIM	
INITIAL SETUP	
Equipment Condition Engine shut down (TM 9-2320-365-10).	Tools and Special Tools Tool Kit, Genl Mech (Item 44, Appendix C) STE/ICE-R (Item 39, Appendix C) Multimeter, Digital (Item 22, Appendix C)
Personnel Required (2)	Materials/Parts Wire, Elect, 50 ft (Item 77, Appendix D)
References TM 9-4910-571-12&P	

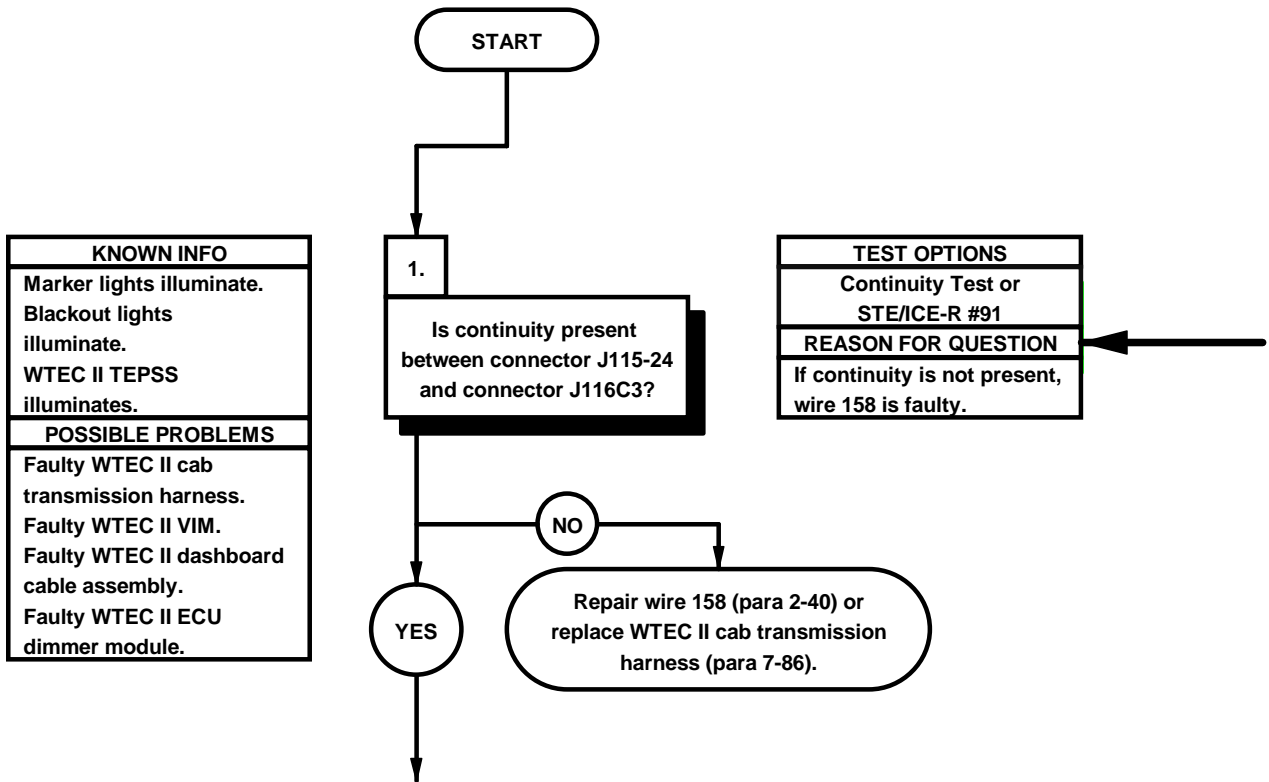

CONTINUITY TEST

- (1) Remove kick panel (para 16-3).
- (2) Disconnect connector J116 from WTEC II VIM.
- (3) Remove instrument panel assembly for access (para 7-15).
- (4) Disconnect connector J115 (top connector) from WTEC II TEPSS.
- (5) Set multimeter to ohms.
- (6) Connect positive (+) probe of multimeter to connector J115-24.
- (7) Connect negative (-) probe of multimeter to connector J116C3.
- (8) If continuity is not present, repair wire 158 (para 2-40) or replace WTEC II cab transmission harness (para 7-86).
- (9) Connect connector J115 to WTEC II TEPSS.
- (10) Install instrument panel assembly (para 7-15).

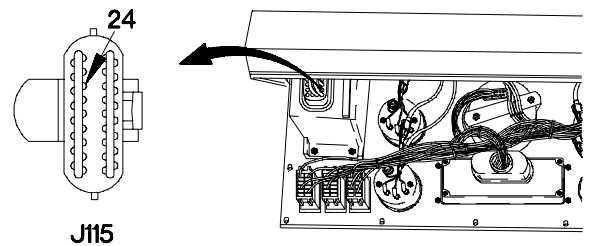
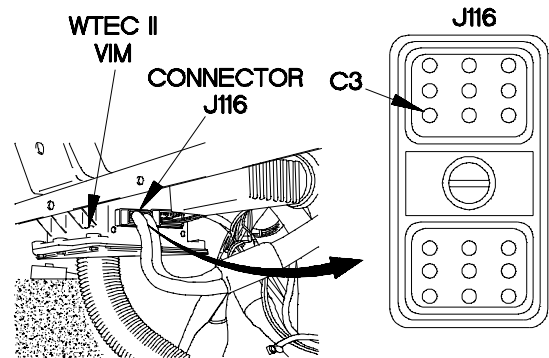

X2E93011

e90. WTEC II TRANSMISSION ECU PUSHBUTTON SHIFT SELECTOR (TEPSS) ILLUMINATION DOES NOT DIM (CONT)

KNOWN INFO
Marker lights illuminate. Blackout lights illuminate. WTEC II TEPSS illuminates. WTEC II cab transmission harness OK.
POSSIBLE PROBLEMS
Faulty WTEC II VIM. Faulty WTEC II dashboard cable assembly. Faulty WTEC II ECU dimmer module.

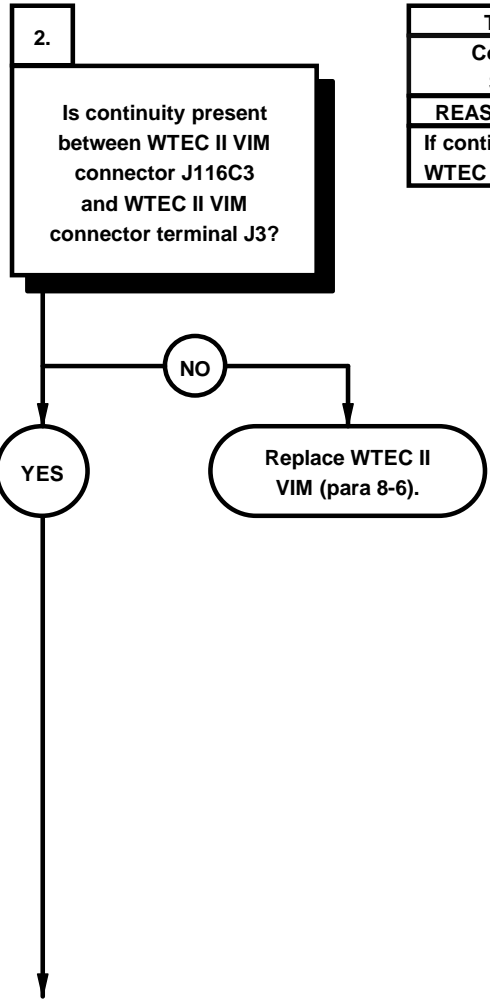

TEST OPTIONS
Continuity Test or STE/ICE-R #91
REASON FOR QUESTION
If continuity is not present, WTEC II VIM is faulty.



CONTINUITY TEST

- (1) Loosen screw and disconnect connector PX33 from WTEC II VIM.
- (2) Set multimeter to ohms.
- (3) Connect positive (+) probe of multimeter to WTEC II VIM connector J116C3.
- (4) Connect negative (-) probe of multimeter to WTEC II VIM connector terminal J3 and note reading on multimeter.
- (5) If continuity is not present, replace WTEC II VIM (para 8-6).
- (6) Connect connector J116 to WTEC II VIM.
- (7) Connect connector PX33 to WTEC II VIM and tighten screw.

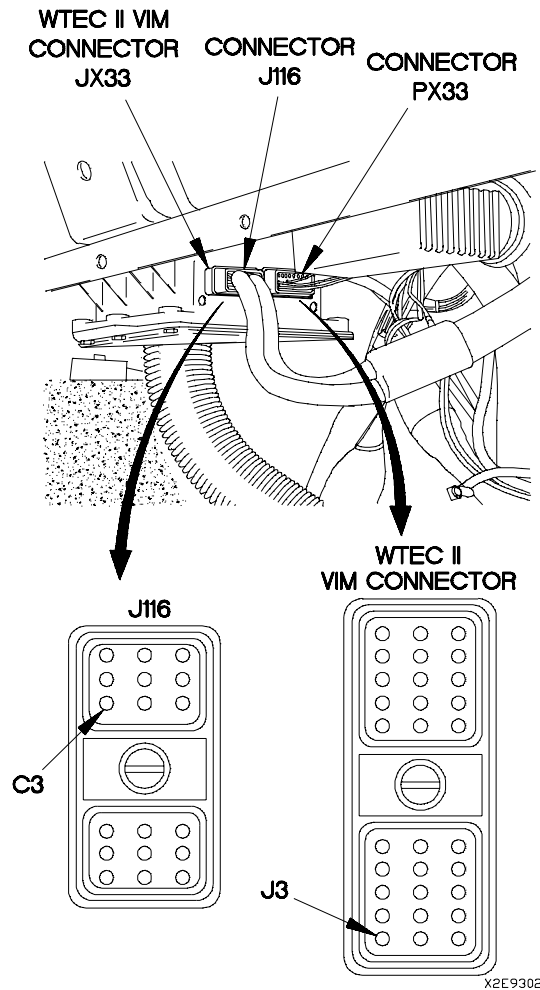

X2E93021

e90. WTEC II TRANSMISSION ECU PUSHBUTTON SHIFT SELECTOR (TEPSS) ILLUMINATION DOES NOT DIM (CONT)

KNOWN INFO
Marker lights illuminate. Blackout lights illuminate. WTEC II TEPSS illuminates. WTEC II VIM OK. WTEC II cab transmission harness OK.
POSSIBLE PROBLEMS
Faulty WTEC II dashboard cable assembly. Faulty WTEC II ECU dimmer module.

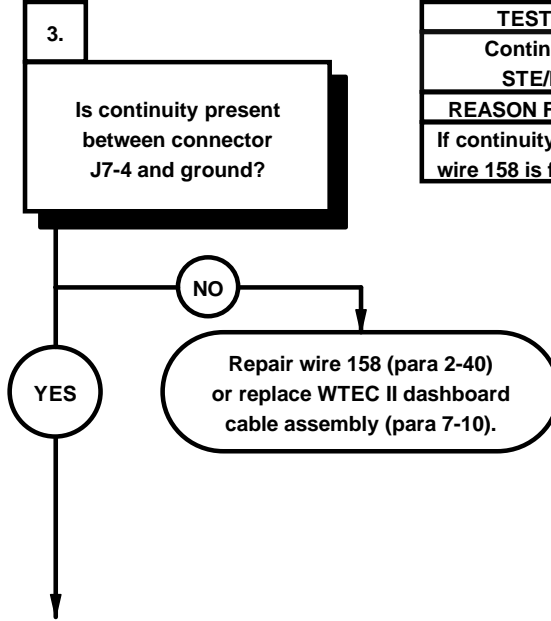

TEST OPTIONS
Continuity Test or STE/ICE-R #91
REASON FOR QUESTION
If continuity is not present, wire 158 is faulty.



CONTINUITY TEST

- (1) Remove three screws and washers from PDP.
- (2) Remove three screws from PDP.
- (3) Lift PDP outward to gain access.
- (4) Disconnect connector J7 from WTEC II ECU dimmer module.
- (5) Set multimeter to ohms.
- (6) Connect positive (+) probe of multimeter to connector J7-4.
- (7) Connect negative (-) probe of multimeter to ground and note reading on multimeter.
- (8) If continuity is not present, repair wire 158 (para 2-40) or replace WTEC II dashboard cable assembly (para 7-10).

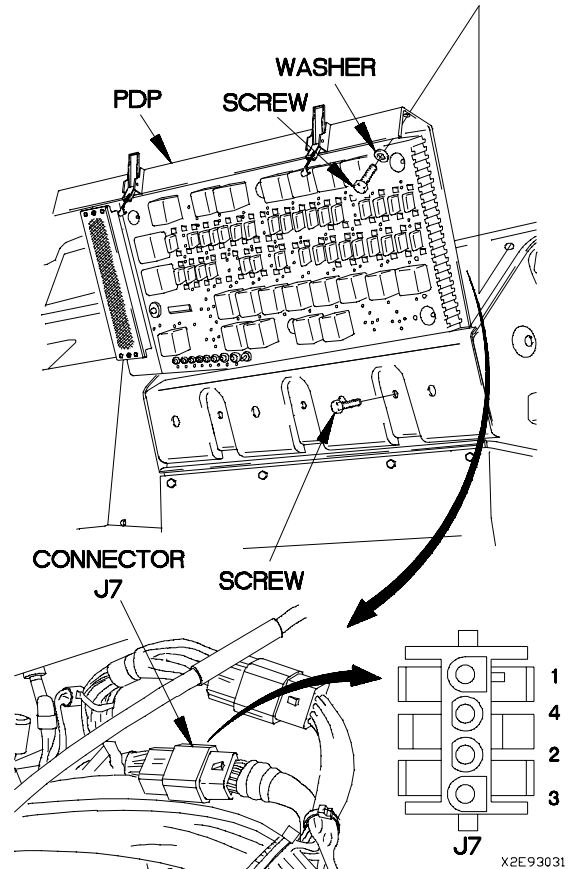

e90. WTEC II TRANSMISSION ECU PUSHBUTTON SHIFT SELECTOR (TEPSS) ILLUMINATION DOES NOT DIM (CONT)

KNOWN INFO
Marker lights illuminate. Blackout lights illuminate. WTEC II TEPSS illuminates. WTEC II cab transmission harness OK. WTEC II VIM OK.
POSSIBLE PROBLEMS
Faulty WTEC II dashboard cable assembly. Faulty WTEC II ECU dimmer module.

4.
Is continuity present between connector J7-1 and a known good ground?

TEST OPTIONS
Continuity Test or STE/ICE-R #91
REASON FOR QUESTION
If continuity is not present, wire 1426 is faulty.

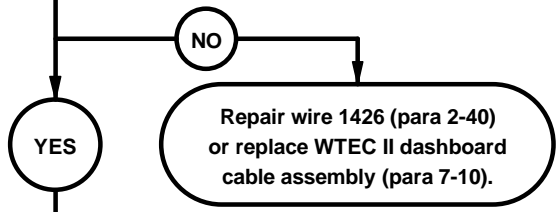

KNOWN INFO
Marker lights illuminate. Blackout lights illuminate. WTEC II TEPSS illuminates. WTEC II cab transmission harness OK. WTEC II VIM OK.
POSSIBLE PROBLEMS
Faulty WTEC II dashboard cable assembly. Faulty WTEC II ECU dimmer module.

5.
Is continuity present between connector J7-2 and a known good ground?

TEST OPTIONS
Continuity Test or STE/ICE-R #91
REASON FOR QUESTION
If continuity is not present, wire 1408 is faulty.

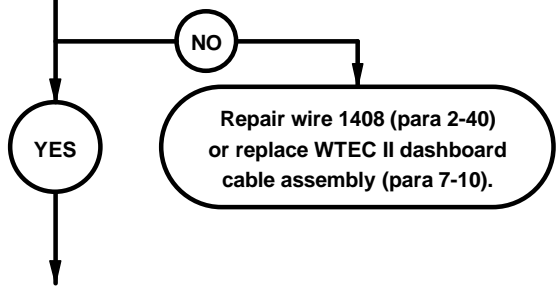

CONTINUITY TEST

- (1) Set multimeter to ohms.
- (2) Connect positive (+) probe of multimeter to connector J7-1.
- (3) Connect negative (-) probe of multimeter to ground and note reading on multimeter.
- (4) If continuity is not present, repair wire 1426 (para 2-40) or replace WTEC II dashboard cable assembly (para 7-10).

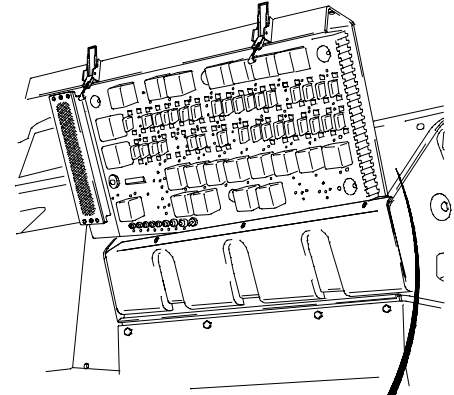

CONNECTOR

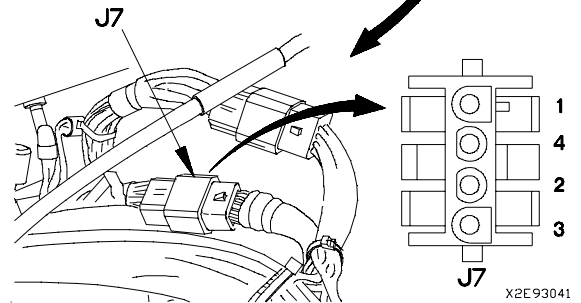

CONTINUITY TEST

- (1) Set multimeter to ohms.
- (2) Connect positive (+) probe of multimeter to connector J7-2.
- (3) Connect negative (-) probe of multimeter to ground and note reading on multimeter.
- (4) If continuity is not present, repair wire 1408 (para 2-40) or replace WTEC II dashboard cable assembly (para 7-10).

e90. WTEC II TRANSMISSION ECU PUSHBUTTON SHIFT SELECTOR (TEPSS) ILLUMINATION DOES NOT DIM (CONT)

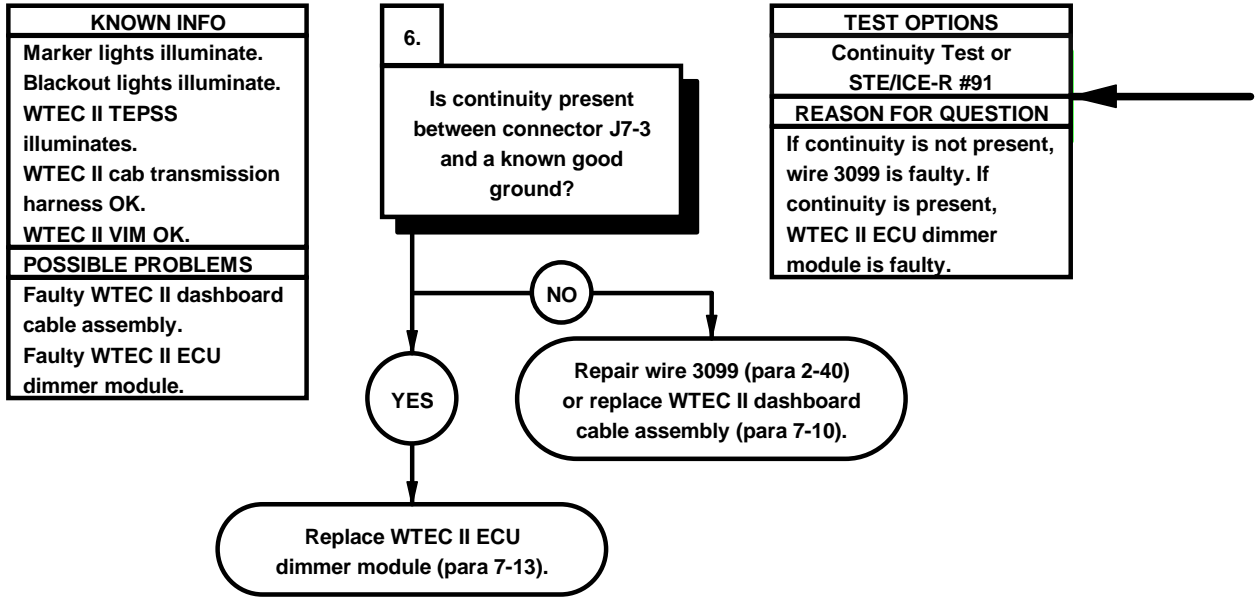

CONTINUITY TEST

- (1) Set multimeter to ohms.
- (2) Connect positive (+) probe of multimeter to connector J7-3.
- (3) Connect negative (-) probe of multimeter to ground and note reading on multimeter.
- (4) If continuity is not present, repair wire 3099 (para 2-40) or replace WTEC II dashboard cable assembly (para 7-10).
- (5) If continuity is present, replace WTEC II ECU dimmer module (para 7-13).
- (6) Connect connector J7 to WTEC II ECU dimmer module.
- (7) Install PDP on dashboard with three screws.
- (8) Install three washers and screws in PDP.
- (9) Install kick panel (para 16-3).

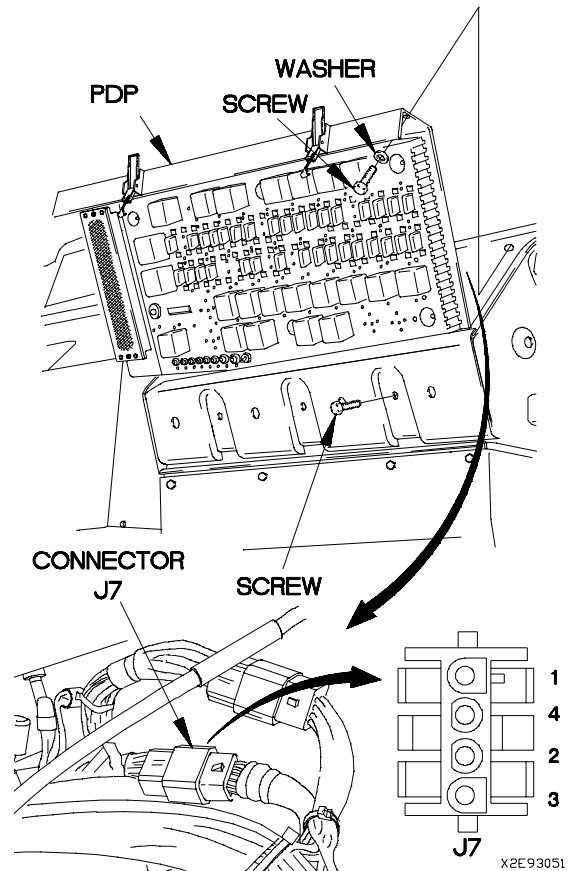

e91. ENGINE FAN RUNS CONSTANTLY	
INITIAL SETUP	
Equipment Condition Engine shut down (TM 9-2320-365-10).	Tools and Special Tools Tool Kit, Genl Mech (Item 44, Appendix C) STE/ICE-R (Item 39, Appendix C) Multimeter, Digital (Item 22, Appendix C)
Personnel Required (2)	References TM 9-4910-571-12&P

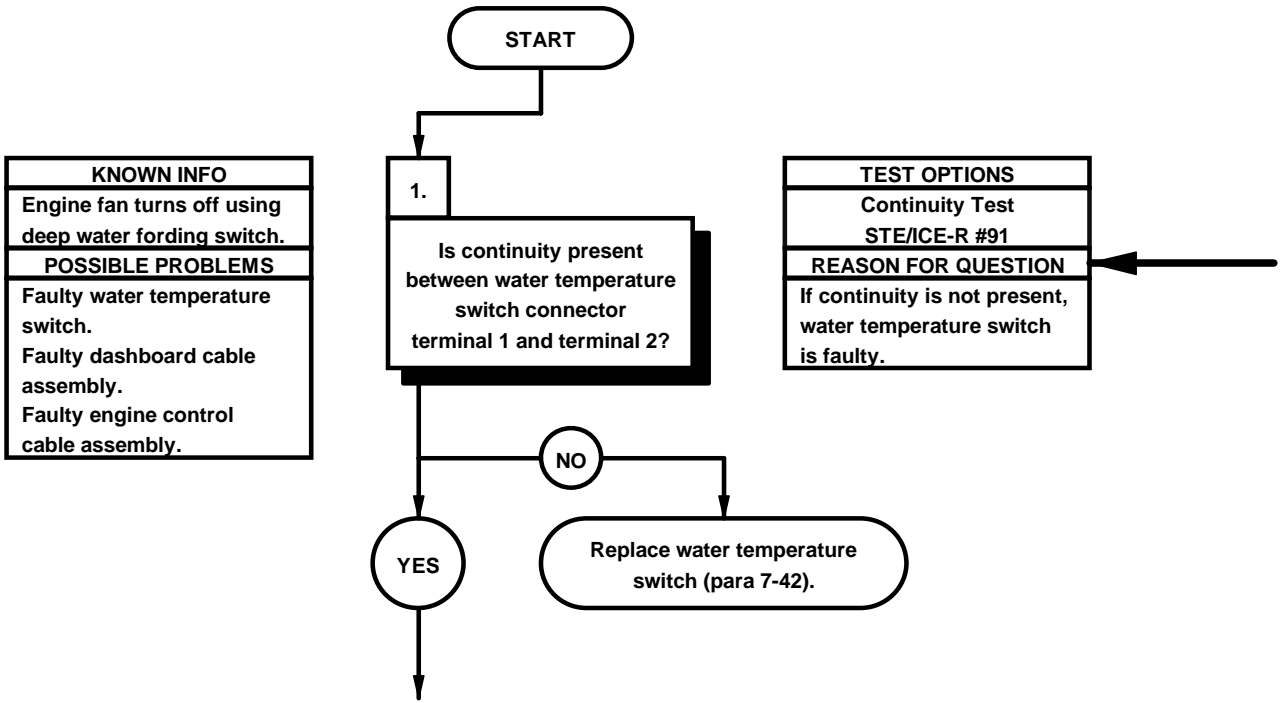

CONTINUITY TEST	
<p>NOTE Engine must be cool during test.</p>	
<ol style="list-style-type: none"> (1) Raise cab (TM 9-2320-365-10). (2) Disconnect connector clamp from water temperature switch connector. (3) Disconnect connector P36 from water temperature switch connector. (4) Set multimeter to ohms. (5) Connect positive (+) probe of multimeter to water temperature switch connector terminal 1. (6) Connect negative (-) probe of multimeter to water temperature switch connector terminal 2 and note reading on multimeter. (7) If continuity is not present, replace water temperature switch (para 7-42). 	

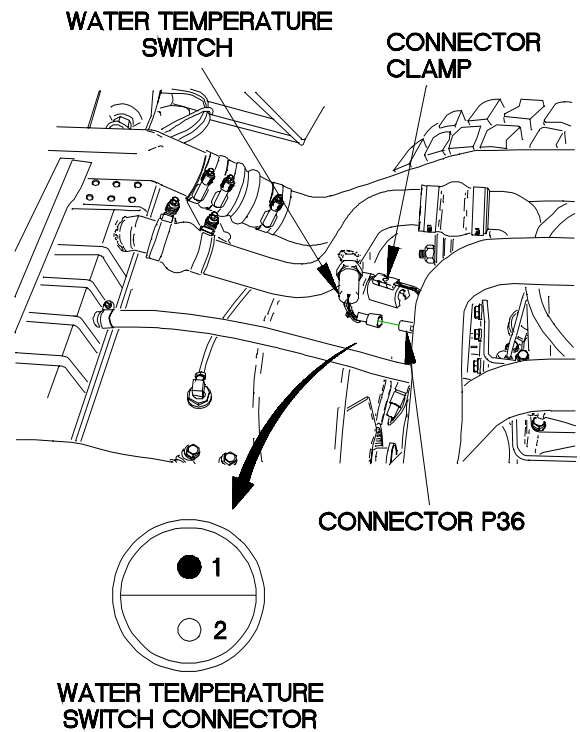

X2E9501A

e91. ENGINE FAN RUNS CONSTANTLY (CONT)

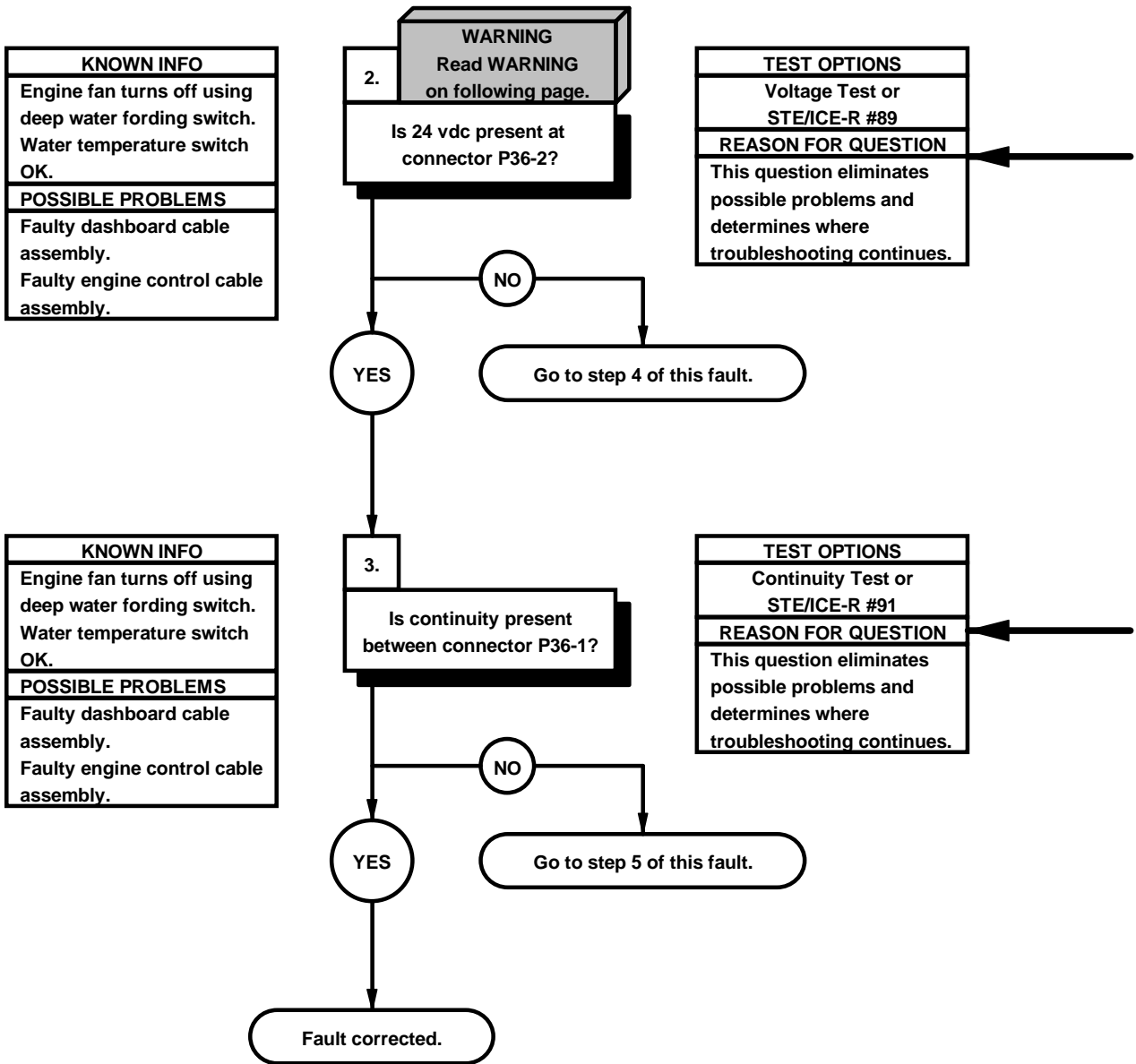

WARNING

Remove rings, bracelets, watches, necklaces, and any other jewelry before working around vehicle. Jewelry can catch on equipment and cause injury or short across electrical circuit and cause severe burns or electrical shock.

VOLTAGE TEST

- (1) Set multimeter to volts dc.
- (2) Connect positive (+) probe of multimeter to connector P36-2.
- (3) Connect negative (-) probe of multimeter to ground.
- (4) Position master power switch to on (TM 9-2320-365-10) and note reading on multimeter.
- (5) If 24 vdc is not present, go to step 4 of this fault.
- (6) Position master power switch to off (TM 9-2320-365-10).

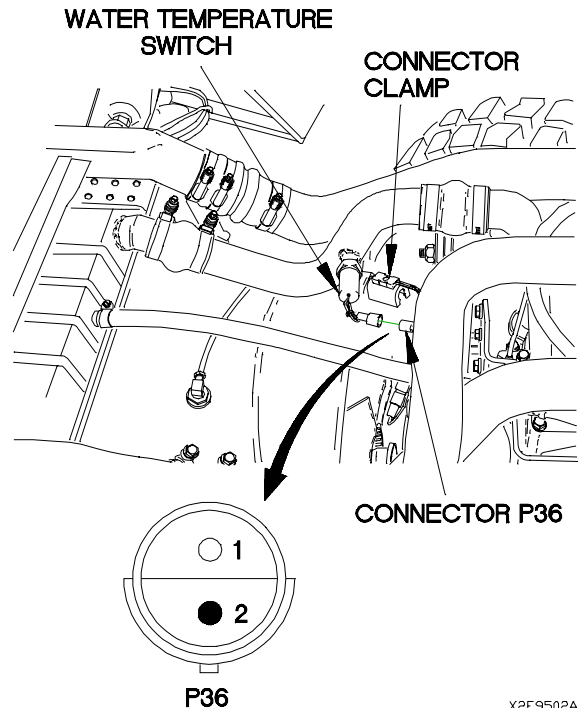

CONTINUITY TEST

- (1) Set multimeter to ohms.
- (2) Connect positive (+) probe of multimeter to connector P36-1.
- (3) Connect negative (-) probe of multimeter to ground and note reading on multimeter.
- (4) If continuity is not present, go to step 5 of this fault.
- (5) If continuity is present, fault corrected.
- (6) Connect connector P36 to water temperature switch connector.
- (7) Connect connector clamp on water temperature switch connector.

X2E9502A

e91. ENGINE FAN RUNS CONSTANTLY (CONT)

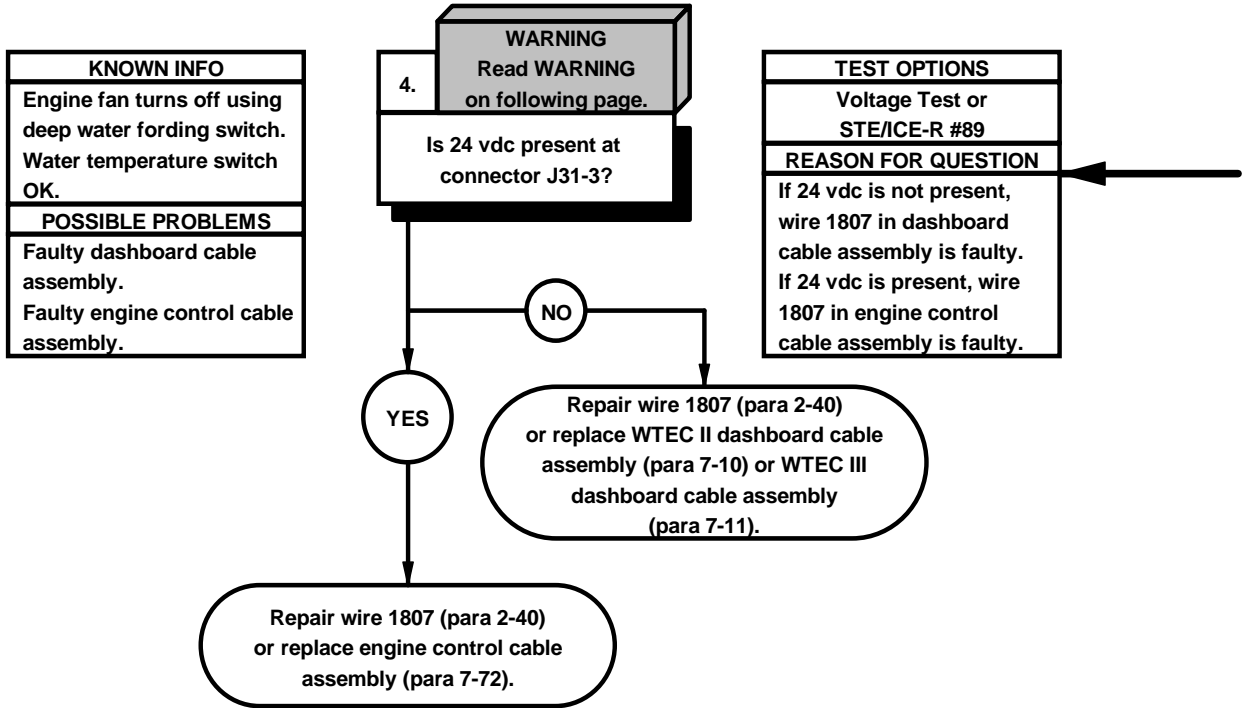

WARNING

Remove rings, bracelets, watches, necklaces, and any other jewelry before working around vehicle. Jewelry can catch on equipment and cause injury or short across electrical circuit and cause severe burns or electrical shock.

VOLTAGE TEST

- (1) Lower cab (TM 9-2320-365-10).
- (2) Remove instrument panel assembly for access (para 7-15).
- (3) Disconnect connector J31 from connector P31.
- (4) Set multimeter to volts dc.
- (5) Connect positive (+) probe of multimeter to connector J31-3.
- (6) Connect negative (-) probe of multimeter to ground.
- (7) Position master power switch to on (TM 9-2320-365-10) and note reading on multimeter.
- (8) If 24 vdc is not present, repair wire 1807 (para 2-40) or replace WTEC II dashboard cable assembly (para 7-10) or WTEC III dashboard cable assembly (para 7-11).
- (9) If 24 vdc is present, repair wire 1807 (para 2-40) or replace engine control cable assembly (para 7-72).
- (10) Position master power switch to off (TM 9-2320-365-10).
- (11) Connect connector J31 to connector P31.
- (12) Install instrument panel assembly (para 7-15).

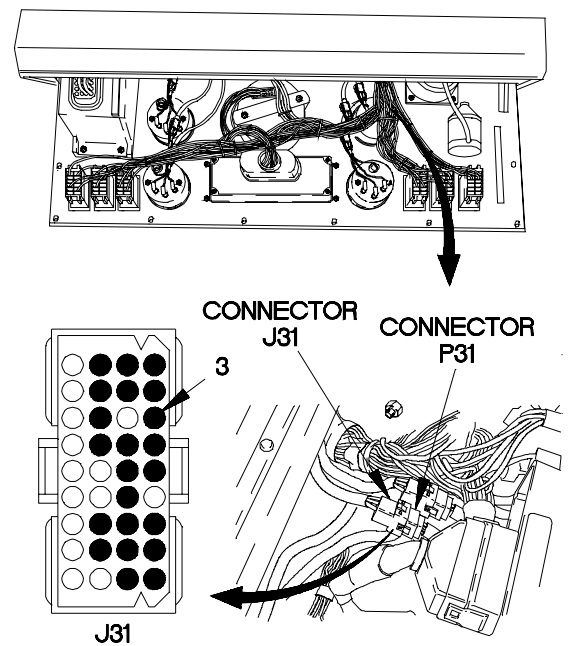

X2E9503A

e91. ENGINE FAN RUNS CONSTANTLY (CONT)

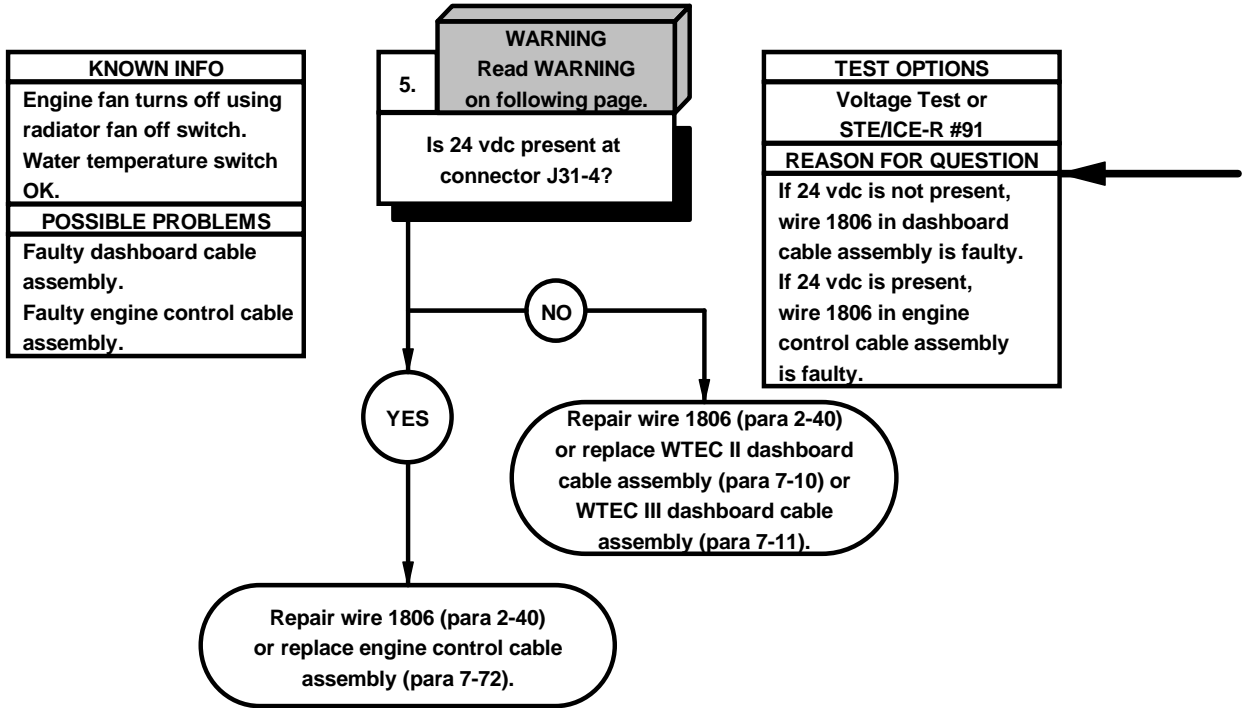

WARNING

Remove rings, bracelets, watches, necklaces, and any other jewelry before working around vehicle. Jewelry can catch on equipment and cause injury or short across electrical circuit and cause severe burns or electrical shock.

VOLTAGE TEST

- (1) Lower cab (TM 9-2320-365-10).
- (2) Remove instrument panel assembly for access (para 7-15).
- (3) Disconnect connector J31 from connector P31.
- (4) Set multimeter to volts dc.
- (5) Connect positive (+) probe of multimeter to connector J31-4.
- (6) Connect negative (-) probe of multimeter to ground.
- (7) Position master power switch to on (TM 9-2320-365-10) and note reading on multimeter.
- (8) If 24 vdc is not present, repair wire 1806 (para 2-40) or replace WTEC II dashboard cable assembly (para 7-10) or WTEC III dashboard cable assembly (para 7-11).
- (9) If 24 vdc is present, repair wire 1806 (para 2-40) or replace engine control cable assembly (para 7-72).
- (10) Position master power switch to off (TM 9-2320-365-10).
- (11) Connect connector J31 to connector P31.
- (12) Install instrument panel assembly (para 7-15).

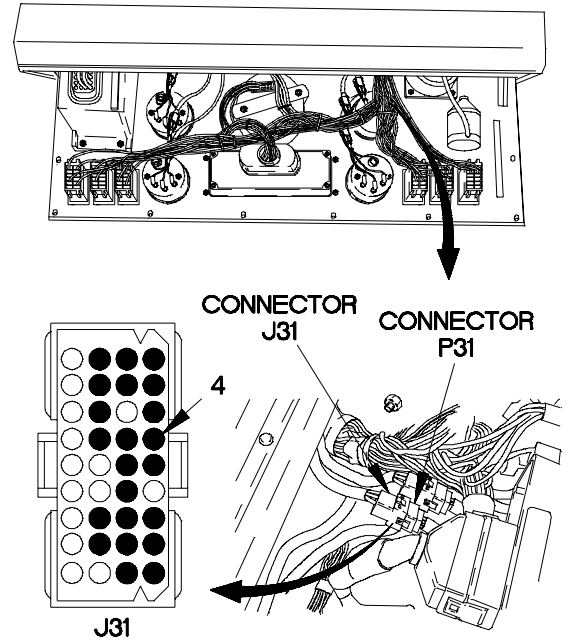

X2E9504A

e92. ENGINE FAN DOES NOT TURN OFF USING RADIATOR FAN OFF SWITCH	
INITIAL SETUP	
Equipment Condition Engine shut down (TM 9-2320-365-10).	Tools and Special Tools Tool Kit, Genl Mech (Item 44, Appendix C) STE/ICE-R (Item 39, Appendix C) Multimeter, Digital (Item 22, Appendix C)
Personnel Required (2)	References TM 9-4910-571-12&P

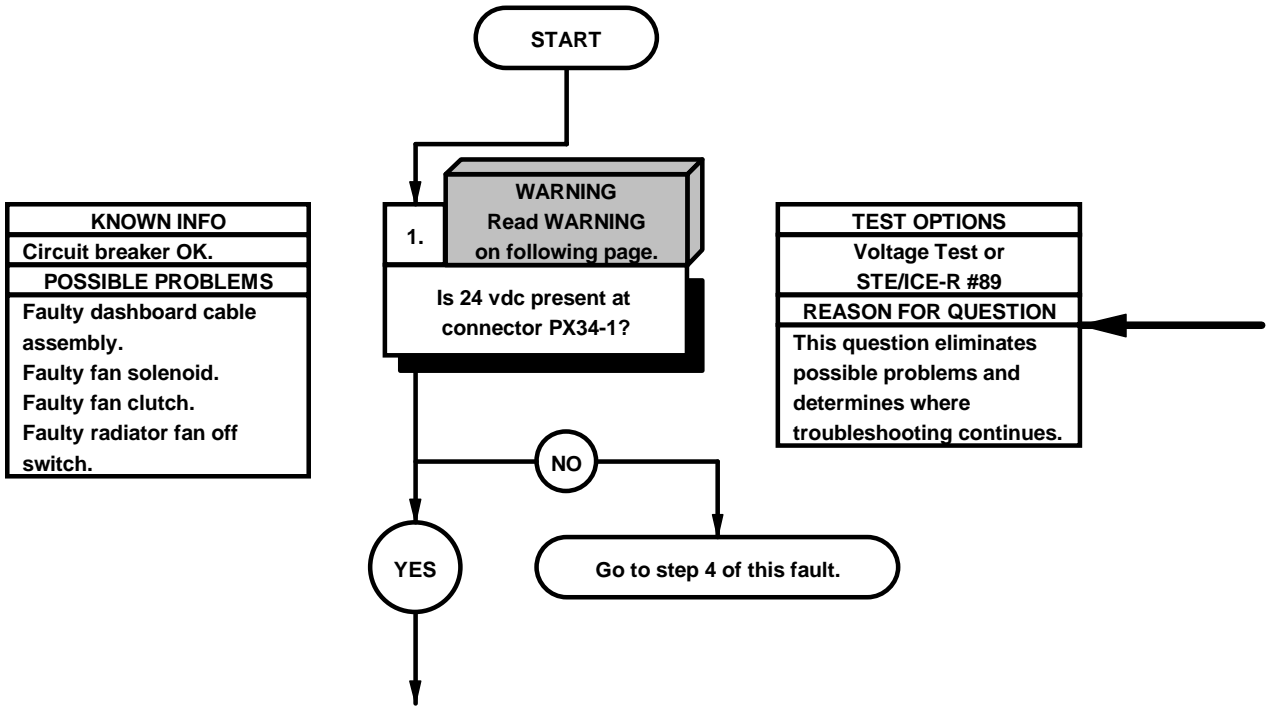

WARNING

Remove rings, bracelets, watches, necklaces, and any other jewelry before working around vehicle. Jewelry can catch on equipment and cause injury or short across electrical circuit and cause severe burns or electrical shock.

VOLTAGE TEST

- (1) Remove kick panel (para 16-3).
- (2) Remove three screws and washers from PDP.
- (3) Remove three screws from PDP.
- (4) Lift PDP outward to gain access.
- (5) Disconnect wire 1807 from terminal board TB1 terminal 38.
- (6) Disconnect connector PX34 from fan solenoid JX34.
- (7) Set multimeter to volts dc.
- (8) Connect positive (+) probe of multimeter to connector PX34-1.
- (9) Connect negative (-) probe of multimeter to ground.
- (10) Position master power switch to on (TM 9-2320-365-10).
- (11) Position radiator fan off switch to on (TM 9-2320-365-10) and note reading on multimeter.
- (12) If 24 vdc is not present, go to step 4 of this fault.
- (13) Position radiator fan off switch to off (TM 9-2320-365-10).
- (14) Position master power switch to off (TM 9-2320-365-10).
- (15) Connect wire 1807 to terminal board TB1 terminal 38.

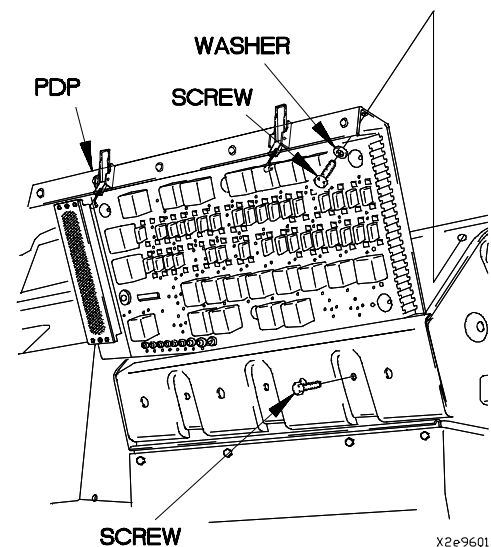
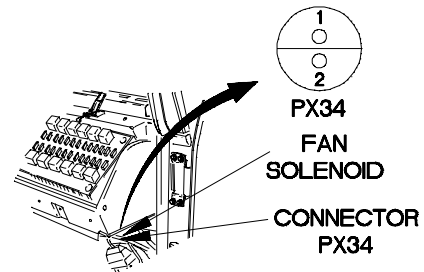
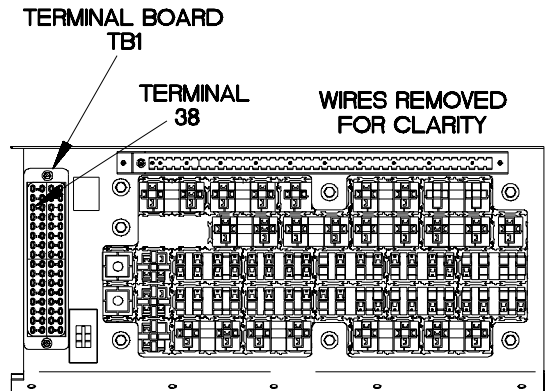

X2e96011

e92. ENGINE FAN DOES NOT TURN OFF USING RADIATOR FAN OFF SWITCH (CONT)

KNOWN INFO
Circuit breaker OK. Radiator fan off switch OK.
POSSIBLE PROBLEMS
Faulty dashboard cable assembly. Faulty fan solenoid. Faulty fan clutch.

2.
Is continuity present between connector PX34-2 and a known good ground?

TEST OPTIONS
Continuity Test or STE/ICE-R #91
REASON FOR QUESTION
If continuity is not present, wire 3011 is faulty.

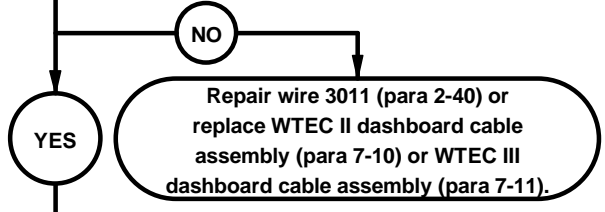

KNOWN INFO
Circuit breaker OK. Radiator fan off switch OK. Dashboard cable assembly OK.
POSSIBLE PROBLEMS
Faulty fan solenoid. Faulty fan clutch.

3.
Does fan solenoid release air pressure to radiator fan?

TEST OPTIONS
Operational Test
REASON FOR QUESTION
If fan solenoid does not release air pressure to engine fan, fan solenoid is faulty.

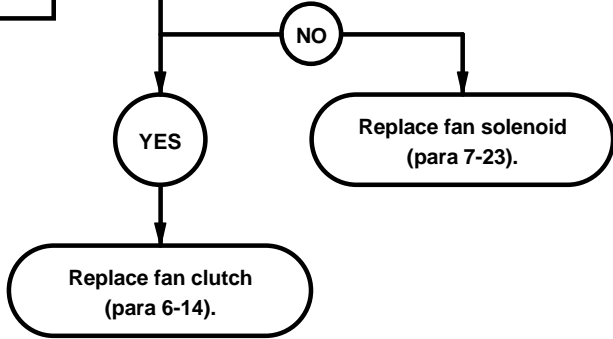

CONTINUITY TEST

- (1) Set multimeter to ohms.
- (2) Connect positive (+) probe of multimeter to connector PX34-2.
- (3) Connect negative (-) probe of multimeter to ground and note reading on multimeter.
- (4) If continuity is not present, repair wire 3011 (para 2-40) or replace WTEC II dashboard cable assembly (para 7-10) or WTEC III dashboard cable assembly (para 7-11).
- (5) Connect connector PX34 to fan solenoid.

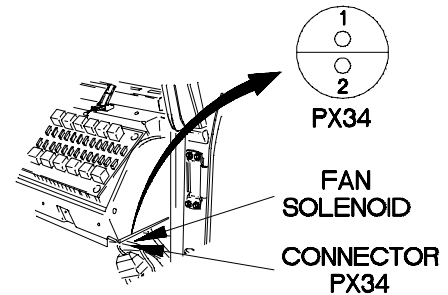

X2E96021

OPERATIONAL TEST

- (1) Remove air hose from fan solenoid.
- (2) Start engine (TM 9-2320-365-10) and allow air pressure to build up to normal level.
- (3) Position radiator fan off switch to on (TM 9-2320-365-10).
- (4) If air pressure is not present, replace fan solenoid (para 7-23).
- (5) If air pressure is present, replace fan clutch (para 6-14).
- (6) Position radiator fan off switch to off (TM 9-2320-365-10).
- (7) Position master power switch to off (TM 9-2320-365-10).
- (8) Connect wire 1807 to terminal board TB1 terminal 38.
- (9) Install PDP on dashboard with three screws.
- (10) Install three washers and screws in PDP.
- (11) Install air hose on fan solenoid.
- (12) Install kick panel (para 16-3).

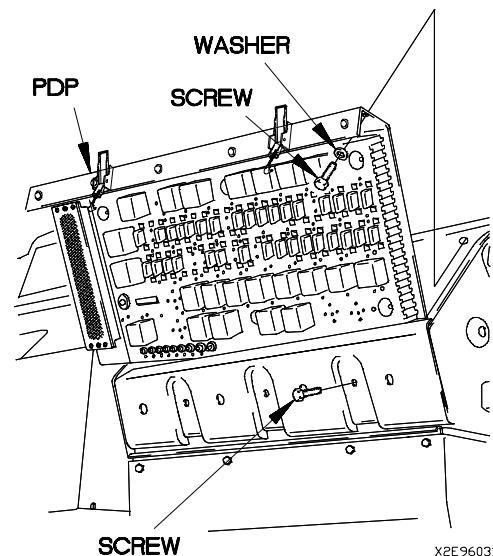
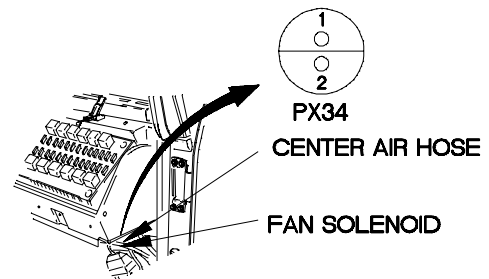
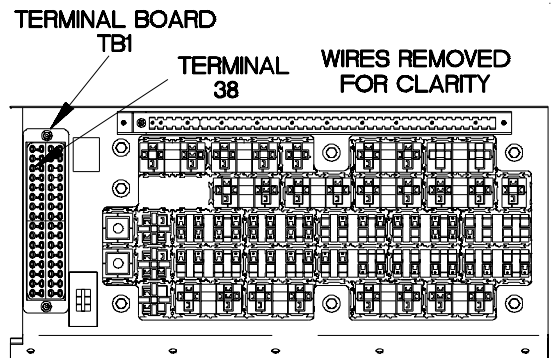

X2E96031

e92. ENGINE FAN DOES NOT TURN OFF USING RADIATOR FAN OFF SWITCH (CONT)

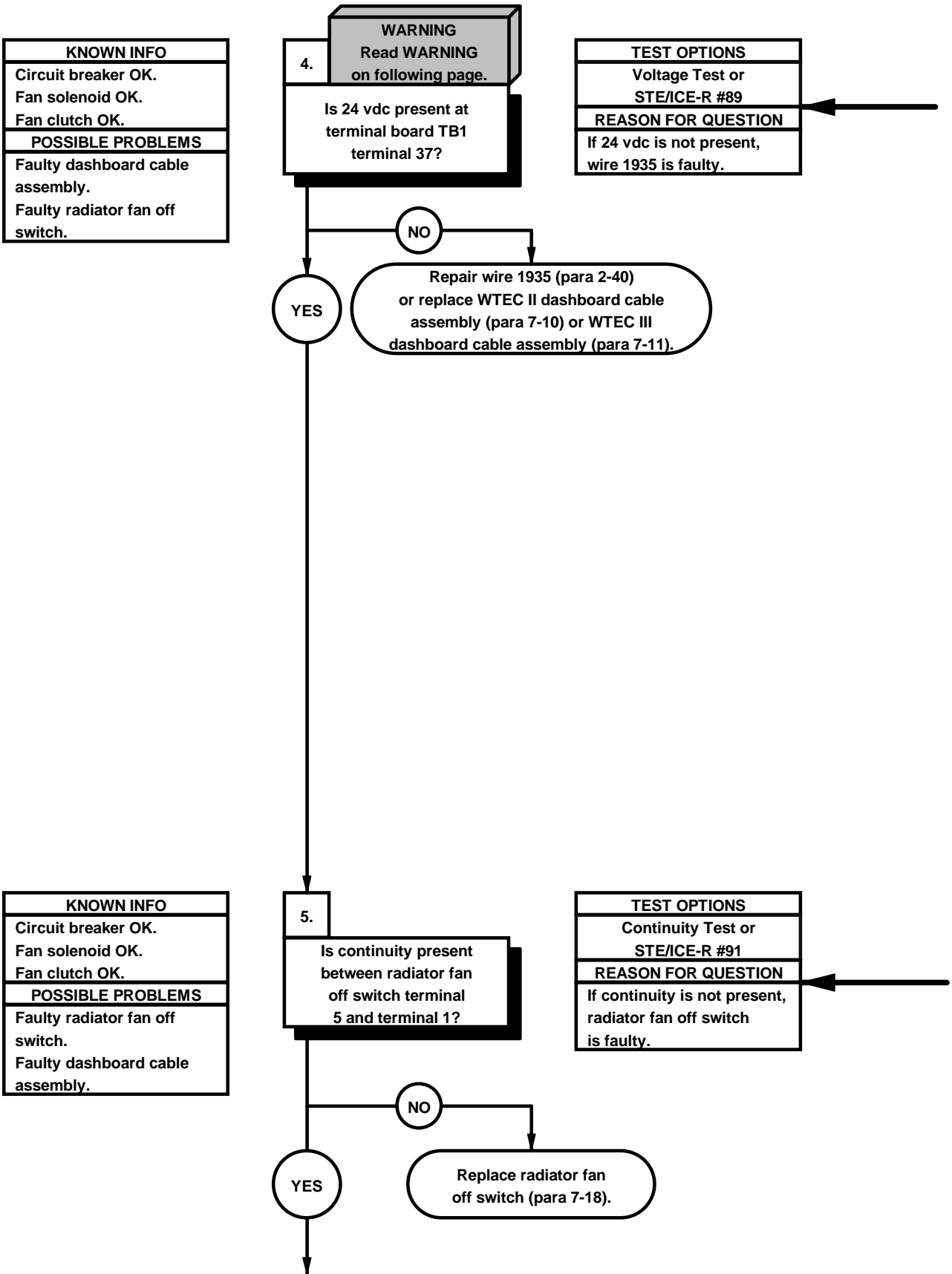

WARNING

Remove rings, bracelets, watches, necklaces, and any other jewelry before working around vehicle. Jewelry can catch on equipment and cause injury or short across electrical circuit and cause severe burns or electrical shock.

VOLTAGE TEST

- (1) Set multimeter to volts dc.
- (2) Connect positive (+) probe of multimeter to terminal board TB1 terminal 37.
- (3) Connect negative (-) probe of multimeter to ground.
- (4) Position master power switch to on (TM 9-2320-365-10) and note reading on multimeter.
- (5) If 24 vdc is not present, repair wire 1935 (para 2-40) or replace WTEC II dashboard cable assembly (para 7-10) or WTEC III dashboard cable assembly (para 7-11).
- (6) Position master power switch to off (TM 9-2320-365-10).
- (7) Install PDP on dashboard with three screws.
- (8) Install three washers and screws in PDP.
- (9) Install kick panel (para 16-3).

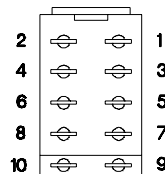
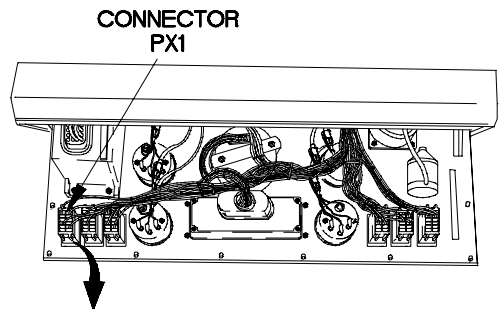
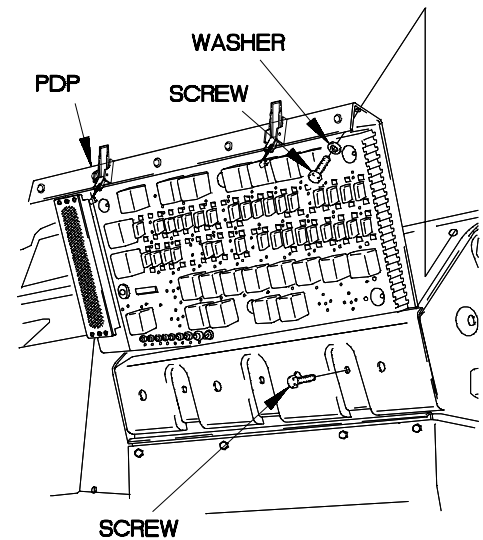
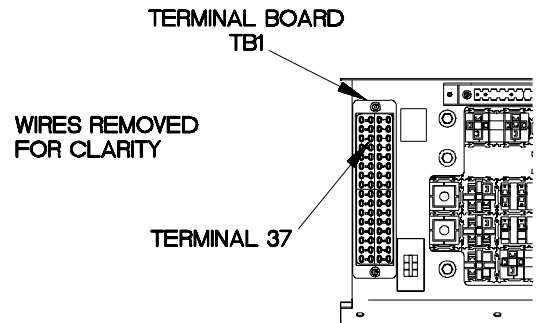

RADIATOR FAN OFF SWITCH

CONTINUITY TEST

- (1) Remove instrument panel assembly for access (para 7-15).
- (2) Disconnect connector PX1 from radiator fan off switch.
- (3) Position radiator fan off switch to on (TM 9-2320-365-10).
- (4) Set multimeter to ohms.
- (5) Connect positive (+) probe of multimeter to radiator fan off switch terminal 5.
- (6) Connect negative (-) probe of multimeter to radiator fan off switch terminal 1.
- (7) If continuity is not present, replace radiator fan off switch (para 7-18).
- (8) Position radiator fan off switch to off (TM 9-2320-365-10).

X2E 96041

e92. ENGINE FAN DOES NOT TURN OFF USING RADIATOR FAN OFF SWITCH (CONT)

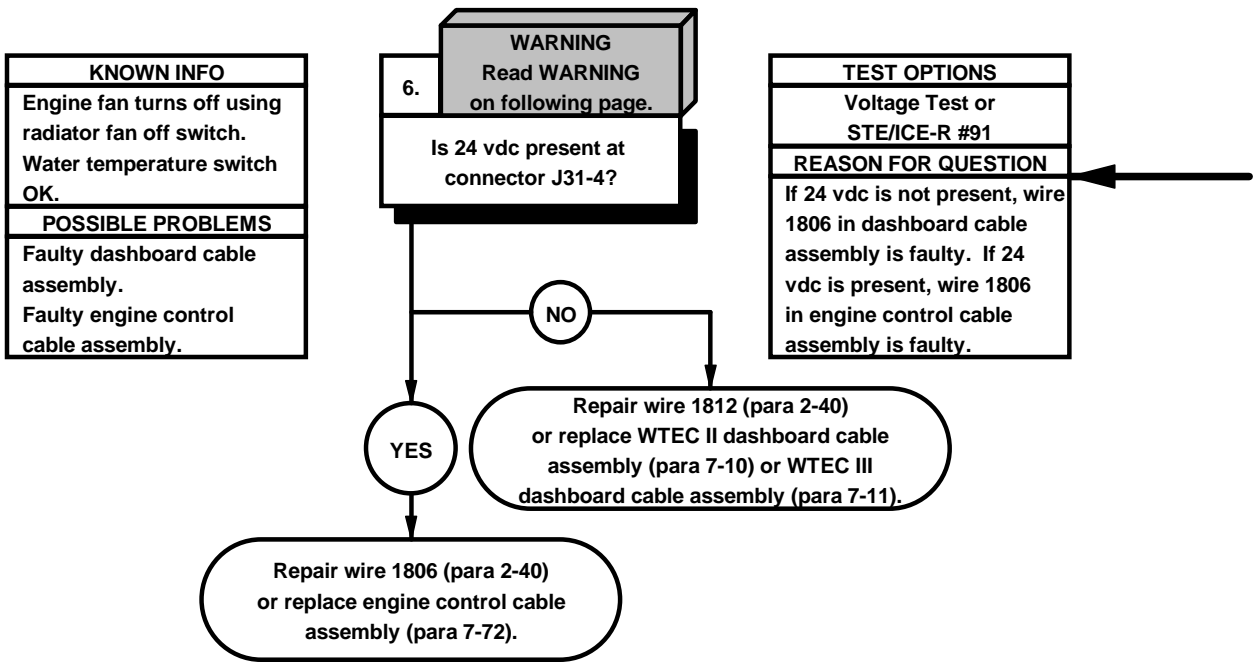

WARNING

Remove rings, bracelets, watches, necklaces, and any other jewelry before working around vehicle. Jewelry can catch on equipment and cause injury or short across electrical circuit and cause severe burns or electrical shock.

VOLTAGE TEST

- (1) Lower cab (TM 9-2320-365-10).
- (2) Remove instrument panel assembly for access (para 7-15).
- (3) Disconnect connector J31 from connector P31.
- (4) Set multimeter to volts dc.
- (5) Connect positive (+) probe of multimeter to connector J31-4.
- (6) Connect negative (-) probe of multimeter to ground.
- (7) Position master power switch to on (TM 9-2320-365-10) and note reading on multimeter.
- (8) If 24 vdc is not present, repair wire 1806 (para 2-40) or replace WTEC II dashboard cable assembly (para 7-10) or WTEC III dashboard cable assembly (para 7-11).
- (9) If 24 vdc is present, repair wire 1806 (para 2-40) or replace engine control cable assembly (para 7-72).
- (10) Position master power switch to off (TM 9-2320-365-10).
- (11) Connect connector J31 to connector P31.
- (12) Install instrument panel assembly (para 7-15).

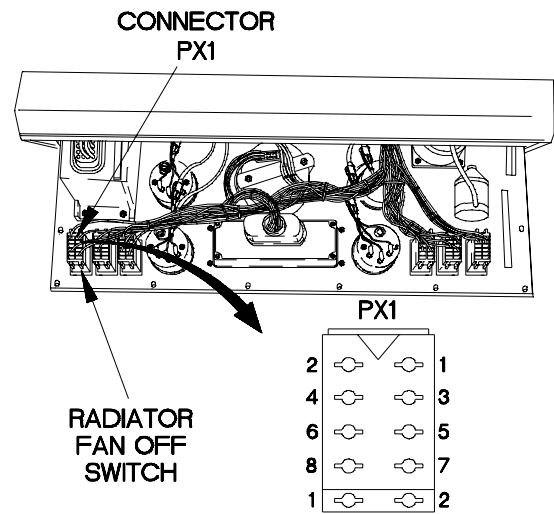

X2E96051

e93. ETHER START DOES NOT OPERATE	
INITIAL SETUP	
Equipment Condition Engine shut down (TM 9-2320-365-10). Spare tire lowered (TM 9-2320-365-10).	Tools and Special Tools Tool Kit, Genl Mech (Item 44, Appendix C) STE/ICE-R (Item 39, Appendix C) Multimeter, Digital (Item 22, Appendix C)
Personnel Required (2)	References TM 9-4910-571-12&P
Materials/Parts Wire, Elect, 50 ft (Item 77, Appendix D)	

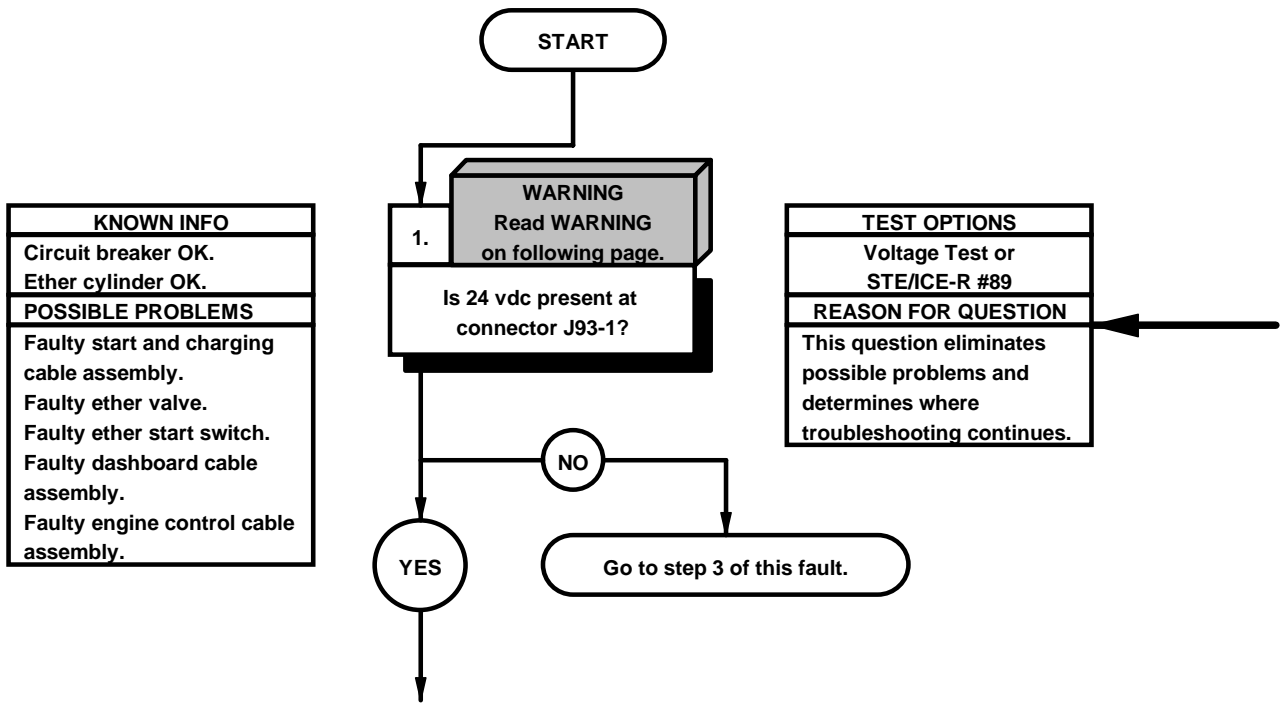

WARNING

Remove rings, bracelets, watches, necklaces, and any other jewelry before working around vehicle. Jewelry can catch on equipment and cause injury or short across electrical circuit and cause severe burns or electrical shock.

VOLTAGE TEST

- (1) Disconnect connector clamp from ether valve connector.
- (2) Disconnect ether valve connector from connector J93.
- (3) Disconnect connector clamp from ether sensor connector.
- (4) Disconnect connector P42 from ether sensor connector.
- (5) Install jumper wire from connector P42-1 to connector P42-2.
- (6) Set multimeter to volts dc.
- (7) Connect positive (+) probe of multimeter to connector J93-1.
- (8) Connect negative (-) probe of multimeter to ground.
- (9) Position master power switch to on (TM 9-2320-365-10).
- (10) Press ether start switch (TM 9-2320-365-10) and note reading on multimeter.
- (11) If 24 vdc is not present, go to step 3 of this fault.
- (12) Release ether start switch (TM 9-2320-365-10).
- (13) Position master power switch to off (TM 9-2320-365-10).
- (14) Remove jumper wire from connector P42-1 and connector P42-2.
- (15) Connect connector P42 to ether sensor connector.
- (16) Lower cab (TM 9-2320-365-10).

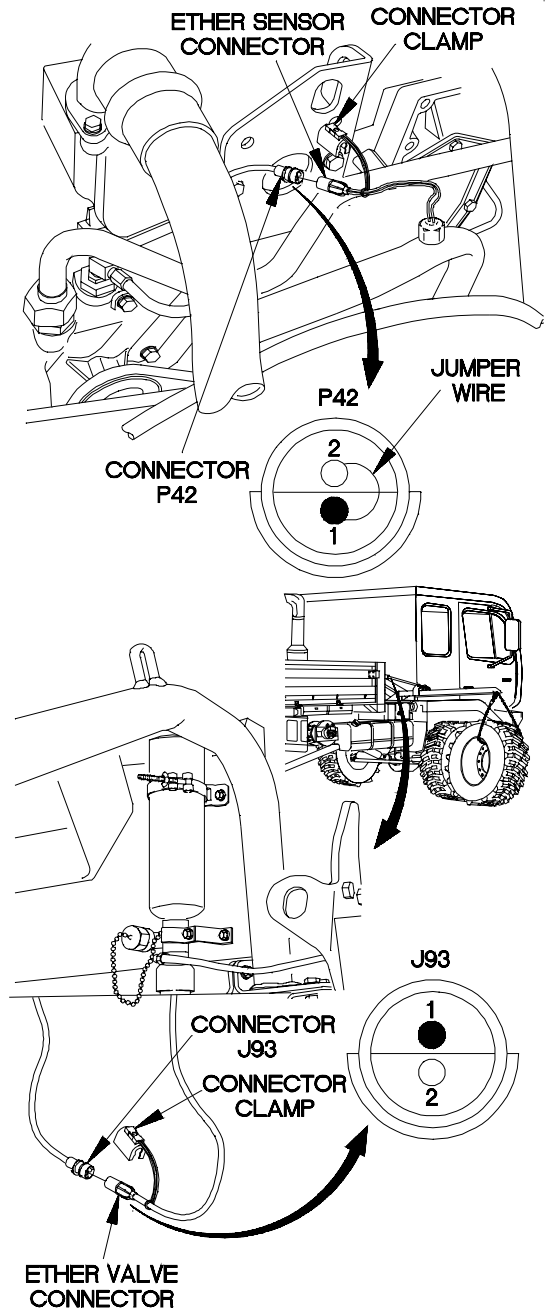

X2E9701A

ø93. ETHER START DOES NOT OPERATE (CONT)

KNOWN INFO
Circuit breaker OK. Ether cylinder OK. Ether start switch OK. Dashboard cable assembly OK. Engine control cable assembly OK.
POSSIBLE PROBLEMS
Faulty start and charging cable assembly. Faulty ether valve.

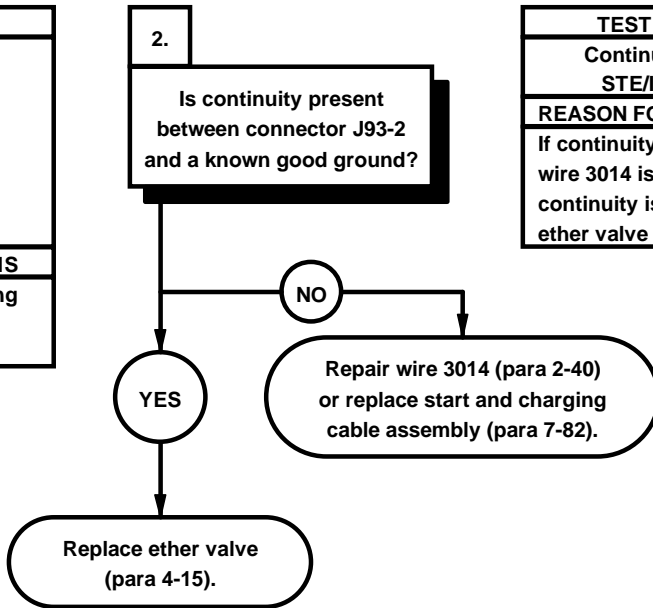

TEST OPTIONS
Continuity Test or STE/ICE-R #91
REASON FOR QUESTION
If continuity is not present, wire 3014 is faulty. If continuity is present, ether valve is faulty.

KNOWN INFO
Circuit breaker OK. Ether cylinder OK. Start and charging cable assembly OK. Ether valve OK.
POSSIBLE PROBLEMS
Faulty ether start switch. Faulty dashboard cable assembly. Faulty engine control cable assembly.

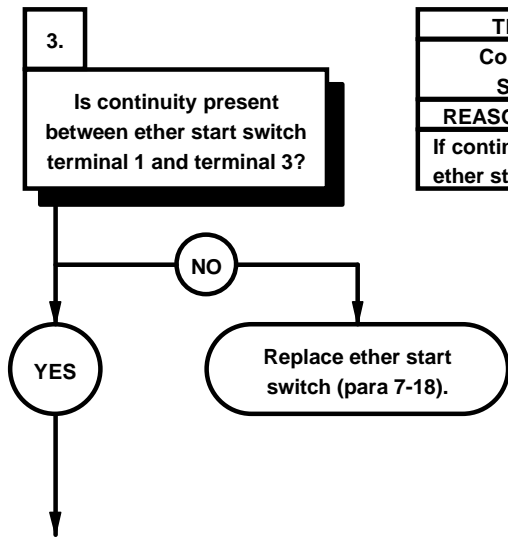

TEST OPTIONS
Continuity Test or STE/ICE-R #91
REASON FOR QUESTION
If continuity is not present, ether start switch is faulty.

CONTINUITY TEST

- (1) Set multimeter to ohms.
- (2) Connect positive (+) probe of multimeter to connector J93-2.
- (3) Connect negative (-) probe of multimeter to ground and note reading on multimeter.
- (4) If continuity is not present, repair wire 3014 (para 2-40) or replace start and charging cable assembly (para 7-82).
- (5) If continuity is present, replace ether valve (para 4-15).
- (6) Raise spare tire (TM 9-2320-365-10).

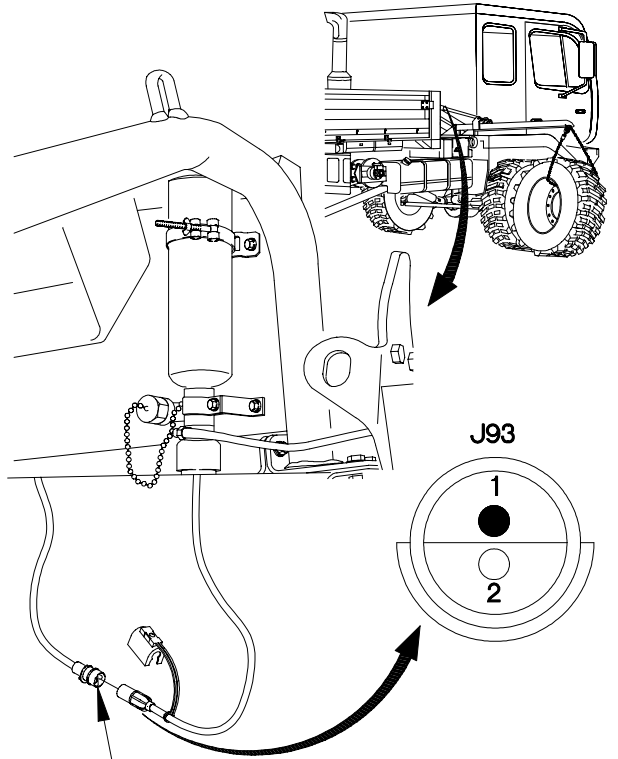

CONNECTOR J93

X2E9702A

CONTINUITY TEST

- (1) Remove instrument panel assembly for access (para 7-15).
- (2) Disconnect connector PX13 from ether start switch.
- (3) Set multimeter to ohms.
- (4) Connect positive (+) probe of multimeter to ether start switch terminal 1.
- (5) Connect negative (-) probe of multimeter to ether start switch terminal 3.
- (6) Position ether start switch to on (TM 9-2320-365-10) and note reading on multimeter.
- (7) If continuity is not present, replace ether start switch (para 7-18).

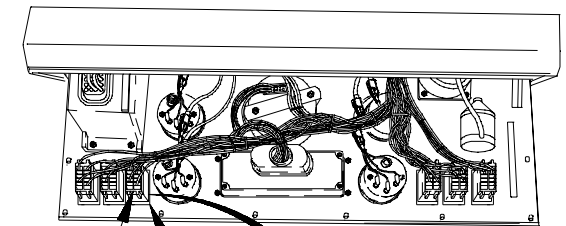

CONNECTOR PX13

ETHER START SWITCH

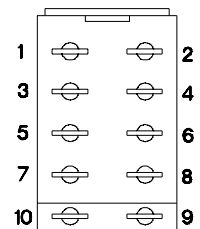

ETHER START SWITCH

X2E9703A

ø93. ETHER START DOES NOT OPERATE (CONT)

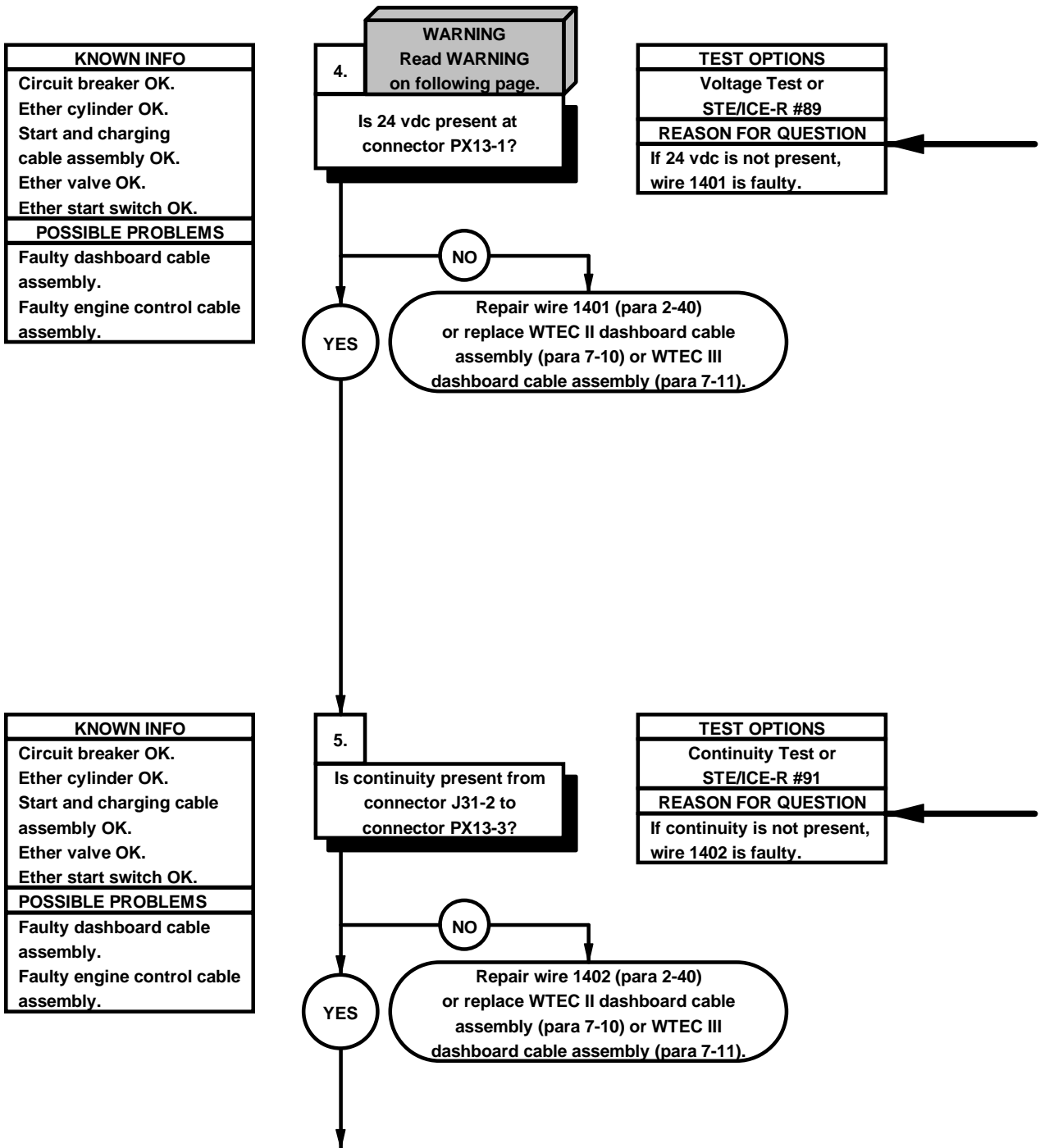

WARNING

Remove rings, bracelets, watches, necklaces, and any other jewelry before working around vehicle. Jewelry can catch on equipment and cause injury or short across electrical circuit and cause severe burns or electrical shock.

VOLTAGE TEST

- (1) Set multimeter to volts dc.
- (2) Connect positive (+) probe of multimeter to connector PX13-1.
- (3) Connect negative (-) probe of multimeter to ground.
- (4) Position master power switch to on (TM 9-2320-365-10) and note reading on multimeter.
- (5) If 24 vdc is not present, repair wire 1401 (para 2-40) or replace WTEC II dashboard cable assembly (para 7-10) or WTEC III dashboard cable assembly (para 7-11).
- (6) Position master power switch to off (TM 9-2320-365-10).

CONTINUITY TEST

- (1) Disconnect connector P31 from connector J31.
- (2) Set multimeter to ohms.
- (3) Connect positive (+) probe of multimeter to connector PX13-3.
- (4) Connect negative (-) probe of multimeter to connector J31-2 and note reading on multimeter.
- (5) If continuity is not present, repair wire 1402 (para 2-40) or replace WTEC II dashboard cable assembly (para 7-10) or WTEC III dashboard cable assembly (para 7-11).

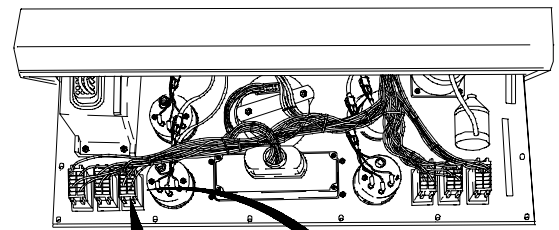

**CONNECTOR
PX13**

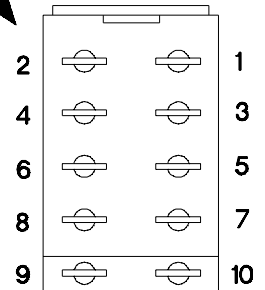

PX13
X2E9704A

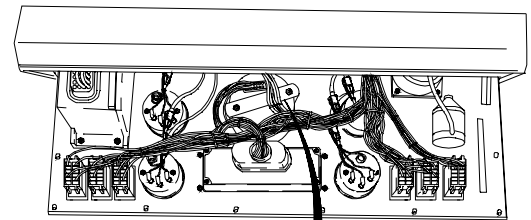

CONNECTOR P31

CONNECTOR J31

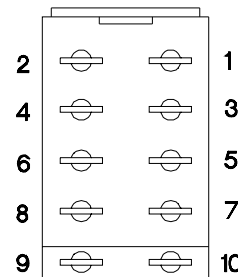
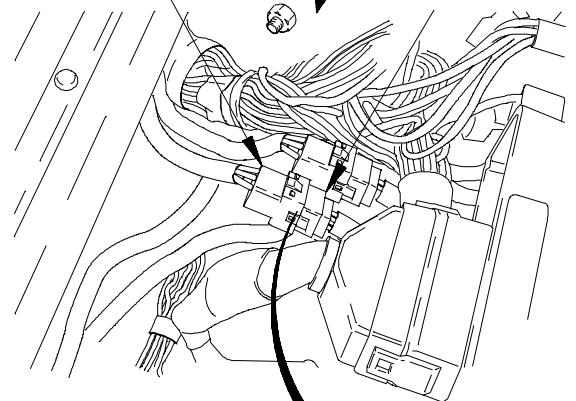

PX13

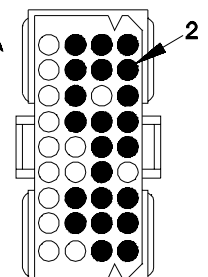

J31

X2E9705A

ø93. ETHER START DOES NOT OPERATE (CONT)

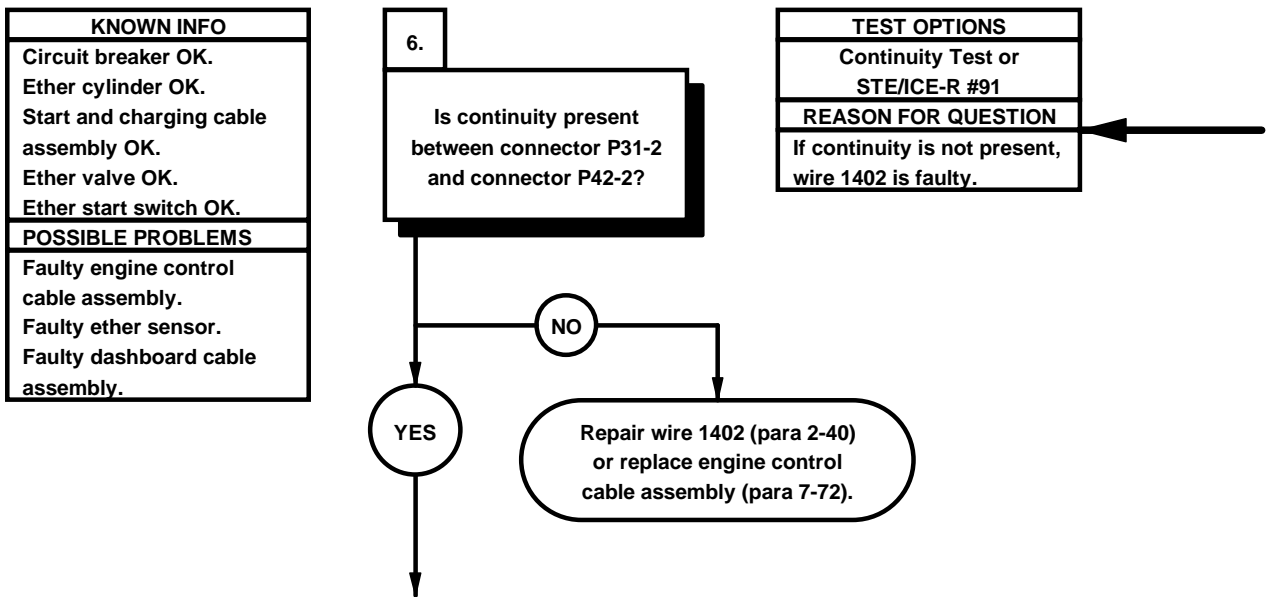

- | CONTINUITY TEST | |
|-----------------|--|
| | (1) Raise cab (TM 9-2320-365-10). |
| | (2) Disconnect connector P42 from ether sensor connector. |
| | (3) Connect jumper wire to connector P42-2. |
| | (4) Set multimeter to ohms. |
| | (5) Connect positive (+) probe of multimeter to connector P31-2. |
| | (6) Connect negative (-) probe of multimeter to jumper wire and note reading on multimeter. |
| | (7) If continuity is not present, repair wire 1402 (para 2-40) or replace engine control cable assembly (para 7-72). |

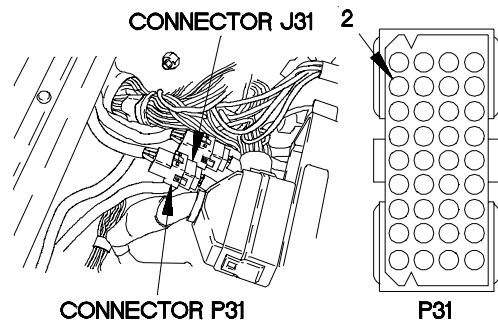
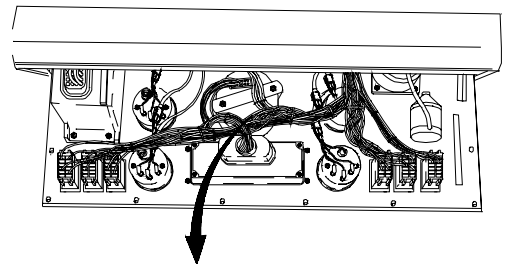
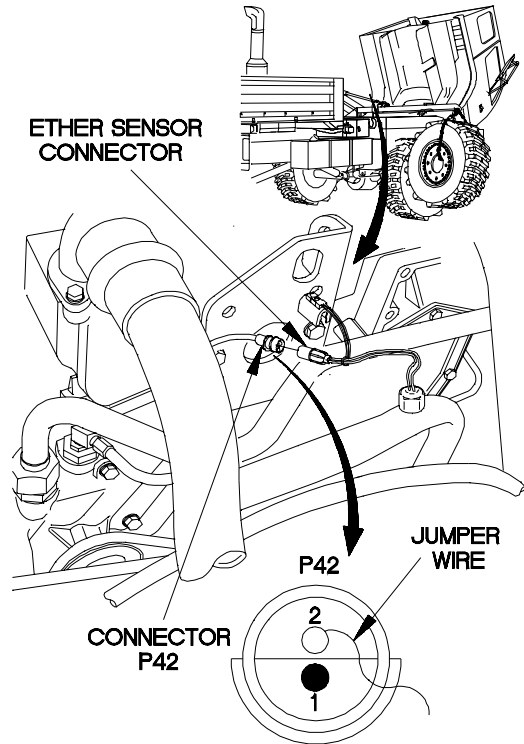

X2E9706A

ø93. ETHER START DOES NOT OPERATE (CONT)

KNOWN INFO
Circuit breaker OK. Ether cylinder OK. Start and charging cable assembly OK. Ether valve OK. Ether start switch OK. Dashboard cable assembly OK.
POSSIBLE PROBLEMS
Faulty engine control cable assembly. Faulty ether sensor.

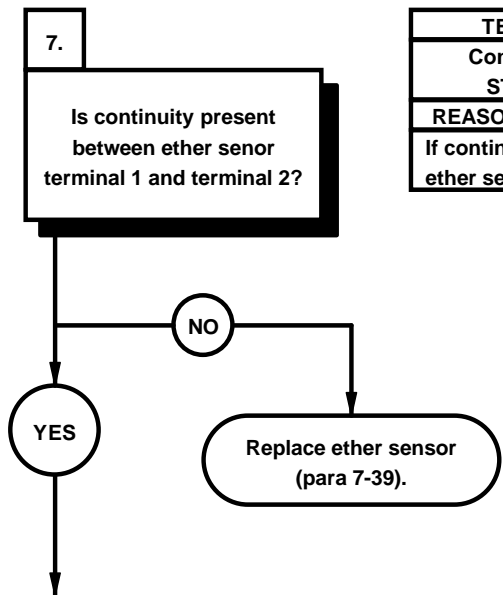

TEST OPTIONS
Continuity Test or STE/ICE-R #91
REASON FOR QUESTION
If continuity is not present, ether sensor is faulty.



CONTINUITY TEST	
	(1) Set multimeter to ohms.
	(2) Connect positive (+) probe of multimeter to ether sensor terminal 1.
	(3) Connect negative (-) probe of multimeter to ether sensor terminal 2 and note reading on multimeter.
	(4) If continuity is not present, replace ether sensor (para 7-39).

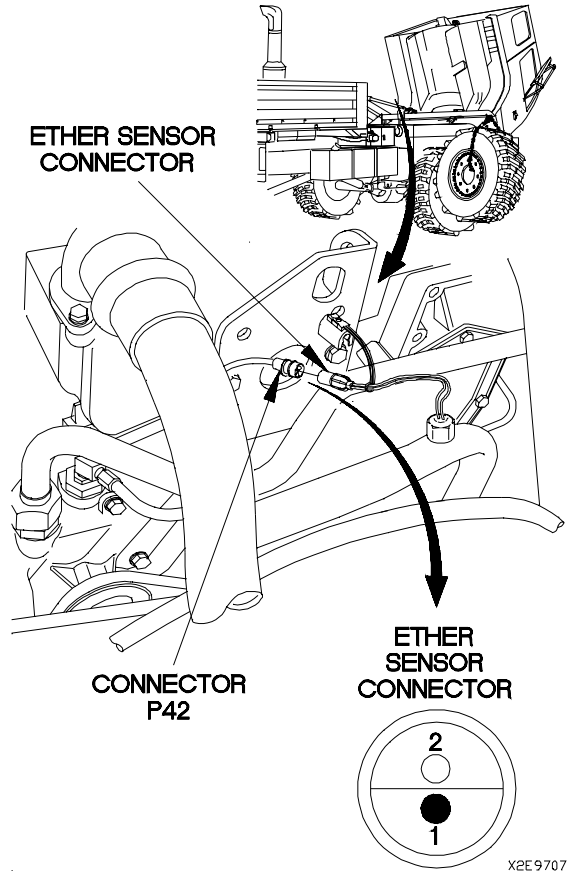

X2E9707A

ø93. ETHER START DOES NOT OPERATE (CONT)

KNOWN INFO
Circuit breaker OK.
Ether cylinder OK.
Start and charging cable assembly OK.
Ether valve OK.
Ether start switch OK.
Dashboard cable assembly OK.
POSSIBLE PROBLEMS
Faulty engine control cable assembly.
Faulty ether sensor.

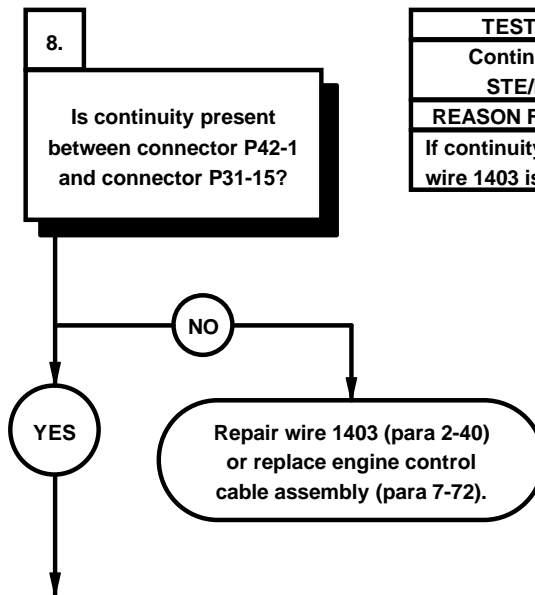

TEST OPTIONS
Continuity Test or STE/ICE-R #91
REASON FOR QUESTION
If continuity is not present, wire 1403 is faulty.



- | CONTINUITY TEST | |
|-----------------|--|
| | (1) Set multimeter to ohms. |
| | (2) Connect jumper wire to connector P42-1. |
| | (3) Lower cab (TM 9-2320-365-10). |
| | (4) Connect positive (+) probe of multimeter to connector P31-15. |
| | (5) Connect negative (-) probe of multimeter to jumper wire and note reading on multimeter. |
| | (6) If continuity is not present, repair wire 1403 (para 2-40) or replace engine control cable assembly (para 7-72). |
| | (7) Raise cab (TM 9-2320-365-10). |
| | (8) Remove jumper wire from connector P42. |
| | (9) Connect connector P42 to ether sensor connector. |
| | (10) Connect connector clamp on ether sensor connector. |
| | (11) Lower cab (TM 9-2320-365-10). |

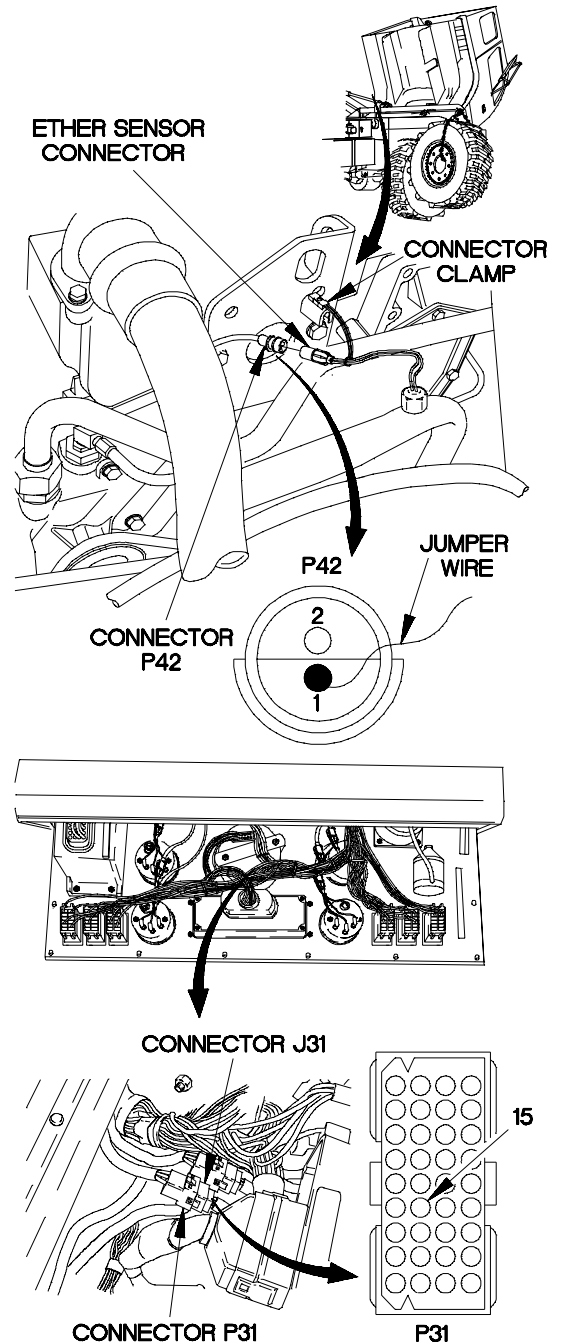

X2E9708A

ø93. ETHER START DOES NOT OPERATE (CONT)

KNOWN INFO
Circuit breaker OK. Ether cylinder OK. Start and charging cable assembly OK. Ether valve OK. Ether start switch OK. Dashboard cable assembly OK.
POSSIBLE PROBLEMS
Faulty engine control cable assembly. Faulty ether sensor.

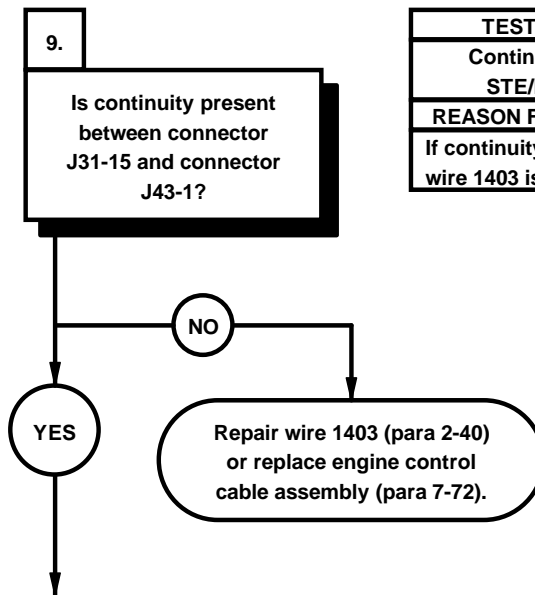

TEST OPTIONS
Continuity Test or STE/ICE-R #91
REASON FOR QUESTION
If continuity is not present, wire 1403 is faulty.

CONTINUITY TEST

- (1) Set multimeter to ohms.
- (2) Connect positive (+) probe of multimeter to connector J31-15.
- (3) Connect negative (-) probe of multimeter to connector J43-1 and note reading on multimeter.
- (4) If continuity is not present, repair wire 1403 (para 2-40) or replace engine control cable assembly (para 7-72).

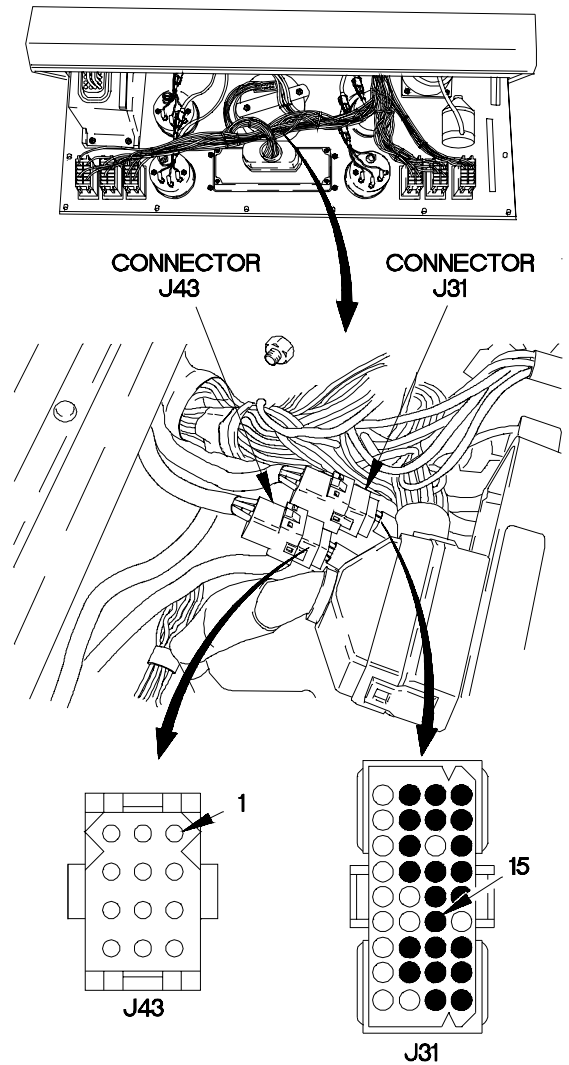

X2E9709A

ø93. ETHER START DOES NOT OPERATE (CONT)

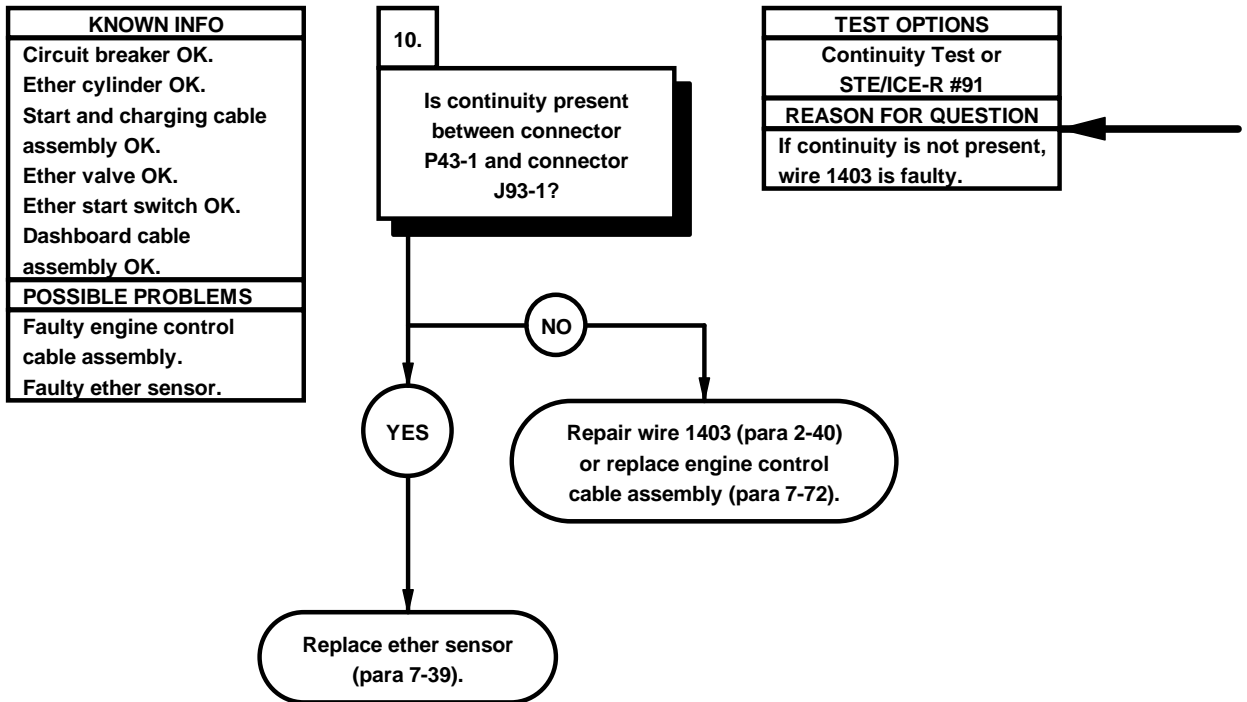

- CONTINUITY TEST**
- (1) Set multimeter to ohms.
 - (2) Connect jumper wire to connector J93-1.
 - (3) Connect positive (+) probe of multimeter to connector P43-1.
 - (4) Connect negative (-) probe of multimeter to jumper wire and note reading on multimeter.
 - (5) If continuity is not present, repair wire 1403 (para 2-40) or replace engine control cable assembly (para 7-72).
 - (6) If continuity is present, replace ether sensor (para 7-39).
 - (7) Remove jumper wire from connector J93.
 - (8) Connect connector J93 to ether valve connector.
 - (9) Connect connector clamp to ether valve connector.
 - (10) Connect connector J43 to connector P43.
 - (11) Install instrument panel assembly (para 7-15).

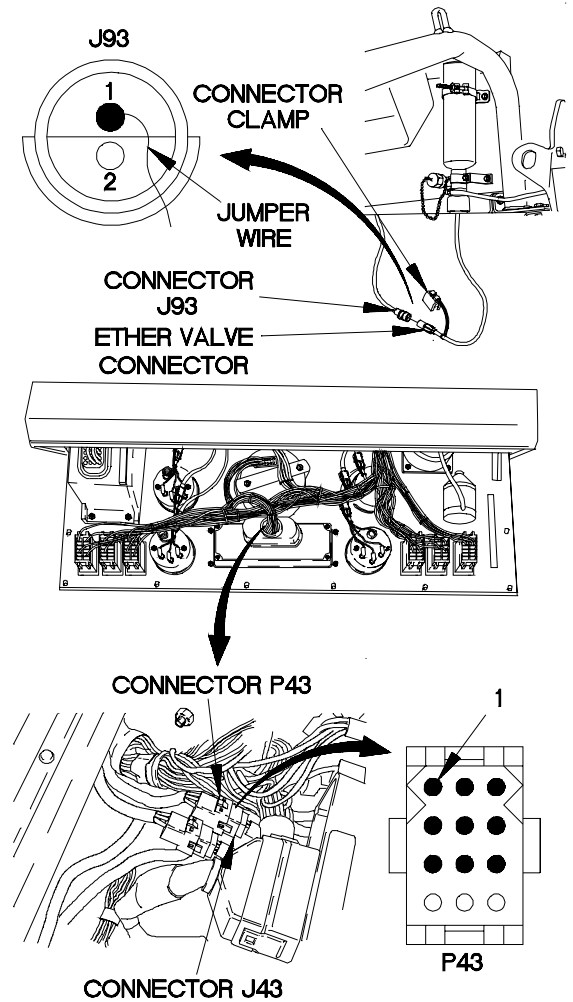

X2E9710A

e94. EXCESSIVE CONDENSATION IN FUEL	
INITIAL SETUP	
Equipment Condition Engine shut down (TM 9-2320-365-10).	Tools and Special Tools Tool Kit, Genl Mech (Item 44, Appendix C) STE/ICE-R (Item 39, Appendix C) Multimeter, Digital (Item 22, Appendix C)
Personnel Required (2)	Materials/Parts Wire, Elect, 50 ft (Item 77, Appendix D)
References TM 9-4910-571-12&P	

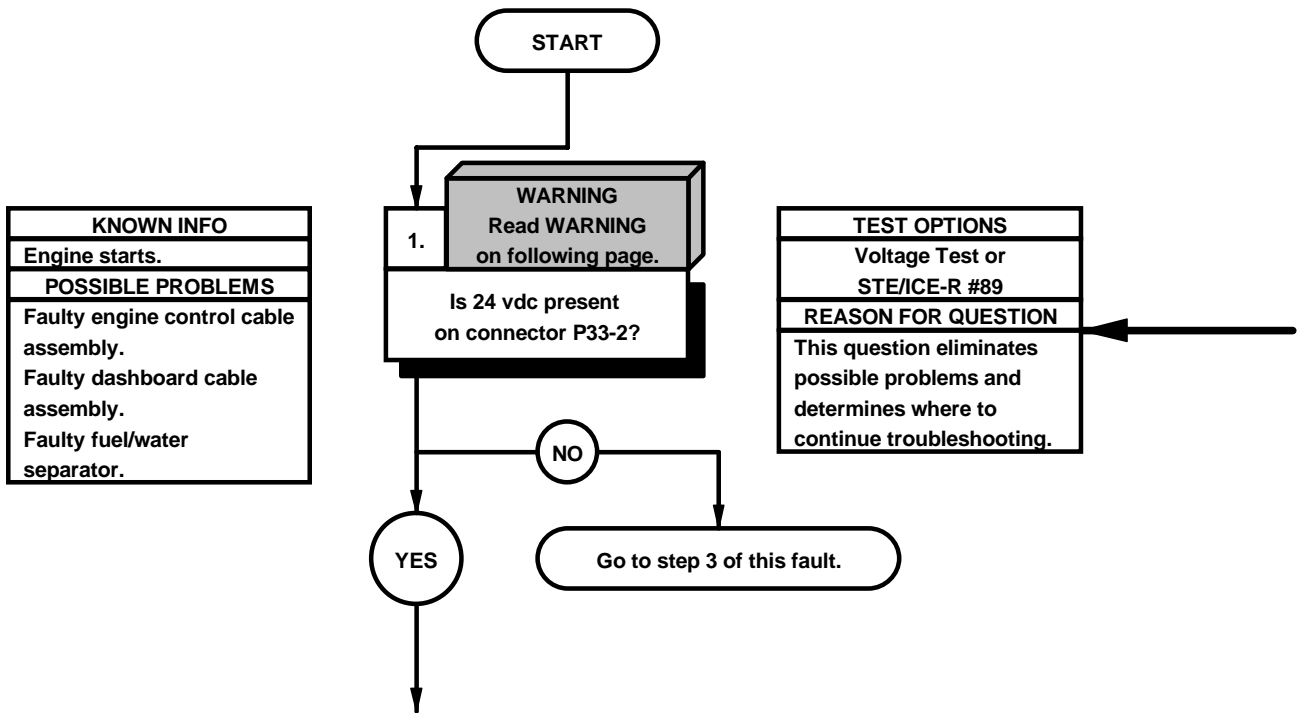

WARNING

Remove rings, bracelets, watches, necklaces, and any other jewelry before working around vehicle. Jewelry can catch on equipment and cause injury or short across electrical circuit and cause severe burns or electrical shock.

VOLTAGE TEST

- (1) Raise cab (TM 9-2320-365-10).
- (2) Disconnect connector clamp from fuel/water separator.
- (3) Disconnect connector P33 from fuel/water separator.
- (4) Set multimeter to volts dc.
- (5) Connect positive (+) probe of multimeter to connector P33-2.
- (6) Connect negative (-) probe of multimeter to ground.
- (7) Position master power switch to on (TM 9-2320-365-10) and note reading on multimeter.
- (8) If 24 vdc is not present, go to step 3 of this fault.
- (9) Position master power switch to off (TM 9-2320-365-10).

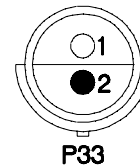
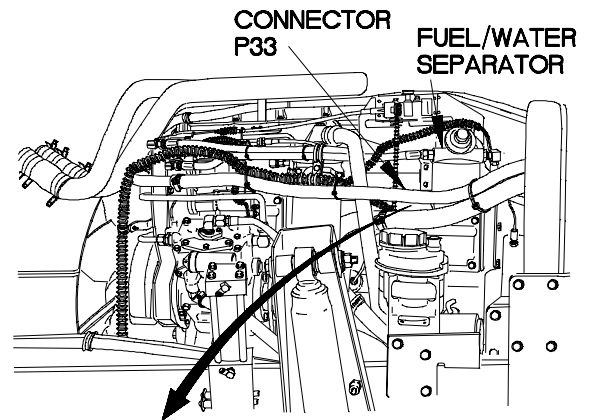

X2E9801A

e94. EXCESSIVE CONDENSATION IN FUEL (CONT)

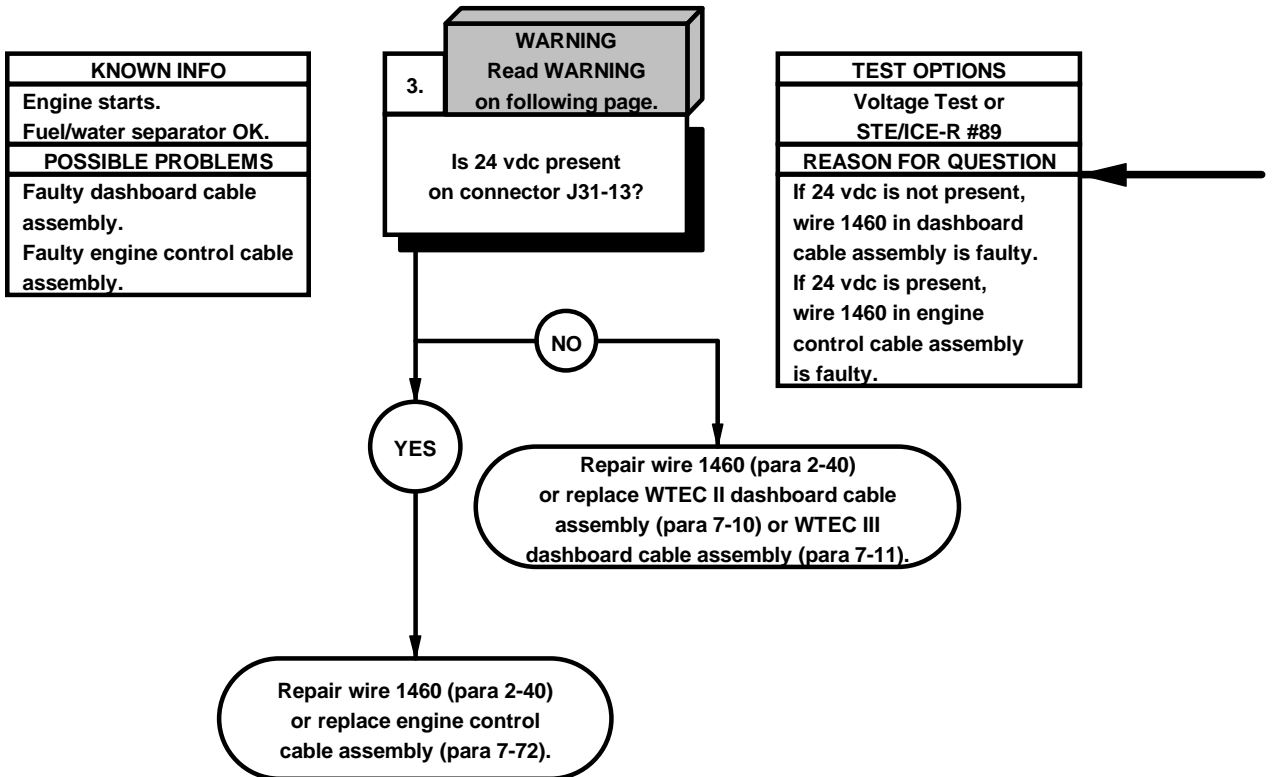
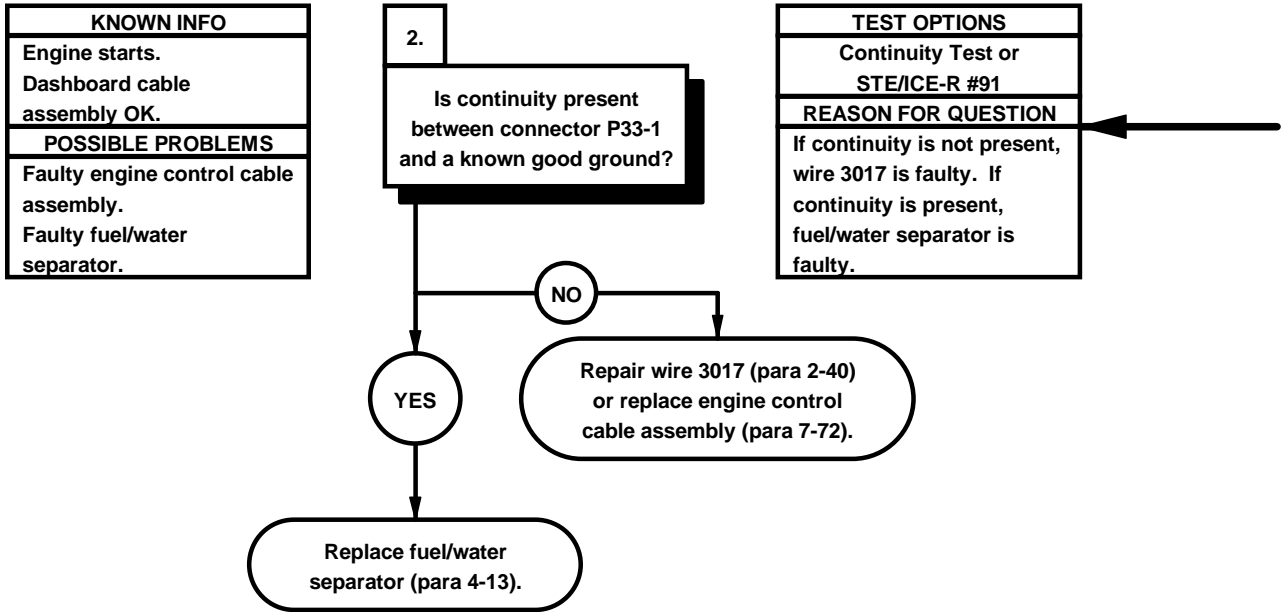

CONTINUITY TEST

- (1) Set multimeter to ohms.
- (2) Connect positive (+) probe of multimeter to connector P33-1.
- (3) Connect negative (-) probe of multimeter to ground and note reading on multimeter.
- (4) If continuity is not present, repair wire 3017 (para 2-40) or replace engine control cable assembly (para 7-72).
- (5) If continuity is present, replace fuel/water separator (para 4-13).
- (6) Connect connector P33 to fuel/water separator.
- (7) Connect connector clamp on fuel/water separator.
- (8) Lower cab (TM 9-2320-365-10).

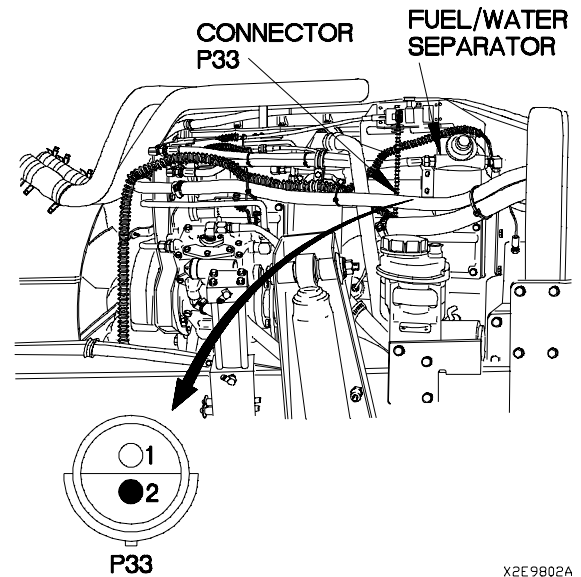

X2E9802A

WARNING

Remove rings, bracelets, watches, necklaces, and any other jewelry before working around vehicle. Jewelry can catch on equipment and cause injury or short across electrical circuit and cause severe burns or electrical shock.

VOLTAGE TEST

- (1) Remove instrument panel assembly for access (para 7-15).
- (2) Disconnect connector P31 from connector J31.
- (3) Set multimeter to volts dc.
- (4) Connect positive (+) probe of multimeter to connector J31-13.
- (5) Connect negative (-) probe of multimeter to ground.
- (6) Position master power switch to on (TM 9-2320-365-10) and note reading on multimeter.
- (7) If 24 vdc is not present, repair wire 1460 (para 2-40) or replace WTEC II dashboard cable assembly (para 7-10) or WTEC III dashboard cable assembly (para 7-11).
- (8) If 24 vdc is present, repair wire 1460 (para 2-40) or replace engine control cable assembly (para 7-72).
- (9) Position master power switch to off (TM 9-2320-365-10).
- (10) Connect connector P31 to connector J31.
- (11) Install instrument panel assembly on (para 7-15).

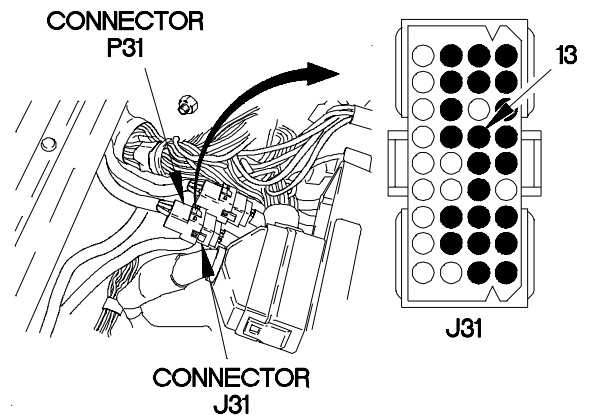

X2E9803A

e95. RADIO DOES NOT OPERATE	
INITIAL SETUP	
Equipment Condition Engine shut down (TM 9-2320-365-10).	Tools and Special Tools Tool Kit, Genl Mech (Item 44, Appendix C) STE/ICE-R (Item 39, Appendix C) Multimeter, Digital (Item 22, Appendix C)
Personnel Required (2)	References TM 9-4910-571-12&P

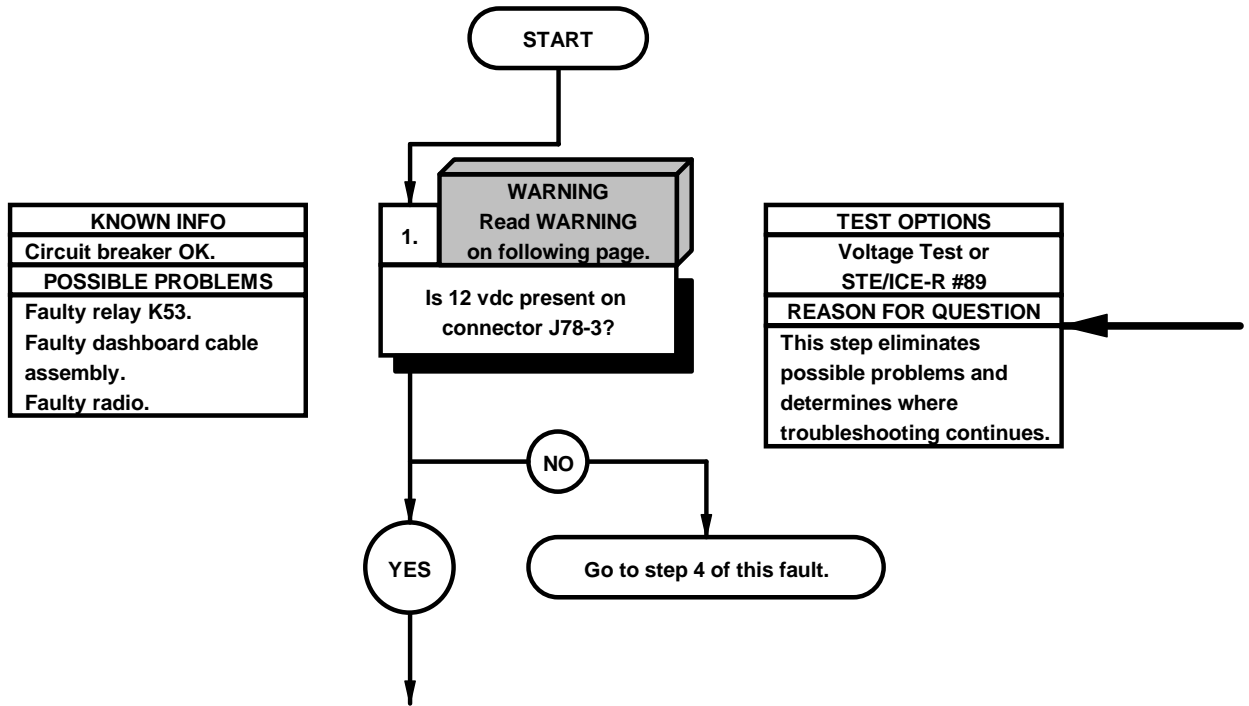

WARNING

Remove rings, bracelets, watches, necklaces, and any other jewelry before working around vehicle. Jewelry can catch on equipment and cause injury or short across electrical circuit and cause severe burns or electrical shock.

VOLTAGE TEST

- (1) Remove kick panel (para 16-3).
- (2) Disconnect connector J78 from radio.
- (3) Set multimeter to volts dc.
- (4) Connect positive (+) probe of multimeter to connector J78-3.
- (5) Connect negative (-) probe of multimeter to ground.
- (6) Position master power switch to on (TM 9-2320-365-10) and note reading on multimeter.
- (7) If 12 vdc is not present, go to step 4 of this fault.
- (8) Position master power switch to off (TM 9-2320-365-10).

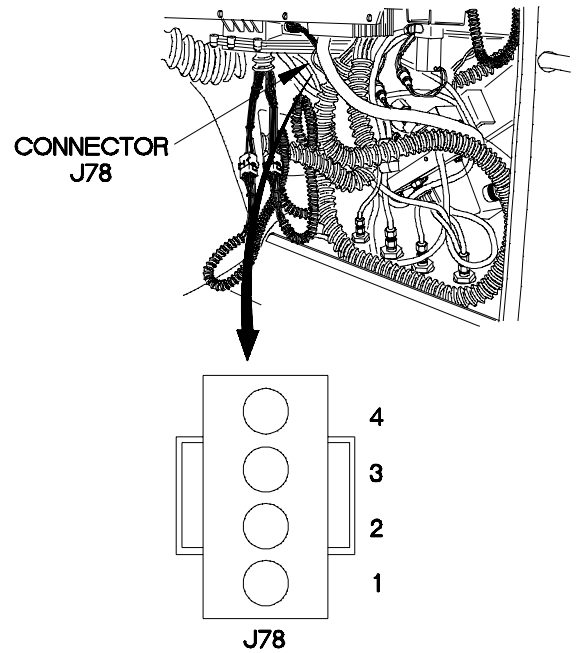

32E99011

e95. RADIO DOES NOT OPERATE (CONT)

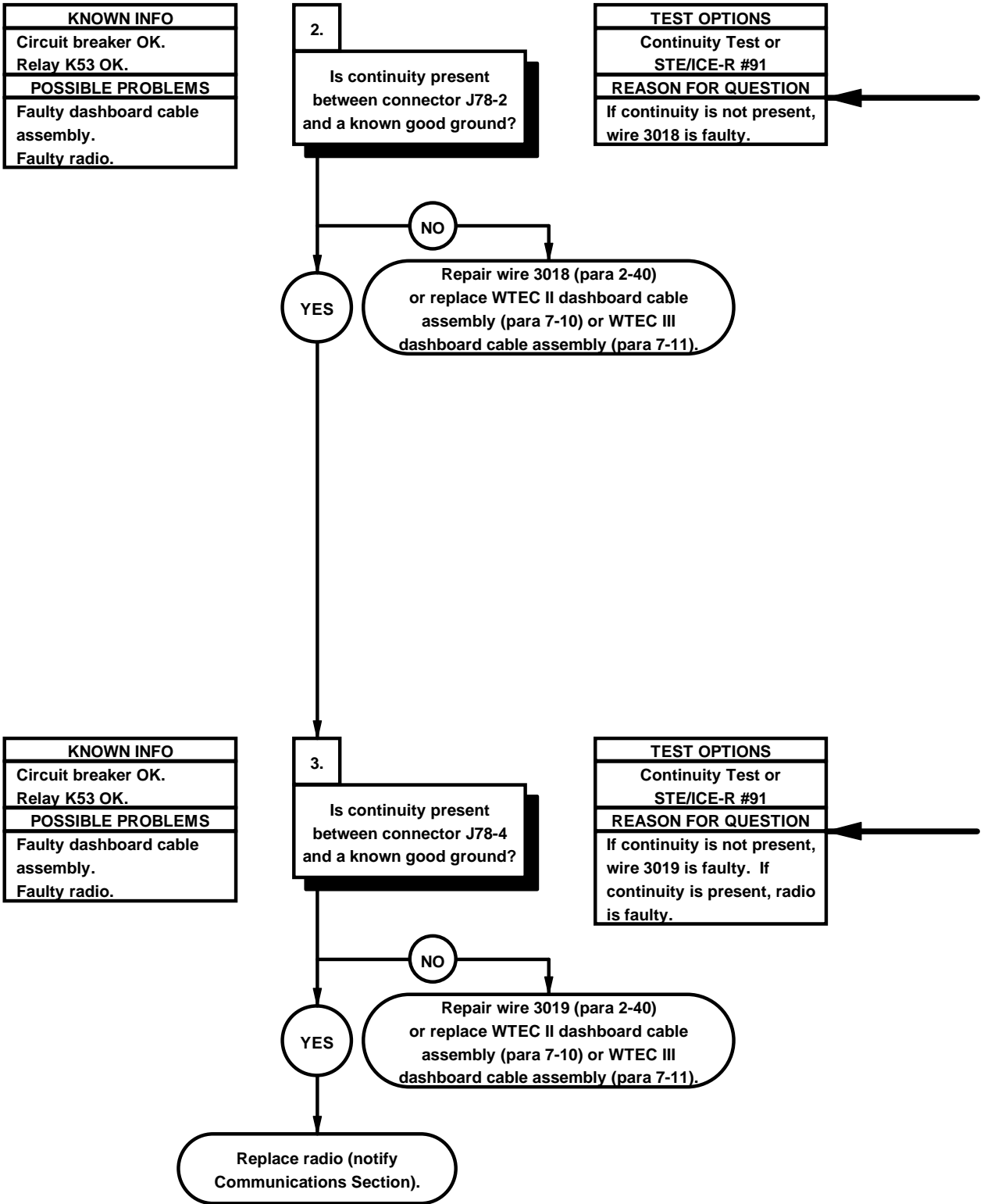

- | CONTINUITY TEST | |
|-----------------|--|
| | (1) Set multimeter to ohms. |
| | (2) Connect positive (+) probe of multimeter to connector J78-2. |
| | (3) Connect negative (-) probe of multimeter to ground and note reading on multimeter. |
| | (4) If continuity is not present, repair wire 3018 (para 2-40) or replace WTEC II dashboard cable assembly (para 7-10) or WTEC III dashboard cable assembly (para 7-11). |

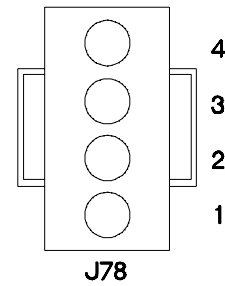
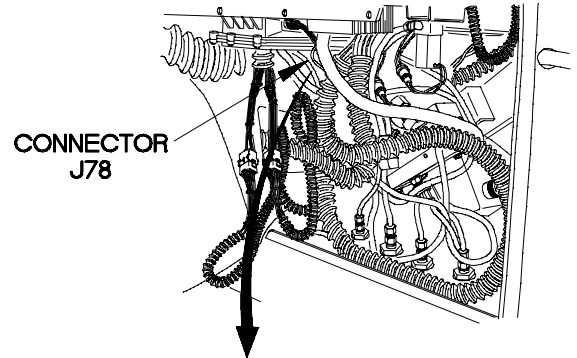

32E99021

- | CONTINUITY TEST | |
|-----------------|--|
| | (1) Set multimeter to ohms. |
| | (2) Connect positive (+) probe of multimeter to connector J78-4. |
| | (3) Connect negative (-) probe of multimeter to ground and note reading on multimeter. |
| | (4) If continuity is not present, repair wire 3019 (para 2-40) or replace WTEC II dashboard cable assembly (para 7-10) or WTEC III dashboard cable assembly (para 7-11). |
| | (5) If continuity is present, replace radio (notify Communications Section). |
| | (6) Connect connector J78 to radio. |
| | (7) Install kick panel (para 16-3). |

ø95. RADIO DOES NOT OPERATE (CONT)

KNOWN INFO
Circuit breaker OK. Radio OK.
POSSIBLE PROBLEMS
Faulty relay K53. Faulty dashboard cable assembly.

4.
Is continuity present between relay K53 terminals 30 and 87A?

TEST OPTIONS
Continuity Test or STE/ICE-R #91
REASON FOR QUESTION
If continuity is not present, relay K53 is faulty.

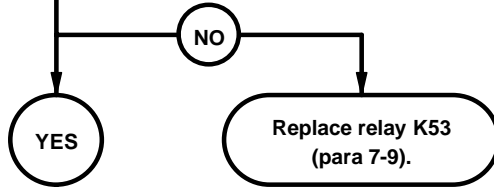

KNOWN INFO
Circuit breaker OK. Radio OK. Relay K53 OK.
POSSIBLE PROBLEMS
Faulty dashboard cable assembly.

5.
Is 24 vdc present at relay K53 terminal 85?

TEST OPTIONS
Voltage Test or STE/ICE-R #89
REASON FOR QUESTION
If 24 vdc is not present, wire 1960 is faulty. If 24 vdc is present, wire 1906 is faulty.

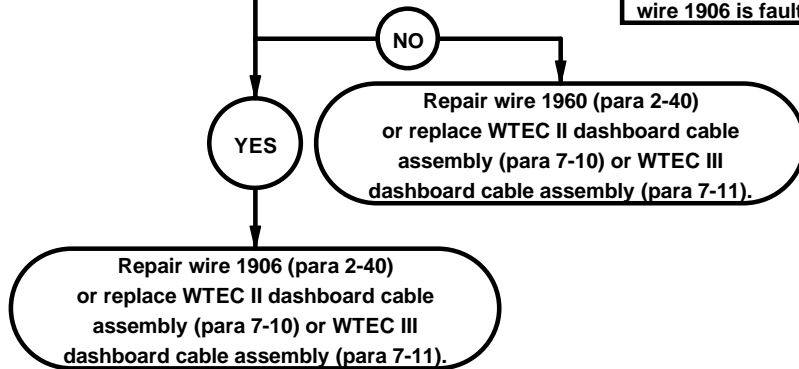

CONTINUITY TEST

- (1) Remove relay K53 from PDP.
- (2) Set multimeter to ohms.
- (3) Connect positive (+) probe of multimeter to relay K53 terminal 30.
- (4) Connect negative (-) probe of multimeter to relay K53 terminal 87A and note reading on multimeter.
- (5) If continuity is not present, replace relay K53 (para 7-9).

WARNING

Remove rings, bracelets, watches, necklaces, and any other jewelry before working around vehicle. Jewelry can catch on equipment and cause injury or short across electrical circuit and cause severe burns or electrical shock.

VOLTAGE TEST

- (1) Set multimeter to volts dc.
- (2) Connect positive (+) probe of multimeter to PDP, terminal 85, where relay K53 was removed.
- (3) Connect negative (-) probe of multimeter to ground.
- (4) Position master power switch to on (TM 9-2320-365-10) and note reading on multimeter.
- (5) If 24 vdc is not present, repair wire 1960 (para 2-40) or replace WTEC II dashboard cable assembly (para 7-10) or WTEC III dashboard cable assembly (para 7-11).
- (6) If 24 vdc is present, repair wire 1906 (para 2-40) or replace WTEC II dashboard cable assembly (para 7-10) or WTEC III dashboard cable assembly (para 7-11).
- (7) Position master power switch to off (TM 9-2320-365-10).
- (8) Install relay K53 in PDP.
- (9) Connect connector J78 to radio.
- (10) Install kick panel (para 16-3).

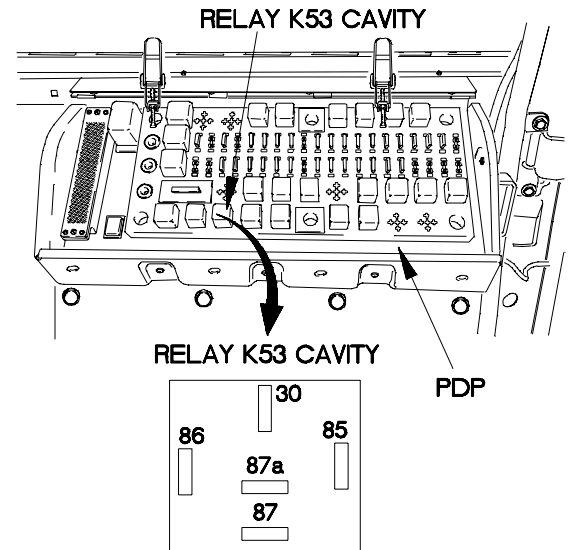

X2E99031

e96. START INHIBIT PUSHBUTTON DOES NOT OPERATE	
INITIAL SETUP	
Equipment Condition Engine shut down (TM 9-2320-365-10).	Tools and Special Tools Tool Kit, Genl Mech (Item 44, Appendix C) STE/ICE-R (Item 39, Appendix C) Multimeter, Digital (Item 22, Appendix C)
Personnel Required (2)	References TM 9-4910-571-12&P
Materials/Parts Wire, Elect, 50 ft (Item 77, Appendix D)	

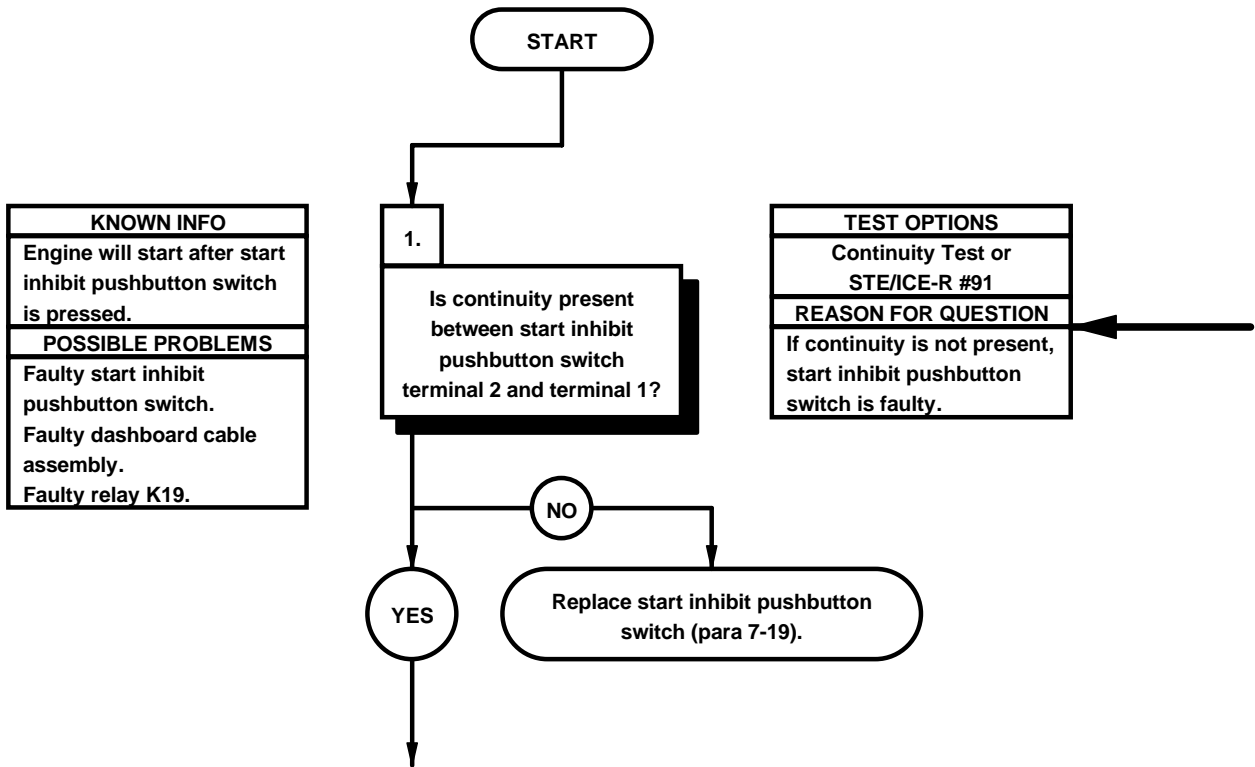

CONTINUITY TEST

- (1) Remove PDP cover (para 16-2).
- (2) Remove three screws and washers from PDP.
- (3) Remove three screws from PDP.
- (4) Lift PDP outward to gain access.
- (5) Disconnect terminal lugs TL158 and TL159 from start inhibit pushbutton switch.
- (6) Set multimeter to ohms.
- (7) Connect positive (+) probe of multimeter to start inhibit pushbutton switch terminal 1.
- (8) Connect negative (-) probe of multimeter to start inhibit pushbutton switch terminal 2.
- (9) Press start inhibit pushbutton switch and hold (TM 9-2320-365-10) and note reading on multimeter.
- (10) If continuity is not present, replace start inhibit pushbutton switch (para 7-19).
- (11) Install PDP on dashboard with three screws.
- (12) Install three washers and screws in PDP.

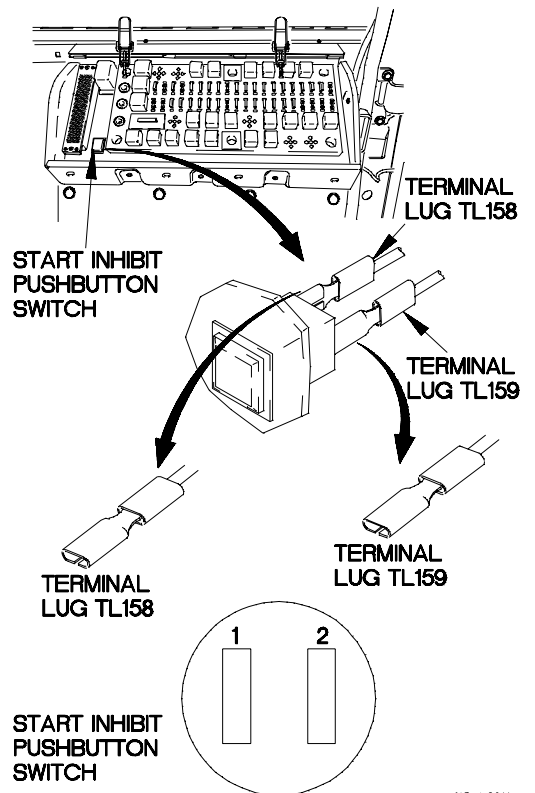
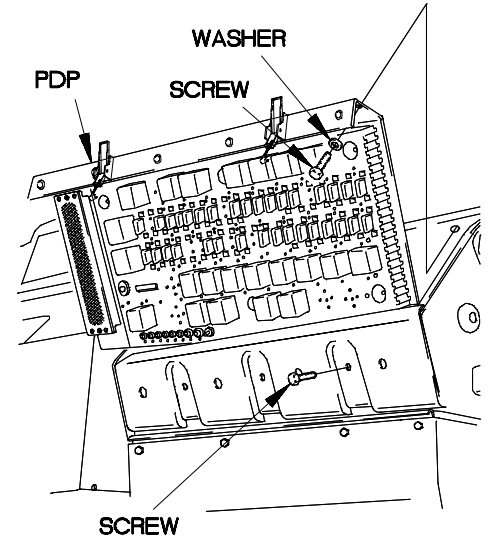

X2ek0011

e96. START INHIBIT PUSHBUTTON DOES NOT OPERATE (CONT)

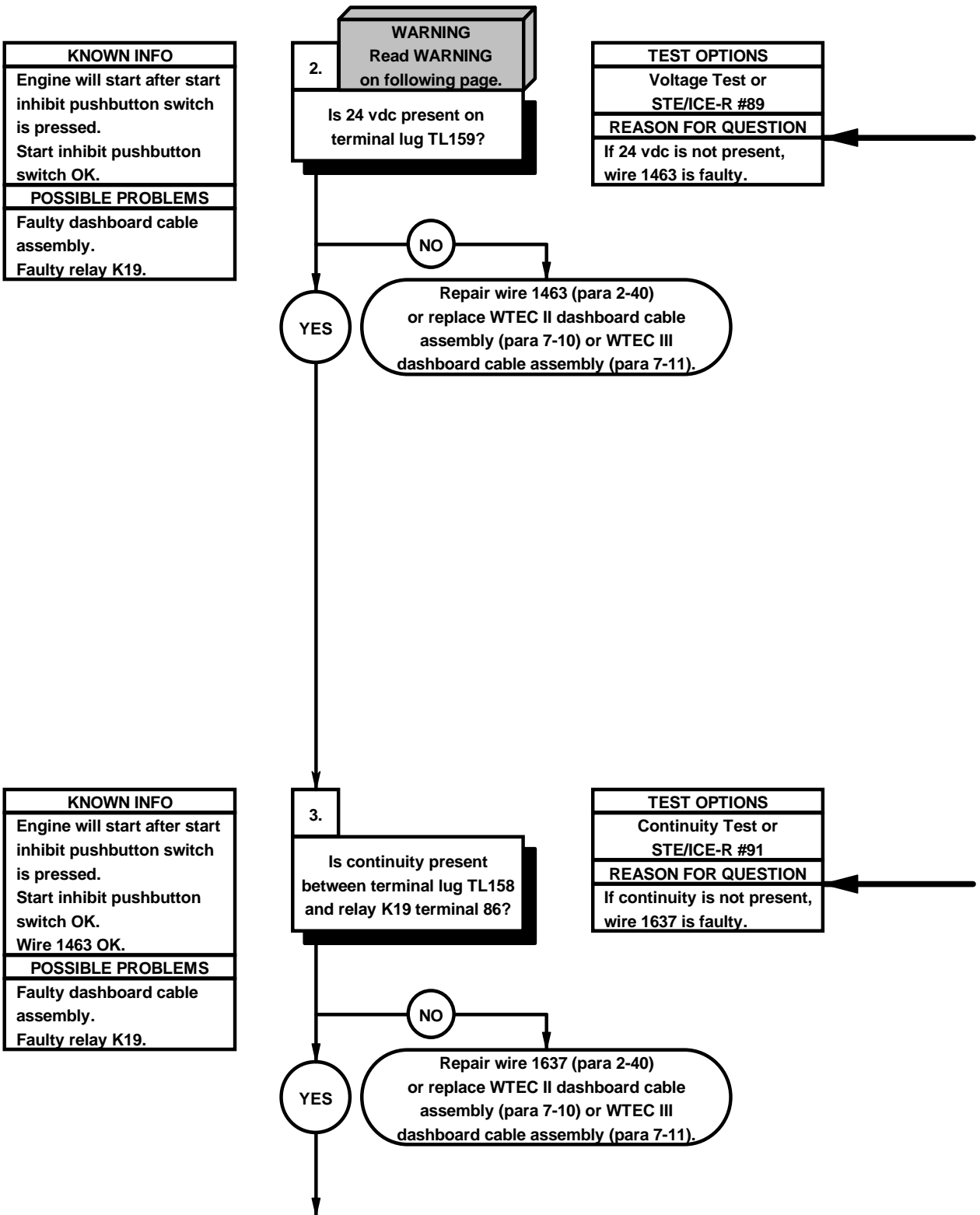

WARNING

Remove rings, bracelets, watches, necklaces, and any other jewelry before working around vehicle. Jewelry can catch on equipment and cause injury or short across electrical circuit and cause severe burns or electrical shock.

VOLTAGE TEST

- (1) Set multimeter to volts dc.
- (2) Connect positive (+) probe of multimeter to terminal lug TL159.
- (3) Connect negative (-) probe of multimeter to ground.
- (4) Position master power switch to on (TM 9-2320-365-10) and note reading on multimeter.
- (5) If 24 vdc is not present, repair wire 1463 (para 2-40) or replace WTEC II dashboard cable assembly (para 7-10) or WTEC III dashboard cable assembly (para 7-11).
- (6) Position master power switch to off (TM 9-2320-365-10).

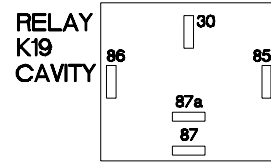

FRONT

RELAY K19 CAVITY

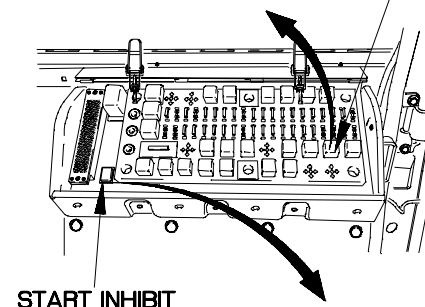

TERMINAL LUG TL158

START INHIBIT PUSHBUTTON SWITCH

TERMINAL LUG TL159

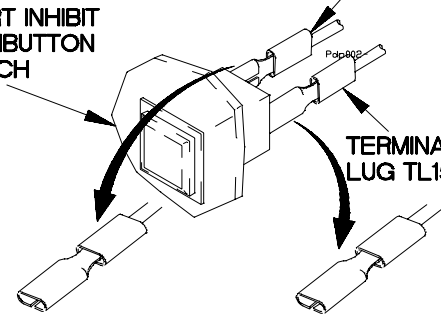

X2EK0021

CONTINUITY TEST

- (1) Remove relay K19 from PDP.
- (2) Set multimeter to ohms.
- (3) Connect positive (+) probe of multimeter to terminal lug TL158.
- (4) Connect negative (-) probe of multimeter to PDP, terminal 86, where relay K19 was removed, and note reading on multimeter.
- (5) If continuity is not present, repair wire 1637 (para 2-40) or replace WTEC II dashboard cable assembly (para 7-10) or WTEC III dashboard cable assembly (para 7-11).
- (6) Connect terminal lugs TL158 and TL159 to start inhibit pushbutton switch.

e96. START INHIBIT PUSHBUTTON DOES NOT OPERATE (CONT)

KNOWN INFO
Engine will start after start inhibit pushbutton switch is pressed. Start inhibit pushbutton switch OK. Wire 1463 OK. Wire 1637 OK.
POSSIBLE PROBLEMS
Faulty dashboard cable assembly. Faulty relay K19.

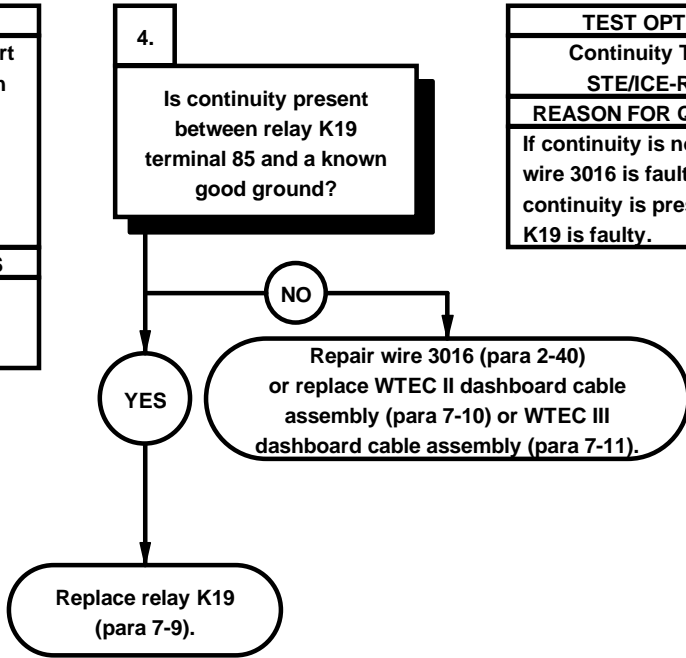

TEST OPTIONS
Continuity Test or STE/ICE-R #91
REASON FOR QUESTION
If continuity is not present, wire 3016 is faulty. If continuity is present, relay K19 is faulty.



CONTINUITY TEST

- (1) Set multimeter to ohms.
- (2) Connect positive (+) probe of multimeter to PDP, terminal 85, where relay K19 was removed.
- (3) Connect negative (-) probe of multimeter to ground and note reading on multimeter.
- (4) If continuity is not present, repair wire 3016 (para 2-40) or replace WTEC II dashboard cable assembly (para 7-10) or WTEC III dashboard cable assembly (para 7-11).
- (5) If continuity is present, replace relay K19 (para 7-9).
- (6) Install relay K19 in PDP.
- (7) Install PDP cover (para 16-2).

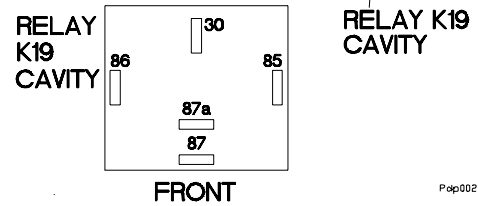
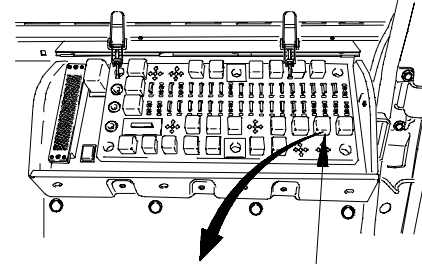

Pop002-

X2EK0031

e97. AIR DRYER DOES NOT OPERATE	
INITIAL SETUP	
Equipment Condition Engine shut down (TM 9-2320-365-10).	Tools and Special Tools Tool Kit, Genl Mech (Item 44, Appendix C) STE/ICE-R (Item 39, Appendix C) Multimeter, Digital (Item 22, Appendix C)
Personnel Required (2)	References TM 9-4910-571-12&P

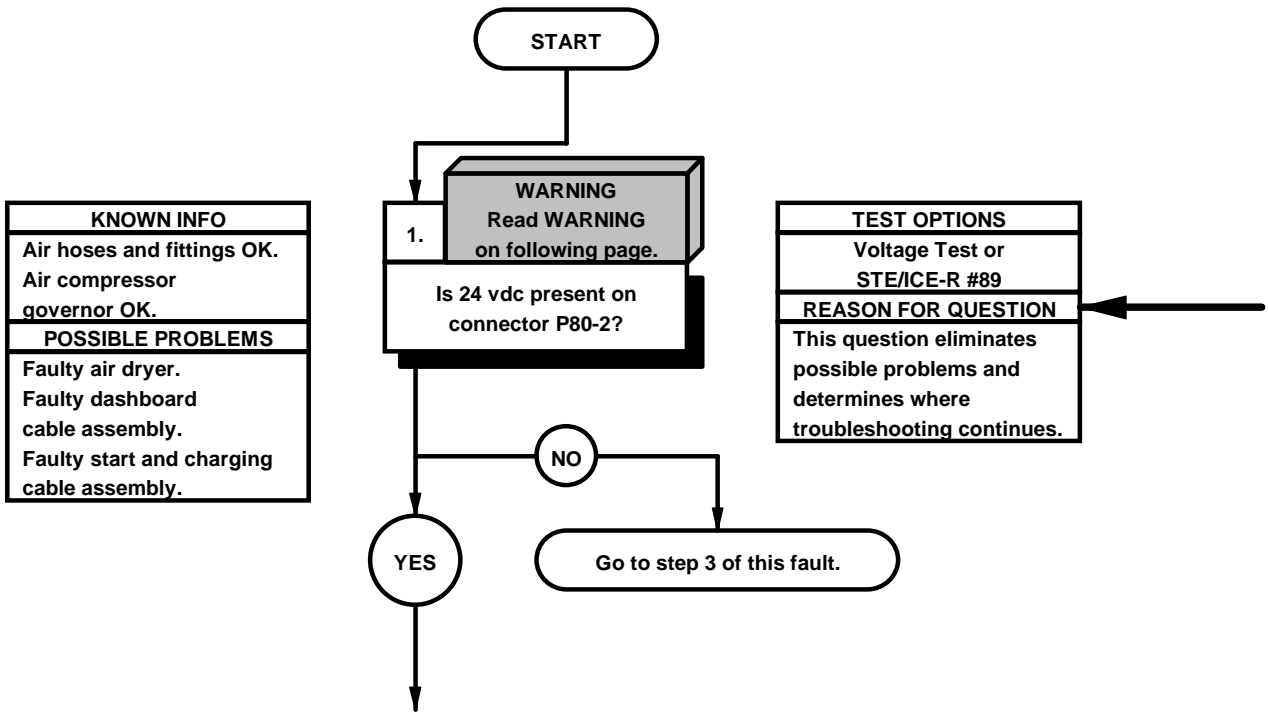

WARNING

Remove rings, bracelets, watches, necklaces, and any other jewelry before working around vehicle. Jewelry can catch on equipment and cause injury or short across electrical circuit and cause severe burns or electrical shock.

VOLTAGE TEST

- (1) Disconnect connector P80 from air dryer connector.
- (2) Set multimeter to volts dc.
- (3) Connect positive (+) probe of multimeter to connector P80-2.
- (4) Connect negative (-) probe of multimeter to ground.
- (5) Position master power switch to on (TM 9-2320-365-10) and note reading on multimeter.
- (6) If 24 vdc is not present, go to step 3 of this fault.
- (7) Position master power switch to off (TM 9-2320-365-10).

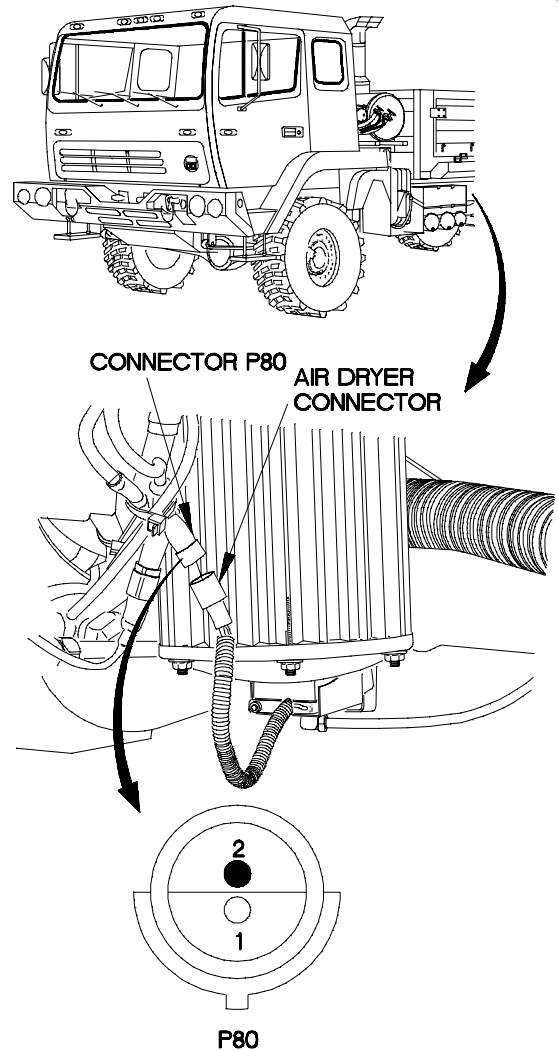

X2EK1011

e97. AIR DRYER DOES NOT OPERATE (CONT)

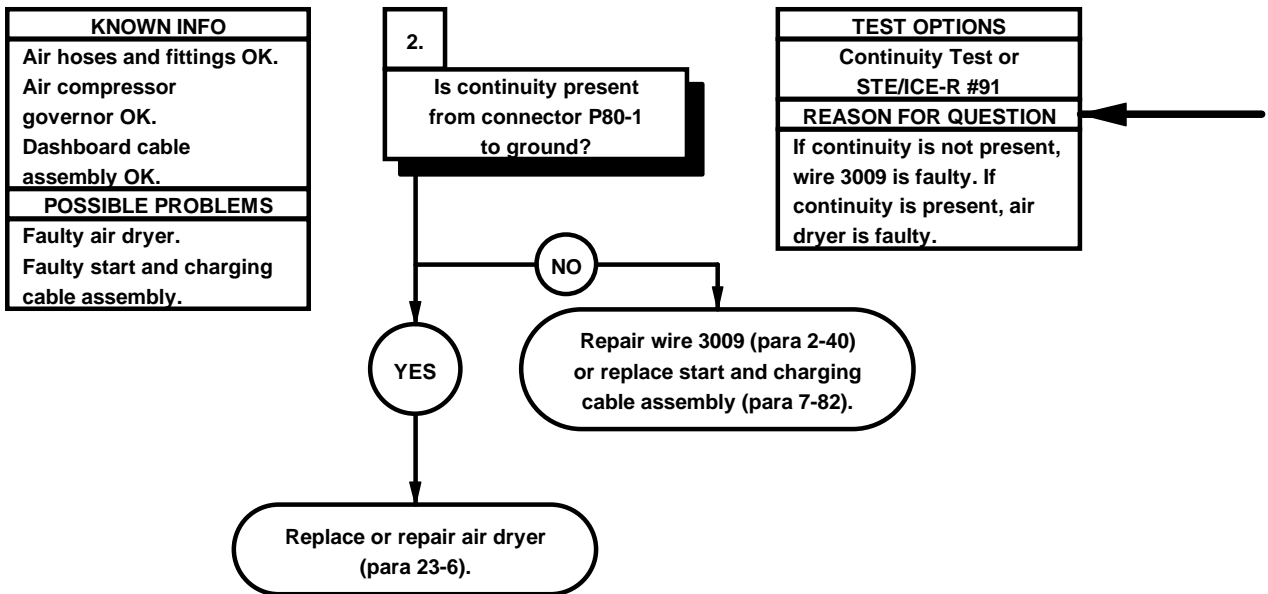

- | CONTINUITY TEST |
|--|
| (1) Set multimeter to ohms. |
| (2) Connect positive (+) probe of multimeter to connector P80-1. |
| (3) Connect negative (-) probe of multimeter to ground and note reading on multimeter. |
| (4) If continuity is not present, repair wire 3009 (para 2-40) or replace start and charging cable assembly (para 7-82). |
| (5) If continuity is present, replace or repair air dryer (para 23-6). |
| (6) Connect connector P80 to air dryer connector. |

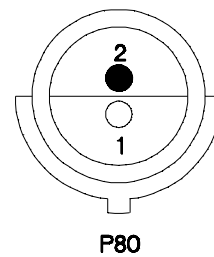
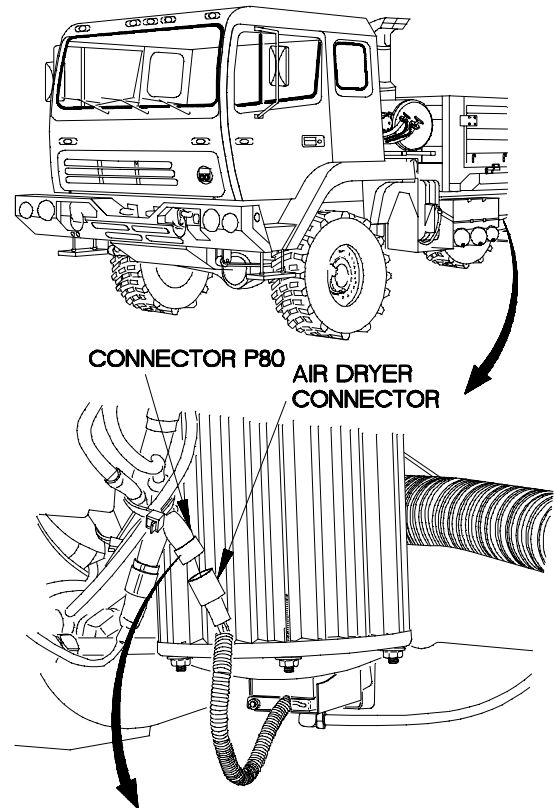

X2EK1021

97. AIR DRYER DOES NOT OPERATE (CONT)

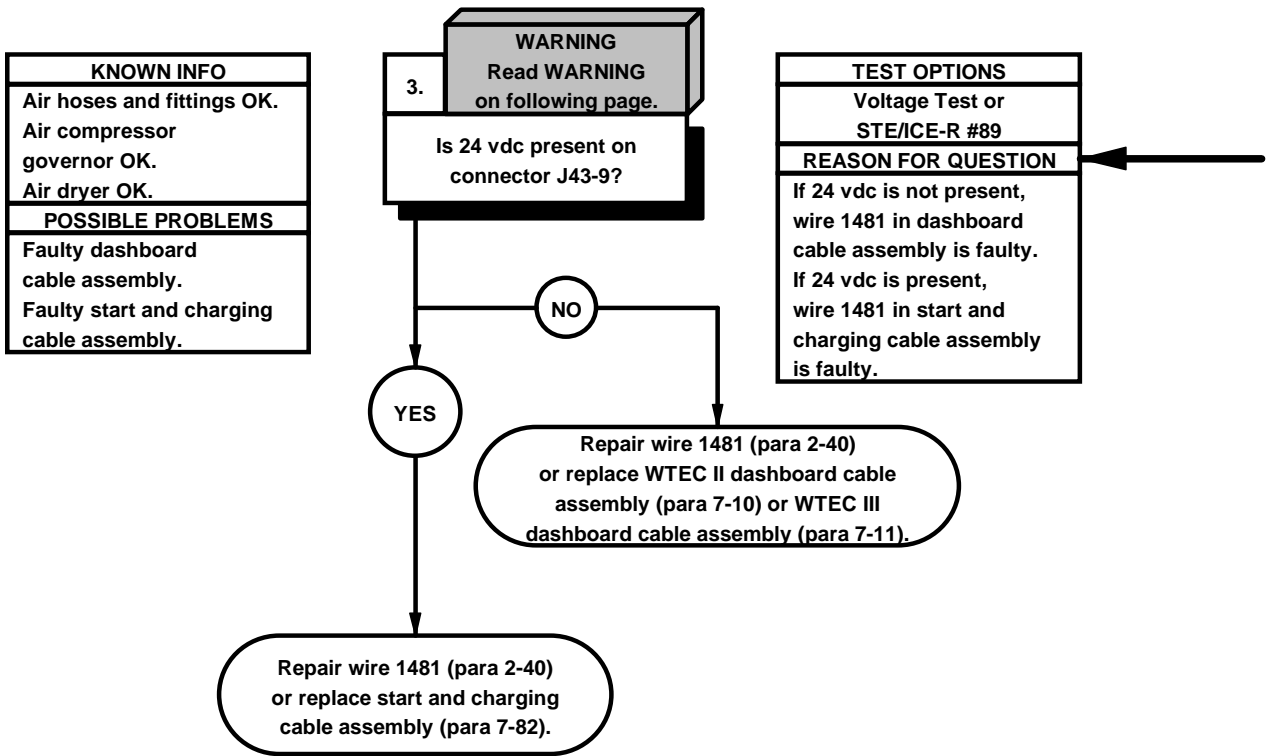

WARNING

Remove rings, bracelets, watches, necklaces, and any other jewelry before working around vehicle. Jewelry can catch on equipment and cause injury or short across electrical circuit and cause severe burns or electrical shock.

VOLTAGE TEST

- (1) Remove instrument panel assembly for access (para 7-15).
- (2) Disconnect connector J43 from connector P43.
- (3) Set multimeter to volts dc.
- (4) Connect positive (+) probe of multimeter to connector J43-9.
- (5) Connect negative (-) probe of multimeter to ground.
- (6) Position master power switch to on (TM 9-2320-365-10) and note reading on multimeter.
- (7) If 24 vdc is not present, repair wire 1481 (para 2-40) or replace WTEC II dashboard cable assembly (para 7-10) or WTEC III dashboard cable assembly (para 7-11).
- (8) If 24 vdc is present, repair wire 1481 (para 2-40) or replace start and charging cable assembly (para 7-82).
- (9) Position master power switch to off (TM 9-2320-365-10).
- (10) Connect connector J43 to connector P43.
- (11) Install instrument panel assembly (para 7-15).

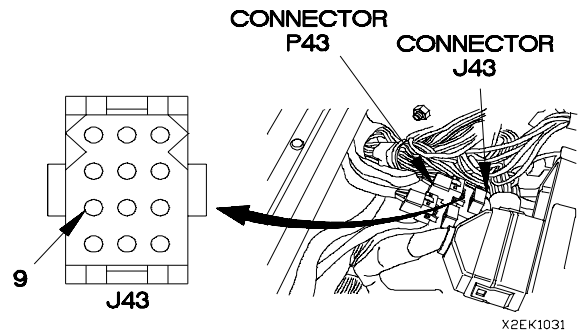

e98. BATTERY TESTER DOES NOT OPERATE	
INITIAL SETUP	
Equipment Condition Engine shut down (TM 9-2320-365-10).	Tools and Special Tools STE/ICE-R (Item 39, Appendix C) Multimeter, Digital (Item 22, Appendix C) Goggles, Industrial (Item 15, Appendix C) Gloves, Rubber (Item 13, Appendix C) Apron, Rubber (Item 3, Appendix C)
Personnel Required (2)	
References TM 9-4910-571-12&P	

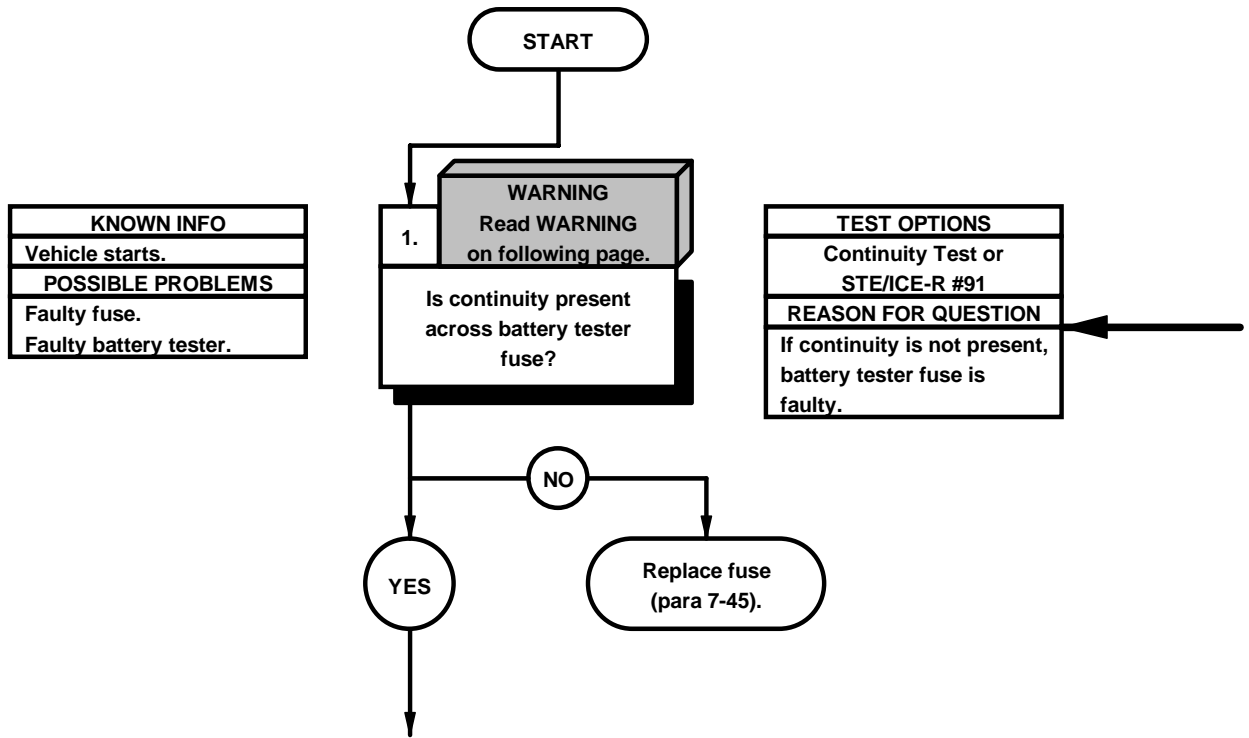

WARNING

Remove rings, bracelets, watches, necklaces, and any other jewelry before working around vehicle. Jewelry can catch on equipment and cause injury or short across electrical circuit and cause severe burns or electrical shock. Batteries can explode from a spark. Battery acid is harmful to skin and eyes. Always wear eye protection and rubber gloves when working with batteries.

CONTINUITY TEST

- (1) Remove battery box cover (TM 9-2320-365-10).
- (2) Open fuse holder on battery tester.
- (3) Remove fuse from fuse holder.
- (4) Set multimeter to ohms.
- (5) Connect positive (+) probe of multimeter to one end of fuse.
- (6) Connect negative (-) probe of multimeter to other end of fuse and note reading on multimeter.
- (7) If continuity is not present, replace battery tester 3 milliamp fuse (para 7-45).

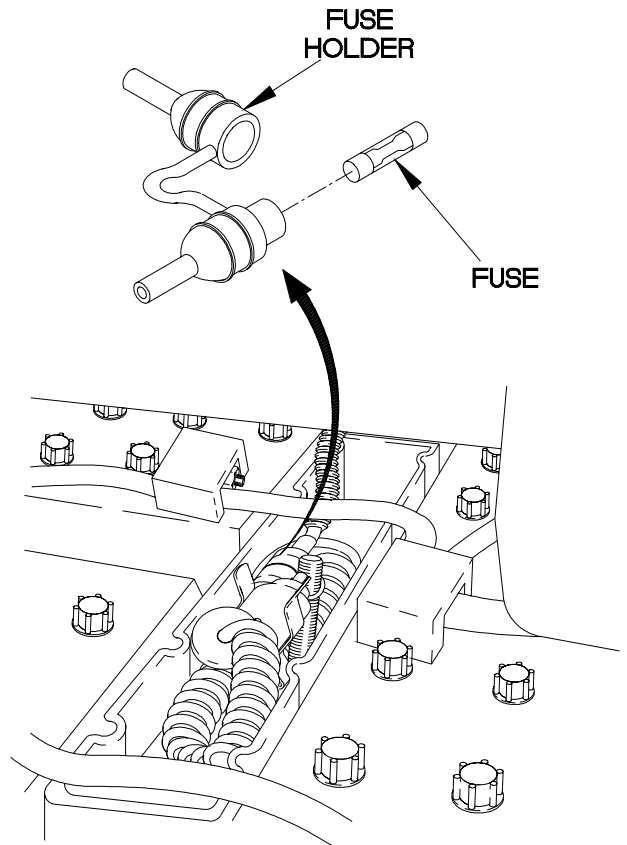

X2EK3011

e98. BATTERY TESTER DOES NOT OPERATE (CONT)

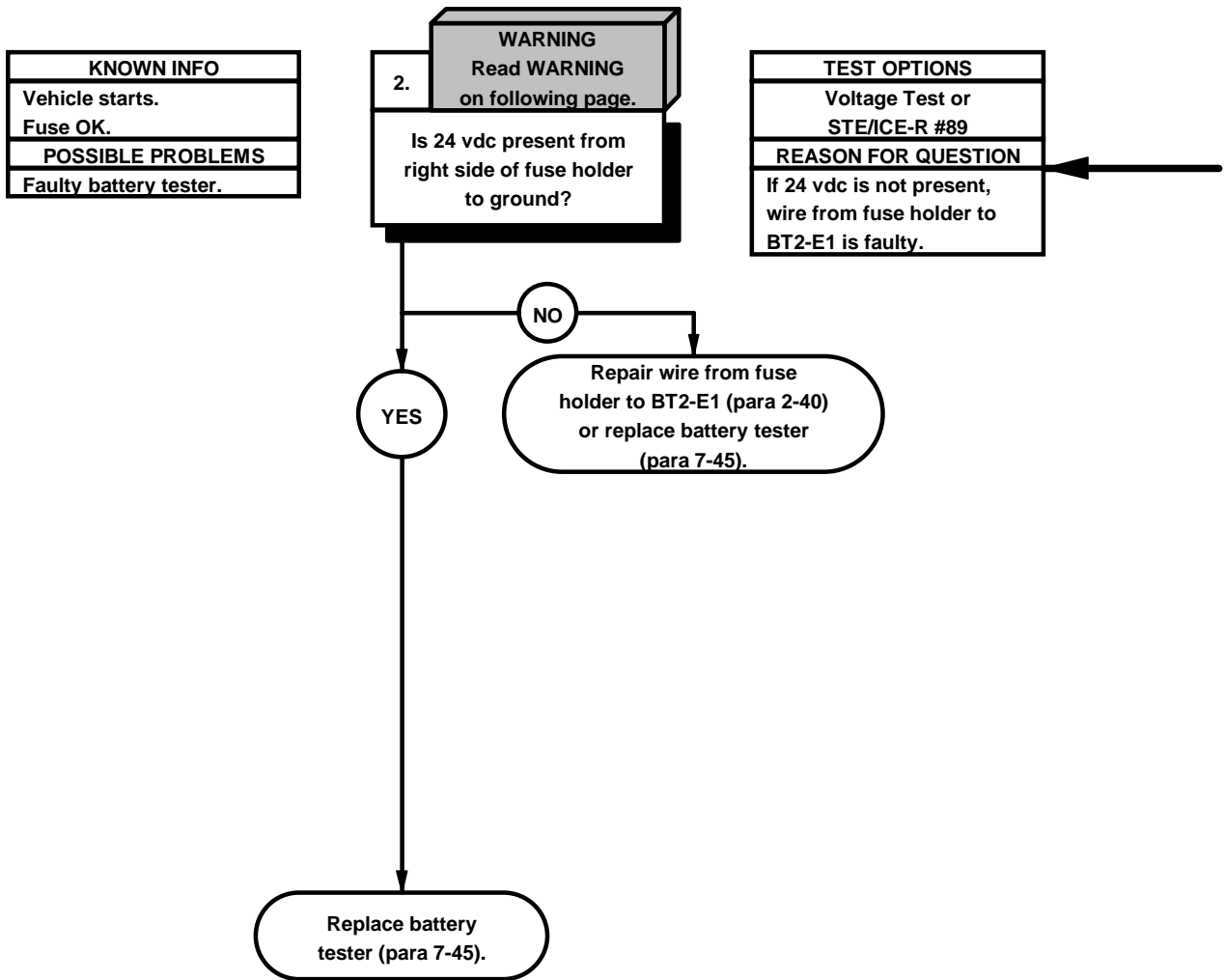

WARNING

Remove rings, bracelets, watches, necklaces, and any other jewelry before working around vehicle. Jewelry can catch on equipment and cause injury or short across electrical circuit and cause severe burns or electrical shock. Batteries can explode from a spark. Battery acid is harmful to skin and eyes. Always wear eye protection and rubber gloves when working with batteries.

VOLTAGE TEST

- (1) Set multimeter to volts dc.
- (2) Connect positive (+) probe of multimeter to terminal in right side of fuse holder.
- (3) Connect negative (-) probe of multimeter to ground and note reading on multimeter.
- (4) If 24 vdc is not present, repair wire from right side of fuse holder to BT2-E1 (para 2-40) or replace battery tester (para 7-45).
- (5) If 24 vdc is present, replace battery tester (para 7-45).
- (6) Install fuse in battery tester fuse holder.
- (7) Close battery tester fuse holder.
- (8) Install battery box cover (TM 9-2320-365-10).

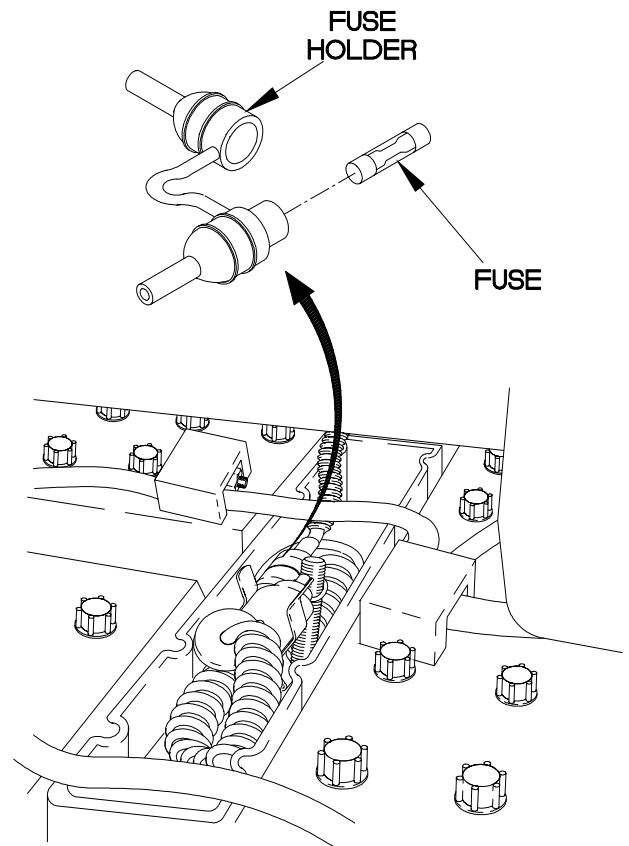

X2EK3011

APPENDIX A REFERENCES

A-1. SCOPE

This appendix lists all forms, field manuals, technical manuals, and other publications referenced in this manual. Those publications that should be consulted for additional information about vehicle operations are also listed.

A-2. PUBLICATIONS INDEX

The following index should be consulted frequently for latest changes or revisions and for new publications relating to material covered in this technical manual.

Consolidated Index of Army Publications and Blank Forms DA Pam 25-30

A-3. FORMS

The following forms pertain to this manual. See DA Pam 25-30 for index of blank forms. See DA Pam 738-750, The Army Maintenance Management System (TAMMS), for instructions on the use of maintenance forms pertaining to this material.

- Equipment Control Record DA Form 2408-9
- Equipment Inspection and Maintenance Worksheet DA Form 2404
- Maintenance Request DA Form 2407
- Packaging Improvement Report DD Form 6
- Processing and Deprocessing Record of Shipping, Storage, and Issue of Vehicles and Spare Engines DD Form 1397
- Product Quality Deficiency Report SF 368
- Recommended Changes to DA Publications and Blank Forms DA Form 2028-2
- Report of Item Discrepancy (ROID) SF 364

A-4. OTHER PUBLICATIONS

The following publications contain information pertinent to the LMTV and associated equipment.

a. Safety.

- First Aid for Soldiers FM 21-11
- Security of Tactical Wheeled Vehicles TB 9-2300-422-20
- Safety Inspection and Testing of Lifting Devices TB 43-0142

A-4. OTHER PUBLICATIONS (CONT)

b. LMTV.

Direct Support and General Support Maintenance Manual for M1078 Series, 2 1/2-Ton, 4x4, Light Medium Tactical Vehicle (LMTV) TM 9-2320-365-34

Hand Receipt Covering Contents of Components of End Item (COEI), Basic Issue Items (BII), and Additional Authorization List (AAL), for M1078 Series, 2 1/2-Ton, 4x4, Light Medium Tactical Vehicles (LMTV) TM 9-2320-365-10-HR

Operator's Manual for M1078 Series, 2 1/2-Ton, 4x4, Light Medium Tactical Vehicle (LMTV) TM 9-2320-365-10

Unit, Direct Support, and General Support Repair Parts and Special Tools List for M1078 Series, 2 1/2-Ton, 4x4, Light Medium Tactical Vehicle (LMTV) TM 9-2320-365-24P

Warranty Program for M1078 Series, 2 1/2-Ton, 4x4, Light Medium Tactical Vehicle (LMTV) TB 9-2300-365-15

c. General Vehicle Operation.

Army Motor Transport Units and Operations FM 55-30

Deleted

Manual for the Wheeled Vehicle Driver FM 21-305

Safety Prevention of Motor Vehicle Accidents AR 385-55

Vehicle Recovery Operations FM 20-22

d. General Maintenance and Repair.

Army Oil Analysis Program TB 43-0211

Camouflage Pattern Painting FM 5-20

Charging System Troubleshooting DA Pam 750-33

Color, Marking, and Camouflage Painting of Military Vehicles TB 43-0209

Cooling Systems: Tactical Vehicles TM 750-254

Corrosion Prevention and Control Including Rustproofing Procedures for Tactical Vehicles and Trailers TB 43-0213

Description, Use, Bonding Techniques, and Properties of Adhesives TB ORD 1032

Equipment Improvement Report and Maintenance Digest: TACOM Equipment TB 43-0001-39-1

Equipment Improvement Report and Maintenance Summary TM 43-0143

Installation Instructions for Installation Kit, Electronic Equipment, MK-2700/VRC (NSN 5895-01-421-0814) (EIC: N/A) to Permit Installation of Radio Set AN/VRC-87/88/90 Series into M1078, M1080, M1081, M1083-M1086, M1088-M1094 and M1096 Family of Medium Tactical Vehicles TB 11-5820-890-20-101

Installation Instructions for Installation Kit, Electronic Equipment, MK-2715/VRC (NSN 5895-01-421-0812) (EIC: N/A) to Permit Installation of Radio Set AN/VRC-89/91/92 Series into M1078, M1080, M1081, M1083-M1086, M1088-M1094 and M1096 Family of Medium Tactical Vehicles TB 11-5820-890-20-92

Metal Body Repair and Related Operations FM 43-2

Materials Used for Cleaning, Preserving, Abrading, and Cementing Ordnance Materiel and Related Materials Including Chemicals TM 9-247

Operator's and Organizational Maintenance Manual for Radio Sets TM 11-5820-498-12

Operator's and Organizational Maintenance Manual Including Repair Parts and Special Tools List Simplified Test Equipment for Internal Combustion Engines Reprogrammable (STE/ICE-R) (NSN 4910-01-222-6589) TM 9-4910-571-12&P

Operator's Manual, Radio Set, AN/VRC-46 TM 11-5820-401-10-1

Operator's Manual, Radio Set, AN/VRC-90A TM 11-5820-890-10-1

Operator's, Unit, Direct Support, and General Support Maintenance Manual
for Lead-Acid Storage Batteries TM 9-6140-200-14

Ordnance Tracked and Wheeled Vehicle Hull and Chassis Wiring, Repair of TB ORD 650

Organizational Care, Maintenance, and Repair of Pneumatic Tires and Inner Tubes TM 9-2610-200-14

Painting Instructions for Field Use TM 43-0139

Purging, Cleaning, and Coating Interior Ferrous and Terne Sheet Vehicle Fuel Tanks TB 43-0212

Repair of Tents, Canvas, and Webbing FM 10-16

Rigging Techniques, Procedures, and Applications FM 5-125

Use and Care of Hand Tools and Measuring Tools TM 9-243

Use of Antifreeze Solutions and Cleaning Compounds in Engine Cooling Systems TB 750-651

Welding Theory and Application TM 9-237

e. Cold Weather Operation.

Basic Cold Weather Manual FM 31-70

Northern Operations FM 31-71

Operation and Maintenance of Ordnance Materiel in Cold Weather (0° to -65°F) FM 9-207

f. Decontamination.

Decontamination Operations Facilities & Equipment TB 700-4

NBC Protection FM 3-4

NBC Decontamination FM 3-5

g. Maintenance of Special Purpose Kits.

Operator and Organizational Maintenance Manual for Chemical Alarm TM 3-6665-225-12

Operator's and Unit Maintenance Manual Including Repair Parts and Special Tools
List for Decontaminating Apparatus: M13 TM 3-4230-214-12&P

Operator's, Organizational, Direct Support, and General Support Maintenance Manual
Including Repair Parts and Special Tools List for Various Machine Gun Mounts TM 9-1005-245-14

Operator's, Organizational, Direct Support, and General Support Maintenance
Manual, Air Conditioner, Horizontal Compact, 18,000 BTU/HR, 208 Volt, 3 Phase,
50/60 Hertz, Model F18H-3S TM 5-4120-384-14

Unit and Direct Support Maintenance, Repair Parts and Special Tools List for
Heater, Space, Multifuel with Blower, 60,000 BTU/HR, 120V, Model UH-68G,
NSN 4520-01-203-4410, and Model UH-68GI, NSN 4520-01-297-6803 TM 5-4520-253-23P

h. General.

Operator's Manual (M998 Series) TM 9-2320-280-10

Operator's Manual (M1008 Series) TM 9-2320-289-10

Operator's Manual (M35 Series) TM 9-2320-361-10

Operator's Manual (M939 Series) TM 9-2320-272-10

Principles of Automotive Vehicles TM 9-8000

Procedures for Destruction of Tank-Automotive Equipment to Prevent Enemy Use
(US Army Tank-automotive and Armaments Command) TM 750-244-6

Route Reconnaissance and Classification FM 5-36

Soldier's Manual MOS 88M Motor Transport Operator, Skill Levels 1/2 STP 55-88-M12-SM

A-4. OTHER PUBLICATIONS (CONT)

i. Land, Sea, and Air Shipment.

Airdrop of Supplies and Equipment: Rigging 2 1/2-Ton Trucks FM 10-520
Containerization of Military Vehicles MTMCTEA Ref 95-55-23
Lifting and Tiedown of U.S. Military Helicopters MTMCTEA Ref 95-55-21
Marine Lifting and Lashing Handbook MTMCTEA Ref 95-55-22
Marine Terminal Lifting Guidance MTMCTEA Pam 56-1
Multiservice Helicopter External Air Transport: Basic Operations and Equipment FM 55-450-3
Multiservice Helicopter External Air Transport: Dual-Point Load Rigging Procedures FM 55-450-5
Multiservice Helicopter External Air Transport: Single-Point Load Rigging Procedures FM 55-450-4
Standard Characteristics (Dimensions, Weight, and Cube) for Transportability of Military
Vehicles and Other Outsize/Overweight Equipment (in TOE Line Sequence) TB 55-46-1
Tiedown Handbook for Rail Movements MTMCTEA Pam 55-19
Tiedown Handbook for Truck Movements MTMCTEA Ref 92-55-20

APPENDIX B MAINTENANCE ALLOCATION CHART (MAC)

SECTION I

INTRODUCTION

B-1. The Army Maintenance System MAC.

a.This introduction (Section I) provides a general explanation of all maintenance and repair functions authorized at various maintenance levels under the standard Army Maintenance System concept.

b.The Maintenance Allocation Chart (MAC) in Section II designates overall authority and responsibility for the performance of maintenance functions on the identified end item or component. The application of the maintenance functions to the end item or component will be consistent with the capacities and capabilities of the designated maintenance levels, which are shown on the MAC in column (4) as:

Unit/Field - includes two subcolumns, C (Operator/Crew) and O (Unit) maintenance.

Direct Support/Field - includes an F subcolumn.

General Support/Sustainment - includes an H subcolumn.

Depot/Sustainment - includes a D subcolumn.

c.Section III lists the tools and test equipment (both special tools and common tool sets) required for each maintenance function as referenced from Section II.

d.Section IV contains supplemental instructions and explanatory notes for a particular maintenance function.

B-2. Maintenance Functions. Maintenance functions are limited to and defined as follows:

a.**Inspect.** To determine the serviceability of an item by comparing its physical, mechanical, and/or electrical characteristics with established standards through examination (e.g. by sight, sound, or feel).

b.**Test.** To verify serviceability by measuring the mechanical, pneumatic, hydraulic, or electrical characteristics of an item and comparing those characteristics with prescribed standards.

c.**Service.** Operations required periodically to keep an item in proper operating condition; e.g. to clean (includes decontaminate, when required), to preserve, to drain, to paint, or to replenish fuel, lubricants, chemicals fluids, or gases.

d.**Adjust.** To maintain or regulate, within prescribed limits, by bringing into proper position, or by setting the operating characteristics to specified parameters.

e.**Align.** To adjust specified variable elements of an item to bring about optimum or desired performance.

f.**Calibrate.** To determine and cause corrections to be made or to be adjusted on instruments or Test, Measurement, and Diagnostic Equipment (TMDE) used in precision measurement. Consists of comparison of two instruments, one of which is a certified standard of known accuracy, to detect and adjust any discrepancy in the accuracy of the instrument being compared.

TM 9-2320-365-20-1

g.**Remove/Install.** To remove and install the same item when required to perform service or other maintenance functions. Install may be the act of emplacing, seating, or fixing into position a spare, repair part, or module (component or assembly) in a manner to allow the proper functioning of an equipment or system.

h.**Replace.** To remove an unserviceable item and install a serviceable counterpart in its place. "Replace " is authorized by the MAC and assigned maintenance level is shown as the 3d position code of the SMR code.

i.**Repair.** The application of maintenance services¹ including fault location/troubleshooting², removal/installation, and disassembly/assembly³ procedures, and maintenance actions⁴ to identify troubles and restore serviceability to an item by correcting specific damage, fault, malfunction, or failure in a part, subassembly, module (component or assembly), end item, or system.

j.**Overhaul.** That maintenance effort (service/action) prescribed to restore an item to a completely serviceable/operational condition as required by maintenance standards in appropriate technical publications (i.e., DMWR). Overhaul is normally the highest degree of maintenance performed by the Army. Overhaul does not normally return an item to like new condition.

k.**Rebuild.** Consists of those services/actions necessary for the restoration of unserviceable equipment to a like new condition in accordance with original manufacturing standards. Rebuild is the highest degree of material maintenance applied to Army equipment. The rebuild operation includes the act of returning to zero those age measurements (e.g., hours/miles) considered in classifying Army equipment/components.

B-3. Explanation of Columns in the MAC, Section II.

a.**Column 1, Group Number.** Column 1 lists functional group code numbers, the purpose of which is to identify maintenance significant components, assemblies, subassemblies, and modules with the next higher assembly.

b.**Column 2, Component/Assembly.** Column 2 contains the item names of components , assemblies, subassemblies, and modules for which maintenance is authorized.

c.**Column 3, Maintenance Function.** Column 3 lists the functions to be performed on the items listed in Column 2. (For detailed explanation of these functions, see Paragraph B-2.)

d.**Column 4, Maintenance Level.** Column 4 specifies each level of maintenance authorized to perform each function listed in Column 3, by indicating work time required (expressed in man-hours in whole hours or decimals) in the appropriate subcolumn. This work-time figure represents the active time required to perform that maintenance function at the indicated level of maintenance. If the number or complexity of the tasks within the listed maintenance function vary at different maintenance levels, appropriate work-time figures are to be shown for each level. The work-time figure represents the average time required to restore an item (assembly, subassembly, component, module, end item, or system) to a serviceable condition under typical field operating conditions.

¹Services - Inspect, test, service, adjust, align calibrate, and/or replace.

²Fault location/troubleshooting - The process of investigating and detecting the cause of equipment malfunction; the act of isolating a fault within a system or Unit Under Test (UUT).

³Disassembly/assembly - The step-by-step breakdown (taking apart) of a spare/functional group coded item, to the level of its least component, that is assigned an SMR code for the level of maintenance under consideration (i.e., identified as maintenance significant).

⁴Actions - Welding, grinding, riveting, straightening, facing, machining, and/or resurfacing.

This time includes preparation time (including any necessary disassembly/assembly time), troubleshooting/fault location time, and quality assurance time in addition to the time required to perform the specific tasks identified for the maintenance functions authorized in the maintenance allocation chart. The symbol designations for the various maintenance levels are as follows:

- C Operator or crew maintenance
- O Unit/Field maintenance
- F Direct Support/Field maintenance
- L Specialized Repair Activity (SRA)⁵
- H General Support/Sustainment maintenance
- D Depot/Sustainment maintenance

e. **Column 5, Tools and Test Equipment Reference Code.** Column 5 specifies, by code, those common tools sets (not individual tools), common TMDE, and special tools, special TMDE, and special support equipment required to perform the designated functions. Codes are keyed to tools and test equipment in Section III.

f. **Column 6, Remarks.** When applicable, this column contains a letter code, in alphabetical order, which is keyed to the remarks contained in Section IV.

B-4. Explanation of Columns in Tool and Test Equipment Requirements, Section III.

a. **Column 1, Reference Code.** The tool and test equipment reference code correlates with a code used in the MAC, Section II column 5.

b. **Column 2, Maintenance Level.** The lowest level of maintenance authorized to use the tool or test equipment.

c. **Column 3, Nomenclature.** Name or identification of the tool or test equipment.

d. **Column 4, National Stock Number.** The National Stock Number of tool or test equipment.

e. **Column 5, Tool Number.** The manufacturer's part number, model number, or type number.

B-5. Explanation of Columns in Remarks, Section IV.

a. **Column 1, Remarks Code.** The code recorded in column 6, Section II.

b. **Column 2, Remarks.** This column lists information pertinent to the maintenance function being performed as indicated in the MAC, Section II.

⁵This maintenance level is not included in Section II, Column (4) of the Maintenance Allocation Chart. Functions to this level of maintenance are identified by a work-time figure in the "H" column of Section II, Column (4), and an associated reference code is used in the Remarks column (6). This code is keyed to Section IV, Remarks, and the SRA complete repair application is explained there.

Section II. MAINTENANCE ALLOCATION CHART FOR THE LMTV VEHICLE

(1) Group Number	(2) Component/Assembly	(3) Maintenance Function	(4) Maintenance Level					(5) Tools and Equipment Ref Code	(6) Remarks Code
			FIELD		SUSTAINMENT				
			Unit		Direct Support	General Support	Depot		
			C	O	F	H	D		
0100	ENGINE ASSEMBLY	Inspect		0.1				78	
		Test		1.5	0.3			78,79	
		Adjust			3.0			56,60,78,80	
		Service		0.8				57,59,78	
		Replace			7.0			16,56,59,61,78,79	
		Repair		0.4	1.6	3.3		16,31,32,44,56,59,60,61,78,79	
0101	CYLINDER HEAD ASSEMBLY	Inspect			0.1			78	
		Replace			2.0			44,56,59,60,78	
		Repair				2.5		56,59,60,61,62,78,81	
0102	CRANKSHAFT	Replace				16.0		56,57,60,71,78	
		Repair			3.8	16.0		16,31,32,56,59,60,61,78	
0103	FLEXPLATE, ENGINE	Replace			6.5			56,59,78	
		Repair			1.0			56,49,78	
0104	PISTON ASSEMBLY	Replace				9.0		56,57,59,60,62,78,79	
		Repair				0.6		78	
0105	CAMSHAFT ASSEMBLY	Replace				3.1		14,56,57,49,60,78	
		Repair				1.2		56,78	
0105	ROCKER ARM AND PUSH RODS	Replace			2.0			44,59,60,61,78	
		Repair			0.3			44,78	
0106	COOLER, ENGINE OIL	Replace			1.3			56,78	
		Repair			0.3			56,78	
0108	MANIFOLDS, INLET AND EXHAUST	Replace			1.5			56,60,61,78,79	
0301	INJECTOR ASSEMBLY, FUEL	Replace			2.1			44,57,78,80	
		Adjust			1.6			56,78,79,80	
0304	AIR INTAKE SYSTEM	Service		0.3					
		Repair		0.3				46,57	

Section II. MAINTENANCE ALLOCATION CHART FOR THE LMTV VEHICLE (CONT)

(1) Group Number	(2) Component/Assembly	(3) Maintenance Function	(4) Maintenance Level					(5) Tools and Equipment Ref Code	(6) Remarks Code
			FIELD		SUSTAINMENT				
			Unit		Direct Support	General Support	Depot		
			C	O	F	H	D		
0304	INTAKE AIR CLEANER	Service		0.2					
		Replace		0.8			6,46,57, 78		
		Repair		0.4			57,78		
0305	TURBOCHARGER	Replace			0.8		56,61,78,79		
0306	FUEL TANK	Inspect	0.1						
		Replace		1.5			57,59,78		
0308	GOVERNOR, ENGINE SPEED	Replace			1.0			57,60,76,78,79	
		Repair		0.5	0.7		57,78		
0309	FILTER, FUEL/WATER SEPARATOR	Inspect	0.2						
		Service	0.2	0.3			78		
		Replace		0.5			57,78		
0311	ETHER STARTING AID	Replace		0.6			57,59,78		
0312	ACCELERATOR/HAND THROTTLE	Replace		0.5				57,78	
		Adjust		0.2			57,78		
0401	EXHAUST MUFFLER/PIPES	Inspect	0.1	0.2					
		Replace		0.9			57,59,78		
		Inspect	0.1						
0501	RADIATOR/CHARGE AIR COOLER	Replace		2.5				2,27,53,59,78	
		Service		1.5			59,79		
		Repair		0.6	2.0		2,27,53,59,78		
		Replace		0.5			46,57,78		
0501	RADIATOR OVERFLOW TANK	Repair		0.3			78		
		Replace		1.0			57,59,78,86		
0502	SHROUD, FAN	Replace		1.0			57,59,78,86		
0503	HOSES, WATER	Replace		0.5			57,59,78,86		
0504	PUMP, WATER	Replace		0.8			15,57,59,78,86		
0505	CLUTCH, ENGINE FAN	Inspect		1.0			57		
		Replace		1.5			2,53,57, 78		
		Repair			1.2		56,59,60,61,78,79		

Section II. MAINTENANCE ALLOCATION CHART FOR THE LMTV VEHICLE (CONT)

(1) Group Number	(2) Component/Assembly	(3) Maintenance Function	(4) Maintenance Level					(5) Tools and Equipment Ref Code	(6) Remarks Code
			FIELD		SUSTAINMENT				
			Unit		Direct Support	General Support	Depot		
			C	O	F	H	D		
0601	ALTERNATOR, 100 AMP	Inspect		0.2					
		Test		0.5	1.5			59,63,78	
		Replace		1.0				59,78	
		Repair		0.2	0.5			38,56,57,59,63,78,79	
0603	STARTING MOTOR, ENGINE	Inspect		0.1					
		Test		0.5	0.5			57,63	
		Replace		1.5				2,9,57,59,78	
		Repair			2.1			52,56,59,60,76,78	
0606	SOLENOID, FUEL SHUTOFF	Replace			1.0			60,78,80	
0607	CABLE ASSEMBLY, DASHBOARD	Test		0.5				56	
		Replace		2.9				57,59,76,78	
		Repair		1.0	0.6			56,57,61,78	
0607	DISPLAY, LIGHTED INDICATOR	Test		0.3					
		Replace		0.5				78,86	
		Repair		0.3				78	
		Inspect	0.1						
0609	LIGHT ASSEMBLY, BACKUP	Replace		0.8				57,78	
		Repair		0.3				78	
		Inspect	0.1						
0609	LIGHT, BLACKOUT DRIVE	Inspect	0.1						
		Replace		0.8				57,59,78	
		Repair		0.5				78	
0609	TAILLIGHT ASSEMBLY, COMPOSITE	Inspect	0.1						
		Replace		0.8				57,59,78	
		Repair		0.5				78	
0609	LIGHT ASSEMBLY, FRONT TURN SIGNAL AND PARK	Inspect	0.1						
		Replace		0.8				57,59,78	
		Repair		0.5				78	
0609	HEADLIGHT	Inspect	0.1						
		Adjust		0.4				78	
		Replace		1.0				57,59,78	
0610	AUDIBLE ALARM	Inspect	0.1						
0611	HORN, CAB	Inspect	0.1						

Section II. MAINTENANCE ALLOCATION CHART FOR THE LMTV VEHICLE (CONT)

(1) Group Number	(2) Component/Assembly	(3) Maintenance Function	(4) Maintenance Level					(5) Tools and Equipment Ref Code	(6) Remarks Code
			FIELD		SUSTAINMENT				
			Unit		Direct Support	General Support	Depot		
			C	O	F	H	D		
0612	BOX ASSEMBLY, BATTERY	Replace		0.4				57,78	A
		Inspect	0.1					57,78	
		Test		0.5				57	
		Service		0.3				57,59,78	
		Replace		1.0				63	
0613	CABLE ASSEMBLY, LH/RH CAB AND DOOR MARKER LIGHTS	Repair		0.2				78	
		Inspect	0.1					63	
		Replace		0.8				63	
0613	CABLE ASSEMBLY, LOWER, CAB MARKER LIGHTS, M1081	Repair		0.7				78,86	
		Inspect	0.1					63	
		Replace		0.6				63	
0613	CABLE ASSEMBLY, UPPER, CAB CLEARANCE AND MARKER LIGHTS, M1081	Repair		0.5				78,86	
		Inspect	0.1					63	
		Replace		0.8				78	
0613	CABLE ASSEMBLY, STE/ICE-R	Repair		1.0				63	
		Inspect	0.1		0.8			63	
		Replace		0.5				63	
0613	CABLE ASSEMBLY, CAB CLEARANCE AND MARKER LIGHTS	Inspect	0.1					57,78	
		Replace		1.2				63	
		Repair		0.5	0.8			48,78,86	
0613	CABLE ASSEMBLY, WARNING LIGHT	Replace		0.5				63	
		Inspect	0.1		0.5			63	
		Repair		0.3				78	
0613	CABLE ASSEMBLY, WINDSHIELD WASHER PUMP/EMI	Replace		0.5				63	
		Inspect	0.1		0.5			63	
		Repair		0.3				57,78	
0613	CABLE ASSEMBLY, ENGINE CONTROL	Inspect	0.1					63	
		Replace		2.3				59,78	
		Repair		0.5	0.5			63	
0613	CABLE ASSEMBLY, FRONT INTERVEHICULAR, 12 VDC	Replace		0.8				63	
		Inspect	0.1					63	
		Repair		0.2	1.3			63	

Section II. MAINTENANCE ALLOCATION CHART FOR THE LMTV VEHICLE (CONT)

(1) Group Number	(2) Component/Assembly	(3) Maintenance Function	(4) Maintenance Level					(5) Tools and Equipment Ref Code	(6) Remarks Code
			FIELD		SUSTAINMENT				
			Unit		Direct Support	General Support	Depot		
			C	O	F	H	D		
0613	CABLE ASSEMBLY, FRONT LIGHTS	Replace		2.0				57,59,78,86	
		Repair		0.5	0.5			63	
0613	CABLE ASSEMBLY, REAR LIGHTS	Replace		2.8				57,59,78	
		Repair		0.5	0.5			63	
0613	CABLE ASSEMBLY, PTO	Replace		1.6				57,59,78	
		Repair		0.5	0.8			63	
0613	CABLE ASSEMBLY, REAR INTERVEHICULAR, 24 VDC	Replace		0.6				59,78	
		Repair		0.5	0.8			63	
0613	CABLE ASSEMBLY, START AND CHARGING	Replace		2.0				57,78	
		Repair		0.5	0.8			63	
0613	CABLE ASSEMBLY, WINCH CONTROL VALVE	Replace		1.8				57,59,78	
		Repair		0.5	0.8			63	
0705	WTEC II VEHICLE INTERFACE MODULE (VIM)	Replace		0.6				78	
		Repair		0.8				78	
0708	TORQUE CONVERTER	Adjust			0.9			18,59,60,78	
		Remove/Install			0.8			56,59,60,61,78	
		Repair			1.3			30,56,59,60,62,78	
0710	TRANSMISSION	Inspect		0.4				78	
		Service		1.5				57,59,78	
		Replace			7.0			56,59,60,61,78,79,84	
		Repair		0.4	2.7	1.9		3,18,19,24,25,27,41,56,57,59,60,61,78,79,84	
0710	MODULE, FRONT SUPPORT	Remove/Install				2.0		56,57,59,60,61,78	
		Repair				0.7		30,56,57,59,60,61,78	
0710	MODULE, PLANETARY GEAR (P1)	Remove/Install				2.0		59,60,71,78	

Section II. MAINTENANCE ALLOCATION CHART FOR THE LMTV VEHICLE (CONT)

(1) Group Number	(2) Component/Assembly	(3) Maintenance Function	(4) Maintenance Level					(5) Tools and Equipment Ref Code	(6) Remarks Code
			FIELD		SUSTAINMENT				
			Unit		Direct Support	General Support	Depot		
			C	O	F	H	D		
0710	MODULE, PLANETARY (P2)	Repair				1.5		59,60,71,78	
		Remove/Install				2.0		3,56,59,60,61,78	
		Repair				1.9		3,19,56,59,60,61,71,78	
0710	PLANETARY CARRIER (P3)	Remove/Install				2.0		3,56,60,78	
		Repair				1.9		3,27,56,60,78	
0710	MODULE, MAIN SHAFT	Remove/Install				2.0		59,60,78	
0710	MODULE, CONVERTER HOUSING	Repair				0.4		59,60,78	
		Remove/Install				4.3		3,56,57,59,60,78	
0710		Repair				2.0		3,19,25,56,57,59,60,78	
		Remove/Install				2.0		56,57,59,60,78	
0713	CLUTCH ASSEMBLY, C3/C4/C5, TRANSMISSION	Remove/Install				2.0		56,57,59,60,78	
		Repair				1.0		41,56,57,59,60,78	
0713	MODULE, ROTATING CLUTCH	Remove/Install				2.0		3,56,59,60,78	
		Repair				2.4		3,19,24,56,59,60,78	
0714	VALVE ASSEMBLY, CONTROL MODULE	Remove/Install				2.0		56,59,60,61,78,79	
0714	BODY ASSEMBLY, MAIN VALVE	Repair		1.0		2.5		59,61,78,79	
		Service		1.5				57,59,78	
0714		Remove/Install				2.0		56,59,60,61,78,79	
		Repair		1.5		2.5		56,59,60,61,78,79	
0801	MODULE, TRANSFER CASE	Adjust				1.0			
		Remove/Install				2.0		21,56,57,59,60,61,71,74,78,79	
		Repair				1.1		23,27,33,50,56,57,60,78	

Section II. MAINTENANCE ALLOCATION CHART FOR THE LMTV VEHICLE (CONT)

(1) Group Number	(2) Component/Assembly	(3) Maintenance Function	(4) Maintenance Level					(5) Tools and Equipment Ref Code	(6) Remarks Code
			FIELD		SUSTAINMENT				
			Unit		Direct Support	General Support	Depot		
			C	O	F	H	D		
0802	HOUSING ASSEMBLY, C6 AND C7 CLUTCH	Remove/Install					2.0	56,59,60,61,78	
		Repair					0.8	19,23,26,27,28,29,56,59,60,61,62,71,78	
0802	CONTROL VALVE ASSEMBLY	Remove/Install					2.0	56,59,61,78,79	
		Repair					1.0	56,59,61,78,79	
0804	PUMP ASSEMBLY, OIL	Replace					1.0	79	
		Repair					0.8	79	
0900	PROPELLER SHAFT	Inspect		0.1					
		Service		0.5					59
		Repair		0.6					57,59,78
		Replace		0.5					57,59,78
1000	AXLE ASSEMBLY, FRONT	Inspect	0.1	0.3	0.7				78
		Adjust			1.0				57,79
		Service		0.5					59,78
		Replace			4.5				56,57,59,60,61,70,78
		Repair		2.3	2.2	6.0			56,57,59,60,61,78
1002	CARRIER ASSEMBLY, DIFFERENTIAL	Inspect		0.1	0.1	0.1			78,79
		Service			0.3				78
		Replace				4.6			21,56,57,59,60,78,79
		Repair					2.7		56,57,59,60,78,79
1004	STEERING KNUCKLE, AXLE	Inspect			0.2				
		Adjust			2.5				79
		Service			0.3				79
		Replace			5.1				56,57,59,60,71,78
1100	AXLE ASSEMBLY, REAR	Inspect	0.1	0.4	0.7				
		Service		0.8					57,59,78
		Replace			4.5				34,56,57,59,60,78,84

Section II. MAINTENANCE ALLOCATION CHART FOR THE LMTV VEHICLE (CONT)

(1) Group Number	(2) Component/Assembly	(3) Maintenance Function	(4) Maintenance Level					(5) Tools and Equipment Ref Code	(6) Remarks Code
			FIELD		SUSTAINMENT				
			Unit		Direct Support	General Support	Depot		
			C	O	F	H	D		
1102	CARRIER ASSEMBLY, DIFFERENTIAL	Repair			0.9		6.0	21,56,57,59,60,78,84,85	
		Inspect		0.1	0.1		1.0	78,79	
		Service			0.3			78	
		Replace					4.6	21,56,57,59,60,78,79,85	
1202	BRAKE ASSEMBLY, FRONT AXLE	Repair					2.7	21,37,56,57,59,60,71,73,78	
		Inspect		0.1	1.0			59,78,79	
		Adjust		0.4				57,59,78	
1202	BRAKE ASSEMBLY, REAR AXLE	Repair		1.5	0.5			57,59,78,83	
		Inspect		0.1	1.0			59,78,79	
		Adjust		0.4				57,59,78	
1208	BRAKE AIR CHAMBER	Repair		1.5	0.5			57,59,78,83	
		Inspect		0.1					
1209	AIR COMPRESSOR	Replace		0.5				57,59,78	
		Adjust		0.6				59,78	
1311	WHEEL ASSEMBLY, PNEUMATIC TIRE	Replace			1.2			56,60,61,78,79	
		Inspect	0.1					57	B
1313	TIRE, PNEUMATIC	Replace	1.0	1.2				57,59	
		Repair		2.0				57,59	
1401	STEERING SYSTEM	Replace		2.0				57,59	
		Inspect		0.2					
1407	STEERING GEAR ASSEMBLY	Adjust			1.0			56,60,78	
		Repair		1.0	1.5			54,56,57,59,60,61,78,79	
1410	PUMP, POWER STEERING	Replace			4.0			56,60,78	
		Replace			1.5			47,56,59,60,78	
1411	HOSES, POWER STEERING	Replace		0.3				57,59,78,88	
1413	HYDRAULIC RESERVOIR,	Service	0.1	0.5				78	

Section II. MAINTENANCE ALLOCATION CHART FOR THE LMTV VEHICLE (CONT)

(1) Group Number	(2) Component/Assembly	(3) Maintenance Function	(4) Maintenance Level					(5) Tools and Equipment Ref Code	(6) Remarks Code
			FIELD		SUSTAINMENT				
			Unit		Direct Support	General Support	Depot		
			C	O	F	H	D		
1501	POWER STEERING	Replace		0.8				59,78,86	
	FRAME ASSEMBLY	Inspect	0.1	0.3					
1504	RETAINER, SPARE TIRE	Repair		0.8	14.0			56,57,59,60,61,78,79	
		Inspect	0.1	0.1					
		Replace		3.0				57,59,78	
1601	LEAF SPRING ASSEMBLIES	Repair		0.6				57,59,78	
		Inspect	0.1	0.2					
		Service		0.3				57	
1604	SHOCK ABSORBERS	Replace			2.7			56,57,59,60,78,79	
		Inspect	0.1	0.3					
		Replace		0.5				57,59,78	
1605	STABILIZER BAR, REAR	Inspect		0.2					
		Replace		2.0				57,59,68,78	
		Repair		1.5				57,78	
1801	CAB BODY, STANDARD	Inspect	0.1						
		Replace			60.0			56,57,60,61,78,79	
1801	CAB BODY, AIR DROP	Repair		0.6				57,59,78	
		Inspect	0.1						
1801	CAB DOORS, STANDARD	Replace			60.0			56,57,60,61,78,79	
		Inspect	0.1						
		Repair		0.6				57,59,78	
1801	CAB DOORS, AIR DROP	Replace			1.0			55,59,78	
		Inspect	0.1						
		Repair		2.7				49,57,78	
1801	SUPPORT ASSEMBLY, CAB FRONT	Inspect	0.1						
		Replace			1.0			55,59,78	
		Repair		2.7				49,57,78	
1801	SUPPORT ASSEMBLY, CAB REAR	Inspect	0.1						
		Repair		1.1				57,59,78	
1801	SUPPORT ASSEMBLY, CAB REAR	Replace			3.0			8,13,57,59,60,78,79	
		Inspect	0.1						

Section II. MAINTENANCE ALLOCATION CHART FOR THE LMTV VEHICLE (CONT)

(1) Group Number	(2) Component/Assembly	(3) Maintenance Function	(4) Maintenance Level					(5) Tools and Equipment Ref Code	(6) Remarks Code
			FIELD		SUSTAINMENT				
			Unit		Direct Support	General Support	Depot		
			C	O	F	H	D		
1802	WINDSHIELD	Replace		1.0				57,59,78	
		Repair		0.8				57,78	
1802		Replace			0.6			55,59,78	
1802	FENDER, VEHICULAR, FRONT	Inspect	0.1						
		Replace		2.0				57,59,78	
		Repair		0.5				57,78	
1803	ROOF, CAB, M1081	Replace		1.0				45,50,57,59,78	
		Replace		1.0				57,78	
1805		Replace		1.0				57,78	
1806	FLOOR COVERING, CAB SEATS	Replace							
1808	TOOL BOX ASSEMBLY	Inspect	0.1						
		Replace		0.5				47,57,59,78	
		Repair		0.5				57,59,78	
1808	STOWAGE BOX, CAB	Replace		0.8				57,78	
		Repair		0.5				57,78	
1810		Inspect	0.1						
	BODY, CARGO	Replace			4.0			56,57,59,60,78	
		Repair		0.5				57,59,78	
1812		Inspect	0.1	0.1					
	BODY ASSEMBLY, VAN	Repair		0.5				20,35,36,42,43,47,57,59,64,72,76,78	
		Repair		0.5				36,64,78	
1812		Replace		1.9				78	
	DOOR, ACCESS, LEFT	Inspect	0.1					57,59,78	
		Replace		2.3				78	
		Repair		0.1				57,59,78	
1812	DOOR, ACCESS, RIGHT	Inspect	0.1						
		Replace		1.4				78	
		Repair		0.4				57,59,78	
1812	WINDOW SASH ASSEMBLY	Inspect	0.1						
		Replace		0.2				78	
		Repair		0.4				57,59,78	
1812	BOX ASSEMBLY, RELAY	Inspect	0.1	0.1					
		Replace		0.6				78	
		Repair		0.1				78	
	FAN ASSEMBLY	Test	0.1	0.5				59,78	
1812		Inspect	0.1						

Section II. MAINTENANCE ALLOCATION CHART FOR THE LMTV VEHICLE (CONT)

(1) Group Number	(2) Component/Assembly	(3) Maintenance Function	(4) Maintenance Level					(5) Tools and Equipment Ref Code	(6) Remarks Code
			FIELD		SUSTAINMENT				
			Unit		Direct Support	General Support	Depot		
			C	O	F	H	D		
2001	WINCH, 11K SELF-RECOVERY (SRW)	Replace		1.8				20,76,78	
		Repair		0.5				78	
		Inspect	0.1	4.0					
		Service		0.2				59	
2004	POWER TAKEOFF ASSEMBLY (PTO)	Replace			1.0			59,60,78	
		Repair			0.9			59,60,78	
		Inspect	0.1						
		Replace			1.0			56,57,59,60,78	
2202	MOTOR, WIPER, WINDSHIELD	Repair			0.8			56,57,59,60,78	
		Test		0.5					
2207	HEATER ASSEMBLY, PERSONNEL	Replace		1.0				78	
2210	DECALS	Replace		2.0				57,59,78	
2401	POWER UNIT, AIR/HYDRAULIC	Repair		1.0				57,59,78	
		Inspect	0.1						
2402	MANIFOLD, HYDRAULIC	Replace		1.0				78	
		Inspect	0.1						
		Test		0.2					
		Service		1.0					
2402	LATCH, HYDRAULIC, CAB	Replace		3.0				57,59,78	
		Repair			2.0			57,59,60,69,78,79	
		Inspect	0.1						
		Test		0.2					
2404	SUSPENSION CYLINDER	Replace		1.5				51,57,59,78	
		Repair		1.0				51,57,59,78	
		Inspect	0.1						
2406	FILTER, HYDRAULIC	Adjust		0.5				57,59,78	
		Replace		0.5				57,59,78	
2408	RESERVOIR, HYDRAULIC	Inspect							
		Replace		0.3				59,78	
2408	RESERVOIR, HYDRAULIC	Replace		0.2				59,78	
		Replace		1.0				57,59,78	

Section II. MAINTENANCE ALLOCATION CHART FOR THE LMTV VEHICLE (CONT)

(1) Group Number	(2) Component/Assembly	(3) Maintenance Function	(4) Maintenance Level					(5) Tools and Equipment Ref Code	(6) Remarks Code
			FIELD		SUSTAINMENT				
			Unit		Direct Support	General Support	Depot		
			C	O	F	H	D		
3303	HEATER KIT, M1079	Repair		0.5				57,59,78	
		Inspect	0.1						
		Remove/Install		2.5				78	
3307	ALTERNATOR KIT, 200 AMP	Inspect	0.1	0.2					
		Test		0.5				59	
		Remove/Install		2.0				57,59,78	
		Replace		1.0				57,59,78	
		Repair			0.5			56,57,60,62,78	
3307	ALTERNATOR, 200 AMP	Inspect		0.2					
		Test		0.5	1.5			59,63,78	
		Replace		1.0				57,59,78	
		Repair		0.2	0.5			56,57,60,61,63,78	
3307	CRANE (LMHC), MATERIAL HANDLING, LIGHT	Inspect	0.1	0.1					
		Repair		0.5				59,76,78	
		Replace		0.5					
		Test		0.5					
3307	WEIGHT BLOCK AND WIRE ROPE, LMHC	Inspect	0.1						
		Replace		0.1				59,78	
		Repair		0.5				59,78	
		Test			0.5				
3307	WINCH, LMHC	Inspect	0.1						
		Replace			0.5			59,78	
		Repair			1.0			59,78	
		Test		0.5					
3307	MAST/SWING ASSEMBLY, LMHC	Inspect	0.1						
		Repair		1.0				59,78	
		Test		0.5					
3307	CONTROL BOX, LMHC	Inspect	0.1						
		Replace		0.1					
		Repair		0.5				76,78	
		Test	0.1	0.5					
3307	TROOPSEAT KIT	Remove/Install	1.0						

Section II. MAINTENANCE ALLOCATION CHART FOR THE LMTV VEHICLE (CONT)

(1) Group Number	(2) Component/Assembly	(3) Maintenance Function	(4) Maintenance Level					(5) Tools and Equipment Ref Code	(6) Remarks Code
			FIELD		SUSTAINMENT				
			Unit		Direct Support	General Support	Depot		
			C	O	F	H	D		
3307	COVER KIT, CARGO SOFT TOP	Inspect	0.1						
		Replace		1.0					
		Repair		0.5			78		
3307	AIR CONDITIONER KIT, M1079	Remove/Install	1.5						
		Inspect	0.1						
		Replace		2.0					
3307	WARNING LIGHT ASSEMBLY, AMBER	Repair		0.5					
		Inspect	0.1						
		Remove/Install		1.5			59,78		
3401	MACHINE GUN RING KIT	Inspect	0.1						
		Remove/Install			4.0		56,57,60,78,79,84		
		Repair		1.1			10,57,78		
3402	MOUNT, SMALL ARMS	Inspect	0.1						
		Replace		0.3			78		
3909	CABLE ASSEMBLY, WARNING LIGHT	Inspect	0.1						
		Replace		0.5			78		
4316	AIR HOSE, CTIS	Inspect	0.1						
		Replace		0.4			59,78		
4317	VALVE, INVERSION	Replace		0.5			59,78		
4321	AIR DRYER	Inspect	0.1	0.1					
		Replace		1.0			57,59,78		
		Repair		0.6			57,59,78		
4702	GAUGE, AIR FILTER RESTRICTION	Replace		0.5			78		

Section III. TOOLS AND TEST EQUIPMENT FOR LMTV VEHICLES

Tool or Test Equipment REF Code	Maintenance Level	Nomenclature	National Stock Number	Tool Number
1	O,F	ADAPTER, RADIATOR	4910-01-170-4928	J29003-A
2	O	ADAPTER, SOCKET WRENCH	5120-00-240-8702	11655788-2
2.1	O	BASE, MAGNETIC		P5646
3	H	BUSHING DRIVER SET	5120-01-391-3541	J35922
4	O	CRIMPING TOOL, TERMINAL, HAND	5120-00-165-3912	M22520/1-01
5	O	CROWFOOT ATTACHMENT, SOCKET WRENCH	5120-00-078-3809	10935497
6	O	CROWFOOT ATTACHMENT, SOCKET WRENCH	5120-00-293-1010	5120-293-1282
7	F	CROWFOOT ATTACHMENT, SOCKET WRENCH	5120-00-181-6754	GGG-C-1507
8	F	CROWFOOT ATTACHMENT, SOCKET WRENCH	5120-01-074-7557	FCOM19
9	O	CROWFOOT ATTACHMENT, SOCKET WRENCH	5120-01-236-9996	FCOM15
10	O	CROWFOOT ATTACHMENT, SOCKET WRENCH	5120-01-335-1091	FCO32
11	O	CROWFOOT ATTACHMENT, SOCKET WRENCH	5120-01-335-1119	SCO34
12	O	CROWFOOT ATTACHMENT, SOCKET WRENCH	5120-01-335-1122	SCO40
12.1	O	CROWFOOT ATTACHMENT, SOCKET WRENCH	5120-01-335-1126	SCO48
13	F	CROWFOOT ATTACHMENT, SOCKET WRENCH	5120-01-348-9473	AN8508-19A
13.1	O	DISPENSER, SEALANT	5120-00-061-1283	45RCT
13.2	F	DRILL SET, STOPCOLLAR	5133-01-383-7665	1955
14	H	DRIVER KIT, BEARING	4910-01-032-3128	8S0602
14.1	O	FRAME, HAND HACKSAW	5110-00-289-9657	163-20
15		DELETED		
16	O,F	GAGE, BELT TENSION	6635-01-143-2237	GA-424
17	O,F	GAGE, PRESSURE, 0-150 psi	6685-00-474-5721	111T1D05A01
18	F,H	GAGE, PROFILE	5220-01-388-1460	J-38548-1
19	H	HANDLE, DRIVE	5120-00-377-2259	J8092
20	O	HEATER, GUN TYPE, ELECTRIC	4940-00-561-1002	500A
21	F,H	HOLDING BAR, PINION	5120-01-166-0573	J3453
21.1	O	INDICATOR, DIAL		P36491
22	O	INSERTER AND REMOVER, ELECTRICAL CONTACT	5120-00-915-4588	MS3447-16
23	H	INSERTER AND REMOVER, SPRING	5120-01-388-3660	J38573
24	H	INSERTER AND REMOVER, SPRING	5120-01-388-4436	J35923
25	H	INSERTER, BEARING AND BUSHING	5120-01-388-7841	J-38565

Section III. TOOLS AND TEST EQUIPMENT FOR LMTV VEHICLES (Cont)

Tool or Test Equipment REF Code	Maintenance Level	Nomenclature	National Stock Number	Tool Number
26	H	INSERTER, BEARING AND BUSHING	5120-01-389-0658	J35921-1
27	H	INSERTER, BEARING AND BUSHING	5120-01-390-1104	J 38569
28	H	INSERTER, BEARING AND BUSHING	5120-01-390-1105	J 38568-3
29	H	INSERTER, BEARING AND BUSHING	5120-01-391-5133	J 38579
30	F,H	INSERTER, BEARING AND BUSHING	5120-01-414-7398	J38566
31	F	INSERTER, SEAL	5120-01-362-2026	1U7430
32	F	INSERTER, SEAL	5120-01-362-2027	1U7598
33	F	INSTALLER, SEAL	N/A	J38574
33.1	F	JACK, DOLLY TYPE HYDRAULIC	4910-01-396-5044	TTJ3
34	F	JACK, LEVELING SUPPORT, VEHICLE	2590-00-231-7418	10876244
35.1	O	KEY, SOCKET HEAD SCREW	5120-01-355-1670	AWML2.5
35.2	F	LIFTING SADDLE ASSEMBLY		TTJ-ZIFA
36	O	LINK, CHAIN, END	4010-00-932-5013	NAS1049-16
36.1	F	NOSE ASSEMBLY		99-3307
36.2	O	PLIERS, HOG RING STAPLE	5120-01-413-8837	0012
37	H	PULLER KIT, UNIVERSAL	5180-00-089-3660	A57QB
38	F	PULLER KIT, UNIVERSAL	5180-01-124-1903	1P3075
39	O	REMOVER, ELECTRICAL CONTACT	5120-00-148-9844	MS3448-001B
40	F	RIVETER, BLIND, HAND	5120-01-289-4310	HP-2
40.1	F	RIVETER, BLIND, PNEUMATIC	5130-01-232-4042	245
41	H	RIVETER, YOKE, HAND	5120-01-415-3558	J-39354
42	O	SCREWDRIVER ATTACHMENT, SOCKET WRENCH	5120-00-180-0881	5120-00-180-0881
43	O	SCREWDRIVER ATTACHMENT, SOCKET WRENCH	5120-01-053-4158	FAM5A
44	O,F,H	SCREWDRIVER ATTACHMENT, SOCKET WRENCH	5120-01-055-1308	ANSIB18.3.2M
45	O	SCREWDRIVER ATTACHMENT, SOCKET WRENCH	5120-01-079-8032	SAM8A
46	O	SCREWDRIVER ATTACHMENT, SOCKET WRENCH	5120-01-160-8862	S 6 HBS
47	O,F	SCREWDRIVER ATTACHMENT, SOCKET WRENCH	5120-01-367-3462	SA10A
47.1	O,F	SCREWDRIVER ATTACHMENT, SOCKET WRENCH	5120-01-367-3483	FA5LE
48	O,F	SCREWDRIVER ATTACHMENT, SOCKET WRENCH	5120-01-367-3497	TMP12A
49	O	SCREWDRIVER ATTACHMENT, SOCKET WRENCH	5120-01-367-3519	F23D
50	O	SCREWDRIVER ATTACHMENT, SOCKET WRENCH	5120-01-367-3526	FP24
51	O	SCREWDRIVER ATTACHMENT, SOCKET WRENCH	5120-01-367-3527	FP32A
52	F,H	SCREWDRIVER ATTACHMENT, SOCKET WRENCH	5120-01-367-3536	FTX40A
53	O	SCREWDRIVER ATTACHMENT, SOCKET WRENCH	5120-01-367-3574	GFA8A

Section III. TOOLS AND TEST EQUIPMENT FOR LMTV VEHICLES (Cont)

Tool or Test Equipment REF Code	Maintenance Level	Nomenclature	National Stock Number	Tool Number
53.1	F	SCREWDRIVER ATTACHMENT, SOCKET WRENCH	5120-01-430-5715	SZ-21
54	O	SEPARATOR, BALL JOINT	5120-01-255-8238	2287
55	F	SETTING TOOL, WINDSHIELD	5120-01-316-4995	CRL216
56	O,F	SHOP EQUIPMENT, AUTOMOTIVE VEHICLE	4910-00-348-7696	SC4910-95CLA02
57	O,F,H	SHOP EQUIPMENT, AUTOMOTIVE VEHICLE	4910-00-754-0650	SC4910-95CLA72
58	O	SHOP EQUIPMENT, AUTOMOTIVE VEHICLE	4910-00-754-0653	SC4910-95CLA73
59	O,F,H	SHOP EQUIPMENT, AUTOMOTIVE VEHICLE	4910-00-754-0654	SC4910-95CLA74
60	F,H	SHOP EQUIPMENT, AUTOMOTIVE VEHICLE	4910-00-754-0705	SC4910-95CLA31
61	F,H	SHOP EQUIPMENT, AUTOMOTIVE VEHICLE	4910-00-754-0706	SC4910-95CLA62
62	O,F,H	SHOP EQUIPMENT, AUTOMOTIVE VEHICLE	4910-00-754-0707	SC4910-95CLA63
63	O,F	SHOP EQUIPMENT, FUEL AND ELECTRICAL	4910-00-754-0714	SC4910-95CLA01
64	O	SLING, EYE	3940-01-334-0749	EE1-202
65	F	SLING, MULTIPLE LEG	3940-00-777-5744	A170
66	H	SOCKET SET, SOCKET WRENCH	5120-01-195-0640	208FA
67	F,H	SOCKET, SOCKET WRENCH	5120-01-068-5643	5555M
68	O	SOCKET, SOCKET WRENCH	5120-01-161-5907	GLDH382
69	F	SOCKET, SOCKET WRENCH	5120-01-335-0784	TW321
70	O	SOCKET, SOCKET WRENCH	5120-01-144-5324	ANS 1913A
71	F	SOLDERING AND BRAZING OUTFIT, RESISTANCE HEATING	3439-00-460-7198	SC4940-95-CLB20
72	O	SOLDERING IRON, ELECTRIC	3439-01-036-3308	3112-S3-40W
73	H	STAND, DIFFERENTIAL CARRIER REPAIR	4910-01-085-7729	J3409-D
74	H	STAND, MAINTENANCE, AUTOMOTIVE ENGINE	4910-00-808-3372	J29109
75	F	TOOL, DISTORTER	5120-01-119-1748	5P-7312
76	O,F	TOOL KIT, AUTO FUEL AND ELECTRICAL SYSTEM REPAIR	5180-00-754-0655	SC4910-95CLA50
77	F	TOOL KIT, BODY AND FENDER	5180-00-754-0643	SC5180-90-N34
78	O,F,H	TOOL KIT, GENERAL MECHANIC'S	5180-00-177-7033	SC5180-90-CL-N26
79	F,H	TOOL KIT, GENERAL MECHANIC'S	5180-00-699-5273	SC5180-90-CL-N05
80	F	TOOL KIT, INTERNAL COMBUSTION ENGINE	5180-01-356-8155	1U6680
81	H	TOOL KIT, DIESEL INJECTOR	5180-01-466-3966	143-2099
82	F	TOOL OUTFIT, HYDRAULIC	4940-01-036-5784	SC4940-95-CL-B07

Section III. TOOLS AND TEST EQUIPMENT FOR LMTV VEHICLES (Cont)

Tool or Test Equipment REF Code	Maintenance Level	Nomenclature	National Stock Number	Tool Number
83	O	TOOL, SPRING REMOVAL	5120-01-360-1918	TV940010
84	F	WRENCH SET, CROWFOOT, RATCHETING	5120-00-293-0013	GGG-W-646
85	F	WRENCH SET, SOCKET	5120-00-148-3706	ANSI-B107.5
86	O	WRENCH, TORQUE, 0-75 LB-IN.	5120-01-112-9532	TQSC6A

Section IV. REMARKS FOR THE LMTV VEHICLE

Remarks Code	Remarks
A	Battery service will be in accordance with TM 9-6140-200-14.
B	Repair of tires will be in accordance with TM 9-2610-200-14.

APPENDIX C TOOLS IDENTIFICATION LIST

Section I. INTRODUCTION

C-1. INTRODUCTION

This appendix lists common tools, supplements, and special tools/fixtures that are suggested for maintenance tasks performed at the Unit Maintenance level.

C-2. EXPLANATION OF COLUMNS

a. Column (1) - Item Number. This number is assigned to the entry in the listing and is referenced in the narrative instructions to identify the item, e.g., "Bar, Pry (Item 1, Appendix C)."

b. Column (2) - Item Name. This column contains the nomenclature for the item.

c. Column (3) - National Stock Number. This is the national stock number assigned to the item which you can use to requisition it.

d. Column (4) - Part Number. This provides the Government, manufacturer, or vendor part number for the item.

e. Column (5) - Reference. This column contains the shop catalog (SC), technical manual, or other publication which provides an illustration and description of the item, or lists whether the item is fabricated.

APPENDIX C Section II. TOOLS IDENTIFICATION LIST

(1) ITEM NUMBER	(2) ITEM NAME	(3) NATIONAL STOCK NUMBER	(4) PART NUMBER	(5) REFERENCE
1	ADAPTER, SOCKET WRENCH	5120-00-227-8088	A-A-2172	SC 4910-95-CL-A74
2	ADJUSTING TOOL, BRAKE SHOE	5120-00-154-3029	J34061	SC 4910-95-CL-A74
3	APRON, RUBBER	8145-00-082-6108	MIL-A-41829	SC 4910-95-CL-A74
4	CAPS, VISE JAW	5120-00-221-1506	GGG-C-137	SC 4910-95-CL-A74
5	DISPENSING PUMP, HAND DRIVEN	4930-00-263-9886	43D15069	SC 4910-95-CL-A74
6	DRILL SET, TWIST	5130-00-293-0983	58	SC 4910-95-CL-A74
7	DRILL, PORTABLE, ELECTRIC	5130-00-293-1849	W-D-661	SC 4910-95-CL-A74
8	DRILL, TWIST	5133-01-120-3519		SC 4910-95-CL-A74

Section II. TOOLS IDENTIFICATION LIST (CONT)

(1) ITEM NUMBER	(2) ITEM NAME	(3) NATIONAL STOCK NUMBER	(4) PART NUMBER	(5) REFERENCE
9	FISHING TOOL, PNEUMATIC TIRE VALVE	5120-00-516-4220	991	SC 4910-95-CL-A74
10	GAGE, DEPTH, MICROMETER	5210-00-619-4045	445BZ-6RL	CTA 50-909
11	GAGE, TIRE PRESSURE	4910-01-117-2994	955	SC 4910-95-CL-A72
12	GAGE, WHEEL ALIGNMENT	5210-01-223-3701	WA361	SC 4910-95-CL-A72
13	GLOVES, RUBBER	8415-00-641-4601	ZZ-G-381	SC 4910-95-CL-A74
14	GLOVES, WELDER'S	8415-00-268-7859	A-A-50022	SC 4910-95-CL-A72
15	GOGGLES, INDUSTRIAL	4240-00-052-3776	A-A-1110	SC 4910-95-CL-A74
16	GUN, LUBRICATING	4930-00-253-2478	1142	SC 4910-95-CL-A74
17	HAMMER, HAND	5120-00-224-4130	A-A-1292	SC 4910-95-CL-A74
18	HAMMER, HAND	5120-01-065-9037	57-533	SC 4910-95-CL-A72
19	HOSE ASSEMBLY, NONMETALLIC	4720-00-356-8557	ZZ-H-461	SC 4910-95-CL-A74
20	IRON, TIRE	5120-00-765-8536	T48A	SC 4910-95-CL-A74
21	JACK, HYDRAULIC, HAND	5120-00-224-7330	D120	SC 4910-95-CL-A74
22	MULTIMETER, DIGITAL	6625-01-139-2512	T00377	SC 4910-95-CL-A74
23	MULTIPLIER, TORQUE WRENCH	5120-00-574-9318	292	SC 4910-95-CL-A72
24	PAN, DRAIN	4910-00-387-9592	450	SC 4910-95-CL-A72
25	PAN, WASH	4940-00-617-9859	5582281	SC 4910-95-CL-A72
26	PRESSURE TESTER, RADIATOR	4910-01-170-4929	J24460-01	SC 4910-95-CL-A74
27	PULLER KIT, MECHANICAL	5120-00-313-9496	1178	SC 4910-95-CL-A74
28	PULLER, BATTERY TERMINAL	5120-00-944-4268	21	SC 4910-95-CL-A74
29	RESPIRATOR, AIR FILTER	4240-00-022-2524	GGG-M-125/6	SC 4910-95-CL-A72
30	SCALE, WEIGHING	6670-00-254-4634	AAA-5-133	SC 4910-95-CL-A72
31	SLING, CARGO	1670-00-823-5043	63J4261-13	CTA 50-970
32	SLING, ENDLESS	3940-00-675-5003	PD101-96	CTA 50-970
33	SOCKET SET, IMPACT	5120-01-117-0466	4151MMY	SC 4910-95-CL-A74
34	SOCKET SET, SOCKET WRENCH	5120-01-073-2821	217FMY	SC 4910-95-CL-A72

Section II. TOOLS IDENTIFICATION LIST (CONT)

(1) ITEM NUMBER	(2) ITEM NAME	(3) NATIONAL STOCK NUMBER	(4) PART NUMBER	(5) REFERENCE
35	SOCKET SET, SOCKET WRENCH	5120-01-117-3876	221FSMY	SC 4910-95-CL-A02
36	SOCKET, SOCKET WRENCH	5120-00-181-6813	5530	SC 4910-95-CL-A74
37	SOCKET, SOCKET WRENCH	5120-00-232-5681	1242	SC 4910-95-CL-A74
38	SOCKET, SOCKET WRENCH	5120-01-112-0581	SIMM190	SC 4910-95-CL-A74
39	STE/ICE-R	4910-01-222-6589	12259266	SC 4910-95-CL-A74
40	TAPE, MEASURING	5210-00-081-4719	GA508A	CTA 50-970
40.1	TEST KIT, RADIATOR	4910-00-728-8227		SC 4910-95-CL-A74
40.2	TAP AND DIE SET	5136-01-119-0005	TDM99117	SC 4910-95-CL-A72
40.3	TAP, THREAD, CUTTING	5136-00-729-5692	B94.9 1/2 13 UNCHSGH3	SC 4910-95-CL-A72
41	TESTER, ANTIFREEZE AND BATTERY	6630-00-105-1418	10425	SC 4910-95-CL-A74
42	TOOL KIT, AUTO FUEL	5780-00-754-0655		SC 5180-95-CL-A50
43	TOOL KIT, BLIND RIVET	5180-01-201-4978	D-100-MIL-1	SC 4910-95-CL-A72
44	TOOL KIT, GENERAL MECHANIC'S	5180-00-177-7033		SC 5180-90-N26
44.1	TOOL KIT, ELECTRICAL CONTACT REPAIR	5780-00-876-9336	7550526	SC 4940-95-B09
45	TRESTLE, MOTOR VEHICLE MAINTENANCE	4910-00-251-8013	306	SC 4910-95-CL-A72
46	WISE, MACHINIST	5120-00-293-1439	504M2	SC 4910-95-CL-A74
47	WRENCH SET, SOCKET	5120-00-081-2305	GGG-W-641	SC 4910-95-CL-A74
48	WRENCH SET, SOCKET	5120-00-204-1999	GGG-W-641	SC 4910-95-CL-A74
49	WRENCH SET, SOCKET	5120-00-322-6231	51200017510	SC 4910-95-CL-A74
50	WRENCH, ADJUSTABLE	5120-00-264-3793	2117080	SC 4910-95-CL-A72
51	WRENCH, ADJUSTABLE, AUTOMOTIVE	5120-00-449-8083	1B7536	SC 4910-95-CL-A74
51.1	WRENCH, BOX AND OPEN END	5120-00-228-9518	1174	SC 4910-95-CL-A74
52	WRENCH, BOX AND OPEN END	5120-00-277-8833	1244	SC 4910-95-CL-A74
53	WRENCH, BOX AND OPEN END	5120-00-277-8834	GGG-W-636	SC 4910-95-CL-A74
54	WRENCH, PIPE	5120-00-277-1461		SC 4910-95-CL-A74

Section II. TOOLS IDENTIFICATION LIST (CONT)

(1) ITEM NUMBER	(2) ITEM NAME	(3) NATIONAL STOCK NUMBER	(4) PART NUMBER	(5) REFERENCE
55	WRENCH, PIPE	5120-00-277-1485		SC 4910-95-CL-A74
56	WRENCH, STRAP, ADJUSTABLE	5120-00-020-2947	A91C	SC 4910-95-CL-A74
57	WRENCH, TORQUE, 0-175 lb- ft	5120-00-640-6364	1753LDF	SC 4910-95-CL-A72
58	WRENCH, TORQUE, 0-200 lb- in.	5120-00-853-4538	F2001	SC 4910-95-CL-A72
58.1	WRENCH, TORQUE, 0-300 lb- in.	5120-00-776-1841	2163993	SC 4910-95-CL-A74
59	WRENCH, TORQUE, 0-600 lb- ft	5120-00-221-7983	SW130-301	SC 4910-95-CL-A72

APPENDIX D EXPENDABLE/DURABLE SUPPLIES AND MATERIALS LIST

Section I. INTRODUCTION

D-1. SCOPE

This appendix lists expendable and durable items that you will need to operate and maintain the LMTV vehicle. This listing is for information only and is not authority to requisition the listed items. These items are authorized to you by CTA 50-970, Expendable/Durable Items (except medical, class V repair parts, and heraldic items), or CTA 8-100, Army Medical Department Expendable/Durable Items.

D-2. EXPLANATION OF COLUMNS

- a. **Column (1) - Item Number.** This number is assigned to the entry in the listing and is referenced in the narrative instructions to identify the item, e.g., "Oil, Lubricating (Item 25, Appendix D).
- b. **Column (2) - Level.** This column identifies the lowest level of maintenance that requires the item.
- c. **Column (3) - National Stock Number.** This is the national stock number assigned to the item which you can use to requisition it.
- d. **Column (4) - Item Name, Description, Commercial and Government Entity Code (CAGEC), and Part Number.** This provides the other information you need to identify the item.
- e. **Column (5) - Unit of Measure.** This code shows the physical measurement or count of an item, such as gallon, dozen, gross, etc.

Section II. EXPENDABLE/DURABLE SUPPLIES AND MATERIALS LIST

(1) Item Number	(2) Level	(3) National Stock Number	(4) Description	(5) U/M
1	O	4730-00-248-9340	Adapter, Pipe to Tube (81343) 4-4 010103B	ea
1.1	O	4730-01-453-9651	Adapter, Straight, Pipe to Boss (19207) 12421890-001	ea
1.2	O	4730-01-457-4025	Adapter, Straight, Pipe to Tube (96906) MS51503B4-4	ea
1.3	O	4730-00-760-3525	Adapter, Straight, Tube to Boss (81361) C116-3-71	ea
2	O	8040-00-273-8717	Adhesive (81348) MMM-A-121	pt
3	O	8040-00-152-0063	Adhesive (81348) MMM-A-1617 TY 3	bt
4	O	8040-01-250-3969	Adhesive (05972) 242	ea
5	O	8040-01-117-7872	Adhesive (04963) 08031	tu
6	O	8040-00-117-8510	Adhesive (71984) 3145 RTV Clear	tu
7	O	8040-00-776-9602	Adhesive (73168) 80055-31	kt
8	O	8040-00-118-2695	Adhesive (72799) RTV162	kt

Section II. EXPENDABLE/DURABLE SUPPLIES AND MATERIALS LIST (CONT)

(1) Item Number	(2) Level	(3) National Stock Number	(4) Description	(5) U/M
9	O	8040-01-446-7842	Adhesive (01139) RTV123	ca
10	O	8040-01-331-7473	Adhesive (81349) (MIL-A-46106 GP3TY1)	tu
11	O	8040-01-331-7470	Adhesive (81349) (MIL-A-46106 GP1TY1)	tu
11.1	O	8040-00-728-3088	Adhesive (78500) 1199-T-3842 6 oz	kt
12	C	6850-00-174-1806	Antifreeze, Arctic Type (81349) (MIL-A-11755) 55 gl drum	dr
13	C	6850-01-441-3218 6850-01-441-3221 6850-01-441-3257	Antifreeze, Multi-Engine Type (58536) (A-A-52624A) Type I (Green) - 1 gal Type I (Green) - 5 gal Type II (Purple) - 5 gal	gal co co
14	O	8030-00-597-5367	Antiseize Compound (81349) (MIL-A-907)	lb
14.1	O	5110-00-277-4588	Blade, Hand Hacksaw (54940) 31-51024	ea
14.2	O	5340-01-454-4336	Bracket, Angle (0FW39) 12421859-001	ea
15	O	5340-00-450-5718	Cap and Plug Set 10935405	ea
15.1	O	5340-01-423-0972	Clamp, Loop (18076) S630H-20	ea
16	O	6850-00-926-2275	Cleaning Compound, Windshield (81349) O-C-1901 16 oz bottle	bt
17	O	7920-00-044-9281	Cloth, Cleaning (81349) (MIL-C-85043)	bx
18	O	8030-00-062-6950 8030-01-149-1731 8030-00-837-6557 8030-00-903-0931	Corrosion Preventive Compound (81349) (MIL-C-16173) Grade 1 - 1 qt can Grade 2 - 1 qt can Grade 3 - 1 pt can Grade 4 - 1 pt can	qt qt pt pt
19	O	8030-00-033-4291	Corrosion Preventive Compound (MIL-C-82594) 8 oz can	bt
19.1	O	2540-01-460-8048	Cover, Seat, Vehicular (27797) WM1059	ea
19.2	O	2540-01-463-8394	Cover, Seat, Vehicular (0FW39) WM1058	ea
20	C	9150-00-664-0047	Damping Fluid (81348) VV-D-1078 1 lb can	lb
21	O	7520-01-209-1152	Dispenser, Pressure Sensitive Adhesive Tape (75037) STD-0-9	ea
21.1	O	4730-01-454-1233	Elbow, Pipe to Boss (19207) 12421891-001	ea
21.2	O	4730-00-863-9098	Elbow, Pipe to Tube (30780) 4VBTXB	ea
22	O	5330-01-325-6993	Gasket Forming Compound (05972) 515	ea
22.1	O		Gasket Maker, RTV Silicone (05972) 5699	ea

Section II. EXPENDABLE/DURABLE SUPPLIES AND MATERIALS LIST (CONT)

(1) Item Number	(2) Level	(3) National Stock Number	(4) Description	(5) U/M
23	C		Grease, Automotive and Artillery (GAA) (81349) (MIL-G-10924)	
		9150-01-197-7688	2-1/4 oz tube	tu
		9150-01-197-7690	1.75 lb can	cn
		9150-01-197-7689	6.5 lb can	cn
		9150-01-197-7692	35 lb can	cn
24	O	9150-00-530-6814	Grease, Wire Rope-Exposed Gear (81349) (MIL-G-18458)	cn
			35 lb can	
25	O	9150-00-935-4018	Grease, Molybdenum Disulfide (81349) (MIL-G-21164)	ca
			14 oz cartridge	
25.1	O	4720-00-988-3842	Hose Assembly, Nonmetallic (50599) R25679-1	ea
25.2	O	4720-01-384-0995	Hose Assembly, Nonmetallic (19207) 12421858-006	ea
25.3	O	4720-01-453-9530	Hose Assembly, Nonmetallic (0FW39) 12421857	ea
25.4	O	4720-01-469-9208	Hose Assembly, Nonmetallic (19207) 12418004-002	ea
26	C		Hydraulic Fluid A (MIL-H-5606)	
		9150-00-252-6383	1 qt can	cn
		9150-00-223-4134	1 gl can	cn
27	O	7510-00-145-0559	Ink, Marking Stencil (MIL-I-43553)	oz
28	O	7510-01-386-0787	Inking Pad, Rubber Stamp	ea
29	O	9150-01-360-1905	Insulating Compound, Electrical	tu
30	O	5970-00-838-5951	Insulation Sleeving, Electrical (06090) CRN3-16BLACK	ft
30.1	O	5970-01-378-3018	Insulation Sleeving, Electrical (06090) ATUM-1/4-0-4FT	lg
31	O	5970-01-422-3579	Insulation Sleeving, Electrical (06090) ATUM 1/2 4 ft length	lg
32	O	1650-00-166-4834	Lockwire (90166) 68A32	ea
33	O	9150-01-360-1905	Lubricant, Solid Film (MIL-L-46147) 16 oz can	cn
34	O	4730-00-019-0608	Nipple, Pipe	ea
35	O	4730-00-825-7304	Nipple, Tube MS51501B4	ea
36	O	5310-00-059-4265	Nut, Plain, Hex	ea

Section II. EXPENDABLE/DURABLE SUPPLIES AND MATERIALS LIST (CONT)

(1) Item Number	(2) Level	(3) National Stock Number	(4) Description	(5) U/M
36.1	C		Oil, Commercial Burner Fuel, Grade FO-1 (ASTM D396)	
36.2	C		Oil, Commercial Burner Fuel, Grade FO-2 (ASTM D396)	
37	C	9140-00-286-5282 9140-00-286-5283 9140-00-286-5284 9140-00-286-5285	Oil, Fuel Diesel, DF-A, Arctic (VV-F-800) (81348) 5 gl can Bulk 55 gl drum, 16 gauge 55 gl drum, 18 gauge	cn gl dr dr
38	C	9140-00-286-5286 9140-00-286-5287 9140-00-286-5288 9140-00-286-5289	Oil, Fuel, Diesel, DF-1, Winter (VV-F-800) (81348) Bulk 5 gl can 55 gl drum, 16 gauge 55 gl drum, 18 gauge	gl cn dr dr
39	C	9140-00-286-5294 9140-00-286-5295 9140-00-286-5296 9140-00-286-5297	Oil, Fuel, Diesel, DF-2, Regular (VV-F-800) (81348) Bulk Can 55 gl drum, 16 gauge 55 gl drum, 18 gauge	gl cn dr dr
40	C	9150-00-402-2372 9150-00-491-7197	Oil, Lubricating, Arctic (MIL-L-46167) 5 gl can 55 gl drum	cn dr
41	C	9150-00-035-5390 9150-00-035-5391	Oil, Lubricating, Gear, GO 75W (MIL-L-2105C) 1 qt can 5 gl can	cn cn
42	C	9150-01-035-5392 9150-01-035-5393 9150-01-035-5394	Oil, Lubricating, Gear, 80W-90 (MIL-L-2105C) 1 qt can 5 gl can 55 gl drum, 16 gauge	qt cn dr
43	C	9150-00-183-7807 9150-00-186-6668 9150-00-191-2772	Oil, Lubricating, OE/HDO 10 (MIL-L-2104) Bulk 5 gl can 55 gl drum	gl cn dr
44	C	9150-00-189-6727	Oil, Lubricating, OE/HDO 10W (MIL-L-2104) 1 qt can	cn
45	C	9150-01-152-4117 9150-01-152-4118 9150-01-152-4119	Oil, Lubricating, OE/HDO 15W-40 (MIL-L-2104) 1 qt can 5 gl can 55 gl drum	cn cn dr

Section II. EXPENDABLE/DURABLE SUPPLIES AND MATERIALS LIST (CONT)

(1) Item Number	(2) Level	(3) National Stock Number	(4) Description	(5) U/M
46	C	9150-00-183-7808 9150-00-186-6681 9150-00-188-9858 9150-00-189-6729	Oil, Lubricating, OE/HDO 30 (SAE 30) (MIL-L-2104) Bulk 1 qt can 5 gl can 55 gl drum, 18 gauge	gl cn cn dr
47	C	9150-00-405-2987 9150-00-189-6730 9150-00-188-9862	Oil, Lubricating, OE/HDO 40 (MIL-L-2104) Bulk 1 qt can 5 gl can	gl cn cn
48	O	5350-00-067-7639	Paper, Abrasive (28124) 02347 pg contains 100 sheets	pg
49	O	8010-01-146-2650	Polyurethane Coating (MIL-C-46168)	kt
50	O	8030-00-181-8372	Primer, Sealing Compound (05972) 747-56	cn
51	C	7920-00-205-1711	Rag, Wiping A-A-531	be
52		DELETED		
53	O	4020-00-855-2767	Rope, Fibrous (MIL-R-17343) 75 ft	cl
54	O	7520-00-634-2442	Rubber Stamp Set, Fixed Type	ea
55	O	5330-01-337-1108	Rubber Strip (12624) V4062	ft
56	O	5330-01-181-6482	Rubber Strip (19207) 12328583-3	ft
56.1	O	5305-00-021-3740	Screw, Cap, Hex Hd (97942) 645A560H43	ea
56.2	O	5305-01-299-4602	Screw, Cap, Hex Hd (64678) 000933 006058	ea
56.3	O	5305-01-454-5938	Screw, Cap, Hex Hd (19207) 12419954-093	ea
57	O	5305-01-296-0019	Screw, Cap, Socket Head (06888) SHCM75275 50 ct box	bx
58	O	1015-01-255-4144	Sealant, Pipe, Teflon (19207) 12297953 50 ml tube	tu
59	O	8030-00-081-2327	Sealing Compound (05972) 079-21	bx
60	O	8030-00-111-2762	Sealing Compound (05972) 290-31	bt
61	O	8030-00-133-3164	Sealing Compound (05972) 571-31	bt
62	O	8030-00-148-9833	Sealing Compound (05972) 271-21	bx
63	O	8030-00-204-9149	Sealing Compound (05972) 592-41	tu
64	O	8030-00-656-1426	Sealing Compound (81349) (MIL-S-45180)	pt
65	O	8030-01-025-1692	Sealing Compound (05972) 242-41 (MIL-S-46163)	bt
66	O	8030-01-088-8140	Sealing Compound (52571) 9001512-0011	bt

Section II. EXPENDABLE/DURABLE SUPPLIES AND MATERIALS LIST (CONT)

(1) Item Number	(2) Level	(3) National Stock Number	(4) Description	(5) U/M
67	O	8030-00-753-5006 8030-00-753-4599 8030-00-723-2746 8030-00-685-0915	Sealing Compound (81349) (MIL-S-8802TY2CLB-2) 2 oz cartridge 6 oz can 12 oz can 24 oz can	ca kt kt kt
68	O	8030-01-155-3238	Sealing Compound (11083) 6V6640	ml
68.1	O	8030-01-371-8405	Sealing Compound (83574) PR-1422 B-1/2 6 oz	ca
68.2	O	8030-01-255-4144	Sealant (19207) 12297953	tb
68.3	O	8030-00-956-2397	Sealing Compound 104	tb
69	C	7930-00-634-3935	Soap, Laundry (81348) P-S-1792	lb
70	O	3439-00-006-7764	Solder, Tin Alloy (81348) SN63WRAP3	sl
71	C	6850-00-281-1985 6850-00-664-5685	Solvent, Dry Cleaning SD (P-D-680) 1 gl can 1 qt can	cn cn
71.1	O		Strap, Tiedown, Electrical Components (06383) PLP2S	ea
72	O		Tape, Adhesive (0SHR6) 70P00002	ea
72.1	O	9320-01-244-0046	Tape, Adhesive, Rubber (18876) MIS-41157-08 180 ft	ro
73	O	8030-00-889-3534	Tape, Antiseizing (81349) (MIL-T-27730)	ea
74	O	5640-00-103-2254	Tape, Duct (39428) 1791K70	ea
75	O	5970-00-644-3167	Tape, Insulation, Electrical (80063) TL83	ro
75.1	O	4730-00-138-8050	Tee, Pipe (81343) 8-8-8 140424C	ea
76	O	5975-01-379-4997	Ties, Cable, Plastic (06383) PLT 35-C-O	hd
	C		Turbine Fuel, Aviation, Kerosene Type (MIL-T-83133), Grade JP-8	
	C		Turbine Fuel, (MIL-F-16884), (NATO Code No. F75 or F-72)	
		9140-00-255-7764 9140-00-273-2378 9140-00-273-2377	5 gl can 55 gl drum 1 gl can	cn dr cn
	C		Turbine Fuel, (MIL-F-5624), Grade JP-4 (NATO Code No. F40)	
		9130-00-273-2380	Drum, 16 gage	dr
	C		Turbine Fuel, (MIL-T-5624), Grade JP-5 (NATO Code No. F-44)	
		9130-01-305-5596 9130-01-250-6353	Bulk Drum, 16 gage	gl dr
77	O	6145-01-148-2263	Wire, Electrical (80009) 175-0825-00 50 ft	ft

APPENDIX E

ILLUSTRATED LIST OF MANUFACTURED ITEMS

Section I. INTRODUCTION

E-1. INTRODUCTION

This appendix includes complete instructions for manufacturing or fabricating authorized items locally. All bulk materials needed to manufacture an item are listed by part number or specification number. Figures are provided as needed. See standards and specifications DoD-Std-00100D(AR) and ANSI Y14.5M1982 for required details.

Section II. MANUFACTURED ITEMS INDEX

ITEM NAME/PART NUMBER	ITEM DESCRIPTION	PARA NO.
Brake Adjusting Tool Support		E-2
Brake Plunger Seal Driver		E-3
Cab Support Tool		E-4
Headlight Adjustment Screen		E-5
M1079 Blackout Shield Seals		E-6
M1079 Door Gaskets		E-7
M1079 Window Sash Glazing Seals		E-8
Relay Test Wire		E-9
Wheel Bearing Shim Tool Rest		E-10
12414690-001	Pneumatic Tube	E-11
12414690-002	Pneumatic Tube	E-11
12414690-004	Pneumatic Tube	E-11
12414690-005	Pneumatic Tube	E-11
12414690-010	Pneumatic Tube	E-11
12414690-101	Pneumatic Tube	E-11
12414690-102	Pneumatic Tube	E-11
12414690-103	Pneumatic Tube	E-11
12414690-104	Pneumatic Tube	E-11
12414690-105	Pneumatic Tube	E-11
12414690-106	Pneumatic Tube	E-11
12414690-107	Pneumatic Tube	E-11
12414690-108	Pneumatic Tube	E-11
12414690-109	Pneumatic Tube	E-11
12414690-112	Pneumatic Tube	E-11
12414690-113	Pneumatic Tube	E-11
12414690-115	Pneumatic Tube	E-11
12414690-117	Pneumatic Tube	E-11
12414690-118	Pneumatic Tube	E-11
12414690-119	Pneumatic Tube	E-11
12414690-120	Pneumatic Tube	E-11
12414690-121	Pneumatic Tube	E-11
12414690-122	Pneumatic Tube	E-11
12414690-123	Pneumatic Tube	E-11
12414690-124	Pneumatic Tube	E-11
12414690-125	Pneumatic Tube	E-11
12414690-126	Pneumatic Tube	E-11
12414690-127	Pneumatic Tube	E-11
12414690-201	Pneumatic Tube	E-11
12414690-202	Pneumatic Tube	E-11

Section II. MANUFACTURED ITEMS INDEX (CONT)

ITEM NAME/PART NUMBER	ITEM DESCRIPTION	PARA NO.
12414690-203	Pneumatic Tube	E-11
12414690-205	Pneumatic Tube	E-11
12414690-206	Pneumatic Tube	E-11
12414690-207	Pneumatic Tube	E-11
12414690-208	Pneumatic Tube	E-11
12414690-209	Pneumatic Tube	E-11
12414690-210	Pneumatic Tube	E-11
12414690-211	Pneumatic Tube	E-11
12414690-212	Pneumatic Tube	E-11
12414690-213	Pneumatic Tube	E-11
12414690-214	Pneumatic Tube	E-11
12414690-215	Pneumatic Tube	E-11
12414690-216	Pneumatic Tube	E-11
12414690-217	Pneumatic Tube	E-11
12414690-218	Pneumatic Tube	E-11
12414690-219	Pneumatic Tube	E-11
12414690-220	Pneumatic Tube	E-11
12414690-221	Pneumatic Tube	E-11
12414690-222	Pneumatic Tube	E-11
12414690-223	Pneumatic Tube	E-11
12414690-224	Pneumatic Tube	E-11
12414690-225	Pneumatic Tube	E-11
12414690-226	Pneumatic Tube	E-11
12414690-227	Pneumatic Tube	E-11
12414690-228	Pneumatic Tube	E-11
12414690-229	Pneumatic Tube	E-11
12414690-230	Pneumatic Tube	E-11
12414690-231	Pneumatic Tube	E-11
12414690-301	Pneumatic Tube	E-11
12414690-302	Pneumatic Tube	E-11
12414690-303	Pneumatic Tube	E-11
12416381P1	Non-Metallic Electrical Cable Conduit	E-12
12416381P10	Non-Metallic Electrical Cable Conduit	E-12
12416381P11	Non-Metallic Electrical Cable Conduit	E-12
12416381P12	Non-Metallic Electrical Cable Conduit	E-12
12416381P13	Non-Metallic Electrical Cable Conduit	E-12
12416381P14	Non-Metallic Electrical Cable Conduit	E-12
12416381P15	Non-Metallic Electrical Cable Conduit	E-12
12416381P16	Non-Metallic Electrical Cable Conduit	E-12
12416381P17	Non-Metallic Electrical Cable Conduit	E-12
12416381P2	Non-Metallic Electrical Cable Conduit	E-12
12416381P20	Non-Metallic Electrical Cable Conduit	E-12
12416381P21	Non-Metallic Electrical Cable Conduit	E-12
12416381P22	Non-Metallic Electrical Cable Conduit	E-12
12416381P23	Non-Metallic Electrical Cable Conduit	E-12
12416381P26	Non-Metallic Electrical Cable Conduit	E-12
12416381P3	Non-Metallic Electrical Cable Conduit	E-12
12416381P30	Non-Metallic Electrical Cable Conduit	E-12
12416381P32	Non-Metallic Electrical Cable Conduit	E-12
12416381P34	Non-Metallic Electrical Cable Conduit	E-12
12416381P35	Non-Metallic Electrical Cable Conduit	E-12

ITEM NAME/PART NUMBER	ITEM DESCRIPTION	PARA NO.
12416381P36	Non-Metallic Electrical Cable Conduit	E-12
12416381P37	Non-Metallic Electrical Cable Conduit	E-12
12416381P38	Non-Metallic Electrical Cable Conduit	E-12
12416381P4	Non-Metallic Electrical Cable Conduit	E-12
12416381P5	Non-Metallic Electrical Cable Conduit	E-12
12416381P6	Non-Metallic Electrical Cable Conduit	E-12
12416381P7	Non-Metallic Electrical Cable Conduit	E-12
12416381P8	Non-Metallic Electrical Cable Conduit	E-12
12416381P9	Non-Metallic Electrical Cable Conduit	E-12
12418037	Steering Gear Return Hose	E-13
12418460-001	Transmission Oil Cooler Hose	E-13
12418460-002	Transmission Oil Cooler Hose	E-13
12418763	Lanyard Assembly	E-14
12420196	Lanyard Assembly	E-14
12420197-001	Non-Metallic Vent Air Hose	E-15
12420197-002	Non-Metallic Vent Air Hose	E-15
12420197-003	Non-Metallic Vent Air Hose	E-15
12420197-004	Non-Metallic Vent Air Hose	E-15
12420197-005	Non-Metallic Vent Air Hose	E-15
12420197-006	Non-Metallic Vent Air Hose	E-15
12420198-001	Non-Metallic Vent Air Hose	E-15
12420198-002	Non-Metallic Vent Air Hose	E-15
12420308-457	Personnel Heater Air Duct Hose	E-16
12420308-760	Personnel Heater Air Duct Hose	E-16
12420489	Block Seal	E-17
3256-H-1048	CTIS Seal Driver	E-18
3256-K-1051	Wheel Hub Grease Seal Driver	E-19
Dimmer Switch Test Wire		E-20
Purge Valve Tool		E-21

Section III. MANUFACTURED ITEMS

E-2. BRAKE ADJUSTING TOOL SUPPORT

Make the brake adjusting tool support from 0.134 in. (3.4 mm) flat steel stock according to the following instructions. Refer to the parts list and **Figure E-1. Brake Adjusting Tool Support** for details.

Item	Part Number	Material Description	Size	Qty
1	N/A	Steel, ASTM A569 Sheet, Hot Rolled	6.0 in. (152.4 mm) x 6.0 in. (152.4 mm) x 0.134 in. (3.4 mm)	2

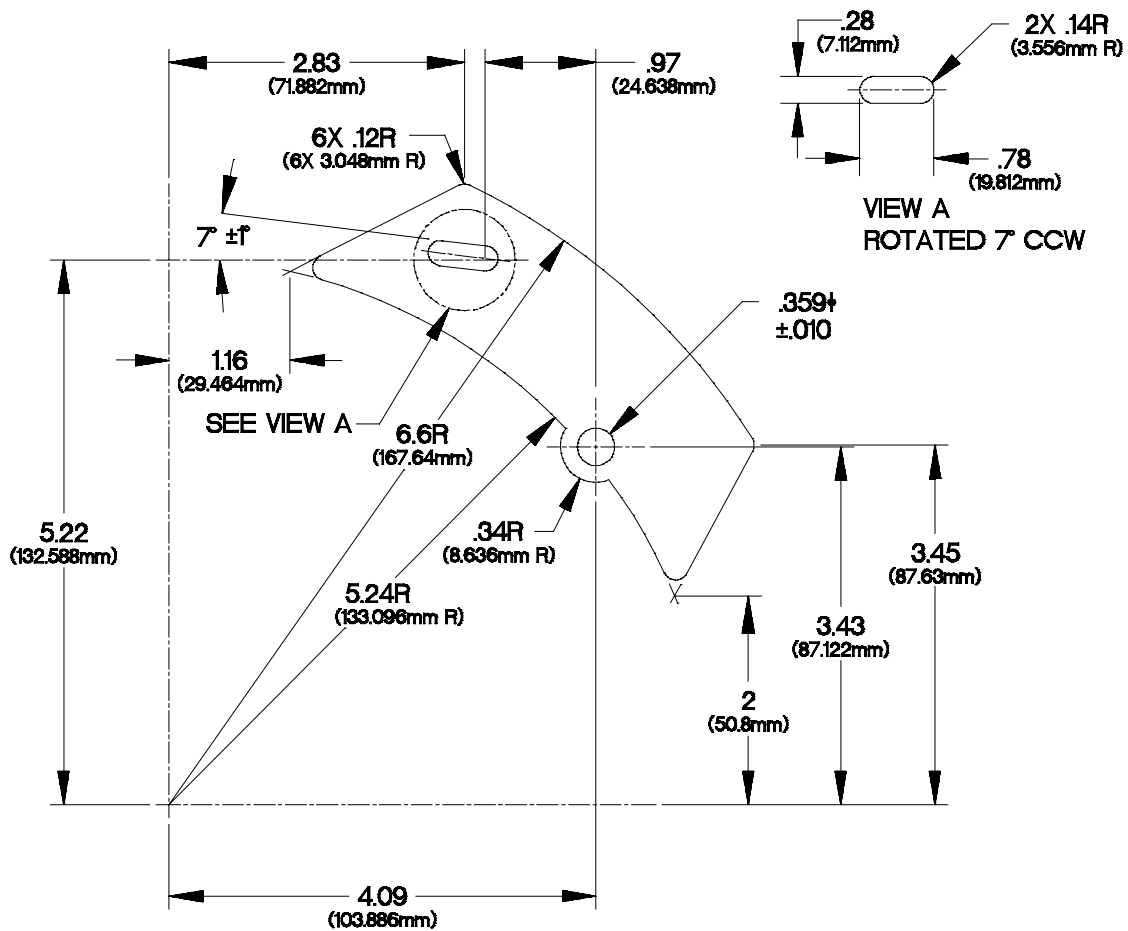

XAPPE011

Figure E-1. Brake Adjusting Tool Support

- a. All dimensions are in inches (millimeters).
- b. Cut steel sheet as shown by dimensions on **Figure E-1. Brake Adjusting Tool Support**.
- c. De-burr and remove sharp edges.

E-3. BRAKE PLUNGER SEAL DRIVER

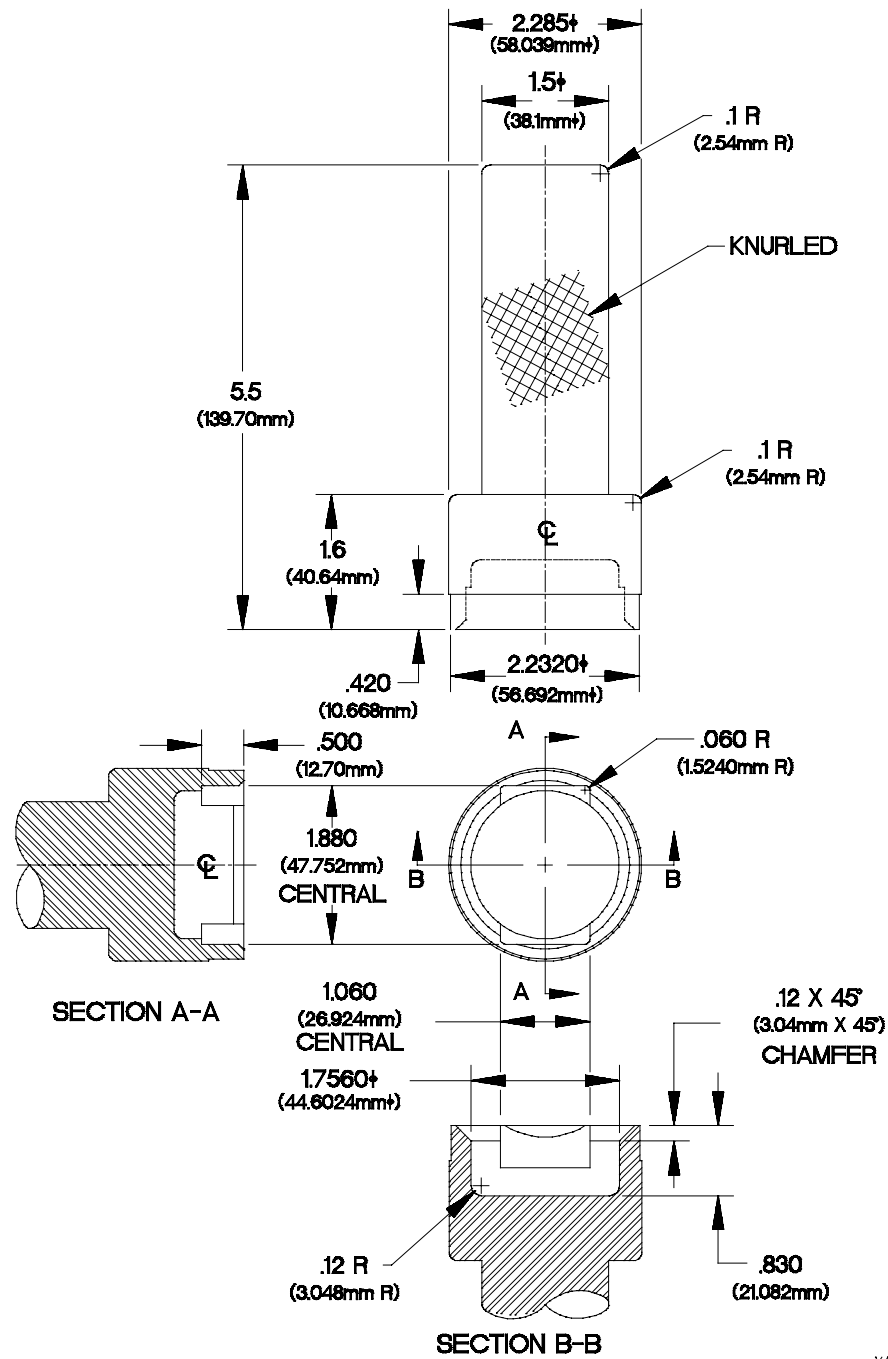

XAPPE021

Figure E-2. Brake Plunger Seal Driver

- a. All dimensions are in inches (millimeters).
- b. Manufacture from round steel stock.
- c. De-burr and remove sharp edges.

E-4. CAB SUPPORT TOOL

Make the cab support tool from .38 inch (.96 cm) flat steel stock and angle iron according to the following instructions. Refer to the parts list and **Figure E-3. Cab Support Tool Strut and Cab Rest** for details.

Item	Part Number	Material Description	Size	Qty
1	N/A	Steel, Flat Bar	4.0 in. (10.2 cm) X 33.38 in. X (84.8 cm) X 0.38 in. (0.96 cm)	1
2	N/A	Steel, Flat Bar	4.0 in. (10.2 cm) X 12.0 in. (30.5 cm) X 0.38 in. (0.96 cm)	1
3	N/A	Angle Iron	2.0 in. (5.1 cm) X 2.0 in. (5.1 cm) X 3.5 in. (8.9 cm)	2
4	H.S.105VW-1	Insulgrip, CSA 105 C		

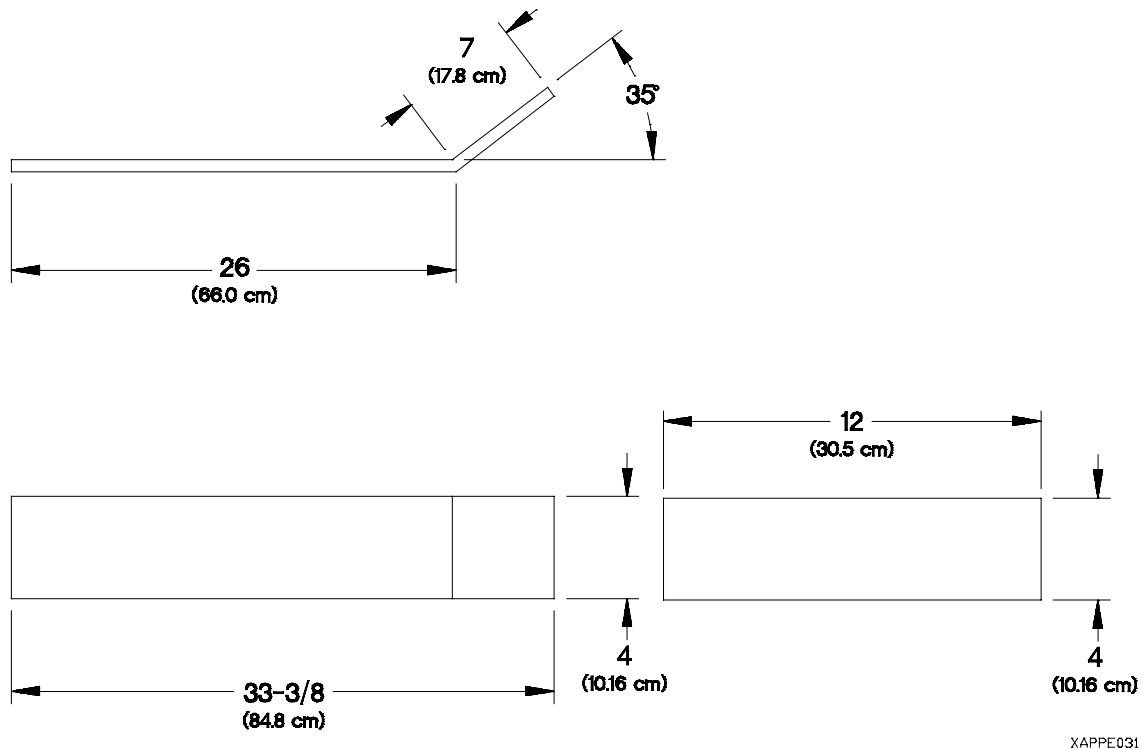

XAPPE031

Figure E-3. Cab Support Tool Strut and Cab Rest

- All dimensions are in inches (centimeters).
- Cut cab support tool strut (1) from steel flat bar and bend to shape as shown in **Figure E-3. Cab Support Tool Strut and Cab Rest**.
- Cut cab support tool cab rest (2) from steel flat bar.
- De-burr and remove sharp edges.

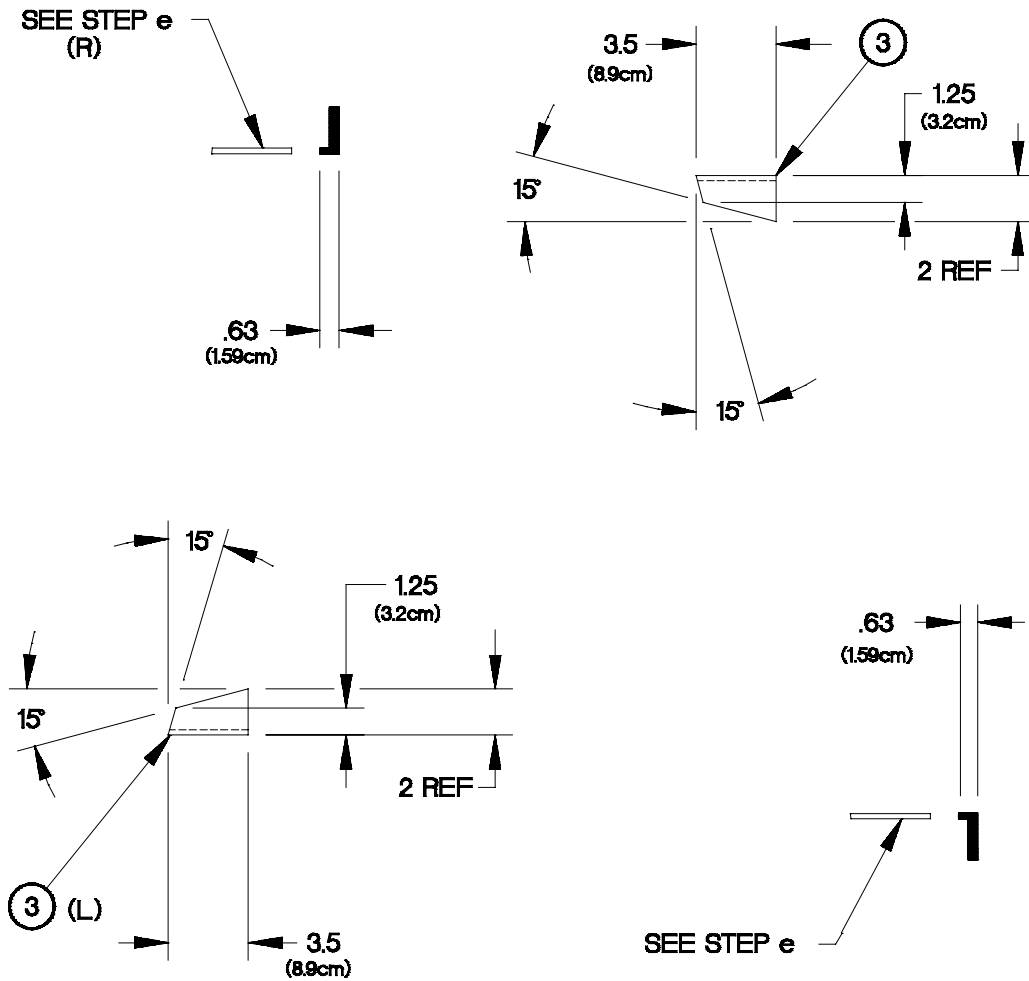

XAPPE041

Figure E-4. Cab Support Tool Seat

- e. Remove flange side of cab support tool seats (3) as shown in **Figure E-4. Cab Support Tool Seat**.
- f. Cut cab support tool seats (3) L and (3) R according to dimensions and left/right orientation shown on **Figure E-4. Cab Support Tool Seat**.
- g. De-burr and remove sharp edges.

E-4. CAB SUPPORT TOOL (CONT)

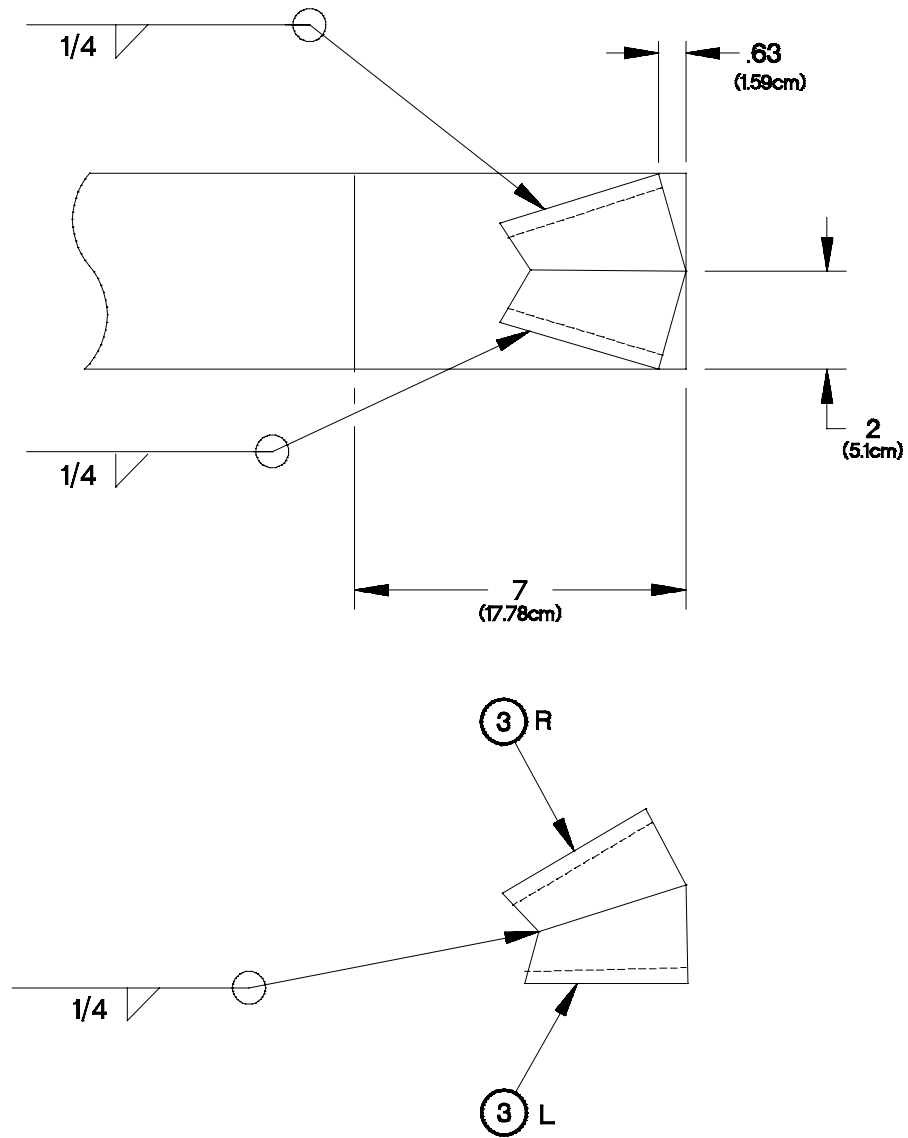

XAPPE051

Figure E-5. Cab Support Tool Seat Layout

- h. Position and clamp cab support tool seats (3) L and (3) R together as shown by dimensions on **Figure E-5. Cab Support Tool Seat Layout.**
- i. Weld cab support tool seat (3) L to cab support tool seat (3) R as identified on assembly table and **Figure E-5. Cab Support Tool Seat Layout.**
- j. Position and clamp cab support tool seats (3) L and (3) R to cab support tool strut (1) as shown by dimensions on **Figure E-5. Cab Support Tool Seat Layout.**
- k. Weld items clamped in step (f) as shown in **Figure E-5. Cab Support Tool Seat Layout.**
- l. De-burr and remove sharp edges.

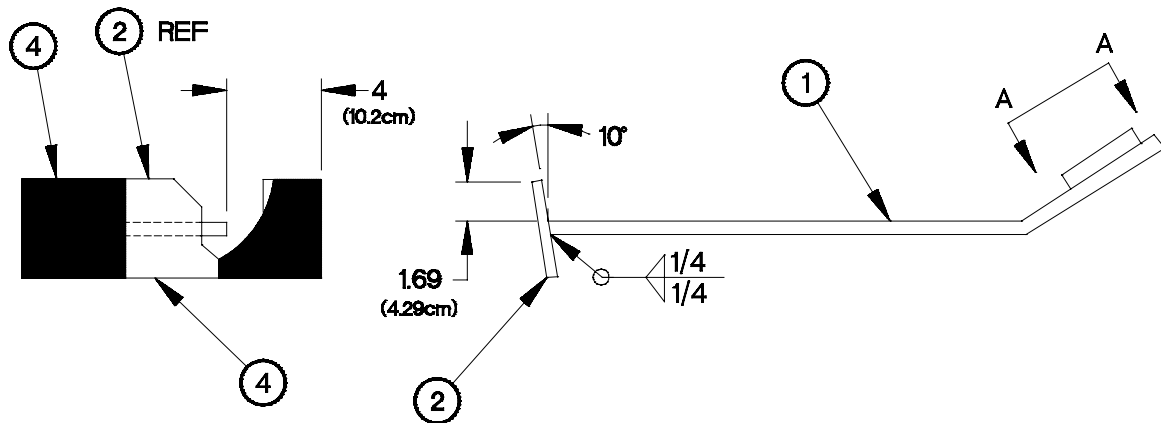

XAPPE061

Figure E-6. Cab Support Tool Assembly

- m. Position and clamp cab support tool strut (1) to cab support tool cab rest (2) as shown by dimensions on **Figure E-6. Cab Support Tool Assembly**, before insulgrip (4) is applied.
- n. Weld cab support tool strut (1) to cab support tool cab rest (2).
- o. Apply Insulgrip (4) to cab support tool cab rest (2) as described on material container.

E-5. HEADLIGHT ADJUSTMENT SCREEN

The headlight adjustment screen may be drawn on any vertical surface at least 50 in. (127 cm) high and 100 in. (254 cm) wide.

- a. Draw two vertical lines (1) 50 in. (127 cm) high and 90.6 in. (230 cm) apart (centered on headlight adjustment screen).
- b. Locate two points 40 in. (101.6 cm) from floor and 13 in. (33 cm) toward the center from each vertical line (1).
- c. Draw vertical line (2) about 3-5 in. (8-13 cm) centered on each of the two points.
- d. Draw horizontal line (3) about 3-5 in. (8-13 cm) centered on each of the two points.
- e. Measure out 4 in. (10 cm) along each vertical line (2) and horizontal line (3) from each of the two points to make 8 in. (20 cm) squares (4).

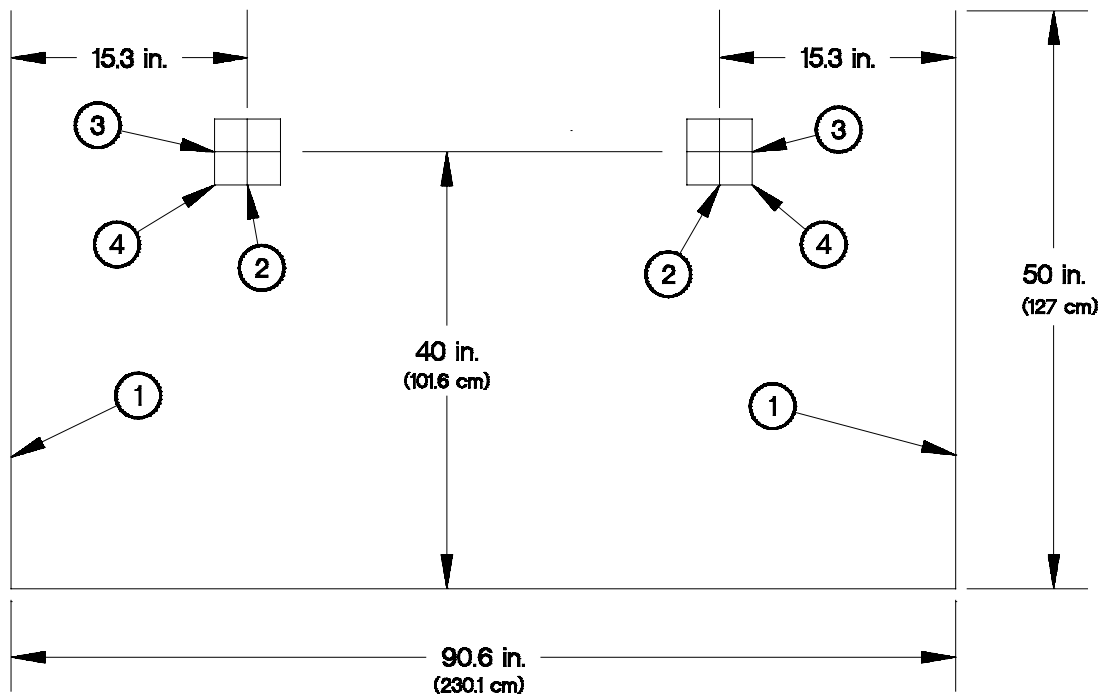

XAPPE101

Figure E-7. Headlight Adjustment Screen

E-6. M1079 BLACKOUT SHIELD SEALS

Fabricate the M1079 blackout shield seals according to the following steps. Refer to the following parts list for materials.

Description	Material Part Number	CAGE Code	Cut Length
Blackout Shield Header Seal	942P00001	0SHR6	28-3/4 in. (730 mm)
Blackout Shield Jamb Seal (van body serial numbers 001 through 190)	942P00001	0SHR6	63-3/8 in. (1610 mm)
Blackout Shield Jamb Seal (van body serial number 191 and higher)	942P00001	0SHR6	33 in. (838 mm)

- a. Dimensions are in inches (millimeters).
- b. Cut seal material to the specified length using a fine-toothed hacksaw or other suitable cutting tool.

E-7. M1079 DOOR GASKETS

Fabricate the M1079 door gaskets according to the following steps. Refer to the following parts list for materials.

Description	Material Part Number	CAGE Code	Cut Length
LH Door Gasket	12416417	19207	214 in. (5435 mm)
RH Door Gasket	12416417	19207	197 in. (5004 mm)

- a. Dimensions are in inches (millimeters).
- b. Cut seal material to the specified length using a fine-toothed hacksaw or other suitable cutting tool.
- c. Glue ends of gasket to each other using adhesive MIL-A-46106 GP1TY1 (Item 11, Appendix D).

E-8. M1079 WINDOW SASH GLAZING SEALS

Fabricate the M1079 window sash glazing seals according to the following steps. Refer to the following parts list for materials.

Description	Material Part Number	CAGE Code	Cut Length
Window Sash Top/Bottom Seal	941P00001	0SHR6	26-13/16 in. (681 mm)
Window Sash Side Seal (van body serial numbers 001 through 190)	941P00001	0SHR6	28-1/2 in. (724 mm)
Window Sash Side Seal (van body serial number 191 and higher)	941P00001	0SHR6	12-11/16 in. (322 mm)

- a. Dimensions are in inches (millimeters).
- b. Cut seal material to the specified length using a fine-toothed hacksaw or other suitable cutting tool.

NOTE

Cut miters so that short side of seal faces toward glass.

- c. Cut 45-degree miters on ends of window sash seals.

E-9. RELAY TEST WIRE

Fabricate the relay test wire according to the following steps. Refer to the following parts list for materials.

Material Description	National Stock Number	Cut Length
Wire, Electrical (MIL-W-16878)	6145-00-330-3318	6 in. (152 mm)

- a. Dimensions are in inches (millimeters).
- b. Cut a length of wire six inches (152 mm) long.
- c. Remove approximately 3/4 in. (19 mm) of electrical insulation from each end of wire.

E-10. WHEEL BEARING SHIM TOOL REST

Fabricate the wheel bearing shim tool rest according to the following steps. Refer to the following parts list for materials.

Part Number	National Stock Number	Description
QQ-T-570	9510-00-866-1037	Bar, Metal

- a. Dimensions are in inches (millimeters).
- b. Cut metal bar to 9.0 inches (228.6 mm) long.
- c. De-burr and remove sharp edges from ends of metal bar.

E-11. PNEUMATIC TUBES FABRICATION
--

Cut pneumatic tubes from bulk tubing stock listed **Table E-1. Pneumatic Tube Lengths**. Use a fine-toothed hacksaw or suitable cutting device and cut tubing to required length.

Table E-1. Pneumatic Tube Lengths

Tube Part Number	Bulk Tubing Part Number	Cut Length	
		inches	cm
12414690-001	NT-100-4 (79470)	18.1	46.0
12414690-002	NT-100-4 (79470)	16.0	40.6
12414690-004	NT-100-4 (79470)	74.8	190.0
12414690-005	NT-100-4 (79470)	69.7	177.0
12414690-010	NT-100-4 (79470)	180.0	457.2
12414690-101	J844TYBSIZE 3/8 (81343)	18.0	45.7
12414690-102	J844TYBSIZE 3/8 (81343)	35.4	90.0
12414690-103	J844TYBSIZE 3/8 (81343)	20.9	53.0
12414690-104	J844TYBSIZE 3/8 (81343)	13.8	35.0
12414690-105	J844TYBSIZE 3/8 (81343)	11.8	30.0
12414690-106	J844TYBSIZE 3/8 (81343)	20.5	52.0
12414690-107	J844TYBSIZE 3/8 (81343)	39.0	99.0
12414690-108	J844TYBSIZE 3/8 (81343)	15.4	39.0
12414690-109	J844TYBSIZE 3/8 (81343)	23.0	58.4
12414690-112	J844TYBSIZE 3/8 (81343)	80.0	198.0
12414690-113	J844TYBSIZE 3/8 (81343)	11.4	29.0
12414690-115	J844TYBSIZE 3/8 (81343)	82.8	210.2
12414690-117	J844TYBSIZE 3/8 (81343)	156.5	397.5
12414690-118	J844TYBSIZE 3/8 (81343)	11.8	30.0
12414690-119	J844TYBSIZE 3/8 (81343)	269.5	684.5
12414690-120	J844TYBSIZE 3/8 (81343)	11.9	30.2
12414690-121	J844TYBSIZE 3/8 (81343)	43.0	109.2
12414690-122	J844TYBSIZE 3/8 (81343)	44.1	112.0
12414690-123	J844TYBSIZE 3/8 (81343)	259.4	659.0
12414690-124	J844TYBSIZE 3/8 (81343)	288.2	732.0
12414690-125	J844TYBSIZE 3/8 (81343)	10.8	27.3
12414690-126	J844TYBSIZE 3/8 (81343)	17.0	43.2
12414690-127	J844TYBSIZE 3/8 (81343)	17.0	43.2

E-11. PNEUMATIC TUBES FABRICATION (CONT)

Table E-1. Pneumatic Tube Lengths (Cont)

Tube Part Number	Bulk Tubing Part Number	Cut Length	
		inches	cm
12414690-201	C608-100BLK (13174)	14.8	37.5
12414690-202	C608-100BLK (13174)	14.0	35.7
12414690-203	C608-100BLK (13174)	6.5	16.5
12414690-205	C608-100BLK (13174)	14.5	36.8
12414690-206	C608-100BLK (13174)	14.9	37.7
12414690-207	C608-100BLK (13174)	15.5	39.5
12414690-208	C608-100BLK (13174)	6.7	17.0
12414690-209	C608-100BLK (13174)	19.5	49.5
12414690-210	C608-100BLK (13174)	15.5	39.3
12414690-211	C608-100BLK (13174)	8.0	20.3
12414690-212	C608-100BLK (13174)	16.9	43.0
12414690-213	C608-100BLK (13174)	118.5	301.0
12414690-214	C608-100BLK (13174)	124.0	315.0
12414690-215	C608-100BLK (13174)	163.0	414.0
12414690-216	C608-100BLK (13174)	160.0	406.4
12414690-217	C608-100BLK (13174)	62.6	159.0
12414690-218	C608-100BLK (13174)	119.8	304.2
12414690-219	C608-100BLK (13174)	69.0	175.3
12414690-220	C608-100BLK (13174)	45.5	115.6
12414690-221	C608-100BLK (13174)	12.6	32.0
12414690-222	C608-100BLK (13174)	5.5	14.0
12414690-223	C608-100BLK (13174)	14.6	37.1
12414690-224	C608-100BLK (13174)	170.0	431.8
12414690-225	C608-100BLK (13174)	174.0	442.0
12414690-226	C608-100BLK (13174)	103.5	263.0
12414690-227	C608-100BLK (13174)	32.8	83.2
12414690-228	C608-100BLK (13174)	3.5	8.9
12414690-229	C608-100BLK (13174)	62.2	158.1
12414690-230	C608-100BLK (13174)	14.6	37.0
12414690-231	C608-100BLK (13174)	60.5	153.7
12414690-301	PFT-10B-BLK-100 (61424)	19.0	48.3
12414690-302	PFT-10B-BLK-100 (61424)	56.0	142.2
12414690-303	PFT-10B-BLK-100 (61424)	118.1	300.0

E-12. NON-METALLIC ELECTRICAL CABLE CONDUIT FABRICATION
--

Make conduit to cover electrical cables described on 1241638 from bulk tube stock listed in **Table E-2. Non-Metallic Electrical Cable Conduit Lengths**. Use a fine-toothed hacksaw or suitable cutting device and cut hose/tube to required length.

Table E-2. Non-Metallic Electrical Cable Conduit Lengths

Tube Part Number	Bulk Tube Part Number	Cut Length	
		inch	cm
12416381P1	49008	8.9	22.6
12416381P10	49008	17.8	45.2
12416381P11	49008	29.9	75.9
12416381P12	49008	33.0	83.8
12416381P13	49008	13.9	35.3
12416381P14	49008	4.0	10.2
12416381P15	49008	17.4	44.2
12416381P16	49008	3.2	8.1
12416381P17	49008	4.5	11.4
12416381P2	49008	16.2	41.1
12416381P20	27413	32.8	83.3
12416381P21	27413	9.2	23.4
12416381P22	27413	8.0	20.3
12416381P23	27413	23.3	59.2
12416381P26	49008	2.5	6.4
12416381P3	27413	7.3	18.5
12416381P30	49007	17.0	43.2
12416381P32	49005	1.7	4.3
12416381P34	49005	20.7	52.6
12416381P35	49005	21.8	55.4
12416381P36	49005	5.5	14.0
12416381P37	49005	8.0	20.3
12416381P38	49008	3.7	9.4
12416381P4	49008	12.0	30.5
12416381P5	49008	26.0	66.0
12416381P6	49008	7.7	19.6
12416381P7	49008	26.7	67.8
12416381P8	49008	5.2	13.2
12416381P9	49008	16.8	42.7

E-13. STEERING GEAR RETURN HOSE AND TRANSMISSION OIL COOLER HOSES FABRICATION

Cut the following hoses from bulk hose using a fine-toothed hacksaw or suitable cutting device.

Hose Part Number	Bulk Hose Part Number	Cut Length	
		inches	cm
12418037	A110 (30327)	75.5	191.7
12418460-001	MS521302B110360 (96906)	17.5	44.4
12418460-002	MS521301A206R (96906)	16.0	40.6

E-14. LANYARD ASSEMBLIES P/N 12418763 AND 12420196 FABRICATION

Make the following lanyard assemblies from bulk cable material, sleeves, and tab material and assemble according to **Figure E-8. Lanyard Assembly**. The following parts list identifies part numbers and lengths of cut pieces.

Item	Part Number	Material Description	Size	Qty
1	MIL-W-83420 Type 1, Comp B	1/16 in. stranded wire cable	4 in. (102 mm)	1
2	MS51844-22	Sleeve		2
3	N/A	Tab, Stainless Steel ASTM A617	.06 in. (16 mm) X .37 in. (9.5 mm) X 1.25 in. (32 mm)	1

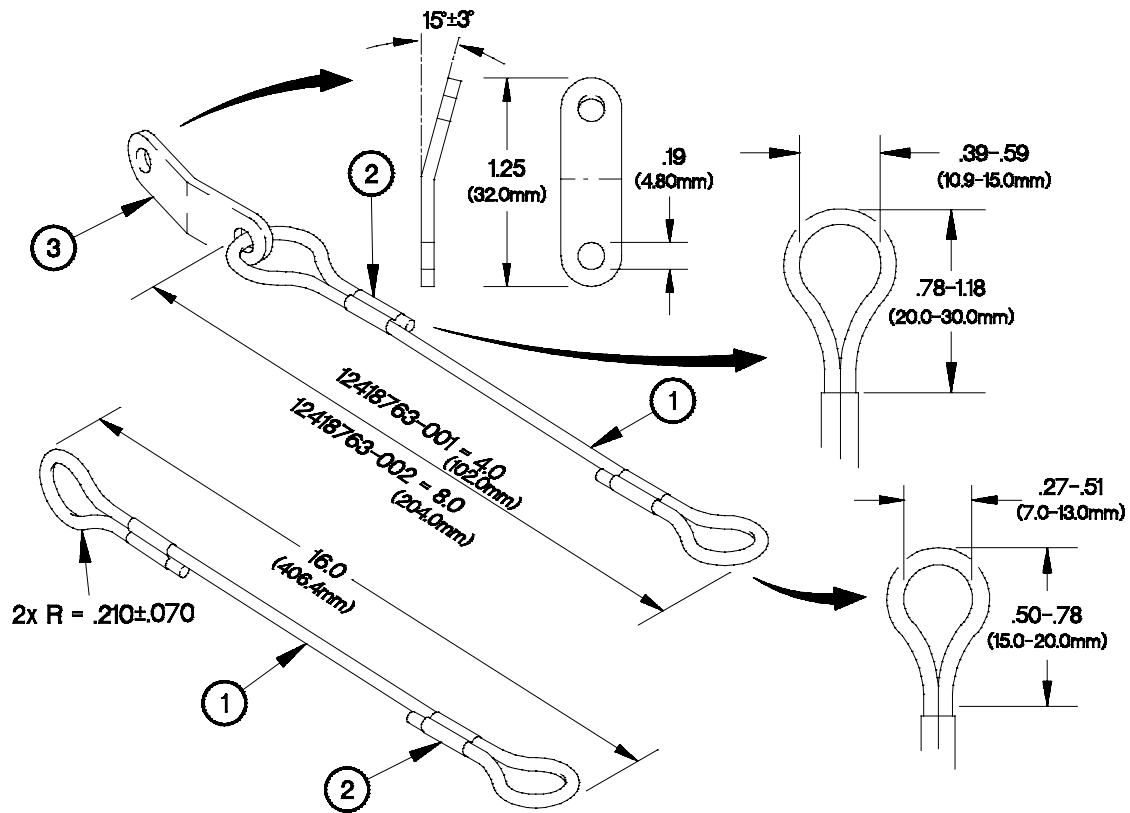

XAPPE131

Figure E-8. Lanyard Assembly

- a. All dimensions are in inches (millimeters).
- b. Make from bulk cable and flat steel material as identified in parts list.
- c. Drill two 0.19 in. (4.8 mm) diameter holes through tab material as shown on **Figure E-14. Lanyard Assembly.**
- d. De-burr and remove sharp edges.
- e. Bend tab as shown on **Figure E-14. Lanyard Assembly.**
- f. Form loops on cable ends and insert sleeve material over cable on one end of cable and over cable and through sleeve at other end of cable as shown in **Figure E-14. Lanyard Assembly.**
- g. Crimp two sleeves over cable ends.

E-15. NON-METALLIC VENT AIR HOSES FABRICATION

Cut the following vent air hoses from bulk hose using a fine-toothed hacksaw or suitable cutting device.

Hose Part Number	Bulk Hose Part Number	Cut Length	
		inches	cm
12420197-001	483666 (02280)	180.0	457.2
12420197-002	483666 (02280)	120.0	304.8
12420197-003	483666 (02280)	96.0	243.8
12420197-004	483666 (02280)	36.0	91.4
12420197-005	483666 (02280)	156.0	396.2
12420197-006	483666 (02280)	72.0	182.9
12420198-001	881-16 (98441)	120.0	304.8
12420198-002	11657469	36.0	91.4

E-16. PERSONNEL HEATER AIR DUCT HOSE FABRICATION

Cut the following hoses from bulk hose using a fine-toothed hacksaw or suitable cutting device.

Hose Part Number	Bulk Hose Part Number	Cut Length	
		inches	cm
12420308-457	8711054 (19207)	18.3	46.4
12420308-760	8711054 (19207)	30.4	77.2

E-17. BLOCK SEAL 12420489 FABRICATION

Make block seal from P/N (0VXY8) STN2.38X.5. Use a suitable cutting tool to cut seal to 0.52 inch (1.3 cm) long.

E-18. CTIS SEAL DRIVER 3256-H-1048

Used on Front and Rear Axle CTIS Seals.

NOTES ON USE OF DRIVER

- 1) SEAL END OF DRIVER TO BE CLEAN OF DEBRIS, DIRT, NICKS AND BURRS
- 2) DO NOT USE A METAL HAMMER ON DRIVER
A RUBBER, PLASTIC, WOOD OR SOME OTHER DEAD BLOW TYPE Mallet IS TO BE USED
- 3) SLIGHTLY GREASE SEAL END OF DRIVER PRIOR TO INSTALLING SEAL

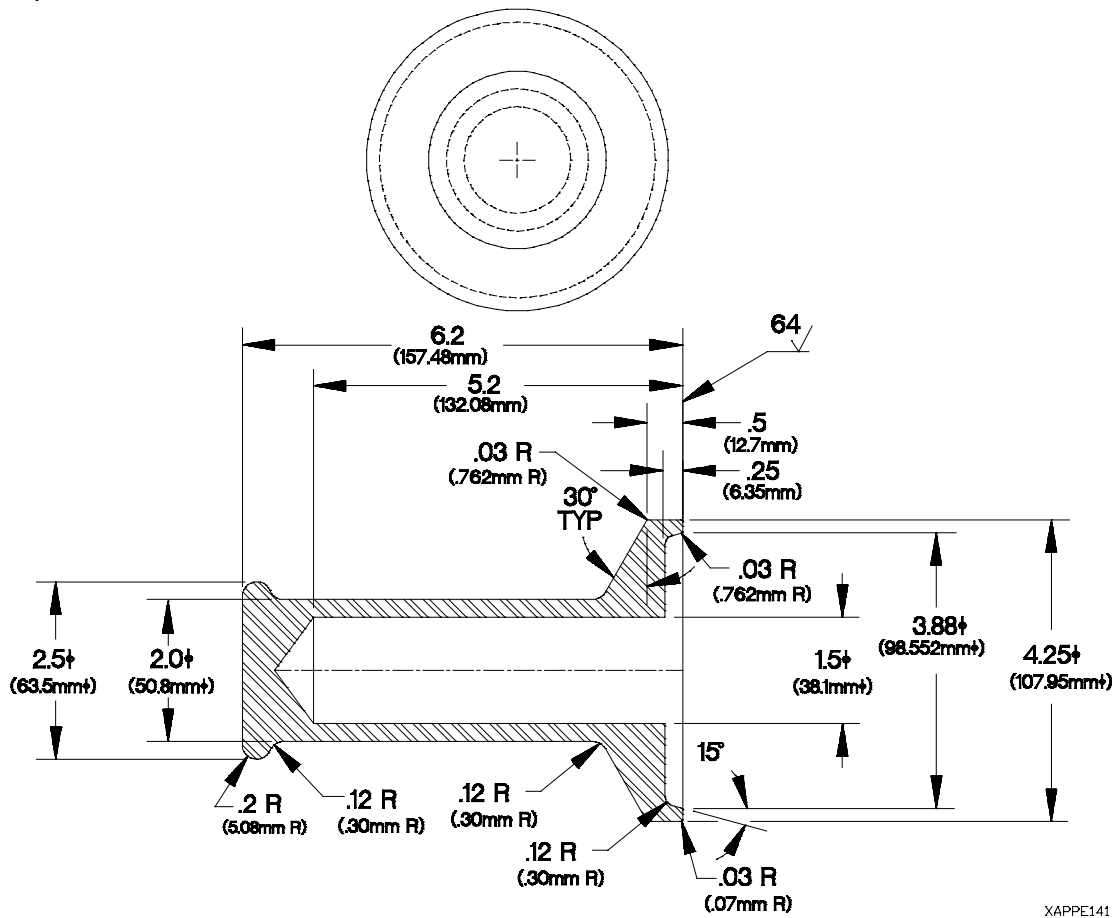

Figure E-9. CTIS Seal Driver

- a. All dimensions are in inches (millimeters).
- b. Manufacture from round steel stock.
- c. De-burr and remove sharp edges.

E-19. WHEEL HUB GREASE SEAL DRIVER 3256-K-1051

NOTES ON USE OF DRIVER

- 1) SEAL END OF DRIVER TO BE CLEAN OF DEBRIS, DIRT, NICKS AND BURRS
- 2) DO NOT USE A METAL HAMMER ON DRIVER
A RUBBER, PLASTIC, WOOD OR SOME OTHER DEAD BLOW TYPE Mallet IS TO BE USED
- 3) SLIGHTLY GREASE SEAL END OF DRIVER PRIOR TO INSTALLING SEAL

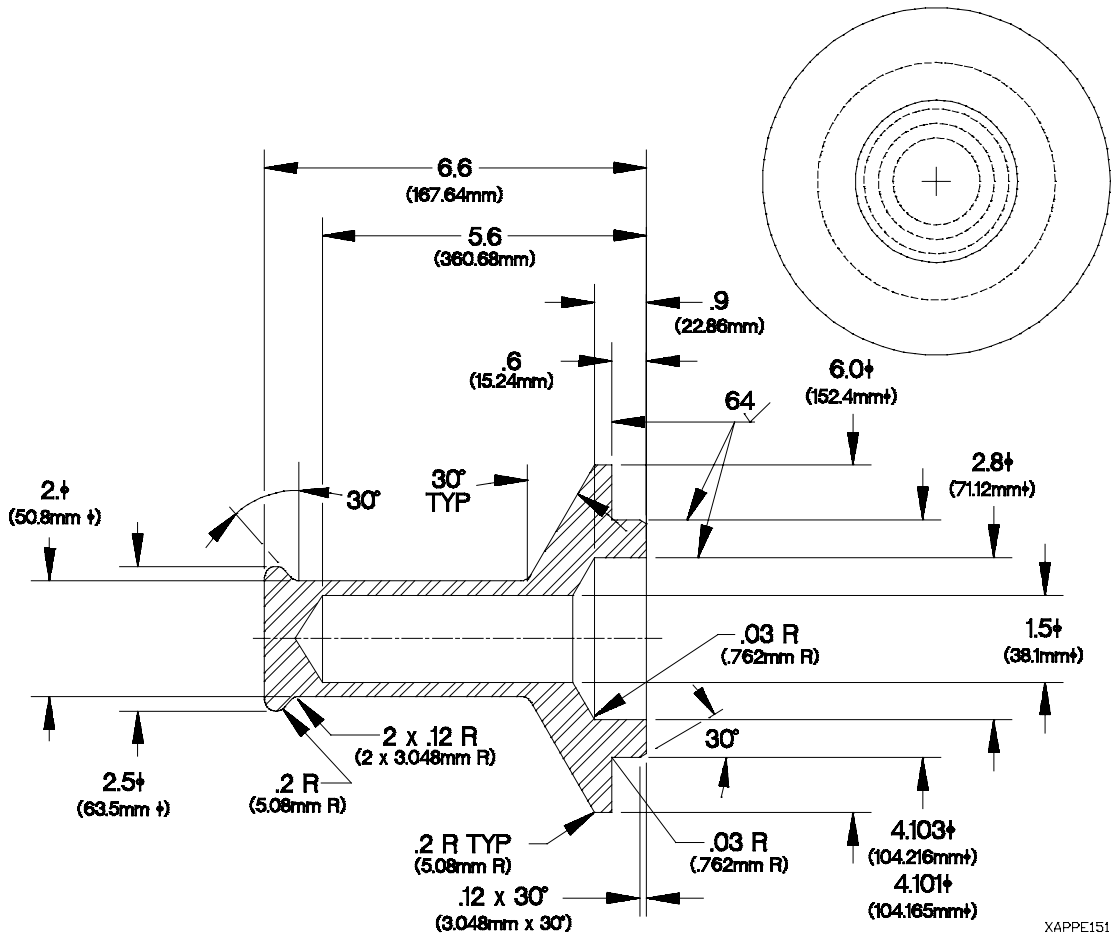

Figure E-10. Wheel Hub Grease Seal Driver

- a. All dimensions are in inches (millimeters).
- b. Manufacture from round steel stock.
- c. De-burr and remove sharp edges.

E-20. DIMMER SWITCH TEST WIRE

Fabricate the dimmer switch test wire according to the following steps. Refer to the following parts list for materials.

Material Description	National Stock Number	Quantity	Cut Length
Wire, Electrical (M168678/14BKE9)	6145-01-229-4134	1	12 in (305 mm)
Pin, Grooved, Headless (12258939-1)	5315-01-156-6314	1	
Contact, Electrical (12258939-2)	5999-01-150-8808	1	

- a. Dimensions are in inches (millimeters).
- b. Cut a length of electrical wire approximately 12 in. (305 mm) long.
- c. Remove approximately 1/4 in. (6 mm) of insulation from each end of electrical wire.
- d. Crimp headless grooved pin on one end of electrical wire.
- e. Crimp electrical contact on opposite end of electrical wire.

E-21. PURGE VALVE TOOL

Fabricate Purge Valve Tool according to the following instructions. Refer to Figure E-11. Purge Valve Tool for details.

Item	Part Number	Material Description	Size	Qty
1	N/A	Steel, ASTM A 108 or A576 Grade 1015-1025, BAR (Ref UNS G10150-G10250). Finish Black Oxide Coat, Class I, IAW MIL-C-13924.	14.0 in. (356 mm)	1

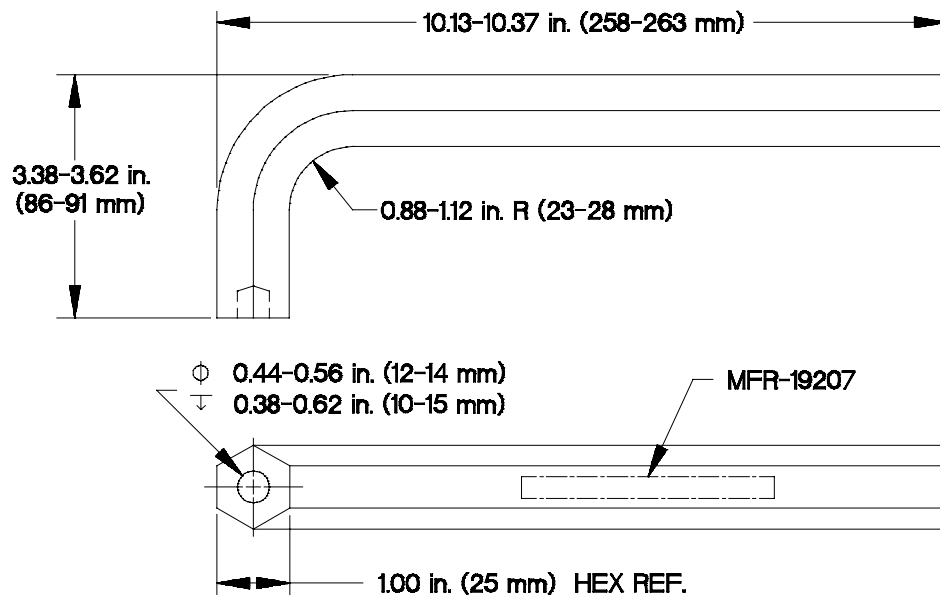

Xappe17b

Figure E-11. Purge Valve Tool

- All dimensions are in inches (cm).
- Cut steel bar (1) and bend to shape as shown in Figure E-11.
- Dimensional limits apply after coating.
- All edges shall be broken and free from burrs.
- Metal Stamp, electro etch, or engrave with the following marking IAW MIL-STD-130: 19207-12379968 MFR-19207.

APPENDIX F TORQUE LIMITS

F-1. GENERAL

This appendix provides general torque limits for screws and nuts used on the vehicle. Special torque limits are shown in the maintenance procedures for applicable components. Use the general torque limit given in this appendix when specific torque limits are not given in the maintenance procedure. These general torque limits can not be applied to screws that retain rubber components. The rubber components will be damaged before the torque limit is reached. If a special torque limit is not given in the maintenance instructions for a fastener which retains a rubber component, tighten the screw or nut until it touches metal, then tighten one more turn. Whenever possible, the tightening force (torque) should be applied to the nut side of the fastener group.

F-2. TORQUE LIMITS

Refer to [Table F-1. Torque Limits for SAE and ANSI Fasteners](#) for torque limits on standard (SAE and ANSI) screws and free spinning nuts. Refer to [Table F-2. Torque Limits for SAE and ANSI Prevailing Torque Nuts](#) for torque limits on standard (SAE and ANSI) self-locking nuts. Refer to [Table F-3. Torque Limits for Metric Screws and Free Spinning Nuts](#) for torque limits on metric screws and free spinning nuts. Refer to [Table F-4. Torque Limits for Metric Prevailing Torque Nuts](#) for torque limits on metric self-locking nuts.

F-3. USE OF TORQUE TABLES

- (1) Measure the diameter of the screw to be installed.
- (2) Count the number of threads per inch.
- (3) Under the heading DIAMETER look down the column until the diameter of the screw is found. (There are usually two lines beginning with the same diameter.)
- (4) Under the heading THREADS PER INCH (SAE and ANSI) or THREAD PITCH (metric), find the number of threads per inch that matches the number counted in step (2).
- (5) To find the grade of the screw, match the markings on the head to the correct picture under CAPSCREW HEAD MARKINGS on the torque table.
- (6) Look down the column under the picture found in step (5) until the torque limit (lb-ft or N·m) for the diameter and threads per inch (or thread pitch, in the case of metric fasteners) of the screw are located.

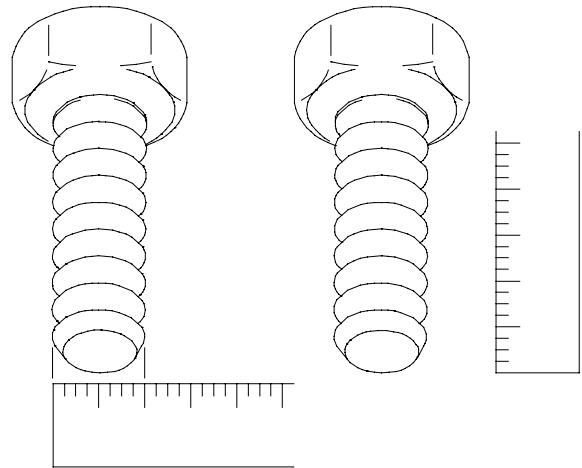

XAPPF01A

APPENDIX F TORQUE LIMITS

Table F-1. Dry Torque Limits for SAE and ANSI Screws and Free Spinning Nuts

 <p style="text-align: center; margin-top: 5px;">NOTE Manufacturer's marks may vary. These are all SAE Grade 5.</p>		Material Grade Markings					
		 XAPPF03A SAE Grade 2	 XAPPF04A SAE Grade 5	 XAPPF051 SAE Grade 8			
		Torque					
Diameter	Threads per inch						
inch		lb-ft	N-m	lb-ft	N-m	lb-ft	N-m
1/4	20	3-5	5-7	5-7	8-10	8-10	10-14
1/4	28	4-6	5-7	6-8	9-11	8-12	12-16
1/4	32	4-6	5-7	7-9	9-11	9-13	12-16
5/16	18	7-9	9-13	11-15	15-21	15-21	21-29
5/16	24	8-10	11-15	12-16	17-23	17-23	24-32
5/16	32	9-11	12-16	14-18	18-24	19-25	27-34
3/8	16	13-17	17-23	20-26	27-35	28-38	38-50
3/8	24	15-19	20-26	22-30	31-41	32-42	43-57
3/8	32	15-21	21-27	24-32	33-43	33-45	55-61
7/16	14	20-28	28-38	32-42	43-57	44-60	61-81
7/16	20	23-31	31-41	35-47	48-64	49-67	68-90
7/16	28	25-33	33-45	37-51	51-69	54-72	73-97
1/2	13	32-42	43-57	49-65	66-88	68-92	93-123
1/2	20	35-47	48-64	55-73	74-98	77-103	105-139
1/2	28	38-50	51-67	58-78	79-105	82-110	111-149
9/16	12	55-61	62-82	70-94	95-127	98-132	134-178
9/16	18	50-68	69-91	78-104	105-141	109-147	149-199
9/16	24	53-71	72-96	82-110	111-149	115-155	158-210
5/8	11	62-84	85-113	95-129	131-175	136-182	184-246
5/8	18	70-94	96-128	108-146	148-198	154-206	209-279
5/8	24	73-99	100-134	114-154	155-207	161-217	219-293

Table F-1. Dry Torque Limits for SAE and ANSI Screws and Free Spinning Nuts (Cont)

 Manufacturer's marks may vary. These are all SAE Grade 5		Material Grade Markings					
		 SAE Grade 2	 SAE Grade 5	 SAE Grade 8	Torque		
Diameter	Threads per inch	lb-ft	N-m	lb-ft	N-m	lb-ft	N-m
inch							
11/16	24	99-133	135-181	153-207	209-279	217-291	296-394
3/4	10	110-148	150-200	171-229	232-310	240-324	328-438
3/4	16	123-165	168-224	190-256	259-345	269-361	366-488
3/4	20	127-171	174-232	197-265	268-358	278-374	379-505
13/16	20			252-340	345-459	357-481	487-649
7/8	9			275-369	374-498	387-521	528-704
7/8	14			303-407	413-551	427-575	583-777
7/8	20			319-429	435-579	450-606	614-818
15/16	20			395-531	538-718	558-750	760-1014
1	8			411-553	560-748	581-781	792-1056
1	12			450-606	614-818	636-856	867-1155
1	20			483-649	658-878	681-917	929-1239
1-1/16	18			576-776	782-1044	813-1095	1109-1479
1-1/8	7			507-683	693-923	824-1108	1123-1497
1-1/8	12			570-766	776-1034	923-1241	1258-1678
1-1/8	18			600-806	817-1089	971-1307	1324-1766
1-3/16	18			709-953	966-1288	1149-1545	1566-2088
1-1/4	7			716-964	976-1302	1161-1563	1584-2112
1-1/4	12			793-1067	1081-1441	1286-1730	1754-2338
1-1/4	18			831-1117	1132-1510	1346-1812	1835-2447
1-5/16	18			965-1299	1316-1754	1565-2105	2134-2846
1-3/8	6			939-1263	1281-1707	1523-2049	2076-2768

APPENDIX F TORQUE LIMITS

Table F-2. Dry Torque Limits for SAE and ANSI Prevailing Torque Nuts

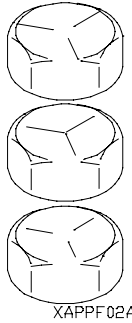
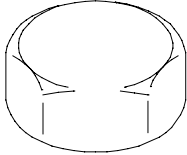
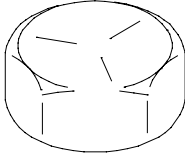
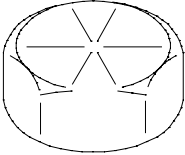
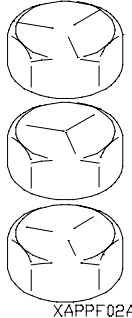
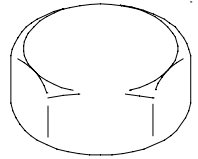
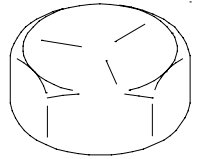
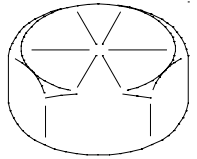
		Material Grade Markings				
		 XAPPF061 SAE Grade 5				 XAPPF071 SAE Grade 8
Hole Diameter	Threads per inch	Torque				
		lb-ft	N-m	lb-ft	N-m	
inch						
1/4	20	10-12	14-16	15-17	20-24	
1/4	28	12-14	16-18	14-18	21-25	
5/16	18	20-24	27-33	26-32	36-44	
5/16	24	22-26	30-36	29-35	40-48	
3/8	16	35-41	47-55	48-58	65-77	
3/8	24	38-46	53-63	53-63	72-86	
7/16	14	55-65	74-88	75-91	103-123	
7/16	20	60-70	81-97	80-98	110-132	
1/2	13	86-102	116-138	113-137	154-184	
1/2	20	92-110	125-149	127-153	177-207	
9/16	12	120-144	162-194	168-202	229-273	
9/16	18	135-161	183-219	179-217	244-294	
5/8	11	165-199	226-270	226-272	306-368	
5/8	18	181-219	246-296	244-296	331-401	
3/4	10	296-354	402-480	395-479	538-648	
3/4	16	310-376	422-508	424-516	576-698	
7/8	9	460-554	625-749	612-746	833-1009	
7/8	14	503-607	684-822	652-800	888-1082	
1	8	686-828	933-1121	941-1141	1280-1544	

Table F-3. Dry Torque Limits for Metric Screws and Free Spinning Nuts

		Material Grade Markings							
		 XAPPF081 Metric Grade 4.8	 XAPPF091 Metric Grade 8.8	 XAPPF101 Metric Grade 10.9	 XAPPF111 Metric Grade 12.9				
Diameter	Thread Pitch	Torque							
		lb-ft	N-m	lb-ft	N-m	lb-ft	N-m	lb-ft	N-m
6	1	3	4-5	5-7	7-9	7-9	10-13	8-11	11-15
8	1.25	7-9	9-11	13-17	17-23	17-23	23-31	21-27	27-37
8	1	7-9	9-13	14-18	18-24	19-25	25-33	21-29	29-39
10	1.5	13-17	17-23	25-33	33-45	34-46	46-62	40-54	54-72
10	1.25	14-18	18-24	26-34	35-47	36-48	49-65	42-56	57-77
10	0.75	15-19	21-27	29-39	39-53	40-54	54-72	47-63	63-85
12	1.75	22-30	30-40	43-57	58-78	60-80	81-107	69-93	94-126
12	1.5	23-31	32-42	46-60	61-81	63-83	85-113	73-97	99-131
12	1.25	24-32	33-45	47-63	65-85	65-87	88-118	76-102	104-138
12	1	26-34	34-46	49-65	67-89	68-90	93-123	80-106	108-144
14	2	36-48	48-74	69-91	93-125	95-127	129-173	112-148	151-201
14	1.5	39-51	52-70	75-99	99-135	103-137	140-186	120-160	163-217
15	1	51-69	69-93	100-132	135-179	137-183	187-249	160-214	218-290
16	2	55-73	75-99	107-143	145-193	148-198	201-267	173-231	235-313
16	1.5	59-79	80-106	114-152	155-207	158-210	214-286	184-246	250-334
18	1.5			166-222	225-301	230-306	311-415	268-358	364-486
20	2.5			209-279	283-377	289-385	392-522	338-450	458-610
20	1.5			232-308	315-419	321-427	435-579	375-499	508-678
20	1			244-324	330-440	337-449	457-609	394-524	534-712
22	2.5			285-379	387-515	394-524	534-712	461-613	624-832
22	1.5			313-417	424-566	432-576	586-782	664-884	900-1200
24	3			361-481	489-653	499-665	677-903	584-778	791-1055
24	2			394-524	534-712	545-725	738-984	725-965	982-1310
25	1.5			467-621	633-843	645-859	875-1167	754-1004	1023-1363

APPENDIX F TORQUE LIMITS

Table F-4. Dry Torque Limits for Metric Prevailing Torque Nuts

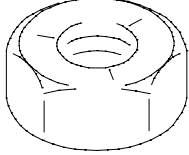
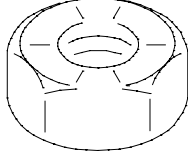
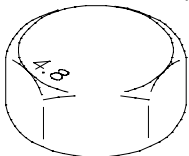
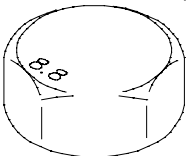
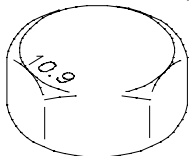
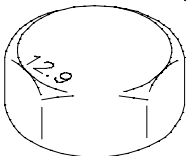
		Material Grade Markings							
		 XAPPF121 Metric Grade 4.8	 XAPPF131 Metric Grade 8.8	 XAPPF141 Metric Grade 10.9			 XAPPF151 Metric Grade 12.9		
Diameter	Thread Pitch	Torque							
		lb-ft	N-m	lb-ft	N-m	lb-ft	N-m	lb-ft	N-m
6	1	5-6	7-8	7-9	10-12	10-12	14-17	11-14	15-19
8	1.25	12-14	16-18	18-22	24-30	24-30	32-40	27-33	36-46
8	1	12-14	16-20	19-23	25-31	25-31	34-42	28-36	38-48
10	1.5	21-25	28-34	33-41	44-56	44-56	60-76	50-64	68-86
10	1.25	21-25	29-35	34-42	46-58	46-58	63-79	53-67	71-91
10	0.75	23-27	31-37	37-47	49-63	50-64	68-86	57-73	77-99
12	1.75	33-41	46-56	55-69	74-94	75-95	102-128	85-109	115-147
12	1.5	35-43	47-57	56-72	77-97	78-98	106-134	89-113	120-152
12	1.25	36-44	48-60	58-74	79-101	81-103	109-139	91-117	125-159
12	1	37-45	50-62	61-77	82-104	84-106	114-144	95-121	129-165
14	2	53-65	72-88	87-109	117-149	118-150	160-204	134-172	182-232
14	1.5	57-69	76-94	92-116	125-159	126-160	171-217	143-183	194-248
16	2	79-97	107-131	130-166	177-225	178-228	243-309	204-262	277-355
16	1.5	82-102	112-138	138-176	187-239	189-241	256-328	215-277	292-376
18	1.5			197-253	267-343	271-347	367-471	309-399	420-542
20	2.5			248-318	337-431	342-438	464-594	391-503	530-682
20	1.5			271-349	369-473	374-480	507-651	428-552	580-750
20	1			283-365	384-494	390-502	529-681	447-577	606-784
22	2.5			335-429	455-583	460-592	624-802	526-680	714-922
22	1.5			363-467	492-634	499-643	676-872	730-950	990-1290
24	3			420-540	569-733	577-743	783-1009	662-856	897-1161
24	2			453-583	614-792	622-804	844-1090	803-1043	1088-1416

Table F-5. Wet Torque Limits for SAE and ANSI Screws and Free Spinning Nuts

 <p>NOTE Manufacturer's marks may vary. These are all SAE Grade 5.</p>		Material Grade Markings					
		 XAPPF03A SAE Grade 2	 XAPPF04A SAE Grade 5	 XAPPF051 SAE Grade 8	Torque		
Diameter	Threads per inch	lb-ft	N-m	lb-ft	N-m	lb-ft	N-m
inch							
1/4	20	4	6	6	8	9	12
1/4	28	5	7	7	9	10	14
5/16	18	8	11	13	18	18	24
5/16	24	9	12	14	19	20	27
3/8	16	15	20	23	31	35	47
3/8	24	17	23	25	34	35	47
7/16	14	24	33	35	47	55	75
7/16	20	25	34	40	54	60	81
1/2	13	35	47	55	75	80	108
1/2	20	40	54	65	88	90	122
9/16	12	50	68	80	108	110	149
9/16	18	55	75	90	122	130	176
5/8	11	70	95	110	149	170	231
5/8	18	80	108	130	176	180	244
3/4	10	120	163	200	271	280	380
3/4	16	140	190	220	298	320	434
7/8	9	110	149	300	407	460	624
7/8	14	120	163	320	434	500	678
1	8	160	217	440	597	680	922
1	12	170	231	480	651	740	1003
1-1/8	7	220	298	600	814	960	1302
1-1/8	12	260	353	660	895	1080	1464

APPENDIX F TORQUE LIMITS

Table F-5. Wet Torque Limits for SAE and ANSI Screws and Free Spinning Nuts (Cont)

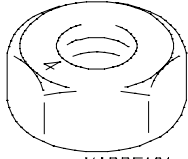
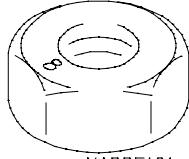
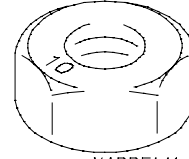
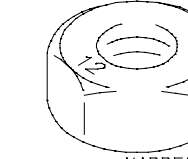
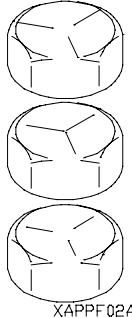
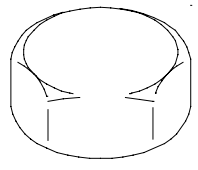
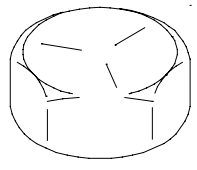
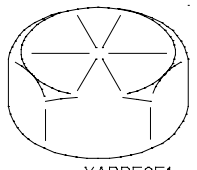
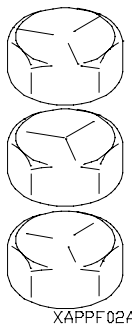
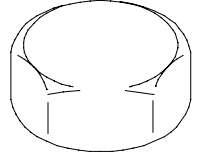
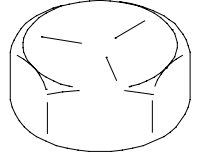
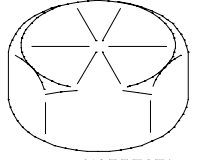
 <p style="text-align: center; font-size: small;">XAPPF02A</p> <p style="text-align: center;">Manufacturer's marks may vary. These are all SAE Grade 5</p>		Material Grade Markings					
		 <p style="text-align: center; font-size: small;">XAPPF03A</p> <p style="text-align: center;">SAE Grade 2</p>		 <p style="text-align: center; font-size: small;">XAPPF04A</p> <p style="text-align: center;">SAE Grade 5</p>		 <p style="text-align: center; font-size: small;">XAPPF051</p> <p style="text-align: center;">SAE Grade 8</p>	
		Torque					
Diameter	Threads per inch						
inch		lb-ft	N·m	lb-ft	N·m	lb-ft	N·m
1-1/4	7	320	434	840	1139	1360	1844
1-1/4	12	360	488	920	1248	1500	2034
1-3/8	6	420	570	1100	1492	1780	2414
1-3/8	12	460	624	1260	1709	2040	2766

APPENDIX G MANDATORY REPLACEMENT PARTS

Section I. INTRODUCTION

G-1. SCOPE

This appendix lists mandatory replacement parts you will need to maintain the LMTV vehicle.

G-2. EXPLANATION OF COLUMNS

- a. Column (1) - Item Number.** This number is assigned to each entry in the listing and is referenced in the Initial Setup of the applicable task under Materials/Parts.
- b. Column (2) - Nomenclature.** Name or identification of the part.
- c. Column (3) - Part Number.** The manufacturer's part number.
- d. Column (4) - National Stock Number.** The National stock number of the part.

Section II. MANDATORY REPLACEMENT PARTS LIST

(1) ITEM NO.	(2) NOMENCLATURE	(3) PART NUMBER	(4) NATIONAL STOCK NUMBER
1	BLADE, WINDSHIELD WIPER	105.384	2540-01-364-1621
2	BOLT, MACHINE	12414307-065	5306-01-382-5054
3	BOOT KIT, EXHAUST	DQ6025	4730-01-417-3197
4	BUMPER, RUBBER	12419182	5340-01-410-8397
5	BUSHING, SLEEVE	7-199-002668	3120-01-367-6894
6	CHANNEL, RUBBER	ZZR765/2-001A7	9390-01-420-4560
7	CLAMP	12421183-005	4730-01-447-4312
8	CLAMP	12421183-006	4730-01-447-4313
9	DECAL	12340917	7690-01-256-4909
10	FASTENER TAPE	MIL-F-21840	8315-00-006-9855
11	FASTENER TAPE	50-534718-19	8315-00-935-6762
12	FILTER ASSEMBLY	75223-11	2940-01-417-9333
13	FILTER ELEMENT	1048011	2940-01-385-8931
14	FILTER ELEMENT, FLUID	R22146	2910-01-360-6366
14.1	FILTER ELEMENT, FLUID	ST117073098-000	2910-01-467-4594
15	FILTER ELEMENT, FLUID	29507750	2940-01-361-2406
16	FILTER ELEMENT, FLUID	599791	4460-01-284-2344

Section II. MANDATORY REPLACEMENT PARTS LIST (CONT)

(1) ITEM NO.	(2) NOMENCLATURE	(3) PART NUMBER	(4) NATIONAL STOCK NUMBER
17	FILTER ELEMENT, FLUID	931558	2940-01-363-4377
18	FILTER ELEMENT, INTAKE AIR CLEANER	P52-7750	2940-01-361-2407
19	FILTER, AIR	12416539	
20	FILTER, AIR	12416563	4730-01-398-5654
21	FILTER, FUEL	7E9763	2940-01-363-3089
22	FILTER, OIL	1R0739	2940-00-029-0388
23	GASKET	F337576M6	
24	GASKET	M28840/24HA	5935-01-421-9754
25	GASKET	QS-1181	5330-01-058-3788
26	GASKET	10-36675-18	5330-00-298-0190
26.1	GASKET	11446	5330-00-247-4174
27	GASKET	119-2940	5330-01-424-7905
28	GASKET	12421469	5330-01-453-2980
29	GASKET	12422254	
30	GASKET	13848	5330-01-211-0717
31	GASKET	350700	5330-01-295-3053
32	GASKET	350903	5330-00-576-4626
33	GASKET	352200	5330-01-421-6105
34	GASKET	352302	5330-01-421-6107
35	GASKET	353400	5330-01-421-6102
36	GASKET	353806	5330-01-421-6103
37	GASKET	353810	5330-01-450-6666
38	GASKET	355148	5330-01-423-0596
39	GASKET	355175	5330-01-423-0623
40	GASKET	3K3257	5330-01-305-6550
40.1	GASKET	3N4087	5330-01-061-8003
41	GASKET	4P1624	5330-01-360-5934
42	GASKET	9Y8103	5330-01-360-5931
42.1	GASKET AND PREFORMED PACKING SET	9X8318	5330-01-360-9098
43	GASKET, FUEL FILTER	7C1159	5330-01-360-5941
44	NOT USED		

Section II. MANDATORY REPLACEMENT PARTS LIST (CONT)

(1) ITEM NO.	(2) NOMENCLATURE	(3) PART NUMBER	(4) NATIONAL STOCK NUMBER
45	GASKET, THERMOSTAT	2W7212	5330-01-347-3206
46	GROMMET, NONMETALLIC	MS35489-6	5325-00-263-6632
47	GROMMET, NONMETALLIC	12417598	5325-01-375-1299
48	GROMMET, NONMETALLIC	12421402	5325-01-440-2178
49	GROMMET, NONMETALLIC	4082-37634-01	5325-01-194-3076
50	GROMMET, NONMETALLIC	50S12-1-1AA	5325-01-145-0105
51	GROMMET, NONMETALLIC	8741442	5325-00-088-6147
51.1	HEAD, FLUID FILTER	7632-002-144	2940-01-387-4397
52	INSULATOR, TANK	A1394J	5970-01-385-7317
53	INSULATOR, TANK	A1394K	5970-01-385-7262
54	KIT, FILTER	29503829	
55	KIT, FILTER	29526899	5330-01-453-0770
56	NOT USED		
57	LAMP, INCANDESCENT	CM7-7373	6240-00-270-6824
58	LAMP, INCANDESCENT	CM7376	6240-00-499-6278
59	LATCH, BAIL HEAD	68-20-101-10	2540-01-232-2470
60	LOCKNUT	0770-023-003	5310-01-423-3725
61	LOCKWASHER	ABCH207-LW-1/2	
62	LOCKWASHER	ABCH207-LW-3/8	
63	LOCKWASHER	B7949000161	
64	LOCKWASHER	D70336/1-20	5310-01-110-7933
65	LOCKWASHER	D70336/3-50	5310-01-439-2542
66	LOCKWASHER	D70336/3-52	5310-01-439-2543
66.1	LOCKWASHER	MS35333-78	5310-01-110-7953
66.2	LOCKWASHER	ERNA245	5310-00-584-5272
67	LOCKWASHER	MS35335-30	5310-00-209-0788
68	LOCKWASHER	MS35335-31	5310-00-596-7693
69	LOCKWASHER	MS35335-33	5310-00-209-0786
70	LOCKWASHER	MS35335-36	5310-00-550-3503
71	LOCKWASHER	MS35335-38	5310-00-616-6354
72	LOCKWASHER	MS35335-58	5310-00-209-1366
73	LOCKWASHER	MS35335-61	5310-00-527-3634
74	LOCKWASHER	MS35335-62	5310-00-184-9562

Section II. MANDATORY REPLACEMENT PARTS LIST (CONT)

(1) ITEM NO.	(2) NOMENCLATURE	(3) PART NUMBER	(4) NATIONAL STOCK NUMBER
75	LOCKWASHER	MS35337-25	5310-00-013-8502
76	LOCKWASHER	MS35338-100	5310-00-261-8278
77	LOCKWASHER	MS35338-102	5310-00-167-0671
78	LOCKWASHER	MS35338-103	5310-00-184-8971
79	LOCKWASHER	MS35338-135	5310-00-933-8118
80	LOCKWASHER	MS35338-136	5310-00-929-6395
81	LOCKWASHER	MS35338-137	5310-00-933-8119
82	LOCKWASHER	MS35338-138	5310-00-933-8120
83	LOCKWASHER	MS35338-139	5310-00-933-8121
84	LOCKWASHER	MS35338-140	5310-00-974-6623
85	LOCKWASHER	MS35338-141	5310-00-984-7042
86	LOCKWASHER	MS35338-143	5310-00-933-8778
87	LOCKWASHER	MS35338-158	5310-00-883-9417
88	LOCKWASHER	MS35338-171	5310-01-130-9066
89	LOCKWASHER	MS35338-42	5310-00-045-3299
90	LOCKWASHER	MS35338-43	5310-00-045-3296
91	LOCKWASHER	MS35338-45	5310-00-407-9566
92	LOCKWASHER	MS35338-46	5310-01-334-4710
93	LOCKWASHER	MS35338-51	5310-00-584-7888
94	LOCKWASHER	MS35340-44	5310-00-682-5930
95	LOCKWASHER	MS51414-1	5310-01-235-2057
96	LOCKWASHER	MS51414-2	5310-01-310-1098
97	LOCKWASHER	MS51848-50	5310-01-033-8615
98	LOCKWASHER	N9015	5310-01-369-6073
99	LOCKWASHER	N9018	5310-01-032-4827
100	LOCKWASHER	N9459	5310-01-348-8393
101	LOCKWASHER	N9461	5310-01-348-8392
101.1	LOCKWASHER	XP1113	5310-01-460-5991
101.2	LOCKWASHER	10241	5310-01-416-3010
101.3	LOCKWASHER	10030	
102	LOCKWASHER	1229-S-513C	5310-01-062-3384
102.1	LOCKWASHER	12414570-011	5310-01-374-3292

Section II. MANDATORY REPLACEMENT PARTS LIST (CONT)

(1) ITEM NO.	(2) NOMENCLATURE	(3) PART NUMBER	(4) NATIONAL STOCK NUMBER
102.2	LOCKWASHER	12414570-013	5310-01-374-4515
103	LOCKWASHER	12414570-015	5310-01-388-2043
103.1	LOCKWASHER	12414570-019	5310-01-470-2362
104	LOCKWASHER	12414570-021	5310-01-374-4516
105	LOCKWASHER	MS35338-40	5310-00-543-2410
106	LOCKWASHER	MS35338-47	5310-00-550-3741
107	NOT USED		
108	LOCKWASHER	1729B262	5310-00-964-7811
109	NOT USED		
110	NUT, BLIND RIVET	MS27130-S136	5310-01-409-4435
111	NUT, BLIND RIVET	MS27130-S148	5310-01-370-5548
112	NUT, BLIND RIVET	12421403-060	
113	NUT, BLIND RIVET	12421403-065	
114	NUT, BLIND RIVET	12421634-017	
115	NUT, BLIND RIVET	12442158-5	
115.1	NUT, PLAIN, ROUND	1727N40	5310-00-123-2572
116	NUT, SELF-LOCKING	DIN-934STM6	5310-01-342-2739
117	NUT, SELF-LOCKING	MS16228-10C	5310-00-245-8826
118	NUT, SELF-LOCKING	MS16228-5C	5310-00-584-7992
119	NUT, SELF-LOCKING	MS20500-524	5310-00-208-4023
120	NUT, SELF-LOCKING	MS21042-04	5310-00-811-6419
121	NUT, SELF-LOCKING	MS21042-5	5310-00-807-1469
122	NUT, SELF-LOCKING	MS21044C08	5310-00-982-6814
122.1	NUT, SELF-LOCKING	MS21045L5	5310-00-857-5559
123	NUT, SELF-LOCKING	MS21083N08	5310-00-941-6019
124	NUT, SELF-LOCKING	MS21083N6	5310-00-926-1852
125	NUT, SELF-LOCKING	MS51922-1	5310-00-088-1251
126	NUT, SELF-LOCKING	MS51922-2	5310-00-929-1807
127	NUT, SELF-LOCKING	MS51922-33	5310-00-225-6993
128	NUT, SELF-LOCKING	MS51922-5	5310-00-959-7600
129	NUT, SELF-LOCKING	N9406	5310-01-362-6171
130	NUT, SELF-LOCKING	N9410	5310-01-348-8398

Section II. MANDATORY REPLACEMENT PARTS LIST (CONT)

(1) ITEM NO.	(2) NOMENCLATURE	(3) PART NUMBER	(4) NATIONAL STOCK NUMBER
130.1	NUT, SELF-LOCKING	N9453	5310-01-348-8314
131	NUT, SELF-LOCKING	N9467	5310-01-350-4257
131.1	NUT, SELF-LOCKING	N9556	5310-01-423-0880
132	NUT, SELF-LOCKING	12301125	5310-01-210-0199
132.1	NUT, SELF-LOCKING	12411174-008	
133	NUT, SELF-LOCKING	12412476-04	5310-01-466-0565
134	NUT, SELF-LOCKING	12414308-002	5310-01-381-2819
135	NUT, SELF-LOCKING	12414308-003	5310-01-377-1549
136	NUT, SELF-LOCKING	12414308-004	5310-01-369-5703
137	NUT, SELF-LOCKING	12414308-007	5310-01-046-0186
138	NUT, SELF-LOCKING	12414308-017	5310-01-381-9830
139	NUT, SELF-LOCKING	12414308-018	5310-01-369-3337
140	NUT, SELF-LOCKING	12414308-019	5310-01-369-9522
141	NUT, SELF-LOCKING	12414308-020	5310-01-381-9849
142	NUT, SELF-LOCKING	12414308-021	5310-01-369-3338
143	NUT, SELF-LOCKING	12414308-022	5310-01-417-1262
144	NUT, SELF-LOCKING	12414308-025	5310-01-367-6706
145	NUT, SELF-LOCKING	12414308-027	5310-01-369-3339
146	NUT, SELF-LOCKING	12414315-003	5310-01-374-1382
147	NUT, SELF-LOCKING	12414315-005	5310-01-372-3023
148	NUT, SELF-LOCKING	12414315-006	5310-01-369-3332
149	NUT, SELF-LOCKING	12414315-009	5310-01-365-7236
150	NUT, SELF-LOCKING	12414315-012	5310-01-369-3331
151	NUT, SELF-LOCKING	12414315-017	5310-01-368-8065
152	NUT, SELF-LOCKING	12414420-004	5310-01-370-0010
152.1	NUT, SELF-LOCKING	12417642-002	5310-01-374-3288
153	NUT, SELF-LOCKING	12419003	5310-01-376-0773
154	NUT, SELF-LOCKING	270W10000	
155	NUT, SELF-LOCKING	29514660	
156	NUT, SELF-LOCKING	7951286	5310-00-789-0398
157	PACKING, PREFORMED	A82777	5330-00-579-6495
158	PACKING, PREFORMED	F4001-16	5331-01-466-0354
158.1	PACKING, PREFORMED	J515-16-3	5331-01-465-3634

Section II. MANDATORY REPLACEMENT PARTS LIST (CONT)

(1) ITEM NO.	(2) NOMENCLATURE	(3) PART NUMBER	(4) NATIONAL STOCK NUMBER
158.2	PACKING, PREFORMED	J515-4-1	5331-01-387-9490
159	PACKING, PREFORMED	J515-8-1	5330-00-292-8171
160	PACKING, PREFORMED	5999807	5331-01-456-9156
161	PACKING, PREFORMED	MS28775-011	5330-00-582-2133
162	PACKING, PREFORMED	MS28775-227	5330-00-576-9731
162.1	PACKING, PREFORMED	MS28775-910	5331-00-448-6753
163	PACKING, PREFORMED	MS28778-10	5330-00-285-9842
164	PACKING, PREFORMED	MS28778-12	5330-00-251-8839
165	PACKING, PREFORMED	MS28778-16	5330-00-816-3546
166	PACKING, PREFORMED	MS28778-4	5330-00-805-2966
166.1	PACKING, PREFORMED	MS28778-6	5331-00-804-5695
167	PACKING, PREFORMED	MS9955-113	5330-01-374-2325
168	PACKING, PREFORMED	M25988/1-246	5330-01-189-6351
168.1	PACKING, PREFORMED	M83461/1-442	5330-01-183-0987
169	PACKING, PREFORMED	OR420A	5330-01-389-6028
170	PACKING, PREFORMED	11639519-1	5330-00-463-0200
170.1	PACKING, PREFORMED	12422548-004	5331-01-059-1141
171	PACKING, PREFORMED	1509	5330-00-172-1919
171.1	PACKING, PREFORMED	195045	5331-00-618-5361
171.2	PACKING, PREFORMED	19755	5331-01-415-9632
171.3	PACKING, PREFORMED	198336	5331-00-584-1840
172	PACKING, PREFORMED	2M4453	5330-00-074-3768
173	PACKING, PREFORMED	22617-16	5330-01-168-0885
174	PACKING, PREFORMED	23043446	5330-01-424-6629
174.1	PACKING, PREFORMED	250192	5331-01-417-5105
174.2	PACKING, PREFORMED	251216	5330-01-417-5107
175	PACKING, PREFORMED	29500969	5330-01-360-7852
176	PACKING, PREFORMED	29503383	5330-01-360-6017
177	PACKING, PREFORMED	3-906N522-90	5330-01-104-1093
178	PACKING, PREFORMED	3-908N522-90	5330-00-929-8171
179	PACKING, PREFORMED	3D2824	5330-00-944-8281
180	PACKING, PREFORMED	3J1907	5330-01-333-6444

Section II. MANDATORY REPLACEMENT PARTS LIST (CONT)

(1) ITEM NO.	(2) NOMENCLATURE	(3) PART NUMBER	(4) NATIONAL STOCK NUMBER
181	PACKING, PREFORMED	3J7354	5330-00-954-8008
182	PACKING, PREFORMED	3K0360	5330-00-948-6482
183	PACKING, PREFORMED	4J5477	5330-00-855-8059
184	PACKING, PREFORMED	4L9564	5330-00-828-8639
184.1	PACKING, PREFORMED	420828	5340-01-417-3788
185	PACKING, PREFORMED	5-X-1155	5330-01-392-1637
186	PACKING, PREFORMED	5F7054	5330-00-339-6224
187	PACKING, PREFORMED	5P7813	5330-01-335-0042
188	PACKING, PREFORMED	6V8397	5330-00-579-6495
189	PACKING, PREFORMED	673268	
190	PACKING, PREFORMED	673269	5330-01-395-1252
191	PACKING, PREFORMED	7F8267	5330-01-291-7353
192	PACKING, PREFORMED	7320658	5330-00-297-7106
193	PACKING, PREFORMED	9604792-001	5330-01-429-3089
194	PAD, CUSHIONING	12416479-001	2590-01-397-7844
195	PAD, CUSHIONING	12416479-002	2590-01-412-2663
196	PARTS KIT, DEHYDRATOR	RN-60-A	4440-01-337-7324
197	PARTS KIT, SEAL REPLACEMENT	SK10-2	5330-01-350-4474
198	PARTS KIT, SEAL REPLACEMENT	SK10-3	5330-01-350-4472
199	PARTS KIT, SEAL REPLACEMENT	SK10-4	5330-01-343-2745
200	PIN, COTTER	K-2412-Z	5315-01-179-9882
201	PIN, COTTER	MS171659	5315-00-846-8337
202	PIN, COTTER	MS24665-151	5315-00-815-1405
203	PIN, COTTER	MS24665-298	5315-00-234-1861
204	PIN, COTTER	MS24665-385	5315-00-187-9382
205	PIN, COTTER	MS24665-423	5315-00-013-7228
206	PIN, COTTER	MS24665-457	5315-00-187-9393
207	PIN, COTTER	MS24665-459	5315-00-187-9394
208	PIN, COTTER	MS24665-69	5315-00-828-8190
208.1	PIN, COTTER	XB-781-1	5315-01-369-1346
209	NOT USED		

Section II. MANDATORY REPLACEMENT PARTS LIST (CONT)

(1) ITEM NO.	(2) NOMENCLATURE	(3) PART NUMBER	(4) NATIONAL STOCK NUMBER
210	PIN, SPRING	MS16562-142	5315-00-058-6115
211	PIN, SPRING	MS16552-146	5315-00-853-3814
212	PLASTIC STRIP	352700	5330-01-296-2109
213	RECEPTACLE	50R4-1-1AA	5325-01-049-2049
213.1	REPAIR KIT, GOVERNOR	RN32W	
213.2	RETAINER, PACKING	11863-012	5330-01-417-7795
213.3	RETAINER, PACKING	202624	5330-01-417-7794
214	RETAINER	A-1205-D-2344	5330-01-360-5253
215	RIVET, BLIND	AK42H	5320-00-874-4477
216	RIVET, BLIND	AK43H	5320-00-143-6149
217	RIVET, BLIND	MS20600AD5W12	5320-01-047-0467
217.1	RIVET, BLIND	MS20601B4W2	5320-00-616-5274
218	RIVET, BLIND	MS20604B3W2	5320-00-721-9075
219	RIVET, BLIND	M24243/1-A806	5320-00-850-3256
220	RIVET, BLIND	M24243/1-B302	5320-00-999-0397
221	RIVET, BLIND	M24243/1-D502	5320-00-850-3248
222	RIVET, BLIND	M24243/1-D608	5320-00-850-3246
223	RIVET, BLIND	M24243/1-F402	5320-00-129-9706
223.1	RIVET, BLIND	M24243/1-F608	5320-01-392-0699
223.2	RIVET, BLIND	M24243/1-F610	
224	RIVET, BLIND	M24243/6-A403H	5320-00-882-8388
225	RIVET, BLIND	M24243/6-A405H	5320-01-291-9121
226	RIVET, BLIND	M24243/6-A406H	5320-01-421-0484
227	RIVET, BLIND	M24243/6-A602H	5320-00-956-7362
228	RIVET, BLIND	M24243/6-A604H	5320-00-956-7355
229	RIVET, BLIND	M24243/6-A606H	5320-00-882-8385
230	RIVET, BLIND	M24243/6-A608H	5320-01-032-6534
231	RIVET, BLIND	M24243/7-A402H	5320-00-874-4477
232	RIVET, BLIND	M24243/7-A403H	5320-00-143-6149
233	RIVET, BLIND	M24243/7-A604H	5320-00-420-2165
234	RIVET, BLIND	M24243/7-A606H	5320-00-490-5523

Section II. MANDATORY REPLACEMENT PARTS LIST (CONT)

(1) ITEM NO.	(2) NOMENCLATURE	(3) PART NUMBER	(4) NATIONAL STOCK NUMBER
235	RIVET, BLIND	SD64BSLF	5320-01-397-3347
236	RIVET, BLIND	206057	5320-01-411-0081
237	RIVET, COMPRESSION	12418469	5320-01-376-0699
237.1	SCREW, CAP	CSH5-24-39	5305-01-479-7857
238	SCREW, CAP	12414475-131	5303-01-363-0703
239	SCREW, CAP	6V-2315	5306-01-433-4753
240	SCREW, MACHINE	MS24693-144	
241	SCREW, MACHINE	MS51958-83	5305-00-071-2095
242	SCREW, SELF-LOCKING	MS16998-61L	5305-01-211-3097
243	SEAL	VC08G1R0B	5330-01-389-6109
244	SEAL	12421431	9320-01-398-6317
245	SEAL	125128-5	
246	SEAL	125128-6	
247	SEAL	355150	5330-01-423-0689
247.1	SEAL	12422401-001	5999-01-478-5940
247.2	SEAL	12422401-002	5999-01-478-5932
247.3	SEAL	12422401-003	5999-01-478-5937
248	SEAL ASSEMBLY, CTIS	A1205-Q-2435	5330-01-360-7753
249	SEAL ASSEMBLY, HUB	A1205-R-2254	5330-01-360-5252
250	SEAL, DOOR	12416467	5330-01-385-3769
251	SEAL RING, METAL	29505809	5330-01-360-5329
252	SEAL, NONMETALLIC	CC3550	5330-01-431-7575
253	SEAL, NONMETALLIC	12417725	5330-01-375-2908
254	SEAL, NONMETALLIC	2418974-1	5330-01-257-1709
255	SEAL, NONMETALLIC	673999	5310-01-454-5553
255.1	SEAL, PLAIN	N72143	5330-01-453-4462
255.2	SEAL, SHAFT	SERUR25-2	5330-01-135-3376
256	SEAL, URETHANE FOAM	12420420-001	5680-01-453-8912
257	SEAL, URETHANE FOAM	12420420-002	5680-01-453-8485
258	SEAL, URETHANE FOAM	12420420-003	5680-01-453-8486
259	SEAL, WEATHER	147P00039	
259.1	SPACER	12422545	5365-01-490-6790

Section II. MANDATORY REPLACEMENT PARTS LIST (CONT)

(1) ITEM NO.	(2) NOMENCLATURE	(3) PART NUMBER	(4) NATIONAL STOCK NUMBER
260	SPACER, RING	4P2987	5365-01-433-8407
260.1	SPIDER, UNIVERSAL JOINT, VEHICULAR	R279X	
261	SPLICE, CONDUCTOR	12420927-001	5940-01-456-1319
262	SPLICE, CONDUCTOR	12420927-002	5940-01-421-6955
263	STRAIN RELIEF	10280870-3	5975-00-376-1585
263.1	STRIP, RUBBER	12412581	9320-01-399-4888
264	TERMINAL, LUG	MS20659-163	5940-00-113-3145
265	TERMINAL, LUG	MS20659-164	5940-00-113-3148
266	TERMINAL, LUG	MS25036-108	5940-00-143-4780
267	TERMINAL, LUG	MS25036-122	5940-00-113-8190
268	TERMINAL, LUG	12414275-001	
269	TERMINAL, LUG	12416409-006	
269.1	TERMINAL, LUG	12420344	5940-01-082-3321
270	WASHER, FLAT	MS27183-10	5310-00-809-4058
270.1	WASHER, FLAT	12414473-010	5310-01-374-6990
271	WASHER, FLAT	12417948-004	5365-01-436-8308
271.1	WASHER, FLAT	251391	5310-01-417-1041
272	WASHER, FLAT RUBBER	900.032	5330-01-378-7541
273	WASHER, NYLON	MS51859-16	5310-00-964-7811
274	WASHER, SPRING	D63474/1-30	5310-01-413-8475
275	WASHER, SPRING	WW579S18	
276	WASHER, SPRING	110 7289	5310-01-246-1387
277	WASHER, SPRING	12414559-021	5310-01-374-4517
278	WASHER, SPRING	12414560-017	5310-01-395-0820
279	WASHER, SPRING	12414560-018	5310-01-381-3281
280	WASHER, SPRING	12414560-019	5310-01-369-6074
281	WASHER, SPRING	12417503	5310-01-406-6326
282	WASHER, SPRING	12418220	5310-01-372-3495
283	WASHER, SPRING	12414560-009	5310-01-333-5517

APPENDIX H LUBRICATION ORDER AND SERVICES

SECTION I. INTRODUCTION

H-1. GENERAL

The information contained in this appendix provides the lubrication/services requirements for the LMTV vehicle.

- a. **Adherence.** Intervals (on-condition or hardtime) and the related man-hour times are based on normal operation. The man-hour time specified is the time needed to do all the services prescribed for a particular interval. On-condition (OC) oil sample intervals will be applied unless changed by the Army Oil Analysis Program (AOAP) laboratory. Change the hardtime interval if the lubricants are contaminated or if operating the equipment under adverse operating conditions, including longer-than-usual operating hours. The calendar interval may be extended during periods of low activity. If extended, adequate preservation precautions must be taken. Hardtime intervals will be applied in the event AOAP laboratory support is not available. Hardtime intervals must be applied during the warranty period.

Intervals shown in this lubrication order and services are based on mileage/calendar, and in some cases mileage alone. An example of a mileage/calendar interval is: **Q**, which means every 3,000 miles (4,827 km) or quarterly (every three months). The lubrication is to be performed at whichever interval occurs first for the vehicle. An example of a mileage alone interval is: **6K**, which stands for every 6,000 miles (9,654 km). The lubrication/services is to be performed at the mileage indicated regardless of the calendar interval.

WARNING

- **Dry Cleaning Solvent (P-D-680) is TOXIC and flammable. Wear protective goggles and gloves; use only in well-ventilated area; avoid contact with skin, eyes, and clothes, and do not breath vapors. Keep away from heat or flame. Never smoke when using solvent; the flashpoint for Type I Dry Cleaning Solvent is 100°F (38 C) and for Type II is 138 F (50 C). Failure to comply may result in serious injury or death to personnel.**
 - **If personnel become dizzy while using cleaning solvent, immediately get fresh air and medical help. If solvent contacts skin or clothes, flush with cold water. If solvent contacts eyes, immediately flush eyes with water and get medical attention. Failure to comply may result in injury to personnel.**
- b. **Cleaning fittings before lubricating.** Clean parts with dry cleaning solvent (SD P-D-680) (Item 71, Appendix D) or equivalent. Dry before lubricating. Dashed arrows indicate lubrication on both sides of the equipment.
- c. **Lubricating after fording.** If fording occurs, lubricate all fittings below fording depth and check submerged gearboxes for presence of water.
- d. **Lubricating after high-pressure washing.** After a thorough washing, lubricate all grease fittings and oil can points outside and underneath vehicle.
- e. **Level of Maintenance.** The lowest level of maintenance authorized to lubricate a point is Operator/Unit Maintenance (O). Operator/crew (C) may lubricate points authorized for Unit Maintenance (O) when authorized by Unit Maintenance (O).
- f. **Localized views.** A reference to the appropriate localized view is given after most lubrication entries. Localized views begin on page H-9.

H-1. GENERAL (CONT)

g. Interval Symbols. The lubrication/service interval symbols will be used as applicable:

- Q-quarterly/3,000 mi (4,827 km) (whichever occurs first)
- S-semiannually/6,000 mi (9,654 km) (whichever occurs first)
- A-annually/12,000 mi (19,308 km) (whichever occurs first)
- B-biennially/24,000 mi (38,616 km) (whichever occurs first)
- 3K-every 3,000 mi (4,827 km) (no calendar interval)
- 6K-every 6,000 mi (9,654 km) (no calendar interval)
- 12K-every 12,000 mi (19,308 km) (no calendar interval)
- 24K-every 24,000 mi (38,616 km) (no calendar interval)

H-2. OIL FILTERS

Oil filters shall be serviced/changed as applicable, when:

- a. They are known to be contaminated, or clogged;
- b. Service is recommended by AOAP laboratory analysis; or
- c. At prescribed hardtime intervals while vehicle is under warranty, or if AOAP is not available/used as required.

H-3. AOAP SAMPLING INTERVAL

WARNING

- **Engine oil is hot and under pressure. The oil sampling valve releases oil proportionally to the amount of pressure applied to valve. Activate oil sampling valve by pressing in slowly to prevent injury to personnel. Failure to comply may result in injury to personnel.**
- **Wear safety goggles when taking oil sample. Oil is under pressure and could cause injury to personnel. Failure to comply may result in injury to personnel.**

Units participating in AOAP will sample engine oil every 3,000 miles (4,827 km) or 6 months, whichever occurs first and change engine oil as directed by AOAP. Units participating in AOAP will sample transmission oil every 6,000 miles (9,654 km) or 12 months, whichever occurs first and change transmission oil as directed by AOAP. Units participating in AOAP will sample hydraulic system oil initially after 6 weeks or 10 hours of operation, whichever occurs first. After initial oil change samples should be taken every 12 months or 50 hours of operation, whichever occurs first and change hydraulic oil as directed by AOAP.

H-4. WARRANTY HARDTIME STATEMENT

"For equipment under manufacturer's warranty, hardtime oil service intervals shall be followed. Intervals shall be shortened if lubricants are known to be contaminated or if operation is under adverse conditions (such as longer than usual operating hours, extended idling periods, extreme dust)."

SECTION II. LUBRICATION/SERVICE CHART

H-5. LUBRICATION/SERVICE KEY

LUBRICANTS	
Specification	Type
MIL-L-2104 (OE/HDO)	Lubricating Oil, Internal Combustion Engine, Combat/Tactical Service
MIL-L-46167 (OEA)	Lubricating Oil, Internal Combustion Engine, Arctic
MIL-L-2105 (GO)	Lubricating Oil, Gear, Multipurpose
MIL-G-10924 (GAA)	Grease, Automotive and Artillery
MIL-G-18458 (GW)	Grease, Wire-Rope and Exposed Gear
MIL-H-5606 (OHA)	Hydraulic Fluid, Petroleum Base, Aircraft, Missile, and Ordnance

DESCRIPTION	CAPACITY	EXPECTED TEMPERATURES		
		Above +40 F (Above +4 C)	+40 F to -15 F (+4 C to -26 C)	-15 F to -50 F (-26 C to -46 C)
Engine crankcase	25 qt (24 L)	OE/HDO-15/40	OE/HDO-15/40	OEA
Transmission (total system)	43.3 qt (41 L)	OE/HDO-15/40	OE/HDO-10	OEA
Transmission (at oil change)	31.8 qt (30.0 L)	OE/HDO-15/40	OE/HDO-10	OEA
Transmission (after overhaul)	39.0 qt (37.0 L)	OE/HDO-15/40	OE/HDO-10	OEA
Steering system	5 qt (4.8 L)	OE/HDO-10	OE/HDO-10	OEA
Hydraulic reservoir	27 gal (102.2 L)	OE/HDO-10	OE/HDO-10	OEA
Front axle differential (maximum capacity)	9.5 qt (9.0 L)	GO-80/90	GO-80/90	SAE 75W90 OR GO-75
Rear axle differential (maximum capacity)	18.05 qt (17.1 L)	GO-80/90	GO-80/90	SAE 75W90 OR GO-75
Front axle planetary hubs	11-13 oz (0.33-0.38 L)	GO-80/90	GO-80/90	SAE 75W90 OR GO-75
11K Self-Recovery Winch (SRW)	As Required	GO-85/140	GO-80/90	GO-75
Propeller shaft universal and slip joints	As Required	GAA	GAA	GAA
Tie rod ends	As Required	GAA	GAA	GAA
Towing pintle assembly	As Required	GAA	GAA	GAA
Spring bolts and spring shackles	As Required	GAA	GAA	GAA
Front axle shaft U-joints and steering knuckles	As Required	GAA	GAA	GAA

H-5. LUBRICATION/SERVICE KEY (CONT)

DESCRIPTION	CAPACITY	EXPECTED TEMPERATURES		
		Above +40 F (Above +4 C)	+40 F to -15 F (+4 C to -26 C)	-15 F to -50 F (-26 C to -46 C)
Front axle inner wheel bearing	As Required	GAA	GAA	GAA
Rear axle inner wheel bearing	As Required	GAA	GAA	GAA
Front lifting beam	As Required	GAA	GAA	GAA
11K Self-Recovery Winch (SRW) cable	As Required	GW	GW	GW
Air/hydraulic power unit	3 pt (1.4 L)	OHA	OHA	OHA
Backup hydraulic pump	19 oz (562 ml)	OHA	OHA	OHA

COOLANT	
Specification	Type
A-A-52624A	Antifreeze, Multi-Engine Type
MIL-A-11755	Antifreeze, Arctic-Type

DESCRIPTION	CAPACITY	EXPECTED TEMPERATURES		
		Above +40 F (Above +4 C)	+40 F to -15 F (+4 C to -26 C)	-15 F to -50 F (-26 C to -46 C)
Cooling system (engine only)	14 qt (13 L)	A-A-52624A	A-A-52624A	N/A
Cooling system (total system)	43.8 qt (41.5 L)	A-A-52624A	A-A-52624A	N/A
Cooling system, Arctic (total system)	58.3 qt (55.2 L)	N/A	N/A	MIL-A-11755

CLEANING AGENT	
Specification	Type
P-D-680	Dry Cleaning Solvent, SD-II
O-C-1901	Cleaning Compound, Windshield

DESCRIPTION	CAPACITY	EXPECTED TEMPERATURES		
		Above +15 F (Above -9 C)	+15 F to -15 F (-9 C to -26 C)	-15 F to -50 F (-26 C to -46 C)
All metal parts as required	N/A	SD-II (all temperatures)		
Windshield washer reservoir	7.5 qt (7.1 L)	2/3 water to 1/3 O-C-1901	1/2 water to 1/2 O-C-1901	1/3 water to 2/3 O-C-1901

For arctic operation refer to FM 9-207.

H-6. LUBRICATION/SERVICE INTERVALS

Intervals		Total Man-Hours
Quarterly (Q)	Lubrication performed once every three months or 3,000 mi (4,827 km).*	2.0
Semi-annually (S)	Lubrication performed once every six months or 6,000 mi (9,654 km).*	2.5
Annually (A)	Lubrication performed once every year or every 12,000 mi (19,308 km).*	1.5
Biennially (B)	Lubrication performed once every two years or every 24,000 mi (38,616 km).*	3.5
3K	Lubrication performed once every 3,000 mi (4,827 km).**	1.0
6K	Lubrication performed once every 6,000 mi (9,654 km).**	1.0
12K	Lubrication performed once every 12,000 mi (19,308 km).**	4.0
24K	Lubrication performed once every 24,000 mi (38,616 km).**	0.5
* Whichever occurs first.		
** No calendar interval.		

H-7. LOCATOR VIEWS

LUBRICANT INTERVAL

INTERVAL LUBRICANT

Engine Crankcase Breather (O)
(See note 17 and view A)

Fuel Filter (O)
(See note 6 and view A)

Fuel/Water Separator (O)
(See note 5 and view B)

Cooling System (O)
(See note 7)

Transmission Filter (O)
(See note 3 and view F)

Transmission Drain and Fill (O)
(See note 3 and views D, E, and F)

Towing Pintle Fill (O)
(See note 16 and views J and K)

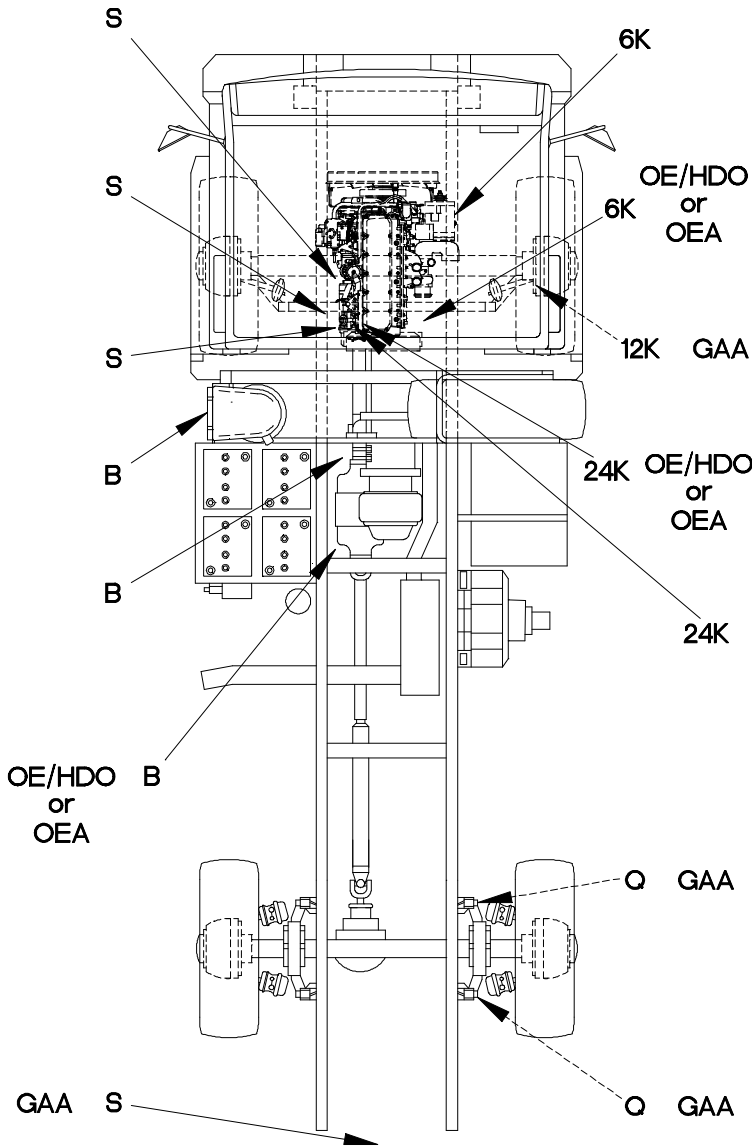

Engine Oil Filter (O)
(See note 2 and view C)

Crankcase Drain and Fill (O)
(See note 1 and views C and D)

Front Axle Inner Wheel Bearing Repack (O)
(See note 22)

Power Steering Reservoir Drain and Fill (O)
(See note 4 and view G)

Power Steering Filter (O)
(See note 4 and view G)

Spring Bolt Fill (O)
(See note 18 and view H)

Spring Shackle Fill (O)
(See note 18 and view AE)

CHASSIS

NOTE: Dashed arrows indicate lubrication on both sides of vehicle.

3APPH011

LUBRICANT INTERVAL

INTERVAL LUBRICANT

**Spring Bolt
Fill (O)**
(See note 18 and view H)

**Spring Shackle
Fill (O)**
(See note 18 and view I)

**Tie Rod Ends
Fill (O)**
(See note 13 and view N)

**Universal and Slip Joints
Fill (O)**
(See note 9 and view P)

Battery Posts (O)
(See note 19 and view Q)

Air Dryer (O)
(See note 25 and view AF)

**Universal and Slip Joints
Fill (O)**
(See note 9 and view P)

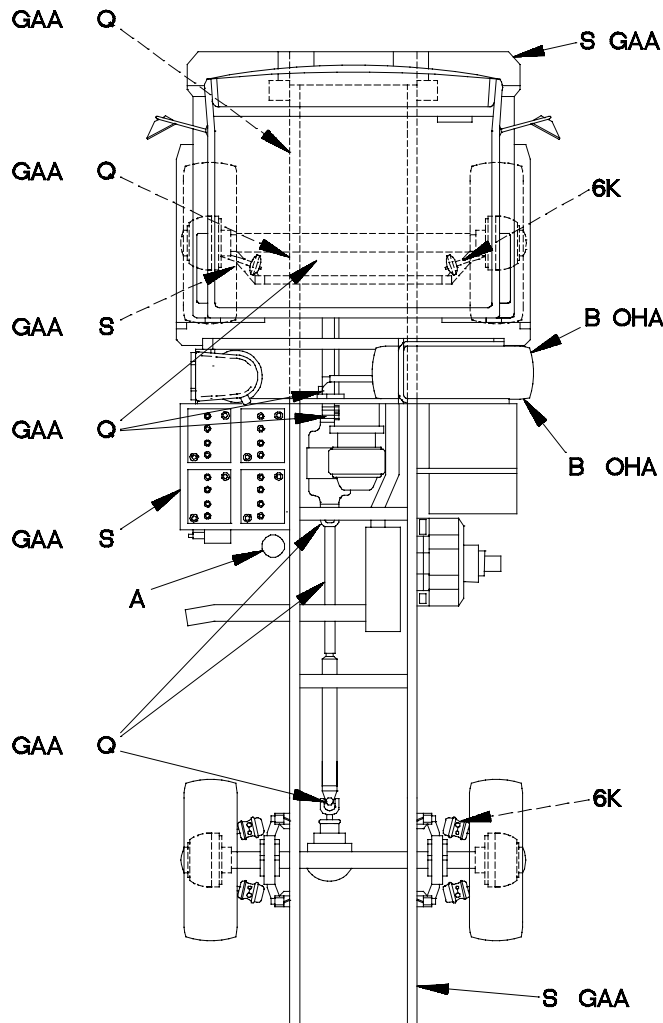

**11K Self-Recovery Winch
(SRW) Cable Front Roller
Fairlead
Fill (O)**
(See note 23 and views Z
and AA)

**Brake Wedge and Air
Chamber (O)**
(See note 21 and view L)

**Backup Hydraulic Pump
Drain and Fill (O)**
(See note 10 and view R)

**Air/Hydraulic Power Unit
Drain and Fill (O)**
(See note 10 and view S)

**Brake Wedge and Air
Chamber (O)**
(See note 21 and view M)

**11K Self-Recovery Winch
(SRW) Cable Rear Roller
Fairlead
Fill (O)**
(See note 23 and views AB
and AC)

3APP021

CHASSIS

NOTE: Dashed arrows indicate lubrication on both sides of vehicle.

H-7. LOCATOR VIEWS (CONT)

LUBRICANT INTERVAL

INTERVAL LUBRICANT

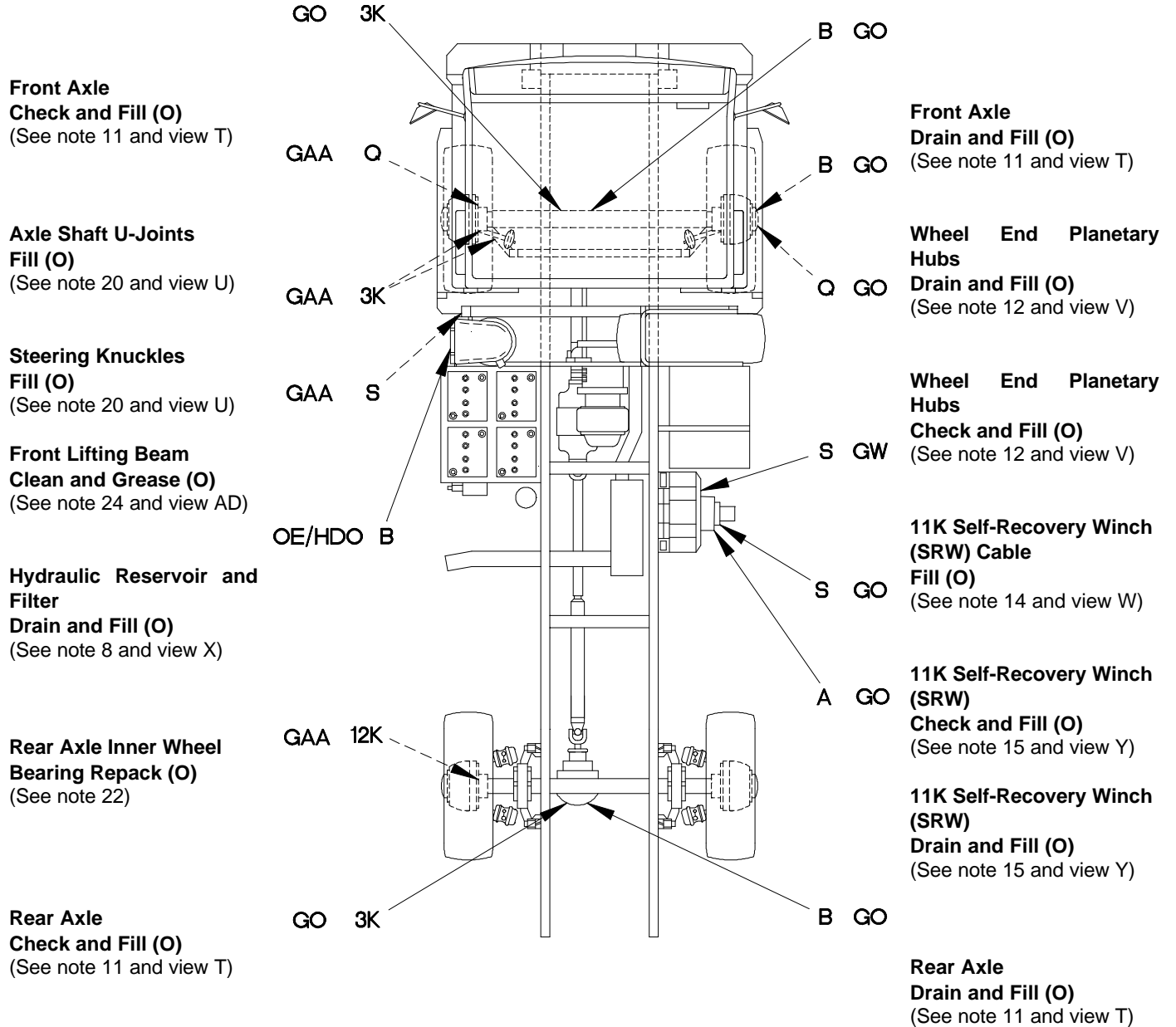

3APPH031

CHASSIS

NOTE: Dashed arrows indicate lubrication on both sides of vehicle.

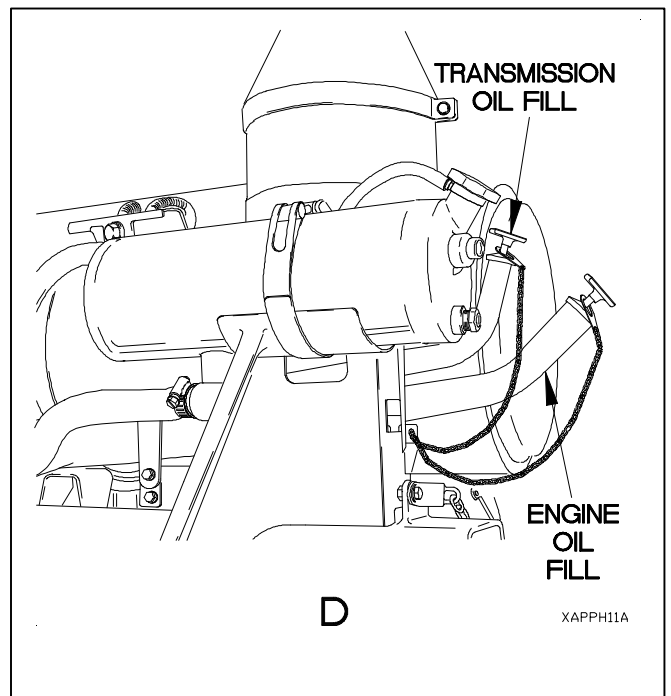
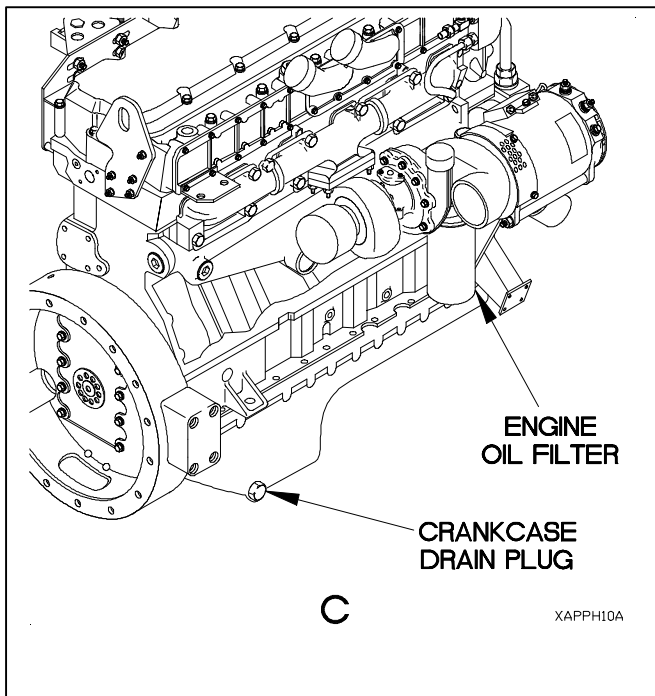
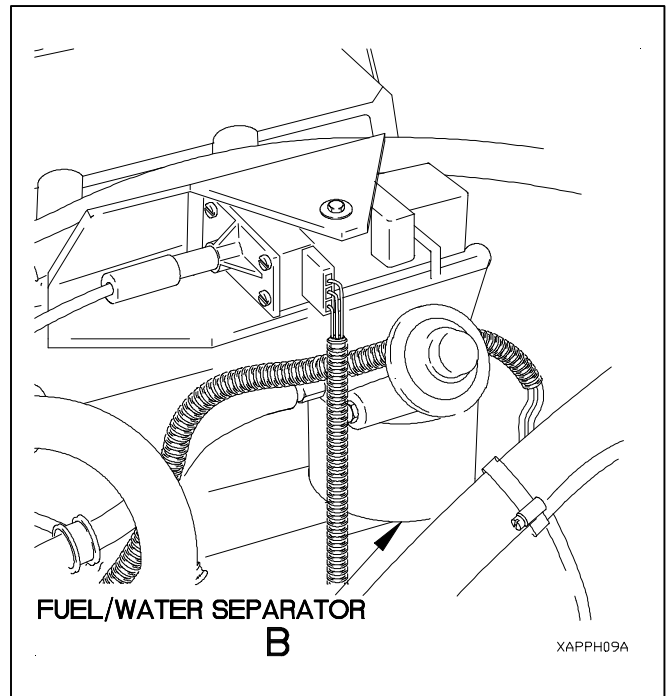
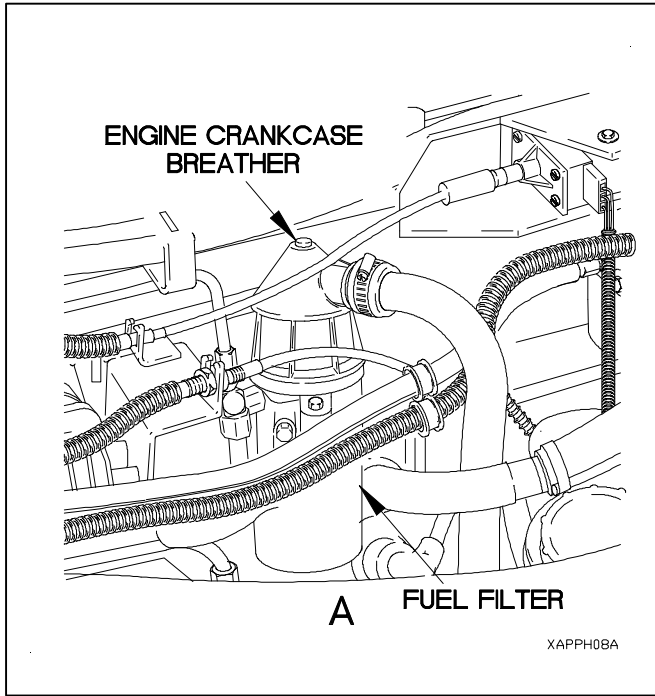

H-8. LOCAL VIEWS (CONT)

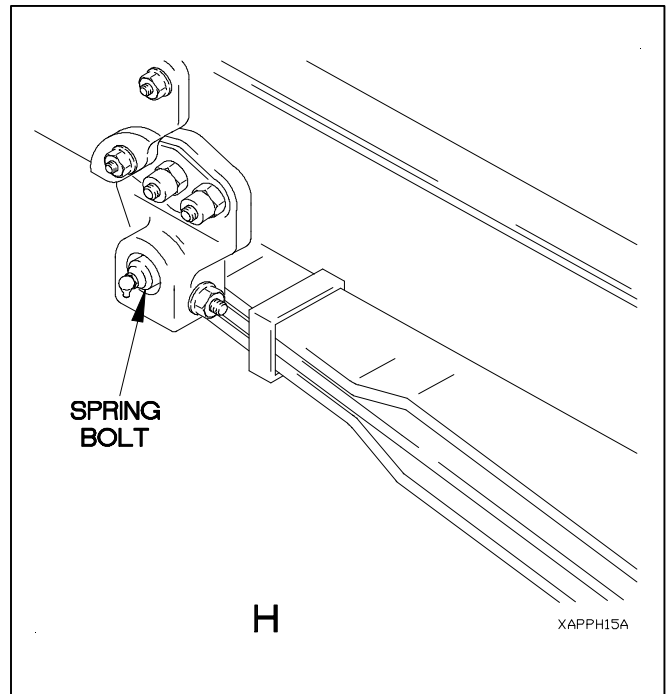
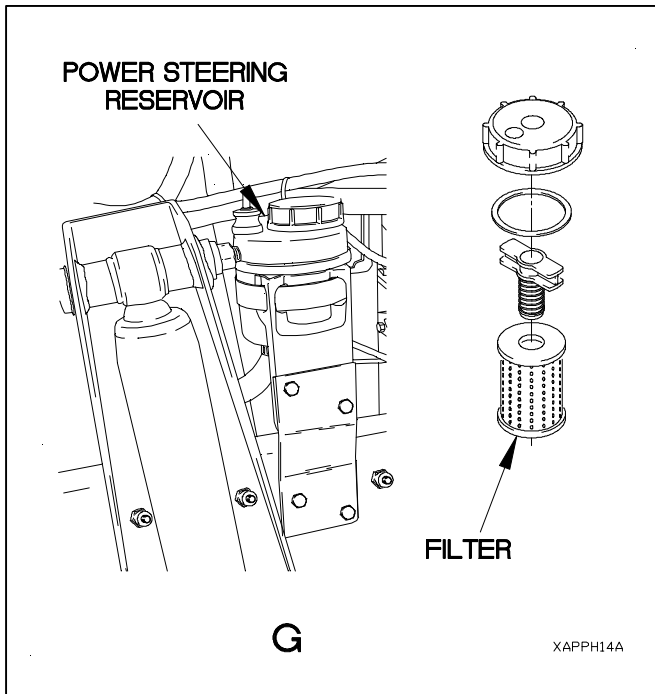
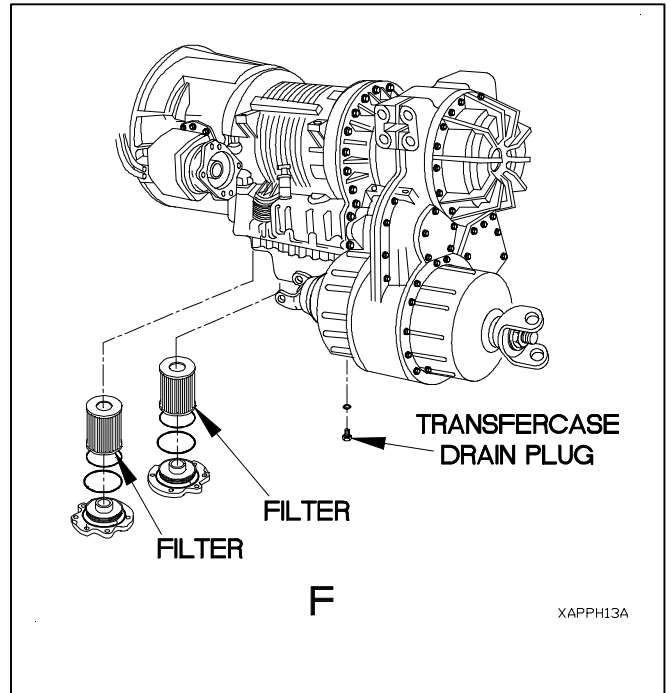
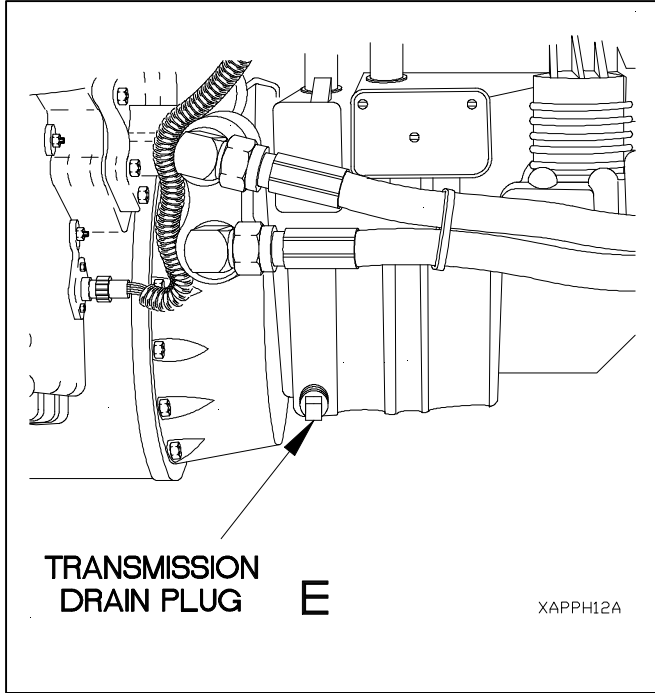

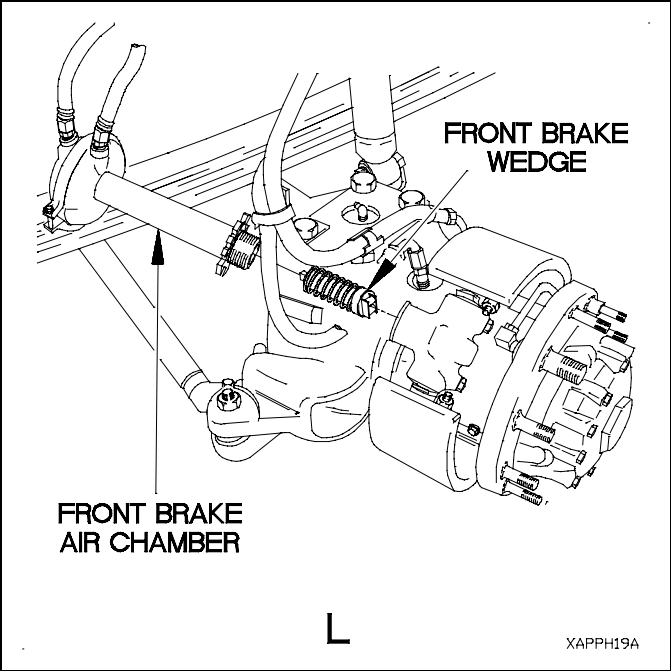
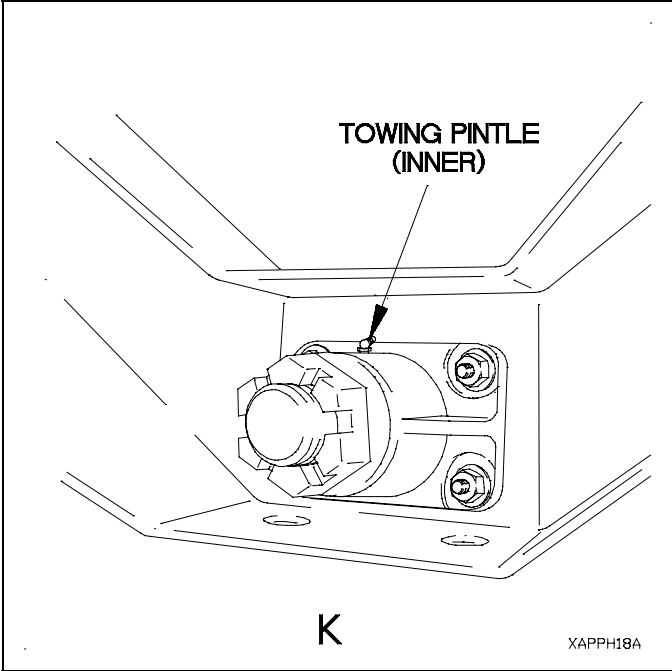
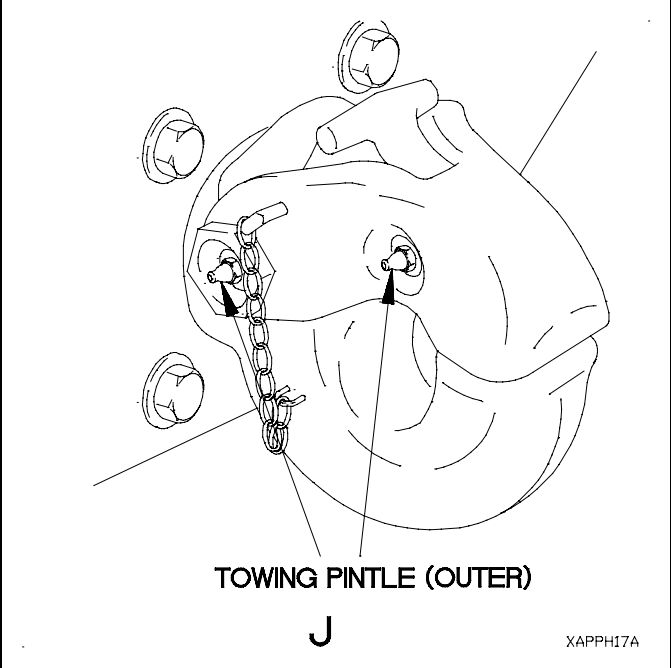
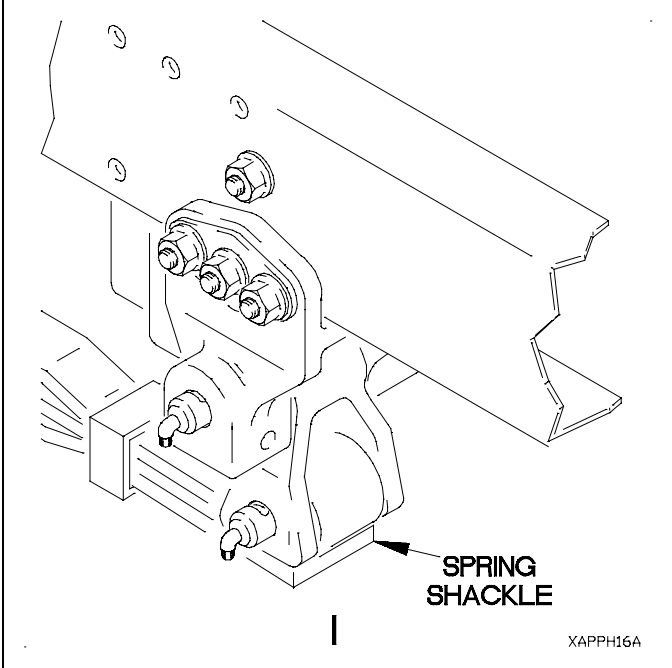

H-8. LOCAL VIEWS (CONT)

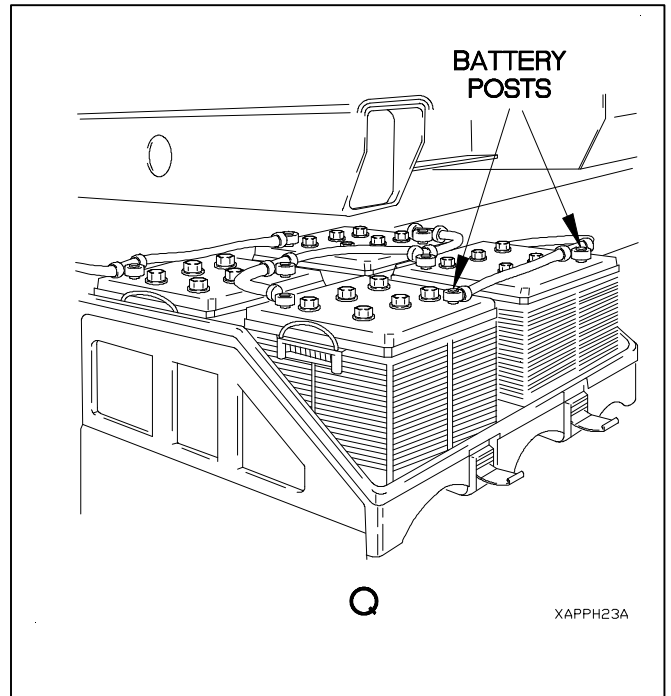
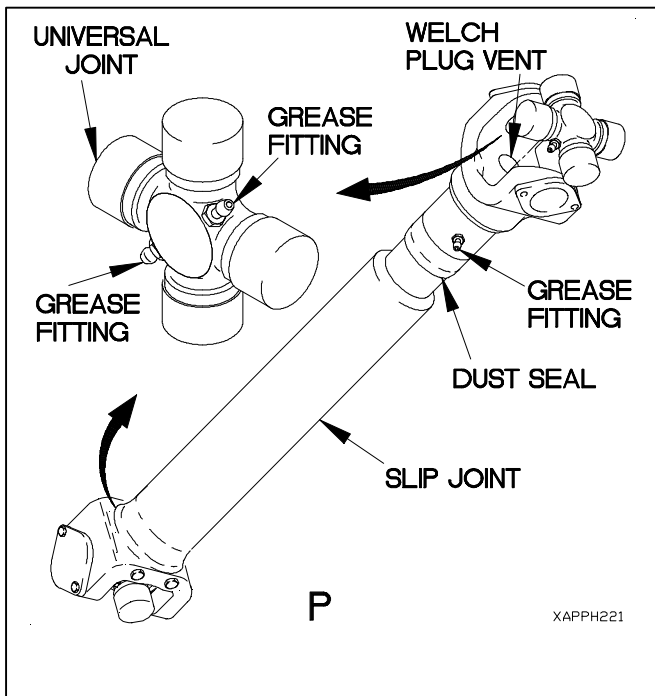
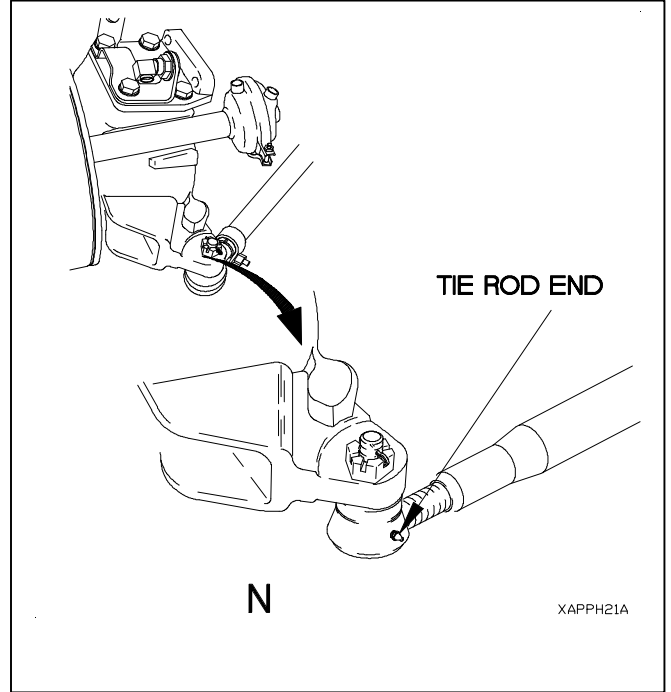
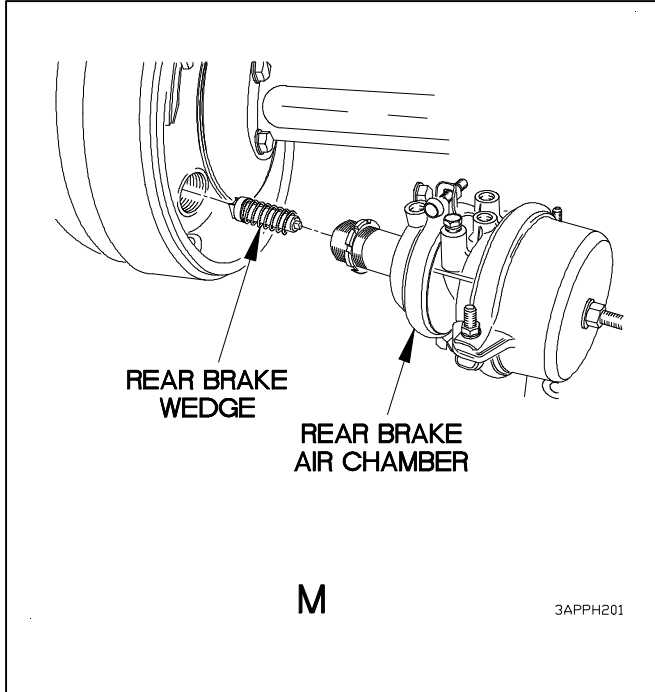

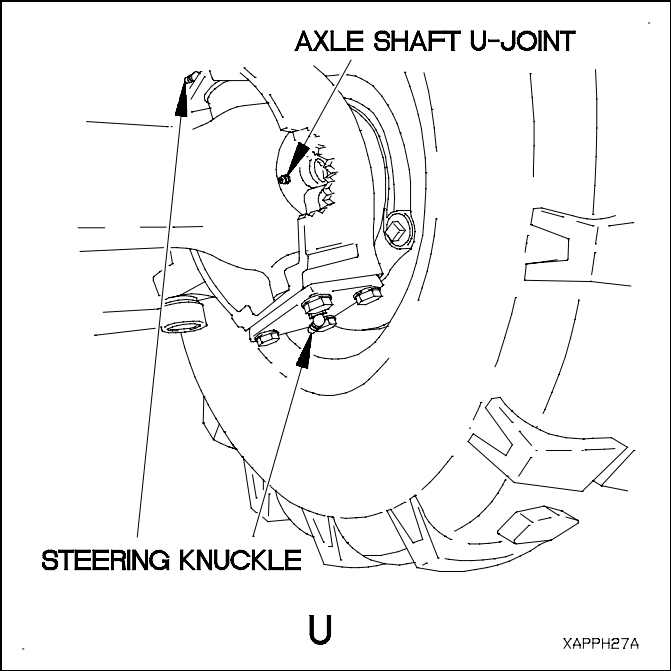
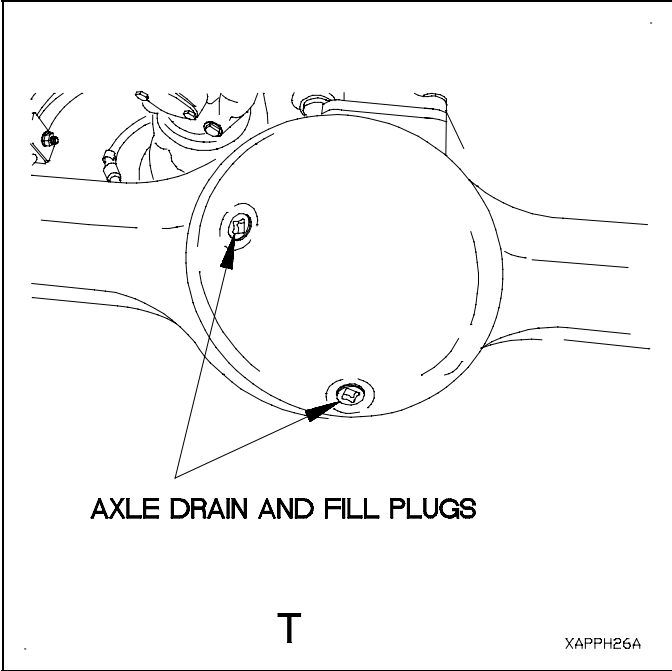
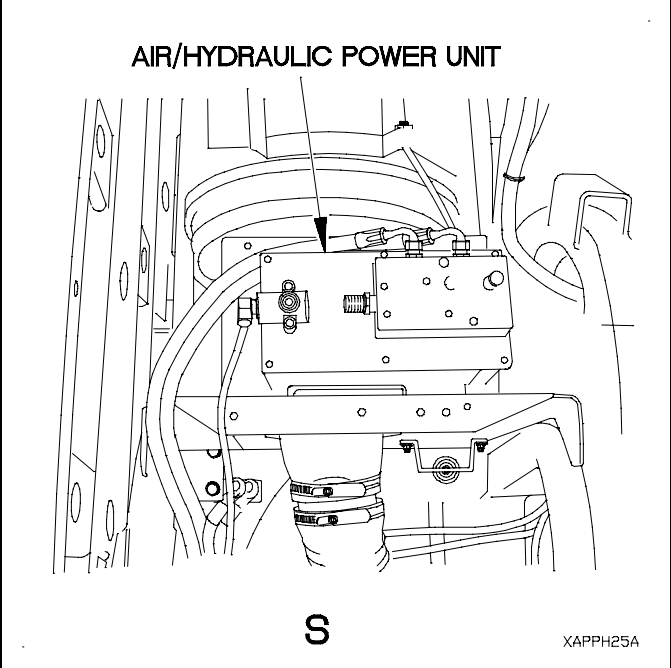
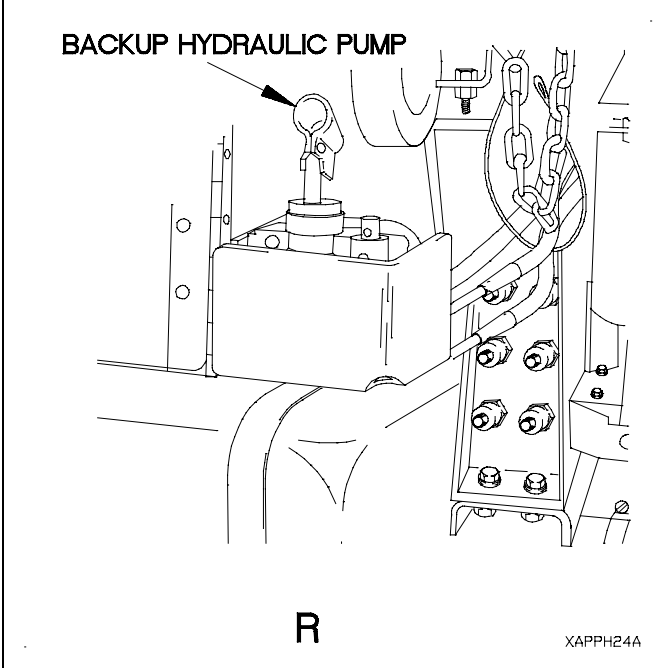

H-8. LUBRICATION LOCAL VIEWS (CONT)

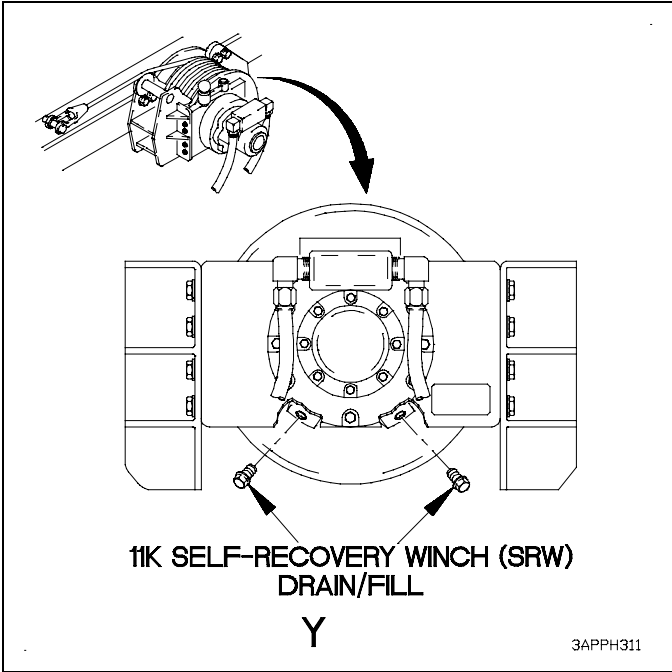
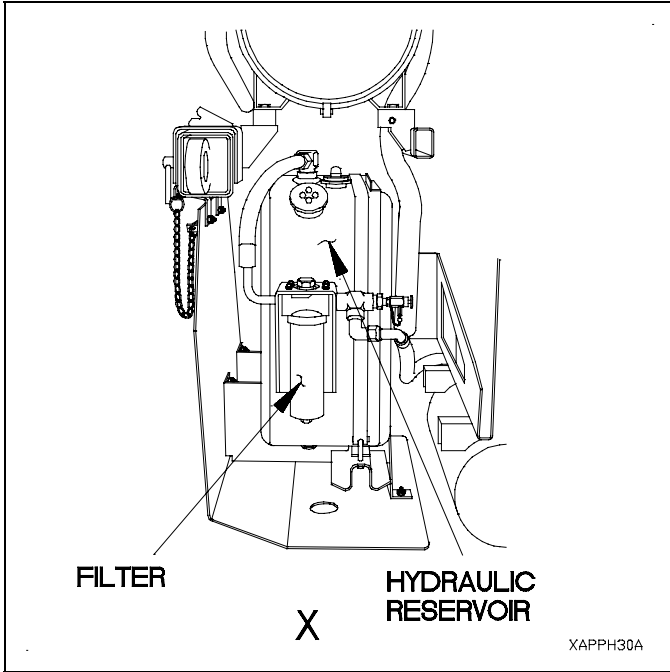
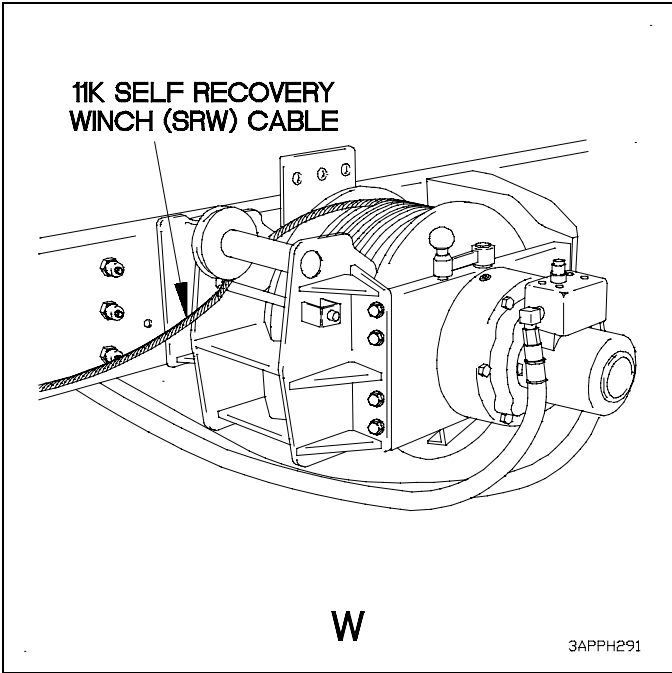
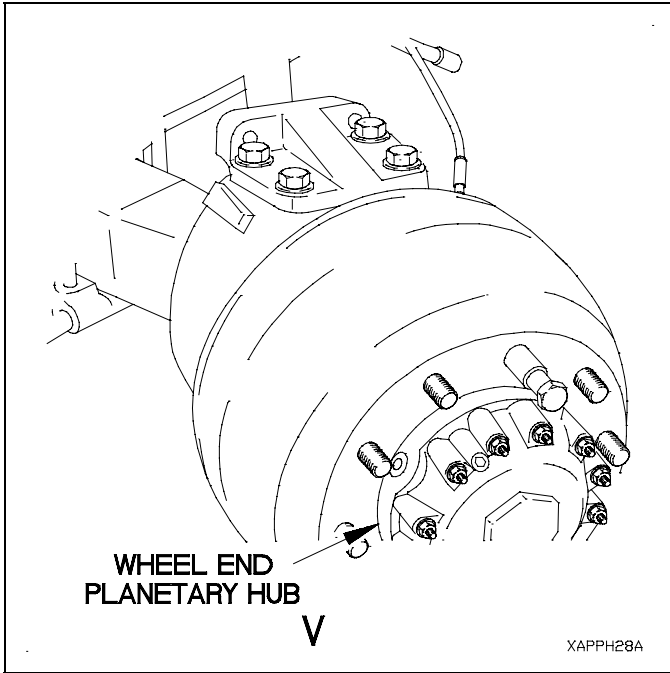

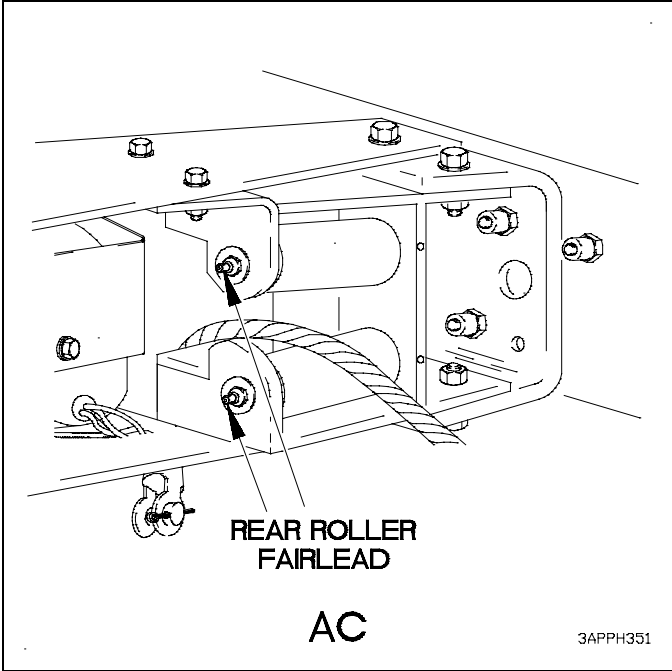
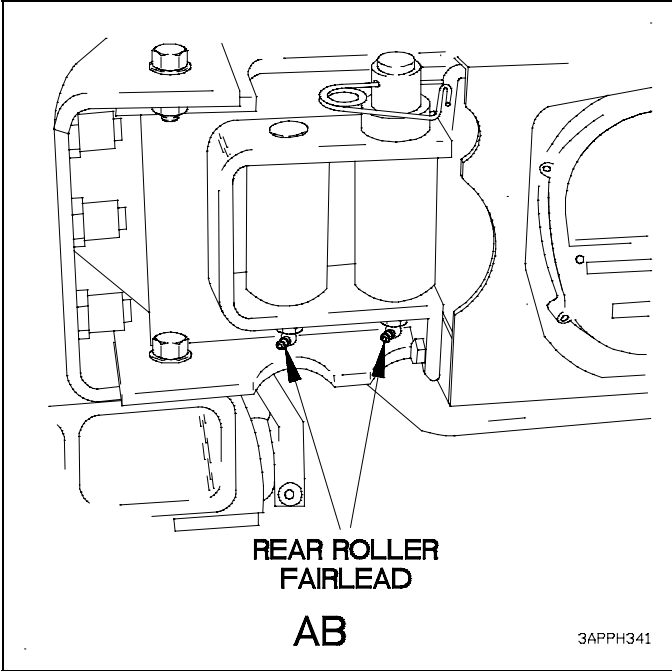
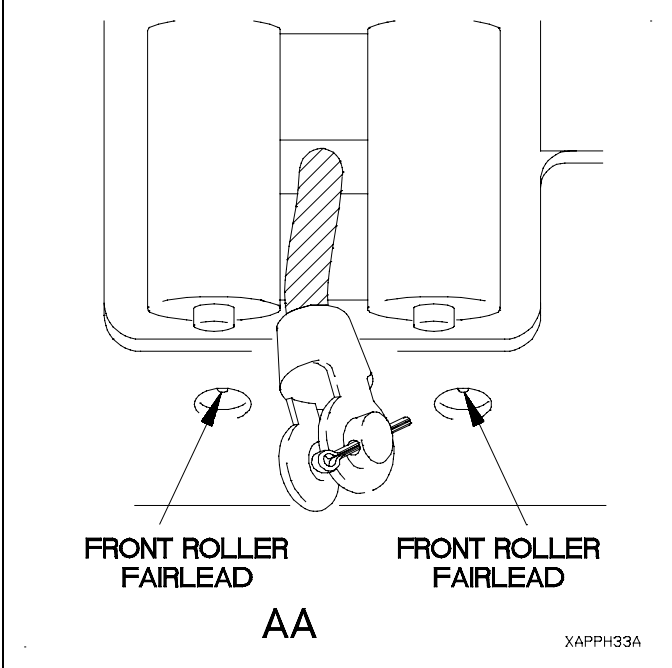
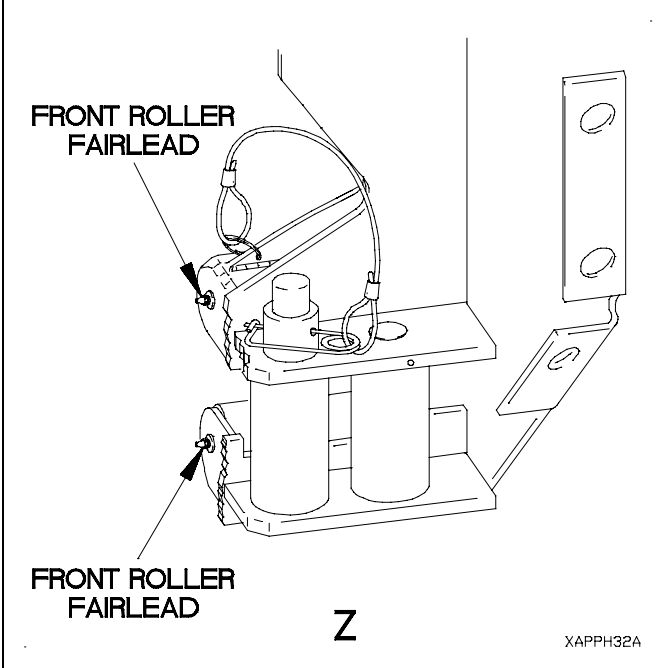

H-8. LOCAL VIEWS (CONT)

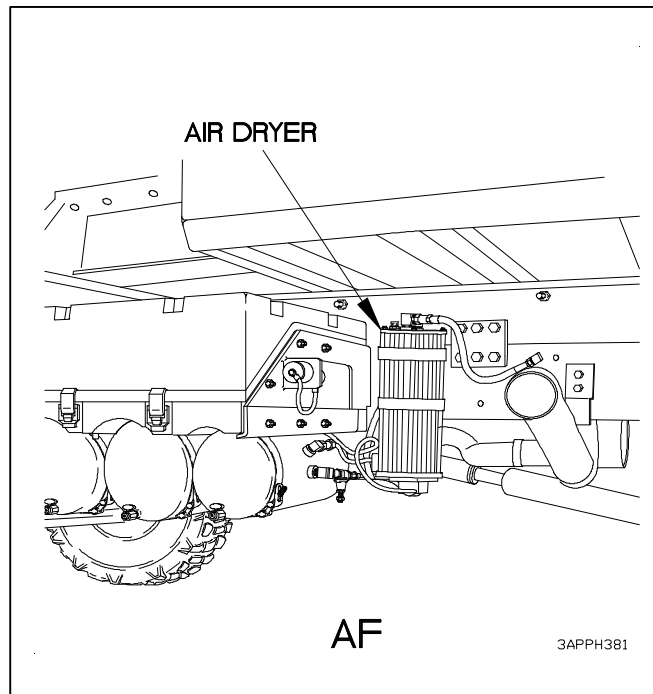
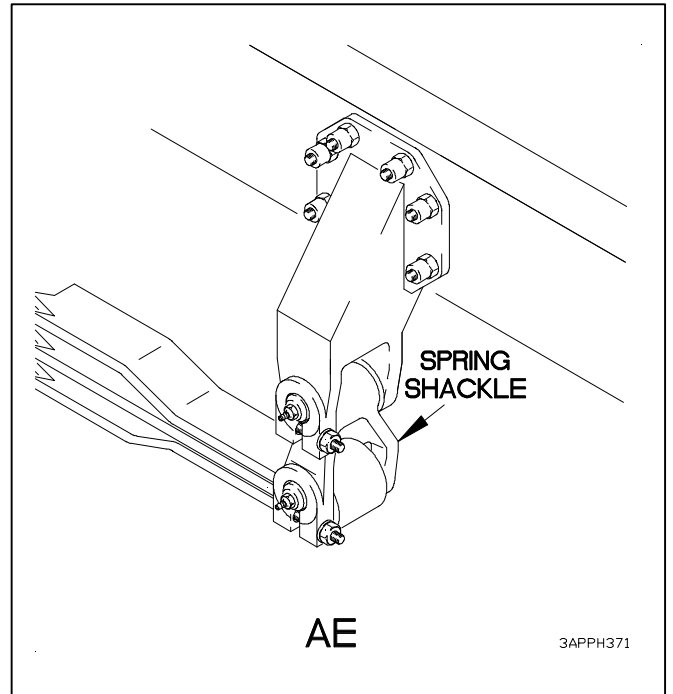
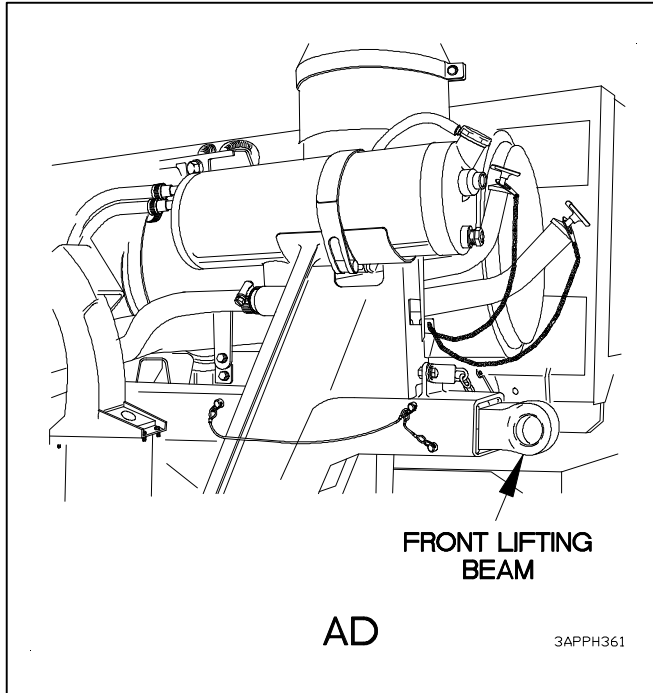

H-9. LUBRICATION/SERVICES NOTES

1. **ENGINE CRANKCASE.** Check engine oil level daily. Change engine oil at initial 5,000 miles (8,045 km). During the remainder of the 12,000 mile (19,308 km)/18 month warranty period, Units participating in AOAP will sample engine oil every 3,000 miles (4,827 km) or 6 months, whichever occurs first and change engine oil as directed by AOAP. Units not participating in AOAP, will change engine oil every 6,000 miles (9,654 km) or every six months, whichever occurs first. After expiration of engine warranty period, Units participating in AOAP will perform engine oil change as directed by AOAP. Units not participating in AOAP will change engine oil every 6,000 miles (9,654 km) or every six months, whichever occurs first, or when operating in dusty areas or under severe operating conditions, change the oil every 3,000 miles (4,827 km) or every three months, whichever occurs first. Drain engine oil when engine is warm. Refill engine crankcase with OE/HDO specified for the ambient temperature. Engine oil is full when level is within crosshatch marks on the dipstick. Do not overfill.
2. **ENGINE OIL FILTER.** Filter is replaced each time the crankcase is drained. If water or metal particles are detected during oil filter replacement, notify Direct Support Maintenance personnel before refilling crankcase (para 3-4).
3. **TRANSMISSION.** Check transmission oil level daily. Change transmission oil at initial 5,000 miles (8,045 km). During the remainder of the 24 month/unlimited mileage warranty, Units participating in AOAP will sample transmission oil every 6,000 miles (9,654 km) or 12 months, whichever occurs first and change transmission oil as directed by AOAP. Units not participating in AOAP will perform transmission oil change every 24,000 miles (38,616 km) or once every two years, whichever occurs first. Drain transmission oil when engine is warm. Refill with OE/HDO specified for ambient temperature. Add oil until the proper level is reached (TM 9-2320-365-10). Do not overfill. Replace oil filters each time transmission oil is changed (para 8-9).
4. **POWER STEERING.** Check power steering oil level weekly. Change the oil every 24,000 miles (38,616 km). Disconnect upper and lower hoses from steering gear and drain oil. Refill power steering pump reservoir with OE/HDO specified for the ambient temperature. Reservoir is full when oil is between the two marks on the dipstick. Do not overfill. Remove dipstick, wipe clean and install dipstick fully into reservoir. Remove dipstick and read oil level. Replace oil filter each time power steering oil is changed (para 13-8).
5. **FUEL/WATER SEPARATOR.** Replace filter element every 6,000 miles (9,654 km) or once every six months, whichever occurs first (para 4-13).
6. **FUEL FILTER.** The fuel particle filter is replaced when a new fuel/water separator filter element is installed. The normal replacement interval is every 6,000 miles (9,654 km) or once every six months, whichever occurs first (para 4-14).
7. **ENGINE COOLANT.** Check engine coolant level daily. Change the coolant and flush the cooling system every 24,000 miles (38,616 km) or once every two years, whichever occurs first. Fill radiator overflow tank with an Ethylene Glycol/water mixture as specified in 0-A-548D. Service the cooling system before the specified interval if:
 - Coolant is heavily contaminated.
 - Engine overheats.
 - Oil cooler has failed allowing oil and coolant to mix.
8. **HYDRAULIC RESERVOIR and FILTER.** Check oil level weekly and make sure oil level gage reads **F (full)**. Units participating in AOAP will sample oil annually and change oil and filter as directed by AOAP. Units not participating in AOAP will change oil and filter every two years. Drain oil and refill hydraulic reservoir with OE/HDO specified for ambient operating temperature. Fill hydraulic reservoir until oil level gage reads **F (full)**. Do not overfill. Replace oil filter each time oil is changed (para 9-12).

H-9. LUBRICATION/SERVICE NOTES (CONT)
--

9. DRIVE SHAFT UNIVERSAL and SLIP YOKE.

Lubricate drive shafts with GAA every 3,000 miles (4,827 km) or once every three months, whichever occurs first, using a low pressure lubrication gun. If operating conditions are severe or abnormal, service at 1,000 miles (1,609 km) or once every month, whichever occurs first. Perform drive shaft hinging inspection every time drive shafts are serviced (para 9-3).

- UNIVERSAL JOINT:

- A. Apply grease to both grease fittings until new grease purges from all four bearing caps.
- B. If grease does not purge from all four bearing caps, perform the following steps:
 - (1) Loosen two screws on bearing cap that does not purge, approximately 1/4 in.
 - (2) Apply grease to grease fitting for bearing cap that does not purge until bearing cap purges.
 - (3) Remove and discard the two screws loosened in step (1).
 - (4) Position two replacement screws in bearing cap and tighten down evenly.
 - (5) Tighten two screws to 26-35 lb-ft (35-47 N•m).

- SLIP JOINT:

- A. Apply grease until grease appears at the vent in the welch plug.
- B. Place your finger over the welch plug vent and add grease until grease purges from the dust seal.
- C. If grease does not purge from the dust seal, inspect drive shaft slip yoke (para 9-2).

10. AIR/HYDRAULIC POWER UNIT and BACKUP HYDRAULIC PUMP. Change OHA oil every 24,000 miles (38,616 km) or once every two years, whichever occurs first. To service air/hydraulic power unit and backup hydraulic pump refer to vehicle para 19-7, Air Transportability Hydraulic System Service.

11. ALL AXLE DIFFERENTIALS. Check oil level in differentials every 3,000 miles (4,827 km). Check oil level with vehicle parked on level surface and axle differential at ambient temperature, allowing at least one hour to cool down after vehicle operation. If oil is checked when axle differential is hot, it is normal for oil to spill out of the port due to expansion from the heat. Oil level is considered full if it is within one inch of the bottom of the fill port. If oil spills from the fill port when the axle differential is cool, it is overfull. Allow oil to drain until no more drains out. If the oil level is more than one inch below the bottom of the fill port, refill axle differential with GO specified for the ambient temperature until level with bottom of fill port. Change the oil every 24,000 miles (38,616 km) or once every two years, whichever occurs first. Drain oil when hot after operation.

12. FRONT AXLE WHEEL END PLANETARY HUBS. There are two lube intervals for the front axle wheel end planetary hubs.

- a. Check and fill front axle wheel end planetary hubs every 3,000 miles (4,827 km) or once every three months, whichever occurs first, as follows:

- (1) Position vehicle on a level surface. Allow 15 minutes for vehicle to cool before checking oil levels.
- (2) Position fill port at 4 o'clock position. If oil flows from fill port when plug is loosened, let oil drain to correct level. If oil level is below fill port, fill hub with GO specified for the ambient temperature until oil is level with fill port.

- b. Drain and fill front axle wheel end planetary hubs every 24,000 miles (38,616 km) or once every two years, whichever occurs first, following the repacking of the inner wheel bearings or whenever wheel end assemblies are taken apart for other maintenance as follows:

- (1) Position vehicle on a level surface.
- (2) Position fill port at the 6 o'clock (down) position.
- (3) Drain hub oil (allow a minimum of 15 minutes for oil to drain down from vent tubes).
- (4) Refill hubs with 11-13 ounces of GO specified for the ambient temperature.

13. TIE ROD ENDS. Lubricate tie rod ends with GAA every 6,000 miles (9,654 km) or once every six months, whichever occurs first, using a low pressure lubrication gun, until new grease is seen purging from the boot area. If operating conditions are severe or abnormal, service at 1,000 miles (1,609 km) or once every month, whichever occurs first.

14. 11K SELF-RECOVERY WINCH (SRW) CABLE:

CAUTION

Do not use dry cleaning solvent to clean 11K Self-Recovery Winch (SRW) cables. Use of dry cleaning solvent will remove lubricant from inner strands of 11K SRW cables. Failure to comply may result in damage to equipment.

a. After winch operation:

Refer to FM 5-125.

b. Care of wire rope:

Refer to FM 5-125.

c. Inspection of wire rope:

Refer to FM 5-125.

d. Every six months:

- (1) Unwind entire length of 11K SRW cable (TM 9-2320-365-10).
- (2) Soak and clean 11K SRW cable with new OE/HDO 30.
- (3) Wipe off excess OE/HDO 30.
- (4) Coat 11K SRW cable with GW.
- (5) Rewind 11K SRW cable (TM 9-2320-365-10).

15. 11K SRW. Check 11K SRW gear oil level every 6,000 miles (9,654 km) or once every six months, whichever occurs first. Refill 11K SRW with GO specified for ambient temperature. Change oil every 12,000 miles (19,308 km) or once every year, whichever occurs first. Use procedure (a) to check and fill oil level; use procedure (b) to change oil.

a. Check and fill oil level as follows:

- (1) Shift the freespool mechanism to the disengage position so the drum can be freely rotated.
- (2) Rotate the drum to where either plug is near the top of the 11K SRW. Remove the plug.
- (3) Rotate the drum 90 degrees in the direction that allows the other plug to be near the top of the 11K SRW. Remove the plug.

NOTE

Oil level is full if a small amount of oil runs out of lower plug.

- (4) Add oil until a small amount of oil runs out of lower plug hole.
- (5) Apply adhesive (Item 2, Appendix D) to plug and position plug in top hole.
- (6) Rotate drum until open hole is at top.
- (7) Apply adhesive (Item 2, Appendix D) to plug and position plug in top hole.
- (8) Tighten plugs to 13-15 lb-ft (18-20 N·m).

H-9. LUBRICATION/SERVICE NOTES (CONT)

b. Change oil as follows:

- (1) Shift the freespool mechanism to the disengage position so the drum can be freely rotated.
- (2) Rotate the drum to where either plug is near the top of the 11K SRW. Remove the plug.
- (3) Rotate the drum 90 degrees in the direction that allows the other plug to be near the top of the 11K SRW. Remove the plug.
- (4) Position drain pan (Item 17, Appendix C) under 11K SRW.
- (5) Rotate the drum until either hole is straight down to the bottom of the 11K SRW. Allow the oil to drain completely.
- (6) Rotate the drum until either hole is at top.

NOTE

Oil level is full if a small amount of oil runs out of lower plug.

- (7) Add oil until a small amount of oil runs out of lower plug hole.
- (8) Apply adhesive (Item 2, Appendix D) to plug and position plug in top hole.
- (9) Rotate drum until open hole is at top.
- (10) Apply adhesive (Item 2, Appendix D) to plug and position plug in top hole.
- (11) Tighten plugs to 13-15 lb-ft (18-20 N•m).

16. TOWING PINTLE. Lubricate towing pintle with GAA every 6,000 miles (9,654 km) or once every six months, whichever occurs first, using a low pressure lubrication gun until new grease is seen purging.

WARNING

- **Dry Cleaning Solvent (P-D-680) is TOXIC and flammable. Wear protective goggles and gloves; use only in well-ventilated area; avoid contact with skin, eyes, and clothes, and do not breath vapors. Keep away from heat or flame. Never smoke when using solvent; the flashpoint for Type I Dry Cleaning Solvent is 100 F (38 C) and for Type II is 138 F (50 C). Failure to comply may result in serious injury or death to personnel.**
- **If personnel become dizzy while using cleaning solvent, immediately get fresh air and medical help. If solvent contacts skin or clothes, flush with cold water. If solvent contacts eyes, immediately flush eyes with water and get medical attention. Failure to comply may result in injury to personnel.**

17. ENGINE CRANKCASE BREATHER. Remove crankcase breather and clean with Dry Cleaning Solvent (SD P-D-680) (Item 71, Appendix D) or equivalent, and replace o-ring seal every 6,000 miles (9,654 km) or once every six months, whichever occurs first (para 3-5).

18. FRONT and REAR AXLE SPRING BOLT and SPRING SHACKLE. Lubricate front and rear axle spring bolts and spring shackles with GAA every 3,000 miles (4,827 km) or once every three months, whichever occurs first, using a low pressure lubrication gun until grease appears between pins and bushings at both ends of spring bolt and spring shackle. If pins do not accept grease, notify Direct Support to remove pins. Clean and inspect pins and bushings, replace if necessary. If operating conditions are severe or abnormal, service at 1,000 miles (1,609 km) or once every month, whichever occurs first.

19. BATTERY POSTS. Service batteries in accordance with TM 9-6140-200-14, every 6,000 miles (9,654 km) or once every six months, whichever occurs first.

20. FRONT AXLE SHAFT UNIVERSAL JOINTS and STEERING KNUCKLES. Lubricate universal joints every 3,000 miles (4,827 km) or once every three months, whichever occurs first. Lubricate steering knuckles with GAA every 6,000 miles (9,654 km) or once every six months, whichever occurs first, using a low pressure lubrication gun. If operating conditions are severe or abnormal, service at 1,000 miles (1,609 km) or once every month, whichever occurs first.

21. BRAKE WEDGE and AIR CHAMBER: BRAKE SPIDER, SELF-ADJUSTER MECHANISM, AND WEDGE ASSEMBLY. Clean and lubricate (with GAA) areas of spider and hardware that contact the brake shoes. Disassemble, clean and lubricate the self-adjuster mechanism. Clean and lubricate the wedge head, rollers and ramps in the plungers. Clean and lubricate every 6,000 miles (9,654 km). If operating conditions are severe or abnormal, service at 3,000 miles (4,827 km) or once every three months, whichever occurs first, or when any of the following occur: Refer to para 11-4 and 11-5.

- Seals are replaced
- Plungers are removed
- Brakes are relined
- Grease becomes contaminated or hardened

22. FRONT and REAR AXLE INNER WHEEL BEARINGS. Repack inner wheel bearings with GAA every 12,000 miles (19,308 km), when semiannual PMCS inspection of service brakes reveals oil leak from inner hub, or whenever wheel end assemblies are taken apart for other maintenance (para 10-2).

23. 11K SRW CABLE ROLLER FAIRLEADS. Lubricate with GAA every 6,000 miles (9,654 km) or once every six months, whichever occurs first, using a low pressure lubrication gun. If operating conditions are severe or abnormal, service at 1,000 miles (1,609 km) or once every month, whichever occurs first.

WARNING

- **Dry Cleaning Solvent (P-D-680) is TOXIC and flammable. Wear protective goggles and gloves; use only in well-ventilated area; avoid contact with skin, eyes, and clothes, and do not breath vapors. Keep away from heat or flame. Never smoke when using solvent; the flashpoint for Type I Dry Cleaning Solvent is 100 F (38 C) and for Type II is 138 F (50 C). Failure to comply may result in serious injury or death to personnel.**
- **If personnel become dizzy while using cleaning solvent, immediately get fresh air and medical help. If solvent contacts skin or clothes, flush with cold water. If solvent contacts eyes, immediately flush eyes with water and get medical attention. Failure to comply may result in injury to personnel.**

24. FRONT LIFTING BEAM. Remove left and right lifting beams and clean with Dry Cleaning Solvent (SD P-D-680) (Item 71, Appendix D) or equivalent, every 6,000 miles (9,654 km) or once every six months, whichever occurs first. Apply a light coat of GAA to lifting beams. If operating conditions are severe or abnormal, service at 1,000 miles (1,609 km) or once every month, whichever occurs first.

25. AIR DRYER. Service air dryer (para 23-6) every 12,000 miles (19,308 km) or annually, whichever occurs first.

26. FRONT AND REAR LEAF SPRING. At initial 1000 miles (1609 km) of vehicle operation, tighten U-bolts to 390-510 lb-ft (529-692 N•m).

APPENDIX J ADDITIONAL AUTHORIZATION LIST (AAL)

Section I. INTRODUCTION

J-1. SCOPE

This appendix lists additional items you are authorized for the support of the LMTV.

J-2. GENERAL

This list identifies items that do not have to accompany the LMTV and that do not have to be turned in with it. These items are all authorized to you by Common Tables of Allowance (CTA), Modification Table of Organization and Equipment (MTOE), Tables of Distribution and Allowances (TDA), or Joint Table of Allowance (JTA).

J-3. EXPLANATION OF LISTING

National Stock Numbers, description, and quantities are provided to help you identify and request the additional items you require to support this equipment.

Section II. ADDITIONAL AUTHORIZATION LIST

(1) National Stock Number	(2) Description (CAGE) Part Number	(3) U/M	(4) Qty Auth
6685-01-193-1733	10,000 PSI Transducer: (19207) 12258956	EA	1

APPENDIX K TRANSMISSION/TRANSMISSION CONTROLS ADAPTABILITY CHART

Section I. INTRODUCTION

K-1. INTRODUCTION

This appendix lists the various transmission controls and configuration modifications that may be required to permit the transmission to function correctly. This appendix will guide the mechanic through the hardware selection process by identifying compatibility issues between the transmission controls (WTEC II/WTEC III) and the numerous revisions of the Allison MD3070PT transmission (PRE-ID w/ 24-pin connector, PRE-ID w/ 31-pin connector, TID 1, TID 2, and TID 3). Refer to Figure 1. After replacing any component of the transmission controls or the transmission assembly, perform calibration procedures in TM 9-2320-365-20-3 paragraph 8-2 or 8-3.

K-2. EXPLANATION OF COLUMNS

- a. **Column (1) - Installed Controls or Controls Being Installed.** This column lists all of the variables concerning which version of transmission controls are installed in the vehicle, or may need to be installed, to communicate correctly with the transmission.
- b. **Column (2) - Installed Transmission or Transmission Being Installed.** This column lists all of the various revisions of the Allison MD3070PT transmissions that may be installed in the vehicle.
- c. **Column (3) - Required Modification.** This column lists the various electrical interface (hardware) modifications that may be required to allow the transmission controls to communicate with the transmission.

K-3. HOW TO USE THIS CHART

- a. Determine which controls and transmission are installed in the vehicle.
- b. Determine which component requires replacement.
- c. Read across the row to column (3) to determine the required modification.

Section II.

TRANSMISSION/TRANSMISSION CONTROLS ADAPTABILITY CHART

(1) Installed Controls or Controls Being Installed	(2) Installed Transmission or Transmission Being Installed	(3) Required Modification (Refer to Section III)
WTEC II (with 24-pin connector)	PRE-ID w/ 24-pin connector (transmission serial number prior to 6510032369)	No modification required.
WTEC II (with 24-pin connector)	PRE-ID w/ 31-pin connector (transmission serial number 6510032369 to 6510090785)	Install 31-pin connector.
WTEC II (with 24-pin connector)	TID 1 (transmission serial number 6510090786 to 6510142171)	Install 31-pin connector.
WTEC II (with 24-pin connector)	TID 2 (transmission serial number 6510142172 to 6510262116)	Install 31-pin connector and replace transmission internal wiring harness.

TRANSMISSION/TRANSMISSION CONTROLS ADAPTABILITY CHART (CONT)

(1) Installed Controls or Controls Being Installed	(2) Installed Transmission or Transmission Being Installed	(3) Required Modification (Refer to Section III)
WTEC II (with 24-pin connector)	TID 3 (transmission serial number 6510262117 and subsequent)	Install 31-pin connector, replace transmission internal wiring harness, and reprogram WTEC II TEPSS. ¹
WTEC II (with 31-pin connector)	PRE-ID w/ 24-pin connector (transmission serial number prior to 6510032369)	Install adapter cable assembly.
WTEC II (with 31-pin connector)	PRE-ID w/ 31-pin connector (transmission serial number 6510032369 to 6510090785)	No modification required.
WTEC II (with 31-pin connector)	TID 1 (transmission serial number 6510090786 to 6510142171)	No modification required.
WTEC II (with 31-pin connector)	TID 2 (transmission serial number 6510142172 to 6510262116)	Replace transmission internal wiring harness.
WTEC II (with 31-pin connector)	TID 3 (transmission serial number 6510262117 and subsequent)	Replace transmission internal wiring harness and reprogram WTEC II TEPSS. ¹
WTEC III (with ECU manufactured prior to October 1999) ²	PRE-ID w/ 24-pin connector (transmission serial number prior to 6510032369)	Install adapter cable assembly and ID harness.
WTEC III (with ECU manufactured prior to October 1999) ²	PRE-ID w/ 31-pin connector (transmission serial number 6510032369 to 6510090785)	Install ID harness.
WTEC III (with ECU manufactured prior to October 1999) ²	TID 1 (transmission serial number 6510090786 to 6510142171)	No modification required.
WTEC III (with ECU manufactured prior to October 1999) ²	TID 2 (transmission serial number 6510142172 to 6510262116)	No modification required.
WTEC III (with ECU manufactured prior to October 1999) ²	TID 3 (transmission serial number 6510262117 and subsequent)	Reprogram WTEC III ECU ¹ or install new WTEC III ECU (P/N 12421787- 002).
WTEC III (with ECU manufactured after October 1999) ³	PRE-ID w/ 24-pin connector (transmission serial number prior to 6510032369)	Install adapter cable assembly and ID harness.
WTEC III (with ECU manufactured after October 1999) ³	PRE-ID w/ 31-pin connector (transmission serial number 6510032369 to 6510090785)	Install ID harness.
WTEC III (with ECU manufactured after October 1999) ³	TID 1 (transmission serial number 6510090786 to 6510142171)	No modification required.

¹ Reprogramming can only be accomplished by an authorized Allison Transmission distributor. You must provide the transmission serial number of the transmission being installed to ensure correct reprogramming. If at a later time, an earlier version transmission is installed in a WTEC II equipped vehicle, WTEC II TEPSS will require reprogramming again.

² Vehicle serial number 012477 and lower. Refer to Figure 1.

³ Vehicle serial number 012478 and higher. Refer to Figure 1.

(1) Installed Controls or Controls Being Installed	(2) Installed Transmission or Transmission Being Installed	(3) Required Modification (Refer to Section III)
WTEC III (with ECU manufactured after October 1999) ³	TID 2 (transmission serial number 6510142172 to 6510262116)	No modification required.
WTEC III (with ECU manufactured after October 1999) ³	TID 3 (transmission serial number 6510262117 and subsequent)	No modification required.

Section III.

MODIFICATION PARTS IDENTIFICATION

Identification	Part Number/NSN	Description
31-pin connector	300130 5935-21-921-1813	Converts a transmission external wiring harness from a 24-pin ("D" type) connector to a 31-pin (round type) connector.
Transmission internal wiring harness	29529474 6150-01-481-8088	Converts a TID 2 transmission to a TID 1 configuration to allow WTEC II controls to communicate with the transmission.
Gasket	29503283 5330-01-360-9035	Required when replacing transmission internal wiring harness.
ID harness	200100 6150-21-921-1191	Allows WTEC III controls to communicate with a PRE-ID transmission.
Adapter cable assembly	29519210 6150-01-420-5987	Adapts a PRE-ID transmission with 24-pin ("D" type) connector to a transmission external wiring harness with a 31-pin (round) connector.

MODIFICATION PARTS IDENTIFICATION (CONT)

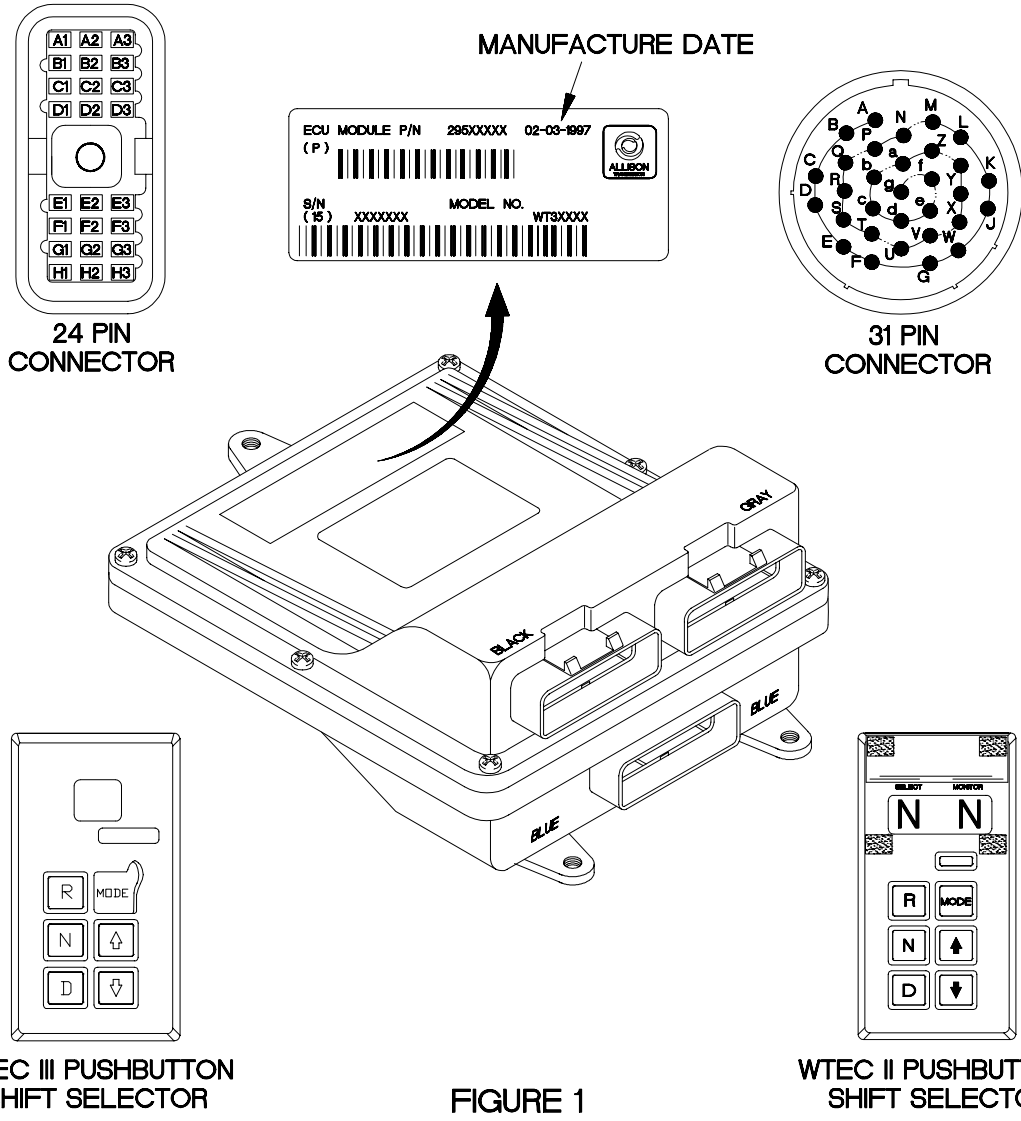

FIGURE 1

4WTEC111

SUBJECT INDEX

Subject	Para	Subject	Para
A		A (Cont)	
Absorber		Air (Cont)	
Rear Axle Shock Absorber		M1079 Air Conditioner ECU	
Replacement	15-4	Connector Replacement	16-47
Accessory		M1079 Air Conditioner Kit Installation/ Removal	20-81
Introduction, Body, Chassis, and		M1079 Air Conditioner Power Cable	
Accessory Items Maintenance	18-1	Replacement	20-82
M1079 Van Body Interior Accessory		M1079 Air Filter Replacement	16-33
Mounting Locations	16-44	M1079 Heater and Air Conditioner	
Accelerator Pedal Replacement	4-21	Cover Replacement	16-31
Air		M1079 Van Preparation For Air	
Brake Air Hoses Replacement	11-19	Transport	16-73
Brake Protecting Valve Replacement	11-16	No Air Pressure Present At Rear	
Brake System Loses Air When Brakes		Gladhands	2-21
Are Applied	2-20	Noisy Air Compressor Operation	2-21
Cab Leveling Air Springs Will Not		Pressure Transmitter Replacement	7-36
Operate	2-30	Primary and Central Tire Inflation System	
Charge Air Cooler to Air Inlet Elbow		(CTIS) Air Hoses Replacement	23-2
Tubes and Hoses Replacement	4-5	Radiator/Charge Air Cooler	
Compressor Governor Adjustment	11-29	Replacement	6-2
Compressor Inlet and Outlet Coolant		REAR BRAKE AIR Gage Does Not	
Tubes Replacement	6-11	Illuminate	2-16
Dryer Does Not Operate	2-16	REAR BRAKE AIR Pressure Gage Does	
Dryer Purges Constantly	2-21	Not Operate or Is Inaccurate	2-16
Dryer Replacement/Repair	21-14	Rear Brake Air Indicator Does Not	
Engine Air Intake System	1-11	Illuminate When Air Pressure Is	
Filter Restriction Gauge		Below 65 PSI	2-16
Replacement	24-2	Rear Brake Air Chamber	
Front Brake Air Chamber		Replacement	11-8
Replacement	11-7	Secondary and Primary Air Tanks	
Front Brake Air Indicator Does Not		Replacement	11-20
Illuminate When Air Pressure Is		Spring and Bracket Replacement	16-9
Below 65 PSI	2-16	System	1-19
FRONT BRAKE AIR Gage Does Not		System Loses Pressure During Operation/ Slow, No, or Incorrect Air Pressure	
Illuminate	2-16	Buildup	2-21
Front Brake Air Pressure Gage		System Park and Trailer Air Supply	
Does Not Operate or Is Inaccurate	2-16	Valves Replacement	11-18
/Hydraulic Power Unit and Bracket		System Pressure Builds Up to More	
Replacement/Repair	19-3	Than 120 psi (827 kPa) (Compressor	
Intake Air Cleaner Filter Element, Air		Fails to Unload)	2-21
Cleaner Assembly, and Particle		System Troubleshooting	2-21
Extraction Tube Replacement	4-2	Transport Troubleshooting	2-30
Introduction, Air System		Transportability Air Hoses	
Maintenance	23-1	Replacement	23-3
Large Quantity of Moisture Expelled			
From Air Reservoirs	2-21		
M1079 Air Conditioner Does Not			
Operate	2-16		

SUBJECT INDEX (CONT)

Subject	Para	Subject	Para
A (Cont)		A (Cont)	
Air (Cont)		Amp	
Transportability Hydraulic Hose Replacement	19-11	100 Amp Alternator Replacement	7-2
Transportability Hydraulic System	1-18	100 Amp Reverse Polarity Relay to Power Distribution Panel (PDP) 12 VDC Cable Replacement	7-80
Transportability Hydraulic System Service	19-7	100 Amp Reverse Polarity Relay to Power Distribution Panel (PDP) 24 VDC Cable Replacement	7-81
Alarm		100 Amp Reverse Polarity Relay Replacement	7-27
Audible Alarm Does Not Operate	2-16	100 Amp Voltage Regulator Replacement	7-5
Audible Alarm Replacement	7-35	24 VDC Circuits Do Not Operate 12 VDC and/or 24 VDC Circuits Do Not Operate	2-16
Chemical Alarm Does Not Operate	2-16	200 Amp Alternator Kit Installation	20-54
Chemical Alarm Kit Cable Assembly Replacement	7-52	200 Amp Alternator Kit Removal	20-55
M1079 Van Door Open Light Does Not Illuminate and Audible Alarm Does Not Operate	2-16	200 Amp Alternator Replacement	20-56
Troop Transport Alarm Cable Replacement	20-79	200 Amp Alternator to Terminal Block 12 VDC Cable Replacement	20-59
Troop Transport Alarm Does Not Operate	2-31	200 Amp Alternator to Terminal Block 24 VDC Cable Replacement	20-61
Troop Transport Audible Alarm Does Not Operate	2-16	200 Amp Reverse Polarity Relay Replacement	20-58
Troop Transport Alarm Switch, Connector, and Bracket Replacement	20-80	200 Amp Terminal Block Replacement	20-69
All Marker Lights Do Not Illuminate In Normal Mode	2-16	200 Amp Terminal Block to Power Distribution Panel (PDP) 12 VDC Cable Replacement	20-65
Alternator		200 Amp Terminal Block to Power Distribution Panel (PDP) 24 VDC Cable Replacement	20-68
Belts Replacement	7-3	200 Amp Terminal Block to Reverse Polarity Relay 12 VDC Load Cable Replacement	20-60
Brackets Replacement	7-4	200 Amp Terminal Block to Reverse Polarity Relay 24 VDC Load Cable Replacement	20-62
Ground Strap Replacement	7-64	200 Amp Voltage Regulator Replacement	20-57
100 Amp Alternator Replacement	7-2	Anchor	
100 Amp Alternator to Reverse Polarity Relay 12 VDC Cable Replacement	7-65	Latch and Cab Anchor Brackets Replacement	16-74
100 Amp Alternator to Reverse Polarity Relay 24 VDC Cable Replacement	7-66	Anti-Compounding Relay Valve Replacement	11-11
24 VDC Circuits Do Not Operate	2-16	Armament	
200 Amp Alternator Kit Installation	20-54	Introduction, Armament/Sighting and Fire Control Materiel Maintenance	21-1
200 Amp Alternator Kit Removal	20-55		
200 Amp Alternator to Terminal Block 12 VDC Cable Replacement	20-59		
200 Amp Alternator to Terminal Block 24 VDC Cable Replacement	20-61		
200 Amp Alternator Replacement	20-56		
Amber Warning Light Switch Does Not Illuminate	2-16		

Subject	Para
A (Cont)	
Assembly	
General Assembly Instructions	2-41
Audible	
Alarm Does Not Operate	2-16
Alarm Replacement	7-35
Troop Transport Audible Alarm Does Not Operate	2-16
Auxiliary	
M1079 W/O Winch Auxiliary Panel Cable Assembly Replacement	7-50
Panel Cable Assembly Replacement (All Models Except M1079 W/O Winch)	7-49
Panel Does Not Illuminate	2-16
Panel, Instrument Panel, and Personnel Heater Do Not Illuminate	2-16
Panel Replacement	7-8
Panel Switch Does Not Illuminate	2-16
Starter Solenoid Replacement	7-6
Axle	
Differential(s) Noisy	2-25
Introduction, Front and Rear Axle Maintenance	10-1
Front Axle Central Tire Inflation System (CTIS) Quick Release Valve Replacement	12-8
Rear Axle Central Tire Inflation System (CTIS) Quick Release Valve Replacement	12-9
Rear Axle Shaft Replacement	10-4
Rear Axle Shock Absorber Replacement	15-4
Troubleshooting	2-25
B	
Backup	
Light Assembly Replacement/Repair	7-29
Light Does Not Illuminate	2-16
Back-Up	
Hydraulic Pump Replacement	19-2
Batteries	
Disconnecting/Connecting Batteries	7-48
Battery	
Box Replacement	7-47
/Battery Cables Replacement	7-46
Tester Does Not Operate	2-16
Tester Replacement	7-45
to Shunt Cable Assembly Replacement	7-69
to Starter Cable Assembly Replacement	7-70

Subject	Para
B (Cont)	
Battery (Cont)	
to 100 Amp Reverse Polarity Relay 12 VDC Cable Replacement	7-67
to 100 Amp Reverse Polarity Relay 24 VDC Cable Replacement	7-68
to 200 Amp Terminal Block 12 VDC Cable Assembly Replacement	20-63
to 200 Amp Terminal Block 24 VDC Cable Assembly Replacement	20-64
Beams	
One or Both Headlights (High and Low Beams) Do Not Illuminate	2-16
One or Both Headlight High Beams Do Not Illuminate	2-16
One or Both Headlight Low Beams Do Not Illuminate	2-16
Turn Signal Indicators and High Beams on Indicator Do Not Operate	2-16
Belt	
Drive Belt and Tension Pulley Replacement	6-13
Seat Belt Replacement	16-15
Belts	
Alternator Belts Replacement	7-3
Binding	
M1079 Field Telephone Binding Post/Box and Conduit Replacement	16-51
M1079 24 VDC Binding Post/Box and Conduit Replacement	16-52
Blackout	
Drive Light Does Not Illuminate	2-16
Drive Light Replacement/Repair	7-30
Marker Lights Do Not Illuminate	2-16
M1079 Blackout Light(s) Does Not Operate	2-16
M1079 Blackout Override Switch Replacement	16-56
M1079 Blackout Shield and Frame Replacement/Repair	16-37
M1079 Blackout Switch Replacement	16-57
M1079 Blackout/Emergency Light Replacement	16-58
M1079 Fluorescent Lights Do Not Operate In Blackout Override Mode	2-16
M1079 110 VAC Outlet J232 and J233 Do Not Operate In Blackout Override Mode	2-16
One or Both Blackout Stoplights Do Not Illuminate	2-16
Boarding Handles Replacement	16-76

SUBJECT INDEX (CONT)

Subject	Para	Subject	Para
B (Cont)		B (Cont)	
Body		Brake (Cont)	
All M1079 Van Body Marker Lights		REAR BRAKE AIR Pressure Gage Does	
Do Not Operate	2-16	Not Operate or Is Inaccurate	2-16
Introduction, Body and Cab		Rear Brake Air Indicator Does Not	
Maintenance	16-1	Illuminate When Air Pressure Is	
Introduction, Body, Chassis, and		Below 65 PSI	2-16
Accessory Items Maintenance	18-1	Rear Brake Air Chamber	
M1079 Van Body Floor Tapping Plate		Replacement	11-8
Initial Installation (Serial Numbers 001		Rear Brake Plunger Assembly	
through 190)	16-43	Replacement/Repair	11-5
M1079 Van Body Interior Mounting		Rear Brake Shoes Replacement/	
Locations	16-44	Adjustment	11-3
M1079 Van Body Clearance Marker Light		Rear Spring Brake Caging	11-6
Does Not Illuminate	2-16	System	1-15
M1079 Van Body Replacement	16-19	System Loses Air When Brakes	
Boom		Are Applied	2-20
Light Material Handling Crane (LMHC)		System Troubleshooting	2-20
Boom Replacement	20-74	Braking	
Light Material Handling Crane (LMHC)		Excessive Braking Distance	2-20
Boom Sheave Replacement	20-75	Brakes	
Brackets		Brake System Loses Air When Brakes	
Alternator Brackets Replacement	7-4	Are Applied	2-20
Brake		Front Brakes Do Not Apply	2-20
Air Brake Protecting Valve		Front Brakes Overheat and/or	
Replacement	11-16	Do Not Release	2-20
Air Hoses Replacement	11-19	Parking Brakes Does Not Apply	2-20
Foot Control Valve and Brake Foot		Rear Brakes Do Not Apply	2-20
Pedal Replacement	11-9	Rear Brakes Overheat	2-20
Front Brake Air Chamber		Vehicle Brakes Unevenly, Brakes Pull	
Replacement	11-7	to One Side or Grab	2-20
FRONT BRAKE AIR Gage Does Not		Breather	
Illuminate	2-16	Crankcase Breather Replacement	3-5
Front Brake Air Indicator Does Not		Bumper	
Illuminate When Air Pressure Is		Front Bumper Replacement	14-2
Below 65 PSI	2-16	M1079 Rubber Bumper and Tee Latch	
FRONT BRAKE AIR Pressure Gage Does		Replacement	16-29
Not Operate or Is Inaccurate	2-16	C	
Front Brake Plunger Assembly		Cab	
Replacement/Repair	11-4	Clearance Marker Lights Cable	
Front Brake Shoes Replacement/		Assembly Replacement	7-59
Adjustment	11-2	Does Not Raise	2-32
Introduction, Brake System		Does Not Lower	2-32
Maintenance	11-1	Emergency Cab Lift Procedure	19-8
Parking Brake Indicator and/or		Exhaust Fumes in Cab	2-14
Emergency Brake Indicator Does Not			
Operate	2-16		
Parking Brake Does Not Release	2-20		
REAR BRAKE AIR Gage Does Not			
Illuminate	2-16		

Subject	Para	Subject	Para
C (Cont)		C (Cont)	
Cab (Cont)		Cable (Cont)	
Floor Covering Replacement	16-12	Central Tire Inflation System (CTIS)	
Hydraulic Cylinder Replacement	19-10	Cable Assembly Replacement	7-53
Hydraulic Latch Replacement/ Adjustment	19-6	Engine Control Cable Assembly Replacement	7-72
Introduction, Body and Cab Maintenance	16-1	Front Intervehicular 12 VDC (7 Pin) Cable Replacement	7-73
Latch and Cab Anchor Brackets Replacement	16-74	Front Lights Cable Assembly Replacement	7-74
Left-Hand Door and Cab Marker Lights Cable Assembly Replacement	7-54	Left-Hand Door and Cab Marker Lights Cable Assembly Replacement	7-54
Leveling Air Springs Will Not Operate	2-30	Load Sensing Valve and Control Cable Replacement/Adjustment	11-10
Leveling Valve and linkage Replacement/ Adjustment	16-8	Rear Lights Cable Assembly Replacement	7-75
Panel Liners Replacement	16-13	M1079 Air Conditioner Power Cable Replacement	20-82
M1081 Cab Clearance and Marker Lights Lower Cable Assembly Replacement	7-55	M1079 Heater Control Cable Replacement	20-43
M1081 Cab Clearance and Marker Lights Upper Cable Assembly Replacement	7-56	M1079 Heater Fuel Pump Power Cable Replacement	20-49
M1081 Cab Roof Replacement	16-4	M1079 Heater Power Cable Replacement	20-42
Mirror Replacement	18-7	M1079 Heater Thermostat Cable Replacement	20-45
Convex Mirror Initial Installation	20-3	M1079 W/O Winch Auxiliary Panel Cable Assembly Replacement	7-50
RH Convex Mirror Initial Installation	20-2	M1079 110/208 VAC Power In/Out Cable Replacement	16-68
RH Convex Mirror Replacement	18-13	M1079 12/24 VDC Power Cable Replacement	7-51
One or More Cab Top Marker Lights Do Not Illuminate	2-16	M1081 Cab Clearance and Marker Lights Lower Cable Assembly Replacement	7-55
Power Distribution Panel (PDP) to Cab Ground Cable Replacement	7-76	M1081 Cab Clearance and Marker Lights Upper Cable Assembly Replacement	7-56
Rear Cab Support Assembly Replacement	16-7	NATO Power Cable Replacement	7-63
Right-Hand Door and Cab Marker Lights Cable Assembly Replacement	7-57	Power Distribution Panel (PDP) to Cab Ground Cable Replacement	7-76
Step Replacement	16-11	Power Take-Off (PTO) Cable Assembly Replacement	7-77
Storage Box Replacement/Repair	16-17	Rear Intervehicular 12 VDC (7 Pin) Cable Replacement	7-78
Tilt and Spare Tire Retainer Troubleshooting	2-32	Rear Intervehicular 24 VDC (12 Pin) Cable Replacement	7-79
Tilt, Spare Tire Retainer, and Suspension Compression Will Not Work	2-30	Right-Hand Door and Cab Marker Lights Cable Assembly Replacement	7-57
to Chassis Ground Strap Replacement	7-71	Start and Charging Cable Assembly Replacement	7-82
Will Not Raise or Lower Properly	2-32		
WTEC II Cab Transmission Harness Replacement	7-86		
WTEC III Cab Transmission Harness Replacement	7-87		
Cable			
Auxiliary Panel Cable Assembly Replacement (All Models Except M1079 W/O winch)	7-49		
Battery/Battery Cables Replacement	7-46		
Battery to Shunt Cable Assembly Replacement	7-69		
Battery to Starter Cable Assembly Replacement	7-70		

SUBJECT INDEX (CONT)

Subject	Para	Subject	Para
C (Cont)		C (Cont)	
Cable (Cont)		Cable (Cont)	
Starter to Chassis Ground Cable Replacement	7-83	200 Amp Terminal Block to Reverse Polarity Relay 24 VDC Battery Cable Replacement	20-67
Starter to Shunt 24 VDC Cable Replacement	7-84	200 Amp Terminal Block to Reverse Polarity Relay 12 VDC Load Cable Replacement	20-60
STE/ICE-R Cable Assembly Replacement	7-58	200 Amp Terminal Block to Reverse Polarity Relay 24 VDC Load Cable Replacement	20-62
Throttle Control Cable Replacement/Adjustment	4-18	Caging	
Throttle Position Sensor (TPS) Cable Assembly Replacement	4-16	Rear Spring Brake Caging	11-6
Troop Transport Alarm Cable Assembly Replacement	20-79	Central	
Warning Light Cable Assembly Replacement	22-2	Tire Inflation System (CTIS) Cable Assembly Replacement	7-53
Winch Control Valve Cable Assembly Replacement	7-85	Tire Inflation System (CTIS) Does Not Deflate Tires	2-16
Windshield Washer Pump Electromagnetic Interference (EMI) Cable Assembly Replacement	7-60	Tire Inflation System (CTIS) Does Not Inflate Tires	2-16
Windshield Wiper Electromagnetic Interference (EMI) Cable Replacement	7-61	Tire Inflation System (CTIS) Does Not Operate	2-16
WTEC II Dashboard Cable Assembly Replacement/Repair	7-10	Tire Inflation System (CTIS) ECU Indicates No Fault Code But Fails to Inflate or Deflate	2-24
WTEC III Dashboard Cable Assembly Replacement/Repair	7-11	Tire Inflation System (CTIS) ECU Replacement	12-6
100 Amp Reverse Polarity Relay to Power Distribution Panel (PDP) 12 VDC Cable Replacement	7-80	Tire Inflation System (CTIS) Hose Assemblies, Manifold Valve, Kneeling Valve and Bracket Replacement	12-5
100 Amp Reverse Polarity Relay to Power Distribution Panel (PDP) 24 VDC Cable Replacement	7-81	Tire Inflation System (CTIS) Overspeed Indicator Does Not Operate	2-16
11K Self-Recovery Winch (SRW) Cable Replacement	17-5	Tire Inflation System (CTIS) Repeatedly Resumes Cycling 30 Seconds After Indicator Lights Stop Flashing	2-24
200 Amp Alternator to Terminal Block 12 VDC Cable Replacement	20-59	Tire Inflation System (CTIS) Troubleshooting	2-24
200 Amp Alternator to Terminal Block 24 VDC Cable Replacement	20-61	Charge	
200 Amp Terminal Block to Power Distribution Panel (PDP) 12 VDC Cable Replacement	20-65	Radiator/Charge Air Cooler Replacement	6-2
200 Amp Terminal Block to Power Distribution Panel (PDP) 24 VDC Cable Replacement	20-68	Turbocharger to Charge Air Cooler Tube and Hoses Replacement	4-4
200 Amp Terminal Block to Reverse Polarity Relay 12 VDC Battery Cable Replacement	20-66	Charging	
		Start and Charging Cable Assembly Replacement	7-82
		Chassis	
		Introduction, Body, Chassis, and Accessory Items Maintenance	18-1
		M1079 Chassis Ground Lug Replacement	16-69

Subject	Para
C (Cont)	
Checking and Stenciling High/Low Hand Throttle Positions	4-22
Chemical	
Alarm Does Not Operate	2-16
Alarm Kit Cable Assembly Replacement	7-52
Detector Does Not Operate	2-16
Detector Indicator Does Not Operate	2-16
Circuit	
Breaker, Diode, and Relay Replacement	7-9
Breaker Does Not Operate	2-16
M1079 15/20/30 and 50 Amp AC Circuit Breaker Replacement	16-64
M1079 200 Amp AC Circuit Breaker Replacement	16-65
M1079 5/20 Amp DC Circuit Breaker Replacement	16-61
Circuits	
24 VDC Circuits Do Not Operate	2-16
12 VDC and/or 24 VDC Circuits Do Not Operate	2-16
Cleaning	
General Cleaning Instructions	2-38
Clearance	
And Marker Light Assemblies Replacement	7-31
Intervehicle Clearance Lights Do Not Operate	2-16
M1079 Clearance and Marker Lights Replacement	16-60
Code	
WTEC II Code Reading and Code Clearing Procedures	8-4
WTEC II Transmission ECU Pushbutton Shift Selector (TEPSS) Emits Eight Seconds of Beeps and/or Transmission Does Not Shift Gears	2-17
WTEC II Transmission ECU Pushbutton Shift Selector (TEPSS) Displays Main Code 22 Sub Code 14	2-17
WTEC II Transmission ECU Pushbutton Shift Selector (TEPSS) Displays Main Code 22 Sub Code 15	2-17
WTEC II Transmission ECU Pushbutton Shift Selector (TEPSS) Displays Main Code 22 Sub Code 16	2-17
WTEC II Transmission ECU Pushbutton Shift Selector (TEPSS) Displays Main Code 24 and/or 33 and Any Sub Code	2-17

Subject	Para
C (Cont)	
Code (Cont)	
WTEC II Transmission ECU Pushbutton Shift Selector (TEPSS) Displays Main Code 32 and Any Sub Code	2-17
WTEC II Transmission ECU Pushbutton Shift Selector (TEPSS) Displays Main Code 41, 42, 44, 45, 66, and/or 69 and Any Sub Code	2-17
WTEC II Transmission ECU Pushbutton Shift Selector (TEPSS) Displays Main Code 43 and Any Sub Code	2-17
WTEC II Transmission ECU Pushbutton Shift Selector (TEPSS) Displays Main Code 52 and Any Sub Code	2-17
WTEC II Transmission ECU Pushbutton Shift Selector (TEPSS) Displays Main Code 57 and Any Sub Code	2-17
WTEC II Transmission ECU Pushbutton Shift Selector (TEPSS) Displays Main Code 21 and Any Sub Code	2-17
WTEC II Transmission ECU Pushbutton Shift Selector (TEPSS) Displays Main Code 51 Sub Code 10, 12, 21, 43, 45, or 65	2-17
WTEC II Transmission ECU Pushbutton Shift Selector (TEPSS) Displays Main Code 25 and Any Sub Code	2-17
WTEC II Transmission ECU Pushbutton Shift Selector (TEPSS) Displays Main Code 53 and Any Sub Code	2-17
WTEC II Transmission ECU Pushbutton Shift Selector (TEPSS) Displays Main Code 54 Sub Code 01, 07, 10, 12, 17, 21, 23, 27, 32, 34, 43, 45, 54, 56, 65, 70, 71, 72, 80, 81, 82, 83, 85, 86, 92, 93, 95, 96, or 97	2-17
WTEC II Transmission ECU Pushbutton Shift Selector (TEPSS) Displays Main Code 55 and Any Sub Code	2-17
WTEC II Transmission ECU Pushbutton Shift Selector (TEPSS) Displays Main Code 56 and Any Sub Code	2-17
WTEC II Transmission ECU Pushbutton Shift Selector (TEPSS) Displays Main Code 13 and Any Sub Code	2-17
WTEC II Transmission ECU Pushbutton Shift Selector (TEPSS) Displays Main Code 23 and Any Sub Code	2-17

SUBJECT INDEX (CONT)

Subject	Para	Subject	Para
C (Cont)		C (Cont)	
Code (Cont)		Code (Cont)	
WTEC II Transmission ECU Pushbutton Shift Selector (TEPSS) Does Not Illuminate	2-17	WTEC III Transmission Pushbutton Shift Selector (TPSS) Displays Main Code 55 and Any Sub Code	2-17
WTEC III Transmission Pushbutton Shift Selector (TPSS) Displays Main Code 22 Sub Code 14	2-17	WTEC III Transmission Pushbutton Shift Selector (TPSS) Displays Main Code 56 and Any Sub Code	2-17
WTEC III Transmission Pushbutton Shift Selector (TPSS) Displays Main Code 22 Sub Code 15	2-17	WTEC III Transmission Pushbutton Shift Selector (TPSS) Displays Main Code 13 and Any Sub Code	2-17
WTEC III Transmission Pushbutton Shift Selector (TPSS) Displays Main Code 22 Sub Code 16	2-17	WTEC III Transmission Pushbutton Shift Selector (TPSS) Indicator Displays "--" and/or Transmission Does Not Shift Gears	2-17
WTEC III Transmission Pushbutton Shift Selector (TPSS) Displays Main Code 24 and/or 33 and Any Sub Code	2-17	WTEC III Transmission Pushbutton Shift Selector (TPSS) Displays Main Code 23 and Any Sub Code	2-17
WTEC III Transmission Pushbutton Shift Selector (TPSS) Displays Main Code 32 and Any Sub Code	2-17	WTEC III Transmission Pushbutton Shift Selector (TPSS) Does Not Illuminate	2-17
WTEC III Transmission Pushbutton Shift Selector (TPSS) Displays Main Code 42, 44, 45, 46, 66, and/or 69 and Any Sub Code	2-17	Column	
WTEC III Transmission Pushbutton Shift Selector (TPSS) Displays Main Code 52 and Any Sub Code	2-17	Steering Column Replacement	13-6
WTEC III Transmission Pushbutton Shift Selector (TPSS) Displays Main Code 57 and Any Sub Code	2-17	Common Tools and Equipment, Vehicle Compressor	
WTEC III Transmission Pushbutton Shift Selector (TPSS) Displays Main Code 21 and Any Sub Code	2-17	Air Compressor Governor Adjustment	11-29
WTEC III Transmission Pushbutton Shift Selector (TPSS) Displays Main Code 51 and Any Sub Code	2-17	Air Compressor Inlet and Outlet Coolant Tubes Replacement	6-11
WTEC III Transmission Pushbutton Shift Selector (TPSS) Displays Main Code 25 and Any Sub Code	2-17	Noisy Air Compressor Operation	2-21
WTEC III Transmission Pushbutton Shift Selector (TPSS) Displays Main Code 53 and Any Sub Code	2-17	Conduit	
WTEC III Transmission Pushbutton Shift Selector (TPSS) Displays Main Code 54 and Any Sub Code	2-17	M1079 Door Ajar Switch/Box and Conduit Replacement	16-55
		M1079 Fan Switch/Box and Conduit Replacement	16-54
		M1079 Field Telephone Binding Post/Box and Conduit Replacement	16-51
		M1079 Interior Lights Switch/Box and Conduit Replacement	16-50
		M1079 Lighting Fixture and Conduit Replacement	16-59
		M1079 110 VAC Outlet/Box and Conduit Replacement	16-53
		M1079 110/208 VAC Power Entry Panel and Conduit Replacement	16-70
		M1079 12/24 VDC Power Entry Panel and Conduit Replacement	16-72
		M1079 24 VDC Binding Post/Box and Conduit Replacement	16-52

Subject Para

C (Cont)

Coolant

Bypass Tube Replacement 6-7

In Engine Lubrication Oil 2-12

Loss of Coolant 2-15

Lower Coolant Hose Replacement 6-10

Temperature Gage Sensor Replacement 7-37

Temperature Light Switch Replacement 7-22

Upper Coolant Tube and Hoses Replacement 6-9

Cooler

Radiator/Charge Air Cooler Replacement 6-2

Transmission Oil Cooler Hoses Initial Installation 8-14

Transmission Oil Cooler Hoses Replacement 8-15

Transmission Oil Cooler Hose Bracket Replacement 8-16

Transmission Oil Cooler Replacement 8-10

Transmission Oil Cooler Tubes Replacement 8-11

Cooling

Introduction, Cooling System Maintenance 6-1

Oil In Cooling System 2-15

System 1-13

System Troubleshooting 2-15

Cover

Cold Weather Radiator Cover Installation/Removal 18-12

Defrost Cover Replacement 18-8

M1079 Heater and Air Conditioner Cover Replacement 16-31

M1079 Raceway Cover Replacement 16-45

M1079 Vent Cover Replacement 16-32

M1079 Window Cover Replacement 16-41

Rim Cover Initial Installation 20-4

Rim Cover Replacement 12-10

Crane

Light Material Handling Crane (LMHC) Assembly/Disassembly 20-70

Light Material Handling Crane (LMHC) Boom Replacement 20-74

Light Material Handling Crane (LMHC) Boom Sheave Replacement 20-75

Light Material Handling Crane (LMHC) Control Box Repair 20-77

Light Material Handling Crane (LMHC) Does Not Operate 2-31

Light Material Handling Crane (LMHC) Hoist IN Does Not Operate 2-31

C (Cont)

Crane (Cont)

Light Material Handling Crane (LMHC) Hoist OUT Does Not Operate 2-31

Light Material Handling Crane (LMHC) Mast and Swing Assembly Repair 20-78

Light Material Handling Crane (LMHC) Replacement 20-71

Light Material Handling Crane (LMHC) Turret Replacement 20-76

Light Material Handling Crane (LMHC) Weight Block and Wire Rope Replacement/Repair 20-72

Light Material Handling Crane (LMHC) Winch Replacement/Repair 20-73

Crankcase Breather Replacement 3-5

Cranks

Engine Cranks But Does Not Start 2-12

Engine Cranks But Does Not Start 2-16

Engine Cranks But Does Not Start or Engine Stalls After Starting 2-13

Engine Does Not Crank 2-12

Engine Does Not Crank 2-16

CTIS

Central Tire Inflation System (CTIS) Cable Assembly Replacement 7-53

Central Tire Inflation System (CTIS) Does Not Operate 2-16

Central Tire Inflation System (CTIS) ECU Replacement 12-6

Central Tire Inflation System (CTIS) Hose Assemblies, Manifold Valve, Kneeling Valve and Bracket Replacement 12-5

Central Tire Inflation System (CTIS) ECU Indicates No Fault Code But Fails to Inflate or Deflate 2-24

Central Tire Inflation System (CTIS) Troubleshooting 2-24

Does Not Deflate Tires 2-16

Does Not Inflate Tires 2-16

Does Not Operate 2-16

Five Central Tire Inflation System (CTIS) ECU Indicator Lights Flashing 2-24

Four CTIS ECU Indicator Lights Flashing 2-24

Front Axle Central Tire Inflation System (CTIS) Quick Release Valve Replacement 12-8

Rear Axle Central Tire Inflation System (CTIS) Quick Release Valve Replacement 12-9

SUBJECT INDEX (CONT)

Subject	Para	Subject	Para
C (Cont)		D (Cont)	
CTIS (Cont)		Dimmer	
Overspeed Indicator Does Not Operate	2-16	WTEC II Transmission ECU Pushbutton	
Primary and Central Tire Inflation		Shift Selector (TEPSS) Dimmer Module	
System (CTIS) Air Hoses		Replacement	7-13
Replacement	23-2	Switch Replacement	7-12
Repeatedly Resumes Cycling 30		Disassembly	
Seconds After Indicator Lights Stop		General Disassembly Instructions	2-37
Flashing	2-24	Door	
Wheel Bearing/Central Tire Inflation		Left-Hand Door and Cab Marker lights	
System (CTIS) Seal Replacement	10-2	Cable Assembly Replacement	7-54
D		LH Door and/or LH Front Marker Lights	
Dashboard		Do Not Illuminate	2-16
WTEC II Dashboard Cable Assembly		M1079 Door Ajar Switch and Conduit	
Replacement/Repair	7-10	Replacement 16-55	
WTEC III Dashboard Cable Assembly		Door (Cont)	
Replacement/Repair	7-11	M1079 Door Seal, Retainer, and Latch	
Defrost Cover Replacement	18-8	Striker Replacement	16-30
Deprocessing		M1079 Pod Door and Panel	
Unpacking and Deprocessing	2-4	Replacement	16-22
Destruction of Army Materiel to Prevent		M1079 LH Door Assembly	
Enemy Use	1-3	Replacement/Repair	16-36
Detector		M1079 RH Door Assembly	
Chemical Detector Does Not Operate	2-16	Replacement/Repair	16-35
Chemical Detector Indicator Does Not		M1079 Van Door Open Light Does	
Operate	2-16	Not Illuminate and Audible	
Differences Between Models	1-9	Alarm Does Not Operate	2-16
Differential		M1081 Door Repair/Adjustment	16-6
Axle Differential(s) Noisy	2-25	Panel Stowage Door Assembly Repair	16-18
Spider Assembly Replacement	10-3	Repair/Adjustment (All Models Except	
Digitization Kit		M1081)	16-5
Aft Storage Box Replacement	20-90	Drag Link Replacement/Repair	13-3
Circuit Breaker Replacement	20-87	Drive	
Co-Drivers Seat Replacement	20-92	Belt and Tension Pulley Replacement	6-13
Drivers Storage Box Replacement	20-91	Shaft and Universal Joint Replacement	9-2
Installation	20-86	Shaft Hinging Inspection	9-3
No Power to Digitization Rack	2-31	Shaft or Universal Joint	
No Power to Driver Visual Enhancement		Unusually Noisy When Operating	2-18
(DVE)	2-31	Dryer	
No Power to Enhanced Position Location		Air Dryer Does Not Operate	2-16
Reporting System (EPLRS)	2-31	Air Dryer Purges Constantly	2-21
No Power to Mobile Tracking system (MTS)	2-31	Air Dryer Replacement/Repair	23-6
No Power to Mobile Tracking System (MTS)		E	
Sense	2-31	ECU	
No Power to Precision Lightweight Global		Central Tire Inflation System (CTIS)	
Positioning System Receiver (PLGR)	2-31	ECU Indicates No Fault Code But	
No Power to SINCGAR/Force XXI Battle		Fails to Inflate or Deflate	2-24
Command Brigade and Below (FBCB)	2-31	Central Tire Inflation System (CTIS)	
Power Cable Replacement	20-88	ECU Replacement	12-6
Radio Rack Replacement	20-89	Five Central Tire Inflation System (CTIS)	
Removal	20-86	ECU Indicator Lights Flashing	2-24

Subject	Para
E (Cont)	
ECU (Cont)	
Four CTIS ECU Indicator Lights	
Flashing	2-24
Frequency ECU Replacement	7-28
M1079 Air Conditioner ECU Connector	
Replacement	16-47
Windshield Wiper ECU Replacement	7-62
WTEC II Transmission ECU Pushbutton	
Shift Selector (TEPSS) and Bracket	
Replacement and Calibration	8-2
WTEC II Transmission ECU Pushbutton	
Shift Selector (TEPSS) Dimmer Module	
Replacement	7-13
WTEC II Transmission ECU Pushbutton	
Shift Selector (TEPSS) Illumination	
Does Not Dim	2-16
WTEC III Transmission ECU	
Replacement	8-7
Electrical	
Gages Replacement	7-14
Introduction, Electrical System	
Maintenance	7-1
System	1-14
System Does Not Maintain a Charge	2-16
System Troubleshooting	2-16
Emergency	
Cab Lift Procedure	19-8
Gladhand Two-Way Check Valve	
Replacement	11-24
M1079 Blackout/Emergency Light	
Replacement	16-58
M1079 Emergency Light(s) Does Not	
Operate	2-16
EMI	
Windshield Washer Pump	
Electromagnetic Interference (EMI)	
Cable Assembly Replacement	7-60
Windshield Wiper Electromagnetic	
Interference (EMI) Cable	
Replacement	7-61
Engine	
Air Intake System	1-11
And Transmission Oil Sampling Valves	
Replacement	3-6
Control Cable Assembly Replacement	7-72
Coolant In Engine Lubrication Oil	2-12
Cranks But Does Not Start	2-12
Cranks But Does Not Start	2-16
Cranks But Does Not Start or	
Engine Stalls After Starting	2-13
Does Not Crank	2-12
Does Not Crank	2-16
Excessive Black or Gray	
Exhaust Smoke	2-12
Excessive Engine Oil Consumption	2-12

Subject	Para
E (Cont)	
Engine (Cont)	
Exhaust System Unusually Noisy or	
Vibrates Excessively During Engine	
Operation	2-14
Fan and Fan Clutch Assembly	
Replacement	6-14
Fan Does Not Turn Off Using Radiator	
Fan Off Switch	2-16
Fan Runs Constantly	2-16
High Engine Temperature Indicator	
Does Not Operate	2-16
High Engine Temperature Indicator	
Illuminates	2-16
Introduction, Engine Maintenance	3-1
Low Engine Oil Pressure	2-12
Low Engine Power	2-12
Master Power Switch Does Not Shut	
Down Engine	2-16
Oil Pressure Gage Does Not Operate	
or Is Inaccurate	2-16
Oil Pressure Indicator Does Not	
Operate	2-16
Overheats	2-12
Overheats	2-15
Overspeeds on Start	2-12
Speed Sensor Replacement/	
Adjustment	7-38
Stalls at Low RPM	2-12
System Troubleshooting	2-12
Too Much Engine Vibration	2-12
Transmission Engine Speed Sensor	
Replacement	7-43
Equipment Characteristics, Capabilities,	
and Features	1-7
Ether	
Sensor Replacement	7-39
Start Switch Does Not Illuminate	2-16
Start Does Not Operate	2-16
Starting Aid Does Not Operate	2-13
Starting Aid Replacement	4-15
Excessive	
Black or Gray Exhaust Smoke	2-12
Braking Distance	2-20
Condensation in Fuel	2-16
Engine Oil Consumption	2-12
Play When Turning Steering Wheel	2-26
Exhaust	
Excessive Black or Gray Exhaust	
Smoke	2-12
Fumes in Cab	2-14
Introduction, Exhaust System	
Maintenance	5-1
Muffler and Exhaust Heat Shields	
Replacement	5-2
Pipe Replacement	5-3
System Troubleshooting	2-14

SUBJECT INDEX (CONT)

Subject	Para	Subject	Para
E (Cont)		F (Cont)	
Exhaust (Cont)		Fluorescent	
System Unusually Noisy or Vibrates		All M1079 Fluorescent Lights Do Not	
Excessively During Engine Operation	2-14	Operate	2-16
White Exhaust Smoke	2-12	M1079 Fluorescent Lights Do Not	
		Operate In Blackout Override Mode	2-16
F		Folding	
Fan		M1079 Folding Step Replacement	16-28
Engine Fan and Fan Clutch Assembly		Foot Control Valve and Brake Foot Pedal	
Replacement	6-14	Replacement	11-9
Engine Fan Does Not Turn Off Using		Forms	
Radiator Fan Off Switch	2-16	Maintenance Forms, Records, and	
Engine Fan Runs Constantly	2-16	Reports	1-2
M1079 Fan Assembly Replacement/		Four CTIS ECU Indicator Lights Flashing	2-24
Repair	16-67	Frame	
M1079 Fan Does Not Operate	2-16	Introduction, Frame, Towing	
M1079 Fan Switch/Box and Conduit		Attachments, and Drawbars	
Replacement	16-54	Maintenance	14-1
Off Indicator Does Not Operate	2-16	M1079 Blackout Shield and Frame	
Personnel Heater Fan Does Not Operate . . .	2-16	Replacement/Repair	16-37
Radiator Fan Off Switch Does		M1079 Pod Frame Replacement/	
Not Illuminate	2-16	Repair	16-23
Radiator Fan Shrouds Replacement	6-4	M1079 Window Main Frame	
Solenoid Replacement	7-23	Replacement	16-40
Fender and Splash Guard Replacement	16-10	Troubleshooting	2-33
Filter		Frequency ECU Replacement	7-28
Air Filter Restriction Gauge		Front	
Replacement	24-2	And Rear Hazard Lights Do Not	
Fuel Filter and Filter Base		Illuminate	2-16
Replacement	4-14	And Rear Turn Signals Do Not	
Fuel Filter Tubes Replacement	4-10	Operate	2-16
Intake Air Cleaner Filter Element, Air		Axle Central Tire Inflation System	
Cleaner Assembly, and Particle		(CTIS) Quick Release Valve	
Extraction Tube Replacement	4-2	Replacement	12-8
M1079 Air Filter Replacement	16-33	Axle Quick Release Valve	
Oil Filter Replacement	3-4	Replacement	11-15
Transmission Oil Filter Replacement	8-9	Axle Shock Absorber Replacement	15-3
Five Central Tire Inflation System (CTIS)		Brake Air Chamber Replacement	11-7
ECU Indicator Lights Flashing	2-24	BRAKE AIR Gage Does Not	
Flasher Unit Replacement	7-24	Illuminate	2-16
Floor		Brake Air Indicator Does Not	
Cab Floor Covering Replacement	16-12	Illuminate When Air Pressure Is	
M1079 Van Body Floor Tapping Plate		Below 65 PSI	2-16
Initial Installation (Serial Numbers 001		Brake Air Pressure Gage Does Not	
through 190)	16-43	Operate or Is Inaccurate	2-16
		Brake Plunger Assembly Replacement/	
		Repair	11-4

Subject Para

F (Cont)

Front (Cont)

- Brake Shoes Replacement/Adjustment 11-2
- Brakes Do Not Apply 2-20
- Brakes Overheat and/or Do Not Release 2-20
- Bumper Replacement 14-2
- Composite Front Light Assembly Replacement/Repair 7-33
- Gladhand Replacement 11-21
- Hazard Lights Do Not Illuminate 2-16
- Intervehicular 12 VDC (7 Pin) Cable Replacement 7-73
- Left or Right Front Turn Signals Do Not Operate 2-16
- Lights Cable Assembly Replacement 7-74
- One or Both Front Blackout Marker Lights Do Not Illuminate 2-16
- RH Door and/or RH Front Marker Lights Do Not Illuminate 2-16
- Wheel Toe-In Alignment/Adjustment 13-5

Fuel

- Consumption Too High 2-13
- Excessive Condensation in Fuel 2-16
- Filter and Filter Base Replacement 4-14
- Filter Tubes Replacement 4-10
- Gage Does Not Illuminate 2-16
- Gage Does Not Operate or Is Inaccurate 2-16
- Hoses Replacement 4-9
- Introduction, Fuel System Maintenance 4-1
- M1079 Heater Fuel Pump Power Cable Replacement 20-49
- M1079 Heater Fuel Pump Replacement 20-48
- M1079 Heater Fuel Regulator Replacement 20-47
- M1079 Heater Fuel Tubes/Hoses Replacement 20-46
- Pressure Regulating Valve Replacement 4-3
- Ratio Control Tube Replacement 4-6
- System 1-12
- System Bleeding 4-11
- System Troubleshooting 2-13
- Tank and Brackets Replacement 4-8
- /Water Separator and Filter Replacement 4-13

G

Gage

- Engine Oil Pressure Gage Does Not Operate or Is Inaccurate 2-16

Subject Para

G (Cont)

Gage (Cont)

- FRONT BRAKE AIR Gage Does Not Illuminate 2-16
- Front Brake Air Pressure Gage Does Not Operate or Is Inaccurate 2-16
- FUEL Gage Does Not Illuminate 2-16
- FUEL Gage Does Not Operate or Is Inaccurate 2-16
- OIL PRESS Gage Does Not Illuminate 2-16
- REAR BRAKE AIR Gage Does Not Illuminate 2-16
- REAR BRAKE AIR Pressure Gage Does Not Operate or Is Inaccurate 2-16
- VOLTS Gage Does Not Illuminate 2-16
- VOLTS Gage Does Not Operate or Is Inaccurate 2-16
- WATER TEMP Gage Does Not Illuminate 2-16
- WATER TEMP Gage Does Not Operate or Is Inaccurate 2-16

Gages

- Electrical Gages Replacement 7-14
- Introduction, Gages (Non-Electrical) Maintenance 24-1

General

- Assembly Instructions 2-41
- Cleaning Instructions 2-38
- Disassembly Instructions 2-37
- Inspection Instructions 2-39
- Installation Instructions 2-42
- Maintenance Procedures 2-8
- Removal Instructions 2-36
- Repair Instructions 2-40

Gladhand

- Emergency Gladhand Two-Way Check Valve Replacement 11-24
- Front Gladhand Replacement 11-21
- Rear Gladhand Replacement 11-22
- Service Gladhand Two-Way Check Valve Replacement 11-23

Gladhands

- No Air Pressure Present At Rear Gladhands 2-21

Governor Linkage Replacement 4-12

Gravel

- Gravel Deflector and Gravel Deflector Extension Replacement 14-2

Ground

- Alternator Ground Strap Replacement 7-64
- Cab to Chassis Ground Strap Replacement 7-71
- Handling 2-35

SUBJECT INDEX (CONT)

Subject	Para	Subject	Para
G (Cont)		H (Cont)	
Ground (Cont)		Heater (Cont)	
M1079 Chassis Ground Lug		M1079 Heater Deflector/Duct	
Replacement	16-69	Replacement	20-50
Power Distribution Panel (PDP) to Cab		M1079 Heater Does Not Operate	2-16
Ground Cable Replacement	7-76	M1079 Heater Fuel Pump Power Cable	
Starter to Chassis Ground Cable		Replacement	20-49
Replacement	7-83	M1079 Heater Fuel Pump	
Guides		Replacement	20-48
M1079 Sling Spreader and Guides		M1079 Heater Fuel Regulator	
Replacement	16-24	Replacement	20-47
H		M1079 Heater Fuel Tubes/Hoses	
Hand		Replacement	20-46
Checking and Stenciling High/Low Hand		M1079 Heater Connector	
Throttle Positions	4-22	Replacement	16-49
Receipt Manual and Inventory of		M1079 Heater Control Cable	
Equipment	2-5	Replacement	20-43
Right-Hand Door and Cab Marker Lights		M1079 Heater Kit Installation	
Cable Assembly Replacement	7-57	/Removal	20-41
Throttle Lever Replacement/		M1079 Heater Power Cable	
Adjustment	4-17	Replacement	20-42
Handle(s)		M1079 Heater Replacement	20-51
Boarding Handles Replacement	16-76	M1079 Heater Thermostat Cable	
M1079 Roof Bail Handle Replacement	16-27	Replacement	20-45
Hard to Steer	2-26	M1079 Heater Thermostat Connector	
Hatch		Replacement	16-48
Roof Hatch Replacement (All Models		M1079 Heater Thermostat	
Except M1081)	16-75	Replacement	20-44
Hazard		Personnel Heater Fan Does Not	
Front Hazard Lights Do Not Illuminate	2-16	Operate	2-16
Lights Switch Does Not Illuminate	2-16	Personnel Heater Hoses Replacement	6-8
Rear Hazard Lights Do Not Illuminate	2-16	Personnel Heater Illumination Does	
Headlight		Not Operate	2-16
One or Both Headlight High Beams Do		Personnel Heater Replacement/Repair	18-9
Not Illuminate	2-16	High	
One or Both Headlight Low Beams Do		Beams Indicator Does Not Operate	2-16
Not Illuminate	2-16	Engine Temperature Indicator Does	
and Housing Replacement/Repair/		Not Operate	2-16
Adjustment	7-34	Engine Temperature Indicator Illuminates	2-16
Headlights		Hinging	
One or Both Headlights (High and Low		Drive Shaft Hinging Inspection	9-3
Beams) Do Not Illuminate	2-16	Hoist	
Heater		Light Material Handling Crane (LMHC)	
Fan Control Switch Replacement	18-10	Hoist IN Does Not Operate	2-31
M1079 Heater and Air Conditioner		Light Material Handling Crane (LMHC)	
Cover Replacement	16-31	Hoist OUT Does Not Operate	2-31
		Horn	
		And Bracket Replacement	7-44
		Does Not Operate	2-16

Subject	Para
H (Cont)	
Hose	
Lower Coolant Hose Replacement	6-10
Transmission Oil Cooler Hose Bracket Replacement	8-16
Transmission Scavenge Pump Hose Replacement	8-12
Hoses	
Brake Air Hoses Replacement	11-19
Fuel Hoses Replacement	4-9
M1079 Heater Tubes/Hoses Replacement	20-46
Personnel Heater Hoses Replacement	6-8
Power Steering Hoses and Tube Replacement	13-7
Primary and Central Tire Inflation System (CTIS) Air Hoses Replacement	23-2
Transmission Oil Cooler Hoses Initial Installation	8-14
Transmission Oil Cooler Hoses Replacement	8-15
Upper Coolant Tube and Hoses Replacement	6-9
Windshield Washer Hoses and Connector Replacement	18-6
11K Self-Recovery Winch (SRW) Hoses Replacement	17-7
Hubs	
Introduction, Wheels, Tires, and Hubs Maintenance	12-1
Hydraulic	
Air/Hydraulic Power Unit and Bracket Replacement/Repair	19-3
Back-Up Hydraulic Pump Replacement	19-2
Cab Hydraulic Cylinder Replacement	19-10
Cab Hydraulic Latch Replacement/ Adjustment	19-6
Introduction, Hydraulic System Maintenance	19-1
Loss of Hydraulic Pressure (Single Stage Pump)	2-23
Manifold Filter Replacement	19-5
Manifold Replacement/Repair	19-4
Oil Filter Assembly Service/ Replacement	19-12
Reservoir and Bracket Replacement	19-13
System Troubleshooting	2-23
Steering Hydraulic System Troubleshooting	2-29

Subject	Para
I	
Illumination	
Personnel Heater Illumination Does Not Operate	2-16
Inclinometer Replacement	16-77
Indicator	
CTIS Overspeed Indicator Does Not Operate	2-16
CTIS Repeatedly Resumes Cycling 30 Seconds After Indicator Lights Stop Flashing	2-24
Engine Oil Pressure Indicator Does Not Operate	2-16
Fan Off Indicator Does Not Operate	2-16
Five Central Tire Inflation System (CTIS) ECU Indicator Lights Flashing	2-24
Four CTIS ECU Indicator Lights Flashing	2-24
Front Brake Air Indicator Does Not Illuminate When Air Pressure Is Below 65 PSI	2-16
High Beams Indicator Does Not Operate	2-16
High Engine Temperature Indicator Does Not Operate	2-16
High Engine Temperature Indicator Illuminates	2-16
Left Turn Signal Indicator Does Not Operate	2-16
Lighted Indicator Display Replacement/ Repair	7-16
Master Stop Indicator Does Not Operate	2-16
Parking Brake Indicator and/or Emergency Brake Indicator Does Not Operate	2-16
PTO Indicator Does Not Operate	2-16
Rear Brake Air Indicator Does Not Illuminate When Air Pressure Is Below 65 PSI	2-16
Right Turn Signal Indicator Does Not Operate	2-16
Transmission Temperature Indicator Does Not Operate	2-16
Turn Signal Indicators and High Beams on Indicator Do Not Operate	2-16
Indicators	
Turn Signal Indicators and High Beams on Indicator Do Not Operate	2-16
Inflation	
Central Tire Inflation System (CTIS) Cable Assembly Replacement	7-53
Central Tire Inflation System (CTIS) Does Not Operate	2-16
Central Tire Inflation System (CTIS) ECU Replacement	12-6

SUBJECT INDEX (CONT)

Subject	Para	Subject	Para
I (Cont)		I (Cont)	
Inflation (Cont)		Intervehicular	
Central Tire Inflation System (CTIS)		Front Intervehicular 12 VDC (7 Pin)	
Hose Assemblies, Manifold Valve,		Cable Replacement	7-73
Kneeling Valve and Bracket		Rear Intervehicular 12 VDC (7 Pin)	
Replacement	12-5	Cable Replacement	7-78
Central Tire Inflation System (CTIS)		Rear Intervehicular 24 VDC (12 Pin)	
Troubleshooting	2-24	Cable Replacement	7-79
Front Axle Central Tire Inflation		Introduction	
System (CTIS) Quick Release Valve		Air System Maintenance	23-1
Replacement	12-8	Armament/Sighting and Fire Control	
Primary and Central Tire Inflation		Materiel Maintenance	21-1
System (CTIS) Air Hoses		Body and Cab Maintenance	16-1
Replacement	23-2	Body, Chassis, and Accessory Items	
Rear Axle Central Tire Inflation		Maintenance	18-1
System (CTIS) Quick Release Valve		Brake System Maintenance	11-1
Replacement	12-9	Cooling System Maintenance	6-1
Wheel Bearing/Central Tire Inflation		Electrical Illuminating Equipment	
System (CTIS) Seal Replacement	10-2	Maintenance	22-1
Initial Installation		Electrical System Maintenance	7-1
Convex Mirror Initial Installation	20-3	Engine Maintenance	3-1
RH Convex Mirror Initial Installation	20-2	Exhaust System Maintenance	5-1
Rim Cover Initial Installation	20-4	Frame, Towing Attachments, and	
Transmission Oil Cooler Hoses		Drawbars Maintenance	14-1
Initial Installation	8-14	Front and Rear Axle Maintenance	10-1
Inspection		Fuel System Maintenance	4-1
Drive Shaft Hinging Inspection	9-3	Gages (Non-Electrical) Maintenance	24-1
General Inspection Instructions	2-39	Hydraulic System Maintenance	19-1
Installation		Propeller Shaft Maintenance	9-1
General Installation Instructions	2-42	Special Purpose Kits Maintenance	20-1
Instructions		Steering System Maintenance	13-1
General Assembly Instructions	2-41	Suspension System Maintenance	15-1
General Cleaning Instructions	2-38	To Logic Tree Troubleshooting	2-10
General Disassembly Instructions	2-37	Transmission Maintenance	8-1
General Inspection Instructions	2-39	Wheels, Tires, and Hubs Maintenance	12-1
General Installation Instructions	2-42	11K Self-Recovery Winch (SRW)	
General Removal Instructions	2-36	Maintenance	17-1
General Repair Instructions	2-40	Inversion	
Instrument Panel Assembly		Valve Replacement	11-12
Replacement/Repair	7-15	Valve Replacement	23-4
Intake Air Cleaner Filter Element, Air			
Cleaner Assembly, and Particle Extraction		J	
Tube Replacement	4-2		
Intervehicle		Joint	
Clearance Lights Do Not Operate	2-16	Drive Shaft or Universal Joint	
Left Turn Signal Does Not Illuminate	2-16	Unusually Noisy When Operating	2-18
Right Turn Signal Does Not Illuminate	2-16		
Stoplights Do Not Illuminate	2-16		
Taillights Do Not Operate	2-16		

Subject	Para
K	
Kick Panel Replacement Kit	16-3
M1078/M1081 S-280 Shelter Tiedown Kit Installation/Removal	20-84
M1079 Air Conditioner Kit Installation/Removal	20-81
M1079 Heater Kit Installation/Removal	20-41
200 Amp Alternator Kit Installation	20-54
200 Amp Alternator Kit Removal	20-55
L	
Ladder	
M1079 Ladder, Mounting Bracket, and Stowage Bracket Replacement/Repair	16-34
Lamp	
Test Switch Does Not Illuminate	2-16
Large Quantity of Moisture Expelled From Air Reservoirs	2-21
Latch	
and Cab Anchor Brackets Replacement	16-74
Cab Hydraulic Latch Replacement/Adjustment	19-6
M1079 Door Seal, Retainer, and Latch Striker Replacement	16-30
M1079 Rubber Bumper and Tee Latch Replacement	16-29
M1079 Window Latch and Prop Replacement	16-38
Power Distribution Panel (PDP) Cover and Latch Replacement/Adjustment	16-2
Leans to One Side or Rear Of Vehicle Sags	2-27
Left	
Hand Door and Cab Marker Lights Cable Assembly Replacement	7-54
Intervehicle Left Turn Signal Does Not Illuminate	2-16
LH	
Door and/or LH Front Marker Lights Do Not Illuminate	2-16
M1079 LH Door Assembly Replacement/Repair	16-36
Lift	
M1079 Lift Casting Replacement	16-25
Lifting Plate Replacement	3-2
Light	
Amber Warning Light Assembly Repair	20-83
Amber Warning Light Switch Does Not Illuminate	2-16

Subject	Para
L (Cont)	
Light (Cont)	
Backup Light Assembly Replacement/Repair	7-29
Backup Light Does Not Illuminate	2-16
Blackout Drive Light Does Not Illuminate	2-16
Blackout Drive Light Replacement/Repair	7-30
Clearance and Marker Light Assemblies Replacement	7-31
Composite Front Light Assembly Replacement/Repair	7-33
Main Light Switch Replacement	7-17
Material Handling Crane (LMHC) Assembly/Disassembly	20-70
Material Handling Crane (LMHC) Boom Replacement	20-74
Material Handling Crane (LMHC) Boom Sheave Replacement	20-75
Material Handling Crane (LMHC) Control Box Repair	20-77
Material Handling Crane (LMHC) Does Not Operate	2-31
Material Handling Crane (LMHC) Hoist IN Does Not Operate	2-31
Material Handling Crane (LMHC) Hoist OUT Does Not Operate	2-31
Material Handling Crane (LMHC) Mast and Swing Assembly Repair	20-78
Material Handling Crane (LMHC) Replacement	20-71
Material Handling Crane (LMHC) Turret Replacement	20-76
Material Handling Crane (LMHC) Weight Block and Wire Rope Replacement/Repair	20-72
Material Handling Crane (LMHC) Winch Replacement/Repair	20-73
M1079 Van Body Clearance Marker Light Does Not Illuminate	2-16
M1079 Van Door Open Light Does Not Illuminate and Audible Alarm Does Not Operate	2-16
No Overspeed Warning Light and/or Overspeed Pressure Change	2-24
Trailer Left Stop/Turn Light Does Not Illuminate	2-16
Trailer Right Stop/Turn Light Does Not Illuminate	2-16
Warning Light Cable Assembly Replacement	22-2
Warning Light Does Not Illuminate	2-16

SUBJECT INDEX (CONT)

Subject	Para	Subject	Para
L (Cont)		L (Cont)	
Lighted Indicator Display Replacement/ Repair	7-16	Lights (Cont)	
Lighting		M1081 Cab Clearance and Marker Lights Lower Cable Replacement	7-55
M1079 Lighting Fixture and Conduit Replacement	16-59	M1081 Cab Clearance and Marker Lights Upper Cable Replacement	7-56
M1079 Lighting Fixture(s) DS80 and/ or DS81 Do Not Operate	2-16	One or Both Composite Lights Do Not Illuminate	2-16
M1079 Lighting Fixture(s) DS82 and/ or DS83 Do Not Operate	2-16	One or Both Front Blackout Marker Lights Do Not Illuminate	2-16
Lights		One or Both Rear Blackout Marker Lights Do Not Illuminate	2-16
All M1079 Van Body Fluorescent Lights Do Not Operate	2-16	One or More Cab Top Marker Lights Do Not Illuminate	2-16
All M1079 Van Body Marker Lights Do Not Operate	2-16	Parking Lights Do Not Illuminate	2-16
All Marker Lights Do Not Illuminate In Normal Mode	2-16	Rear Hazard Lights Do Not Illuminate	2-16
Cab Clearance Marker Lights Cable Assembly Replacement	7-59	Rear Lights Cable Assembly Replacement	7-75
Blackout Marker Lights Do Not Illuminate	2-16	RH Door and/or RH Front Marker Lights Do Not Illuminate	2-16
Five Central Tire Inflation System (CTIS) ECU Indicator Lights Flashing	2-24	Right-Hand Door and Cab Marker Lights Cable Assembly Replacement	7-57
Four CTIS ECU Indicator Lights Flashing	2-24	Side and/or Rear Marker Lights Do Not Illuminate	2-16
Front and Rear Hazard Lights Do Not Illuminate	2-16	Two Steady Mode Lights Illuminate on Central Tire Inflation System (CTIS) ECU	2-24
Front Hazard Lights Do Not Illuminate	2-16	LMHC	
Front Lights Cable Assembly Replacement	7-74	Light Material Handling Crane (LMHC) Assembly/Disassembly	20-70
Hazard Lights Switch Does Not Illuminate	2-16	Light Material Handling Crane (LMHC) Boom Replacement	20-74
Intervehicle Clearance Lights Do Not Operate	2-16	Light Material Handling Crane (LMHC) Boom Sheave Replacement	20-75
Left Door and/or LH Front Marker Lights Do Not Illuminate	2-16	Light Material Handling Crane (LMHC) Control Box Repair	20-77
Left-Hand Door and Cab Marker Lights Cable Assembly Replacement	7-54	Light Material Handling Crane (LMHC) Does Not Operate	2-31
M1079 Blackout Light(s) Does Not Operate	2-16	Light Material Handling Crane (LMHC) Hoist IN Does Not Operate	2-31
M1079 Emergency Light(s) Does Not Operate	2-16	Light Material Handling Crane (LMHC) Hoist OUT Does Not Operate	2-31
M1079 Clearance and Marker Lights Replacement	16-60	Light Material Handling Crane (LMHC) Mast and Swing Assembly Repair	20-78
M1079 Fluorescent Lights Do Not Operate In Blackout Override Mode	2-16	Light Material Handling Crane (LMHC) Replacement	20-71
M1079 Interior Lights Switch/Box and Conduit Replacement	16-50	Light Material Handling Crane (LMHC) Turret Replacement	20-76

Subject	Para
L (Cont)	
LMHC (Cont)	
Light Material Handling Crane (LMHC)	
Weight Block and Wire Rope	
Replacement/Repair	20-72
Light Material Handling Crane (LMHC)	
Winch Replacement/Repair	20-73
Load Sensing Valve and Control Cable	
Replacement/Adjustment	11-10
Location and Description of Major	
Components	1-8
Loss	
of Coolant	2-15
of Hydraulic Pressure (Single Stage	
Pump)	2-23
Low	
Engine Oil Pressure	2-12
Engine Power	2-12
Pressure Transmitter Replacement	7-88
Pressure Transmitter Two-Way Check	
Valve Replacement	11-28
Windshield Wiper Does Not Operate	
On Low Speed	2-16
Lower	
Cab Does Not Lower	2-32
Coolant Hose Replacement	6-10
M1079 Lower Spreader Bar	
Replacement	16-21
Lubrication	
AOAP Sampling Intervals	H-3
General	H-1
Intervals	H-6
Key	H-5
Local Views	H-8
Locator Views	H-7
Notes	H-9
Oil Filters	H-2
Warranty Hardtime Statement	H-4

M

Machine Gun	
Ring Center Seat Replacement	21-5
Ring Lower Platform Replacement	21-3
Ring Replacement	21-2
Ring Roof Support Replacement	21-6
Ring Top Platform Replacement	21-4
Main Light Switch Replacement	7-17
Maintenance	
Common Tools and Equipment, Vehicle	
Maintenance	2-1
Forms, Records, and Reports	1-2

Subject	Para
M (Cont)	
Maintenance (Cont)	
General Maintenance Procedures	2-8
Introduction	2-34
Manifold	
Hydraulic Manifold Filter Replacement	19-5
Hydraulic Manifold Replacement/	
Repair	19-4
Valve Assembly Replacement	12-7
Marker	
All Marker Lights Do Not Illuminate	
In Normal Mode	2-16
Left Door and/or LH Front Marker Lights	
Do Not Illuminate	2-16
Left-Hand Door and Cab Marker Lights	
Cable Assembly Replacement	7-54
M1079 Clearance and Marker Lights	
Replacement	16-60
Trailer Marker/Taillights Do Not	
Illuminate	2-16
Mast	
Light Material Handling Crane (LMHC)	
Mast and Swing Assembly Repair	20-78
Master	
Power Switch Does Not Shut Down Engine	2-16
Power Switch Does Not Operate	2-16
Master Stop Indicator Does Not Operate	2-16
Mechanical	
Resilient Mount and Mechanical Stop	
Replacement	15-2
Mirror	
Cab Mirror Replacement	18-7
Convex Mirror Initial Installation	20-3
RH Convex Mirror Initial Installation	20-2
RH Convex Mirror Replacement	18-13
Module	
WTEC II Transmission ECU Pushbutton	
Shift Selector (TEPSS) Dimmer Module	
Replacement	7-13
WTEC II Vehicle Interface Module (VIM)	
Replacement/Repair	8-6
Motor	
Windshield Wiper Motor Replacement	18-4
Muffler and Exhaust Heat Shields	
Replacement	5-2
M1079	
Air Conditioner Does Not Operate	2-16
Air Conditioner ECU Connector	
Replacement	16-47
Air Filter Replacement	16-33
All M1079 Fluorescent Lights Do Not	
Operate	2-16
All M1079 Van Body Marker Lights Do	
Not Operate	2-16
Blackout Light(s) Does Not Operate	2-16

SUBJECT INDEX (CONT)

Subject	Para	Subject	Para
M (Cont)		M (Cont)	
M1079 (Cont)		M1079 (Cont)	
Blackout Override Switch Replacement	16-56	Lift Casting Replacement	16-25
Blackout Switch Replacement	16-57	Lighting Fixture and Conduit Replacement	16-59
Blackout Shield and Frame Replacement/ Repair	16-37	Lighting Fixture(s) DS80 and/or DS81 Do Not Operate	2-16
Blackout/Emergency Light Replacement	16-58	Lighting Fixture(s) DS82 and/or DS83 Do Not Operate	2-16
Chassis Ground Lug Replacement	16-69	LH Door Assembly Replacement/ Repair	16-36
Clearance and Marker Lights Replacement	16-60	Lower Spreader Bar Replacement	16-21
Door Ajar Switch and Conduit Replacement	16-55	Pod Door and Panel Replacement	16-22
Door Seal, Retainer, and Latch Striker Replacement	16-30	Pod Frame Replacement/Repair	16-23
Emergency Light(s) Does Not Operate	2-16	Raceway Replacement	16-46
Fan Assembly Replacement/Repair	16-67	Raceway Cover Replacement	16-45
Fan Does Not Operate	2-16	Relay Box Assembly Replacement/ Repair	16-63
Fan Switch/Box and Conduit Replacement	16-54	RH Door Assembly Replacement/ Repair	16-35
Field Phone 1 and/or 2 Binding Post Does Not Operate	2-16	Roof Bail Handle Replacement	16-27
Field Telephone Binding Post/Box and Conduit Replacement	16-51	Rubber Bumper and Tee Latch Replacement	16-28
Fluorescent Lights Do Not Operate In Blackout Override Mode	2-16	Sling Bearing Angle Replacement	16-26
Folding Step Replacement	16-28	Sling Spreader and Guides Replacement	16-24
Heater and Air Conditioner Cover Replacement	16-31	Tapping Plate Replacement	16-42
Heater Connector Replacement	16-49	Upper Sub-Frame Replacement	16-20
Heater Control Cable Replacement	20-43	Van Body Floor Tapping Plate Initial Installation (Serial Numbers 001 through 190)	16-43
Heater Deflector/Duct Replacement	20-50	Van Body Interior Accessory Mounting Locations	16-44
Heater Does Not Operate	2-16	Van Body Clearance Marker Light Does Not Illuminate	2-16
Heater Fuel Pump Power Cable Replacement	20-49	Van Body Replacement	16-19
Heater Fuel Pump Replacement	20-48	Van Door Open Light Does Not Illuminate and Audible Alarm Does Not Operate	2-16
Heater Fuel Regulator Replacement	20-47	Van Preparation for Air Transport	16-73
Heater Fuel Tubes/Hoses Replacement	20-46	Vent Cover Replacement	16-32
Heater Kit Installation/Removal	20-41	Window Cover Replacement	16-41
Heater Power Cable Replacement	20-42	Window Latch and Prop Replacement	16-38
Heater Replacement	20-51	Window Main Frame Replacement	16-40
Heater Thermostat Cable Replacement	20-45	Window Sash Assembly Replacement/ Repair	16-39
Heater Thermostat Connector Replacement	16-48	110 VAC and 24 VDC Relay Replacement	16-62
Heater Thermostat Replacement	20-44		
Interior Lights Switch/Box and Conduit Replacement	16-50		
Ladder, Mounting Bracket, and Stowage Bracket Replacement/Repair	16-34		

Subject	Para
M (Cont)	
M1079 (Cont)	
110 VAC Outlet J230 Does Not Operate	2-16
110 VAC Outlet J231 Does Not Operate	2-16
110 VAC Outlet J232 and J233 Do Not Operate In Blackout Override Mode	2-16
110 VAC Outlet J232 Does Not Operate	2-16
110 VAC Outlet J232 Does Not Operate In Normal Mode	2-16
110 VAC Outlet J233 Does Not Operate	2-16
110 VAC Outlet J234 Does Not Operate	2-16
110 VAC Outlet J235 Does Not Operate	2-16
110 VAC Outlet/Box and Conduit Replacement	16-53
110 VAC Power Does Not Operate	2-16
110/208 VAC Power Distribution Panel Replacement	16-66
110/208 VAC Power Entry Panel and Conduit Replacement	16-70
110/208 VAC Power In/Out Cable Replacement	16-68
12/24 VDC Power Entry Connector Replacement	16-71
12/24 VDC Power Entry Panel Replacement	16-72
15/20/30 and 50 Amp AC Circuit Breaker Replacement	16-64
200 Amp AC Circuit Breaker Replacement	16-65
24 VDC Binding Post Does Not Operate	2-16
24 VDC Binding Post/Box and Conduit Replacement	16-52
5/20 Amp DC Circuit Breaker Replacement	16-61
M1081	
Cab Clearance and Marker Lights Lower Cable Assembly Replacement	7-55
Cab Clearance and Marker Lights Upper Cable Assembly Replacement	7-56
Cab Roof Replacement	16-4
Door Repair/Adjustment	16-6
Parachute Suspension Slides Replacement	14-3
N	
NATO Power Cable Replacement	7-63
No	
Air Pressure Present At Rear Gladhands	2-21

Subject	Para
N (Cont)	
No (Cont)	
Overspeed Warning Light and/or Overspeed Pressure Change	2-24
Response When Turning Steering Wheel	2-26
Power to Digitization Rack	2-31
Power to Driver Visual Enhancement (DVE)	2-31
Power to Enhanced Position Location Reporting System (EPLRS)	2-31
Power to Mobile Tracking system (MTS)	2-31
Power to Mobile Tracking System (MTS) Sense	2-31
Power to Precision Lightweight Global Positioning System Receiver (PLGR)	2-31
Power to SINCGAR/Force XXI Battle Command Brigade and Below (FBCB)	2-31
Noisy Air Compressor Operation	2-21
Nozzle	
Windshield Wiper and Nozzle Replacement	18-3
O	
Official Nomenclature, Names and Designations	1-4
Oil	
Engine Oil Filter Replacement	3-4
Engine Oil Pressure Gage Does Not Operate or Is Inaccurate	2-16
Engine Oil Pressure Indicator Does Not Operate	2-16
Hydraulic Oil Filter Assembly Service/Replacement	19-12
In Cooling System	2-15
Low Engine Oil Pressure	2-12
PRESS Gage Does Not Illuminate	2-16
Pressure Switch Replacement	7-40
Pressure Transmitter Replacement	7-41
Transmission Oil Cooler Hoses Initial Installation	8-14
Transmission Oil Cooler Hoses Replacement	8-15
Transmission Oil Cooler Hose Bracket Replacement	8-16
Transmission Oil Cooler Replacement	8-10
Transmission Oil Cooler Tubes Replacement	8-11
Transmission Oil Fill Tube Replacement	8-13
Transmission Oil Filter Replacement	8-9
One	
Or Both Blackout Stoplights Do Not Illuminate	2-16

SUBJECT INDEX (CONT)

Subject	Para	Subject	Para
O (Cont)		P (Cont)	
One (Cont)		Panel (Cont)	
Or Both Composite Lights Do Not Illuminate	2-16	M1079 110/208 VAC Power Entry Panel and Conduit Replacement	16-70
Or Both Front Blackout Marker Lights Do Not Illuminate	2-16	M1079 12/24 VDC Power Entry Panel and Conduit Replacement	16-72
Or Both Headlight High Beams Do Not Illuminate	2-16	Power Distribution Panel (PDP) Cover and Latch Replacement/Adjustment	16-2
Or Both Headlight Low Beams Do Not Illuminate	2-16	Power Distribution Panel (PDP) to Cab Ground Cable Replacement	7-76
Or Both Headlights (High and Low Beams) Do Not Illuminate	2-16	Stowage Door Assembly Repair	16-18
Or Both Rear Blackout Marker Lights Do Not Illuminate	2-16	100 Amp Reverse Polarity Relay to Power Distribution Panel (PDP) 12 VDC Cable Replacement	7-80
Or Both Stoplights Do Not Illuminate	2-16	100 Amp Reverse Polarity Relay to Power Distribution Panel (PDP) 24 VDC Cable Replacement	7-81
Or More Cab Top Marker Lights Do Not Illuminate	2-16	200 Amp Terminal Block to Power Distribution Panel (PDP) 12 VDC Cable Replacement	20-65
Orifice Tube Assembly Replacement	4-7	200 Amp Terminal Block to Power Distribution Panel (PDP) 24 VDC Cable Replacement	20-68
Overflow		Parachute	
Radiator Overflow Tank and Bracket Replacement/Repair	6-3	M1081 Parachute Suspension Slides Replacement	14-3
Overheat		Park Control Two-Way Check Valve Replacement	11-17
Front Brakes Overheat and/or Do Not Release	2-20	Parking	
Rear Brakes Overheat	2-20	Brake Indicator and/or Emergency Brake Indicator Does Not Operate	2-16
Overheats		Brake Does Not Release	2-20
Engine Overheats	2-12	Brake Does Not Apply	2-20
Engine Overheats	2-15	Lights Do Not Illuminate	2-16
Overspeed		PDP	
No Overspeed Warning Light and/or Overspeed Pressure Change	2-24	Power Distribution Panel (PDP) Cover and Latch Replacement/Adjustment	16-2
P		Power Distribution Panel (PDP) to Cab Ground Cable Replacement	7-76
Panel		100 Amp Reverse Polarity Relay to Power Distribution Panel (PDP) 12 VDC Cable Replacement	7-80
Auxiliary Panel Cable Assembly Replacement (All Models Except M1079 W/O Winch)	7-49	100 Amp Reverse Polarity Relay to Power Distribution Panel (PDP) 24 VDC Cable Replacement	7-81
Auxiliary Panel Does Not Illuminate	2-16		
Auxiliary Panel, Instrument Panel, and Personnel Heater Do Not Illuminate	2-16		
Auxiliary Panel Replacement	7-8		
Auxiliary Panel Switch Does Not Illuminate	2-16		
Instrument Panel Assembly Replacement/Repair	7-15		
Kick Panel Replacement	16-3		
M1079 Pod Door and Panel Replacement	16-22		
M1079 W/O Winch Auxiliary Panel Cable Assembly Replacement	7-50		
M1079 110/208 VAC Power Distribution Panel Replacement	16-66		

Subject	Para
P (Cont)	
PDP (Cont)	
200 Amp Terminal Block to Power Distribution Panel (PDP) 12 VDC Cable Replacement	20-65
200 Amp Terminal Block to Power Distribution Panel (PDP) 24 VDC Cable Replacement	20-68
Personnel	
Heater Fan Does Not Operate	2-16
Heater Hoses Replacement	6-8
Heater Illumination Does Not Operate	2-16
Heater Replacement/Repair	18-9
Pipe	
Exhaust Pipe Replacement	5-3
Platform	
Machine Gun Ring Lower Platform Replacement	21-3
Machine Gun Ring Top Platform Replacement	21-4
Plunger	
Front Brake Plunger Assembly Replacement/Repair	11-4
Rear Brake Plunger Assembly Replacement/Repair	11-5
PMCS	
Preventive Maintenance Checks and Services (PMCS) Introduction	2-7
Preventive Maintenance Checks and Services (PMCS) Table	2-9
Pod	
M1079 Pod Door and Panel Replacement	16-22
M1079 Pod Frame Replacement/Repair	16-23
Power	
Distribution Panel (PDP) Cover and Latch Replacement/Adjustment	16-2
Distribution Panel (PDP) to Cab Ground Cable Replacement	7-76
Low Engine Power	2-12
M1079 Air Conditioner Power Cable Replacement	20-82
M1079 Heater Fuel Pump Power Cable Replacement	20-49
M1079 Heater Power Cable Replacement	20-42
M1079 110/208 VAC Power Distribution Panel Replacement	16-66
M1079 110/208 VAC Power Does Not Operate	2-16
M1079 101/208 VAC Power Entry Panel and Conduit Replacement	16-70

Subject	Para
P (Cont)	
Power (Cont)	
M1079 110/208 VAC Power In/Out Cable Replacement	16-68
M1079 12/24 VDC Power Entry Connector Replacement	16-71
M1079 12/24 VDC Power Entry Panel and Conduit Replacement	16-72
Master Power Switch Does Not Shut Down Engine	2-16
No Power to Digitization Rack	2-31
No Power to Driver Visual Enhancement (DVE)	2-31
No Power to Enhanced Position Location Reporting System (EPLRS)	2-31
No Power to Mobile Tracking system (MTS)	2-31
No Power to Mobile Tracking System (MTS) Sense	2-31
No Power to Precision Lightweight Global Positioning System Receiver (PLGR)	2-31
No Power to SINCGAR/Force XXI Battle Command Brigade and Below (FBCB)	2-31
Steering Hoses and Tube Replacement	13-7
Steering Pump Replacement	13-9
Steering Pump Reservoir and Bracket Replacement	13-8
Take-Off (PTO) Cable Assembly Replacement	7-77
Take Off (PTO) Troubleshooting	2-19
100 Amp Reverse Polarity Relay to Power Distribution Panel (PDP) 12 VDC Cable Replacement	7-80
100 Amp Reverse Polarity Relay to Power Distribution Panel (PDP) 24 VDC Cable Replacement	7-81
200 Amp Terminal Block to Power Distribution Panel (PDP) 12 VDC Cable Replacement	20-65
200 Amp Terminal Block to Power Distribution Panel (PDP) 24 VDC Cable Replacement	20-68
Powertrain	1-10
Preparation	
for Storage or Shipment	2-44
for Storage or Shipment Introduction	2-43
M1079 Van Preparation For Air Transport	16-73
Pressure	
Air Pressure Transmitter Replacement	7-36
Engine Oil Pressure Gage Does Not Operate or Is Inaccurate	2-16
Engine Oil Pressure Indicator Does Not Operate	2-16

SUBJECT INDEX (CONT)

Subject	Para	Subject	Para
P (Cont)		P (Cont)	
Pressure (Cont)		Pushbutton (Cont)	
Low Pressure Transmitter Replacement	7-88	Start Inhibit Pushbutton Switch	
Oil Pressure Switch Replacement	7-40	Replacement	7-19
Oil Pressure Transmitter Replacement	7-41	Starter Pushbutton Switch	
Protection Valve Replacement	11-27	Replacement	7-20
Switch Replacement	23-8	WTEC II Transmission ECU Pushbutton	
Preventive		Shift Selector (TEPSS) and Bracket	
Maintenance Checks and Services (PMCS)		Replacement and Calibration	8-2
Introduction	2-7	WTEC II Transmission ECU Pushbutton	
Maintenance Checks and Services (PMCS)		Shift Selector (TEPSS) Dimmer Module	
Table	2-9	Replacement	7-13
Primary and Central Tire Inflation System		WTEC II Transmission ECU Pushbutton	
(CTIS) Air Hoses Replacement	23-2	Shift Selector (TEPSS) Emits Eight	
Procedures		Seconds of Beeps and/or	
General Maintenance Procedures	2-8	Transmission Does Not Shift Gears	2-17
Propeller		WTEC II Transmission ECU Pushbutton	
Introduction, Propeller Shaft		Shift Selector (TEPSS) Displays Main	
Maintenance	9-1	Code 22 Sub Code 14	2-17
Shaft Troubleshooting	2-18	WTEC II Transmission ECU Pushbutton	
PTO		Shift Selector (TEPSS) Displays Main	
Power Take-Off (PTO) Cable Assembly		Code 22 Sub Code 15	2-17
Replacement	7-77	WTEC II Transmission ECU Pushbutton	
Does Not Engage	2-19	Shift Selector (TEPSS) Displays Main	
Does Not Operate	2-16	Code 22 Sub Code 16	2-17
Indicator Does Not Operate	2-16	WTEC II Transmission ECU Pushbutton	
Power Take Off (PTO) Troubleshooting	2-19	Shift Selector (TEPSS) Displays Main	
Pulls		Code 24 and/or 33 and Any	
Wanders, Pulls to One Side, or		Sub Code	2-17
Shimmies	2-26	WTEC II Transmission ECU Pushbutton	
Wanders, Pulls to One Side, or		Shift Selector (TEPSS) Displays Main	
Shimmies	2-27	Code 32 and Any Sub Code	2-17
Pump		WTEC II Transmission ECU Pushbutton	
Loss of Hydraulic Pressure (Single Stage		Shift Selector (TEPSS) Displays	
Pump)	2-23	Main Code 41, 42, 44, 45, 66, and/or	
M1079 Heater Fuel Pump Power Cable		69 and Any Sub Code	2-17
Replacement	20-49	WTEC II Transmission ECU Pushbutton	
M1079 Heater Fuel Pump		Shift Selector (TEPSS) Displays Main	
Replacement	20-48	Code 43 and Any Sub Code	2-17
Power Steering Pump Replacement	13-9	WTEC II Transmission ECU Pushbutton	
Power Steering Pump Reservoir and		Shift Selector (TEPSS) Displays Main	
Bracket Replacement	13-8	Code 52 and Any Sub Code	2-17
Power Steering Pump Reservoir Filter		WTEC II Transmission ECU Pushbutton	
Replacement	13-10	Shift Selector (TEPSS) Displays Main	
Transmission Scavenge Pump Hose		Code 57 and Any Sub Code	2-17
Replacement	8-12	WTEC II Transmission ECU Pushbutton	
Water Pump and Fittings		Shift Selector (TEPSS) Displays Main	
Replacement	6-12	Code 21 and Any Sub Code	2-17
Windshield Washer Pump		WTEC II Transmission ECU Pushbutton	
Electromagnetic Interference (EMI)		Shift Selector (TEPSS) Displays Main	
Cable Assembly Replacement	7-60	Code 51 Sub Code 10, 12, 21, 43,	
Pushbutton		45, or 65	2-17
Start Inhibit Pushbutton Does Not			
Operate	2-16		

Subject	Para
P (Cont)	
Pushbutton (Cont)	
WTEC II Transmission ECU Pushbutton Shift Selector (TEPSS) Displays Main Code 25 and Any Sub Code	2-17
WTEC II Transmission ECU Pushbutton Shift Selector (TEPSS) Displays Main Code 53 and Any Sub Code	2-17
WTEC II Transmission ECU Pushbutton Shift Selector (TEPSS) Displays Main Code 54 Sub Code 01, 07, 10, 12, 17, 21, 23, 27, 32, 34, 43, 45, 54, 56, 65, 70, 71, 72, 80, 81, 82, 83, 85, 86, 92, 93, 95, 96, or 97	2-17
WTEC II Transmission ECU Pushbutton Shift Selector (TEPSS) Displays Main Code 55 and Any Sub Code	2-17
WTEC II Transmission ECU Pushbutton Shift Selector (TEPSS) Displays Main Code 56 and Any Sub Code	2-17
WTEC II Transmission ECU Pushbutton Shift Selector (TEPSS) Displays Main Code 13 and Any Sub Code	2-17
WTEC II Transmission ECU Pushbutton Shift Selector (TEPSS) Displays Main Code 23 and Any Sub Code	2-17
WTEC II Transmission ECU Pushbutton Shift Selector (TEPSS) Does Not Illuminate	2-17
WTEC III Transmission Pushbutton Shift Selector (TPSS) Displays Main Code 22 Sub Code 14	2-17
WTEC III Transmission Pushbutton Shift Selector (TPSS) Displays Main Code 22 Sub Code 15	2-17
WTEC III Transmission Pushbutton Shift Selector (TPSS) Displays Main Code 22 Sub Code 16	2-17
WTEC III Transmission Pushbutton Shift Selector (TPSS) Displays Main Code 24 and/or 33 and Any Sub Code	2-17
WTEC III Transmission Pushbutton Shift Selector (TPSS) Displays Main Code 32 and Any Sub Code	2-17
WTEC III Transmission Pushbutton Shift Selector (TPSS) Displays Main Code 42, 44, 45, 46, 66, and/or 69 and Any Sub Code	2-17
WTEC III Transmission Pushbutton Shift Selector (TPSS) Displays Main Code 52 and Any Sub Code	2-17
WTEC III Transmission Pushbutton Shift Selector (TPSS) Displays Main Code 57 and Any Sub Code	2-17

Subject	Para
P (Cont)	
Pushbutton (Cont)	
WTEC III Transmission Pushbutton Shift Selector (TPSS) Displays Main Code 21 and Any Sub Code	2-17
WTEC III Transmission Pushbutton Shift Selector (TPSS) Displays Main Code 51 and Any Sub Code	2-17
WTEC III Transmission Pushbutton Shift Selector (TPSS) Displays Main Code 25 and Any Sub Code	2-17
WTEC III Transmission Pushbutton Shift Selector (TPSS) Displays Main Code 53 and Any Sub Code	2-17
WTEC III Transmission Pushbutton Shift Selector (TPSS) Displays Main Code 54 and Any Sub Code	2-17
WTEC III Transmission Pushbutton Shift Selector (TPSS) Displays Main Code 55 and Any Sub Code	2-17
WTEC III Transmission Pushbutton Shift Selector (TPSS) Displays Main Code 56 and Any Sub Code	2-17
WTEC III Transmission Pushbutton Shift Selector (TPSS) Displays Main Code 13 and Any Sub Code	2-17
WTEC III Transmission Pushbutton Shift Selector (TPSS) Indicator Displays "--" and/or Transmission Does Not Shift Gears	2-17
WTEC III Transmission Pushbutton Shift Selector (TPSS) Displays Main Code 23 and Any Sub Code	2-17
WTEC III Transmission Pushbutton Shift Selector (TPSS) Does Not Illuminate	2-17

R

Raceway	
M1079 Raceway Replacement	16-46
M1079 Raceway Cover Replacement	16-45
Radiator	
Cold Weather Radiator Cover Installation/ Removal	18-12
/Charge Air Cooler Replacement	6-2
Radiator Fan Off Switch Does Not Illuminate	
Fan Shrouds Replacement	6-4
Overflow Tank and Bracket Replacement/ Repair	
Repair	6-3
Radio Does Not Operate	2-16

SUBJECT INDEX (CONT)

Subject	Para	Subject	Para
R (Cont)		R (Cont)	
Rear		Relay	
Axle Central Tire Inflation System (CTIS) Quick Release Valve Replacement	12-9	Anti-Compounding Relay Valve Replacement	11-11
Axle Shaft Replacement	10-4	Circuit Breaker, Diode, and Relay Replacement	7-9
Axle Shock Absorber Replacement	15-4	M1079 Relay Box Assembly Replacement/Repair	16-63
BRAKE AIR Gage Does Not Illuminate	2-16	M1079 110 VAC and 24 VDC Relay Replacement	16-62
BRAKE AIR Pressure Gage Does Not Operate or Is Inaccurate	2-16	Relay Valve Replacement	11-13
Brake Air Indicator Does Not Illuminate When Air Pressure Is Below 65 PSI	2-16	100 Amp Alternator to Reverse Polarity Relay 12 VDC Cable Replacement	7-65
Brake Air Chamber Replacement	11-8	100 Amp Alternator to Reverse Polarity Relay 24 VDC Cable Replacement	7-66
Brake Plunger Assembly Replacement/ Repair	11-5	100 Amp Reverse Polarity Relay Replacement	7-27
Brake Shoes Replacement/Adjustment	11-3	100 Amp Reverse Polarity Relay to Power Distribution Panel (PDP) 12 VDC Cable Replacement	7-80
Brakes Do Not Apply	2-20	100 Amp Reverse Polarity Relay to Power Distribution Panel (PDP) 24 VDC Cable Replacement	7-81
Brakes Overheat	2-20	200 Amp Reverse Polarity Relay Replacement	20-58
Cab Support Assembly Replacement	16-7	200 Amp Terminal Block to Reverse Polarity Relay 12 VDC Battery Cable Replacement	20-66
Front and Rear Hazard Lights Do Not Illuminate	2-16	200 Amp Terminal Block to Reverse Polarity Relay 12 VDC Load Cable Replacement	20-60
Front and Rear Turn Signals Do Not Operate	2-16	200 Amp Terminal Block to Reverse Polarity Relay 24 VDC Battery Cable Replacement	20-67
Gladhand Replacement	11-22	200 Amp Terminal Block to Reverse Polarity Relay 24 VDC Load Cable Replacement	20-62
Hazard Lights Do Not Illuminate	2-16	Removal General Removal Instructions	2-36
Intervehicular 12 VDC (7 Pin) Cable Replacement	7-78	Repair General Repair Instructions	2-40
Intervehicular 24 VDC (12 Pin) Cable Replacement	7-79	Repair Parts	2-3
Leans to One Side or Rear Of Vehicle Sags	2-27	Reporting Equipment Improvement Recommendations (EIR)	1-5
Rear Lights Cable Assembly Replacement	7-75	Reports Maintenance Forms, Records, and Reports	1-2
No Air Pressure Present At Rear Gladhands	2-21		
One or Both Rear Blackout Marker Lights Do Not Illuminate	2-16		
Side and/or Rear Marker Lights Do Not Illuminate	2-16		
Spring Brake Caging	11-6		
Stabilizer Bar Replacement/Repair	15-5		
11K Self-Recovery Winch (SRW) Rear Roller Fairlead Replacement	17-3		
Records			
Maintenance Forms, Records, and Reports	1-2		
Regulator			
M1079 Heater Fuel Regulator Replacement	20-47		

Subject	Para
R (Cont)	
Reservoir	
Hydraulic Reservoir and Bracket Replacement	19-13
Power Steering Pump Reservoir and Bracket Replacement	13-8
Reservoirs	
Large Quantity of Moisture Expelled From Air Reservoirs	2-21
Resilient Mount and Mechanical Stop Replacement	15-2
Restriction	
Air Filter Restriction Gauge Replacement	24-2
Reverse	
100 Amp Alternator to Reverse Polarity Relay 12 VDC Cable Replacement	7-65
100 Amp Alternator to Reverse Polarity Relay 24 VDC Cable Replacement	7-66
100 Amp Reverse Polarity Relay Replacement	7-27
100 Amp Reverse Polarity Relay to Power Distribution Panel (PDP) 12 VDC Cable Replacement	7-80
100 Amp Reverse Polarity Relay to Power Distribution Panel (PDP) 24 VDC Cable Replacement	7-81
200 Amp Reverse Polarity Relay Replacement	20-58
200 Amp Terminal Block to Reverse Polarity Relay 12 VDC Battery Cable Replacement	20-66
200 Amp Terminal Block to Reverse Polarity Relay 12 VDC Load Cable Replacement	20-60
200 Amp Terminal Block to Reverse Polarity Relay 24 VDC Battery Cable Replacement	20-67
200 Amp Terminal Block to Reverse Polarity Relay 24 VDC Load Cable Replacement	20-62
RH	
Door and/or RH Front Marker Lights Do Not Illuminate	2-16
M1079 RH Door Assembly Replacement/Repair	16-35
Right	
Door and/or RH Front Marker Lights Do Not Illuminate	2-16
Hand Door and Cab Marker Lights Cable Assembly Replacement	7-57
Intervehicle Right Turn Signal Does Not Illuminate	2-16

Subject	Para
R (Cont)	
Right (Cont)	
Left or Right Front Turn Signals Do Not Operate	2-16
Turn Signal Indicator Does Not Operate	2-16
Rim	
Cover Initial Installation	20-4
Cover Replacement	12-10
Ring	
Machine Gun Ring Center Seat Replacement	21-5
Machine Gun Ring Lower Platform Replacement	21-3
Machine Gun Ring Replacement	21-2
Machine Gun Ring Roof Support Replacement	21-6
Machine Gun Ring Top Platform Replacement	21-4
Rocker Switches Replacement	7-18
Roller	
11K Self-Recovery Winch (SRW) Front Roller Fairlead Replacement	17-2
11K Self-Recovery Winch (SRW) Rear Roller Fairlead Replacement	17-3
Roof	
Hatch Replacement (All Models Except M1081)	16-74
M1079 Roof Bail Handle Replacement	16-27
M1081 Cab Roof Replacement	16-4
Machine Gun Ring Roof Support Replacement	21-6
S	
Scope, Introduction	1-1
Seat	
Machine Gun Ring Center Seat Replacement	21-5
Seat Belt Replacement	16-15
Seats Replacement/Repair	16-14
Secondary and Primary Air Tanks Replacement	11-20
Self-Recovery	
Introduction, 11K Self-Recovery Winch (SRW) Maintenance	17-1
11K Self-Recovery Winch (SRW)	1-17
11K Self-Recovery Winch (SRW) Cable Replacement	17-5
11K Self-Recovery Winch (SRW) Cable Pulleys Replacement	17-4
11K Self-Recovery Winch (SRW) Does Not Pay Out	2-16
11K Self-Recovery Winch (SRW) Does Not Reel In	2-16

SUBJECT INDEX (CONT)

Subject	Para	Subject	Para
S (Cont)		S (Cont)	
Self-Recovery (Cont)		Shift (Cont)	
11K Self-Recovery Winch (SRW) Does Not Reel In or Pay Out	2-16	WTEC II Transmission ECU Pushbutton Shift Selector (TEPSS) Dimmer Module Replacement	7-13
11K Self-Recovery Winch (SRW) Does Not Work	2-28	WTEC II Transmission ECU Pushbutton Shift Selector (TEPSS) Emits Eight Seconds of Beeps and/or Transmission Does Not Shift Gears	2-17
11K Self-Recovery Winch (SRW) Front Roller Fairlead Replacement	17-2	WTEC II Transmission ECU Pushbutton Shift Selector (TEPSS) Displays Main Code 22 Sub Code 14	2-17
11K Self-Recovery Winch (SRW) Hoses Replacement	17-7	WTEC II Transmission ECU Pushbutton Shift Selector (TEPSS) Displays Main Code 22 Sub Code 15	2-17
11k Self-Recovery Winch (SRW) Rear Roller Fairlead Replacement	17-3	WTEC II Transmission ECU Pushbutton Shift Selector (TEPSS) Displays Main Code 22 Sub Code 16	2-17
11K Self-Recovery Winch (SRW) System Troubleshooting	2-28	WTEC II Transmission ECU Pushbutton Shift Selector (TEPSS) Displays Main Code 24 and/or 33 and Any Sub Code	2-17
Sensor		WTEC II Transmission ECU Pushbutton Shift Selector (TEPSS) Displays Main Code 32 and Any Sub Code	2-17
Coolant Temperature Gage Sensor Replacement	7-37	WTEC II Transmission ECU Pushbutton Shift Selector (TEPSS) Displays Main Code 41, 42, 44, 45, 66, and/or 69 and Any Sub Code	2-17
Ether Sensor Replacement	7-39	WTEC II Transmission ECU Pushbutton Shift Selector (TEPSS) Displays Main Code 43 and Any Sub Code	2-17
Transmission Engine Speed Sensor Replacement	7-43	WTEC II Transmission ECU Pushbutton Shift Selector (TEPSS) Displays Main Code 52 and Any Sub Code	2-17
Throttle Position Sensor (TPS) Cable Assembly Replacement	4-16	WTEC II Transmission ECU Pushbutton Shift Selector (TEPSS) Displays Main Code 57 and Any Sub Code	2-17
Service		WTEC II Transmission ECU Pushbutton Shift Selector (TEPSS) Displays Main Code 21 and Any Sub Code	2-17
Before Operation	2-6	WTEC II Transmission ECU Pushbutton Shift Selector (TEPSS) Displays Main Code 51 Sub Code 10, 12, 21, 43, 45, or 65	2-17
Gladhand Two-Way Check Valve Replacement	11-23	WTEC II Transmission ECU Pushbutton Shift Selector (TEPSS) Displays Main Code 25 and Any Sub Code	2-17
Shaft			
Drive Shaft and Universal Joint Replacement	9-2		
Drive Shaft or Universal Joint Unusually Noisy When Operating	2-18		
Rear Axle Shaft Replacement	10-4		
Propeller Shaft Troubleshooting	2-18		
Shelter			
M1078/M1081 S-280 Shelter Tiedown Kit Installation/Removal	20-84		
Shield			
Muffler and Exhaust Heat Shields Replacement	5-2		
M1079 Blackout Shield and Frame Replacement/Repair	16-37		
Shift			
Transmission Does Not Shift or Is Slow to Shift When Cold	2-17		
WTEC II Transmission ECU Pushbutton Shift Selector (TEPSS) and Bracket Replacement and Calibration	8-2		

Subject	Para
S (Cont)	
Shift (Cont)	
WTEC II Transmission ECU Pushbutton Shift Selector (TEPSS) Displays Main Code 53 and Any Sub Code	2-17
WTEC II Transmission ECU Pushbutton Shift Selector (TEPSS) Displays Main Code 54 Sub Code 01, 07, 10, 12, 17, 21, 23, 27, 32, 34, 43, 45, 54, 56, 65, 70, 71, 72, 80, 81, 82, 83, 85, 86, 92, 93, 95, 96, or 97	2-17
WTEC II Transmission ECU Pushbutton Shift Selector (TEPSS) Displays Main Code 55 and Any Sub Code	2-17
WTEC II Transmission ECU Pushbutton Shift Selector (TEPSS) Displays Main Code 56 and Any Sub Code	2-17
WTEC II Transmission ECU Pushbutton Shift Selector (TEPSS) Displays Main Code 13 and Any Sub Code	2-17
WTEC II Transmission ECU Pushbutton Shift Selector (TEPSS) Displays Main Code 23 and Any Sub Code	2-17
WTEC II Transmission ECU Pushbutton Shift Selector (TEPSS) Does Not Illuminate	2-17
WTEC III Transmission Pushbutton Shift Selector (TPSS) Displays Main Code 22 Sub Code 14	2-17
WTEC III Transmission Pushbutton Shift Selector (TPSS) Displays Main Code 22 Sub Code 15	2-17
WTEC III Transmission Pushbutton Shift Selector (TPSS) Displays Main Code 22 Sub Code 16	2-17
WTEC III Transmission Pushbutton Shift Selector (TPSS) Displays Main Code 24 and/or 33 and Any Sub Code	2-17
WTEC III Transmission Pushbutton Shift Selector (TPSS) Displays Main Code 32 and Any Sub Code	2-17
WTEC III Transmission Pushbutton Shift Selector (TPSS) Displays Main Code 42, 44, 45, 46, 66, and/or 69 and Any Sub Code	2-17
WTEC III Transmission Pushbutton Shift Selector (TPSS) Displays Main Code 52 and Any Sub Code	2-17
WTEC III Transmission Pushbutton Shift Selector (TPSS) Displays Main Code 57 and Any Sub Code	2-17

Subject	Para
S (Cont)	
Shift (Cont)	
WTEC III Transmission Pushbutton Shift Selector (TPSS) Displays Main Code 21 and Any Sub Code	2-17
WTEC III Transmission Pushbutton Shift Selector (TPSS) Displays Main Code 51 and Any Sub Code	2-17
WTEC III Transmission Pushbutton Shift Selector (TPSS) Displays Main Code 25 and Any Sub Code	2-17
WTEC III Transmission Pushbutton Shift Selector (TPSS) Displays Main Code 53 and Any Sub Code	2-17
WTEC III Transmission Pushbutton Shift Selector (TPSS) Displays Main Code 54 and Any Sub Code	2-17
WTEC III Transmission Pushbutton Shift Selector (TPSS) Displays Main Code 55 and Any Sub Code	2-17
WTEC III Transmission Pushbutton Shift Selector (TPSS) Displays Main Code 56 and Any Sub Code	2-17
WTEC III Transmission Pushbutton Shift Selector (TPSS) Displays Main Code 13 and Any Sub Code	2-17
WTEC III Transmission Pushbutton Shift Selector (TPSS) Indicator Displays "--" and/or Transmission Does Not Shift Gears	2-17
WTEC III Transmission Pushbutton Shift Selector (TPSS) Displays Main Code 23 and Any Sub Code	2-17
WTEC III Transmission Pushbutton Shift Selector (TPSS) Does Not Illuminate	2-17
Shimmies	
Wanders, Pulls to One Side, or Shimmies	2-26
Wanders, Pulls to One Side, or Shimmies	2-27
Shipment	
Preparation for Storage or Shipment	2-44
Preparation for Storage or Shipment Introduction	2-43
Shock	
Front Axle Shock Absorber Replacement	15-3
Rear Axle Shock Absorber Replacement	15-4
Shoes	
Front Brake Shoes Replacement/Adjustment	11-2

SUBJECT INDEX (CONT)

Subject	Para	S (Cont)
		S (Cont)
Shoes (Cont)		SRW
Rear Brake Shoes Replacement/ Adjustment	11-3	Introduction, 11K Self-Recovery Winch (SRW) Maintenance
Shrouds		11K Self-Recovery Winch (SRW)
Radiator Fan Shrouds Replacement	6-4	11K Self-Recovery Winch (SRW) Cable Replacement
Shunt		11K Self-Recovery Winch (SRW) Does Not Pay Out
Replacement	7-26	11K Self-Recovery Winch (SRW) Does Not Reel In
Starter to Shunt 24 VDC Cable Replacement	7-84	11K Self-Recovery Winch (SRW) Does Not Reel In or Pay Out
Shuttle Valve Replacement	23-5	11K Self-Recovery Winch (SRW) Does Not Work
Side and/or Rear Marker Lights Do Not Illuminate	2-16	11K Self-Recovery Winch (SRW) Front Roller Fairlead Replacement
Slides		11K Self-Recovery Winch (SRW) Hoses Replacement
M1081 Parachute Suspension Slides Replacement	14-3	11K Self-Recovery Winch (SRW) Maintenance
Sling		11K Self-Recovery Winch (SRW) Cable Pulleys Replacement
M1079 Sling Bearing Angle Replacement	16-26	11K Self-Recovery Winch (SRW) Rear Roller Fairlead Replacement
M1079 Sling Spreader and Guides Replacement	16-24	11K Self-Recovery Winch (SRW) System Troubleshooting
Small Arms Mount Replacement	21-7	Stabilizer
Spare		Rear Stabilizer Bar Replacement/Repair
Tire Retainer Replacement/Repair	14-4	Stalls
Tire Retainer Does Not Lower	2-32	Engine Stalls at Low RPM
Tire Retainer Does Not Raise	2-32	Start
Special		and Charging Cable Assembly Replacement
Introduction, Special Purpose Kits Maintenance	20-1	Engine Overspeeds on Start
Purpose Kit Troubleshooting	2-31	Ether Start Does Not Operate
Tools, TMDE, and Support Equipment	2-2	Ether Start Switch Does Not Illuminate
Speed		Hazard Lights Switch Does Not Illuminate
Engine Speed Sensor Replacement/ Adjustment	7-38	Inhibit Pushbutton Does Not Operate
Speedometer		Inhibit Pushbutton Switch Replacement
Does Not Illuminate	2-16	Starter
Does Not Operate or Is Inaccurate	2-16	Auxiliary Starter Solenoid Replacement
Spider		Battery to Starter Cable Assembly Replacement
Differential Spider Assembly Replacement	10-3	Pushbutton Switch Replacement
Spindle Replacement	10-5	to Chassis Ground Cable Replacement
Spreader		to Shunt 24 VDC Cable Replacement
M1079 Lower Spreader Bar Replacement	16-21	
M1079 Sling Spreader and Guides Replacement	16-24	
Spring		
Air Spring and Bracket Replacement	16-9	
Rear Spring Brake Caging	11-6	

Subject	Para
S (Cont)	
Starting	
Ether Starting Aid Does Not Operate	2-13
Ether Starting Aid Replacement	4-15
Motor Replacement	7-7
STE/ICE-R Cable Assembly Replacement	7-58
Steering	
Column Replacement	13-6
Excessive Play When Turning Steering	
Wheel	2-26
Hard or Does Not Work	2-29
Hydraulic System Troubleshooting	2-29
Introduction, Steering System	
Maintenance	13-1
No Response When Turning Steering	
Wheel	2-26
Power Steering Hoses and Tube	
Replacement	13-7
Power Steering Pump Replacement	13-9
Power Steering Pump Reservoir and	
Bracket Replacement	13-8
System	1-16
Troubleshooting	2-26
Wheel Replacement	13-2
Step	
Cab Step Replacement	16-11
M1079 Folding Step Replacement	16-28
Stop	
Master Stop Indicator Does Not	
Operate	2-16
Trailer Left Stop/Turn Light Does	
Not Illuminate	2-16
Trailer Right Stop/Turn Light Does	
Not Illuminate	2-16
Stoplights	
and Blackout Stoplights Do Not	
Operate	2-16
Intervehicle Stoplights Do Not	
Illuminate	2-16
One or Both Blackout Stoplights Do	
Not Illuminate	2-16
One or Both Stoplights Do Not	
Illuminate	2-16
Stoplight Switch Replacement	11-25
Storage	
Cab Storage Box Replacement/Repair	16-17
Preparation for Storage or Shipment	2-44
Preparation for Storage or Shipment	
Introduction	2-43
Storage Maintenance Procedures	2-45
Stowage	
Panel Stowage Door Assembly Repair	16-18

Subject	Para
S (Cont)	
Stud	
Wheel Stud Replacement	12-3
Wheel Stud Tightening Sequence	12-4
Sub-Frame	
M1079 Upper Sub-Frame	
Replacement	16-20
Suspension	
Introduction, Suspension System	
Maintenance	15-1
M1081 Parachute Suspension	
Slides Replacement	14-3
System Troubleshooting	2-27
Will Not Compress or Return to Normal	2-30
Swing	
Light Material Handling Crane (LMHC)	
Mast and Swing Assembly Repair	20-78
Switch	
Amber Warning Light Switch Does	
Not Illuminate	2-16
Dimmer Switch Replacement	7-12
Heater Fan Control Switch	
Replacement	18-10
Lamp Test Switch Does Not Illuminate	2-16
Main Light Switch Replacement	7-17
Master Power Switch Does Not	
Illuminate	2-16
Master Power Switch Does Not Shut	
Down Engine	2-16
M1079 Blackout Override Switch	
Replacement	16-56
M1079 Blackout Switch Replacement	16-57
M1079 Door Ajar Switch and Conduit	
Replacement	16-55
M1079 Fan Switch/Box and Conduit	
Replacement	16-54
M1079 Interior Lights Switch/Box and	
Conduit Replacement	16-50
Oil Pressure Switch Replacement	7-40
Pressure Switch Replacement	23-8
Radiator Fan Off Switch Does	
Not Illuminate	2-16
Start Inhibit Pushbutton Switch	
Replacement	7-19
Starter Pushbutton Switch	
Replacement	7-20
Stoplight Switch Replacement	11-25
Troop Transport Alarm Switch, Connector,	
and Bracket Replacement	20-80
Turn Signal Switch Replacement	7-25
Water Temperature Switch	
Replacement	7-42

SUBJECT INDEX (CONT)

Subject	Para	Subject	Para
S (Cont)		S (Cont)	
Switches		System (Cont)	
Rocker Switches Replacement	7-18	Park and Trailer Air Supply Valves	
System		Replacement	11-18
11K Self-Recovery Winch (SRW) System		Steering Hydraulic System	
Troubleshooting	2-28	Troubleshooting	2-29
Air System	1-19	Steering System	1-16
Air System Loses Pressure During		Suspension System Troubleshooting	2-27
Operation/Slow, No, or Incorrect		Transmission System Troubleshooting	2-17
Air Pressure Buildup	2-21		
Air System Troubleshooting	2-21	T	
Brake System	1-15	Tachometer	
Brake System Loses Air When Brakes		Does Not Illuminate	2-16
Are Applied	2-20	Does Not Operate or Is Inaccurate	2-16
Brake System Troubleshooting	2-20	Replacement	7-21
Cooling System	1-13	Taillight	
Cooling System Troubleshooting	2-15	Composite Taillight Assembly	
Electrical System	1-14	Replacement/Repair	7-32
Electrical System Does Not Maintain A		Trailer Marker/Taillights Do Not	
Charge	2-16	Illuminate	2-16
Electrical System Troubleshooting	2-16	Taillights	
Engine System Troubleshooting	2-12	Intervehicle Taillights Do Not Illuminate	2-16
Exhaust System Troubleshooting	2-14	Tailpipe Replacement	5-4
Exhaust System Unusually Noisy or		Tank	
Vibrates Excessively During Engine		Fuel Tank and Brackets Replacement	4-8
Operation	2-14	Radiator Overflow Tank and	
Fuel System	1-12	Bracket Replacement/Repair	6-3
Fuel System Bleeding	4-11	Wet Tank Replacement	23-7
Fuel System Troubleshooting	2-13	Tanks	
Hydraulic System Troubleshooting	2-23	Secondary and Primary Air Tanks	
Introduction, Air System Maintenance	23-1	Replacement	11-20
Introduction, Brake System		Tapping	
Maintenance	11-1	M1079 Tapping Plate Replacement	16-42
Introduction, Cooling System		M1079 Van Body Floor Tapping Plate	
Maintenance	6-1	Initial Installation (Serial Numbers 001	
Introduction, Electrical System		through 190)	16-43
Maintenance	7-1	Temperature	
Introduction, Exhaust System		Coolant Temperature Gage Sensor	
Maintenance	5-1	Replacement	7-37
Introduction, Fuel System Maintenance	4-1	Coolant Temperature Light Switch	
Introduction, Hydraulic System		Replacement	7-22
Maintenance	19-1	High Engine Temperature Indicator	
Introduction, Steering System		Illuminates	2-16
Maintenance	13-1	Terminal Block	
Introduction, Suspension System		Battery to 200 Amp Terminal Block	
Maintenance	15-1	12 VDC Cable Assembly	
Oil In Cooling System	2-15	Replacement	20-63

Subject	Para
T (Cont)	
Terminal Block (Cont)	
Battery to 200 Amp Terminal Block 24 VDC Cable Assembly Replacement	20-64
200 Amp Alternator to Terminal Block 12 VDC Cable Replacement	20-59
200 Amp Alternator to Terminal Block 24 VDC Cable Replacement	20-61
200 Amp Terminal Block Replacement	20-69
200 Amp Terminal Block to Reverse Polarity Relay 12 VDC Battery Cable Replacement	20-66
200 Amp Terminal Block to Reverse Polarity Relay 12 VDC Load Cable Replacement	20-60
200 Amp Terminal Block to Reverse Polarity Relay 24 VDC Battery Cable Replacement	20-67
200 Amp Terminal Block to Reverse Polarity Relay 24 VDC Load Cable Replacement	20-62
200 Amp Terminal Block to Power Distribution Panel (PDP) 12 VDC Cable Replacement	20-65
200 Amp Terminal Block to Power Distribution Panel (PDP) 24 VDC Cable Replacement	20-68
Test	
Lamp Test Switch Does Not Illuminate	2-16
Tester	
Battery Tester Does Not Operate	2-16
Battery Tester Replacement	7-45
Thermostat	
Housing Replacement	6-6
M1079 Heater Thermostat Connector Replacement	16-48
Replacement	6-5
Throttle	
Checking and Stenciling High/Low Hand Throttle Positions	4-22
Hand Throttle Lever Replacement/ Adjustment	4-17
Control Cable Replacement/ Adjustment	4-18
Control Lever Replacement	4-20
Control Threaded Rod Replacement	4-19
Position Sensor (TPS) Cable Assembly Replacement	4-16
Tiedown	
M1078/M1081 S-280 Shelter Tiedown Kit Installation/Removal	20-84
Tie-Rod Replacement/Repair	13-4

Subject	Para
T (Cont)	
Tilt	
Cab Tilt and Spare Tire Retainer Troubleshooting	2-32
Cab Tilt, Spare Tire Retainer, and Suspension Compression Will Not Work	2-30
Tire	
Central Tire Inflation System (CTIS) Cable Assembly Replacement	7-53
Central Tire Inflation System (CTIS) Does Not Operate	2-16
Central Tire Inflation System (CTIS) ECU Replacement	12-6
Central Tire Inflation System (CTIS) Hose Assemblies, Manifold Valve, Kneeling Valve and Bracket Replacement	12-5
Central Tire Inflation System (CTIS) Troubleshooting	2-24
Front Axle Central Tire Inflation System (CTIS) Quick Release Valve Replacement	12-8
Primary and Central Tire Inflation System (CTIS) Air Hoses Replacement	23-2
Rear Axle Central Tire Inflation System (CTIS) Quick Release Valve Replacement	12-9
Spare Tire Retainer Replacement/ Repair	14-5
Spare Tire Retainer Does Not Lower	2-32
Spare Tire Retainer Does Not Raise	2-32
Wheel Bearing/Central Tire Inflation System (CTIS) Seal Replacement	10-2
Tires	
CTIS Does Not Deflate Tires	2-16
CTIS Does Not Inflate Tires	2-16
Introduction, Wheels, Tires, and Hubs Maintenance	12-1
Wear Unevenly or Excessively	2-22
Too Much Engine Vibration	2-12
Tool Box Replacement/Repair	16-16
Trailer	
Left Stop/Turn Light Does Not Illuminate	2-16
Marker/Taillights Do Not Illuminate	2-16
Right Stop/Turn Light Does Not Illuminate	2-16

SUBJECT INDEX (CONT)

Subject	Para	Subject	Para
T (Cont)		T (Cont)	
Transmission		Transmission (Cont)	
Does Not Shift or Is Slow to Shift When Cold	2-17	WTEC II Transmission ECU Pushbutton Shift Selector (TEPSS) Displays Main Code 41, 42, 44, 45, 66, and/or 69 and Any Sub Code	2-17
Engine and Transmission Oil Sampling Valves Replacement	3-6	WTEC II Transmission ECU Pushbutton Shift Selector (TEPSS) Displays Main Code 43 and Any Sub Code	2-17
Engine Speed Sensor Replacement	7-43	WTEC II Transmission ECU Pushbutton Shift Selector (TEPSS) Displays Main Code 52 and Any Sub Code	2-17
Introduction, Transmission Maintenance	8-1	WTEC II Transmission ECU Pushbutton Shift Selector (TEPSS) Displays Main Code 57 and Any Sub Code	2-17
Metal Particles Found During Transmission Oil Change	2-17	WTEC II Transmission ECU Pushbutton Shift Selector (TEPSS) Displays Main Code 21 and Any Sub Code	2-17
Oil Cooler Hoses Initial Installation	8-14	WTEC II Transmission ECU Pushbutton Shift Selector (TEPSS) Displays Main Code 51 Sub Code 10, 12, 21, 43, 45, or 65	2-17
Oil Cooler Hoses Replacement	8-15	WTEC II Transmission ECU Pushbutton Shift Selector (TEPSS) Displays Main Code 25 and Any Sub Code	2-17
Oil Cooler Hose Bracket Replacement	8-16	WTEC II Transmission ECU Pushbutton Shift Selector (TEPSS) Displays Main Code 53 and Any Sub Code	2-17
Oil Cooler Replacement	8-10	WTEC II Transmission ECU Pushbutton Shift Selector (TEPSS) Displays Main Code 54 Sub Code 01, 07, 10, 12, 17, 21, 23, 27, 32, 34, 43, 45, 54, 56, 65, 70, 71, 72, 80, 81, 82, 83, 85, 86, 92, 93, 95, 96, or 97	2-17
Oil Cooler Tubes Replacement	8-11	WTEC II Transmission ECU Pushbutton Shift Selector (TEPSS) Displays Main Code 55 and Any Sub Code	2-17
Oil Filter Replacement	8-9	WTEC II Transmission ECU Pushbutton Shift Selector (TEPSS) Displays Main Code 56 and Any Sub Code	2-17
Scavenge Pump Hose Replacement	8-12	WTEC II Transmission ECU Pushbutton Shift Selector (TEPSS) Displays Main Code 13 and Any Sub Code	2-17
System Troubleshooting	2-17	WTEC II Transmission ECU Pushbutton Shift Selector (TEPSS) Displays Main Code 23 and Any Sub Code	2-17
Temperature Indicator Does Not Operate	2-16		
Unusually Noisy When Operating	2-17		
WTEC II Cab Transmission Harness Replacement	7-86		
WTEC II Transmission ECU Pushbutton Shift Selector (TEPSS) and Bracket Replacement and Calibration	8-2		
WTEC II Transmission ECU Pushbutton Shift Selector (TEPSS) Dimmer Module Replacement	7-13		
WTEC II Transmission ECU Pushbutton Shift Selector (TEPSS) Emits Eight Seconds of Beeps and/or Transmission Does Not Shift Gears	2-17		
WTEC II Transmission ECU Pushbutton Shift Selector (TEPSS) Displays Main Code 22 Sub Code 14	2-17		
WTEC II Transmission ECU Pushbutton Shift Selector (TEPSS) Displays Main Code 22 Sub Code 15	2-17		
WTEC II Transmission ECU Pushbutton Shift Selector (TEPSS) Displays Main Code 22 Sub Code 16	2-17		
WTEC II Transmission ECU Pushbutton Shift Selector (TEPSS) Displays Main Code 24 and/or 33 and Any Sub Code	2-17		
WTEC II Transmission ECU Pushbutton Shift Selector (TEPSS) Displays Main Code 32 and Any Sub Code	2-17		

Subject	Para
T (Cont)	
Transmission (Cont)	
WTEC II Transmission ECU Pushbutton Shift Selector (TEPSS) Does Not Illuminate	2-17
WTEC III Transmission Pushbutton Shift Selector (TPSS) Displays Main Code 22 Sub Code 14	2-17
WTEC III Transmission Pushbutton Shift Selector (TPSS) Displays Main Code 22 Sub Code 15	2-17
WTEC III Transmission Pushbutton Shift Selector (TPSS) Displays Main Code 22 Sub Code 16	2-17
WTEC III Transmission Pushbutton Shift Selector (TPSS) Displays Main Code 24 and/or 33 and Any Sub Code	2-17
WTEC III Transmission Pushbutton Shift Selector (TPSS) Displays Main Code 32 and Any Sub Code	2-17
WTEC III Transmission Pushbutton Shift Selector (TPSS) Displays Main Code 42, 44, 45, 46, 66, and/or 69 and Any Sub Code	2-17
WTEC III Transmission Pushbutton Shift Selector (TPSS) Displays Main Code 52 and Any Sub Code	2-17
WTEC III Transmission Pushbutton Shift Selector (TPSS) Displays Main Code 57 and Any Sub Code	2-17
WTEC III Transmission Pushbutton Shift Selector (TPSS) Displays Main Code 21 and Any Sub Code	2-17
WTEC III Transmission Pushbutton Shift Selector (TPSS) Displays Main Code 51 and Any Sub Code	2-17
WTEC III Transmission Pushbutton Shift Selector (TPSS) Displays Main Code 25 and Any Sub Code	2-17
WTEC III Transmission Pushbutton Shift Selector (TPSS) Displays Main Code 53 and Any Sub Code	2-17
WTEC III Transmission Pushbutton Shift Selector (TPSS) Displays Main Code 54 and Any Sub Code	2-17
WTEC III Transmission Pushbutton Shift Selector (TPSS) Displays Main Code 55 and Any Sub Code	2-17
WTEC III Transmission Pushbutton Shift Selector (TPSS) Displays Main Code 56 and Any Sub Code	2-17

Subject	Para
T (Cont)	
Transmission (Cont)	
WTEC III Transmission Pushbutton Shift Selector (TPSS) Displays Main Code 13 and Any Sub Code	2-17
WTEC III Transmission Pushbutton Shift Selector (TPSS) Indicator Displays "--" and/or Transmission Does Not Shift Gears	2-17
WTEC III Transmission Pushbutton Shift Selector (TPSS) Displays Main Code 23 and Any Sub Code	2-17
WTEC III Transmission Pushbutton Shift Selector (TPSS) Does Not Illuminate	2-17
Transmitter	
Low Pressure Transmitter Replacement	7-88
Oil Pressure Transmitter Replacement	7-41
Transport/Transportability	
Air Transport Troubleshooting	2-30
Air Transportability Air Hoses Replacement	23-3
Air Transportability Hydraulic Hose Replacement	19-11
Air Transportability Hydraulic System	1-18
Air Transportability Hydraulic System Service	19-7
M1079 Van Preparation for Air Transport	16-73
Troop Transport Alarm Cable Assembly Replacement	20-79
Troop Transport Alarm Does Not Operate	2-31
Troop Transport Audible Alarm Does Not Operate	2-16
Troop Transport Alarm Switch, Connector, and Bracket Replacement	2-80
Troop Transport Audible Alarm Does Not Operate	2-16
Troubleshooting	
Axle Troubleshooting	2-25
Electrical System Troubleshooting	2-16
Engine System Troubleshooting	2-12
Exhaust System Troubleshooting	2-14
Fuel System Troubleshooting	2-13
Hydraulic System Troubleshooting	2-23
Introduction to Logic Tree	
Troubleshooting	2-10
Power Take Off (PTO) Troubleshooting	2-19
Special Purpose Kit Troubleshooting	2-31
Steering Hydraulic System	
Troubleshooting	2-29
Steering Troubleshooting	2-26
Suspension System Troubleshooting	2-27

SUBJECT INDEX (CONT)

Subject	Para	Subject	Para
T (Cont)		T (Cont)	
Troubleshooting (Cont)		Turn (Cont)	
Transmission System Troubleshooting	2-17	Signal Switch Replacement	7-25
Wheel Troubleshooting	2-22	Trailer Left Stop/Turn Light Does Not Illuminate	2-16
11K Self-Recovery Winch (SRW) System Troubleshooting	2-28	Trailer Right Stop/Turn Light Does Not Illuminate	2-16
Tube		Turret	
Coolant Bypass Tube Replacement	6-7	Light Material Handling Crane (LMHC) Turret Replacement	20-76
Engine Oil Fill Tube Replacement	3-7	Two	
Fuel Ratio Control Tube Replacement	4-6	Steady Mode Lights Illuminate on Central Tire Inflation System (CTIS) ECU	2-24
Intake Air Cleaner Filter Element, Air Cleaner Assembly, and Particle Extraction Tube Replacement	4-2	Way Check Valve Replacement	11-14
Orifice Tube Assembly Replacement	4-7		
Power Steering Hoses and Tube Replacement	13-7	U	
Transmission Oil Fill Tube Replacement	8-13	Universal	
Turbocharger to Charge Air Cooler Tube and Hoses Replacement	4-4	Drive Shaft or Universal Joint Unusually Noisy When Operating	2-18
Upper Coolant Tube and Hoses Replacement	6-9	Universal Joint	
Tubes		Drive Shaft and Universal Joint Replacement	9-2
Air Compressor Inlet and Outlet Coolant Tubes Replacement	6-11	Unpacking and Deprocessing	2-4
Charge Air Cooler to Air Inlet Elbow Tubes and Hoses Replacement	4-5	Upper	
Fuel Filter Tubes Replacement	4-10	Coolant Tube and Hoses Replacement	6-9
M1079 Heater Fuel Tubes/Hoses Replacement	20-46	M1079 Upper Sub-Frame Replacement	16-20
Transmission Oil Cooler Tubes Replacement	8-11		
Turn		V	
Intervehicle Left Turn Signal Does Not Illuminate	2-16	Valve	
Intervehicle Right Turn Signal Does Not Illuminate	2-16	Cab Leveling Valve and Linkage Replacement/Adjustment	16-8
Front and Rear Turn Signals Do Not Operate	2-16	Cover and Gasket Replacement	3-3
Left or Right Front Turn Signals Do Not Operate	2-16	Emergency Gladhand Two-Way Check Valve Replacement	11-24
Left Turn Signal Indicator Does Not Operate	2-16	Front Axle Central Tire Inflation System (CTIS) Quick Release Valve Replacement	12-8
Right Turn Signal Indicator Does Not Operate	2-16	Front Axle Quick Release Valve Replacement	11-15
Signal Indicators and High Beams on Indicator Do Not Operate	2-16	Front Gladhand One-Way Check Valve Replacement	11-26
		Fuel Pressure Regulating Valve Replacement	4-3

Subject	Para
V (Cont)	
Valve (Cont)	
Rear Axle Central Tire Inflation System (CTIS) Quick Release Valve Replacement	12-9
Inversion Valve Replacement	11-12
Inversion Valve Replacement	23-4
Load Sensing Valve and Control Cable Replacement/Adjustment	11-10
Low Pressure Transmitter Two-Way Check Valve Replacement	11-28
Manifold Valve Assembly Replacement	12-7
Park Control Two-Way Check Valve Replacement	11-17
Pressure Protection Valve Replacement	11-27
Relay Valve Replacement	11-13
Service Gladhand Two-Way Check Valve Replacement	11-23
Shuttle Valve Replacement	23-5
Two-Way Check Valve Replacement	11-14
Winch Control Valve Assembly and Bracket Replacement	17-6
Winch Control Valve Cable Assembly Replacement	7-85
Valves	
System Park and Trailer Air Supply Valves Replacement	11-18
Van	
All M1079 Van Body Marker Lights Do Not Operate	2-16
M1079 Van Body Floor Tapping Plate Initial Installation (Serial Numbers 001 through 190)	16-43
M1079 Van Body Interior Accessory Mounting Locations	16-44
M1079 Van Body Clearance Marker Light Does Not Illuminate	2-16
M1079 Van Body Replacement	16-19
M1079 Van Door Open Light Does Not Illuminate and Audible Alarm Does Not Operate	2-16
M1079 Van Preparation for Air Transport	16-73
Vehicle	
Brakes Unevenly, Brakes Pull to One Side or Grab	2-20
WTEC II Vehicle Interface Module (VIM) Replacement/Repair	8-6
Vent	
M1079 Vent Cover Replacement	16-32

Subject	Para
V (Cont)	
Voltage Regulator	
100 Amp Voltage Regulator Replacement	7-5
200 Amp Voltage Regulator Replacement	20-57
VOLTS	
Gage Does Not Illuminate	2-16
Gage Does Not Operate or Is Inaccurate	2-16
W	
Wanders	
Pulls to One Side, or Shimmies	2-26
Pulls to One Side, or Shimmies	2-27
Warning	
Amber Warning Light Assembly Repair	20-83
Amber Warning Light Switch Does Not Illuminate	2-16
Light Cable Assembly Replacement	22-2
Light Does Not Illuminate	2-16
No Overspeed Warning Light and/or Overspeed Pressure Change	2-24
Warranty Information	1-6
Washer	
Windshield Washer Does Not Operate	2-16
Windshield Washer Does Not Operate on Low Speed	2-16
Windshield Washer Hoses and Connector Replacement	18-6
Windshield Washer Pump Electromagnetic Interference (EMI) Cable Replacement	7-60
Windshield Washer Reservoir and Pump Replacement	18-2
Water	
Fuel/Water Separator and Filter Replacement	4-13
Pump and Fittings Replacement	6-12
TEMP Gage Does Not Illuminate	2-16
TEMP Gage Does Not Operate or Is Inaccurate	2-16
Temperature Switch Replacement	7-42
Wet Tank Replacement	23-7
Wheel	
Bearing/Central Tire Inflation System (CTIS) Seal Replacement	10-2
Front Wheel Toe-In Alignment/Adjustment	13-5
No Response When Turning Steering Wheel	2-26

SUBJECT INDEX (CONT)

Subject	Para	Subject	Para
W (Cont)		W (Cont)	
Wheel (Cont)		Windshield	
Repair	12-2	All Windshield Wiper Speeds Do Not Operate	2-16
Steering Wheel Replacement	13-2	Washer Does Not Operate	2-16
Stud Replacement	12-3	Washer Does Not Operate on Low Speed	2-16
Stud Tightening Sequence	12-4	Washer Hoses and Connector Replacement	18-6
Troubleshooting	2-22	Washer Pump Electromagnetic Interference (EMI) Cable Assembly Replacement	7-60
Wheels		Washer Reservoir and Pump Replacement	18-2
Introduction, Wheels, Tires, and Hubs Maintenance	12-1	Wiper and Nozzle Replacement	18-3
Wobbles or Shimmys	2-22	Wiper Does Not Operate on High Speed	2-16
White Exhaust Smoke	2-12	Wiper Does Not Operate on Intermittent Speed	2-16
Winch		Wiper ECU Replacement	7-62
Control Valve Assembly and Bracket Replacement	17-6	Wiper Electromagnetic Interference (EMI) Cable Replacement	7-61
Control Valve Cable Assembly Replacement	7-85	Wiper Linkage Replacement	18-5
Light Material Handling Crane (LMHC) Winch Replacement/Repair	20-73	Wiper Motor Replacement	18-4
11K Self-Recovery Winch (SRW)	1-17	Wiper Speed Does Not Operate On Low Speed	2-16
11K Self-Recovery Winch (SRW) Cable Replacement	17-5	Wiper	
11K Self-Recovery Winch (SRW) Does Not Pay Out	2-16	All Windshield Wiper Speeds Do Not Operate	2-16
11K Self-Recovery Winch (SRW) Does Not Reel In	2-16	Windshield Wiper and Nozzle Replacement	18-3
11K Self-Recovery Winch (SRW) Does Not Reel In or Pay Out	2-16	Windshield Wiper Does Not Operate on High Speed	2-16
11K Self-Recovery Winch (SRW) Does Not Work	2-28	Windshield Wiper Does Not Operate on Intermittent Speed	2-16
11K Self-Recovery Winch (SRW) Front Roller Fairlead Replacement	17-2	Windshield Wiper Does Not Operate on Low Speed	2-16
11K Self-Recovery Winch (SRW) Hoses Replacement	17-7	Windshield Wiper ECU Replacement	7-62
11K Self-Recovery Winch (SRW) Cable Pulleys Replacement	17-4	Windshield Wiper Electromagnetic Interference (EMI) Cable Replacement	7-61
11K Self-Recovery Winch (SRW) Rear Roller Fairlead Replacement	17-3	Windshield Wiper Linkage Replacement	18-5
11K Self-Recovery Winch (SRW) System Troubleshooting	2-28	Windshield Wiper Motor Replacement	18-4
Window		Wire	
M1079 Window Latch and Prop Replacement	16-38	Light Material Handling Crane (LMHC) Weight Block and Wire Rope Replacement/Repair	20-72
M1079 Window Main Frame Replacement	16-40		
M1079 Window Sash Assembly Replacement/Repair	16-39		
M1079 Window Cover Replacement	16-41		

GLOSSARY ABBREVIATIONS

A/C	Air Conditioner
ANSI	American National Standards Institute
CCW	Counterclockwise
CTIS	Central Tire Inflation System
CW	Clockwise
ECU	Electronic Control Unit
EMI	Electromagnetic Interference
LED	Light Emitting Diode
LH	Left Hand
LMHC	Light Material Handling Crane
MAC	Maintenance Allocation Chart
NATO	North Atlantic Treaty Organization
NBC	Nuclear, Biological, or Chemical
NO/NC	Normally Open/Normally Closed
PDP	Power Distribution Panel
PMCS	Preventive Maintenance Checks and Services
PTO	Power Takeoff
RH	Right Hand
SAE	Society of Automotive Engineers
SRW	Self-Recovery Winch
STE/ICE-R	Simplified Test Equipment/Internal Combustion Engine-Reprogrammable
TEPSS	Transmission ECU Pushbutton Shift Selector
TPS	Throttle Position Sensor
VDC	Volts Direct Current
VIM	Vehicle Interface Module

WTEC II World Transmission Electronic Controls (version 2)
WTEC III World Transmission Electronic Controls (version 3)

By Order of the Secretary of the Army:

DENNIS J. REIMER
General, United States Army
Chief of Staff

Official:

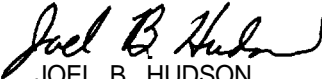
JOEL B. HUDSON
Administrative Assistant to the
Secretary of the Army
05140

DISTRIBUTION: To be distributed in accordance with the initial distribution number (IDN) 380934 requirements for TM 9-2320-365-20-1.

RECOMMENDED CHANGES TO PUBLICATIONS AND BLANK FORMS For use of this form, see AR 25-30; the proponent agency is OAASA	Use Part II (reverse) for Repair Parts and Special Tool Lists (RPSTL) and Supply Catalogs/Supply Manuals (SC/SM).	DATE Date you filled out this form
---	---	---------------------------------------

TO: (Forward to proponent of publication or form) (Include ZIP Code)	FROM: (Activity and location) (Include ZIP Code) Enter your mailing address
---	---

PART I - ALL PUBLICATIONS (EXCEPT RPSTL AND SC/SM) AND BLANK FORMS

PUBLICATION/FORM NUMBER	DATE Publication Date	TITLE Publication Title
-------------------------	--------------------------	----------------------------

ITEM	PAGE	PARA-GRAPH	LINE	FIGURE NO.	TABLE	RECOMMENDED CHANGES AND REASON
10	15-33	15-7		4		Item 10. Change Illustration. Reason: Text calls out 90-degree fitting. Art shows straight fitting. Text is correct. Step (4) of removal says to disconnect four hydraulic hoses from manifold. The correct number of hydraulic hoses is five. correct the text to reflect the actual quantity of hydraulic hoses. The supporting illustration is correct.
	19-6	19-2				

* Reference to line numbers within the paragraph or subparagraph.

TYPED NAME, GRADE OR TITLE Your title	TELEPHONE EXCHANGE/AUTOVON, PLUS EXTENSION Your telephone number	SIGNATURE Your signature
--	---	---------------------------------

TO: <i>(Forward direct to addressee listed in publication)</i>	FROM: <i>(Activity and location) (Include ZIP Code)</i>	DATE
Enter your mailing address		Date you filled out this form.

PART II - REPAIR PARTS AND SPECIAL TOOL LISTS AND SUPPLY CATALOGS/SUPPLY MANUALS

PUBLICATION NUMBER			DATE				TITLE	
			Publication Date				Your Title	
PAGE NO.	COLM NO.	LINE NO.	NATIONAL STOCK NUMBER	REFERENCE NO.	FIGURE NO.	ITEM NO.	TOTAL NO. OF MAJOR ITEMS SUPPORTED	RECOMMENDED ACTION

PART III - REMARKS *(Any general remarks or recommendations, or suggestions for improvement of publications and blank forms. Additional blank sheets may be used if more space is needed.)*

TYPED NAME, GRADE OR TITLE	TELEPHONE EXCHANGE/AUTOVON, PLUS EXTENSION	SIGNATURE
Your title	Your telephone number	Your signature

RECOMMENDED CHANGES TO PUBLICATIONS AND BLANK FORMS						Use Part II (<i>reverse</i>) for Repair Parts and Special Tool Lists (RPSTL) and Supply Catalogs/Supply Manuals (SC/SM).	DATE
For use of this form, see AR 25-30; the proponent agency is OAASA							
TO: (<i>Forward to proponent of publication or form</i>) (<i>Include ZIP Code</i>)				FROM: (<i>Activity and location</i>) (<i>Include ZIP Code</i>)			
PART I - ALL PUBLICATIONS (EXCEPT RPSTL AND SC/SM) AND BLANK FORMS							
PUBLICATION/FORM NUMBER						DATE	TITLE
ITEM	PAGE	PARA- GRAPH	LINE	FIGURE NO.	TABLE	RECOMMENDED CHANGES AND REASON	
<i>* Reference to line numbers within the paragraph or subparagraph.</i>							
TYPED NAME, GRADE OR TITLE				TELEPHONE EXCHANGE/AUTOVON, PLUS EXTENSION		SIGNATURE	

TO: <i>(Forward direct to addressee listed in publication)</i>	FROM: <i>(Activity and location) (Include ZIP Code)</i>	DATE
---	--	-------------

PART II - REPAIR PARTS AND SPECIAL TOOL LISTS AND SUPPLY CATALOGS/SUPPLY MANUALS

PUBLICATION NUMBER			DATE		TITLE			
PAGE NO.	COLM NO.	LINE NO.	NATIONAL STOCK NUMBER	REFERENCE NO.	FIGURE NO.	ITEM NO.	TOTAL NO. OF MAJOR ITEMS SUPPORTED	RECOMMENDED ACTION

PART III - REMARKS *(Any general remarks or recommendations, or suggestions for improvement of publications and blank forms. Additional blank sheets may be used if more space is needed.)*

TYPED NAME, GRADE OR TITLE	TELEPHONE EXCHANGE/AUTOVON, PLUS EXTENSION	SIGNATURE
----------------------------	--	-----------

RECOMMENDED CHANGES TO PUBLICATIONS AND BLANK FORMS						Use Part II (<i>reverse</i>) for Repair Parts and Special Tool Lists (RPSTL) and Supply Catalogs/Supply Manuals (SC/SM).	DATE
For use of this form, see AR 25-30; the proponent agency is OAASA							
TO: (<i>Forward to proponent of publication or form</i>) (<i>Include ZIP Code</i>)				FROM: (<i>Activity and location</i>) (<i>Include ZIP Code</i>)			
PART I - ALL PUBLICATIONS (EXCEPT RPSTL AND SC/SM) AND BLANK FORMS							
PUBLICATION/FORM NUMBER						DATE	TITLE
ITEM	PAGE	PARA- GRAPH	LINE	FIGURE NO.	TABLE	RECOMMENDED CHANGES AND REASON	
<i>* Reference to line numbers within the paragraph or subparagraph.</i>							
TYPED NAME, GRADE OR TITLE				TELEPHONE EXCHANGE/AUTOVON, PLUS EXTENSION		SIGNATURE	

TO: <i>(Forward direct to addressee listed in publication)</i>	FROM: <i>(Activity and location) (Include ZIP Code)</i>	DATE
---	--	-------------

PART II - REPAIR PARTS AND SPECIAL TOOL LISTS AND SUPPLY CATALOGS/SUPPLY MANUALS

PUBLICATION NUMBER			DATE		TITLE			
PAGE NO.	COLM NO.	LINE NO.	NATIONAL STOCK NUMBER	REFERENCE NO.	FIGURE NO.	ITEM NO.	TOTAL NO. OF MAJOR ITEMS SUPPORTED	RECOMMENDED ACTION

PART III - REMARKS *(Any general remarks or recommendations, or suggestions for improvement of publications and blank forms. Additional blank sheets may be used if more space is needed.)*

TYPED NAME, GRADE OR TITLE	TELEPHONE EXCHANGE/AUTOVON, PLUS EXTENSION	SIGNATURE
----------------------------	--	-----------

RECOMMENDED CHANGES TO PUBLICATIONS AND BLANK FORMS						Use Part II (<i>reverse</i>) for Repair Parts and Special Tool Lists (RPSTL) and Supply Catalogs/Supply Manuals (SC/SM).	DATE
For use of this form, see AR 25-30; the proponent agency is OAASA							
TO: (<i>Forward to proponent of publication or form</i>) (<i>Include ZIP Code</i>)				FROM: (<i>Activity and location</i>) (<i>Include ZIP Code</i>)			
PART I - ALL PUBLICATIONS (EXCEPT RPSTL AND SC/SM) AND BLANK FORMS							
PUBLICATION/FORM NUMBER						DATE	TITLE
ITEM	PAGE	PARA-GRAPH	LINE	FIGURE NO.	TABLE	RECOMMENDED CHANGES AND REASON	
<i>* Reference to line numbers within the paragraph or subparagraph.</i>							
TYPED NAME, GRADE OR TITLE					TELEPHONE EXCHANGE/AUTOVON, PLUS EXTENSION		SIGNATURE

TO: <i>(Forward direct to addressee listed in publication)</i>	FROM: <i>(Activity and location) (Include ZIP Code)</i>	DATE
---	--	-------------

PART II - REPAIR PARTS AND SPECIAL TOOL LISTS AND SUPPLY CATALOGS/SUPPLY MANUALS

PUBLICATION NUMBER			DATE		TITLE			
PAGE NO.	COLM NO.	LINE NO.	NATIONAL STOCK NUMBER	REFERENCE NO.	FIGURE NO.	ITEM NO.	TOTAL NO. OF MAJOR ITEMS SUPPORTED	RECOMMENDED ACTION

PART III - REMARKS *(Any general remarks or recommendations, or suggestions for improvement of publications and blank forms. Additional blank sheets may be used if more space is needed.)*

TYPED NAME, GRADE OR TITLE	TELEPHONE EXCHANGE/AUTOVON, PLUS EXTENSION	SIGNATURE
----------------------------	--	-----------











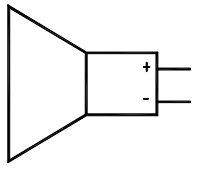

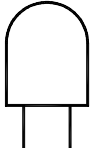
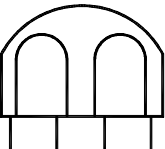

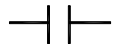

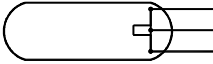
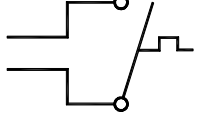
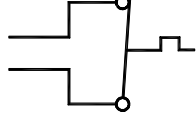
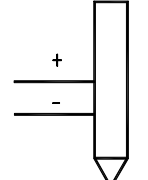
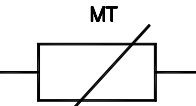
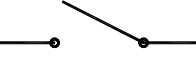
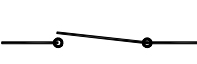
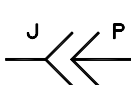
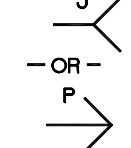
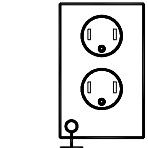

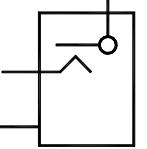

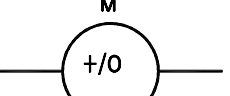

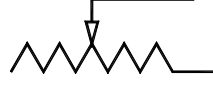
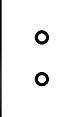
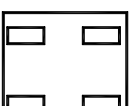
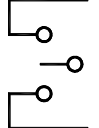
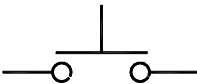
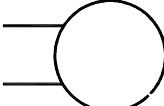
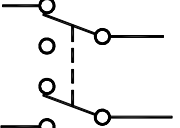
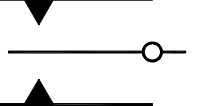
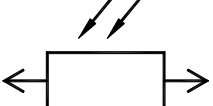

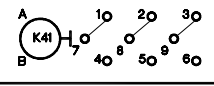
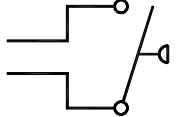
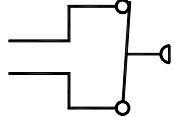
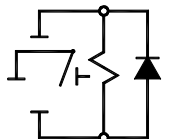
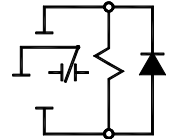
	1	2	3	4	5	6	7	8	9
A									
B	 HORN	 BLACKOUT LAMP	 LAMP	 DUALBEAM LAMP	 GROUND	 POWER LAMP	 OPEN CONTACT	 BATTERY	 FLUORESCENT LIGHT
C	 TEMPERATURE SWITCH OPEN	 TEMPERATURE SWITCH CLOSED	 MAGNETIC PICKUP	 SENSOR	 NORMALLY OPEN	 NORMALLY CLOSED	 CONNECTOR	 RECEPTACLE	 ELECTRICAL OUTLET
D	 MOTOR	 SOLENOID	 LEVEL SENSOR	 FILTER	 LED	 METER OR GAGE	 CLOSED CONTACT	 DIMMER MODULE	 TELEPHONE RECEPTACLE
E	 CIRCUIT BREAKER	 TWO-WAY SWITCH	 PUSHBUTTON	 CIRCULATING PUMP	 DPDT SWITCH	 DPST SWITCH	 PHOTOCELL	 FUSE	 RELAY
F	 PRESSURE SWITCH OPEN	 PRESSURE SWITCH CLOSED	 NORMALLY OPEN	 NORMALLY CLOSED	 ALTERNATOR	 RESISTOR	 TERMINAL LUG	 ELECTRONIC IGNITION UNIT	
G	 DIODE	 SPLICE	 SENSING SWITCH	 MOTOR	 GROUND RELAY	 RELAY	 CIRCUIT BREAKER	 FLASHER	
H									

FIGURE FO-1 ELECTRICAL SYSTEM SCHEMATIC
 FOLDOUT 1 OF 34
 SIZE B ILL. NO. 5WD011B FP-1/ (FP-2 BLANK)

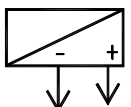
	10	11	12	13	14	15	16	17	18							
	CONNECTORS		CONNECTORS (CONTINUED)		CONNECTORS (CONTINUED)		CONNECTORS (CONTINUED)									
	NUMBER	ZONE	SH	DESCRIPTION	NUMBER	ZONE	SH	DESCRIPTION	NUMBER	ZONE	SH	DESCRIPTION				
A	A13	A66	8	WTEC II TRANSMISSION CONNECTOR A	J154	A271	31	VAN FRONT MARKER LIGHT	P53R	D196	22	ALL MODELS EXCEPT WRECKER, TRACTOR, AND LONG WHEEL BASE	P132	B85	10	CAB MARKER LIGHT FRONT LOWER RIGHT
	A13	A70	8	WTEC II TRANSMISSION CONNECTOR B	J155	B287	32	VAN CURBSIDE MARKER LIGHT	P54	D197	22	LEFT REAR MARKER	P150	B272	31	VAN FRONT MARKER LIGHT
	A13	A74	9	WTEC II TRANSMISSION CONNECTOR C	J156	B287	32	VAN CURBSIDE MARKER LIGHT	P55	C85	10	CAB MARKER LIGHT FRONT UPPER RIGHT	P151	B272	31	VAN FRONT MARKER LIGHT
	J1	D285	32	VAN 110 VAC POWER ENTRY	J157	C287	32	VAN ROADSIDE MARKER LIGHT	P55	D206	23	RH FRONT TOP CAB MARKER LIGHT	P152	B272	31	VAN FRONT MARKER LIGHT
	J2	A185	21	EMI FILTER	J158	C287	32	VAN ROADSIDE MARKER LIGHT	P56	E197	22	MIDDLE REAR MARKER	P153	A272	31	VAN FRONT MARKER LIGHT
	J2	E285	32	VAN 110 VAC POWER ENTRY	J159	D287	32	VAN REAR CENTER MARKER LIGHT	P57	D85	10	CAB MARKER LIGHT FRONT UPPER MIDDLE LEFT	P154	A272	31	VAN FRONT MARKER LIGHT
	J3	D205	23	AIRDROP ONLY	J160	E287	32	VAN REAR CENTER MARKER LIGHT	P57	F206	23	LH FRONT TOP CAB CLEARANCE LIGHT	P155	B287	32	VAN CURBSIDE MARKER LIGHT
	J5	A38	5	VEHICLE HORN	J161	E287	32	VAN REAR CENTER MARKER LIGHT	P58	E197	22	RIGHT REAR MARKER	P156	B287	32	VAN CURBSIDE MARKER LIGHT
	J6	A38	5	VEHICLE HORN	J162	B273	31	VAN CURBSIDE BLACKOUT LIGHT	P59	C85	10	CAB MARKER LIGHT FRONT UPPER MIDDLE RIGHT	P157	C287	32	VAN ROADSIDE MARKER LIGHT
B	J7	A188	21	WTEC II TRANSMISSION DIMMER MODULE	J163	B274	31	VAN CURBSIDE EMERGENCY LIGHT	P59	D206	23	RH FRONT TOP CAB CLEARANCE LIGHT	P158	C287	32	VAN ROADSIDE MARKER LIGHT
	J8	B38	5	BLACKOUT MARKER RIGHT FRONT	J164	H274	31	VAN ROADSIDE BLACKOUT LIGHT	P60	D85	10	CAB MARKER LIGHT FRONT UPPER MIDDLE MIDDLE	P159	D287	32	VAN REAR CENTER MARKER LIGHT
	J9	C38	5	FRONT RIGHT TURN SIGNAL	J165	H275	31	VAN ROADSIDE EMERGENCY LIGHT	P60	E206	23	MIDDLE FRONT TOP CLEARANCE LIGHT	P160	E287	32	VAN REAR CENTER MARKER LIGHT
	J10	B38	5	PARKING LIGHT FRONT RIGHT	J166	C271	31	VAN FRONT EMERGENCY LIGHT	P61	F197	22	RH COMPOSITE LIGHT	P161	D287	32	VAN REAR CENTER MARKER LIGHT
	J12	D38	5	RIGHT HEADLIGHT	J167	D287	32	VAN REAR EMERGENCY LIGHT	P62	F197	22	RH COMPOSITE LIGHT	P162	B273	31	VAN CURBSIDE BLACKOUT LIGHT
	J13	C38	5	RIGHT HEADLIGHT	J173	G272	31	VAN 12/24 VDC POWER RECEPTACLE	P63	G197	22	RH COMPOSITE LIGHT	P163	B274	31	VAN CURBSIDE EMERGENCY LIGHT
	J14	C38	5	RIGHT HEADLIGHT	J209A	C230	26	PTO EQUIPPED	P64	F197	22	RH COMPOSITE LIGHT	P164	G274	31	VAN ROADSIDE BLACKOUT LIGHT
	J17	H38	5	BLACKOUT DRIVE LIGHT	J209B	D230	26	PTO EQUIPPED	P65	E186	21	ROTARY WARNING LIGHT CONNECTOR	P165	G275	31	VAN ROADSIDE EMERGENCY LIGHT
	J18	D38	5	LEFT HEADLIGHT	J210	F222	25	CAB - DASH - CENTER - OPTIONS PANEL	P67	A74	9	PRE-BLOCK SEVEN W/PIGTAIL TRANSMISSION EXTERNAL	P166	C272	32	VAN FRONT EMERGENCY LIGHT
	J19	E38	5	LEFT HEADLIGHT	J215	E230	26	PTO EQUIPPED				WIRING HARNESS TO TRANSMISSION CONNECTOR	P167	D287	31	VAN REAR EMERGENCY LIGHT
	J19	C177	20	CAB - DASH - LEFT - UNDERDASH	J230	A282	32	VAN CURBSIDE 110 VAC OUTLET	P67	B69	8	TID1, TID2, AND TID3 TRANSMISSION EXTERNAL WIRING	P172	E264	30	DUMP BODY CONNECTOR
	J20	D38	5	LEFT HEADLIGHT	J231	A283	32	VAN CURBSIDE 110 VAC OUTLET				HARNESS TO TRANSMISSION CONNECTOR	P173	G271	31	VAN 12/24 VDC POWER
	J22	G38	5	PARKING LIGHT FRONT LEFT	J232	A284	32	VAN CURBSIDE 110 VAC OUTLET	P69	D59	7	ENGINE	P201	G61	7	ENGINE
	J23	F38	5	FRONT LEFT TURN SIGNAL	J233	H282	32	VAN ROADSIDE 110 VAC OUTLET	P71	E66	8	PRE-BLOCK SEVEN TRANSMISSION OUTPUT SPEED SENSOR	P210	F222	25	CAB - DASH - CENTER - OPTIONS PANEL
	J24	H38	5	BLACKOUT MARKER LEFT FRONT	J234	H283	32	VAN ROADSIDE 110 VAC OUTLET				CONNECTOR	P210	C227	26	PTO EQUIPPED
	J25	G85	10	WINDSHIELD WASHER ROTARY PUMP (B3)	J235	H284	32	VAN ROADSIDE 110 VAC OUTLET	P71	E70	8	TID1, TID2, AND TID3 TRANSMISSION OUTPUT SPEED	P215	E230	26	PTO EQUIPPED
	J27	A43	5	CHASSIS - FRONT	J236	H275	31	VAN ROADSIDE 24 VDC OUTLET				SENSOR CONNECTOR	P216	E229	26	PTO EQUIPPED
	J31	E55	7	ENGINE	J237	275	31	VAN CURBSIDE 24 VDC OUTLET	P71	E75	9	PRE-BLOCK SEVEN W/PIGTAIL TRANSMISSION OUTPUT	P217	C229	26	PTO EQUIPPED
	J31X	F175	20	CAB - DASH - LEFT - UNDERDASH	J242	D271	31	VAN A/C				SPEED SENSOR CONNECTOR	P217	B268	30	PTO EQUIPPED
	J39	G61	7	ENGINE	J244	E271	31	VAN THERMOSTAT	P72	F66	8	PRE-BLOCK SEVEN TRANSMISSION ENGINE SPEED	P901	A209	24	CAB - DASH - CENTER - OPTIONS PANEL
	J43	G42	5	CHASSIS - FRONT	J245	F271	31	VAN HEATER				SENSOR CONNECTOR	P902A	D214	24	CAB - DASH - CENTER - OPTIONS PANEL
	J43X	F42	5	CHASSIS - FRONT	J912	B124	14	CAB - DASH - CENTER - HEATER / CTIS ECU	P72	F70	8	TID1, TID2, AND TID3 TRANSMISSION ENGINE SPEED	P903	C212	24	CAB - DASH - CENTER - OPTIONS PANEL
	J43X	G175	20	CAB - DASH - LEFT - UNDERDASH	J912	D209	24	CAB - DASH - CENTER - OPTIONS PANEL				SENSOR CONNECTOR	P903A	D212	24	CAB - DASH - CENTER - OPTIONS PANEL
	J50	E85	10	CAB MARKER LIGHT FRONT UPPER LEFT	J913	B122	14	CAB - DASH - CENTER - HEATER / CTIS ECU	P72	E75	9	PRE-BLOCK SEVEN W/PIGTAIL TRANSMISSION ENGINE	P904	C211	24	CAB - DASH - CENTER - OPTIONS PANEL
	J51	D42	5	CHASSIS - FRONT	J921	G62	7	TROOP TRANSPORT ALARM				SPEED SENSOR CONNECTOR	P904A	D211	24	CAB - DASH - CENTER - OPTIONS PANEL
	J52	E38	5	CHASSIS - FRONT BUMPER	P2	A185	21	EMI FILTER	P73	F66	8	PRE-BLOCK SEVEN TRANSMISSION THROTTLE POSITION	P905	A211	24	CAB - DASH - CENTER - OPTIONS PANEL
	J52	B203	23	CHASSIS - FRONT	P3	D204	23	AIRDROP ONLY				SENSOR CONNECTOR	P905A	B211	24	CAB - DASH - CENTER - OPTIONS PANEL
	J53	F200	23	AIRDROP ONLY	P5	A38	5	VEHICLE HORN	P73	F70	8	TID1, TID2, AND TID3 TRANSMISSION THROTTLE POSITION	P906	A212	24	CAB - DASH - CENTER - OPTIONS PANEL
	J55	C85	10	CAB MARKER LIGHT FRONT UPPER RIGHT	P6	A38	5	VEHICLE HORN				SENSOR CONNECTOR	P906A	B212	24	CAB - DASH - CENTER - OPTIONS PANEL
	J57	D85	10	CAB MARKER LIGHT FRONT UPPER MIDDLE LEFT	P8	B38	5	BLACKOUT MARKER RIGHT FRONT	P73	F75	9	PRE-BLOCK SEVEN W/PIGTAIL TRANSMISSION THROTTLE	P908	A215	24	CAB - DASH - CENTER - OPTIONS PANEL
	J59	C85	10	CAB MARKER LIGHT FRONT UPPER MIDDLE RIGHT	P9	C38	5	FRONT RIGHT TURN SIGNAL				POSITION SENSOR CONNECTOR	P908A	B215	24	CAB - DASH - CENTER - OPTIONS PANEL
	J60	D85	10	CAB MARKER LIGHT FRONT UPPER MIDDLE MIDDLE	P10	B38	5	PARKING LIGHT FRONT RIGHT	P74	B197	22	LH COMPOSITE LIGHT	P909	A220	25	CAB - DASH - CENTER - OPTIONS PANEL
	J62	E88	10	ROTARY WARNING LIGHT CONNECTOR	P12	D38	5	RIGHT HEADLIGHT	P76	C197	22	LH COMPOSITE LIGHT	P909A	B220	25	CAB - DASH - CENTER - OPTIONS PANEL
	J65	E186	21	ROTARY WARNING LIGHT CONNECTOR	P13	C38	5	RIGHT HEADLIGHT	P77	C197	22	LH COMPOSITE LIGHT	P910	C215	24	CAB - DASH - CENTER - OPTIONS PANEL
	J78	F185	21	CAB RADIO CONNECTOR	P14	C38	5	RIGHT HEADLIGHT	P78	B197	22	LH COMPOSITE LIGHT	P910A	D215	24	CAB - DASH - CENTER - OPTIONS PANEL
	J80	D78	9	AIR DRYER (EXCEPT DUMP)	P17	H38	5	BLACKOUT DRIVE LIGHT	P80	G51	6	CHASSIS - REAR	P911	C220	25	CAB - DASH - CENTER - OPTIONS PANEL
	J93	B50	6	CHASSIS - SPARE TIRE	P18	D38	5	LEFT HEADLIGHT	P81	C47	6	CHASSIS - FRONT	P911A	D220	25	CAB - DASH - CENTER - OPTIONS PANEL
	J95	E38	5	12V INTERVEHICULAR	P18	A177	20	CAB - DASH - LEFT - UNDERDASH	P81	D62	7	STARTER THERMO SWITCH	P912	B124	14	CAB - DASH - CENTER - HEATER / CTIS ECU
	J95	B206	23	ENGINE	P19	E38	5	LEFT HEADLIGHT	P82	B51	6	FUEL TANK LEVEL SENSOR	P913	B122	14	CAB - DASH - CENTER - HEATER / CTIS ECU
	J99	E187	21	CHEMICAL ALARM CONNECTOR	P20	D38	5	LEFT HEADLIGHT	P83	B172	20	CAB - DASH - LEFT - UNDERDASH	P913	F209	24	CAB - DASH - CENTER - OPTIONS PANEL
	J106	F50	6	CHEMICAL DETECTOR RECEPTACLE	P22	G38	5	PARKING LIGHT FRONT LEFT	P84	F51	6	CHASSIS - REAR	P914	A214	24	CAB - DASH - CENTER - OPTIONS PANEL
	J108	B222	25	CAB - DASH - CENTER - OPTIONS PANEL	P23	F38	5	FRONT LEFT TURN SIGNAL	P85	A197	22	LH SIDE MARKER LIGHT	P914A	B214	24	CAB - DASH - CENTER - OPTIONS PANEL
	J111	E122	14	CTIS ELECTRONIC CONTROL UNIT	P24	H38	5	BLACKOUT MARKER LEFT FRONT	P86	A197	22	LH REAR MARKER LIGHT	P921	G62	7	TROOP TRANSPORT ALARM
	J113	G186	21	CTIS PRESSURE TRANSDUCER	P25	G85	10	WINDSHIELD WASHER ROTARY PUMP (B3)	P87	C197	22	BACKUP LIGHT	PBSS	C93	11	WTEC II PUSHBUTTON SHIFT SELECTOR
	J114	B165	21	CAB - DASH - LEFT - WTEC II TRANSMISSION HARNESS	P27	A43	5	CHASSIS - FRONT	P88	H197	22	RH SIDE MARKER LIGHT	PX1	A92	11	ENGINE FAN OFF SWITCH
	J114	D298	34	WTEC III TRANSMISSION HARNESS (TID1)	P31	E56	7	ENGINE	P89	G197	22	RH REAR MARKER LIGHT	PX10	D107	12	CAB - DASH - LEFT - INSTRUMENT PANEL
	J114	D303	34	WTEC III TRANSMISSION HARNESS (TID2)	P31X	D56	7	ENGINE	P99	F186	21	CHEMICAL ALARM CONNECTOR	PX11	G107	12	CAB - DASH - LEFT - INSTRUMENT PANEL
	J115	C154	18	CAB - DASH - LEFT - WTEC II TRANSMISSION HARNESS	P32	F59	7	ENGINE OIL PRESSURE SENSOR	P10	B38	5	PARKING LIGHT FRONT RIGHT	PX12	C112	13	ROTATING WARNING LIGHT SWITCH
	J116	C159	18	CAB - DASH - LEFT - WTEC II TRANSMISSION HARNESS	P33	H59	7	FUEL/WATER SEPARATOR	P10	E119	14	CTIS ELECTRONIC CONTROL UNIT	PX12A	E112	13	CAB - DASH - LEFT - INSTRUMENT PANEL
	J117	F161	18	CAB - DASH - LEFT - WTEC II TRANSMISSION HARNESS	P34	E59	7	OIL PRESSURE WARNING LIGHT SWITCH	P111	E122	14	CTIS ELECTRONIC CONTROL UNIT	PX13	F92	11	ETHER STARTER SWITCH
	J117	B289	33	WTEC III DIAGNOSTIC CONNECTOR	P36	A57	7	WATER COOLER TEMPERATURE	P112	G123	14	CAB - DASH - CENTER - HEATER / CTIS ECU	PX13A	G92	11	CAB - DASH - LEFT - INSTRUMENT PANEL
	J118	D161	18	CAB - DASH - LEFT - WTEC II TRANSMISSION HARNESS	P37	C57	7	WATER TEMPERATURE SWITCH	P113	F123	14	CTIS ELECTRONIC CONTROL UNIT	PX14	F112	13	FULL HAZARD WARNING SWITCH
	J119	B169	19	CAB - DASH - LEFT - WTEC II TRANSMISSION HARNESS	P38	F61	7	ENGINE SPEED MAGNETIC PICKUP	P115	C290	33	WTEC III - CAB - DASH - RIGHT - KICK PANEL	PX14A	H112	13	CAB - DASH - LEFT - INSTRUMENT PANEL
	J119	D301	34	WTEC III CAB TRANSMISSION HARNESS (TID1)	P39	G61	7	ENGINE	P116	C185	21	CAB - DASH - RIGHT - UNDERDASH	PX15	C115	13	MAIN LIGHT SWITCH
	J119	D305	34	WTEC III CAB TRANSMISSION HARNESS (TID2)	P41	B57	7	WATER TEMPERATURE SENSOR	P118	D161	18	CAB - DASH - LEFT - WTEC II TRANSMISSION HARNESS	PX17	A112	13	IGNITION SWITCH
	J129	F85	10	CAB MARKER LIGHT FRONT LOWER LEFT	P410	E240	27	ARCTIC KIT W/PTO EQUIPPED	P116	E291	33	WTEC III - CAB - DASH - RIGHT - KICK PANEL	PX17A	C112	13	CAB - DASH - LEFT - INSTRUMENT PANEL
	J130	F85	10	CAB MARKER LIGHT LEFT DOOR	P42	F57	7	ETHER SENSOR SWITCH	P119	A64	8	PRE-BLOCK SEVEN TRANSMISSION CONNECTOR	PX1A	B92	11	CAB - DASH - LEFT - INSTRUMENT PANEL
	J130	F202	23	12 PIN CONNECTOR	P43	G42	5	CHASSIS - FRONT	P119	A69	8	TID1, TID2, AND TID3 TRANSMISSION CONNECTOR	PX2	D92	11	LAMP TEST SWITCH
	J131	B85	10	CAB MARKER LIGHT RIGHT DOOR	P43X	F42	5	CHASSIS - FRONT	P119	A73	9	PRE-BLOCK SEVEN W/PIGTAIL TRANSMISSION CONNECTOR	PX20	C188	21	TURN SIGNAL FLASHER
	J132	B85	10	CAB MARKER LIGHT FRONT LOWER RIGHT	P50	E85	10	CAB MARKER LIGHT FRONT UPPER LEFT	P119	B169	19	CAB - DASH - LEFT - WTEC II TRANSMISSION HARNESS	PX21	A134	15	WIPER DELAY MODULE
	J150	B271	31	VAN FRONT MARKER LIGHT	P50	F206	23	LH FRONT TOP CAB MARKER LIGHT	P125	G84	10	WINDSHIELD WASHER ROTARY PUMP (B3)				
	J151	B271	31	VAN FRONT MARKER LIGHT	P51	D190	22	CAB - DASH - RIGHT - POWER DISTRIBUTION PANEL	P129	F85	10	CAB MARKER LIGHT FRONT LOWER LEFT				
	J152	B271	31	VAN FRONT MARKER LIGHT	P52F	E38	5	CHASSIS - FRONT	P130	F85	10	CAB MARKER LIGHT LEFT DOOR				
	J153	A271	31	VAN FRONT MARKER LIGHT	P52R	E196	22	ALL MODELS EXCEPT WRECKER, TRACTOR, AND LONG WHEEL BASE	P131	A85	10	CAB MARKER LIGHT RIGHT DOOR				
					</											

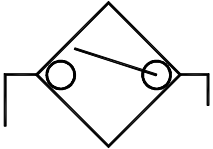
		19	20	21	22	23	24	25	26	27															
A	CONNECTORS (CONTINUED)	NUMBER	ZONE	SH	DESCRIPTION	LIGHTS (CONTINUED)	NUMBER	ZONE	SH	DESCRIPTION	CIRCUIT BREAKERS (CONTINUED)	NUMBER	ZONE	SH	DESCRIPTION	TERMINAL LUGS (CONTINUED)	NUMBER	ZONE	SH	DESCRIPTION	TERMINAL LUGS (CONTINUED)	NUMBER	ZONE	SH	DESCRIPTION
		PX22	A184	21	EMI FILTER		DS56	C84	10	CAB MARKER LIGHT FRONT UPPER MIDDLE RIGHT		CB40	C150	17	CTIS COOLER		TL31	E98	22	MIDDLE REAR MARKER		TL99	D52	6	CHASSIS - REAR (REF E2)
		PX24	G115	13	INSTRUMENT PANEL LIGHTS DIMMER MODULE		DS56	D206	23	RH FRONT TOP CAB CLEARANCE LIGHT		CB41	C142	16	TRAILER REAR LIGHTS POWER		TL32	E98	22	RIGHT REAR MARKER		TL100	E54	6	POLARITY PROTECTION
		PX25	C119	14	CAB DASH CENTER HEATER / CTIS ECU		DS57	C84	10	CAB MARKER LIGHT FRONT UPPER RIGHT		CB42	C142	16	BLACKOUT MARKER LIGHTS POWER		TL33	E47	6	24V AUXILIARY STARTER SOLENOID		TL110	D61	7	ALTERNATOR
		PX26	B179	20	CAB - DASH - LEFT - UNDERDASH		DS57	D206	23	RH FRONT TOP CAB MARKER LIGHT		CB43	C143	16	REAR COMPOSITE LIGHTS/WTEC III ECU		TL35	D61	7	ALTERNATOR		TL111	D230	26	PTO EQUIPPED
		PX2A	E92	11	CAB - DASH - LEFT - INSTRUMENT PANEL		DS58	E84	10	CAB MARKER LIGHT FRONT UPPER LEFT		CB44	C143	16	REAR COMPOSITE LIGHTS		TL36	B54	6	POLARITY PROTECTION		TL123	E38	5	CHASSIS - FRONT (REF J19)
		PX33	B182	21	CAB - DASH - RIGHT - UNDERDASH		DS58	F206	23	LH FRONT TOP CAB MARKER LIGHT		CB45	C139	16	FUEL PRE-HEAT		TL37	F54	6	POLARITY PROTECTION		TL126	E126	14	CHASSIS GROUND
		PX33	G292	33	WTEC III TRANSMISSION PUSHBUTTON SHIFT SELECTOR		DS59	B84	10	CAB MARKER LIGHT RIGHT DOOR		CB48	C140	16	ARCTIC CAB/ENGINE KILL		TL37	C54	6	POLARITY PROTECTION		TL130	F85	10	CAB - MARKER LIGHTS
		PX34	E188	21	FRONT AIR PRESSURE METER		DS60	F84	10	CAB MARKER LIGHT FRONT LOWER LEFT		CB49	C151	17	PTO POWER		TL38	E50	6	SHUNT		TL131	A85	10	CAB - MARKER LIGHTS
		PX4	F97	11	FAN SOLENOID		DS61	A84	10	CAB MARKER LIGHT RIGHT DOOR		CB50	F256	29	MAIN POWER CIRCUIT BREAKER SWITCH		TL39	C52	6	CHASSIS - REAR (REF E1)		TL133	F85	10	CAB - MARKER LIGHTS
B	CONNECTORS (CONTINUED)	PX5	B97	11	REAR AIR PRESSURE METER	DS62	F84	10	CAB MARKER LIGHT LEFT DOOR	CB53	D140	16	CAB - DASH - RIGHT - POWER DISTRIBUTION PNL	TL41	C53	6	POLARITY PROTECTION	TL134	B85	10	CAB - MARKER LIGHTS				
		PX6	B107	12	CAB - DASH - LEFT - INSTRUMENT PANEL	DS63	B210	24	CAB - DASH - CENTER - OPTIONS PANEL	CB54	D142	16	BLACKOUT HEADLIGHT	TL42	B54	6	POLARITY PROTECTION	TL150	F177	20	SENSOR/FRONT AIR PRESSURE TRANSMITTER				
		PX7	A104	12	CAB - DASH - LEFT - INSTRUMENT PANEL	DS64	B212	24	CAB - DASH - CENTER - OPTIONS PANEL	CB61	D153	17	CAB - DASH - RIGHT - POWER DISTRIBUTION PNL	TL44	B54	6	POLARITY PROTECTION	TL151	G177	20	SENSOR/REAR AIR PRESSURE TRANSMITTER				
		PX8	G102	12	CAB - DASH - LEFT - INSTRUMENT PANEL	DS65	A198	22	LH SIDE MARKER LIGHT	CB62	D153	17	CAB - DASH - RIGHT - POWER DISTRIBUTION PNL	TL44	E54	6	POLARITY PROTECTION	TL152	C179	20	STOPLIGHT SWITCH				
		PX9	D97	11	FUEL LEVEL METER	DS66	A198	22	LH REAR MARKER LIGHT	CB63	D151	17	CAB - DASH - RIGHT - POWER DISTRIBUTION PNL	TL45	D50	6	SHUNT	TL153	C179	20	STOPLIGHT SWITCH				
		C	LIGHTS	NUMBER	ZONE	SH	DESCRIPTION	DS67	H198	22	RH SIDE MARKER LIGHT	CB64	D151	17	CAB - DASH - RIGHT - POWER DISTRIBUTION PNL	TL46	D49	6	SHUNT	TL154	D179	20	STOPLIGHT SWITCH		
				D51	B257	29	POWER LAMP	DS68	G198	22	RH REAR MARKER LIGHT	CB65	D140	16	PARKING LIGHTS	TL46	D62	7	STARTER/STARTER SOLENOID	TL154	D179	20	STOPLIGHT SWITCH		
				D52	B257	29	POWER LAMP	DS69	D198	22	LEFT REAR MARKER	CB66	D143	16	BLACKOUT MARKER POWER	TL47	C54	6	POLARITY PROTECTION	TL155	D179	20	STOPLIGHT SWITCH		
				DS1	D296	11	CAB - DASH - LEFT - INSTRUMENT PANEL	DS70	E198	22	MIDDLE REAR MARKER	CB67	D139	16	MARKER LIGHTS	TL48	E52	6	CHASSIS - REAR (REF E2)	TL156	F177	20	SWITCH/FRONT AIR PRESSURE TRANSMITTER		
				DS2	G106	12	CAB - DASH - LEFT - INSTRUMENT PANEL	DS71	E198	22	RIGHT REAR MARKER	CB68	C152	17	CAB - DASH - RIGHT - POWER DISTRIBUTION PNL	TL49A	D52	6	CHASSIS - REAR (REF E1)	TL157	G177	20	SWITCH/REAR AIR PRESSURE TRANSMITTER		
DS3	F96			11	CAB - DASH - LEFT - INSTRUMENT PANEL	DS72	B198	22	REAR LH COMPOSITE LIGHT	CB70	D146	17	IGNITION/MAIN LIGHT SWITCH	TL49A	F52	6	NATO SLAVE RECEPTACLE	TL158	E37	16	START INHIBIT PUSHBUTTON				
DS4	B96			11	CAB - DASH - LEFT - INSTRUMENT PANEL	DS73	F198	22	REAR RH COMPOSITE LIGHT	CB71	D149	17	HAZARD/FLASHER WORKLIGHTS	TL50	G121	14	CHASSIS GROUND	TL159	E36	16	START INHIBIT PUSHBUTTON				
DS5	B106			12	CAB - DASH - LEFT - INSTRUMENT PANEL	DS74	D37	5	LEFT HEADLIGHT	CB72	D139	16	CAB - DASH - RIGHT - POWER DISTRIBUTION PNL	TL50A	F52	6	NATO SLAVE RECEPTACLE	TL160	H102	12	AUDIBLE ALARM				
DS6	G101			12	CAB - DASH - LEFT - INSTRUMENT PANEL	DS75	A273	31	VAN CURBSIDE BLACKOUT LIGHT	CB73	D150	17	BACK-UP LIGHT POWER	TL51	E50	6	SHUNT	TL161	H102	12	AUDIBLE ALARM				
DS7	D106			12	CAB - DASH - LEFT - INSTRUMENT PANEL	DS76	H274	31	VAN ROADSIDE BLACKOUT LIGHT	CB74	D150	17	CAB - DASH - RIGHT - POWER DISTRIBUTION PNL	TL52	E50	6	SHUNT	TL162	B114	13	STARTER PUSHBUTTON				
D	LIGHTS	DS8	C91	11	CAB - DASH - LEFT - INSTRUMENT PANEL	DS78	A274	31	VAN CURBSIDE EMERGENCY LIGHT	CB76	D143	16	BLACKOUT STOP RELAY POWER	TL53	B47	6	CHASSIS - FRONT	TL163	B114	13	STARTER PUSHBUTTON				
		DS9	B101	12	DUMP BODY UP	DS79	H275	31	VAN ROADSIDE EMERGENCY LIGHT	CB77	C152	17	ENGINE INSTR POWER	TL53	B62	7	STARTER/STARTER SOLENOID	TL164	G62	7	ENGINE (REF J92)				
		DS10	E111	13	CAB - DASH - LEFT - INSTRUMENT PANEL	DS80	H284	32	VAN ROADSIDE FLUORESCENT LIGHT	CB78	D147	17	HEADLIGHTS	TL55	B47	6	CHASSIS - FRONT	TL165	G62	7	ENGINE (REF J92)				
		DS11	G91	11	CAB - DASH - LEFT - INSTRUMENT PANEL	DS81	H286	32	VAN ROADSIDE FLUORESCENT LIGHT	CB79	C150	17	WTEC II VIM POWER/WTEC III REVERSE WARNING RELAY	TL55	C62	7	STARTER/STARTER SOLENOID	TL166	F54	6	TERMINAL BLOCK				
		DS12	H111	13	CAB - DASH - LEFT - INSTRUMENT PANEL	DS82	A286	32	VAN CURBSIDE FLUORESCENT LIGHT	CB80	D142	16	TAILLIGHTS	TL56	F36	16	X3 GROUND	TL167	E54	6	TERMINAL BLOCK				
		DS13	C111	13	CAB - DASH - LEFT - INSTRUMENT PANEL	DS83	A284	32	VAN CURBSIDE FLUORESCENT LIGHT	TL1	B54	6	POLARITY PROTECTION	TL57	F36	16	CAB GROUND	TL169	D53	6	POLARITY PROTECTION (P/P)				
		DS14	B101	12	LEFT TURN SIGNAL	DS84	B271	31	VAN FRONT MARKER LIGHT	TL2	E60	7	ALTERNATOR	TL58	D60	7	ALTERNATOR	TL171	F54	6	TERMINAL BLOCK				
		DS15	B101	12	RIGHT TURN SIGNAL	DS85	B271	31	VAN FRONT MARKER LIGHT	TL2	B53	6	POLARITY PROTECTION	TL59	C61	7	ALTERNATOR	TL172	F54	6	TERMINAL BLOCK				
		DS16	E101	12	HIGH BEAM	DS86	B271	31	VAN FRONT MARKER LIGHT	TL2	D60	7	ALTERNATOR	TL60	C53	6	POLARITY PROTECTION	TL173	E54	6	POLARITY PROTECTION (P/P)				
		DS17	D119	14	HEATER CONTROL PANEL ILLUMINATION	DS87	A271	31	VAN FRONT MARKER LIGHT	TL2	D53	6	POLARITY PROTECTION (P/P)	TL60	D60	7	ALTERNATOR	TL174	D54	6	POLARITY PROTECTION (P/P)				
E	CONNECTORS (CONTINUED)	DS18	A208	24	CAB - DASH - CENTER - OPTIONS PANEL	DS88	A271	31	VAN FRONT MARKER LIGHT	TL3	C85	10	CAB MARKER LIGHT FRONT UPPER RIGHT	TL61	C54	6	POLARITY PROTECTION	TL190	D290	33	WTEC III PRESSURE SWITCH GROUND				
		DS19	E101	12	RADIATOR FAN OFF	DS88	B288	32	VAN CURBSIDE MARKER LIGHT	TL3	D206	23	RH FRONT TOP CAB MARKER LIGHT	TL61	E60	7	ALTERNATOR	TL201	E125	14	PARKING BRAKE SWITCH				
		DS21	C101	12	EMERGENCY BRAKE	DS89	B288	32	VAN CURBSIDE MARKER LIGHT	TL3	C85	10	CAB MARKER LIGHT FRONT UPPER MIDDLE RIGHT	TL62	C47	6	CHASSIS - FRONT	TL202	E125	14	PARKING BRAKE SWITCH				
		DS22	D101	12	PARKING BRAKE	DS90	B288	32	VAN CURBSIDE MARKER LIGHT	TL4	C85	10	CAB MARKER LIGHT FRONT UPPER MIDDLE LEFT	TL63	C47	6	CHASSIS - FRONT	TL320	E232	26	PTO EQUIPPED				
		DS23	C101	12	PTO ON	DS91	C288	32	VAN ROADSIDE MARKER LIGHT	TL4	D206	23	RH FRONT TOP CAB CLEARANCE LIGHT	TL66	H61	7	ENGINE (REF P20)	TL320	C241	27	ARCTIC KIT W/PTO EQUIPPED				
		DS24	D101	12	OIL PRESSURE	DS92	C288	32	VAN ROADSIDE MARKER LIGHT	TL5	D60	7	ALTERNATOR	TL68	D224	25	CAB - DASH - CENTER - OPTIONS PANEL	SWITCHES	S3	A177	20	COLUMN SWITCH			
		DS25	C101	12	WATER TEMPERATURE	DS93	D288	32	VAN REAR CENTER MARKER LIGHT	TL5	D60	7	ALTERNATOR	TL69	E224	25	CAB - DASH - CENTER - OPTIONS PANEL		S3	C177	20	COLUMN SWITCH			
		DS27	C101	12	REAR BRAKE AIR	DS94	E288	32	VAN REAR CENTER MARKER LIGHT	TL6	D60	7	ALTERNATOR	TL70	B38	5	FRONT RH COMPOSITE LIGHT		S4	D114	13	MAIN LIGHT SWITCH			
		DS28	E101	12	FRONT AIR BRAKE	DS95	E288	32	VAN REAR CENTER MARKER LIGHT	TL6	D60	7	ALTERNATOR	TL71	A85	10	CAB MARKER LIGHT RIGHT DOOR		S5/1	B111	13	IGNITION SWITCH			
		DS29	D101	12	ENGINE OIL LEVEL	DS96	B215	24	CAB - DASH - CENTER - OPTIONS PANEL	TL8	D85	10	CAB MARKER LIGHT FRONT UPPER MIDDLE MIDDLE	TL72	H38	5	BLACKOUT DRIVE LIGHT		S5/11	A91	11	ENGINE FAN OFF SWITCH			
DS30	F101	12	MASTER STOP	DS97	B219	25	CAB - DASH - CENTER - OPTIONS PANEL	TL8	E206	23	MIDDLE FRONT TOP CLEARANCE LIGHT	TL73	B86	10	CAB - MARKER LIGHTS	S5/14	C213		24	WINCH ON OFF					
DS31	D213	24	CAB - DASH - CENTER - OPTIONS PANEL	DS98	C271	31	VAN FRONT EMERGENCY LIGHT	TL9	D47	6	24V AUXILIARY STARTER SOLENOID	TL74	D86	10	CAB - MARKER LIGHTS	S5/15	B212		24	WINCH IN-OUT					
DS32	B101	12	CHEMICAL DETECT	DS99	B219	25	CAB - DASH - CENTER - OPTIONS PANEL	TL10	C52	6	CHASSIS - REAR (REF E1)	TL74	E204	23	AIRDROP ONLY	S5/16	F91		11	ETHER STARTER SWITCH					
DS34	C101	12	CTIS OVERSPEED	DS100	B213	24	CAB - DASH - CENTER - OPTIONS PANEL	TL12	C49	6	BATTERIES	TL76	F87	10	CAB - MARKER LIGHTS	S5/2	D91		11	LAMP TEST SWITCH					
DS35	C198	22	REAR LH COMPOSITE LIGHT	DS101	D119	14	HEATER CONTROL PANEL ILLUMINATION	TL12	C62	7	STARTER/STARTER SOLENOID	TL79	F38	5	FRONT LH COMPOSITE LIGHT	S5/2	D111		13	ROTATING WARNING LIGHT SWITCH					
F	CONNECTORS (CONTINUED)	DS36	G198	22	REAR RH COMPOSITE LIGHT	DS108	E91	11	CAB - DASH - LEFT - INSTRUMENT PANEL	TL14	E88	10	ROTARY WARNING LIGHT CONNECTOR	TL80	F54	6	200 AMP	S5/22	G111	13	FULL HAZARD WARNING SWITCH				
		DS37	B198	22	REAR LH COMPOSITE LIGHT	CIRCUIT BREAKERS	NUMBER	ZONE	SH	DESCRIPTION	TL81	C39	5	CHASSIS GROUND	TL81	C39	5	CHASSIS GROUND	S5/25	A219	25	SWINGFIRE PUMP SWITCH			
		DS38	F198	22	REAR RH COMPOSITE LIGHT		CB1	C285	32	VAN 110 VAC MAIN CIRCUIT BREAKER	TL82	F38	5	CHASSIS GROUND	TL82	F38	5	CHASSIS GROUND	S5/6	B210	24	PTO ON/OFF SWITCH			
		DS39	F37	5	FRONT LEFT TURN SIGNAL		CB2	C284	32	VAN A/C	TL83	B52	6	FUEL TANK LEVEL SENSOR	TL83	B52	6	FUEL TANK LEVEL SENSOR	S5/8	A213	24	BLACKOUT OVERRIDE SWITCH			
		DS41	D101	12	TRANSMISSION OIL TEMPERATURE		CB3	D284	32	VAN 110 VAC POWER OUT	TL84	B49	6	CHASSIS - SPARE TIRE (REF J93)	TL84	B49	6	CHASSIS - SPARE TIRE (REF J93)	S5/9	A214	24	FUEL PRE-HEAT SWITCH			
		DS42	C38	5	FRONT RIGHT TURN SIGNAL		CB4	D284	32	VAN NOT USED	TL85	G52	6	CHASSIS - REAR	TL85	G52	6	CHASSIS - REAR	S6	A114	13	STARTER PUSHBUTTON			
		DS43	D212	24	CAB - DASH - CENTER - OPTIONS PANEL		CB5	E284	32	VAN BLACKOUT OVERRIDE	TL86	C86	10	CAB - MARKER LIGHTS	TL86	C86	10	CAB - MARKER LIGHTS	S7	F137	16	START INHIBIT PUSHBUTTON			
		DS44	D37	5	RIGHT HEADLIGHT		CB6	E284	32	VAN LIGHTS	TL86	D204	23	AIRDROP ONLY	TL86	D204	23	AIRDROP ONLY	S10A	C179	20	STOPLIGHT SWITCH			
		DS45	C198	22	BACKUP LIGHT		CB7	E284	32	VAN 110 VAC OUTLETS	TL87	F86	10	CAB - MARKER LIGHTS	TL87	F86	10	CAB - MARKER LIGHTS	S10B	D179	20	STOPLIGHT SWITCH			
		DS46	D210	24	CAB - DASH - CENTER - OPTIONS PANEL		CB8	E284	32	VAN THERMOSTAT/FAN	TL87	B86	10	CAB - MARKER LIGHTS	TL87	B86	10	CAB - MARKER LIGHTS	S11	A287	32	VAN CURBSIDE WINDOW BLACKOUT SWITCH			
DS47	G37	5	PARKING LIGHT FRONT LEFT	CB9	E284		32	VAN 110 VAC OUTLETS	TL89	F195	22	ALL MODELS EXCEPT WRECKER, TRACTOR, AND LONG WHEEL BASE	TL89	F195	22	ALL MODELS EXCEPT WRECKER, TRACTOR, AND LONG WHEEL BASE	S12	A287	32	VAN CURBSIDE WINDOW BLACKOUT SWITCH					
G	CONNECTORS (CONTINUED)	DS48	B38	5																					

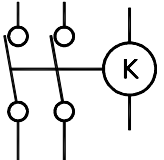
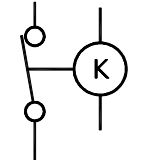
28				29				30				31				32				33				34				35				36			
A	SWITCHES (CONTINUED)																																		
	NUMBER	ZONE	SH	DESCRIPTION																															
	S17	G288	32	VAN CURBSIDE WINDOW BLACKOUT SWITCH (S/N 001 THROUGH 190)																															
	S18	D269	30	PTO PRESSURE SWITCH																															
	S20	E177	20	SWITCH/FRONT AIR PRESSURE TRANSMITTER																															
	S23	F52	6	AIR PRESSURE SWITCH FOR CTIS																															
	S24	E125	14	PARKING BRAKE SWITCH																															
	S26	C57	7	WATER TEMPERATURE SENSOR																															
	S27	E59	7	OIL PRESSURE WARNING LIGHT SWITCH																															
	S29	G177	20	SWITCH/REAR AIR PRESSURE TRANSMITTER																															
B	S31	A216	24	ARCTIC TROOP HEATER SWITCH																															
	S32	F288	32	VAN LIGHTS ON/OFF SWITCH																															
	S33	E277	31	VAN BLACKOUT SWITCH																															
	S34	D278	31	VAN BLACKOUT SWITCH																															
	S35	H273	31	VAN BLACKOUT OVERRIDE SWITCH																															
	S40	F58	7	ETHER SENSOR SWITCH																															
	S45	E62	7	TROOP ALARM SWITCH																															
	S45	G62	31	VAN FAN ON/OFF SWITCH																															
	S56	A57	7	WATER TEMPERATURE SWITCH																															
	S57	G77	9	LMHC IN/OUT SWITCH																															
C	GAGES																																		
	NUMBER	ZONE	SH	DESCRIPTION																															
	M2	D106	12	VOLTMETER																															
	M3	B106	12	ENGINE OIL PRESSURE METER																															
	M4	F96	11	FRONT AIR PRESSURE METER																															
	M5	B96	11	REAR AIR PRESSURE METER																															
	M6	G107	12	WATER TEMPERATURE METER																															
	M7	D96	11	FUEL LEVEL METER																															
	M8	G102	12	SPEEDOMETER																															
	M9	A210	24	TACHOMETER																															
D	RELAYS																																		
	NUMBER	ZONE	SH	DESCRIPTION																															
	K1	F149	17	STARTER RELAY																															
	K2	B143	16	CONTROL PANEL RELAY																															
	K6	F144	16	STOPLIGHT RELAY																															
	K7	G153	17	HEADLIGHT RELAY																															
	K8	G151	17	HEADLIGHT LO/HI-BEAM RELAY																															
	K9	A142	16	HAZARD FLASHER BLACKOUT OVERRIDE																															
	K10	F150	17	STOP HAZARD FLASHER RELAY																															
	K11	F146	17	ALTERNATOR EXCITATION RELAY																															
E	K12	B139	16	WORKLIGHT RELAY																															
	K13	B149	17	ROTATING BEACON BLACKOUT OVERRIDE RELAY																															
	K15	B140	16	AUXILIARY COOLER RELAY																															
	K19	B150	17	START INHIBIT RELAY																															
	K20	H138	16	MARKER LIGHTS RELAY																															
	K24	B151	17	CRANKING LOCKOUT RELAY																															
	K25	B292	33	WTEC III REVERSE WARNING RELAY																															
	K26	B290	33	WTEC III NEUTRAL START RELAY																															
	K27	H143	16	BLACKOUT STOP RELAY																															
	K28	H142	16	TRAILER REAR LIGHTS RELAY																															
F	K29	F142	16	BLACKOUT MARKER RELAY/WTEC II BLACKOUT DRIVE RELAY																															
	K30	H147	17	REAR LEFT COMPOSITE LAMP RELAY																															
	K31	H149	17	REAR RIGHT COMPOSITE LAMP RELAY																															
	K32	B147	17	HORN RELAY																															
	K35	E277	31	VAN 110 VAC OUTLETS																															
	K36	F277	31	VAN FLUORESCENT LIGHTS																															
	K37	B294	33	WTEC III PTO ENABLE OUTPUT RELAY																															
	K52	H139	16	CTIS OVERSPEED INDICATION RELAY																															
	K53	H140	16	RADIO POWER RELAY																															
	G	RESISTORS																																	
NUMBER		ZONE	SH	DESCRIPTION																															
R2		E172	20	CAB - DASH - LEFT - UNDERDASH																															
R4		D175	20	CAB - DASH - LEFT - UNDERDASH																															
R5		C175	20	CAB - DASH - LEFT - UNDERDASH																															
R6		F172	20	CAB - DASH - LEFT - UNDERDASH																															
SOLENOIDS																																			
NUMBER		ZONE	SH	DESCRIPTION																															
KS	D47	6	24V AUXILIARY STARTER SOLENOID																																
L1	E189	21	FAN SOLENOID																																
L2	H57	7	FUEL SOLENOID																																
L3	D269	30	PTO SOLENOID																																
L4	E233	26	WINCH IN SOLENOID																																
L5	D233	26	SOLENOID																																
L15	B51	6	CHASSIS - SPARE TIRE																																
	E80	9	LMHC IN SOLENOID																																
	F80	9	LMHC OUT SOLENOID																																
H	HORNS AND ALARMS																																		
	NUMBER	ZONE	SH	DESCRIPTION																															
	LS1	A37	5	VEHICLE HORN																															
	LS2	H101	12	AUDIBLE ALARM																															
MOTORS																																			
NUMBER	ZONE	SH	DESCRIPTION																																
B2	A183	21	WINDSHIELD WIPER MOTOR																																
B4	C118	14	FAN MOTOR																																
	F81	9	LMHC HOIST MOTOR																																
BATTERIES																																			
NUMBER	ZONE	SH	DESCRIPTION																																
BT1	C52	6	BATTERY																																
BT2	D52	6	BATTERY																																
BT3	D52	6	BATTERY																																
BT4	E52	6	BATTERY																																
MISCELLANEOUS																																			
NUMBER	ZONE	SH	DESCRIPTION																																
10A	C183	21	WTEC II VEHICLE INTERFACE MODULE																																
10A	E183	21	WTEC II VEHICLE INTERFACE MODULE																																
A2	F118	14	CTIS ELECTRONIC CONTROL UNIT																																
A3	G114	13	INSTRUMENT PANEL LIGHTS DIMMER MODULE																																
A5	A135	15	WIPER DELAY MODULE																																
A7	B179	20	FREQUENCY DIMMER																																
A18	A103	12	LIGHTED INDICATOR DISPLAY																																
A20	H59	7	FUEL/WATER SEPARATOR																																
B1	C63	7	STARTER/STARTER SOLENOID																																
B3	G83	10	WINDSHIELD WASHER ROTARY PUMP																																
B10	E67	8	WTEC II TRANSFER CASE (SERIAL # 29513233)																																
B10	E70	8	WTEC II TRANSFER CASE (SERIAL # 29513233)																																
B10	E66	8	WTEC II TRANSMISSION (SERIAL # 29513233)																																
B10	E71	8	WTEC II TRANSFER CASE (SERIAL # 29517497)																																
B10	E70	8	WTEC II TRANSMISSION (SERIAL # 29517497)																																
B10	E76	9	WTEC II TRANSFER CASE (SERIAL # 29513233)																																
B10	E74	9	WTEC II TRANSMISSION (SERIAL # 29513233)																																
B11	A175	20	JUNCTION BOX																																
BL1	F257	29	FURNACE CONTROL UNIT																																
BL2	F256	29	FURNACE CONTROL UNIT																																
BL3	F256	29	FURNACE CONTROL UNIT																																
D1A	C138	16	CAB - DASH - RIGHT - POWER DISTRIBUTION PNL																																
D1B	C138	16	CAB - DASH - RIGHT - POWER DISTRIBUTION PNL																																
D2A	D138	16	CAB - DASH - RIGHT - POWER DISTRIBUTION PNL																																
D2B	D138	16	CAB - DASH - RIGHT - POWER DISTRIBUTION PNL																																
D3A	B138	16	CAB - DASH - RIGHT - POWER DISTRIBUTION PNL																																
D3B	B138	16	CAB - DASH - RIGHT - POWER DISTRIBUTION PNL																																
E1	C52	6	BATTERY																																
E1	D52	6	BATTERY																																
E1	D52	6	BATTERY																																
E1	E52	6	BATTERY																																
E2	C43	5	CHASSIS FRONT BUMPER (REF J27)																																
E2	C52	6	BATTERY																																
E2	D52	6	BATTERY																																
E2	E52	6	BATTERY																																
E2	E52	6	BATTERY																																
E3	H148	17	CAB - DASH - RIGHT - POWER DISTRIBUTION PNL																																
E4	H150	17	CAB - DASH - RIGHT - POWER DISTRIBUTION PNL																																
E5	B151	17	CAB - DASH - RIGHT - POWER DISTRIBUTION PNL																																
E14	E194	22	ALL MODELS EXCEPT WRECKER, TRACTOR, AND LONG WHEEL BASE																																
MISCELLANEOUS (CONTINUED)																																			
NUMBER	ZONE	SH	DESCRIPTION																																
E15	E197	22	ALL MODELS EXCEPT WRECKER, TRACTOR, AND LONG WHEEL BASE																																
E16	A197	22	ALL MODELS EXCEPT WRECKER, TRACTOR, AND LONG WHEEL BASE																																
E17	G195	22	ALL MODELS EXCEPT WRECKER, TRACTOR, AND LONG WHEEL BASE																																
E18	G194	22	ALL MODELS EXCEPT WRECKER, TRACTOR, AND LONG WHEEL BASE																																
E19	F194	22	ALL MODELS EXCEPT WRECKER, TRACTOR, AND LONG WHEEL BASE																																
E20	E194	22	ALL MODELS EXCEPT WRECKER, TRACTOR, AND LONG WHEEL BASE																																
E21	D195	22	ALL MODELS EXCEPT WRECKER, TRACTOR, AND LONG WHEEL BASE																																
E22	B86	10	CAB - MARKER LIGHTS																																
E23	D86	10	CAB - MARKER LIGHTS																																
E23	D205	23	AIRDROP ONLY																																
E24	C85	10	CAB - MARKER LIGHTS																																
E24	D205	23	AIRDROP ONLY																																
E25	F86	10	CAB - MARKER LIGHTS																																
E60	B41	31	24 VDC VAN POWER																																
E65	B41	5	CHASSIS - FRONT																																
E66	C41	5	CHASSIS - FRONT																																
E66	D300	34	WTEC III CAB TRANSMISSION HARNESS (TID1)																																
E66	D305	34	WTEC III CAB TRANSMISSION HARNESS (TID2)																																
E67	D38	5	CHASSIS - FRONT																																
E68	D40	5	CHASSIS - FRONT																																
E70	C229	26	PTO EQUIPPED																																
E71	F173	20	CAB - DASH - LEFT - UNDERDASH																																
E88	B106	12	CAB - DASH - LEFT - INSTRUMENT PANEL																																
E89	C106	12	CAB - DASH - LEFT - INSTRUMENT PANEL																																
E90	D300	34	WTEC III CAB TRANSMISSION HARNESS (TID1)																																
E90	D305	34	WTEC III CAB TRANSMISSION HARNESS (TID2)																																
E91	C300	34	WTEC III CAB TRANSMISSION HARNESS (TID1)																																
E91	C305	34	WTEC III CAB TRANSMISSION HARNESS (TID2)																																
E501	B275	31	VAN EMERGENCY/BLACKOUT LIGHT/24 VDC OUTLET																																
E502	G274	31	VAN EMERGENCY/BLACKOUT LIGHT																																
E503	B273	31	VAN MARKER LIGHT																																
E504	B272	31	VAN MARKER LIGHT																																
E505	B287	32	VAN REAR MARKER LIGHTS																																
E506	C287	32	VAN REAR MARKER LIGHTS																																
E514	C274	31	VAN EMERGENCY LIGHT																																
E516	H272	31	VAN 24 VDC																																
F2	H271	31	VAN 24 VDC POWER																																
FL	E183	21	WTEC II VEHICLE INTERFACE MODULE																																
FL1	G85	10	EMI FILTER																																
FL2	A184	21	EMI FILTER																																
FL3	C118	14	FAN MOTOR																																
GI	D60	7	ALTERNATOR																																
MPUI	F61	7	ENGINE SPEED MAGNETIC PICKUP																																
MT3	F60	7	ENGINE OIL PRESSURE SENSOR																																
MT4	E177	20	SENSOR/FRONT AIR PRESSURE TRANSMITTER																																
MT5	G177	20	SENSOR/REAR AIR PRESSURE TRANSMITTER																																
MT6	B57	7	WATER COOLER TEMPERATURE																																
MT7	B52	6	FUEL TANK LEVEL SENSOR																																
NS	E183	21	WTEC II VEHICLE INTERFACE MODULE																																
P/P	B54	6	POLARITY PROTECTION																																
P/P	D54	6	POLARITY PROTECTION																																
R11	D50	6	SHUNT																																
R1	D79	9	AIR DRYER																																
TB1	C128	15	CAB - DASH - RIGHT - POWER DISTRIBUTION PNL																																
TB2	F130	15	CAB - DASH - RIGHT - POWER DISTRIBUTION PNL																																
X1	C137	16	24 VDC																																
X11	F52	6	NATO SLAVE RECEPTACLE																																
X2	D137	16	24 VDC																																
X3	F137	16	GROUND																																
X5	D137	16	24 VDC																																
X7	D137	16	24 VDC																																
PHONE 1	A285	32	VAN PHONE 1																																
PHONE 2	H287	32	VAN PHONE 2																																
MISCELLANEOUS (CONTINUED)																																			
NUMBER	ZONE	SH	DESCRIPTION																																
	E77	9	LIGHT MATERIAL HANDLING CRANE (LMHC)																																
	E77	9	LMHC REMOTE CONTROL BOX																																
	E77	9	LMHC POWER CABLE																																
	G78	9	LMHC REMOTE CONTROL IN/OUT																																
	G302	34	WTEC III TRANSMISSION PRESSURE SWITCH																																
	B304	34	WTEC III OUTPUT SPEED SENSOR																																
	C304	34	WTEC III ENGINE SPEED SENSOR																																
	E304	34	WTEC III SUMP TEMP SENSOR																																
TRANSMISSION																																			
NUMBER	ZONE	SH	DESCRIPTION																																
A10	B183	21	WTEC II VEHICLE INTERFACE MODULE																																
A13	B67	8	WTEC II TRANSMISSION A13 (SERIAL # 29513233)																																
A13	A72	8	WTEC II TRANSMISSION A13 (SERIAL # 29517497)																																
A13	A76	9	WTEC II TRANSMISSION A13 (SERIAL # 29513233)																																
B10	E67	8	PRE-BLOCK SEVEN TRANSMISSION OUTPUT SPEED SENSOR																																
B10	E72	8	TID1, TID2, AND TID3 TRANSMISSION OUTPUT SPEED SENSOR																																
B10	E76	9	PRE-BLOCK SEVEN W/PIGTAIL TRANSMISSION OUTPUT SPEED SENSOR																																
MT9	F67	8	PRE-BLOCK SEVEN TRANSMISSION ENGINE SPEED SENSOR																																
MT9	F72	8	TID1, TID2, AND TID3 TRANSMISSION ENGINE SPEED SENSOR																																
MT9	F76	9	PRE-BLOCK SEVEN W/PIGTAIL TRANSMISSION ENGINE SPEED SENSOR																																
MT11	F67	8	PRE-BLOCK SEVEN TRANSMISSION THROTTLE POSITION SENSOR																																
MT11	F72	8	TID1, TID2, AND TID3 TRANSMISSION THROTTLE POSITION SENSOR																																
MT11	F76	9	PRE-BLOCK SEVEN W/PIGTAIL TRANSMISSION THROTTLE POSITION SENSOR																																
REV	C183	21	WTEC II VEHICLE INTERFACE MODULE																																
RW	D183	21	WTEC II VEHICLE INTERFACE MODULE																																
S02	F183	21	WTEC II VEHICLE INTERFACE MODULE																																
S03	F183	21	WTEC II VEHICLE INTERFACE MODULE																																
SF01	D183	21	WTEC II VEHICLE INTERFACE MODULE																																
SF01	D183	21	WTEC II VEHICLE INTERFACE MODULE																																
SF02	C183	21	WTEC II VEHICLE INTERFACE MODULE																																
SF04	C183	21	WTEC II VEHICLE INTERFACE MODULE																																
SF3	F183	21	WTEC II VEHICLE INTERFACE MODULE																																
SF4	D183	21	WTEC II VEHICLE INTERFACE MODULE																																

FIGURE FO-1. ELECTRICAL SYSTEM SCHEMATIC FOLDOUT 4 OF 34
 SIZE B ILL. NO. 5WD01L4B FP-7/ (FP-8 BLANK)

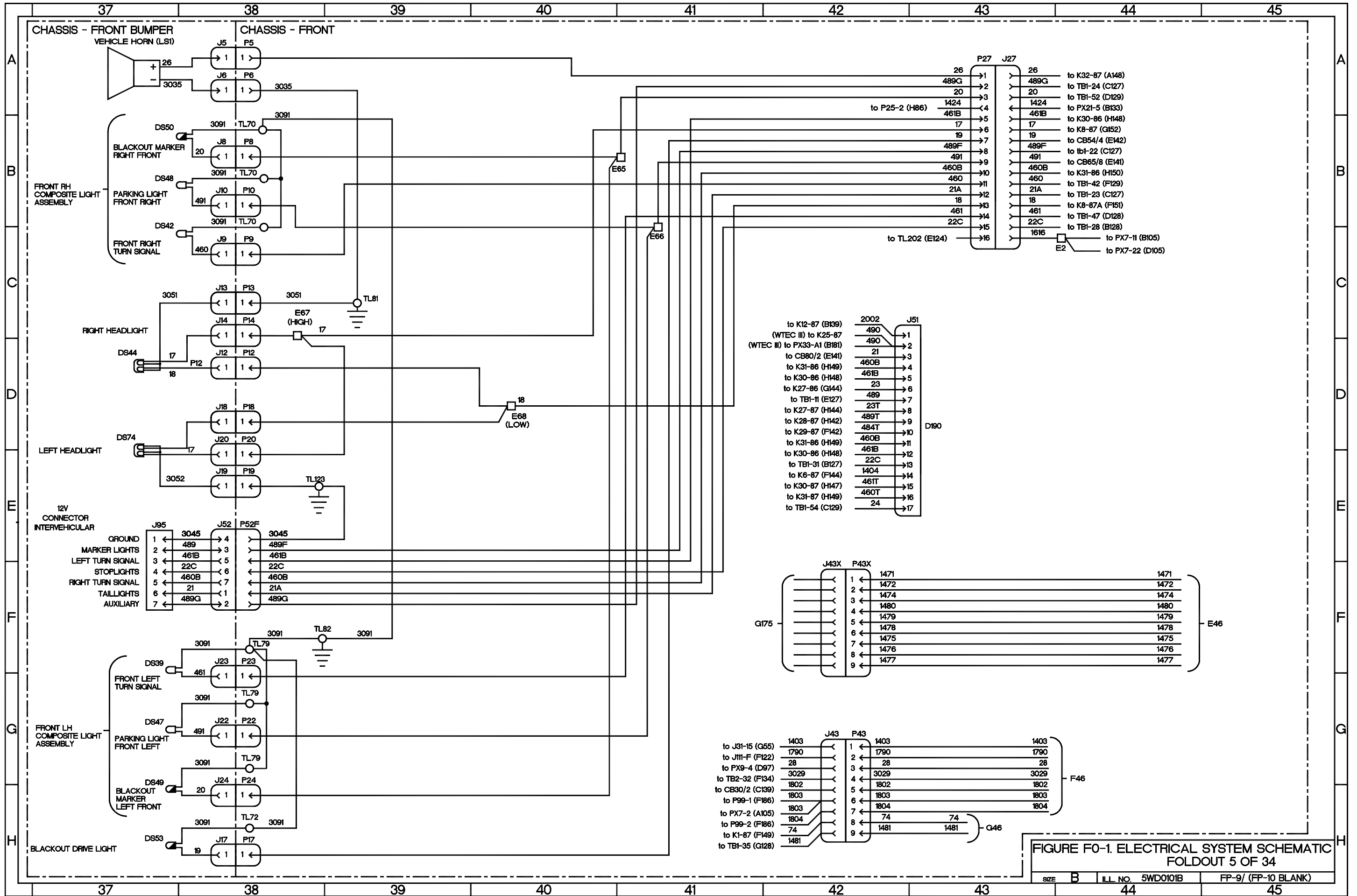

FIGURE FO-1. ELECTRICAL SYSTEM SCHEMATIC FOLDOUT 5 OF 34

SIZE	B	ILL. NO.	5WD0101B	FP-9/ (FP-10 BLANK)
------	---	----------	----------	---------------------

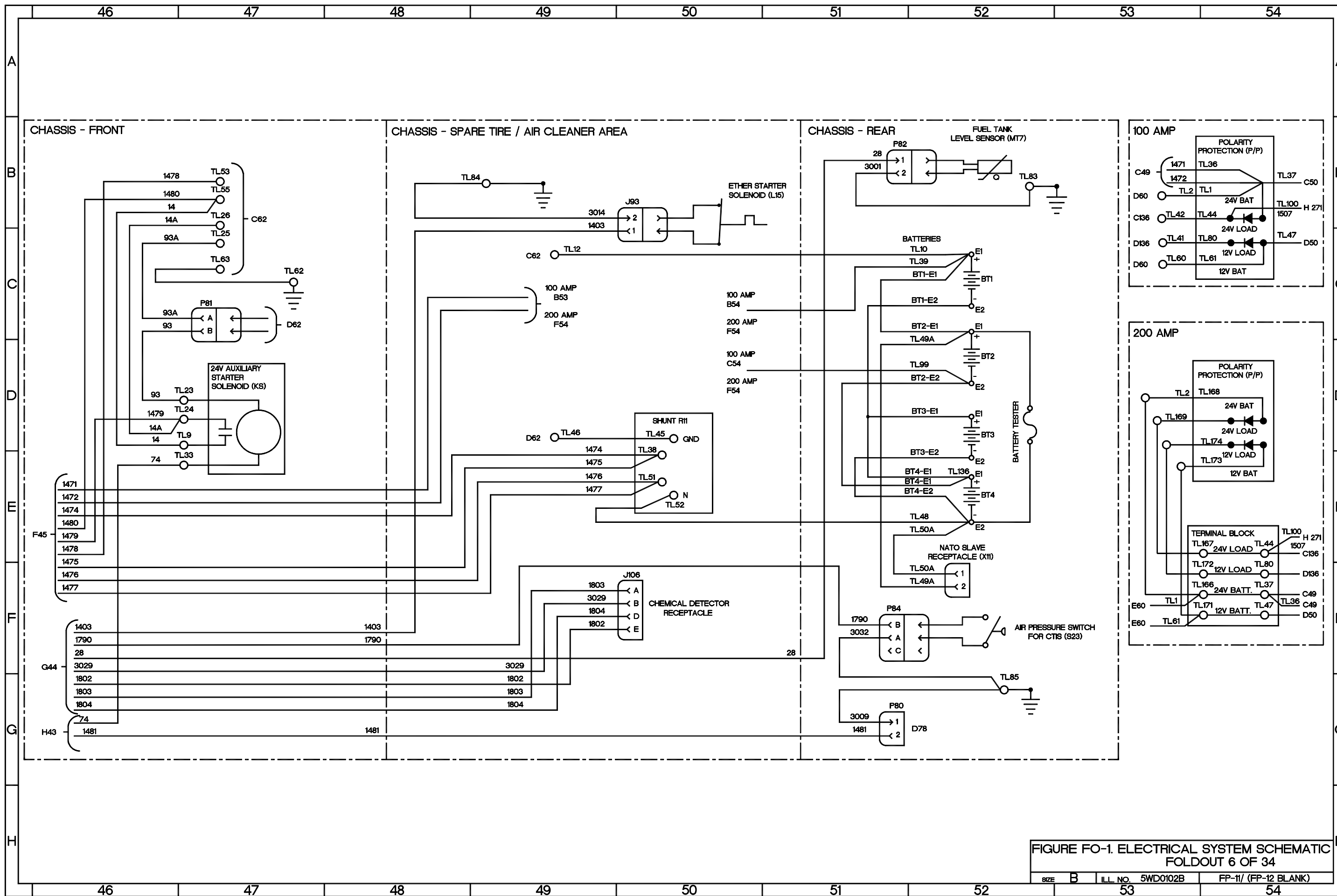

FIGURE FO-1. ELECTRICAL SYSTEM SCHEMATIC FOLDOUT 6 OF 34

SIZE	B	ILL. NO.	5WD0102B	FP-11/ (FP-12 BLANK)
------	---	----------	----------	----------------------

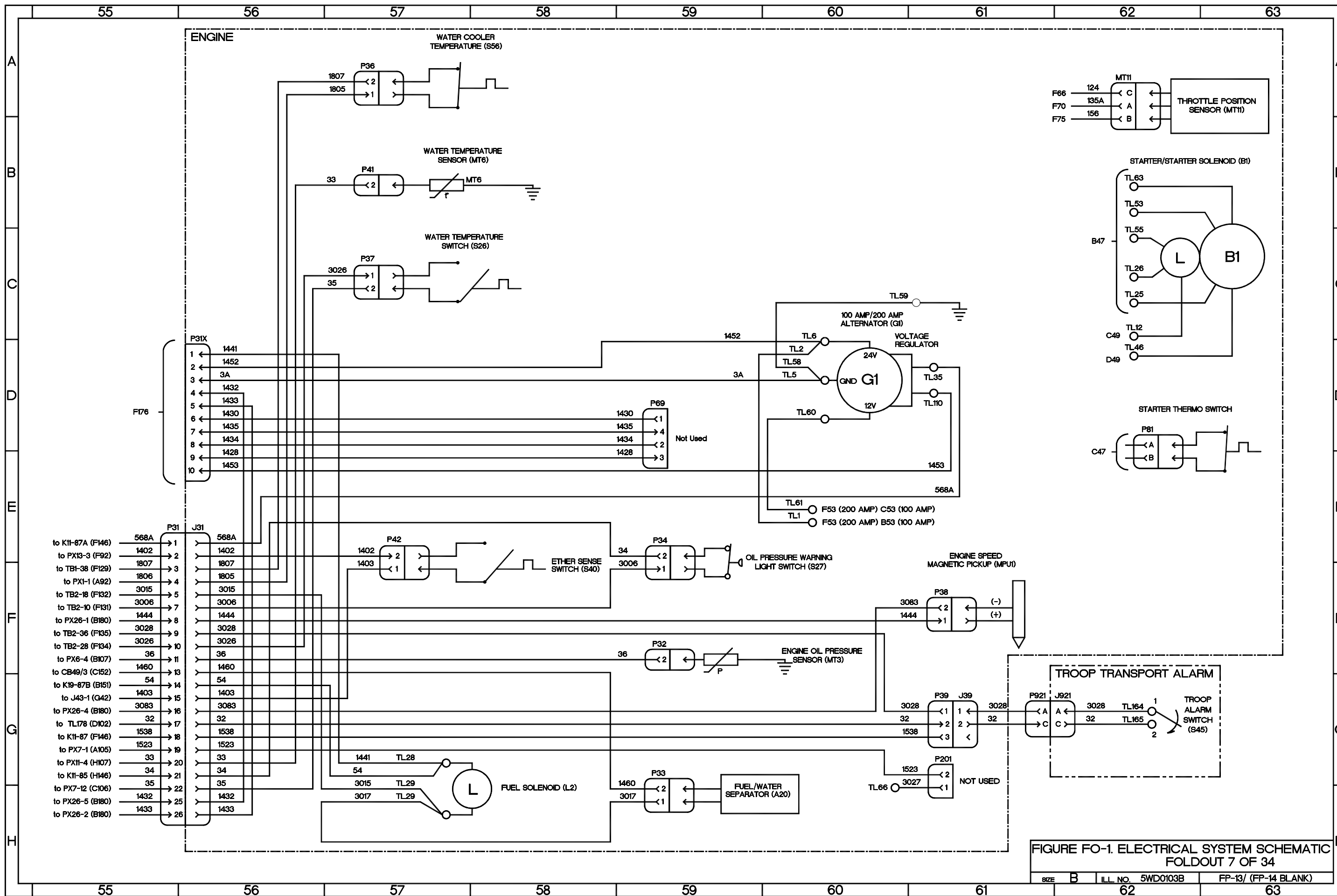

FIGURE FO-1. ELECTRICAL SYSTEM SCHEMATIC FOLDOUT 7 OF 34

SIZE	B	ILL. NO.	5WD0103B	FP-13/ (FP-14 BLANK)
------	---	----------	----------	----------------------

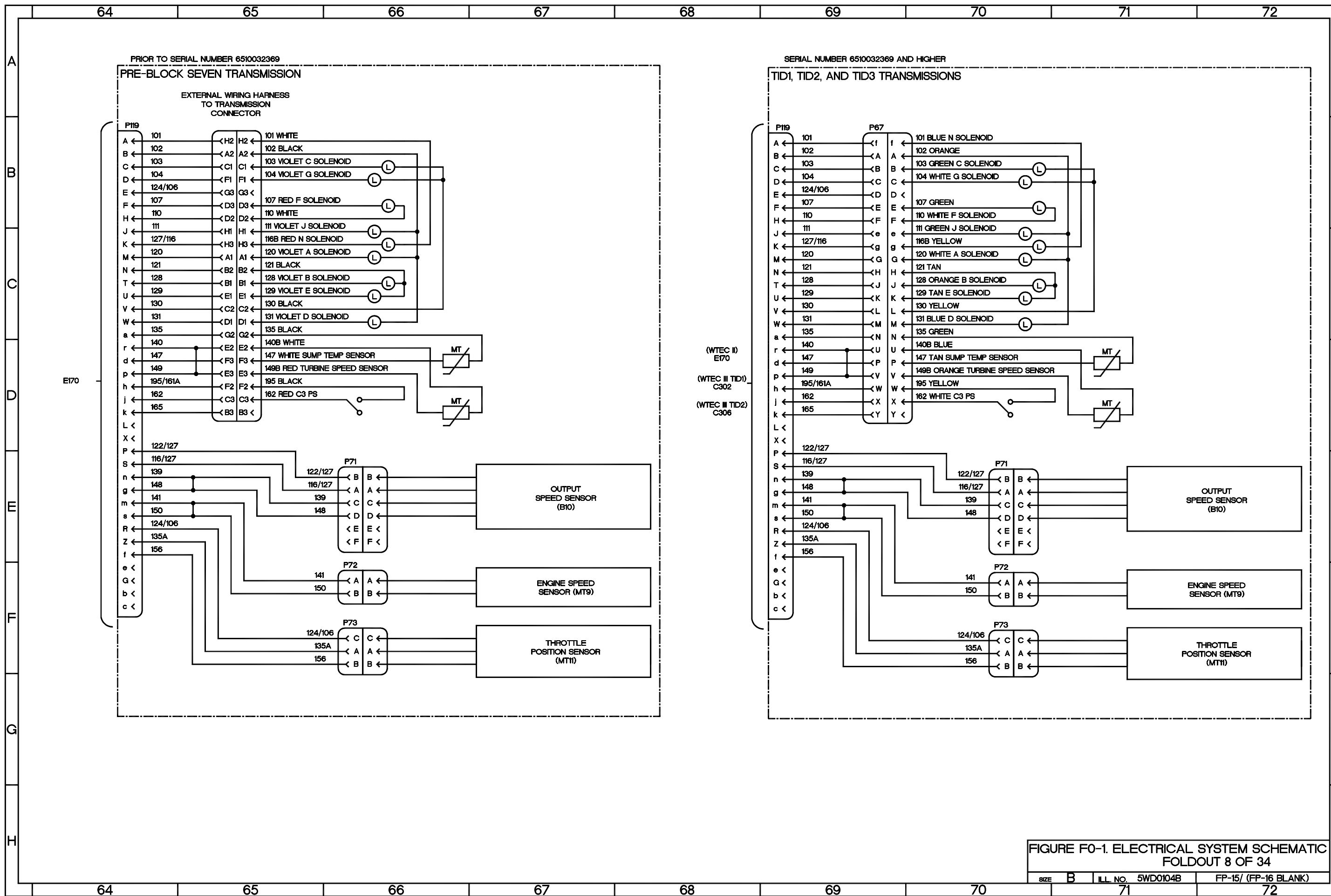

FIGURE F0-1. ELECTRICAL SYSTEM SCHEMATIC FOLDOUT 8 OF 34

SIZE	B	ILL. NO.	5WD0104B	FP-15/ (FP-16 BLANK)
------	---	----------	----------	----------------------

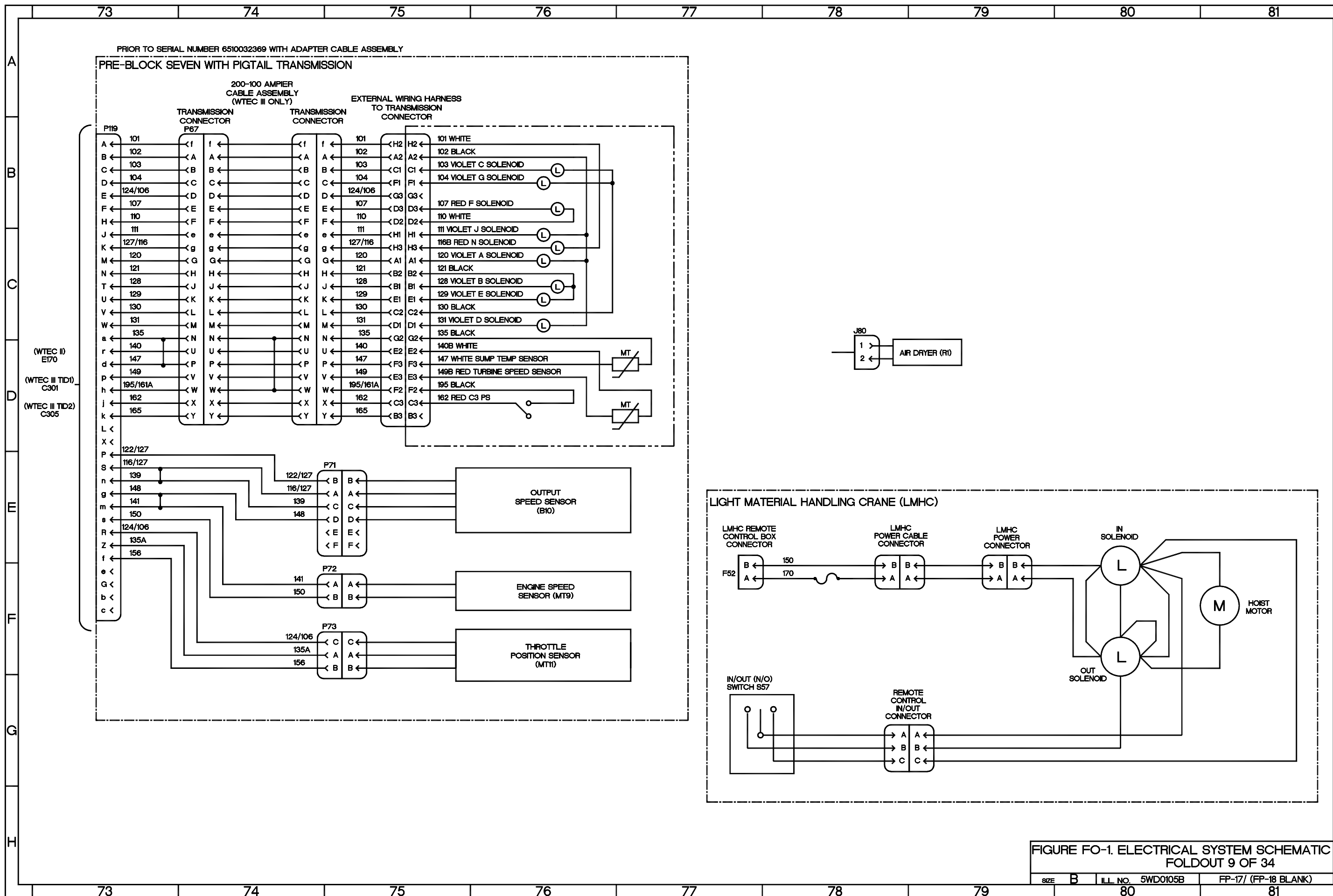

FIGURE FO-1. ELECTRICAL SYSTEM SCHEMATIC FOLDOUT 9 OF 34

SIZE	B	ILL. NO.	5WD0105B	FP-17/ (FP-18 BLANK)
------	---	----------	----------	----------------------

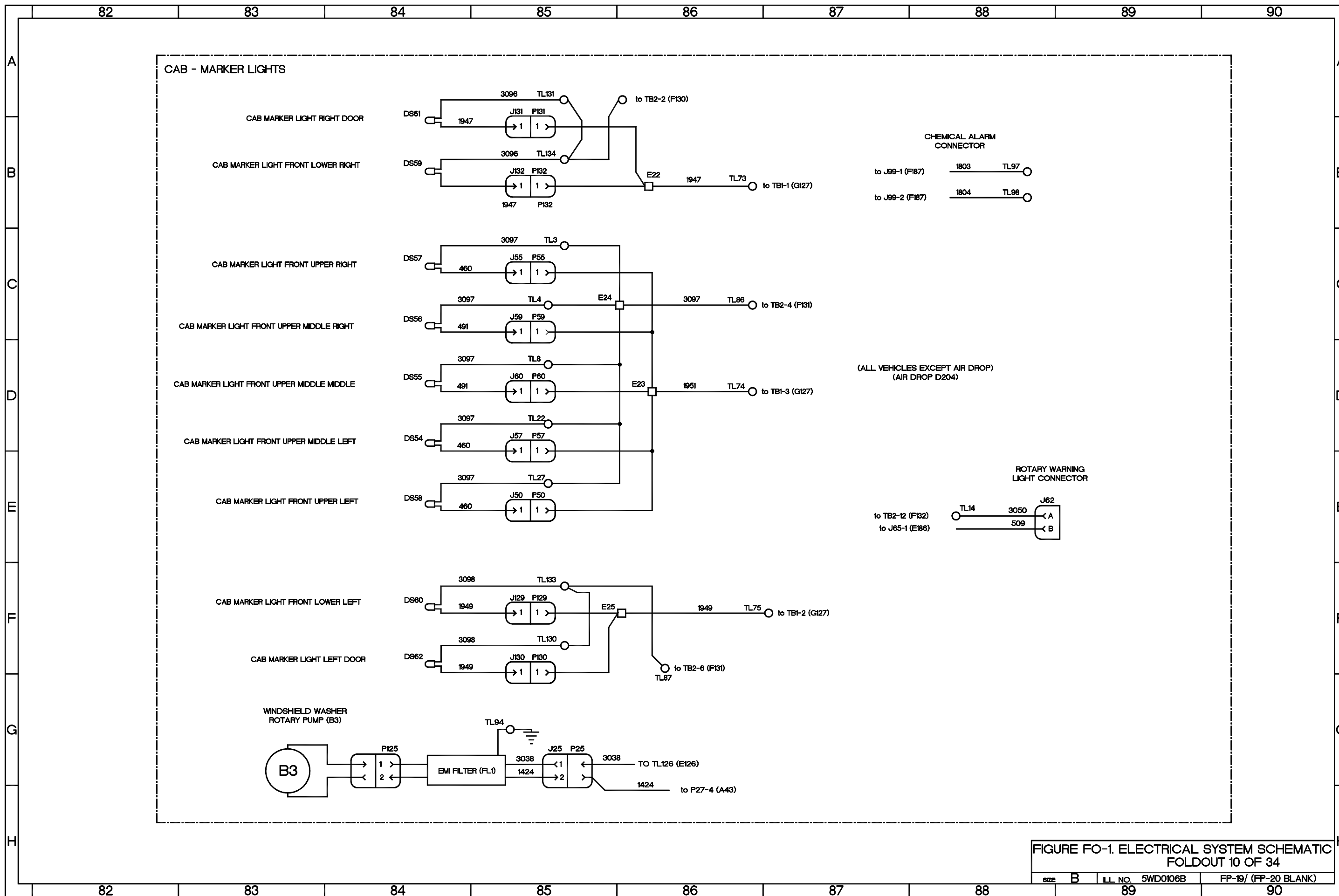

FIGURE FO-1. ELECTRICAL SYSTEM SCHEMATIC FOLDOUT 10 OF 34

SIZE	B	ILL. NO.	5WD0106B	FP-19/ (FP-20 BLANK)
			89	90

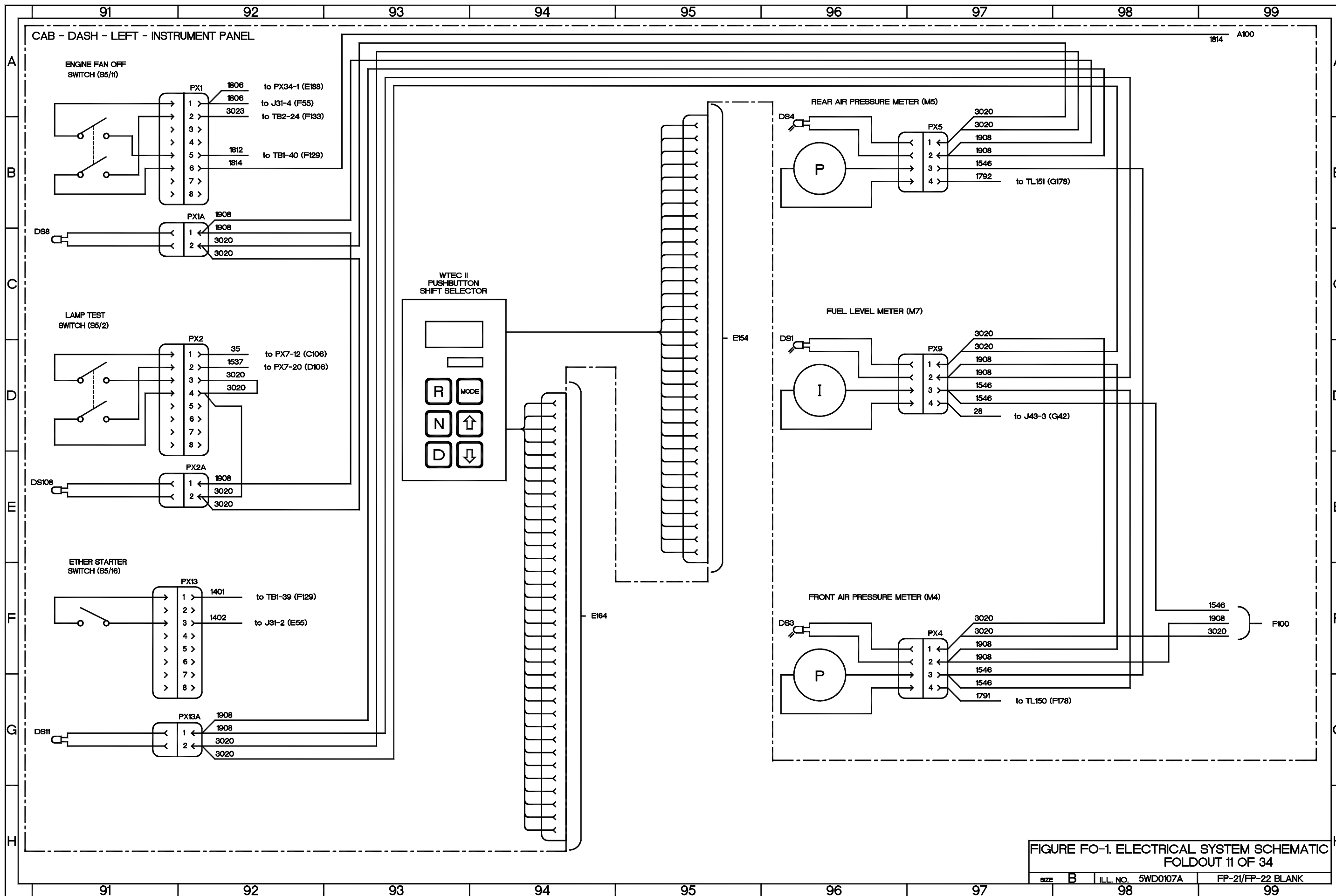
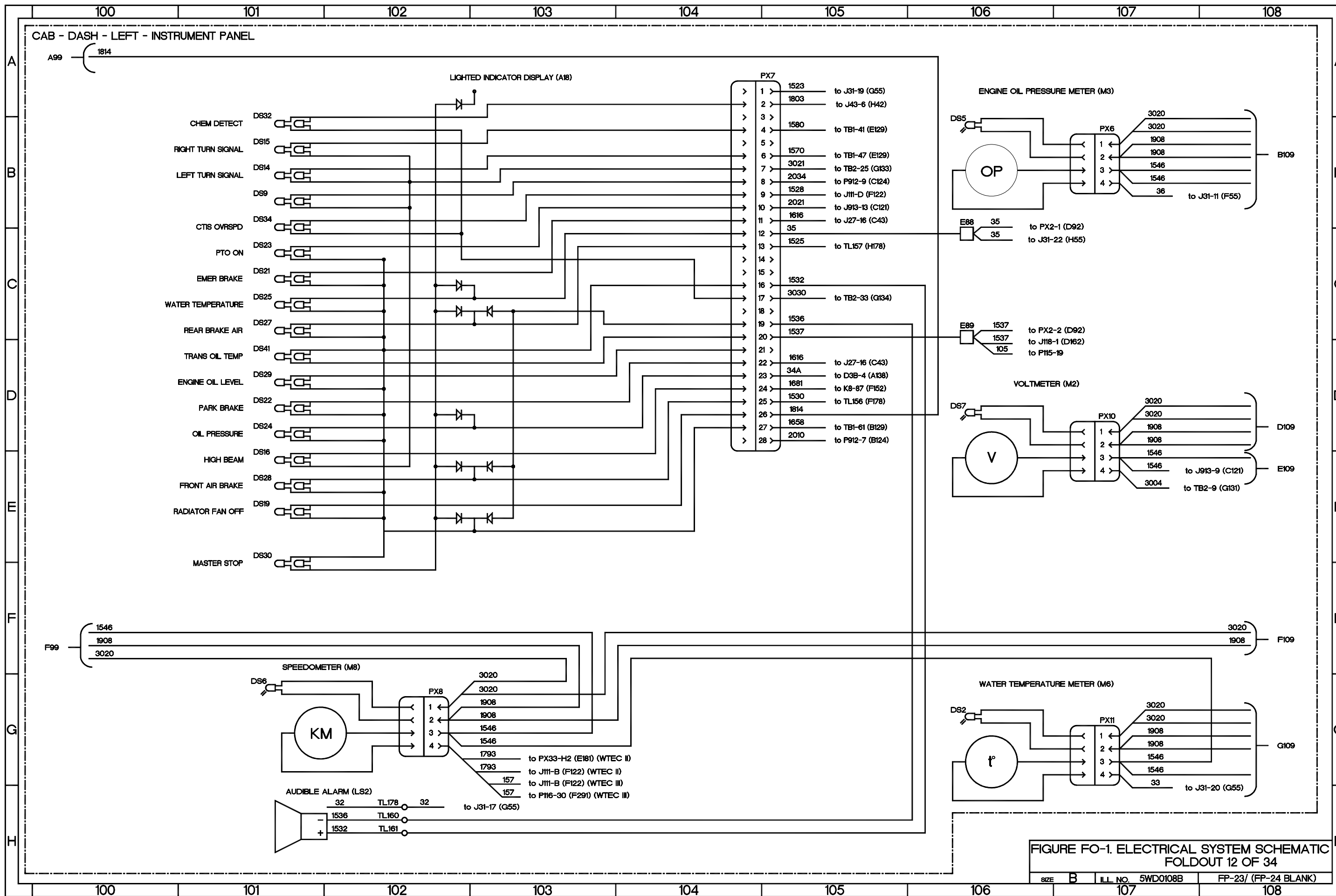

FIGURE FO-1. ELECTRICAL SYSTEM SCHEMATIC FOLDOUT 11 OF 34



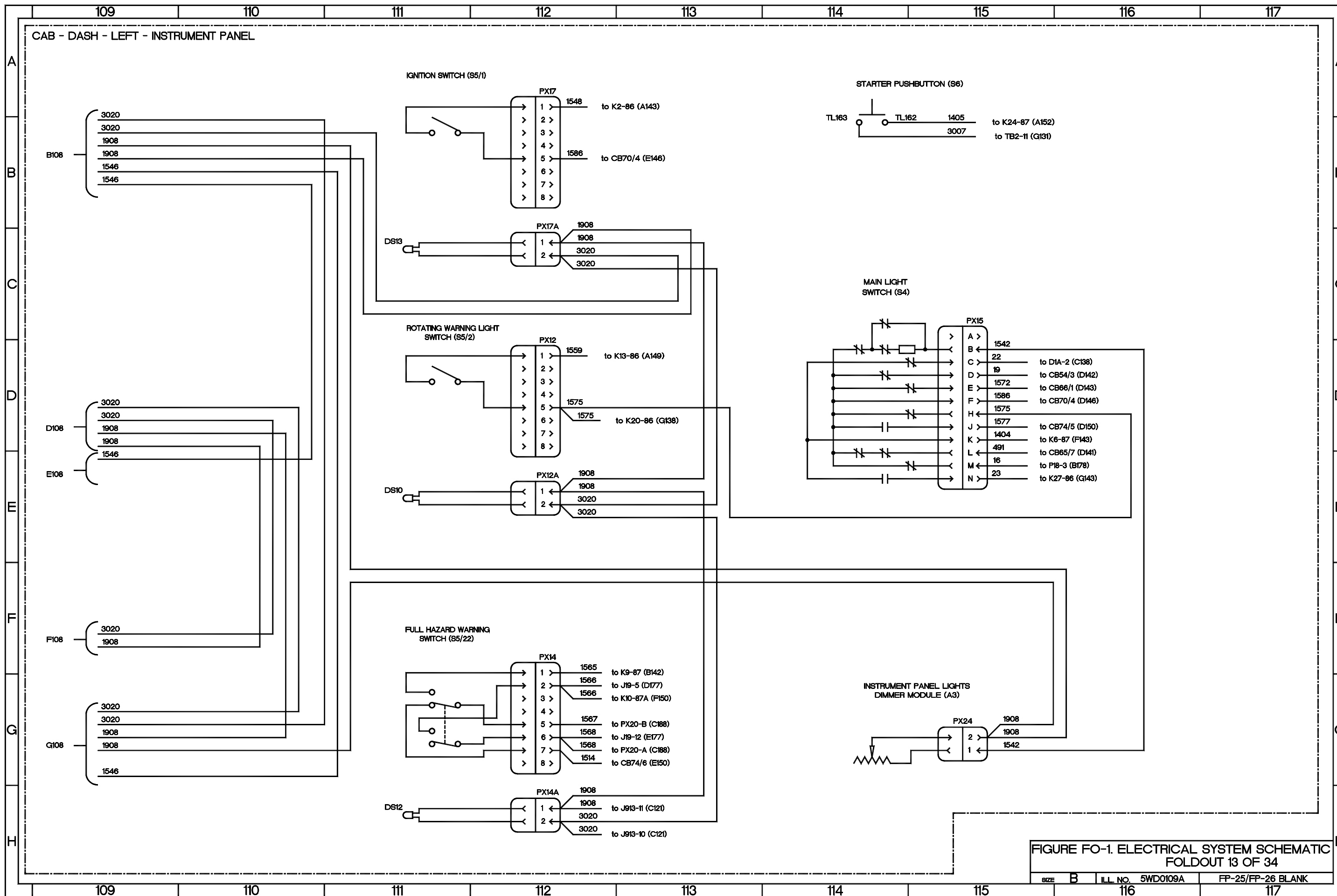

FIGURE FO-1. ELECTRICAL SYSTEM SCHEMATIC FOLDOUT 13 OF 34

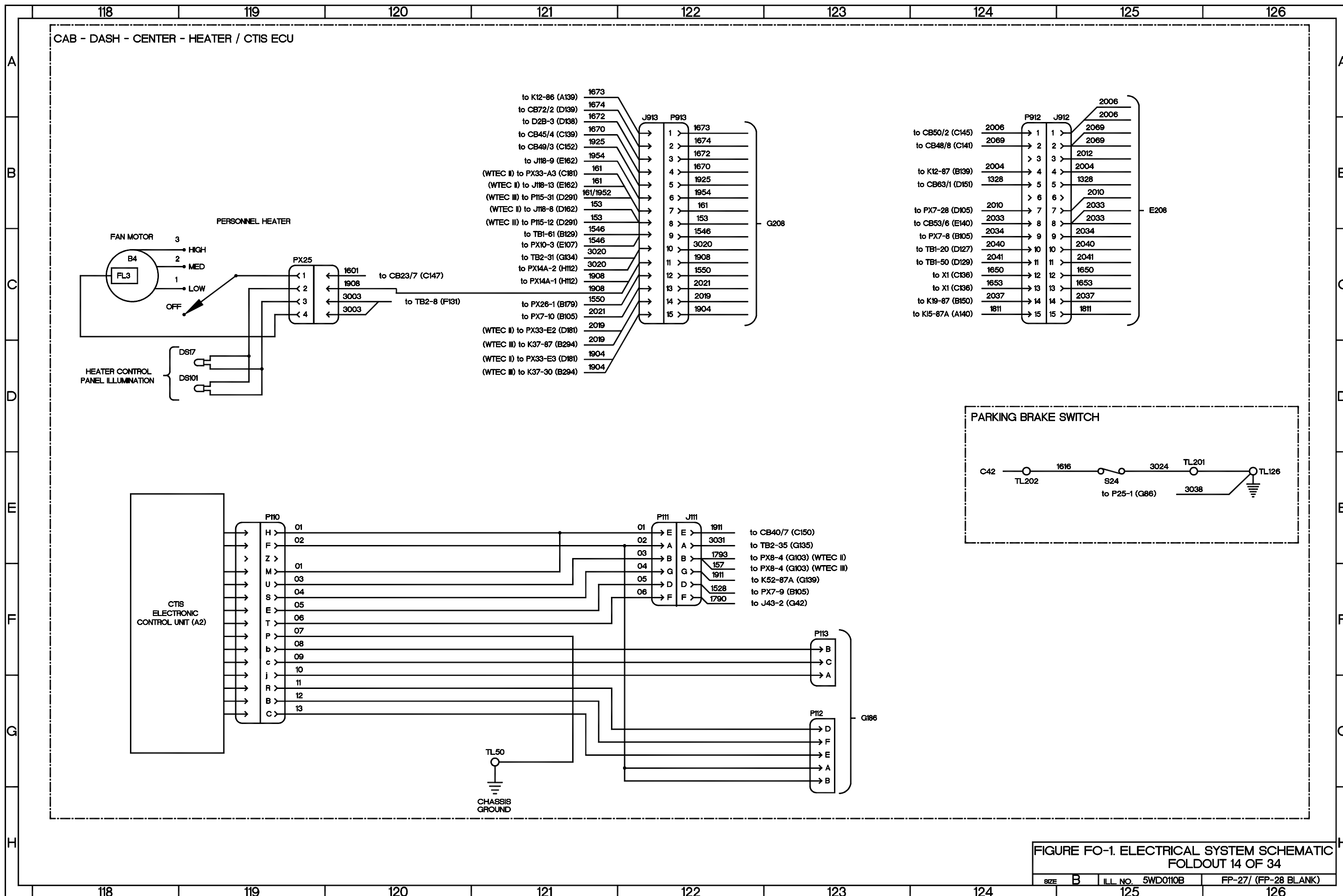

FIGURE FO-1. ELECTRICAL SYSTEM SCHEMATIC FOLDOUT 14 OF 34

SIZE	B	ILL. NO.	5WD0110B	FP-27/ (FP-28 BLANK)
------	---	----------	----------	----------------------

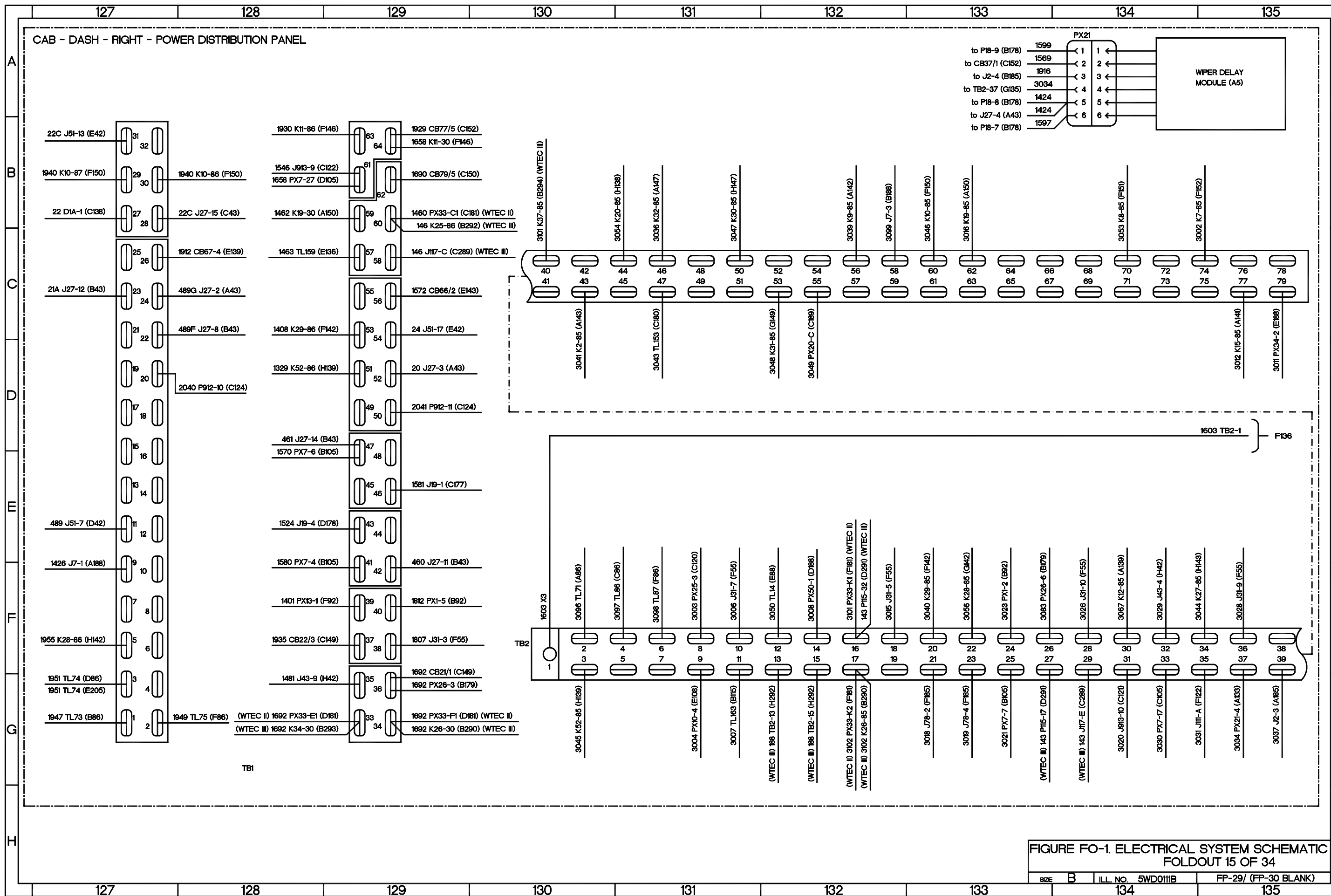
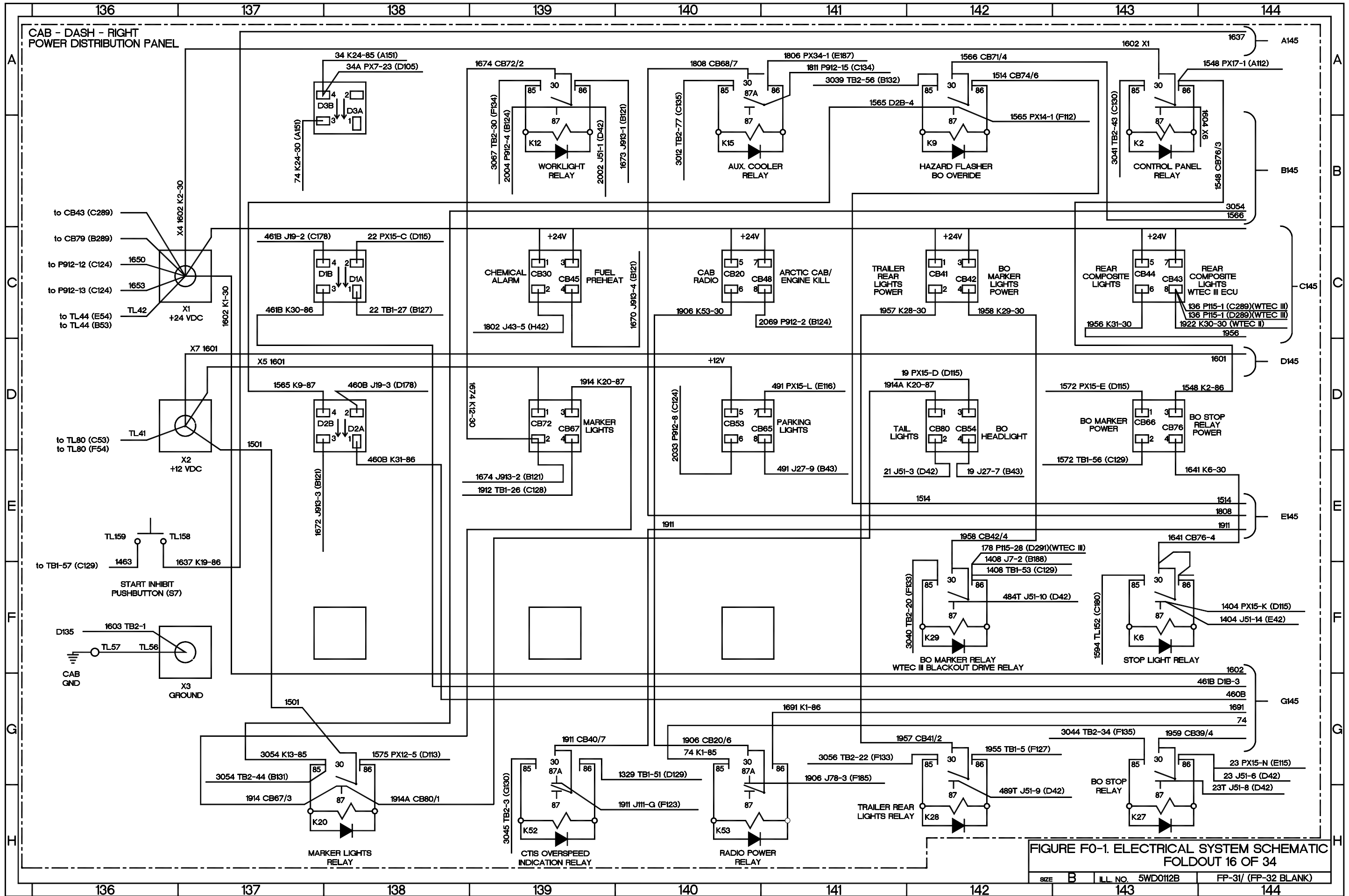
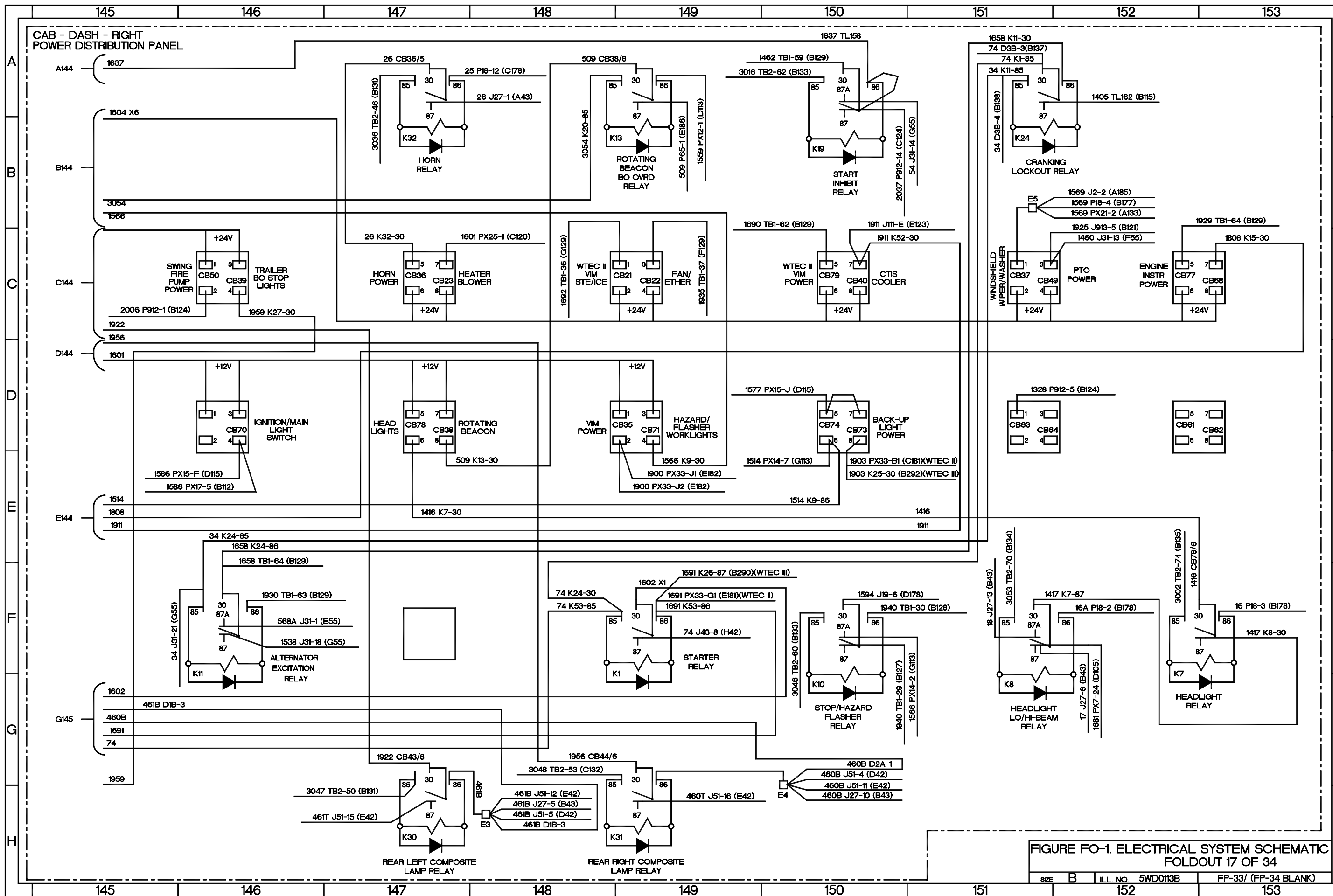

FIGURE FO-1. ELECTRICAL SYSTEM SCHEMATIC FOLDOUT 15 OF 34

SIZE	B	ILL. NO.	5WD0111B	FP-29/ (FP-30 BLANK)
------	---	----------	----------	----------------------





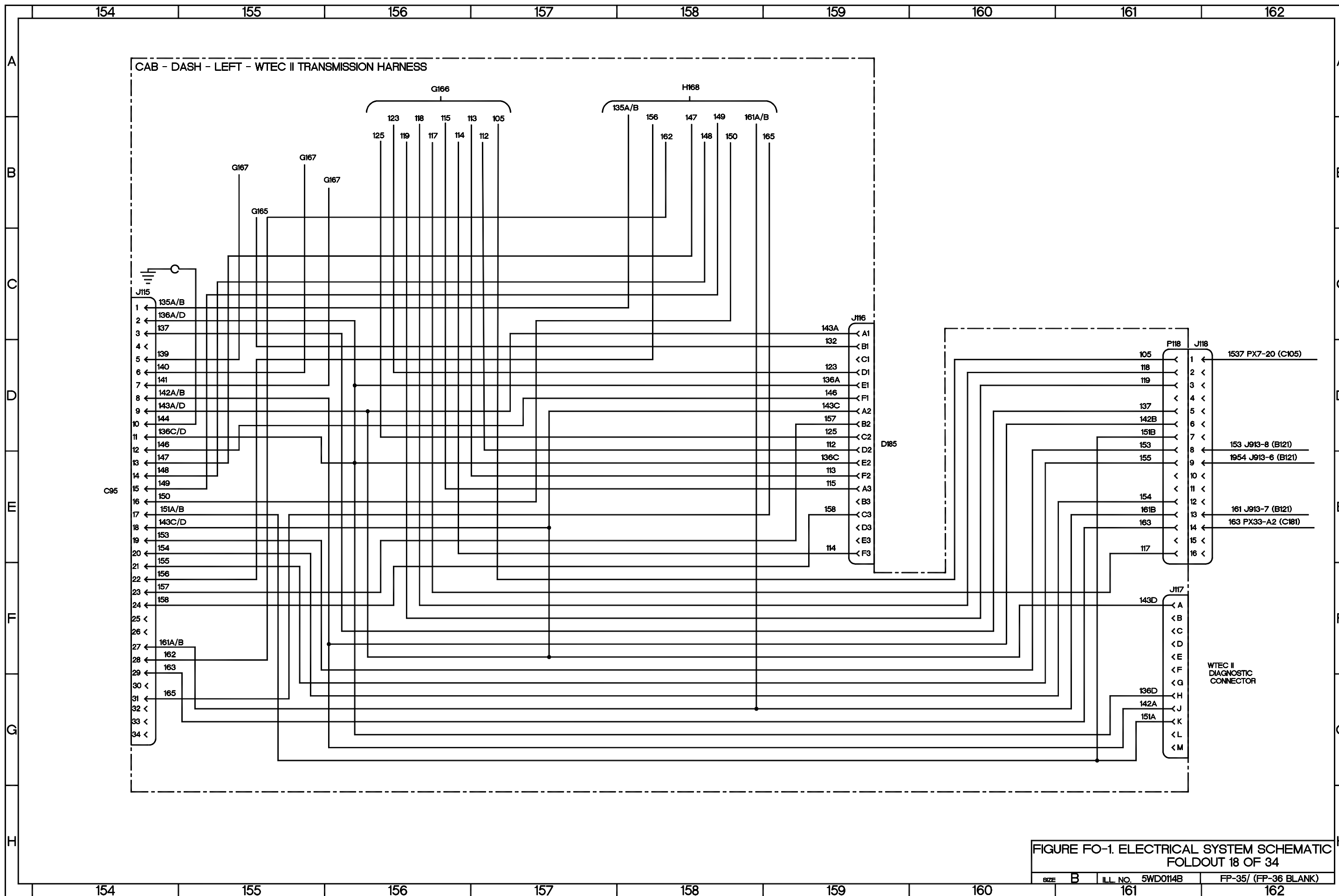

FIGURE FO-1. ELECTRICAL SYSTEM SCHEMATIC FOLDOUT 18 OF 34

SIZE	B	ILL. NO.	5WD0114B	FP-35/ (FP-36 BLANK)
			161	162

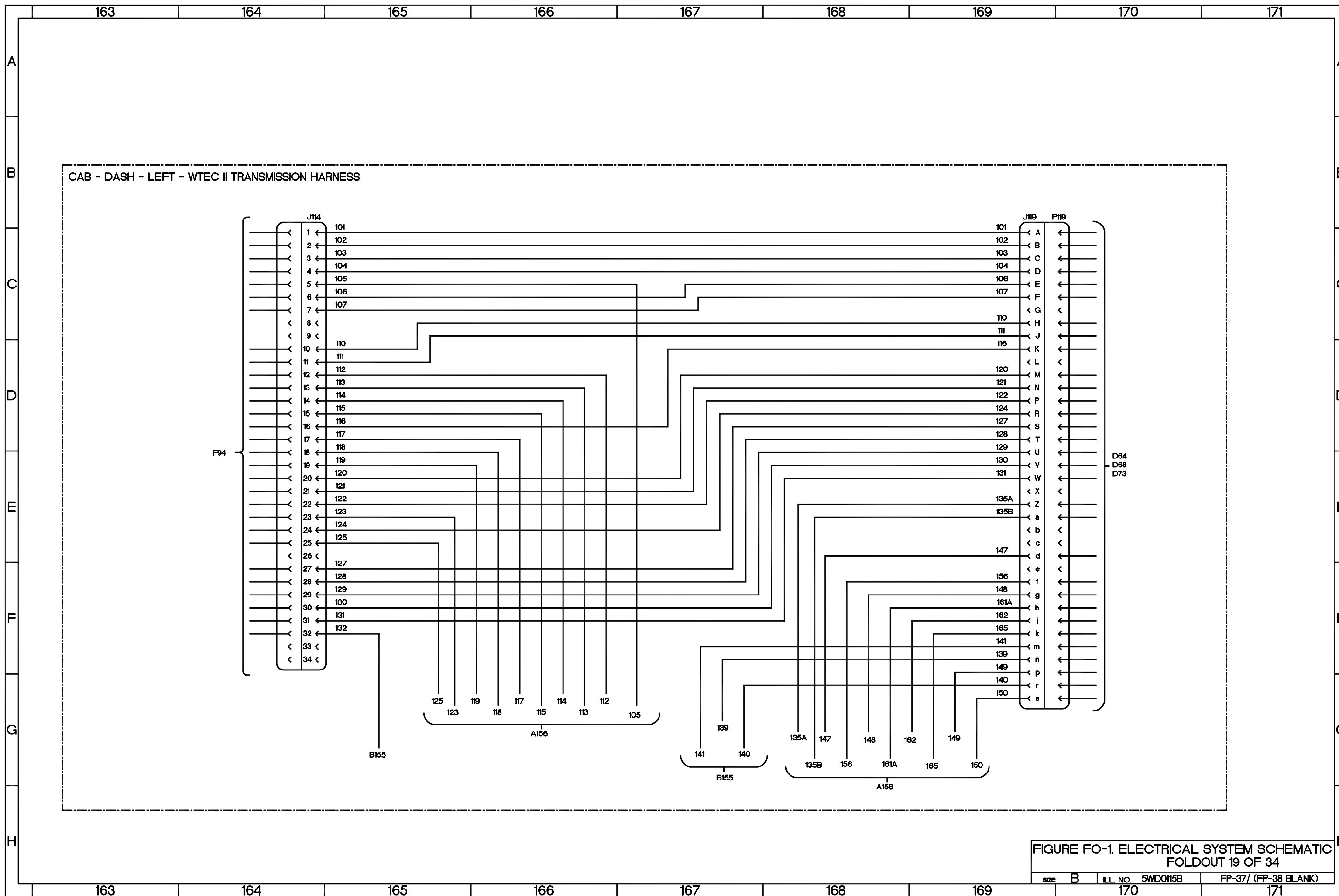

FIGURE FO-1. ELECTRICAL SYSTEM SCHEMATIC FOLDOUT 19 OF 34

SIZE	B	ILL. NO.	5WD0115B	FP-37/ (FP-38 BLANK)
------	---	----------	----------	----------------------

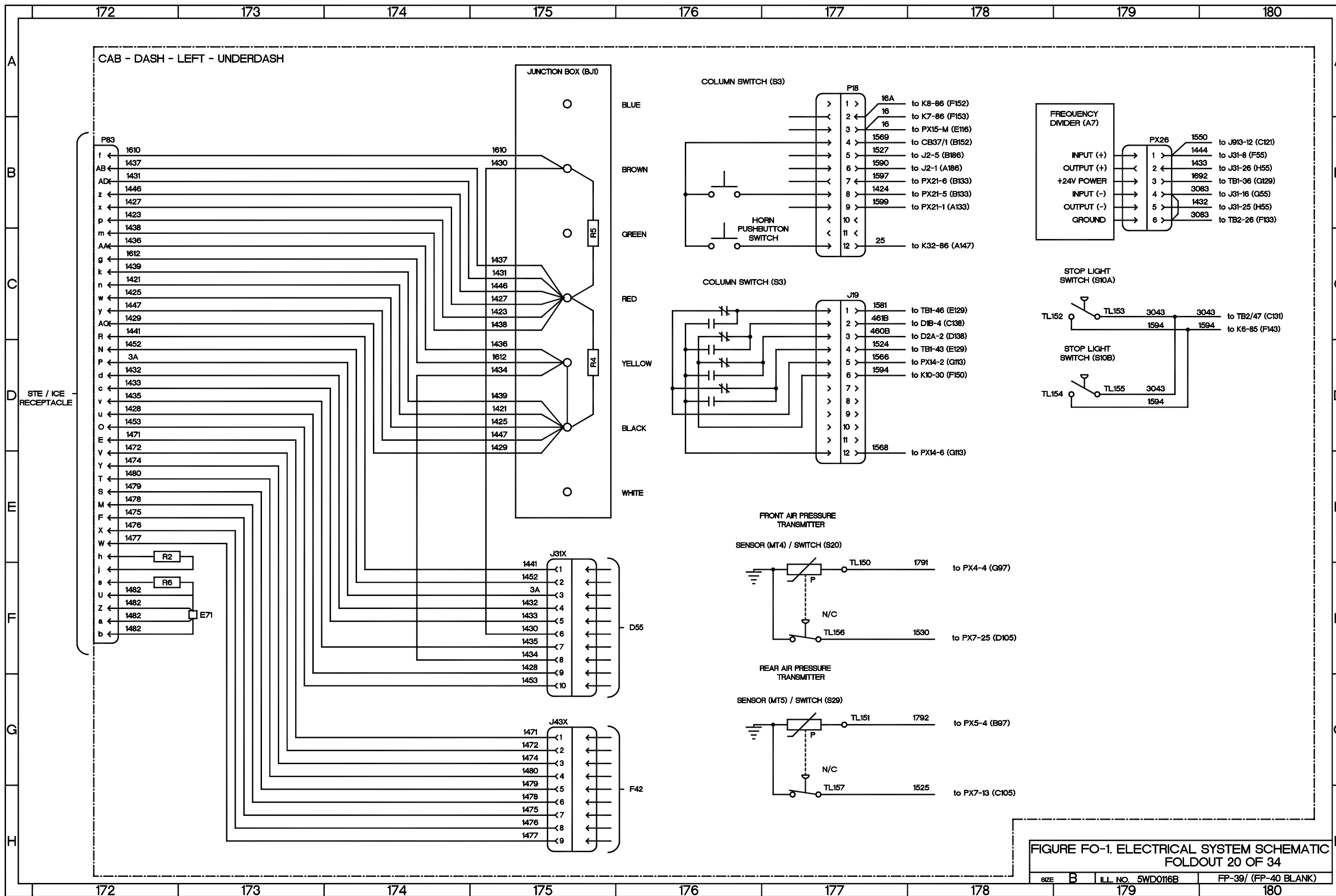
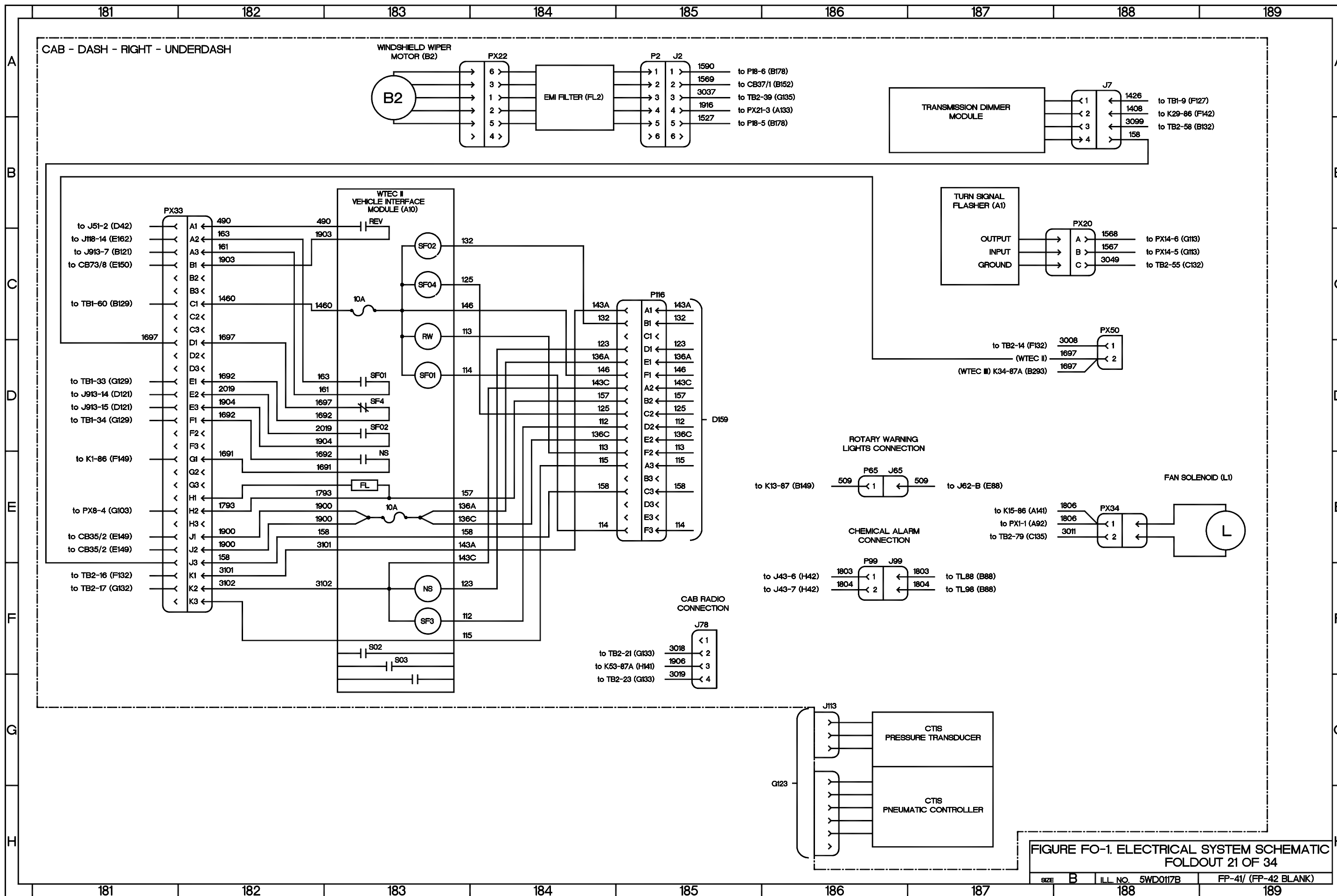

FIGURE FO-1. ELECTRICAL SYSTEM SCHEMATIC FOLDOUT 20 OF 34

SIZE	B	ILL. NO.	5WD0116B	FP-39/ (FP-40 BLANK)
------	---	----------	----------	----------------------



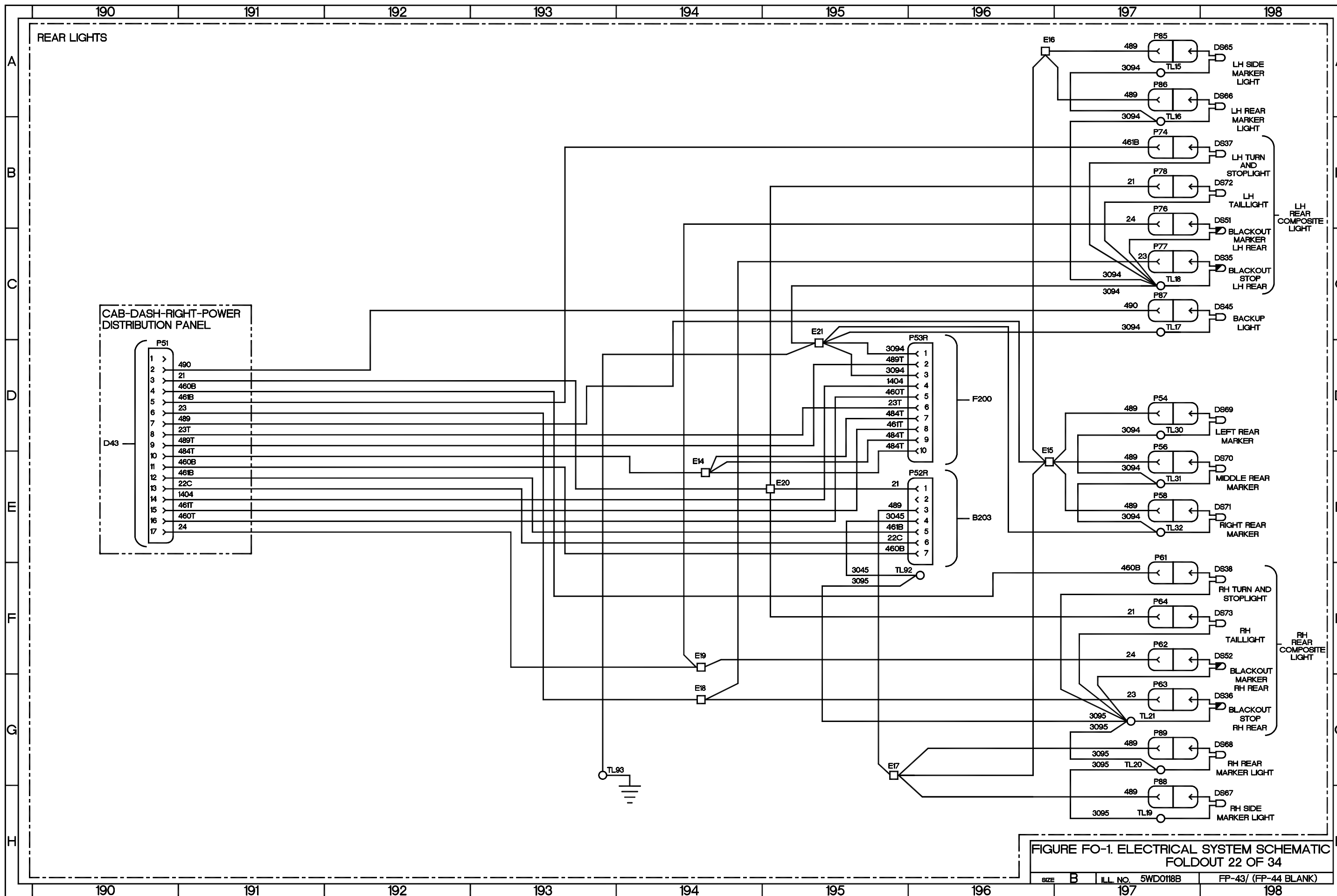

FIGURE FO-1. ELECTRICAL SYSTEM SCHEMATIC FOLDOUT 22 OF 34
 SIZE B ILL. NO. 5WD018B FP-43/ (FP-44 BLANK)

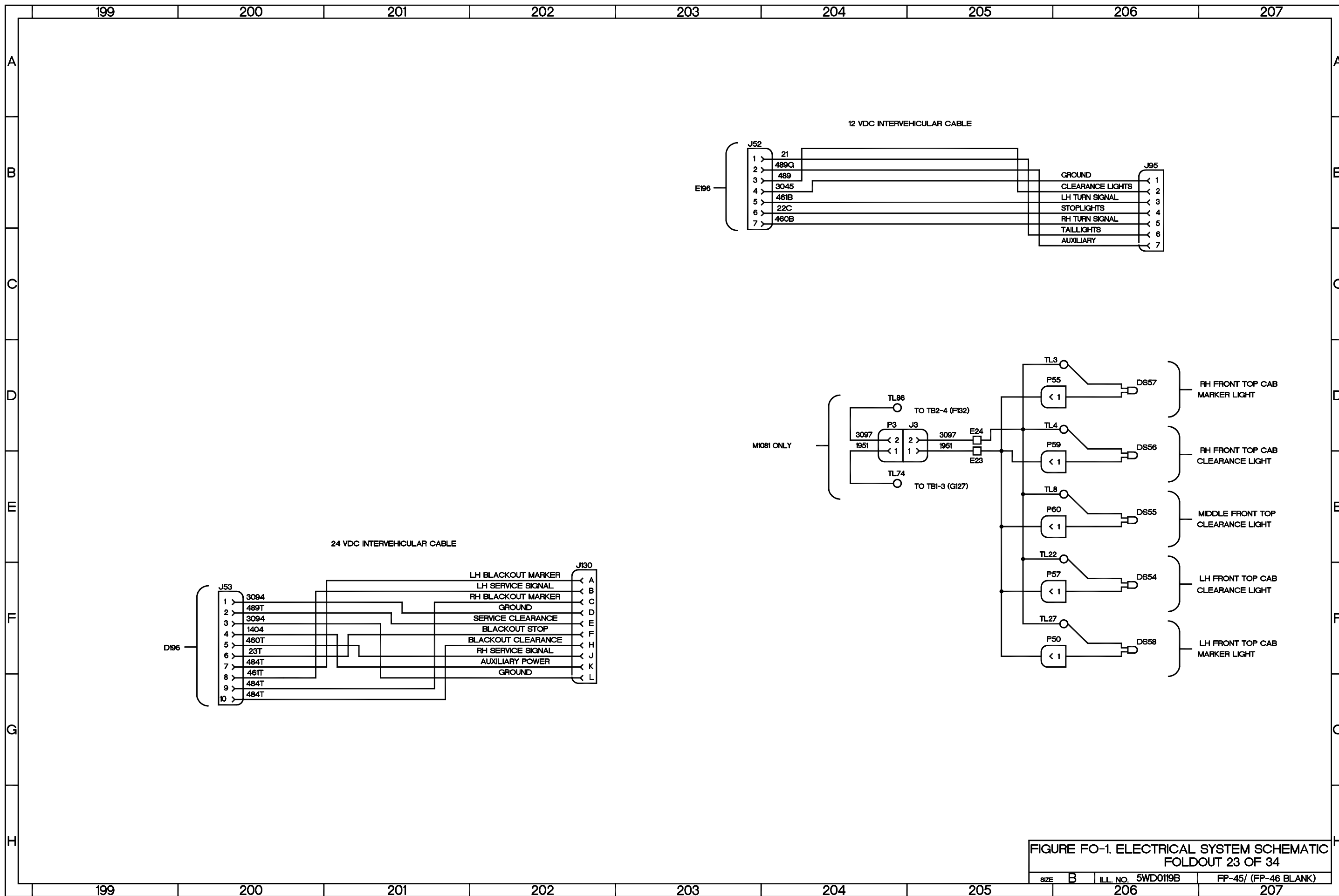

FIGURE FO-1. ELECTRICAL SYSTEM SCHEMATIC FOLDOUT 23 OF 34

SIZE	B	ILL. NO.	5WD019B	FP-45/ (FP-46 BLANK)
------	---	----------	---------	----------------------

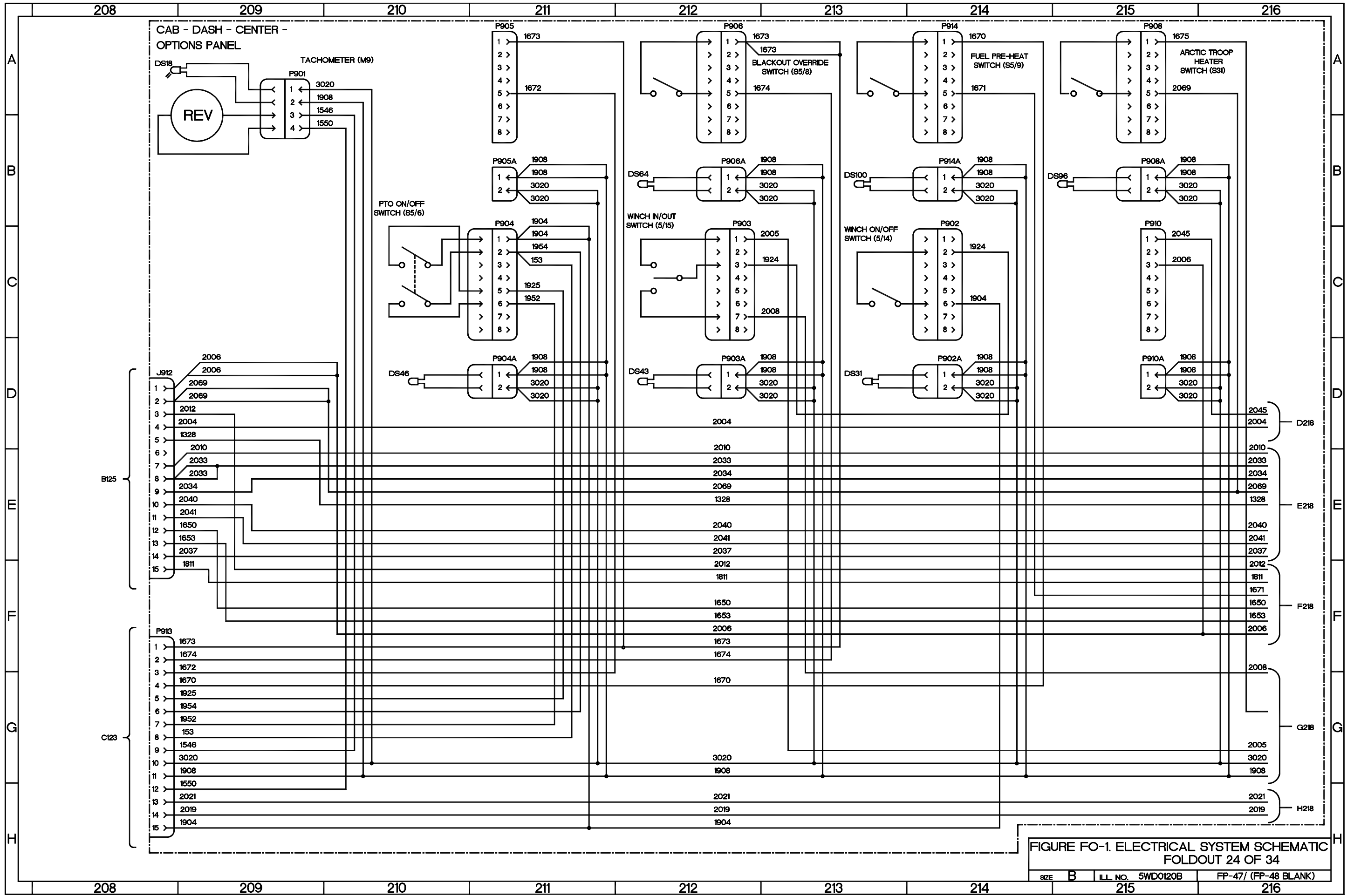

FIGURE FO-1. ELECTRICAL SYSTEM SCHEMATIC FOLDOUT 24 OF 34

SIZE B ILL. NO. 5WD0120B FP-47/ (FP-48 BLANK)

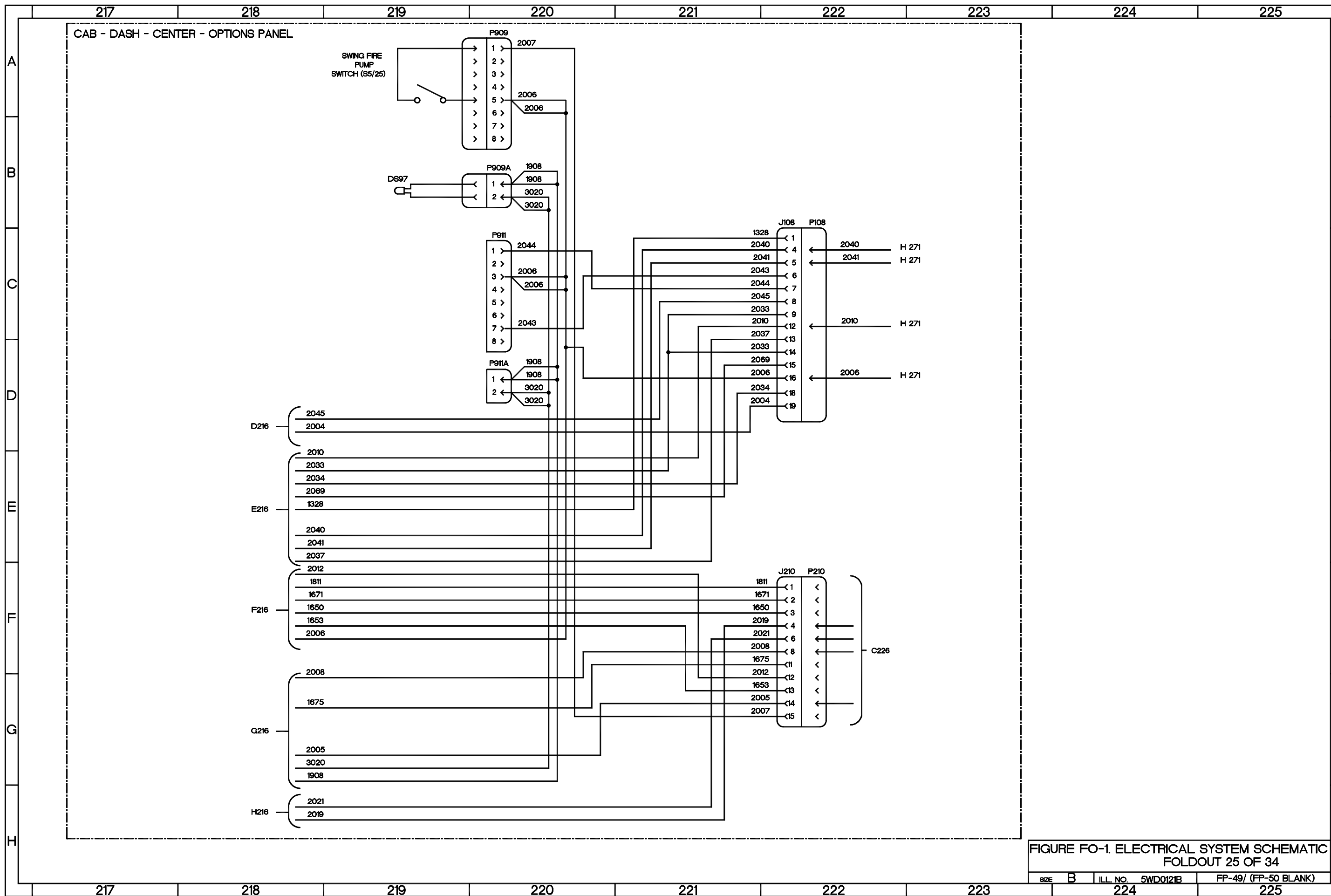

FIGURE FO-1. ELECTRICAL SYSTEM SCHEMATIC FOLDOUT 25 OF 34

SIZE	B	ILL. NO.	5WD0121B	FP-49/ (FP-50 BLANK)
			224	225

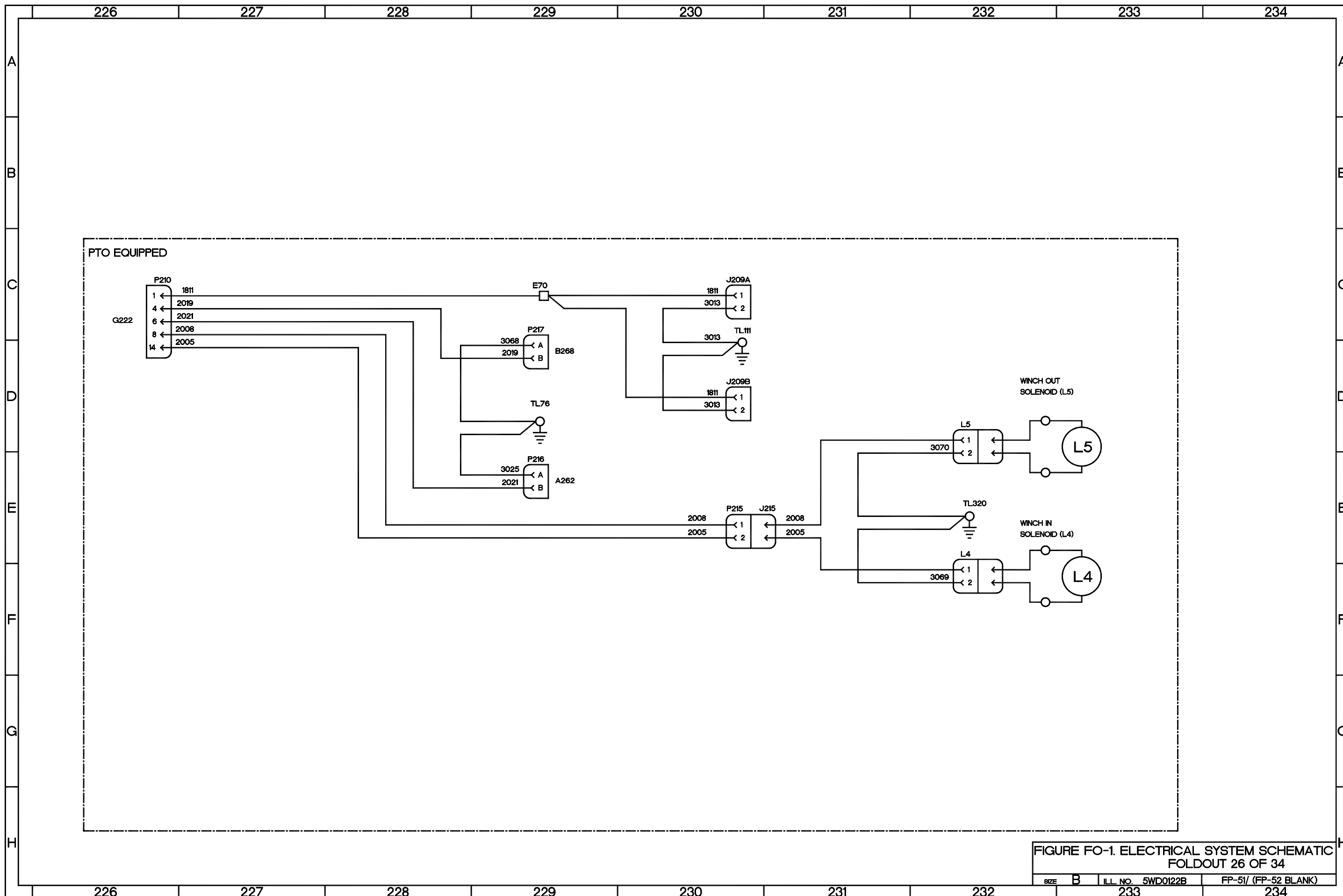

FIGURE FO-1. ELECTRICAL SYSTEM SCHEMATIC
 FOLDOUT 26 OF 34
 SIZE B ILL. NO. 5WD0122B FP-51/ (FP-52 BLANK)







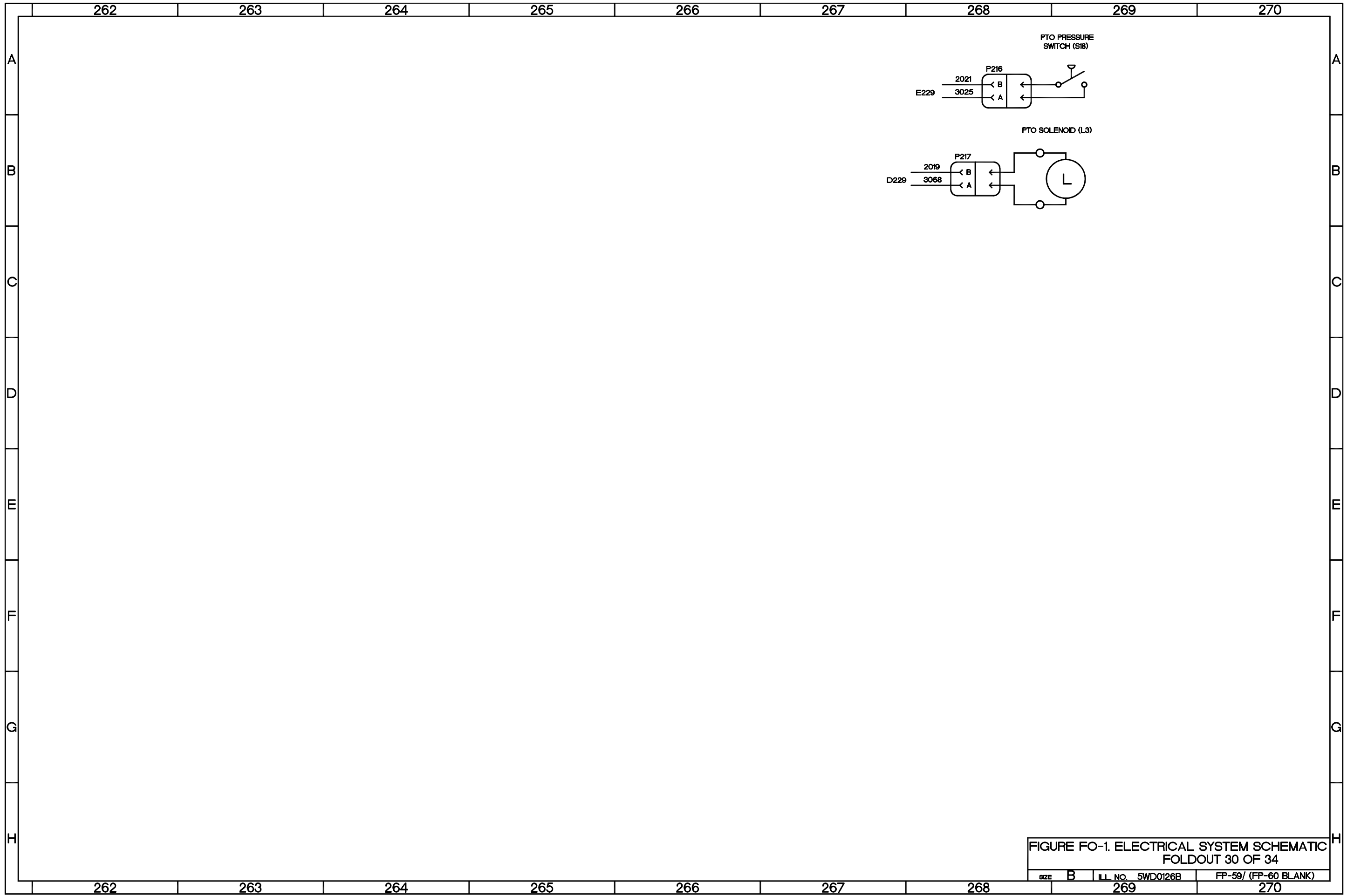

FIGURE FO-1. ELECTRICAL SYSTEM SCHEMATIC
FOLDOUT 30 OF 34

SIZE	B	ILL. NO.	5WD0126B	FP-59/ (FP-60 BLANK)
------	---	----------	----------	----------------------

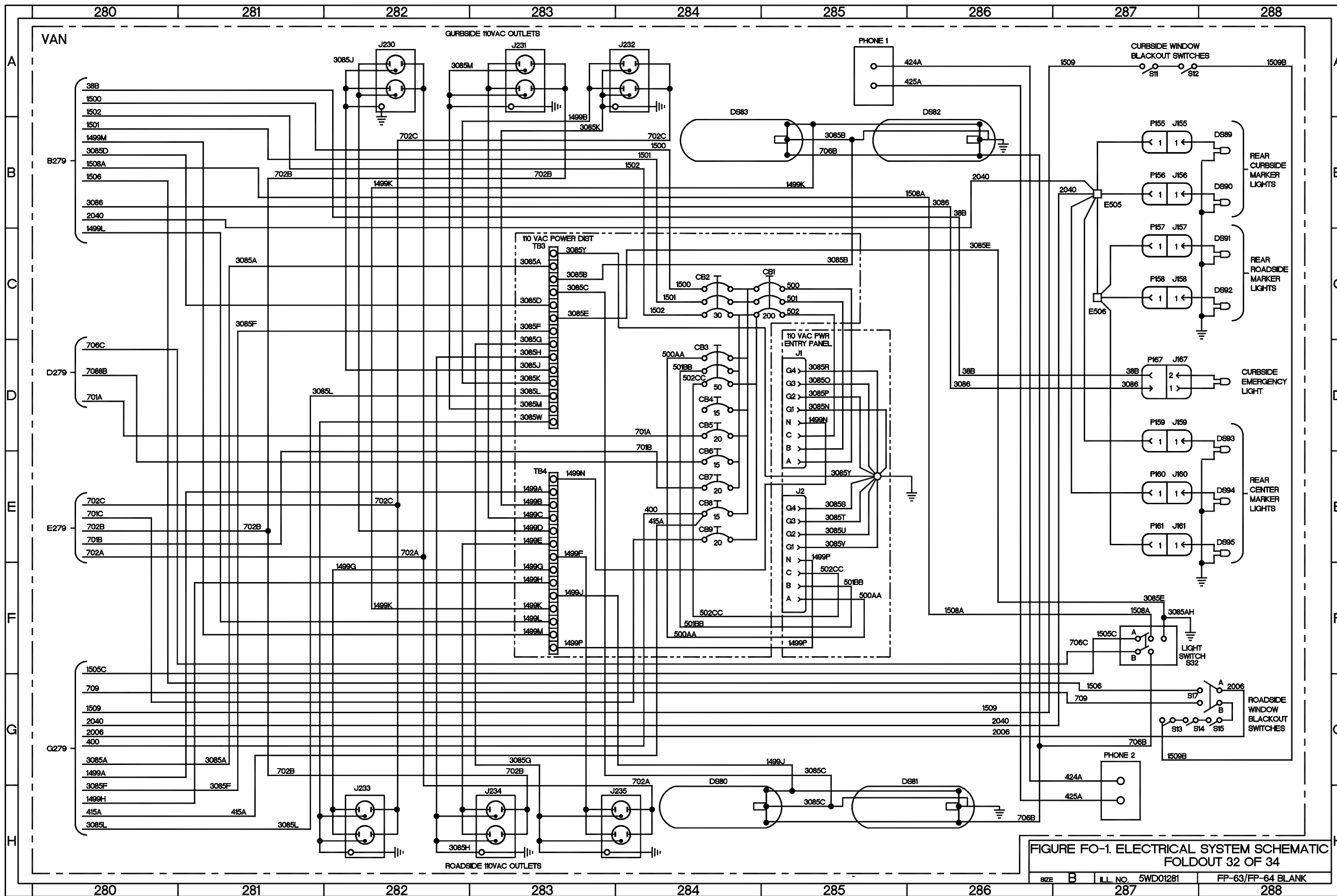

FIGURE FO-1. ELECTRICAL SYSTEM SCHEMATIC FOLDOUT 32 OF 34

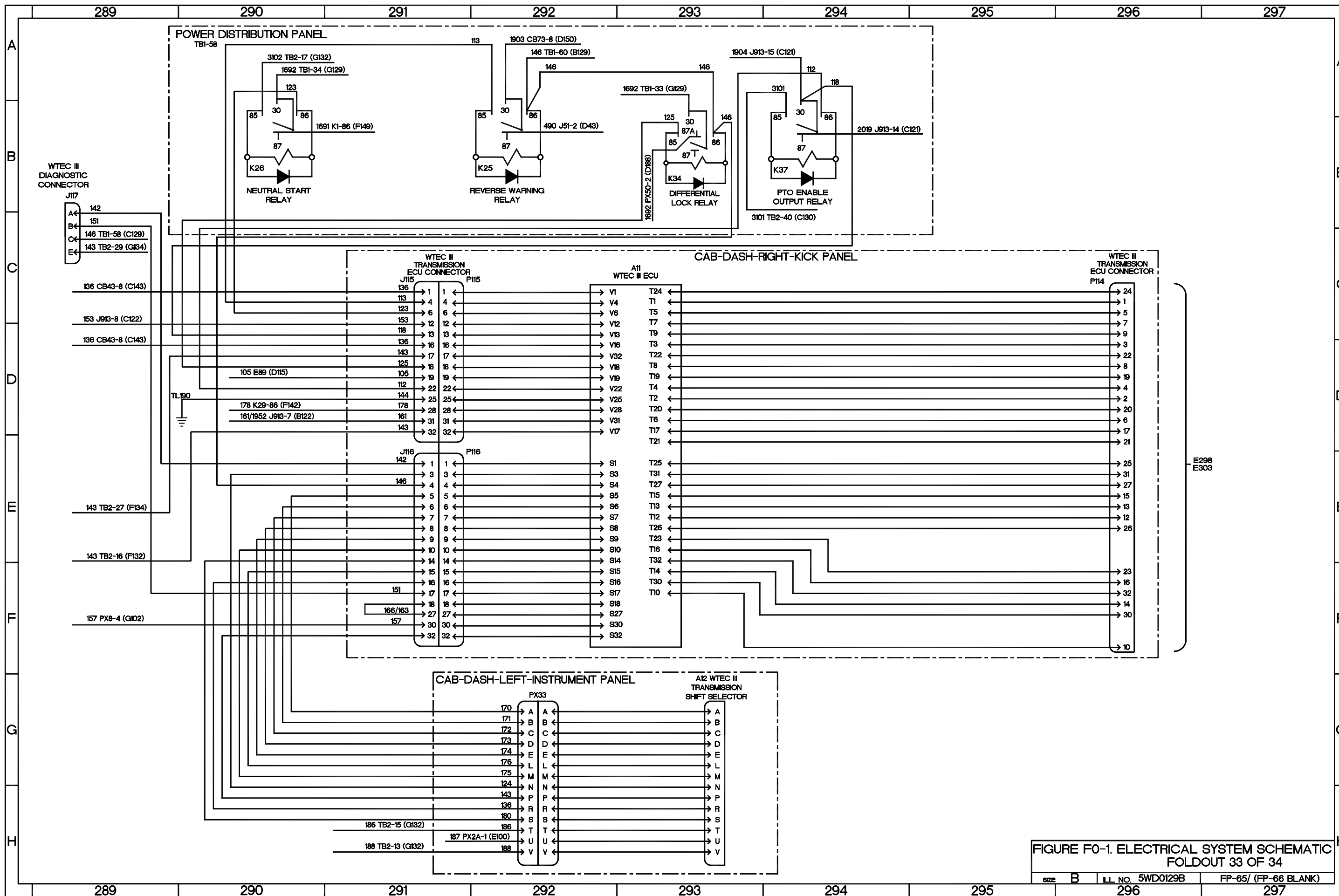

FIGURE F0-1. ELECTRICAL SYSTEM SCHEMATIC FOLDOUT 33 OF 34
 SIZE B ILL. NO. 5WD0129B FP-65/ (FP-66 BLANK)

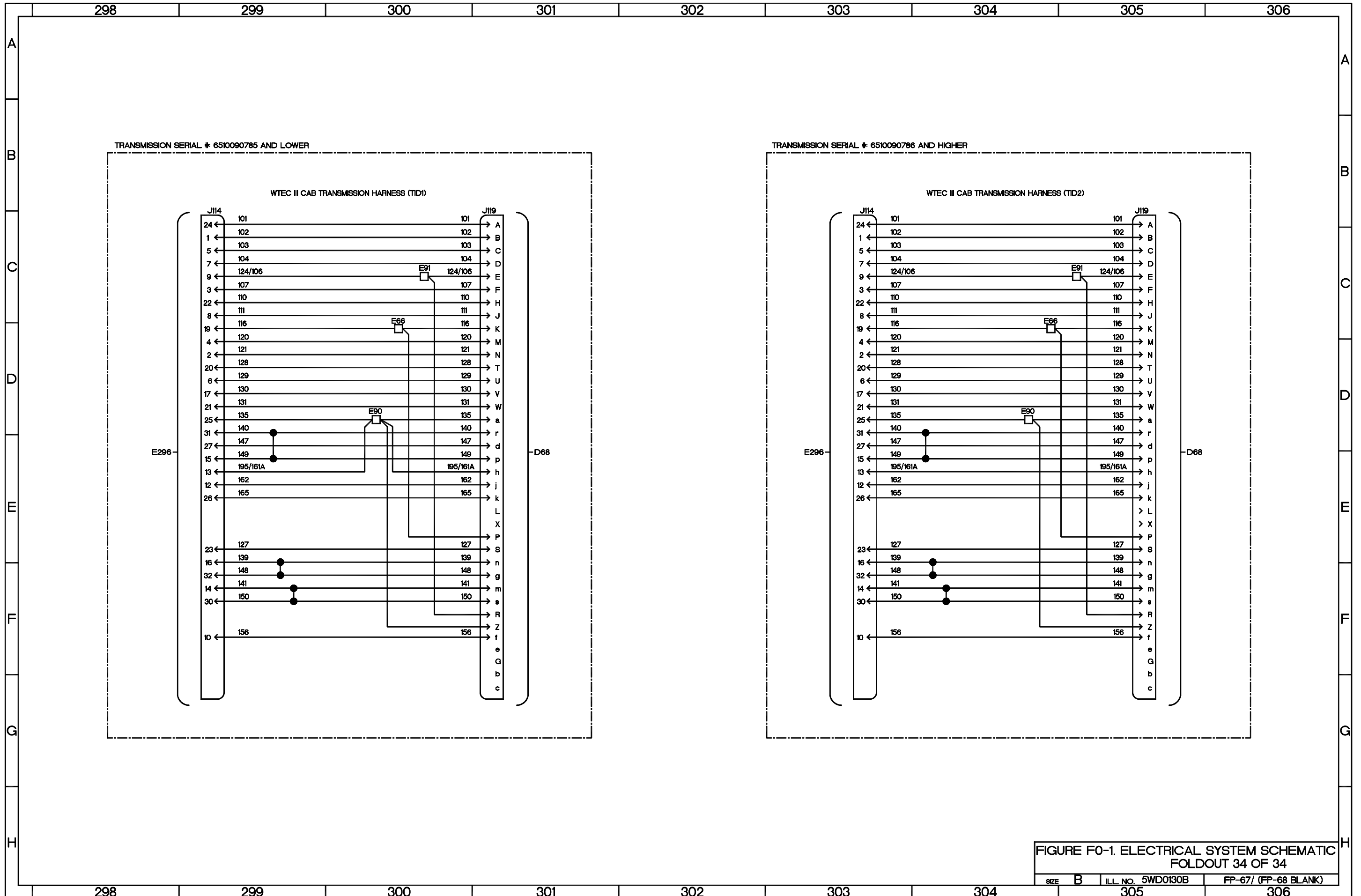

FIGURE FO-1. ELECTRICAL SYSTEM SCHEMATIC FOLDOUT 34 OF 34

SIZE	B	ILL. NO.	5WD0130B	FP-67/ (FP-68 BLANK)
------	---	----------	----------	----------------------







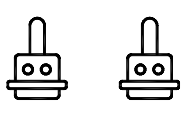
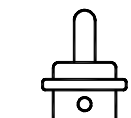
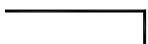
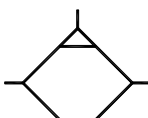
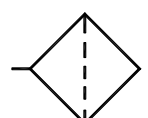
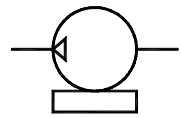
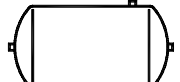

	1	2	3	4	5	6	7	8	9
A									
B									
C		 REAR AXLE BRAKE CHAMBER	 FRONT AXLE BRAKE CHAMBER	 COUPLER AIR BRAKE	 AIR DRYER	 AIR CLEANER INTAKE	 AIR COMPRESSOR WITH GOVERNOR	 AIR TANKS	 DASH GAUGE
D	 MANUAL VALVE	 ONE WAY CHECK VALVE	 FAN CLUTCH	 MODULATED CONTROL VALVE	 QUICK RELEASE VALVE	 TWO WAY CHECK VALVE	 TIRE	 PRESSURE SWITCH	
E	 PRESSURE RELIEF VALVE	 FOOT CONTROL VALVE	 PARK CONTROL VALVE (HAND OPERATED)	 TRAILER AIR SUPPLY VALVE (HAND OPERATED)	 LOAD SENSING VALVE (MECHANICALLY CONTROLLED)	 DIRECTIONAL RELAY VALVE	 CONTROL VALVE WITH TWO WAY CHECK VALVE	 STOPLIGHT SWITCH	
F	 CONNECTION	 SUPPLY AIR HOSE	 NO CONNECTION	 DELIVERY AIR HOSE	 PARK/EMERGENCY AIR HOSE	 AIR BRAKE PROTECTING VALVE	 CTIS MANIFOLD VALVE	 AIR BR AKE PRESSURE TRANSMITTER	
G	 EXH KNEELING VALVE	 AIR/HYDRAULIC INVERSION VALVE	 DELIVERY AIR HOSE NO CONNECTION	 WHEEL VALVE	 BLEED VALVE				
H									

FIGURE F0-2 PNEUMATIC SYSTEM SCHEMATIC
FOLDOUT 1 OF 4

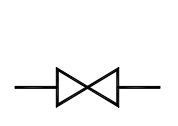
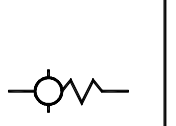
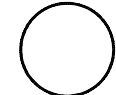
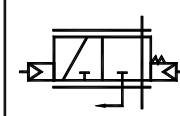
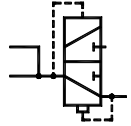
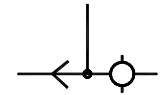
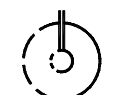
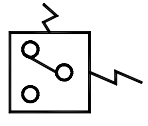
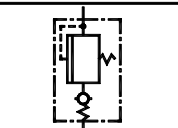
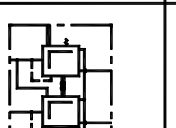
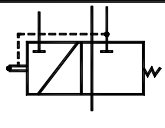
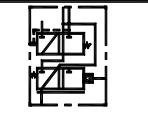
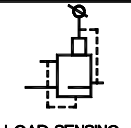
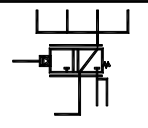
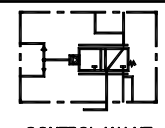
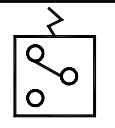
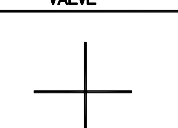
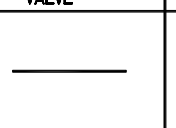
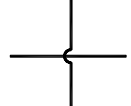

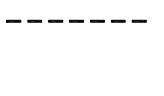
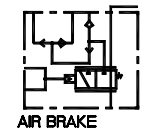
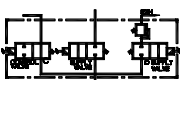
SH	ZONE	DESCRIPTION
3	E22	AIR BRAKE PRESSURE GAGE
3	F22	AIR BRAKE PRESSURE GAGE
3	A23	AIR BRAKE PROTECTING VALVE
3	F20	AIR COMPRESSOR
3	F20	AIR DRYER
3	E22	AIR PRESSURE TRANSMITTER
3	E22	AIR PRESSURE TRANSMITTER
3	C24	ANTI-COMPOUNDING VALVE
4	E31	CONTROL VALVE
4	E31	CTIS MANIFOLD VALVE
4	E32	DEFLATE VALVE
3	G19	EMERGENCY GLADHAND
3	B24	EMERGENCY GLADHAND
3	H20	FAN CLUTCH
3	G20	FAN SOLENOID
3	C22	FOOT CONTROL VALVE
3	F20	INTAKE AIR CLEANER
3	G25	INVERSION VALVE
3	E23	INVERSION VALVE
4	C28	KNEELING VALVE
4	E28	KNEELING VALVE
3	C25	LOAD SENSING VALVE
3	E23	LOW PRESSURE SWITCH
3	F21	LOW PRESSURE SWITCH
3	F22	MANUAL VALVE
3	G22	MANUAL VALVE
3	G21	MANUAL VALVE
3	F22	ONE WAY CHECK VALVE
3	G22	ONE WAY CHECK VALVE
3	G20	ONE WAY CHECK VALVE
3	G21	PRESSURE PROTECTION VALVE
3	G22	PRIMARY AIR TANK
3	C20	QUICK RELEASE VALVE
4	C34	QUICK RELEASE VALVE
4	D30	QUICK RELEASE VALVE
3	D26	RELAY VALVE
3	F22	SECONDARY AIR TANK

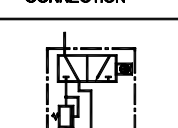
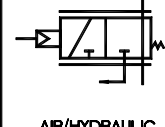
SH	ZONE	DESCRIPTION
3	D19	SERVICE GLADHAND
3	B24	SERVICE GLADHAND
3	C20	STOPLIGHT SWITCH
3	E21	STOPLIGHT SWITCH
4	F32	SUPPLY VALVE
3	B21	SYSTEM PARK SUPPLY VALVE
3	B22	TRAILER SUPPLY VALVE
3	D21	TWO WAY CHECK VALVE
3	E24	TWO WAY CHECK VALVE
3	F23	TWO WAY CHECK VALVE
3	G23	TWO WAY CHECK VALVE
3	F21	WET TANK
4	C29	WHEEL VALVE
4	C33	WHEEL VALVE
4	E29	WHEEL VALVE
4	E33	WHEEL VALVE

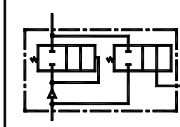
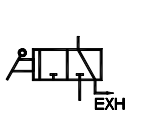
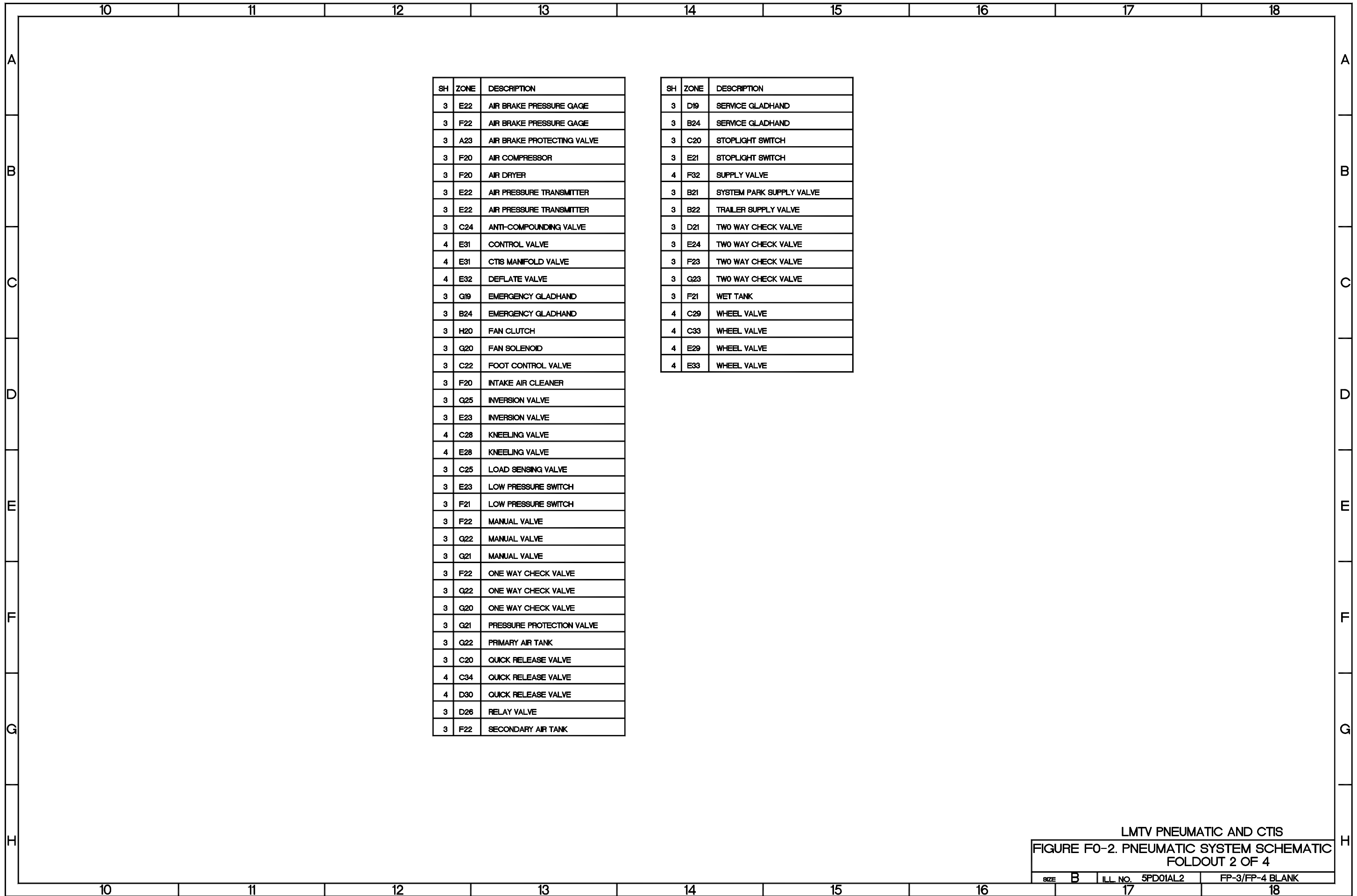
LMTV PNEUMATIC AND CTIS
 FIGURE FO-2. PNEUMATIC SYSTEM SCHEMATIC
 FOLDOUT 2 OF 4

SIZE	B	ILL. NO.	5PD01A2	FP-3/FP-4	BLANK

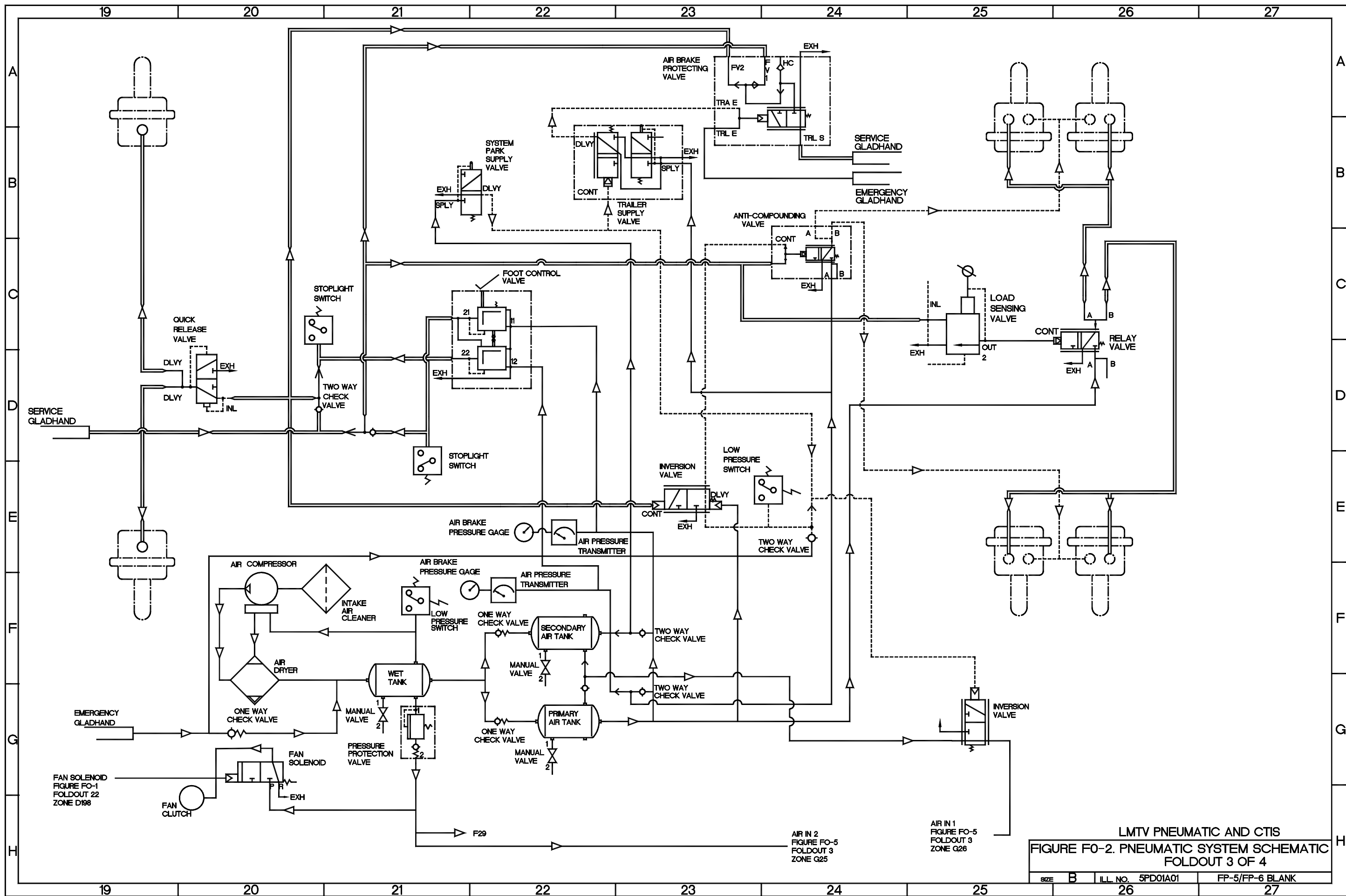

LMTV PNEUMATIC AND CTIS
 FIGURE FO-2. PNEUMATIC SYSTEM SCHEMATIC
 FOLDOUT 3 OF 4

SIZE	B	ILL. NO.	5PD01A01	FP-5/FP-6	BLANK
------	---	----------	----------	-----------	-------

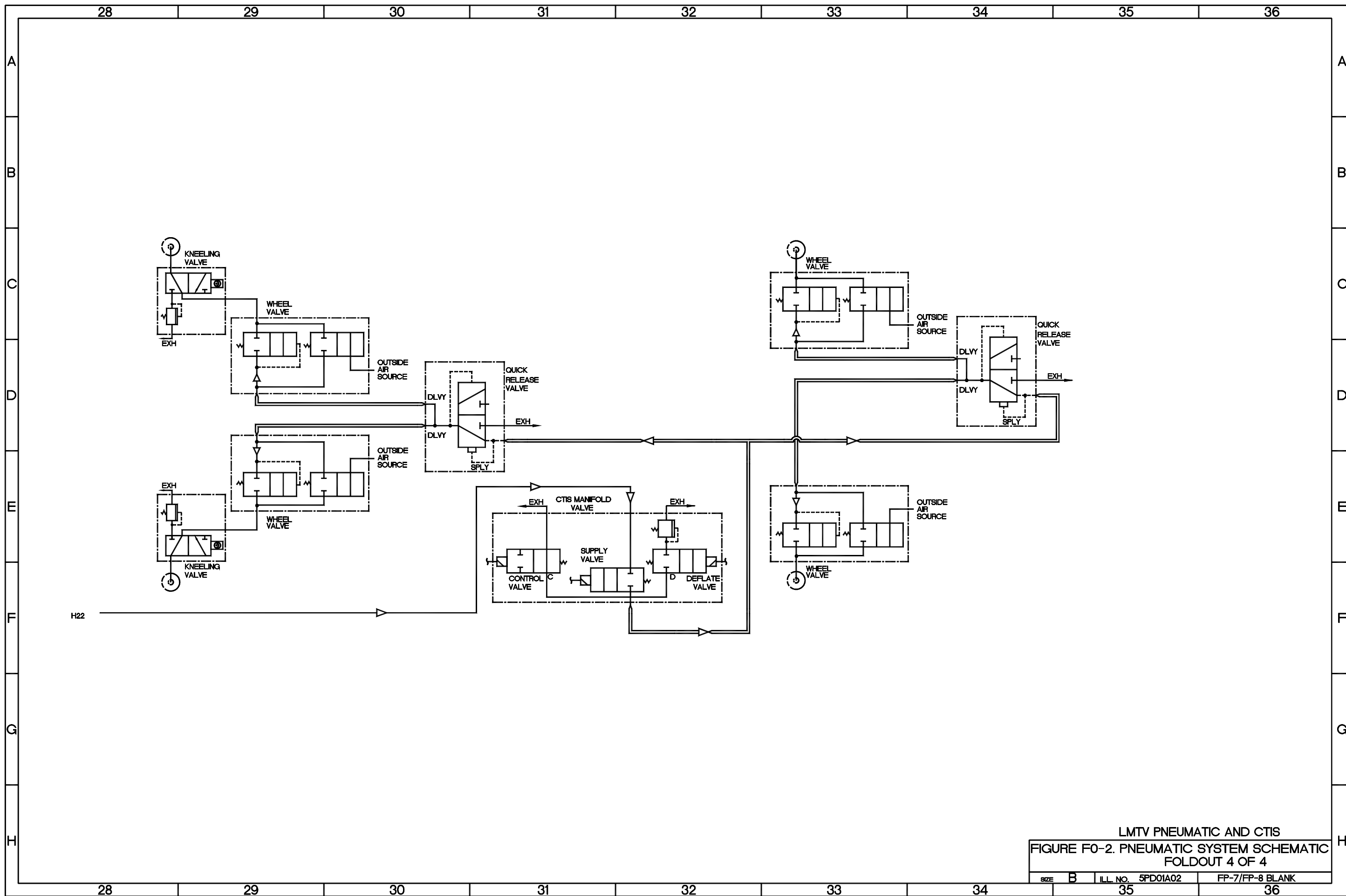

LMTV PNEUMATIC AND CTIS
 FIGURE FO-2. PNEUMATIC SYSTEM SCHEMATIC
 FOLDOUT 4 OF 4

SIZE	B	ILL. NO.	5PD01A02	FP-7/FP-8	BLANK
------	---	----------	----------	-----------	-------

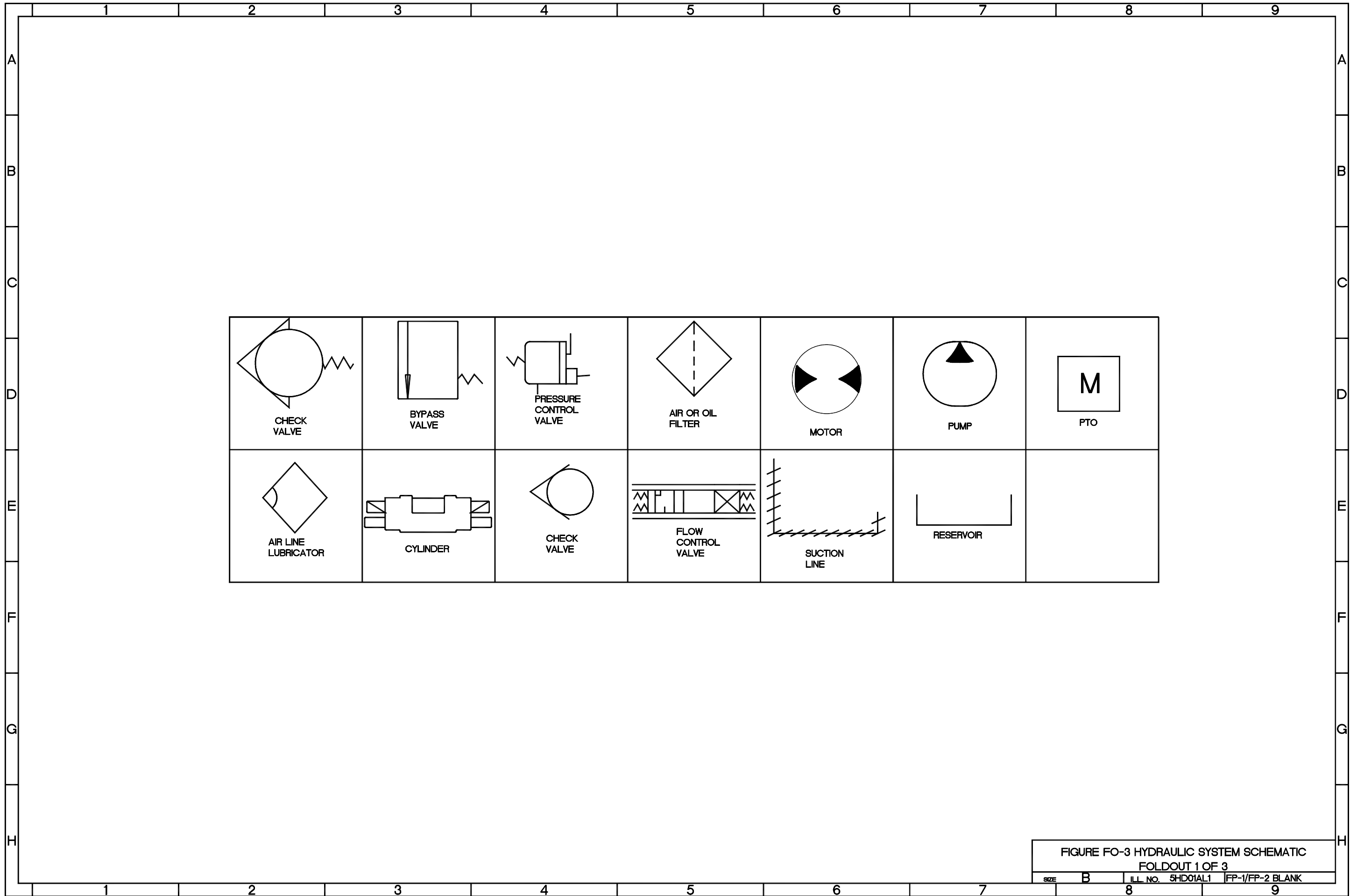
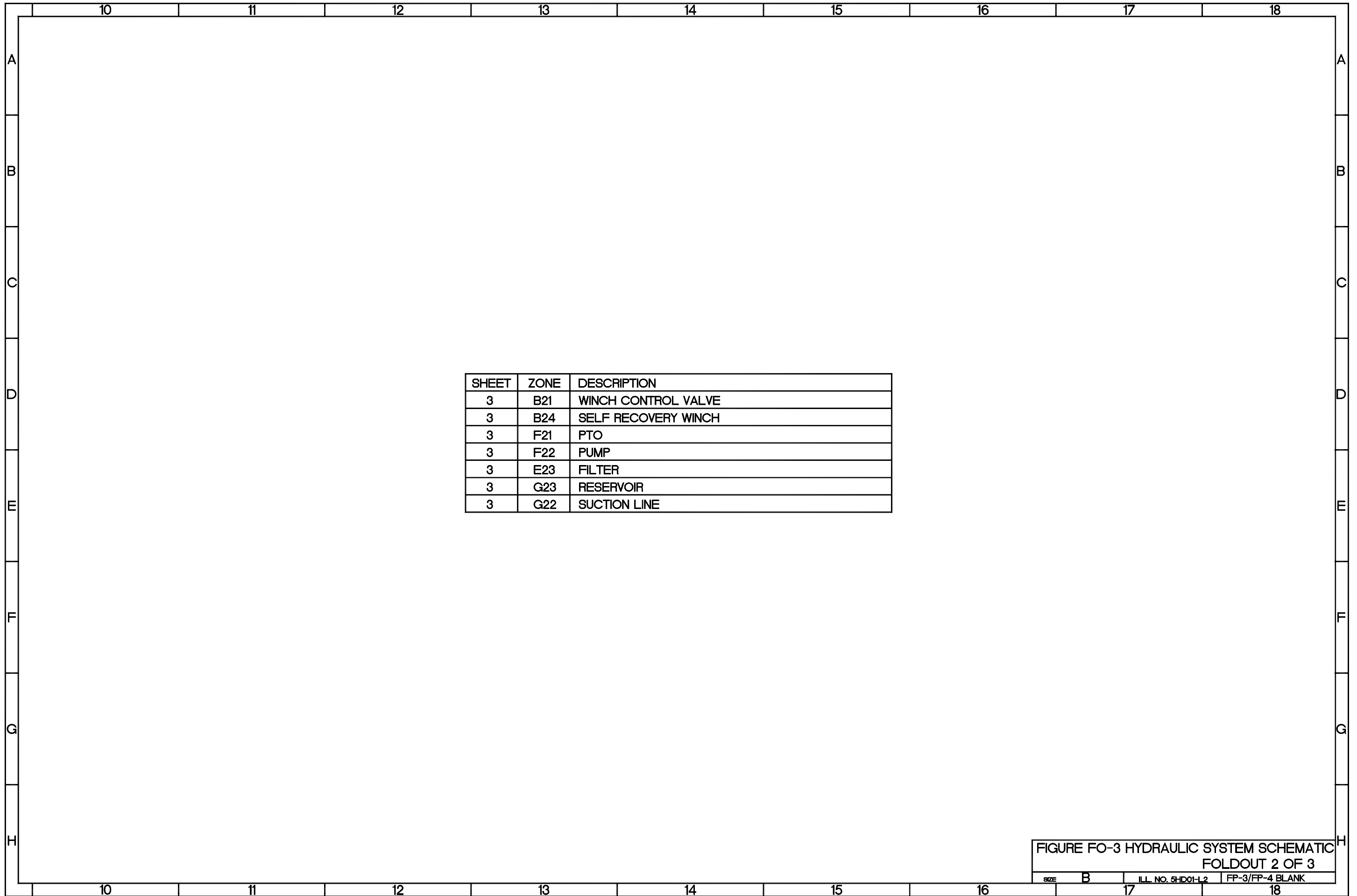

FIGURE FO-3 HYDRAULIC SYSTEM SCHEMATIC
 FOLDOUT 1 OF 3
 SIZE B ILL. NO. 5HDO1AL1 FP-1/FP-2 BLANK



SHEET	ZONE	DESCRIPTION
3	B21	WINCH CONTROL VALVE
3	B24	SELF RECOVERY WINCH
3	F21	PTO
3	F22	PUMP
3	E23	FILTER
3	G23	RESERVOIR
3	G22	SUCTION LINE

FIGURE FO-3 HYDRAULIC SYSTEM SCHEMATIC
 FOLDOUT 2 OF 3

SIZE B ILL. NO. 5H-D01-L2 FP-3/FP-4 BLANK

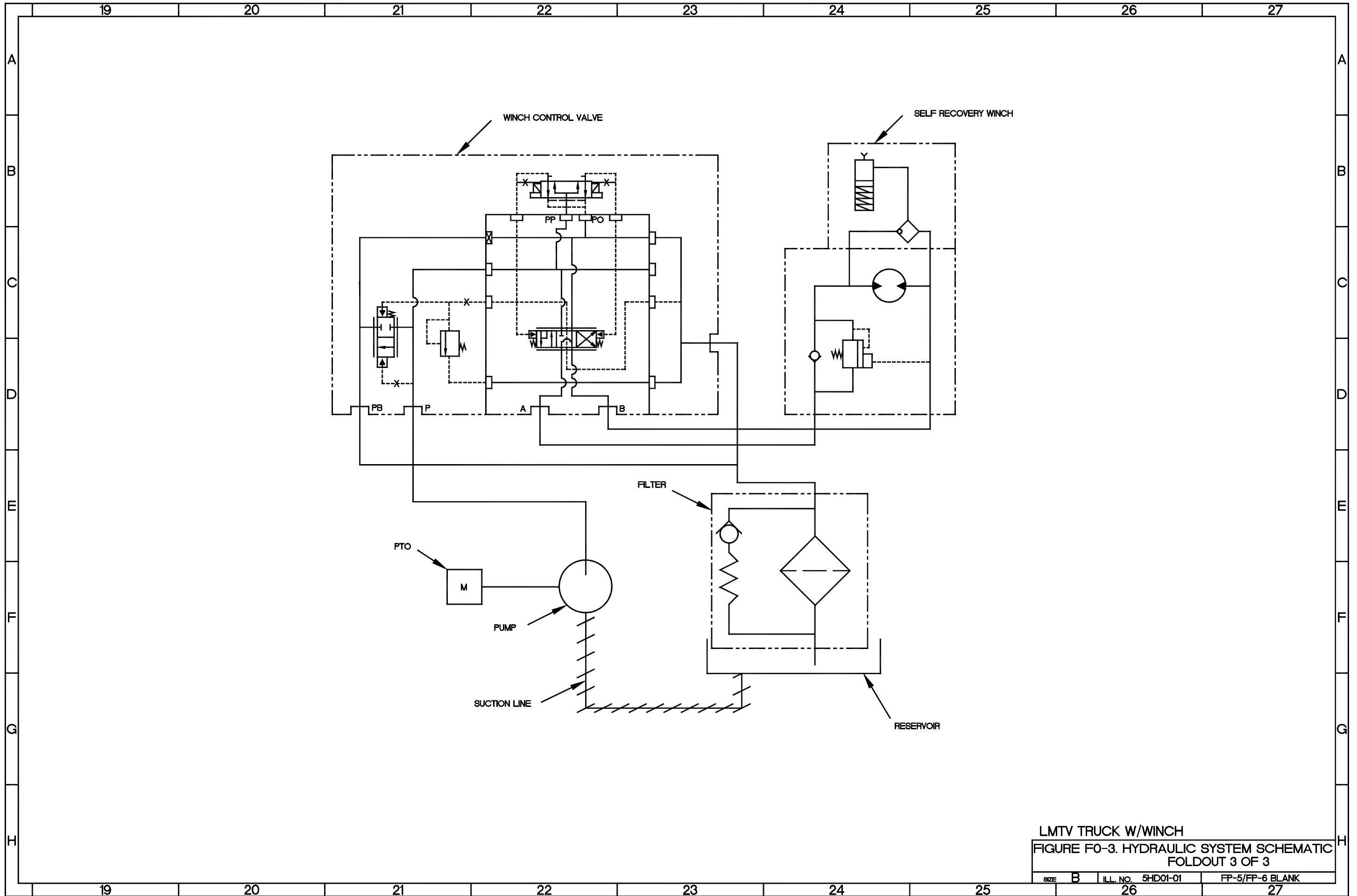

LMTV TRUCK W/WINCH
 FIGURE FO-3. HYDRAULIC SYSTEM SCHEMATIC
 FOLDOUT 3 OF 3

SIZE	B	ILL. NO.	5HD01-01	FP-5/FP-6	BLANK
------	---	----------	----------	-----------	-------

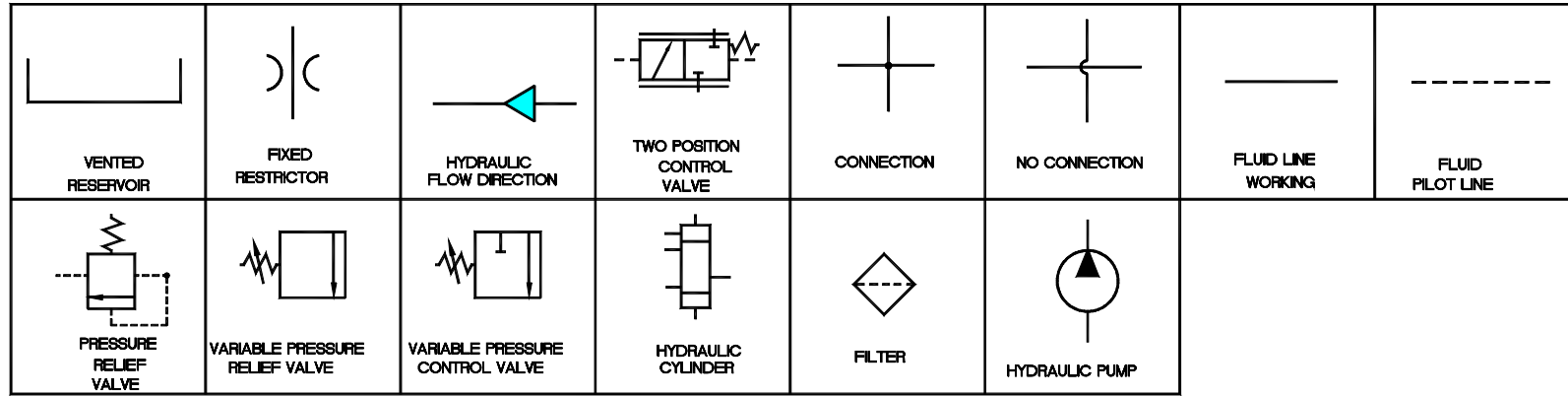
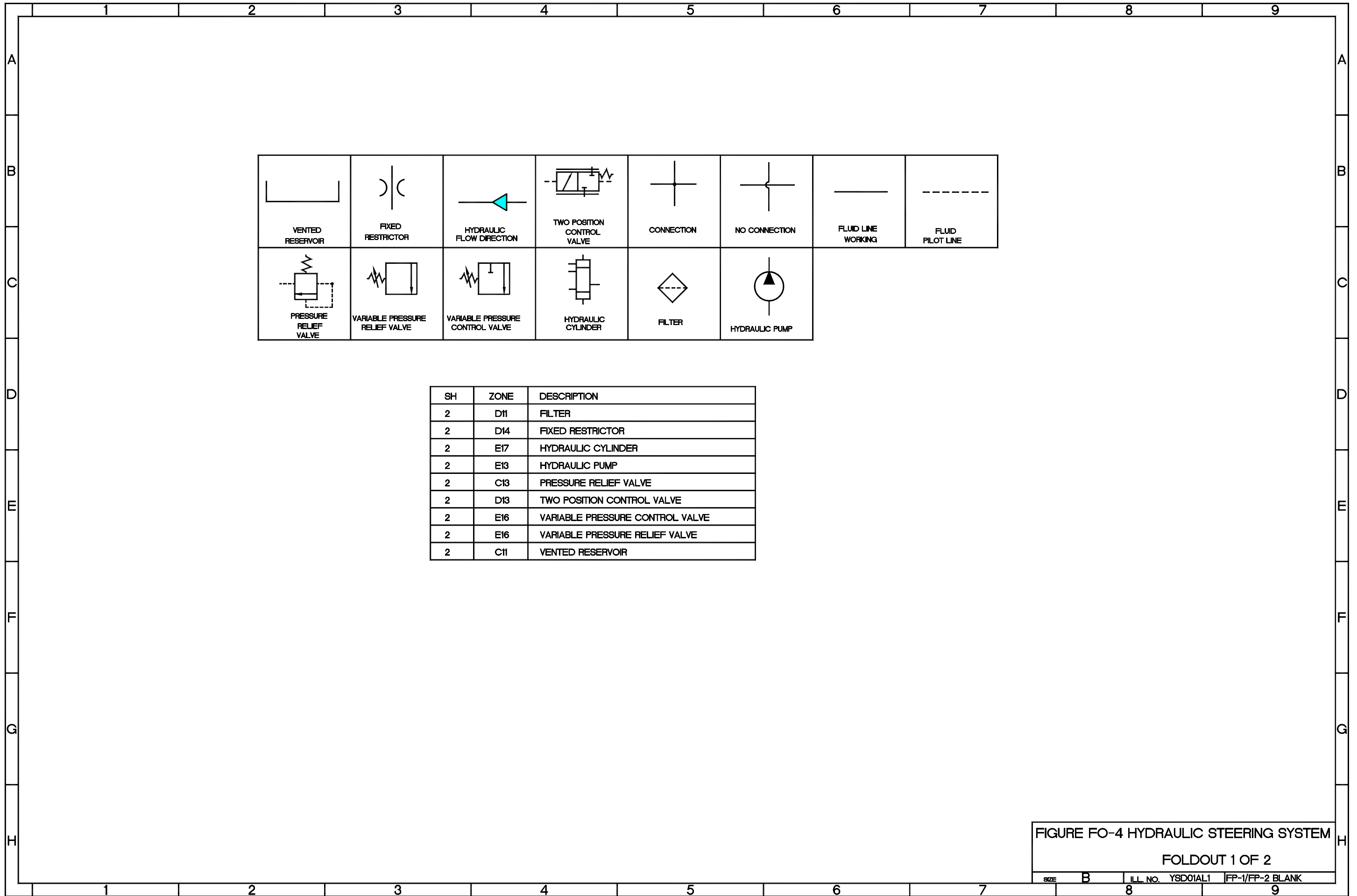

SH	ZONE	DESCRIPTION
2	D11	FILTER
2	D14	FIXED RESTRICTOR
2	E17	HYDRAULIC CYLINDER
2	E13	HYDRAULIC PUMP
2	C13	PRESSURE RELIEF VALVE
2	D13	TWO POSITION CONTROL VALVE
2	E16	VARIABLE PRESSURE CONTROL VALVE
2	E16	VARIABLE PRESSURE RELIEF VALVE
2	C11	VENTED RESERVOIR

FIGURE FO-4 HYDRAULIC STEERING SYSTEM
 FOLDOUT 1 OF 2
 SIZE B ILL. NO. YSD01A11 FP-1/FP-2 BLANK

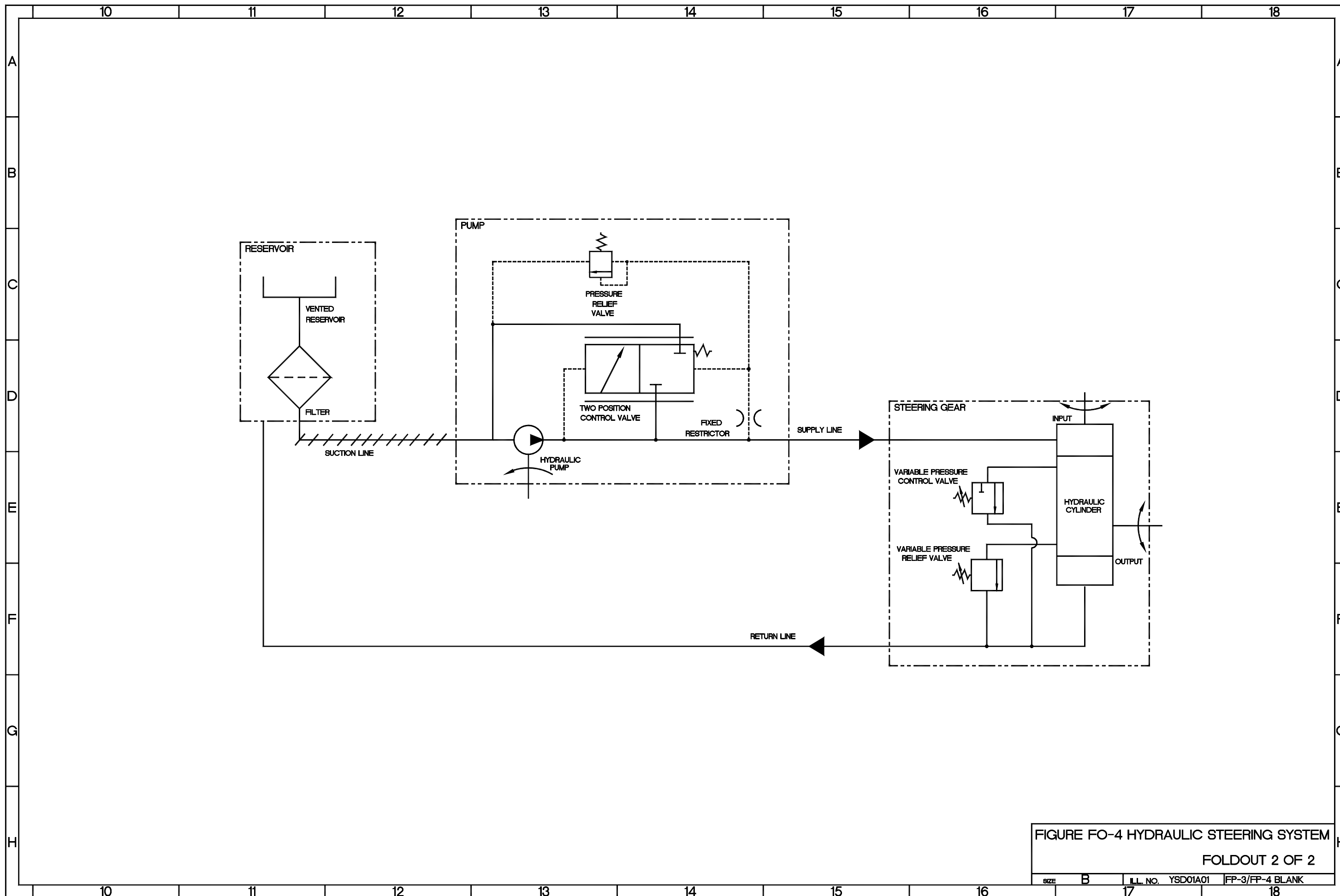

FIGURE FO-4 HYDRAULIC STEERING SYSTEM
 FOLDOUT 2 OF 2
 SIZE B ILL. NO. YSD01A01 FP-3/FP-4 BLANK

	1	2	3	4	5	6	7	8	9
A									
B									
C									
D									
E									
F									
G									
H									







							
VENTED RESERVOIR	ABOVE FLUID LEVEL RESERVOIR	HYDRAULIC FLOW DIRECTION	PNEUMATIC FLOW DIRECTION	CONNECTION	NO CONNECTION	FLUID LINE WORKING	FLUID PILOT LINE
							
FIXED RESTRICTOR	CHECK VALVE	VARIABLE CONTROL CHECK VALVE	CHECK PILOT	PRESSURE RELIEF VALVE	FILTER	HAND PUMP	DETENT
							
TWO POSITION CAB SUSPENSION VALVE	MUFFLER	HYDRAULIC CYLINDER	CAB AIR SUSPENSION W/DAMPER	REAR CAB LATCH	TWO POSITION AIR PUMP VALVE	PRESSURE INTENSIFIER	HEIGHT CONTROL VALVE
							
TWO POSITION CAB TILT VALVE	TWO POSITION SUSPENSION VALVE	TWO POSITION SPARE TIRE VALVE	THREE POSITION SELECTION VALVE				

FIGURE F0-5 AIR TRANSPORTABILITY HYDRAULIC/PNEUMATIC SYSTEM SCHEMATIC
 FOLDOUT 1 OF 3
 SIZE B ILL. NO. YADO1A11 FP-1/FP-2 BLANK

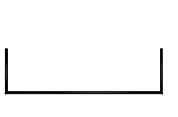
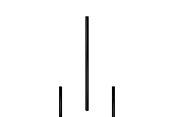
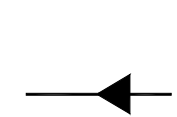
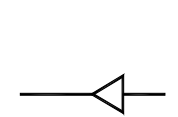
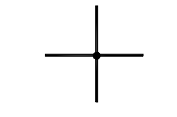
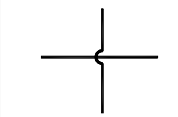
	10	11	12	13	14	15	16	17	18	
A										A
B										B
C										C
D										D
E										E
F										F
G										G
H										H
	10	11	12	13	14	15	16	17	18	

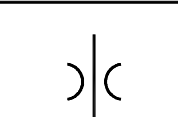
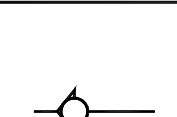
SH	ZONE	DESCRIPTION
3	A25	CAB AIR SUSPENSION W/DAMPER
3	F21	CHECK PILOT
3	A22	CHECK VALVE
3	A23	CHECK VALVE
3	B22	CHECK VALVE
3	B23	CHECK VALVE
3	B25	CHECK VALVE
3	C20	CHECK VALVE
3	C21	CHECK VALVE
3	E19	CHECK VALVE
3	E24	CHECK VALVE
3	E25	CHECK VALVE
3	F19	CHECK VALVE
3	F21	CHECK VALVE
3	G21	CHECK VALVE
3	A22	FILTER
3	B22	FILTER
3	A24	FILTER
3	B24	FILTER
3	D19	FILTER
3	D20	FILTER
3	D21	FILTER
3	E19	FILTER
3	G19	FILTER
3	G21	FILTER
3	A22	FIXED RESTRICTOR
3	B22	FIXED RESTRICTOR
3	A23	FIXED RESTRICTOR
3	B23	FIXED RESTRICTOR
3	F19	HAND PUMP
3	B25	HEIGHT CONTROL VALVE
3	B22	HYDRAULIC CYLINDER
3	B23	HYDRAULIC CYLINDER
3	C21	HYDRAULIC CYLINDER
3	F20	MUFFLER
3	F21	PRESSURE INTENSIFIER
3	F19	PRESSURE RELIEF VALVE
3	A24	REAR CAB LATCH
3	E21	THREE POSITION SELECTION VALVE
3	D26	TWO POSITION AIR PUMP VALVE
3	D25	TWO POSITION CAB SUSPENSION VALVE
3	C24	TWO POSITION CAB TILT VALVE
3	C23	TWO POSITION SPARE TIRE VALVE
3	D21	TWO POSITION SUSPENSION VALVE
3	G22	VARIABLE CONTROL CHECK VALVE
3	G22	VENTED RESERVOIR

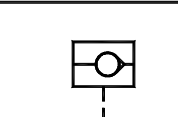
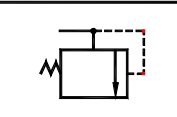
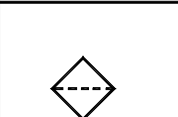
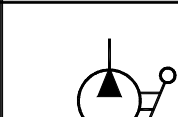
FIGURE FO-5 AIR TRANSPORTABILITY
HYDRAULIC/PNEUMATIC SYSTEM SCHEMATIC
FOLDOUT 2 OF 3

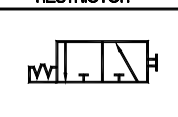
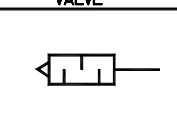
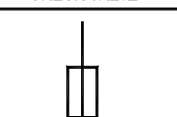
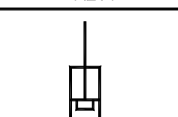
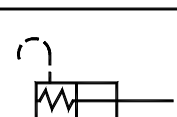
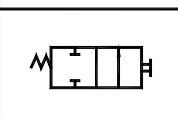
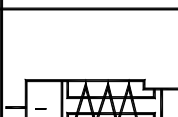
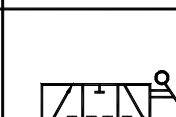
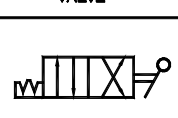
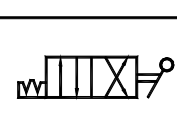
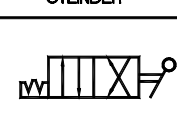
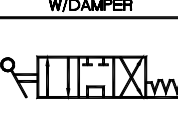
SIZE B ILL. NO. YAD01AL2 FP-3/FP-4 BLANK

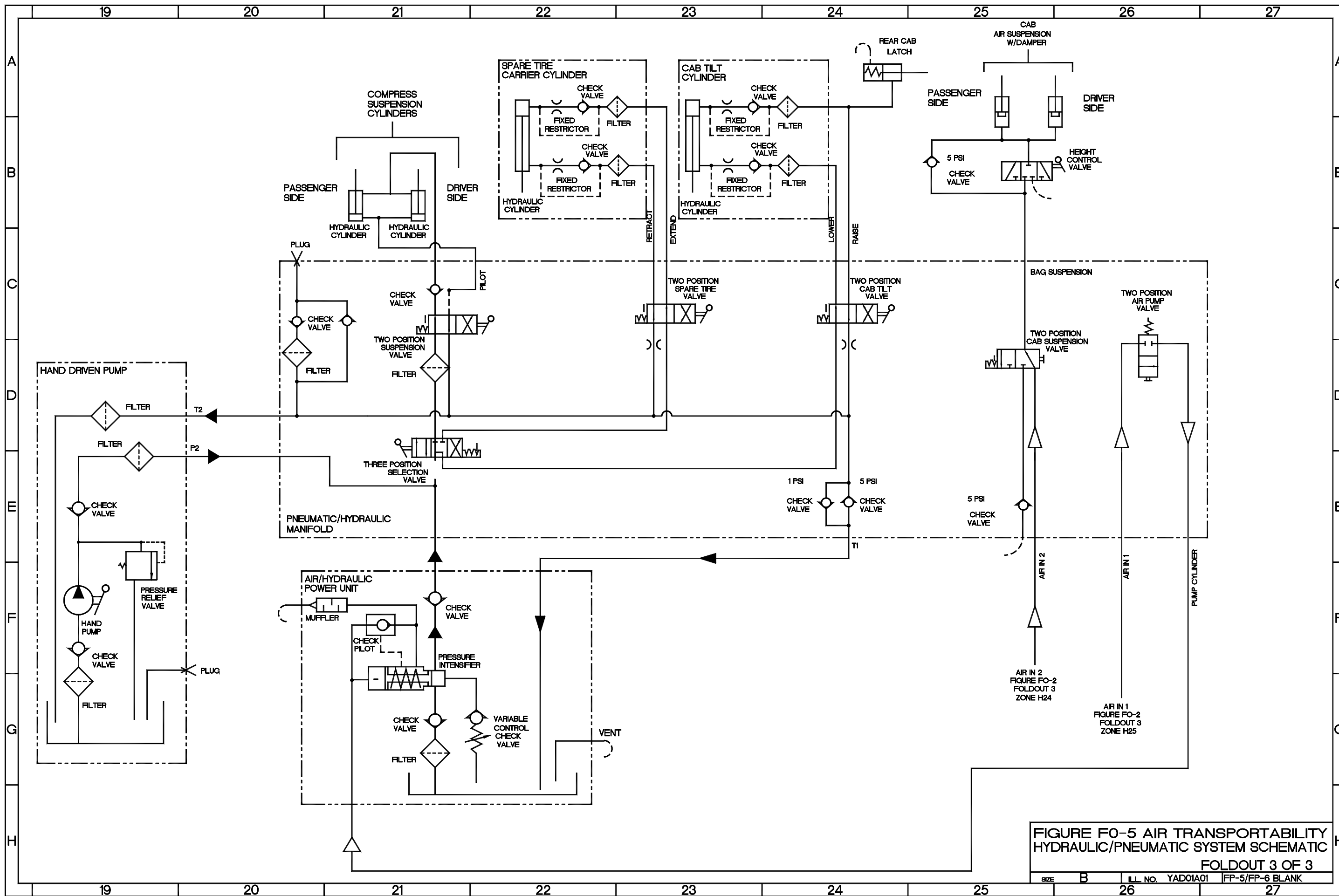

FIGURE FO-5 AIR TRANSPORTABILITY
HYDRAULIC/PNEUMATIC SYSTEM SCHEMATIC
FOLDOUT 3 OF 3
SIZE B ILL. NO. YAD01A01 FP-5/FP-6 BLANK

THE METRIC SYSTEM AND EQUIVALENTS

LINEAR MEASURE

1 Centimeter = 10 Millimeters = 0.01 Meters = 0.3937 Inches
 1 Meter = 100 Centimeters = 1000 Millimeters = 39.37 Inches
 1 Kilometer = 1000 Meters = 0.621 Miles

SQUARE MEASURE

1 Sq Centimeter = 100 Sq Millimeters = 0.155 Sq Inches
 1 Sq Meter = 10,000 Sq Centimeters = 10.76 Sq Feet
 1 Sq Kilometer = 1,000,000 Sq Meters = 0.386 Sq Miles

WEIGHTS

1 Gram = 0.001 Kilograms = 1000 Milligrams = 0.035 Ounces
 1 Kilogram = 1000 Grams = 2.2 Lb
 1 Metric Ton = 1000 Kilograms = 1 Megagram = 1.1 Short Tons

CUBIC MEASURE

1 Cu Centimeter = 1000 Cu Millimeters = 0.06 Cu Inches
 1 Cu Meter = 1,000,000 Cu Centimeters = 35.31 Cu Feet

LIQUID MEASURE

1 Milliliter = 0.001 Liters = 0.0338 Fluid Ounces
 1 Liter = 1000 Milliliters = 33.82 Fluid Ounces

TEMPERATURE

$5/9 (^{\circ}\text{F} - 32) = ^{\circ}\text{C}$
 212° Fahrenheit is equivalent to 100° Celsius
 90° Fahrenheit is equivalent to 32.2° Celsius
 32° Fahrenheit is equivalent to 0° Celsius
 $9/5 \text{ C}^{\circ} + 32 = \text{F}^{\circ}$

APPROXIMATE CONVERSION FACTORS

<u>TO CHANGE</u>	<u>TO</u>	<u>MULTIPLY BY</u>	<u>TO CHANGE</u>	<u>TO</u>	<u>MULTIPLY BY</u>
Inches	Centimeters	2.540	Centimeters	Inches	0.394
Inches	Millimeters	25.4	Millimeters	Inches	0.0394
Feet	Meters	0.305	Meters	Feet	3.280
Yards	Meters	0.914	Meters	Yards	1.094
Miles	Kilometers	1.609	Kilometers	Miles	0.621
Square Inches	Square Centimeters	6.451	Sq Centimeters	Square Inches	0.155
Square Feet	Square Meters	0.093	Square Meters	Square Feet	10.764
Square Yards	Square Meters	0.836	Square Meters	Square Yards	1.196
Square Miles	Square Kilometers	2.590	Square Kilometers	Square Miles	0.386
Acres	Square Hectometers	0.405	Sq Hectometers	Acres	2.471
Cubic Feet	Cubic Meters	0.028	Cubic Meters	Cubic Feet	35.315
Cubic Yards	Cubic Meters	0.765	Cubic Meters	Cubic Yards	1.308
Fluid Ounces	Milliliters	29.57	Milliliters	Fluid Ounces	0.034
Pints	Liters	0.473	Liters	Pints	2.113
Quarts	Liters	0.946	Liters	Quarts	1.057
Gallons	Liters	3.785	Liters	Gallons	0.264
Ounces	Grams	28.35	Grams	Ounces	0.035
Pounds	Kilograms	0.454	Kilograms	Pounds	2.205
Pounds (force)	Newtons	4.448	Newtons	Pounds (force)	0.2248
Short Tons	Metric Tons	0.907	Metric Tons	Short Tons	1.102
Pound-Feet	Newton-Meters	1.356	Newton-Meters	Pound-Feet	0.738
Pounds/Sq Inch	Kilopascals	6.895	Kilopascals	Pounds per Sq Inch	0.145
Miles per Gallon	Kilometers per Liter	0.425	Km per Liter	Miles per Gallon	2.354
Miles per Hour	Kilometers per Hour	1.609	Km per Hour	Miles per Hour	0.621

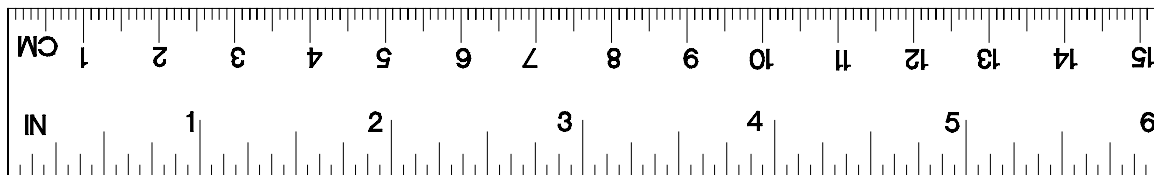

YMET001A

