

TB 9-2320-279-13-1

TECHNICAL BULLETIN

**OPERATOR'S, UNIT AND DIRECT SUPPORT
MAINTENANCE MANUAL, INSTALLATION INSTRUCTIONS, AND
REPAIR PARTS AND SPECIAL TOOLS LISTS**

FOR

AIR CONDITIONING SYSTEM

NSN 4120-01-526-9153

P/N 3528313

FOR

M977 SERIES 8X8

HEAVY EXPANDED MOBILITY TACTICAL TRUCKS (HEMTT)

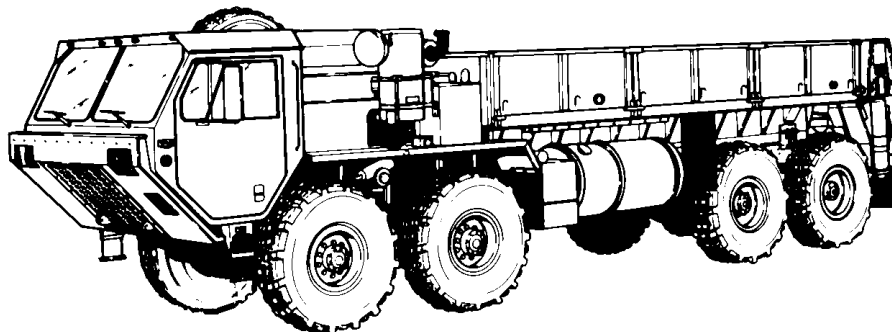

DISTRIBUTION STATEMENT A: Approved for public release; distribution is unlimited.

HEADQUARTERS, DEPARTMENT OF THE ARMY

DECEMBER 2005

TB 9-2320-279-13-1

This list summarizes critical warnings in this technical bulletin. They are repeated here to let you know how important they are. Study these warnings carefully. They can save your life and the lives of personnel you work with. If there is any doubt about handling tools, materials, equipment, and procedures, see TB 43-0216, Safety and Hazard Warnings for Operation and Maintenance of TACOM Equipment.

FOR INFORMATION ON FIRST AID, REFER TO FM 4-25.11.

WARNING

Adhesives, solvents, and sealing compounds can burn easily, can give off harmful vapors and are harmful to skin and clothing. To avoid injury or death, keep away from open fire and use in well-ventilated areas. If adhesive, solvent, or sealing compound gets on skin or clothing, wash immediately with soap and water.

WARNING

Ensure engine is cool prior to checking AC compressor belts. Failure to comply may result in injury to personnel.

WARNING

Dry cleaning solvent is TOXIC and flammable. Wear protective goggles and gloves; use only in a well-ventilated area; avoid contact with skin, eyes, and clothes; and DO NOT breathe vapors. Keep away from heat or flame. Never smoke when using dry cleaning solvent; the flashpoint for Type II is 140°F (60°C), and for Type III it is 200°F (93°C). Failure to follow this warning may result in death or injury to personnel.

WARNING

If personnel become dizzy while using dry cleaning solvent, immediately get fresh air and medical help. If solvent contacts skin or clothes, flush with cold water. If solvent contacts eyes, immediately flush eyes with water and get immediate medical attention.

WARNING

Use care to prevent refrigerant from touching skin or eyes. Liquid refrigerant, when exposed to air, quickly evaporates and will freeze skin or eye tissues. Use care to prevent refrigerant from touching your skin or eyes. Serious injury or blindness may result if you come in contact with liquid refrigerant.

WARNING

Refrigerant R-134a air conditioning systems should not be pressure tested or leak tested with compressed air. Combustible mixtures of air and R-134a may form, resulting in fire or explosion, which could cause personnel injury or death.

WARNING

Ensure engine is cool before performing maintenance. Failure to comply may result in severe burns.

WARNING

Do not work in an area where refrigerant may contact an open flame or any burning material, such as a cigarette. When it contacts extreme heat, refrigerant breaks down into poisonous phosgene gas. Which if breathed, causes severe respiratory irritation. Do not breathe fumes from an open flame leak detector.

WARNING

Remove rings, bracelets, wristwatches, neck chains, and any other jewelry before working around vehicle. Jewelry can catch on equipment and cause serious injury. Jewelry or tools may short across electrical circuits or terminals and cause damage to equipment or severe burns or electrical shock to personnel.

WARNING

Circuit breakers No. 4, 5, 6, and 10 are always electrically live and can cause severe injury to personnel. Care must be taken when working around these circuit breakers.

WARNING

Wear protective goggles and nonleather gloves when servicing air conditioner system. Failure to comply may result in injury to personnel.

WARNING

Moving engine components can cause severe injury. Keep away from fan, belts, and pulleys while engine is running.

WARNING

AC condenser and AC condenser output hose can get extremely hot. Use caution when checking temperature of AC condenser output hose. Place hand near hose to check for heat, but do not touch hose. Failure to comply may cause serious burns to personnel.

WARNING

Alternator is heavy. Do not remove alternator from mounting bracket without the aid of an assistant. Failure to comply may result in serious injury to personnel and/or damage to equipment.

WARNING

Alternator is heavy. Do not install alternator on mounting bracket without the aid of an assistant. Failure to comply may result in serious injury to personnel and/or damage to equipment.

WARNING

AC condenser assembly weighs 75 lbs. (34 kg). Do not lift AC condenser assembly without the aid of an assistant. Failure to comply may result in injury to personnel and/or damage to equipment.

WARNING

Do not remove heater/evaporator without the aid of an assistant. Failure to comply may result in injury to personnel and/or damage to equipment.

WARNING

Do not install heater/evaporator without the aid of an assistant. Failure to comply may result in injury to personnel and/or damage to equipment.

INSERT LATEST CHANGED PAGES/WORK PACKAGES, DESTROY SUPERSEDED DATA.

LIST OF EFFECTIVE PAGES/WORK PACKAGES

NOTE

The portion of text or illustration effected by the update is indicated by a vertical line in the outer margin of the page.

Dates of issue for original and changed pages/work packages are:

Original 0. 14 December 2005

TOTAL NUMBER OF PAGES IN THIS PUBLICATION IS 522 AND TOTAL NUMBER OF WORK PACKAGES IN THIS PUBLICATION IS 58 CONSISTING OF THE FOLLOWING:

Page/WP No.	*Change No.	Page/WP No.	*Change No.
Cover	0		
a and b.	0		
i thru iv	0		
WP 0001 thru WP 0058.	0		
INDEX-1 thru INDEX-3	0		
INDEX-4 blank.	0		

*Zero in this column indicates an original page or work package.

TECHNICAL BULLETIN

**OPERATOR'S, UNIT AND DIRECT SUPPORT
MAINTENANCE MANUAL, INSTALLATION INSTRUCTIONS, AND
REPAIR PARTS AND SPECIAL TOOLS LISTS**

FOR

AIR CONDITIONING SYSTEM

**NSN 4120-01-526-9153
P/N 3528313**

FOR

**M977 SERIES 8X8
HEAVY EXPANDED MOBILITY TACTICAL TRUCKS (HEMTT)**

REPORTING ERRORS AND RECOMMENDING IMPROVEMENTS

You can help improve this publication. If you find any mistakes or if you know of a way to improve the procedures, please let us know. Submit your DA Form 2028 (Recommended Changes to Equipment Technical Publications), through the Internet, on the Army Electronic Product Support (AEPS) website. The Internet address is <https://aeps.ria.army.mil>. The DA Form 2028 is located under the Public Applications section in the AEPS Public Home Page. Fill out the form and click on SUBMIT. Using this form on the AEPS will enable us to respond quicker to your comments and better manage the DA Form 2028 program. You may also mail, fax or E-mail your letter or DA Form 2028 direct to: AMSTA-LC-LMIT/TECH PUBS, TACOM-RI, 1 Rock Island Arsenal, Rock Island, IL 61299-7630. The email address is TACOM-TECH-PUBS@ria.army.mil. The fax number is DSN 793-0726 or Commercial (309) 782-0726.

TABLE OF CONTENTS

Work Package		Page
CHAPTER 1	GENERAL INFORMATION AND DATA	
0001	General Information	0001-1
CHAPTER 2	OPERATOR'S INSTRUCTIONS	
0002	Operator's Controls and Indicators	0002-1
0003	Operator's Preventive Maintenance Checks and Services (PMCS)	0003-1
0004	System Operation	0004-1

TABLE OF CONTENTS (Continued)

Work Package	Page
CHAPTER 3 OPERATOR'S TROUBLESHOOTING	
0005 Operator's Troubleshooting Introduction	0005-1
0006 AC Heater/Evaporator Blower Does Not Operate	0006-1
0007 AC Heater/Evaporator Blower Operates But No Cold Air From Ducts During AC Operations	0007-1
 CHAPTER 4 FIELD LEVEL PMCS	
0008 Field Level Preventive Maintenance Checks and Services (PMCS)	0008-1
 CHAPTER 5 FIELD LEVEL TROUBLESHOOTING	
0009 Field Level Troubleshooting Introduction	0009-1
0010 AC Heater/Evaporator Blower Does Not Operate	0010-1
0011 AC Heater/Evaporator Blower Does Not Operate In All Speeds (Low, Medium, and High)	0011-1
0012 AC Heater/Evaporator Blower Operates But No Cold Air From Ducts During AC Operations	0012-1
0013 AC Compressor Excessively Noisy	0013-1
0014 AC Compressor Does Not Shut Off Or Cycles Constantly	0014-1
0015 AC Does Not Cool Or Cools Inadequately	0015-1
 CHAPTER 6 FIELD LEVEL MAINTENANCE	
0016 Field Level Maintenance Introduction	0016-1
0017 AC 20 AMP Circuit Breaker Replacement	0017-1
0018 AC Alternator/Compressor Mounting Bracket Replacement	0018-1
0019 AC Alternator Drive Belts Replacement/Adjustment	0019-1
0020 AC Alternator and Pulley Replacement	0020-1
0021 AC Cable Replacement	0021-1
0022 AC Compressor Drive Belts Replacement/Adjustment	0022-1
0023 AC Compressor Replacement	0023-1
0024 AC Condenser Core Replacement	0024-1
0025 AC Condenser Dryer Replacement	0025-1
0026 AC Condenser Fan Motor Replacement	0026-1
0027 AC Condenser Fan Motor Solenoid Replacement	0027-1
0028 AC Condenser Replacement	0028-1

TABLE OF CONTENTS (Continued)

Work Package		Page
0029	AC Defrost Cable Replacement	0029-1
0030	AC Evaporator Core And Expansion Valve Replacement.	0030-1
0031	AC Fan Control Switch Replacement	0031-1
0032	AC Heater Cable Replacement	0032-1
0033	AC Heater Core Replacement.	0033-1
0034	AC Heater/Evaporator Blower Motor Assembly Replacement	0034-1
0035	AC Heater/Evaporator Blower Motor Resistor Replacement.	0035-1
0036	AC Heater/Evaporator Blower Motor Resistor Harness Replacement . . .	0036-1
0037	AC Heater/Evaporator Cover And Defrost Louvers Replacement.	0037-1
0038	AC Heater/Evaporator Replacement.	0038-1
0039	AC High Pressure Switch Replacement	0039-1
0040	AC Hoses Replacement	0040-1
0041	AC Low Pressure Switch Replacement.	0041-1
0042	AC Lower Plenum and Damper Replacement.	0042-1
0043	AC Optic Ribbon Replacement	0043-1
0044	AC Temperature Control Switch Replacement	0044-1
0045	AC Upper Plenum Replacement	0045-1
0046	AC Wiring Harness Replacement	0046-1
0047	AC Wire 1082 Harness Replacement	0047-1
0048	AC Wire 1156 Harness Replacement	0048-1
0049	Air Conditioning Leak Test	0049-1
0050	AC System Refrigerant (R-134a) Maintenance.	0050-1
APPENDIX A	INSTALLATION DRAWINGS AND SCHEMATICS	
0051	Installation Drawings And Schematics	0051-1
APPENDIX B	INITIAL INSTALLATION INSTRUCTIONS OF AC KIT	
0052	Initial Installation Instructions of AC Kit	0052-1
APPENDIX C	REFERENCES	
0053	References	0053-1

TABLE OF CONTENTS (Continued)

Work Package	Page
APPENDIX D MAINTENANCE ALLOCATION CHART (MAC)	
0054 Maintenance Allocation Chart (MAC)	0054-1
APPENDIX E EXPENDABLE AND DURABLE SUPPLIES AND MATERIALS LIST	
0055 Expendable and Durable Supplies And Materials List	0055-1
APPENDIX F COMMON TOOLS AND SPECIAL TOOLS LIST	
0056 Common Tools And Special Tools List.	0056-1
APPENDIX G ILLUSTRATED PARTS LIST (RPSTL)	
0057 Illustrated Parts List (RPSTL).	0057-1
APPENDIX H ADDITIONAL AUTHORIZATION LIST (AAL)	
0058 Additional Authorization List (AAL).	0058-1

TB 9-2320-279-13-1

CHAPTER 1

GENERAL INFORMATION AND DATA

GENERAL INFORMATION

GENERAL INFORMATION INDEX

CONTENTS	WP PAGE NO.
Scope	0001-1
Maintenance Forms and Procedures	0001-1
Reporting Equipment Improvement Recommendations (EIR)	0001-1
Material and Workmanship Warranty	0001-2
Nomenclature Cross-Reference List	0001-2
List of Abbreviations	0001-3
Principles of Operation	0001-4

SCOPE

a. Type of Manual. This Technical Bulletin provides instructions for the installation, operation, and maintenance of the Air Conditioner kit for the HEMTT.

b. Name. HEMTT Air Conditioner Kit.

c. Purpose of Equipment. The HEMTT AC kit is a Field Level Maintenance-installed cab air conditioning system for the HEMTT. Under the new regulations, shops not having the required recovery and recycling equipment (and properly trained and certified personnel) will not be allowed to do any of this service work. Once installed, the air conditioning system provides cooled air for the HEMTT cab compartment during normal operations.

MAINTENANCE FORMS AND PROCEDURES

Department of the Army forms and procedures used for equipment maintenance will be those prescribed by DA Pam 750-8 (The Army Maintenance Management System (TAMMS) Users Manual).

REPORTING EQUIPMENT IMPROVEMENT RECOMMENDATIONS (EIR)

If your HEMTT needs improvement, let us know. Send us an EIR. You, the user, are the only one who can tell us what you don't like about your equipment. Let us know why you don't like the design or performance. Put it on an SF 368 (Product Quality Deficiency Report). Mail it to us at: Commander, U.S. Army Tank-Automotive and Armament Command, ATTN: AMSTA-TR-EMPA, Warren, MI 48397-5000, DOD AAC:W81D19. We'll send you a reply.

GENERAL INFORMATION - Continued

MATERIAL AND WORKMANSHIP WARRANTY

Regardless of Government inspections and product acceptance, the contractor shall warrant the supplies and services are free from defects in material and workmanship, and conform to the specifications and other requirements of the contract. The contractor shall be liable for the costs of correction of all defects resulting from breach of this warranty as set forth below:

The basic warranty shall be effective for 6 months from the date of shipment. The date of shipment shall be as shown on the Requisition and Invoice/Shipping Document (DD Form 1149). The contractor shall provide greater warranty coverage on components, to the extent that the contractor's suppliers customarily provide such greater coverage to their commercial customers.

NOMENCLATURE CROSS-REFERENCE LIST

<u>Common Name</u>	<u>Official Nomenclature</u>
AC	Air Conditioner
Engine Coolant	Antifreeze, Ethylene Glycol Mixture
HEMTT	8 x 8, Heavy Expanded Mobility Tactical Trucks (HEMTT)
R-134a	AC Refrigerant

GENERAL INFORMATION - Continued

LIST OF ABBREVIATIONS

AC	Air Conditioner
AAL	Additional Authorization List
amp	Amperes
BII	Basic Issue Item
°C	Degree Celsius
cm	Centimeter
DA	Department of the Army
EIR	Equipment Improvement Recommendation
°F	Degree Fahrenheit
ft	Foot
ft-lbs.	Foot Pounds
HEMTT	Heavy Expanded Mobility Tactical Trucks
in.	Inch
JTA	Joint Tables of Allowances
kPa	Kilopascal
lb	Pound
m	Meter
mm	Millimeter
MTOE	Modification Table of Organization and Equipment
N•m	Newton Meter
PMCS	Preventive Maintenance Checks and Services
psi	Pound-Force Per Square Inch
TAMMS	The Army Maintenance Management System
TDA	Tables of Distribution and Allowance
TM	Technical Manual
vdc	Volts Direct Current

GENERAL INFORMATION - Continued

PRINCIPLES OF OPERATION

The HEMTT AC kit is a Field Level Maintenance-installed cab air conditioning system for the HEMTT. The kit consists of an engine driven AC compressor, AC condenser, AC dryer, AC heater/evaporator, AC blower, and AC hoses.

In the HEMTT AC system, the engine driven AC compressor pressurizes R-134a refrigerant gas. The pressurized R-134a gas is then passed through the AC condenser, where it is cooled and converted to a high-pressure liquid. The liquid R-134a is then passed through the AC dryer, where moisture is removed and the liquid R-134a is stored until it is required by the system. When cooling is required, the high-pressure R-134a liquid is passed through the AC expansion valve and AC evaporator, where it is converted to a low-pressure gas. This process cools the R-134a refrigerant and AC evaporator coil. Cab air is then passed across the cooled AC evaporator coil by the AC blower, which cools and dehumidifies the air. The cooled air is then passed back into the cab, cooling the cab. The R-134a gas from the AC evaporator is then passed back to the AC compressor, to complete the refrigerant cycle.

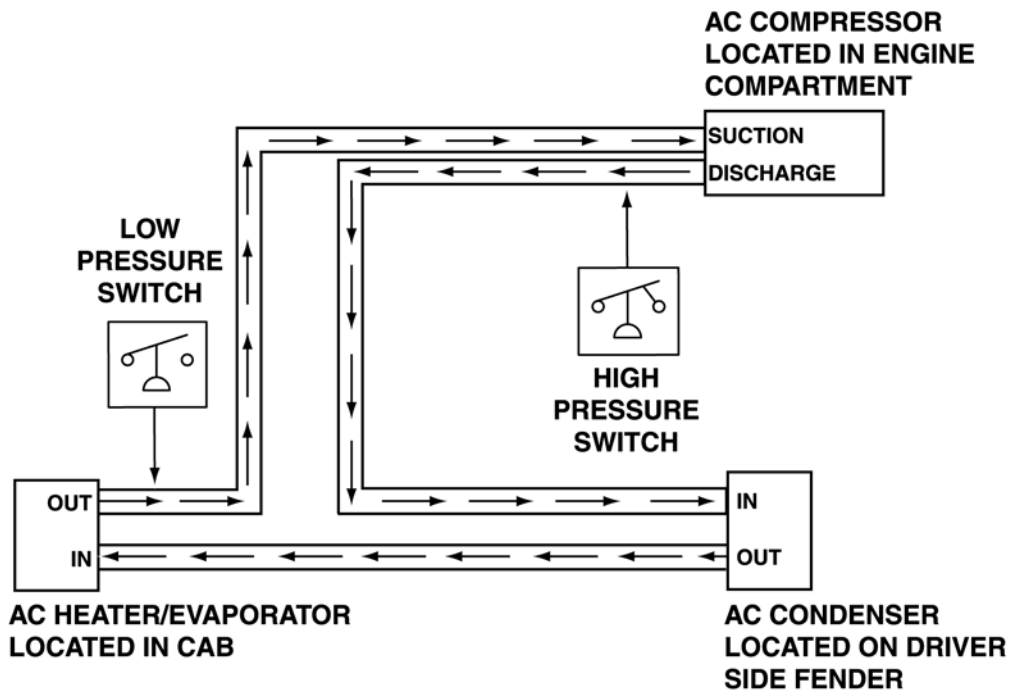

HEMTT AC SYSTEM SCHEMATIC

END OF WORK PACKAGE

TB 9-2320-279-13-1

CHAPTER 2

OPERATOR'S INSTRUCTIONS

OPERATOR'S CONTROLS AND INDICATORS

This work package shows location and describes use of controls and indicators used to operate the HEMTT AC system. Operator/crew must become thoroughly familiar with contents of this work package before attempting to operate the HEMTT AC system.

Know the location and proper use of every control and indicator before operating the HEMTT AC system.

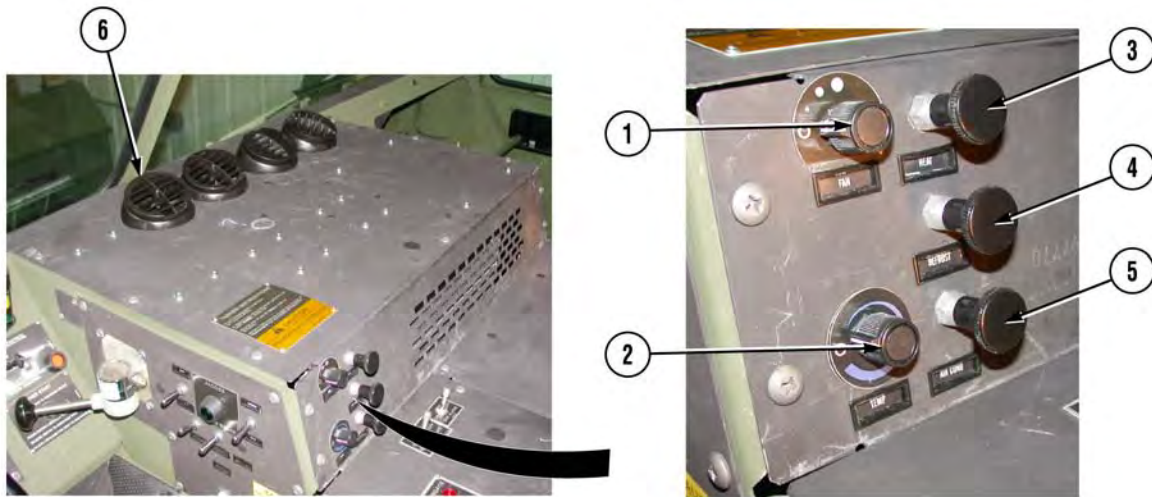

1. **Fan Control Switch.** Four-position switch used to turn the blower motor ON and OFF, and control blower motor speed. When switch is in fully counter-clockwise position, the blower motor is OFF. As the switch is rotated clockwise, blower motor is turned on, and blower motor speed increases.
2. **Temperature Control Switch.** Controls temperature of cold air entering cab. Temperature control switch is OFF when in O position. As temperature control switch is turned clockwise, temperature of cold air entering cab decreases.
3. **Heater Cable.** Controls amount of hot air entering cab. Amount of hot air entering cab increases as heater cable is pulled out and decreases as heater cable is pushed in.
4. **AC Defrost Cable.** Controls amount of hot air blown on windshield. Amount of air blown on windshield increases as AC defrost cable is pulled out and decreases as AC defrost cable is pushed in.
5. **AC Cable.** Controls amount of cold air entering cab. Amount of cold air entering cab increases as AC cable is pulled out and decreases as AC cable is pushed in.
6. **Louvers.** Louvers are used to direct airflow. Adjust louvers for desired airflow.

OPERATOR'S CONTROLS AND INDICATORS - Continued



7. Air Diffuser Balls. Air diffuser balls are used to direct airflow to cab floor. Adjust air diffuser balls for desired airflow.

END OF WORK PACKAGE

OPERATOR'S PREVENTIVE MAINTENANCE CHECKS AND SERVICES (PMCS)

INTRODUCTION

This work package contains Operator's PMCS requirements for the HEMTT AC system. The PMCS table in this work package contains checks and services necessary to ensure that the AC system is ready for operation. Using PMCS tables, perform maintenance at specified intervals. Perform PMCS listed in TM 9-2320-279-10, before performing these PMCS checks.

GENERAL MAINTENANCE PROCEDURES

WARNING

Adhesives, solvents, and sealing compounds can burn easily, can give off harmful vapors and are harmful to skin and clothing. To avoid injury or death, keep away from open fire and use in well-ventilated areas. If adhesive, solvent, or sealing compound gets on skin or clothing, wash immediately with soap and water.

- a. Cleanliness.** Dirt, grease, oil, and debris may cause or cover a serious problem. Clean all metal surfaces.
- b. Bolts, nuts, and screws.** Check bolts, nuts, and screws for obvious looseness, missing, bent, or broken condition. Look for chipped paint, bare metal, or rust around bolt heads. If any part seems loose, tighten it, or have the part repaired or replaced.
- c. Welds.** Look for loose or chipped paint, rust, or gaps on welds. If a bad weld is found, notify Field Level Maintenance.
- d. Electrical wires and connectors.** Look for cracked or broken insulation, bare wires, and loose or broken connectors. Tighten loose connectors and make sure wires are in good shape. If a wire or connector is bad, notify Field Level Maintenance.
- e. AC system leaks.** Look for air conditioner lubrication leakage and corrosion, and damage to fittings, hoses, and other components. Inspect lowest points of fittings, and hoses for indication of lubrication leakage. If lubrication leakage is found, notify Field Level Maintenance.

NOTE

Always observe the warnings and cautions appearing in your PMCS table. Warnings and cautions appear before applicable procedures. You must observe these warnings and cautions to prevent serious injury to yourself and others or prevent equipment from being damaged.

EXPLANATION OF TABLE ENTRIES

- a. "Item No." Column.** Items in this column are for reference. When completing DA Form 2404 (Equipment Inspection and Maintenance Worksheet), include the item number for the check/service indicating a fault. Item numbers also appear in the order that you must do the checks and services for the intervals listed.
- b. "Interval" Column.** This column describes when, and how often, the check is to be made. Thus, if a given check is performed before operation, the word Before is opposite the check in the Interval column.

**OPERATOR'S PREVENTIVE MAINTENANCE CHECKS AND SERVICES (PMCS) -
Continued**

1. Perform the (Before) CHECKS before operating AC system.
2. Perform the (During) CHECKS while operating AC system. During operation means to monitor AC system and its related components while being operated.
3. Perform the (After) CHECKS right after operating this AC system.
4. Perform the (Weekly) CHECKS once a week.

c. "Location Item To Check/Service" Column. The items listed in this column are divided into groups indicating the portion of the equipment of which they are a part, i.e. front, left, engine. Under these groupings, a few common words are used to identify the specific item being checked.

d. "Procedure" Column. This column contains a brief description of the procedure by which the check is performed.

e. "Not Fully Mission Capable If:" Column. This column contains the criteria that causes the equipment to be classified as NOT READY/NOT AVAILABLE because of inability to perform its primary mission. An entry in this column will identify conditions that will make the equipment not ready/available for readiness reporting purposes.

**OPERATOR'S PREVENTIVE MAINTENANCE CHECKS AND SERVICES (PMCS) -
Continued**

OPERATOR'S PREVENTIVE MAINTENANCE CHECKS AND SERVICES (PMCS) TABLES

Refer to Tables 2-1 and 2-2 for Operator's Preventive Maintenance Checks and Services (PMCS) for the HEMTT AC System.

Table 2-1. Operator's Preventive Maintenance Checks and Services (During)

Item No.	Interval	Location Item to Check/Service	Procedure	Not Fully Mission Capable if:
1	During	AC System	<p style="text-align: center;">NOTE</p> <p>Perform the following inspection only if air conditioner is required due to climate conditions.</p> <p>(a) Turn AC on (WP 0004).</p> <p>(b) Wait 5 minutes to allow AC temperature to stabilize.</p> <p>(c) Check temperature.</p> <p>(d) Turn AC off (WP 0004).</p>	

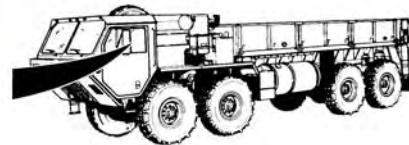

**OPERATOR'S PREVENTIVE MAINTENANCE CHECKS AND SERVICES (PMCS) -
Continued**

Table 2-2. Operator's Preventive Maintenance Checks and Services (Weekly)

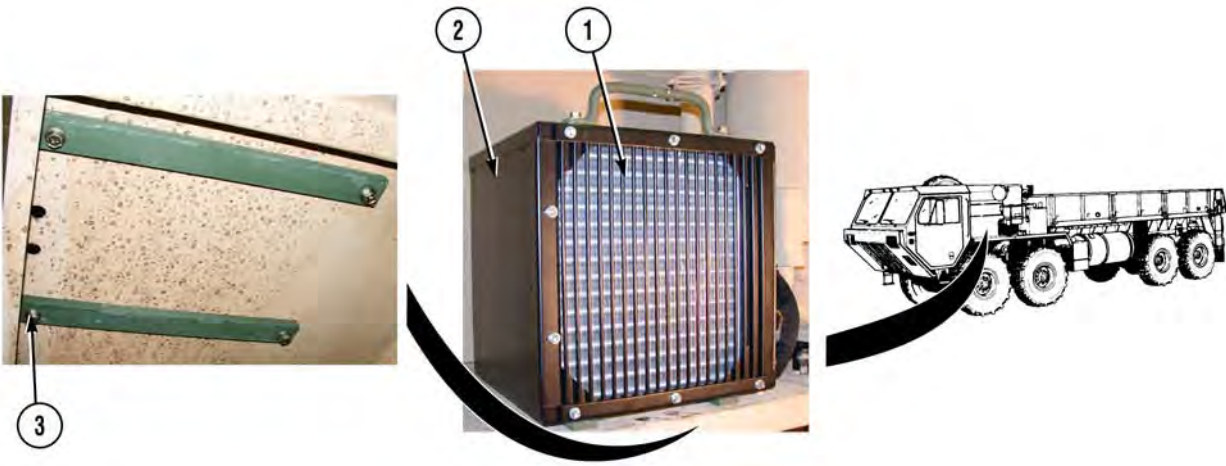
Item No.	Interval	Location Item to Check/Service	Procedure	Not Fully Mission Capable if:
2	Weekly	AC Condenser	 <p>(a) Check AC condenser core (1) for debris, dirt, sand, and damage. Clean any debris, dirt, or sand from AC condenser core (1).</p> <p>(b) Check AC condenser core (1) for corrosion, bent fins, oil leakage, and damage.</p> <p>(c) Check AC condenser (2) mounting hardware for loose or missing screws (3).</p>	

OPERATOR'S PREVENTIVE MAINTENANCE CHECKS AND SERVICES (PMCS) - Continued

Table 2-2. Operator's Preventive Maintenance Checks and Services (Weekly) (Continued)

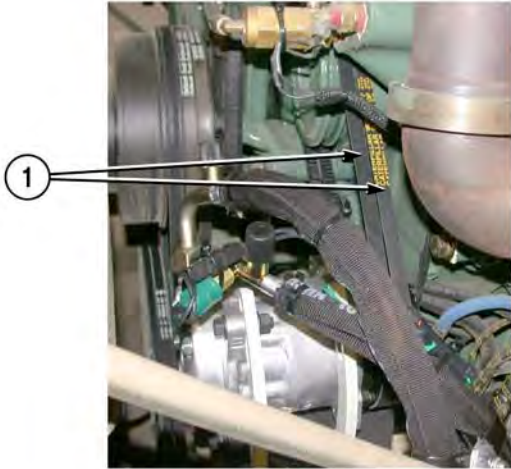
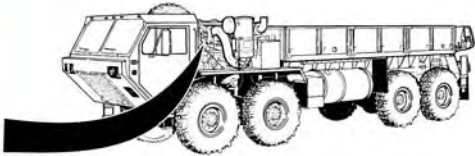
Item No.	Interval	Location Item to Check/Service	Procedure	Not Fully Mission Capable if:
3	Weekly	AC Compressor Belts and Compressor	 	
			<p>(a) Engine cover opened and engine side panel removed (TM 9-2320-279-10).</p> <p style="text-align: center;"><u>WARNING</u></p> <p>Ensure engine is cool prior to checking AC compressor belts. Failure to comply may result in injury to personnel.</p> <p>(b) Check two AC compressor belts (1) for cracking, glazing, fraying, and breaks.</p> <p>(c) Check two AC compressor belts (1) for tightness. There should be approximately 1/2 in. (1.27 cm) of play when pushing on AC compressor belts (1) in center between two pulleys. If tightness appears incorrect, notify Field Level Maintenance.</p>	

**OPERATOR'S PREVENTIVE MAINTENANCE CHECKS AND SERVICES (PMCS) -
Continued**

Table 2-2. Operator's Preventive Maintenance Checks and Services (Weekly) (Continued)

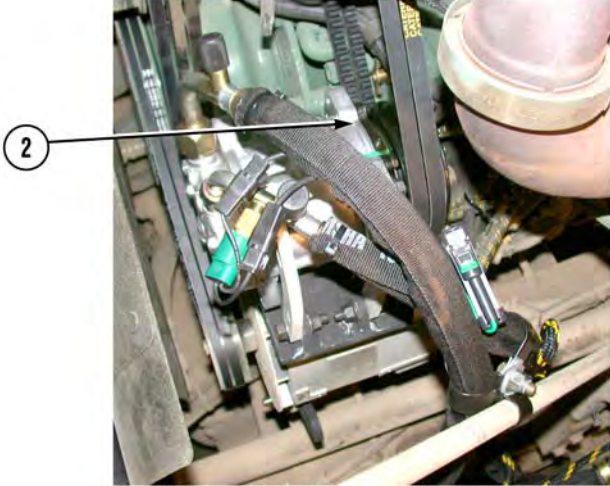
Item No.	Interval	Location Item to Check/Service	Procedure	Not Fully Mission Capable if:
			<p>(d) Check AC compressor (2) mounting hardware for loose or missing screws or locknuts.</p>	

OPERATOR'S PREVENTIVE MAINTENANCE CHECKS AND SERVICES (PMCS) - Continued

Table 2-2. Operator's Preventive Maintenance Checks and Services (Weekly) (Continued)

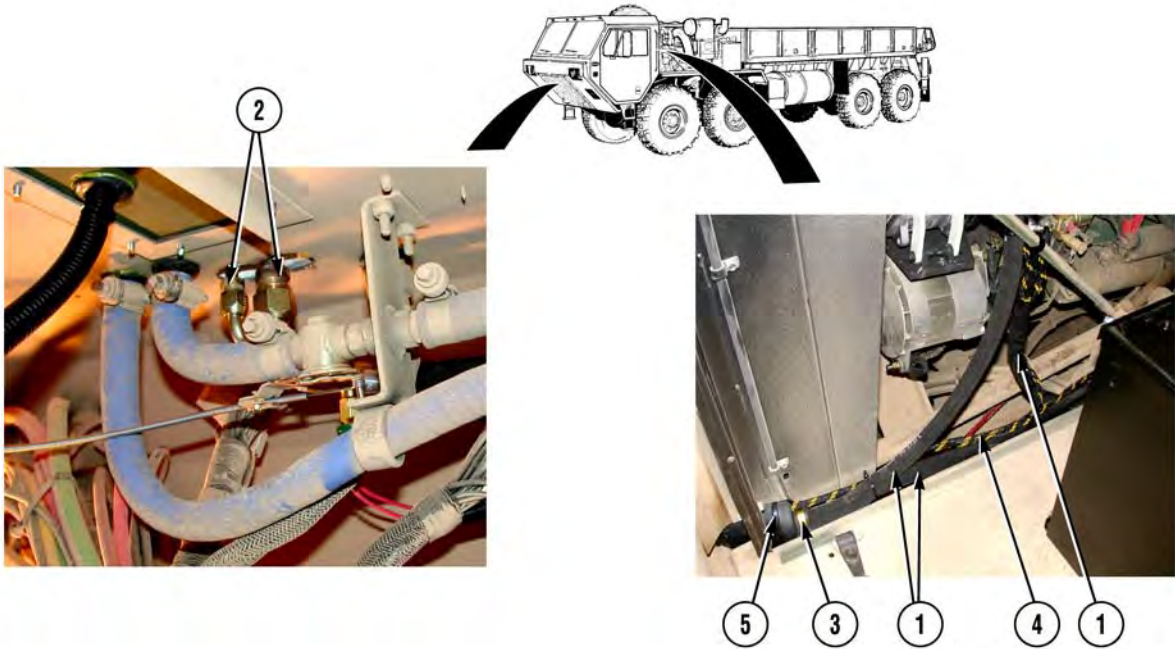
Item No.	Interval	Location Item to Check/Service	Procedure	Not Fully Mission Capable if:
4	Weekly	AC Hoses, Fittings, and Wire Harness	<div style="text-align: center;">  </div> <p>(a) Check three AC hoses (1), fittings (2), and cushion clips (3) for looseness or damage. Notify Field Level Maintenance if AC hoses (1) are loose or damaged.</p> <p>(b) Check three AC hoses (1) at connections for oil leakage, cracking, and chafing. Notify Field Level Maintenance if leaks, cracks, or chafing are found on AC hoses (1).</p> <p>(c) Check AC wire harness (4) for corrosion, breakage, fraying, and loose connections. Notify Field Level Maintenance if wire harness (4) is damaged.</p> <p>(d) Check two hose shields (5) for damage and proper placement.</p>	

**OPERATOR'S PREVENTIVE MAINTENANCE CHECKS AND SERVICES (PMCS) -
Continued**

Table 2-2. Operator's Preventive Maintenance Checks and Services (Weekly) (Continued)

Item No.	Interval	Location Item to Check/Service	Procedure	Not Fully Mission Capable if:
5	Weekly	AC Heater/ Evaporator and Drain Hoses	<p>(a) Check AC evaporator core (1) for debris, dirt, damage, and oil residue.</p> <p>(b) Check two AC evaporator drain hoses (2) underneath cab. Notify Field Level Maintenance if drain hoses are clogged or kinked.</p>	

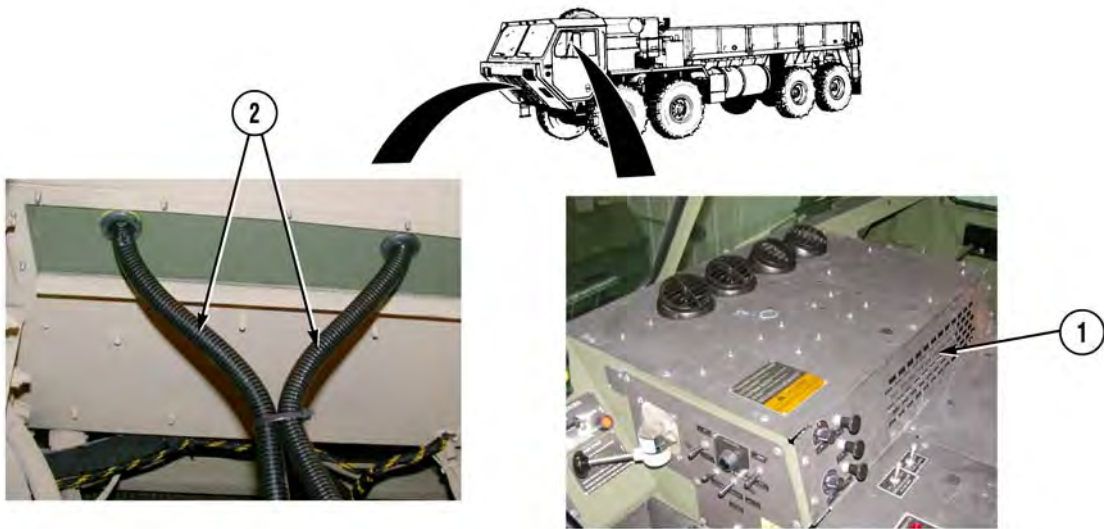

END OF WORK PACKAGE

SYSTEM OPERATION

This work package provides all instructions necessary to operate the HEMTT AC system.

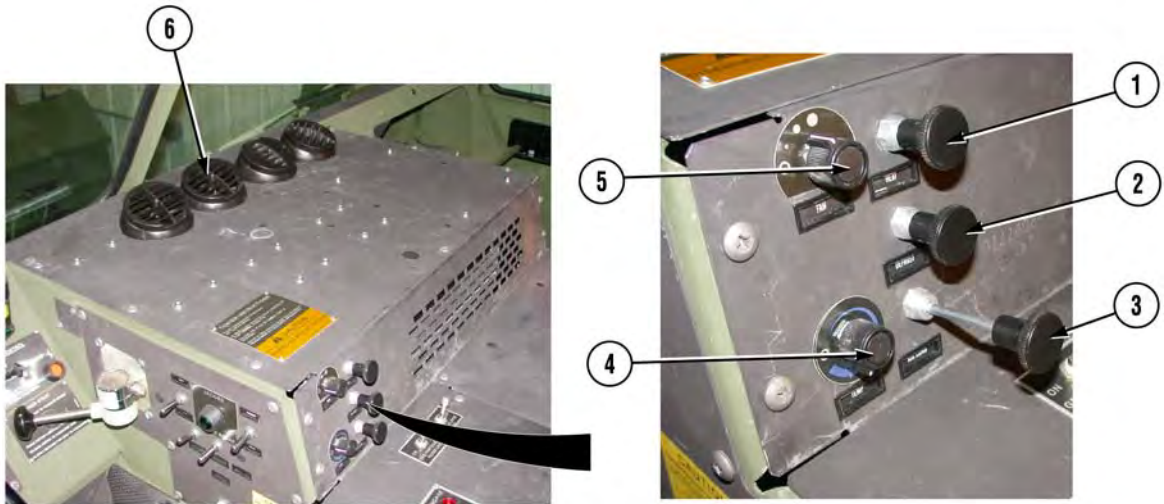
TO TURN AC ON

1. Start engine (TM 9-2320-279-10).
2. Push in heater cable (1).

NOTE

AC defrost cable can be pushed in or pulled out for AC operation. Airflow to upper louvers will be increased as AC defrost cable is pulled out. Airflow to lower louvers will be increased as AC defrost cable is pushed in.

3. Push in or pull out AC defrost cable (2) for desired airflow.
4. Pull out AC cable (3).

NOTE

AC temperature is controlled by position of temperature control switch. When temperature control switch is in the O position, the AC compressor is off. The AC compressor is turned ON, and the temperature entering cab decreases as the temperature control switch is turned clockwise.

5. Turn temperature control switch (4) clockwise to desired temperature.
6. Turn fan control switch (5) clockwise to desired fan speed.
7. Adjust four louvers (6) to desired airflow.
8. As soon as cool air is flowing from four louvers (6), close cab windows.

SYSTEM OPERATION - Continued

TO TURN AC OFF

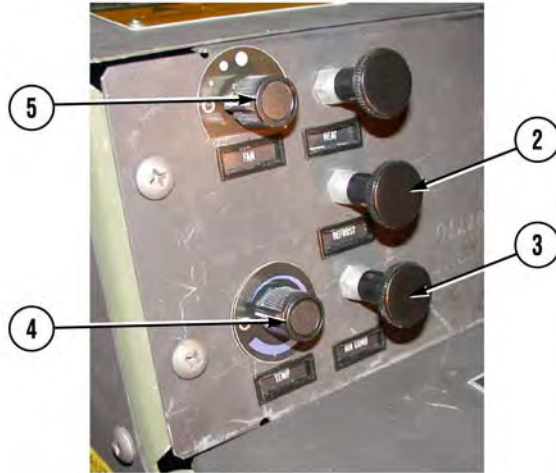

1. Turn fan control switch (5) to O (fully counter-clockwise) position.
2. Turn temperature control switch (4) to O (fully counter-clockwise) position.
3. Push in AC cable (3).
4. Push in AC defrost cable (2).

END OF WORK PACKAGE

TB 9-2320-279-13-1

CHAPTER 3

OPERATOR'S TROUBLESHOOTING

OPERATOR'S TROUBLESHOOTING INTRODUCTION

This chapter lists common malfunctions that you may find with the HEMTT AC system. Perform the tests, inspections, and corrective actions in the order they appear in the table. This chapter cannot list all malfunctions that may occur, all tests or inspections needed to find the fault, or all corrective actions needed to correct the fault. If a malfunction is not listed or actions listed do not correct the fault, notify your supervisor.

TROUBLESHOOTING SYMPTOMS

To quickly find a troubleshooting procedure, use the Malfunction Index. Work packages 0006 and 0007 contain the operator's troubleshooting steps.

MALFUNCTION INDEX

Troubleshooting Procedure		WP Page No.
0006	AC Heater/Evaporator Blower Does Not Operate	0006-1
0007	AC Heater/Evaporator Blower Operates But No Cold Air From Ducts During AC Operations	0007-1

END OF WORK PACKAGE

AC HEATER/EVAPORATOR BLOWER DOES NOT OPERATE

Table 3-1. Operator's Troubleshooting

MALFUNCTION TEST OR INSPECTION CORRECTIVE ACTION	WP SEQUENCE NO.
<p>AC HEATER/EVAPORATOR BLOWER DOES NOT OPERATE.</p> <div style="display: flex; justify-content: space-around; align-items: center;"> <div style="text-align: center;"> <p>ENGINE START SWITCH</p>  </div> <div style="text-align: center;">  </div> <div style="text-align: center;"> <p>FAN CONTROL SWITCH</p>  </div> </div> <p>Step 1. Check if engine start switch is positioned to ON (TM 9-2320-279-10). Position engine start switch to ON.</p> <p>Step 2. Check if fan control switch is set to the correct operating position (WP 0004). Place fan control switch in the correct operating position.</p> <p>If fan control switch is in the correct operating position and AC heater/evaporator blower does not operate, notify Field Level Maintenance.</p>	<p>0006</p>

END OF WORK PACKAGE

AC HEATER/EVAPORATOR BLOWER OPERATES BUT NO COLD AIR FROM DUCTS DURING AC OPERATIONS

Table 3-2. Operator's Troubleshooting

<p>MALFUNCTION</p> <p>TEST OR INSPECTION</p> <p>CORRECTIVE ACTION</p>	<p>WP SEQUENCE NO.</p>
<p>AC HEATER/EVAPORATOR BLOWER OPERATES BUT NO COLD AIR FROM DUCTS DURING AC OPERATIONS.</p> <div data-bbox="256 814 1433 1318" data-label="Image"> </div> <p>Step 1. Inspect intake vent for dust and debris that may restrict airflow. Clear dust and debris from intake vent.</p> <p>Step 2. Check if temperature control switch is set to the desired operating position (WP 0004). Place temperature control switch in the desired operating position.</p>	<p>0007</p>

AC HEATER/EVAPORATOR BLOWER OPERATES BUT NO COLD AIR FROM DUCTS DURING AC OPERATIONS - Continued

Table 3-2. Operator's Troubleshooting (Continued)

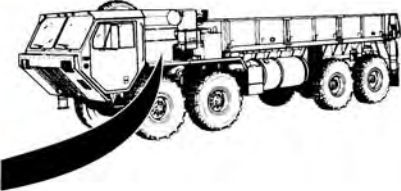
MALFUNCTION TEST OR INSPECTION CORRECTIVE ACTION	WP SEQUENCE NO.
<p style="text-align: center;">NOTE</p> <p style="text-align: center;">Defrost cable can be pushed in or pulled out for AC operation. Airflow to upper air duct will be increased when defrost cable is pulled out.</p> <p>Step 3. Check if heater cable is pushed in (WP 0004). Push in heater cable.</p> <p>Step 4. Check if AC cable is pulled out (WP 0004). Pull out AC cable.</p> <p>Step 5. If engine is on, turn engine OFF (TM 9-2320-279-10).</p> <p>Step 6. Inspect AC condenser assembly for debris and damage. Clean debris from AC condenser assembly. If AC condenser is damaged, notify Field Level Maintenance.</p> <div style="display: flex; justify-content: space-around; align-items: center; margin-top: 20px;">   </div> <p style="text-align: center; margin-top: 10px;">AC CONDENSER ASSEMBLY</p>	

AC HEATER/EVAPORATOR BLOWER OPERATES BUT NO COLD AIR FROM DUCTS DURING AC OPERATIONS - Continued

Table 3-2. Operator's Troubleshooting (Continued)

<p>MALFUNCTION</p> <p>TEST OR INSPECTION</p> <p>CORRECTIVE ACTION</p>	<p>WP SEQUENCE NO.</p>
<p>Step 7. Open driver side engine cover and remove engine side panel (TM 9-2320-279-10).</p> <div data-bbox="328 753 1401 1186" data-label="Image"> </div> <p>Step 8. Inspect AC compressor belts for looseness and damage. If AC compressor belts are loose, damaged, or missing, notify Field Level Maintenance.</p> <p>Step 9. Install engine side panel and close driver side engine cover (TM 9-2320-279-10).</p> <p>Step 10. Start engine and operate AC system (WP 0004). If AC system fails to provide cold air, or stops providing cold air during normal operations, notify Field Level Maintenance.</p>	

END OF WORK PACKAGE

TB 9-2320-279-13-1

CHAPTER 4

FIELD LEVEL PMCS

FIELD LEVEL PREVENTIVE MAINTENANCE CHECKS AND SERVICES (PMCS)

INTRODUCTION

This work package contains Field Level Maintenance PMCS requirements for the HEMTT AC system. These PMCS requirements are in addition to those listed in TM 9-2320-279-20. The PMCS tables contain checks and services necessary to ensure that the AC system is ready for operation. Using PMCS listed tables, perform maintenance at specified intervals. Perform PMCS listed in TM 9-2320-279-10, TM 9-2320-279-20, and Chapter 2 before performing these PMCS checks.

GENERAL MAINTENANCE PROCEDURES

WARNING

- **Dry cleaning solvent is TOXIC and flammable. Wear protective goggles and gloves; use only in a well-ventilated area; avoid contact with skin, eyes, and clothes; and DO NOT breathe vapors. Keep away from heat or flame. Never smoke when using dry cleaning solvent; the flashpoint for Type II is 140°F (60°C), and for Type III it is 200°F (93°C). Failure to follow this warning may result in death or injury to personnel.**
 - **If personnel become dizzy while using cleaning solvent, immediately get fresh air and medical help. If solvent contacts skin or clothes, flush with cold water. If solvent contacts eyes, immediately flush eyes with water and get immediate medical attention.**
 - **Use care to prevent refrigerant from touching skin or eyes. Liquid refrigerant, when exposed to air, quickly evaporates and will freeze skin or eye tissues. Use care to prevent refrigerant from touching your skin or eyes. Serious injury or blindness may result if you come in contact with liquid refrigerant.**
 - **Refrigerant R-134a air conditioning systems should not be pressure tested or leak tested with compressed air. Combustible mixtures of air and R-134a may form, resulting in fire or explosion, which could cause personnel injury or death.**
- a. Cleanliness.** Dirt, grease, oil, and debris may cause or cover a serious problem. Use dry cleaning solvent (Item 8, Appendix E) on metal surfaces and soapy water on rubber items.
- b. Bolts, nuts, and screws.** Check bolts, nuts, and screws for obvious looseness, missing, bent, or broken condition and tighten or replace as necessary. If they cannot be checked with a tool, look for chipped paint, bare metal, or rust around bolt heads.
- c. Welds.** Look for loose or chipped paint, rust, or gaps on welds. If a bad weld is found, notify supervisor.
- d. Electrical wires and connectors.** Look for cracked or broken insulation, bare wires, and loose or broken connectors. Tighten loose connectors and ensure wires are in good shape.
- e. AC system leaks.** Look for air conditioner lubrication leakage and corrosion, and damage to fittings, hoses, and other components. Inspect lowest points of fittings and hoses for indication of lubrication leakage.
- f. Damage.** Damage is defined as any condition that affects safety or would make the AC system unserviceable for mission requirements.

**FIELD LEVEL PREVENTIVE MAINTENANCE CHECKS AND SERVICES (PMCS) -
Continued**

EXPLANATION OF TABLE ENTRIES

- a. Do the SEMI-ANNUAL PREVENTIVE MAINTENANCE (Table 4-1) once every 6 months and/or every 3,000 miles (4,828 km) whichever comes first.
- b. If anything looks wrong and is not fixed, write a DA Form 2404 and notify supervisor.
- c. The following is a breakdown of the PMCS table:
 - 1. **“Item No.” Column.** Checks and services are numbered in a logical order for moving around the truck. The item number column is used as a source of item numbers for the TM Number Column on DA Form 2404, Equipment Inspection and Maintenance Worksheet, for recording results of the PMCS.
 - 2. **“Interval” Column.** The column identifies when the PMCS should be performed.
 - 3. **“Location Item To Check/Service” Column.** This column identifies the item to be inspected.
 - 4. **“Procedure” Column.** This column contains all the information required to do the check/inspection. Art is integrated into the column to aid the user in identifying items. Whenever replacement or repair is recommended, reference is made to the applicable work package.
 - 5. **“Not Fully Mission Capable If:” Column.** This column contains a brief statement of the condition (e.g., malfunction, shortage) that would cause the vehicle to be less than fully ready to perform its assigned mission.

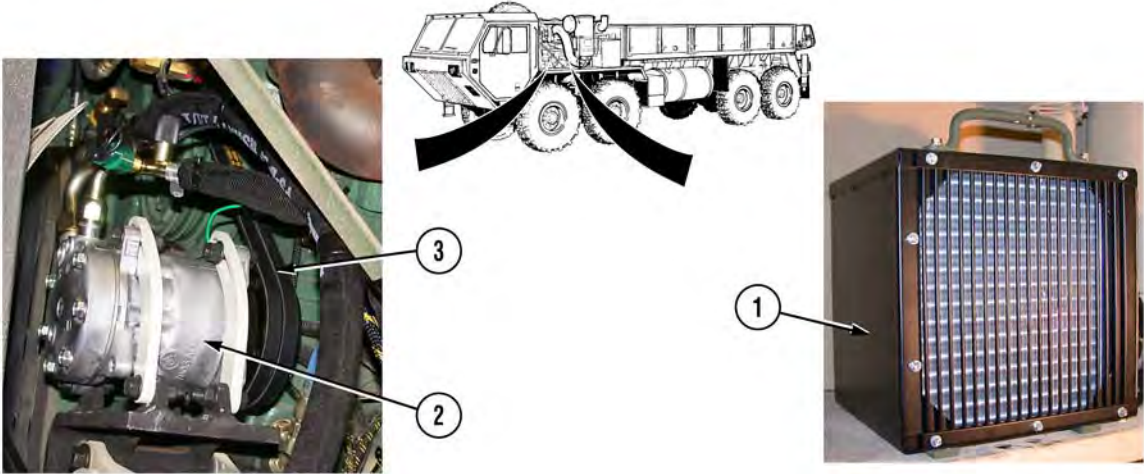

FIELD LEVEL PREVENTIVE MAINTENANCE CHECKS AND SERVICES (PMCS) - Continued

Table 4-1. Field Level Preventive Maintenance Checks and Services (Semi-Annual)

Item No.	Interval	Location Item to Check/Service	Procedure	Not Fully Mission Capable if:
1	Semi-Annual	AC System (Engine Compartment)	<div style="text-align: center;">  </div> <p style="text-align: center;"><u>WARNING</u></p> <p>Ensure engine is cool before performing maintenance. Failure to comply may result in severe burns.</p> <p style="text-align: center;">NOTE</p> <p>Ensure operator/crew has performed Operator's PMCS listed in Chapter 2 of this technical bulletin, before continuing.</p> <p>(a) Engine cover opened and engine side panel removed (TM 9-2320-279-10).</p> <p>(b) Check AC condenser (1) and AC compressor (2) for damage and missing or loose mounting hardware.</p> <p>(c) Check two AC compressor drive belts (3) for damage and proper tension. Belt tension gage reading should be 90-100 lbs. (400-445 N). If gage reading is not correct, adjust drive belt tension (WP 0022).</p>	

FIELD LEVEL PREVENTIVE MAINTENANCE CHECKS AND SERVICES (PMCS) - Continued

Table 4-1. Field Level Preventive Maintenance Checks and Services (Semi-Annual) (Continued)

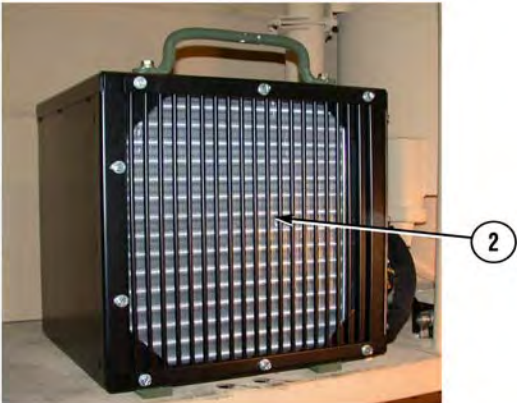
Item No.	Interval	Location Item to Check/Service	Procedure	Not Fully Mission Capable if:
2	Semi-Annual	AC System	 <p>(d) Check three AC hoses (4) for cracks and damage.</p> <p>(e) Perform AC system leak test (WP 0049).</p> <p>NOTE Heater/evaporator shown removed for clarity.</p>	
			  <p>(a) Clean AC evaporator core (1); check for damage.</p> <p>(b) Clean AC condenser core (2); check for damage.</p>	

END OF WORK PACKAGE

TB 9-2320-279-13-1

CHAPTER 5

FIELD LEVEL TROUBLESHOOTING

FIELD LEVEL TROUBLESHOOTING INTRODUCTION

This chapter contains step-by-step procedures for identifying, locating, isolating, and repairing the HEMTT AC system equipment malfunctions.

This technical bulletin cannot list all malfunctions that may occur, nor all test or inspections and corrective actions. If a malfunction is not listed or is not corrected by listed corrective actions, notify Supervisor.

a. Page Layout. Troubleshooting procedures are divided into logic tree pages and test pages.

1. A logic tree page is always a left-hand page, facing the test page on the right. The logic tree page provides the sequence of steps required to isolate a fault to a failed component. All critical information for decision making is on the left-hand page. Each logic tree page contains the following information:
 - (a) **INITIAL SETUP** – This box is located only on the first logic tree page of a fault. INITIAL SETUP lists tools, materials, references, personnel, and equipment needed to troubleshoot the fault.
 - (b) **KNOWN INFO** – This box is located in the top left-hand column. KNOWN INFO lists conditions and information that will eliminate specific components as the cause of the fault.
 - (c) **POSSIBLE PROBLEMS** – This box is located directly below KNOWN INFO. All of the system components that could cause a fault are listed in the POSSIBLE PROBLEMS box. The first component listed in the POSSIBLE PROBLEMS box is the one that will be tested at that step in the logic sequence. When one of the components is tested and found to be operational, it is entered at the bottom of the KNOWN INFO box as OK.
 - (d) **QUESTION** – Each question, located in the middle column, refers to the first possible problem listed in POSSIBLE PROBLEMS. If the answer to the question is YES, proceed to the next step. If the answer is NO, follow the NO arrow to obtain directions for correcting the problem. If the step contains a WARNING or CAUTION message, a small shadow box is printed above the question. Text for WARNINGS and CAUTIONS is on the following right-hand page.
 - (e) **TEST OPTIONS** – This box is located in the top right-hand column. TEST OPTIONS lists tests available for testing parts suspected of failing.
 - (f) **REASON FOR QUESTION** – This box is located directly below TEST OPTIONS. It explains the purpose for the question in the middle column.
2. A test page is always a right-hand page, facing the logic tree page on the left. The test provides detailed instructions for testing the first component listed in the POSSIBLE PROBLEMS box. This test will also provide an answer for the question in the middle column. Note the arrow connecting the test on the right-hand page to the REASON FOR QUESTION. When possible, illustrations are included to provide visual details. Warnings, cautions, and notes contain additional information for testing.

FIELD LEVEL TROUBLESHOOTING INTRODUCTION - Continued

b. How to Begin Troubleshooting.

1. Determine the symptom or condition that indicates a problem or failure. Troubleshooting is divided into symptoms peculiar to a component, for example: AC heater/evaporator blower or AC compressor. Refer to the Troubleshooting Fault Index on page 0009-8.
2. Go to the referenced page to begin troubleshooting. Open the technical bulletin flat so both the left-hand and right-hand pages are displayed before you. The information on both pages is important to resolve the problem or failure. However, the experienced technician can follow the left-hand page instructions and refer to the right-hand page when necessary.
3. Follow the diagnostic procedure. Answer question No. 1 on the left-hand page and follow the YES or NO path to either the remedy or the next question. If necessary, look on the right-hand page for test instructions and illustrations.
4. Observe warnings, cautions, and notes. The formatting and symbols used in this manual for warnings, cautions, and notes are as follows:

WARNING

This is the symbol for a warning statement. If you see the word WARNING above a question on the left-hand page, look on the right-hand page for the text of the message. WARNINGS describe a situation which could cause severe injury or death to personnel.

CAUTION

This is the symbol for a caution statement. If you see the word CAUTION above a question on the left-hand page, look on the right-hand page for the text of the message. CAUTIONS describe a situation which could cause damage to equipment.

NOTE

This is the symbol for a note. Notes are located directly above the test to which they refer. Notes provide additional information for performing a test.

c. Measurements Required for Troubleshooting.

CAUTION

Use proper-sized test leads and ensure care is used when checking for resistance, continuity, or voltage at connectors, or damage to equipment may result.

1. **Resistance measurements.**
 - (a) Connect red test lead to volt-ohm input connector and black lead to COM input connector on meter.
 - (b) Set the function/range switch to the desired ohm position. If the magnitude of the resistance is not known, set the switch to the highest range, then reduce until a satisfactory reading is obtained.

FIELD LEVEL TROUBLESHOOTING INTRODUCTION - Continued

- (c) If the resistance being measured is connected to a circuit, turn ENGINE switch OFF.
- (d) Connect test leads to the circuit being measured. When measuring high resistance, be careful not to contact adjacent points, even if they are insulated. Some insulators have a relatively low insulation resistance which can affect the resulting measurement.
- (e) Read the resistance value on the digital display.

2. Continuity checks.

- (a) Place the function/range switch in any ohm range.

NOTE

Some meters show "l+m", or simply "l" when functioning/range switch is in any ohm position.

- (b) Connect the red test lead to the volt-ohm connector and black lead to COM input connector on the meter. When the test leads are separated or measuring an out-of-range resistance, the digital display will indicate "OL" (Over Limit).
 - (c) Put one test probe at one end of the wire or circuit to be tested. Use the other test lead to trace the circuit. When continuity is established, an ohm symbol will appear in the upper left corner of the digital display. If contact in the wire is maintained long enough (about 1/4 of a second), the OL display will disappear and the resistance value of the wire or circuit will appear next to the symbol. A resistance value of 200 ohms or less indicates continuity is being measured.
 - (d) If your multimeter does not work in this manner, learn how it operates before performing troubleshooting.
3. **Voltage measurements.** The HEMTT truck is equipped with 24 vdc circuits. Troubleshooting procedures will reference 24 vdc measurements, however these values can vary. When the batteries are fully charged, 25.2 vdc can be measured on an open 24 volt circuit and 29 vdc can be measured when the engine is running at 1000 rpm.
- (a) Connect the red test lead to the volt-ohm input connector and the black lead to the COM input on the meter. If a DC-AC switch is present, make sure it is set to the DC position.
 - (b) Set the function/range switch to the desired volts position. If the magnitude of the voltage is not known, set the switch to a range which will be able to read most voltages seen on the truck (typically, a 200V range will do). Then reduce the range until a satisfactory reading is obtained.
 - (c) Connect the test leads to the circuit being measured. Following the voltage measurement point, the color test lead tube used is given in parenthesis (red is volt-ohm connection and black is the COM connection).

FIELD LEVEL TROUBLESHOOTING INTRODUCTION - Continued

4. **AC system performance checks.** Troubleshooting procedure for the HEMTT AC system includes system performance checks. A properly functioning AC system will have the following characteristics:
- (a) The fan control switch is set to the desired AC heater/evaporator blower speed position (low, medium, or high).
 - (b) The temperature control switch is set to the desired temperature position.
 - (c) The AC low and high pressure switches are closed.
 - (d) The AC condenser fan motor cycles with AC evaporator temperature.
 - (e) The AC compressor clutch engages and cycles with AC evaporator temperature.
 - (f) The AC compressor suction line is cool.
 - (g) The AC compressor discharge line is hot.
 - (h) The AC condenser core is hot/warm.
 - (i) The AC hose between the AC condenser core and AC condenser receiver/dryer is warm.
 - (j) The AC condenser receiver/dryer is at outside temperature.
 - (k) The inlet to the AC expansion valve is warm.
 - (l) The AC evaporator core is cold.
 - (m) The AC discharge air temperature is approximately 20°F cooler than the ambient air temperature.
 - (n) Condensation water may drain from the AC evaporator core.
5. **AC system fault symptoms.** The following is a brief description of some of the symptoms or conditions that may exist if a component fails in the refrigerant circuit of the AC system:
- (a) If moisture, air, or other contaminants enter the refrigerant circuit, the AC system will not cool properly and the refrigerant and AC condenser receiver/dryer must be replaced after locating and correcting the cause of the contamination.
 - (b) AC compressor failure will show up as abnormal noise, seizure, leakage, or low suction and discharge pressures.
 - (c) A faulty or improperly installed temperature control switch temperature probe may cause quick or delayed AC compressor cycling.
 - (d) A blockage in the AC condenser core will cause high system high-side pressure. Frost may form at the location of the blockage.

FIELD LEVEL TROUBLESHOOTING INTRODUCTION - Continued

- (e) The AC condenser receiver/dryer is normally at outside temperature. If the AC condenser receiver/dryer is cool or cool spots form, a blockage has formed in the AC condenser receiver/dryer.
 - (f) A blockage at the inlet of the AC condenser receiver/dryer will cause high system high-side pressure.
 - (g) A blockage at the outlet of the AC condenser receiver/dryer will cause low system high-side pressure and little or no cooling.
 - (h) If the AC expansion valve is stuck closed, the AC expansion valve and AC evaporator core will be at outside temperature.
 - (i) If the AC expansion valve is stuck open, the AC expansion valve and AC evaporator core will be extremely cold and frost or ice buildup may occur.
 - (j) If ice is forming in the AC expansion valve, the system may stop cooling when the ice forms, and start cooling when the expansion valve warms up enough to melt the ice, causing the system to appear to cycle ON and OFF.
 - (k) A blockage in the AC evaporator core will cause low system low-side pressure and little or no cooling.
 - (l) A leak in the AC evaporator core or AC expansion valve fittings may not be detectable with leak detector.
 - (m) A restriction in a low system side AC hose will cause low system low-side pressure and little or no cooling. Cool spots and frost may form at location of restriction.
 - (n) A restriction in a high system side AC hose will cause high system high-side and low system low-side pressure and insufficient cooling. Cool spots and frost may form at location of restriction.
6. **AC system pressure checks.** In addition to the performance checks noted above, the troubleshooting procedures for the HEMTT AC system will also include system pressure checks, using standard AC test set recovery/recycling manifold gages. Before using the manifold gages to measure AC system pressure, ensure that the system is fully charged and stabilize the system by ensuring that all cab windows and vents are closed, personnel heater is OFF, and by running the system at high heater/evaporator blower speed for 5 to 10 minutes.

d. Wire Repair. Refer to TM 9-2320-279-20 for the repair of wire harness connectors. Wire harness repair is limited to splicing and taping of wires at Field Level Maintenance. If a wire harness cannot be repaired, notify Supervisor.

FIELD LEVEL TROUBLESHOOTING INTRODUCTION - Continued

e. AC System Leak Repair. The majority of all AC system services will consist of locating and repairing AC system leaks. Many leaks will be located at points of connections, and are caused by vibration. Occasionally, an AC hose will rub on a structural part or deteriorate, creating a leak. Or, an AC system component will develop a leak. These leaks can be repaired in the following manner.

1. **Minor leaks at connectors.** Most minor leaks at connectors can be repaired by tightening the connectors or replacing the preformed packing. Use two wrenches when loosening or tightening connectors to avoid strain on AC hoses. Recover refrigerant before tightening connectors or replacing preformed packing. See work package 0050 for refrigerant recovery.
2. **Defective AC hoses.** Damaged or deteriorated AC hoses must be replaced. See work package 0040 for AC hose replacement.
3. **AC component leaks.** If an AC component develops a leak, which cannot be repaired by tightening fittings or replacing preformed packing, the component may have to be replaced. See the associated work package for component replacement.

f. Safety Precautions.

1. Whenever repairs are made to any AC part that holds refrigerant, you must recover, purge or flush (if contaminated), evacuate, charge, and leak test the system. In a good system, refrigerant lines are always under pressure and you should disconnect them only after the refrigerant has been recovered with an AC test set recovery/recycling unit through service valves. See work package 0050.

WARNING

Use care to prevent refrigerant from touching your skin or eyes. Liquid refrigerant, when exposed to air, quickly evaporates and will freeze skin or eye tissues. Serious injury or blindness may result if you come in contact with liquid refrigerant.

2. Refrigerants are safe when used under the right conditions. Always wear safety goggles and nonleather gloves while discharging, purging, flushing, evacuating, charging, and leak testing the system. Do not wear leather gloves. When refrigerant gas or liquid contacts leather, the leather will stick to your skin.
3. Refrigerant splashed in the eyes should be treated with a few drops of sterile mineral oil in the eyes, then rinsed with a weak boric acid solution. Do not rub the eyes. Call a doctor immediately.
4. Refrigerant splashed on the skin should be treated the same as for frostbite. Gently pour cool water on the area, but do not rub the skin. Keep the skin warm with layers of soft, sterile cloth. Call a doctor immediately.

FIELD LEVEL TROUBLESHOOTING INTRODUCTION - Continued

WARNING

Do not work in an area where refrigerant may contact an open flame or any burning material, such as a cigarette. When it contacts extreme heat, refrigerant breaks down into poisonous phosgene gas. Which if breathed, causes severe respiratory irritation. Do not breathe fumes from an open flame leak detector.

5. Even though refrigerant does not burn, when it contacts extreme heat or flame, a poisonous phosgene gas is created. This gas is also produced when an open flame leak detector is used. Phosgene gas fumes have an acrid (bitter) smell.
6. You must work in a well ventilated area when the AC system is discharged, purged, flushed, evacuated, charged, and leak tested using an open flame leak detector.
7. Under current federal laws, refrigerant must be recovered and recycled by all users to protect the environment. Many service operations not directly involving the air conditioning system, require the release of the refrigerant charge. Under new regulations, shops not having the required recovery and recycling equipment (and properly trained and certified personnel) will not be allowed to do any of this service work.
8. Because of its very low boiling point, refrigerant must be stored under pressure. To prevent the refrigerant cans from exploding, never expose them to temperatures higher than 125°F (52°C). Never leave refrigerant cans in the sun, or store them in sun-exposed areas where heat can build up, such as in gloveboxes, automobile trunks, etc.

g. Abbreviations and Commonly Used Terms.

1. AC - Air Conditioner: either component, subsystem, or system.
2. BAT - Battery.
3. CKT - Circuit.
4. COM - Common.
5. R-134a - AC refrigerant.
6. System - A collection of devices which are related to each other because they depend on each other to do some function or job.
7. Test Chain - A series of tests to be followed in a particular order or sequence (numbered).
8. Troubleshooting - The process of making measurements and observing the operation of the vehicle to find out if, and where any problems exist.

FIELD LEVEL TROUBLESHOOTING INTRODUCTION - Continued

TROUBLESHOOTING FAULT INDEX

Troubleshooting Procedure	WP Page No.
0010 AC Heater/Evaporator Blower Does Not Operate	0010-1
0011 AC Heater/Evaporator Blower Does Not Operate In All Speeds (Low, Medium, and High)	0011-1
0012 AC Heater/Evaporator Blower Operates But No Cold Air From Ducts During AC Operations	0012-1
0013 AC Compressor Excessively Noisy	0013-1
0014 AC Compressor Does Not Shut Off Or Cycles Constantly	0014-1
0015 AC Does Not Cool Or Cools Inadequately	0015-1

END OF WORK PACKAGE

AC HEATER/EVAPORATOR BLOWER DOES NOT OPERATE

INITIAL SETUP:

Maintenance Level

Field Level Maintenance

Materials/Parts

None

Equipment Condition

Shut off engine (TM 9-2320-279-10).
 Parking brake applied (TM 9-2320-279-10).
 Wheels chocked (TM 9-2320-279-10).

Personnel Required

MOS 52C, Utilities equipment repairer

References

TM 9-2320-279-10
 TM 9-2320-279-20

Tools and Special Tools

Tool Kit, General Mechanic's (Item 7, Appendix F)
 Multimeter (Item 2, Appendix F)

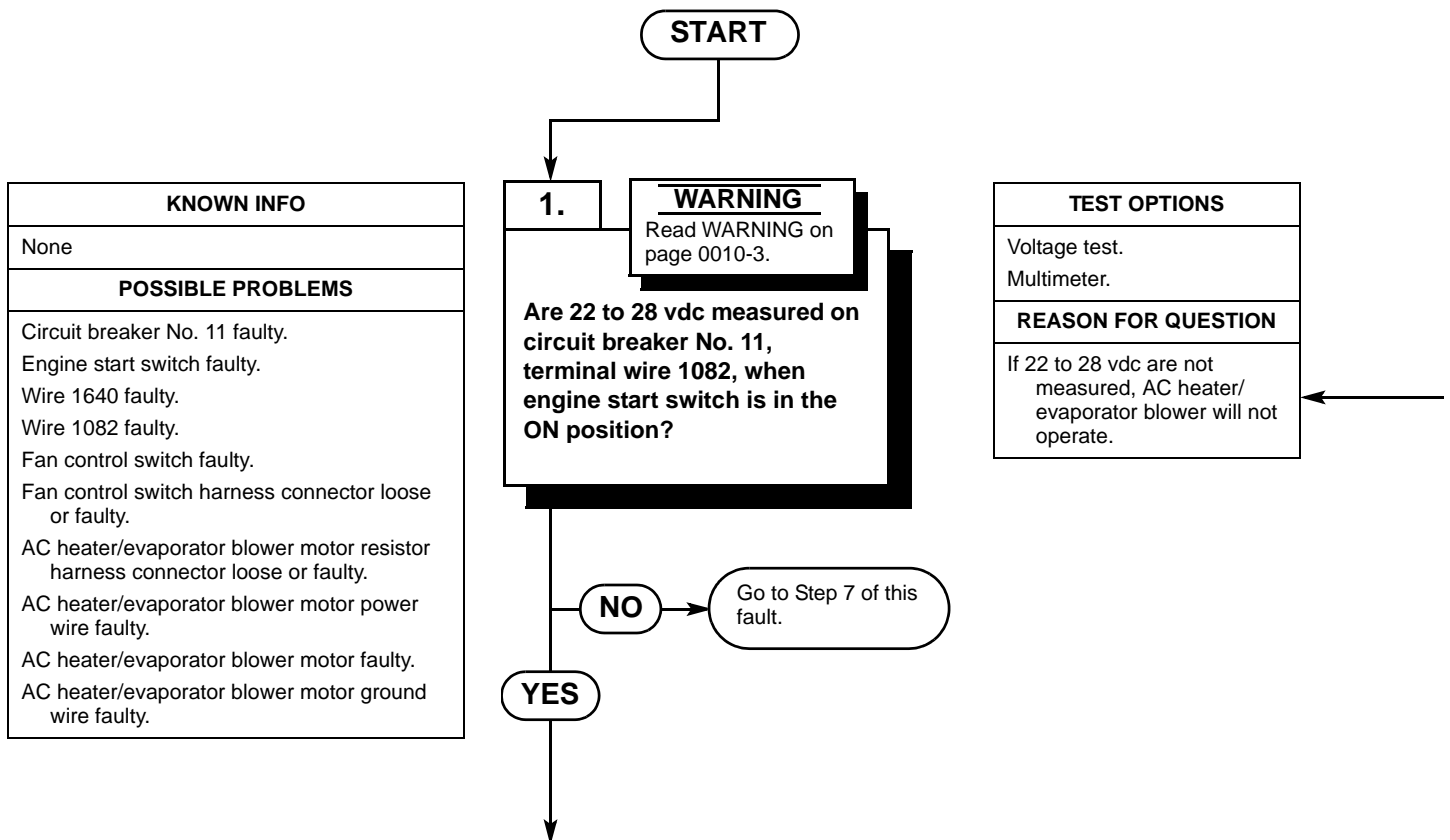

AC HEATER/EVAPORATOR BLOWER DOES NOT OPERATE - Continued

WARNING

- Remove rings, bracelets, wristwatches, neck chains, and any other jewelry before working around vehicle. Jewelry can catch on equipment and cause serious injury. Jewelry or tools may short across electrical circuits or terminals and cause damage to equipment or severe burns or electrical shock to personnel.
- Circuit breakers No. 4, 5, 6, and 10 are always electrically live and can cause severe injury to personnel. Care must be taken when working around these circuit breakers.

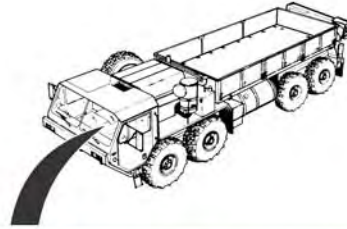

SCREWS
CIRCUIT
BREAKER NO. 11
LEFT HEATER
COVER



WIRE 1082

VOLTAGE TEST

- (1) Remove six screws and left heater cover (TM 9-2320-279-20).
- (2) Turn engine start switch ON (TM 9-2320-279-10).
- (3) Place positive (+) probe of multimeter on circuit breaker No. 11 at terminal wire 1082.
- (4) Place negative (-) probe of multimeter on a known good ground.
 - (a) If 22 to 28 vdc are not measured, go to Step 7 of this fault.
 - (b) If 22 to 28 vdc are measured, turn engine start switch OFF and go to Step 2 of this fault.

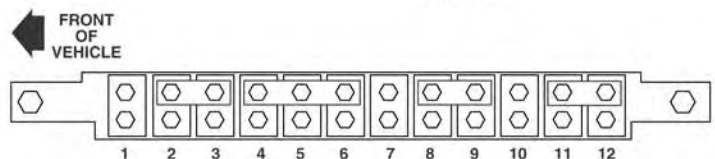

AC HEATER/EVAPORATOR BLOWER DOES NOT OPERATE - Continued

KNOWN INFO
Circuit breaker No. 11 OK. Engine start switch OK. Wire 1640 OK.
POSSIBLE PROBLEMS
Wire 1082 faulty. Fan control switch faulty. Fan control switch harness connector loose or faulty. AC heater/evaporator blower motor resistor harness connector loose or faulty. AC heater/evaporator blower motor power wire faulty. AC heater/evaporator blower motor faulty. AC heater/evaporator blower motor ground wire faulty.

2.

WARNING
Read WARNING on page 0010-5.

Are 22 to 28 vdc measured on wire 1082 at fan control switch, when engine start switch is in the ON position?

TEST OPTIONS
Voltage test. Multimeter.
REASON FOR QUESTION
If 22 to 28 vdc are not measured, wire 1082 is faulty.

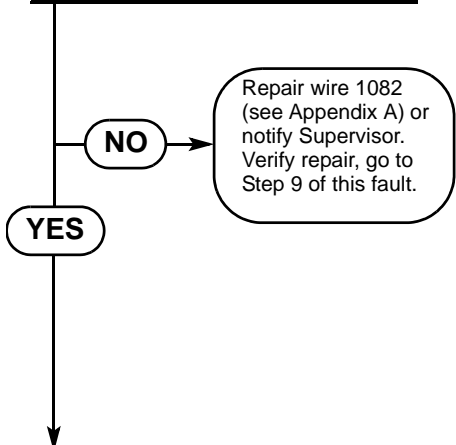

KNOWN INFO
Circuit breaker No. 11 OK. Engine start switch OK. Wire 1640 OK. Wire 1082 OK.
POSSIBLE PROBLEMS
Fan control switch faulty. Fan control switch harness connector loose or faulty. AC heater/evaporator blower motor resistor harness connector loose or faulty. AC heater/evaporator blower motor power wire faulty. AC heater/evaporator blower motor faulty. AC heater/evaporator blower motor ground wire faulty.

3.

WARNING
Read WARNING on page 0010-5.

Is continuity measured across fan control switch from terminal wire 1082 to terminal orange wire, when switch is in high speed (fully clockwise) position?

TEST OPTIONS
Continuity test. Multimeter.
REASON FOR QUESTION
If continuity is not measured, fan control switch is faulty.

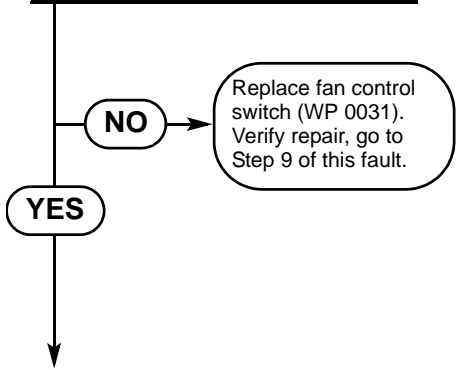

AC HEATER/EVAPORATOR BLOWER DOES NOT OPERATE - Continued

WARNING

Remove rings, bracelets, wristwatches, neck chains, and any other jewelry before working around vehicle. Jewelry can catch on equipment and cause serious injury. Jewelry or tools may short across electrical circuits or terminals and cause damage to equipment or severe burns or electrical shock to personnel.

VOLTAGE TEST

- (1) Remove eight screws and top heater cover (WP 0037).
- (2) Turn engine start switch ON (TM 9-2320-279-10).
- (3) Place positive (+) probe of multimeter on wire 1082 at fan control switch.
- (4) Place negative (-) probe of multimeter on a known good ground.
 - (a) If 22 to 28 vdc are not measured, turn engine start switch OFF and repair wire 1082 (see Appendix A) or notify Supervisor. Verify repair, go to Step 9 of this fault.
 - (b) If 22 to 28 vdc are measured, turn engine start switch OFF and go to Step 3 of this fault.

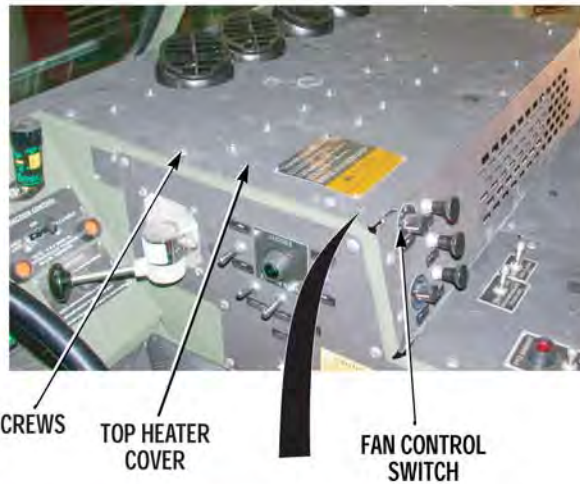
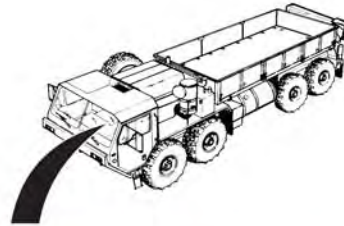

CONTINUITY TEST

- (1) Disconnect wire 1082 from fan control switch (WP 0031).
- (2) Turn fan control switch to high speed (fully clockwise) position (WP 0004).
- (3) Set multimeter switch to ohms.
- (4) Place positive (+) probe of multimeter on fan control switch at terminal orange wire.
- (5) Place negative (-) probe of multimeter on fan control switch at terminal orange wire.
 - (a) If there is no continuity, replace fan control switch (WP 0031). Verify repair, go to Step 9 of this fault.
 - (b) If there is continuity, connect wire 1082 on fan control switch and go to Step 4 of this fault.

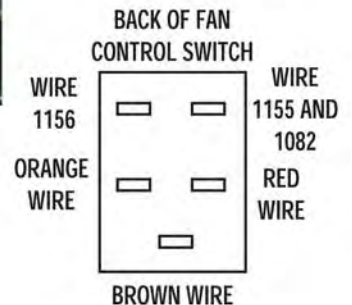
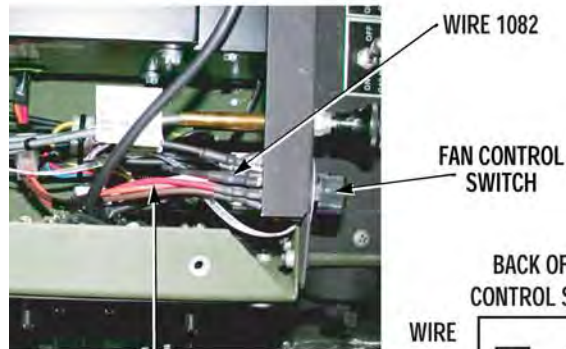

AC HEATER/EVAPORATOR BLOWER DOES NOT OPERATE - Continued

KNOWN INFO
Circuit breaker No. 11 OK. Engine start switch OK. Wire 1640 OK. Wire 1082 OK. Fan control switch OK.
POSSIBLE PROBLEMS
Fan control switch harness connector loose or faulty. AC heater/evaporator blower motor resistor harness connector loose or faulty. AC heater/evaporator blower motor power wire faulty. AC heater/evaporator blower motor faulty. AC heater/evaporator blower motor ground wire faulty.

4.

WARNING
Read WARNING on page 0010-7.

Are fan control switch and AC heater/evaporator blower motor resistor harness wires free from damage and loose connectors?

TEST OPTIONS
Visual inspection.
REASON FOR QUESTION
If connectors are loose or wires are damaged, AC heater/evaporator blower will not operate.

NO

Repair wires (see Appendix A) or replace fan control switch harness (WP 0031) or AC heater/evaporator blower motor resistor harness (WP 0036) as required. Verify repair, go to Step 9 of this fault.

YES

KNOWN INFO
Circuit breaker No. 11 OK. Engine start switch OK. Wire 1640 OK. Wire 1082 OK. Fan control switch OK. Fan control switch harness connector OK. AC heater/evaporator blower motor resistor harness connector OK.
POSSIBLE PROBLEMS
AC heater/evaporator blower motor power wire faulty. AC heater/evaporator blower motor faulty. AC heater/evaporator blower motor ground wire faulty.

5.

WARNING
Read WARNING on page 0010-7.

Is continuity measured across AC heater/evaporator blower power wire from AC heater/evaporator blower motor resistor to blower motor power wire splice?

TEST OPTIONS
Continuity test. Multimeter.
REASON FOR QUESTION
If continuity is not measured, AC heater/evaporator blower power wire is faulty.

NO

Repair AC heater/evaporator blower motor power wire (see Appendix A) or replace AC heater/evaporator blower motor resistor harness (WP 0036). Verify repair, go to Step 9 of this fault.

YES

AC HEATER/EVAPORATOR BLOWER DOES NOT OPERATE - Continued

WARNING

Remove rings, bracelets, wristwatches, neck chains, and any other jewelry before working around vehicle. Jewelry can catch on equipment and cause serious injury. Jewelry or tools may short across electrical circuits or terminals and cause damage to equipment or severe burns or electrical shock to personnel.

VISUAL INSPECTION

- (1) Remove four screws, washers, lockwashers, and cover from AC heater/evaporator assembly (WP 0035).
- (2) Check fan control switch and AC heater/evaporator blower motor resistor harness for damaged wires and loose connection.
 - (a) If wires are damaged, repair wires (see Appendix A) or replace fan control switch harness (WP 0031) or AC heater/evaporator blower motor resistor harness (WP 0036) as required. Verify repair, go to Step 9 of this fault.
 - (b) If harness connector is loose, connect connector. Verify repair, go to Step 9 of this fault.
 - (c) If harness is free from damage and loose connections, go to Step 5 of this fault.

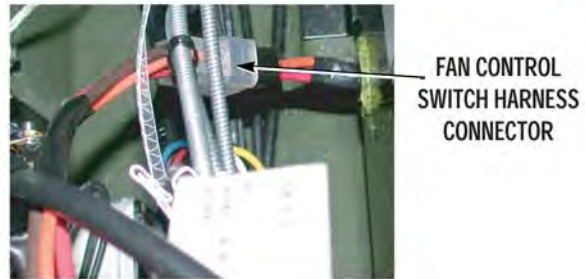
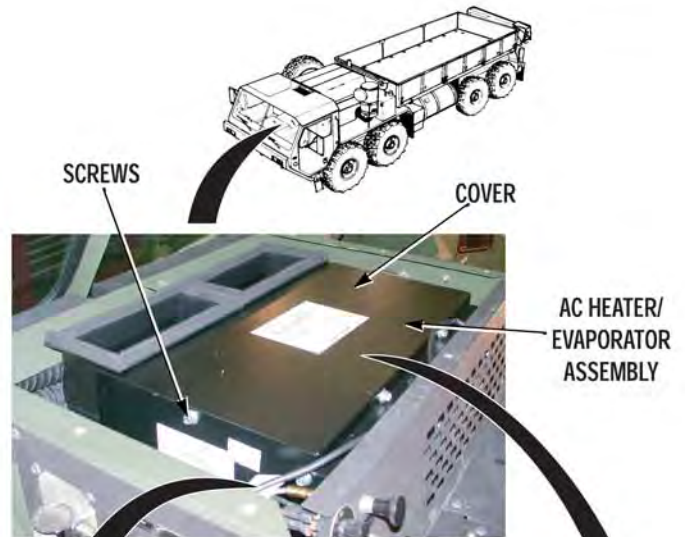

CONTINUITY TEST

- (1) Disconnect AC heater/evaporator blower motor power wire at splice (WP 0034).
- (2) Set multimeter switch to ohms.
- (3) Place positive (+) probe of multimeter on AC heater/evaporator blower motor power wire at AC heater/evaporator blower motor resistor.
- (4) Place negative (-) probe of multimeter on AC heater/evaporator blower motor power wire at splice.
 - (a) If there is no continuity, repair AC heater/evaporator blower motor power wire (see Appendix A) or replace AC heater/evaporator blower motor resistor harness (WP 0036). Verify repair, go to Step 9 of this fault.
 - (b) If there is continuity, connect AC heater/evaporator blower power wire at splice and go to Step 6 of this fault.

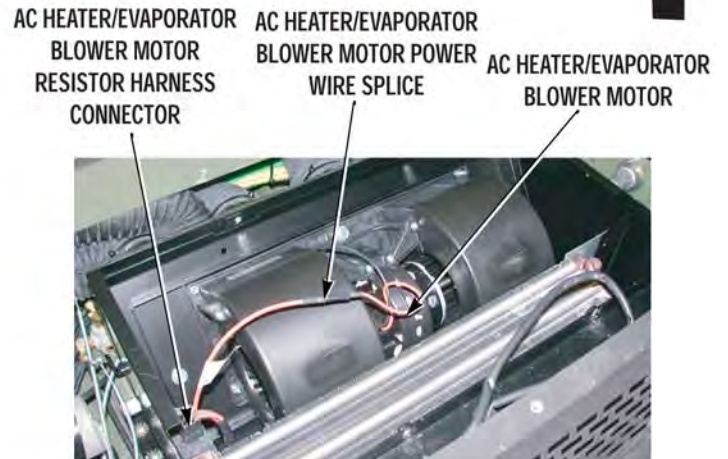

AC HEATER/EVAPORATOR BLOWER DOES NOT OPERATE - Continued

KNOWN INFO
Circuit breaker No. 11 OK. Engine start switch OK. Wire 1640 OK. Wire 1082 OK. Fan control switch OK. Fan control switch harness connector OK. AC heater/evaporator blower motor resistor harness connector OK. AC heater/evaporator blower motor power wire OK.
POSSIBLE PROBLEMS
AC heater/evaporator blower motor faulty. AC heater/evaporator blower motor ground wire faulty.

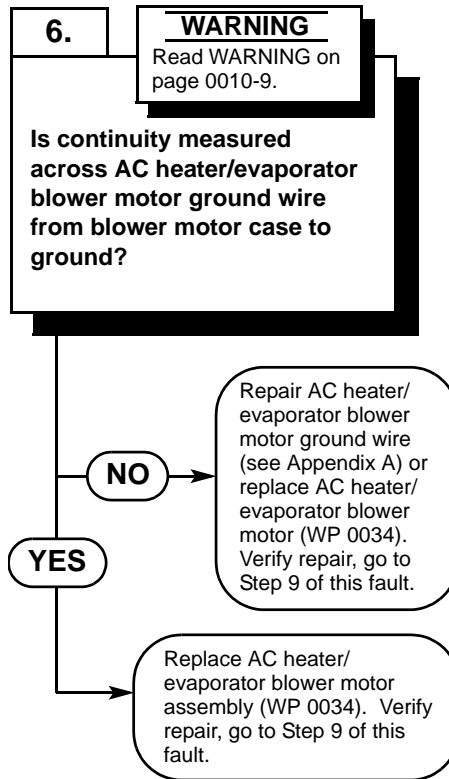

TEST OPTIONS
Continuity test. Multimeter.
REASON FOR QUESTION
If continuity is measured, AC heater/evaporator blower motor is faulty. If not, AC heater/evaporator blower motor ground wire is faulty.

KNOWN INFO
Wire 1082 OK. Fan control switch OK. Fan control switch harness connector OK. AC heater/evaporator blower motor resistor harness connector OK. AC heater/evaporator blower motor power wire OK. AC heater/evaporator blower motor OK. AC heater/evaporator blower motor ground wire OK.
POSSIBLE PROBLEMS
Circuit breaker No. 11 faulty. Engine start switch faulty. Wire 1640 faulty.

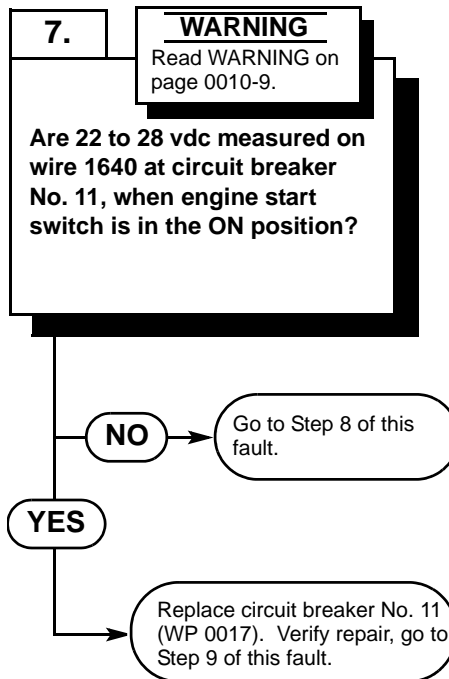

TEST OPTIONS
Voltage test. Multimeter.
REASON FOR QUESTION
If 22 to 28 vdc are measured, circuit breaker No. 11 is faulty.

AC HEATER/EVAPORATOR BLOWER DOES NOT OPERATE - Continued

WARNING

- Remove rings, bracelets, wristwatches, neck chains, and any other jewelry before working around vehicle. Jewelry can catch on equipment and cause serious injury. Jewelry or tools may short across electrical circuits or terminals and cause damage to equipment or severe burns or electrical shock to personnel.
- Circuit breakers No. 4, 5, 6, and 10 are always electrically live and can cause severe injury to personnel. Care must be taken when working around these circuit breakers.

CONTINUITY TEST

- (1) Set multimeter switch to ohms.
- (2) Place positive (+) probe of multimeter on AC heater/evaporator blower motor case.
- (3) Place negative (-) probe of multimeter on a known good ground.
 - (a) If there is no continuity, repair AC heater/evaporator blower motor ground wire (see Appendix A) or replace AC heater/evaporator blower motor (WP 0034). Verify repair, go to Step 9 of this fault.
 - (b) If there is continuity, replace AC heater/evaporator blower motor assembly (WP 0034). Verify repair, go to Step 9 of this fault.

AC HEATER/EVAPORATOR BLOWER MOTOR GROUND WIRE
AC HEATER/EVAPORATOR BLOWER MOTOR CASE

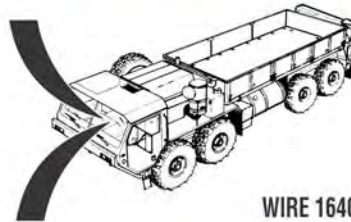

WIRE 1640 CIRCUIT BREAKER NO. 11



VOLTAGE TEST

- (1) Place positive (+) probe of multimeter on wire 1640 at circuit breaker No. 11.
- (2) Place negative (-) probe of multimeter on a known good ground.
 - (a) If 22 to 28 vdc are not measured, go to Step 8 of this fault.
 - (b) If 22 to 28 vdc are measured, turn engine start switch OFF and replace circuit breaker No. 11 (WP 0017). Verify repair, go to Step 9 of this fault.

FRONT OF VEHICLE

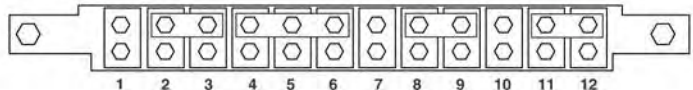

AC HEATER/EVAPORATOR BLOWER DOES NOT OPERATE - Continued

KNOWN INFO
Wire 1082 OK. Fan control switch OK. Fan control switch harness connector OK. AC heater/evaporator blower motor resistor harness connector OK. AC heater/evaporator blower motor power wire OK. AC heater/evaporator blower motor OK. AC heater/evaporator blower motor ground wire OK. Circuit breaker No. 11 OK.
POSSIBLE PROBLEMS
Engine start switch faulty. Wire 1640 faulty.

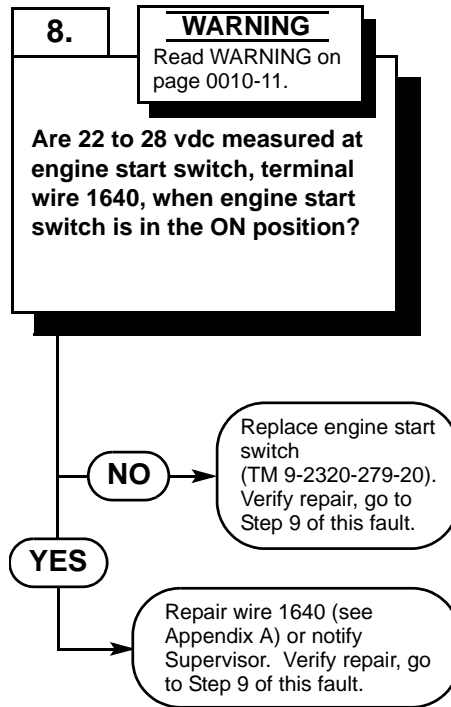

TEST OPTIONS
Voltage test. Multimeter.
REASON FOR QUESTION
If voltage is measured, wire 1640 is faulty. If not, engine start switch is faulty.

KNOWN INFO
Circuit breaker No. 11 OK. Engine start switch OK. Wire 1640 OK. Wire 1082 OK. Fan control switch OK. Fan control switch harness connector OK. AC heater/evaporator blower motor resistor harness connector OK. AC heater/evaporator blower motor power wire OK. AC heater/evaporator blower motor OK. AC heater/evaporator blower motor ground wire OK.
POSSIBLE PROBLEMS
None

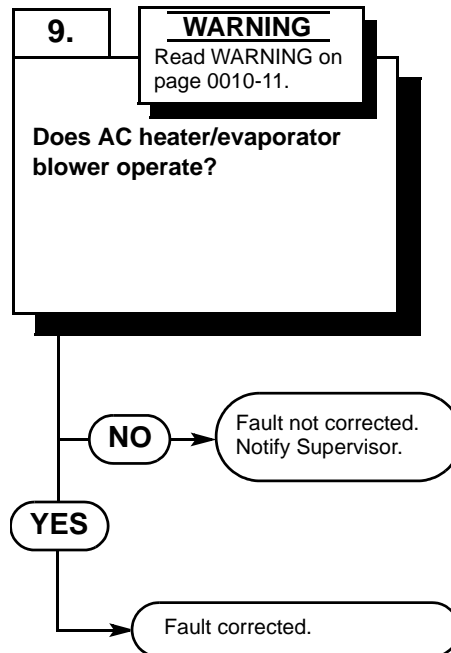

TEST OPTIONS
Verify repair.
REASON FOR QUESTION
If AC heater/evaporator blower operates, fault has been corrected.

AC HEATER/EVAPORATOR BLOWER DOES NOT OPERATE - Continued

WARNING

Remove rings, bracelets, wristwatches, neck chains, and any other jewelry before working around vehicle. Jewelry can catch on equipment and cause serious injury. Jewelry or tools may short across electrical circuits or terminals and cause damage to equipment or severe burns or electrical shock to personnel.

VOLTAGE TEST

- (1) Place positive (+) probe of multimeter on engine start switch ACC terminal (wire 1640).
- (2) Place negative (-) probe of multimeter on a known good ground.
 - (a) If 22 to 28 vdc are not measured, disconnect batteries and replace engine start switch (TM 9-2320-279-20). Verify repair, go to Step 9 of this fault.
 - (b) If 22 to 28 vdc are measured, disconnect batteries and repair wire 1640 (see Appendix A) or notify Supervisor. Verify repair, go to Step 9 of this fault.

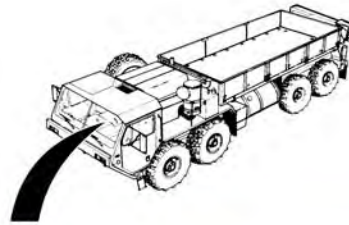

ENGINE START SWITCH

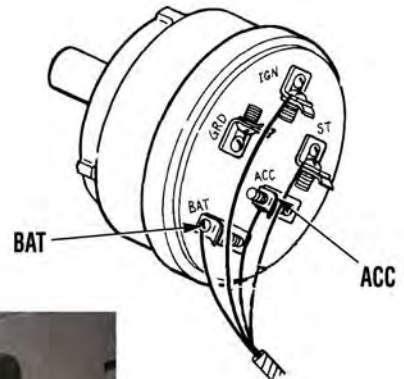

VERIFY REPAIR

- (1) If removed, install cover and four screws, washers, and lockwashers on AC heater/evaporator assembly (WP 0034).
- (2) If removed, install top heater cover and eight screws (WP 0037).
- (3) If removed, install left heater cover and six screws (TM 9-2320-279-20).
- (4) Turn engine start switch ON (TM 9-2320-279-10).
- (5) Verify AC heater/evaporator blower operation (WP 0004).
 - (a) If AC heater/evaporator blower does not operate, fault is not corrected. Turn fan control and engine start switch OFF and notify Supervisor.
 - (b) If AC heater/evaporator blower operates, fault has been corrected.



END OF WORK PACKAGE

**AC HEATER/EVAPORATOR BLOWER DOES NOT OPERATE IN ALL SPEEDS
(LOW, MEDIUM, AND HIGH)**

INITIAL SETUP:

Maintenance Level

Field Level Maintenance

Materials/Parts

None

Equipment Condition

Shut off engine (TM 9-2320-279-10).
Parking brake applied (TM 9-2320-279-10).
Wheels chocked (TM 9-2320-279-10).

Personnel Required

MOS 52C, Utilities equipment repairer

References

TM 9-2320-279-10
TM 9-2320-279-20

Tools and Special Tools

Tool Kit, General Mechanic's (Item 7, Appendix F)
Multimeter (Item 2, Appendix F)

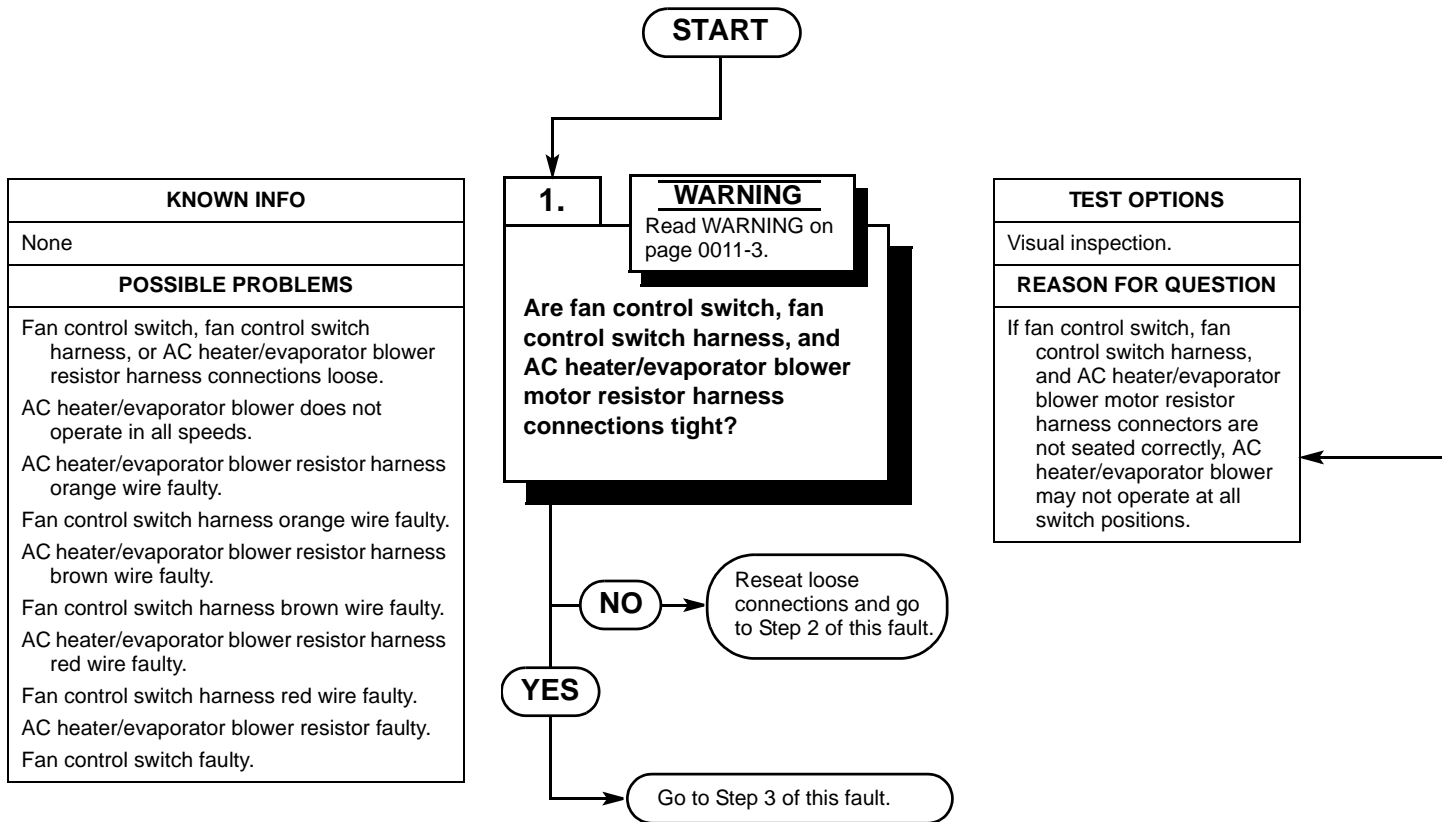

AC HEATER/EVAPORATOR BLOWER DOES NOT OPERATE IN ALL SPEEDS (LOW, MEDIUM, AND HIGH) - Continued

WARNING

Remove rings, bracelets, wristwatches, neck chains, and any other jewelry before working around vehicle. Jewelry can catch on equipment and cause serious injury. Jewelry or tools may short across electrical circuits or terminals and cause damage to equipment or severe burns or electrical shock to personnel.



SCREW TOP HEATER COVER

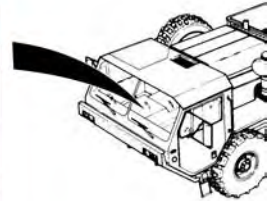

FAN CONTROL SWITCH

AC HEATER/EVAPORATOR BLOWER MOTOR RESISTOR HARNESS CONNECTOR

FAN CONTROL SWITCH HARNESS CONNECTOR



VISUAL INSPECTION

- (1) Remove eight screws and top heater cover (WP 0037).
- (2) Remove four screws, washers, lockwashers, and cover from AC heater/evaporator assembly (WP 0035).
- (3) Inspect fan control switch, fan control switch harness, and AC heater/evaporator blower motor resistor harness for loose connections.
 - (a) If fan control switch harness connections are loose, connect connections (WP 0031) and go to Step 2 of this fault.
 - (b) If AC heater/evaporator blower motor resistor harness connections are loose, connect connections (WP 0036) and go to Step 2 of this fault.
 - (c) If connections are tight, go to Step 3 of this fault.

AC HEATER/EVAPORATOR BLOWER DOES NOT OPERATE IN ALL SPEEDS (LOW, MEDIUM, AND HIGH) - Continued

KNOWN INFO
Fan control switch, fan control switch harness, and AC heater/evaporator blower resistor harness connections OK.
POSSIBLE PROBLEMS
AC heater/evaporator blower does not operate in all speeds.
AC heater/evaporator blower resistor harness orange wire faulty.
Fan control switch harness orange wire faulty.
AC heater/evaporator blower resistor harness brown wire faulty.
Fan control switch harness brown wire faulty.
AC heater/evaporator blower resistor harness red wire faulty.
Fan control switch harness red wire faulty.
AC heater/evaporator blower resistor faulty.
Fan control switch faulty.

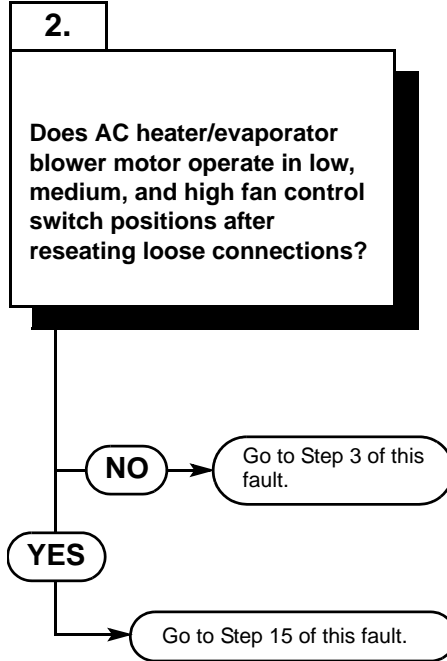

TEST OPTIONS
Visual inspection.
REASON FOR QUESTION
If AC heater/evaporator blower operates in all blower speed switch positions, problem has been corrected.

KNOWN INFO
Fan control switch, fan control switch harness, and AC heater/evaporator blower resistor harness connections OK.
POSSIBLE PROBLEMS
AC heater/evaporator blower does not operate in all speeds.
AC heater/evaporator blower resistor harness orange wire faulty.
Fan control switch harness orange wire faulty.
AC heater/evaporator blower resistor harness brown wire faulty.
Fan control switch harness brown wire faulty.
AC heater/evaporator blower resistor harness red wire faulty.
Fan control switch harness red wire faulty.
AC heater/evaporator blower resistor faulty.
Fan control switch faulty.

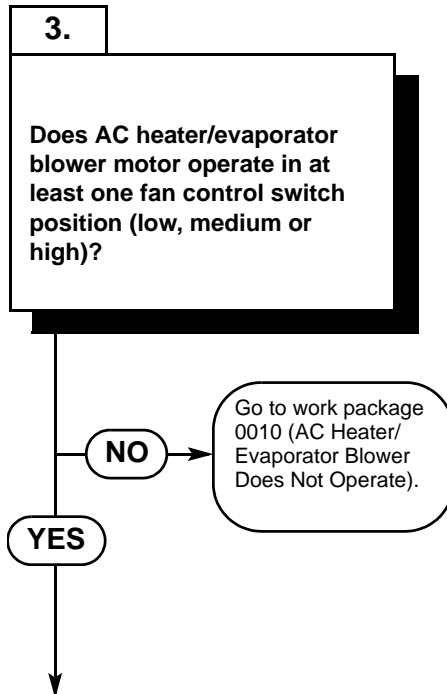

TEST OPTIONS
Visual inspection.
REASON FOR QUESTION
If AC blower operates in at least one speed, power to fan control switch and AC heater/evaporator blower motor circuit is OK.

AC HEATER/EVAPORATOR BLOWER DOES NOT OPERATE IN ALL SPEEDS (LOW, MEDIUM, AND HIGH) - Continued

VISUAL INSPECTION

- (1) Turn engine start switch ON (TM 9-2320-279-10).
- (2) Turn fan control switch to low, medium, and high speed positions (WP 0004). Verify AC heater/evaporator blower operation in all positions.
 - (a) If AC heater/evaporator blower does not operate in all positions, go to Step 3 of this fault.
 - (b) If AC heater/evaporator blower operates at all positions, turn engine start switch OFF and go to Step 15 of this fault.

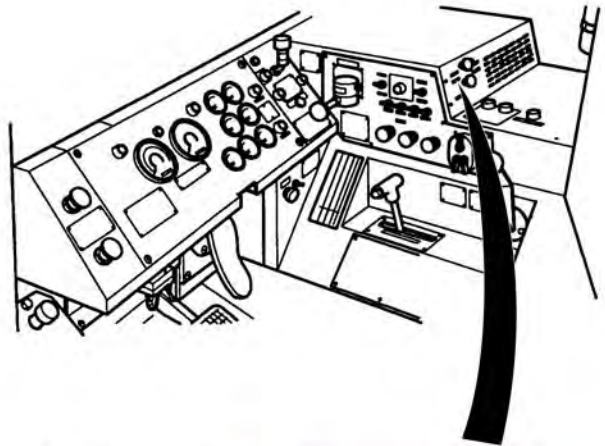

VISUAL INSPECTION

- (1) If OFF, turn engine start switch ON (TM 9-2320-279-10).
- (2) Turn fan control switch to low, medium, and high speed positions (WP 0004). Verify AC heater/evaporator blower operation in all positions.
 - (a) If AC heater/evaporator blower does not operate in at least one switch position, go to work package 0010 (AC Heater/Evaporator Blower Does Not Operate).
 - (b) If AC heater/evaporator blower operates in at least one fan control switch position, go to Step 4 of this fault.



FAN CONTROL SWITCH

AC HEATER/EVAPORATOR BLOWER DOES NOT OPERATE IN ALL SPEEDS (LOW, MEDIUM, AND HIGH) - Continued

KNOWN INFO
Fan control switch, fan control switch harness, and AC heater/evaporator blower resistor harness connections OK. AC heater/evaporator blower operates in at least one speed.
POSSIBLE PROBLEMS
AC heater/evaporator blower resistor harness orange wire faulty. Fan control switch harness orange wire faulty. AC heater/evaporator blower resistor harness brown wire faulty. Fan control switch harness brown wire faulty. AC heater/evaporator blower resistor harness red wire faulty. Fan control switch harness red wire faulty. AC heater/evaporator blower resistor faulty. Fan control switch faulty.

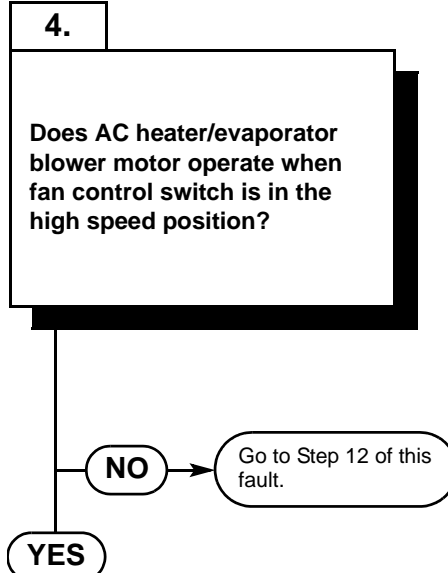

TEST OPTIONS
Visual inspection.
REASON FOR QUESTION
If AC heater/evaporator blower operates at high speed, high speed blower circuit is OK.

KNOWN INFO
Fan control switch, fan control switch harness, and AC heater/evaporator blower resistor harness connections OK. AC heater/evaporator blower operates in at least one speed. AC heater/evaporator blower resistor harness orange wire OK. Fan control switch harness orange wire OK.
POSSIBLE PROBLEMS
AC heater/evaporator blower resistor harness brown wire faulty. Fan control switch harness brown wire faulty. AC heater/evaporator blower resistor harness red wire faulty. Fan control switch harness red wire faulty. AC heater/evaporator blower resistor faulty. Fan control switch faulty.

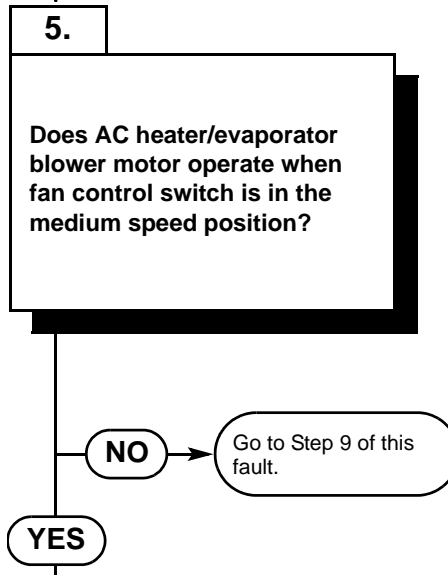

TEST OPTIONS
Visual inspection.
REASON FOR QUESTION
If AC heater/evaporator blower operates at medium speed, medium speed blower circuit is OK.

AC HEATER/EVAPORATOR BLOWER DOES NOT OPERATE IN ALL SPEEDS (LOW, MEDIUM, AND HIGH) - Continued

VISUAL INSPECTION

- (1) If OFF, turn engine start switch ON (TM 9-2320-279-10).
- (2) Turn fan control switch to high speed position (WP 0004). Verify AC heater/evaporator blower operation.
 - (a) If AC heater/evaporator blower does not operate when the fan control switch is in the high speed position, go to Step 12 of this fault.
 - (b) If AC heater/evaporator blower operates when the fan control switch is in the high speed position, go to Step 5 of this fault.

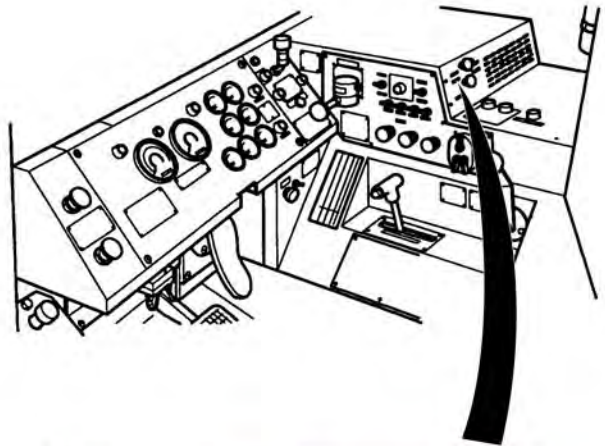

VISUAL INSPECTION

- (1) Turn fan control switch to medium speed position (WP 0004). Verify AC heater/evaporator blower operation.
 - (a) If AC heater/evaporator blower does not operate when the fan control switch is in the medium speed position, go to Step 9 of this fault.
 - (b) If AC heater/evaporator blower operates when the fan control switch is in the medium speed position, turn engine start switch OFF and go to Step 6 of this fault.



FAN CONTROL SWITCH

**AC HEATER/EVAPORATOR BLOWER DOES NOT OPERATE IN ALL SPEEDS
(LOW, MEDIUM, AND HIGH) - Continued**

KNOWN INFO
Fan control switch, fan control switch harness, and AC heater/evaporator blower resistor harness connections OK.
AC heater/evaporator blower operates in at least one speed.
AC heater/evaporator blower resistor harness orange wire OK.
Fan control switch harness orange wire OK.
AC heater/evaporator blower resistor harness brown wire OK.
Fan control switch harness brown wire OK.
POSSIBLE PROBLEMS
AC heater/evaporator blower resistor harness red wire faulty.
Fan control switch harness red wire faulty.
AC heater/evaporator blower resistor faulty.
Fan control switch faulty.

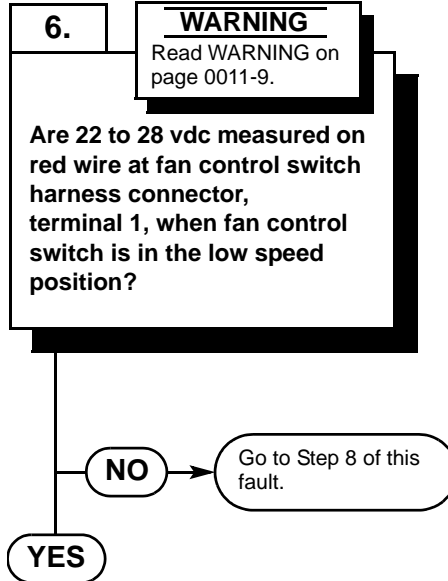

TEST OPTIONS
Voltage test. Multimeter.
REASON FOR QUESTION
If 22 to 28 vdc are not measured, AC heater/evaporator blower will not operate at low speed.

KNOWN INFO
Fan control switch, fan control switch harness, and AC heater/evaporator blower resistor harness connections OK.
AC heater/evaporator blower operates in at least one speed.
AC heater/evaporator blower resistor harness orange wire OK.
Fan control switch harness orange wire OK.
AC heater/evaporator blower resistor harness brown wire OK.
Fan control switch harness brown wire OK.
Fan control switch harness red wire OK.
Fan control switch OK.
POSSIBLE PROBLEMS
AC heater/evaporator blower resistor harness red wire faulty.
AC heater/evaporator blower resistor faulty.

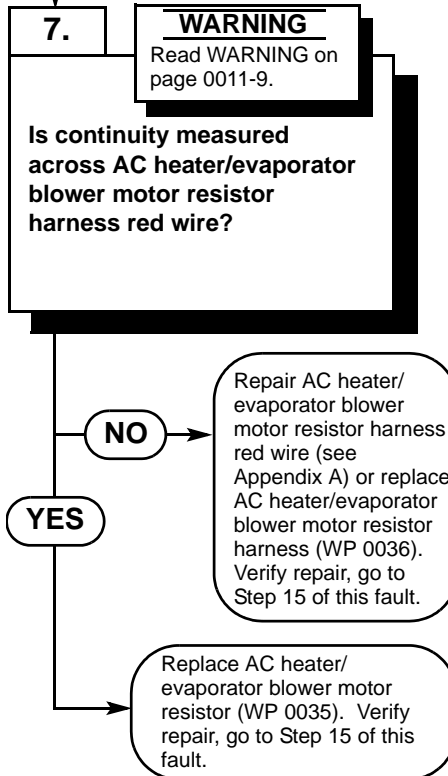

TEST OPTIONS
Continuity test. Multimeter.
REASON FOR QUESTION
If continuity is measured, AC heater/evaporator blower motor resistor is faulty. If not, AC heater/evaporator blower motor resistor harness red wire is faulty.

AC HEATER/EVAPORATOR BLOWER DOES NOT OPERATE IN ALL SPEEDS (LOW, MEDIUM, AND HIGH) - Continued

WARNING

Remove rings, bracelets, wristwatches, neck chains, and any other jewelry before working around vehicle. Jewelry can catch on equipment and cause serious injury. Jewelry or tools may short across electrical circuits or terminals and cause damage to equipment or severe burns or electrical shock to personnel.

VOLTAGE TEST

- (1) Disconnect fan control switch harness connector (WP 0031).
- (2) Turn engine start switch ON (TM 9-2320-279-10).
- (3) Turn fan control switch to low speed position (WP 0004).
- (4) Place positive (+) probe of multimeter on red wire at fan control switch harness connector, terminal 1.
- (5) Place negative (-) probe of multimeter on a known good ground.
 - (a) If 22 to 28 vdc are not measured, turn engine start switch OFF and go to Step 8 of this fault.
 - (b) If 22 to 28 vdc are measured, turn engine start switch OFF and go to Step 7 of this fault.

AC HEATER/EVAPORATOR BLOWER MOTOR RESISTOR HARNESS CONNECTOR

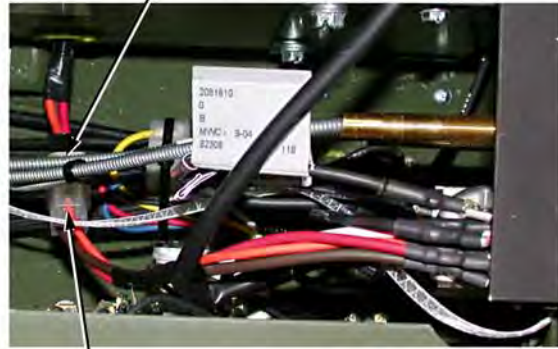

FAN CONTROL SWITCH HARNESS CONNECTOR

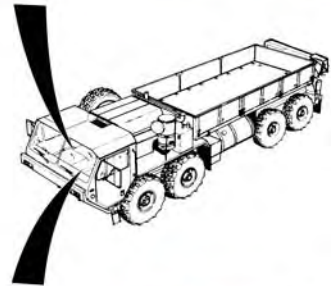

CONTINUITY TEST

- (1) Disconnect AC heater/evaporator blower motor resistor harness connector from AC heater/evaporator blower motor resistor (WP 0036).
- (2) Set multimeter switch to ohms.
- (3) Place positive (+) probe of multimeter on AC heater/evaporator blower motor resistor harness red wire at AC heater/evaporator blower motor resistor connector.
- (4) Place negative (-) probe of multimeter on AC heater/evaporator blower motor resistor harness red wire at fan control switch harness connector, terminal 1.
 - (a) If there is no continuity, repair AC heater/evaporator blower motor resistor harness red wire (see Appendix A) or replace AC heater/evaporator blower motor resistor harness (WP 0036). Verify repair, go to Step 15 of this fault.
 - (b) If there is continuity, replace AC heater/evaporator blower motor resistor (WP 0035). Verify repair, go to Step 15 of this fault.

RED WIRE



AC HEATER/EVAPORATOR BLOWER MOTOR RESISTOR HARNESS CONNECTOR

AC HEATER/EVAPORATOR BLOWER MOTOR RESISTOR

AC HEATER/EVAPORATOR BLOWER DOES NOT OPERATE IN ALL SPEEDS (LOW, MEDIUM, AND HIGH) - Continued

KNOWN INFO
Fan control switch, fan control switch harness, and AC heater/evaporator blower resistor harness connections OK.
AC heater/evaporator blower operates in at least one speed.
AC heater/evaporator blower resistor harness orange wire OK.
Fan control switch harness orange wire OK.
AC heater/evaporator blower resistor harness brown wire OK.
Fan control switch harness brown wire OK.
AC heater/evaporator blower resistor harness red wire OK.
AC heater/evaporator blower resistor OK.
POSSIBLE PROBLEMS
Fan control switch harness red wire faulty.
Fan control switch faulty.

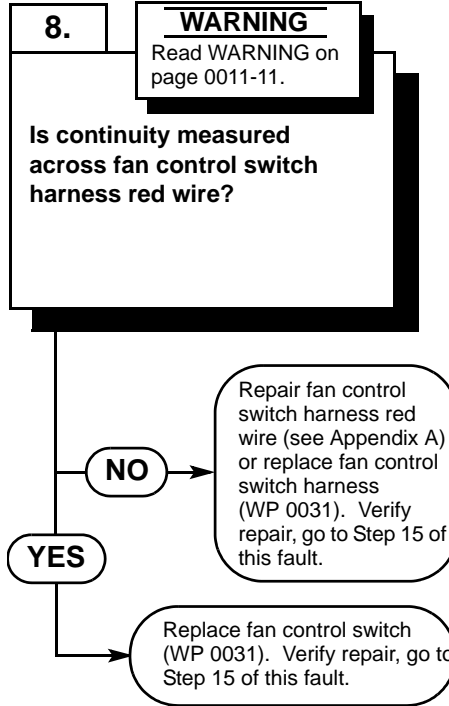

TEST OPTIONS
Continuity test. Multimeter.
REASON FOR QUESTION
If continuity is measured, fan control switch is faulty. If not, fan control switch harness red wire is faulty.

KNOWN INFO
Fan control switch, fan control switch harness, and AC heater/evaporator blower resistor harness connections OK.
AC heater/evaporator blower operates in at least one speed.
AC heater/evaporator blower resistor harness orange wire OK.
Fan control switch harness orange wire OK.
AC heater/evaporator blower resistor harness red wire OK.
Fan control switch harness red wire OK.
POSSIBLE PROBLEMS
AC heater/evaporator blower resistor harness brown wire faulty.
Fan control switch harness brown wire faulty.
AC heater/evaporator blower resistor faulty.
Fan control switch faulty.

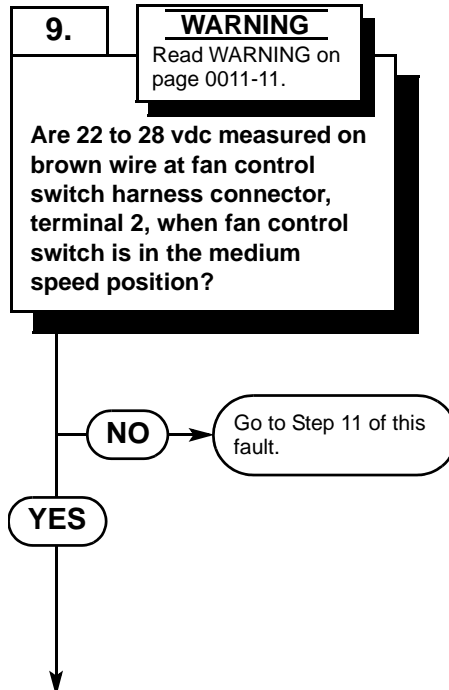

TEST OPTIONS
Voltage test. Multimeter.
REASON FOR QUESTION
If 22 to 28 vdc are not measured, AC heater/evaporator blower will not operate at medium speed.

AC HEATER/EVAPORATOR BLOWER DOES NOT OPERATE IN ALL SPEEDS (LOW, MEDIUM, AND HIGH) - Continued

WARNING

Remove rings, bracelets, wristwatches, neck chains, and any other jewelry before working around vehicle. Jewelry can catch on equipment and cause serious injury. Jewelry or tools may short across electrical circuits or terminals and cause damage to equipment or severe burns or electrical shock to personnel.

CONTINUITY TEST

- (1) Disconnect fan control switch harness red wire from fan control switch (WP 0031).
- (2) Set multimeter switch to ohms.
- (3) Place positive (+) probe of multimeter on fan control switch harness red wire AC heater/evaporator blower motor resistor harness connector, terminal 1.
- (4) Place negative (-) probe of multimeter on fan control switch harness red wire at fan control switch.
 - (a) If there is no continuity, repair fan control switch harness red wire (see Appendix A) or replace fan control switch harness (WP 0031). Verify repair, go to Step 15 of this fault.
 - (b) If there is continuity, replace fan control switch (WP 0031). Verify repair, go to Step 15 of this fault.

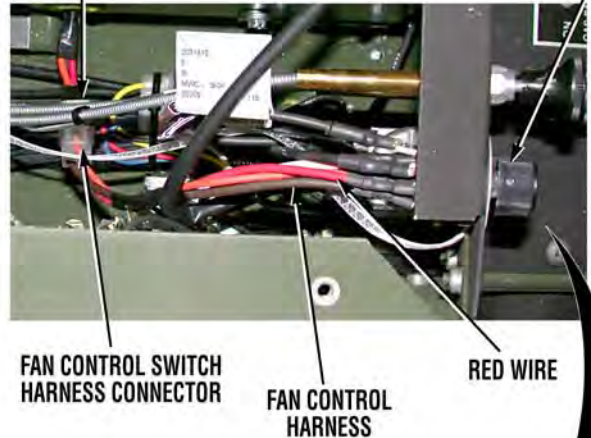
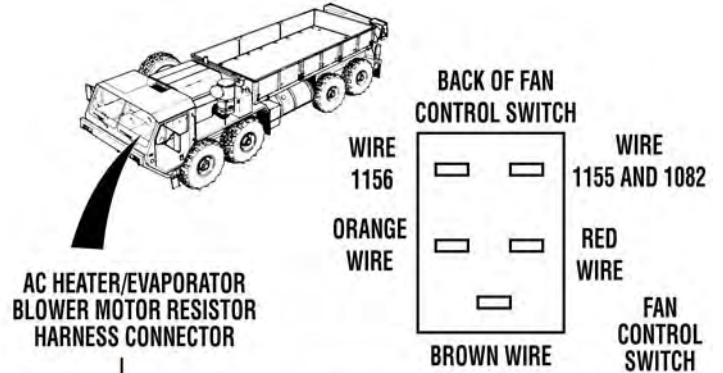

VOLTAGE TEST

- (1) Disconnect fan control switch harness connector (WP 0031).
- (2) Turn engine start switch ON (TM 9-2320-279-10).
- (3) Turn fan control switch to medium speed position (WP 0004).
- (4) Place positive (+) probe of multimeter on brown wire at fan control switch harness connector, terminal 2.
- (5) Place negative (-) probe of multimeter on a known good ground.
 - (a) If 22 to 28 vdc are not measured, turn engine start switch OFF and go to Step 11 of this fault.
 - (b) If 22 to 28 vdc are measured, turn engine start switch OFF and go to Step 10 of this fault.

FAN CONTROL SWITCH



AC HEATER/EVAPORATOR BLOWER DOES NOT OPERATE IN ALL SPEEDS (LOW, MEDIUM, AND HIGH) - Continued

KNOWN INFO
Fan control switch, fan control switch harness, and AC heater/evaporator blower resistor harness connections OK.
AC heater/evaporator blower operates in at least one speed.
AC heater/evaporator blower resistor harness orange wire OK.
Fan control switch harness orange wire OK.
AC heater/evaporator blower resistor harness red wire OK.
Fan control switch harness red wire OK.
Fan control switch harness brown wire OK.
Fan control switch OK.
POSSIBLE PROBLEMS
AC heater/evaporator blower resistor harness brown wire faulty.
AC heater/evaporator blower resistor faulty.

10. **WARNING**
Read WARNING on page 0011-13.

Is continuity measured across AC heater/evaporator blower motor resistor harness brown wire?

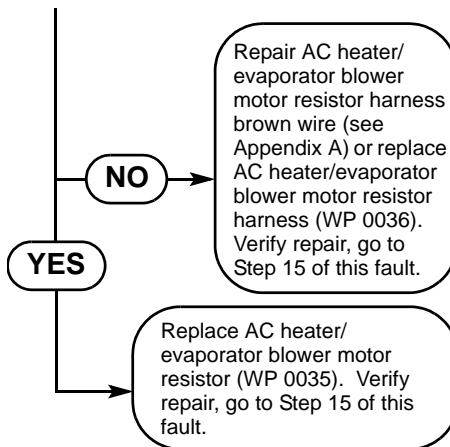

TEST OPTIONS
Continuity test. Multimeter.
REASON FOR QUESTION
If continuity is measured, AC heater/evaporator blower motor resistor is faulty. If not, AC heater/evaporator blower motor resistor harness brown wire is faulty.

KNOWN INFO
Fan control switch, fan control switch harness, and AC heater/evaporator blower resistor harness connections OK.
AC heater/evaporator blower operates in at least one speed.
AC heater/evaporator blower resistor harness orange wire OK.
Fan control switch harness orange wire OK.
Fan control switch harness red wire OK.
AC heater/evaporator blower resistor harness red wire OK.
AC heater/evaporator blower resistor harness brown wire OK.
AC heater/evaporator blower resistor OK.
POSSIBLE PROBLEMS
Fan control switch harness brown wire faulty.
Fan control switch faulty.

11. **WARNING**
Read WARNING on page 0011-13.

Is continuity measured across fan control switch harness brown wire?

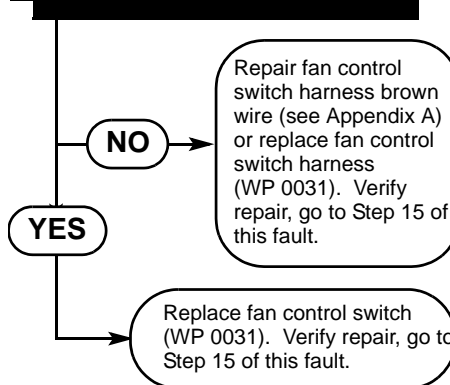

TEST OPTIONS
Continuity test. Multimeter.
REASON FOR QUESTION
If continuity is measured, fan control switch is faulty. If not, fan control switch harness brown wire is faulty.

AC HEATER/EVAPORATOR BLOWER DOES NOT OPERATE IN ALL SPEEDS (LOW, MEDIUM, AND HIGH) - Continued

WARNING

Remove rings, bracelets, wristwatches, neck chains, and any other jewelry before working around vehicle. Jewelry can catch on equipment and cause serious injury. Jewelry or tools may short across electrical circuits or terminals and cause damage to equipment or severe burns or electrical shock to personnel.

CONTINUITY TEST

- (1) Disconnect AC heater/evaporator blower motor resistor harness connector from AC heater/evaporator blower motor resistor (WP 0036).
- (2) Set multimeter switch to ohms.
- (3) Place positive (+) probe of multimeter on AC heater/evaporator blower motor resistor harness brown wire at AC heater/evaporator blower motor resistor connector.
- (4) Place negative (-) probe of multimeter on AC heater/evaporator blower motor resistor harness brown wire at fan control switch harness connector, terminal 2.
 - (a) If there is no continuity, repair AC heater/evaporator blower motor resistor harness brown wire (see Appendix A) or replace AC heater/evaporator blower motor resistor (WP 0036). Verify repair, go to Step 15 of this fault.
 - (b) If there is continuity, replace AC heater/evaporator blower motor resistor (WP 0035). Verify repair, go to Step 15 of this fault.



AC HEATER/EVAPORATOR BLOWER MOTOR RESISTOR
AC HEATER/EVAPORATOR BLOWER MOTOR RESISTOR HARNESS CONNECTOR
BROWN WIRE



AC HEATER/EVAPORATOR BLOWER MOTOR RESISTOR HARNESS CONNECTOR

BACK OF FAN CONTROL SWITCH

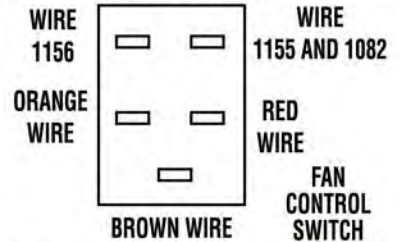

FAN CONTROL SWITCH HARNESS CONNECTOR
FAN CONTROL SWITCH HARNESS
BROWN WIRE

CONTINUITY TEST

- (1) Disconnect fan control switch harness brown wire from fan control switch (WP 0031).
- (2) Set multimeter switch to ohms.
- (3) Place positive (+) probe of multimeter on fan control switch harness brown wire at AC heater/evaporator blower resistor harness connector, terminal 2.
- (4) Place negative (-) probe of multimeter on fan control switch harness brown wire at fan control switch.
 - (a) If there is no continuity, repair fan control switch harness brown wire (see Appendix A) or replace fan control switch harness (WP 0031). Verify repair, go to Step 15 of this fault.
 - (b) If there is continuity, replace fan control switch (WP 0031). Verify repair, go to Step 15 of this fault.

AC HEATER/EVAPORATOR BLOWER DOES NOT OPERATE IN ALL SPEEDS (LOW, MEDIUM, AND HIGH) - Continued

KNOWN INFO
Fan control switch, fan control switch harness, and AC heater/evaporator blower resistor harness connections OK.
AC heater/evaporator blower operates in at least one speed.
AC heater/evaporator blower resistor harness brown wire OK.
Fan control switch harness brown wire OK.
AC heater/evaporator blower resistor harness red wire OK.
Fan control switch harness red wire OK.
POSSIBLE PROBLEMS
AC heater/evaporator blower resistor harness orange wire faulty.
Fan control switch harness orange wire faulty.
AC heater/evaporator blower resistor faulty.
Fan control switch faulty.

12.

WARNING
Read WARNING on page 0011-15.

Are 22 to 28 vdc measured on orange wire at fan control switch harness connector, terminal 3, when fan control switch is in the high speed position?

NO

YES

TEST OPTIONS
Voltage test. Multimeter.
REASON FOR QUESTION
If 22 to 28 vdc is not measured, AC heater/evaporator blower will not operate at high speed.

KNOWN INFO
Fan control switch, fan control switch harness, and AC heater/evaporator blower resistor harness connections OK.
AC heater/evaporator blower operates in at least one speed.
AC heater/evaporator blower resistor harness brown wire OK.
Fan control switch harness brown wire OK.
AC heater/evaporator blower resistor harness red wire OK.
Fan control switch harness red wire OK.
Fan control switch harness orange wire OK.
Fan control switch OK.
POSSIBLE PROBLEMS
AC heater/evaporator blower resistor harness orange wire faulty.
AC heater/evaporator blower resistor faulty.

13.

WARNING
Read WARNING on page 0011-15.

Is continuity measured across AC heater/evaporator blower motor resistor harness orange wire?

NO

YES

TEST OPTIONS
Continuity test. Multimeter.
REASON FOR QUESTION
If continuity is measured, AC heater/evaporator blower motor resistor is faulty. If not, AC heater/evaporator blower motor resistor harness orange wire is faulty.

AC HEATER/EVAPORATOR BLOWER DOES NOT OPERATE IN ALL SPEEDS (LOW, MEDIUM, AND HIGH) - Continued

WARNING

Remove rings, bracelets, wristwatches, neck chains, and any other jewelry before working around vehicle. Jewelry can catch on equipment and cause serious injury. Jewelry or tools may short across electrical circuits or terminals and cause damage to equipment or severe burns or electrical shock to personnel.

VOLTAGE TEST

- (1) Disconnect fan control switch harness connector (WP 0031).
- (2) Turn engine start switch ON (TM 9-2320-279-10).
- (3) Turn fan control switch to high speed position (WP 0004).
- (4) Place positive (+) probe of multimeter on orange wire at fan control switch harness connector, terminal 3.
- (5) Place negative (-) probe of multimeter on a known good ground.
 - (a) If 22 to 28 vdc are not measured, turn engine start switch OFF and go to Step 14 of this fault.
 - (b) If 22 to 28 vdc are measured, turn engine start switch OFF and go to Step 13 of this fault.

AC HEATER/EVAPORATOR BLOWER MOTOR RESISTOR HARNESS CONNECTOR

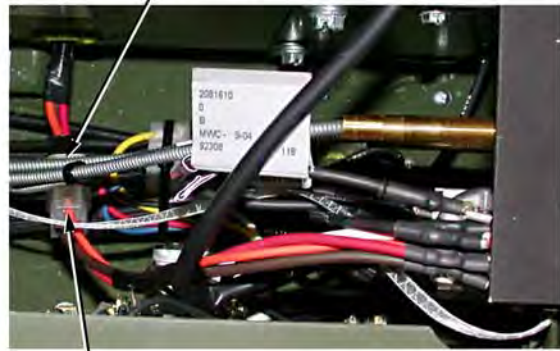

FAN CONTROL SWITCH HARNESS CONNECTOR

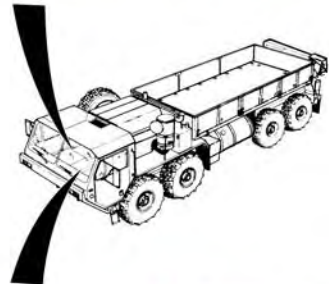

ORANGE WIRE



AC HEATER/EVAPORATOR BLOWER MOTOR RESISTOR CONNECTOR HARNESS

AC HEATER/EVAPORATOR BLOWER MOTOR RESISTOR

CONTINUITY TEST

- (1) Disconnect AC heater/evaporator blower motor resistor harness connector from AC heater/evaporator blower motor resistor (WP 0036).
- (2) Set multimeter switch to ohms.
- (3) Place positive (+) probe of multimeter on AC heater/evaporator blower motor resistor harness orange wire at AC heater/evaporator blower motor resistor connector.
- (4) Place negative (-) probe of multimeter on AC heater/evaporator blower motor resistor harness orange wire at fan control switch harness connector, terminal 3.
 - (a) If there is no continuity, repair AC heater/evaporator blower motor resistor harness orange wire (see Appendix A) or replace AC heater/evaporator blower motor resistor harness (WP 0036). Verify repair, go to Step 15 of this fault.
 - (b) If there is continuity, replace AC heater/evaporator blower motor resistor (WP 0035). Verify repair, go to Step 15 of this fault.

**AC HEATER/EVAPORATOR BLOWER DOES NOT OPERATE IN ALL SPEEDS
(LOW, MEDIUM, AND HIGH) - Continued**

KNOWN INFO
Fan control switch, fan control switch harness, and AC heater/evaporator blower resistor harness connections OK.
AC heater/evaporator blower operates in at least one speed.
AC heater/evaporator blower resistor harness brown wire OK.
Fan control switch harness brown wire OK.
AC heater/evaporator blower resistor harness red wire OK.
Fan control switch harness red wire OK.
AC heater/evaporator blower resistor harness orange wire OK.
AC heater/evaporator blower resistor OK.
POSSIBLE PROBLEMS
Fan control switch harness orange wire faulty.
Fan control switch faulty.

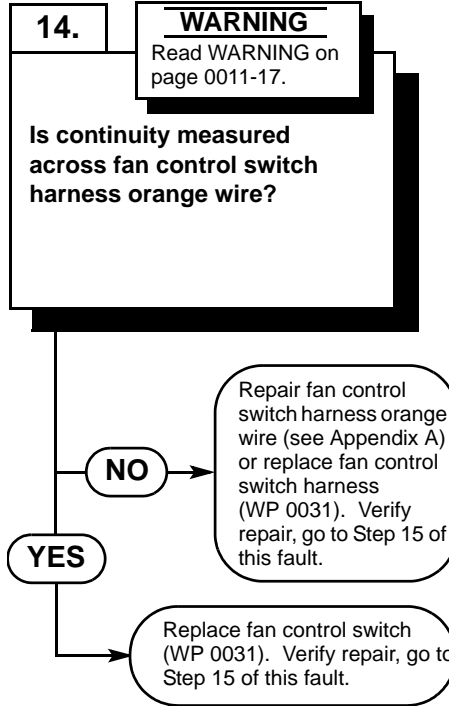

TEST OPTIONS
Continuity test. Multimeter.
REASON FOR QUESTION
If continuity is measured, fan control switch is faulty. If not, fan control switch harness orange wire is faulty.

KNOWN INFO
Fan control switch, fan control switch harness, and AC heater/evaporator blower resistor harness connections OK.
AC heater/evaporator blower operates in at least one speed.
AC heater/evaporator blower resistor harness orange wire OK.
Fan control switch harness orange wire OK.
AC heater/evaporator blower resistor harness brown wire OK.
Fan control switch harness brown wire OK.
AC heater/evaporator blower resistor harness red wire OK.
Fan control switch harness red wire OK.
AC heater/evaporator blower resistor OK.
Fan control switch OK.
POSSIBLE PROBLEMS
None

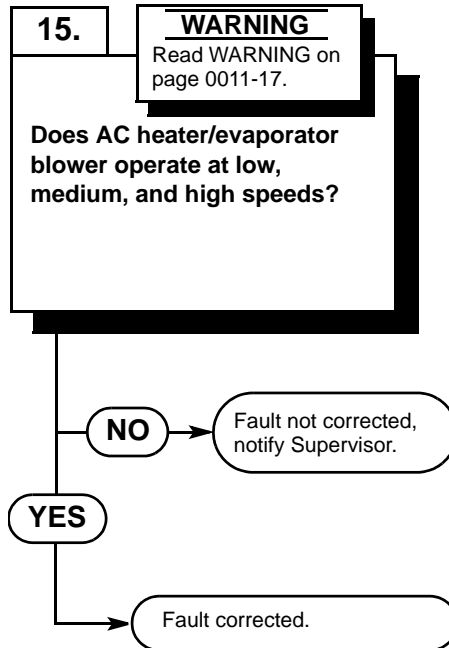

TEST OPTIONS
Verify repair.
REASON FOR QUESTION
If AC heater/evaporator blower operates at low, medium, and high speeds, fault has been corrected.

AC HEATER/EVAPORATOR BLOWER DOES NOT OPERATE IN ALL SPEEDS (LOW, MEDIUM, AND HIGH) - Continued

WARNING

Remove rings, bracelets, wristwatches, neck chains, and any other jewelry before working around vehicle. Jewelry can catch on equipment and cause serious injury. Jewelry or tools may short across electrical circuits or terminals and cause damage to equipment or severe burns or electrical shock to personnel.

CONTINUITY TEST

- (1) Disconnect fan control switch harness orange wire from fan control switch (WP 0031).
- (2) Set multimeter switch to ohms.
- (3) Place positive (+) probe of multimeter on fan control switch harness orange wire AC heater/evaporator blower motor resistor harness connector, terminal 3.
- (4) Place negative (-) probe of multimeter on fan control switch harness orange wire at fan control switch.
 - (a) If there is no continuity, repair fan control switch harness orange wire (see Appendix A) or replace fan control switch harness (WP 0031). Verify repair, go to Step 15 of this fault.
 - (b) If there is continuity, replace fan control switch (WP 0031). Verify repair, go to Step 15 of this fault.

VERIFY REPAIR

- (1) If disconnected, connect fan control switch harness connector (WP 0031).
- (2) If disconnected, connect AC heater/evaporator blower motor resistor harness connector (WP 0036).
- (3) If disconnected, connect red, brown, and orange wires on fan control switch (WP 0031).
- (4) Install cover and four screws, washers, and lockwashers on AC heater/evaporator assembly (WP 0034).
- (5) Install top heater compartment cover and eight screws (WP 0037).
- (6) Turn engine start switch ON (TM 9-2320-279-10).
- (7) Turn fan control switch to low, medium, and high speed positions (WP 0004). Verify AC heater/evaporator blower operation in all positions.
 - (a) If AC heater/evaporator blower does not operate in all positions, fault is not corrected. Turn fan control switch and engine start switch to OFF and notify Supervisor.
 - (b) If AC heater/evaporator blower operates at all positions, fault has been corrected.

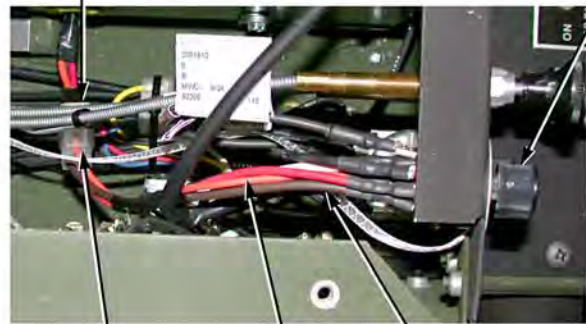
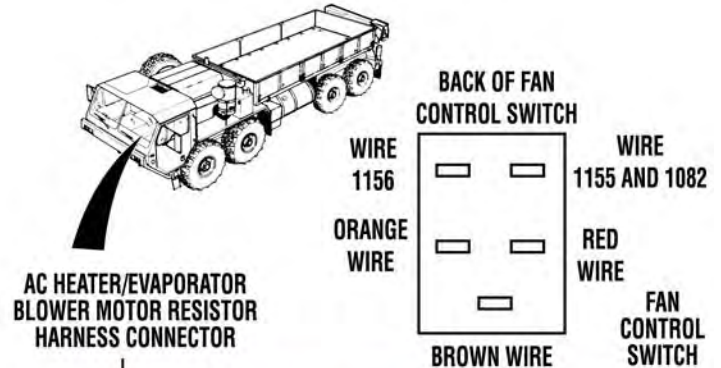

FAN CONTROL SWITCH HARNESS CONNECTOR ORANGE WIRE FAN CONTROL SWITCH HARNESS



END OF WORK PACKAGE

**AC HEATER/EVAPORATOR BLOWER OPERATES BUT NO COLD AIR FROM
DUCTS DURING AC OPERATIONS**

INITIAL SETUP:

Maintenance Level

Field Level Maintenance

Equipment Condition

Shut off engine (TM 9-2320-279-10).
Parking brake applied (TM 9-2320-279-10).
Wheels chocked (TM 9-2320-279-10).

Tools and Special Tools

Tool Kit, General Mechanic's (Item 7, Appendix F)
Multimeter (Item 2, Appendix F)

Materials/Parts

None

Personnel Required

MOS 52C, Utilities equipment repairer (2)

References

TM 9-2320-279-10
TM 9-2320-279-20

AC HEATER/EVAPORATOR BLOWER OPERATES BUT NO COLD AIR FROM DUCTS DURING AC OPERATIONS - Continued

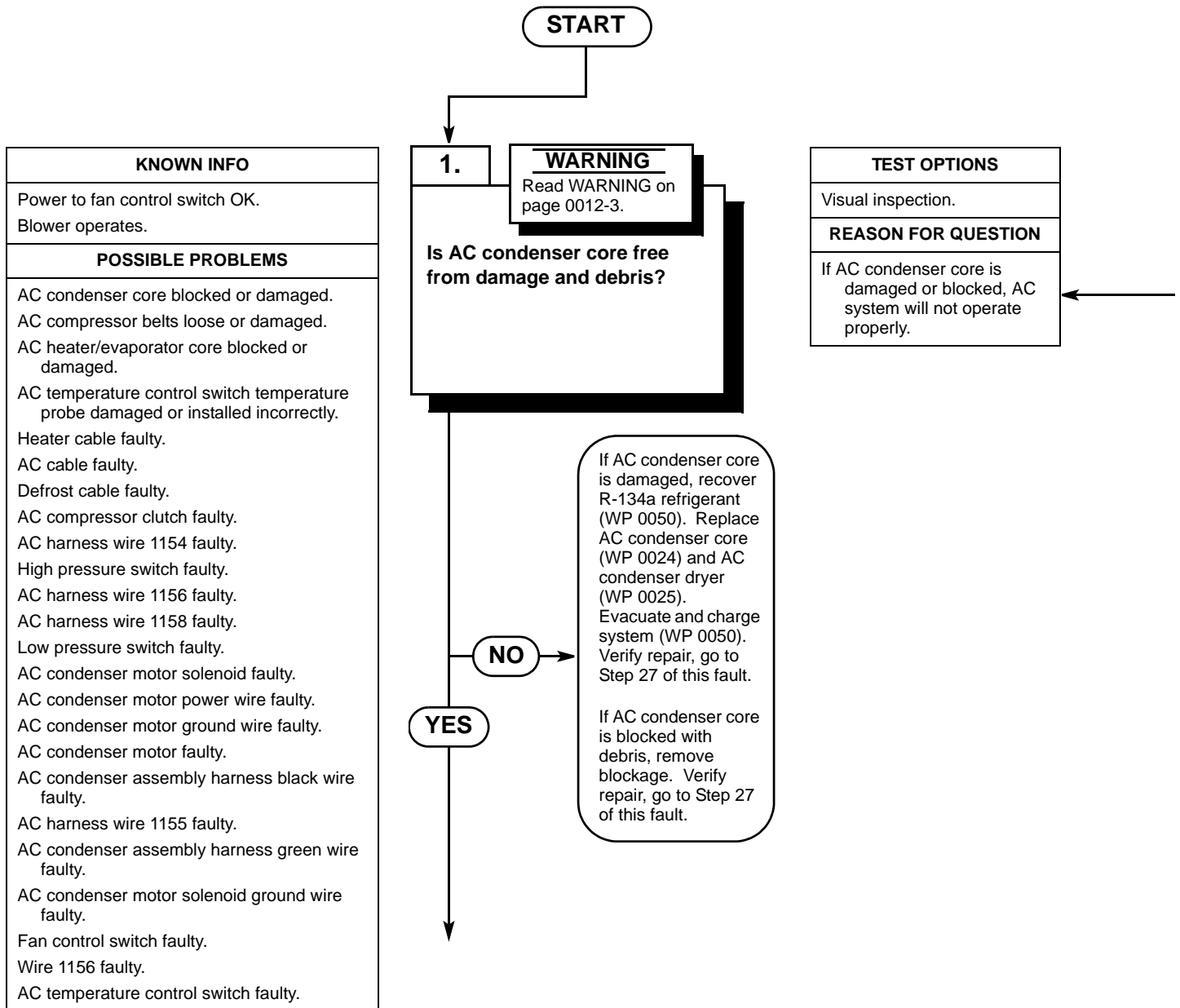

AC HEATER/EVAPORATOR BLOWER OPERATES BUT NO COLD AIR FROM DUCTS DURING AC OPERATIONS - Continued

WARNING

Wear protective goggles and nonleather gloves when servicing air conditioner system. Failure to comply may result in injury to personnel.

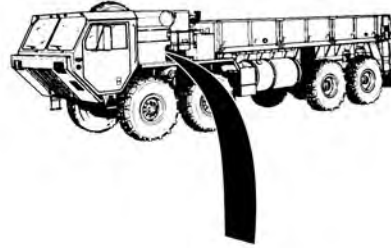

VISUAL INSPECTION

- (1) Inspect AC condenser core for damage and blockage from debris.
 - (a) If AC condenser core is damaged:
 1. Recover R-134a refrigerant (WP 0050).
 2. Replace AC condenser core (WP 0024).
 3. Replace AC condenser dryer (WP 0025).
 4. Evacuate and charge system (WP 0050).
 5. Verify repair, go to Step 27 of this fault.
 - (b) If AC condenser core is blocked with debris, remove blockage. Verify repair, go to Step 27 of this fault.
 - (c) If AC condenser core is free from damage and blockage, go to Step 2 of this fault.



AC CONDENSER CORE

AC HEATER/EVAPORATOR BLOWER OPERATES BUT NO COLD AIR FROM DUCTS DURING AC OPERATIONS - Continued

KNOWN INFO
Power to fan control switch OK. Blower operates. AC condenser core not blocked or damaged.
POSSIBLE PROBLEMS
AC compressor belts loose or damaged. AC heater/evaporator core blocked or damaged. AC temperature control switch temperature probe damaged or installed incorrectly. Heater cable faulty. AC cable faulty. Defrost cable faulty. AC compressor clutch faulty. AC harness wire 1154 faulty. High pressure switch faulty. AC harness wire 1156 faulty. AC harness wire 1158 faulty. Low pressure switch faulty. AC condenser motor solenoid faulty. AC condenser motor power wire faulty. AC condenser motor ground wire faulty. AC condenser motor faulty. AC condenser assembly harness black wire faulty. AC harness wire 1155 faulty. AC condenser assembly harness green wire faulty. AC condenser motor solenoid ground wire faulty. Fan control switch faulty. Wire 1156 faulty. AC temperature control switch faulty.

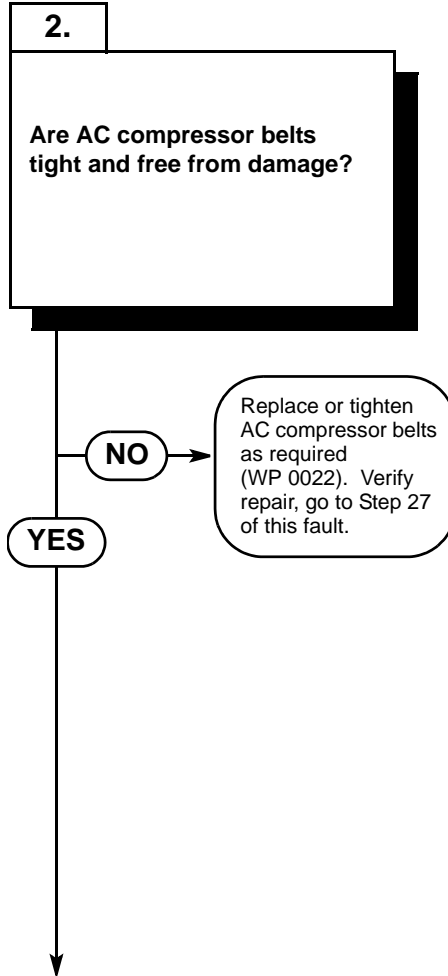

TEST OPTIONS
Visual inspection.
REASON FOR QUESTION
If AC compressor belts are missing, loose, or damaged, AC compressor will not operate properly.



AC HEATER/EVAPORATOR BLOWER OPERATES BUT NO COLD AIR FROM DUCTS DURING AC OPERATIONS - Continued

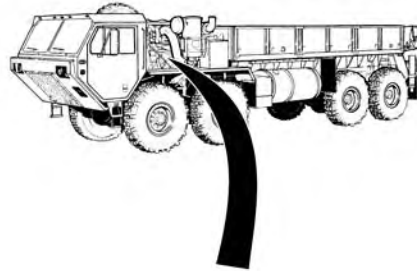

VISUAL INSPECTION

- (1) Open driver side engine cover and remove engine side panel (TM 9-2320-279-10).
- (2) Inspect AC compressor belts for looseness and damage.
 - (a) If AC compressor belts are missing, damaged, or loose, replace or tighten belts as required (WP 0022).
 - (b) If AC compressor belts are tight and free from damage, go to Step 3 of this fault.

AC COMPRESSOR

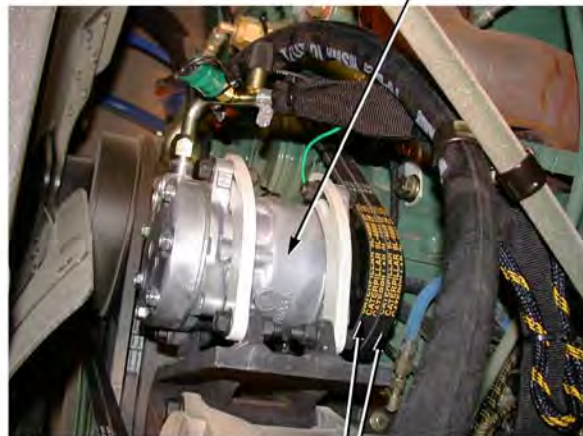

AC COMPRESSOR BELTS

AC HEATER/EVAPORATOR BLOWER OPERATES BUT NO COLD AIR FROM DUCTS DURING AC OPERATIONS - Continued

KNOWN INFO
Power to fan control switch OK. Blower operates. AC condenser core not blocked or damaged. AC compressor belts OK.
POSSIBLE PROBLEMS
AC heater/evaporator core blocked or damaged. AC temperature control switch temperature probe damaged or installed incorrectly. Heater cable faulty. AC cable faulty. Defrost cable faulty. AC compressor clutch faulty. AC harness wire 1154 faulty. High pressure switch faulty. AC harness wire 1156 faulty. AC harness wire 1158 faulty. Low pressure switch faulty. AC condenser motor solenoid faulty. AC condenser motor power wire faulty. AC condenser motor ground wire faulty. AC condenser motor faulty. AC condenser assembly harness black wire faulty. AC harness wire 1155 faulty. AC condenser assembly harness green wire faulty. AC condenser motor solenoid ground wire faulty. Fan control switch faulty. Wire 1156 faulty. AC temperature control switch faulty.

3.

WARNING
Read WARNING on page 0012-7.

Is AC heater/evaporator core free from damage and debris?

TEST OPTIONS
Visual inspection.
REASON FOR QUESTION
If AC heater/evaporator core is damaged or blocked, AC system will not operate properly.

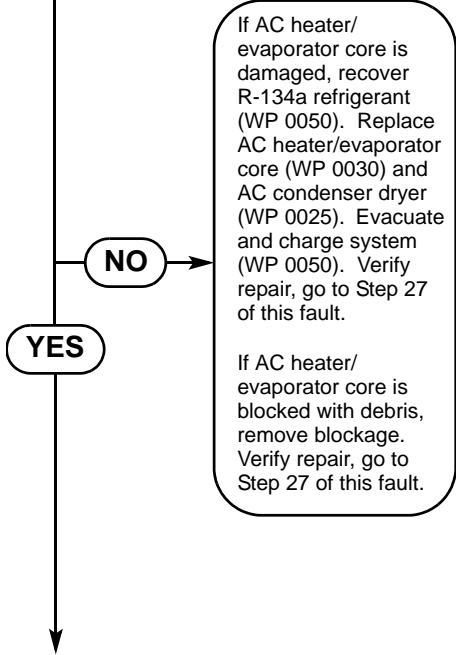

AC HEATER/EVAPORATOR BLOWER OPERATES BUT NO COLD AIR FROM DUCTS DURING AC OPERATIONS - Continued

WARNING

- Wear protective goggles and nonleather gloves when servicing air conditioner system. Failure to comply may result in injury to personnel.
- Remove rings, bracelets, wristwatches, neck chains, and any other jewelry before working around vehicle. Jewelry can catch on equipment and cause serious injury. Jewelry or tools may short across electrical circuits or terminals and cause damage to equipment or severe burns or electrical shock to personnel.

VISUAL INSPECTION

- (1) Inspect AC heater/evaporator core for damage and blockage from debris.
 - (a) If AC heater/evaporator core is damaged:
 1. Recover R-134a refrigerant (WP 0050).
 2. Replace AC heater/evaporator core (WP 0030).
 3. Replace AC condenser dryer (WP 0025).
 4. Evacuate and charge system (WP 0050).
 5. Verify repair, go to Step 27 of this fault.
 - (b) If AC heater/evaporator core is blocked with debris, remove eight screws and top heater cover (WP 0037), loosen four screws and pull center heater cover aside (WP 0038), and remove blockage. Verify repair, go to Step 27 of this fault.
 - (c) If AC heater/evaporator core is free from damage and blockage, go to Step 4 of this fault.

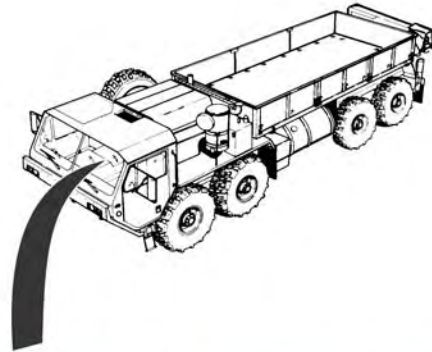

INTAKE VENT AND
AC HEATER/EVAPORATOR CORE

AC HEATER/EVAPORATOR BLOWER OPERATES BUT NO COLD AIR FROM DUCTS DURING AC OPERATIONS - Continued

KNOWN INFO
Power to fan control switch OK. Blower operates. AC condenser core not blocked or damaged. AC compressor belts OK. AC heater/evaporator core not blocked or damaged.
POSSIBLE PROBLEMS
AC temperature control switch temperature probe damaged or installed incorrectly. Heater cable faulty. AC cable faulty. Defrost cable faulty. AC compressor clutch faulty. AC harness wire 1154 faulty. High pressure switch faulty. AC harness wire 1156 faulty. AC harness wire 1158 faulty. Low pressure switch faulty. AC condenser motor solenoid faulty. AC condenser motor power wire faulty. AC condenser motor ground wire faulty. AC condenser motor faulty. AC condenser assembly harness black wire faulty. AC harness wire 1155 faulty. AC condenser assembly harness green wire faulty. AC condenser motor solenoid ground wire faulty. Fan control switch faulty. Wire 1156 faulty. AC temperature control switch faulty.

4.

WARNING
Read WARNING on page 0012-9.

Is temperature control switch temperature probe free from damage and installed correctly in AC heater/evaporator core?

TEST OPTIONS
Visual inspection.
REASON FOR QUESTION
If temperature control switch temperature probe is damaged or installed incorrectly, AC system will not operate properly.

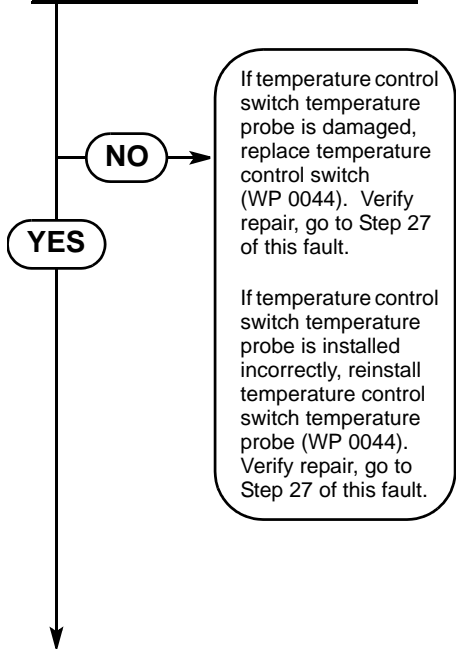

AC HEATER/EVAPORATOR BLOWER OPERATES BUT NO COLD AIR FROM DUCTS DURING AC OPERATIONS - Continued

WARNING

Remove rings, bracelets, wristwatches, neck chains, and any other jewelry before working around vehicle. Jewelry can catch on equipment and cause serious injury. Jewelry or tools may short across electrical circuits or terminals and cause damage to equipment or severe burns or electrical shock to personnel.

VISUAL INSPECTION

NOTE: Temperature control switch temperature probe is installed correctly when it is inserted into the AC evaporator core until it touches the bottom of the insertion hole.

- (1) Remove eight screws and top heater cover (WP 0037).
- (2) Inspect temperature control switch temperature probe for damage.
 - (a) If temperature control switch temperature probe is damaged, replace temperature control switch (WP 0044). Verify repair, go to Step 27 of this fault.
- (3) Check if temperature control switch temperature probe is installed correctly.
 - (a) If temperature control switch temperature probe is installed incorrectly, reinstall temperature control switch temperature probe (WP 0044). Verify repair, go to Step 27 of this fault.
 - (b) If temperature control switch temperature probe is installed correctly, go to Step 5 of this fault.

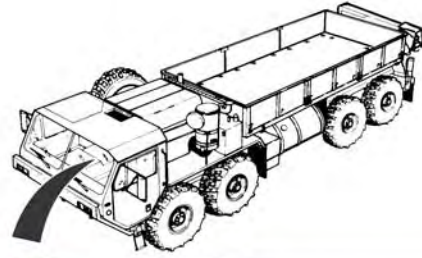

SCREWS
TOP HEATER
COVER

AC TEMPERATURE
CONTROL SWITCH
TEMPERATURE PROBE

AC HEATER/EVAPORATOR
CORE COVER

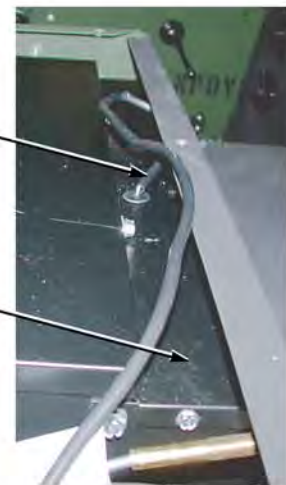

AC HEATER/EVAPORATOR BLOWER OPERATES BUT NO COLD AIR FROM DUCTS DURING AC OPERATIONS - Continued

KNOWN INFO
Power to fan control switch OK. Blower operates. AC condenser core not blocked or damaged. AC compressor belts OK. AC heater/evaporator core not blocked or damaged. AC temperature control switch temperature probe OK.
POSSIBLE PROBLEMS
Heater cable faulty. AC cable faulty. Defrost cable faulty. AC compressor clutch faulty. AC harness wire 1154 faulty. High pressure switch faulty. AC harness wire 1156 faulty. AC harness wire 1158 faulty. Low pressure switch faulty. AC condenser motor solenoid faulty. AC condenser motor power wire faulty. AC condenser motor ground wire faulty. AC condenser motor faulty. AC condenser assembly harness black wire faulty. AC harness wire 1155 faulty. AC condenser assembly harness green wire faulty. AC condenser motor solenoid ground wire faulty. Fan control switch faulty. Wire 1156 faulty. AC temperature control switch faulty.

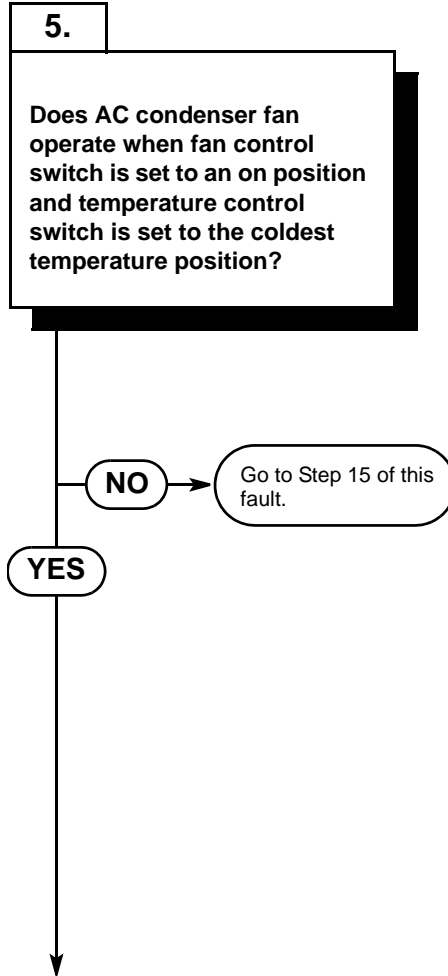

TEST OPTIONS
Visual inspection.
REASON FOR QUESTION
If AC condenser fan does not operate, AC system will not operate properly.



AC HEATER/EVAPORATOR BLOWER OPERATES BUT NO COLD AIR FROM DUCTS DURING AC OPERATIONS - Continued



VISUAL INSPECTION

- (1) Turn engine start switch ON (TM 9-2320-279-10).
- (2) Turn fan control switch to an on position (low, medium, or high) (WP 0004).
- (3) Turn temperature control switch to the coldest position (fully clockwise) (WP 0004).
- (4) Verify operation of AC condenser fan.
 - (a) If AC condenser fan does not operate, turn engine start switch OFF and go to Step 15 of this fault.
 - (b) If AC condenser fan operates, turn engine start switch OFF and go to Step 6 of this fault.



AC CONDENSER FAN



(BACK SIDE OF AC CONDENSER ASSEMBLY SHOWN)

AC HEATER/EVAPORATOR BLOWER OPERATES BUT NO COLD AIR FROM DUCTS DURING AC OPERATIONS - Continued

KNOWN INFO
Power to fan control switch OK. Blower operates. AC condenser core not blocked or damaged. AC compressor belts OK. AC heater/evaporator core not blocked or damaged. AC temperature control switch temperature probe OK. AC condenser motor solenoid OK. AC condenser motor power wire OK. AC condenser motor ground wire OK. AC condenser motor OK. AC condenser assembly harness black wire OK. AC harness wire 1155 OK. AC condenser assembly harness green wire OK. AC condenser motor solenoid ground wire OK. Fan control switch OK. Wire 1156 OK. AC temperature control switch OK.
POSSIBLE PROBLEMS
Heater cable faulty. AC cable faulty. Defrost cable faulty. AC compressor clutch faulty. AC harness wire 1154 faulty. Low pressure switch faulty. AC harness wire 1156 faulty. AC harness wire 1158 faulty. High pressure switch faulty.

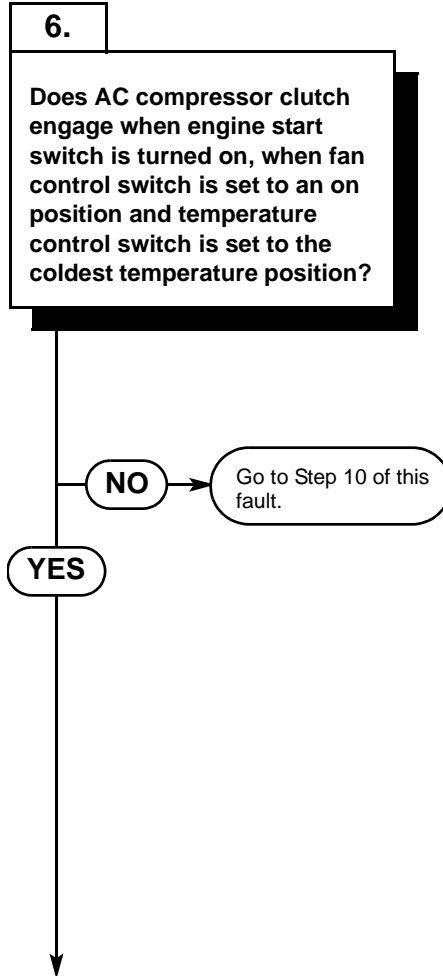

TEST OPTIONS
Audible test.
REASON FOR QUESTION
If AC compressor clutch does not engage, AC compressor will not operate.



AC HEATER/EVAPORATOR BLOWER OPERATES BUT NO COLD AIR FROM DUCTS DURING AC OPERATIONS - Continued

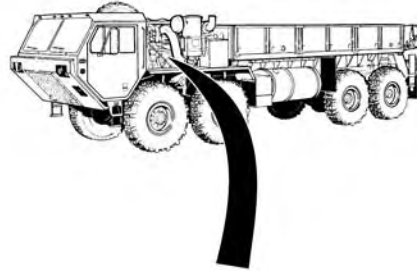

AUDIBLE TEST

NOTE: Do not start engine during this procedure. AC compressor clutch operation will be checked by listening for a clicking sound from the AC compressor when the engine start switch is turned to ON position.

- (1) Turn fan control switch to an on position (low, medium, or high) (WP 0004).
- (2) Turn temperature control switch to the coldest position (fully clockwise) (WP 0004).
- (3) While assistant turns engine start switch ON (TM 9-2320-279-10), verify operation of AC compressor clutch by listening for a click when engine start switch is turned ON.
 - (a) If AC compressor clutch does not engage, turn engine start switch OFF and go to Step 10 of this fault.
 - (b) If AC compressor clutch engages, turn engine start switch OFF and go to Step 7 of this fault.

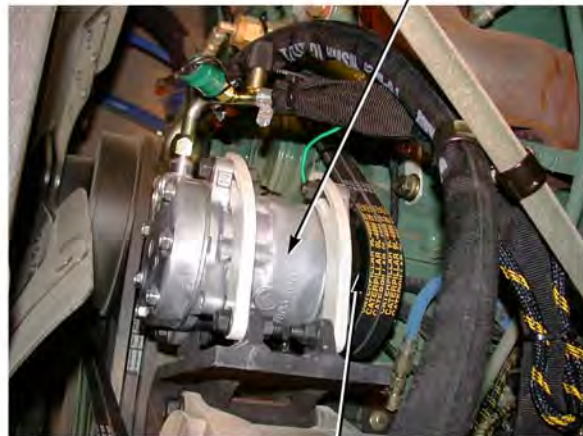

AC COMPRESSOR

AC COMPRESSOR PULLEY/CLUTCH ASSEMBLY

AC HEATER/EVAPORATOR BLOWER OPERATES BUT NO COLD AIR FROM DUCTS DURING AC OPERATIONS - Continued

KNOWN INFO
Power to fan control switch OK.
Blower operates.
AC condenser core not blocked or damaged.
AC compressor belts OK.
AC heater/evaporator core not blocked or damaged.
AC temperature control switch temperature probe OK.
AC condenser motor solenoid OK.
AC condenser motor power wire OK.
AC condenser motor ground wire OK.
AC condenser motor OK.
AC condenser assembly harness black wire OK.
AC harness wire 1155 OK.
AC condenser assembly harness green wire OK.
AC condenser motor solenoid ground wire OK.
Fan control switch OK.
Wire 1156 OK.
AC temperature control switch OK.
AC compressor clutch OK.
AC harness wire 1154 OK.
Low pressure switch OK.
AC harness wire 1156 OK.
AC harness wire 1158 OK.
High pressure switch OK.
POSSIBLE PROBLEMS
Heater cable faulty.
AC cable faulty.
Defrost cable faulty.

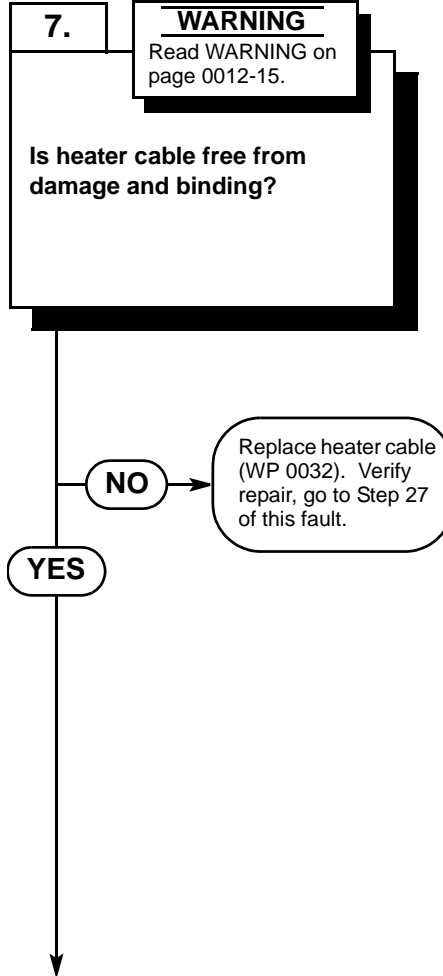

TEST OPTIONS
Visual inspection.
REASON FOR QUESTION
If heater cable is binding or damaged, the heater control valve may not be closed completely during AC operations.



AC HEATER/EVAPORATOR BLOWER OPERATES BUT NO COLD AIR FROM DUCTS DURING AC OPERATIONS - Continued

WARNING

Remove rings, bracelets, wristwatches, neck chains, and any other jewelry before working around vehicle. Jewelry can catch on equipment and cause serious injury. Jewelry or tools may short across electrical circuits or terminals and cause damage to equipment or severe burns or electrical shock to personnel.

VISUAL INSPECTION

- (1) Inspect heater cable for binding and damage.
 - (a) If heater cable is binding or damaged, replace heater cable (WP 0032). Verify repair, go to Step 27 of this fault.
 - (b) If heater cable is free from binding and damage, go to Step 8 of this fault.



HEATER CABLE

HEATER VALVE

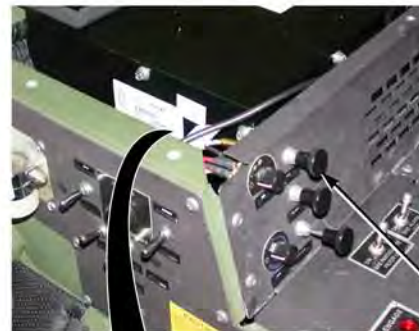
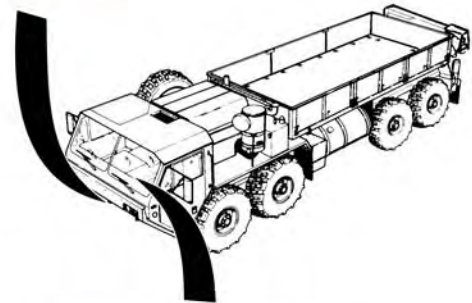

HEATER CABLE



AC HEATER/EVAPORATOR BLOWER OPERATES BUT NO COLD AIR FROM DUCTS DURING AC OPERATIONS - Continued

KNOWN INFO
Power to fan control switch OK.
Blower operates.
AC condenser core not blocked or damaged.
AC compressor belts OK.
AC heater/evaporator core not blocked or damaged.
AC temperature control switch temperature probe OK.
AC condenser motor solenoid OK.
AC condenser motor power wire OK.
AC condenser motor ground wire OK.
AC condenser motor OK.
AC condenser assembly harness black wire OK.
AC harness wire 1155 OK.
AC condenser assembly harness green wire OK.
AC condenser motor solenoid ground wire OK.
Fan control switch OK.Heater cable OK.
Wire 1156 OK.
AC temperature control switch OK.
AC compressor clutch OK.
AC harness wire 1154 OK.
Low pressure switch OK.
AC harness wire 1156 OK.
AC harness wire 1158 OK.
High pressure switch OK.
Heater cable OK.
POSSIBLE PROBLEMS
AC cable faulty.
Defrost cable faulty.

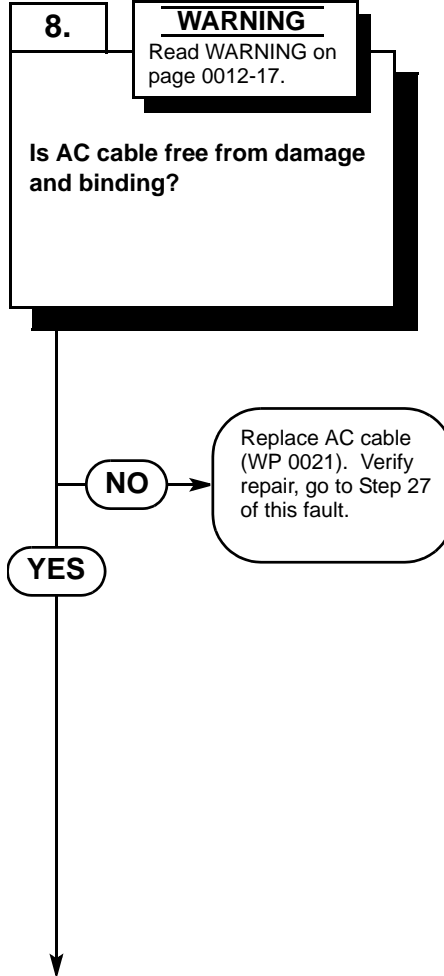

TEST OPTIONS
Visual inspection.
REASON FOR QUESTION
If AC cable is binding or damaged, the AC louver may not be positioned correctly for AC operations.



AC HEATER/EVAPORATOR BLOWER OPERATES BUT NO COLD AIR FROM DUCTS DURING AC OPERATIONS - Continued

WARNING

Remove rings, bracelets, wristwatches, neck chains, and any other jewelry before working around vehicle. Jewelry can catch on equipment and cause serious injury. Jewelry or tools may short across electrical circuits or terminals and cause damage to equipment or severe burns or electrical shock to personnel.

VISUAL INSPECTION
(1) Inspect AC cable for binding and damage. (a) If AC cable is binding or damaged, replace AC cable (WP 0021). Verify repair, go to Step 27 of this fault. (b) If AC cable is free from binding and damage, go to Step 9 of this fault.

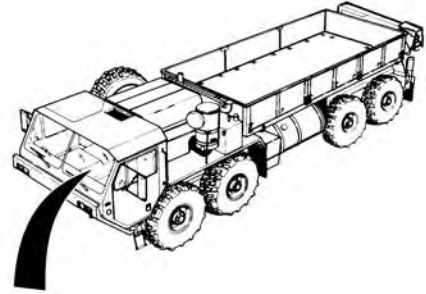

AC CABLE



AC HEATER/EVAPORATOR BLOWER OPERATES BUT NO COLD AIR FROM DUCTS DURING AC OPERATIONS - Continued

KNOWN INFO
Power to fan control switch OK.
Blower operates.
AC condenser core not blocked or damaged.
AC compressor belts OK.
AC heater/evaporator core not blocked or damaged.
AC temperature control switch temperature probe OK.
AC condenser motor solenoid OK.
AC condenser motor power wire OK.
AC condenser motor ground wire OK.
AC condenser motor OK.
AC condenser assembly harness black wire OK.
AC harness wire 1155 OK.
AC condenser assembly harness green wire OK.
AC condenser motor solenoid ground wire OK.
Fan control switch OK.
Wire 1156 OK.
AC temperature control switch OK.
AC compressor clutch OK.
AC harness wire 1154 OK.
Low pressure switch OK.
AC harness wire 1156 OK.
AC harness wire 1158 OK.
High pressure switch OK.
Heater cable OK.
AC cable OK.
POSSIBLE PROBLEMS
Defrost cable faulty.

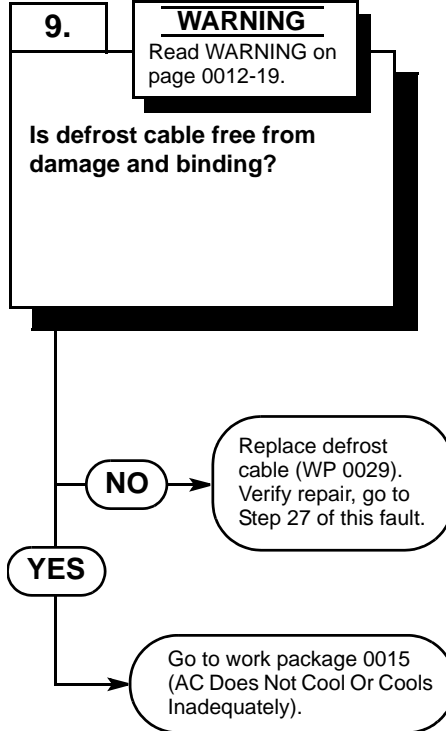

TEST OPTIONS
Visual inspection.
REASON FOR QUESTION
If defrost cable is binding or damaged, the defrost louver may not be positioned correctly for AC operations.



AC HEATER/EVAPORATOR BLOWER OPERATES BUT NO COLD AIR FROM DUCTS DURING AC OPERATIONS - Continued

WARNING

Remove rings, bracelets, wristwatches, neck chains, and any other jewelry before working around vehicle. Jewelry can catch on equipment and cause serious injury. Jewelry or tools may short across electrical circuits or terminals and cause damage to equipment or severe burns or electrical shock to personnel.

VISUAL INSPECTION

- (1) Inspect defrost cable for binding and damage.
 - (a) If defrost cable is binding or damaged, replace defrost cable (WP 0029). Verify repair, go to Step 27 of this fault.
 - (b) If defrost cable is free from binding and damage, go to work package 0015 (AC Does Not Cool Or Cools Inadequately).

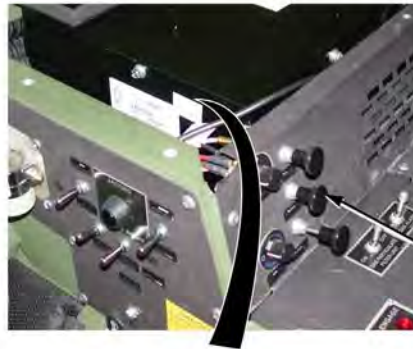
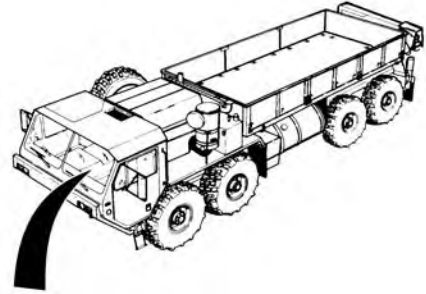

DEFROST CABLE



AC HEATER/EVAPORATOR BLOWER OPERATES BUT NO COLD AIR FROM DUCTS DURING AC OPERATIONS - Continued

KNOWN INFO
Power to fan control switch OK. Blower operates. AC condenser core not blocked or damaged. AC compressor belts OK. AC condenser motor solenoid OK. AC condenser motor power wire OK. AC condenser motor ground wire OK. AC condenser motor OK. AC condenser assembly harness black wire OK. AC harness wire 1155 OK. AC condenser assembly harness green wire OK. AC condenser motor solenoid ground wire OK. Fan control switch OK. Wire 1156 OK. AC temperature control switch OK. AC heater/evaporator core not blocked or damaged. AC temperature control switch temperature probe OK. Heater cable OK. AC cable OK. Defrost cable OK.
POSSIBLE PROBLEMS
AC compressor clutch faulty. AC harness wire 1154 faulty. Low pressure switch faulty. AC harness wire 1156 faulty. AC harness wire 1158 faulty. High pressure switch faulty.

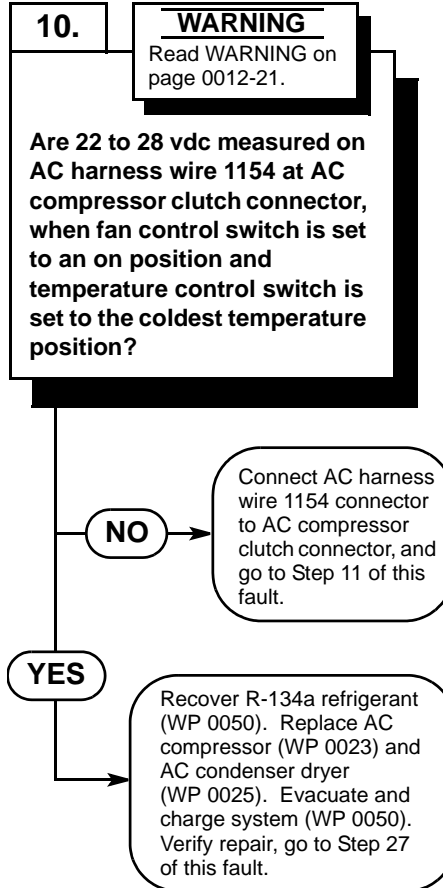

TEST OPTIONS
Voltage test. Multimeter.
REASON FOR QUESTION
If 22 to 28 vdc are measured, AC compressor clutch is faulty. ←

AC HEATER/EVAPORATOR BLOWER OPERATES BUT NO COLD AIR FROM DUCTS DURING AC OPERATIONS - Continued

WARNING

- Remove rings, bracelets, wristwatches, neck chains, and any other jewelry before working around vehicle. Jewelry can catch on equipment and cause serious injury. Jewelry or tools may short across electrical circuits or terminals and cause damage to equipment or severe burns or electrical shock to personnel.
- Wear protective goggles and nonleather gloves when servicing air conditioner system. Failure to comply may result in injury to personnel.

VOLTAGE TEST

- (1) Disconnect AC harness wire 1154 from AC compressor clutch connector (WP 0023).
- (2) Turn fan control switch to an on position (low, medium, or high) (WP 0004).
- (3) Turn AC temperature control switch to the coldest position (fully clockwise) (WP 0004).
- (4) Turn engine start switch ON (TM 9-2320-279-10).
- (5) Place positive (+) probe of multimeter on AC harness wire 1154 at AC compressor clutch connector.
- (6) Place negative (-) probe of multimeter on a known good ground.
 - (a) If 22 to 28 vdc are not measured, turn engine start switch OFF, connect AC harness wire 1154 to AC compressor clutch connector and go to Step 11 of this fault.
 - (b) If 22 to 28 vdc are measured:
 1. Turn engine start switch OFF (TM 9-2320-279-10).
 2. Recover R-134a refrigerant (WP 0050).
 3. Replace AC compressor (WP 0023).
 4. Replace AC condenser dryer (WP 0025).
 5. Evacuate and charge system (WP 0050).
 6. Verify repair, go to Step 27 of this fault.

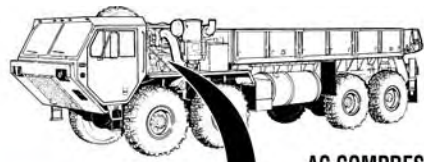

AC COMPRESSOR



AC COMPRESSOR CLUTCH CONNECTOR

AC HARNESS WIRE 1154

AC HEATER/EVAPORATOR BLOWER OPERATES BUT NO COLD AIR FROM DUCTS DURING AC OPERATIONS - Continued

KNOWN INFO
Power to fan control switch OK. Blower operates. AC condenser core not blocked or damaged. AC compressor belts OK. AC condenser motor solenoid OK. AC condenser motor power wire OK. AC condenser motor ground wire OK. AC condenser motor OK. AC condenser assembly harness black wire OK. AC harness wire 1155 OK. AC condenser assembly harness green wire OK. AC condenser motor solenoid ground wire OK. Fan control switch OK. Wire 1156 OK. AC temperature control switch OK. AC heater/evaporator core not blocked or damaged. AC temperature control switch temperature probe OK. Heater cable OK. AC cable OK. Defrost cable OK. AC compressor clutch OK.
POSSIBLE PROBLEMS
AC harness wire 1154 faulty. Low pressure switch faulty. AC harness wire 1156 faulty. AC harness wire 1158 faulty. High pressure switch faulty.

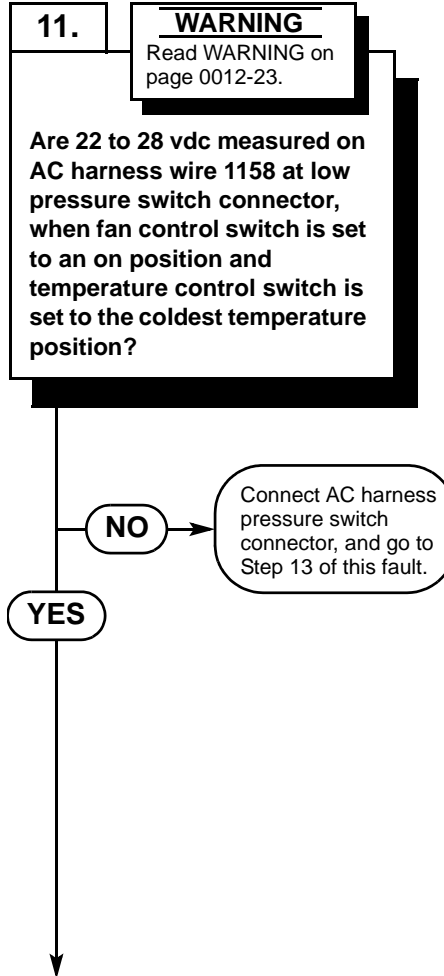

TEST OPTIONS
Voltage test. Multimeter.
REASON FOR QUESTION
To isolate system fault.



AC HEATER/EVAPORATOR BLOWER OPERATES BUT NO COLD AIR FROM DUCTS DURING AC OPERATIONS - Continued

WARNING

Remove rings, bracelets, wristwatches, neck chains, and any other jewelry before working around vehicle. Jewelry can catch on equipment and cause serious injury. Jewelry or tools may short across electrical circuits or terminals and cause damage to equipment or severe burns or electrical shock to personnel.

VOLTAGE TEST

- (1) Disconnect AC harness wire 1158 from low pressure switch connector (WP 0041).
- (2) Turn fan control switch to an on position (low, medium, or high) (WP 0004).
- (3) Turn AC temperature control switch to the coldest position (fully clockwise) (WP 0004).
- (4) Turn engine start switch ON (TM 9-2320-279-10).
- (5) Place positive (+) probe of multimeter on AC harness wire 1158 at low pressure switch connector.
- (6) Place negative (-) probe of multimeter on a known good ground.
 - (a) If 22 to 28 vdc are not measured, turn engine start switch OFF, connect AC harness wire 1158 to low pressure switch connector and go to Step 13 of this fault.
 - (b) If 22 to 28 vdc are measured, turn engine switch OFF and go to Step 12 of this fault.

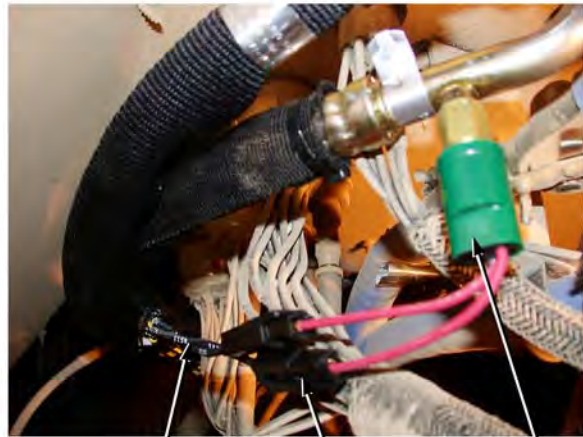
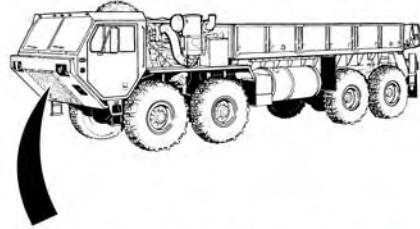

AC HARNESS
WIRE 1158

LOW PRESSURE
SWITCH CONNECTOR

LOW PRESSURE
SWITCH

AC HEATER/EVAPORATOR BLOWER OPERATES BUT NO COLD AIR FROM DUCTS DURING AC OPERATIONS - Continued

KNOWN INFO
Power to fan control switch OK. Blower operates. AC condenser core not blocked or damaged. AC compressor belts OK. AC condenser motor solenoid OK. AC condenser motor power wire OK. AC condenser motor ground wire OK. AC condenser motor OK. AC condenser assembly harness black wire OK. AC harness wire 1155 OK. AC condenser assembly harness green wire OK. AC condenser motor solenoid ground wire OK. Fan control switch OK. Wire 1156 OK. AC temperature control switch OK. AC heater/evaporator core not blocked or damaged. AC temperature control switch temperature probe OK. Heater cable OK. AC cable OK. Defrost cable OK. AC compressor clutch OK. AC harness wire 1156 OK. AC harness wire 1158 OK. High pressure switch OK.
POSSIBLE PROBLEMS
AC harness wire 1154 faulty. Low pressure switch faulty.

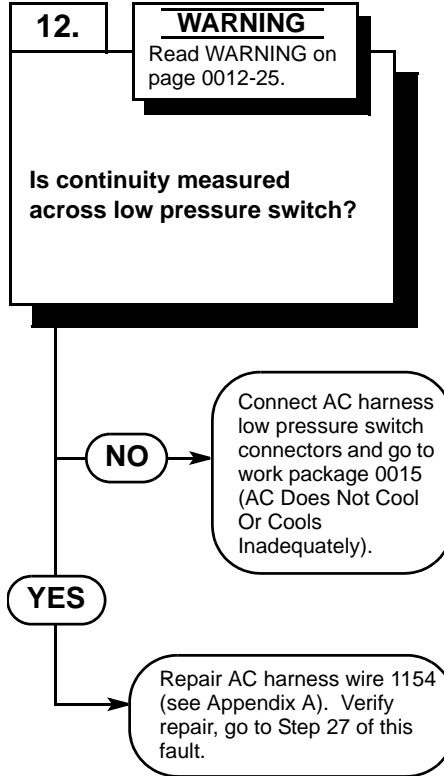

TEST OPTIONS
Continuity test. Multimeter.
REASON FOR QUESTION
If continuity is measured, AC harness wire 1154 is faulty.



AC HEATER/EVAPORATOR BLOWER OPERATES BUT NO COLD AIR FROM DUCTS DURING AC OPERATIONS - Continued

WARNING

Remove rings, bracelets, wristwatches, neck chains, and any other jewelry before working around vehicle. Jewelry can catch on equipment and cause serious injury. Jewelry or tools may short across electrical circuits or terminals and cause damage to equipment or severe burns or electrical shock to personnel.

CONTINUITY TEST

- (1) Disconnect AC harness wire 1154 from low pressure switch connector (WP 0041).
- (2) Set multimeter switch to ohms.
- (3) Place positive (+) probe of multimeter on low pressure switch wire 1158 connector.
- (4) Place negative (-) probe of multimeter on low pressure switch wire 1154 connector.
 - (a) If there is no continuity, connect AC harness low pressure switch connectors and go to work package 0015 (AC Does Not Cool Or Cools Inadequately).
 - (b) If there is continuity, repair AC harness wire 1154 (see Appendix A) or replace AC wiring harness (WP 0046). Verify repair, go to Step 27 of this fault.

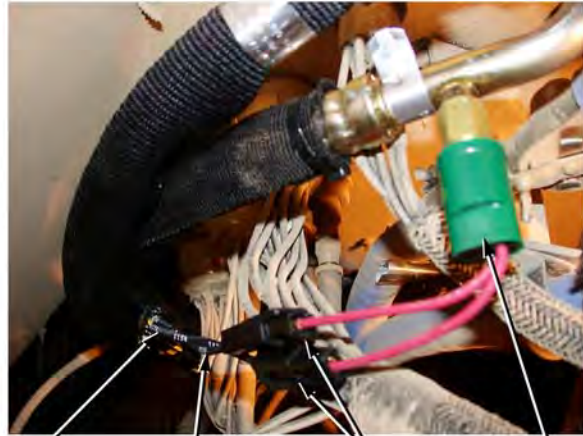
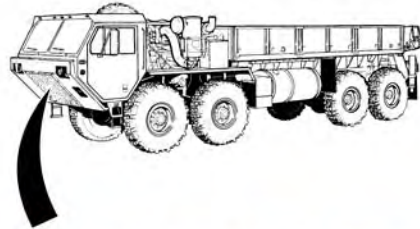

AC HARNESS
WIRE 1158

AC HARNESS
WIRE 1154

LOW PRESSURE
SWITCH CONNECTORS

LOW PRESSURE
SWITCH

AC HEATER/EVAPORATOR BLOWER OPERATES BUT NO COLD AIR FROM DUCTS DURING AC OPERATIONS - Continued

KNOWN INFO
Power to fan control switch OK. Blower operates. AC condenser core not blocked or damaged. AC compressor belts OK. AC condenser motor solenoid OK. AC condenser motor power wire OK. AC condenser motor ground wire OK. AC condenser motor OK. AC condenser assembly harness black wire OK. AC harness wire 1155 OK. AC condenser assembly harness green wire OK. AC condenser motor solenoid ground wire OK. Fan control switch OK. Wire 1156 OK. AC temperature control switch OK. AC heater/evaporator core not blocked or damaged. AC temperature control switch temperature probe OK. Heater cable OK. AC cable OK. Defrost cable OK. AC compressor clutch OK. AC harness wire 1154 OK. Low pressure switch OK.
POSSIBLE PROBLEMS
AC harness wire 1156 faulty. AC harness wire 1158 faulty. High pressure switch faulty.

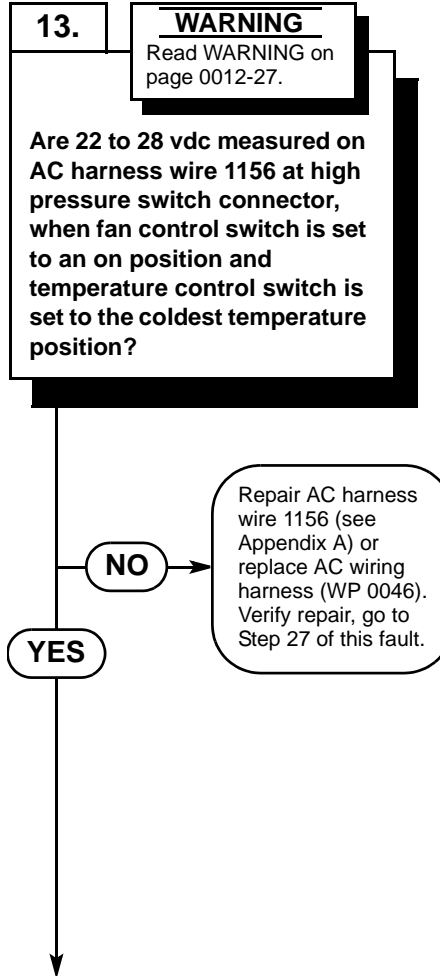

TEST OPTIONS
Voltage test. Multimeter.
REASON FOR QUESTION
If 22 to 28 vdc are not measured, AC harness wire 1156 is faulty.



AC HEATER/EVAPORATOR BLOWER OPERATES BUT NO COLD AIR FROM DUCTS DURING AC OPERATIONS - Continued

WARNING

Remove rings, bracelets, wristwatches, neck chains, and any other jewelry before working around vehicle. Jewelry can catch on equipment and cause serious injury. Jewelry or tools may short across electrical circuits or terminals and cause damage to equipment or severe burns or electrical shock to personnel.

VOLTAGE TEST

- (1) Disconnect AC harness wire 1156 from high pressure switch connector (WP 0039).
- (2) Turn fan control switch to an on position (low, medium, or high) (WP 0004).
- (3) Turn AC temperature control switch to the coldest position (fully clockwise) (WP 0004).
- (4) Turn engine start switch ON (TM 9-2320-279-10).
- (5) Place positive (+) probe of multimeter on AC harness wire 1156 at high pressure switch connector.
- (6) Place negative (-) probe of multimeter on a known good ground.
 - (a) If 22 to 28 vdc are not measured, turn engine start switch OFF and repair AC harness wire 1156 (see Appendix A) or replace AC wiring harness (WP 0046). Verify repair, go to Step 27 of this fault.
 - (b) If 22 to 28 vdc are measured, turn engine switch OFF, and go to Step 14 of this fault.



AC COMPRESSOR

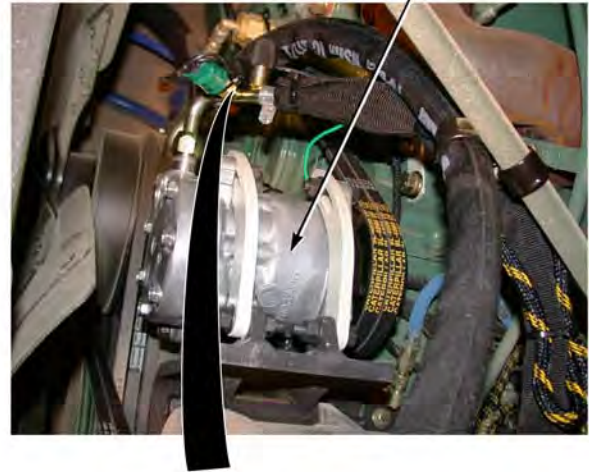

HIGH PRESSURE SWITCH AC COMPRESSOR HIGH PRESSURE SWITCH CONNECTOR AC HARNESS WIRE 1156

AC HEATER/EVAPORATOR BLOWER OPERATES BUT NO COLD AIR FROM DUCTS DURING AC OPERATIONS - Continued

KNOWN INFO
Power to fan control switch OK. Blower operates. AC condenser core not blocked or damaged. AC compressor belts OK. AC condenser motor solenoid OK. AC condenser motor power wire OK. AC condenser motor ground wire OK. AC condenser motor OK. AC condenser assembly harness black wire OK. AC harness wire 1155 OK. AC condenser assembly harness green wire OK. AC condenser motor solenoid ground wire OK. Fan control switch OK. Wire 1156 OK. AC temperature control switch OK. AC heater/evaporator core not blocked or damaged. AC temperature control switch temperature probe OK. Heater cable OK. AC cable OK. Defrost cable OK. AC compressor clutch OK. AC harness wire 1154 OK. Low pressure switch OK. AC harness wire 1156 OK.
POSSIBLE PROBLEMS
AC harness wire 1158 faulty. High pressure switch faulty.

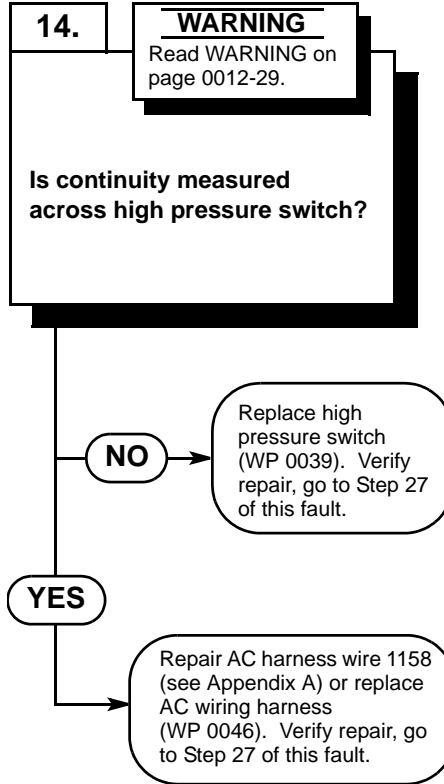

TEST OPTIONS
Continuity test. Multimeter.
REASON FOR QUESTION
If continuity is measured, AC harness wire 1158 is faulty. If not, high pressure switch is faulty.



AC HEATER/EVAPORATOR BLOWER OPERATES BUT NO COLD AIR FROM DUCTS DURING AC OPERATIONS - Continued

WARNING

Remove rings, bracelets, wristwatches, neck chains, and any other jewelry before working around vehicle. Jewelry can catch on equipment and cause serious injury. Jewelry or tools may short across electrical circuits or terminals and cause damage to equipment or severe burns or electrical shock to personnel.

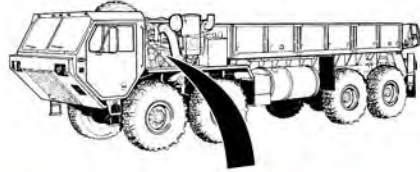

CONTINUITY TEST

- (1) Disconnect AC harness wire 1158 from high pressure switch connector (WP 0039).
- (2) Set multimeter switch to ohms.
- (3) Place positive (+) probe of multimeter on high pressure switch wire 1156 connector.
- (4) Place negative (-) probe of multimeter on high pressure switch wire 1158 connector.
 - (a) If there is no continuity, replace high pressure switch (WP 0039). Verify repair, go to Step 27 of this fault.
 - (b) If there is continuity, repair AC harness wire 1158 (see Appendix A) or replace AC wiring harness (WP 0046). Verify repair, go to Step 27 of this fault.



HIGH PRESSURE SWITCH AC COMPRESSOR HIGH PRESSURE SWITCH WIRE 1158 CONNECTOR HIGH PRESSURE SWITCH WIRE 1156 CONNECTOR

AC HEATER/EVAPORATOR BLOWER OPERATES BUT NO COLD AIR FROM DUCTS DURING AC OPERATIONS - Continued

KNOWN INFO
Power to fan control switch OK. Blower operates. AC condenser core not blocked or damaged. AC compressor belts OK. AC heater/evaporator core not blocked or damaged. AC temperature control switch temperature probe OK. Heater cable OK. AC cable OK. Defrost cable OK. AC compressor clutch OK. AC harness wire 1154 OK. Low pressure switch OK. AC harness wire 1158 OK. High pressure switch OK.
POSSIBLE PROBLEMS
AC harness wire 1156 faulty. AC condenser motor solenoid faulty. AC condenser motor power wire faulty. AC condenser motor ground wire faulty. AC condenser motor faulty. AC condenser assembly harness black wire faulty. AC harness wire 1155 faulty. AC condenser assembly harness green wire faulty. AC condenser motor solenoid ground wire faulty. Fan control switch faulty. Wire 1156 faulty. AC temperature control switch faulty.

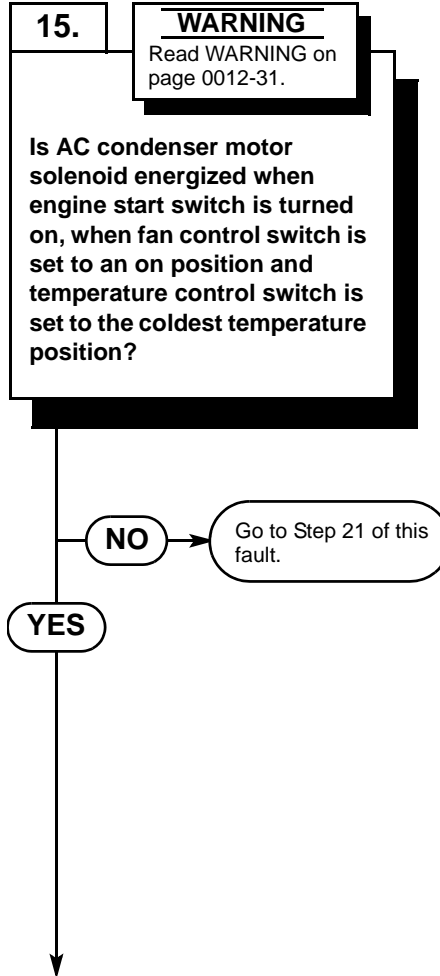

TEST OPTIONS
Audible test.
REASON FOR QUESTION
To isolate system fault.



AC HEATER/EVAPORATOR BLOWER OPERATES BUT NO COLD AIR FROM DUCTS DURING AC OPERATIONS - Continued

WARNING

Remove rings, bracelets, wristwatches, neck chains, and any other jewelry before working around vehicle. Jewelry can catch on equipment and cause serious injury. Jewelry or tools may short across electrical circuits or terminals and cause damage to equipment or severe burns or electrical shock to personnel.

AUDIBLE TEST

NOTE: Do not start engine during this procedure. AC condenser motor solenoid operation will be checked by listening for a clicking sound from the AC condenser motor solenoid when the engine start switch is turned to ON position.

- (1) Remove four screws, lockwashers, washers, and cover from AC condenser assembly (WP 0027).
- (2) Turn fan control switch to an on position (low, medium, or high) (WP 0004).
- (3) Turn temperature control switch to the coldest position (fully clockwise) (WP 0004).
- (4) While assistant turns engine start switch ON (TM 9-2320-279-10), check operation of AC condenser motor solenoid by listening for a click when engine start switch is turned ON.
 - (a) If AC condenser motor solenoid is not energized, turn engine start switch OFF and go to Step 21 of this fault.
 - (b) If AC condenser motor solenoid is energized, go to Step 16 of this fault.

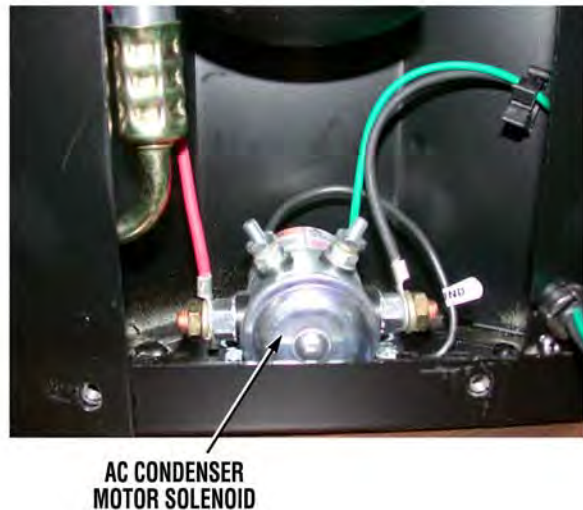
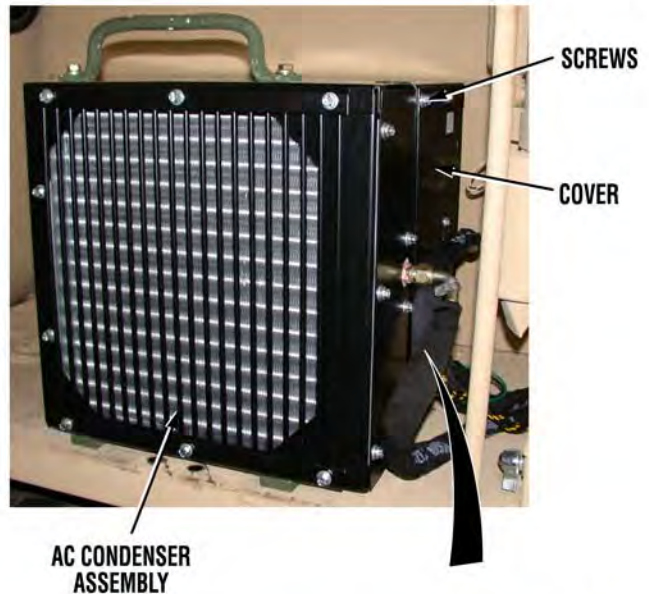

AC HEATER/EVAPORATOR BLOWER OPERATES BUT NO COLD AIR FROM DUCTS DURING AC OPERATIONS - Continued

KNOWN INFO
Power to fan control switch OK. Blower operates. AC condenser core not blocked or damaged. AC compressor belts OK. AC heater/evaporator core not blocked or damaged. AC temperature control switch temperature probe OK. Heater cable OK. AC cable OK. Defrost cable OK. AC compressor clutch OK. AC harness wire 1154 OK. Low pressure switch OK. AC harness wire 1158 OK. High pressure switch OK. AC harness wire 1156 OK. AC condenser assembly harness green wire OK. AC condenser motor solenoid ground wire OK. Fan control switch OK. Wire 1156 OK. AC temperature control switch OK.
POSSIBLE PROBLEMS
AC condenser motor solenoid faulty. AC condenser motor power wire faulty. AC condenser motor ground wire faulty. AC condenser motor faulty. AC condenser assembly harness black wire faulty. AC harness wire 1155 faulty.

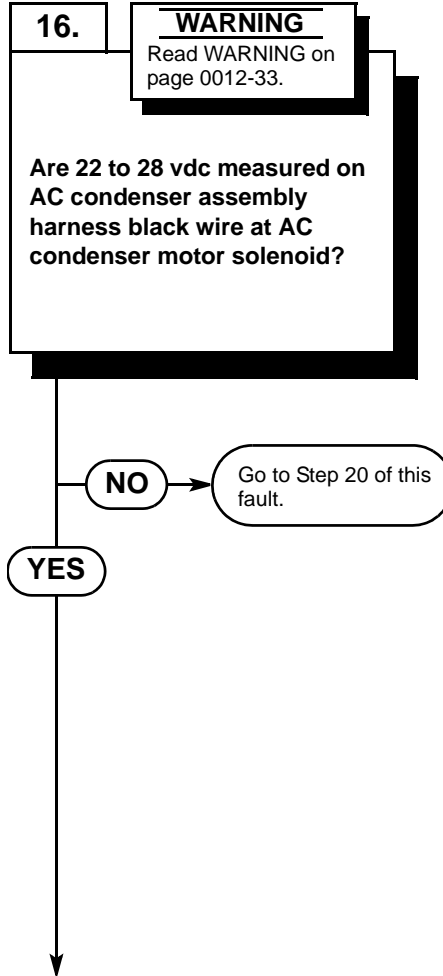

TEST OPTIONS
Voltage test. Multimeter.
REASON FOR QUESTION
To isolate system fault.



AC HEATER/EVAPORATOR BLOWER OPERATES BUT NO COLD AIR FROM DUCTS DURING AC OPERATIONS - Continued

WARNING

Remove rings, bracelets, wristwatches, neck chains, and any other jewelry before working around vehicle. Jewelry can catch on equipment and cause serious injury. Jewelry or tools may short across electrical circuits or terminals and cause damage to equipment or severe burns or electrical shock to personnel.

VOLTAGE TEST

- (1) If OFF, turn engine start switch ON (TM 9-2320-279-10).
- (2) Place positive (+) probe of multimeter on AC condenser assembly harness black wire at AC condenser motor solenoid terminal.
- (3) Place negative (-) probe of multimeter on a known good ground.
 - (a) If 22 to 28 vdc are not measured, turn engine start switch OFF and go to Step 20 of this fault.
 - (b) If 22 to 28 vdc are measured, go to Step 17 of this fault.

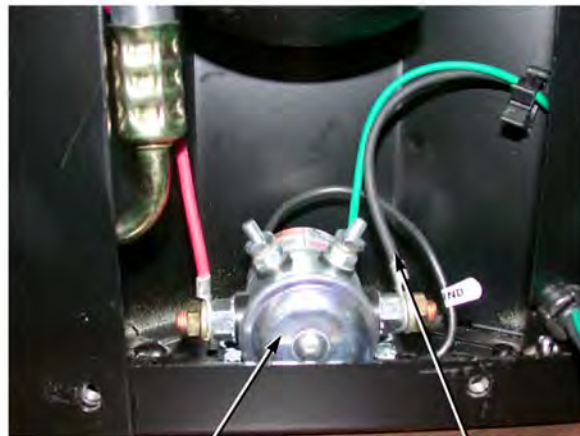
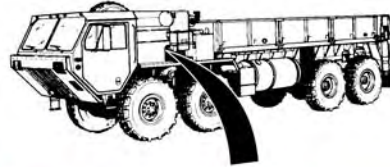

AC CONDENSER MOTOR SOLENOID

AC CONDENSER ASSEMBLY HARNESS BLACK WIRE

AC HEATER/EVAPORATOR BLOWER OPERATES BUT NO COLD AIR FROM DUCTS DURING AC OPERATIONS - Continued

KNOWN INFO
Power to fan control switch OK. Blower operates. AC condenser core not blocked or damaged. AC compressor belts OK. AC heater/evaporator core not blocked or damaged. AC temperature control switch temperature probe OK. Heater cable OK. AC cable OK. Defrost cable OK. AC compressor clutch OK. AC harness wire 1154 OK. Low pressure switch OK. AC harness wire 1158 OK. High pressure switch OK. AC harness wire 1156 OK. AC condenser assembly harness green wire OK. AC condenser motor solenoid ground wire OK. Fan control switch OK. Wire 1156 OK. AC temperature control switch OK. AC condenser assembly harness black wire OK. AC harness wire 1155 OK.
POSSIBLE PROBLEMS
AC condenser motor solenoid faulty. AC condenser motor power wire faulty. AC condenser motor ground wire faulty. AC condenser motor faulty.

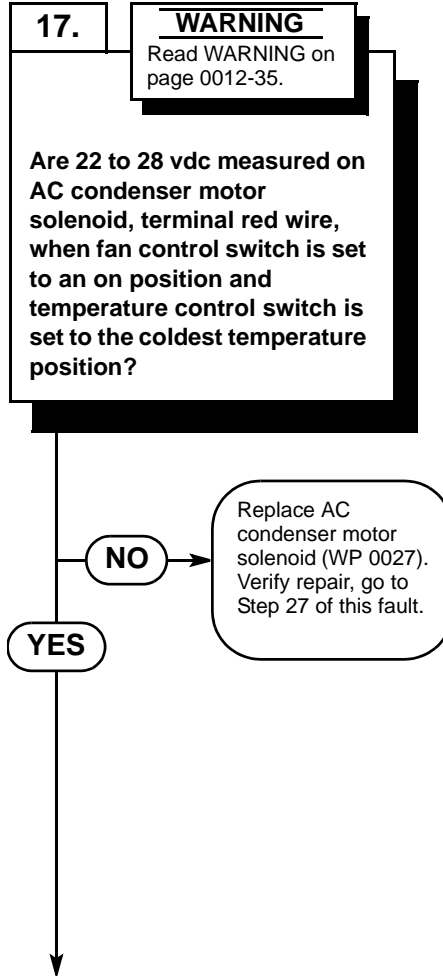

TEST OPTIONS
Voltage test. Multimeter.
REASON FOR QUESTION
If 22 to 28 vdc are not measured, AC condenser motor solenoid is faulty. ←

AC HEATER/EVAPORATOR BLOWER OPERATES BUT NO COLD AIR FROM DUCTS DURING AC OPERATIONS - Continued

WARNING

Remove rings, bracelets, wristwatches, neck chains, and any other jewelry before working around vehicle. Jewelry can catch on equipment and cause serious injury. Jewelry or tools may short across electrical circuits or terminals and cause damage to equipment or severe burns or electrical shock to personnel.



VOLTAGE TEST

- (1) Turn fan control switch to an on position (low, medium, or high) (WP 0004).
- (2) Turn AC temperature control switch to the coldest position (fully clockwise) (WP 0004).
- (3) If OFF, turn engine start switch ON (TM 9-2320-279-10).
- (4) Place positive (+) probe of multimeter on AC condenser motor solenoid, terminal red wire.
- (5) Place negative (-) probe of multimeter on a known good ground.
 - (a) If 22 to 28 vdc are not measured, turn engine start switch OFF and replace AC condenser motor solenoid (WP 0027). Verify repair, go to Step 27 of this fault.
 - (b) If 22 to 28 vdc are measured, turn engine switch OFF and go to Step 18 of this fault.

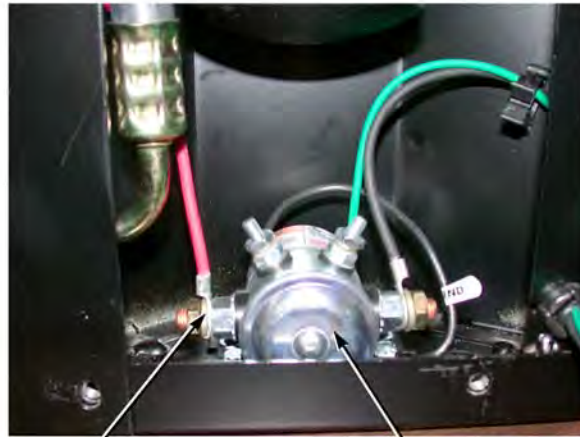

AC CONDENSER MOTOR SOLENOID TERMINAL RED WIRE

AC CONDENSER MOTOR SOLENOID

AC HEATER/EVAPORATOR BLOWER OPERATES BUT NO COLD AIR FROM DUCTS DURING AC OPERATIONS - Continued

KNOWN INFO
Power to fan control switch OK. Blower operates. AC condenser core not blocked or damaged. AC compressor belts OK. AC heater/evaporator core not blocked or damaged. AC temperature control switch temperature probe OK. Heater cable OK. AC cable OK. Defrost cable OK. AC compressor clutch OK. AC harness wire 1154 OK. Low pressure switch OK. AC harness wire 1158 OK. High pressure switch OK. AC harness wire 1156 OK. AC condenser assembly harness green wire OK. AC condenser motor solenoid ground wire OK. Fan control switch OK. Wire 1156 OK. AC temperature control switch OK. AC condenser assembly harness black wire OK. AC harness wire 1155 OK. AC condenser motor solenoid OK.
POSSIBLE PROBLEMS
AC condenser motor power wire faulty. AC condenser motor ground wire faulty. AC condenser motor faulty.

18.

WARNING
Read WARNING on page 0012-37.

Is continuity measured across AC condenser motor power wire?

TEST OPTIONS
Continuity test. Multimeter.
REASON FOR QUESTION
If continuity is not measured, AC condenser motor power wire is faulty.

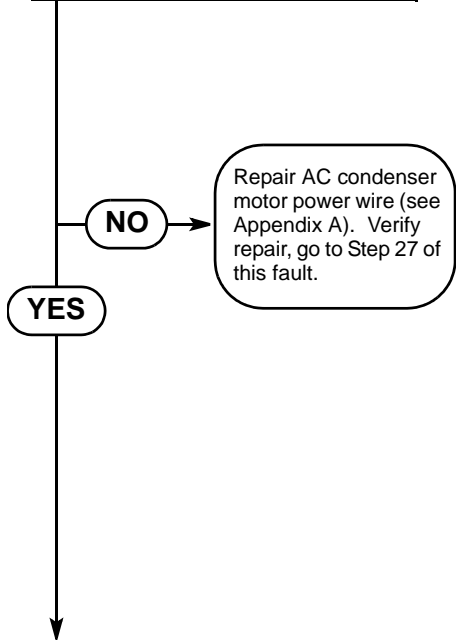

AC HEATER/EVAPORATOR BLOWER OPERATES BUT NO COLD AIR FROM DUCTS DURING AC OPERATIONS - Continued

WARNING

Remove rings, bracelets, wristwatches, neck chains, and any other jewelry before working around vehicle. Jewelry can catch on equipment and cause serious injury. Jewelry or tools may short across electrical circuits or terminals and cause damage to equipment or severe burns or electrical shock to personnel.

CONTINUITY TEST

NOTE: Do not disconnect wires from AC condenser motor.

- (1) Remove AC condenser motor (WP 0026).
- (2) Set multimeter switch to ohms.
- (3) Place positive (+) probe of multimeter on red wire at AC condenser motor terminal.
- (4) Place negative (-) probe of multimeter on red wire at AC condenser motor solenoid terminal.
 - (a) If there is no continuity, repair AC condenser motor power wire (see Appendix A). Verify repair, go to Step 27 of this fault.
 - (b) If there is continuity, go to Step 19 of this fault.



(BACK SIDE OF AC CONDENSER ASSEMBLY SHOWN)

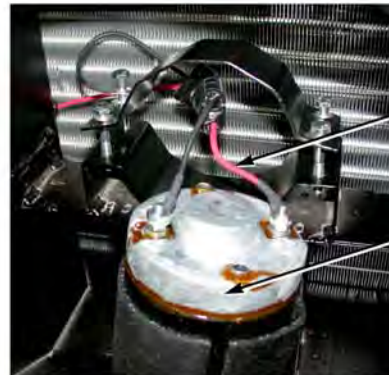

RED WIRE

AC CONDENSER MOTOR

AC CONDENSER MOTOR SOLENOID

RED WIRE



AC HEATER/EVAPORATOR BLOWER OPERATES BUT NO COLD AIR FROM DUCTS DURING AC OPERATIONS - Continued

KNOWN INFO
Power to fan control switch OK. Blower operates. AC condenser core not blocked or damaged. AC compressor belts OK. AC heater/evaporator core not blocked or damaged. AC temperature control switch temperature probe OK. Heater cable OK. AC cable OK. Defrost cable OK. AC compressor clutch OK. AC harness wire 1154 OK. Low pressure switch OK. AC harness wire 1158 OK. High pressure switch OK. AC harness wire 1156 OK. AC condenser assembly harness green wire OK. AC condenser motor solenoid ground wire OK. Fan control switch OK. Wire 1156 OK. AC temperature control switch OK. AC condenser assembly harness black wire OK. AC harness wire 1155 OK. AC condenser motor solenoid OK. AC condenser motor power wire OK.
POSSIBLE PROBLEMS
AC condenser motor ground wire faulty. AC condenser motor faulty.

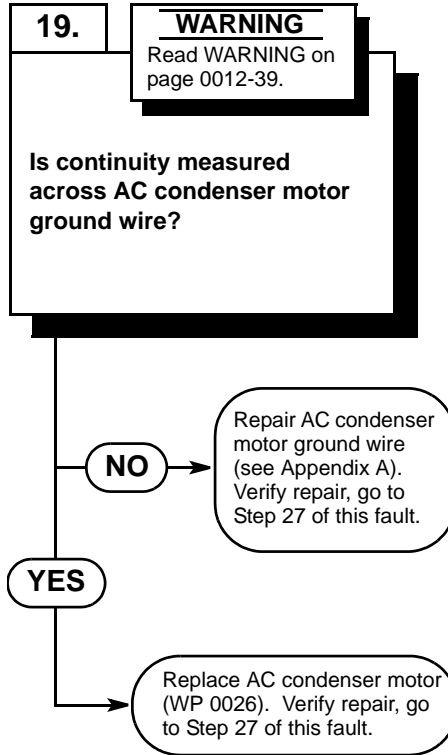

TEST OPTIONS
Continuity test. Multimeter.
REASON FOR QUESTION
If continuity is measured, AC condenser motor is faulty. If not, AC condenser motor ground wire is faulty.

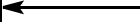

AC HEATER/EVAPORATOR BLOWER OPERATES BUT NO COLD AIR FROM DUCTS DURING AC OPERATIONS - Continued

WARNING

Remove rings, bracelets, wristwatches, neck chains, and any other jewelry before working around vehicle. Jewelry can catch on equipment and cause serious injury. Jewelry or tools may short across electrical circuits or terminals and cause damage to equipment or severe burns or electrical shock to personnel.



CONTINUITY TEST

- (1) Set multimeter switch to ohms.
- (2) Place positive (+) probe of multimeter on ground wire at AC condenser motor terminal.
- (3) Place negative (-) probe of multimeter on ground wire at other end.
 - (a) If there is no continuity, repair AC condenser motor ground wire (see Appendix A). Verify repair, go to Step 27 of this fault.
 - (b) If there is continuity, replace AC condenser motor (WP 0026). Verify repair, go to Step 27 of this fault.

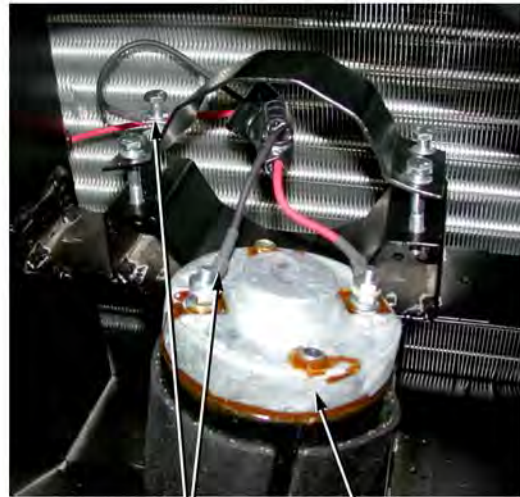

GROUND WIRE
TERMINALS

AC CONDENSER
MOTOR

AC HEATER/EVAPORATOR BLOWER OPERATES BUT NO COLD AIR FROM DUCTS DURING AC OPERATIONS - Continued

KNOWN INFO
Power to fan control switch OK. Blower operates. AC condenser core not blocked or damaged. AC compressor belts OK. AC heater/evaporator core not blocked or damaged. AC temperature control switch temperature probe OK. Heater cable OK. AC cable OK. Defrost cable OK. AC compressor clutch OK. AC harness wire 1154 OK. Low pressure switch OK. AC harness wire 1158 OK. High pressure switch OK. AC harness wire 1156 OK. AC condenser assembly harness green wire OK. AC condenser motor solenoid ground wire OK. Fan control switch OK. Wire 1156 OK. AC temperature control switch OK. AC condenser motor solenoid OK. AC condenser motor power wire OK. AC condenser motor ground wire OK. AC condenser motor OK.
POSSIBLE PROBLEMS
AC condenser assembly harness black wire faulty. AC harness wire 1155 faulty.

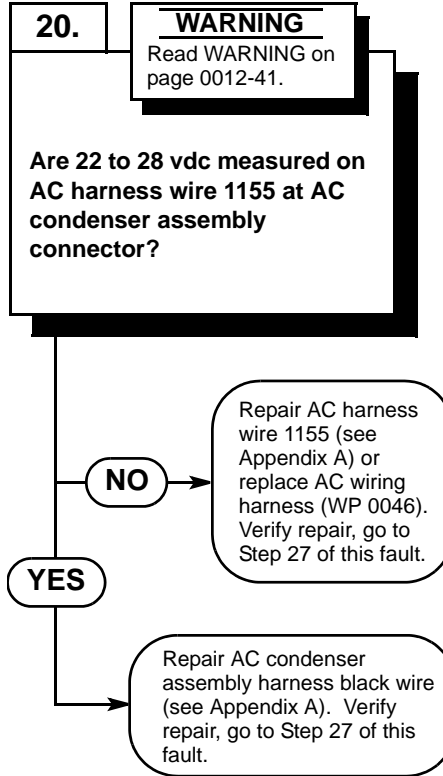

TEST OPTIONS
Voltage test. Multimeter.
REASON FOR QUESTION
If 22 to 28 vdc are measured, AC condenser assembly harness black wire is faulty. If not, AC harness wire 1155 is faulty.



AC HEATER/EVAPORATOR BLOWER OPERATES BUT NO COLD AIR FROM DUCTS DURING AC OPERATIONS - Continued

WARNING

Remove rings, bracelets, wristwatches, neck chains, and any other jewelry before working around vehicle. Jewelry can catch on equipment and cause serious injury. Jewelry or tools may short across electrical circuits or terminals and cause damage to equipment or severe burns or electrical shock to personnel.

VOLTAGE TEST

- (1) Disconnect AC harness AC condenser assembly connector (WP 0028).
- (2) Turn engine start switch ON (TM 9-2320-279-10).
- (3) Place positive (+) probe of multimeter on AC harness wire 1155 at AC condenser assembly connector, terminal A.
- (4) Place negative (-) probe of multimeter on a known good ground.
 - (a) If 22 to 28 vdc are not measured, turn engine start switch OFF and repair AC harness wire 1155 (see Appendix A) or replace AC wiring harness (WP 0046). Verify repair, go to Step 27 of this fault.
 - (b) If 22 to 28 vdc are measured, turn engine start switch OFF and repair AC condenser assembly harness black wire (see Appendix A). Verify repair, go to Step 27 of this fault.



AC HARNESS

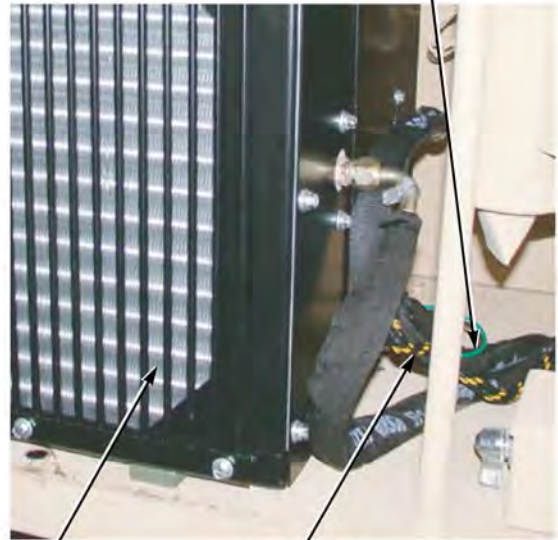

AC CONDENSER ASSEMBLY

AC CONDENSER ASSEMBLY HARNESS

AC HEATER/EVAPORATOR BLOWER OPERATES BUT NO COLD AIR FROM DUCTS DURING AC OPERATIONS - Continued

KNOWN INFO
Power to fan control switch OK. Blower operates. AC condenser core not blocked or damaged. AC compressor belts OK. AC heater/evaporator core not blocked or damaged. AC temperature control switch temperature probe OK. Heater cable OK. AC cable OK. Defrost cable OK. AC compressor clutch OK. AC harness wire 1154 OK. Low pressure switch OK. AC harness wire 1158 OK. High pressure switch OK. AC condenser motor power wire OK. AC condenser motor ground wire OK. AC condenser motor OK. AC condenser assembly harness black wire OK. AC harness wire 1155 OK.
POSSIBLE PROBLEMS
AC condenser assembly harness green wire faulty. AC condenser motor solenoid faulty. AC condenser motor solenoid ground wire faulty. Fan control switch faulty. Wire 1156 faulty. AC harness wire 1156 faulty. AC temperature control switch faulty.

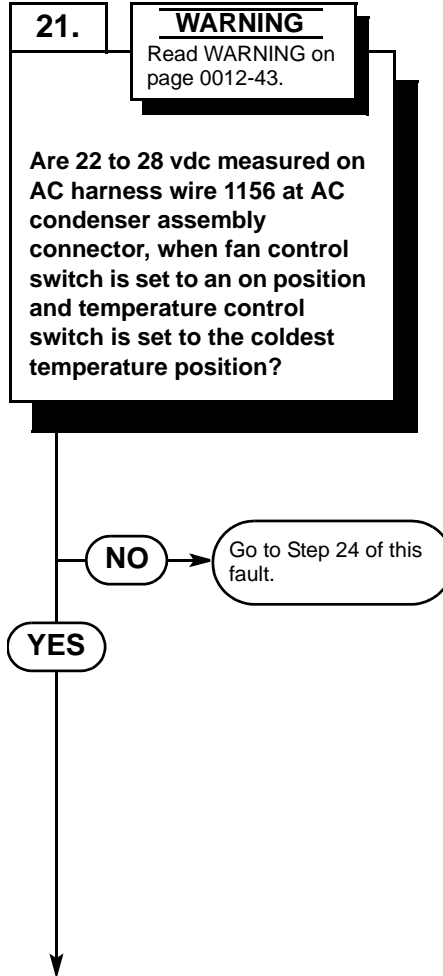

TEST OPTIONS
Voltage test. Multimeter.
REASON FOR QUESTION?
To isolate system fault.



AC HEATER/EVAPORATOR BLOWER OPERATES BUT NO COLD AIR FROM DUCTS DURING AC OPERATIONS - Continued

WARNING

Remove rings, bracelets, wristwatches, neck chains, and any other jewelry before working around vehicle. Jewelry can catch on equipment and cause serious injury. Jewelry or tools may short across electrical circuits or terminals and cause damage to equipment or severe burns or electrical shock to personnel.

VOLTAGE TEST

- (1) Disconnect AC harness AC condenser assembly connector (WP 0028).
- (2) Turn fan control switch to an on position (low, medium, or high) (WP 0004).
- (3) Turn AC temperature control switch to the coldest position (fully clockwise) (WP 0004).
- (4) Turn engine start switch ON (TM 9-2320-279-10).
- (5) Place positive (+) probe of multimeter on AC harness wire 1156 at AC condenser assembly connector, terminal B.
- (6) Place negative (-) probe of multimeter on a known good ground.
 - (a) If 22 to 28 vdc are not measured, turn engine start switch OFF, connect AC harness AC condenser assembly connector and go to Step 24 of this fault.
 - (b) If 22 to 28 vdc are measured, turn engine start switch OFF and go to Step 22 of this fault.



AC HARNESS

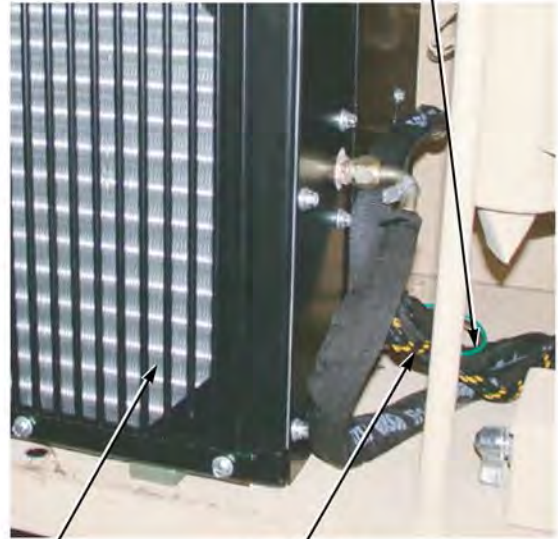

AC CONDENSER ASSEMBLY

AC CONDENSER ASSEMBLY HARNESS

AC HEATER/EVAPORATOR BLOWER OPERATES BUT NO COLD AIR FROM DUCTS DURING AC OPERATIONS - Continued

KNOWN INFO
Power to fan control switch OK. Blower operates. AC condenser core not blocked or damaged. AC compressor belts OK. AC heater/evaporator core not blocked or damaged. AC temperature control switch temperature probe OK. Heater cable OK. AC cable OK. Defrost cable OK. AC compressor clutch OK. AC harness wire 1154 OK. Low pressure switch OK. AC harness wire 1158 OK. High pressure switch OK. AC condenser motor power wire OK. AC condenser motor ground wire OK. AC condenser motor OK. AC condenser assembly harness black wire OK. AC harness wire 1155 OK. Fan control switch OK. Wire 1156 OK. AC harness wire 1156 OK. AC temperature control switch OK.
POSSIBLE PROBLEMS
AC condenser assembly harness green wire faulty. AC condenser motor solenoid faulty. AC condenser motor solenoid ground wire faulty.

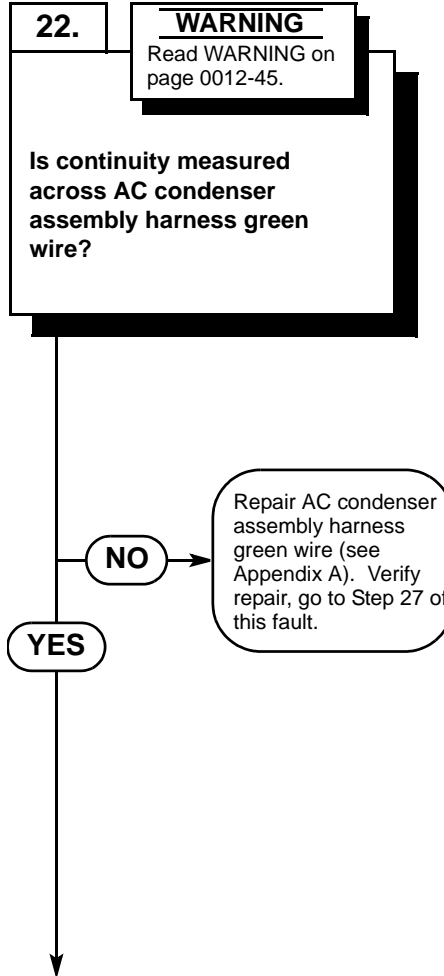

TEST OPTIONS
Continuity test. Multimeter.
REASON FOR QUESTION
If continuity is not measured, AC condenser assembly harness green wire is faulty.



AC HEATER/EVAPORATOR BLOWER OPERATES BUT NO COLD AIR FROM DUCTS DURING AC OPERATIONS - Continued

WARNING

Remove rings, bracelets, wristwatches, neck chains, and any other jewelry before working around vehicle. Jewelry can catch on equipment and cause serious injury. Jewelry or tools may short across electrical circuits or terminals and cause damage to equipment or severe burns or electrical shock to personnel.

CONTINUITY TEST

- (1) Set multimeter switch to ohms.
- (2) Place positive (+) probe of multimeter on AC condenser assembly harness green wire at AC harness connector, terminal B.
- (3) Place negative (-) probe of multimeter on AC condenser assembly harness green wire at AC condenser motor solenoid terminal.
 - (a) If there is no continuity, repair AC condenser assembly harness green wire (see Appendix A). Verify repair, go to Step 27 of this fault.
 - (b) If there is continuity, connect AC harness AC condenser assembly connector (WP 0028) and go to Step 23 of this fault.



AC CONDENSER ASSEMBLY HARNESS

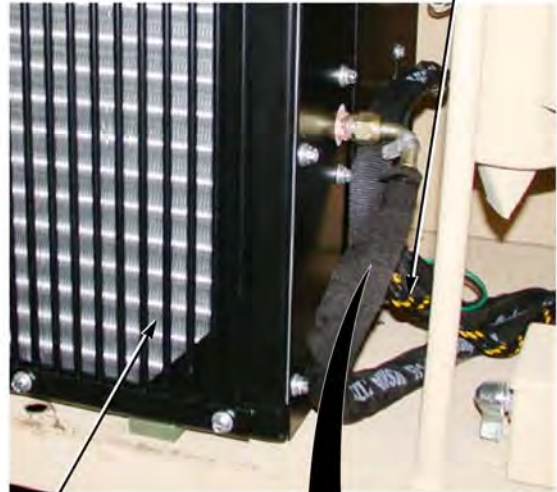

AC CONDENSER ASSEMBLY

AC CONDENSER MOTOR SOLENOID

AC CONDENSER ASSEMBLY HARNESS GREEN WIRE

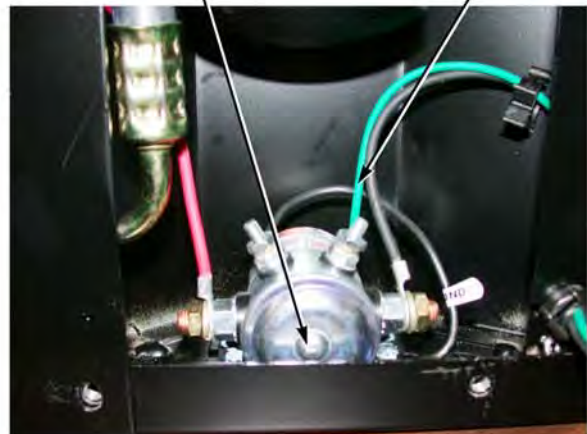

AC HEATER/EVAPORATOR BLOWER OPERATES BUT NO COLD AIR FROM DUCTS DURING AC OPERATIONS - Continued

KNOWN INFO
Power to fan control switch OK. Blower operates. AC condenser core not blocked or damaged. AC compressor belts OK. AC heater/evaporator core not blocked or damaged. AC temperature control switch temperature probe OK. Heater cable OK. AC cable OK. Defrost cable OK. AC compressor clutch OK. AC harness wire 1154 OK. Low pressure switch OK. AC harness wire 1158 OK. High pressure switch OK. AC condenser motor power wire OK. AC condenser motor ground wire OK. AC condenser motor OK. AC condenser assembly harness black wire OK. AC harness wire 1155 OK. Fan control switch OK. Wire 1156 OK. AC harness wire 1156 OK. AC temperature control switch OK. AC condenser assembly harness green wire OK.
POSSIBLE PROBLEMS
AC condenser motor solenoid faulty. AC condenser motor solenoid ground wire faulty.

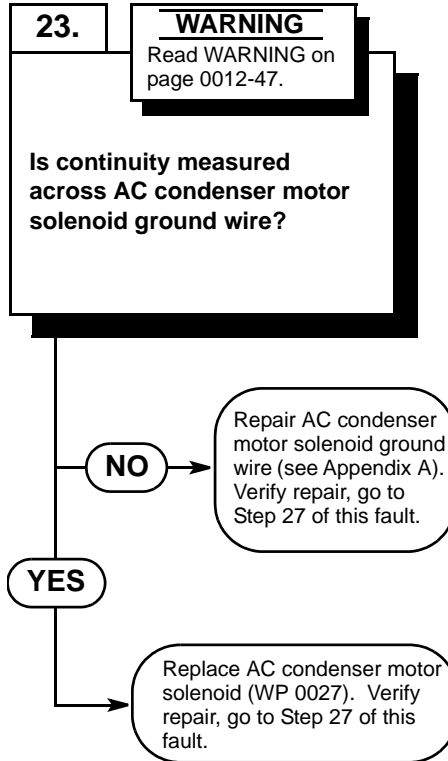

TEST OPTIONS
Continuity test. Multimeter.
REASON FOR QUESTION
If continuity is measured, AC condenser motor solenoid is faulty. If not, AC condenser motor solenoid ground wire is faulty.



AC HEATER/EVAPORATOR BLOWER OPERATES BUT NO COLD AIR FROM DUCTS DURING AC OPERATIONS - Continued

WARNING

Remove rings, bracelets, wristwatches, neck chains, and any other jewelry before working around vehicle. Jewelry can catch on equipment and cause serious injury. Jewelry or tools may short across electrical circuits or terminals and cause damage to equipment or severe burns or electrical shock to personnel.

CONTINUITY TEST

- (1) Set multimeter switch to ohms.
- (2) Place positive (+) probe of multimeter on ground wire at AC condenser motor solenoid terminal.
- (3) Place negative (-) probe of multimeter on a known good ground.
 - (a) If there is no continuity, repair AC condenser motor solenoid ground wire (see Appendix A). Verify repair, go to Step 27 of this fault.
 - (b) If there is continuity, replace AC condenser motor solenoid (WP 0027). Verify repair, go to Step 27 of this fault.

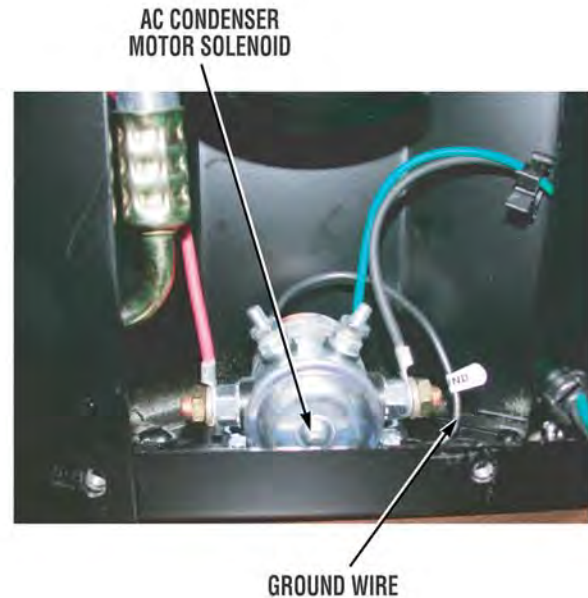

AC HEATER/EVAPORATOR BLOWER OPERATES BUT NO COLD AIR FROM DUCTS DURING AC OPERATIONS - Continued

KNOWN INFO
Power to fan control switch OK. Blower operates. AC condenser core not blocked or damaged. AC compressor belts OK. AC heater/evaporator core not blocked or damaged. AC temperature control switch temperature probe OK. Heater cable OK. AC cable OK. Defrost cable OK. AC compressor clutch OK. AC harness wire 1154 OK. Low pressure switch OK. AC harness wire 1158 OK. High pressure switch OK. AC condenser motor power wire OK. AC condenser motor ground wire OK. AC condenser motor OK. AC condenser assembly harness black wire OK. AC harness wire 1155 OK. AC condenser assembly harness green wire OK. AC condenser motor solenoid OK. AC condenser motor solenoid ground wire OK.
POSSIBLE PROBLEMS
Fan control switch faulty. Wire 1156 faulty. AC harness wire 1156 faulty. AC temperature control switch faulty.

24.

WARNING
Read WARNING on page 0012-49.

Are 22 to 28 vdc measured on fan control switch, terminal C (wire 1156), when fan control switch is set to an on position?

TEST OPTIONS
Voltage test. Multimeter.
REASON FOR QUESTION
If 22 to 28 vdc are not measured, fan control switch is faulty.

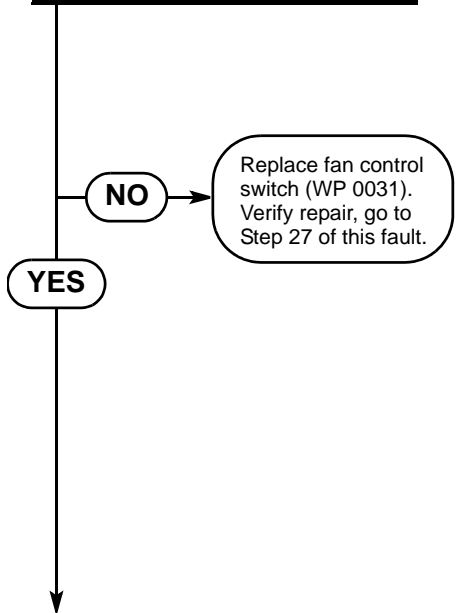

AC HEATER/EVAPORATOR BLOWER OPERATES BUT NO COLD AIR FROM DUCTS DURING AC OPERATIONS - Continued

WARNING

Remove rings, bracelets, wristwatches, neck chains, and any other jewelry before working around vehicle. Jewelry can catch on equipment and cause serious injury. Jewelry or tools may short across electrical circuits or terminals and cause damage to equipment or severe burns or electrical shock to personnel.

VOLTAGE TEST

- (1) Turn fan control switch to an on position (low, medium, or high) (WP 0004).
- (2) Turn engine start switch ON (TM 9-2320-279-10).
- (3) Place positive (+) probe of multimeter on AC fan control switch, terminal C (wire 1156).
- (4) Place negative (-) probe of multimeter on a known good ground.
 - (a) If 22 to 28 vdc are not measured, turn engine start switch OFF and replace fan control switch (WP 0031). Verify repair, go to Step 27 of this fault.
 - (b) If 22 to 28 vdc are measured, turn engine start switch OFF and go to Step 25 of this fault.

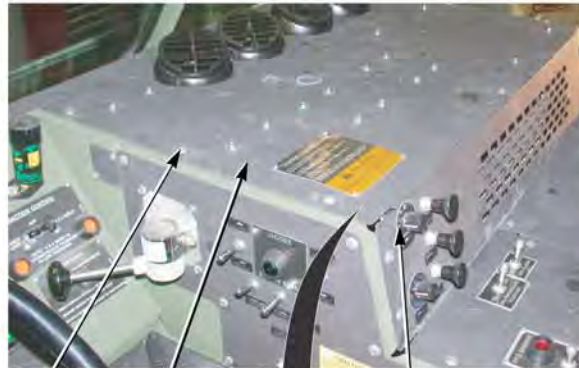
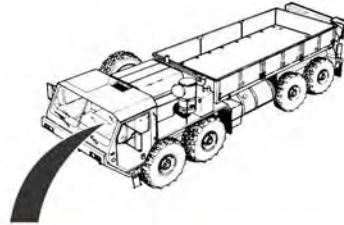

SCREWS TOP HEATER COVER FAN CONTROL SWITCH

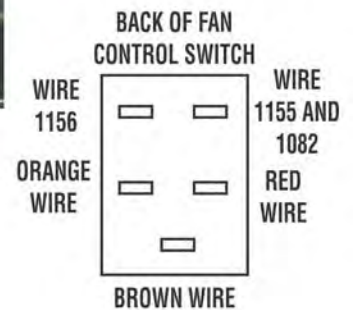
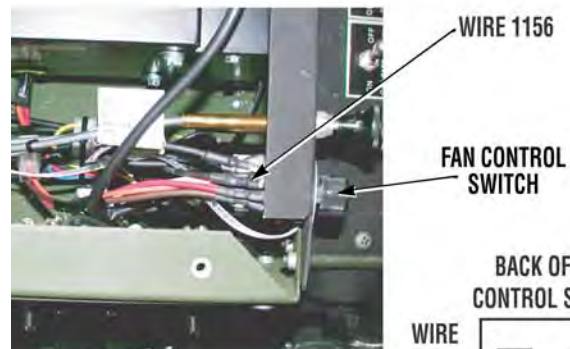

AC HEATER/EVAPORATOR BLOWER OPERATES BUT NO COLD AIR FROM DUCTS DURING AC OPERATIONS - Continued

KNOWN INFO
Power to fan control switch OK. Blower operates. AC condenser core not blocked or damaged. AC compressor belts OK. AC heater/evaporator core not blocked or damaged. AC temperature control switch temperature probe OK. Heater cable OK. AC cable OK. Defrost cable OK. AC compressor clutch OK. AC harness wire 1154 OK. Low pressure switch OK. AC harness wire 1158 OK. High pressure switch OK. AC condenser motor power wire OK. AC condenser motor ground wire OK. AC condenser motor OK. AC condenser assembly harness black wire OK. AC harness wire 1155 OK. AC condenser assembly harness green wire OK. AC condenser motor solenoid OK. AC condenser motor solenoid ground wire OK. Fan control switch OK.
POSSIBLE PROBLEMS
Wire 1156 faulty. AC harness wire 1156 faulty. AC temperature control switch faulty.

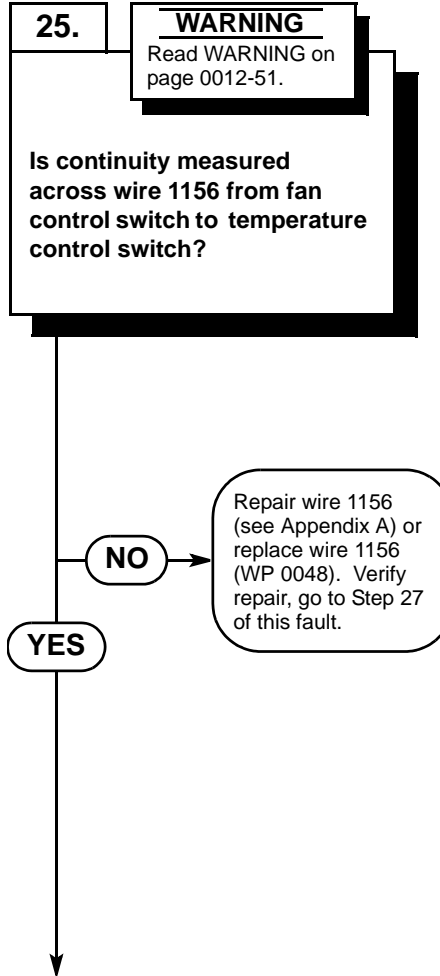

TEST OPTIONS
Continuity test. Multimeter.
REASON FOR QUESTION
If continuity is not measured, wire 1156 is faulty.



AC HEATER/EVAPORATOR BLOWER OPERATES BUT NO COLD AIR FROM DUCTS DURING AC OPERATIONS - Continued

WARNING

Remove rings, bracelets, wristwatches, neck chains, and any other jewelry before working around vehicle. Jewelry can catch on equipment and cause serious injury. Jewelry or tools may short across electrical circuits or terminals and cause damage to equipment or severe burns or electrical shock to personnel.

CONTINUITY TEST

- (1) Set multimeter switch to ohms.
- (2) Place positive (+) probe of multimeter on wire 1156 at fan control switch, terminal C.
- (3) Place negative (-) probe of multimeter on wire 1156 at temperature control switch input terminal.
 - (a) If there is no continuity, repair wire 1156 (see Appendix A) or replace wire 1156 (WP 0048). Verify repair, go to Step 27 of this fault.
 - (b) If there is continuity, go to Step 26 of this fault.

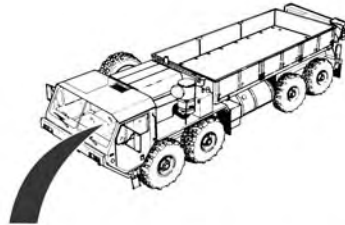

TEMPERATURE CONTROL SWITCH

FAN CONTROL SWITCH

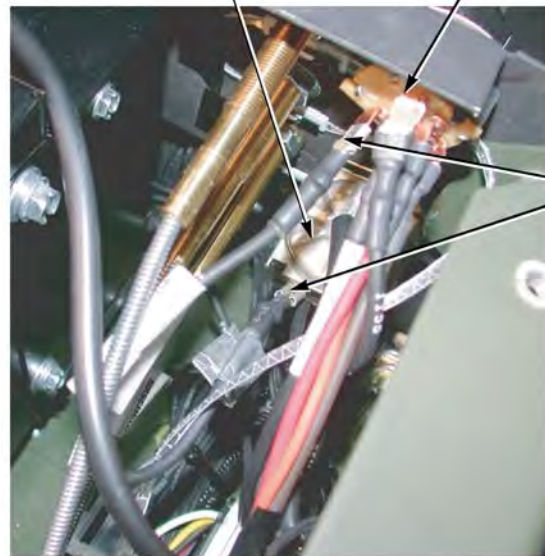

WIRE 1156 TERMINALS

AC HEATER/EVAPORATOR BLOWER OPERATES BUT NO COLD AIR FROM DUCTS DURING AC OPERATIONS - Continued

KNOWN INFO
Power to fan control switch OK. Blower operates. AC condenser core not blocked or damaged. AC compressor belts OK. AC heater/evaporator core not blocked or damaged. AC temperature control switch temperature probe OK. Heater cable OK. AC cable OK. Defrost cable OK. AC compressor clutch OK. AC harness wire 1154 OK. Low pressure switch OK. AC harness wire 1158 OK. High pressure switch OK. AC condenser motor power wire OK. AC condenser motor ground wire OK. AC condenser motor OK. AC condenser assembly harness black wire OK. AC harness wire 1155 OK. AC condenser assembly harness green wire OK. AC condenser motor solenoid OK. AC condenser motor solenoid ground wire OK. Fan control switch OK. Wire 1156 OK.
POSSIBLE PROBLEMS
AC harness wire 1156 faulty. AC temperature control switch faulty.

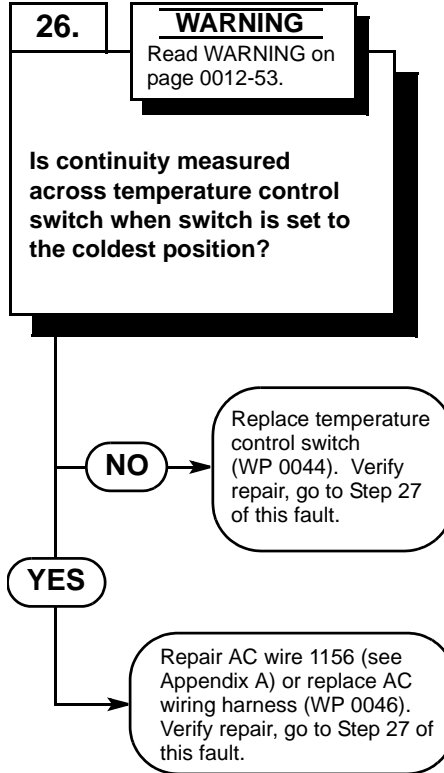

TEST OPTIONS
Continuity test. Multimeter.
REASON FOR QUESTION
If continuity is measured, AC harness wire 1156 is faulty. If not, temperature control switch is faulty.



AC HEATER/EVAPORATOR BLOWER OPERATES BUT NO COLD AIR FROM DUCTS DURING AC OPERATIONS - Continued

WARNING

Remove rings, bracelets, wristwatches, neck chains, and any other jewelry before working around vehicle. Jewelry can catch on equipment and cause serious injury. Jewelry or tools may short across electrical circuits or terminals and cause damage to equipment or severe burns or electrical shock to personnel.

CONTINUITY TEST

- (1) Set multimeter switch to ohms.
- (2) Turn AC temperature control switch to the coldest position (fully clockwise) (WP 0004).
- (3) Place positive (+) probe of multimeter on temperature control switch, input terminal.
- (4) Place negative (-) probe of multimeter on temperature control switch, output terminal.
 - (a) If there is no continuity, replace temperature control switch (WP 0044). Verify repair, go to Step 27 of this fault.
 - (b) If there is continuity, repair AC harness wire 1156 (see Appendix A) or replace AC wiring harness (WP 0046). Verify repair, go to Step 27 of this fault.

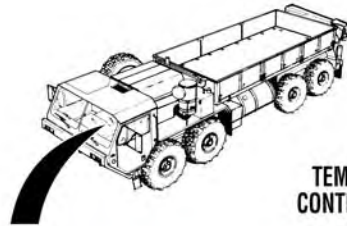

TEMPERATURE CONTROL SWITCH



TEMPERATURE CONTROL SWITCH TERMINALS

TEMPERATURE CONTROL SWITCH

AC HEATER/EVAPORATOR BLOWER OPERATES BUT NO COLD AIR FROM DUCTS DURING AC OPERATIONS - Continued

KNOWN INFO
Power to fan control switch OK. Blower operates. AC condenser core not blocked or damaged. AC compressor belts OK. AC heater/evaporator core not blocked or damaged. AC temperature control switch temperature probe OK. Heater cable OK. AC cable OK. Defrost cable OK. AC compressor clutch OK. AC harness wire 1154 OK. Low pressure switch OK. AC harness wire 1156 OK. AC harness wire 1158 OK. High pressure switch OK. AC condenser motor solenoid OK. AC condenser motor power wire OK. AC condenser motor ground wire OK. AC condenser motor OK. AC condenser assembly harness black wire OK. AC harness wire 1155 OK. AC condenser assembly harness green wire OK. AC condenser motor solenoid ground wire OK. Fan control switch OK. Wire 1156 OK. AC temperature control switch OK.
POSSIBLE PROBLEMS
None

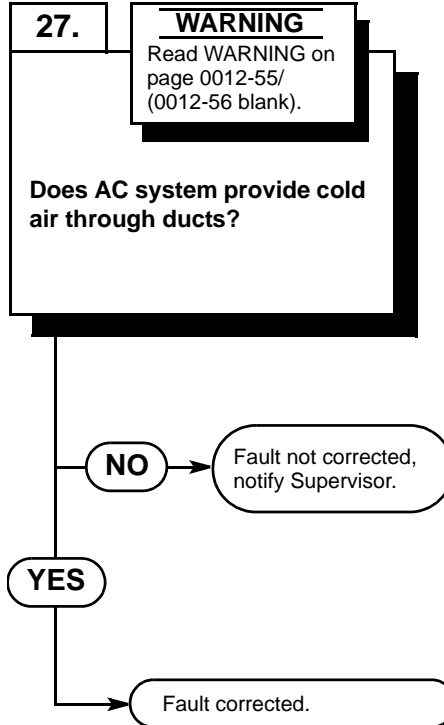

TEST OPTIONS
Verify repair.
REASON FOR QUESTION
If AC system does not provide cold air, fault has not been corrected.



AC HEATER/EVAPORATOR BLOWER OPERATES BUT NO COLD AIR FROM DUCTS DURING AC OPERATIONS - Continued

WARNING

Remove rings, bracelets, wristwatches, neck chains, and any other jewelry before working around vehicle. Jewelry can catch on equipment and cause serious injury. Jewelry or tools may short across electrical circuits or terminals and cause damage to equipment or severe burns or electrical shock to personnel.

VERIFY REPAIR

- (1) If disconnected, connect AC harness wires 1154 and 1158 to low pressure switch connectors (WP 0041).
- (2) If removed, install driver side engine panel and close cover (TM 9-2320-279-10).
- (3) If removed, install AC condenser motor (WP 0026).
- (4) If removed, install cover and four washers, lockwashers, and screws on AC condenser assembly (WP 0028).
- (5) If disconnected, connect AC harness wire 1156 and 1158 to high pressure switch connectors (WP 0039).
- (6) If disconnected, connect AC harness AC condenser assembly connector (WP 0028).
- (7) If removed, install top heater cover and eight screws (WP 0037).
- (8) Start engine (TM 9-2320-279-10).
- (9) Operate AC system for 10 minutes at high blower speed (WP 0004).
 - (a) If AC system does not provide cold air through ducts, fault has not been corrected. Shut off engine, turn fan control switch and temperature control switch to off position, and notify Supervisor.
 - (b) If AC system provides cold air through ducts, fault has been corrected.

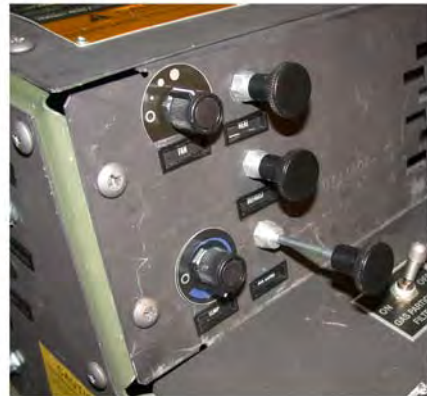

END OF WORK PACKAGE

AC COMPRESSOR EXCESSIVELY NOISY

INITIAL SETUP:

Maintenance Level

Field Level Maintenance

Materials/Parts

None

Equipment Condition

Shut off engine (TM 9-2320-279-10).
 Parking brake applied (TM 9-2320-279-10).
 Wheels chocked (TM 9-2320-279-10).

Personnel Required

MOS 52C, Utilities equipment repairer

References

TM 9-2320-279-10
 TM 9-2320-279-20

Tools and Special Tools

None

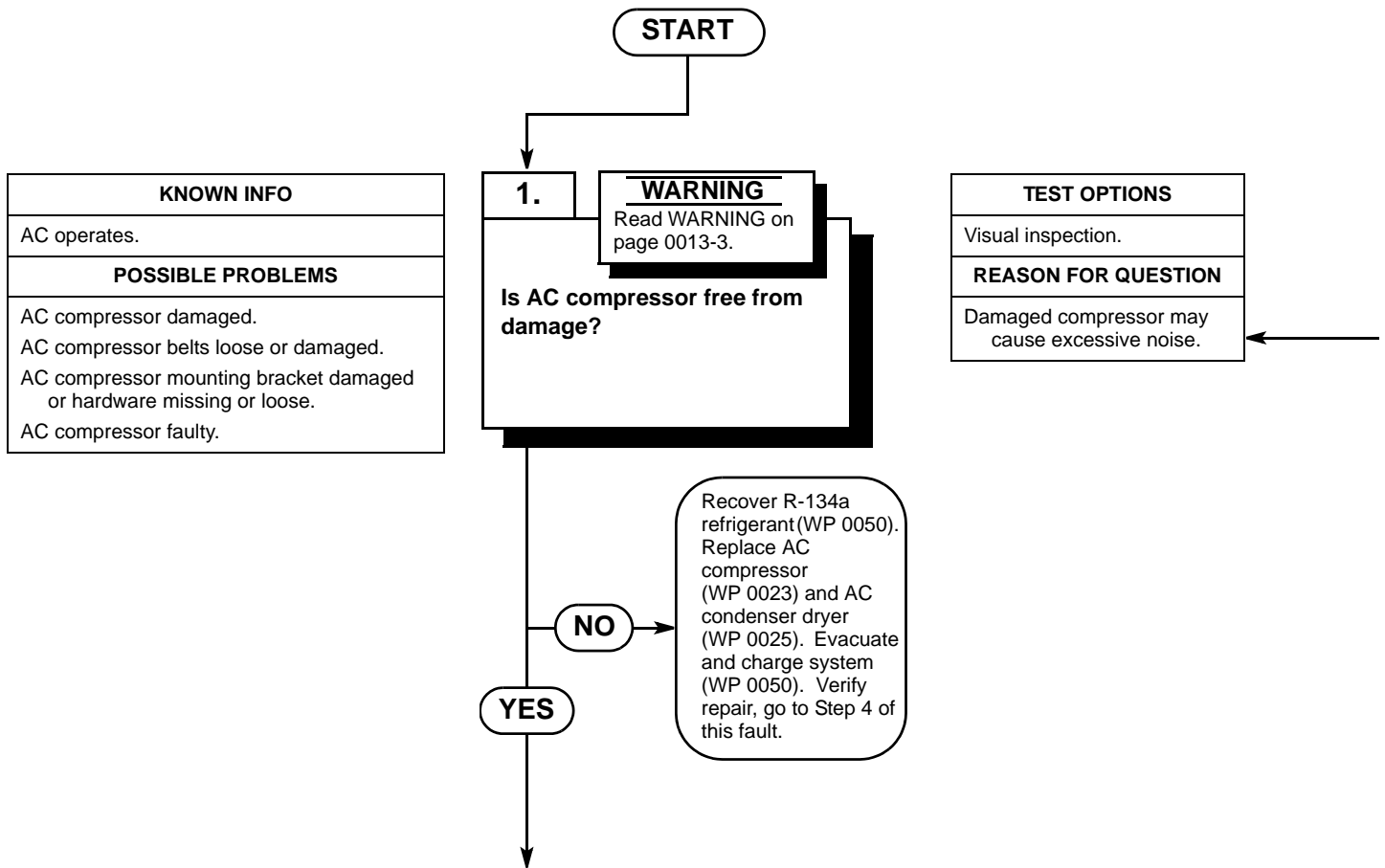

AC COMPRESSOR EXCESSIVELY NOISY - Continued

WARNING

Wear protective goggles and nonleather gloves when servicing air conditioner system. Failure to comply may result in injury to personnel.

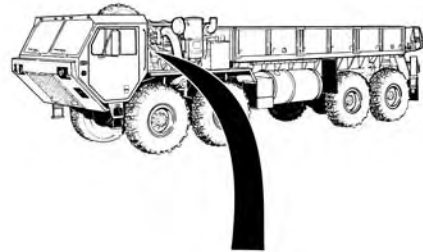

AC COMPRESSOR



AC COMPRESSOR
PULLEY/CLUTCH ASSEMBLY

VISUAL INSPECTION
(1) Open driver side engine cover and remove engine side panel (TM 9-2320-279-10).
(2) Inspect AC compressor and AC compressor pulley/clutch assembly for damage. (a) If AC compressor or AC compressor pulley/clutch assembly is damaged: 1. Recover R-134a refrigerant (WP 0050). 2. Replace AC compressor (WP 0023). 3. Replace AC condenser dryer (WP 0025). 4. Evacuate and charge system (WP 0050). 5. Verify repair, go to Step 4 of this fault. (b) If AC compressor or AC compressor pulley/clutch assembly are free from damage, go to Step 2 of this fault.

AC COMPRESSOR EXCESSIVELY NOISY - Continued

KNOWN INFO
AC operates. AC compressor not damaged.
POSSIBLE PROBLEMS
AC compressor belts loose or damaged. AC compressor mounting bracket damaged or hardware missing or loose. AC compressor faulty.

2.

Are AC compressor belts tight and free from damage?

TEST OPTIONS
Visual inspection.
REASON FOR QUESTION
If AC compressor belts are loose or damaged, AC compressor may be excessively noisy.

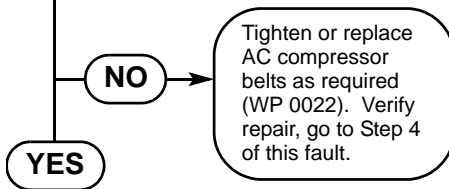

KNOWN INFO
AC operates. AC compressor not damaged. AC compressor belts OK.
POSSIBLE PROBLEMS
AC compressor mounting bracket damaged or hardware missing or loose. AC compressor faulty.

3.

WARNING
Read WARNING on page 0013-5.

Is AC compressor mounting bracket hardware secure and free from damage?

TEST OPTIONS
Visual inspection.
REASON FOR QUESTION
If AC compressor mounting bracket hardware is damaged, loose, or missing, or AC compressor is damaged internally, AC compressor may be excessively noisy.

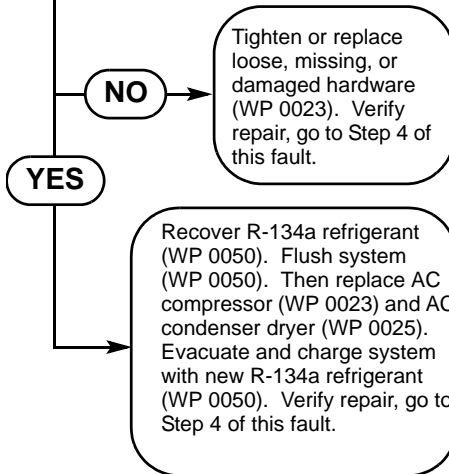

AC COMPRESSOR EXCESSIVELY NOISY - Continued

WARNING

Wear protective goggles and nonleather gloves when servicing air conditioner system. Failure to comply may result in injury to personnel.

VISUAL INSPECTION

Inspect AC compressor belts for looseness and damage.

- (a) If AC compressor belts are missing, damaged, or loose, replace or tighten belts as required (WP 0022). Verify repair, go to Step 4 of this fault.
- (b) If AC compressor belts are tight and free from damage, go to Step 3 of this fault.

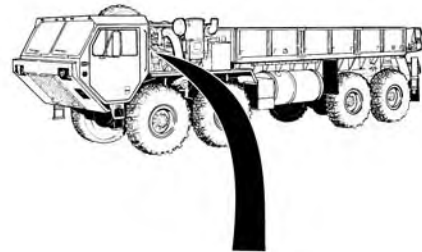

AC COMPRESSOR

VISUAL INSPECTION

NOTE: Do not disconnect AC hoses from AC compressor during repairs unless required. If AC hoses need to be disconnected during repair, recover R-134a refrigerant (WP 0050) before disconnecting AC hoses. Then replace AC condenser dryer (WP 0025) and evacuate and charge system (WP 0050) after repairs are completed.

Inspect AC compressor mounting bracket for damage and missing or loose hardware.

- (a) If AC compressor mounting bracket is damaged or hardware is missing or loose, replace or tighten damaged missing or loose mounting hardware (WP 0023). Verify repair, go to Step 4 of this fault.

CAUTION: Do not flush AC condenser dryer, AC compressor, or AC expansion valve. After flushing system, add required refrigerant oil or damage to equipment may result.

- (b) If AC compressor mounting bracket is secure and free from damage and missing hardware:
 1. Recover R-134a refrigerant (WP 0050).
 2. Flush system (WP 0050).
 3. Replace AC compressor (WP 0023).
 4. Replace AC condenser dryer (WP 0025).
 5. Evacuate and charge system with new R-134a refrigerant (WP 0050).
 6. Verify repair, go to Step 4 of this fault.



AC COMPRESSOR MOUNTING BRACKET

AC COMPRESSOR BELTS

AC COMPRESSOR EXCESSIVELY NOISY - Continued

KNOWN INFO
AC operates. AC compressor not damaged. AC compressor belts OK. AC compressor mounting brackets OK. AC compressor OK.
POSSIBLE PROBLEMS
None

4.

WARNING
Read WARNING on page 0013-7/ (0013-8 blank).

Is AC compressor free from excessive noise?

TEST OPTIONS
Verify repair.
REASON FOR QUESTION
If AC compressor is excessively noisy, fault was not corrected.

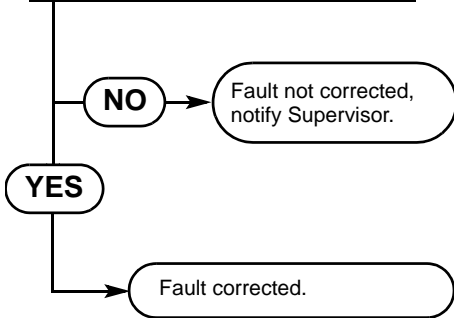

AC COMPRESSOR EXCESSIVELY NOISY - Continued

WARNING

Moving engine components can cause severe injury. Keep away from fan, belts, and pulleys while engine is running.

VERIFY REPAIR
<ol style="list-style-type: none">(1) Start engine (TM 9-2320-279-10).(2) Operate AC system (WP 0004).(3) Inspect AC compressor for excessive noise.<ol style="list-style-type: none">(a) If AC compressor is excessively noisy, fault has not been corrected. Shut off engine, turn fan control switch and temperature control switch to off, and notify Supervisor.(b) If AC compressor is free from excessive noise, fault has been corrected.(4) Install driver side engine panel and close engine cover (TM 9-2320-279-10).



AC COMPRESSOR



END OF WORK PACKAGE

AC COMPRESSOR DOES NOT SHUT OFF OR CYCLES CONSTANTLY

INITIAL SETUP:

Maintenance Level

Field Level Maintenance

Materials/Parts

None

Equipment Condition

Shut off engine (TM 9-2320-279-10).
 Parking brake applied (TM 9-2320-279-10).
 Wheels chocked (TM 9-2320-279-10).

Personnel Required

MOS 52C, Utilities equipment repairer (2)

References

TM 9-2320-279-10
 TM 9-2320-279-20

Tools and Special Tools

Tool Kit, General Mechanic's (Item 7, Appendix F)
 Multimeter (Item 2, Appendix F)

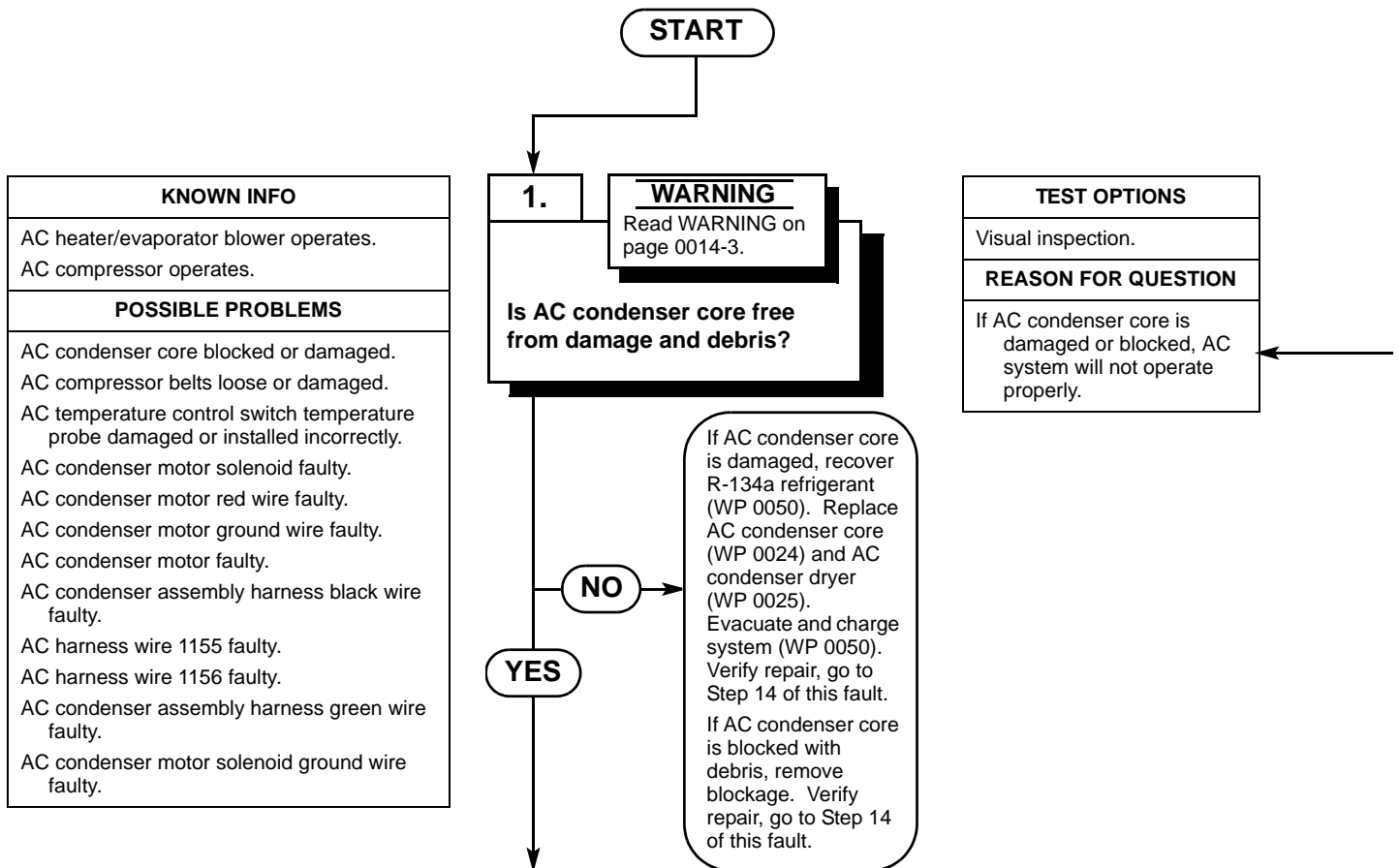

AC COMPRESSOR DOES NOT SHUT OFF OR CYCLES CONSTANTLY - Continued

WARNING

Wear protective goggles and nonleather gloves when servicing air conditioner system. Failure to comply may result in injury to personnel.

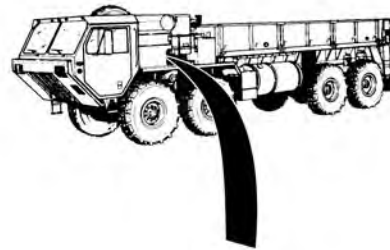

VISUAL INSPECTION

Inspect AC condenser core for damage and blockage from debris.

- (1) If AC condenser core is damaged:
 - (a) Recover R-134a refrigerant (WP 0050).
 - (b) Replace AC condenser core (WP 0024).
 - (c) Replace AC condenser dryer (WP 0025).
 - (d) Evacuate and charge system (WP 0050).
 - (e) Verify repair, go to Step 14 of this fault.
- (2) If AC condenser core is blocked with debris, remove blockage. Verify repair, go to Step 14 of this fault.
- (3) If AC condenser core is free from damage and blockage, go to Step 2 of this fault.

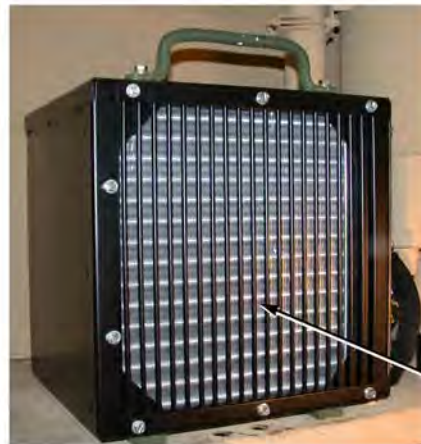

AC CONDENSER
CORE

AC COMPRESSOR DOES NOT SHUT OFF OR CYCLES CONSTANTLY - Continued

KNOWN INFO
AC heater/evaporator blower operates. AC compressor operates. AC condenser core not blocked or damaged.
POSSIBLE PROBLEMS
AC compressor belts loose or damaged. AC temperature control switch temperature probe damaged or installed incorrectly. AC condenser motor solenoid faulty. AC condenser motor red wire faulty. AC condenser motor ground wire faulty. AC condenser motor faulty. AC condenser assembly harness black wire faulty. AC harness wire 1155 faulty. AC harness wire 1156 faulty. AC condenser assembly harness green wire faulty. AC condenser motor solenoid ground wire faulty.

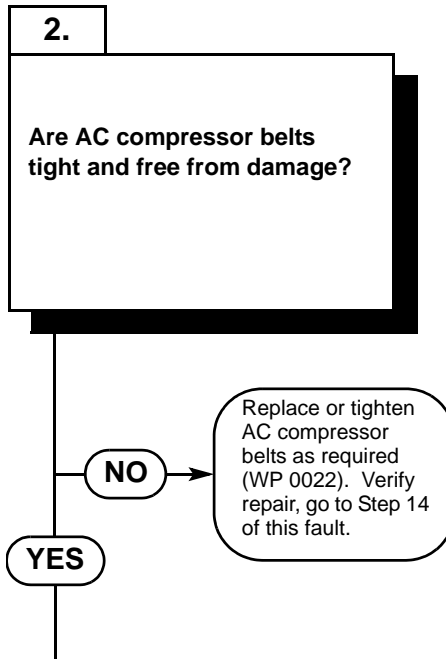

TEST OPTIONS
Visual inspection.
REASON FOR QUESTION
If AC compressor belts are missing, loose, or damaged, AC compressor will not operate properly.

KNOWN INFO
AC heater/evaporator blower operates. AC compressor operates. AC condenser core not blocked or damaged. AC compressor belts OK.
POSSIBLE PROBLEMS
AC temperature control switch temperature probe damaged or installed incorrectly. AC condenser motor solenoid faulty. AC condenser motor red wire faulty. AC condenser motor ground wire faulty. AC condenser motor faulty. AC condenser assembly harness black wire faulty. AC harness wire 1155 faulty. AC harness wire 1156 faulty. AC condenser assembly harness green wire faulty. AC condenser motor solenoid ground wire faulty.

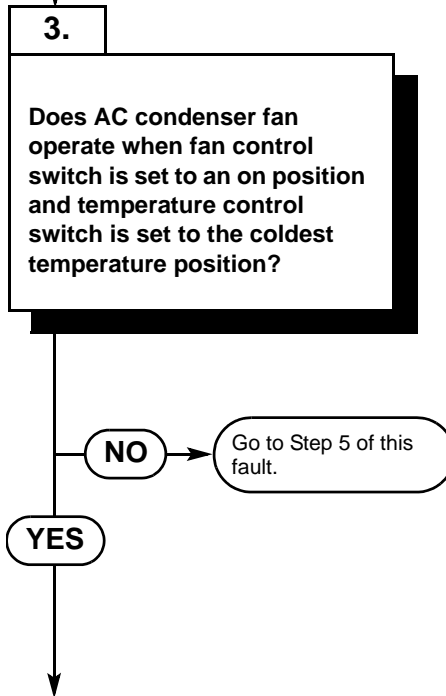

TEST OPTIONS
Visual inspection.
REASON FOR QUESTION
If AC condenser fan does not operate, AC system will not operate properly.

AC COMPRESSOR DOES NOT SHUT OFF OR CYCLES CONSTANTLY - Continued

VISUAL INSPECTION

- (1) Open driver side engine cover and remove engine side panel (TM 9-2320-279-10).
- (2) Inspect AC compressor belts for looseness and damage.
 - (a) If AC compressor belts are missing, damaged, or loose, replace or tighten belts as required (WP 0022).
 - (b) If AC compressor belts are tight and free from damage, go to Step 3 of this fault.

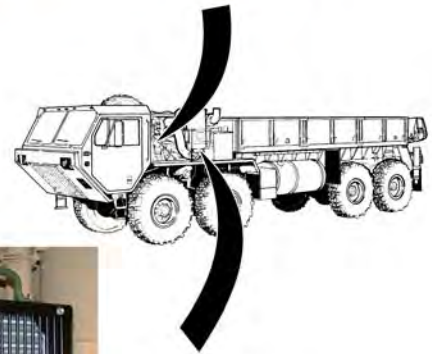
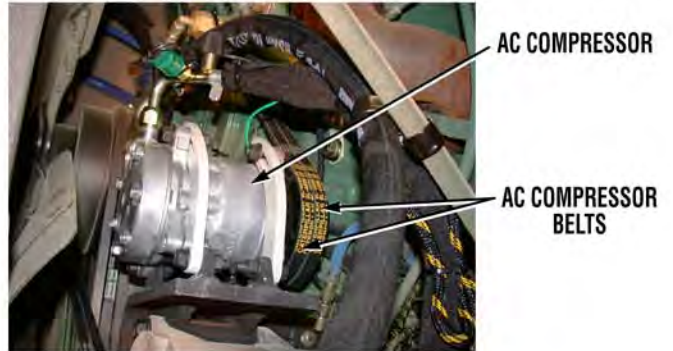

VISUAL INSPECTION

- (1) Turn engine start switch ON (TM 9-2320-279-10).
- (2) Turn fan control switch to an on position (low, medium, or high) (WP 0004).
- (3) Turn temperature control switch to the coldest position (fully clockwise) (WP 0004).
- (4) Verify operation of AC condenser fan.
 - (a) If AC condenser fan does not operate, turn engine start switch OFF and go to Step 5 of this fault.
 - (b) If AC condenser fan operates, turn engine start switch OFF and go to Step 4 of this fault.

(BACK SIDE OF AC CONDENSER ASSEMBLY SHOWN)



AC COMPRESSOR DOES NOT SHUT OFF OR CYCLES CONSTANTLY - Continued

KNOWN INFO
AC heater/evaporator blower operates.
AC compressor operates.
AC condenser core not blocked or damaged.
AC compressor belts OK.
AC condenser motor solenoid OK.
AC condenser motor red wire OK.
AC condenser motor ground wire OK.
AC condenser motor OK.
AC condenser assembly harness black wire OK.
AC harness wire 1155 OK.
AC harness wire 1156 OK.
AC condenser assembly harness green wire OK.
AC condenser motor solenoid ground wire OK.
POSSIBLE PROBLEMS
AC temperature control switch temperature probe damaged or installed incorrectly.

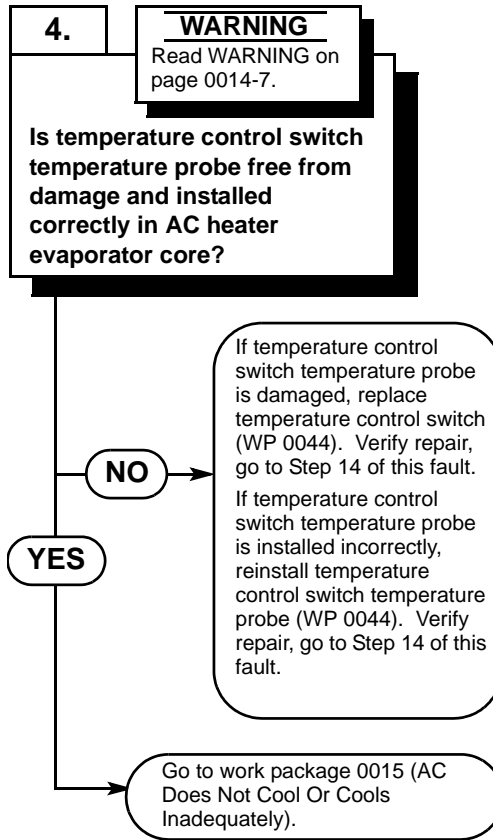

TEST OPTIONS
Visual inspection.
REASON FOR QUESTION
If temperature control switch temperature probe is damaged or installed incorrectly, AC system will not operate properly.

KNOWN INFO
AC heater/evaporator blower operates.
AC compressor operates.
AC condenser core not blocked or damaged.
AC compressor belts OK.
AC temperature control switch temperature probe OK.
POSSIBLE PROBLEMS
AC condenser motor solenoid faulty.
AC condenser motor red wire faulty.
AC condenser motor ground wire faulty.
AC condenser motor faulty.
AC condenser assembly harness black wire faulty.
AC harness wire 1155 faulty.
AC harness wire 1156 faulty.
AC condenser assembly harness green wire faulty.
AC condenser motor solenoid ground wire faulty.

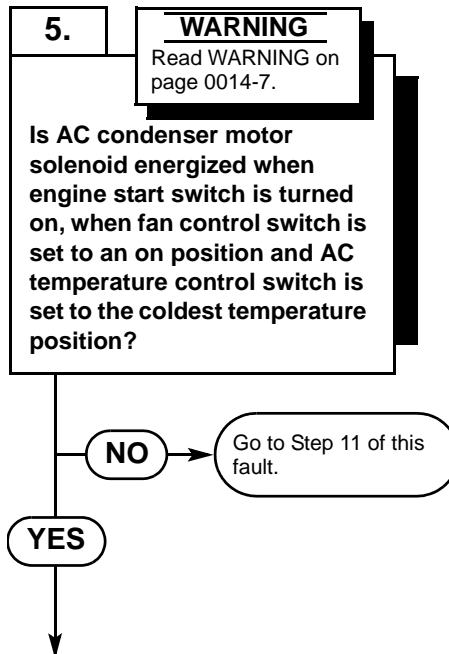

TEST OPTIONS
Audible test.
REASON FOR QUESTION
To isolate system fault.

AC COMPRESSOR DOES NOT SHUT OFF OR CYCLES CONSTANTLY - Continued

WARNING

Remove rings, bracelets, wristwatches, neck chains, and any other jewelry before working around vehicle. Jewelry can catch on equipment and cause serious injury. Jewelry or tools may short across electrical circuits or terminals and cause damage to equipment or severe burns or electrical shock to personnel.

VISUAL INSPECTION

NOTE: Temperature control switch temperature probe is installed correctly when it is inserted into the AC heater/evaporator core until it touches the bottom of the insertion hole.

- (1) Remove eight screws and top heater cover (WP 0037).
- (2) Inspect temperature control switch temperature probe for damage.
 - (a) If temperature control switch temperature probe is damaged, replace temperature control switch (WP 0044). Verify repair, go to Step 14 of this fault.
- (3) Check if temperature control switch temperature probe is installed correctly.
 - (a) If temperature control switch temperature probe is installed incorrectly, reinstall temperature control switch temperature probe (WP 0044). Verify repair, go to Step 14 of this fault.
 - (b) If temperature control switch temperature probe is installed correctly, go to work package 0015 (AC Does Not Cool Or Cools Inadequately).

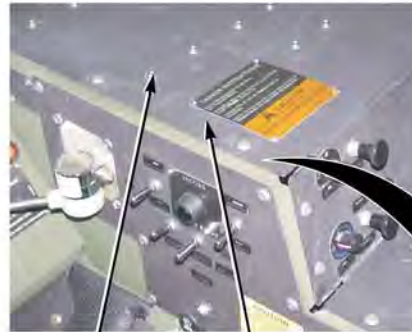

SCREWS
TOP HEATER COVER

AC TEMPERATURE CONTROL SWITCH TEMPERATURE PROBE

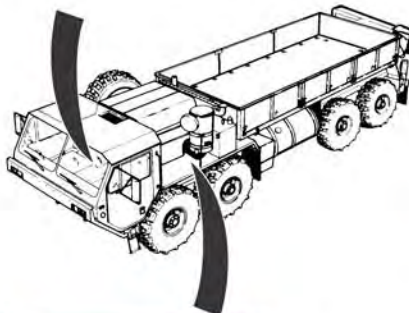

AC HEATER/EVAPORATOR CORE COVER

AUDIBLE TEST

NOTE: Do not start engine during this procedure. AC condenser motor solenoid operation will be checked by listening for a clicking sound from the AC condenser motor solenoid when the engine start switch is turned to ON position.

- (1) Remove four screws, lockwashers, washers, and cover from AC condenser assembly (WP 0028).
- (2) Turn fan control switch to an on position (low, medium, or high) (WP 0004).
- (3) Turn temperature control switch to the coldest position (fully clockwise) (WP 0004).
- (4) While assistant turns engine start switch ON (TM 9-2320-279-10), check operation of AC condenser motor solenoid by listening for a click when engine start switch is turned ON.
 - (a) If AC condenser motor solenoid is not energized, turn engine start switch OFF and go to Step 11 of this fault.
 - (b) If AC condenser motor solenoid is energized, go to Step 6 of this fault.

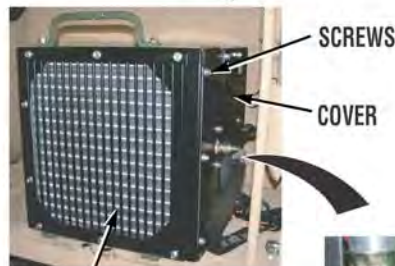

AC CONDENSER ASSEMBLY



AC CONDENSER MOTOR SOLENOID

AC COMPRESSOR DOES NOT SHUT OFF OR CYCLES CONSTANTLY - Continued

KNOWN INFO
AC heater/evaporator blower operates.
AC compressor operates.
AC condenser core not blocked or damaged.
AC compressor belts OK.
AC temperature control switch temperature probe OK.
AC harness wire 1156 OK.
AC condenser assembly harness green wire OK.
AC condenser motor solenoid ground wire OK.
POSSIBLE PROBLEMS
AC condenser motor solenoid faulty.
AC condenser motor red wire faulty.
AC condenser motor ground wire faulty.
AC condenser motor faulty.
AC condenser assembly harness black wire faulty.
AC harness wire 1155 faulty.

6.

WARNING
Read WARNING on page 0014-9.

Are 22 to 28 vdc measured on AC condenser assembly harness black wire at AC condenser motor solenoid?

TEST OPTIONS
Voltage test. Multimeter.
REASON FOR QUESTION
To isolate system fault.

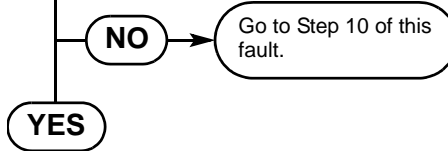

KNOWN INFO
AC heater/evaporator blower operates.
AC compressor operates.
AC condenser core not blocked or damaged.
AC compressor belts OK.
AC temperature control switch temperature probe OK.
AC harness wire 1156 OK.
AC condenser assembly harness green wire OK.
AC condenser motor solenoid ground wire OK.
AC condenser assembly harness black wire OK.
AC harness wire 1155 OK.
POSSIBLE PROBLEMS
AC condenser motor solenoid faulty.
AC condenser motor red wire faulty.
AC condenser motor ground wire faulty.
AC condenser motor faulty.

7.

WARNING
Read WARNING on page 0014-9.

Are 22 to 28 vdc measured on AC condenser motor solenoid, terminal red wire, when fan control switch is set to an on position and temperature control switch is set to the coldest temperature position?

TEST OPTIONS
Voltage test. Multimeter.
REASON FOR QUESTION
If 22 to 28 vdc are not measured, AC condenser motor solenoid is faulty.

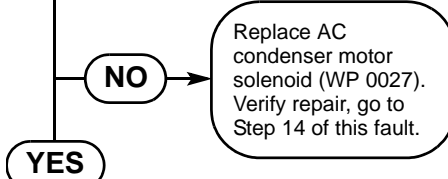

AC COMPRESSOR DOES NOT SHUT OFF OR CYCLES CONSTANTLY - Continued

WARNING

Remove rings, bracelets, wristwatches, neck chains, and any other jewelry before working around vehicle. Jewelry can catch on equipment and cause serious injury. Jewelry or tools may short across electrical circuits or terminals and cause damage to equipment or severe burns or electrical shock to personnel.

VOLTAGE TEST

- (1) If OFF, turn engine start switch ON (TM 9-2320-279-10).
- (2) Place positive (+) probe of multimeter on AC condenser assembly harness black wire at AC condenser motor solenoid terminal.
- (3) Place negative (-) probe of multimeter on a known good ground.
 - (a) If 22 to 28 vdc are not measured, turn engine start switch OFF and go to Step 10 of this fault.
 - (b) If 22 to 28 vdc are measured, go to Step 7 of this fault.

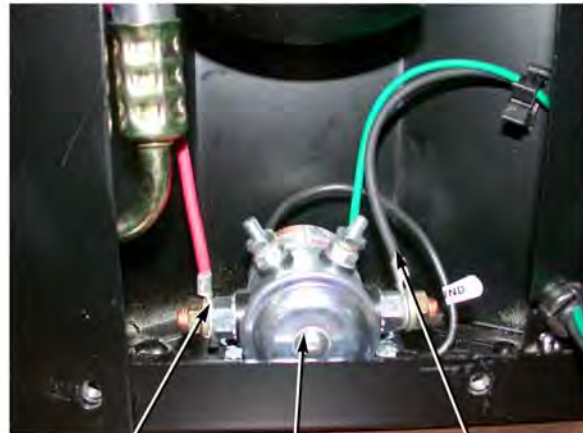
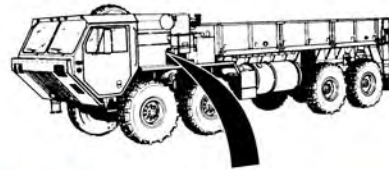

AC CONDENSER MOTOR SOLENOID TERMINAL RED WIRE

AC CONDENSER MOTOR SOLENOID

AC CONDENSER ASSEMBLY HARNESS BLACK WIRE

VOLTAGE TEST

- (1) Turn fan control switch to an on position (low, medium, or high) (WP 0004).
- (2) Turn AC temperature control switch to the coldest position (fully clockwise) (WP 0004).
- (3) Turn engine start switch ON (TM 9-2320-279-10).
- (4) Place positive (+) probe of multimeter on AC condenser motor solenoid, terminal red wire.
- (5) Place negative (-) probe of multimeter on a known good ground.
 - (a) If 22 to 28 vdc are not measured, turn engine start switch OFF and replace AC condenser motor solenoid (WP 0027). Verify repair, go to Step 14 of this fault.
 - (b) If 22 to 28 vdc are measured, turn engine start switch OFF and go to Step 8 of this fault.

AC COMPRESSOR DOES NOT SHUT OFF OR CYCLES CONSTANTLY - Continued

KNOWN INFO
AC heater/evaporator blower operates.
AC compressor operates.
AC condenser core not blocked or damaged.
AC compressor belts OK.
AC temperature control switch temperature probe OK.
AC harness wire 1156 OK.
AC condenser assembly harness green wire OK.
AC condenser motor solenoid ground wire OK.
AC condenser assembly harness black wire OK.
AC harness wire 1155 OK.
AC condenser motor solenoid OK.
POSSIBLE PROBLEMS
AC condenser motor red wire faulty.
AC condenser motor ground wire faulty.
AC condenser motor faulty.

8.

WARNING
Read WARNING on page 0014-11.

Is continuity measured across AC condenser motor red wire?

TEST OPTIONS
Continuity test. Multimeter.
REASON FOR QUESTION
If continuity is not measured, AC condenser motor red wire is faulty.

NO → Repair AC condenser motor red wire (see Appendix A). Verify repair, go to Step 14 of this fault.

YES

KNOWN INFO
AC heater/evaporator blower operates.
AC compressor operates.
AC condenser core not blocked or damaged.
AC compressor belts OK.
AC temperature control switch temperature probe OK.
AC harness wire 1156 OK.
AC condenser assembly harness green wire OK.
AC condenser motor solenoid ground wire OK.
AC condenser assembly harness black wire OK.
AC harness wire 1155 OK.
AC condenser motor solenoid OK.
AC condenser motor red wire OK.
POSSIBLE PROBLEMS
AC condenser motor ground wire faulty.
AC condenser motor faulty.

9.

WARNING
Read WARNING on page 0014-11.

Is continuity measured across AC condenser motor ground wire?

TEST OPTIONS
Continuity test. Multimeter.
REASON FOR QUESTION
If continuity is measured, AC condenser motor is faulty. If not, AC condenser motor ground wire is faulty.

NO → Repair AC condenser motor ground wire (see Appendix A). Verify repair, go to Step 14 of this fault.

YES → Replace AC condenser motor (WP 0026). Verify repair, go to Step 14 of this fault.

AC COMPRESSOR DOES NOT SHUT OFF OR CYCLES CONSTANTLY - Continued

WARNING

Remove rings, bracelets, wristwatches, neck chains, and any other jewelry before working around vehicle. Jewelry can catch on equipment and cause serious injury. Jewelry or tools may short across electrical circuits or terminals and cause damage to equipment or severe burns or electrical shock to personnel.

CONTINUITY TEST

NOTE: Do not disconnect wires from AC condenser motor.

- (1) Remove AC condenser motor (WP 0026).
- (2) Set multimeter switch to ohms.
- (3) Place positive (+) probe of multimeter on red wire at AC condenser motor terminal.
- (4) Place negative (-) probe of multimeter on red wire at AC condenser motor solenoid terminal.
 - (a) If there is no continuity, repair AC condenser motor red wire (see Appendix A). Verify repair, go to Step 14 of this fault.
 - (b) If there is continuity, go to Step 9 of this fault.



(BACK SIDE OF AC CONDENSER ASSEMBLY SHOWN)

CONTINUITY TEST

- (1) Set multimeter switch to ohms.
- (2) Place positive (+) probe of multimeter on ground wire at AC condenser motor terminal.
- (3) Place negative (-) probe of multimeter on ground wire at other end.
 - (a) If there is no continuity, repair AC condenser motor ground wire (see Appendix A). Verify repair, go to Step 14 of this fault.
 - (b) If there is continuity, replace AC condenser motor (WP 0026). Verify repair, go to Step 14 of this fault.

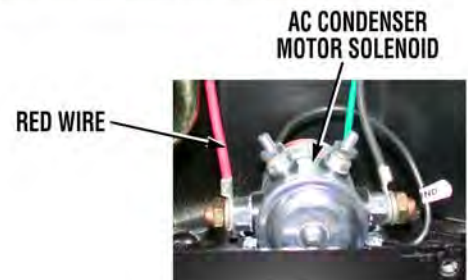
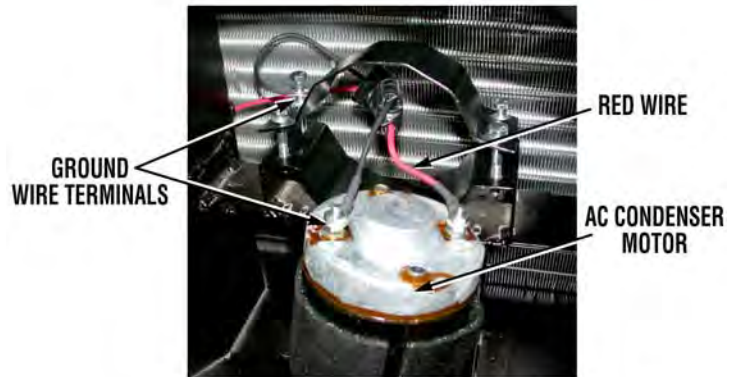

AC COMPRESSOR DOES NOT SHUT OFF OR CYCLES CONSTANTLY - Continued

KNOWN INFO
AC heater/evaporator blower operates.
AC compressor operates.
AC condenser core not blocked or damaged.
AC compressor belts OK.
AC temperature control switch temperature probe OK.
AC harness wire 1156 OK.
AC condenser assembly harness green wire OK.
AC condenser motor solenoid ground wire OK.
AC condenser motor solenoid OK.
AC condenser motor red wire OK.
AC condenser motor ground wire OK.
AC condenser motor OK.
POSSIBLE PROBLEMS
AC condenser assembly harness black wire faulty.
AC harness wire 1155 faulty.

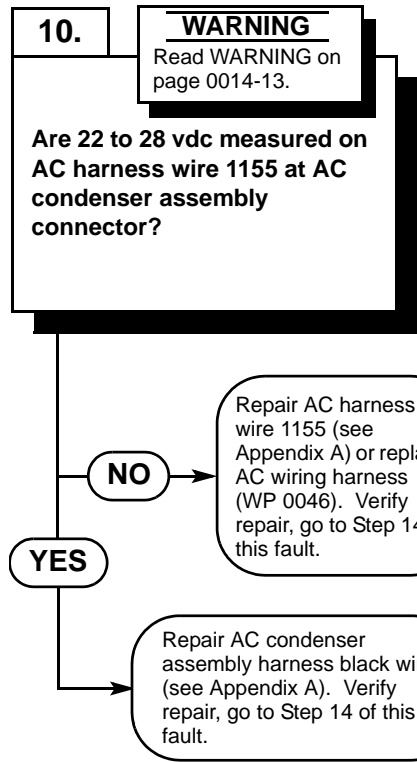

TEST OPTIONS
Voltage test. Multimeter.
REASON FOR QUESTION
If 22 to 28 vdc are measured, AC condenser assembly harness black wire is faulty. If not, AC harness wire 1155 is faulty.

KNOWN INFO
AC heater/evaporator blower operates.
AC compressor operates.
AC condenser core not blocked or damaged.
AC compressor belts OK.
AC temperature control switch temperature probe OK.
AC condenser motor red wire OK.
AC condenser motor ground wire OK.
AC condenser motor OK.
AC condenser assembly harness black wire OK.
AC harness wire 1155 OK.
POSSIBLE PROBLEMS
AC harness wire 1156 faulty.
AC condenser assembly harness green wire faulty.
AC condenser motor solenoid ground wire faulty.
AC condenser motor solenoid faulty.

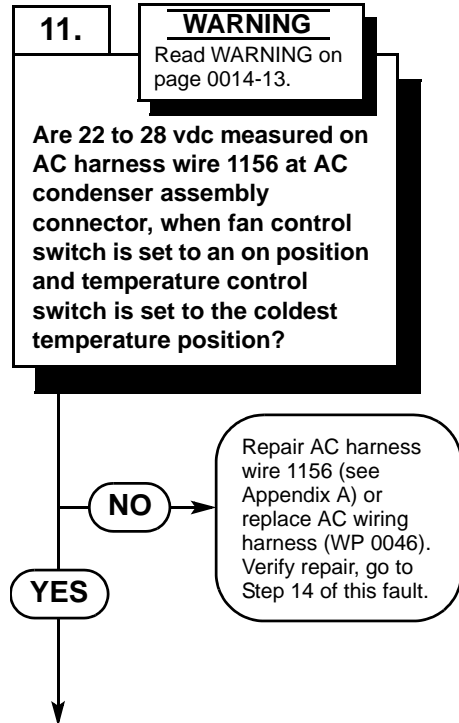

TEST OPTIONS
Voltage test. Multimeter.
REASON FOR QUESTION
If 22 to 28 vdc are not measured, AC harness wire 1156 is faulty.

AC COMPRESSOR DOES NOT SHUT OFF OR CYCLES CONSTANTLY - Continued

WARNING

Remove rings, bracelets, wristwatches, neck chains, and any other jewelry before working around vehicle. Jewelry can catch on equipment and cause serious injury. Jewelry or tools may short across electrical circuits or terminals and cause damage to equipment or severe burns or electrical shock to personnel.

VOLTAGE TEST

- (1) Disconnect AC harness AC condenser assembly connector (WP 0028).
- (2) Turn engine start switch ON (TM 9-2320-279-10).
- (3) Place positive (+) probe of multimeter on AC harness wire 1155 at AC condenser assembly connector, terminal A.
- (4) Place negative (-) probe of multimeter on a known good ground.
 - (a) If 22 to 28 vdc are not measured, turn engine start switch OFF and repair AC harness wire 1155 (see Appendix A) or replace AC wiring harness (WP 0046). Verify repair, go to Step 14 of this fault.
 - (b) If 22 to 28 vdc are measured, turn engine start switch OFF and repair AC condenser assembly harness black wire (see Appendix A). Verify repair, go to Step 14 of this fault.



AC HARNESS

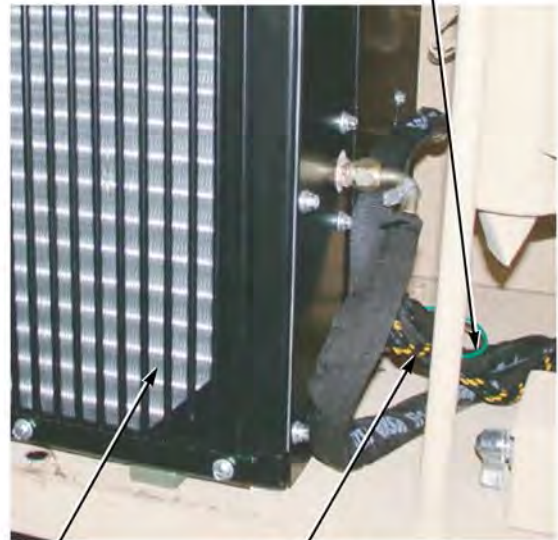

AC CONDENSER ASSEMBLY

AC CONDENSER ASSEMBLY HARNESS

VOLTAGE TEST

- (1) Disconnect AC harness AC condenser assembly connector (WP 0028).
- (2) Turn fan control switch to an on position (low, medium, or high) (WP 0004).
- (3) Turn AC temperature control switch to the coldest position (fully clockwise) (WP 0004).
- (4) Turn engine start switch ON (TM 9-2320-279-10).
- (5) Place positive (+) probe of multimeter on AC harness wire 1156 at AC condenser assembly connector, terminal B.
- (6) Place negative (-) probe of multimeter on a known good ground.
 - (a) If 22 to 28 vdc are not measured, turn engine start switch OFF and repair AC harness wire 1156 (see Appendix A) or replace AC wiring harness (WP 0046). Verify repair, go to Step 14 of this fault.
 - (b) If 22 to 28 vdc are measured, turn engine start switch OFF and go to Step 12 of this fault.

AC COMPRESSOR DOES NOT SHUT OFF OR CYCLES CONSTANTLY - Continued

KNOWN INFO
AC heater/evaporator blower operates.
AC compressor operates.
AC condenser core not blocked or damaged.
AC compressor belts OK.
AC temperature control switch temperature probe OK.
AC condenser motor red wire OK.
AC condenser motor ground wire OK.
AC condenser motor OK.
AC condenser assembly harness black wire OK.
AC harness wire 1155 OK.
AC harness wire 1156 OK.
POSSIBLE PROBLEMS
AC condenser assembly harness green wire faulty.
AC condenser motor solenoid ground wire faulty.
AC condenser motor solenoid faulty.

12. **WARNING**
Read WARNING on page 0014-15.

Is continuity measured across AC condenser assembly harness green wire?

TEST OPTIONS
Continuity test. Multimeter.
REASON FOR QUESTION
If continuity is not measured, AC condenser assembly harness green wire is faulty.

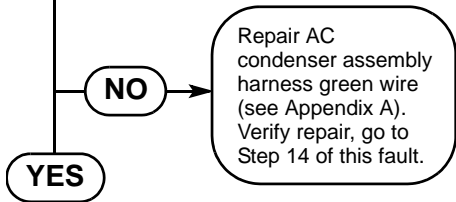

KNOWN INFO
AC heater/evaporator blower operates.
AC compressor operates.
AC condenser core not blocked or damaged.
AC compressor belts OK.
AC temperature control switch temperature probe OK.
AC condenser motor red wire OK.
AC condenser motor ground wire OK.
AC condenser motor OK.
AC condenser assembly harness black wire OK.
AC harness wire 1155 OK.
AC harness wire 1156 OK.
AC condenser assembly harness green wire OK.
POSSIBLE PROBLEMS
AC condenser motor solenoid ground wire faulty.
AC condenser motor solenoid faulty.

13. **WARNING**
Read WARNING on page 0014-15.

Is continuity measured across AC condenser motor solenoid ground wire?

TEST OPTIONS
Continuity test. Multimeter.
REASON FOR QUESTION
If continuity is measured, AC condenser motor solenoid is faulty. If not, AC condenser motor solenoid ground wire is faulty.

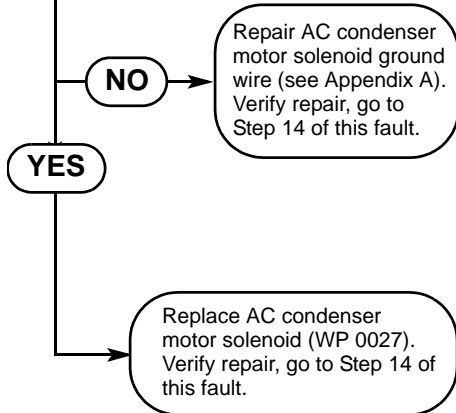

AC COMPRESSOR DOES NOT SHUT OFF OR CYCLES CONSTANTLY - Continued

WARNING

Remove rings, bracelets, wristwatches, neck chains, and any other jewelry before working around vehicle. Jewelry can catch on equipment and cause serious injury. Jewelry or tools may short across electrical circuits or terminals and cause damage to equipment or severe burns or electrical shock to personnel.

CONTINUITY TEST

- (1) Set multimeter switch to ohms.
- (2) Place positive (+) probe of multimeter on AC condenser assembly harness green wire at AC harness connector, terminal B.
- (3) Place negative (-) probe of multimeter on AC condenser assembly harness green wire at AC condenser fan motor solenoid terminal.
 - (a) If there is no continuity, repair AC condenser assembly harness green wire (see Appendix A). Verify repair, go to Step 14 of this fault.
 - (b) If there is continuity, connect AC harness AC condenser assembly connector (WP 0028) and go to Step 13 of this fault.



AC CONDENSER ASSEMBLY HARNESS

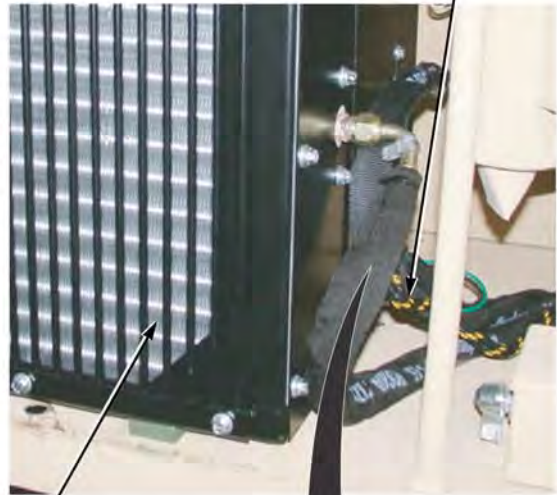

AC CONDENSER ASSEMBLY

CONTINUITY TEST

- (1) Set multimeter switch to ohms.
- (2) Place positive (+) probe of multimeter on ground wire at AC condenser motor solenoid terminal.
- (3) Place negative (-) probe of multimeter on a known good ground.
 - (a) If there is no continuity, repair AC condenser motor solenoid ground wire (see Appendix A). Verify repair, go to Step 14 of this fault.
 - (b) If there is continuity, replace AC condenser motor solenoid (WP 0027). Verify repair, go to Step 14 of this fault.

AC CONDENSER MOTOR SOLENOID

AC CONDENSER ASSEMBLY HARNESS GREEN WIRE

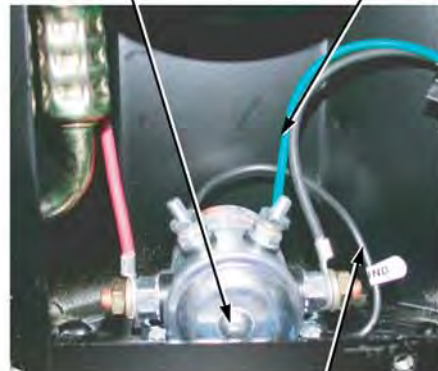

GROUND WIRE

AC COMPRESSOR DOES NOT SHUT OFF OR CYCLES CONSTANTLY - Continued

KNOWN INFO
AC heater/evaporator blower operates.
AC compressor operates.
AC condenser core not blocked or damaged.
AC compressor belts OK.
AC temperature control switch temperature probe OK.
AC condenser motor solenoid OK.
AC condenser motor red wire OK.
AC condenser motor ground wire OK.
AC condenser motor OK.
AC condenser assembly harness black wire OK.
AC harness wire 1155 OK.
AC harness wire 1156 OK.
AC condenser assembly harness green wire OK.
AC condenser motor solenoid ground wire OK.
POSSIBLE PROBLEMS
None

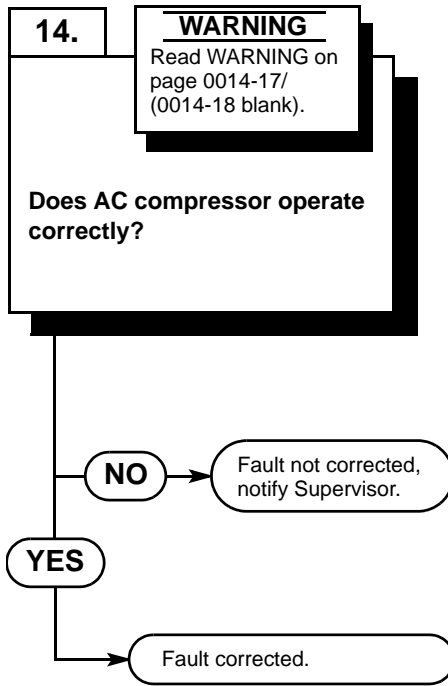

TEST OPTIONS
Verify repair.
REASON FOR QUESTION
If AC compressor does not shut off or is cycling constantly, fault has not been corrected.



AC COMPRESSOR DOES NOT SHUT OFF OR CYCLES CONSTANTLY - Continued

WARNING

Remove rings, bracelets, wristwatches, neck chains, and any other jewelry before working around vehicle. Jewelry can catch on equipment and cause serious injury. Jewelry or tools may short across electrical circuits or terminals and cause damage to equipment or severe burns or electrical shock to personnel.

VERIFY REPAIR

- (1) If removed, install AC condenser motor (WP 0026).
- (2) If removed, install cover and four washers, lockwashers, and screws on AC condenser assembly (WP 0028).
- (3) If disconnected, connect AC harness AC condenser assembly connector (WP 0028).
- (4) If removed, install top heater cover and eight screws (WP 0037).
- (5) If closed, open driver side engine cover and remove engine side panel (TM 9-2320-279-10).
- (6) Turn engine start switch ON (TM 9-2320-279-10).
- (7) Operate AC system for 10 minutes at high blower speed (WP 0004).
 - (a) If AC compressor does not shut off or cycles constantly, fault has not been corrected. Shut off engine, turn fan control switch and temperature control switch to off position, and notify Supervisor.
 - (b) If AC compressor operates correctly, fault has been corrected.
- (8) Install driver side engine panel and close engine cover (TM 9-2320-279-10).



END OF WORK PACKAGE

AC DOES NOT COOL OR COOLS INADEQUATELY

INITIAL SETUP:

Maintenance Level

Field Level Maintenance

Equipment Condition

Shut off engine (TM 9-2320-279-10).
 Parking brake applied (TM 9-2320-279-10).
 Wheels chocked (TM 9-2320-279-10).

Tools and Special Tools

Goggles (Item 1, Appendix F)
 Tool Kit, General Mechanic's (Item 7, Appendix F)
 Leak Detector, Refrigerant (Item 1, Appendix H)
 Reclaimer, Refrigerant (Item 2, Appendix H)

Materials/Parts

Gloves, Rubber (Item 2, Appendix E)

Personnel Required

MOS 52C, Utilities equipment repairer (2)

References

TM 9-2320-279-10
 TM 9-2320-279-20

NOTE

- Work package 0012 or 0014 must be performed before performing this work package.
- AC condenser dryer must be replaced whenever system R-134a refrigerant is recovered.

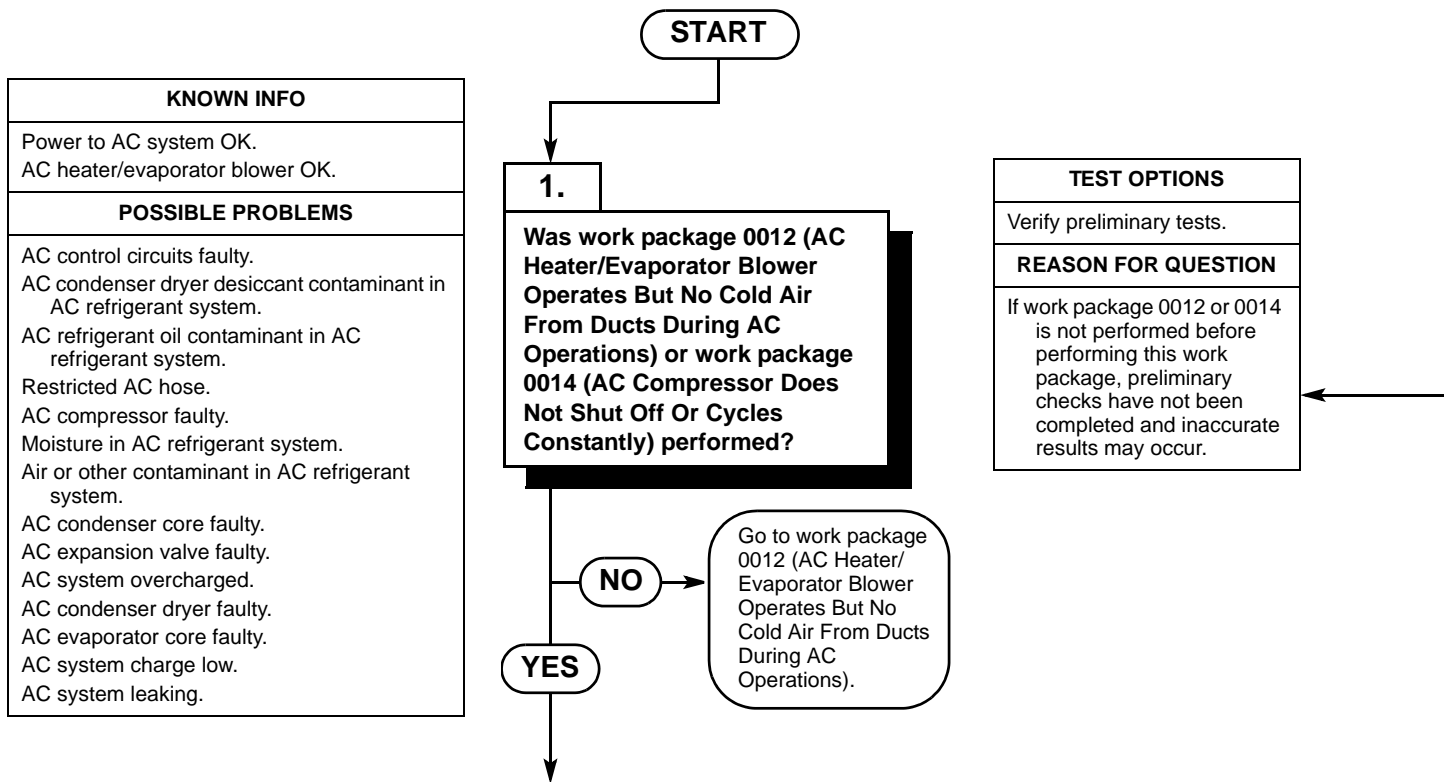

AC DOES NOT COOL OR COOLS INADEQUATELY - Continued

VERIFY PRELIMINARY TESTS

Verify that either work package 0012 (AC Heater/ Evaporator Blower Operates But No Cold Air From Ducts During AC Operations) or work package 0014 (AC Compressor Does Not Shut Off Or Cycles Constantly) was performed.

- (a) If neither work package was performed, go to work package 0012 (AC Heater/Evaporator Blower Operates But No Cold Air From Ducts During AC Operations).
- (b) If one of the work packages was performed and you were directed to this work package, go to Step 2 of this fault.



AC DOES NOT COOL OR COOLS INADEQUATELY - Continued

KNOWN INFO
Power to AC system OK. AC heater/evaporator blower OK. AC control circuits OK (except for temperature control and low pressure switches).
POSSIBLE PROBLEMS
AC condenser dryer desiccant contaminant in AC refrigerant system. AC refrigerant oil contaminant in AC refrigerant system. Restricted AC hose. AC compressor faulty. Temperature control switch faulty. Moisture in AC refrigerant system. Air or other contaminant in AC refrigerant system. AC condenser core faulty. AC expansion valve faulty. AC system overcharged. AC condenser dryer faulty. AC evaporator core faulty. AC low pressure switch faulty. AC system charge low. AC system leaking.

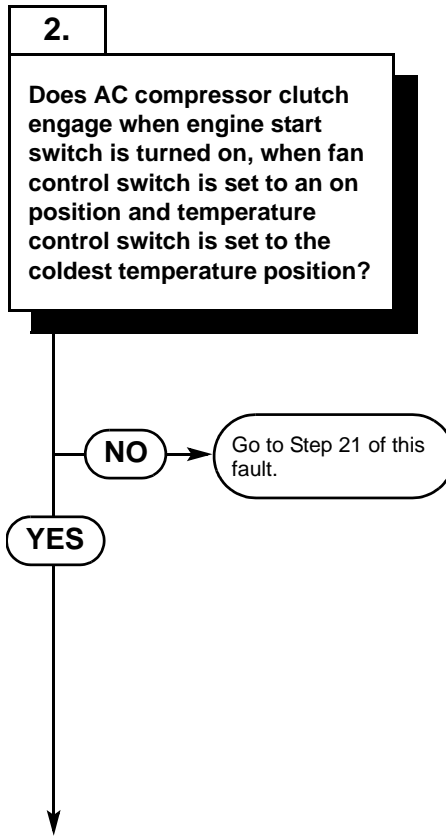

TEST OPTIONS
Audible test.
REASON FOR QUESTION
If AC compressor clutch does not engage, AC compressor will not operate.



AC DOES NOT COOL OR COOLS INADEQUATELY - Continued

AUDIBLE TEST

NOTE: Do not start engine during this procedure. AC compressor clutch operation will be checked by listening for a clicking sound from the AC compressor when the engine start switch is turned to ON position.

- (1) Open driver side engine cover and remove engine side panel (TM 9-2320-279-10).
- (2) Turn fan control switch to an on position (low, medium, or high) (WP 0004).
- (3) Turn temperature control switch to the coldest position (fully clockwise) (WP 0004).
- (4) While assistant turns engine start switch ON (TM 9-2320-279-10), check operation of AC compressor clutch by listening for a click when engine start switch is turned ON.
 - (a) If AC compressor clutch does not engage, turn engine start switch OFF and go to Step 21 of this fault.
 - (b) If AC compressor clutch engages, turn engine start switch OFF and go to Step 3 of this fault.



AC COMPRESSOR



AC DOES NOT COOL OR COOLS INADEQUATELY - Continued

KNOWN INFO
Power to AC system OK. AC heater/evaporator blower OK. AC control circuits OK (except for temperature control and low pressure switches). AC low pressure switch OK.
POSSIBLE PROBLEMS
AC condenser dryer desiccant contaminant in AC refrigerant system. AC refrigerant oil contaminant in AC refrigerant system. Restricted AC hose. AC compressor faulty. Temperature control switch faulty. Moisture in AC refrigerant system. Air or other contaminant in AC refrigerant system. AC condenser core faulty. AC expansion valve faulty. AC system overcharged. AC condenser dryer faulty. AC evaporator core faulty. AC system charge low. AC system leaking.

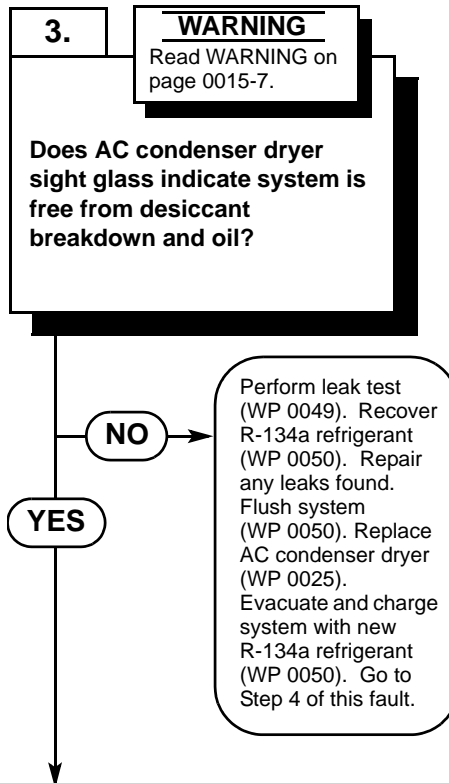

TEST OPTIONS
Visual inspection. AC test set manifold gages.
REASON FOR QUESTION
If AC condenser dryer sight glass indicates desiccant breakdown or oil in system, system must be flushed.



AC DOES NOT COOL OR COOLS INADEQUATELY - Continued

WARNING

- **Moving engine components can cause severe injury. Keep away from fan, belts, and pulleys while engine is running.**
- **Wear protective goggles and nonleather gloves when servicing air conditioner system. Failure to comply may result in injury to personnel.**

VISUAL INSPECTION

- (1) Connect AC test set recovery/recycling manifold gages to AC service valves (WP 0050). Ensure test set valves are closed.
- (2) Remove AC condenser dryer sight glass access hole cover.
- (3) Start engine (TM 9-2320-279-10).
- (4) Operate AC system for 5 to 10 minutes at high blower speed (WP 0004).
- (5) Inspect AC condenser dryer sight glass.
 - (a) If AC condenser dryer sight glass indicates desiccant breakdown or oil in system:
 1. Shut off engine (TM 9-2320-279-10).
 2. Perform leak test (WP 0049).
 3. Recover R-134a refrigerant (WP 0050).
 4. Repair leaks found.

CAUTION: Do not flush AC condenser dryer, AC compressor, or AC expansion valve. After flushing system, add required refrigerant oil or damage to equipment may result.

 5. Flush system (WP 0050).
 6. Replace AC condenser dryer (WP 0025).
 7. Evacuate and charge system with new R-134a refrigerant (WP 0050).
 8. Start engine.
 9. Operate AC system for 5 to 10 minutes at high blower speed (WP 0004).
 10. Go to Step 4 of this fault.
 - (b) If AC condenser dryer sight glass does not indicate desiccant breakdown or oil in system, go to Step 4 of this fault.

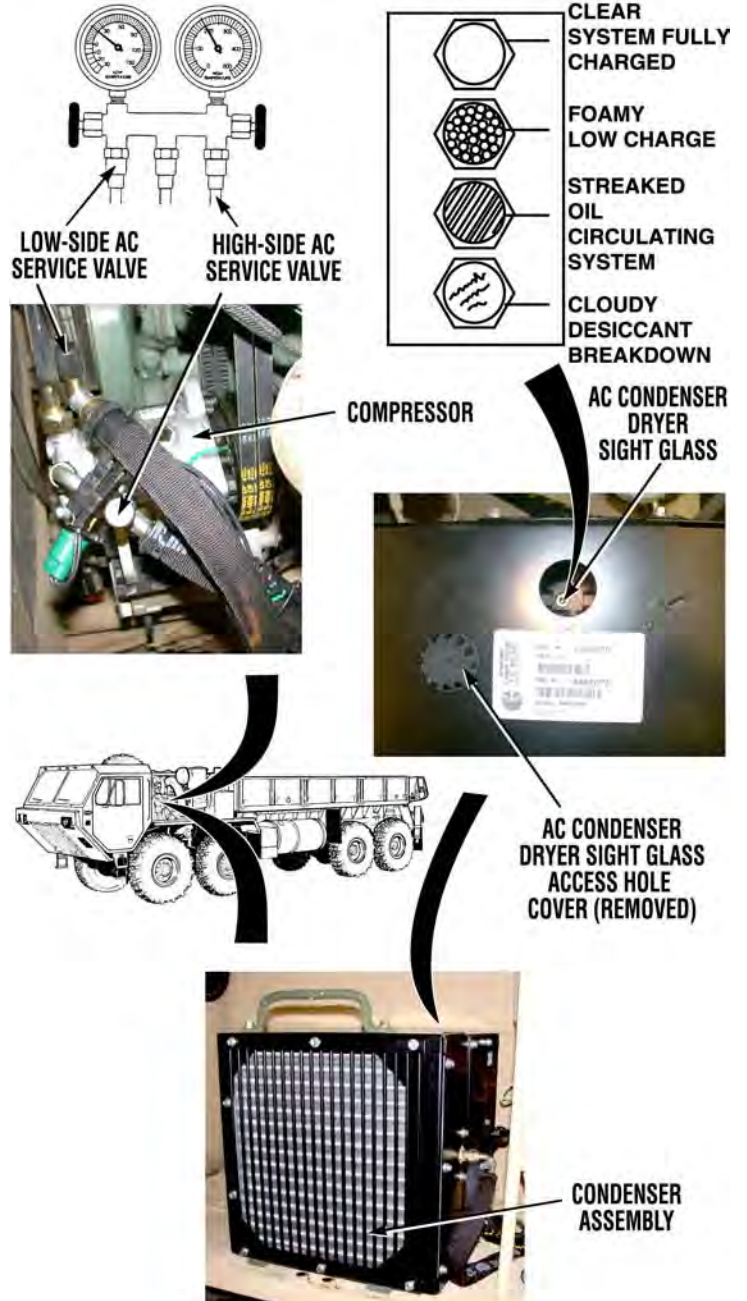

AC DOES NOT COOL OR COOLS INADEQUATELY - Continued

KNOWN INFO
Power to AC system OK. AC heater/evaporator blower OK. AC control circuits OK (except for temperature control and low pressure switches). AC low pressure switch OK. No AC condenser dryer desiccant contaminant in AC refrigerant system. No AC refrigerant oil contaminant in AC refrigerant system.
POSSIBLE PROBLEMS
Restricted AC hose. AC compressor faulty. Temperature control switch faulty. Moisture in AC refrigerant system. Air or other contaminant in AC refrigerant system. AC condenser core faulty. AC expansion valve faulty. AC system overcharged. AC condenser dryer faulty. AC evaporator core faulty. AC system charge low. AC system leaking.

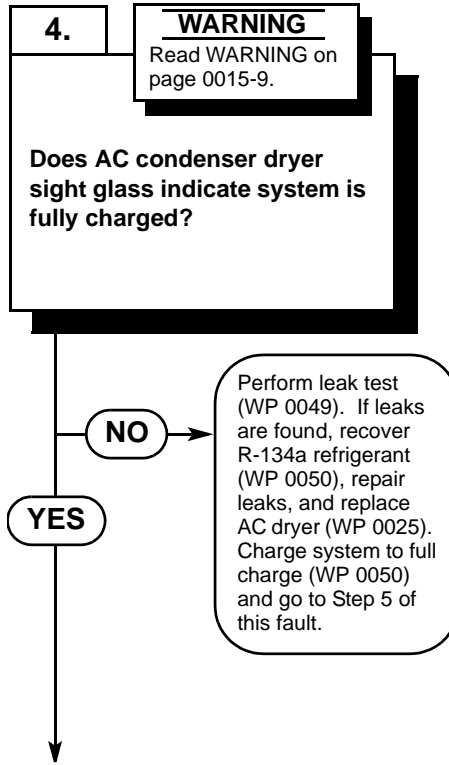

TEST OPTIONS
Visual inspection.
REASON FOR QUESTION
If system is not fully charged, system may not cool properly.



AC DOES NOT COOL OR COOLS INADEQUATELY - Continued

WARNING

- **Moving engine components can cause severe injury. Keep away from fan, belts, and pulleys while engine is running.**
- **Wear protective goggles and nonleather gloves when servicing air conditioner system. Failure to comply may result in injury to personnel.**

VISUAL INSPECTION

- (1) Inspect AC condenser dryer moisture sight glass.
- (a) If AC condenser dryer sight glass indicates a low charge:
1. Shut off engine (TM 9-2320-279-10).
 2. Perform leak test (WP 0049).
- NOTE:** Perform Steps 3 through 6 only if leaks are found.
3. Recover R-134a refrigerant (WP 0050).
 4. Repair leaks found.
 5. Replace AC condenser dryer (WP 0025).
 6. Evacuate system (WP 0050).
 7. Charge system (WP 0050).
 8. Start engine.
 9. Operate AC system for 5 to 10 minutes at high blower speed (WP 0004).
 10. Go to Step 5 of this fault.
- (b) If AC condenser dryer sight glass indicates system is fully charged, go to Step 5 of this fault.

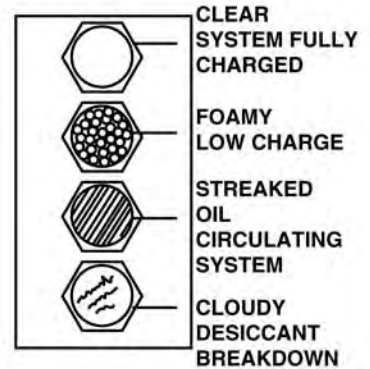

AC CONDENSER DRYER SIGHT GLASS



AC DOES NOT COOL OR COOLS INADEQUATELY - Continued

KNOWN INFO
Power to AC system OK. AC heater/evaporator blower OK. AC control circuits OK (except for temperature control and low pressure switches). AC low pressure switch OK. No AC condenser dryer desiccant contaminant in AC refrigerant system. No AC refrigerant oil contaminant in AC refrigerant system. AC system charge is not low. No AC system leaks.
POSSIBLE PROBLEMS
Restricted AC hose. AC compressor faulty. Temperature control switch faulty. Moisture in AC refrigerant system. Air or other contaminant in AC refrigerant system. AC condenser core faulty. AC expansion valve faulty. AC system overcharged. AC condenser dryer faulty. AC evaporator core faulty.

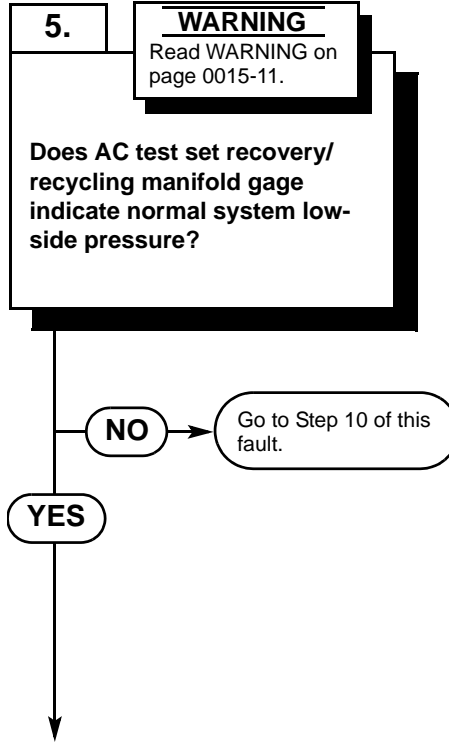

TEST OPTIONS
Pressure test. AC test set manifold gages.
REASON FOR QUESTION
To isolate system fault.



AC DOES NOT COOL OR COOLS INADEQUATELY - Continued

WARNING

- Moving engine components can cause severe injury. Keep away from fan, belts, and pulleys while engine is running.
- Wear protective goggles and nonleather gloves when servicing air conditioner system. Failure to comply may result in injury to personnel.

Pressure Temperature Chart

°F	°C	HFC-134a (PSI)	°F	°C	HFC-134a (PSI)
0	-17.8	6.5	85	29.4	94.9
5	-15.0	9.0	90	32.2	103.9
10	-12.2	12.0	95	35.0	113.5
15	-9.4	15.0	100	37.8	123.6
20	-6.7	18.4	105	40.6	134.3
25	-3.9	22.1	110	43.3	145.3
30	-1.1	26.1	115	46.1	157.6
35	1.7	30.4	120	48.9	170.3
40	4.4	35.0	125	51.7	183.6
45	7.2	40.0	130	54.4	197.6
50	10.0	45.3	135	57.2	212.4
55	12.8	51.1	140	60.0	227.9
60	15.6	57.3	145	62.8	244.3
65	18.3	63.9	150	65.6	261.4
70	21.1	70.9	155	68.3	279.5
75	23.8	78.4	160	71.1	298.4
80	26.7	88.4	165	73.9	318.3

NOTE

- System low-side pressure is determined by the temperature of the R-134a refrigerant at the low-side service valve.
- System high-side pressure is determined by the ambient temperature of the air surrounding the AC condenser. The ambient temperature is determined by measuring the temperature 2 in. (5 cm) in front of the AC condenser.

PRESSURE TEST
Inspect AC test set recovery/recycling manifold low-side gage reading.
(a) If gage reading is not within the range indicated in the chart shown above for normal low-side pressure, go to Step 10 of this fault.
(b) If gage reading is within the range indicated in the chart shown above for normal low-side pressure, go to Step 6 of this fault.

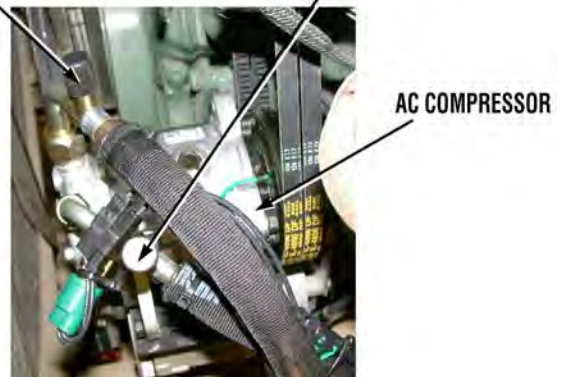
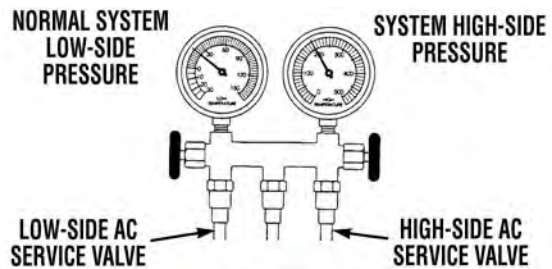

AC DOES NOT COOL OR COOLS INADEQUATELY - Continued

KNOWN INFO
Power to AC system OK. AC heater/evaporator blower OK. AC control circuits OK (except for temperature control and low pressure switches). AC low pressure switch OK. No AC condenser dryer desiccant contaminant in AC refrigerant system. No AC refrigerant oil contaminant in AC refrigerant system. AC system charge is not low. No AC system leaks. AC condenser core OK. AC expansion valve OK. AC system not overcharged. AC condenser dryer OK. AC evaporator core OK.
POSSIBLE PROBLEMS
Restricted AC hose. AC compressor faulty. Temperature control switch faulty. Moisture in AC refrigerant system. Air or other contaminant in AC refrigerant system.

6.

WARNING
Read WARNING on page 0015-13.

Does AC test set recovery/recycling manifold gage indicate low system high-side pressure?

TEST OPTIONS
Pressure test. AC test set manifold gages.
REASON FOR QUESTION
To isolate system fault.

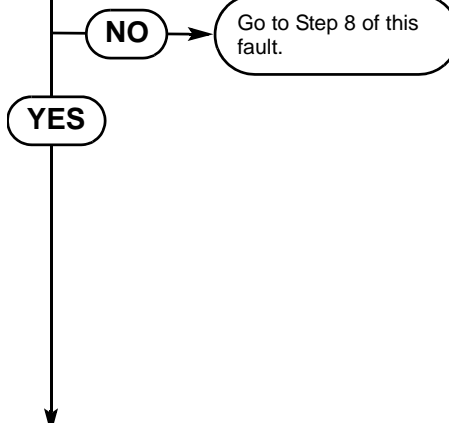

KNOWN INFO
Power to AC system OK. AC heater/evaporator blower OK. AC control circuits OK (except for temperature control and low pressure switches). No moisture in AC refrigerant system. AC low pressure switch OK. No AC condenser dryer desiccant contaminant in AC refrigerant system. No AC refrigerant oil contaminant in AC refrigerant system. AC system charge is not low. No AC system leaks. AC condenser core OK. AC expansion valve OK. AC system not overcharged. AC condenser dryer OK. AC evaporator core OK. Temperature control switch OK. No air or other contaminant in AC refrigerant system.
POSSIBLE PROBLEMS
Restricted AC hose. AC compressor faulty.

7.

WARNING
Read WARNING on page 0015-13.

Are AC hoses from low-side AC service valve to high-side AC service valve free from frost and cool spots?

TEST OPTIONS
Visual inspection.
REASON FOR QUESTION
If frost or cool spots are forming on AC hoses, AC hoses are restricting R-134a refrigerant flow. If not, AC compressor is faulty.

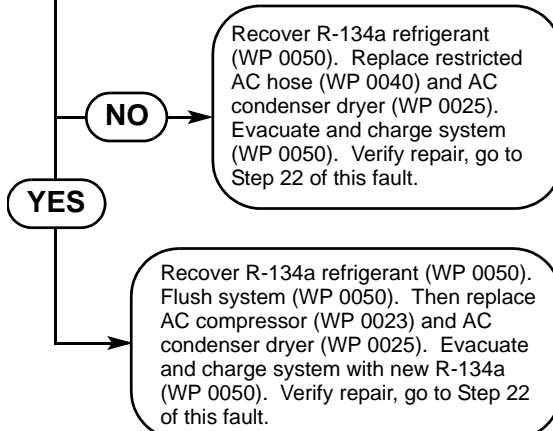

AC DOES NOT COOL OR COOLS INADEQUATELY - Continued

WARNING

- **Moving engine components can cause severe injury. Keep away from fan, belts, and pulleys while engine is running.**
- **Wear protective goggles and nonleather gloves when servicing air conditioner system. Failure to comply may result in injury to personnel.**

PRESSURE TEST
<p>(1) Inspect AC test set recovery/recycling manifold high-side gage reading.</p> <p>(a) If gage reading is not lower than the range for the ambient temperature indicated in the chart shown on page 0015-11 for normal high-side pressure, go to Step 8 of this fault.</p> <p>(b) If gage reading is lower than the range for the ambient temperature indicated in the chart shown on page 0015-11 for normal high-side pressure, go to Step 7 of this fault.</p>

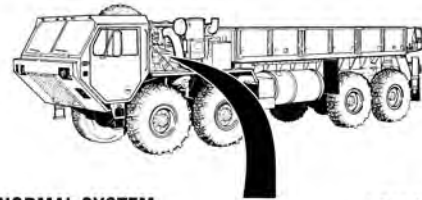

NORMAL SYSTEM
LOW-SIDE
PRESSURE

LOW SYSTEM
HIGH-SIDE
PRESSURE

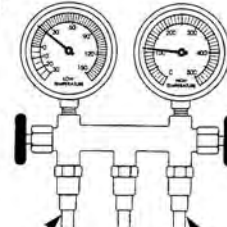

LOW-SIDE AC
SERVICE VALVE

HIGH-SIDE AC SERVICE
VALVE

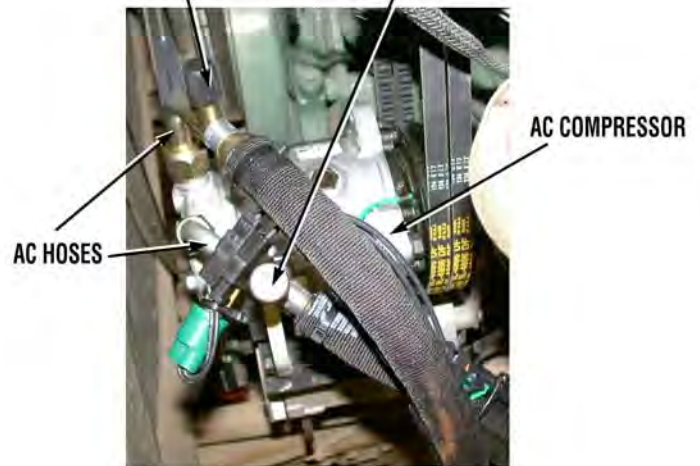

VISUAL INSPECTION
<p>(1) Shut off engine (TM 9-2320-279-10).</p> <p>(2) Inspect AC hoses from system low-side AC service valve to system high-side AC service valve for frost and cool spots.</p> <p>(a) If hoses are not free from frost and cool spots:</p> <ol style="list-style-type: none"> 1. Recover R-134a refrigerant (WP 0050). 2. Replace restricted AC hose (WP 0040). 3. Replace AC condenser dryer (WP 0025). 4. Evacuate and recharge system (WP 0050). 5. Verify repair, go to Step 22 of this fault. <p>CAUTION: Do not flush AC condenser dryer, AC compressor, or AC expansion valve. After flushing system, add required refrigerant oil or damage to equipment may result.</p> <p>(b) If hoses are free from frost and cool spots:</p> <ol style="list-style-type: none"> 1. Recover R-134a refrigerant (WP 0050). 2. Purge and flush system (WP 0050). 3. Replace AC compressor (WP 0023). 4. Replace AC condenser dryer (WP 0025). 5. Evacuate and recharge system with new R-134a refrigerant (WP 0050). 6. Verify repair, go to Step 22 of this fault.

AC DOES NOT COOL OR COOLS INADEQUATELY - Continued

KNOWN INFO
Power to AC system OK. AC heater/evaporator blower OK. AC control circuits OK (except for temperature control and low pressure switches). AC low pressure switch OK. No AC condenser dryer desiccant contaminant in AC refrigerant system. No AC refrigerant oil contaminant in AC refrigerant system. AC system charge is not low. No AC system leaks. AC condenser core OK. AC expansion valve OK. AC system not overcharged. AC condenser dryer OK. AC evaporator core OK. No restricted AC hoses. AC compressor OK.
POSSIBLE PROBLEMS
Temperature control switch faulty. Moisture in AC refrigerant system. Air or other contaminant in AC refrigerant system.

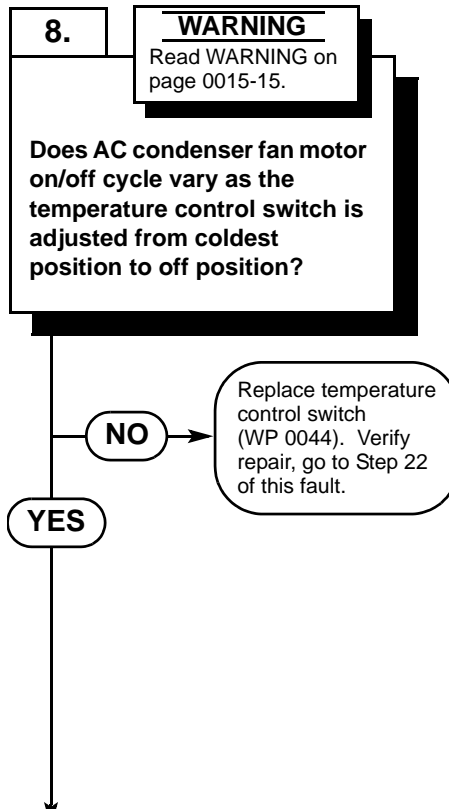

TEST OPTIONS
Visual inspection.
REASON FOR QUESTION
If AC condenser fan motor on/off cycle does not vary as the temperature control switch is adjusted, temperature control switch is faulty.

KNOWN INFO
Power to AC system OK. AC heater/evaporator blower OK. AC control circuits OK (except for temperature control and low pressure switches). AC low pressure switch OK. No AC condenser dryer desiccant contaminant in AC refrigerant system. No AC refrigerant oil contaminant in AC refrigerant system. AC system charge is not low. No AC system leaks. AC condenser core OK. AC expansion valve OK. AC system not overcharged. AC condenser dryer OK. AC evaporator core OK. No restricted AC hoses. AC compressor OK. Temperature control switch OK.
POSSIBLE PROBLEMS
Moisture in AC refrigerant system. Air or other contaminant in AC refrigerant system.

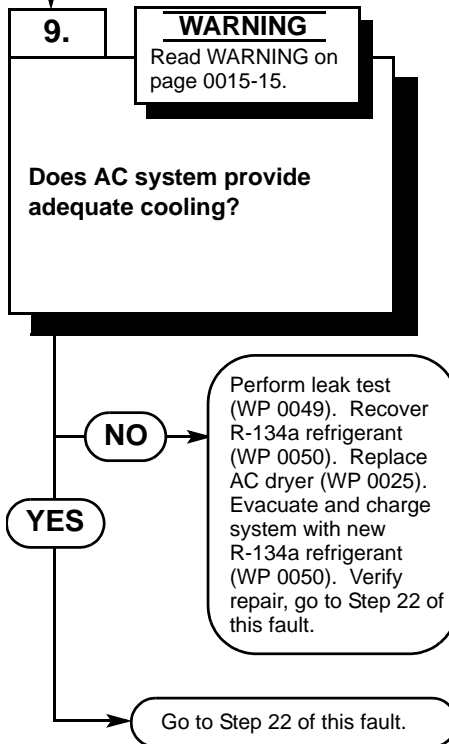

TEST OPTIONS
Visual inspection.
REASON FOR QUESTION
If AC system does not cool adequately, air or other contaminant may have entered system.

AC DOES NOT COOL OR COOLS INADEQUATELY - Continued

WARNING

- **Moving engine components can cause severe injury. Keep away from fan, belts, and pulleys while engine is running.**
- **Wear protective goggles and nonleather gloves when servicing air conditioner system. Failure to comply may result in injury to personnel.**

VISUAL INSPECTION

NOTE: AC condenser fan may not turn on in extremely cold, or off in extremely hot ambient temperatures.

While assistant slowly adjusts temperature control switch from its coldest position to off position, verify that the on/off cycle for the AC condenser fan motor varies as the temperature control switch is adjusted.

- (a) If the AC condenser on/off cycle does not vary when the temperature control switch is adjusted, turn engine switch OFF (TM 9-2320-279-10) and replace temperature control switch (WP 0044). Verify repair, go to Step 22 of this fault.
- (b) If the AC condenser on/off cycle varies when the temperature control switch is adjusted, go to Step 9 of this fault.

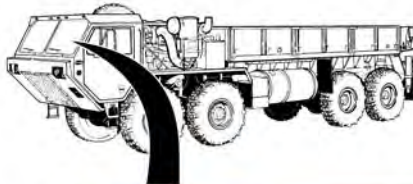

TEMPERATURE CONTROL SWITCH

VISUAL INSPECTION

- (1) Turn temperature control switch to the coldest position (fully clockwise) (WP 0004).
- (2) Inspect AC system operation. System output should be 20°F (-6.67°C) cooler than ambient temperature of cab.
 - (a) If AC system is not providing adequate cooling.
 1. Shut off engine (TM 9-2320-279-10).
 2. Perform leak test (WP 0049).
 3. Recover R-134a refrigerant (WP 0050).
 4. Repair leaks found.
 5. Replace AC condenser dryer (WP 0025).
 6. Evacuate and charge system with new R-134a refrigerant (WP 0050).
 7. Verify repair, go to Step 22 of this fault.
 - (b) If AC system is providing adequate cooling, go to Step 22 of this fault.

AC DOES NOT COOL OR COOLS INADEQUATELY - Continued

KNOWN INFO
Power to AC system OK. AC heater/evaporator blower OK. AC control circuits OK (except for temperature control and low pressure switches). AC low pressure switch OK. No AC condenser dryer desiccant contaminant in AC refrigerant system. No AC refrigerant oil contaminant in AC refrigerant system. AC system charge is not low. No AC system leaks. Temperature control switch OK. No air or other contaminant in AC refrigerant system.
POSSIBLE PROBLEMS
Restricted AC hoses. AC compressor faulty. AC condenser core faulty. Moisture in AC refrigerant system. AC expansion valve faulty. AC system overcharged. AC condenser dryer faulty. AC evaporator core faulty.

10.

WARNING
 Read WARNING on page 0015-17.

Does AC test set recovery/recycling manifold gages indicate high system low-side pressure?

NO

Go to Step 16 of this fault.

TEST OPTIONS
Pressure test. AC test set manifold gage.
REASON FOR QUESTION
To isolate system fault.

KNOWN INFO
Power to AC system OK. AC heater/evaporator blower OK. AC control circuits OK (except for temperature control and low pressure switches). AC low pressure switch OK. No AC condenser dryer desiccant contaminant in AC refrigerant system. No AC refrigerant oil contaminant in AC refrigerant system. AC system charge is not low. No AC system leaks. Temperature control switch OK. No air or other contaminant in AC refrigerant system. AC condenser dryer OK. AC evaporator core OK.
POSSIBLE PROBLEMS
Restricted AC hoses. AC compressor faulty. AC condenser core faulty. Moisture in AC refrigerant system. AC expansion valve faulty. AC system overcharged.

11.

WARNING
 Read WARNING on page 0015-17.

Does AC test set recovery/recycling manifold gages indicate high system high-side pressure?

NO

Go to Step 14 of this fault.

YES

TEST OPTIONS
Pressure test. AC test set manifold gage.
REASON FOR QUESTION
To isolate system fault.

AC DOES NOT COOL OR COOLS INADEQUATELY - Continued

WARNING

- Moving engine components can cause severe injury. Keep away from fan, belts, and pulleys while engine is running.
- Wear protective goggles and nonleather gloves when servicing air conditioner system. Failure to comply may result in injury to personnel.

PRESSURE TEST
<p>(1) Inspect AC test set recovery/recycling manifold low-side gage reading.</p> <p>(a) If gage reading is not indicating a high system low-side pressure as indicated in the chart shown on page 0015-11 (less than 30 psi), go to Step 16 of this fault.</p> <p>(b) If gage reading is indicating a high system low-side pressure as indicated in the chart shown on page 0015-11 (greater than 30 psi), go to Step 11 of this fault.</p>

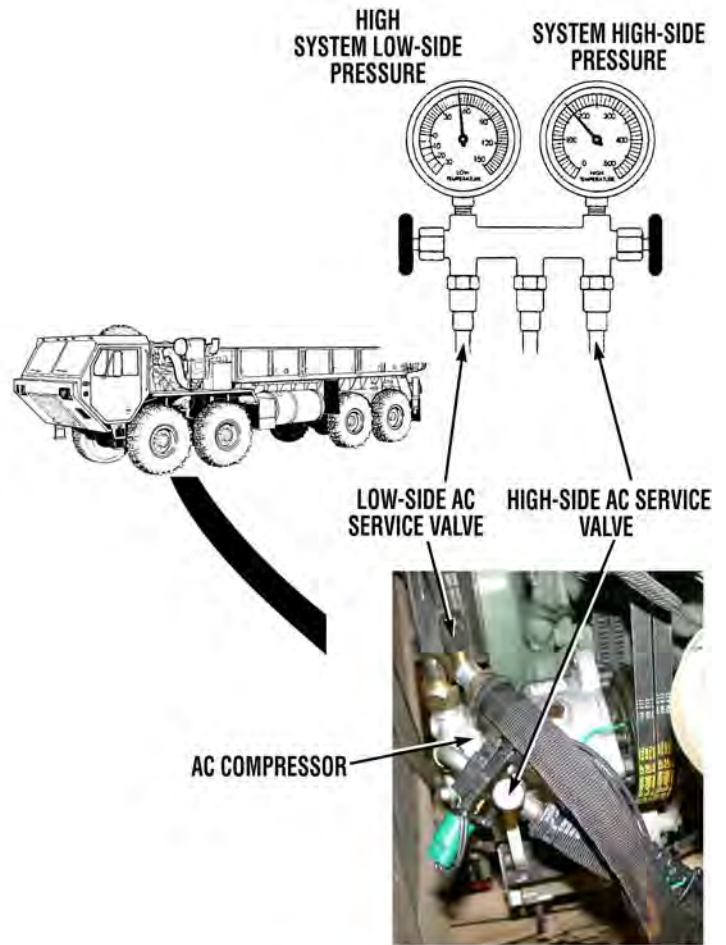

PRESSURE TEST
<p>(1) Inspect AC test set recovery/recycling manifold high-side gage reading.</p> <p>(a) If gage reading is not indicating a high system high-side pressure for the ambient temperature indicated in the chart shown on page 0015-11, go to Step 14 of this fault.</p> <p>(b) If gage reading is indicating a high system high-side pressure for the ambient temperature indicated in the chart shown on page 0015-11, go to Step 12 of this fault.</p>

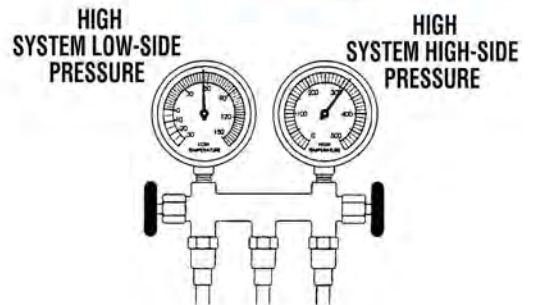

AC DOES NOT COOL OR COOLS INADEQUATELY - Continued

KNOWN INFO
Power to AC system OK. AC heater/evaporator blower OK. AC control circuits OK (except for temperature control and low pressure switches). AC low pressure switch OK. No AC condenser dryer desiccant contaminant in AC refrigerant system. No AC refrigerant oil contaminant in AC refrigerant system. No AC system leaks. Temperature control switch OK. No air or other contaminant in AC refrigerant system. AC condenser dryer OK. AC evaporator core OK. No restricted AC hoses. AC compressor OK.
POSSIBLE PROBLEMS
AC condenser core faulty. Moisture in AC refrigerant system. AC expansion valve faulty. AC system overcharged.

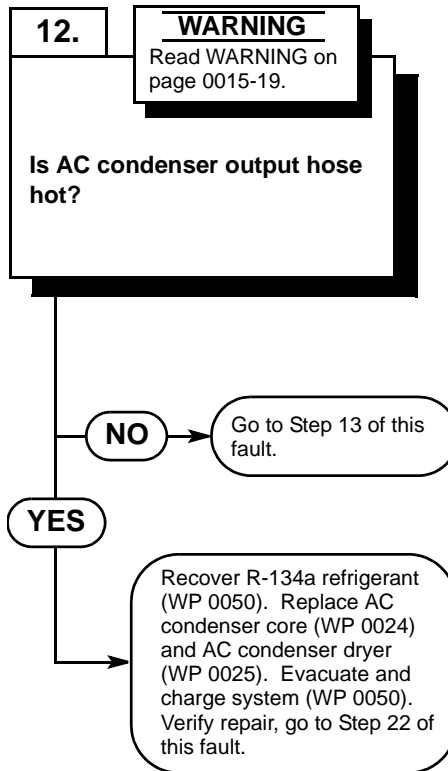

TEST OPTIONS
Visual inspection.
REASON FOR QUESTION
If AC condenser output hose is hot, AC condenser is faulty.



AC DOES NOT COOL OR COOLS INADEQUATELY - Continued

WARNING

- Moving engine components can cause severe injury. Keep away from fan, belts, and pulleys while engine is running.
- Remove rings, bracelets, wristwatches, neck chains, and any other jewelry before working around vehicle. Jewelry can catch on equipment and cause serious injury. Jewelry or tools may short across electrical circuits or terminals and cause damage to equipment or severe burns or electrical shock to personnel.
- AC condenser and AC condenser output hose can get extremely hot. Use caution when checking temperature of AC condenser output hose. Place hand near hose to check for heat, but do not touch hose. Failure to comply may cause serious burns to personnel.
- Wear protective goggles and nonleather gloves when servicing air conditioner system. Failure to comply may result in injury to personnel.

VISUAL INSPECTION

- (1) Remove four screws, lockwashers, washers, and cover from AC condenser assembly (WP 0027).
- (2) Inspect AC hose between AC condenser core and AC condenser dryer.
 - (a) If AC hose is not hot, go to Step 13 of this fault.
 - (b) If AC hose is hot:
 1. Shut off engine (TM 9-2320-279-10).
 2. Recover R-134a refrigerant (WP 0050).
 3. Replace AC condenser core (WP 0024).
 4. Replace AC condenser dryer (WP 0025).
 5. Evacuate and charge system (WP 0050).
 6. Verify repair, go to Step 22 of this fault.

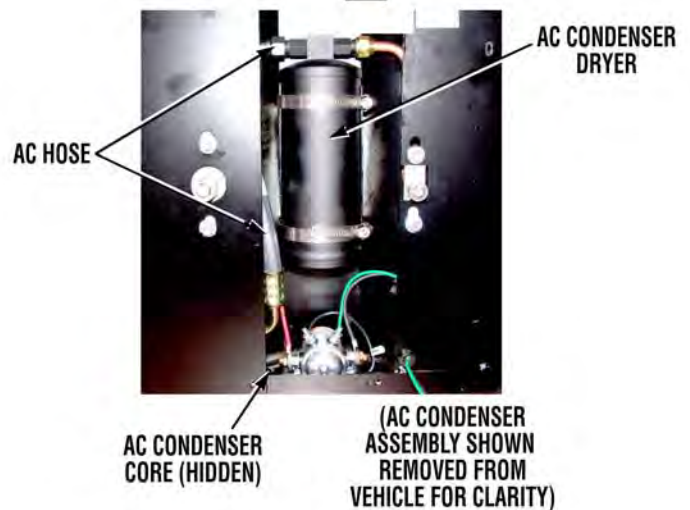

AC DOES NOT COOL OR COOLS INADEQUATELY - Continued

KNOWN INFO
Power to AC system OK. AC heater/evaporator blower OK. AC control circuits OK (except for temperature control and low pressure switches). AC low pressure switch OK. No AC condenser dryer desiccant contaminant in AC refrigerant system. No AC refrigerant oil contaminant in AC refrigerant system. AC system charge is not low. No AC system leaks. Temperature control switch OK. No air or other contaminant in AC refrigerant system. AC condenser dryer OK. AC evaporator core OK. No restricted AC hoses. AC compressor OK. AC condenser core OK.
POSSIBLE PROBLEMS
Moisture in AC refrigerant system. AC expansion valve faulty. AC system overcharged.

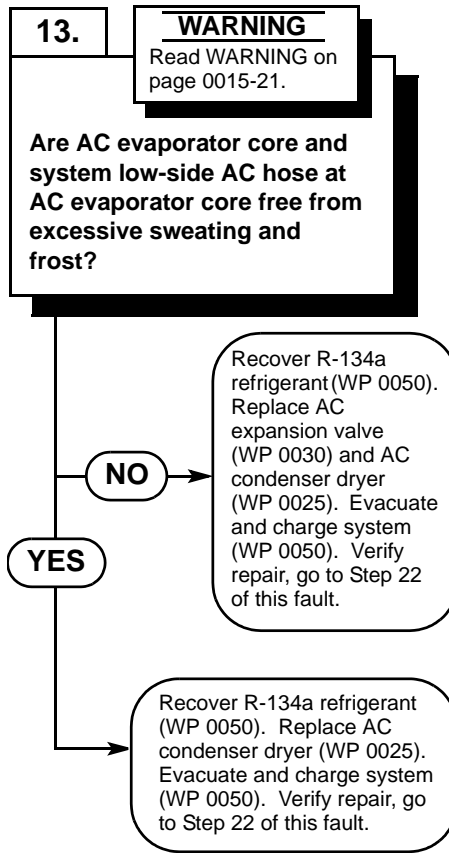

TEST OPTIONS
Visual inspection.
REASON FOR QUESTION
If AC evaporator core and system low-side AC hose at AC evaporator core are free from excessive sweating and frost, AC system may be overcharged. If not, AC expansion valve is faulty or moisture may have entered system.

AC DOES NOT COOL OR COOLS INADEQUATELY - Continued

WARNING

- Remove rings, bracelets, wristwatches, neck chains, and any other jewelry before working around vehicle. Jewelry can catch on equipment and cause serious injury. Jewelry or tools may short across electrical circuits or terminals and cause damage to equipment or severe burns or electrical shock to personnel.
- Wear protective goggles and nonleather gloves when servicing air conditioner system. Failure to comply may result in injury to personnel.

VISUAL INSPECTION
(1) Shut off engine (TM 9-2320-279-10).
(2) Remove eight screws and top heater cover (WP 0037).
(3) Remove four screws, lockwashers, washers, and cover from AC heater/evaporator assembly (WP 0037).
CAUTION: Slide temperature probe slowly from heater/evaporator. Failure to comply may result in damage to equipment.
(4) Remove temperature control switch temperature probe from evaporator core (WP 0044).
(5) Remove four screws and pull center heater cover aside (WP 0037).
(6) Remove four screws and evaporator core cover from AC heater/evaporator assembly (WP 0030).
(7) Inspect AC evaporator core and system low-side AC hose at AC evaporator core for excessive sweating and frost.
(a) If AC evaporator core and system low-side AC hose are not free from excessive sweating and frost:
1. Recover R-134a refrigerant (WP 0050).
2. Replace AC expansion valve (WP 0030).
(b) If AC evaporator core and system low-side AC hose are free from excessive sweating and frost, recover R-134a refrigerant (WP 0050).
(8) If removed, install evaporator core cover and four screws on AC heater/evaporator assembly.
(9) If removed, install center heater cover and four screws.
(10) If removed, install cover and four washers, lockwashers, and screws on AC heater/evaporator assembly.
CAUTION: Do not puncture temperature probe. Failure to comply will cause gas in tube to leak out.
NOTE: Slide temperature probe in AC heater/evaporator slowly. Temperature probe must slide into AC evaporator core until it touches the bottom of insertion hole.
(11) Install temperature control switch temperature probe in AC evaporator core.
(12) Replace AC condenser dryer (WP 0025).
(13) Evacuate and recharge system (WP 0050).
(14) Verify repair, go to Step 22 of this fault.

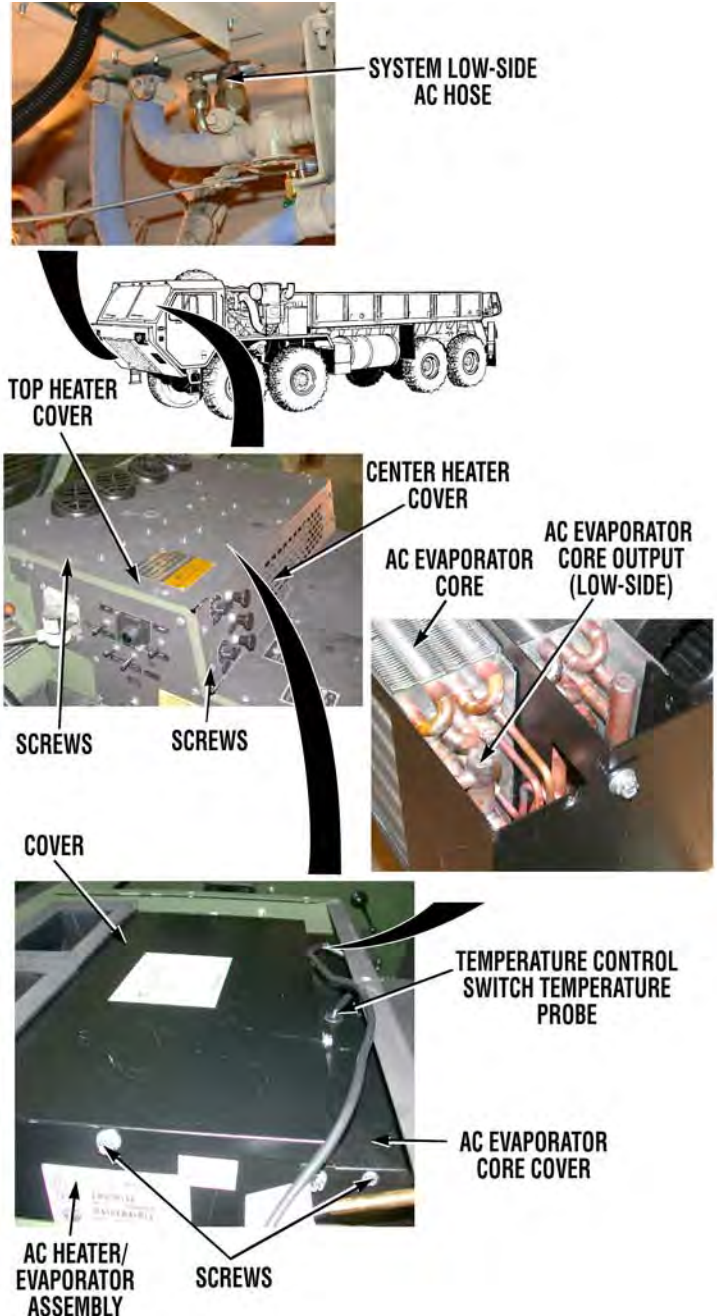

AC DOES NOT COOL OR COOLS INADEQUATELY - Continued

KNOWN INFO
Power to AC system OK. AC heater/evaporator blower OK. AC control circuits OK (except for temperature control and low pressure switches). No moisture in AC refrigerant system. AC low pressure switch OK. No AC condenser dryer desiccant contaminant in AC refrigerant system. No AC refrigerant oil contaminant in AC refrigerant system. AC system charge is not low. No AC system leaks. Temperature control switch OK. No air or other contaminant in AC refrigerant system. AC condenser dryer OK. AC evaporator core OK. AC condenser core OK. AC system not overcharged.
POSSIBLE PROBLEMS
Restricted AC hose. AC compressor faulty. AC expansion valve faulty.

14.

WARNING
Read WARNING on page 0015-23.

Is AC hose from low-side AC service valve to AC compressor free from frost and cool spots?

TEST OPTIONS
Visual inspection.
REASON FOR QUESTION
If frost or cool spots are forming on AC hose, AC hose is restricting R-134a refrigerant flow.

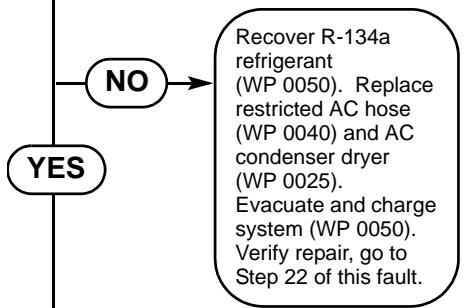

KNOWN INFO
Power to AC system OK. AC heater/evaporator blower OK. AC control circuits OK (except for temperature control and low pressure switches). No moisture in AC refrigerant system. AC low pressure switch OK. No AC condenser dryer desiccant contaminant in AC refrigerant system. No AC refrigerant oil contaminant in AC refrigerant system. AC system charge is not low. No AC system leaks. AC condenser core OK. AC expansion valve OK. AC system not overcharged. AC condenser dryer OK. AC evaporator core OK. No restricted AC hoses. AC compressor OK. Temperature control switch OK.
POSSIBLE PROBLEMS
Air or other contaminant in AC refrigerant system.

15.

WARNING
Read WARNING on page 0015-23.

Does system high-side pressure vary with engine RPM?

TEST OPTIONS
Pressure test. AC test set manifold gage.
REASON FOR QUESTION
If system high pressure varies with engine RPM, AC expansion valve is faulty. If not, AC compressor is faulty.

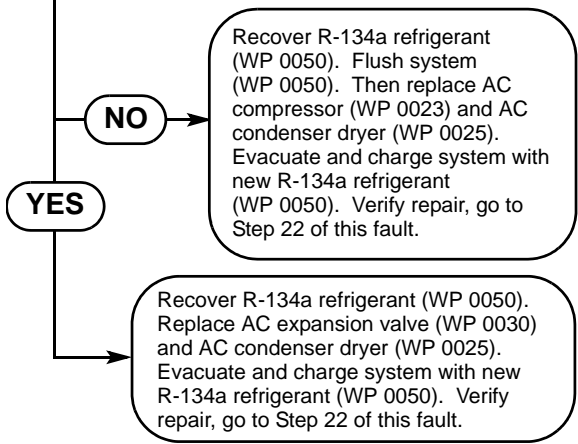

AC DOES NOT COOL OR COOLS INADEQUATELY - Continued

WARNING

- **Moving engine components can cause severe injury. Keep away from fan, belts, and pulleys while engine is running.**
- **Wear protective goggles and nonleather gloves when servicing air conditioner system. Failure to comply may result in injury to personnel.**

VISUAL INSPECTION

- (1) Shut off engine (TM 9-2320-279-10).
- (2) Inspect AC hose from system low-side AC service valve to AC compressor for frost and cool spots.
 - (a) If hoses are not free from frost and cool spots:
 1. Recover R-134a refrigerant (WP 0050).
 2. Replace restricted AC hose (WP 0040).
 3. Replace AC condenser dryer (WP 0025).
 4. Evacuate and charge system (WP 0050).
 5. Verify repair, go to Step 22 of this fault.
 - (b) If hoses are free from frost and cool spots, go to Step 15 of this fault.

PRESSURE TEST

NOTE: System high-side pressure should vary as engine RPM varies.

- (1) While assistant varies engine RPM with accelerator pedal (TM 9-2320-279-10), monitor AC test set recovery/recycling manifold high-side pressure gage. Note whether system high-side pressure varies with engine RPM.

- (2) Shut off engine (TM 9-2320-279-10).

- (3) Recover R-134a refrigerant (WP 0050).

CAUTION: Do not flush AC condenser dryer, AC compressor, or AC expansion valve. After flushing system, add required refrigerant oil or damage to equipment may result.

- (4) If system high-side pressure did not vary with engine RPM in Step (1) above:
 1. Purge and flush system (WP 0050).
 2. Replace AC compressor (WP 0023).
 3. Replace AC condenser dryer (WP 0025).
 4. Evacuate and charge system with new R-134a refrigerant (WP 0050).
 5. Verify repair, go to Step 22 of this fault.
- (5) If system high-side pressure varied with engine RPM in Step (1) above:
 1. Replace AC expansion valve (WP 0030).
 2. Replace AC condenser dryer (WP 0025).
 3. Evacuate and charge system with new R-134a refrigerant (WP 0050).
 4. Verify repair, go to Step 22 of this fault.

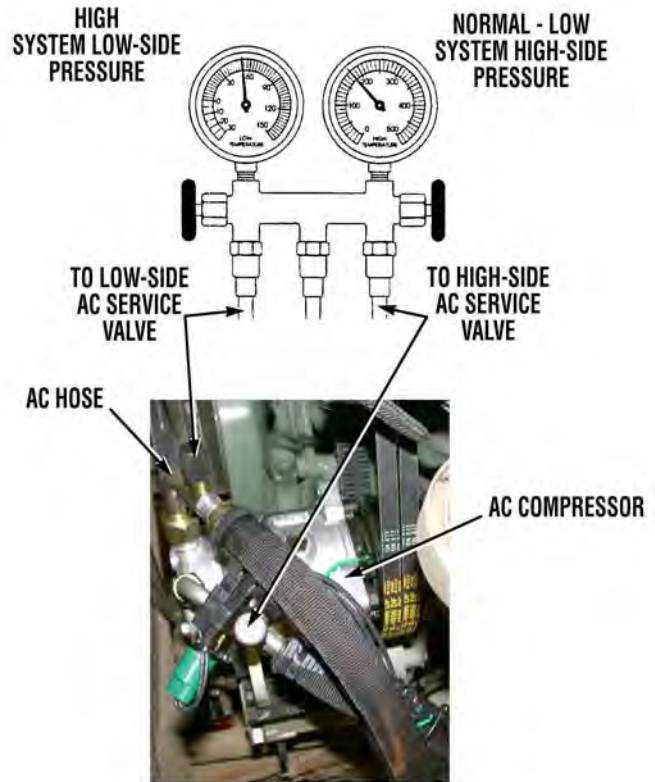

AC DOES NOT COOL OR COOLS INADEQUATELY - Continued

KNOWN INFO
Power to AC system OK. AC heater/evaporator blower OK. AC control circuits OK (except for temperature control and low pressure switches). No moisture in AC refrigerant system. AC low pressure switch OK. No AC condenser dryer desiccant contaminant in AC refrigerant system. No AC refrigerant oil contaminant in AC refrigerant system. AC system charge is not low. No AC system leaks. Temperature control switch OK. No air or other contaminant in AC refrigerant system. AC compressor OK. AC condenser core OK. AC system not overcharged.
POSSIBLE PROBLEMS
Restricted AC hose. AC expansion valve faulty. AC condenser dryer faulty. AC evaporator core faulty.

16. **WARNING**
Read WARNING on page 0015-25.

Does AC test set recovery/recycling manifold gages indicate high system high-side pressure?

NO → Go to Step 19 of this fault.

YES

TEST OPTIONS
Pressure test. AC test set manifold gage.
REASON FOR QUESTION
To isolate system fault.

KNOWN INFO
Power to AC system OK. AC heater/evaporator blower OK. AC control circuits OK (except for temperature control and low pressure switches). No moisture in AC refrigerant system. AC low pressure switch OK. No AC condenser dryer desiccant contaminant in AC refrigerant system. No AC refrigerant oil contaminant in AC refrigerant system. AC system charge is not low. No AC system leaks. Temperature control switch OK. No air or other contaminant in AC refrigerant system. AC compressor OK. AC condenser core OK. AC system not overcharged. AC evaporator core OK.
POSSIBLE PROBLEMS
Restricted AC hose. AC expansion valve faulty. AC condenser dryer faulty.

17. **WARNING**
Read WARNING on page 0015-25.

Are AC hoses from AC compressor output to AC expansion valve free from frost and cool spots?

NO → Recover R-134a refrigerant (WP 0050). Replace restricted AC hose (WP 0040) and AC condenser dryer (WP 0025). Evacuate and charge system (WP 0050). Verify repair, go to Step 22 of this fault.

YES

TEST OPTIONS
Visual inspection.
REASON FOR QUESTION
If frost or cool spots are forming on AC hoses, AC hoses are restricting R-134a refrigerant flow.

AC DOES NOT COOL OR COOLS INADEQUATELY - Continued

WARNING

- Moving engine components can cause severe injury. Keep away from fan, belts, and pulleys while engine is running.
- Remove rings, bracelets, wristwatches, neck chains, and any other jewelry before working around vehicle. Jewelry can catch on equipment and cause serious injury. Jewelry or tools may short across electrical circuits or terminals and cause damage to equipment or severe burns or electrical shock to personnel.
- Wear protective goggles and nonleather gloves when servicing air conditioner system. Failure to comply may result in injury to personnel.

PRESSURE TEST
(1) Inspect AC test set recovery/recycling manifold high-side gage reading. (a) If gage reading is not indicating a high system high-side pressure for the ambient temperature indicated in the chart shown on page 0015-11, go to Step 19 of this fault. (b) If gage reading is indicating a high system high-side pressure for the ambient temperature indicated in the chart shown on page 0015-11, go to Step 17 of this fault.

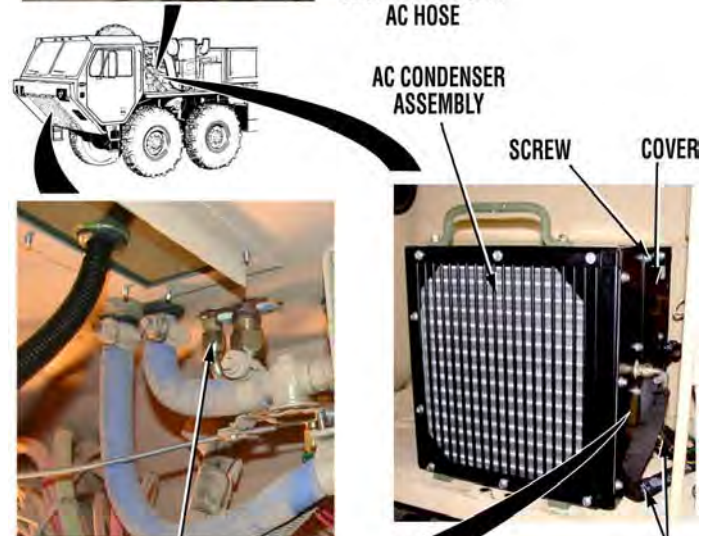
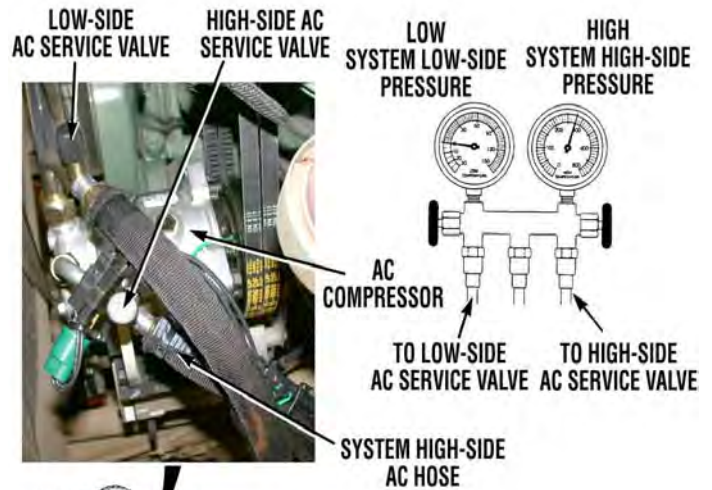

VISUAL INSPECTION
(1) Remove four screws, lockwashers, washers, and cover from AC condenser assembly (WP 0027). (2) Inspect system high-side AC hoses from AC compressor output to AC heater/evaporator assembly for frost and cool spots. (a) If hoses are not free from frost and cool spots: 1. Shut off engine (TM 9-2320-279-10). 2. Recover R-134a refrigerant (WP 0050). 3. Replace restricted AC hose (WP 0040). 4. Replace AC condenser dryer (WP 0025). 5. Evacuate and charge system (WP 0050). 6. Verify repair, go to Step 22 of this fault. (b) If hoses are free from frost and cool spots, go to Step 18 of this fault.

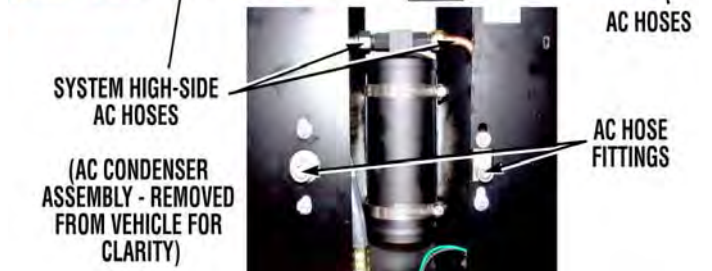

AC DOES NOT COOL OR COOLS INADEQUATELY - Continued

KNOWN INFO
Power to AC system OK. AC heater/evaporator blower OK. AC control circuits OK (except for temperature control and low pressure switches). No moisture in AC refrigerant system. AC low pressure switch OK. No AC condenser dryer desiccant contaminant in AC refrigerant system. No AC refrigerant oil contaminant in AC refrigerant system. AC system charge is not low. No AC system leaks. Temperature control switch OK. No air or other contaminant in AC refrigerant system. AC compressor OK. AC condenser core OK. AC system not overcharged. AC evaporator core OK. No restricted AC hoses.
POSSIBLE PROBLEMS
AC expansion valve faulty. AC condenser dryer faulty.

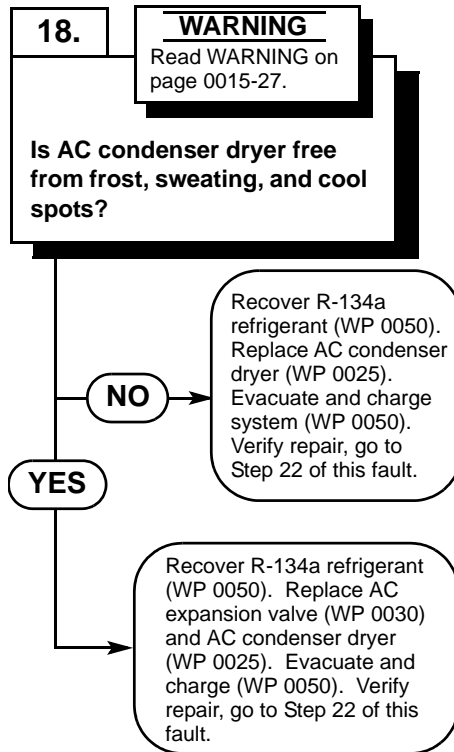

TEST OPTIONS
Visual inspection.
REASON FOR QUESTION
If AC condenser dryer is free from frost and cool spots, AC expansion valve is faulty. If not, AC condenser dryer is faulty.

KNOWN INFO
Power to AC system OK. AC heater/evaporator blower OK. AC control circuits OK (except for temperature control and low pressure switches). No moisture in AC refrigerant system. AC low pressure switch OK. No AC condenser dryer desiccant contaminant in AC refrigerant system. No AC refrigerant oil contaminant in AC refrigerant system. AC system charge is not low. No AC system leaks. Temperature control switch OK. No air or other contaminant in AC refrigerant system. AC compressor OK. AC condenser core OK. AC system not overcharged. AC evaporator core OK.
POSSIBLE PROBLEMS
Restricted AC hose. AC expansion valve faulty. AC condenser dryer faulty.

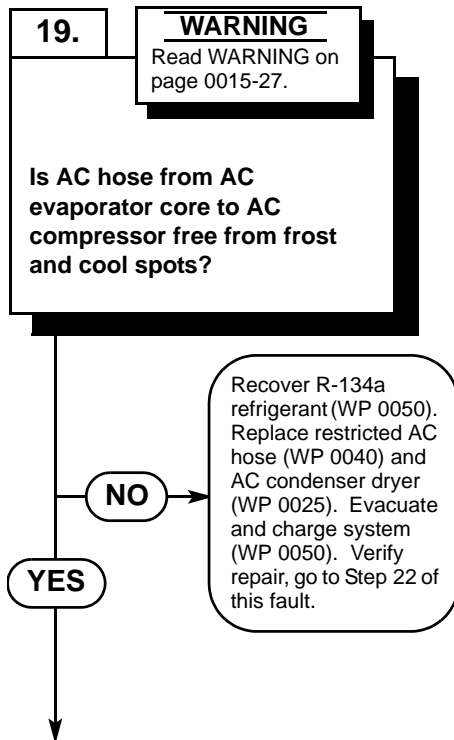

TEST OPTIONS
Visual inspection.
REASON FOR QUESTION
If frost or cool spots are forming on AC hose, AC hose is restricting R-134a refrigerant flow.

AC DOES NOT COOL OR COOLS INADEQUATELY - Continued

WARNING

- Moving engine components can cause severe injury. Keep away from fan, belts, and pulleys while engine is running.
- Remove rings, bracelets, wristwatches, neck chains, and any other jewelry before working around vehicle. Jewelry can catch on equipment and cause serious injury. Jewelry or tools may short across electrical circuits or terminals and cause damage to equipment or severe burns or electrical shock to personnel.
- Wear protective goggles and nonleather gloves when servicing air conditioner system. Failure to comply may result in injury to personnel.

VISUAL INSPECTION

- (1) Inspect AC condenser dryer. Note if frost or cool spots are forming on AC condenser dryer.
- (2) Shut off engine (TM 9-2320-279-10).
- (3) Recover R-134a refrigerant (WP 0050).
- (4) If AC condenser dryer was free from frost and cool spots in Step (1) above, replace AC expansion valve (WP 0030).
- (5) Replace AC condenser dryer (WP 0025).
- (6) Evacuate and charge system (WP 0050).
- (7) Verify repair, go to Step 22 of this fault.

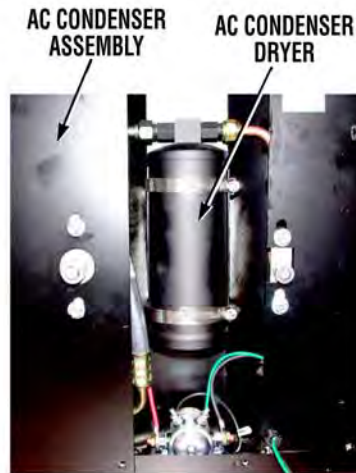

(AC CONDENSER ASSEMBLY - REMOVED FROM VEHICLE FOR CLARITY)



SYSTEM LOW-SIDE AC HOSE
(AC EVAPORATOR CORE OUTPUT)

SYSTEM LOW-SIDE AC HOSE

VISUAL INSPECTION

- (1) Inspect system low-side AC hose from AC evaporator core to AC compressor for frost and cool spots.
 - (a) If hose is not free from frost and cool spots:
 1. Shut off engine (TM 9-2320-279-10).
 2. Recover R-134a refrigerant (WP 0050).
 3. Replace restricted AC hose (WP 0040).
 4. Replace AC condenser dryer (WP 0025).
 5. Evacuate and charge system (WP 0050).
 6. Verify repair, go to Step 20 of this fault.
 - (b) If hose is free from frost and cool spots, go to Step 20 of this fault.



AC DOES NOT COOL OR COOLS INADEQUATELY - Continued

KNOWN INFO
Power to AC system OK. AC heater/evaporator blower OK. AC control circuits OK (except for temperature control and low pressure switches). No moisture in AC refrigerant system. AC low pressure switch OK. No AC condenser dryer desiccant contaminant in AC refrigerant system. No AC refrigerant oil contaminant in AC refrigerant system. AC system charge is not low. No AC system leaks. Temperature control switch OK. No air or other contaminant in AC refrigerant system. AC compressor OK. AC condenser core OK. AC system not overcharged. AC condenser dryer OK. No restricted AC hoses.
POSSIBLE PROBLEMS
AC expansion valve faulty. AC evaporator core faulty.

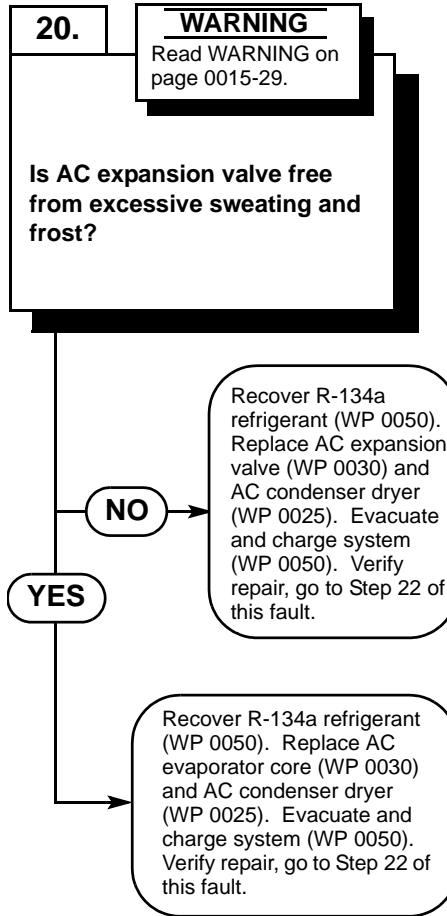

TEST OPTIONS
Visual inspection.
REASON FOR QUESTION
If AC expansion valve is free from excessive sweating and frost, AC evaporator core is faulty. If not, AC expansion valve is faulty.



AC DOES NOT COOL OR COOLS INADEQUATELY - Continued

WARNING

- Remove rings, bracelets, wristwatches, neck chains, and any other jewelry before working around vehicle. Jewelry can catch on equipment and cause serious injury. Jewelry or tools may short across electrical circuits or terminals and cause damage to equipment or severe burns or electrical shock to personnel.
- Wear protective goggles and nonleather gloves when servicing air conditioner system. Failure to comply may result in injury to personnel.

PRESSURE TEST

- (1) Shut off engine (TM 9-2320-279-10).
- (2) Remove eight screws and top heater cover (WP 0037).
- (3) Remove four screws, lockwashers, washers, and cover from AC heater/evaporator assembly (WP 0030).

CAUTION: Slide temperature probe slowly from heater/evaporator. Failure to comply may result in damage to equipment.
- (4) Remove temperature control switch temperature probe from evaporator core (WP 0044).
- (5) Remove four screws and center heater cover (WP 0037).
- (6) Remove four screws and evaporator core cover from AC heater/evaporator assembly (WP 0030).
- (7) Inspect AC expansion valve for excessive sweating and frost.
 - (a) If AC expansion valve is not free from excessive sweating and frost:
 1. Recover R-134a refrigerant (WP 0050).
 2. Replace AC expansion valve (WP 0030).
 - (b) If AC expansion valve is free from excessive sweating and frost:
 1. Recover R-134a refrigerant (WP 0050).
 2. Replace AC evaporator core (WP 0030).
- (8) If removed, install evaporator core cover and four screws on AC heater/evaporator assembly.
- (9) If removed, install center heater cover and four screws.
- (10) If removed, install cover and four washers, lockwashers, and screws on AC heater/evaporator assembly.

CAUTION: Do not puncture temperature probe. Failure to comply will cause gas in tube to leak out.

NOTE: Slide temperature probe in AC heater/evaporator slowly. Temperature probe must slide into AC evaporator core until it touches the bottom of insertion hole.
- (11) Install temperature control switch temperature probe in AC evaporator core.
- (12) Replace AC condenser dryer (WP 0025).
- (13) Evacuate and charge system (WP 0050).
- (14) Verify repair, go to Step 22 of this fault.

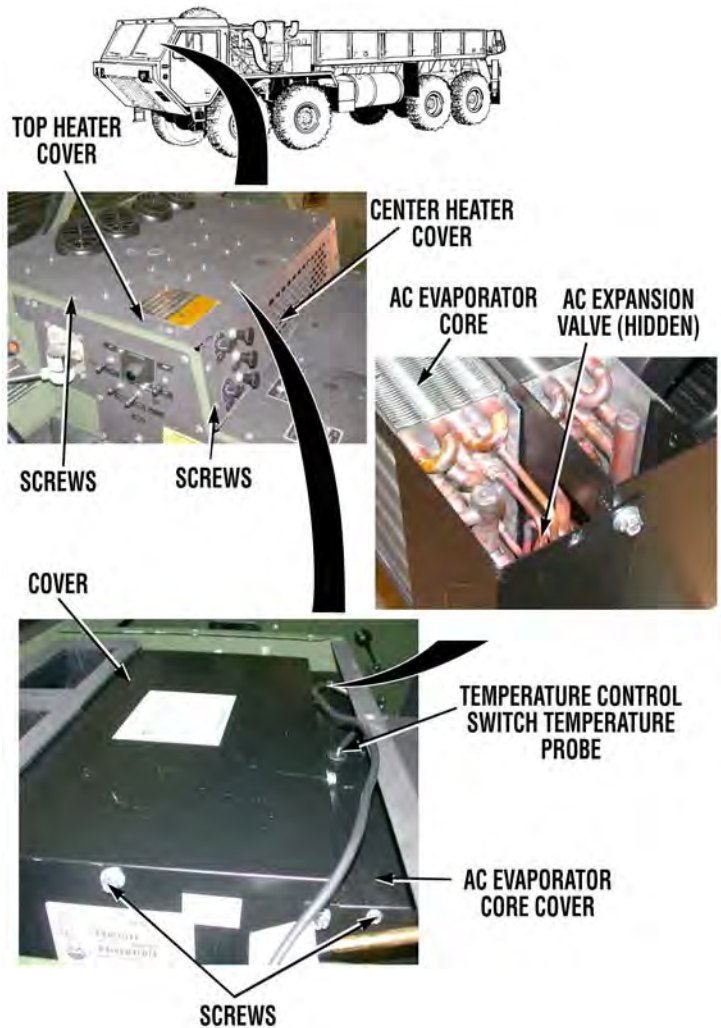

AC DOES NOT COOL OR COOLS INADEQUATELY - Continued

KNOWN INFO
Power to AC system OK. AC heater/evaporator blower OK. AC control circuits OK (except for temperature control and low pressure switches). No moisture in AC refrigerant system. AC low pressure switch OK. No AC condenser dryer desiccant contaminant in AC refrigerant system. No AC refrigerant oil contaminant in AC refrigerant system. No restricted AC hoses. AC compressor OK. Temperature control switch OK. No air or other contaminant in AC refrigerant system. AC condenser core OK. AC expansion valve OK. AC system not overcharged. AC condenser dryer OK. AC evaporator core OK.
POSSIBLE PROBLEMS
AC low pressure switch faulty. AC system charge low. AC system leaking.

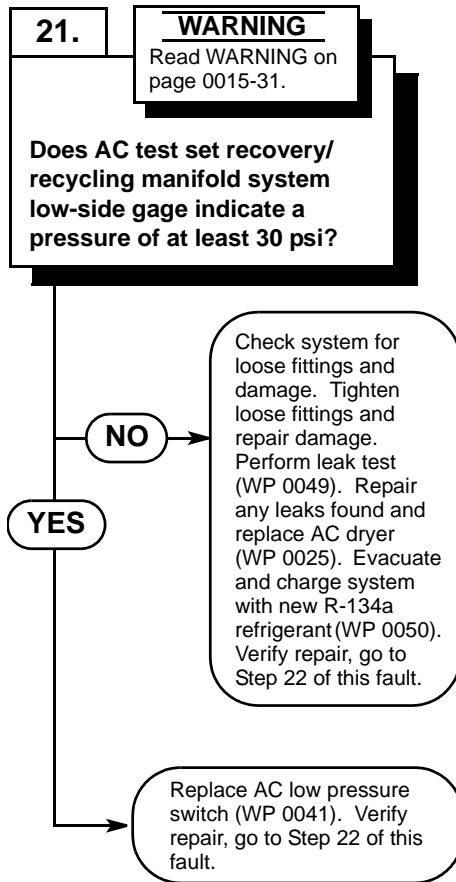

TEST OPTIONS
Pressure test. AC test set manifold gage.
REASON FOR QUESTION
If at least 30 psi pressure is measured, AC low pressure switch is faulty. If not, AC system charge is low.



AC DOES NOT COOL OR COOLS INADEQUATELY - Continued

WARNING

Wear protective goggles and nonleather gloves when servicing air conditioner system. Failure to comply may result in injury to personnel.

PRESSURE TEST

- (1) Connect AC test set recovery/recycling manifold gages to AC service valves (WP 0050). Ensure test set valves are closed.
- (2) Inspect AC test set recovery/recycling manifold low-side gage reading.
 - (a) If gage reading does not indicate at least 30 psi pressure:
 1. Inspect system for damage. Repair any damage found.
 2. Inspect system for loose fittings. Tighten fittings as required.
 3. Perform leak test (WP 0049). Add R-134a refrigerant if required to perform test (WP 0050).
 4. Recover R-134a refrigerant (WP 0050).
 5. Repair leaks found.
 6. Replace AC condenser dryer (WP 0025).
 7. Evacuate and charge system with new R-134a refrigerant (WP 0050).
 8. Verify repair, go to Step 22 of this fault.
 - (b) If gage reading indicates at least 30 psi pressure, replace low pressure switch (WP 0041). Verify repair, go to Step 22 of this fault.

SYSTEM LOW-SIDE PRESSURE **SYSTEM HIGH-SIDE PRESSURE**

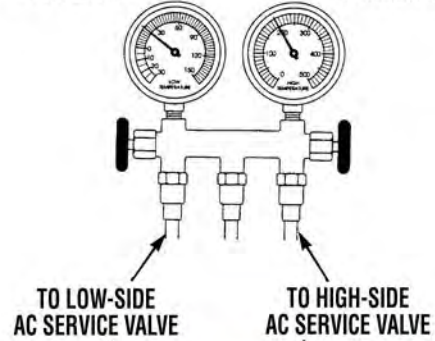

AC DOES NOT COOL OR COOLS INADEQUATELY - Continued

KNOWN INFO
Power to AC system OK. AC heater/evaporator blower OK. AC control circuits OK (except for temperature control and low pressure switches). No moisture in AC refrigerant system. No AC condenser dryer desiccant contaminant in AC refrigerant system. No AC refrigerant oil contaminant in AC refrigerant system. No restricted AC hoses. AC compressor OK. Temperature control switch OK. No air or other contaminant in AC refrigerant system. AC condenser core OK. AC expansion valve OK. AC system not overcharged. AC condenser dryer OK. AC evaporator core OK. AC low pressure switch OK. AC system charge is not low. No AC system leaks.
POSSIBLE PROBLEMS
None

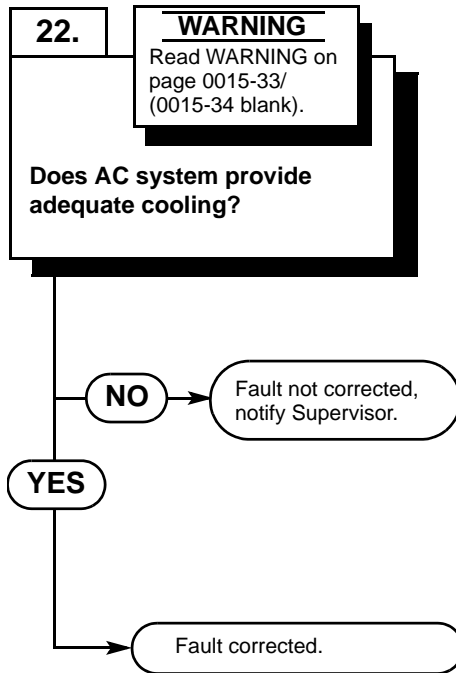

TEST OPTIONS
Verify Repair.
REASON FOR QUESTION
If AC system provides adequate cooling, fault has been corrected.



AC DOES NOT COOL OR COOLS INADEQUATELY - Continued

WARNING

Remove rings, bracelets, wristwatches, neck chains, and any other jewelry before working around vehicle. Jewelry can catch on equipment and cause serious injury. Jewelry or tools may short across electrical circuits or terminals and cause damage to equipment or severe burns or electrical shock to personnel.

VERIFY REPAIR

- (1) If running, shut off engine (TM 9-2320-279-10).
- (2) If removed, install top heater cover and eight screws (WP 0037).
- (3) Install AC condenser dryer sight glass access hole cover (WP 0025).
- (4) If removed, install cover and four washers, lockwashers, and screws on AC condenser assembly (WP 0027).
- (5) Remove AC test set recovery/recycling gages (WP 0050).
- (6) Perform leak test (WP 0049). Concentrate on AC system service valves.
- (7) Repair any leaks found.
- (8) Install driver side engine panel and close engine cover (TM 9-2320-279-10).
- (9) Start engine (TM 9-2320-279-10).
- (10) Operate AC system for 10 minutes at high blower speed (WP 0004).
 - (a) If AC system does not provide adequate cooling, fault has not been corrected. Shut off engine, turn fan control switch and temperature control switch to off position, and notify Supervisor.
 - (b) If AC system provides adequate cooling, fault has been corrected.

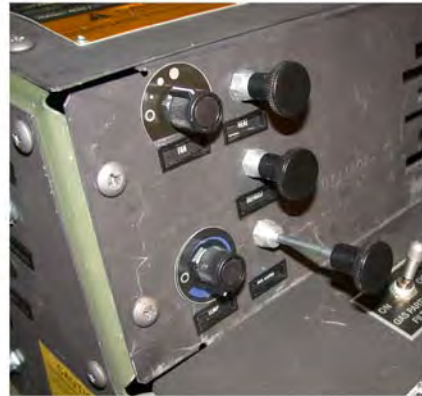

END OF WORK PACKAGE

TB 9-2320-279-13-1

CHAPTER 6

FIELD LEVEL MAINTENANCE

FIELD LEVEL MAINTENANCE INTRODUCTION

This chapter contains instructions for replacement of air conditioning components at the Field Level Maintenance. Some subassemblies and parts must be removed before air conditioning components can be accessed. They are referenced to other paragraphs of this manual or other technical manuals.

FIELD LEVEL MAINTENANCE INDEX

MAINTENANCE PROCEDURE	WP PAGE NO.
AC 20 AMP Circuit Breaker Replacement	0017-1
AC Alternator/Compressor Mounting Bracket Replacement	0018-1
AC Alternator Drive Belts Replacement/Adjustment	0019-1
AC Alternator and Pulley Replacement	0020-1
AC Cable Replacement	0021-1
AC Compressor Drive Belts Replacement/Adjustment	0022-1
AC Compressor Replacement	0023-1
AC Condenser Core Replacement	0024-1
AC Condenser Dryer Replacement	0025-1
AC Condenser Fan Motor Replacement	0026-1
AC Condenser Fan Motor Solenoid Replacement	0027-1
AC Condenser Replacement	0028-1
AC Defrost Cable Replacement	0029-1
AC Evaporator Core And Expansion Valve Replacement	0030-1
AC Fan Control Switch Replacement	0031-1
AC Heater Cable Replacement	0032-1
AC Heater Core Replacement	0033-1
AC Heater/Evaporator Blower Motor Assembly Replacement	0034-1
AC Heater/Evaporator Blower Motor Resistor Replacement	0035-1
AC Heater/Evaporator Blower Motor Resistor Harness Replacement	0036-1
AC Heater/Evaporator Cover And Defrost Louvers Replacement	0037-1
AC Heater/Evaporator Replacement	0038-1
AC High Pressure Switch Replacement	0039-1
AC Hoses Replacement	0040-1
AC Low Pressure Switch Replacement	0041-1
AC Lower Plenum and Damper Replacement	0042-1

FIELD LEVEL MAINTENANCE INTRODUCTION - Continued

MAINTENANCE PROCEDURE	WP PAGE NO.
AC Optic Ribbon Replacement	0043-1
AC Temperature Control Switch Replacement	0044-1
AC Upper Plenum Replacement	0045-1
AC Wiring Harness Replacement	0046-1
AC Wire 1082 Harness Replacement	0047-1
AC Wire 1156 Harness Replacement	0048-1
Air Conditioning Leak Test	0049-1
AC System Refrigerant (R-134a) Maintenance	0050-1

END OF WORK PACKAGE

AC 20 AMP CIRCUIT BREAKER REPLACEMENT

THIS WORK PACKAGE (WP) COVERS:

- Removal
- Installation
- Follow-On Maintenance

INITIAL SETUP:

Maintenance Level

Field Level Maintenance

Materials/Parts

Tags, Identification (Item 9, Appendix E)

Equipment Condition

Batteries disconnected (TM 9-2320-279-20).

Personnel Required

MOS 52C, Utilities equipment repairer

Tools and Special Tools

Tool Kit, General Mechanic's (Item 7, Appendix F)

References

TM 9-2320-279-20

REMOVAL

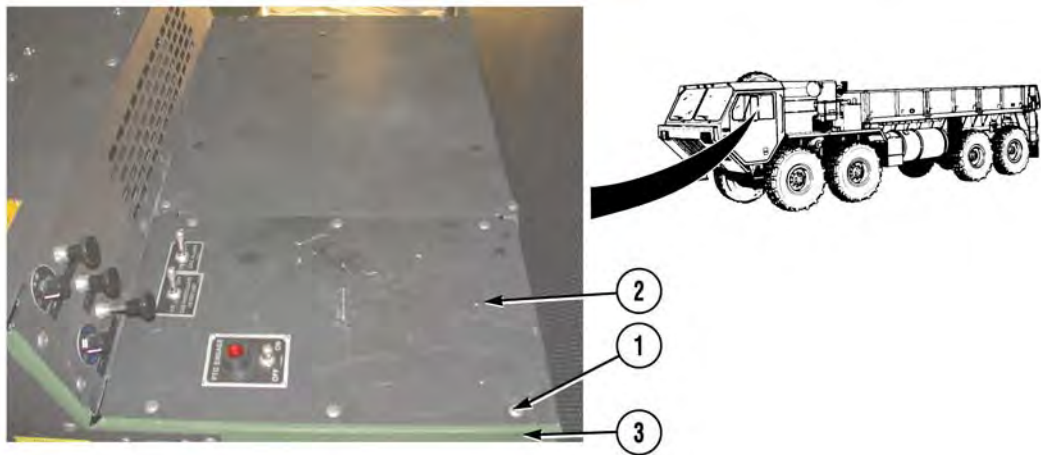

1. Remove six screws (1) and console cover (2) from console (3).

AC 20 AMP CIRCUIT BREAKER REPLACEMENT - Continued



2. Remove locknut (4) from terminal (5).

NOTE

Tag and mark wires prior to removal to ensure proper installation.

3. Remove locknut (6) and wire (7) from terminal (8).
4. Remove bus bar (9) from two terminals (5 and 8).
5. Remove locknut (10), wire (11), and wire (12) from terminal (13).

NOTE

Note position of circuit breaker prior to removal to ensure proper installation.

6. Remove circuit breaker (14).

AC 20 AMP CIRCUIT BREAKER REPLACEMENT - Continued

INSTALLATION



NOTE

Install circuit breaker as noted prior to removal.

1. Install circuit breaker (14).
2. Install wire (12) and wire (11) on terminal (13) with locknut (10).
3. Install bus bar (9) on two terminals (5 and 8).
4. Install wire (7) on terminal (8) with locknut (6).
5. Install locknut (4) on terminal (5).

AC 20 AMP CIRCUIT BREAKER REPLACEMENT - Continued

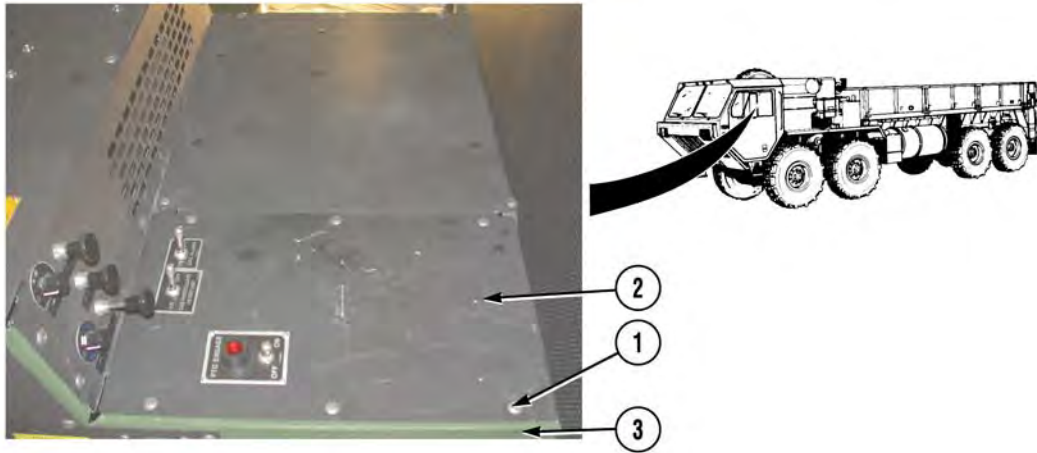

6. Install console cover (2) on console (3) with six screws (1).

FOLLOW-ON MAINTENANCE

1. Connect batteries (TM 9-2320-279-20).

END OF WORK PACKAGE

AC ALTERNATOR/COMPRESSOR MOUNTING BRACKET REPLACEMENT

THIS WORK PACKAGE (WP) COVERS:

- Removal
- Installation
- Follow-On Maintenance

INITIAL SETUP:

Maintenance Level

Field Level Maintenance

Equipment Condition

- AC condenser removed (WP 0028).
- AC compressor removed (WP 0023).
- AC alternator removed (WP 0020).

Tools and Special Tools

Tool Kit, General Mechanic's (Item 7, Appendix F)

Materials/Parts

Sealant, Loctite 242 (Item 5, Appendix E)

Personnel Required

MOS 52C, Utilities equipment repairer

References

TM 9-2320-279-20

AC ALTERNATOR/COMPRESSOR MOUNTING BRACKET REPLACEMENT - Continued

REMOVAL

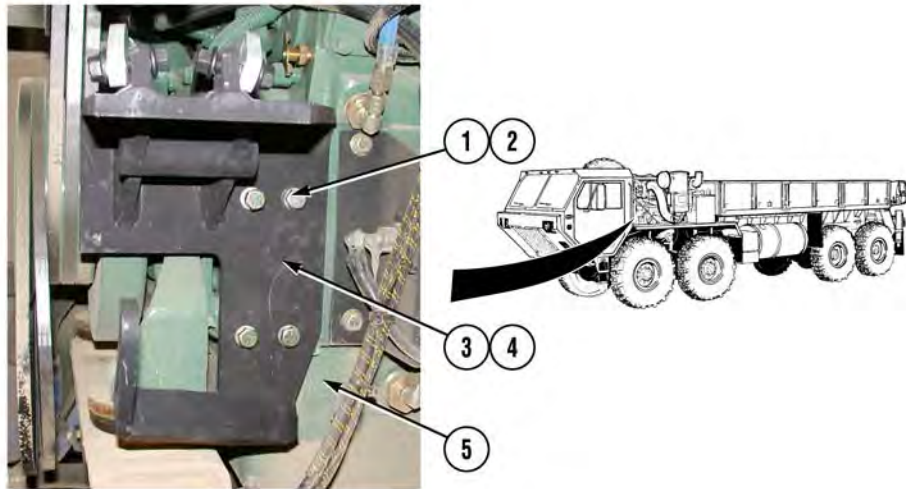

1. Remove four screws (1), lockwashers (2), mounting bracket (3), and pad (4) from engine (5).

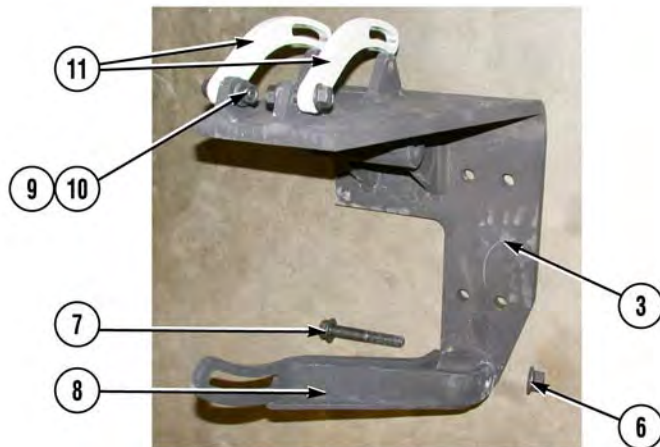

2. Remove locknut (6), screw (7), and strap (8) from mounting bracket (3).
3. Remove two locknuts (9), screws (10), and compressor straps (11) from mounting bracket (3).

AC ALTERNATOR/COMPRESSOR MOUNTING BRACKET REPLACEMENT - Continued

INSTALLATION

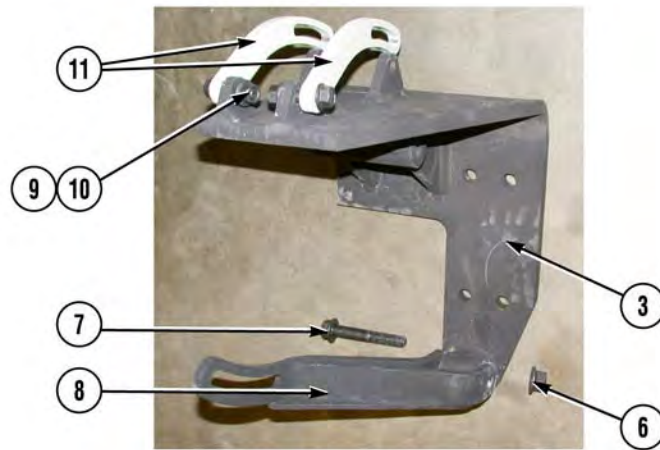

1. Install two compressor straps (11) on mounting bracket (3) with two screws (10) and locknuts (9). Do not tighten locknuts (9).
2. Install strap (8) on mounting bracket (3) with screw (7) and locknut (6). Do not tighten locknut (6).

AC ALTERNATOR/COMPRESSOR MOUNTING BRACKET REPLACEMENT - Continued

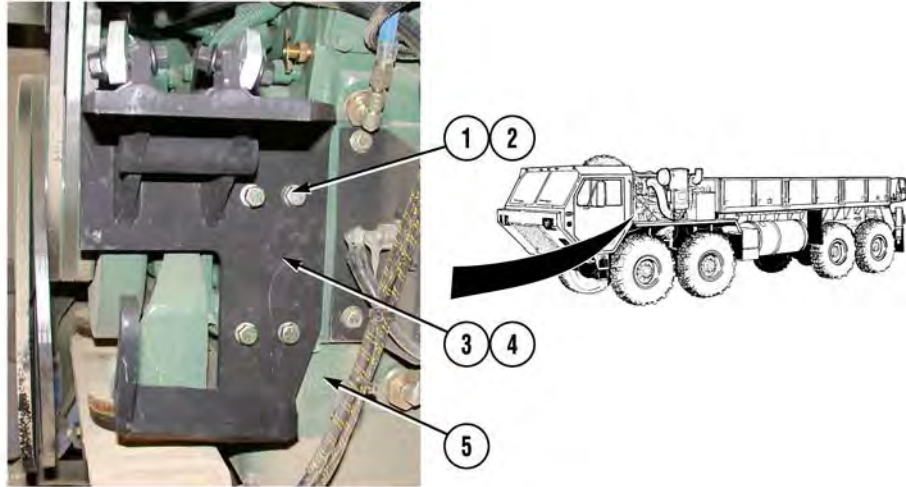

WARNING

Adhesives, solvents, and sealing compounds can burn easily, can give off harmful vapors, and are harmful to skin and clothing. To avoid injury or death, keep away from open fire and use in well-ventilated area. If adhesive, solvent, or sealing compound gets on skin or clothing, wash immediately with soap and water.

3. Apply sealing compound to threads of four screws (1).
4. Install pad (4) and mounting bracket (3) on engine (5) with four lockwashers (2) and screws (1).

FOLLOW-ON MAINTENANCE

1. Install AC alternator (WP 0020).
2. Install AC compressor (WP 0023).
3. Install AC condenser (WP 0028).

END OF WORK PACKAGE

AC ALTERNATOR DRIVE BELTS REPLACEMENT/ADJUSTMENT

THIS WORK PACKAGE (WP) COVERS:

Removal
Installation
Adjustment
Follow-On Maintenance

INITIAL SETUP:**Maintenance Level**

Field Level Maintenance

Materials/Parts

None

Equipment Condition

Shut off engine (TM 9-2320-279-10).
Engine cover open and engine side panel
removed (TM 9-2320-279-10).

Personnel Required

MOS 52C, Utilities equipment repairer (2)

Tools and Special Tools

Tensiometer, Dial In (Item 6, Appendix F)
Tool Kit, General Mechanic's (Item 7, Appendix F)

References

TM 9-2320-279-10
TM 9-2320-279-20

AC ALTERNATOR DRIVE BELTS REPLACEMENT/ADJUSTMENT - Continued

REMOVAL

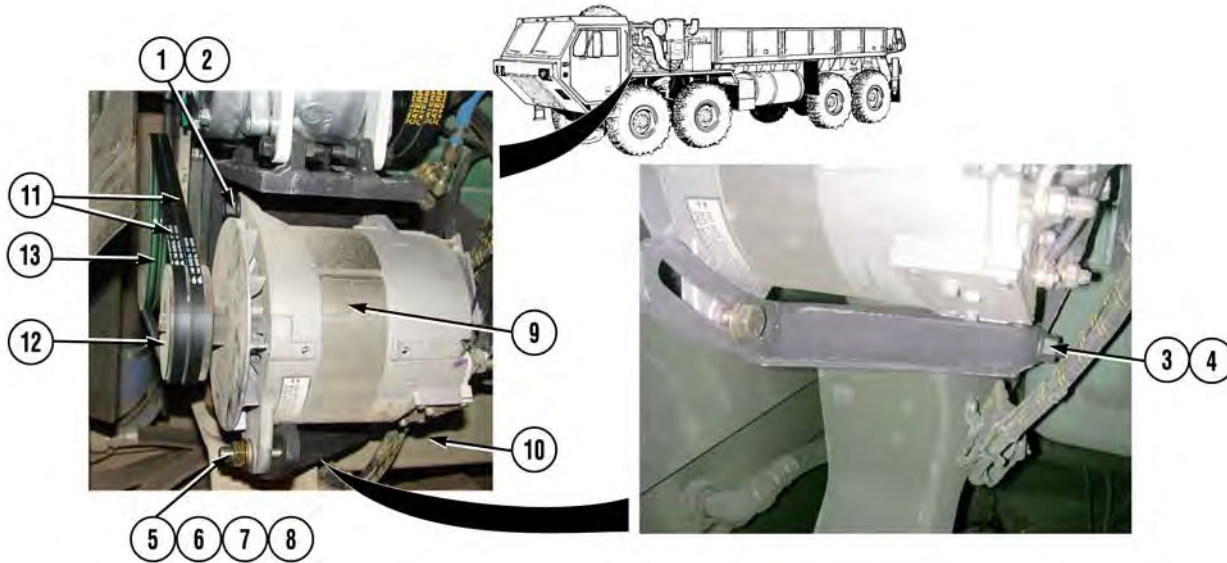

1. Loosen locknut (1) and screw (2).
2. Loosen locknut (3) and screw (4).
3. Loosen locknut (5), lockwasher (6), washer (7), and screw (8).
4. Pivot alternator (9) in toward engine (10) and remove two belts (11) from alternator pulley (12) and engine pulley (13).

INSTALLATION

1. Install two belts (11) on engine pulley (13) and alternator pulley (12).

AC ALTERNATOR DRIVE BELTS REPLACEMENT/ADJUSTMENT - Continued

ADJUSTMENT

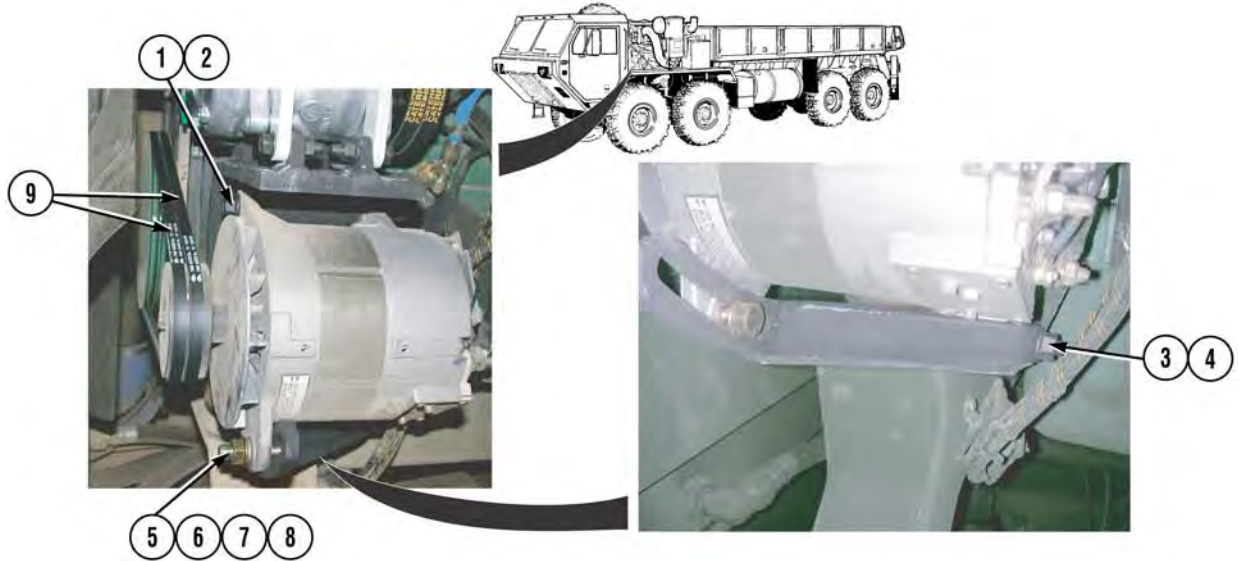

NOTE

Perform Steps 1 through 3 if alternator belts were not removed.

1. Loosen locknut (1) and screw (2).
2. Loosen locknut (3) and screw (4).
3. Loosen locknut (5), lockwasher (6), washer (7), and screw (8).
4. Using a belt tension gage, Soldier A tightens two belts (9) to 70-90 lbs. (310-400 N).
5. Soldier B tightens screw (8), washer (7), lockwasher (6), and locknut (5).
6. Soldier B tightens screw (4) and locknut (3).
7. Soldier B tightens screw (2) and locknut (1).

FOLLOW-ON MAINTENANCE

1. Install engine side panel and close engine cover (TM 9-2320-279-10).

END OF WORK PACKAGE

AC ALTERNATOR AND PULLEY REPLACEMENT

THIS WORK PACKAGE (WP) COVERS:

- Removal
- Installation
- Follow-On Maintenance

INITIAL SETUP:

Maintenance Level

Field Level Maintenance

Equipment Condition

Batteries disconnected (TM 9-2320-279-20).
 Left splash guard removed (TM 9-2320-279-20).
 AC alternator drive belts removed (WP 0019).

Tools and Special Tools

Shop Equipment, Common No. 1 (Item 4, Appendix F)
 Shop Equipment, Common No. 2 (Item 5, Appendix F)
 Tool Kit, General Mechanic's (Item 7, Appendix F)

Materials/Parts

Sealant, RTV200 Electrical (Item 6, Appendix E)
 Tags, Identification (Item 9, Appendix E)

Personnel Required

MOS 52C, Utilities equipment repairer (2)

References

TM 9-2320-279-20

REMOVAL

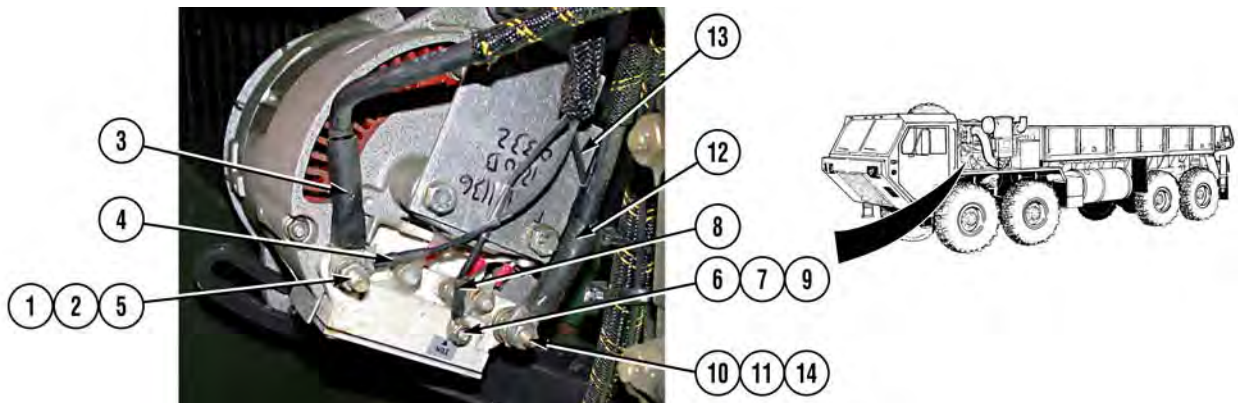

NOTE

Tag and mark wires prior to removal to ensure proper installation.

1. Remove nut (1), lockwasher (2), and two wires (3 and 4) from terminal (5).
2. Remove nut (6), lockwasher (7), and wire (8) from terminal (9).
3. Remove nut (10), lockwasher (11), and two wires (12 and 13) from terminal (14).

AC ALTERNATOR AND PULLEY REPLACEMENT - Continued

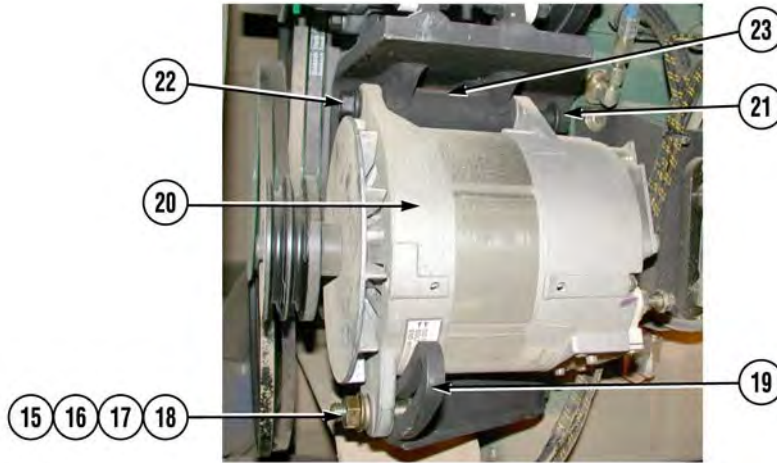

NOTE

Note position of washers prior to removal to ensure proper installation.

4. Remove locknut (15), lockwasher (16), washer (17), screw (18), and strap (19) from alternator (20).

WARNING

Alternator is heavy. Do not remove alternator from mounting bracket without the aid of an assistant. Failure to comply may result in serious injury to personnel and/or damage to equipment.

5. Soldier A supports alternator (20) while Soldier B removes locknut (21), screw (22), and alternator (20) from mounting bracket (23).

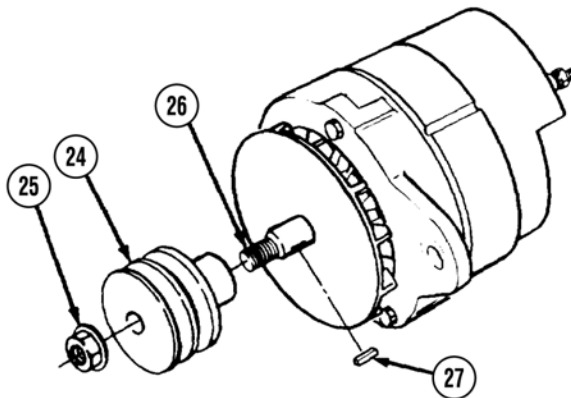

6. Clamp pulley (24) in vise with soft jaws.
7. Remove locknut (25) from shaft (26).
8. Remove pulley (24) from vise and remove pulley (24) and key (27) from shaft (26).

AC ALTERNATOR AND PULLEY REPLACEMENT - Continued

INSTALLATION

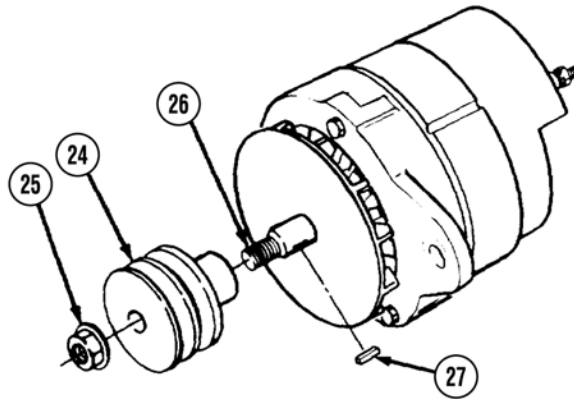

1. Install key (27) and pulley (24) on shaft (26).
2. Clamp pulley (24) in vise with soft jaws.
3. Install locknut (25) on shaft (26) and tighten locknut (25) to 70-80 ft-lbs. (95-108 N•m).

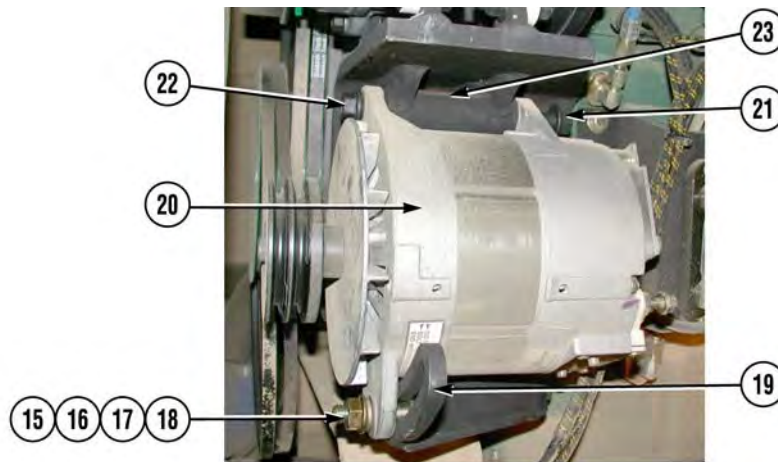

WARNING

Alternator is heavy. Do not install alternator on mounting bracket without the aid of an assistant. Failure to comply may result in serious injury to personnel and/or damage to equipment.

4. Soldier A supports alternator (20) while Soldier B installs alternator (20) on mounting bracket (23) with screw (22) and locknut (21). Do not tighten locknut (21).

NOTE

Install washers as noted prior to removal.

5. Install alternator (20) on strap (19) with screw (18), washer (17), lockwasher (16), and locknut (15). Do not tighten locknut (15).

AC ALTERNATOR AND PULLEY REPLACEMENT - Continued

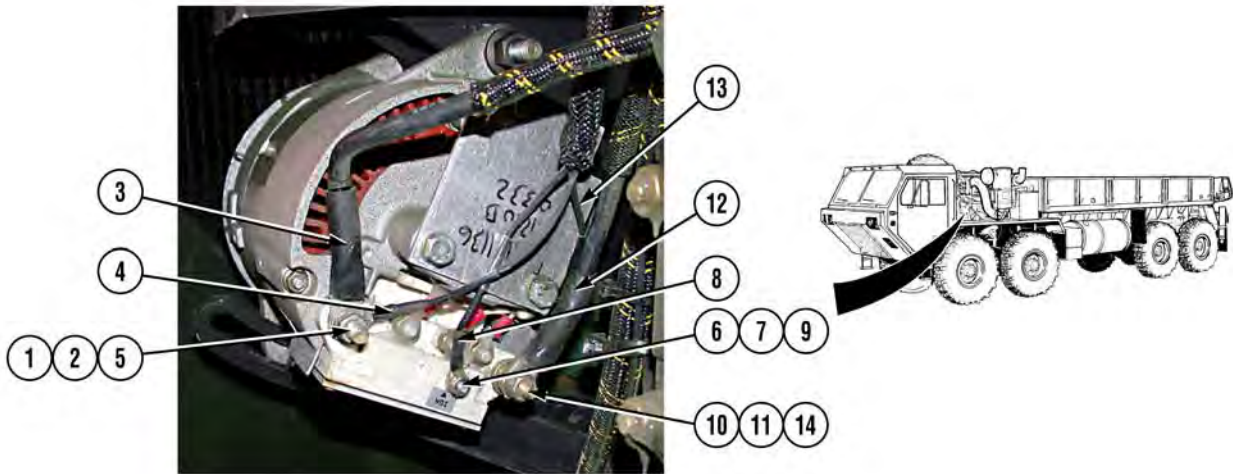

6. Install two wires (12 and 13) on terminal (14) with lockwasher (11) and nut (10).
7. Install wire (8) on terminal (9) with lockwasher (7) and nut (6).
8. Install two wires (3 and 4) on terminal (5) with lockwasher (2) and nut (1).

WARNING

Adhesives, solvents, and sealing compounds can burn easily, can give off harmful vapors, and are harmful to skin and clothing. To avoid injury or death, keep away from open fire and use in well-ventilated area. If adhesive, solvent, or sealing compound gets on skin or clothing, wash immediately with soap and water.

9. Apply electrical sealant to wires and mounting hardware on three terminals (5, 9, and 14).

FOLLOW-ON MAINTENANCE

1. Install AC alternator drive belts (WP 0019).
2. Install left splash guard (TM 9-2320-279-20).
3. Connect batteries (TM 9-2320-279-20).

END OF WORK PACKAGE

AC CABLE REPLACEMENT

THIS WORK PACKAGE (WP) COVERS:

Removal
 Installation
 Follow-On Maintenance

INITIAL SETUP:

Maintenance Level

Field Level Maintenance

Materials/Parts

None

Equipment Condition

AC heater/evaporator cover removed (WP 0037).

Personnel Required

MOS 52C, Utilities equipment repairer

Tools and Special Tools

Tool Kit, General Mechanic's (Item 7, Appendix F)

References

TM 9-2320-279-20

REMOVAL

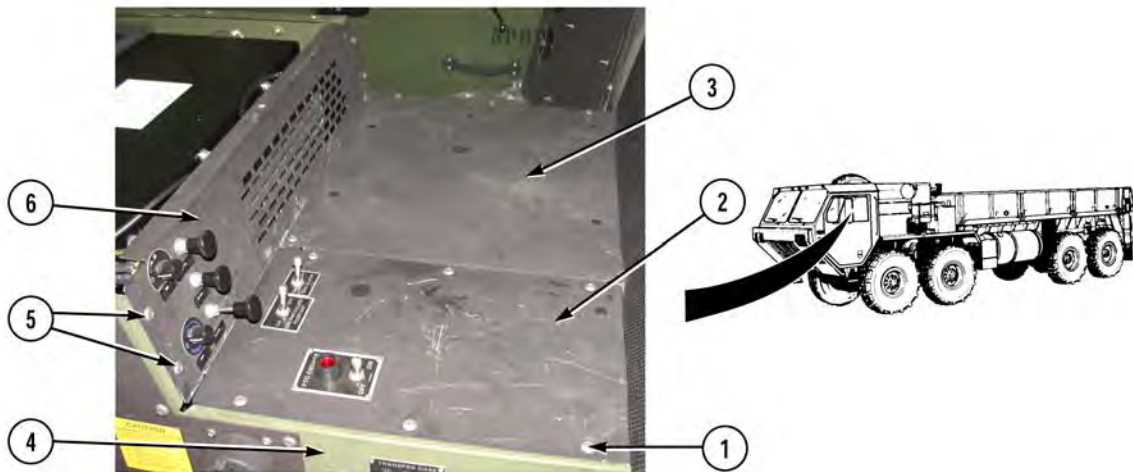

1. Remove 11 screws (1) and two console covers (2 and 3) from console (4).
2. Remove four screws (5) and center cover (6) from console (4).

AC CABLE REPLACEMENT - Continued

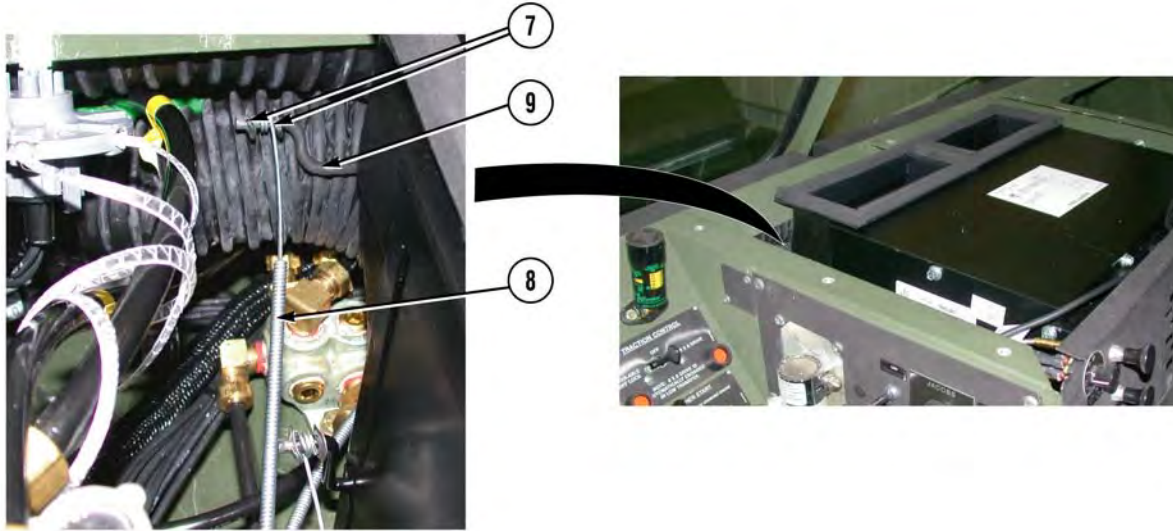

3. Remove two speed nuts (7) and AC cable (8) from damper control arm (9).

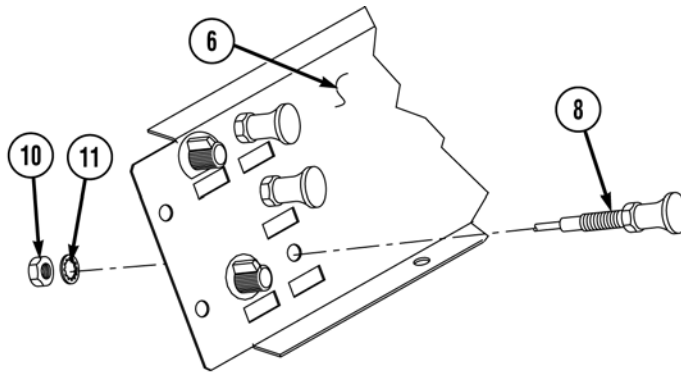

4. Remove nut (10), lockwasher (11), and AC cable (8) from center cover (6).

AC CABLE REPLACEMENT - Continued

INSTALLATION

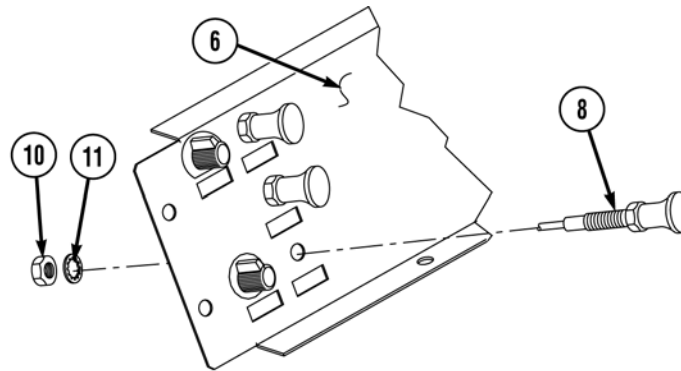

1. Install AC cable (8) on center cover (6) with lockwasher (11) and nut (10).

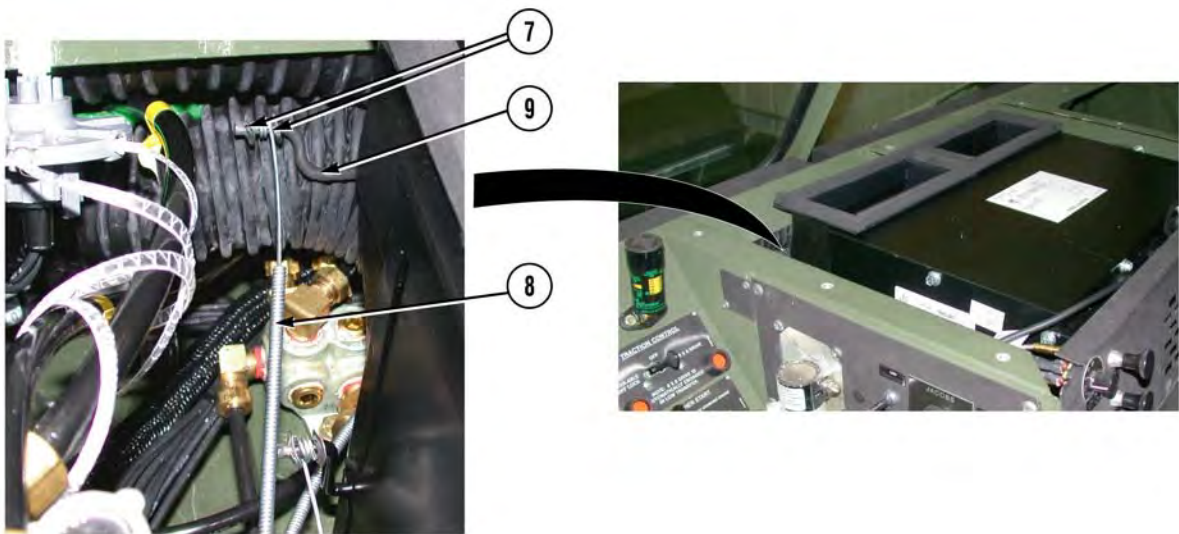

2. Install AC cable (8) on damper control arm (9) with two speed nuts (7).

AC CABLE REPLACEMENT - Continued

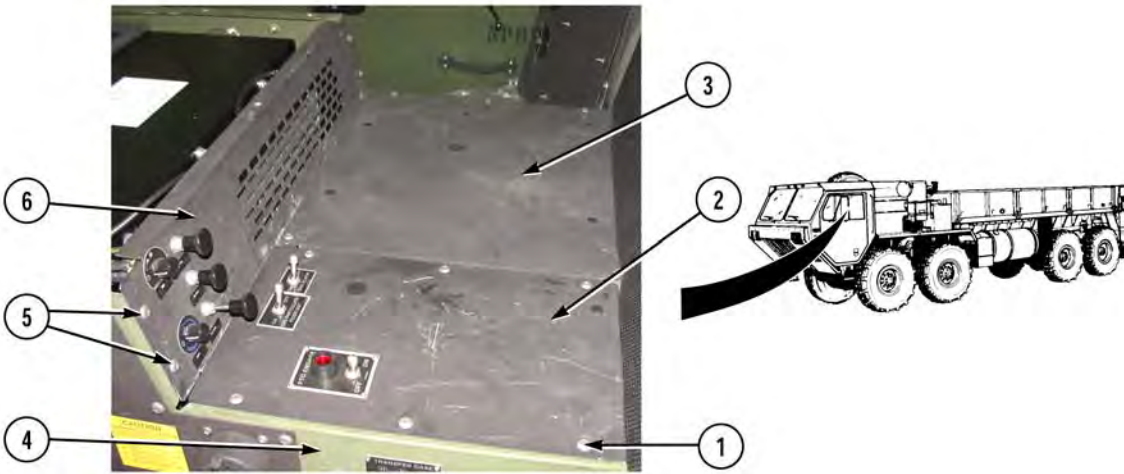

3. Install center cover (6) on console (4) with four screws (5).
4. Install two console covers (2 and 3) on console (4) with 11 screws (1).

FOLLOW-ON MAINTENANCE

1. Install AC heater/evaporator cover (WP 0037).

END OF WORK PACKAGE

AC COMPRESSOR DRIVE BELTS REPLACEMENT/ADJUSTMENT

THIS WORK PACKAGE (WP) COVERS:

Removal
Installation
Adjustment
Follow-On Maintenance

INITIAL SETUP:**Maintenance Level**

Field Level Maintenance

Materials/Parts

None

Equipment Condition

Shut off engine (TM 9-2320-279-10).
Engine cover open and engine side panel
removed (TM 9-2320-279-10).

Personnel Required

MOS 52C, Utilities equipment repairer (2)

Tools and Special Tools

Tensiometer, Dial In (Item 6, Appendix F)
Tool Kit, General Mechanic's (Item 7, Appendix F)

References

TM 9-2320-279-10
TM 9-2320-279-20

AC COMPRESSOR DRIVE BELTS REPLACEMENT/ADJUSTMENT - Continued

REMOVAL

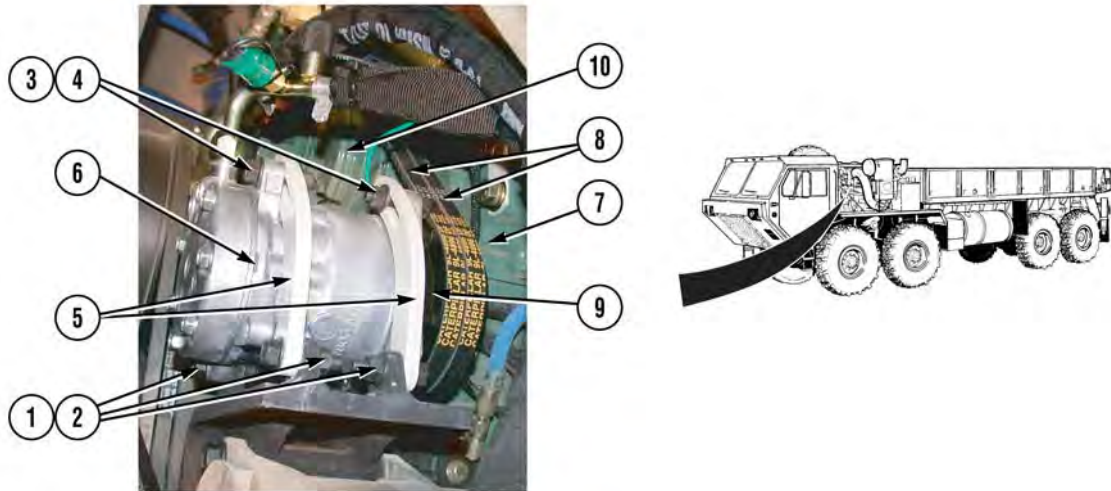

1. Loosen four locknuts (1) and screws (2).
2. Remove two locknuts (3), screws (4), and compressor straps (5) from compressor (6).

NOTE

Loosen hose clamps as required to allow air conditioner hoses enough slack to move.

3. Pivot compressor (6) in toward engine (7) and remove two belts (8) from compressor pulley (9) and engine pulley (10).

AC COMPRESSOR DRIVE BELTS REPLACEMENT/ADJUSTMENT - Continued

INSTALLATION

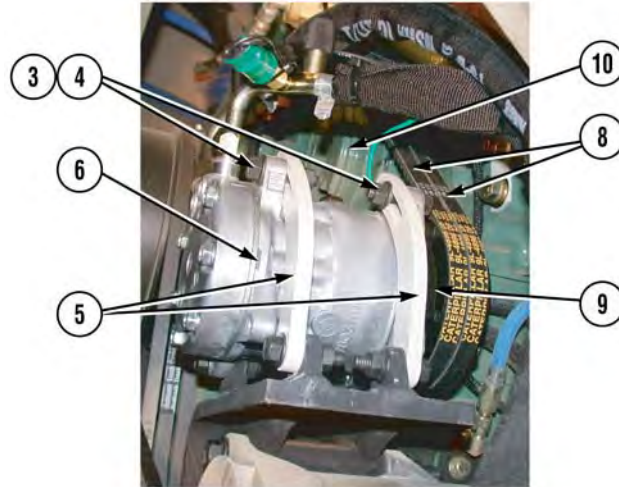

1. Install two belts (8) on engine pulley (10) and compressor pulley (9).
2. Install two compressor straps (5) on compressor (6) with two screws (4) and locknuts (3). Do not tighten locknuts (3).

AC COMPRESSOR DRIVE BELTS REPLACEMENT/ADJUSTMENT - Continued

ADJUSTMENT

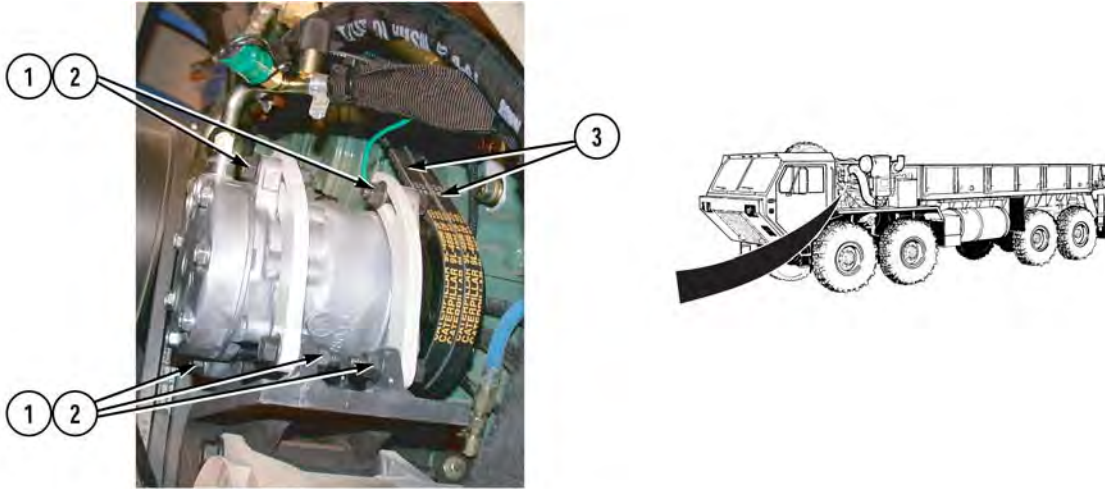

NOTE

Perform Step 1 if compressor belts were not removed.

1. Loosen six locknuts (1) and screws (2).

CAUTION

Do not over tighten belts. Failure to comply may result in damage to equipment.

2. Using a belt tension gage, Soldier A tightens two belts (3) to 90-100 lbs. (400-445 N), while Soldier B tightens six locknuts (1) and screws (2).

FOLLOW-ON MAINTENANCE

1. Install engine side panel and close engine cover (TM 9-2320-279-10).

END OF WORK PACKAGE

AC COMPRESSOR REPLACEMENT

THIS WORK PACKAGE (WP) COVERS:

- Removal
- Installation
- Follow-On Maintenance

INITIAL SETUP:

Maintenance Level

Field Level Maintenance

Equipment Condition

- Batteries disconnected (TM 9-2320-279-20).
- Refrigerant recovered (WP 0050).
- AC compressor drive belts removed (WP 0022).

Tools and Special Tools

- Set, Cap and Plug (Item 3, Appendix F)
- Shop Equipment, Common No. 1 (Item 4, Appendix F)
- Shop Equipment, Common No. 2 (Item 5, Appendix F)
- Tool Kit, General Mechanic's (Item 7, Appendix F)

Materials/Parts

- Tags, Identification (Item 9, Appendix E)
- Ties, Cable (Item 12, Appendix E)

Personnel Required

MOS 52C, Utilities equipment repairer

References

TM 9-2320-279-20

AC COMPRESSOR REPLACEMENT - Continued

REMOVAL

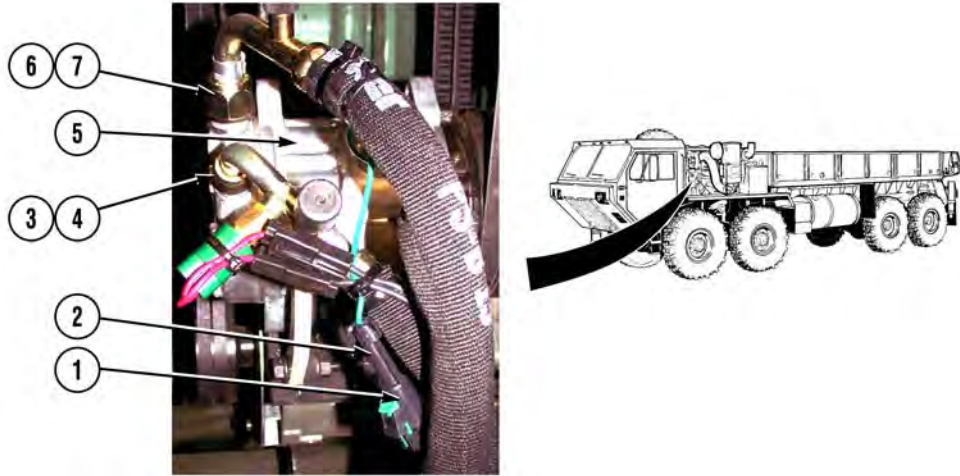

NOTE

- Tag and mark hoses and connectors prior to removal to ensure proper installation.
- Remove cable ties as required.

1. Disconnect connector (1) from connector (2).

NOTE

Cap and plug hoses upon removal.

2. Remove hose (3) and preformed packing (4) from compressor (5).
3. Remove hose (6) and preformed packing (7) from compressor (5).

AC COMPRESSOR REPLACEMENT - Continued

NOTE

Note position of washer prior to removal to ensure proper installation.

4. Remove locknut (8), washer (9), and screw (10) from compressor (5) and mounting bracket (11).
5. Remove locknut (12), screw (13), and compressor (5) from mounting bracket (11).

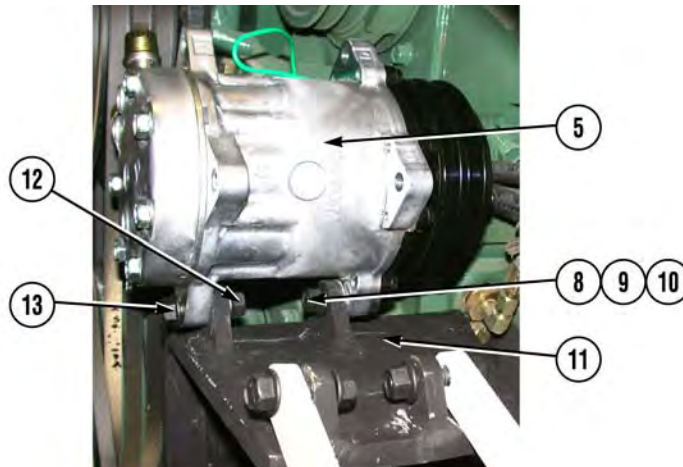

INSTALLATION

1. Install compressor (5) on mounting bracket (11) with screw (13) and locknut (12). Do not tighten locknut (12).

CAUTION

A washer may need to be installed as a shim between outside of mounting bracket flange and inside of compressor flange. Failure to comply may result in compressor flange breaking off if there is space between mounting bracket flange and compressor flange when locknut is tightened.

NOTE

Install washer as noted prior to removal.

2. Install compressor (5) on mounting bracket (11) with screw (10), washer (9), and locknut (8). Do not tighten locknut (8).

AC COMPRESSOR REPLACEMENT - Continued

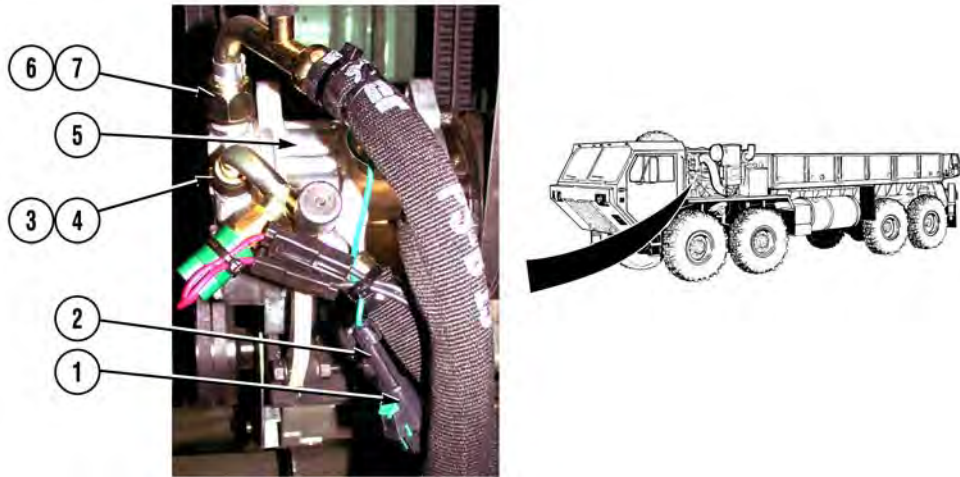

NOTE

Ensure preformed packings are in place in hoses prior to installation.

3. Install preformed packing (7) and hose (6) on compressor (5). Torque hose (6) to 18-22 ft-lbs. (24-30 N•m).
4. Install preformed packing (4) and hose (3) on compressor (5). Torque hose (3) to 15-18 ft-lbs. (20-24 N•m).

NOTE

Install cable ties as required.

5. Connect connector (1) to connector (2).

FOLLOW-ON MAINTENANCE

1. Install AC compressor drive belts (WP 0022).
2. Connect batteries (TM 9-2320-279-20).
3. Charge AC system (WP 0050).
4. Perform leak test inspection (WP 0049).

END OF WORK PACKAGE

AC CONDENSER CORE REPLACEMENT

THIS WORK PACKAGE (WP) COVERS:

- Removal
- Installation
- Follow-On Maintenance

INITIAL SETUP:

Maintenance Level

Field Level Maintenance

Equipment Condition

AC condenser removed (WP 0028).

Tools and Special Tools

Set, Cap and Plug (Item 3, Appendix F)
Tool Kit, General Mechanic's (Item 7, Appendix F)

Materials/Parts

Tags, Identification (Item 9, Appendix E)

Personnel Required

MOS 52C, Utilities equipment repairer

References

TM 9-2320-279-20

AC CONDENSER CORE REPLACEMENT - Continued

REMOVAL

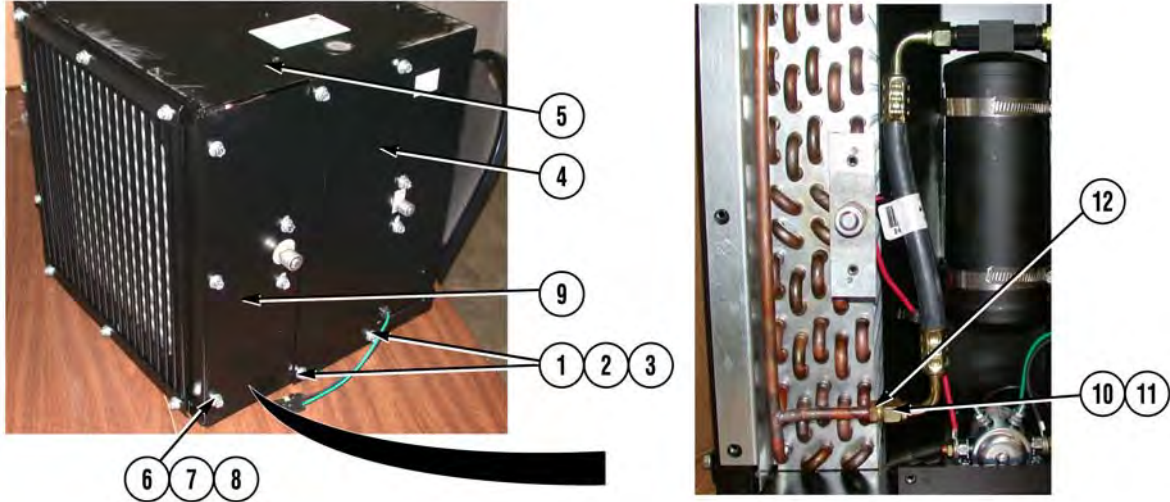

1. Remove four screws (1), lockwashers (2), washers (3), and cover (4) from condenser (5).
2. Remove five screws (6), lockwashers (7), washers (8), and cover (9) from condenser (5).

NOTE

- Tag and mark hose prior to removal to ensure proper installation.
 - Cap and plug hose upon removal.
3. Remove hose (10) and preformed packing (11) from pipe (12).

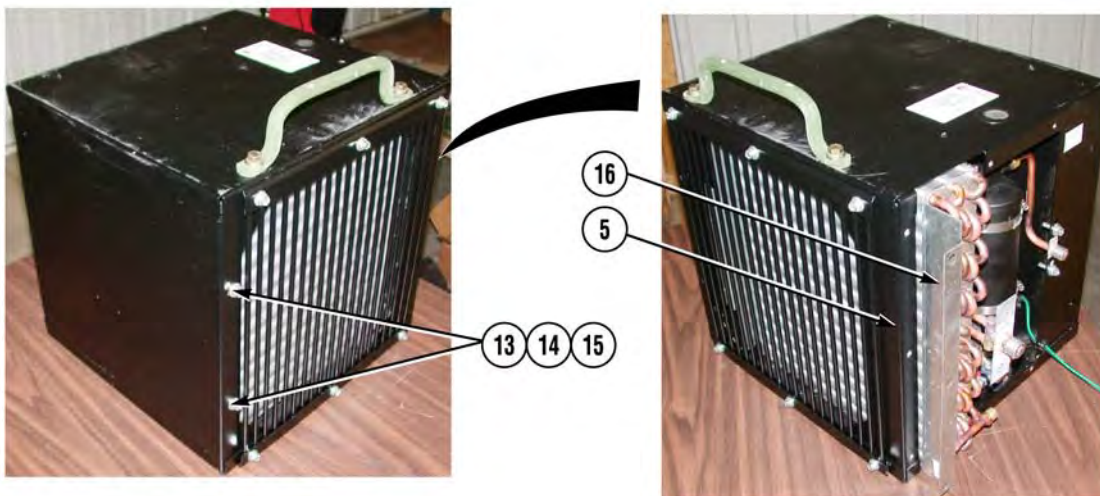

4. Remove two screws (13), lockwashers (14), washers (15), and condenser core (16) from condenser (5).

AC CONDENSER CORE REPLACEMENT - Continued

INSTALLATION

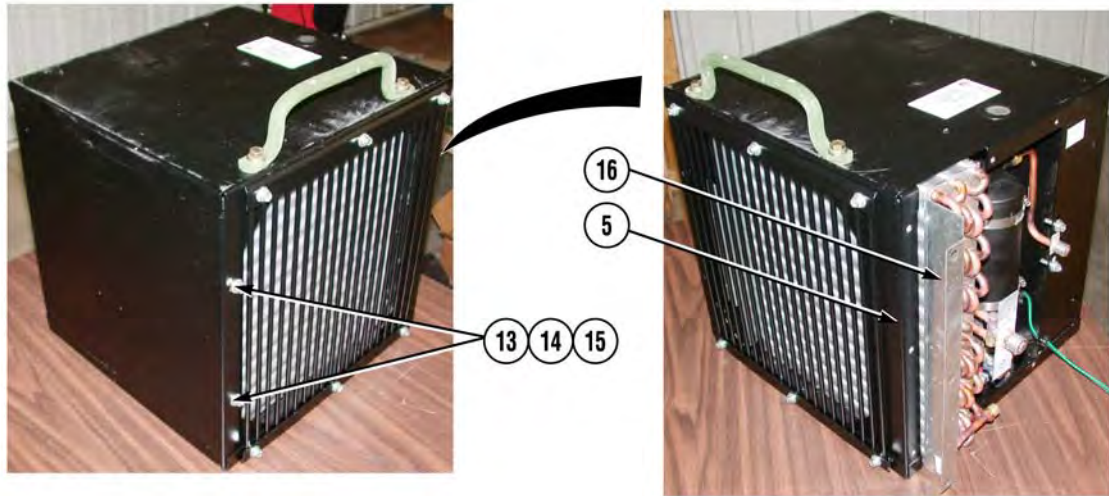

1. Install condenser core (16) in condenser (5) with two washers (15), lockwashers (14), and screws (13).

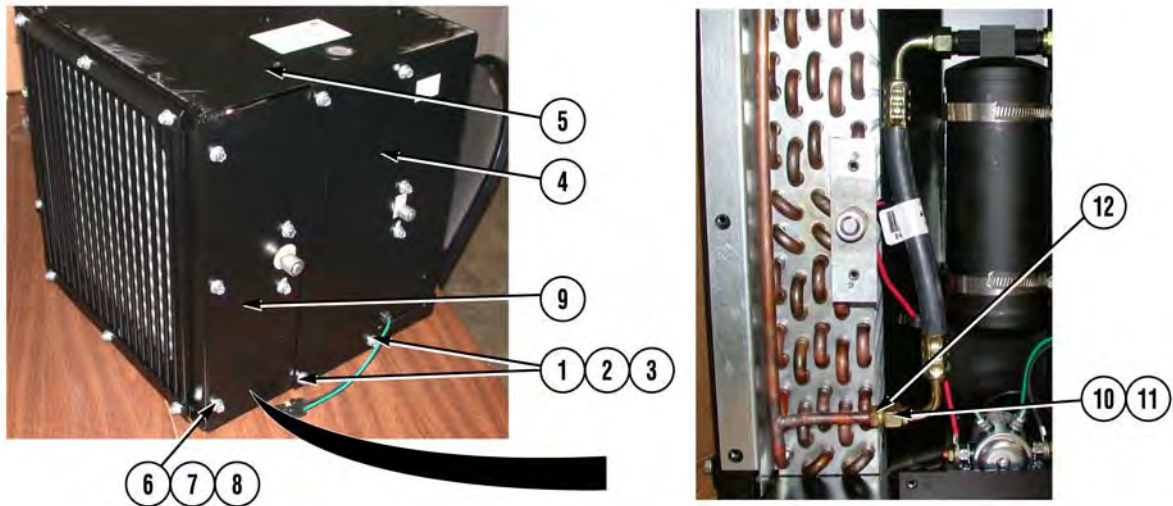

NOTE

Ensure preformed packing is in place in hose prior to installation.

2. Install preformed packing (11) and hose (10) on pipe (12).
3. Install cover (9) on condenser (5) with five washers (8), lockwashers (7), and screws (6).
4. Install cover (4) on condenser (5) with four washers (3), lockwashers (2), and screws (1).

AC CONDENSER CORE REPLACEMENT - Continued

FOLLOW-ON MAINTENANCE

1. Install AC condenser (WP 0028).

END OF WORK PACKAGE

AC CONDENSER DRYER REPLACEMENT

THIS WORK PACKAGE (WP) COVERS:

- Removal
- Installation
- Follow-On Maintenance

INITIAL SETUP:

Maintenance Level

Field Level Maintenance

Materials/Parts

Tags, Identification (Item 9, Appendix E)

Equipment Condition

Refrigerant recovered (WP 0050).

Personnel Required

MOS 52C, Utilities equipment repairer

Tools and Special Tools

Set, Cap and Plug (Item 3, Appendix F)
 Tool Kit, General Mechanic's (Item 7, Appendix F)

References

None

REMOVAL

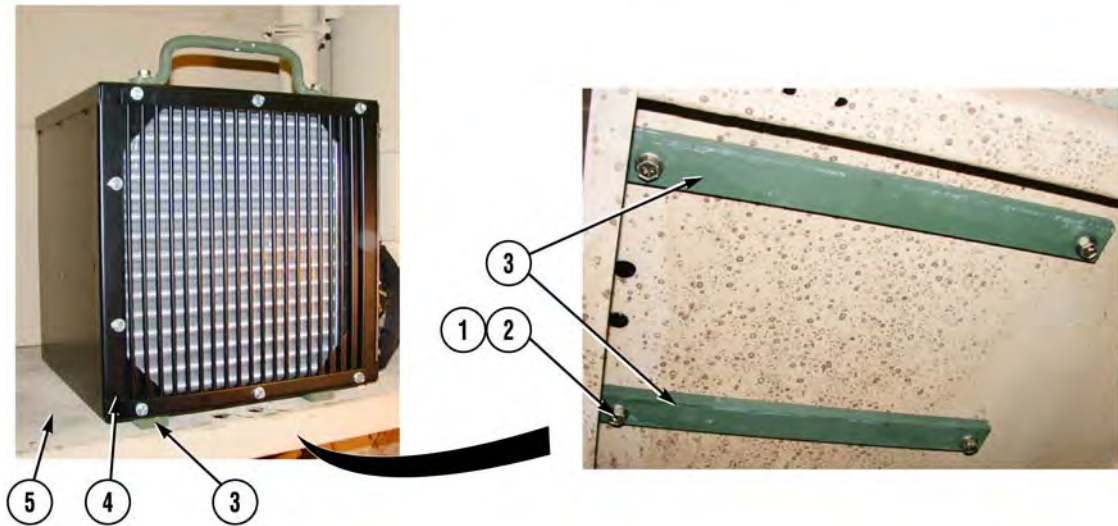

NOTE

Condenser does not need to be removed from driver side front fender after mounting hardware is removed.

1. Remove four screws (1), lockwashers (2), and plates (3) from condenser (4) and driver side front fender (5).

AC CONDENSER DRYER REPLACEMENT - Continued

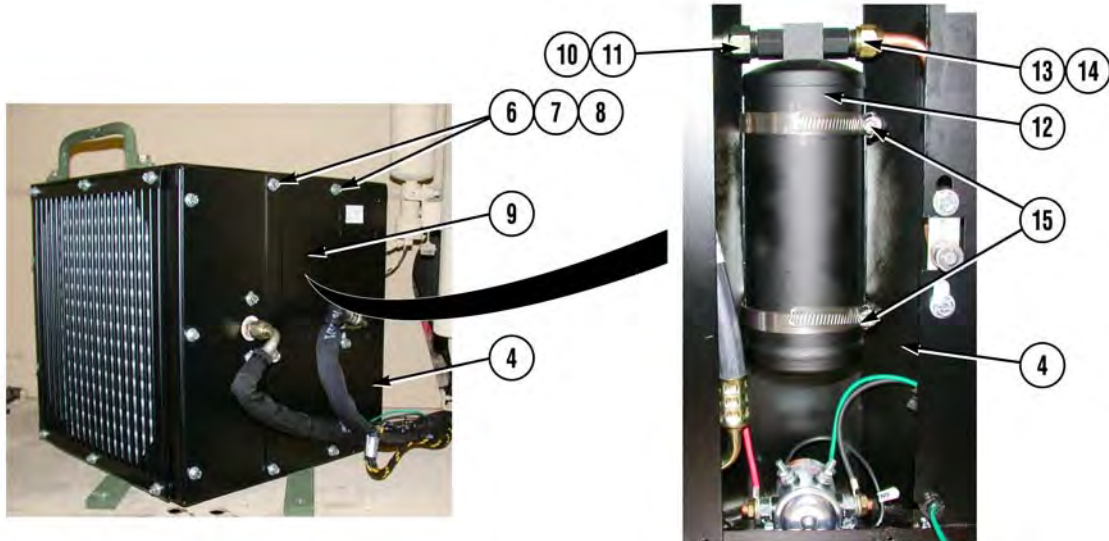

2. Slide condenser (4) toward cab.
3. Remove four screws (6), lockwashers (7), washers (8), and cover (9) from condenser (4).

NOTE

- Tag and mark hoses prior to removal to ensure proper installation.
 - Cap and plug hoses and tubes upon removal.
4. Remove hose (10) and preformed packing (11) from dryer (12).
 5. Remove tube (13) and preformed packing (14) from dryer (12).

NOTE

Note position of dryer prior to removal to ensure proper installation.

6. Remove two clamps (15) and dryer (12) from condenser (4).

AC CONDENSER DRYER REPLACEMENT - Continued

INSTALLATION

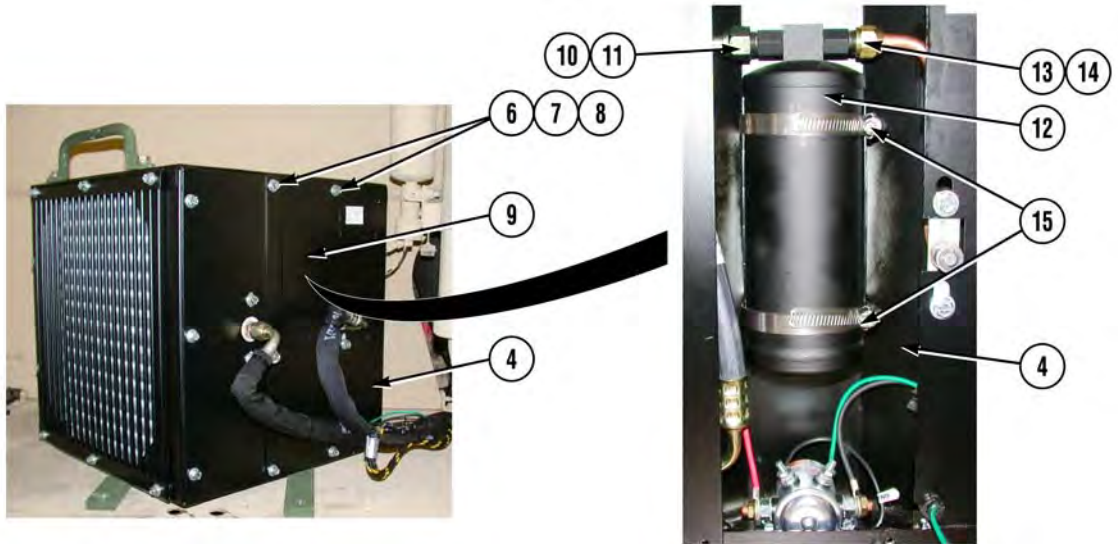

NOTE

Install dryer as noted prior to removal.

1. Install dryer (12) in condenser (4) with two clamps (15). Do not tighten clamps (15).

NOTE

Ensure preformed packings are in place in hoses and tubes prior to installation.

2. Install preformed packing (14) and tube (13) on dryer (12).
3. Install preformed packing (11) and hose (10) on dryer (12).
4. Tighten two clamps (15).
5. Install cover (9) on condenser (4) with four washers (8), lockwashers (7), and screws (6).

AC CONDENSER DRYER REPLACEMENT - Continued

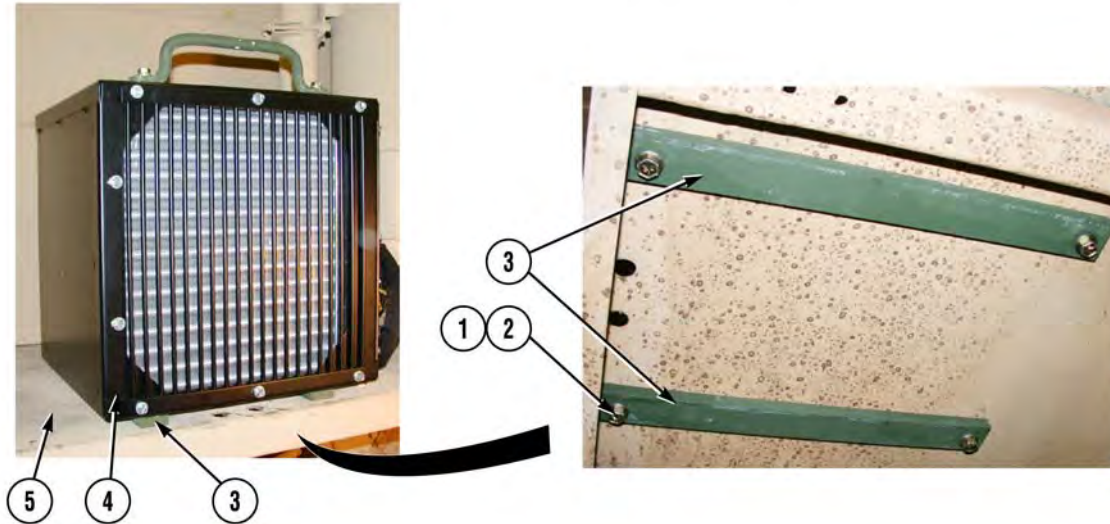

6. Install four plates (3) and condenser (4) on driver side front fender (5) with four lockwashers (2) and screws (1).

FOLLOW-ON MAINTENANCE

1. Charge AC system (WP 0050).
2. Perform leak test inspection (WP 0049).

END OF WORK PACKAGE

AC CONDENSER FAN MOTOR REPLACEMENT

THIS WORK PACKAGE (WP) COVERS:

- Removal
- Installation
- Follow-On Maintenance

INITIAL SETUP:

Maintenance Level

Field Level Maintenance

Equipment Condition

Batteries disconnected (TM 9-2320-279-20).
Engine cover opened and engine side panel removed (TM 9-2320-279-10).

Tools and Special Tools

Tool Kit, General Mechanic's (Item 7, Appendix F)

Materials/Parts

Tags, Identification (Item 9, Appendix E)

Personnel Required

MOS 52C, Utilities equipment repairer

References

TM 9-2320-279-10
TM 9-2320-279-20

REMOVAL

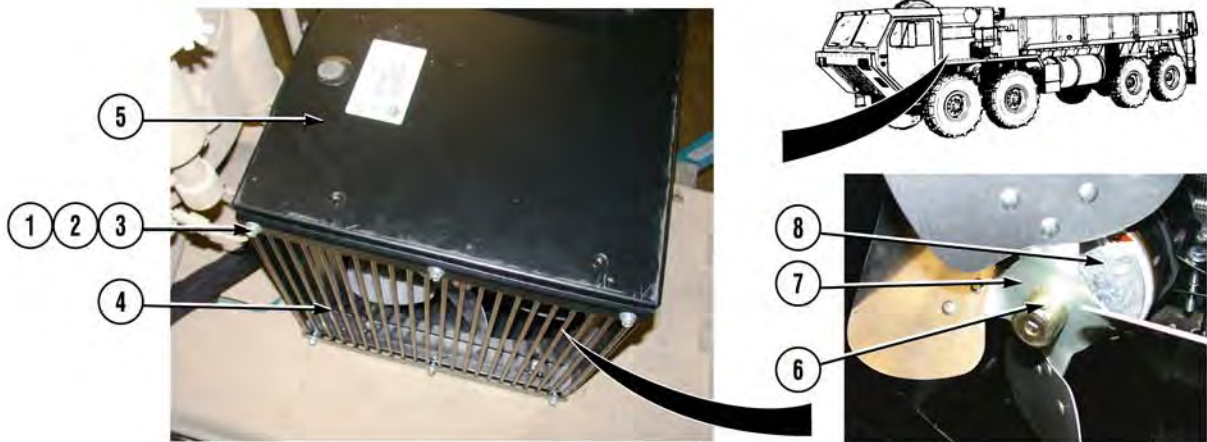

1. Remove six screws (1), lockwashers (2), washers (3), and grille (4) from condenser (5).

NOTE

Note position of fan on fan motor prior to removal to ensure proper installation.

2. Loosen setscrew (6) and remove fan (7) from fan motor (8).

AC CONDENSER FAN MOTOR REPLACEMENT - Continued



3. Loosen four screws (9) and lockwashers (10).

CAUTION

Use care when removing fan motor from bracket. Wires are still attached to back of fan motor and will be removed when fan motor is pulled forward. Failure to comply may result in damage to equipment.

NOTE

Note position of fan motor prior to removal to ensure proper installation.

4. Remove fan motor (8) from bracket (11).

AC CONDENSER FAN MOTOR REPLACEMENT - Continued

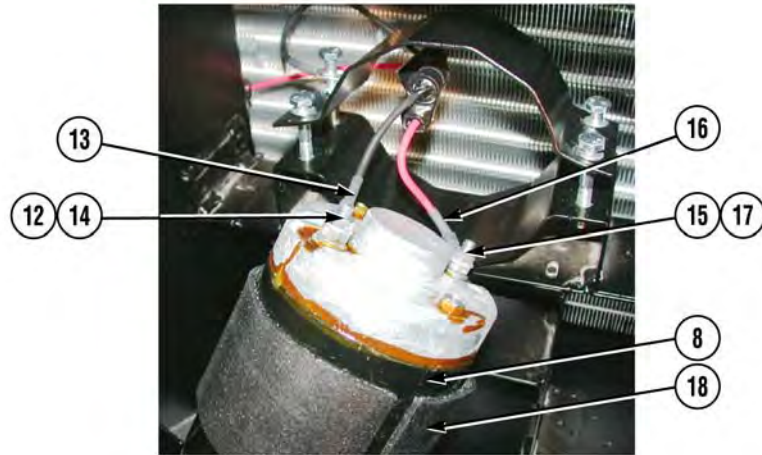

NOTE

Tag and mark wires prior to removal to ensure proper installation.

5. Remove nut (12) and wire (13) from terminal (14).
6. Remove nut (15) and wire (16) from terminal (17).
7. Remove gasket (18) from fan motor (8).

AC CONDENSER FAN MOTOR REPLACEMENT - Continued

INSTALLATION

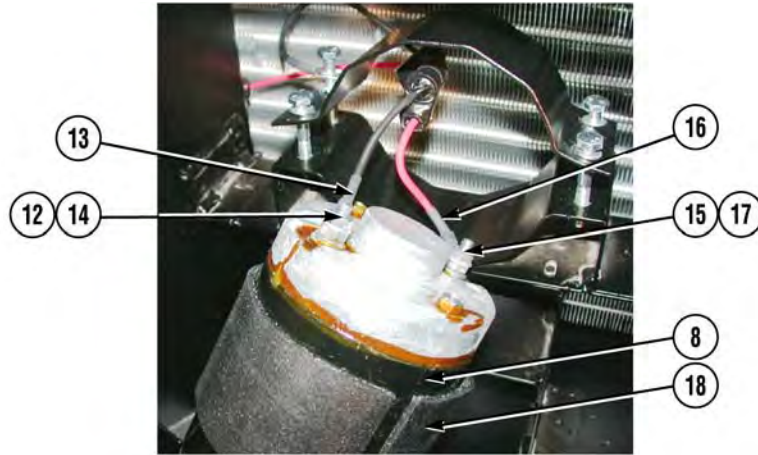

1. Install gasket (18) on fan motor (8).
2. Install wire (16) on terminal (17) with nut (15).
3. Install wire (13) on terminal (14) with nut (12).

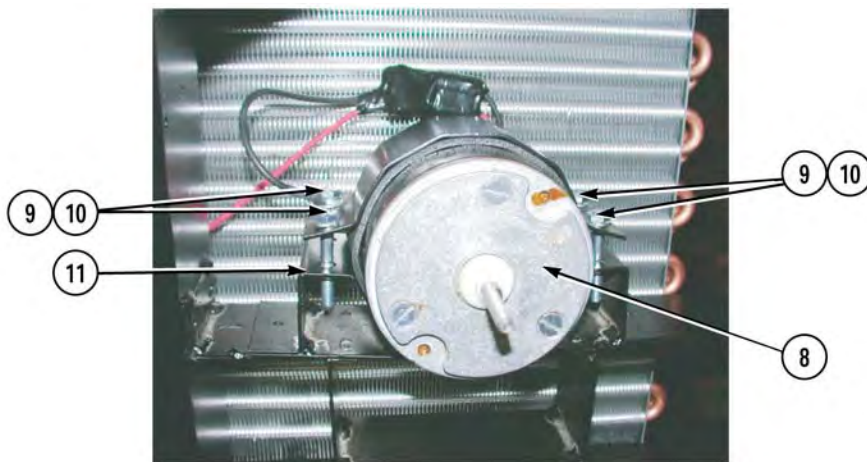

NOTE

Install fan motor as noted prior to removal.

4. Install fan motor (8) in bracket (11) and tighten four lockwashers (10) and screws (9).

AC CONDENSER FAN MOTOR REPLACEMENT - Continued

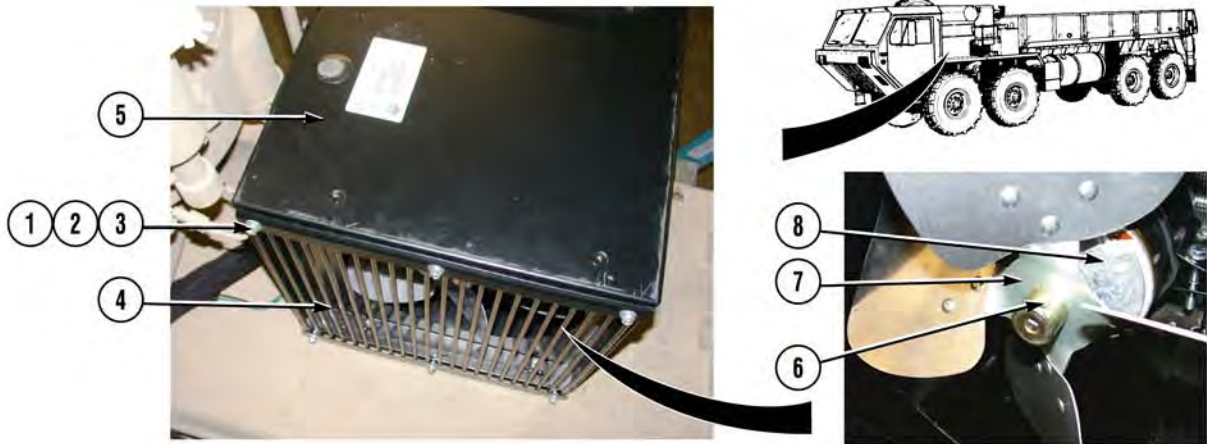

CAUTION

Fan needs to be centered on fan motor shaft. Failure to comply may result in fan blades hitting condenser when fan motor is running causing damage to equipment.

NOTE

Install fan on fan motor as noted prior to removal.

5. Install fan (7) on fan motor (8) and tighten setscrew (6).
6. Install grille (4) on condenser (5) with six washers (3), lockwashers (2), and screws (1).

FOLLOW-ON MAINTENANCE

1. Install engine side panel and close engine cover (TM 9-2320-279-10).
2. Connect batteries (TM 9-2320-279-20).

END OF WORK PACKAGE

AC CONDENSER FAN MOTOR SOLENOID REPLACEMENT

THIS WORK PACKAGE (WP) COVERS:

Removal
Installation
Follow-On Maintenance

INITIAL SETUP:**Maintenance Level**

Field Level Maintenance

Materials/Parts

Tags, Identification (Item 9, Appendix E)

Equipment Condition

Batteries disconnected (TM 9-2320-279-20).

Personnel Required

MOS 52C, Utilities equipment repairer

Tools and Special Tools

Tool Kit, General Mechanic's (Item 7, Appendix F)

References

TM 9-2320-279-20

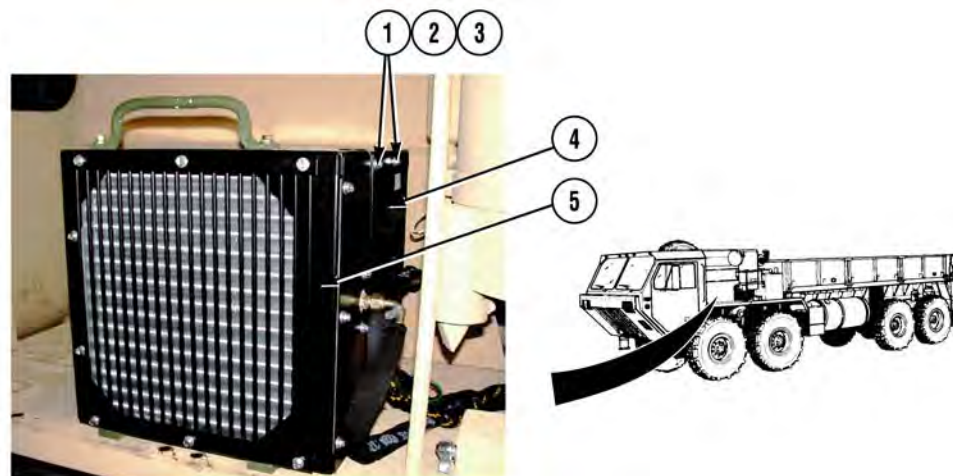
REMOVAL

1. Remove four screws (1), lockwashers (2), washers (3), and cover (4) from condenser (5).

AC CONDENSER FAN MOTOR SOLENOID REPLACEMENT - Continued

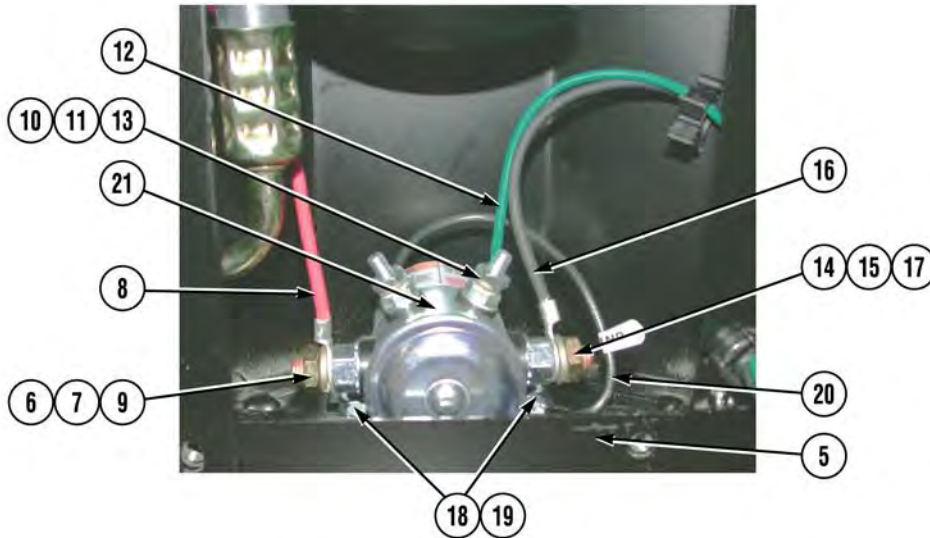

NOTE

Tag and mark wires prior to removal to ensure proper installation.

2. Remove nut (6), lockwasher (7), and wire (8) from terminal (9).
3. Remove nut (10), lockwasher (11), and wire (12) from terminal (13).
4. Remove nut (14), lockwasher (15), and wire (16) from terminal (17).

NOTE

Note position of solenoid prior to removal to ensure proper installation.

5. Remove two nuts (18), lockwashers (19), wire (20), and solenoid (21) from condenser (5).

AC CONDENSER FAN MOTOR SOLENOID REPLACEMENT - Continued

INSTALLATION

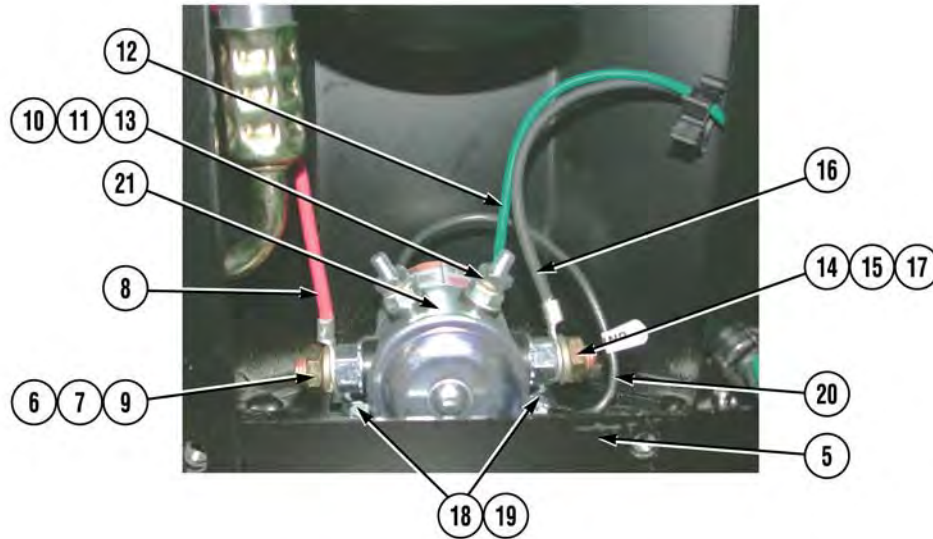

NOTE

Install solenoid as noted prior to removal.

1. Install solenoid (21) and wire (20) on condenser (5) with two lockwashers (19) and nuts (18).
2. Install wire (16) on terminal (17) with lockwasher (15) and nut (14).
3. Install wire (12) on terminal (13) with lockwasher (11) and nut (10).
4. Install wire (8) on terminal (9) with lockwasher (7) and nut (6).

AC CONDENSER FAN MOTOR SOLENOID REPLACEMENT - Continued

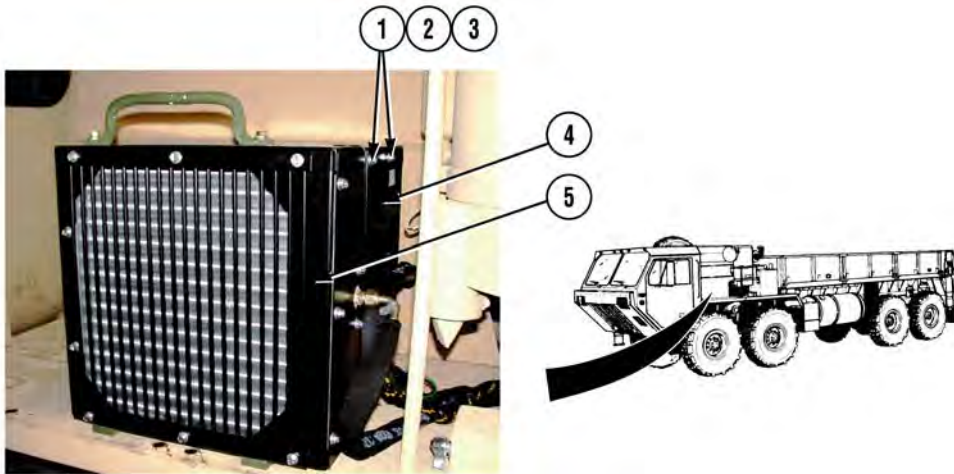

5. Install cover (4) on condenser (5) with four washers (3), lockwashers (2), and screws (1).

FOLLOW-ON MAINTENANCE

1. Connect batteries (TM 9-2320-279-20).

END OF WORK PACKAGE

AC CONDENSER REPLACEMENT

THIS WORK PACKAGE (WP) COVERS:

- Removal
- Installation
- Follow-On Maintenance

INITIAL SETUP:

Maintenance Level

Field Level Maintenance

Equipment Condition

Batteries disconnected (TM 9-2320-279-20).
Refrigerant recovered (WP 0050).

Tools and Special Tools

Set, Cap and Plug (Item 3, Appendix F)
Shop Equipment, Common No. 1 (Item 4,
Appendix F)
Shop Equipment, Common No. 2 (Item 5,
Appendix F)
Tool Kit, General Mechanic's (Item 7, Appendix F)

Materials/Parts

Tags, Identification (Item 9, Appendix E)

Personnel Required

MOS 52C, Utilities equipment repairer (2)

References

TM 9-2320-279-20

AC CONDENSER REPLACEMENT - Continued

REMOVAL

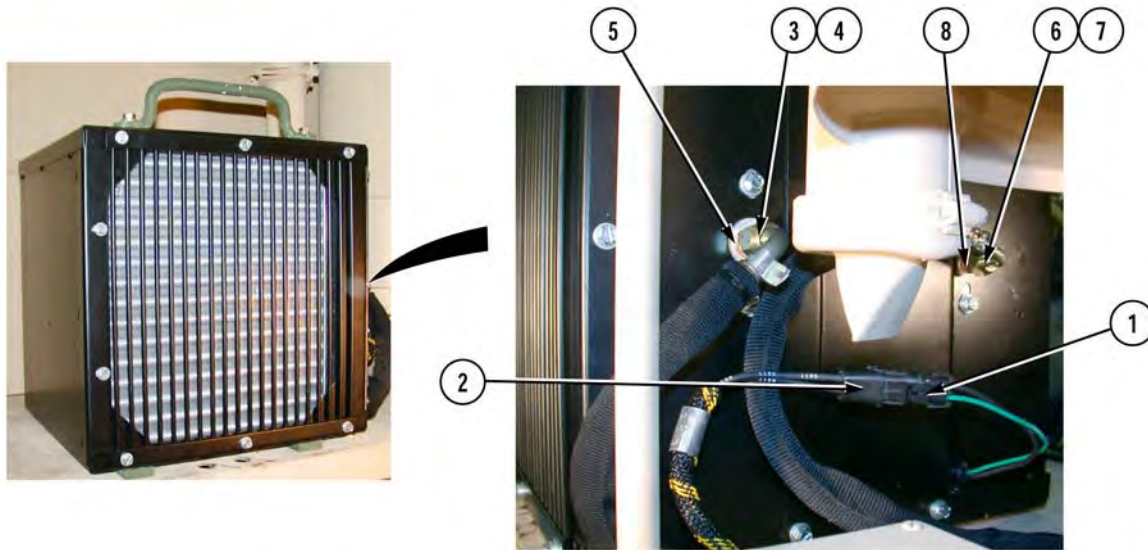

NOTE

Tag and mark connectors and hoses prior to removal to ensure proper installation.

1. Disconnect connector (1) from connector (2).

NOTE

Cap and plug hoses upon removal.

2. Remove hose (3) and preformed packing (4) from fitting (5).
3. Remove hose (6) and preformed packing (7) from fitting (8).

AC CONDENSER REPLACEMENT - Continued

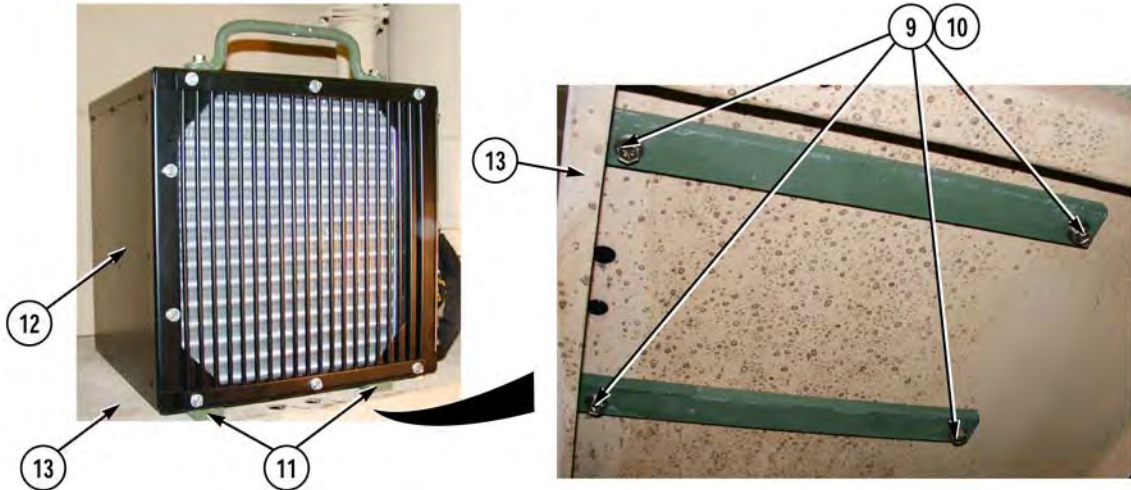

WARNING

AC condenser assembly weighs 75 lbs. (34 kg). Do not lift AC condenser assembly without the aid of an assistant. Failure to comply may result in injury to personnel and/or damage to equipment.

- Soldier A and Soldier B remove four screws (9), lockwashers (10), plates (11), and condenser (12) from driver side front fender (13).

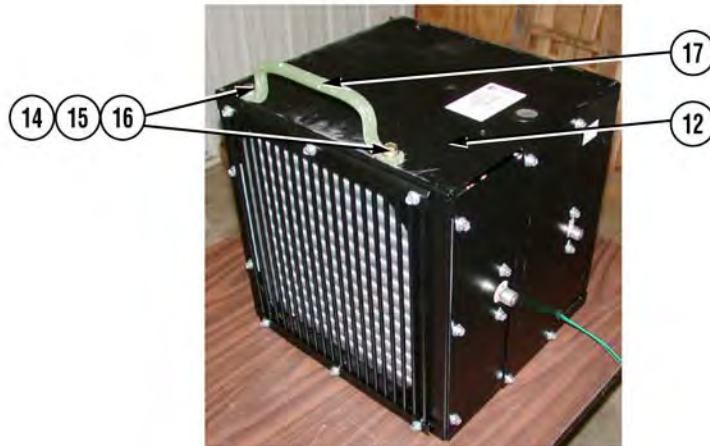

NOTE

Perform Step 5 if grab handle needs to be removed.

- Remove two screws (14), lockwashers (15), washers (16), and grab handle (17) from condenser (12).

AC CONDENSER REPLACEMENT - Continued

INSTALLATION

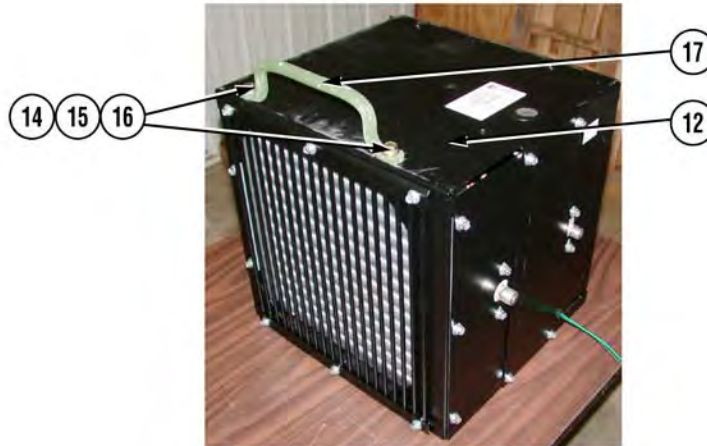

NOTE

Perform Step 1 if grab handle was removed.

1. Install grab handle (17) on condenser (12) with two washers (16), lockwashers (15), and screws (14).

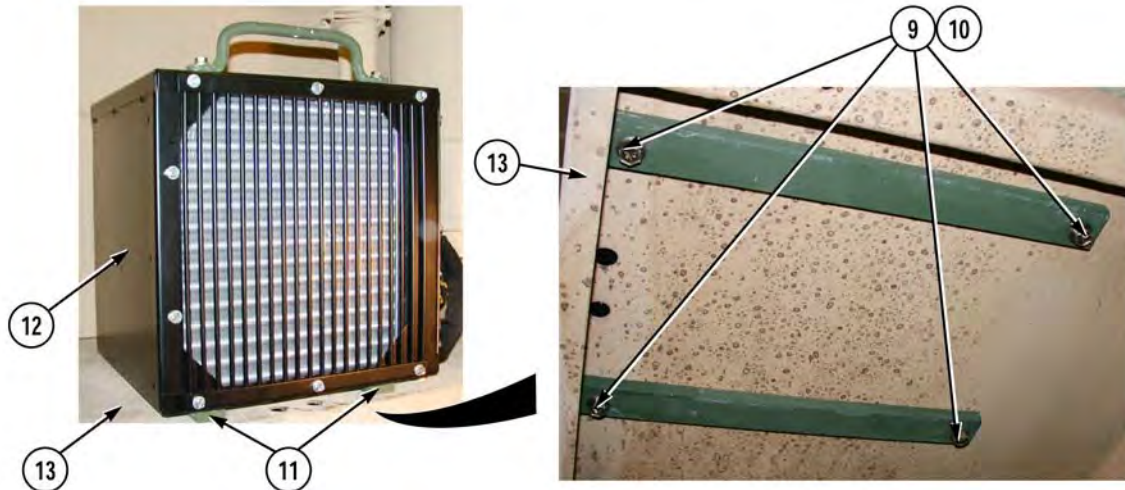

WARNING

AC condenser assembly weighs 75 lbs. (34 kg). Do not lift AC condenser assembly without the aid of an assistant. Failure to comply may result in injury to personnel and/or damage to equipment.

2. Soldier A and Soldier B install four plates (11) and condenser (12) on driver side front fender (13) with four lockwashers (10) and screws (9).

AC CONDENSER REPLACEMENT - Continued

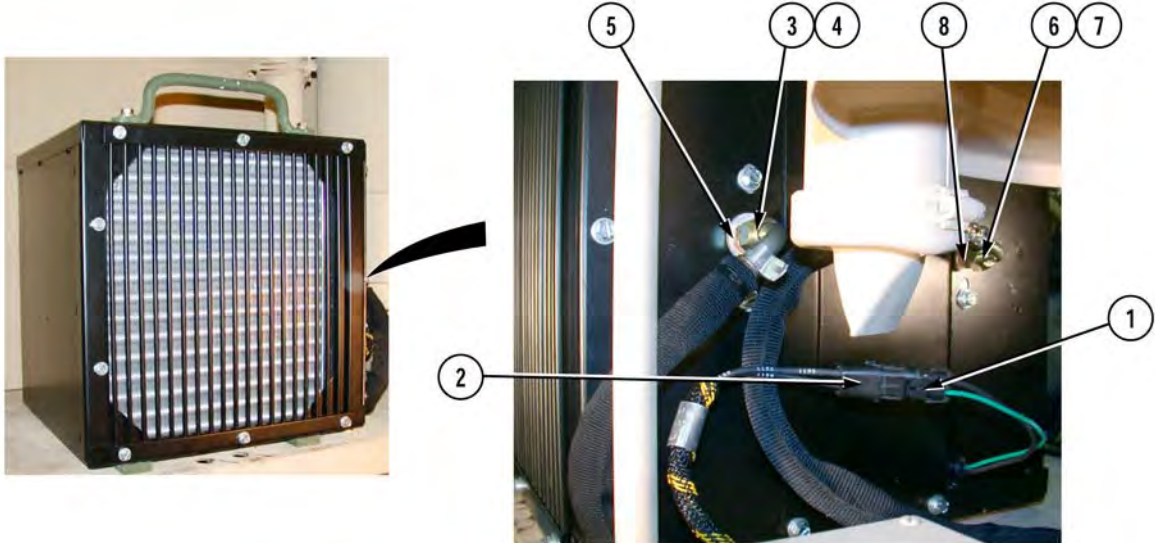

NOTE

Ensure preformed packings are in place in hoses prior to installation.

3. Install preformed packing (7) and hose (6) on fitting (8). Torque hose (6) to 11-13 ft-lbs. (15-18 N•m).
4. Install preformed packing (4) and hose (3) on fitting (5). Torque hose (3) to 15-18 ft-lbs. (20-24 N•m).
5. Connect connector (1) to connector (2).

FOLLOW-ON MAINTENANCE

1. Connect batteries (TM 9-2320-279-20).
2. Charge AC system (WP 0050).
3. Perform leak test inspection (WP 0049).

END OF WORK PACKAGE

AC DEFROST CABLE REPLACEMENT

THIS WORK PACKAGE (WP) COVERS:

Removal
 Installation
 Follow-On Maintenance

INITIAL SETUP:

Maintenance Level

Field Level Maintenance

Equipment Condition

AC heater/evaporator cover removed (WP 0037).

Tools and Special Tools

Tool Kit, General Mechanic's (Item 7, Appendix F)

Materials/Parts

Ties, Cable (Item 13, Appendix E)

Personnel Required

MOS 52C, Utilities equipment repairer

References

TM 9-2320-279-20

REMOVAL

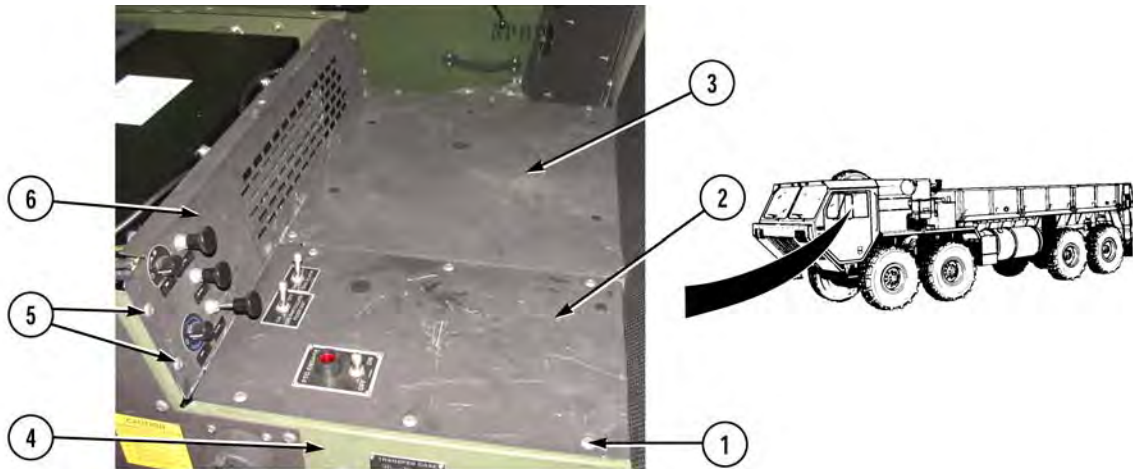

1. Remove 11 screws (1) and two console covers (2 and 3) from console (4).
2. Remove four screws (5) and center cover (6) from console (4).

AC DEFROST CABLE REPLACEMENT - Continued

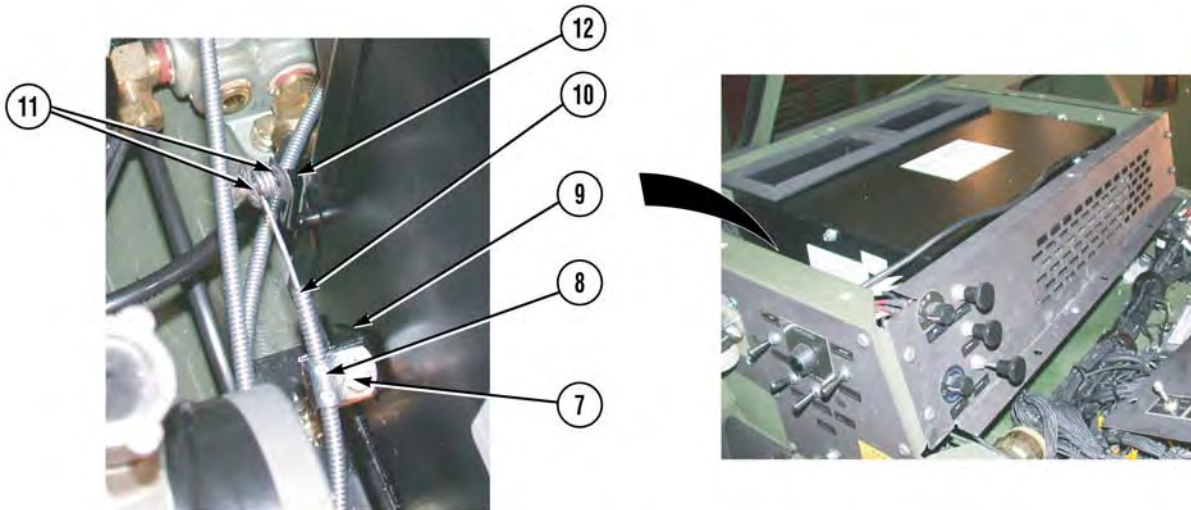

3. Remove screw (7) and retainer (8) from heater/evaporator (9).
4. Remove retainer (8) from AC defrost cable (10).
5. Remove two speed nuts (11) and AC defrost cable (10) from control arm (12).

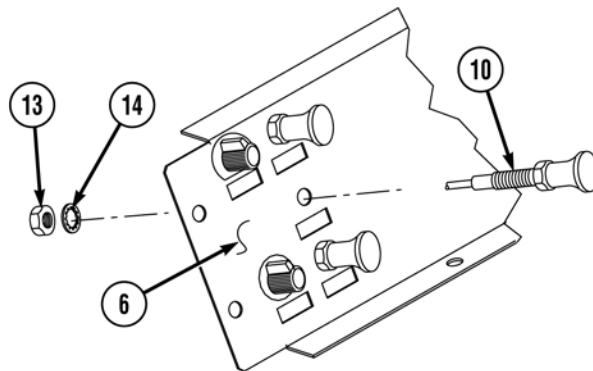

NOTE

Remove cable ties as required.

6. Remove nut (13), lockwasher (14), and AC defrost cable (10) from center cover (6).

AC DEFROST CABLE REPLACEMENT - Continued

INSTALLATION

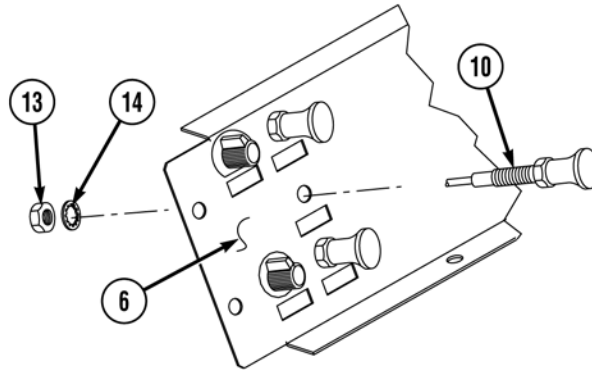

1. Install AC defrost cable (10) on center cover (6) with lockwasher (14) and nut (13).

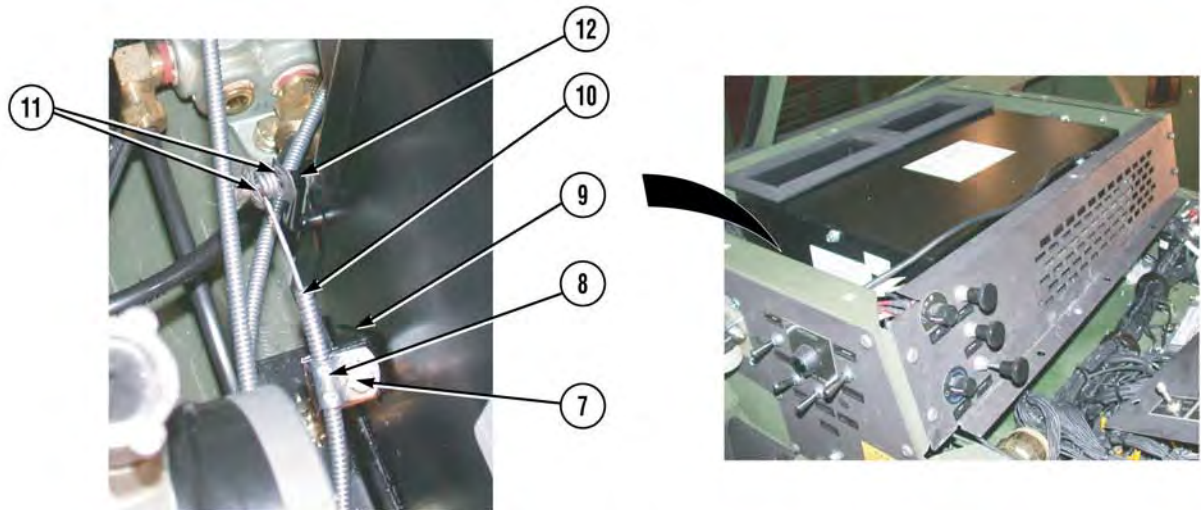

2. Install AC defrost cable (10) on control arm (12) with two speed nuts (11).
3. Place retainer (8) on AC defrost cable (10).
4. Install retainer (8) on heater/evaporator (9) with screw (7).

AC DEFROST CABLE REPLACEMENT - Continued

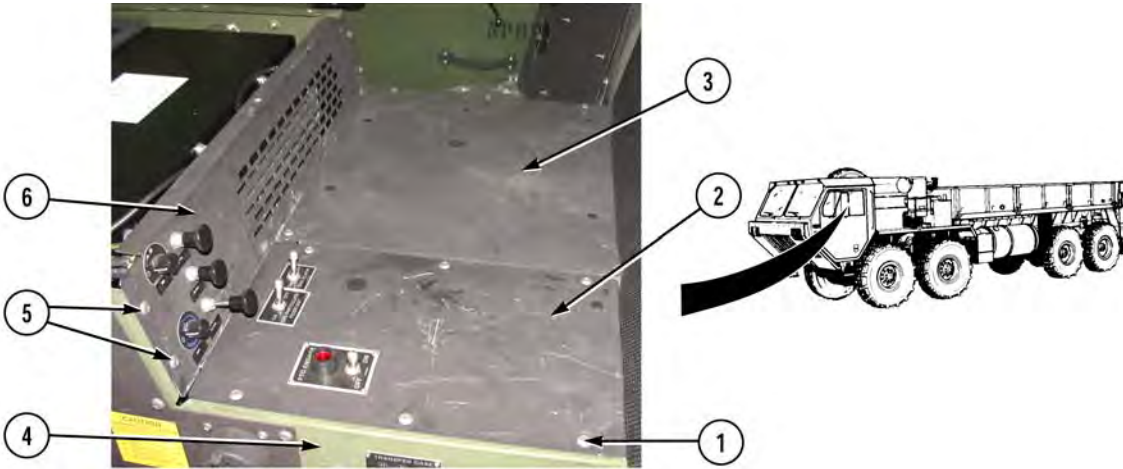

5. Install center cover (6) on console (4) with four screws (5).

NOTE

Install cable ties as required.

6. Install two console covers (2 and 3) on console (4) with 11 screws (1).

FOLLOW-ON MAINTENANCE

1. Install AC heater/evaporator cover (WP 0037).

END OF WORK PACKAGE

AC EVAPORATOR CORE AND EXPANSION VALVE REPLACEMENT

THIS WORK PACKAGE (WP) COVERS:

- Removal
- Installation
- Follow-On Maintenance

INITIAL SETUP:

Maintenance Level

Field Level Maintenance

Equipment Condition

AC heater/evaporator removed (WP 0038).

Tools and Special Tools

- Shop Equipment, Common No. 1 (Item 4, Appendix F)
- Shop Equipment, Common No. 2 (Item 5, Appendix F)
- Tool Kit, General Mechanic's (Item 7, Appendix F)

Materials/Parts

Adhesive, 3M #1300 (Item 1, Appendix E)

Personnel Required

MOS 52C, Utilities equipment repairer

References

TM 9-2320-279-20

REMOVAL

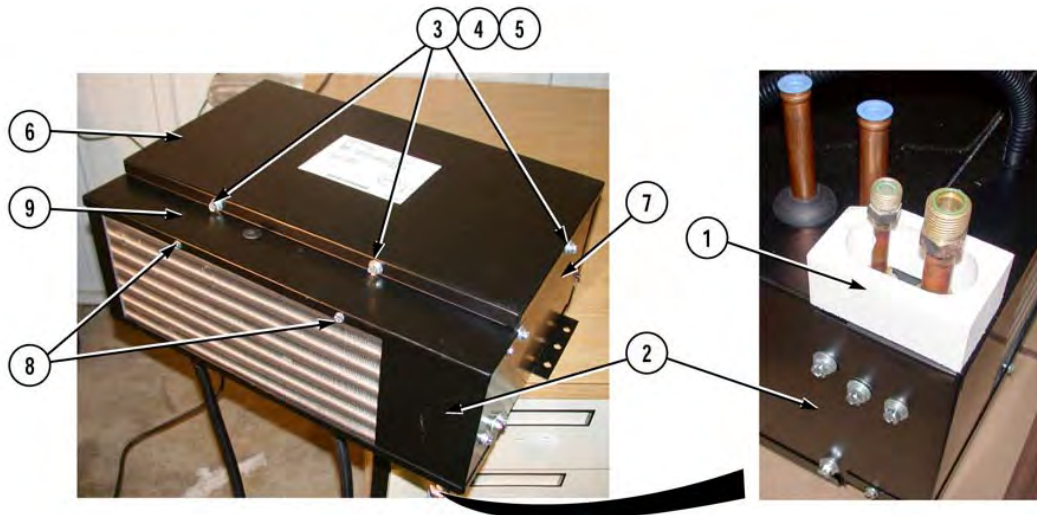

1. Remove insulation (1) from evaporator core housing (2).
2. Remove four screws (3), lockwashers (4), washers (5), and cover (6) from heater/evaporator (7).
3. Remove four screws (8) and evaporator core cover (9) from evaporator core housing (2).

AC EVAPORATOR CORE AND EXPANSION VALVE REPLACEMENT - Continued

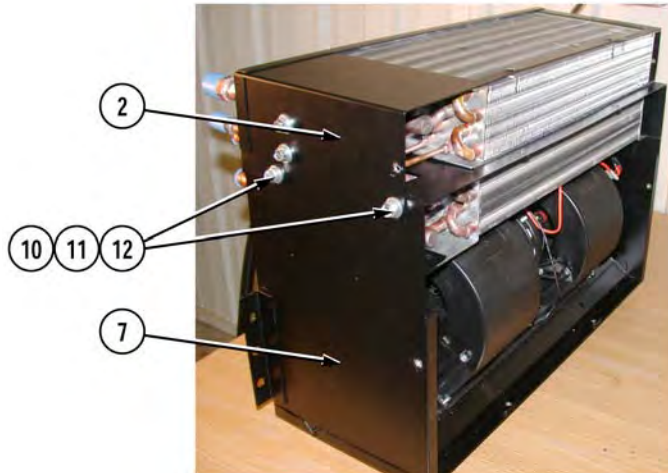

4. Remove four screws (10), lockwashers (11), washers (12), and evaporator core housing (2) from heater/evaporator (7).

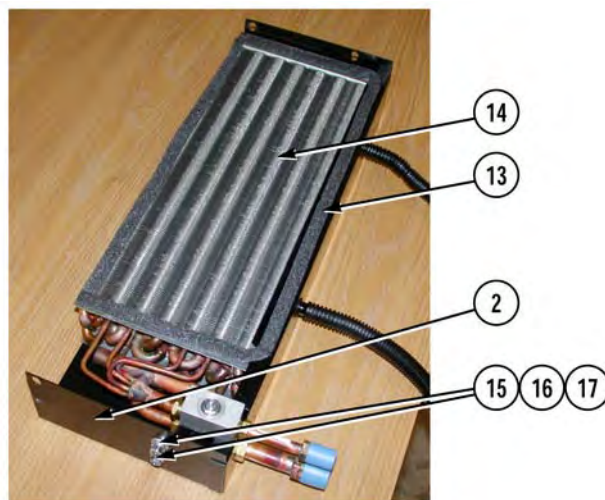

5. Remove foam tape (13) from evaporator core housing (2) and evaporator core (14).
6. Remove two screws (15), lockwashers (16), washers (17), and evaporator core (14) from evaporator core housing (2).

AC EVAPORATOR CORE AND EXPANSION VALVE REPLACEMENT - Continued

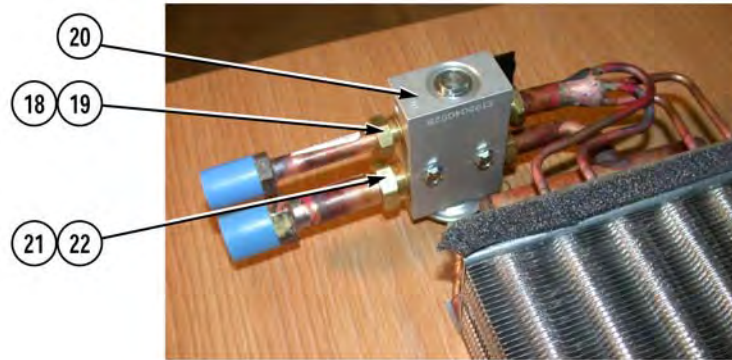

7. Remove fitting (18) and preformed packing (19) from expansion valve (20).
8. Remove fitting (21) and preformed packing (22) from expansion valve (20).

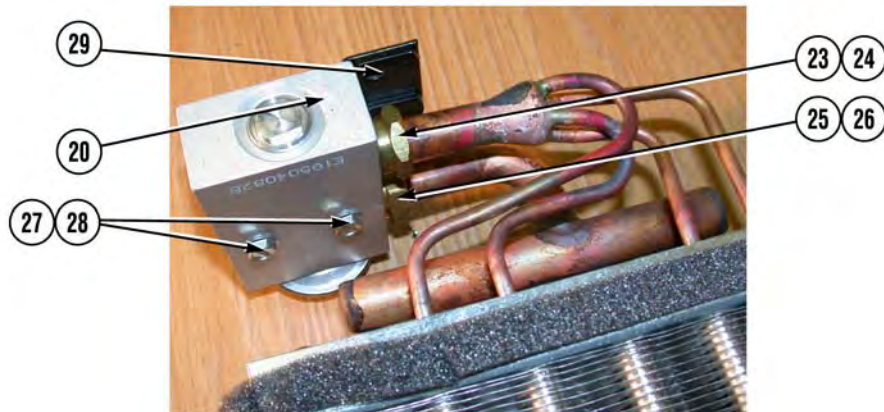

9. Remove fitting (23) and preformed packing (24) from expansion valve (20).
10. Remove fitting (25) and preformed packing (26) from expansion valve (20).

NOTE

Note position of bracket prior to removal to ensure proper installation.

11. Remove two screws (27), lockwashers (28), and bracket (29) from expansion valve (20).

AC EVAPORATOR CORE AND EXPANSION VALVE REPLACEMENT - Continued

INSTALLATION



NOTE

Install bracket as noted prior to removal.

1. Install bracket (29) on expansion valve (20) with two lockwashers (28) and screws (27).

NOTE

Ensure preformed packings are on fittings prior to installation.

2. Install preformed packing (26) and fitting (25) on expansion valve (20).
3. Install preformed packing (24) and fitting (23) on expansion valve (20).

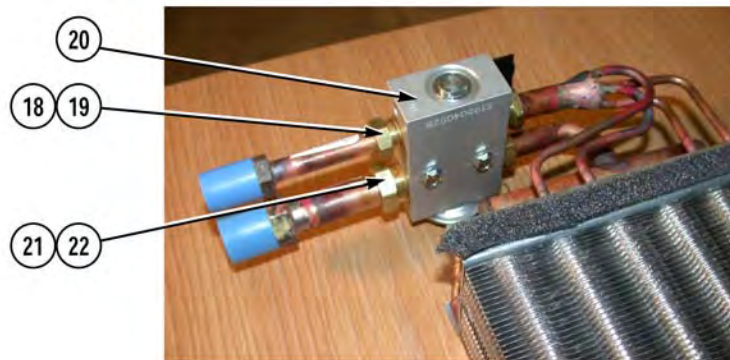

4. Install preformed packing (22) and fitting (21) on expansion valve (20). Torque fitting (21) to 18-22 ft-lbs. (24-30 N•m).
5. Install preformed packing (19) and fitting (18) on expansion valve (20). Torque fitting (18) to 11-13 ft-lbs. (15-18 N•m).

AC EVAPORATOR CORE AND EXPANSION VALVE REPLACEMENT - Continued

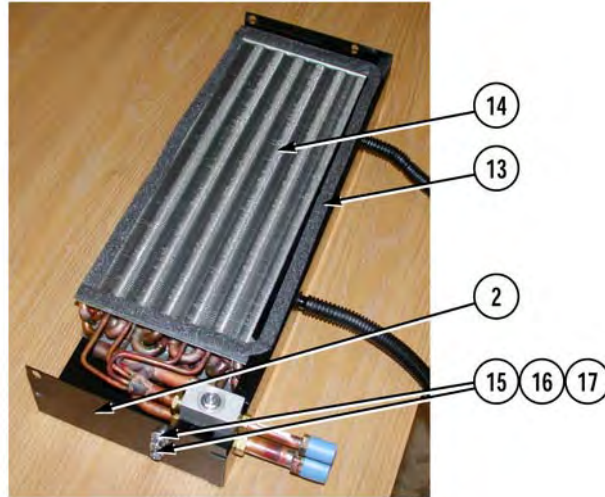

6. Install evaporator core (14) on evaporator core housing (2) with two washers (17), lockwashers (16), and screws (15).
7. Install foam tape (13) on evaporator core (14) and evaporator core housing (2).

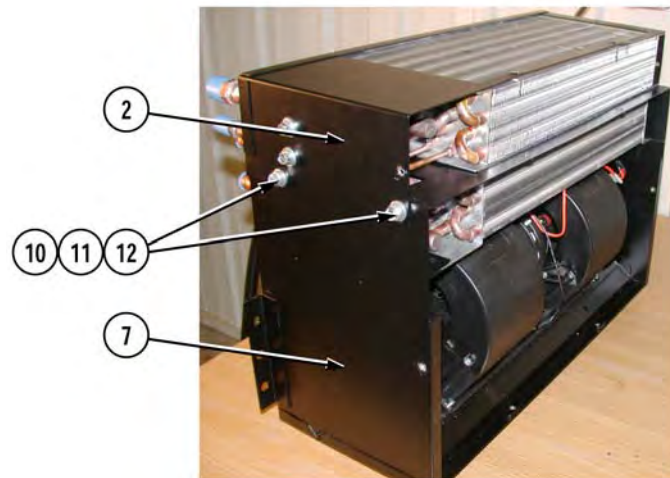

8. Install evaporator core housing (2) on heater/evaporator (7) with four washers (12), lockwashers (11), and screws (10).

AC EVAPORATOR CORE AND EXPANSION VALVE REPLACEMENT - Continued

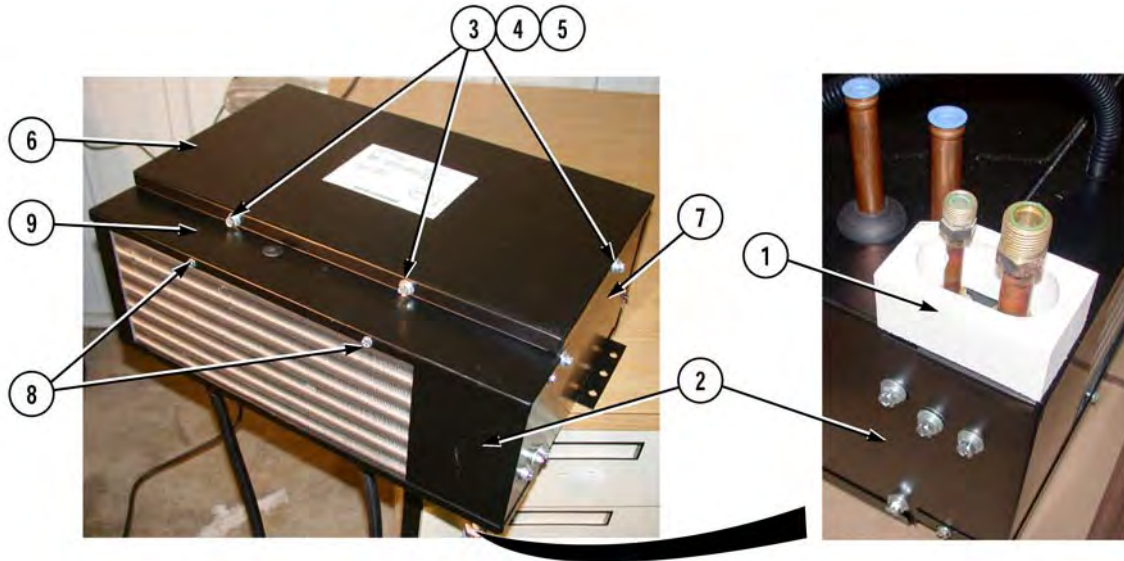

9. Install evaporator core cover (9) on evaporator core housing (2) with four screws (8).
10. Install cover (6) on heater/evaporator (7) with four washers (5), lockwashers (4), and screws (3).

WARNING

Adhesives, solvents, and sealing compounds can burn easily, can give off harmful vapors, and are harmful to skin and clothing. To avoid injury or death, keep away from open fire and use in well-ventilated area. If adhesive, solvent, or sealing compound gets on skin or clothing, wash immediately with soap and water.

11. Apply adhesive to bottom of insulation (1).
12. Install insulation (1) on evaporator core housing (2).

FOLLOW-ON MAINTENANCE

1. Install AC heater/evaporator (WP 0038).

END OF WORK PACKAGE

AC FAN CONTROL SWITCH REPLACEMENT

THIS WORK PACKAGE (WP) COVERS:

- Removal
- Installation
- Follow-On Maintenance

INITIAL SETUP:

Maintenance Level

Field Level Maintenance

Equipment Condition

Batteries disconnected (TM 9-2320-279-20).
AC heater/evaporator cover removed (WP 0037).

Tools and Special Tools

Goggles (Item 1, Appendix F)
Tool Kit, General Mechanic's (Item 7, Appendix F)

Materials/Parts

Solvent, Dry Cleaning (Item 8, Appendix E)
Tags, Identification (Item 9, Appendix E)

Personnel Required

MOS 52C, Utilities equipment repairer

References

TM 9-2320-279-20

REMOVAL

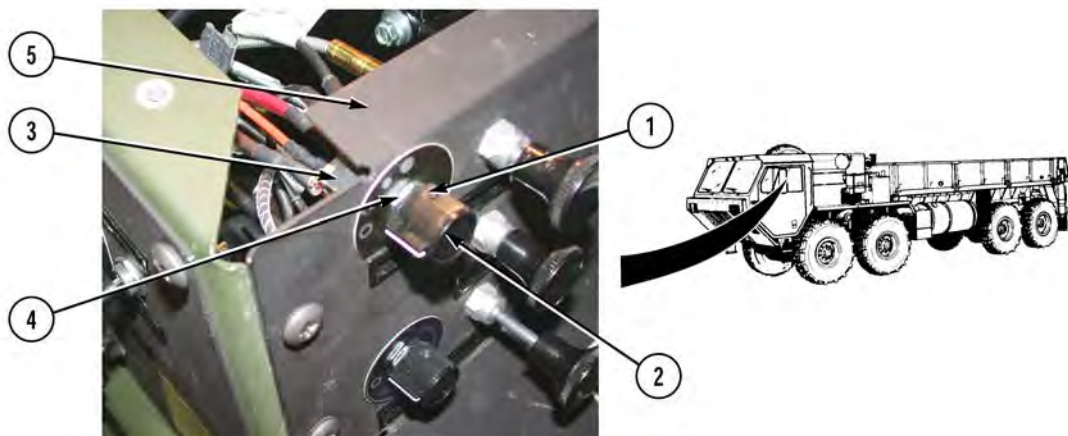

1. Loosen two screws (1) and remove knob (2) from fan control switch (3).

NOTE

Note position of fan control switch prior to removal to ensure proper installation.

2. Remove nut (4) and fan control switch (3) from center cover (5).

AC FAN CONTROL SWITCH REPLACEMENT - Continued



NOTE

Tag and mark connectors and wires prior to removal to ensure proper installation.

3. Disconnect connector (6) from connector (7).

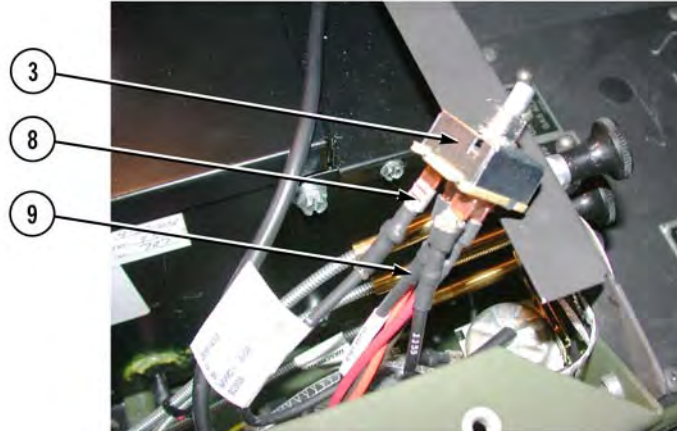

4. Remove wire 1156 (8) from terminal C of fan control switch (3).
5. Remove wire 1082 (9) from terminal B of fan control switch (3).

AC FAN CONTROL SWITCH REPLACEMENT - Continued

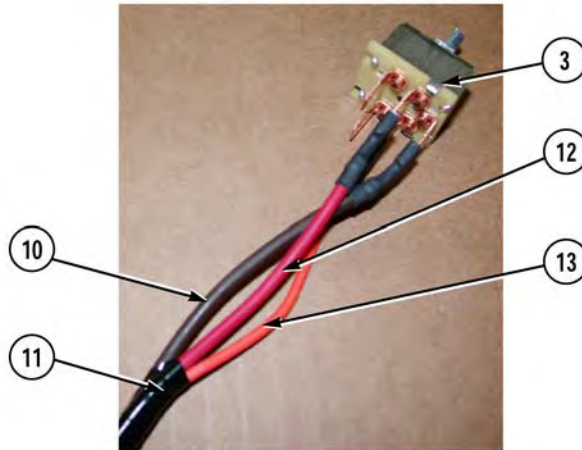

6. Remove brown wire (10) of wire harness (11) from terminal M of fan control switch (3).
7. Remove red wire (12) of wire harness (11) from terminal L of fan control switch (3).
8. Remove orange wire (13) of wire harness (11) from terminal H of fan control switch (3).



NOTE

Perform Step 9 if fan label needs to be removed.

9. Remove fan label (14) from center cover (5).

AC FAN CONTROL SWITCH REPLACEMENT - Continued

INSTALLATION



WARNING

- Dry cleaning solvent is TOXIC and flammable. Wear protective goggles and gloves; use only in a well-ventilated area; avoid contact with skin, eyes, and clothes; and DO NOT breathe vapors. Keep away from heat or flame. Never smoke when using dry cleaning solvent; the flashpoint for Type II is 140°F (60°C), and for Type III it is 200°F (93°C). Failure to follow this warning may result in death or injury to personnel.
- If personnel become dizzy while using dry cleaning solvent, immediately get fresh air and medical help. If solvent contacts skin or clothes, flush with cold water. If solvent contacts eyes, immediately flush them with water and get immediate medical attention.

NOTE

Perform Steps 1 through 3 if fan label was removed.

1. Clean center cover (5) where fan label (14) was mounted with dry cleaning solvent.
2. Peel paper back off of fan label (14).
3. Install fan label (14) on center cover (5).

AC FAN CONTROL SWITCH REPLACEMENT - Continued

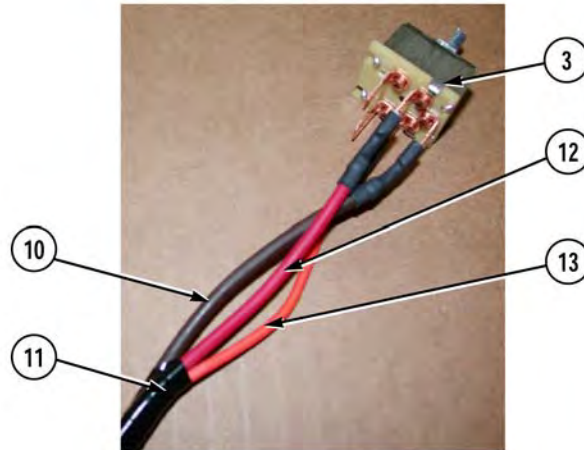

4. Install orange wire (13) of wire harness (11) on terminal H of fan control switch (3).
5. Install red wire (12) of wire harness (11) on terminal L of fan control switch (3).
6. Install brown wire (10) of wire harness (11) on terminal M of fan control switch (3).

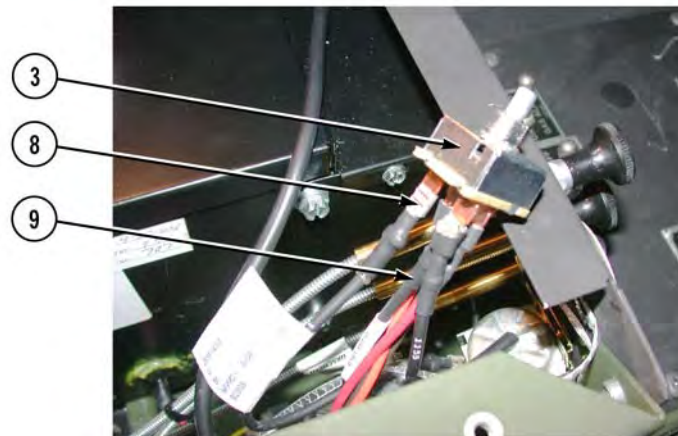

7. Install wire 1082 (9) on terminal B of fan control switch (3).
8. Install wire 1156 (8) on terminal C of fan control switch (3).

AC FAN CONTROL SWITCH REPLACEMENT - Continued

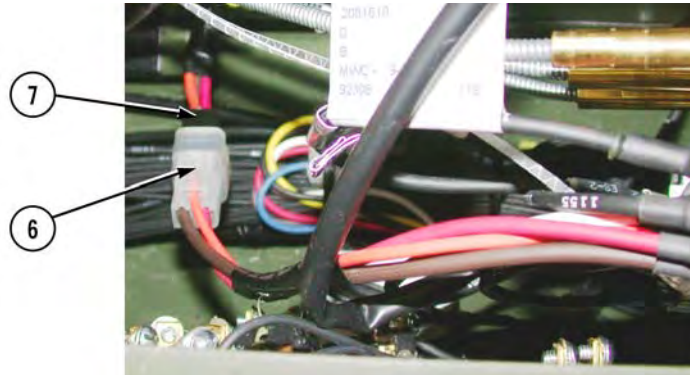

9. Connect connector (6) to connector (7).

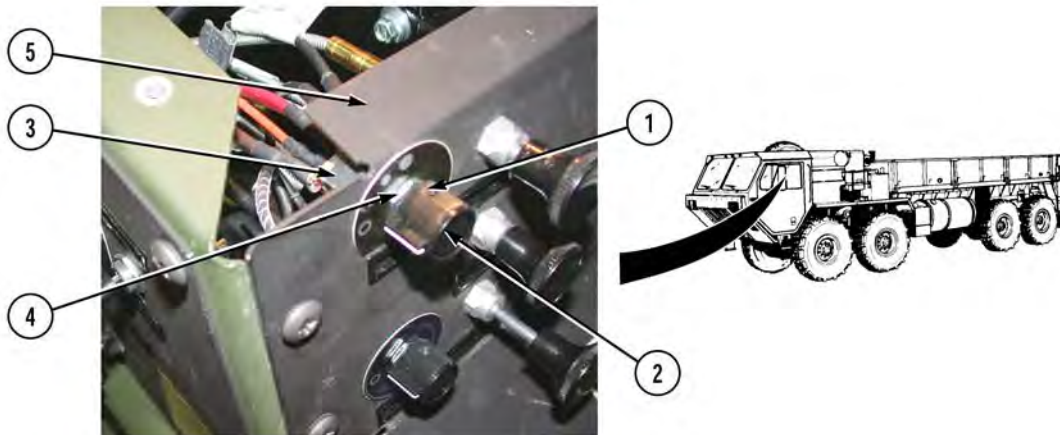

NOTE

Install fan control switch as noted prior to removal.

10. Install fan control switch (3) on center cover (5) with nut (4).
11. Install knob (2) on fan control switch (3) and tighten two screws (1).

FOLLOW-ON MAINTENANCE

1. Install AC heater/evaporator cover (WP 0037).
2. Connect batteries (TM 9-2320-279-20).

END OF WORK PACKAGE

AC HEATER CABLE REPLACEMENT

THIS WORK PACKAGE (WP) COVERS:

- Removal
- Installation
- Follow-On Maintenance

INITIAL SETUP:**Maintenance Level**

Field Level Maintenance

Equipment Condition

AC heater/evaporator removed (WP 0038).

Tools and Special Tools

Tool Kit, General Mechanic's (Item 7, Appendix F)

Materials/Parts

Ties, Cable (Item 12, Appendix E)

Personnel Required

MOS 52C, Utilities equipment repairer

ReferencesTM 9-2320-279-20

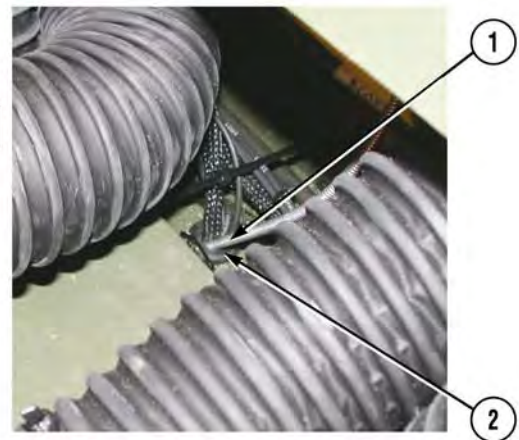
REMOVAL**NOTE**

- Remove cable ties as required.
 - Note routing of heater cable prior to removal to ensure proper installation.
1. Pull heater cable (1) through grommet (2).

AC HEATER CABLE REPLACEMENT - Continued

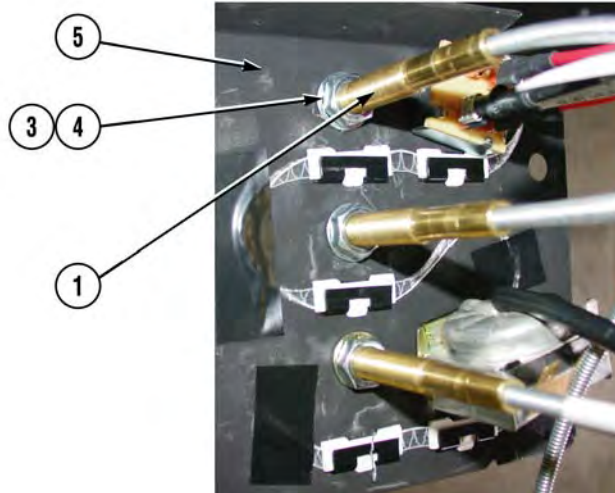

2. Remove nut (3), lockwasher (4), and heater cable (1) from center cover (5).

INSTALLATION

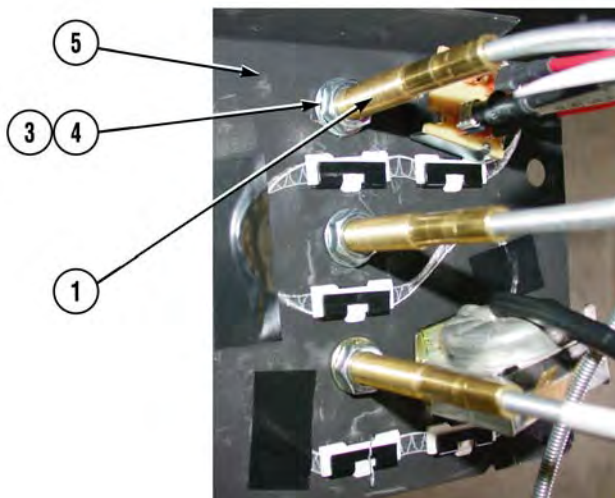

NOTE

Install cable ties as required.

1. Install heater cable (1) on center cover (5) with lockwasher (4) and nut (3).

AC HEATER CABLE REPLACEMENT - Continued

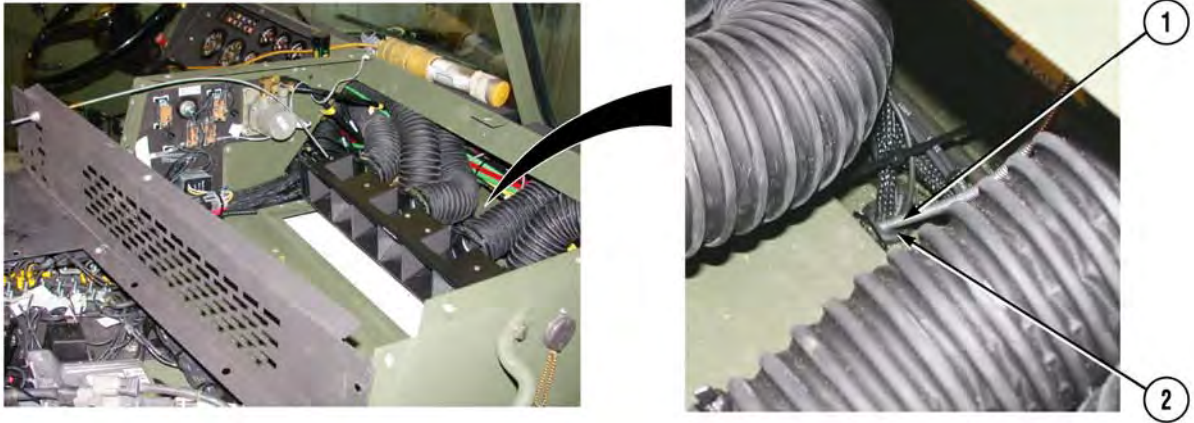

NOTE

Route heater cable as noted prior to removal.

2. Pull heater cable (1) through grommet (2).

FOLLOW-ON MAINTENANCE

1. Install AC heater/evaporator (WP 0038).

END OF WORK PACKAGE

AC HEATER CORE REPLACEMENT

THIS WORK PACKAGE (WP) COVERS:

Removal
Installation
Follow-On Maintenance

INITIAL SETUP:**Maintenance Level**

Field Level Maintenance

Materials/Parts

None

Equipment Condition

AC heater/evaporator removed (WP 0038).

Personnel Required

MOS 52C, Utilities equipment repairer

Tools and Special Tools

Tool Kit, General Mechanic's (Item 7, Appendix F)

References

TM 9-2320-279-20

AC HEATER CORE REPLACEMENT - Continued

REMOVAL

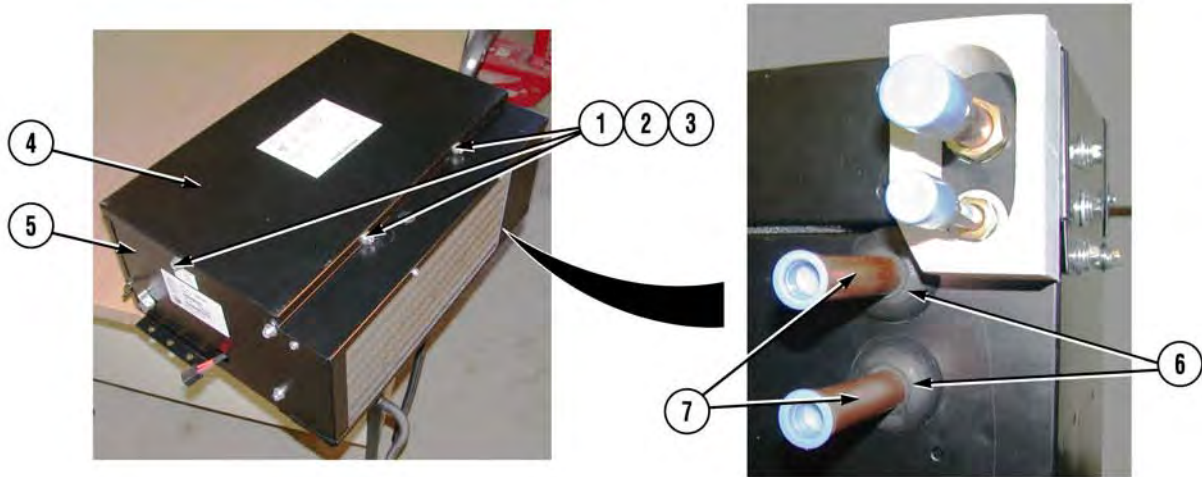

1. Remove four screws (1), lockwashers (2), washers (3), and cover (4) from heater/evaporator (5).
2. Remove two grommets (6) from flanges (7).

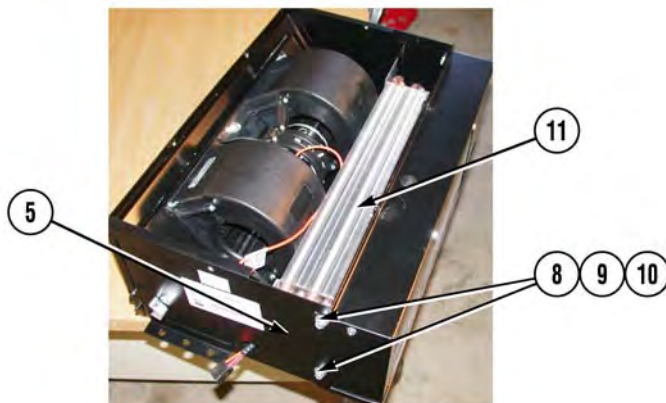

3. Remove two screws (8), lockwashers (9), and washers (10) from heater core (11) and heater/evaporator (5).
4. Remove heater core (11) from heater/evaporator (5).

AC HEATER CORE REPLACEMENT - Continued

INSTALLATION

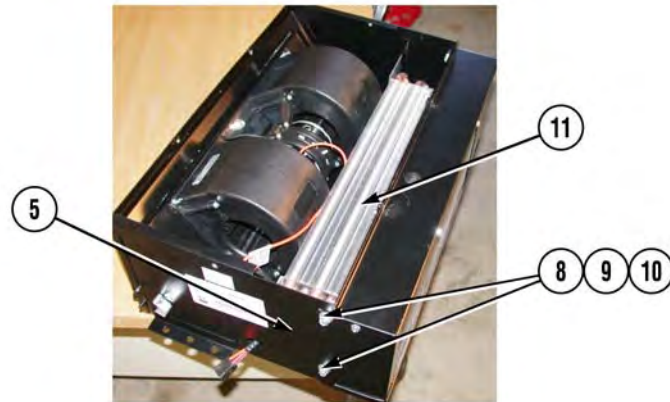

1. Install heater core (11) in heater/evaporator (5) with two washers (10), lockwashers (9), and screws (8).

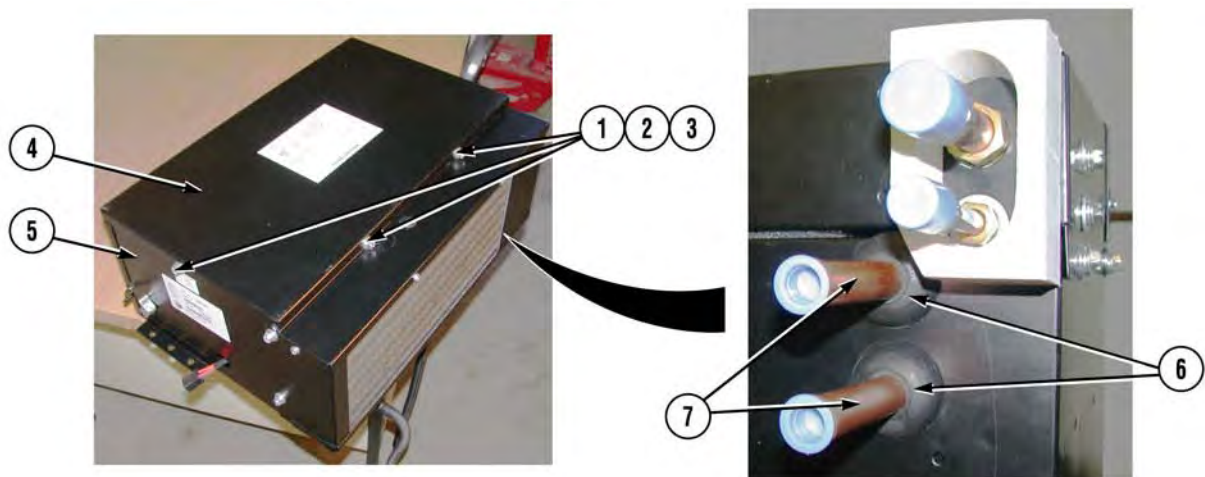

2. Install two grommets (6) on flanges (7).
3. Install cover (4) on heater/evaporator (5) with four washers (3), lockwashers (2), and screws (1).

FOLLOW-ON MAINTENANCE

1. Install AC heater/evaporator (WP 0038).

END OF WORK PACKAGE

AC HEATER/EVAPORATOR BLOWER MOTOR ASSEMBLY REPLACEMENT

THIS WORK PACKAGE (WP) COVERS:

Removal
 Installation
 Follow-On Maintenance

INITIAL SETUP:**Maintenance Level**

Field Level Maintenance

Equipment Condition

Batteries disconnected (TM 9-2320-279-20).
 AC upper plenums removed (WP 0045).

Tools and Special Tools

Tool Kit, General Mechanic's (Item 7, Appendix F)

Materials/Parts

Tags, Identification (Item 9, Appendix E)
 Tape, Insulation, Electrical (Item 10, Appendix E)

Personnel Required

MOS 52C, Utilities equipment repairer

References

TM 9-2320-279-20

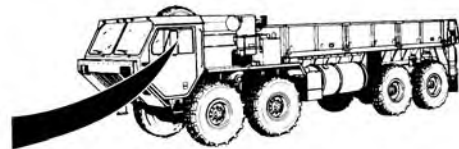
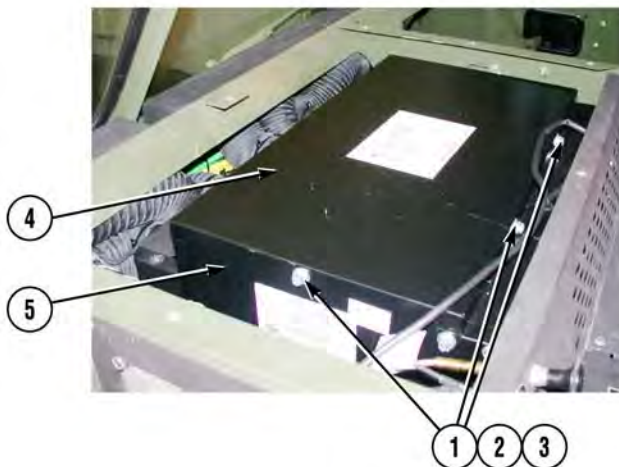
REMOVAL

1. Remove four screws (1), lockwashers (2), washers (3), and cover (4) from heater/evaporator (5).

**AC HEATER/EVAPORATOR BLOWER MOTOR ASSEMBLY REPLACEMENT -
Continued**

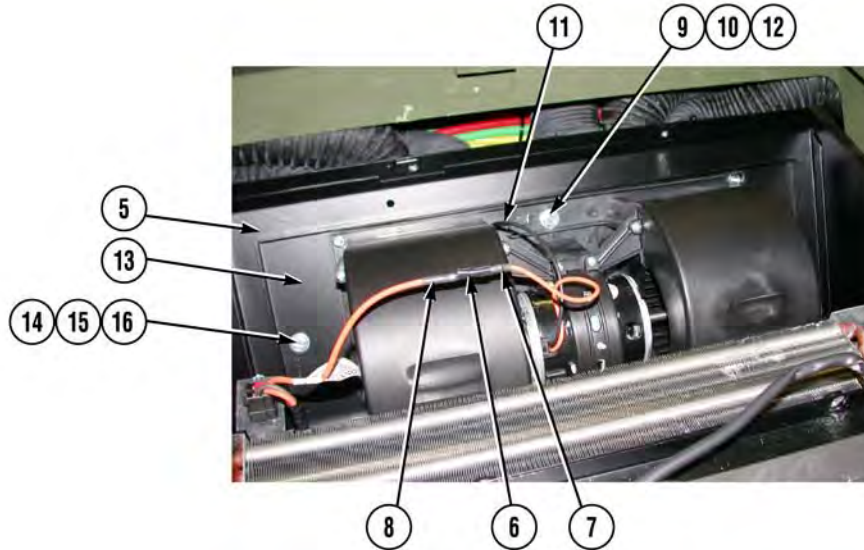

2. Remove electrical tape (6) from wire (7) and wire (8).

NOTE

Tag and mark wires prior to removal to ensure proper installation.

3. Disconnect wire (7) from wire (8).
4. Remove screw (9), lockwasher (10), wire (11), and washer (12) from blower motor assembly (13).
5. Remove two screws (14), lockwashers (15), washers (16), and blower motor assembly (13) from heater/evaporator (5).

AC HEATER/EVAPORATOR BLOWER MOTOR ASSEMBLY REPLACEMENT - Continued

INSTALLATION

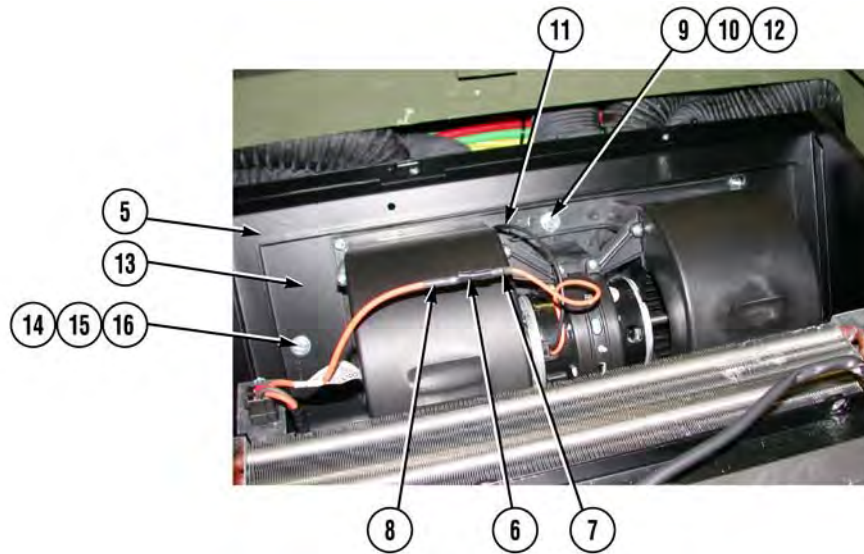

1. Install blower motor assembly (13) on heater/evaporator (5) with two washers (16), lockwashers (15), and screws (14).
2. Install washer (12), wire (11), lockwasher (10), and screw (9) on blower motor assembly (13).
3. Connect wire (7) to wire (8).
4. Apply electrical tape (6) to wire (7) and wire (8).

AC HEATER/EVAPORATOR BLOWER MOTOR ASSEMBLY REPLACEMENT - Continued

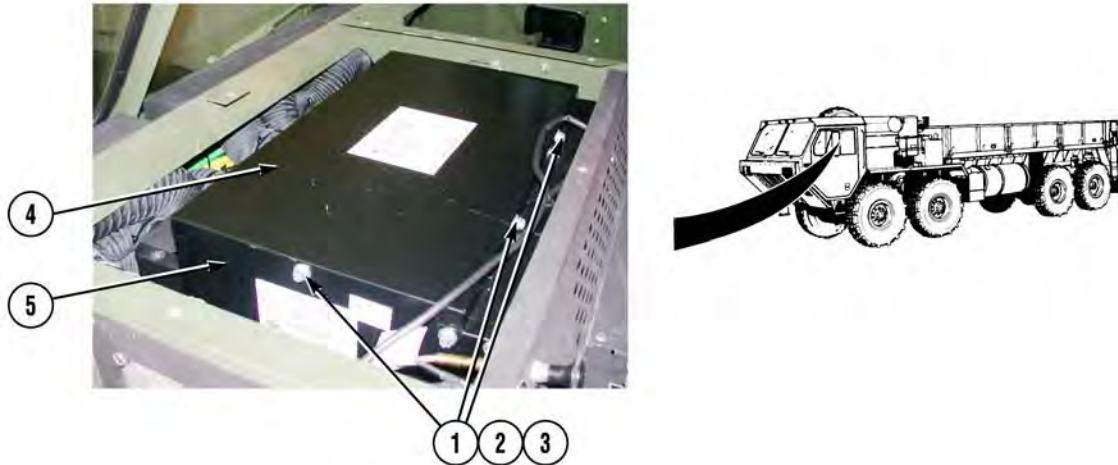

5. Install cover (4) on heater/evaporator (5) with four washers (3), lockwashers (2), and screws (1).

FOLLOW-ON MAINTENANCE

1. Install AC upper plenums (WP 0045).
2. Connect batteries (TM 9-2320-279-20).

END OF WORK PACKAGE

AC HEATER/EVAPORATOR BLOWER MOTOR RESISTOR REPLACEMENT

THIS WORK PACKAGE (WP) COVERS:

- Removal
- Installation
- Follow-On Maintenance

INITIAL SETUP:

Maintenance Level

Field Level Maintenance

Equipment Condition

Batteries disconnected (TM 9-2320-279-20).
AC upper plenums removed (WP 0045).

Tools and Special Tools

Tool Kit, General Mechanic's (Item 7, Appendix F)

Materials/Parts

Tags, Identification (Item 9, Appendix E)

Personnel Required

MOS 52C, Utilities equipment repairer

References

TM 9-2320-279-20

AC HEATER/EVAPORATOR BLOWER MOTOR RESISTOR REPLACEMENT - Continued

REMOVAL

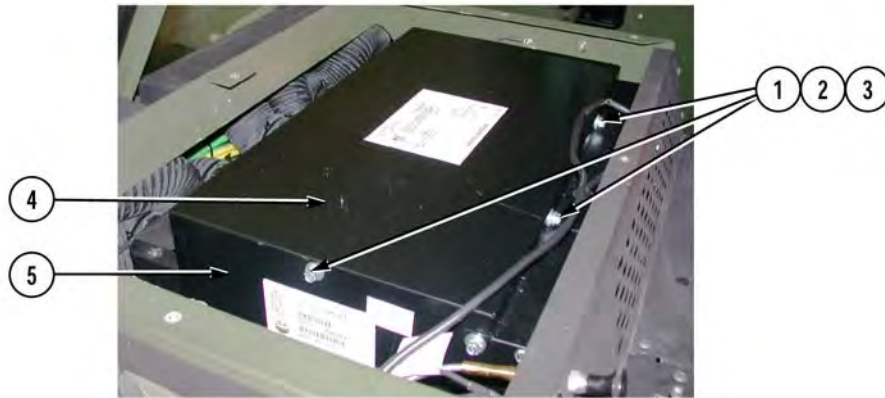

1. Remove four screws (1), lockwashers (2), washers (3), and cover (4) from heater/evaporator (5).

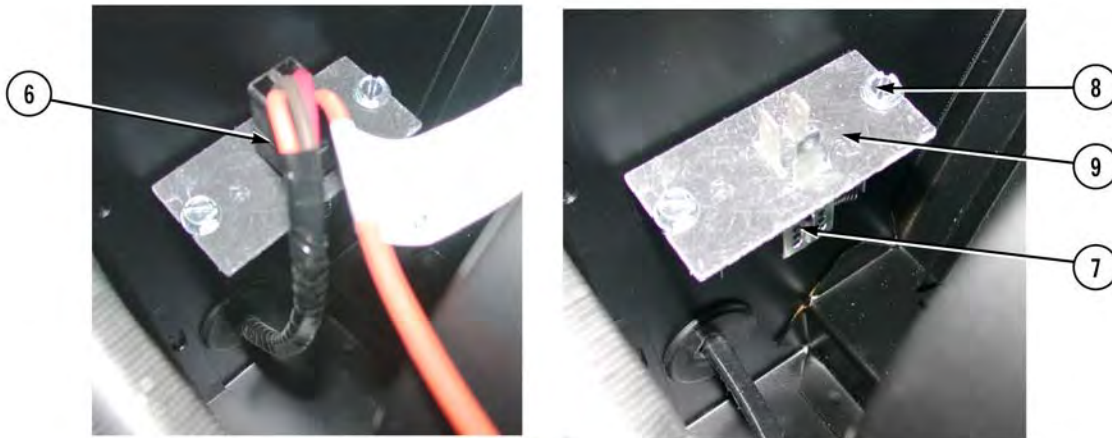

NOTE

Tag and mark connectors prior to removal to ensure proper installation.

2. Disconnect connector (6) from resistor (7).
3. Remove two screws (8) and resistor (7) from bracket (9).

AC HEATER/EVAPORATOR BLOWER MOTOR RESISTOR REPLACEMENT - Continued

INSTALLATION

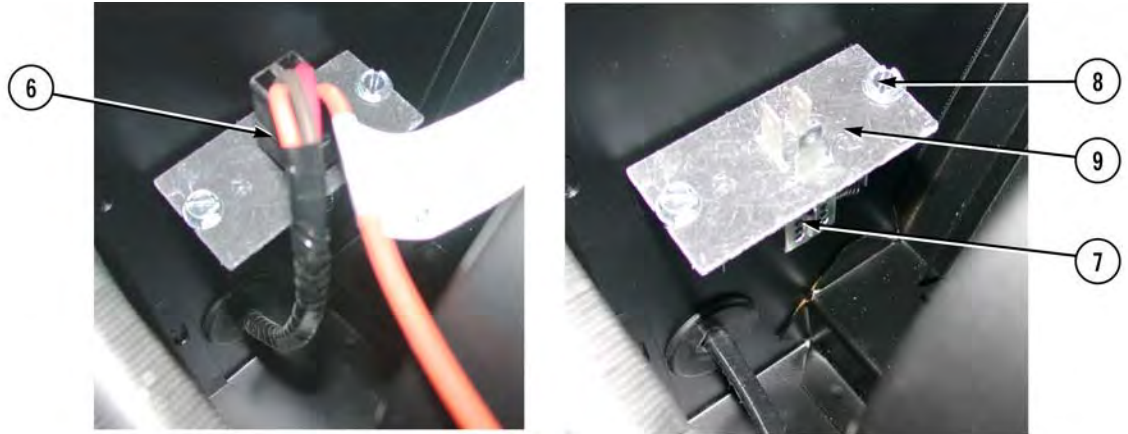

1. Install resistor (7) on bracket (9) with two screws (8).
2. Connect connector (6) to resistor (7).

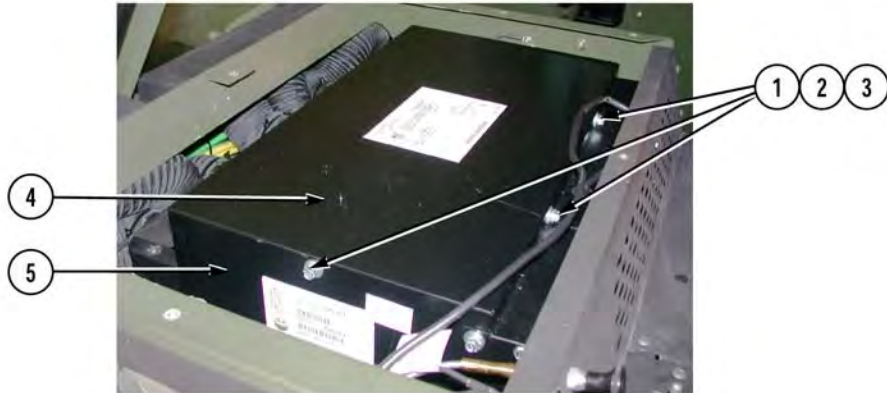

3. Install cover (4) on heater/evaporator (5) with four washers (3), lockwashers (2), and screws (1).

FOLLOW-ON MAINTENANCE

1. Install AC upper plenums (WP 0045).
2. Connect batteries (TM 9-2320-279-20).

END OF WORK PACKAGE

AC HEATER/EVAPORATOR BLOWER MOTOR RESISTOR HARNESS REPLACEMENT

THIS WORK PACKAGE (WP) COVERS:

- Removal
- Installation
- Follow-On Maintenance

INITIAL SETUP:

Maintenance Level

Field Level Maintenance

Equipment Condition

Batteries disconnected (TM 9-2320-279-20).
AC upper plenums removed (WP 0045).

Tools and Special Tools

Tool Kit, General Mechanic's (Item 7, Appendix F)

Materials/Parts

Tags, Identification (Item 9, Appendix E)
Tape, Insulation, Electrical (Item 10, Appendix E)

Personnel Required

MOS 52C, Utilities equipment repairer

References

TM 9-2320-279-20

REMOVAL

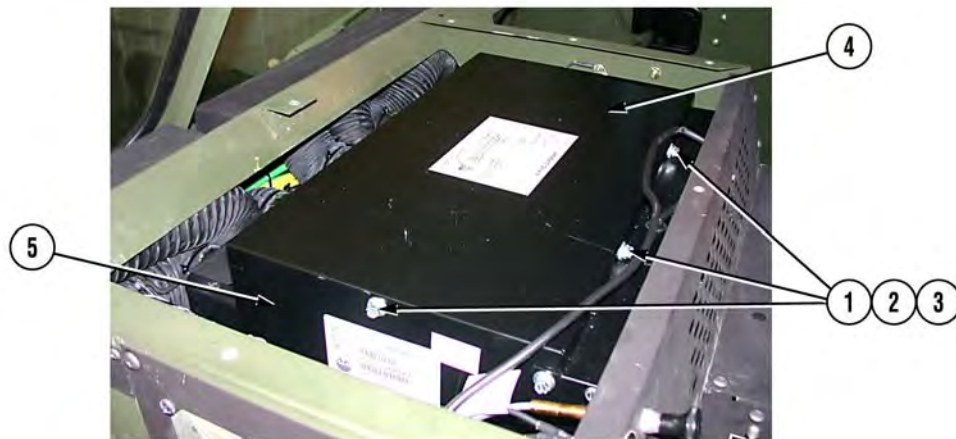

1. Remove four screws (1), lockwashers (2), washers (3), and cover (4) from heater/evaporator (5).

AC HEATER/EVAPORATOR BLOWER MOTOR RESISTOR HARNESS REPLACEMENT - Continued

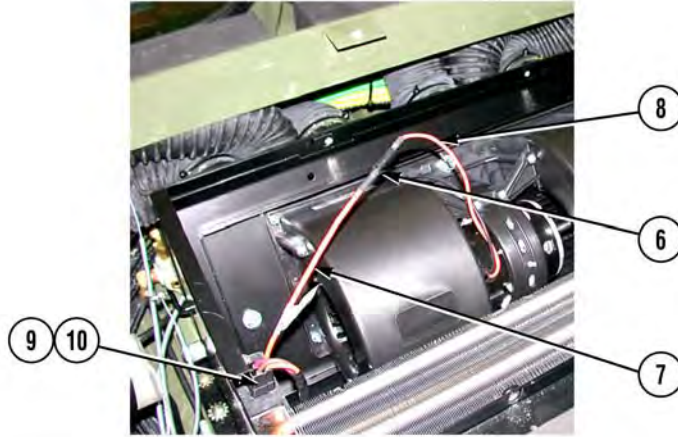

2. Remove electrical tape (6) from wire (7) and wire (8).

NOTE

Tag and mark wires and connectors prior to removal to ensure proper installation.

3. Disconnect wire (7) from wire (8).
4. Disconnect connector (9) from resistor (10).

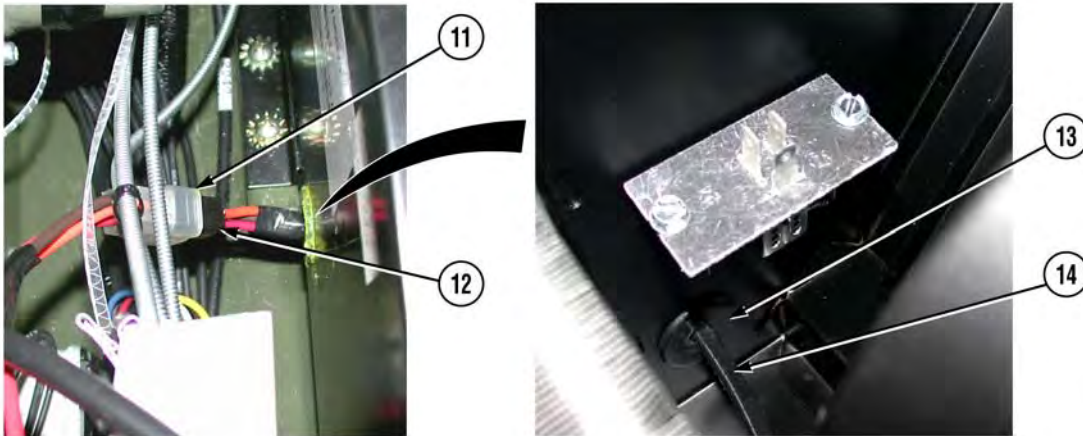

5. Disconnect connector (11) from connector (12).
6. Pull connector (12) through grommet (13) and remove wire harness (14) from vehicle.

AC HEATER/EVAPORATOR BLOWER MOTOR RESISTOR HARNESS REPLACEMENT - Continued

INSTALLATION

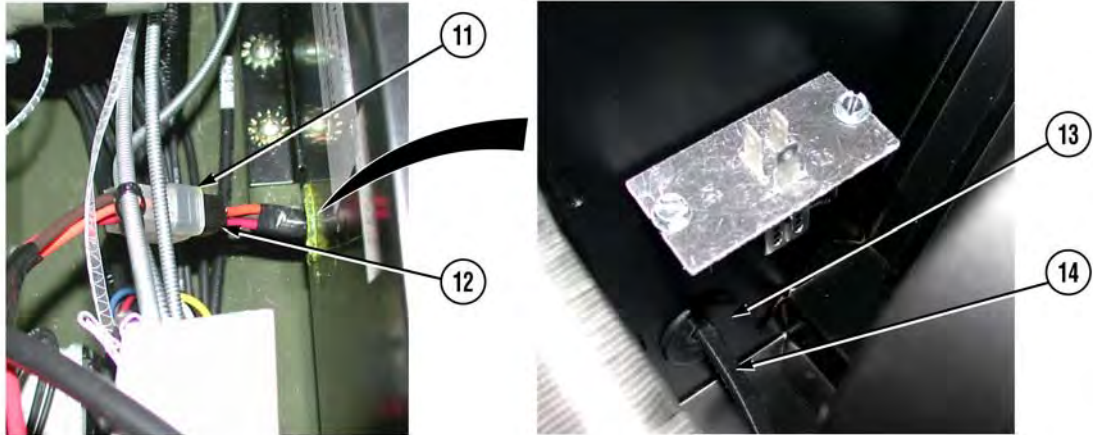

1. Route connector (12) through grommet (13).
2. Connect connector (11) to connector (12).



3. Connect connector (9) to resistor (10).
4. Connect wire (7) to wire (8).
5. Apply electrical tape (6) to wire (7) and wire (8).

AC HEATER/EVAPORATOR BLOWER MOTOR RESISTOR HARNESS REPLACEMENT - Continued

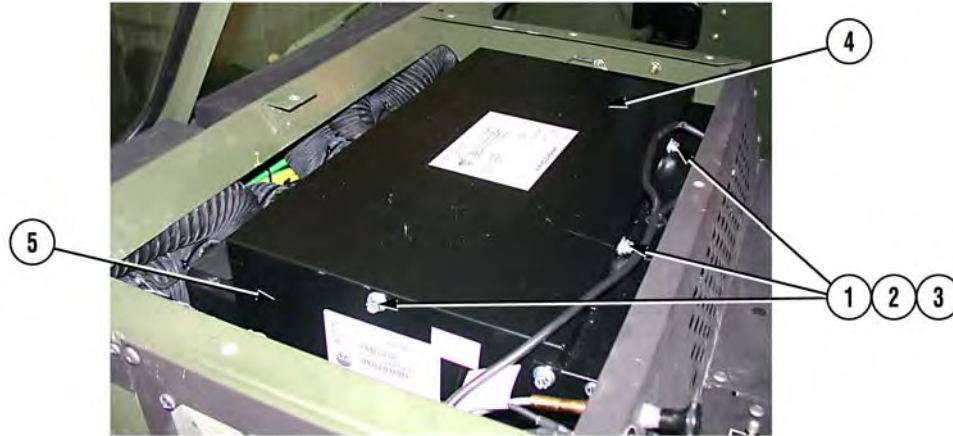

6. Install cover (4) on heater/evaporator (5) with four washers (3), lockwashers (2), and screws (1).

FOLLOW-ON MAINTENANCE

1. Install AC upper plenums (WP 0045).
2. Connect batteries (TM 9-2320-279-20).

END OF WORK PACKAGE

AC HEATER/EVAPORATOR COVER AND DEFROST LOUVERS REPLACEMENT

THIS WORK PACKAGE (WP) COVERS:

Removal
Installation
Follow-On Maintenance

INITIAL SETUP:**Maintenance Level**

Field Level Maintenance

Materials/Parts

None

Equipment Condition

Shut off engine (TM 9-2320-279-10).

Personnel Required

MOS 52C, Utilities equipment repairer

Tools and Special Tools

Tool Kit, General Mechanic's (Item 7, Appendix F)

References

TM 9-2320-279-10
TM 9-2320-279-20

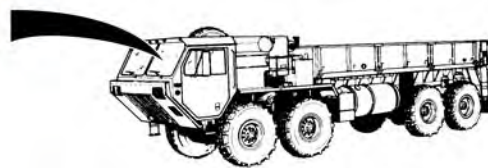
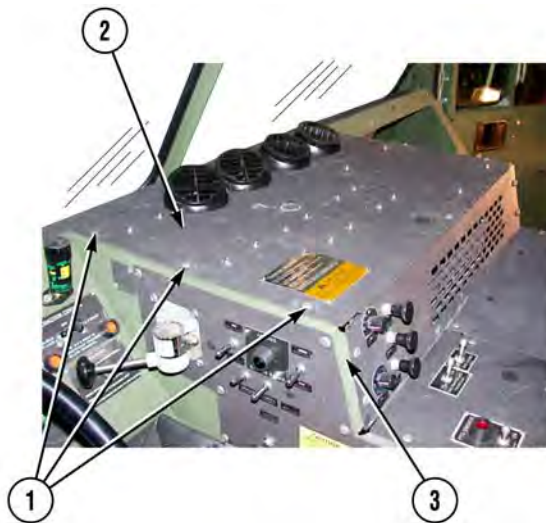
REMOVAL

1. Remove eight screws (1) and heater/evaporator cover (2) from console (3).

**AC HEATER/EVAPORATOR COVER AND DEFROST LOUVERS REPLACEMENT -
Continued**

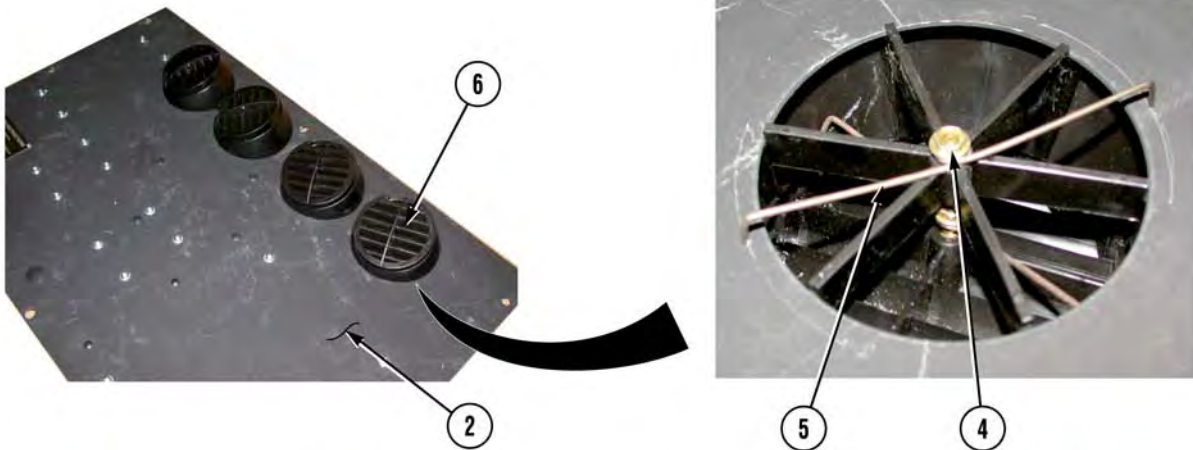

NOTE

- Perform Step 2 if defrost louvers need to be removed.
 - All defrost louvers are removed the same way.
 - Note position of defrost louvers prior to removal to ensure proper installation.
2. Remove screw (4), spring (5), and defrost louver (6) from heater/evaporator cover (2).

AC HEATER/EVAPORATOR COVER AND DEFROST LOUVERS REPLACEMENT - Continued

INSTALLATION

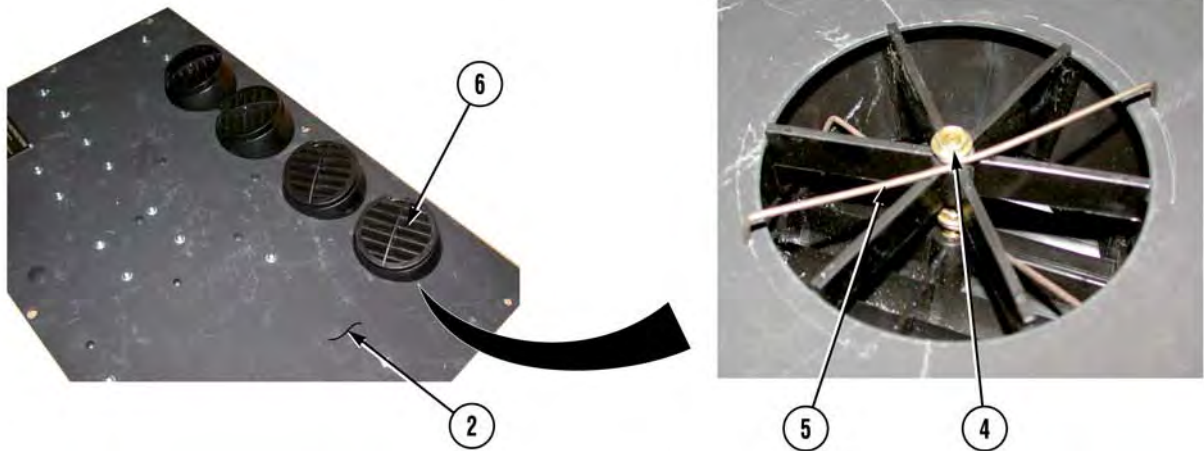

NOTE

- Perform Step 1 if defrost louvers were removed.
 - All defrost louvers are installed the same way.
 - Install defrost louvers as noted prior to removal.
1. Install defrost louver (6) on heater/evaporator cover (2) with spring (5) and screw (4).

**AC HEATER/EVAPORATOR COVER AND DEFROST LOUVERS REPLACEMENT -
Continued**

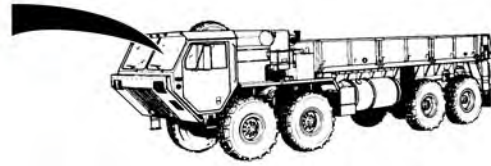
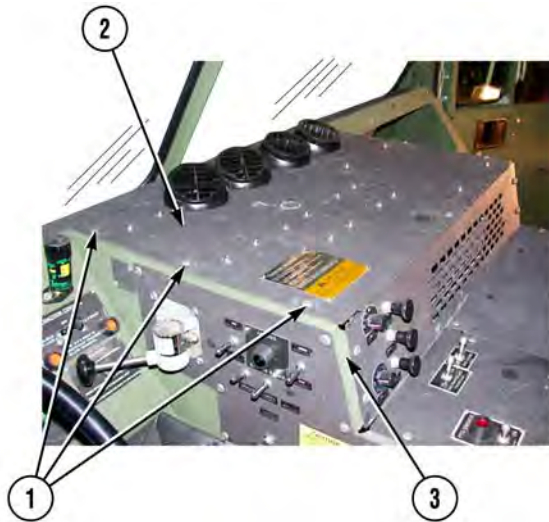

2. Install heater/evaporator cover (2) on console (3) with eight screws (1).

FOLLOW-ON MAINTENANCE

None

END OF WORK PACKAGE

AC HEATER/EVAPORATOR REPLACEMENT

THIS WORK PACKAGE (WP) COVERS:

- Removal
- Installation
- Follow-On Maintenance

INITIAL SETUP:

Maintenance Level

Field Level Maintenance

Equipment Condition

Batteries disconnected (TM 9-2320-279-20).
 Cooling system drained (TM 9-2320-279-20).
 Refrigerant recovered (WP 0050).
 Skid plate grille removed (TM 9-2320-279-20).
 AC upper plenums removed (WP 0045).

Tools and Special Tools

Set, Cap and Plug (Item 3, Appendix F)
 Shop Equipment, Common No. 1 (Item 4, Appendix F)
 Shop Equipment, Common No. 2 (Item 5, Appendix F)
 Tool Kit, General Mechanic's (Item 7, Appendix F)

Materials/Parts

Solution, Soap (Item 7, Appendix E)
 Tags, Identification (Item 9, Appendix E)
 Ties, Cable (Item 13, Appendix E)

Personnel Required

MOS 52C, Utilities equipment repairer (2)

References

TM 9-2320-279-10
 TM 9-2320-279-20

REMOVAL

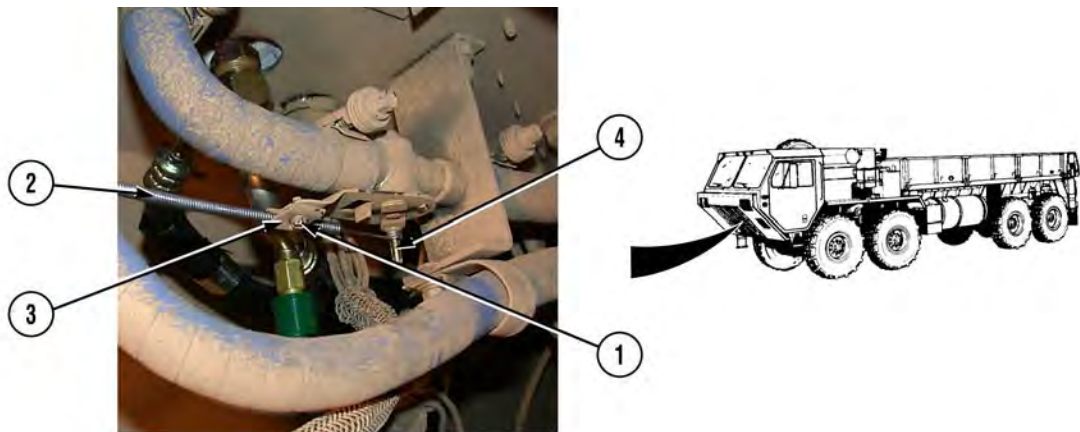

1. Loosen screw (1) and remove heater cable (2) from retainer (3).
2. Remove heater cable (2) from heater control valve (4).

AC HEATER/EVAPORATOR REPLACEMENT - Continued



NOTE

- Tag and mark hoses, connectors, and wires prior to removal to ensure proper installation.
 - Cap and plug hoses upon removal.
3. Loosen two clamps (5) and remove heater hoses (6) from flanges (7).
 4. Remove hose (8) and preformed packing (9) from fitting (10).
 5. Remove hose (11) and preformed packing (12) from fitting (13).



6. Remove cable tie (14) from two drain hoses (15).

AC HEATER/EVAPORATOR REPLACEMENT - Continued

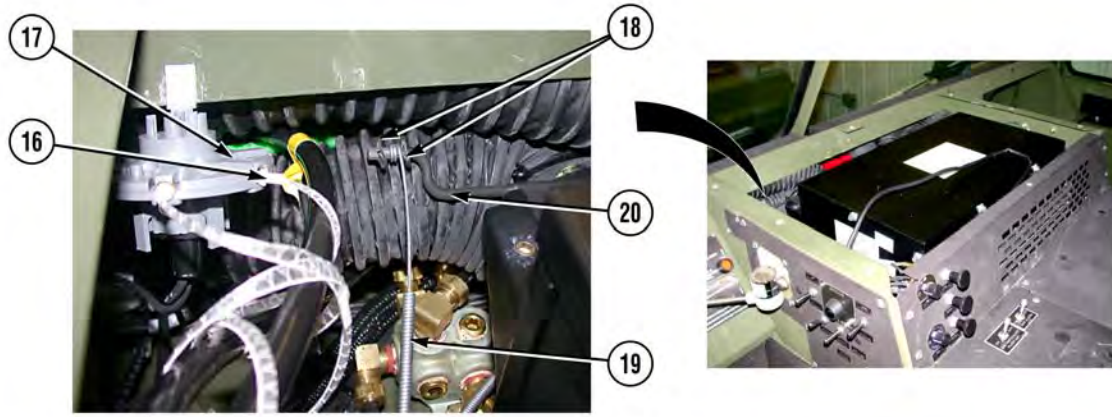

7. Unplug optic ribbon (16) from light source (17).
8. Remove two speed nuts (18) and AC cable (19) from damper control arm (20).

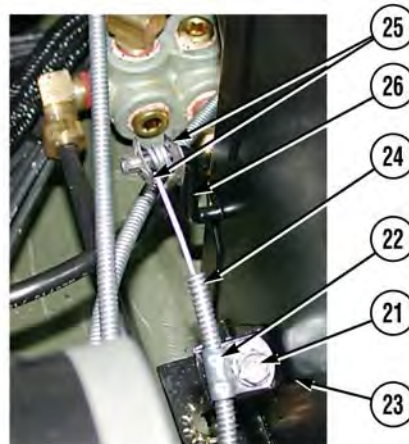

9. Remove screw (21) and retainer (22) from heater/evaporator (23).
10. Remove retainer (22) from defrost cable (24).
11. Remove two speed nuts (25) and defrost cable (24) from control arm (26).

AC HEATER/EVAPORATOR REPLACEMENT - Continued

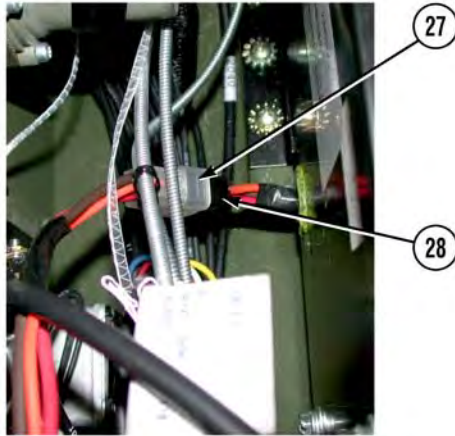

12. Disconnect connector (27) from connector (28).

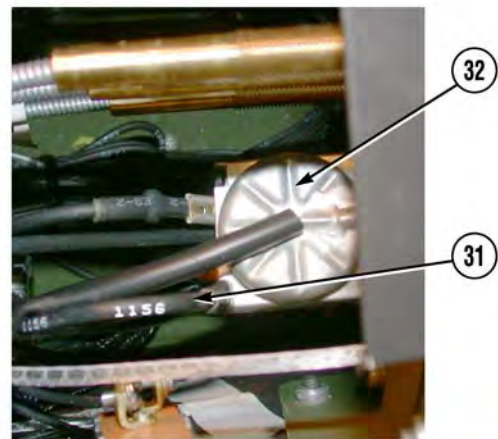
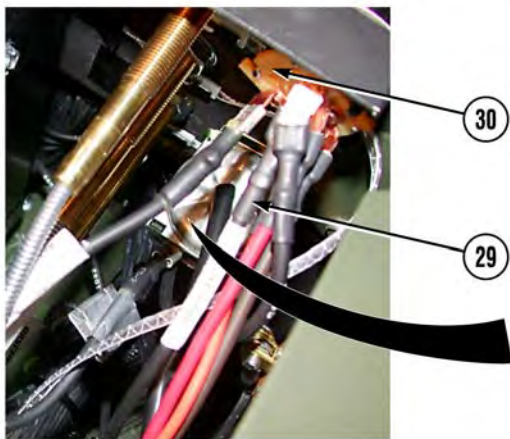

FAN CONTROL SWITCH REMOVED FOR CLARITY

13. Remove wire 1082 (29) from terminal B of fan control switch (30).

14. Remove wire 1156 (31) from OUT terminal of temperature control switch (32).

AC HEATER/EVAPORATOR REPLACEMENT - Continued

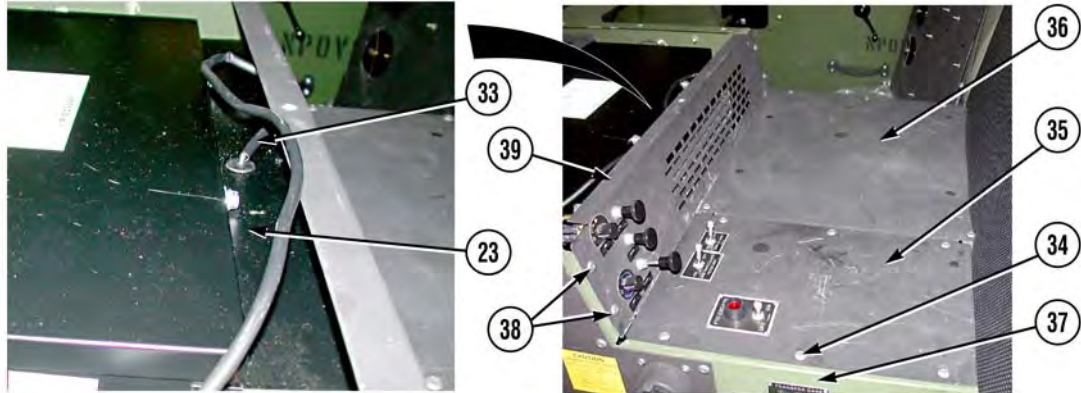

CAUTION

Remove temperature probe slowly from heater/evaporator. Failure to comply may result in damage to temperature probe.

15. Remove temperature probe (33) from heater/evaporator (23).
16. Remove 11 screws (34) and two console covers (35 and 36) from console (37).
17. Remove four screws (38) and center cover (39) from console (37).

AC HEATER/EVAPORATOR REPLACEMENT - Continued

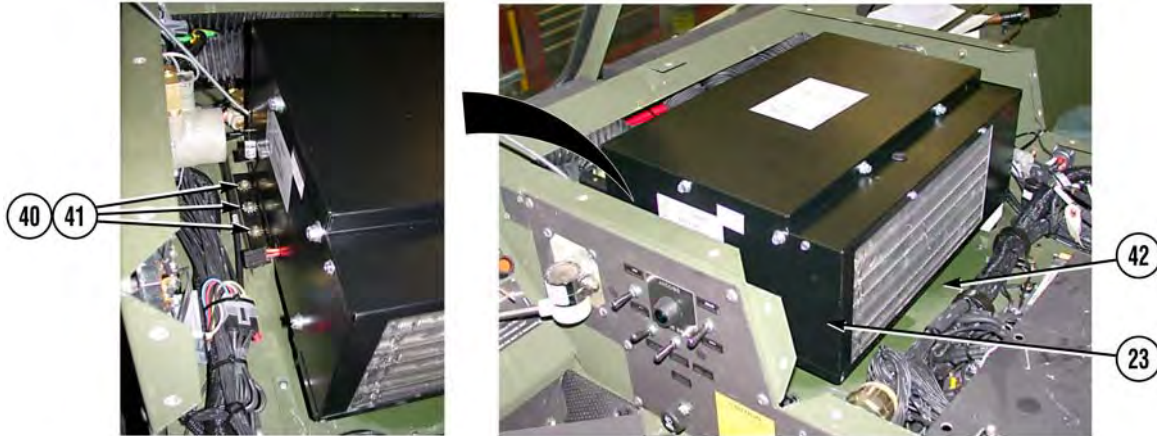

18. Remove six screws (40) and lockwashers (41) from heater/evaporator (23) and cab (42).

WARNING

Do not remove heater/evaporator without the aid of an assistant. Failure to comply may result in injury to personnel and/or damage to equipment.

CAUTION

Use extreme care when removing heater/evaporator from cab. Failure to comply may result in damage to equipment.

19. With Soldier A on driver side of cab and Soldier B on passenger side of cab, remove heater/evaporator (23) from cab (42).

AC HEATER/EVAPORATOR REPLACEMENT - Continued



20. Remove two grommets (43) from cab (42).

21. Remove two grommets (44) from plate (45).

AC HEATER/EVAPORATOR REPLACEMENT - Continued

INSTALLATION



1. Install two grommets (44) on plate (45).
2. Install two grommets (43) on cab (42).

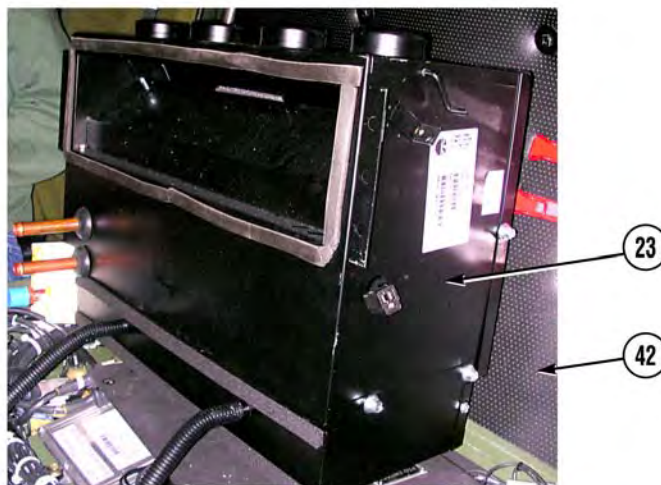

WARNING

Do not install heater/evaporator without the aid of an assistant. Failure to comply may result in injury to personnel and/or damage to equipment.

3. Soldier A and Soldier B position heater/evaporator (23) in cab (42).

AC HEATER/EVAPORATOR REPLACEMENT - Continued

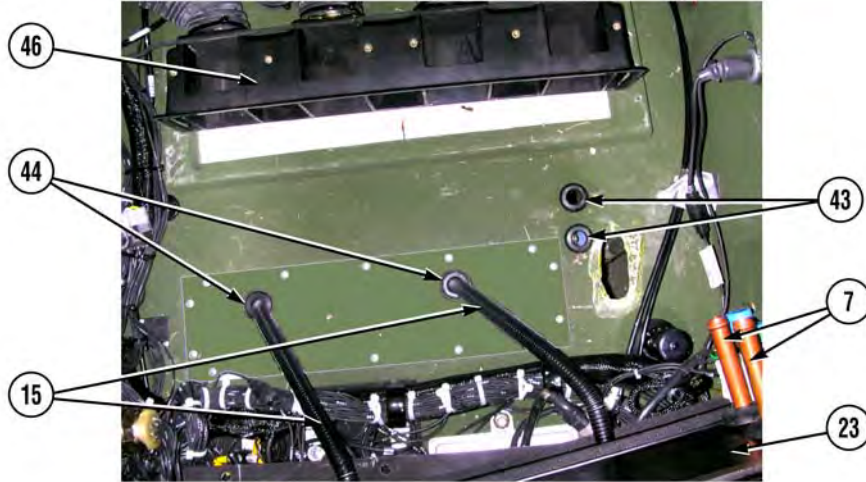

4. Coat four grommets (43 and 44) with soap solution.

CAUTION

Ensure that grommets are not dislodged during installation of heater/evaporator. If grommets are not positioned properly, flanges and drain hoses may be damaged.

5. Soldier A and Soldier B position two flanges (7) through grommets (43), and drain hoses (15) through grommets (44) while positioning lower plenum (46) on heater/evaporator (23).

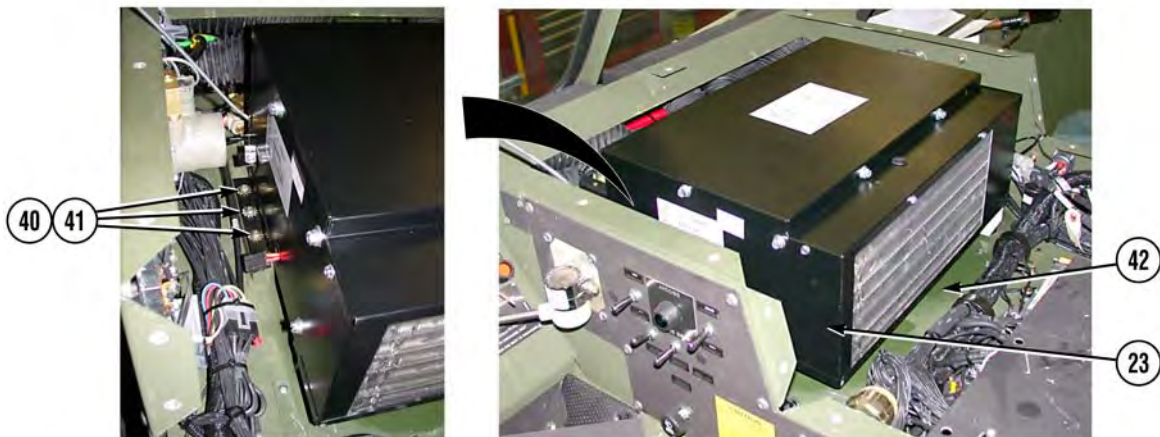

6. Install heater/evaporator (23) in cab (42) with six lockwashers (41) and screws (40).

AC HEATER/EVAPORATOR REPLACEMENT - Continued

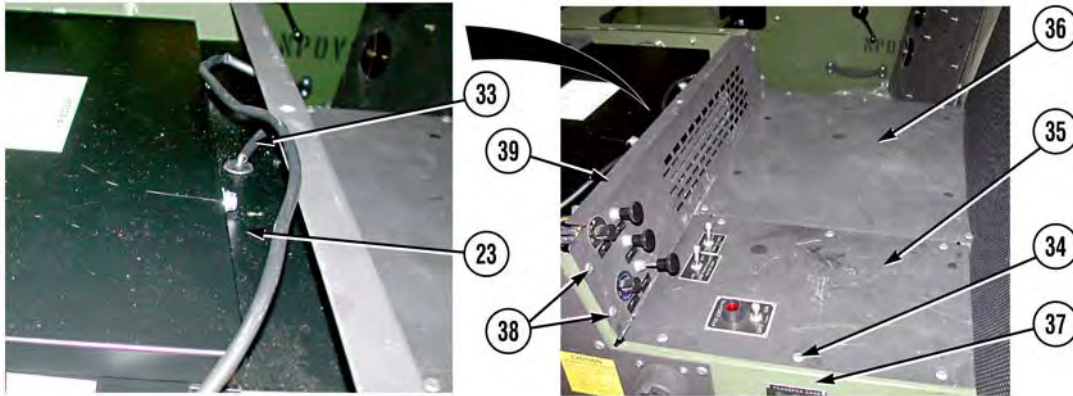

7. Install center cover (39) on console (37) with four screws (38).
8. Install two console covers (35 and 36) on console (37) with 11 screws (34).

CAUTION

- **Do not puncture temperature probe. Failure to comply will cause gas in tube to leak out.**
- **Install temperature probe slowly into heater/evaporator. Failure to comply may result in damage to temperature probe.**

NOTE

Temperature control switch temperature probe is installed correctly when it is inserted into the AC evaporator core until it touches the bottom of the insertion hole.

9. Install temperature probe (33) into heater/evaporator (23).

AC HEATER/EVAPORATOR REPLACEMENT - Continued

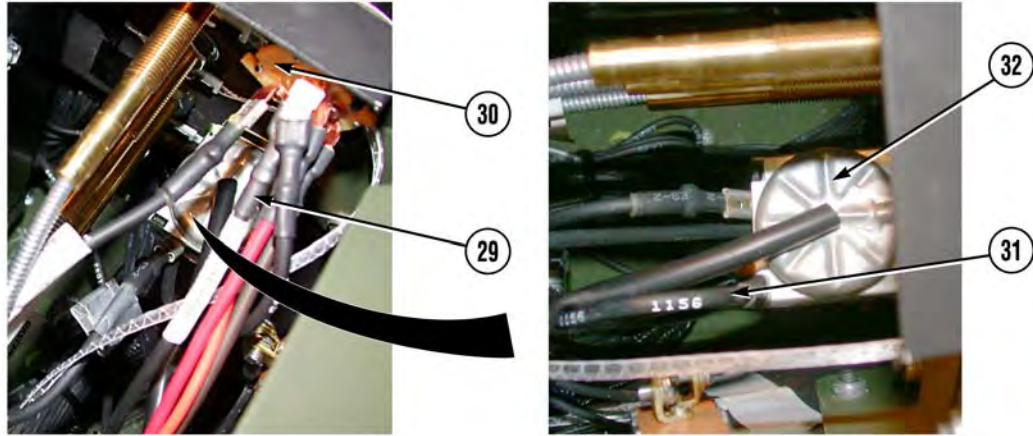

FAN CONTROL SWITCH REMOVED FOR CLARITY

10. Install wire 1156 (31) on OUT terminal of temperature control switch (32).
11. Install wire 1082 (29) on terminal B of fan control switch (30).

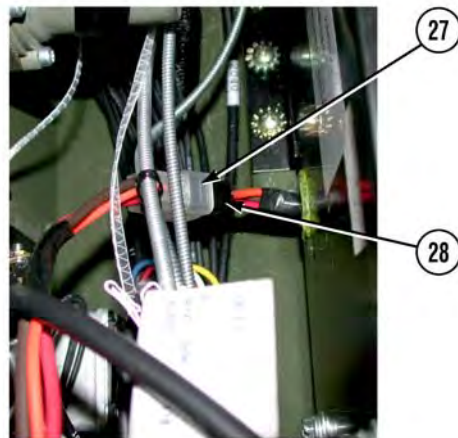

12. Connect connector (27) to connector (28).

AC HEATER/EVAPORATOR REPLACEMENT - Continued

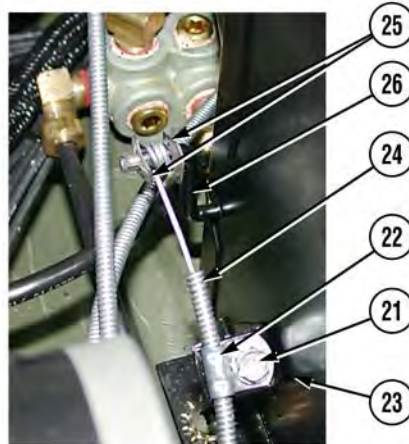

13. Install defrost cable (24) on control arm (26) with two speed nuts (25).
14. Place retainer (22) on defrost cable (24).
15. Install retainer (22) on heater/evaporator (23) with screw (21).

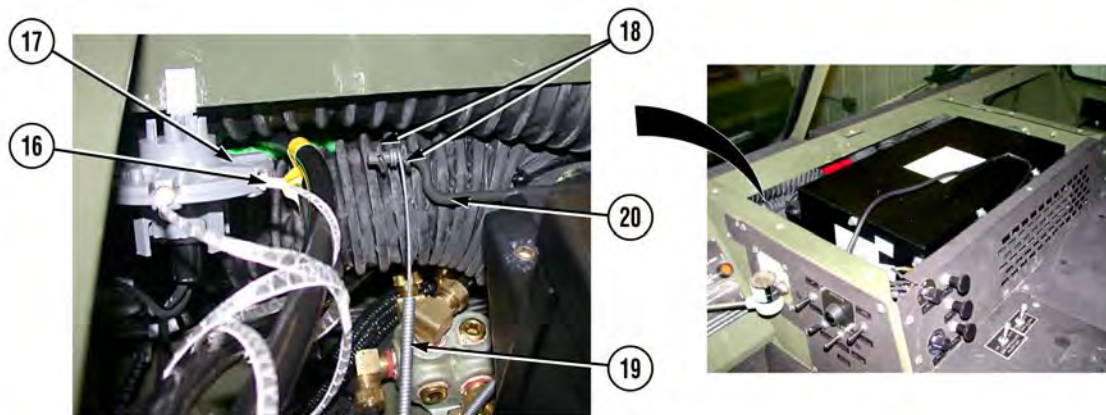

16. Install AC cable (19) on damper control arm (20) with two speed nuts (18).
17. Plug optic ribbon (16) into light source (17).

AC HEATER/EVAPORATOR REPLACEMENT - Continued



18. Secure two drain hoses (15) together with cable tie (14).



19. Install preformed packing (12) and hose (11) on fitting (13). Torque hose (11) to 11-13 ft-lbs. (15-18 N•m).
20. Install preformed packing (9) and hose (8) on fitting (10). Torque hose (8) to 18-22 ft-lbs. (24-30 N•m).
21. Install two heater hoses (6) on flanges (7) and tighten clamps (5).

AC HEATER/EVAPORATOR REPLACEMENT - Continued

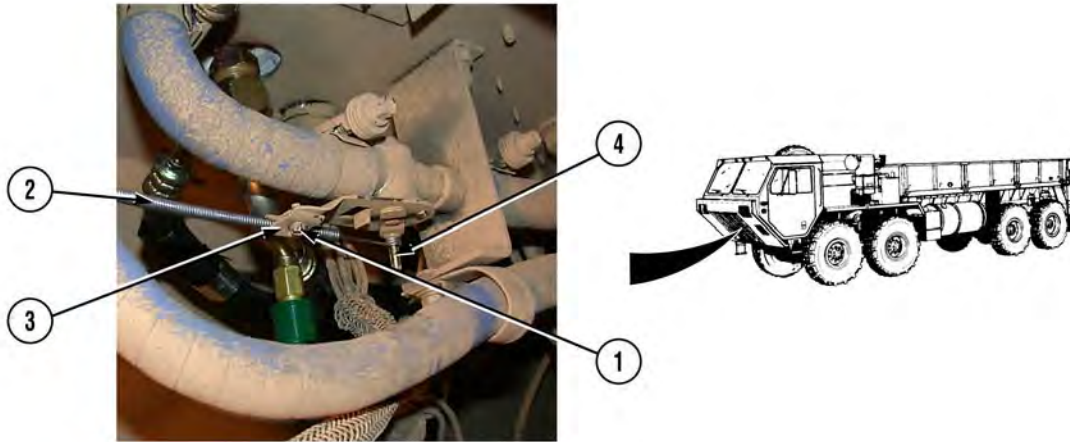

22. Install heater cable (2) on heater control valve (4).
23. Install heater cable (2) in retainer (3) and tighten screw (1).

FOLLOW-ON MAINTENANCE

1. Install AC upper plenums (WP 0045).
2. Connect batteries (TM 9-2320-279-20).
3. Fill cooling system (TM 9-2320-279-20).
4. Charge AC system (WP 0050).
5. Perform leak test inspection (WP 0049).
6. Start engine and warm up to normal operating temperature (TM 9-2320-279-10).
7. Check operation of heater/evaporator.
8. Check heater hoses for leaks.
9. Shut off engine (TM 9-2320-279-10).
10. Install skid plate grille (TM 9-2320-279-20).

END OF WORK PACKAGE

AC HIGH PRESSURE SWITCH REPLACEMENT

THIS WORK PACKAGE (WP) COVERS:

- Removal
- Installation
- Follow-On Maintenance

INITIAL SETUP:

Maintenance Level

Field Level Maintenance

Equipment Condition

Batteries disconnected (TM 9-2320-279-20).
Engine cover opened and engine side panel removed (TM 9-2320-279-10).

Tools and Special Tools

Shop Equipment, Common No. 1 (Item 4, Appendix F)
Shop Equipment, Common No. 2 (Item 5, Appendix F)

Tool Kit, General Mechanic's (Item 7, Appendix F)

Materials/Parts

Tags, Identification (Item 9, Appendix E)
Ties, Cable (Item 12, Appendix E)

Personnel Required

MOS 52C, Utilities equipment repairer

References

TM 9-2320-279-10
TM 9-2320-279-20

REMOVAL

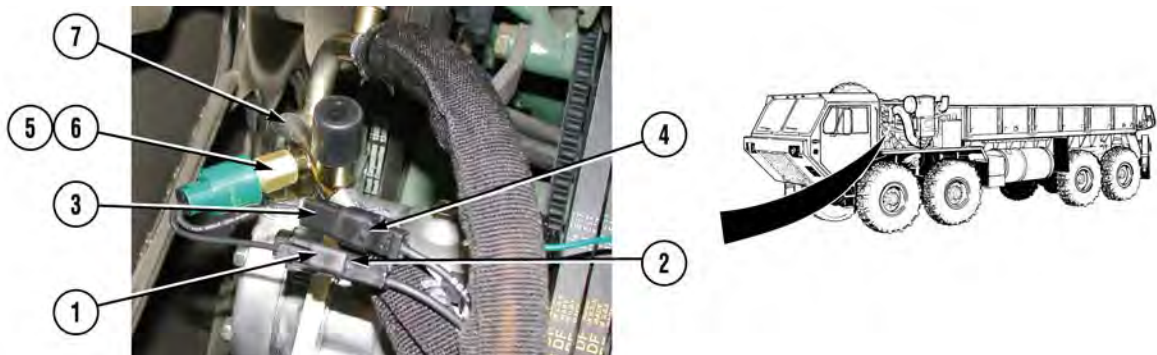

NOTE

- Tag and mark connectors prior to removal to ensure proper installation.
 - Remove cable ties as required.
1. Disconnect connector (1) from connector (2).
 2. Disconnect connector (3) from connector (4).
 3. Remove high pressure switch (5) and preformed packing (6) from hose (7).

AC HIGH PRESSURE SWITCH REPLACEMENT - Continued

INSTALLATION

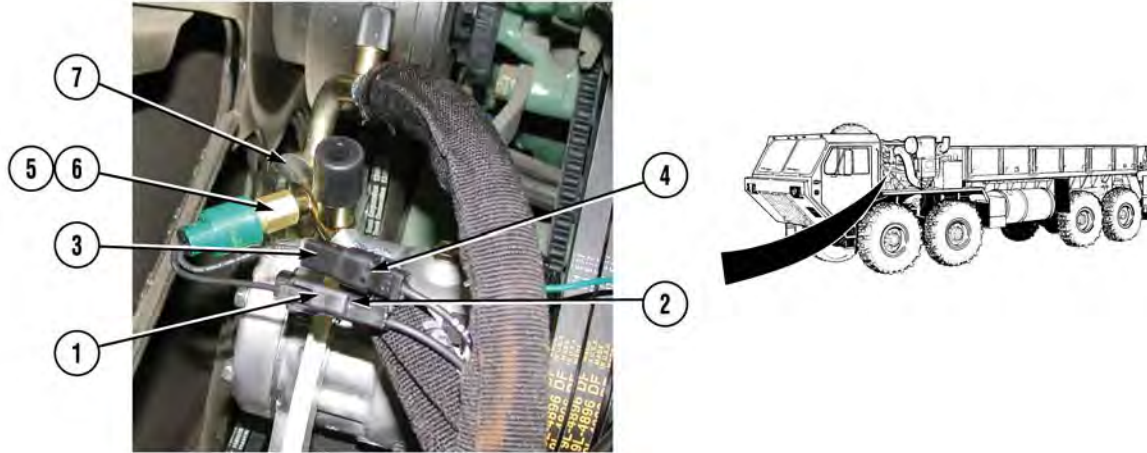

NOTE

Ensure preformed packing is in place in high pressure switch prior to installation.

1. Install preformed packing (6) and high pressure switch (5) on hose (7). Torque high pressure switch (5) to 7.5-10 ft-lbs. (10-14 N•m).

NOTE

Install cable ties as required.

2. Connect connector (3) to connector (4).
3. Connect connector (1) to connector (2).

FOLLOW-ON MAINTENANCE

1. Install engine side panel and close engine cover (TM 9-2320-279-10).
2. Connect batteries (TM 9-2320-279-20).
3. Perform leak test inspection (WP 0049).

END OF WORK PACKAGE

AC HOSES REPLACEMENT

THIS WORK PACKAGE (WP) COVERS:

Hose Assembly #6 2524 Removal
Hose Assembly #6 2524 Installation
Hose Assembly #8 2521 Removal
Hose Assembly #8 2521 Installation
Hose Assembly #10 2522 Removal
Hose Assembly #10 2522 Installation
Follow-On Maintenance

INITIAL SETUP:**Maintenance Level**

Field Level Maintenance

Equipment Condition

Refrigerant recovered (WP 0050).
Left splash guard removed (TM 9-2320-279-20).
Skid plate grille removed (TM 9-2320-279-20).
AC high pressure switch removed, if hose assembly #8 2521 needs to be replaced (WP 0039).
AC low pressure switch removed, if hose assembly #10 2522 needs to be replaced (WP 0041).

Tools and Special Tools

Set, Cap and Plug (Item 3, Appendix F)
Shop Equipment, Common No. 1 (Item 4, Appendix F)
Shop Equipment, Common No. 2 (Item 5, Appendix F)
Tool Kit, General Mechanic's (Item 7, Appendix F)

Materials/Parts

Tags, Identification (Item 9, Appendix E)
Ties, Cable (Item 11, Appendix E)
Ties, Cable (Item 12, Appendix E)

Personnel Required

MOS 52C, Utilities equipment repairer

References

TM 9-2320-279-20

AC HOSES REPLACEMENT - Continued

HOSE ASSEMBLY #6 2524 REMOVAL

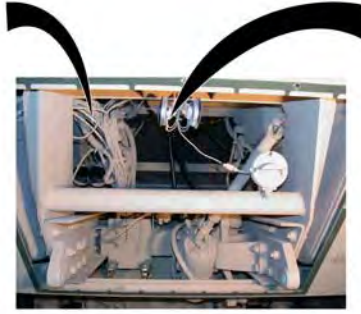
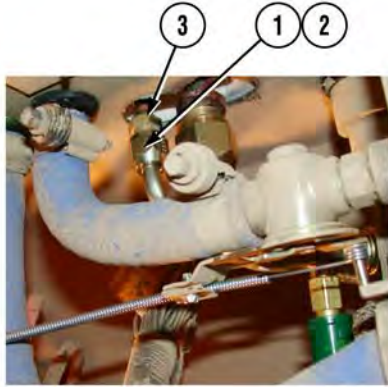

NOTE

- Refer to Appendix A, Figure A-2, for routing and location of AC hoses.
 - Remove cable ties as required to remove AC hose.
 - Note routing of AC hose prior to removal to ensure proper installation.
 - Tag and mark AC hose prior to removal to ensure proper installation.
 - Cap and plug hoses upon removal.
1. Remove hose 2524 (1) and preformed packing (2) from fitting (3).
 2. Remove locknut (4) and cushion clip (5) from screw (6).
 3. Remove hose 2524 (1) from cushion clip (5).

AC HOSES REPLACEMENT - Continued

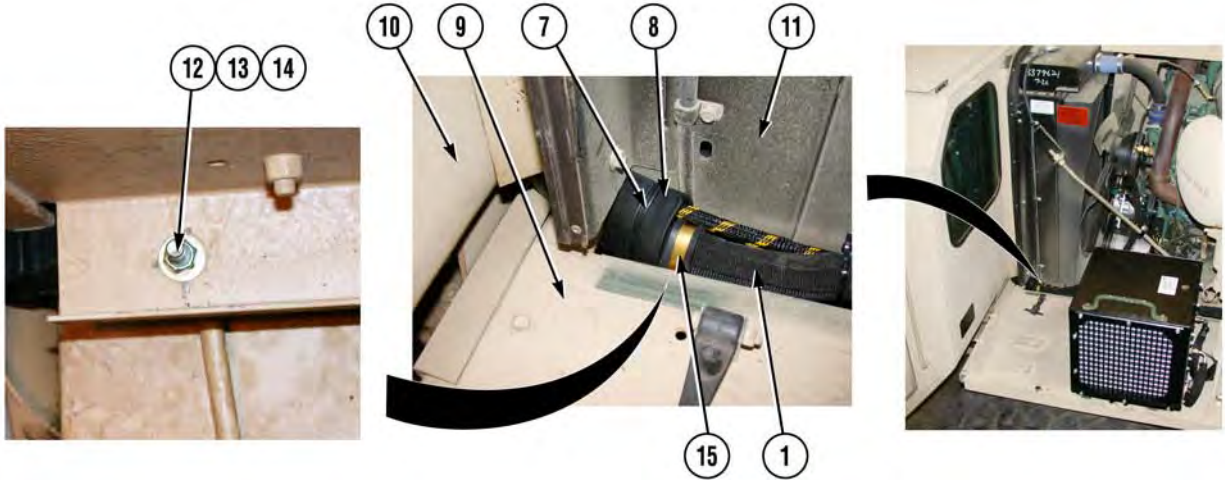

NOTE

Note position of hose shields prior to removal to ensure proper installation.

4. Remove three cable ties (7) and two hose shields (8) from opening between fender (9), cab (10), and radiator (11).
5. Remove locknut (12), washer (13), screw (14), and cushion clip (15) from fender (9).
6. Remove hose 2524 (1) from cushion clip (15).
7. Pull hose 2524 (1) through opening between fender (9), cab (10), and radiator (11).

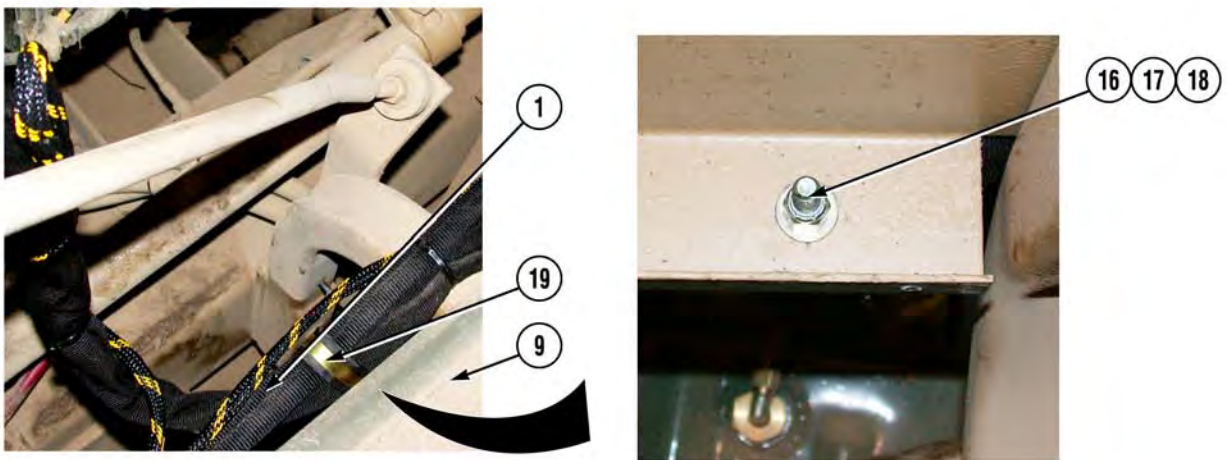

8. Remove locknut (16), washer (17), screw (18), and cushion clip (19) from fender (9).
9. Remove hose 2524 (1) from cushion clip (19).

AC HOSES REPLACEMENT - Continued



10. Remove locknut (20), screw (21), and cushion clip (22) from bracket (23).

11. Remove hose 2524 (1) from cushion clip (22).

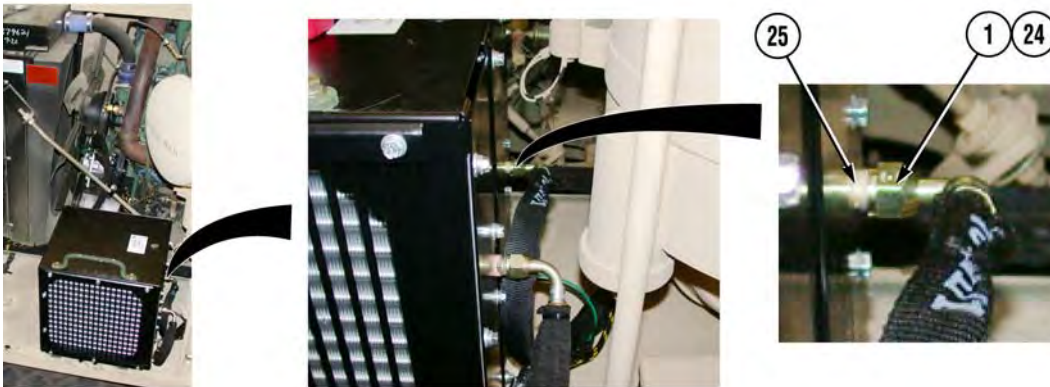

12. Remove hose 2524 (1) and preformed packing (24) from fitting (25).

13. Remove hose 2524 (1) from vehicle.

AC HOSES REPLACEMENT - Continued

HOSE ASSEMBLY #6 2524 INSTALLATION

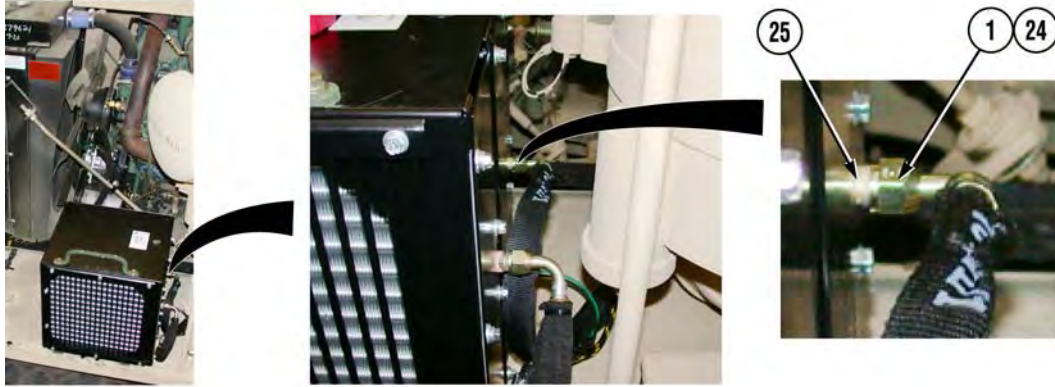

NOTE

- Refer to Appendix A, Figure A-2, for routing and location of AC hoses.
 - Install cable ties as required.
 - Route AC hose as noted prior to removal.
 - Ensure preformed packings are in place in AC hose prior to installation.
1. Install preformed packing (24) and hose 2524 (1) on fitting (25). Torque hose 2524 (1) to 11-13 ft-lbs. (15-18 N•m).



2. Position hose 2524 (1) in cushion clip (22).
3. Install cushion clip (22) on bracket (23) with screw (21) and locknut (20).

AC HOSES REPLACEMENT - Continued

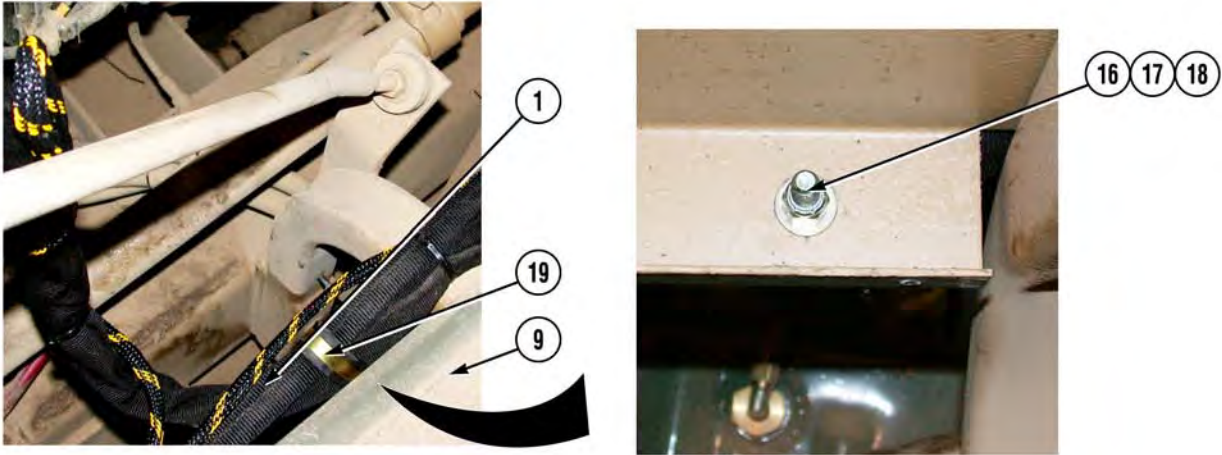

4. Install hose 2524 (1) in cushion clip (19).
5. Install cushion clip (19) on fender (9) with screw (18), washer (17), and locknut (16).

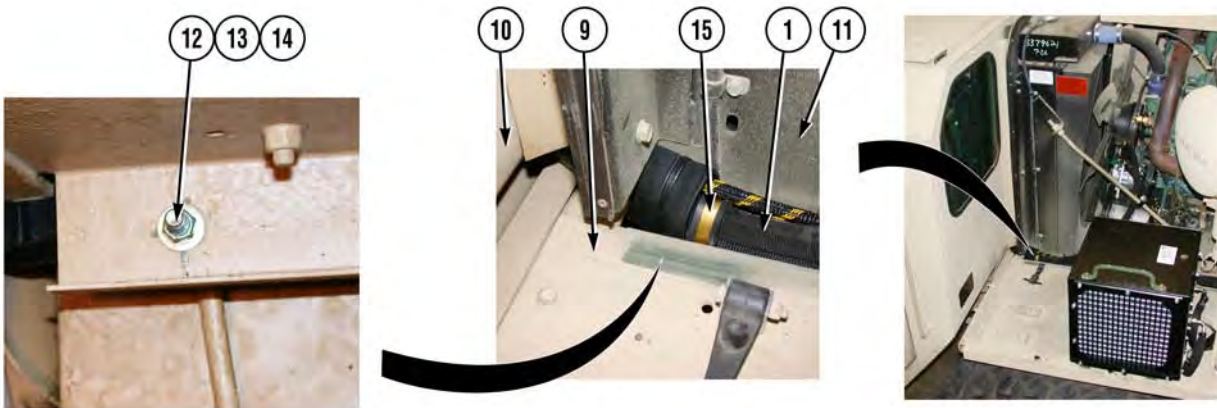

6. Route hose 2524 (1) through opening between fender (9), cab (10), and radiator (11).
7. Install hose 2524 (1) in cushion clip (15).
8. Install cushion clip (15) on fender (9) with screw (14), washer (13), and locknut (12).

AC HOSES REPLACEMENT - Continued

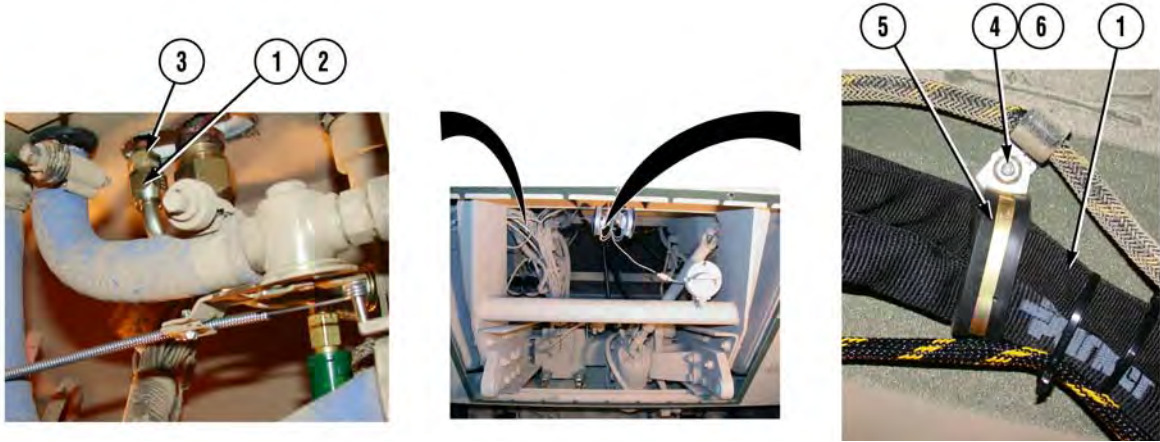

9. Install hose 2524 (1) in cushion clip (5).
10. Install cushion clip (5) on screw (6) with locknut (4).
11. Install preformed packing (2) and hose 2524 (1) on fitting (3). Torque hose 2524 (1) to 11-13 ft-lbs. (15-18 N•m).

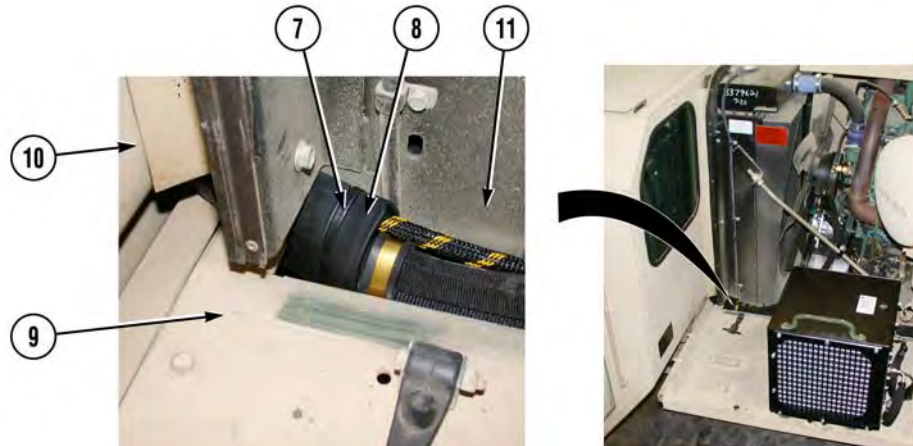

CAUTION

Hose shields must be positioned so that AC hoses and wire harness are protected from fender, cab, and radiator. Failure to comply may cause damage to equipment.

NOTE

Install hose shields as noted prior to removal.

12. Install two hose shields (8) between opening between fender (9), cab (10), and radiator (11) with three cable ties (7).

AC HOSES REPLACEMENT - Continued

HOSE ASSEMBLY #8 2521 REMOVAL

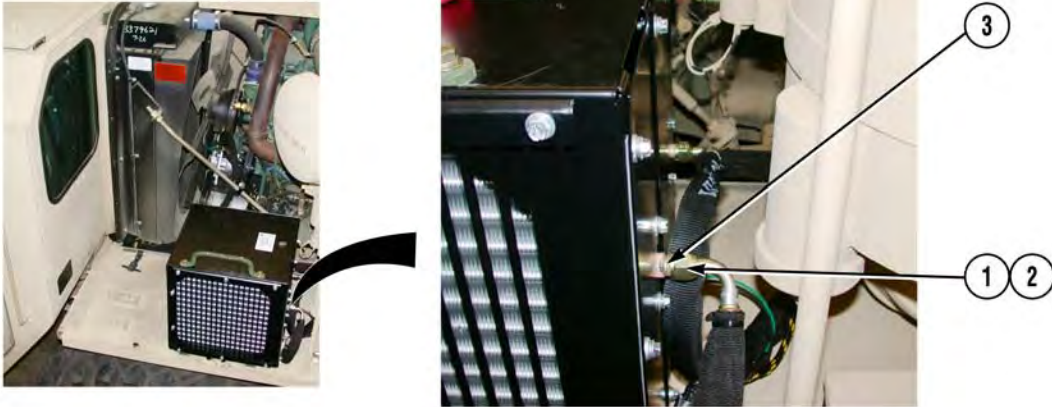

NOTE

- Refer to Appendix A, Figure A-2, for routing and location of AC hoses.
- Remove cable ties as required to remove AC hose.
- Note routing of AC hose prior to removal to ensure proper installation.
- Tag and mark AC hose prior to removal to ensure proper installation.
- Cap and plug hoses prior to removal.

1. Remove hose 2521 (1) and preformed packing (2) from fitting (3).



2. Remove locknut (4), screw (5), and cushion clip (6) from bracket (7).
3. Remove hose 2521 (1) from cushion clip (6).

AC HOSES REPLACEMENT - Continued

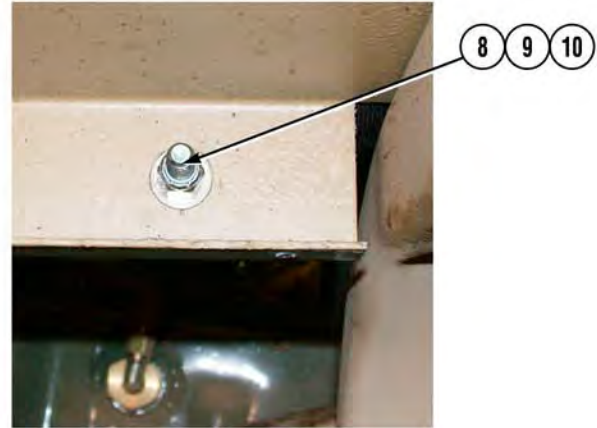
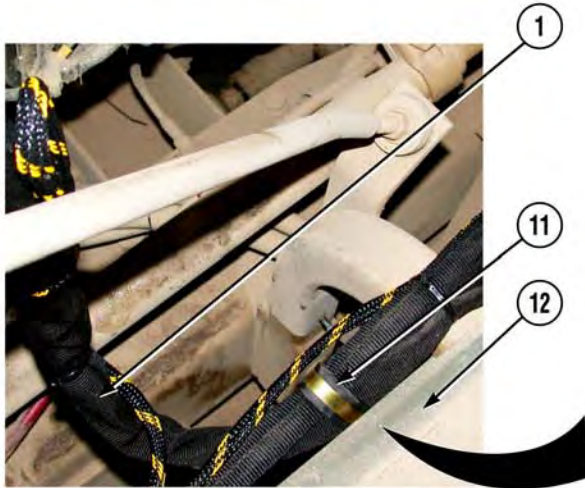

4. Remove locknut (8), washer (9), screw (10), and cushion clip (11) from fender (12).
5. Remove hose 2521 (1) from cushion clip (11).

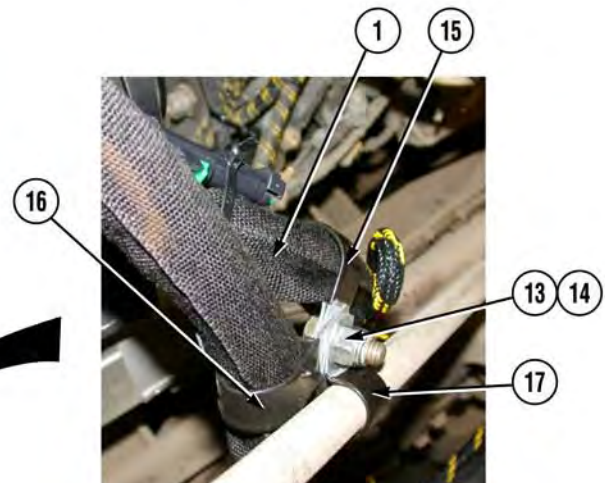
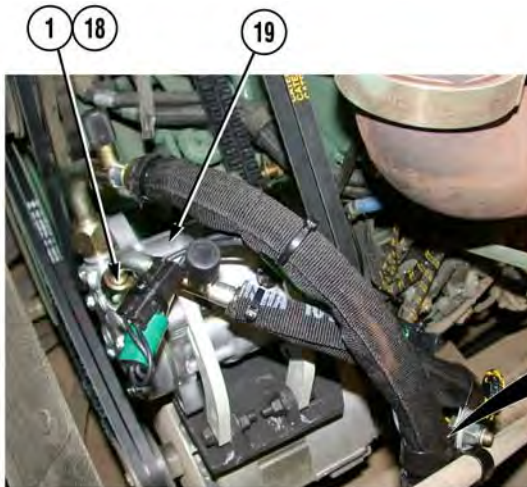

NOTE

Note position of cushion clips prior to removal to ensure proper installation.

6. Remove locknut (13), screw (14), cushion clip (15), and cushion clip (16) from cushion clip (17).
7. Remove hose 2521 (1) from cushion clip (15).
8. Remove hose 2521 (1) and preformed packing (18) from compressor (19).
9. Remove hose 2521 (1) from vehicle.

AC HOSES REPLACEMENT - Continued

HOSE ASSEMBLY #8 2521 INSTALLATION

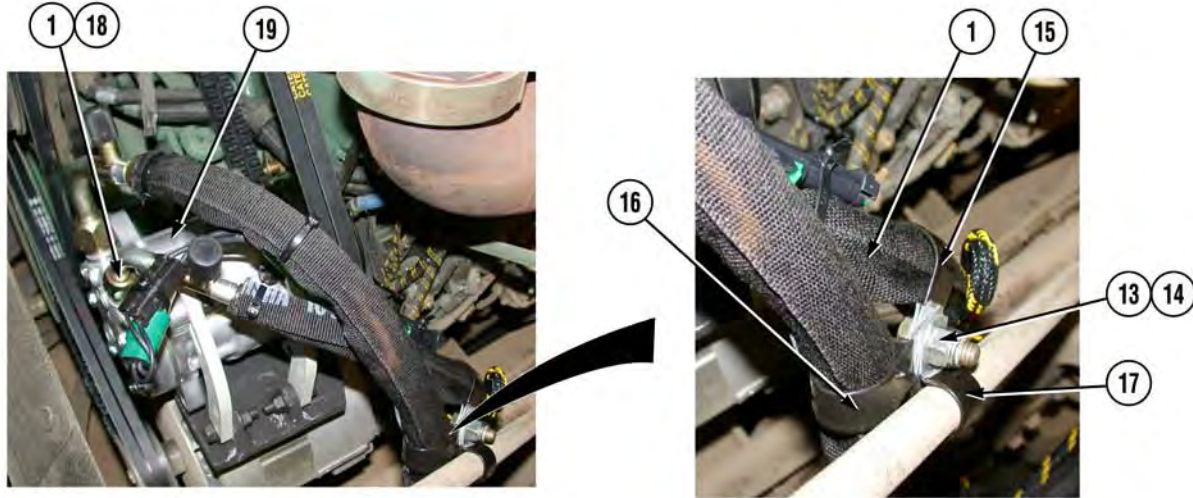

NOTE

- Refer to Appendix A, Figure A-2, for routing and location of AC hoses.
 - Install cable ties as required.
 - Route AC hose as noted prior to removal.
 - Ensure preformed packings are in place in AC hose prior to installation.
1. Install preformed packing (18) and hose 2521 (1) on compressor (19). Torque hose 2521 (1) to 15-18 ft-lbs. (20-24 N•m).
 2. Install hose 2521 (1) in cushion clip (15).

NOTE

Install cushion clips as noted prior to removal.

3. Install cushion clip (16) and cushion clip (15) on cushion clip (17) with screw (14) and locknut (13).

AC HOSES REPLACEMENT - Continued

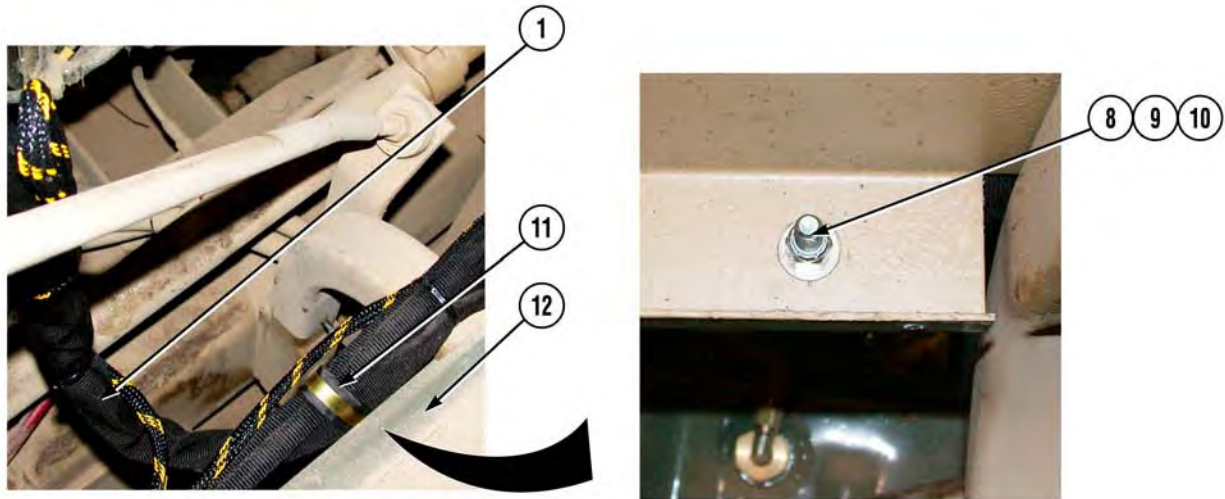

4. Install hose 2521 (1) in cushion clip (11).
5. Install cushion clip (11) on fender (12) with screw (10), washer (9), and locknut (8).



6. Install hose 2521 (1) in cushion clip (6).
7. Install cushion clip (6) on bracket (7) with screw (5) and locknut (4).

AC HOSES REPLACEMENT - Continued

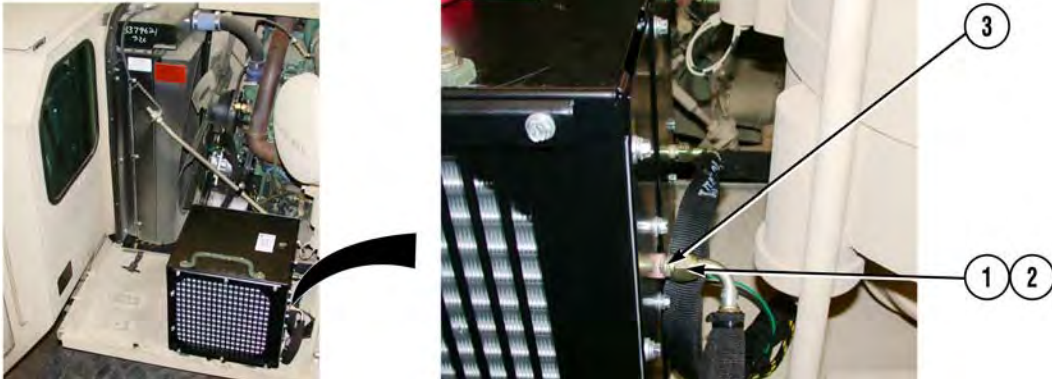

8. Install preformed packing (2) and hose 2521 (1) on fitting (3). Torque hose 2521 (1) to 15-18 ft-lbs. (20-24 N•m).

HOSE ASSEMBLY #10 2522 REMOVAL

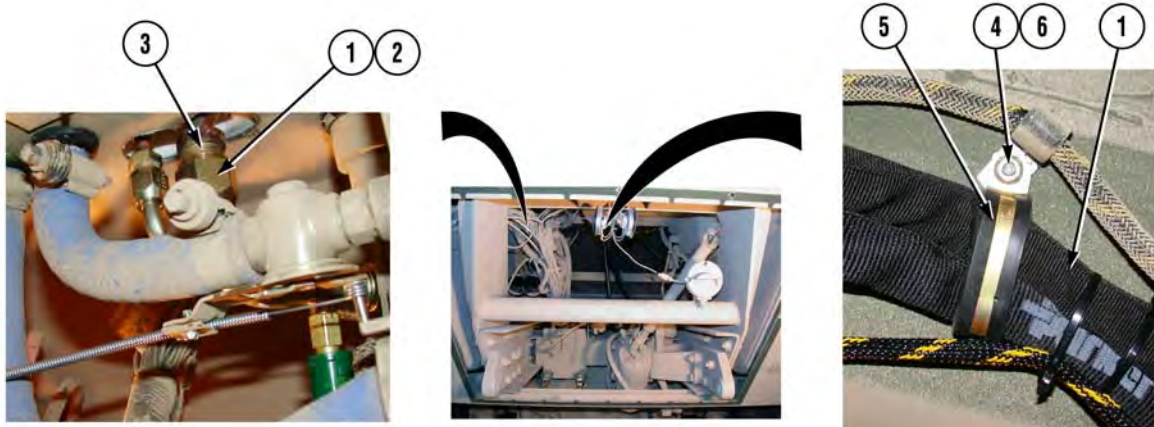

NOTE

- Refer to Appendix A, Figure A-2, for routing and location of AC hoses.
 - Remove cable ties as required to remove AC hose.
 - Note routing of AC hose prior to removal to ensure proper installation.
 - Tag and mark AC hose prior to removal to ensure proper installation.
 - Cap and plug hoses upon removal.
1. Remove hose 2522 (1) and preformed packing (2) from fitting (3).
 2. Remove locknut (4) and cushion clip (5) from screw (6).
 3. Remove hose 2522 (1) from cushion clip (5).

AC HOSES REPLACEMENT - Continued

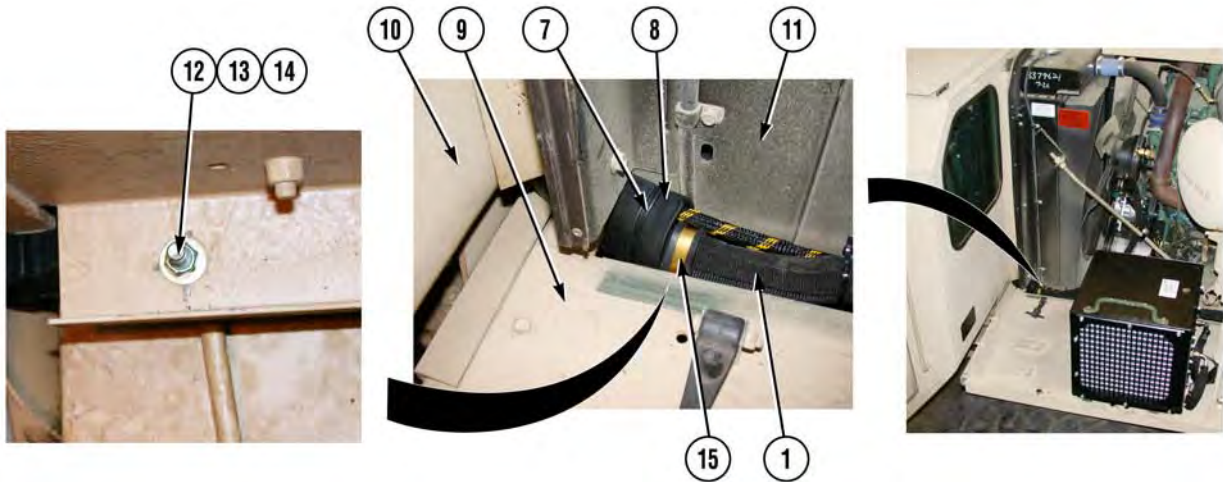

NOTE

Note position of hose shields prior to removal to ensure proper installation.

4. Remove three cable ties (7) and two hose shields (8) from opening between fender (9), cab (10), and radiator (11).
5. Remove locknut (12), washer (13), screw (14), and cushion clip (15) from fender (9).
6. Remove hose 2522 (1) from cushion clip (15).
7. Pull hose 2522 (1) through opening between fender (9), cab (10), and radiator (11).

AC HOSES REPLACEMENT - Continued

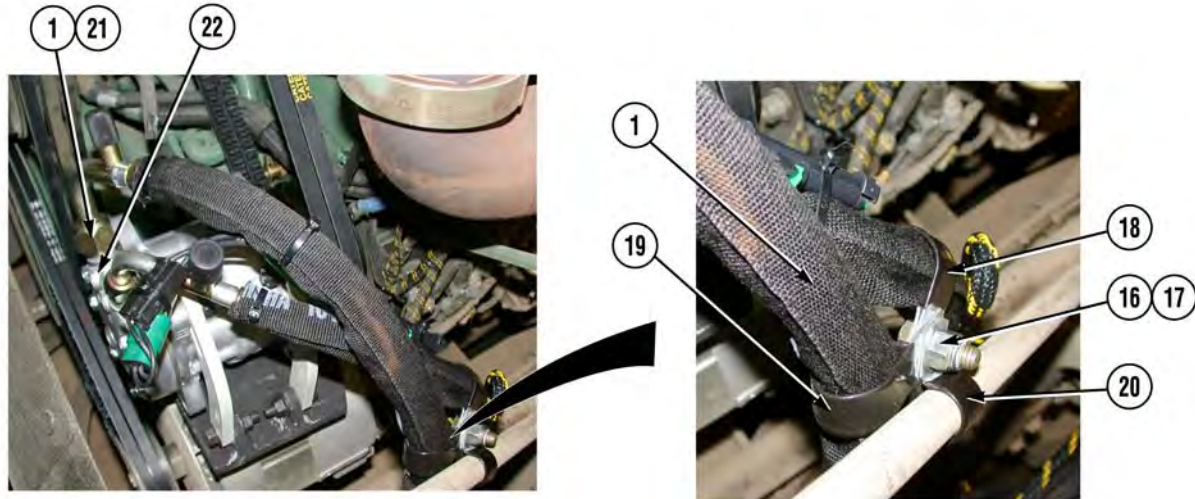

NOTE

Note position of cushion clips prior to removal to ensure proper installation.

8. Remove locknut (16), screw (17), cushion clip (18), and cushion clip (19) from cushion clip (20).
9. Remove hose 2522 (1) from cushion clip (19).
10. Remove hose 2522 (1) and preformed packing (21) from compressor (22).
11. Remove hose 2522 (1) from vehicle.

AC HOSES REPLACEMENT - Continued

HOSE ASSEMBLY #10 2522 INSTALLATION

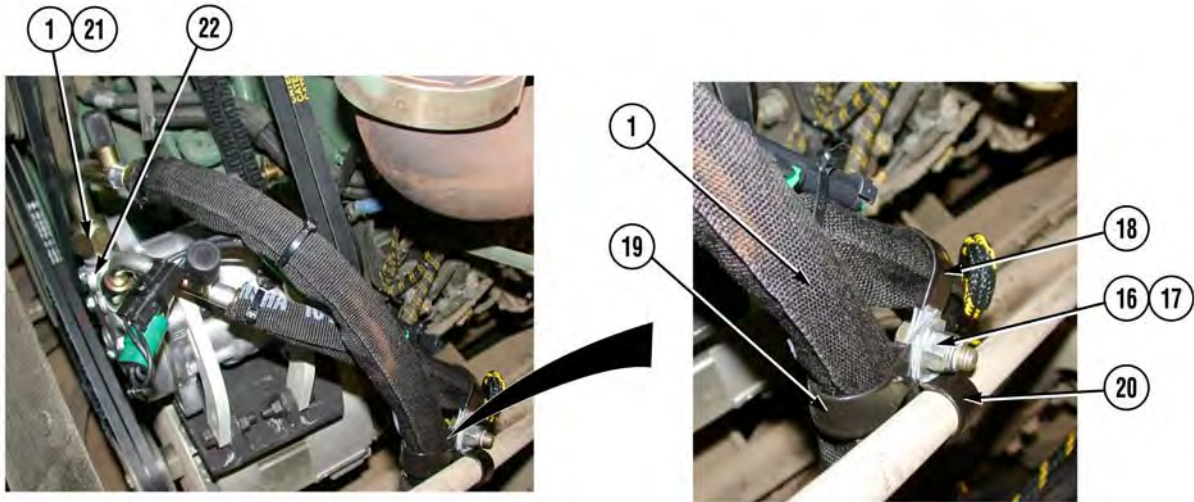

NOTE

- Refer to Appendix A, Figure A-2, for routing and location of AC hoses.
 - Install cable ties as required.
 - Route AC hose as noted prior to removal.
 - Ensure preformed packings are in place in AC hose prior to installation.
1. Install preformed packing (21) and hose 2522 (1) on compressor (22). Torque hose 2522 (1) to 18-22 ft-lbs. (24-30 N•m).
 2. Install hose 2522 (1) in cushion clip (19).

NOTE

Install cushion clips as noted prior to removal.

3. Install cushion clip (19) and cushion clip (18) on cushion clip (20) with screw (17) and locknut (16).

AC HOSES REPLACEMENT - Continued

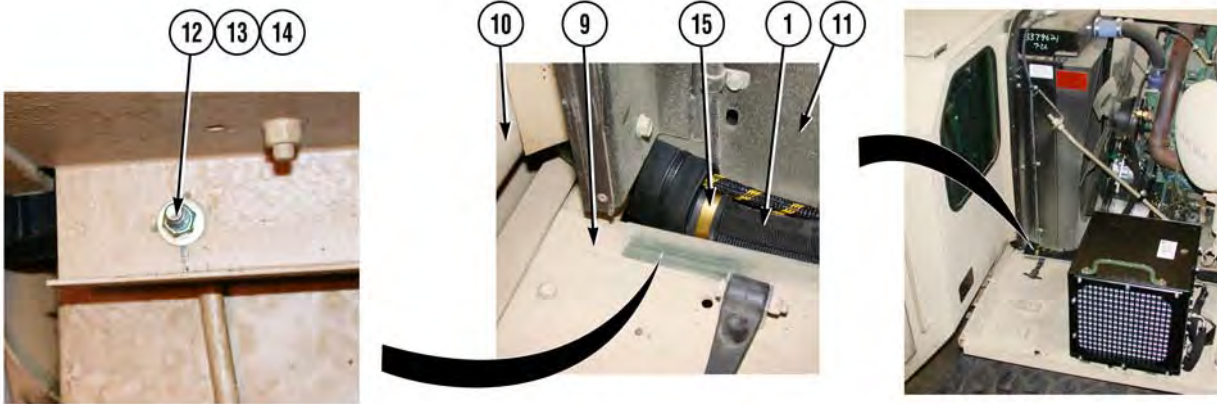

4. Route hose 2522 (1) through opening between fender (9), cab (10), and radiator (11).
5. Install hose 2522 (1) in cushion clip (15).
6. Install cushion clip (15) on fender (9) with screw (14), washer (13), and locknut (12).

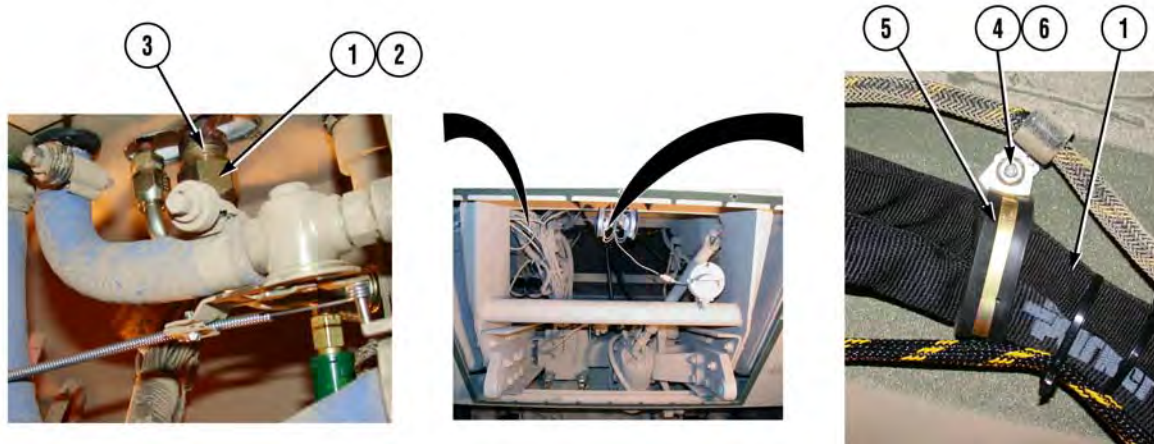

7. Install hose 2522 (1) in cushion clip (5).
8. Install cushion clip (5) on screw (6) with locknut (4).
9. Install preformed packing (2) and hose 2522 (1) on fitting (3). Torque hose 2522 (1) to 18-22 ft-lbs. (24-30 N•m).

AC HOSES REPLACEMENT - Continued

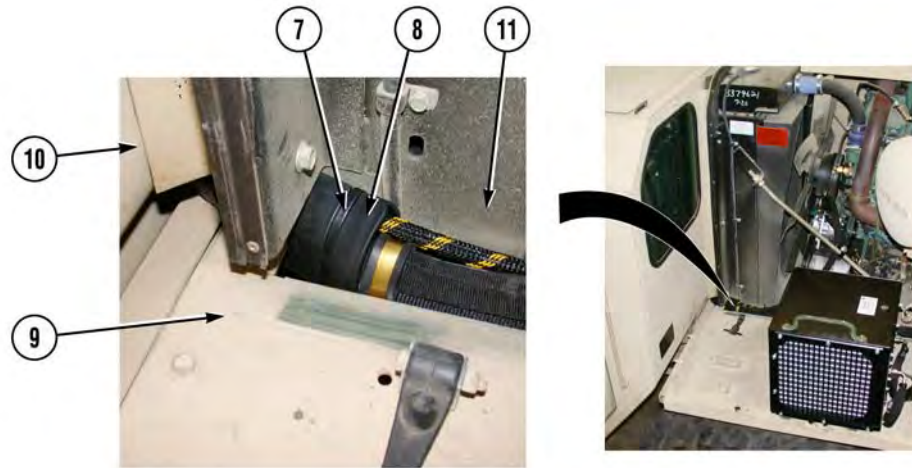

CAUTION

Hose shields must be positioned so that AC hoses and wire harness are protected from fender, cab, and radiator. Failure to comply may cause damage to equipment.

NOTE

Install hose shields as noted prior to removal.

10. Install two hose shields (8) between opening between fender (9), cab (10), and radiator (11) with three cable ties (7).

FOLLOW-ON MAINTENANCE

1. Install AC low pressure switch, if hose assembly #10 2522 was replaced (WP 0041).
2. Install AC high pressure switch, if hose assembly #8 2521 was replaced (WP 0039).
3. Install skid plate grille (TM 9-2320-279-20).
4. Install left splash guard (TM 9-2320-279-20).
5. Charge AC system (WP 0050).
6. Perform leak test inspection (WP 0049).

END OF WORK PACKAGE

AC LOW PRESSURE SWITCH REPLACEMENT

THIS WORK PACKAGE (WP) COVERS:

- Removal
- Installation
- Follow-On Maintenance

INITIAL SETUP:**Maintenance Level**

Field Level Maintenance

Equipment Condition

Batteries disconnected (TM 9-2320-279-20).
 Skid plate grille removed (TM 9-2320-279-20).

Tools and Special Tools

Shop Equipment, Common No. 1 (Item 4,
 Appendix F)
 Shop Equipment, Common No. 2 (Item 5,
 Appendix F)
 Tool Kit, General Mechanic's (Item 7, Appendix F)

Materials/Parts

Tags, Identification (Item 9, Appendix E)
 Ties, Cable (Item 12, Appendix E)

Personnel Required

MOS 52C, Utilities equipment repairer

References

TM 9-2320-279-20

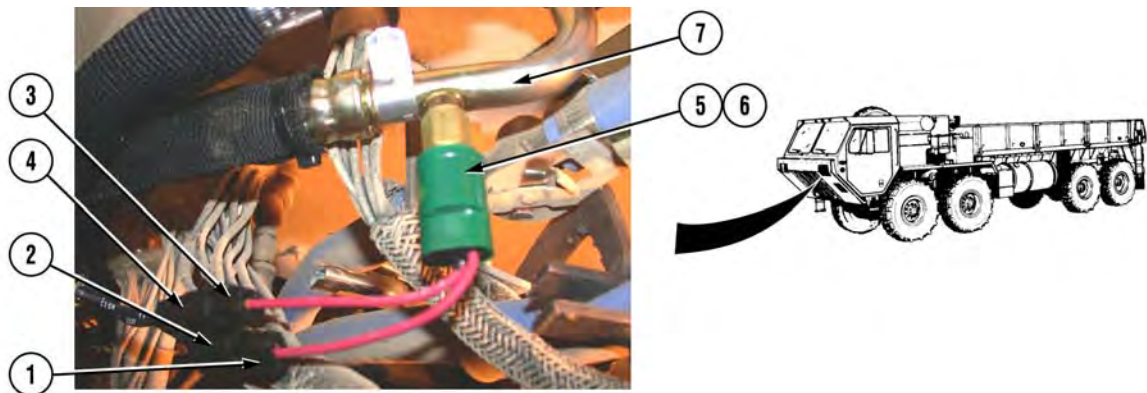
REMOVAL**NOTE**

- Tag and mark connectors prior to removal to ensure proper installation.
 - Remove cable ties as required.
1. Disconnect connector (1) from connector (2).
 2. Disconnect connector (3) from connector (4).
 3. Remove low pressure switch (5) and preformed packing (6) from hose (7).

AC LOW PRESSURE SWITCH REPLACEMENT - Continued

INSTALLATION

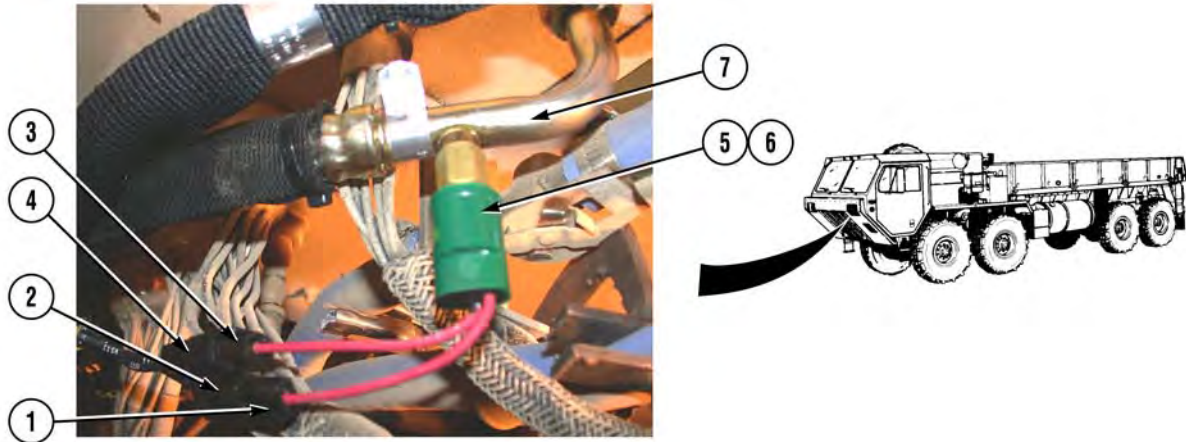

NOTE

Ensure preformed packing is in place in low pressure switch prior to installation.

1. Install preformed packing (6) and low pressure switch (5) on hose (7). Torque low pressure switch (5) to 7.5-10 ft-lbs. (10-14 N•m).

NOTE

Install cable ties as required.

2. Connect connector (3) to connector (4).
3. Connect connector (1) to connector (2).

FOLLOW-ON MAINTENANCE

1. Install skid plate grille (TM 9-2320-279-20).
2. Connect batteries (TM 9-2320-279-20).
3. Perform leak test inspection (WP 0049).

END OF WORK PACKAGE

AC LOWER PLENUM AND DAMPER REPLACEMENT

THIS WORK PACKAGE (WP) COVERS:

- Removal
- Installation
- Follow-On Maintenance

INITIAL SETUP:**Maintenance Level**

Field Level Maintenance

Equipment Condition

AC heater/evaporator removed (WP 0038).

Tools and Special Tools

Tool Kit, General Mechanic's (Item 7, Appendix F)

Materials/Parts

Adhesive, 3M #1300 (Item 1, Appendix E)
 Ties, Cable (Item 12, Appendix E)

Personnel Required

MOS 52C, Utilities equipment repairer

References

None

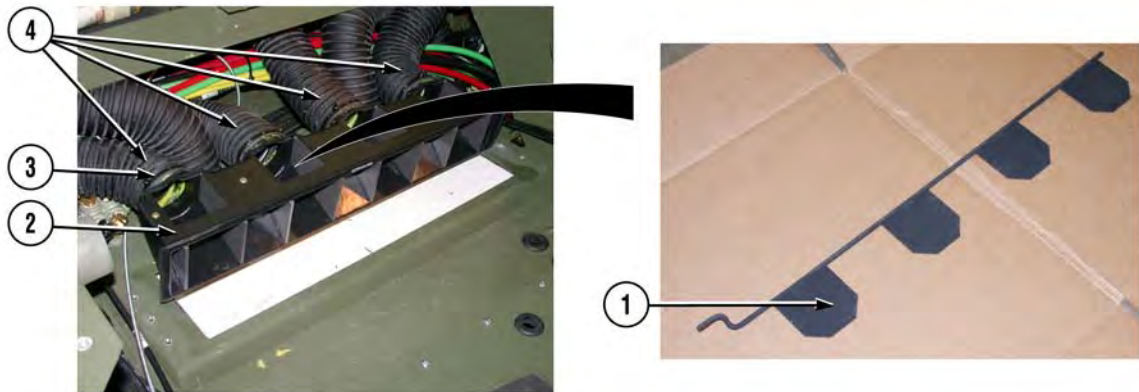
REMOVAL**NOTE**

Note position of damper prior to removal to ensure proper installation.

1. Remove damper (1) from lower plenum (2).
2. Remove four cable ties (3) and lower plenum (2) from four defrost tubes (4).

AC LOWER PLENUM AND DAMPER REPLACEMENT - Continued

INSTALLATION

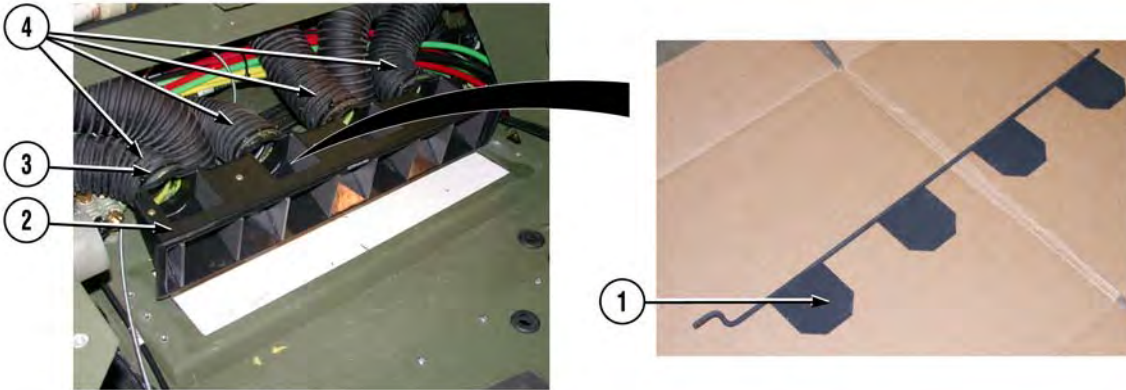

WARNING

Adhesives, solvents, and sealing compounds can burn easily, can give off harmful vapors, and are harmful to skin and clothing. To avoid injury or death, keep away from open fire and use in well-ventilated area. If adhesive, solvent, or sealing compound gets on skin or clothing, wash immediately with soap and water.

1. Apply adhesive to inner edge of four defrost tubes (4).
2. Install lower plenum (2) on four defrost tubes (4) with cable ties (3).

NOTE

Install damper as noted prior to removal.

3. Install damper (1) in lower plenum (2).

FOLLOW-ON MAINTENANCE

1. Install AC heater/evaporator (WP 0038).

END OF WORK PACKAGE

AC OPTIC RIBBON REPLACEMENT

THIS WORK PACKAGE (WP) COVERS:

- Removal
- Installation
- Follow-On Maintenance

INITIAL SETUP:

Maintenance Level

Field Level Maintenance

Equipment Condition

- AC cable removed (WP 0021).
- AC defrost cable removed (WP 0029).

Tools and Special Tools

Tool Kit, General Mechanic's (Item 7, Appendix F)

Materials/Parts

Tape, Insulation, Electrical (Item 10, Appendix E)

Personnel Required

MOS 52C, Utilities equipment repairer

References

TM 9-2320-279-20

REMOVAL

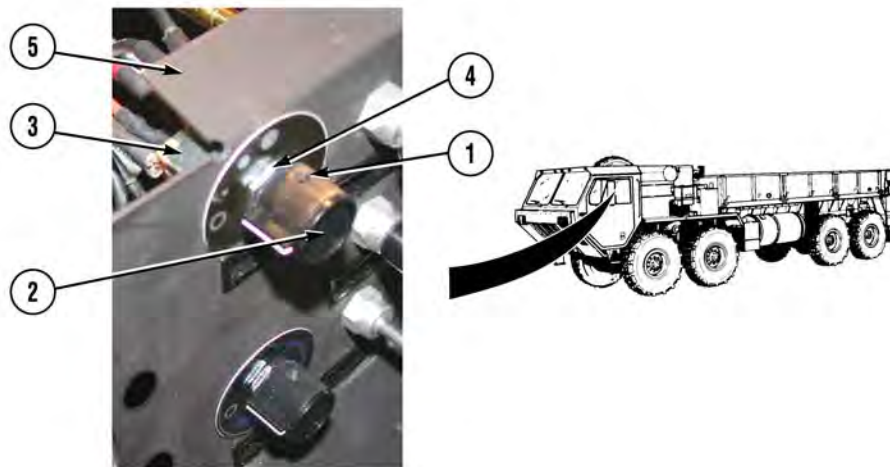

1. Loosen two screws (1) and remove knob (2) from fan control switch (3).

NOTE

Note position of fan control switch prior to removal to ensure proper installation.

2. Remove nut (4) and fan control switch (3) from center cover (5).

AC OPTIC RIBBON REPLACEMENT - Continued

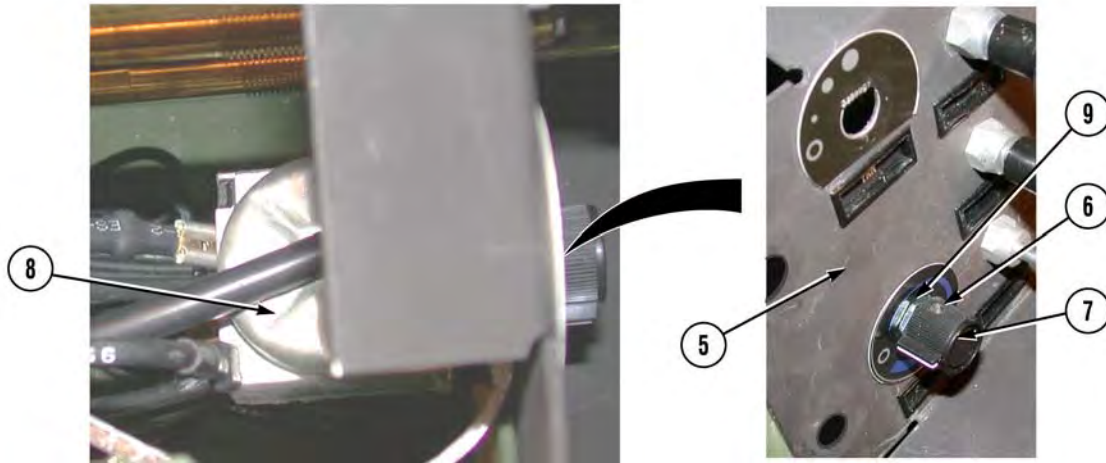

3. Loosen two screws (6) and remove knob (7) from temperature control switch (8).

NOTE

Note position of temperature control switch prior to removal to ensure proper installation.

4. Remove nut (9) and temperature control switch (8) from center cover (5).

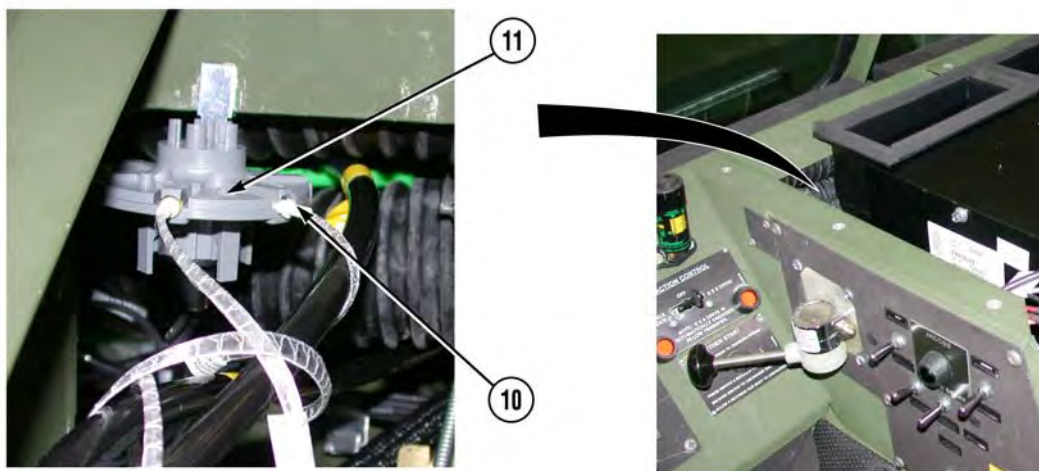

5. Unplug optic ribbon (10) from light source (11).

AC OPTIC RIBBON REPLACEMENT - Continued

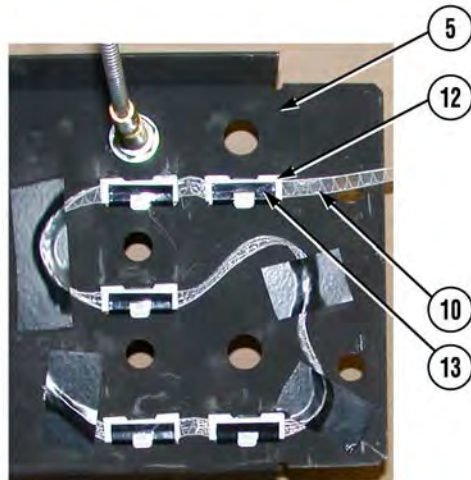

NOTE

- Remove electrical tape as needed.
 - Note routing of optic ribbon prior to removal to ensure proper installation.
6. Remove five identification markers (12) of optic ribbon (10) from five bezels (13).

NOTE

Perform Step 7 if bezels need to be removed.

7. Remove five bezels (13) from center cover (5).

AC OPTIC RIBBON REPLACEMENT - Continued

INSTALLATION

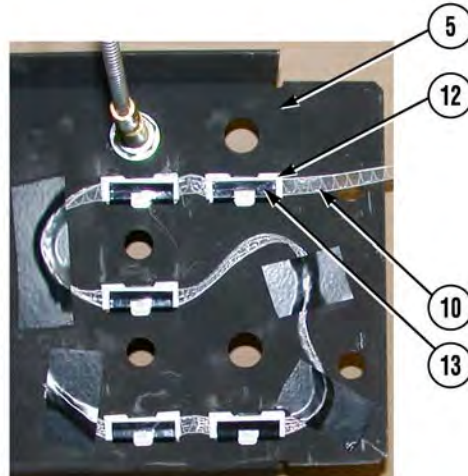

NOTE

Perform Step 1 if bezels were removed.

1. Install five bezels (13) on center cover (5).

NOTE

- Route optic ribbon as noted prior to removal.
 - Use electrical tape as needed to secure optic ribbon to center cover.
2. Install five identification markers (12) of optic ribbon (10) in five bezels (13).

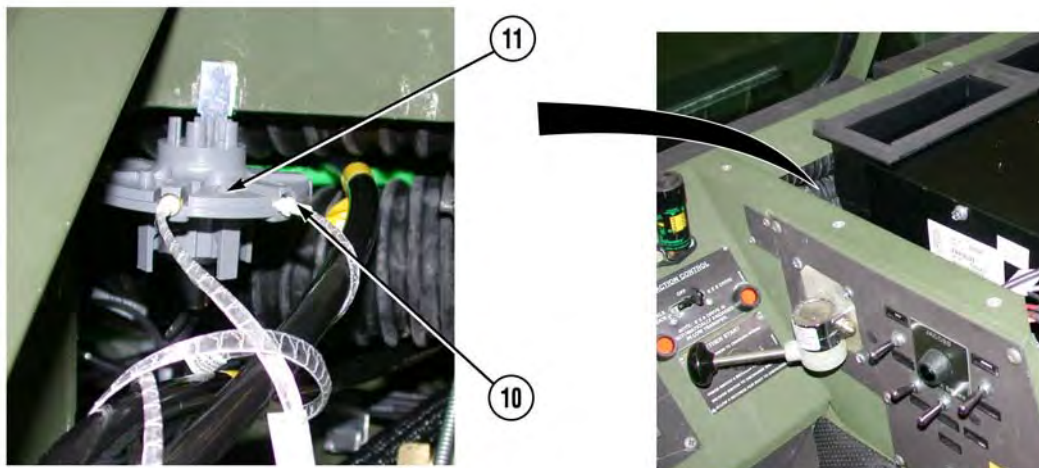

3. Plug optic ribbon (10) into light source (11).

AC OPTIC RIBBON REPLACEMENT - Continued

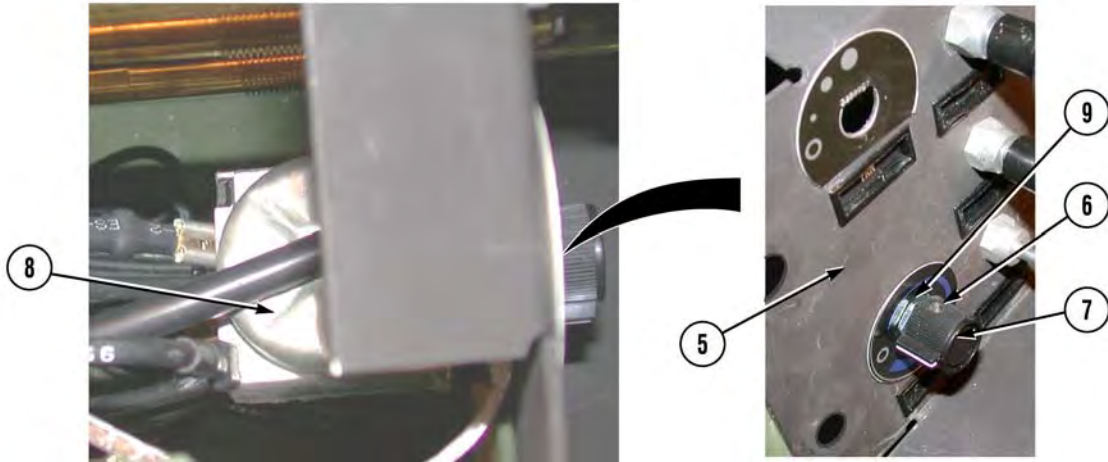

NOTE

Install temperature control switch as noted prior to removal.

4. Install temperature control switch (8) on center cover (5) with nut (9).
5. Install knob (7) on temperature control switch (8) and tighten two screws (6).

AC OPTIC RIBBON REPLACEMENT - Continued

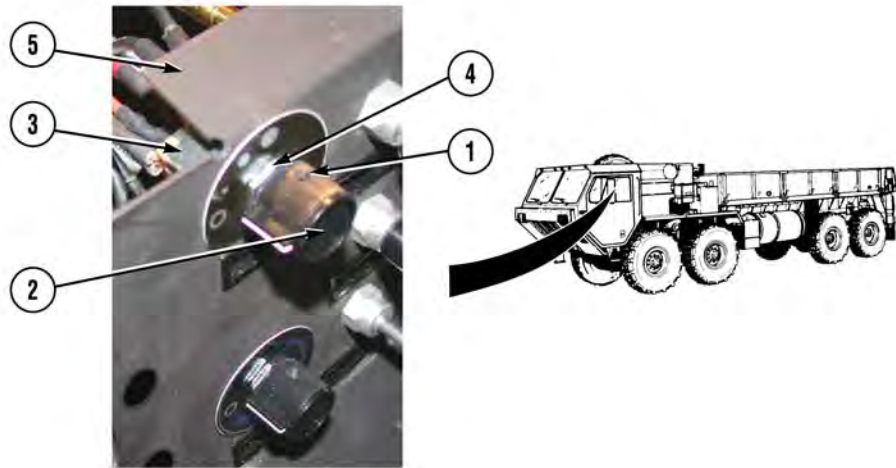

NOTE

Install fan control switch as noted prior to removal.

6. Install fan control switch (3) on center cover (5) with nut (4).
7. Install knob (2) on fan control switch (3) and tighten two screws (1).

FOLLOW-ON MAINTENANCE

1. Install AC defrost cable (WP 0029).
2. Install AC cable (WP 0021).

END OF WORK PACKAGE

AC TEMPERATURE CONTROL SWITCH REPLACEMENT

THIS WORK PACKAGE (WP) COVERS:

- Removal
- Installation
- Follow-On Maintenance

INITIAL SETUP:

Maintenance Level

Field Level Maintenance

Equipment Condition

Batteries disconnected (TM 9-2320-279-20).
AC heater/evaporator cover removed (WP 0037).

Tools and Special Tools

Goggles (Item 1, Appendix F)
Tool Kit, General Mechanic's (Item 7, Appendix F)

Materials/Parts

Solvent, Dry Cleaning (Item 8, Appendix E)
Tags, Identification (Item 9, Appendix E)

Personnel Required

MOS 52C, Utilities equipment repairer

References

TM 9-2320-279-20

AC TEMPERATURE CONTROL SWITCH REPLACEMENT - Continued

REMOVAL

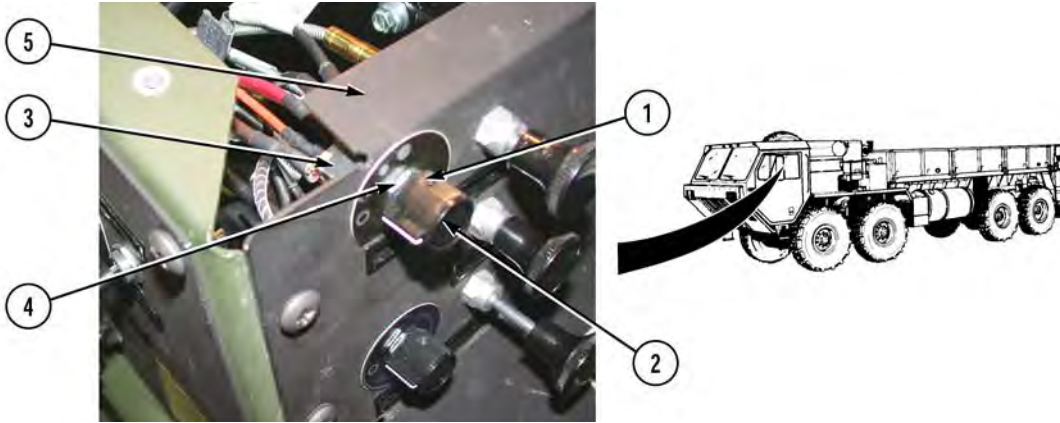

NOTE

Fan control switch needs to be removed from center cover to access temperature control switch.

1. Loosen two screws (1) and remove knob (2) from fan control switch (3).

NOTE

Note position of fan control switch prior to removal to ensure proper installation.

2. Remove nut (4) and fan control switch (3) from center cover (5).

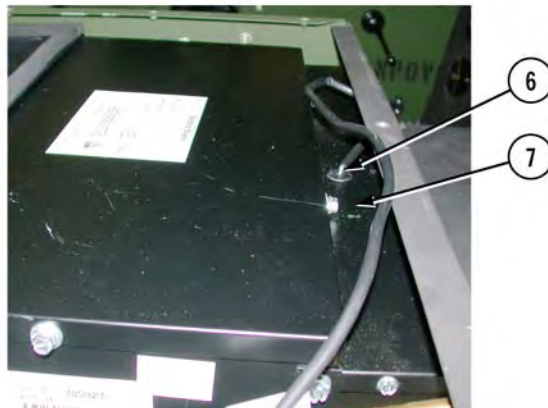

CAUTION

Remove temperature probe slowly from heater/evaporator. Failure to comply may result in damage to temperature probe.

3. Remove temperature probe (6) from heater/evaporator (7).

AC TEMPERATURE CONTROL SWITCH REPLACEMENT - Continued

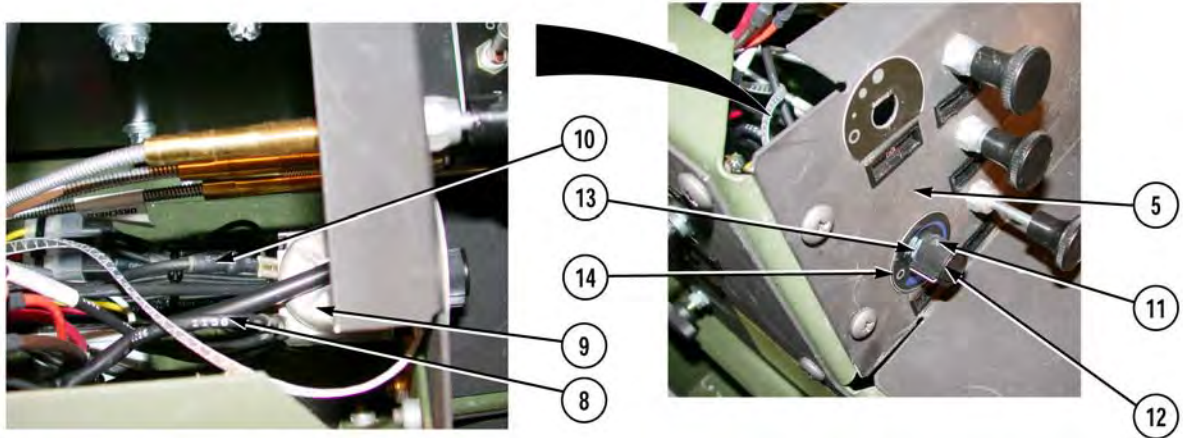

NOTE

Tag and mark wires prior to removal to ensure proper installation.

4. Remove wire 1156 (8) from OUT terminal of temperature control switch (9).
5. Remove wire assembly 1156 (10) from IN terminal of temperature control switch (9).
6. Loosen two screws (11) and remove knob (12) from temperature control switch (9).

NOTE

Note position of temperature control switch prior to removal to ensure proper installation.

7. Remove nut (13) and temperature control switch (9) from center cover (5).

NOTE

Perform Step 8 if temperature label needs to be removed.

8. Remove temperature label (14) from center cover (5).

AC TEMPERATURE CONTROL SWITCH REPLACEMENT - Continued

INSTALLATION

WARNING

- Dry cleaning solvent is **TOXIC** and flammable. Wear protective goggles and gloves; use only in a well-ventilated area; avoid contact with skin, eyes, and clothes; and **DO NOT** breathe vapors. Keep away from heat or flame. Never smoke when using dry cleaning solvent; the flashpoint for Type II is 140°F (60°C), and for Type III it is 200°F (93°C). Failure to follow this warning may result in death or injury to personnel.
- If personnel become dizzy while using dry cleaning solvent, immediately get fresh air and medical help. If solvent contacts skin or clothes, flush with cold water. If solvent contacts eyes, immediately flush them with water and get immediate medical attention.

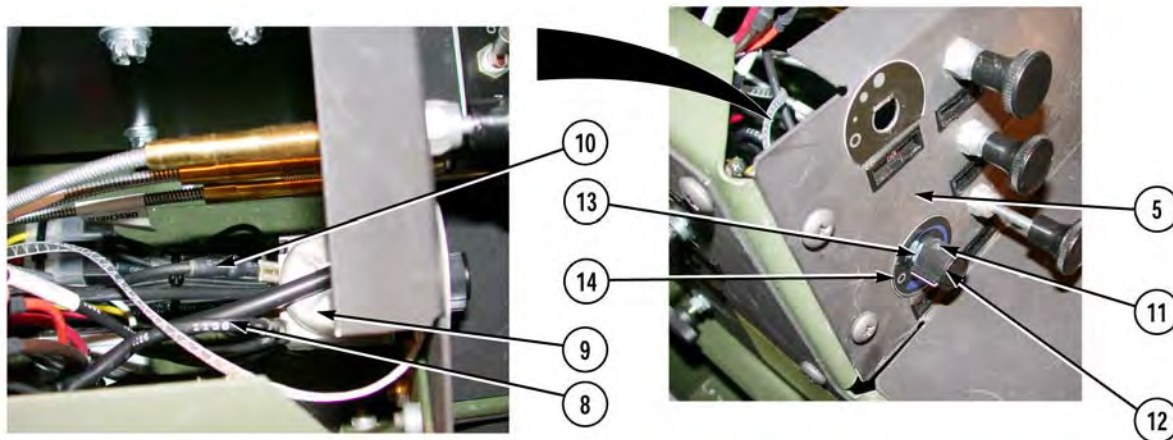

NOTE

Perform Steps 1 through 3 if temperature label was removed.

1. Clean center cover (5) where temperature label (14) was mounted with dry cleaning solvent.
2. Peel paper back off of temperature label (14).
3. Install temperature label (14) on center cover (5).

NOTE

Install temperature control switch as noted prior to removal.

4. Install temperature control switch (9) on center cover (5) with nut (13).
5. Install knob (12) on temperature control switch (9) and tighten two screws (11).

AC TEMPERATURE CONTROL SWITCH REPLACEMENT - Continued

6. Install wire assembly 1156 (10) on IN terminal of temperature control switch (9).
7. Install wire 1156 (8) on OUT terminal of temperature control switch (9).

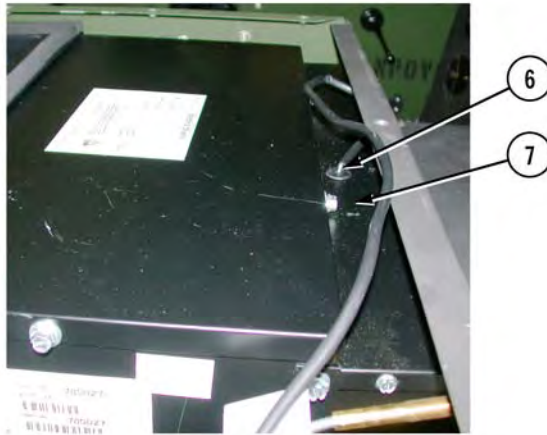

CAUTION

- **Do not puncture temperature probe. Failure to comply will cause gas in tube to leak out.**
- **Install temperature probe slowly into heater/evaporator. Failure to comply may result in damage to temperature probe.**

NOTE

Temperature control switch temperature probe is installed correctly when it is inserted into the AC evaporator core until it touches the bottom of the insertion hole.

8. Install temperature probe (6) into heater/evaporator (7).

AC TEMPERATURE CONTROL SWITCH REPLACEMENT - Continued

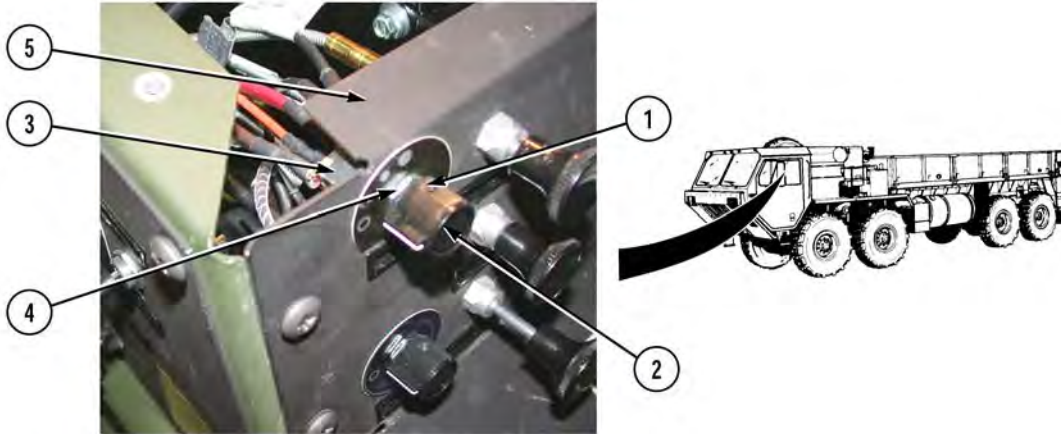

NOTE

Install fan control switch as noted prior to removal.

9. Install fan control switch (3) on center cover (5) with nut (4).
10. Install knob (2) on fan control switch (3) and tighten two screws (1).

FOLLOW-ON MAINTENANCE

1. Install AC heater/evaporator cover (WP 0037).
2. Connect batteries (TM 9-2320-279-20).

END OF WORK PACKAGE

AC UPPER PLENUM REPLACEMENT

THIS WORK PACKAGE (WP) COVERS:

Removal
 Installation
 Follow-On Maintenance

INITIAL SETUP:

Maintenance Level

Field Level Maintenance

Materials/Parts

None

Equipment Condition

AC heater/evaporator cover removed (WP 0037).

Personnel Required

MOS 52C, Utilities equipment repairer

Tools and Special Tools

Tool Kit, General Mechanic's (Item 7, Appendix F)

References

TM 9-2320-279-20

REMOVAL

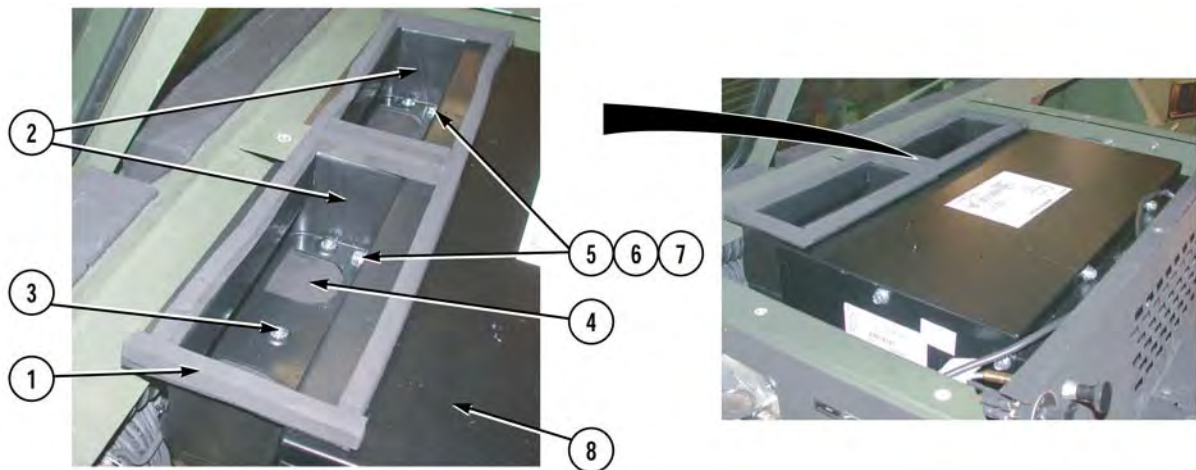

NOTE

Perform Step 1 if gasket needs to be replaced.

1. Remove gasket (1) from two upper plenums (2).
2. Remove six screws (3) from two upper plenums (2) and lower plenum (4).
3. Remove two screws (5), lockwashers (6), washers (7), and two upper plenums (2) from cover (8).

AC UPPER PLENUM REPLACEMENT - Continued

INSTALLATION

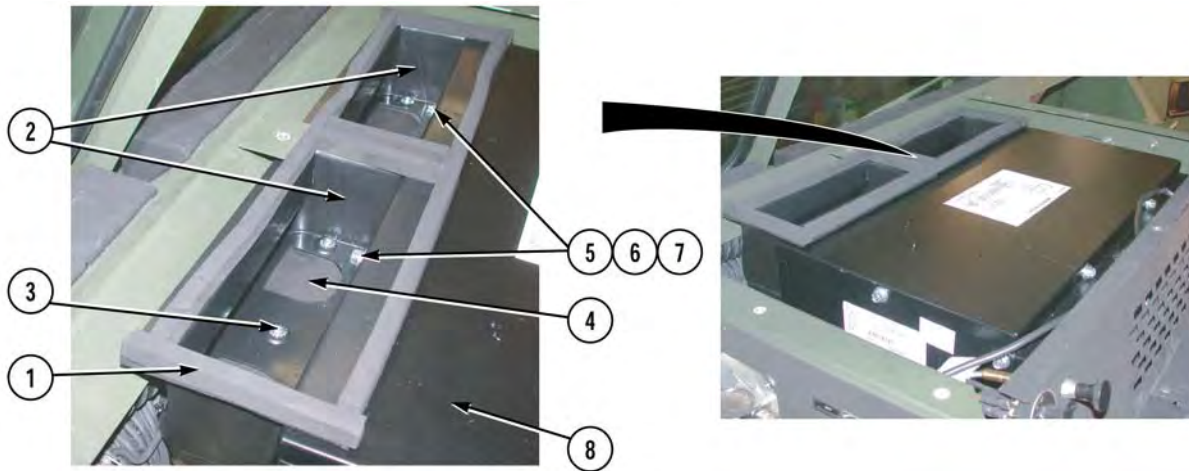

1. Install two upper plenums (2) on cover (8) with two washers (7), lockwashers (6), and screws (5). Do not tighten screws (5).
2. Install two upper plenums (2) on lower plenum (4) with six screws (3).
3. Tighten two screws (5).

NOTE

Perform Step 4 if gasket was removed.

4. Install gasket (1) around outside edges of two upper plenums (2).

FOLLOW-ON MAINTENANCE

1. Install AC heater/evaporator cover (WP 0037).

END OF WORK PACKAGE

AC WIRING HARNESS REPLACEMENT

THIS WORK PACKAGE (WP) COVERS:

Removal
 Installation
 Follow-On Maintenance

INITIAL SETUP:

Maintenance Level

Field Level Maintenance

Equipment Condition

Batteries disconnected (TM 9-2320-279-20).
 Skid plate grille removed (TM 9-2320-279-20).
 Engine cover open and engine side panel removed (TM 9-2320-279-10).
 AC heater/evaporator cover removed (WP 0037).

Tools and Special Tools

Tool Kit, General Mechanic's (Item 7, Appendix F)

Materials/Parts

Tags, Identification (Item 9, Appendix E)
 Ties, Cable (Item 11, Appendix E)
 Ties, Cable (Item 12, Appendix E)

Personnel Required

MOS 52C, Utilities equipment repairer

References

TM 9-2320-279-10
 TM 9-2320-279-20

REMOVAL

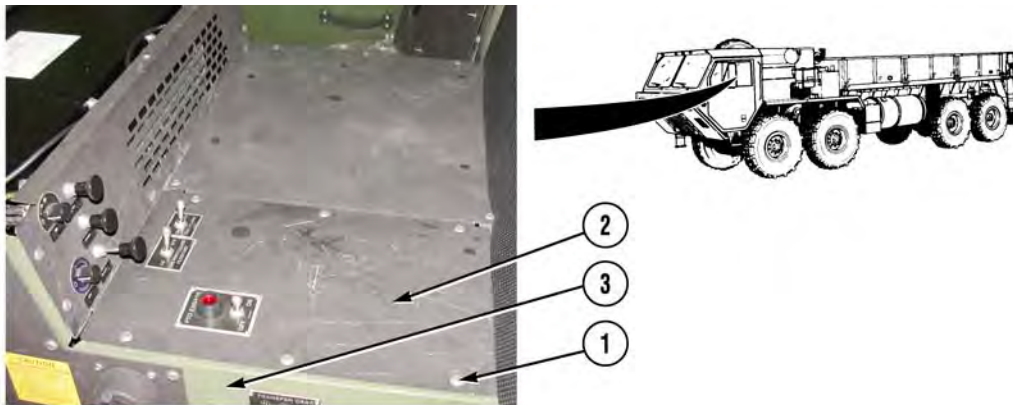

NOTE

- Refer to Appendix A, Figure A-1, for electrical schematics.
 - Tag and mark connectors and wires prior to removal to ensure proper installation.
 - Remove cable ties as required.
1. Remove six screws (1) and cover (2) from center console (3).

AC WIRING HARNESS REPLACEMENT - Continued

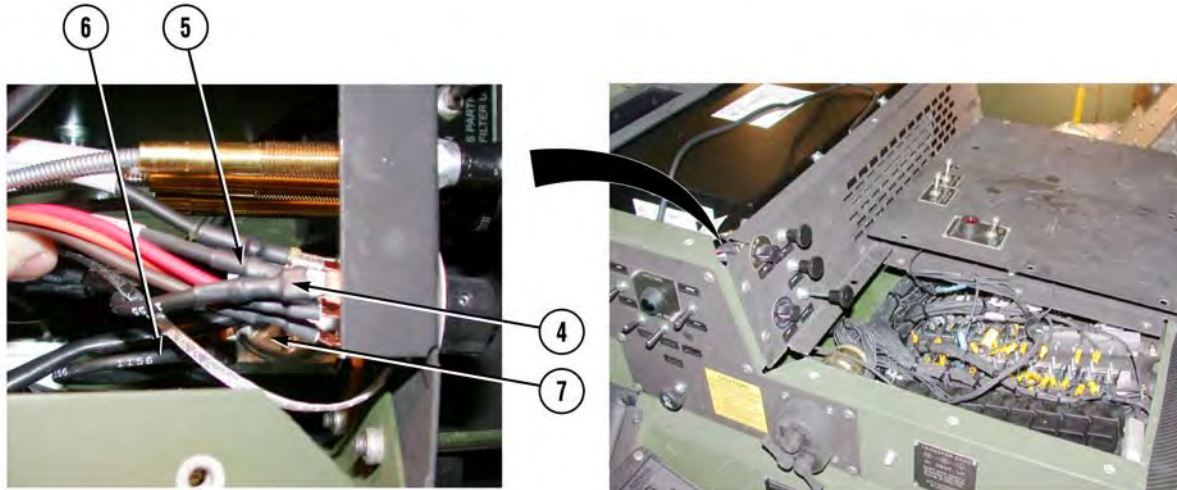

2. Remove wire 1155 (4) from wire 1082 (5).
3. Remove wire 1156 (6) from OUT terminal of temperature control switch (7).



4. Pull wire 1155 (4) and wire 1156 (6) of AC wire harness (8) through grommet (9).
5. Disconnect connector (10) from connector (11).
6. Disconnect connector (12) from connector (13).

AC WIRING HARNESS REPLACEMENT - Continued

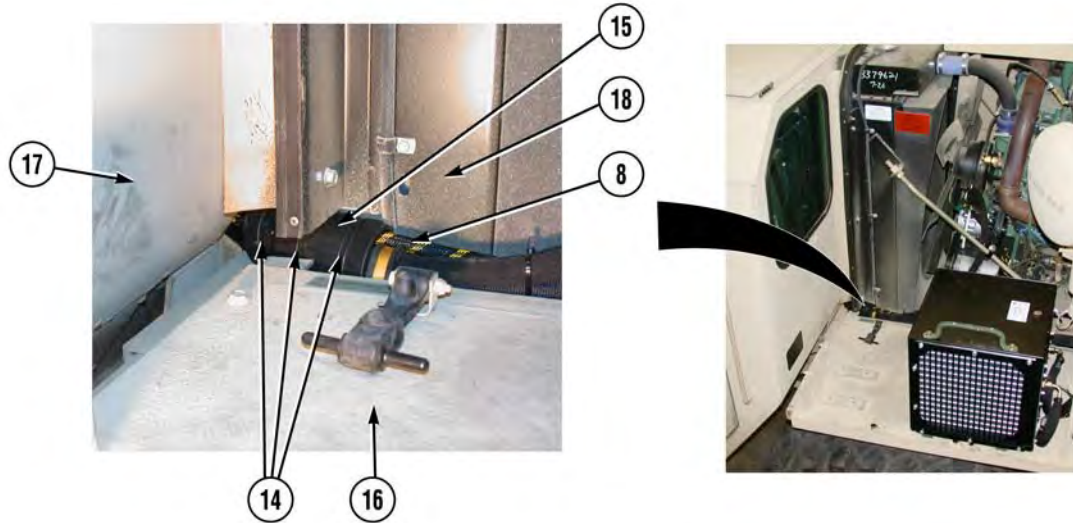

NOTE

Note position of hose shields prior to removal to ensure proper installation.

7. Remove three cable ties (14) and two hose shields (15) from opening between fender (16), cab (17), and radiator (18).
8. Pull AC wire harness (8) through opening between fender (16), cab (17), and radiator (18).

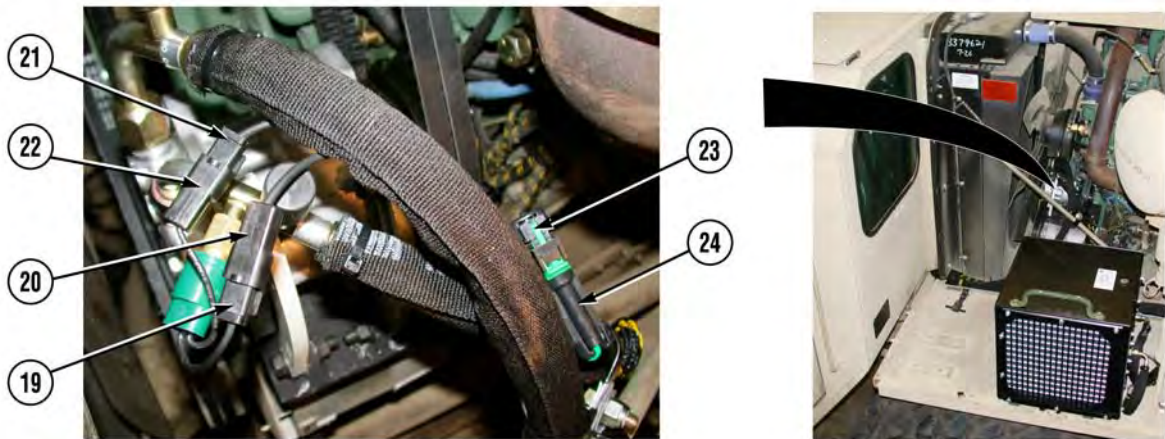

9. Disconnect connector (19) from connector (20).
10. Disconnect connector (21) from connector (22).
11. Disconnect connector (23) from connector (24).

AC WIRING HARNESS REPLACEMENT - Continued

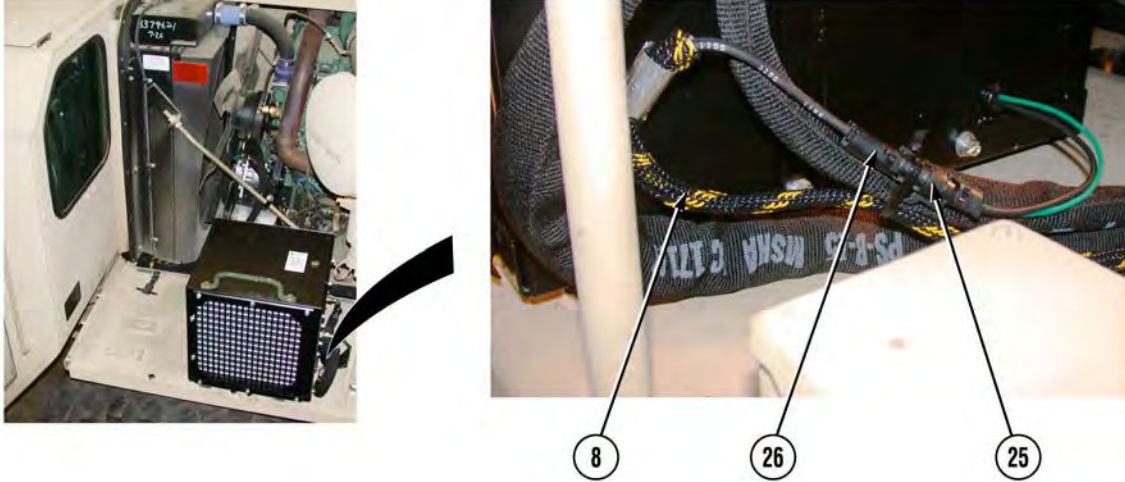

12. Disconnect connector (25) from connector (26).
13. Remove AC wire harness (8) from vehicle.

INSTALLATION

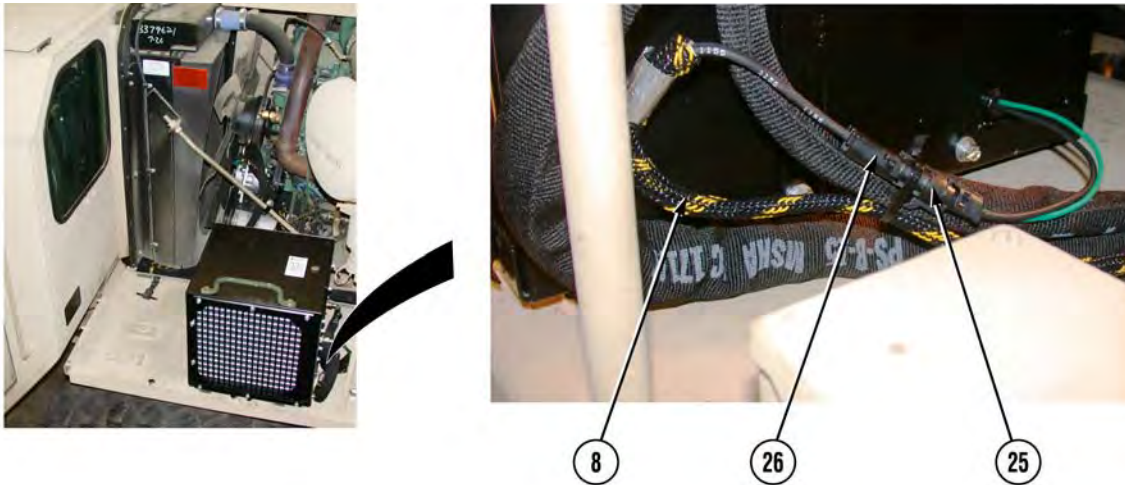

NOTE

Refer to Appendix A, Figure A-1, for electrical schematics.

1. Position AC wire harness (8) on vehicle.
2. Connect connector (25) to connector (26).

AC WIRING HARNESS REPLACEMENT - Continued

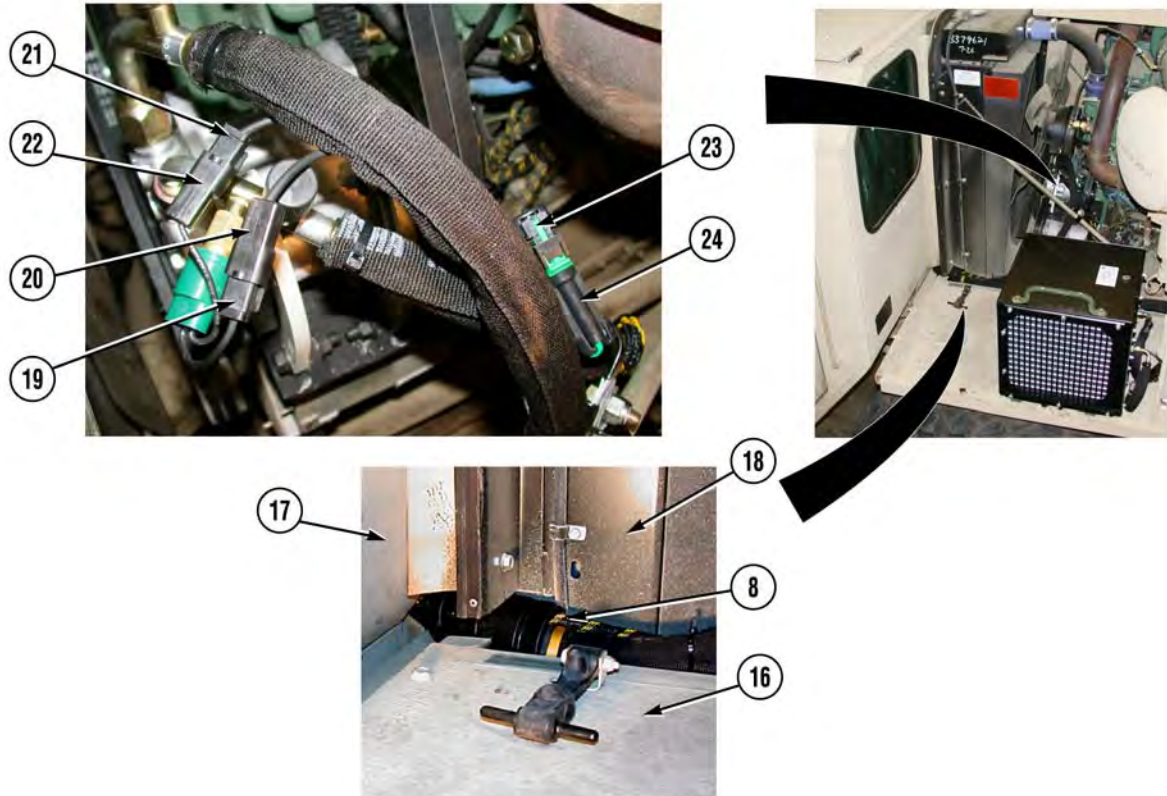

3. Connect connector (23) to connector (24).
4. Connect connector (21) to connector (22).
5. Connect connector (19) to connector (20).
6. Route AC wire harness (8) through opening between fender (16), cab (17), and radiator (18).

AC WIRING HARNESS REPLACEMENT - Continued

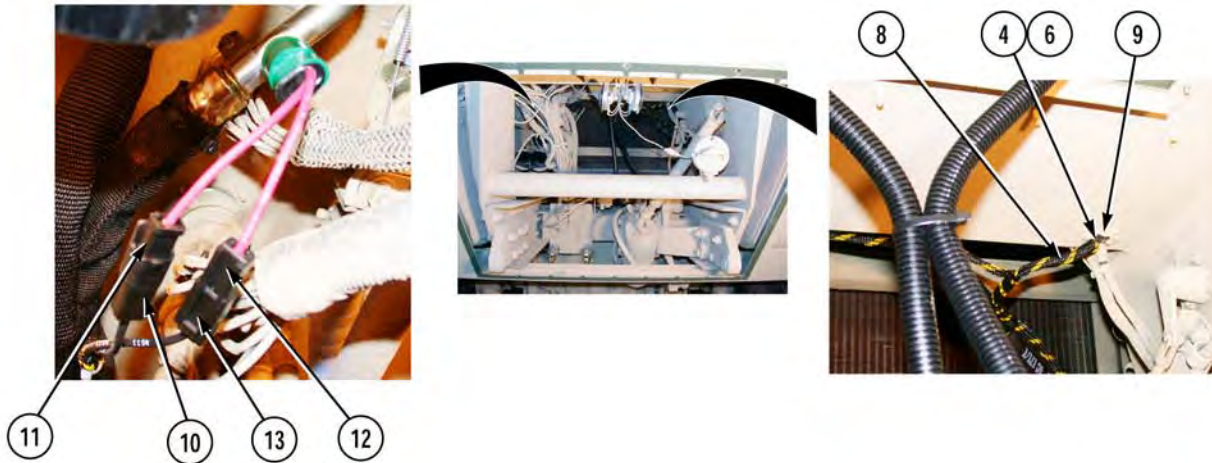

7. Connect connector (12) to connector (13).
8. Connect connector (10) to connector (11).
9. Route wire 1155 (4) and wire 1156 (6) of AC wire harness (8) through grommet (9).

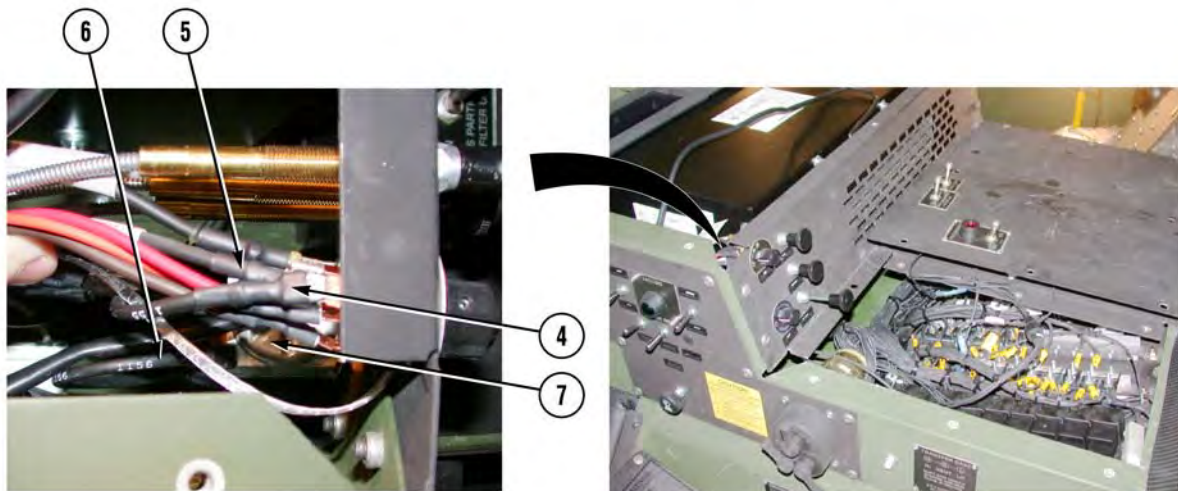

10. Install wire 1156 (6) on OUT terminal of temperature control switch (7).
11. Install wire 1155 (4) on wire 1082 (5).

AC WIRING HARNESS REPLACEMENT - Continued

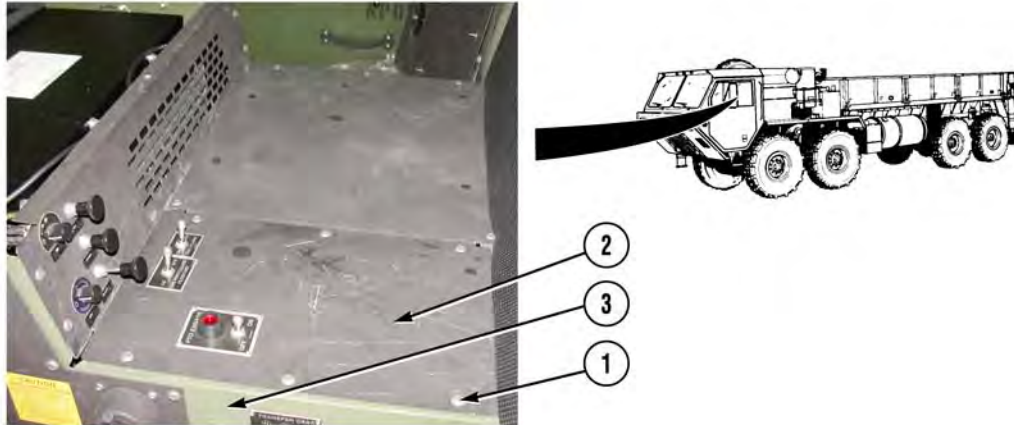

CAUTION

AC wire harness needs to be secured to AC hoses and away from moving parts with cable ties. Failure to comply may cause damage to equipment.

NOTE

Install cable ties as needed to secure AC wire harness to AC hoses and away from moving parts.

12. Install cover (2) on center console (3) with six screws (1).

AC WIRING HARNESS REPLACEMENT - Continued

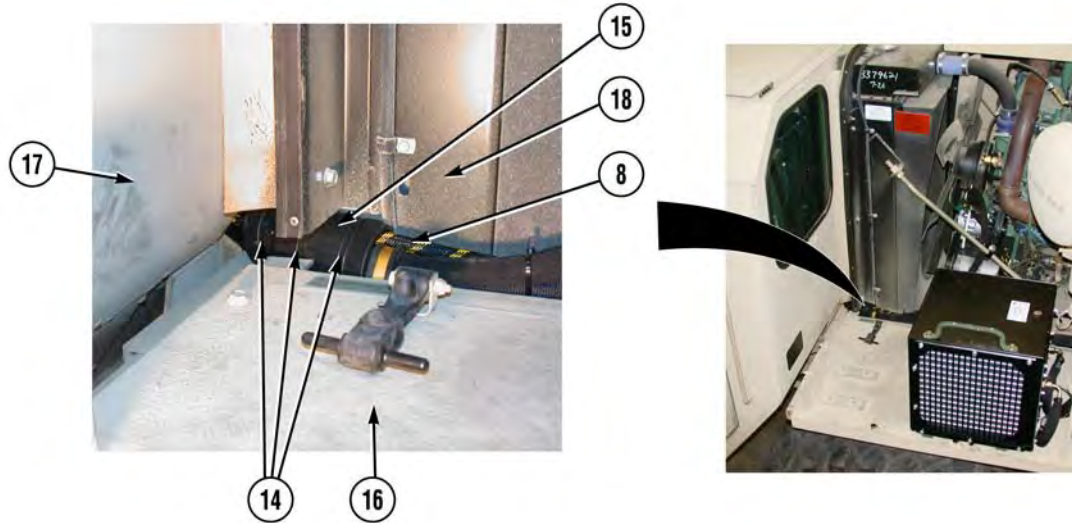

CAUTION

Hose shields must be positioned so that AC hoses and AC wire harness are protected from fender, cab, and radiator. Failure to comply may cause damage to equipment.

NOTE

Install hose shields as noted prior to removal.

13. Install two hose shields (15) between opening between fender (16), cab (17), and radiator (18) with three cable ties (14).

FOLLOW-ON MAINTENANCE

1. Install AC heater/evaporator cover (WP 0037).
2. Install engine side panel and close engine cover (TM 9-2320-279-10).
3. Install skid plate grille (TM 9-2320-279-20).
4. Connect batteries (TM 9-2320-279-20).
5. Check operation of air conditioning system (WP 0004).

END OF WORK PACKAGE

AC WIRE 1082 HARNESS REPLACEMENT

THIS WORK PACKAGE (WP) COVERS:

Removal
Installation
Follow-On Maintenance

INITIAL SETUP:**Maintenance Level**

Field Level Maintenance

Equipment Condition

Batteries disconnected (TM 9-2320-279-20).
AC heater/evaporator cover removed (WP 0037).

Tools and Special Tools

Tool Kit, General Mechanic's (Item 7, Appendix F)

Materials/Parts

Tags, Identification (Item 9, Appendix E)

Personnel Required

MOS 52C, Utilities equipment repairer

References

TM 9-2320-279-20

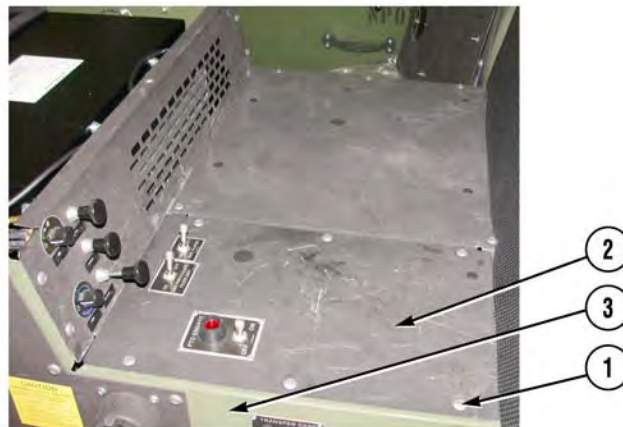
REMOVAL

1. Remove six screws (1) and cover (2) from center console (3).

AC WIRE 1082 HARNESS REPLACEMENT - Continued



NOTE

Tag and mark connectors and wires prior to removal to ensure proper installation.

2. Disconnect wire 1082 harness (4) from wire (5).
3. Remove wire 1082 harness (4) from terminal B of fan control switch (6).
4. Remove wire 1155 (7) from wire 1082 harness (4).

INSTALLATION

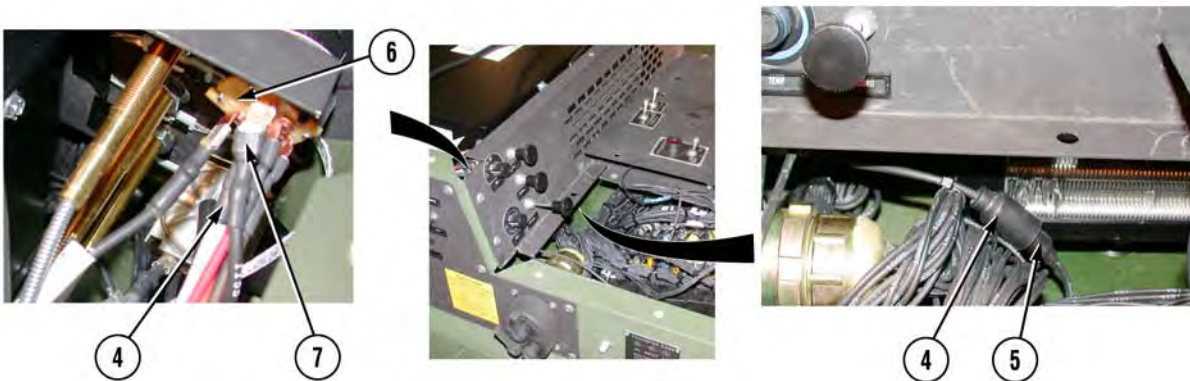

1. Install wire 1155 (7) on wire 1082 harness (4).
2. Install wire 1082 harness (4) on terminal B of fan control switch (6).
3. Connect wire 1082 harness (4) to wire (5).

AC WIRE 1082 HARNESS REPLACEMENT - Continued

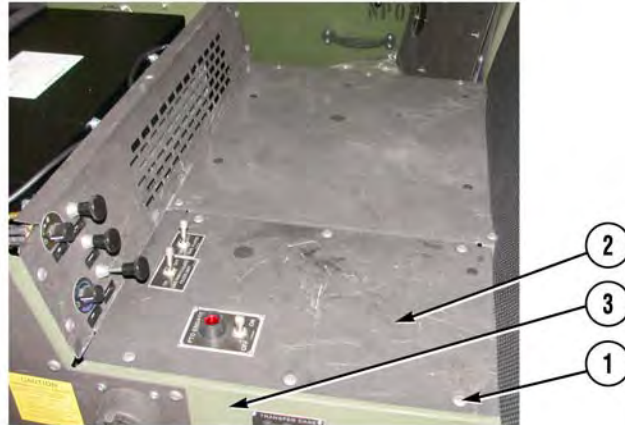

4. Install cover (2) on center console (3) with six screws (1).

FOLLOW-ON MAINTENANCE

1. Install AC heater/evaporator cover (WP 0037).
2. Connect batteries (TM 9-2320-279-20).

END OF WORK PACKAGE

AC WIRE 1156 HARNESS REPLACEMENT

THIS WORK PACKAGE (WP) COVERS:

- Removal
- Installation
- Follow-On Maintenance

INITIAL SETUP:**Maintenance Level**

Field Level Maintenance

Equipment Condition

Batteries disconnected (TM 9-2320-279-20).
AC heater/evaporator cover removed (WP 0037).

Tools and Special Tools

Tool Kit, General Mechanic's (Item 7, Appendix F)

Materials/Parts

Tags, Identification (Item 9, Appendix E)

Personnel Required

MOS 52C, Utilities equipment repairer

References

TM 9-2320-279-20

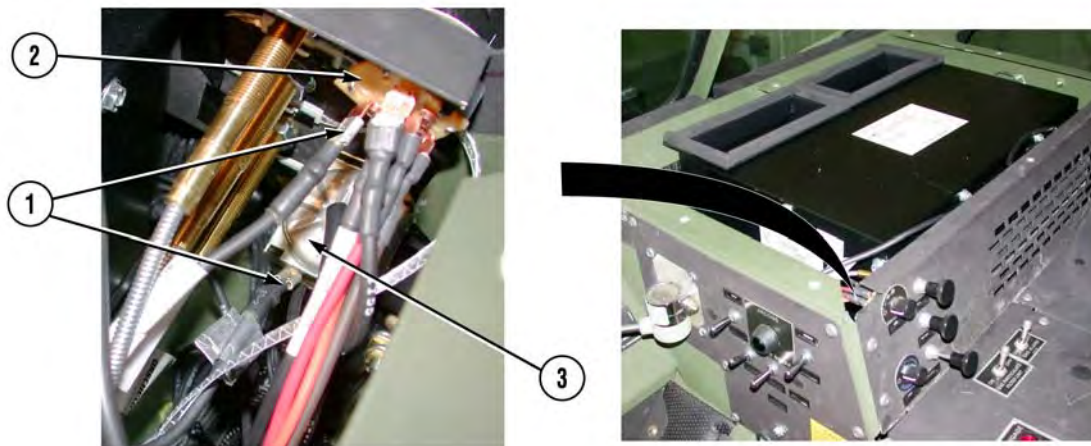
REMOVAL**NOTE**

Tag and mark wires prior to removal to ensure proper installation.

1. Remove wire 1156 harness (1) from terminal C of fan control switch (2).
2. Remove wire 1156 harness (1) from IN terminal of temperature control switch (3).

AC WIRE 1156 HARNESS REPLACEMENT - Continued

INSTALLATION

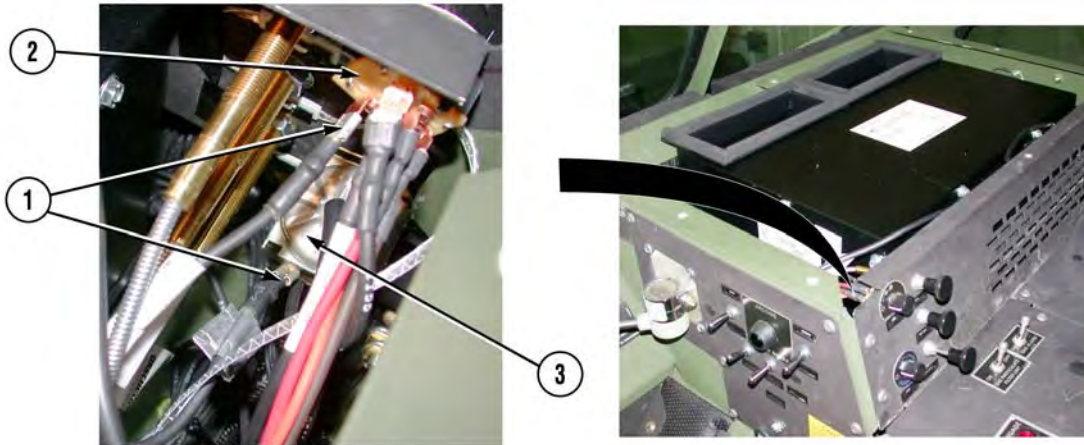

1. Install wire 1156 harness (1) on IN terminal of temperature control switch (3).
2. Install wire 1156 harness (1) on terminal C of fan control switch (2).

FOLLOW-ON MAINTENANCE

1. Install AC heater/evaporator cover (WP 0037).
2. Connect batteries (TM 9-2320-279-20).

END OF WORK PACKAGE

AIR CONDITIONING LEAK TEST

THIS WORK PACKAGE (WP) COVERS:

Inspection
 Test
 Follow-On Maintenance

INITIAL SETUP:

Maintenance Level

Field Level Maintenance

Materials/Parts

None

Equipment Condition

Engine cover opened and engine side panel removed (TM 9-2320-279-10).

Personnel Required

MOS 52C, Utilities equipment repairer

Tools and Special Tools

Tool Kit, General Mechanic's (Item 7, Appendix F)
 Leak Detector, Refrigerant (Item 1, Appendix H)

References

TM 9-2320-279-10

INSPECTION

WARNING

- Use care to prevent refrigerant from touching your skin or eyes. Liquid refrigerant, when exposed to air, quickly evaporates and will freeze skin or eye tissues. Serious injury or blindness may result if you come in contact with liquid refrigerant.
- Refrigerant R-134a air conditioning systems should not be pressure tested or leak tested with compressed air. Combustible mixtures of air and R-134a may form, resulting in a fire or explosion, which could cause personnel injury or death.

NOTE

- Refrigerant is odorless. As a result, all of it may leak away and not be noticed until system stops cooling. All vehicle refrigerant systems lose some refrigerant depending on condition of system. Higher loss rates signal a need to locate and repair leaks.
 - Leaks are most often found at compressor hose connections and at various fittings and joints in system. If unapproved replacement hoses are installed, refrigerant can be lost through hose permeation.
1. Visually inspect refrigerant system for air conditioning lubricant leakage and corrosion and damage to lines, hoses, and other components.
 2. Visually inspect lowest points of fittings, hoses, and lines for indication of lubricant leakage.

AIR CONDITIONING LEAK TEST - Continued

TEST

1. AC system should be charged with a sufficient amount of refrigerant to have a gage pressure of at least 50 psi (345 kPa) when not in operation. At temperatures below 59°F (15°C), leaks may not be measurable, since this pressure may not be reached.
2. Take care not to contaminate detector probe tip if part being tested is contaminated. If part is particularly dirty, or moisture is present, it should be wiped off with a dry shop towel or blown off with shop air. No cleaners or solvents should be used, since detector may be sensitive to the ingredients in cleaner or solvent.
3. Visually trace entire refrigerant system, and look for signs of air conditioning lubricant leakage, damage, and corrosion on all lines, hoses, and components. Each questionable area should be carefully checked with detector probe, as well as, all fittings, hoses, service ports with caps in place, and areas around cushion clips and cable ties.
4. Always follow AC system around in a continuous path so that no areas of potential leaks are missed. If a leak is found, always continue to test remainder of the AC system.
5. At each area checked, probe should be moved around location at a rate no more than 1 to 2 in./second (3 to 5 cm/second), and no more than 1/4 in. (0.64 cm) from surface, completely around position. Slower and closer movement of the probe greatly improves likelihood of finding a leak. Any increase in beep rate is indicative of a leak.
6. An apparent leak should be verified at least once as follows:
 - (a) Blow shop air in area of suspected leak if necessary, and repeat check of area. In cases of very large leaks, blowing out area with shop air often helps locate exact position of leak.
 - (b) Move probe to fresh air and reset. Then hold probe tip as close as possible to indicate leak source and slowly move around it until leak is confirmed.
7. If leaks are indicated, repair leaks as necessary.

FOLLOW-ON MAINTENANCE

1. Install engine side panel and close engine cover (TM 9-2320-279-10).

END OF WORK PACKAGE

AC SYSTEM REFRIGERANT (R-134a) MAINTENANCE

THIS WORK PACKAGE (WP) COVERS:

Recovery
Evacuation
Charging

INITIAL SETUP:

Maintenance Level

Field Level Maintenance

Equipment Condition

Engine cover opened and engine side panel removed (TM 9-2320-279-10).

Tools and Special Tools

Goggles (Item 1, Appendix F)
Set, Cap and Plug (Item 3, Appendix F)
Tool Kit, General Mechanic's (Item 7, Appendix F)
Leak Detector, Refrigerant (Item 1, Appendix H)
Reclaimer, Refrigerant (Item 2, Appendix H)

Materials/Parts

Gloves, Rubber (Item 2, Appendix E)
Oil, PAG 46 (Item 3, Appendix E)
Refrigerant, R-134a (Item 4, Appendix E)

Personnel Required

MOS 52C, Utilities equipment repairer

References

TM 9-2320-279-10

AC SYSTEM REFRIGERANT (R-134a) MAINTENANCE - Continued

RECOVERY

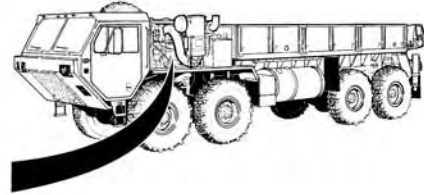

1. Start engine (TM 9-2320-279-10) and run at idle until normal operating temperature is reached.
2. Shut engine OFF (TM 9-2320-279-10).

WARNING

- Use care to prevent refrigerant from touching skin or eyes. Liquid refrigerant, when exposed to air, quickly evaporates and will freeze skin or eye tissues. Serious injury or blindness may result if you come in contact with liquid refrigerant.
- Refrigerant R-134a air conditioning systems should not be pressure tested or leak tested with compressed air. Combustible mixtures of air and R-134a may form, resulting in a fire or explosion, which could cause personnel injury or death.
- Wear protective goggles and nonleather gloves when servicing air conditioner system. Failure to comply may result in injury to personnel.

NOTE

Service valves are located on two AC hoses attached to AC compressor.

3. Remove cap (1) from service valve (2) on hose (3).
4. Remove cap (4) from service valve (5) on hose (6).

AC SYSTEM REFRIGERANT (R-134a) MAINTENANCE - Continued

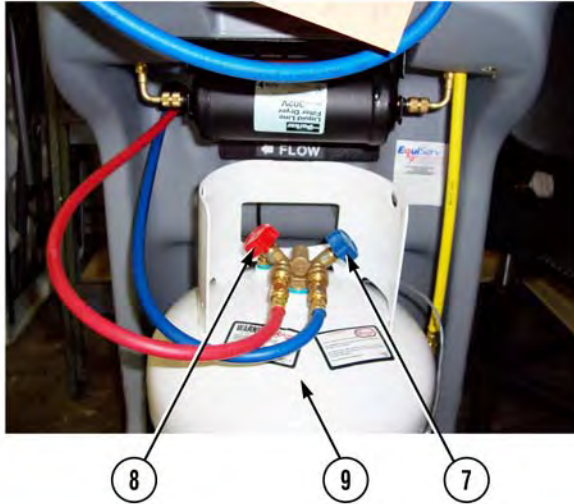

5. Open blue valve (7) and red valve (8) on recovery tank (9).

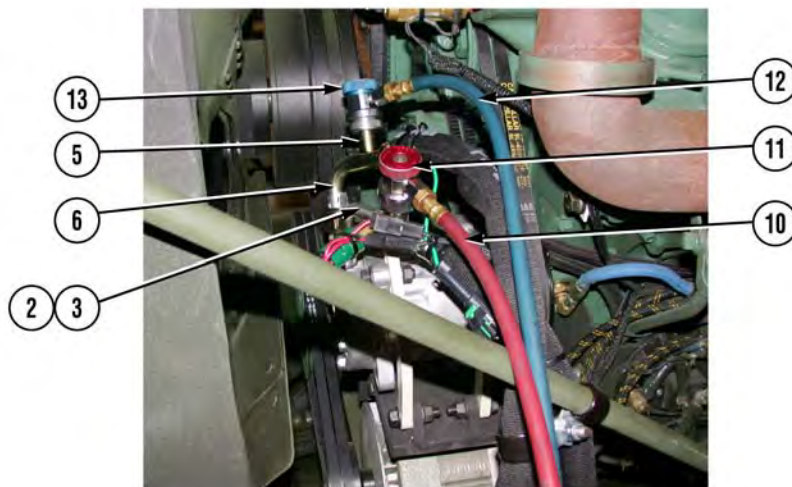

6. Connect red hose (10) to service valve (2) on hose (3) and open service hose coupler (11).

7. Connect blue hose (12) to service valve (5) on hose (6) and open service hose coupler (13).

AC SYSTEM REFRIGERANT (R-134a) MAINTENANCE - Continued

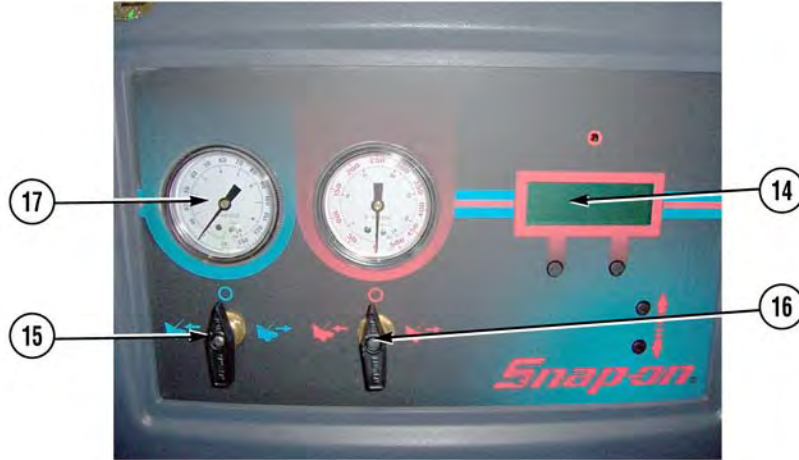

8. Select RECOVER and press ENTER on LCD screen (14).
9. Turn panel low side valve (15) and panel high side valve (16) to 3 o'clock position, then press START.

NOTE

As refrigerant is recovered, the panel gages will show increasing vacuum.

10. Recover refrigerant until the low side pressure gage (17) indicates 15 inHG, then press PAUSE.
11. Monitor low side pressure gage (17) for five minutes.

NOTE

- If pressure increases above vacuum (0 psi), perform Step 12, more recovery time is required.
 - If there is no change in pressure after five minutes, proceed to Step 13, recovery is complete.
12. Repeat Steps 8 through 11 until system pressure remains stable for 2 minutes, then press START to continue recovering refrigerant.
 13. Press EXIT, turn panel low side valve (15) and panel high side valve (16) to 12 o'clock position, then press NEXT.

AC SYSTEM REFRIGERANT (R-134a) MAINTENANCE - Continued

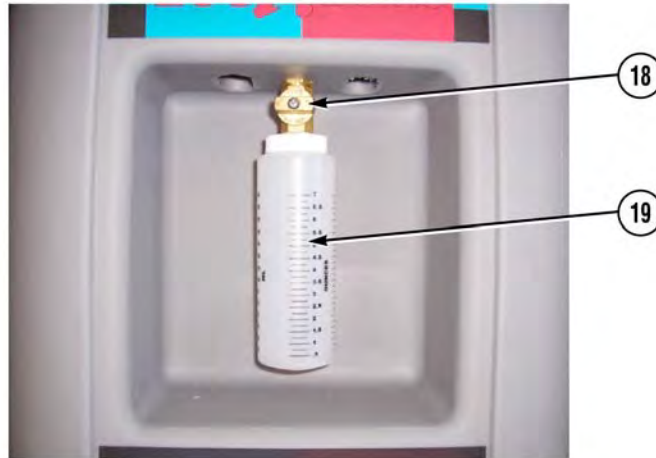

14. Open oil drain valve (18) and drain waste oil into bottle (19).
15. Close oil drain valve (18).

NOTE

- The amount of oil recorded in Step 16 will be the same amount of oil that will need to be added back into the AC system when charging.
 - Always comply with local, state, and federal regulations regarding oil disposal. Failure to comply may result in penalties for improper disposal.
16. Remove bottle (19) from oil drain valve (18) and record amount of oil that drained into bottle.
 17. Install bottle (19) on oil drain valve (18).

AC SYSTEM REFRIGERANT (R-134a) MAINTENANCE - Continued

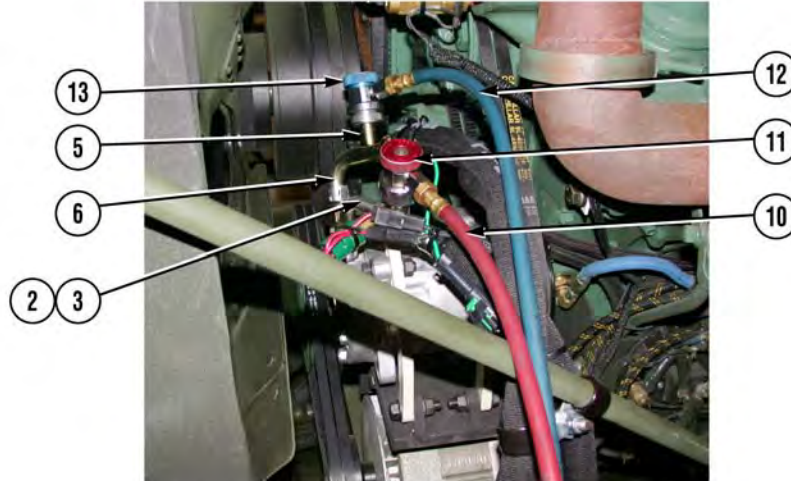

18. Press NEXT, wait for Main Menu.
19. When Main Menu screen appears, close service hose coupler (11) and service hose coupler (13).
20. Remove blue hose (12) from service valve (5) on hose (6).
21. Remove red hose (10) from service valve (2) on hose (3).

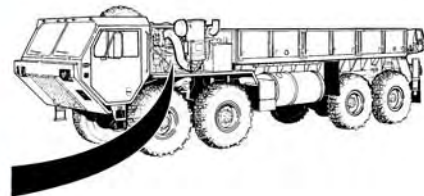

22. Install cap (4) on service valve (5) of hose (6).
23. Install cap (1) on service valve (2) of hose (3).

AC SYSTEM REFRIGERANT (R-134a) MAINTENANCE - Continued

CAUTION

AC condenser dryer must be replaced each time AC system refrigerant is recovered or damage to AC system may result.

24. Replace AC condenser dryer (WP 0025).

EVACUATION

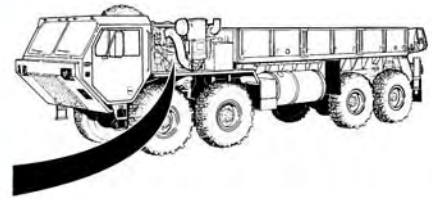

WARNING

Wear protective goggles and nonleather gloves when servicing AC system. Failure to comply may result in injury to personnel.

NOTE

Service valves are located on two AC hoses attached to AC compressor.

1. Remove cap (1) from service valve (2) on hose (3).
2. Remove cap (4) from service valve (5) on hose (6).

AC SYSTEM REFRIGERANT (R-134a) MAINTENANCE - Continued

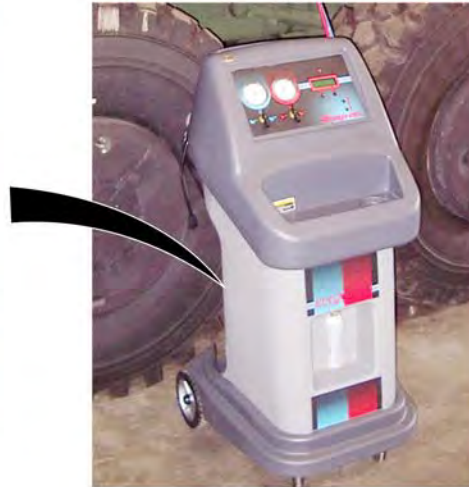
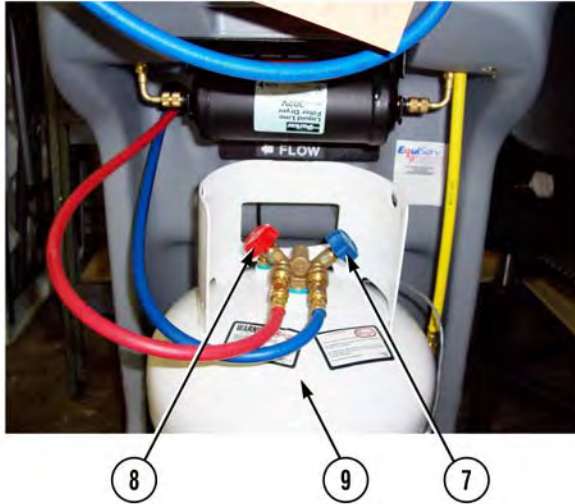

3. Open blue valve (7) and red valve (8) on recovery tank (9).

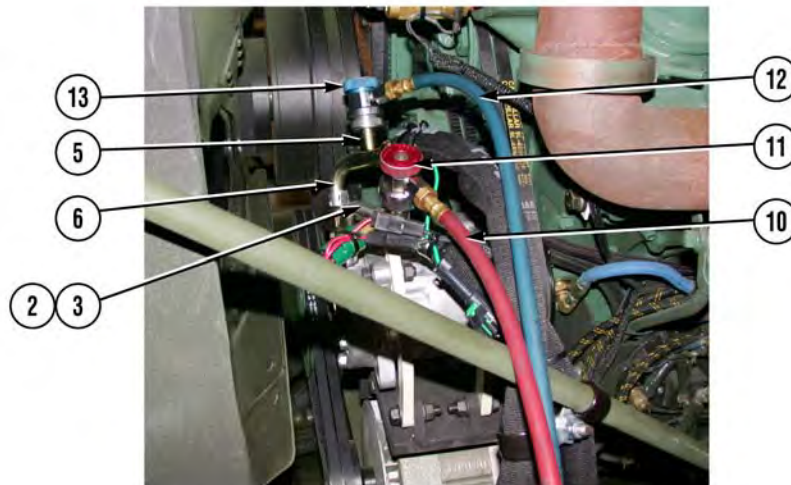

4. Connect red hose (10) to service valve (2) on hose (3) and open service hose coupler (11).

5. Connect blue hose (12) to service valve (5) on hose (6) and open service hose coupler (13).

AC SYSTEM REFRIGERANT (R-134a) MAINTENANCE - Continued

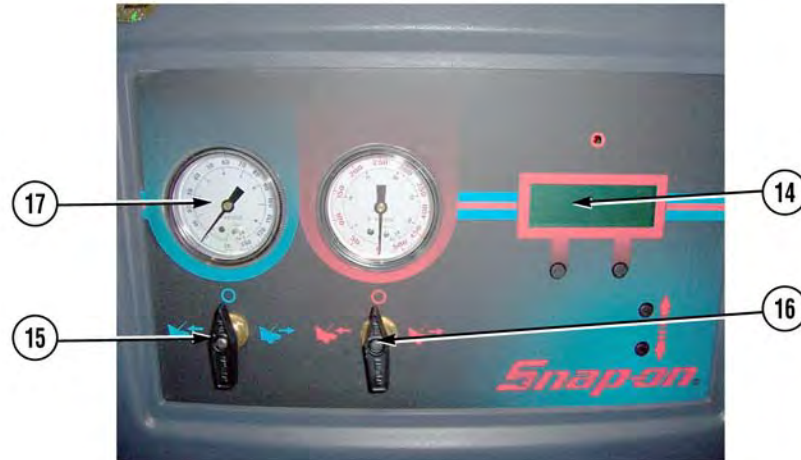

NOTE

If two gages indicate pressure, recover refrigerant from service station hoses before performing Step 6.

6. Select VACUUM and press ENTER on LCD screen (14).
7. Adjust time to 30 minutes.
8. Turn panel low side valve (15) and panel high side valve (16) to 3 o'clock position, then press START.
9. When evacuation time is FINISHED, press EXIT.
10. Turn panel low side valve (15) and panel high side valve (16) to 12 o'clock position, then press NEXT.

NOTE

Any rise in vacuum indicates a leak in the AC system.

11. Monitor low side pressure gage (17) for five minutes.

NOTE

- If there is a change in pressure after five minutes, perform Steps 12 through 15. Change of pressure indicates a leak in the system.
- If there is no change in pressure after five minutes, proceed to Step 16, evacuation is complete.

12. Partially charge AC system.
13. Perform a leak test inspection (WP 0049).

AC SYSTEM REFRIGERANT (R-134a) MAINTENANCE - Continued

14. If a leak is found, repair leak as required.
15. Recover refrigerant and repeat evacuation procedure.

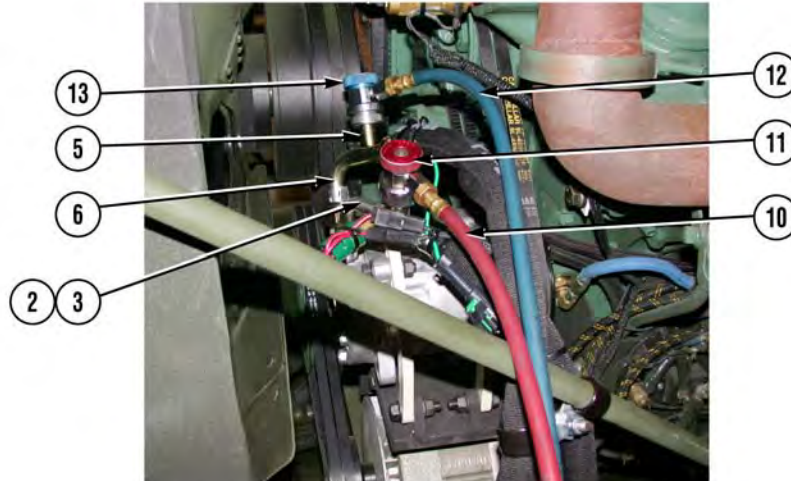

16. Close service hose coupler (11) and service hose coupler (13).
17. Remove blue hose (12) from service valve (5) on hose (6).
18. Remove red hose (10) from service valve (2) on hose (3).

AC SYSTEM REFRIGERANT (R-134a) MAINTENANCE - Continued

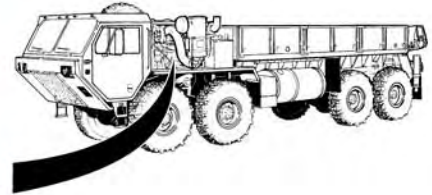

19. Install cap (4) on service valve (5) of hose (6).
20. Install cap (1) on service valve (2) of hose (3).

CAUTION

AC condenser dryer must be replaced each time AC system is evacuated or damage to AC system may result.

21. Replace AC condenser dryer (WP 0025).

AC SYSTEM REFRIGERANT (R-134a) MAINTENANCE - Continued

CHARGING

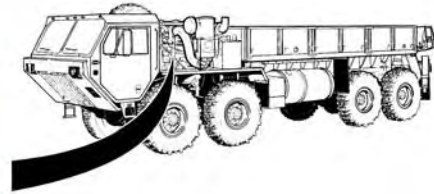

WARNING

- Use care to prevent refrigerant from touching skin or eyes. Liquid refrigerant, when exposed to air, quickly evaporates and will freeze skin or eye tissues. Serious injury or blindness may result if you come in contact with liquid refrigerant.
- Refrigerant R-134a air conditioning systems should not be pressure tested or leak tested with compressed air. Combustible mixtures of air and R-134a may form, resulting in a fire or explosion, which could cause personnel injury or death.

1. Remove hose (1) and preformed packing (2) from compressor (3). Discard preformed packing (2).

CAUTION

PAG oil must be added to AC system before charging or AC compressor will be damaged.

NOTE

Add same amount of PAG oil in AC system as was noted during recovery, unless AC system is being charged for the first time. If charging AC system for the first time, add 1 oz. (28 g) of PAG oil into AC system.

2. Pour PAG oil into hose (1).
3. Install hose (1) and preformed packing (2) on compressor (3).
4. Remove cap (4) from service valve (5) on hose (1).
5. Remove cap (6) from service valve (7) on hose (8).

AC SYSTEM REFRIGERANT (R-134a) MAINTENANCE - Continued

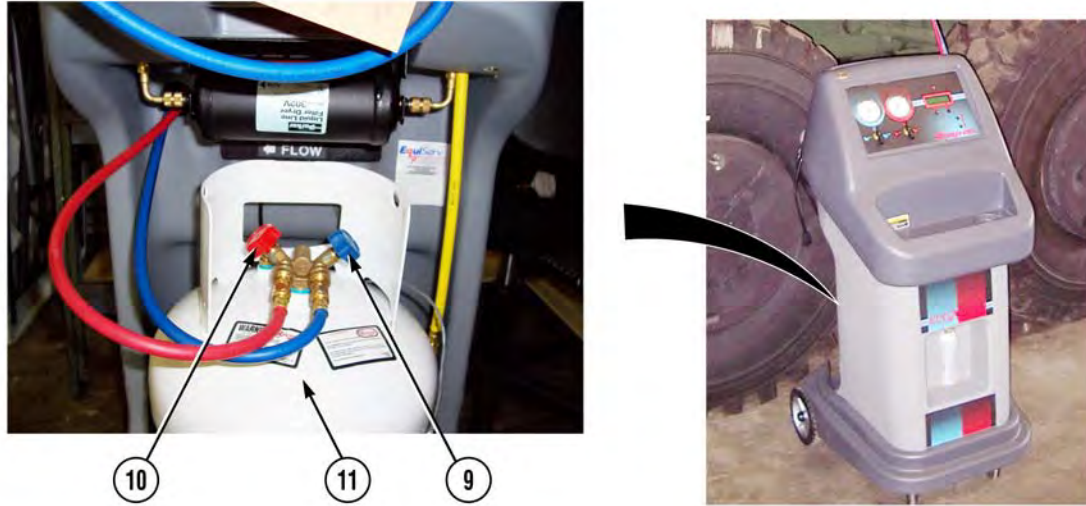

6. Open blue valve (9) and red valve (10) on recovery tank (11).



7. Connect red hose (12) to service valve (5) on hose (1) and open service hose coupler (13).

8. Connect blue hose (14) to service valve (7) on hose (8) and open service hose coupler (15).

AC SYSTEM REFRIGERANT (R-134a) MAINTENANCE - Continued

NOTE

AC system must be in a 15 inHG vacuum status before charging.

9. Charge AC system as noted in Table 6-1 for proper system pressure levels at measured temperatures.

Table 6-1. Proper System Pressure Levels at Measured Temperatures.

°F	°C	HFC-134a (psi)	°F	°C	HFC-134a (psi)
-60	-51.1	21.8	55	12.8	51.1
-55	-48.3	20.4	60	15.6	57.3
-50	-45.6	18.7	65	18.3	63.9
-45	-42.8	16.9	70	21.1	70.9
-40	-40.0	14.8	75	23.8	78.4
-35	-37.2	12.5	80	26.7	88.4
-30	-34.4	9.8	85	29.4	94.9
-25	-31.7	6.9	90	32.2	103.9
-20	-28.9	3.7	95	35.0	113.5
-15	-26.1	0.0	100	37.8	123.6
-10	-23.3	1.9	105	40.6	134.3
-5	-20.6	4.1	110	43.3	145.3
0	-17.8	6.5	115	46.1	157.6
5	-15.0	9.0	120	48.9	170.3
10	-12.2	12.0	125	51.7	183.6
15	-9.4	15.0	130	54.4	197.6
20	-6.7	18.4	135	57.2	212.4
25	-3.9	22.1	140	60.0	227.9
30	-1.1	26.1	145	62.8	244.3
35	1.7	30.4	150	65.6	261.4
40	4.4	35.0	155	68.3	279.5
45	7.2	40.0	160	71.1	298.4
50	10.0	45.3	165	73.9	318.3

AC SYSTEM REFRIGERANT (R-134a) MAINTENANCE - Continued

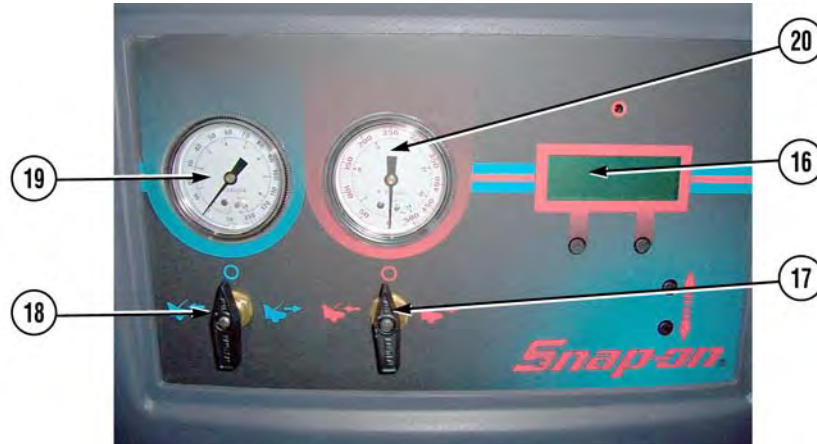

10. Select CHARGE and press ENTER on LCD screen (16).

CAUTION

Use care not to overcharge AC system. The AC system is fully charged when there is 3 lbs. (1.4 kg) of refrigerant in AC system. Failure to comply may result in damage to compressor.

11. Turn panel high side valve (17) to 9 o'clock position, then press START.

NOTE

A slow charge condition may occur due to a pressure equalization between the service station and vehicle AC system.

12. Monitor the charge weight and turn panel high side valve (17) to 12 o'clock position after 3 lbs. (1.4 kg) of refrigerant has entered AC system.

WARNING

Never operate vehicle AC system with the panel high side valve in 9 o'clock position.

NOTE

- Perform Steps 13 through 19 if a slow charge condition occurs.
 - Proceed to Step 20 if a slow charge condition did not occur.
13. Ensure panel low side valve (18) and high side valve (17) are in 12 o'clock position.
 14. Start engine (TM 9-2320-279-10).
 15. Turn AC system ON (WP 0004).

AC SYSTEM REFRIGERANT (R-134a) MAINTENANCE - Continued

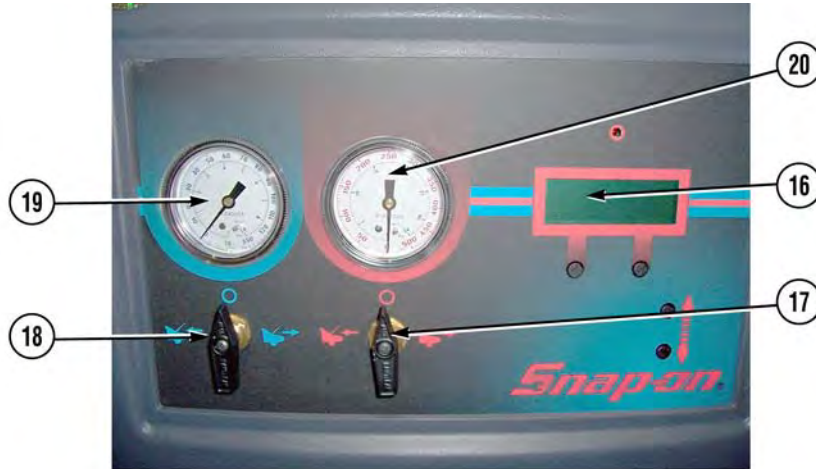

16. Turn panel low side valve (18) to 9 o'clock position.
17. Monitor the charge weight and turn panel low side valve (18) to 12 o'clock position after 3 lbs. (1.4 kg) of refrigerant has entered AC system.
18. Turn AC system OFF (WP 0004).
19. Shut engine OFF (TM 9-2320-279-10).

NOTE

Any rise in vacuum indicates a leak in the AC system.

20. Monitor low side pressure gage (19) and high side pressure gage (20) for five minutes.

NOTE

- If there is a change in pressure after five minutes, perform Steps 21 through 23. Change of pressure indicates a leak in the system.
- If there is no change in pressure after five minutes, proceed to Step 24, charging is complete.

21. Perform a leak test inspection (WP 0049).
22. If a leak is found, recover refrigerant and repair leak as required.
23. Repeat charging procedure.

AC SYSTEM REFRIGERANT (R-134a) MAINTENANCE - Continued

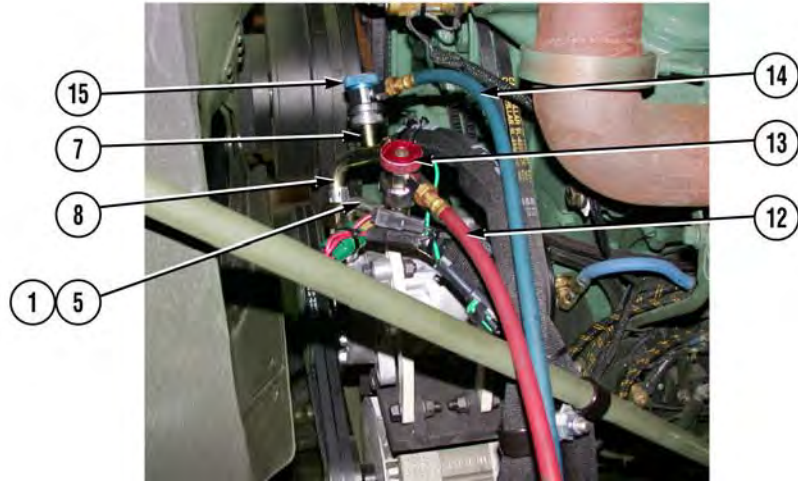

- 24. Close service hose coupler (13) and service hose coupler (15).
- 25. Remove blue hose (14) from service valve (7) on hose (8).
- 26. Remove red hose (12) from service valve (5) on hose (1).

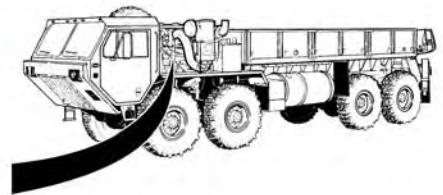

- 27. Install cap (6) on service valve (7) of hose (8).
- 28. Install cap (4) on service valve (5) of hose (1).

AC SYSTEM REFRIGERANT (R-134a) MAINTENANCE - Continued

FOLLOW-ON MAINTENANCE

1. Leak test air conditioning system (WP 0049).
2. Check operation of AC system (WP 0004).
3. Engine OFF (TM 9-2320-279-10).

END OF WORK PACKAGE

TB 9-2320-279-13-1

APPENDIX A

INSTALLATION DRAWINGS AND SCHEMATICS

INSTALLATION DRAWINGS AND SCHEMATICS

APPENDIX A INDEX

FIGURE	FIGURE TITLE	WP PAGE NO.
Figure A-1.	AC Electrical Diagram and Schematic	0051-2
Figure A-2.	AC Refrigerant Schematic	0051-3

INSTALLATION DRAWINGS AND SCHEMATICS - Continued

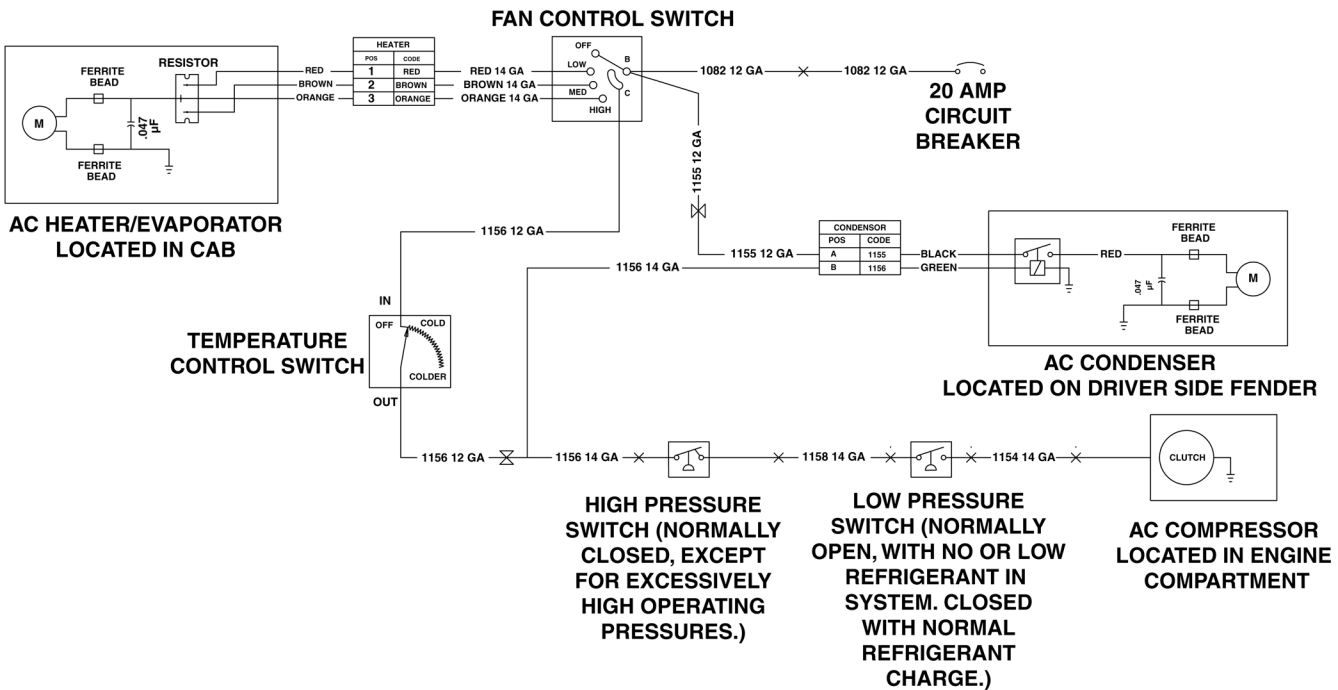
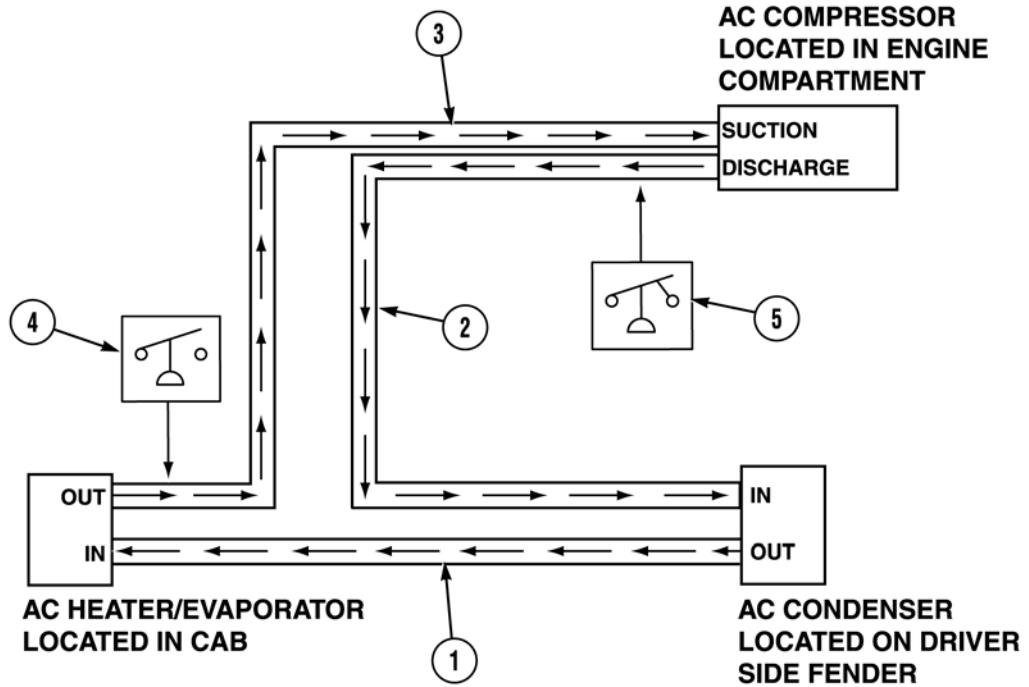

Figure A-1. AC Electrical Diagram and Schematic

INSTALLATION DRAWINGS AND SCHEMATICS - Continued



LEGEND:

- 1. HOSE ASSEMBLY No. 6 (2524)
- 2. HOSE ASSEMBLY No. 8 (2521)
- 3. HOSE ASSEMBLY No. 10 (2522)
- 4. LOW PRESSURE SWITCH
- 5. HIGH PRESSURE SWITCH

Figure A-2. AC Refrigerant Schematic

END OF WORK PACKAGE

TB 9-2320-279-13-1

APPENDIX B

INITIAL INSTALLATION INSTRUCTIONS OF AC KIT

INITIAL INSTALLATION INSTRUCTIONS OF AC KIT

APPENDIX B

SCOPE

This appendix contains the HEMTT Air Conditioner Kit Installation Instructions manual.

**HEMTT
AIR CONDITIONER KIT
INSTALLATION INSTRUCTIONS
AND OTC ENGINEERING DRAWING
KIT NUMBER-3528313**

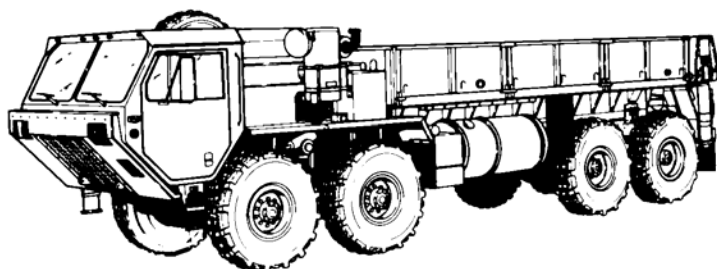

KIT CONTENTS	Pg. 3
COMPRESSOR INSTALLATION	Pg. 9
CONDENSOR INSTALLATION	Pg. 17
HOSE AND WIRE HARNESS ROUTING	Pg. 21
HEATER/ EVAPORATOR INSTALLATION	Pg. 29
AIR CONDITIONER CHARGE/SERVICE	Pg. 43

TB 9-2320-279-13-1**Kit Contents.**

The HEMTT Air Conditioner kit contains the following items:

1. Compressor Installation.		
ITEM	QUANTITY	PART NUMBER
Alternator Pad	1	1935350
Bracket Assembly	1	1935280 W
Screw-7/16-14 x 1 3/4 in.	4	2016HX1
Lockwasher-7/16 in.	4	352AX
Loctite 242	A/R	65270AX
Alternator, 130 AMP	1	2071710
Alternator Pulley	1	1698110
Screw-1/2-13 in. x 6 1/2 in.	1	119097B
Flange Nut-1/2-13 in.	2	110310A
Alternator Strap	1	1935480 W
Flange Screw-1/2-13 x 3 1/4 in.	1	124129A
Screw-1/2-13 x 2 in.	1	1867HX1
Washer-1/2 in.	1	720HX2
Lockwasher-1/2 in.	1	355AX
Flange Nut-1/2 in.	1	1598030
Alternator Drive Belt Set	1	1942510
Compressor and Clutch	1	2081570
Washer-3/8 in.	1	362AX
Screw-3/8-16 x 1 1/2 in.	6	120699A
Flange Nut-3/8 in.	6	115307A
Compressor Strap	2	1935360
Compressor Drive Belt Set	1	4853OAX
Bracket	1	1138010
Washer-1/2 in.	1	720HX
Lockwasher-1/2 in.	1	355AX

TB 9-2320-279-13-1

1. Compressor Installation (Cont'd).		
ITEM	QUANTITY	PART NUMBER
Cushion Clip	1	2290HX
Screw-1/2-13 x 1 in.	1	740AX1
Screw-1/4-20 x 3/4 in.	1	1606140
Locknut-1/4 in.	1	1600460
Cable Tie	1	5193HX

2. Condensor Installation.		
ITEM	QUANTITY	PART NUMBER
Air Conditioner Condensor	1	3561838
• Connector 2 Pin	1	1570890
• Socket Contact	2	1624070
• Seal	2	1624130
Grab Handle	1	3292745
Washer-3/8 in.	2	362AX
Lockwasher-3/8 in.	2	351AX
Screw-3/8-16 x 1 in.	2	420AX1
Plate	4	3523596
Flange Screw-3/8-16 x 2 in.	4	1754290

TB 9-2320-279-13-1

3. Hose and Wire Harness Routing.		
ITEM	QUANTITY	PART NUMBER
Air Conditioning Wire Harness	1	3072190
Cable Tie	10	5201HX
Hose Assembly #6	1	3072189
Hose Assembly #8	1	3242406
Hose Assembly #10	1	2081300
High Pressure Switch	1	2081600
Low Pressure Switch	1	2081590
Air Conditioner Installation Label	1	3343685
Cushion Clip-3/4 in.	1	2291HX
Cushion Clip-1 in.	1	2287HX
Cushion Clip-1 1/8 in.	1	2289HX
Screw-3/8-16 x 1 in.	1	420AX1
Locknut-3/8 in.	3	108708A
Double Cushion Clip	3	1532000
Washer-3/8 in.	2	362AX
Screw-3/8-16 x 1 1/4 in.	2	715HX1
Hose Shield	2	3423730
Cable Tie	3	60459AX
Double Cushion Clip-1 1/16 in.	1	1667780
Locknut-1/4 in.	1	1600460
20 amp Circuit Breaker	1	11001GX

TB 9-2320-279-13-1

4. Heater/Evaporator Installation.		
ITEM	QUANTITY	PART NUMBER
Heater/Evaporator	1	3472628
Lower Plenum	1	2042380
Damper	1	2042510
Upper Plenum	2	2042390
Screw-8-32 x 3/4 in.	6	2050700
Gasket-1/2 in. x 1/2 in.	55 in.	2050690
Straight Fitting	1	2099480
Straight Fitting	1	2099490
Insulation	1	2203020
1300 3M Adhesive	A/R	32167AX
Grommet	4	571FX
PVC Foam Tape	53 in.	EE100969
Lockwasher-1/4 in.	6	2251HX
Screw-1/4-20 x 3/4 in.	6	2872HX
Cable Tie	8	5201HX
Fresh Air Box Opening Cover	1	3291224
PVC Foam Tape	43 in.	107685A
Screw-10-32 x 1/2 in.	14	2763HX
Heat Cover	1	2049640
Hole Plug-5/16 in.	4	1362830
Hole Plug-3/8 in.	4	59281AX
Hole Plug-3/4 in.	1	59284AX
Defrost Louver	4	1969290
Threaded Insert	16	2026040
Washer-#10	16	1379HX
Screw-10-32 x 3/4 in.	16	3431969

TB 9-2320-279-13-1

4. Heater/Evaporator Installation (Cont'd).		
ITEM	QUANTITY	PART NUMBER
Lockscrew-1/4-20 x 1/2 in.	12	1344950
Heater Compartment Center Cover	1	2097770
Heater Cable	1	1325470
Defrost Cable	1	1379260
Air Conditioner Cable	1	2199830
Speed Nut-3/16 in.	4	20491FX1
Fan Label	1	3399967
Air Conditioner Temperature Label	1	3398711
Rotary Switch Kit	1	2099510
Hose Clamp	3	1976250
Heater Hose Elbow	1	1333180
Optic Ribbon	1	2187070
Bezel	5	47262CX
Wire Assembly	1	2081610
Wire Assembly	1	2214920
Air Diffuser Ball	2	90017562

5. Air Conditioner Charge/Service.		
ITEM	QUANTITY	PART NUMBER
Dye, R134A/PAG Tracer 32	7 mL	3290249
Oil, PAG 46	1 oz.	3289224
Freon, R134A	27 oz.	3289223

1. COMPRESSOR INSTALLATION.	
This task covers: a. Compressor Installation.	
<p>INITIAL SETUP</p> <p><i>Models</i></p> <p>All</p> <p><i>Test Equipment</i></p> <p>None</p> <p><i>Special Tools</i></p> <p>Belt Tension Gage</p> <p><i>Supplies</i></p> <p>Alternator Pad Bracket Assembly (4) Screw-7/16-14 x 1 3/4 in. (4) Lockwasher-7/16 in. Loctite 242 Alternator, 130 AMP Alternator Pulley Screw-1/2-13 in. x 6 1/2 in. (2) Flange nut-1/2-13 in. Alternator strap Flange screw-1/2-13 x 3 1/4 in. Screw-1/2-13 x 2 in. Washer-1/2 in. Lockwasher-1/2 in. Flange nut-1/2 in. Alternator drive belt set Compressor and clutch Washer-3/8 in. (6) Screw-3/8-16 x 1 1/2 in. (6) Flange nut-3/8 in. (2) Compressor strap Compressor drive belt set Bracket Washer-1/2 in. Lockwasher-1/2 in. Cushion Clip Screw-1/2-13 x 1 in. Screw-1/4-20 x 3/4 in. Locknut-1/4 in. Cable tie</p> <p><i>Personnel Required</i></p> <p>MOS 52C, Utilities equipment repairer (2)</p>	<p><i>References</i></p> <p>None</p> <p><i>Equipment Condition</i></p> <p>Shut off engine (TM 9-2320-279-10) Alternator and pulley removed (TM 9-2320-279-20) Left splash guard removed (TM 9-2320-279-20) Engine cover opened (TM 9-2320-279-10) Skid plate grill removed (TM 9-2320-279-20) Heater compartment covers removed (TM 9-2320-279-20) Heater assembly removed (TM 9-2320-279-20) Heater control panel optic ribbon removed (TM 9-2320-279-20)</p> <p><i>Special Environmental Conditions</i></p> <p>None</p> <p><i>General Safety Instructions</i></p> <p>None</p>

a. **Compressor Installation.**

1. Cut off existing alternator adjustment strap (1).

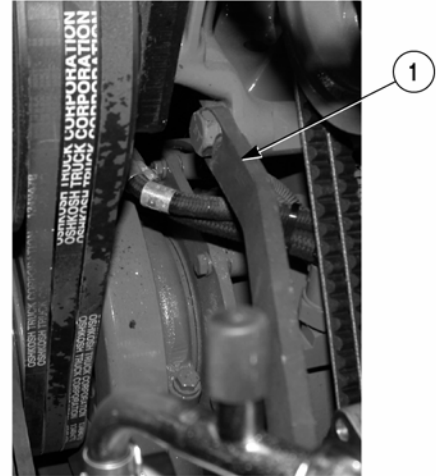
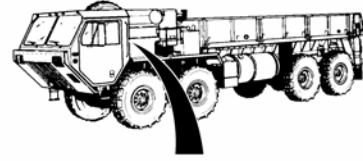

2. Remove four screws (2), lockwashers (3), and alternator mounting bracket (4) from engine (5).

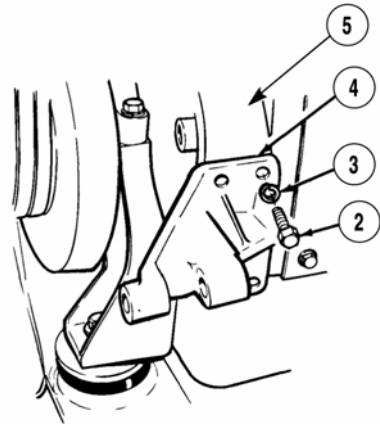

3. Install compressor (6) on mounting bracket (7) with screw (8) and locknut (9). Do not tighten locknut (9).

CAUTION

A washer may need to be installed as a shim between outside of mounting bracket flange and inside of compressor flange. Failure to comply may result in compressor flange breaking off if there is space between mounting bracket flange and compressor flange when locknut is tightened.

4. Install compressor (6) on mounting bracket (7) with screw (10), washer (11), and locknut (12). Do not tighten locknut (12).
5. Install two compressor straps (13) on compressor (6) with two screws (14) and locknuts (15). Do not tighten locknuts (15).
6. Install two compressor straps (13) on mounting bracket (7) with two screws (16) and locknuts (17). Do not tighten locknuts (17).

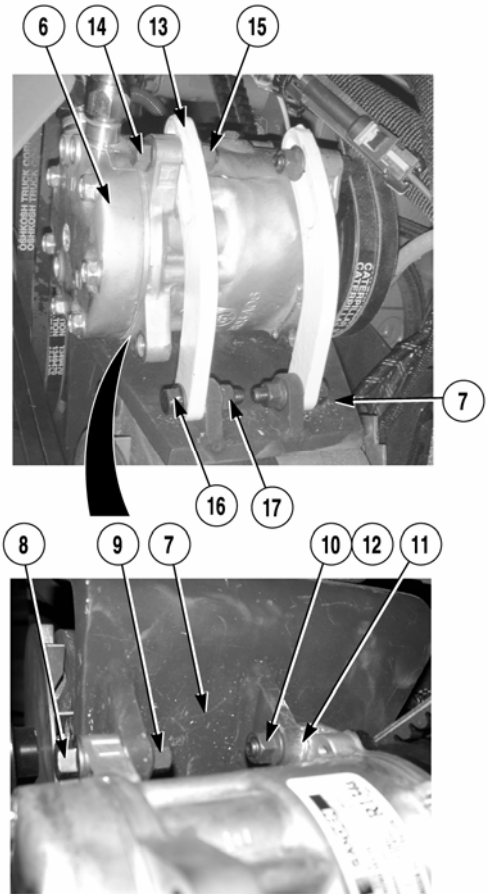

7. Install strap (18) on mounting bracket (7) with screw (19) and locknut (20). Do not tighten locknut (20).

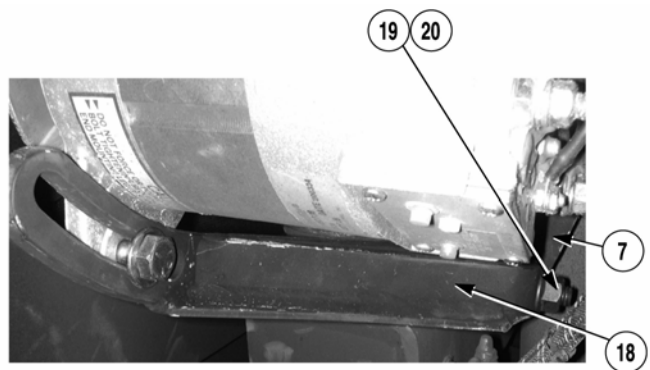

WARNING

Adhesives, solvents, and sealing compounds can burn easily, can give off harmful vapors, and are harmful to skin and clothing. To avoid injury or death, keep away from open fire and use in well-ventilated area. If adhesive, solvent, or sealing compound gets on skin or clothing, wash immediately with soap and water.

8. Apply Loctite 242 to threads of four screws (21).

WARNING

Mounting bracket and compressor are heavy. Do not install without the aid of an assistant. Failure to comply may result in injury to personnel and/or damage to equipment.

9. Solider A supports mounting bracket (7) while Soldier B installs pad (22) and mounting bracket (7) on engine (5) with four screws (21) and lockwashers (23).

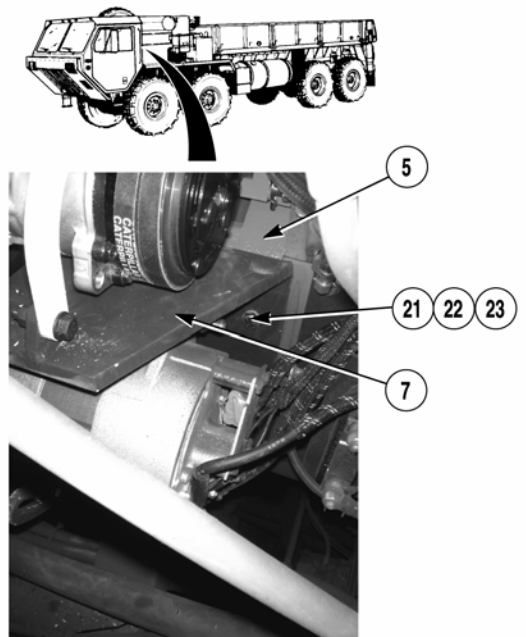

10. Install two compressor drive belts (24 and 25) on compressor (6) and pulley (26).

CAUTION

Do not over-tighten drive belts. Failure to comply may result in damage to equipment.

11. Using a belt tension gage, tighten two compressor belts (24 and 25) to 90-100 lbs. (400-445 N).
12. Tighten two locknuts (9 and 12) on compressor (6) and mounting bracket (7).
13. Tighten two locknuts (15) on compressor (6) and two compressor straps (13).
14. Tighten two locknuts (17) on two compressor straps (13) and mounting bracket (7).

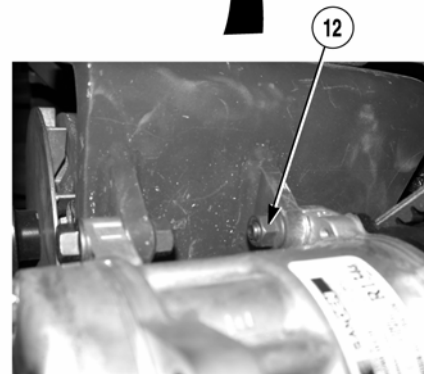
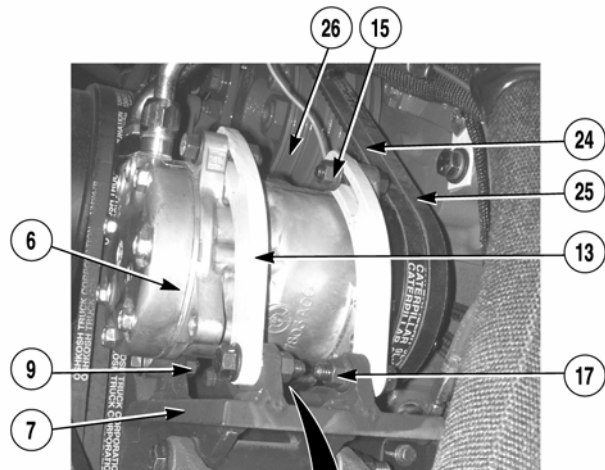

NOTE

If vehicle was already equipped with a 130 amp alternator, reuse 130 amp alternator and return 130 amp alternator included with kit to stock. If vehicle was equipped with 65 amp alternator, replace with 130 amp alternator included with kit.

15. Install key (27) and pulley (28) on shaft (29).
16. Clamp pulley (28) in vise with soft jaws.
17. Install locknut (30) on shaft (29) and tighten locknut (30) until shaft (29) begins to turn.
18. Using lockjaw pliers, hold inside flange (31) of pulley (28) and tighten locknut (30) to 70-85 ft-lbs. (95-115 N•m).
19. Remove lockjaw pliers and retorque locknut (30).

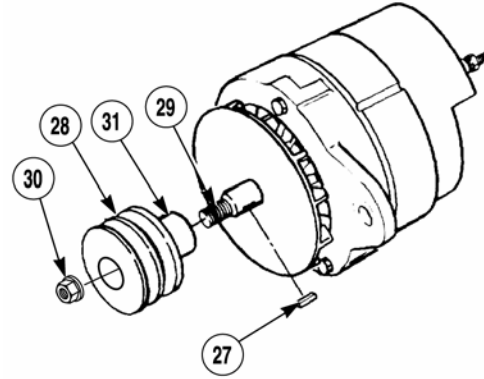

NOTE

Install alternator on mounting bracket with positive terminal of alternator positioned towards driver's side of vehicle.

20. Install alternator (32) on mounting bracket (7) with screw (33) and locknut (34). Do not tighten locknut (34).
21. Install alternator (32) on strap (18) with screw (35), washer (36), lockwasher (37), and locknut (38). Do not tighten locknut (38).

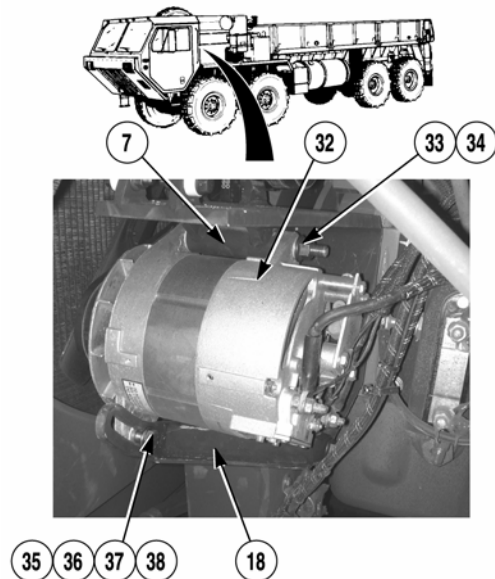

22. Install two alternator drive belts (39 and 40) on pulley (28) and pulley (41).

CAUTION

Do not over-tighten alternator drive belts. Failure to comply may result in damage to equipment.

23. Using a belt tension gage, tighten two alternator drive belts (39 and 40) to 70-90 lbs. (310-400 N).
24. Tighten locknut (38).
25. Tighten locknut (34).
26. Tighten locknut (20).

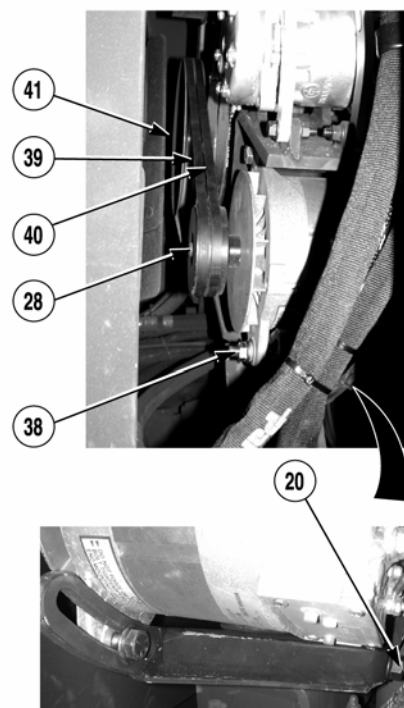

27. Install two wires (42 and 43) on terminal (44) with lockwasher (45) and nut (46).
28. Install wire (47) on terminal (48) with nut (49).
29. Install two wires (50 and 51) on terminal (52) with lockwasher (53) and nut (54).

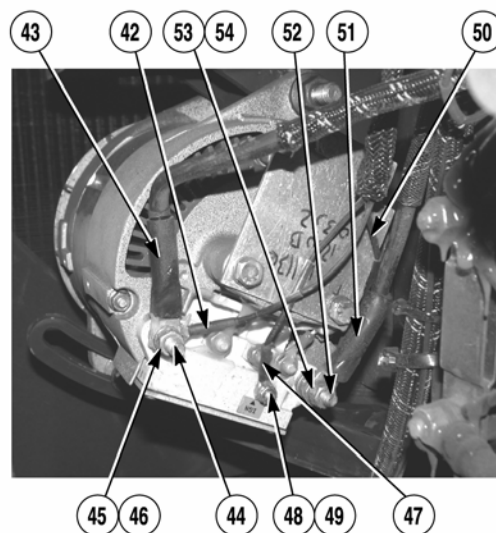

NOTE

Some vehicles will use 7/16 in. (11 mm) screw to mount bracket to engine, others will use 1/2 in. (13 mm) screw to mount bracket to engine.

30. Apply Loctite 242 to threads of screw (55).
31. Install bracket (56) on engine (5) with screw (55), lockwasher (57), and washer (58).
32. Secure electrical harness (59) to bracket (56) with cushion clip (60), screw (61), and locknut (62).
33. Secure electrical harness (59) to air valve (63) with cable tie (64).

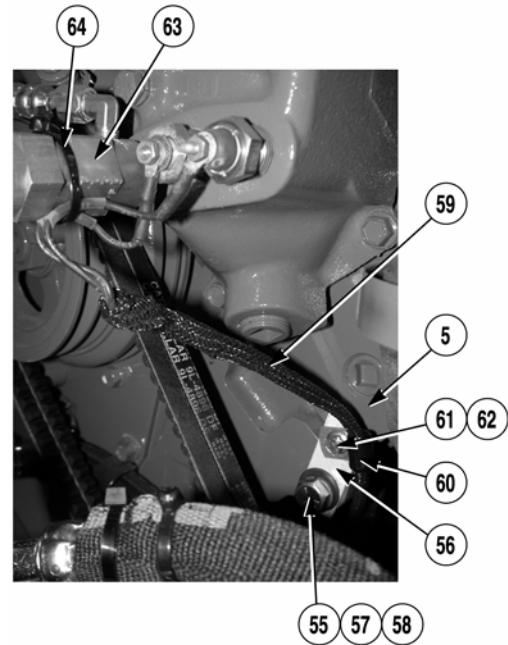

2. CONDENSOR INSTALLATION.	
This task covers:	
a. Condenser Installation.	
<p>INITIAL SETUP</p> <p><i>Models</i></p> <p>All</p> <p><i>Test Equipment</i></p> <p>None</p> <p><i>Special Tools</i></p> <p>None</p> <p><i>Supplies</i></p> <p>Air Conditioner Condensor Connector 2 Pin (2) Socket Contact (2) Seal Grab Handle (2) Flat Washer-3/8 in. (6) Lockwasher-3/8 in. (2) Screw-3/8-16 x 1 in. (4) Plate (4) Flange Screw-3/8-16 x 2 in.</p> <p><i>Personnel Required</i></p> <p>MOS 52C, Utilities equipment repairer (2)</p>	<p><i>References</i></p> <p>None</p> <p><i>Equipment Condition</i></p> <p>None</p> <p><i>Special Environmental Conditions</i></p> <p>None</p> <p><i>General Safety Instructions</i></p> <p>None</p>

a. Condenser Installation.

1. Install grab handle (1) on condenser (2) with two screws (3), lockwashers (4), and washers (5).

NOTE

- If condenser does not have connector installed on two wires, perform Steps 2 through 12.
 - If condenser has connector installed on two wires, go to Step 13.
2. From edge of condenser (2), cut two wires (6 and 7) to 8 in. (203 mm).

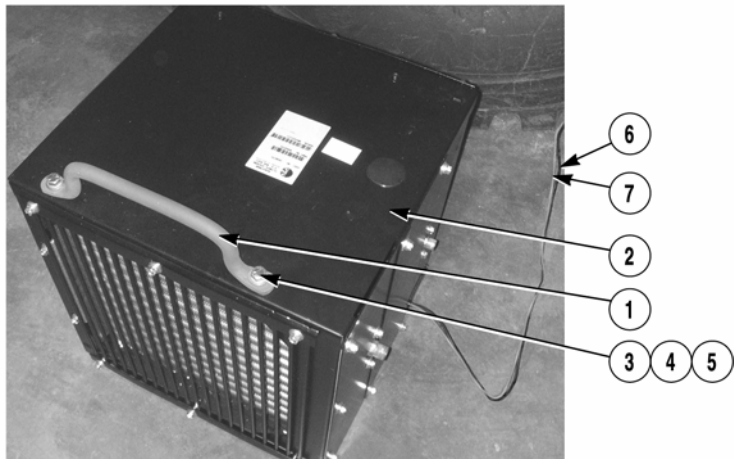

CAUTION

**Strip wire after placing it through seal.
Failure to comply may cause damage to
equipment.**

3. Insert 1 in. (25 mm) of wire (6) through seal (8).
4. Strip end of wire (6), leaving 1/4 in. (6 mm) of bare wire.
5. Insert contact socket (9) in locating hole of crimper using proper hole according to the gage of wire (6).
6. Slide seal (8) down to end of insulation on wire (6).
7. Position wire (6) on contact socket (9).
8. Press handles of crimper together until ratchet releases and crimping is complete.
9. Repeat Steps 3 through 8 for wire (7).
10. Push contact socket (9), seal (8), and wire (6) through position A on connector (10).
11. Push contact socket (9), seal (8), and wire (7) through position B on connector (10).
12. Close secondary lock (11) on connector (10).

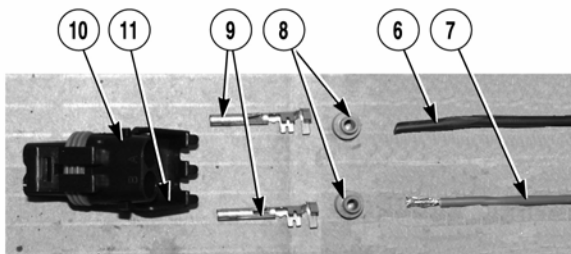

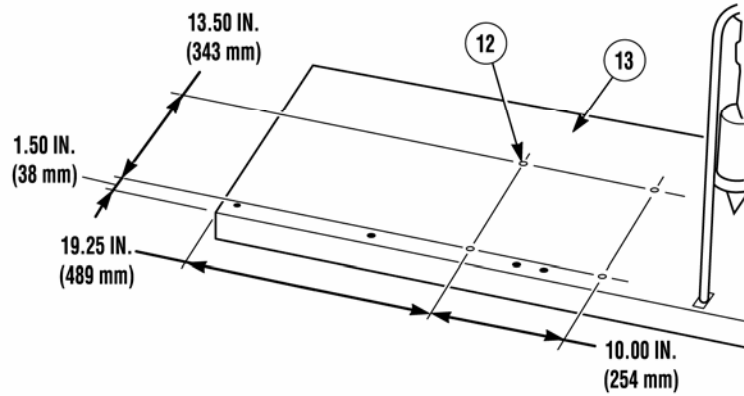
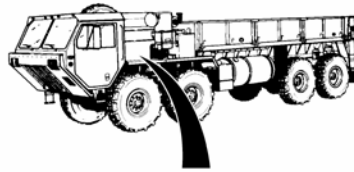

13. Drill four 1/2 in. (13 mm) holes (12) in driver side front fender (13).

WARNING

Condenser is heavy. Do not lift condenser without the aid of an assistant. Failure to comply may result in injury to personnel.

14. Soldier A and Soldier B install four plates (14) and condenser (2) on driver side front fender (13) with four screws (15) and lockwashers (16).

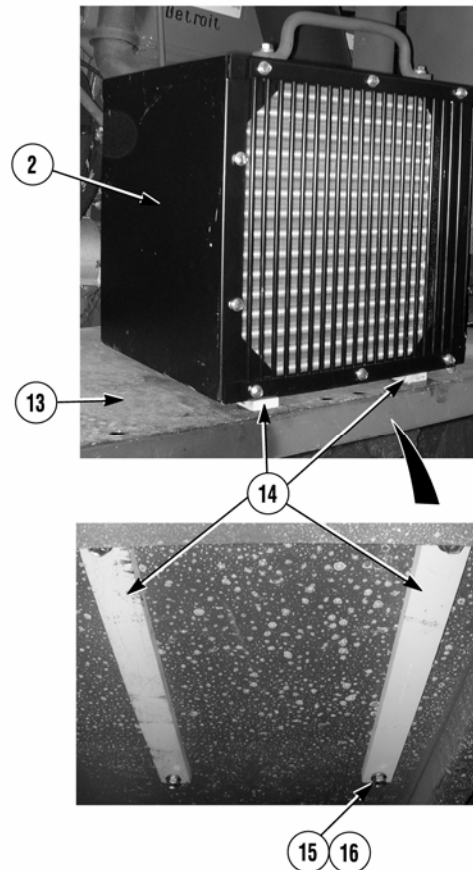

3. HOSE AND WIRE HARNESS ROUTING.	
This task covers: a. Hose Routing. b. Wire Routing.	
<p>INITIAL SETUP</p> <p><i>Models</i></p> <p>All</p> <p><i>Test Equipment</i></p> <p>None</p> <p><i>Special Tools</i></p> <p>Torque Wrench</p> <p><i>Supplies</i></p> <p>Air Conditioning Wire Harness (10) Cable Ties Hose Assembly #6 Hose Assembly #8 Hose Assembly #10 High Pressure Switch Low Pressure Switch Air Conditioner Installation Label Cushion Clip-3/4 in. Cushion Clip-1 in. Cushion Clip-1 1/8 in. Screw-3/8-16 x 1 in. (3) Locknut-3/8 in. (3) Double Cushion Clip-3/4 in. (2) Washer-3/8 in. (2) Screw-3/8-16 x 1 1/4 in. (2) Hose Shield (3) Cable Tie Double Cushion Clip-1 1/16 in. Locknut-1/4 in. 20 amp Circuit Breaker</p>	<p><i>Personnel Required</i></p> <p>MOS 52C, Utilities equipment repairer</p> <p><i>References</i></p> <p>None</p> <p><i>Equipment Condition</i></p> <p>None</p> <p><i>Special Environmental Conditions</i></p> <p>None</p> <p><i>General Safety Instructions</i></p> <p>None</p>

a. Hose Routing.

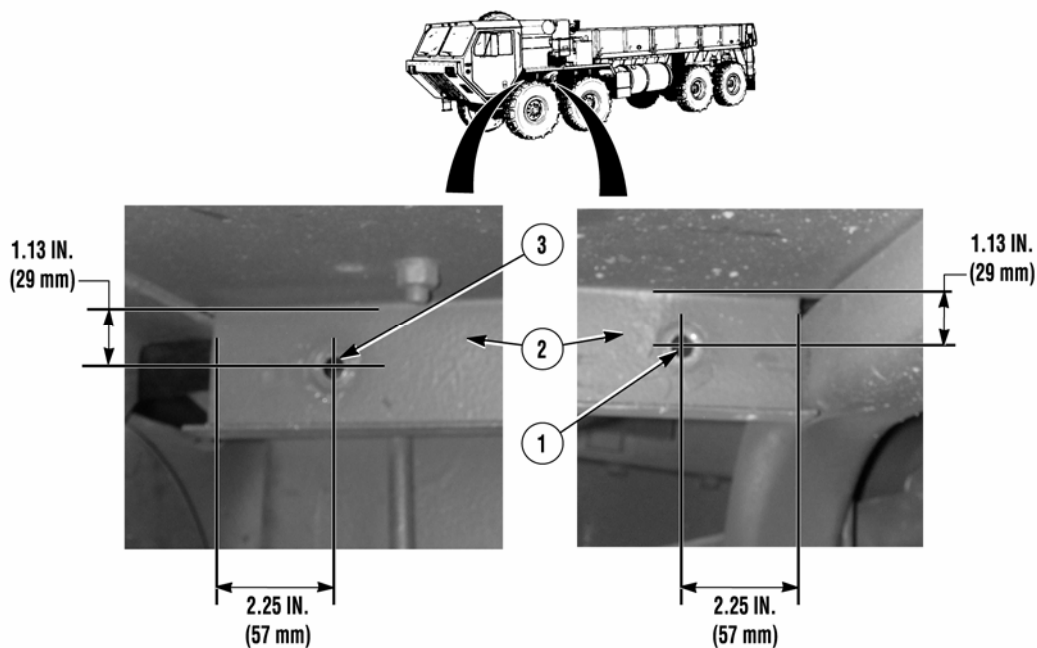

1. Drill one 13/32 in. (10 mm) hole (1) in fender (2).
2. Drill one 13/32 in. (10 mm) hole (3) in fender (2).

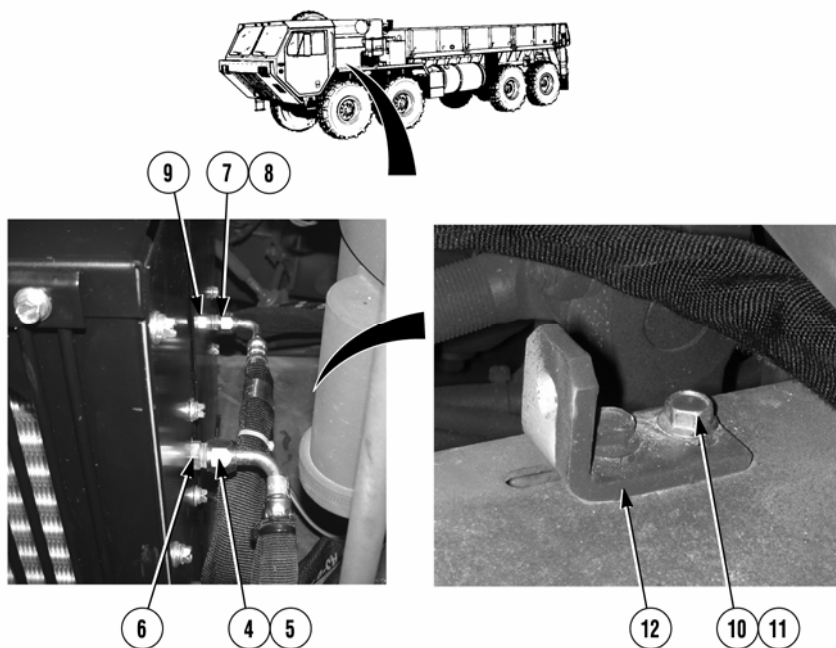

3. Install preformed packing (4) and hose 2521 (5) on fitting (6).
4. Install preformed packing (7) and hose 2424 (8) on fitting (9).
5. Remove locknut (10) and screw (11) from bracket (12). Retain locknut (10) and screw (11).

TB 9-2320-279-13-1

6. Install hose 2521 (5) and hose 2424 (8) on bracket (12) with double cushion clip (13), screw (11), and locknut (10).

NOTE

Use hole drilled in Step 1 to mount double cushion clip to fender in Step 7.

7. Install hose 2521 (5) and hose 2424 (8) on fender (2) with double cushion clip (14), screw (15), washer (16), and locknut (17).

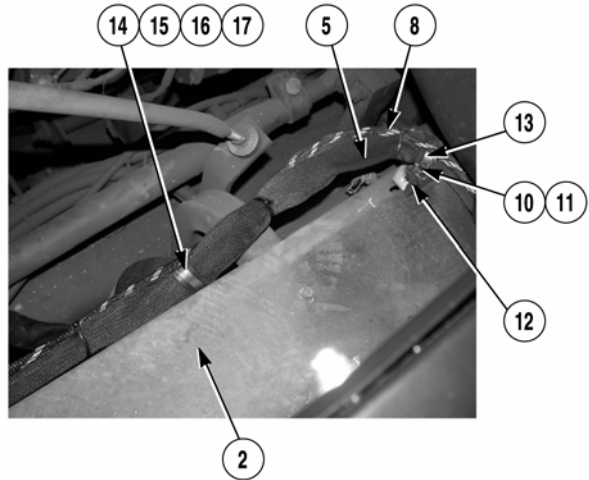

8. Install preformed packing (18) and hose 2521 (5) on compressor (19). Torque hose 2521 (5) to 15-18 ft-lbs. (20-24 N•m).
9. Install preformed packing (20) and high pressure switch (21) on hose 2521 (5). Torque high pressure switch (21) to 7.5-10 ft-lbs. (10-14 N•m).
10. Install preformed packing (22) and hose 2522 (23) on compressor (19). Torque hose 2522 (23) to 18-22 ft-lbs. (24-30 N•m).

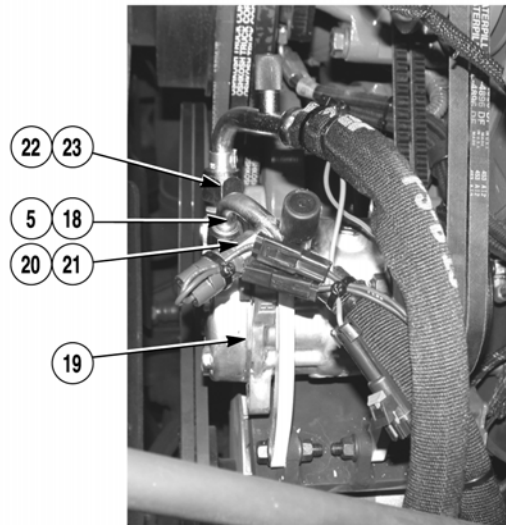
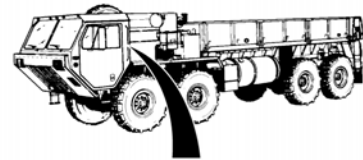

11. Position cushion clip (24) on hose 2521 (5).
12. Position cushion clip (25) on hose 2522 (23).
13. Install two cushion clips (24 and 25) on radiator support rod (26) with cushion clip (27), screw (28), and locknut (29).

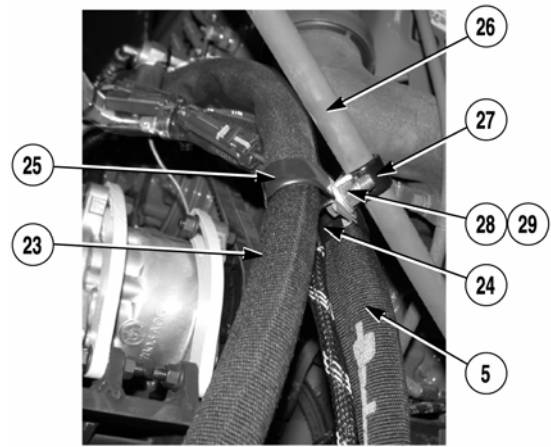

14. Route hose 2424 (8) and hose 2522 (23) through opening between fender (2), cab (30), and radiator (31).

NOTE

Use hole drilled in Step 2 to mount double cushion clip to fender in Step 15.

15. Install hose 2424 (8) and hose 2522 (23) on fender (2) with double cushion clip (32), screw (33), washer (34), and locknut (35).

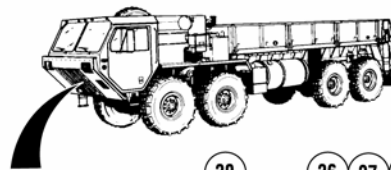
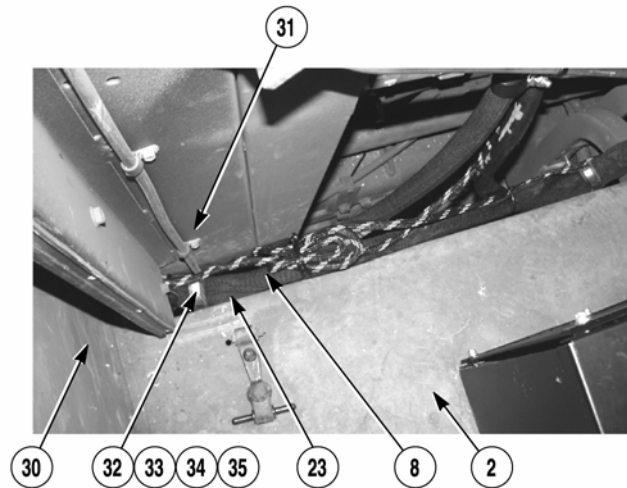

16. Install hose 2424 (8) and hose 2522 (23) on capscrew (36) on back of cab (30) with double cushion clip (37) and locknut (38).

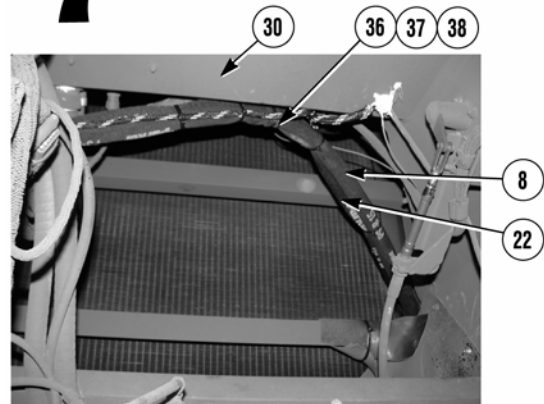

17. Install preformed packing (39) and low pressure switch (40) on hose 2522 (23). Torque low pressure switch (40) to 7.5-10 ft-lbs. (10-14 N•m).



b. Wire Harness Routing.

1. Connect connector (1) of wire harness (2) on connector (3).
2. Secure connector (1) to two hoses (4 and 5) with cable tie (6).

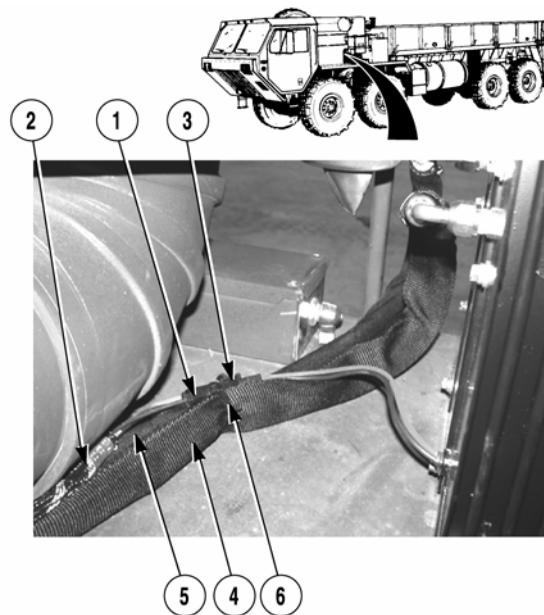

3. Secure wire harness (2) to two hoses (4 and 5) with three cable ties (7).

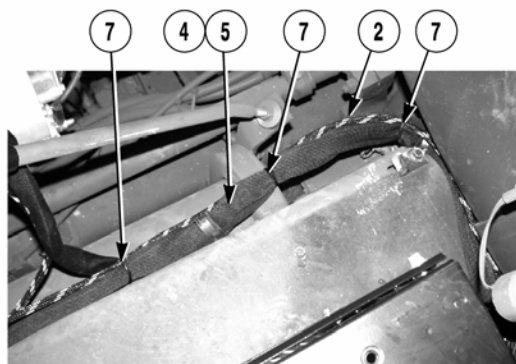

TB 9-2320-279-13-1

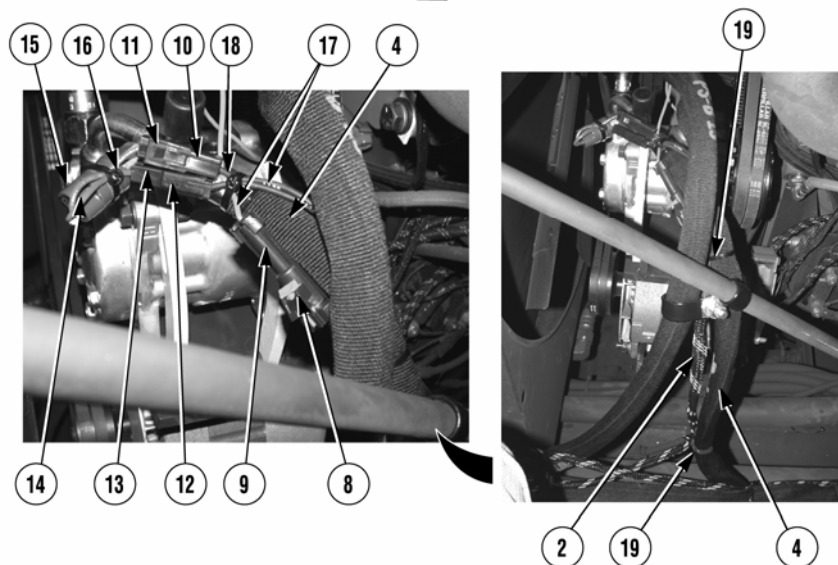
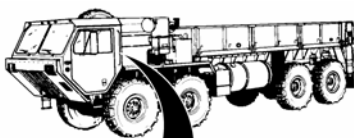

4. Connect connector (8) of wire harness (2) on connector (9).
5. Connect connector (10) of wire harness (2) on connector (11).
6. Connect connector (12) of wire harness (2) on connector (13).
7. Secure two wires (14) on high pressure switch (15) with cable tie (16).
8. Secure three wires (17) to hose (4) with cable tie (18).
9. Secure wire harness (2) to hose (4) with two cable ties (19).

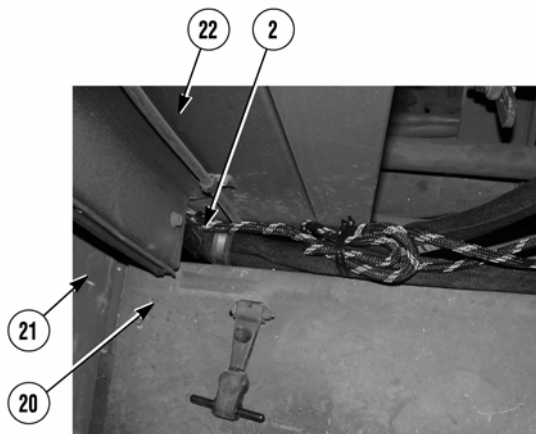

10. Route wire harness (2) through opening between fender (20), cab (21), and radiator (22).

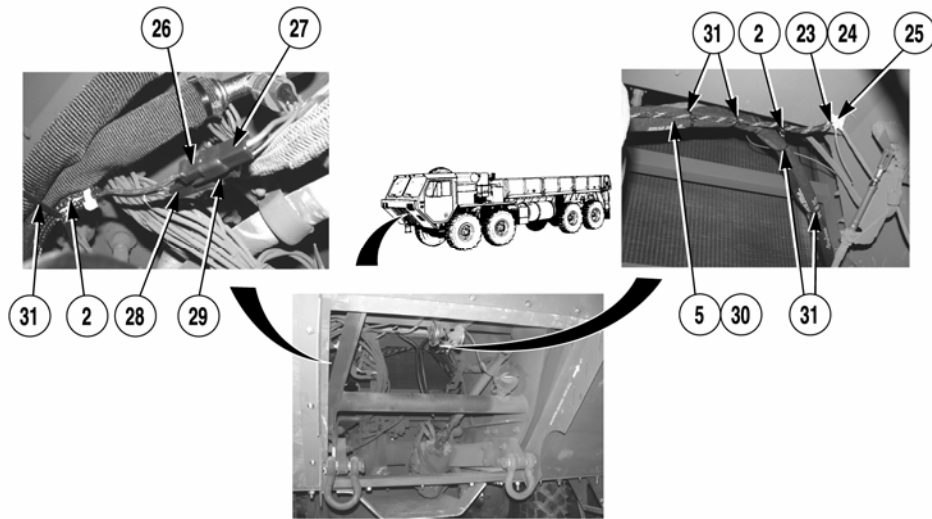

11. Route wire 1155 (23) and wire 1156 (24) of wire harness (2) through grommet (25).
12. Connect connector (26) of wire harness (2) on connector (27).
13. Connect connector (28) of wire harness (2) on connector (29).
14. Secure wire harness (2) to two hoses (5 and 30) with five cable ties (31).

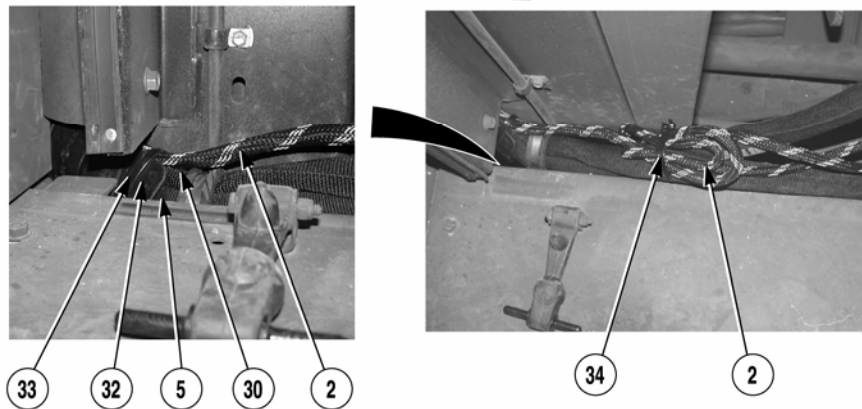
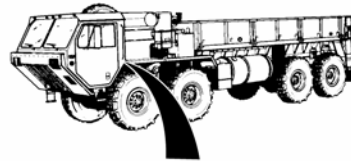

CAUTION

Hose shields must be positioned so that hoses and wire harness are protected from fender, cab, and radiator. Failure to comply may result in damage to equipment.

15. Install two hose shields (32) around hoses (5 and 30) and wire harness (2) with three cable ties (33).
16. Secure excess wire harness (2) to hoses (5 and 30) with cable tie (34).

TB 9-2320-279-13-1

17. Install air conditioner installation label (35) on radiator (22).



18. Install 20 amp circuit breaker in position No. 11 on circuit breaker rack (TM 9-2320-279-20).

4. HEATER/EVAPORATOR INSTALLATION.	
This task covers:	
a. Heater/Evaporator Installation.	
b. Follow-On Maintenance.	
<p>INITIAL SETUP</p> <p><i>Models</i></p> <p>All</p> <p><i>Test Equipment</i></p> <p>None</p> <p><i>Special Tools</i></p> <p>Nutsert Tool Torque Wrench</p> <p><i>Supplies</i></p> <p>Heater/Evaporator Lower Plenum Damper (2) Upper Plenum (6) Screw-8-32 x 3/4 in. Gasket-1/2 in. x 1/2 in. Straight Fitting Straight Fitting Insulation 1300 3M Adhesive (4) Grommet PVC Foam Tape (6) Lockwasher-1/4 in. (6) Screw-1/4-20 x 3/4 in. (8) Cable Tie Fresh Air Box Opening Cover PVC Foam Tape (14) Screw-10-32 x 1/2 in. Heat Cover (4) Hole Plug-5/16 in. (4) Hole Plug-3/8 in. Hole Plug-3/4 in. (4) Defrost Louver (16) Threaded Insert (16) Washer-#10 (16) Screw-10-32 x 3/4 in. (12) Lockscrew-1/4-20 x 1/2 in. Heater Compartment Center Cover Heater Cable</p>	<p><i>Supplies (Cond't)</i></p> <p>Defrost Cable Air Conditioner Cable (4) Speed Nut-3/16 in. Fan Label Air Conditioner Temperature Label Rotory Switch Kit Optic Ribbon (5) Bezel (2) Wire Assembly (2) Air Diffuser Ball Heater Hose Elbow (3) Hose Clamp</p> <p><i>Personnel Required</i></p> <p>MOS 52C, Utilities equipment repairer (3)</p> <p><i>References</i></p> <p>None</p> <p><i>Equipment Condition</i></p> <p>None</p> <p><i>Special Environmental Conditions</i></p> <p>None</p> <p><i>General Safety Instructions</i></p> <p>None</p>

a. Heater/Evaporator Installation.

1. Install preformed packing (1) and fitting (2) on heater/evaporator (3). Torque fitting (2) to 11-13 ft-lbs. (15-18 N•m).
2. Install preformed packing (4) and fitting (5) on heater/evaporator (3). Torque fitting (5) to 18-22 ft-lbs. (24-30 N•m).

WARNING

Adhesives, solvents, and sealing compounds can burn easily, can give off harmful vapors, and are harmful to skin and clothing. To avoid injury or death, keep away from open fire and use in well-ventilated area. If adhesive, solvent, or sealing compound gets on skin or clothing, wash immediately with soap and water.

NOTE

Insulation is held to heater/evaporator using 3M adhesive.

3. Apply 3M adhesive to insulation (6).
4. Install insulation (6) on heater/evaporator (3).
5. Install two PVC foam tape strips (7) on heater/evaporator (3).
6. Install four PVC foam tape strips (8) on heater/evaporator (3).

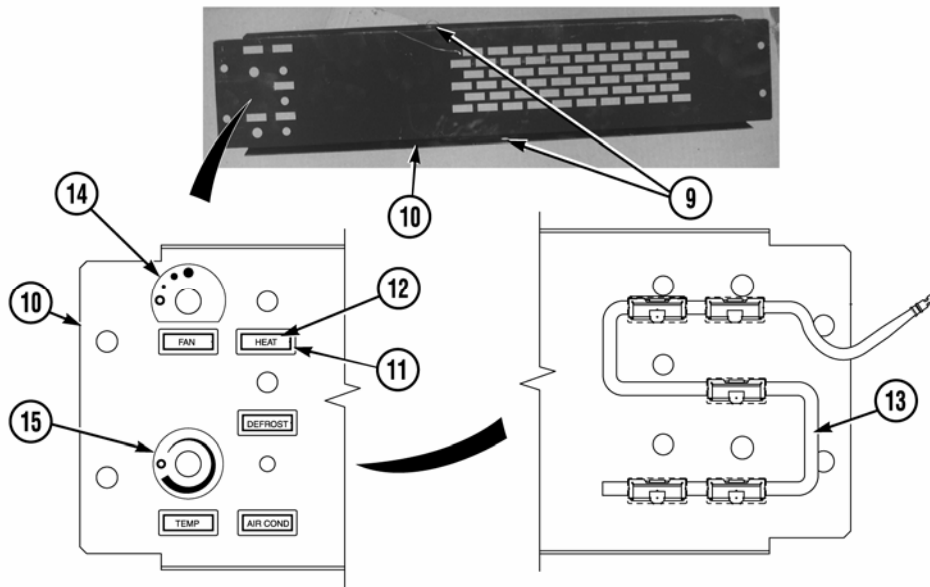
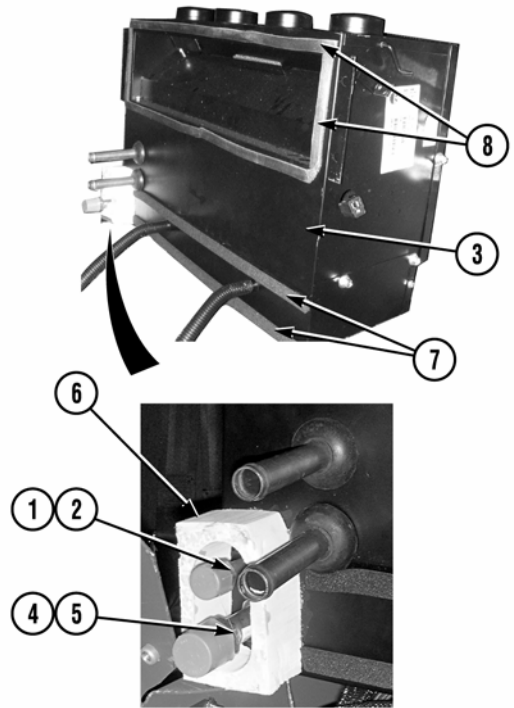

7. Install two nutserts (9) on heater center compartment cover (10).
8. Install five bezels (11) on heater center compartment cover (10).
9. Install five identification markers (12) on optic ribbon (13) in five bezels (11) on heater center compartment cover (10).
10. Install fan label (14) on heater center compartment cover (10).
11. Install A/C temperature label (15) on heater center compartment cover (10).

12. Install heater cable (16) on heater center compartment cover (10) with lockwasher (17) and nut (18).

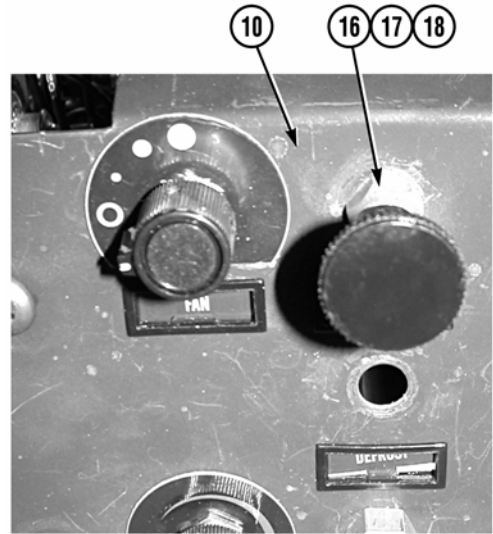

WARNING

Use extreme care when cutting defrost tubes.
Failure to comply may result in injury to personnel.

13. Cut off 6 in. (152 mm) of defrost tube (19).
14. Cut off 8 in. (203 mm) of defrost tube (20).

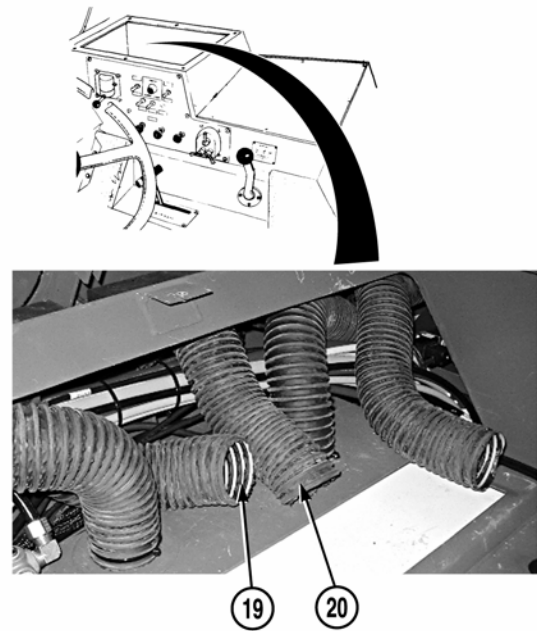

15. Coat inner edge of four defrost tubes (19, 20, 21, and 22) with 3M adhesive.
16. Install four defrost tubes (19, 20, 21, and 22) on lower plenum (23) with four cable ties (24).

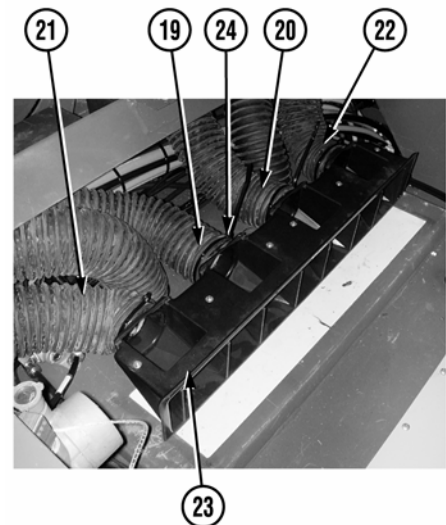

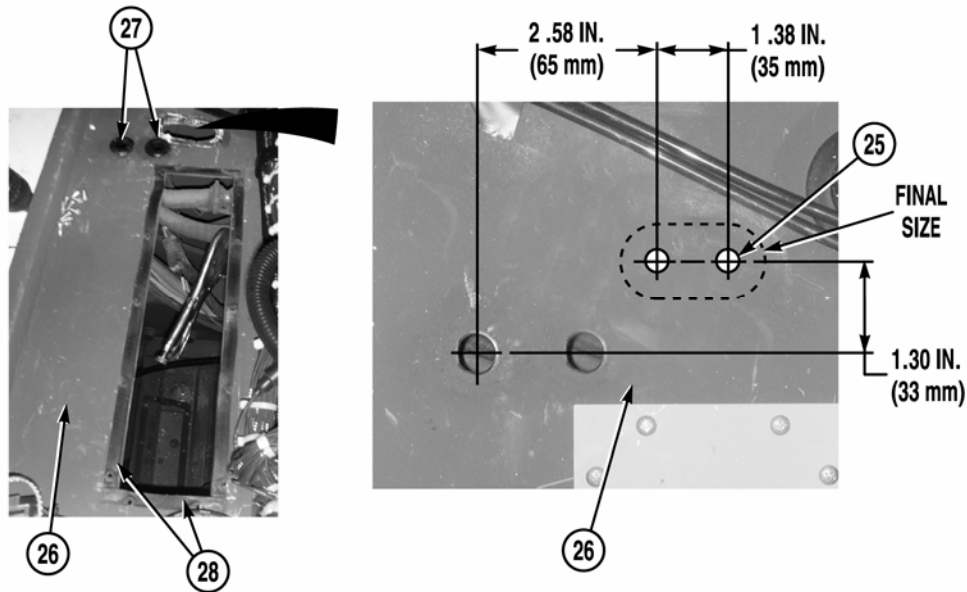

17. Drill two pilot holes (25) in cab (26).

NOTE

Do not enlarge two pilot holes bigger than opening in insulation (6).

- 18. Enlarge two pilot holes (25) with “nibbling” tool to allow two fittings (2 and 5) on heater/evaporator (3) to pass through cab (26).
- 19. Install two grommets (27) in cab (26).
- 20. Install four PVC foam tape strips (28) on cab (26).

CAUTION

If fresh air box cover is not installed as shown, evaporator vent tubes will not be installed correctly. Failure to comply may cause damage to equipment.

- 21. Soldier A supports plate (29) on underside of vehicle while Soldier B installs fresh air box cover (30) and plate (29) on cab (26) with 14 screws (31).
- 22. Install two grommets (32) in fresh air box cover (30).

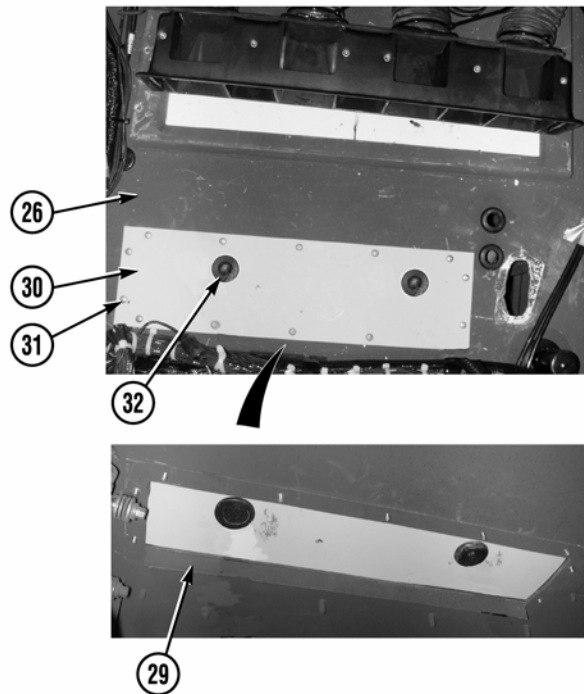

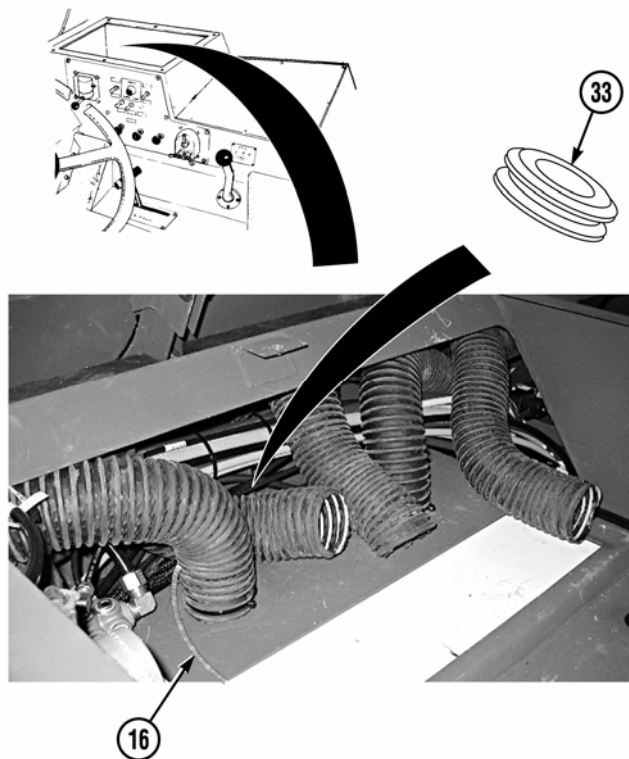

NOTE

Heater center compartment cover will need to be loosely positioned in cab so that heater cable can be routed through grommet under lower plenum.

23. Position heater center compartment cover (10) in cab (26) and route heater cable (16) through grommet (33).

24. Soldier A and Soldier B position heater/evaporator (3) in cab (26).

25. Apply 3M adhesive to bottom of insulation (6).

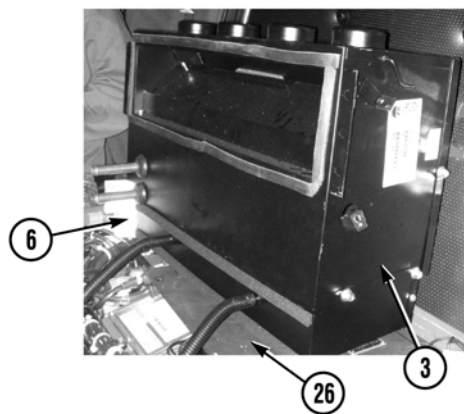

26. Coat four grommets (27 and 32) with soap solution.

CAUTION

Ensure that grommets are not dislodged during installation of heater/evaporator. If grommets are not positioned properly, coolant tubes and evaporator vent tubes could be damaged.

27. Soldier A and Soldier B position two coolant tubes (34) through grommets (27) and two evaporator vent tubes (35) through grommets (32) while positioning lower plenum (23) on heater/evaporator (3) while Soldier C guides two evaporator vent tubes (35) through two grommets (32) on underside of cab (26).
28. Secure two evaporator vent tubes (35) together with cable tie (36).

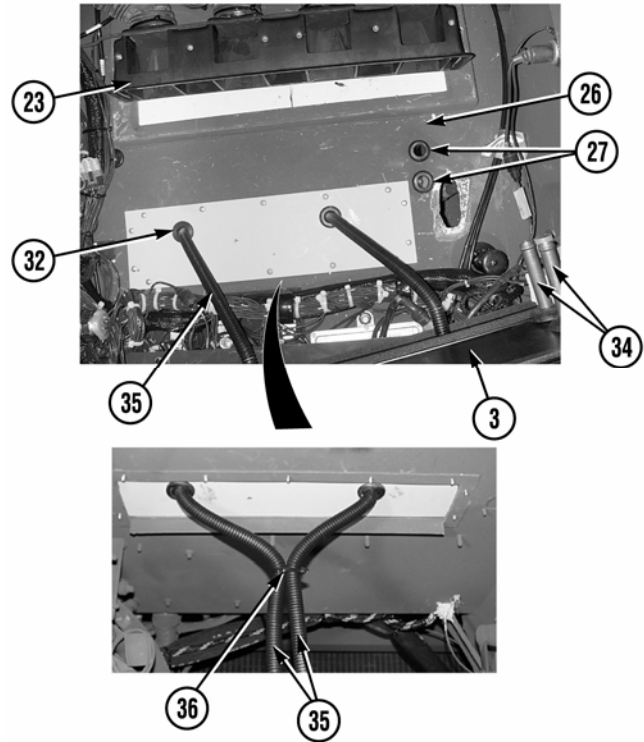

29. Position damper (37) in lower plenum (23).

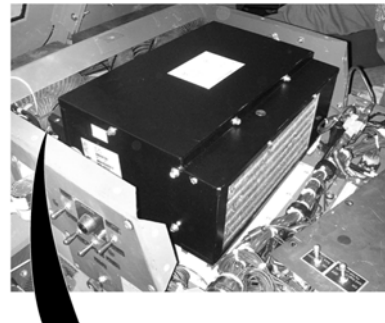

NOTE

Hardware mounting two upper plenums to heater/evaporator will have to be removed from heater/evaporator prior to installing two upper plenums on lower plenum and heater/evaporator.

- 30. Install two upper plenums (38) on lower plenum (23) with six lockscrews (39).
- 31. Install two upper plenums (38) on heater/evaporator (3) with two screws (40), lockwashers (41), and washers (42).

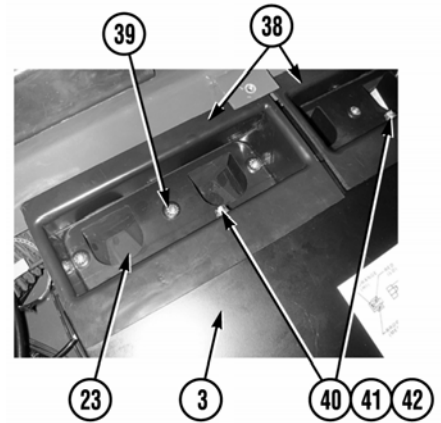

- 32. Install heater/evaporator (3) on cab (26) with six screws (43) and lockwashers (44).

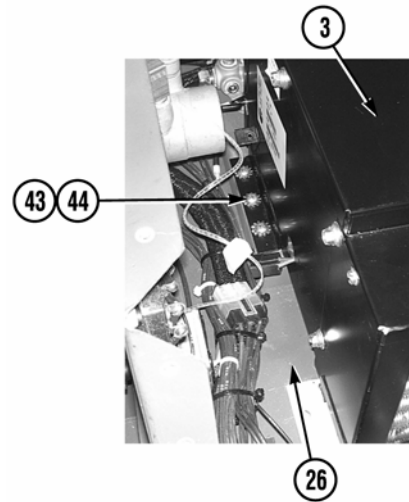

- 33. Install ½ in. x ½ in. (13 mm x 13 mm) gasket (45) on edge of two upper plenums (38).
- 34. Install heater center compartment cover (10) on cab (26) with four lockscrews (46).

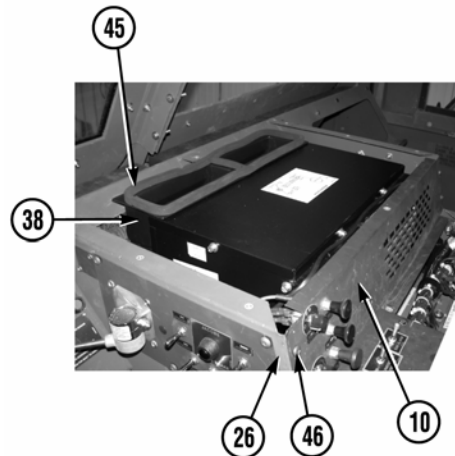

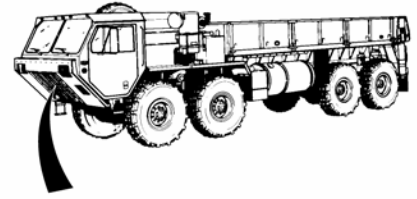

35. Remove two caps (47) from two fittings (2 and 5).

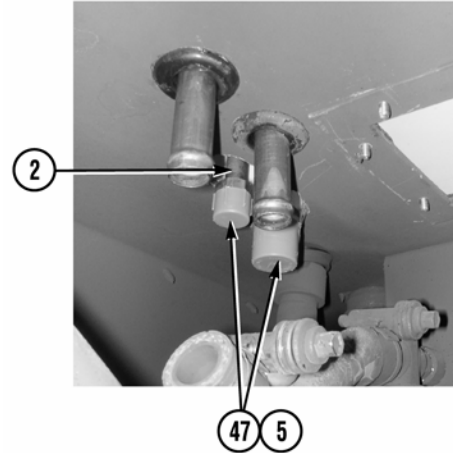

36. Install preformed packing (48) and hose 2522 (49) on fitting (5). Torque hose 2522 (49) to 18-22 ft-lbs. (24-30 N•m).

37. Install preformed packing (50) and hose 2524 (51) on fitting (2). Torque hose 2524 (51) to 11-13 ft-lbs. (15-18 N•m).

NOTE

If heater hose elbow attached to heater control valve (55) is damaged, replace with heater hose included with kit.

38. Install two heater hoses (52) on coolant tubes (34) with two hose clamps (53). Tighten two hose clamps (53).

39. Install heater cable (16) on shaft (54) of heater control valve (55).

40. Place heater cable (16) in retainer (56) and tighten screw (57).

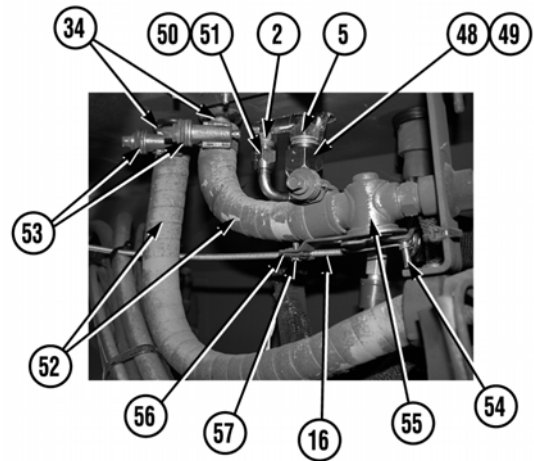

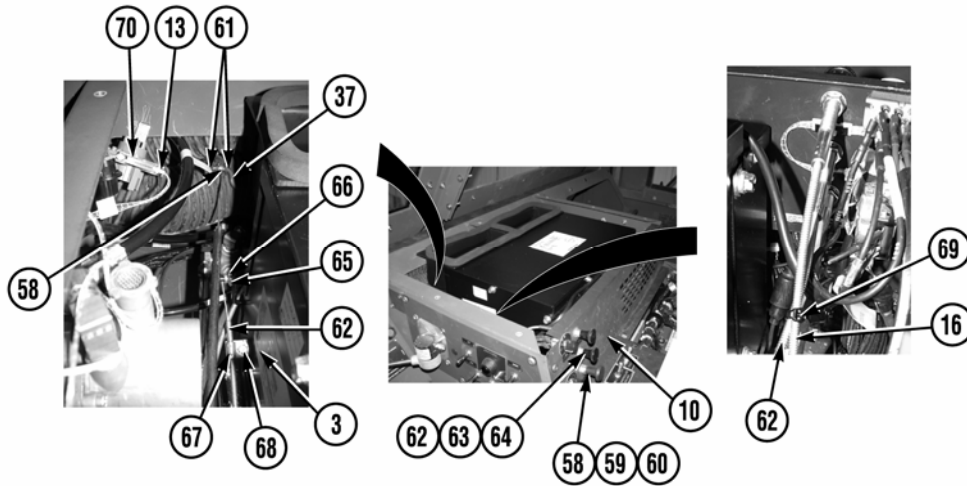

41. Install A/C cable (58) on heater center compartment cover (10) with lockwasher (59) and nut (60).
42. Install A/C cable (58) on damper (37) with two speed nuts (61).
43. Install defrost cable (62) on heater center compartment cover (10) with lockwasher (63) and nut (64).
44. Install defrost cable (62) on control (65) with two speed nuts (66).
45. Place defrost cable (62) in retainer (67) and install retainer (67) on heater/evaporator (3) with screw (68).
46. Secure heater cable (16) to defrost cable (62) with cable tie (69).
47. Plug optic ribbon (13) into light source (70).

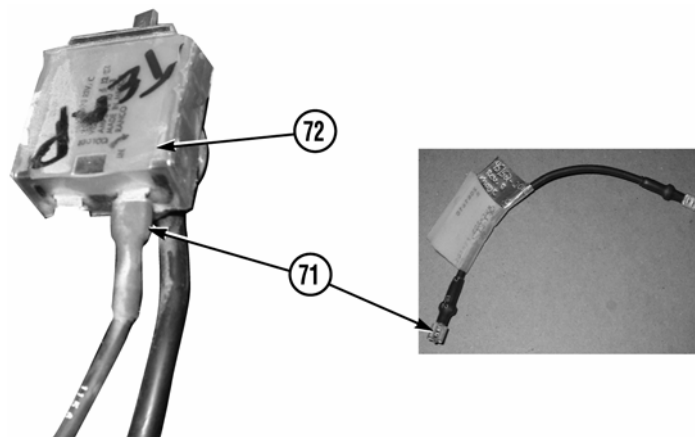

48. Install one end of wire assembly 1156 (71) on IN terminal of temperature control switch (72).

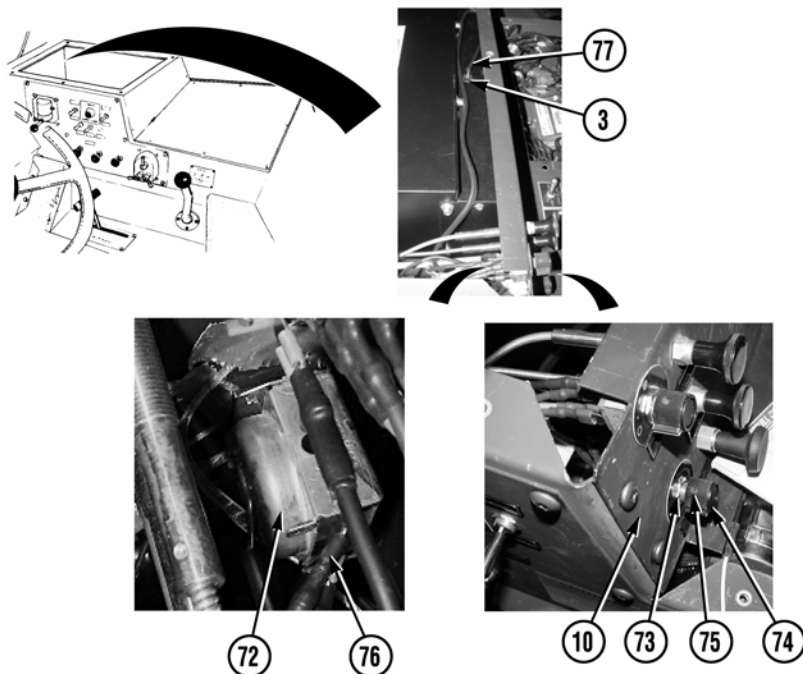

49. Install temperature control switch (72) on heater center compartment cover (10) with nut (73).
50. Install knob (74) on temperature control switch (72) with two screws (75).
51. Install wire 1156 (76) from A/C wiring harness on OUT terminal of temperature control switch (72).

CAUTION

Do not puncture temperature probe. Gas in tube will leak out if temperature probe is punctured.

NOTE

Slide temperature probe in heater/evaporator slowly. Temperature probe must slide into evaporator core.

52. Install temperature probe (77) in heater/evaporator (3).

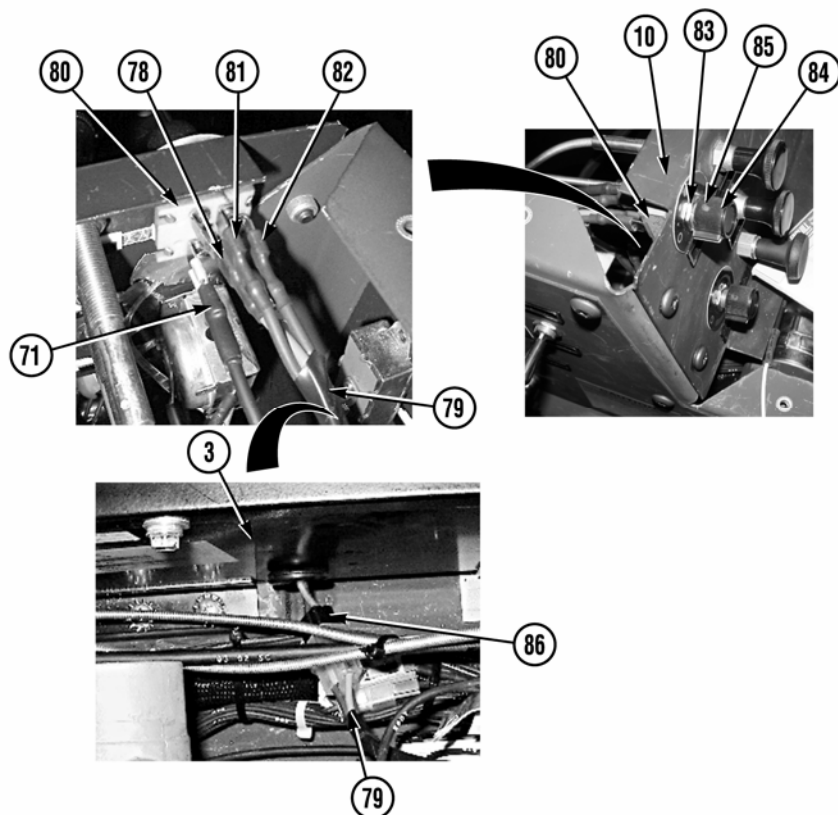

53. Install orange wire (78) from wire harness (79) on terminal H of fan switch (80).
54. Install red wire (81) from wire harness (79) on terminal L of fan switch (80).
55. Install brown wire (82) from wire harness (79) on terminal M of fan switch (80).
56. Install fan switch (80) on heater center compartment cover (10) with nut (83).
57. Install knob (84) on fan switch (80) with two screws (85).
58. Connect wire harness (79) to connector (86) on heater/evaporator (3).
59. Install other end of wire assembly 1156 (71) on terminal C of fan switch (80).

NOTE

Wire assembly 1082 attached to cab wiring harness will need to be removed and discarded prior to performing Step 60 so new wire assembly can be installed.

60. Install wire assembly 1082 (87) on cab wiring harness (88).
61. Install wire assembly 1082 (87) on terminal B of fan switch (80).
62. Install wire 1155 (89) from A/C wiring harness on terminal of wire assembly 1082 (87).

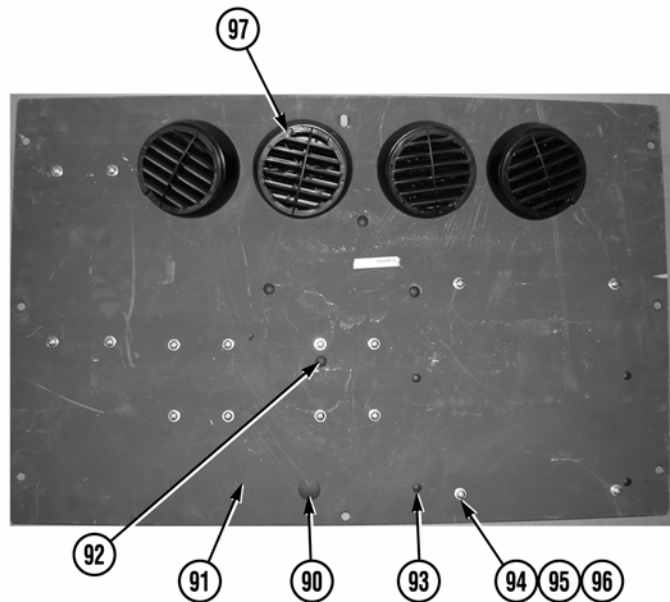
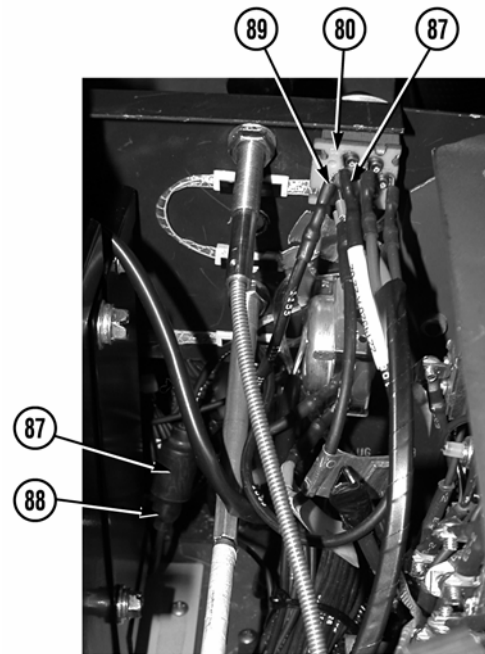

63. Install $\frac{3}{4}$ in. (19 mm) hole plug (90) on heater cover (91).
64. Install four $\frac{3}{8}$ in. (10 mm) hole plugs (92) on heater cover (91).
65. Install four $\frac{5}{16}$ in. (8 mm) hole plugs (93) on heater cover (91).
66. Install 16 inserts (94) on heater cover (91).
67. Install 16 screws (95) and washers (96) in inserts (94) on heater cover (91).
68. Install four defrost louvers (97) on heater cover (91).

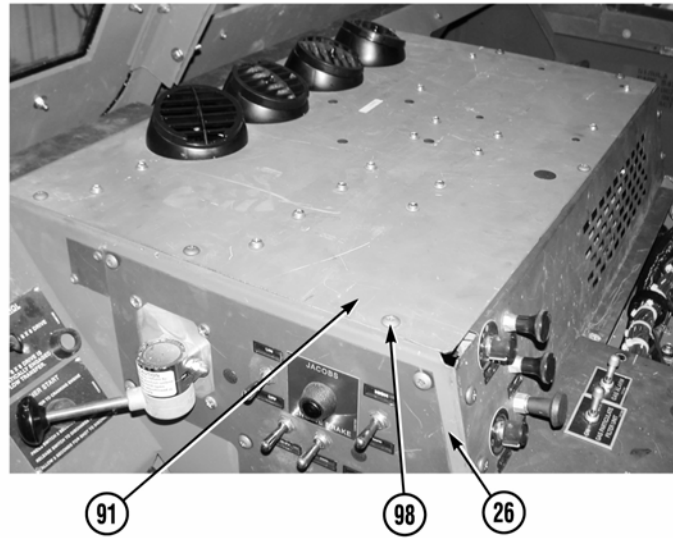

69. Install heater cover (91) on cab (26) with eight lock screws (98).

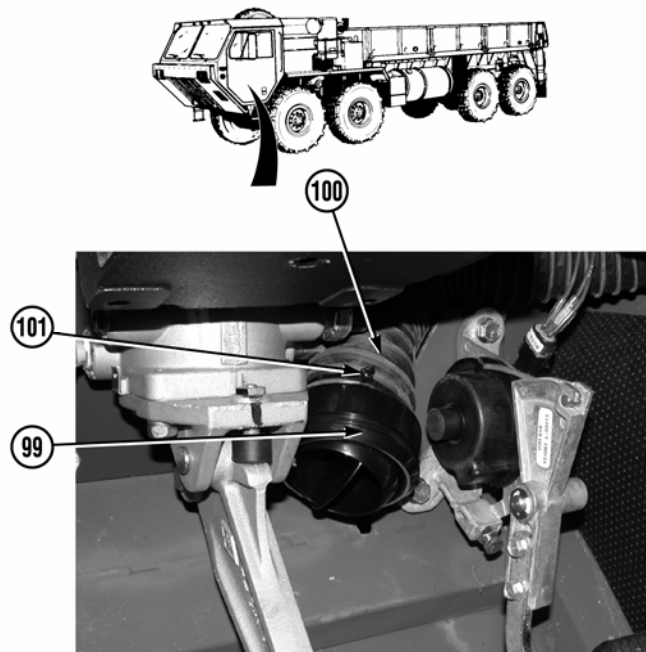

70. Install air diffuser ball (99) on driver side tube (100) with cable tie (101).

71. Install air diffuser ball (102) on passenger side tube (103) with cable tie (104).

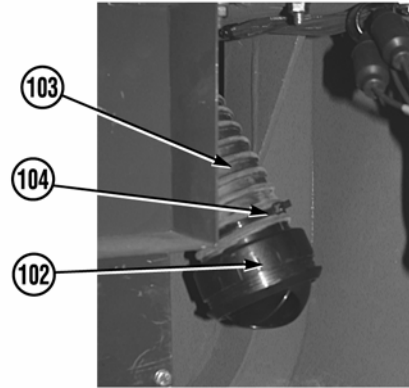
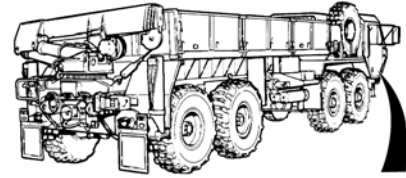

b. Follow-On Maintenance.

1. Connect batteries (TM 9-2320-279-20).
2. Install heater compartment covers (TM 9-2320-279-20).
3. Install skid plate grill (TM 9-2320-279-20).
4. Close engine cover (TM 9-2320-279-10).
5. Install left splash guard (TM 9-2320-279-20).

5. AIR CONDITIONER CHARGE/SERVICE.	
This task covers:	
a. Charging.	d. Purging.
b. Recovery.	e. Flushing.
c. Evacuation/Recycling.	f. Follow-On Maintenance.
INITIAL SETUP	
<i>Models</i>	<i>References</i>
All	None
<i>Test Equipment</i>	<i>Equipment Condition</i>
Test Set Subassembly Leak Detector, Refrigerant Gas	Shut off engine (TM 9-2320-279-10) Engine cover opened (TM 9-2320-279-10)
<i>Special Tools</i>	<i>Special Environmental Conditions</i>
None	None
<i>Supplies</i>	<i>General Safety Instructions</i>
Dye, R134A/PAG Tracer 32 Oil, Pag 46 Freon, R134A	None
<i>Personnel Required</i>	
MOS 52C, Utilities equipment repairer	

a. Charging.

WARNING

- Use care to prevent refrigerant from touching skin or eyes. Liquid refrigerant, when exposed to air, quickly evaporates and will freeze skin or eye tissues. Serious injury or blindness may result if you come in contact with liquid refrigerant.
- Refrigerant R-134a air conditioning systems should not be pressure tested or leak tested with compressed air. Combustible mixtures of air and R-134a may form, resulting in a fire or explosion, which could cause personnel injury or death.

CAUTION

- Refrigerant oil must be added to air conditioner system before charging with refrigerant or air conditioner compressor will be damaged. Add same amount of new refrigerant oil in air conditioner compressor as was noted during recovery or evacuation, except if charging for the first time. Maximum amount of refrigerant oil required for air conditioner system is 13 oz (369 g).
- RECOVERY and EVACUATION/RECYCLING procedures must be performed before system is charged or damage to system may result, except if charging for the first time.
- Air conditioner system must be in a 10 to 15 in. Hg vacuum status before charging.
- Use care to prevent overcharging or damage to compressor may result.

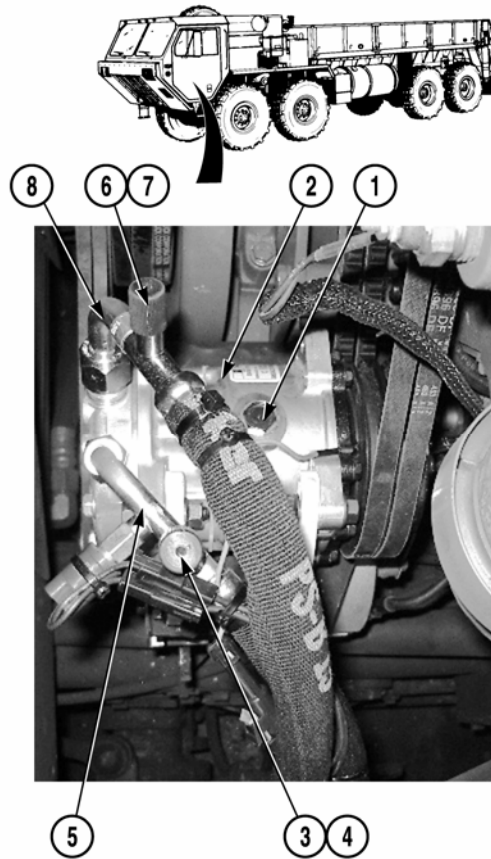

1. Remove plug (1) and add 1 oz. (29.6 mL) of 46 pag oil to air conditioner compressor (2).
2. Install plug (1) in compressor (2).
3. Position R-134a tank on a scale to make sure enough refrigerant is available to fully charge system. Weight of R-134a should be 3 lbs. (1.362 kg).
4. Remove cap (3) from service valve (4) on hose 2521 (5).
5. Remove cap (6) from service valve (7) on hose 2522 (8).

TB 9-2320-279-13-1

6. Refer to Table 1 for proper system pressure levels at measured temperatures.

7. Charge refrigerant system as noted:

TABLE 1					
°F	°C	HFC-134a (psi)	°F	°C	HFC-134a (psi)
-60	-51.1	21.8	55	12.8	51.1
-55	-48.3	20.4	60	15.6	57.3
-50	-45.6	18.7	65	18.3	63.9
-45	-42.8	16.9	70	21.1	70.9
-40	-40.0	14.8	75	23.8	78.4
-35	-37.2	12.5	80	26.7	88.4
-30	-34.4	9.8	85	29.4	94.9
-25	-31.7	6.9	90	32.2	103.9
-20	-28.9	3.7	95	35.0	113.5
-15	-26.1	0.0	100	37.8	123.6
-10	-23.3	1.9	105	40.6	134.3
-5	-20.6	4.1	110	43.3	145.3
0	-17.8	6.5	115	46.1	157.6
5	-15.0	9.0	120	48.9	170.3
10	-12.2	12.0	125	51.7	183.6
15	-9.4	15.0	130	54.4	197.6
20	-6.7	18.4	135	57.2	212.4
25	-3.9	22.1	140	60.0	227.9
30	-1.1	26.1	145	62.8	244.3
35	1.7	30.4	150	65.6	261.4
40	4.4	35.0	155	68.3	279.5
45	7.2	40.0	160	71.1	298.4
50	10.0	45.3	165	73.9	318.3

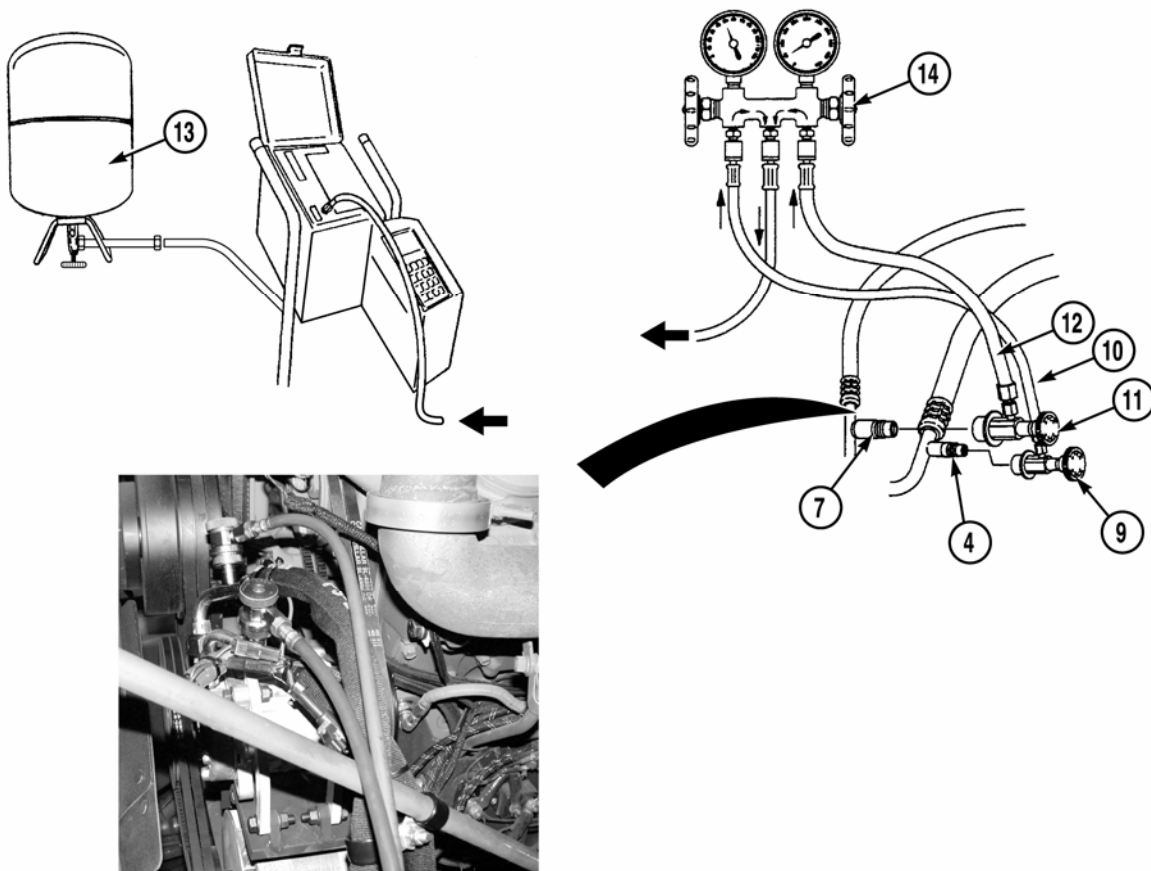

8. Connect hand valve (9) on hose (10) to service valve (4).
9. Connect hand valve (11) on hose (12) to service valve (7).

NOTE

Perform Step 10 with engine off and low-side hand valve closed.

10. When charging from bulk container, position bulk container (13) upside down and open high side hand valve (14).
11. Allow refrigerant to enter system until 27 oz. (765 g) has been added. Close high side hand valve (14).
12. Start engine (TM 9-2320-279-10). Position personnel cab air conditioner controls at maximum cooling and fan speed. Refrigerant compressor must engage.
13. Shut OFF engine (TM 9-2320-279-10).

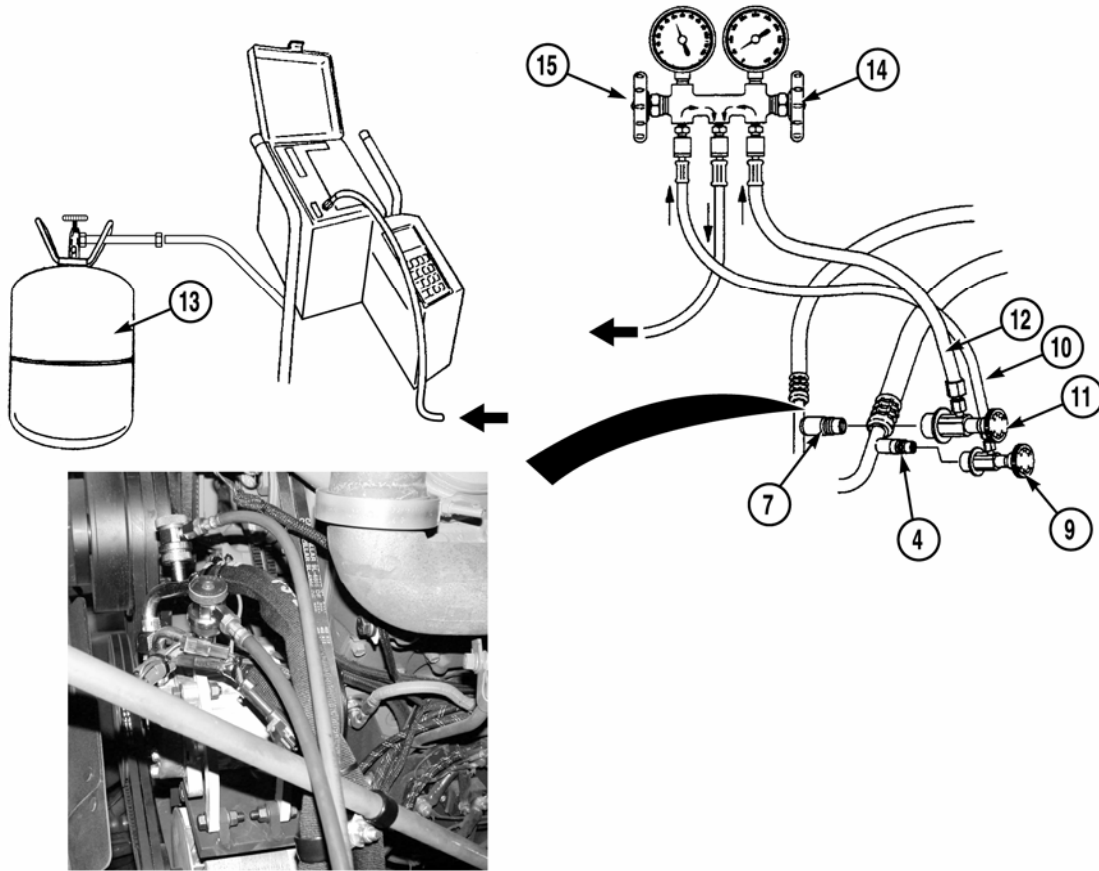

NOTE

Perform Step 14 if charge did not enter system.

14. Position bulk container (13) in upright position and open low-side hand valve (15) to draw vapor into system. Leave low-side hand valve (15) open until correct weight of refrigerant has entered system. Close low-side hand valve (15).

NOTE

If refrigerant is slow to enter system because of low outside temperatures, vaporization may be quickened by placing refrigerant in tub of warm water. Temperature should not exceed 125°F (52°C).

15. Disconnect hose (10).
16. Start engine (TM 9-2320-279-10).
17. Open high side and low-side hand valves (14) and (15) to recover refrigerant from lines.
18. Check for leaks.
19. Check operation of air conditioning system.
20. Shut OFF engine (TM 9-2320-279-10).

b. Recovery.

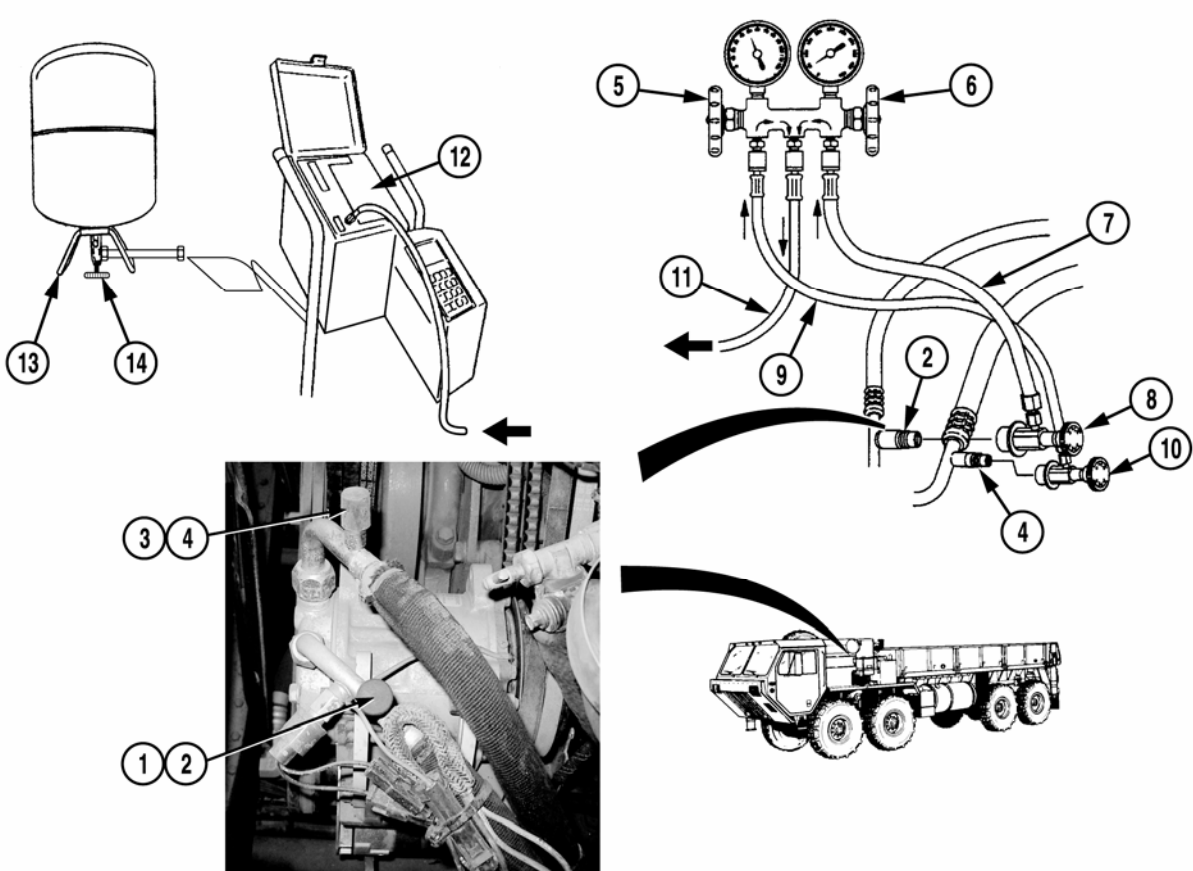

WARNING

- Use care to prevent refrigerant from touching skin or eyes. Liquid refrigerant, when exposed to air, quickly evaporates and will freeze skin or eye tissues. Serious injury or blindness may result if you come in contact with liquid refrigerant.
- Refrigerant R-134a air conditioning systems should not be pressure tested or leak tested with compressed air. Combustible mixtures of air and R-134a may form, resulting in a fire or explosion, which could cause personnel injury or death.

NOTE

Service valves are located on compressor, on engine.

1. Remove cap (1) from service valve (2).
2. Remove cap (3) from service valve (4).
3. Close two recovery/recycling station hand valves (5 and 6).

NOTE

Push down firmly on hose connectors until a clicking sound is heard to make sure coupler is locked.

4. Connect hose (7) to hand valve (8).
5. Connect hose (7) and hand valve (8) to service valve (2).
6. Connect hose (9) to hand valve (10).
7. Connect hose (9) and hand valve (10) to service valve (4).
8. Connect center hose (11) to recovery/recycling station (12) and receiving container (13).
9. Open valve (14) on receiving container (13).
10. Turn knob clockwise to open hand valve (8).
11. Turn knob clockwise to open hand valve (10).

NOTE

Recovery/recycling station will also recover refrigerant oil from air conditioner system. Refrigerant oil will be separated from refrigerant in a container on recovery/recycling station. Amount of refrigerant oil recovered must be noted. Not all refrigerant oil will be recovered; some refrigerant oil will stay in air conditioner system.

12. Recover all refrigerant from system to 10 to 15 in. Hg vacuum on low-side gage of recovery/recycling station.

CAUTION

- **Always comply with all local regulations regarding refrigerant disposal. Failure to comply may result in penalties for improper disposal.**
- **Air conditioner receiver/dryer must be replaced each time air conditioning system refrigerant is evacuated or damage to system may result.**

13. Replace air conditioner receiver/dryer.

c. Evacuation/Recycling.

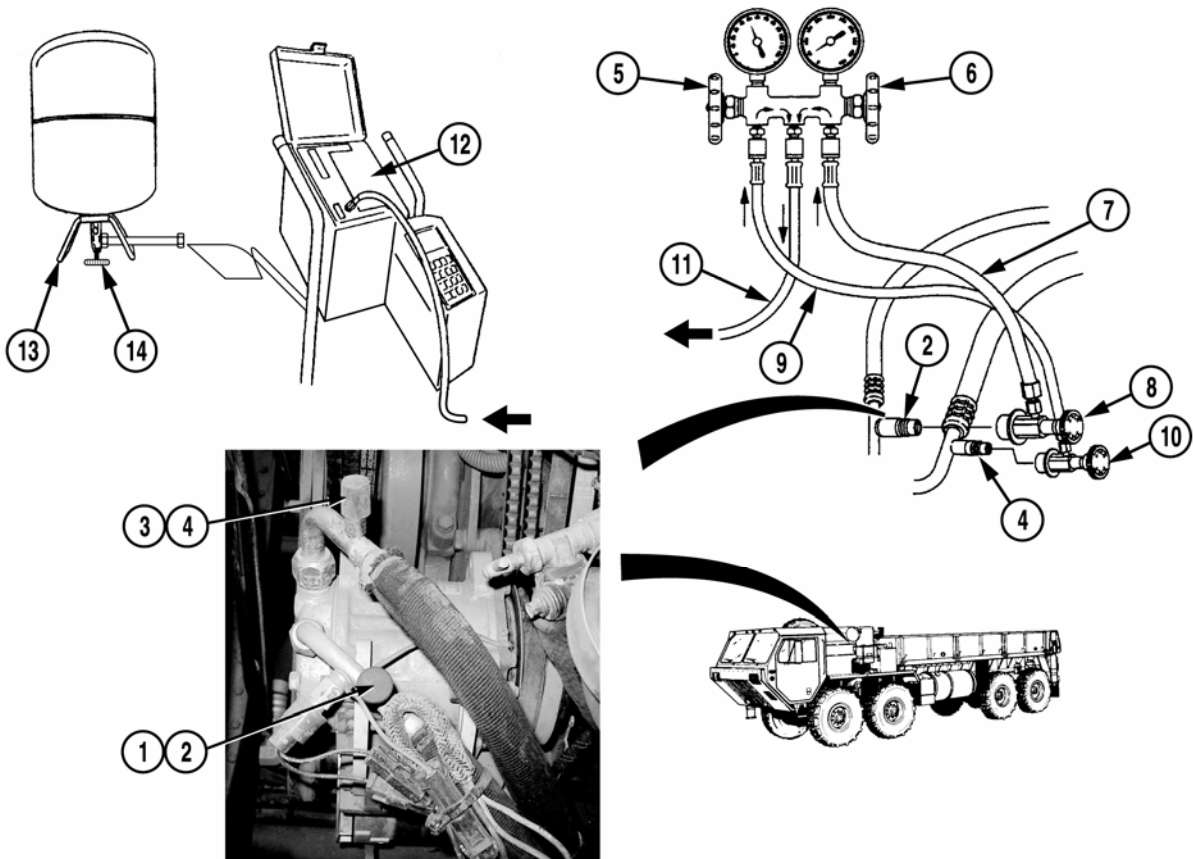

WARNING

Wear protective goggles and nonleather gloves when servicing air conditioner or injury may result.

CAUTION

- Always comply with all local regulations regarding refrigerant disposal. Failure to comply may result in penalties for improper disposal.
- System must have been recovered and compressor filled with correct amount of refrigerant oil.
- Air conditioner receiver/dryer must be replaced each time air conditioning system refrigerant is evacuated or damage to system may result.

NOTE

Service valves are located on compressor, on engine.

1. Remove cap (1) from service valve (2).
2. Remove cap (3) from service valve (4).

3. Close recovery/recycling station hand valves (5 and 6).

NOTE

Push down firmly on hose connectors until a clicking sound is heard to make sure coupler is locked.

4. Connect hose (7) to hand valve (8).
5. Connect hose (7) and hand valve (8) to service valve (2).
6. Connect hose (9) to hand valve (10).
7. Connect hose (9) and hand valve (10) to service valve (4).
8. Connect center hose (11) to recovery/recycling station (12) and receiving container (13).
9. Open valve (14) on receiving container (13).
10. Turn knob clockwise to open hand valve (8).
11. Turn knob clockwise to open hand valve (10).
12. Recover all refrigerant from system to 10 to 15 in. Hg vacuum on low-side gage of recovery/recycling station.

CAUTION

- **Always comply with all local regulations regarding refrigerant disposal. Failure to comply may result in penalties for improper disposal.**
 - **Air conditioner receiver/dryer must be replaced each time air conditioning system refrigerant is evacuated or damage to system may result.**
13. Replace air conditioner receiver/dryer.

d. Purging.

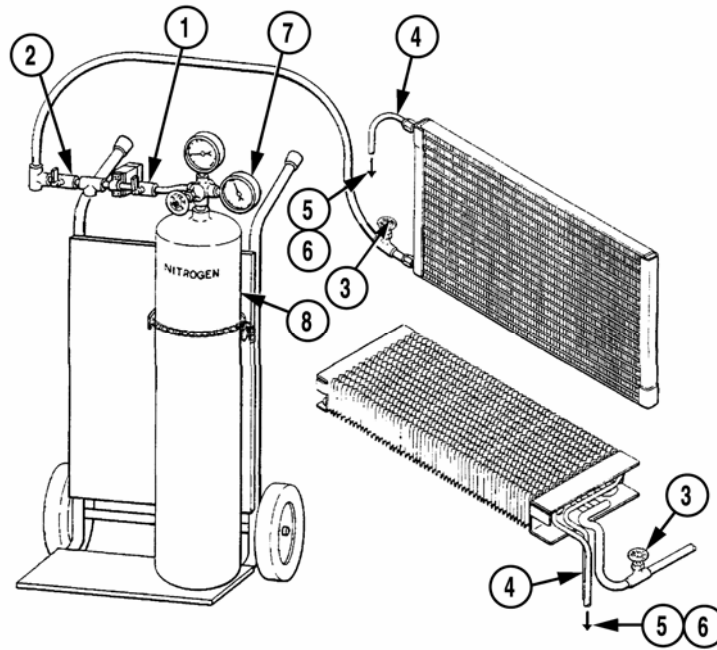

WARNING

Wear protective goggles and nonleather gloves when servicing air conditioner or injury may result.

CAUTION

Dry nitrogen gas is recommended for purging. A pressure regulator is required to regulate gas pressure between 0 and 200 psi (0-1,379 kPa). Commercial cylinders of nitrogen contain pressures in excess of 2,000 psi (13,790 kPa). This pressure must be reduced to 200 psi (1,379 kPa) for purging or damage to equipment may result.

1. Recover system refrigerant (refer to **b. Recovery**).
2. Disconnect component to be purged from air conditioning system.
3. Install caps or plugs tightly on air conditioning system lines that were disconnected from component.
4. Close three valves (1, 2, and 3).
5. Connect supply line valve (3) to outlet end of component or line.
6. Connect drain line (4) to inlet end of component or line.
7. Connect outlet end of drain line (4) to recycling system container (5) or to waste container (6).
8. Adjust nitrogen bottle regulator/gage (7) to 200 psi (1,379 kPa).
9. Open nitrogen bottle control valve (1) and purging control valve (2), then slowly open supply line valve (3). Check drain line (4) for gas flow.
10. Let nitrogen flow 200 psi (1,379 kPa) for 1 to 2 minutes. If component or line was very wet, let nitrogen flow until there is no trace of refrigerant oil or solid bits of dirt or grit flowing from drain line (4).
11. Close nitrogen bottle control valve (1) and purging control valve (2) first, then close supply line valve (3).
12. Disconnect supply line valve (3) and drain line (4). Tightly cap both ends of component or line.

e. Flushing.

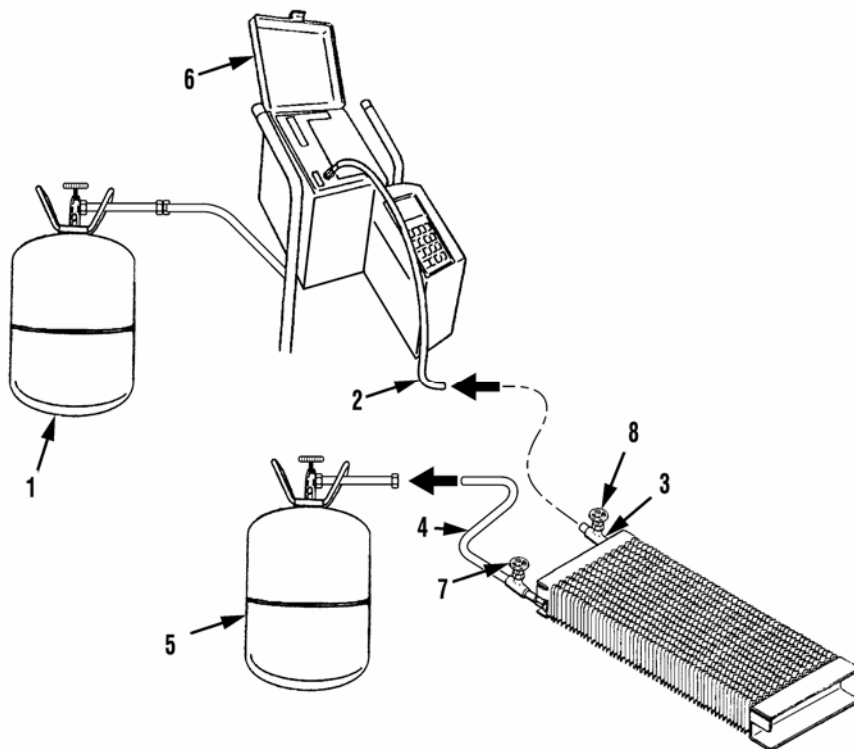

WARNING

- Use care to prevent refrigerant from touching skin or eyes. Liquid refrigerant, when exposed to air, quickly evaporates and will freeze skin or eye tissues. Serious injury or blindness may result if you come in contact with liquid refrigerant.
- Refrigerant R-134a air conditioning systems should not be pressure tested or leak tested with compressed air. Combustible mixtures of air and R-134a may form, resulting in a fire or explosion, which could cause personnel injury or death.

1. Recover system refrigerant (refer to **b. Recovery**).
2. Disconnect both ends of line or component to be purged.
3. Install caps or plugs tightly on system lines or components at disconnect points.
4. Charge or pressurize R-134a refrigerant (1) as recommended by manufacturer.
5. Connect recovery/recycling station flushing supply line (2) to outlet hose (3) side of system to reverse flow system.

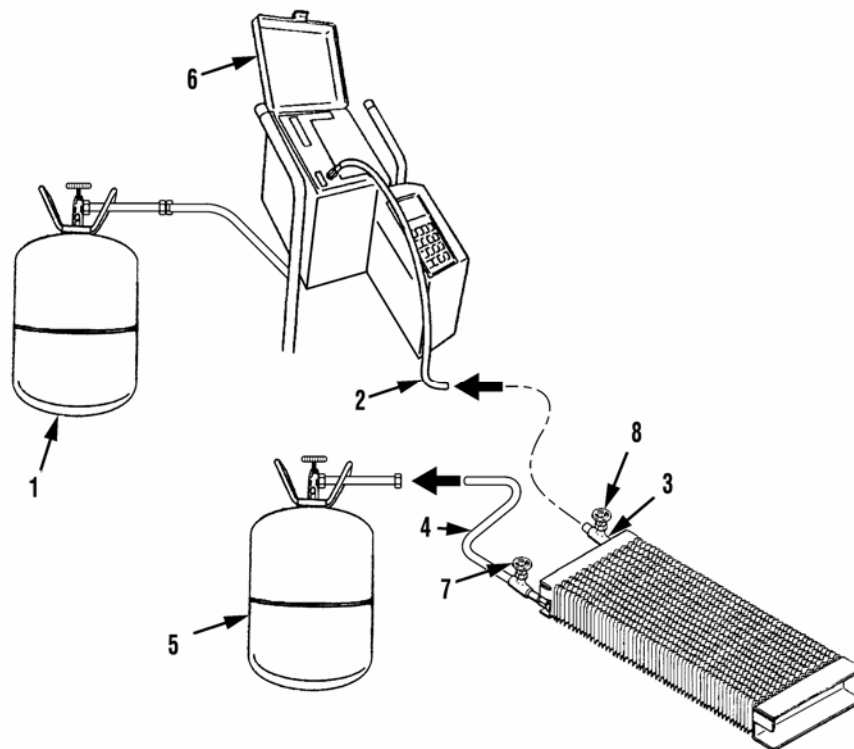

NOTE

If system is extremely contaminated, install a receiver/dryer in-line as a prefilter for recovery/recycling station.

6. Connect recovery/recycling station flushing drain line (4) from inlet valve side of system to receiving container (5).
7. Turn on recovery/recycling station (6) and open inlet valve (7). Allow about 2 lbs. (1 kg) of R-134a to flow through system.
8. Close supply line valve (8) and wait for recovery/recycling station (6) to shut off.
9. Disconnect recovery/recycling station flushing supply line (2) from outlet hose (3).
10. Disconnect recovery/recycling station flushing drain line (4) from inlet valve (7).
11. Purge system and check collection bottle for contaminants.

f. Follow-On Maintenance.

1. Close engine cover (TM 9-2320-279-10).

END OF WORK PACKAGE

APPENDIX C

REFERENCES

REFERENCES

APPENDIX C

SCOPE

This appendix lists all forms, field manuals, technical manuals, and other publications referenced in this manual. Also, those publications that should be consulted for additional information about vehicle operations are listed.

PUBLICATION INDEXES

The following indexes should be consulted frequently for latest changes or revisions and for new publications relating to material covered in this technical manual.

Consolidated Index of Army Publications and Blank Forms DA Pam 25-30

FORMS

The following forms pertain to this manual. Refer to DA Pamphlet 25-30 for index of blank forms.

Equipment Inspection and Maintenance Worksheet DA Form 2404
 Maintenance Request DA Form 2407
 Recommended Changes to DA Publication and Blank Forms DA Form 2028

Refer to DA Pam 750-8, The Army Maintenance Management Systems (TAMMS) Users Manual, for instructions for the use of maintenance forms pertaining to this material.

OTHER PUBLICATIONS

The following publications contain information pertinent to the M977 series vehicles and associated equipment.

a. Safety.

First Aid FM 4-25.11
 Safety Inspection and Testing of Lifting Devices TB 43-0142
 Security of Tactical Wheeled Vehicles. TB 9-2300-422-20

b. Vehicle Operation.

Operator's Manual, M977 Series Vehicles. TM 9-2320-279-10
 Army Motor Transport Units and Operations FM 55-30
 Manual for the Wheeled Vehicle Driver FM 21-305
 Recovery and Battlefield Damage Assessment and Repair FM 9-43-2
 Deepwater Fording of Ordnance Material TM 9-238
 Concepts and Equipment of Petroleum Operations FM 10-67-1

REFERENCES - Continued

c. Cold Weather Operation and Maintenance.

Basic Cold Weather Manual FM 31-70
 Northern Operations FM 31-71
 Operations and Maintenance of Ordnance Material in Extreme Cold Weather
 (0 degrees to -65 degrees F) FM 9-207

d. Maintenance and Repair.

Lubrication Order for M977 Series Vehicles LO 9-2320-279-12
 Organization Repair Parts and Special Tools List for M977 Series Vehicle TM 9-2320-279-24P
 Direct Support and General Support Maintenance for M977 Series Vehicles TM 9-2320-279-34
 Organizational, Direct Support, and General Support Maintenance Repair Parts and
 Special Tools List for M977 Series Vehicles TM 9-2320-279-24P
 Direct Support and General Support Maintenance with Repair Parts and
 Special Tools List for Diesel Engine (8V92TA) for M977 Series Vehicles TM 9-2815-224-34&P
 Operator's, Unit, Direct Support, and General Support Maintenance Manual for
 Care, Maintenance, Repair, and Inspection of Pneumatic Tires and Inner Tubes TM 9-2610-200-14
 Cooling Systems: Tactical Vehicles TM 750-254
 Use of Antifreeze Solutions and Cleaning Compounds in Engine Cooling Systems TB 750-651
 Maintenance Advisory Message for Purging All Fuel Tankers Using a Biodegradable
 Purging Solution. GPM 94-02
 Repair of Tents, Canvas, and Webbing FM 10-16
 Painting Instructions for Field Use TM 43-0139
 Color, Marking, and Camouflage Painting of Military Vehicles TB 43-0209
 Materials Used for Cleaning, Preserving, Abrading, and Cementing Ordnance Materiel
 and Related Materiels Including Chemicals TM 9-247
 Metal Body Repair and Related Operations TC 9-510
 Operator's Circular Welding Theory and Application TC 9-237
 Inspection, Care, and Maintenance of Antifriction Bearings. TM 9-214
 Care and Use of Handtools and Measuring Tools TM 9-243
 Purging, Cleaning, and Coating Interior Ferrous and Terne Sheet Vehicle Fuel Tanks TB 43-0212
 Operator's Organizational, Direct Support, and General Support Maintenance Manual
 for Lead-Acid Storage Batteries TM 9-6140-200-14
 Rigging Techniques, Procedures, and Applications FM 5-125

e. Maintenance of Auxiliary Equipment and Special Purpose Kits.

Operator's and Organizational Maintenance Manual Radio Sets TM 11-5820-498-12
 Operator and Organizational Maintenance Manual Generator Set TM 5-6115-465-12
 Operator and Organizational Maintenance Manual for Chemical Alarm TM 3-6665-225-12
 Operator and Organizational Maintenance Manual Including Repair Parts
 and Special Tools List for Decontamination Apparatus TM 3-4230-214-12&P

REFERENCES - Continued

f. General.

Hand Receipt Manual for M977 Series Vehicles TM 2320-279-10-HR
Procedures for Destruction of Tank-Automotive Equipment to Prevent Enemy Use TM 750-244-6
Principles of Automotive Vehicles TM 9-8000

g. Warranty.

Warranty Technical Bulletin for M977 Series Vehicles TB 9-2300-295-15/19

END OF WORK PACKAGE

APPENDIX D

MAINTENANCE ALLOCATION CHART (MAC)

MAINTENANCE ALLOCATION CHART (MAC)

APPENDIX D**Section I. INTRODUCTION****THE ARMY MAINTENANCE SYSTEM MAC**

a. This introduction (Section I) provides a general explanation of all maintenance and repair functions authorized at various maintenance levels under The Army Maintenance Management System (TAMMS) concept.

b. The Maintenance Allocation Chart (MAC) in Section II designates overall authority and responsibility for the performance of maintenance functions on the identified end item or component. The application of the maintenance functions to the end item or component will be consistent with the capacities and capabilities of the designated maintenance levels, which are shown on the MAC in Column (4) as:

- Operators - Includes a C subcolumn.
- Field Level - Includes an F subcolumn.
- Sustainment - Includes a H subcolumn.

c. Section III lists the tools and test equipment (both special tools and common tool sets) required for each maintenance function as referenced from Section II.

d. Section IV contains supplemental instructions and explanatory notes for a particular maintenance function.

MAINTENANCE FUNCTIONS

Maintenance functions are limited to and defined as follows:

a. *Inspect.* To determine the serviceability of an item by comparing its physical, mechanical, and/or electrical characteristics with established standards through examination (e.g., by sight, sound, or feel).

b. *Test.* To verify serviceability by measuring the mechanical, pneumatic, hydraulic, or electrical characteristics of an item and comparing those characteristics with prescribed standards.

c. *Service.* Operations required periodically to keep an item in proper operating condition; e.g., to clean (includes decontaminate, when required), to preserve, to drain, to paint, or to replenish fuel, lubricants, chemical fluids, or gases.

d. *Adjust.* To maintain or regulate, within prescribed limits, by bringing into proper position, or by setting the operating characteristics to specified parameters.

e. *Align.* To adjust specified variable elements of an item to bring about optimum or desired performance.

MAINTENANCE ALLOCATION CHART (MAC) - Continued

f. Calibrate. To determine and cause corrections to be made or to be adjusted on instruments or test, measuring, and diagnostic equipment used in precision measurement. Consists of comparisons of two instruments, one of which is a certified standard of known accuracy, to detect and adjust any discrepancy in the accuracy of the instrument being compared.

g. Remove/Install. To remove and install the same item when required to perform service or other maintenance functions. Install may be the act of emplacing, seating, or fixing into position a spare, repair part, or module (component or assembly) in a manner to allow the proper functioning of an equipment or system.

h. Replace. To remove an unserviceable item and install a serviceable counterpart in its place. "Replace" is authorized by the MAC and the assigned maintenance level is shown as the third position code of the SMR code.

i. Repair. The application of maintenance services¹ including fault location/troubleshooting², removal/installation and disassembly/assembly³ procedures, and maintenance actions⁴ to identify troubles and restore serviceability to an item by correcting specific damage, fault, malfunction, or failure in a part, subassembly, module (component or assembly), end item, or system.

j. Overhaul. That maintenance effort (service/action) prescribed to restore an item to a completely serviceable/operational condition as required by maintenance standards in appropriate technical publications (i.e. DMWR). Overhaul is normally the highest degree of maintenance performed by the Army. Overhaul does not normally return an item to like new condition.

k. Rebuild. Consists of those services/actions necessary for the restoration of unserviceable equipment to a like new condition in accordance with original manufacturing standards. Rebuild is the highest degree of material maintenance applied to Army equipment. The rebuild operation includes the act of returning to zero those age measurements (e.g. hours/miles) considered in classifying Army equipment/components.

EXPLANATION OF COLUMNS IN THE MAC, SECTION II

a. Column (1), Group Number. Column 1 lists functional group code numbers, the purpose of which is to identify maintenance significant components, assemblies, subassemblies, and modules with the next higher assembly.

b. Column (2), Component/Assembly. Column 2 contains the item names of components, assemblies, subassemblies, and modules for which maintenance is authorized.

c. Column (3), Maintenance Function. Column 3 lists functions to be performed on the item listed in Column 2.

-
1. Services - Inspect, test, service, adjust, align, calibrate, and/or replace.
 2. Fault location/troubleshooting - The process of investigating and detecting the cause of equipment malfunctioning; the act of isolating a fault within a system or unit under test (UUT).
 3. Disassembly/assembly - The step-by-step breakdown (taking apart) of a spare/functional group coded item to the level of its least component, that is assigned an SMR code for the level of maintenance under consideration (i.e. identified as maintenance significant).
 4. Actions - Welding, grinding, riveting, straightening, facing, machining, and/or resurfacing.

MAINTENANCE ALLOCATION CHART (MAC) - Continued

d. Column (4), Maintenance Level. Column 4 specifies each level of maintenance authorized to perform each function listed in Column 3, by indicating work time required (expressed as man-hours in whole hours or decimals) in the appropriate subcolumn. This work-time figure represents the active time required to perform that maintenance function at the indicated level of maintenance. If the number or complexity of the tasks within the listed maintenance function vary at different maintenance levels, appropriate work-time figures are shown for each level. The work-time figure represents the average time required to restore an item (assembly, subassembly, component, module, end item, or system) to a serviceable condition under typical field operating conditions. This time includes preparation time (including any necessary disassembly/assembly time), troubleshooting/fault location time, and quality assurance time in addition to the time required to perform the specific tasks identified for the maintenance functions authorized in the maintenance allocation chart. The symbol designations for the various maintenance levels are as follows:

- C Operators
- F Field Level Maintenance
- H Sustainment

*Asterisk indicates level of maintenance authorized to complete this function. No specific times established. Times required for replacement will depend on extent of work required.

e. Column (5), Tools and Equipment Ref Code. Column 5 specifies, by code, those common tool sets (not individual tools), common Test, Measurement, and Diagnostic Equipment, and special tools, special TMDE, and special support equipment required to perform the designated function. Codes are keyed to tools and test equipment in Section III.

f. Column (6), Remarks Code. When applicable, this column contains a letter code, in alphabetical order, which is keyed to the remarks contained in Section IV.

EXPLANATION OF COLUMNS IN TOOL AND TEST EQUIPMENT REQUIREMENTS, SECTION III

a. Column (1), Tool or Test Equipment Reference Code. The tool and test equipment reference code correlates with a code used in the MAC, Section II, Column 5.

b. Column (2), Maintenance Level. The lowest level of maintenance authorized to use the tool or test equipment.

c. Column (3), Nomenclature. Name or identification of the tool or test equipment.

d. Column (4), National Stock Number. The National Stock Number of the tool or test equipment.

e. Column (5), Tool Number. The manufacturer's part number, model number, or type number.

EXPLANATION OF COLUMNS IN REMARKS, SECTION IV

a. Column (1), Remarks Code. The code recorded in Column 6, Section II.

b. Column (2), Remarks. This column lists information pertinent to the maintenance function being performed as indicated in the MAC, Section II.

MAINTENANCE ALLOCATION CHART (MAC) - Continued

Section II. MAINTENANCE ALLOCATION CHART FOR HEMTT AIR CONDITIONER

Table D-1. Maintenance Allocation Chart for HEMTT Air Conditioner

(1) Group Number	(2) Component/Assembly	(3) Maintenance Function	(4) Maintenance Level			(5) Tools and Equipment Ref Code	(6) Remarks Code
			Operators	Field Level	Sustainment		
			C	F	H		
06	ELECTRICAL SYSTEM						
0601	AC Alternator and Pulley	Replace		1.7		4, 5, 7	
	AC Alternator Drive Belts	Adjust		0.6		6, 7	
		Replace		0.7		6, 7	
	AC Alternator/ Compressor Mounting Bracket	Replace		0.7		7	
0607	Instrument Panel:						
	AC 20 AMP Circuit Breaker	Replace		0.3		7	
0608	Miscellaneous Electrical Components:						
	AC Optic Ribbon	Replace		0.8		7	
0613	Wiring Harness:						
	AC Heater/Evaporator Blower Motor Resistor Harness	Replace		0.6		7	
	AC Wiring Harness	Inspect	*				
		Replace		2.0		7	
	AC Wire 1082 Harness	Replace		0.6		7	
	AC Wire 1156 Harness	Replace		0.6		7	
52	REFRIGERATION AND AIR CONDITIONING COMPONENTS						
5200	Air Conditioning System	Inspect	*				A, B
		Service		*		1, 3, 7	B
	AC Heater/Evaporator Cover and Defrost Louvers	Replace		0.2		7	
	AC Lower Plenum and Damper	Replace		0.6		7	
	AC Upper Plenum	Replace		0.6		7	

MAINTENANCE ALLOCATION CHART (MAC) - Continued

Table D-1. Maintenance Allocation Chart for HEMTT Air Conditioner (Continued)

(1) Group Number	(2) Component/Assembly	(3) Maintenance Function	(4) Maintenance Level			(5) Tools and Equipment Ref Code	(6) Remarks Code
			Operators	Field Level	Sustainment		
			C	F	H		
5217	AC Compressor	Inspect	0.2	0.2			A
		Replace		0.5		3, 4, 5, 7	
	AC Compressor Drive Belts	Inspect	0.1	0.2			A
		Replace		1.0		7	
		Adjust		0.5		6, 7	
5230	AC Hoses	Inspect	0.3	0.3			A
		Replace		*		3, 4, 5, 7	
5241	AC High Pressure Switch	Replace		0.3		4, 5, 7	A
	AC Low Pressure Switch	Replace		0.3		4, 5, 7	
	AC Condenser	Inspect	0.2	0.5			
		Replace		0.6		3, 4, 5, 7	
	AC Condenser Core	Inspect	*	*			
		Replace		0.5		3, 7	
	AC Condenser Dryer	Inspect	0.1				
		Replace		0.3		3, 7	
	AC Condenser Fan Motor	Replace		0.8		7	
	AC Condenser Fan Motor Solenoid	Replace		0.4		7	
5243	AC Heater/Evaporator	Inspect	0.1				
		Replace		3.5		3, 4, 5, 7	
	AC Evaporator Core and Expansion Valve	Replace		1.0		4, 5, 7	
5243	AC Heater Core	Replace		0.7		7	
	AC Heater/Evaporator Blower Motor Assembly	Replace		1.0		7	
	AC Heater/Evaporator Blower Motor Resistor	Replace		0.4		7	
	AC Cable	Replace		0.6		7	
	AC Defrost Cable	Replace		0.6		7	
	AC Heater Cable	Replace		0.6		7	

MAINTENANCE ALLOCATION CHART (MAC) - Continued

Table D-1. Maintenance Allocation Chart for HEMTT Air Conditioner (Continued)

(1) Group Number	(2) Component/Assembly	(3) Maintenance Function	(4) Maintenance Level			(5) Tools and Equipment Ref Code	(6) Remarks Code
			Operators	Field Level	Sustainment		
			C	F	H		
5244	AC Fan Control Switch	Replace		0.6		7	
	AC Temperature Control Switch	Replace		0.4		7	

Section III. TOOLS AND TEST EQUIPMENT FOR HEMTT AIR CONDITIONER

Table D-2. Tools and Test Equipment for HEMTT Air Conditioner

Tool or Test Equipment Reference Code	Maintenance Level	Nomenclature	National Stock Number	Tool Number
1	F	Goggles	6930-00-355-7398	1F4B
2	F	Multimeter, Digital	6625-01-139-2512	T00377
3	F	Set, Cap and Plug	5340-00-450-5718	10935405
4	F	Shop Equipment, Automotive Maintenance and Repair: Common No. 1	4910-00-754-0654	SC 4910-95-A74
5	F	Shop Equipment, Automotive Maintenance and Repair: Common No. 2	4910-00-754-0650	SC 4910-95-A72
6	F	Tensiometer, Dial In	6635-01-093-3710	BT-3373-F
7	F	Tool Kit, General Mechanic's	5180-00-177-7033 or 5180-01-481-8389	SC 5180-90-CL-N26 or DFP389J

Section IV. REMARKS FOR HEMTT AIR CONDITIONER

(1) Remarks Code	(2) Remarks
A	Inspect for leakage.
B	See Additional Authorization List (AAL) (Appendix H).

END OF WORK PACKAGE

TB 9-2320-279-13-1

APPENDIX E

EXPENDABLE AND DURABLE SUPPLIES AND MATERIALS LIST

EXPENDABLE AND DURABLE SUPPLIES AND MATERIALS LIST

APPENDIX E**Section I. INTRODUCTION****SCOPE**

This appendix lists expendable and durable supplies and materials you will need to operate and maintain the HEMTT AC. This listing is for informational purposes only and is not authority to requisition the listed items. These items are authorized to you by CTA 50-970, Expendable/Durable Items (Except Medical, Class V, Repair Parts, and Heraldic Items), or CTA 8-100, Army Medical Department Expendable/Durable Items.

EXPLANATION OF COLUMNS

a. Column (1) - Item Number. This number is assigned to the entry in the listing and is referenced in the narrative instructions to identify the material (e.g., "Use cleaning compound, Item 5, Appendix E").

b. Column (2) - Level. This column identifies the lowest level of maintenance that requires the listed item.

C - Operator/Crew

F - Field Level Maintenance

c. Column (3) - National Stock Number. This is the National Stock Number assigned to the item; use it to request or requisition the item.

d. Column (4) - Description. Indicates the Federal item name, and, if required, a description to identify the item. The last line for each item indicates the part number followed by the Commercial and Government Entity (CAGE) Code in parentheses.

e. Column (5) - Unit of Measure (U/M). Indicates the measure used in performing the actual maintenance function. This measure is expressed by two-character alphabetical abbreviations (e.g., ea, in, pr). If the unit of measure differs from the unit of issue, requisition the lowest unit of issue that will satisfy your requirements.

EXPENDABLE AND DURABLE SUPPLIES AND MATERIALS LIST - Continued

Section II. EXPENDABLE AND DURABLE SUPPLIES AND MATERIALS LIST

(1) Item Number	(2) Level	(3) National Stock Number	(4) Description	(5) U/M
1	F	8040-00-148-7182	Adhesive, 3M #1300 32167AX (45152)	tu
2	F	9320-01-237-1157	Gloves, Rubber 509891 (19428)	pr
3	F		Oil, PAG 46V 3289224 (45152)	
4	F	6830-01-439-0614	Refrigerant R-134a (4V886)	cy
5	F	8030-01-014-5869	Sealant, Loctite 242 24231 (05972)	oz
6	F	9160-01-515-2484	Sealant, RTV200 Electrical 3119525 (45152)	ea
7	F	6810-00-252-1345	Solution, Soap MIL-W-15000 Class C (81349) 1 quart bottle	qt
8	F	6850-00-664-5685	Solvent, Dry Cleaning AA59601-1D (58536)	qt
9	F	8135-00-178-9200	Tags, Identification A-A-1916 (58536)	ct
10	F	5970-00-644-3167	Tape, Insulation, Electrical 17 3-4IN (75037)	ro
11	F	5975-01-048-2922	Tie, Cable 60459AX (45152)	ea
12	F	5975-01-053-1331	Tie, Cable 5201HX (45152)	ea
13	F	5975-01-513-6305	Tie, Cable 5193HX (45152)	ea

END OF WORK PACKAGE

APPENDIX F

COMMON TOOLS AND SPECIAL TOOLS LIST

COMMON TOOLS AND SPECIAL TOOLS LIST

APPENDIX F**Section I. INTRODUCTION****SCOPE**

This appendix lists the tools you will need to operate and maintain the HEMTT AC.

EXPLANATION OF COLUMNS

- a. Column (1) - Item Number.** This number is assigned to the entry in the listing and is referenced in the narrative task box to identify the tool (e.g., "Tool Kit, General Mechanic's (Item 7, Appendix F)").
- b. Column (2) - Item Name.** This column identifies the tool.
- c. Column (3) - National Stock Number.** This is the National Stock Number assigned to the item; use it to request or requisition the item.
- d. Column (4) - Part Number.** This is the manufacturer's part number assigned to the item.
- e. Column (5) - Reference.** This column references the Supply Catalog Number and tools which are part of/ components of shop set authorized to section/teams; tools authorized by RPSTL and CTA 50-970; special and fabricated tools; and items of TMDE.

COMMON TOOLS AND SPECIAL TOOLS LIST - Continued

Section II. TOOL IDENTIFICATION LIST

(1) Item Number	(2) Item Name	(3) National Stock Number	(4) Part Number	(5) Reference
1	Goggles	6930-00-355-7398	1F4B	SC 4910-95-A31
2	Multimeter, Digital	6625-01-139-2512	T00377	SC 4910-95-A72
3	Set, Cap and Plug	5340-00-450-5718	10935405	
4	Shop Equipment, Automotive Maintenance and Repair: Common No. 1	4910-00-754-0654	SC 4910-95-A74	
5	Shop Equipment, Automotive Maintenance and Repair: Common No. 2	4910-00-754-0650	SC 4910-95-A72	
6	Tensiometer, Dial In	6635-01-093-3710	BT-3373-F	
7	Tool Kit, General Mechanic's	5180-00-177-7033 or 5180-01-481-8389	SC 5180-90-CL-N26 or DFP389J	

END OF WORK PACKAGE

TB 9-2320-279-13-1

APPENDIX G

ILLUSTRATED PARTS LIST (RPSTL)

ILLUSTRATED PARTS LIST (RPSTL)

APPENDIX G**Section I. INTRODUCTION****SCOPE**

This RPSTL lists and authorizes spares and repair parts; special tools; special test, measurement, and diagnostic equipment (TMDE); and other special support equipment required for performance of Field Level Maintenance of the HEMTT AC. It authorizes the requisitioning, issue, and disposition of spares, repair parts, and special tools as indicated by the source, maintenance, and recoverability (SMR) codes.

GENERAL

This repair parts and special tools list is divided into the following sections:

a. Section II. Repair Parts List. A list of spares and repair parts authorized by this RPSTL for use in the performance of maintenance. The list also includes parts which must be removed for replacement of the authorized parts. Parts lists are composed of functional groups in ascending alphanumeric sequence, with the parts in each group listed in ascending figure and item number sequence. Bulk materials are listed by item name in FIG. BULK at the end of the section. Repair parts kits or sets are listed separately in their own functional group within Section II. Repair parts for repairable special tools are also listed in Section II. Items listed are shown on the associated illustration.

b. Section III. Special Tools List. A list of special tools, special TMDE, and other special support equipment authorized by this RPSTL (as indicated by Basis of Issue (BOI) information in DESCRIPTION AND USABLE ON CODE (UOC) column).

c. Section IV. Cross-Reference Indexes. There are two cross-reference indexes in this RPSTL: The National Stock Number Index and the Part Number Index. The National Stock Number Index refers you to the figure and item number. The Part Number Index refers you to the figure and item number.

ILLUSTRATED PARTS LIST (RPSTL) - Continued

EXPLANATION OF COLUMNS (SECTION II AND III)

a. ITEM NO. (Column (1)). Indicates the number used to identify items called out in the illustration.

b. SMR CODE (Column (2)). The source, maintenance, and recoverability (SMR) code contains supply/requisitioning information, maintenance level authorization criteria, and disposition instruction, as shown in the following breakout:

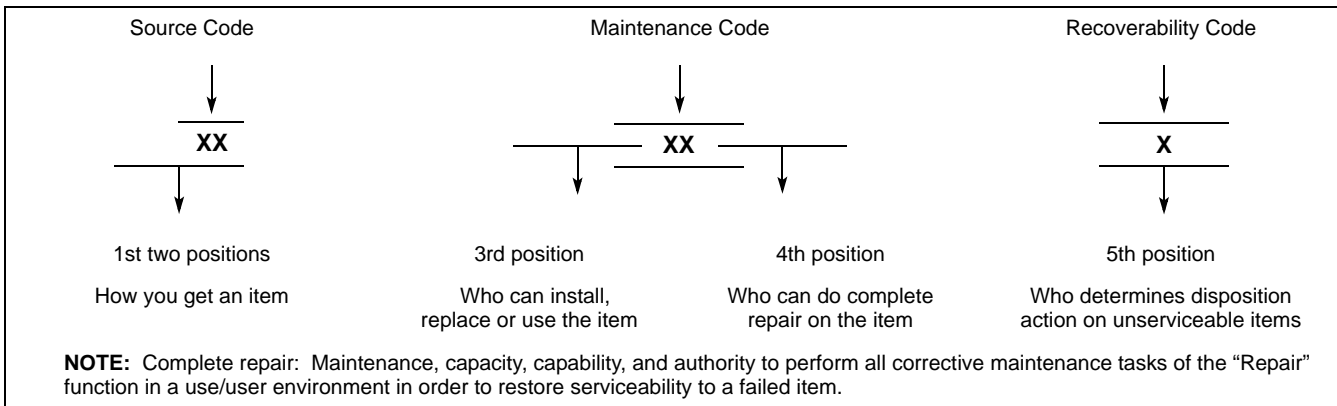

1. *Source Code.* The source code tells you how to get an item needed for maintenance, repair or overhaul of an end item/equipment. Explanations of source codes follow:

Code	Explanation
PA	Stock items; use the applicable NSN to requisition/request items with these source codes. They are authorized to the category indicated by the code entered in the 3d position of the SMR code. NOTE: Items coded PC are subject to deterioration.
PB	
PC	
PD	
PE	
PF	
PG	
KD	Items with these codes are not to be requested/requisitioned individually. They are part of a kit which is authorized to the maintenance level indicated in the 3rd position of the SMR code. The complete kit must be requisitioned and applied.
KF	
KB	
MO – Made at unit level	Items with these codes are not to be requisitioned/requested individually. They must be made from bulk material which is identified by the part number in the DESCRIPTION AND USABLE ON CODE (UOC) column and listed in the bulk material group of the repair parts list of the RPSTL. If the 3d position of the SMR code authorizes you to replace the item, but the source code indicates it is made at a higher level, order the item from the higher level of maintenance.
MF – Made at DS level	
MH – Made at GS level	
ML – Made at SRA	
MD – Made at depot	

ILLUSTRATED PARTS LIST (RPSTL) - Continued

Code	Explanation
AO – Assembled by unit level	Items with these codes are not to be requested/requisitioned individually. The parts that make up the assembled item must be requisitioned or fabricated and assembled at the level of maintenance indicated by the source code. If the 3d position code of the SMR code authorizes you to replace the item, but the source code indicates it is assembled at a higher level, order the item from the higher level of maintenance.
AF – Assembled by DS level	
AH – Assembled by GS level	
AL – Assembled by SRA	
AD – Assembled by depot	
XA	Do not requisition an “XA” coded item. Order the next higher assembly. (Refer to the NOTE below.)
XB	If an item is not available from salvage, order it using the CAGEC and part number.
XC	Installation drawing, diagrams, instruction sheet, field service drawing; identified by manufacturer's part number.
XD	Item is not stocked. Order an “XD”-coded item through normal supply channels using the CAGEC and part number given, if no NSN is available.

NOTE

Cannibalization or controlled exchange, when authorized, may be used as a source of supply for items with the above source codes, except for those coded “XA”.

2. *Maintenance Code.* Maintenance codes tell you the level(s) of maintenance authorized to use and repair support items. The maintenance codes are entered in the third and fourth position of the SMR code as follows:
 - (a) The maintenance code entered in the third position tells you the lowest maintenance level authorized to remove, replace, and use the item. The maintenance code entered in the third position will indicate authorization to the following levels of maintenance.

Maintenance Code	Application/Explanation
C	Crew or operator maintenance done within unit maintenance.
O	Unit level maintenance can remove, replace, and use the item.
F	Direct support maintenance can remove, replace, and use the item.
H	General support maintenance can remove, replace, and use the item.
L	Specialized repair activity can remove, replace, and use the item.
D	Depot can remove, replace, and use the item.

- (b) The maintenance code entered in the fourth position tells you whether or not the item is to be repaired and identifies the lowest maintenance level with the capability to perform complete repair (perform all authorized maintenance functions).

ILLUSTRATED PARTS LIST (RPSTL) - Continued

NOTE

Some limited repair may be done on the item at a lower level of maintenance, if authorized by the maintenance allocation chart and SMR codes.

Maintenance Code	Application/Explanation
O	Unit is the lowest level that can do complete repair of the item.
F	Direct support is the lowest level that can do complete repair of the item.
H	General support is the lowest level that can do complete repair of the item.
L	Specialized repair activity (designate the specialized repair activity) is the lowest level that can do complete repair of the item.
D	Depot is the lowest level that can do complete repair of the item.
Z	Nonreparable. No repair is authorized.
B	No repair is authorized. No parts or special tools are authorized for the maintenance of a "B" coded item. However, the item may be reconditioned by adjusting, lubrication, etc., at the user level.

3. *Recoverability Code.* Recoverability codes are assigned to items to indicate the disposition action on unserviceable items. The recoverability code is shown in the fifth position of the SMR code as follows:

Recoverability Code	Application/Explanation
Z	Nonreparable item. When unserviceable, condemn and dispose of the item at the level of maintenance shown in the 3rd position of the SMR code.
O	Reparable item. When uneconomically reparable, condemn and dispose of the item at unit level.
F	Reparable item. When uneconomically reparable, condemn and dispose of the item at the direct support level.
H	Reparable item. When uneconomically reparable, condemn and dispose of the item at the general support level.
D	Reparable item. When beyond lower level repair capability, return to depot. Condemnation and disposal of item are not authorized at below depot level.
L	Reparable item. Condemnation and disposal not authorized below specialized repair activity (SRA).
A	Item requires special handling or condemnation procedures because of specific reasons (such as precious metal content, high dollar value, critical material or hazardous materiel). Refer to appropriate manuals/directives for specific instructions.

ILLUSTRATED PARTS LIST (RPSTL) - Continued

c. NSN (Column (3)). The national stock number for the item is listed in this column.

d. CAGEC (Column (4)). The commercial and government entity code is a 5-digit code which is used to identify the manufacturer, distributor, or government agency/activity, that supplies the item.

e. PART NUMBER (Column (5)). Indicates the primary number used by the manufacturer (individual, company, firm, corporation, or government activity), which controls the design and characteristics of the item by means of its engineering drawings, specifications standards, and inspection requirements to identify an item or range of items.

NOTE

When you use a NSN to requisition an item, the item you receive may have a different part number from the number listed.

f. DESCRIPTION AND USABLE ON CODES (UOC) (Column (6)). This column includes the following information:

1. The Federal item name, and when required, a minimum description to identify the item.
2. Part number for bulk materials are referenced in this column in the line item entry to be manufactured/fabricated.
3. The statement "END OF FIGURE" appears just below the last item description in column 6 for a given figure in both Section II and Section III.

g. QTY (Column (7)). The QTY (quantity per figure) column indicates the quantity of the item used in the breakout shown on the illustration/figure, which is prepared for a functional group, subfunctional group, or an assembly. A "V" appearing in this column instead of a quantity indicates that the quantity is variable and the quantity may vary from application to application.

EXPLANATION OF INDEX FORMAT AND COLUMNS (SECTION IV)

a. National Stock Number (NSN) Index.

1. *STOCK NUMBER Column.* This column lists the NSN in national item identification number (NIIN) sequence. The NIIN consists of the last nine digits of the NSN.

NSN e.g.	$\frac{\text{NSN}}{(5385-01-574-1467)}$
	NIIN

NOTE

When using this column to locate an item, ignore the first 4 digits of the NSN. Use the complete NSN (13 digits) when requisitioning items by stock number.

2. *FIG. Column.* This column lists the number of the figure where the item is identified/located. The figures are in numerical order in sections II and III.

ILLUSTRATED PARTS LIST (RPSTL) - Continued

3. *ITEM Column.* The item number identifies the item associated with the figure listed in the adjacent FIG. column. This item is also identified by the NSN listed on the same line.

b. Part Number Index. Part numbers in this index are listed by part number in ascending alphanumeric sequence (vertical arrangement of letters and number combination which places the first letter or digit of each group in order A through Z, followed by the numbers 0 through 9 and each following letter or digit in like order).

1. *CAGEC Column.* The commercial and government entity code is a code used to identify the manufacturer, distributor, or government agency, etc., that supplies the item.
2. *PART NUMBER Column.* Indicates the part number assigned to the item.
3. *STOCK NUMBER Column.* This column lists the NSN for the associated part number and manufacturer identified in the PART NUMBER and CAGEC columns to the left.
4. *FIG. Column.* This column lists the number of the figure where the item is identified/located in Section II or Section III.
5. *ITEM Column.* The item number is the number assigned to the item as it appears in the figure referenced in the adjacent figure number column.

SPECIAL INFORMATION

a. Usable on Code. The usable on code appears in the lower left corner of the Description column heading. Usable on codes are shown as "UOC..." in the Description Column (justified left) on the first line applicable item/ nomenclature. Uncoded items are applicable to all models. Identification of the usable code used in this RPSTL is:

Code	Used On
H01/H51/H71	M977 With Winch
H02/H55/H75	M978 With Winch
H03/H59/H79	M983 Without Crane
H05/H53/H73	M985 With Winch
H06/H50/H70	M977 Without Winch
H07/H54/H74	M978 Without Winch
H09/H52/H72	M985 Without Winch
H04	M984
H40/H60/H80	M984A1
H41/H61/H81	M985E1 With Winch
LHS/H58/H78	M1120
CBW/H57/H77	M1977 With Winch
CBT/H56/H76	M1977 Without Winch

b. Fabrication Instructions. Bulk materials required to manufacture items are listed in the bulk material functional group of this RPSTL. Part numbers for bulk materials are also referenced in the Description Column of the line item entry for the item to be manufactured/fabricated. Detailed fabrication instructions for items source coded to be manufactured or fabricated are found in TM 9-2320-279-24P.

ILLUSTRATED PARTS LIST (RPSTL) - Continued

c. Index Numbers. Items which have the word BULK in the figure column will have an index number shown in the item number column. This index number is a cross-reference between the national stock number/part number index and the bulk material list in Section II.

d. Associated Publications. The publications listed below pertain to the HEMTT and its components:

Publication	Short Title
TM 9-2320-279-10	Operator's Manual
TM 9-2320-279-20	Organizational Maintenance
TM 9-2320-279-34	Direct Support and General Support Maintenance
LO 9-2320-279-12	Lubrication Order

HOW TO LOCATE REPAIR PARTS

a. When National Stock Numbers or Part Numbers are Not Known.

- First.* Using the table of contents, determine the assembly or subassembly group to which the item belongs. This is necessary since figures are prepared for assembly groups and subassembly groups, and listings are divided into the same groups.
- Second.* Find the figure covering the functional group or the subfunctional group to which the item belongs.
- Third.* Identify the item on the figure and note the item number.
- Fourth.* Look in the repair parts list for the figure and item numbers. The NSNs and part numbers are on the same line as the associated item numbers.

b. When National Stock Number or Part Number is Known.

- First.* If you have the national stock number, look in the STOCK NUMBER column of the National Stock Number Index. The NSN is arranged in national item identification number (NIIN) sequence (see *Explanation of Index Format and Columns (Section IV)*). Note the figure and item number next to the NSN.
- Second.* Turn to the figure and locate the item number. Verify that the item is the one you are looking for.

NOTE

If you have the part number, look in the PART NUMBER column of the part number index. Identify the figure and item number, look up the item on the figure in Section II.

ABBREVIATIONS

Abbreviations used in this manual are in accordance with MIL-STD-12.

Section II. REPAIR PARTS LIST

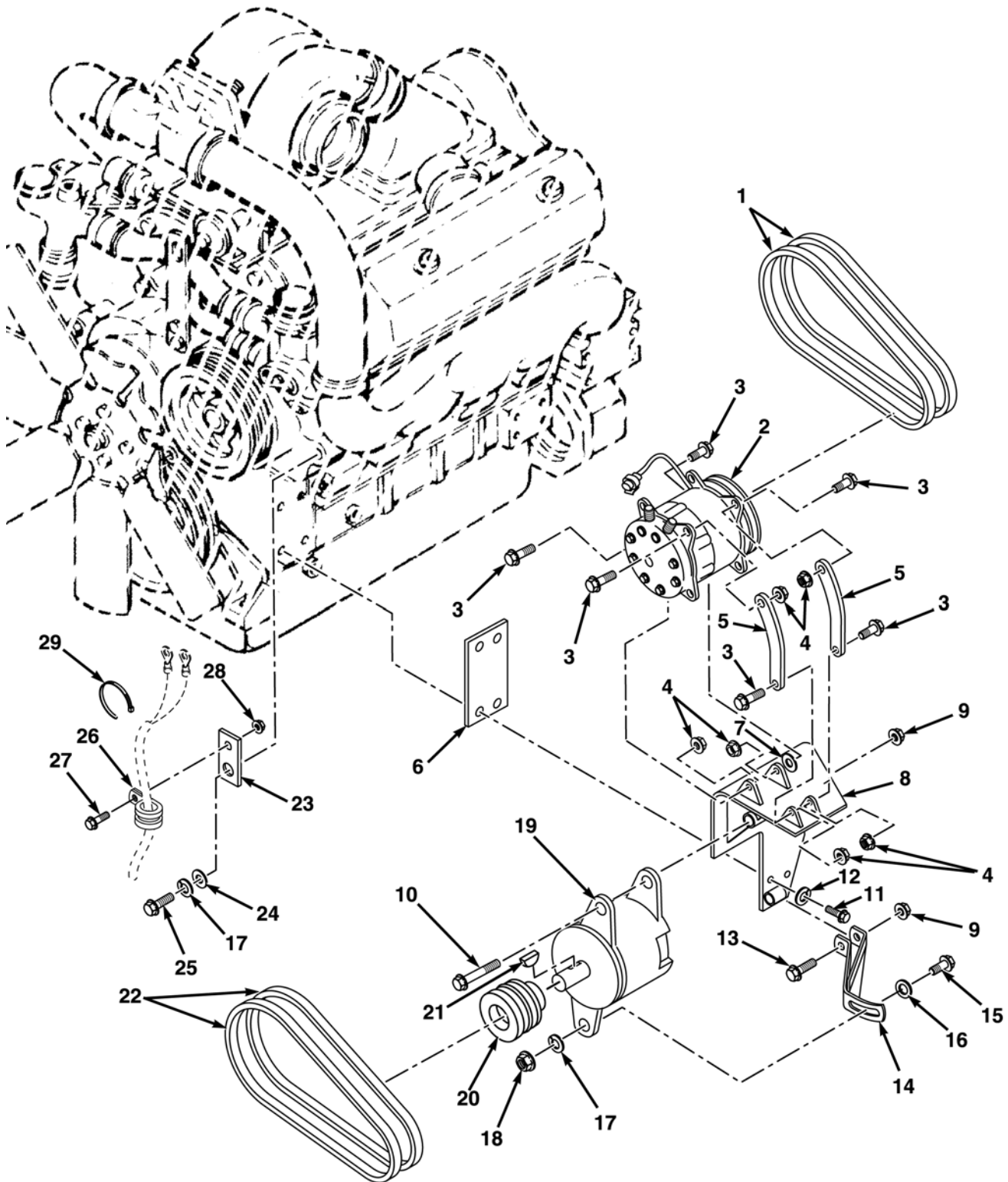

FIG. 1 AC ALTERNATOR/COMPRESSOR MOUNTING

TB 9-2320-279-13-1

(1)	(2)	(3)	(4)	(5)	(6)	(7)
ITEM NO.	SMR CODE	NSN	CAGEC	PART NUMBER	DESCRIPTION AND USABLE ON CODES (UOC)	QTY
GROUP 5200						
FIG. 1 AC ALTERNATOR/ COMPRESSOR MOUNTING						
1	PAOZZ	3030-01-518-9765	45152	2SK308	• TWO BELT SET	1
2	PAFZZ	2520-01-517-8979	45152	2081570	• COMPRESSOR & CLUTCH A/C	1
3	PAOZZ	5305-01-242-0655	45152	120699A	• SCREW, CAP	6
4	PAOZZ	5310-01-151-1036	45152	115307A	• NUT, SELF-LOCKING	6
5	PBFZZ	5340-01-530-4119	45152	1935360	• STRAP, COMPRESSOR	2
6	PBOZZ	5340-01-530-2603	45152	1935350	• PAD, ALTERNATOR	1
7	PAOZZ	5310-01-062-3379	45152	362AX	• WASHER, FLAT	1
8	PBFZZ	5340-01-530-4098	45152	1935280W	• BRACKET, ALTERNATOR/ COMPRESSOR	1
9	PAOZZ	5310-01-159-8178	45152	110310A	• NUT, SELF-LOCKING	2
10	PAOZZ	5306-01-102-5498	45152	119097B	• BOLT, MACHINE	1
11	PAOZZ	5305-01-516-8362	45152	2016HX1	• SCREW, CAP	4
12	PAOZZ	5310-01-081-1283	45152	352AX	• WASHER, LOCK	4
13	PAOZZ	5305-01-156-5445	45152	124129A	• SCREW, CAP	1
14	PAOZZ	5340-01-530-6842	45152	1935480W	• STRAP ASSEMBLY	1
15	PAOZZ	5305-01-165-2452	45152	1867HX1	• SCREW, CAP	1
16	PAOZZ	5310-01-236-1710	45152	720HX2	• WASHER, FLAT	1
17	PAOZZ	5310-01-133-2130	45152	355AX	• WASHER, LOCK	2
18	PAOZZ	5310-01-342-8595	45152	1598030	• NUT, SELF-LOCKING	1
19	PAOHH	6115-01-482-8799	24975	A001 4827 JB	• ALTERNATOR, 24V	1
20	PAOZZ	3020-01-337-9342	45152	1698110	• PULLEY, ALTERNATOR	1
21	PAOZZ	5315-00-616-5523	96906	MS35756-11	• KEY, WOODRUFF	1
22	PAOZZ	3030-00-844-3305	81348	A-A-52155-146AIR	• BELT SET	1
23	PFOZZ	5340-01-155-1919	45152	1338010	• PLATE, MENDING	1
24	PAOZZ	5310-01-457-8573	45152	720HX	• WASHER, FLAT .50X1.06X.09	1
25	PAOZZ	5305-01-151-7363	45152	740HX1	• SCREW, CAP .50 - 13X1.00	1
26	PAOZZ	5340-01-479-9054	45152	2290HX	• CLAMP, LOOP	1
27	PAOZZ	5305-01-344-8899	45152	1606140	• SCREW, CAP .25 - 20X.75	1
28	PAOZZ	5310-01-346-9445	45152	1600460	• NUT, SELF-LOCKING .25 - 20	1
29	PAOZZ	5975-01-513-6305	45152	5193HX	• STRAP, TIEDOWN	1
END OF FIGURE						

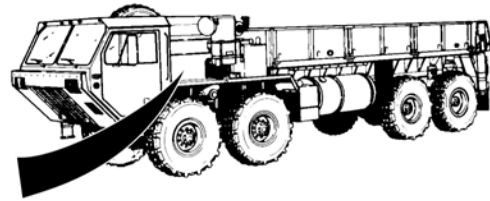
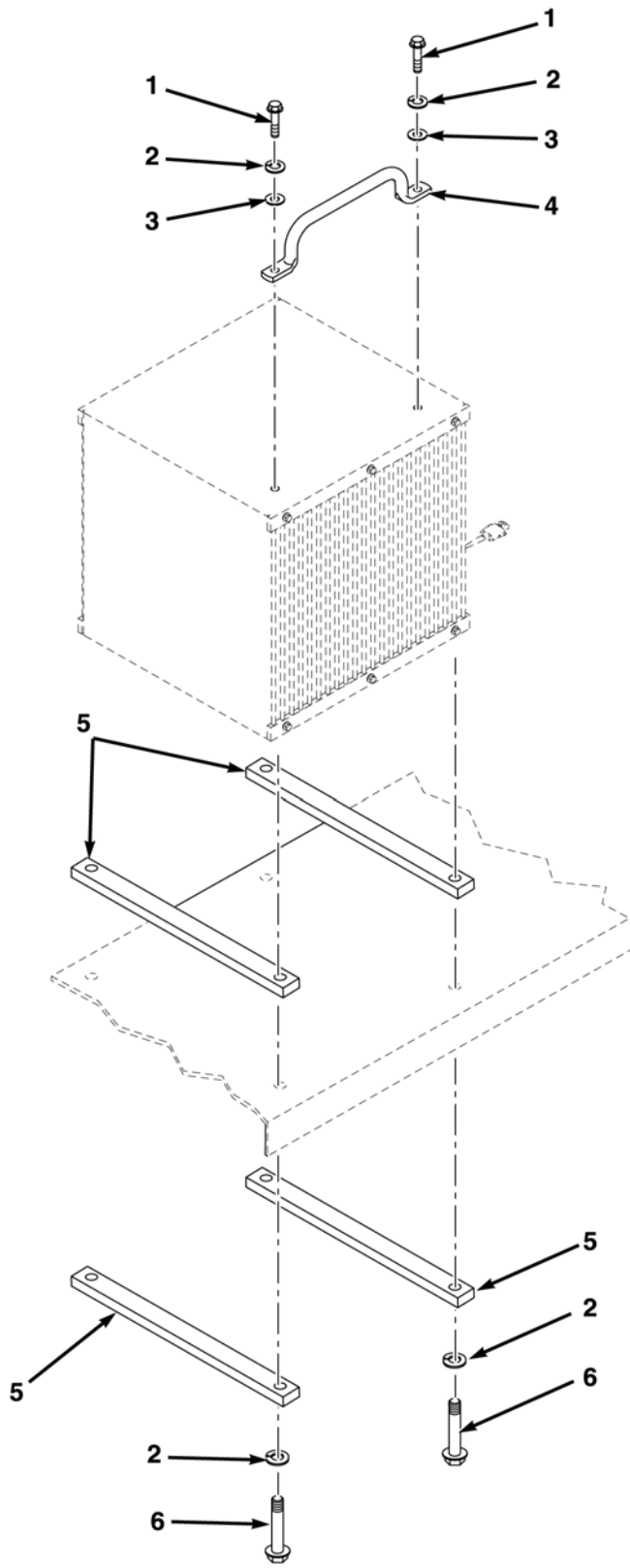

FIG. 2 AC CONDENSER W/CONNECTOR

TB 9-2320-279-13-1

(1)	(2)	(3)	(4)	(5)	(6)	(7)
ITEM NO.	SMR CODE	NSN	CAGEC	PART NUMBER	DESCRIPTION AND USABLE ON CODES (UOC)	QTY
					GROUP 5200 FIG. 2 AC CONDENSER W/CONNECTOR	
1	PAOZZ	5306-01-084-5390	78500	S-268-1	• BOLT, MACHINE	2
2	PAOZZ	5310-01-129-0450	45152	351AX	• WASHER, LOCK .38X.68X30X.09	6
3	PAOZZ	5310-01-062-3379	45152	362AX	• WASHER, FLAT .38X.81X.07	2
4	PAOZZ	2590-01-512-6096	45152	3292745	• HANDRAIL, VEHICULAR	1
5	PAFZZ	5340-01-530-2613	45152	3523596	• PLATE	4
6	PAFZZ	5305-01-352-2049	45152	1754290	• SCREW, CAP, HEXAGON .38-16X2.00	4
					END OF FIGURE	

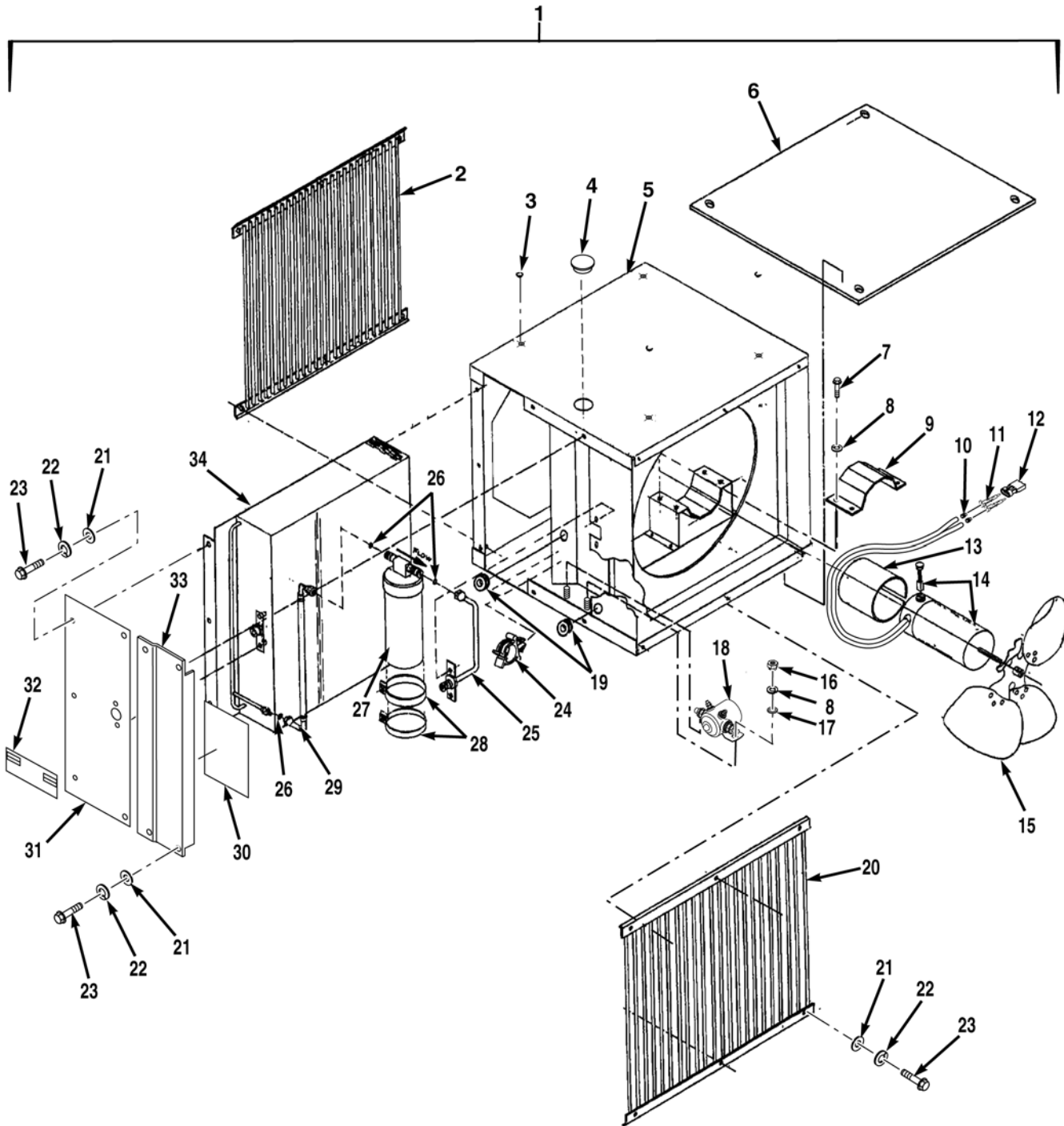

FIG. 3 AC CONDENSER ASSEMBLY

TB 9-2320-279-13-1

(1)	(2)	(3)	(4)	(5)	(6)	(7)
ITEM NO.	SMR CODE	NSN	CAGEC	PART NUMBER	DESCRIPTION AND USABLE ON CODES (UOC)	QTY
					GROUP 5200	
					FIG. 3 AC CONDENSER ASSEMBLY	
1	PAFZZ	4130-01-518-5348	24234	942073	• HEAT INTERCHANGER	1
2	PAFZZ	2510-01-530-1652	24234	511786	•• GRILLE	1
3	PAFZZ	5340-01-530-2691	24234	360161	•• PLUG, HOLE	8
4	PAFZZ	5340-01-530-4126	24234	208250	•• PLUG, HOLE	1
5	XAFZZ		24234	511729	•• CASE	1
6	XAFZZ		24234	354753	•• PAD, MOUNTING	1
7	PAFZZ		24234	201038	•• SCREW, CAP	4
8	PAFZZ	5310-01-105-2652	96195	HLKW025EG	•• WASHER, LOCK	6
9	PAFZZ	5340-01-530-2605	24234	511790	•• STRAP, MOTOR	1
10	PAFZZ	5975-01-333-5974	77060	12015193	•• CABLE, SEAL	2
11	PAFZZ	5940-01-347-5576	77060	12124581L	•• TERMINAL, QUICK DISCONNECT	2
12	PAFZZ	5935-01-214-5259	77060	12015792	•• CONNECTOR, BODY PLUG	1
13	PAFZZ	5330-01-530-6833	24234	354754	•• GASKET, MOTOR	1
14	PAFZZ	6105-01-531-7141	24234	411161	•• MOTOR 24V	1
15	PAFZZ	4140-01-530-5973	24234	265606	•• FAN	1
16	PAFZZ	5310-01-532-0210	24234	203305	•• NUT, LOCK	2
17	PAFZZ	5310-01-101-2490	64484	9700-1	•• WASHER, LOCK	2
18	PAFZZ	5945-01-530-5296	24234	221522	•• SOLENOID 24V.	1
19	PAFZZ	5325-01-398-5091	0H1F5	300011	•• GROMMET	2
20	PAFZZ	2510-01-530-6110	24234	511785	•• GRILLE	1
21	PAFZZ	5310-01-354-5726	24234	202208	•• WASHER, FLAT .25	25
22	PAFZZ	5310-01-105-2652	96195	HLKW025EG	•• WASHER, LOCK	25
23	PAFZZ	5305-01-280-7671	24234	201070	•• SCREW, MACHINE	25
24	PAFZZ	5990-01-530-5157	24234	290372	•• CLIP, CABLE	2
25	PAFZZ	4710-01-530-4110	24234	405518	•• ASSEMBLY TUBE	1
26	PAFZZ	5330-01-306-3266	24234	300448	•• PREFORMED PACKING	3
27	PAFZZ	4130-01-211-0003	24234	402529	•• RECEIVER, LIQUID, REFRIGERANT	1
28	PAFZZ	5340-01-530-6372	24234	290038	•• CLAMP, DRIER	2
29	PAFZZ	4720-01-530-2622	24234	403457	•• ASSEMBLY, HOSE & FITTING	1
30	XDFZZ		24234	342456	•• DECAL, WIRING DIAGRAM	1
31	PAFZZ	5340-01-530-2612	24234	511977	•• PLATE, COIL MOUNTING	1
32	XDFZZ		24234	341621	•• DECAL, KYSOR	1
33	PAFZZ	5340-01-530-3335	24234	511725	•• COVER, ACCESS	1
34	PAFZZ	4130-01-531-1130	24234	401039	•• COIL, CONDENSER	1
					END OF FIGURE	

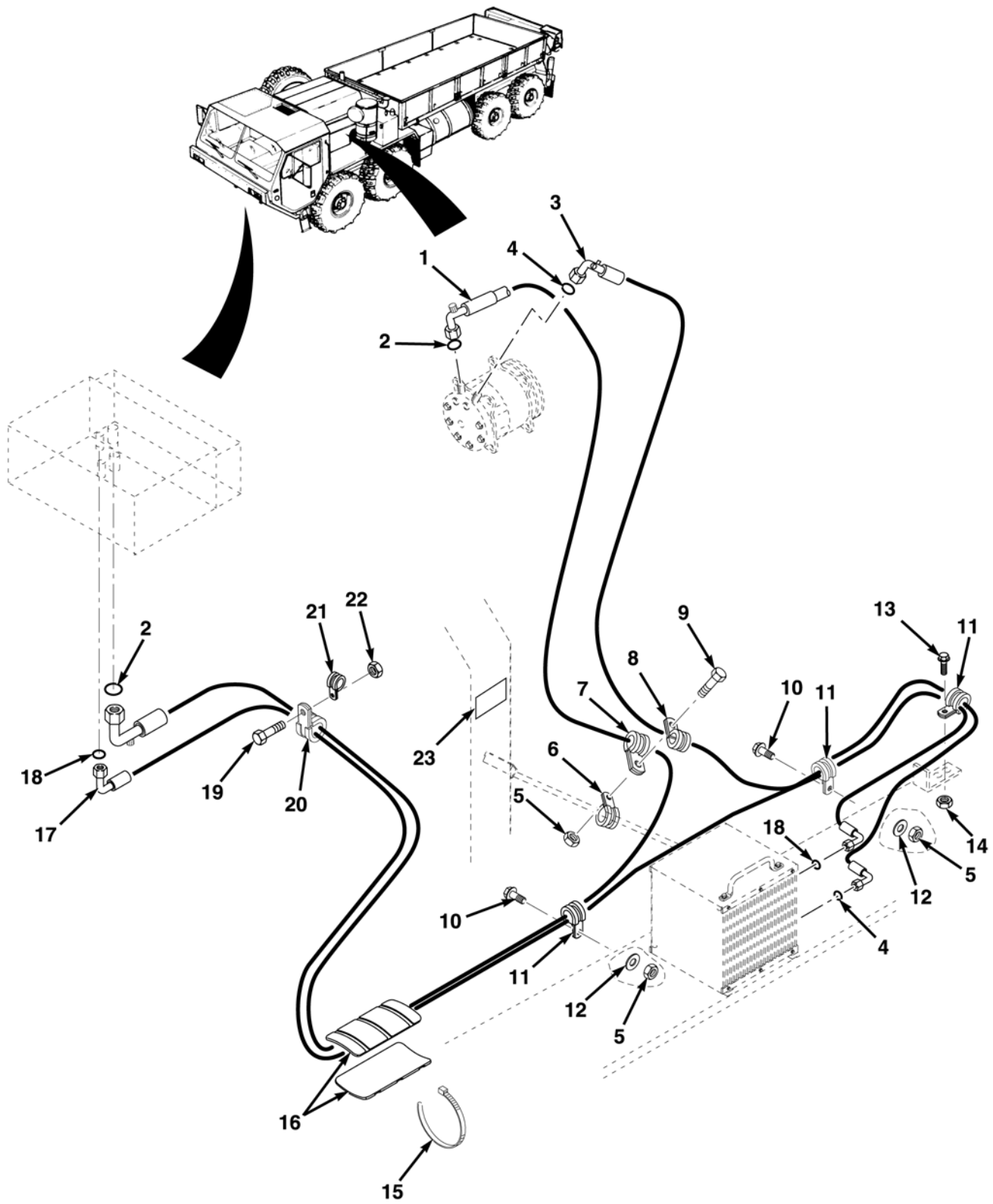

FIG. 4 AC HOSES

TB 9-2320-279-13-1

(1)	(2)	(3)	(4)	(5)	(6)	(7)
ITEM NO.	SMR CODE	NSN	CAGEC	PART NUMBER	DESCRIPTION AND USABLE ON CODES (UOC)	QTY
					GROUP 5200	
					FIG. 4 AC HOSES	
1	PAFFF	4720-01-517-0339	45152	2081300	• HOSE ASSEMBLY, METALLIC	1
2	PAFZZ	5331-01-530-4135	45681	526914	•• PREFORMED PACKING	2
3	PAFFF	4720-01-517-0337	45152	3242406	• HOSE ASSEMBLY, METALLIC	1
4	PAFZZ	5331-01-530-4135	45681	526914	•• PREFORMED PACKING	2
5	PAFZZ	5310-01-177-4625	45152	108708A	• NUT, SELF-LOCKING	3
6	PAFZZ	5340-00-404-4098	75272	COV-1713	• CLAMP, LOOP	1
7	PAFZZ	5340-01-288-6485	45152	2289HX	• CLAMP, LOOP	1
8	PAFZZ	5340-00-404-4101	75272	C0V1313	• CLAMP, LOOP	1
9	PAFZZ	5306-01-084-5390	78500	S-268-1	• BOLT, MACHINE	1
10	PAFZZ	5305-01-058-0611	45152	715HX1	• SCREW, CAP .38 - 16X1.25	2
11	PAFZZ	5340-01-365-9712	18076	S344G12	• CLAMP, LOOP	3
12	PAFZZ	5310-01-062-3379	45152	362AX	• WASHER, FLAT .38X.81X.07	2
13	PAFZZ	5306-01-156-8678	45152	115305A	• BOLT, MACHINE .31-18X1.00	1
14	PAFZZ	5310-01-155-1905	45152	115303A	• NUT, SELF-LOCKING .31-18	1
15	PAFZZ	5975-01-048-2922	96906	MS3367-6-0	• TIE, CABLE	3
16	PAFZZ	4720-01-530-4113	87373	HP-B-15	• SHIELD, HOSE	2
17	PAFFF	4720-01-518-0476	45152	3072189	• HOSE ASSEMBLY, METALLIC	1
18	PAFZZ	5331-01-530-2714	45681	367989	•• O-RING	2
19	PAFZZ	5305-01-337-9120	45152	1754140	• SCREW, CAP	1
20	PAFZZ	5340-01-465-4050	45152	1667780	• CLAMP, LOOP	1
21	PAFZZ	5340-01-038-9481	75272	C0V050971	• CLAMP, LOOP	1
22	PAFZZ	5310-01-346-9445	45152	1600460	• NUT, SELF-LOCKING	1
23	XDFZZ		45152	3343685	• LABEL, A/C INSTALLATION	1
					END OF FIGURE	

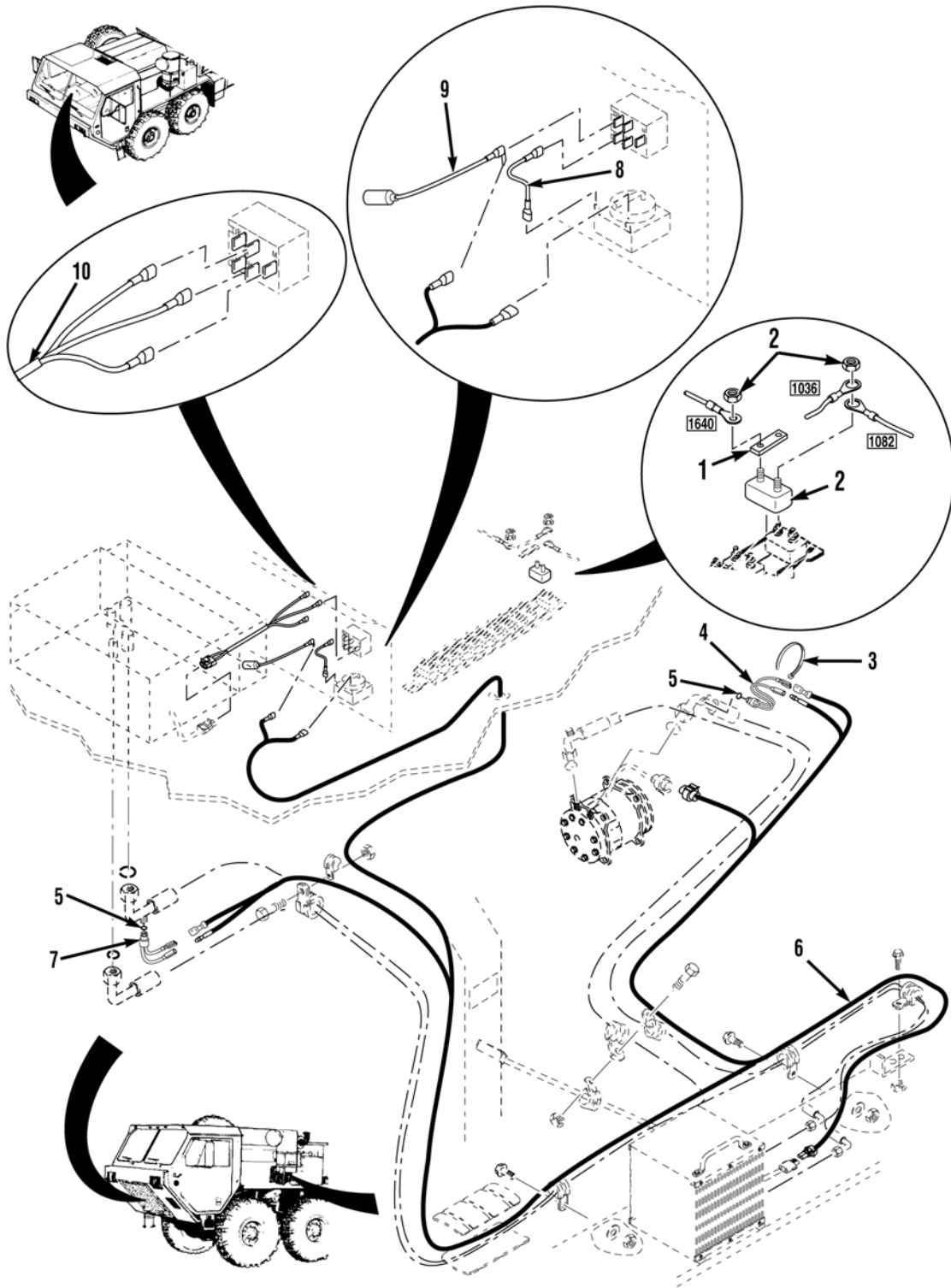

FIG. 5 AC WIRING HARNESS

TB 9-2320-279-13-1

(1)	(2)	(3)	(4)	(5)	(6)	(7)
ITEM NO.	SMR CODE	NSN	CAGEC	PART NUMBER	DESCRIPTION AND USABLE ON CODES (UOC)	QTY
					GROUP 5200	
					FIG. 5 AC WIRING HARNESS	
1	PAOZZ	6150-01-148-1698	45152	124621A	• BUS, CONDUCTOR	1
2	PAOZZ	5925-01-085-5767	45152	EE-102803	• CIRCUIT BREAKER	1
3	PAOZZ	5975-01-053-1331	45152	5201HX	• STRAP, TIEDOWN, ELECTRICAL	10
4	PAOZZ	5930-01-517-5327	24234	404277	• SWITCH, PRESSURE.....	1
5	PAOZZ	5331-01-530-2714	45681	367989	• O-RING	2
6	PAOZZ	6150-01-517-9938	45152	3072190	• WIRING HARNESS, AIR CONDITIONING	1
7	PAOZZ	5930-01-517-5325	24234	404279	• SWITCH, PRESSURE.....	1
8	PAOZZ	6150-01-517-9903	45152	2081610	• LEAD, ELECTRICAL	1
9	PAOZZ	6150-01-518-0479	45152	2214920	• LEAD, ELECTRICAL	1
10	PAOZZ	6150-01-358-1100	24234	222554	• WIRING HARNESS.....	1
					END OF FIGURE	

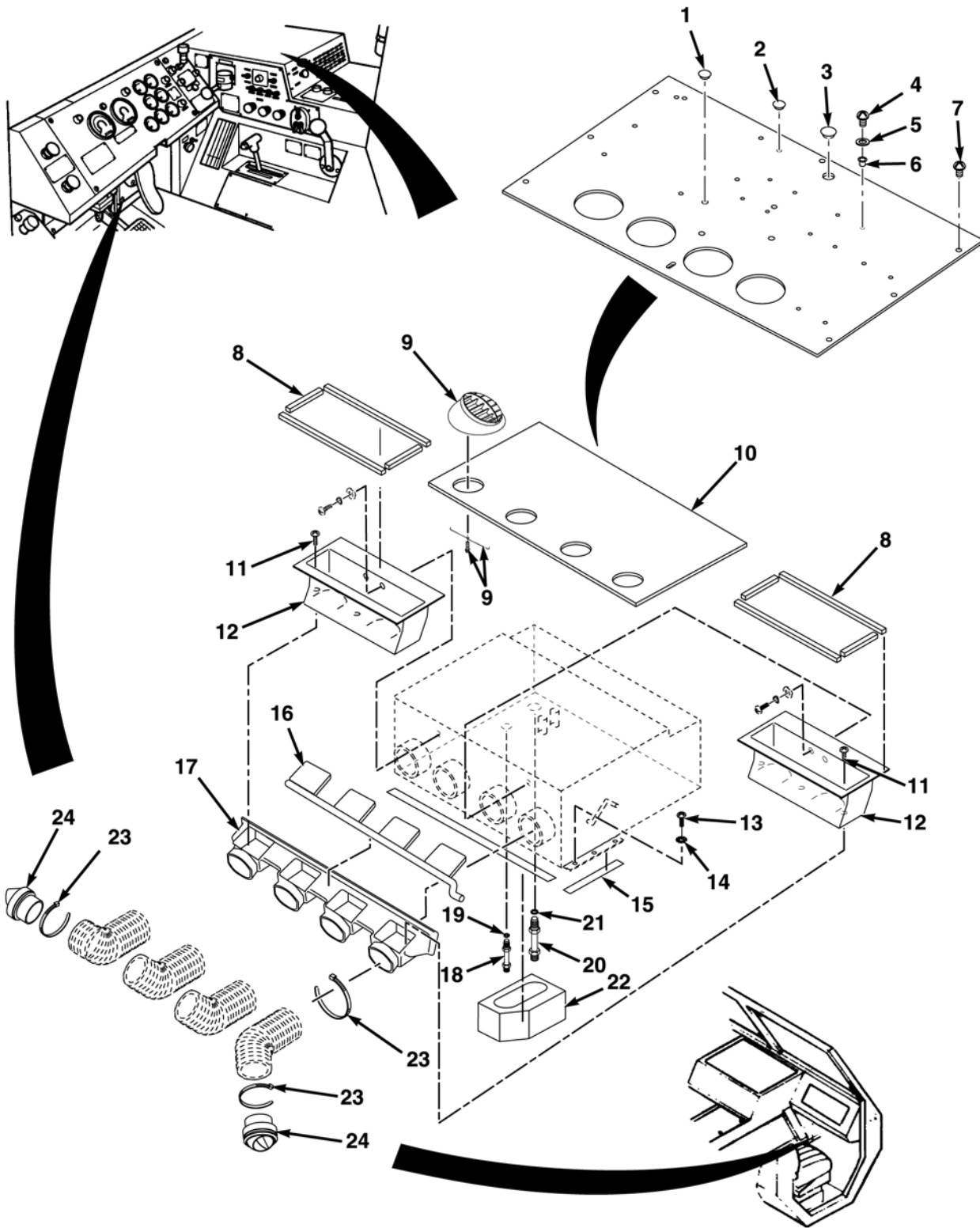

FIG. 6 AC HEATER/EVAPORATOR

TB 9-2320-279-13-1

(1)	(2)	(3)	(4)	(5)	(6)	(7)
ITEM NO.	SMR CODE	NSN	CAGEC	PART NUMBER	DESCRIPTION AND USABLE ON CODES (UOC)	QTY
					GROUP 5200	
					FIG. 6 AC HEATER/EVAPORATOR	
1	PAOZZ	5340-01-081-1718	28520	DP-312	• BUTTON, PLUG	4
2	PAOZZ	5340-01-155-8039	28520	DP-375	• BUTTON, PLUG	4
3	PAOZZ	5340-01-156-0021	76301	ST9M621-750	• BUTTON, PLUG	1
4	PAOZZ	5305-01-530-3347	45152	3431969	• SCREW, PAN.	16
5	PAOZZ	5310-01-361-8388	45152	1379HX	• WASHER, FLAT.	16
6	PAOZZ	5325-01-476-3041	45152	2026040	• INSERT, SCREW THREAD.	16
7	PAOZZ	5305-01-155-6107	45152	1344950	• SCREW	8
8	MOOZZ	5330-01-394-8346	45152	2050690-55	• RUBBER STRIP, MAKE FROM P/N 2050690, 55 in.	1
9	PAOZZ	2540-01-394-6176	24234	170145	• VENTILATOR, AIR CIRCULATING	4
10	PAOZZ	5340-01-394-2419	45152	2049640	• COVER, HEATER	1
11	PAOZZ	6305-01-394-3551	45152	2050700	• SCREW, ASSEMBLED WASHER	6
12	PAOZZ	4140-01-394-8046	45152	2042390	• PLENUM, UPPER	2
13	PAOZZ	5305-01-487-2268	45152	2872HX	• SCREW, TAPPING	6
14	PAOZZ	5310-01-354-3729	45152	2251HX	• WASHER, LOCK	6
15	MOOZZ	9330-01-185-4466	45152	EE100969-53	• TAPE PVC FOAM MAKE FROM P/N EE100969, 53 in.	1
16	PAOZZ	2990-01-394-6177	45152	2042510	• DAMPER	1
17	PAOZZ	4140-01-394-8043	45152	2042380	• PLENUM, UPPER	1
18	PAOZZ	4730-01-517-9040	24234	405983	• ADAPTER, STRAIGHT, PIPE TO TUBE	1
19	PAOZZ	5330-01-306-3266	24234	300448	•• PACKING, PREFORMED	1
20	PAOZZ	4730-01-517-9041	24234	405984	• ADAPTER, STRAIGHT, PIPE TO TUBE	1
21	PAOZZ	5331-01-166-1712	02697	2-015C557-70	•• O-RING	1
22	PAOZZ	2540-01-530-9887	45152	2203020	• INSULATION	1
23	PAOZZ	5975-01-053-1331	45152	5201HX	• STRAP, TIEDOWN	6
24	PAOZZ	2540-01-493-7841	45152	90017562	• AIR DIFFUSER BAL	2
					END OF FIGURE	

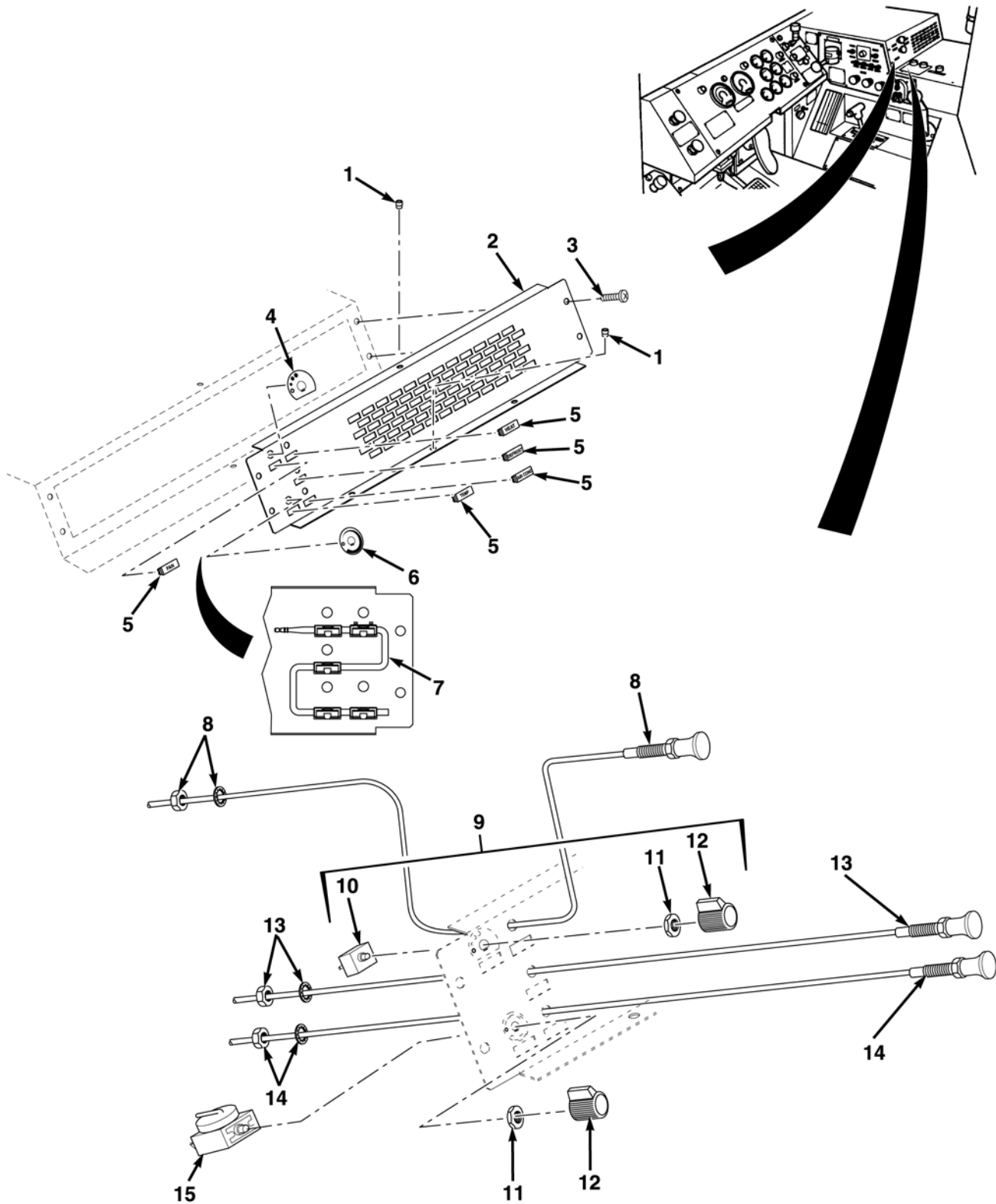

FIG. 7 AC HEATER CENTER COMPARTMENT COVER

TB 9-2320-279-13-1

(1)	(2)	(3)	(4)	(5)	(6)	(7)
ITEM NO.	SMR CODE	NSN	CAGEC	PART NUMBER	DESCRIPTION AND USABLE ON CODES (UOC)	QTY
					GROUP 5200	
					FIG. 7 AC HEATER CENTER COMPARTMENT COVER	
1	PAOZZ	5310-01-257-5065	45152	66223AX	• NUT, CLIP-ON	2
2	PFOZZ	5340-01-530-2629	45152	2097770	• COVER, HEATER CENTER	1
3	PAOZZ	5305-01-155-6107	45152	1344950	• SCREW	4
4	PFOZZ	7690-01-530-2618	3V1N6	3399967	• LABEL, FAN.	1
5	PAOZZ	6695-01-149-9080	45152	47262CX	• BEZEL, APPLIQUE	5
6	PFOZZ	7690-01-530-3355	3V1N6	3398711	• LABEL, A/C TEMP.	1
7	PAOZZ	6015-01-530-5918	28803	102-0087-00	• RIBBON ASSY, OPTIC	1
8	PAOZZ	2590-01-156-8033	72055	24169	• CONTROL ASSY, PUSH-PULL HEAT.	1
9	PAOZZ	5930-01-517-5329	24234	417222	• SWITCH SUBASSEMBLY	1
10	PAOZZ	5930-01-207-6337	24234	220635	•• SWITCH, ROTARY	1
11	PAOZZ	5310-01-162-2515	99688	62028	•• NUT, PLAIN, HEXAGON	2
12	PAOZZ	5355-01-290-1619	24234	380087	•• KNOB	2
13	PAOZZ	2590-01-234-8060	45152	1379260	• CONTROL ASSY, PUSH-PULL DEFROST	1
14	PAOZZ	2590-01-518-1349	45152	2199830	• CONTROL ASSY, PUSH-PULL A/C	1
15	PAOZZ	5930-01-165-1657	99688	65139	• SWITCH, THERMOSTATIC.	1
					END OF FIGURE	

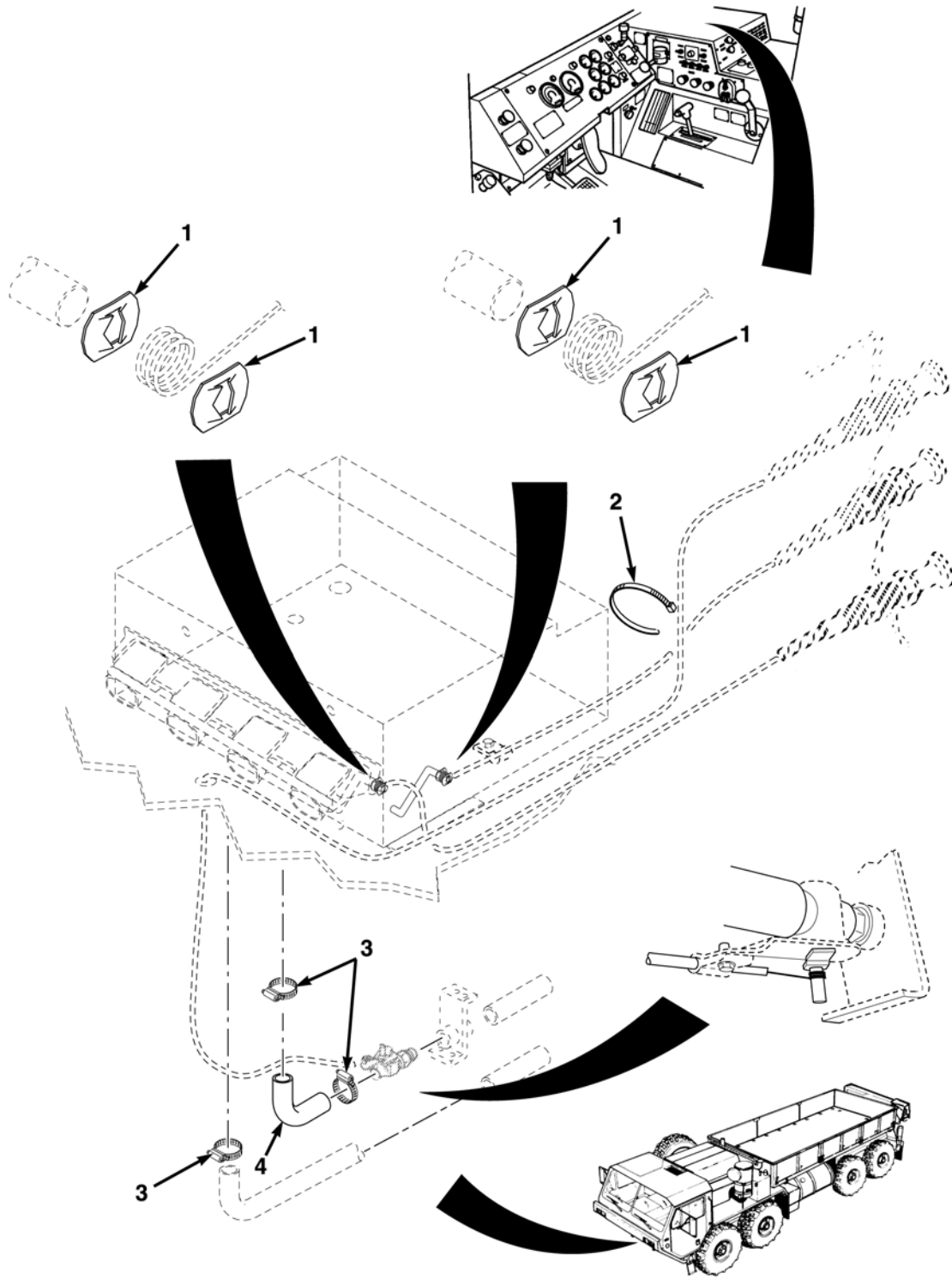

FIG. 8 AC HEATER/EVAPORATOR CABLES

TB 9-2320-279-13-1

(1)	(2)	(3)	(4)	(5)	(6)	(7)
ITEM NO.	SMR CODE	NSN	CAGEC	PART NUMBER	DESCRIPTION AND USABLE ON CODES (UOC)	QTY
					GROUP 5200 FIG. 8 AC HEATER/EVAPORATOR CABLES	
1	PAOZZ	5310-00-110-8742	78553	C12044-017-4	• PUSH IN NUT	4
2	PAOZZ	5975-01-513-6305	45152	5193HX	• STRAP, TIEDOWN	1
3	PAOZZ	4730-01-398-8329	7Z588	CT-9410	• CLAMP, HOSE.....	3
4	PAOZZ	4720-01-151-4027	45152	1333180	• HOSE, PREFORMED	1
					END OF FIGURE	

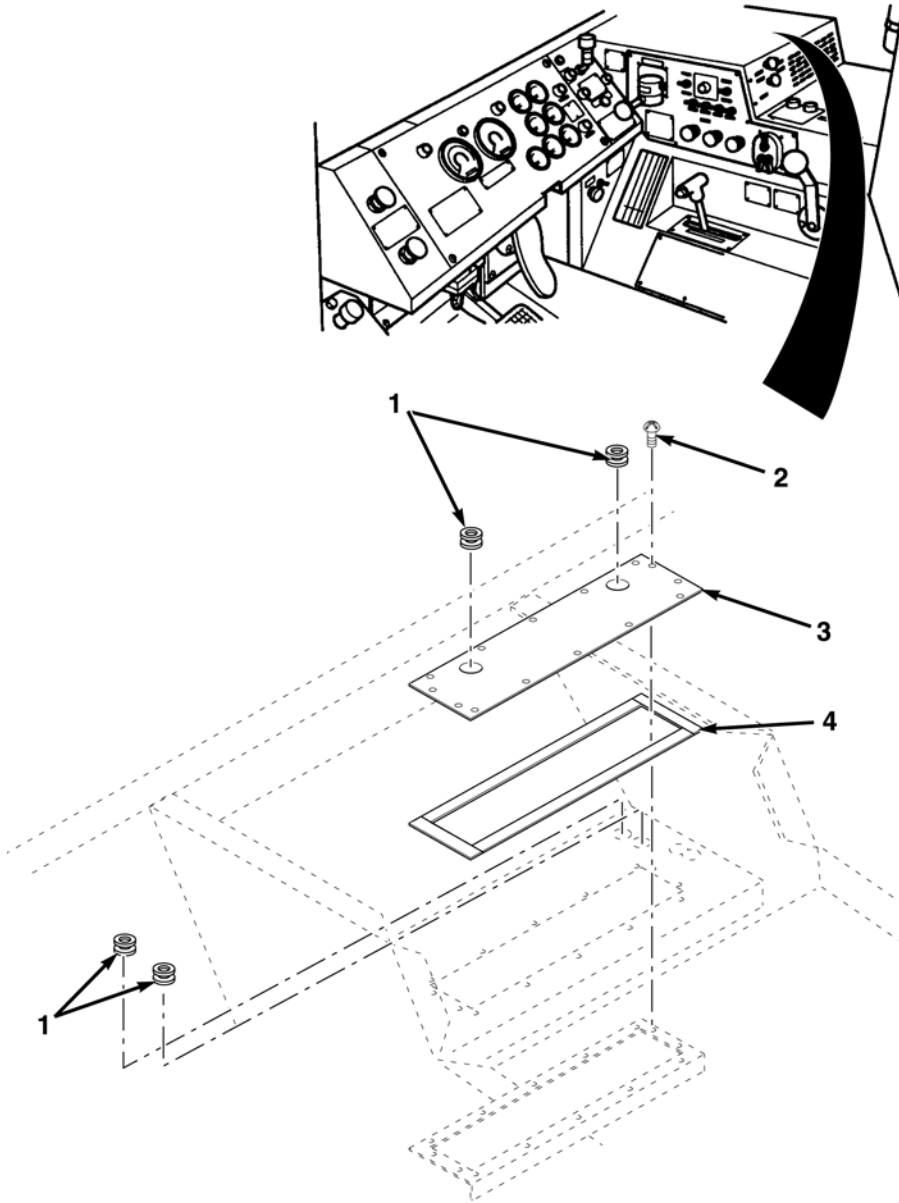

FIG. 9 AC CAB HEATER COMPARTMENT

TB 9-2320-279-13-1

(1)	(2)	(3)	(4)	(5)	(6)	(7)
ITEM NO.	SMR CODE	NSN	CAGEC	PART NUMBER	DESCRIPTION AND USABLE ON CODES (UOC)	QTY
					GROUP 5200	
					FIG. 9 AC CAB HEATER COMPARTMENT	
1	PAOZZ	5325-00-276-5954	96906	MS35489-49	• GROMMET, NONMETALLIC	4
2	PAOZZ	5305-01-353-6120	45152	2763HX	• SCREW, TAPPING	14
3	PFOZZ	5340-01-530-6851	45152	3291224	• COVER, FRESH AIR BOX OPENING. .	1
4	MOOZZ	5330-01-084-5058	24234	107685A-43	• PLASTIC STRIP, MAKE FROM P/N 107685A, 43 in.	1
					END OF FIGURE	

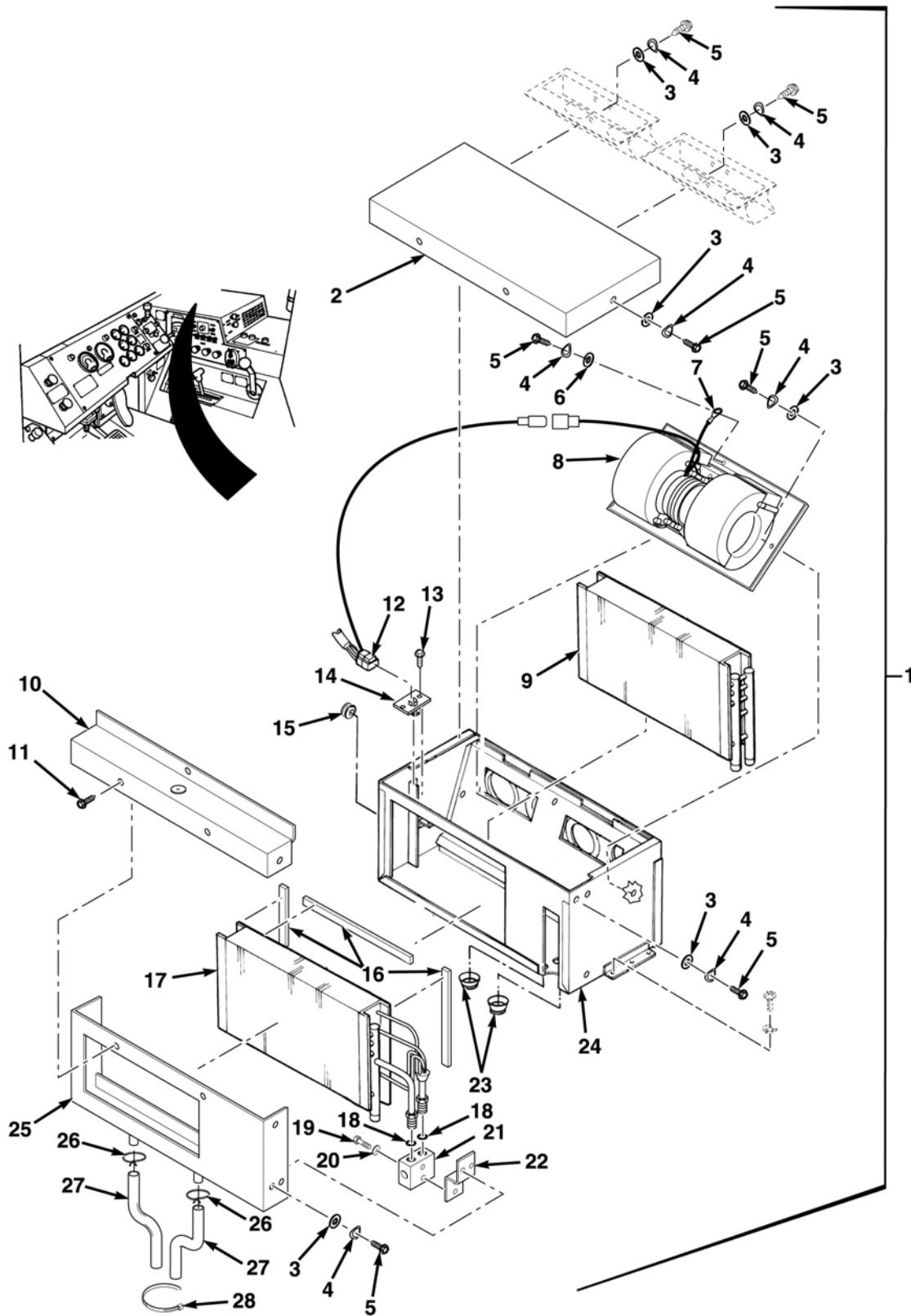

FIG. 10 AC HEATER/EVAPORATOR ASSEMBLY

TB 9-2320-279-13-1

(1)	(2)	(3)	(4)	(5)	(6)	(7)
ITEM NO.	SMR CODE	NSN	CAGEC	PART NUMBER	DESCRIPTION AND USABLE ON CODES (UOC)	QTY
					GROUP 5200	
					FIG. 10 AC HEATER/EVAPORATOR ASSEMBLY	
1	PAFHH	2540-01-530-4560	24234	785027	• HEATER & EVAPORATOR	1
2	PAHZZ	2540-01-155-3796	24234	512401	•• COVER	1
3	PAHZZ	5310-01-354-5726	24234	202208	•• WASHER, FLAT .25.....	15
4	PAHZZ	5355-01-105-2652	96195	HLKW025EG	•• WASHER, LOCK	13
5	PAHZZ	5305-01-280-7671	24234	201070	•• SCREW, MACHINE.....	15
6	PAHZZ	5310-01-101-2490	64484	9700-1	•• WASHER, LOCK	1
7	PAHZZ	5940-01-150-1427	45152	2AL712	•• TERMINAL, QUICK DISC	1
8	PAHZZ	4140-01-531-1545	24234	869736	•• BLOWER	1
9	PAHZZ	2540-01-153-9445	24234	280264	•• COIL, HEATER	1
10	PAHZZ	2540-01-157-4366	24234	512421	•• COVER, EVAPORATOR	1
11	PAHZZ	5305-01-280-7670	24234	200307	•• SCREW, MACHINE.....	4
12	PAHZZ	5995-01-164-6196	24234	221770	•• WIRING HARNESS.....	1
13	PAHZZ	5305-01-280-7670	24234	200307	•• SCREW, MACHINE.....	2
14	PAHZZ	5905-01-154-2354	99688	65158	•• RESISTOR ASSEMBLY	1
15	PAHZZ	5325-01-157-6663	24234	300047	•• GROMMET	1
16	PAHZZ	5330-01-295-3053	24234	350700	•• GASKET	1
17	PAHZZ	2540-01-153-9446	24234	400066	•• COIL, EVAPORATOR	1
18	PAHZZ	5331-01-160-9857	24234	300442	••• O-RING	2
19	PAHZZ	5305-01-530-4145	24234	200910	••• SCREW, MACHINE.....	2
20	PAHZZ	5310-01-530-2719	24234	202103	••• WASHER, LOCK.....	2
21	PAHZZ	2540-01-153-9447	24234	404255	••• BLOCK VALVE	1
22	PAHZZ	2540-01-156-7179	24234	512423	••• BRACKET, VALVE.....	1
23	PAHZZ	5325-01-500-8097	24234	300024	•• GROMMET	2
24	PAHZZ	2540-01-155-4150	24234	512400	•• CASE, HEATER.....	1
25	PAHZZ	2540-01-155-4149	24234	512422	•• CASE, EVAPORATOR.....	1
26	PAOZZ	4730-00-230-2959	96906	MS39326-11	•• CLAMP, HOSE.....	2
27	MOOZZ	4720-01-153-9402	24234	300404	•• TUBING, NONMETALLIC.....	2
28	PAOZZ	5975-01-513-6305	45152	5193HX	•• STRAP, TIEDOWN	1
					END OF FIGURE	

TB 9-2320-279-13-1

(1)	(2)	(3)	(4)	(5)	(6)	(7)
ITEM NO.	SMR CODE	NSN	CAGEC	PART NUMBER	DESCRIPTION AND USABLE ON CODES (UOC)	QTY
					GROUP 95 GENERAL USE STANDARDIZED PARTS	
					GROUP 9501 HARDWARE SUPPLIES AND BULK MATERIAL	
					FIG. BULK BULK MATERIALS	
1	MOOZZ	5330-01-394-8346	45152	2050690	RUBBER STRIP.....	V
2	MOOZZ	9330-01-185-4466	45152	EE100969	PLASTIC STRIP, PRESS.....	V
3	MOOZZ	5330-01-084-5058	45152	107685A	PLASTIC STRIP.....	V
					END OF FIGURE	

Section III. SPECIAL TOOLS LIST

There are no special tools listed for the HEMTT Air Conditioner kit.

Section IV. CROSS-REFERENCE INDEXES

NATIONAL STOCK NUMBER INDEX

STOCK NUMBER	FIG.	ITEM	STOCK NUMBER	FIG.	ITEM
5310-00-110-8742	8	1	6150-01-148-1698	5	1
4730-00-230-2959	10	26	6695-01-149-9080	7	5
5325-00-276-5954	9	1	5940-01-150-1427	10	7
5340-00-404-4098	4	6	5310-01-151-1036	1	4
5340-00-404-4101	4	8	4720-01-151-4027	8	4
5315-00-616-5523	1	21	5305-01-151-7363	1	25
3030-00-844-3305	1	22	4720-01-153-9402	10	27
5340-01-038-9481	4	21	2540-01-153-9445	10	9
5975-01-048-2922	4	15	2540-01-153-9446	10	17
5975-01-053-1331	5	3	2540-01-153-9447	10	21
	6	23	5905-01-154-2354	10	14
5305-01-058-0611	4	10	5310-01-155-1905	4	14
5310-01-062-3379	1	7	5340-01-155-1919	1	23
	2	3	2540-01-155-3796	10	2
	4	12	2540-01-155-4149	10	25
5310-01-081-1283	1	12	2540-01-155-4150	10	24
5340-01-081-1718	6	1	5305-01-155-6107	6	7
5330-01-084-5058	9	4		7	3
	BULK		5340-01-155-8039	6	2
5306-01-084-5390	2	1	5340-01-156-0021	6	3
	4	9	5305-01-156-5445	1	13
5925-01-085-5767	5	2	2540-01-156-7179	10	22
5310-01-101-2490	3	17	2590-01-156-8033	7	8
	10	6	5306-01-156-8678	4	13
5306-01-102-5498	1	10	2540-01-157-4366	10	10
5335-01-105-2652	3	8	5325-01-157-6663	10	15
	3	22	5310-01-159-8178	1	9
	10	4	5331-01-160-9857	10	18
5310-01-129-0450	2	2	5310-01-162-2515	7	11
5310-01-133-2130	1	17	5995-01-164-6196	10	12

TB 9-2320-279-13-1

STOCK NUMBER	FIG.	ITEM	STOCK NUMBER	FIG.	ITEM
5930-01-165-1657	7	15	5310-01-361-8388	6	5
5305-01-165-2452	1	15	5340-01-365-9712	4	11
5331-01-166-1712	6	21	5340-01-394-2419	6	10
5310-01-177-4625	4	5	5305-01-394-3551	6	11
9330-01-185-4466	6	15	2540-01-394-6176	6	9
	BULK		2990-01-394-6177	6	16
5930-01-207-6337	7	10	4140-01-394-8043	6	17
4130-01-211-0003	3	27	4140-01-394-8046	6	12
5935-01-214-5259	3	12	5330-01-394-8346	6	8
2590-01-234-8060	7	13		BULK	
5310-01-236-1710	1	16	5325-01-398-5091	3	19
5305-01-242-0655	1	3	4730-01-398-8329	8	3
5310-01-257-5065	7	1	5310-01-457-8573	1	24
5305-01-280-7670	10	11	5340-01-465-4050	4	20
	10	13	5325-01-476-3041	6	6
5305-01-280-7671	3	23	5340-01-479-9054	1	26
	10	5	6115-01-482-8799	1	19
5340-01-288-6485	4	7	5305-01-487-2268	6	13
5355-01-290-1619	7	12	2540-01-493-7841	6	24
5330-01-295-3053	10	16	5325-01-500-8097	10	23
5330-01-306-3266	3	26	2590-01-512-6096	2	4
	6	19	5975-01-513-6305	1	29
5975-01-333-5974	3	10		8	2
5305-01-337-9120	4	19		10	28
3020-01-337-9342	1	20	5305-01-516-8362	1	11
5310-01-342-8595	1	18	4720-01-517-0337	4	3
5305-01-344-8899	1	27	4720-01-517-0339	4	1
5310-01-346-9445	1	28	5930-01-517-5325	5	7
	4	22	5930-01-517-5327	5	4
5940-01-347-5576	3	11	5930-01-517-5329	7	9
5305-01-352-2049	2	6	2520-01-517-8979	1	2
5305-01-353-6120	9	2	4730-01-517-9040	6	18
5310-01-354-3729	6	14	4730-01-517-9041	6	20
5310-01-354-5726	3	21	6150-01-517-9903	5	8
	10	3	6150-01-517-9938	5	6
6150-01-358-1100	5	10	4720-01-518-0476	4	17

TB 9-2320-279-13-1

STOCK NUMBER	FIG.	ITEM	STOCK NUMBER	FIG.	ITEM
6150-01-518-0479	5	9	2540-01-530-9887	6	22
2590-01-518-1349	7	14	4130-01-531-1130	3	34
4130-01-518-5348	3	1	4140-01-531-1545	10	8
3030-01-518-9765	1	1	6105-01-531-7141	3	14
2510-01-530-1652	3	2	5310-01-532-0210	3	16
5340-01-530-2603	1	6			
5340-01-530-2605	3	9			
5340-01-530-2612	3	31			
5340-01-530-2613	2	5			
7690-01-530-2618	7	4			
4720-01-530-2622	3	29			
5340-01-530-2629	7	2			
5340-01-530-2691	3	3			
5331-01-530-2714	4	18			
	5	5			
5310-01-530-2719	10	20			
5340-01-530-3335	3	33			
5305-01-530-3347	6	4			
7690-01-530-3355	7	6			
5340-01-530-4098	1	8			
4710-01-530-4110	3	25			
4720-01-530-4113	4	16			
5340-01-530-4119	1	5			
5340-01-530-4126	3	4			
5331-01-530-4135	4	2			
	4	4			
5305-01-530-4145	10	19			
2540-01-530-4560	10	1			
5990-01-530-5157	3	24			
5945-01-530-5296	3	18			
6015-01-530-5918	7	7			
4140-01-530-5973	3	15			
2510-01-530-6110	3	20			
5340-01-530-6372	3	28			
5330-01-530-6833	3	13			
5340-01-530-6842	1	14			
5340-01-530-6851	9	3			

TB 9-2320-279-13-1

PART NUMBER INDEX

CAGEC	PART NUMBER	STOCK NUMBER	FIG.	ITEM
28803	102-0087-00	6015-01-530-5918	7	7
45152	107685A	5330-01-084-5058	BULK	
45152	107685A-43	5330-01-084-5058	9	4
45152	108708A	5310-01-177-4625	4	5
45152	110310A	5310-01-159-8178	1	9
45152	115303A	5310-01-155-1905	4	14
45152	115305A	5306-01-156-8678	4	13
45152	115307A	5310-01-151-1036	1	4
45152	119097-B	5306-01-102-5498	1	10
77060	12015193	5975-01-333-5974	3	10
77060	12015792	5935-01-214-5259	3	12
45152	120699A	5305-01-242-0655	1	3
77060	12124581L	5940-01-347-5576	3	11
45152	124129A	5305-01-156-5445	1	13
45152	124621A	6150-01-148-1698	5	1
45152	1333180	4720-01-151-4027	8	4
45152	1338010	5340-01-155-1919	1	23
45152	1344950	5305-01-155-6107	6	7
45152	1344950	5305-01-155-6107	7	3
45152	1379260	2590-01-234-8060	7	13
45152	1379HX	5310-01-361-8388	6	5
45152	1598030	5310-01-342-8595	1	18
45152	1600460	5310-01-346-9445	1	28
45152	1600460	5310-01-346-9445	4	22
45152	1606140	5305-01-344-8899	1	27
45152	1667780	5340-01-465-4050	4	20
45152	1698110	3020-01-337-9342	1	20
24234	170145	2540-01-394-6176	6	9
45152	1754140	5305-01-337-9120	4	19
45152	1754290	5305-01-352-2049	2	6
45152	1867HX1	5305-01-165-2452	1	15
45152	1935280W	5340-01-530-4098	1	8
45152	1935350	5340-01-530-2603	1	6
45152	1935360	5340-01-530-4119	1	5
45152	1935480W	5340-01-530-6842	1	14

TB 9-2320-279-13-1

CAGEC	PART NUMBER	STOCK NUMBER	FIG.	ITEM
24234	200307	5305-01-280-7670	10	11
24234	200307	5305-01-280-7670	10	13
24234	200910	5305-01-530-4145	10	19
24234	201038		3	7
24234	201070	5305-01-280-7671	3	23
24234	201070	5305-01-280-7671	10	5
02697	2-015C557-70	5331-01-166-1712	6	21
45152	2016HX1	5305-01-516-8362	1	11
24234	202103	5310-01-530-2719	10	20
24234	202208	5310-01-354-5726	3	21
24234	202208	5310-01-354-5726	10	3
45152	2026040	5325-01-476-3041	6	6
24234	203305	5310-01-532-0210	3	16
45152	2042380	4140-01-394-8043	6	17
45152	2042390	4140-01-394-8046	6	12
45152	2042510	2990-01-394-6177	6	16
45152	2049640	5340-01-394-2419	6	10
45152	2050690	5330-01-394-8346	BULK	
45152	2050690-55	5330-01-394-8346	6	8
45152	2050700	5305-01-394-3551	6	11
45152	2081300	4720-01-517-0339	4	1
45152	2081570	2520-01-517-8979	1	2
45152	2081610	6150-01-517-9903	5	8
24234	208250	5340-01-530-4126	3	4
45152	2097770	5340-01-530-2629	7	2
45152	2199830	2590-01-518-1349	7	14
45152	2203020	2540-01-530-9887	6	22
24234	220635	5930-01-207-6337	7	10
45152	2214920	6150-01-518-0479	5	9
24234	221522	5945-01-530-5296	3	18
24234	221770	5995-01-164-6196	10	12
24234	222554	6150-01-358-1100	5	10
45152	2251HX	5310-01-354-3729	6	14
45152	2289HX	5340-01-288-6485	4	7
45152	2290HX	5340-01-479-9054	1	26
72055	24169	2590-01-156-8033	7	8
24234	265606	4140-01-530-5973	3	15

TB 9-2320-279-13-1

CAGEC	PART NUMBER	STOCK NUMBER	FIG.	ITEM
45152	2763HX	5305-01-353-6120	9	2
24234	280264	2540-01-153-9445	10	9
45152	2872HX	5305-01-487-2268	6	13
24234	290038	5340-01-530-6372	3	28
24234	290372	5990-01-530-5157	3	24
45152	2AL712	5940-01-150-1427	10	7
45152	2SK308	3030-01-518-9765	1	1
0H1F5	300011	5325-01-398-5091	3	19
24234	300024	5325-01-500-8097	10	23
24234	300047	5325-01-157-6663	10	15
24234	300404	4720-01-153-9402	10	27
24234	300442	5331-01-160-9857	10	18
24234	300448	5330-01-306-3266	3	26
24234	300448	5330-01-306-3266	6	19
45152	3072189	4720-01-518-0476	4	17
45152	3072190	6150-01-517-9938	5	6
45152	3242406	4720-01-517-0337	4	3
45152	3291224	5340-01-530-6851	9	3
45152	3292745	2590-01-512-6096	2	4
45152	3343685		4	23
3V1N6	3398711	7690-01-530-3355	7	6
3V1N6	3399967	7690-01-530-2618	7	4
24234	341621		3	32
24234	342456		3	30
45152	3431969	5305-01-530-3347	6	4
24234	350700	5330-01-295-3053	10	16
45152	351AX	5310-01-129-0450	2	2
45152	3523596	5340-01-530-2613	2	5
45152	352AX	5310-01-081-1283	1	12
24234	354753		3	6
24234	354754	5330-01-530-6833	3	13
45152	355AX	5310-01-133-2130	1	17
24234	360161	5340-01-530-2691	3	3
45152	362AX	5310-01-062-3379	1	7
45152	362AX	5310-01-062-3379	2	3
45152	362AX	5310-01-062-3379	4	12
45681	367989	5331-01-530-2714	4	18

TB 9-2320-279-13-1

CAGEC	PART NUMBER	STOCK NUMBER	FIG.	ITEM
45681	367989	5331-01-530-2714	5	5
24234	380087	5355-01-290-1619	7	12
24234	400066	2540-01-153-9446	10	17
24234	401039	4130-01-531-1130	3	34
24234	402529	4130-01-211-0003	3	27
24234	403457	4720-01-530-2622	3	29
24234	404255	2540-01-153-9447	10	21
24234	404277	5930-01-517-5327	5	4
24234	404279	5930-01-517-5325	5	7
24234	405518	4710-01-530-4110	3	25
24234	405983	4730-01-517-9040	6	18
24234	405984	4730-01-517-9041	6	20
24234	411161	6105-01-531-7141	3	14
24234	417222	5930-01-517-5329	7	9
45152	47262CX	6695-01-149-9080	7	5
24234	511725	5340-01-530-3335	3	33
24234	511729		3	5
24234	511785	2510-01-530-6110	3	20
24234	511786	2510-01-530-1652	3	2
24234	511790	5340-01-530-2605	3	9
24234	511977	5340-01-530-2612	3	31
24234	512400	2540-01-155-4150	10	24
24234	512401	2540-01-155-3796	10	2
24234	512421	2540-01-157-4366	10	10
24234	512422	2540-01-155-4149	10	25
24234	512423	2540-01-156-7179	10	22
45152	5193HX	5975-01-513-6305	1	29
45152	5193HX	5975-01-513-6305	8	2
45152	5193HX	5975-01-513-6305	10	28
45152	5201HX	5975-01-053-1331	5	3
45152	5201HX	5975-01-053-1331	6	23
45681	526914	5331-01-530-4135	4	2
45681	526914	5331-01-530-4135	4	4
99688	62028	5310-01-162-2515	7	11
99688	65139	5930-01-165-1657	7	15
99688	65158	5905-01-154-2354	10	14
45152	66223AX	5310-01-257-5065	7	1

TB 9-2320-279-13-1

CAGEC	PART NUMBER	STOCK NUMBER	FIG.	ITEM
45152	715HX1	5305-01-058-0611	4	10
45152	720HX	5310-01-457-8573	1	24
45152	720HX2	5310-01-236-1710	1	16
45152	740HX1	5305-01-151-7363	1	25
24234	785027	2540-01-530-4560	10	1
24234	869736	4140-01-531-1545	10	8
45152	90017562	2540-01-493-7841	6	24
24234	942073	4130-01-518-5348	3	1
64484	9700-1	5310-01-101-2490	3	17
64484	9700-1	5310-01-101-2490	10	6
24975	A001 4827 JB	6115-01-482-8799	1	19
81348	A-A-52155-146AIR	3030-00-844-3305	1	22
75272	C0V050971	5340-01-038-9481	4	21
75272	C0V1313	5340-00-404-4101	4	8
78553	C12044-017-4	5310-00-110-8742	8	1
75272	COV-1713	5340-00-404-4098	4	6
7Z588	CT-9410	4730-01-398-8329	8	3
28520	DP-312	5340-01-081-1718	6	1
28520	DP-375	5340-01-155-8039	6	2
45152	EE100969	9330-01-185-4466	BULK	
45152	EE100969-53	9330-01-185-4466	6	15
45152	EE-102803	5925-01-085-5767	5	2
96195	HCLKW025EG	5335-01-105-2652	3	8
96195	HCLKW025EG	5335-01-105-2652	3	22
96195	HCLKW025EG	5335-01-105-2652	10	4
87373	HP-B-15	4720-01-530-4113	4	16
96906	MS3367-6-0	5975-01-048-2922	4	15
96906	MS35489-49	5325-00-276-5954	9	1
80205	MS35756-11	5315-00-616-5523	1	21
96906	MS39326-11	4730-00-230-2959	10	26
78500	S-268-1	5306-01-084-5390	2	1
78500	S-268-1	5306-01-084-5390	4	9
18076	S344G12	5340-01-365-9712	4	11
76301	ST9M621-750	5340-01-156-0021	6	3

END OF WORK PACKAGE

APPENDIX H

ADDITIONAL AUTHORIZATION LIST (AAL)

ADDITIONAL AUTHORIZATION LIST (AAL)

APPENDIX H**Section I. INTRODUCTION****SCOPE**

This appendix lists additional items that are authorized for the support of the AC system.

GENERAL

This list identifies items that do not have to accompany the M977 series and that do not have to be turned in with it. These items are all authorized for use by CTA, MTOE, TDA, or JTA.

EXPLANATION OF LISTING

National Stock Numbers, descriptions, and quantities are provided to help to identify and request the additional items required to support this equipment. The items are listed in alphabetical sequence by item name under the type document (CTA, MTOE, TDA, or JTA) which authorizes the item(s) to you. If item required differs for different models of this equipment, the model is shown under the "Usable On Code" heading in this column. If no code is entered in this column, item is used on all models. These codes are as identified.

Code	Used On
H01/H51/H71	M977 With Winch
H02/H55/H75	M978 With Winch
H03/H59/H79	M983 Without Crane
H05/H53/H73	M985 With Winch
H06/H50/H70	M977 Without Winch
H07/H54/H74	M978 Without Winch
H09/H52/H72	M985 Without Winch
H04	M984
H40/H60/H80	M984A1
H41/H61/H81	M985E1 With Winch
LHS/H58/H78	M1120
CBW/H57/H77	M1977 With Winch
CBT/H56/H76	M1977 Without Winch

ADDITIONAL AUTHORIZATION LIST (AAL) - Continued

Section II. ADDITIONAL AUTHORIZATION LIST (AAL)

(1) Item Number	(2) National Stock Number	(3) Description CAGE & Part Number Usable On Code	(4) U/M	(5) Qty Auth
1	1290-01-077-2418	Leak Detector, Refrigerant (45225) TIFXL-1A	ea	1
2	4250-01-396-8928	Reclaimer, Refrigerant (55719) EEAC318A	ea	1

END OF WORK PACKAGE

ALPHABETICAL INDEX

<u>Subject</u>	<u>WP No.</u>
A	
AC 20 AMP Circuit Breaker Replacement	WP 0017
AC Alternator/Compressor Mounting Bracket Replacement	WP 0018
AC Alternator Drive Belts Replacement/Adjustment	WP 0019
AC Alternator and Pulley Replacement	WP 0020
AC Cable Replacement	WP 0021
AC Compressor Does Not Shut Off Or Cycles Constantly	WP 0014
AC Compressor Drive Belts Replacement/Adjustment	WP 0022
AC Compressor Excessively Noisy	WP 0013
AC Compressor Replacement	WP 0023
AC Condenser Core Replacement	WP 0024
AC Condenser Dryer Replacement	WP 0025
AC Condenser Fan Motor Replacement	WP 0026
AC Condenser Fan Motor Solenoid Replacement	WP 0027
AC Condenser Replacement	WP 0028
AC Defrost Cable Replacement	WP 0029
AC Does Not Cool Or Cools Inadequately	WP 0015
AC Evaporator Core And Expansion Valve Replacement	WP 0030
AC Fan Control Switch Replacement	WP 0031
AC Heater Cable Replacement	WP 0032
AC Heater Core Replacement	WP 0033
AC Heater/Evaporator Blower Does Not Operate	WP 0006
AC Heater/Evaporator Blower Does Not Operate	WP 0010
AC Heater/Evaporator Blower Does Not Operate In All Speeds (Low, Medium, and High) . . .	WP 0011
AC Heater/Evaporator Blower Motor Assembly Replacement	WP 0034
AC Heater/Evaporator Blower Motor Resistor Replacement	WP 0035
AC Heater/Evaporator Blower Motor Resistor Harness Replacement	WP 0036
AC Heater/Evaporator Blower Operates But No Cold Air From Ducts During AC Operations .	WP 0007
AC Heater/Evaporator Blower Operates But No Cold Air From Ducts During AC Operations .	WP 0012

ALPHABETICAL INDEX - Continued

<u>Subject</u>	<u>WP No.</u>
A - CONTINUED	
AC Heater/Evaporator Cover And Defrost Louvers Replacement	WP 0037
AC Heater/Evaporator Replacement	WP 0038
AC High Pressure Switch Replacement	WP 0039
AC Hoses Replacement	WP 0040
AC Low Pressure Switch Replacement	WP 0041
AC Lower Plenum and Damper Replacement	WP 0042
AC Optic Ribbon Replacement	WP 0043
AC Temperature Control Switch Replacement	WP 0044
AC Upper Plenum Replacement	WP 0045
AC Wiring Harness Replacement	WP 0046
AC Wire 1082 Harness Replacement	WP 0047
AC Wire 1156 Harness Replacement	WP 0048
AC System Refrigerant (R-134a) Maintenance	WP 0050
Additional Authorization List (AAL)	WP 0058
Air Conditioning Leak Test	WP 0049
C	
Common Tools And Special Tools List	WP 0056
E	
Expendable and Durable Supplies And Materials List	WP 0055
F	
Field Level Maintenance Introduction	WP 0016
Field Level Preventive Maintenance Checks and Services (PMCS)	WP 0008
Field Level Troubleshooting Introduction	WP 0009
G	
General Information	WP 0001

ALPHABETICAL INDEX - Continued

<u>Subject</u>	<u>WP No.</u>
I	
Illustrated Parts List (RPSTL)	WP 0057
Initial Installation Instructions of AC Kit	WP 0052
Installation Drawings And Schematics.	WP 0051
M	
Maintenance Allocation Chart (MAC)	WP 0054
O	
Operator's Controls and Indicators	WP 0002
Operator's Preventive Maintenance Checks and Services (PMCS)	WP 0003
Operator's Troubleshooting Introduction	WP 0005
R	
References	WP 0053
S	
System Operation	WP 0004

By Order of the Secretary of the Army:

Official:

SANDRA R. RILEY
*Administrative Assistant to the
Secretary of the Army*
0525101

PETER J. SCHOOMAKER
*General, United States Army
Chief of Staff*

DISTRIBUTION: To be distributed in accordance with the initial distribution requirements for IDN: 344831, requirements for TB 9-2320-279-13-1.

RECOMMENDED CHANGES TO PUBLICATIONS AND BLANK FORMS For use of this form, see AR 25-30; the proponent agency is OAASA	Use Part II (<i>reverse</i>) for Repair Parts and Special Tool Lists (RPSTL) and Supply Catalogs/Supply Manuals (SC/SM).	DATE
---	--	------

TO: (<i>Forward to proponent of publication or form</i>) (<i>Include ZIP Code</i>)	FROM: (<i>Activity and location</i>) (<i>Include ZIP Code</i>)
---	---

PART I - ALL PUBLICATIONS (EXCEPT RPSTL AND SC/SM) AND BLANK FORMS

PUBLICATION/FORM NUMBER	DATE	TITLE
-------------------------	------	-------

ITEM	PAGE	PARA- GRAPH	LINE	FIGURE NO.	TABLE	RECOMMENDED CHANGES AND REASON
------	------	----------------	------	---------------	-------	--------------------------------

--	--	--	--	--	--	--

** Reference to line numbers within the paragraph or subparagraph.*

TYPED NAME, GRADE OR TITLE	TELEPHONE EXCHANGE/AUTOVON, PLUS EXTENSION	SIGNATURE
----------------------------	---	-----------

TO: <i>(Forward direct to addressee listed in publication)</i>	FROM: <i>(Activity and location) (Include ZIP Code)</i>	DATE
---	--	-------------

PART II - REPAIR PARTS AND SPECIAL TOOL LISTS AND SUPPLY CATALOGS/SUPPLY MANUALS

PUBLICATION NUMBER			DATE		TITLE			
PAGE NO.	COLM NO.	LINE NO.	NATIONAL STOCK NUMBER	REFERENCE NO.	FIGURE NO.	ITEM NO.	TOTAL NO. OF MAJOR ITEMS SUPPORTED	RECOMMENDED ACTION

PART III - REMARKS *(Any general remarks or recommendations, or suggestions for improvement of publications and blank forms. Additional blank sheets may be used if more space is needed.)*

TYPED NAME, GRADE OR TITLE	TELEPHONE EXCHANGE/AUTOVON, PLUS EXTENSION	SIGNATURE
----------------------------	--	-----------

RECOMMENDED CHANGES TO PUBLICATIONS AND BLANK FORMS						Use Part II (<i>reverse</i>) for Repair Parts and Special Tool Lists (RPSTL) and Supply Catalogs/Supply Manuals (SC/SM).	DATE
For use of this form, see AR 25-30; the proponent agency is OAASA							
TO: (<i>Forward to proponent of publication or form</i>) (<i>Include ZIP Code</i>)				FROM: (<i>Activity and location</i>) (<i>Include ZIP Code</i>)			
PART I - ALL PUBLICATIONS (EXCEPT RPSTL AND SC/SM) AND BLANK FORMS							
PUBLICATION/FORM NUMBER					DATE		TITLE
ITEM	PAGE	PARA- GRAPH	LINE	FIGURE NO.	TABLE	RECOMMENDED CHANGES AND REASON	
* Reference to line numbers within the paragraph or subparagraph.							
TYPED NAME, GRADE OR TITLE					TELEPHONE EXCHANGE/AUTOVON, PLUS EXTENSION		SIGNATURE

TO: <i>(Forward direct to addressee listed in publication)</i>	FROM: <i>(Activity and location) (Include ZIP Code)</i>	DATE
---	--	-------------

PART II - REPAIR PARTS AND SPECIAL TOOL LISTS AND SUPPLY CATALOGS/SUPPLY MANUALS

PUBLICATION NUMBER			DATE		TITLE			
PAGE NO.	COLM NO.	LINE NO.	NATIONAL STOCK NUMBER	REFERENCE NO.	FIGURE NO.	ITEM NO.	TOTAL NO. OF MAJOR ITEMS SUPPORTED	RECOMMENDED ACTION

PART III - REMARKS *(Any general remarks or recommendations, or suggestions for improvement of publications and blank forms. Additional blank sheets may be used if more space is needed.)*

TYPED NAME, GRADE OR TITLE	TELEPHONE EXCHANGE/AUTOVON, PLUS EXTENSION	SIGNATURE
----------------------------	--	-----------

RECOMMENDED CHANGES TO PUBLICATIONS AND BLANK FORMS <small>For use of this form see DA Form 28, the proposed change to DA Form 28</small>						Use Part II (overhead) for Repair Parts and Special Tool Lists (RPSTL) and Supply Catalogs/Supply Manuals (SC/SM)	DATE
TO: <i>(Forward to proponent of publication or form) (include ZIP Code)</i>						FROM: <i>(Activity and location) (include ZIP Code)</i>	
PART I - ALL PUBLICATIONS (EXCEPT RPSTL AND SC/SM) AND BLANK FORMS							
PUBLICATION/FORM NUMBER:						DATE	TITLE
ITEM	PAGE	PARA-GRAPH	LINE	FIGURE NO.	TABLE	RECOMMENDED CHANGES AND REASON	
<small>* Refer to line numbers within the paragraph or subparagraph.</small>							
TYPED NAME, GRADE OR TITLE						TELEPHONE EXCHANGE/AUTOVON PLUS EXTENSION	SIGNATURE

TO: <i>(Forward direct to addressee listed in publication)</i>			FROM: <i>(Locality and location include ZIP Code)</i>				DATE	
PART B - REPAIR PARTS AND SPECIAL TOOL LISTS AND SUPPLY CATALOGS/SUPPLY MANUALS								
PUBLICATION NUMBER				DATE			TITLE	
PAGE NO.	COLM NO.	LINE NO.	NATIONAL STOCK NUMBER	REFERENCE NO.	FIGURE NO.	ITEM NO.	TOTAL NO. OF MAJOR ITEMS SUPPORTED	RECOMMENDED ACTION
PART III - REMARKS <i>(Any general remarks or recommendations, or suggestions for improvement of publications and blank forms. Additional blank sheets may be used if more space is needed.)</i>								
TYPED NAME, GRADE OR TITLE			TELEPHONE EXCHANGE/AUTOVON. PLUS EXTENSION			SIGNATURE		

THE METRIC SYSTEM AND EQUIVALENTS

LINEAR MEASURE

1 Centimeter=10 Millimeters=0.01 Meters=0.3937 Inches
 1 Meter=100 Centimeters=1000 Millimeters=39.37 Inches
 1 Kilometer=1000 Meters=0.621 Miles

SQUARE MEASURE

1 Sq Centimeter=100 Sq Millimeters=0.155 Sq Inches
 1 Sq Meter=10,000 Sq Centimeters=10.76 Sq Feet
 1 Sq Kilometer=1,000,000 Sq Meters=0.386 Sq Miles

WEIGHTS

1 Gram=0.001 Kilograms=1000 Milligrams=0.035 Ounces
 1 Kilogram=1000 Grams=2.2 Lb
 1 Metric Ton=1000 Kilograms=1 Megagram=1.1 Short Tons

CUBIC MEASURE

1 Cu Centimeter=1000 Cu Millimeters=0.06 Cu Inches
 1 Cu Meter=1,000,000 Cu Centimeters=35.31 Cu Feet

LIQUID MEASURE

1 Milliliter=0.001 Liters=0.0338 Fluid Ounces
 1 Liter=1000 Milliliters=33.82 Fluid Ounces

TEMPERATURE

$5/9 (^{\circ}\text{F} - 32) = ^{\circ}\text{C}$
 212° Fahrenheit is equivalent to 100° Celsius
 90° Fahrenheit is equivalent to 32.2° Celsius
 32° Fahrenheit is equivalent to 0° Celsius
 $9/5 \text{ C}^{\circ} + 32 = \text{F}^{\circ}$

APPROXIMATE CONVERSION FACTORS

<u>TO CHANGE</u>	<u>TO</u>	<u>MULTIPLY BY</u>
Inches.....	Centimeters.....	2.540
Feet	Meters	0.305
Yards	Meters	0.914
Miles.....	Kilometers.....	1.609
Square Inches.....	Square Centimeters.....	6.451
Square Feet.....	Square Meters.....	0.093
Square Yards.....	Square Meters.....	0.836
Square Miles.....	Square Kilometers.....	2.590
Acres.....	Square Hectometers.....	0.405
Cubic Feet.....	Cubic Meters.....	0.028
Cubic Yards.....	Cubic Meters.....	0.765
Fluid Ounces.....	Milliliters.....	29.573
Pints.....	Liters.....	0.473
Quarts.....	Liters.....	0.946
Gallons.....	Liters.....	3.785
Ounces.....	Grams.....	28.349
Pounds.....	Kilograms.....	0.454
Short Tons.....	Metric Tons.....	0.907
Pound-Feet.....	Newton-Meters.....	1.356
Pounds/Sq Inch.....	Kilopascals.....	6.895
Miles per Gallon.....	Kilometers per Liter.....	0.425
Miles per Hour.....	Kilometers per Hour.....	1.609

<u>TO CHANGE</u>	<u>TO</u>	<u>MULTIPLY BY</u>
Centimeters.....	Inches.....	0.394
Meters	Feet	3.280
Meters	Yards	1.094
Kilometers.....	Miles.....	0.621
Sq Centimeters.....	Square Inches.....	0.155
Square Meters.....	Square Feet.....	10.764
Square Meters.....	Square Yards.....	1.196
Square Kilometers.....	Square Miles.....	0.386
Sq Hectometers.....	Acres.....	2.471
Cubic Meters.....	Cubic Feet.....	35.315
Cubic Meters.....	Cubic Yards.....	1.308
Milliliters.....	Fluid Ounces.....	0.034
Liters.....	Pints.....	2.113
Liters.....	Quarts.....	1.057
Liters.....	Gallons.....	0.264
Grams.....	Ounces.....	0.035
Kilograms.....	Pounds.....	2.205
Metric Tons.....	Short Tons.....	1.102
Newton-Meters.....	Pound-Feet.....	0.738
Kilopascals.....	Pounds per Sq Inch.....	0.145
Km per Liter.....	Miles per Gallon.....	2.354
Km per Hour.....	Miles per Hour.....	0.621

