

OPERATOR'S MANUAL

M977 SERIES, 8 x 8 HEAVY EXPANDED MOBILITY TACTICAL TRUCKS (HEMTT)

MODEL	NSN
TRUCK, CARGO, WITH WINCH , M977	2320-01-097-0260
TRUCK, CARGO, WITHOUT WINCH, M977	2320-01-099-6426
TRUCK, TANK, FUEL, WITH WINCH, M978	2320-01-097-0249
TRUCK, TANK, FUEL, WITHOUT WINCH, 1978	2320-01-100-7672
TRUCK, TRACTOR, WITH WINCH, WITHOUT CRANE, M983	232 0-01-097-0247
TRUCK, TRACTOR, WITH WINCH, WITH CRANE, M983	2320-02-099-6421
TRUCK, WRECKER-RECOVERY, M984	2320-01-097-0248
TRUCK, WRECKER-RECOVERY, M984E1	2320-01-195-7641
TRUCK, CARGO, WITH WINCH, M985	2320-01-097-0261
TRUCK, CARGO, WITHOUT WINCH, M985	2320-01-100-7673
TRUCK, CARGO, WITH WINCH, M985E1	2320-01-194-7032
TRUCK, CARGO, WITHOUT WINCH, M985E1	2320-01-194-7031

Approved for public release; distribution is unlimited.

HEADQUARTERS,
DEPARTMENT OF THE ARMY
NOVEMBER 1986

TABLE OF
CONTENTS
PAGE i

HOW TO USE
THIS MANUAL
PAGE ii

EQUIPMENT
DESCRIPTION
PAGE 1-13

DESCRIPTION AND
USE OF OPERATORS
CONTROLS AND
INDICATORS
PAGE 2-2

PREVENTIVE
MAINTENANCE
CHECKS AND
SERVICES
PAGE 2-33

OPERATION UNDER
USUAL CONDITIONS
PAGE 2-144

OPERATION UNDER
UNUSUAL CONDITIONS
PAGE 2-374

TROUBLESHOOTING
PROCEDURES
PAGE 3-1

MAINTENANCE
PROCEDURES
PAGE 3-40

ALPHABETICAL
INDEX
PAGE INDEX 1

CHANGE

NO. 5

HEADQUARTERS
DEPARTMENT OF THE ARMY
Washington, D. C., 15 December 1998

OPERATOR'S MANUAL

M977 SERIES, 8 X 8 HEAVY EXPANDED MOBILITY
TACTICAL TRUCKS (HEMTT)

MODEL	NSN
TRUCK, CARGO, WITH WINCH, M977	2320-01-097-0260
TRUCK, CARGO, WITHOUT WINCH, M977	2320-01-099-6426
TRUCK, TANK, FUEL, WITH WINCH, M978	2320-01-097-0249
TRUCK, TANK, FUEL, WITHOUT WINCH, M978	2320-01-100-7672
TRUCK, TRACTOR, WITH WINCH, WITHOUT CRANE, M983	2320-01-097-0247
TRUCK, TRACTOR, WITH WINCH, WITH CRANE, M983	2320-01-099-6421
TRUCK, WRECKER-RECOVERY, M984	2320-01-097-0248
TRUCK, WRECKER-RECOVERY, M984E1	2320-01-195-7641
TRUCK, CARGO, WITH WINCH, M985	2320-01-097-0261
TRUCK, CARGO, WITHOUT WINCH, M985	2320-01-100-7673
TRUCK, CARGO, WITH WINCH, M985E1	2320-01-194-7032
TRUCK, CARGO, WITHOUT WINCH, M985E1	2320-01-194-7031

Approved for public release; distribution is unlimited.

TM 9-2320-279-10-1,21 November 1986, is changed as follows:

1. Remove old pages and insert new pages as indicated below.
2. New or changed material is indicated by a vertical bar in the margin of the page.
3. Minor changes to illustrations are indicated by a miniature pointing hand.
4. Illustrations that are new or that have major revisions are indicated by a vertical bar adjacent to the illustration.
5. Changes on cover are: Removed VOLUME NO. 1 and added distribution statement.

Remove Pages	Insert Pages
i	i
a	a
c/(d blank)	c/(d blank)
1-1 and 1-2	1-1 and 1-2
1-11 and 1-12	1-11 and 1-12
1-13 and 1-14	1-13 and 1-14

Remove Pages

1-23 thru 1-26
none
1-29 thru 1-32
2-1 thru 2-12
none
2-15 and 2-16
2-19 and 2-20
(2-25 blank)/2-26
2-35 and 2-36
none
2-37 and 2-38
2-41 thru 2-46
2-55 thru 2-58
none
2-63 and 2-64
none
2-65 thru 2-68
2-79 and 2-80
none
2-83 and 2-84
none
2-87 and 2-88
2-93 and 2-94
2-101 and 2-102
2-131 and 2-132
2-142.7 and 2-142.8
2-142.11 thru 2-142.16
2-143 and 2-144
none
2-145 thru 2-148
2-157 and 2-162
2-165 and 2-166
2-173 and 2-174
none
2-189 and 2-190
none
2-191 thru 2-194
none
2-211 and 2-212
2-217 thru 2-220
none
2-221 and 2-222
2-225 thru 2-228
2-233 thru 2-238
2-241 and 2-242
none

Insert Pages

1-23 thru 1-26
1-28.1/(1-28.2 blank)
1-29 thru 1-32
2-1 thru 2-12
2-12.1/(2-12.2 blank)
2-15 and 2-16
2-19 and 2-20
(2-25 blank)/2-26
2-35 and 2-36
2-36.1/(2-36.2 blank)
2-37 and 2-38
2-41 thru 2-46
2-55 thru 2-58
(2-62.1 blank)/2-62.2
2-63 and 2-64
2-64.1 and 2-64.2
2-65 thru 2-68
2-79 and 2-80
2-80.1/(2-80.2 blank)
2-83 and 2-84
2-84.1/(2-84.2 blank)
2-87 and 2-88
2-93 and 2-94
2-101 and 2-102
2-131 and 2-132
2-142.7 and 2-142.8
2-142.11 thru 2-142.20
2-143 and 2-144
(2-144.1 blank)/2-144.2
2-145 thru 2-148
2-157 and 2-162
2-165 and 2-166
2-173 and 2-174
2-188.1 thru 2-188.4
2-189 and 2-190
2-190.1/(2-190.2 blank)
2-191 thru 2-194
2-194.1/(2-194.2 blank)
2-211 and 2-212
2-217 thru 2-220
2-220.1/(2-220.2 blank)
2-221 and 2-222
2-225 thru 2-228
2-233 thru 2-238
2-241 and 2-242
2-242.1/(2-242.2 blank)

Remove Pages

2-243 and 2-244
2-247 and 2-248
none
2-249 and 2-250
2-253 and 2-254
2-257 and 2-258
2-261 and 2-262
2-265 and 2-266
none
2-267 thru 2-272
2-273 and 2-214
2-279 and 2-280
none
none
2-281 thru 2-284
none
2-285 and 2-286
2-289 thru 2-302
2-305 thru 2-314
none
2-317 thru 2-320
(2-321 blank)/2-322
none
2-325 and 2-326
none
2-327 and 2-328
(2-361 blank)/2-362
none
2-363 and 2-364
2-375 and 2-378
none
2-383 and 2-384
none
2-397 and 2-398
2-431 and 2-432
none
2-432 and 2-434
none
2-437 and 2-438
2-449 and 2-450
none
2-455 and 2-456
none
3-5 and 3-6
3-9 and 3-10
3-15 and 3-16

Insert Pages

2-243 and 2-244
2-247 and 2-248
2-248.1/(2-248.2 blank)
2-249 and 2-250
2-253 and 2-254
2-257 and 2-258
2-261 and 2-262
2-265 and 2-266
2-266.1/(2-266.2 blank)
2-267 thru 2-272
2-273 and 2-274
2-279 and 2-280
2-272.1 and 2-272.2
2-280.1/(2-280.2 blank)
2-281 thru 2-284
2-284.1/(2-284.2 blank)
2-285 and 2-286
2-289 thru 2-302
2-305 thru 2-314
(2-316.1 blank)/2-316.2
2-317 thru 2-320
(2-321 blank)/2-322
2-324.1 thru 2-324.5/(2-324.6 blank)
2-325 and 2-326
2-326.1 thru 2-326.4
2-327 and 2-328
2-361 and 2-362
2-362.1 thru 2-362.4
2-363 and 2-364
2-375 and 2-378
2-378.1 thru 2-378.2
2-383 and 2-384
(2-384.1 blank)/2-384.2
2-397 and 2-398
2-431 and 2-432
2-432.1/(2-432.2 blank)
2-432 and 2-434
2-436.1/(2-436.2 blank)
2-437 and 2-438
2-449 and 2-450
2-450.1/(2-450.2 blank)
2-455 and 2-456
2-456.1/(2-456.2 blank)
3-5 and 3-6
3-9 and 3-10
3-15 and 3-16

Remove Pages	Insert Pages
3-29 thru 3-32	3-29 thru 3-32
3-35 and 3-36	3-35 and 3-36
3-39 and 3-40	3-39 and 3-40
none	3-40.1 thru 3-40.4
3-41 and 3-42	3-41 and 3-42
none	3-46.1 and 3-46.2
3-47 thru 3-50	3-47 thru 3-50
none	3-50.1/(3-50.2 blank)
3-57 and 3-58	3-57 and 3-58
3-61 and 3-62	3-61 and 3-62
none	3-62.1 thru 3-62.9/(3-62.10 blank)
3-63 and 3-64	3-63 and 3-64
A-1 and A-2	A-1 and A-2
B-3 thru B-20	B-3 thru B-20
C-1 thru C-5/(C-6 blank)	C-1 thru C-6
E-1 and E-2	E-1 and E-2
E-11 thru E-18	E-11 thru E-18
F-1 thru F-6	F-1 thru F-6
none	F-6.1/(F-6.2 blank)
F-7 thru F-12	F-7 thru F-15/(F-16 blank)
Index 3 and Index 4	Index 3 and Index 4
Index 11 and Index 12	Index 11 and Index 12
Index 15 thru Index 18	Index 15 thru Index 18
Index 23 and Index 24	Index 23 and Index 24
Index 27 thru Index 30	Index 27 thru Index 30
DA 2028 sample F & B	DA 2028 sample F & B
DA 2028 F & B	DA 2028 F & B
DA 2028 F & B	DA 2028 F & B
DA 2028 F & B	DA 2028 F & B
Cover	Cover

File this change sheet in front of the publication for reference purposes.

By Order of the Secretary of the Army:

DENNIS J. REIMER
General, United States Army
Chief of Staff

Official:


JOEL B. HUDSON

Administrative Assistant to the
Secretary of the Army
05634

DISTRIBUTION: To be distributed in accordance with the Initial Distribution Number (IDN) 380265, requirements for TM 9-2320-279-10-1.

CHANGE

HEADQUARTERS
DEPARTMENT OF THE ARMY
Washington D.C., 1 April 1992

NO. 4

Operator's Manual

**M977 SERIES, 8X8 HEAVY EXPANDED MOBILITY
TACTICAL TRUCKS (HEMTT)**

MODEL	NSN
TRUCK, CARGO, WITH WINCH, M977	2320-01-097-0260
TRUCK, CARGO, WITHOUT WINCH, M977	2320-01-099-6426
TRUCK, TANK, FUEL, WITH WINCH, M978	2320-01-097-0249
TRUCK, TANK, FUEL, WITHOUT WINCH, M978	2320-01-100-7672
TRUCK, TRACTOR, WITH WINCH, WITHOUT CRANE, M983	2320-01-097-0247
TRUCK, TRACTOR, WITH WINCH, WITH CRANE, M983	2320-01-099-6421
TRUCK, WRECKER-RECOVERY, M984	2320-01-097-0248
TRUCK, WRECKER-RECOVERY, M984E1	2320-01-195-7641
TRUCK, CARGO, WITH WINCH, M985	2320-01-097-0261
TRUCK, CARGO, WITHOUT WINCH, M985	2320-01-100-7673
TRUCK, CARGO, WITH WINCH, M985E1	2320-01-194-7032
TRUCK, CARGO, WITHOUT WINCH, M985E1	2320-01-194-7031

TM 9-2320-279-10-1,21 November 1986, is changed as follows:

1. Remove old pages and insert new pages as indicated below.
2. New or changed information is indicated by a vertical bar in the margin of the page.

Remove Pages	Insert Pages
2-245 and 2-246	2-245 and 2-246
none	2-246.1/(2-246.2 blank)
2-251 and 2-252	2-251 and 2-252
2-257 and 2-258	2-257 and 2-258
2-265 through 2-270	2-265 through 2-270
2-293 and 2-294	2-293 and 2-294
2-301 and 2-302	2-301 and 2-302
2-307 and 2-308	2-307 and 2-308
2-321 and 2-322	2-320.1 through 2-322

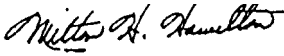
File this change sheet in front of the publication for reference purposes.

Approved for public release; distribution is unlimited.

By Order of the Secretary of the Army:

Official:

GORDON R. SULLIVAN
General, United States Army
Chief of Staff



MILTON H. HAMILTON
Administrative Assistant to the
Secretary of the Army
00806

Distribution:

To be distributed in accordance with DA Form 12-38-E (Block 0265) Operator maintenance requirements for TM9-2320-279-10-1.

CHANGE

HEADQUARTERS
DEPARTMENT OF THE ARMY
Washington D.C., 31 October 1997

NO. 3

OPERATOR'S MANUAL

**M977 SERIES, 8 x 8 HEAVY EXPANDED MOBILITY
TACTICAL TRUCKS (HEM-I-I)**

MODEL	NSN
TRUCK, CARGO, WITH WINCH, M977	2320-01-097-0260
TRUCK, CARGO, WITHOUT WINCH, M977	2320-01-099-6426
TRUCK, TANK, FUEL, WITH WINCH, M978	2320-O-I -097-0249
TRUCK, TANK, FUEL, WITHOUT WINCH, M978	2320-01-I 00-7672
TRUCK, TRACTOR, WITH WINCH, WITHOUT CRANE, M983	2320-01-097-0247
TRUCK, TRACTOR, WITH WINCH, WITH CRANE, M983	2320-01-099-6421
TRUCK, WRECKER-RECOVERY, M984	2320-01-097-0248
TRUCK, WRECKER-RECOVERY, M984E1	2320-01-I 95-7641
TRUCK, CARGO, WITH WINCH, M985	2320-01-097-0261
TRUCK, CARGO, WITHOUT WINCH, M985	2320-01-I 00-7673
TRUCK, CARGO, WITH WINCH, M985E1	2320-01-I 94-7032
TRUCK, CARGO, WITHOUT WINCH, M985E1	2320-01-I 94-7031

TM 9-2320-279-10-1, 21 November 1986, is changed as follows:

1. Remove old pages and insert new pages as indicated below.
2. New or changed material is indicated by a vertical bar in the margin of the page.
3. The Preventive Maintenance Checks and Services have been completely replaced; no change bars or pointing hands will appear on pages 2-35 through 2-144.

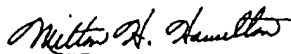
Remove Pages
2-35 through 2-144

Insert Pages
2-35 through 2-144

4. File this change sheet in front of the publication for references purposes.

By Order of the Secretary of the Army

Official:



MILTON H. HAMILTON
Administrative Assistant to the
Secretary of the Army

00073

GORDON R. SULLIVAN
General, United States Army
Chief of Staff

Distribution:

To be distributed in accordance with DA Form 12-38-E (Block 0265) Operator maintenance requirements for TM 9-2320-279-1 0.

Approved for public release distribution is unlimited.

CHANGE

HEADQUARTERS
DEPARTMENT OF THE ARMY
Washington, D.C., 15 April 1989

NO. 2

OPERATOR'S MANUAL

M977 SERIES, 8 x 8 HEAVY EXPANDED MOBILITY TACTICAL TRUCKS (HEMTT)

MODEL	NSN
TRUCK, CARGO, WITH WINCH, M977	2320-01-097-0260
TRUCK, CARGO, WITHOUT WINCH, M977	2320-01-099-6426
TRUCK, TANK, FUEL, WITH WINCH, M978	2320-01-097-0249
TRUCK, TANK, FUEL WITHOUT WINCH, M978	2320-01-00-7672
TRUCK, TRACTOR, WITH WINCH, WITHOUT CRANE, M983	2320-01-097-0247
TRUCK, TRACTOR, WITH WINCH, WITH CRANE, M983	2320-01-099-6421
TRUCK, WRECKER-RECOVERY, M984	2320-01-097-0248
TRUCK, WRECKER-RECOVERY, M984E1	2320-01-195-7641
TRUCK, CARGO, WITH WINCH, M985	2320-01-097-0261
TRUCK, CARGO, WITHOUT WINCH, M985	2320-01-100-7673
TRUCK, CARGO, WITH WINCH, M985E1	2320-01-194-7032
TRUCK, CARGO, WITHOUT WINCH, M985E1	2320-01-194-7031

TM 9-2320-279-10-1, 21 November 1986, Is changed as follows:

1. Remove old pages and insert new pages as indicated below.
2. New or changed material is indicated by a vertical bar in the margin of the page.
3. Minor changes to illustrations are indicated by a miniature pointing hand.
4. **Illustrations** that are new or that have major revisions are indicated by a vertical bar **adjacent** to the illustration identification number.

Remove Pages

2-1 and 2-2
2-19 and 2-20
2-25 and 2-26
2-51 and 2-52'
2-61 and 2-62
2-95 and 2-96
2-131 thru 2-138
2-155 and 2-156
2-361 and 2-362
2-381 thru 2-384

Insert Pages

2-1 and 2-2
2-19 and 2-20
(2-25 blank)/2-26
2-51 and 2-52
2-61 and 2-62
2-95 and 2-96
2-135 thru 2-138
2-155 and 2-156
(2-361 blank)/2-362
2-381 thru 2-384

Remove Pages

B-3 **thru** B-20
C-1 thru **C-5/(C-6** blank)
Index 1 and Index 2
Index 9 and Index 10
Index 17 **thru** Index 22
Index 25 and Index **26**

Insert Pages

B-3 **thru** B-28
c-1 thru **C-5/(C-6** blank)
Index 1 and Index 2
Index 9 and Index 10
Index 17 **thru** Index 22
Index **25** and Index **26**

File this change sheet in front of the publication for reference purposes.

By Order of the Secretary of the Army:

Official:

WILLIAM J. MEEHAN II
Brigadier General, United States Army
The Adjutant General

CARL E. VUONO
General, United States Army
Chief of Staff

Distribution:

To be distributed in accordance **with** DA Form **12-38**, Operator maintenance requirements for Truck, Cargo, IO-Ton, **8X8**, Heavy Expanded Mobility Tactical Truck, **HEMTT, M977, M978, M983, M984, M985.**

CHANGE

NO. 1

HEADQUARTERS
DEPARTMENT OF THE ARMY
Washington, D.C., **7 July 1988**

OPERATOR'S MANUAL

**M977 SERIES, 8 X 8 HEAVY EXPANDED MOBILITY
TACTICAL TRUCKS (HEMTT)**

MODEL	NSN
TRUCK , CARGO, WITH WINCH, M977	2320-01-097-0260
TRUCK , CARGO, WITHOUT WINCH, M977	2320-01-099-6426
TRUCK , TANK, FUEL, WITH WINCH, M978	2320-01-097-0249
TRUCK , TANK, FUEL, WITHOUT WINCH, M978	2320-01-100-7672
TRUCK, TRACTOR , WITH WINCH, WITHOUT CRANE, M983	2320-01-097-0247
TRUCK, TRACTOR , WITH WINCH, WITH CRANE, M983	2320-01-099-6421
TRUCK , WRECKER-RECOVERY, M984	2320-01-097-0248
TRUCK , WRECKER-RECOVERY, M984E 1	2320-01-195-7641
TRUCK , CARGO, WITH WINCH, M986	2320-01-097-0261
TRUCK , CARGO, WITHOUT WINCH, M985	2320-01-100-7673
TRUCK , CARGO, WITH WINCH, M985E1	2320-01-194-7032
TRUCK , CARGO, WITHOUT WINCH, M985E1	2320-01-194-7031

TM Q-2320-279-10-1, 21 November, 1988 is changed as follows:

1. Remove old pages and insert new pages as indicated below.
2. New or changed material is indicated by a vertical bar in the margin of the page.

Remove Pages

Insert Pages

C-1 through G4

C-1 through C-5/(C-6 Blank:

File this change sheet in front of the publication for reference purposes:

By Order of the Secretary of the **Army**:

CARL E. VUONO
General, United States Army
Chief of Staff

Official:

R. L. DILWORTH
Brigadier General, United States Army
The Adjutant General

Distribution:

To be distributed in accordance with DA Form **12-38-R**, Operator requirements for Truck, Cargo, 10-ton, 8x8, Heavy Expanded Mobility **Tactical Truck, HEMTT, M977, M978, M983, M984, M985.**

WARNING

CARBON MONOXIDE (EXHAUST GAS) CAN CAUSE DEATH.

Carbon monoxide does not have color or smell, but can cause death. Breathing air with carbon monoxide produces symptoms of headache, dizziness, loss of muscular control, a sleepy feeling and coma. Brain damage or death can result from heavy exposure. Carbon monoxide is in exhaust fumes of fuel-burning heaters and internal combustion engines. Carbon monoxide can become dangerously concentrated under conditions of no ventilation. Precautions must be followed to ensure crew safety when the personnel heater or engine of any vehicle is operated for any purpose.

1. DO NOT operate vehicle engine in a closed place unless the place has a lot of ventilation.
2. DO NOT drive any vehicle with inspection plates, cover plates, or engine compartment covers removed unless necessary for maintenance purposes.
3. BE ALERT at all times during vehicle operation for exhaust odors and exposure symptoms. If either are present, IMMEDIATELY VENTILATE personnel compartments. If symptoms continue, remove affected crew to fresh air and keep warm. DO NOT PERMIT PHYSICAL EXERCISE. If necessary, give artificial respiration and get immediate medical attention. For artificial respiration, refer to FM 21-11.
4. BE AWARE that the gas particulate filter unit or the field protection mask for nuclear-biological-chemical protection WILL NOT offer safety from carbon monoxide poisoning.

THE BEST DEFENSE AGAINST CARBON MONOXIDE POISONING IS GOOD VENTILATION.

WARNING

If required to remain inside the vehicle during extreme heat, occupants should follow the water intake, work/rest cycle, and other heat stress preventive medicine measures contained in FM 21-10, Field Hygiene and Sanitation.

WARNING

Adhesives, solvents and sealing compounds can burn easily, can give off harmful vapors, and are harmful to skin and clothing. To avoid injury or death, keep away from open fire and use in well-ventilated area. If adhesive, solvent, or sealing compound gets on skin or clothing, wash immediately with soap and water.

WARNING

Never use parking brake for normal braking or wheels will lock up causing severe skid. Skidding vehicle could result in serious personal injury or death.

WARNING

Fuel is very flammable and can explode easily. To avoid serious injury or death. keep fuel away from open fire and keep fire extinguisher within easy reach when working with fuel. Do not work on fuel system when engine is hot. Fuel can be ignited by hot engine. When working with fuel, post signs that read NO SMOKING WITHIN 50 FEET OF VEHICLE.

WARNING

Remove rings, bracelets, wristwatches, neck chains, and any other jewelry, before working around the vehicle. Jewelry can catch on equipment and cause injury, or may short across an electrical circuit and cause severe burns or electrical shock.

WARNING

The radiator is very hot and pressurized during vehicle operation. Let radiator cool before removing cap. Failure to do so can result in serious burns.

WARNING

The exhaust pipe and muffler can become very hot during vehicle operation. Be careful not to touch these parts with bare hands, or allow body to come in contact with exhaust pipe or muffler. Exhaust system parts can become hot enough to cause serious burns.

WARNING

Do not use trailer brakes as a parking brake. Trailer brakes may not hold loaded vehicle and trailer on a grade. A runaway vehicle may cause severe personal injury or death.

WARNING

Always use seatbelts when operating vehicle. Failure to use seatbelt can result in serious injury or death in case of accident.

WARNING

Avoid quick, jerking, winch operation. Keep other personnel well away from vehicles involved in winching operations. A snapped cable or shifting load can cause serious injury or death.

WARNING

Always wear heavy gloves when handling winch cables. Never let cable run through hands. Frayed cables can cut. Never operate winch with less than five wraps of cable on winch drum.

WARNING

When using crane on any vehicle, park vehicle clear of all overhead powerlines. Do not operate crane near overhead powerlines. If crane comes in contact with powerlines, serious injury or death can result.

WARNING

Be careful when working on or with electrical equipment. Do not be misled by the term "low voltage". Voltages as low as 50 volts can cause death. For artificial respiration, refer to FM 21-11.

WARNING

Be careful not to short out battery terminals. Do not smoke or use open flame near batteries. Batteries may explode from a spark. Battery acid is harmful to skin and eyes.

WARNING

If NBC exposure is suspected, all air filter media should be handled by personnel wearing protective equipment. Consult your unit NBC Officer or NBC NCO for appropriate handling or disposal procedures.

WARNING

Do not operate crane unless outriggers are set up. Always chock front wheels when using outriggers. Vehicle could turn over causing personal injury or death.

WARNING

Improperly seated lockrings and side rings may blow off during inflation. Never attempt to seat a lockring or side ring during or after inflation. Serious injury or death may result.

WARNING

Operating a vehicle with a tire in an overinflated or underinflated condition, or with a questionable defect, may lead to premature tire failure and may cause equipment damage, or injury or death to personnel.

TECHNICAL MANUAL

HEADQUARTERS
DEPARTMENT OF THE ARMY

No. 9-2320-279-10-1

Washington, DC, 21 November 1986

OPERATOR'S MANUAL

**M977 SERIES, 8 X 8 HEAVY EXPANDED MOBILITY
TACTICAL TRUCKS (HEMTT)**

MODEL	NSN
TRUCK, CARGO, WITH WINCH, M977	2320-01-097-0260
TRUCK, CARGO, WITHOUT WINCH, M977	2320-01-099-6426
TRUCK, TANK, FUEL, WITH WINCH, M978	2320-01-097-0249
TRUCK, TANK, FUEL, WITHOUT WINCH, M978	2320-01-100-7672
TRUCK, TRACTOR, WITH WINCH, WITHOUT CRANE, M983	2320-01-097-0247
TRUCK, TRACTOR, WITH WINCH, WITH CRANE, M983	2320-01-099-6421
TRUCK, WRECKER-RECOVERY, M984	2320-01-097-0248
TRUCK, WRECKER-RECOVERY, M984E1	2320-01-195-7641
TRUCK, CARGO, WITH WINCH, M985	2320-01-097-0261
TRUCK, CARGO, WITHOUT WINCH, M985	2320-01-100-7673
TRUCK, CARGO, WITH WINCH, M985E1	2320-01-194-7032
TRUCK, CARGO, WITHOUT WINCH, M985E1	2320-01-194-7031

Approved for public release; distribution is unlimited.

REPORTING ERRORS AND RECOMMENDING IMPROVEMENTS

You can help improve this Technical Manual. If you find any mistakes or if you know of a way to improve the procedures, please let us know. Mail a letter or your DA Form 2028 (Recommended Changes to Publications and Blank Forms) directly to: Commander, U.S. Army Tank-automotive and Armaments Command, ATTN: AMSTA-AC-NML, Rock Island, IL 61299-7630. You can also provide information to TACOM via datafax or e-mail. TACOM's datafax number is: DSN 793-0726 or (309) 782-0726. E-mail address: amsta-ac-nm1@ria-emh1.army.mil

M983 with crane and M985E1 without winch are no longer in the fleet. Ignore all references to these vehicles. The M984E1 and M984A1 are the same vehicle. All references to M984E1 shall be interpreted as the M984A1 model.

TABLE OF CONTENTS

	Page
HOW TO USE THIS MANUAL	ii
CHAPTER 1 INTRODUCTION	1-1
Section I General Information	1-1
Section II Equipment Description	1-13
Section III Technical Principles of Operation	1-32

TABLE OF CONTENTS (CONT)

	Page
CHAPTER 2 OPERATING INSTRUCTIONS	2-1
Section I Description and Use of Operator's Controls and Indicators	2-2
Section II Preventive Maintenance Checks and Services (PMCS)	2-33
Section III Operation under Usual Conditions	2-144
Section IV Operation under Unusual Conditions	2-374
CHAPTER 3 MAINTENANCE INSTRUCTIONS.	3-1
Section I Lubrication Instructions	3-1
Section II Troubleshooting Procedures	3-1
Section III Maintenance Procedures	3-40
APPENDIXES	
A REFERENCES	A-1
B COMPONENTS OF END ITEM AND BASIC ISSUE ITEMS LISTS	B-1
ADDITIONAL AUTHORIZATION LIST	C-1
C EXPENDABLE SUPPLIES AND MATERIALS LIST	D-1
E PREPARATION FOR TRANSPORT AND OPERATION.	E-1
F STOWAGE AND SIGN GUIDE	F-1
ALPHABETICAL INDEX	INDEX 1

HOW TO USE THIS MANUAL

This manual is designed to help operate and maintain the M977 series vehicles. Volume 1 of this manual contains instructions that are common to the M984E1 and other M977 series vehicles. Volume 2 contains unique operator instructions for the M984E1 Wrecker-Recovery vehicle. In addition to this manual, TM 9-2320-355-10 provides unique operator instructions for the M985E1 Guided Missile Transporter (GMT) and TM 9-2320-354-10 provides unique operator instructions for the M984 wrecker vehicle. Listed below are some of the special features which have been included to help locate and use the needed information.

- A front cover Table of Contents is provided for quick reference to chapters and sections that will be used often.
- Each chapter begins with a Table of Contents listing all paragraph headings in the chapter.
- Warning, caution, and note headings, subject headings, and certain other essential information are printed in bold type to make them easier to see.

FOLLOW THESE GUIDELINES WHEN USING THIS MANUAL:

- The driver must read through this manual and become familiar with the content before attempting to operate the vehicle.
- Read all WARNINGS and CAUTIONS before performing any procedures.

CHAPTER 1 INTRODUCTION

Contents	Para	Page
Scope	1-1	1-1
Maintenance Forms and Records	1-2	1-10
Equipment Improvement Report and Maintenance Digest (EIR MD) and Equipment Improvement Report and Maintenance Summary (EIR MS)	1-3	1-10
Hand Receipt (HR) Manuals	1-4	1-11
Submitting Quality Deficiency Reports (QDR)	1-5	1-11
Warranty Information	1-6	1-11
Metric System..	1-7	1-11
Reference Information	1-8	1-12
Equipment Characteristics, Capabilities, and Features	1-9	1-13
Location and Description of Major Components	1-10	1-14
Differences Between Models	1-11	1-22
Equipment Data	1-12	1-23
Systems Introduction	1-13	1-32
Electrical System	1-14	1-32
Air System	1-15	1-34
Main Hydraulic System (All models except M984E1)	1-16	1-36
Main Hydraulic System (M984E1)	1-17	1-37
Power Steering Hydraulic System	1-18	1-38

Section I. GENERAL INFORMATION

Vehicle Models

1-1. SCOPE This manual is used for operation and operator-performed maintenance of the 60,000-lb (27 240 kg) GVWR, 8x8, M977 series, Heavy Expanded Mobility Tactical Truck (HEMTT). The M977 series vehicles consists of a number of different models all built on similar chassis but specially equipped to perform different missions. The models are as follows:

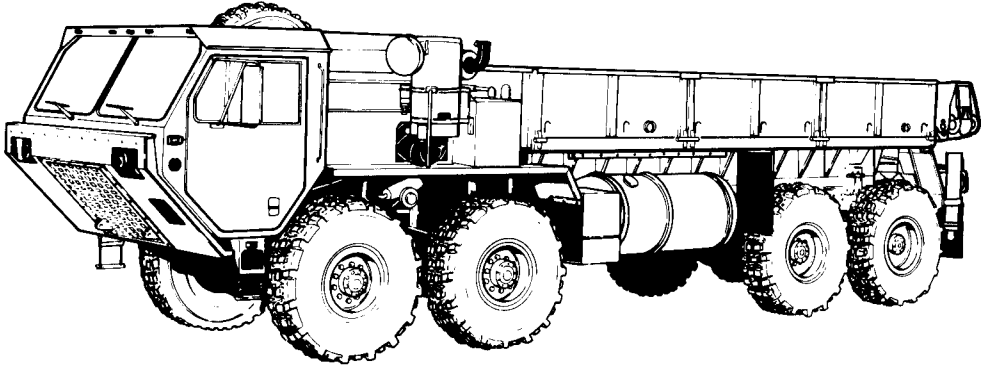
Model	Description
M977	Cargo vehicle with 62,000-lb (28 100 kg) GVWR and 100,000-lb (45 400 kg) GCWR. Vehicle is equipped with material handling crane with 2500-lb (1 135 kg) load capacity at 19 ft (5.8 m) boom radius and has 18-foot cargo body (fig. 1-1).
M978	Tanker vehicle with 2500-gal (9 463 L) tank and fuel resupply module (fig. 1-2).
M983	Tractor vehicle with 100,000-lb (45 400 kg) GCWR. Vehicle is equipped with fifth wheel, 2-inch or 3 1/2-inch kingpin.

Vehicle Models (Cont)

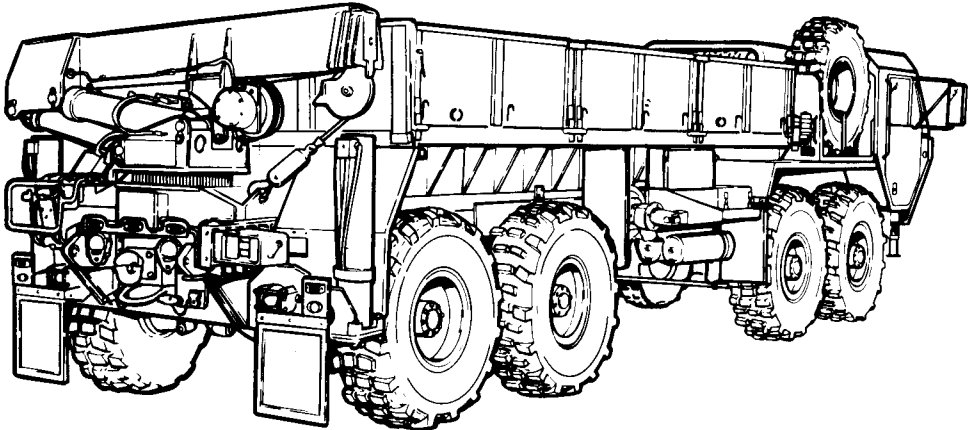
1-1. SCOPE (CONT).

Model	Description
M984	Wrecker vehicle with 82,000-lb (37 200 kg) GVWR and 100,000-lb (45 400 kg) GCWR. Vehicle is equipped with material handling crane with 10,000-lb (4 540 kg) load capacity at 12 ft (3.7 m) or 24,000-lb (10 896 kg) with boom extension retracted and resting on boom support tubes, 60,000-lb (27 240 kg) recovery winch, and 10-foot cargo body (fig. 1-5).
M984E1	Wrecker vehicle with 95,000-lb (43 000 kg) GVWR and 114,000-lb (51 700 kg) GCWR that can be increased to 155,000-lb (70 370 kg) GCWR under certain conditions. Vehicle is equipped with material handling crane with 6,000-lb (2 722 kg) load capacity at 18.2 ft (5.5 m) boom radius, 60,000-lb (27 240 kg) recovery winch, and equipment body with 10 stowage compartments (fig. 1-6).
M985	Cargo vehicle with 68,000-lb (30 800 kg) GVWR and 100,000-lb (45 400 kg) GCWR. Vehicle is equipped with material handling crane with 5,400-lb (2 452 kg) load capacity at 16.5 ft (5.0 m) boom radius and has 18-foot cargo body (fig. 1-7).
M985E1	Cargo vehicle with 58,000-lb (26 332 kg) GVWR and 100,000-lb (45 400 kg) GCWR. Vehicle is equipped with material handling crane with 5,400-lb (2 452 kg) load capacity at 16.5 ft (5.03 m) or 4,500-lb (2 043 kg) at 20.5 ft (6.25 m). Maximum reach in knuckle position (inner boom 10° - 15° above horizontal and outer boom horizontal) is 20.5 ft (6.25 m) (fig. 1-8).

Vehicle Models (Cont)



LEFT FRONT VIEW



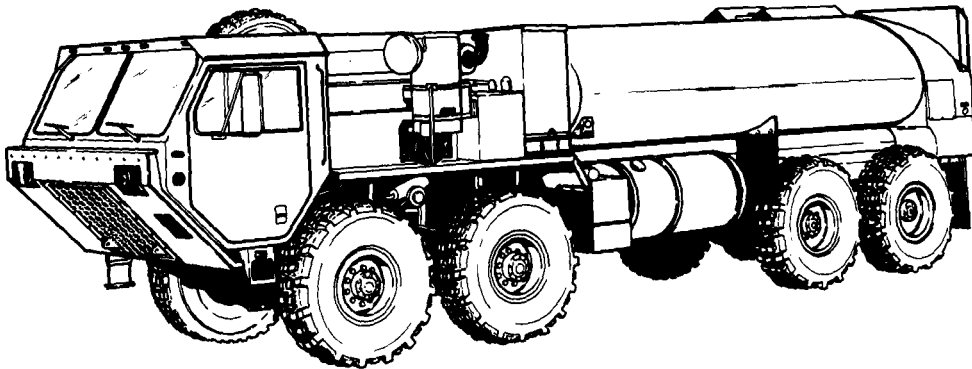
RIGHT REAR VIEW

TA185094

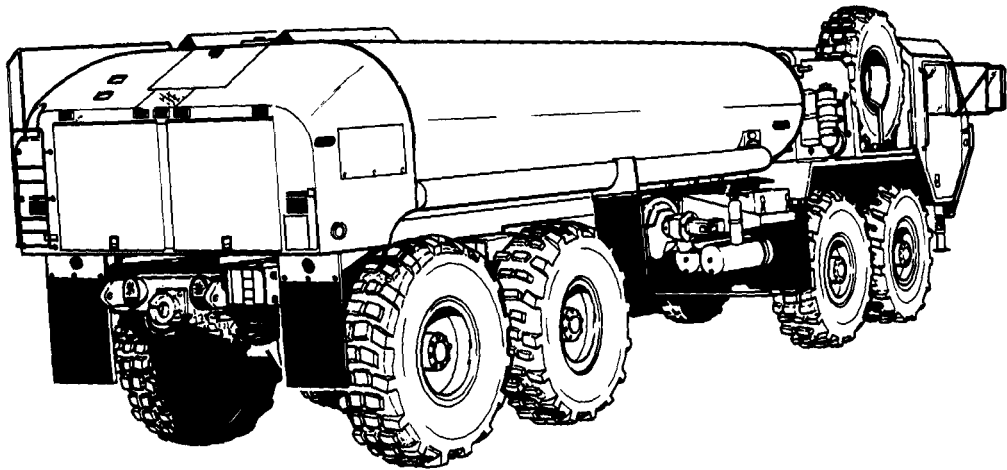
Figure 1-1. M977 Cargo Vehicle.

Vehicle Models (Cont)

1-1. SCOPE (CONT).



LEFT FRONT VIEW

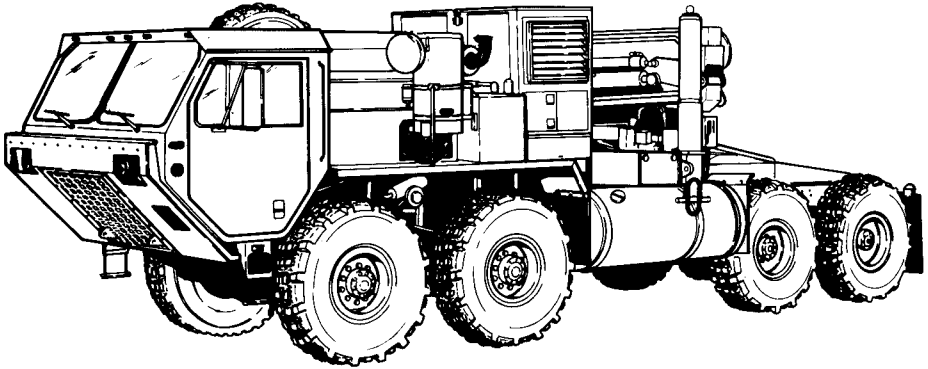


RIGHT REAR VIEW

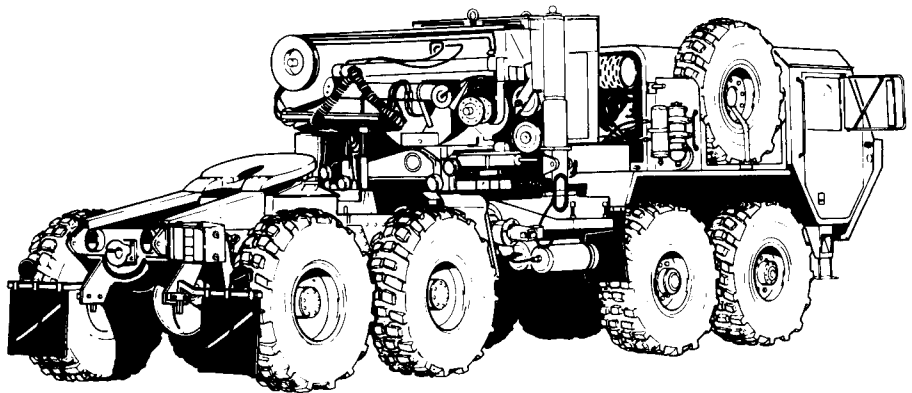
TA185085

Figure 1-2. M978 Tanker Vehicle.

Vehicle Models (Cont)



LEFT FRONT VIEW



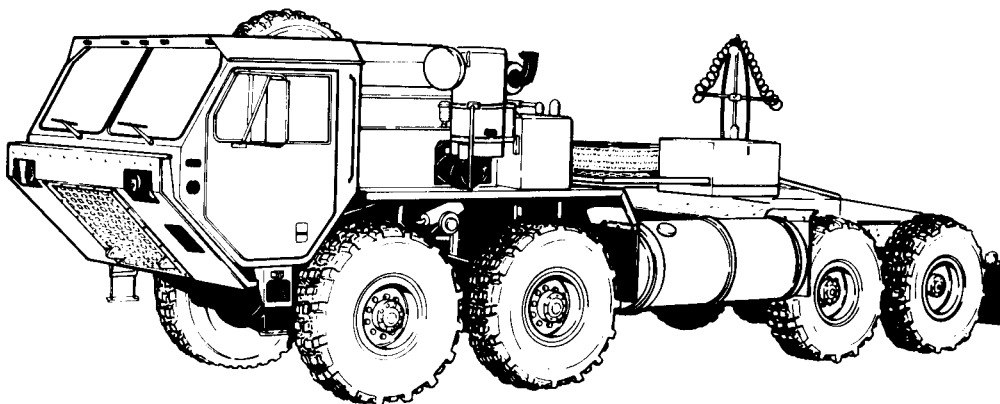
RIGHT REAR VIEW

TA185096

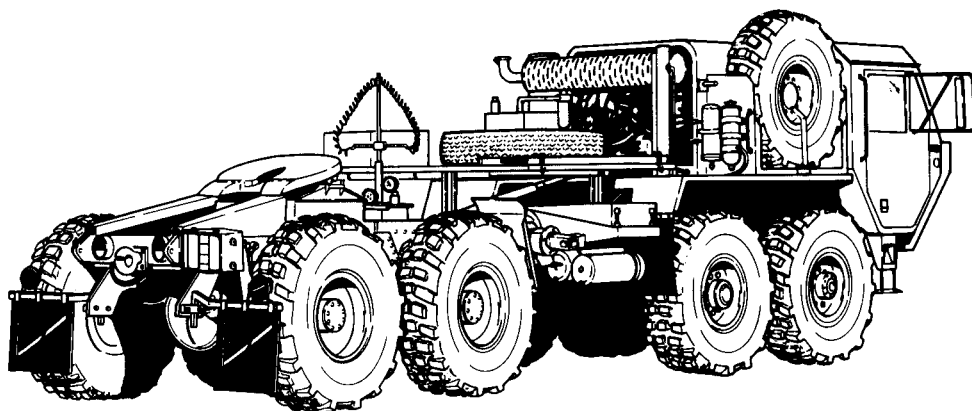
Figure 1-3. M983 Tractor Vehicle with Crane.

Vehicle Models (Cont)

1-1. SCOPE (CONT).



LEFT FRONT VIEW

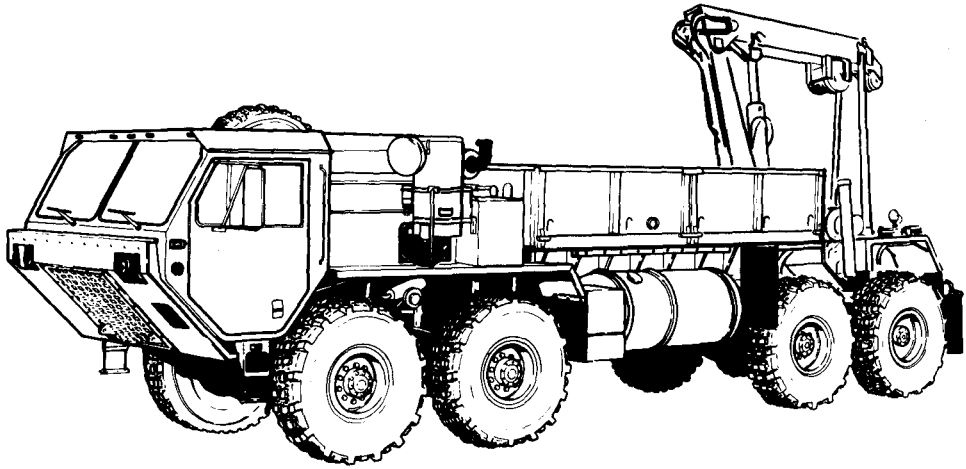


RIGHT REAR VIEW

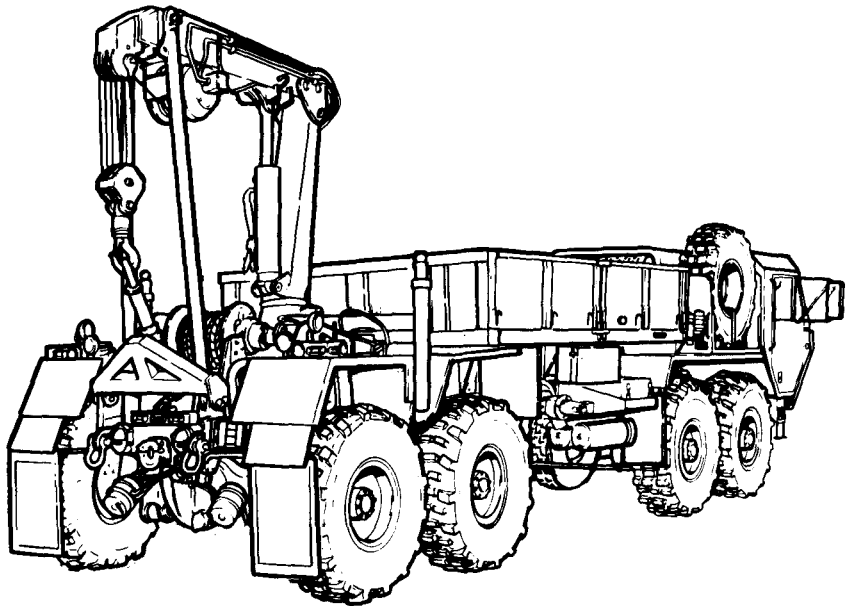
TA185097

Figure 1-4. M983 Tractor Vehicle without Crane.

Vehicle Models (Cont)



LEFT FRONT VIEW



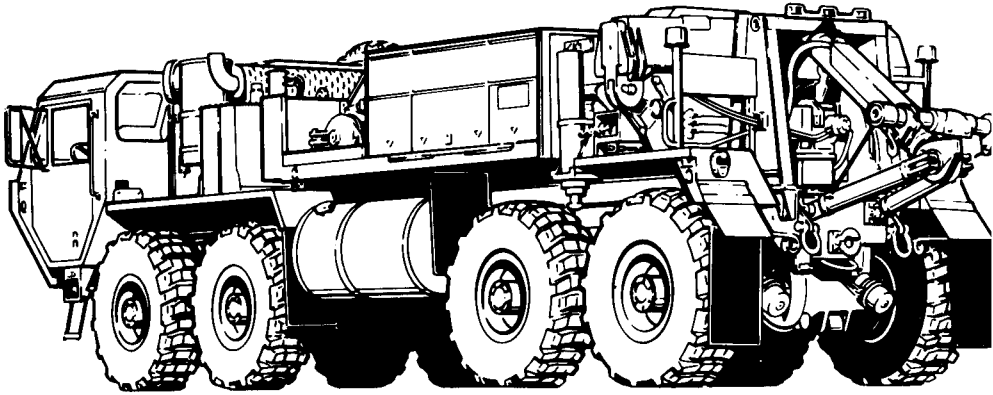
RIGHT REAR VIEW

TA185008

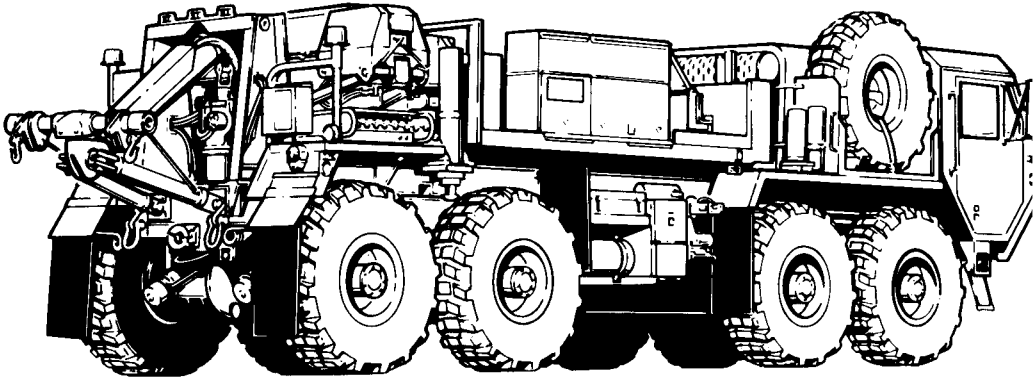
Figure 1-5. M984 Wrecker-Recovery Vehicle.

Vehicle Models (Cont)

1-1. SCOPE (CONT).



LEFT REAR VIEW

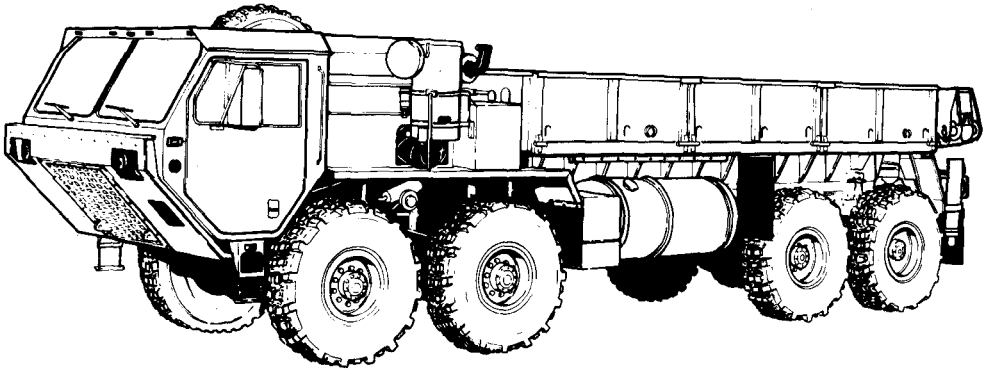


RIGHT REAR VIEW

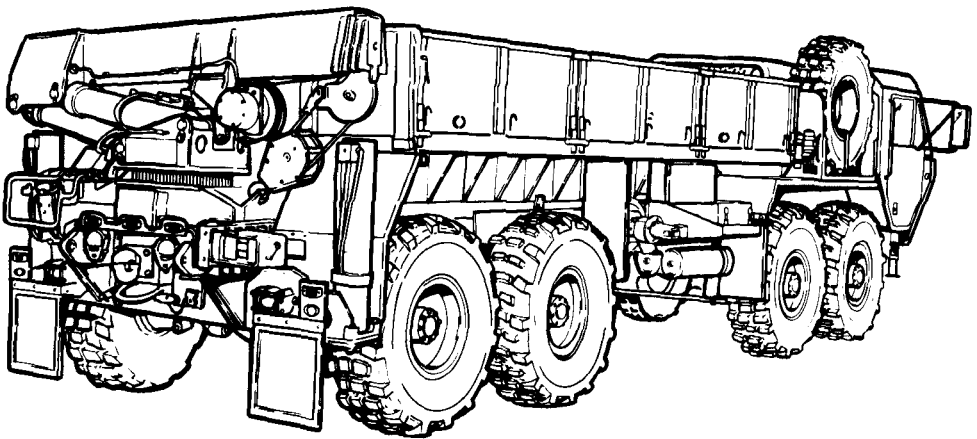
TA3565

Figure 1-6. M984E1 Wrecker-Recovery Vehicle.

Vehicle Models (Cont)



LEFT FRONT VIEW



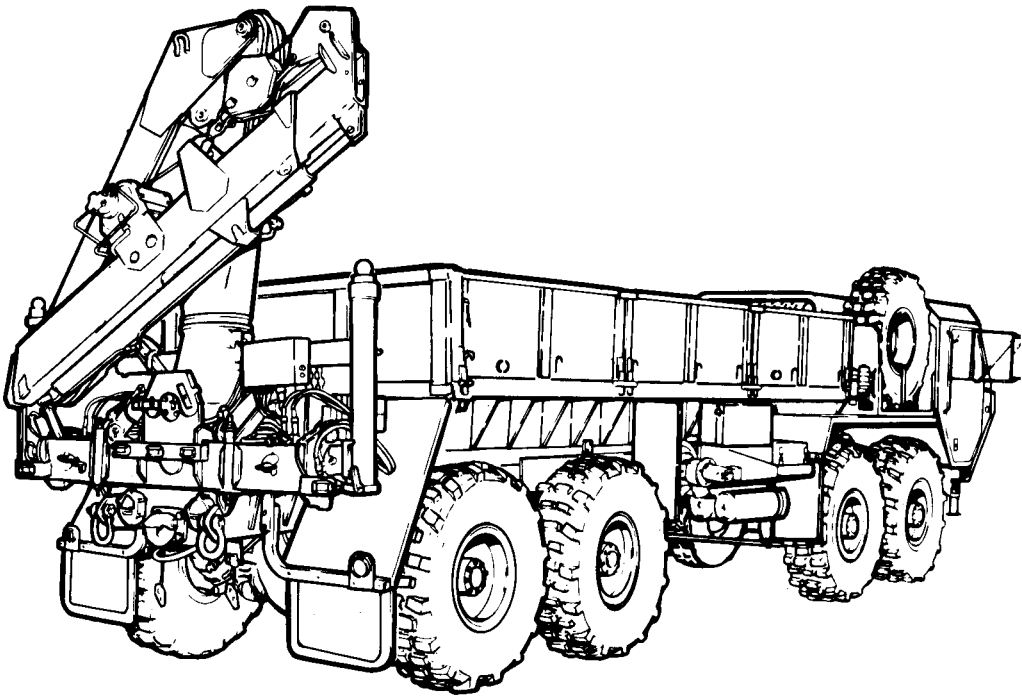
RIGHT REAR VIEW

TA185000

Figure 1-7. M985 Cargo Vehicle.

Vehicle Models (Cont)

1-1. SCOPE (CONT).



RIGHT REAR VIEW

TA358841

Figure 1-8. M985E1 Cargo Vehicle.

Equipment and Maintenance Reports

1-2. MAINTENANCE FORMS AND RECORDS. Department of the Army forms and procedures used for equipment maintenance will be those prescribed by PAM 738-750, The Army Maintenance Management System (TAMMS).

1-3. EQUIPMENT IMPROVEMENT REPORT AND MAINTENANCE DIGEST (EIR MD) AND EQUIPMENT IMPROVEMENT REPORT AND MAINTENANCE SUMMARY (EIR MS). The quarterly Equipment Improvement Report and Maintenance Digest, TB 43-0001-39 series contains valuable field information on equipment covered in this manual. Information in the TB 43-0001-39 series is compiled from some of the Equipment Improvement Reports that have been prepared on vehicles covered in this manual. Many of these articles result from comments, suggestions, and improvement recommendations that were submitted to the EIR program. The TB 43-0001-39 series contains information on equipment improvements, minor alterations,

Equipment and Maintenance Reports (Cont)

proposed Modification Work Orders (MWO's), warranties (if applicable), actions taken on some of the DA Form 2028's (Recommended Changes to Publications), and advance information on proposed changes that may affect this manual. Significant maintenance articles, including minor alterations and field-fixes, are republished in the Equipment Improvement Report and Maintenance Summary (EIR MS) for TACOM Equipment (TM 43-0143). Refer to the TB 43-0001-62 series and TM 43-0143 periodically for the most current and authoritative information on the equipment. The information will help to do a better job and will advise of the latest changes to this manual. Also refer to DA Pam 25-30, Consolidated Index of Army Publications and Blank Forms, and Appendix A, References, of this manual.

1-4. HAND RECEIPT (HR) MANUALS. This manual has a companion document with a TM number followed by "-HR" (Hand Receipt). The TM 9-2320-279-10-HR consists of preprinted hand receipts (DA Form 2062) that list end item related equipment (COEI, BII, and AAL) which must be accounted for. As an aid to property accountability, additional -HR manuals may be requisitioned from the following source in accordance with procedures in AR 25-30:

Commander
US Army Publications Distribution Center - St. Louis
ATTN: SAIS-PRS
1655 Woodsen Rd.
St. Louis, MO 63114-6181

1-5. SUBMITTING QUALITY DEFICIENCY REPORTS (QDR). If your vehicle needs improvement, let us know. Send us a QDR. You, the user, are the only one who can tell us what you don't like about your equipment. Let us know why you don't like the design or performance. Put it on an SF368 (Quality Deficiency Report). Mail it to Commander, U.S. Army Tank-automotive and Armaments Command, ATTN: AMSTA-AC-NML, Rock Island, IL 61299-7630. You can also provide information to TACOM via datafax or e-mail. TACOM's datafax number is: DSN 793-0726 or (309) 782-0726. E-mail address: amsta-ac-nm1@ria-emh1.army.mil

1-6. WARRANTY INFORMATION. The M977 series vehicles are warranted by Oshkosh Truck Corporation for 12 months or 12,000 miles (19 308 km), whichever comes first. The warranty starts on the date found in block 23, DA Form 2408-9, in the logbook. Report all defects in material or workmanship to the supervisor, who will take appropriate action through the organizational maintenance shop. Refer to TB 9-2320-279-14 for more information on the warranty procedures for the M977 series vehicles.

1-7. METRIC SYSTEM. The equipment described herein contains metric components and requires metric, common, and special tools. Therefore, metric units and English units will be used throughout this publication. An English-to-metric conversion table is included as the last page of this manual inside the back cover.

Abbreviation References

1-8. REFERENCE INFORMATION. This listing includes the nomenclature cross-reference list and a list of abbreviations used in this manual.

a. Nomenclature Cross-Reference List.

Common Name	Official Nomenclature
Engine Coolant	- Antifreeze, ethylene glycol mixture
Cold Start System	- Ether quick-start system
Cable	- Wire rope
Jacobs® Brake	- Engine retarder
Glad Hand	- Quick disconnect coupling

b. Abbreviations.

AAL	Additional Authorization List
BII	Basic Issue Items
C	Celsius
CID	Cubic Inch Displacement
COEI	Components of End Item
EIR's	Equipment Improvement Recommendations
F	Fahrenheit
GCWR	Gross Combination Weight Rating
GPFU	Gas Particulate Filter Unit
GVWR	Gross Vehicle Weight Rating
kg	Kilogram
kPa	Kilopascals
Kmh	Kilometer per hour
KW	Kilowatt
L	Liter
mm	Millimeter
N·m	Newton meter
PMCS	Preventive Maintenance Checks and Services
XHD	Extra heavy-duty

Section II. EQUIPMENT DESCRIPTION

Features and Capabilities

1-9. EQUIPMENT CHARACTERISTICS, CAPABILITIES, AND FEATURES.)

a. Characteristics.

- (1) The M977 cargo vehicle is used for ammunition resupply and other resupply missions.
- (2) The M978 tanker is used to refuel wheeled and tracked vehicles and for other fuel resupply missions.
- (3) The M983 tractor is used to transport Pershing II and Patriot missile systems semitrailers.
- (4) The M984E1 vehicle is used as a multipurpose vehicle capable of recovering and towing a full spectrum of loaded, wheeled vehicles. This vehicle has lift and reach capability to perform maintenance assistance associated with removing and replacing power packs and heavy components from a wide range of wheeled and tracked vehicles.
- (5) The M985 cargo vehicle is used to resupply the Multiple Launch Rocket System (MLRS).

b. Capabilities.

- (1) All models are capable of operating in temperatures from -25° to 120°F (-32° to 49°C) and to -50°F (-46°C) with arctic kit installed.
- (2) All models can ford water up to 48-in. (1 219 mm) deep for 5 minutes without damage or without requiring maintenance before operation can continue.
- (3) Normal operating range of all models is 300 miles (483 km), based upon 154 gallons (583 L) of fuel and 100,000-lb (45 400 kg) GCWR, traveling over mixed terrain. Varying loads, prolonged idle, use of power takeoff (PTO), offroad driving, and climatic conditions affect operating range.
- (4) All models are provided with sufficient tiedown points located so vehicles can be restrained in all directions during air transport in C-130, C-141, and C-5A type aircraft. All models are capable of being transported by highway, rail, and sea.

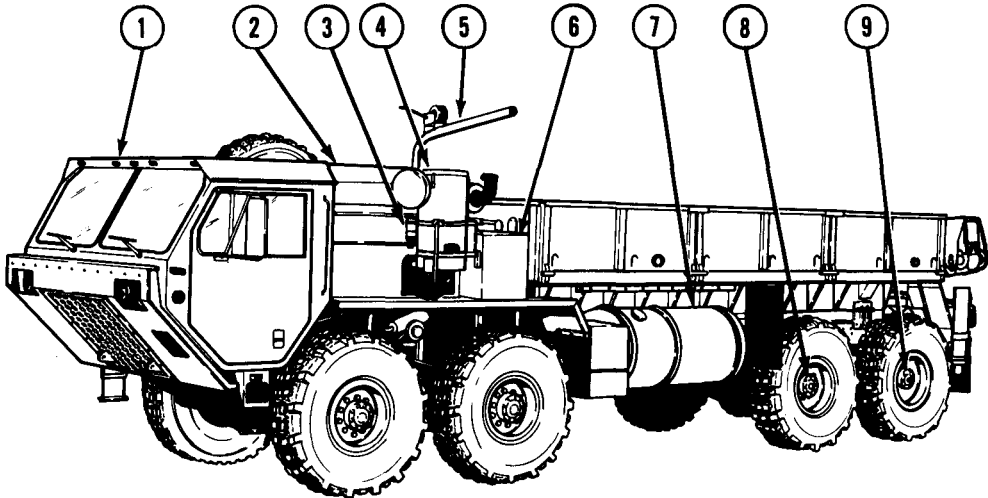
c. Features.

- (1) Eight-cylinder, V-type, a-cycle, turbocharged diesel engine.
- (2) Automatic transmission with one reverse speed and four forward speeds.
- (3) Operator controlled 4-wheel/8-wheel drive and high and low range transfer case for positive traction in areas of unimproved road surfaces.
- (4) Power steering system consists of basic manual steering system with hydraulic boost. Mechanical linkage also provides operator control in event of hydraulic oil pressure loss.
- (5) Fuel system includes one fuel tank, fuel lines, fuel-water separator, fuel pump, secondary filter, fuel pipes, and fuel injectors.
- (6) Two front and two rear towing eyes.
- (7) Manual-release-type rear pintle hook which will allow towing of a trailer.
- (8) Radio frequency interference suppression to permit voice radio communications during all phases of operation.

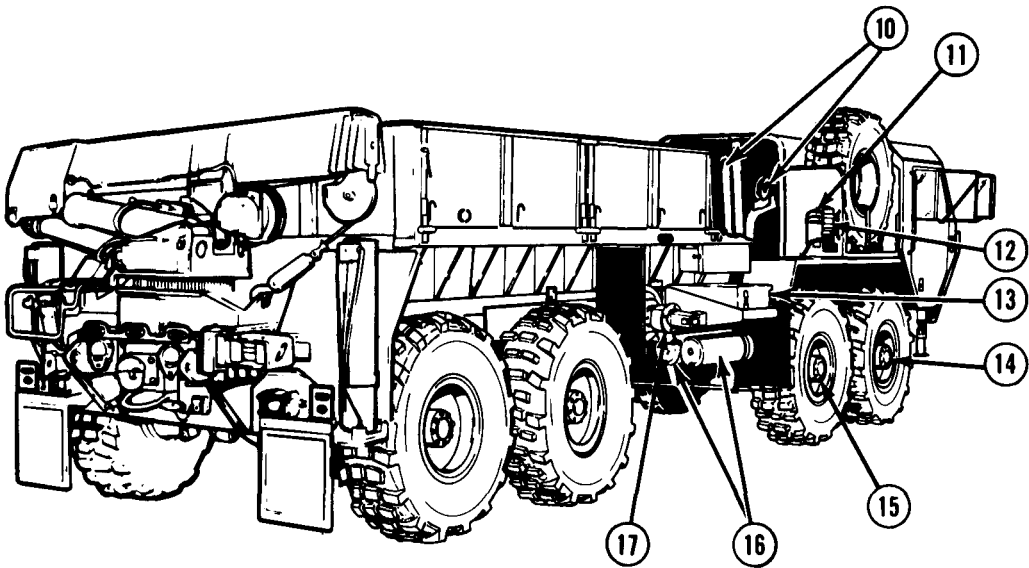
Component Locations

1-10. LOCATION AND DESCRIPTION OF MAJOR COMPONENTS.

Figures 1-9 through 1-15 illustrate major components of all models.



LEFT FRONT VIEW



RIGHT REAR VIEW

TA182543

Figure 1-9. M977 through M985 Components Location.

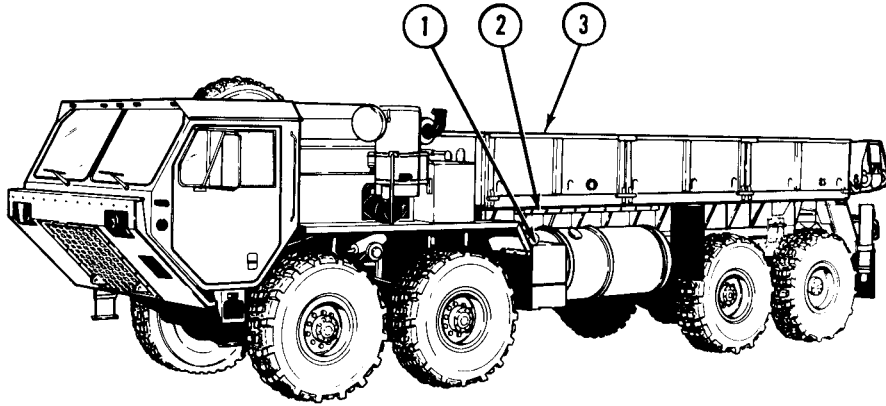
Component Locations (Cont)

Legend for Figure 1-9. M977 through M985 Components Location.

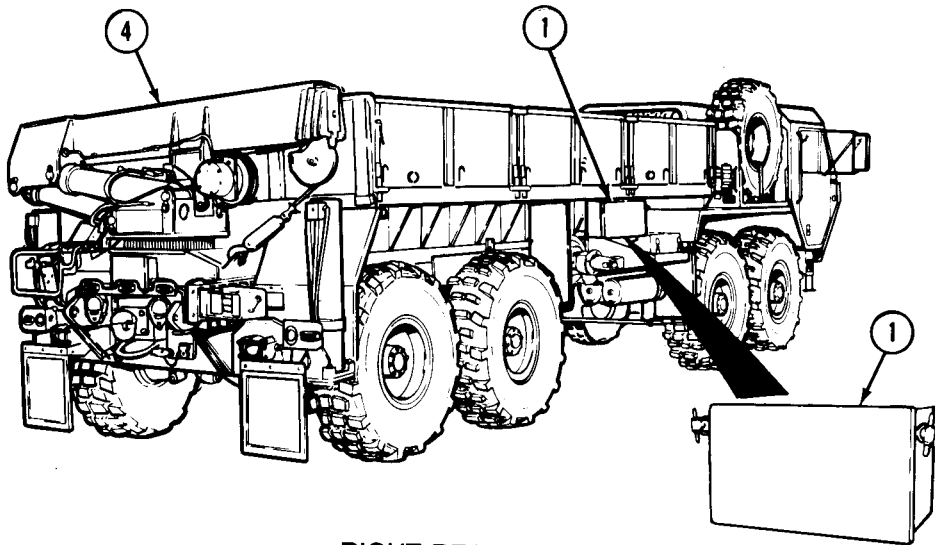
1. PERSONNEL CAB. Provides protection from weather for crew and vehicle controls, gages, and indicators.
2. ENGINE COMPARTMENT. Engine supplies power to move vehicle and operate equipment and accessories.
3. ETHER CANISTER. Contains ether for use as cold weather starting aid.
4. AIR CLEANER. Filters out dust and debris from air entering air induction system.
5. TIRE DAVIT (shown assembled). Used to raise and lower spare tire.
6. HYDRAULIC RESERVOIR. Stores, cools, and filters oil used in hydraulic and power steering systems.
7. FUEL TANK. Stores fuel used to operate engine. Receives excess fuel not used by engine's fuel injection system.
8. NO. 3 DRIVING AXLE. Supports weight of vehicle and transmits power to hubs to turn rear wheels.
9. NO. 4 DRIVING AXLE. Supports weight of vehicle and transmits power to hubs to turn rear wheels.
10. TIRE DAVIT (shown in stowed position). Used to raise and lower spare tire.
11. AIR DRYER. Used to remove dirt and moisture from compressed air before air enters air reservoirs.
12. FUEL-WATER SEPARATOR. Acts as primary fuel filter and removes any water from fuel before entering engine.
13. BATTERY BOX. Houses and protects four storage batteries.
14. NO. 1 DRIVING AXLE. Controls direction of vehicle when in motion. When needed, transmits power to hubs to turn wheels.
15. NO. 2 DRIVING AXLE. Controls direction of vehicle when in motion. When needed, transmits power to hubs to turn wheels.
16. AIR RESERVOIRS. Used to store air system air.
17. SELF-RECOVERY WINCH (not used on all vehicles). Used to help vehicle pull itself free of obstructions.

Component Locations (Cont)

1-10. LOCATION AND DESCRIPTION OF MAJOR COMPONENTS (CONT).



LEFT FRONT VIEW



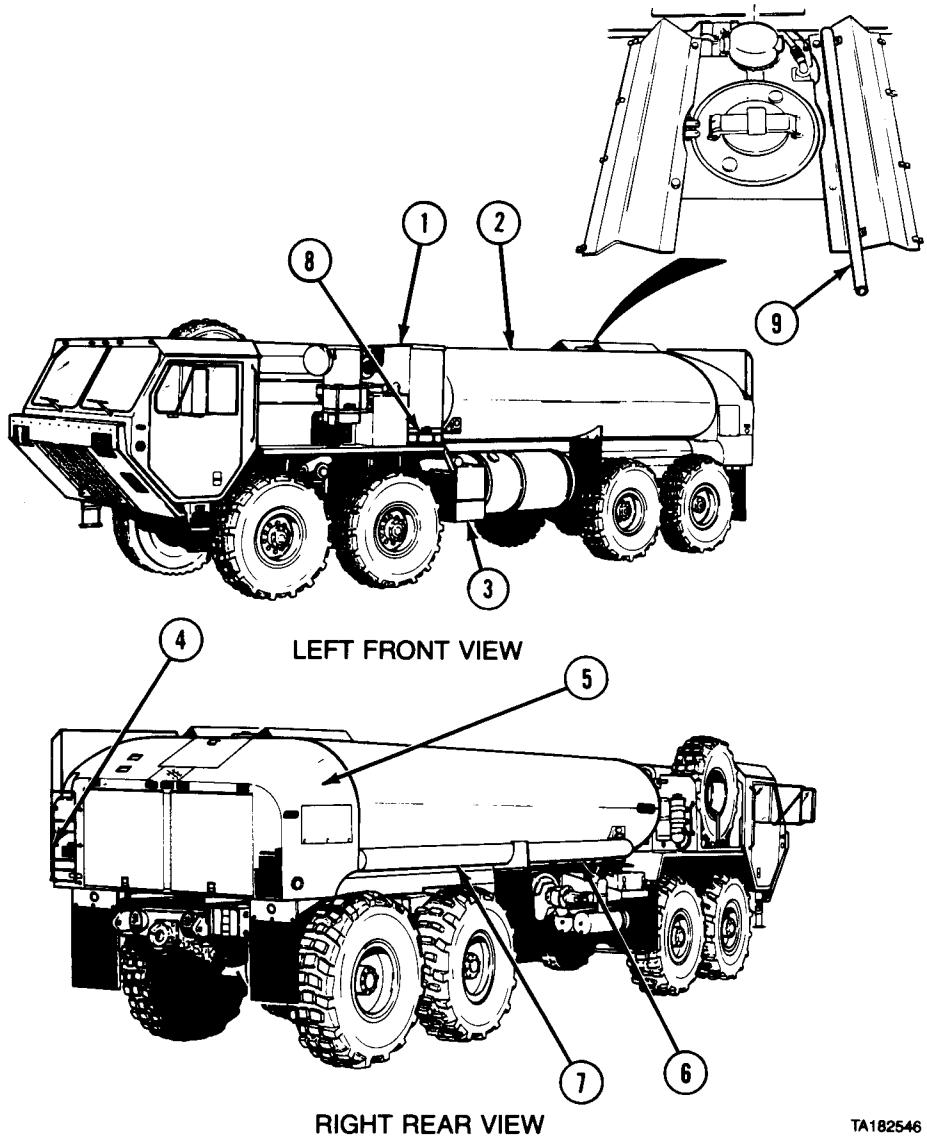
RIGHT REAR VIEW

TA182545

Figure 1-10. M977 Cargo Vehicle Components Location.

- 1. STOWAGE BOXES. Used to stow BII.
- 2. ACCESS LADDER. Used by crew to clean windows, check oil, or perform other tasks requiring access to parts of vehicle out of normal reach.
- 3. CARGO BODY. Used to carry palletized ammunition. Tiedowns are provided to allow ammunition pallets to be tied down.
- 4. MATERIAL HANDLING CRANE. Used to load and unload cargo.

Component Locations (Cont)



TA182546

Figure 1-11. M978 Tanker Vehicle Components Location.

1. **STORAGE BOX.** Used to stow fuel cans or fuel hoses.
2. **TANK.** Stores 2500 gallons (9 463 L) of automotive, diesel, or jet fuel.
3. **STORAGE BOX.** Used to stow BII.
4. **TANK ACCESS LADDER** (shown in stowed position). Provides access to top of tank.
5. **PUMP MODULE.** Contains fuel servicing controls, indicators, and connections.
6. **ACCESS LADDER.** Used by crew to clean windows, check oil, or perform other tasks requiring access to parts of vehicle out of normal reach.
7. **STORAGE COMPARTMENT.** Used to stow 3-inch suction hose assembly.
8. **CHOCK STORAGE BOX.** Used to stow wooden wheel chocks.
9. **DIPSTICK STORAGE TUBE.** Used to stow dipstick.

Component Locations (Cont)

1-10. LOCATION AND DESCRIPTION OF MAJOR COMPONENTS (CONT).

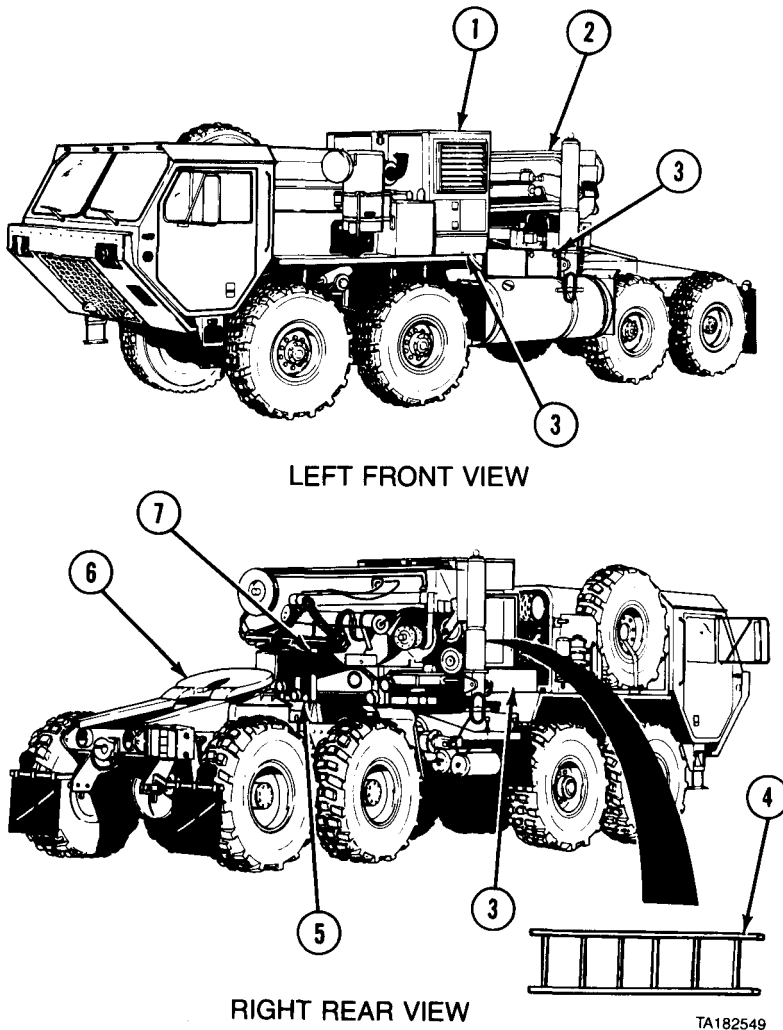
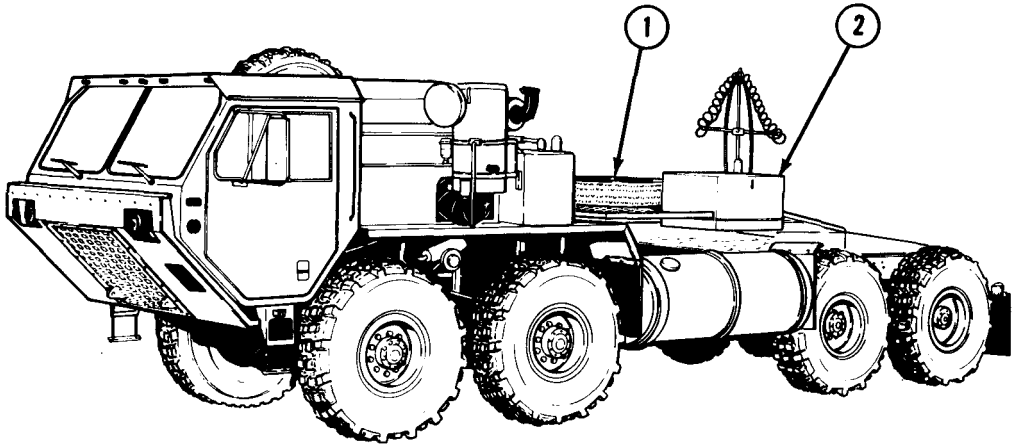


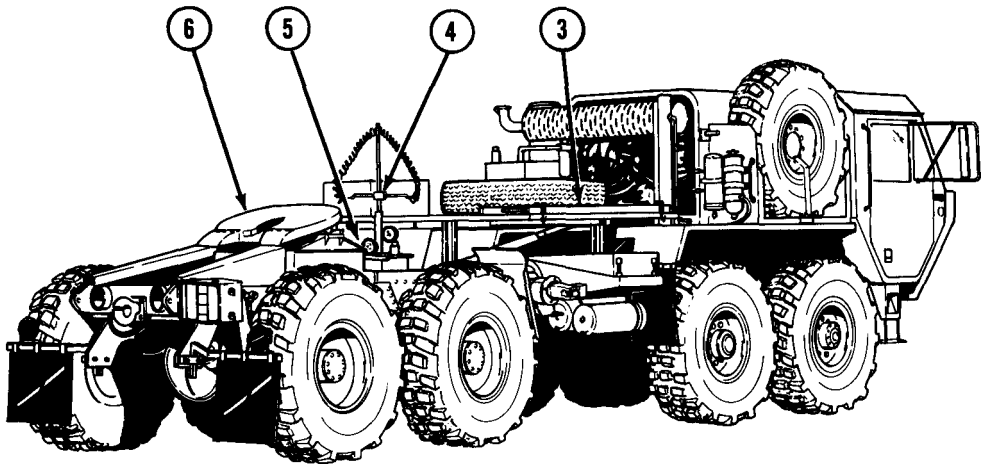
Figure 1-12. M983 Tractor Vehicle (W/Crane) Components Location.

1. ELECTRICAL GENERATOR SET. Provides auxiliary electrical power.
2. MATERIAL HANDLING CRANE. Used to load and unload guided missiles.
3. STOWAGE BOXES. Used to stow BII.
4. ACCESS LADDER. Stowed between generator set and crane. Used by crew to clean windows, check oil, or perform other tasks requiring access to parts of vehicle out of normal reach.
5. SEMITRAILER ELECTRICAL CONNECTOR. Supplies power to semitrailer electrical system through intervehicular cable.
6. FIFTH WHEEL. Couples semitrailer to tractor vehicle.
7. SEMITRAILER GLAD HANDS. Provides air to semitrailer brake system through interconnecting hoses.

Component Locations (Cont)



LEFT FRONT VIEW



RIGHT REAR VIEW

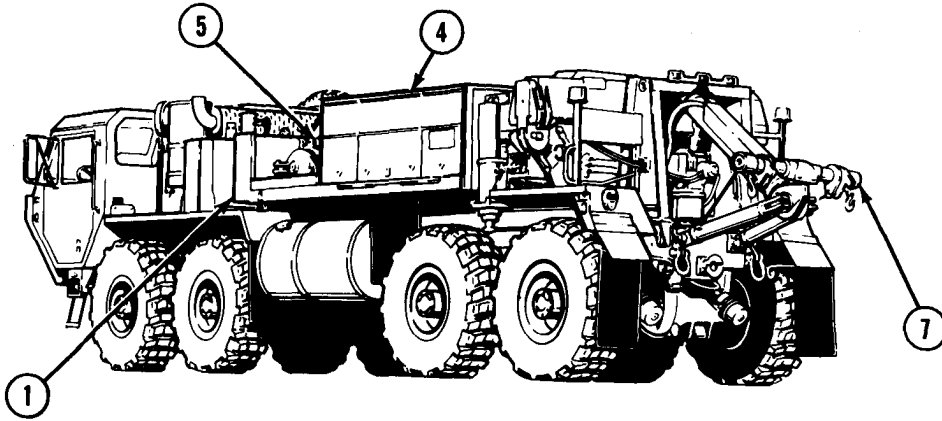
TA182550

Figure 1-13. M983 Tractor Vehicle (W/O Crane) Components Location.

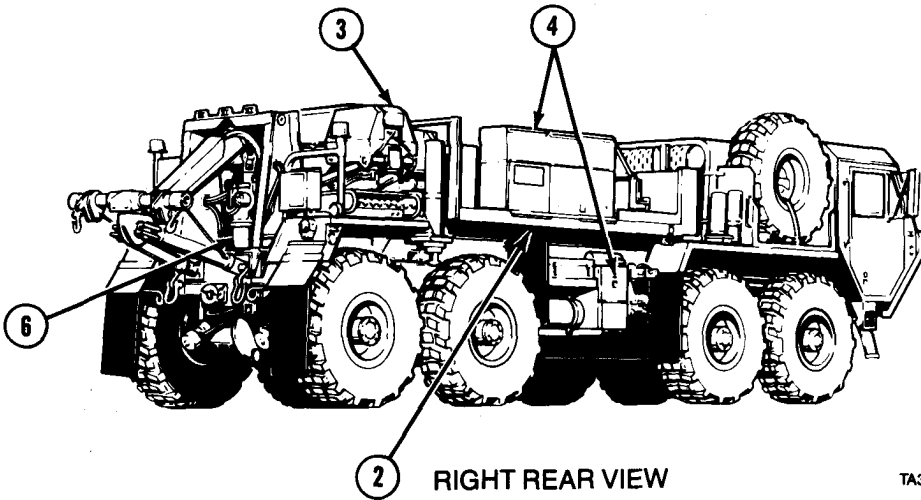
1. SEMITRAILER SPARE TIRE. Semitrailer replacement tire.
2. STOWAGE BOX. Used to stow BII.
3. ACCESS LADDER. Used by crew to clean windows, check oil, or perform other tasks requiring access to parts of vehicle out of normal reach.
4. SEMITRAILER GLAD HANDS. Provides air to semitrailer brake system through interconnecting hoses.
5. SEMITRAILER ELECTRICAL CONNECTOR. Supplies power to semitrailer electrical system through intervehicular cable.
6. FIFTH WHEEL. Couples semitrailer to tractor vehicle.

Component Locations (Cont)

1-10. LOCATION AND DESCRIPTION OF MAJOR COMPONENTS (CONT).



LEFT REAR VIEW



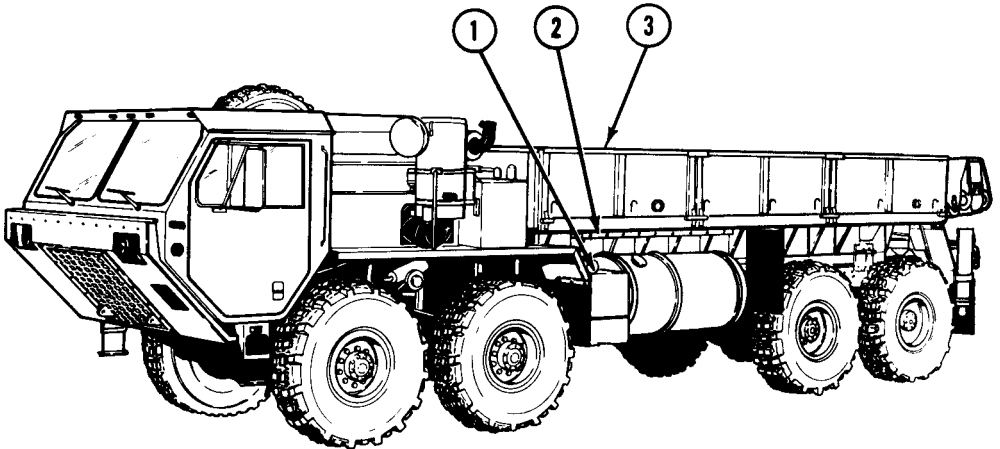
RIGHT REAR VIEW

TA356503

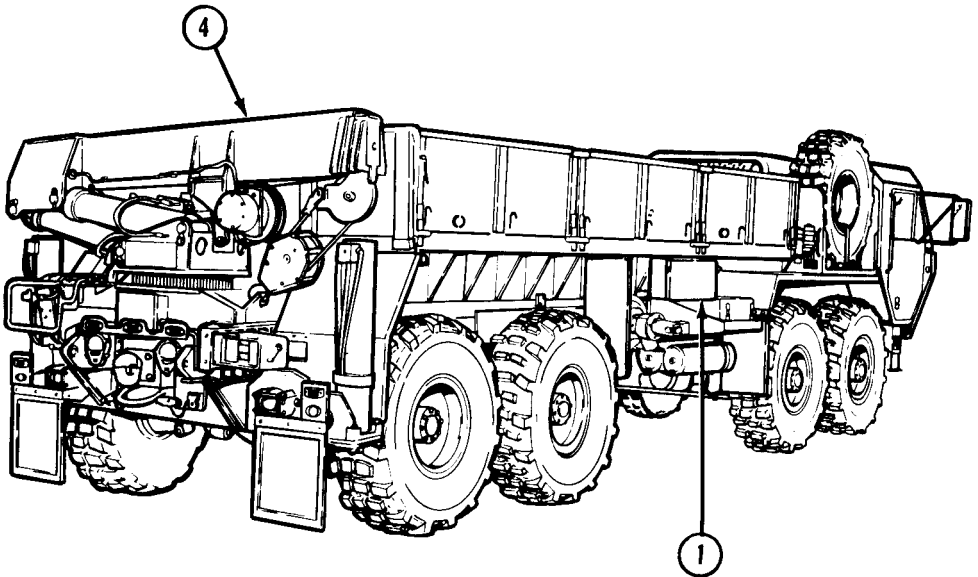
Figure 1-14. M984E1 Wrecker-Recovery Vehicle Components Location.

1. EQUIPMENT BODY. Used to carry AAL, BII, COEI, and repair parts.
2. ACCESS LADDER. Used by crew to clean windows, check oil, or perform other tasks requiring access to parts of vehicle out of normal reach.
3. MATERIAL HANDLING CRANE. Used to load and unload equipment and cargo.
4. STOWAGE BOXES. Used to stow AAL, BII, and COEI.
5. HEAVY-DUTY WINCH. Used to pull vehicles out of ditches, mud, and other areas as needed.
6. FAIRLEAD TENSIONER. Used to help guide and feed heavy-duty winch cable out with hydraulic motor. Used also to keep tension on cable when reeling cable back in as needed.
7. RETRIEVAL SYSTEM. Used for lifting and towing disabled vehicles.

Component Locations (Cont)



LEFT FRONT VIEW



RIGHT REAR VIEW

TA185101

Figure 1-15. M985 Cargo Vehicle Components Location.

1. STOWAGE BOXES. Used to stow BII.
2. ACCESS LADDER. Used by crew to clean windows, check oil, or perform other tasks requiring access to parts of vehicle out of normal reach.
3. CARGO BODY. Used to carry Multiple Launch Rocket System (MLRS) rocket pods. Tiedowns are provided to allow rocket pods to be tied down.
4. MATERIAL HANDLING CRANE. Used to load and unload MLRS rocket pods.

Equipment Differences and Technical Data

1-11. DIFFERENCES BETWEEN MODELS. Refer to Table 1-1 for major differences between models.

Table 1-1. Principal Differences Between Models

Item	Vehicle Model								
	M977		M978		M983		M984E1	M985	
	W/ Winch	W/O Winch	W/ Winch	W/O Winch	W/ Crane	W/O Crane		W/ Winch	W/O Winch
Equipment Body							•		
18 Foot Cargo body	•	•						•	•
Cargo cover kit	•	•						•	•
HD winch							•		
Work lamps					•	•	•		
Beacon lights							•		
Model MHC977 crane	•	•							
Model MHC985 crane								•	•
Model MHC984 crane							•		
Model 8001 crane					•				
Fifth wheel					•	•			
2.0-inch Kingpin					•				
3.5-inch Kingpin						•			
30 KW Generator					•				
Tire carrier						•			
100 Amp alternator					•	•			
65 Amp alternator	•	•	•	•			•	•	•

Equipment Differences and Technical Data (Cont)

1-12, EQUIPMENT DATA. Refer to Table 1-2 for typical equipment data.

Table 1-2. Equipment Data

Model	Item
ALL ALL ALL M977 M978 M983 M984E1 M985 M977 M978 M983 M984E1 M985 M977 M978 M983 M984E1 M985 ALL M977 M978 M983 w/crane M983 w/o crane M984E1 M985	<p>DIMENSIONS</p> <p>Width (overall): 96 in. (2 440 mm)</p> <p>Height (overall): 112 in. (2 840 mm)</p> <p>Height (reduced for shipping): 102 in. (2 590 mm)</p> <p>Length (overall)</p> <p>401 in. (10 170 mm)</p> <p>401 in. (10 170 mm)</p> <p>351 in. (8 920 mm)</p> <p>392 in. (9 960 mm)</p> <p>401 in. (10 170 mm)</p> <p>Wheelbase</p> <p>110 in. (5 330 mm)</p> <p>110 in. (5 330 mm)</p> <p>181 in. (4 600 mm)</p> <p>191 in. (4 850 mm)</p> <p>210 in. (5 330 mm)</p> <p>Turn Circle (wall-to-wall)</p> <p>100 ft (31 m)</p> <p>100 ft (31 m)</p> <p>95 ft (29 m)</p> <p>100 ft (31 m)</p> <p>100 ft (31 m)</p> <p>Ground Clearance: 24 in. (609.6 mm)</p> <p>Center of Gravity (See shipping data plate on left rear outside of cab.)</p> <p>202 in. (5 130 mm)</p> <p>195 in. (4 950 mm)</p> <p>174 in. (4 420 mm)</p> <p>165 in. (4 190 mm)</p> <p>207 in. (5 258 mm)</p> <p>208 in. (5 280 mm)</p>
M977 w/ winch M977 w/o winch M978 w/ winch M978 w/o winch M983 w/ crane M983 w/o crane M984E1 M985 w/ winch M985 w/o winch	<p>WEIGHT</p> <p>Curb Weight:</p> <p>38,800 lb (17 600 kg)</p> <p>37,900 lb (17 200 kg)</p> <p>38,200 lb (17 300 kg)</p> <p>37,300 lb (16 900 kg)</p> <p>39,200 lb (17 800 kg)</p> <p>32,200 lb (14 600 kg)</p> <p>50,900 lb (23 100 kg)</p> <p>39,600 lb (18 000 kg)</p> <p>38,700 lb (17 600 kg)</p>

Equipment Differences and Technical Data (Cont)

1-12. EQUIPMENT DATA (CONT).

Table 1-2. Equipment Data (Cont)

Model	Item
M977 M978 M983 w/ crane M983 w/o crane M984E1 M985 ALL except M984E1 M984E1	<p>WEIGHT (CONT)</p> <p>Gross Vehicle Weight Rating: 59,500 lb (27 000 kg) 54,000 lb (24 500 kg) 54,400 lb (24 600 kg) 46,500 lb (21 000 kg) 72,300 lb (32 800 kg) 60,800 lb (27 500 kg)</p> <p>Gross Combination Weight Rating: 100,000 lb (45 400 kg) 114,000 lb (51 700 kg) (Off-road, LO range, 30% maximum grade) 114,000 lb (51 700 kg) (Primary or Secondary road, LO or HI range, 7% maximum grade) 155,000 lb (70 370 kg) (Primary road, LO range)</p>
M983 w/ crane M983 w/o crane M977 w/ winch M977 w/o winch M978 w/ winch M978 w/o winch M983 w/ crane M983 w/o crane M984E1 M985 w/ winch M985 w/o winch ALL M977 w/ winch M977 w/o winch M978 w/ winch M978 w/o winch M983 w/ crane M983 w/o crane M984E1 M985 w/ winch M985 w/o winch M977 through M983 M984E1 M985	<p>WEIGHT DISTRIBUTION</p> <p>Fifth Wheel Maximum Capacity: 15,000 lb (6 800 kg) 20,000 lb (9 100 kg)</p> <p>Front Tandem Axles - Curb: 21,300 lb (9 650 kg) 20,900 lb (9 490 kg) 22,100 lb (10 010 kg) 21,800 lb (9 860 kg) 24,600 lb (11 170 kg) 21,800 lb (9 900 kg) 23,900 lb (10 800 kg) 20,900 lb (9 530 kg) 20,600 lb (9 370 kg)</p> <p>Front Tandem Axles - Loaded: 30,000 lb (13 600 kg)</p> <p>Rear Tandem Axles - Curb: 17,500 lb (7 950 kg) 17,000 lb (7 710 kg) 16,100 lb (7 290 kg) 15,500 lb (7 040 kg) 14,600 lb (6 630 kg) 10,400 lb (4 700 kg) 27,000 lb (12 300 kg) 18,700 lb (8 470 kg) 18,100 lb (8 230 kg)</p> <p>Rear Tandem Axles - Loaded: 32,000 lb (14 500 kg) 65,000 lb (29 500 kg) 38,000 lb (17 200 kg)</p>

Equipment Differences and Technical Data (Cent)

Table 1-2. Equipment Data (Cont)

Model	Item
ALL	<p>PERFORMANCE</p> <p>Cruising Range at GCWR: 300 mi (483 km)</p> <p>Maximum Sustained Forward Speed (at 2100 rpm) - 4th Gear: 57 mph (92 kmh)</p>
ALL	<p>Maximum Sustained Forward Speed (at 2100 rpm) - 3rd Gear: 41 mph (66 kmh)</p>
ALL	<p>Maximum Sustained Forward Speed (at 2100 rpm) - 2nd Gear: 28 mph (45 kmh)</p>
ALL	<p>Maximum Sustained Forward Speed (at 2100 rpm) - 1st Gear: 15 mph (24 kmh)</p>
ALL	<p>Speed on 3% Grade at GCWR: 25 mph (40 kmh)</p>
ALL	<p>Speed on 3% Grade at GVWR: 40 mph (64 kmh)</p>
ALL	<p>Speed on 30% Grade at GCWR: 3 mph (5 kmh)</p>
ALL	<p>Speed on 30% Grade at GVWR: 5 mph (8 kmh)</p>
ALL	<p>Maximum Grade at GCWR: 30 percent</p>
ALL	<p>Maximum Grade at GVWR: 60 percent</p>
ALL	<p>Maximum Side Slope w/Adequate Traction Surface: 30 percent</p>
ALL	<p>Maximum Towed Speed (Reference FM 20-22): 15 mph (24 kmh)</p>
ALL	<p>Maximum Ford Depth: 48 in. (1 219 mm)</p>
ALL	<p>Approach Angle: 41 degrees</p>
ALL	<p>Departure Angle: 45 degrees</p>
ALL	<p>Limp Home Speed: 10 mph (16 kmh) for up to 30 miles (48 km)</p>
ALL	<p>CAPACITIES</p> <p>Engine Oil w/o Filters: 28 qt (26.5 L)</p> <p>Engine Oil w/Filters: 30 qt (28.4 L)</p> <p>Cooling System: 80 qt (76 L)</p> <p>Transmission w/o Filter: 37 qt (35 L)</p> <p>Transmission w/Filter: 38 qt (36 L)</p> <p>Front Tandem - Front Axle (No. 1): 17.5 qt (16.5 L)</p> <p>Front Tandem - Rear Axle (No. 2): 21.5 qt (20.3 L)</p>

Equipment Differences and Technical Data (Cont)

Table 1-2. Equipment Data (Cont)

Model	Item
ALL ALL ALL ALL ALL	<p>FUEL SYSTEM</p> <p>Type: Diesel Injection</p> <p>Tank Quantity: 1</p> <p>Air Cleaner Type: Dry element</p> <p>Element Quantity: (1 primary, 1 secondary)</p> <p>COOLING SYSTEM</p> <p>Radiator Working Pressure: 7 psi (48 kPa)</p>
ALL M977 M978 M983 M984E1 M985 ALL ALL ALL ALL ALL ALL ALL ALL	<p>ELECTRICAL SYSTEM</p> <p>Voltage: 24</p> <p>Alternator (amps)</p> <p>65 65 100 65 65</p> <p>RFI Suppression Ability: Yes</p> <p>Number of Batteries: 4</p> <p>Battery Voltage (each): 12 volts</p> <p>Battery Connection: Series - parallel</p> <p>Battery Capacity (at 20 hour rate): 900 amp</p> <p>Battery Reserve Capacity (each, at 80°F, 27°C): 180 minutes</p> <p>Battery Cold Cranking Amps (each, at 0°F, - 18°C): 575 CCA</p> <p>Battery Amp Hours (each, at 20 hour rate): 100 amp</p>
ALL ALL ALL ALL ALL	<p>TRANSMISSION</p> <p>Make: Allison</p> <p>Model: HT740D</p> <p>Type: Automatic</p> <p>Number of Forward Speeds: 4</p> <p>Number of Reverse Speeds: 1</p>

Equipment Differences and Technical Data (Cont)

1-12. EQUIPMENT DATA (CONT).

Table 1-2. Equipment Data (Cont)

Model	Item
ALL ALL ALL ALL	<p>TRANSFER CASE Make: Oshkosh Model: 55000 Type: Air operated front tandem disconnect Ratios: 98:1 and 2.66:1</p>
ALL ALL ALL ALL ALL ALL M977 M978 M983 M984E1 M985 M977 through M983 M984E1 M985	<p>AXLES Front Tandem Make: Oshkosh/Eaton Differential Carrier Model Nos.: No. 1 axle-RS480 No. 2 axle-DS480-P Maximum Load Capacity: 30,000 lb (13 600 kg) Maximum Steering Angle: 32 degrees Rear Tandem Make: Eaton Differential Carrier Model Nos. No. 3 axle No. 4 axle DS480-P RS480 DS480-P RS480 DS480-P RS480 DS650-P RS650 DS480-P RS480 Maximum Load Capacity 32,000 lb (14 500 kg) 65,000 lb (29 500 kg) 38,000 lb (17 200 kg)</p>
ALL ALL ALL	<p>BRAKE SYSTEM Actuation: Air Number of Brake Chambers: 8 Pressure Range: 60 - 120 psi (414 - 827 kPa)</p>
ALL ALL	<p>WHEELS Type: Disk Quantity: 8</p>

Equipment Differences and Technical Data (Cont)

Table 1-2. Equipment Data (Cont)

Model	Item			
	WHEELS (Cont)			
	Vehicle Spare Wheel			
ALL	Quantity: 1			
ALL	Rim Size: 20 x 10			
ALL	Stud Quantity Per Wheel: 10			
	TIRES			
ALL	Type: Radial w/tube			
ALL	Quantity: 8			
ALL	Spare Quantity: 1			
ALL	Tread Type: Radial traction, non-directional			
ALL	Size: 16:OOR x 20 in.			
ALL	Load Range: M			
	TIRE PRESSURES			
	<u>Highway</u>	<u>cross Country-Dry</u>	<u>cross Country-Wet</u>	<u>Sandy Terrain</u>
Front (all models)				
Standard Tire	60 psi (414 kPa)	35 psi (241 kPa)	20 psi (138 kPa)	30 psi (207 kPa)
Sand Tire	60 psi (414 kPa)	NA	NA	25 psi (172 kPa)
Rear				
M977,M978,M983				
Standard Tire	70 psi (483 kPa)	40 psi (276 kPa)	30 psi (207 kPa)	35 psi (241 kPa)
Sand Tire	70 psi (483 kPa)	NA	NA	30 psi (207 kPa)
M984E1				
Standard Tire	100 psi (690 kPa)	100 psi (690 kPa)	100 psi (690 kPa)	30 psi (207 kPa)
Sand Tire	100 psi (690 kPa)	NA	NA	25 psi (172 kPa)
M984E1 (when towing another vehicle)				
Standard Tire	100 psi (690 kPa)	100 psi (690 kPa)	100 psi (690 kPa)	80 psi (551 kPa)
Sand Tire	100 psi (690 kPa)	NA	NA	80 psi (551 kPa)

Equipment Differences and Technical Data (Cont)

Table 1-2. Equipment Data (Cont)

Model	Item			
Front (all models) M985 Standard Tire Sand Tire Spare Tire (all models) Standard Tire Sand Tire	TIRE PRESSURES (Cont)			
	<u>Highway</u>	Cross <u>Country-Dry</u>	Cross <u>Country-Wet</u>	Sandy <u>Terrain</u>
	90 psi (621 kPa)	50 psi (345 kPa)	40 psi (276 kPa)	40 psi (276 kPa)
	100 psi (690 kPa)	NA	NA	40 psi (276 kPa)
	100 psi (690 kPa)	100 psi (690 kPa)	100 psi (690 kPa)	100 psi (690 kPa)
	100 psi (690 kPa)	NA	NA	100 psi (690 kPa)
Maximum Speed (all models) Standard Tire Sand Tire M984E1 (when towing another vehicle) Standard Tire Sand Tire	OPERATING SPEEDS			
	<u>Highway</u>	Cross <u>Country-Dry</u>	Cross <u>Country-Wet</u>	Sandy <u>Terrain</u>
	55 mph (88 kmh)	40 mph (64 kmh)	20 mph (32 kmh)	20 mph (32 kmh)
	55 mph (88 kmh)	NA	NA	20 mph (32 kmh)
	15 mph (24 kmh)*	15 mph (24 kmh)	15 mph (24 kmh)	15 mph (24 kmh)
	15 mph (24 kmh)*	NA	NA	15 mph (24 kmh)
	* Operation at speeds over 15 mph (24 kmh) on paved road can be achieved when the operator determines that the vehicle being towed and the terrain allow for safe operation. Under no condition can speeds exceed 35 mph (55 kmh) on paved roads and 15 mph (24 kmh) off paved roads.			

Equipment Differences and Technical Data (Cont)

1-12. EQUIPMENT DATA (CONT).

Table 1-2. Equipment Data (Cont)

Model	Item
ALL	STEERING SYSTEM Type: Dual gear with integrated hydraulic power assist
ALL M983 w/crane M983 w/o crane	FIFTH WHEEL Type: Full (4-way) oscillating, w/kingpin lock Kingpin Size: 2 in. (51 mm) 3.5 in. (89 mm)
ALL ALL ALL	PINTLE Type: Manual Release Maximum Load Capacity - Pulling: 30,000 lb (13 607.8 kg) (In Off Road Application) Maximum Load Capacity - Vertical: 1700 lb (771.1 kg)
M1977-CBT M1977CBT M1977CBT	PINTLE/COUPLER Type: Self-guiding, automatically locking Maximum Gross Trailer Weight: 100,000 lb (45 400 kg) Maximum Load Capacity - Vertical: 20,000 lb (9 080 kg)
ALL ALL	TOWING EYES Quantity: 4 (2 front, 2 rear) Maximum Load Capacity Each: 60,000 lb (27 240 kg)
ALL ALL	CAB Windshield: Tinted, 2 piece, safety glass Personnel Capacity: 2
M977 M977 M977 M983 w/crane M983 w/crane M983 w/crane M984E1 M984E1 M984E1	MATERIAL HANDLING CRANES Make: Grove Model: MHC977 Maximum Capacity at Boom Length of 19 ft (5.8 m): 2500 lb (1 135 kg) Make: Hiab Model: 8001 Maximum Capacity of Boom Length of 10 ft (3.1 m): 14,620 lb (6 637 kg) Make: Grove Model: MHC984 Maximum Capacity of Boom Length of 18.2 ft (5.5 m): 6000 lb (2 722 kg)

Equipment Differences and Technical Data (Cont)

Table 1-2. Equipment Data (Cont)

Model	Item
M985 M985 M985	Make: Grove Model: MHC985 Maximum Capacity of Boom Length of 16.5 ft (5.0 m): 5400 lb (2 452 kg)
M977 w/winch M978 w/winch M983 M9843E1 M985 w/winch	SELF-RECOVERY WINCH Make: DP Manufacturing Model: 20K-HEMTT Wire Rope Diameter: 9/16 in. (14.3 mm) Wire Rope Length: 200 ft (61 m) Line Pull - 1st Layer (Five Wraps Minimum): 20,000 lb (9 080 kg) Line Pull - 2nd Layer: 18,173 lb (8 251 kg) Line Pull - 3rd Layer: 16,663 lb (7 565 kg) Line Pull - 4th Layer: 15,361 lb (6 974 kg) Line Pull - 5th Layer: 14,254 lb (6 471 kg)
M98431 M984E1 M984E1 M984E1 M984E1 M984E1 M984E1	RECOVERY WINCH Make: DP Manufacturing Model: 51022 60K Type: Automatic Two Speed Wire Rope Diameter: 1 in. (25 mm) Wire Rope Length: 220 ft (67 m) Line Pull - First Layer (with five wraps): 60,000 lb (27 240 kg) Line Pull -Third Layer: 45,000 lb (20 430 kg)
ALL*	AUXILIARY EQUIPMENT Arctic Kit - Engine Chemical Alarm Cargo Cover Kit Decontamination Unit Gas Particulate Filter Unit Machine Gun Ring Radio Installation Kit Rifle Mounting Kit * Vehicle may or may not be equipped with any of these item depending on mission, climate, or other factors.

Equipment Differences and Technical Data (Cont)

1-12. EQUIPMENT DATA (CONT).

Table 1-3. Load Classification

Model	Unloaded (ton)	Full Load (ton)	With Loaded Trailer (ton)
M977	16	28	
M978	15	25	
M983 w/o crane	14		C-29 (w/Patriot)
M983 w/crane	16		C-33 (w/Pershing)
M984E1	19		C-57 (towing loaded M985)
M985	17	28	C-38 (towing HEMAT M989)

Section III. TECHNICAL PRINCIPLES OF OPERATION

Vehicle Operation Systems

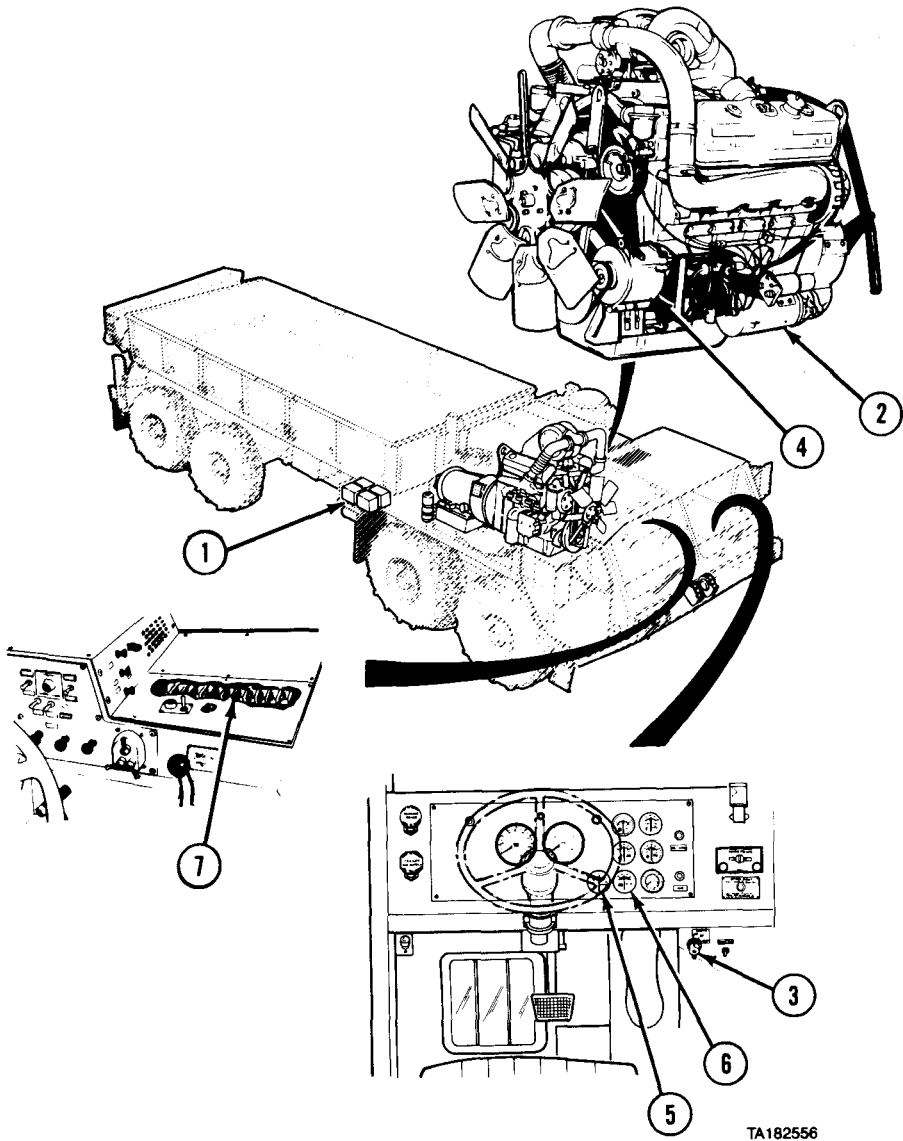
1-13. SYSTEMS INTRODUCTION.

All M977 vehicles contain three functional systems. They are the electrical system, air system, and hydraulic system. This section explains the overall operation of the functional systems.

1-14. ELECTRICAL SYSTEM.

The electrical system (fig. 1-16) is a 24 Vdc system. Four 12 Vdc storage batteries (1) are connected in series-parallel with the negative terminal grounded. The starting motor (2) operates directly from the 24 Vdc source through the engine start switch (3). A belt-driven 24 Vdc alternator (4) having a capacity of 65 amps (M983 - 100 amps) maintains the charge on the batteries. The AMPERES gage (5) shows the alternator output. The BATTERY gage (6) shows the state of charge of the batteries and alternator voltage output. The vehicle electrical circuits are protected against overloads by automatic reset circuit breakers (7) located below the heater compartment panel. Wiring harnesses are used to carry current to operate equipment and accessories.

Vehicle Operation Systems (Cont)



TA182556

Figure 1-16. Electrical System Components Location.

Vehicle Operation Systems (Cont)

1-15. AIR SYSTEM. The air system (fig. 1-17) consists of an engine driven air compressor (1) and four air reservoirs (2, 3, 4, and 5). Reservoir (4) is used on all vehicles except the M983 tractor which has reservoir (6) instead.

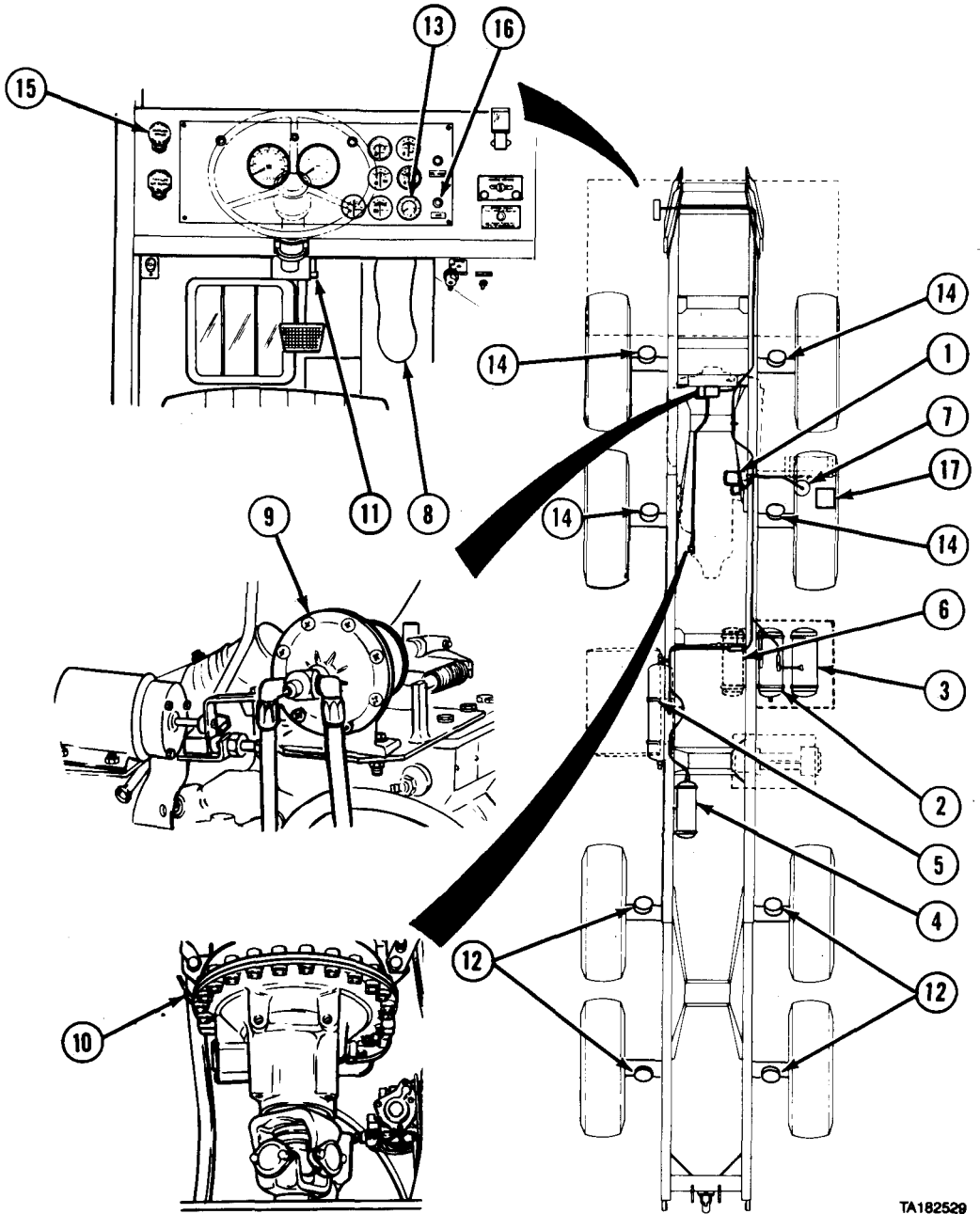
The air system includes the necessary valves and air lines to control the vehicle's air operated parts. Pressurized air from the air compressor is passed through the air dryer (7) to the quick buildup reservoir (2). The air dryer removes dirt and moisture from the pressurized air. Air from reservoir goes to the throttle treadle (8). Depending on how far the throttle treadle is depressed, 0 to 60 psi (0 to 414 kPa) is supplied to the engine throttle air cylinder (9) and to the transmission modulator (10). This air pressure controls the vehicle speed.

Once air pressure in reservoir (2) rises above 75 psi (517 kPa), a valve opens and allows reservoirs (3, 4 or 6, and 5) to be pressurized up to 120 psi (827 kPa). Air from reservoir (4 or 6) goes to the brake treadle valve (11). This air controls the rear axle service parking brakes (12). Air pressure in this system is shown by the red needle on the AIR PRESS gage (13). Air from reservoir (3) goes to the brake treadle valve. This air controls the front axle service brakes (14). Air pressure in this system is shown by the green needle on the AIR PRESS gage.

The PARKING BRAKE valve (15) controls air from reservoirs (3 and 5) and applies or releases the rear axle service (parking) brakes. Reservoirs (3, 4 or 6, and 5) are interconnected so that if one reservoir fails, air is supplied to release the rear axle service (parking) brakes from whichever reservoir is functioning. If air pressure falls below 60 to 75 psi (414 kPa to 517 kPa), a buzzer will sound and the AIR indicator (16) will light.

On the M984E1 the front brake actuator valve (17) is used to apply the front axle service brakes when using heavy-duty winch.

Vehicle Operation Systems (Cont)

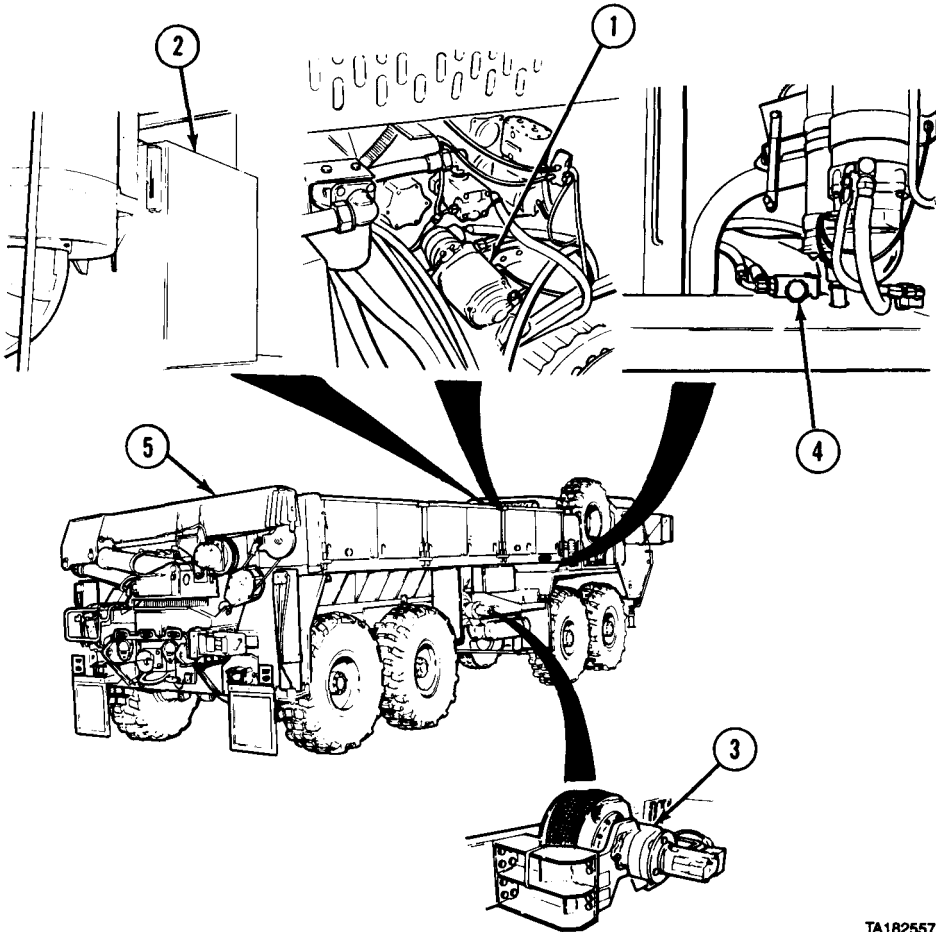


TA182529

Figure 1-17. Air System Components Location.

Vehicle Operation Systems (Cont)

1-16. MAIN HYDRAULIC SYSTEM. (A1 models except M984E1) The main hydraulic system (fig. 1-18) consists of a power takeoff (PTO) driven hydraulic pump (1) and a fluid reservoir (2) shared with the power steering hydraulic system. Any vehicle may also be equipped with a self-recovery winch (3) and a selector valve (4). The main hydraulic system includes the material handling cranes (5) on the M977 series vehicles. The fuel pump on the M978 is part of the main hydraulic system.



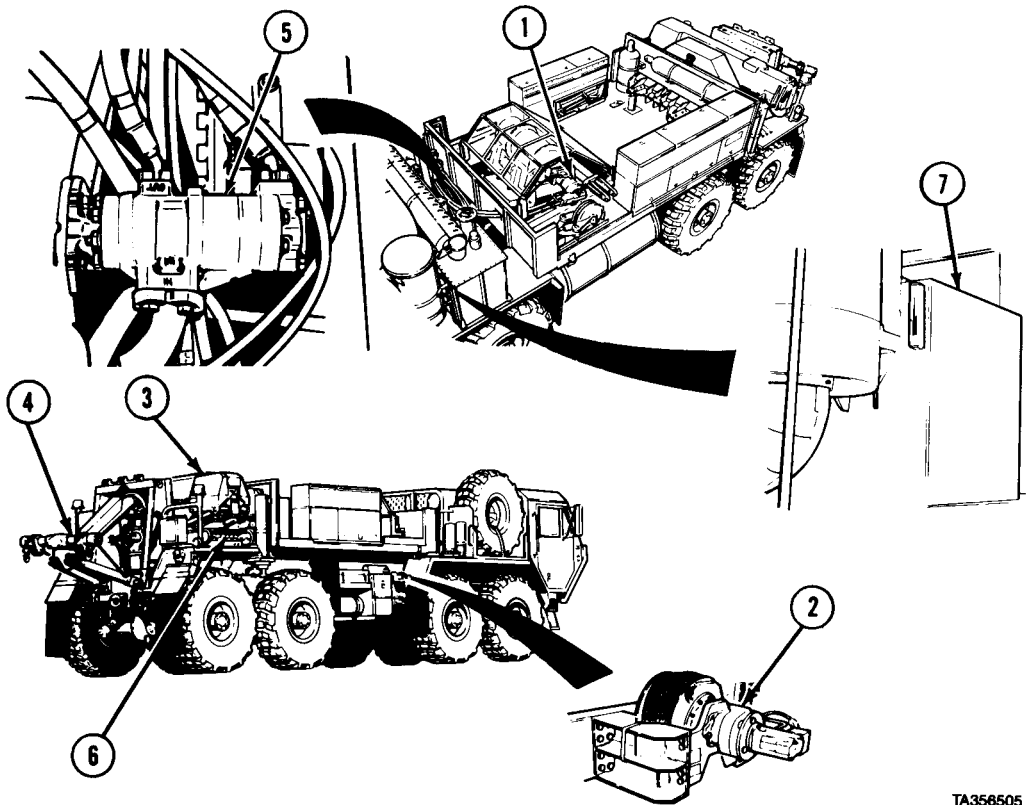
TA182557

Figure 1-18. Main Hydraulic System Components Location.

Vehicle Operation Systems (Cont)

1-17. MAIN HYDRAULIC SYSTEM (M984E1). Fluid power for operating the heavy-duty winch (1), self-recovery winch (2), crane (3), and retrieval system (4) (fig. 1-19) is provided by a steering/tensioner pump (5) mounted on the power takeoff (PTO) on the transmission.

Auxiliary equipment operation by the PTO driven pump is selected from the crane control panel (6) at rear of vehicle. Both hydraulic pumps share the same reservoir (7).



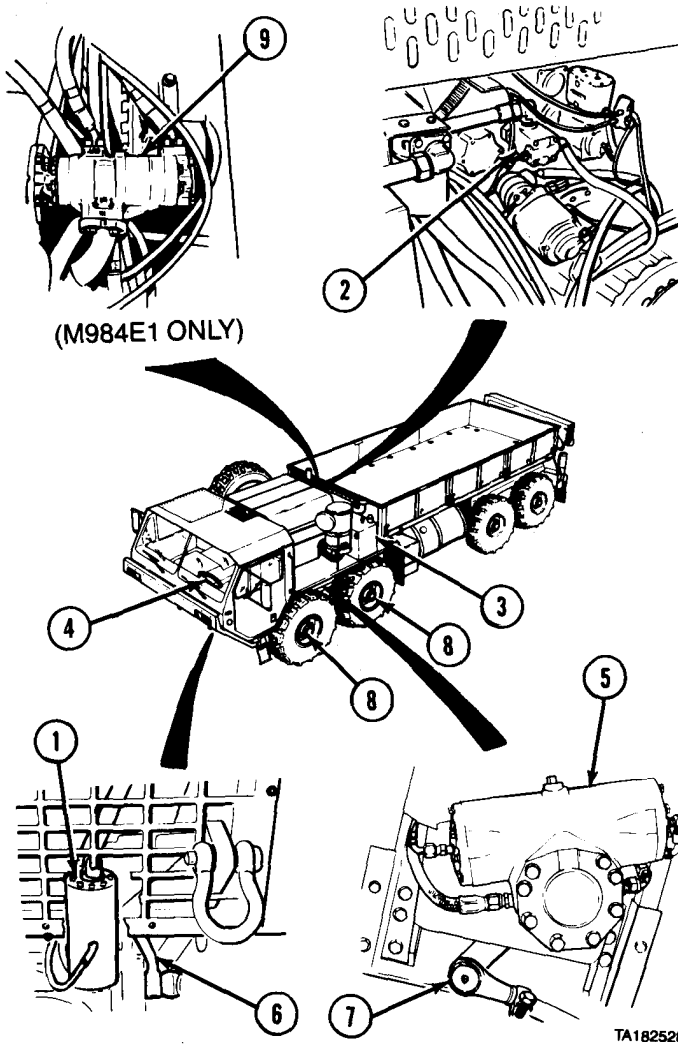
TA358505

Figure 1-19. Main Hydraulic System (M984E1).

Vehicle Operation Systems (Cont)

1-18. POWER STEERING HYDRAULIC SYSTEM. Figure 1-20 shows how power is supplied to the main steering gear (1) by an engine driven pump (2). The fluid reservoir (3) is shared with the main hydraulic system. The steering wheel (4) is mechanically linked to the main steering gear. The steering wheel rotates a gear that positions a spool in the main steering gear. This motion is hydraulically sent to a piston in the slave gear (5) causing it to follow the rotation of the main steering gear. The main gear pitman arm (6) is mechanically connected to the slave gear pitman arm (7). These pitman arms move the steering mechanism on the front axles (8) left or right causing the vehicle to steer left or right.

On the M984E1 the power is supplied to the main steering gear (1) by an engine driven steering/tensioner pump (9).



TA182528

Figure 1-20. Power Steering Hydraulic System Components Location.

**CHAPTER 2
OPERATING INSTRUCTIONS**

Contents	Para	Page
Controls and Indicators Introduction	2-1	2-2
Location and Use of Controls and Indicators	2-2	2-2
PMCS Introduction	2-3	2-33
Maintenance Forms and Records	2-4	2-33
Preventive Maintenance Checks and Services	2-5	2-33
General Maintenance Procedures	2-6	2-34
Fluid Leakage	2-7	2-34
Operator/Crew Preventive Maintenance Checks and Services Table	2-8	2-35
Prepare to Operate Vehicle	2-9	2-144
Operate Lights	2-10	2-146
Drive Vehicle	2-11	2-155
Operate Windshield Wiper/Washer	2-12	2-178
Operate Personnel Heater	2-13	2-179
Operate Fire Extinguisher	2-14	2-180
Use Access Ladder	2-15	2-185
Operate Drain Plug	2-15.1	2-188.2
Operate Work Lamp (M977, M978)	2-15.2	2-188.3
Connect/Disconnect Trailer (M977, M985)	2-16	2-190
M977, M985 Cargo Body Operation	2-17	2-195
M977, M985 Crane Operation (Manual Controls)	2-18	2-212
M977, M985 Crane Operation (Remote Controls)	2-19	2-232
Prepare Tanker for Operation	2-20	2-242
Check Tanker Fuel Level	2-21	2-247
Load Tanker With Fuel	2-22	2-250
Land Vehicle or Aircraft Overwing Fuel Servicing	2-23	2-270
Recirculate Fuel	2-24	2-282
Unload Fuel	2-25	2-292
Changing to Different Fuel or Fuel Grade	2-26	2-310
Transfer of Fuel Between Tanker Vehicles	2-26.1	2-320.1
Connect/Disconnect Semitrailer to M983	2-27	2-320.2
M983 Crane Operation (Manual Controls)	2-28	2-328
M983 Crane Operation (Remote Controls)	2-29	2-346
Beacon Light Operation	2-30	2-357
Auxiliary Equipment Operating Procedures	2-31	2-361
Operate Vehicle in Extreme Heat	2-32	2-374
Operate Vehicle in Extreme Dust	2-33	2-376
Operate Vehicle in Sand or Mud	2-34	2-377
Operate Vehicle in Desert Environment	2-35	2-379
Operate Vehicle in Cold Environment (32°F, 0°C, To - 25 F, -32°C	2-36	2-379
Operate Vehicle in Extreme Cold Environment (-26°F, -32°C, To -65°F, -54°C)	2-37	2-382
Operate Vehicle in Forest or Rocky Terrain	2-38	2-384
Install/Remove Tire Chains	2-39	2-384.2
Ford Water Obstacle	2-40	2-392
Self-Recover Vehicle Using Self-Recovery Winch	2-41	2-393

Contents	Para	Page
Snatch Block Installation/Removal	2-42	2-419
Connect/Disconnect Self-Recovery Winch Cable to Another Vehicle	2-43	2-420
Set Up/Secure Highway Emergency Marker Kit	2-44	2-423
Tow Disabled Vehicle	2-45	2-428
Connect/Disconnect Tow Bar	2-46	2-429
Manually Release Spring Brakes	2-47	2-436.1
Emergency Procedures	2-48	2-439
Limp Home/Flat Tire With No Spare	2-49	2-459

Section I. DESCRIPTION AND USE OF OPERATOR'S CONTROL AND INDICATORS

Controls and Indicators

2-1 CONTROLS AND INDICATORS INTRODUCTION This section shows the location and describes the use of controls and indicators used to operate M977 series vehicles. Controls and indicators described in this section are the same for all vehicles, except where otherwise indicated,

2-2. LOCATION AND USE OF CONTROLS AND INDICATORS. Know the location and proper use of every control and indicator before operating the vehicle. Use this section to learn about each control and indicator to be used. Separate illustrations with keys are provided for the following groups of controls and indicators.

Contents	Figure
Cab-Mounted Foot Controls	2-1
Cab-Mounted Hand Controls	2-2
Steering Column Mounted Controls	2-3
Tunnel Panel Controls	2-4
Instrument Panel Controls and Indicators	2-5
Heater Compartment Controls and Indicators	2-6
Operator and Crew Seat Adjustment Controls	2-7
M977 and M985 Crane Control Panel	2-8
M977 and M985 Crane Remote Control Unit	2-9
M978 Tanker Module Controls - Far Right and Left	2-10
M978 Tanker Module Controls - Center	2-11
M978 Tanker Module Controls - Near Right	2-12
M978 Tanker Module Controls - Near Left	2-13
M979 Tanker Controls - Left Side of Vehicle	2-14
M983 Crane Main Control Panel	2-15
M983 Crane Secondary Control Panel	2-16
M983 Crane Remote Control Panel	2-17
Arctic Engine Heater	2-19
Gas Particulate Filter Unit	2-20
Rifle Stowage Mount	2-21
Machine Gun Mount	2-22
M-8 Chemical Alarm	2-23
M-13 Decontamination Unit	2-24
Radio Installation	2-25

Controls and Indicators (Cont)

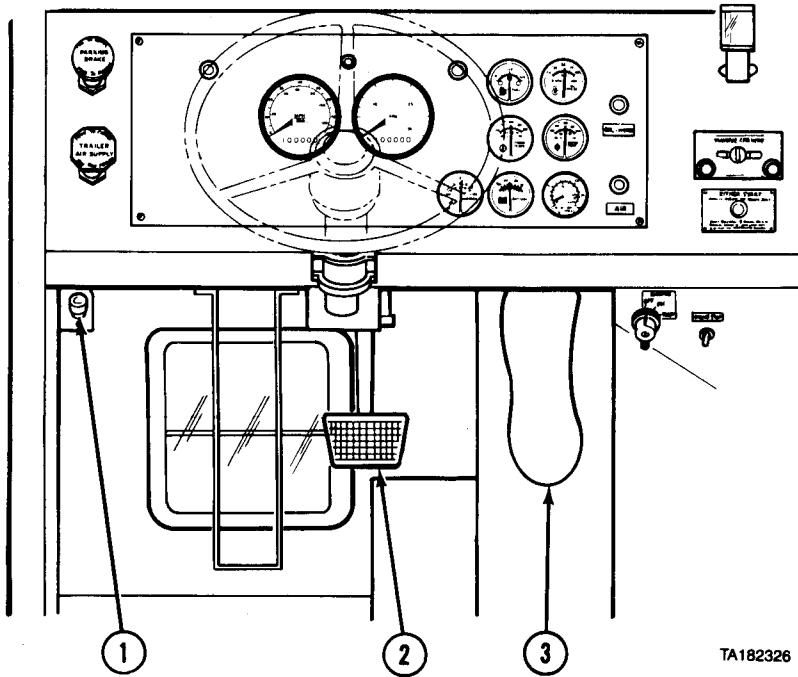


Figure 2-1. Cab-Mounted Foot Controls.

Key	Control or Indicator	Function
1	Headlight Dimmer Switch	Press switch to raise or lower headlight beams. High beam indicator will light (red) when high beams are on.
2	Service Brake Treadle	Applies service brakes. If vehicle is properly coupled to a trailer, trailer service brakes will also operate when vehicle service brakes are applied.
3	Throttle Treadle	Controls vehicle speed.

Controls and indicators (Cont)

2-2. LOCATION AND USE OF CONTROLS AND INDICATORS (CONT).

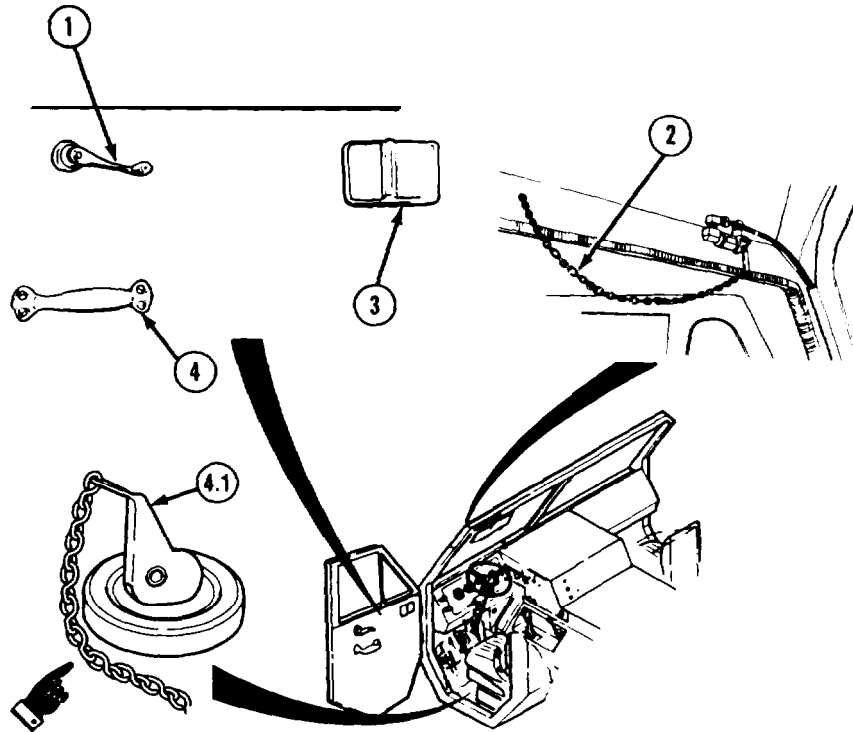
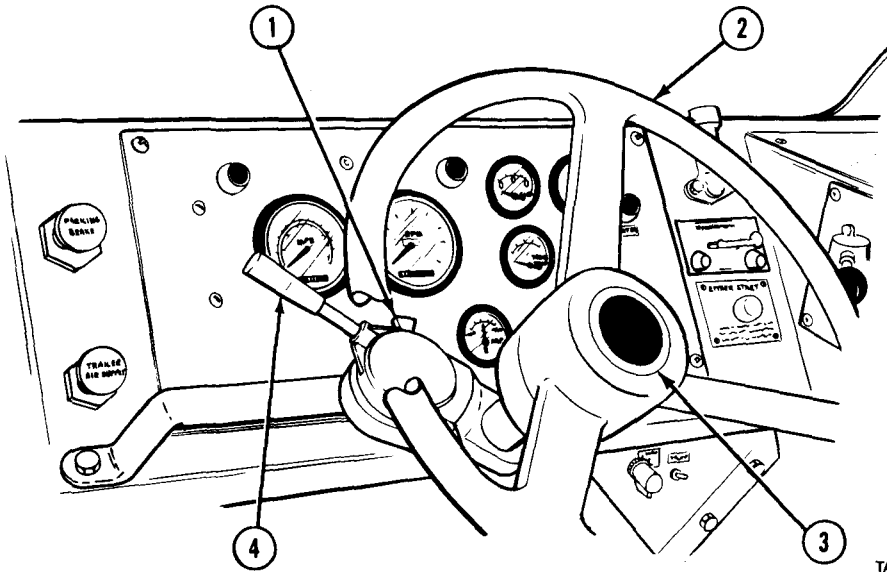


Figure 2-2. Cab-Mounted Hand Controls.

Key	Control or Indicator	Function
1	Cab Door Window Glass Regulator (one on each door)	Rotate left regulator counterclockwise to lower left window glass, clockwise to raise left window glass. Rotate right regulator clockwise to lower right window glass, counterclockwise to raise right window glass.
2	Air Horn Chain	Pull down to sound air horn. Let go to silence air horn.
3	Cab Door Inside Handle (one on each door)	Pull to open cab door from inside of cab.
4	Cab Door Handle (one on each door)	Pull to close cab door from inside of cab.
4.1	Drain Plug (one under operator seat and crew seat)	Pull up on lever to remove drain plug and drain liquid from floor of cab.

Controls and Indicators (Cont)



TA182328

Figure 2-3. Steering Column Mounted Controls.

Key	Control or Indicator	Function
1	Emergency Flasher Control	To turn on hazard warning flashers, move turn signal lever (4) to right turn position, press HAZARD tab down and push turn signal lever up as far as it will go. To turn hazard warning flashers off, push signal lever down to center position. Light control must be in STOP LIGHT or SER DRIVE.
2	Steering Wheel	Controls direction of vehicle.
3	Horn Button	Sounds electric horn when pressed.
4	Turn Signal Lever	Push up to signal right turn. Pull down to signal left turn. When turn is completed, return lever to center position.

Controls and Indicators (Cont)

2-2. LOCATION AND USE OF CONTROLS AND INDICATORS (CONT).

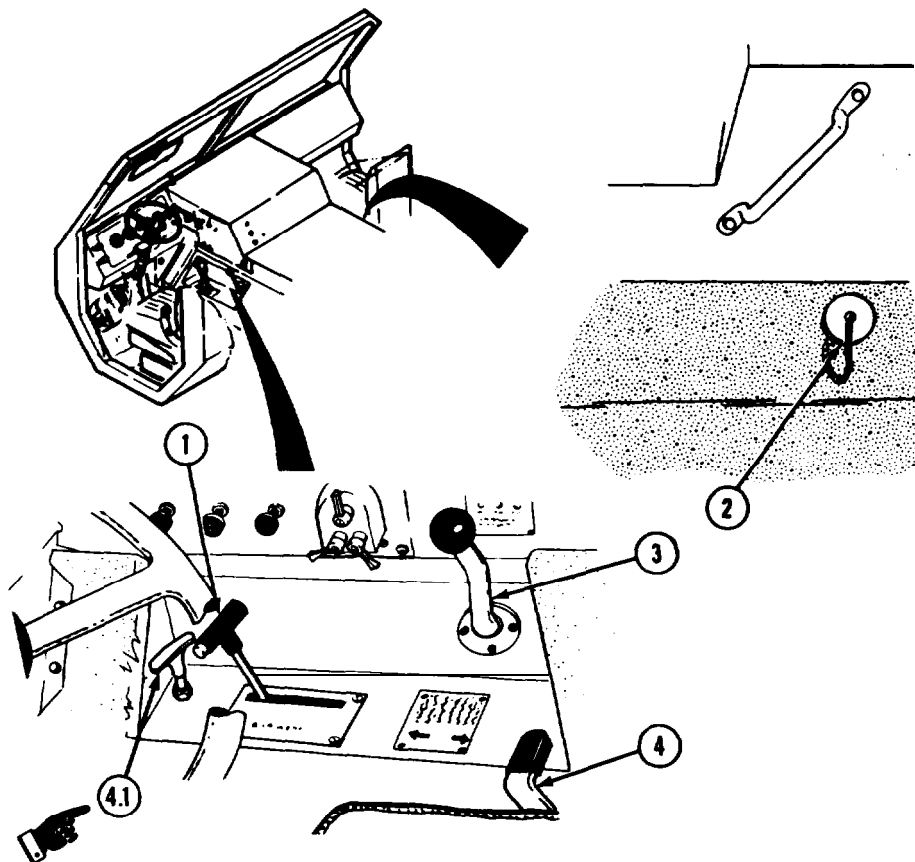
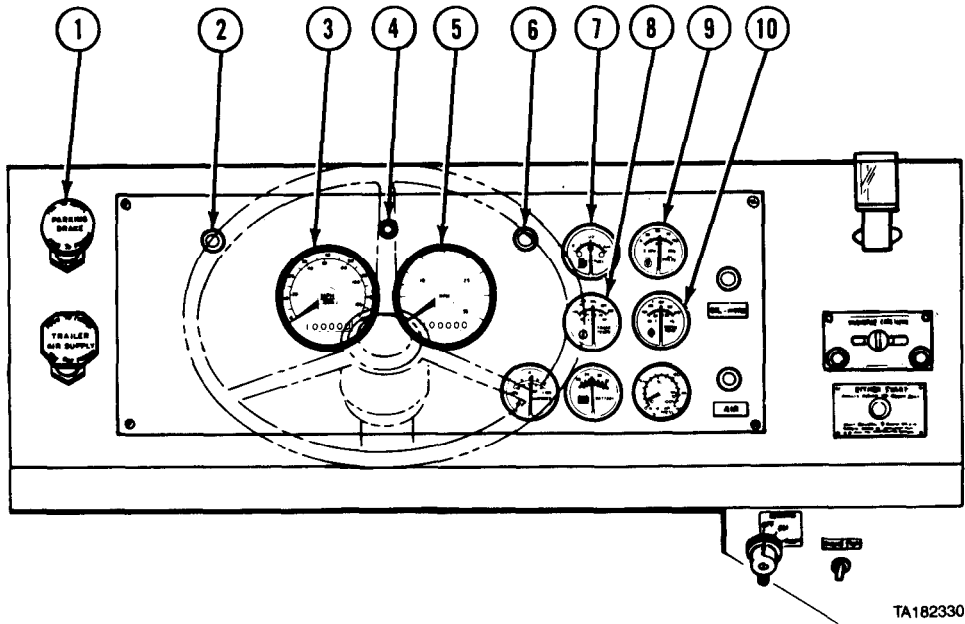


Figure 24. Tunnel Panel Controls.

Key	Control or Indicator	Function
1	Transmission Range Selector	Used to select transmission range.
2	STE/ICE Receptacle	Receptacle for connecting simplified test equipment/internal combustion engine (STE/ICE).
3	TRANSFER CASE Shift Lever	Used to select high (HI) or low (LO) range. Center position is neutral (NEUT).
4	Self-Recovery Winch Shift Lever	Used to pay out and take up winch cable. Center position is neutral.
4.1	Shutdown Cable Handle	Used to shutdown engine in emergencies.

Controls and Indicators (Cont)



TA182330

Figure 2-5. Instrument Panel Controls and Indicators (Sheet 1 of 3).

Key	Control or Indicator	Function
1	PARKING BRAKE Control	Applies and releases vehicle parking brakes.
2	Left Turn Indicator	Flashes (green) when left turn signal is on.
3	Speedometer/Odometer	Shows vehicle traveling speed (in MPH and kmh) and total miles traveled.
4	High Beam Indicator	Lights (red) when vehicle headlights are on high beam.
5	Tachometer/Hourmeter	Shows engine operating speed (R.P.M. \times 100) and total operating time (HOURS).
6	Right Turn Indicator	Flashes (green) when right turn signal is on.
7	FUEL Gage	Shows amount of fuel in fuel tank.
8	TRANS TEMP Gage	Shows transmission fluid temperature (in degrees F and degrees C).
9	OIL PRESS Gage	Shows engine oil pressure (in psi and kPa).
10	WATER TEMP Gage	Shows engine coolant temperature (in degrees F and degrees C).

Controls and Indicators (Cont)

2-2. LOCATION AND USE OF CONTROLS AND INDICATORS (CONT).

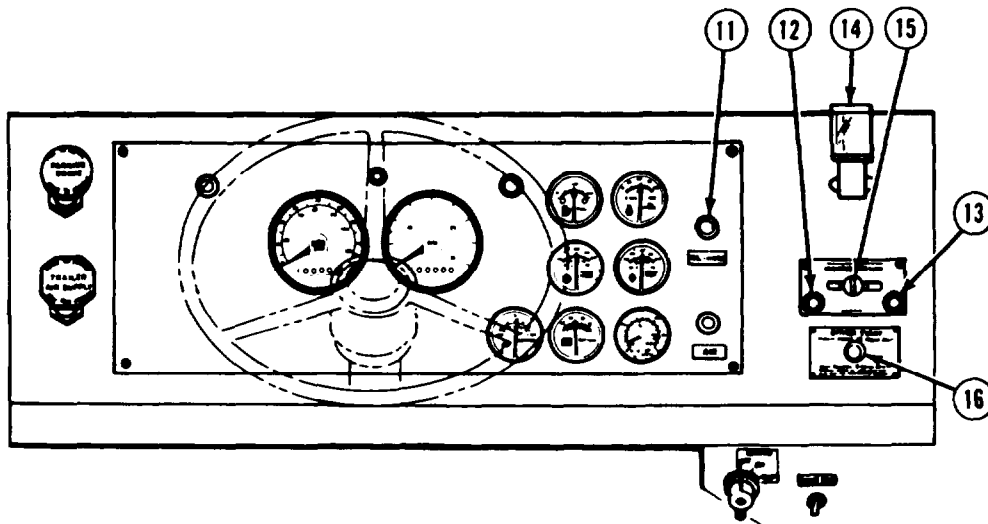


Figure 2-5. Instrument Panel Controls and Indicators (Sheet 2 of 3).

Key	Control or Indicator	Function
11	OIL-WATER Indicator	Lights (red) when engine oil pressure is too low or when engine coolant temperature is too high. Buzzer sounds at the same time.
12	INTER-AXLE DIFF. LOCK Indicator	Lights (red) when TRACTION CONTROL is in INTER-AXLES DIFF. LOCK position.
13	8X8 DRIVE Indicator	Lights (orange) when TRACTION CONTROL is in 8X8 DRIVE position or when TRANSFER CASE is in LO.
14	Air Filter Restriction Indicator	Shows condition of air cleaner filter. Indicator window shows yellow when filter is clean and red when filter becomes clogged. VACUUM INCHES H ₂ O window shows degree of restriction.
15	TRACTION CONTROL	In left position (INTER-AXLE DIFF. LOCK) locks interaxle differentials in front and rear tandems. In right position (8X8 DRIVE), engages transfer case drive to front axle.
16	ETHER START Control	Injects ether into engine intake manifold for cold weather starting.

Controls and Indicators (Cont)

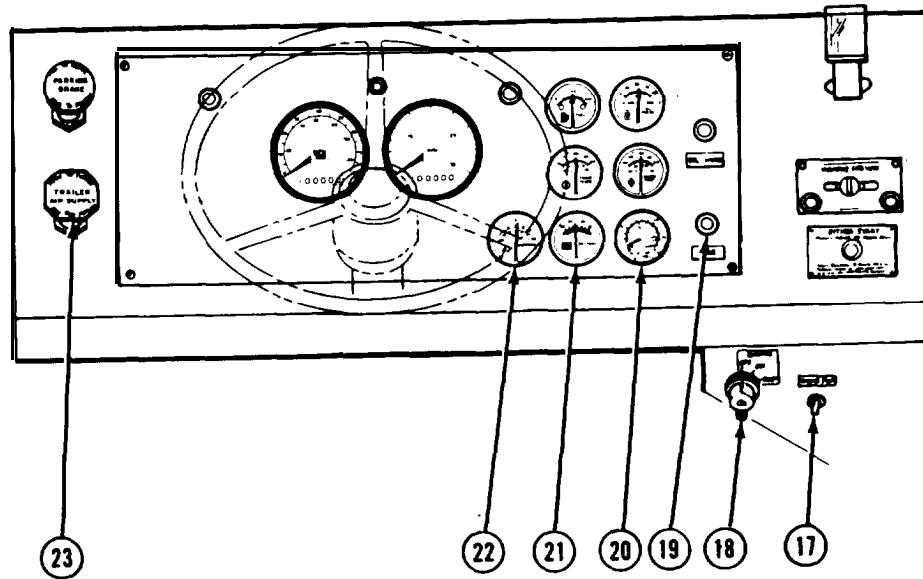
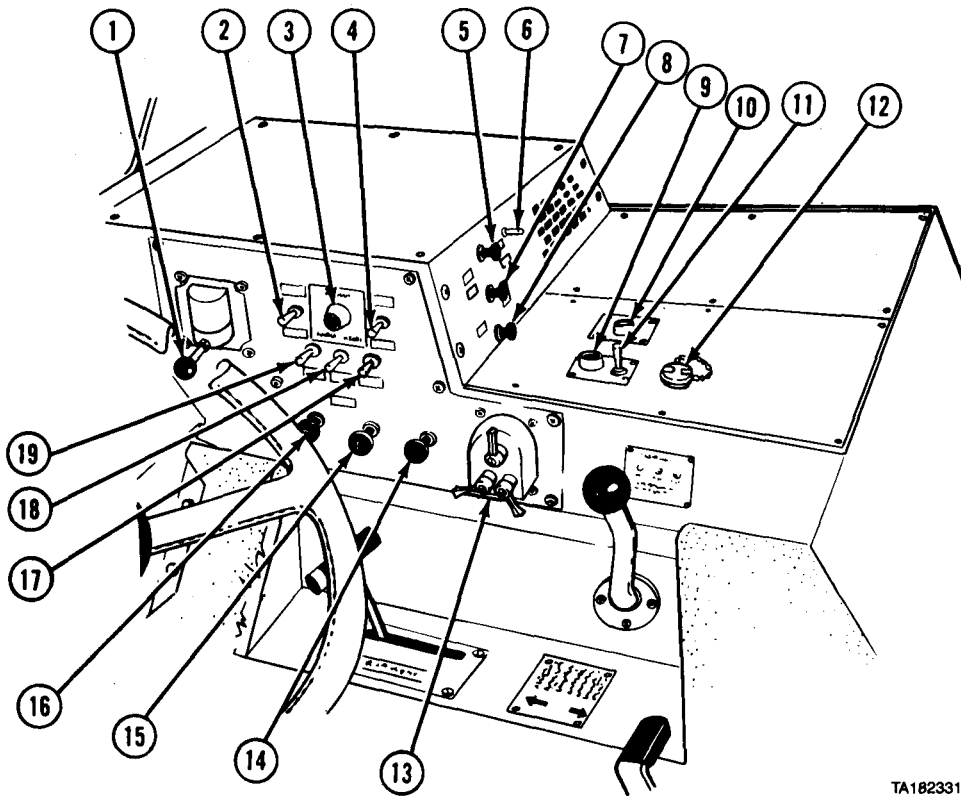


Figure 2-5. Instrument Panel Controls and Indicators (Sheet 3 of 3).

Key	Control or Indicator	Function
17	ENGINE STOP Switch	Used to stop engine. Returns to run position when released.
18	Engine Start Switch	Three position switch. Straight up is OFF position. ON position operates electrical system. START position operates engine cranking circuit. When switch is released after engine starts, switch will return to ON position.
19	AIR Indicator	Lights (red) and remains lit until airbrake air pressure in each section of dual system is between 60 psi (414 kPa) to 75 psi (517 kPa). Buzzer will sound anytime indicator is lit.
20	AIR PRESS Gage	Shows air pressure (in psi and kPa) in both sections of airbrake system. Green needle shows front section air pressure. Red needle shows rear section air pressure.
21	BATTERY Gage	Shows state of charge of batteries and alternator voltage output.
22	AMPERES Gage	Shows alternator output in Amperes.
23	TRAILER AIR SUPPLY Control	Charges trailer airbrake system.

Controls and Indicators (Cont)

2-2. LOCATION AND USE OF CONTROLS AND INDICATORS (CONT).



TA182331

Figure 2-6. Heater Compartment Controls and Indicators.

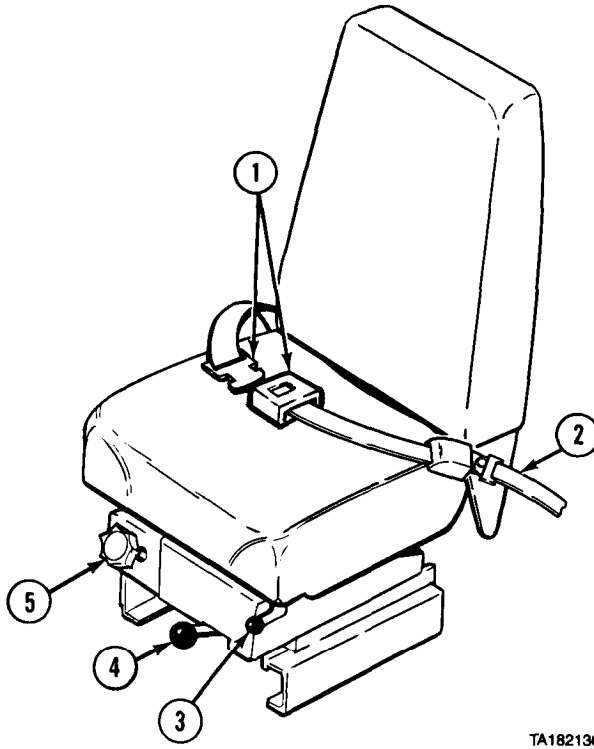
Controls and Indicators (Cont)

Legend for Figure 2-6. Heater Compartment Controls and Indicators.

Key	Control or Indicator	Function
1	Trailer Handbrake Control	Works the trailer brakes and is only used to TEST the trailer brakes.
2	JACOBS® ENGINE BRAKE ON-OFF Switch	Supplies or shuts off electrical power to JACOBS' ENGINE BRAKE.
3	JACOBS® ENGINE BRAKE Indicator	Lights (green) when JACOBS' ENGINE BRAKE ON-OFF switch is in ON position.
4	JACOBS® ENGINE BRAKE HIGH-LOW Switch	Selects number of engine cylinders used for engine braking action. HIGH position provides maximum braking. LOW position provides less engine braking.
5	AIR Control	Controls amount of outside air entering cab through fresh air vent.
6	FAN Control	Controls speed of heater fan.
7	HEAT Control	Controls amount of hot air entering cab.
8	DEFROST Control	Controls amount of hot air blown on windshield
9	PTO ENGAGE Indicator	Lights (red) when PTO ENGAGE control is in ON position.
10	CRANE OUTRIGGER EXTENDED Indicator	Lights (red) when outriggers are extended (M977 and M985 only).
11	PTO ENGAGE Control	Supplies or shuts off electrical power to power takeoff.
12	Utility Outlet	Supplies electrical power to operate beacon light and work lamp.
13	Light Control	Controls all electrical power to all parts of lighting system.
14	WASHER Control	Controls spray of cleaning fluid on windshield.
15	WIPER Control (Right)	Controls operation of right windshield wiper.
16	WIPER Control (Left)	Controls operation of left windshield wiper.
17	WORK LIGHT Switch (M1977-CBT, M983 and M984E1 only)	Up (on) position turns on work lights. Down (off) position turns work lights off.
18	DOMELIGHT Switch	Up position (on) turns cab domelight on. Down position (off) turns cab domelight off.
19	CL LPS Switch	Up position (on) turns clearance lamps on. Down position (off) turns clearance lamps off.

Controls and Indicators (Cont)

2-2. LOCATION AND USE OF CONTROLS AND INDICATORS (CONT).



TA1B2130

Figure 2-7. Operator and Crew Seat Adjustment Controls.

Key	Control or Indicator	Function
	NOTE Controls on both seats are the same.	
1	Seatbelt	Secures personnel in seat.
2	Seat Connector Strap	Secures seat to cab frame.
3	Height Adjustment Control	Use to adjust seat height.
4	Forward/Backward Adjustment Control	Use to move seat forward or backward on slides.
5	Ride Adjustment Control	Use to adjust seat tension and ride firmness.

Controls and Indicators (Cont)

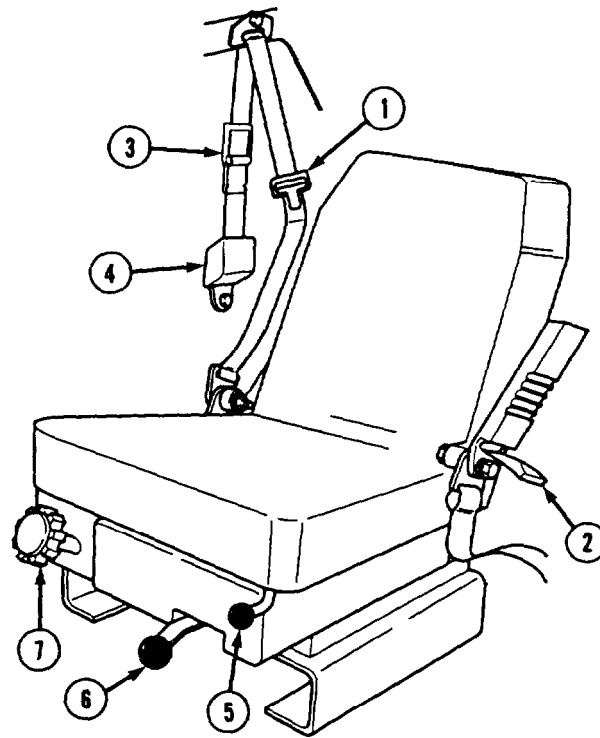
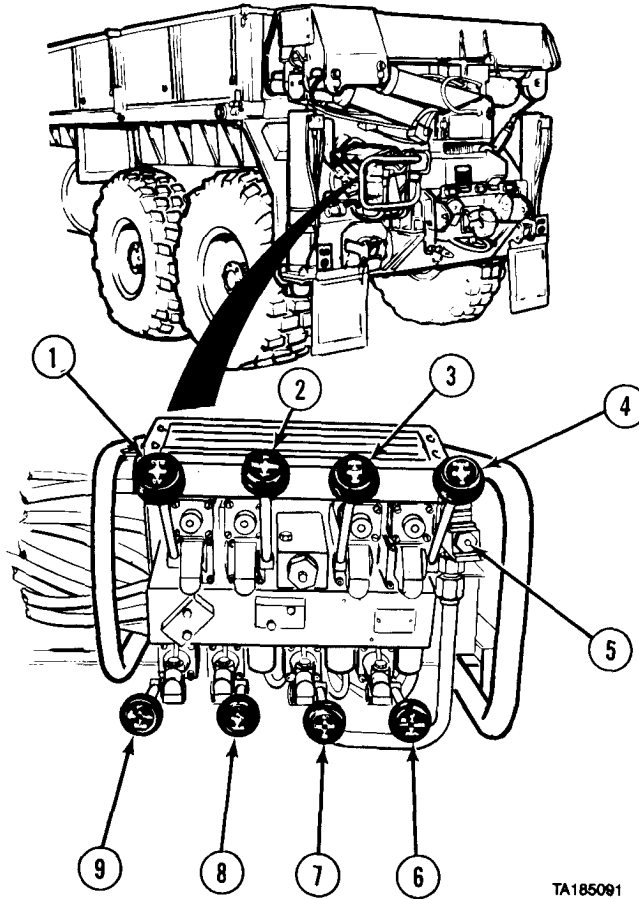


Figure 2-7.1 Operator and Crew Three-Point Seat Belt Adjustment.

Key	Control or Indicator	Function
	NOTE Controls on both seats are the same.	
1	Seatbelt	Secures personnel in seat.
2	Seat Connector Strap	Secures seat to cab frame.
3	Comfort Latch Buckle	Adjusts shoulder belt pressure.
4	Retractor	Locks seatbelt in event of accident, stows belt when not in use.
5	Height Adjustment Control	Use to adjust seat height.
6	Forward/Backward Adjustment Control	Use to move seat forward or backward on slides.
7	Ride Adjustment Control	Use to adjust seat tension and ride firmness.

Controls and Indicators (Cont)



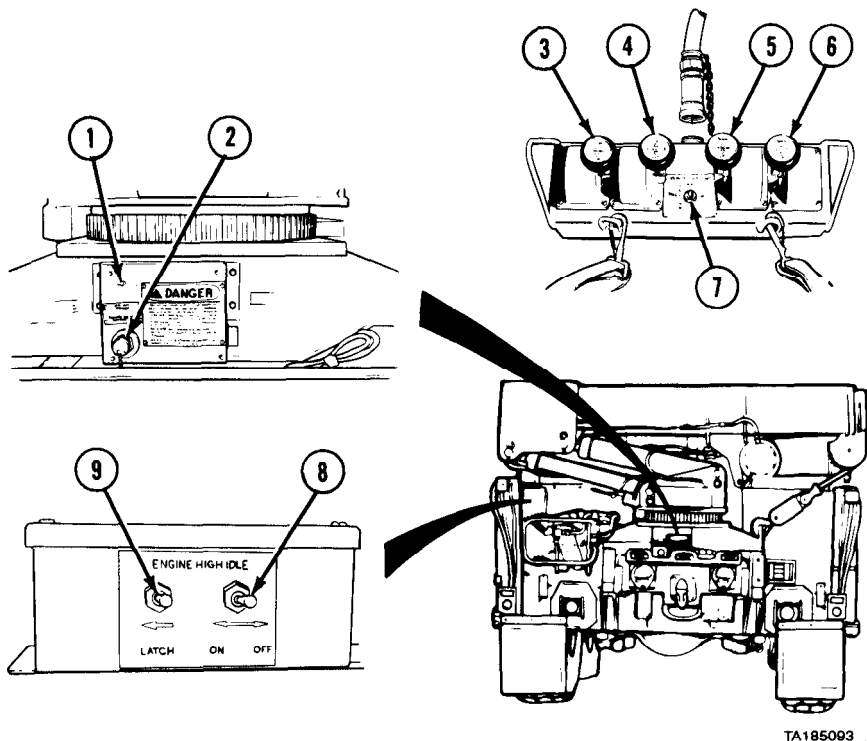
TA185091

Figure 2-8. M977 and M985 Crane Control Panel.

Key	Control or Indicator	Function
1	SWING Control Lever	Moves boom clockwise and counterclockwise.
2	TELESCOPE Control Lever	Lets out and pulls in first and second stages of boom.
3	BOOM Control Lever	Raises and lowers boom.
4	HOIST Control Lever	Reels in and pays out cable.
5	Solenoid Valve Button	Provides emergency hydraulic power when electrical power fails.
6	RH O/R JACK Control Lever	Lowers and raises right outrigger jack.
7	O/R EXT Control Lever	Lets out and pulls in outrigger beams.
8	MAST Control Lever	Raises mast to operating position and lowers mast to stowage position.
9	LH O/R JACK Control	Lowers and raises left outrigger jack.

Controls and Indicators (Cont)

2-2. LOCATION AND USE OF CONTROLS AND INDICATORS (CONT).



TA185093

Figure 2-9. M977 and M985 Crane Remote Control Unit.

Key	Control or Indicator	Function
1	ON/OFF POWER Switch	Supplies and shuts off electrical power to ENGINE HIGH IDLE control.
2	REMOTE CONTROL CONNECTOR	Supplies electrical power to REMOTE CONTROL UNIT.
3	SWING Control Lever	Moves crane clockwise (CW) and counterclockwise (CCW).
4	TELESCOPE Control Lever	Lets out and pulls in first and second stages of boom.
5	BOOM Control Lever	Raises and lowers boom.
6	HOIST Control Lever	Reels in and pays out cable.
7	REMOTE CONTROL UNIT ON/OFF Switch	Supplies and shuts off electrical power to REMOTE CONTROL UNIT.
8	ENGINE HIGH IDLE ON/OFF Switch	Supplies and shuts off electrical power to ENGINE HIGH IDLE LATCH.
9	ENGINE HIGH IDLE LATCH Switch	Increases engine speed to high idle (1500 RPM).

Controls and Indicators (Cont)

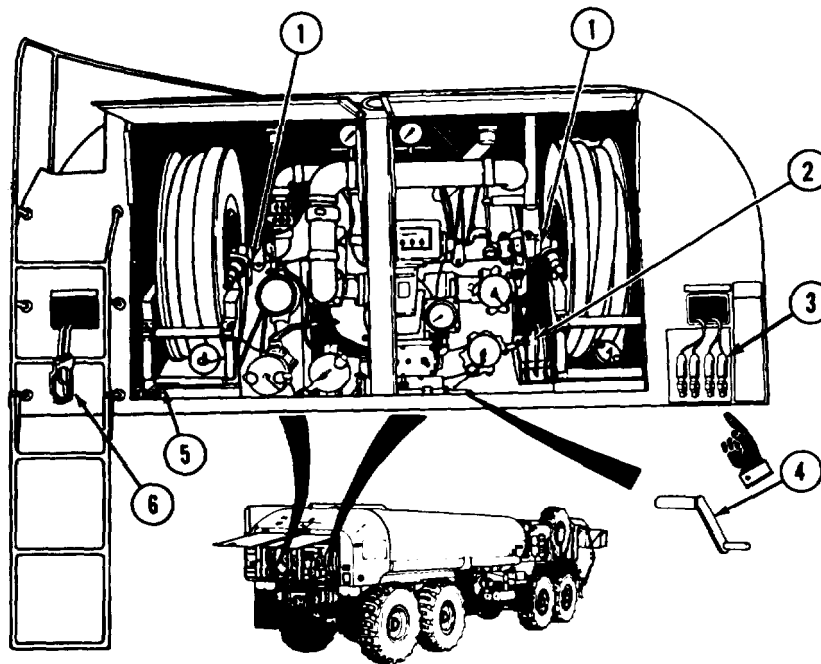


Figure 2-10. M978 Tanker Module Controls - Far Right and Left.

Key	Control or Indicator	Function
1	Hose Reel Tension Knob	Secures reel in position to keep hose from unwinding when not in use.
2	MC MANUAL CONTROL EM VALVE Control	Controls valve (V1) which allows fuel flow out of tank. Valve is pulled back to open in all operations except top load or bottom load.
3	SR1 STATIC REEL SR2 STATIC REEL	Prevents buildup of static electricity during operation. One cable is connected to vehicle being fueled or defueled. Other cable is connected to grounding ring or stake.
4	Handcrank	Rewinds hose onto reel.
5	Pump Engagement Lever	Engages main pump when lever pushed forward. Disengages pump when lever pulled back. Allows use of remote hydraulics when latch lifted and lever pulled full back.
6	HAV HAND ACTUATED CONTROL	Starts fuel flow when handle depressed. Stops fuel flow when handle released.

Controls and Indicators (Cont)

2-2. LOCATION AND USE OF CONTROLS AND INDICATORS (CONT).

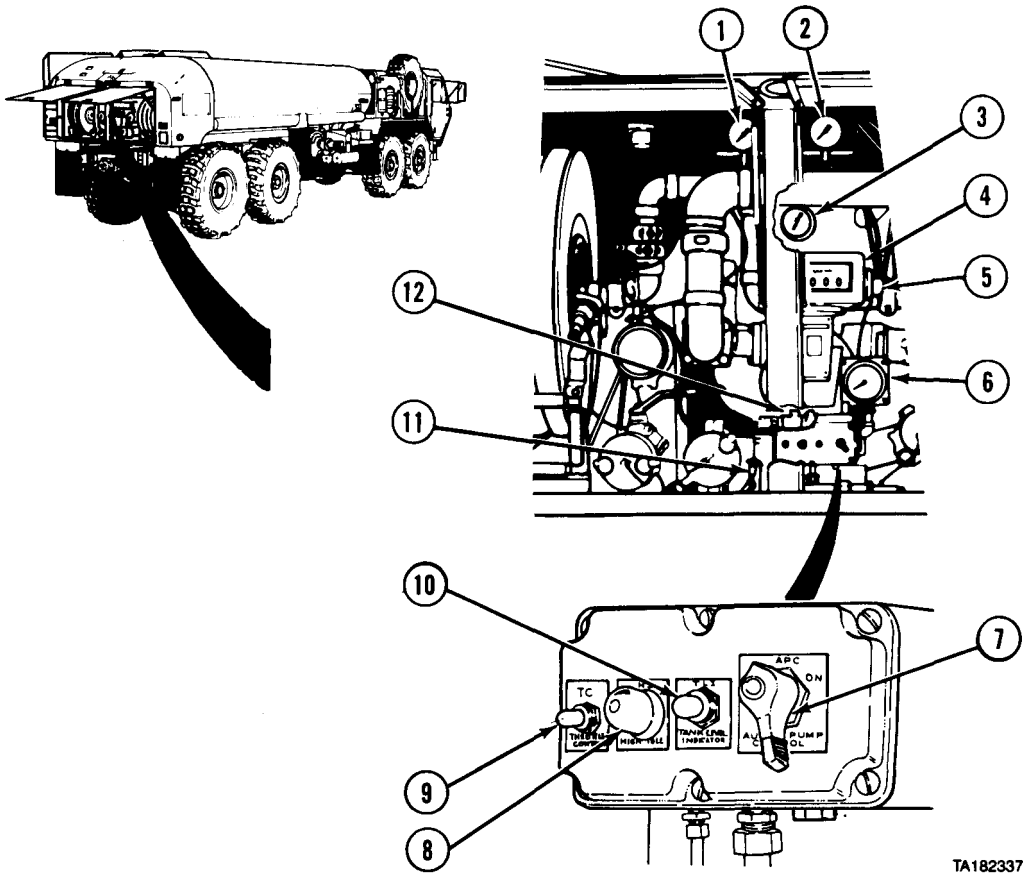


Figure 2-11. M978 Tanker Module Controls - Center.

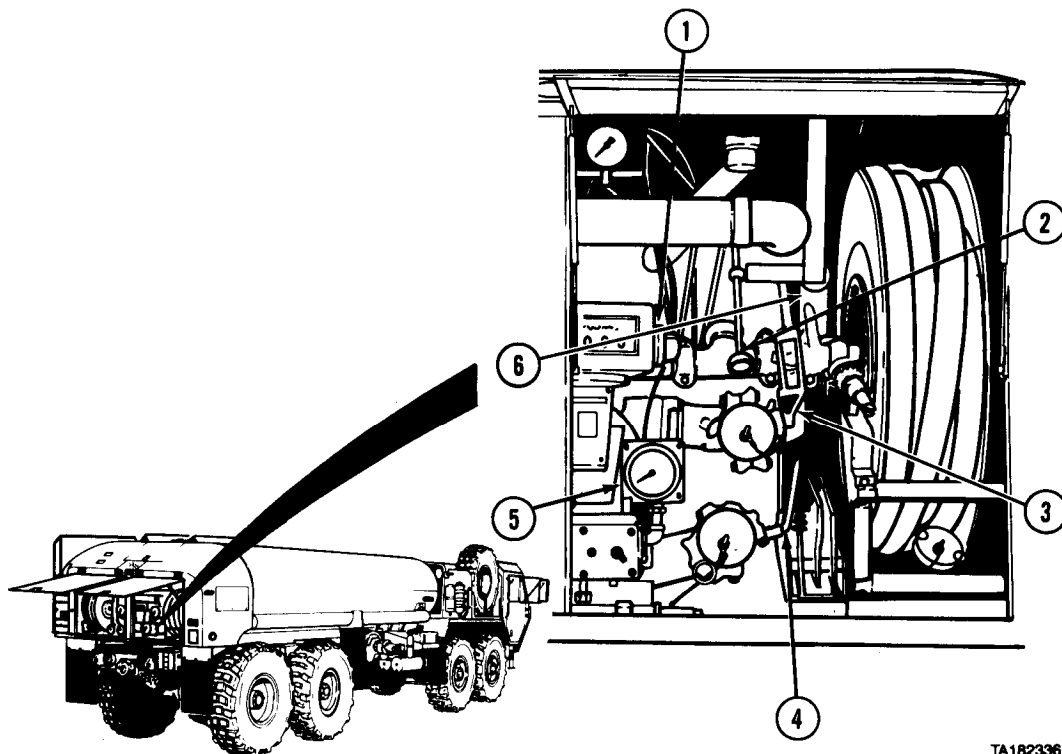
Controls and Indicators (Cont)

Legend for Figure 2-11. M978 Tanker Module Controls - Center.

Key	Control or Indicator	Function
1	Discharge Line Pressure Gage (DLPG)	Indicates pressure of fuel in hose during operation.
2	Venturi-Nozzle Pressure Gage (VNPG)	Indicates pressure of fuel at nozzle during operation.
3	Differential Pressure Gage (DPG)	Indicates whether filter-separator is clean or dirty by measuring pressure drop as fuel flows through filter separator.
4	Flowmeter	Registers amount of fuel dispensed or taken in.
5	Flowmeter Reset Knob	Resets flowmeter to zero when turned after use.
6	LIQUID TANK LEVEL GAGE	Indicates fuel level in tank when TANK LEVEL INDICATOR switch is in ON position.
7	AUXILIARY PUMP CONTROL (APC)/APS AUXILIARY PUMP SWITCH	Turns electrically powered auxiliary pump on and off.
8	HIGH IDLE (HI) BUTTON	Engages high idle. Spring loaded switch will accelerate engine to 1500 rpm.
9	THROTTLE CONTROL (TC) Switch	Turns high idle circuit on and off.
10	TANK LEVEL INDICATOR (TLI) Switch	Turns fuel level gage circuit on and off.
11	V15 DRAIN VALVE	Drains any water or other contaminants from filter separator.
12	SAMPLING PROBE Shutoff Valve	Allows fuel flow from probe when taking fuel sample.

Controls and Indicators (Cont)

2-2. LOCATION AND USE OF CONTROLS AND INDICATORS (CONT.)



TA182336

Figure 2-12. M978 Tanker Module Controls - Near Right.

Key	Control or Indicator	Function
1	Flowmeter Reset Knob	Resets flowmeter to zero when turned after use.
2	V6 FUEL/DEFUEL VALVE	Controls fuel flow through flowmeter during fueling or diverts fuel to eductor (ED) during defueling.
3	V11 FLOW VALVE (REG)	Controls rate of fuel flow through bulk unload connector. Varies rate of flow from 50 to 300 gpm. Each notch in control equals approximately 25 gpm.
4	V18 BULK DELIVERY VALVE	Controls fuel flow through bulk delivery connector.
5	Tank Fuel Level Gage	Indicates fuel level in tank when TANK LEVEL INDICATOR switch is in ON position.
6	V8 REEL VALVE (H2)	Controls fuel flow to hose (H2) on reel at right side of vehicle.

Controls and Indicators (Cont)

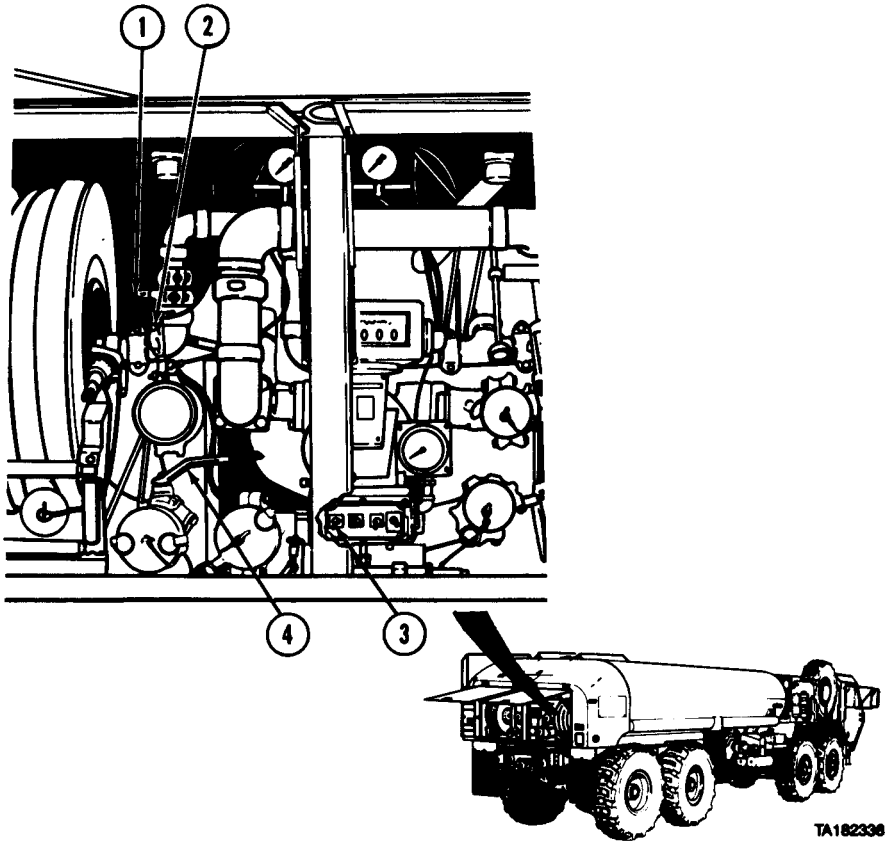


Figure 2-13. M978 Tanker Module Controls - Near Left.

Key	Control or Indicator	Function
1	V7 REEL VALVE (H1)	Controls fuel to hose (H1) on reel at left side of vehicle.
2	V12 B/L PRECHECK VALVE	Valve is used during bulk loading operations to be sure bottom load valve (V10) will close when tank is full.
3	THROTTLE CONTROL Switch (TC)	Turns high idle circuit on and off.
4	V17 GRAVITY VALVE	Controls fuel flow to tanker during gravity unloading. Controls fuel flow into tank during bottom load operation using tanker pump.

Controls and Indicators (Cont)

2-2. LOCATION AND USE OF CONTROLS AND INDICATORS (CONT).

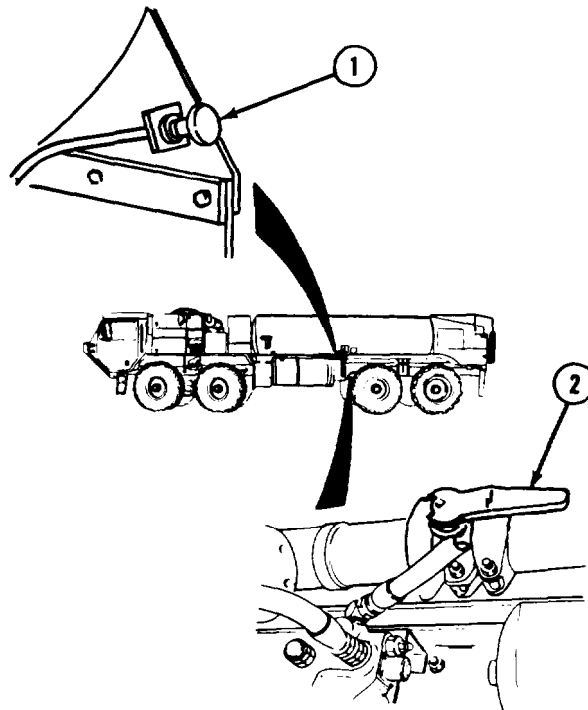
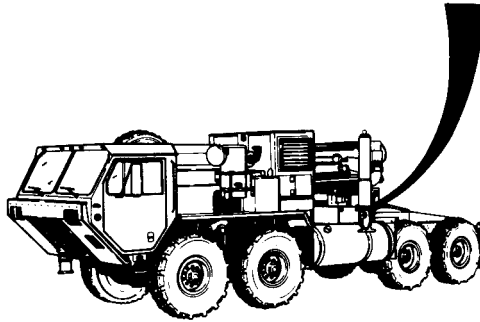
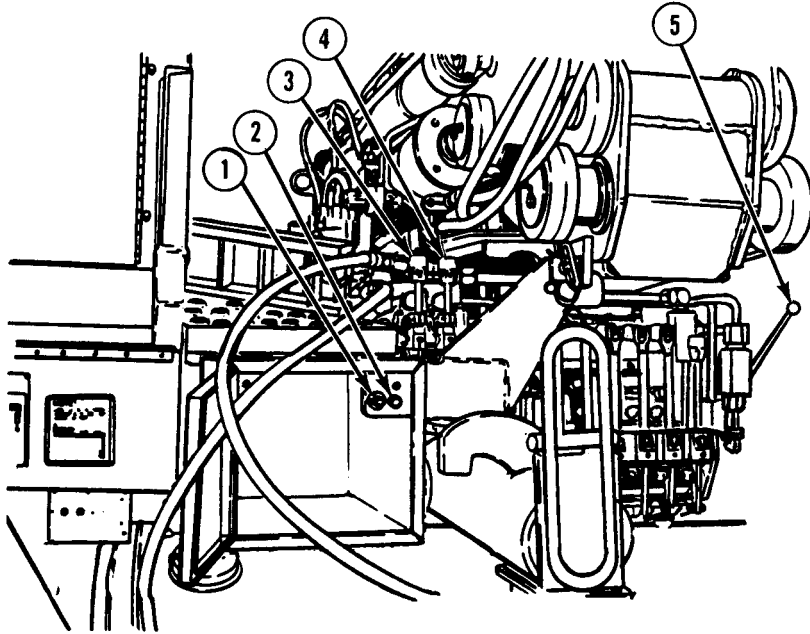


Figure 2-14. M978 Tanker Controls -Left Side of Vehicle

Key	Control or Indicator	Function
1	Emergency Fuel Shutoff (Manual Emergency Control)	When pulled, valve (V1) closes, stopping fuel flow from tank. Valve (V1) can only be reopened by using the MC MANUAL CONTROL EM VALVE lever at the rear of the vehicle.
2	V3 SUCTION LINE VALVE	Diverts fuel from main pump to auxiliary pump. Valve is located inside left frame rail in front of No. 3 axle. Shown in open position.

Controls and Indicators (Cont)



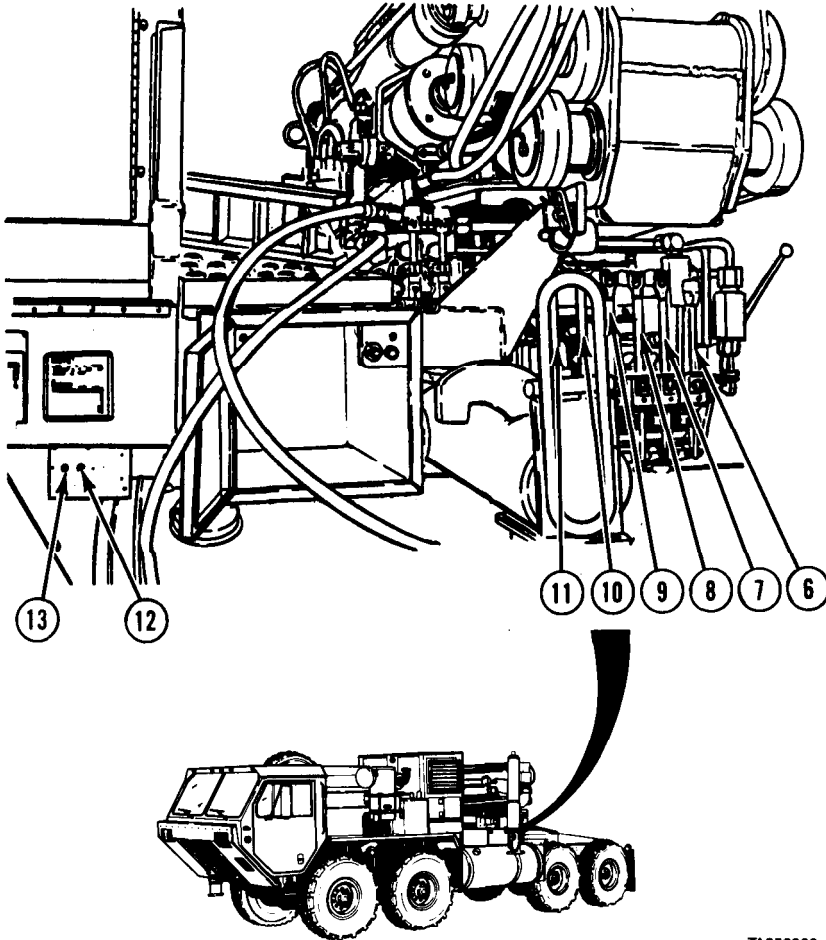
TA182131

Figure 2-15. M983 Crane Main Control Panel (Sheet 1 of 2).

Key	Control or Indicator	Function
1	Remote Control Panel Power Switch	Push button to turn power ON to remote control panel. Push button to turn power OFF to remote control power.
2	Remote Control Panel Power Indicator	Indicator lights (green) when electrical power to remote control panel is ON.
3	Left-Hand Outrigger Control Lever	Raises and lowers left outrigger.
4	Right-Hand Outrigger Control Lever	Raises and lowers right outrigger.
5	Selector Valve	Activates hydraulic system to respond to main controls or to controls on remote control panel.

Controls and Indicators (Cont)

2-2. LOCATION AND USE OF CONTROLS AND INDICATORS (CONT).

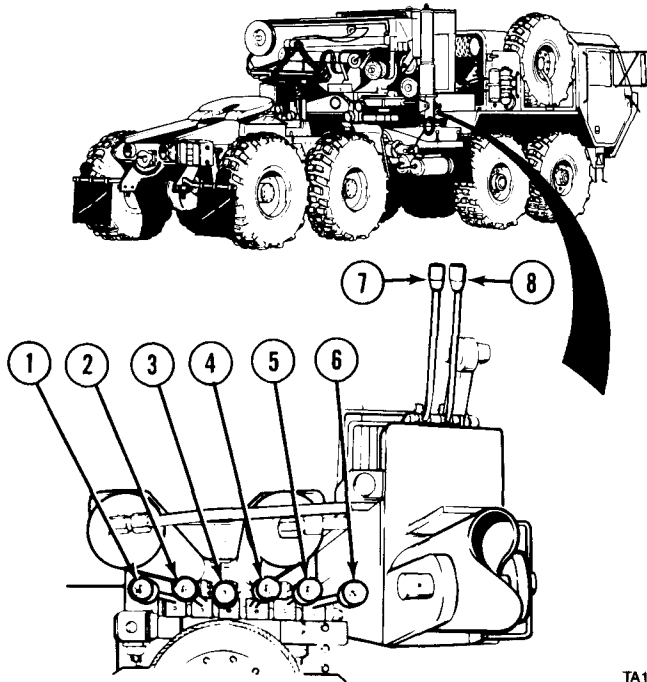


TA356863

Figure 2-15. M983 Crane Main Control Panel (Sheet 2 of 2).

Key	Control or Indicator	Function
6	Mast Control Lever	Raises mast to operating position or lowers mast to stowed position.
7	3 & 4 Extension Lever	Lets out or draws in stages 3 and 4 of boom.
8	1 & 2 Extension Lever	Lets out or draws in stages 1 and 2 of boom.
9	Hoist Control Lever	Pays out or reels in cable.
10	Boom Control Lever	Moves boom up or down.
11	Swing Control Lever	Moves crane clockwise or counterclockwise.
12	Engine Speed Control Engage Switch	Engages speed control increasing engine speed to high idle (1500 rpm).
13	Engine Speed Control On/Off Switch	Supplies or shuts off electrical power to engine speed control circuit.

Controls and Indicators (Cont)



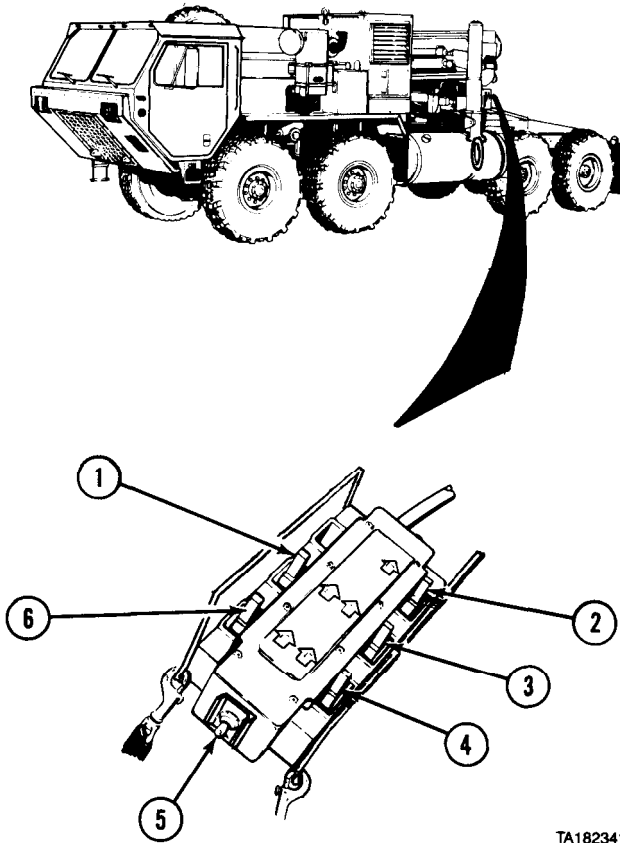
TA182340

Figure 2-16. M983 Crane Secondary Control Panel.

Key	Control or Indicator	Function
1	Swing Control Lever	Moves crane clockwise or counterclockwise.
2	Boom Control Lever	Moves boom up or down.
3	Hoist Control Lever	Pays out or reels in cable.
4	1 & 2 Extension Lever	Lets out or draws in stages 1 and 2 of boom.
5	3 & 4 Extension Lever	Lets out or draws in stages 3 and 4 of boom.
6	Mast Control Lever	Raises mast to operating position or lowers mast to stowed position.
7	Left-Hand Outrigger Control Lever	Raises or lowers left outrigger.
8	Right-Hand Outrigger Control Lever	Raises or lowers right outrigger.

Controls and Indicators (Cont)

2-2. LOCATION AND USE OF CONTROLS AND INDICATORS (CONT).



TA182341

Figure 2-17. M983 Crane Remote Control Panel.

Key	Control or Indicator	Function
1	1 & 2 Extension Lever	Lets out or draws in stages 1 and 2 of boom.
2	3 & 4 Extension Lever	Lets out or draws in stages 3 and 4 of boom.
3	Hoist Control Lever	Pays out or reels in cable.
4	Swing Control Lever	Moves crane clockwise or counterclockwise.
5	Remote Control Panel On/Off Switch	Supplies and shuts off electrical power to panel and activates the five controls.
6	Boom Control Lever	Moves boom up or down.

Controls and Indicators (Cont)

2-2. LOCATION AND USE OF CONTROLS AND INDICATORS (CONT).

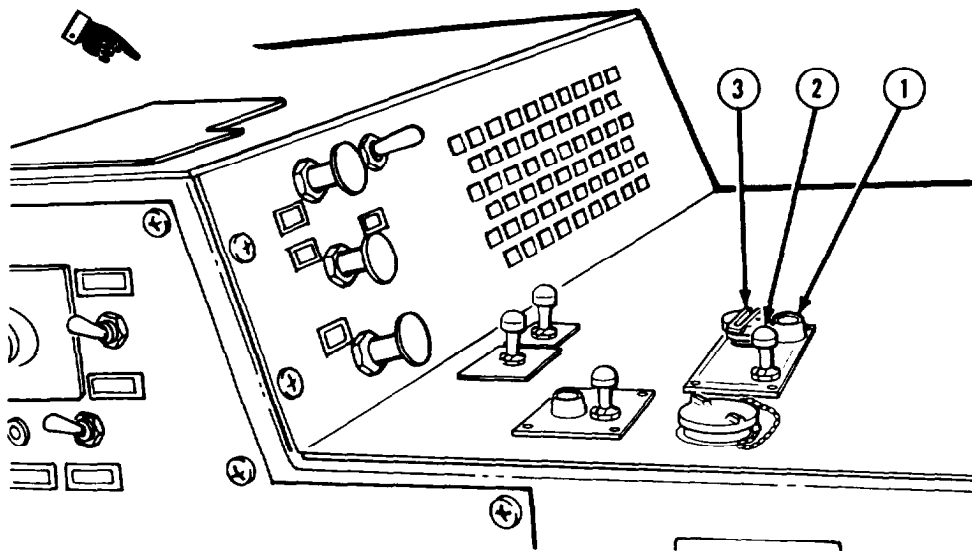
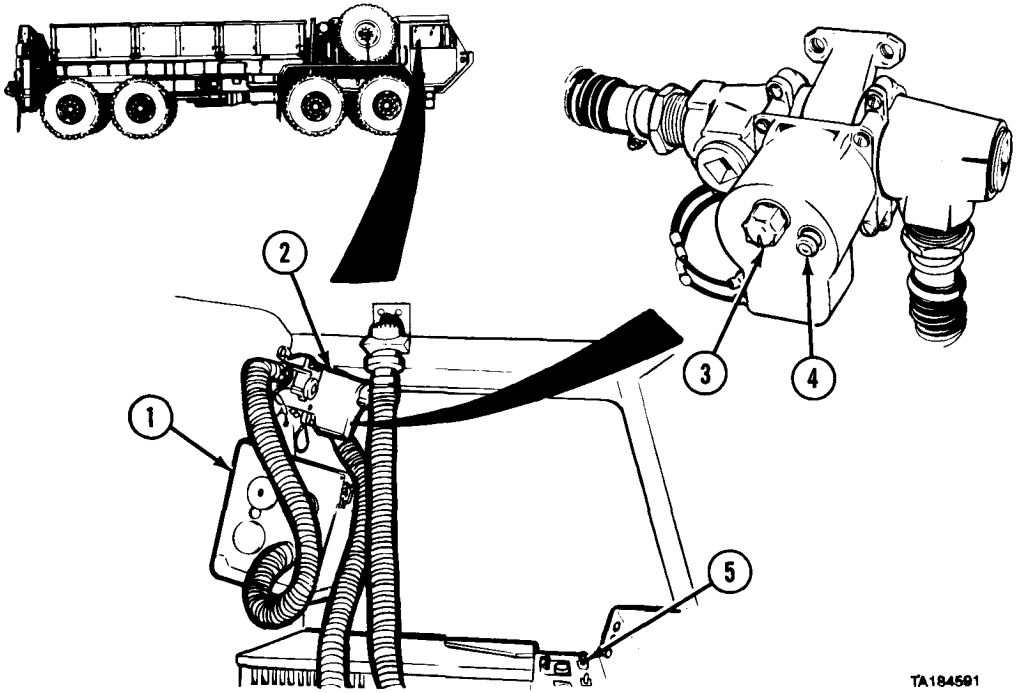


Figure 2- 19. Arctic Heater

Key	Control or Indicator	Function
1	Coolant Pump Indicator	Lights when coolant pump is operating.
2	ON/OFF Switch	Two way toggle switch that starts coolant pump and supplies 24 vdc to heater cable receptacle. Pull up on toggle and push toggle to right to place switch in ON position. Pull toggle to left to place switch in OFF position.
3	Heater Cable Receptacle	Provides 24 vdc to start heater.

Controls and Indicators (Cont)



TA184591

Figure 2-20. Gas Particulate Filter Unit.

Key	Control or Indicator	Function
1	Gas Particulate Filter	Filters nuclear, biological, and chemical (NBC) contaminants from air.
2	M-3 Heater	Warms air entering protective mask.
3	M-3 Heater Control Knob	Turn clockwise for warmer air. Turn counterclockwise for cooler air. Turn to OFF to shut off heater.
4	M-3 Heater Indicator Light	Lights when heater is operating.
5	GAS PARTIC FILTER switch	Turns gas particulate filter on or off.

Controls and Indicators (Cont)

2-2. LOCATION AND USE OF CONTROLS AND INDICATORS (CONT.)

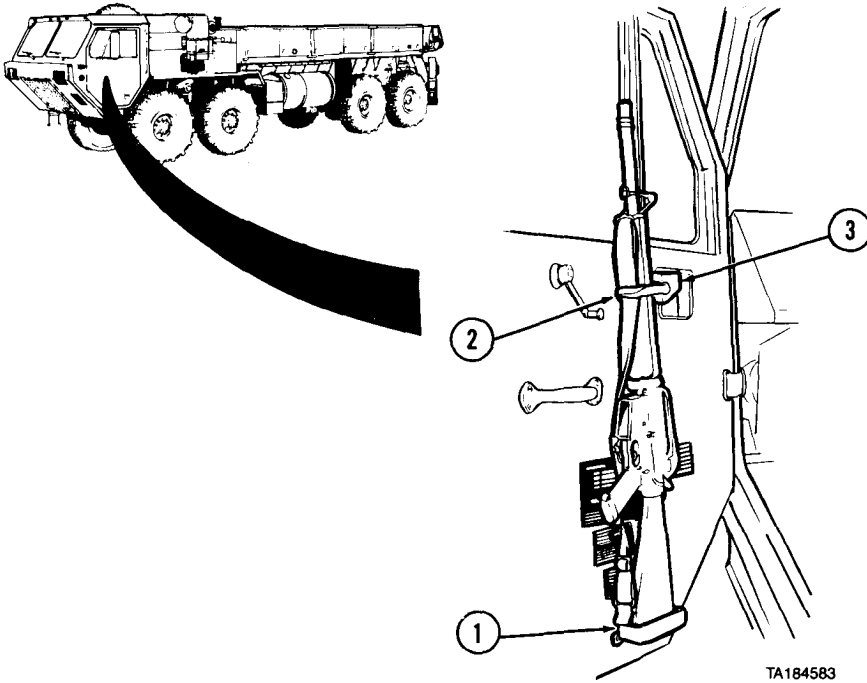
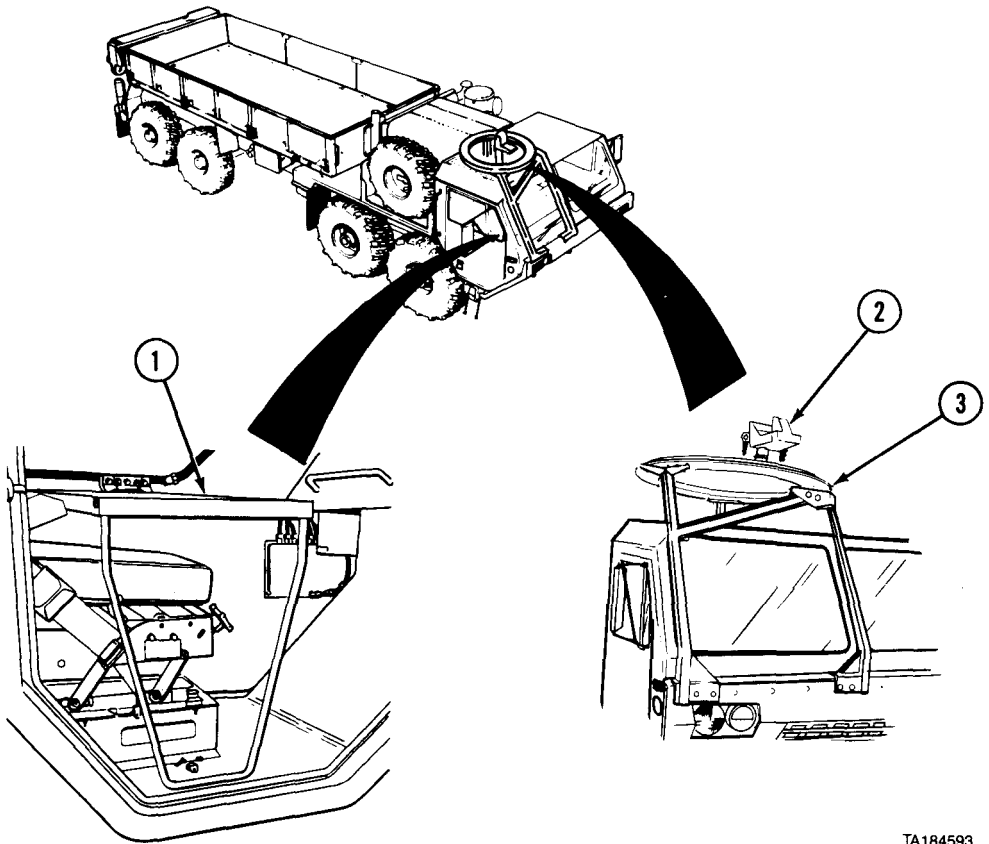


Figure 2-21. Rifle Stowage Mount.

Key	Control or Indicator	Function
1	Lower Rifle Mount	Holds butt of rifle.
2	Rifle Mount Handle	Secures heat guard of rifle against top rifle mount.
3	Top Rifle Mount	Holds heat guard of rifle.

Controls and Indicators (Cont)



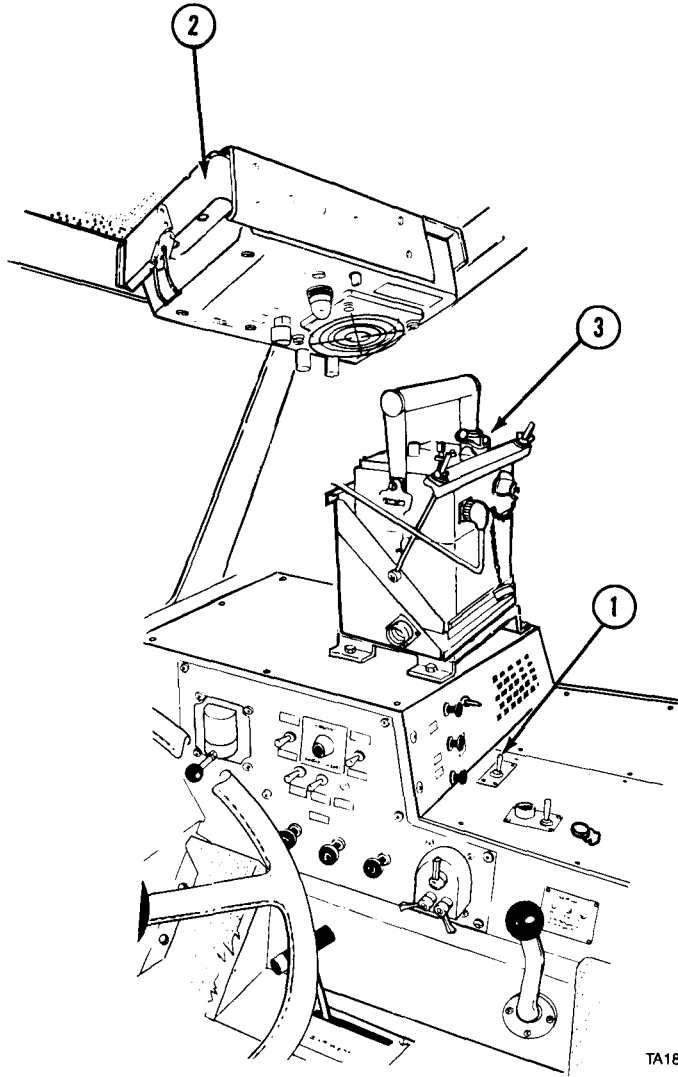
TA184593

Figure 2-22. Machine Gun Mount.

Key	Control or Indicator	Function
1	Machine Gun Operator Platform	Supports machine gun operator.
2	Machine Gun Mount	Secures machine gun to machine gun ring.
3	Machine Gun Ring	Allows machine gun to turn 360 degrees.

Controls and Indicators (Cont)

2-2. LOCATION AND USE OF CONTROLS AND INDICATORS (CONT).

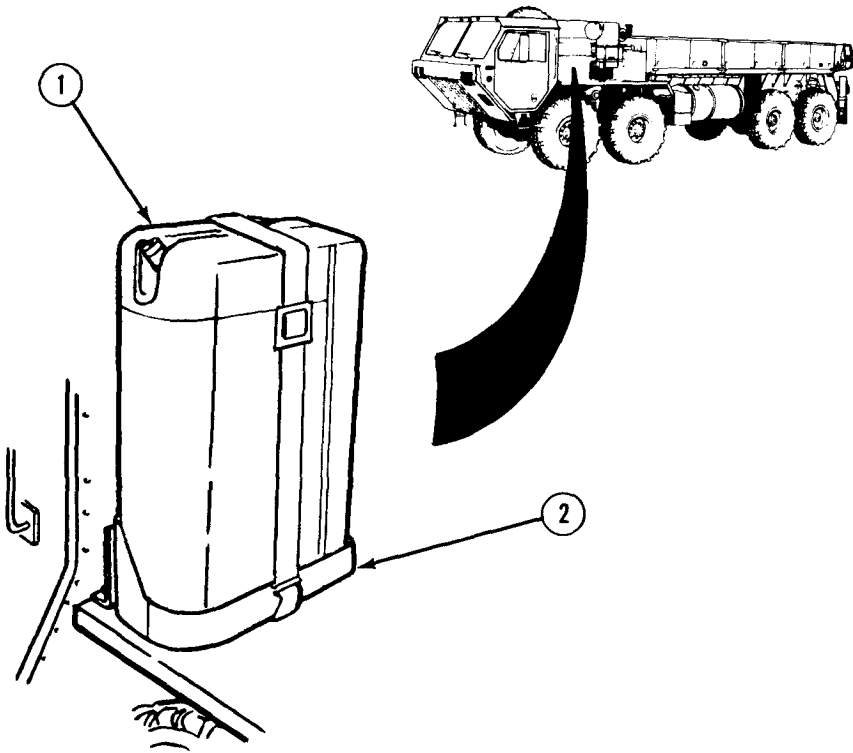


TA184594

Figure 2-23. M-8 Chemical Alarm.

Key	Control or Indicator	Function
1	M-8 Chemical Alarm Switch	Operates alarm.
2	M-8 Chemical Alarm	Sounds alarm when chemicals are detected.
3	Chemical Detector	Detects presence of chemicals in air.

Controls and Indicators (Cont)



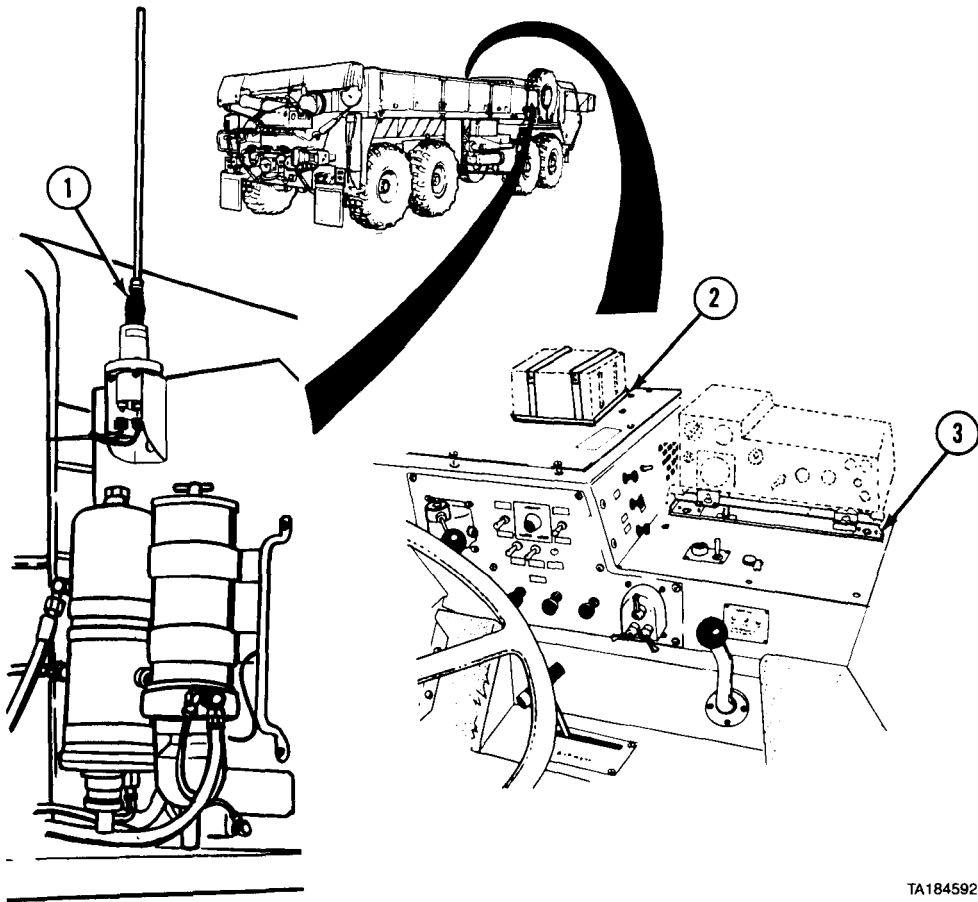
TA184590

Figure 2-24. M-13 Decontamination Unit.

Key	Control or Indicator	Function
1	M-13 Decontamination Unit	Holds and dispenses decontaminant.
2	Decontamination Unit Mount	Holds decontamination unit.

Controls and Indicators (Cont)

2-2. LOCATION AND USE OF CONTROLS AND INDICATORS (CONT).



TA184592

Figure 2-25. Radio Installation.

Key	Control or Indicator	Function
1	Antenna Matching Unit	Holds antenna.
2	Security Unit Mount	Holds security unit.
3	Receiver/Transmitter Mount	Holds receiver/transmitter.

Section II. PREVENTIVE MAINTENANCE CHECKS AND SERVICES (PMCS)

PMCS Tables

2-3. PMCS INTRODUCTION. This section contains PMCS requirements for M977 series vehicles. The PMCS tables contain checks and services necessary to ensure that the vehicle is ready for operation. Using PMCS tables, perform maintenance at specified intervals.

2-4. MAINTENANCE FORMS AND RECORDS. Every mission begins and ends with paperwork. There is not much of it, but it must be kept up. The filled out forms and records have several uses. They are a permanent record of services, repairs, and modifications made on the vehicle. They are reports to organizational maintenance and to your Commander. They are a checklist to know what was wrong with the vehicle after its last use, and whether those faults have been fixed. For the information needed on forms and records, refer to DA PAM 738-750.

2-5. PREVENTIVE MAINTENANCE CHECKS AND SERVICES (TABLES 2-1 TO 2-5).

- a. Do the before (B) PREVENTIVE MAINTENANCE just before operating vehicle. Pay attention to the CAUTIONS and WARNINGS.
- b. Do the during (D) PREVENTIVE MAINTENANCE while vehicle and/or its component systems are in operation. Pay attention to the CAUTIONS and WARNINGS.
- c. Do the after (A) PREVENTIVE MAINTENANCE right after operating vehicle. Pay attention to the CAUTIONS and WARNINGS.
- d. Do the (W) PREVENTIVE MAINTENANCE weekly. Pay attention to the CAUTIONS and WARNINGS.
- e. Do the (M) PREVENTIVE MAINTENANCE once a month. Pay attention to the CAUTIONS and WARNINGS.
- f. If something does not work, troubleshoot with instructions in Chapter 3 and notify the supervisor.
- g. Always do PREVENTIVE MAINTENANCE in the same order until it gets to be habit. Once practiced, problems can be spotted in a hurry.
- h. If something looks wrong and cannot be fixed right then, write it on DA Form 2404. If something seems seriously wrong, report it to organizational maintenance RIGHT NOW.
- i. When doing PREVENTIVE MAINTENANCE, take along the tools needed and a rag or two to make all the checks.

PMCS Tables (Cont)

2-6. GENERAL MAINTENANCE PROCEDURES.WARNING

Adhesives, solvents, and sealing compounds can burn easily, can give off harmful vapors, and are harmful to skin and clothing. To avoid injury or death, keep away from open fire and use in well-ventilated area. If adhesive, solvent, or sealing compound gets on skin or clothing, wash immediately with soap and water.

a. Cleanliness. Dirt, grease, oil, and debris only get in the way and may cover up a serious problem. Use dry cleaning solvent Appendix D, Item 13 on all metal surfaces.

b. Bolts, Nuts, and Screws. Check bolts, nuts, and screws for obvious looseness, missing, bent, or broken condition. Look for chipped paint, bare metal, or rust around boltheads. If any part seems loose, tighten it, or report it to organizational maintenance.

c. Welds. Look for loose or chipped paint, rust, or gaps where parts are welded together. If a bad weld is found, report it to organizational maintenance.

d. Electric Wires and Connectors. Look for cracked or broken insulation, bare wires, and loose or broken connectors. Tighten loose connectors and make sure wires are in good shape. If a bad wire or connector is found, report it to organizational maintenance.

e. Hydraulic Lines and Fittings. Look for wear, damage, and leaks, and make sure clamps and fittings are tight. Wet spots show leaks, and a stain around a fitting or connector can mean a leak. If a leak comes from a loose fitting or connector, tighten it. If something is broken or worn out, report it to organizational maintenance.

f. Damage is defined as: Any conditions that affect safety or would render the vehicle unserviceable for mission requirements.

2-7. FLUID LEAKAGE. It is necessary to know how fluid leakage affects the status of fuel, oil, coolant, and the hydraulic systems. The following are definitions of the different types/classes of leakage that determine the status of the vehicle. Learn, then be familiar with them and REMEMBER – WHEN IN DOUBT, NOTIFY THE SUPERVISOR!

CAUTION

Equipment operation is allowable with minor leakage (Class I or II). Consideration must be given to the fluid capacity in the item/system being checked/inspected. When in doubt, notify the supervisor. When operating with Class I or II leaks, continue to check fluid levels as required in the PMCS. Class III leaks should be reported to the supervisor or to organizational maintenance.

a. Class I. Seepage of fluid (as indicated by wetness or discoloration) not great enough to form drops.

b. Class II. Leakage of fluid great enough to form drops but not enough to cause drops to drip from item being checked/inspected.

c. Class III. Leakage of fluid great enough to form drops that fall from the item being checked/inspected.

2-8. OPERATOR/CREW PREVENTIVE MAINTENANCE CHECKS AND SERVICES TABLES.

NOTE

· Prior to performing your PMCS, check with your PLL clerk to verify that the latest publications are being used by the operator and organizational unit.

· Table 2-1 covers items common to all M977 series vehicles. Tables 2-2 through 2-6 cover items that are only used on certain models.

M977 through M985	Table 2-1
M977 and M985	Table 2-2
M978	Table 2-3
M983	Table 2-4
M984E1	Table 2-6
M985E1	Table 2-6
Auxiliary Equipment	Table 2-7

CAUTION

Vehicles designated or dispatched to transport Class A or B ammunition, explosives, poisons or radioactive yellow III materials over public highways require more stringent inspections. Operators will follow the requirements of AR 55-355 and TM 9-1300-206.

a. Daily "Walk Around" PMCS Diagram, Table 2-1. This routing diagram will be of help to complete the B, D, or A PMCS. It shows the vehicle PMCS routing track which matches the sequence of PMCS to be performed.

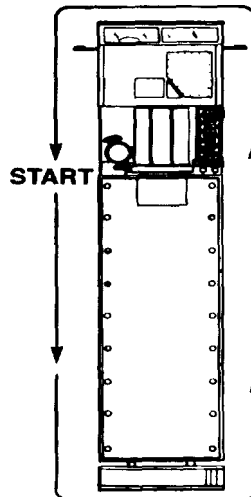


Table 2-1. Preventive Maintenance Checks and Services for Models M977 thru M985E1

Item No.	Interval	Location	<u>Crewmember</u> Procedure	Not Fully Mission Capable If:
		Item to Check/Service		
			<p><u>DRIVER</u></p> <p>NOTE</p> <p>Perform your Before, After, and Weekly PMCS checks if:</p> <ul style="list-style-type: none"> a. You are the assigned driver but have not operated the vehicle since the last weekly inspection. b. You are operating the vehicle for the first time. 	

Table 2-1. Preventive Maintenance Checks and Services for Models M977 thru M985E1

ITEM No.	Interval	Location	<u>Crewmember Procedure</u>	Not Fully Mission Capable If:
		Item to Check/Service		
1	Before	Radiator	<p><u>DRIVER</u></p> <p><u>WARNING</u></p> <p>If vehicle has been operating, use extreme care to avoid being burned when removing cooling system radiator cap. Use heavy rag or gloves to protect hands. Turn radiator cap only one-half turn counterclockwise and allow pressure to be relieved before fully removing cap.</p> <p>NOTE</p> <p>Diesel engine slobber is an inherent condition of diesel engines. When engines are allowed to idle for prolonged periods of time, this characteristic may be interpreted as a Class III leak. Check engine oil level. If there is any doubt, consult with your supervisor or unit maintenance.</p> <p>Remove radiator cap and check radiator for coolant level. Coolant level should be approximately one inch (25 mm) from bottom of fitter neck. If fluid level is low, fill to appropriate level.</p>	

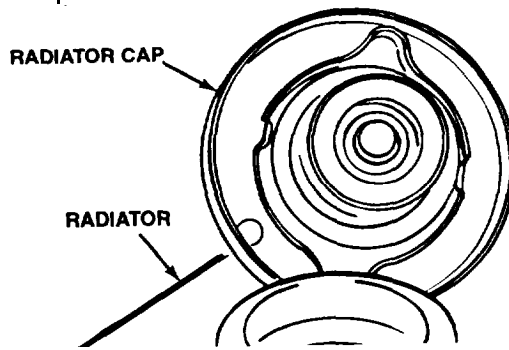


Table 2-1. Preventive Maintenance Checks and Services for Models M977 thru M985E1

Item No.	Interval	Location	Crewmember Procedure	Not Fully Mission Capable If:
		Item to Check/Service		
2	Before	Left Front, Side Exterior	<p><u>DRIVER</u></p> <p>NOTE if leakage is detected, further investigation is needed to determine the location and cause of the leak. If there is any doubt, contact your supervisor or unit maintenance.</p> <p>a. Check underneath vehicle for evidence of fluid leakage.</p> <p>b. Visually check left side of vehicle for obvious damage that would impair operation.</p>	<p>b. Any damage that would impair operation.</p>
3	Before	Left Side Tires	<p><u>WARNING</u> Operating a vehicle with a tire in an overinflated or underinflated condition or with a questionable defect, may lead to premature tire failure and may cause equipment damage, injury or death to personnel.</p> <p>Visually check tire for presence and under-inflation, Refer to paragraph 3-9 for proper inflation procedures.</p>	

Table 2-1. Preventive Maintenance Checks and Services for Models M977 thru M985E1

Item No.	Interval	Location	<u>Crewmember</u> Procedure	Not Fully Mission Capable If:	
		Item to Check/Service			
4	Before	Rear Exterior	<u>DRIVER</u> Visually check rear of vehicle for obvious damage that would impair operation.	Any damage that would impair operation.	
5	Before	Right Front and Side Exterior	<p style="text-align: center;">NOTE</p> If leakage is detected, further investigation is needed to determine the location and cause of the leak. If there is any doubt, contact your supervisor or unit maintenance. <ol style="list-style-type: none"> a. Check underneath vehicle for evidence of fluid leakage. b. visually check right side of vehicle for obvious damage that would impair operation. 		b. Any damage that would impair operation.
6	Before	Right Side Tires and Spare Tire	<p style="text-align: center;"><u>WARNING</u></p> <p>Operating a vehicle with a tire in an overinflated or underinflated condition or with a questionable defect, may lead to premature tire failure and may cause equipment damage, injury or death to personnel.</p> Visually check tire for presence and under-inflation. Refer to paragraph 3-9 for proper inflation procedures.		

Table 2-1. Preventive Maintenance Checks and Services for Models M977 thru M985E1

Item No.	Interval	Location	<u>Crewmember Procedure</u>	Not Fully Mission Capable If:
		Item to Check/ Service		
7	Before	Under Carriage	<p><u>DRIVER</u></p> <p>Look under vehicle for obvious fluid leakage, such as oil, hydraulic fluid, water or diesel fuel.</p> <p>NOTE</p> <p>If leakage is detected, further investigation is needed to determine the location and cause of the leak. If there is any doubt, contact your supervisor or organizational maintenance.</p>	Class III leakage of diesel fuel, oil, or coolant is evident.
8	Before	Chock Blocks	<p>Check for presence of chock blocks in space under spare tire.</p>	
9	Before	Fuel Water Separator	<p><u>WARNING</u></p> <p>Fuel is very flammable and can explode easily. To avoid serious injury or death, keep fuel away from open fire and keep fire extinguisher within easy reach when working with fuel. Do not work on fuel system when engine is hot. Fuel can be ignited by hot engine. When working with fuel, post signs that read: "NO SMOKING WITHIN 50 FEET OF VEHICLE".</p>	

Table 2-1. Preventive Maintenance Checks and Services for Models M977 thru M985E1

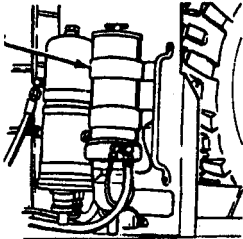
Item No.	Interval	Location	<u>Crewmember</u> Procedure	Not Fully Mission Capable If:
		Item to Check/Service		
9	Before	Fuel Water Separator Continued	<p><u>DRIVER</u></p> <p>NOTE Operation of vehicle with damaged fuel water separator may violate AR 385-55.</p> <p>Check fuel water separator for leaks and/or damage.</p>	Class III leak evident.
<p>FUEL WATER SEPARATOR :</p> 				
10	Before	Seat Belts	<p>NOTE Vehicle operation with inoperative seat belts may violate AR 385-55.</p> <p>Check all seat belts for security, damage and completeness.</p>	
11	Before	Seats	Check operation of seat adjusting mechanism.	Seat adjustment lock broken or missing.
12	Before	Fire Extinguisher	a. Check for missing or damaged fire extinguisher.	a. Fire extinguisher missing or damaged.

Table 2-1. Preventive Maintenance Checks and Services for Models M977 thru M985E1

Item No.	Interval	Location	<u>Crewmember Procedure</u>	Not Fully Mission Capable if:
		Item to Check/Service		
12	Before	Fire Extinguisher Continued	<u>DRIVER</u> b. Check gage for proper pressure of about 150 psi (1 034 kPa). Make sure mounting is secure. c. Check for damaged or missing seal.	b. Pressure gage needle in RE-CHARGE area. c. Seal broken or missing.
13	Before	Instruments	a. Start engine. b. Tachometer. Check for damage, operation and condition. Correct idle is 625 to 725 rpm.	a. Engine will not start. b. Tachometer indicates less than 600 rpm or more than 600 rpm.

Table 2-1. Preventive Maintenance Checks and Services for Models M977 thru M985E1

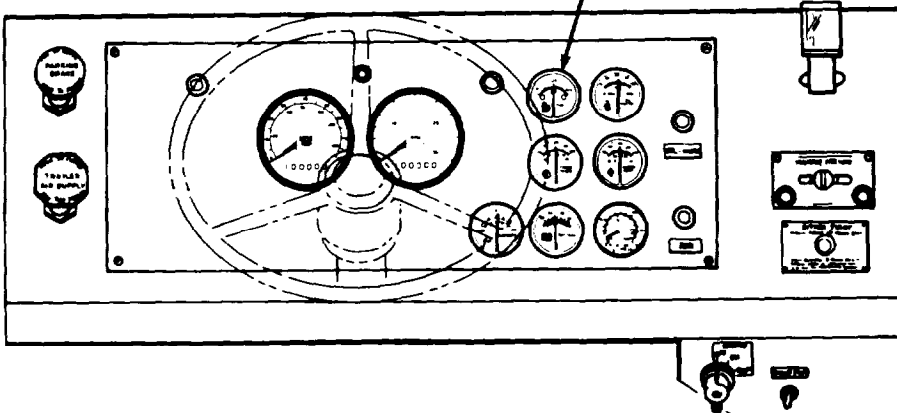
Item No.	Interval	Location	<u>Crewmember</u> Procedure	Not Fully Mission Capable If:
		Item to Check/Service		
13	Before	Instruments Continued	<p><u>DRIVER</u></p> <p>CAUTION</p> <p>Immediately stop engine if oil pressure is zero.</p> <p>NOTE</p> <p>At idle, oil pressure can go as low as 5 psi (34 kPa).</p> <p>c. Oil Pressure Gage. Check gage. Normal operating range is 40 to 60 psi (276 to 414 kPa) between engine speeds of 1800 to 2100 rpm. Minimum for safe operation is 30 psi (207 kPa).</p>	<p>c. Gage indication less than 30 psi (207 kPa) during normal operation or less than 5 psi (34 kPa) at idle.</p>
<p>OIL PRESSURE GAGE</p> 				

Table 2-1. Preventive Maintenance Checks and Services for Models M977 thru M985E1

Item No.	Interval	Location	<u>Crewmember Procedure</u>	Not Fully Mission Capable If:
		item to Check/Service		
13	Before	Instruments	<p><u>DRIVER</u></p> <p>Coolant Temperature Gage.</p> <p>NOTE</p> <p>Several minutes are required for reading.</p> <p>d. Check gage. Normal operating temperature is 180° F (82°C) to 200°F (93°C).</p> <p>WARNING</p> <p>if NBC exposure is suspected, ail air filter media should be handled by personnel wearing protective equipment. Consult your unit NBC Officer or NBC NCO for appropriate handling or disposal instructions.</p> <p>e. Air Cleaner Restriction Indicator. Check that air cleaner restriction indicator is within yellow area. If indicator shows red and/or VACUUM INCHES H2O window shows 18, service air cleaner element (para 3-8).</p>	<p>d. Gage indication less than 140° F (60° C) or more than 230° F (110° C).</p> <p>e. Air Restriction Indicator cracked or un-serviceable.</p>
		Continued		

COOLANT TEMPERATURE GAGE

AIR CLEANER

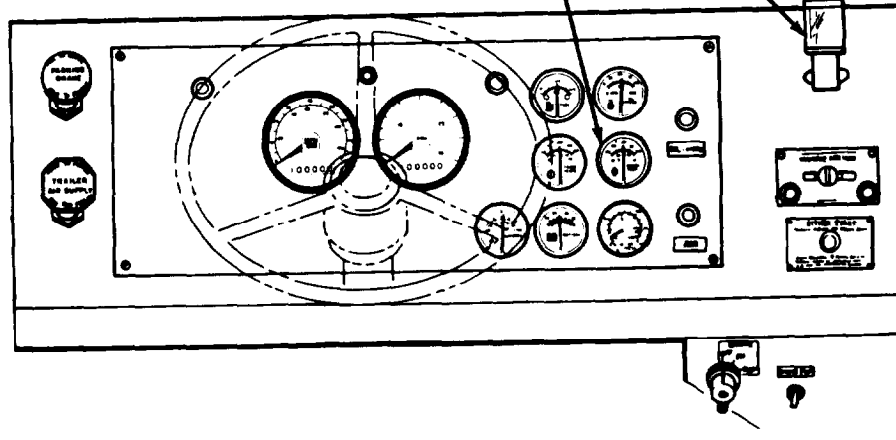


Table 2-1. Preventive Maintenance Checks and Services for Models M977 thru M985E1

Item No.	Interval	Location	Crewmember Procedure	Not Fully Mission Capable If:
		item to Check/Service		
13	Before	Instruments Continued	<p><u>DRIVER</u></p> <p>f. Air Pressure Gage. AIR PRESS gage indicates system air pressure in both front and rear sections. Low air pressure is below 60 psi (414 kPa) to 75 psi (517 kPa) in either section.</p> <p>Buzzer for air pressure gage will sound anytime indicator is lighted. Ensure buzzer goes off at 60 to 75 psi.</p> <p>g. Battery Gage. Battery gage indicates voltage output (24 to 28 Vdc).</p> <p>h. Amperes Gage. Amperes gage indicates alternator output. Should show positive reading.</p> <p>NOTE</p> <p>Automatic transmission may not reach 160° F (71° C) oil temperature at idle for several minutes.</p>	<p>f. Gage indication for either section is less than 60 psi (414 kPa) or low air pressure indicator remains on or does not operate, or warning buzzer remains on or does not operate.</p> <p>g. Gage indication is below 24 or above 28 Vdc.</p> <p>h. Gage indicates negative reading.</p>

The diagram shows a rectangular instrument panel with several gauges and controls. On the left side, there are three large circular gauges: the leftmost is labeled 'AMPERES GAGE', the middle one 'BAT. GAGE', and the rightmost one 'TRANS TEMP GAGE'. Below these is a smaller gauge labeled 'AIR PRESSURE GAGE'. On the right side of the panel, there are several smaller gauges and a control lever labeled 'TRACTION CONTROL LEVER'. The gauges have various scales and markings, and the control lever has a specific shape with a handle.

Table 2-1. Preventive Maintenance Checks and Services for Models M977 thru M965E1

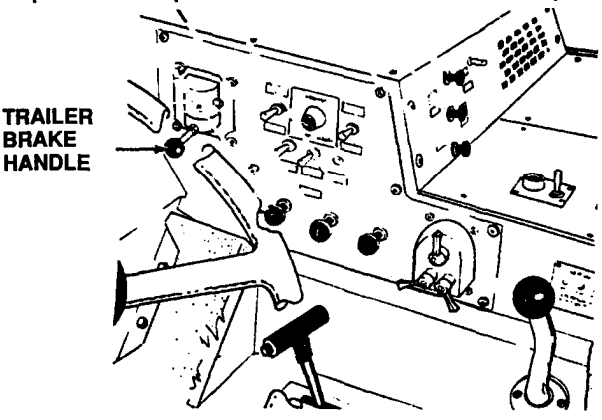
Item No.	Interval	Location	<u>Crewmember</u> Procedure	Not Fully Mission Capable If:
		Item to Check/Service		
13	Before	Continued	<p><u>DRIVER</u></p> <p>i. Transmission Temperature Gage. Transmission temperature gage indicates operating temperature 160° F (71° C) to 220° F (104° C) normal.</p> <p>j. Check wiper motor for operation.</p> <p>k. Check Traction Control Lever for proper operation.</p>	<p>i. Gage indication is 300° F (149° C) or more.</p>
14	Before	Gear Shifter	<p>a. Check transmission shift lever operation. With engine switch in 'ON' position, move shift lever from 'N' to '1' then back to 'N'. Lever should move freely through all range detents.</p> <p style="text-align: center;"><u>CAUTION</u></p> <p>Vehicle must be parked when making this check. Transfer case will be damaged if shifted while vehicle is moving.</p> <p>b. Check transfer shift lever operation. With transmission in 'N' shift transfer lever through all range positions. Lever should move freely through all range positions.</p>	<p>a. Lever inoperable or binds between range detents.</p> <p>b. Lever inoperable or binds between range detents.</p>
15	Before	Engine Retarder	<p>Check engine retarder for propel operation. With engine running and transmission in neutral (N) run engine at 1900 to 2100 rpm Place engine brake switch to 'ON'. Lift foot off throttle treadle and listen for a popping or chattering sound which indicates the engine brake is engaged.</p>	<p>Engine retarder does not engage.</p>

Table 2-1. Preventive Maintenance Checks and Services for Models M977 thru M985E1

Item No.	Interval	Location	<u>Crewmember</u> Procedure	Not Fully Mission Capable If:
		Item to Check/Service		
16	Before	Steering	<p><u>DRIVER</u></p> <p>Check steering wheel for operation. With engine running, turn steering wheel from left to right. Steering wheel should move freely.</p>	Steering wheel inoperable or binds.
17	Before	Parking Brake	<p>Check parking brake while vehicle is stopped. Apply parking brake while transmission is still in drive and engine at idle. Vehicle should not move.</p> <p style="text-align: center;">NOTE</p> <p>To complete exterior checks for each particular model, go to applicable table as listed below:</p> <p>M977 & M985 Table 2-2 M978 Table 2-3 M983 Table 2-4 M984E1 Table 2-5 M985E1 Table 2-6</p>	Vehicle moves with parking brake applied.

Table 2-1. Preventive Maintenance Checks and Services for Models M977 thru M985E1

Item No.	Interval	Location	Crewmember Procedure	Not Fully Mission Capable If:
		Item to Check/Service		
18	During	Engine	<p><u>DRIVER</u></p> <p>Check and/or listen for excessive smoke, unusual noise, rough running, or misfiring.</p>	Any of these conditions are present.
19	During	Trailer Brake Hand Control	<p>NOTE</p> <p>Check trailer brake handle control only if a trailer is hooked up to vehicle by moving vehicle and trailer and applying trailer brakes.</p> <p>Check trailer brake hand control for proper operation.</p> <p>Listen for brake actuation. If none, check trailer TM.</p>	Control does not apply to trailer brakes.



TRAILER BRAKE HANDLE

Table 2-1. Preventive Maintenance Checks and Services for Models M977 thru M985E1

Item No.	Interval	Location	<u>Crewmember</u> Procedure	Not Fully Mission Capable If:
		Item to Check/ Service		
20	During	Instruments	<p><u>DRIVER</u></p> <p>NOTE During operation all gages should maintain the proper readings listed in the BEFORE checks.</p> <p>Monitor all gages, indicators and warning lights for proper reading while operating vehicle.</p>	Gages, indicators and warning lights do not read properly.
21	During	Transmission	Check transmission for proper operation.	Transmission slips or will not shift.
22	During	Steering	Be alert for any unusual noise, binding, or difficulty in steering during operation.	Steering binds or is unresponsive.

Table 2-1. Preventive Maintenance Checks and Services for Models M977 thru M985E1

Item No.	Interval	Location	<u>Crewmember</u> Procedure	Not Fully Mission Capable If:
		Item to Check/Service		
23	During	Service Brake	<p><u>DRIVER</u></p> <p>Be alert for chatter, noise and side pull.</p> <p>NOTE</p> <p>To complete the DURING checks for each particular model, go to applicable table as listed below:</p> <p>M77 & M985 Table 2-2 M978 Table 2-3 M983 Table 2-4 M984E1 Table 2-5 M985E1 Table 2-6</p>	Service brakes do not operate properly.

Table 2-1. Preventive Maintenance Checks and Services for Models M977 thru M985E1

Item No.	Interval	Location	Crewmember Procedure	Not Fully Mission Capable If:
		Item to Check/Service		
24	After	Transmission	<p><u>DRIVER</u></p> <p>NOTE</p> <p>Parking brake must be set, transmission is in N (neutral) position and engine running to properly check transmission fluid level.</p> <p>With engine running, check transmission fluid level on dipstick. If transmission temperature is above 160° F (71° C), fluid level should be within HOT RUN area. Add oil as required. Drain excess or see unit maintenance if overfull.</p>	

The diagram shows a close-up of a transmission dipstick assembly. A label 'DIPSTICK' points to the top of the dipstick. To the right, a vertical scale is shown with two sections: 'COLD RUN' on top and 'HOT RUN' on the bottom. An arrow points from the 'HOT RUN' section to the dipstick's fluid level.

Table 2-1. Preventive Maintenance Checks and Services for Models M977 thru M985E1

Item No.	Interval	Location	Crewmember Procedure	Not Fully Mission Capable If:
		Item to Check/Service		
25	After	Fan Switch	<p><u>DRIVER</u></p> <p>Check fan switch for proper operation in LO and HI positions.</p>	

FAN SWITCH

Table 2-1. Preventive Maintenance Checks and Services for Models M977 thru M985E1

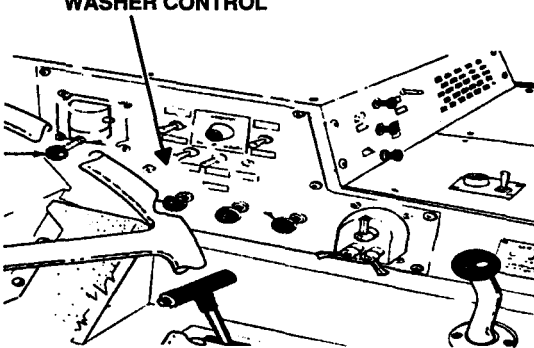
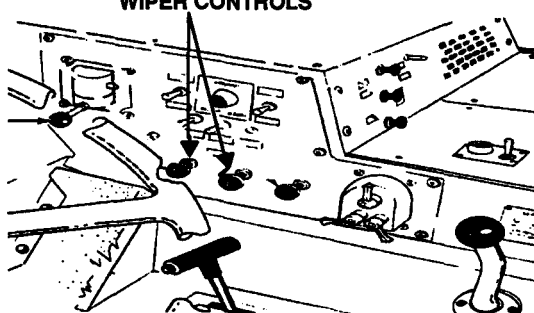
Item No.	Interval	Location	Crewmember Procedure	Not Fully Mission Capable If:
		Item to Check/Service		
26	After	Washer Control	<p>DRIVER</p> <p>NOTE Operation of vehicle with malfunctioning washer control may violate AR 385-55. Check washer control for proper operation.</p> <p>WASHER CONTROL</p> 	
27	After	Wiper Control	<p>NOTE Operation of vehicle with malfunctioning wipers may violate AR 385-55. Check washer control for proper operation.</p> <p>WIPER CONTROLS</p> 	

Table 2-1. Preventive Maintenance Checks and Services for Models M977 thru M985E1

Item No.	Interval	Location	Crewmember Procedure	Not Fully Mission Capable If:
		Item to Check/Service		
28	After	Horns	<p><u>DRIVER</u></p> <p>NOTE Operation of vehicle with malfunctioning horns may violate AR 385-55.</p> <p>Check both horns (air and electric) for proper operation.</p>	
29	After	Turn Signal Control	<p>NOTE Light checks will require assistance.</p> <p>Operation of vehicle with malfunctioning turn signal may violate AR 385-55.</p> <p>Check turn signal control for proper operation.</p>	

TURN SIGNAL CONTROL

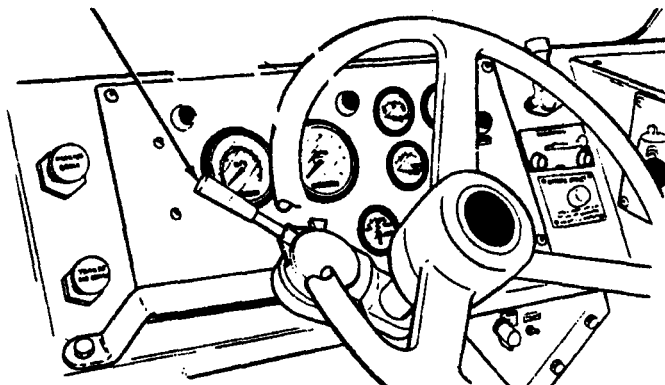


Table 2-1. Preventive Maintenance Checks and Services for Models M977 thru M985E1

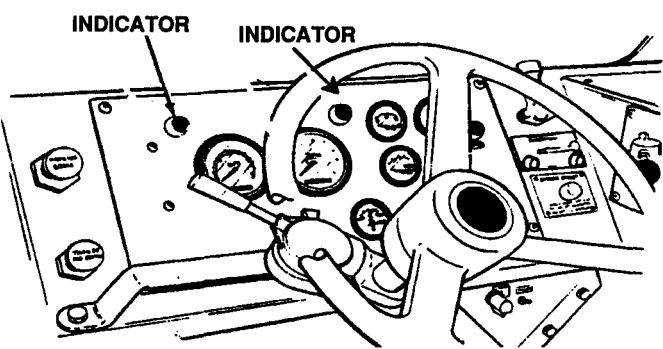
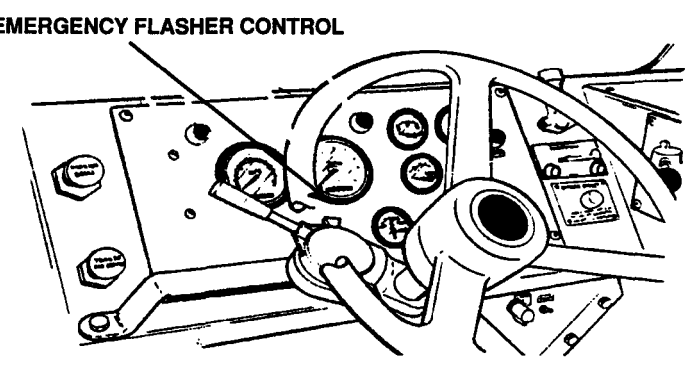
Item No.	Interval	Location	<u>Crewmember</u> Procedure	Not Fully Mission Capable If:
		Item to Check/Service		
30	After	Turn Signal Indicators	<u>DRIVER</u> Check indicators for proper operation.	
 <p>INDICATOR INDICATOR</p>				
31	After	Emergency Flasher Control	NOTE Operation of vehicle with malfunctioning emergency flasher control may violate AR 385-55. Check emergency flasher control for proper operation.	
 <p>EMERGENCY FLASHER CONTROL</p>				

Table 2-1. Preventive Maintenance Checks and Services for Models M977 thru M985E1

Item No.	Interval	Location	<u>Crewmember</u> Procedure	Not Fully Mission Capable If:
		Item to Check/Service		
32	After	Beacon Light	<p><u>DRIVER</u></p> <p>NOTE Operation of vehicle with malfunctioning beacon light may violate AR 385-55.</p> <p>Remove beacon light from glove box and check for proper operation (paragraph 2-33a).</p>	
33	After	Lights	<p>NOTE Operation of vehicle with malfunctioning service light may violate AR 385-55.</p> <p>Check headlights, clearance lamps, turn signals, brake lights. Check all blackout drive lights.</p>	
34	After	Mirrors	<p>NOTE Operation of vehicle with broken/missing mirrors may violate AR 385-55.</p> <p>Check condition of mirrors.</p>	
35	After	Air Lines	Listen for air leaks.	Any air leaks evident.

Table 2-1. Preventive Maintenance Checks and Services for Models M977 thru M985E1

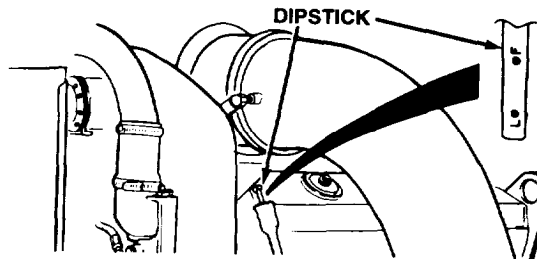
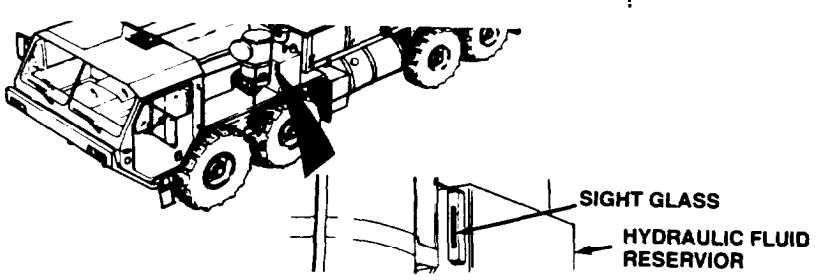
Item No.	Interval	Location	Crewmember Procedure	Not Fully Mission Capable If:
		Item to Check/Service		
36	After	Engine	<p><u>DRIVER</u></p> <p>NOTE</p> <p>Diesel engine slobber is an inherent condition of diesel engines. When engines are allowed to idle for prolonged periods of time this may be interpreted as a Class III leak. Check engine oil level. If there is any doubt, consult with your supervisor or unit maintenance.</p> <p>Check engine oil level on dipstick. Oil level should be between low (L) mark and full (F) mark. Add oil as required. Drain excess oil or see unit maintenance.</p>	
				
37	After	Hydraulic Fluid Reservoir	<p>Check that hydraulic fluid level in sight glass on hydraulic fluid reservoir is between FULL and ADD marks. If low, add hydraulic fluid.</p>	Fluid appears milky or foamy.
				

Table 2-1. Preventive Maintenance Checks and Services for Models M977 thru M985E1

Item No.	Interval	Location	Crewmember Procedure	Not Fully Mission Capable If:
		Item to Check/Service		
38	After	Left wheels	<p><u>DRIVER</u></p> <p>a. Check wheels for cracked, broken or bent surfaces. Check that lockrings and side rings are not damaged and they fit securely in grooves. Refer to paragraph 3-9 for proper inspection procedures.</p> <p>b. Check wheel studs and wheel nuts for obvious looseness. Check for bent or broken studs and missing wheel nuts.</p>	<p>a. A wheel is cracked, broken, bent, or lockrings or side rings are damaged or not secure.</p> <p>b. Two or more wheel studs on the same wheel are missing, broken, or bent.</p>
39	After	Right wheels		
40	After	Spare Tire/Wheel		
			<p>a. Check wheels for cracked, broken or bent surfaces. Check that lockrings and side rings are not damaged and they fit securely in grooves. Refer to paragraph 3-9 for proper inspection procedures.</p> <p>b. Check wheel studs and wheel nuts for obvious looseness. Check for bent or broken studs and missing wheel nuts.</p>	<p>a. A wheel is cracked, broken, bent, or lockrings or side rings are damaged or not secure.</p> <p>b. Two or more wheel studs on the same wheel are missing, broken, or bent.</p>
			<p>a. Check tire for cuts, gouges, cracks, or scratches. Remove any sharp objects.</p> <p>b. Check wheels for cracked, broken or bent surfaces. Check that lockrings and side rings are not damaged and they fit securely in grooves.</p>	<p>a. Tire has cuts, gouges or cracks which would result in tire failure during operation. Tire missing or unserviceable.</p> <p>b. A wheel is cracked, broken, bent, or lockrings or side rings are damaged or not secure.</p>

Table 2-1. Preventive Maintenance Checks and Services for Models M977 thru M985E1

Item No.	Interval	Location	<u>Crewmember</u> Procedure	Not Fully Mission Capable If:
		Item to Check/Service		
41	After	Shock Absorbers	<u>DRIVER</u> Check all shock absorbers for leaks and damage.	Damaged or Class III leak evident.
42	After	Air Reservoirs	Drain only air reservoirs under battery box as follows: NOTE M983 has three reservoirs under battery box. All other vehicles have two reservoirs under battery box, Turn petcock on bottom of reservoirs to open position. Let condensation drain off. Turn petcock to closed position.	

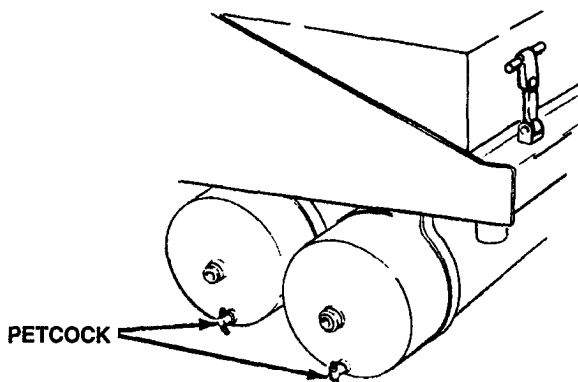


Table 2-1. Preventive Maintenance Checks and Services for Models M977 thru M985E1

Item No.	Interval	Location	Crewmember Procedure	Not Fully Mission Capable If:
		Item to Check/Service		
43	After	Fuel Water Separator	<p><u>DRIVER</u></p> <p><u>WARNING</u></p> <p>Fuel is very flammable and can explode easily. To avoid serious injury or death, keep fuel away from open fire and keep fire extinguisher within easy reach when working with fuel. Do not work on fuel system when engine is hot. Fuel can be ignited by hot engine. When working with fuel, post signs that read: "NO SMOKING WITHIN 50 FEET OF VEHICLE".</p>	

Table 2-1. Preventive Maintenance Checks and Services for Models M977 thru M985E1

Item No.	Interval	Location	Crewmember Procedure	Not Fully Mission Capable If:
		Item to Check/Service		
43	After	Fuel Water Separator Continued	<p><u>DRIVER</u></p> <p>NOTE</p> <ul style="list-style-type: none"> • Drain fuel into suitable container. • Operation of vehicle with malfunctioning fuel-water separator may violate AR 385-55. <p>Check for level of water in bowl of fuel-water separator. If there is water, turn knurled nut on bottom of bowl to open contaminant drain valve. Keep drain open until only pure fuel is flowing out of drain tube. Close drain valve by turning knurled nut.</p>	

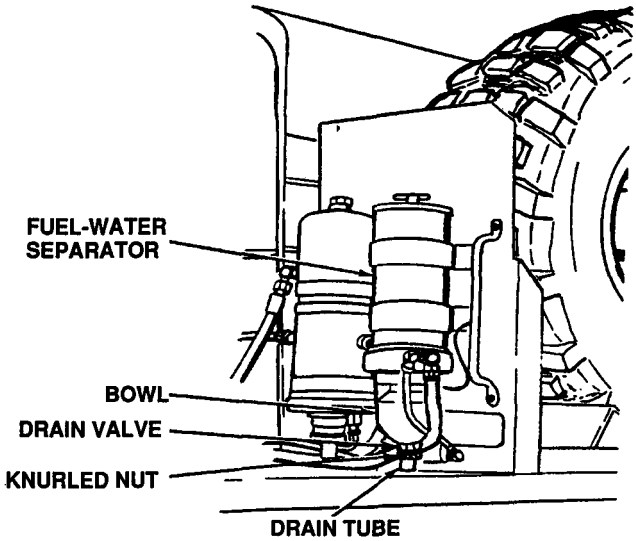


Table 2-1. Preventive Maintenance Checks and Services for Models M977 thru M985E1

Item No.	Interval	Location	Crewmember Procedure	Not Fully Mission Capable If:
		Item to Check/Service		
44	After	Towing Air Hose Glad Hands	<p><u>DRIVER</u></p> <p>Check for presence and condition of glad hands and rubber grommets.</p>	
45	After	Windshield and Wiper Arms/Blades	<p>NOTE</p> <p>Operation of vehicle with damaged or missing windshield may violate AR 385-55.</p> <p>a. Check glass for presence and condition.</p> <p>NOTE</p> <p>Operation of vehicle with damaged wiper arms/blades may violate AR 385-55.</p> <p>b. Check condition of wiper arms and blades.</p>	
46	After	Exterior of Vehicle	<p>a. Visually inspect cab and components for damage.</p> <p>b. Look under vehicle for signs of fluid leakage (fuel, oil and coolant).</p> <p>NOTE</p> <p>To complete the AFTER checks for each particular vehicle model, go to applicable table as listed below:</p> <p>M77 & M985 Table 2-2 M978 Table 2-3 M983 Table 2-4 M984E1 Table 2-5 M985E1 Table 2-6</p>	<p>a. Any component is damaged that would impair vehicle mission.</p> <p>b. Class III leakage of diesel fuel, oil or coolant is evident.</p>

Table 2-1. Preventive Maintenance Checks and Services for Models M977 thru M985E1

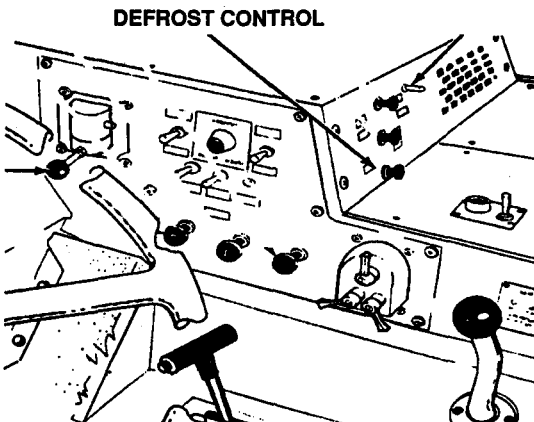
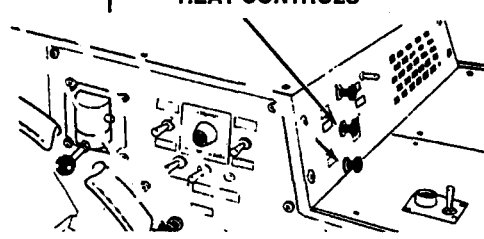
Item No.	Interval	Location	Crewmember Procedure	Not Fully Mission Capable If:
		Item to Check/Service		
47	Weekly	Defrost Control	<u>DRIVER</u> Check defrost control for proper operation.	
 <p style="text-align: center;">DEFROST CONTROL</p>				
48	Weekly	Heat Controls	Check heat controls for proper operation.	
 <p style="text-align: center;">HEAT CONTROLS</p>				

Table 2-1. Preventive Maintenance Checks and Services for Models M977 thru M985E1

Item No.	Interval	Location	<u>Crewmember Procedure</u>	Not Fully Mission Capable If:	
		Item to Check/Service			
49	Weekly	Tires	<u>DRIVER</u> <u>WARNING</u> Operating a vehicle with a tire in an overinflated or underinflated condition or with a questionable defect may lead to premature tire failure and may cause equipment damage, injury or death to personnel. Check tires for correct air pressure. Refer to paragraph 3-9 for proper inflation procedures.		
		TIRE PRESSURES			
Model		<u>Highway</u>	<u>Cross Country-Dry</u>	<u>Cross Country-Wet</u>	<u>Sandy Terrain</u>
Front (all models)					
Standard Tire		60 psi (414 kPa)	35 psi (241 kPa)	20 psi (138 kPa)	30 psi (207 kPa)
Sand Tire		60 psi (414 kPa)	NA	NA	25 psi (172 kPa)
Rear					
M977, M978, M983					
Standard Tire		70 psi (483 kPa)	40 psi (276 kPa)	30 psi (207 kPa)	35 psi (241 kPa)
Sand Tire		70 psi (483 kPa)	NA	NA	30 psi (207 kPa)
M984E1					
Standard Tire		100 psi (690 kPa)	100 psi (690 kPa)	100 psi (690 kPa)	30 psi (207 kPa)
Sand Tire		100 psi (690 kPa)	NA	NA	25 psi (172 kPa)
M984E1 (when towing another vehicle)					
Standard Tire		100 psi (690 kPa)	100 psi (690 kPa)	100 psi (690 kPa)	80 psi (551 kPa)
Sand Tire		100 psi (696 kPa)	NA	NA	80 psi (551 kPa)

Table 2-1. Preventive Maintenance Checks and Services for Models M977 thru M985E1

Item No.	Interval	Location	<u>Crewmember</u> Procedure	Not Fully Mission Capable If:
		Item to Check/Service		
49	Weekly	Tires Continued	<u>DRIVER</u>	
			TIRE PRESSURES (Cont)	
			<u>Highway</u>	<u>Cross Country-Dry</u>
			<u>Cross Country-Wet</u>	<u>Sandy Terrain</u>
M985	Standard Tire		50 psi (345 kPa)	40 psi (276 kPa)
	Sand Tire		100 psi (690 kPa)	40 psi (276 kPa)
	Spare Tire (all models)			
	Standard Tire		100 psi (690 kPa)	100 psi (690 kPa)
	Sand Tire		100 psi (690 kPa)	100 psi (690 kPa)
			OPERATING SPEEDS	
			<u>Highway</u>	<u>Cross Country-Dry</u>
			<u>Cross Country-Wet</u>	<u>Sandy Terrain</u>
Maximum Speed (all models)	Standard Tire		55 mph (88 kmh)	40mph (64 kmh)
	Sand Tire		55 mph (88 kmh)	20mph (32kmh)
M984E1 (when towing another vehicle)	Standard Tire		15mph (24 kmh)*	15mph (24 kmh)
	Sand Tire		15mph (24 kmh)*	15mph (24 kmh)
			* Operation at speeds over 15 mph (24 kmh) on paved road can be achieved when the operator determines that the vehicle being towed and the terrain allow for safe operation. Under no condition can speeds exceed 35 mph (55 kmh) on paved road and 15mph (24 kmh) off paved roads.	

Table 2-1. Preventive Maintenance Checks and Services for Models M977 thru M985E1

Item No.	Interval	Location	<u>Crewmember</u> Procedure	Not Fully Mission Capable If:
		Item to Check/Service		
50	Weekly	Exterior Doors and Windows	<p><u>DRIVER</u></p> <p>NOTE Operation of vehicle with damaged doors or windows may violate AR 385-55.</p> <p>Check condition/operation of doors, handles and windows.</p>	
51	Weekly	Towing Shackles		

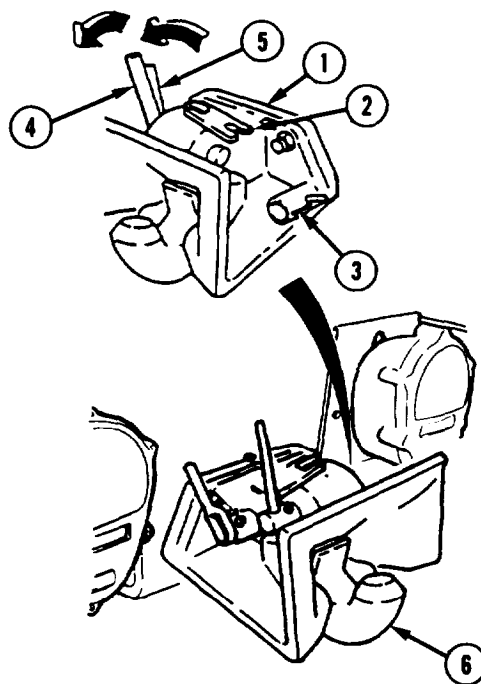


Table 2-1. Preventive Maintenance Checks and Services for Models M977 thru M985E1

Item No.	Interval	Location	<u>Crewmember Procedure</u>	Not Fully Mission Capable If:
		Item to Check/Service		
51.1	Weekly	Self-Guided Coupler M1977-CBT	Check self-guided coupler (1) for obvious damage and presence of the indicator lock (2). (a) Disengage swivel lock (3) and swivel self-guided coupler (1). (b) Engage swivel lock (3). (c) Open safety latch (2) away from hook lock (4). (d) Pull out on hook lock catch (5) and pull out on hook lock (4) to release hook (6). (e) Push up on hook (6). <p style="text-align: center;"><u>WARNING</u></p> Keep fingers clear of top of lift-hook or injury to personnel could result.	Self-guided coupler is damaged or loose. Indicator lock is missing. Self-guided coupler does not rotate freely.
52	Weekly	Pintle Hook	(f) Close safety latch. Check pintle hook for looseness and/or damaged locking mechanism or locking pin.	Pintle hook is loose or locking mechanism and cotter key are damaged and equipment is required for mission.
52.1	Weekly	Rear Spring/Parking Brake Chambers	Check rear spring/parking brake chambers to ensure dust covers are in place and secure.	

Table 2-1. Preventive Maintenance Checks and Services for Models M977 thru M985E1

Item No.	Interval	Location	Crewmember Procedure	Not Fully Mission Capable If:
		Item to Check/Service		
52.2	Weekly	Check Operation of M978 Emergency Fuel Shut-Off System	<p>a. Pull back on MC MANUAL CONTROL EM VALVE lever (Fig 2-10).</p> <p>b. Pull out Emergency Fuel Shut-Off (Fig 2-14).</p> <p>c. Determine if MC MANUAL CONTROL EM VALVE lever has been set in the closed (forward) position.</p>	MC MANUAL CONTROL EM valve does not return to the closed (forward) position when the EMERGENCY FUEL SHUT OFF is pulled out.

Table 2-1. Preventive Maintenance Checks and Services for Models M977 thru M985E1

Item No.	Interval	Location	Crewmember Procedure	Not Fully Mission Capable If:
		Item to Check/Service		
53	Weekly	Rear Lifting Shackles	<u>DRIVER</u> Check rear lifting shackles for serviceability.	Any Class III fuel leakage is evident.
54	Weekly	Electrical Connector	Check electrical connector seal and cable for damage.	
55	Weekly	Fuel Tank	Check fuel tank, fuel hoses, fuel tank connections, and fuel tank socket head pipe plug for leaks and/or damage.	

The diagram shows a cylindrical fuel tank mounted on a structure. Labels with arrows point to various components: 'FUEL HOSES' and 'CONNECTIONS' at the top; 'PIPE PLUG' at the bottom left; and 'FUEL TANK' at the bottom right.

Table 2-1. Preventive Maintenance Checks and Services for Models M977 thru M985E1

Item No.	Interval	Location	<u>Crewmember Procedure</u>	Not Fully Mission Capable If:
		Item to Check/Service		
56	Weekly	Fuel Tank Strainer	<p><u>DRIVER</u></p> <p>Check fuel tank strainer for clogged or damaged strainer. If strainer is clogged, clean strainer (paragraph 3-7).</p>	

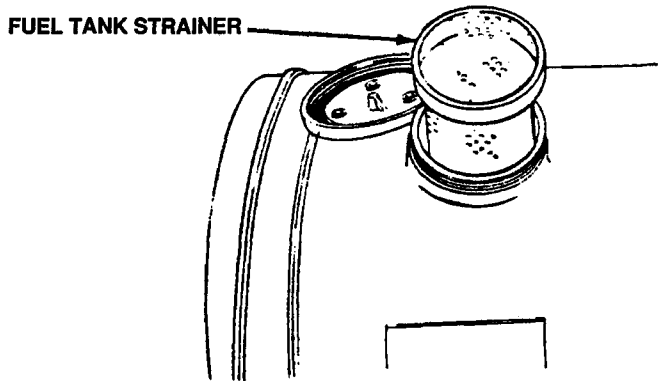
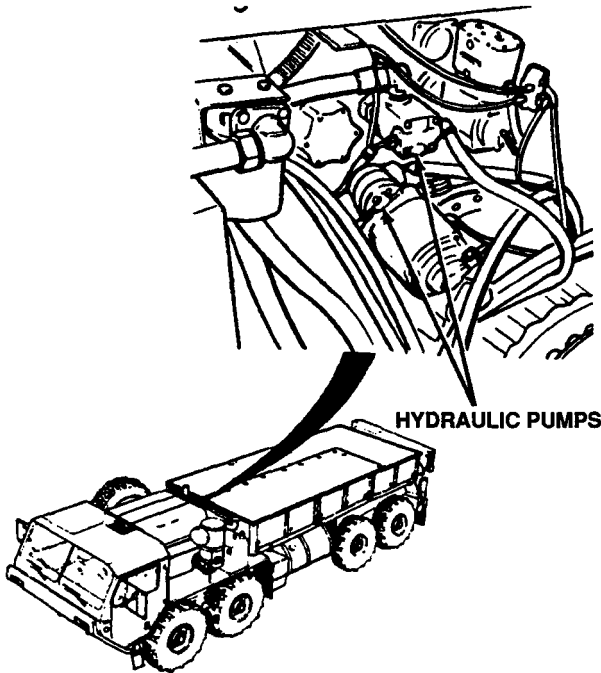


Table 2-1. Preventive Maintenance Checks and Services Models M977 Thru M985E1

Item No.	Interval	Location	Crewmember Procedure	Not Fully Mission Capable If:
		Item to Check/Service		
57	Weekly	Hydraulic Pumps	<p><u>DRIVER</u></p> <p>Check hydraulic pumps from rear of engine for loose bolts, leaks, or damage. Check for loose hose fittings.</p>	Any Class III leakage is evident or any mount bolt loose or missing.



The diagram consists of two parts. The upper part is a detailed line drawing of an engine compartment, showing various hydraulic pumps, hoses, and fittings. A callout line points from the text 'HYDRAULIC PUMPS' to a specific pump. The lower part is a side-view line drawing of a truck, with a callout line pointing from the same text to the location of the hydraulic pumps on the rear of the engine.

Table 2-1. Preventive Maintenance Checks and Services for Models M977 thru M985E1

Item No.	Interval	Location	<u>Crewmember Procedure</u>	Not Fully Mission Capable If:
		Item to Check/Service		
58	Weekly	Self-Recovery Winch (Vehicles equipped with one)	<p><u>DRIVER</u></p> <p><u>WARNING</u> Always wear heavy gloves when handling winch cables. Never let cables run through hands; frayed cables can cut. Never operate winch with less than five wraps of cable on winch drum.</p> <p>a. Check winch cable for kinks, frays, and breaks.</p> <p>b. Check winch control for proper operation in both directions.</p> <p>c. Inspect cable guide for any loose or missing parts and any obvious damage.</p> <p>d. Inspect tensioner for loose or missing parts and any obvious damage.</p> <p>e. Inspect roller cable guides for loose or missing parts and any other obvious damage.</p> <p>f. Inspect rear cable guide for loose or missing parts and any obvious damage.</p>	

Table 2-1. Preventive Maintenance Checks and Services Models M977 Thru M985E1

Item No.	Interval	Location	<u>Crewmember</u> Procedure	Not Fully Mission Capable If:
		Item to Check/Service		
59	Weekly	Spare Tire Retainer	<p><u>DRIVER</u></p> <p>Check that spare tire retainer is in place and locking handle is tight.</p>	

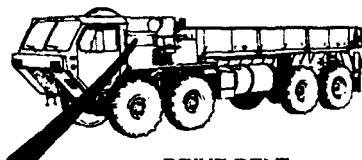
The diagram shows a top-down view of a spare tire retainer assembly. It consists of a circular metal housing with a central locking mechanism. A horizontal locking handle is attached to the center, and a vertical rod extends downwards from the handle. Two lines with arrows point from the text labels 'SPARE TIRE RETAINER' and 'LOCKING HANDLE' to the corresponding parts of the assembly.

Table 2-1. Preventive Maintenance Checks and Services for Models M977 thru M985E1

Item No.	Interval	Location	<u>Crewmember Procedure</u>	Not Fully Mission Capable If:
		Item to Check/Service		
60	Weekly	Spare Tire Davit	<p><u>DRIVER</u></p> <p>Check spare tire davit and carrier.</p>	
61	Weekly	Batteries	<p><u>WARNING</u></p> <ul style="list-style-type: none"> • Don't smoke, have open flames, or make sparks around the batteries, especially if the caps are off. Batteries can explode and cause injury or death. • Remove all jewelry such as rings, dog tags, bracelets, etc. If jewelry or tools contact battery terminal, a direct short may occur, resulting in instant heating, damage to equipment and injury to personnel. <p>Check Electrolyte Level: Electrolyte should be filled to the level/split ring in the battery filler opening (vent). If fluid is low, fill with distilled water to the level ring. If fluid is gassing (boiling) notify Organizational maintenance.</p>	<p>One or more batteries missing, cracked or unserviceable. Any terminal or cable loose, corroded or burnt. Any hold down not secure.</p>

Table 2-1. Preventive Maintenance Checks and Services Models M977 Thru M985E1

Item No.	Interval	Location	Crewmember Procedure	Not Fully Mission Capable If:
		Item to Check/Service		
62	Weekly	Radiator and Hoses	<u>DRIVER</u> Check radiator and radiator hoses for leaks, cloggs or damaged fins. Check for loose clamps.	Any Class III leakage is evident.
63	Weekly	Drive Belts, Fan and Pulleys	a. Check drive belts for cracking, fraying and breaks. Check for tightness. Play should be about 1/2 inch (13 mm).	a. Any drive belt is broken, cracked to the belt fiber, has more than one crack (1/8 inch in depth or 50% of belt thickness), has frays more than 2 inches longer or excessive play.



DRIVE BELT

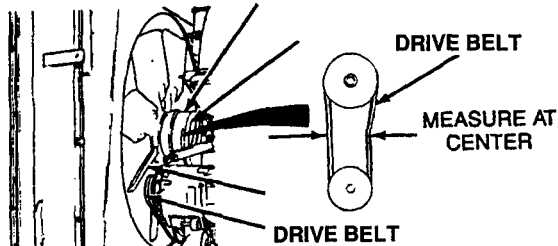


Table 2-1. Preventive Maintenance Checks and Services for Models M977 thru M985E1

Item No.	Interval	Location	Crewmember Procedure	Not Fully Mission Capable If:
		Item to Check/Service		
63	Weekly	Drive Belts, Fan and Pulleys Continued	<u>DRIVER</u> b. Check condition of fan for broken or cracked blades. c. Check for bent or damaged pulley.	b. Fan damaged or unserviceable. c. Pulley damaged or unserviceable.
64	Weekly	Air Intake System	a. Squeeze air cleaner dust cap to remove excess dirt from canister. b. Check that air intake weather cap is secure on air cleaner canister.	

The diagram shows a side view of the engine's air intake system. A circular weather cap is mounted on top of a cylindrical air cleaner canister. Below the canister is a rectangular dust cap. Arrows point from the labels 'AIR INTAKE WEATHER CAP' and 'AIR CLEANER DUST CAP' to their respective parts in the drawing.

Table 2-1. Preventive Maintenance Checks and Services Models M977 Thru M985E1

Item No.	Interval	Location	Crewmember Procedure	Not Fully Mission Capable If:
		Item to Check/Service		
64	Weekly	Air Intake System Continued	<p><u>DRIVER</u></p> <p>NOTE Ether starting cartridges will be removed in tropical environments and the solenoid valve will be capped. Upon deployment of the vehicle, cartridge will be reinstalled.</p> <p>c. Check ether starting aid for loose or damaged mounts and hardware. Check canister for damage.</p> <p>d. Check air intake system for loose clamps and damage tube.</p>	d. Air intake system has loose clamps and damaged tube.

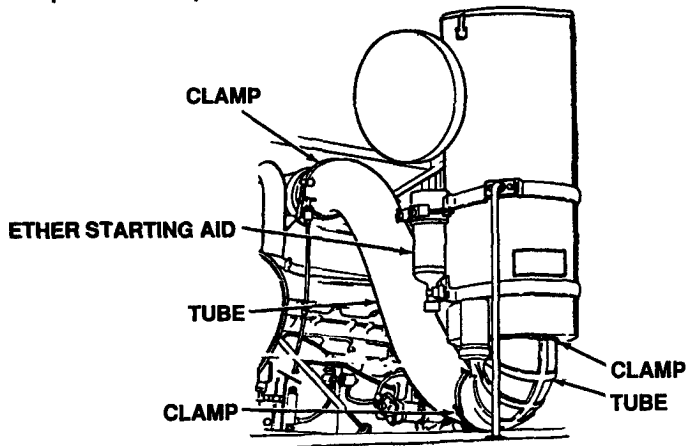


Table 2-1. Preventive Maintenance Checks and Services for Models M977 thru M985E1

Item No.	Interval	Location	Crewmember Procedure	Not Fully Mission Capable If:
		Item to Check/Service		
65	Weekly	Exhaust System	<p><u>DRIVER</u></p> <p>NOTE</p> <p>Operation of vehicle with any exhaust leaks could violate AR 385-55.</p> <p>Check exhaust pipe, muffler, heatshield, tailpipe, raincap, clamps and mountings for obvious damage, looseness, exhaust leak and carbon build up.</p>	Exhaust pipe between turbocharger and exhaust manifold leaks. Any exhaust pipe missing or damaged.

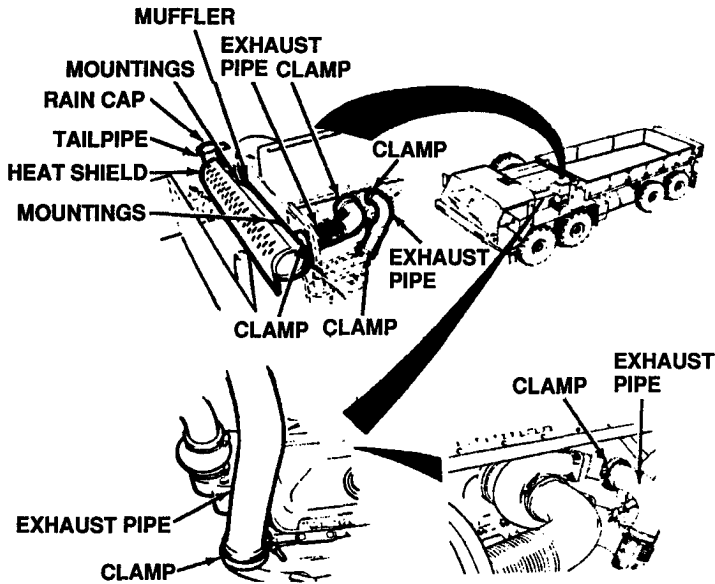


Table 2-1. Preventive Maintenance Checks and Services Models M977 Thru M985E1

Item No.	Interval	Location	Crewmember Procedure	Not Fully Mission Capable If:
		Item to Check/Service		
66	Weekly	Turbo-charger Oil Line	<p><u>DRIVER</u></p> <p>NOTE</p> <p>Open engine cover on passenger side.</p> <p>Check turbocharger oil line and fittings from rear of engine for signs of leaks or damage.</p>	Any Class III leakage is evident.

The diagram consists of two parts. The top part is a perspective view of a truck with a cargo bed. A thick black arrow points from the rear of the truck towards the engine compartment. The bottom part is a cross-sectional view of the engine compartment, showing various components. A line labeled 'OIL LINE' points to a specific line in the engine compartment.

Table 2-1. Preventive Maintenance Checks and Services for Models M977 thru M985E1

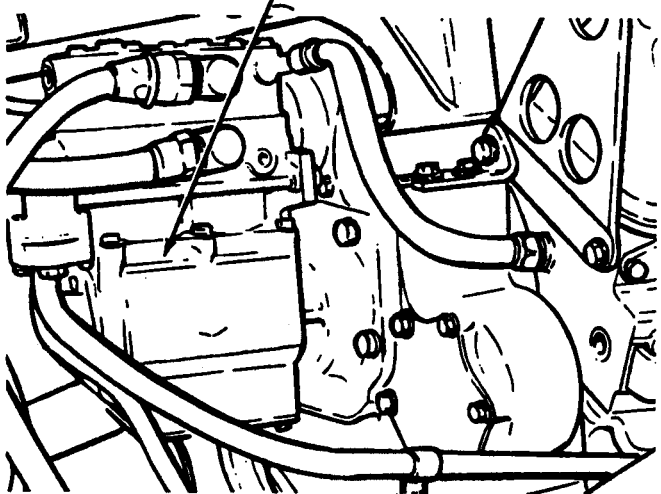
Item No.	Interval	Location	Crewmember Procedure	Not Fully Mission Capable If:
		Item to Check/Service		
67	Weekly	Air Compressor	<p><u>DRIVER</u></p> <p>NOTE Operation of vehicle with damaged/malfunctioning air compressor (air brakes) may violate AR 385-55.</p> <p>Check air compressor for loose bolts or damaged airhoses and connections.</p>	<p>Bolts missing, mounting flange broken, airhoses or fittings loose.</p>
<p>AIR COMPRESSOR</p> 				

Table 2-1. Preventive Maintenance Checks and Services for Models M977 Thru M985E1

Item No.	Interval	Location	<u>Crewmember</u> Procedure	Not Fully Mission Capable If:
		Item to Check/Service		
68	Weekly	Secondary Fuel Filter	<u>DRIVER</u> Check secondary fuel filter for leaks or damage.	Class III fuel leakage is evident.
69	Weekly	Air Dryer	Check air dryer for loose bolts and connections.	

AIR DRYER

Table 2-1. Preventive Maintenance Checks and Services for Models M977 thru M985E1

Item No.	Interval	Location	<u>Crewmember</u> Procedure	Not Fully Mission Capable If:
		Item to Check/Service		
70	Weekly	Air Lines and Hoses	<p><u>DRIVER</u></p> <p>NOTE Pressurize air system.</p> <p>Check for obvious damage to air lines and hoses. Check for leaks.</p>	Any leaks or damage to lines, hoses, or fittings are found.
71	Weekly	Hydraulic Lines and Hoses	Check for leaks or obvious damage to hydraulic lines and hoses.	Any Class III leaks, or cracked, broken, or bent lines or hoses are found,
72	Weekly	U-Joints	Check U-joints for loose or broken nuts and bolts.	One or more nuts or bolts are loose or broken.
73	Weekly	Axle Breather	<p>Check all axle breathers for damage and free movement of vent caps on breather body.</p> <p>NOTE To complete the WEEKLY checks for each particular vehicle model, go to applicable table as listed below:</p> <p>M977 & M985 Table 2-2 M978 Table 2-3 M983 Table 2-4 M984E1 Table 2-5 M985E1 Table 2-6</p>	Any axle breathers are damaged or vent caps do not move freely on breather body.

Table 2-1. Preventive Maintenance Checks and Services for Models M977 thru M985E1

Item No.	Interval	Location	Crewmember Procedure	Not Fully Mission Capable If:
		Item to Check/Service		
74	Monthly	Corrosion Check	<p><u>DRIVER</u></p> <p>Check for obvious damage, rust or corrosion.</p> <p style="text-align: center;">NOTE</p> <p>To complete MONTHLY checks for each particular model, go to applicable table as listed below:</p> <p>M977 & M985 Table 2-2 M978 Table 2-3 M983 Table 2-4 M984E1 Table 2-5 M985E1 Table 2-6</p>	Any broken, cracked or bent frame, side, cross-members, broken welds, or broken bolts are found.

Table 2-2. Preventive Maintenance Checks and Services for Models M977 thru M985

Item No.	Interval	Location	Crewmember Procedure	Not Fully Mission Capable If:
		Item to Check/Service		
75	Before	Left Side Panel	<p><u>DRIVER</u></p> <p>a. Check that left side panel and hinge pins are not bent, broken and have no broken welds.</p> <p>b. Check for missing or broken tie down eyes.</p> <p>c. M985 only. Check MLRS tie down brackets and retainer for looseness, cracks, or damage.</p>	<p>a. Any side panel missing or has broken welds.</p> <p>A latch or one hinge pin is broken</p> <p>b. Any tie down eye is missing or broken.</p> <p>c. Tie down brackets or retainer loose, cracked, or damaged.</p>

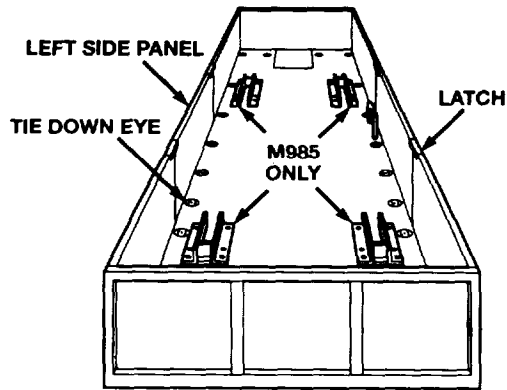


Table 2-1. Preventive Maintenance Checks and Services for Models M977 thru M985E1

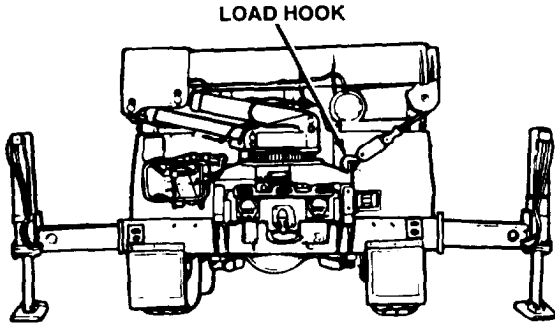
Item No.	Interval	Location	<u>Crewmember</u> Procedure	Not Fully Mission Capable If:
		Item to Check/Service		
76	Before	Load Hook	<p><u>DRIVER</u></p> <p><u>CAUTION</u></p> <p>Do not let load hook fall and hit taillight.</p> <p>NOTE</p> <p>Operation of vehicle with malfunctioning load hook may violate AR 365-55.</p> <p>Check load hook for cracks.</p>	Hook is cracked.
				

Table 2-2. Preventive Maintenance Checks and Services Models M977 and M985

Item No.	Interval	Location	Crewmember Procedure	Not Fully Mission Capable If:
		Item to Check/Service		
77	Before	Hook Spring Safety Latch	<p><u>DRIVER</u></p> <p>NOTE Operation of vehicle with malfunctioning safety latch may violate AR 385-55.</p> <p>Check safety latch for proper operation.</p>	
78	Before	Rear End Side Panel	Check safety latch for proper operation.	One or more lock pins are missing or broken.

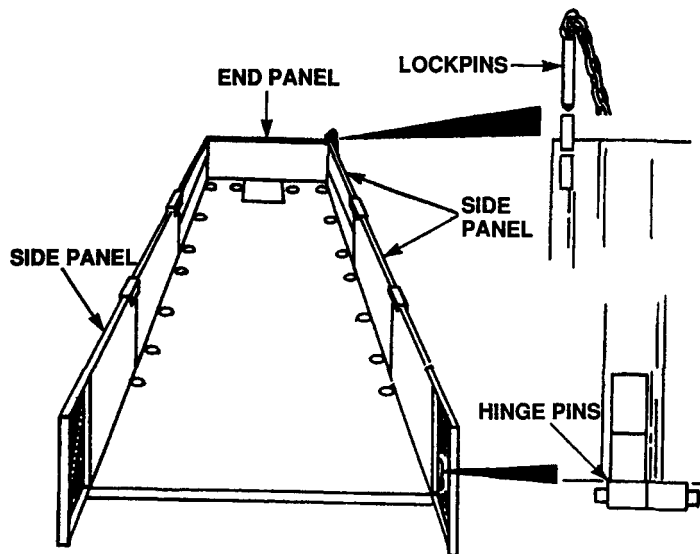


Table 2-2. Preventive Maintenance Checks and Services for Models M977 and M985

Item No.	Interval	Location	<u>Crewmember</u> Procedure	Not Fully Mission Capable If:
		Item to Check/Service		
79	Before	Right Side Panel	<u>DRIVER</u> Check that right side panel is not bent, broken and has no broken welds.	Any side panel missing or has broken welds. A latch is broken or missing. Any tie down eye or hinge pin is broken or missing.
<p>The diagram shows a perspective view of the right side panel assembly. It is a trapezoidal structure with several components labeled: 'LATCHES' at the top corners, 'LOCKPINS' at the top edge, 'SIDE PANEL (RIGHT)' for the main body, 'TIEDOWN EYES' along the bottom edge, and 'HINGE PINS' at the bottom corners. Detailed inset drawings show the locking mechanism and the hinge pin connection.</p>				
80	Before	Front End Panel	Check that front end panel is not bent, broken and has no broken welds.	One or more lock pins are missing or broken.

Table 2-2. Preventive Maintenance Checks and Services Models M977 and M985

Item No.	Interval	Location	Crewmember Procedure	Not Fully Mission Capable If:
		Item to Check/Service		
81	After	Material Handling Crane	<p>DRIVER</p> <p>Inspect crane for loose parts, hydraulic leaks, damage to hydraulic hoses and lines, and obvious damage.</p> <p>NOTE</p> <p>If the vehicle has self-recovery winch, push selector valve in. Start engine (paragraph 2-11a or 2-11b).</p> <p>Put PTO ENGAGE switch in ON position. Indicator light should come on. Set electric control box ON/OFF POWER switch to ON position. Set ENGINE HIGH IDLE ON/OFF switch to ON position.</p> <p>NOTE</p> <p>To prepare the vehicle for crane hydraulic system checks, perform the following:</p>	Class III leakage or damaged hoses, lines and fittings.

Table 2-2. Preventive Maintenance Checks and Services for Models M977 thru M985

Item No.	Interval	Location	<u>Crewmember</u> Procedure	Not Fully Mission Capable If:
		Item to Check/Service		
81	After	Material Handling Crane continued	<p><u>DRIVER</u></p> <p><u>WARNING</u></p> <ul style="list-style-type: none"> • Stand clear of outrigger beams while operating levers or injury could result when beams come out. • Do not operate crane unless outriggers are firmly in place or serious injury or death could result. • Always chock front tires when operating outriggers. <p>NOTE</p> <ul style="list-style-type: none"> • Operate control levers with light, even pressure. Moving lever slightly will cause slow movement of crane. Moving lever to full travel will cause faster movement of crane. • Outrigger beams will come out slower with light pressure on lever. Pushing lever to full travel will cause faster movement. • Either right or left outrigger beam may come out first. 	

Table 2-2. Preventive Maintenance Checks and Services for Models M977 thru M985

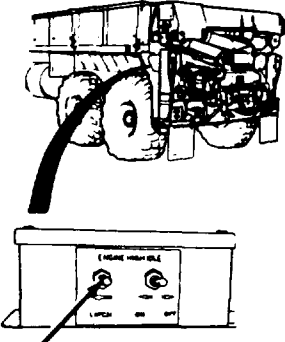
Item No.	Interval	Location	Crewmember Procedure	Not Fully Mission Capable If:
		Item to Check/Service		
81	After	Material Handling Crane Continued	<p><u>DRIVER</u></p> <p>a. Push and release ENGINE HIGH IDLE LATCH switch. Engine speed should increase to approximately 1500 rpm.</p>  <p>ENGINE HIGH IDLE LATCH SWITCH</p>	a. Engine speed does not increase to 1475 to 1525 rpm.

Table 2-2. Preventive Maintenance Checks and Services Models M977 and M985

Item No.	Interval	Location	<u>Crewmember</u> Procedure	Not Fully Mission Capable If:
		Item to Check/Service		
81	After	Material Handling Crane Continued	<p><u>DRIVER</u></p> <p>b. Manual Controls. Check each control separately for malfunction, proper response, obvious damage, missing parts, binding, or extreme looseness.</p> <p>c. O/R EXT Lever. Move O/R EXT lever to OUT position until right and left outrigger beams are completely out.</p> <p>d. Outrigger pads. Set up outrigger pads (paragraph 2-18b). Check that two retaining pins are attached to each pad.</p> <p><u>WARNING</u></p> <p>Keep hands and feet clear of outrigger jack cylinders to avoid injury.</p> <p>NOTE</p> <p>Adjust outrigger pad position as required so rod end will lower into pad socket.</p> <p>e. LH O/R Jack Control Lever. Move LH O/R Jack control lever to DOWN position and lower outrigger jack cylinder until rod end is firmly seated in outrigger pad. Install retaining pins.</p>	<p>b. Controls malfunction, bind, or do not respond.</p> <p>c. One or both outrigger beams do not come out.</p> <p>d. One retaining pin is missing.</p> <p>e. Outrigger jack cylinder will not come out or will not lower completely into pad.</p>

Table 2-2. Preventive Maintenance Checks and Services for Models M977 and M985

Item No.	Interval	Location	Crewmember Procedure	Not Fully Mission Capable If:
		Item to Check/Service		
81	After	Material Handling Crane Continued	<p><u>DRIVER</u></p> <p><u>WARNING</u></p> <p>Do not operate crane unless outriggers are set up. Vehicle could turn over causing serious injury or death.</p> <p>f. RH O/R Jack Control Lever. Move RH O/R Jack control lever to DOWN position and lower outrigger jack cylinder until rod end is firmly seated in outrigger pad. Install retaining pins.</p>	<p>f. Outrigger jack cylinder will not come out or will not lower completely into pad.</p>

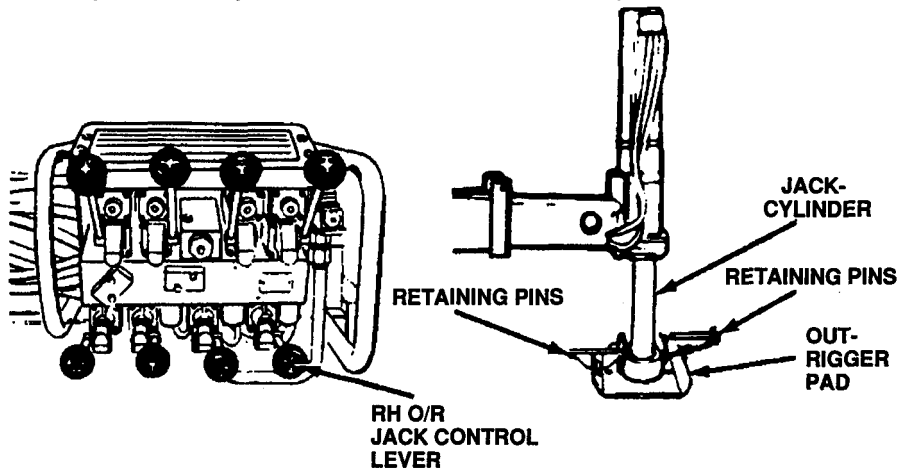


Table 2-2. Preventive Maintenance Checks and Services Models M977 and M985

Item No.	Interval	Location	Crewmember Procedure	Not Fully Mission Capable If:
		Item to Check/Service		
81	After	Material Handling Crane Continued	<p><u>DRIVER</u></p> <p>CAUTION Do not let cable unwind and become slack or cable may get tangled on drum.</p> <p>g. Hoist Control Lever. Disconnect load hook. Move HOIST control lever to DOWN position and lower hoist cable about 12 inches (305 mm).</p> <p>WARNING Keep boom clear of all electrical lines and other obstacles while operating crane. Serious injury or death could result upon contact.</p> <p>CAUTION Do not hit outrigger leg with load hook.</p>	g. Hoist cable drum will not rotate.

Table 2-2. Preventive Maintenance Checks and Services for Models M977 and M985

Item No.	Interval	Location	Crewmember Procedure	Not Fully Mission Capable If:
		Item to Check/Service		
81	After	Material Handling Crane Continued	<p><u>DRIVER</u></p> <p>h. Boom Control Lever. Move BOOM control lever to UP position until the boom is approximately 45° above horizontal.</p> <p>i. Mast and Boom Control Levers. Move MAST control lever to UP position until the mast is fully erect and the cylinders are fully extended. Use BOOM control lever UP simultaneously as required to maintain the boom at approximately 45° above horizontal until the mast is fully erect. Hold the mast control lever to up position for 2-3 seconds after mast is fully erect to ensure cylinders are fully filled with oil.</p>	<p>h. Boom does not raise to 45° above horizontal position.</p> <p>i. Mast cylinders do not raise completely before stopping.</p>

Table 2-2. Preventive Maintenance Checks and Services Models M977 and M985

Item No.	Interval	Location	Crewmember Procedure	Not Fully Mission Capable If:
		Item to Check/Service		
81	After	Material Handling Crane Continued	<p><u>DRIVER</u></p> <p><u>WARNING</u></p> <ul style="list-style-type: none"> • Keep boom clear of all electrical lines and other obstacles while operating crane. Serious injury or death could result upon contact. • Be sure area is clear of personnel before moving SWING lever. Boom should be swung slow enough so crane operator has complete control. Boom moving out of control could cause injury or death. <p><u>CAUTION</u></p> <p>Boom must be above vehicle sides for clearance.</p> <p>j. Swing Control Lever. Move swing control lever to CW position to move boom clockwise, CCW position to move boom counterclockwise.</p>	<p>j. Boom does not turn clockwise or counterclockwise.</p>

SWING CONTROL LEVER

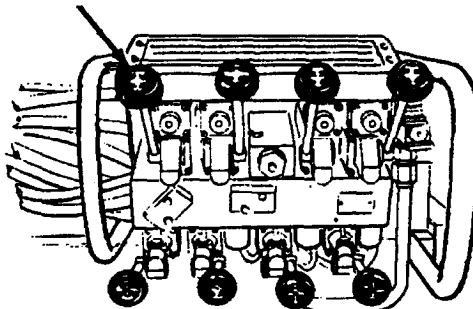


Table 2-2. Preventive Maintenance Checks and Services for Models M977 and M985

Item No.	Interval	Location	Crewmember Procedure	Not Fully Mission Capable If:
		Item to Check/Service		
81	After	Material Handling Crane Continued	<p>DRIVER</p> <p>CAUTION</p> <p>Keep hook block at least 2 feet (0.61 m) from end of boom. If hook block hits end of boom it may damage cable or hook block and crane will lose power. Wait 6 seconds for power to return and check crane for damage.</p> <p>NOTE</p> <p>TELESCOPE and HOIST levers should be operated at same time.</p> <p>Crane movement from one lever may be slower than other when operating two levers together.</p> <p>k. Telescope Control Lever. Move TELESCOPE control lever to OUT position to extend boom while moving HOIST control lever to DOWN position to pay out cable.</p>	k. Extensions do not come out.

Table 2-2. Preventive Maintenance Checks and Services for Models M977 and M985

Item No.	Interval	Location	Crewmember Procedure	Not Fully Mission Capable If:
		Item to Check/ Service		
81	After	Material Handling Crane Continued	<p><u>DRIVER</u></p> <p>TO REAR OUTLET</p> <p><u>WARNING</u></p> <p>Keep boom clear of electrical lines and other obstacles while operating crane. Serious injury or death could result upon contact.</p> <p>Be sure area is clear of personnel before moving SWING lever. Boom should be swung slow enough so crane operator has complete control. Boom moving out of control could cause serious injury or death.</p> <p>If electrical power fails during crane operation, move switch on remote control unit to SHUTDOWN position. Serious injury could result from uncontrolled moving parts.</p> <p><u>CAUTION</u></p> <p>Boom must be above vehicle sides for clearance.</p> <p><u>NOTE</u></p> <p>Operate control levers with light, even pressure. Moving lever slightly will cause slow movement of crane. Moving lever full travel will cause faster movement of crane.</p>	

Table 2-2. Preventive Maintenance Checks and Services Models M977 and M985

Item No.	Interval	Location	<u>Crewmember</u> Procedure	Not Fully Mission Capable If:
		Item to Check/Service		
81	After	Material Handling Crane Continued	<p><u>DRIVER</u></p> <p>n. Remote Control Levers. Check control levers for malfunction, proper response, obvious damage, missing parts, binding and extreme looseness.</p> <p>NOTE Shut off switches (2-19g). Disconnect remote control cable plug from electric control box REMOTE CONTROL CONNECTOR outlet. Screw cover on outlet.</p> <p>o. Remote Control Unit Front Outlet. Connect remote control to forward outlet (paragraph 2-19c) and check control levers for malfunction, proper response, obvious damage, missing parts, binding and extreme looseness.</p> <p>NOTE Return crane to stowed position. Shut off switches (paragraph 2-19f). Disconnect and stow remote control unit (paragraph 2-18f). Shut down crane (paragraph 2-18f).</p>	<p>n. Controls malfunction, bind or do not respond.</p> <p>o. Controls malfunction, bind or do not respond.</p>

Table 2-2. Preventive Maintenance Checks and Services for Models M977 thru M985

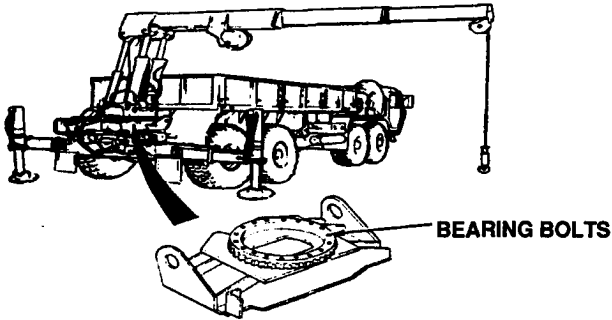
Item No.	Interval	Location	<u>Crewmember</u> Procedure	Not Fully Mission Capable If:
		Item to Check/Service		
82	Weekly	Self-Recovery Winch	<p><u>DRIVER</u></p> <p><u>WARNING</u></p> <p>Always wear heavy gloves when handling winch cables. Never let cables run through lands; frayed cables can cut. Never operate winch with less than five wraps of cable on winch drum.</p> <p>a. Winch Cable. Check for kinks, frays, and breaks.</p> <p>b. Winch Control. Check for proper operation in both directions.</p> <p>c. Cable Guide. Check for loose or missing parts or any obvious damage.</p> <p>d. Tensioner. Check for loose or missing parts and any obvious damage.</p> <p>e. Rear Cable Guide. Check for loose or missing parts and any obvious damage.</p>	

Table 2-2. Preventive Maintenance Checks and Services Models M977 and M985

Item No.	Interval	Location	Crewmember Procedure	Not Fully Mission Capable If:
		Item to Check/Service		
83	Weekly	Cargo Mounting Bolts	<p><u>DRIVER</u></p> <p>NOTE</p> <p>Operation of vehicle with bent, broken, or missing cargo body bolts may violate AR 385-55.</p> <p>Check that cargo bed mounting bolts are not broken or missing.</p>	One or more bolts broken or missing.
84	Weekly	Stowage Box	<p>a. Check stowage box for missing hardware and other obvious damage.</p> <p>b. Check inside stowage box for missing REMOTE CONTROL unit or cable, torn or damaged seal, water in bottom of stowage box, or other obvious damage.</p>	

Table 2-2. Preventive Maintenance Checks and Services for Model M977 and M985

Item No.	Interval	Location	Crewmember Procedure	Not Fully Mission Capable If:
		Item to Check/Service		
85	Weekly	Turntable Bearing Bolts	<p><u>DRIVER</u></p> <p>Visually inspect turntable bearing bolts for obvious looseness.</p>	One turntable bearing bolt is loose.



The diagram shows a side view of a vehicle's turntable mechanism. A long horizontal arm extends from the top of the turntable. Below the turntable, a detailed callout shows a circular bearing assembly with several bolts around its perimeter. A line points from the text 'BEARING BOLTS' to these bolts in the callout.

Table 2-3. Preventive Maintenance Checks and Services Model M978

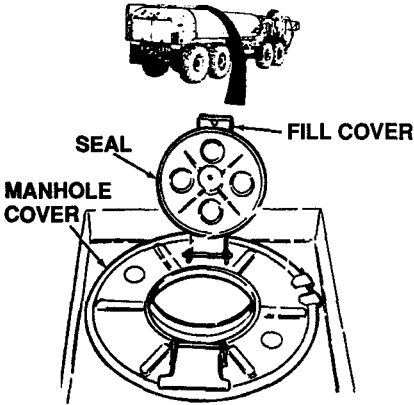
Item No.	Interval	Location	<u>Crewmember Procedure</u>	Not Fully Mission Capable If:
		Item to Check/Service		
86	Before	Fuel Tank	<p>DRIVER</p> <p>a. Check fuel tank for cracks and signs of leakage.</p> <p>b. Inspect manhole cover for damage.</p> <p>c. Inspect fill cover and seal for damage and proper closure.</p>	<p>a. Fuel tank leaks.</p> <p>b. Manhole cover is unserviceable.</p> <p>c. Fill cover is unserviceable.</p>
			 <p>The diagram shows a top-down view of a fuel tank. At the top, a small illustration of a truck is shown. Below it, a circular 'MANHOLE COVER' is shown with a 'SEAL' around its perimeter. To the right, a 'FILL COVER' is shown. The main fuel tank is depicted below these components, showing its internal structure and the location of the manhole and fill covers.</p>	

Table 2-3. Preventive Maintenance Checks and Services for Model M978

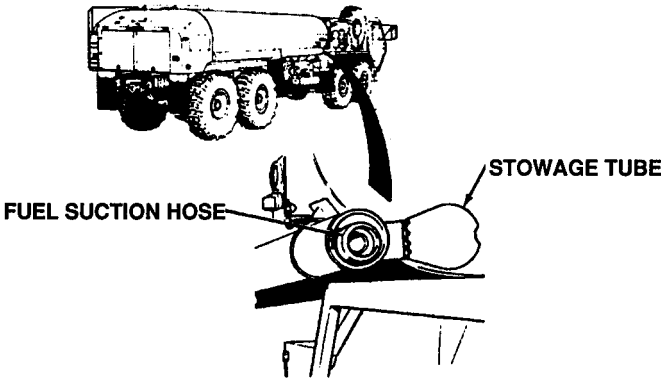
Item No.	Interval	Location	<u>Crewmember</u> Procedure	Not Fully Mission Capable If:
		Item to Check/Service		
87	Before	Fuel Suction Hose	<u>DRIVER</u> Check fuel suction hose in storage tube for obvious damage or missing parts.	Parts are damaged or missing and fuel suction hose is required for mission.
 <p>The diagram consists of two parts. The top part shows a side view of a fuel truck with a large cylindrical tank. A hose is connected to the bottom of the tank. The bottom part is a close-up view of the hose assembly. A label 'FUEL SUCTION HOSE' points to the flexible hose section. Another label 'STOWAGE TUBE' points to the rigid, cylindrical container that houses the hose. The hose is shown partially inserted into the storage tube.</p>				

Table 2-3. Preventive Maintenance Checks and Services Model M978

Item No.	Interval	Location	<u>Crewmember Procedure</u>	Not Fully Mission Capable If:
		Item to Check/Service		
88	Before	Pump Module	<p><u>DRIVER</u></p> <p><u>WARNING</u></p> <ul style="list-style-type: none"> • Stand clear to avoid injury when operating pump module rear doors. When each door is about halfway open, gas pistons push door open quickly and with much force. • Fuel is very flammable and can explode easily. To avoid serious injury or death, keep fuel away from open fire and keep fire extinguisher within easy reach when working with fuel. Do not work on fuel system when engine is hot. Fuel can be ignited by hot engine. When working with fuel, post signs that read: "NO SMOKING WITHIN 50 FEET OF VEHICLE". • Discharge from filter-separator tank shall be drained into suitable non-spark producing container to prevent fire or explosion. 	

Table 2-3. Preventive Maintenance Checks and Services for Model M978

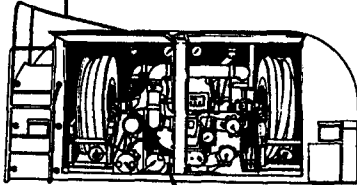

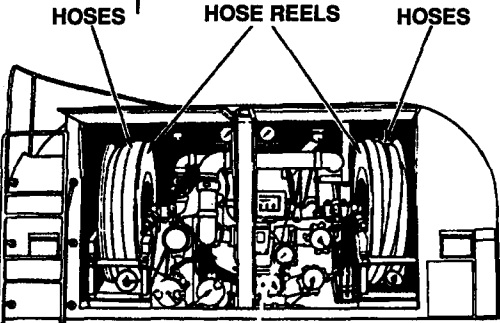
Item No.	Interval	Location	Crewmember Procedure	Not Fully Mission Capable If:	
		Item to Check/Service			
89	Before	V15 Drain Valve	<p><u>DRIVER</u></p> <p>Open V15 DRAIN VALVE and drain water and other contaminants out of filter-separator tank until pure fuel is coming out of valve.</p>		
		 <p>V15 DRAIN VALVE</p> 			
90	Before	Hoses, Hose Reel, and Adapters	<p>a. Check hoses and reels for obvious damage.</p> <p>b. Check nozzles and adapters for obvious damage.</p>	<p>a. Hose or hose reel is damaged and is needed for intended mission.</p> <p>b. Nozzle or reducer adapter is damaged and is needed for intended mission.</p>	
					

Table 2-3. Preventive Maintenance Checks and Services for Model M978

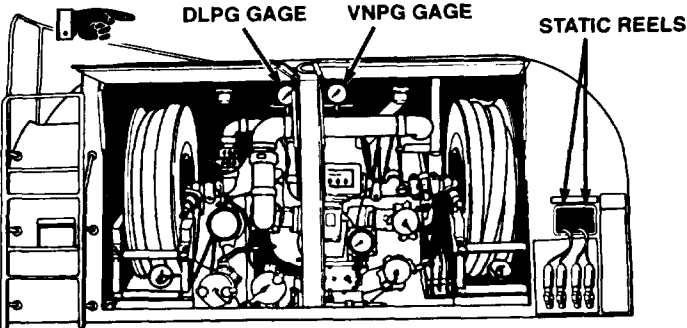
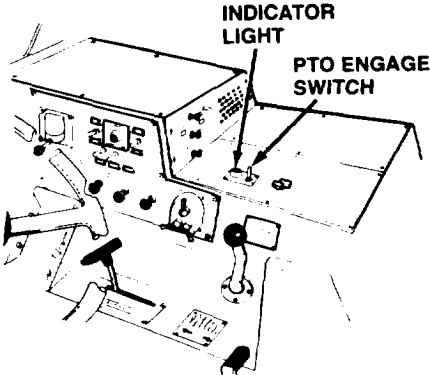
Item No.	Interval	Location	<u>Crewmember</u> Procedure	Not Fully Mission Capable If:
		Item to Check/Service		
91	Before	SR1 and SR2 Static Reels and Cables	<u>DRIVER</u> Check static reels and cables for damage that would prevent their use.	Either static reel is missing or unserviceable.
	19.1 Before	DLPG Gage and VNPG Gage	Check DLPG gage and VNPG gage glass bezels are firmly attached to gage bodies.	Glass bezel is missing or broken and is required for intended mission.
				
92	Before	PTO Switch	Check PTO ENGAGE switch for proper operation. Indicator light should come on.	PTO switch or indicator light is missing or inoperative.
				

Table 2-3. Preventive Maintenance Checks and Services for Model M978

Item No.	Interval	Location	Crewmember Procedure	Not Fully Mission Capable If:
		Item to Check/Service		
			<u>DRIVER</u>	
93	Before	Fusible Plugs	<p>NOTE Perform check for item no. 93 for Model A only.</p> <p>Check that fusible plugs are in place and not damaged.</p>	One or more plugs is missing.
93.1	Before	Gasket	Check that fuel does not leak around fill hole gasket.	Signs of fuel leaks are present.

Table 2-3. Preventive Maintenance Checks and Services Model M978

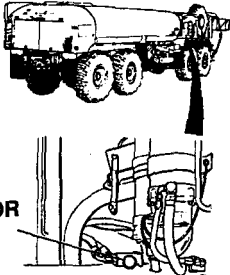
Item No.	Interval	Location	Crewmember Procedure	Not Fully Mission Capable If:
		Item to Check/Service		
94	During	Main Fuel Pump	<p><u>DRIVER</u></p> <p>NOTE</p> <p>TANK LEVEL INDICATOR must indicate at least 1/8 tank to perform this procedure (paragraph 2-21a).</p> <p>Check that main fuel pump operates using the following procedures:</p> <ol style="list-style-type: none"> a. If tank has a self-recovery winch, push selector valve in. b. Start engine (paragraph 2-11a or 2-11b). c. Pull back on MC MANUAL CONTROL EM VALVE lever. d. Push forward on PUMP ENGAGEMENT LEVER. e. CHECK INDICATION OF DLPG DISCHARGE LINE PRESSURE gage. If gage indication is 10 psi (69 kPa) or less, the maine pump is not operable. <div style="text-align: center;">  <p>SELECTOR VALVE</p> </div>	Main fuel pump inoperable.

Table 2-3. Preventive Maintenance Checks and Services for Model M978

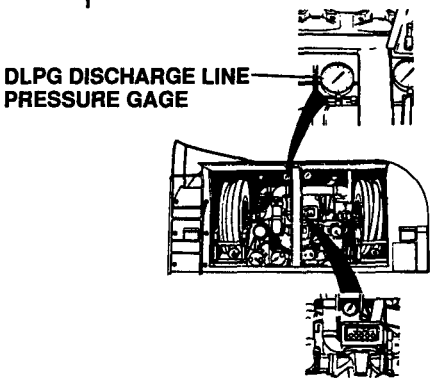
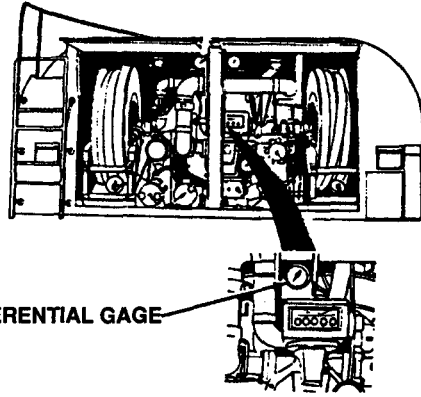
Item No.	Interval	Location	<u>Crewmember Procedure</u>	Not Fully Mission Capable If:
		Item to Check/Service		
95	During	D LPG Discharge Line Pressure Gage	<p><u>DRIVER</u></p> <p>Check D LPG discharge line pressure gage for proper operation and damage.</p> 	Gage indicates more than 90 psi (621 kPa).
96	During	PSI Differential Gage	<p>Check psi differential gage for proper operation and damage.</p> 	Gage indicates in DIRTY range 15-20 psi (103-138 kPa).

Table 2-3. Preventive Maintenance Checks and Services Model M978

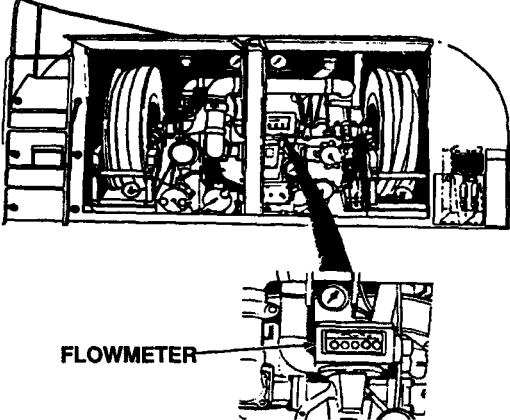
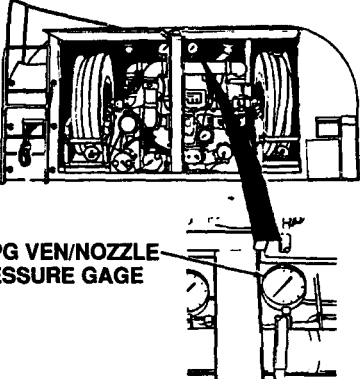
Item No.	Interval	Location	Crewmember Procedure	Not Fully Mission Capable If:
		Item to Check/Service		
97	During	FM Flow Meter	<u>DRIVER</u> Check flowmeter for proper operation and damage.	
				
98	During	VNPG Ven/Nozzle Pressure Gage	Check VNPG ven/nozzle pressure gage for proper operation and any obvious damage.	Gage does not register.
				

Table 2-3. Preventive Maintenance Checks and Services for Model M978

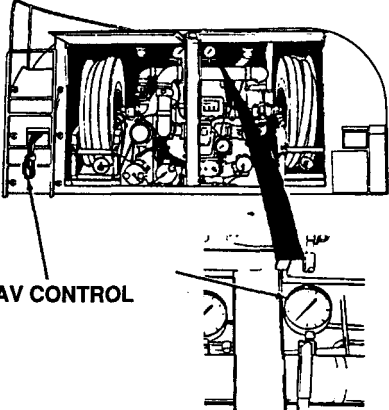
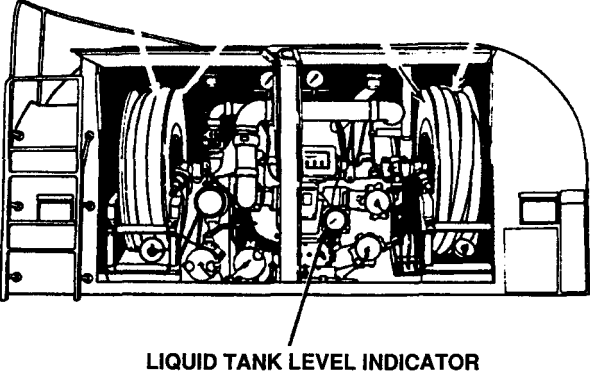
Item No.	Interval	Location	Crewmember Procedure	Not Fully Mission Capable If:
		Item to Check/Service		
99	During	HAV Hand Actuated Control	<p><u>DRIVER</u></p> <p>Check HAV hand actuated control for proper operation and any obvious damage.</p>	HAV control does not operate.
 <p>A technical line drawing showing a side view of the driver's seat area. A thick black arrow points from the text 'HAV CONTROL' to a specific lever or control mechanism on the left side of the seat.</p>				
100	During	Liquid Tank Level Indicator	<p>Check liquid tank level indicator for proper operation and any obvious damage.</p>	
 <p>A technical line drawing showing a side view of the engine compartment. A line points from the text 'LIQUID TANK LEVEL INDICATOR' to a gauge or indicator located in the center of the engine bay.</p>				

Table 2-3. Preventive Maintenance Checks and Services Model M978

Item No.	Interval	Location	Crewmember Procedure	Not Fully Mission Capable If:
		Item to Check/Service		
101	During	Pump Module	<p><u>DRIVER</u></p> <p>Check HAV air lines, fuel delivery hoses, valves, fittings, connectors and piping for leaks, defects and obvious damage.</p>	Any leak is evident and/or no other fuel hoses are available.
102	During	Main Fuel Pump Shut Down	<p>To shut down main fuel pump use the following procedure:</p> <ol style="list-style-type: none"> a. Pull back on PUMP ENGAGEMENT LEVER until locked. b. Push forward on MC MANUAL CONTROL EM VALVE lever. c. Set PTO ENGAGE switch to OFF position. <p>Indicator light should go out.</p>	PTO ENGAGE indicator light will not go out.

Table 2-3. Preventive Maintenance Checks and Services for Model M978

Item No.	Interval	Location	<u>Crewmember</u> Procedure	Not Fully Mission Capable If:
		Item to Check/Service		
103	Weekly	Tank Mounting Bolts	<p><u>DRIVER</u></p> <p>NOTE</p> <ul style="list-style-type: none"> • It is possible for properly tightened rear mounting screws to turn by hand in the mount. Properly tightened front mounting screws can be tilted slightly in mounts. • Mounting bolts have specific torque requirements and at times may appear to be loose. Do not attempt to tighten. If in doubt, notify your supervisor. <p>Check that mounting bolts are not broken or missing.</p>	One or more bolts broken or missing.

Table 2-3. Preventive Maintenance Checks and Services Model M978

Item No.	Interval	Location	<u>Crewmember</u> Procedure	Not Fully Mission Capable If:
		Item to Check/Service		
104	Weekly	Stowage Box	<u>DRIVER</u> Check stowage boxes for obvious damage or presence.	

Table 2-4. Preventive Maintenance Checks and Services for Model M983

Item No.	Interval	Location	<u>Crewmember</u> Procedure	Not Fully Mission Capable If:
		Item to Check/Service		
105	Before	Primary Release Handle	<u>DRIVER</u> Check primary release handle, linkage and locking plunger for damage and proper operation.	Mechanism is damaged or will not operate properly.
106	Before	Fifth Wheel Lubrication	Check that top surface of fifth wheel is lubricated.	
107	Before	Fifth Wheel Ramps	Check that top surfaces of fifth wheel ramps are lubricated.	

Table 2-4. Preventive Maintenance Checks and Services Model M983

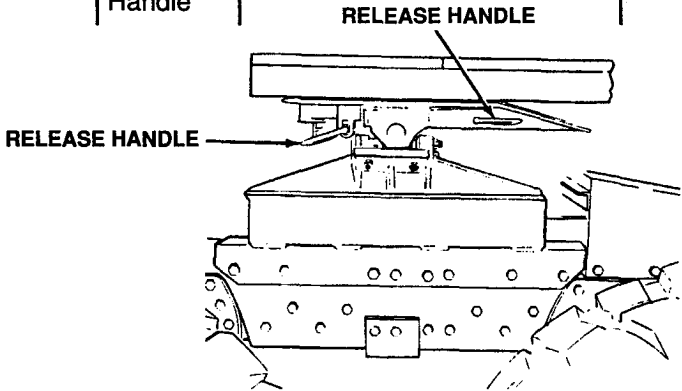
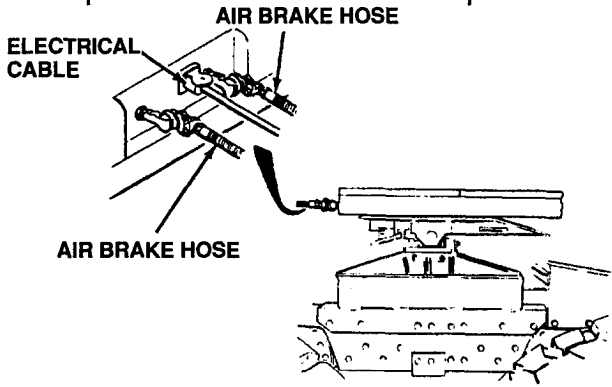
Item No.	Interval	Location	Crewmember Procedure	Not Fully Mission Capable If:
		Item to Check/Service		
108	Before	Fifth Wheel Release Handle	<p><u>DRIVER</u></p> <p>Check that release handles are completely in.</p>	
				
109	Before	Trailer Air Brake Hoses and Electrical Cable	<p>a. Check trailer air brake hoses for obvious damage.</p> <p>b. Check electrical cable and connectors for obvious damage.</p>	<p>One airhose is missing or unserviceable.</p> <p>Electrical cable is missing or unserviceable.</p>
				

Table 2-4. Preventive Maintenance Checks and Services for Model M983

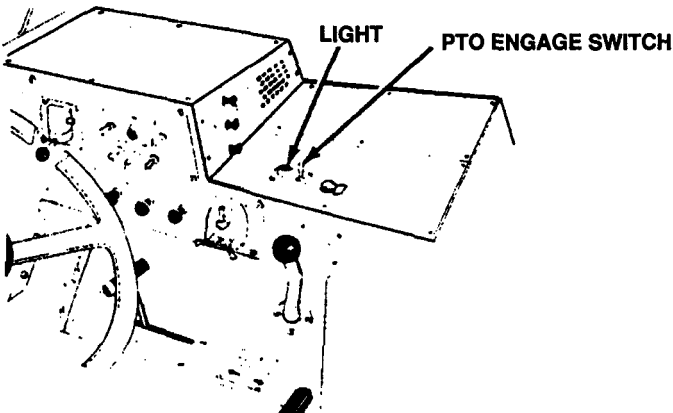
Item No.	Interval	Location		Crewmember Procedure	Not Fully Mission Capable If:
		Item to Check/Service			
110	Before	PTO		<p><u>DRIVER</u></p> <p>Check PTO switch and light.</p>	PTO does not engage or light is inoperative. Light or switch is missing.
 <p>The diagram shows a close-up of the driver's control panel. A rectangular panel is tilted upwards. On the panel, there is a circular light labeled 'LIGHT' and a rectangular switch labeled 'PTO ENGAGE SWITCH'. Below the panel, the steering wheel and other dashboard components are partially visible.</p>					
111	Before	Secondary Release Handle		Check secondary release handle linkage and locking plunger for damage and proper operation.	Mechanism is damaged or will not operate properly.

Table 2-4. Preventive Maintenance Checks and Services Model M983

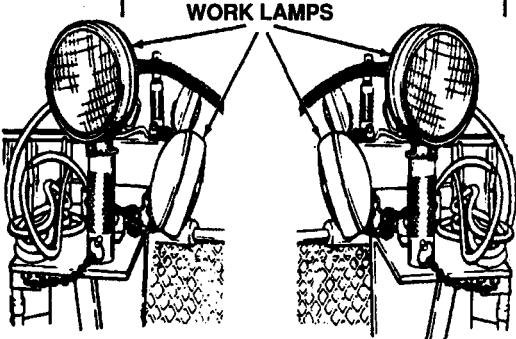
Item No.	Interval	Location	Crewmember Procedure	Not Fully Mission Capable If:
		Item to Check/ Service		
112	After	Worklamps	<p><u>DRIVER</u></p> <p>Check operation of worklamps.</p>	
				

Table 2-5. Preventive Maintenance Checks and Services for Model M984A1

Item No.	Interval	Location	<u>Crewmember</u> Procedure	Not Fully Mission Capable If:
		Item to Check/Service		
113	Before	Retrieval System, Support Assembly, Hydraulic Filter	<p><u>DRIVER</u></p> <p>Check support assembly for secure mounting or obvious damage.</p> <p>Check hydraulic filter for leaks.</p> <p>NOTE</p> <p>Retrieval cylinder thermal relief valves (located on cross tube end of cylinders) can discharge small amounts of oil as part of normal operation.</p>	Any Class III leaks found.

SUPPORT ASSEMBLY

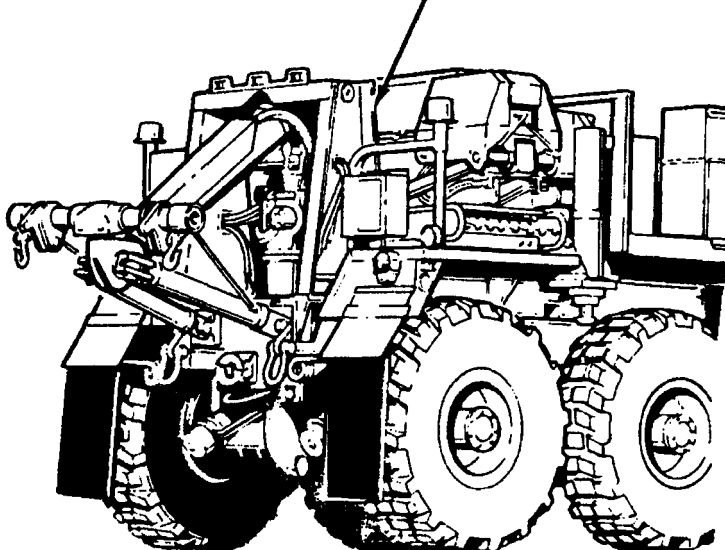


Table 2-5. Preventive Maintenance Checks and Services Model M984A1

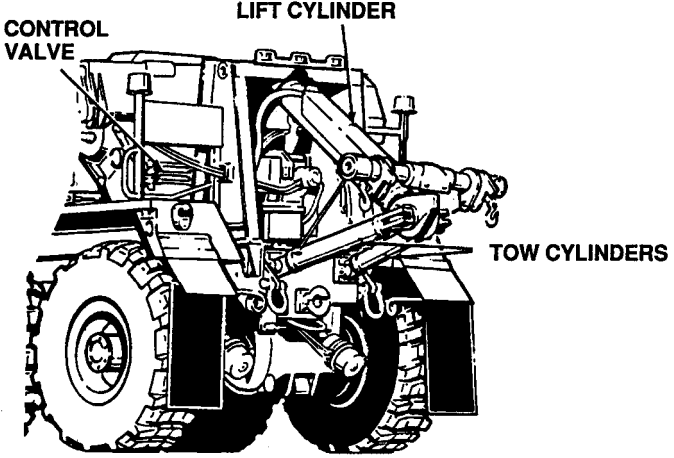
Item No.	Interval	Location	Crewmember Procedure	Not Fully Mission Capable If:
		Item to Check/Service		
114	Before	Lift Cylinders, Tow Cylinders, Control Valves & Hoses	<p><u>DRIVER</u></p> <p>Check lift cylinder, tow cylinders and control valves for leaks and/or obvious damage.</p>	Any Class III leaks found.
 <p>The diagram shows a side view of the vehicle's hydraulic system. A line points from the label 'CONTROL VALVE' to a valve on the left side of the engine compartment. Another line points from 'LIFT CYLINDER' to a cylinder at the top of the lift arm mechanism. A third line points from 'TOW CYLINDERS' to two cylinders located at the rear of the vehicle, near the rear axle.</p>				

Table 2-5. Preventive Maintenance Checks and Services for Model M984A1

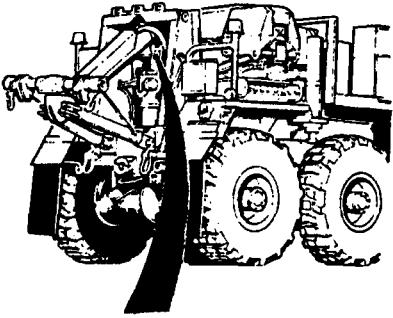
Item No.	Interval	Location	<u>Crewmember Procedure</u>	Not Fully Mission Capable If:
		Item to Check/Service		
115	During	Crane	<u>DRIVER</u> Be alert for unusual operation of crane.	

Table 2-5. Preventive Maintenance Checks and Services Model M984A1

Item No.	Interval	Location	<u>Crewmember Procedure</u>	Not Fully Mission Capable If:
		Item to Check/Service		
116	After	Retrieval Crane and Boom Operations	<u>DRIVER/COMMANDER</u> If used do weekly checks 130 to 139 and perform as an After check.	Inoperative and per weekly check.

Table 2-5. Preventive Maintenance Checks and Services for Model M984A1

Item No.	Interval	Location	<u>Crewmember</u> Procedure	Not Fully Mission Capable If:
		Item to Check/Service		
117	Weekly	Crosstube	<p><u>DRIVER</u></p> <p>a. Check crosstube retainer springs for secure mounting.</p> <p>b. Check crosstube for obvious damage.</p>	
118	Weekly	Winch Cable Clevis Pin	Check for winch cable clevis pin is secure and in place.	Clevis pin missing.



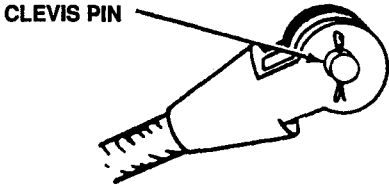


Table 2-5. Preventive Maintenance Checks and Services Model M984A1

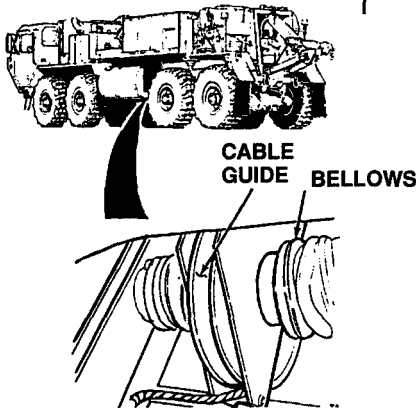
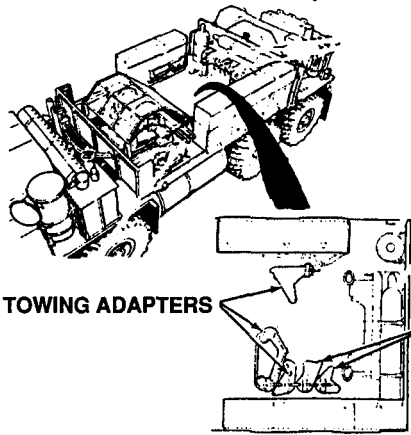
Item No.	Interval	Location	Crewmember Procedure	Not Fully Mission Capable If:
		Item to Check/Service		
119	Weekly	Heavy Duty Winch Cable Guide	<p><u>DRIVER</u></p> <p>Check cable guide for obvious damage. Check bellows for cuts or tears.</p>  <p>CABLE GUIDE BELLOWS</p>	
120	Weekly	Equipment Body (Inside Box) Towing Adapters	<p>Check that towing adapters are properly secured and have no obvious damage.</p>  <p>TOWING ADAPTERS</p>	Towing adapters are worn or broken.

Table 2-5. Preventive Maintenance Checks and Services for Model M984A1

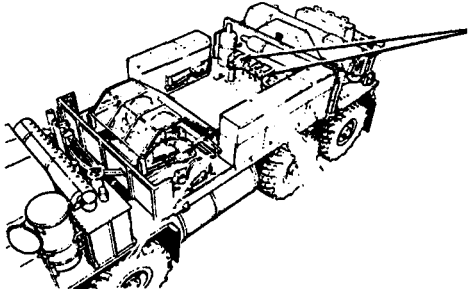
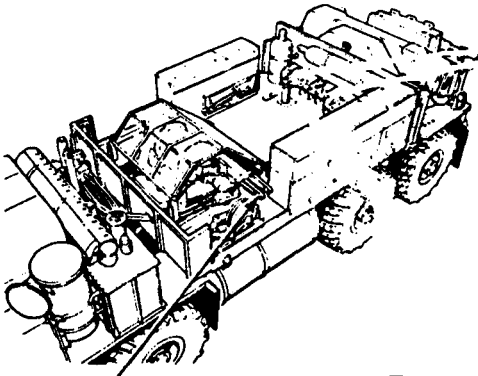
Item No.	Interval	Location	<u>Crewmember</u> Procedure	Not Fully Mission Capable If:
		Item to Check/Service		
121	Weekly	Tow Spades	<u>DRIVER</u> Check that tow spades are properly secured and have no obvious damage.	Tow spades are worn or broken.
 <p style="text-align: right;">TOW SPADES</p>				
122	Weekly	Tow Spades Extensions	Check that tow spade extensions are properly secured and have no obvious damage.	
 <p style="text-align: left;">TOW SPADE EXTENSIONS</p>				

Table 2-5. Preventive Maintenance Checks and Services Model M984A1

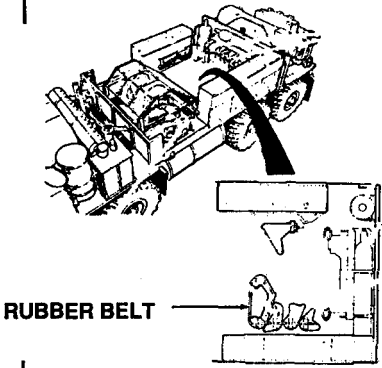
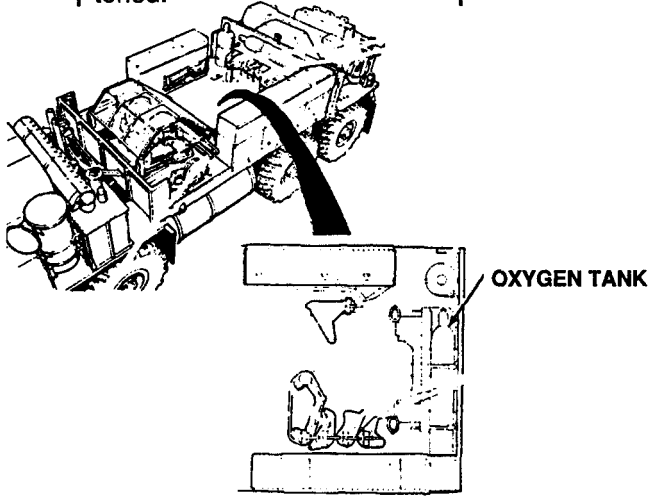
Item No.	Interval	Location	<u>Crewmember</u> Procedure	Not Fully Mission Capable If:
		Item to Check/Service		
123	Weekly	Rubber Belt	<p><u>DRIVER</u></p> <p>Check that width of rubber belt is not cut more than two inches (50 mm) or belt is not worn more than two of the four plies across the entire width of belt.</p> 	Belt is cut more than two inches (50 mm) or worn more than two of the four piles across the width of the belt.
124	Weekly	Oxygen Tank	<p>Check that oxygen tank is properly mounted and securely fastened.</p> 	

Table 2-5. Preventive Maintenance Checks and Services for Model M984A1

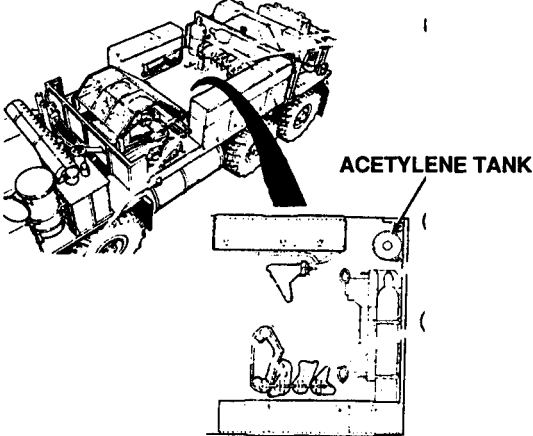
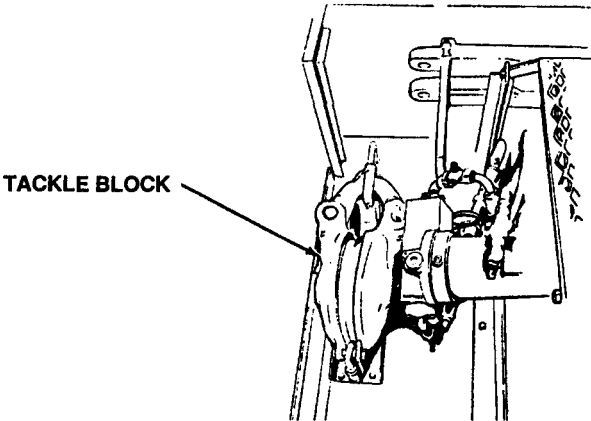
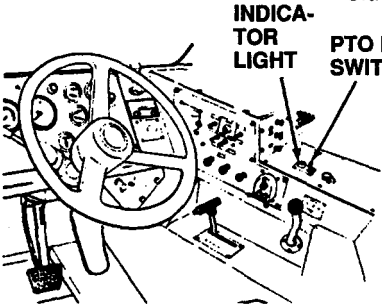
Item No.	Interval	Location	<u>Crewmember Procedure</u>	Not Fully Mission Capable If:
		Item to Check/Service		
125	Weekly	Acetylene Tank	<u>DRIVER</u> Check that acetylene tank is properly mounted and securely fastened.	
				
126	Weekly	60 Ton Tackle Block	Check 60 ton tackle block is present and serviceable.	
				

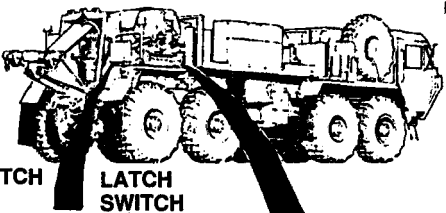
Table 2-5. Preventive Maintenance Checks and Services Model M984A1

Item No.	Interval	Location	Crewmember Procedure	Not Fully Mission Capable If:
		Item to Check/Service		
127	Weekly	Chock Blocks	<p><u>DRIVER</u></p> <p>Check presence of chock blocks in top center stowage box.</p> <p>NOTE</p> <p>To prepare the vehicle for crane hydraulic system checks, perform the following:</p> <ol style="list-style-type: none"> Start engine (paragraph 2-11a or paragraph 2-11b). Put PTO ENGAGE switch on ON position. Indicator light should come on. Set ON/OFF POWER switch to ON position. Set POWER switch to ON position. Set HIGH IDLE CONTROL switch to CRANE position. 	



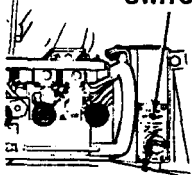
INDICATOR LIGHT

PTO ENGAGE SWITCH

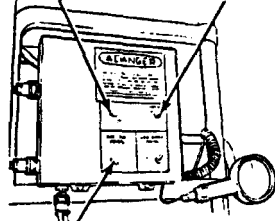


POWER SWITCH

LATCH SWITCH



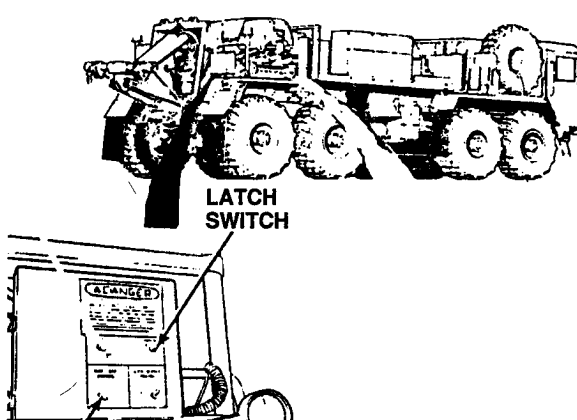
ON/OFF POWER SWITCH



HIGH IDLE CONTROL SWITCH

Table 2-5. Preventive Maintenance Checks and Services for Model M984A1


Item No.	Interval	Location	Crewmember Procedure	Not Fully Mission Capable If:
		Item to Check/ Service		
128	Weekly	Crane Manual Control	<p>DRIVER</p> <p>a. Push and release LATCH switch. Engine speed should increase to approximately 1500 rpm.</p> <p>WARNING</p> <p>Stand clear of outrigger beams while operating levers or injury could result when beams come out. Do not operate crane unless outriggers are firmly in place or serious injury or death could result. Keep boom clear of all electrical lines and other obstacles while operating crane. Serious injury or death could result upon contact.</p>	Engine speed does not increase to 1500 rpm.




The diagram shows a side view of a vehicle with a crane mounted on the front. Below the vehicle, there is a detailed view of the crane's control panel. A label 'LATCH SWITCH' with an arrow points to a specific switch on the panel. The panel also has a 'REANGER' label at the top.

Table 2-5. Preventive Maintenance Checks and Services Model M984A1

Item No.	Interval	Location	Crewmember Procedure	Not Fully Mission Capable If:
		Item to Check/Service		
128	Weekly	Crane Manual Controls Continued	<p><u>DRIVER</u></p> <p>NOTE</p> <ul style="list-style-type: none"> • Operate control levers with light even pressure. Moving lever slightly will cause slow movement of crane. Moving lever to full travel will cause faster movement of crane. • Outrigger beams will come out slower with light pressure of lever. Pushing lever to full travel will cause faster movement. <p>b. Check each control separately for malfunction, proper response, obvious damage, missing parts, binding and extreme looseness.</p>	b. Controls malfunction, binding, or does not respond.
129	Weekly	O/R Extension Lever	MOVE O/R EXT lever to OUT position until right outrigger beam is completely out.	Outrigger beam does not come out.



O/R EXT LEVER



RIGHT OUTRIGGER BEAM

Table 2-5. Preventive Maintenance Checks and Services for Model M984A1

Item No.	Interval	Location	<u>Crewmember</u> Procedure	Not Fully Mission Capable If:
		Item to Check/Service		
130	Weekly	Outrigger Pads	<p><u>DRIVER</u></p> <p>Set up outrigger pads (paragraph 2-63b). Check that two retaining pins are attached to each outrigger pad.</p> <p><u>WARNING</u></p> <p>Keep hands and feet clear of outrigger jack cylinders to avoid injury.</p> <p>NOTE</p> <p>Adjust outrigger pad position as required so rod end will lower into pad socket.</p>	One retaining pin missing from each pad.

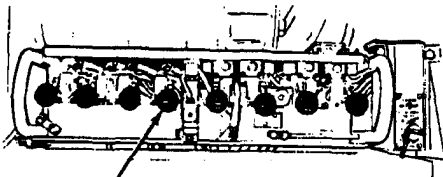
Table 2-5. Preventive Maintenance Checks and Services Model M984A1

Item No.	Interval	Location	Crewmember Procedure	Not Fully Mission Capable If:
		Item to Check/Service		
131	Weekly	LH O/R Jack Control Lever	<p><u>DRIVER</u></p> <p>Move LH O/R JACK control lever to DOWN position and lower outrigger jack cylinder until rod end is firmly seated in outrigger pad. Install retaining pins.</p>	Cylinder will not come out or will not lower completely into pad.

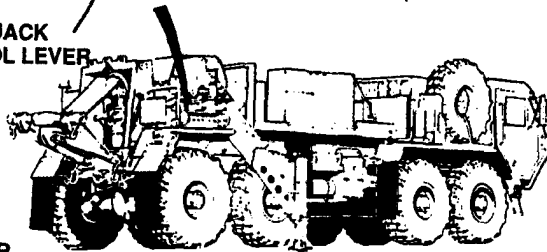
The diagram consists of three parts. At the top, a close-up of the control panel shows three levers; the leftmost one is labeled 'LH O/R JACK CONTROL LEVER'. Below this is a side view of the M984A1 truck with an arrow pointing to the outrigger jack assembly. At the bottom, a detailed view shows the 'JACK-CYLINDER' being lowered into the 'OUTRIGGER PAD' until it is seated, with 'RETAINING PINS' being inserted into the assembly.

Table 2-5. Preventive Maintenance Checks and Services for Model M984A1

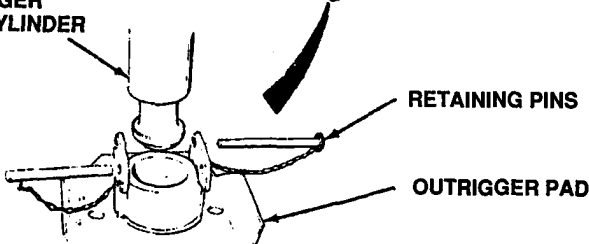
Item No.	Interval	Location	Crewmember Procedure	Not Fully Mission Capable If:
		Item to Check/Service		
132	Weekly	RH O/R Jack Control Lever	<p><u>DRIVER</u></p> <p>Move RH O/R JACK control lever to DOWN position and lower outrigger jack cylinder until rod end is firmly seated in outrigger pad. Install retaining pins.</p>	Outrigger jack cylinder will not come out or will not lower completely into pad.



RH O/R JACK CONTROL LEVER



OUTRIGGER JACK CYLINDER



RETAINING PINS

OUTRIGGER PAD

Table 2-5. Preventive Maintenance Checks and Services Model M984A1

Item No.	Interval	Location	Crewmember Procedure	Not Fully Mission Capable If:
		Item to Check/Service		
133	Weekly	Outrigger Jack Cylinders	<p><u>DRIVER</u></p> <p>Check that outrigger jack cylinder on each side of vehicle is out and down.</p> <p><u>WARNING</u></p> <p>Do not operate crane unless outriggers are set up. Vehicle could turn over causing serious injury or death.</p> <p><u>NOTE</u></p> <p>Move HOIST control lever to DOWN position until hook block rests on fender.</p>	Crane hydraulic system does not operate and crane is required for mission.

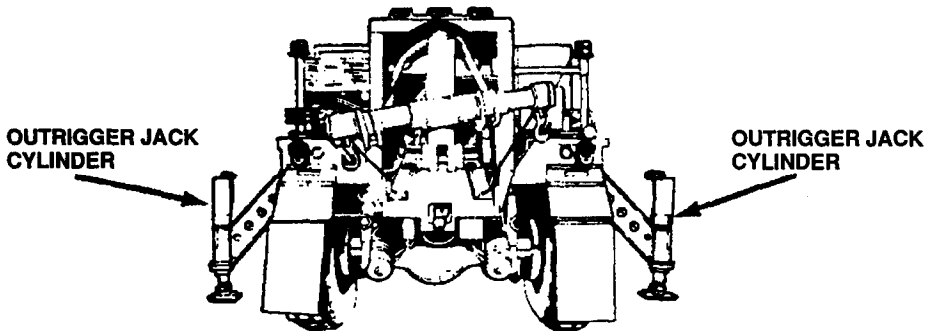


Table 2-5. Preventive Maintenance Checks and Services for Model M984A1

Item No.	Interval	Location	Crewmember Procedure	Not Fully Mission Capable If:
		Item to Check/Service		
134	Weekly	Hook Block	<p><u>DRIVER</u></p> <p>Check hook block for cracks.</p>	
135	Weekly	Boom Control Levers	<p><u>WARNING</u></p> <p>Keep boom clear of all electrical and other obstacles while operating crane. Serious injury or death could result upon contact.</p> <p><u>CAUTION</u></p> <p>Do not hit outrigger leg with hook block.</p>	

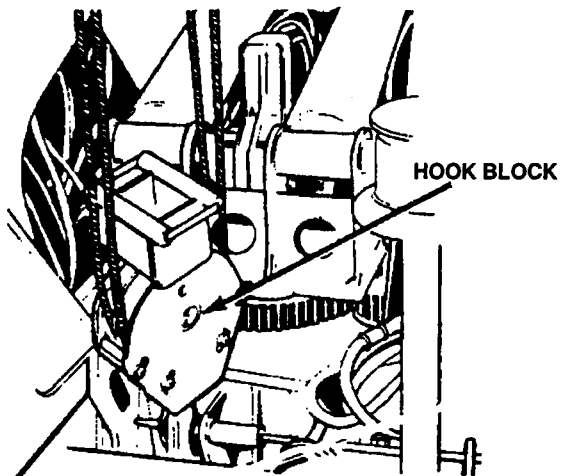


Table 2-5. Preventive Maintenance Checks and Services Model M984E1

Item No.	Interval	Location	Crewmember Procedure	Not Fully Mission Capable If:
		Item to Check/Service		
135	Weekly	Boom Control Levers Continued	<p><u>DRIVER</u></p> <p>a. Boom Control Lever. Move BOOM control lever to UP position until hook is 5 to 6 feet (1.5 to 1.8 m) above left rear fender and boom is approximately 45° above horizontal.</p> <p>b. Mast Control Lever. Move MAST control lever to UP position until the mast is fully erect and the cylinders are fully extended. Use BOOM control lever UP simultaneously as required to maintain the boom at approximately 45° above horizontal until the mast is fully erect. Hold the mast control lever to up position for 2-3 seconds after mast is fully erect to ensure cylinders are fully filled with oil.</p>	<p>a. Boom does not raise.</p> <p>b. Mast cylinder does not raise completely before stopping.</p>

The diagrams illustrate the components mentioned in the procedure:

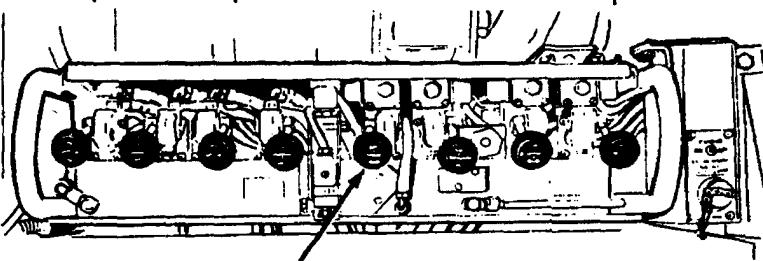
- HOOK:** The end of the boom.
- MAST CONTROL LEVER:** Located on the left side of the control panel.
- BOOM CONTROL LEVER:** Located on the right side of the control panel.
- BOOM:** The main lifting arm.
- MAST CYLINDER:** The hydraulic cylinder that extends the mast.

Table 2-5. Preventive Maintenance Checks and Services for Model M984A1

Item No.	Interval	Location	<u>Crewmember</u> Procedure	Not Fully Mission Capable If:
		Item to Check/ Service		
135	Weekly	Boom Control Levers Continued	<p><u>DRIVER</u></p> <p><u>WARNING</u></p> <p>Keep boom clear of all electrical lines and other obstacles while operating crane. Serious injury or death could result upon contact.</p> <p>Be sure area is clear of personnel before moving SWING lever. Boom should be swung slow enough so crane operator has complete control. Boom moving out of control could cause serious injury or death.</p> <p><u>CAUTION</u></p> <p>Boom must be above vehicle sides for clearance.</p>	

Table 2-5. Preventive Maintenance Checks and Services Model M984A1

Item No.	Interval	Location	Crewmember Procedure	Not Fully Mission Capable If:
		Item to Check/Service		
135	Weekly	Boom Control Levers Continued	<p><u>DRIVER</u></p> <p>c. Swing Control Lever. Move swing control lever to CW position to move boom clockwise and to CCW position to move boom counterclockwise.</p> <p>CAUTION</p> <p>Keep hook block at least 1 ft (30 cm) from end of boom. If hook block hits end of boom it may damage cable or hook block and crane will lose power. Wait 6 seconds for power to return and check crane for damage.</p> <p>NOTE</p> <p>TELESCOPE and HOIST levers should be operated at same time.</p> <p>Crane movement from one lever may be slower than other when operating two levers together.</p>	c. Boom does not turn clockwise or counterclockwise.



SWING CONTROL LEVER

Table 2-5. Preventive Maintenance Checks and Services for Model M984A1

Item No.	Interval	Location	Crewmember Procedure	Not Fully Mission Capable If:
		Item to Check/ Service		
135	Weekly	Boom Control Levers Continued	<u>DRIVER</u> d. Telescope Control Lever. Move TELESCOPE control lever to OUT position to extend boom while moving HOIST control lever to DOWN position to pay out cable,	d. Extensions do not come out.

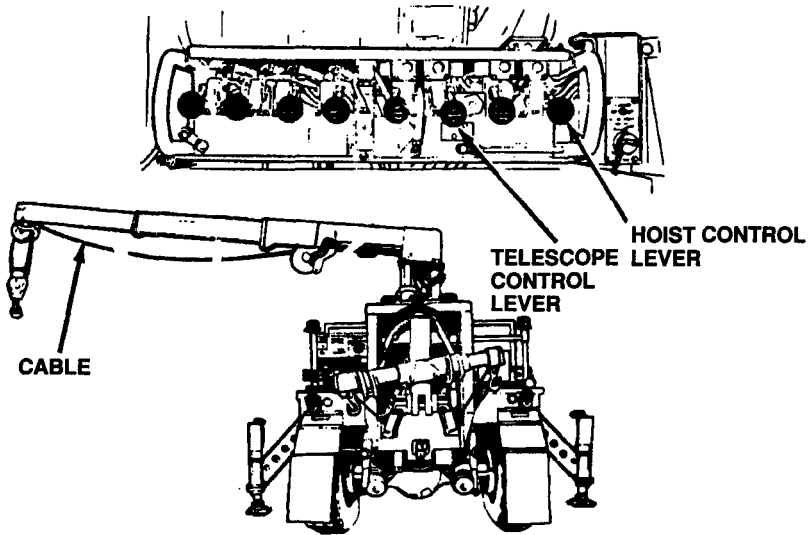


Table 2-5. Preventive Maintenance Checks and Services Model M984A1

Item No.	Interval	Location	Crewmember Procedure	Not Fully Mission Capable If:
		Item to Check/Service		
136	Weekly	Boom	<p><u>DRIVER</u></p> <p>a. Check first, second and third stages of boom for broken welds or obvious damage.</p> <p>b. Check cable on hoist for presence, kinks, frays or breaks.</p>	<p>a. There are any broken welds or obvious damage to the boom.</p> <p>b. Cable missing, evidence of kinks, frays, or breaks.</p>

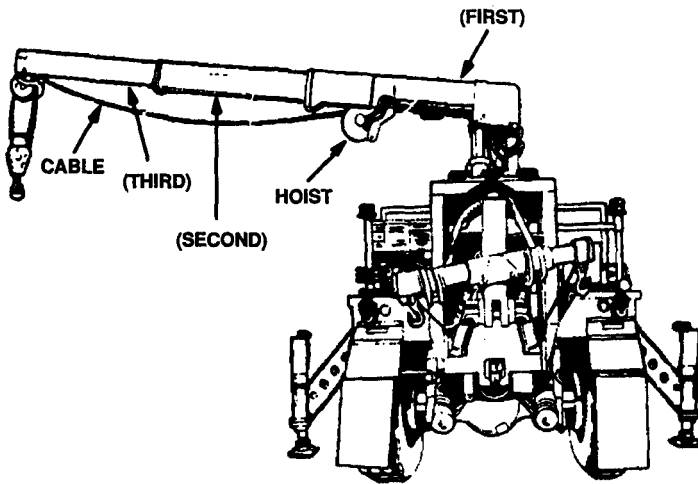


Table 2-5. Preventive Maintenance Checks and Services for Model M984A1

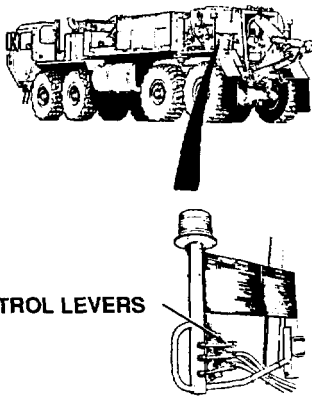
Item No.	Interval	Location	<u>Crewmember</u> Procedure	Not Fully Mission Capable If:
		Item to Check/Service		
137	Weekly	Remote Control Unit Levers	<p><u>DRIVER</u></p> <p>NOTE</p> <ul style="list-style-type: none"> • PMCS for remote control unit should only be performed when it is required for the mission. • Set up REMOTE CONTROL UNIT right side (paragraph 2-64b). <p><u>WARNING</u></p> <p>Keep boom clear of electrical lines and other obstacles while operating crane. Serious injury or death could result upon contact.</p> <p>Be sure area is clear of personnel before moving SWING lever. Boom should be swung slow enough so crane operator has complete control. Boom moving out of control could cause serious injury or death. If electrical power falls during crane operation, move switch on remote control unit to SHUT-DOWN position. Serious injury could result from uncontrolled movement.</p>	

Table 2-5. Preventive Maintenance Checks and Services Model M984A1

Item No.	Interval	Location	Crewmember Procedure	Not Fully Mission Capable If:
		Item to Check/Service		
137	Weekly	Remote Control Unit Levers Continued	<p><u>DRIVER</u></p> <p>CAUTION Boom must be above vehicle sides for clearance.</p> <p>NOTE Operate control levers with light, even pressure. Moving lever slightly will cause slow movement of crane. Moving lever to full travel will cause faster movement of crane.</p> <p>Check control levers for malfunction, proper response, obvious damage, missing parts, binding, and extreme looseness.</p> <p>NOTE</p> <ul style="list-style-type: none"> • Shut off switches (paragraph 2-64f). • Disconnect remote control, right side (paragraph 2-64g). • Connect remote control to left remote control station (paragraph 2-64c). 	Controls malfunction, bind, or do not respond.

Table 2-5. Preventive Maintenance Checks and Services for Model M984A1

Item No.	Interval	Location	Crewmember Procedure	Not Fully Mission Capable If:
		Item to Check/Service		
138	Weekly	Retrieval Control Levers	<p><u>DRIVER</u></p> <p>Operate retrieval control levers. Check for proper operation of levers and cylinder.</p>	Retrieval hydraulic system does not operate and retrieval system is needed for intended mission.



The diagram shows a side view of a military truck with a retrieval system. A thick black cable runs from the truck's rear towards the bottom right. Below this, there is a detailed view of the retrieval control levers, which are hydraulic cylinders with handles and various hoses and wires connected to them.

RETRIEVAL CONTROL LEVERS

Table 2-5. Preventive Maintenance Checks and Services Model M984A1

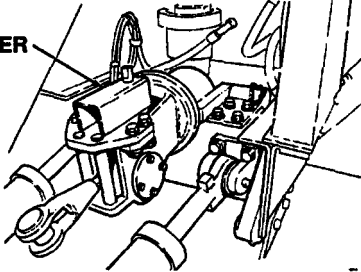
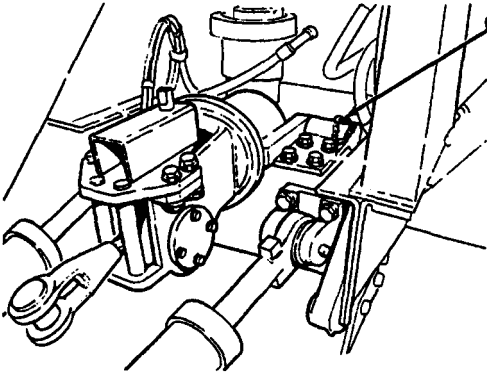
Item No.	Interval	Location	<u>Crewmember</u> Procedure	Not Fully Mission Capable If:
		Item to Check/Service		
139	Weekly	Fairlead Tensioner	<u>DRIVER</u> Check fairlead/tensioner for obvious damage and that fairlead/tensioner can be swivelled and placed in both stowed and operational positions.	Fairlead/tensioner will not swivel, cannot be raised or lowered.
 <p>FAIRLEAD/TENSIONER</p>				
140	Weekly	Fairlead Tensioner Lock Pin and Chain	Check for missing or damaged lock pin and attaching chain.	Has one missing or broken lock pin.
 <p>CHAIN</p>				

Table 2-5. Preventive Maintenance Checks and Services for Model M984A1

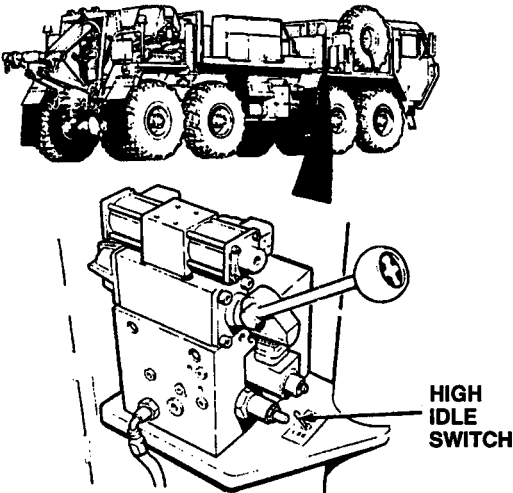
Item No.	Interval	Location	<u>Crewmember Procedure</u>	Not Fully Mission Capable If:
		Item to Check/Service		
141	Weekly	High Idle Switch	<p><u>DRIVER</u></p> <p>Check high idle switch for proper operation, obvious damage, missing parts, binding, and excessive looseness.</p>	Switch malfunctions or does not respond.
 <p>The illustration shows a side view of a military truck (M984A1) with a black arrow pointing to the driver's seat area. Below it is a detailed technical drawing of the high idle switch mechanism, which includes a lever with a circular knob and various electrical components. A label 'HIGH IDLE SWITCH' with a pointer indicates the specific part being checked.</p>				

Table 2-5. Preventive Maintenance Checks and Services Model M984A1

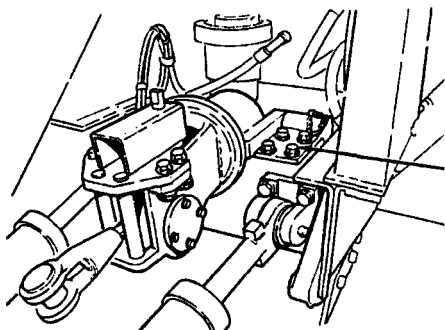
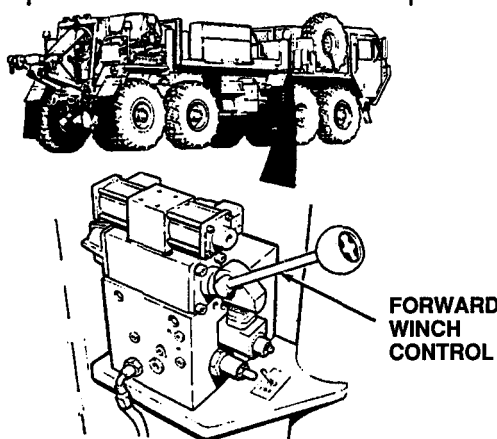
Item No.	Interval	Location	Crewmember Procedure	Not Fully Mission Capable If:
		Item to Check/Service		
142	Weekly	Fairlead Tensioner Mounting Screws	<p><u>DRIVER</u></p> <p>Check that mounting screws are secure.</p>	
 <p>A technical drawing showing a close-up of a fairlead tensioner assembly. Two screws are highlighted with arrows and labeled 'MOUNTING SCREWS'.</p>				
143	Weekly	Forward Winch Control	<p>Check forward winch control for proper operation, obvious damage, missing parts, binding and excessive looseness.</p>	Control malfunctions, binds, or does not respond.
 <p>A technical drawing showing a side view of a vehicle with a winch on the front. Below it is a detailed view of the winch control mechanism, with an arrow pointing to a lever labeled 'FORWARD WINCH CONTROL'.</p>				

Table 2-5. Preventive Maintenance Checks and Services for Model M984A1

Item No.	Interval	Location	Crewmember Procedure	Not Fully Mission Capable If:
		Item to Check/Service		
144	Weekly	Heavy Duty Winch Remote Control and Cable	<p>DRIVER</p> <p><u>WARNING</u> Keep hands clear of heavy duty winch cable. Hands can get caught and cause serious injury or death.</p> <p>a. Check heavy duty winch remote control and cable for proper operation, obvious damage, missing parts, binding, and excessive looseness.</p>	<p>a. Controls malfunction, bind, or do not respond.</p>
			<p>b. Check cable of winch for kinks, frays, or breaks.</p>	

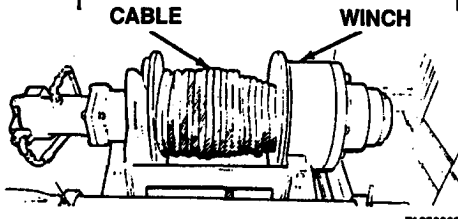
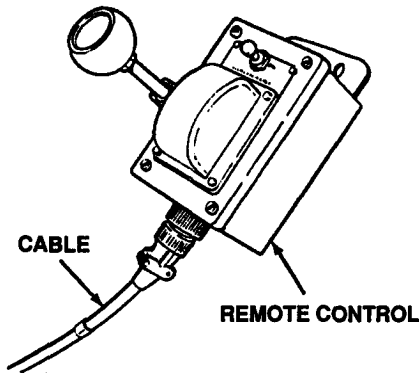


Table 2-5. Preventive Maintenance Checks and Services Model M984A1

Item No.	Interval	Location	<u>Crewmember</u> Procedure	Not Fully Mission Capable If:
		Item to Check/Service		
145	Weekly	Turntable Bearing Bolts	<p><u>DRIVER</u></p> <p>a. Inspect turntable bearing bolts for obvious looseness.</p> <p>b. Check for cracked or broken weld.</p>	<p>a. One turntable bearing bolt is loose.</p> <p>b. Cracked or broken welds.</p>

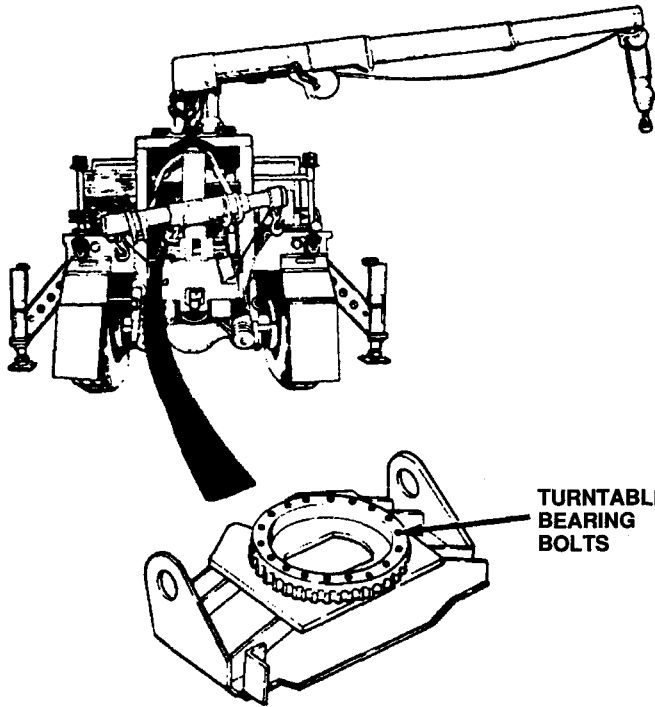


Table 2-5. Preventive Maintenance Checks and Services for Model M984A1

Item No.	Interval	Location	<u>Crewmember Procedure</u>	Not Fully Mission Capable If:
		Item to Check/ Service		
146	Weekly	Equipment Body Mount	<p><u>DRIVER</u></p> <p>NOTE Operation of vehicle with missing or damaged equipment body mount or pin may violate AR 385-55.</p> <p>Check equipment body mount and pin for broken chains, missing pin, or other obvious damage.</p>	Body mount damaged, pin missing, or pin chains broken.

Table 2-5. Preventive Maintenance Checks and Services Model M984A1

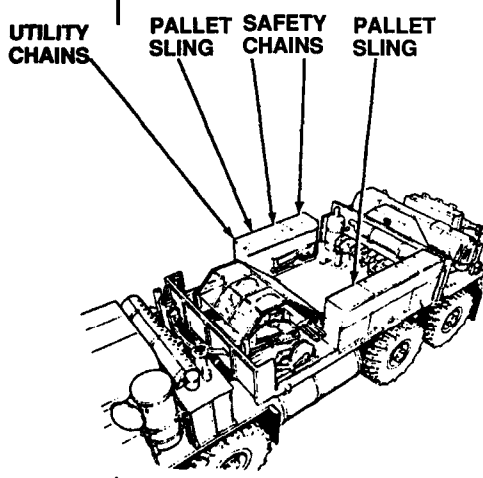
Item No.	Interval	Location	Crewmember Procedure	Not Fully Mission Capable If:
		Item to Check/Service		
147	Weekly	Safety Chains	<p><u>DRIVER</u></p> <p>NOTE</p> <p>Operation of vehicle with damaged safety chains or pallet sling may violate AR 385-55.</p> <p>Check safety chains and pallet sling for any obvious damage.</p>	Chain link, shackles, or hooks cracked, broken, missing or unserviceable.
				
148	Weekly	Winch Hydraulic Lines	Check for evidence of bent or crushed hydraulic lines or leakage at any threaded coupling or quick disconnect fitting.	Lines or fittings are damaged. Class III leakage evident.

Table 2-5. Preventive Maintenance Checks and Services for Model M984A1

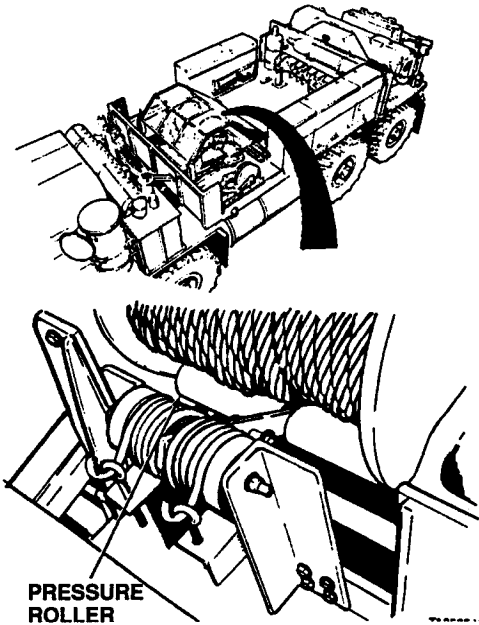
Item No.	Interval	Location	<u>Crewmember Procedure</u>	Not Fully Mission Capable If:
		Item to Check/Service		
149	Weekly	Pressure Roller	<p><u>DRIVER</u></p> <p>Check pressure roller for obvious damage.</p> 	
150	Weekly	Work Lamps	Check operation of work lamps.	
151	Weekly	Wrecker Vise	Check vise for secure mounting.	

Table 2-6. Preventive Maintenance Checks and Services Model M985E1

Item No.	Interval	Location	<u>Crewmember</u> Procedure	Not Fully Mission Capable If:
		Item to Check/Service		
152	Before	Cargo Body	<p><u>DRIVER</u></p> <p>a. Check that side panels and end panel are not bent and have no broken welds.</p> <p>b. Check for broken latches and missing lockpins.</p> <p>c. Check for broken, bent, or damaged hinge pins and tiedown eyes.</p>	<p>a. Side panel or end panel has broken welds.</p> <p>b. A latch is broken or one or more lockpins are missing or broken.</p> <p>c. One hinge pin is broken. Any tiedown eye is missing or broken.</p>

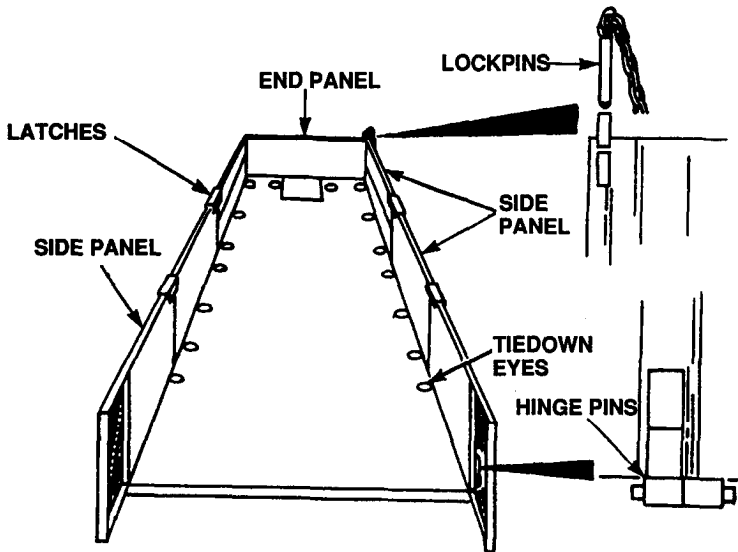


Table 2-6. Preventive Maintenance Checks and Services for Model M985E1

Item No.	Interval	Location	<u>Crewmember Procedure</u>	Not Fully Mission Capable If:
		Item to Check/Service		
152	Before	Cargo Body Continued	<p><u>DRIVER</u></p> <p>d. Check walkway extensions and platform for insecure mounting, broken welds and damaged fasteners.</p> <p>e. Check for broken or binding hinges.</p> <p>f. Check support arms for insecure mounting, broken welds and bent components.</p>	<p>e. One or more hinges are missing or broken.</p> <p>f. One or more support arms are broken, missing or have broken welds.</p>

Table 2-6. Preventive Maintenance Checks and Services Model M985E1

Item No.	Interval	Location	<u>Crewmember</u> Procedure	Not Fully Mission Capable If:
		Item to Check/ service		
153	Before	Material Handling Crane	<p><u>DRIVER</u></p> <p>a. Inspect crane for loose parts, hydraulic leaks and damage to hydraulic hoses and line.</p> <p>b. Check crane for broken welds and obvious damage.</p> <p><u>WARNING</u></p> <p>Ensure that bridge lock is secured and pinned to fasten crane safely in upright position before operating crane. Serious injury or equipment damage can result.</p> <p>c. Check that bridge locking pin is not missing or damaged.</p>	<p>a. Class III leakage is found.</p> <p>b. Welds are broken.</p> <p>c. Pin missing or damaged.</p>

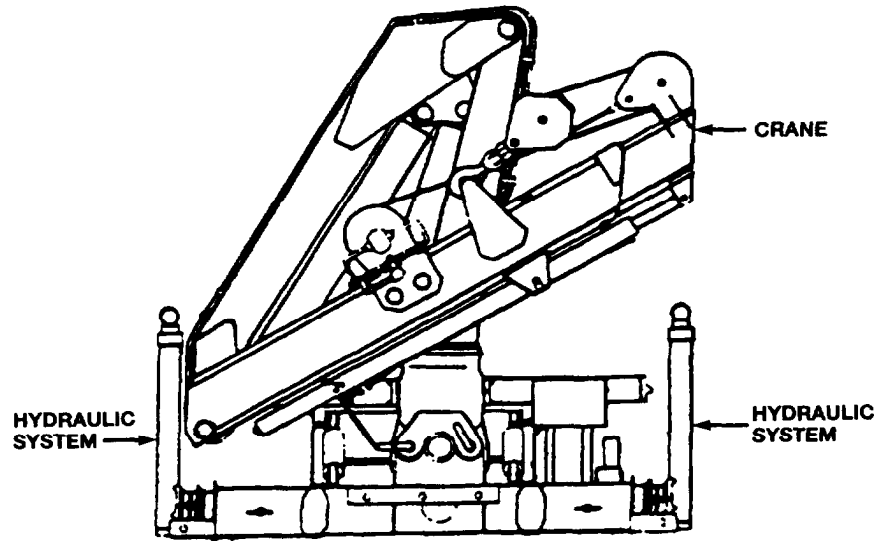


Table 2-6. Preventive Maintenance Checks and Services for Model M985E1

Item No.	Interval	Location	<u>Crewmember Procedure</u>	Not Fully Mission Capable If:
		Item to Check/Service		
153	Before	Materiel Handling Crane Continued	<p><u>DRIVER</u></p> <p>c. Check operation of hydraulic system by operating outrigger legs (refer to paragraph 2-11f, steps 1 through 20).</p> <p><u>WARNING</u></p> <p>Use protective gloves when checking hoist cable. Injury to hands may result if gloves are not worn.</p> <p>d. Visually check cable for presence, kinks, frays and breaks.</p> <p>e. Check hoist hook for cracks.</p>	<p>c. Hydraulic system does not operate.</p> <p>d. Cable is missing, kinked, frayed or broken.</p> <p>e. Hook is cracked.</p>

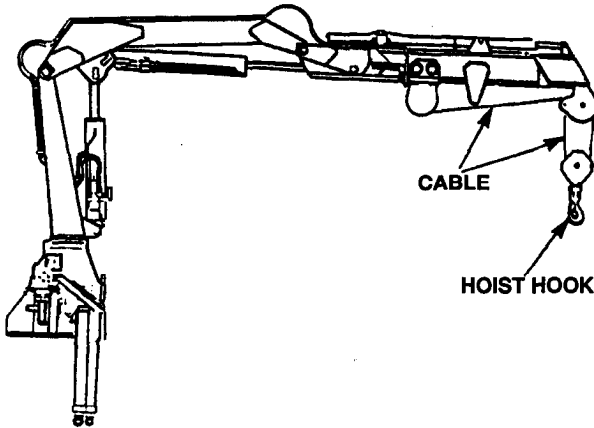


Table 2-6. Preventive Maintenance Checks and Services Model M985E1

Item No.	Interval	Location	<u>Crewmember</u> Procedure	Not Fully Mission Capable If:
		Item to Check/Service		
154	Weekly	Stowage Compartment	<p><u>DRIVER</u></p> <p>a. Check compartments for missing hardware and other obvious damage.</p> <p>b. Check compartments for missing remote-control box or cable, damaged seals, moisture in bottom of compartment, or other obvious damage.</p>	

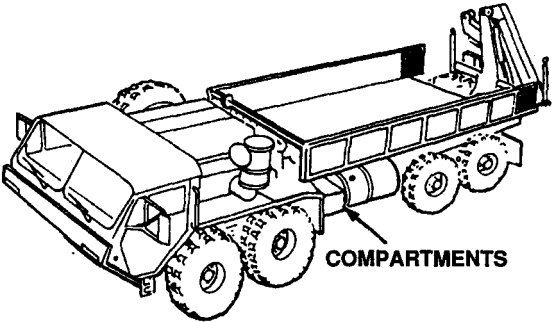
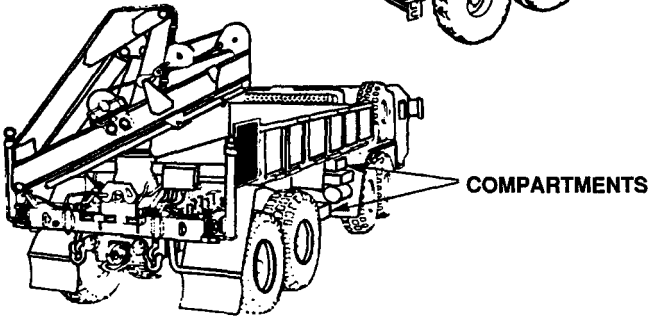



Table 2-7. Preventive Maintenance Checks and Services Auxiliary Equipment

Item No.	Interval	Location	<u>Crewmember Procedure</u>	Not Fully Mission Capable If:
		Item to Check/ Service		
155	Weekly	Generator (M983 Only)	<u>DRIVER</u> Refer to TM 5-6115-465-12 for PMCS.	

Table 2-7. Preventive Maintenance Checks and Services Auxiliary Equipment

Item No.	Interval	Location	Crewmember Procedure	Not Fully Mission Capable If:
		Item to Check/Service		
56	Monthly	Arctic Heater	<u>DRIVER</u> a. Open Valve.	

The diagram consists of two parts. The upper part is a perspective view of a large military truck with a flatbed trailer. A curved arrow points from the front of the truck down to a detailed technical drawing of the Arctic Heater valve mechanism. This drawing shows a valve handle with a curved arrow indicating its range of motion from a 'CLOSED' position to an 'OPEN' position. A label 'VALVE' with a leader line points to the handle mechanism. The entire assembly is mounted on a metal frame with a slatted base.

Table 2-7. Preventive Maintenance Checks and Services Auxiliary Equipment

Item No.	Interval	Location	<u>Crewmember Procedure</u>	Not Fully Mission Capable If:
		Item to Check/Service		
156	Monthly	Arctic Heater Continued	<p><u>DRIVER</u></p> <p>b. Place coolant pump switch in ON position. Coolant pump indicator should illuminate and coolant pump should be running. Audible sound from pump indicates coolant pump is operating.</p>	

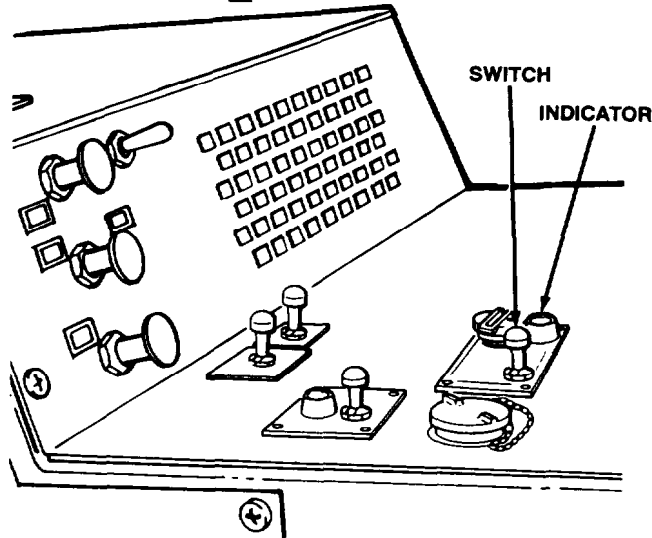
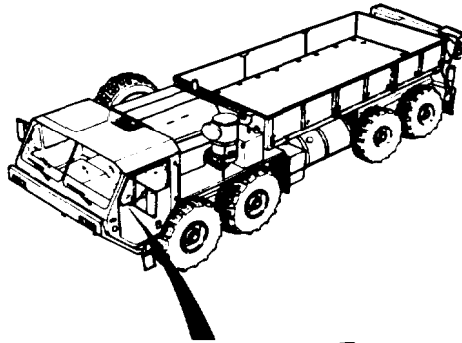


Table 2-7. Preventive Maintenance Checks and Services Auxiliary Equipment

Item No.	Interval	Location	<u>Crewmember</u> Procedure	Not Fully Mission Capable If:
		Item to Check/Service		
156	Monthly	Arctic Heater Continued	<p><u>DRIVER</u></p> <p>c. Check coolant pump and water jacket for security of mounting and obvious damage.</p> <p>d. Check coolant pump for unusual noise.</p> <p>e. Check coolant hoses for leaks, cuts, loose clamps and other obvious damage.</p> <p>f. Check valve for leaks.</p> <p>g. Check heater exhaust pipe at water jacket for loose clamp.</p>	Any Class III coolant leakage.

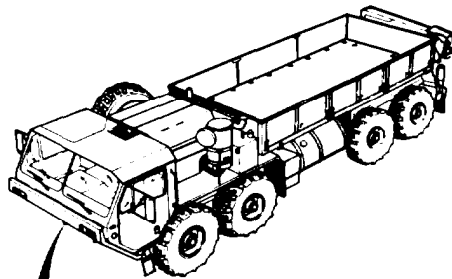
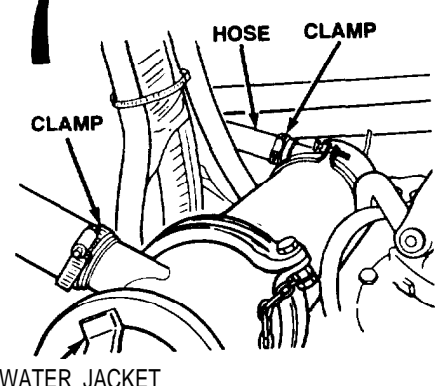
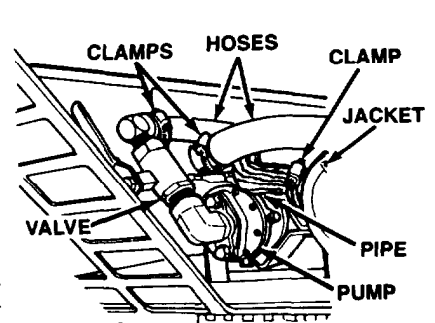




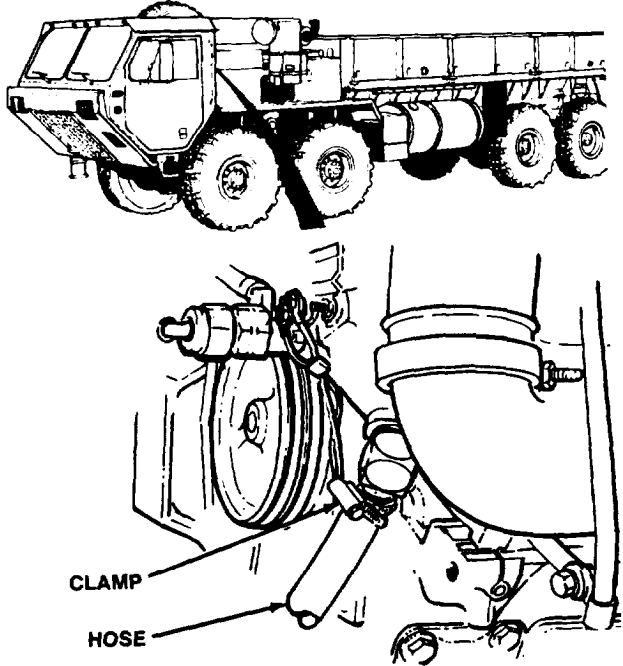
Table 2-7. Preventive Maintenance Checks and Services Auxiliary Equipment

Item No.	Interval	Location	<u>Crewmember</u> Procedure	Not Fully Mission Capable If:
		Item to Ccheck/ Service		
156	Monthly	Arctic Heater Continued	<p><u>DRIVER</u></p> <p>h. Check heater exhaust pipe at battery box for loose clamp and other obvious damage.</p>	

The diagram shows a top-down view of a truck with a callout to a specific area. The callout shows a battery box on the left, an exhaust pipe extending from it, and a clamp securing the pipe. Labels with arrows point to 'EXHAUST PIPE', 'BATTERY BOX', and 'CLAMP'.

Table 2-7. Preventive Maintenance Checks and Services Auxiliary Equipment

Item No.	Interval	Location	Crewmember Procedure	Not Fully Mission Capable If:
		Item to Check/Service		
56	Monthly	Arctic Heater Continued	<u>DRIVER</u> i. Check coolant hose at engine for leaks, cuts, loose clamp and other obvious damage.	Any Class III coolant



The image contains two technical drawings. The top drawing is a side view of a heavy-duty truck with a long trailer, featuring large, treaded tires. The bottom drawing is a close-up of a mechanical component, likely an engine, showing a hose connected to a clamp. Two labels, 'CLAMP' and 'HOSE', have lines pointing to the respective parts in the close-up view.

Table 2-7. Preventive Maintenance Checks and Services Auxiliary Equipment

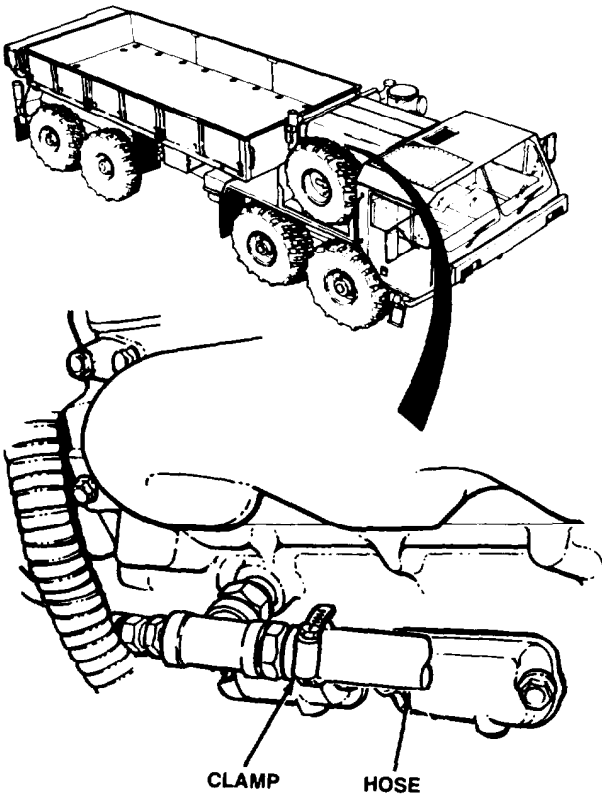
Item No.	Interval	Location	<u>Crewmember</u> Procedure	Not Fully Mission Capable If:
		Item to Check Service		
156	Monthly	Arctic Heater Continued	<u>DRIVER</u> j. Check coolant hose at engine for leaks, cuts, loose clamp and other obvious damage.	Any Class III coolant leakage.
				
157	Deleted			
158	Deleted			
159	Deleted			
160	Deleted			

Table 2-7. Preventive Maintenance Checks and Services Auxiliary Equipment

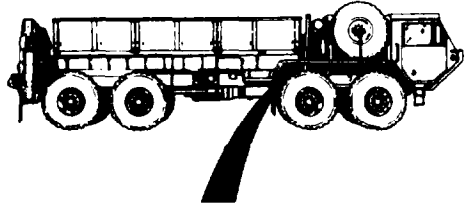
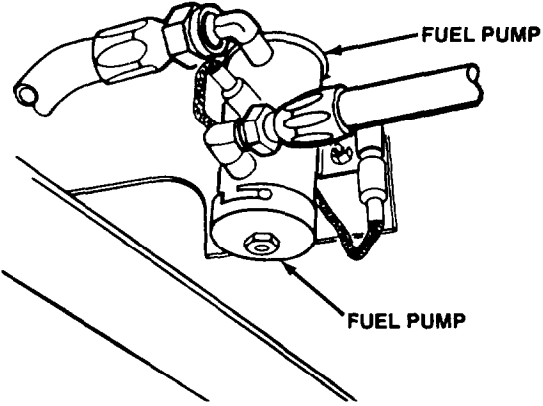
Item No.	Interval	Location	Crewmember Procedure	Not Fully Mission Capable If:
		Item Check/Service		
161	Monthly	Fuel Pump	<p><u>DRIVER</u></p> <p>NOTE Operation of vehicle with leaking/malfunctioning fuel pump may violate AR 365-55. Check fuel pump for fuel leaks.</p>  	Class III leak.

Table 2-7. Preventive Maintenance Checks and Services Auxiliary Equipment

Item No.	Interval	Location	Crewmember Procedure	Not Fully Mission Capable If:
		Item Check/Service		
162	Monthly	Gas Particulate Filter Unit	<p>NOTE</p> <p>Gas particulate filter unit must be in operation to perform the following checks (paragraph 2-35c).</p> <ol style="list-style-type: none"> Check heater for unusual loud noise or improper operation. Disconnect two air duct breakaway sockets from mount and feel for airflow. Turn heater control knob clockwise to make sure indicator light comes on. Hoses. Check hoses for cuts, tears and other obvious damage. Hose Clamps. Make sure hose clamps are secure. 	<ol style="list-style-type: none"> No airflow or not enough airflow.

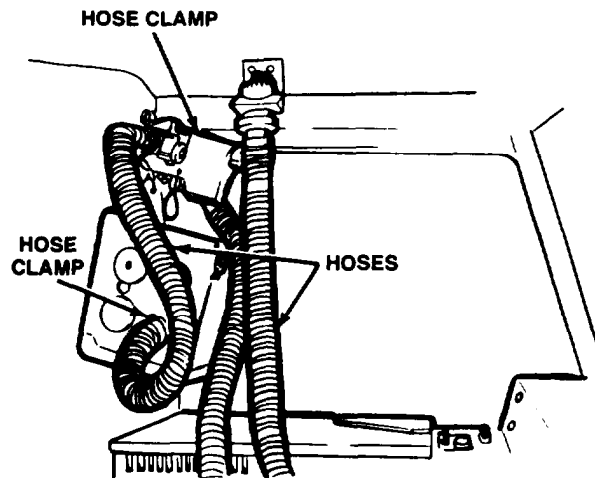


Table 2-7. Preventive Maintenance Checks and Services Auxiliary Equipment

Item No.	Interval	Location	<u>Crewmember</u> Procedure	Not Fully Mission Capable If:
		Item to Check/Service		
163	Monthly	Rifle Stowage Unit	<p><u>DRIVER</u></p> <p>a. Mounting bolts. Check that mounting bolts on top mount and lower mount are not broken or missing.</p> <p>b. Check handle for excessive looseness or binding.</p>	

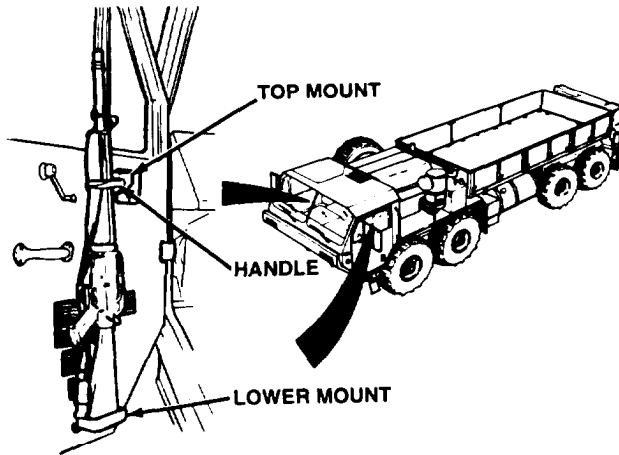


Table 2-7. Preventive Maintenance Checks and Services Auxiliary Equipment

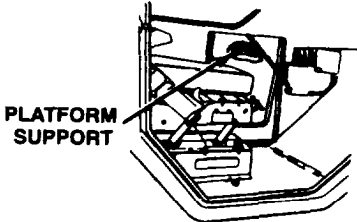
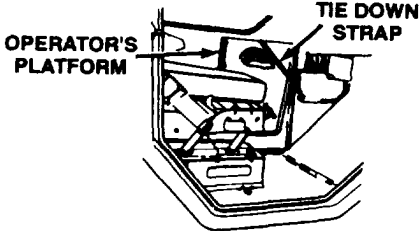
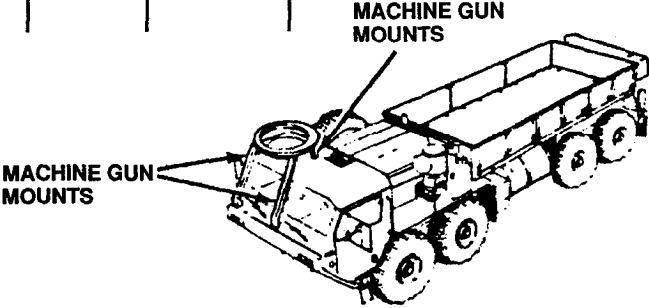
Item No.	Interval	Location	<u>Crewmember</u> Procedure	Not Fully Mission Capable If:
		Item to Check/Service		
164	Monthly	Operator's Platform support	DRIVER Check machine gun operator's platform support for loose, broken, or missing mounting bolts.	
				
165	Monthly	Operator's Platform	Check operator's platform for cracks, loose or broken leg, missing or broken tie down strap.	
				

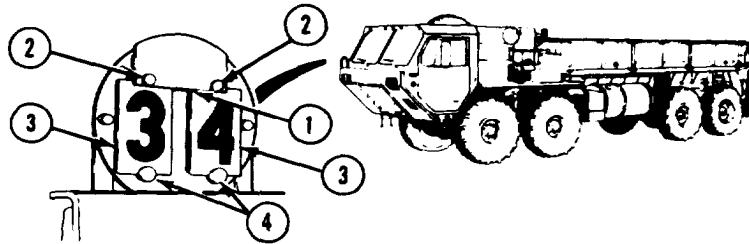
Table 2-7. Preventive Maintenance Checks and Services Auxiliary Equipment

Item No.	Interval	Location	Crewmember Procedure	Not Fully Mission Capable If:
		Item to Check/ Service		
166	Monthly	Ring Mount	<p><u>DRIVER</u></p> <p>Check machine gun mounts for loose, broken, or missing mounting bolts.</p> <p>MACHINE GUN MOUNTS</p>  <p>The diagram shows a side view of a truck with a flatbed trailer. Two machine gun mounts are indicated with lines and the text 'MACHINE GUN MOUNTS'. One is on the front of the truck, and the other is on the side of the cab area.</p>	
167	Monthly	M-8 Chemical Alarm	Refer to TM 3-665-225-12 for PMCS.	
168	Monthly	M-13 Decontamination Unit	Refer to TM 3-4230-214-12&P for PMCS.	
169	Monthly	Radio	Refer to TM 11-5820-498-12 for PMCS.	

M977 Through M985 General Operating Procedures (Cont)

2-9. PREPARE TO OPERATE VEHICLE.

a. *Change Vehicle Weight Indicator.*

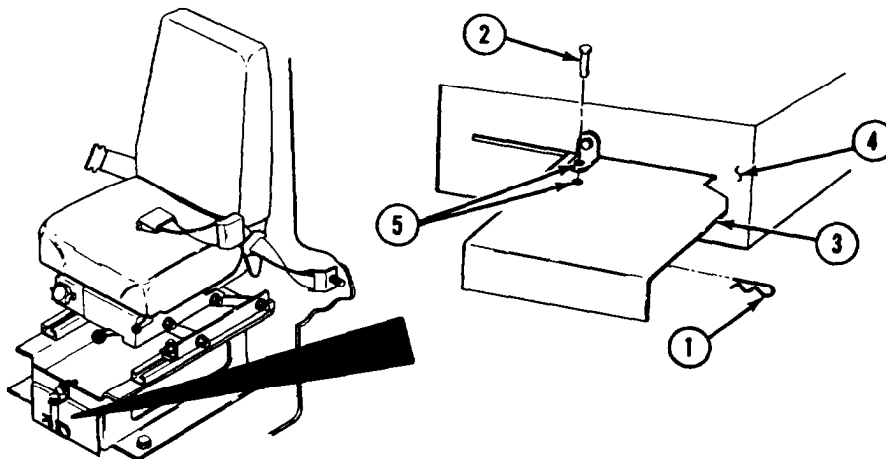


NOTE

Refer to Table 1-2 for appropriate vehicle weight.

- (1) Press in bottom of lockplate (1).
- (2) Push lockplate (1) up and off one lockpin (2).
- (3) Remove number plates (3).
- (4) Place new number on top of number plates (3).
- (5) Install number plates (3) on lockpin (4).
- (6) Push down number plates (3). Slide lockplate (1) on lockpin (2).
- (7) Repeat steps (1) through (6) to change other number.

b. *Install Footrest.*



- (1) Remove safety pin (1) and yoke pin (2).
- (2) Pull out footrest (3).
- (3) Slide footrest (3) toward seat brace (4) so holes (5) are aligned.
- (4) Install yoke pin (2) and safety pin (1).

M977 Through M985 General Operating Procedures (Cont)

c. Stow Footrest.

- (1) Remove safety pin (1) and yoke pin (2).
- (2) Slide footrest (3) under seat brace (4).
- (3) Install yoke pin (2) and safety pin (1).

d. Adjust Seat.

WARNING

Care should be taken when adjusting the knob. The seat collapses when the knob screw is adjusted, and can cause injury if hand is between seat mount and the low neck.

NOTE

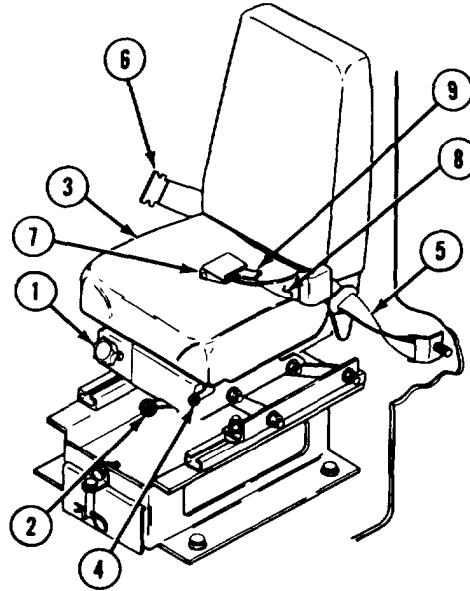
Sit in seat to make the following adjustments.

- (1) Turn knob (1) to control cushion firmness.

NOTE

Retaining straps may need to be loosened before moving seat forward.

- (2) Push lever (2) to left and slide seat (3) forward or backward.
- (3) Let go of lever (2) to lock seat in place.
- (4) Pull up lever (4) and lift self off seat (3) to raise seat.
- (5) Pull up lever (4) and push down on seat (3) to lower seat.
- (6) Let go of lever (4) to lock seat (3) in place.
- (7) Tighten seat retaining straps (5).



e. Operate Seatbelt.

NOTE

If equipped with three-point seatbelt proceed to paragraph **f. Operate Three-Point Seatbelt.**

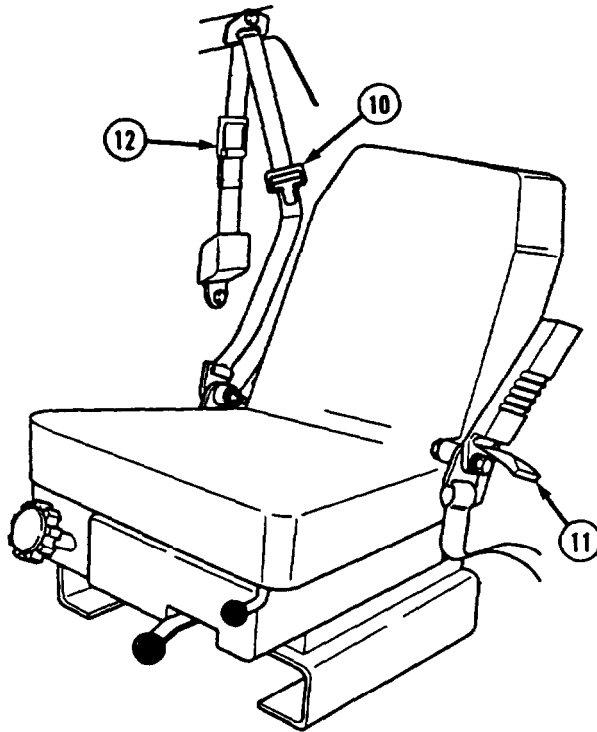
- (1) Put seatbelt flat metal end (6) into buckle (7) until click is heard.
- (2) Place seatbelt (8) as low on hips as possible.

NOTE

Seatbelt does not have self-adjusting lock. Take slack out of seatbelt by pulling on seatbelt end.

- (3) Pull seatbelt end (9) until belt fits snug.
- (4) To release seatbelt (8), lift top of buckle (7) and pull out flat metal end (6).

M977 Through M985 General Operating Procedures (Cont)



f. Operate Three-Point Seatbelt.

- (1) Put seatbelt flat metal end (10) into interconnect (11) until click is heard.
- (2) Pull out on comfort latch (12) locking handle and move comfort latch up and down strap until snug (but not tight) fit at shoulder is felt.
- (3) To release seatbelt, push in button on interconnect (11).

M977 Through M985 General Operating Procedures (Cont)

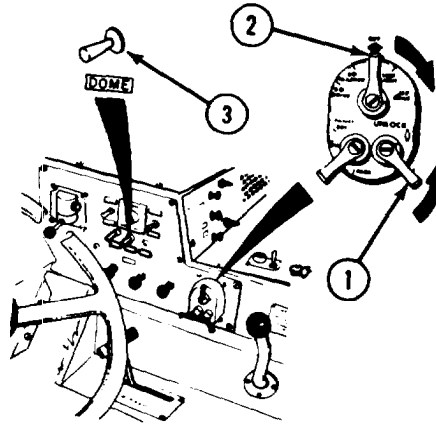
2-10. OPERATE LIGHTS.

CAUTION

Failure to place light switches in the OFF positions when vehicle is not in use may cause battery and/or vehicle damage.

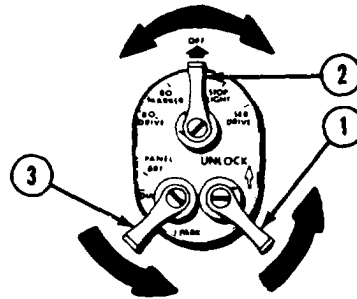
a. Turn Domelight On/Off.

- (1) Lift up and hold UNLOCK lever (1).
- (2) Set lighting control lever (2) to STOP LIGHT or SER DRIVE position.
- (3) Let go of UNLOCK lever (1).
- (4) Set DOME switch (3) to ON. Domelight will come on.
- (5) Set DOME switch (3) to OFF. Domelight will go out.
- (6) Set lighting control lever (2) to off.



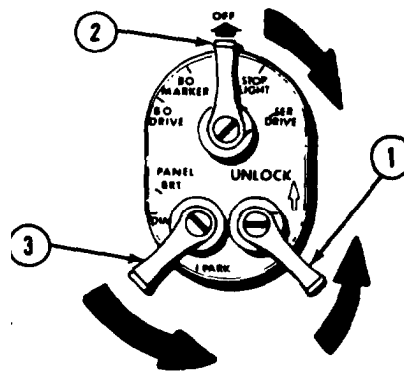
b. Turn Panel Lights On/Off?

- (1) Lift up and hold UNLOCK lever (1).
- (2) Set lighting control lever (2) to one of four positions shown.
- (3) Let go of UNLOCK lever (1).
- (4) Set PANEL lever (3) to DIM or BRT (bright) as needed.
- (5) Set PANEL lever (3) to OFF if outside lights are still needed. Only panel lights go off.
- (6) Set lighting control lever (2) to OFF. Both panel lights and outside lights go off.



c. Turn Parking Lights On/Off.

- (1) Lift up and hold UNLOCK lever (1).
- (2) Set lighting control lever (2) to SER DRIVE.
- (3) Set PANEL lever (3) to PARK.
- (4) Let go of UNLOCK lever (1).
- (5) Set PANEL lever (3) to OFF.
- (6) Set lighting control lever (2) to

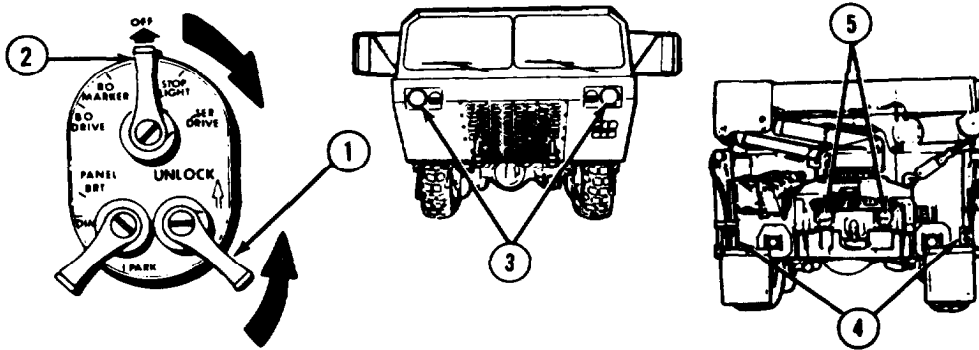


M977 Through M985 General Operating Procedures (Cont)

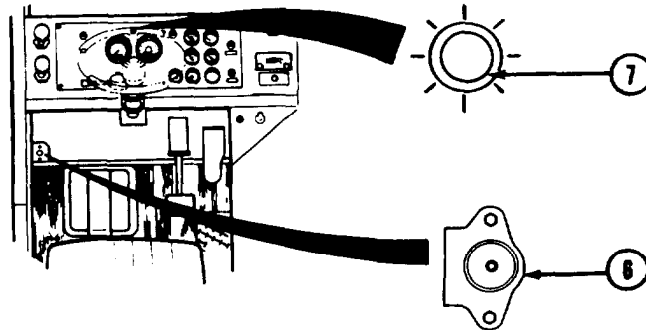
CAUTION

Failure to place light switches in the OFF positions when vehicle is not in use may cause battery and/or vehicle damage.

d. Turn Service Drive Lights On/Off.



- (1) Lift up and hold UNLOCK lever (1).
- (2) Set lighting control lever (2) to SER DRIVE.
- (3) Let go of UNLOCK lever (1). Service headlights (3) and taillights (4) will come on. Service stoplights (5) will light when brakes are used.



- (4) Press dimmer switch (6) with foot to use high or low headlight beam. High beam indicator (7) will light when high beam is on.
- (5) Set lighting control lever (2) to OFF. Service headlights (3) and taillights (4) will go out.

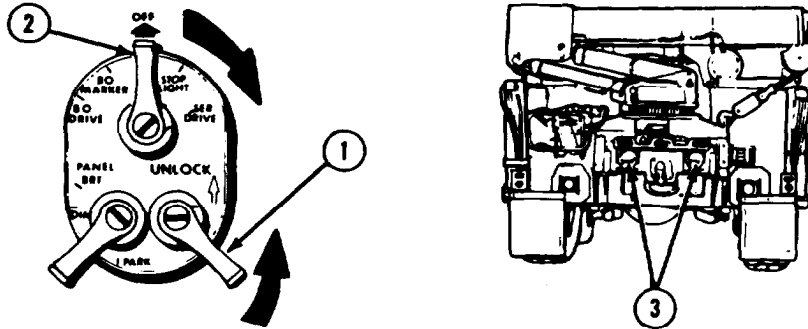
M977 Through M985 General Operating Procedures (Cont)

2-10. OPERATE LIGHTS (CONT.).

CAUTION

Failure to place light switches in the OFF positions when vehicle is not in use may cause battery and/or vehicle damage.

e. Turn Stoplights On/Off.



NOTE

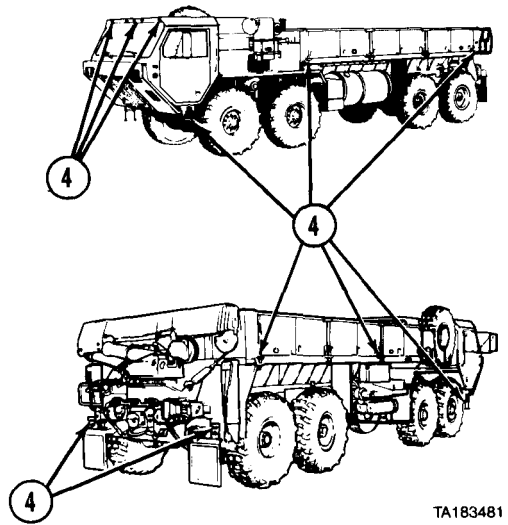
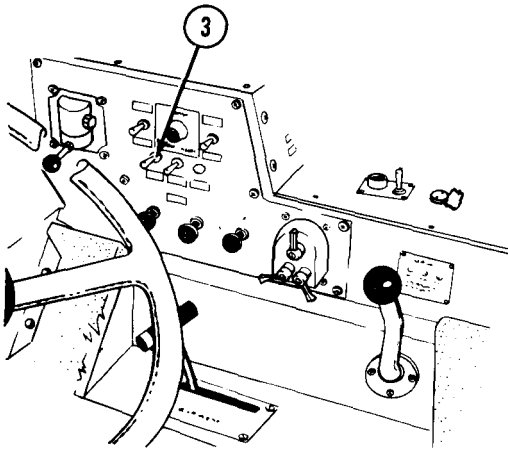
Use service stoplights for daytime driving.

- (1) Lift up and hold UNLOCK lever (1).
- (2) Set lighting control lever (2) to STOP LIGHT.
- (3) Let go of UNLOCK lever (1). Stoplights (3) will light when brakes are used.
- (4) Set lighting control lever (2) to OFF. Stoplights will go out.

f. Turn On Clearance Lamps.

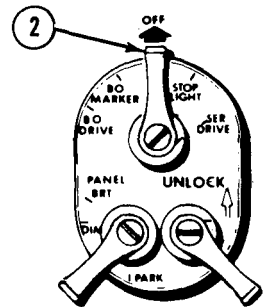
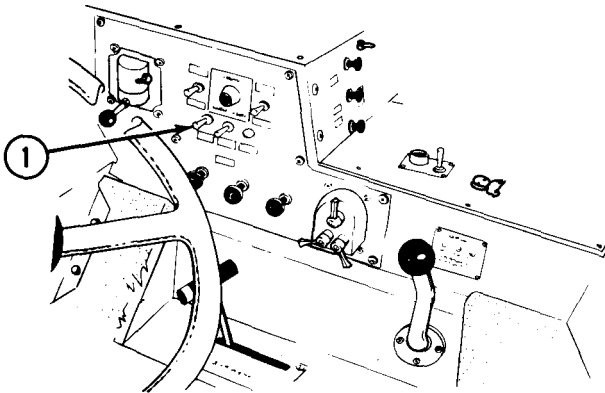
- (1) Lift up and hold UNLOCK lever (1).
- (2) Set lighting control lever (2) to STOP LIGHT or SER DRIVE position.
- (3) Let go of UNLOCK lever (1).

M977 Through M985 General Operating Procedures (Cont)



TA183481

- (4) Push up CL LPS switch (3) to on position. Clearance lamps (4) will light.
- g. Turn Off Clearance Lamps.**

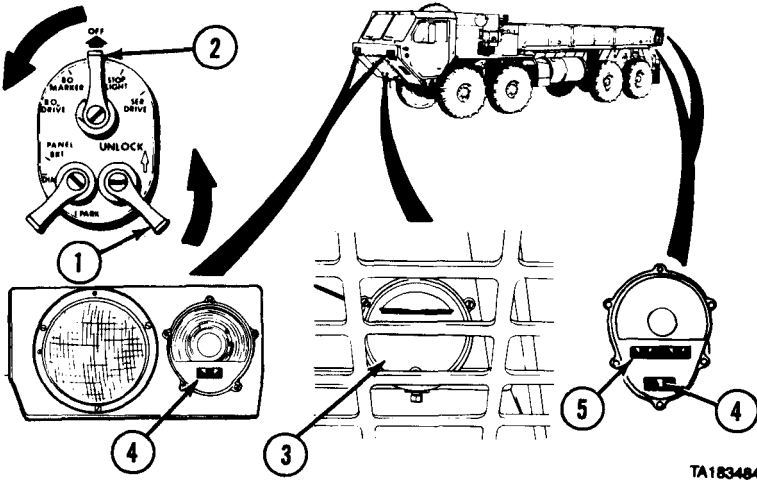


TA183482

- (1) Set CL LPS switch (1) to center (off) position.
- (2) Set lighting control lever (2) to OFF.

2-10. OPERATE LIGHTS (CONT).

h. Turn Blackout Drive Lights On/Off.



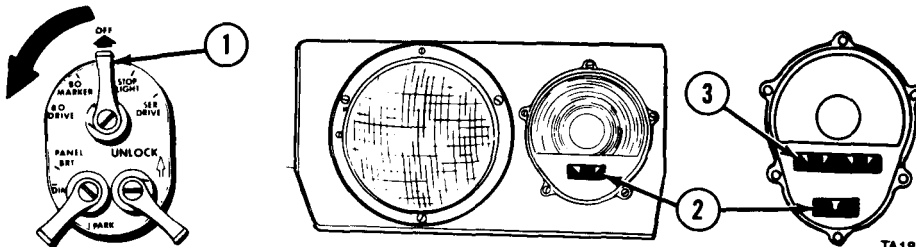
TA183484

NOTE

Use blackout drive lights for night driving under blackout conditions.

- (1) Lift up and hold UNLOCK lever (1).
- (2) Set lighting control lever (2) to B.O. DRIVE.
- (3) Let go of UNLOCK lever (1). Blackout drive lights (3) and blackout markers (4) will light. Blackout stoplight (5) will light when brakes are used.
- (4) Set lighting control lever (2) to OFF. Blackout drive lights (3) and blackout markers (4) will go out.

i. Turn Blackout Markers On/Off.

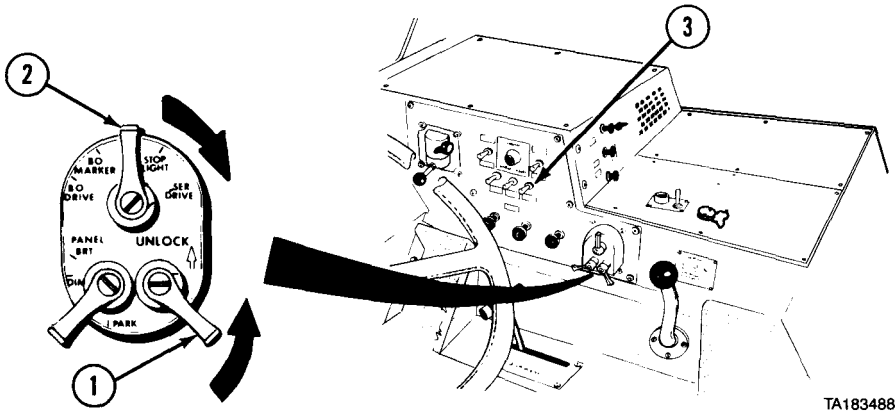


TA183485

- (1) Set lighting control lever (1) to B.O. MARKER. Blackout markers (2) will light. Blackout stoplight (3) will light when brakes are used.
- (2) Set lighting control lever (1) to OFF. Blackout markers (2) will go out.

M977 Through M985 General Operating Procedures (Cont)

j. Turn On Work Lights.



TA183488

NOTE

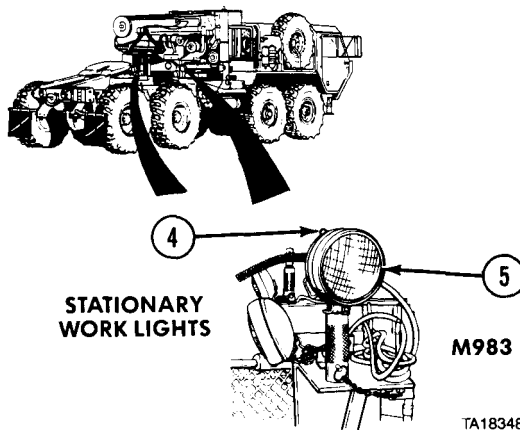
Only M983 and M984E1 vehicles have work lights.
Steps (1) through (5) are for M983 only.

- (1) Lift up and hold UNLOCK lever (1).
- (2) Set lighting control lever (2) to STOP LIGHT or SER DRIVE position.
- (3) Let go of UNLOCK lever (1).

NOTE

M983 only, when WORK LIGHT switch is in ON position, stationary work lights located next to portable work lights will come on.

- (4) Set WORK LIGHT switch (3) to up position.



M983

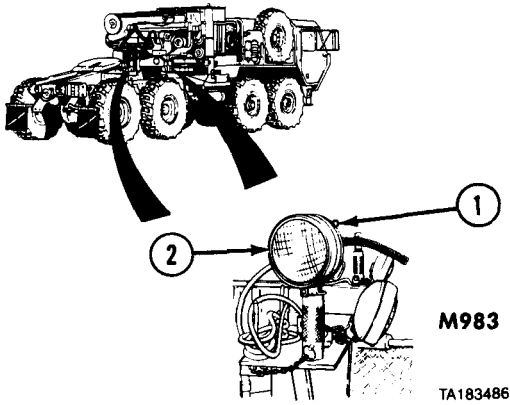
TA183489

- (5) For M983, set switch (4) on work light (5) to on position. Work light will come on.

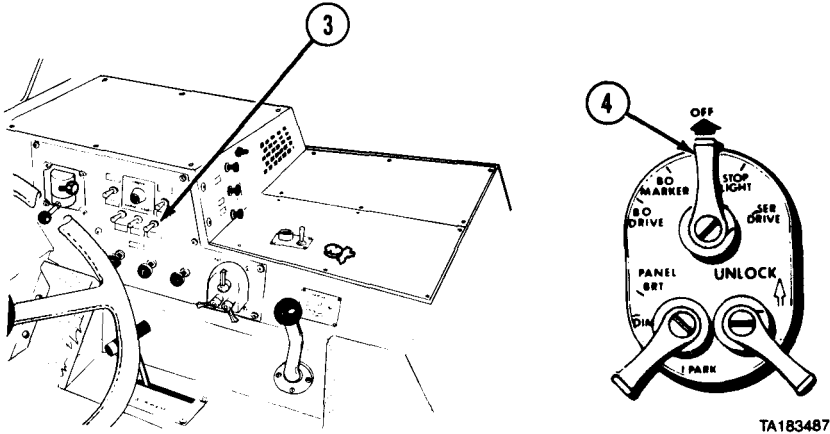
M977 Through M985 General Operating Procedures (Cont)

2-10. OPERATE LIGHTS (CONT.)

k. Turn Off Work Lights.



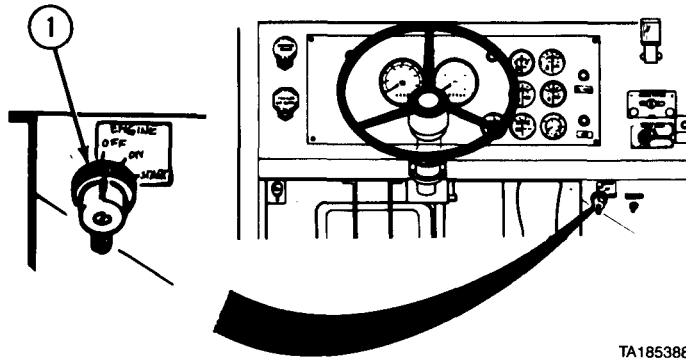
(1) Set switch (1) on work light (2) to off position.



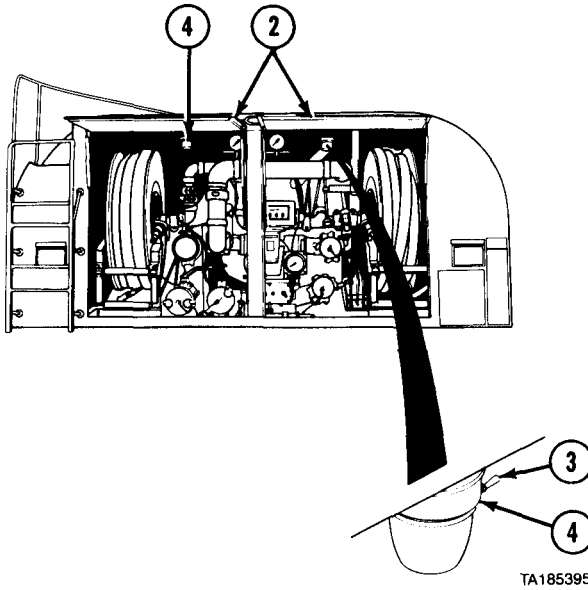
- (2) Set WORK LIGHT switch (3) to center (off) position.
- (3) Set lighting control lever (4) to OFF position.

M977 Through M985 General Operating Procedures (Cont)

I. Turn Tanker Module Lights On.



(1) Turn ENGINE switch (1) to ON position.

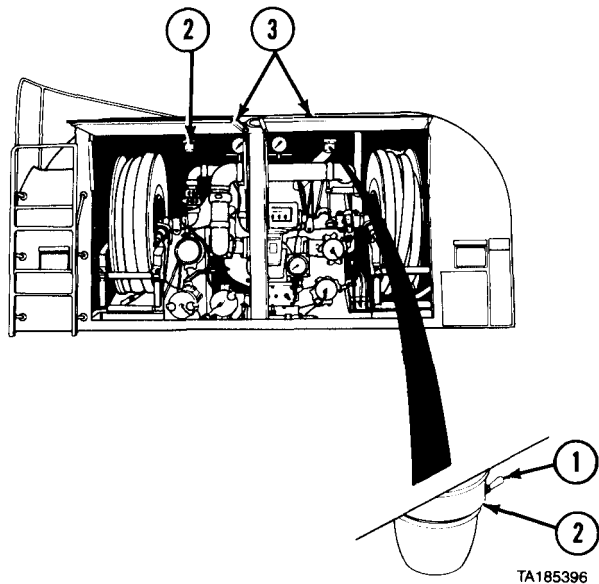


- (2) Open pump module rear doors (2).
- (3) Push switch (3) to turn tanker module light (4) on.
- (4) Repeat step (3) for left-side tanker module light (4).

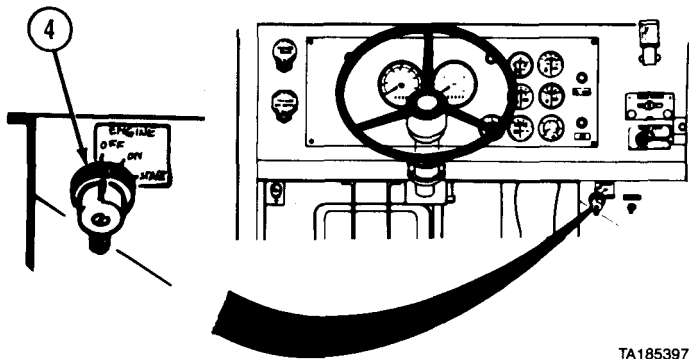
M977 Through M985 General Operating Procedures (Cont)

2-10. OPERATE LIGHTS (CONT).

m. Turn Tanker Module Lights Off.

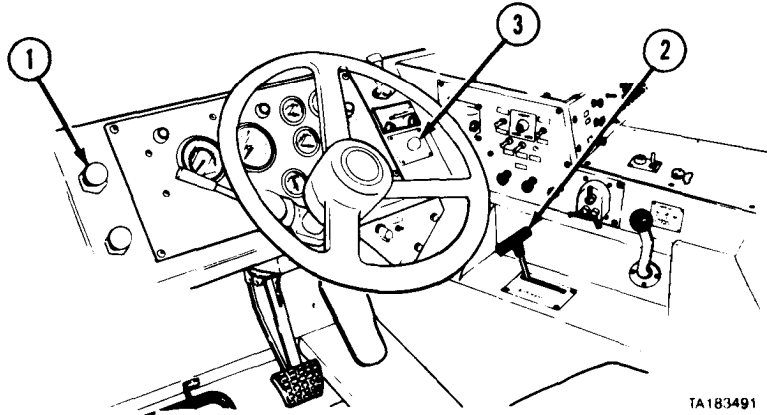


- (1) Push switch (1) to turn tanker module light (2) off.
- (2) Repeat step (1) for left-side tanker module light (2).
- (3) Close pump module rear doors (3).



- (4) Turn ENGINE switch (4) to OFF position.

M977 Through M985 General Operating Procedures (Cont)

2-11. DRIVE VEHICLE.**a. Start Cold Engine.**

- (1) Pull out PARKING BRAKE control (1).
 (2) Set transmission range lever (2) to N (neutral).

CAUTION

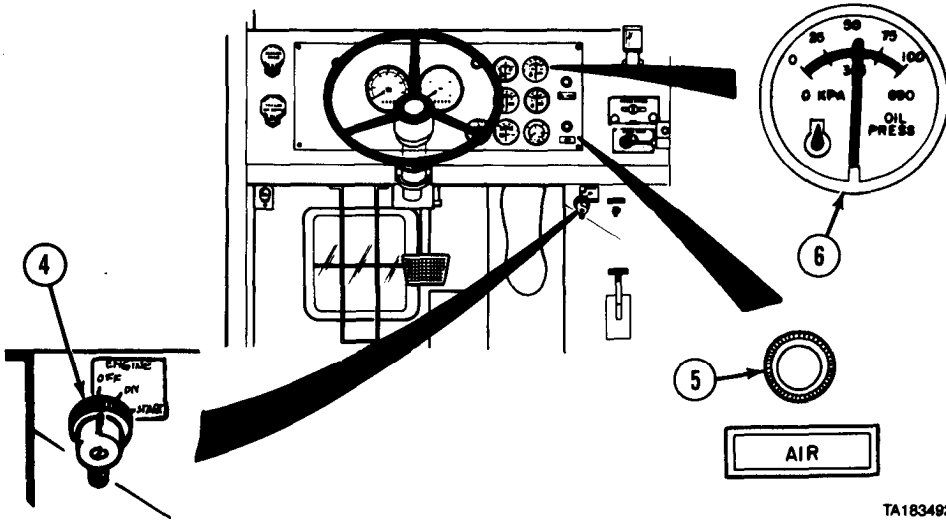
Do not press ETHER START button more than three times in a single starting attempt to prevent severe engine damage.

NOTE

Under extreme cold temperatures, it may be necessary to press the ETHER START button two or three times in a single starting attempt. Wait approximately 3 seconds between each press.

- (3) If outside temperature is above 45 °F (7 °C), go to step (4). If outside temperature is below 45 °F (7 °C), press ETHER START button (3) for 3 seconds and release. Wait 3 seconds more and go to step (4).

2-11. DRIVE VEHICLE (CONT).



TA183492

CAUTION

Do not turn engine switch to start position while motor is still running to prevent engine damage.

NOTE

If engine fails to start, repeat step 3 up to seven times. If engine doesn't start after eight starting attempts, notify organizational maintenance.

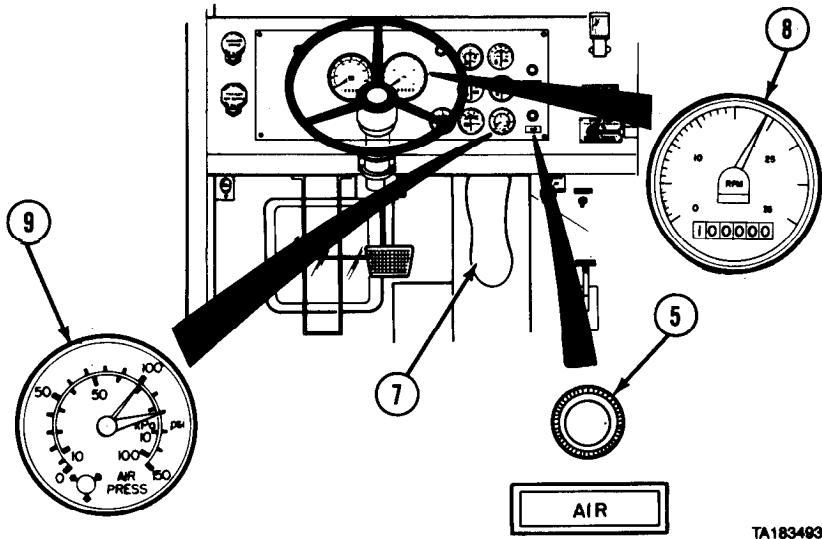
- (4) Turn ENGINE switch (4) to START for about 10 seconds or until engine starts. Release switch. ENGINE switch will spring back to ON position. Air pressure indicator (5) may light and buzzer may sound.

CAUTION

If OIL PRESS gage does not show engine oil pressure within 10 to 15 seconds after starting engine, shut down engine right away and notify organizational maintenance. Lack of lubrication may damage engine.

- (5) Check that OIL PRESS gage (6) reads 40 to 60 psi (276 to 414 kPa).

M977 Through M985 General Operating Procedures (Cont)



TA183493

CAUTION

Do not operate engine above 1000 rpm during warm-up until OIL PRESS gage indicates 40 to 60 psi (276 to 414 kPa). Lack of lubrication may damage engine.

- (6) Press throttle treadle (7) until tachometer (8) reads 800 to 1000 rpm.
- (7) Run engine at 800 to 1000 rpm for about 3 minutes.

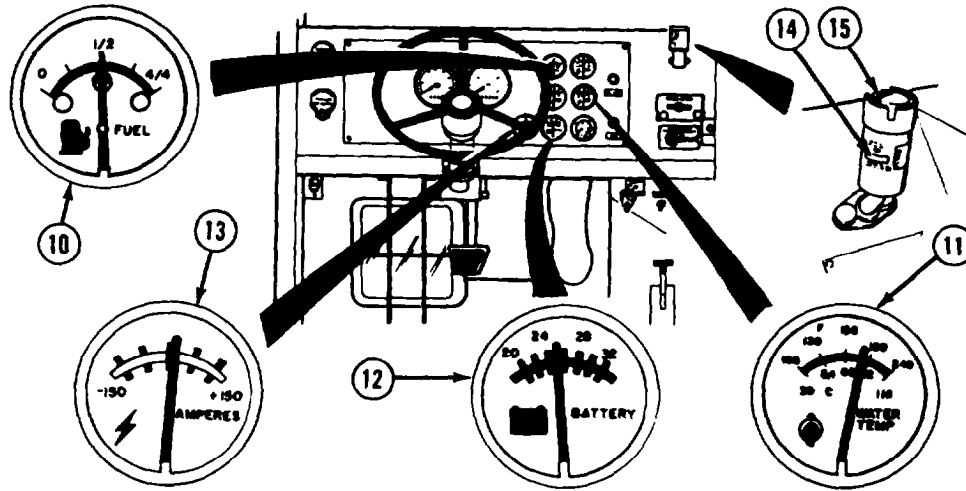
NOTE

If red and green needles on AIR PRESS gage do not read 60 to 120 psi (414 to 827 kPa) after warm-up, shut off engine and notify organizational maintenance.

- (8) Check that AIR PRESS gage (9) reads 60 to 120 psi (414 to 827 kPa). Air pressure indicator (5) will light and buzzer will sound until both needles reach 60 to 75 psi (414 to 517 kPa).

M977 Through M985 General Operating Procedures (Cont)

12-11. DRIVE VEHICLE (CONT).



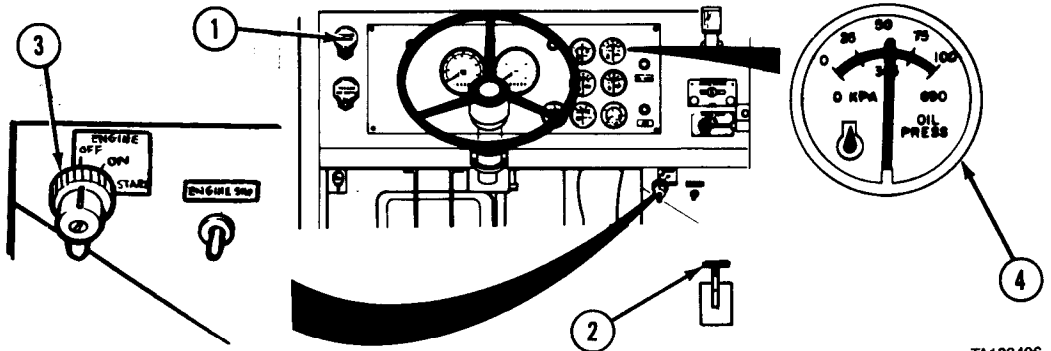
- (9) Check that FUEL gage (10) shows enough fuel to complete mission,

NOTE

WATER TEMP gage may not show reading at engine idle.

- (10) Check that WATER TEMP gage (11) does not read over 230 °F
- (11) Check that BATTERY gage (12) reads between 24 and 28 volts.
- (12) Check that AMPERES gage (13) shows positive reading.
- (13) Check that air filter restriction indicator (14) shows yellow.
- (14) If air filter restriction indicator (14) shows red, press button (15). If indicator still shows red and/or VACUUM INCHES H₂O window shows 18, stop engine and clean air filter elements (para 3-8).

M977 Through M985 General Operating Procedures (Cont)

b. Start Warm Engine.

TA183496

- (1) Pull out PARKING BRAKE control (1).
- (2) Set transmission range lever (2) to N (neutral).
- (3) Turn ENGINE switch (3) to START for about 10 seconds or until engine starts. Release switch. ENGINE switch will spring back to ON position.

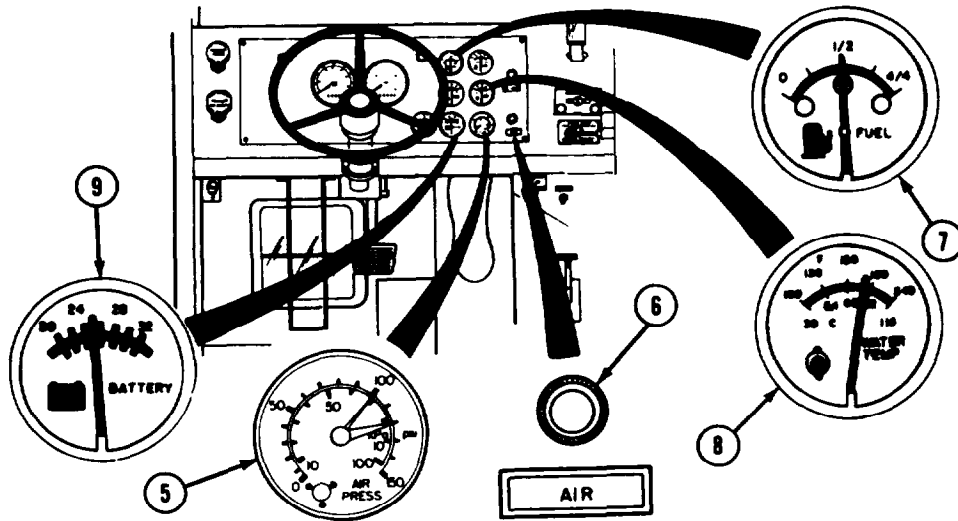
CAUTION

If OIL PRESS gage does not show any engine oil pressure within 10 to 15 seconds after starting engine, shut down engine right away and notify organizational maintenance. Lack of lubrication may damage engine.

- (4) Check that engine OIL PRESS gage (4) indicates normal operating range of 1800 to 2100 rpm, 40 to 60 psi (276 to 414 kPa); minimum for safe operation is 30 psi (207 kPa). At idle, pressure can go as low as 5 psi (34 kPa).

M977 Through M985 General Operating Procedures (Cont)

2-11. DRIVE VEHICLE (CONT)

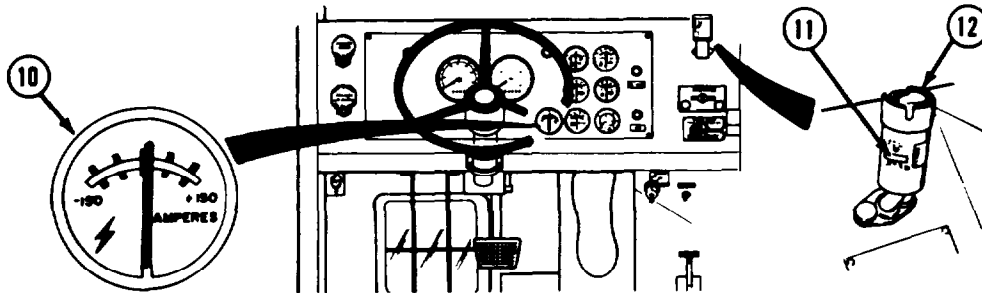


- (5) Check that AIR PRESS gage (5) reads 60 to 120 psi (414 to 827 kPa). Air pressure indicator (6) will light and buzzer will sound until both needles reach 60 to 75 psi (414 to 517 kPa).
- (6) Check that FUEL gage (7) shows enough fuel to complete mission.

NOTE

WATER TEMP gage may not show reading at engine idle.

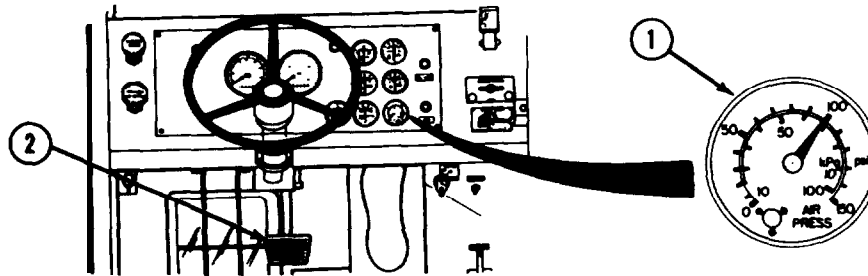
- (7) Check that WATER TEMP gage (8) does not read over 230 °F (110 °C).
- (8) Check that BATTERY gage (9) reads between 24 and 28 volts.



- (9) Check that AMPERES gage (10) shows positive reading.
- (10) Check that air filter restriction indicator (11) shows yellow.
- (11) If air filter restriction indicator (11) shows red, press button (12). If indicator still shows red and/or VACUUM INCHES H₂O window shows 18 or above, shut off engine and clean air filter elements (para 3-8).

M977 Through M985 General Operating Procedures (Cont)

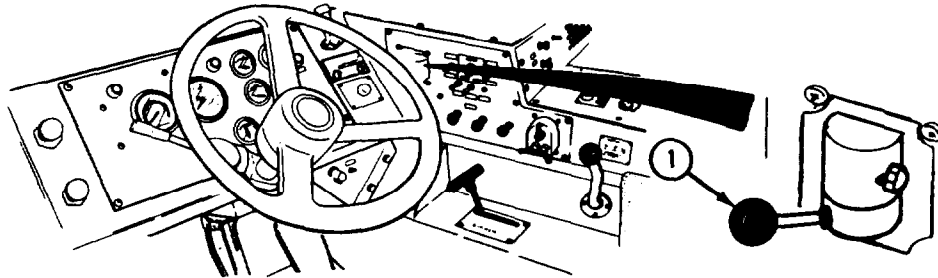
c. Operate Service Brakes.

**WARNING**

Do not press service brake treadle hard three or four times in a row. Air supply will be used up and service brakes will not work until air pressure is built up again. Loss of braking ability can result in serious personal injury or death.

- (1) Make sure AIR PRESS gage (1) reads at least 100 psi (690 kPa).
- (2) Push down and hold service brake treadle (2) as needed to slow or stop vehicle.

d. Operate Trailer Brakes.

**WARNING**

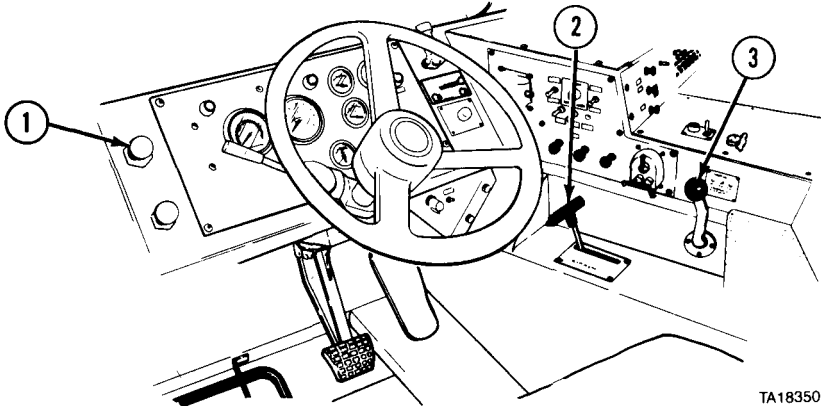
Trailer handbrake control is used only when testing trailer brakes. Do not use trailer handbrake control while driving because there is danger of causing the trailer to skid and jackknife. This could cause an accident resulting in damage to equipment and injury or death to personnel.

- (1) Slowly pull back trailer handbrake control (1) to test application of trailer brakes.
- (2) Push trailer handbrake control (1) forward to test release of trailer

M977 Through M985 General Operating Procedures (Cont)

2-11. DRIVE VEHICLE (CONT).

e. Operate Transmission and Transfer Case.



TA183501

- (1) Start engine (para 2-11a or 2-11b).
- (2) Make sure PARKING BRAKE control (1) is pushed in.
- (3) Make sure transmission range selector (2) is set to N (neutral).

CAUTION

- Do not force TRANSFER CASE shift lever. Lever may work hard if there is drive line windup. Using excessive force on shift lever may cause damage to shift linkage or change linkage adjustment.
- Do not move TRANSFER CASE shift lever when vehicle is moving, or when transmission is in gear. Severe damage to drive line may result.

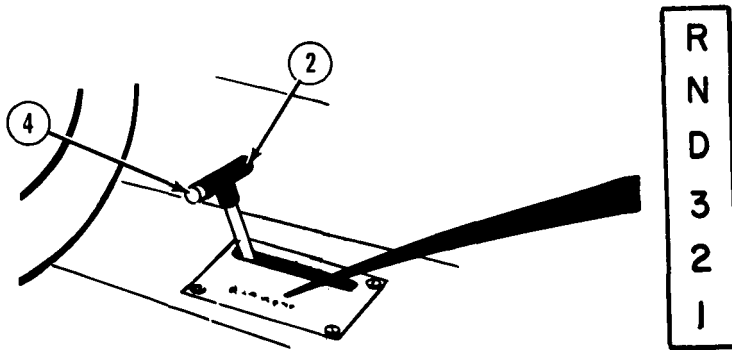
- (4) Select transfer case position:

NOTE

If TRANSFER CASE shift lever is hard to move, push in button and set transmission range selector to D, then back to N. If transfer case will not shift, refer to Table 3-2, Troubleshooting.

- Set TRANSFER CASE shift lever (3) to H (HI) for highway driving.
- Set TRANSFER CASE shift lever (3) to L (LO) for off-road driving.

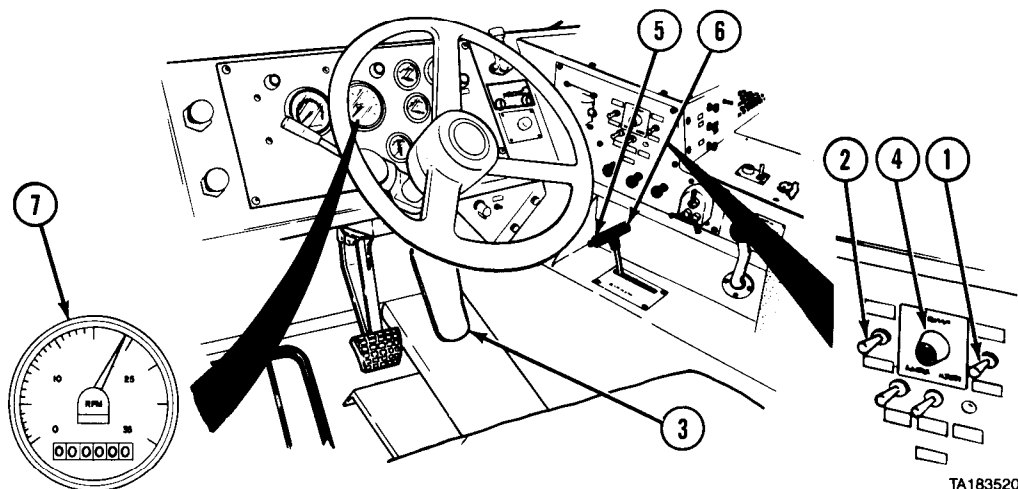
M977 Through M985 General Operating Procedures (Cont)



TA183502

- (5) Push in button (4) and move transmission range selector (2) to desired position.
- (6) Use R (reverse) to:
 - Move vehicle backwards.
- (7) Use N (neutral) to:
 - Start engine.
 - Park vehicle.
 - Perform stationary power takeoff.
- (8) Use D (drive) to:
 - Drive in normal conditions.
 - Move forward from a stop.
- (9) Use 3 (third range) to:
 - Drive in off-road conditions.
 - Drive in city traffic.
 - Haul a heavy load.
- (10) Use 2 (second range) to:
 - Drive down moderate grades.
 - Control vehicle speed.
- (11) Use 1 (first range) to:
 - Drive through mud or snow.
 - Drive up or down steep grades.
 - Give maximum vehicle speed control.

M977 Through M985 General Operating Procedures (Cont)

2-11. DRIVE VEHICLE (CONT).**f. Use Engine Brake.**

TA183520

WARNING

Apply engine brake only when vehicle tires have good traction. Use of engine brake on slick surfaces can cause vehicle to skid and cause personal injury.

NOTE

Wheel brakes must be used in addition to engine brakes for maximum use of brakes.

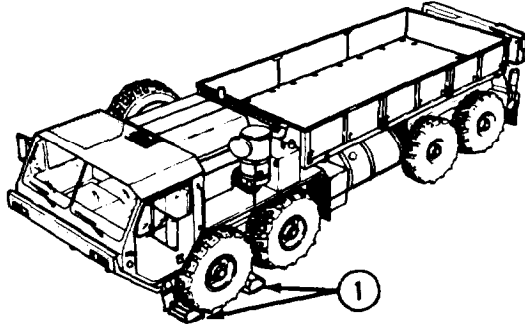
- (1) Set JACOBS ENGINE BRAKE HIGH/LOW switch (1) to LOW.
- (2) Set JACOBS ENGINE BRAKE ON/OFF switch (2) to ON. JACOBS ENGINE BRAKE indicator light (4) will come on.
- (3) Lift foot off throttle treadle (3). Engine brake will automatically slow vehicle.
- (4) If too much braking occurs, push in button (5) and set transmission range selector (6) to a higher range.
- (5) If more braking is required, set JACOBS ENGINE BRAKE HIGH/LOW switch (1) to HIGH.

NOTE

Engine brake operates best when engine speed is between 1650 and 2100 rpm. Transmission torque converter lockup may disengage below 1650 rpm resulting in loss of engine brake.

- (6) Check that tachometer (7) reads between 1650 and 2100 rpm whenever engine brake is used.

M977 Through M985 General Operating Procedures (Cont)

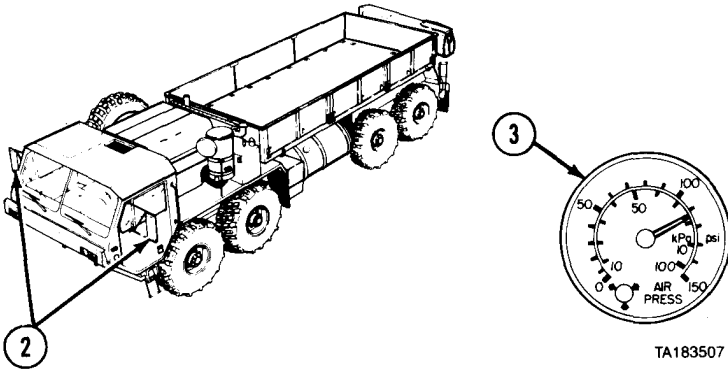
g. Drive forward.**NOTE**

- If vehicle has less than 500 miles (805 km), check controls and indicators often during operation and listen for unusual noises or vibrations. Notify organizational maintenance of any problems.
- Before driving M984E1, refer to paragraph 2-58a.

- (1) Remove and stow wheel chocks (1).
- (2) For M977 and M985 vehicles only:
 - Make sure cargo box end panels are in place.
 - Make sure cargo box side panels are secure (para 2-17c or 2-17d).
 - Make sure material handling crane and crane outriggers are secured in stowed position (para 2-18g).
- (3) For M978 vehicle only:
 - Make sure manhole cover is closed and latched (para 2-21b(10)).
 - Make sure pump module doors are closed and latched (para 2-22a(23)).
 - Make sure tank access ladder is secured in stowed position (para 2-21b(12 through 14)).
- (4) For M983 vehicle only:
 - Make sure trailer spare tire is secured to deck.

M977 Through M985 General Operating Procedures (Cont)

2-11. DRIVE VEHICLE (CONT).



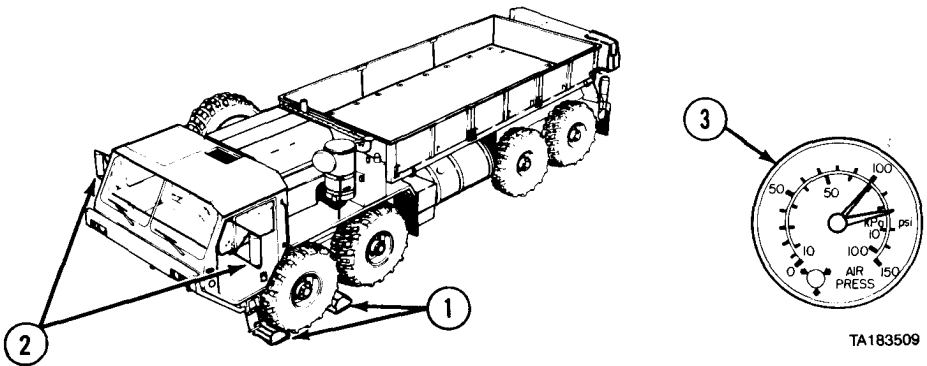
- (5) Turn each rearview mirror (2) so back of vehicle and view of road can be seen.
- (6) Install footrest if required (para 2-9b).
- (7) Adjust seat as needed (para 2-9d).
- (8) Adjust seatbelt as needed (para 2-9e).
- (9) Start engine (para 2-11a or 2-11b).
- (10) Turn on lights as needed (para 2-10).

WARNING

Do not press service brake treadle hard three or four times in a row. Air supply will be used up and brakes will not work until air pressure is built up again. Loss of braking ability can result in serious personal injury or death.

- (11) Make sure AIR PRESS gage (3) reads at least 100 psi (690 kPa) before driving vehicle.

M977 Through M985 General Operating Procedures (Cont)

h. Drive In Reverse.

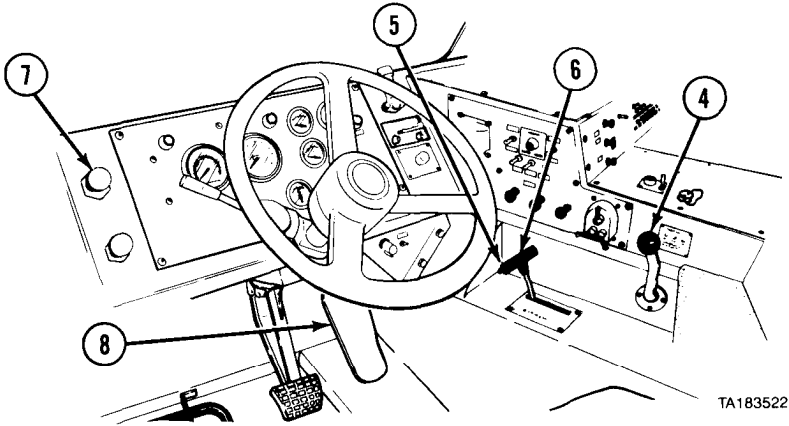
- (1) Remove and stow wheel chocks (1).
- (2) Turn each rearview mirror (2) so back of vehicle and view of road can be seen.
- (3) Install footrest if required (para 2-9b).
- (4) Adjust seat as needed (para 2-9d).
- (5) Adjust seatbelt as needed (para 2-9e).
- (6) Start engine (para 2-11a or 2-11b).
- (7) Turn on lights as needed (para 2-10).

WARNING

Do not press service brake treadle hard three or four times in a row. Air supply will be used up and service brakes will not work until air pressure is built up again. Loss of braking ability can result in serious personal injury or death.

- (8) Check that AIR PRESS gage (3) reads at least 100 psi (690 kPa).

2-11. DRIVE VEHICLE (CONT).



TA183522

WARNING

Driver has limited vision to rear. Ground guide is required when driving vehicle in reverse to prevent possible personal injury.

CAUTION

Do not move TRANSFER CASE shift lever when vehicle is moving or when transmission is in gear. Severe damage to drive line will result.

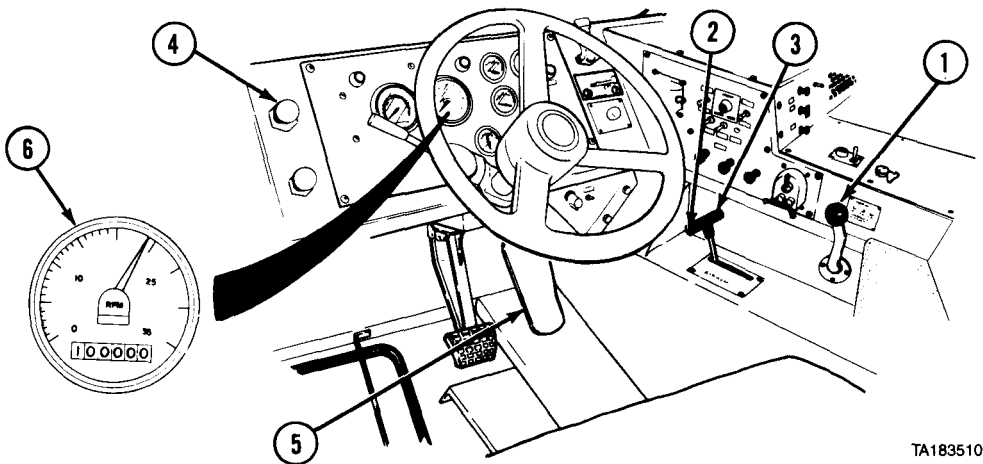
- (9) Set TRANSFER CASE shift lever (4) to HI.
- (10) Push in button (5) and move transmission range selector (6) to R.
- (11) Push in PARKING BRAKE control (7).
- (12) Slowly press down on throttle treadle (8).
- (13) Follow direction from ground guide.

CAUTION

Do not hold steering wheel at full left or full right position for longer than 10 seconds. Oil overheating and pump damage can result.

- (14) Accelerate, brake, and steer as required.

M977 Through M985 General Operating Procedures (Cont)

i. Drive On Highway.

TA183510

CAUTION

Do not move TRANSFER CASE shift lever when vehicle is moving or when transmission is in gear. Severe damage to drive line will result.

- (1) Set TRANSFER CASE shift lever (1) to HI.
- (2) Push in button (2) and move transmission range selector (3) to D.
- (3) Push in PARKING BRAKE control (4).

CAUTION

Maximum no-load governed engine speed is approximately 2250 rpm. Do not let engine speed go above this figure. Under full load, governed speed is approximately 2100 rpm. If engine speed goes above governed speeds, serious engine damage can result.

- (4) Slowly press down throttle treadle (5) until vehicle reaches desired speed. Tachometer (6) should read 1650 to 2100 rpm.

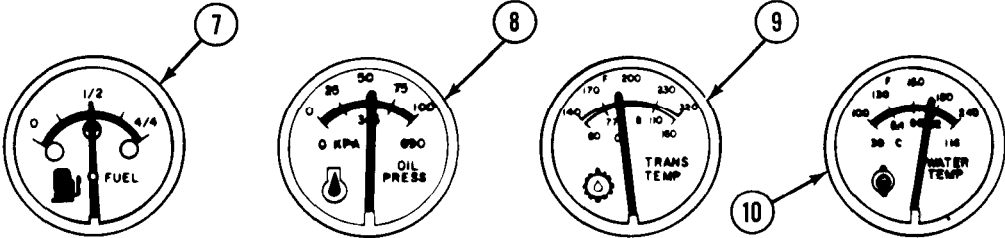
CAUTION

Do not hold steering wheel at full left or full right position for longer than 10 seconds. Power steering oil can overheat and pump can be damaged.

- (5) Accelerate, brake, and steer as required.

M977 Through M985 General Operating Procedures (Cont)

2-11. DRIVE VEHICLE (CONT).

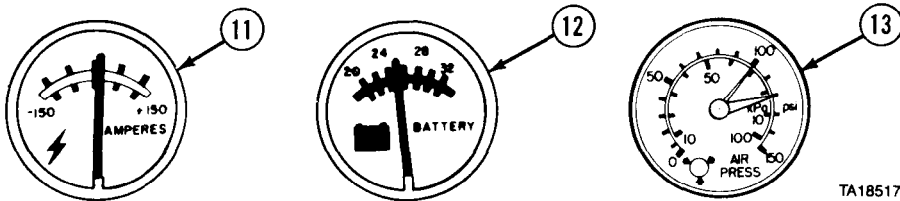


TA185170

NOTE

Check system gages often during vehicle operation. If gages read other than normal, stop engine and troubleshoot problem.

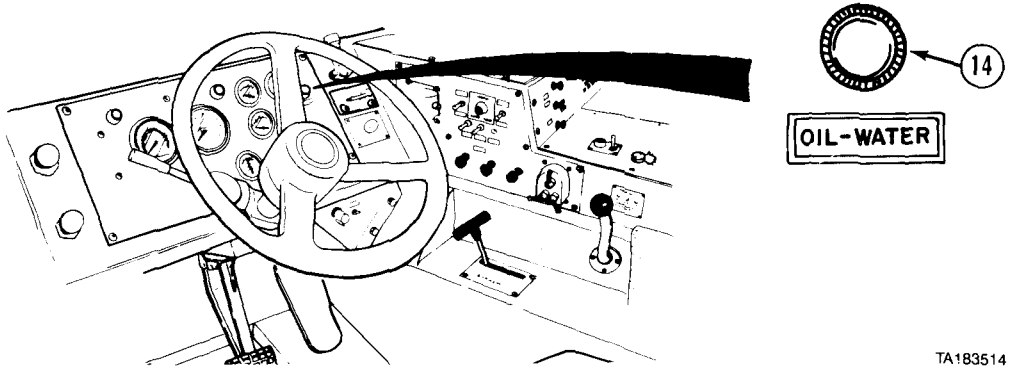
- (6) Check that FUEL gage (7) shows enough fuel to complete mission.
- (7) Check that OIL PRESS gage (8) reads 40 to 60 psi (276 to 414 kPa).
- (8) Check that TRANS TEMP (transmission temperature) gage (9) reads 160 to 220 °F (71 to 104 °C).
- (9) Check that WATER TEMP gage (10) reads 180 to 200 °F (82 to 93 °C).



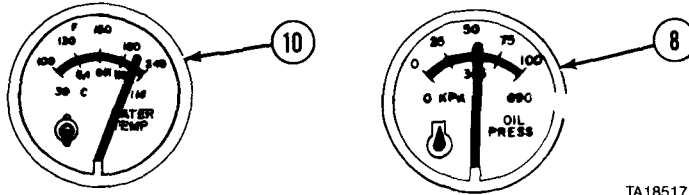
TA185172

- (10) Check that AMPERES gage (11) reads about zero.
- (11) Check that BATTERY gage (12) reads 24 to 28 volts.
- (12) Check that AIR PRESS gage (13) reads 100 to 120 psi (690 to 827 kPa).

M977 Through M985 General Operating Procedures (Cont)



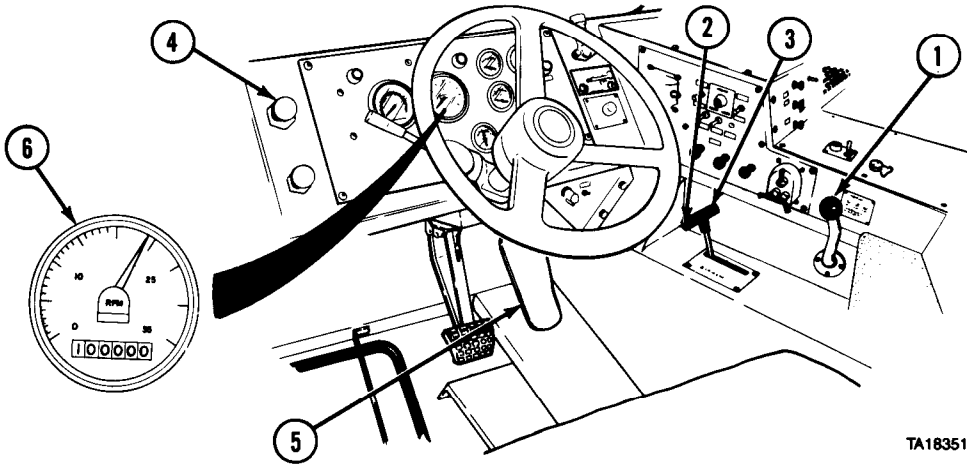
(13) If OIL-WATER indicator (14) lights and buzzer sounds, park vehicle (para 2-11o).



- (14) If WATER TEMP gage (10) reads over 230 °F (110 °C), idle engine until water temperature cools. If water does not cool, shut off engine (para 2-11p) and notify organizational maintenance.
- (15) If OIL PRESS gage (8) reads over 60 psi (414 kPa), or lower than 30 psi (207 kPa), park vehicle (para 2-11o).
- (16) Shut off engine (para 2-11p).
- (17) Notify organizational maintenance.

2-11. DRIVE VEHICLE (CONT).

j. Drive In City Traffic.



TA183510

CAUTION

Do not move TRANSFER CASE shift lever when vehicle is moving or when transmission is in gear. Severe damage to drive line will result.

- (1) Set TRANSFER CASE shift lever (1) to HI.
- (2) Push in button (2) and move transmission range selector (3) to D or 3, depending on traffic (para 2-11e).
- (3) Push in PARKING BRAKE control (4).

CAUTION

Maximum no-load governed engine speed is approximately 2250 rpm. Never allow engine speed to go over this figure. Under full load, governed speed is approximately 2100 rpm. If engine is allowed to go over governed speeds, serious engine damage can result.

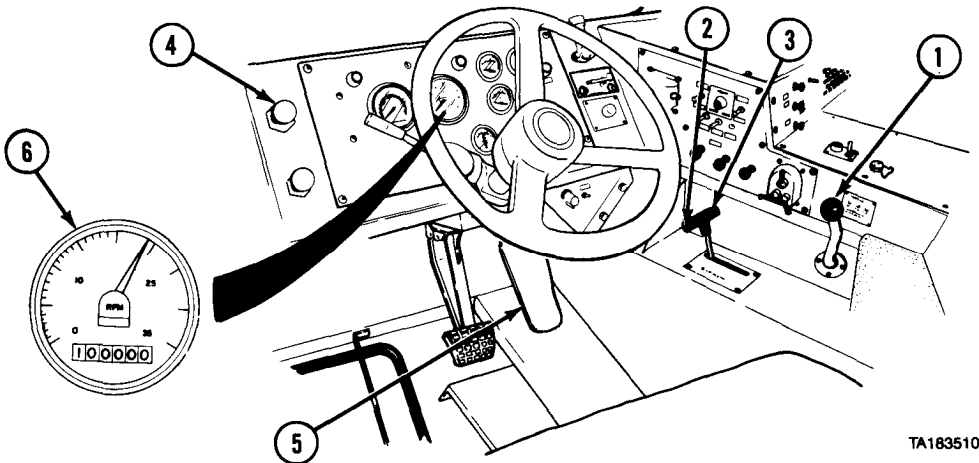
- (4) Slowly press down throttle treadle (5) until vehicle reaches desired speed. Tachometer (6) should read 1650 to 2100 rpm.

CAUTION

Do not hold steering wheel at full left or full right position for longer than 10 seconds. Power steering oil overheating and pump damage can result.

- (5) Accelerate, brake, and steer as required.

M977 Through M985 General Operating Procedures (Cont)

k. Drive In Off-Road Conditions.

TA183510

CAUTION

- Do not move TRANSFER CASE shift lever when vehicle is moving or when transmission is in gear. Severe damage to drive line will result.
- Before driving M984E1 off-road, raise and hook rear mudflaps (para 2-58b). Rear mudflaps on M984E1 can be torn off when working in off-road conditions.

- (1) Set TRANSFER CASE shift lever (1) to L (LO).
- (2) Push in button (2) and move transmission range selector (3) to 2 or 1, depending on ground condition (para 2-11e).
- (3) Push in PARKING BRAKE control (4).

CAUTION

Maximum no-load governed engine speed is approximately 2250 rpm. Never allow engine speed to go over this figure. Under full load, governed speed is approximately 2100 rpm. If engine is allowed to go over governed speeds, serious engine damage can result.

- (4) Slowly press down throttle treadle (5) until vehicle reaches desired speed. Tachometer (6) should read between 1650 and 2100 rpm.

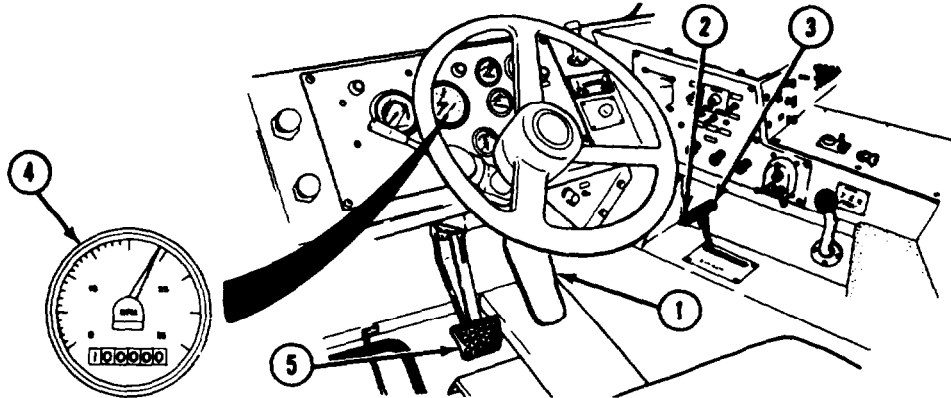
CAUTION

Do not hold steering wheel at full left or full right position for longer than 10 seconds. Power steering oil overheating and pump damage can result.

- (5) Accelerate, brake, and steer as required.

M977 Through M985 General Operating Procedures (Cont)

2-11. DRIVE VEHICLE (CONT.)



l. Drive Up Steep Grades. Press and hold throttle treadle (1) all the way down as vehicle moves up grade. Transmission will automatically downshift gears as needed.

m. Drive Down Steep Grades.

CAUTION

- Do not allow speed to go above 2100 rpm when driving downhill or damage to engine can result.
- Engine brake operates best when engine speed is between 1650 and 2100 rpm. Transmission torque converter lockup valve may disengage below 1650 rpm resulting in loss of engine power.

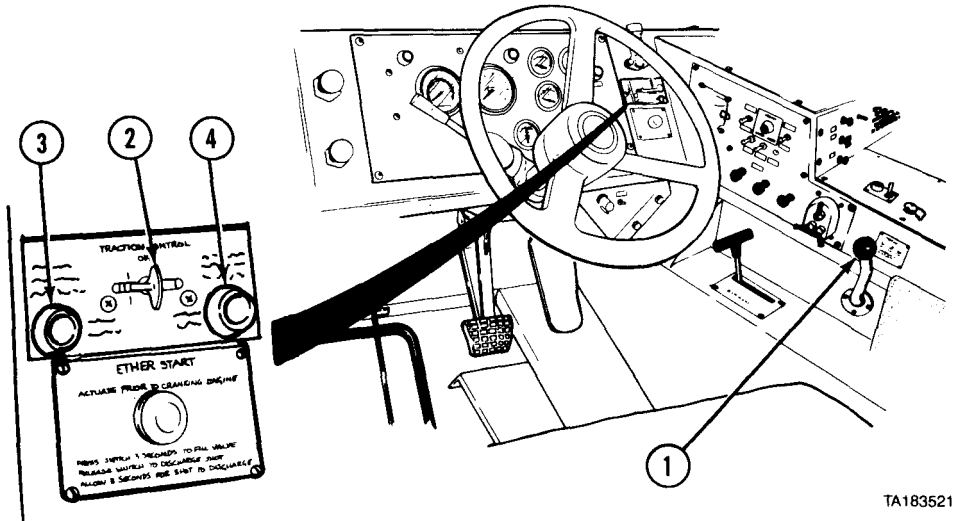
- (1) Push in button (2) and move transmission range selector (3) to lower range as needed to keep engine speed on tachometer (4) between 1650 and 2100 rpm.

WARNING

Do not press service brake treadle hard three or four times in a row. Air supply will be used up and service brakes will not work until air pressure is built up again. Loss of braking ability can result in serious personal injury or death.

- (2) Use service brake (5) as needed to control vehicle speed.
(3) Use engine brake as needed (para 2-11f).

M977 Through M985 General Operating Procedures (Cont)

n. Drive In Slippery Conditions.

TA183521

CAUTION

Do not shift TRACTION CONTROL lever while vehicle is moving. Damage to driveline may result.

NOTE

After traction control lever is shifted, let vehicle creep forward several feet to allow shift collars to fully engage.

- (1) If TRANSFER CASE shift lever (1) is set to LO, set TRACTION CONTROL lever (2) to INTER-AXLE DIFF. LOCK. Indicator light (3) will come on.
- (2) If TRANSFER CASE shift lever (1) is set to HI, set TRACTION CONTROL lever (2) to 8X8 DRIVE. Indicator light (4) will come on.

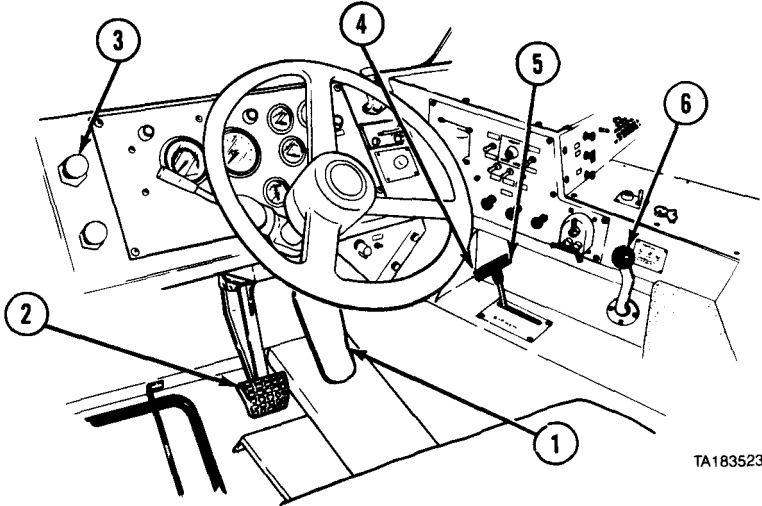
NOTE

After traction control lever is shifted to "OFF" let vehicle creep forward several feet to allow shift collars to fully disengage.

- (3) When vehicle gets good traction again, stop vehicle and set TRACTION CONTROL lever (2) to OFF.

2-11. DRIVE VEHICLE (CONT).

o. Park Vehicle.



- (1) Lift foot off throttle treadle (1). Let automatic downshifting of transmission slow vehicle.

WARNING

Do not press service brake treadle hard three or four times in a row. Air supply will be used up and brakes will not work until air pressure is built up again. Loss of braking ability can result in serious personal injury or death.

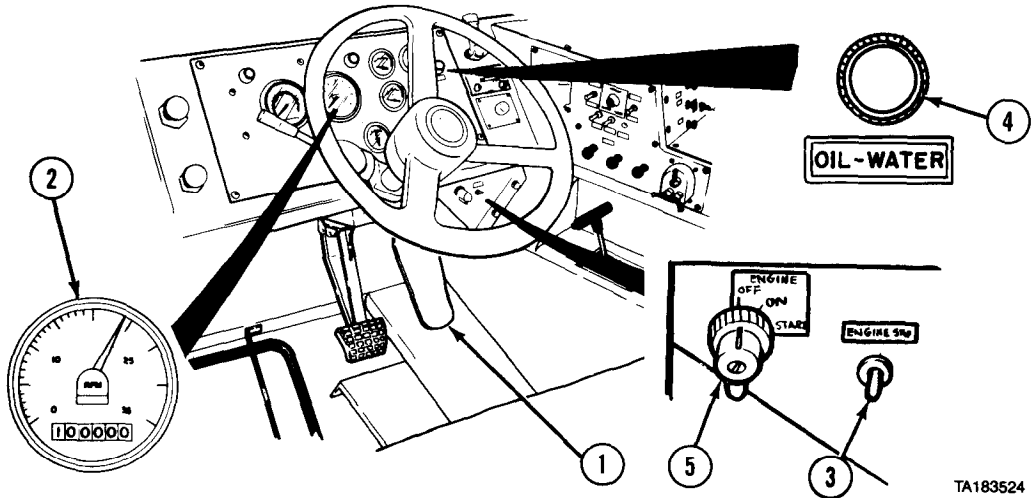
- (2) Push down on service brake treadle (2) until vehicle comes to complete stop.

WARNING

Do not park vehicle on steep grade. Serious personal injury can result or vent on tanker may leak.

- (3) Pull out PARKING BRAKE control (3).
(4) Push in button (4) and set transmission range selector (5) to N.
(5) Set TRANSFER CASE shift lever (6) to N (center position).
(6) Aline front tires in straight-ahead position.
(7) Chock wheels if vehicle is not parked on level ground.

M977 Through M985 General Operating Procedures (Cont)

p. Shut Off Engine.

TA183524

- (1) Park vehicle (para 2-11o).

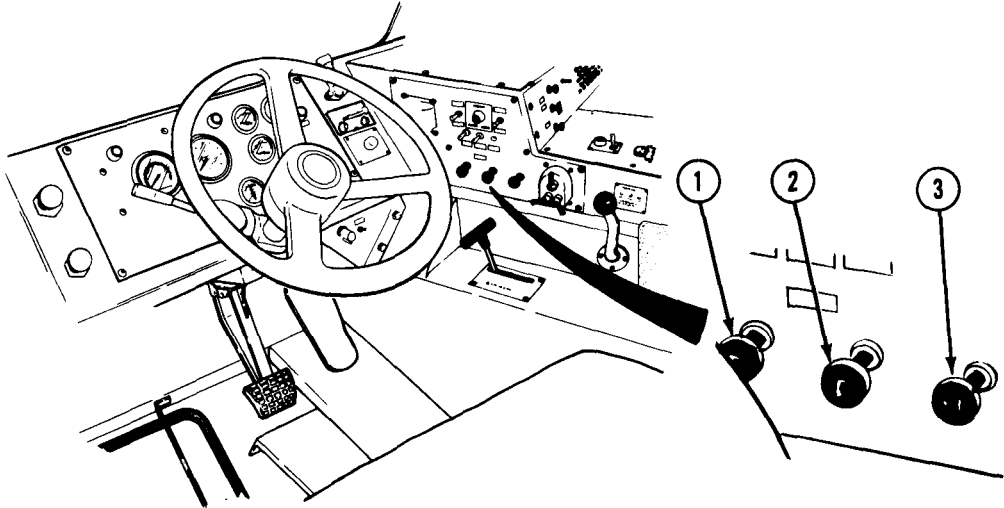
CAUTION

Before shutting down engine, run at reduced speed (800 to 1000 rpm) at no-load for 3 to 5 minutes to allow turbocharger to slow down and cool off. Turbocharger may be damaged if not allowed to cool off.

- (2) Push down and hold throttle treadle (1) until tachometer (2) reads 800 to 1000 rpm.
- (3) Run engine for 3 to 5 minutes.
- (4) Lift foot off throttle treadle (1).
- (5) Hold ENGINE STOP switch (3) all the way down until engine shuts down. Buzzer will sound and OIL-WATER indicator (4) will light.
- (6) Let go of ENGINE STOP switch (3).
- (7) Turn ENGINE stop (5) to OFF. Buzzer and OIL-WATER indicator (4) will go off.
- (8) Turn off lights (para 2-10).

2-12. OPERATE WINDSHIELD WIPERS/WASHER.

a. Turn Windshield Wipers On/Off.



TA183525

- (1) Pull out WIPER knob (1) to start left windshield wiper.
- (2) Pull out WIPER knob (2) to start right windshield wiper.
- (3) Turn WIPER knob (1 or 2) clockwise to speed up wiper.
- (4) Turn WIPER knob (1 or 2) counterclockwise to slow down wiper.
- (5) Push in WIPER knob (1) to stop left windshield wiper.
- (6) Push in WIPER knob (2) to stop right windshield wiper.
- (7) If wipers stop in middle of windshield, push in and hold WIPER knob (1 or 2) until wipers are at bottom of windshield.

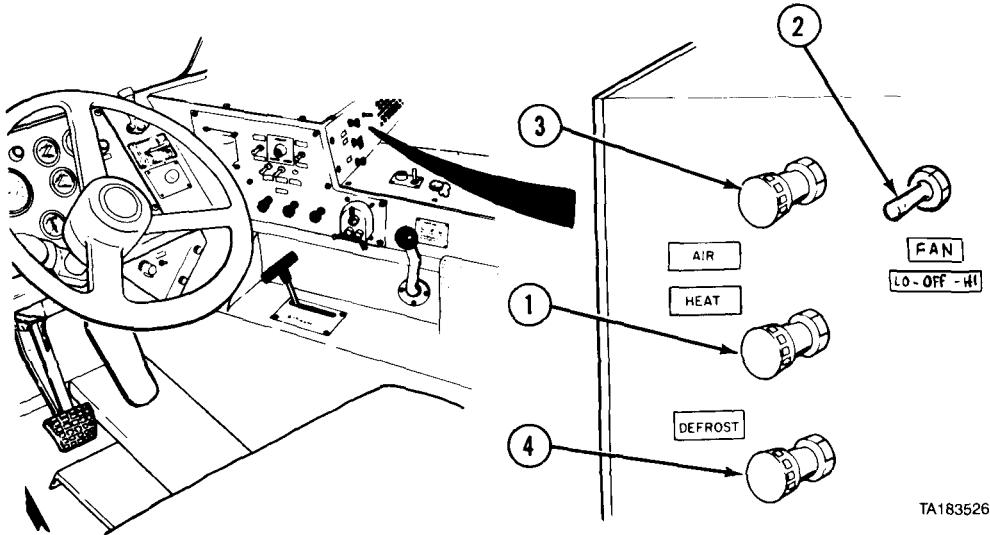
b. Operate Windshield Washer.

- (1) Push in and hold WASHER knob (3) to spray cleaning fluid on windshield.
- (2) Let go of WASHER knob (3) to stop washer spray.

M977 Through M985 General Operating Procedures (Cont)

2-13. OPERATE PERSONNEL HEATER.

a. Turn Heater On/Off.



TA183526

NOTE

Heater temperature is controlled by position of HEAT knob. Temperature will be very warm when HEAT knob is pulled out all the way. Temperature will go down as HEAT knob is pushed in.

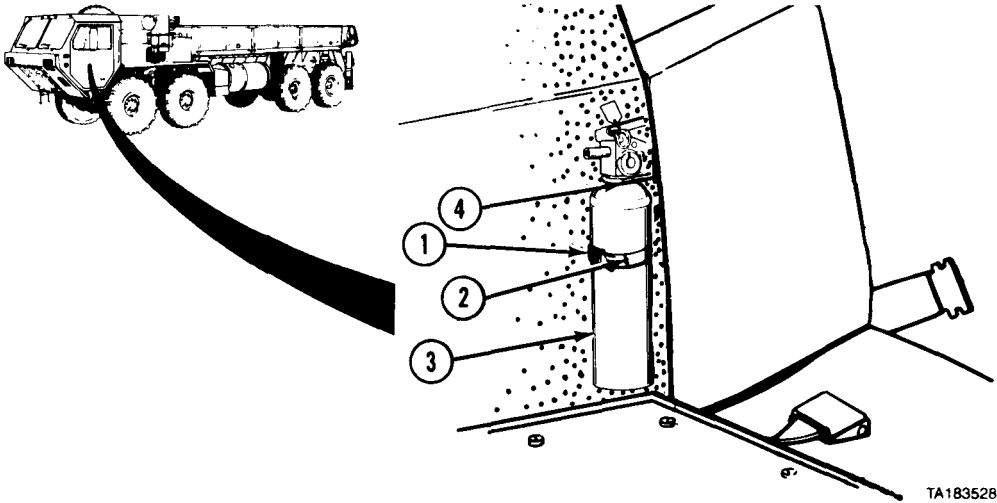
- (1) Pull out HEAT knob (1) to desired position.
 - (2) Set FAN switch (2) to LO or HI airflow.
 - (3) Pull out AIR knob (3) to add outside air for cab ventilation.
 - (4) Push AIR knob (3) in if cab ventilation is not desired.
 - (5) Push in HEAT knob (1) to turn heater off.
 - (6) Set FAN switch (2) to OFF.
- b. Turn Windshield Defrost On/Off.**
- (1) Pull out DEFROST knob (4) to turn on.
 - (2) Set FAN switch (2) to LO or HI position.
 - (3) Push in DEFROST knob (4) to turn off.
 - (4) Set FAN switch (2) to OFF.

2-14. OPERATE FIRE EXTINGUISHER.

NOTE

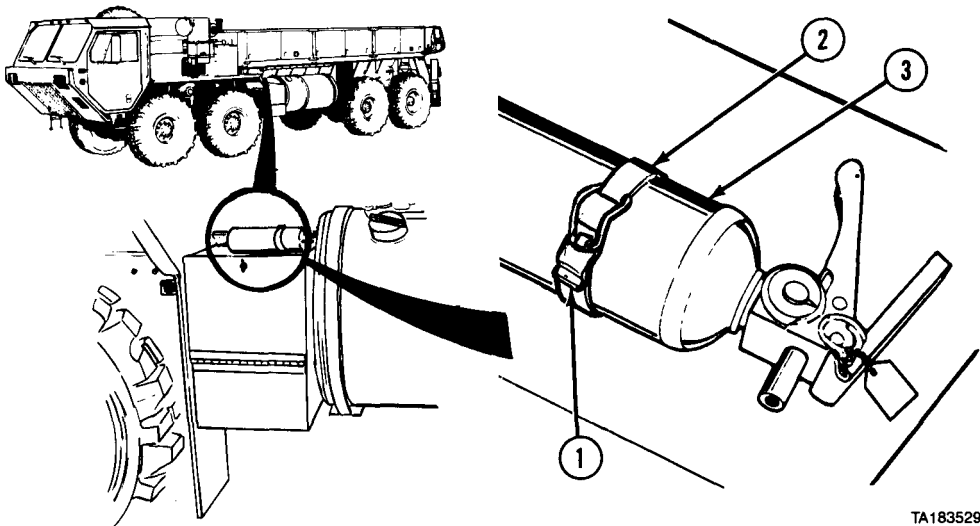
To operate M984E1 fire extinguishers, refer to paragraph 2-59.

a. Remove Fire Extinguisher From Cab.



- (1) Pull up clamp (1) and open strap (2).
- (2) Pull fire extinguisher (3) straight out and off bracket (4).
- (3) Remove fire extinguisher (3).

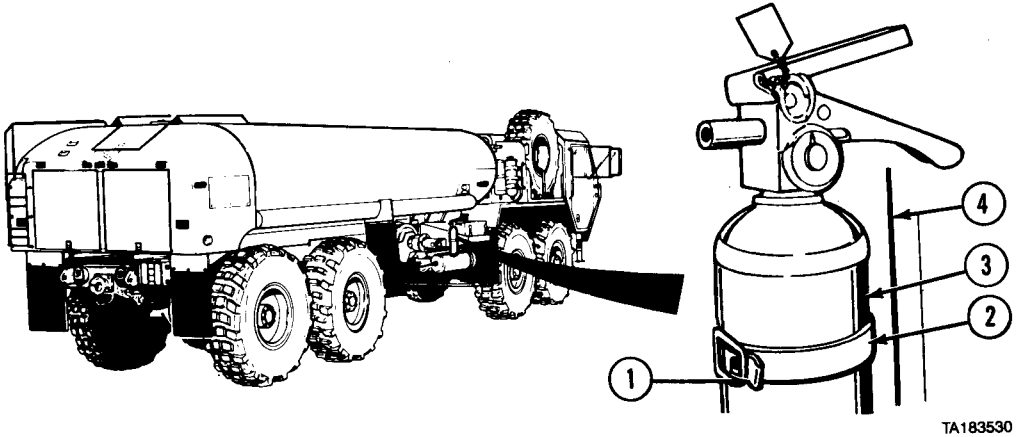
b. Remove Fire Extinguisher From Stowage Box.



- (1) Pull up clamp (1) and open strap (2).
- (2) Remove fire extinguisher (3).

M977 Through M985 General Operating Procedures (Cont)

c. Remove Fire Extinguisher From Battery Box (M978 Only).

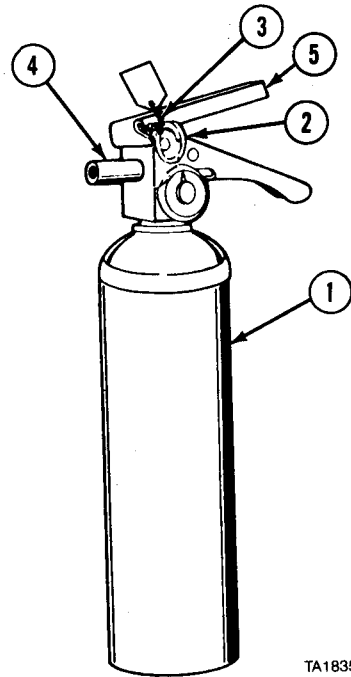


TA183530

- (1) Pull up clamp (1) and open strap (2).
- (2) Pull fire extinguisher (3) straight up and off bracket (4).
- (3) Remove fire extinguisher (3).

d. Extinguish Fire.

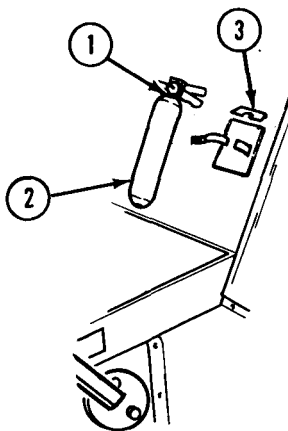
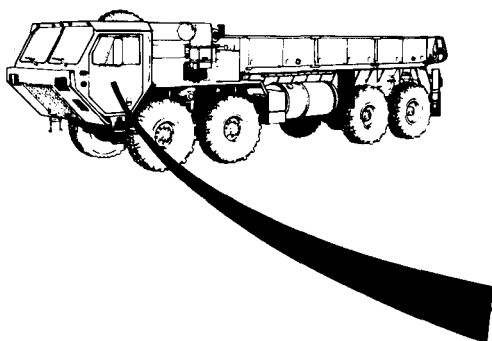
- (1) Hold fire extinguisher (1) upright and pull safety pin (2) to break plastic tie (3).
- (2) Point nozzle (4) at base of fire.
- (3) Press down on stop lever (5) and spray discharge in a side-to-side motion at base of fire.
- (4) Let go of stop lever (5) when fire is out.
- (5) Notify organizational maintenance to replace fire extinguisher.



TA183531

2-14. OPERATE FIRE EXTINGUISHER (CONT).

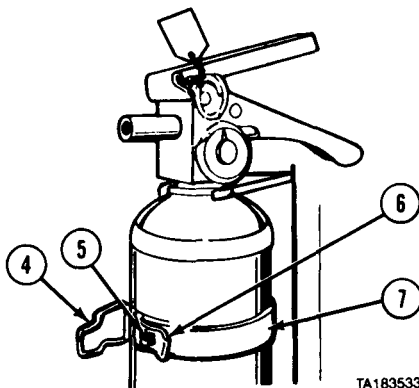
e. Install Fire Extinguisher In Cab.



TA183532

(1) Put neck (1) of fire extinguisher (2) on bracket (3).

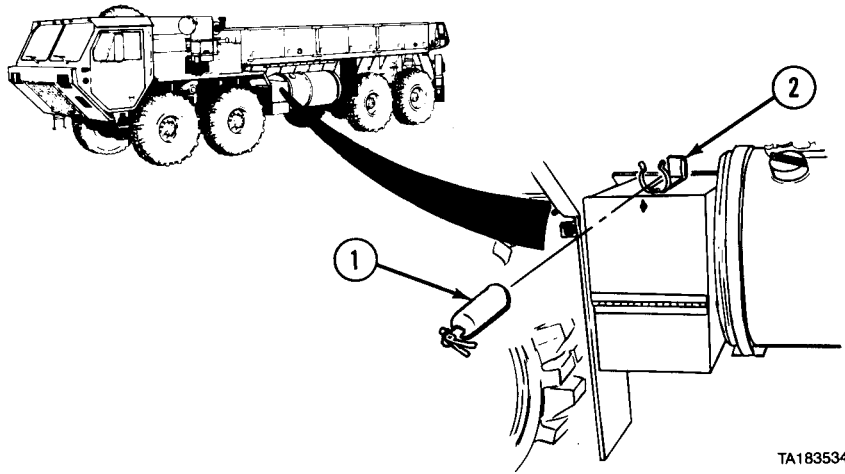
- (2) Put latch (4) on hook (5).
- (3) Push down on clamp (6) to secure strap (7).



TA183533

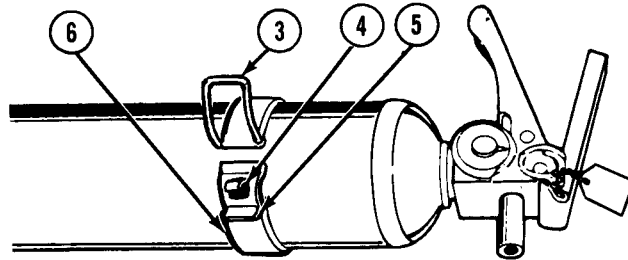
M977 Through M985 General Operating Procedures (Cont)

f. Install Fire Extinguisher On Stowage Box.



TA183534

(1) Put fire extinguisher (1) on bracket (2).



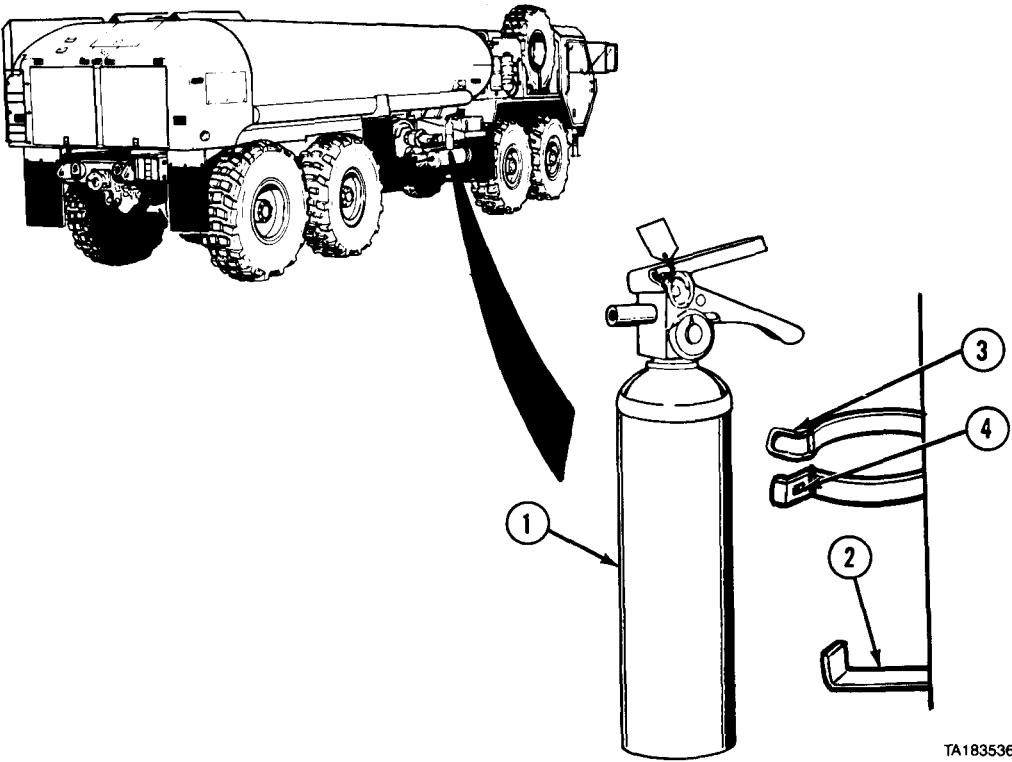
TA183535

(2) Put latch (3) on hook (4).

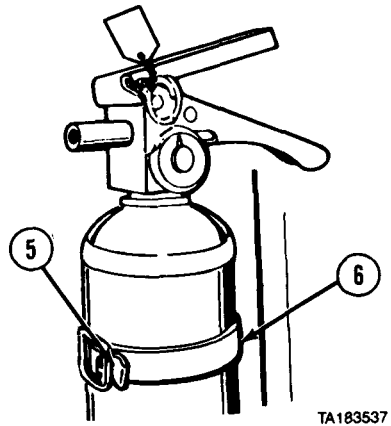
(3) Push down on clamp (5) to secure strap (6).

2-14. OPERATE FIRE EXTINGUISHER (CONT).

g. Install Fire Extinguisher On Battery Box (M978 Only).



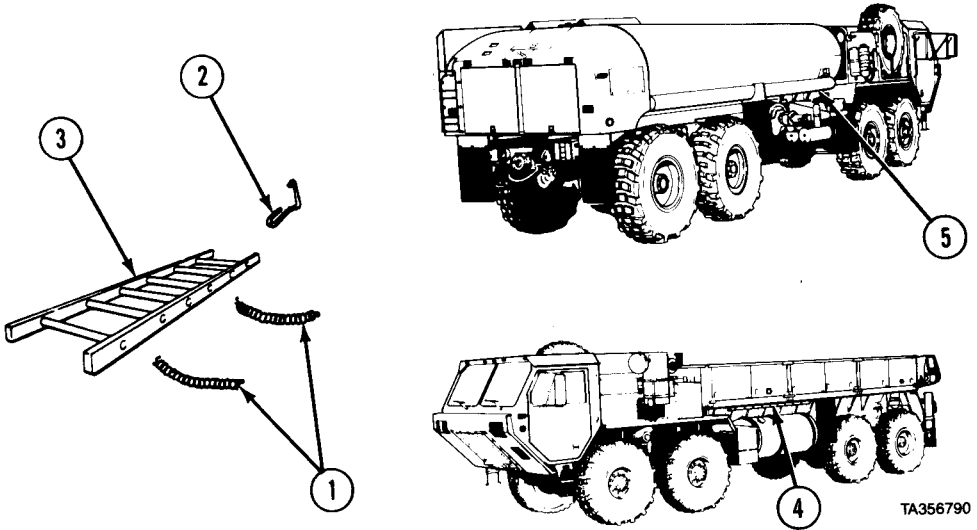
- (1) Put fire extinguisher (1) on bracket (2).
- (2) Put latch (3) on hook (4).
- (3) Push down on clamp (5) to secure strap (6).



M977 Through M985 General Operating Procedures (Cont)

2-15. USE ACCESS LADDER.

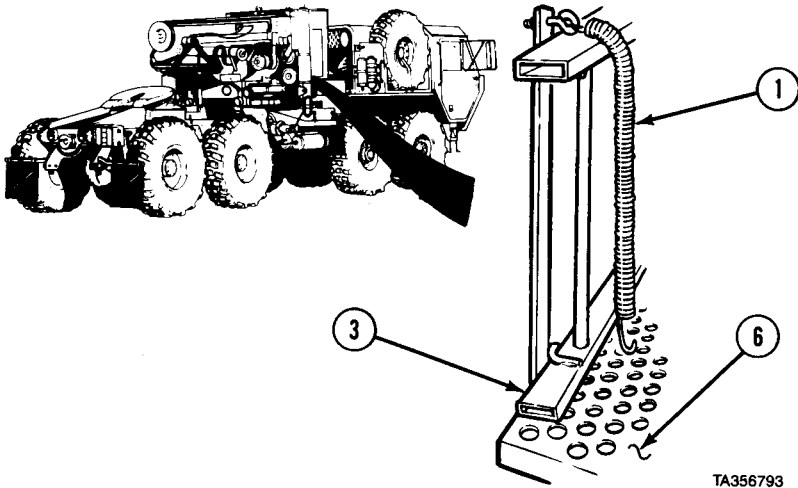
a. Install Access Ladder.



NOTE

All vehicles are equipped with access ladders. For M984E1, refer to paragraph 2-60.

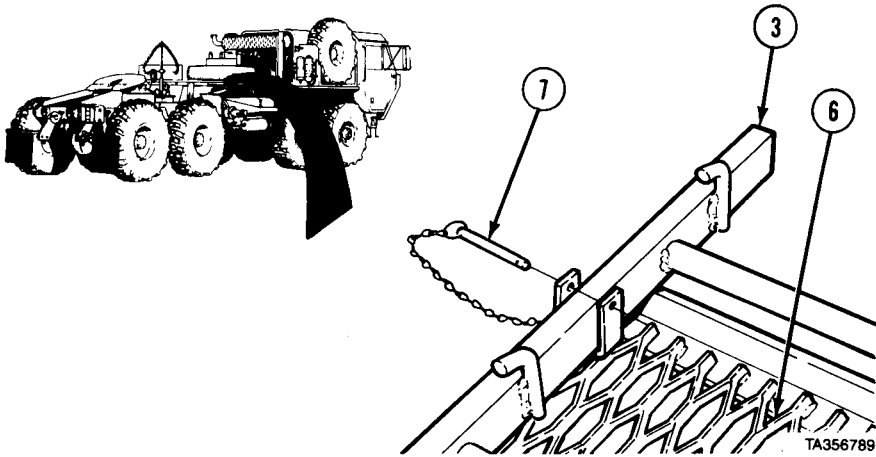
- (1) For M977 and M985 vehicles, unhook two springs (1) from stowage rods (2) and remove access ladder (3) from under cargo body (4).
- (2) For M978 vehicles, unhook spring (1) from stowage rod (2) and remove access ladder (3) from over battery box (5).



- (3) For M983 vehicles with crane, unhook two springs (1) from walkway grating (6) and remove access ladder (3).

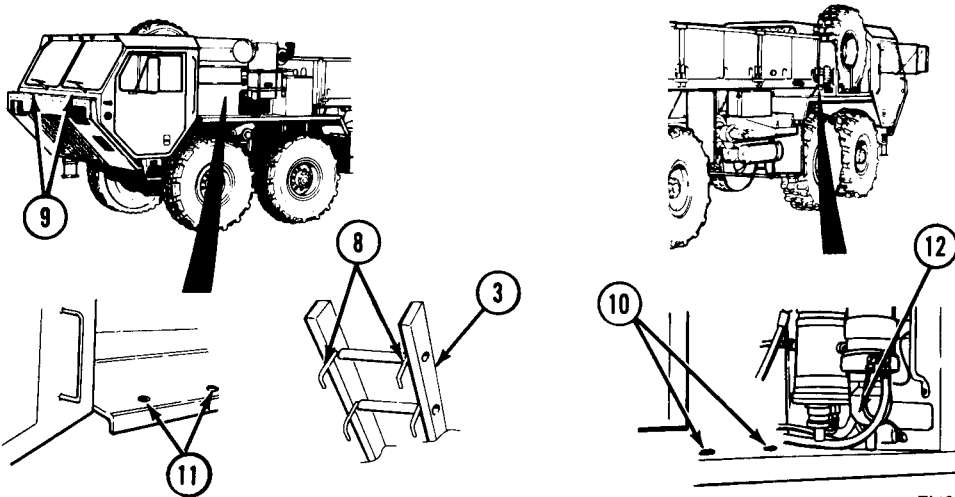
M977 Through M985 General Operating Procedures (Cont)

2-15. USE ACCESS LADDER (CONT).



TA356789

(4) For M983 vehicles without crane, pull two pins (7) and remove access ladder (3) from walkway grating (6).



TA183539

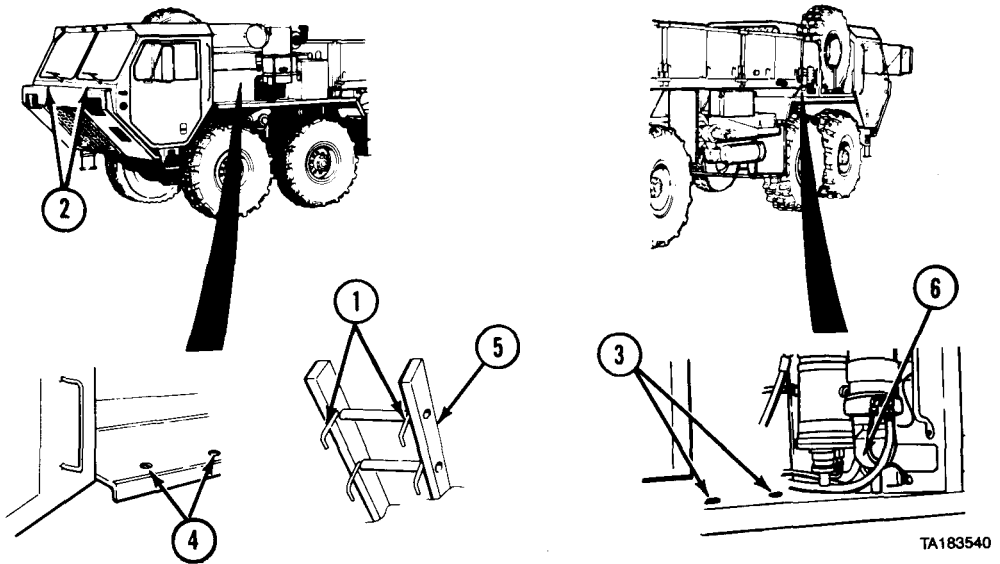
CAUTION

Do not hit fuel-water separator when installing access ladder on right front fender. If access ladder hooks hit fuel-water separator, glass will break.

(5) Install access ladder hooks (8) in front skid plate holes (9), right front fender holes (10), or left front fender holes (11), as required. Keep access ladder (3) clear of fuel-water separator (12).

M977 Through M985 General Operating Procedures (Cont)

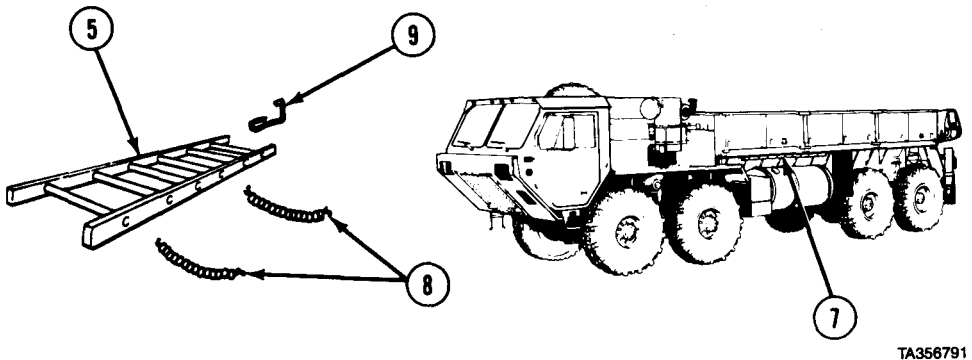
b. Stow Access Ladder.



CAUTION

Do not hit fuel-water separator when removing access ladder from right front fender holes. If access ladder hooks hit fuel-water separator, glass will break.

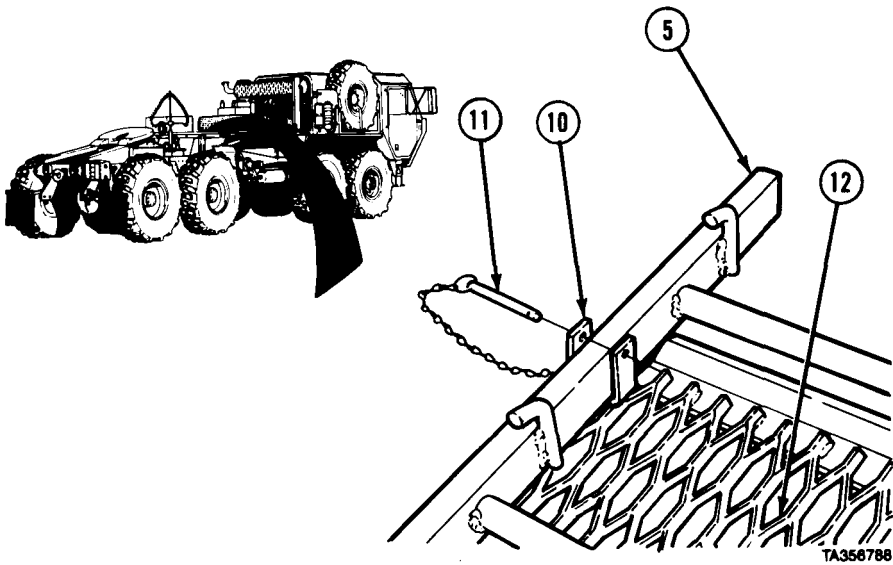
- (1) Remove access ladder hooks (1) from front skid plate holes (2), right front fender holes (3), or left front fender holes (4). Keep access ladder (5) clear of fuel-water separator (6).



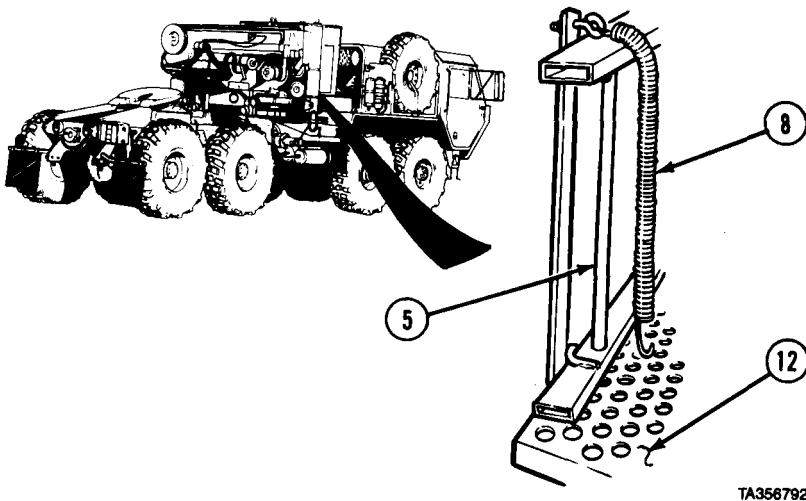
- (2) For M977 and M985 vehicles, secure access ladder (5) under cargo body (7) with two springs (8) and stowage rods (9).

M977 Through M985 General Operating Procedures (Cont)

2-15. USE ACCESS LADDER (CONT).

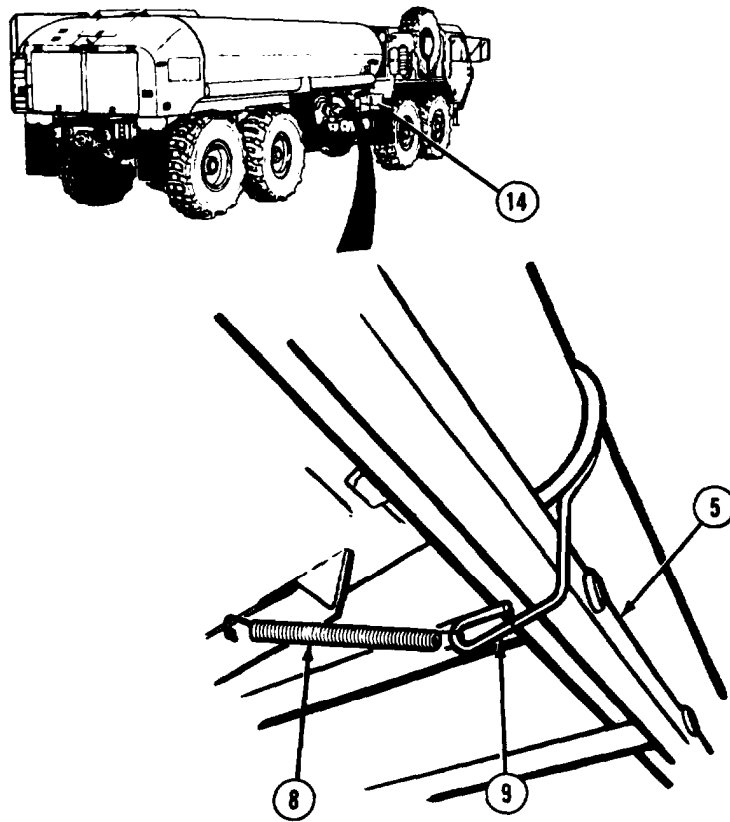


- (3) For M983 vehicles without crane, put access ladder (5) in brackets (10) and install pin (11) on walkway grating (12).



- (4) For M983 vehicles with crane, put access ladder (5) on walkway grating (12) behind generator set (13).
- (5) Pull springs (8) over access ladder (5) and hook springs (8) in walkway grating (12).

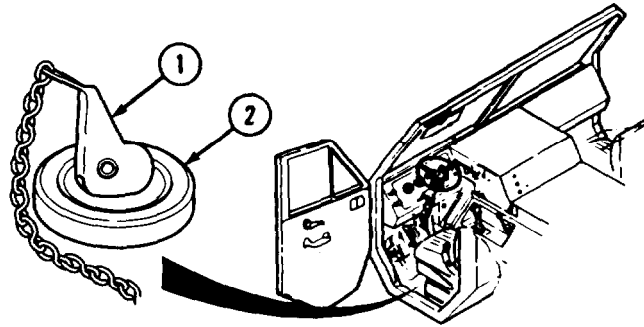
M977 Through M985 General Operating Procedures (Cont)



- (6) For M978 vehicles, secure access ladder (5) above battery box (14) and hook stowage rod (9) around access ladder. Hook spring (8) on stowage rod.

M977 Through M985 General Operating Procedures (Cont)

2-15.1. OPERATE DRAIN PLUG.



NOTE

A drain plug is located under operator seat and crew seat on newer vehicles.

a. Remove Drain Plug.

- (1) Pull up on lever (1).
- (2) Remove drain plug (2) to drain any liquid from floor of cab.

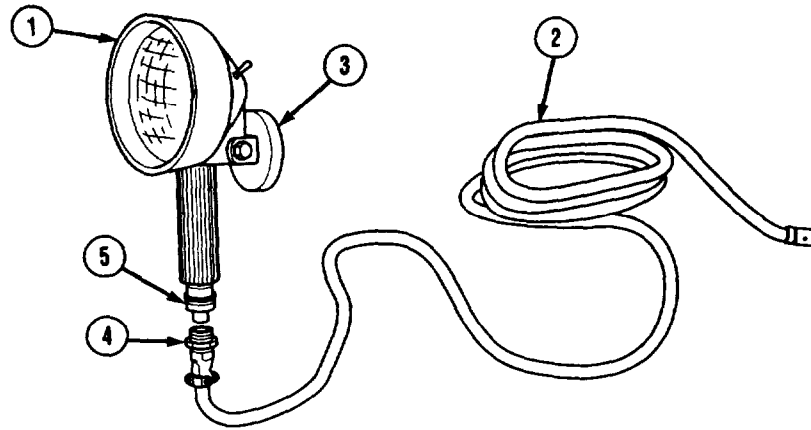
b. Install Drain Plug.

- (1) Push drain plug (2) in opening on cab floor.
- (2) Press down on lever (1) to secure drain plug (2).

M977 Through M985 General Operating Procedures (Cont)

2-15.2 OPERATE WORK LAMP (M977, M978).

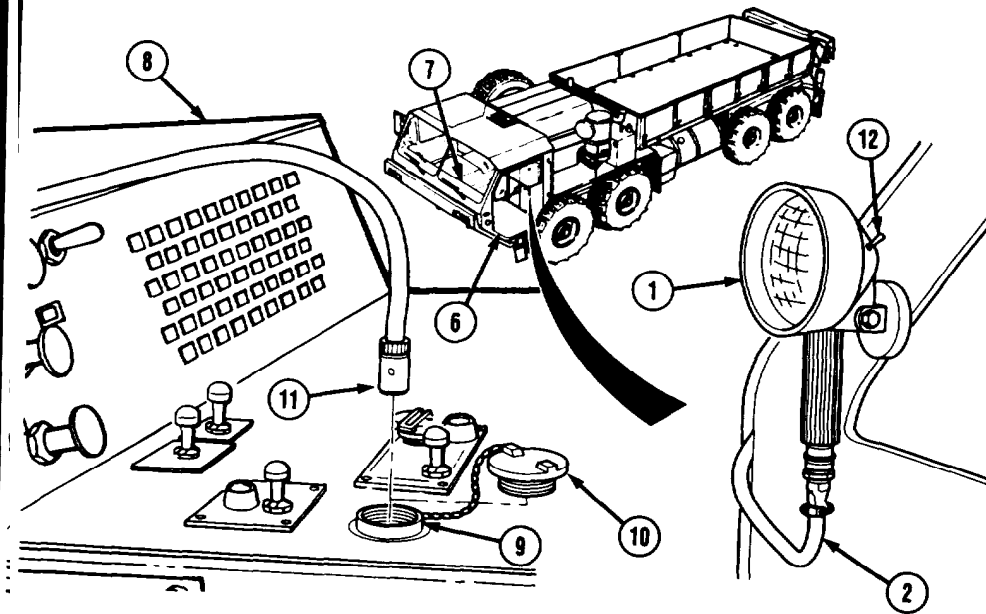
a. *Install work Lamp.*



- (1) Remove work lamp (1) and work lamp harness (2) from stowage.
- (2) Mount lamp (1) on vehicle using magnet (3).
- (3) Install plug (4) on terminal (5).

M977 Through M985 General Operating Procedures (Cont)

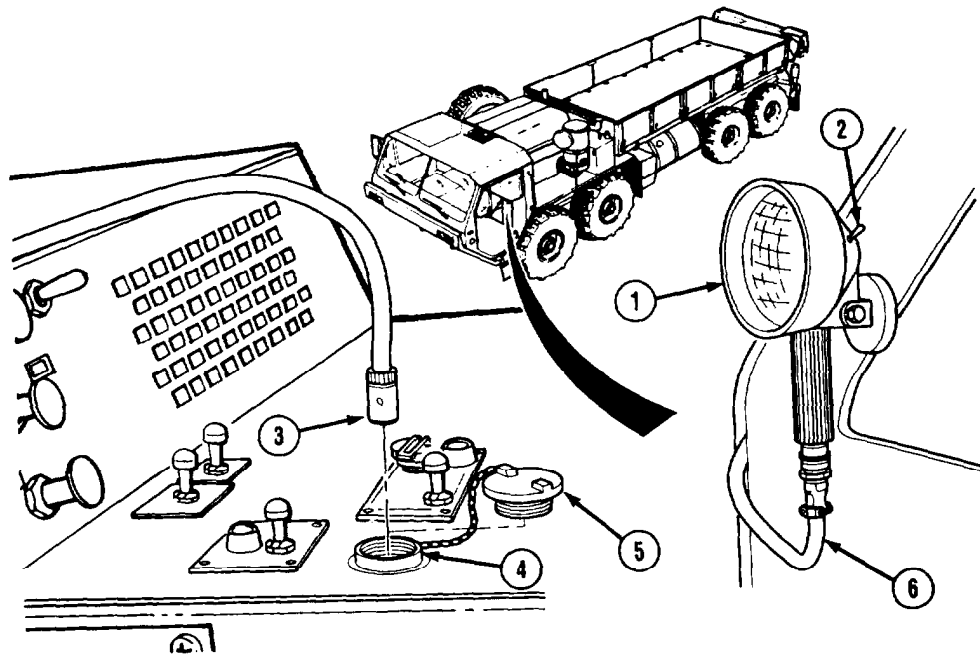
12-15.2. OPERATE WORK LAMP (M977, M978) (CONT).



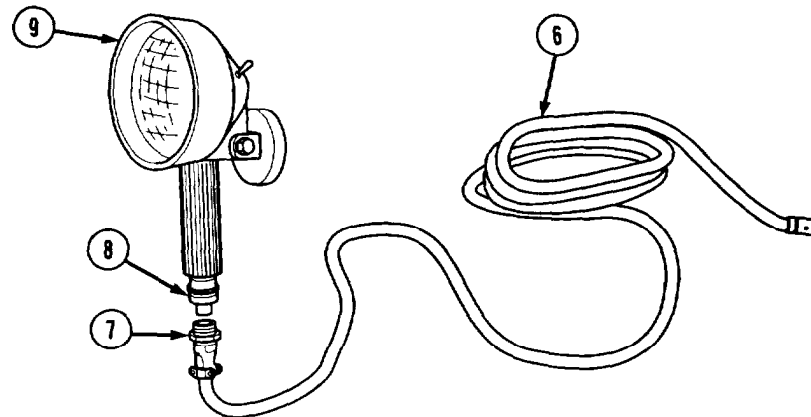
- (4) Route work lamp harness (2) through left door opening (6).
- (5) Route work lamp Harness (2) across driver side defroster (7), and across center console (8) to utility outlet (9).
- (6) Remove cover (10). Insert lamp plug (11) into utility outlet (9).
- (7) Turn on lamp (1) using toggle switch (12).

M977 Through M985 General Operating Procedures (Cont)

b. Remove Work Lamp.



- (1) Turn off lamp (1) using toggle switch (2).
- (2) Remove lamp plug (3) from utility outlet (4). Install cover (5) on utility outlet.
- (3) Remove work lamp harness (6) from interior of cab.

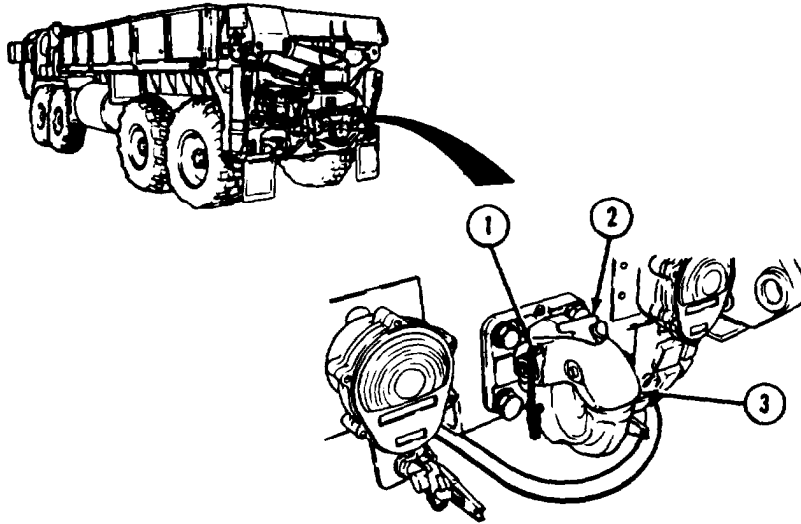


- (4) Remove plug (7) from terminal (8).
- (5) Remove and stow work lamp (9) and work lamp harness (6).

M977 and M985 Operating Procedures

2-18. CONNECT/DISCONNECT TRAILER (M977, M985).

a. *Connect Trailer.*



NOTE

M977 and M985 cargo vehicles pull M105, M332, and M989 trailers using pintle hook. For more information on trailer hook-up and towing procedures, refer to the following manuals:

- M105 Trailer -TM 9-2330-213-14
- M332 Trailer - TM 9-2330-231-14
- M989 Trailer - TM 9-2330-368-14&P

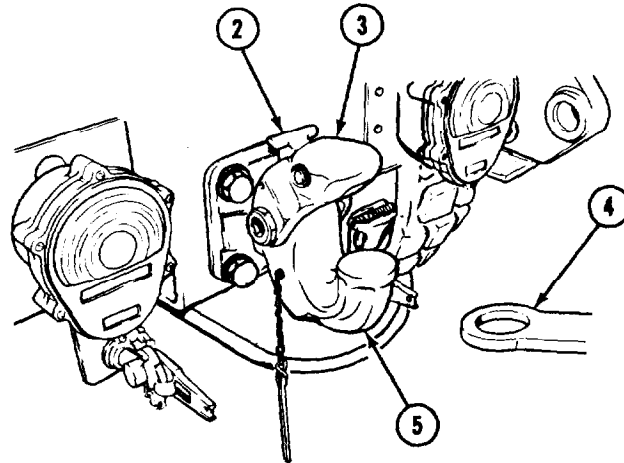
- (1) Park vehicle (para 2-11o).
- (2) Shut off engine (para 2-11p).

NOTE

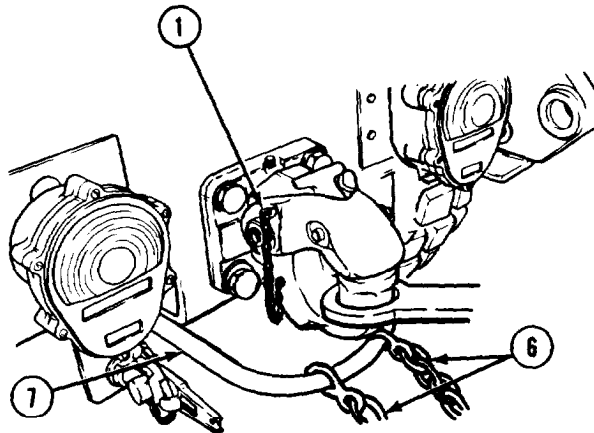
- The M1977-CBT uses a self-guided coupler. M1977-CBT pulls the M1076 trailer.
- Do steps (3) through (9) for all models except M1977-CBT.
- Do steps (9.1) through (9.7) for M1977-CBT only.

- (3) Remove cotter pin (1).
- (4) Pull latch (2) away from vehicle and hold.
- (5) Lift top part of pintle hook (3) and let go of latch (2); hook will be locked open.

M977 and M985 Operating Procedures (Cont)

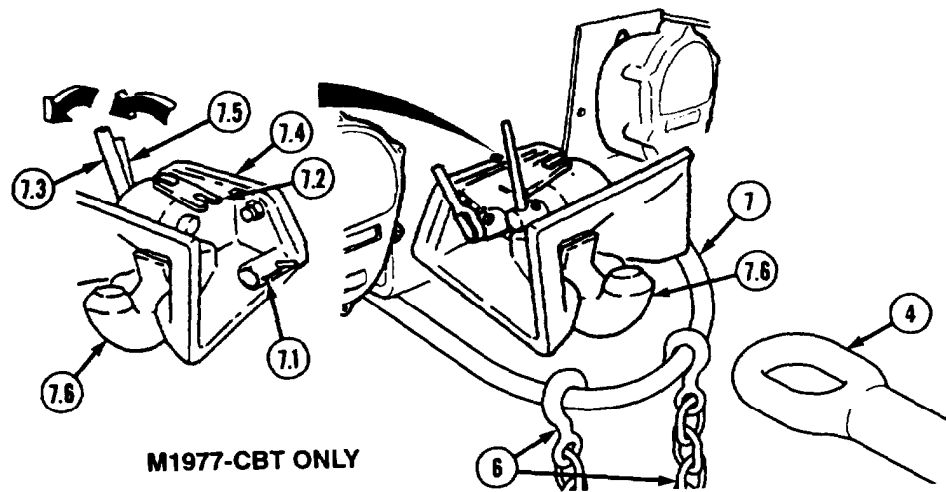


- (6) put trailer connecting eye (4) on bottom part of pintle hook (5).
- (7) Pull latch (2) away from vehicle to free top part of pintle hook (3).



- (8) Install cotter pin (1).
- (9) Install safety chains (6) on safety chain hoop (7).

M977 and M985 Operating Procedures (Cont)

**NOTE**

Position towing vehicle so coupler hook is aligned with trailer connecting eye.

- (9.1) Disengage swivel lock (7.1).
- (9.2) Lift indicator lock (7.2) away from hook lock (7.3) on coupler (7.4).
- (9.3) Push outward on hook lock catch (7.5) and pull on hook lock (7.3) at same time to release coupler hook (7.6).

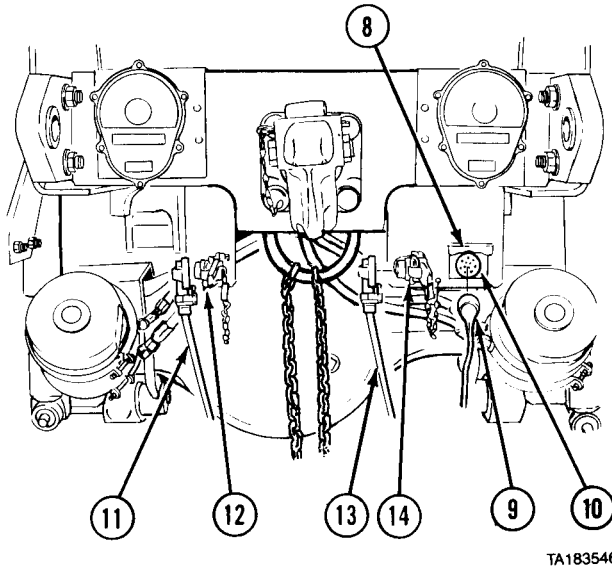
WARNING

Do not put hands near coupler hook while aligning trailer connecting eye with coupler hook. If toting vehicle moves suddenly it may cause serious injury to personnel.

- (9.4) Soldier A and Soldier B adjust position of connecting eye (4) while Soldier C slowly backs up towing vehicle.
- (9.5) Connect trailer connecting eye (4) to coupler hook (7.6). Coupler closes and locks.
- (9.6) Secure hook lock (7.3) with indicator lock (7.2).
- (9.7) Pull towing vehicle forward slightly to verify that coupler hook (7.6) has locked in position.

M977 and M985 Operating Procedures (Cont)

2-16. CONNECT/DISCONNECT TRAILER (M977, M985) (CONT).



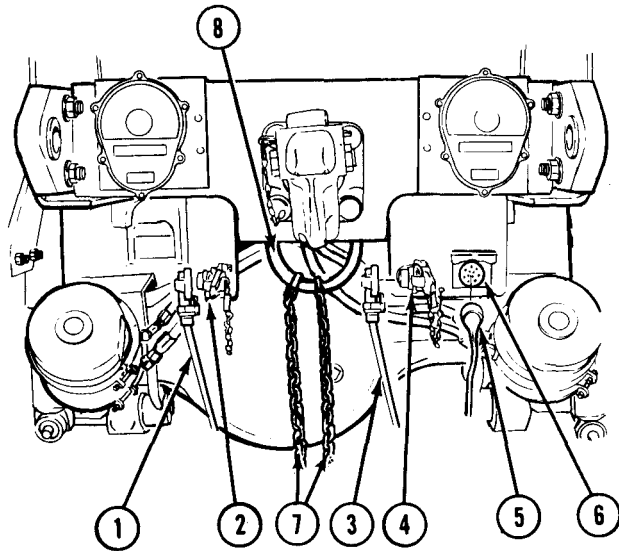
TA183546

NOTE

Trailer tow bar deleted for clarity.

- (10) Lift cover (8) and connect intervehicular wiring harness (9) to connector (10).
- (11) Connect other end of intervehicular wiring harness (9) to trailer.
- (12) Connect red airhose (11) to glad hand (12).
- (13) Connect other end of red airhose (11) to red glad hand on trailer.
- (14) Connect blue airhose (13) to glad hand (14).
- (15) Connect other end of blue airhose (13) to blue glad hand on trailer.

M977 and M985 Operating Procedures (Cont)

b. Disconnect Trailer.

TA356854

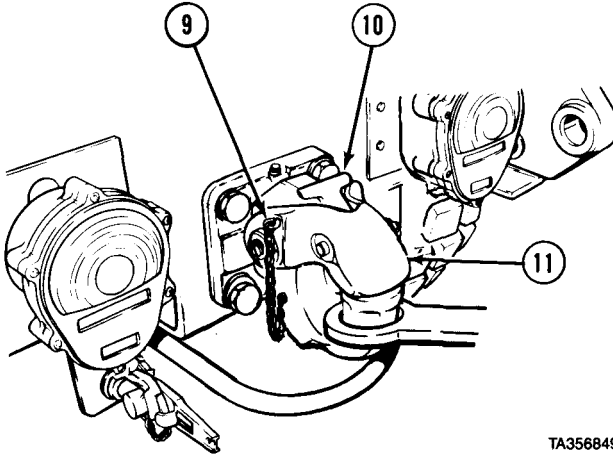
NOTE

Trailer tow bar deleted for clarity.

- (1) Park vehicle (para 2-11o).
- (2) Shut off engine (para 2-11p).
- (3) Remove red airhose (1) from glad hand (2) on vehicle and from glad hand on trailer.
- (4) Remove blue airhose (3) from glad hand (4) on vehicle and from glad hand on trailer.
- (5) Remove intervehicular wiring harness (5) from connector (6) on vehicle and connector on trailer.
- (6) Remove safety chains (7) from safety chain hoop (8).

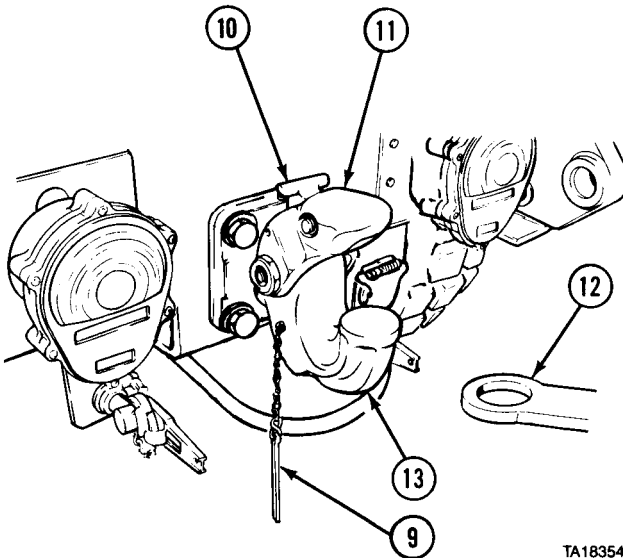
M977 and M985 Operating Procedures (Cont)

2-16. CONNECT/DISCONNECT TRAILER (M977, M985) (CONT).



TA356849

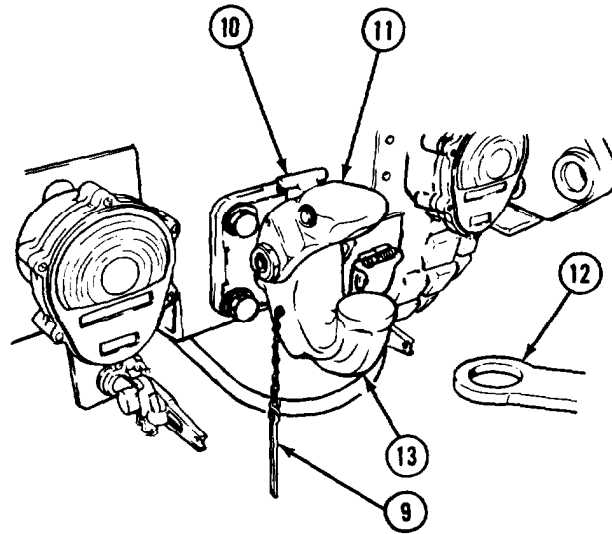
- (7) Remove cotter pin (9).
- (8) Pull latch (10) away from vehicle and hold.
- (9) Lift top part of pintle hook (11) and let go of latch (10), hook will be locked open.



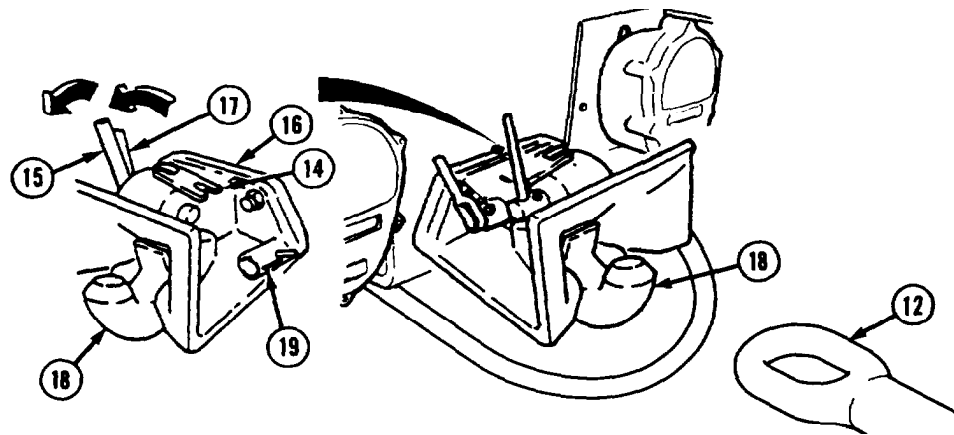
TA183548

- (10) Lift trailer connecting eye (12) off bottom part of pintle hook (13).
- (11) Pull latch (10) away from vehicle to free top part of pintle hook (11).
- (12) Install cotter pin (9).

M977 and M985 Operating Procedures (Cont)



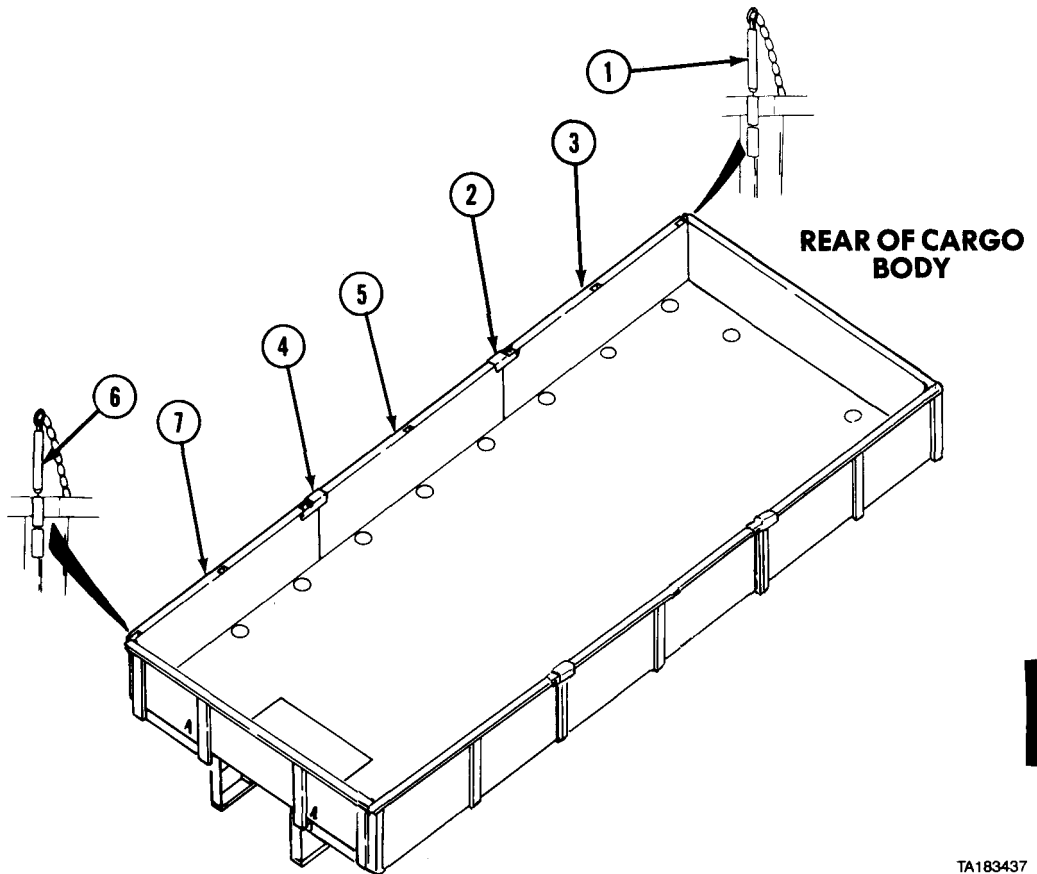
- (10) Lift trailer connecting eye (12) off bottom part of pintle hook (13).
- (11) pull latch (10) away from vehicle to free top part of pintle hook (11).
- (12) Install cotter pin (9).



M1977-CBT ONLY

- (13) Lift indicator lock (14) away from hook lock (15) on coupler (16).
- (14) Bush outward on hook lock catch (17) and pull on hook lock (15) at same time to release coupler hook (18).
- (15) Coupler hook (18) opens.
- (16) Soldier A and Soldier B lift trailer connecting eye (12) clear of coupler hook (18).
- (17) As Soldier C drives towing vehicle forward, Soldier A and Soldier B lower trailer connecting eye (12) to the ground.
- (18) push up on hook (18). Secure hook lock (15) with indicator lock (14). Engage swivel lock (19).

M977 and M985 Operating Procedures (Cont)

2-17. M977, M985 CARGO BODY OPERATION.**a. Lower Cargo Body Side Panels One At A Time.**

TA183437

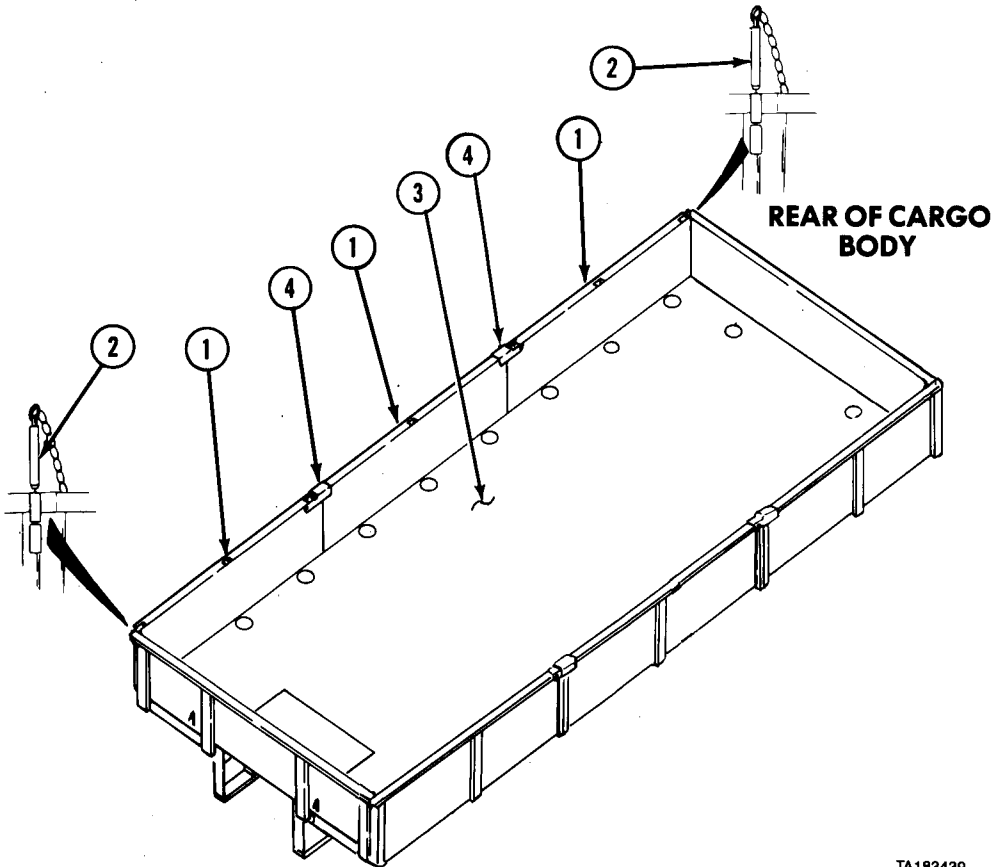
WARNING

Be sure side panels are completely lowered. Side panels can slide off hinge pins when vehicle is parked on grade. Falling side panels can cause serious personal injury.

- (1) Soldier A removes lockpin (1) and pulls latch (2) up while Soldier B holds side panel (3).
- (2) Lower side panel (3).
- (3) Soldier A pulls latch (4) up while Soldier B holds side panel (5).
- (4) Lower side panel (5).
- (5) Soldier A removes lockpin (6) while Soldier B holds side panel (7).
- (6) Lower side panel (7).

2-17. M977, M985 CARGO BODY OPERATION (CONT).

b. Lower Cargo Body Side Panels All At One Time.



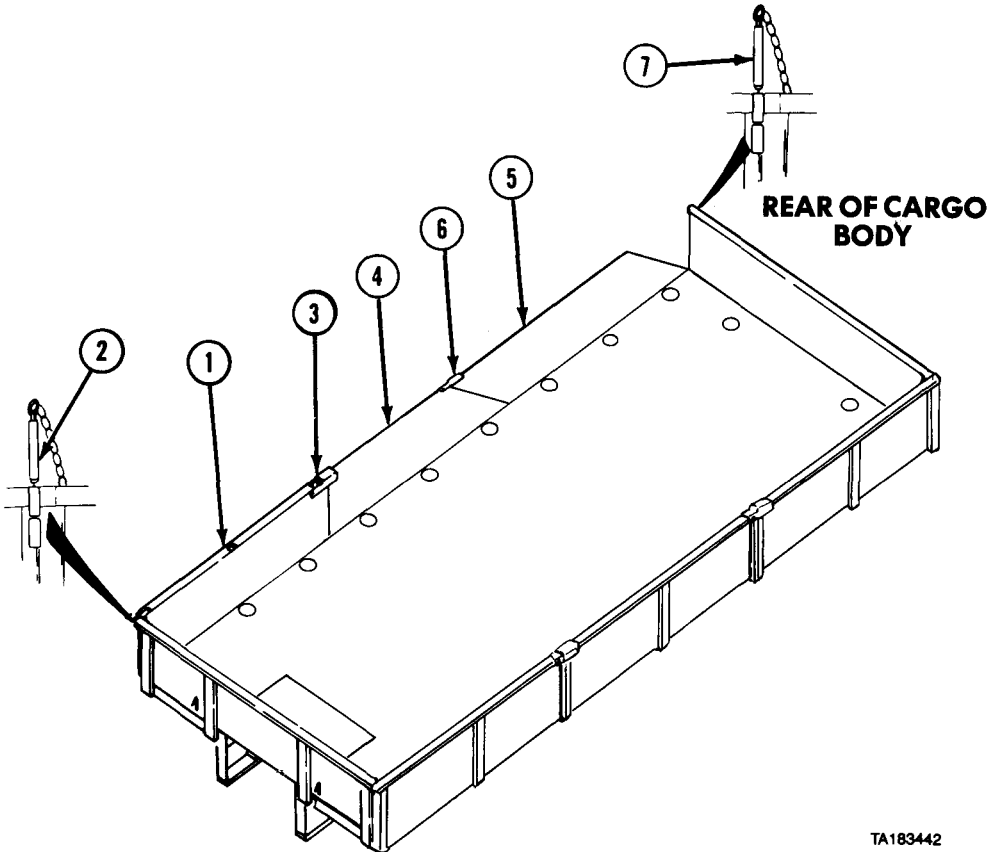
TA183439

WARNING

Side panels can slide off hinge pins when vehicle is parked on grade. Falling side panels can cause serious personal injury.

- (1) Soldier A holds side panels (1) up while Soldier B removes lockpins (2) and climbs out of cargo body to help Soldier A.
- (2) Soldier A and Soldier B lower side panels (1) until side panels are even with cargo body floor (3).
- (3) Soldier A and Soldier B change hand positions so each soldier holds a latch (4).
- (4) Soldier A and Soldier B lower side panels (1).

M977 and M985 Operating Procedures (Cont)

c. Raise and Secure Cargo Body Side Panels One At A Time.

TA183442

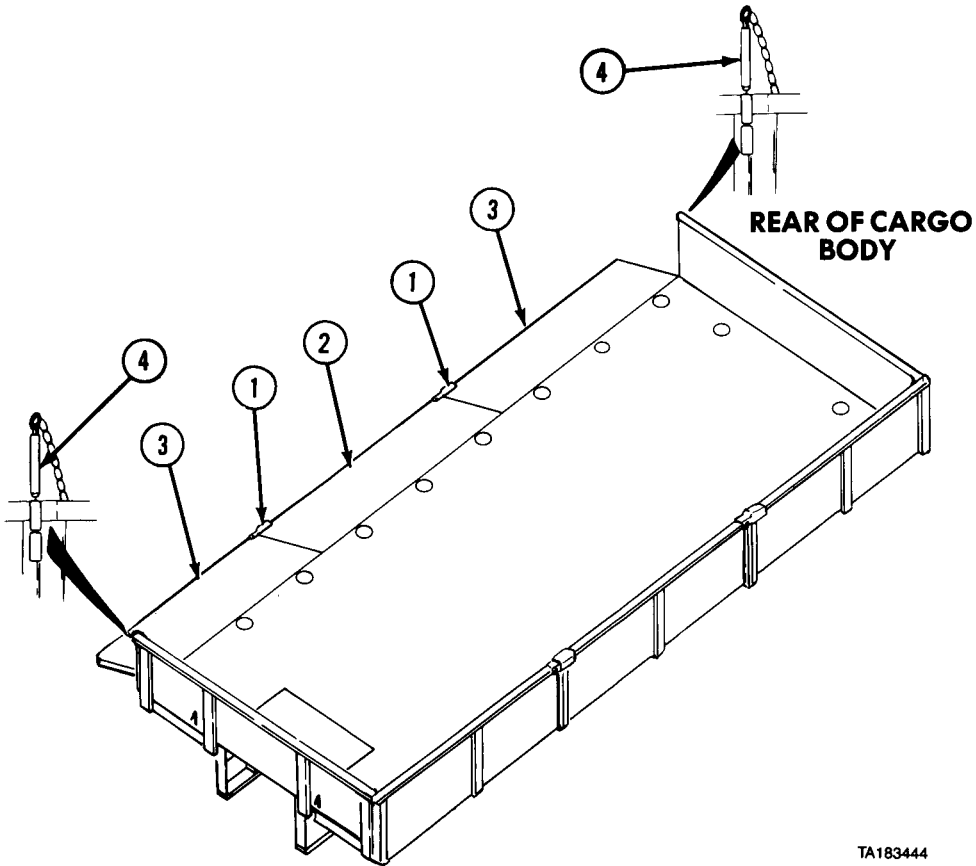
WARNING

Side panels can slide off hinge pins when vehicle is parked on grade. Falling side panels can cause serious personal injury.

- (1) Soldier A raises and holds side panel (1) while Soldier B installs lockpin (2) and pulls latch (3) up.
- (2) Soldier A raises and holds side panel (4) while Soldier B pushes latch (3) down.
- (3) Soldier A raises and holds side panel (5) while Soldier B pulls latch (6) up and installs lockpin (7).
- (4) Push latch (6) down.

2-17. M977, M985 CARGO BODY OPERATION (CONT.)

d. Raise and Secure Cargo Body Side Panels All At One Time.



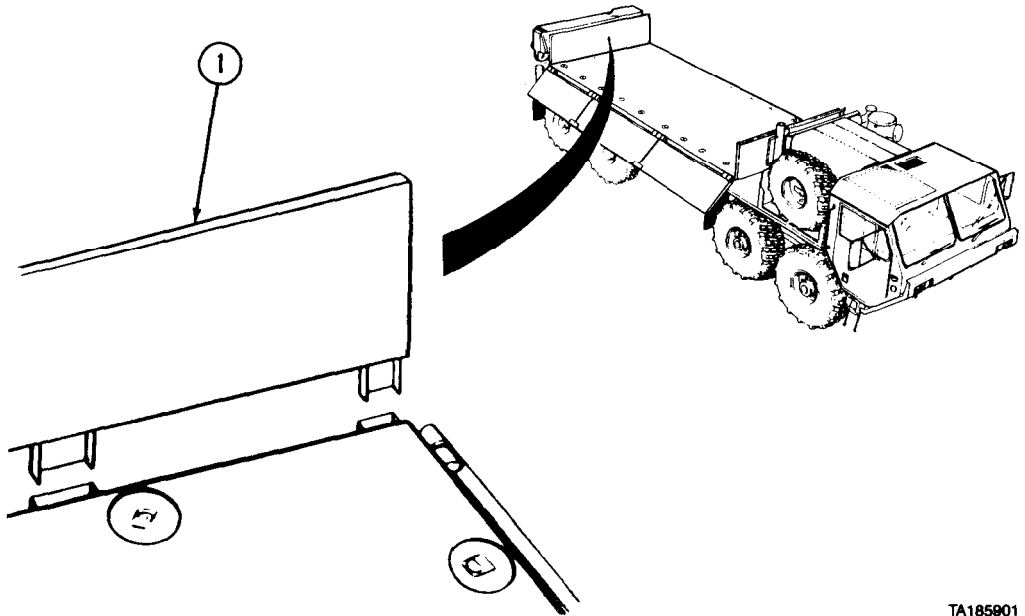
TA183444

WARNING

Side panels can slide off hinge pins when vehicle is parked on grade. Falling side panels can cause serious personal injury.

- (1) Soldier A and Soldier B place latches (1) over edge of adjoining panel (2).
- (2) While holding latches (1) in place, Soldier A and Soldier B raise three side panels (2 and 3).
- (3) Soldier A holds side panels (2 and 3) up, while Soldier B climbs into cargo body and installs lockpins (4).

M977 and M985 Operating Procedures (Cont)

e. Remove Front and Rear Panels.

TA185901

NOTE

- This procedure is a two-soldier task.
- All front and rear panels are removed the same way.

- (1) Lower cargo body side panels all at one time (para 2-17b).
- (2) Remove rear panel (1) from cargo body.

f. Install Front and Rear Panels.**NOTE**

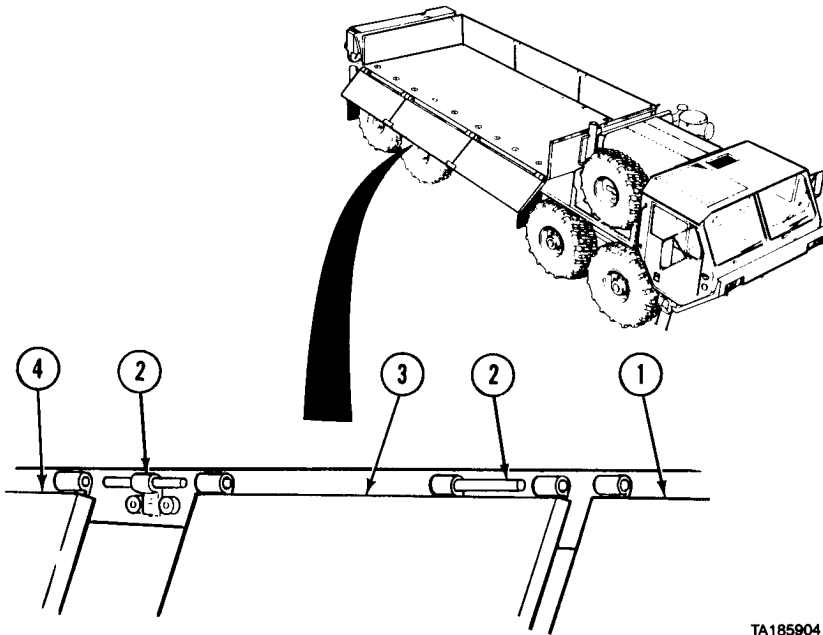
- This procedure is a two-soldier task.
- All front and rear panels are installed the same way.

- (1) Install rear panel (1) on cargo body.
- (2) Raise and secure cargo body side panels all at one time (para 2-17d).

M977 and M985 Operating Procedures (Cont)

2-17. M977, M985 CARGO BODY OPERATION (CONT).

g. Remove Side Panels.



TA185904

NOTE

Cargo body right side panels are shown. Left side panels are removed the same way.

- (1) Lower cargo body side panels one at a time (para 2-17a).
- (2) Raise front side panel (1) and slide panel forward off two pins (2).
- (3) Raise center side panel (3) and slide panel forward off two pins (2).
- (4) Raise rear side panel (4) and slide panel rearward off two pins (2).

h. Install Side Panels.

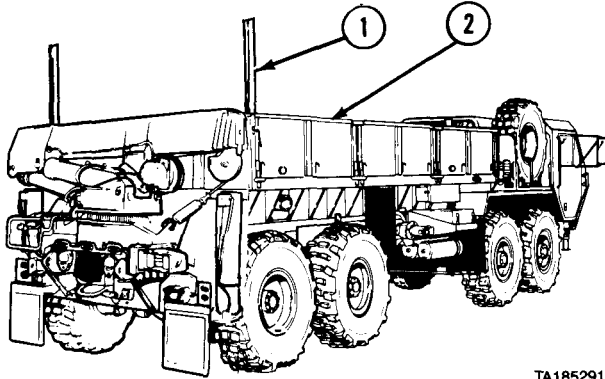
- (1) Install rear side panel (4) on two pins (2) and slide forward.
- (2) Install center side panel (3) on two pins (2) and slide rearward.
- (3) Soldier A and Soldier B install front side panel (1) on two pins (2) and slide rearward.
- (4) Raise and secure cargo body side panels one at a time (para 2-17c).

M977 and M985 Operating Procedures (Cont)

i. Install Cargo Cover Kit.**NOTE**

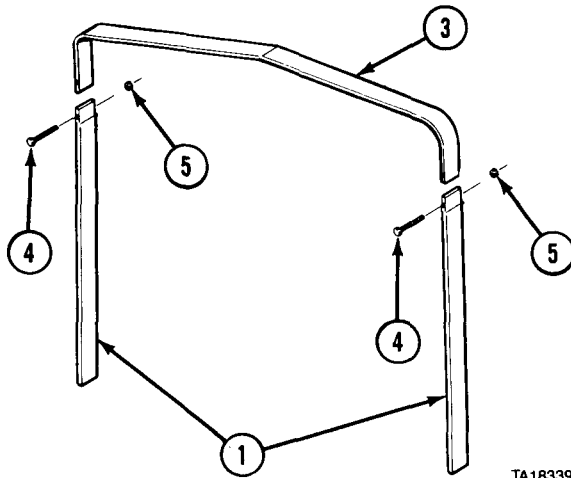
This procedure is a two-soldier task.

- (1) Park vehicle (para 2-11o).
- (2) Shut off engine (para 2-11p).



TA185291

- (3) Install stakes (1) in top edge of side panels (2).

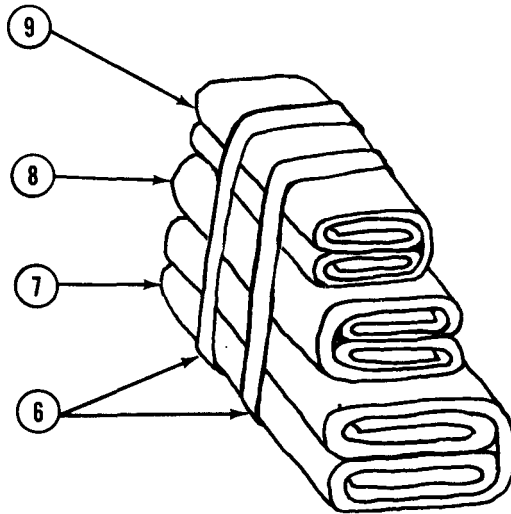


TA183396

- (4) Install bow (3) on stakes (1).
- (5) Install screws (4) and nuts (5).
- (6) Repeat steps (3), (4), and (5) for remaining bows and stakes.

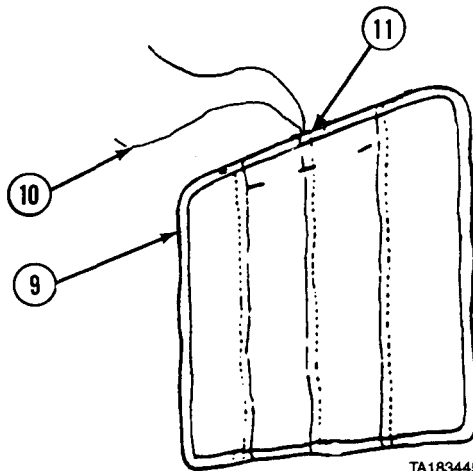
M977 and M985 Operating Procedures (Cont)

2-17. M977, M985 CARGO BODY OPERATION (CONT).



TA183452

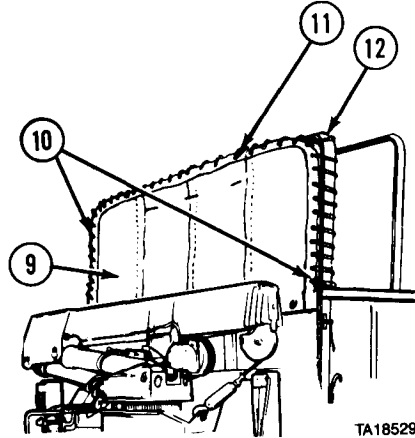
(7) Remove straps (6) from cargo cover (7), frontgate curtain (8), and tailgate curtain (9).



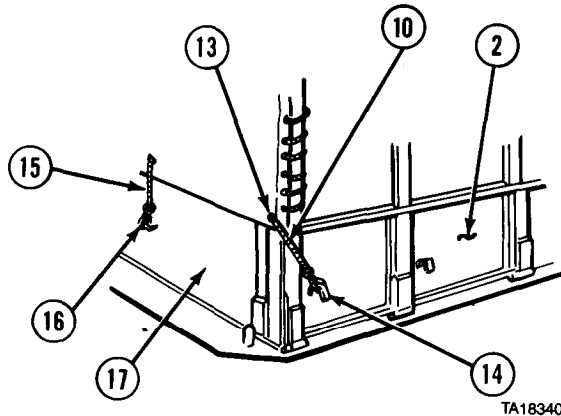
TA183445

(8) Pull one lashing rope (10) through center eyelet (11) on tailgate curtain (9) until both ends of rope are even.

M977 and M985 Operating Procedures (Cont)



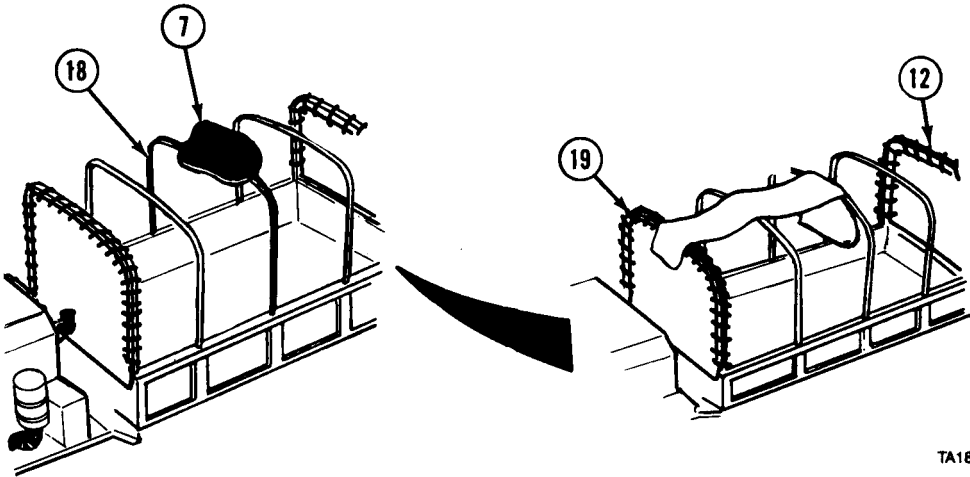
- (9) Soldier A and Soldier B place tailgate curtain (9) on rear rib (12) so stitching is on inside.
- (10) Soldier A holds tailgate curtain (9) in place while Soldier B laces lashing rope (10) around rear rib (12) and through all eyelets (11).



- (11) Run end of lashing rope (10) through bottom-corner eyelet (13).
- (12) Tie end of lashing rope (10) to tiedown hook (14) on side panel (2).
- (13) Tie bottom tiedown ropes (15) to tiedown hooks (16) on end panel (17).
- (14) Repeat steps (11) through (13) for other side.
- (15) Repeat steps (8) through (14) to install frontgate curtain.

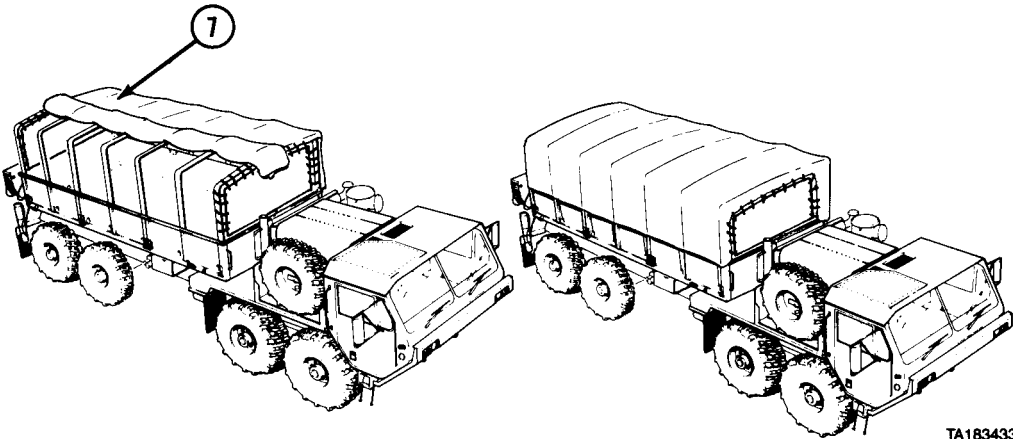
M977 and M985 Operating Procedures (Cont)

2-17. M977, M985 CARGO BODY OPERATION (CONT).



TA183432

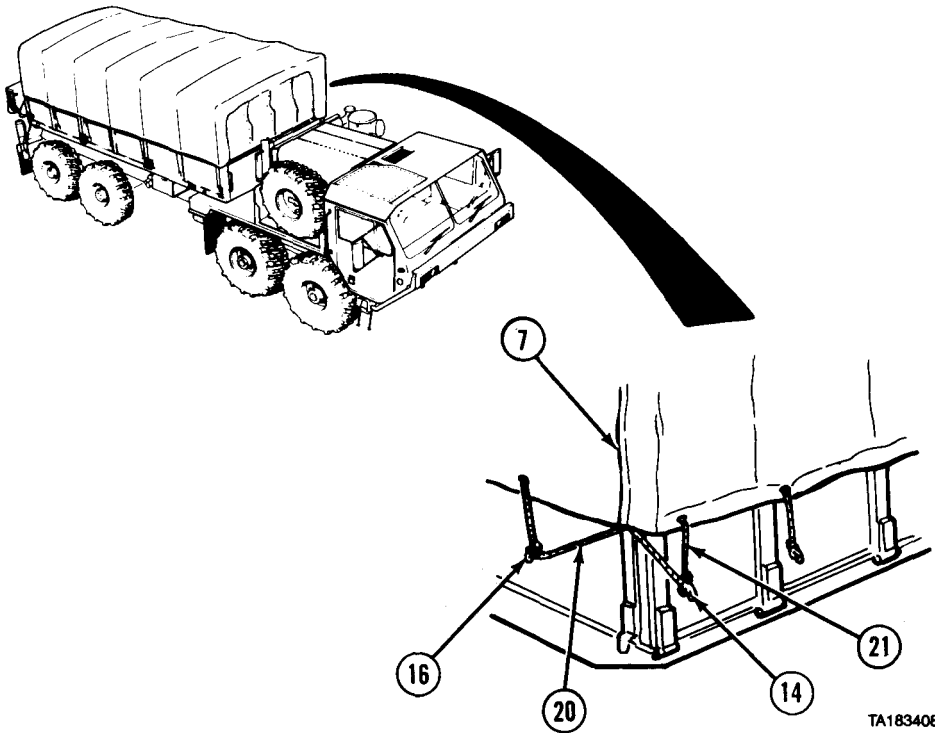
- (16) Soldier A and Soldier B place cargo cover (7) on rib (18).
- (17) Soldier A holds cargo cover (7) steady while Soldier B unfolds cargo cover to front rib (19) and rear rib (12).



TA183433

- (18) Soldier A holds cargo cover (7) in place while Soldier B unfolds cargo cover over sides.

M977 and M985 Operating Procedures (Cont)



TA183408

CAUTION

Do not tie lashing ropes too tight or cargo cover may tear.

- (19) Tie front corner tiedown rope (20) to tiedown hook (16).
- (20) Pull all slack out of cargo cover (7).
- (21) Repeat steps (19) and (20) on remaining three corners.
- (22) Tie remaining lashing ropes (21) to remaining tiedown hooks (14).

M977 and M985 Operating Procedures (Cont)

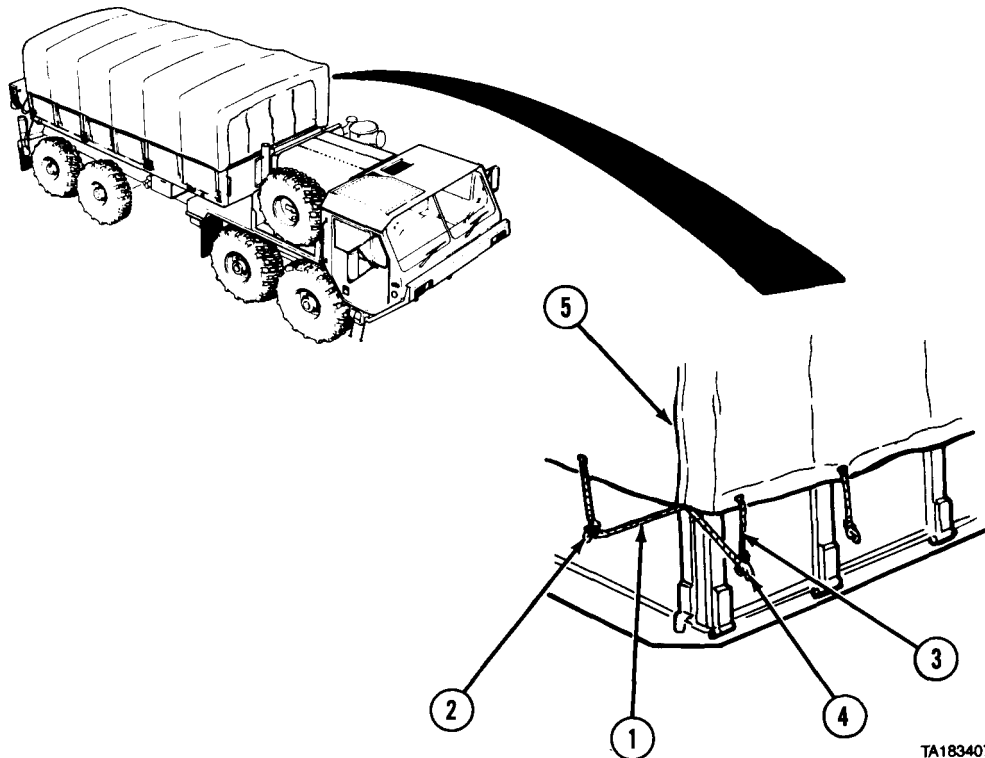
2-17. M977, M985 CARGO BODY OPERATION (CONT).

j. Remove Cargo Cover Kit.

NOTE

This procedure is a two-soldier task.

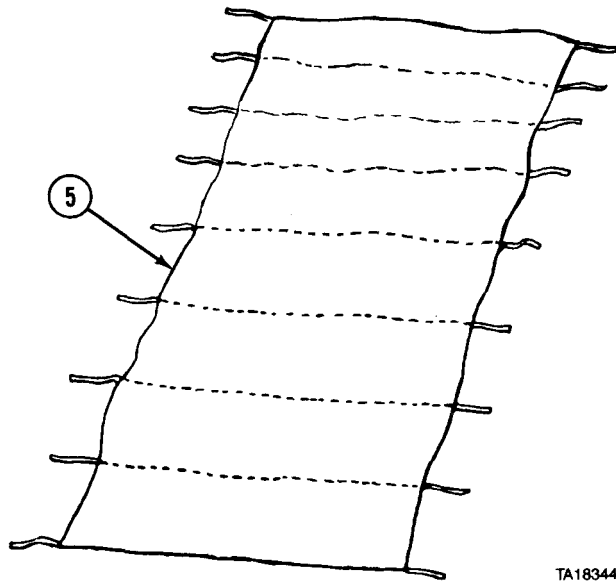
- (1) Park vehicle (para 2-11o).
- (2) Shut off engine (para 2-11p).



TA183407

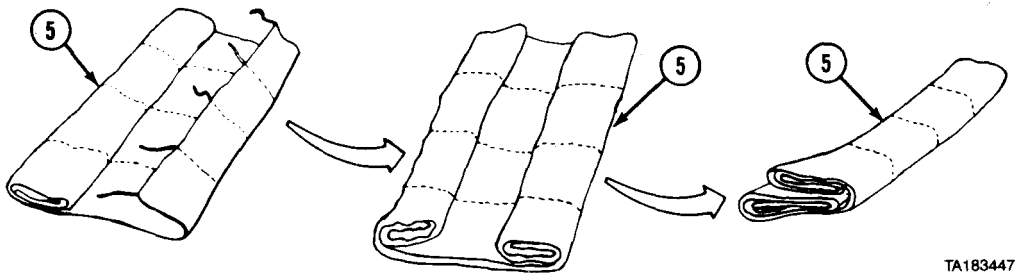
- (3) Untie both front corner tiedown ropes (1) from tiedown hooks (2).
- (4) Repeat step (3) for remaining two corners.
- (5) Untie lashing ropes (3) from all tiedown hooks (4) on each side of vehicle.
- (6) Soldier A and Soldier B remove cargo cover (5) from vehicle.

M977 and M985 Operating Procedures (Cont)



TA183446

- (7) Soldier A and Soldier B spread cargo cover (5) on smooth, dry surface so stitching is facing down.



TA183447

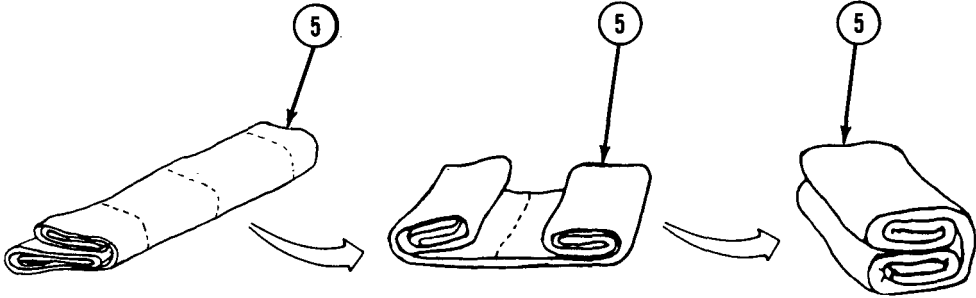
CAUTION

Do not fold cargo cover if it is wet. Cargo cover will mildew if stowed when wet.

- (8) Soldier A and Soldier B fold one side of cargo cover (5) toward center in two folds. Make each fold about 2-feet (0.6 m) wide.
 (9) Soldier A and Soldier B fold other side of cargo cover (5) toward center in two folds.
 (10) Fold both sides of cargo cover (5) together.

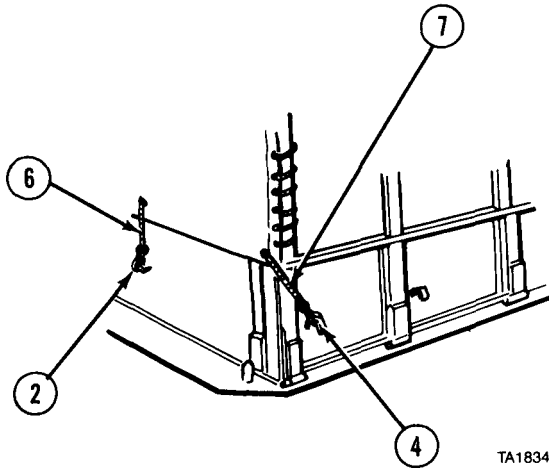
M977 and M985 Operating Procedures (Cont)

2-17. M977, M985 CARGO BODY OPERATION (CONT).



TA183448

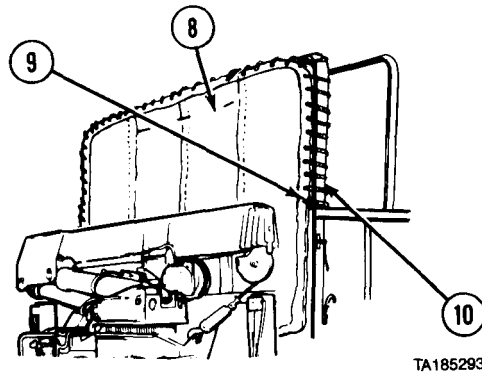
- (11) Fold one end of cargo cover (5) toward center in two folds. Make each fold about 3-feet (1 m) wide.
- (12) Fold other end of cargo cover (5) toward center in two folds.
- (13) Fold both sides of cargo cover (5) together.



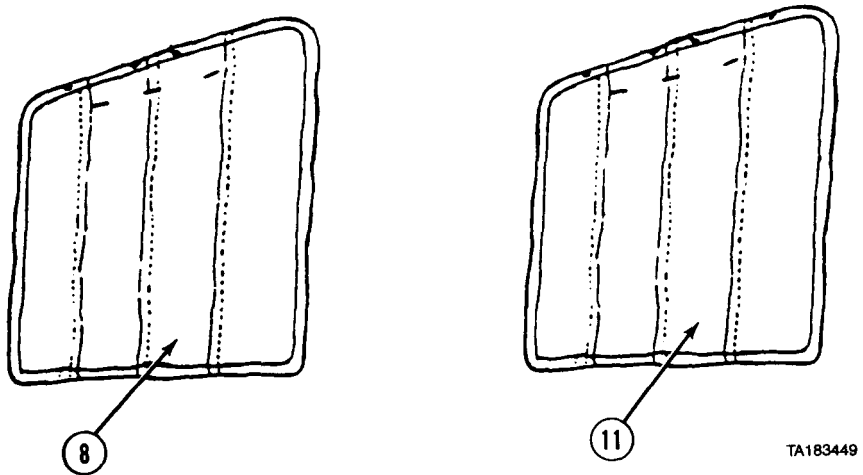
TA183406

- (14) Untie bottom tiedown ropes (6) from tiedown hooks (2) on both sides of vehicle.
- (15) Untie lashing ropes (7) from tiedown hooks (4) on both sides of vehicle.

M977 and M985 Operating Procedures (Cont)



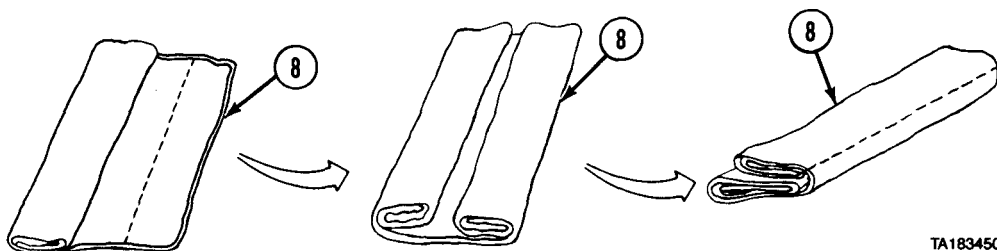
- (16) Soldier A holds tailgate curtain (8) while Soldier B unties lashing rope (9) from rear rib (10).
- (17) Soldier A and Soldier B remove tailgate curtain (8).
- (18) Repeat steps (14) through (17) to remove frontgate curtain.



- (19) Soldier A and Soldier B lay tailgate curtain (8) and frontgate curtain (11) on smooth, dry surface so stitching is facing down.

M977 and M985 Operating Procedures (Cont)

2-17. M977, M985 CARGO BODY OPERATION (CONT).

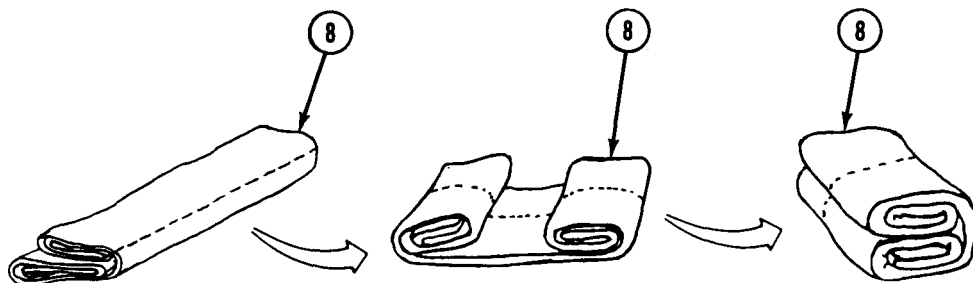


TA183450

CAUTION

Do not fold tailgate or frontgate curtains when wet.
Curtains will mildew if stowed when wet.

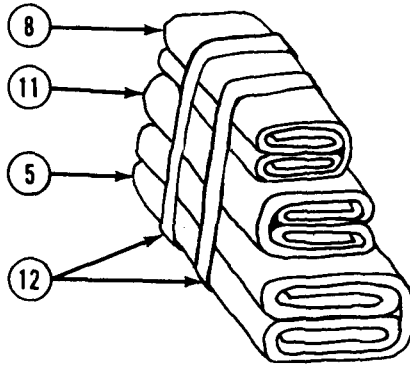
- (20) Soldier A and Soldier B fold one side of tailgate curtain (8) toward center in two folds.
- (21) Soldier A and Soldier B fold other side of tailgate curtain (8) toward center in two folds.
- (22) Fold both sides of tailgate curtain (8) together.



TA183451

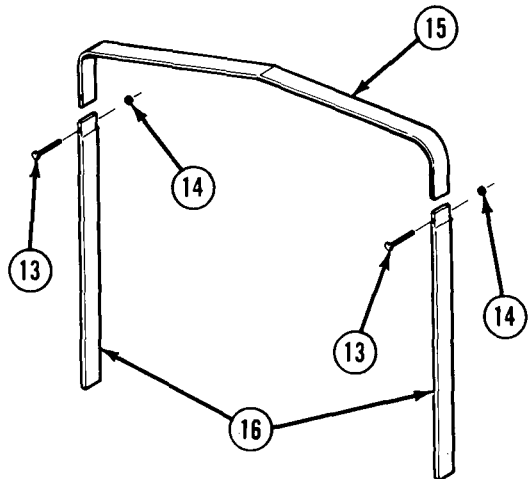
- (23) Fold one end of tailgate curtain (8) toward center in two folds.
- (24) Fold other end of tailgate curtain (8) toward center in two folds.
- (25) Fold both sides of tailgate curtain (8) together.
- (26) Repeat steps (20) through (25) for frontgate curtain.

M977 and M985 Operating Procedures (Cont)

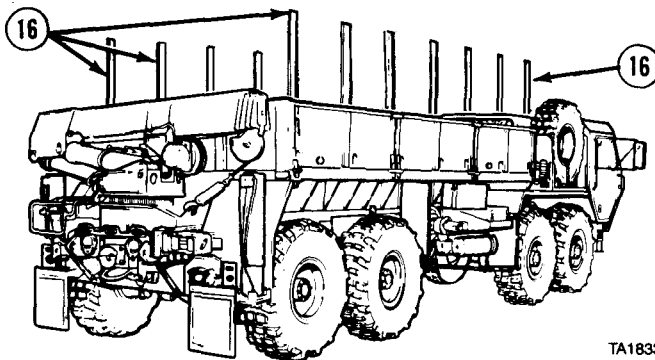


TA185284

- (27) Bind curtains (8 and 11) and cargo cover (5) with straps (12).
- (28) Remove screws (13) and nuts (14).
- (29) Remove bow (15) from stakes (16).
- (30) Repeat steps (28) and (29) for remaining bows and stakes.



TA183367



TA183398

- (31) Soldier A and Soldier B remove stakes (16).

M977 and M985 Tanker Operating Procedures

2-18. M977, M985 CRANE OPERATION (MANUAL CONTROLS).

a. Prepare Crane For Use.

WARNING

- Do not operate crane unless outriggers are set up. Vehicle could turn over causing serious injury or death. Always chock front wheels when using outriggers.
- Operate crane from forward or rear remote control station if operator will not be able to see load at all times during crane operation. Boom and load moving out of control could cause serious injury or death.

NOTE

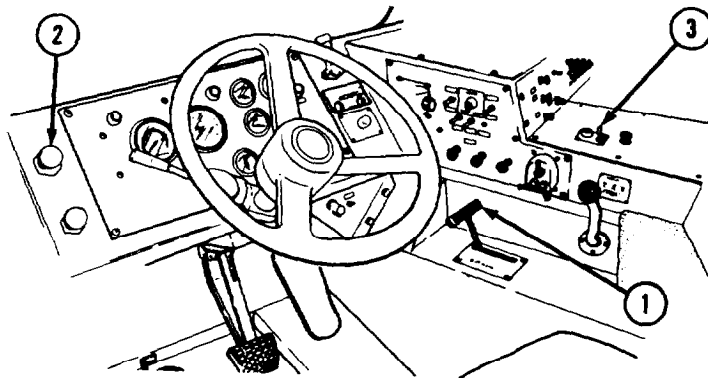
- Failure of hydraulic system will stop crane operation and lock crane in place. If hydraulic system fails during crane operation, refer to paragraph 2-48c.
- If electrical system fails during crane operation, refer to paragraph 2-48d for emergency shutdown procedure.

- (1) Start engine (para 2-11a or 2-11b).

NOTE

Crane can operate on up to 5-degree side slope.

- (2) Position vehicle on level ground so all loading and unloading can be done from one position.



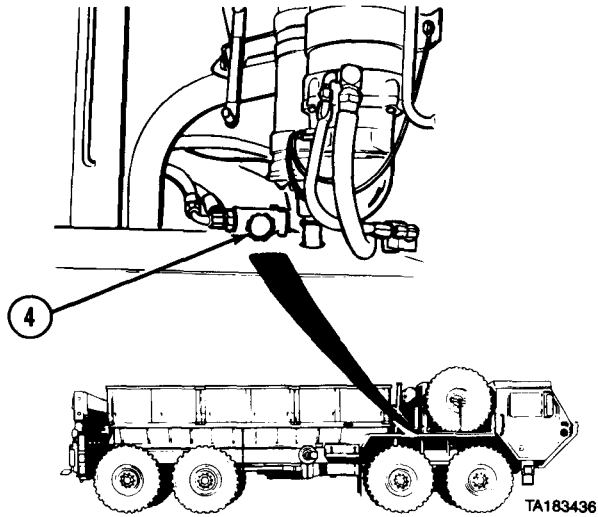
- (3) Put transmission range selector (1) in N (neutral) position and pull PARKING BRAKE control knob (2) out.

M977 and M985 Operating Procedures (Cont)

CAUTION

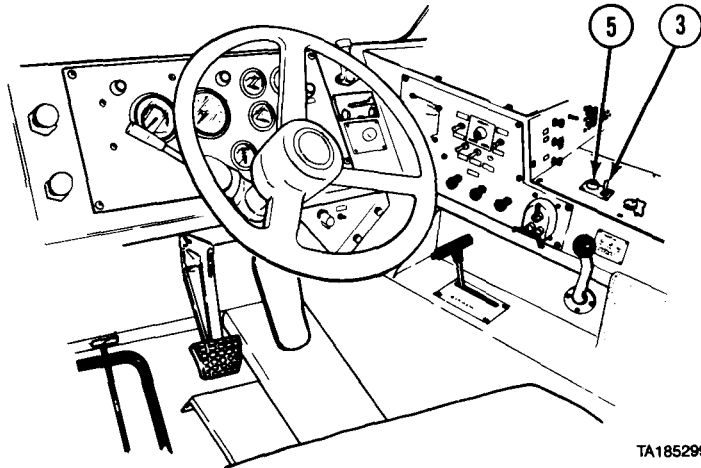
PTO ENGAGE switch must be in OFF position before moving selector valve to prevent equipment damage.

- (4) Make sure PTO ENGAGE switch (3) is in OFF position.

**NOTE**

If vehicle does not have self-recovery winch, skip step (5) and go to step (6).

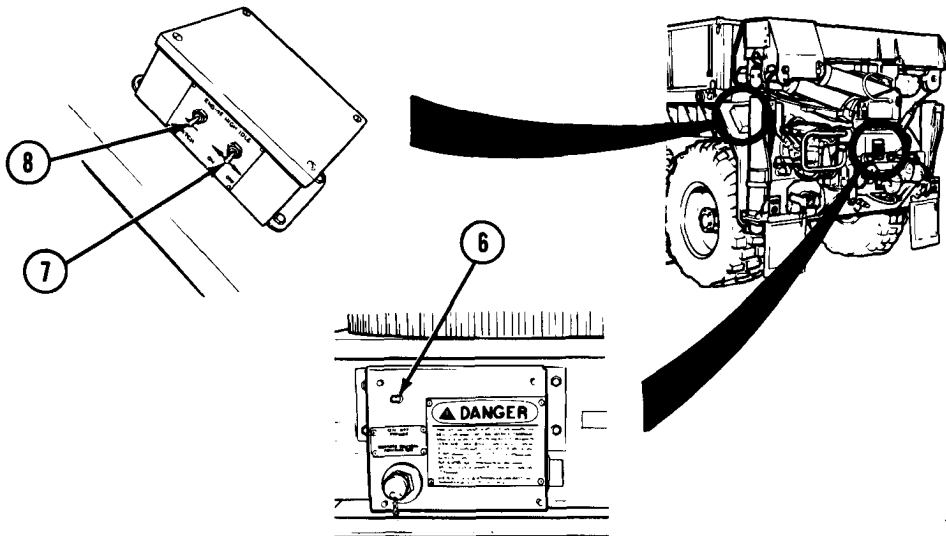
- (5) Push selector valve (4) in for crane operation.



- (6) Put PTO ENGAGE switch (3) in ON position. Indicator light (5) should come on.

M977 and M985 Operating Procedures (Cont)

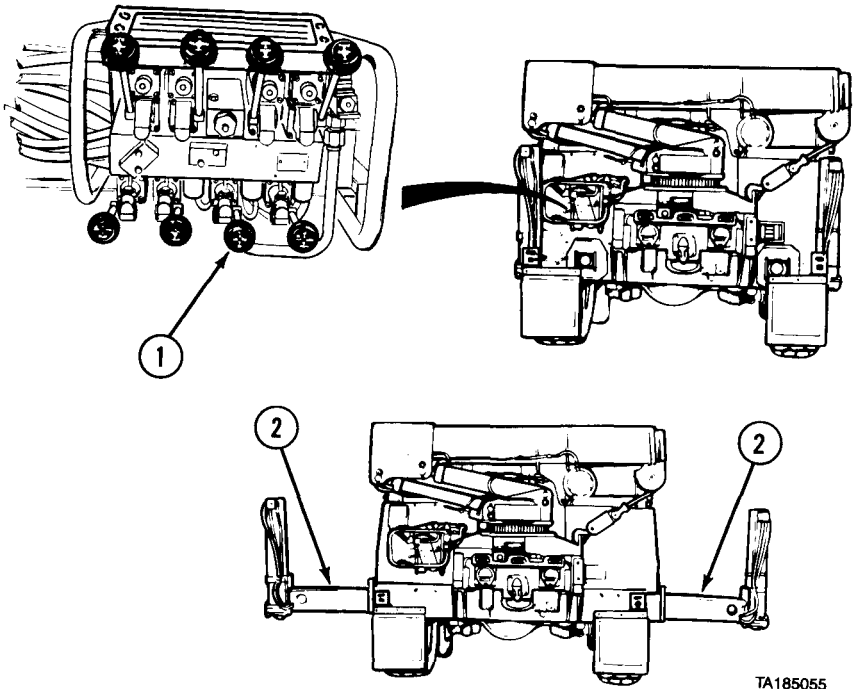
**2-18. M977, M985 CRANE OPERATION (MANUAL CONTROLS)
(CONT).**



TA185302

- (7) Put electric control box ON/OFF POWER switch (6) in ON position.
- (8) Put ENGINE HIGH IDLE ON/OFF switch (7) in ON position.
- (9) Push and release LATCH switch (8) to raise engine speed to approximately 1500 rpm.

M977 and M985 Operating Procedures (Cont)

b. Set Up Outriggers.

TA185055

WARNING

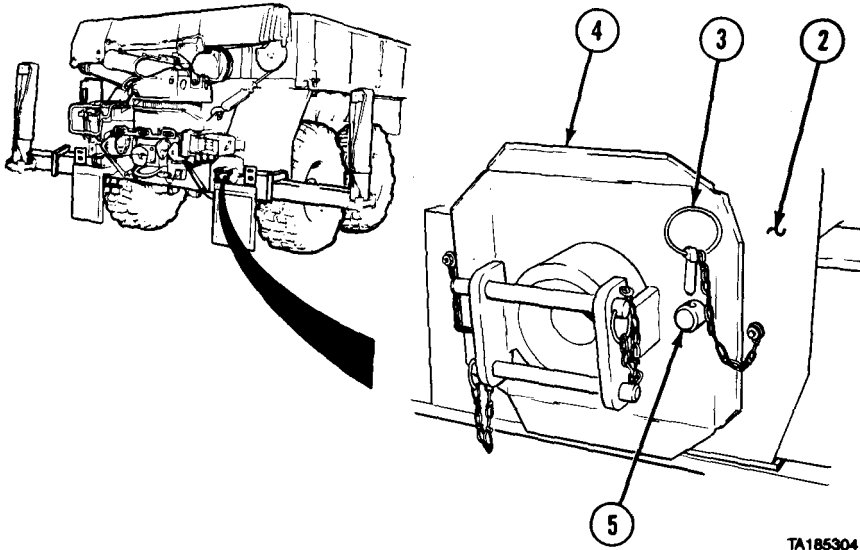
Stand clear of outrigger beams while operating lever or injury could result when beams come out.

NOTE

- Always operate control levers with light, even pressure.
- Outrigger beams will come out slower with light pressure on lever. Pushing lever to full travel will cause faster movement.
- Either right or left outrigger beam may come out first.

(1) Move outrigger extension (O/R EXT) lever (1) to OUT position until right and left outrigger beams (2) are completely out.

**2-18. M977, M985 CRANE OPERATION (MANUAL CONTROLS)
(CONT).**



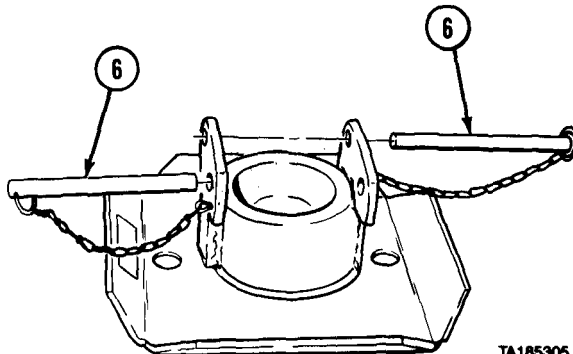
WARNING

Be careful when removing outrigger pads from stowed position. Sharp edges can injure hands.

NOTE

Outrigger pad on right side is shown. Left side is the same.

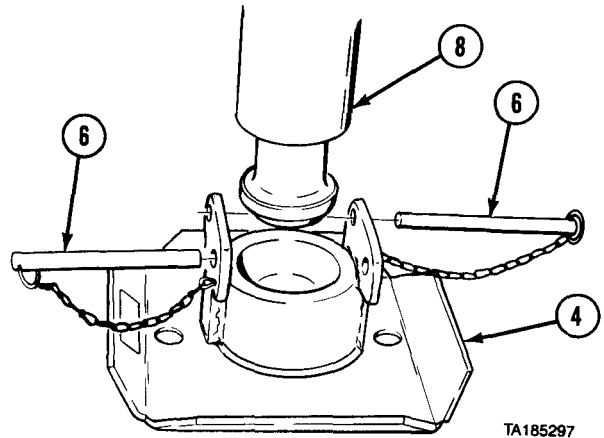
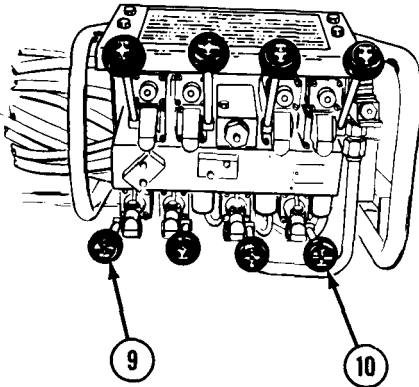
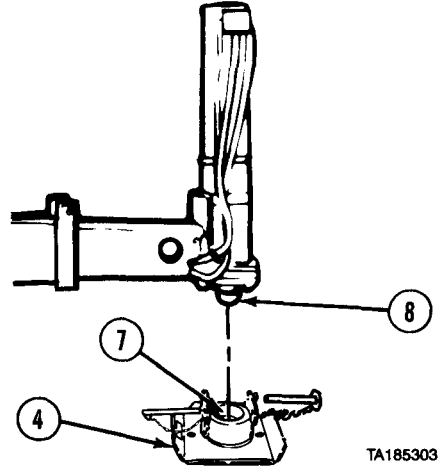
- (2) Remove two safety pins (3) and remove outrigger pad (4) from studs (5) on outrigger beam (2).



- (3) Remove two retaining pins (6).

M977 and M985 Operating Procedures (Cont)

- (4) Clean all foreign material from socket (7) in outrigger pad (4) and from rod end of outrigger jack cylinder (8).
- (5) Position outrigger pad (4) directly below outrigger jack cylinder (8).
- (6) Repeat steps (2) through (5) to set up outrigger pad (4) on other side.



WARNING

Keep hands and feet clear of outrigger jack cylinders to avoid injury.

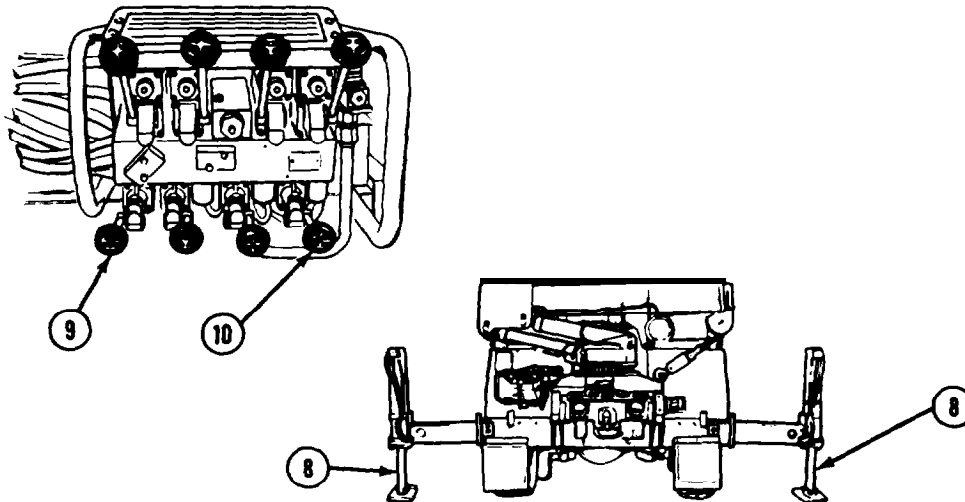
NOTE

Adjust outrigger pad position as required so rod end will lower into pad socket.

- (7) Move left outrigger jack (LH O/R JACK) control lever (9) to DOWN position and lower outrigger jack cylinder (8) until rod end is seated in outrigger pad (4).
- (8) Install retaining pins (6).
- (9) Move right outrigger jack (RH O/R JACK) control lever (10) to DOWN position and lower outrigger jack cylinder (8) until rod end is seated in outrigger pad (4).
- (10) Install retaining pins (6).

M977 and M985 Tanker Operating Procedures

12-18. M977, M985 CRANE OPERATION (MANUAL CONTROLS) (CONT).



WARNING

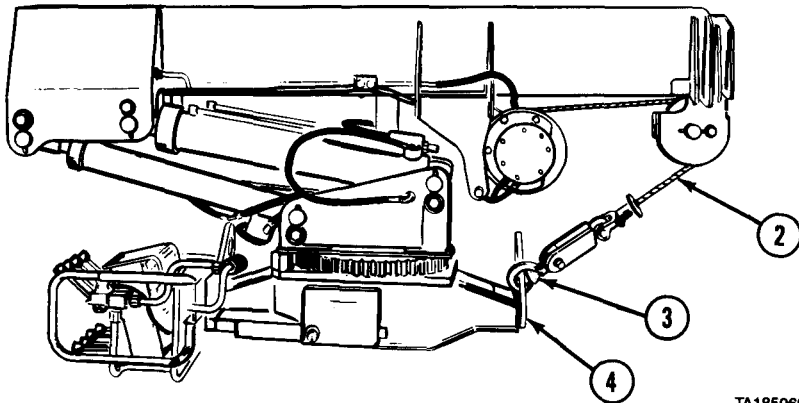
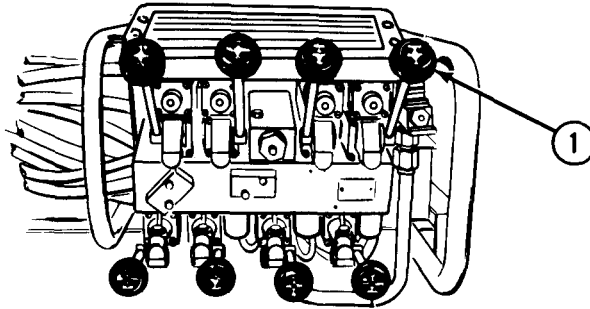
- Do not raise vehicle tires off ground with outrigger jack cylinders. Vehicle could roll causing serious injury or death. Always chock front wheels when using outriggers.
- Crane must be level from side to side. use of crane in unlevel position can cause vehicle to tip over causing possible serious injury or death.

NOTE

- Operate left and right outrigger jack (LH O/R JACK and RH O/R JACK) control levers at same time.
- Crane movement from one lever may be slower than the other when operating two levers together.
- Vehicle weight should be off rear axle just enough so tires still have firm contact with ground but do not bulge from weight.

(11) Move left outrigger jack (LH O/R JACK) and right outrigger jack (RH O/R JACK) control levers (9 and 10) to DOWN position. Lower left and right outrigger jack cylinders (8) until vehicle weight is off rear tires.

M977 and M985 Operating Procedures (Cont)

c. Raise Boom To Operating Position.

TA185060

WARNING

Do not operate crane unless both outriggers are set up. Vehicle could turn over causing serious injury or death.

CAUTION

Do not let cable unwind and become slack or cable may get tangled on drum.

- (1) Move HOIST control lever (1) to DOWN position and lower hoist cable (2) approximately 12-in. (305 mm).

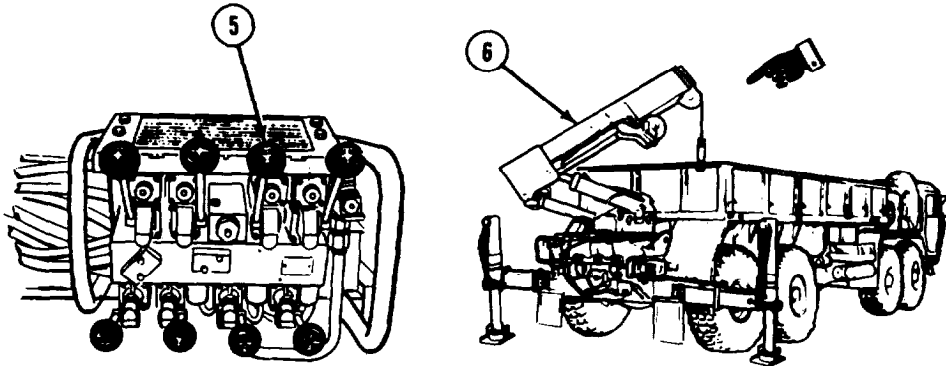
CAUTION

- Release hook lock before disconnecting load hook from stowage ring bracket to avoid hook lock damage.
- Do not let load hook fall and hit taillight.

- (2) Disconnect load hook (3) from stowage ring bracket (4).

M977 and M985 Tanker Operating Procedures (Cont)

2-18. M977, M985 CRANE OPERATION (MANUAL CONTROLS) (CONT).

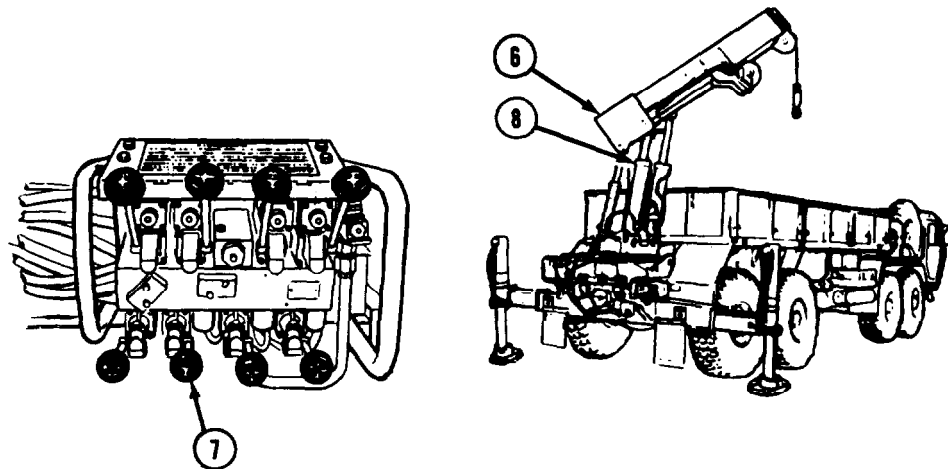


WARNING

Keep boom clear of all electrical lines and other obstacles while operating crane. Serious injury or death could result upon contact.

- (3) Operate BOOM control lever (5) in UP position until boom (6) is approximately 45° above horizontal.

M977 and M985 Tanker Operating Procedures (Cont)

**CAUTION**

To avoid damage to outrigger leg or load hook, do not hit outrigger leg with load hook.

- (4) Operate MAST control lever (7) in UP position until the mast (8) is fully erect and the cylinders are fully extended. Use BOOM control lever (5) simultaneously as required to maintain the boom (6) at approximately 45° above horizontal until the mast is fully erect. Hold the mast control lever (7) to UP position for 2-3 seconds after mast is fully erect to ensure cylinders are fully filled with oil.
- (5) Operate crane with manual controls (para 2-18d and 2-18e) or REMOTE CONTROL UNIT (para 2-19).

M977 and M985 Operating Procedures (Cont)

d. Rotate and Telescope Boom.**WARNING**

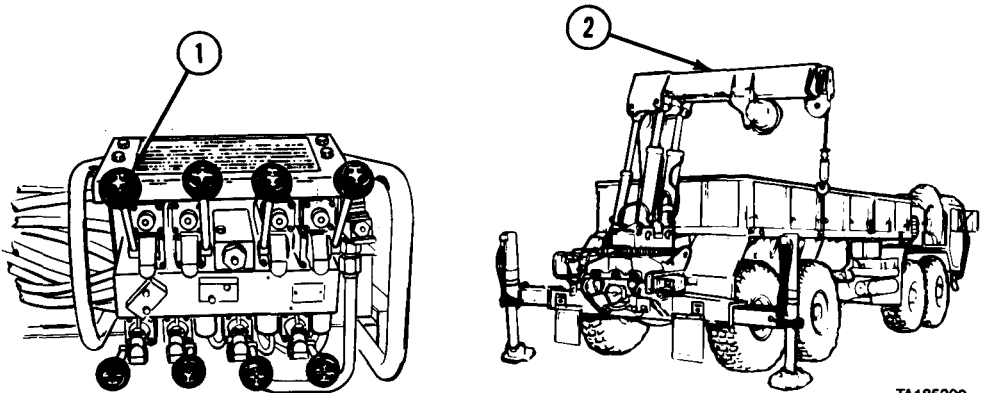
- Keep boom clear of all electrical lines and other obstacles while operating crane. Serious injury or death could result upon contact.
- Be sure that area is clear of personnel before moving SWING control lever. Boom should be swung slow enough so crane operator has complete control. If operator cannot see load during operation, operate crane from REMOTE CONTROL UNIT (para 2-19). Boom moving out of control could cause serious injury or death.
- Operator must keep control of load at all times. If necessary, attach cargo tiedowns to load for control. Load moving out of control could cause serious injury or death.

CAUTION

Boom must be above vehicle sides for clearance. Hitting side of vehicle with boom may cause damage to boom or vehicle.

NOTE

Operate control levers with light, even pressure. Moving lever slightly will cause slow movement of crane. Moving lever to full travel will cause faster movement of crane.

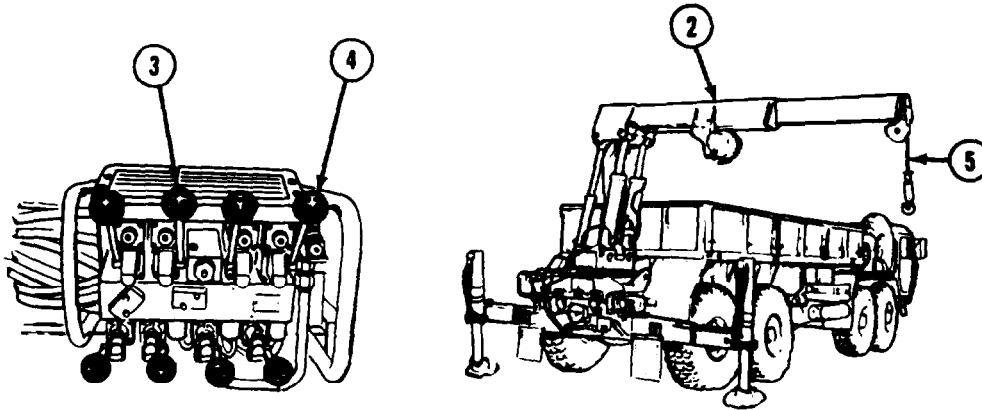


TA185309

- (1) Move SWING control lever (1) to CW position to move boom (2) clockwise.
- (2) Move SWING control lever (1) to CCW position to move boom (2) counterclockwise.

M977 and M985 Tanker Operating Procedures

2-18. M977, M985 CRANE OPERATION (MANUAL CONTROLS) (CONT).



CAUTION

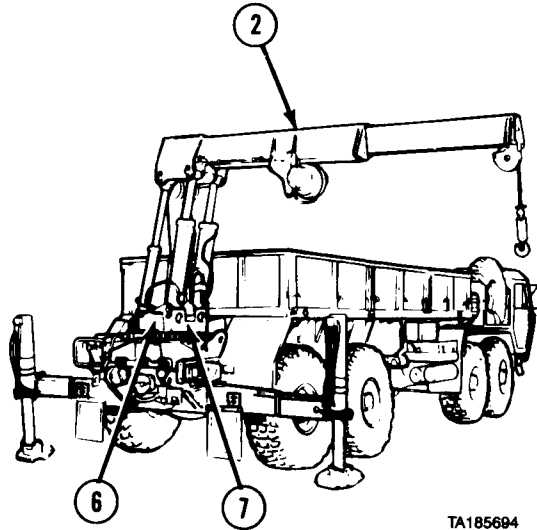
Keep hook block at least 2 ft (0.61 m) from end of boom. If hook block hits end of boom it may damage cable or hook block and crane will lose power. Wait 6 seconds for power to return and check crane for damage.

NOTE

- When crane is overloaded, M977 and M985 overload systems will automatically shut off power to telescope boom out, raise boom, or hoist load any higher. The M977 overload system will also prevent lowering boom. Overload condition can be corrected by lowering load to ground or other supporting surface by using hoist control level only.
- When telescoping the boom, the TELESCOPE and HOIST control levers should be operated at the same time.
- Crane movement from one lever may be slower than the other when operating two levers together.

- (3) Move TELESCOPE control lever (3) to OUT position to extend boom (2) and move HOIST control lever (4) to DOWN position to pay out cable (5).

M977 and M985 Operating Procedures (Cont)

**CAUTION**

Do not go over maximum load rating as shown on RANGE DIAGRAM. Going over load ratings will cause damage to equipment.

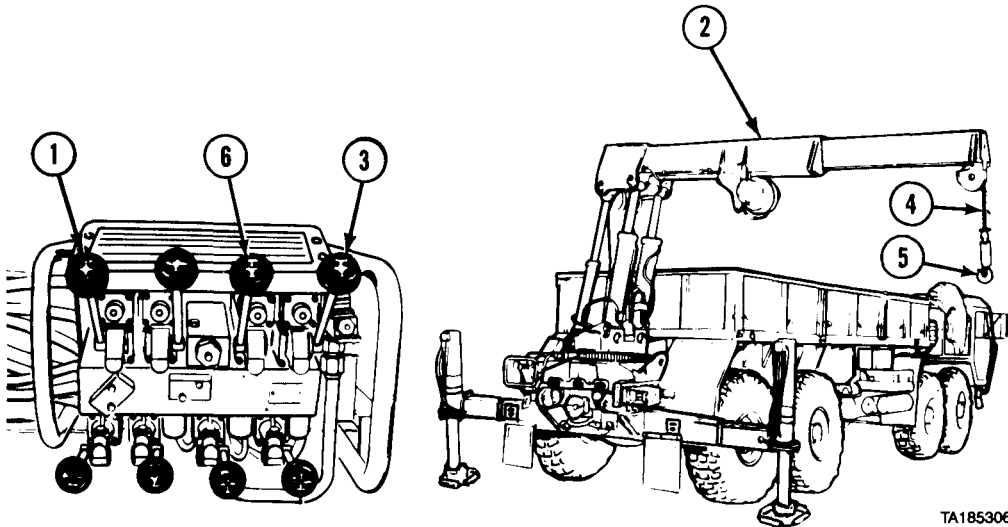
NOTE

When operating M977 crane, raise boom to approximately 60-degree angle to pick up maximum load.

- (4) Refer to RANGE DIAGRAM (6) on turntable panel (7) to raise boom (2) to correct angle before connecting to load.

**2-18. M977, M985 CRANE OPERATION (MANUAL CONTROLS)
(CONT).**

e. Raise and Lower Load.



TA185306

WARNING

Be sure that area is clear of personnel before moving SWING control lever. Boom should be swung slow enough so crane operator has complete control. Boom moving out of control could cause serious injury or death.

CAUTION

- Do not let cable become slack or cable may get tangled on drum.
- Do not drag load sideways on ground or damage to crane may result.

(1) Operate SWING control lever (1) and center end of boom (2) directly over load.

CAUTION

Release hook lock before connecting load hook to avoid damage to hook lock.

(2) Operate HOIST control lever (3) to raise or lower cable (4) and connect load hook (5) to load.

M977 and M985 Tanker Operating Procedures**WARNING**

Be sure there are at least two wraps of cable on hoist drum at all times. Serious injury or death could result if cable comes off hoist drum while lifting load.

CAUTION

- Do not jerk HOIST control lever or load will bounce causing possible damage to crane or load.
- Do not operate crane with boom below horizontal when there is a load on hook.
- For M977, maximum load limit with boom length under 9 ft (2.75 m) is 4500 lbs (2 043 kg). Maximum load limit with boom extended over 9 ft (2.75 m) is 2500 lbs (1 135 kg).
- For M985, maximum load limit is 5400 lbs (2 452 kg) for entire boom reach.

NOTE

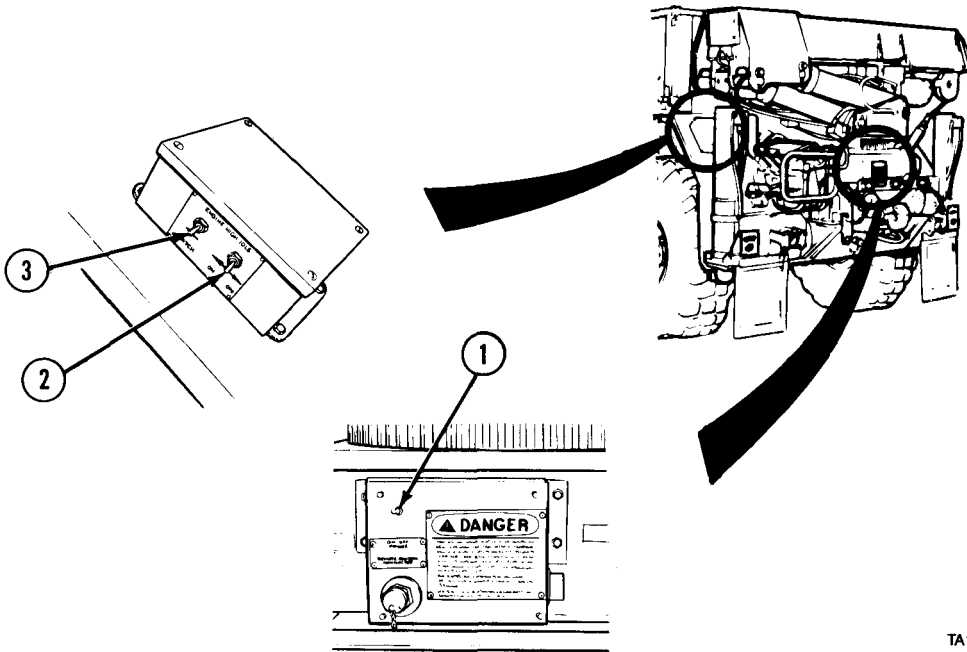
When crane is overloaded, M977 and M985 overload systems will automatically shut off power to telescope boom out, raise boom, or hoist load any higher. The M977 overload system will also prevent lowering load to ground or other supporting surface. All crane functions will be restored in approximately six seconds.

- (3) Move HOIST control lever (3) in UP position to lift load. Move BOOM control lever (6) in UP position to raise load higher.
- (4) Move HOIST control lever (3) in DOWN position to lower load. Move BOOM control lever (6) in DOWN position to lower load further.
- (5) Shut down crane (para 2-180).

M977 and M985 Operating Procedures (Cont)

**2-18. M977, M985 CRANE OPERATION (MANUAL CONTROLS)
(CONT).**

f. Shut Down Crane.



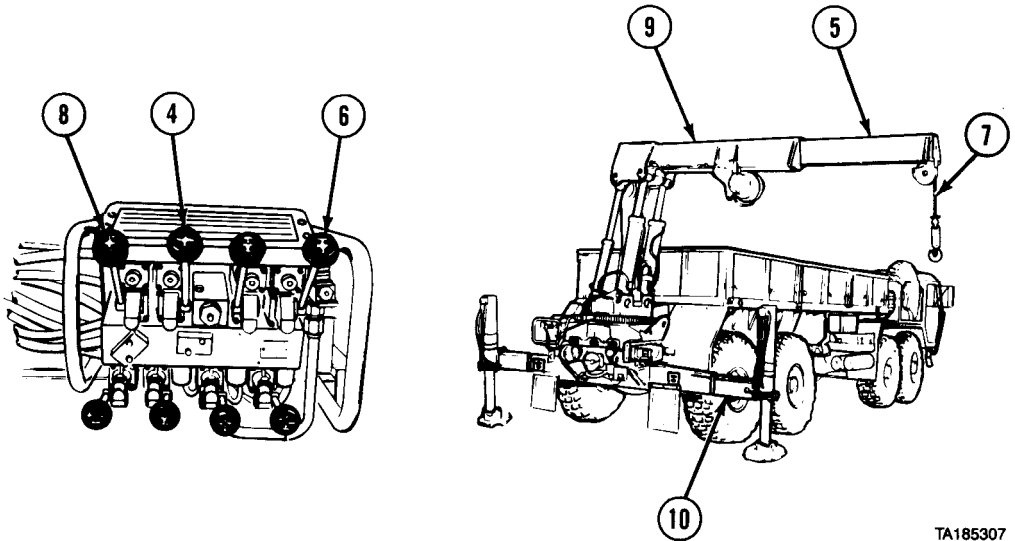
TA185301

NOTE

Steps (1) through (3) are needed only if REMOTE CONTROL UNIT was used during operation.

- (1) Put ON/OFF POWER switch (1) in ON position.
- (2) Put ENGINE HIGH IDLE ON/OFF switch (2) in ON position.
- (3) Push and release LATCH switch (3) to raise engine speed to approximately 1500 rpm.

M977 and M985 Operating Procedures (Cont)



TA185307

CAUTION

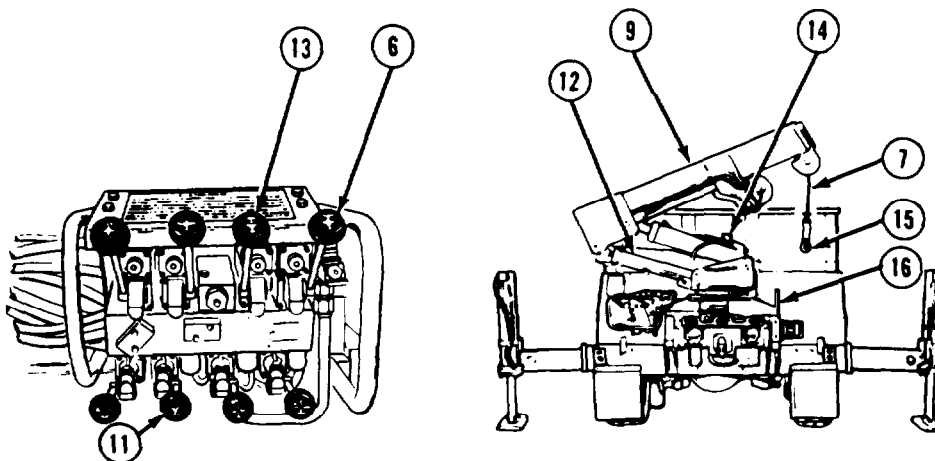
- Leave about 2 ft (0.61 m) of cable between boom sheave and hook block when reeling in cable or damage to equipment could result.
- Do not let cable unwind and become slack or cable may get tangled on drum.

NOTE

- Operate control levers with light, even pressure.
 - TELESCOPE and HOIST control levers should be operated at same time.
 - Crane movement from one lever may be slower than other when operating two levers together.
- (4) Move TELESCOPE control lever (4) to IN position to pull boom extensions (5) in and move HOIST control lever (6) to UP position to reel in cable (7) until boom extensions are fully retracted.
- (5) Operate SWING control lever (8) to position boom (9) parallel with outrigger beam (10) on right side of vehicle.

M977 and M985 Tanker Operating Procedures (Cont)

2-18. M977, M985 CRANE OPERATION (MANUAL CONTROLS) (CONT).



CAUTION

Boom must rest on rest pad when transporting vehicle.
If not, damage to vehicle can result.

- (6) Move MAST control lever (11) to DOWN position to lower mast (12) until mast is completely folded down. Use BOOM control lever (13) simultaneously as required to maintain boom at approximately 45° above horizontal until mast is completely folded down.
- (7) Move BOOM control lever (13) to DOWN position until boom (9) comes to rest on mast rest pad (14).

CAUTION

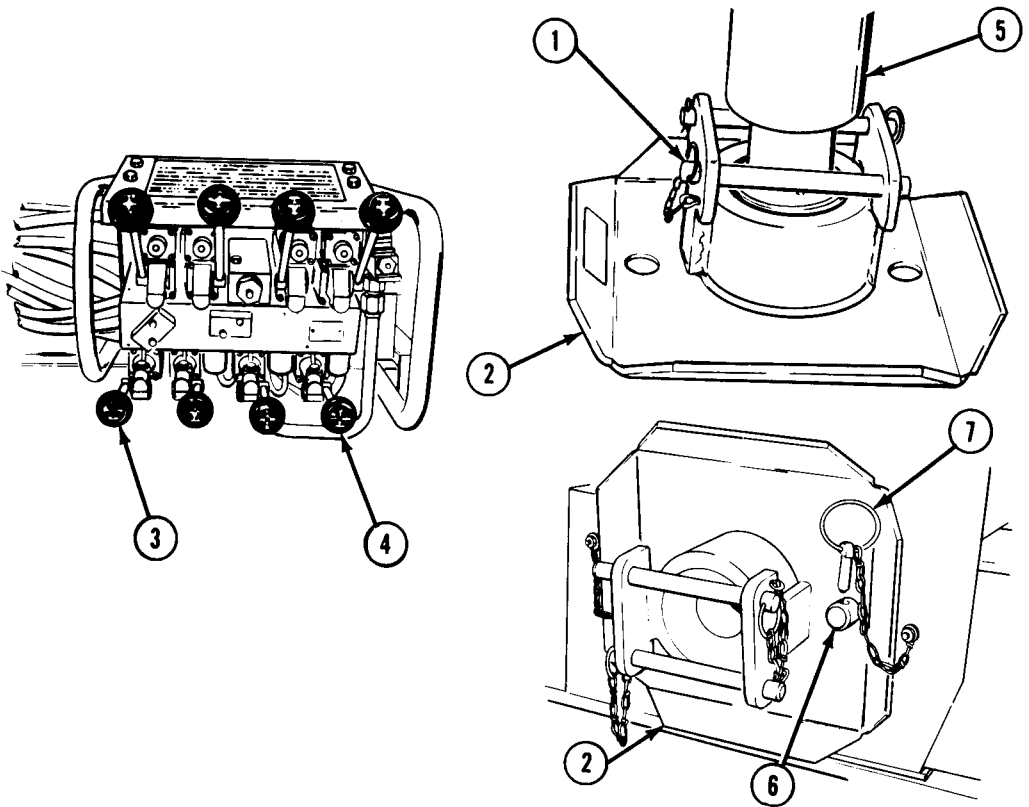
Release hook lock before connecting load hook to stowage ring bracket to avoid damage to hook lock,

NOTE

Stowage ring is smallest hole in bracket.

- (8) Connect load hook (15) to stowage ring bracket (16). Move HOIST control lever (6) in UP position to remove slack from hoist cable (7).

M977 and M985 Operating Procedures (Cont)

g. Stow Outriggers.

TA185070

- (1) Remove two retaining pins (1) from each outrigger pad (2).

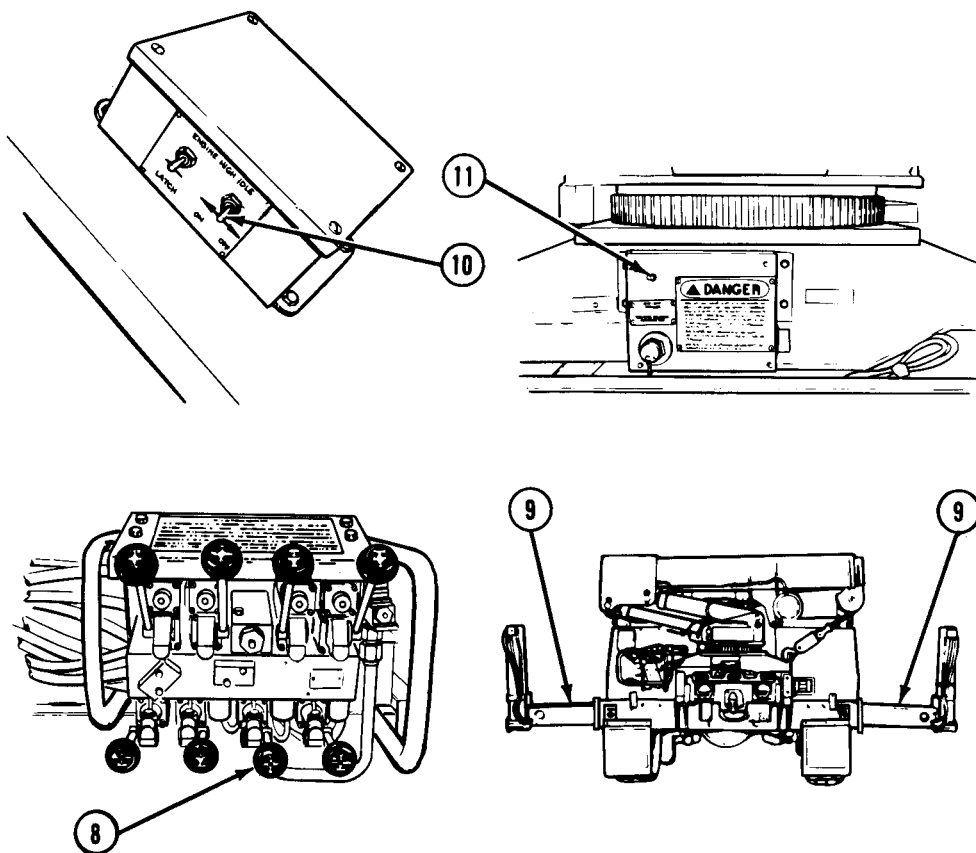
NOTE

Operate left and right outrigger jack (LH O/R JACK and RH O/R JACK) levers at the same time until both outrigger jack cylinders are out of pads.

- (2) Move left outrigger jack (LH O/R JACK) and right outrigger jack (RH O/R JACK) control levers (3 and 4) to UP position to retract outrigger jack cylinders (5) completely.
- (3) Install two retaining pins (1) in outrigger pads (2).
- (4) Stow outrigger pads (2) on studs (6).
- (5) Install safety pins (7) through studs (6).

M977 and M985 Operating Procedures (Cont)

**2-18. M977, M985 CRANE OPERATION (MANUAL CONTROLS)
(CONT).**



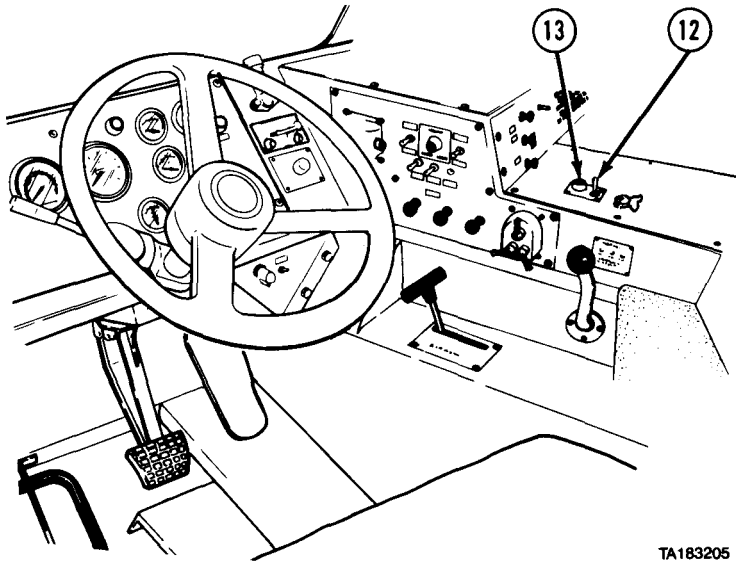
TA185069

WARNING

Keep hands and body away from outrigger beams while operating lever to avoid injury.

- (6) Move outrigger extension (O/R EXT) control lever (8) to IN position to retract outrigger beams (9) completely.
- (7) Turn ENGINE HIGH IDLE ON/OFF switch (10) to OFF position.
- (8) Turn ON/OFF POWER switch (11) to OFF position.

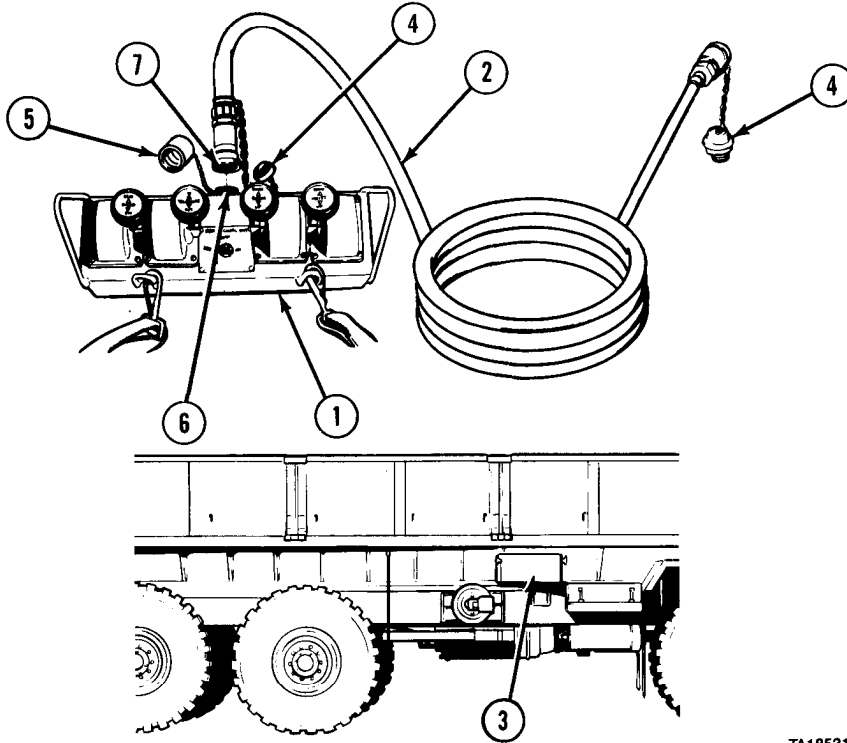
M977 and M985 Operating Procedures (Cont)



- (9) Put PTO ENGAGE switch (12) in OFF position. Indicator light (13) should go out.
- (10) Shut off engine (para 2-11p).

2-19. M977, M985 CRANE OPERATION (REMOTE CONTROLS).

a. Set Up REMOTE CONTROL UNIT.



TA185313

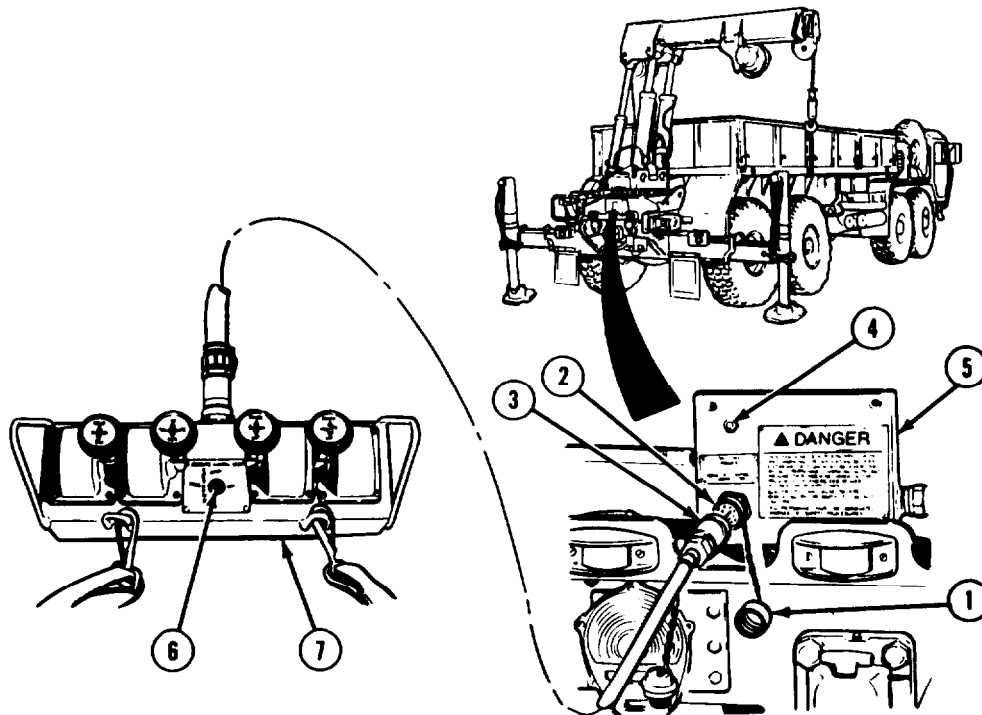
WARNING

Operate crane from forward or rear remote control station if operator will not be able to see load at all times during crane operation. Boom and load moving out of control could cause serious injury or death.

- (1) Prepare crane for use (para 2-18a).
- (2) Set up outriggers (para 2-18b).
- (3) Raise boom to operating position (para 2-18c).
- (4) Remove REMOTE CONTROL UNIT (1) and cable (2) from stowage box (3).
- (5) Remove cover (4) from cable (2) and cover (5) from REMOTE CONTROL UNIT receptacle (6). Clean any dirt or water from receptacle.
- (6) Clean any dirt or water from female connector (7).
- (7) Connect female connector (7) to REMOTE CONTROL UNIT receptacle (6).

M977 and M985 Tanker Operating Procedures

b. Connect Remote Control Unit to Rear Outlet-



- (1) Ensure ON/OFF power switch (4) on electrical control box (5) is in OFF position. Remove cover (1) from REMOTE CONTROL CONNECTOR outlet (2) and clean any dirt or water from outlet.

WARNING

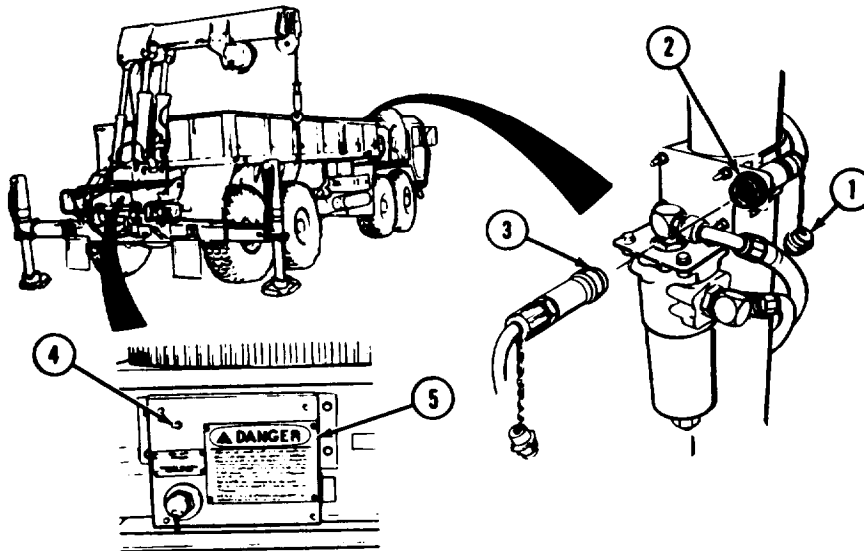
Make sure ON/OFF/MHC-SHUTDOWN power switch is in OFF position before connecting REMOTE CONTROL UNIT. Crane moving out of control could cause serious injury or death.

- (2) Clean any dirt or water from remote control cable plug (3) and connect plug to REMOTE CONTROL CONNECTOR outlet (2).
- (3) Turn ON/OFF POWER switch (4) on electric control box (5) to ON position.
- (4) Turn ON/OFF MHC-SHUTDOWN power switch (6) on REMOTE CONTROL UNIT (7) to ON position.
- (5) Operate crane (para 2-19d).

M977 and M985 Tanker Operating Procedures

12-19. M977, M985 CRANE OPERATION (REMOTE CONTROLS) (CONT).

c. Connect Remote Control Unit to Forward Outlet.

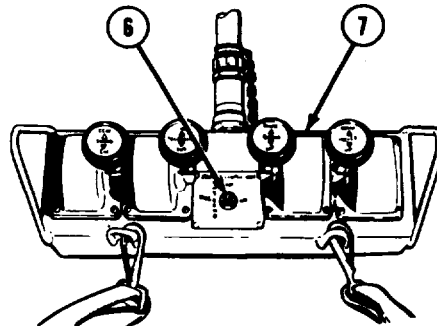


- (1) Ensure ON/OFF power switch (4) on electrical control box (5) is in OFF position. Remove cover (1) from REMOTE CONTROL CONNECTOR outlet (2) and clean any dirt or water from outlet.

WARNING

Make sure ON/OFF/MHC-SHUTDOWN power switch is in OFF position before connecting REMOTE CONTROL UNIT. Crane moving out of control could cause serious injury or death.

- (2) Clean any dirt or water from cable plug (3) and connect plug to REMOTE CONTROL CONNECTOR outlet (2).
- (3) Turn ON/OFF POWER switch (4) on electrical control box (5) to ON position.
- (4) Turn ON/OFF MHC-SHUTDOWN power switch (6) on REMOTE CONTROL UNIT (7) to ON position.
- (5) Operate crane (para 2-19d).



M977 and M985 Operating Procedures (Cont)

d. Rotate and Telescope Boom.**WARNING**

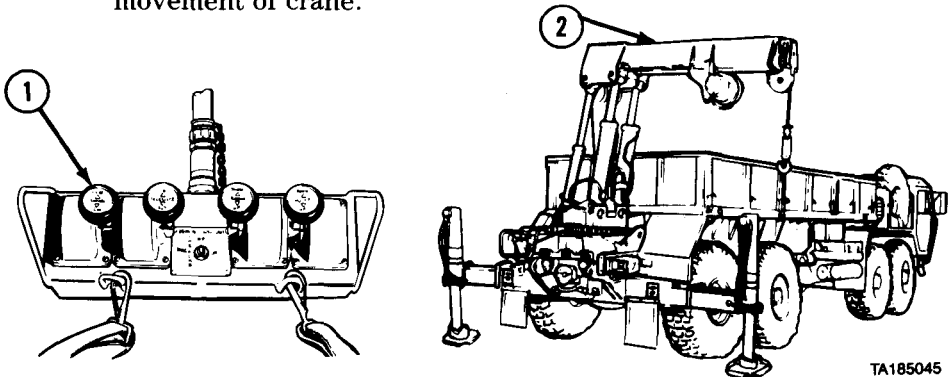
- Keep boom clear of electrical lines and other obstacles while operating crane. Serious injury or death could result upon contact.
- Operator should use REMOTE CONTROL UNIT in position so load will not pass overhead. Load could fall causing serious injury or death.
- Be sure that area is clear of personnel before moving SWING control lever. Boom should be swung slow enough so crane operator has complete control. Boom moving out of control could cause serious injury or death.
- Operator must keep control of load at all times. If necessary, attach cargo tiedowns to load for control. Load moving out of control could cause serious injury or death.
- If electrical power fails during crane operation, move switch on remote control unit to SHUTDOWN position. Serious injury could result from uncontrolled moving parts.

CAUTION

Boom must be above vehicle sides for clearance. Hitting side of vehicle with boom may cause damage to boom or vehicle.

NOTE

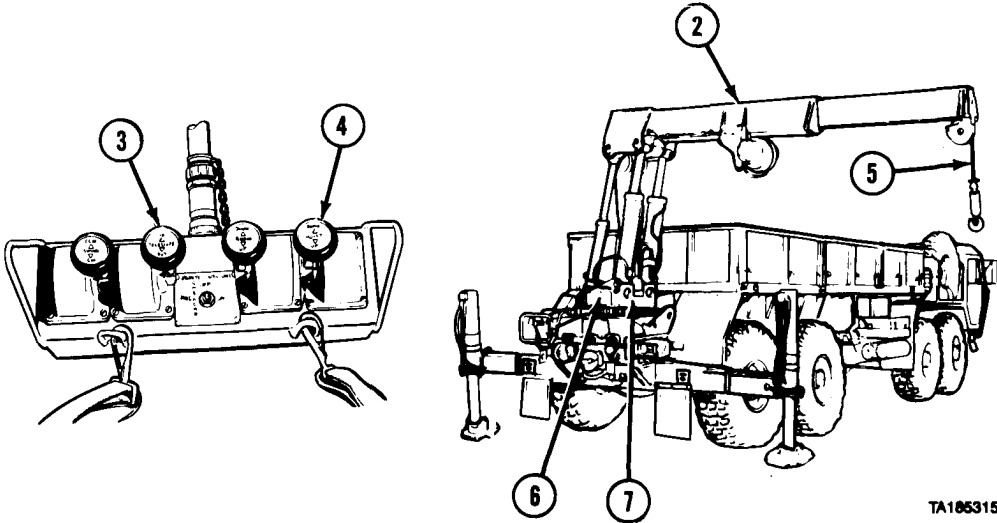
Operate control levers with light, even pressure. Moving lever slightly will cause slow movement of crane. Moving lever to full travel will cause faster movement of crane.



TA185045

- (1) Move SWING control lever (1) to CW position to move boom (2) clockwise.
- (2) Move SWING control lever (1) to CCW position to move boom (2) counterclockwise.

**2-19. M977, M985 CRANE OPERATION (REMOTE CONTROLS)
(CONT).**



TA105315

CAUTION

Keep hook block at least 2 ft (0.61 m) from end of boom. If hook block hits end of boom it may damage cable or hook block and crane will lose power. Wait 6 seconds for power to return and check crane for damage.

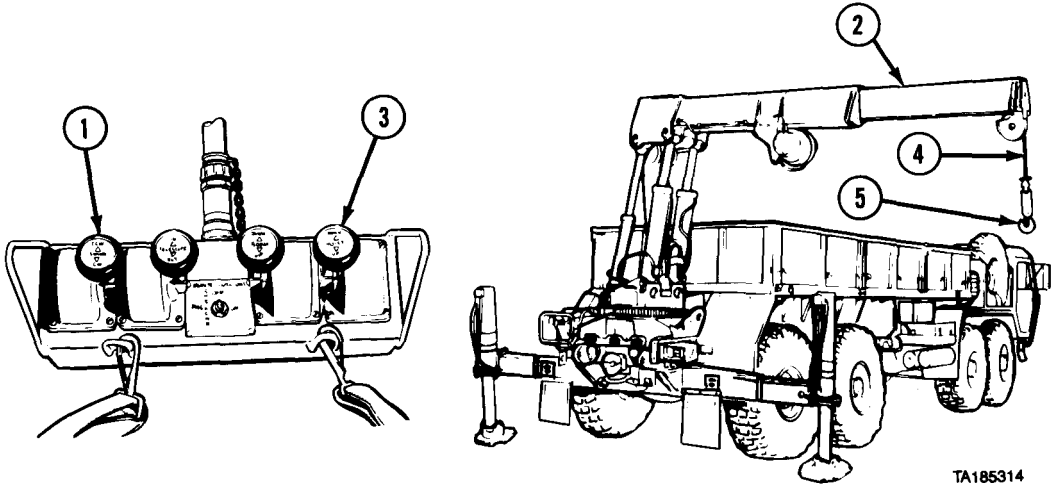
NOTE

- TELESCOPE and HOIST control levers should be operated at same time.
 - Crane movement from one lever may be slower than other when operating two levers together.
- (3) Move TELESCOPE control lever (3) to OUT position to extend boom (2) and move HOIST control lever (4) to DOWN position to pay out cable (5).

CAUTION

- Do not go over maximum load rating as shown on RANGE DIAGRAM. Going over load ratings could cause damage to equipment.
 - When operating M977 crane, raise boom to approximately 60-degree angle to pick up maximum load or equipment could be damaged.
- (4) Refer to RANGE DIAGRAM (6) on turntable panel (7) to raise boom (2) to correct angle before connecting to load.

M977 and M985 Operating Procedures (Cont)

e. Raise and Lower Load.

TA185314

WARNING

Be sure that area is clear of personnel before moving SWING control lever. Boom should be swung slow enough so crane operator has complete control. Boom moving out of control could cause serious injury or death.

CAUTION

- Do not let cable become slack. Cable may get tangled on drum and damage cable.
- Do not drag load sideways on ground. Dragging load could cause damage to crane.

(1) Operate SWING control lever (1) and center end of boom (2) directly over load.

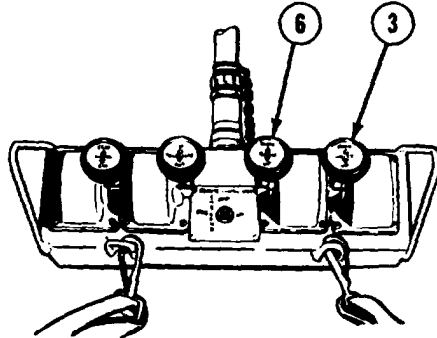
CAUTION

Release hook lock before connecting load to avoid damage to hook lock.

(2) Operate HOIST control lever (3) to raise or lower cable (4) and connect load hook (5) to load.

M977 and M985 Tanker Operating Procedures

2-19. M977, M985 CRANE OPERATION (REMOTE CONTROLS) (CONT).



WARNING

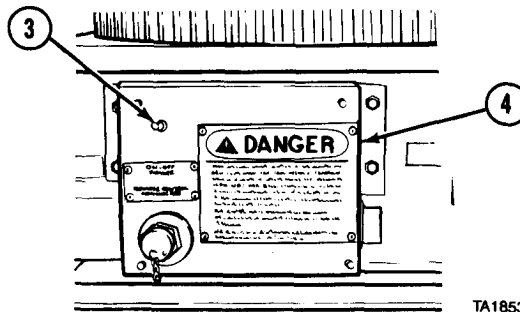
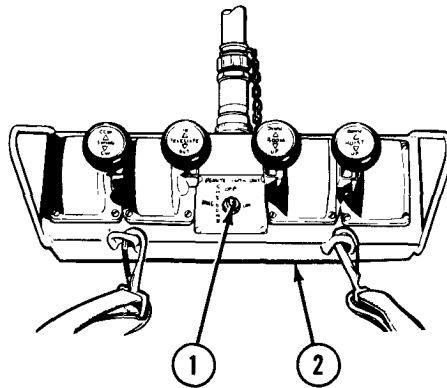
Be sure there are at least two wraps of cable on hoist drum at all times. Serious injury or death could result if cable comes off hoist drum while lifting load.

CAUTION

Do not jerk HOIST control lever or load will bounce causing possible damage to crane or load.

- Do not operate crane with boom below horizontal when there is a load on hook.
 - For M977, maximum load limit with boom length under 9 ft (2.75 m) is 4500 lbs (2 043 kg). Maximum load limit with boom extended over 9 ft (2.75 m) is 2500 lbs (1 135 kg). For M985 maximum load limit is **5400** lbs (2 452 kg).
 - Do not go over maximum load limit. Going over maximum load limit will cause electrical shutdown for 6 seconds or until load is lowered.
- (3) Move HOIST control lever (3) in UP position to lift load. Move BOOM control lever (6)1 in UP position to raise load higher.
- (4) Move HOIST control lever (3) to DOWN position to lower load. Move BOOM control lever (6) to DOWN position to lower load further.

M977 and M985 Operating Procedures (Cont)

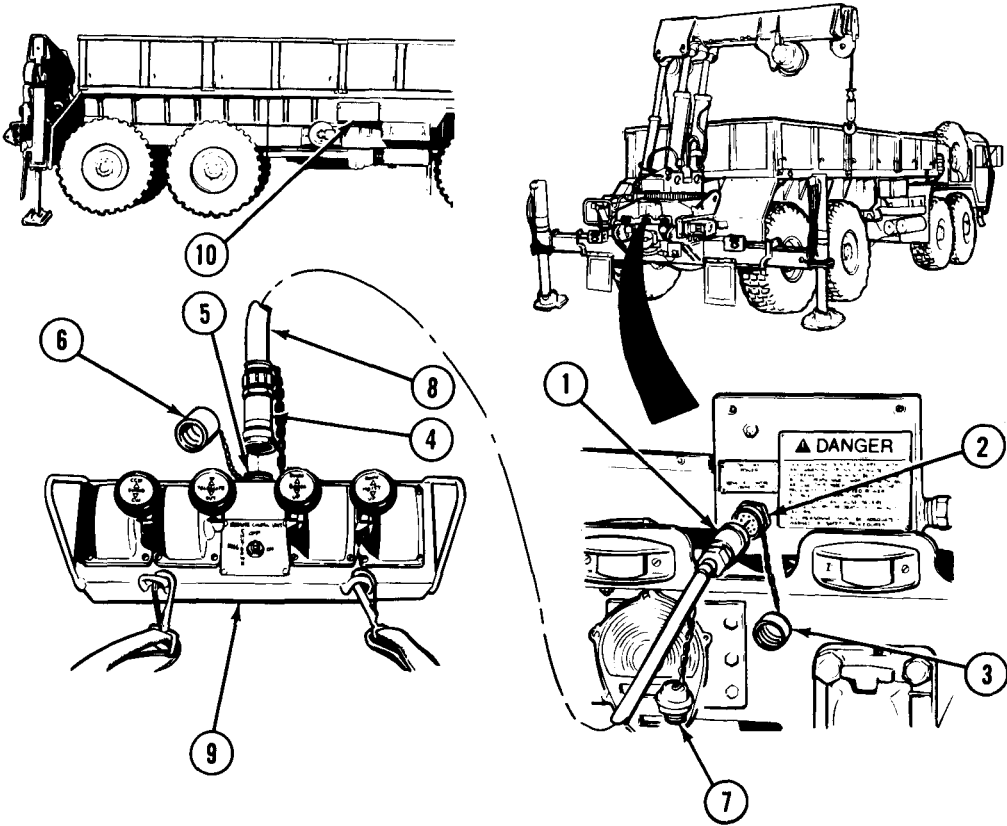
f. Shut Off Switches.

TA185319

- (1) Put ON/OFF/MHC-SHUTDOWN power switch (1) on REMOTE CONTROL UNIT (2) in OFF position.
- (2) Put ON-OFF POWER switch (3) on electric control box (4) in OFF position.
- (3) Disconnect REMOTE CONTROL UNIT (2) from rear remote control station (para 2-19g) or from forward remote control station (para 2-19h).

**2-19. M977, M985 CRANE OPERATION (REMOTE CONTROLS)
(CONT).**

g. Disconnect Remote Control Unit From Rear Outlet.

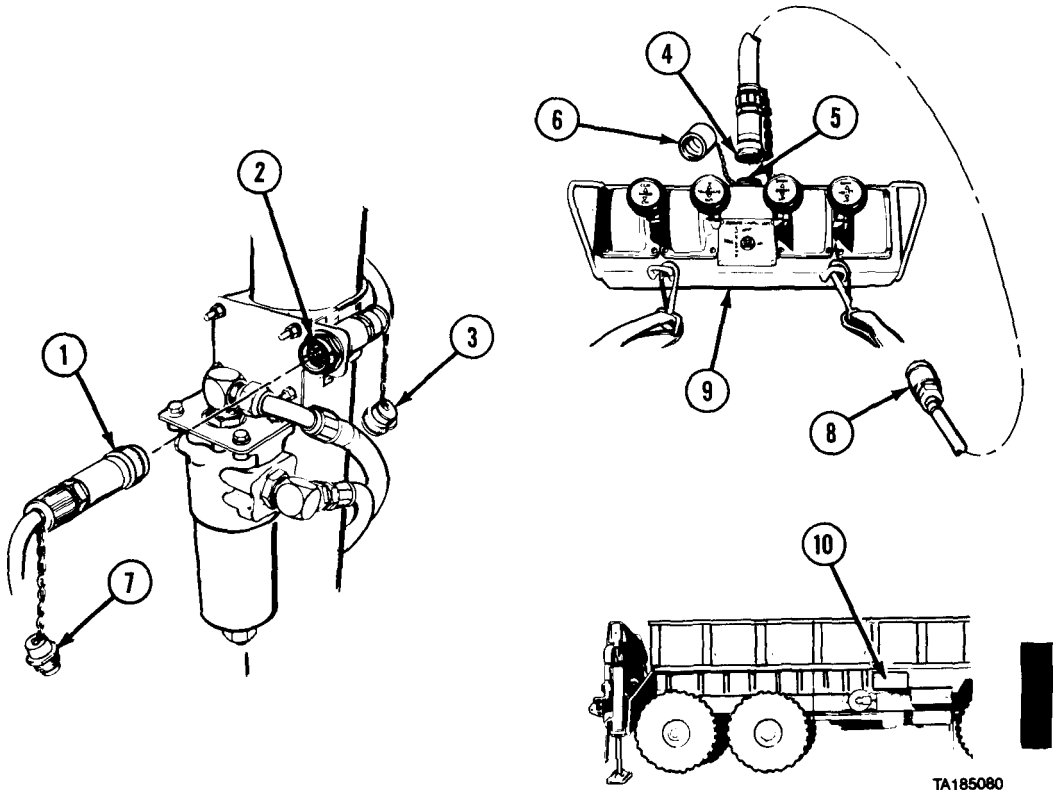


TA185041

- (1) Disconnect cable plug (1) from REMOTE CONTROL CONNECTOR outlet (2) and install cover (3) on outlet.
- (2) Disconnect female connector (4) from REMOTE CONTROL UNIT receptacle (5) and install cover (6) on receptacle.
- (3) Install covers (7) on cable (8) and coil cable.
- (4) Put REMOTE CONTROL UNIT (9) and cable (8) in stowage box (10).
- (5) Shut down crane (para 2-18f).

M977 and M985 Operating Procedures (Cont)

h. Disconnect Remote Control Unit From Forward Outlet.



TA185080

- (1) Disconnect cable plug (1) from forward remote control outlet (2). Install cover (3) on outlet.
- (2) Disconnect female connector (4) from REMOTE CONTROL UNIT receptacle (5) and install cover (6) on receptacle.
- (3) Install covers (7) on cable (8) and coil cable.
- (4) Put REMOTE CONTROL UNIT (9) and cable (8) in stowage box (10).
- (5) Shut down crane (para 2-18f).

M978 Tanker Operating Procedures

2-20. PREPARE TANKER FOR OPERATION.

a. **Prepare Vehicle.**

WARNING

No smoking, flame, sparks, glowing or hot objects allowed within 50 ft (15 m) of vehicle. Fire or explosion may cause personal injury or death.

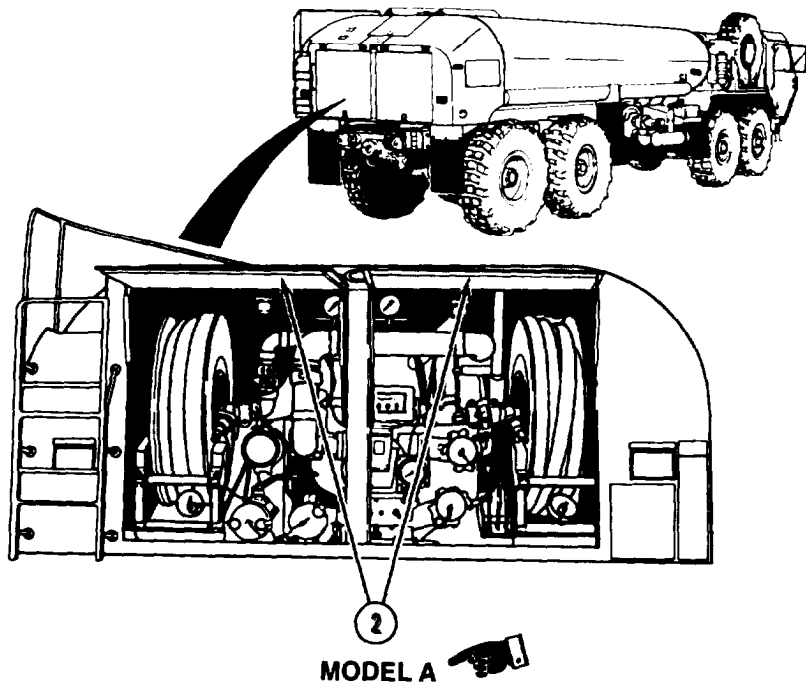
NOTE

This procedure should be performed to prepare tanker before all fuel loading, fuel servicing, defueling, fuel recirculation, and fuel unloading operations.

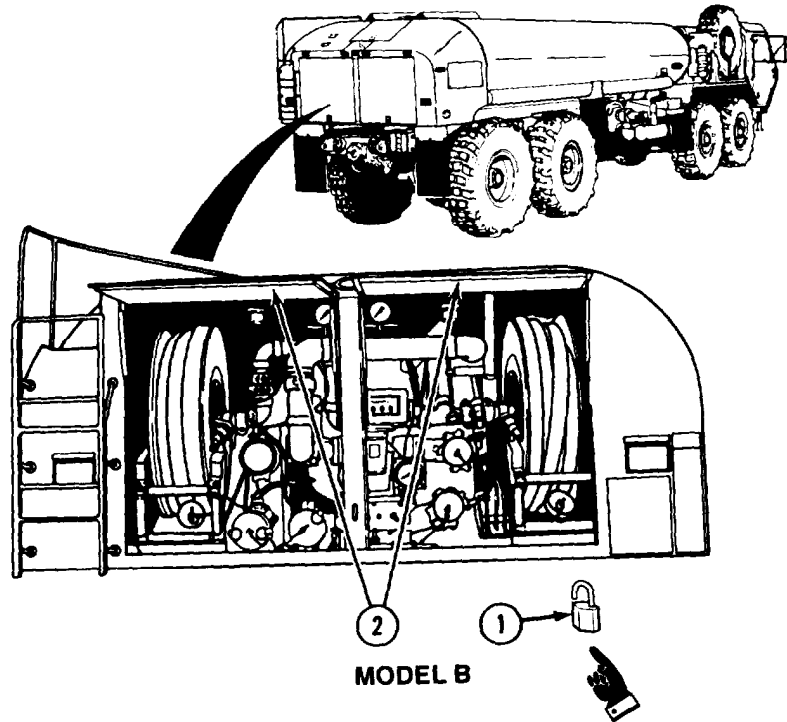
- (1) Start engine (para 2-11a or 2-11b), position vehicle for operation, and park vehicle (para 2-11o).
- (2) Shut off engine (para 2-11p).

NOTE

Perform all before-operation PMCS procedures (Table 2-3).



M978 Tanker Operating Procedures (Cont)



NOTE

Model B has locking pump module rear doors. Do step (2.1) for Model B.

(2.1) Remove lock (1), and stow lock to prevent loss.

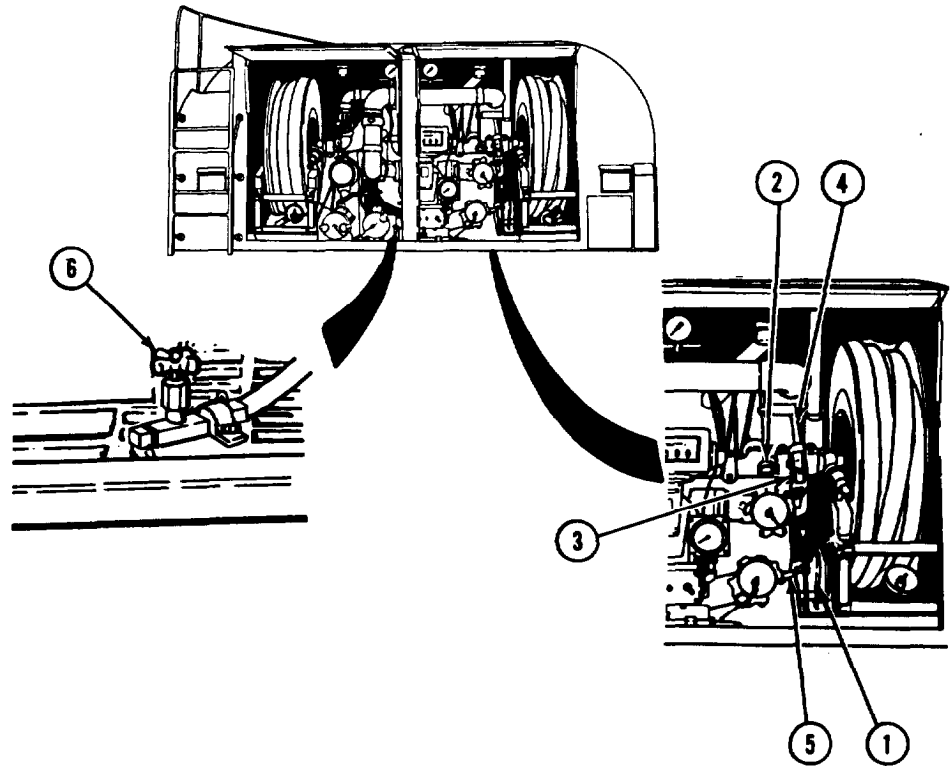
WARNING

Stand clear to avoid injury when opening pump module rear doors. When doors are about halfway open, gas pistons push doors open quickly and with much force.

(3) Open pump module rear doors (2).

M978 Tanker Operating Procedures (Cont)

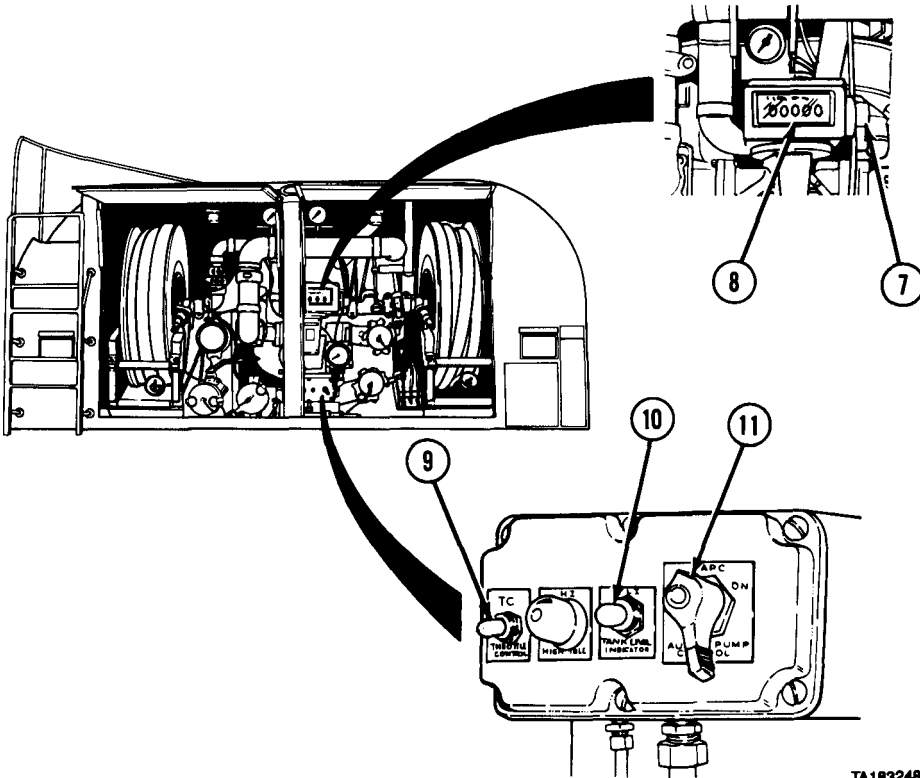
b. Position Tanker Controls.



- (1) Push MC MANUAL CONTROL EM VALVE lever (1) full forward and down.
- (2) Push V6 FUEL/DEFUEL VALVE (2) full into fueling position.
- (3) Close VII FLOW VALVE (REG) (3).
- (4) Push V8 REEL VALVE (H2) (4) straight up to close.
- (5) Close V18 BULK DEL VALVE (5).
- (6) Close V15 DRAIN VALVE (6).

M978 Tanker Operating Procedures (Cont)

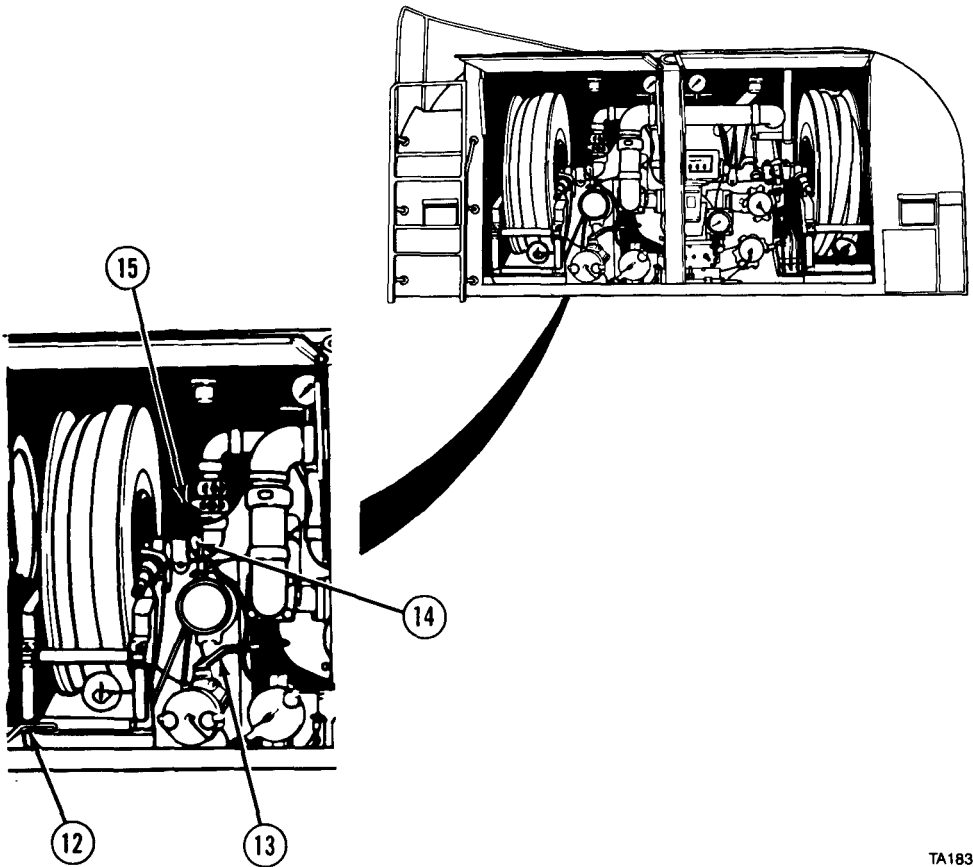
2-20. PREPARE TANKER FOR OPERATION (CONT).



TA183248

- (7) Turn flowmeter reset knob (7) to zero scale (8).
- (8) Set TC/THROTTLE CONTROL switch (9) down to OFF position.
- (9) Set TLI/TANK LEVEL INDICATOR switch (10) down to OFF position.
- (10) Set APC/AUXILIARY PUMP CONTROL switch (11) APC to shut off.

M978 Tanker Operating Procedures (Cont)

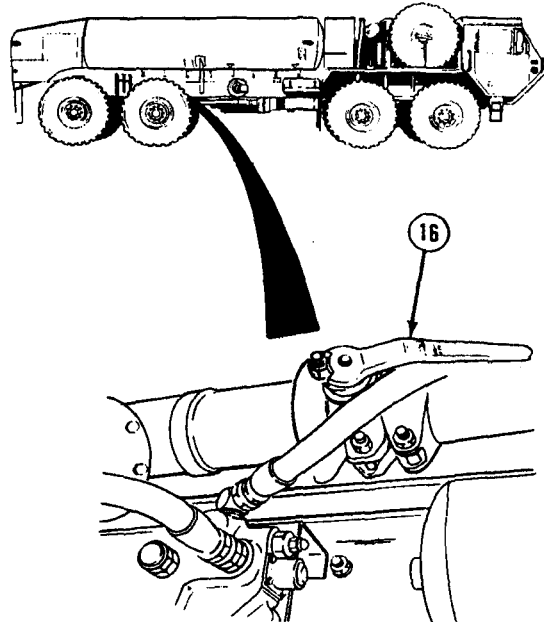


TA183243

- (11) Pull back on PUMP ENGAGEMENT LEVER (12) until locked.
- (12) Close V17 GRAVITY VALVE (13).
- (13) Close V12 B/L PRECHECK VALVE (14).
- (14) Close V7 REEL VALVE (H1) (15).

M978 Tanker Operating Procedures (Cont)

2-20. PREPARE TANKER FOR OPERATION (CONT).



TA183248

NOTE

- V3 SUCTION LINE VALVE is located inside left frame rail above rear end of air tank in front of no. 3 axle.
- V3 SUCTION LINE VALVE is shown in OPEN position. Valve is closed when lever is straight down.

(15) Move V3 SUCTION LINE VALVE handle (16) to OPEN position.

c. Bonding and Grounding.

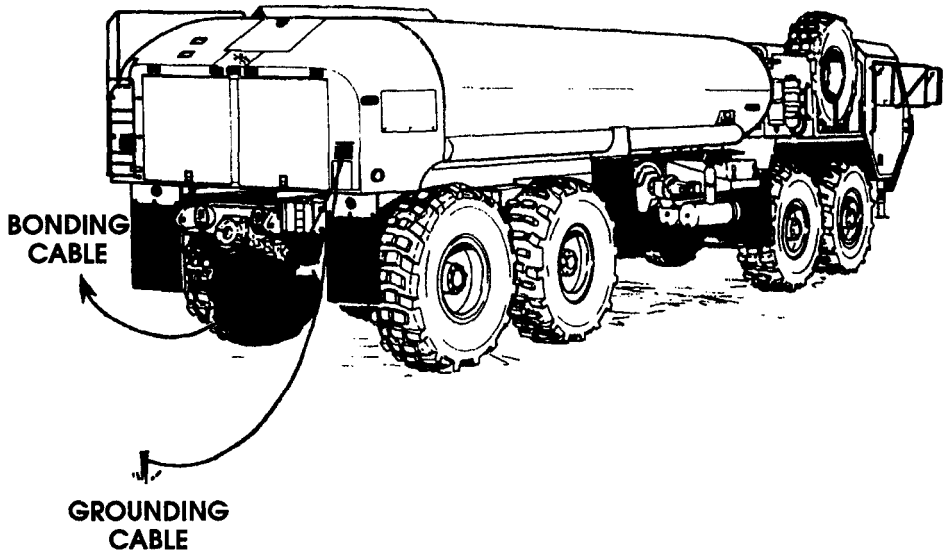
- (1) Bonding is the process of electrically connecting two units to equalize and form a path for any static potential that might develop during fueling procedures. Grounding is the process of electrically connecting single or bonded units to ground rods. This discharges into the earth any static potential that might exist at the beginning of the operation or that might develop during the operation.

M978 Tanker Operating Procedures (Cont)

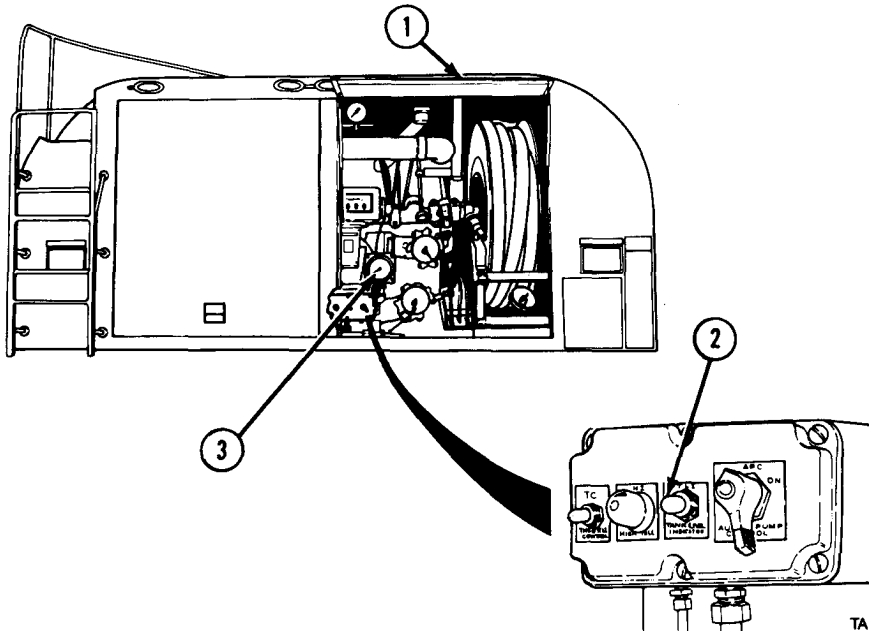
- (2) Both vehicles and equipment involved must be bonded and grounded before performing fueling procedures.

NOTE

If you use only one ground rod to ground both vehicles, you do not need to bond.



M978 Tanker Operating Procedures (Cont)

2-21. CHECK TANKER FUEL LEVEL.**a. Check Fuel Level With Gage.**

TA183246

WARNING

- No smoking, flame, sparks, hot or glowing objects allowed within 50 ft (15 m) of vehicle. Fire or explosion may cause personal injury or death.
- Stand clear to avoid injury when opening pump module rear door. When door is about halfway open, gas pistons push door open quickly and with much force.

- (1) Open right side pump module rear door (1).
- (2) Set TLI/TANK LEVEL INDICATOR switch (2) to ON.
- (3) Read tank fuel level on indicator gage (3).

NOTE

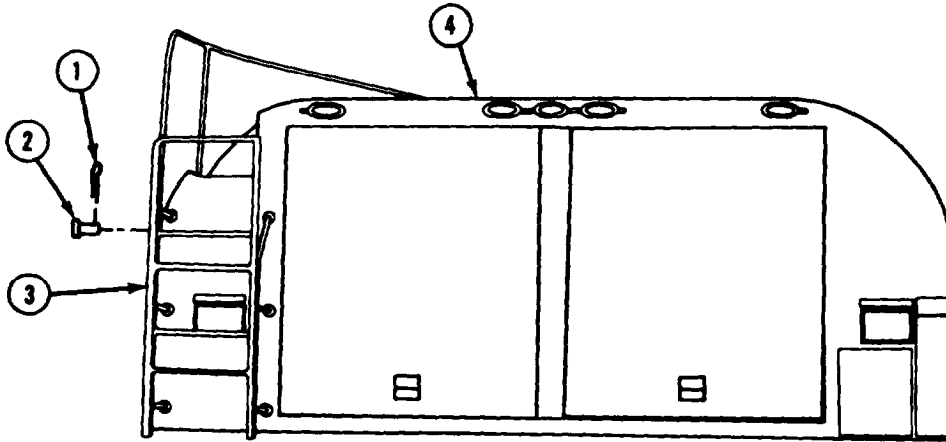
If TLI/TANK LEVEL INDICATOR gage does not show fuel level reading, check fuel level with dipstick (section b. of this para).

- (4) Set TLI/TANK LEVEL INDICATOR switch (2) to OFF.
- (5) Close right side pump module rear door (1).

M978 Tanker Operating Procedures (Cont)

2-21. CHECK TANKER FUEL LEVEL (CONT).

- b. Check Fuel Level With Dipstick.

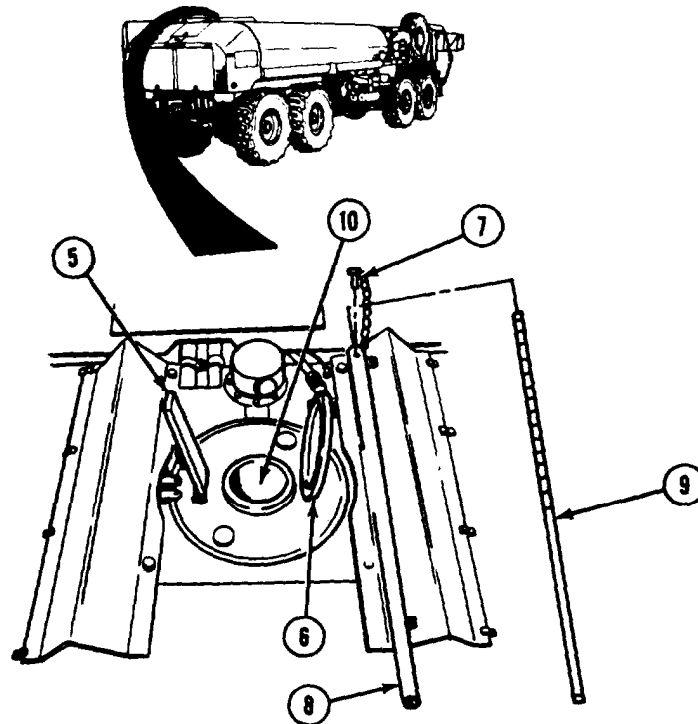


WARNING

Keeps hands clear of ladder hinge. Hands can be pinched and cause severe injury.

- (1) Remove safety pin (1) and pin (2). Lower ladder (3).
- (2) Install pin (2) and safety pin (1) in ladder (3).
- (3) Climb on top of tank (4).

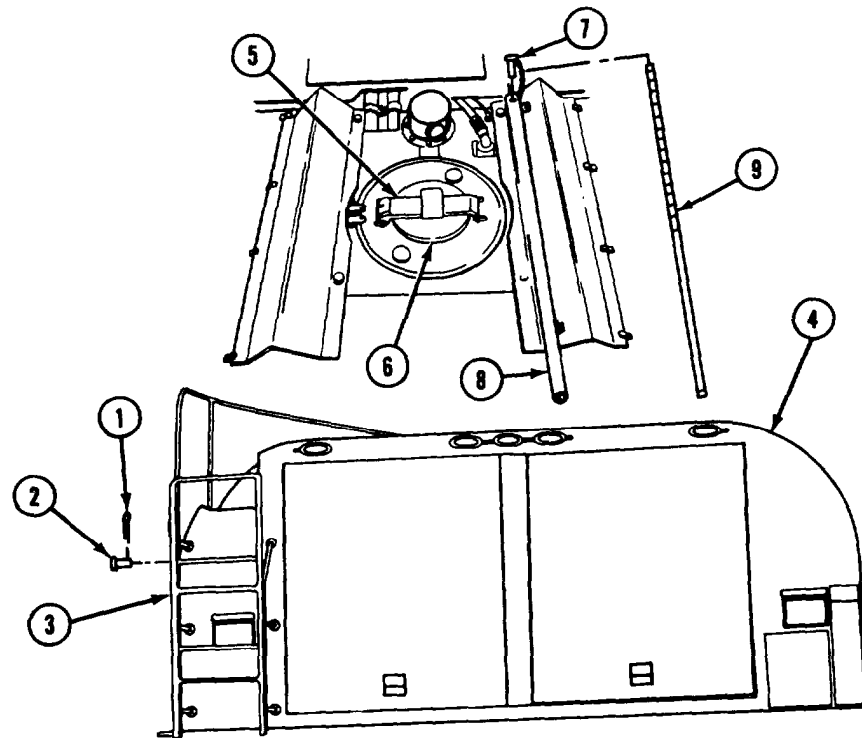
M978 Tanker Operating Procedures (Cont)



WARNING

Open manhole cover slowly to relieve pressure. If there is a pressure buildup, personnel may be injured.

- (4) Lift latch (5) and open manhole cover (6).
- (5) Remove pin (7) from end of sheath (8) and remove dipstick (9).
- (6) Lower dipstick (9) into manhole fill opening (10) until it touches bottom of tank.
- (7) Remove dipstick (9) and check marking for fuel level in tank.



- (8) Wipe off dipstick (9).
- (9) Push dipstick (9) in sheath (8) and install pin (7).
- (10) Close manhole cover (6) and secure latch (5).
- (11) Climb down from top of tank (4).
- (12) Remove safety pin (1) and pin (2).

WARNING

Keep hands clear of ladder hinge. Hands can be pinched and cause severe injury.

- (13) Raise ladder (3).
- (14) Install pin (2) and safety pin (1).

M978 Tanker Operating Procedures (Cont)

2-22. LOAD TANKER WITH FUEL.

a. *Bottom Load Tank With Exterior Pump.*

WARNING

No smoking, flame, sparks, glowing or hot objects allowed within 50 ft (15 m) of vehicle. Fire or explosion may cause personal injury or death.

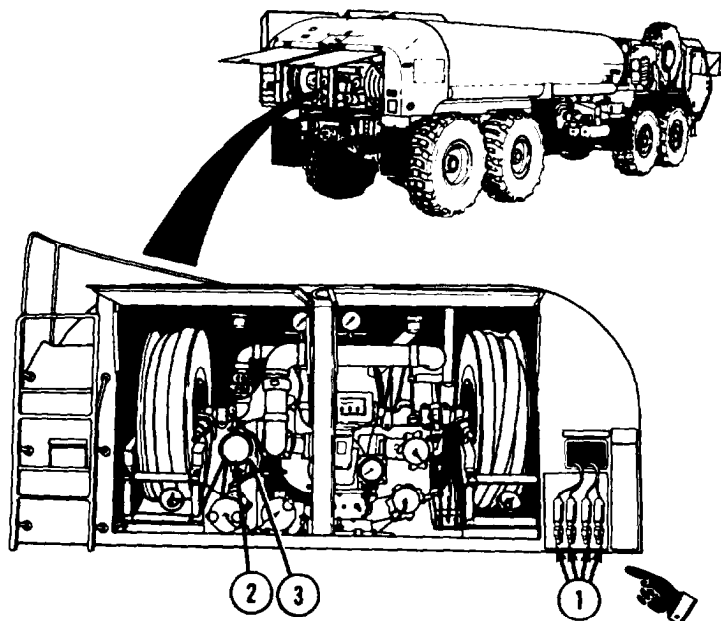
CAUTION

Drain and flush tank compartment, filter-separator and piping system with new product when changing to fuel or grade different from last one carried (para 2-26). Notify organizational maintenance to change all filter elements. Failure to do so may result in equipment damage.

NOTE

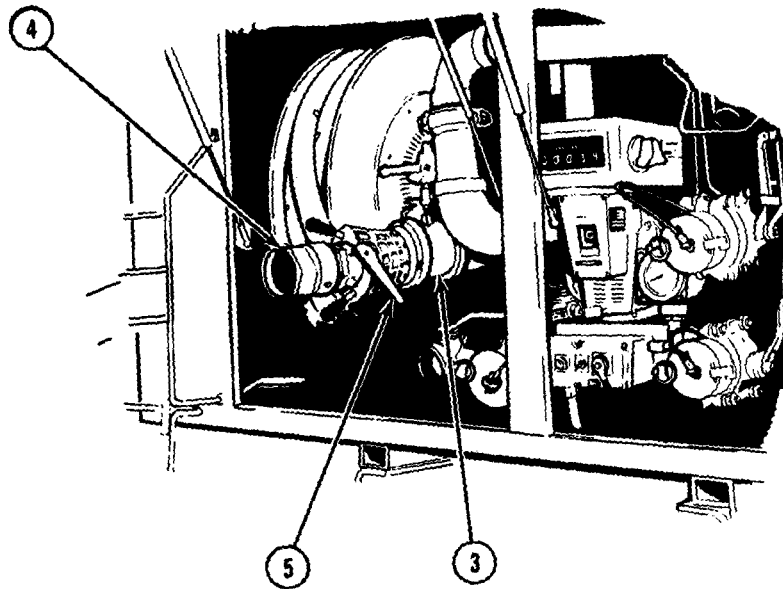
- Refer to FM 10-71 for general operating instructions for tanker vehicles.
- If equipment malfunctions, check that all steps of procedure have been performed in proper order. If equipment still malfunctions, do troubleshooting (Chapter 3).

Prepare tanker for operation (para 2-20).



M978 Tanker Operating Procedures (Cont)

- (2) Connect SR1 and SR2 static cables (1) to source of fuel and to grounding devices.
- (3) Remove dust cap (2) from A B/L RECEPTACLE (3).

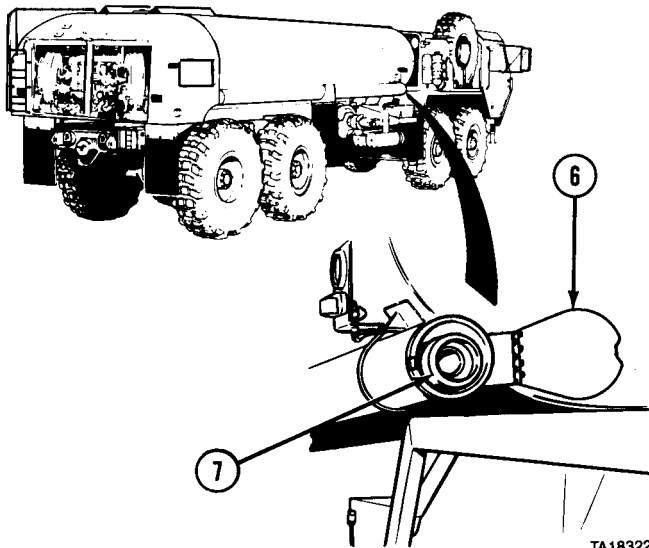


TA183257

- (4) Remove D1 adapter (4) from stowage.
- (5) Place end of D1 adapter (4) on A B/L RECEPTACLE (3) and align keyways.
- (6) Push in and turn D1 adapter (4) clockwise until locked in place.
- (7) Check that D1 adapter valve lever (5) is in CLOSE position.

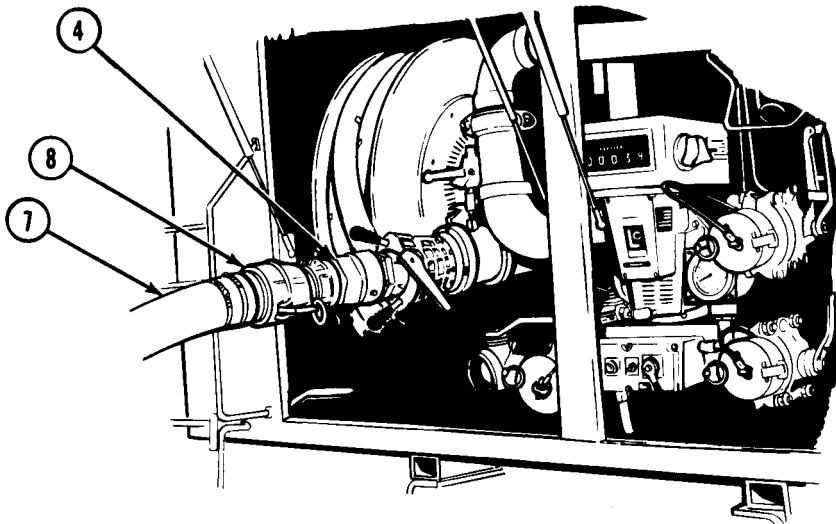
M978 Tanker Operating Procedures (Cont)

2-22. LOAD TANKER WITH FUEL (CONT).



TA183224

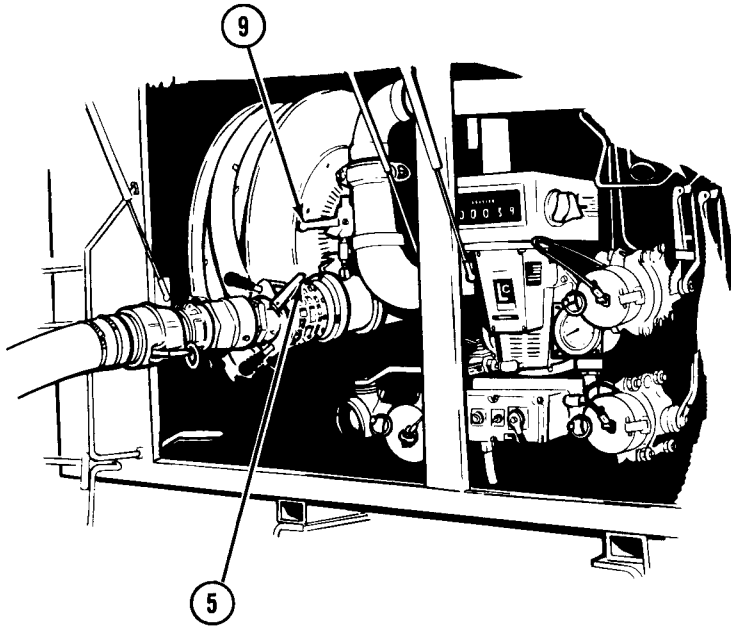
(8) Open stowage tube cover (6) and remove suction hose (7).



TA183225

- (9) Remove 3-inch adapter coupling (8) from stowage and connect to one end of suction hose (7).
- (10) Connect 3-inch adapter coupling (8) to D1 adapter (4).
- (11) Connect other end of suction hose (7) to fuel supply.

M978 Tanker Operating Procedures (Cont)



TA183250

- (12) After fuel flow is started by fuel station operator, move D1 adapter valve lever (5) to OPEN position.

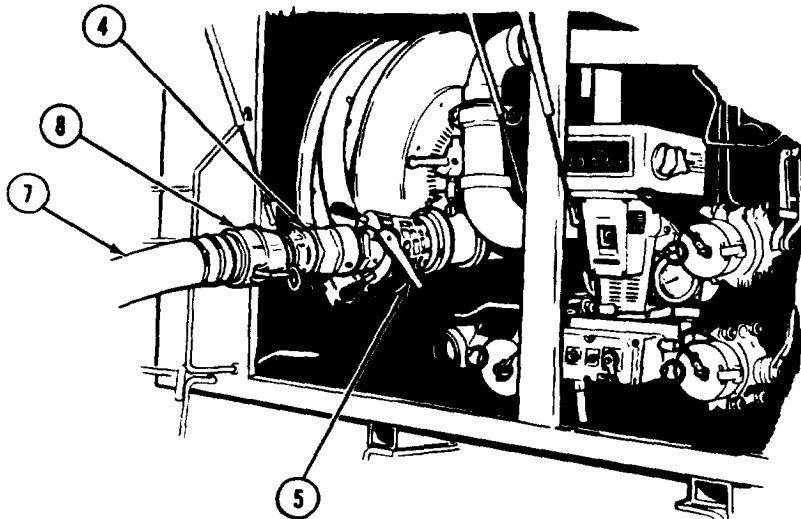
CAUTION

Do not continue fuel loading if fuel flow does not stop within about 15 seconds after V12 B/L PRECHECK VALVE is opened or tanker may be damaged.

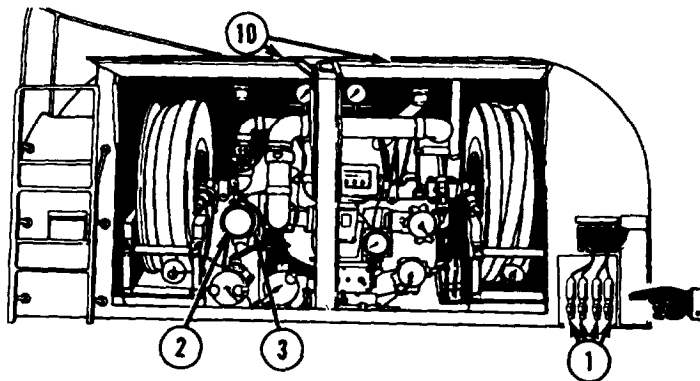
- (13) As soon as fuel starts flowing, open V12 B/L PRECHECK VALVE (9). If fuel flow stops within approximately 15 seconds, close V12 B/L PRECHECK VALVE and continue fuel loading. If fuel flow does not stop within approximately 15 seconds, stop fuel loading and notify organizational maintenance.

M978 Tanker Operating Procedures (Cont)

2-22. LOAD TANKER WITH FUEL (CONT).



- (14) When tank is full and fuel flow stops automatically, move D1 adapter valve lever (5) to CLOSE position.
- (15) After fuel station operator shuts off fuel, disconnect 3-inch adapter coupling (8) from DI adapter (4).
- (16) Remove DI adapter (4).
- (17) Drain fuel from suction hose (7) and dispose of fuel in accordance with unit SOP.
- (18) Disconnect suction hose (7) from fuel supply
- (19) Remove 3-inch adapter coupling (8) from suction hose (7).
- (20) Stow suction hose (7), 3-inch adapter coupling (8), and DI adapter (4).



M978 Tanker Operating Procedures (Cont)

- (21) Install dust cap (2) on A B/L RECEPTACLE (3).
- (22) Disconnect and rewind SR1 and SR2 static cables (1).
- (23) Close pump module rear doors (10).

b. Bottom Load Tank With Tanker Fuel Pump.**WARNING**

No smoking, flame, sparks, glowing or hot objects allowed within 50 ft (15 m) of vehicle. Fire or explosion may cause personal injury or death.

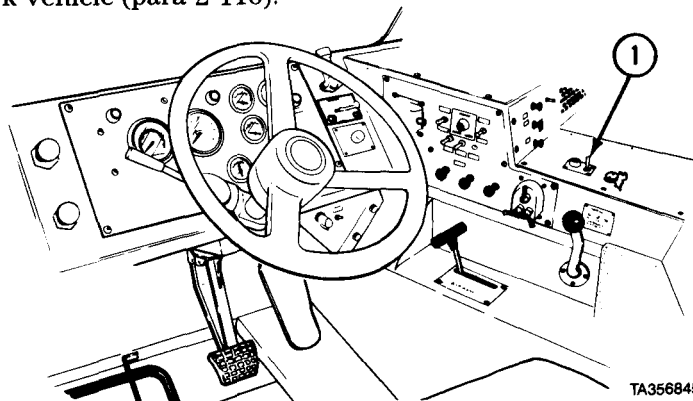
CAUTION

- Do not run tanker pump without fuel in system or damage to fuel pump and hydraulic motor may result.
- Do not press accelerator during tanker primary fuel pump operation. Engine speeds higher than 1500 rpm may cause damage to hydraulic motor and primary pump.
- Drain and flush tank compartment, filter-separator, and piping system with new product when changing to fuel or grade different from last one carried (para 2-26). Notify organizational maintenance to change all filter elements. Failure to do so may result in equipment damage.

NOTE

- Refer to FM 10-71 for general operating instructions for tanker vehicles.
- If equipment malfunctions, check that all steps of procedure have been performed in proper order. If equipment still malfunctions, do troubleshooting (Chapter 3).

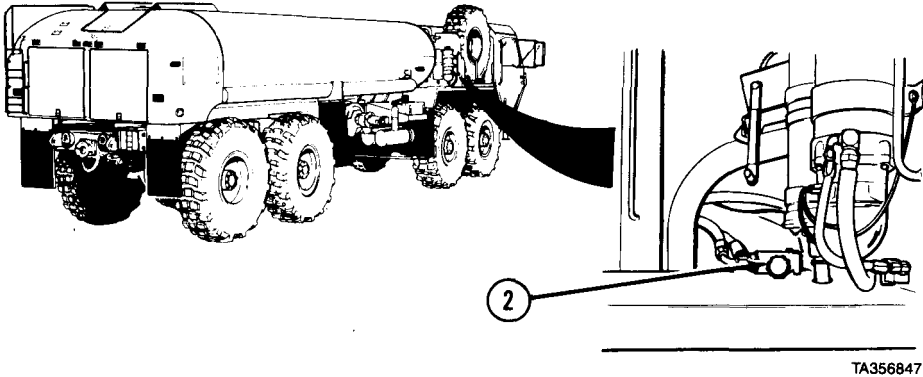
- (1) Start engine (para 2-11a or 2-11b) and position vehicle to load fuel.
- (2) Park vehicle (para 2-11o).



- (3) If vehicle is equipped with self-recovery winch, check that PTO ENGAGE switch (1) is set to OFF.

M978 Tanker Operating Procedures (Cont)

2-22. LOAD TANKER WITH FUEL (CONT).

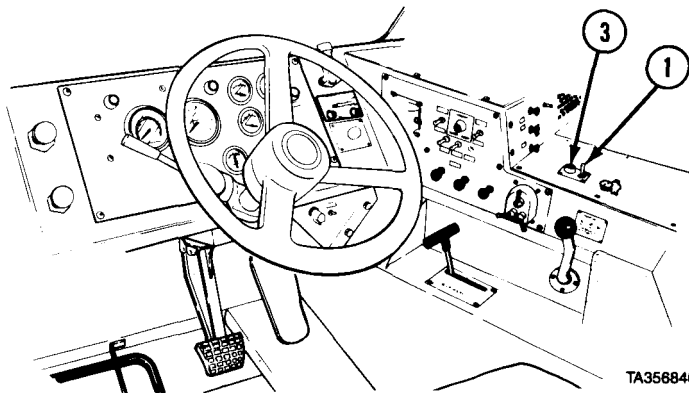


TA356847

CAUTION

Do not move SELECTOR VALVE while PTO is engaged or vehicle hydraulic equipment may be damaged.

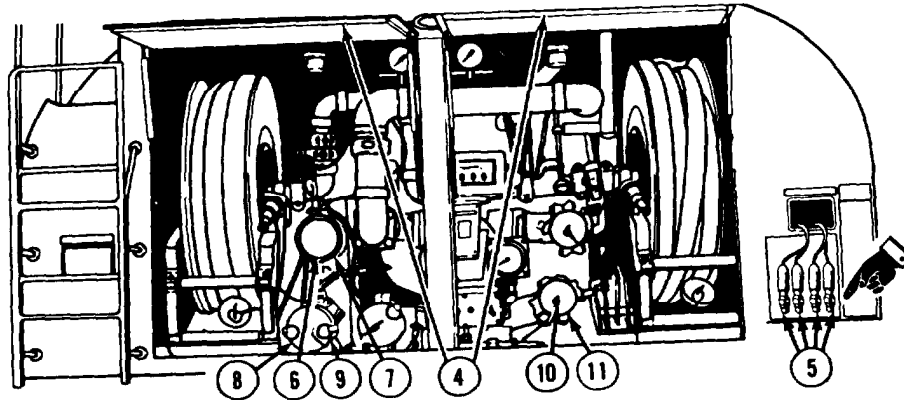
- (4) If vehicle is equipped with self-recovery winch, push in SELECTOR VALVE (2) for tanker pump operation.



TA356846

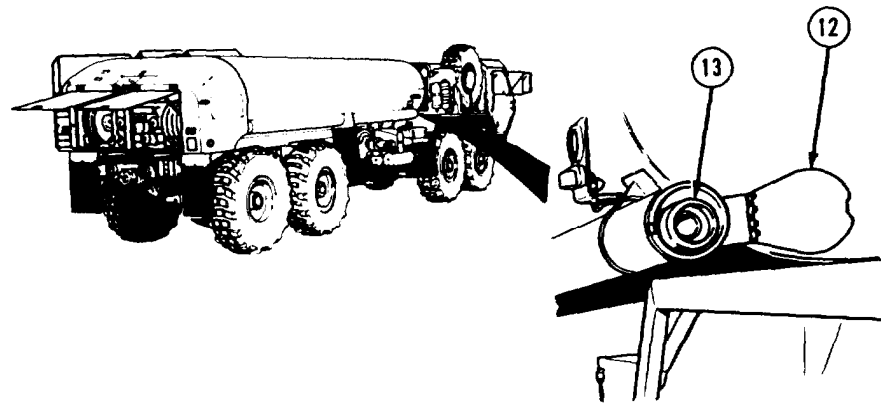
- (5) Set PTO ENGAGE switch (1) to ON position. Check that indicator light (3) comes on.

M978 Tanker Operating Procedures (Cont)

**WARNING**

Stand clear to avoid injury when opening pump module rear doors. When doors are about halfway open, gas pistons push doors open quickly and with much force.

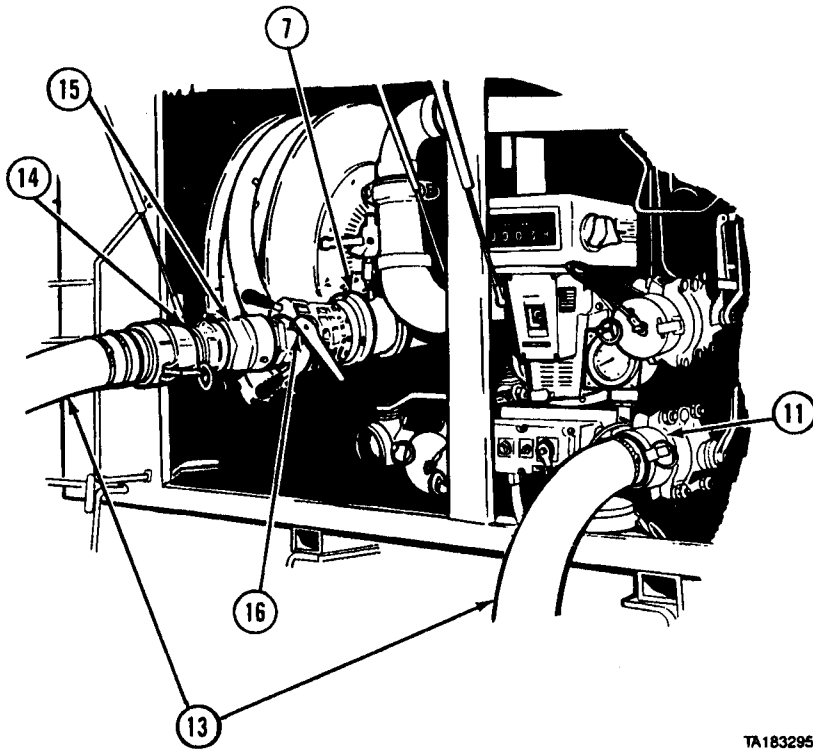
- (6) Open pump module rear doors (4).
- (7) Position tanker controls (para 2-20b).
- (8) Connect SRI and SR2 static cables (5) to source of fuel and to grounding devices.
- (9) Remove dust cap (6) from A B/L RECEPTACLE (7).
- (10) Remove dust cap (8) from B GRAVITY RECEPTACLE (9).
- (11) Remove dust cap (10) from C BULK RECEPTACLE (UNFIL) (11).



- (12) Open stowage tube cover (12) and remove suction hose (18).

M978 Tanker Operating Procedures (Cont)

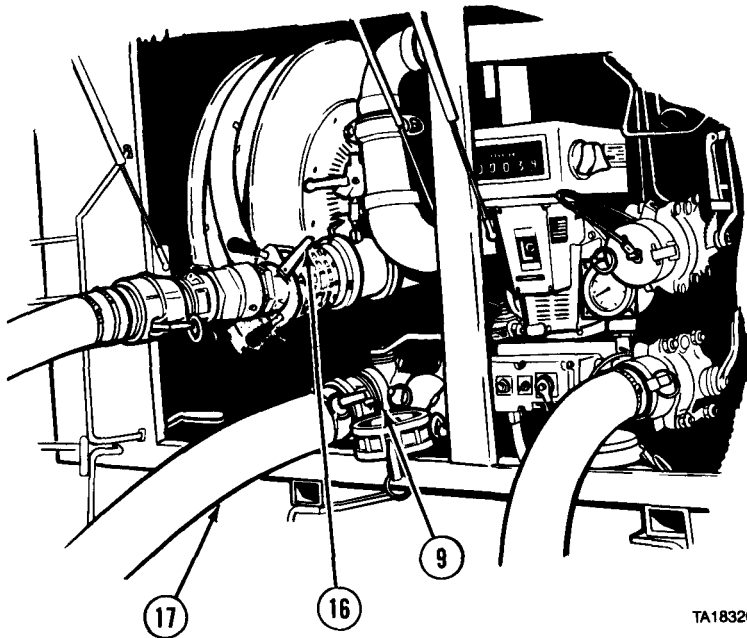
2-22. LOAD TANKER WITH FUEL (CONT).



TA183295

- (13) Remove 3-inch adapter coupling (14) and D1 adapter (15) from stowage.
- (14) Place end of D1 adapter (15) on A B/L RECEPTACLE (7) and aline keyways.
- (15) Push in and turn D1 adapter (15) clockwise until locked in place.
- (16) Check that D1 adapter valve lever (16) is in CLOSE position.
- (17) Connect 3-inch adapter coupling (14) to end of suction hose (13).
- (18) Connect 3-inch adapter coupling (14) to D1 adapter (15).
- (19) Connect other end of suction hose (13) to C BULK RECEPTACLE (UNFIL) (11).

M978 Tanker Operating Procedures (Cont)

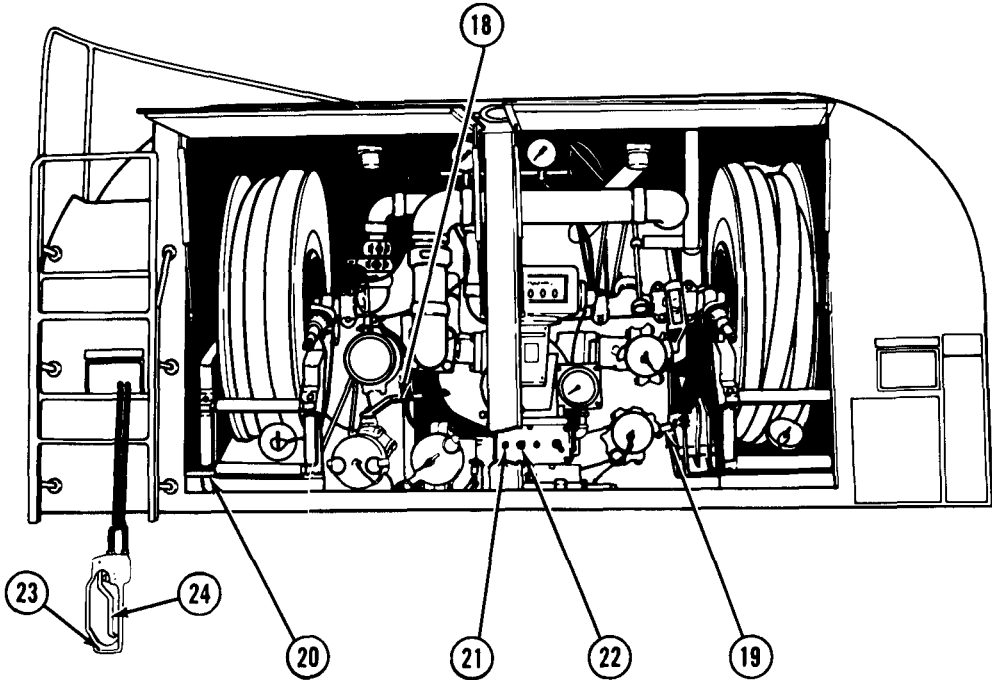


TA183261

- (20) Connect one end of fuel station suction hose (17) to B GRAVITY RECEPTACLE (9).
- (21) Connect other end of fuel station suction hose (17) to fuel supply.
- (22) After fuel flow control valve on fuel supply is opened by fuel station operator, set D1 adapter valve lever (16) to OPEN position.

M978 Tanker Operating Procedures (Cont)

2-22. LOAD TANKER WITH FUEL (CONT).



TA183227

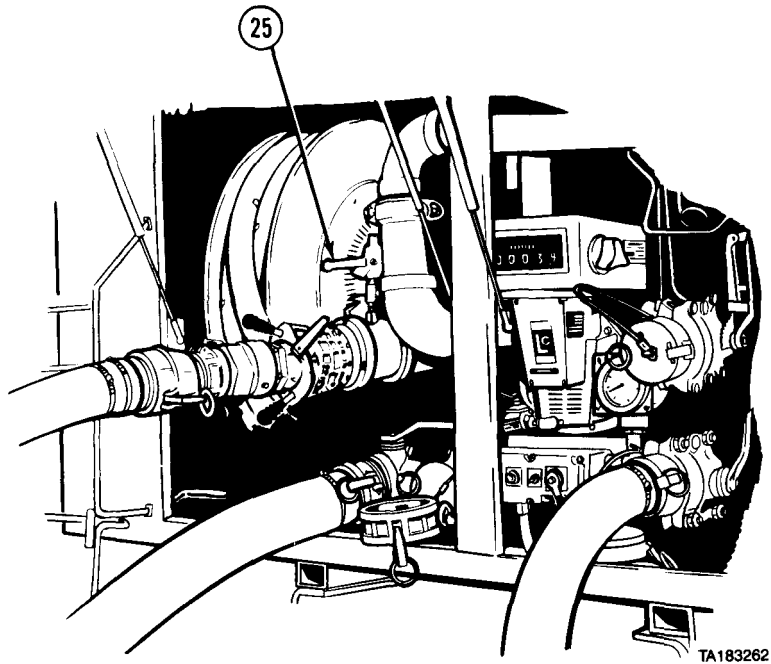
- (23) Open V17 GRAVITY VALVE (18).
- (24) Open V18 BULK DEL VALVE (19).
- (25) Push PUMP ENGAGEMENT LEVER (20) forward.
- (26) Set TC/THROTTLE CONTROL switch (21) up to ON position.
- (27) Press HI/HIGH IDLE switch (22).
- (28) Pull out HAV HAND ACTUATED CONTROL valve (23).

NOTE

HAV HAND ACTUATED CONTROL valve must be open for fuel to flow.

- (29) Squeeze and hold lever (24) to open HAV HAND ACTUATED CONTROL valve (23).

M978 Tanker Operating Procedures (Cont)

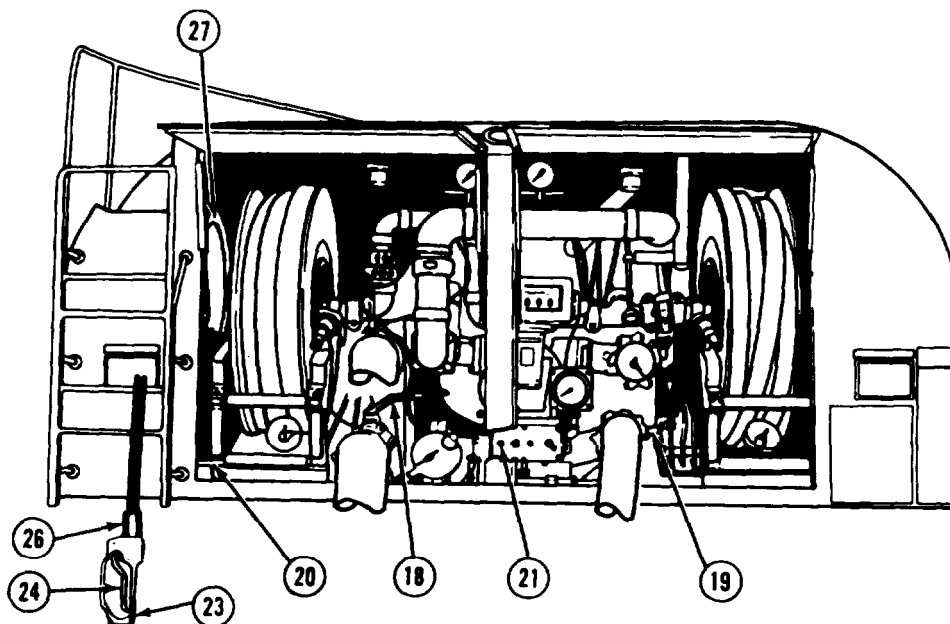
**CAUTION**

Do not continue fuel loading if fuel flow does not stop within about 15 seconds after V12 B/L PRECHECK VALVE is opened or tanker may be damaged.

- (30) As soon as fuel starts flowing, open V12 B/L PRECHECK VALVE (25). If fuel flow stops within approximately 15 seconds, close V12 B/L PRECHECK VALVE and continue fuel loading. If fuel flow does not stop within approximately 15 seconds, stop fuel loading and notify organizational maintenance.

M978 Tanker Operating Procedures (Cont)

2-22. LOAD TANKER WITH FUEL (CONT).



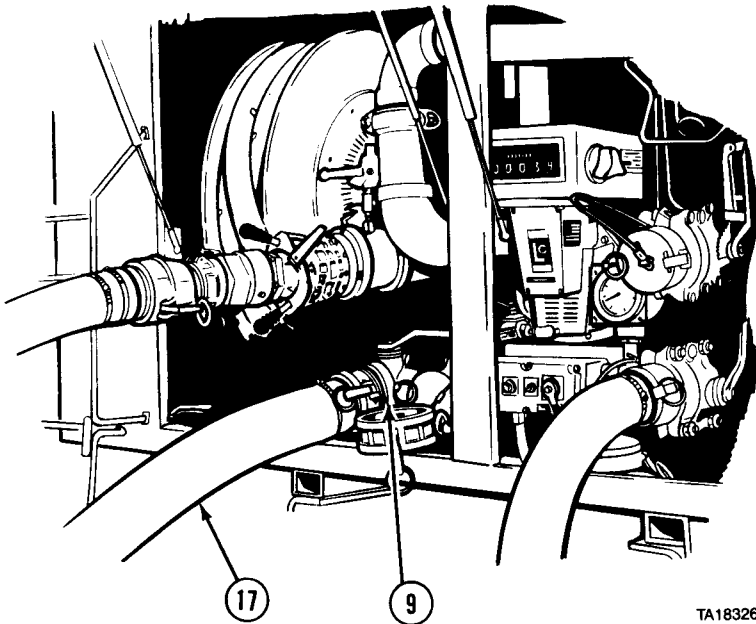
- (31) When tank is full and fuel flow stops automatically, let go of HAV HAND ACTUATED CONTROL valve lever (24).
- (32) Pull back on PUMP ENGAGEMENT LEVER (20) until locked.

CAUTION

Guide hoses back onto reel. Carefully guide control through access hole onto reel. Failure to do so may result in equipment damage.

- (33) Rewind HAV HAND ACTUATED CONTROL valve hoses (26) onto reel (27).
- (34) Set TC/THROTTLE CONTROL switch (21) down to OFF.
- (35) After fuel station operator shuts off fuel flow from fuel supply, close V18 BULK DEL VALVE (19).
- (36) Close V17 GRAVITY VALVE (18).

M978 Tanker Operating Procedures (Cont)



TA183263

- (37) Disconnect fuel station suction hose (17) from B GRAVITY RECEPTACLE (9).

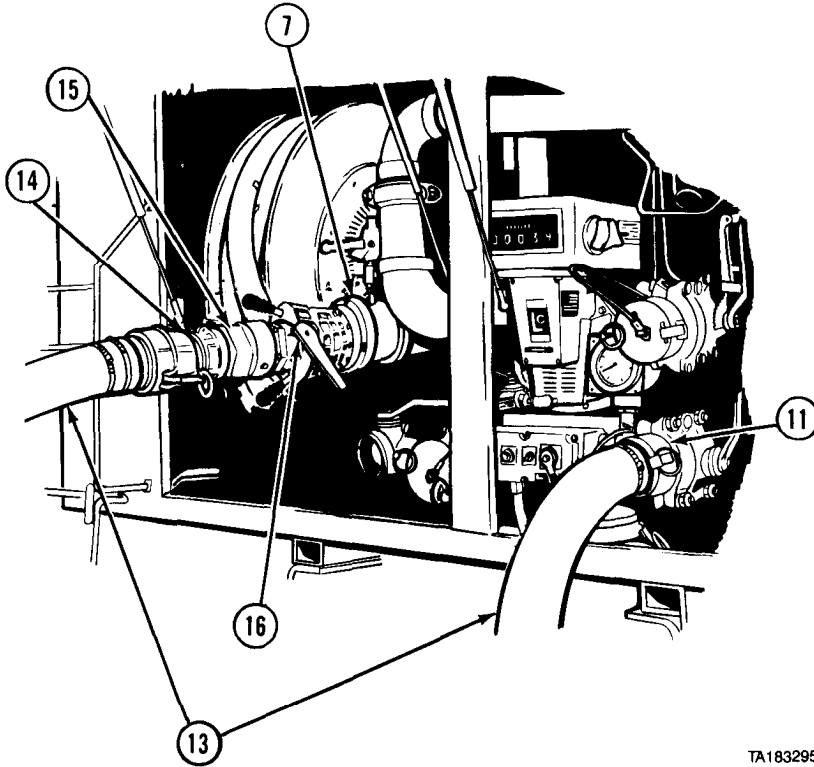
NOTE

Remove remaining fuel in fuel station suction hose by walking out hose.

- (38) Drain fuel from fuel station suction hose (17) and dispose of fuel in accordance with unit SOP.
 (39) Disconnect fuel station suction hose (17) from fuel supply.

M978 Tanker Operating Procedures (Cont)

2-22. LOAD TANKER WITH FUEL (CONT).



TA183295

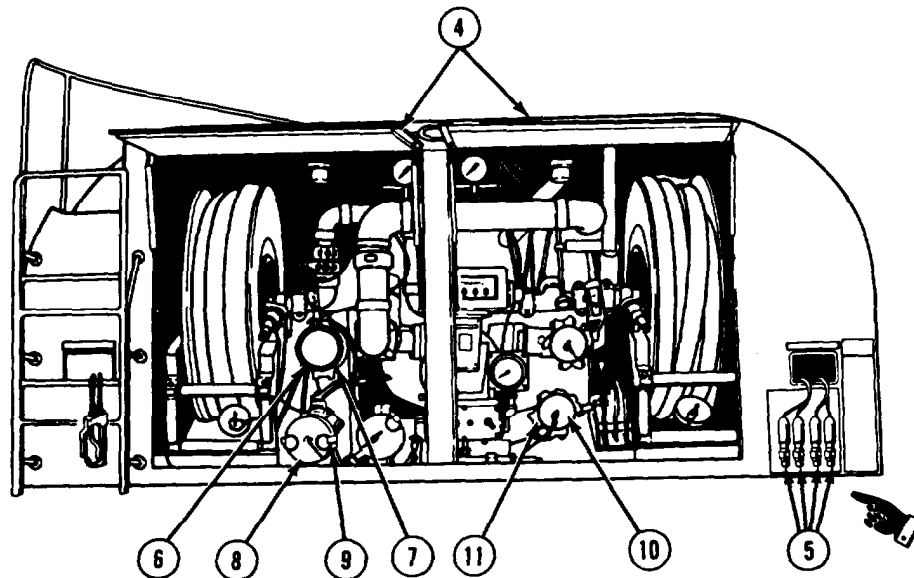
- (40) Set D1 adapter valve lever (16) to CLOSE position.
- (41) Remove D1 adapter (15) from A B/L RECEPTACLE (7).

NOTE

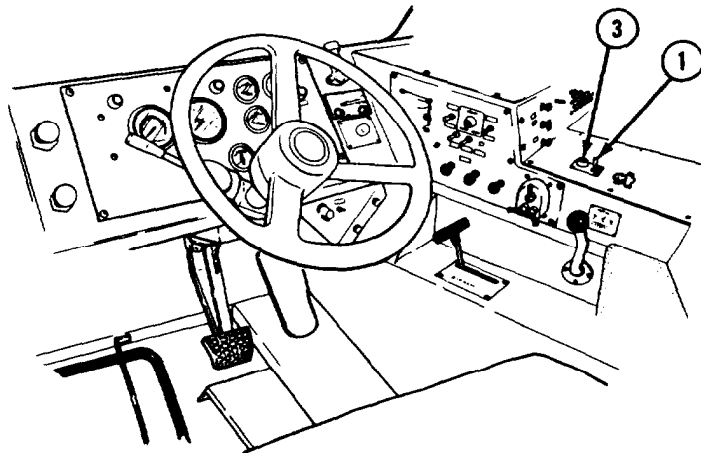
Remove remaining fuel in suction hose by walking out suction hose.

- (42) Drain fuel from suction hose (13) and dispose of fuel in accordance with unit SOP.
- (43) Disconnect 3-inch adapter coupling (14) from D1 adapter (15).
- (44) Disconnect suction hose (13) from C BULK RECEPTACLE (UNFIL) (11).
- (45) Remove 3-inch adapter coupling (14) from suction hose (13).
- (46) Stow 3-inch adapter coupling (14) and D1 adapter (15).
- (47) Stow suction hose (13) and return fuel station suction hose to fuel station operator.

M978 Tanker Operating Procedures (Cont)



- (48) Install dust caps (6, 8, and 10) on A B/L RECEPTACLE (7), B GRAVITY RECEPTACLE (9), and C BULK RECEPTACLE (UNFIL) (11).
- (49) Disconnect and rewind SRI and SR2 static cables (5).
- (50) Close pump module rear doors (4).



- (51) Set PTO ENGAGE switch (1) to OFF. Check that indicator light (3) goes out.
- (52) Shut off engine (para 2-11p).

M978 Tanker Operating Procedures (Cont)

2-22. Load tanker with fuel (cont).

WARNING

- Top loading will be done in emergency situations only, when bottom loading is not possible, and only by order of the Unit Commander. Top loading causes static electricity and vapors. To prevent fire or explosion, no smoking, flame, sparks, glowing or hot objects allowed within 50 ft (15 m) of vehicle. Fire or explosion may cause personal injury or death,
- To prevent explosion caused by electrostatic charge, ground self and equipment before opening manhole cover.

CAUTION

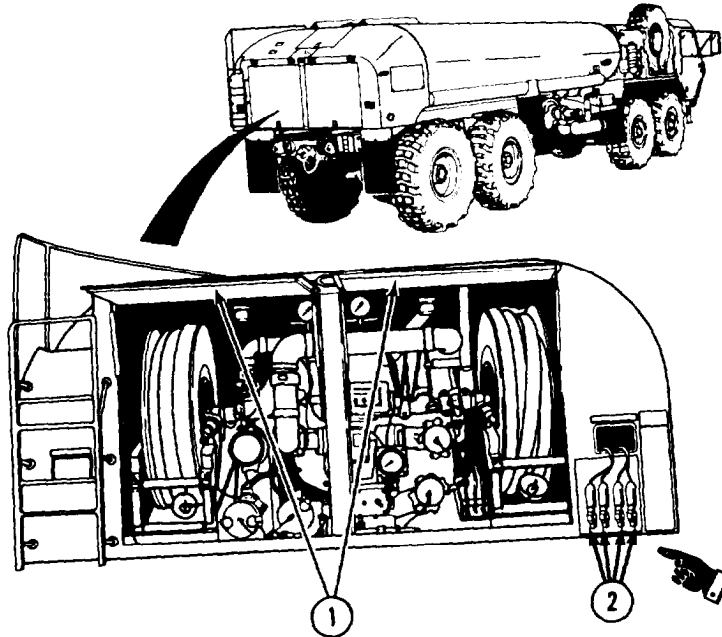
- Drain and flush tank compartment, filter-separator, and piping system with new product when changing to fuel or grade different from last one carried (para 2-26). Notify organizational maintenance to change all filter elements. Failure to do so may result in equipment damage.
- Use top loading only when bottom loading is not possible. An observer should be placed at the manhole cover opening as a safety precaution.

NOTE

- Fuel should only be loaded through manhole when bottom loading cannot be done. Tank should be bottom loaded whenever possible (para 2-22.a or 2-22.b).
- Refer to FM 10-71 for general operating instructions for tanker vehicles.
- If equipment malfunctions, check that all steps of procedure have been performed in proper order. If equipment still malfunctions, do troubleshooting (Chapter 3).
- When top loading, slowly begin the flow of product and continue at a reduced rate until the lower end of the drop tube or discharge hose is covered with product. Then gradually increase the flow rate and fill the tank.

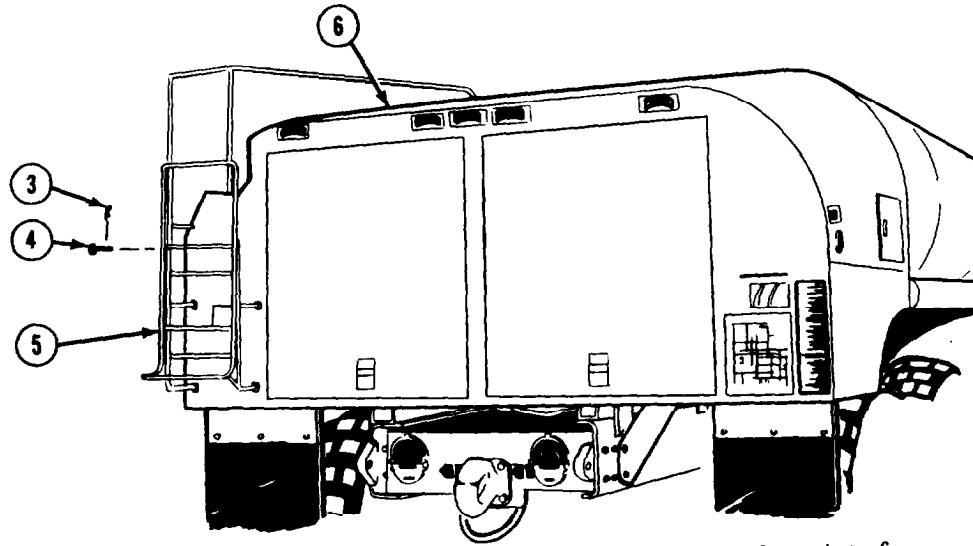
(1) Prepare tanker for operation (para 2-20).

M978 Tanker Operating Procedures (Cont)



- (2) Close pump module rear doors (1).
- (3) Connect SR1 and SR2 static cables (2) to the fuel source and to grounding devices.

M978 Tanker Operating Procedures (Cont)



Remove the fire extinguishers and bring them to the point of operation.

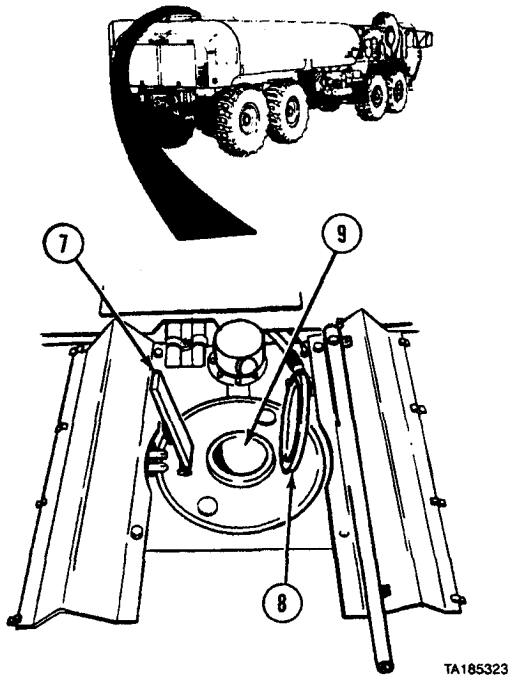
WARNING

Keep hands clear of ladder hinge. Hands can be pinched and cause severe injury.

- (4) Remove safety pin (3) and pin (4). Lower ladder (5).
- (5) Install pin (4) and safety pin (3) in ladder.
- (6) Climb on top of tank (6).

M978 Tanker Operating Procedures (Cont)

2-22. LOAD TANKER WITH FUEL (CONT).

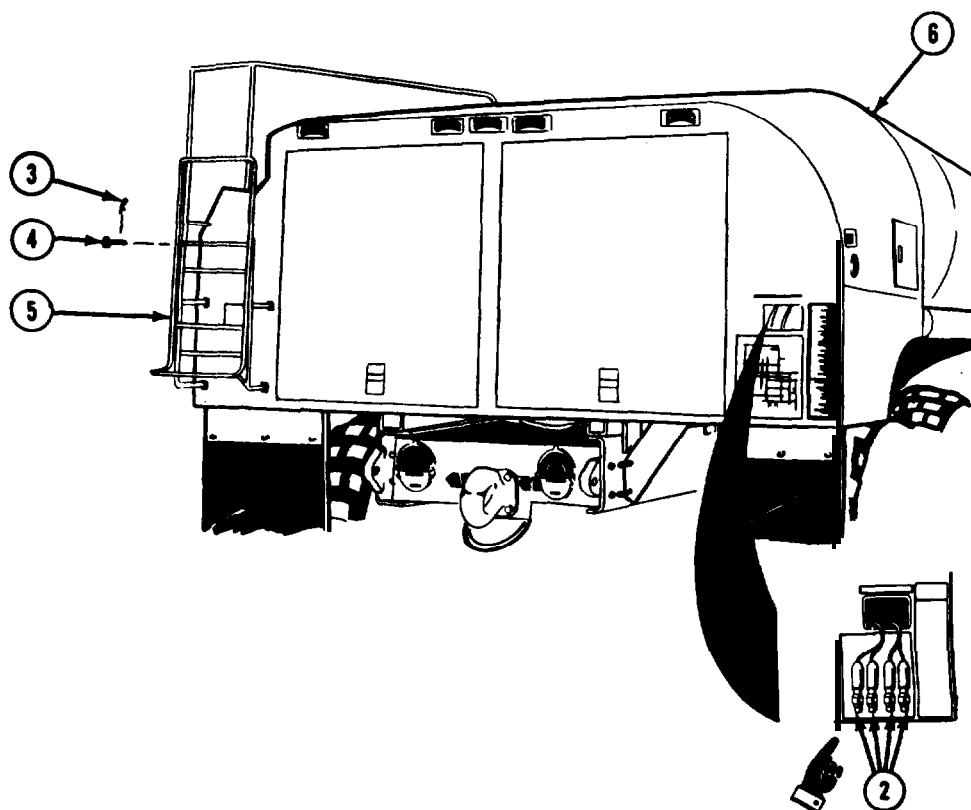


WARNING

Open manhole slowly to relieve pressure. If there is a pressure buildup, personnel may be injured.

- (7) Lift latch (7) and open manhole cover (8).
- (8) Place fillstand downspout in manhole fill opening (9), or place the hose through the manhole fill opening so that it touches the bottom of the tank. This reduces vapor and lessens the chance of fire.
- (9) After fuel station operator fills tank to desired level and stops fuel flow, remove fillstand downspout or hose from manhole fill opening (9).
- (10) Close manhole cover (8) and secure latch (7).

M978 Tanker Operating Procedures (Cont)



- (11) Climb down from top of tank (6).
- (12) Remove safety pin (3) and pin (4) from ladder (5).

WARNING

Keep hands clear of ladder hinge. Hands can be pinched and cause severe injury.

- (13) Raise ladder (5).
- (14) Install pin (4) and safety pin (3).
- (15) Disconnect and rewind SR1 and SR2 static cables (2).
- (16) Stow fire extinguishers.

M978 Tanker Operating Procedures (Cont)

2-23. LAND VEHICLE OR AIRCRAFT OVERWING FUEL SERVICING.

a. Prepare Vehicle.

WARNING

No smoking, flame, sparks, glowing or hot objects allowed within 50 ft (15 m) of vehicle. Fire or explosion may cause personal injury or death.

CAUTION

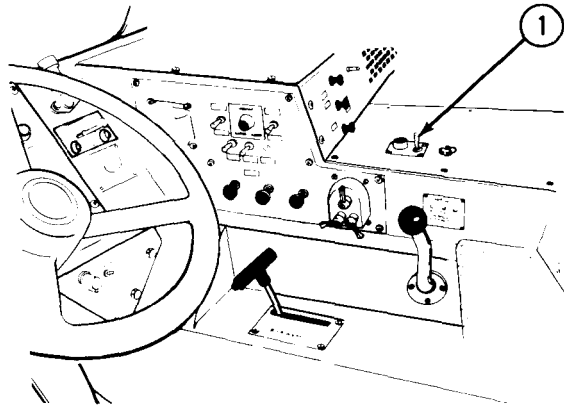
- Do not run tanker pump without fuel in system or damage to fuel pump and hydraulic motor may result.
- Do not press accelerator during tanker primary fuel pump operation. Engine speeds higher than 1500 rpm may cause damage to hydraulic motor and primary pump.

NOTE

- Refer to FM 10-71 for general operating instructions for tank vehicles. Refer to FM 10-68 for information on aircraft fueling.
- If equipment malfunctions, check that all steps of procedure have been performed in proper order. If equipment still malfunctions, do troubleshooting (Chapter 3).

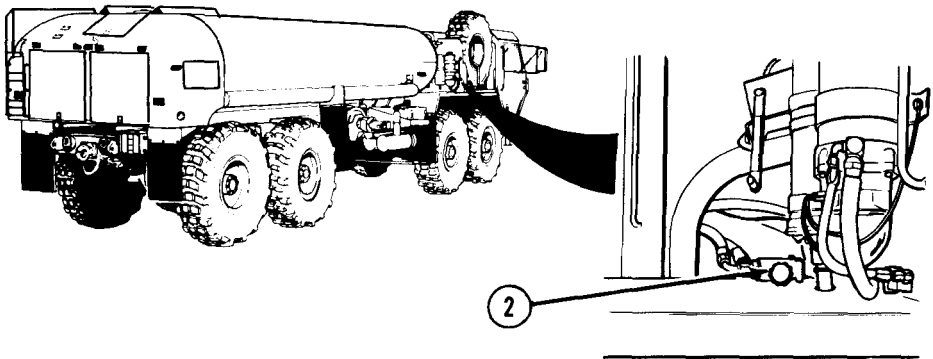
- (1) Start engine (para 2-11a or 2-11b) and position vehicle for fuel servicing.
- (2) Park vehicle (para 2-11o).

M978 Tanker Operating Procedures (Cont)



TA183235

- (3) If vehicle is equipped with self-recovery winch, check that PTO ENGAGE switch (1) is set to OFF.



TA356847

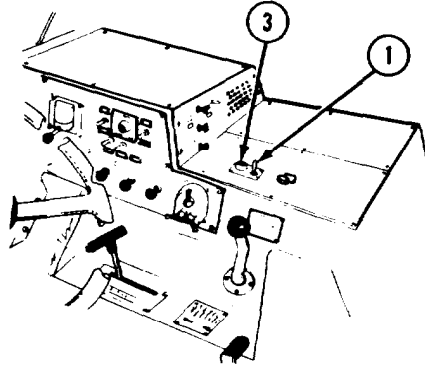
CAUTION

Do not move SELECTOR VALVE while PTO is engaged or vehicle hydraulic equipment may be damaged.

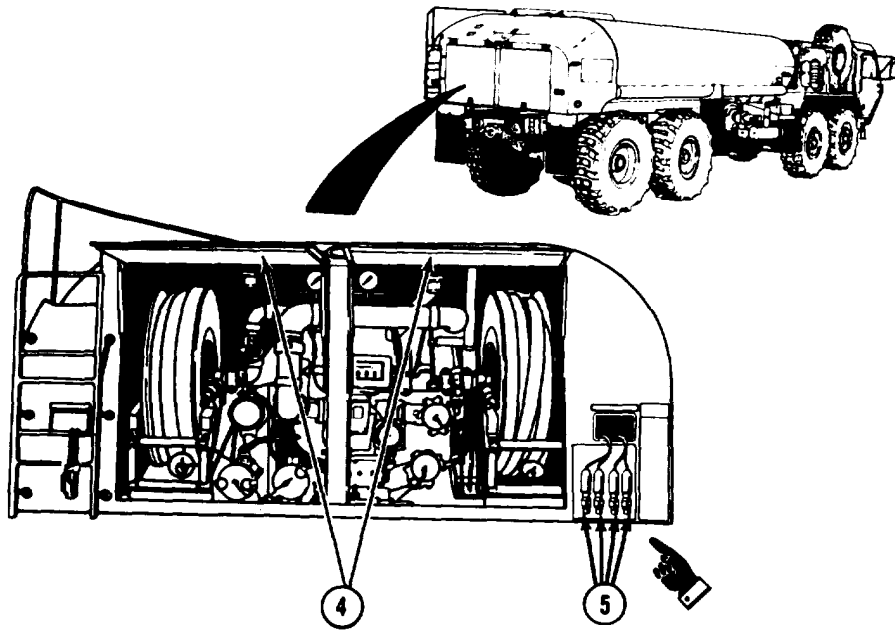
- (4) If vehicle is equipped with self-recovery winch, push in SELECTOR VALVE (2) for tanker pump operation.

M978 Tanker Operating Procedures (Cont)

2-23. LAND VEHICLE OR AIRCRAFT OVERWING FUEL SERVICING (CONT).



- (5) Set PTO ENGAGE switch (1) to ON position. Indicator light (3) should come on.



M978 Tanker Operating Procedures (Cont)

WARNING

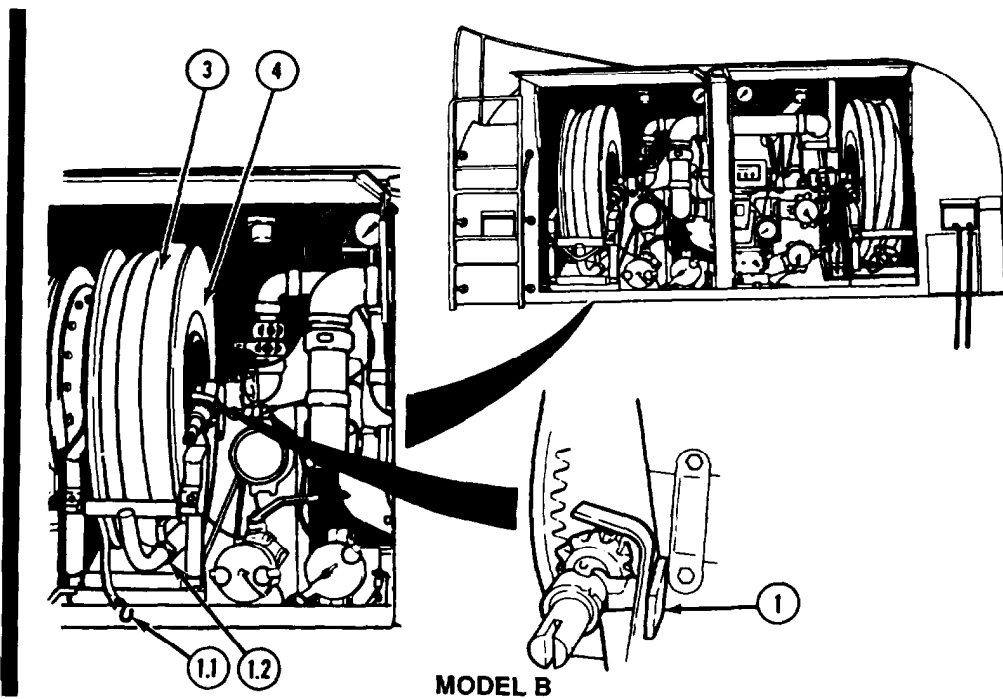
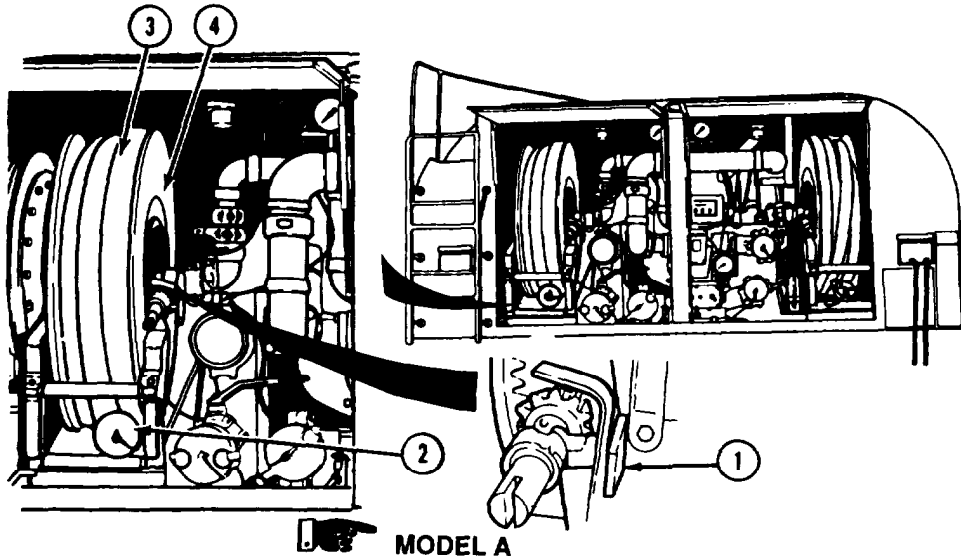
Stand clear to avoid injury when opening pump module rear doors. When doors are about halfway open, gas pistons push doors open quickly and with much force.

- (6) Open pump module rear doors (4).
- (7) Position tanker controls (para 2-20b).
- (8) Connect SRI and SR2 static cables (5) to vehicle being serviced and grounding devices.

M978 Tanker Operating Procedures (Cont)

2-23. LAND VEHICLE OR AIRCRAFT OVERWING FUEL SERVICING (CONT).

b. Fuel Servicing.



M978 Tanker Operating Procedures (Cont)

NOTE

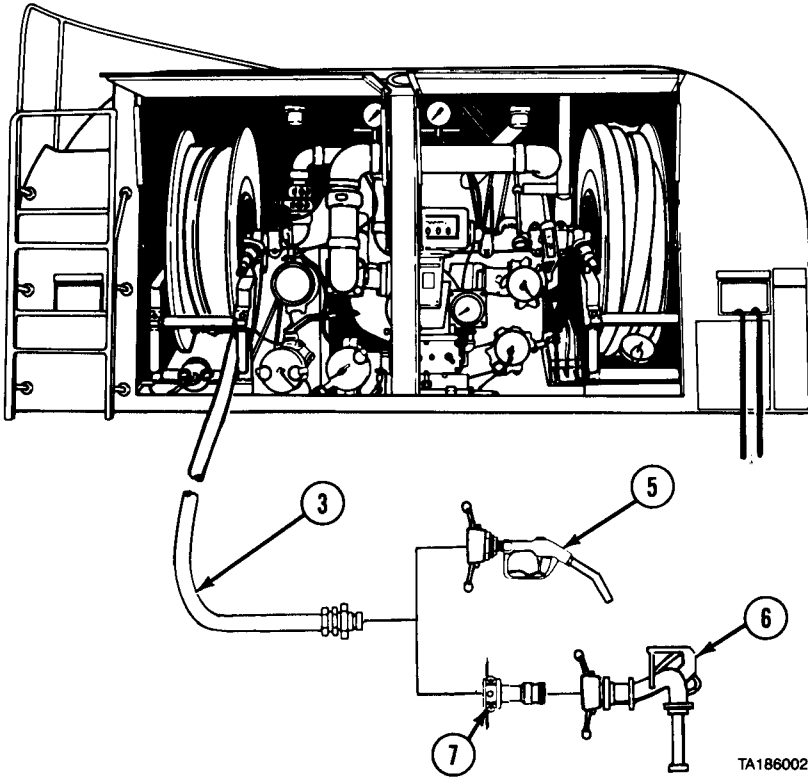
- Left side hose is shown. Procedure for using right side hose is same.

- Model B has a rubber tiedown strap to secure fuel service nozzle in stowage position. If nozzle is in stowage position, do step (1.1) and skip steps (2) and (5) through (8). |

- (1) Disengage hose reel tension knob (1).
- (1.1) Remove rubber tiedown strap (1.1) to release fuel service nozzle (1.2) from stowage position. |
- (2) Remove dust cap (2) from end of hose (3).
- (3) Pull hose (3) completely out from reel (4).
- (4) Engage hose reel tension knob (1).

M978 Tanker Operating Procedures (Cont)

2-23. LAND VEHICLE OR AIRCRAFT OVERWING FUEL SERVICING (CONT).



NOTE

Use fuel service nozzle for fueling land vehicles. Use overwing nozzle for overwing fueling of aircraft.

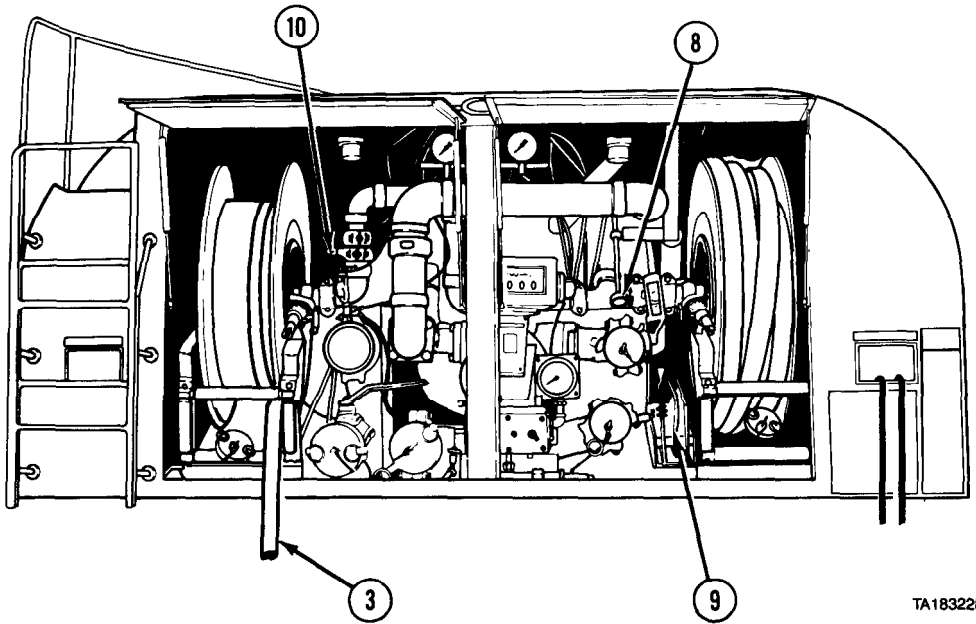
- (5) Remove fuel service nozzle (5) or overwing nozzle (6) from stowage.

NOTE

Reducer adapter is used with overwing nozzle only. If overwing nozzle is not used, skip steps (6) and (7).

- (6) Remove reducer adapter (7) from stowage.
- (7) Install reducer adapter (7) on hose (3).
- (8) Install fuel service nozzle (5) or overwing nozzle (6) on hose (3) or reducer adapter (7).

M978 Tanker Operating Procedures (Cont)



TA183228

- (9) Push in V6 FUEL/DEFUEL VALVE control rod (8).
- (10) Pull back MC MANUAL CONTROL EM VALVE lever (9).

NOTE

Refer to paragraph 2-2., figure 2-11, for information about DLPG discharge line pressure gage and VNPG venturi-nozzle pressure gage.

- (11) Determine required rate of delivery for hose being used (Table 2-6).

NOTE

V8 REEL VALVE controls rate of fuel delivery when right side hose is used for fueling.

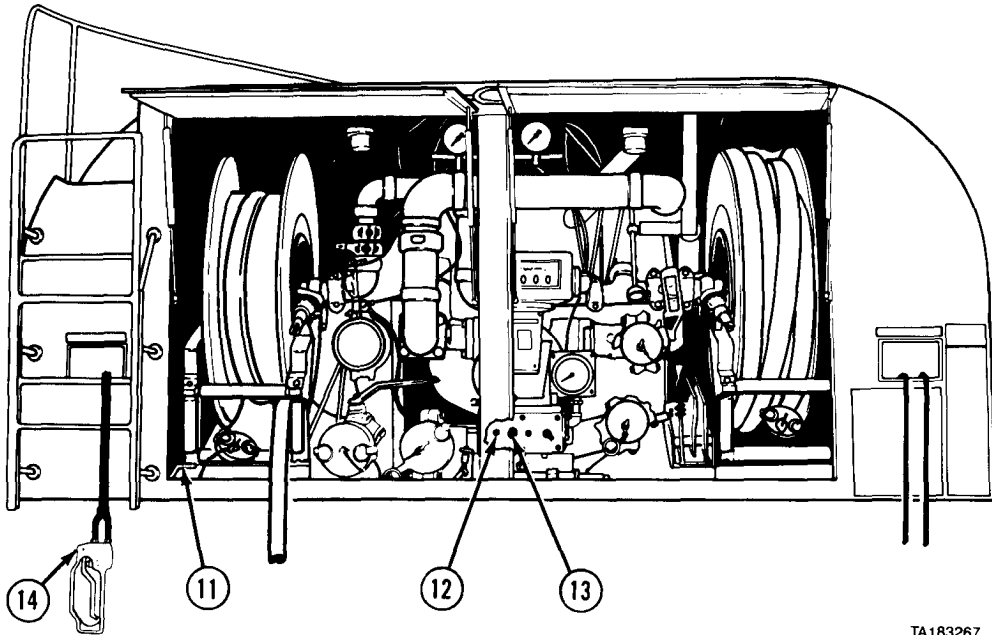
- (12) Adjust V7 REEL VALVE (10) to control rate of fuel delivery through hose (3).

Table 2-6. V7 AND V8 REEL VALVE FUELING DELIVERY RATES

Position	Gallons per Minute
1, 2, 3, 4	105 ± 5
5	90 ± 5
6	75 ± 5
7	50 ± 5
8	15 ± 5

M978 Tanker Operating Procedures (Cont)

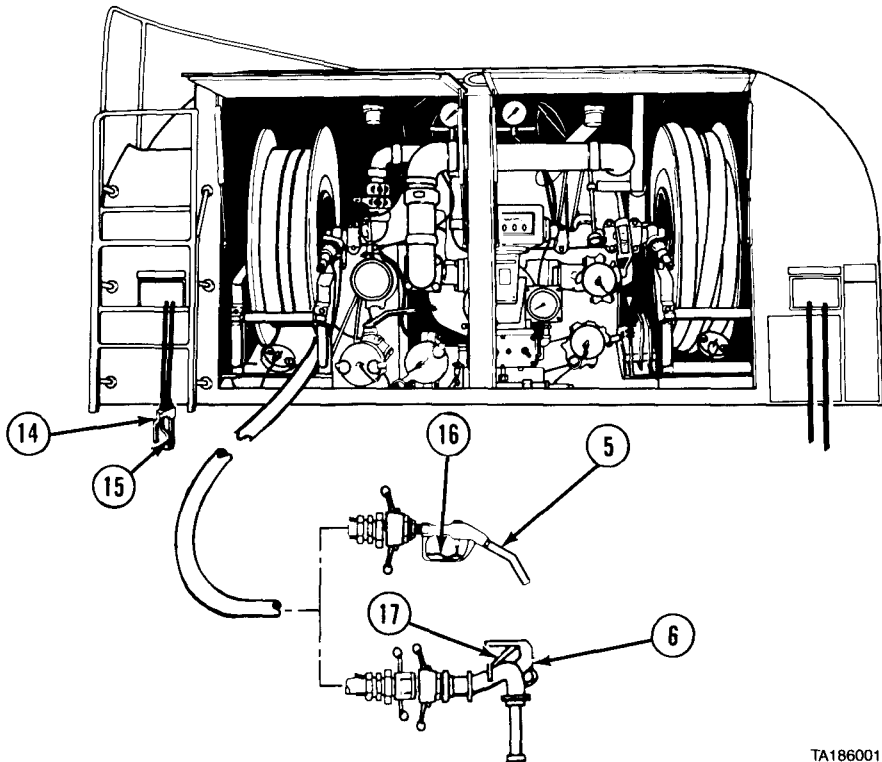
2-23. LAND VEHICLE OR AIRCRAFT OVERWING FUEL SERVICING (CONT).



TA183267

- (13) Push PUMP ENGAGEMENT LEVER (11) forward.
- (14) Set TC/THROTTLE CONTROL switch (12) up to ON position.
- (15) Press HI/HIGH IDLE switch (13).
- (16) Pull out HAV HAND ACTUATED CONTROL valve (14).
- (17) Remove fuel filler cover from receiving vehicle or aircraft.

M978 Tanker Operating Procedures (Cont)



TA186001

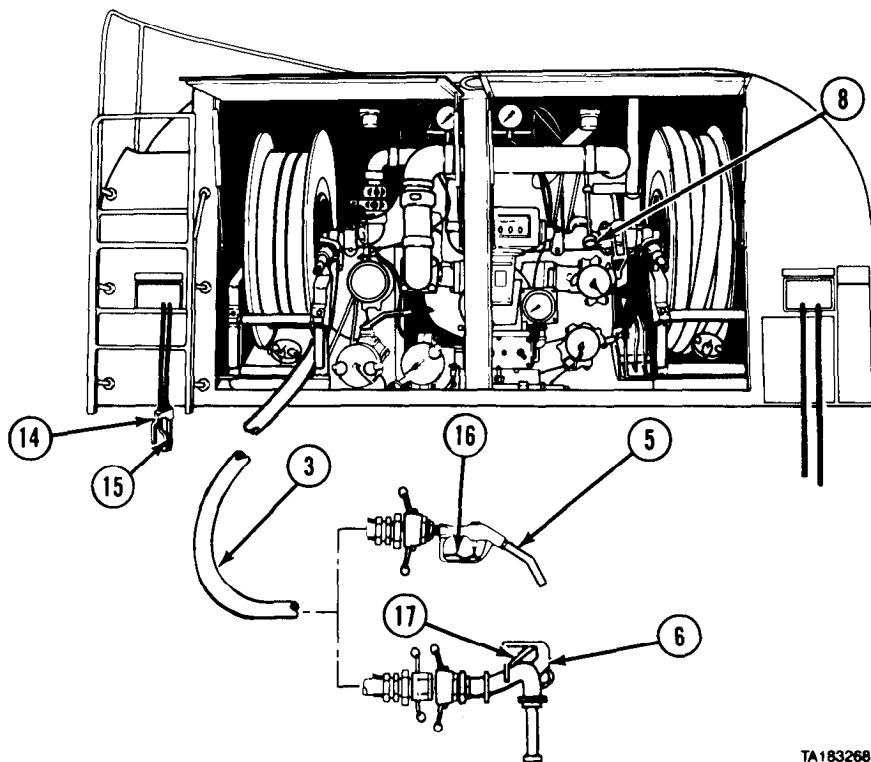
- (18) Insert fuel service nozzle (5) or overwing nozzle (6) through fuel filler of receiving vehicle or aircraft.

NOTE

HAV HAND ACTUATED CONTROL valve must be open for fuel to flow.

- (19) Squeeze and hold lever (15) to open HAV HAND ACTUATED CONTROL valve (14).
- (20) Squeeze and hold lever (16) on fuel service nozzle (5) or lever (17) on overwing nozzle (6) to start fuel flow.
- (21) When receiving vehicle or aircraft tank is filled to desired level, release lever (16 or 17) and HAV HAND ACTUATED CONTROL valve lever (15).

M978 Tanker Operating Procedures (Cont)

2-23. LAND VEHICLE OR AIRCRAFT OVERWING FUEL SERVICING (CONT).

TA183268

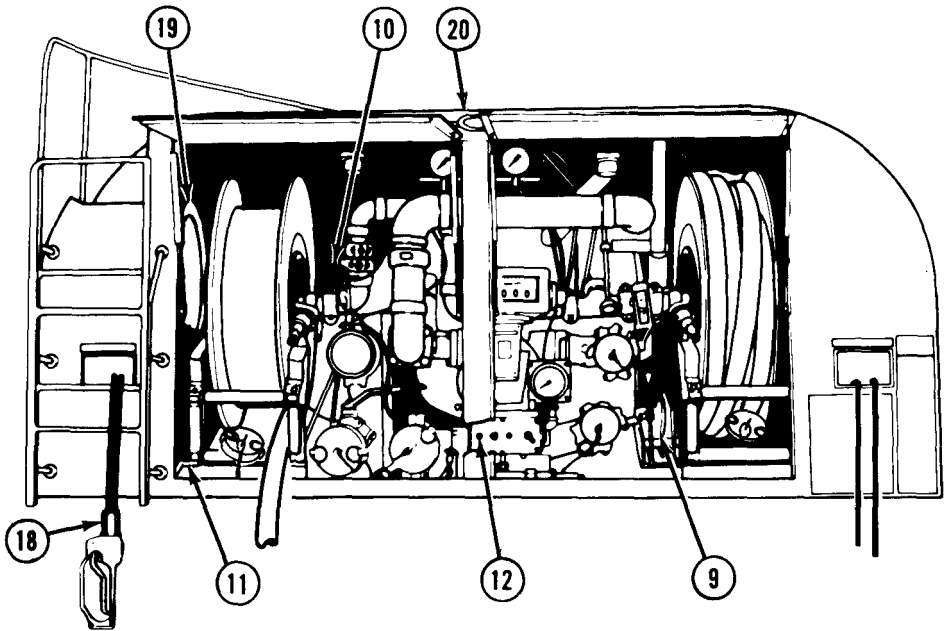
- (22) Remove fuel service nozzle (5) or overwing nozzle (6) from receiving vehicle or aircraft fuel filler.
- (23) Install fuel filler cover on receiving vehicle or aircraft.

NOTE

Tanker must have at least 300 gal (1 136 l) of fuel remaining in order to perform fuel hose evacuation.

- (24) Pull out V6 FUEL/DEFUEL VALVE control rod (8).
- (25) Squeeze and hold lever (15) to open HAV HAND ACTUATED CONTROL valve (14).
- (26) Squeeze and hold lever (16) on fuel service nozzle (5) or lever (17) on overwing nozzle (6) to evacuate fuel from hose (3). Dispose of fuel in accordance with unit SOP.
- (27) When all fuel is evacuated from hose (3), release lever (16 or 17) and lever (15) on HAV HAND ACTUATED CONTROL valve (14).

M978 Tanker Operating Procedures (Cont)

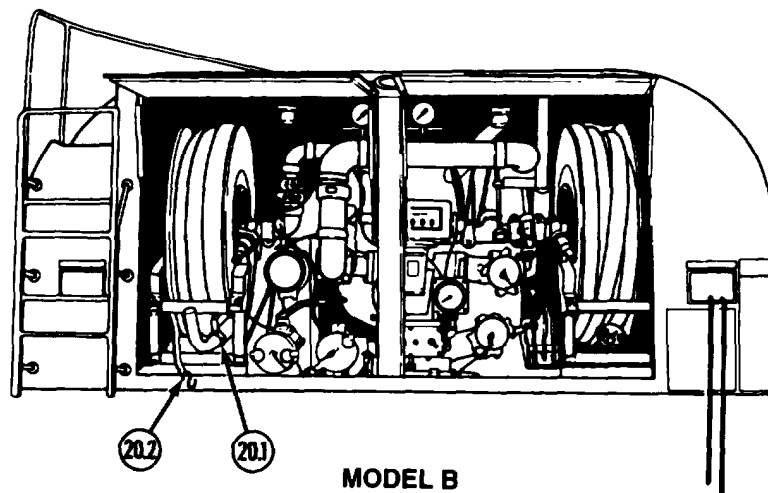
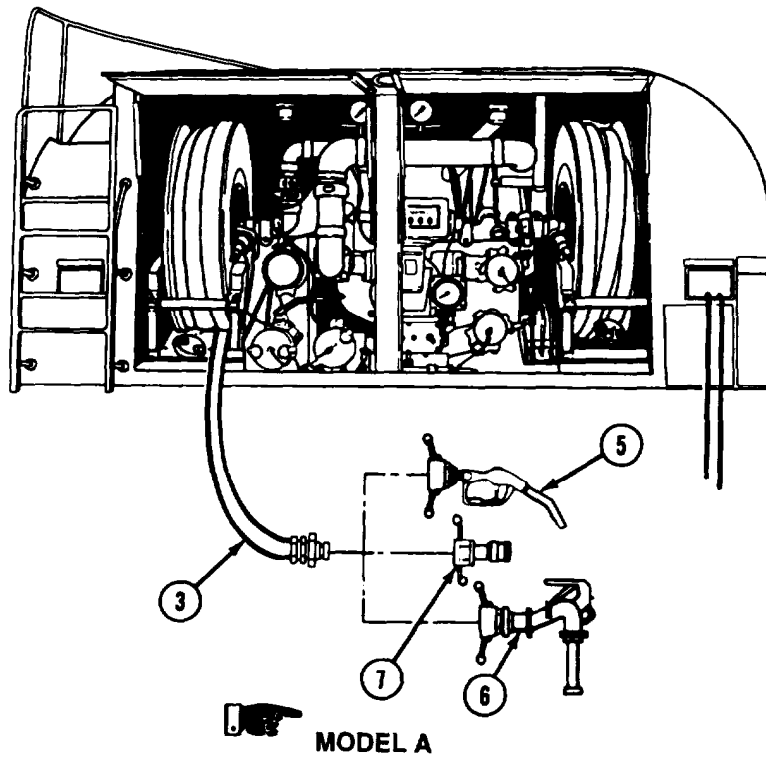


TA183229

- (28) Let HAV HAND ACTUATED CONTROL valve hoses (18) rewind onto reel (19) and stow inside pump module (20).
- (29) Set TC/THROTTLE CONTROL switch (12) down to OFF position.
- (30) Pull back on PUMP ENGAGEMENT LEVER (11) until locked.
- (31) Push MC MANUAL CONTROL EM VALVE lever (9) forward.
- (32) Close V7 REEL VALVE (10).

M978 Tanker Operating Procedure (Cont)

2-23. LAND VEHICLE OR AIRCRAFT OVERWING FUEL SERVICING (CONT).



M978 Tanker Operating Procedures (Cont)

NOTE

Model B has a rubber tiedown strap to secure fuel service nozzle in stowage position. If leaving fuel service nozzle attached to hose, do step (32.1) and skip steps (33) through (35).

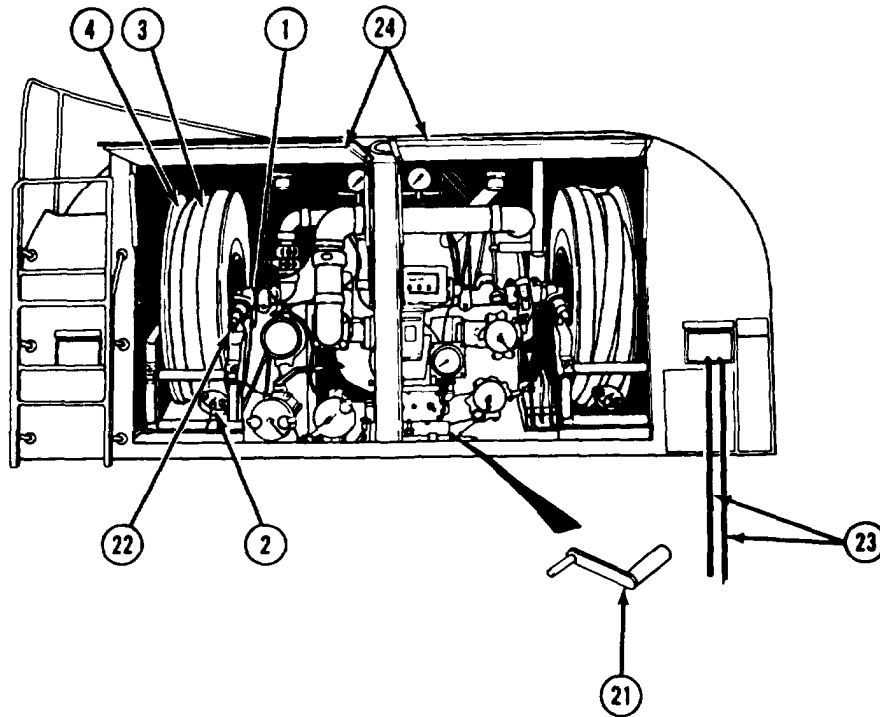
- (32.1) Place fuel service nozzle (20.1) in stowage position and secure with rubber tiedown strap (20.2)
- (33) Remove fuel service nozzle (5) or overwing nozzle (6) from hose (3) or reducer adapter (7).

NOTE

Reducer adapter is used with overwing nozzle only. If overwing nozzle was not used, skip step (34).

- (34) Remove reducer adapter (7) from hose (3).
- (35) Put fuel service nozzle (5) or overwing nozzle (6) and reducer adapter (7) in stowage.

M978 Tanker Operating Procedures (Cont)



- (36) Remove crank (21) from stowage.
- (37) Release hose reel tension knob (1).
- (38) Put crank (21) on crankshaft (22).
- (39) Turn crank (21) to rewind hose (3) onto reel (4).

NOTE

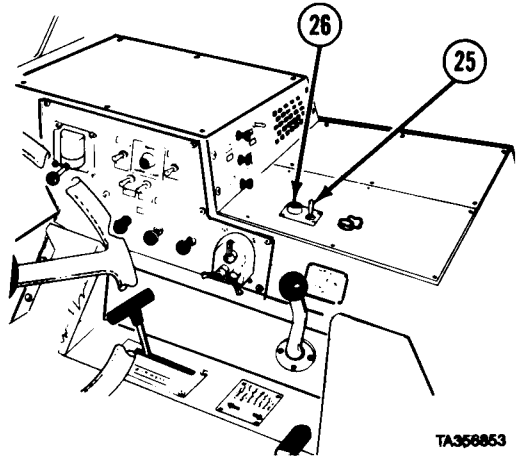
When placing Model B fuel service nozzle in stowage position skip step (40).

- (40) Install dust cap (2) on end of hose (3).
- (41) Engage hose reel tension knob (1).
- (42) Return crank (21) to stowage.
- (43) Disconnect and rewind SR1 and SR2 static cables (23)
- (44) Close pump module rear doors (24).

M978 Tanker Operating Procedures (Cont)

2-23. LAND VEHICLE OR AIRCRAFT OVERWING FUEL SERVICING (CONT).

- (45) Set PTO ENGAGE switch (25) to OFF position. Indicator light (26) should go out.
- (46) Shut off engine (para 2-11p).



2-24. RECIRCULATE FUEL.

a. Prepare Vehicle.

WARNING

No smoking, flame, sparks, glowing or hot objects allowed within 50 ft (15 m) of vehicle. Fire or explosion may cause personal injury or death.

CAUTION

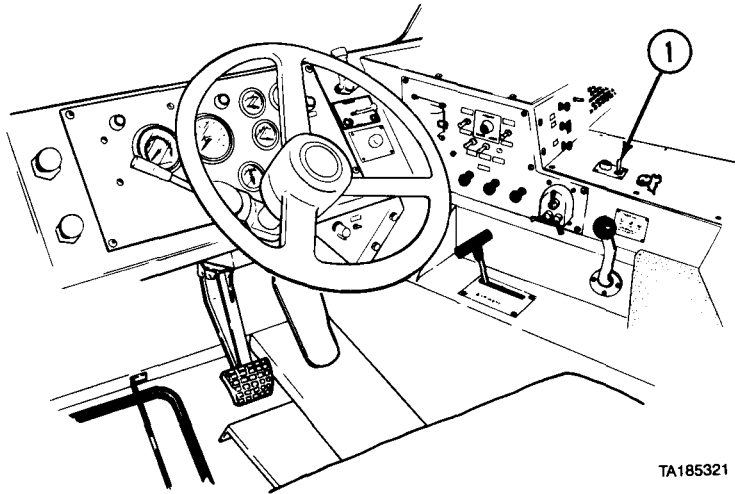
- Do not run tanker pump without fuel in system or damage to fuel pump and hydraulic motor may result.
- Do not press accelerator during tanker primary fuel pump operation. Engine speeds higher than 1500 rpm may cause damage to hydraulic motor and primary pump.

NOTE

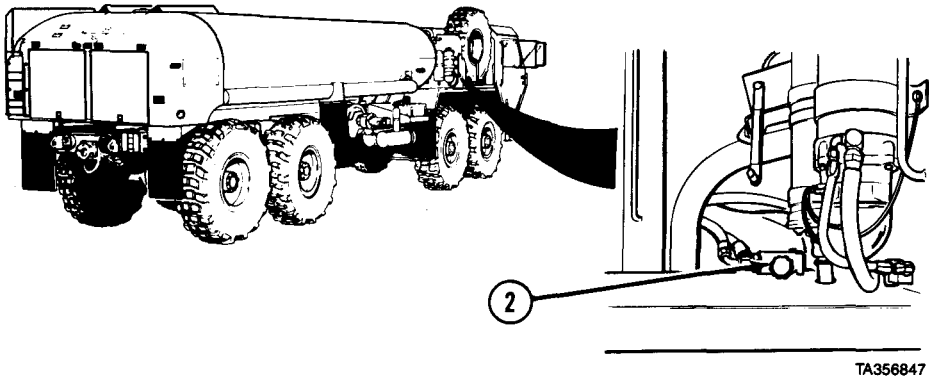
If equipment malfunctions, check that all steps of procedure have been performed in proper order. If equipment still malfunctions, do troubleshooting (Chapter 3).

- (1) Start engine (para 2-11a or 2-11b) and park vehicle (para 2-11o).

M978 Tanker Operating Procedures (Cont)



- (2) If vehicle is equipped with self-recovery winch, check that PTO ENGAGE switch (1) is set to OFF.



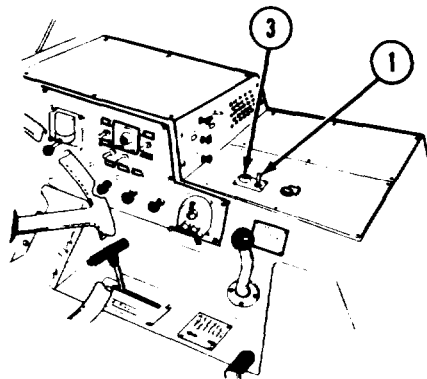
CAUTION

Do not move SELECTOR VALVE while PTO is engaged or vehicle hydraulic equipment may be damaged.

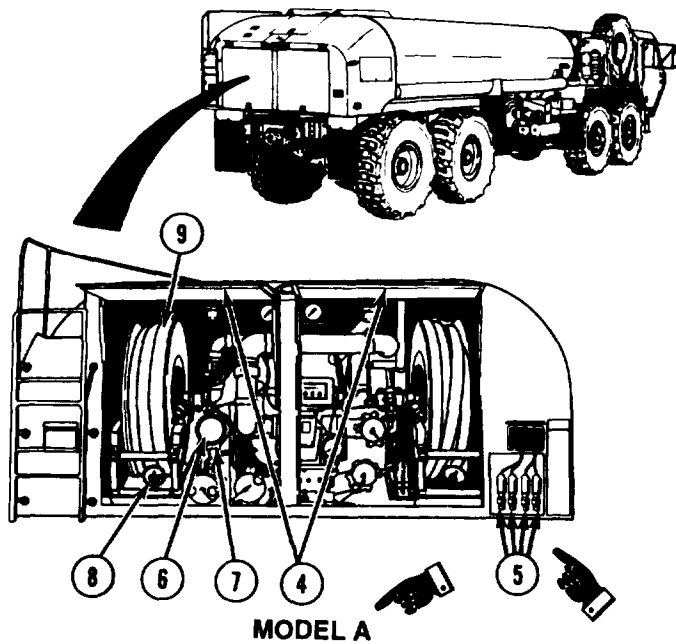
- (3) If vehicle is equipped with self-recovery winch, push in SELECTOR VALVE (2) for tanker pump operation.

M978 Tanker Operating Procedures (Cont)

2-24. RECIRCULATE FUEL (CONT).



- (4) Set PTO ENGAGE switch (1) to ON position. Indicator light (3) should come on.

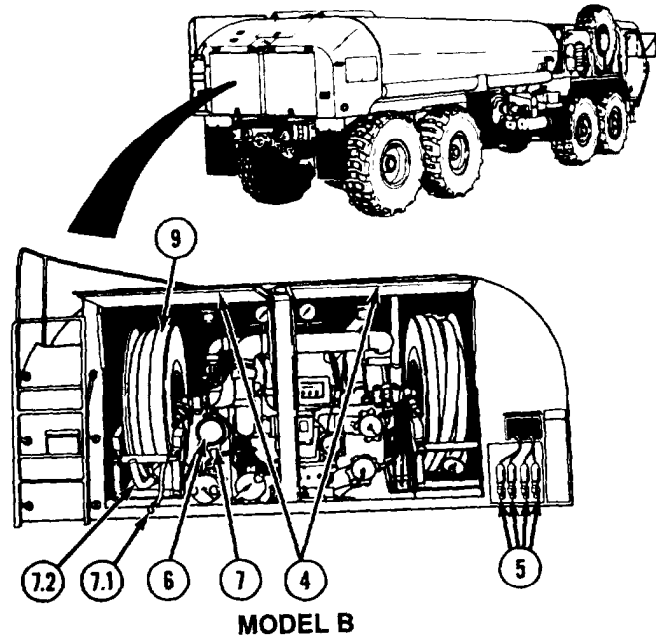


M978 Tanker Operating Procedures (Cont)

WARNING

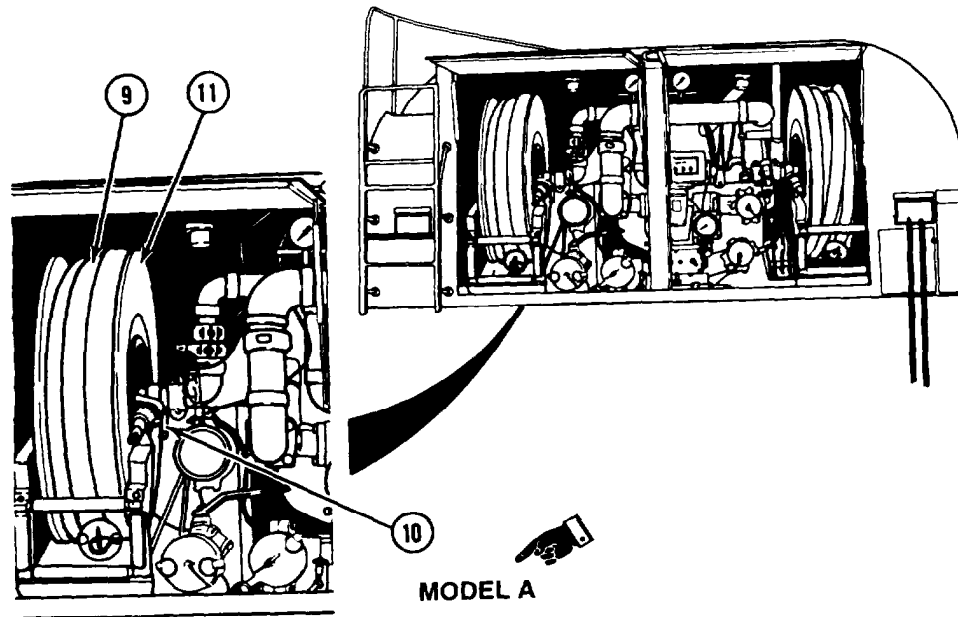
Stand clear to avoid injury when opening pump module rear doors. When doors are about halfway open, gas pistons push doors open quickly and with much force.

- (5) Open pump module rear doors (4).
- (6) Position tanker controls (para 2-20b).
- (7) Connect SR1 and SR2 static cables (5) to grounding devices.
- (8) Remove dust cap (6) from A B/L RECEPTACLE (7).

**NOTE**

Model B has a rubber tiedown strap to secure fuel service nozzle in stowage position. If nozzle is in stowage position do steps (8.1) and (8.2) and skip step (9).

- (8.1) Remove rubber tiedown strap (7.1) to release fuel service nozzle (7.2) from stowage position.
- (8.2) Remove fuel service nozzle (7.2) from hose (9). Put nozzle in stowage.
- (9) Remove dust cap (8) from hose (9).



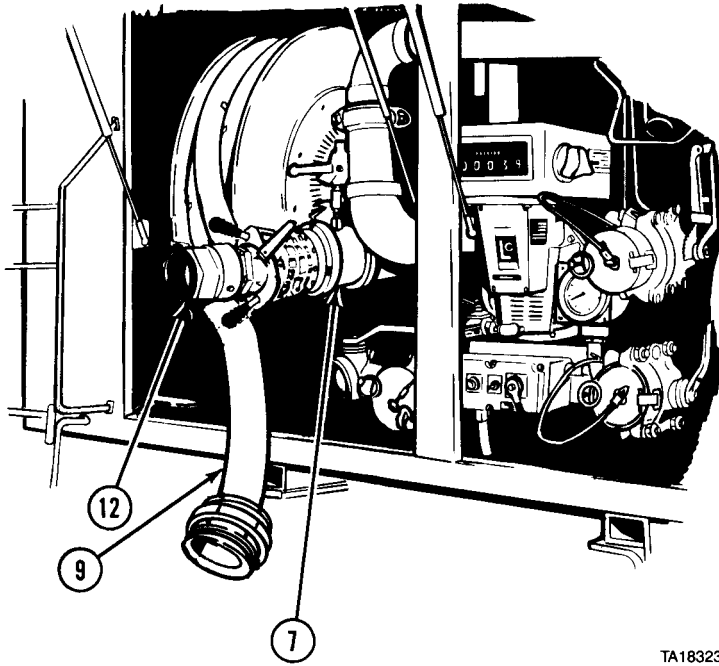
NOTE

- Left side hose is shown. Procedure for using right side hose is same.
- Steps (10) through (12) apply to both Model A and Model B. Model A is shown.

- (10) Disengage hose reel tension knob (10).
- (11) Pull out about 15 ft (5 m) of hose (9) from reel (11).
- (12) Engage hose reel tension knob (10).

M978 Tanker Operating Procedures (Cont)

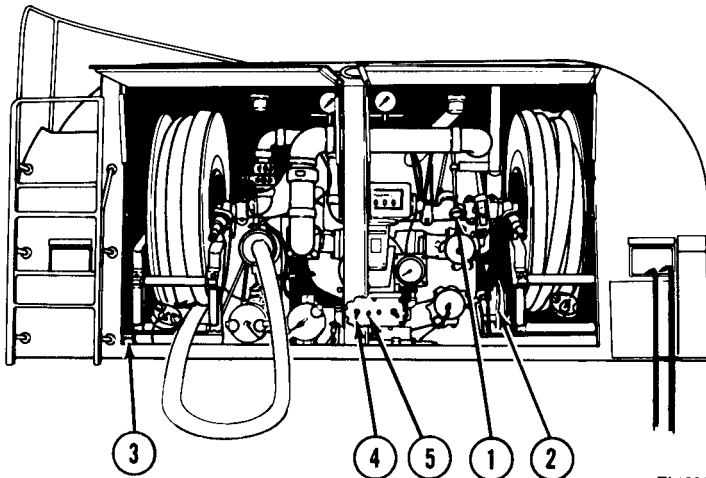
2-24. RECIRCULATE FUEL (CONT).



TA183237

- (13) Remove D1 adapter (12) from stowage.
- (14) Connect D1 adapter (12) to A B/L RECEPTACLE (7).
- (15) Connect hose (9) to D1 adapter (12).

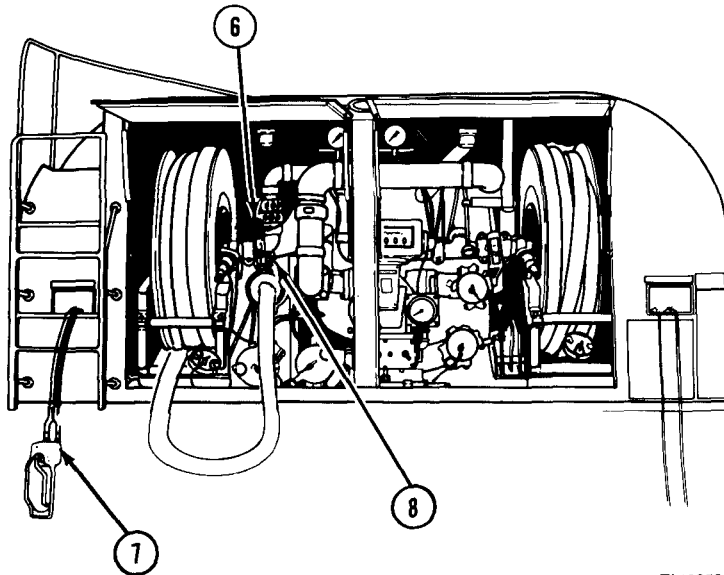
b. Recirculate Fuel.



TA183279

M978 Tanker Operating Procedures (Cont)

- (1) Push in V6 FUEL/DEFUEL valve control rod (1).
- (2) Pull back MC MANUAL CONTROL EM VALVE lever (2).
- (3) Push PUMP ENGAGEMENT LEVER (3) forward.
- (4) Set TC/THROTTLE CONTROL switch (4) up to ON position.
- (5) Press HI/HIGH IDLE switch (5).



TA183280

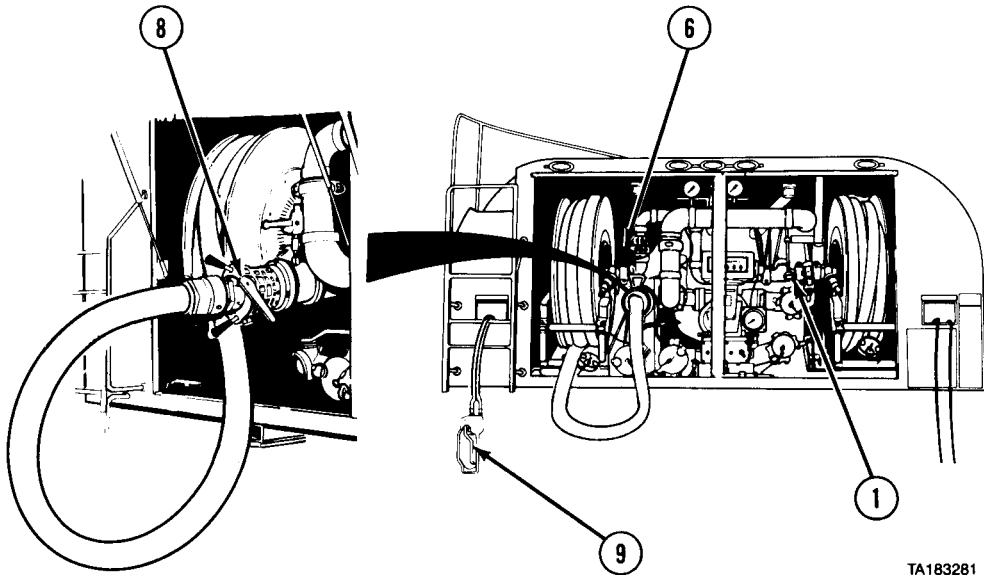
NOTE

- Refer to paragraph 2-2, figure 2-11, for information about DLPG discharge line pressure gage and VNPG venturi-nozzle pressure gage.
- V8 REEL VALVE is used to control flow rate when right side hose is used.

- (6) Open V7 REEL VALVE (6).
- (7) Pull out HAV HAND ACTUATED CONTROL valve (7).
- (8) Move D1 adapter valve lever (8) to OPEN position.

M978 Tanker Operating Procedures (Cont)

2-24. RECIRCULATE FUEL (CONT).



TA183281

NOTE

HAV HAND ACTUATED CONTROL valve must be open for fuel to flow.

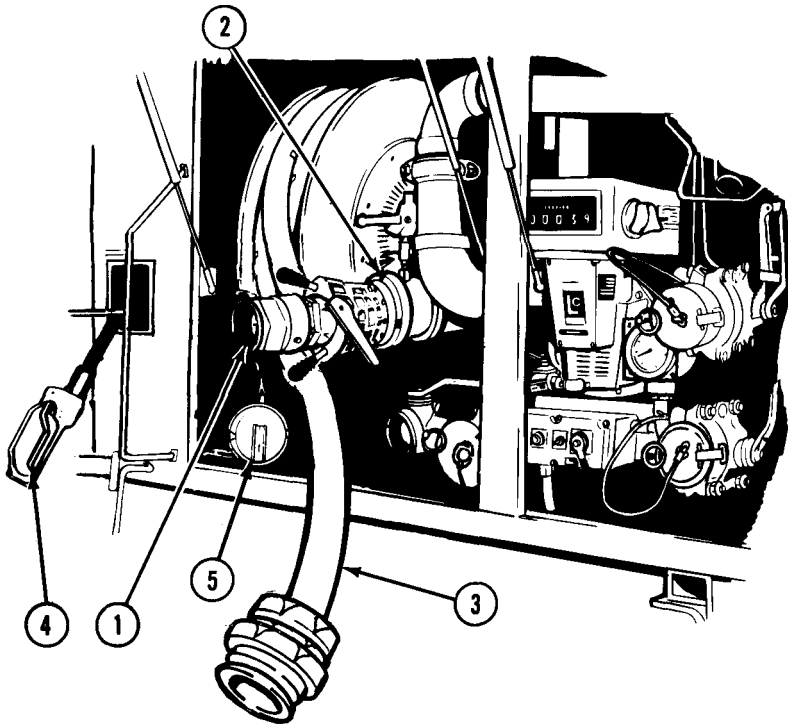
- (9) Squeeze and hold HAV HAND ACTUATED CONTROL valve lever (9) to recirculate fuel.
- (10) When recirculation is completed, release HAV HAND ACTUATED CONTROL valve lever (9).
- (11) Move D1 adapter valve lever (8) to CLOSE position.

NOTE

Tanker must be holding at least 300 gal (1 136 l) of fuel in order to perform fuel hose evacuation.

- (12) Pull out V6 FUEL/DEFUEL VALVE control rod (1).
- (13) Close V7 REEL VALVE (6).

M978 Tanker Operating Procedures (Cont)

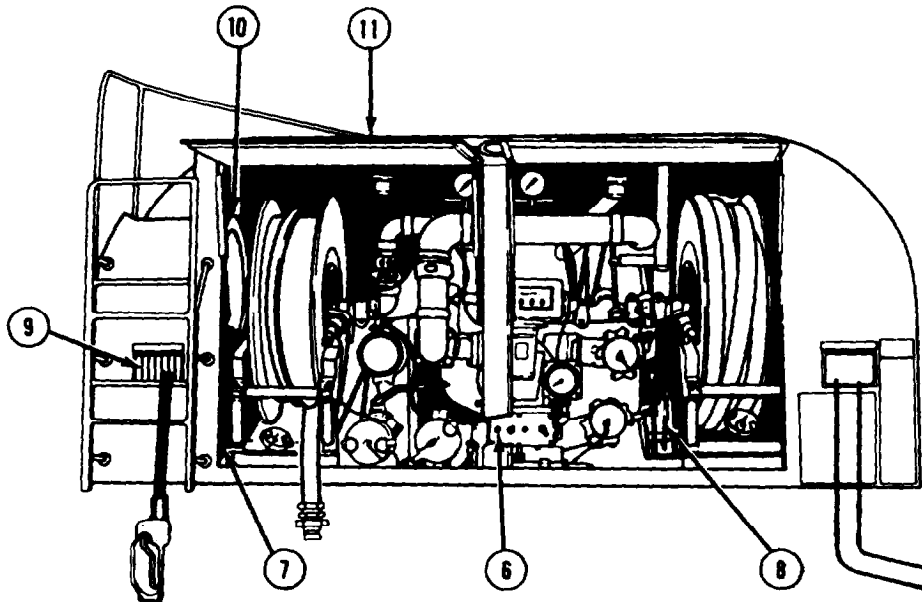
c. Shut Down Recirculation.

TA183244

- (1) Disconnect D1 adapter (1) from A B/L RECEPTACLE (2).
- (2) Disconnect hose (3) from D1 adapter (1).
- (3) Stow D1 adapter (1).
- (4) Squeeze and hold HAV HAND ACTUATED CONTROL valve lever (4) to evacuate fuel from hose (3). Dispose of fuel in accordance with unit SOP.
- (5) When all fuel is emptied from hose (3), release HAV HAND ACTUATED CONTROL valve lever (4).
- (6) Install dust cap (5) on A B/L RECEPTACLE (2).

M978 Tanker Operating Procedures (Cont)

2-24. RECIRCULATE FUEL (CONT).



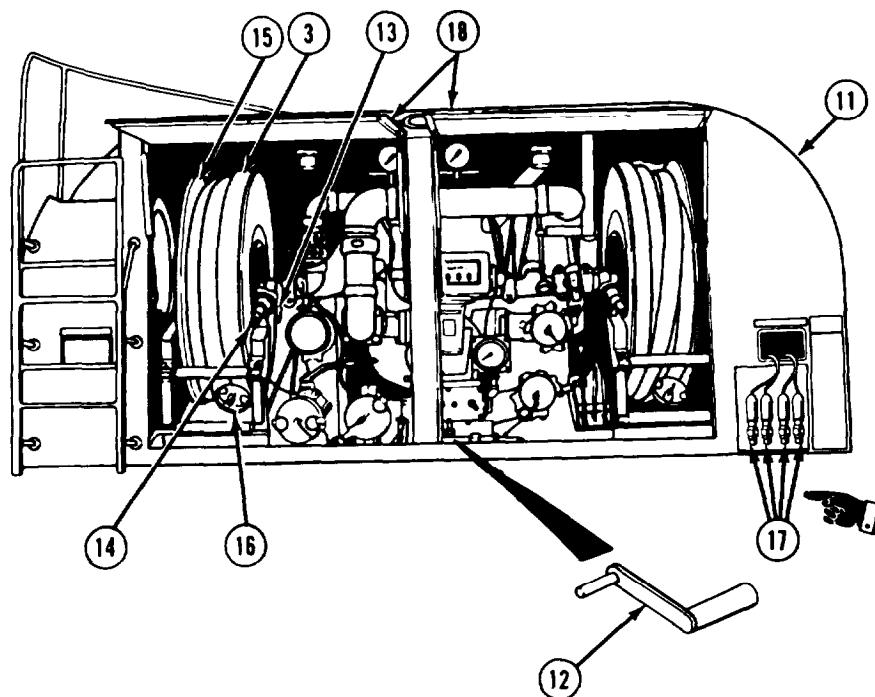
- (7) Set TC/THROTTLE CONTROL switch (6) down to OFF position.
- (8) Pull back on PUMP ENGAGEMENT LEVER (7) until locked.
- (9) Push MC MANUAL CONTROL EM VALVE lever (8) forward.

CAUTION

Guide hoses back onto reel. Carefully guide control through access hole onto reel. Failure to do so may result in equipment damage.

- (10) Rewind HAV HAND ACTUATED CONTROL valve hoses (9) onto reel (10) and stow inside pump module (11).

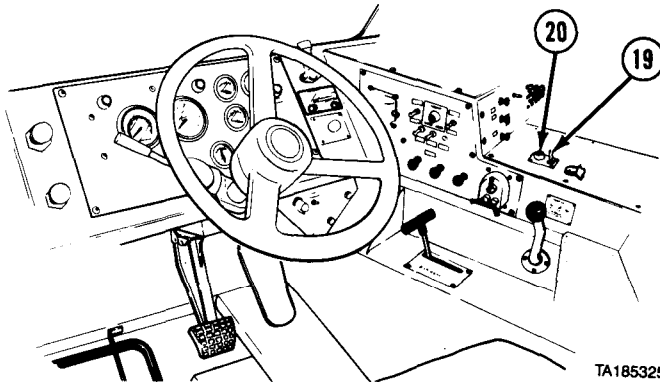
M978 Tanker Operating Procedures (Cont)



- (11) Remove crank (12) from stowage on pump module (11).
- (12) Release hose reel tension knob (13).
- (13) Put crank (12) on crankshaft (14).
- (14) Turn crank (12) to rewind hose (3) onto reel (15).
- (15) Install dust cap (16) on hose (3).
- (16) Engage hose reel tension knob (13).
- (17) Return crank (12) to stowage.
- (18) Disconnect and rewind SR1 and SR2 static cables (17).
- (19) Close pump module rear doors (18).

M978 Tanker Operating Procedures (Cont)

2-24. RECIRCULATE FUEL (CONT).



- (20) Set PTO ENGAGE switch (19) to OFF position. Indicator light (20) should go out.
- (21) Shut off engine (para 2-11p).

2-25. UNLOAD FUEL.

a. Filtered Bulk Unloading.

WARNING

No smoking, flame, sparks, glowing or hot objects allowed within 50 ft (15 m) of vehicle. Fire or explosion can cause personal injury or death.

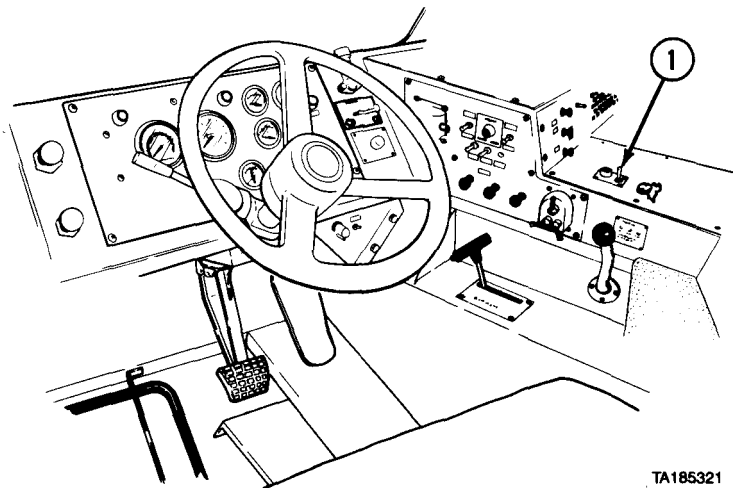
CAUTION

- Do not run tanker pump without fuel in system or damage to fuel pump and hydraulic motor may result.
- Do not press accelerator during tanker primary fuel pump operation. Engine speeds higher than 1500 rpm may cause damage to hydraulic motor and primary pump.

NOTE

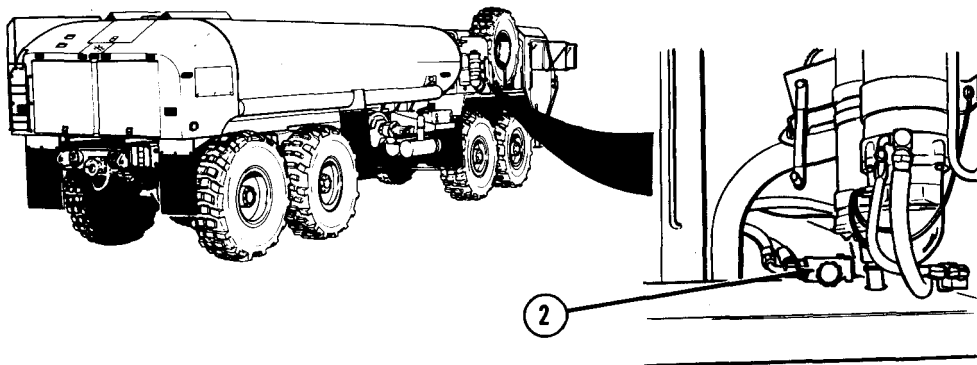
- Dispose of unloaded and drained fuel in accordance with unit SOP.
 - If equipment malfunctions, check that all steps of procedure have been performed in proper order. If equipment still malfunctions, do troubleshooting (Chapter 3).
- (1) Start engine (para 2-11a or 2-11b) and position vehicle for bulk unloading.
 - (2) Park vehicle para 2-11o).

M978 Tanker Operating Procedures (Cont)



TA185321

- (3) If vehicle is equipped with self-recovery winch, check that PTO ENGAGE switch (1) is set to OFF.



TA183236

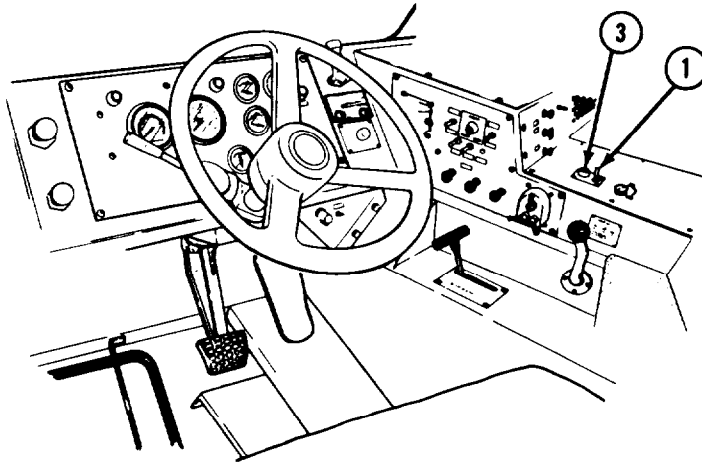
CAUTION

Do not move SELECTOR VALVE while PTO is engaged or vehicle hydraulic equipment may be damaged.

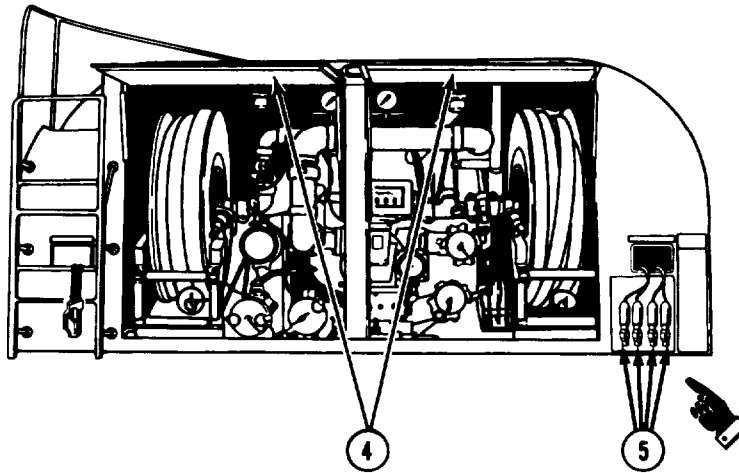
- (4) If vehicle is equipped with self-recovery winch, push in SELECTOR VALVE (2) for tanker pump operation.

M978 Tanker Operating Procedures (Cont)

2-25. UNLOAD FUEL (CONT).



- (5) Set PTO ENGAGE switch (1) to ON position. Indicator light (3) should come on.

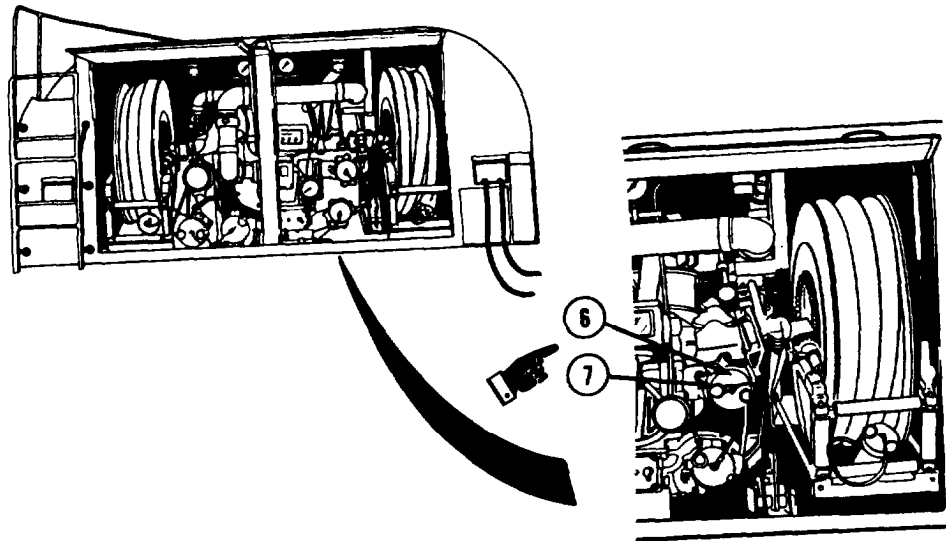


WARNING

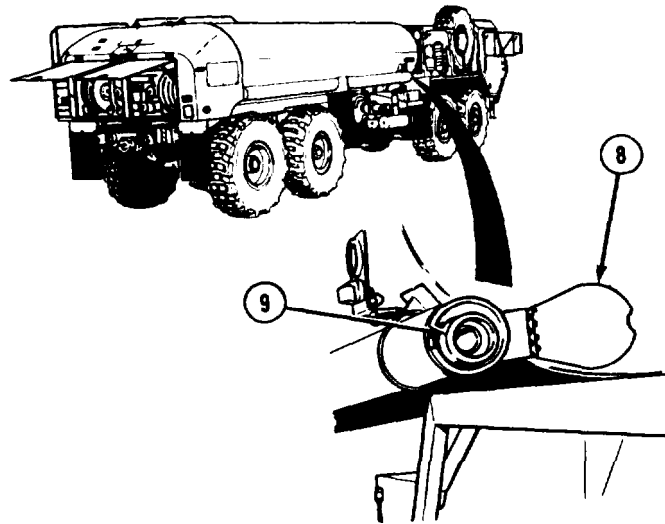
Stand clear to avoid injury when opening pump module rear doors. When doors are about halfway open, gas pistons push doors open quickly and with much force.

- (6) Open pump module rear doors (4).
- (7) Position tanker controls (para 2-20b).
- (8) Connect SR1 and SR2 static cables (5) to equipment receiving fuel and to grounding devices.

M978 Tanker Operating Procedures (Cont)



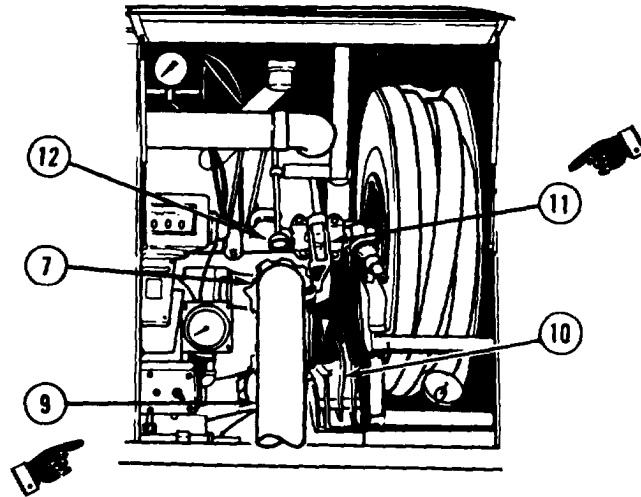
- (9) Remove dust cap (6) from D BULK RECEPTACLE (METERED) (7).



- (10) Open stowage tube cover (8) and remove suction hose (9).

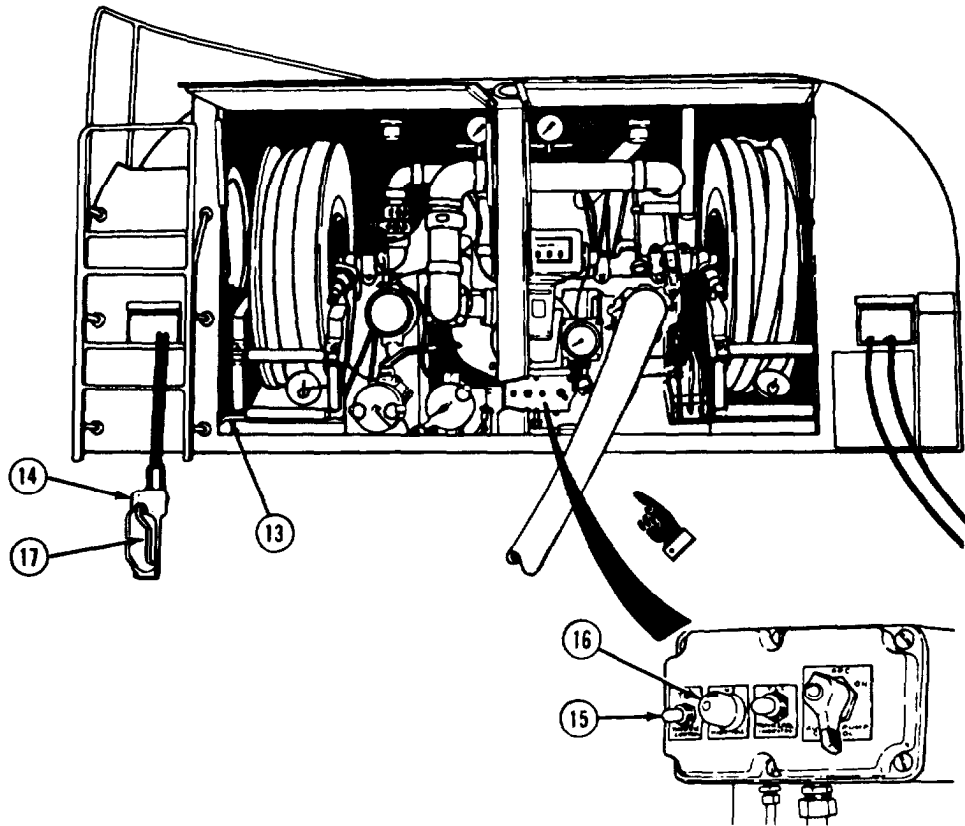
M978 Tanker Operating Procedures (Cont)

2-25. UNLOAD FUEL (CONT).



- █ (12) Connect one end of suction hose (9) to D BULK RECEPTACLE (METERED) (7) and other end to receiving receptacle.
- █ (12) Pull back MC MANUAL CONTROL EM VALVE lever (10).
- (13) Set V11 FLOW VALVE (REG) (11) to desired flow rate.
- (14) Push V6 FUEL/DEFUEL VALVE control rod (12) in.

M978 Tanker Operating Procedures (Cont)



- (15) Push PUMP ENGAGEMENT LEVER (13) forward.
- (16) Pull out HAV HAND ACTUATED CONTROL valve (14).
- (17) Set TC/THROTTLE CONTROL switch (15) up to ON position.
- (18) Press HI/HIGH IDLE switch (16).

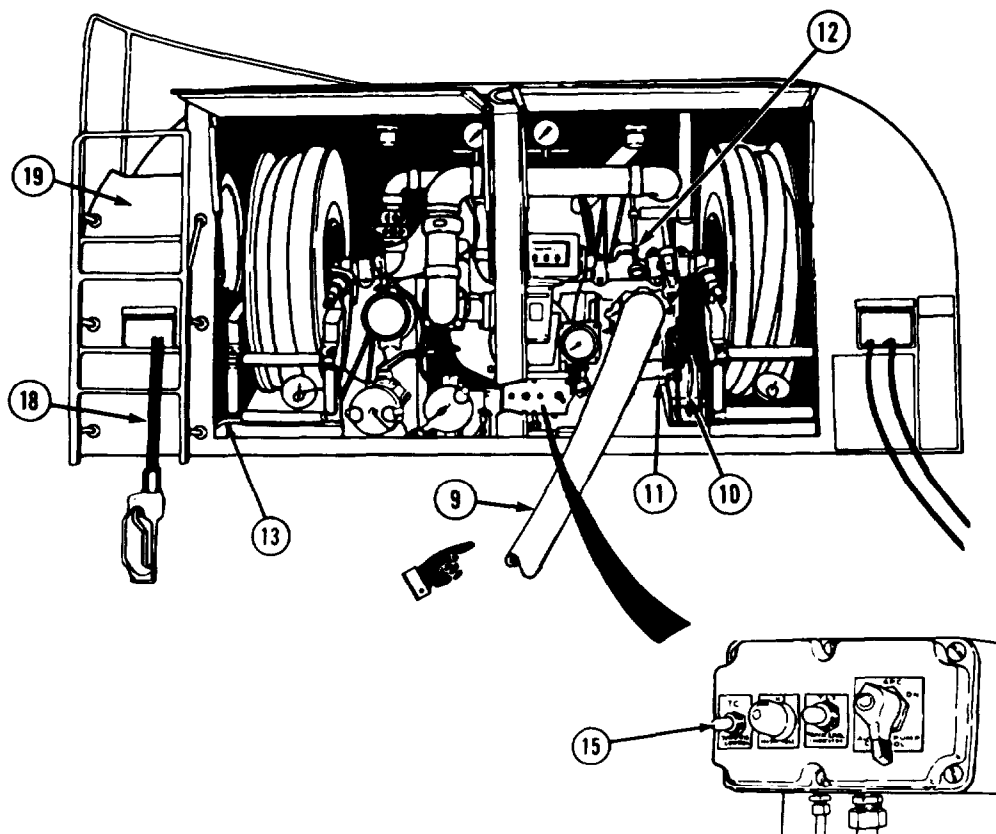
NOTE

HAV HAND ACTUATED CONTROL valve must be open for fuel to flow.

- (19) Squeeze and hold HAV HAND ACTUATED CONTROL valve lever (17) to unload fuel.
- (20) When unloading is finished, release HAV HAND ACTUATED CONTROL valve lever (17).

M978 Tanker Operating Procedures (Cont)

2-25. UNLOAD FUEL (CONT).



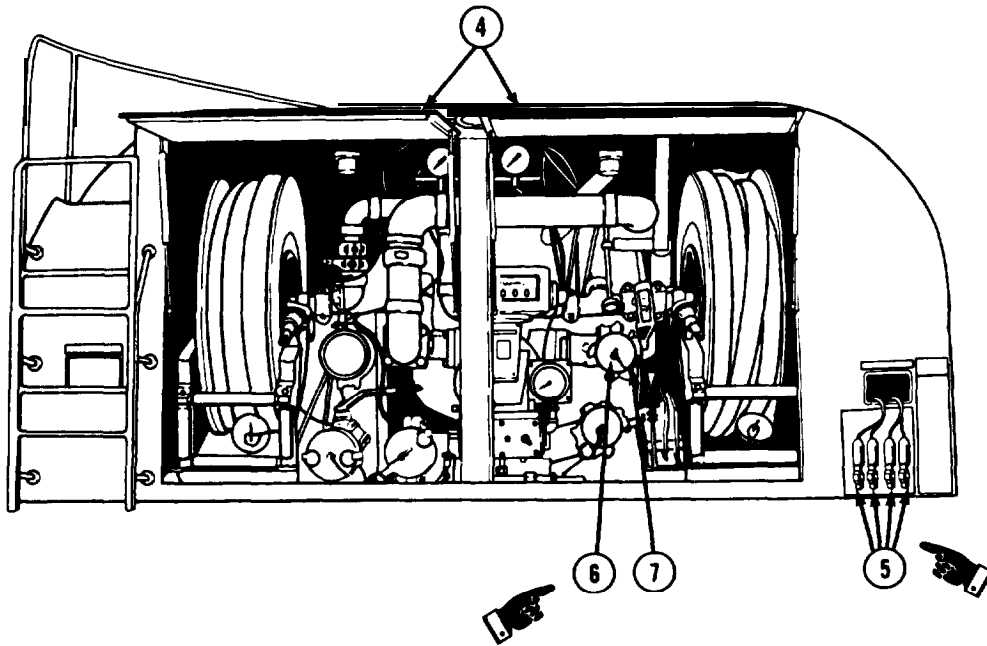
- (21) Set TC/THROTTLE CONTROL switch (15) down to OFF position.
- (22) Pull back on PUMP ENGAGEMENT LEVER (13) until locked.
- (23) Push MC MANUAL CONTROL EM VALVE lever (10) forward.
- (24) Push V6 FUEL/DEFUEL VALVE control rod (12) in.
- (25) Close V18 BULK DELIVERY VALVE (11).
- (26) Rewind HAV HAND ACTUATED CONTROL valve hoses (18) and stow in pump module (19).

NOTE

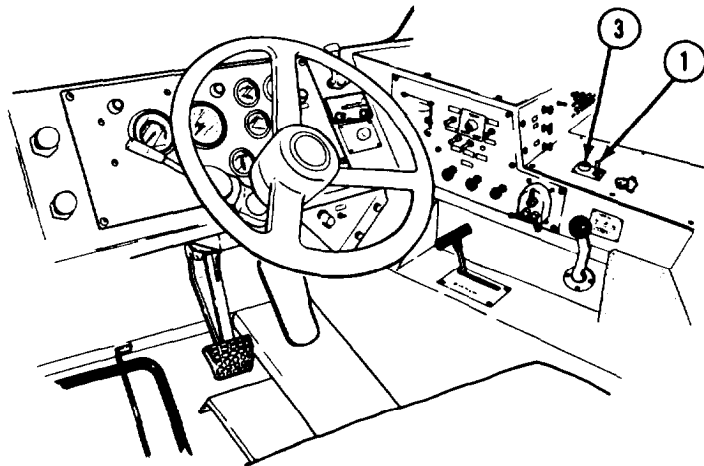
Remove remaining fuel in suction hose by walking out suction hose.

- (27) Remove suction hose (9), drain fuel, and dispose of fuel in accordance with unit SOP. Stow suction hose.

M978 Tanker Operating Procedures (Cont)



- (28) Install dust cap (6) on D BULK RECEPTACLE (METERED) (7).
- (29) Disconnect and rewind SR1 and SR2 static cables (5).
- (30) Close pump module rear doors (4).



- (31) Set FTO ENGAGE switch (1) to OFF position. Indicator light (3) should go out.
- (32) Shut off engine (para 2-11p).

M978 Tanker Operating Procedures (Cont)

2-25. UNLOAD FUEL (CONT).**b. Unfiltered Bulk Unloading.****WARNING**

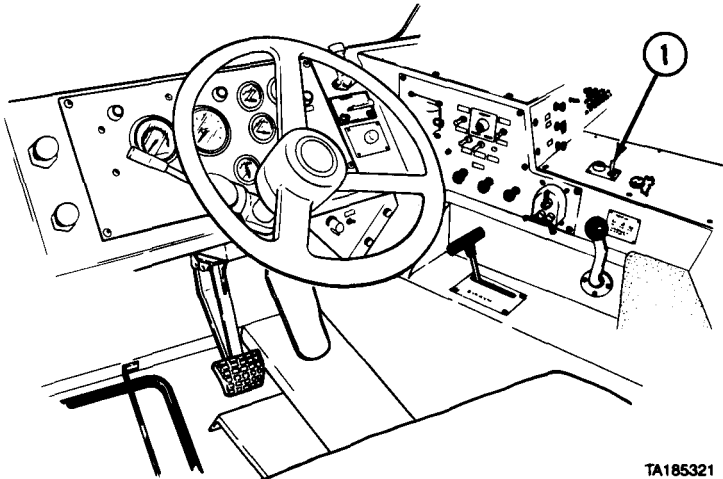
No smoking, flame, sparks, glowing or hot objects allowed within 50 ft (15 m) of vehicle. Fire or explosion may cause personal injury or death.

CAUTION

- Do not run tanker pump without fuel in system or damage to fuel pump and hydraulic motor may result.
- Do not press accelerator during tanker primary fuel pump operation. Engine speeds higher than 1500 rpm may cause damage to hydraulic motor and primary pump.

NOTE

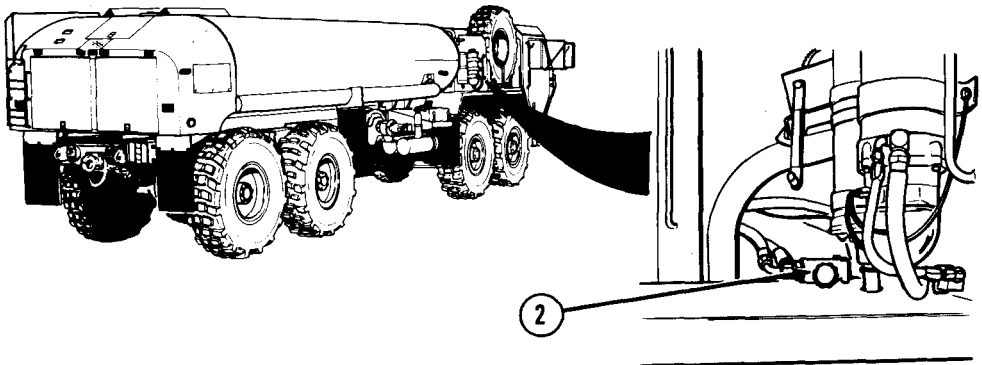
- Dispose of unloaded and drained fuel in accordance with unit SOP.
- If equipment malfunctions, check that all steps of procedure have been performed in proper sequence. If equipment still malfunctions, do troubleshooting (Chapter 3).



TA185321

- (1) Start engine (para 2-11a or 2-11b) and position vehicle for bulk unloading.
- (2) Park vehicle (para 2-11o).
- (3) If vehicle is equipped with self-recovery winch, check that PTO ENGAGE switch (1) is set to OFF.

M978 Tanker Operating Procedures (Cont)

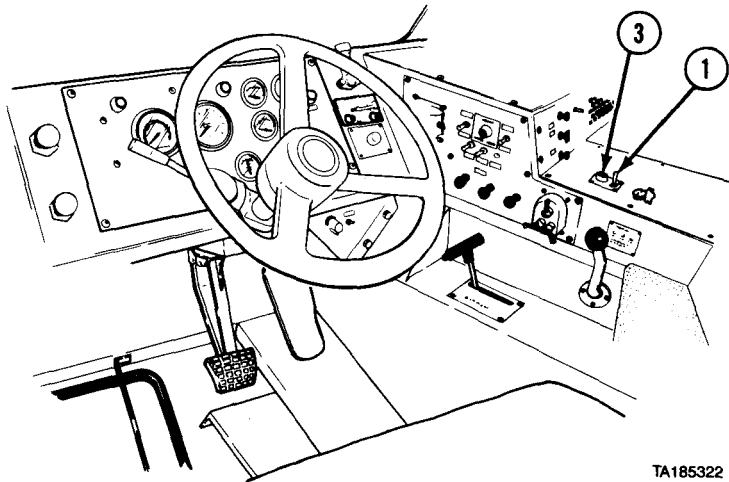


TA183236

CAUTION

Do not move SELECTOR VALVE while PTO is engaged or vehicle hydraulic equipment may be damaged.

- (4) If vehicle is equipped with self-recovery winch, push in SELECTOR VALVE (2) for tanker pump operation.

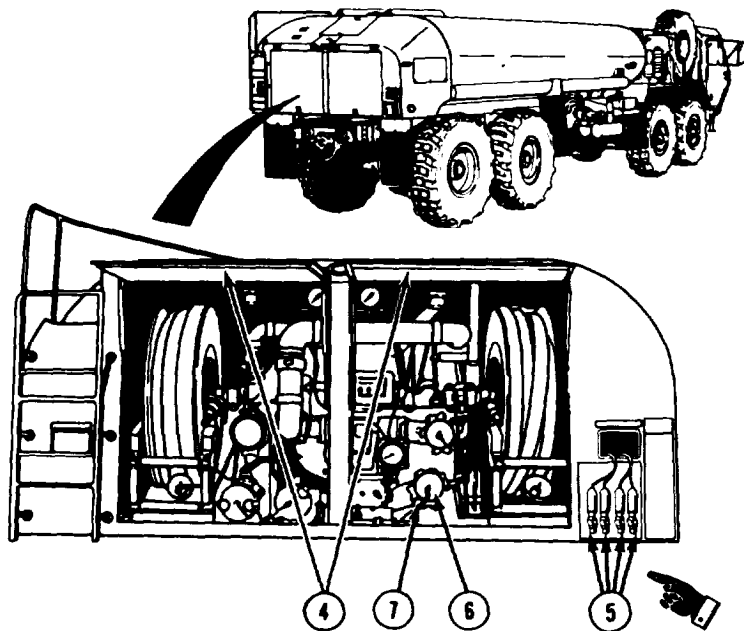


TA185322

- (5) Set PTO ENGAGE switch (1) to ON position. Indicator light (3) should come on.

M978 Tanker Operating Procedures (Cont)

2-25. UNLOAD FUEL (CONT).

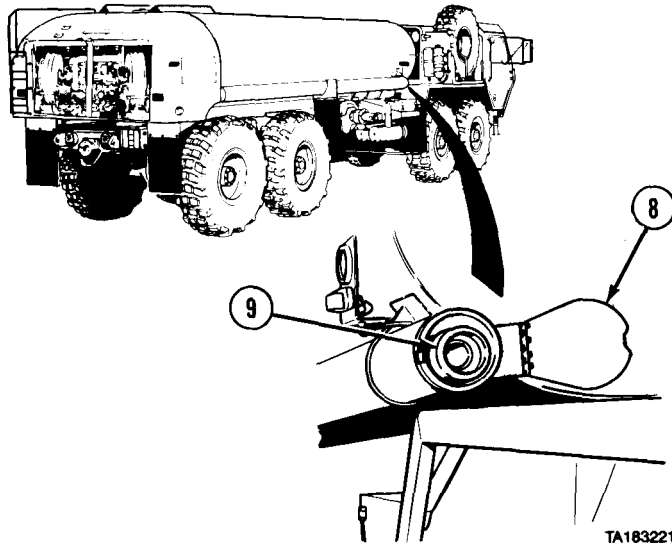


WARNING

Stand clear to avoid injury when opening pump module rear doors. When doors are about halfway open, gas pistons push doors open quickly and with much force.

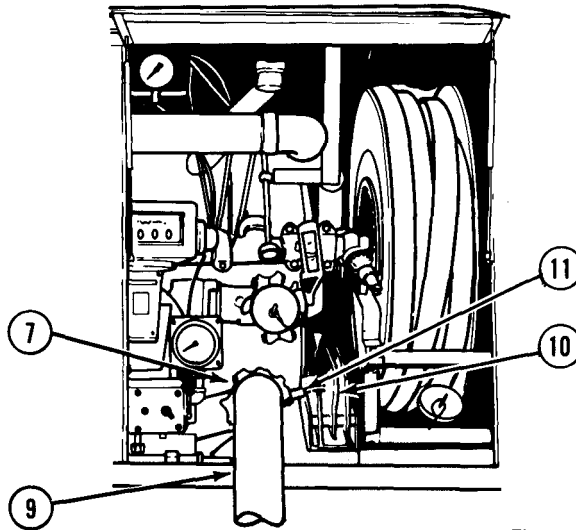
- (6) Open pump module rear doors (4).
- (7) Position tanker controls (para 2-20b).
- (8) Connect SR1 and SR2 static cables (5) to equipment receiving fuel and to grounding devices.
- (9) Remove dust cap (6) from C BULK RECEPTACLE (UNFIL) (7).

M978 Tanker Operating Procedures (Cont)



TA183221

(10) Open storage tube cover (8) and remove suction hose (9).

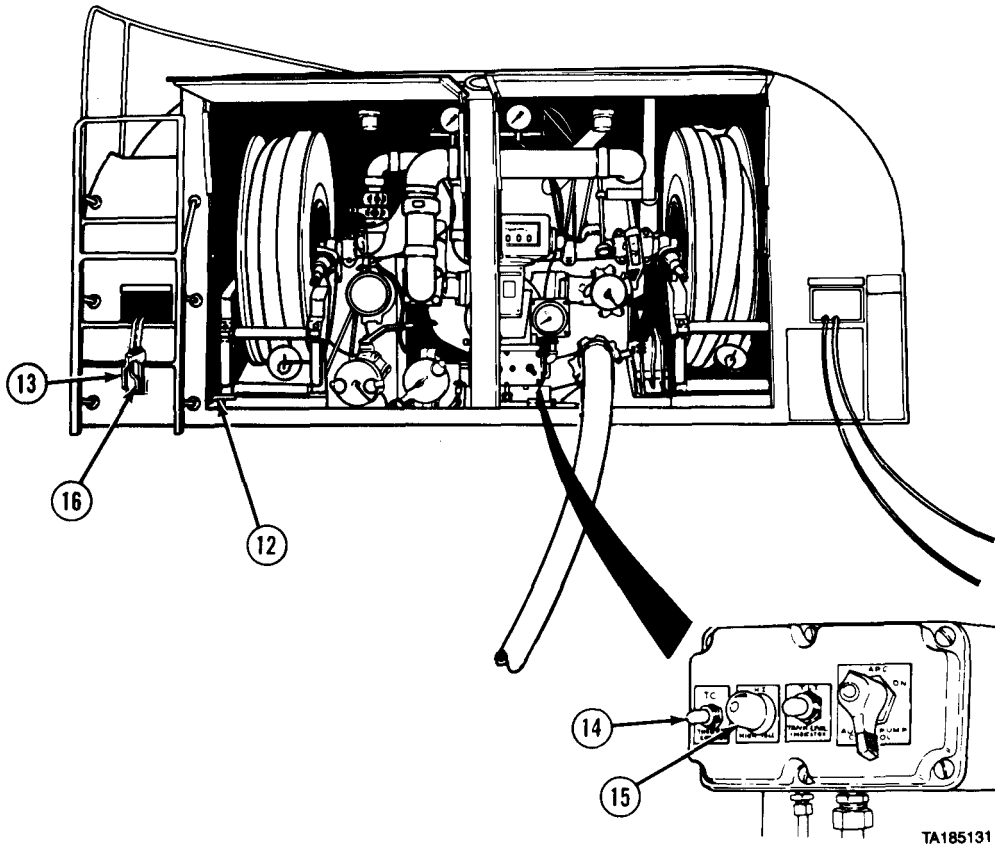


TA185326

- (11) Connect one end of suction hose (9) to C BULK RECEPTACLE (UNFIL) (7) and other end to receiving receptacle.
- (12) Pull back MC MANUAL CONTROL EM VALVE lever (10).
- (13) Open V18 BULK DELIVERY VALVE (11).

M978 Tanker Operating Procedures (Cont)

2-25. UNLOAD FUEL (CONT).



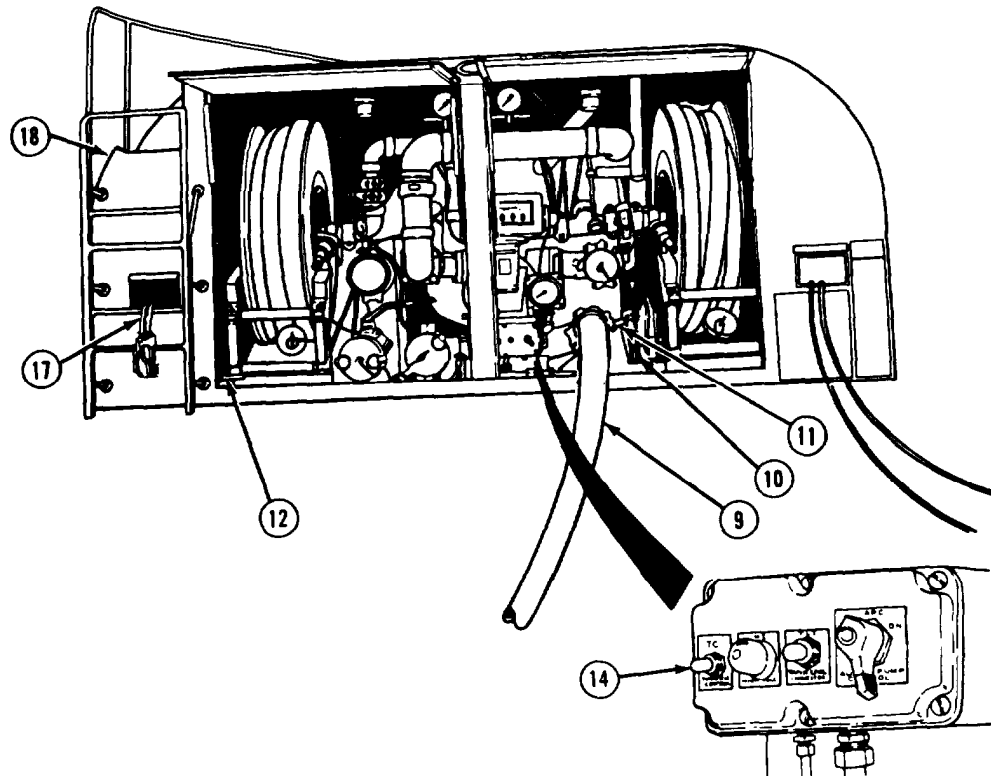
- (14) Push PUMP ENGAGEMENT LEVER (12) forward.
- (15) Pull out HAV HAND ACTUATED CONTROL valve (13).
- (16) Set TC/THROTTLE CONTROL switch (14) up to ON position.
- (17) Press HI/HIGH IDLE switch (15).

NOTE

HAV HAND ACTUATED CONTROL valve must be open for fuel to flow.

- (18) Squeeze and hold HAV HAND ACTUATED CONTROL valve lever (16) to unload fuel.
- (19) When unloading is finished, release HAV HAND ACTUATED CONTROL valve lever (16).

M978 Tanker Operating Procedures (Cont)



- (20) Set TC/THROTTLE CONTROL switch (14) down to OFF position.
- (21) Pull back on PUMP ENGAGEMENT LEVER (12) until locked.
- (22) Push MC MANUAL CONTROL EM VALVE lever (10) forward.
- (23) Close V18 BULK DELIVERY VALVE (11).

CAUTION

Guide hoses back onto reel. Carefully guide control through access hole onto reel. Failure to do so may result in equipment damage.

- (24) Rewind HAV HAND ACTUATED CONTROL valve hoses (17) and stow in pump module (18).

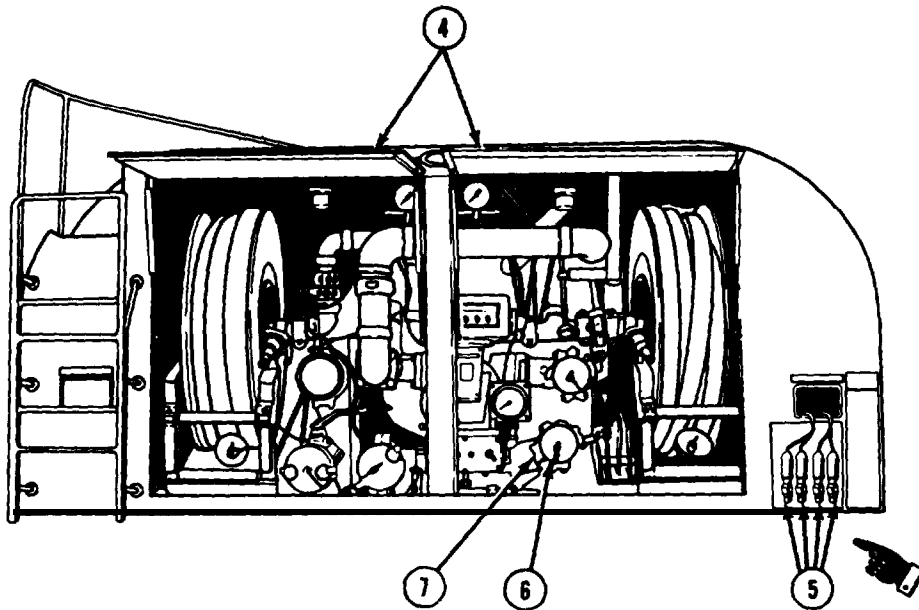
NOTE

Remove remaining fuel in suction hose by walking out suction hose.

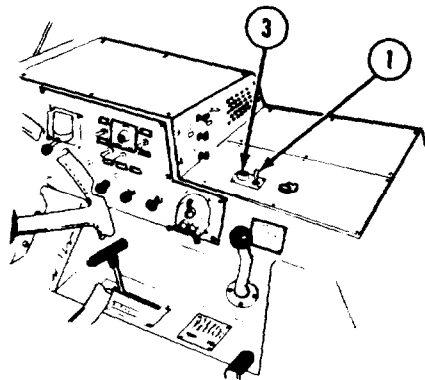
- (25) Remove suction hose (9), drain fuel, and dispose of fuel in accordance with unit SOP. Stow suction hose.

M978 Tanker Operating Procedures (Cont)

2-25. UNLOAD FUEL (CONT).



- (26) Install dust cap (6) on C BULK RECEPTACLE (UNFIL) (7).
- (27) Disconnect and rewind SR1 and SR2 static cables (5).
- (28) Close pump module rear doors (4).



- (29) Set PTO ENGAGE switch (1) to OFF position. Indicator light (3) should go out.
- (30) Shut off engine (para 2-11p).

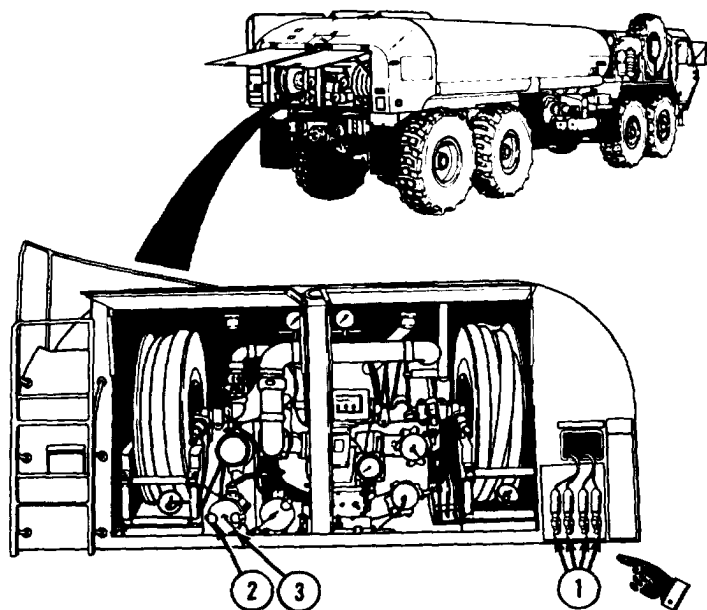
M978 Tanker Operating Procedures (Cont)

c. *Unfiltered Gravity Bulk Unloading.***WARNING**

No smoking, flame, sparks, glowing or hot objects allowed within 50 ft (15 m) of vehicle. Fire or explosion may cause personal injury or death.

NOTE

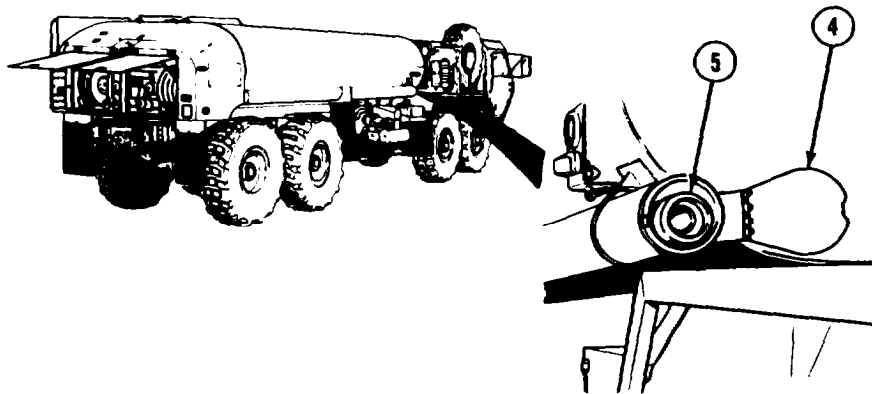
- Dispose of unloaded and drained fuel in accordance with unit SOP.
- If equipment malfunctions, check that all steps of procedure have been performed in proper order. If equipment still malfunctions, do troubleshooting (Chapter 3).



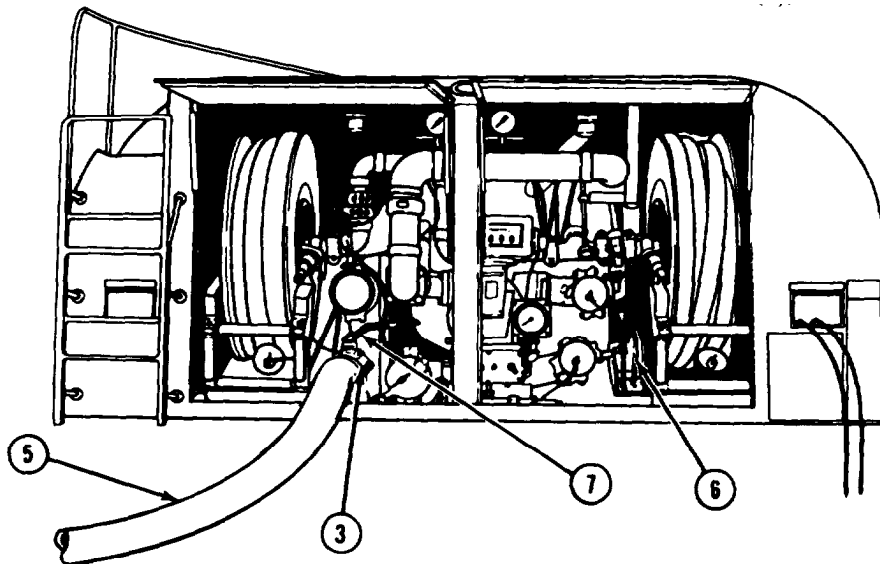
- (1) Prepare tanker for operation (para 2-20).
- (2) Connect SR1 and SR2 static cables (1) to equipment receiving fuel and to grounding devices.
- (3) Remove dust cap (2) from B GRAVITY RECEPTACLE (3).

M978 Tanker Operating Procedures (Cont)

2-25. UNLOAD FUEL (CONT.)



- (4) Open stowage tube cover (4) and remove suction hose (5).



NOTE

B GRAVITY RECEPTACLE is designed for a 4 in. (101.6 mm) hose. Use an army supplied hose for gravity discharge of fuel.

- (5) Connect one end of suction hose (5) to B GRAVITY RECEPTACLE (3) and other end to receiving receptacle.
- (6) Pull back MC MANUAL CONTROL EM VALVE lever (6).
- (7) Open V17 GRAVITY VALVE (7) to unload fuel.

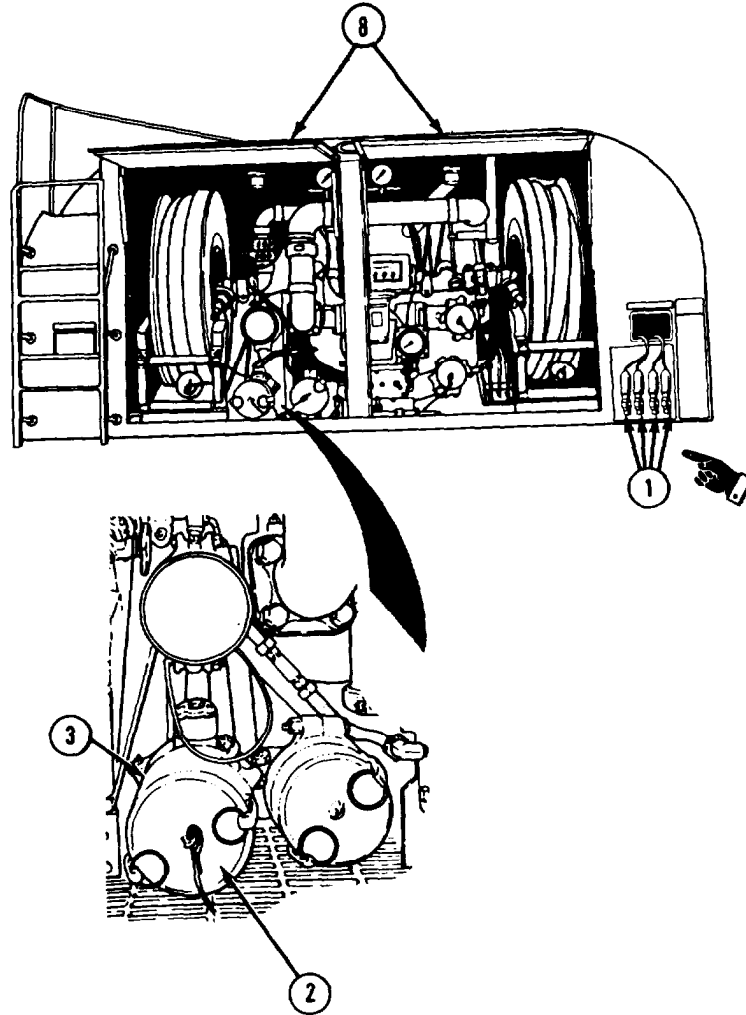
M978 Tanker Operating Procedures (Cont)

- (8) When unloading is finished, close V17 GRAVITY VALVE (7).
- (9) Push MC MANUAL CONTROL EM VALVE lever (6) forward.

NOTE

Remove remaining fuel in suction hose by walking out suction hose.

- (10) Remove suction hose (5), drain fuel, and dispose of fuel in accordance with unit SOP. Stow suction hose.



- (11) Install dust cap (2) on B GRAVITY RECEPTACLE (3).
- (12) Disconnect and rewind SR1 and SR2 static cables (1).
- (13) Close pump module rear doors (8).

M978 Tanker Operating Procedures (Cont)

2-26. CHANGING TO DIFFERENT FUEL OR FUEL GRADE.**a. Drain Existing Fuel.****WARNING**

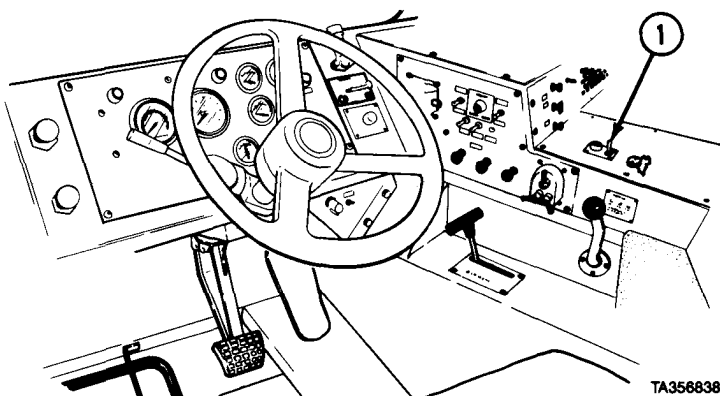
No smoking, flame, sparks, glowing or hot objects allowed within 50 ft (15 m) of vehicle. Fire or explosion may cause personal injury or death.

CAUTION

- Do not run tanker pump without fuel in system or damage to fuel pump and hydraulic motor may result.
- Do not press accelerator during tanker primary fuel pump operation. Engine speeds higher than 1500 rpm may damage hydraulic motor and primary pump.

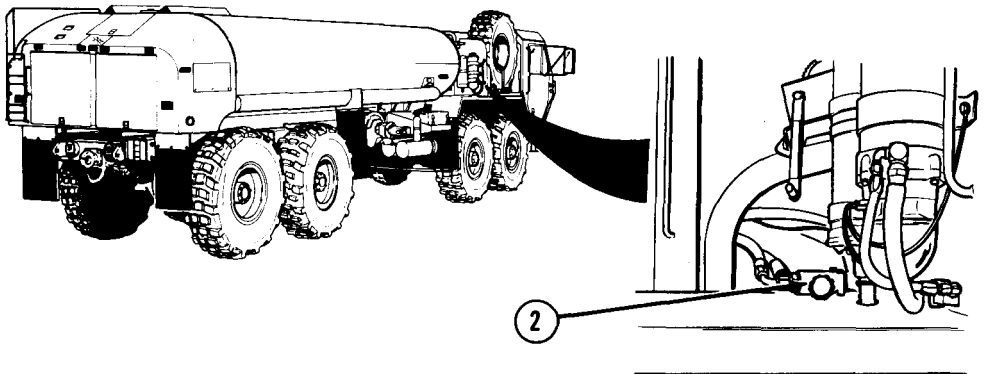
NOTE

- Refer to FM 10-71 for general operating instructions for tanker vehicles.
- If equipment malfunctions, check that all steps of procedure have been performed in proper order. If equipment still malfunctions, do troubleshooting (Chapter 3).
- Tanker must have at least 300 gal (1 136 l) of fuel in tank to perform fuel hose evacuation.



- (1) Start engine (para 2-11a or 2-11b) and position vehicle for bulk unloading.
- (2) Park vehicle (para 2-11o).
- (3) If vehicle is equipped with self-recovery winch, check that PTO ENGAGE switch (1) is set to OFF.

M978 Tanker Operating Procedures (Cont)

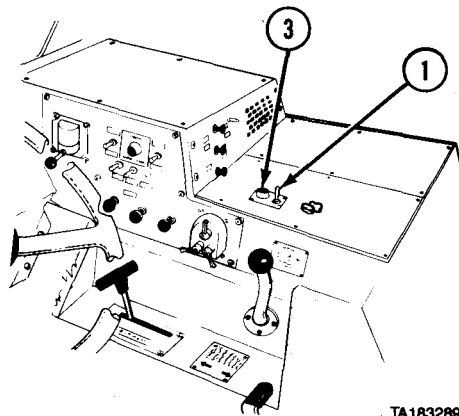


TA183236

CAUTION

Do not move SELECTOR VALVE while PTO is engaged or vehicle hydraulic equipment may be damaged.

- (4) If vehicle is equipped with self-recovery winch, push in SELECTOR VALVE (2) for tanker pump operation.

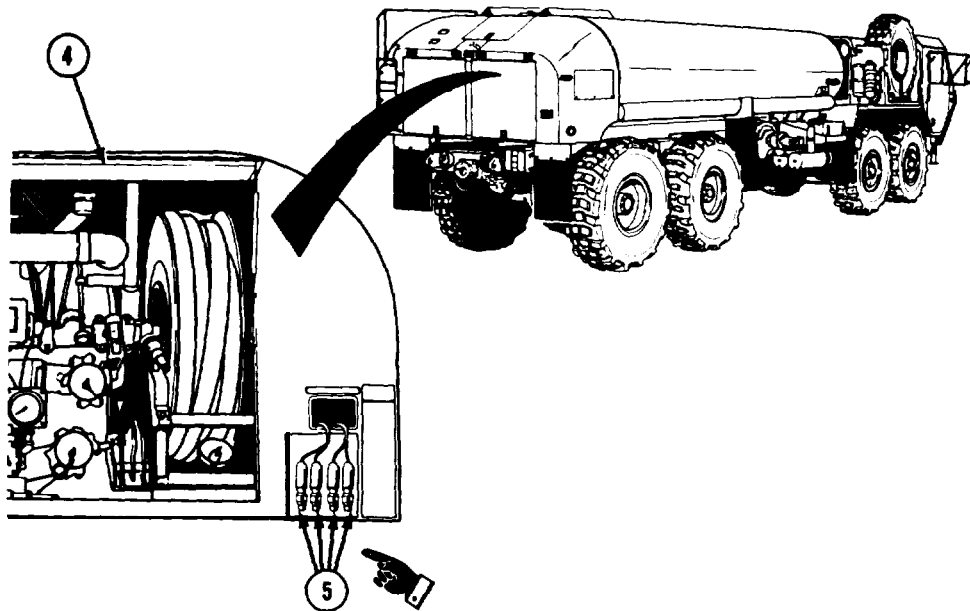


TA183289

- (5) Set PTO ENGAGE switch (1) to ON position. Indicator light (3) should come on.

M978 Tanker Operating Procedures (Cont)

2-26. CHANGING TO DIFFERENT FUEL OR FUEL GRADE (CONT).

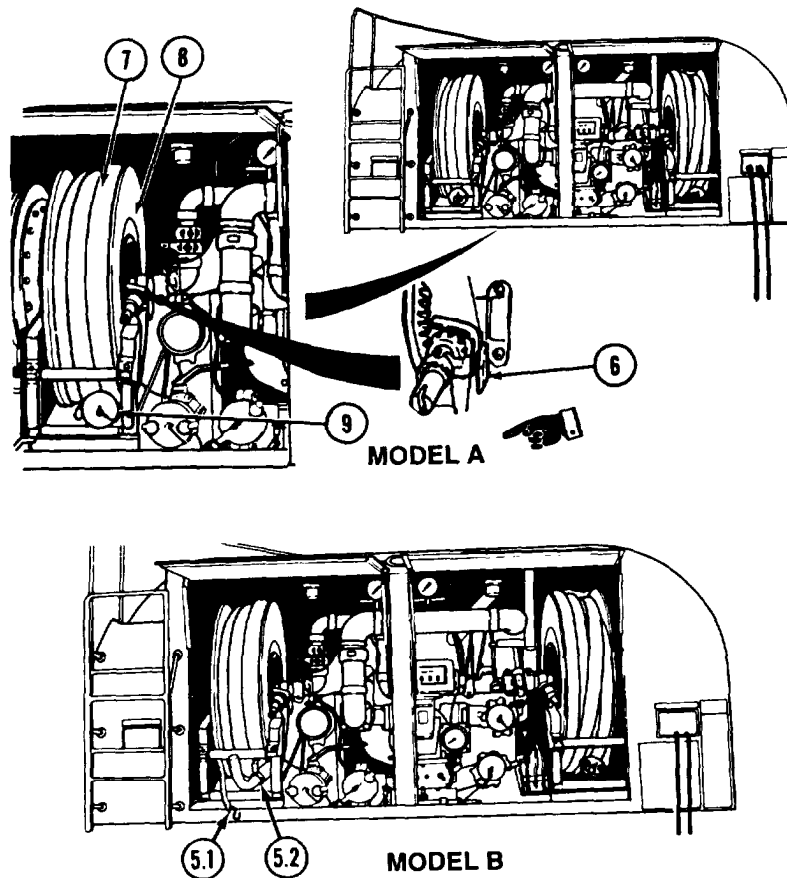


WARNING

Stand clear to avoid injury when opening pump module rear doors. When doors are about halfway open, gas pistons push doors open quickly and with much force.

- (6) Open pump module rear doors (4).
- (7) Position tanker controls (para 2-20b).
- (8) Connect SR1 and SR2 static cables (5) to grounding devices.

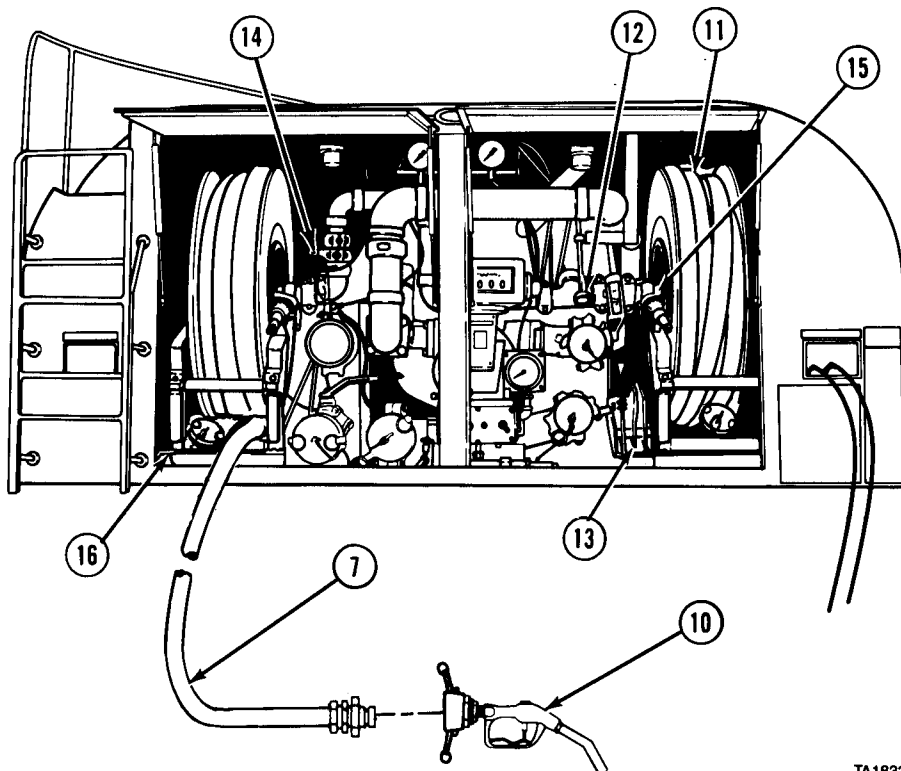
M978 Tanker Operating Procedures (Cont)

**NOTE**

Model B has a rubber tiedown strap to secure fuel service nozzle in stowage position. If nozzle is in stowage position, do step (8.1) and skip steps (12) through (14).

- (8.1) Remove rubber tiedown strap (5.1) to release fuel service nozzle (5.2) from stowage position.
- (9) Disengage hose reel tension knob (6).
- (10) Pull hose (7) out 2 ft (0.61 m) from reel (8).
- (11) Engage hose reel tension knob (6).
- (12) Remove dust cap (9) from end of hose (7).

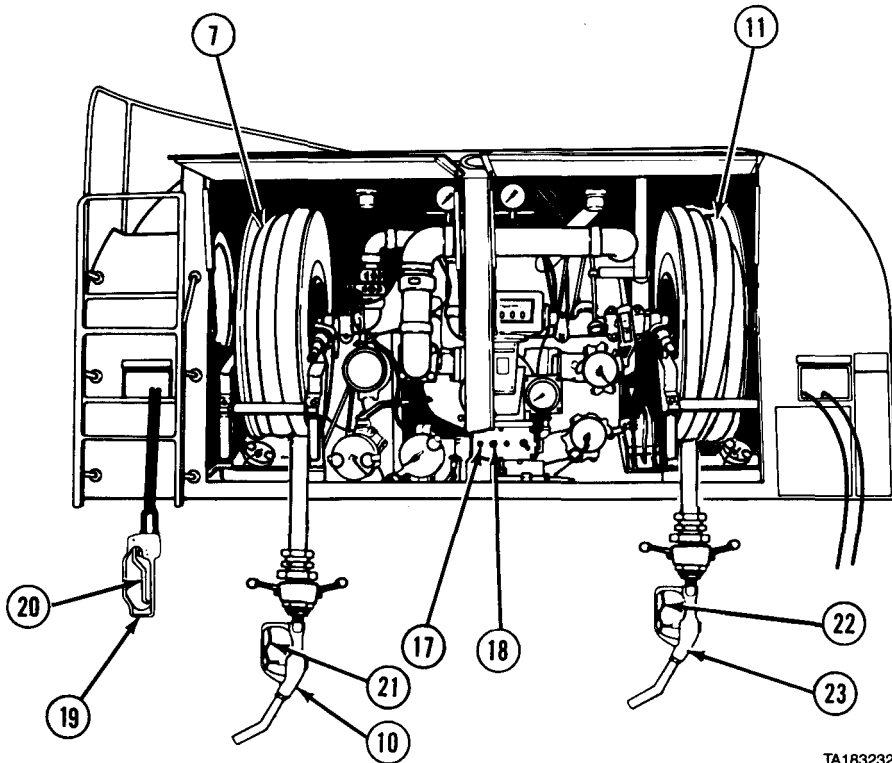
2-26. CHANGING TO DIFFERENT FUEL OR FUEL GRADE (CONT).



TA183258

- (13) Remove service nozzle (10) from stowage. Install service nozzle on hose (7).
- (14) Repeat steps (9) through (13) to set up hose (11) on other side of pump module.
- (15) Pull out V6 FUEL/DEFUEL VALVE control rod (12).
- (16) Pull back MC MANUAL CONTROL EM VALVE lever (13).
- (17) Open V7 and V8 REEL VALVES (14 and 15) all the way.
- (18) Push PUMP ENGAGEMENT LEVER (16) forward.

M978 Tanker Operating Procedures (Cont)

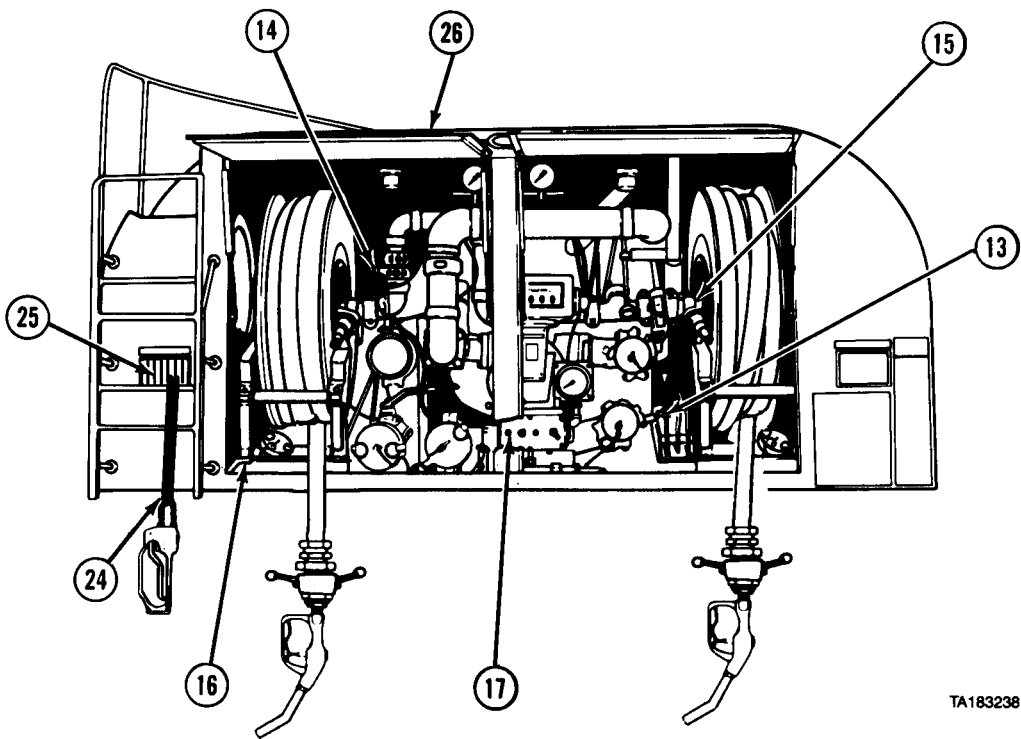


TA183232

- (19) Set TC/THROTTLE CONTROL switch (17) up to ON position.
- (20) Press HI/HIGH IDLE switch (18).
- (21) Pull out HAV HAND ACTUATED CONTROL valve (19) and squeeze and hold lever (20).
- (22) Squeeze and hold lever (21) on service nozzle (10) to empty fuel from hose (7). Dispose of fuel in accordance with unit SOP.
- (23) When all fuel is emptied from hose (7), release nozzle lever (21).
- (24) Squeeze and hold lever (22) on service nozzle (23) to empty fuel from hose (11). Dispose of fuel in accordance with unit SOP.
- (25) When all fuel is emptied from hose (11), release nozzle lever (22) and HAV HAND ACTUATED CONTROL valve lever (20).

M978 Tanker Operating Procedures (Cont)

2-26. CHANGING TO DIFFERENT FUEL OR FUEL GRADE (CONT).

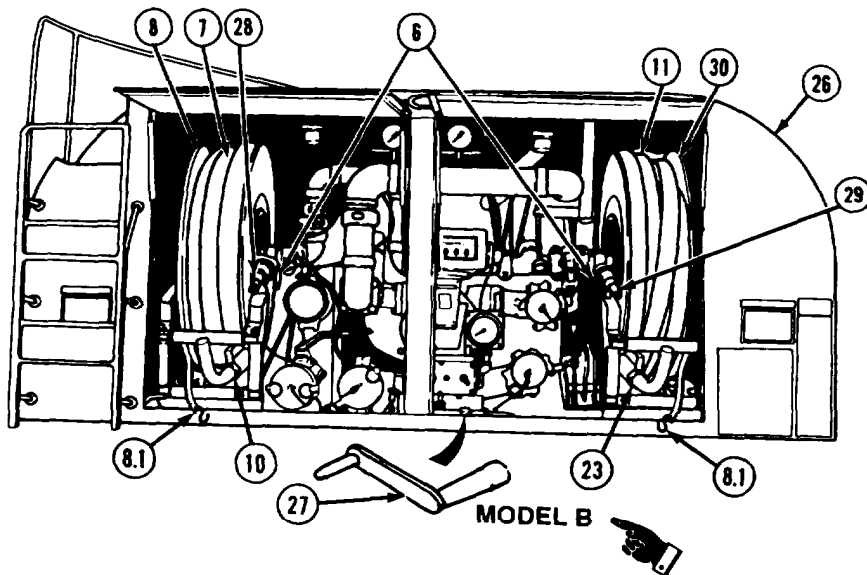
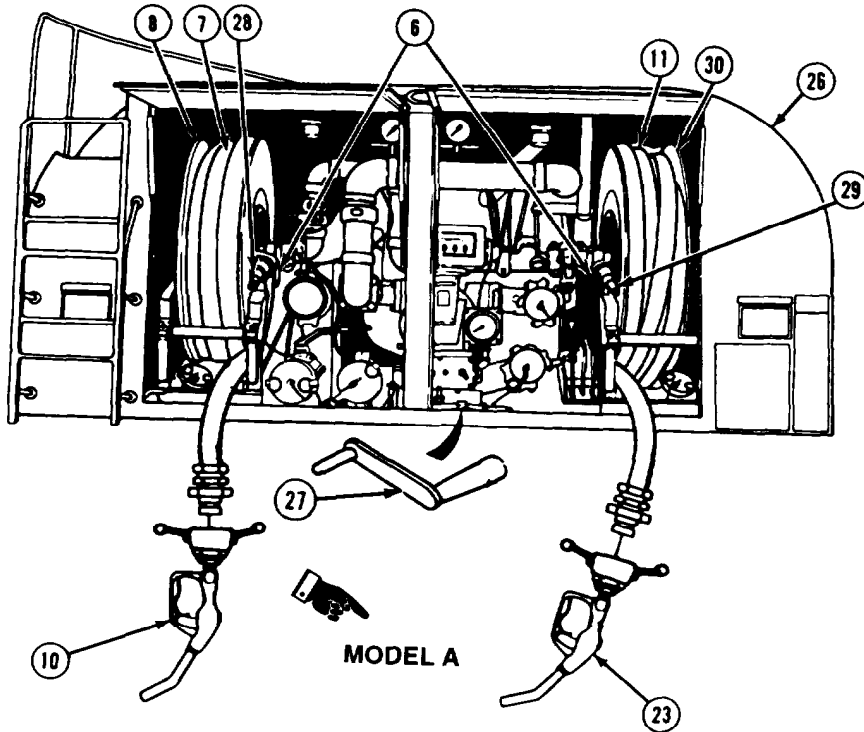


TA183238

- (26) Put TC/THROTTLE CONTROL switch (17) in OFF position.
- (27) Pull back on PUMP ENGAGEMENT LEVER (16) until locked.
- (28) Push MC MANUAL CONTROL EM VALVE lever (13) forward.
- (29) Close V7 and V8 REEL VALVES (14 and 15).
- (30) Rewind HAV HAND ACTUATED CONTROL valve hoses (24) onto reel (25) and stow inside pump module (26).

M978 Tanker Operating Procedures (Cont)

2-26. CHANGING TO DIFFERENT FUEL OR FUEL GRADE (CONT).



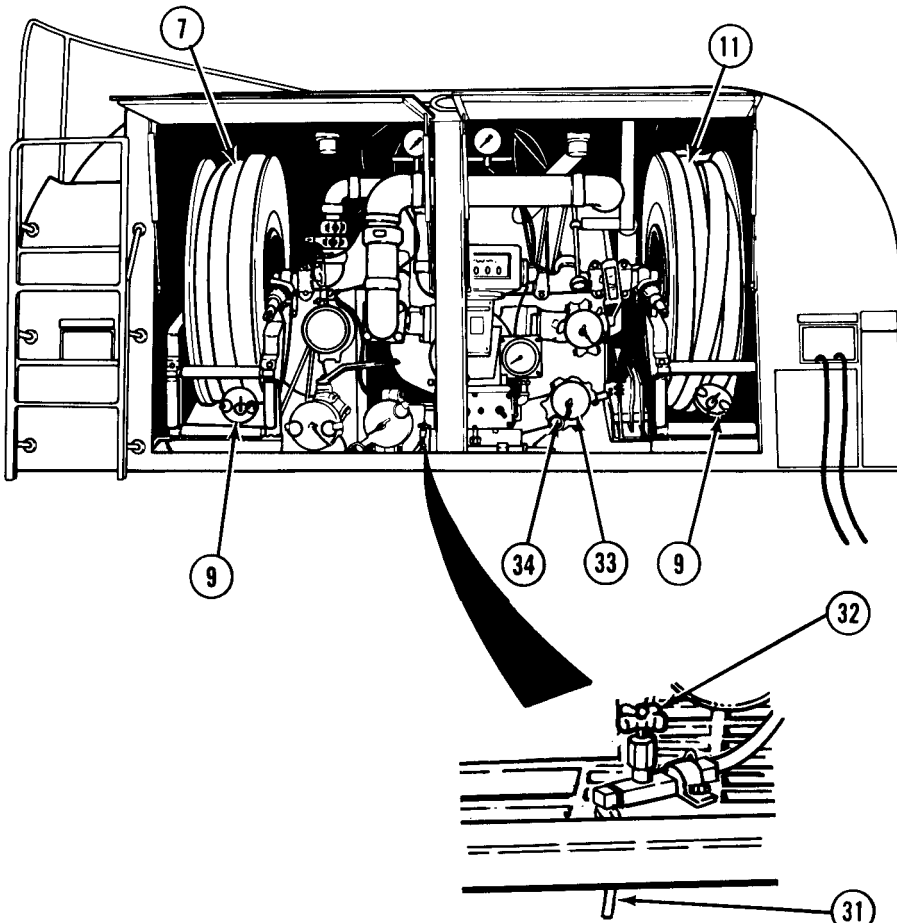
M978 Tanker Operating Procedures (Cont)**NOTE**

Model B has a rubber tiedown strap to secure fuel service nozzles in stowage position. If leaving fuel service nozzle attached to hose, do step (30.1) and skip step (31).

- (30.1) Place fuel service nozzles (10 and 23) in stowage position and secure with rubber tiedown straps (8.1).
- (31) Remove nozzles (10 and 23) from hoses (7 and 11). Stow nozzles.
- (32) Remove crank (27) from stowage on pump module (26).
- (33) Release hose reel tension knobs (6).
- (34) Put crank (27) on crankshaft (28) and turn to rewind hose (7) onto reel (8).
- (35) Put crank (27) on crankshaft (29) and turn to rewind hose (11) onto reel (30).
- (36) Engage hose reel tension knobs (6).
- (37) Stow crank (27).
- (38) Perform gravity bulk unload of tank (para 2-25c).

M978 Tanker Operating Procedures (Cont)

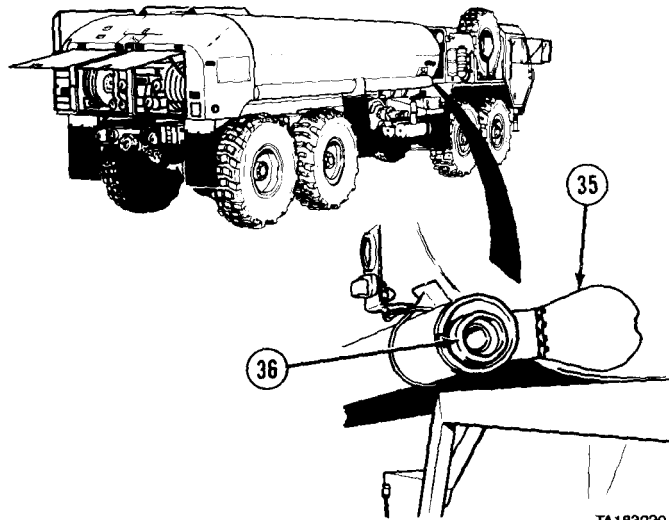
2-26. CHANGING TO DIFFERENT FUEL OR FUEL GRADE (CONT).



TA183214

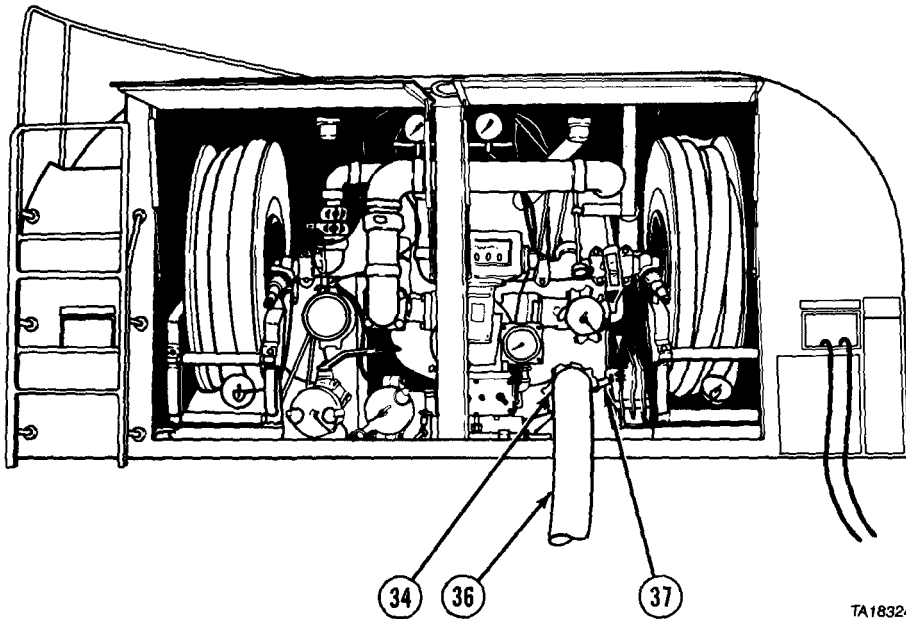
- (39) Install dust caps (9) on hoses (7 and 11).
- (40) Put suitable non-spark producing container under V15 DRAIN VALVE TUBE (31).
- (41) Open V15 DRAIN VALVE (32) to drain all fuel from filter-separator.
- (42) Close V15 DRAIN VALVE (32).
- (43) Dispose of fuel in accordance with unit SOP.
- (44) Remove dust cap (33) from C BULK RECEPTACLE (UNFIL) (34).

M978 Tanker Operating Procedures (Cont)



TA183220

(45) Open storage tube cover (35) and remove suction hose (36).

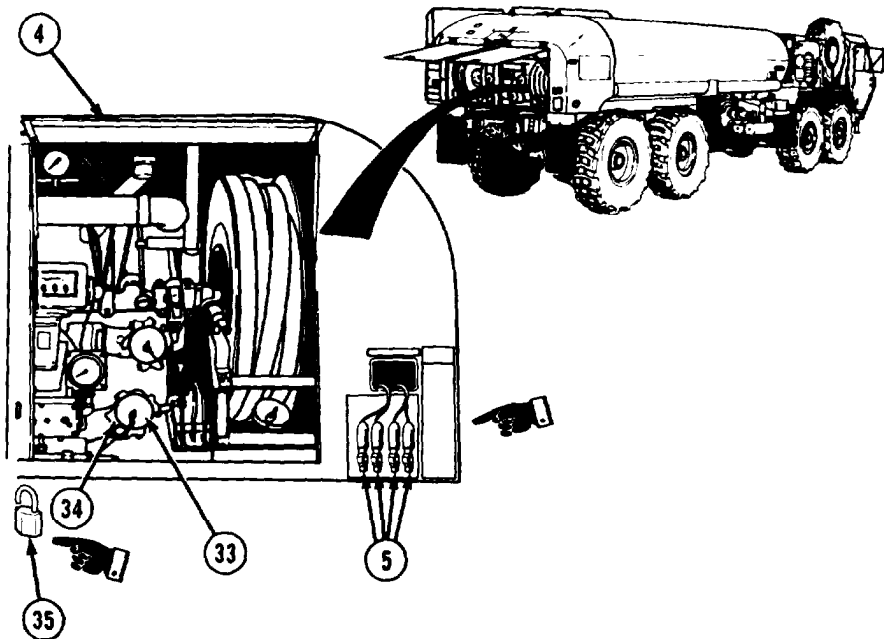


TA183240

- (46) Connect one end of suction hose (36) to C BULK RECEPTACLE (UNFIL) (34) and other end to receiving receptacle or suitable container.
- (47) Open V18 BULK DEL VALVE (37) to drain fuel from piping.
- (48) Close V18 BULK DEL VALVE (37).
- (49) Remove suction hose (36), drain fuel, and dispose of fuel in accordance with unit SOP. Stow suction hose.

M978 Tanker Operating Procedures (Cont)

2-26. CHANGING TO DIFFERENT FUEL OR FUEL GRADE (CONT).

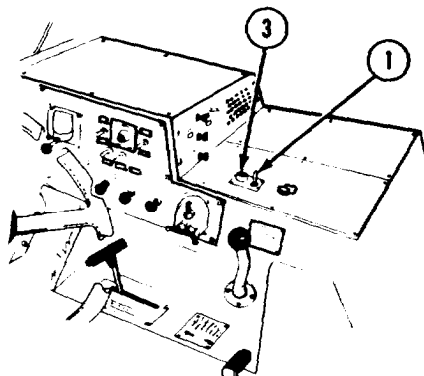


- (50) Install dust cap (33) on C BULK RECEPTACLE (UNFIL) (34).
- (51) Disconnect and rewind SR1 and SR2 static cables (5).
- (52) Close pump module rear doors (4).

NOTE

Model B has locking pump module rear doors. Do step (52.1) for Model B.

- (52.1) Install lock (35).



- (53) Set PTO ENGAGE switch (1) to OFF. Indicator light (3) should go out.
- (54) Shut off engine (para 2-11p).

M978 Tanker Operating Procedures (Cont)

b. Load Tanker With New Fuel.

- (1) Load tank with 300 gal (1 136 l) of fuel or fuel grade to be carried (para 2-22).
- (2) Circulate fuel through complete piping system and both fuel delivery hoses (para 2-24).
- (3) Repeat section (a.) of this procedure.
- (4) Notify organizational maintenance to replace filter elements in filter-separator.
- (5) Load tank with fuel or fuel grade to be carried (para 2-22).
- (6) Shut off engine (para 2-11p).

2-26.1 TRANSFER OF FUEL BETWEEN TANKER VEHICLES.

Note

- Top loading through the manhole will only be done in emergency situations, when bottom loading is not possible, and only by order of the Unit Commander.
- When transferring fuel between tanker vehicles the pump on only one vehicle is required. Procedures for transfer of fuel shall be coordinated between the two vehicle operators so that only one pump is in operation.

a. Transfer Fuel from a Tanker Truck or Trailer to a HEMTT.

- (1) When transferring fuel to a HEMTT from another tanker truck or trailer, follow instructions including all WARNINGS, CAUTIONS, and NOTES, for loading tanker with fuel (para 2-22.a, 2-22.b, or 2-22.c) with the following changes.
- (2) Bond and ground the vehicle. Connect the HEMTT SR1 and SR2 static cables to vehicle from which fuel is to be transferred and to grounding devices.
- (3) If transferring through bottom loading, connect enough suction hoses together to keep at least 25 feet between vehicles. The end of the suction hose which is connected to the fuel supply will be connected in accordance with the applicable tanker truck or trailer technical manuals.
- (4) During fuel transfer between tankers, the fuel station operator is replaced by the operator of the tanker truck or trailer from which fuel is being transferred.
- (5) The transferring tanker may be emptied before the receiving HEMTT is full. In this case the fuel flow WILL NOT shut off automatically. Care should be taken when transferring fuel using the receiving HEMTT pump to avoid running the pump when there is no more fuel to be transferred.

M978 Tanker Operating Procedures (Cont)

- (6) The preferred method for loading transferred fuel is bottom loading with exterior pump (Para 2-22.a).
 - (7) If fuel is transferred through the manhole, follow procedures in paragraph 2-22.c including all WARNINGS, CAUTIONS, and NOTES. The operator of the fuel tank truck or trailer supplying the fuel will follow requirements in para 2-22.c regarding hose placement within the HEMTT and adjustment of product flow rates.
- b. Transfer of Fuel from a HEMTT Tanker to Another Tanker Truck or Trailer.*
- (1) When transferring fuel from a HEMTT to another tank truck or trailer, follow instructions including all WARNINGS, CAUTIONS, and NOTES for unloading fuel (para 2-25) with the following changes.
 - (2) Connect SR1 and SR2 static cables to vehicle to which fuel is being transferred and to grounding devices.
 - (3) The end of the suction hose which is connected to the receiving receptacle shall be connected in accordance with the applicable tanker truck or trailer technical manuals.
 - (4) The preferred method for unloading fuel to another tanker is filtered bulk unloading (para 2-25.a).
 - (5) If fuel is transferred to another tanker using the fuel servicing hose, follow procedures in paragraph 2-23.a, except that the nozzle is not attached. Follow instructions in the receiving tankers technical manuals and FM 10-71 regarding positioning of the hose in the receiving tanker and adjustment of product flow rates.

2-27. CONNECT/DISCONNECT SEMITRAILER TO M983.

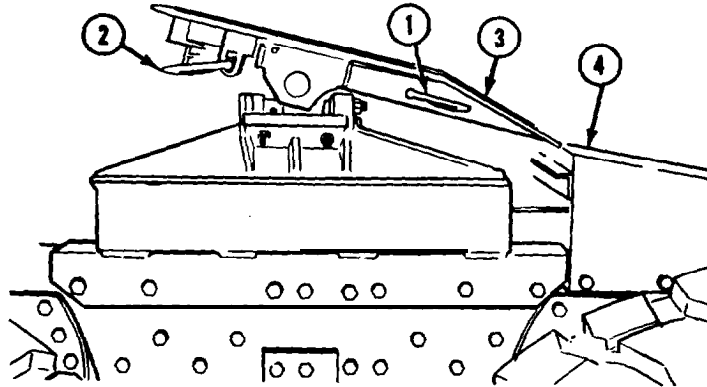
a. Connect Semitrailer to Vehicle.

NOTE

- Tractor used to pull M790 and XM860A1 trailers is equipped with material handling crane, generator set, and fifth wheel to accept 2 inch (51 mm) kingpin. Tractor used to pull XM974trailer is equipped with trailer spare tire and fifth wheel to accept 3.5-inch (89 mm) kingpin.
- This is a two-soldier task if tractor is equipped with crane. One soldier drives vehicle while other soldier stands beside front of semitrailer.
- M983 tractor with crane has one fifth wheel lock release handle. M983 tractor without crane has two fifth wheel lock release handles.
- If tractor is equipped with crane, go to step (2).

M983 Tractor Operating Procedures (Cont)

2-27. CONNECT/DISCONNECT SEMITRAILER TO M983 (CONT).



NOTE

Remove and store rear mud flaps and brackets to allow trailer clearance while towing a M860A1 trailer.

- (1) Pull fifth wheel secondary lock release handle (1) completely out and hook in out position.
- (2) Pull out fifth wheel primary lock release handle (2).
- (3) Push down fifth wheel tail ramps (3) so ramps are level with, or below top surface of, guide ramps (4).
- (4) Prepare semitrailer for coupling (TM 9-2330-357-14&P, TM 9-2330-364-14&P, or TM 9-2330-366-14&P).
- (5) Start engine (para 2-11a or 2-11b).
- (6) Aline vehicle with semitrailer,
- (6.1) Chock semitrailer wheels.

WARNING

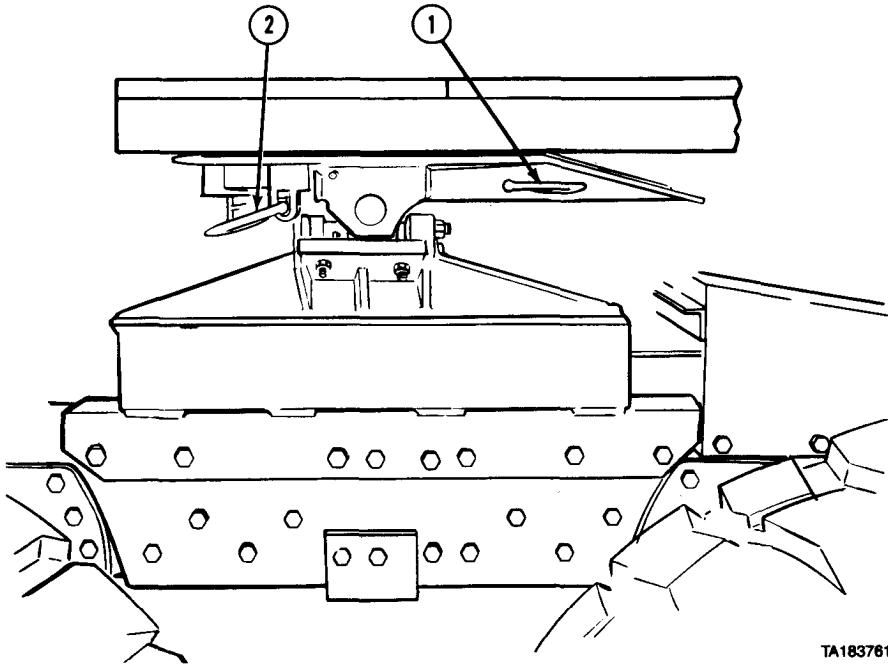
Be careful that no one is standing directly behind vehicle or semitrailer during coupling procedure to prevent personal injury.

CAUTION

Do not run kingpin up guide ramps to prevent damage to kingpin, guide ramps, or fifth wheel.

- (7) Soldier A stands beside semitrailer and gives hand signals while Soldier B slowly backs vehicle under semitrailer to aline kingpin with throat of fifth wheel.
- (8) Check that front of semitrailer is on guide ramps (4).
- (8.1) Stop vehicle and connect gladhands to trailer gladhands.
- (8.2) Pull trailer on supply knob to provide air pressure to trailer.
- (8.3) Apply trailer brakes.
- (9) Adjust semitrailer height, as needed, using landing gear.
- (10) Continue backing slowly until fifth wheel jaws lock around kingpin.

M983 Tractor Operating Procedures (Cont)



TA183761

- (11) Check that kingpin is in fifth wheel throat. Daylight should not show between top of fifth wheelplate and bottom of trailer.
- (12) Inch vehicle forward to check coupling. If coupling is not secure, rock vehicle back and forth slowly until kingpin is locked in fifth wheel.
- (13) Push primary lock release handle (2) completely in.

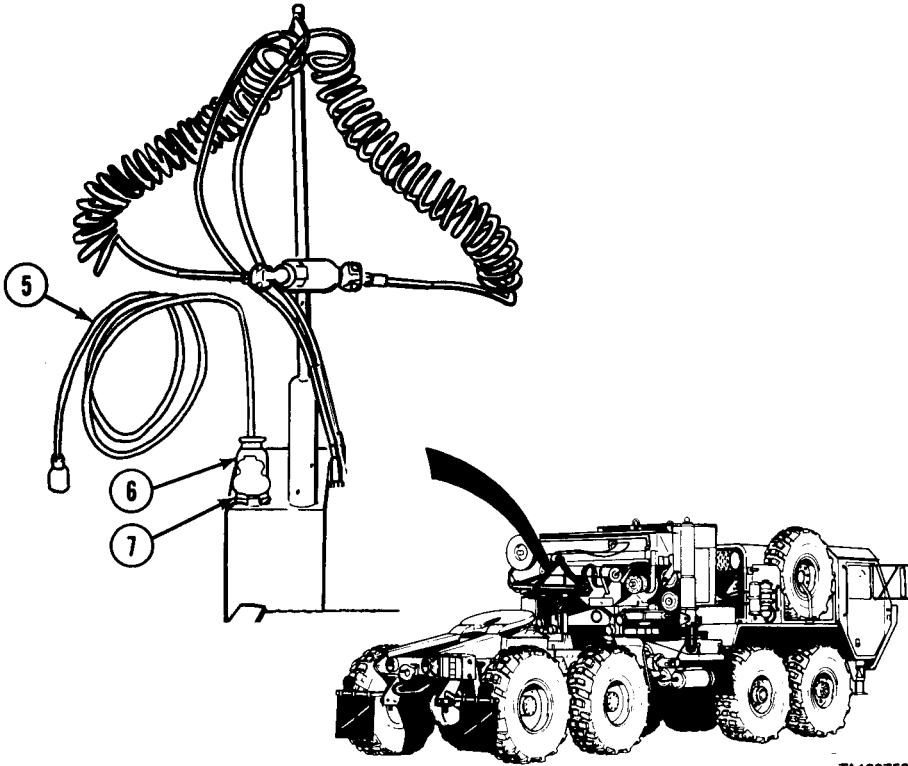
NOTE

If vehicle is equipped with crane, go to step (15).

- (14) Unhook and push secondary lock release handle (1) completely in.

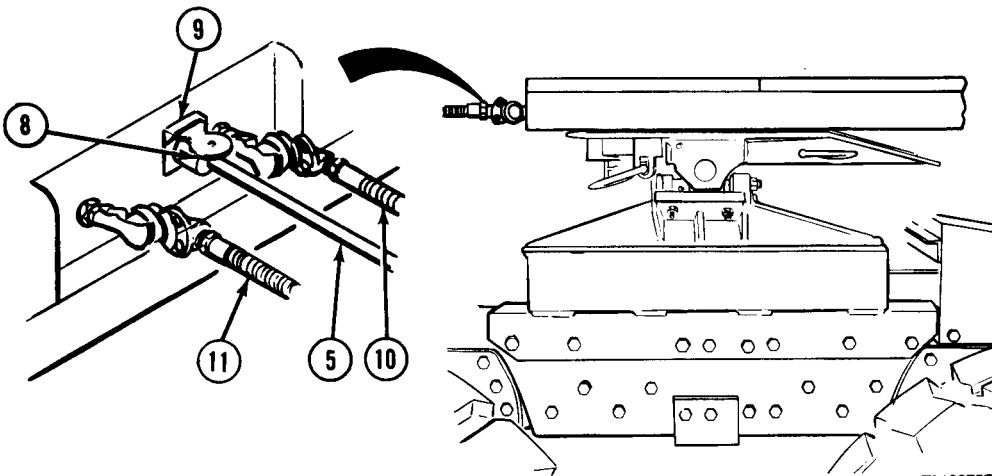
M983 Tractor Operating Procedures (Cont)

2-27. CONNECT/DISCONNECT SEMITRAILER TO M983 (CONT).



TA183758

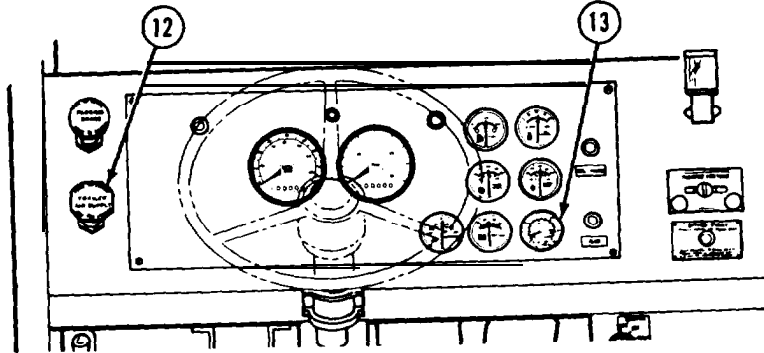
(15) Remove intervehicular wiring harness (5) from storage box and connect cable plug (6) to receptacle (7).



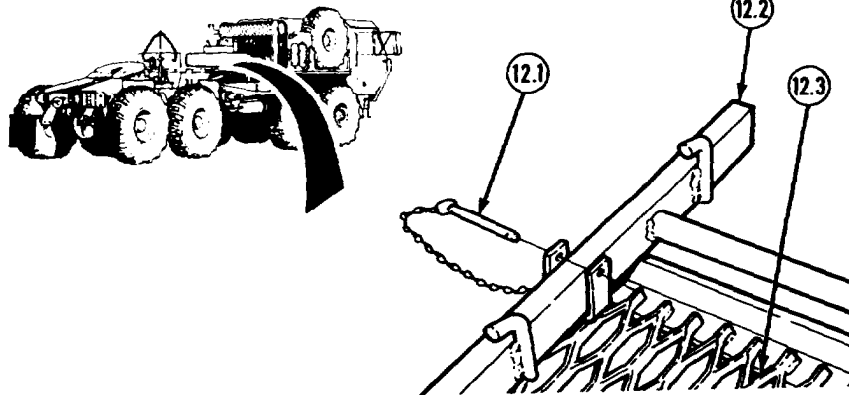
TA183757

M983 Tractor Operating Procedures (Cont)

- (16) Connect plug (8) on intervehicular wiring harness (5) to trailer receptacle (9).
- (17) Connect red airhose to EMERGENCY coupling (10) on trailer and connect blue airhose to SERVICE coupling (11) on trailer.



- (18) Push in TRAILER AIR SUPPLY control knob (12).

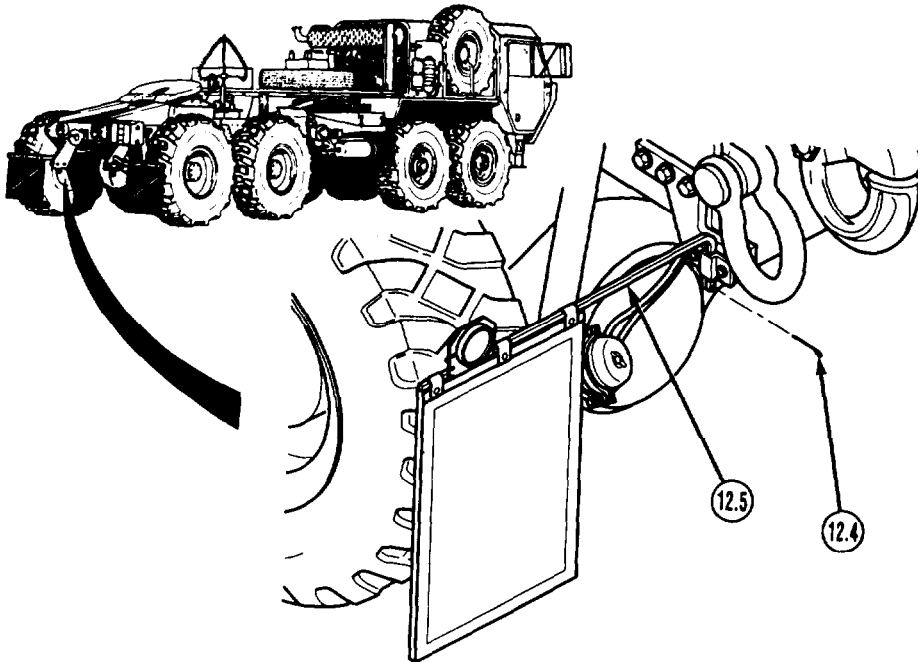


CAUTION

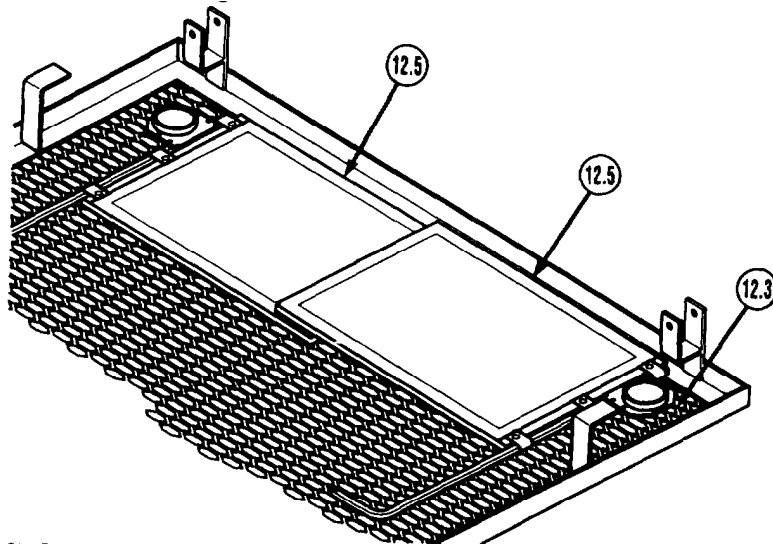
If tractor is used to pull an XM860A1 trailer, the rear mud flaps with mounting arms must be removed or damage to flaps and/or mounting arms may result. To remove mud flaps with mounting arms, do steps (18.1) through (18.4).

- (18.1) Remove two pins (12.1) and remove access ladder (12.2) from walkway grating (12.3).

M983 Tractor Operating Procedures (Cont)

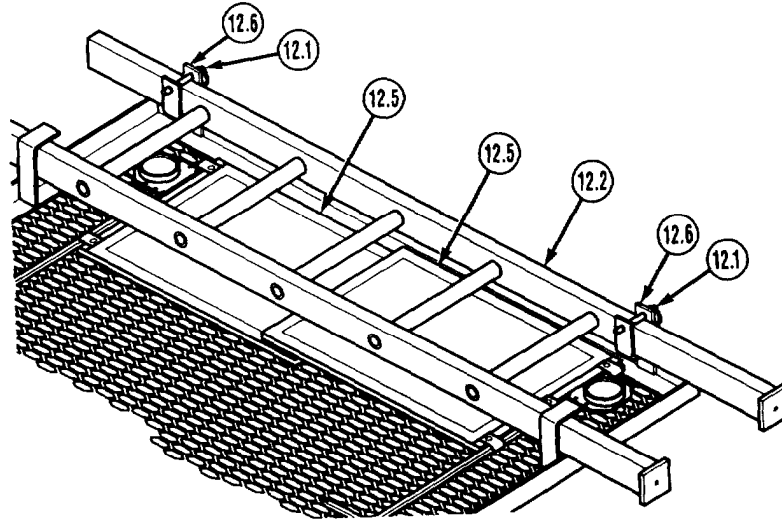


(18.2) Remove two cotter pins (12.4) and two rear mud flaps with mounting arms (12.5) from vehicle. Install two cotter pins in two rear mud flaps with mounting arms.



(18.3) Stow two rear mud flaps with mounting arms (12.5) on walkway grating (12.3).

M983 Tractor Operating Procedures (Cont)



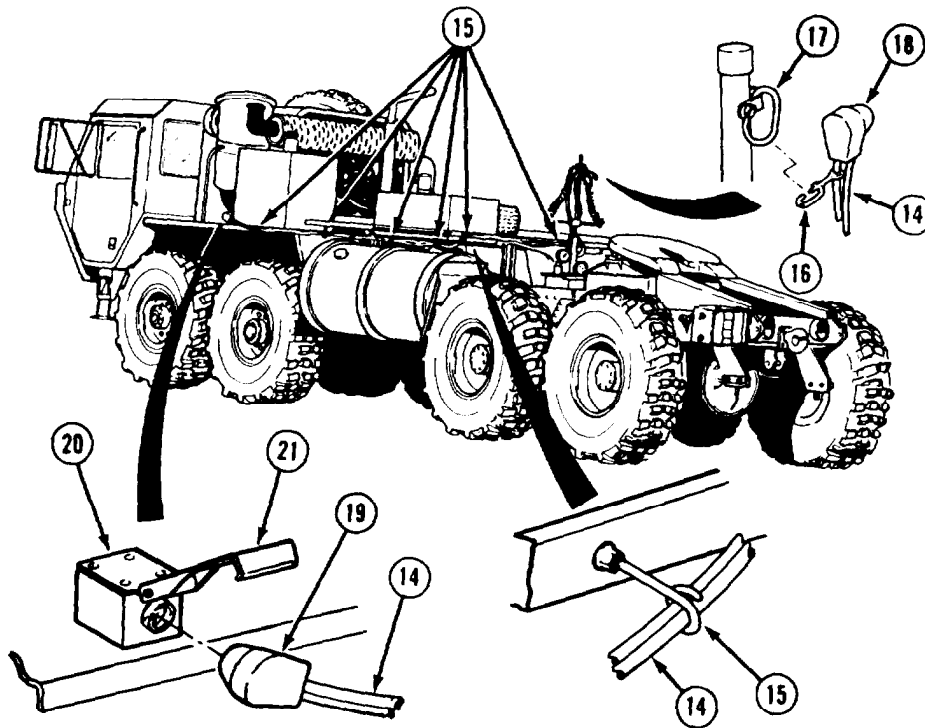
(18.4) Place access ladder (12.2) over mud flaps with mounting arms (12.5) and install two pins (12.1) in two brackets (12.6).

M983 Tractor Operating Procedures (Cont)

2-27. CONNECT/DISCONNECT SEMITRAILER TO M983 (CONT).

NOTE

Do not perform steps (22) through (27) unless slave cable is required.



- (19) Remove slave cable (14) from trailer stowage box.
- (20) Route cable (14) through six support hooks (15).
- (21) Attach clip (16) to ring (17).

WARNING

After routing through support hooks, connect NATO slave cable trailer end first. Damage to equipment or injury to personnel could result.

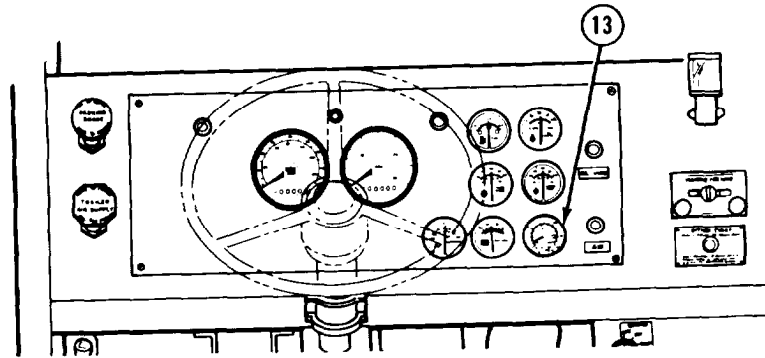
- (22) Connect plug (18) to trailer receptacle.
- (23) Connect plug (19) to slave receptacle (20).

NOTE

When using a slave cable with a small receptacle plug, the retention arm will have 35° bend.

- (24) Secure plug (19) with retention arm (21).

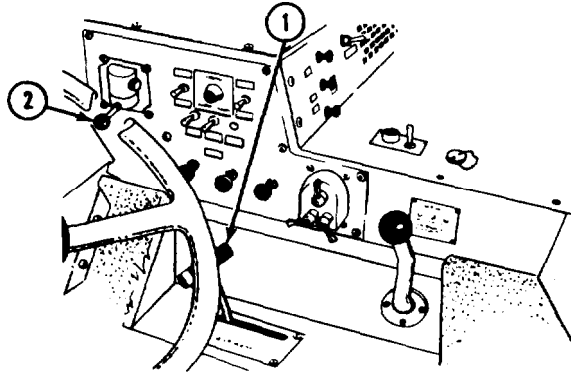
M983 Tractor Operating Procedures (Cont)



- (25) Prepare semitrailer for transport (TM 9-2330-357-14&P, TM 9-2330-364-14&P, or TM 9-2330-366-14&P).
- (26) AIR PRESS gage (13) must indicate at least 100 psi (690 kPa) before starting out.
- (27) Drive vehicle forward (para 2-11g).

M983 Tractor Operating Procedures (Cont)

b. *Disconnect Semitrailer from Vehicle.*



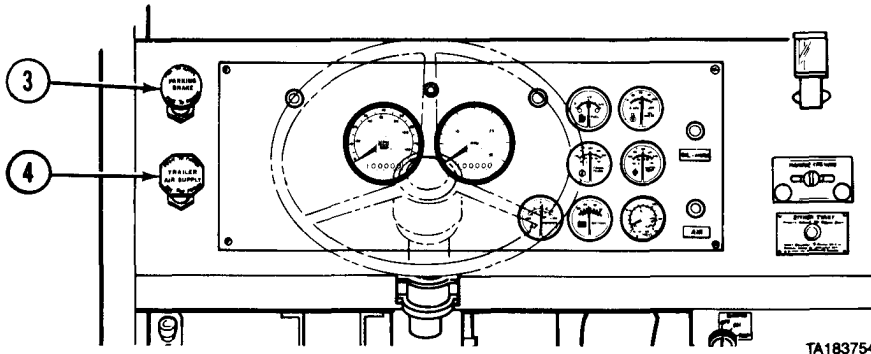
NOTE

This is a two-soldier task if tractor is equipped with crane. One soldier drives vehicle while other soldier stands beside front of semitrailer.

- (1) Position vehicle.
- (2) Put transmission range selector (1) in N (neutral) position.
- (3) Put trailer handbrake control (2) forward in OFF position.

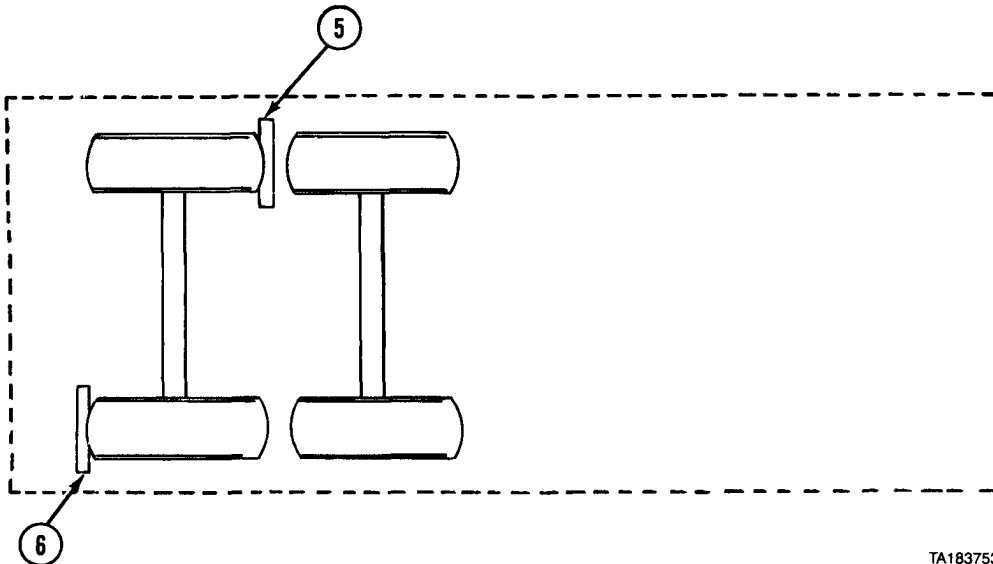
M983 Tractor Operating Procedures (Cont)

2-27. CONNECT/DISCONNECT SEMITRAILER TO M983 (CONT).



TA183754

- (4) Pull out PARKING BRAKE control knob (3).
- (5) Pull out TRAILER AIR SUPPLY control knob (4).



TA183753

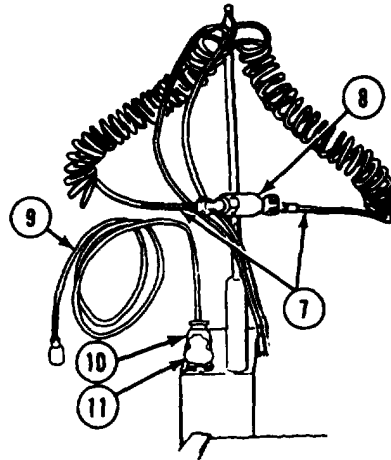
CAUTION

Use wheel chocks when uncoupling to prevent damage to semitrailer.

- (6) Place wheel chocks in back of semitrailer wheels on both sides of vehicle when parked uphill. Place chocks in front of wheels on both sides of vehicle when parked downhill. On level ground, put chock (5) in front of wheel on one side and chock (6) in back of wheel on other side of vehicle.
- (7) Prepare semitrailer for uncoupling (TM 9-2330-357-14&P, TM 9-2330-364-14&P, or TM 9-2330-366-14&P).
- (8) Lower semitrailer landing gear.

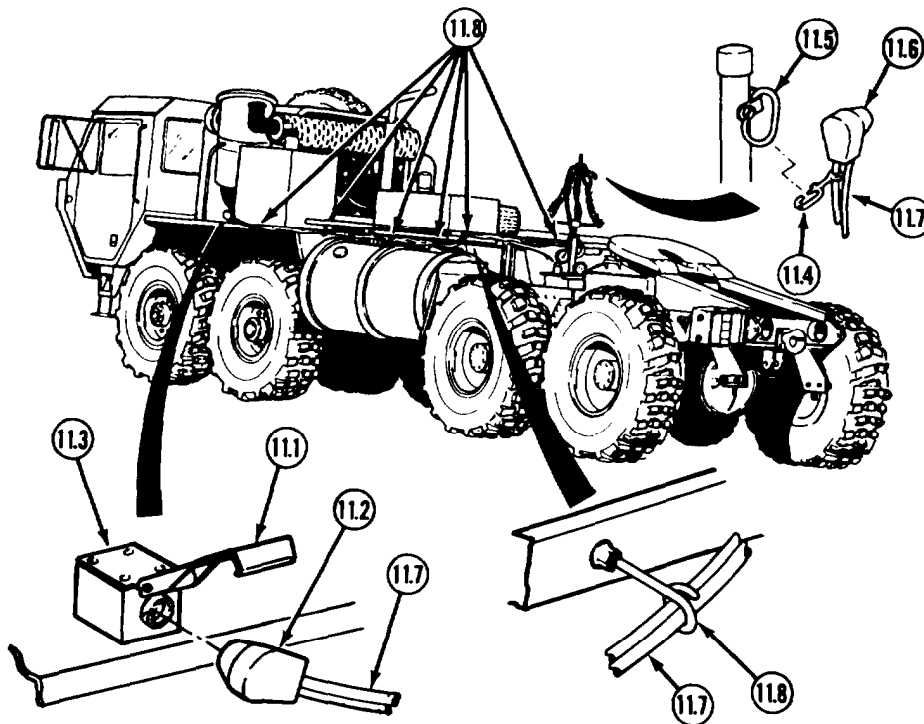
M983 Tractor Operating Procedures (Cont)

- (9) Disconnect airhoses (7) from semitrailer and stow airhoses on tree (8).
- (10) Disconnect intervehicular wiring harness (9) from trailer and remove cable plug (10) from tractor receptacle (11). Stow harness in stowage box.



M983 Tractor Operating Procedures (Cont)

2-27. CONNECT/DISCONNECT SEMITRAILER TO M983 (CONT).



WARNING

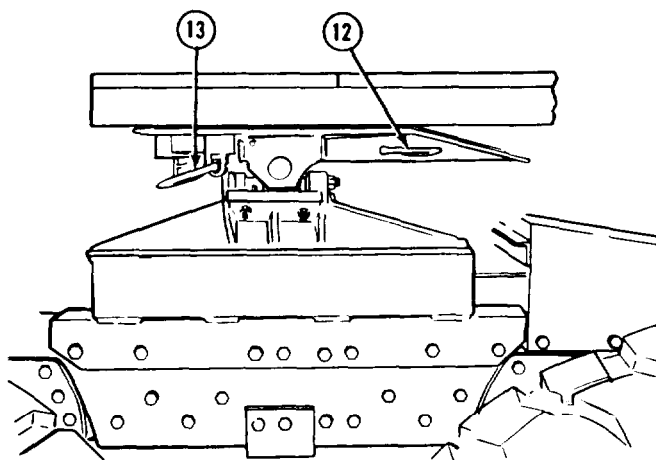
Disconnect NATO slave cable from tractor end first.
Damage to equipment or injury to personnel could result.

NOTE

If slave cable is not used, go to step (11).

- (10.1) Lift retention arm (11.1) and remove plug (11.2) from receptacle (11.3).
- (10.2) Remove clip (11.4) from ring (11.5).
- (10.3) Disconnect plug (11.6) from trailer.
- (10.4) Remove cable (11.7) from support hooks (11.8).
- (10.5) Place cable (11.7) in trailer stowage box.

M983 Tractor Operating Procedures (Cont)

**NOTE**

If tractor is equipped with crane, go to step (12).

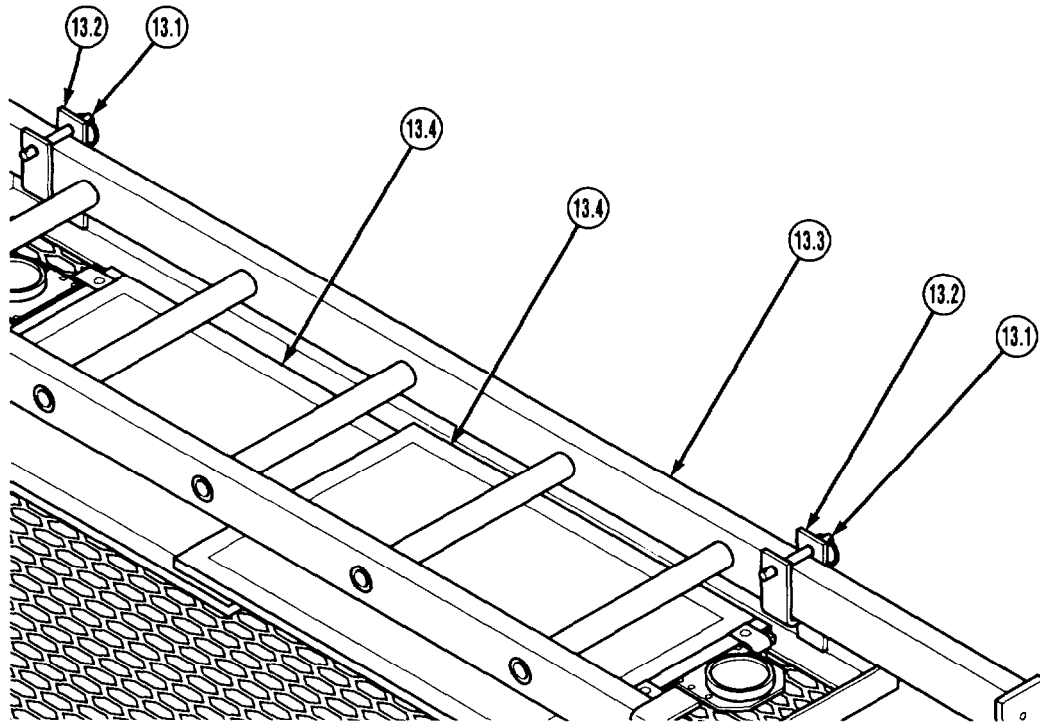
- (11) Pull out secondary lock release handle (12) and hook in out position.
- (12) Pull primary lock release handle (13) completely out.
- (13) Drive tractor forward slowly for approximately 4 ft (1.2 m) and stop.
- (14) Check clearance between kingpin and rear frame crossmember of tractor. Adjust trailer height as needed by lowering landing gear, if kingpin will catch on crossmember.
- (15) Drive tractor forward slowly until semitrailer is clear of tractor and semitrailer landing gear is on ground.
- (16) Soldier A checks semitrailer kingpin to be sure kingpin clears rear frame crossmember while Soldier B drives vehicle forward [para 2-11g (4)].

M983 Tractor Operating Procedures (Cont)

2-27. CONNECT/DISCONNECT SEMITRAILER TO M983 (CONT).

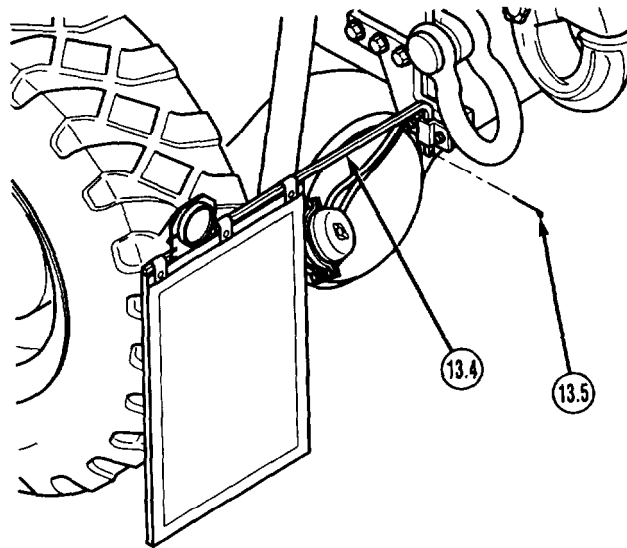
NOTE

If an XM860A1 trailer has been disconnected from tractor, do steps (17) through (21) to install rear mud flaps with mounting arms.

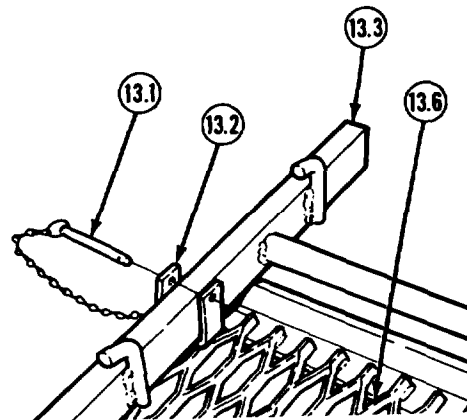


- (17) Remove two pins (13.1) from two brackets (13.2).
- (18) Remove access ladder (13.3) and two rear mud flaps with mounting arms (13.4).

M983 Tractor Operating Procedures (Cont)



- (19) Install two rear mud flaps with mounting arms (13.4) using two cotter pins (13.5).
- (20) Place access ladder (13.3) in two brackets (13.2) of walkway grating (13.6).
- (21) Install two pins (13.1) in two brackets (13.2).



2-28. M983 CRANE OPERATION (MANUAL CONTROLS).

a. Prepare Crane For Use.

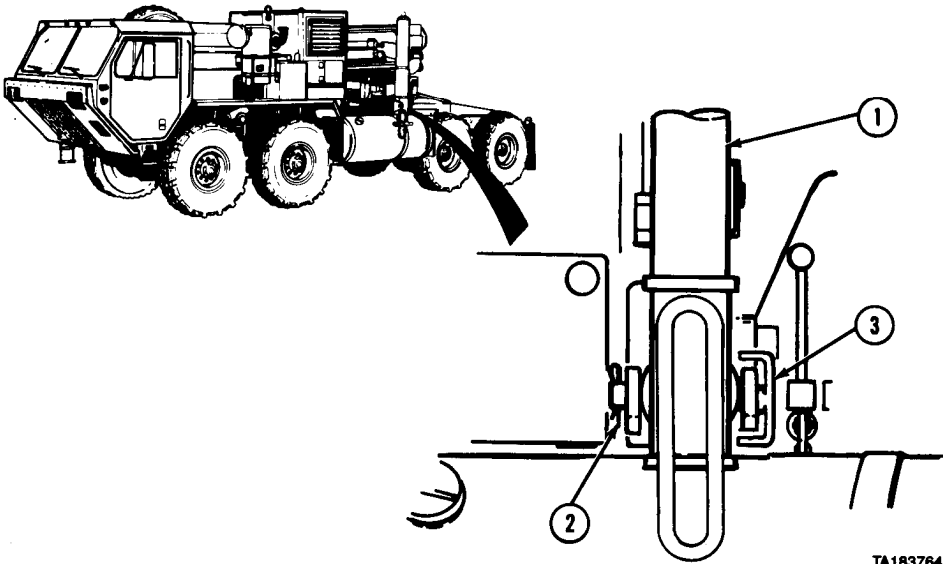
WARNING

Do not operate crane unless outriggers are setup. Vehicle could turn over causing personal injury or death.

NOTE

Failure of hydraulic system will stop crane operation and lock crane in place. If hydraulic system fails during crane operation refer to paragraph 2-48e for emergency shutdown procedures.

- (1) Start engine (para 2-11a or para 2-11b).
- (2) Position vehicle on level ground so all loading and unloading can be done from one position.
- (3) Park vehicle (para 2-11o).
- (4) Shut off engine (para 2-11p).
- (5) Set engine start switch to ON position.



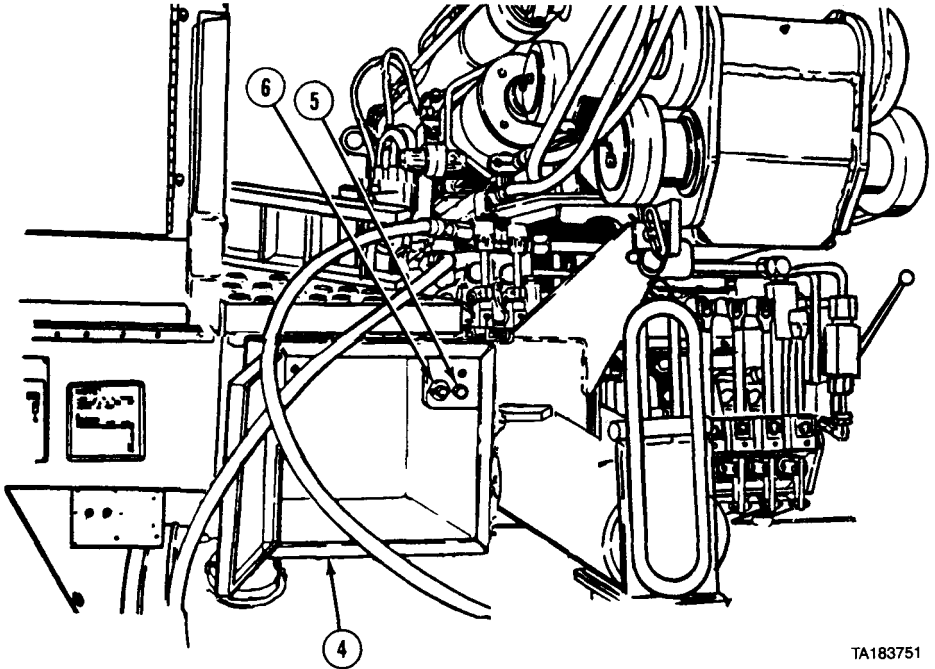
TA183764

WARNING

Outriggers are heavy and can swing when support pin is removed. Falling outrigger may cause personal injury or death.

- (6) Soldier A holds outrigger (1) upright, while Soldier B removes safety pin (2) and outrigger support pin (3), and pulls outrigger completely out from vehicle.

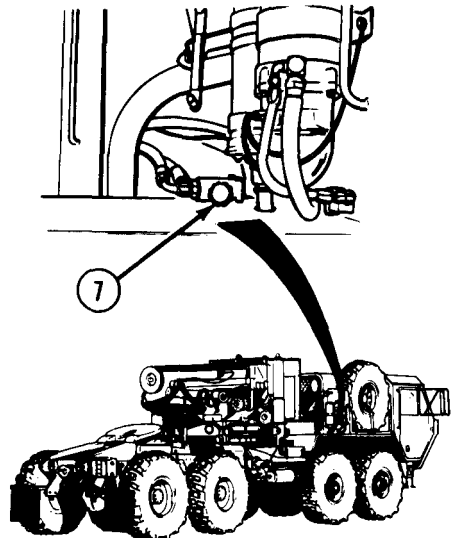
M983 Tractor Operating Procedures (Cont)



TA183751

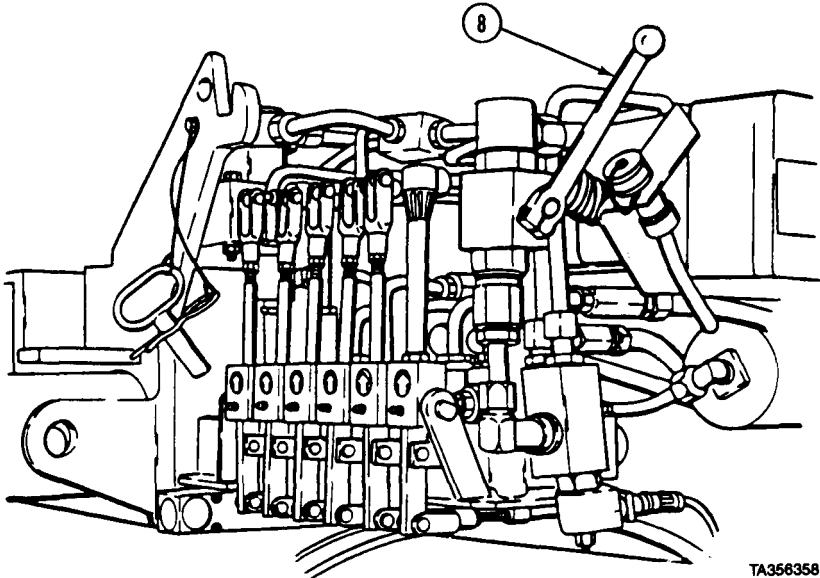
- (7) Open remote control stowage box (4) and check green indicator (5). If green indicator is lit, press pushbutton switch (6) to turn off indicator light. Close stowage box, and go to next step. If indicator is not lit, close stowage box and go to next step.

- (8) Push in hydraulic SELECTOR VALVE knob (7) for crane operation.

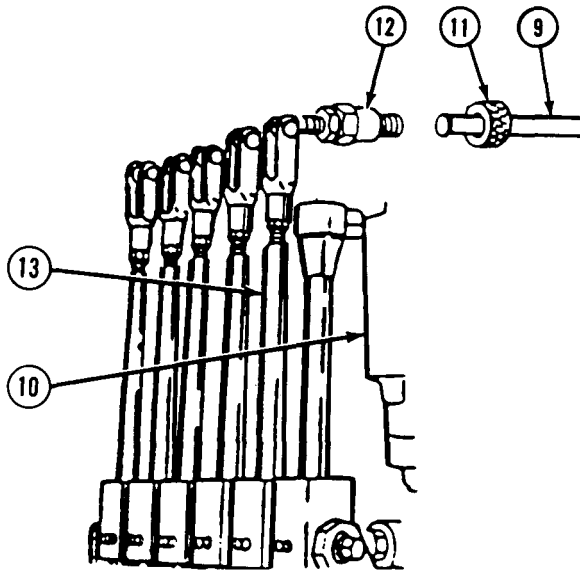


TA183766

2-28. M983 CRANE OPERATION (MANUAL CONTROLS) (CONT).



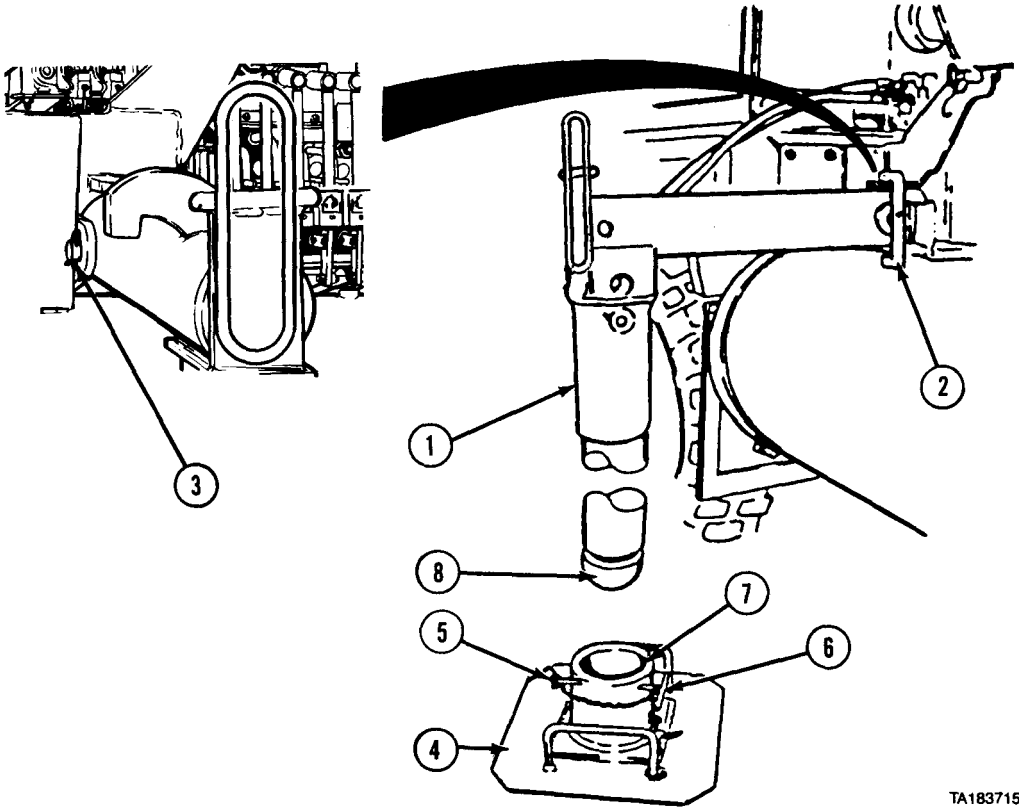
(9) Turn crane hydraulic selector valve handle (8) to MANUAL position.



(10) Disconnect each remote control rod (9) from each control lever (10) on left side of vehicle by unscrewing control rod quick disconnect sleeve (11) from ball end (12) of control lever.

(11) Push each remote control rod (9) straight into hydraulic control unit (13).

M983 Tractor Operating Procedures (Cont)

b. Set Up Outriggers.

TA183715

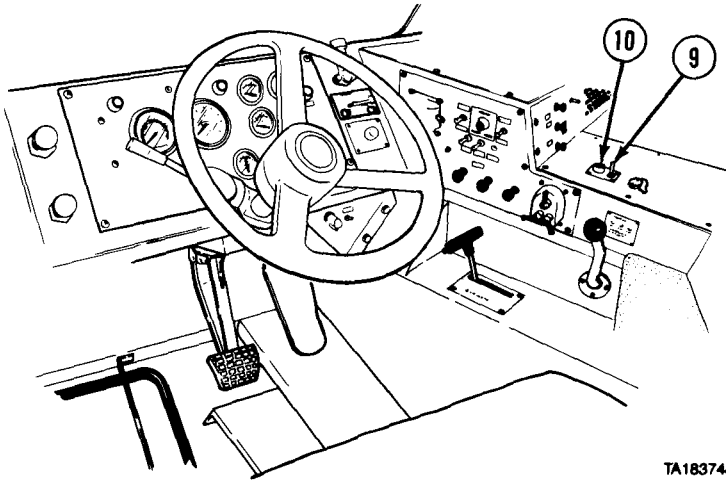
WARNING

Outriggers are heavy and can swing when support pin is removed. Falling outrigger may cause personal injury or death.

- (1) Soldier A and Soldier B carefully rotate outrigger (1) to lower it to down position. Soldier B inserts outrigger support pin (2) and installs safety pin (3) in support pin.
- (2) Remove outrigger pad (4) from stowage.
- (3) Remove safety pin (5) and retaining pin (6) and position pad (4) under end of outrigger (1).
- (4) Clean pad socket (7) and outrigger ball (8).
- (5) Repeat steps (1) through (5) to position other outrigger.
- (6) Start engine (para 2-11a or 2-11b).

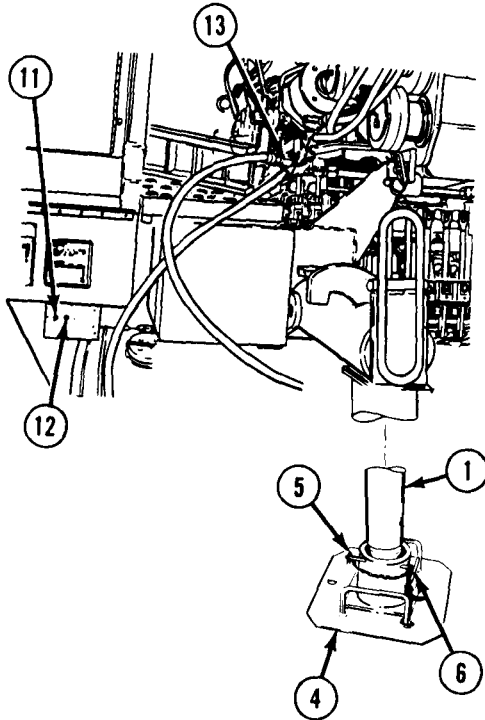
M983 Tractor Operating Procedures (Cont)

2-28. M983 CRANE OPERATION (MANUAL CONTROLS) (CONT).



TA183748

(7) Put PTO ENGAGE switch (9) in ON position. Make sure indicator light (10) comes on.



TA183710

M983 Tractor Operating Procedures (Cont)

- (8) Set engine speed control switch (11) to on position and set engine speed control engage switch (12) to engage position.

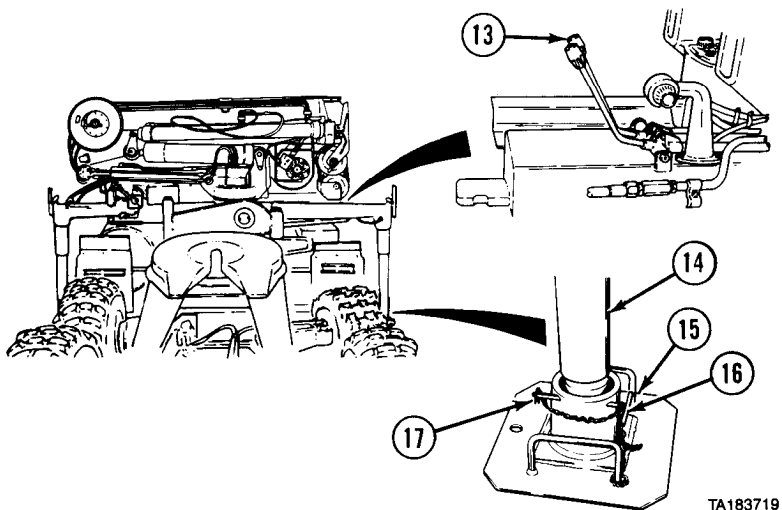
WARNING

Do not raise tires off ground with outriggers. Vehicle could roll causing personal injury or death.

NOTE

Moving lever slightly will cause slow movement of outriggers. Moving lever to full travel will cause outriggers to move faster.

- (9) Pull outrigger control lever (13) on left side of vehicle to lower left outrigger (1) into outrigger pad (4) only enough to get vehicle weight off springs.
- (10) Install retaining pin (6) in outrigger pad (4) and install safety pin (5).



TA183719

WARNING

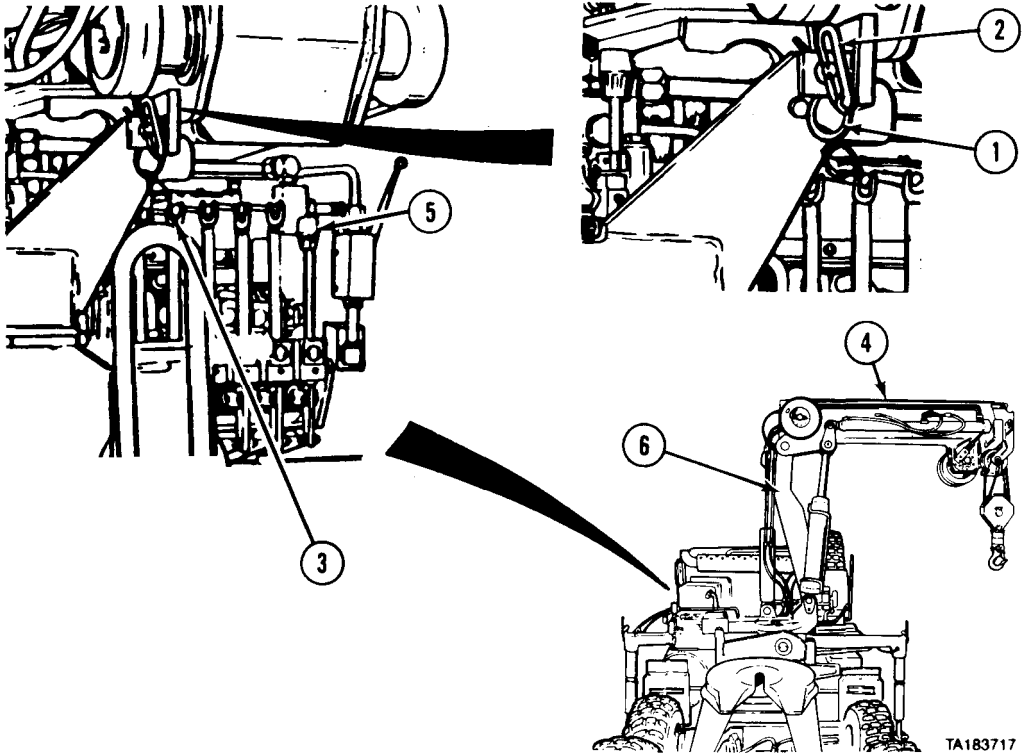
Do not raise tires off ground with outriggers. Vehicle could roll causing personal injury or death.

- (11) Pull outrigger control lever (13) on right side of vehicle to lower right outrigger (14) into outrigger pad (15).
- (12) Install retaining pin (16) in outrigger pad (15) and install safety pin (17).

M983 Tractor Operating Procedures (Cont)

2-28. M983 CRANE OPERATION (MANUAL CONTROLS) (CONT).

c. Raise Boom to Operating Position.



TA183717

WARNING

- Do not operate crane unless outriggers are set up. Vehicle could turn over causing personal injury or death.
- Keep boom clear of all electrical lines and other obstacles while operating crane. Serious injury or death could result upon contact.

- (1) Remove lockpin (1) and pull out mast stowage pin (2).
- (2) Pull boom control lever (3), raise boom (4) to approximate 90° angle, then lower slightly.
- (3) Pull mast control lever (5) and raise mast (6) as far as it will go.

M983 Tractor Operating Procedures (Cont)

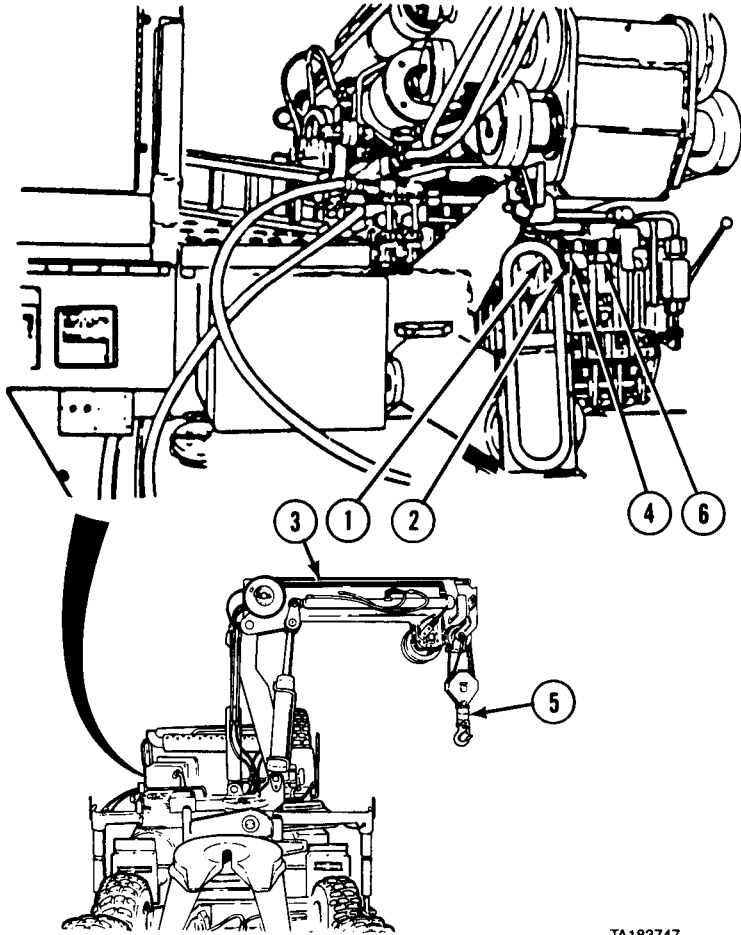
*d. Operate Crane Using Left-Side Controls.*W A R N I N G

- Keep boom clear of electrical lines and other obstacles while operating crane. Serious injury or death could result upon contact.
- Operator should use crane controls so load will not pass overhead. Load could fall causing serious injury or death.
- Boom should be swung slow enough so crane operator has complete control. Boom moving out of control could cause serious injury or death.

N O T E

- Moving lever slightly will cause slow movement of crane. Moving lever to full travel will cause crane to move faster.
- Use controls that provide clear view of boom at all times.

2-28. M983 CRANE OPERATION (MANUAL CONTROLS) (CONT).



TA183747

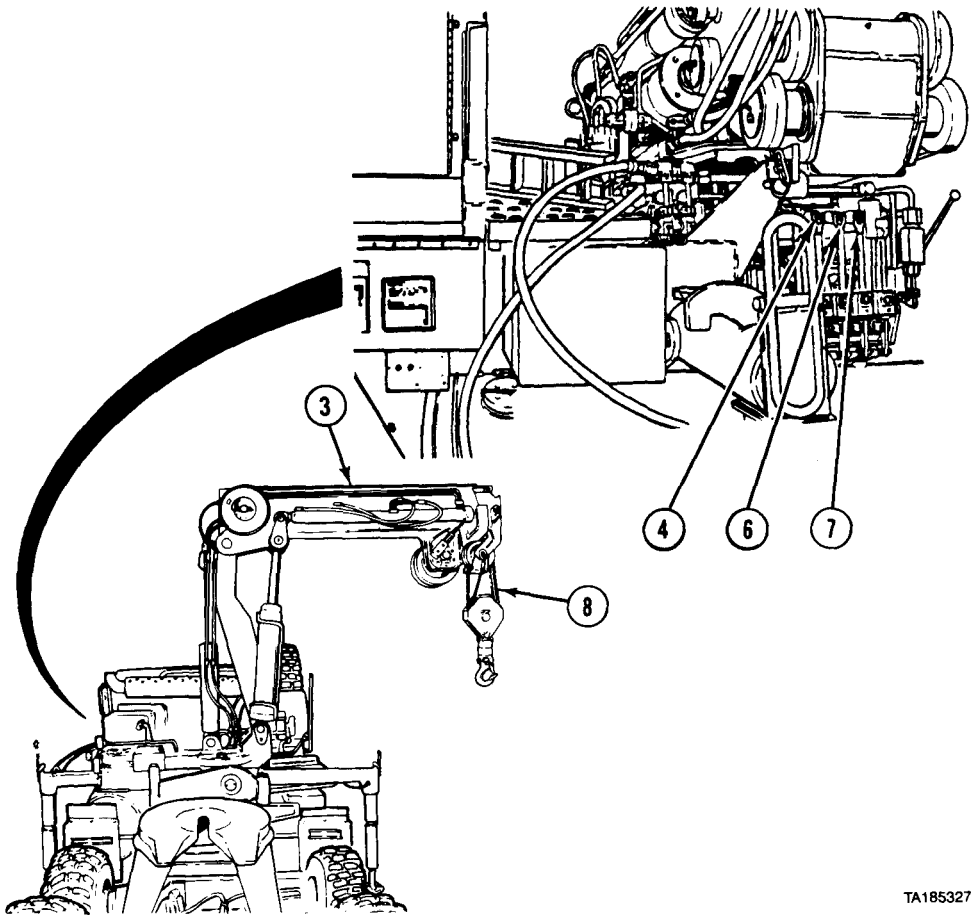
- (1) Push swing lever (1) in to rotate crane clockwise. Pull lever out to rotate crane counterclockwise.
- (2) Pull boom lever (2) out to raise boom (3). Push in boom lever to lower boom.

CAUTION

When boom is being extended, hoist lever must be pushed in to allow space between sheave at end of boom and sheave at load hook to prevent cable from breaking.

- (3) Push hoist lever (4) in to lower load hook (5).
- (4) At same time, push extend 1 + 2 lever (6) in to extend first and second stages of boom (3).

M983 Tractor Operating Procedures (Cont)



TA185327

- (5) Push extend 3 + 4 lever (7) in to extend third and fourth stages of boom (3).
- (6) Push hoist lever (4) in to lower load hook. Connect load straps or rigging to hook.
- (7) Pull hoist lever (4) out to raise load hook.
- (8) Pull extend 3 + 4 lever (7) out and retract third and fourth stages of boom (3).
- (9) Pull hoist lever (4) out and reel in excess cable (8).
- (10) Pull extend 1 + 2 lever (6) out and retract first and second stages of boom (3).
- (11) Pull hoist lever (4) out and reel in excess cable (8).

2-28. M983 CRANE OPERATION (MANUAL CONTROLS) (CONT).

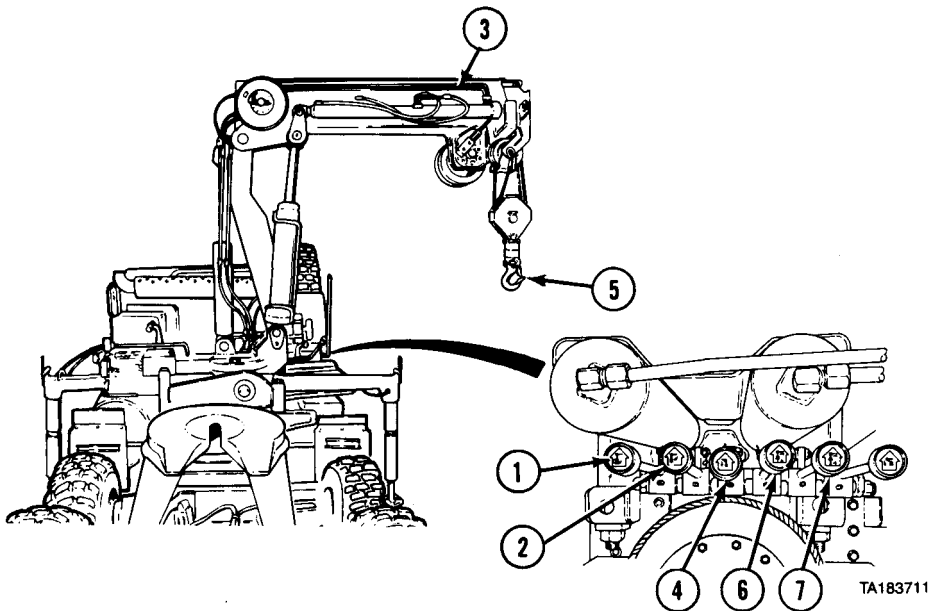
e. Operate Crane Using Right-Side Controls.

WARNING

- Keep boom clear of electrical lines and other obstacles while operating crane. Serious injury or death could result upon contact.
- Operator should use crane controls so load will not pass overhead. Load could fall causing serious injury or death.
- Boom should be swung slow enough so crane operator has complete control. Boom moving out of control could cause serious injury or death.

NOTE

- Moving lever slightly will cause slow movement of crane. Moving lever to full travel will cause crane to move faster.
- Use controls that provide clear view of boom at all times.



M983 Tractor Operating Procedures (Cont)

- (1) Push swing lever (1) up to rotate crane clockwise. Pull lever (1) down to rotate crane counterclockwise.
- (2) Pull boom lever (2) down to raise boom (3). Push boom lever up to lower boom.

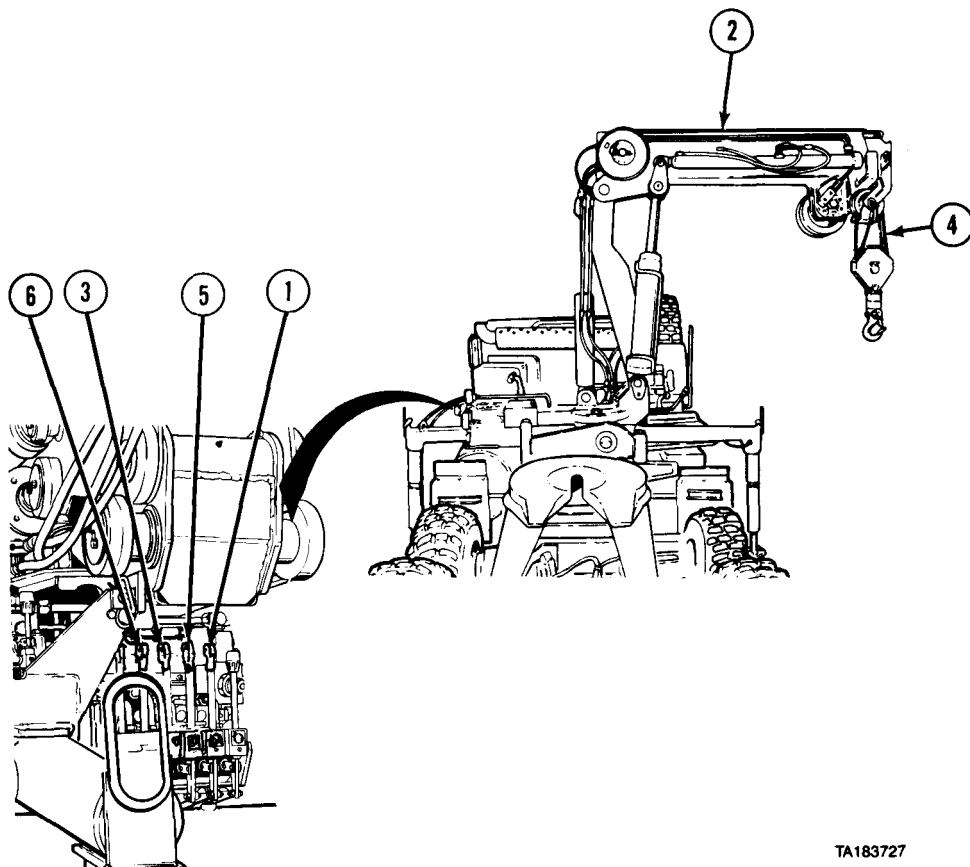
CAUTION

When boom is being extended, hoist lever must be pushed up to allow space between sheave at end of boom and sheave at load hook to prevent cable from breaking.

- (3) Push hoist lever (4) up to lower load hook (5).
- (4) At same time, push extend 1 + 2 lever (6) up to extend first and second stages of boom.
- (5) Push extend 3 + 4 lever (7) up to extend third and fourth stages of boom (3).
- (6) Push hoist lever (4) up to lower load hook (5). Connect load straps or rigging to hook.
- (7) Pull hoist lever (4) down to raise load hook (5).
- (8) Pull extend 3 + 4 lever (7) down to retract third and fourth stages of boom (3).
- (9) Pull hoist lever (4) down to raise load hook (5).
- (10) Pull extend 1 + 2 lever (6) down to retract first and second stages of boom (3).
- (11) Pull hoist lever (4) down to raise load hook (5).

2-28. M983 CRANE OPERATION (MANUAL CONTROLS) (CONT).

f. Shut Down and Return Crane to Transport Position.



TA183727

NOTE

If boom is already retracted, go to step (5).

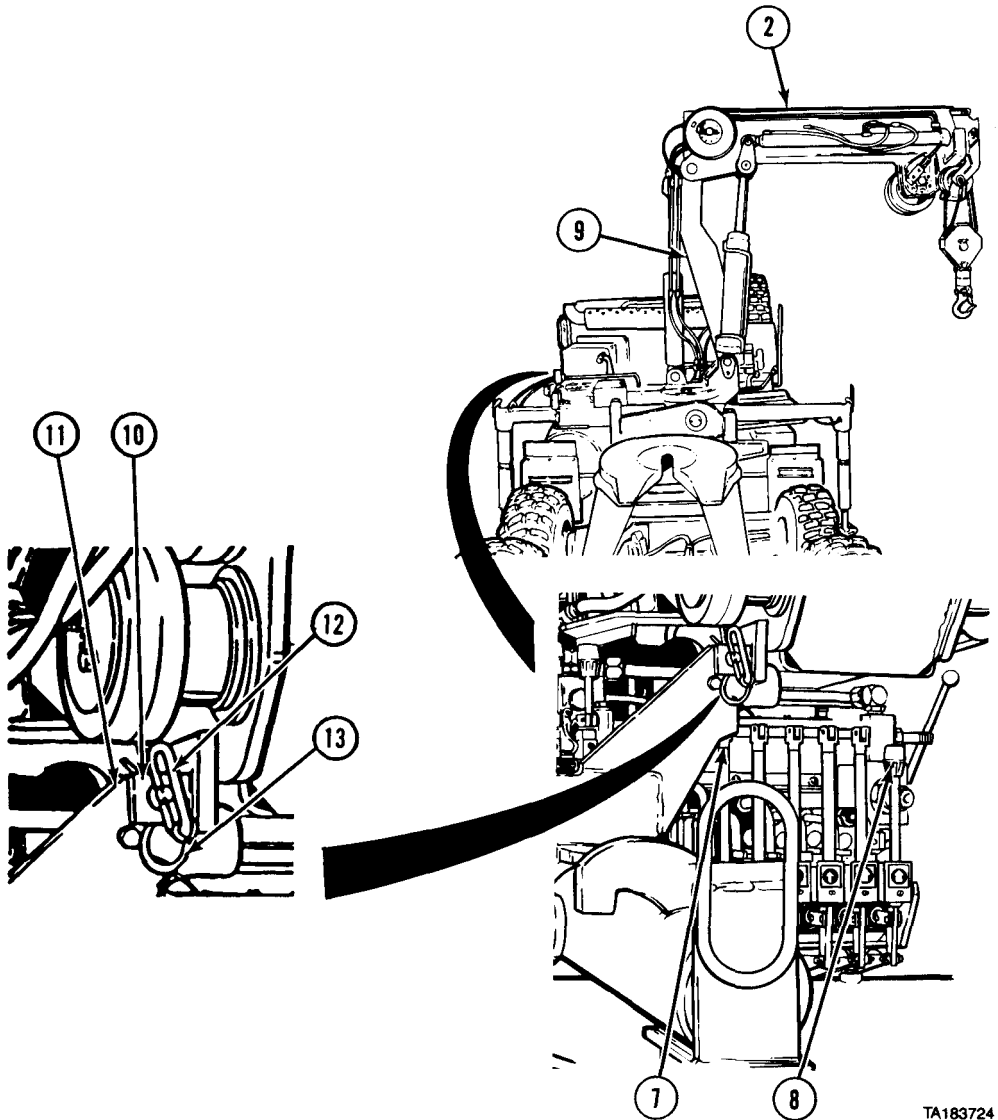
- (1) Pull extend 3 + 4 lever (1) out and retract third and fourth stages of boom (2).

CAUTION

Do not let hook block come in contact with boom sheave or cable could break causing damage to equipment.

- (2) Pull hoist lever (3) out and reel in excess cable (4).
- (3) Pull extend 1 + 2 lever (5) out and retract first and second stages of boom (2).
- (4) Pull hoist lever (3) out and reel in excess cable (4).
- (5) Push boom lever (6) in to lower boom (2) so end is tilted down slightly.

M983 Tractor Operating Procedures (Cont)

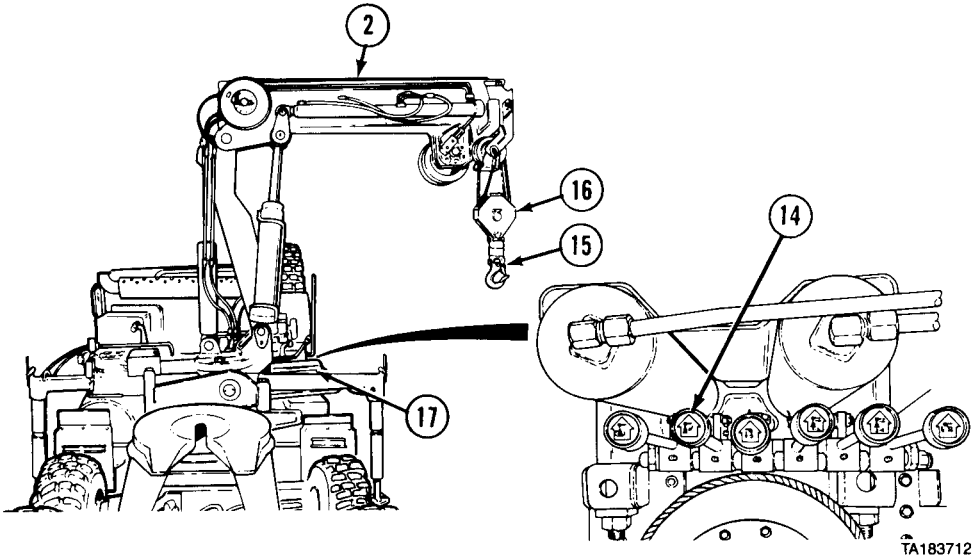


TA183724

- (6) Pull up swing lever (7) so hoist end of boom (2) is to right side of vehicle and crane is placed across vehicle frame, parallel with generator set.
- (7) Push up mast lever (8) in to lower mast (9) to stowed position so latch (10) fits over latch support (11).
- (8) Install mast stowage pin (12) and secure with retaining pin (13).

M983 Tractor Operating Procedures (Cont)

2-28. M983 CRANE OPERATION (MANUAL CONTROLS) (CONT).

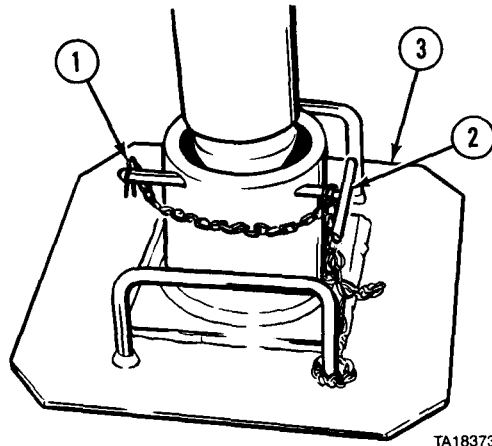


WARNING

Do not let hook block hit boom when taking up slack in cable. Hook block will jerk out of control and may cause serious personal injury.

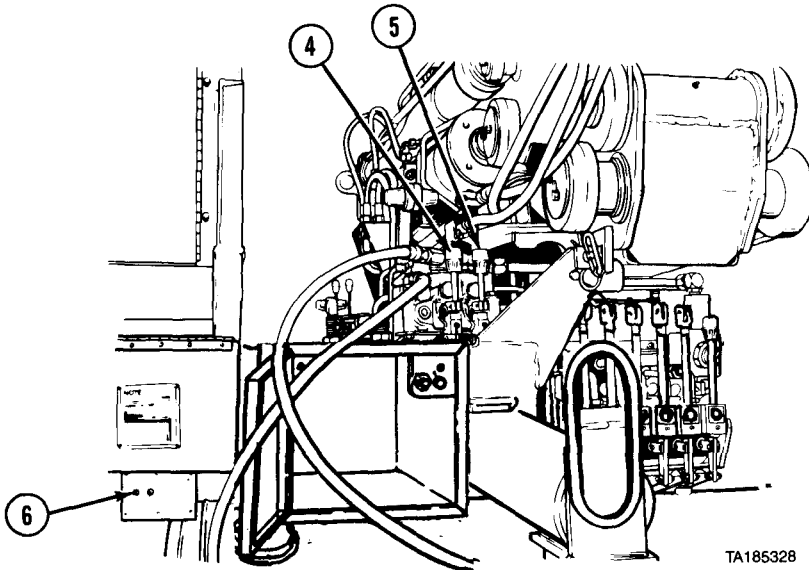
- (9) Push boom lever (14) up to lower boom (2). Make sure load hook (15) and lower sheave (16) rest on support plate (17).

M983 Tractor Operating Procedures (Cont)

g. Stow Outriggers.

TA183732

- (1) Soldier A removes safety pin (1) and retaining pin (2) from left outrigger pad (3) while Soldier B removes safety pin and retaining pin from right outrigger pad.

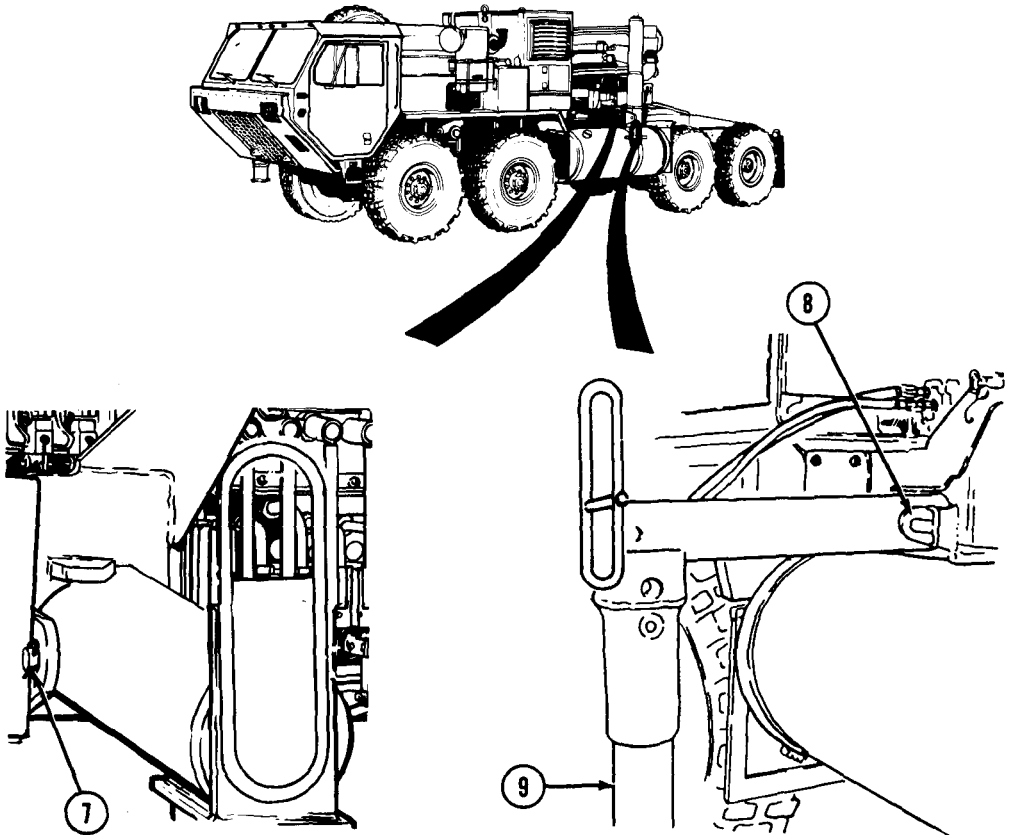


TA185328

- (2) Push in two outrigger control levers (4 and 5) and retract both outriggers completely.
 (3) Soldier A and Soldier B place outrigger pads in stowage.
 (4) Set engine speed control switch (6) to OFF position.

M983 Tractor Operating Procedures (Cont)

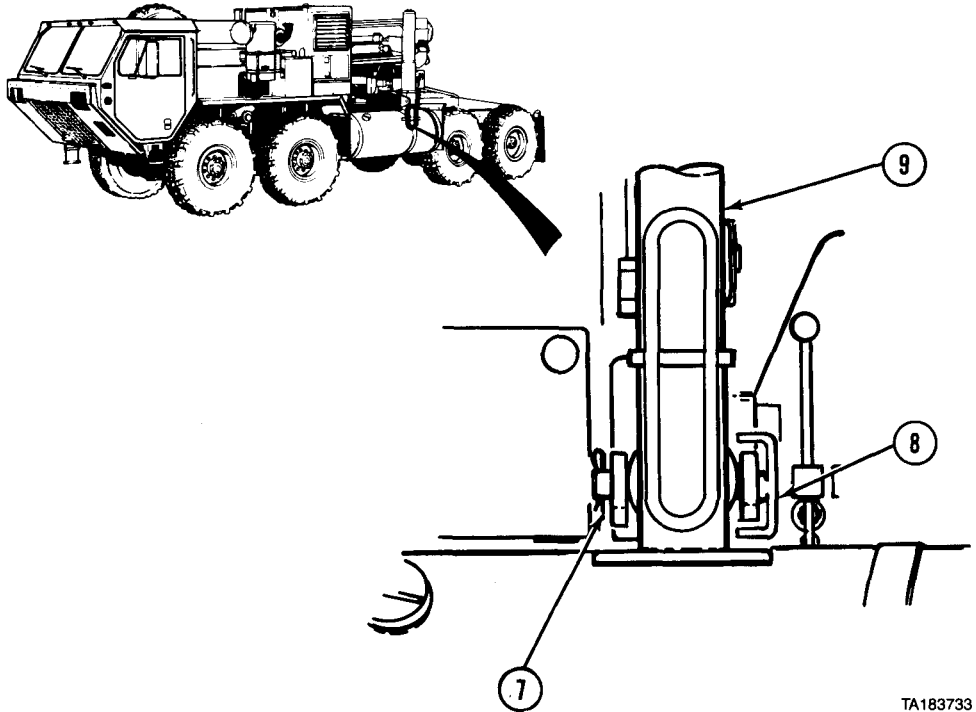
2-28. M983 CRANE OPERATION (MANUAL CONTROLS) (CONT).



TA183716

- (5) Remove safety pin (7) and outrigger support pin (8).
- (6) Soldier A and Soldier B rotate outrigger (9) up 180°.

M983 Tractor Operating Procedures (Cont)



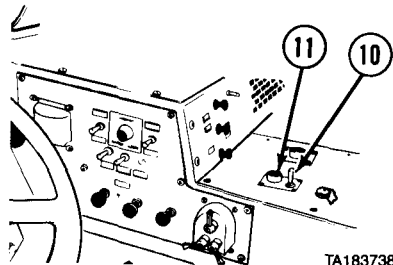
TA183733

WARNING

Keep fingers away from behind outriggers while they are being stowed. Fingers can be pinched between outrigger and other parts of vehicle.

- (7) Soldier A holds outrigger (9) up while Soldier B pushes outrigger completely in toward vehicle.
- (8) Install outrigger support pin (8) and safety pin (7).
- (9) Repeat steps (5) through (8) to stow other outrigger.

- (10) Put PTO ENGAGE switch (10) in OFF position. Make sure indicator light (11) goes off.
- (11) Shut off engine (para 2-11p).

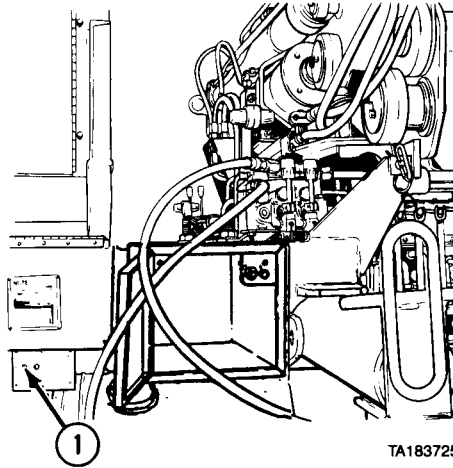


TA183738

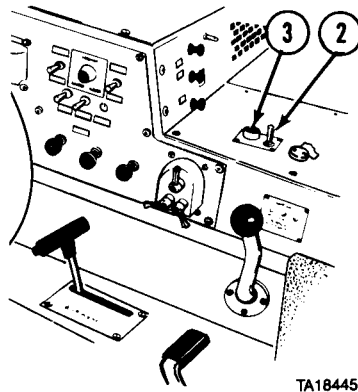
M983 Tractor Operating Procedures (Cont)

2-29. M983 CRANE OPERATION (REMOTE CONTROLS).

a. Set Up Remote Control Panel.

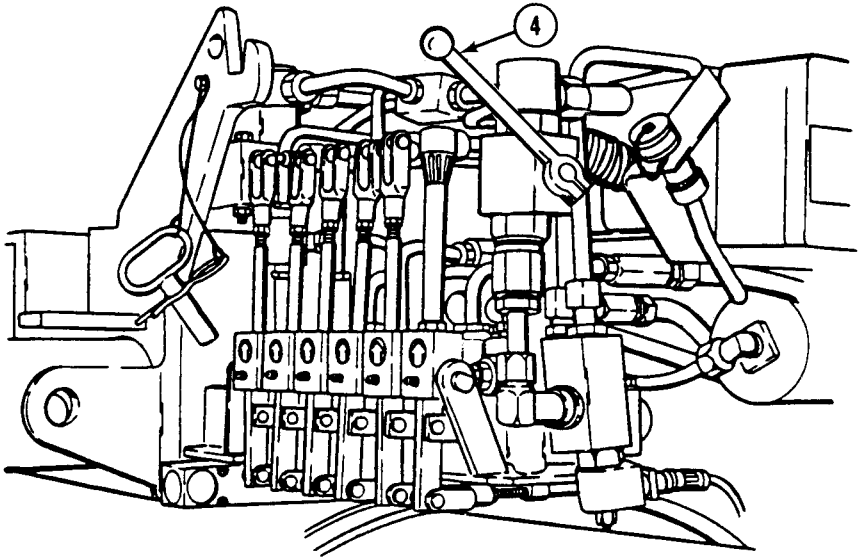


- (1) Prepare crane for use (para 2-28a).
- (2) Set up outriggers (para 2-28b).
- (3) Raise boom to operating position (para 2-28c).
- (4) Set engine speed control switch (1) to OFF position.



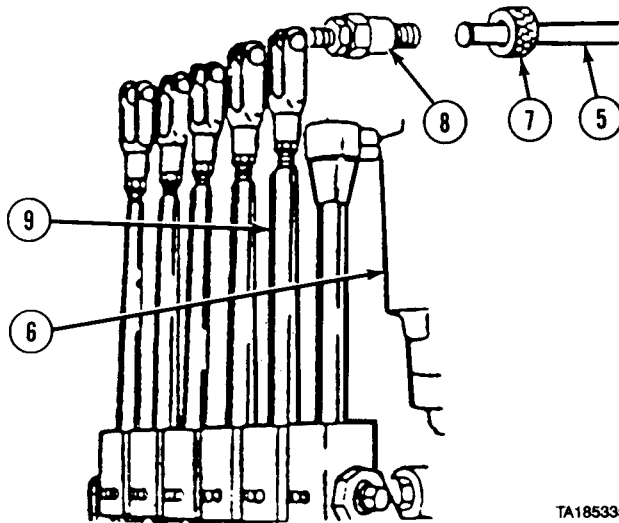
- (5) Set PTO ENGAGE switch (2) to OFF position. Make sure indicator light (3) goes out.

M983 Tractor Operating Procedures [Cont]



TA185334

- (6) Turn crane hydraulic selector valve handle (4) to REMOTE position.

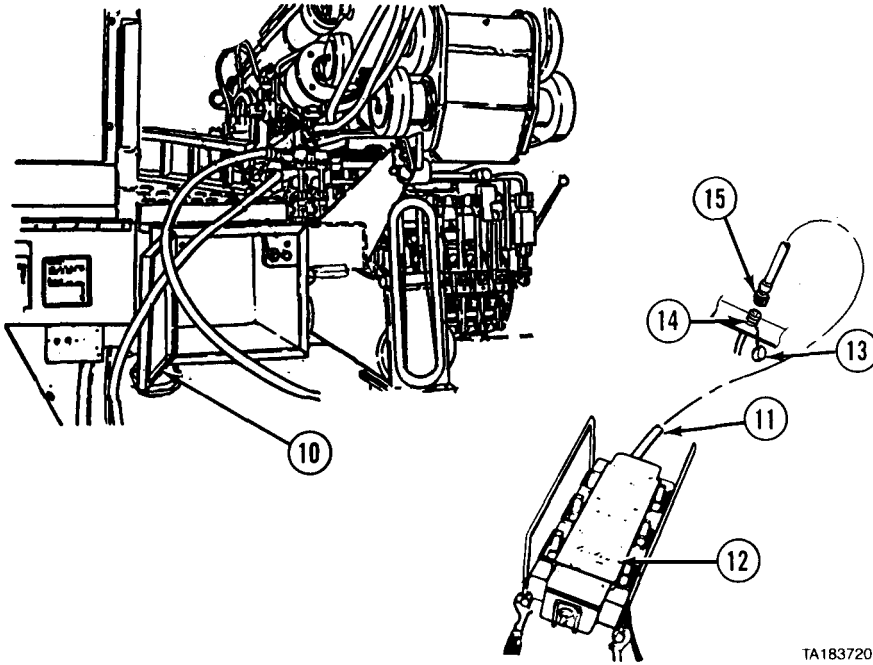


TA185335

- (7) Pull each remote control rod (5) forward out of hydraulic control unit (6). Hold control rod with one hand and slide spring-loaded sleeve (7) toward crane with other hand. Place end of control rod over end (8) of control lever (9) and tighten sleeve.

M983 Tractor Operating Procedures (Cont)

2-29. M983 CRANE OPERATION (REMOTE CONTROLS) (CONT).



TA183720

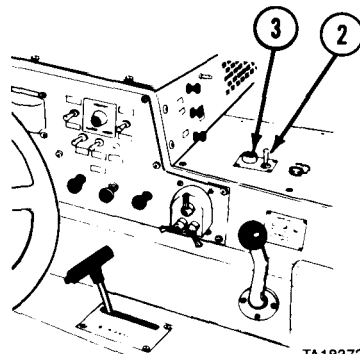
- (8) Open remote control stowage box (10) and remove remote control cable (11) and panel (12).

CAUTION

Make sure REMOTE CONTROL PANEL power switch is in OFF position before connecting REMOTE CONTROL PANEL.

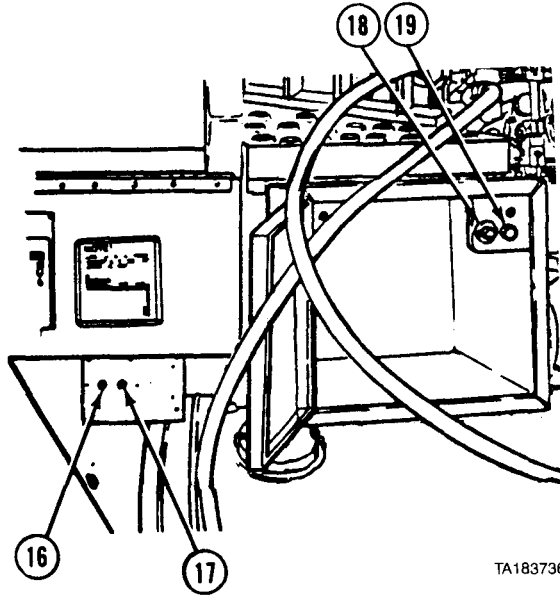
- (9) Remove cover (13) from remote control receptacle (14) and connect remote control cable plug (15) into receptacle.

- (10) Set PTO ENGAGE switch (2) to ON position. Make sure indicator light (3) comes on.



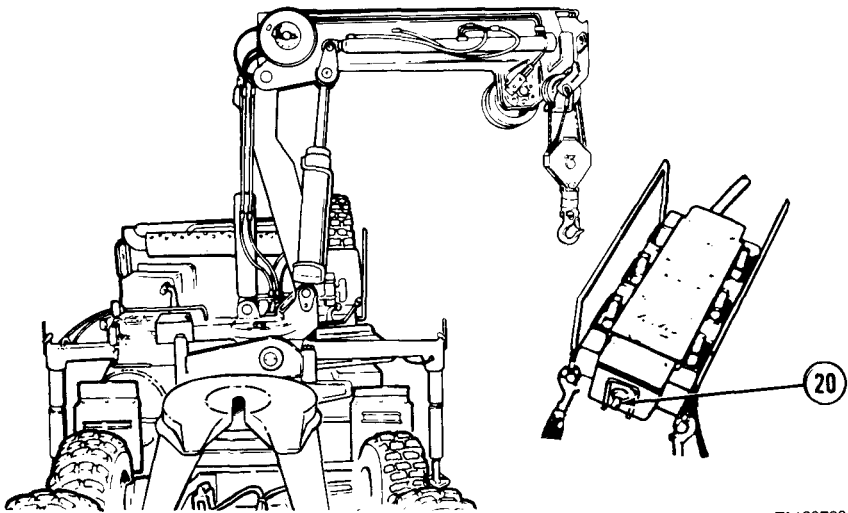
TA183739

M983 Tractor Operating Procedures (Cont)



TA183736

- (11) Set engine speed control switch (16) to ON position and engine speed control engage switch (17) to ENGAGE position.
- (12) Press pushbutton switch (18). Green indicator (19) should light.



TA183723

- (13) Set REMOTE CONTROL PANEL power switch (20) to ON position.
- (14) Operate crane (para 2-29b).

2-29. M983 CRANE OPERATION (REMOTE CONTROLS) (CONT).

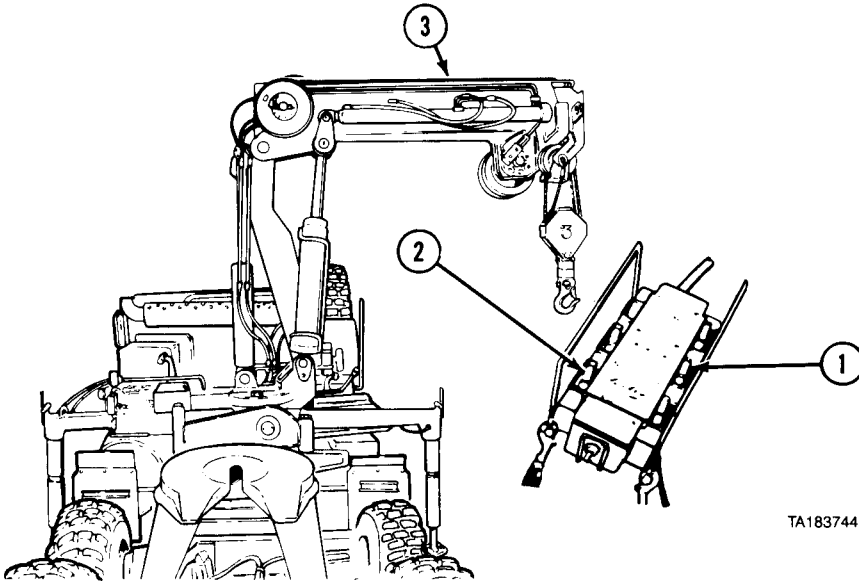
b. Operate Crane Using Remote Control Panel.

WARNING

- Keep boom clear of electrical lines and other obstacles while operating crane. Serious injury or death could result upon contact.
- Operator should use crane controls so load will not pass overhead. Load could fall causing serious injury or death.
- Boom should be swung slow enough so crane operator has complete control. Boom moving out of control could cause serious injury or death.

NOTE

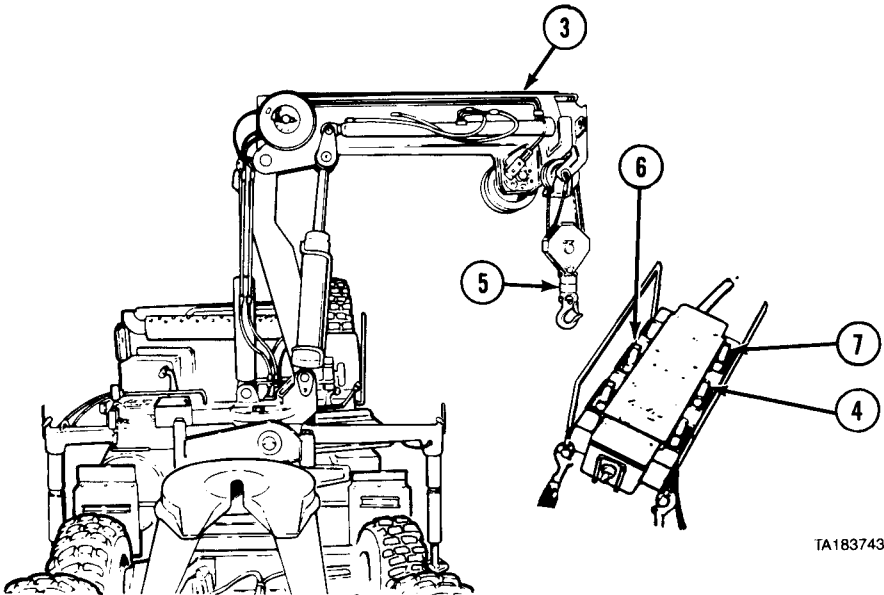
- Moving lever slightly will cause slow movement of crane. Moving lever to full travel will cause crane to move faster.
- Use controls that provide clear view of boom at all times.



TA183744

- (1) Set Up REMOTE CONTROL PANEL (para 2-29a).
- (2) Push swing switch (1) forward to rotate crane clockwise. Pull swing switch back to rotate crane counterclockwise.
- (3) Pull boom switch (2) back to raise boom (3). Push boom switch forward to lower boom.

M983 Tractor Operating Procedures (Cont)



TA183743

CAUTION

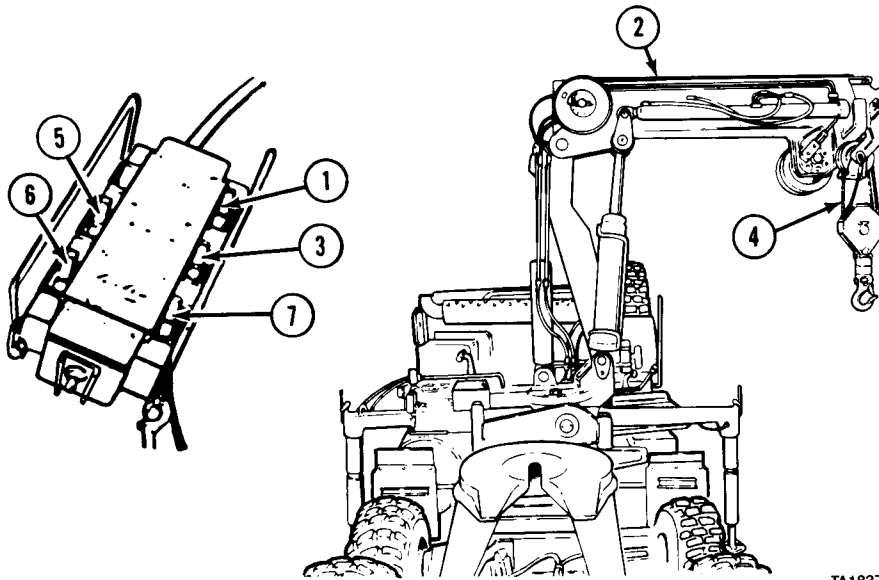
When boom is being extended, hoist switch must be pushed forward to allow space between sheave at end of boom and sheave at load hook to prevent cable from breaking.

- (4) Push hoist switch (4) forward to lower load hook (5).
- (5) At same time, push extend 1 + 2 switch (6) to extend first and second stages of boom (3).
- (6) Push extend 3 + 4 switch (7) forward to extend third and fourth stages of boom (3).
- (7) Push hoist switch (4) forward to lower load hook (5). Connect load straps or rigging to load hook.
- (8) Pull hoist switch (4) back to raise load hook (5).

M983 Tractor Operating Procedures (Cont)

2-29. M983 CRANE OPERATION (REMOTE CONTROLS) (CONT).

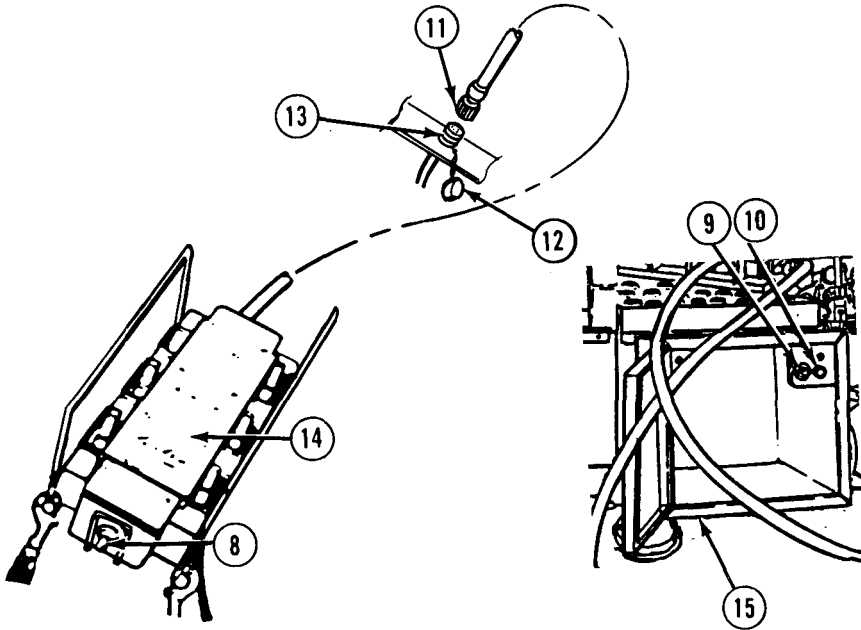
c. Shut Down and Return Crane to Transport Position.



TA183714

- (1) Pull extend 3 + 4 switch (1) to retract third and fourth stages of boom (2).
- (2) Pull hoist switch (3) to reel in excess cable (4).
- (3) Pull extend 1 + 2 switch (5) to retract first and second stages of boom (2).
- (4) Pull hoist switch (3) to reel in excess cable (4).
- (5) Push boom switch (6) to lower boom (2) so end is tilted down slightly.
- (6) Operate swing switch (7) so hoist end of boom is to right side of vehicle and crane is placed across vehicle frame, parallel with generator set.

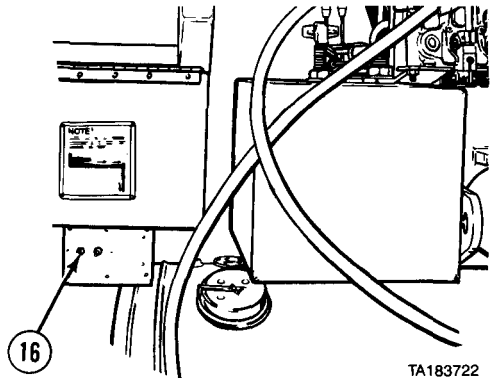
M983 Tractor Operating Procedures (Cont)



TA183721

- (7) Set REMOTE CONTROL PANEL power switch (8) to OFF position.
- (8) Press remote control pushbutton switch (9) in remote control panel storage box. Green indicator light (10) will go out.
- (9) Remove remote control cable (11) and put cover (12) on remote control receptacle (13).
- (10) Coil up remote control cable (11), put panel (14) and cable in storage box (15), and secure storage box cover.

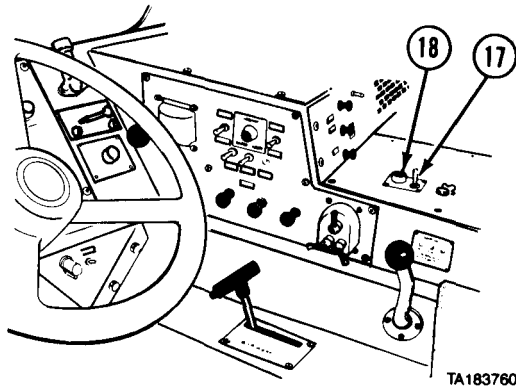
- (11) Set engine speed control switch (16) to OFF position.



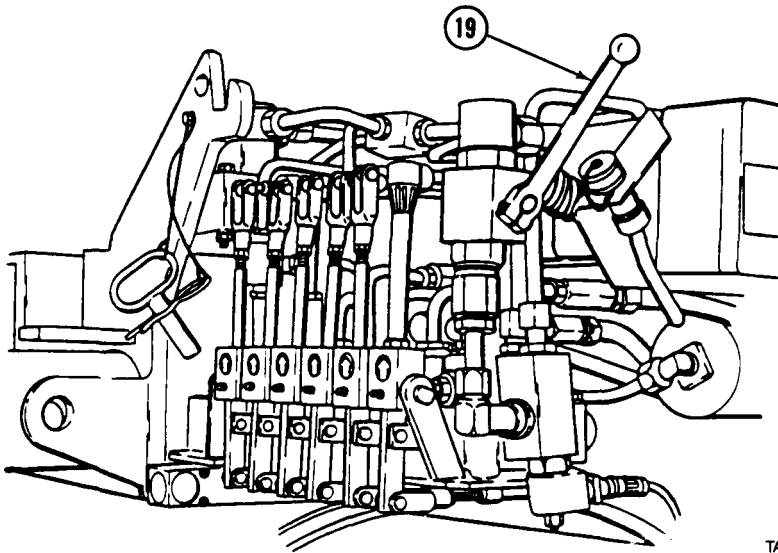
TA183722

M983 Tractor Operating Procedures (Cont)

2-29. M983 CRANE OPERATION (REMOTE CONTROLS) (CONT).

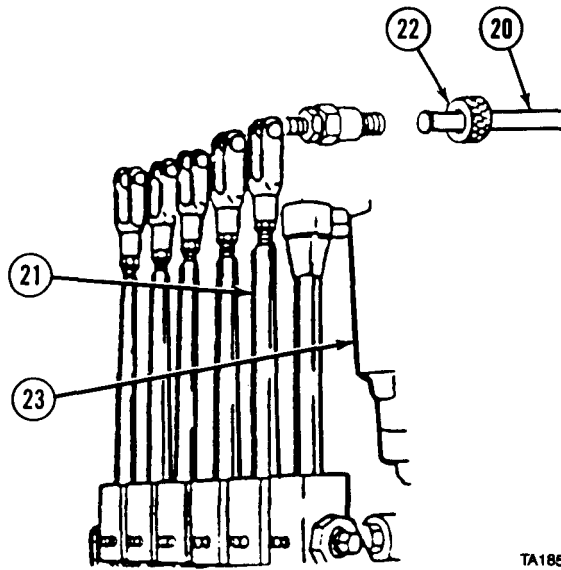


(12) Set PTO ENGAGE switch (17) to OFF position. Indicator light (18) should go off.



(13) Turn crane hydraulic selector valve handle (19) so handle is in MANUAL position.

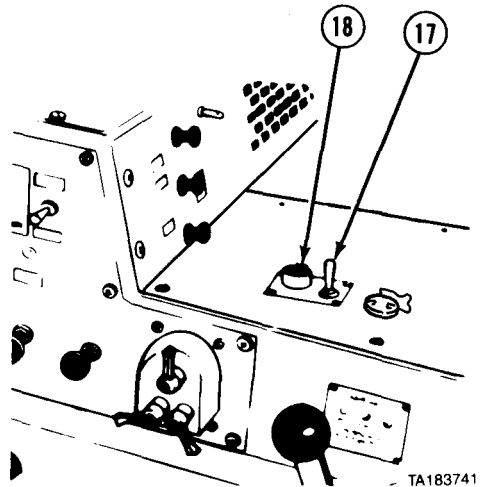
M983 Tractor Operating Procedures (Cont)



TA185331

- (14) Disconnect each remote control rod (20) from each control lever (21) by unscrewing control rod quick disconnect sleeve (22).
- (15) Push each remote control rod (20) straight into hydraulic control unit (23).

- (16) Set PTO ENGAGE switch (17) to ON position. Indicator light (18) should come on.

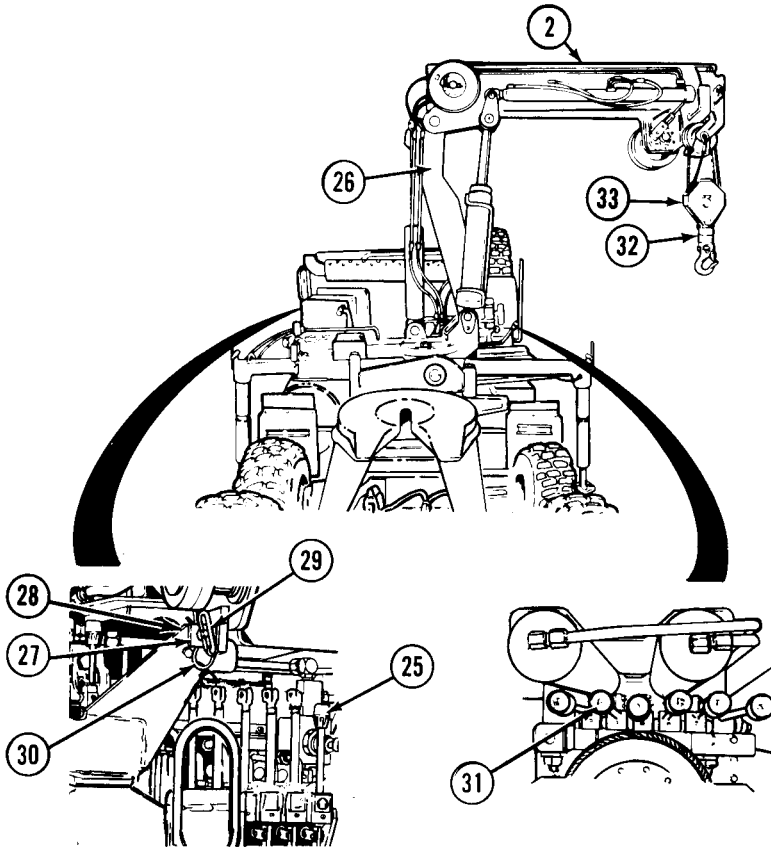
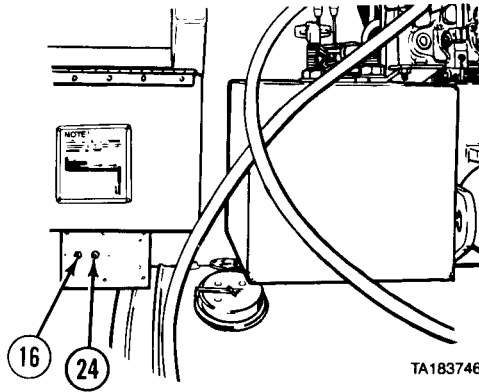


TA183741

M983 Tractor Operating Procedures (Cont)

2-29. M983 CRANE OPERATION (REMOTE CONTROLS) (CONT).

(17) Set engine speed control switch (16) to ON position and engine speed control engage switch (24) to ENGAGE position.



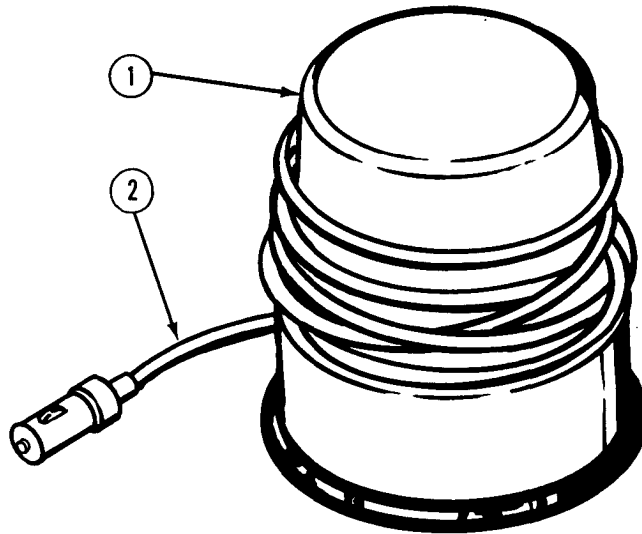
(18) Push mast lever (25) in to lower mast (26) to stowed position so latch (27) fits over latch support (28).

M983 Tractor Operating Procedures (Cont)

WARNING

Do not let hook block hit boom when taking up slack in cable. Hook block will jerk out of control and may cause serious personal injury.

- (20) Push boom lever (31) up to lower boom (2). Make sure load hook (32) and lower sheave (33) rest on support plate (34).
- (21) Stow outriggers (para 2-28g).

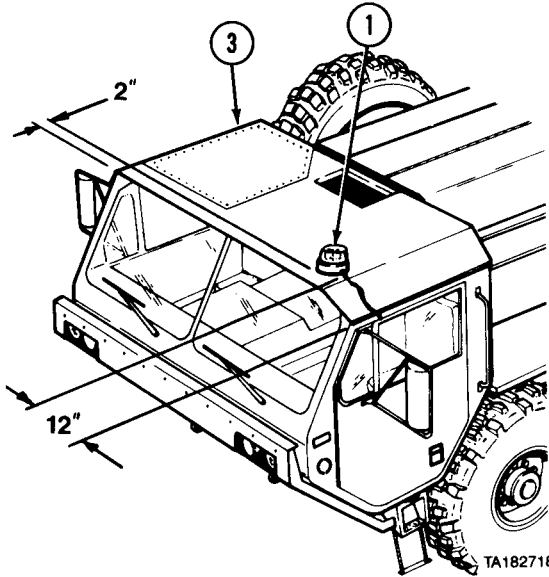
Emergency Beacon Operation**2-30. BEACON LIGHT OPERATION.****a. Install Beacon Light.**

TA182748

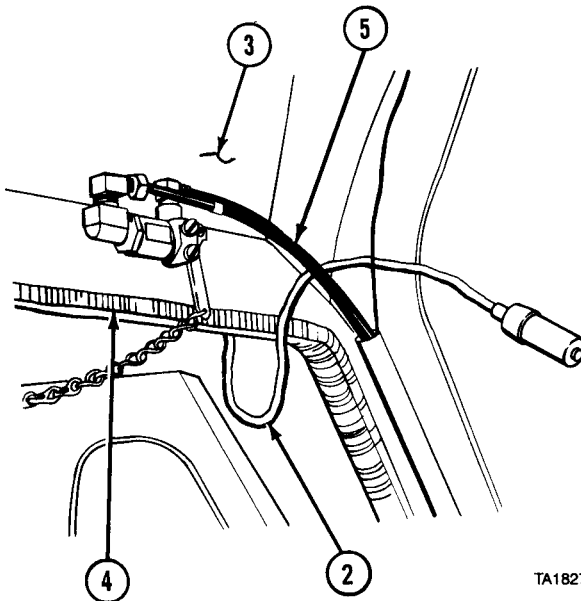
- (1) Remove beacon light (1) from stowage and unwind cord (2).

Emergency Beacon Operation (Cont)

2-30. BEACON LIGHT OPERATION (CONT).

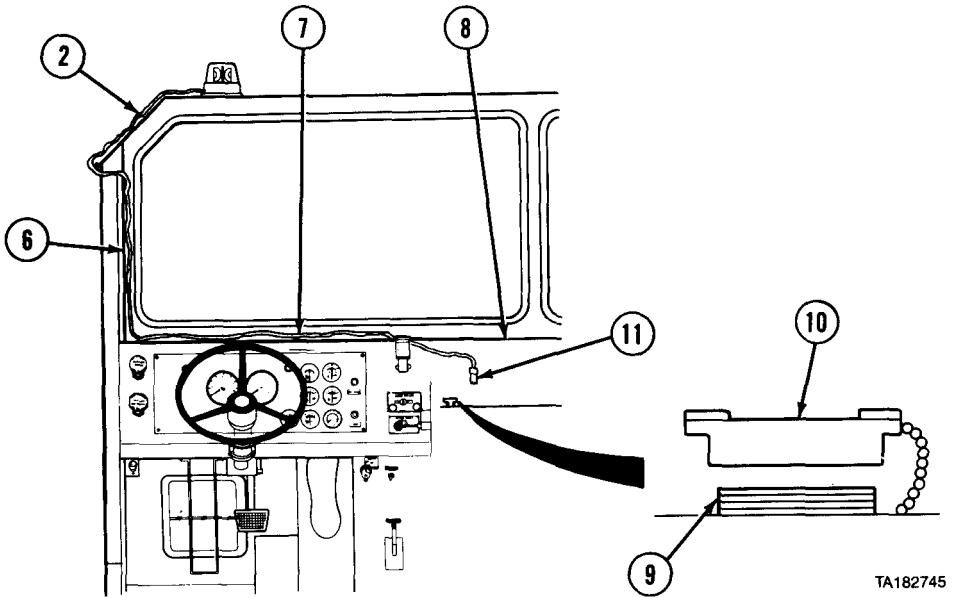


- (2) Place beacon light (1) on left front corner of cab roof (3) approximately 12 in. (305 mm) from left side of cab and approximately 2 in. (51 mm) from front edge of cab roof.



- (3) Route cord (2) through left door opening (4) and between inside of cab roof (3) and air horn valve hoses (5).

Emergency Beacon Operation (Cont)

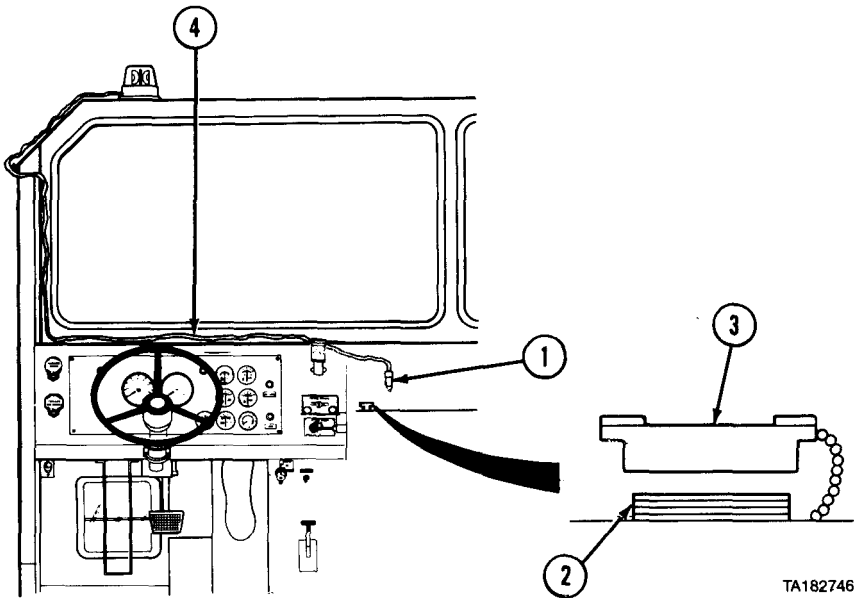


TA182745

(4) Route cord (2) down left side of windshield (6), across driver side defroster (7), and across center console (8) to utility outlet (9).

(5) Remove cover (10). Insert light plug (11) into utility outlet (9).

b. Remove Beacon Light.



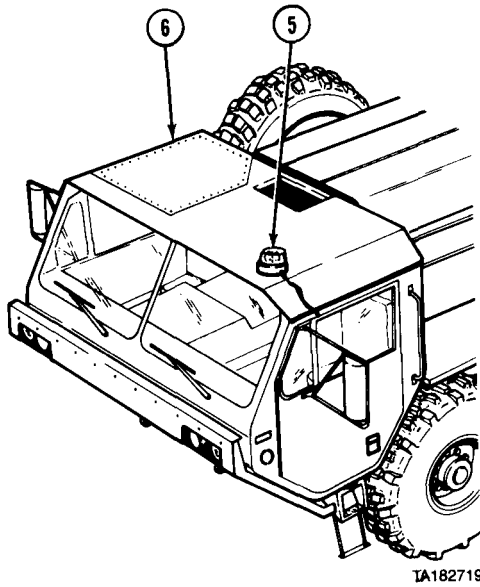
TA182746

(1) Remove light plug (1) from utility outlet (2). Install cover (3) on utility outlet.

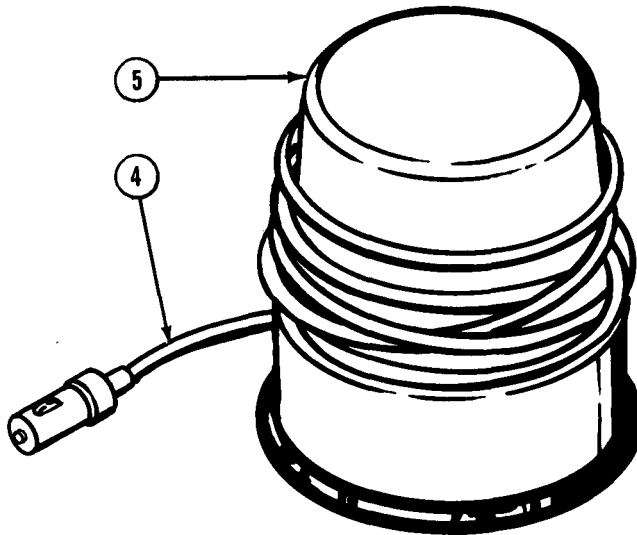
(2) Unstring light cord (4).

Emergency Beacon Operation (Cont)

2-30. BEACON LIGHT OPERATION (CONT).



(3) Remove beacon light (5) from cab roof (6).



(4) Wrap cord (4) around beacon light (5) and stow.

Auxiliary Equipment Operation

2-31. AUXILIARY EQUIPMENT OPERATING PROCEDURES.

- a. *Deleted.*
- b. *Operate Arctic Heater.*

WARNING**CARBON MONOXIDE (EXHAUST GAS) CAN CAUSE DEATH.**

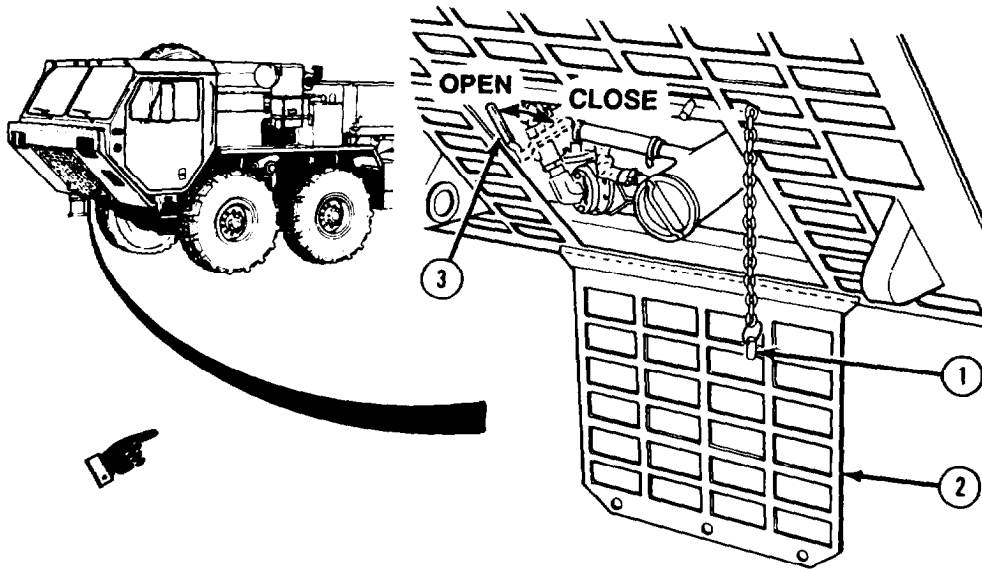
Carbon monoxide does not have color or smell, but can cause death. Breathing air with carbon monoxide produces symptoms of headache, dizziness, loss of muscular control, a sleepy feeling, and coma. Brain damage or death can result from heavy exposure. Carbon monoxide is in exhaust fumes of fuel-burning heaters and internal combustion engines. Carbon monoxide can become dangerously concentrated under conditions of no ventilation. Precautions must be followed to ensure crew safety when the personnel heater or engine of any vehicle is operated for any purpose.

1. DO NOT operate vehicle engine in a closed place unless the place has a lot of ventilation.
2. DO NOT drive any vehicle with inspection plates, cover plates, or engine compartment covers removed unless necessary for maintenance purposes.
3. BE ALERT at all times during vehicle operation for exhaust odors and exposure symptoms. If either are present, IMMEDIATELY VENTILATE personnel compartments. If symptoms continue, remove affected crew to fresh air and keep warm. DO NOT PERMIT PHYSICAL EXERCISE. If necessary, give artificial respiration and get immediate medical attention. For artificial respiration, refer to FM 21-11.
4. BE AWARE that the gas particulate filter unit of the field protection mask for nuclear-biological-chemical protection WILL NOT offer safety from carbon monoxide poisoning.

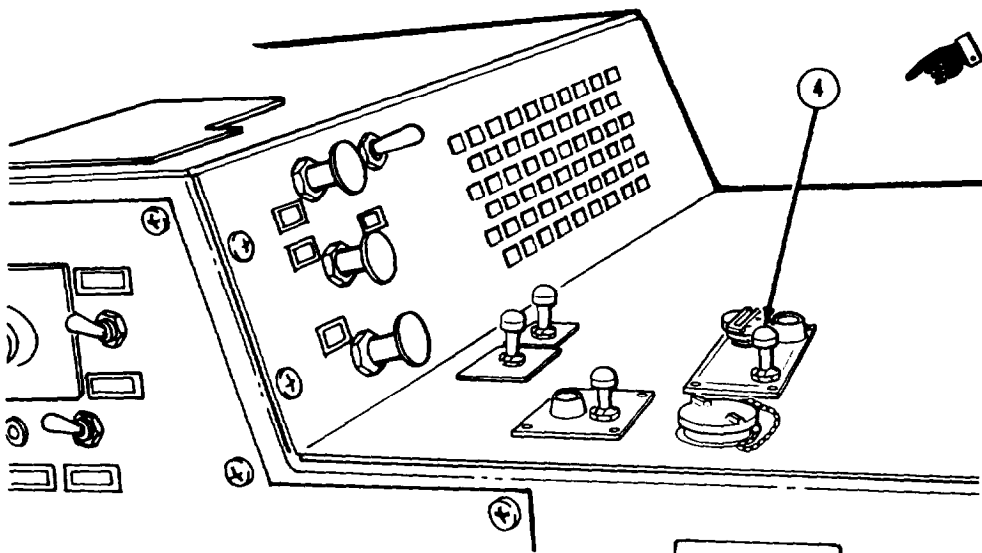
THE BEST DEFENSE AGAINST CARBON MONOXIDE POISONING IS GOOD VENTILATION.

Auxiliary Equipment Operation (Cont)

2-31. AUXILIARY EQUIPMENT OPERATING PROCEDURES (CONT).

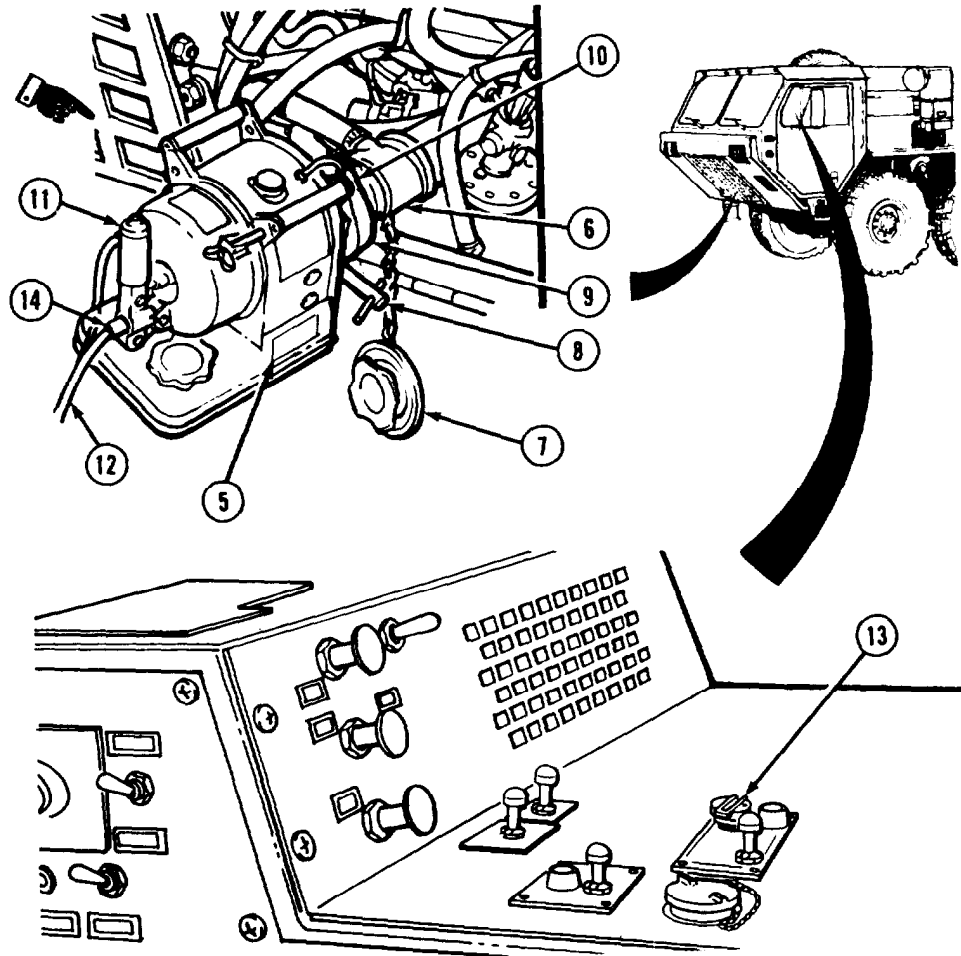


- (1) Pull two pins (1) and open door (2).
- (2) Open valve (3).



- (3) Place coolant pump switch (4) in ON position.

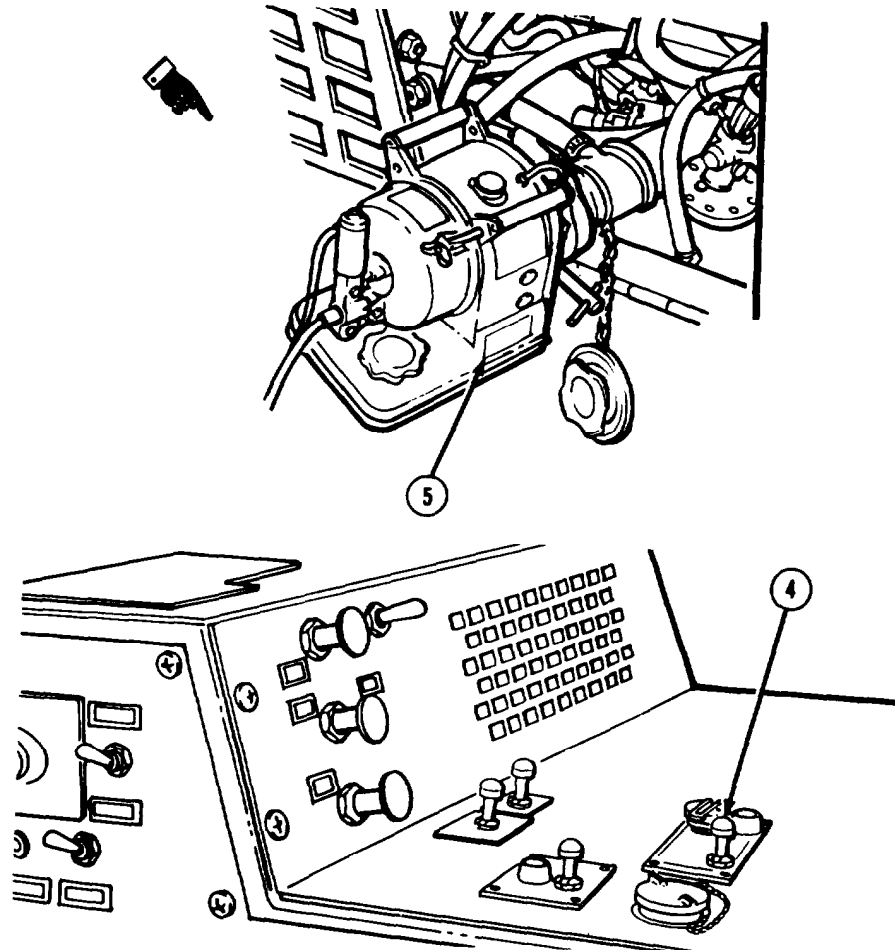
Auxiliary Equipment Operation (Cont)



- (4) Install arctic heater (5) into water jacket (6) as follows:
 - (a) Remove cover (7) from water jacket (6).
 - (b) Turn wingnut (8) on heater (5) counterclockwise to open mounting clamp (9).
 - (c) Check gasket (10) for proper placement and cuts, tears, and deterioration.
 - (d) Insert, heater (5) into water jacket (6) with hand pump lever (11) in vertical position.
 - (e) Turn wingnut (6) clockwise to tighten mounting clamp (9) securing heater (5) in water jacket (6).
 - (f) Insert heater cable (12) into cable receptacle (13) in cab, and receptacle (14) on heater (5).

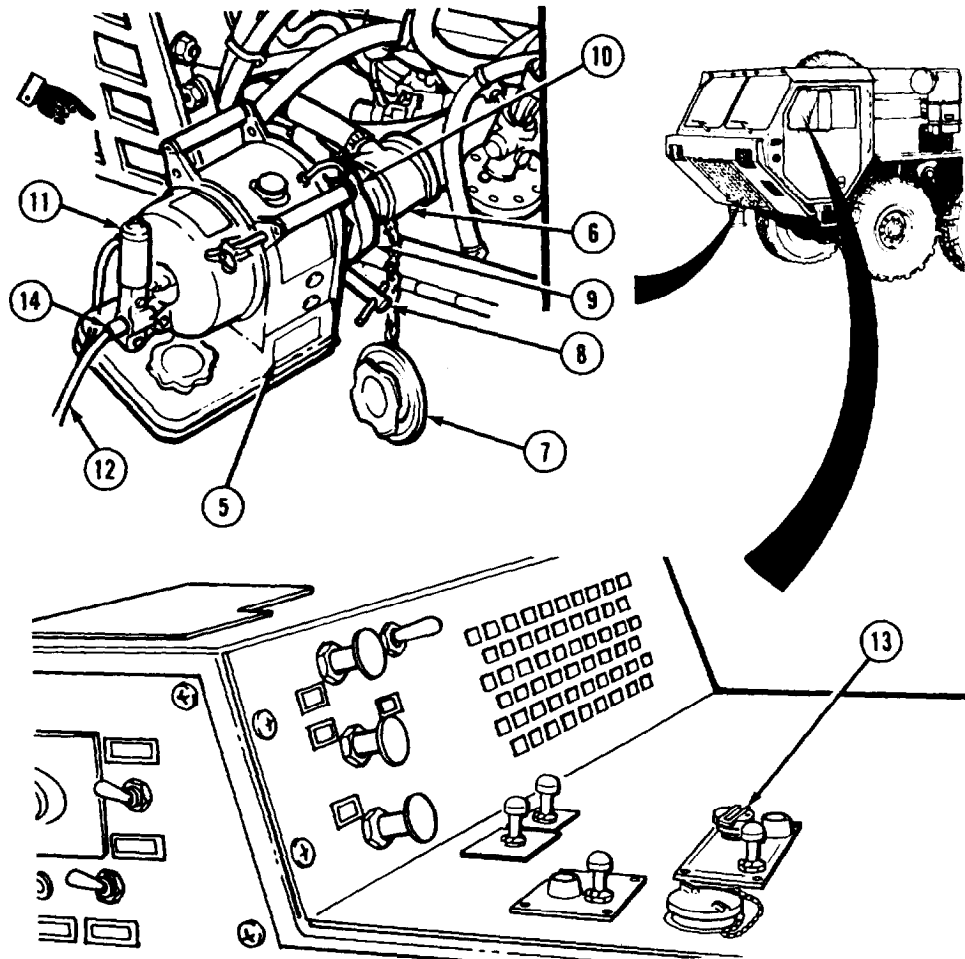
Auxiliary Equipment Operation (Cont)

2-31. AUXILIARY EQUIPMENT OPERATING PROCEDURES (CONT).



- (5) To start and operate arctic heater (5), refer to instructions provided with arctic heater.
- (6) Operate arctic heater (5) for approximately 35 minutes to warm engine properly.
- (7) To shutdown coolant pump, place coolant pump switch (4) in OFF position.

Auxiliary Equipment Operation (Cont)



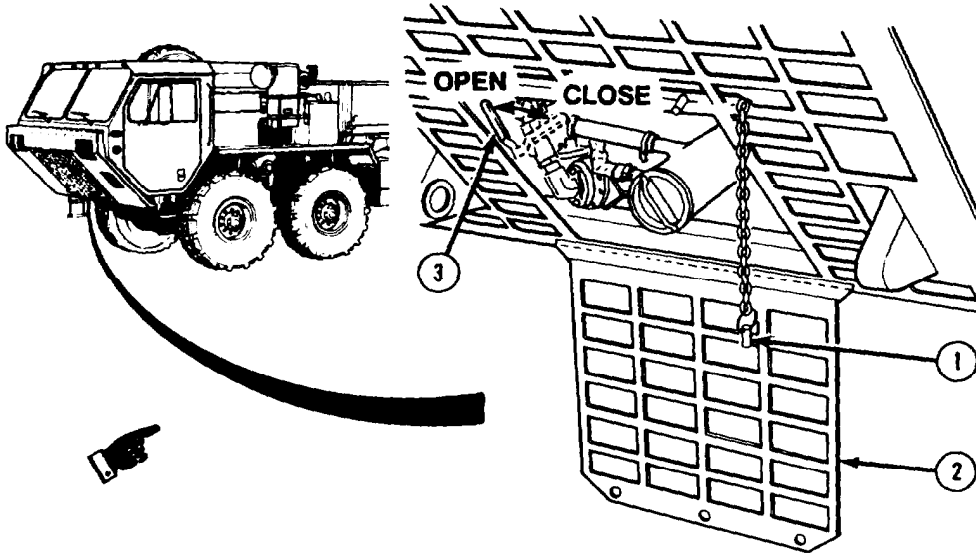
WARNING

The exhaust system of arctic heater can become very hot during operation, Be careful not to touch exhaust system parts with bare hands or allow body to come into contact with exhaust system parts. Exhaust system parts can become hot enough to cause serious burns.

- (8) Remove arctic heater (5) from water jacket (6) as follows:
 - (a) Remove heater cable (12) from cable receptacle (13) in cab, and receptacle (14) on heater (5).
 - (b) Turn wingnut (3) counterclockwise to loosen mounting clamp (9).
 - (c) Remove arctic heater (5) with gasket (10) from water jacket (6).
 - (d) Install cover (7) on water jacket (6).

Auxiliary Equipment Operation (Cont)

2-31. AUXILIARY EQUIPMENT OPERATING PROCEDURES (CONT).



CAUTION

Valve must be closed during normal operation of engine.
If valve is left open, improper cooling of engine may
occur causing engine damage.

- (9) Close valve (3).
- (10) Close door (2) and secure with two pins (1).

Auxiliary Equipment Operation (Cont)**c. Operate Gas Particulate Filter Unit.****WARNING**

- Protective mask and filter unit will not protect against carbon monoxide.
- If NBC exposure is suspected, all air filter media should be handled by personnel wearing protective equipment. Consult your unit NBC Officer or NBC NCO for appropriate handling or disposal procedures.
- If required to remain inside the vehicle during extreme heat, occupants should follow the water intake, work/rest cycle, and other heat stress preventive medicine measures contained in FM 21-10, Field Hygiene and Sanitation.

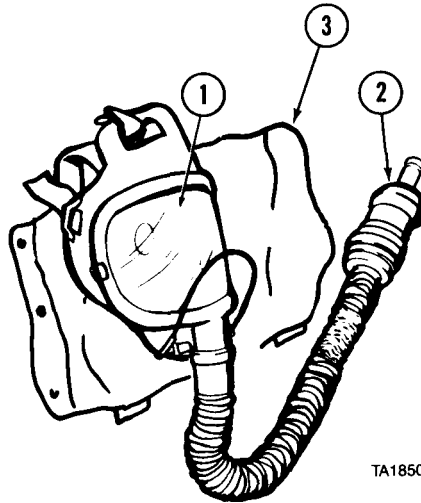
NOTE

- Do steps (1) through (9) only when under Nuclear, Biological, or Chemical (NBC) attack or when ordered to do so.
- For detailed information concerning protective mask, refer to TM 3-4240-280-10.
- Both crew stations have M-3 heater, hose, and air duct sockets.

Auxiliary Equipment Operation (Cpnt)

2-31. AUXILIARY EQUIPMENT OPERATING PROCEDURES (CONT).

- (1) Remove two protective masks (1) and canisters (2) from pouches (3).
- (2) Put on protective masks (1).
- (3) Clear and seal protective masks (1).

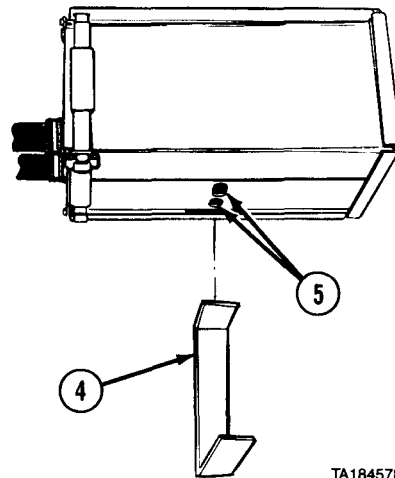


TA185072

NOTE

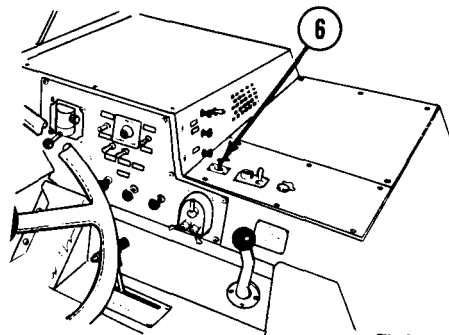
Spring clip must be repositioned on filter assembly air intake so intake holes are open for gas particulate filter system to work. Clip is repositioned through bottom of bracket.

- (4) Pull down on spring clip (4) to uncover intake holes (5).



TA184578

- (5) Set GAS PARTICULATE FILTER switch (6) to ON.



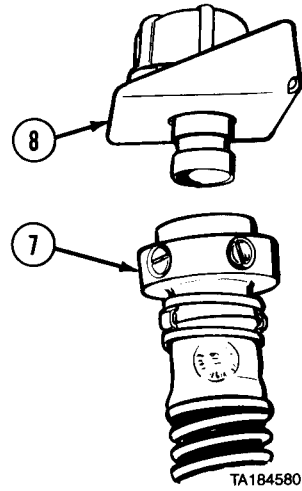
TA184581

Auxiliary Equipment Operation (Cont)

NOTE

One mount is located to left of driver's seat at roof brace.
Second mount is located on middle cab roof brace to left of passenger seat.

- (6) Disconnect two air duct hose breakaway sockets (7) from mounts (8).

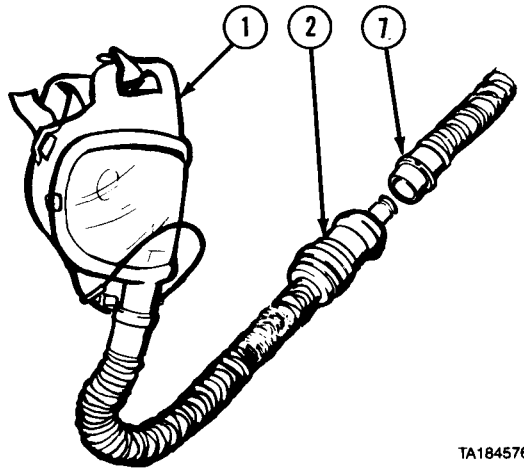


TA184580

WARNING

Under arctic conditions, danger of frostbite exists. Mask can be put on, but air duct hose socket shall not be connected to mask canister until M-3 heater has been on for 15 minutes.

- (7) Connect two air duct hose breakaway sockets (7) to canisters (2) of protective masks (1) and breathe through masks.



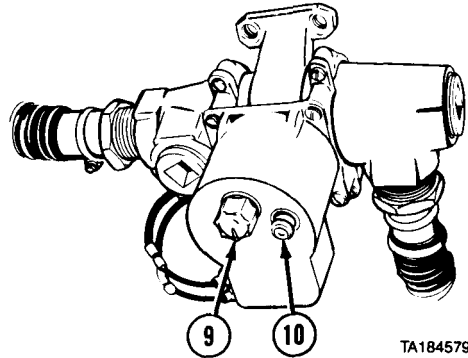
TA184576

Auxiliary Equipment Operation (Cont)

2-31. AUXILIARY EQUIPMENT OPERATING PROCEDURES (CONT).

NOTE

- There are two M-3 heaters. Both are the same.
 - Heater indicator light will go off and on during normal heater operation.
- (8) If air is too cold to breathe comfortably, turn knob (9) clockwise until heater indicator (10) lights. To adjust temperature:
- (a) Turn knob (9) clockwise for warmer air.
 - (b) Turn knob (9) counterclockwise for cooler air.
- (9) When heater is no longer needed, turn control knob (9) counterclockwise to OFF position.

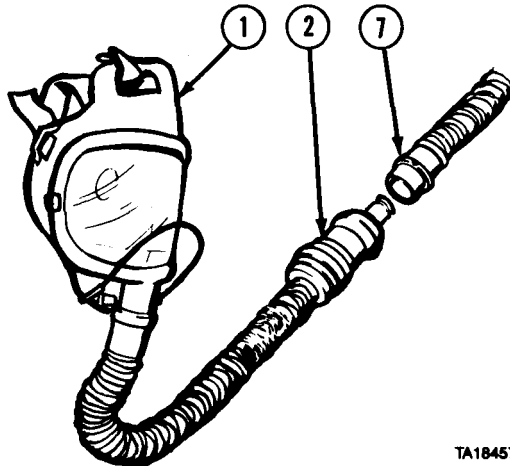


TA184579

NOTE

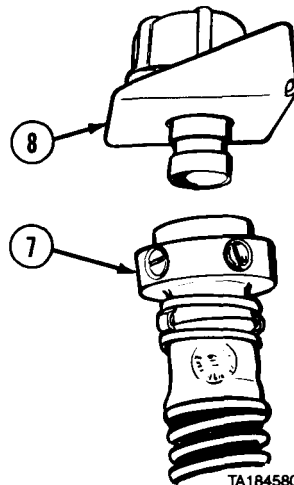
Do steps (10) through (14) only when Nuclear, Biological, or Chemical (NBC) attack is over or when ordered to do so.

- (10) When protective masks (1) are no longer needed, disconnect air duct hose breakaway sockets (7) from canisters (2).



TA184576

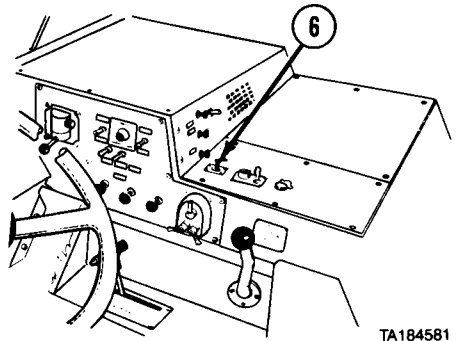
- (11) Connect two air duct hose breakaway sockets (7) to mounts (8).



TA184580

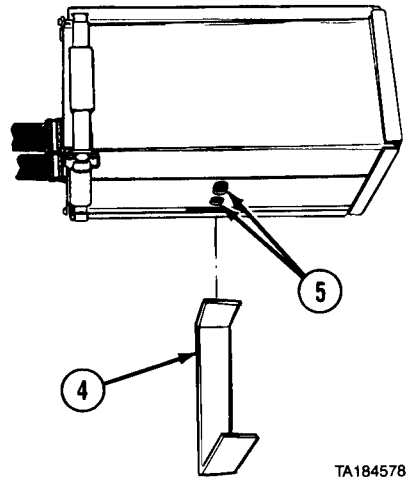
Auxiliary Equipment Operation (Cont)

- (12) Turn GAS PARTICULATE FILTER switch (6) to OFF.



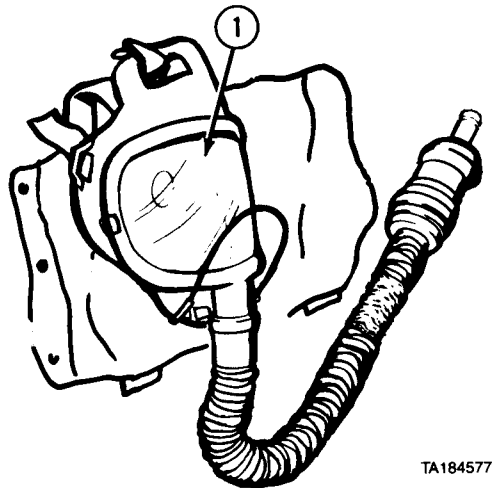
TA184581

- (13) Push up on spring clip (4) to cover intake holes (5).



TA184578

- (14) Remove and stow two protective masks (1).



TA184577

Auxiliary Equipment Operation (Cont)

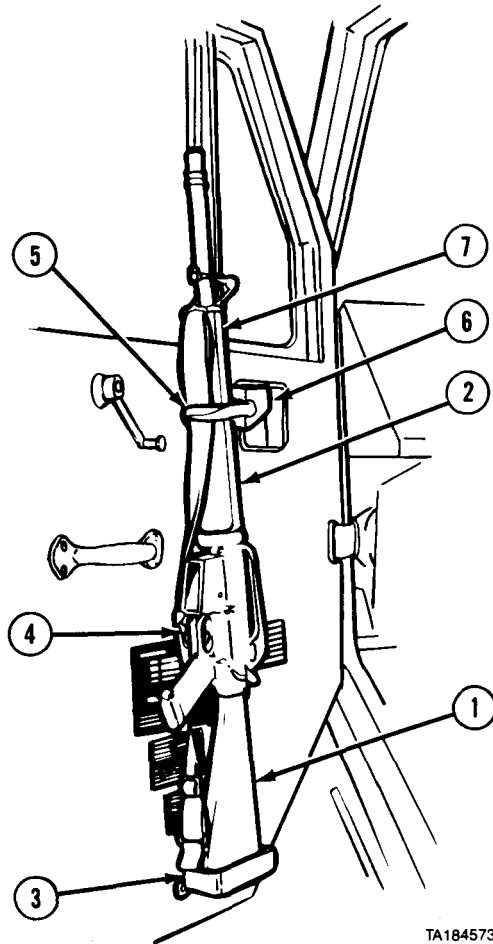
2-31. AUXILIARY EQUIPMENT OPERATING PROCEDURES (CONT).

d. Stow Rifle In Stowage Mount.

- (1) Position butt (1) of M-16 rifle (2) in lower mount (3) with trigger guard (4) toward rear of vehicle.
- (2) Pull handle (5) of top mount (6) toward middle of cab.
- (3) Place heat guard (7) of M-16 rifle (2) in top mount (6).
- (4) Push handle (5) across heat guard (7).
- (5) Check that M-16 rifle (2) is held tightly.

e. Remove Rifle from Stowage Mount.

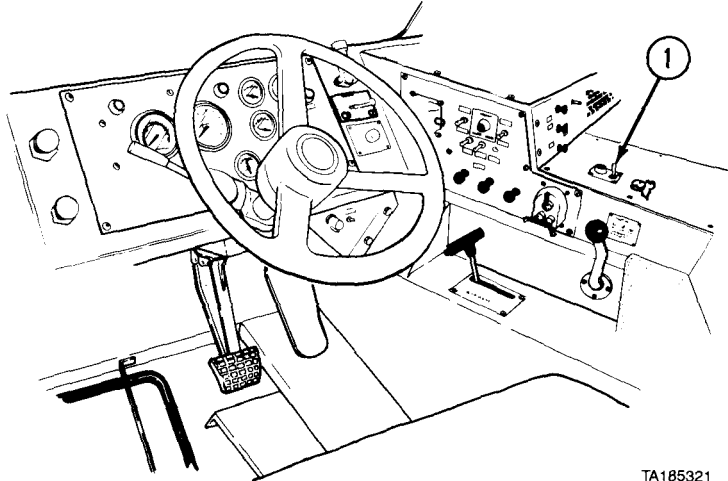
- (1) Pull handle (5) of top mount (6) down and toward middle of cab.
- (2) Remove heat guard (7) of M-16 rifle (2) from top mount (6).
- (3) Remove butt (1) of M-16 rifle (2) from lower mount (3).



TA184573

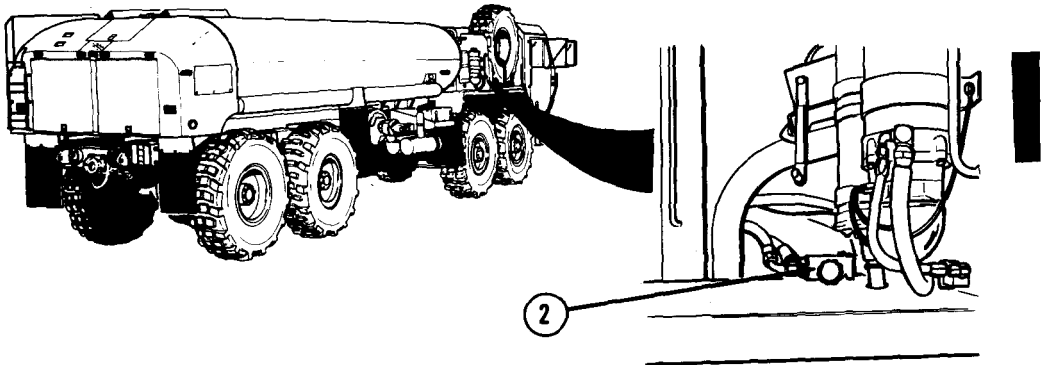
Auxiliary Equipment Operation (Cont)

f. Connect Auxiliary Hydraulic Equipment.



TA185321

- (1) Position vehicle for auxiliary hydraulic connection.
- (2) Shut off engine (para 2-11p).
- (3) If vehicle is equipped with self-recovery winch, set PTO ENGAGE switch (1) to OFF.

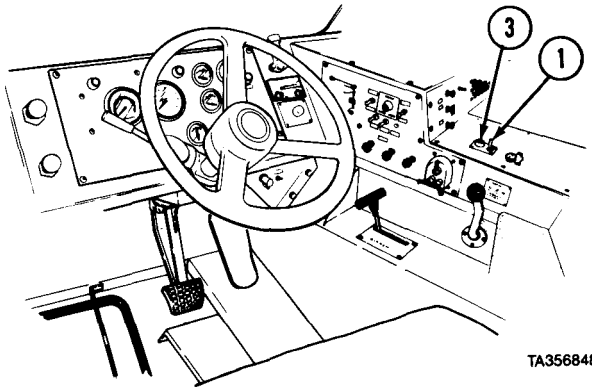


TA183236

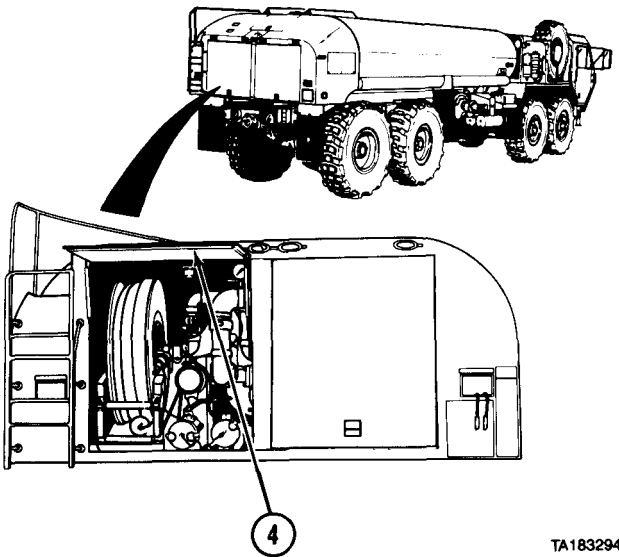
- (4) If vehicle is equipped with self-recovery winch, push in SELECTOR VALVE (2) for tanker pump operation.

Auxiliary Equipment Operation (Cont)

2-31. AUXILIARY EQUIPMENT OPERATING PROCEDURES (CONT).



(5) Set PTO ENGAGE switch (1) to ON position. Indicator light (3) should come on.

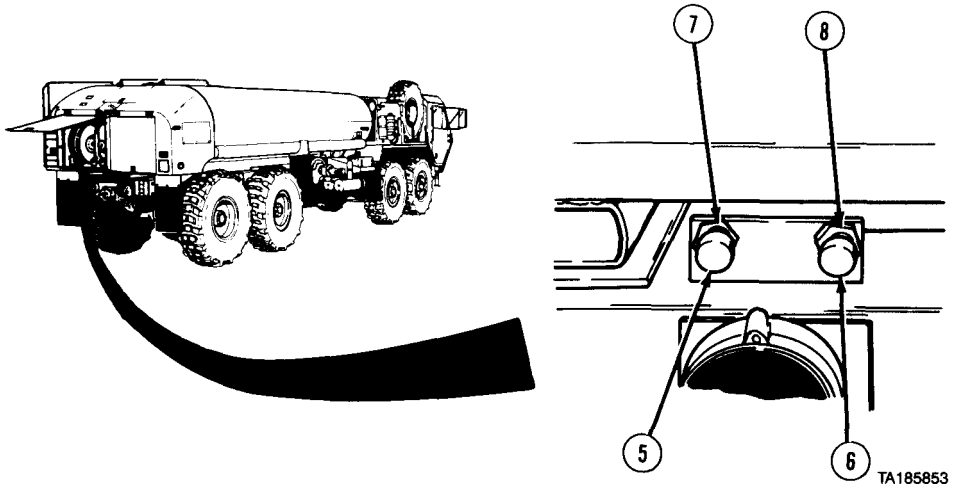


WARNING

To avoid injury stand clear when opening pump module rear door. When door is about halfway open, gas pistons push door open quickly and with much force.

(6) Open left-side pump module rear door (4).

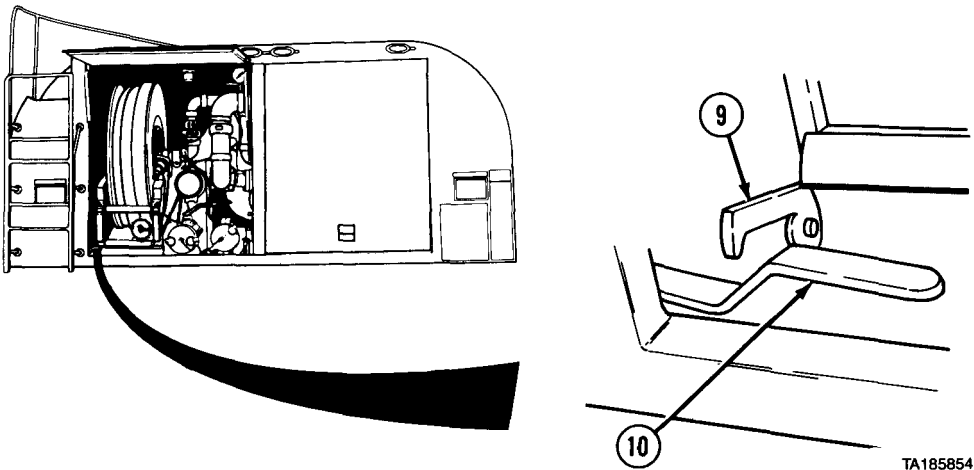
Auxiliary Equipment Operation (Cont)



NOTE

Small amount of hydraulic fluid may leak out when caps are removed.

- (7) Remove return line cap (5) and supply line cap (6).
- (8) Connect hydraulic lines from auxiliary hydraulic equipment to return fitting (7) and supply fitting (8).
- (9) Start engine (para 2-11a).

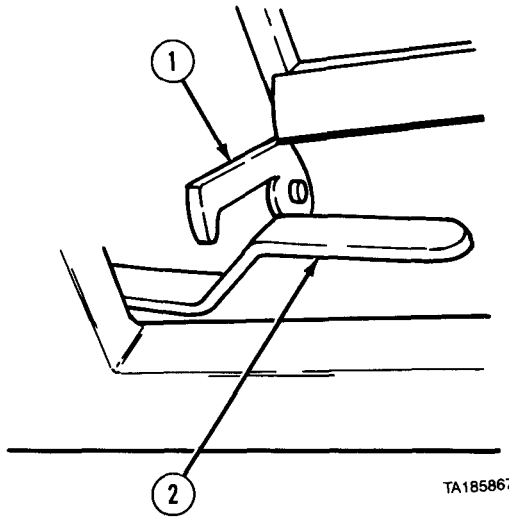


- (10) Lift latch (9) and pull pump engagement lever (10) completely back.
- (11) Continue operation of auxiliary hydraulic equipment.

Auxiliary Equipment Operation (Cont)

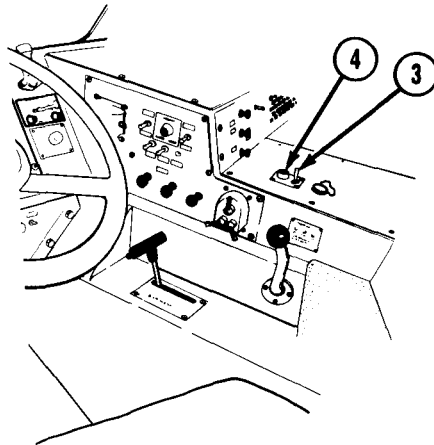
2-31. AUXILIARY EQUIPMENT OPERATING PROCEDURES (CONT).

g. Disconnect Auxiliary Hydraulic Equipment.



TA185867

- (1) Shut down auxiliary hydraulic equipment.
- (2) Lift latch (1) and push pump engagement lever (2) to off (center position).

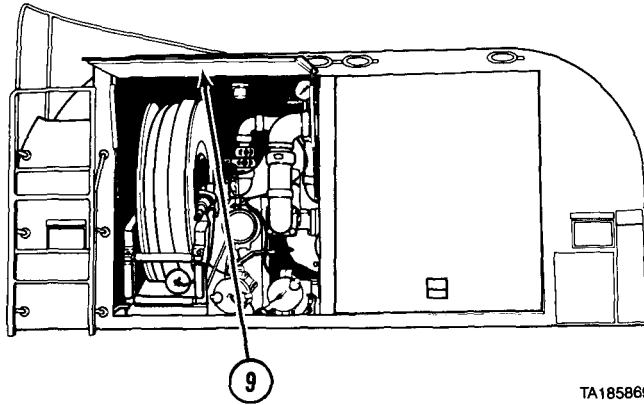
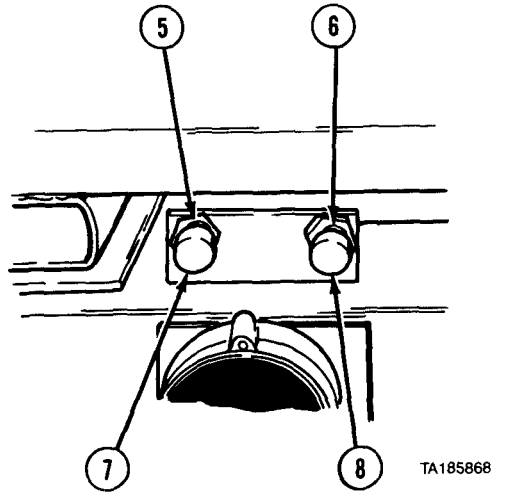


TA185875

- (3) Set PTO ENGAGE switch (3) to OFF position. Indicator light (4) should go out.
- (4) Shut off engine (para 2-11p).

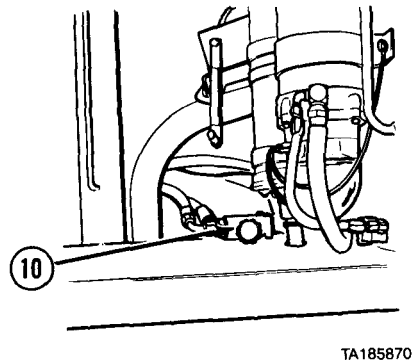
Auxiliary Equipment Operation (Cont)

- (5) Disconnect hydraulic lines from auxiliary hydraulic equipment from return fitting (5) and supply fitting (6).
- (6) Install return line cap (7) and supply line cap (8).



- (7) Close left-side pump module rear door (9).

- (8) Pull out SELECTOR VALVE (10).



Auxiliary Equipment Operation (Cont)

2-31. AUXILIARY EQUIPMENT OPERATING PROCEDURES (CONT).

h. Operate Machine Gun Mount. Refer to TM 9-1005-245-14 for operating instructions.

i. Operate M-8 Chemical Alarm. Refer to TM 3-6665-225-12 for operating instructions.

j. Operate M-13 Decontamination Unit. Refer to TM 3-4230-214-12&P for operating instructions.

k. Operate Radio. Refer to TM 11-5820-498-12 for operating instructions.

l. Operate Generator Set. Refer to TM 5-6115-465-12 for operating instructions.

Section IV. OPERATION UNDER UNUSUAL CONDITIONS

2-32. OPERATE VEHICLE IN EXTREME HEAT.

CAUTION

- When operating vehicle in very hot temperatures of above 100° F (38°C), extra care must be taken to prevent overheating engine (temperatures over 230°F, 110°C) and transmission (temperatures over 250°F, 121°C). Watch water and transmission temperature gages closely.
- Check oil levels often and keep operating strain as low as possible. Vehicle cooling and lubrication systems support each other. Failure of one system will rapidly cause failure of other system.

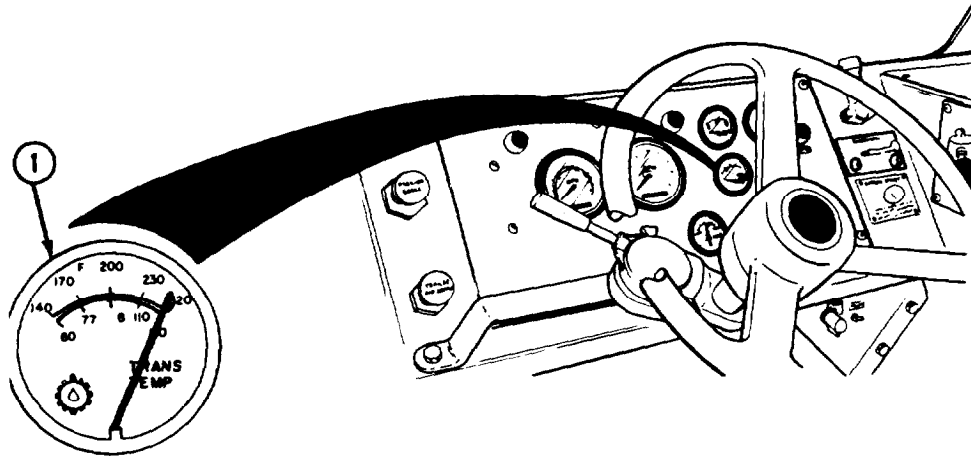
a. Keep operating strain as low as possible.

- (1) Put transmission in N (neutral) position while engine is running. Let engine idle for about 2 minutes before shutting down. Idling will cool engine faster than quick shutdown and may prevent damage from remaining engine heat.
- (2) Use low gear ranges only when necessary.

b. Stop vehicle for cooling off periods, and idle engine as often as possible.

c. Check oil levels often. Oil seals are more likely to leak in extreme hot weather.

Operation Under Unusual Conditions (Cont)



- d.** If TRANS TEMP gage (1) reads higher than 250°F (121°C), do the following:
- (1) Downshift to next lower gear range and continue operation.
 - (2) When TRANS TEMP gage (1) reads in normal range, upshift to normal gear range and continue operation.
 - (3) If TRANS TEMP gage (1) does not return to normal range, stop vehicle and let transmission cool.
 - (4) When TRANS TEMP gage (1) reads in normal range, shift to normal gear range and continue operation.
- d.** Check cooling system often and notify organizational maintenance if any of the following are found:
- (1) Low coolant level in radiator.
 - (2) Leaking hose connections which have been tightened but still leak.
 - (3) Loose fan belt.
 - (4) Cracked or leaking hoses.
 - (5) Radiator fins plugged with dust, leaves, or insects.

NOTE

Batteries do not hold charge well in extreme heat.
Battery specific gravity must be changed to adjust for heat (TM 9-6140-200-14).

- f.** Keep batteries full, but do not overfill (Table 2-1, Item 4). Check battery electrolyte daily.
- g.** In hot, damp climates check body and chassis often and notify organizational maintenance if any of the following are found:
- (1) Signs of pitting or paint blistering on metal surfaces.
 - (2) Signs of mildew, mold, or fungus on fabrics and rubber.
- h.** Adjust lubrication intervals as specified in applicable LO.
- i.** Park so vehicle does not face into wind and is under shelter. Cover windows, cab, and engine compartment with tarpaulin when shelter is not available.

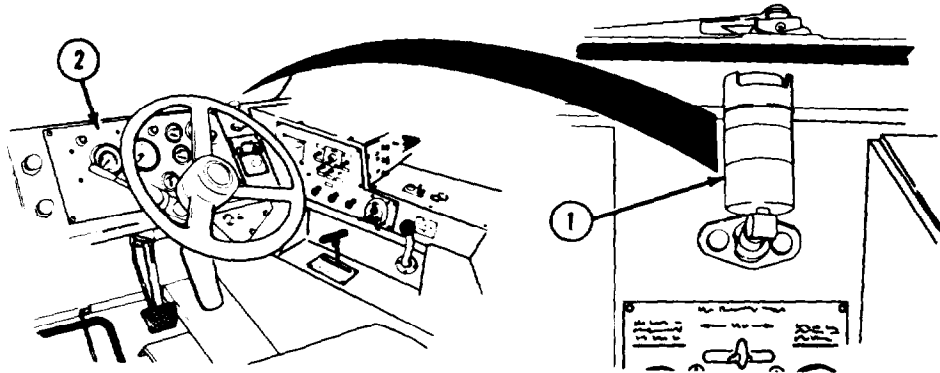
Operation Under Unusual Conditions (Cont)

2-33. OPERATE VEHICLE IN EXTREME DUST.

CAUTION

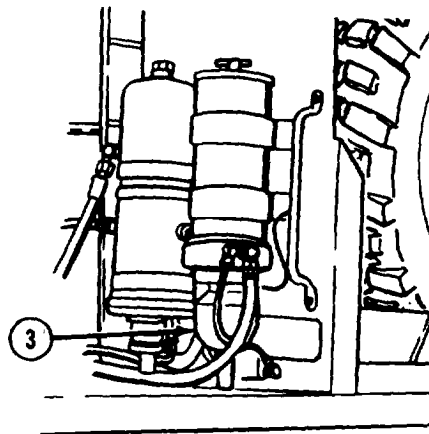
Clouds of dust can scratch glass surfaces. Keep glass surfaces covered as much as possible in these conditions to prevent scratching.

a. Leave glass surfaces covered if not needed for operations. Take extra care when cleaning glass to prevent scratching surfaces.



b. Keep close watch on air filter restriction indicator (1), gages, and lights on driver's instrument panel (2) to be sure dust does not affect equipment.

c. Allow as much distance as possible between vehicles and operate at low speeds.

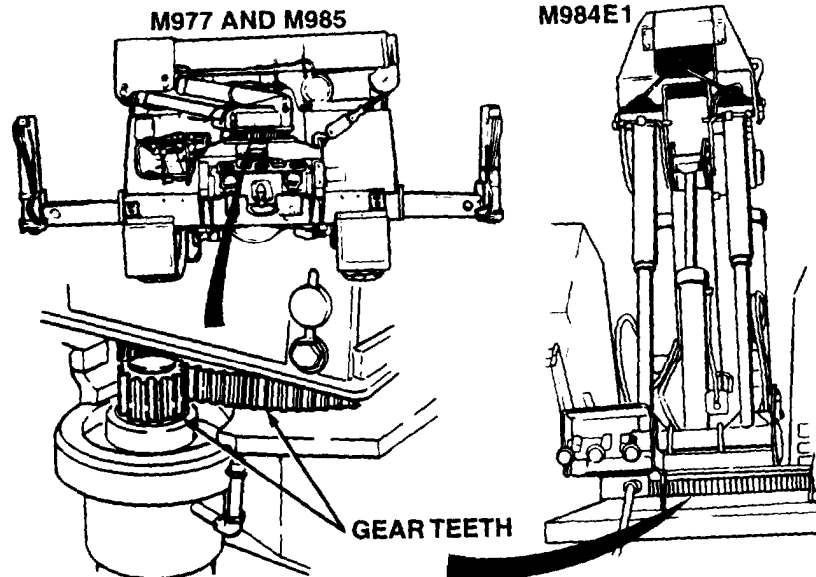


d. At stops, check and drain fuel-water separator (3).

e. When operating M977, M984E1, or M985 vehicle in a blowing dust environment, perform the following:

Operation Under Unusual Conditions (Cont)

- (1) Check gear teeth of rotation gear bearing and pinion for an accumulation of dust within the lubricant.



- (2) If level of dust prevents rotation of crane, notify organizational maintenance and have lubricant removed.
 - (3) If necessary, notify organizational maintenance to apply a light coating of wax to gear teeth for rust prevention.
 - (4) Refer to LO 9-2320-279-12 for proper lubrication of gear teeth when returning to normal operating conditions.
- f. When possible, park so vehicle does not face into wind.

2-34. OPERATE VEHICLE IN SAND OR MUD.

CAUTION

Blowing sand may scratch glass surfaces. Glass surfaces should remain covered as much as possible in these conditions to prevent scratching.

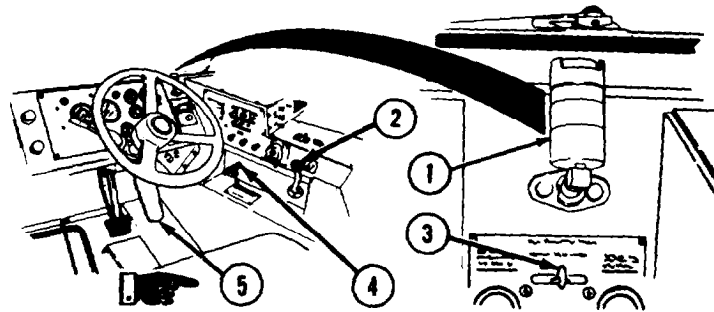
NOTE

Operating in mud can worsen vehicle braking and speed up brakeshoe wear. If braking worsens while operating in mud, dry brakes by driving vehicle approximately 500 ft (153 m) with service brakes frequently applied. This must be done with brakedrums totally out of mud, so that drying action can take place. If adequate braking is not restored by drying brakes, notify organizational maintenance.

- a. Leave glass surfaces covered if not needed for operations. Extra care should be taken when cleaning glass surfaces to prevent scratching surfaces.

Operation Under Unusual Conditions (Cont)

2-34. OPERATE VEHICLE IN SAND OR MUD (CONT).



NOTE

- Principles of driving in sand can also be applied to driving in mud.
- Best time to drive on sand is at night or early morning when sand is damp. Damp sand gives better traction.

- b.* Check air filter restriction indicator (1) often.
- c.* Adjust tire pressure (para 3-9).
- d.* Set transfer case shift lever (2) to LO.

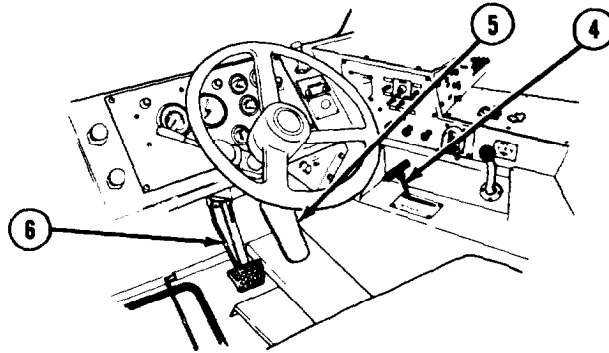
CAUTION

Wheel hop condition should be avoided to prevent possible damage to drivetrain. If wheel hop begins to occur, ease up on throttle to allow tires to grip surface. If wheel hop continues, release throttle and apply brakes. Apply throttle slowly as traction permits.

- e.* Start slowly. Do not spin wheels when starting to move vehicle.
- f.* Set TRACTION CONTROL lever (3) to INTER-AXLE DIFF. LOCK for added traction.
- g.* Set transmission range selector (4) to 2 or 1, as needed, for added traction.
- h.* Do not straddle sand mounds or drive on sides of two sand mounds. Loose sand will not support vehicle on steep slopes.
- i.* Keep throttle treadle (5) steady after vehicle reaches desired speed.

Operation Under Unusual Conditions (Cont)

- j.* Turn vehicle slowly when on loose sand or mud.
- k.* Steer vehicle straight up and down hills if possible.



l. To move vehicle forward and turn after vehicle is stopped in loose sand or mud, do the following:

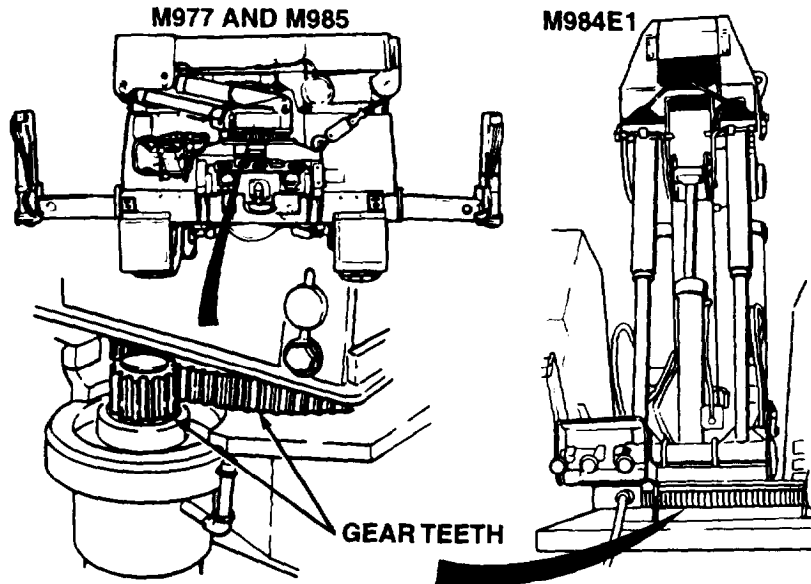
- (1) Set transmission range selector (4) to R.
- (2) Press throttle treadle (5) and move vehicle straight back about 20 ft (6.1 m).
- (3) Release throttle treadle (5) and press brake treadle (6).
- (4) Set transmission range selector (4) to position 1.
- (5) Release brake treadle (6) and press throttle treadle (5) to move vehicle forward.
- (6) Turn vehicle gradually.
- (7) Move transmission range selector (4) to position D when vehicle picks up speed and is moving forward smoothly.

m. If vehicle starts to skid, do the following:

- (1) Release throttle treadle (5).
- (2) Steer in direction of skid until vehicle stops skidding.
- (3) Press throttle treadle (5) slowly and steer vehicle on straight course.

Operation Under Unusual Conditions (Cont)

2-34. OPERATE VEHICLE IN SAND OR MUD (CONT).



n. When operating M977, M984E1, or M985 vehicle in a blowing sand environment, perform the following:

- (1) Check gear teeth of rotation gear bearing and pinion for an accumulation of sand within the lubricant.
- (2) If level of sand prevents rotation of crane, notify organizational maintenance and have lubricant removed.
- (3) If necessary, notify organizational maintenance to apply a light coating of wax to gear teeth for rust prevention.
- (4) Refer to LO 9-2320-279-12 for proper lubrication of gear teeth when returning to normal operating conditions.

o. Park vehicle as follows:

- (1) Park so vehicle does not face into wind.
- (2) Clean mud off vehicle as soon as possible.

CAUTION

- Do not hit axle breathers when cleaning mud from axles.
 - Do not direct high pressure water stream at glass surfaces, seals, air intake, axle breathers, exhaust outlet, or any other component of vehicle that could be easily damaged by high pressure water stream.
- (3) Clean mud from wheels, brakes, axles, universal joints, steering mechanism, and radiator as soon as possible.
 - (4) Make sure axle breather vent caps move freely on breather body.

Operation Under Unusual Conditions (Cont)

2-35. OPERATE VEHICLE IN DESERT ENVIRONMENT.**NOTE**

FM 90-3 contains detailed instructions for living and working in desert.

a. Principles for operating in extreme heat and extreme dust, sand, or mud apply to desert environment (para 2-32, 2-33, and 2-34).

b. Temperatures may change as much as 70 degrees between day and night. These changes may damage equipment if vehicle is not properly prepared.

- (1) Due to expansion and contraction of all fluids and air, care should be taken when filling fuel tank and fluid reservoirs to prevent overflow when temperatures change.
- (2) Precision instruments may be affected by temperature changes and may need adjustment more often.

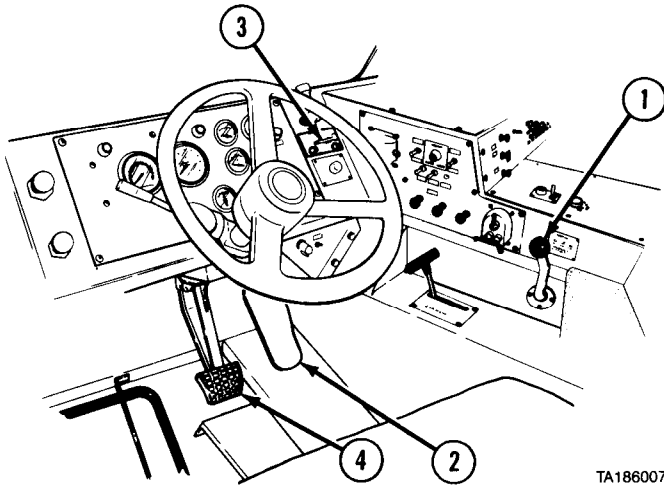
2-36. OPERATE VEHICLE IN COLD ENVIRONMENT (32°F, 0°C TO -25°F, -32°C).**CAUTION**

- Before operating vehicle in severe cold environment make sure it has been prepared as described in FM 9-207. Refer to FM 31-70, FM 31-71, and FM 21-305 for additional information on operation in cold environment.
 - Watch instrument panel closely. If there are any unusual readings, stop vehicle and shut off engine. Check immediately.
 - Park in shelter when possible. If shelter is not available, park so vehicle does not face wind. Place planks or brush under wheels so vehicle will not freeze in place.
 - Fuel filter should be drained before topping off fuel tank. Keep fuel tank as full as possible during cold operations. Water forms in empty fuel tank as it cools. Water in fuel system could freeze and block system.
 - All snow and ice should be removed from vehicle as soon as possible. Snow and ice may slow or stop movement of critical parts if allowed to pile up.
 - Special care must be used during operations in cold environment. In severe cold, engine coolant and fluid in windshield washer can freeze. Batteries can freeze and crack. Oil and grease may get thick and stiff. Rubber may crack or break easily.
- a. Install tire chains, if needed (para 2-39).
 - b. Use ether start unit when starting engine (para 2-11a).
 - c. Let engine warm up thoroughly.

Operation Under Unusual Conditions (Cont)

2-36. OPERATE VEHICLE IN COLD ENVIRONMENT (32 °F, 0 °C TO - 25 °F, - 32 °C) (CONT).

d. Drive vehicle at lowest possible speed in gear range 1 and LO transfer case range to warm drive line components and tires.



- e.** Drive on mud, snow, ice, and slippery surfaces as follows:
- (1) Set TRANSFER CASE shift lever (1) to LO for added traction.
 - (2) Press throttle treadle (2) slowly when changing speed.
 - (3) Keep throttle treadle (2) steady after vehicle reaches desired speed.

NOTE

TRACTION CONTROL lever should be set to 8X8 DRIVE when transfer case is in HI range while driving on slippery surfaces. TRACTION CONTROL lever should be set to INTER-AXLE DIFF. LOCK or 8×8 DRIVE when transfer case is in LO range while driving on slippery surfaces.

- (4) Set TRACTION CONTROL lever (3) to INTER-AXLE DIFF. LOCK or 8×8 DRIVE, as needed, when driving on slippery surfaces.
- (5) Turn vehicle slowly when on slippery surfaces.
- (6) Steer vehicle away from ruts and large snowbanks.
- (7) Steer vehicle straight up and down hills if possible.
- (8) Use 2nd or 3rd gear to go down medium grades.
- (9) Use 1st gear to go down steep or very slippery grades.
- (10) Drive at slower speeds and stay twice normal distance from vehicle ahead.
- (11) Give turn signals sooner.

Operation Under Unusual Conditions (Cont)

WARNING

Do not apply engine brake when vehicle is on slick surface. Applying engine brake on slick surfaces may cause vehicle to skid and result in injury or death.

NOTE

Pressing brake treadle lightly will help keep vehicle from skidding.

- (12) Apply brakes sooner and press brake treadle (4) lightly to give early warning that vehicle will slow or stop.
 - (13) Downshift, if necessary, when slowing or stopping vehicle on slick surfaces.
 - (14) Keep windshield, windows, mirrors, headlights, stoplights, and body lights clean and free of snow and ice. Use defroster and windshield wipers to keep windshield free of snow and ice.
- f. Drive slowly and test brakes after driving through slush or water. If brakes slip, do the following:
- (1) Continue to drive slowly.
 - (2) Apply moderate pressure on brake treadle (4) to cause slight brake drag.
 - (3) When brakes are dry and no longer slip, let up on brake treadle (4).
 - (4) Resume normal driving speed.

NOTE

Refer to FM 21-305 for additional information on driving in dangerous conditions.

- g. If rear of vehicle skids, do the following:
- (1) Let upon throttle treadle (2).
 - (2) Steer in same direction in which vehicle is skidding.
 - (3) When vehicle is under control, press brake treadle (4) lightly.
 - (4) Steer vehicle on straight course and slowly press throttle treadle (2).
- h. If vehicle starts to slide while climbing hill, do the following:
- (1) Let upon throttle treadle (2).
 - (2) Steer vehicle in direction of slide until vehicle stops.
 - (3) Slowly press throttle treadle (2) and steer vehicle on straight course.
- i. If absolutely necessary for better traction, lower tire air pressure to emergency air pressure (para 3-9). Make sure each tire has valve cap. Drive at low speed when tire air pressures are reduced.

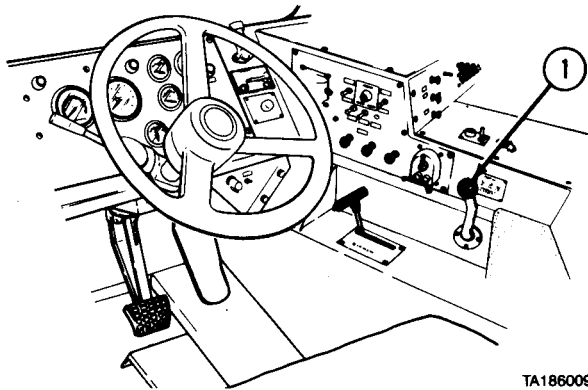
NOTE

Refer to FM 20-22 for detailed information on vehicle recovery.

- j. If vehicle becomes stuck, do the following:
- (1) Shovel clear path ahead of each wheel. Put boards, brush, or similar material in cleared paths to get better traction.
 - (2) If vehicle remains stuck, use another vehicle to winch or tow stuck vehicle.
 - (3) If another vehicle is not available, use self-recovery winch to free vehicle (para 2-41).

Operation Under Unusual Conditions (Cont)

2-36. OPERATE VEHICLE IN COLD ENVIRONMENT (32 °F, 0 °C TO -25 °F, -32 °C) (CONT).



k. Park vehicle as follows:

- (1) Park vehicle in sheltered area out of wind if possible. If no shelter is available, park so vehicle does not face into wind.
- (2) Park vehicle on high, dry ground if possible. If high, dry ground is not available, spread out planks or brush to make raised and dry area so tires will not freeze in snow, water, ice, or mud.
- (3) Park vehicle on level ground so body does not twist.
- (4) Set transfer case shift lever (1) to LO.
- (5) Clean snow, ice, and mud off vehicle as soon as possible.

CAUTION

Do not hit axle breathers when cleaning mud, snow, and ice from axles.

- (6) Clean mud, snow, and ice from wheels, brakes, axles, universal joints, mirrors, steering mechanism, and radiator as soon as possible.
- (7) Make sure axle breather vent caps move freely on breather body.

2-37. OPERATE VEHICLE IN EXTREME COLD ENVIRONMENT (-26 °F, -32 °C TO -65 °F, -54 °C).

WARNING

Do not touch extremely cold metal (below -26 °F, -32 °C). Bare skin may freeze to cold metal.

CAUTION

- Before operating vehicle in extreme cold environment make sure engine arctic kit is installed and vehicle has been prepared as described in FM 9-207. Refer to FM 31-70, FM 31-71, and FM 21-305 for additional information on operations in extreme cold environment.

Operation Under Unusual Conditions (Cont)

CAUTION

- Watch instrument panel closely. If any unusual readings occur stop vehicle and shut off engine. Check immediately.
 - Park in shelter when possible. If shelter is not available, park so vehicle does not face into wind. Place planks or brush under wheels so vehicle will not freeze in place.
 - Fuel filter should be drained before topping off fuel tank. Keep fuel tank as full as possible during cold operations. Water forms in empty fuel tank as it cools. Water in fuel system could freeze and block system.
 - All snow and ice should be removed from vehicle as soon as possible. Snow and ice may slow or stop movement of critical parts if allowed to pile up.
 - Special care must be used during operations in extreme cold environment. In extreme cold, engine coolant and fluid in windshield washer can freeze. Batteries can freeze and crack. Oil and grease may get thick and stiff. Rubber may crack or break easily.
- a.** Principles for operating in cold environment apply to extreme cold environment (para 2-36).
- b.** Make sure engine arctic kit has been installed.
- c.** Step deleted.
- d.** Operate engine arctic kit as needed (para 2-31b).

WARNING

Tire air pressure must be checked properly or serious injury or death may result.

- e.** In areas where temperatures reach -50°F (-46°C) or colder, put about 10 pounds of air above normal in tires for long standby periods and overnight.
- f.** If additional air is put in tires for standby periods, lower tire pressure to normal amounts before driving vehicle (para 3-9).
- g.** Before operating crane, perform warm-up as follows:
- (1) Start engine (para 2-11a).
 - (2) While engine is at low idle, fully exercise all functions of crane for at least 5 minutes.

Operation Under Unusual Conditions (Cont)

2-37. OPERATE VEHICLE IN EXTREME COLD ENVIRONMENT (-26°F, -32°C TO -65°F, -54°C) (CONT).

(3) With engine at high idle, fully exercise all functions of crane for at least 10 minutes.

(4) Continue with operation of crane.

h. For M978 only, before performing fuel handling operations, perform warm-up as follows:

(1) Prepare tanker for operations (para 2-20).

(2) Start engine (para 2-11a).

(3) Engage power takeoff (PTO).

(4) With engine at low idle, engage primary pump for at least 5 minutes.

(5) Disengage primary pump.

(6) Continue with fuel handling operations.

2-38. OPERATE VEHICLE IN FOREST OR ROCKY TERRAIN.

CAUTION

Make sure vehicle can clear ground obstructions, such as stumps and large rocks, before driving over. Stumps and rocks may damage components underneath vehicle.

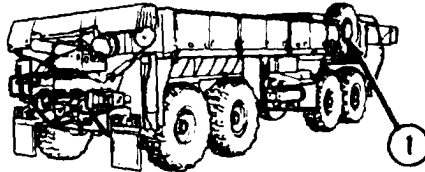
a. Avoid driving over obstructions if possible.

CAUTION

Make sure vehicle can clear overhanging tree limbs and other obstructions. Low overhead obstructions may damage cargo, cargo cover and other parts on top of vehicle.

b. Avoid low overhanging obstructions if possible.

c. Check traction and braking. Rocks and fallen leaves can be very slick, especially when wet.



WARNING

Tire air pressure must be checked properly or serious injury or death may result.

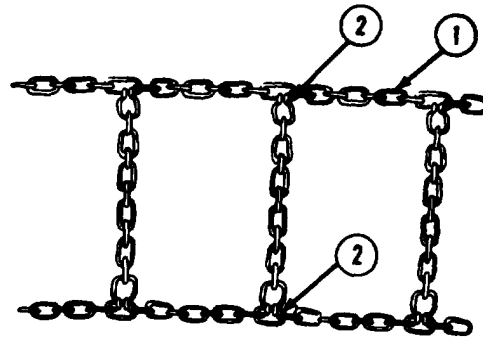
d. When driving over very rocky terrain, be sure spare wheel and tire (1) are on vehicle, in good repair and at correct pressure (para 3-9). There is greater chance of tire punctures when operating in rocky terrain.

e. Fold vehicle side mirrors in far enough so area to rear of vehicle can still be seen, but mirrors will not be damaged by rocks, trees, and other obstructions.

Operation Under Unusual Conditions (Cont)

2-39. INSTALL/REMOVE TIRE CHAINS.

a. *Install Tire Chains.*



Operation Under Unusual Conditions (Cont)

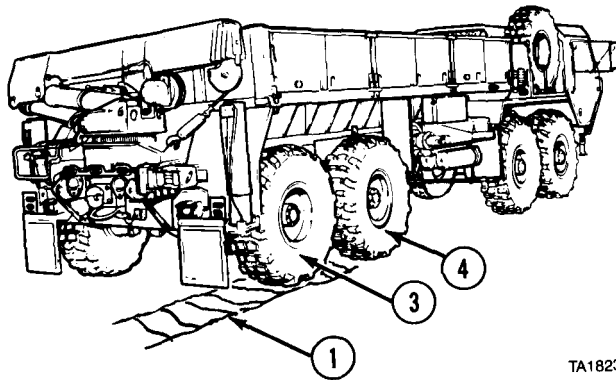
CAUTION

When tire chains are used they must be used on all four rear wheels. Chains must not be used when driving on hard surfaces where there is no wheel slippage. Improper use of tire chains may result in severe equipment damage.

NOTE

Maximum speed limit for vehicles with chains on highway is 10 mph (16 kmh). Maximum speed limit for vehicles with chains off highway is 15 mph (24 kmh).

- (1) Soldier A and Soldier B place tire chain (1) on ground with cross chain connecting links (2) facing down.

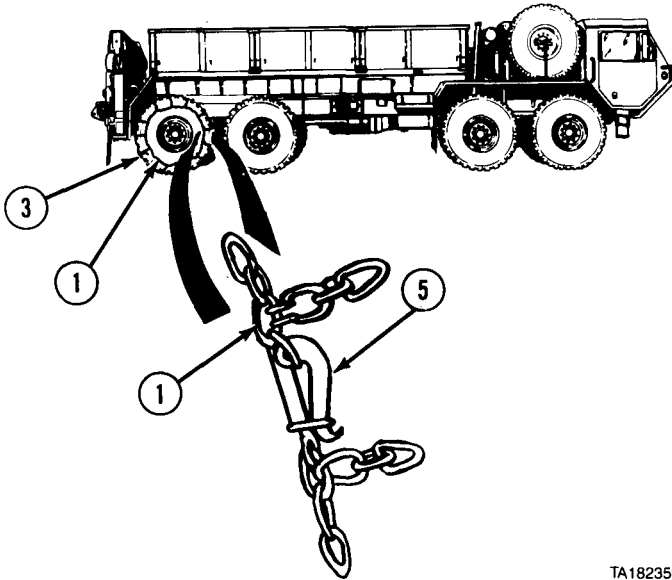


TA182358

- (2) Soldier A moves vehicle onto tire chain (1) while Soldier B guides vehicle so tire (3) is about one-third of way on tire chain (para 2-11g).
 (3) Park vehicle (para 2-11o).
 (4) Make sure tire (4) is not on tire chain (1).

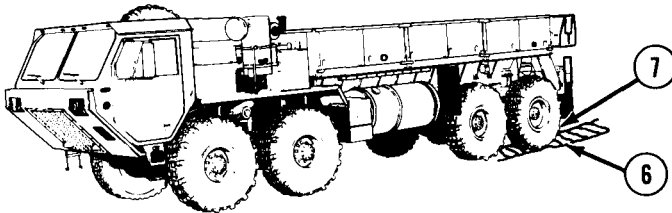
Operation Under Unusual Conditions (Cont)

2-39. INSTALL/REMOVE TIRE CHAINS (CONT).



TA182359

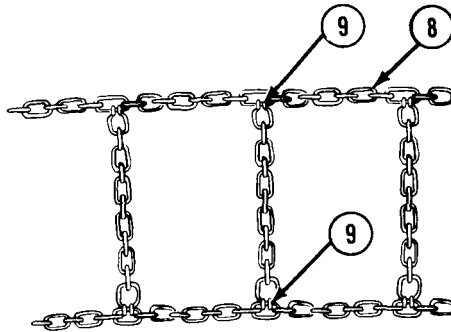
- (5) Soldier A and Soldier B wrap tire chain (1) around tire (3).
- (6) Soldier A and Soldier B connect and secure inside and outside clamps (5) so tire chain (1) is as tight as possible.



TA182360

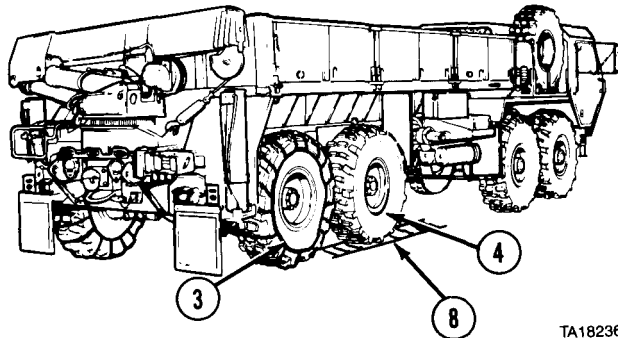
- (7) Soldier A and Soldier B install tire chain (6) on tire (7) by repeating steps (1) through (6).

Operation Under Unusual Conditions (Cont)



TA182361

- (8) Soldier A and Soldier B place tire chain (8) on ground with cross chain connecting links (9) facing down.

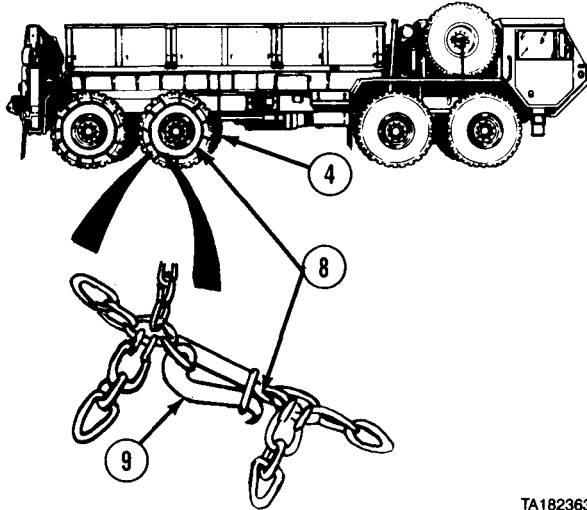


TA182362

- (9) Soldier A moves vehicle onto tire chain (8) while Soldier B guides vehicle so tire (4) is about one-third of way on tire chain (para 2-11g).
 (10) Park vehicle (para 2-11o).
 (11) Make sure tire (3) is not on tire chain (8).

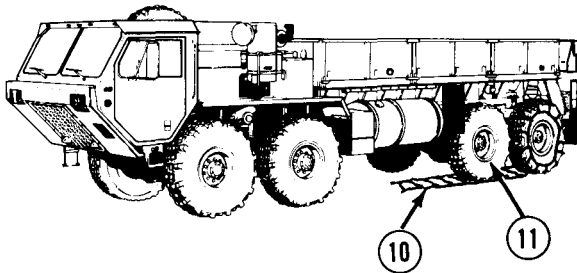
Operation Under Unusual Conditions (Cont)

2-39. INSTALL/REMOVE TIRE CHAINS (CONT).



TA182363

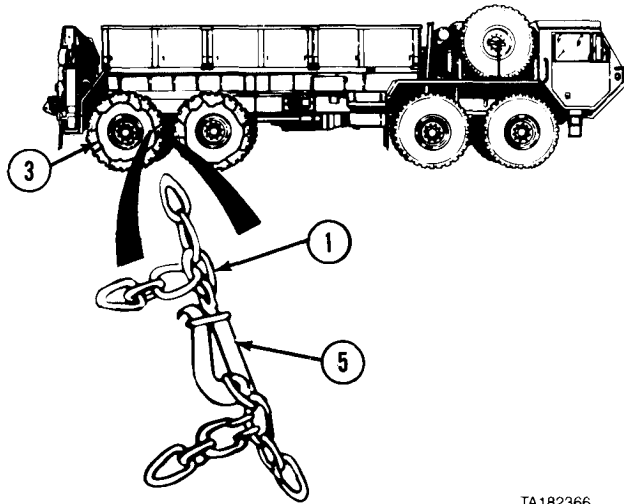
- (12) Soldier A and Soldier B wrap tire chain (8) around tire (4).
- (13) Soldier A and Soldier B connect and secure inside and outside clamps (9) so tire chain (8) is as tight as possible.



TA182364

- (14) Soldier A and Soldier B install tire chain (10) on tire (11) by repeating steps (8) through (13).
- (15) Soldier A drives vehicle forward about 15 ft (4.6 m) and then back about 15 ft (4.6 m) as guided by Soldier B (para 2-11g).
- (16) Park vehicle (para 2-11o).

Operation Under Unusual Conditions (Cont)



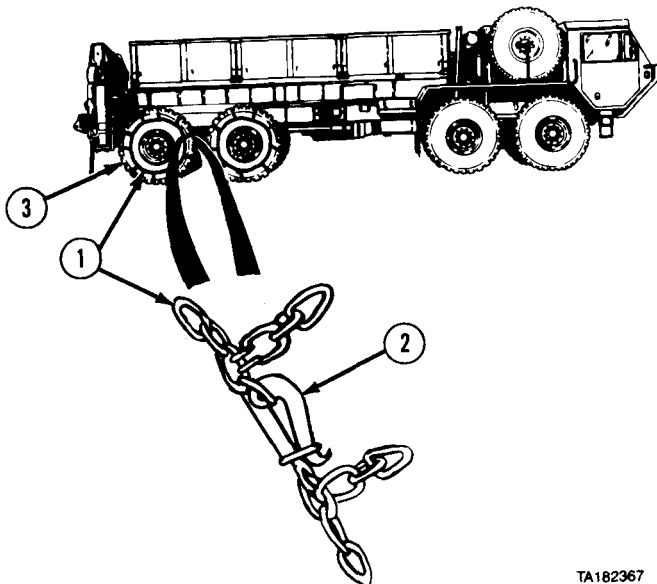
TA182366

- (17) Soldier A and Soldier B disconnect inside clamp (5) of tire chain (1) on tire (3).
- (18) Soldier A and Soldier B take up slack in tire chain (1).
- (19) Soldier A and Soldier B connect inside clamp (5).
- (20) Soldier A and Soldier B disconnect outside clamp (5) of tire chain (1) on tire (3).
- (21) Soldier A and Soldier B take up slack in tire chain (1).
- (22) Soldier A and Soldier B connect outside clamp (5).
- (23) Soldier A and Soldier B take up slack in tire chains on other three rear tires by repeating steps (17) through (22).

Operation Under Unusual Conditions (Cont)

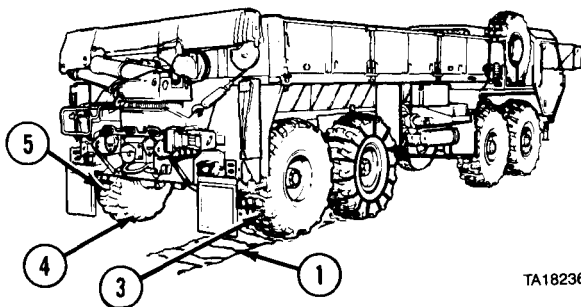
2-39. INSTALL/REMOVE TIRE CHAINS (CONT).

b. Remove Tire Chains.



TA182367

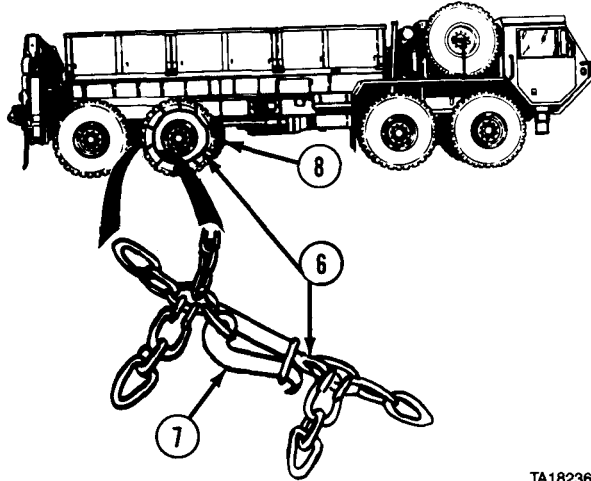
- (1) Start engine (para 2-11a or 2-11b).
- (2) Soldier A moves vehicle into position so tire chain (1) clamps (2) on tire (3) are at 4 o'clock position while Soldier B guides vehicle (para 2-11g).
- (3) Park vehicle (para 2-11o).
- (4) Soldier A and Soldier B disconnect inside and outside clamps (2) of tire chain (1).



TA182369

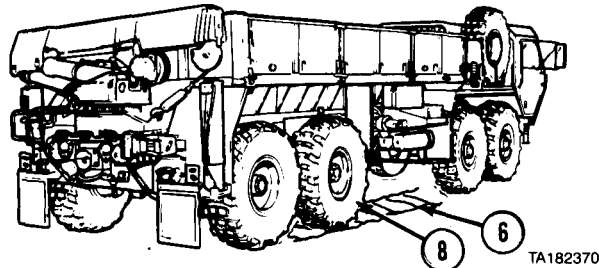
- (5) Soldier A and Soldier B unwrap tire chain (1) from tire (3) and spread tire chain out on ground behind vehicle.
- (6) Soldier A drives vehicle forward off tire chain (1) while Soldier B guides vehicle (para 2-11f).
- (7) Soldier A and Soldier B remove tire chain (4) from tire (5) by repeating steps (2) through (6).

Operation Under Unusual Conditions (Cont)



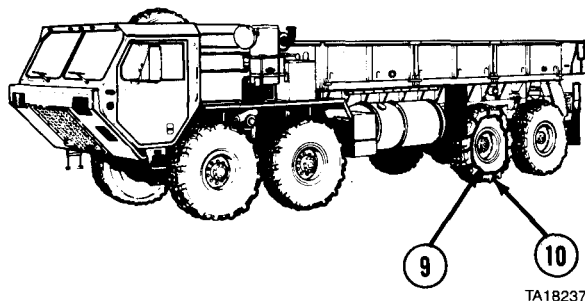
TA182368

- (8) Soldier A moves vehicle into position so tire chain (6) clamps (7) on tire (8) are at 8 o'clock position while Soldier B guides vehicle (para 2-11g).
- (9) Park vehicle (para 2-11o).
- (10) Soldier A and Soldier B disconnect inside and outside clamps (7) of tire chain (6).



TA182370

- (11) Soldier A and Soldier B unwrap tire chain (6) from tire (8) and spread tire chain out on ground in front of tire.
- (12) Soldier A drives vehicle off tire chain (6) while Soldier B guides vehicle (para 2-11g).



TA182371

- (13) Soldier A and Soldier B remove tire chain (9) from tire (10) by repeating steps (8) through (12).

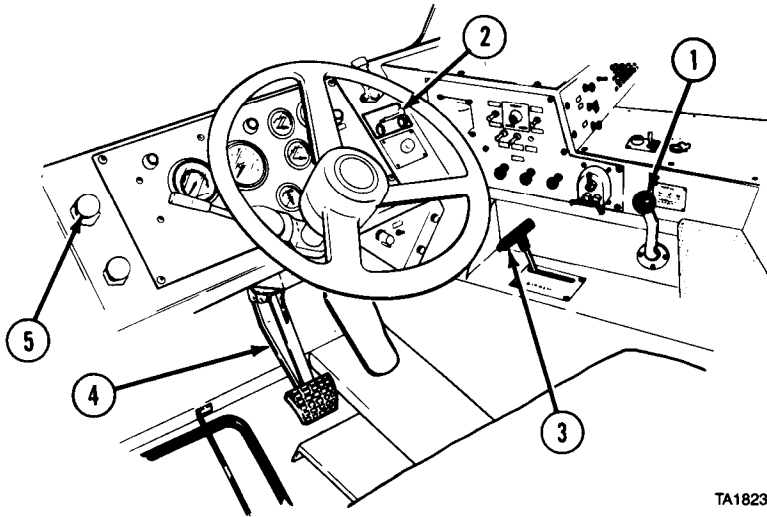
Operation Under Unusual Conditions (Cont)

2-40. FORD WATER OBSTACLE.

WARNING

Do not ford water unless depth is known. Water deeper than 4 ft (1.2 m) may enter vehicle and injure personnel.

- a.** Make sure depth of fording site is not more than 4 ft (1.2 m).
- b.** Make sure bottom at fording site is firm enough that 4 ft (1.2 m) maximum fording depth will not be exceeded and vehicle will not become mired.
- c.** Stop vehicle at edge of water.
- d.** If brakes have been used heavily and are hot, allow drums and shoes to cool before entering water if possible.
- e.** Make sure engine is operating correctly before entering water.



TA182372

- f.** Set TRANSFER CASE shift lever (1) to LO.
- g.** Set TRACTION CONTROL lever (2) to INTER-AXLE DIFF. LOCK.
- h.** Set transmission range selector (3) to position 1.
- i.** Drive vehicle slowly into water.
- j.** If engine stops, immediately attempt to restart engine. If engine will not start, tow or winch vehicle from water with another vehicle as soon as possible.
- k.** Drive vehicle at 3 to 4 mph (5 to 6 kmh), or less, through water.
- l.** Unless absolutely necessary, do not stop while in water.

Operation Under Unusual Conditions (Cont)

m. If vehicle accidentally enters water deeper than 4 ft (1.2 m), do the following:

- (1) Press on brake treadle (4) and hold to stop vehicle.
- (2) Set transmission range selector (3) to R.
- (3) Let up on brake treadle (4).
- (4) Slowly back vehicle out of deep water.

n. After leaving water, press brake treadle (4) lightly and hold while driving slowly to dry out brake linings.

o. When clear of fording area, stop vehicle.

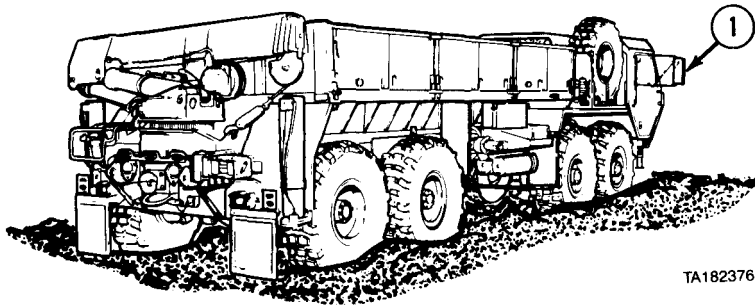
p. Apply and release parking brake (5) several times to remove water from brake components (para 2-11c).

q. Remove water and clean deposits from all vehicle parts as soon as possible.

r. Deliver vehicle to organizational maintenance as soon as possible.

2-41. SELF-RECOVER VEHICLE USING SELF-RECOVERY WINCH.

a. Winch Mired Vehicle Forward.



TA182376

NOTE

- For additional information on vehicle self-recovery, refer to FM 20-22.
- Vehicle self-recovery is a two soldier task. Soldiers must communicate by hand signals.

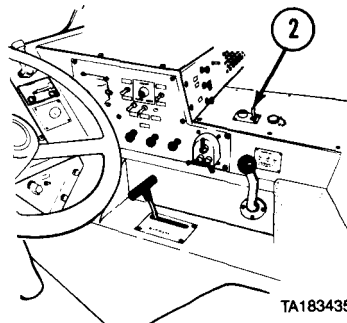
(1) Shut off engine (para 2-11p).

(2) Soldier A adjusts mirror (1) so Soldier B can be clearly seen during procedure.

CAUTION

PTO ENGAGE switch must be in OFF position before moving selector valve to prevent equipment damage.

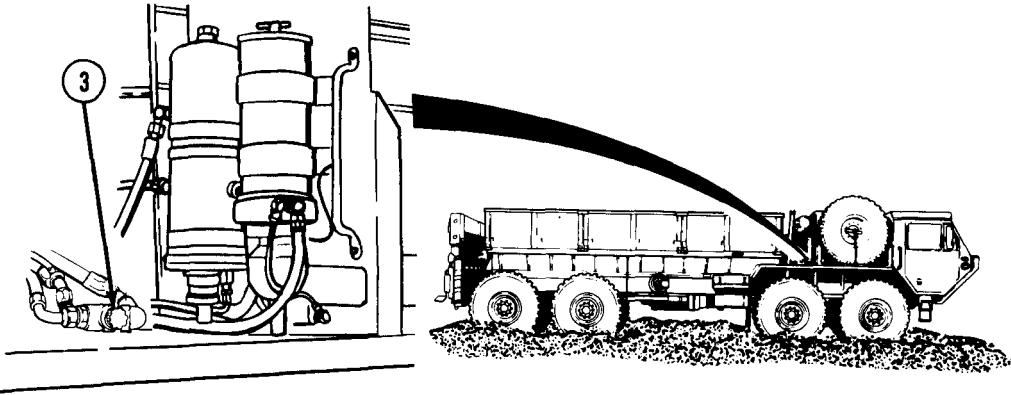
(3) Make sure PTO ENGAGE switch (2) is in OFF position.



TA183435

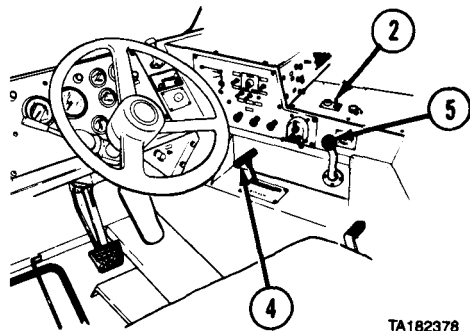
Operation Under Unusual Conditions (Cont)

2-41. SELF-RECOVER VEHICLE USING SELF-RECOVERY WINCH (CONT).

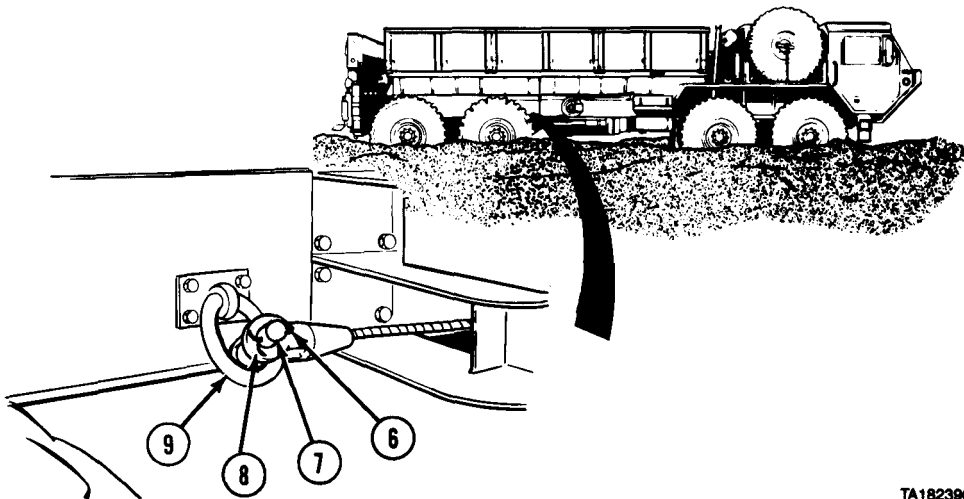


TA182377

- (4) Pull out selector valve control (3).
- (5) Start engine (para 2-11b).
- (6) Check that transmission range selector (4) is set to N (neutral).
- (7) Set PTO ENGAGE switch (2) to ON.
- (8) Move winch shift lever (5) to OUT position to pay out small amount of cable.
- (9) Set winch shift lever (5) to center position.
- (10) Set PTO ENGAGE switch (2) to OFF.



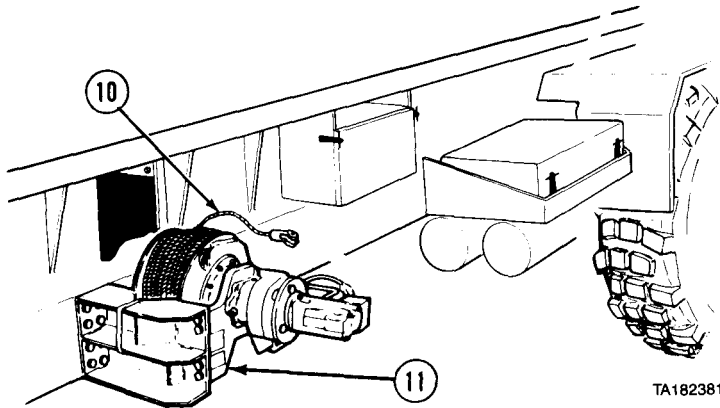
TA182378



TA182396

Operation Under Unusual Conditions (Cont)

- (11) Remove cotter pin (6) from pin (7).
- (12) Remove pin (7) from clevis (8) and disconnect clevis from tiedown ring (9).
- (13) Install pin (7) in clevis (8) with cotter pin (6).

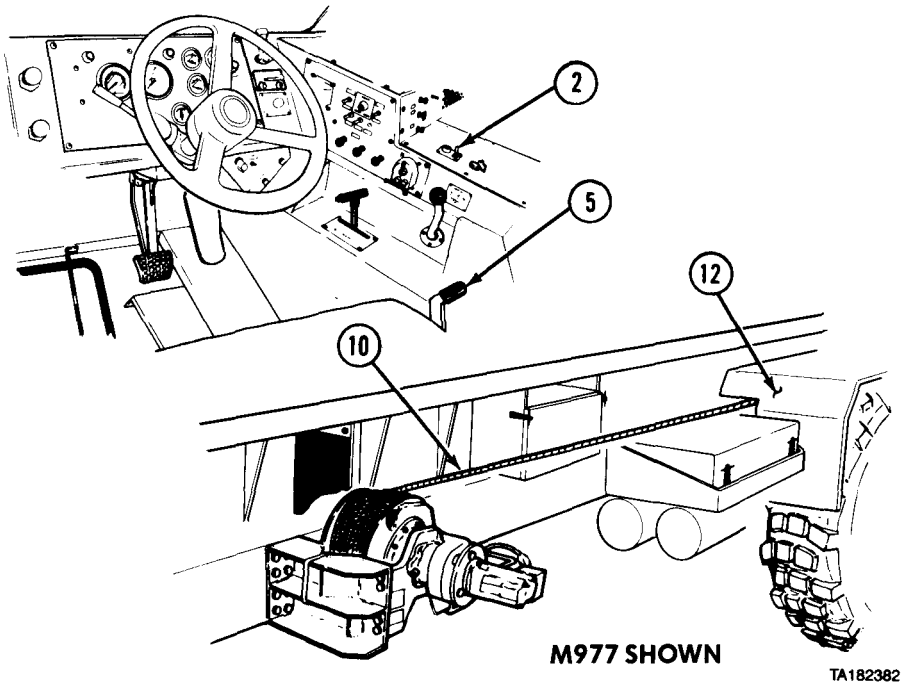
**WARNING**

Always wear heavy work gloves when handling winch cable. Never let cable run through hands. Frayed cable may cut severely.

- (14) Pull winch cable (10) under winch (11) and up along front face of winch toward front of vehicle.

Operation Under Unusual Conditions (Cont)

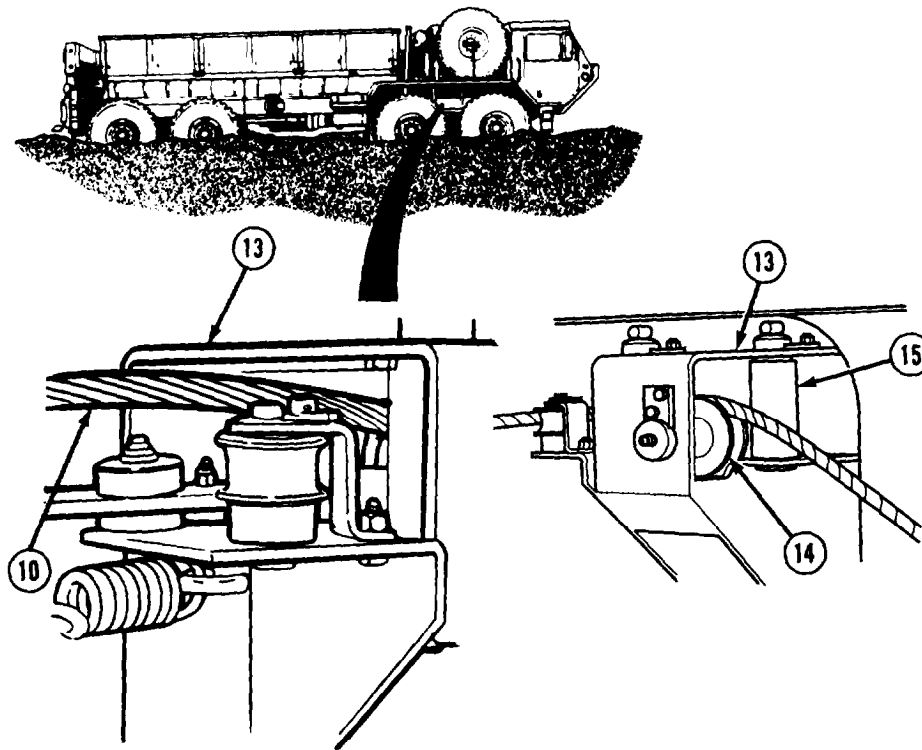
2-41. SELF-RECOVER VEHICLE USING SELF-RECOVERY WINCH (CONT).



(15) Set PTO ENGAGE switch (2) to ON.

(16) Soldier A moves winch shift lever (5) to OUT and pays out winch cable (10), while Soldier B routes cable through notch in fender (12).

Operation Under Unusual Conditions (Cont)



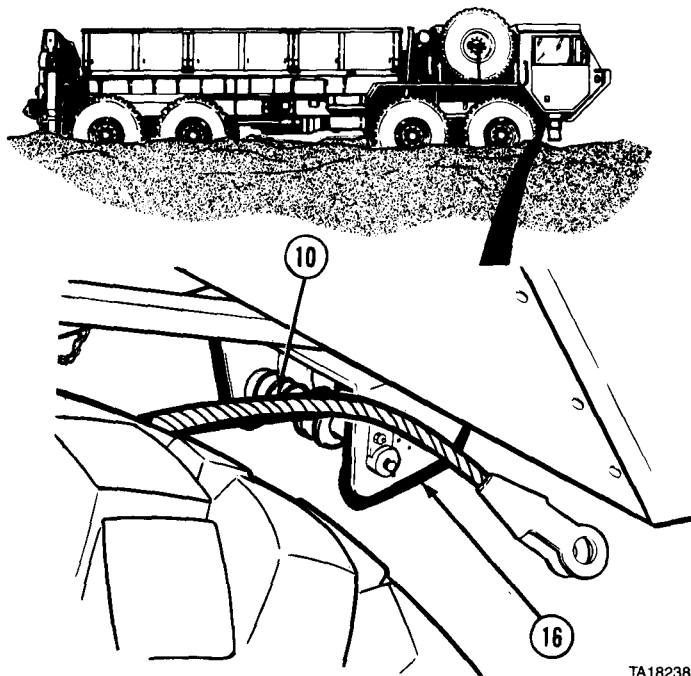
NOTE

Do not place cable between tensioning device pulleys.

- (17) Soldier A pays out cable while Soldier B pulls cable until cable is 6 to 12 inches (15 cm to 30 cm) past the rear roller guide. Soldier A then stops paying out cable and Soldier B routes cable through cable guide (13), over sheave (14), between roller (15), and side of cable guide.

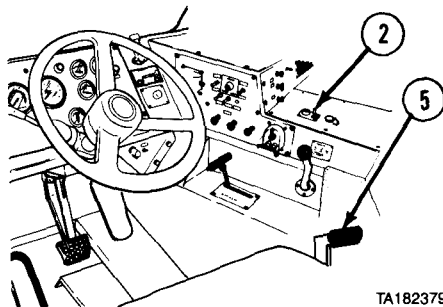
Operation Under Unusual Conditions (Cont)

2-41. SELF-RECOVER VEHICLE USING SELF-RECOVERY WINCH (CONT).



TA182384

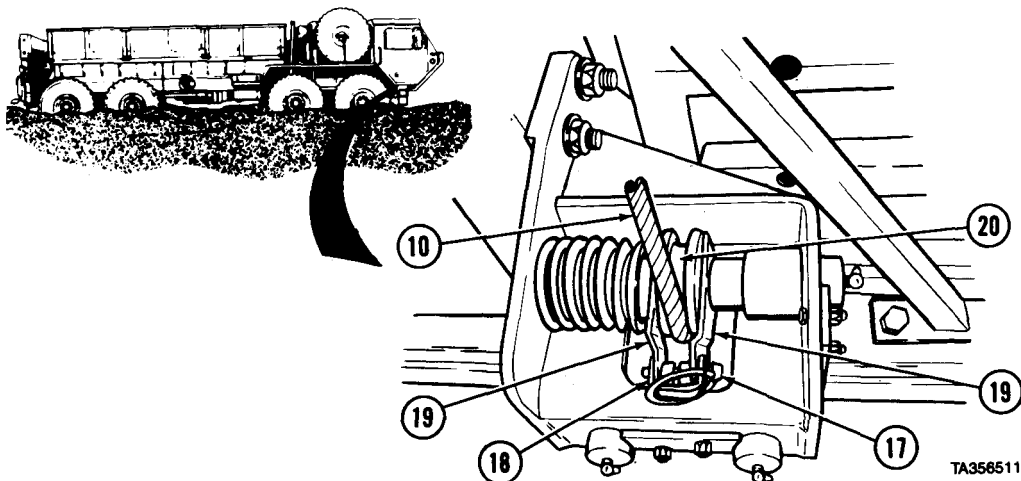
(18) While Soldier A continues to pay out winch cable (10), Soldier B routes cable over first axle and 1 ft (0.31 m) past roller guide assembly (16).



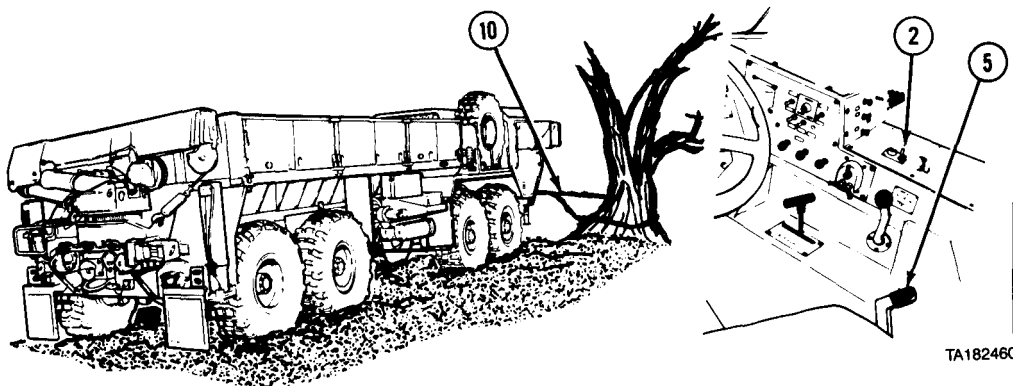
TA182379

(19) Set winch shift lever (5) to center position.
(20) Set PTO ENGAGE switch (2) to OFF.

Operation Under Unusual Conditions (Cont)



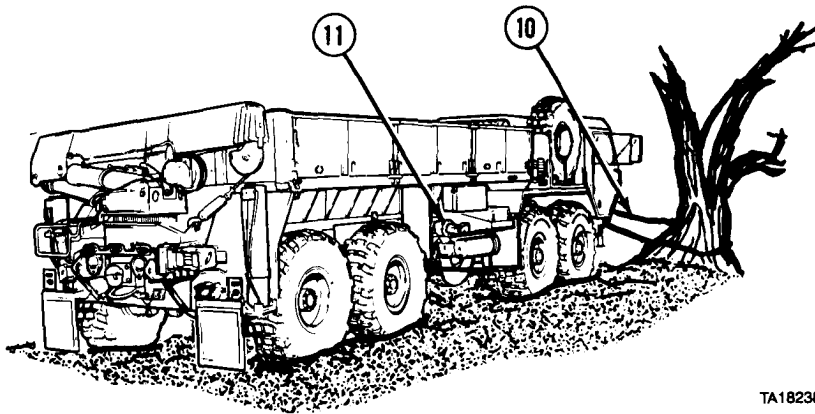
- (21) Remove quick release pin (17) and guide bracket (18). Move cable guide brackets (19) apart so cable (10) can be placed against bottom of sheave (20).
- (22) Move cable guide brackets (19) together. Install guide bracket (18) and quick release pin (17).



- (23) Set PTO ENGAGE switch (2) to ON.
- (24) Soldier A moves winch shift lever (5) to OUT and pays out winch cable (10) while Soldier B pulls cable to tree, another heavy vehicle (para 2-43.a), or heavy object (FM 20-22).
- (25) When winch cable (10) is let out to heavy object, set winch shift lever (5) to center position.
- (26) Set PTO ENGAGE switch (2) to OFF.

Operation Under Unusual Conditions (Cont)

2-41. SELF-RECOVER VEHICLE USING SELF-RECOVERY WINCH (CONT).



TA182385

- (27) If snatch block must be used for self-recovery operation, attach self-recovery winch cable (10) to snatch block (para 2-42a) and connect end of self-recovery winch cable to mired vehicle left front towing eye (para 2-43a). Attach snatch block to tree, another vehicle, or heavy object (FM 20-22).

CAUTION

There must always be at least five wraps of cable on winch. If load is applied with less than five wraps of cable on winch, cable may come loose on drum.

- (28) Check that there are at least five wraps of winch cable (10) left on winch (11). If there are not at least five wraps of winch cable left on winch, stop using self-recovery winch and continue with step (55) of this procedure.

CAUTION

Do not go over winch pull capacity or winch may be damaged.

- (29) Make sure weight of mired vehicle and amount of winch cable (10) left on winch (11) does not go over pull capacity (FM 20-22 and Table 2-7). If pull will go over capacity, stop using self-recovery winch and continue with step (55) of this procedure.

Table 2-7. Self-Recovery Winch Pull Capacity

Cable Layer	Maximum Line Pull
1st layer (five wraps)	20,000 lb (9 080 kg)
2nd layer	18,173 lb (8 251 kg)
3rd layer	16,663 lb (7 565 kg)
4th layer	15,361 lb (6 974 kg)
5th layer	14,254 lb (6 471 kg)

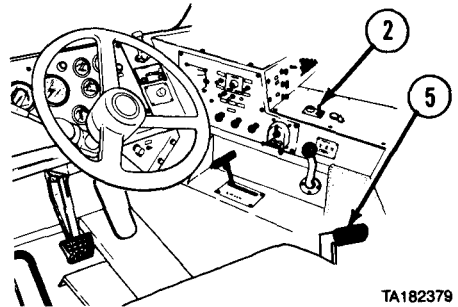
Operation Under Unusual Conditions (Cont)

NOTE

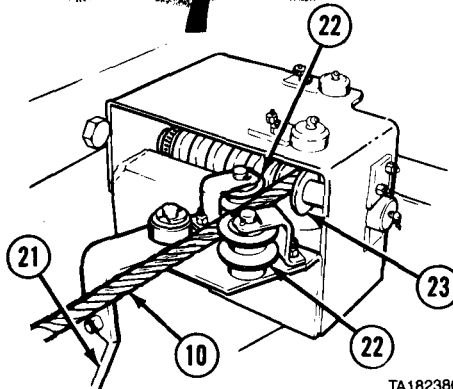
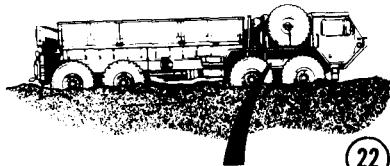
If winch cable will be connected to another vehicle acting as a stationary anchor refer to FM 20-22 or (para 2-43a) for connecting procedures.

- (30) Connect winch cable (10) to heavy object, if using self-recovery winch (11) will not go over winch pull capacity.

- (31) Make sure winch shift lever (5) is at center position.
 (32) Make sure PTO ENGAGE switch (2) is set to OFF.



TA182379



TA182386

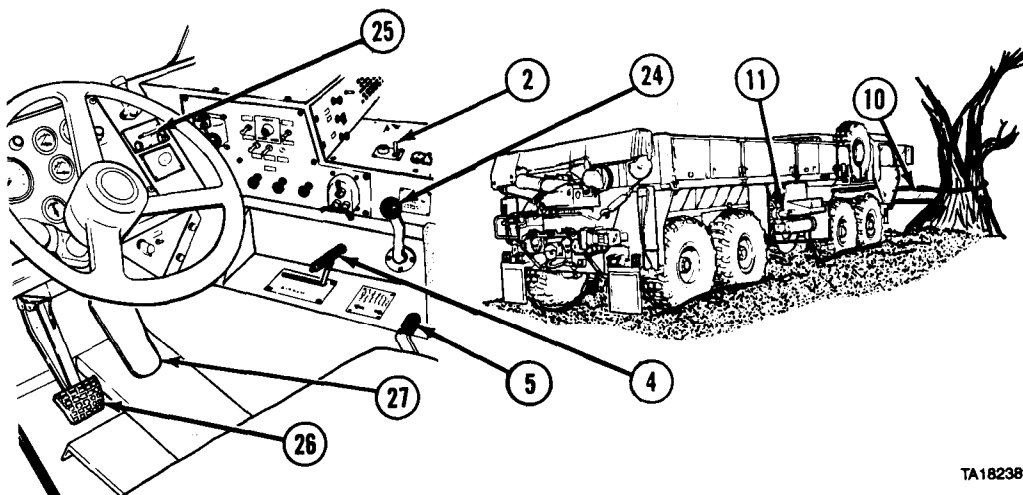
WARNING

Do not operate winch while personnel are working on or around tensioning device. Severe injury to arms, hands, and fingers may result if cable moves while working with cable and tensioning device.

- (33) Pull back and hold tension pulley lever (21).
 (34) Put winch cable (10) between tensioning device pulleys (22).
 (35) Release tension pulley lever (21).
 (36) Check that winch cable rests inside grooves of both tensioning device pulleys (22) and sheave (23).

Operation Under Unusual Conditions (Cont)

2-41. SELF-RECOVER VEHICLE USING SELF-RECOVERY WINCH (CONT).



TA182389

- (37) Check that winch cable (10) is not caught on vehicle or any other objects.
- (38) When Soldier A operates winch controls, Soldier B takes cover in protected area away from winch (11) and winch cable (10).
- (39) Make sure all personnel are clear of winch (11) and winch cable (10).

WARNING

Keep all personnel clear of area near winch cable when tension is on cable. If winch cable breaks, it can cause severe injury or death.

CAUTION

If winch does not move vehicle, stop using winch, overheat damage may result.

- (40) Set PTO ENGAGE switch (26) to ON.
- (41) Move winch shift lever (5) to IN until slack is out of cable.
- (42) Move winch shift lever (5) to center position.

CAUTION

Self-recovery winch is not designed to winch mired vehicle by itself. Vehicle drive system power must always be used with winch to self-recover vehicle, or damage to equipment can result.

- (43) Make sure TRANSFER CASE shift lever (24) is set to LO.
- (44) Make sure TRACTION CONTROL lever (25) is set to INTER-AXLE DIFF. LOCK.

Operation Under Unusual Conditions (Cont)

- (45) Press brake treadle (26).
- (46) Set transmission range selector (4) to 1.
- (47) Release brake treadle (26).
- (48) Move winch shift lever (5) to IN and apply slight pressure to throttle treadle (27).

NOTE

Keep winch cable tight at all times so cable does not get tangled with vehicle.

- (49) Adjust position of throttle treadle (27) to change engine speed as needed to keep winch cable (10) tight and vehicle moving.
- (50) When vehicle is on solid ground, set winch shift lever (5) to center position.
- (51) Park vehicle (para 2-11o).
- (52) Set winch shift lever (5) to OUT and pay out winch cable (10) until all tension is off cable.
- (53) When all tension is off winch cable (10), set winch shift lever (5) to center position.
- (54) Set PTO ENGAGE switch (2) to OFF.

NOTE

If winch cable is connected to another vehicle, refer to paragraph 2-43b for disconnecting procedures.

- (55) Disconnect winch cable (10) from heavy object.
- (56) If snatch block was used, disconnect end of winch cable (10) from vehicle (para 2-43b) and remove snatch block from winch cable (para 2-42b) and from tree, vehicle, or heavy object (FM 20-22).

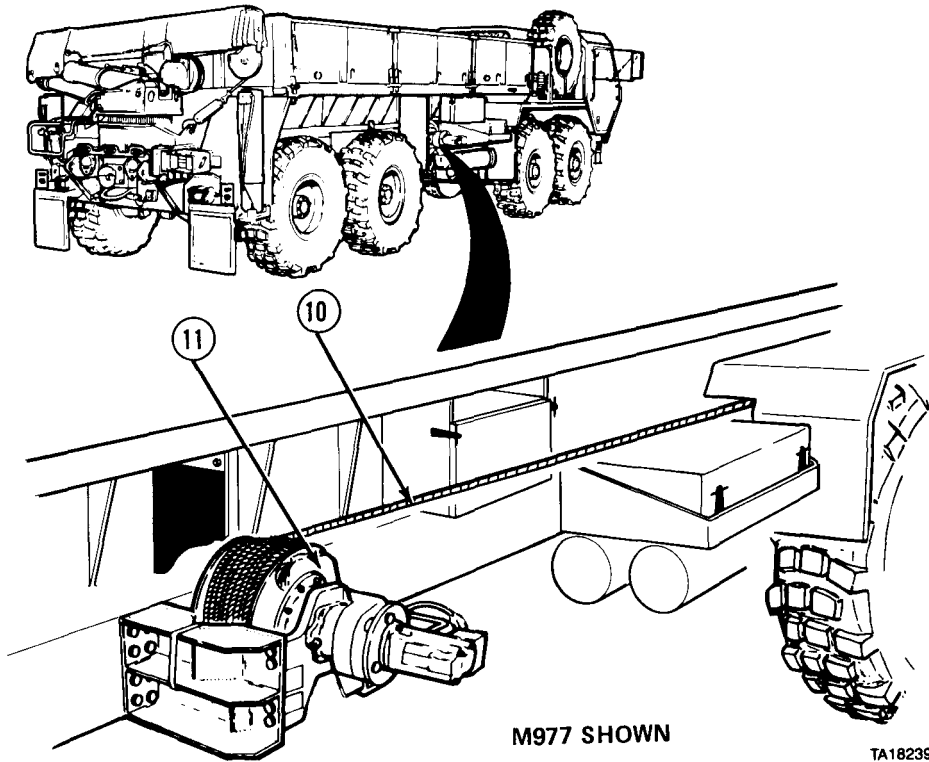
CAUTION

Do not reel clevis end of winch cable through roller guides. Clevis may catch on roller guide and cause cable or roller guide to break.

- (57) Set PTO ENGAGE switch (2) to ON.
- (58) Set winch shift lever (5) to IN.

Operation Under Unusual Conditions (Cont)

2-41. SELF-RECOVER VEHICLE USING SELF-RECOVERY WINCH (CONT).



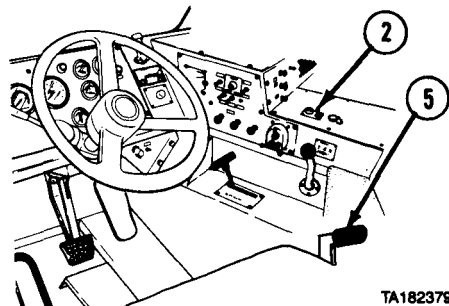
WARNING

Always wear heavy work gloves when handling winch cable. Never let cable run through hands. Frayed cable may cut severely.

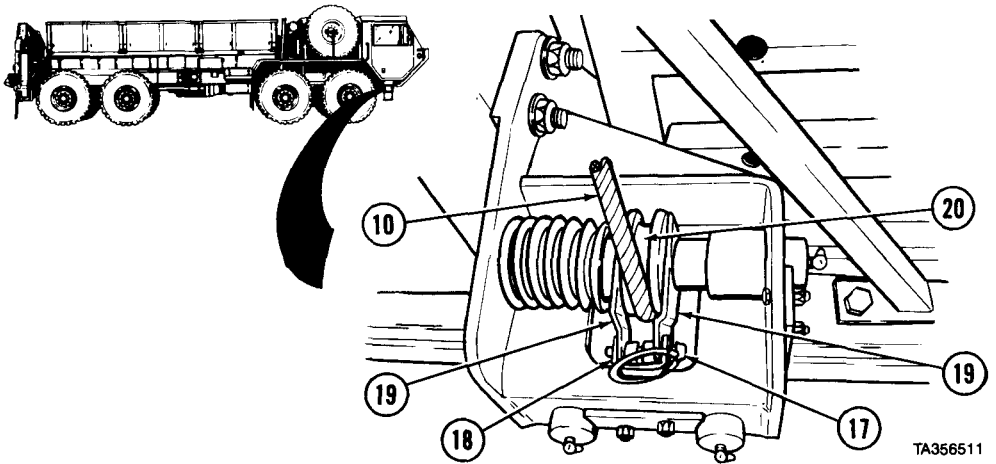
(59) While Soldier A reels in winch cable (10), Soldier B uses tire iron extension handle to guide cable onto winch (11) so cable wraps are level across face of winch.

(60) When end of cable is near front of vehicle, move winch shift lever (5) to center position.

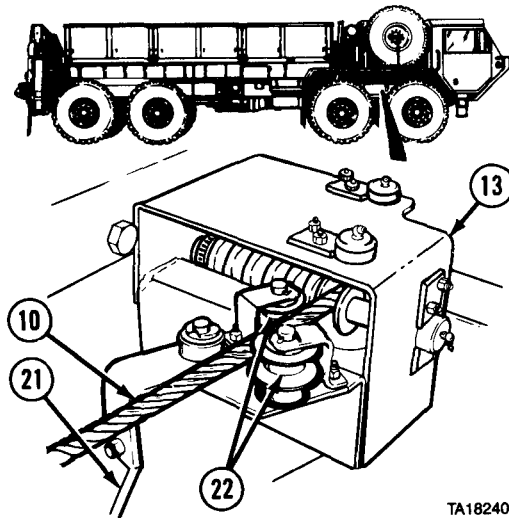
(61) Set PTO ENGAGE switch (2) to OFF.



Operation Under Unusual Conditions (Cont)



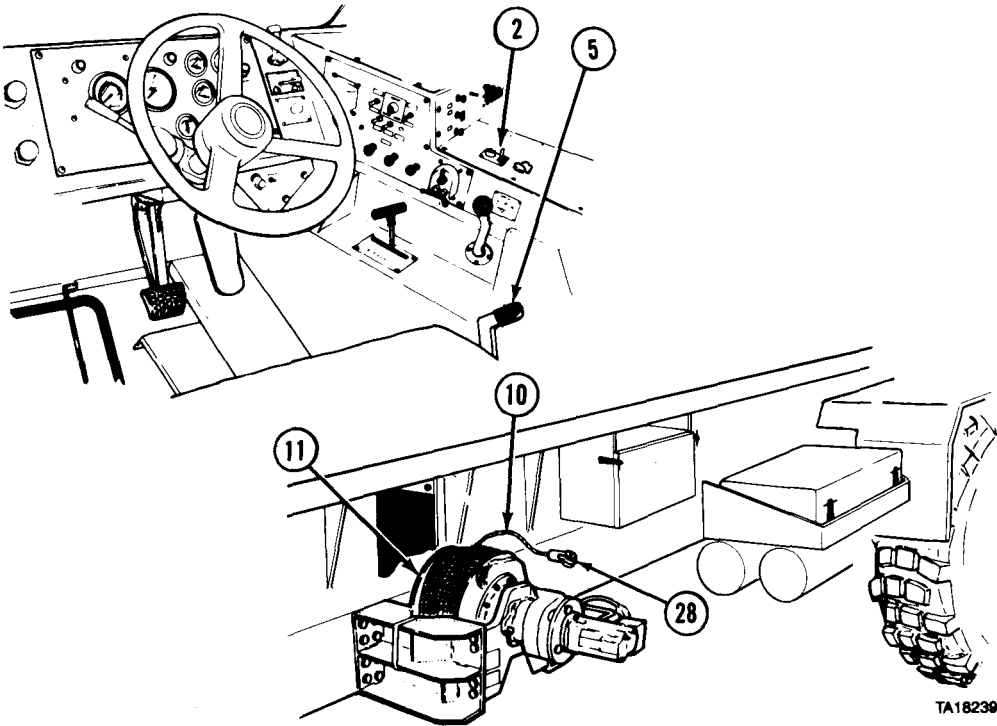
- (62) Remove quick release pin (17) and guide bracket (18). Move cable guide brackets (19) apart so winch cable (10) can be removed from sheave (20).
- (63) Move cable guide bracket (19) together. Install guide bracket (18) and quick release pin (17).



- (64) Pull back and hold tension pulley lever (21).
- (65) Lift winch cable (10) out of tensioning device pulleys (22).
- (66) Release tension pulley lever (21).
- (67) Pull winch cable (10) back and out of cable guide (13).

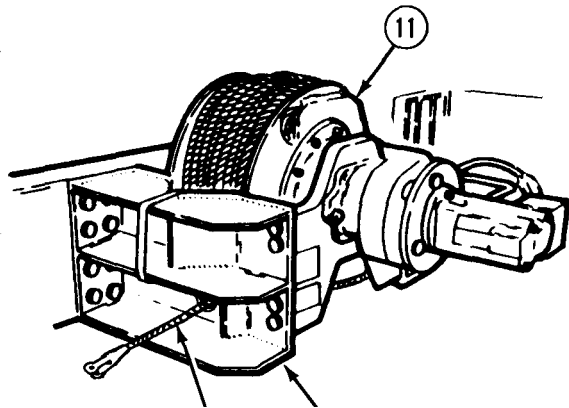
Operation Under Unusual Conditions (Cont)

2-41. SELF-RECOVER VEHICLE USING SELF-RECOVERY WINCH (CONT).

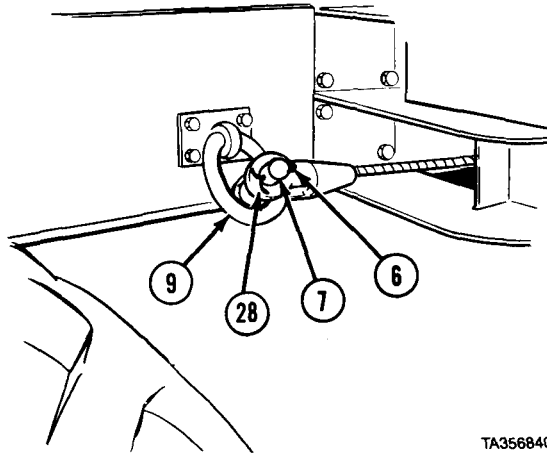


TA182394

- (68) Set PTO ENGAGE switch (2) to ON.
- (69) Soldier A moves winch shift lever (5) to IN and reels in winch cable (10) while Soldier B guides winch cable.
- (70) When clevis (28) is approximately 2 ft (0.6 m) from winch (11) move winch shift lever (5) to center position.
- (71) Set PTO ENGAGE switch to OFF.
- (72) Route end of winch cable (10) down along front face of winch (11).
- (73) Route end of winch cable (10) under winch (11) and out through hole in bottom of rear winch frame (29).

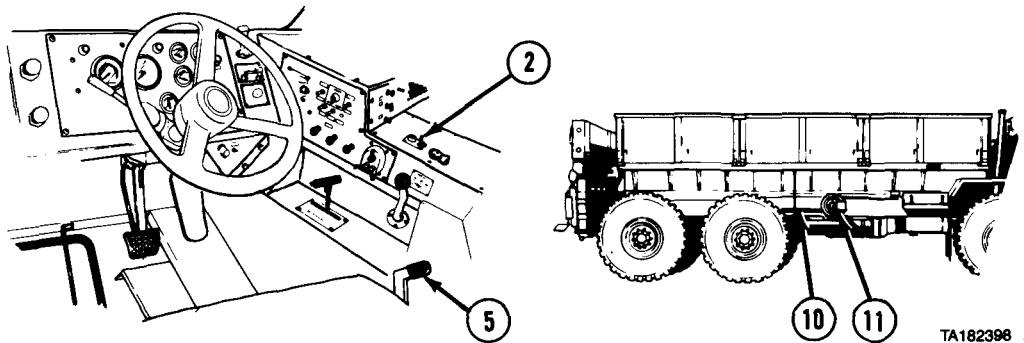


Operation Under Unusual Conditions (Cont)



TA356840

(74) Connect clevis (28) to tiedown ring (9) with pin (7) and cotter pin (6).



TA182398

(75) Set PTO ENGAGE switch (2) to ON.

WARNING

Keep all personnel clear of winch area when winch is reeling in cable. If hands are caught in winch or cable, or if cable breaks under tension, severe injury or death could result.

(76) Stand clear of area near winch (11).

CAUTION

Do not reel in winch cable too tightly. If too much tension is applied, cable or tiedown ring can break, or winch may be damaged.

(77) When Soldier B is clear of area, Soldier A sets winch shift lever (5) to IN and takes all slack out of winch cable (10).

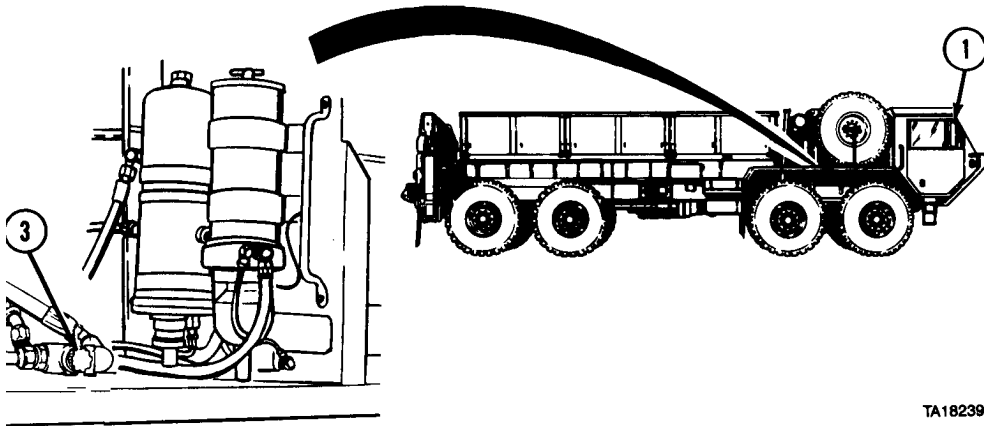
(78) When cable is tight, move winch shift lever (5) to center position.

(79) Set PTO ENGAGE switch (2) to OFF.

(80) Shut off engine (para 2-11p).

Operation Under Unusual Conditions (Cont)

2-41. SELF-RECOVER VEHICLE USING SELF-RECOVERY WINCH (CONT).



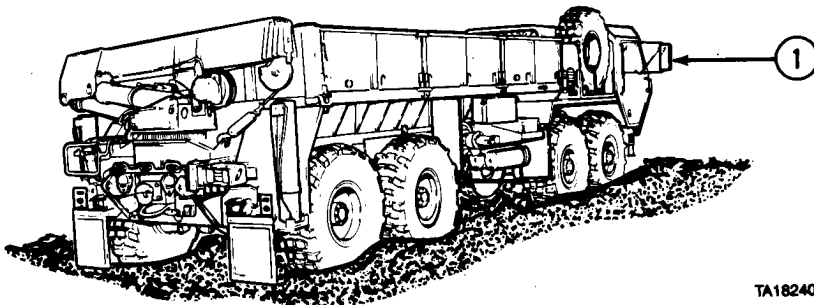
TA182399

- (81) Push in selector valve control (3).
- (82) Adjust mirror (1) for driving.

b. Winch Mired Vehicle To The Rear.

NOTE

For additional information on vehicle self-recovery, refer to FM 20-22.



TA182400

NOTE

Vehicle self-recovery is a two soldier task. Soldiers must communicate by hand signals.

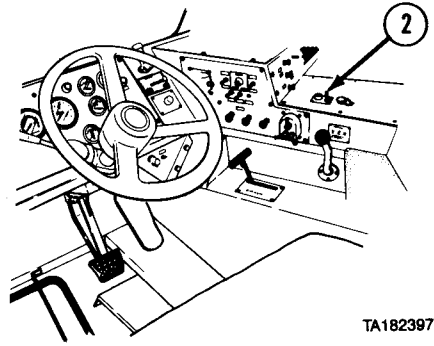
- (1) Shut off engine (para 2-11p).
- (2) Soldier A adjusts mirror (1) so Soldier B can be clearly seen during procedure.

Operation Under Unusual Conditions (Cont)

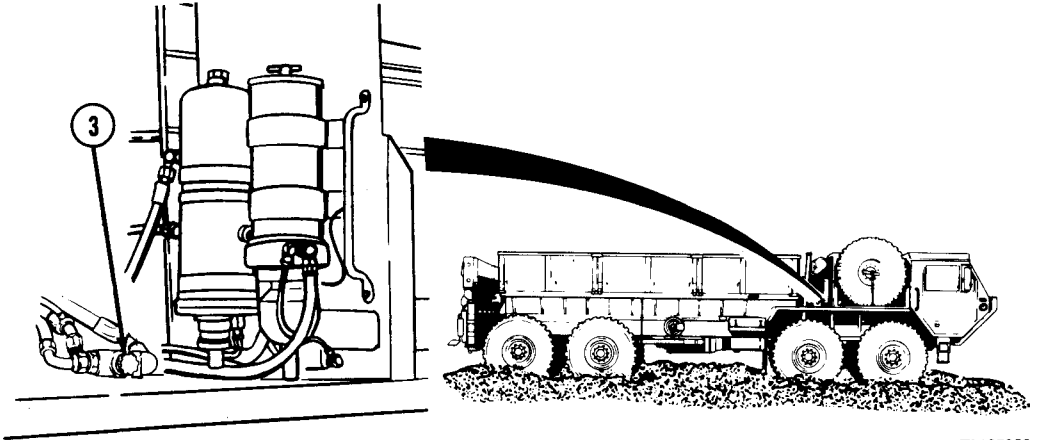
CAUTION

PTO ENGAGE switch must be in OFF position before moving selector valve to prevent equipment damage.

- (3) Make sure PTO ENGAGE switch (2) is in OFF position.



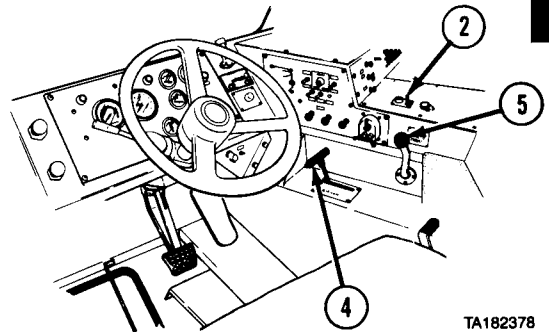
TA182397



TA185329

- (4) Pull out selector valve control (3).
- (5) Start engine (para 2-11b).

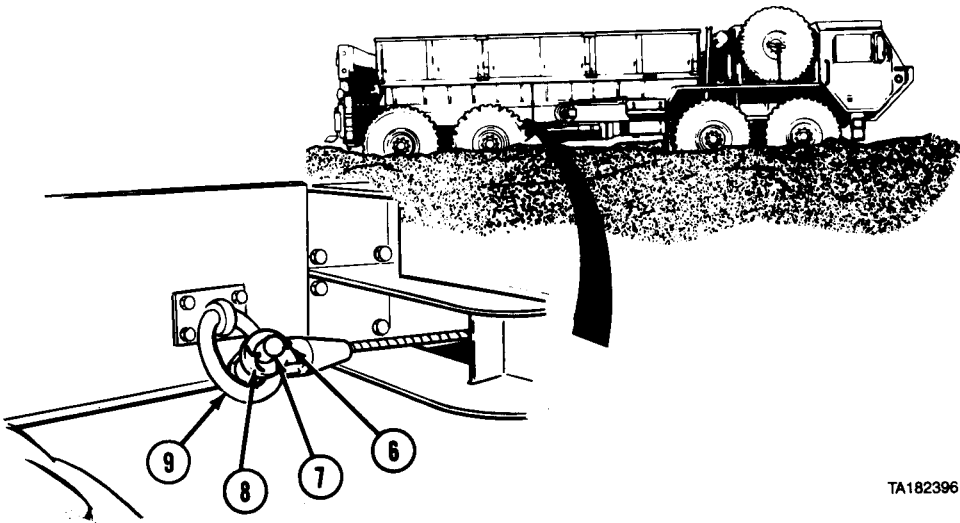
- (6) Check that transmission range selector (4) is set to N (neutral).
- (7) Set PTO ENGAGE switch (2) to ON.
- (8) Move winch shift lever (5) to OUT position to pay out small amount of cable.
- (9) Set winch shift lever (5) to center position.
- (10) Set PTO ENGAGE switch (2) to OFF.



TA182378

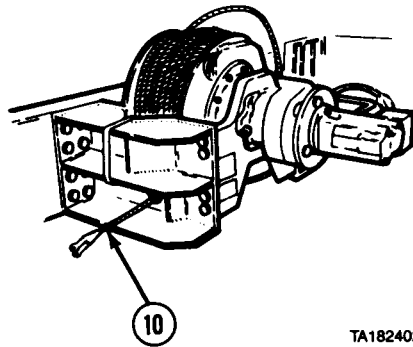
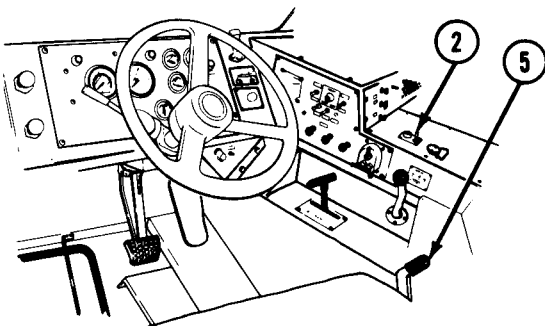
Operation Under Unusual Conditions (Cont)

2-41. SELF-RECOVER VEHICLE USING SELF-RECOVERY WINCH (CONT).



TA182396

- (11) Remove cotter pin (6) from pin (7).
- (12) Remove pin (7) from clevis (8) and disconnect clevis from tiedown ring (9).



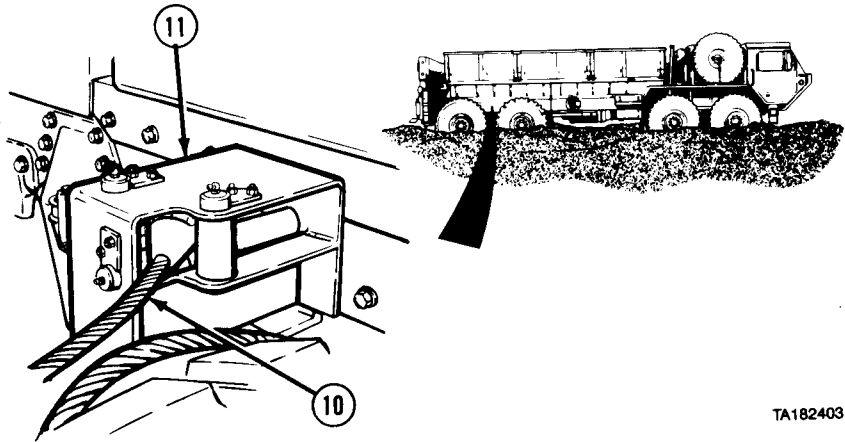
TA182402

WARNING

Always wear heavy work gloves when handling winch cable. Never let cable run through hands. Frayed cable may cut severely.

- (13) Set PTO ENGAGE switch (2) to ON.
- (14) While Soldier A moves winch shift lever (5) to OUT, Soldier B pulls winch cable (10) toward rear of vehicle.

Operation Under Unusual Conditions (Cont)

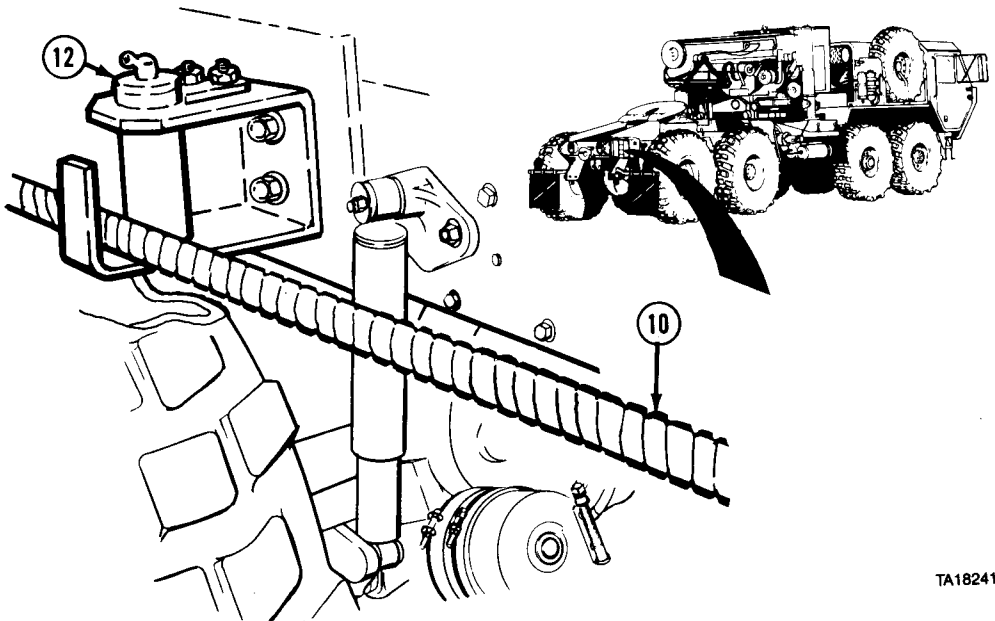


TA182403

NOTE

Do not place winch cable between tensioning device pulleys at this time.

(15) While Soldier A continues to pay out winch cable (10), Soldier B routes cable through cable guide (11).



TA182412

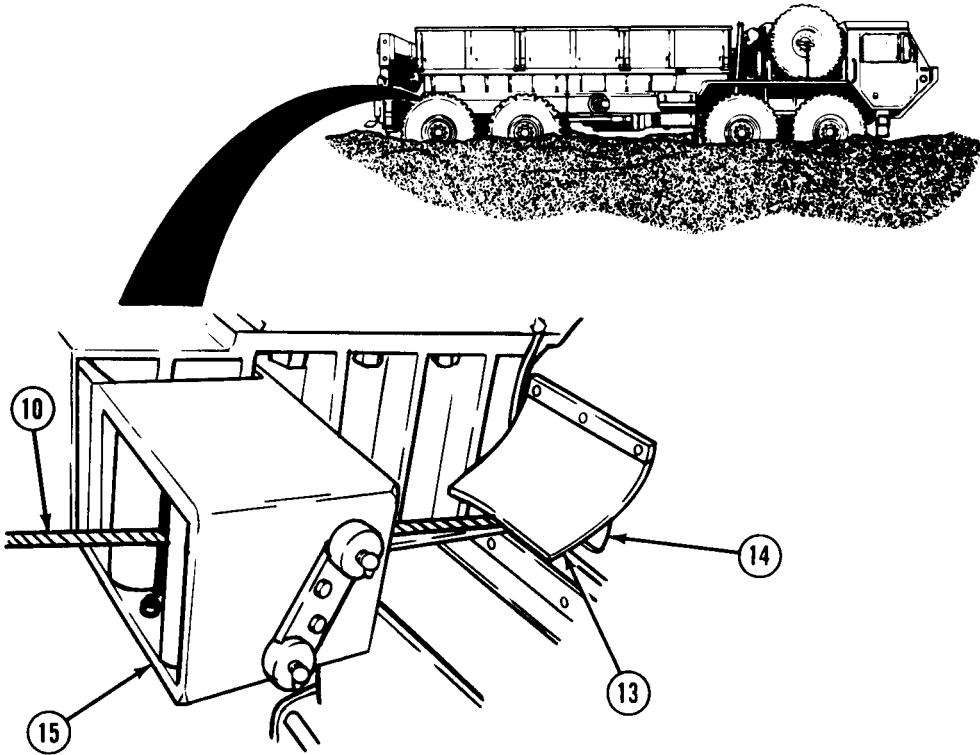
NOTE

- Step (16) applies only to M978 and M983 vehicles.
- Roller guide is located in same area.

(16) While Soldier A continues to pay out winch cable (10), Soldier B routes cable through roller guide (12).

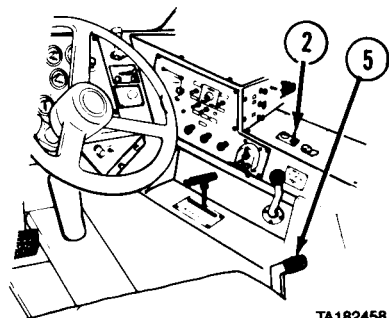
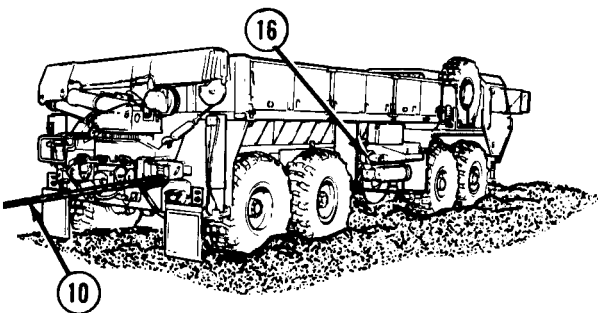
Operation Under Unusual Conditions (Cont)

2-41. SELF-RECOVER VEHICLE USING SELF-RECOVERY WINCH (CONT).



TA182405

(17) While Soldier A continues to pay out winch cable (10), Soldier B opens flap (13) and routes cable through hole (14) in fender and through roller guide (15).



TA182458

Operation Under Unusual Conditions (Cont)

- (18) While Soldier A pays out winch cable (10), Soldier B pulls cable to tree, another heavy vehicle (para 2-48a), or heavy object.
- (19) When winch cable (10) is let out to heavy object, set winch shift lever (5) to center position.
- (20) Set PTO ENGAGE switch (2) to OFF.
- (21) If snatch block must be used for self-recovery operation, attach self-recovery winch cable (10) to snatch block (para 2-42a) and connect end of self-recovery winch cable to mired vehicle left rear towing eye (para 2-43a). Attach snatch block to tree, vehicle, or heavy object (FM 20-22).

CAUTION

There must be at least five wraps of cable on winch. If load is applied with less than five wraps of cable on winch, cable may come loose on drum.

- (22) Check that there are at least five wraps of winch cable (10) left on winch (16). If there are not at least five wraps of winch cable left on winch, stop using self-recovery winch and continue with step (50) of this procedure.

CAUTION

Do not go over winch pull capacity or winch could be damaged.

- (23) Make sure weight of mired vehicle and amount of winch cable (10) left on winch (16) does not go over pull capacity (FM 20-22 and Table 2-8). If pull will go over capacity, stop using self-recovery winch and continue with step (50) of this procedure.

Table 2-8. Self-Recovery Winch Pull Capacity

Cable Layer	Maximum Line Pull
1st layer (five wraps)	20,000 lb (9 080 kg)
2nd layer	18,173 lb (8 251 kg)
3rd layer	16,663 lb (7 565 kg)
4th layer	15,361 lb (6 974 kg)
5th layer	14,254 lb (6 471 kg)

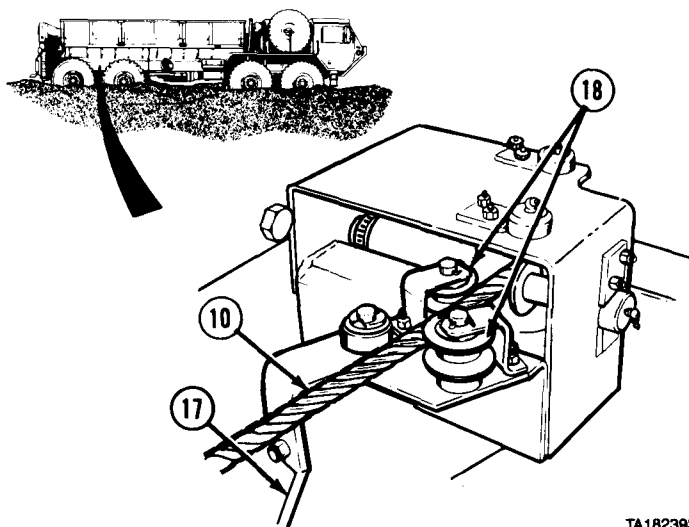
N O T E

If winch cable will be connected to another vehicle acting as a stationary anchor, refer to FM 20-22 or (para 2-43a) for connecting procedures.

- (24) Connect winch cable (10) to heavy object, if using self-recovery winch (16) will not go over winch pull capacity.
- (25) Make sure winch shift lever (5) is at center position.
- (26) Make sure PTO ENGAGE switch (2) is set to OFF.

Operation Under Unusual Conditions (Cont)

2-41. SELF-RECOVER VEHICLE USING SELF-RECOVERY WINCH (CONT).

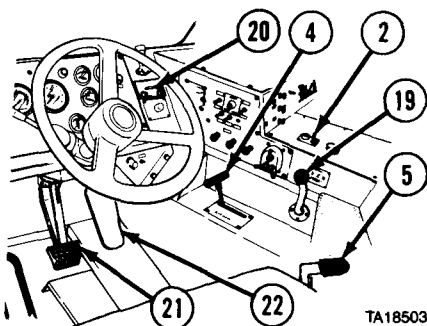
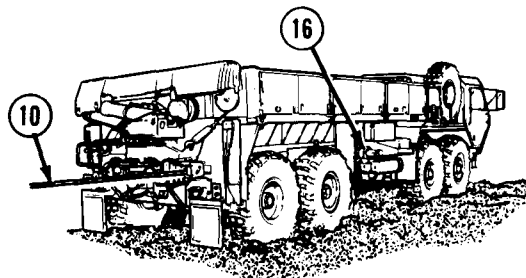


TA182393

WARNING

Do not operate winch while personnel are working on or around tensioning device. Severe injury could result if cable moves while working with cable and tensioning device.

- (27) Pull back and hold tension pulley lever (17).
- (28) Put winch cable (10) between pulleys (18).
- (29) Release tension pulley lever (17).
- (30) Make sure winch cable (10) rests inside grooves of both pulleys (18).



TA185035

- (31) Make sure winch cable (10) is not caught on vehicle or any other objects.
- (32) Make sure all personnel are clear of winch (16) and winch cable (10).
- (33) Take cover in protected area away from winch (16) and winch cable (10).

Operation Under Unusual Conditions (Cont)

WARNING

Keep all personnel clear of area near winch cable when tension is on cable. If winch cable breaks, it may cause severe injury or death.

CAUTION

If winch does not move vehicle, stop using winch, overheat damage may result.

- (34) Make sure recovery area is clear of personnel.
- (35) Set PTO ENGAGE switch (2) to ON.
- (36) Move winch shift lever (5) to IN until slack is out of cable.
- (37) Move winch shift lever (5) to center position.

CAUTION

Self-recovery winch is not designed to winch mired vehicle by itself. Vehicle drive system power must always be used with winch to self-recover vehicle or damage to equipment may result.

- (38) Check that TRANSFER CASE shift lever (19) is set to LO.
- (39) Check that TRACTION CONTROL lever (20) is set to INTER-AXLE DIFF. LOCK.
- (40) Press brake treadle (21).
- (41) Set transmission range selector (4) to R.
- (42) Release brake treadle (21).
- (43) Slightly press throttle treadle (22) and move winch shift lever (5) to IN.

NOTE

Keep winch cable tight at all times so cable does not get tangled with vehicle.

- (44) Adjust position of throttle treadle (22) to change engine speed as needed to keep winch cable (10) tight and vehicle moving.
- (45) When vehicle is on solid ground, set winch shift lever (5) to center position.
- (46) Park vehicle (para 2-11o).
- (47) Set winch shift lever (5) to OUT and pay out winch cable (10) until all tension is off cable.
- (48) When all tension is off winch cable (10), set winch shift lever (5) to center position.
- (49) Set PTO ENGAGE switch (2) to OFF.

NOTE

If winch cable is connected to another vehicle, refer to paragraph 2-43b for disconnecting procedures.

- (50) Disconnect winch cable (10) from heavy object.
- (51) If snatch block was used, disconnect end of winch cable (10) from vehicle (para 2-43b). Remove snatch block from winch cable (para 2-42b) and from tree, vehicle, or heavy object (FM 20-22).

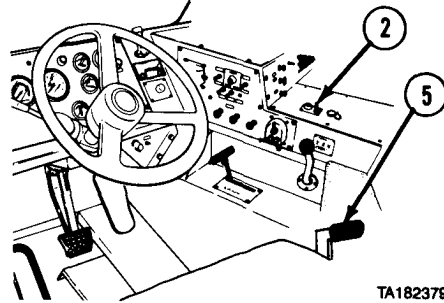
Operation Under Unusual Conditions (Cont)

2-41. SELF-RECOVER VEHICLE USING SELF-RECOVERY WINCH (CONT).

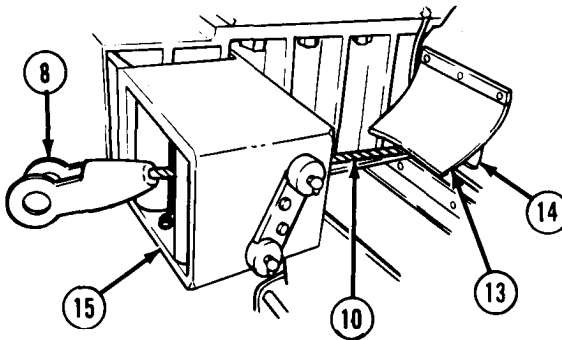
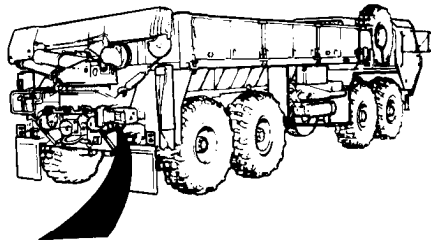
CAUTION

Do not reel clevis end of winch cable through roller guides. Clevis may catch on roller guide and cause cable or roller guide to break.

- (52) Set PTO ENGAGE switch (2) to ON.
- (53) Set winch shift lever (5) to IN.
- (54) When end of cable is near rear of vehicle, set winch shift lever (5) to center position.
- (55) Set PTO ENGAGE switch (2) to OFF.



TA182379



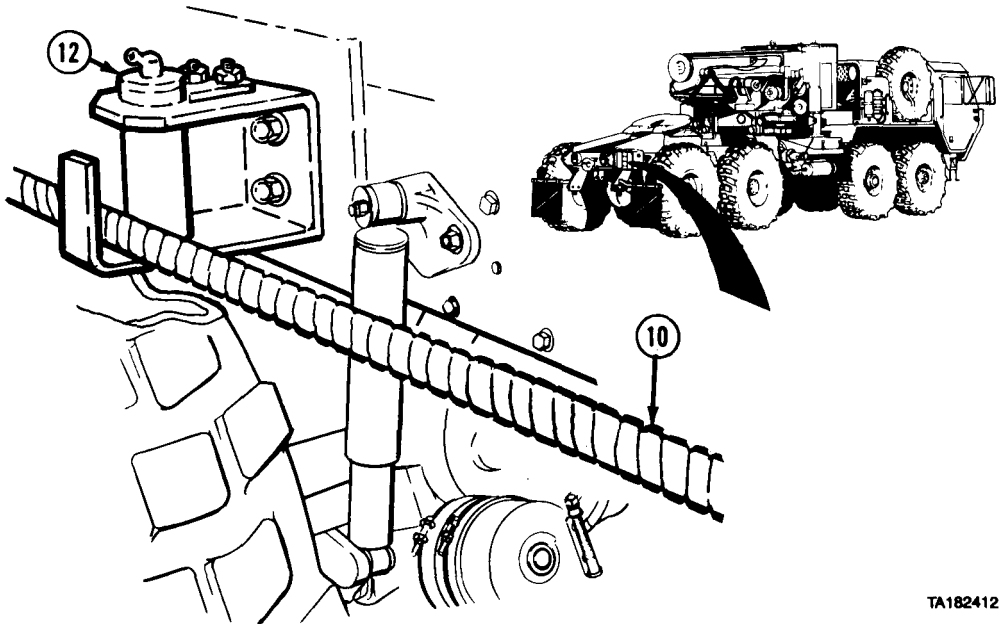
TA182411

WARNING

Always wear heavy work gloves when handling winch cable. Never let cable run through hands. Frayed cable may cut severely.

- (56) Pull clevis (8) end of winch cable (10) forward through roller guide (15). Lift flap (13) and pull winch cable forward through hole (14) in fender.

Operation Under Unusual Conditions (Cont)

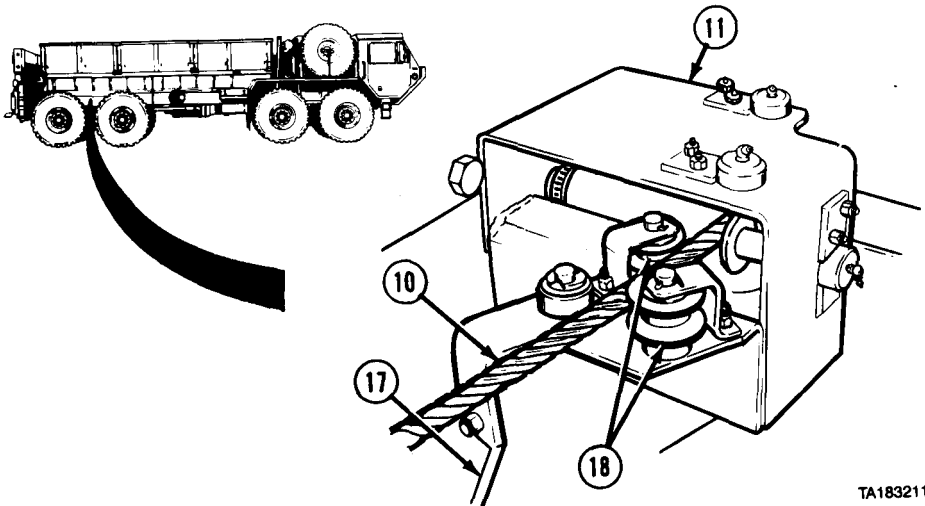


TA182412

NOTE

- Step (57) applies only to M978 and M983 vehicles.
- Roller guide is located in same area.

(57) Lift winch cable (10) out of roller guide (12).



TA183211

(58) Pull back and hold tension pulley lever (17).

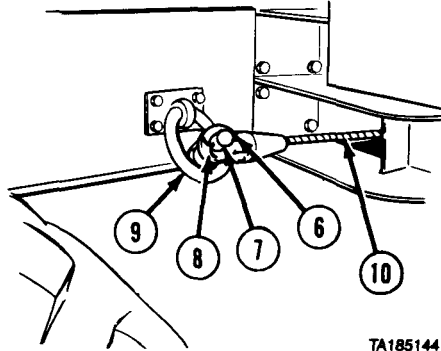
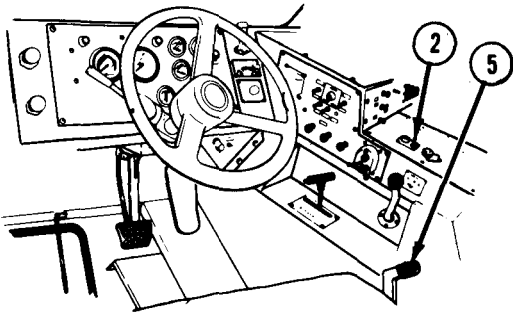
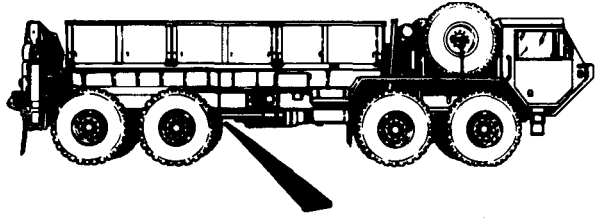
(59) Lift winch cable (10) out of pulleys (18).

(60) Release tension pulley lever (17).

(61) Pull winch cable (10) forward and out of cable guide (11).

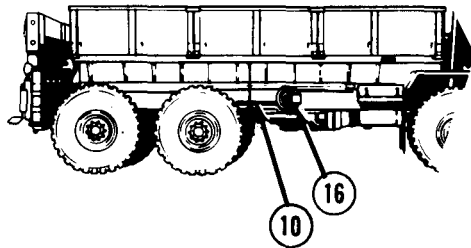
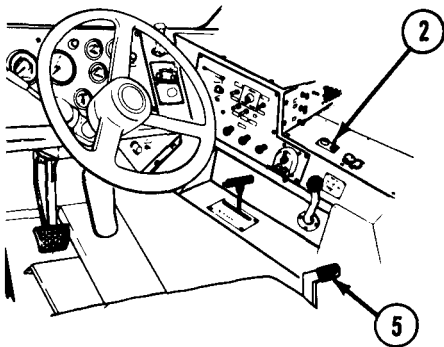
Operation Under Unusual Conditions (Cont)

2-41. SELF-RECOVER VEHICLE USING SELF-RECOVERY WINCH (CONT).



TA185144

- (62) Set PTO ENGAGE switch (2) to ON.
- (63) Soldier A sets winch shift lever (5) to IN position to reel in cable, while Soldier B guides winch cable (10) to tiedown ring (9).
- (64) Soldier A sets winch shift lever (5) to center position while Soldier B connects clevis (8) to tiedown ring (9) with pin (7) and cotter pin (6).



TA185330

WARNING

Keep all personnel clear of winch area when winch is reeling in cable. If hands are caught in winch or cable, or if cable breaks under tension, severe injury or death could result.

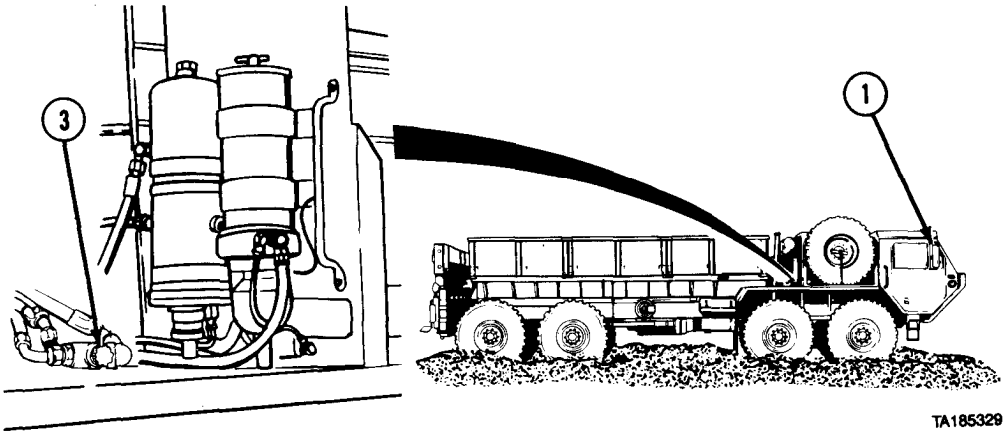
- (65) Stand clear of area near winch (16).

Operation Under Unusual Conditions (Cont)

CAUTION

Do not reel in winch cable too tightly. If too much tension is applied, cable or tiedown ring may break, or winch can be damaged.

- (66) When Soldier B is clear of area, Soldier A sets winch shift lever (5) to IN and takes all slack out of winch cable (10).
- (67) When cable is tight, set winch shift lever (5) to center position.
- (68) Set PTO ENGAGE switch (2) to OFF.
- (69) Shut off engine (para 2-11p).



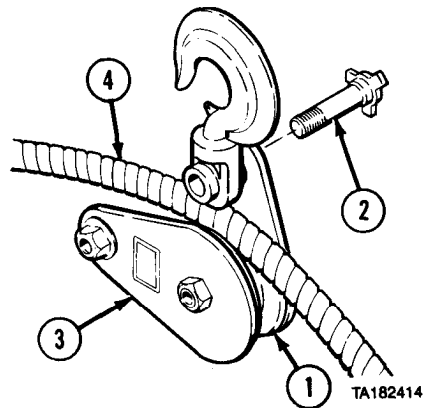
TA185329

- (70) Push in selector valve control (3).
- (71) Adjust mirror (1) for driving.

2-42. SNATCH BLOCK INSTALLATION/REMOVAL.

a. Attach Snatch Block To Self-Recovery Winch Cable.

- (1) Remove snatch block (1) from stowage.
- (2) Remove screw (2).
- (3) Move plate (3) to side to open snatch block (1).
- (4) Place winch cable (4) in snatch block (1).
- (5) Close plate (3) and aline holes.
- (6) Install screw (2).
- (7) Make sure screw (2) is tight and winch cable (4) can move freely through snatch block (1).
- (8) Continue with self-recovery operation (para 2-41).

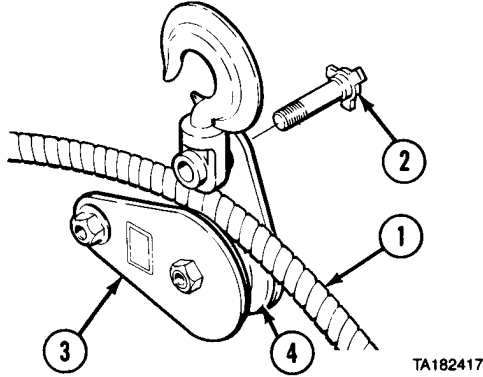


TA182414

Operation Under Unusual Conditions (Cont)

2-42. SNATCH BLOCK INSTALLATION/REMOVAL (CONT).

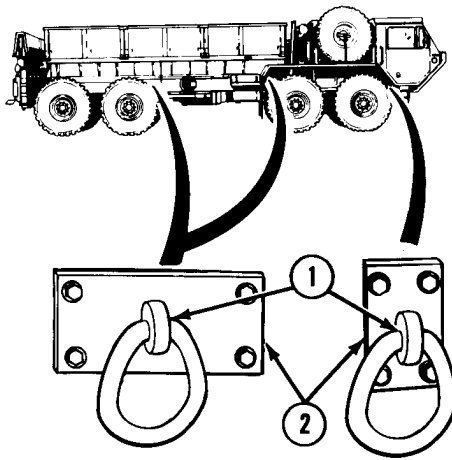
b. Remove Snatch Block From Self-Recovery Winch Cable.



- (1) Check that there is enough slack in winch cable (1).
- (2) Remove screw (2).
- (3) Move plate (3) to side to open snatch block (4).
- (4) Take winch cable (1) out of snatch block (4).
- (5) Close plate (3) and aline holes.
- (6) Install screw (2).
- (7) Stow snatch block (4) in stowage box.
- (8) Continue with self-recovery operation (para 2-41).

2-43. CONNECT/DISCONNECT SELF-RECOVERY WINCH CABLE TO ANOTHER VEHICLE.

a. Connect Cable to Vehicle.



Operation Under Unusual Conditions (Cont)

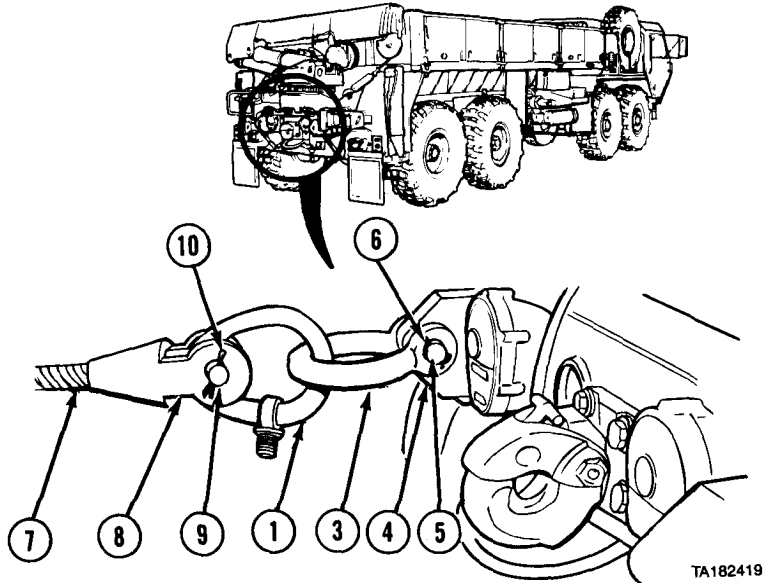
CAUTION

When attaching self-recovery winch cable to another vehicle, that vehicle must be used only as an anchor point or damage to equipment can result.

NOTE

There are three tiedown rings on each side of vehicle.

- (1) Unscrew one tiedown ring (1) from mounting plate (2).

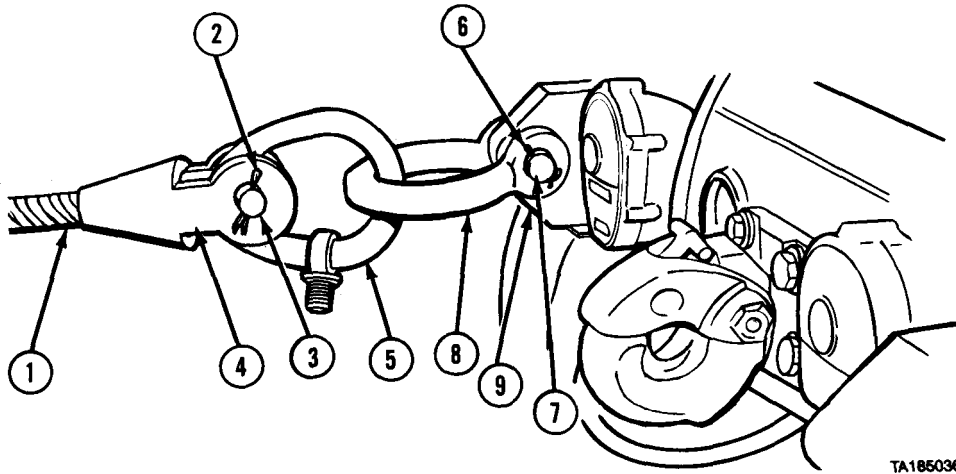


- (2) Remove lifting shackle (3) from stowage.
 (3) Put lifting shackle (3) through tiedown ring (1).
 (4) Connect lifting shackle (3) to left front or left rear tow eye (4) with pin (5).
 (5) Install cotter pin (6).
 (6) Connect self-recovery winch cable (7) with clevis (8) to tiedown ring (1) with pin (9).
 (7) Install cotter pin (10).
 (8) Continue with self-recovery operation (para 2-41).

Operation Under Unusual Conditions (Cont)

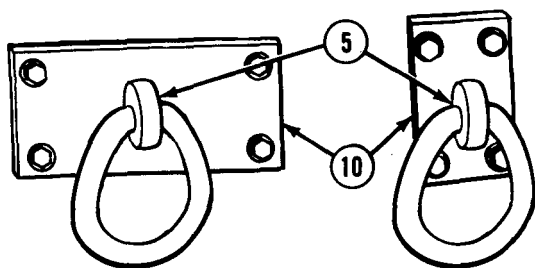
2-43. CONNECT/DISCONNECT SELF-RECOVERY WINCH CABLE TO ANOTHER VEHICLE (CONT).

b. Disconnect Cable From Vehicle.



TA185036

- (1) Make sure there is enough slack in winch cable (1).
- (2) Remove cotter pin (2).
- (3) Remove pin (3) and disconnect clevis (4) from tiedown ring (5).
- (4) Remove cotter pin (6).
- (5) Remove pin (7) and disconnect lifting shackle (8) from tow eye (9).
- (6) Remove tiedown ring (5) from lifting shackle (8).
- (7) Stow lifting shackle (8).



TA182421

NOTE

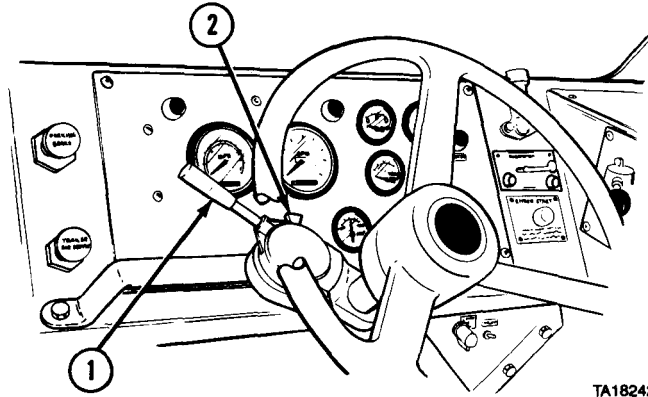
There are three tiedown ring locations on each side of vehicle.

- (8) Install tiedown ring (5) into mounting plate (10).
- (9) Continue with self-recovery operation (para 2-41).

Operation Under Unusual Conditions (Cont)

2-44. SET UP/SECURE HIGHWAY EMERGENCY MARKER KIT.

a. Turn On Emergency Flashers.



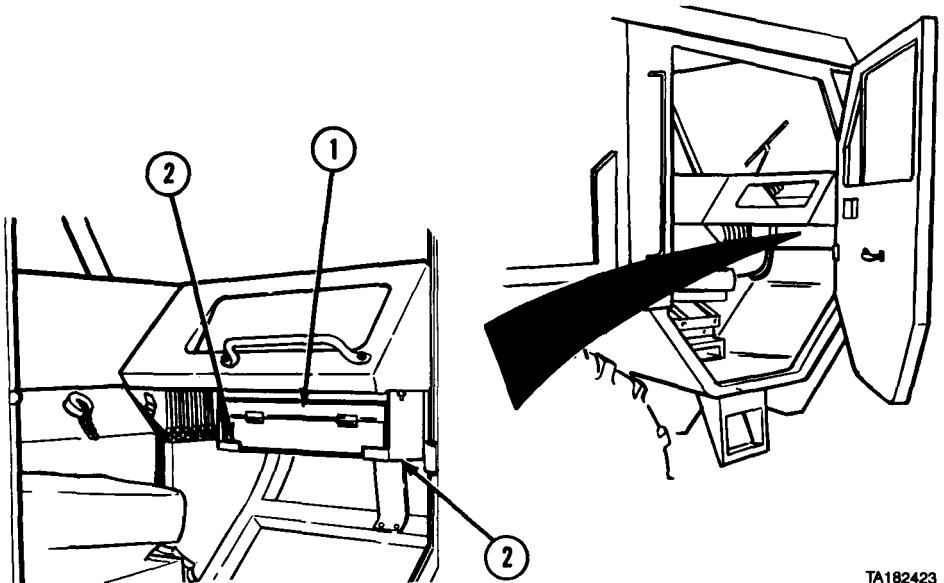
TA182422

NOTE

Highway emergency kit should be used to mark location and caution on-coming traffic whenever vehicle is disabled or must park in areas where there is other traffic.

- (1) Set turn signal lever (1) to right turn position.
- (2) Push down tab (2) and push turn signal lever (1) up as far as it will go.

b. Prepare Each Marker For Use.



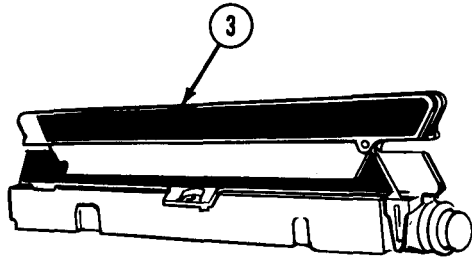
TA182423

- (1) Remove emergency marker kit (1) from stowage brackets (2).

Operation Under Unusual Conditions (Cont)

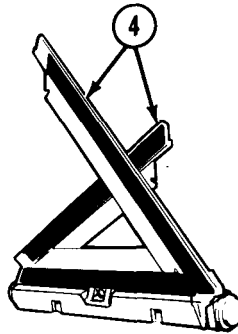
2-44. SET UP/SECURE HIGHWAY EMERGENCY MARKER KIT (CONT).

(2) Remove markers (3) from case.



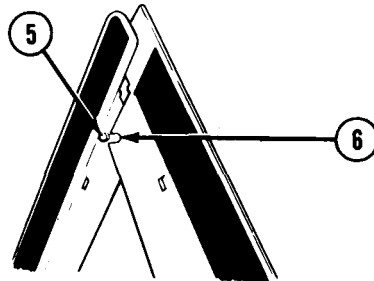
TA182424

(3) Raise arms (4).



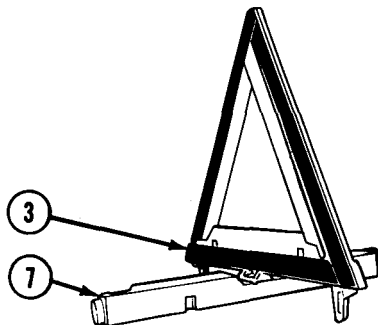
TA182425

(4) Snap pin (5) into slot (6).



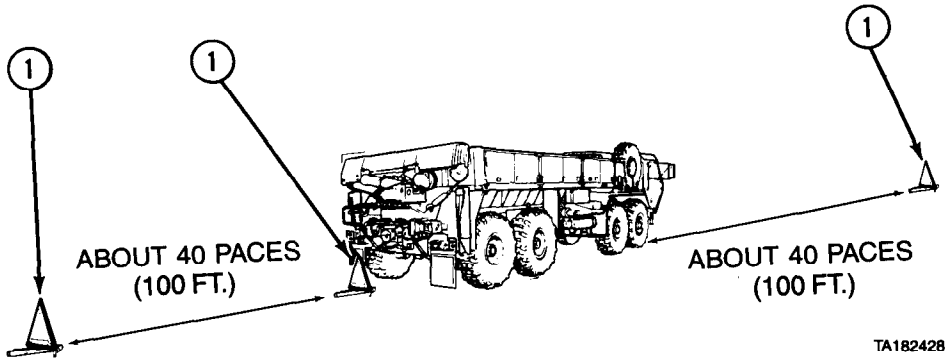
TA182426

(5) Rotate marker (3) about 1/4 turn on base (7) until it stops.

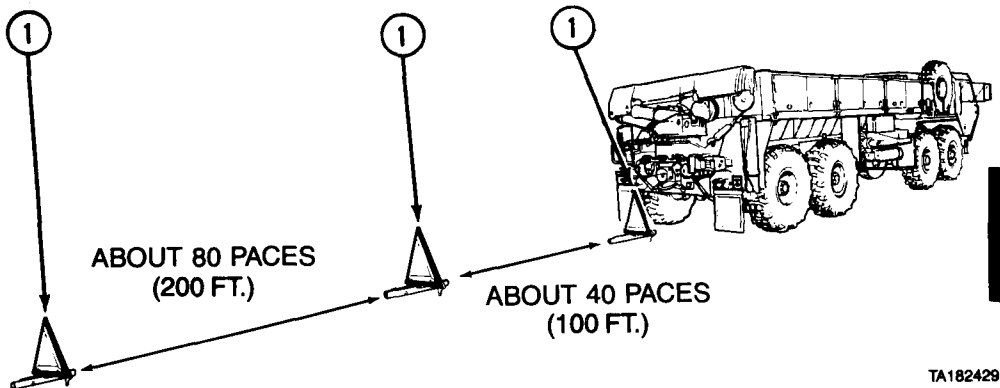


TA182427

Operation Under Unusual Conditions (Cont)

c. Place Markers On Undivided Highway.

- (1) Place one marker (1) about 40 paces (100 ft) in front of vehicle, so marker faces traffic approaching from front.
- (2) Place another marker (1) directly behind vehicle, so marker faces traffic approaching from rear.
- (3) Place third marker (1) about 40 paces (100 ft) behind vehicle, so marker faces traffic approaching from rear.

d. Place Markers On Divided Highway.

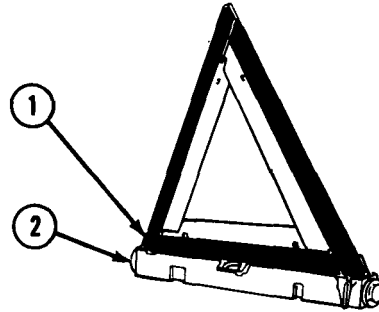
- (1) Place one marker (1) directly behind vehicle, so marker faces traffic approaching from rear.
- (2) Place second marker (1) about 40 paces (100 ft) behind vehicle, so marker faces traffic approaching from rear.
- (3) Place third marker (1) about 80 paces (200 ft) behind second marker so marker faces traffic approaching from rear.

Operation Under Unusual Conditions (Cont)

2-44. SET UP/SECURE HIGHWAY EMERGENCY MARKER KIT (CONT).

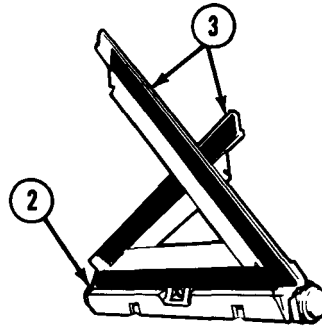
e. Secure Markers.

(1) Rotate marker (1) over base (2).



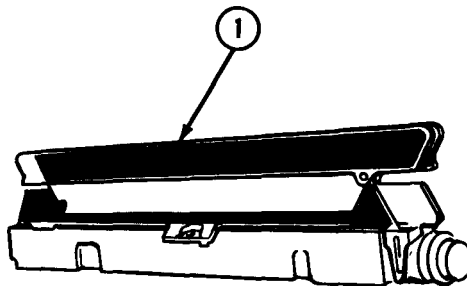
TA182430

(2) Separate arms (3).
(3) Fold arms (3) down onto base (2).



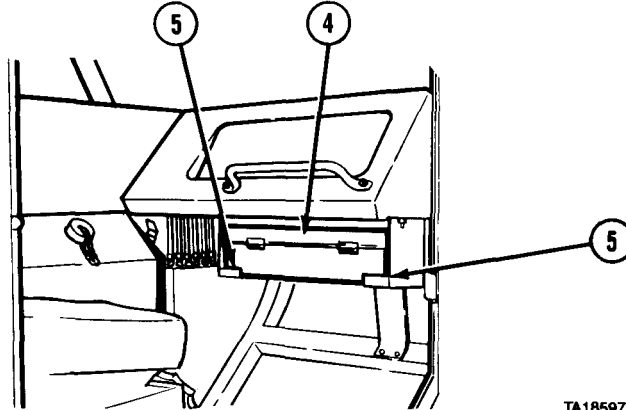
TA182432

(4) Put markers (1) in case.



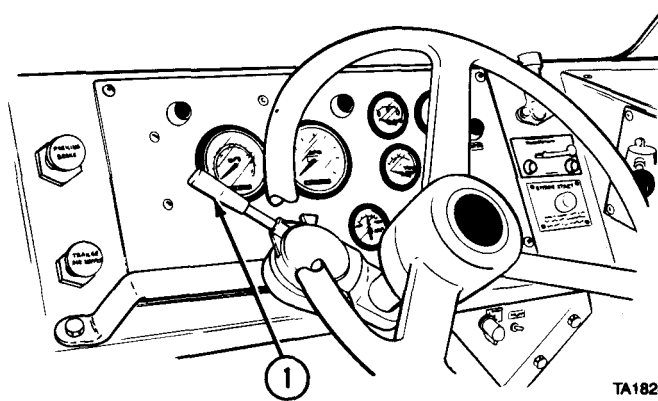
TA185974

Operation Under Unusual Conditions (Cont)



TA185975

(5) Put emergency marker kit (4) in stowage brackets (5).

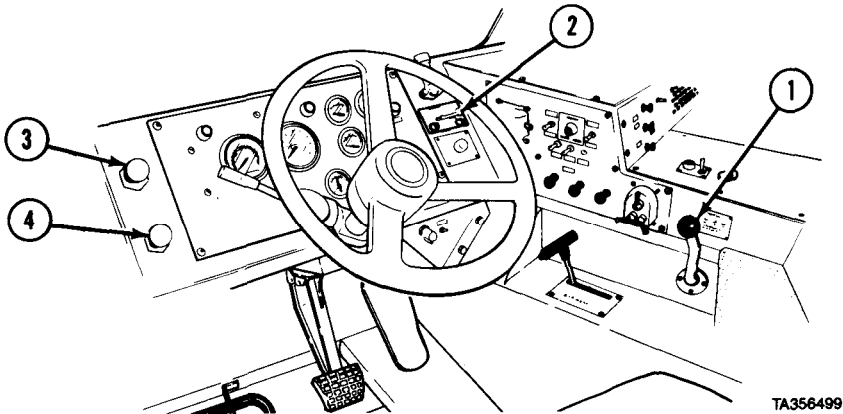


TA182433

f. When emergency flashers are no longer needed, set turn signal lever (1) to center position.

Operation Under Unusual Conditions (Cont)

2-45. TOW DISABLED VEHICLE.



CAUTION

- When towing another vehicle do not go over GCVWR given in Table 1-2. Going over GCVWR will cause damage to towed and towing vehicle.
- Propeller shaft must be removed by organizational maintenance before towing disabled vehicle or equipment may be damaged.

NOTE

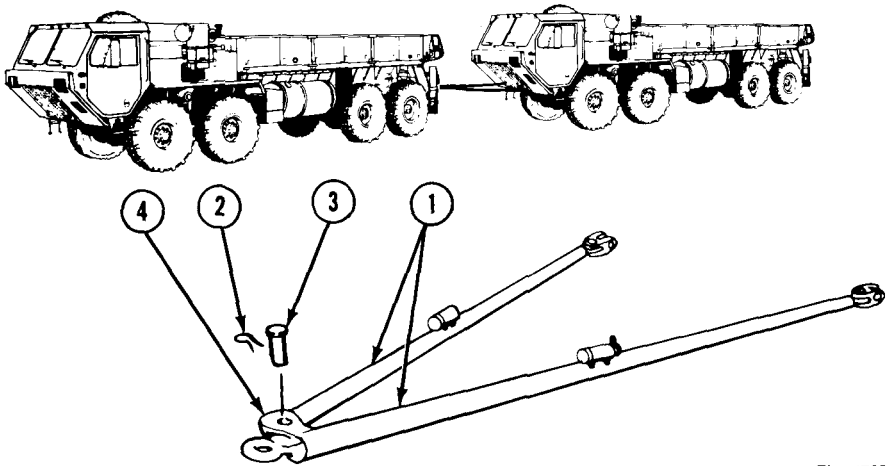
Disabled vehicles must be prepared and moved in accordance with FM 20-22 and FM 21-305. If instructed to do so, manually release spring brakes as part of preparing disabled vehicle for towing in paragraph 2-47.

- (1) Install beacon light (para 2-30).
- (2) Place TRANSFER CASE shift lever (1) in NEUTRAL position.
- (3) Place traction control switch (2) to OFF.
- (4) Push in PARKING BRAKE control (3) on disabled vehicle.
- (5) Push in TRAILER AIR SUPPLY control (4) on recovery vehicle.
- (6) Transport disabled vehicle.

Operation Under Unusual Conditions (Cont)

2-46. CONNECT/DISCONNECT TOW BAR.**a. Connect Tow Bar.****NOTE**

Position rear of towing vehicle near front of disabled vehicle.



TA474729

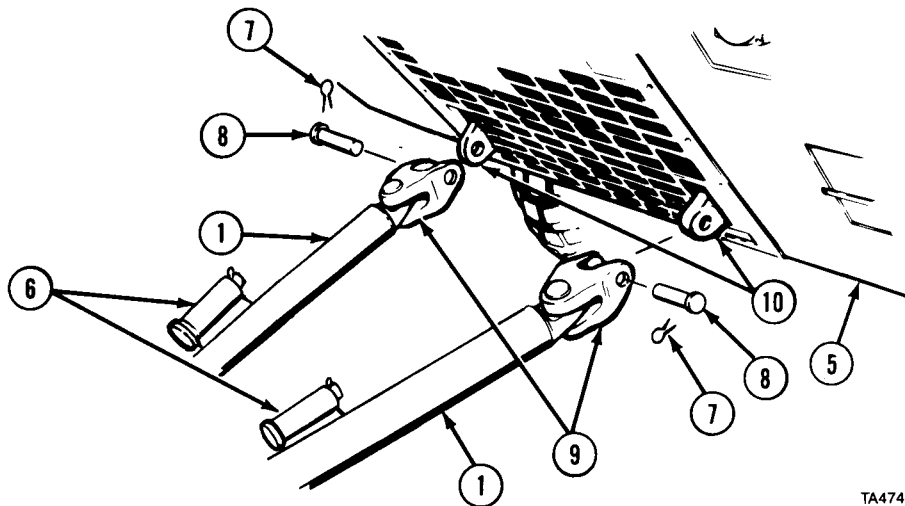
CAUTION

Tow bar is very heavy and requires three soldiers to carry. Do not drop tow bar. Injury to personnel can result.

- (1) Remove tow bar (1) from stowage.
- (2) Remove cotter hairpin (2) and pin (3) from tow bar (1).
- (3) Separate tow bar (1) at pivot point (4).

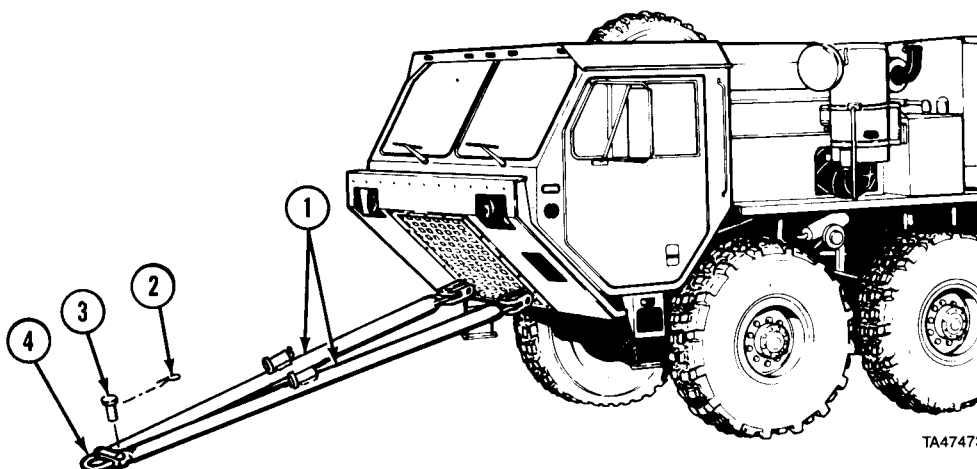
Operation Under Unusual Conditions (Cont)

2-46. CONNECT/DISCONNECT TOW BAR (CONT).



TA474730

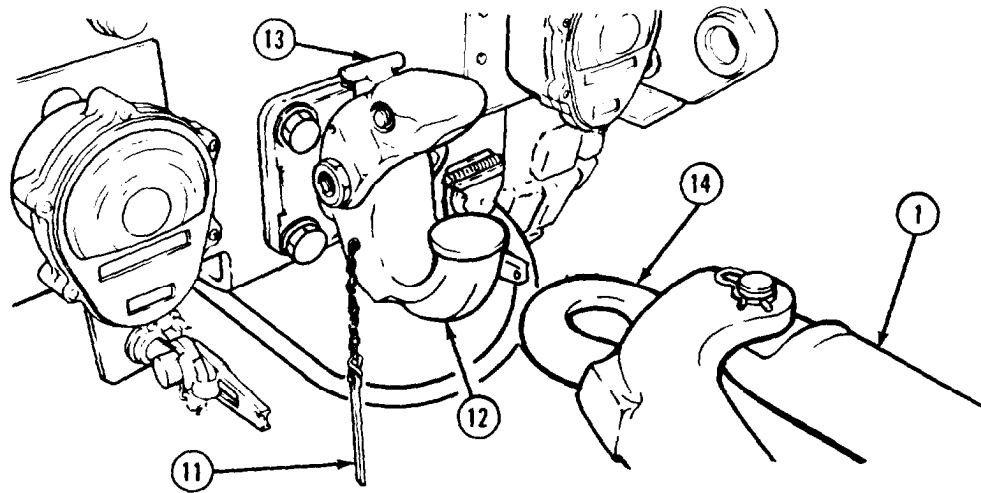
- (4) Position legs of tow bar (1) in front of disabled vehicle (5) with spare pins (6) facing up.
- (5) Remove two cotter hairpins (7) and pins (8) from tow bar shackles (9).
- (6) Soldier A and Soldier B hold one leg of tow bar (1) and aline shackle (9) with towing eye (10) while Soldier C installs pin (8) and cotter hairpin (7).
- (7) Soldier A and Soldier B hold other leg of tow bar (1) and aline shackle (9) with other towing eye (10) while Soldier C installs pin (8) and cotter hairpin (7).



TA474731

- (8) Aline legs of tow bar (1) at pivot point (4) and install pin (3) and cotter hairpin (2).

Operation Under Unusual Conditions (Cont)

**WARNING**

Do not use tow bar with M1977-CBT coupler. If tow bar is used, damage to equipment or injury to personnel may occur.

NOTE

Position towing vehicle so pintle hook is aligned with tow bar lunette eye.

- (9) Remove cotter pin (11) from pintle hook (12).
- (10) Pull latch (13) away from vehicle and hold.
- (11) Lift top of pintle hook (12) and let go of latch (13). Pintle hook will be locked open.

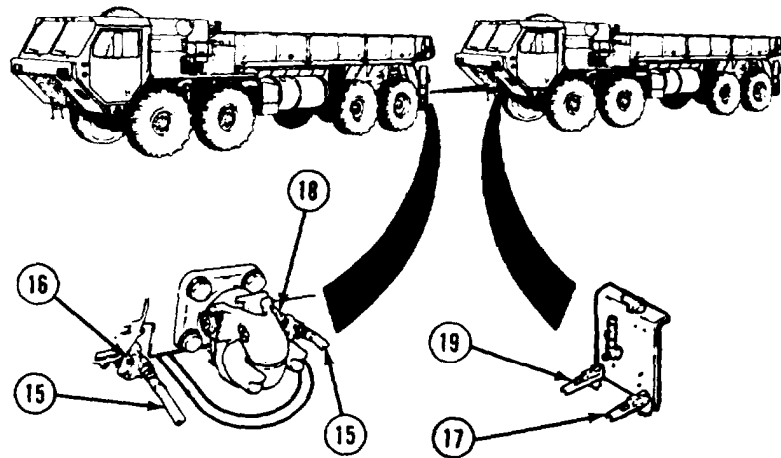
WARNING

Do not put hands near pintle hook while aligning lunette eye with pintle hook. If towing vehicle moves suddenly it may cause serious injury to personnel.

- (12) Soldier A and Soldier B lift tow bar (1) while Soldier C SLOWLY backs up towing vehicle.
- (13) Connect tow bar lunette eye (14) to pintle hook (12).
- (14) Pull latch (13) and close top half of pintle hook (12).
- (15) Install cotter pin (11) in pintle hook (12).

Operation Under Unusual Conditions (Cont)

2-46. CONNECT/DISCONNECT TOW BAR (CONT).

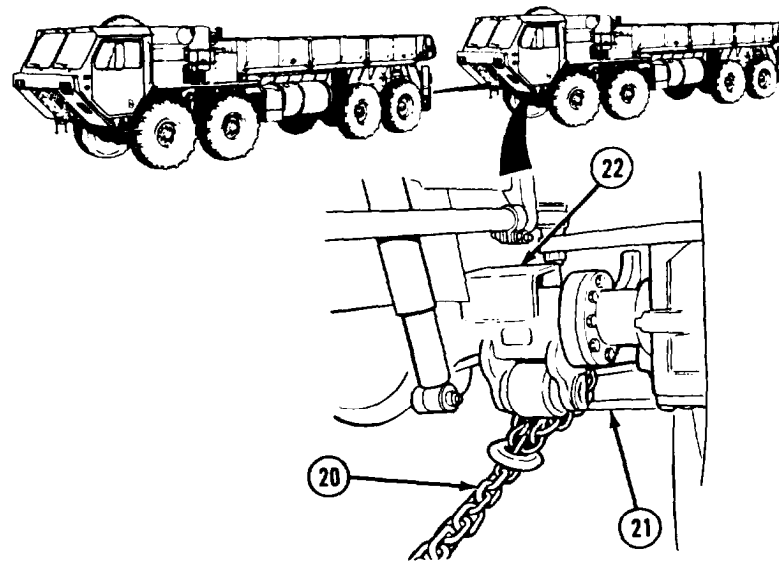


NOTE

If air system of disabled vehicle is damaged, manually release spring brakes (para 2-47) and go to step (19).

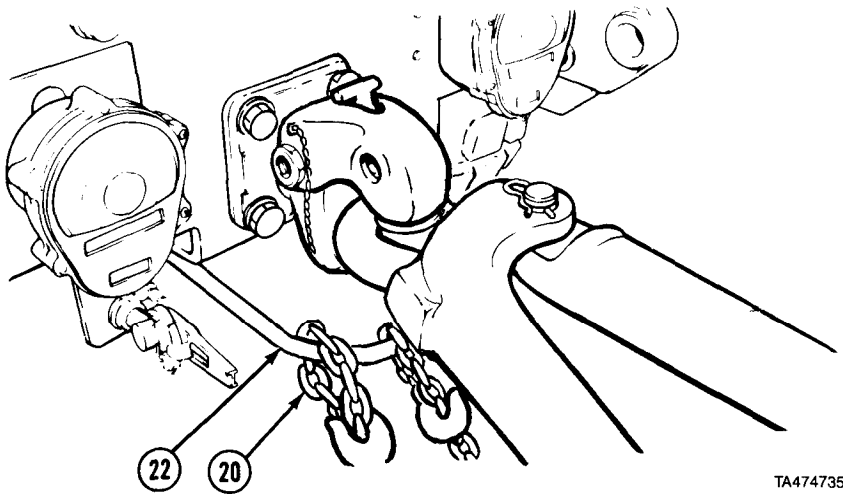
- (16) Remove two intervehicular air hoses (15) from stowage.
- (17) Connect air hose (15) to left rear glad hand (16) of towing vehicle and left front glad hand (17) of disabled vehicle.
- (18) Connect air hose (15) to right rear glad hand (18) of towing vehicle to right front glad hand (19) of disabled vehicle.

Operation Under Unusual Conditions (Cont)



- (19) Remove two 16-foot (5 m) safety chains (20) from stowage,. Route chain over walking beam (21) behind No. 1 axle (22) on disabled vehicle.
- (20) Hook safety chain (20) together under walking beam (21).
- (20.1) Repeat steps (19) and (20) for other side of disabled vehicle.

Operation Under Unusual Conditions (Cont)

**NOTE**

Utility chain may be attached to safety chain loop or towing shackles.

- (21) Attach one end of utility chain (20) to safety chain loop (22) on towing vehicle.

CAUTION

Operation at speeds over 15 mph (24 kph) on paved road can be achieved when the operator determines that the vehicle being towed and the terrain allow safe operation. Under no condition can speeds over 35 mph (55 kph) on paved road and 15 mph (24 kph) off-road be allowed. Loss of control can cause serious injury or death. Excessive speed can cause damage to vehicle being towed.

- (22) Transport vehicle (para 2-45).

Operation Under Unusual Conditions (Cont)

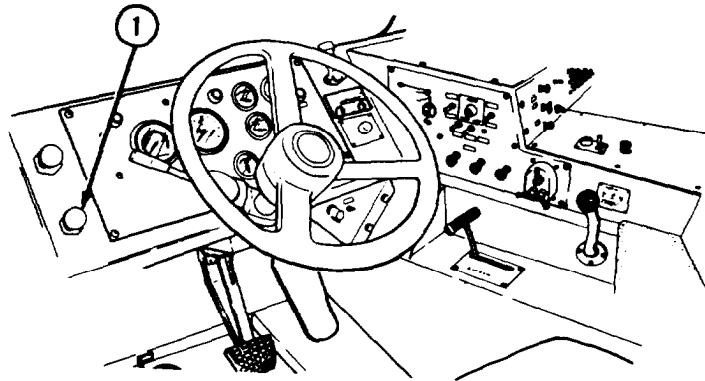
2-46. CONNECT/DISCONNECT TOW BAR (CONT).

b. Disconnect Tow Bar.

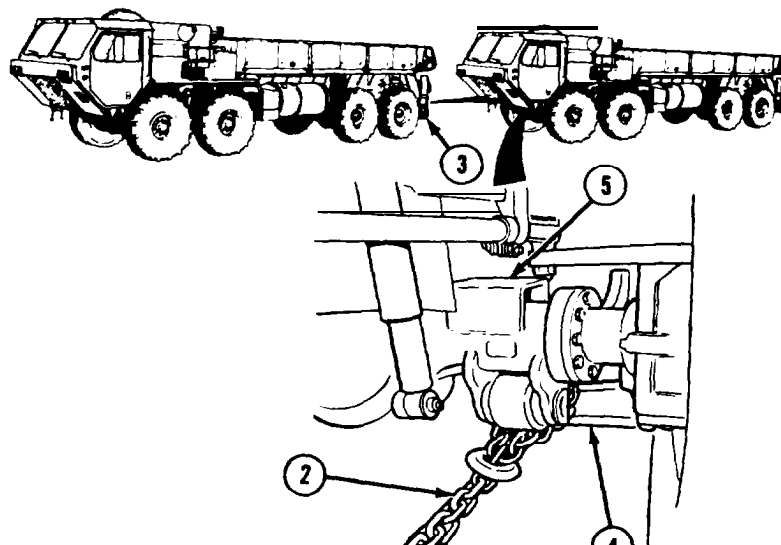
NOTE

Vehicle should be parked and disconnected on level ground.

- (1) Park towing vehicle (para 2-11o).

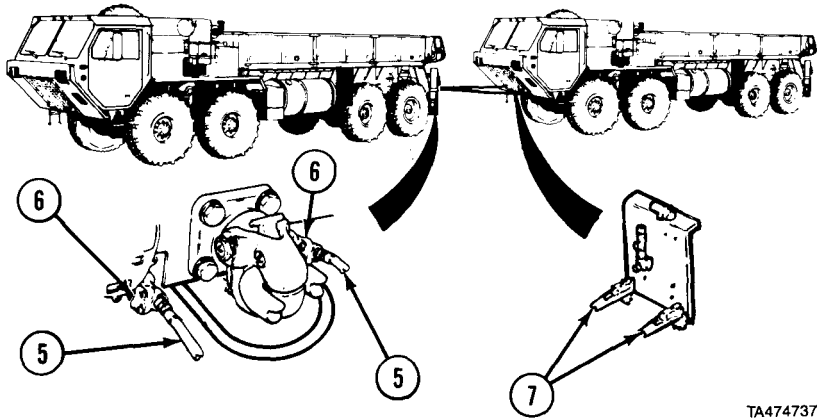


- (2) Pull out TRAILER AIR SUPPLY control (1) on towing vehicle.
- (3) Set parking brake on disabled vehicle.



- (4) Disconnect two safety chains (2) from rear of towing vehicle (3) and from walking beam (4) behind No. 1 axle (5) of disabled vehicle and stow safety chains.

Operation Under Unusual Conditions (Cont)

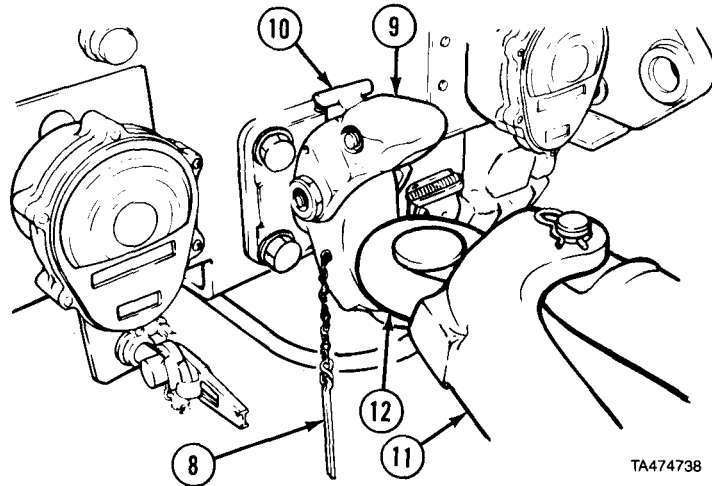


TA474737

NOTE

If spring brakes on towed vehicle were manually released before towing, chock wheels and go to step (6).

- (5) Disconnect two intervehicular air hoses (5) from rear glad hands (6) of towing vehicle and from front glad hands (7) on disabled vehicle and stow air hoses.

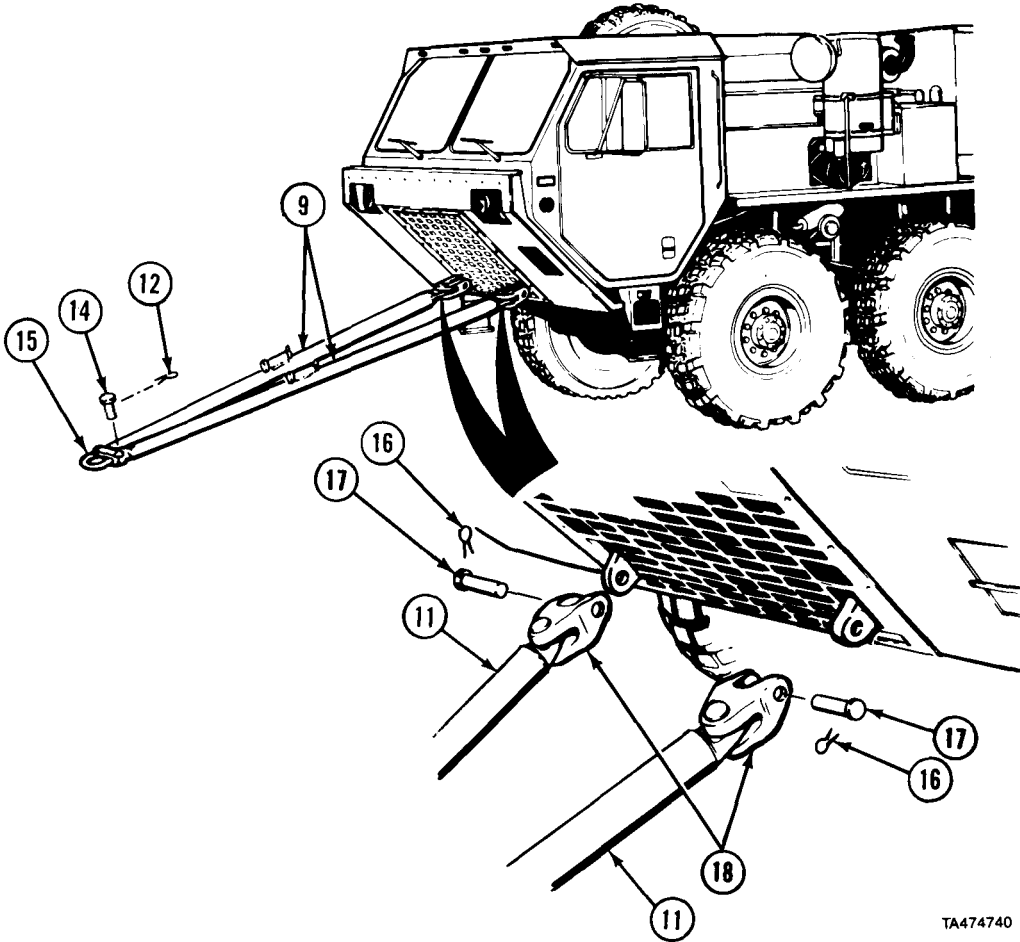


TA474738

- (6) Remove cotter pin (8) from pintle hook (9).
 (7) Pull latch (10) away from vehicle and hold.
 (8) Lift top of pintle hook (9) and let go of latch (10). Pintle hook will be locked open.
 (9) Soldier A and Soldier B lift tow bar (11) until lunette eye (12) is clear of pintle hook (9).
 (10) As Soldier C drives towing vehicle forward, Soldier A and Soldier B lower tow bar (11) to the ground.
 (11) Pull latch (10) to close pintle hook (9) and install cotter pin (8) in pintle hook (9).

Operation Under Unusual Conditions (Cont)

2-46. CONNECT/DISCONNECT TOW BAR (CONT).



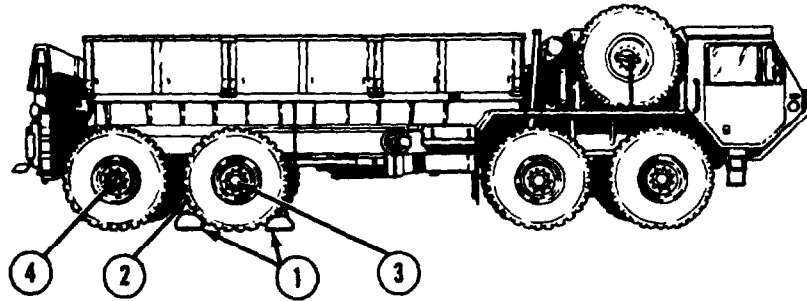
TA474740

- (12) Remove cotter hairpin (13) and pin (14) and separate tow bar (11) at pivot point (15).
- (13) Soldier A and Soldier B hold one leg of tow bar (11) while Soldier C removes cotter hairpin (16) and pin (17) from shackle (18).
- (14) Soldier A and Soldier B hold other leg of tow bar (11) while Soldier C removes cotter hairpin (16) and pin (17) from shackle (18).
- (15) Install two pins (17) and cotter hairpins (16) in shackles (18).
- (16) Aline legs of tow bar (11) at pivot point (15) and install pin (14) and cotter hairpin (13).
- (17) Stow tow bar (11).

Operation Under Unusual Conditions (Cont)

2-47. MANUALLY RELEASE SPRING BRAKES.*a. Chock Wheels.***NOTE**

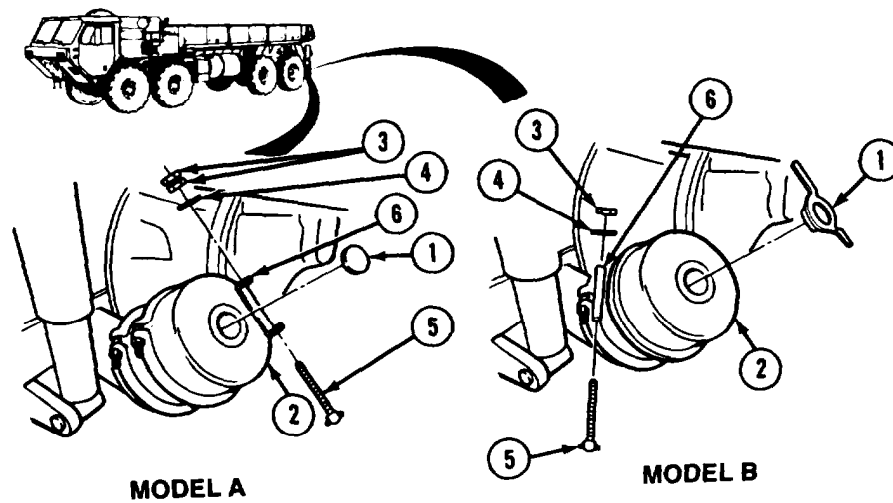
This procedure should only be used when vehicle air system is totally inoperative and vehicle cannot be towed with rear end raised by M984E1 wrecker.



- (1) Remove wheel chocks (1) from stowage.
- (2) Place wheel chocks (1) in front and back of one wheel (2) on third or fourth axle (3 or 4).

Operation Under Unusual Conditions (Cont)

b. Release Brakes.



WARNING

Failure to ensure brake chamber is caged while releasing brakes can result in serious injury or death. Spring is under 2500 lb tension.

NOTE

- There are two types of brake chambers: Model A and Model B.
- Left brake chamber on fourth axle is shown. Steps are same for right side and third axle.

- (1) Remove dust cap (1) from brake chamber (2).

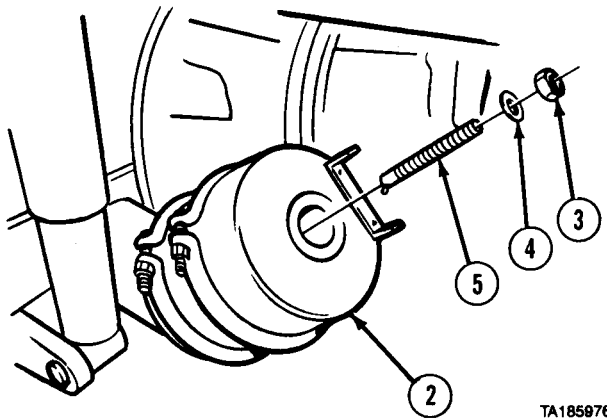
NOTE

Model B brake chamber has only one nut.

- (2) Remove two nuts (3), washer (4), and release bolt (5) from bracket (6).

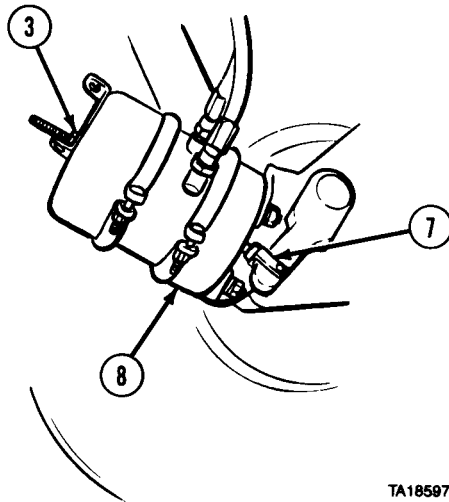
Operation Under Unusual Conditions (Cont)

2-47. MANUALLY RELEASE SPRING BRAKES (CONT).



TA185976

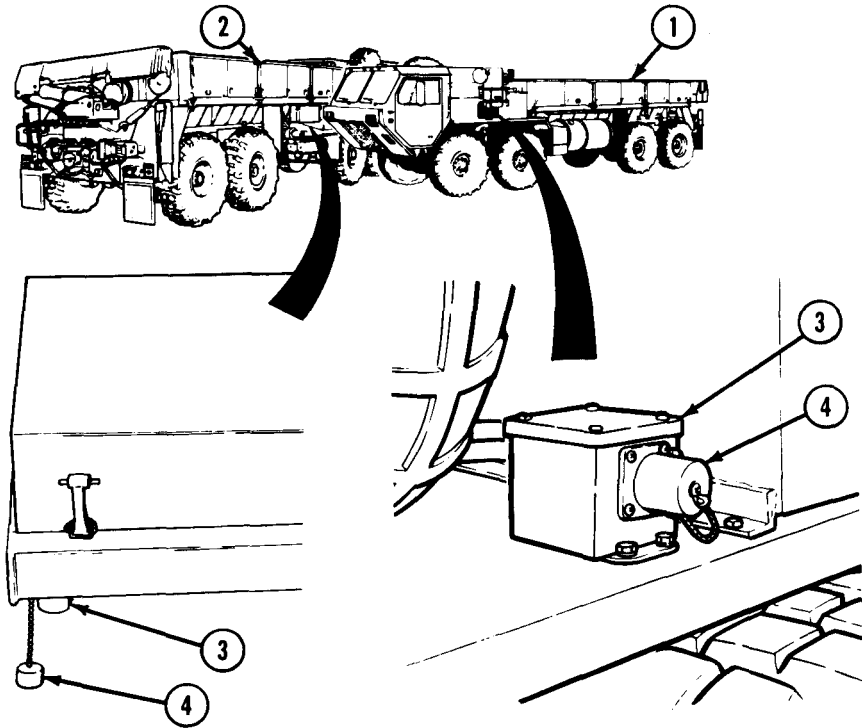
- (3) Insert release bolt (5) into brake chamber (2).
- (4) Turn release bolt (5) 1/4 turn to engage inside brake chamber (2).
- (5) Install washer (4) and nut (3) on release bolt (5).



TA185977

- (6) Tighten nut (3) until clevis (7) is pulled to rear of brake chamber (2).
- (7) Repeat steps (1) through (6) to release three other spring brakes.

Operation Under Unusual Conditions (Cont)

2-48. EMERGENCY PROCEDURES.**a. Slave Start Vehicle.**

TA357061

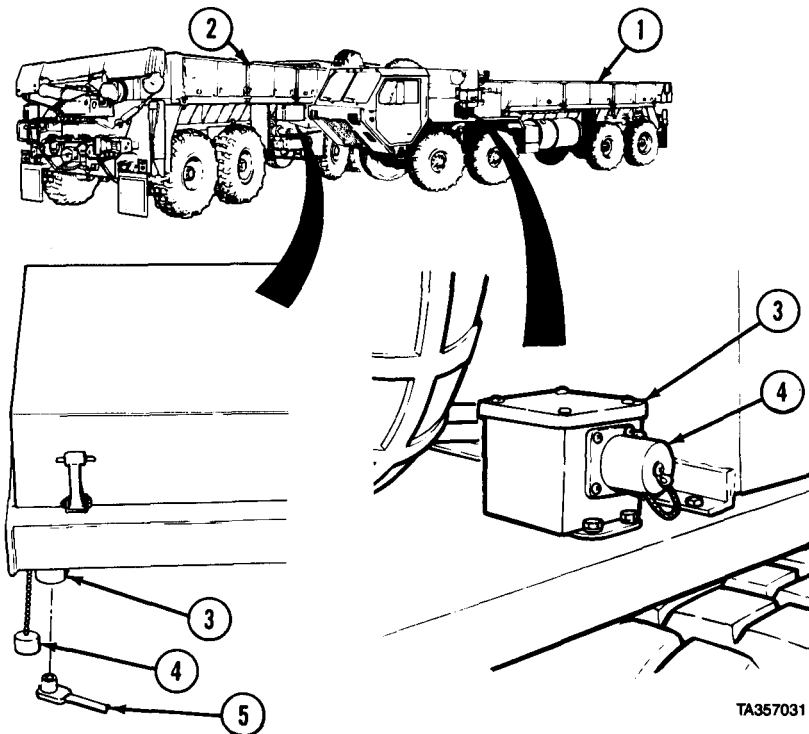
NOTE

- Slave starting is a two-soldier task.
- Slave receptacle may be located either on battery box or left front fender.

- (1) Start engine of vehicle (1) (para 2-11a or 2-11b).
- (2) Move vehicle (1) into position beside vehicle (2) so slave receptacles (3) on both vehicles are side by side.
- (3) Park vehicle (1) (para 2-11o).
- (4) Shut off engine of vehicle (1) (para 2-11p).
- (5) Remove caps (4) from slave receptacles (3) on vehicle (1) and vehicle (2).

Operation Under Unusual Conditions (Cont)

2-48. EMERGENCY PROCEDURES (CONT).



WARNING

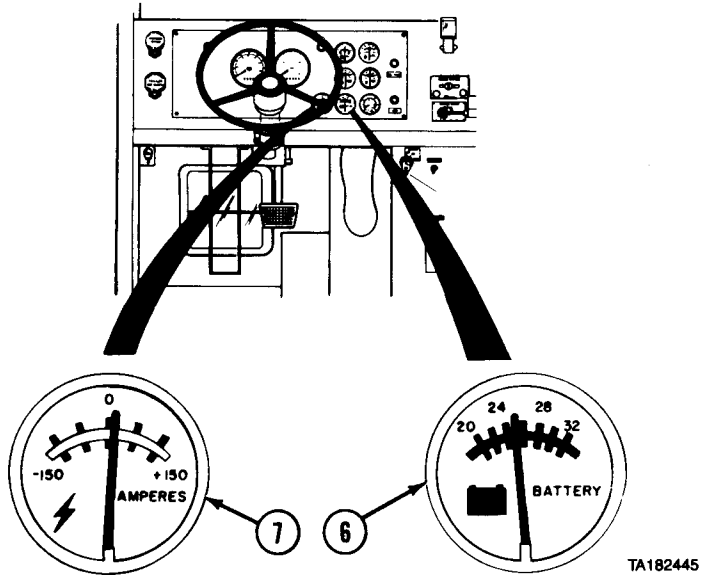
Do not wear jewelry, smoke, have open flame, or make sparks around batteries. Batteries can explode and cause personal injury.

CAUTION

Make sure connectors and receptacles are free of dirt, sand, and debris.

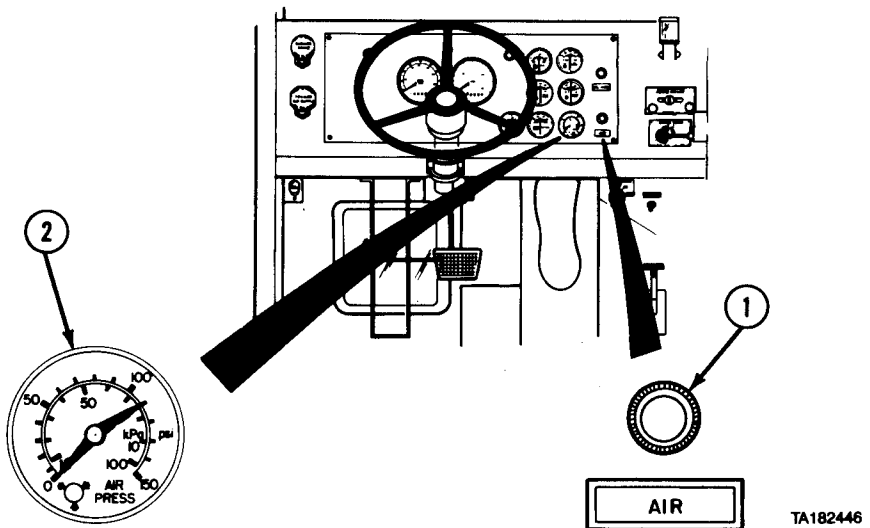
- (6) Plug NATO slave cable connectors (5) into slave receptacles (3) on vehicle (2) and vehicle (1).
- (7) Start engine of vehicle (1) (para 2-11b).
- (8) Soldier A operates vehicle (1) at more than 1000 rpm while Soldier B starts engine of vehicle (2) (para 2-11a or 2-11b).
- (9) As soon as engine is running smoothly, remove NATO slave cable connectors (5) from slave receptacles (3) on both vehicles.
- (10) Install caps (4) on slave receptacles (3) of both vehicles.
- (11) Move vehicle (1) (para 2-11f).
- (12) Park vehicle (1) (para 2-11o).
- (13) Shut off engine of vehicle (1) (para 2-11p).

Operation Under Unusual Conditions (Cont)



- (14) Check BATTERY gage (6). If BATTERY gage shows less than 24 volts, notify organizational maintenance. If BATTERY gage shows 24 volts or more, continue with step (15).
- (15) Check AMPERES gage (7). If AMPERES gage shows discharge condition, notify organizational maintenance. If AMPERES gage shows charging, continue operation of vehicle.

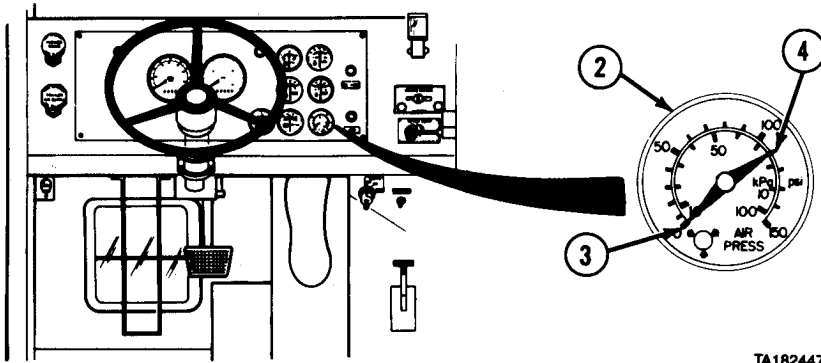
b. Perform Immediate Action For Loss of Air Supply System Pressure.



- (1) If AIR indicator (1) lights and warning buzzer sounds while driving vehicle, check AIR PRESS gage (2).

Operation Under Unusual Conditions (Cont)

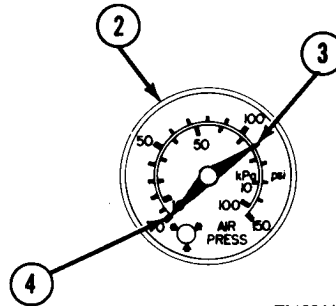
2-48. EMERGENCY PROCEDURES (CONT).



TA182447

- (2) If red pointer (3) on AIR PRESS gage (2) is at zero and green pointer (4) shows normal air pressure of 100 to 120 psi (690 to 827 kPa), do the following:
- (a) Continue operation of vehicle. Brakes on all eight wheels and trailer will work even though air pressure from No. 2 air tank has been lost.
 - (b) Notify organizational maintenance as soon as possible.

- (3) If green pointer (4) on AIR PRESS gage (2) is at zero and red pointer (3) shows normal air pressure of 100 to 120 psi (690 to 827 kPa), do the following:



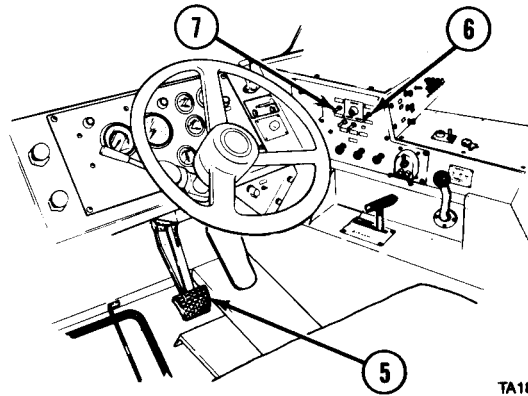
TA182448

WARNING

When green pointer of AIR PRESS gage is at zero, braking capability is greatly reduced. Extra care must be used to avoid collision which could result in severe injury or death.

- (a) Continue operation of vehicle. Brakes on third and fourth axles and trailer will work even though air pressure from No. 3 air tank has been lost.
- (b) Leave additional distance between vehicles.

Operation Under Unusual Conditions (Cont)



TA182449

- (c) Apply brake treadle (5) earlier than usual when slowing vehicle.
- (d) Downshift, if necessary, when slowing vehicle.

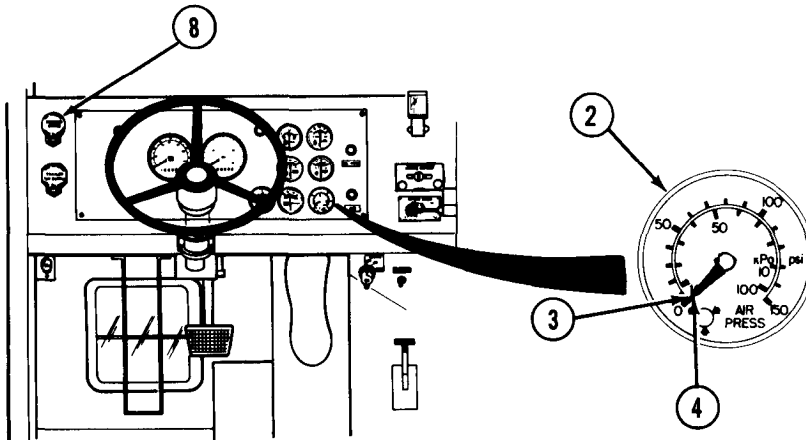
WARNING

Do not use Jacobs engine brake when vehicle is on slippery surface. If engine brake is used incorrectly, vehicle control may be lost and may cause severe injury or death.

- (e) If necessary to slow vehicle, set Jacobs engine brake HIGH/LOW switch (6) to LOW and set ON/OFF switch (7) to ON.
- (f) Notify organizational maintenance as soon as possible.

Operation Under Unusual Conditions (Cont)

2-48. EMERGENCY PROCEDURES (CONT).



TA182450

- (4) If both red pointer (3) and green pointer (4) on AIR PRESS gage (2) read zero, do the following:

NOTE

When spring brakes are applied, vehicle will stop quickly. Vehicle cannot be driven again until malfunction is repaired and there is enough air supply for operation of service brakes.

- (a) Look for place to stop vehicle without blocking other traffic.
- (b) Downshift, as needed, to control vehicle speed until place is found to stop.

WARNING

Use of brake treadle will not slow or stop vehicle when both pointers of AIR PRESS gage read zero. Following procedure must be used to safely stop vehicle after loss of air pressure.

- (c) When suitable area is found to stop vehicle, pull out PARKING BRAKE control knob (8) to apply spring brakes on four rear wheels.
- (d) Notify organizational maintenance.

Operation Under Unusual Conditions (Cont)

c. Perform Immediate Action For Loss of Hydraulic System.

NOTE

Failure of hydraulic system will stop operation of any crane, winch, or hydraulic motor on vehicle. All cranes and winches are equipped with automatic locking mechanisms to hold cranes and winches in position they were in before hydraulics failed.

- (1) Do not try to continue operation of any crane or winch (except M983 crane).
- (2) Perform emergency hydraulic operations using hand pump for M983 crane (para 2-48e).
- (3) Do not try to repair hydraulic system.
- (4) Perform fuel handling operations using auxiliary pump (M978 tanker only, para 2-48f).

NOTE

Steering wheel will be harder to turn after failure of hydraulic system.

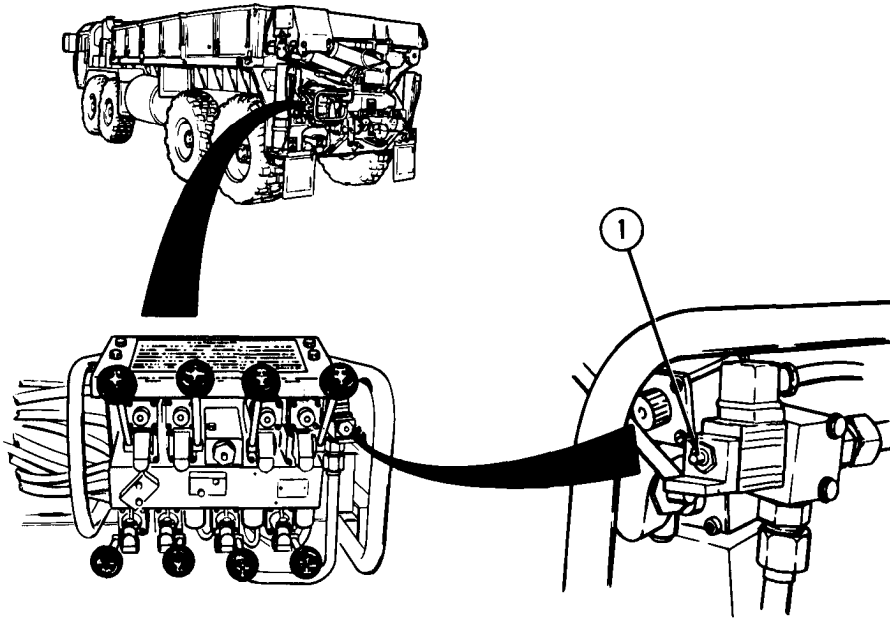
- (5) If failure occurs while driving, continue steering as before.
- (6) Notify organizational maintenance.

Operation Under Unusual Conditions (Cont)

2-48. EMERGENCY PROCEDURES (CONT).

d. Perform Emergency Hydraulic Operation When Crane Electrical Power Fails (M977, M985 Cranes).

- (1) If crane electrical power system fails during crane operation, crane will be locked in position it was in at time of failure.
- (2) Do not try to operate any electrical equipment on vehicle or crane.
- (3) Do not try to repair electrical system.

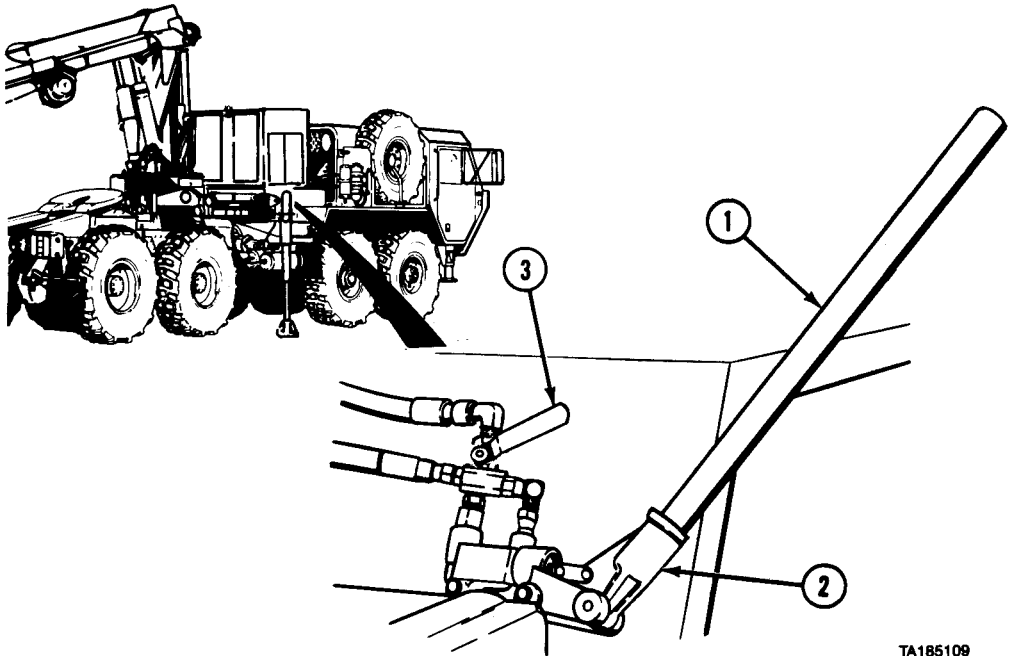


TA185128

NOTE

- This procedure will provide emergency hydraulic power to lower crane and load when electrical power has failed.
 - Screwdriver can be put in slot in front of solenoid valve button to hold button in while operating controls.
- (4) Push up and hold solenoid valve button (1).
 - (5) Shut down crane (para 2-18f).
 - (6) Notify organizational maintenance.

Operation Under Unusual Conditions (Cont)

e. Perform Emergency Hydraulic Operation When Hydraulic Power Fails (M983).

TA185109

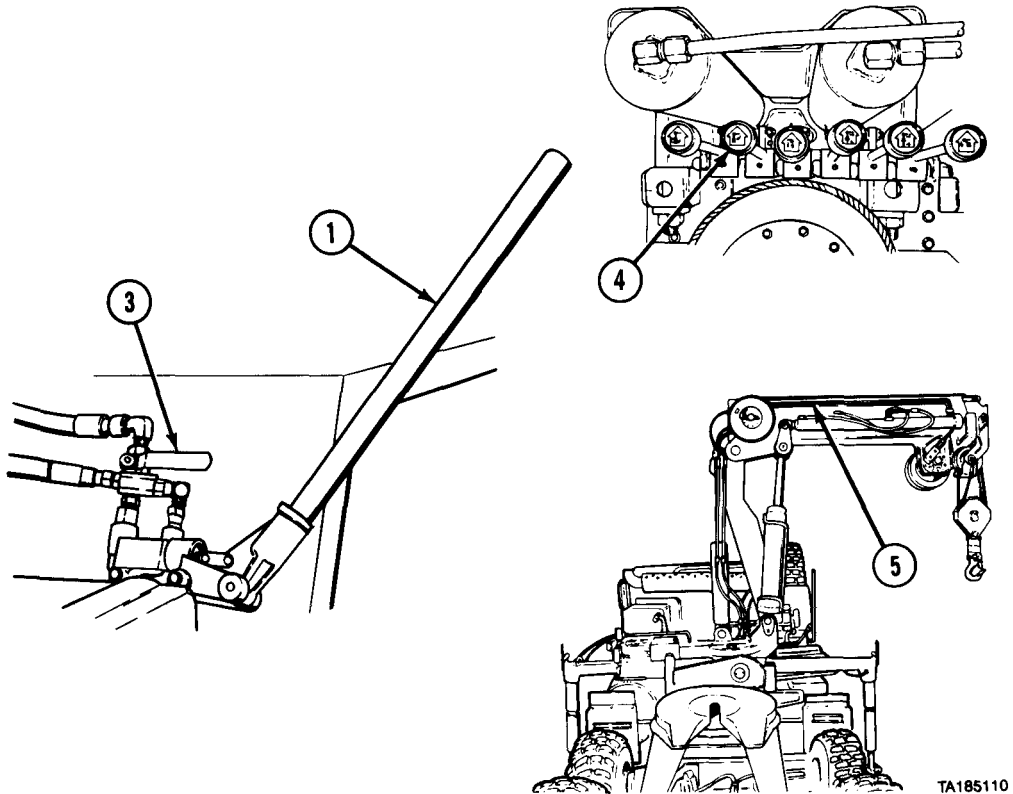
NOTE

- This is a two-soldier task. One soldier operates hand pump while other soldier operates manual controls.
- Use crane hand pump only if hydraulic pump has failed and boom and load have to be lowered from horizontal position.

- (1) Remove pipe handle (1) from stowage box.
- (2) Install pipe handle (1) on hand pump (2).
- (3) Turn hand pump control lever (3) to ON (up) position.

Operation Under Unusual Conditions (Cont)

2-48. EMERGENCY PROCEDURES (CONT).



TA185110

NOTE

- Soldier A must continue pumping until boom is in desired position.
 - This procedure can only be done with manual controls.
 - Boom will lower very slowly.
- (4) Soldier A operates pipe handle (1) with steady up and down pressure while Soldier B operates crane controls (4) and lowers boom (5).
- (5) When boom has been lowered to desired position, turn hand pump control lever (3) to OFF (down) position.
- (6) Remove pipe handle (1) and put in stowage box.
- (7) Notify organizational maintenance.

Operation Under Unusual Conditions (Cont)

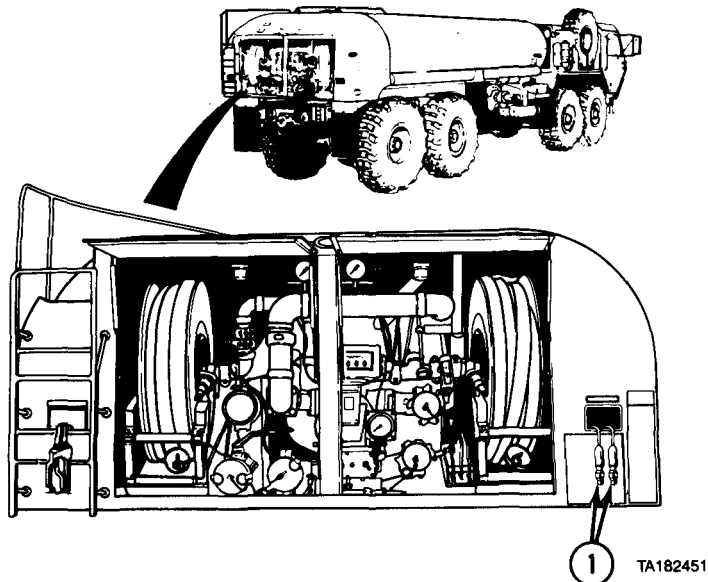
f. Perform Fuel Servicing Using Auxiliary Pump (M978 Tanker Only).**WARNING**

No smoking, flame, sparks, glowing or hot objects allowed within 50 ft (15 m) of vehicle. Fire or explosion may cause personal injury or death.

NOTE

- This procedure should be used to perform fuel servicing of land vehicles when tanker primary pump cannot be used. Whenever possible, use tanker primary pump for fuel handling operations, paragraphs 2-20 through 2-26.
- Refer to FM 10-71 for general operating instructions for tanker vehicles.
- If equipment malfunctions, check that all steps of procedure have been performed in proper sequence. If equipment still malfunctions, do troubleshooting (Chapter 3).

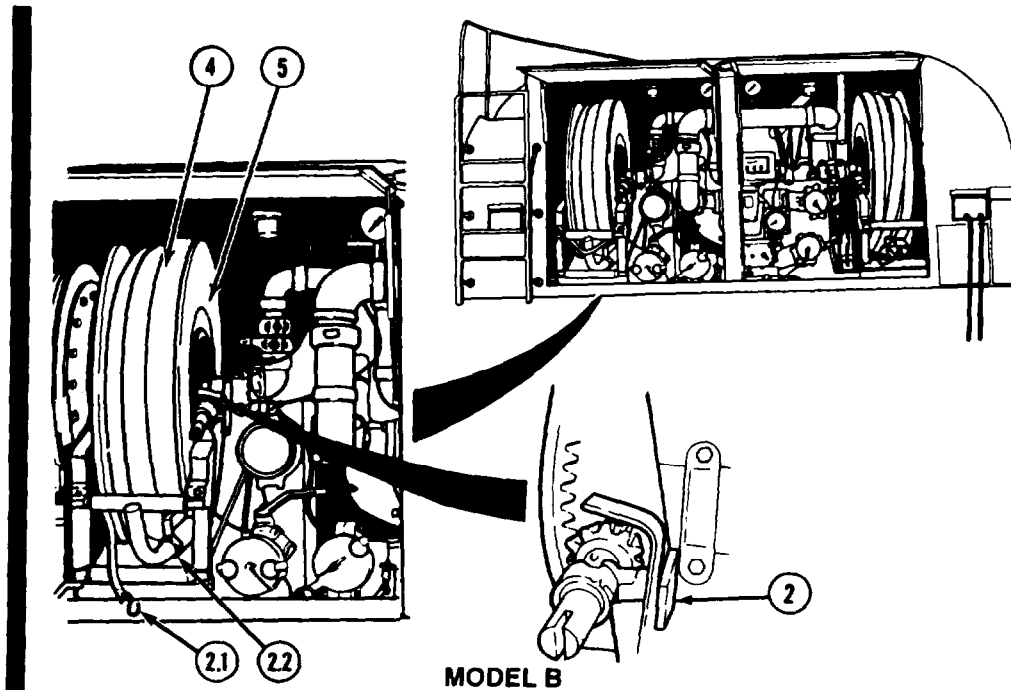
- (1) Notify organizational maintenance that primary pump is inoperative as soon as possible.
- (2) Prepare tanker for operation (para 2-20).



- (3) Connect SR1 and SR2 static cables (1) to grounding devices and vehicle being serviced.

Operation Under Unusual Conditions (Cont)

2-48. EMERGENCY PROCEDURES (CONT).



NOTE

Left-side hose is shown in this procedure. Procedure for using right-side hose is same.

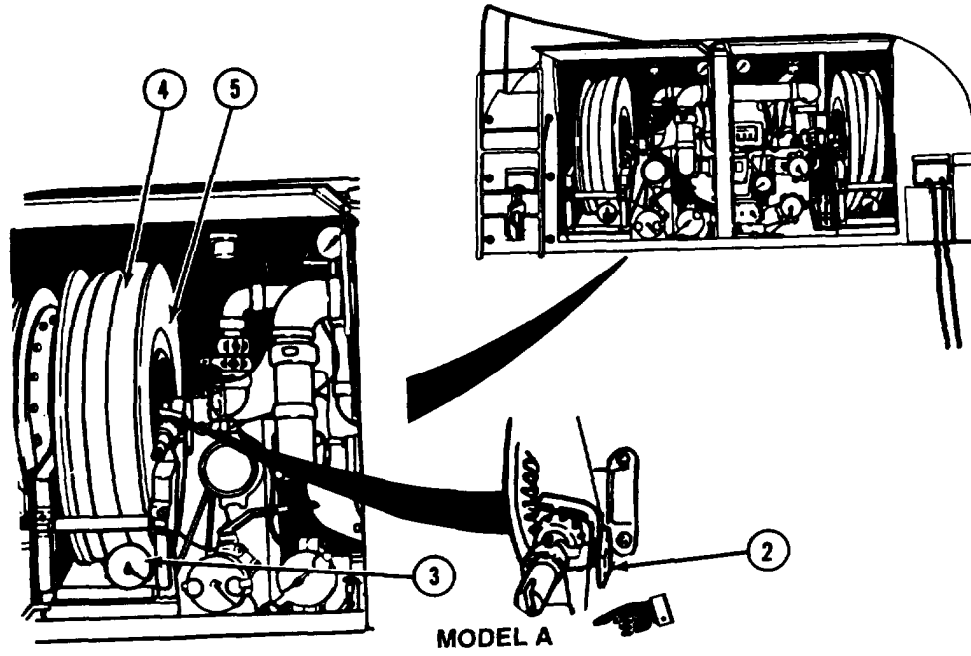
- (4) Disengage hose reel tension knob (2).

NOTE

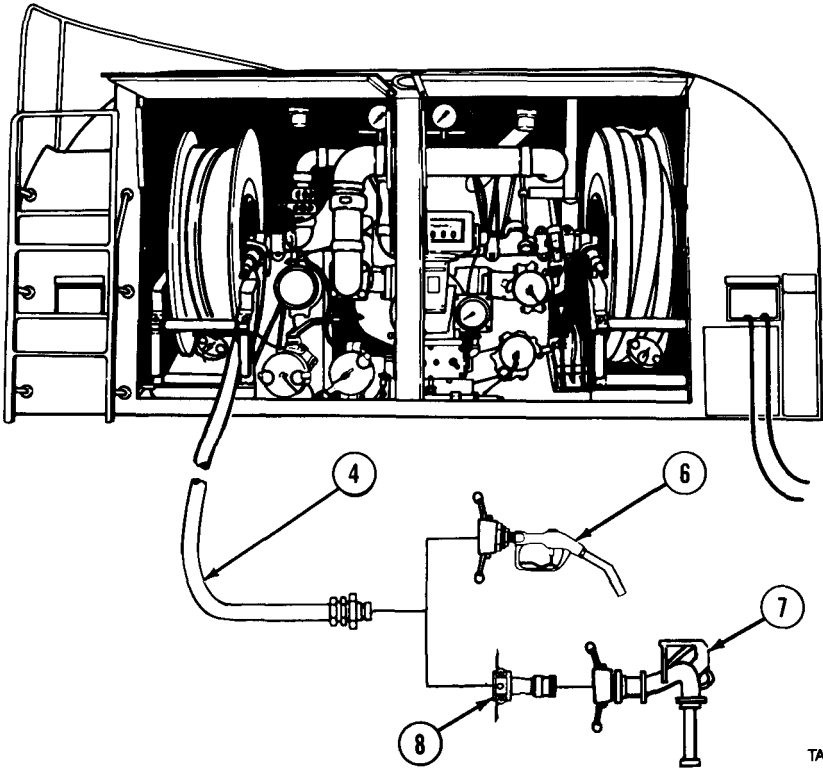
Model B has a rubber tiedown strap to secure fuel service nozzle in stowage position. If nozzle is in stowage position, do step (4.1) and skip steps (5) and (8) through (11).

- (4.1) Remove rubber tiedown strap (2.11) to release fuel service nozzle (2.2) from stowage position.
- (5) Remove dust cap (3) from end of hose (4).
- (6) Pull hose (4) completely out from reel (5).
- (7) Engage hose reel tension knob (2).

Operation Under Unusual Conditions (Cont)



Operation Under Unusual Conditions (Cont)



TA183266

NOTE

Use fuel service nozzle for fueling land vehicles. Use overwing nozzle for overwing fueling of aircraft.

- (8) Remove fuel service nozzle (6) or overwing nozzle (7) from stowage.

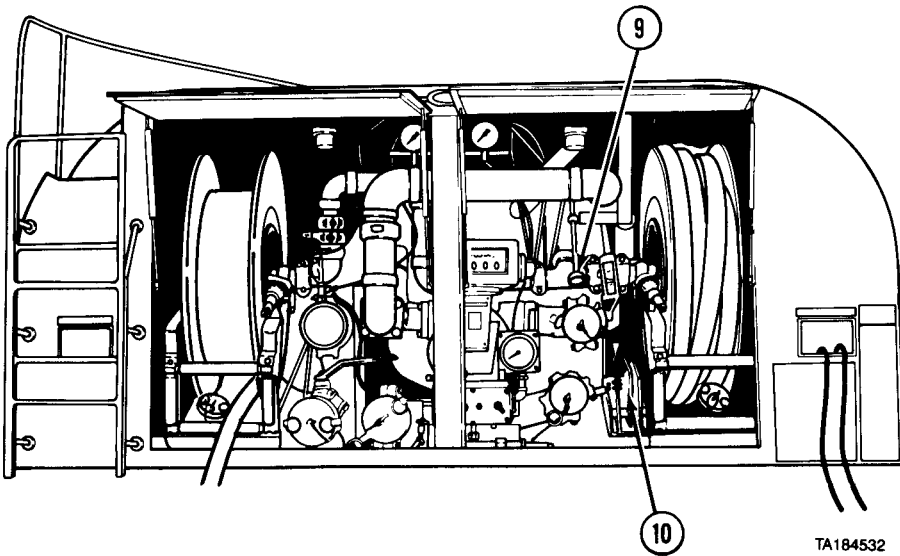
NOTE

Reducer adapter is used with overwing nozzle only. If overwing nozzle is not used, skip steps (9) and (10).

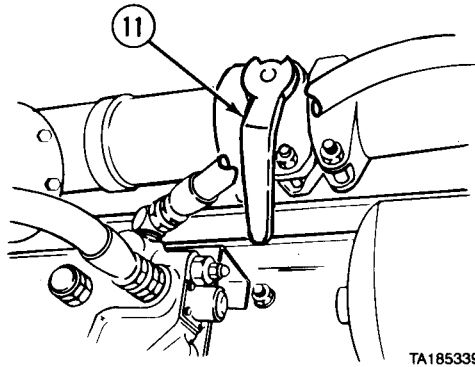
- (9) Remove reducer adapter (8) from stowage.
- (10) Install reducer adapter (8) on hose (4).
- (11) Install fuel service nozzle (6) or overwing nozzle (7) on hose (4) or reducer adapter (8).

Operation Under Unusual Conditions (Cont)

2-48. EMERGENCY PROCEDURES (CONT).



- (12) Push in V6 FUEL/DEFUEL VALVE control rod (9).
- (13) Pull back MC MANUAL CONTROL EM VALVE lever (10).

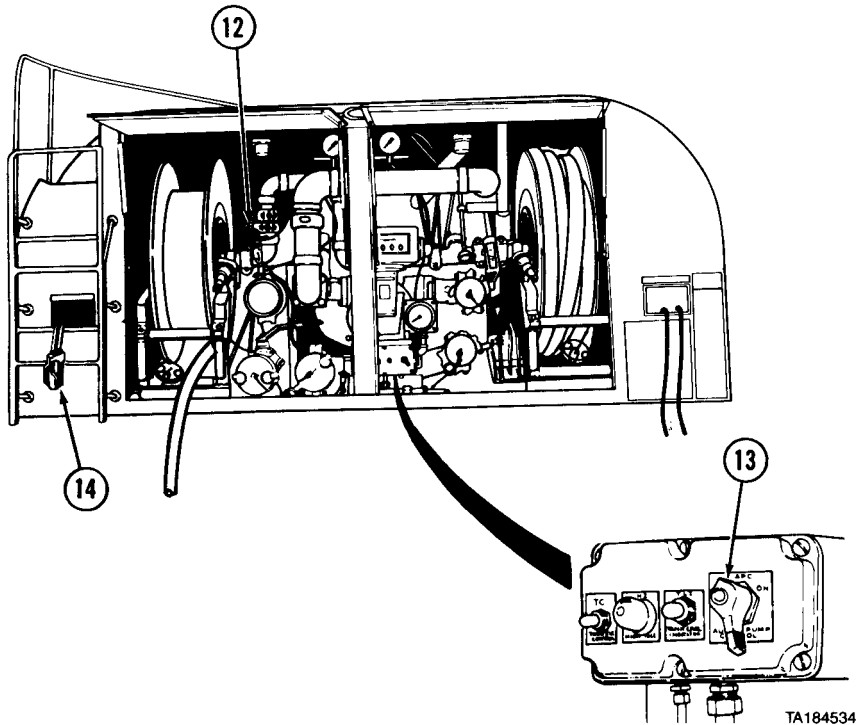


NOTE

V3 SUCTION LINE VALVE is located inside left frame rail above rear end of air tank in front of No. 3 axle.

- (14) Set V3 SUCTION LINE VALVE handle (11) to CLOSE position.

Operation Under Unusual Conditions (Cont)



TA184534

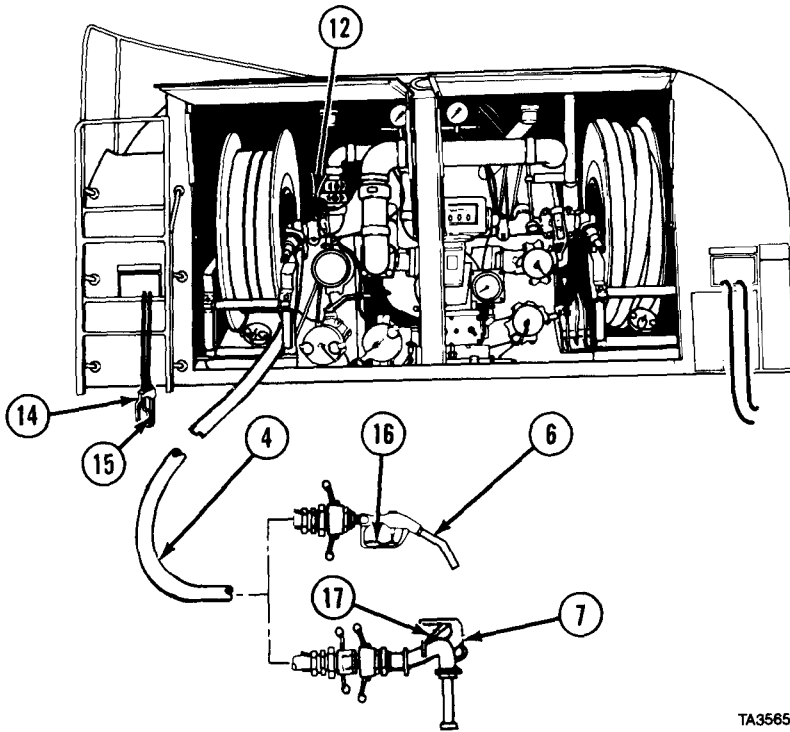
NOTE

V8 REEL VALVE controls delivery when right-side hose is used for fueling.

- (15) Adjust V7 REEL VALVE (12) to full open position.
- (16) Set APC AUXILIARY PUMP CONTROL switch (13) to ON.
- (17) Pull out HAV HAND ACTUATED CONTROL valve (14).
- (18) Remove fuel filler cover from receiving vehicle or aircraft.

Operation Under Unusual Conditions (Cont)

2-48. EMERGENCY PROCEDURES (CONT).



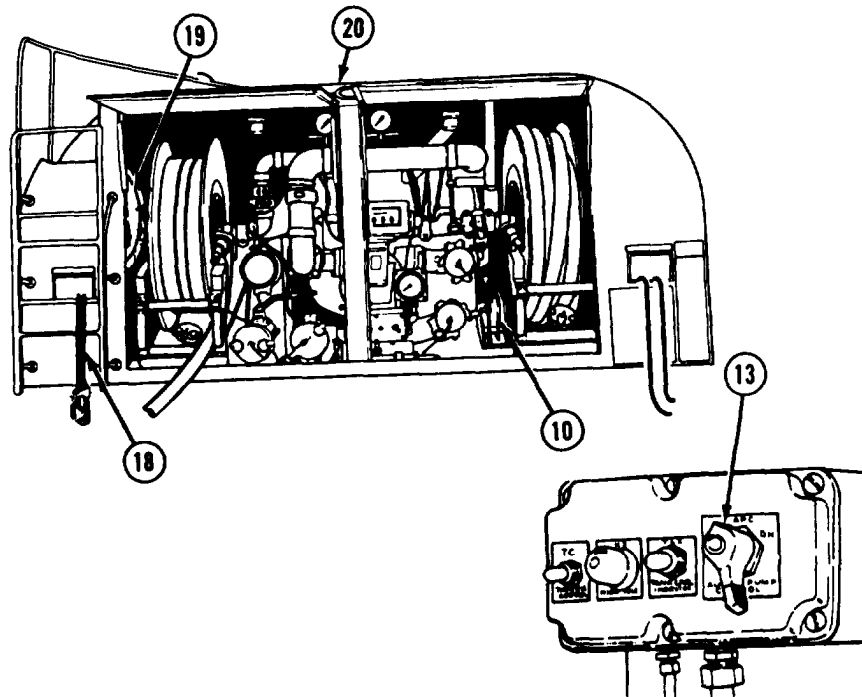
(19) Insert fuel service nozzle (6) or overwing nozzle (7) through fuel filler of receiving vehicle or aircraft.

NOTE

HAV HAND ACTUATED CONTROL valve must be open for fuel to flow.

- (20) Squeeze and hold lever (15) to open HAV HAND ACTUATED CONTROL valve (14).
- (21) Squeeze and hold lever (16) on fuel service nozzle (6) or lever (17) on overwing nozzle (7) to start fuel flow.
- (22) When receiving vehicle or aircraft tank is filled to desired level, release lever (16 or 17) and HAV HAND ACTUATED CONTROL valve lever (15).
- (23) Remove fuel service nozzle (6) or overwing nozzle (7) from receiving vehicle or aircraft fuel filler.
- (24) Install fuel filler cover on receiving vehicle or aircraft.
- (25) Close V7 REEL valve (12).
- (26) Drain fuel from hose (4) by squeezing and holding lever (16) on fuel service nozzle (6) or lever (17) on overwing nozzle (7) and dispose of fuel in accordance with unit SOP.

Operation Under Unusual Conditions (Cont)



- (27) Set APC AUXILIARY PUMP CONTROL switch (13) to APC to shut Off.
- (28) Push MC MANUAL CONTROL EM VALVE lever (10) forward.

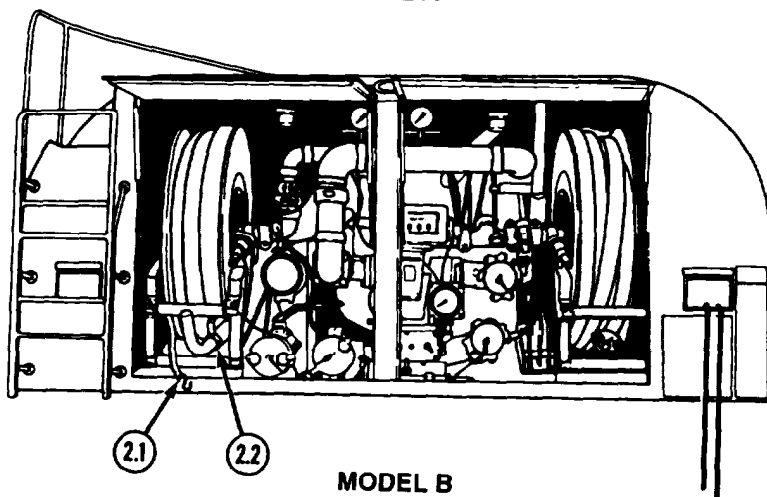
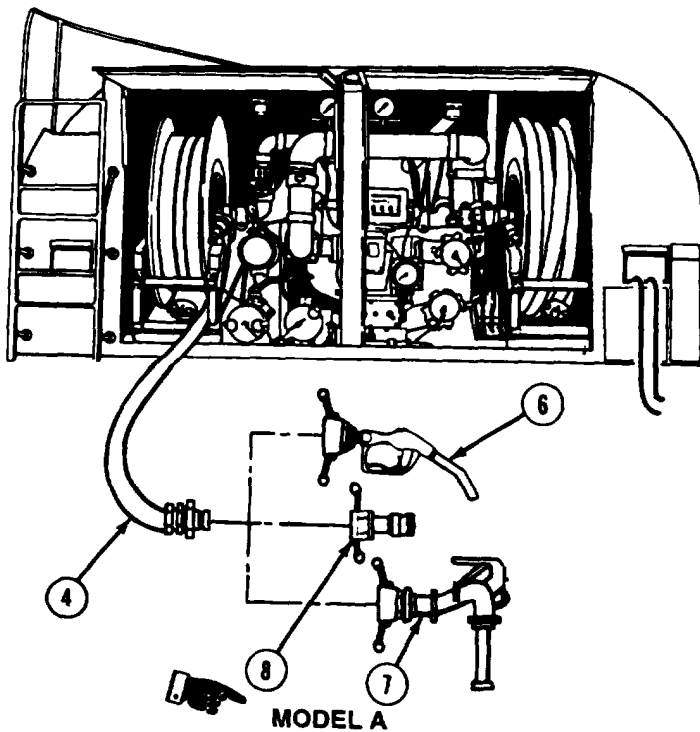
CAUTION

Guide hoses back onto reel. Carefully guide control through access hole onto reel. Failure to do so may result in equipment damage.

- (29) Let HAV HAND ACTUATED CONTROL valve hoses (18) rewind onto reel (19) and stow inside pump module (20).

Operation Under Unusual Conditions (Cont)

2-48. EMERGENCY PROCEDURES (CONT).



NOTE

Model B has a rubber tiedown strap to secure fuel service nozzle in stowage position. If leaving fuel service nozzle attached to hose, do step (29.1) and skip steps (30) through (32) and step (37).

Operation Under Unusual Conditions (Cont)

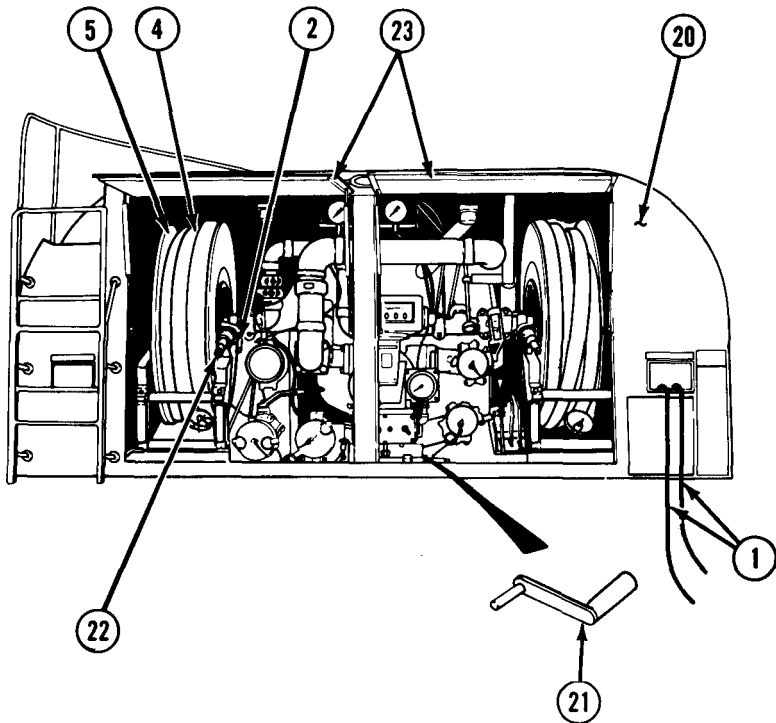
- (29.1) Place fuel service nozzle (2.2) in stowage position and secure with rubber tiedown strap (2.1).
- (30) Remove fuel service nozzle (6) or overwing nozzle (7) from hose (4) or reducer adapter (8).

NOTE

Reducer adapter is used with over-wing nozzle only. If overwing nozzle was not used, skip step (31).

- (31) Remove reducer adapter (8) from hose (4).
- (32) Put fuel service nozzle (6) or over-wing nozzle (7), and reducer adapter (8) in stowage.

Operation Under Unusual Conditions (Cont)

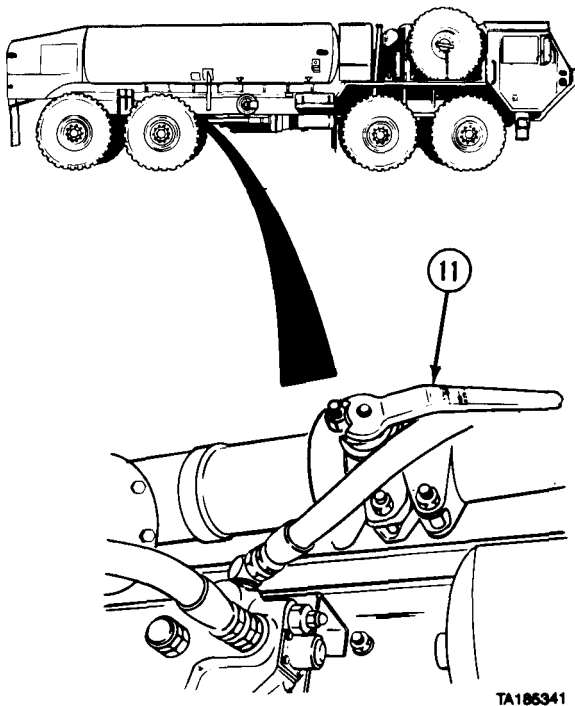


TA185979

- (33) Remove crank (21) from stowage on pump module (20).
- (34) Release hose reel tension knob (2).
- (35) Put crank (21) on crankshaft (22).
- (36) Turn crank (21) to rewind hose (4) onto reel (5).
- (37) Install dust cap (3) on end of hose (4).
- (38) Engage hose reel tension knob (2).
- (39) Return crank (21) to stowage.
- (40) Disconnect and rewind SR1 and SR2 static ground cables (1).
- (41) Close pump module rear doors (23).

Operation Under Unusual Conditions (Cont)

2-48. EMERGENCY PROCEDURES (CONT).



TA185341

NOTE

V3 SUCTION LINE VALVE is located inside left frame rail above rear of air tank in front of No. 3 axle.

(42) Set V3 SUCTION LINE VALVE handle (11) to OPEN position.

Operation Under Unusual Conditions (Cont)

2-49. LIMP HOME/FLAT TIRE WITH NO SPARE.

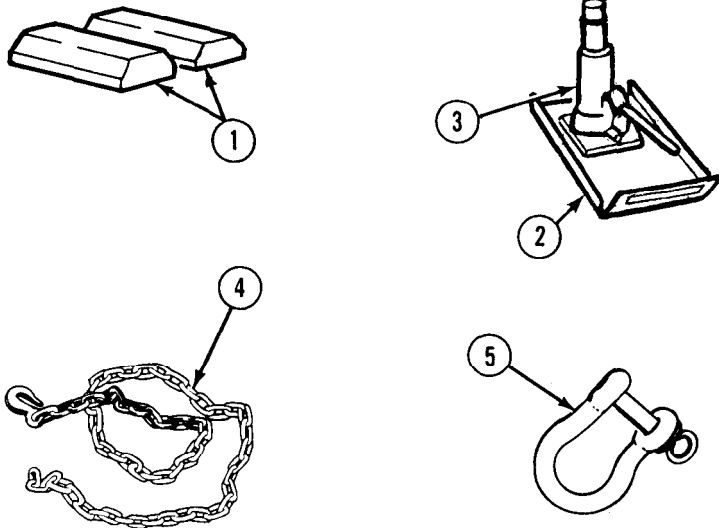
a. Right Front or Any Rear Wheel.

CAUTION

- Do not use this procedure on fully loaded M983 vehicle with trailer in tow. Limp home setup will not support extra weight and equipment could be damaged.
- Vehicle must not be driven faster than 10 MPH (16 kmh) or farther than 30 miles (48 km) in limp home condition.

NOTE

- Use limp home procedure for emergency only in case of wheel bearing failure, wheel damage, or when unable to change wheel and tire.
- For limp home setup on left front axles Nos. 1 and 2, refer to paragraph 2-49c.
- Limp home setup for No. 4 axle is shown. Other limp home setups are done in same manner.

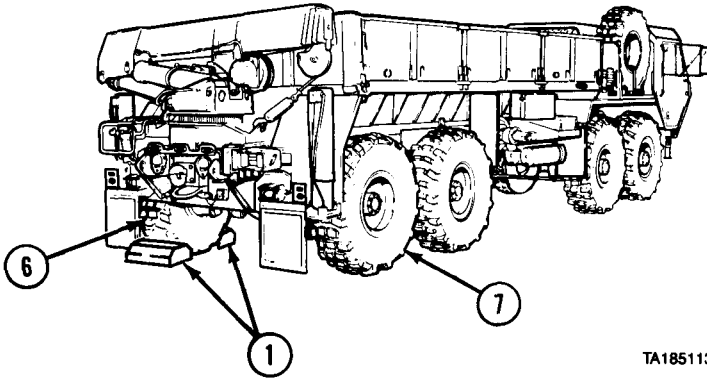


TA185342

- (1) Remove two wheel chocks (1), jack base plate (2), jack (3), chain (4), and shackle (5) from stowage.

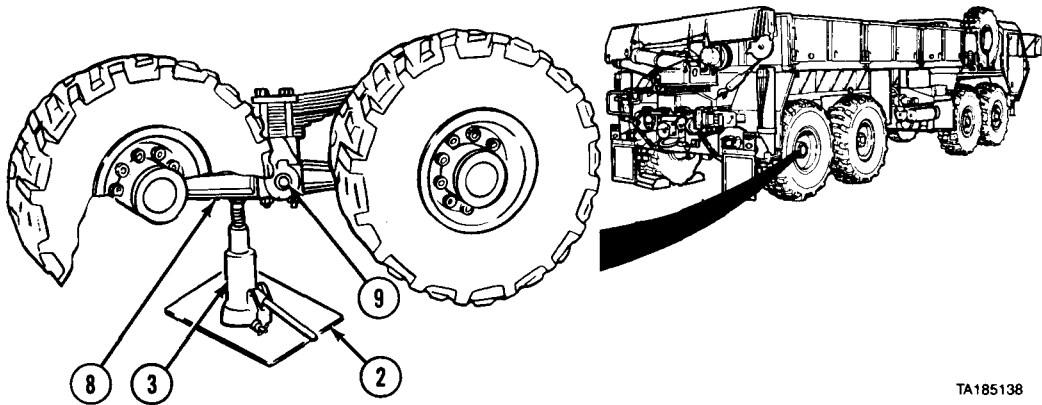
Operation Under Unusual Conditions (Cont)

2-49. LIMP HOME/FLAT TIRE WITH NO SPARE (CONT).



TA185113

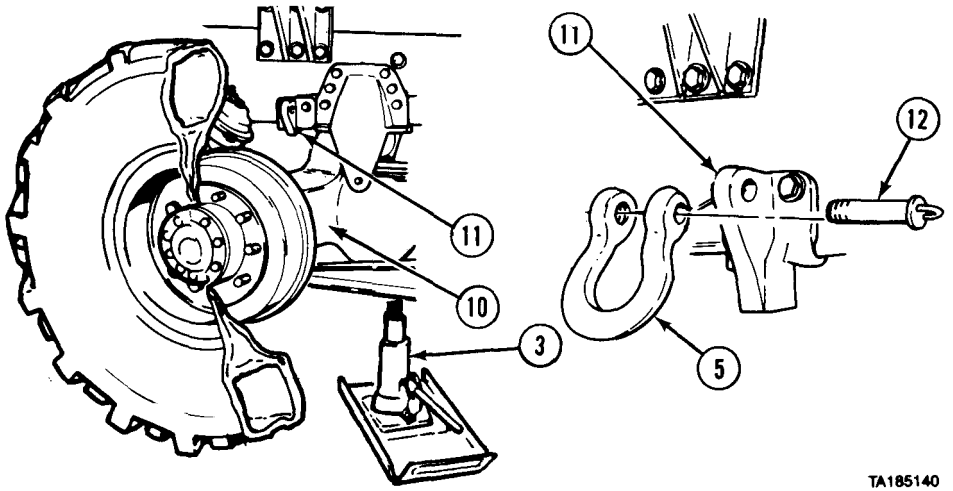
- (2) Place two wheel chocks (1) in front of and behind tire (6) across from tire (7) being raised.



TA185138

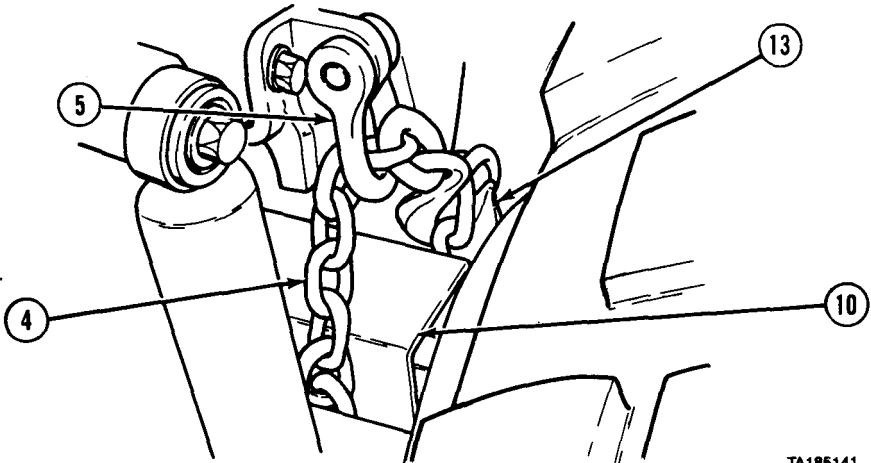
- (3) Position jack base plate (2) and jack (3) under equalizer beam (8) 4 to 5 in. (102 to 127 mm) from center pivot point (9).
- (4) Raise jack (3) until it touches equalizer beam (8).

Operation Under Unusual Conditions (Cont)



TA185140

- (5) Raise jack (3) until axle (10) is as close as it will go to axle stop (11).
- (6) Install shackle (5) on axle stop (11) with pin (12).



TA185141

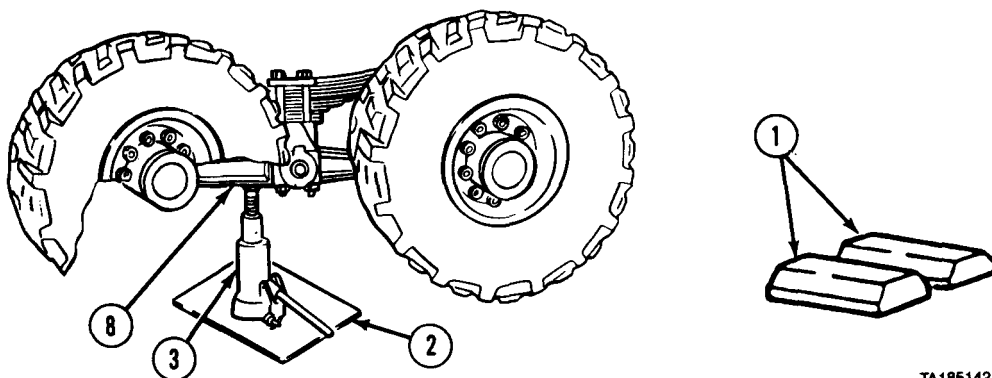
CAUTION

Do not wrap chain around any airhose or brake chamber bracket. Airhose could be crushed and damage to bracket could result.

- (7) Put chain (4) through shackle (5).
- (8) Loop end of chain (4) around axle (10).
- (9) Bring chain (4) up to chain hook (13) and fasten as tight as possible.

Operation Under Unusual Conditions (Cont)

2-49. LIMP HOME/FLAT TIRE WITH NO SPARE (CONT).



TA185142

WARNING

Keep hands away from chain when lowering jack.
Hands and fingers could be crushed.

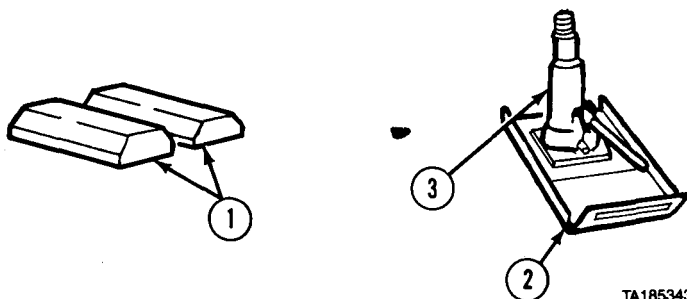
NOTE

Axle will drop slightly when jack is lowered.

(10) Lower jack (3) and remove jack from equalizer beam (8).

(11) Put jack (3), jack base plate (2), and two wheel chocks (1) in stowage.

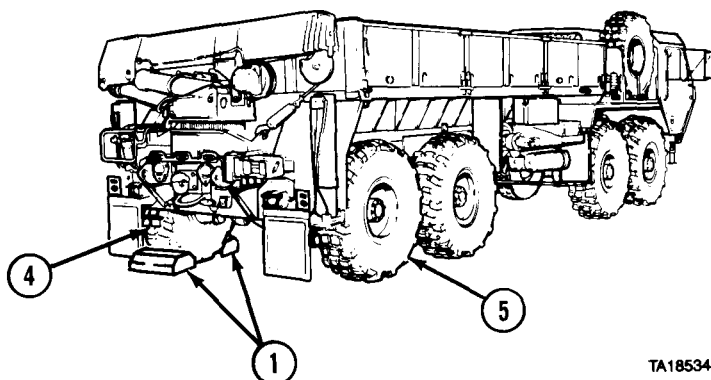
b. Remove Limp Home Setup/Right Front or Any Rear Wheel.



TA185343

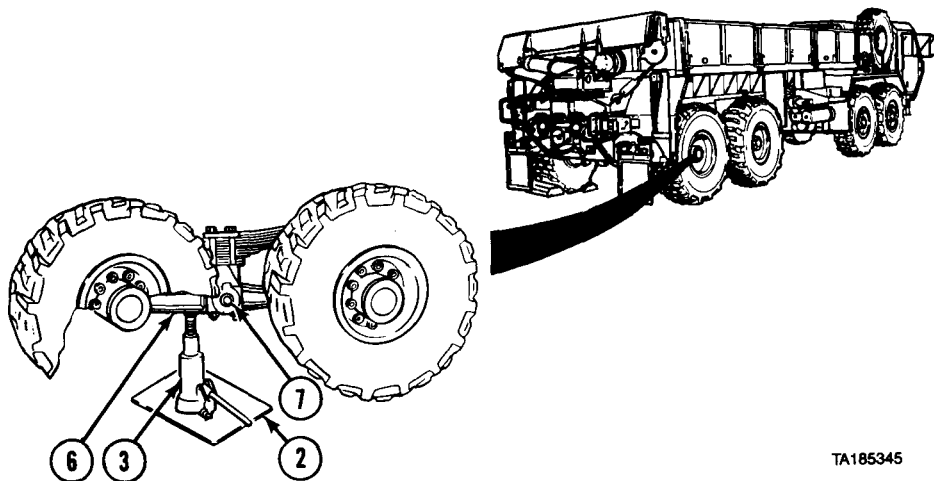
(1) Remove two wheel chocks (1), jack base plate (2), and jack (3) from stowage.

Operation Under Unusual Conditions (Cont)



TA185344

- (2) Place two wheel chocks (1) in front of and behind tire (4) across from tire (5) being raised.



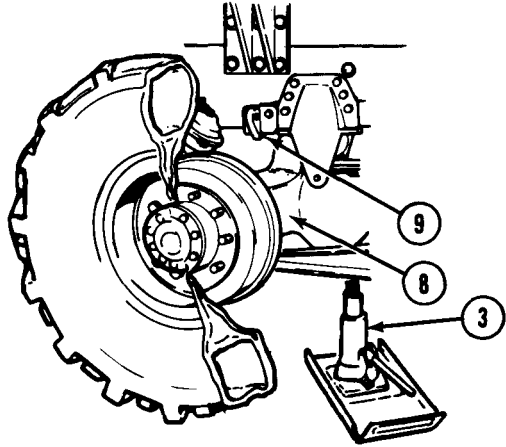
TA185345

- (3) Position jack base plate (2) and jack (3) under equalizer beam (6) 4 to 5 in. (102 to 127 mm) from center pivot point (7).
 (4) Raise jack (3) until it touches equalizer beam (6).

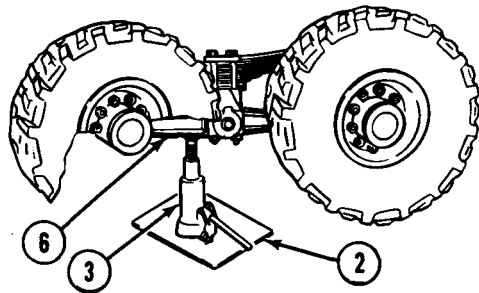
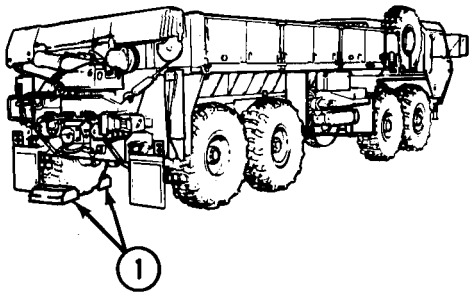
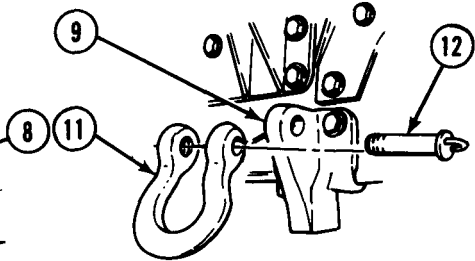
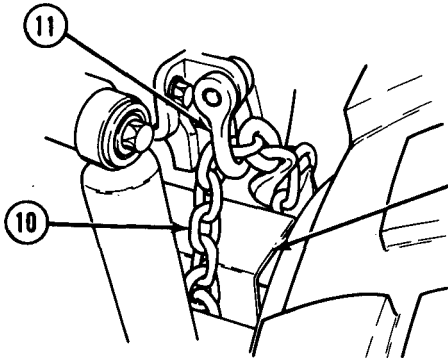
Operation Under Unusual Conditions (Cont)

2-49. LIMP HOME/FLAT TIRE WITH NO SPARE (CONT).

(5) Raise jack (3) until axle (8) is as close as it will go to axle stop (9).



TA185139



TA185143

Operation Under Unusual Conditions (Cont)

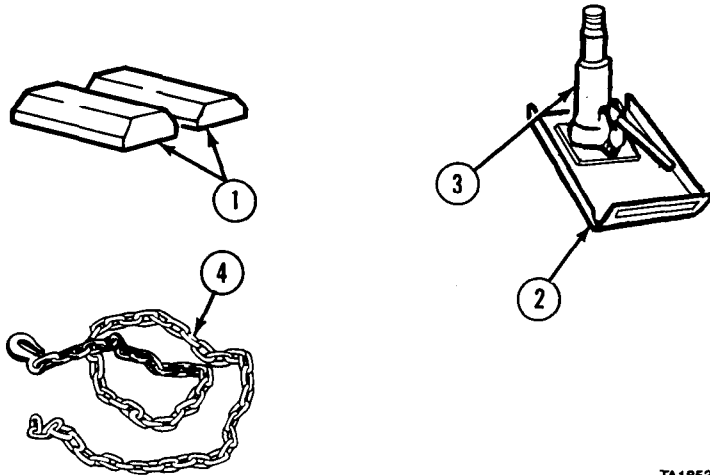
- (6) Unhook chain (10) and remove from shackle (11) and axle (8).
- (7) Remove pin (12) from shackle (11) and axle stop (9).
- (8) Lower jack (3) and remove jack from equalizer beam (6).
- (9) Put chain (10), shackle and pin (11 and 12), two wheel chocks (1), jack (3), and jack base plate (2) in stowage.

c. Limp Home Setup/Left Front.**CAUTION**

- Do not use this procedure on fully loaded M983 vehicle with trailer in tow. Limp home setup will not support extra weight and equipment could be damaged.
- Vehicle must not be driven faster than 10 MPH (16 kmh) or farther than 30 miles (48 km) in limp home condition.

NOTE

- Use limp home procedure for emergency only in case of wheel bearing failure, wheel damage, or when unable to change wheel and tire.
- Limp home setup on No. 1 axle is shown. Setup for axle No. 2 is done in same manner.
- For limp home setup on other axles, refer to paragraph 2-49a.

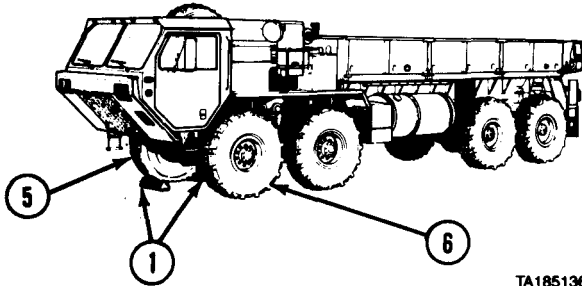


TA185346

- (1) Remove two wheel chocks (1), jack base plate (2), jack (3), and chain (4) from stowage.

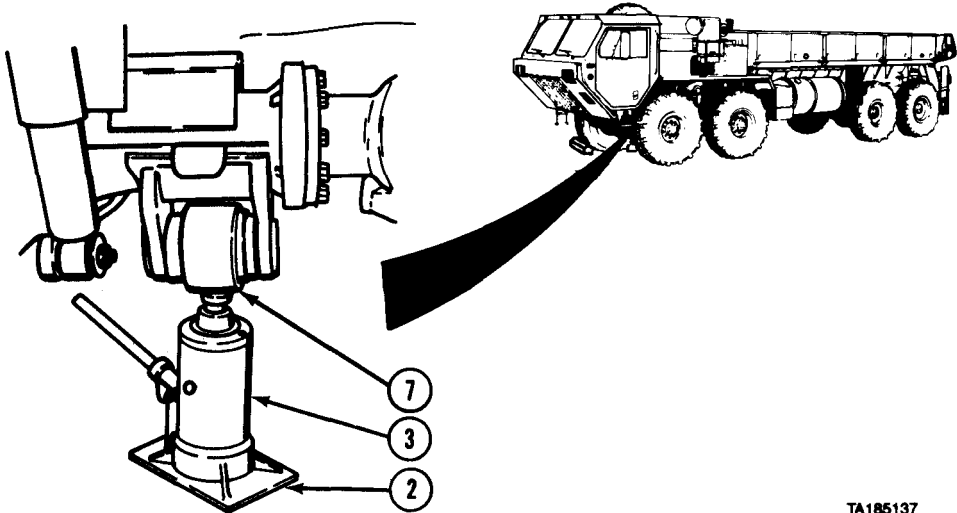
Operation Under Unusual Conditions (Cont)

2-49. LIMP HOME/FLAT TIRE WITH NO SPARE (CONT).



TA185136

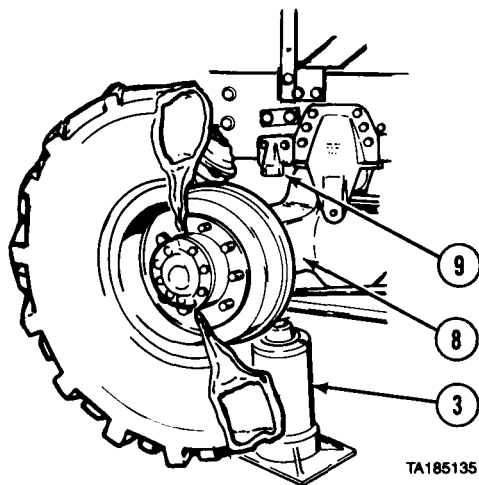
(2) Place two wheel chocks (1) in front of and behind tire (5) across from tire (6) being raised.



TA185137

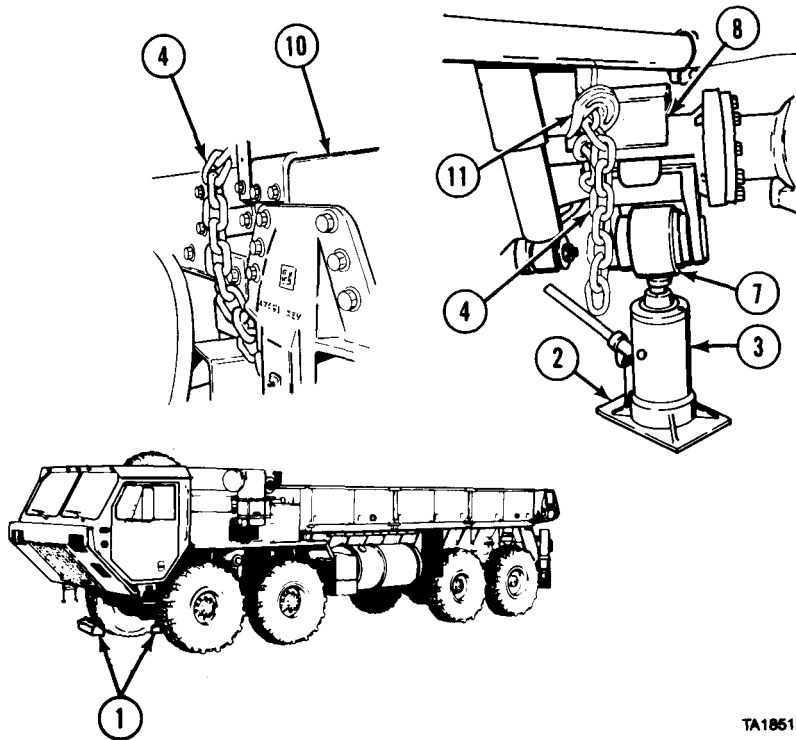
(3) Place jack base plate (2) and jack (3) under end of equalizer beam (7).
(4) Raise jack (3) until it touches end of equalizer beam (7).

(5) Raise jack (3) until axle (8) is as close as it will go to axle stop (9).



TA185135

Operation Under Unusual Conditions (Cont)



TA185134

CAUTION

Do not wrap chain around lateral torque rod or shift cables. They could be crushed.

- (6) Loop end of chain (4) around frame (10) and axle (8).
- (7) Bring end of chain (4) up to chain hook (11) and fasten as tight as possible.

WARNING

Keep hands away from chain when lowering jack. Hands and fingers could be crushed.

NOTE

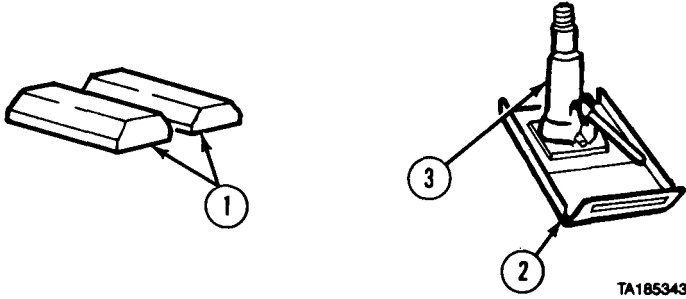
Axle will drop slightly when jack is lowered.

- (8) Lower jack (3) and remove jack from end of equalizer beam (7).
- (9) Put jack (3), jack base plate (2), and two wheel chocks (1) in stowage.

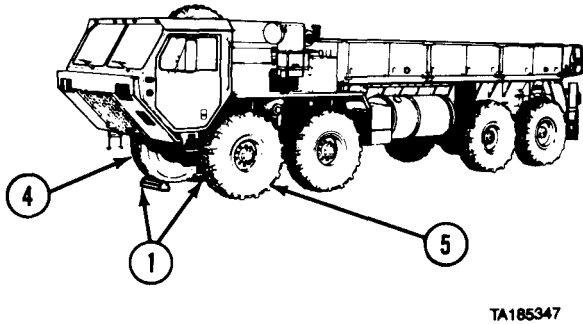
Operation Under Unusual Conditions (Cont)

2-49. LIMP HOME/FLAT TIRE WITH NO SPARE (CONT).

d. Remove Limp Home Setup/Left Front.

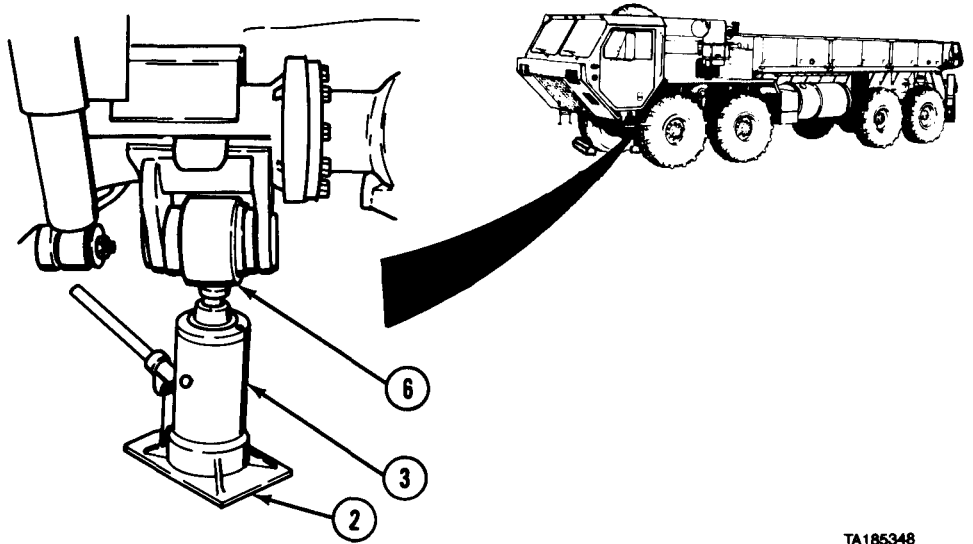


(1) Remove two wheel chocks (1), jack base plate (2), and jack (3) from stowage.



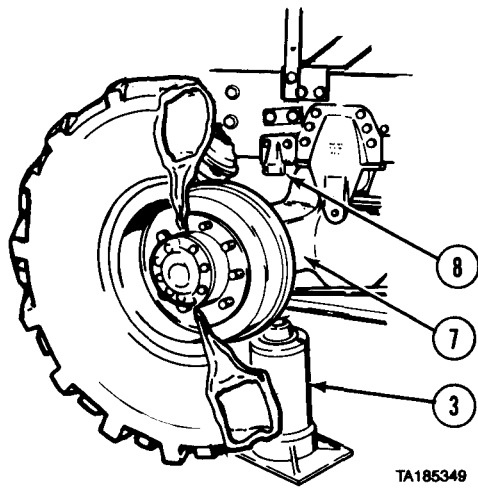
(2) Place two wheel chocks (1) in front of and behind tire (4) across from tire (5) being raised.

Operation Under Unusual Conditions (Cont)



TA185348

- (3) Place jack base plate (2) and jack (3) under end of equalizer beam (6).
- (4) Raise jack (3) until it touches end of equalizer beam (6).

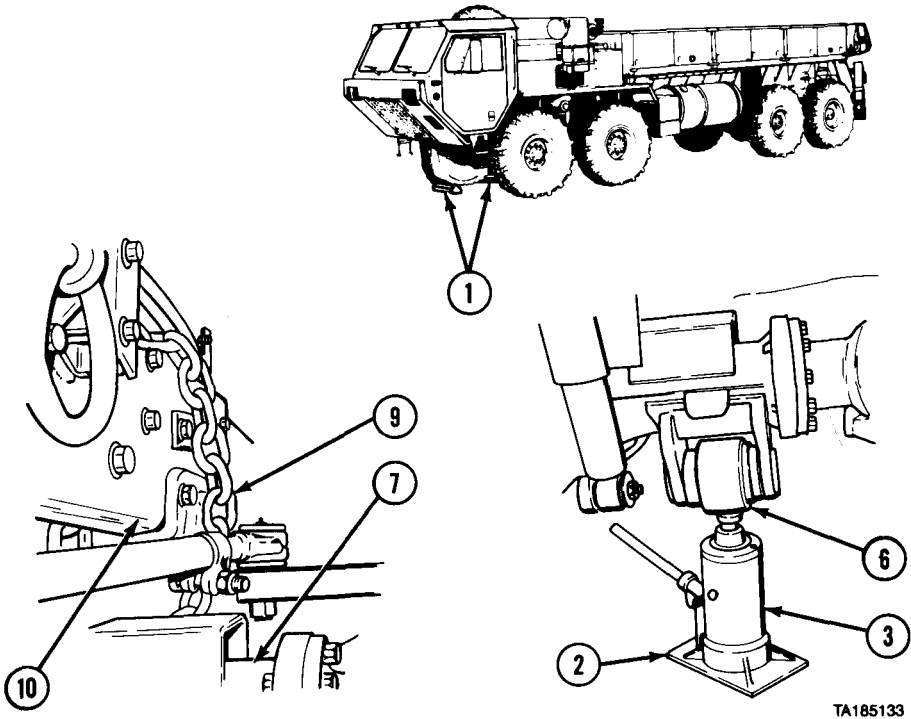


TA185349

- (5) Raise jack (3) until axle (7) is as close as it will go to axle stop (8).

Operation Under Unusual Conditions (Cont)

2-49. LIMP HOME/FLAT TIRE WITH NO SPARE (CONT).



TA185133

- (6) Unhook chain (9) and remove from around frame (10) and axle (7).
- (7) Lower jack (3) and remove jack from equalizer beam (6).
- (8) Put two wheel chocks (1), jack (3), jack base plate (2), and chain (9) in stowage.

CHAPTER 3

MAINTENANCE INSTRUCTIONS

Contents	Para	Page
Lubrication	3-1	3-1
Troubleshooting Introduction.	3-2	3-1
Troubleshooting Symptoms.. . . .	3-3	3-1
Maintenance Introduction	3-4	3-40
Clean Vehicle	3-5	3-40
Change Wheel and Tire Assembly.	3-6	3-41
Clean Fuel Tank Strainer	3-7	3-56
Service Air Cleaner Element.	3-8	3-57
Service Tires	3-9	3-61
Open/Close Battery Box	3-10	3-63
Open/Close Engine Cover	3-11	3-64

Section I. LUBRICATION INSTRUCTIONS

3-1. LUBRICATION. Refer to LO 9-2320-279-12 for materials and instructions to be used for lubrication of M977 series vehicles covered in this technical manual.

Section II. TROUBLESHOOTING PROCEDURES

Troubleshooting Index

3-2. Troubleshooting INTRODUCTION. To quickly find the required troubleshooting procedure, use the fault Symptom Index, Table 3-1. Components and symptoms are listed alphabetically. Common malfunctions are listed alphabetically under those components or system headings.

NOTE

Troubleshooting the M984E1 wrecker-recovery vehicle steering system, heavy-duty winch, material handling crane, and retrieval system will be found in Volume 2 of this manual. Troubleshooting other M984E1 operating systems is covered in this volume.

3-3. TROUBLESHOOTING SYMPTOMS. Table 3-2 lists the most common malfunctions found during operation or maintenance of the M977 series vehicle or its components. Tests or inspections and corrective actions should be performed in the order listed.

This manual cannot list all malfunctions that may occur, nor all tests or inspections, and corrective actions. If a malfunction is not listed, or is not corrected by listed corrective actions, notify the supervisor.

Troubleshooting Index (Cont)

3-3. TROUBLESHOOTING SYMPTOMS (CONT).

Table 3-1. Symptom Index

	Troubleshooting Procedure Page
AIR SYSTEM	
Air horn will not operate	3-22
Buzzer sounds and AIR indicator is lit	3-18
Loses pressure or AIR indicator lights and buzzer sounds during operation	3-20
Trailer brake does not apply when service brake treadle or parking brake is used	3-20
Windshield washer will not operate.	3-21
ELECTRICAL SYSTEM	
One or more lighting circuits not operating	3-24
ENGINE	
Cranks but fails to start	3-4
Excessive engine oil consumption.	3-10
Fails to crank when engine start switch is turned to start position.	3-4
Low OIL PRESS gage indication..	3-9
Overheats	3-7
Starts or runs roughly after proper warmup. Does not develop full power or makes excessive exhaust smoke	3-6
Will not stop running when ENGINE STOP switch is activated	3-10
HYDRAULIC SYSTEM	
One or more hydraulic circuits will not operate	3-25
Operates either too slow, too fast, or with jerky movements	3-25
MATERIAL HANDLING CRANE (M977, M985)	
Boom operation abnormal when telescoping in or out.	3-28
Boom raises or lowers slowly	3-29
Boom will not raise or lower	3-30
Boom will not telescope in or out.	3-31
Crane controls sticking in engaged position	3-32
Crane will not operate or operates abnormally.	3-33
Hoist operation slow or abnormal when lifting or lowering load.	3-34
Hoist will not lift load	3-35
Mast raises or lowers abnormally	3-36
Mast raises or lowers slowly	3-36
Outrigger operation slow or abnormal	3-37
Swing operation abnormal in both directions	3-37
Swing operation abnormal in one direction only	3-38

Troubleshooting Index (Cont)

Table 3-1. Symptom Index (Cont)

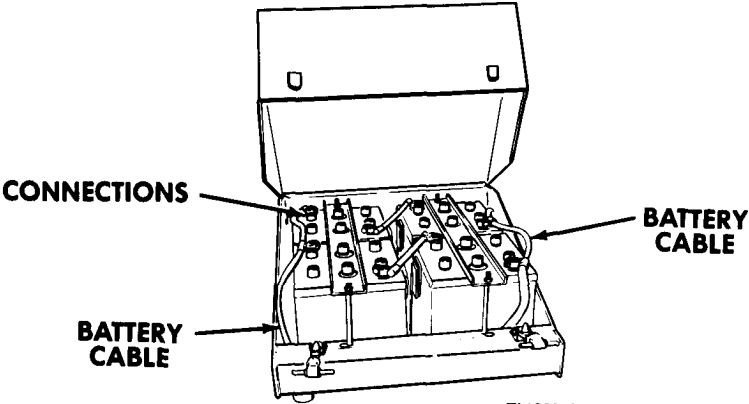
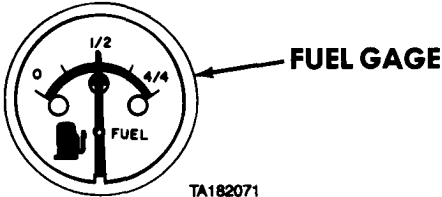
	Troubleshooting Procedure Page
SELF-RECOVERY WINCH	
Does not work	3-27
Unusually noisy when operating	3-27
SPECIAL PURPOSE KITS	
M-8 Chemical alarm	3-39
Radio	3-39
STEERING	
Vehicle is hard to steer, shimmies, or wanders	3-16
Vehicle steering slow to respond or intermittent	3-17
TANKER	
Water is dispensed with fuel.	3-26
TRANSMISSION AND TRANSFER CASE	
Slow or difficult engagement.	3-13
TRANSFER CASE shift lever will not shift	3-13
TRANS TEMP gage indicates overheating during normal operation	3-13
Unusually noisy when operating	3-13
WHEELS, TIRES, AND HUBS	
Tires worn unevenly or excessively	3-16
Vehicle wanders or pulls to one side on level surface	3-14
Wheel wobbles	3-14



Troubleshooting Malfunctions

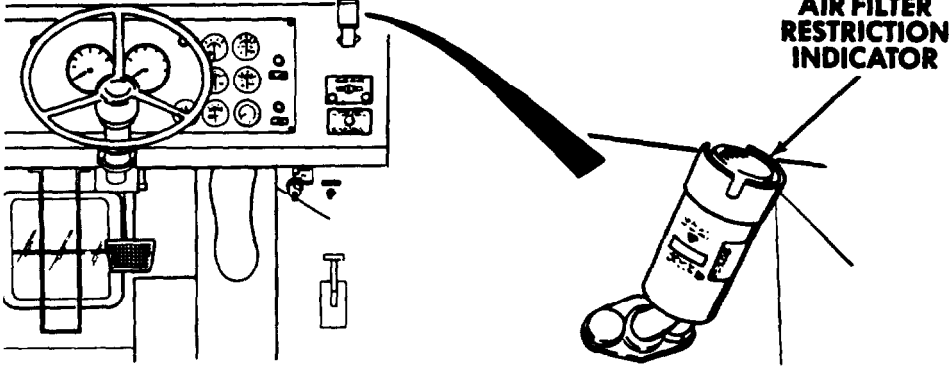
3-3. TROUBLESHOOTING SYMPTOMS (CONT).

Table 3-2. Troubleshooting

Malfunction	Test or Inspection	Corrective Action
ENGINE		
1. FAILS TO CRANK WHEN ENGINE START SWITCH IS TURNED TO START POSITION.	<p>Step 1. Check that transmission range selector is in N (neutral) position. Place range selector in N (neutral) position several times.</p>	 <p style="text-align: right;">TA182068</p>
	<p>Step 2. If engine still fails to crank, check for dirty connections, and loose or broken battery cables. If battery connections are dirty, or cables are damaged, notify organizational maintenance.</p>	
2. CRANKS BUT FAILS TO START.	<p>Step 1. Check indication on FUEL gage.</p>	 <p style="text-align: right;">TA182071</p>
	<p>If fuel gage shows there is enough fuel but engine still will not start, go to Step 2.</p>	
	<p>Step 2. Visually check fuel level in fuel tank.</p>	

Troubleshooting Malfunctions (Cont)

Table 3-2. Troubleshooting (Cont)

Malfunction	Test or Inspection	Corrective Action
ENGINE (CONT)		
2. CRANKS BUT FAILS TO START (CONT).		
		
Step 3. Check air filter restriction indicator.		
If indicator shows yellow, but engine still will not start, notify organizational maintenance.		
If indicator shows red and/or VACUUM INCHES H ₂ O window shows 18 or more, clean air filter (para 3-8).		
If indicator still shows red after cleaning air filter, notify organizational maintenance.		

Troubleshooting Malfunctions (Cont)

3-3. TROUBLESHOOTING SYMPTOMS (CONT).

Table 3-2. Troubleshooting (Cont)

Malfunction	Test or Inspection	Corrective Action
ENGINE (CONT)		
3.	STARTS OR RUNS ROUGHLY AFTER PROPER WARMUP. DOES NOT DEVELOP FULL POWER OR MAKES EXCESSIVE EXHAUST SMOKE.	<p>Step 1. Check PTO ENGAGE switch and light to make sure that PTO is disengaged. Light should be off. Disengage PTO.</p> <p>Step 2. Check air filter restriction indicator.</p> <p>If indicator shows red and/or VACUUM INCHES H₂O window shows 18 or more, press reset button.</p> <p>If indicator still shows red and/or VACUUM INCHES H₂O window shows 18 or more, clean air filter (para 3-8).</p> <p>If indicator still shows red after cleaning filter, notify organizational maintenance.</p>

Troubleshooting Malfunctions (Cont)
 Table 3-2. Troubleshooting (Cont)

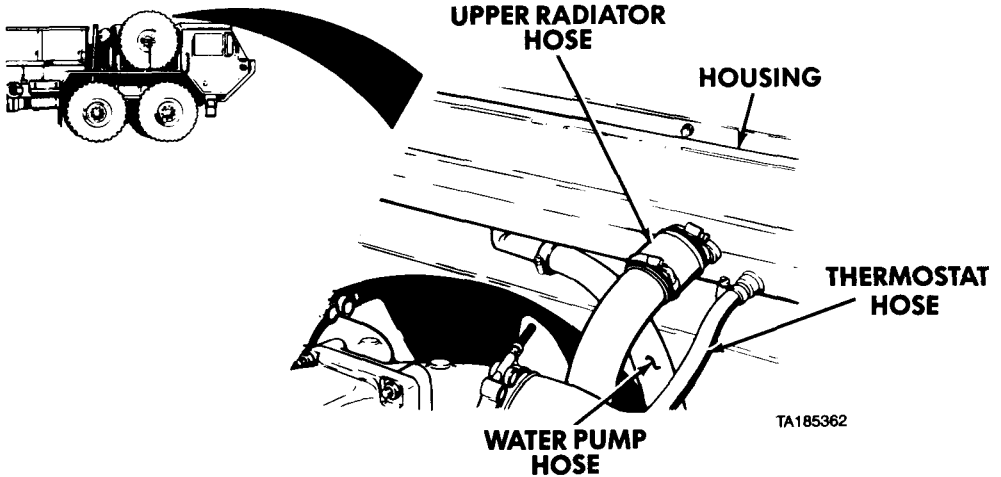
Malfunction	Test or Inspection	Corrective Action
-------------	--------------------	-------------------

ENGINE (CONT)

4. ENGINE OVERHEATS.

WARNING

Radiator coolant hoses are very hot and pressurized during vehicle operation. Let radiator cool before checking hoses. Failure to follow this procedure may result in serious burns.



- Step 1. Open right side engine cover (para 3-11a).
- Step 2. Check upper radiator hoses and housing.

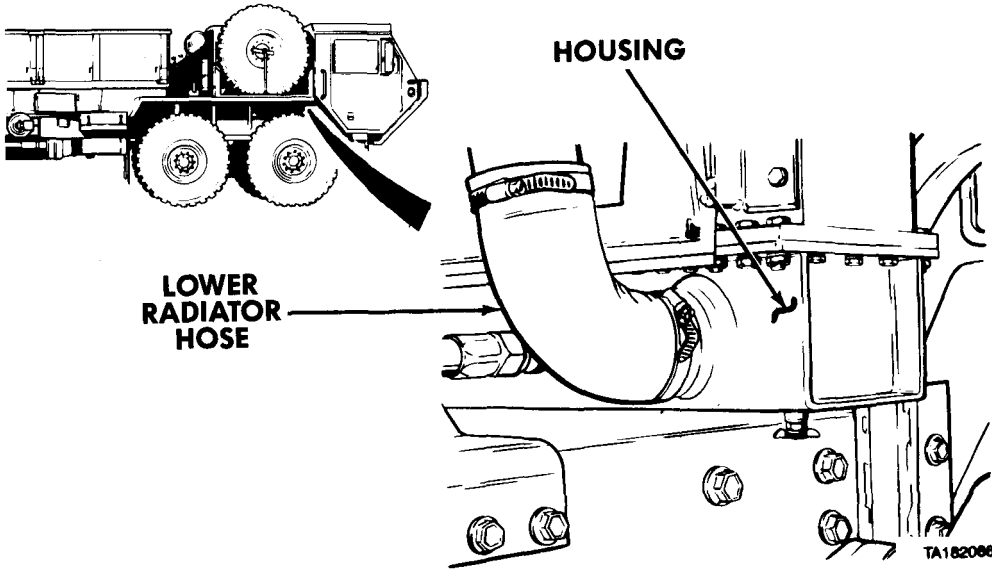
Tighten loose hose clamps.

If housing or hoses leak, notify organizational maintenance.

Troubleshooting Malfunctions (Cont)

3-3. TROUBLESHOOTING SYMPTOMS (CONT).

Table 3-2. Troubleshooting (Cont)

Malfunction	Test or Inspection	Corrective Action
ENGINE (CONT)		
4. ENGINE OVERHEATS (CONT).		
		
Step 3. Close right side engine cover (para 3-11b).		
Step 4. Check lower radiator hose and housing for leaks.		
Tighten loose hose clamps. If housing or hose leaks, notify organizational maintenance.		

Troubleshooting Malfunctions (Cont)

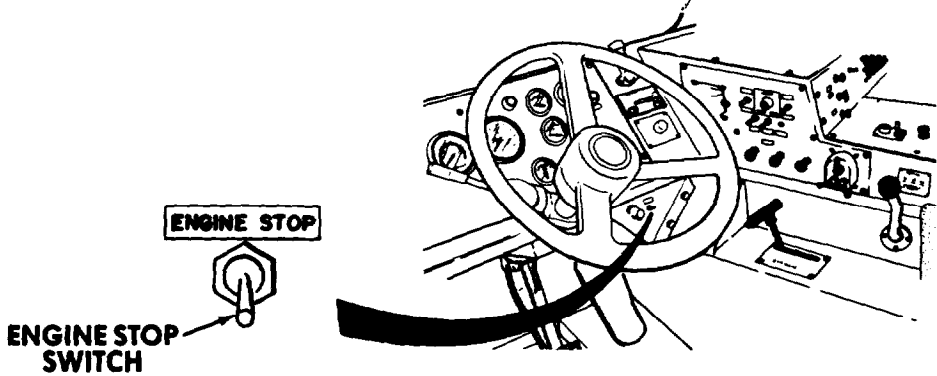
Table 3-2. Troubleshooting (Cont)

Malfunction	Test or Inspection	Corrective Action
ENGINE (CONT)		
4. ENGINE OVERHEATS (CONT).		
<p>The diagram shows a cross-section of an engine compartment. A hose is connected to a housing. Labels point to the 'HOUSING', 'UPPER END/HOSE', and 'LOWER END/HOSE (HIDDEN)'. A secondary diagram shows a truck with a hose connected to its engine area.</p>		
	<p>Step 5. Open left side engine cover (para 3-11a).</p>	
	<p>Step 6. Check upper and lower ends of hose and housing for leaks.</p>	
	<p style="text-align: center;">Tighten loose hose clamps. If housing or hoses leak, notify organizational maintenance.</p>	
5. LOW OIL PRESSURE GAGE INDICATION.		
	<p>LOW OIL PRESSURE INDICATION</p>	<p>The gauge is circular with a scale from 0 to 100 KPA. The needle is pointing to approximately 10 KPA. Below the gauge is a small oil can icon and the text 'OIL PRESS'.</p>
	<p>Step 1. Check engine oil level (Table 2-1, Item 7a).</p>	
	<p style="text-align: center;">If oil level is low, notify organizational maintenance.</p>	

Troubleshooting Malfunctions (Cont)

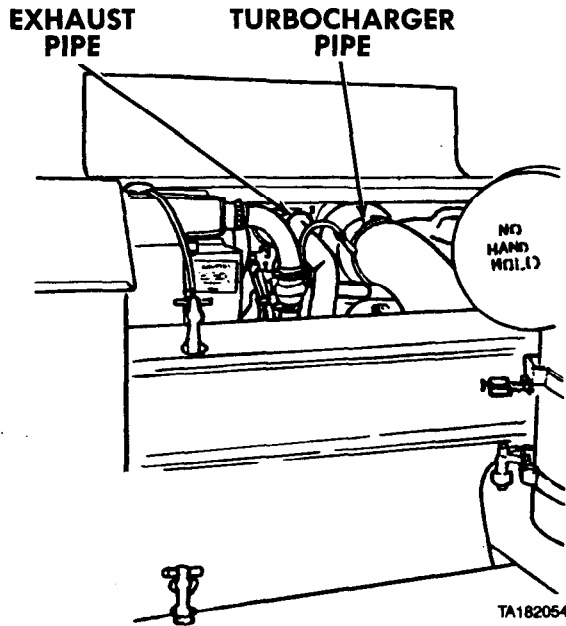
3-3. TROUBLESHOOTING SYMPTOMS (CONT).

Table 3-2. Troubleshooting (Cont)

Malfunction	Test or Inspection	Corrective Action
ENGINE (CONT)		
6. EXCESSIVE ENGINE OIL CONSUMPTION.	<p>Step 1. Check engine for loose oil lines. If unable to tighten lines, notify organizational maintenance.</p>	<p>If any leaks or broken lines are found, notify organizational maintenance.</p>
<u>WARNING</u>		
<p>Do not use this procedure when engine is in a runaway condition. A runaway engine may cause severe personal injury or death.</p>		
7. WILL NOT STOP RUNNING WHEN ENGINE STOP SWITCH IS ACTIVATED.		
 <p>The diagram shows a close-up of an engine stop switch on the left, which is a hexagonal button with a pin protruding from the top. A label 'ENGINE STOP SWITCH' with an arrow points to the pin. To the right is a line drawing of a cockpit interior, showing a steering wheel with various gauges and instruments, and a control panel with several buttons and a joystick.</p>		
<p>Step 1. Make sure switch is held in down position. If engine does not stop running go to Step 2.</p> <p>Step 2. Remove jack handle from stowage.</p>		

Troubleshooting Malfunctions (Cont)

Table 3-2. Troubleshooting (Cont)

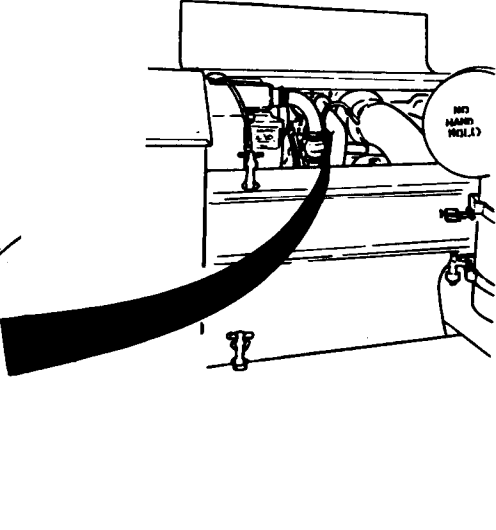
Malfunction**Test or Inspection****Corrective Action****ENGINE (CONT)****7. WILL NOT STOP RUNNING WHEN ENGINE STOP SWITCH IS ACTIVATED (CONT).**

Step 3. Open left side engine cover (para 3-11a).

Step 4. Put end of jack handle between exhaust pipe and turbocharger pipe.

3-3. TROUBLESHOOTING SYMPTOMS (CONT).

Table 3-2. Troubleshooting (Cont)

Malfunction	Test or Inspection	Corrective Action
ENGINE (CONT)		
7. WILL NOT STOP RUNNING WHEN ENGINE STOP SWITCH IS ACTIVATED (CONT).		
ENGINE SHUT-OFF SOLENOID LEVER	THROTTLE CONTROL	
TA182063		
<p>Step 5. Put end of jack handle under throttle control and against engine shut-off solenoid lever.</p> <p>Step 6. Push lever as far as it will go. Hold until engine stops.</p> <p>Step 7. Notify organizational maintenance.</p>		

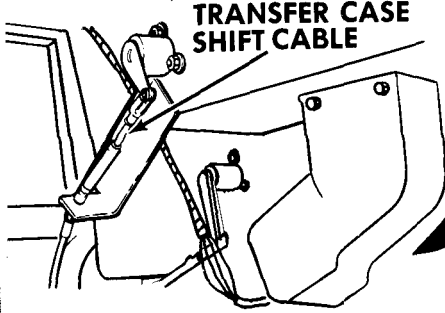
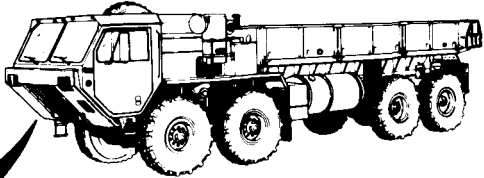
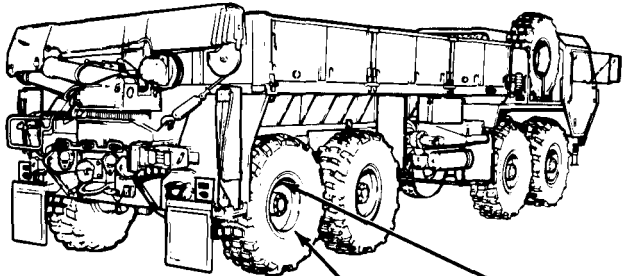
Troubleshooting Malfunctions (Cont)
 Table 3-2. Troubleshooting (Cont)

Malfunction Test or Inspection	Corrective Action
TRANSMISSION AND TRANSFER CASE	
1. UNUSUALLY NOISY WHEN OPERATING.	Notify organizational maintenance.
2. TRANS TEMP GAGE INDICATES OVERHEATING DURING NORMAL OPERATION.	<p>Step 1. Check transmission fluid level (Table 2-1, Item No. 11).</p> <p style="padding-left: 40px;">If fluid level is low or too high, notify organizational maintenance.</p> <p style="padding-left: 40px;">If fluid level is correct and problem still exists, notify organizational maintenance.</p>
3. SLOW OR DIFFICULT ENGAGEMENT.	Notify organizational maintenance.
4. TRANSFER CASE SHIFT LEVER WILL NOT SHIFT.	<p>Step 1. Move transmission range selector from N to D. Apply throttle to roll vehicle slightly and shift transmission from D to N. As vehicle stops, shift TRANSFER CASE shift lever.</p> <p>Step 2. Move transmission range selector from N to R. Apply throttle to roll vehicle slightly and shift transmission from R to N. As vehicle stops, shift TRANSFER CASE shift lever.</p>

Troubleshooting Malfunctions (Cont)

3-3. TROUBLESHOOTING SYMPTOMS (CONT).

Table 3-2. Troubleshooting (Cont)

Malfunction	Test or Inspection	Corrective Action
TRANSMISSION AND TRANSFER CASE (CONT)		
4. TRANSFER CASE SHIFT LEVER WILL NOT SHIFT (CONT).		
 <p>TRANSFER CASE SHIFT CABLE</p>		TA185092
Step 3. Clean off any mud or debris from around shift cable.		
Step 4. If transfer case still will not shift, notify organizational maintenance.		
WHEELS, TIRES, AND HUBS		
1. WHEEL WOBBLES.		
		
WHEEL	LUGNUTS (HIDDEN)	TA182056
Step 1. Check wheel for loose, missing, or broken lugnuts.		
Tighten loose lugnuts and notify organizational maintenance to have lugnuts tightened to torque requirements.		

Troubleshooting Malfunctions (Cont)

Table 3-2. Troubleshooting (Cont)

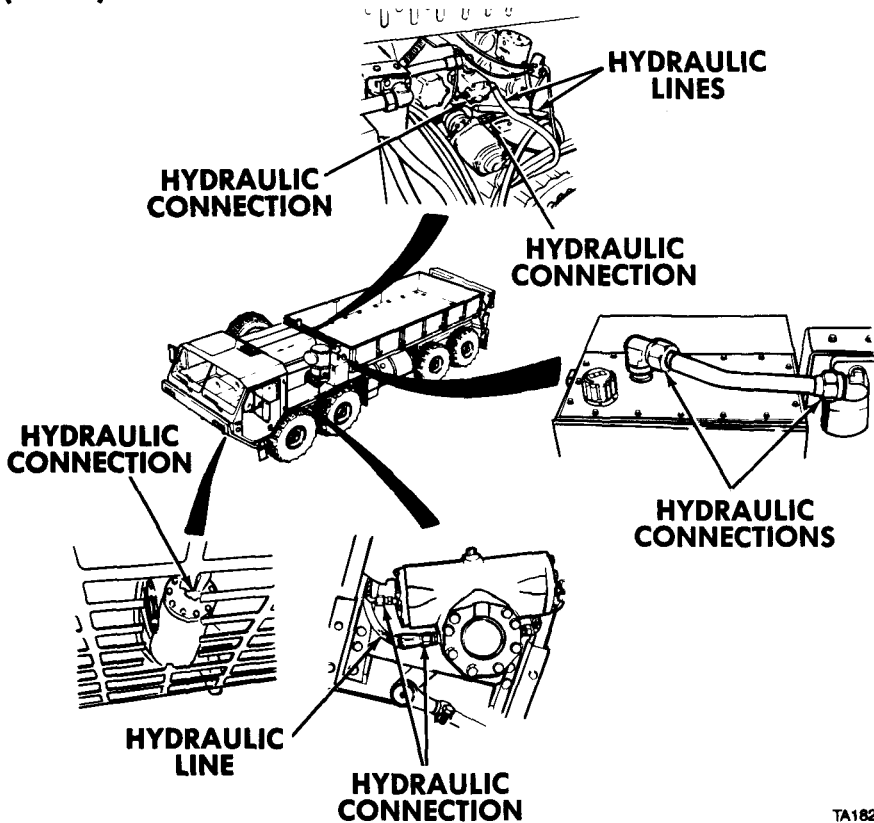
Malfunction Test or Inspection	Corrective Action
WHEELS, TIRES, AND HUBS (CONT)	
<p>1. WHEEL WOBBLES (CONT).</p>	
<p>Step 2. Check to see if wheel is bent.</p>	<p>If wheel is bent, change wheel and tire assembly (para 3-6). If wheel still wobbles, notify organizational maintenance.</p>
<p>2. TIRES WORN UNEVENLY OR EXCESSIVELY.</p>	
<p><u>WARNING</u></p>	
<p>Tire air pressure must be checked properly or serious injury or death may result.</p>	
<p>NOTE</p>	
<ul style="list-style-type: none"> • Inflate tires only when they are cool. Inflate tires to proper pressure for road condition. • Tire tread is nondirectional. Vehicle operation is not affected by direction of traction bars. 	
<p>Step 1. Check tires for proper inflation (Table 2-1, Item No. 3c).</p>	<p>Inflate or deflate tires to proper pressure (para 3-9a).</p>

Troubleshooting Malfunctions (Cont)
 Table 3-2. Troubleshooting (Cont)

Malfunction	Test or Inspection	Corrective Action
-------------	--------------------	-------------------

STEERING (CONT)

2. VEHICLE STEERING SLOW TO RESPOND OR INTERMITTENT (CONT).



Step 2. Check for loose or leaking hydraulic connections and damaged hydraulic lines.

Tighten loose connections. If leak does not stop, notify organizational maintenance.

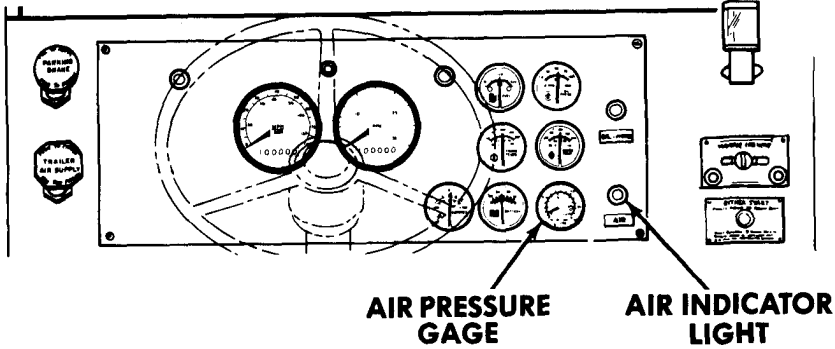
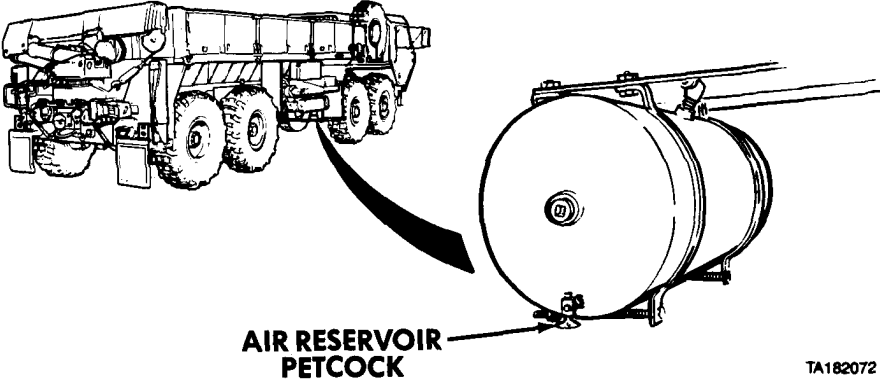
If lines are damaged, notify organizational maintenance.

If vehicle still steers slow, notify organizational maintenance.

Troubleshooting Malfunctions (Cont)

3-3. TROUBLESHOOTING SYMPTOMS (CONT).

Table 3-2. Troubleshooting (Cont)

Malfunction	Test or Inspection	Corrective Action
AIR SYSTEM		
1. BUZZER SOUNDS AND AIR INDICATOR IS LIT.		
		
TA182059		
Step 1. Check air pressure gage.		
<p>If gage shows 75 psi (517 kPa) or more, but buzzer and light are still on, notify organizational maintenance.</p>		
		
TA182072		
Step 2. Check to make sure all four air reservoir petcocks are closed.		
Close all petcocks.		
If buzzer and light are still on, go to Step 3.		

Troubleshooting Malfunctions (Cont)

Table 3-2. Troubleshooting (Cont)

Malfunction	Test or Inspection	Corrective Action
AIR SYSTEM (CONT)		
1. BUZZER SOUNDS AND AIR INDICATOR IS LIT (CONT).		
<p style="text-align: right;">TA182073</p>		
<p>Step 3. Check that TRAILER AIR SUPPLY control is pulled out (off position).</p>		
<p>Pull out TRAILER AIR SUPPLY control.</p>		
<p>Step 4. Check for leaks at air reservoir, hoses, lines, fittings, and connectors.</p>		
<p>If leak is found, tighten connections and notify organizational maintenance.</p>		
<p>If no leaks are found and problem still exists, go to Step 5.</p>		
<p>Step 5. If vehicle is coupled to trailer and troubleshooting of vehicle does not show trouble with vehicle air system, disconnect trailer.</p>		
<p>Step 6. Check air pressure gage again.</p>		
<p>If gage does not increase above 75 psi (517 kPa), notify organizational maintenance.</p>		

3-3. TROUBLESHOOTING SYMPTOMS (CONT).

Table 3-2. Troubleshooting (Cont)

Malfunction	Test or Inspection	Corrective Action
AIR SYSTEM (CONT)		
2. AIR SYSTEM LOSES PRESSURE DURING OPERATION.		
	Step 1. Check to make sure all four air reservoir petcocks are closed.	Close all petcocks. If problem still exists, go to Step 2.
	Step 2. Pull out TRAILER AIR SUPPLY control. If vehicle is coupled to trailer, push in TRAILER AIR SUPPLY control.	
	Step 3. Accelerate engine until AIR PRESS gage indicates 120 psi (827 kPa).	If 120 psi (827 kPa) cannot be reached, notify organizational maintenance.
	Step 4. Shut off engine.	
	Step 5. Press service brake treadle completely down while crew member listens for leaks.	If leak is found, notify organizational maintenance. If no leak is found, and problem still exists, notify organizational maintenance.
3. TRAILER BRAKE DOES NOT APPLY WHEN SERVICE BRAKE TREADLE OR PARKING BRAKE IS USED.		
	Step 1. Check to make sure that intervehicular airhoses are securely and correctly connected.	Connect airhoses. Push in TRAILER AIR SUPPLY control (ON position). If problem continues, notify organizational maintenance.

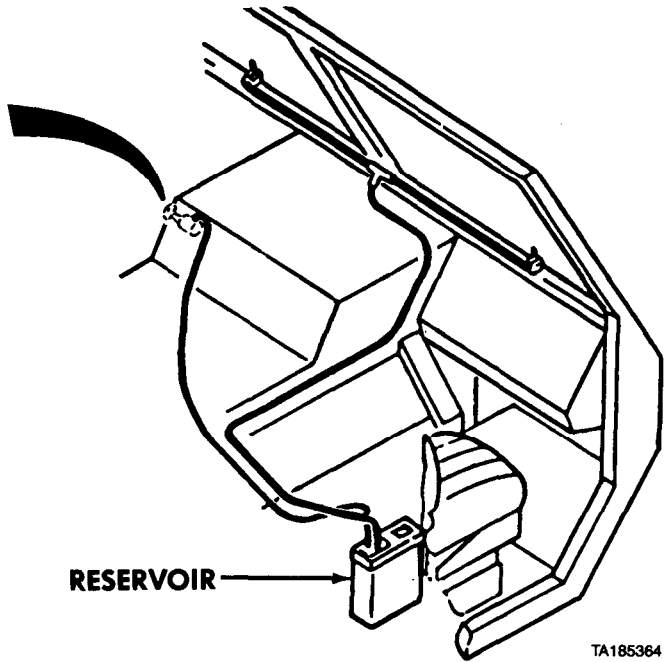
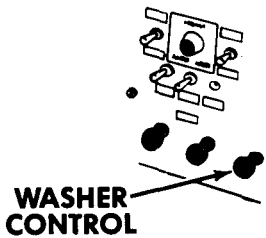
Troubleshooting Malfunctions (Cont)

Table 3-2. Troubleshooting (Cont)

Malfunction	Test or Inspection	Corrective Action
-------------	--------------------	-------------------

AIR SYSTEM (CONT)

4. WINDSHIELD WASHER WILL NOT OPERATE.



CAUTION

Do not fill windshield washer reservoir with water when temperatures are likely to be 32°F (0°C) or less. If water freezes, reservoir can crack or break.

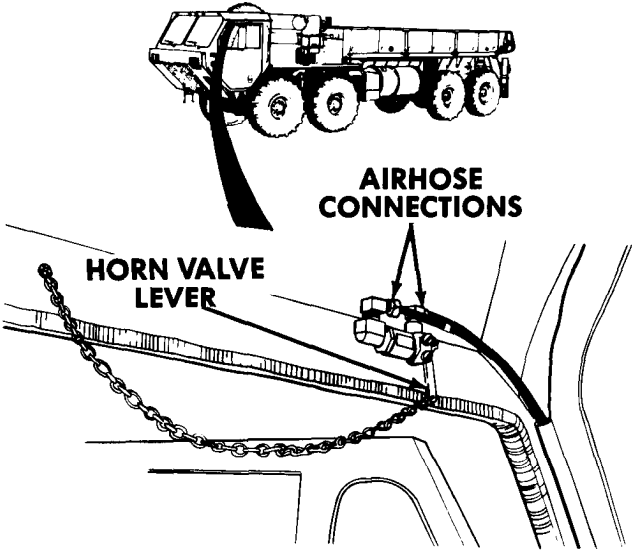
Step 1. Check washer fluid level in reservoir.

If fluid is low, check reservoir. If reservoir is not cracked, fill with windshield cleaning compound (Item 3, Appendix D).

If reservoir is cracked, notify organizational maintenance.

3-3. TROUBLESHOOTING SYMPTOMS (CONT).

Table 3-2. Troubleshooting

Malfunction	Test or Inspection	Corrective Action
AIR SYSTEM (CONT)		
4. WINDSHIELD WASHER WILL NOT OPERATE (CONT).		
	<p>Step 2. If washers do not operate, or if only one washer operates, check that hoses are securely connected to reservoir.</p>	<p>If any hoses are loose, secure to reservoir.</p> <p>If hoses are split or broken, notify organizational maintenance.</p>
	<p>Step 3. Check washer spray opening on wipers for clogs.</p>	<p>Clear washer spray opening, using pin, wire, or similar item.</p>
5. AIR HORN WILL NOT OPERATE.		
 <p>The diagram consists of two parts. The upper part shows a side view of a large truck with a long trailer. A thick black line representing an air hose runs from the front of the truck towards the rear. The lower part is a detailed view of the truck's front end, focusing on the horn valve lever and the air hose connections. The lever is a long metal bar with a chain attached to its end. The air hose is connected to a valve assembly. Labels 'AIRHOSE CONNECTIONS' and 'HORN VALVE LEVER' point to their respective parts. A small code 'TA185365' is located at the bottom right of the diagram.</p>		

Troubleshooting Malfunctions (Cont)
 Table 3-2. Troubleshooting (Cont)

Malfunction	Test or Inspection	Corrective Action
-------------	--------------------	-------------------

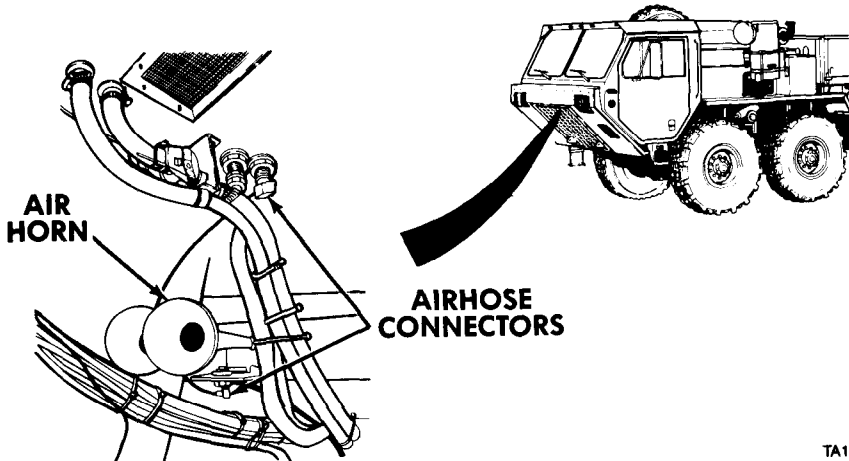
AIR SYSTEM (CONT)

5. AIR HORN WILL NOT OPERATE (CONT).

Step 1. Check to make sure airhose connectors are connected and horn valve lever is not stuck.

If connections are loose, tighten air horn connections.

If valve is stuck, notify organizational maintenance.



TA182061

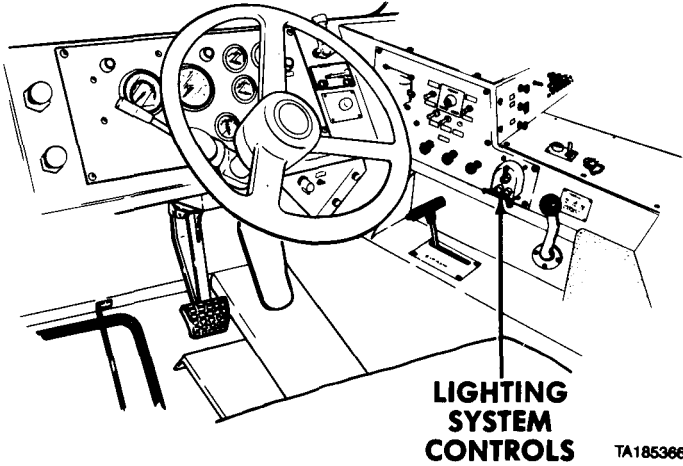
Step 2. Check to make sure airhose connectors are connected.

If connections are loose, tighten air horn connections.

If air horn still does not operate, notify organizational maintenance.

3-3. TROUBLESHOOTING SYMPTOMS (CONT).

Table 3-2. Troubleshooting (Cont)

Malfunction	Test or Inspection	Corrective Action
ELECTRICAL SYSTEM		
1. ONE OR MORE LIGHTING CIRCUITS NOT OPERATING.		
 <p>LIGHTING SYSTEM CONTROLS TA185366</p>		
<p>Step 1. Check to make sure lighting system controls are in ON or operating position.</p> <p style="padding-left: 40px;">If lights do not go on, notify organizational maintenance.</p> <p>Step 2. If trailer is attached and trailer lighting system is not working, check intervehicular connection.</p> <p style="padding-left: 40px;">If trailer lights are the problem, make sure cable is securely connected.</p> <p style="padding-left: 40px;">If problem with any lights still exists, notify organizational maintenance.</p>		

Troubleshooting Malfunctions (Cont)

Table 3-2. Troubleshooting (Cont)

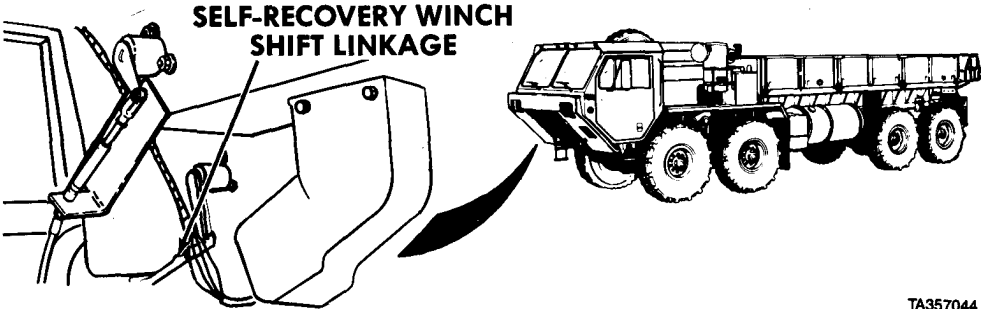
Malfunction Test or Inspection	Corrective Action
HYDRAULIC SYSTEM	
1. OPERATES EITHER TOO SLOW, TOO FAST, OR WITH JERKY MOVEMENTS OR ONE OR MORE HYDRAULIC CIRCUITS WILL NOT OPERATE.	<p>Step 1. Check for low hydraulic fluid level (Table 2-1, Item No. 5).</p> <p style="padding-left: 40px;">If fluid level is low, notify organizational maintenance.</p> <p>Step 2. Check to see if hydraulic connections and hoses are loose, damaged, or leaking.</p> <p style="padding-left: 40px;">Tighten loose connections. If leak does not stop, notify organizational maintenance.</p> <p style="padding-left: 40px;">If hoses are damaged or leaking, notify organizational maintenance.</p> <p style="padding-left: 40px;">If hydraulic system still does not operate, notify organizational maintenance.</p>

3-3. TROUBLESHOOTING SYMPTOMS (CONT).

Table 3-2. Troubleshooting (Cont)

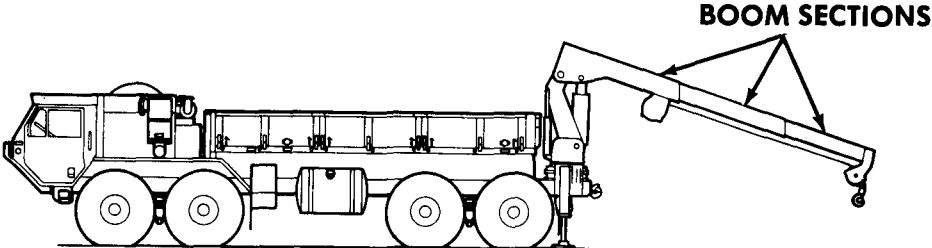
Malfunction	Test or Inspection	Corrective Action
TANKER		
1. WATER IS DISPENSED WITH FUEL.		
NOTE		
<p>Drain fuel from filter-separator tank into suitable, non-spark producing container.</p>		
TA182063		
<p>Step 1. Open V15 DRAIN VALVE on filter-separator. Step 2. Check fuel for water contamination.</p>		
<p style="text-align: center;">If fuel is cloudy, water is mixed in with fuel. Drain filter-separator until clean fuel comes out.</p>		

Troubleshooting Malfunctions (Cont)
 Table 3-2. Troubleshooting (Cont)

Malfunction	Test or Inspection	Corrective Action
SELF-RECOVERY WINCH		
1. DOES NOT WORK.		
Step 1. Check for low hydraulic fluid level (Table 2-1, Item 5).		
If fluid level is low, notify organizational maintenance.		
		
TA357044		
Step 2. Clean off any mud or debris from around shift linkage.		
2. UNUSUALLY NOISY WHEN OPERATING.		
Step 1. Check to make sure cable is not twisted, tangled, or causing drum to bind.		
Pay out or take up cable as necessary to straighten cable. If winch is still noisy when operating, notify organizational maintenance.		

3-3. TROUBLESHOOTING SYMPTOMS (CONT).

Table 3-2. Troubleshooting (Cont)

Malfunction Test or Inspection	Corrective Action
MATERIAL HANDLING CRANE (M977, M985)	
NOTE	
<ul style="list-style-type: none">• Common problems that crane operators may see are:<ol style="list-style-type: none">1. Slow or abnormal operation.2. Crane will not pick up load. • Common causes of the problem are:<ol style="list-style-type: none">1. Cold hydraulic oil (slow operation).2. Low engine speed (slow or abnormal operation).3. Operating two craning functions at same time (slow operation).4. Load too heavy (will not pick up load).5. Air in cylinders or hoist motor (abnormal operation). • Report all problems to organizational maintenance.	
1. BOOM OPERATION ABNORMAL WHEN TELESCOPING IN OR OUT.	
 <p style="text-align: right;">BOOM SECTIONS</p>	
TA185108	

Troubleshooting Malfunctions (Cont)
 Table 3-2. Troubleshooting (Cont)

Malfunction	Test or Inspection	Corrective Action
MATERIAL HANDLING CRANE (M977, M985) (CONT)		
1. BOOM OPERATION ABNORMAL WHEN TELESCOPING IN OR OUT (CONT).		
Step 1.	Ensure that HIGH IDLE ON/OFF Switch is in ON position (para 2-18a(8)).	
Step 2.	Check that boom sections are lubricated (LO 9-2320-279-12).	If there are dry sections, notify organizational maintenance.
Step 3.	If boom operation is still abnormal, there may be air in cylinders.	Lower boom below horizontal position. Fully TELESCOPE boom IN and OUT several times to remove air from cylinders.
Step 4.	If boom operation is still abnormal, air may still be trapped in cylinders. Air can be removed when parking vehicle overnight.	Swing boom to rear of vehicle. Fully telescope boom OUT. Lower boom as far as possible. Shut down operation and allow boom to remain in lowered position overnight. When starting operation, TELESCOPE boom IN (not OUT). Telescoping OUT can force air back into cylinders.
Step 5.	If problem remains, notify organizational maintenance.	
2. BOOM RAISES OR LOWERS SLOWLY.		
Step 1.	Check outside temperature. If temperature is less than 0°F (-17°C), hydraulic oil may not flow easily.	Operate engine for 20 minutes with PTO ENGAGE switch set to ON to bring oil to operating temperature. If oil is still not warmed, lower crane to stowed position. Operate MAST control DOWN. Hold MAST control DOWN for approximately 30 seconds, then return control to neutral position. Repeat procedure several times until oil is warmed.
Step 2.	If problem remains, notify organizational maintenance.	

Troubleshooting Malfunctions (Cont)

3-3. TROUBLESHOOTING SYMPTOMS (CONT).

Table 3-2. Troubleshooting (Cont)

Malfunction	Test or Inspection	Corrective Action
MATERIAL HANDLING CRANE (M977, M985) (CONT)		
3. BOOM WILL NOT RAISE OR LOWER.		
RANGE DIAGRAM M977 ALL DIMENSIONS ARE IN FEET UNLESS OTHERWISE SPECIFIED		
RANGE DIAGRAM M985 ALL DIMENSIONS ARE IN FEET UNLESS OTHERWISE SPECIFIED		
<p>Step 1. Check that load is not over load limit shown on range diagram. Reduce load to correct weight.</p> <p>Step 2. If problem remains, notify organizational maintenance.</p>		

Troubleshooting Malfunctions (Cont)

Table 3-2. Troubleshooting (Cont)

Malfunction	Test or Inspection	Corrective Action
MATERIAL HANDLING CRANE (M977, M985) (CONT)		
4. BOOM WILL NOT TELESCOPE IN OR OUT.		
RANGE DIAGRAM M977 ALL DIMENSIONS ARE IN FEET UNLESS OTHERWISE SPECIFIED		
RANGE DIAGRAM M985 ALL DIMENSIONS ARE IN FEET UNLESS OTHERWISE SPECIFIED		
<p>Step 1. Check that load is not over load limit shown on range diagram. Reduce load to correct weight.</p> <p>Step 2. Refer to MALFUNCTION 1 BOOM OPERATION ABNORMAL WHEN TELESCOPING IN OR OUT.</p> <p>Step 3. If problem remains, notify organizational maintenance.</p>		

Troubleshooting Malfunctions (Cont)

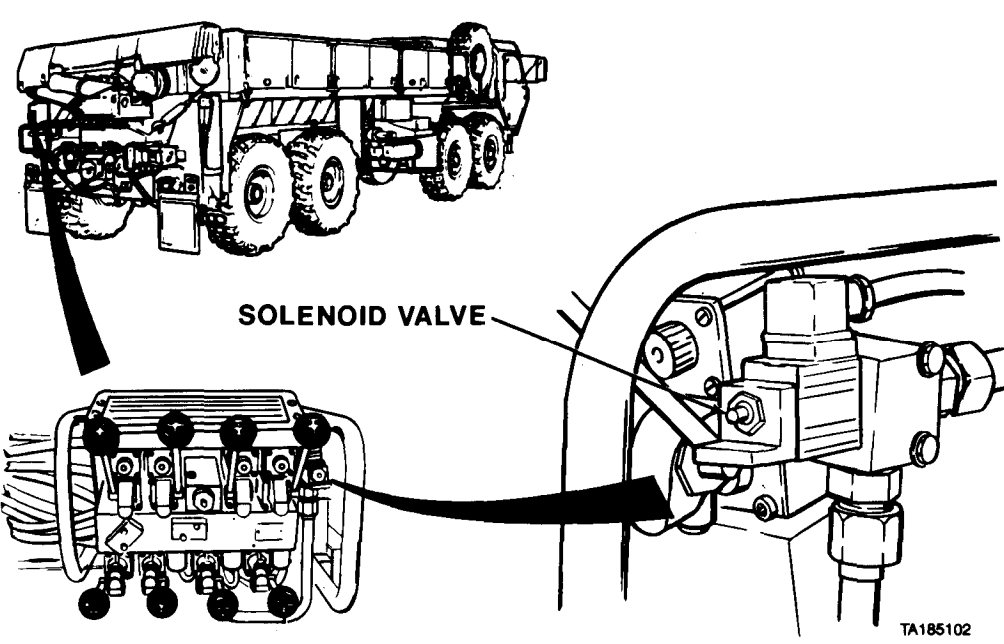
3-3. TROUBLESHOOTING SYMPTOMS (CONT).

Table 3-2. Troubleshooting (Cont)

Malfunction	Test or Inspection	Corrective Action
MATERIAL HANDLING CRANE (M977, M985) (CONT)		
5. CRANE CONTROLS STICKING IN ENGAGED POSITION.		
	Step 1. Check outside temperature. If temperature is less than 0°F (-17°C), hydraulic oil may not flow easily and controls may move slowly.	Operate engine with PTO ENGAGE switch set to ON for 20 minutes to bring oil to operating temperature. If oil is still not warmed, lower crane to stowed position. Operate MAST control DOWN. Hold MAST control DOWN for approximately 30 seconds, then return control to neutral position. Repeat procedure several times until oil is warmed.
	Step 2. Check for overheated hydraulic oil by carefully placing hand near hydraulic reservoir.	If reservoir is very hot, shut off engine, let oil cool, then continue operation.
	Step 3. If controls continue sticking, notify organizational maintenance.	

Troubleshooting Malfunctions (Cont)

Table 3-2. Troubleshooting (Cont)

Malfunction	Test or Inspection	Corrective Action
MATERIAL HANDLING CRANE (M977, M985) (CONT)		
6. CRANE WILL NOT OPERATE OR OPERATES ABNORMALLY.		
		
<p>Step 1. Check solenoid valve to be sure electrical connector is not loose. Tighten loose connector.</p> <p>Step 2. Check solenoid valve to see that it operates when POWER switch is set to ON.</p> <p>If solenoid does not operate properly, place screwdriver in slot in front of solenoid to hold solenoid closed until mission can be completed. Report problem to organizational maintenance.</p>		

3-3. TROUBLESHOOTING SYMPTOMS (CONT).

Table 3-2. Troubleshooting (Cont)

Malfunction	Test or Inspection	Corrective Action
MATERIAL HANDLING CRANE (M977, M985) (CONT)		
7. HOIST OPERATION SLOW OR ABNORMAL WHEN LIFTING OR LOWERING LOAD.		
	Step 1. Check for air in motor.	
	<u>CAUTION</u>	
	Be sure to keep tension on cable. If not, cable may get tangled on drum. Set load down and disconnect load hook. Reel cable in and out several times to remove air from hoist motor.	
	Step 2. Check outside temperature. If temperature is less than 0°F (-17°C), hydraulic oil may not flow easily.	
	Operate engine for 20 minutes with PTO ENGAGE switch set to ON to bring oil to operating temperature. If oil is still not warmed, lower crane to stowed position. Operate MAST control DOWN. Hold MAST control DOWN for approximately 30 seconds, then return control to neutral position. Repeat procedure several times until oil is warmed.	
	Step 3. Set load down and disconnect load hook.	
	Step 4. If operation is still slow or abnormal, notify organizational maintenance.	

Troubleshooting Malfunctions (Cont)

Table 3-2. Troubleshooting (Cont)

Malfunction	Test or Inspection	Corrective Action
MATERIAL HANDLING CRANE (M977, M985) (CONT)		
8. HOIST WILL NOT LIFT LOAD		
RANGE DIAGRAM M977 ALL DIMENSIONS ARE IN FEET UNLESS OTHERWISE SPECIFIED		
RANGE DIAGRAM M985 ALL DIMENSIONS ARE IN FEET UNLESS OTHERWISE SPECIFIED		
<p>Step 1. Check that load is not over load limit shown on range diagram. Reduce load to correct weight.</p>		

3-3. TROUBLESHOOTING SYMPTOMS (CONT).

Table 3-2. Troubleshooting (Cont)

Malfunction	Test or Inspection	Corrective Action
MATERIAL HANDLING CRANE (M977, M985) (CONT)		
8. HOIST WILL NOT LIFT LOAD (CONT).		
	Step 2. Refer to MALFUNCTION 1 BOOM OPERATION ABNORMAL WHEN TELESCOPING IN OR OUT.	
	Step 3. If problem remains, notify organizational maintenance.	
9. MAST RAISES OR LOWERS ABNORMALLY.		
	Step 1. If mast operation is abnormal, there may be air in cylinders.	Fully raise and lower mast several times to remove air from cylinders.
	Step 2. If mast operation is still abnormal, air may be trapped in cylinders. Air can be removed when parking vehicle overnight.	Raise boom to vertical position. Fully raise mast. Shut down operation and leave mast in raised position overnight. When starting operations, operate MAST control DOWN (not UP). Operating control UP can force air back into cylinders.
	Step 3. If problem remains, notify organizational maintenance.	
10. MAST RAISES OR LOWERS SLOWLY.		
	Step 1. Check outside temperature. If temperature is less than 0°F (-17°C), hydraulic oil may not flow easily.	Operate engine for 20 minutes with PTO ENGAGE switch set to ON to bring oil to operating temperature.
		If oil is still not warmed, lower crane to stowed position. Operate MAST control DOWN. Hold MAST control DOWN for approximately 30 seconds, then return control to neutral position. Repeat procedure several times until oil is warmed.
	Step 2. If problem remains, notify organizational maintenance.	

Troubleshooting Malfunctions (Cont)

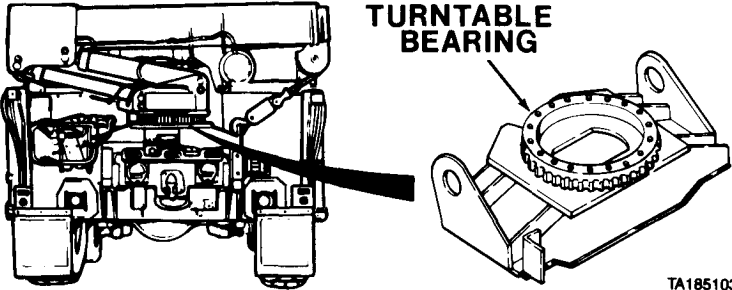
Table 3-2. Troubleshooting (Cont)

Malfunction	Test or Inspection	Corrective Action
MATERIAL HANDLING CRANE (M977, M985) (CONT)		
11. OUTRIGGER OPERATION SLOW OR ABNORMAL.		
<p>Step 1. Check outside temperature. If temperature is less than 0°F (-17°C), hydraulic oil may not flow easily.</p>	<p>Operate engine for 20 minutes with PTO ENGAGE switch set to ON to bring oil to operating temperature.</p> <p>If oil is still not warmed, lower crane to stowed position. Operate MAST control DOWN. Hold MAST control DOWN for approximately 30 seconds, then return control to neutral position. Repeat procedure several times until oil is warmed.</p>	
<p>Step 2. If outrigger operation is still abnormal, there may be air in cylinders.</p>	<p>Fully let out and draw back outriggers several times to remove air from cylinders.</p>	
<p>Step 3. If problem remains, notify organizational maintenance.</p>		
12. SWING OPERATION ABNORMAL IN BOTH DIRECTIONS.		
<p>Step 1. Check that abnormal operation is not caused by sharp movement of controls to neutral.</p>	<p>Feather control lever to neutral to maintain smooth stopping action.</p>	
<p>Step 2. Check if vehicle is level.</p>	<p>Level vehicle.</p>	

Troubleshooting Malfunctions

3-3. TROUBLESHOOTING SYMPTOMS (CONT).

Table 3-2. Troubleshooting

Malfunction	Test or Inspection	Corrective Action
MATERIAL HANDLING CRANE (M977, M985) (CONT)		
12. SWING OPERATION ABNORMAL IN BOTH DIRECTIONS (CONT).		
		
Step 3.	Check for dry turntable bearing by swinging turntable slowly from side to side without load and watching for abnormal movement.	Rotate turntable 360 degrees in both directions several times and lubricate turntable bearing (LO 9-2320-279-12).
Step 4.	Check maximum load limits (para 2-18e).	Reduce load to correct weight.
Step 5.	If problem remains, notify organizational maintenance.	
13. SWING OPERATION ABNORMAL IN ONE DIRECTION ONLY.		
Step 1.	Check if vehicle is level.	
	Level vehicle.	
Step 2.	Check for dry turntable bearing by swinging turntable slowly from side to side without load and watching for abnormal movement.	Rotate turntable 360 degrees in both directions several times and lubricate turntable bearing (LO 9-2320-279-12).
Step 3.	Notify organizational maintenance if problem remains.	

Troubleshooting Malfunctions (Cont)

Table 3-2. Troubleshooting (Cont)

Malfunction	Test or Inspection	Corrective Action
SPECIAL PURPOSE KITS		
1. M-8 CHEMICAL ALARM.		
	Step 1. Refer to TM 3-6665-225-12 for M-8 Chemical alarm troubleshooting instructions.	
2. RADIO.		
	Step 1. Refer to TM 11-5820-498-12 for radio troubleshooting instructions.	

Section III. MAINTENANCE PROCEDURES

Operators Maintenance

3-4. MAINTENANCE INTRODUCTION. This section covers maintenance tasks authorized at the operator/crew level of maintenance. The tasks given in this section do not include maintenance tasks done on a scheduled basis (PMCS).

For operator/crew maintenance information for machine gun mounts, refer to TM 9-1005-245-14.

For more information on maintenance, refer to Appendix A for maintenance publications.

3-5. CLEAN VEHICLE.

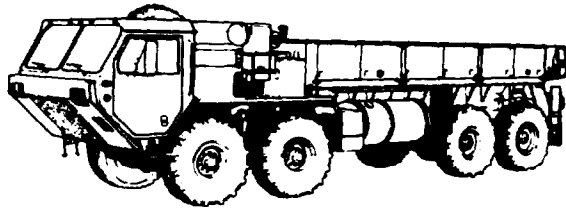
MODELS: All

TOOLS: None

SUPPLIES: Rags

PERSONNEL REQUIRED: MOS 88M, Motor Transport Operator

a. Clean Exterior.

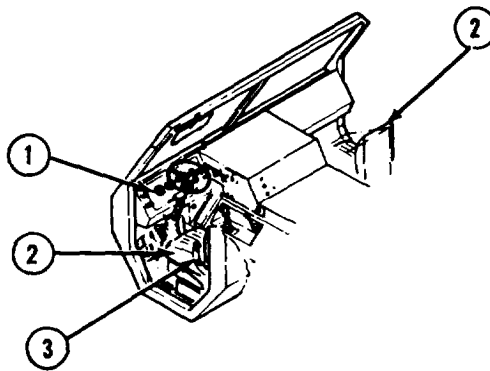


CAUTION

Do not wipe dirt off vehicle when vehicle is dry. Dirt, stones, or debris may scratch and damage vehicle.

- (1) Wash vehicle often with cool or warm water. Do not use strong detergent or abrasives.
- (2) While cleaning vehicle, look closely for rust, corrosion, bare metal, or other damage. Report any damage to organizational maintenance.

b. Clean Interior.



Operators Maintenance (Cont)

- (1) Remove loose dirt and dust from cab interior components (1).
- (2) Clean seat cushions (2) and seatbelts (3) with warm soapy water. Do not use abrasives or solvents.
- (3) Wipe seat cushions (2) and seatbelts (3) dry.

3-6. CHANGE WHEEL AND TIRE ASSEMBLY.

MODELS: All

TOOLS: Chocks, wheel (2)
 Extension, handle
 Handle, wrench
 Jack, 12-ton, with handle
 Jack, base plate
 Warning device set, triangular
 Wrench, wheel lugnut
 Wrench, adjustable

SUPPLIES: None

PERSONNEL REQUIRED: MOS 88M, Motor Transport Operator (2)

NOTE

This task is the same for all eight tire assemblies.

a. Prepare Vehicle.**WARNING**

Park vehicle in safe area out of traffic where there is no danger to personnel changing tire assembly. Park vehicle on hard level ground.

- (1) Park vehicle (para 2-11o).
- (2) Shut off engine (para 2-11p).
- (3) Turn on emergency flasher (para 2-44a). Set out emergency marker kit, if necessary (para 2-44).

Operators Maintenance (Cont)

3-6. CHANGE WHEEL AND TIRE ASSEMBLY (CONT).

WARNING

- If spare tire is under-inflated, overinflated or if wheel or tire has obvious damage, or is suspected of damage, the tire must be completely deflated by removing the valve core from the valve stem. Any attempt to inflate an underinflated, overinflated, or damaged spare tire could result in serious injury or death.
- Tire air pressure must be checked properly or serious injury or death may result.
- Stand clear of trajectory area during deflation or personal injury or death could result.

NOTE

Tire valve stem can be rotated in wheel so it points away from vehicle. Cap must be removed to rotate valve stem.

- (3.1) Check spare tire air pressure and compare reading to Table 3-2.1. If tire is underinflated, overinflated or there is obvious or suspected damage to wheel or tire, completely deflate tire (para 3-9).

Operators Maintenance (Cont)

Table 3-2.1. Unsafe Inflation Pressures

WARNING

If tire has been run flat, or is over- or under-inflated when tire pressure is measured and operating terrain is compared to Table 3-2.1, or if wheel/tire assembly has obvious or suspected damage, it is not safe to adjust tire pressure. Completely deflate tire according to para 3-9, and remove the tire from the axle. Failure to follow these procedures may result in serious personal injury or death.

	Spare Tire is:	Spare Tire is:	Front Tires are: (All models)	Front Tires are: (All models)
	Overinflated. Tire pressure measured is 25% or more above the standard tire pressure.	Underinflated. Tire pressure measured is 80% or less than the standard tire pressure.	Overinflated. Tire pressure measured is 25% or more above the standard tire pressure.	Underinflated. Tire pressure measured is 80% or less than the standard tire pressure.
	Do not adjust pressure if above pressure shown below.	Do not adjust pressure if below pressure shown below.	Do not adjust pressure if above pressure shown below.	Do not adjust pressure if below pressure shown below.
<u>Highway</u>				
Standard Tire	125 psi (862 kPa)	80 psi (552 kPa)	75 psi (517 kPa)	48 psi (331 kPa)
Sand Tire	125 psi (862 kPa)	80 psi (552 kPa)	75 psi (517 kPa)	48 psi (331 kPa)
<u>Cross Country-Dry</u>				
Standard Tire	125 psi (862 kPa)	80 psi (552 kPa)	44 psi (303 kPa)	28 psi (193 kPa)
Sand Tire	NA	NA	NA	NA
<u>Cross Country-Wet</u>				
Standard Tire	125 psi (862 kPa)	80 psi (552 kPa)	25 psi (172 kPa)	*20 psi (138 kPa)
Sand Tire	NA	NA	NA	NA
<u>Sand</u>				
Standard Tire	125 psi (862 kPa)	80 psi (552 kPa)	38 psi (262 kPa)	24 psi (165 kPa)
Sand Tire	125 psi (862 kPa)	80 psi (552 kPa)	31 psi (214 kPa)	*25 psi (172 kPa)

* Absolute minimum pressure.

Operators Maintenance (Cont)

3-5. CHANGE WHEEL AND TIRE ASSEMBLY (CONT).

Table 3-2.1. Unsafe Inflation Pressures (Cont)

WARNING

If tire has been run flat, or is over- or underinflated when tire pressure is measured and operating terrain is compared to Table 3-2.1, or if wheel/tire assembly has obvious or suspected damage, it is not safe to adjust tire pressure. Completely deflate tire according to para 3-9, and remove the tire from the axle. Failure to follow these procedures may result in serious personal injury or death.

	Rear Tires are: (M977, M978, M983)	Rear Tires are: (M977, M978, M983)	Rear Tires are: (M985)	Rear Tires are: (M985)
	Overinflated. Tire pressure measured is 25% or more above the standard tire pressure. Do not adjust pressure if above pressure shown below.	Underinflated. Tire pressure measured is 80% or less than the standard tire pressure. Do not adjust pressure if below pressure shown below.	Overinflated. Tire pressure measured is 25% or more above the standard tire pressure. Do not adjust pressure if above pressure shown below.	Underinflated. Tire pressure measured is 80% or less than the standard tire pressure. Do not adjust pressure if below pressure shown below.
<u>Highway</u>				
Standard Tire	88 psi (607 kPa)	56 psi (386 kPa)	113 psi (779 kPa)	72 psi (496 kPa)
Sand Tire	88 psi (607 kPa)	56 psi (386 kPa)	125 psi (862 kPa)	80 psi (552 kPa)
<u>Cross Country-Dry</u>				
Standard Tire	50 psi (345 kPa)	32 psi (221 kPa)	63 psi (434 kPa)	40 psi (276 kPa)
Sand Tire	NA	NA	NA	NA
<u>Cross Country-Wet</u>				
Standard Tire	38 psi (262 kPa)	24 psi (165 kPa)	50 psi (345 kPa)	32 psi (221 kPa)
Sand Tire	NA	NA	NA	NA
<u>Sand</u>				
Standard Tire	44 psi (304 kPa)	28 psi (193 kPa)	50 psi (345 kPa)	32 psi (221 kPa)
Sand Tire	38 psi (262 kPa)	*25 psi (172 kPa)	50 psi (345 kPa)	32 psi (221 kPa)

* Absolute minimum pressure.

Operators Maintenance (Cont)

Table 3-2.1. Unsafe Inflation Pressures (Cont)

WARNING

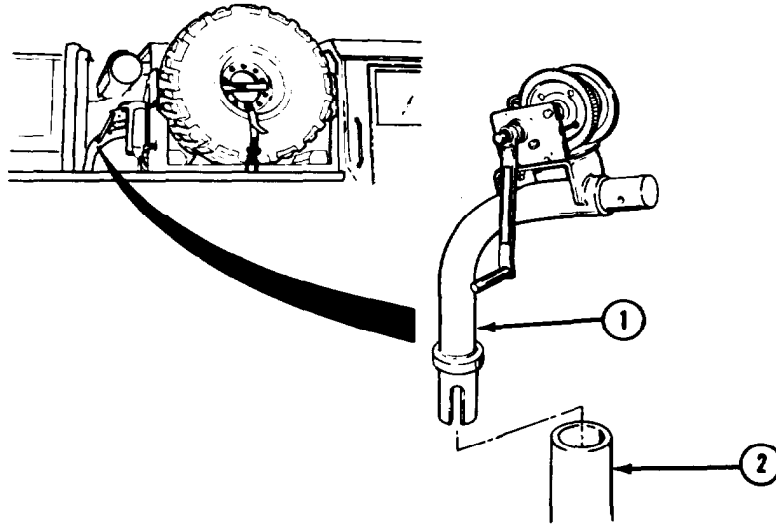
If tire has been run flat, or is over- or underinflated when tire pressure is measured and operating terrain is compared to Table 3-2.1, or if wheel/tire assembly has obvious or suspected damage, it is not safe to adjust tire pressure. Completely deflate tire according to para 3-9, and remove the tire from the axle. Failure to follow these procedures may result in serious personal injury or death.

	Rear Tires are: (M984E1)	Rear Tires are: (M984E1)	Rear Tires are: (M984E1 when towing another vehicle)	Rear Tires are: (M984E1 when towing another vehicle)
	Overinflated. Tire pressure measured is 25% or more above the standard tire pressure.	Underinflated. Tire pressure measured is 80% or less than the standard tire pressure.	Overinflated. Tire pressure measured is 25% or more above the standard tire pressure.	Underinflated. Tire pressure measured is 80% or less than the standard tire pressure.
	Do not adjust pressure if above pressure shown below.	Do not adjust pressure if below pressure shown below.	Do not adjust pressure if above pressure shown below.	Do not adjust pressure if below pressure shown below.
<u>Highway</u>				
Standard Tire	125 psi (862 kPa)	80 psi (552 kPa)	125 psi (862 kPa)	80 psi (552 kPa)
Sand Tire	125 psi (862 kPa)	80 psi (552 kPa)	125 psi (862 kPa)	80 psi (552 kPa)
<u>Cross Country-Dry</u>				
Standard Tire	125 psi (862 kPa)	80 psi (552 kPa)	125 psi (862 kPa)	80 psi (552 kPa)
Sand Tire	NA	NA	NA	NA
<u>Cross Country-Wet</u>				
Standard Tire	125 psi (862 kPa)	80 psi (552 kPa)	125 psi (862 kPa)	80 psi (552 kPa)
Sand Tire	NA	NA	NA	NA
<u>Sand</u>				
Standard Tire	38 psi (262 kPa)	24 psi (165 kPa)	99 psi (683 kPa)	64 psi (441 kPa)
Sand Tire	31 psi (214 kPa)	*25 psi (172 kPa)	99 psi (683 kPa)	64 psi (441 kPa)

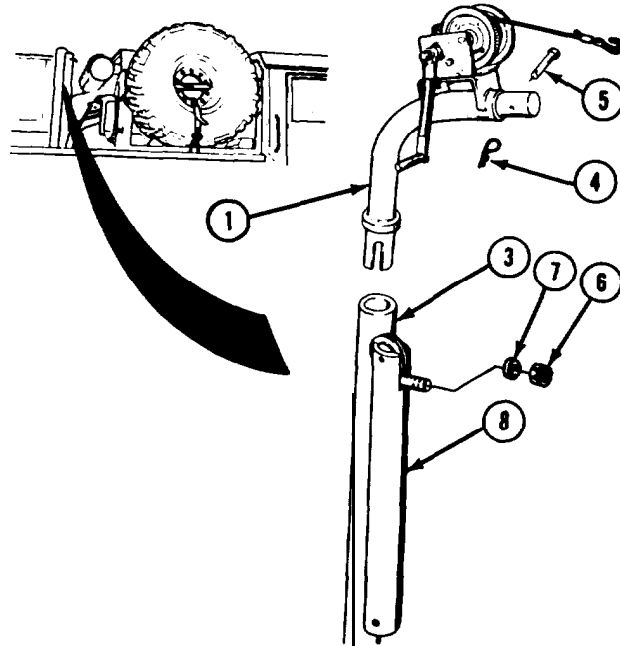
* Absolute minimum pressure.

Operators Maintenance (Cont)

3-6. CHANGE WHEEL AND TIRE ASSEMBLY (CONT).

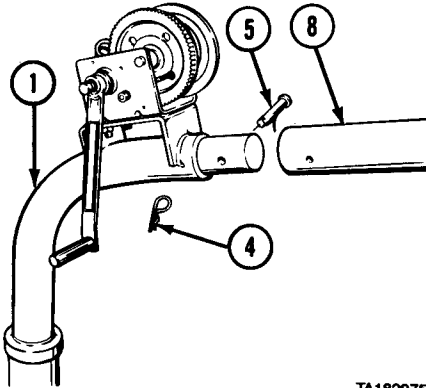


(4) Remove hoist arm (1) from mounting bracket (2).



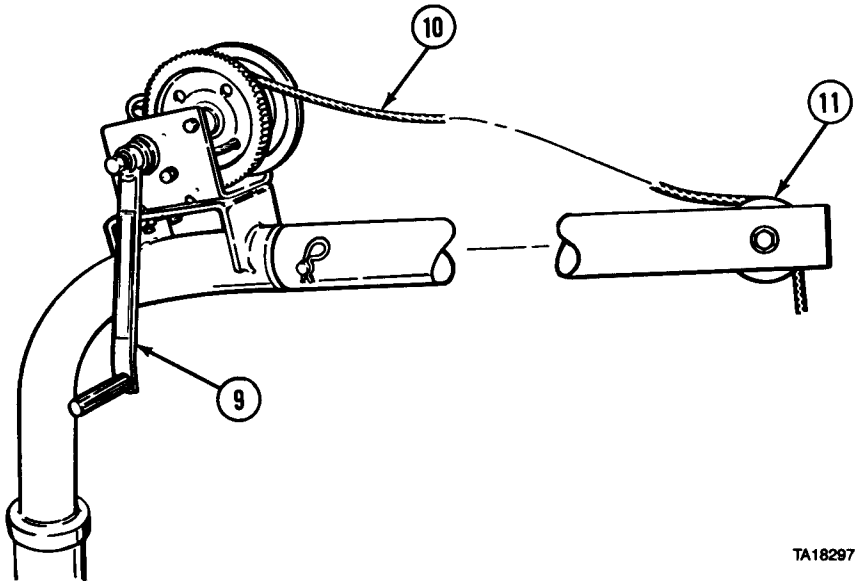
Operators Maintenance (Cont)

- (5) Install hoist arm (1) in mount (3).
- (6) Remove and keep safety pin (4) and pin (5) from hoist arm (1).
- (7) Remove nut (6), washer (7), and extension (8) from mount (3).



TA182975

- (8) Install extension (8) on hoist arm (1).
- (9) Line up holes in extension (8) and hoist arm (1).
- (10) Install pin (5) and safety pin (4).



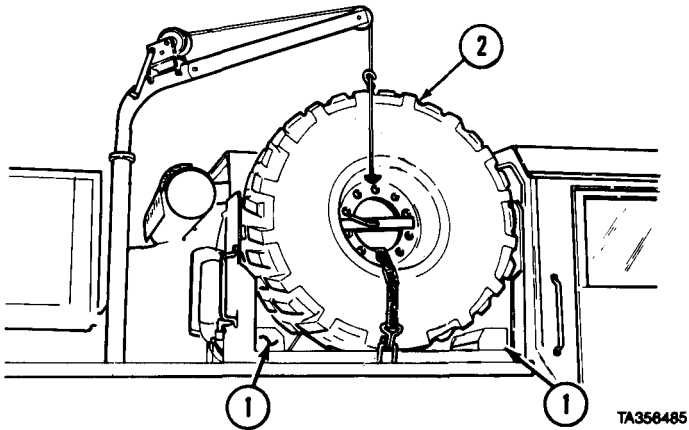
TA182976

- (11) Turn handcrank (9) counterclockwise and route cable (10) over end of pulley (11).

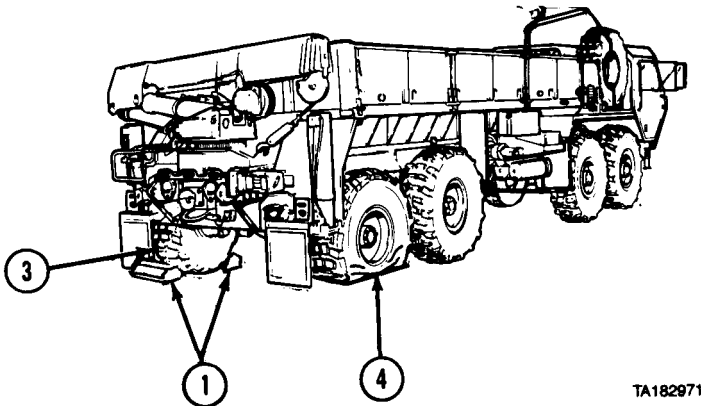
Operators Maintenance (Cont)

3-6. CHANGE WHEEL AND TIRE ASSEMBLY (CONT).

b. Remove Spare Tire.

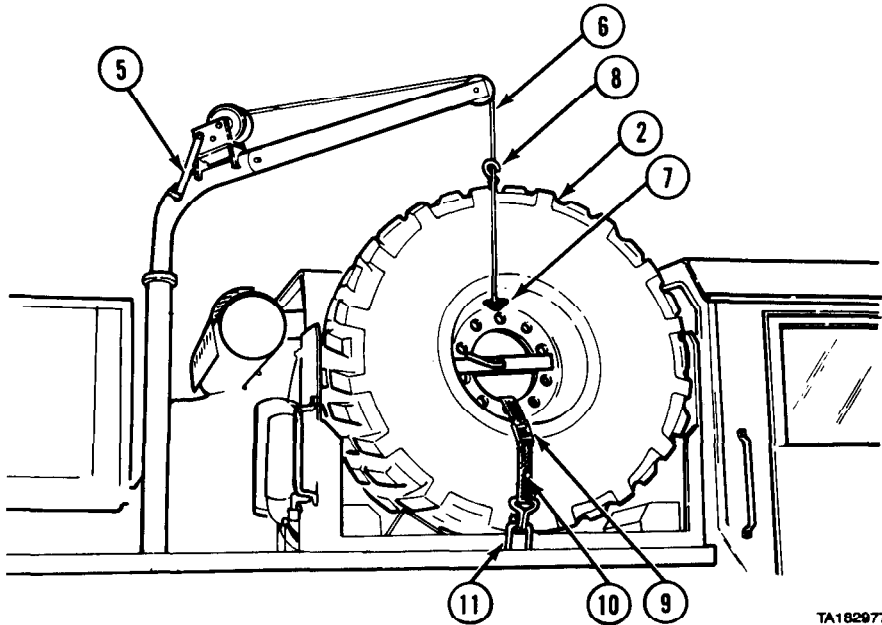


(1) Remove two chocks (1) from under spare tire (2).



(2) Place two chocks (1) against tire (3) that is across from flat tire (4).

Operators Maintenance (Cont)



TA182977

CAUTION

Never use slot that has valve stem or spare tire might be damaged.

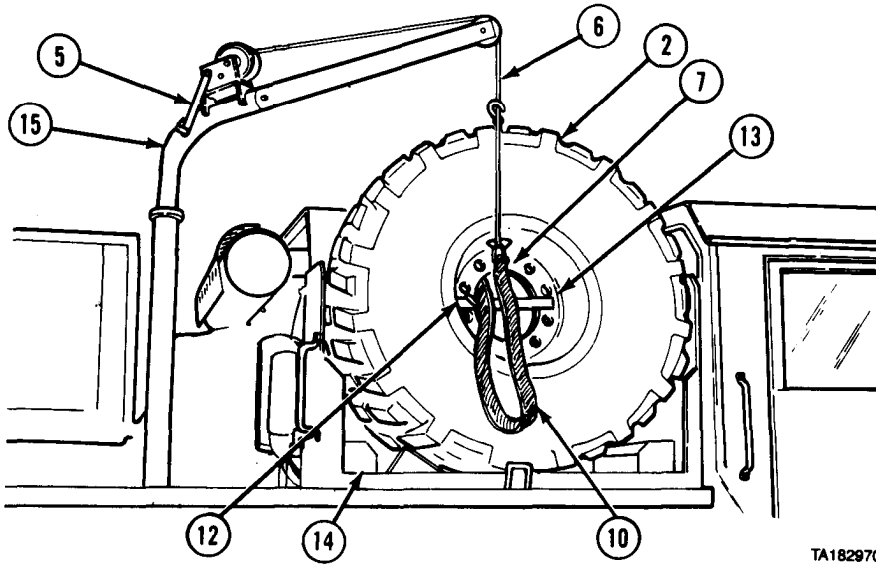
- (3) Turn handcrank (5) counterclockwise to let out enough cable (6) to push through wheel (7) and wrap around spare tire (2).

NOTE

If spare tire is not mounted as shown, route cable through axle hole and dismount spare tire.

- (4) Wrap cable (6) around spare tire (2) and secure with hook (8).
 (5) Turn handcrank (5) clockwise to put light tension on cable (6).
 (6) Release clamp (9) and disconnect tiedown strap (10) from bracket (11) on both sides of spare tire (2).

3-6. CHANGE WHEEL AND TIRE ASSEMBLY (CONT).



- (7) Hook tiedown strap (10) on hole in wheel (7) on both sides of spare tire (2).
- (8) Turn lever (12) counterclockwise.
- (9) Remove lever (12) and holddown plate (13). Keep lever and holddown plate for later use.

WARNING

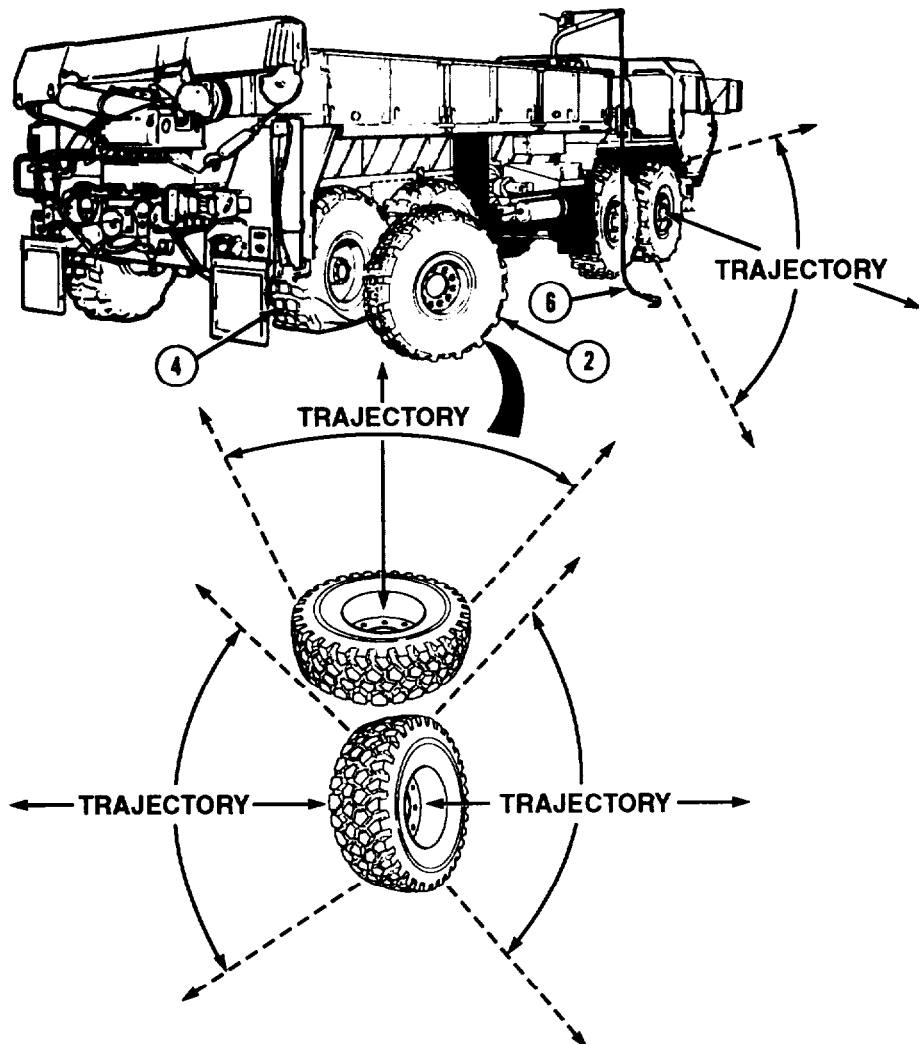
Do not let tire hang in midair for long period of time. Place tire on carrier or on ground as soon as possible. Tire is very heavy and could cause serious injury if it falls.

NOTE

One Soldier stands on right fender to operate tire davit winch while other Soldier stands on ground near second axle to guide tire assembly down.

- (10) Turn handcrank (5) clockwise to lift spare tire (2) just above carrier (14).
- (11) Soldier A swings hoist arm (15) so spare tire (2) is clear of vehicle, while Soldier B pulls on tiedown strap (10) to guide spare tire out of carrier (14).
- (12) Soldier A turns handcrank (5) counterclockwise to lower spare tire (2) to ground while Soldier B holds spare tire steady with tiedown strap (10).
- (13) Remove tiedown strap (10).

Operators Maintenance (Cont)

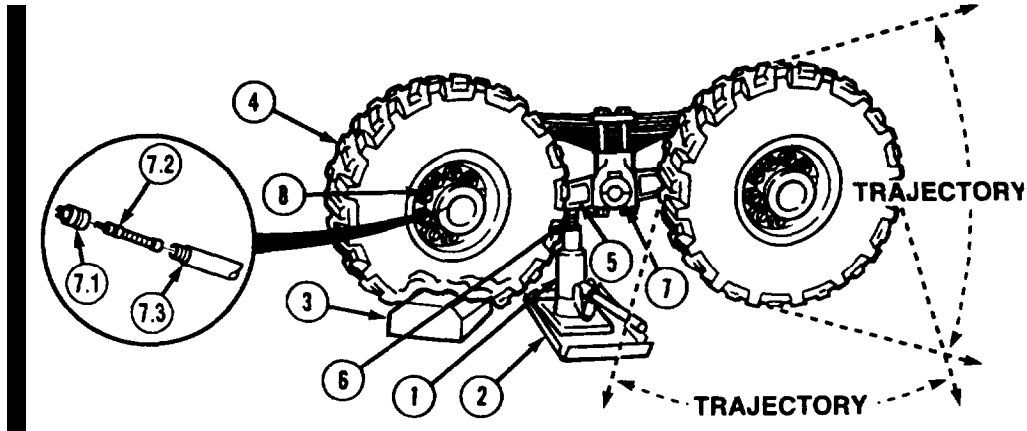


- (14) Push spare tire (2) against vehicle.
- (15) Remove cable (6) from spare tire (2). Roll spare tire next to axle of flat tire (4).
- (16) Check spare tire air pressure. Service if required (para 3-9).

Operators Maintenance (Cont)

3-6. CHANGE WHEEL AND TIRE ASSEMBLY (CONT).

c. Remove Flat Tire or Wheel.



- (1) Remove jack (1) and jack base plate (2) from stowage.
- (2) It may be necessary to place wheel chock (3) under flat tire (4) to get jack (1) under equalizer beam (5).
- (3) Position jack (1) and jack base plate (2) under equalizer beam (5).
- (4) Unscrew jack ram (6) until it touches equalizer beam (5) approximately 4 to 5 in. (102 to 127 mm) from beam center pivot point (7).

Operators Maintenance (Cont)**WARNING**

- Tire must be completely deflated before trying to remove from vehicle, or serious injury or death could result.
- Stand clear of trajectory area during deflation or personal injury or death could result.
- Always completely deflate tire by removing valve core from valve stem before attempting removal operation. After air has finished exhausting from valve stem, carefully run a piece of wire through valve stem to ensure it is not plugged and tire is completely deflated. Failure to comply may result in injury to personnel.
- High air pressure may be released from valve stem when valve core is removed. Stay clear of valve stem after core is removed. Ensure all personnel wear suitable eye protection. Failure to comply may result in injury to personnel.

NOTE

Trajectory as shown applies to all wheel/tire assemblies.

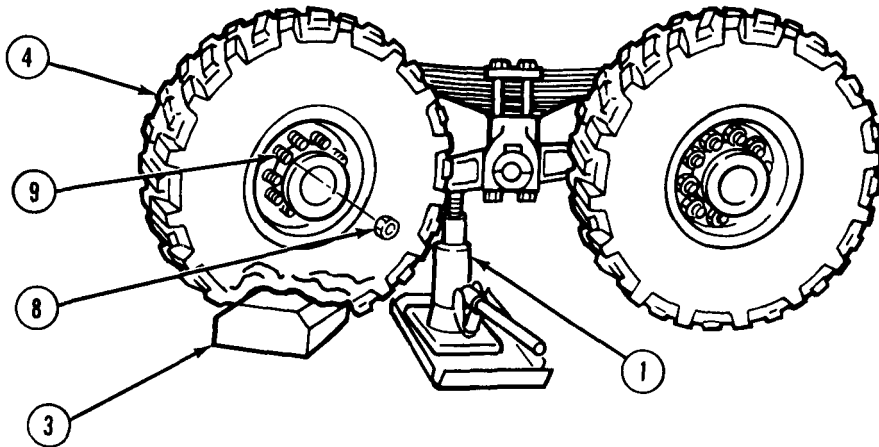
- (4.1) Tire must be completely deflated by removing valve cap (7.1) and valve core (7.2) until tire is completely deflated. When all air is deflated, install valve core (7.2) in valve stem (7.3). Cover with valve cap (7.1). Take tire to unit maintenance for disassembly and repair.

NOTE

Studs and lugnuts on left side of vehicle have left-hand threads. Rotate lugnuts clockwise to loosen, counterclockwise to tighten. Studs and lugnuts on right side of vehicle have right-hand threads. Rotate lugnuts counterclockwise to loosen, clockwise to tighten.

- (5) Loosen 10 lugnuts (8) until they turn easily.

3-6. CHANGE WHEEL AND TIRE ASSEMBLY (CONT).



TA185074

NOTE

If chock was used to help position jack, tire does not have to be clear of chock.

- (6) Raise jack (1) until flat tire (4) can be removed.

WARNING

One Soldier should steady tire during removal. Falling tire may cause injury.

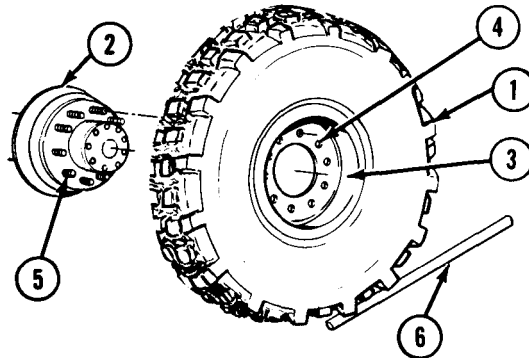
- (7) Remove 10 lugnuts (8) from studs (9). Set lugnuts aside.

NOTE

If wheel chock was not used to position jack, skip step (8).

- (8) Remove wheel chock (3) and put in stowage.
 (9) Using jack (1), lower vehicle until flat tire (4) is just touching ground.
 (10) Soldier A tilts top of flat tire (4) forward, while Soldier B raises jack (1) slightly. Tire should move forward.
 (11) Repeat steps (9) and (10) to walk flat tire (4) off studs (9).
 (12) Remove flat tire (4) and lean flat tire against vehicle.

Operators Maintenance (Cont)

d. Install Spare Tire/Wheel.

TA182983

NOTE

Tire tread is non-directional. Vehicle operation is not affected by direction of traction bars.

- (1) Roll spare tire (1) up to axle (2) where flat tire was removed.

NOTE

Check that spare tire wheel dish is in same position as flat tire wheel dish. Deep side of wheel dish will face toward vehicle on four front wheels. Deep side of wheel dish will face away from vehicle on four rear wheels except M984E1. All eight wheels on M984E1 are installed with deep side of wheel dish facing toward vehicle.

- (2) Make sure deep side of spare tire wheel dish (3) is in same position as flat tire wheel dish when flat tire was removed.

NOTE

Tire valve stem can be rotated in wheel so it points out away from vehicle. Cap must be removed to rotate valve stem.

- (3) Make sure tire valve stem is pointing out away from vehicle.
 (4) Line up holes (4) in spare tire (1) with studs (5).

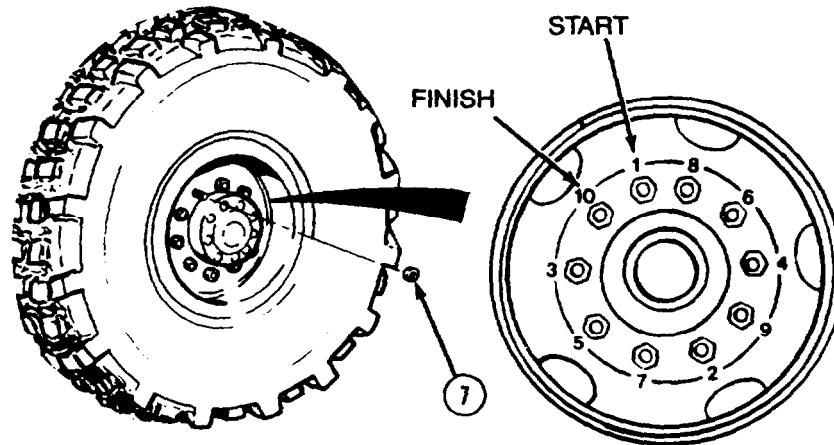
WARNING

Tire assembly is very heavy. Do not try to lift or catch tire assembly. Injury to personnel could result.

- (5) Lean top of spare tire (1) against studs (5) and axle (2).
 (6) Using handle extension (6), Soldier A slides spare tire onto studs (5) while Soldier B raises vehicle with jack. Bottom of spare tire (1) should swing toward vehicle.
 (7) Lower vehicle with jack until spare tire (1) just touches ground.
 (8) Repeat steps (5) through (7) until spare tire (1) is seated on axle (2) and studs (5).

Operators Maintenance (Cont)

3-6. CHANGE WHEEL AND TIRE ASSEMBLY (CONT.)

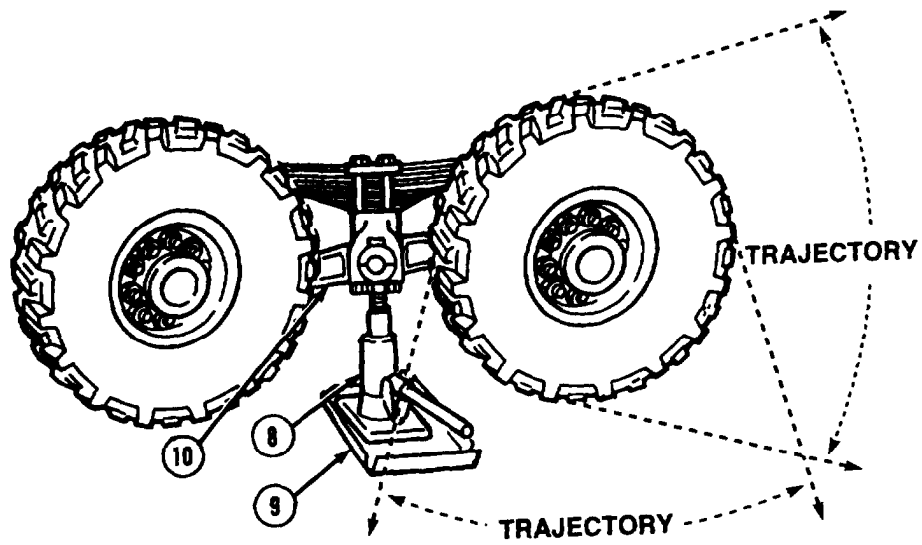


NOTE

Studs and lugnuts on left side of vehicle have left-hand threads. Rotate lugnuts clockwise to loosen, counterclockwise to tighten. Studs and lugnuts on right side of vehicle have right-hand threads. Rotate lugnuts counterclockwise to loosen, clockwise to tighten.

- (9) Install and tighten 10 lugnuts (7) using wheel lugnut wrench to tighten in order shown.

Operators Maintenance (Cont)

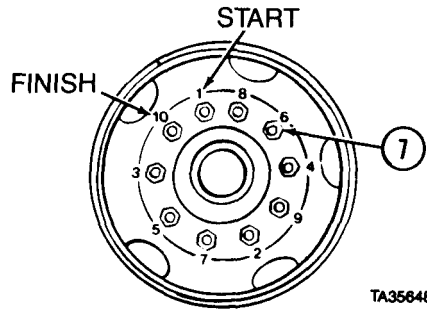
**WARNING**

When returning axle to the ground, ensure personnel are out of the trajectory as shown by the area indicated. Failure to comply may result in serious injury or death to personnel.

- (10) Use jack (8) to lower vehicle to ground.
- (11) Remove jack (8) and jack base plate (9) from under equalizer beam (10).

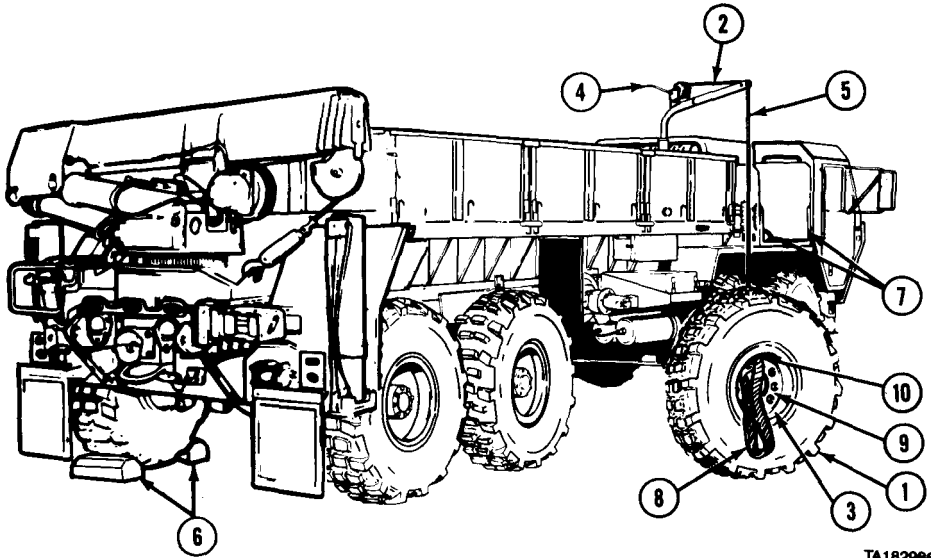
Operators Maintenance (Cont)

- (12) Tighten 10 lugnuts (7) in order shown until they no longer tighten.
- (13) Return all tools to stowage box.
- (14) As soon as possible, take vehicle to organizational maintenance and have lugnuts tightened to torque requirements.



TA356486

e. Stow Flat Tire.



TA182966

- (1) Roll flat tire (1) under hoist arm (2) so deep side of wheel dish (3) is facing out and away from vehicle.

NOTE

One Soldier stands on right front fender to operate tire davit winch while other Soldier stands on ground near second axle to guide tire assembly into carrier.

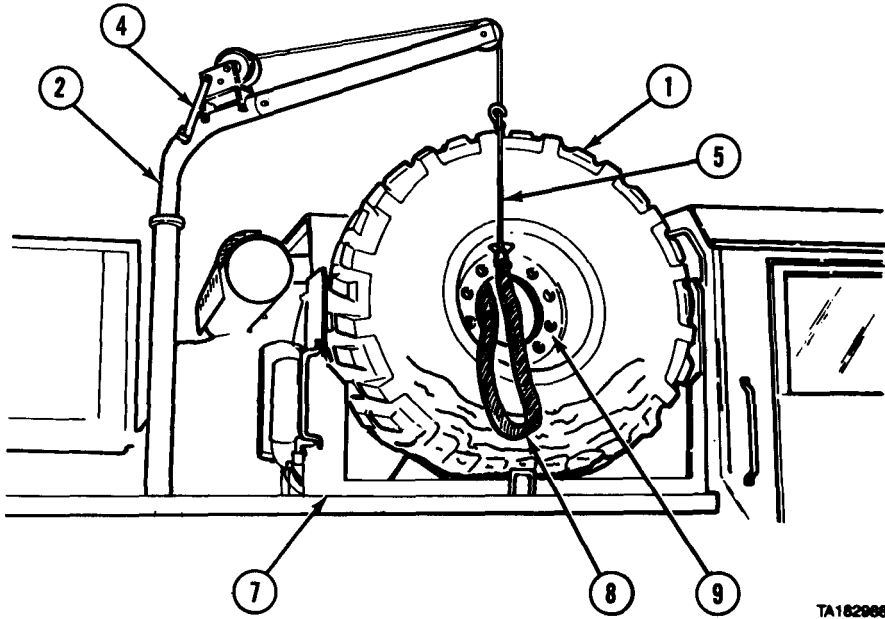
- (2) Turn handcrank (4) counterclockwise to let out cable (5).
- (3) Remove two wheel chocks (6).
- (4) Stow wheel chocks (6) on carrier (7).

CAUTION

Never use slot that has valve stem or spare tire could be damaged.

- (5) Pull tiedown strap (8) through wheel (9) and hook ends to hole (10) on both sides of wheel.

3-6. CHANGE WHEEL AND TIRE ASSEMBLY (CONT).



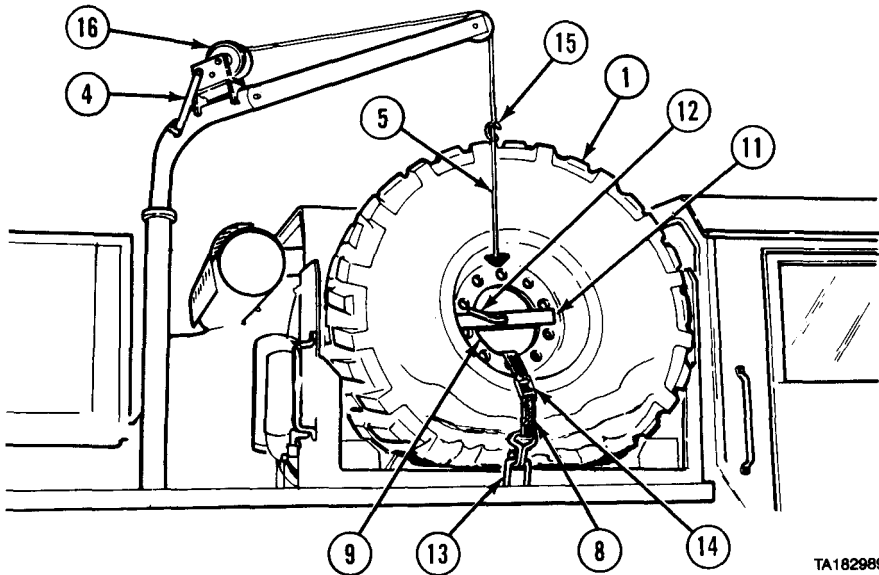
(6) Pull cable (5) through wheel (9) and hook to top of cable.

WARNING

Do not let tire hang in midair for long period of time. Place tire on carrier or ground as soon as possible. Tire is very heavy and could seriously injure personnel if it falls.

- (7) Soldier A turns handcrank (4) clockwise to raise flat tire (1) just above carrier (7) while Soldier B holds tiedown strap (8) to steady tire.
- (8) Soldier A swings hoist arm (2) so flat tire (1) is over carrier (7) while Soldier B guides tire with tiedown strap (8).
- (9) Turn handcrank (4) counterclockwise to lower flat tire (1) into carrier (7).
- (10) Remove tiedown strap (8).

Operators Maintenance (Cont)

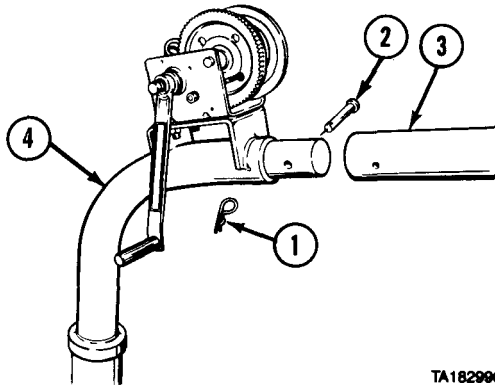


- (11) Soldier A holds flat tire (1) steady, while Soldier B installs holddown plate (11).
- (12) Install lever (12) and turn clockwise to tighten.
- (13) Slide tiedown strap (8) through wheel (9).
- (14) Soldier A connects tiedown strap (8) to outside holddown bracket (13), while Soldier B connects tiedown strap to inside holddown bracket.
- (15) Pull latch (14) down and lock to secure flat tire (1).
- (16) Turn handcrank (4) counterclockwise to loosen cable (5).
- (17) Remove hook (15) and cable (5) from wheel (9).
- (18) Turn handcrank (4) clockwise and wind cable (5) fully onto reel (16).

Operators Maintenance (Cont)

3-6. CHANGE WHEEL AND TIRE ASSEMBLY (CONT).

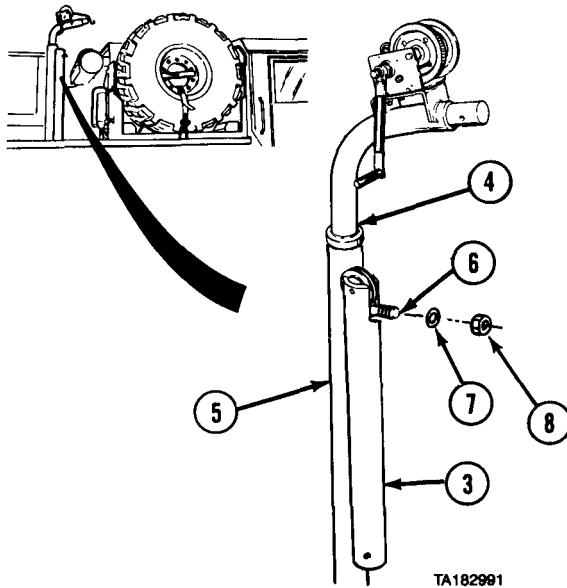
f. Stow Tire Davit Winch.



NOTE

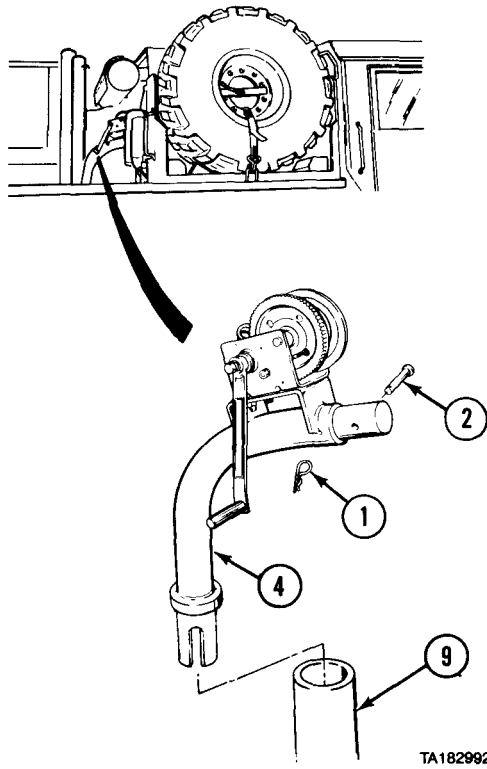
On M983 with crane, tire davit winch is located on extension, not on hoist arm.

- (1) Remove safety pin (1) and pin (2) from extension (3).
- (2) Pull extension (3) from hoist arm (4).



- (3) Install extension (3) on mount (5).
- (4) Slide top of extension (3) over stud (6).
- (5) Secure extension (3) with washer (7) and nut (8).
- (6) Pull hoist arm (4) from mount (5).

Operators Maintenance (Cont)



- (7) Put hoist arm (4) into mounting bracket (9).
- (8) Install pin (2) through hoist arm (4).
- (9) Secure pin (2) with safety pin (1).
- (10) Pick up and stow emergency marker kit (para 2-44).

3-7. CLEAN FUEL TANK STRAINER.

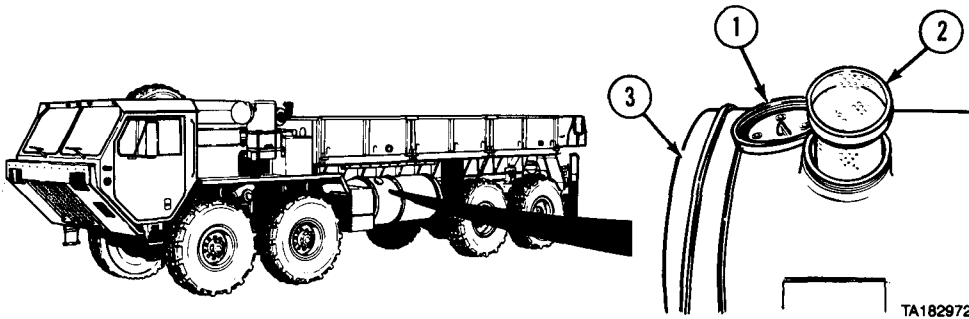
MODELS: All

TOOLS: None

SUPPLIES: Clean rags

PERSONNEL REQUIRED: MOS 64C10, Heavy vehicle driver

a. Remove/Clean Fuel Tank Strainer.



- (1) Park vehicle (para 2-11o).
- (2) Shut off engine (para 2-11p).

WARNING

Fuel is very flammable and can explode easily. To avoid serious injury or death when working with fuel, keep fuel away from open fire and keep fire extinguisher within easy reach. Do not work on fuel system when engine is hot. Fuel can be ignited by hot engine. Shut off engine and do not smoke while refueling.

- (3) Wipe off dirt from fuel filler cap (1).
- (4) Remove fuel filler cap (1).
- (5) Pull strainer (2) out of fuel tank (3).
- (6) Clean strainer (2) with clean dry rag.

b. Install Fuel Tank Strainer.

- (1) Put strainer (1) in fuel tank (2).
- (2) Install and tighten fuel filler cap (3).

Operators Maintenance (Cont)

3-8. SERVICE AIR CLEANER ELEMENT.

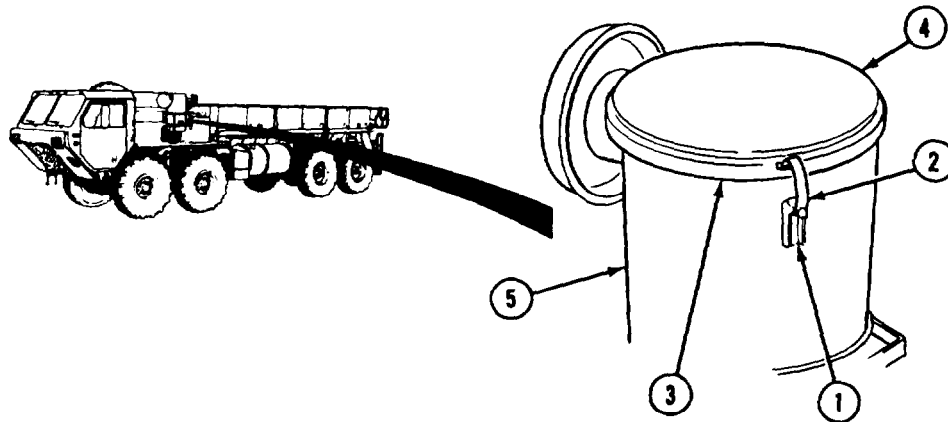
MODELS: All

TOOLS: Ladder
Screwdriver, flat tip

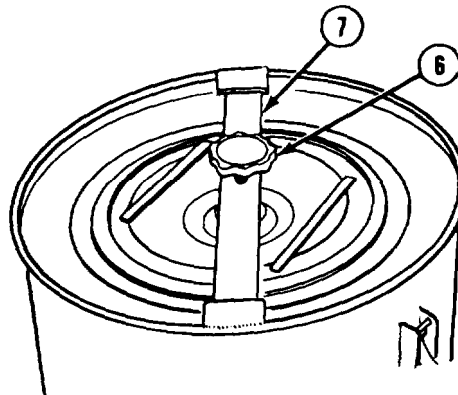
SUPPLIES: Rags

PERSONNEL REQUIRED: MOS 88M, Motor Transport Operator

a. Remove Air Cleaner Element.



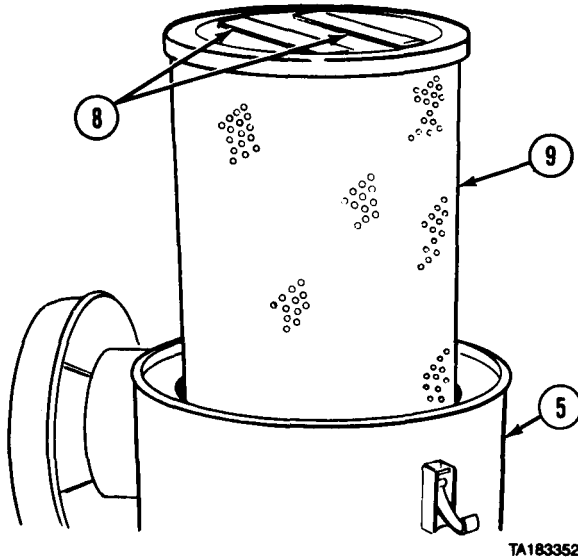
- (1) Lift up three levers (1).
- (2) Unhook three latches (2) from cover groove (3).
- (3) Remove cover (4) from canister (5).



- (4) Unscrew knob (6) until retaining bar (7) is loose.
- (5) Remove knob (6) and retaining bar (7).

Operators Maintenance (Cont)

3-8. SERVICE AIR CLEANER ELEMENT (CONT).

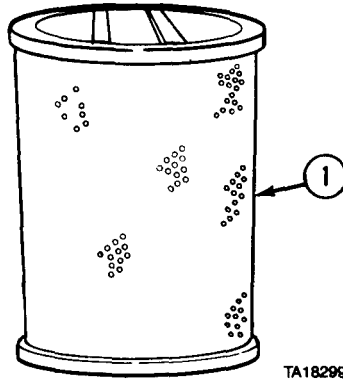


CAUTION

Do not remove secondary filter element. Dirt and debris can fall into canister and cause damage to engine.

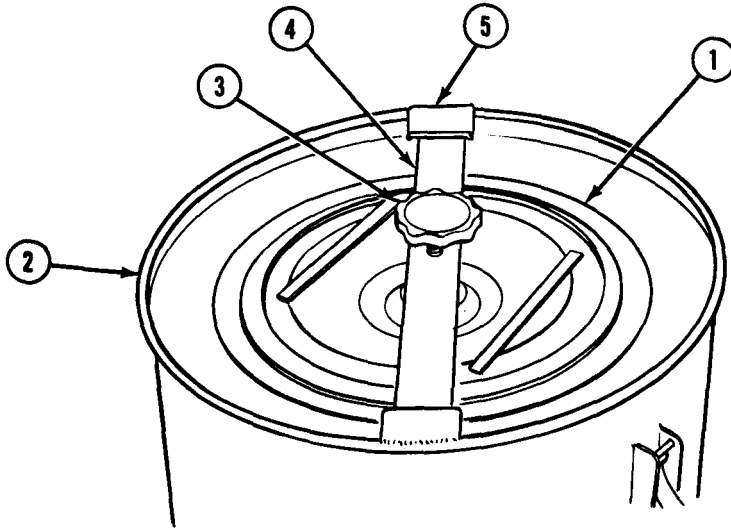
- (6) Take hold of handles (8) and remove primary element (9) from canister (5).

Operators Maintenance (Cont)

b. Clean Air Cleaner Element.**NOTE**

Notify organizational maintenance if primary filter element is damaged or cannot be cleaned by tapping.

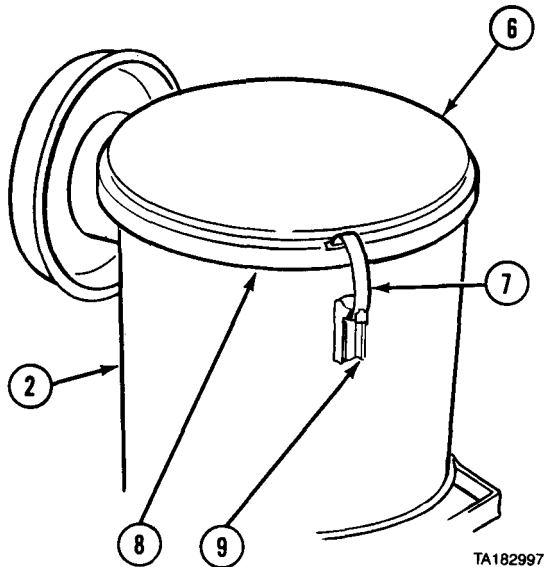
- (1) Tap side of primary element (1) lightly against hand.
- (2) Dump out dirt and dust from primary element (1).
- (3) Wipe primary element (1) with clean rag.

c. Install Air Cleaner Element.

- (1) Install primary element (1) in air cleaner canister (2).
- (2) Position knob (3) and retaining bar (4) over primary element (1). Make sure ends of retaining bar are in tabs (5).
- (3) Tighten knob (3) to secure primary element (1).

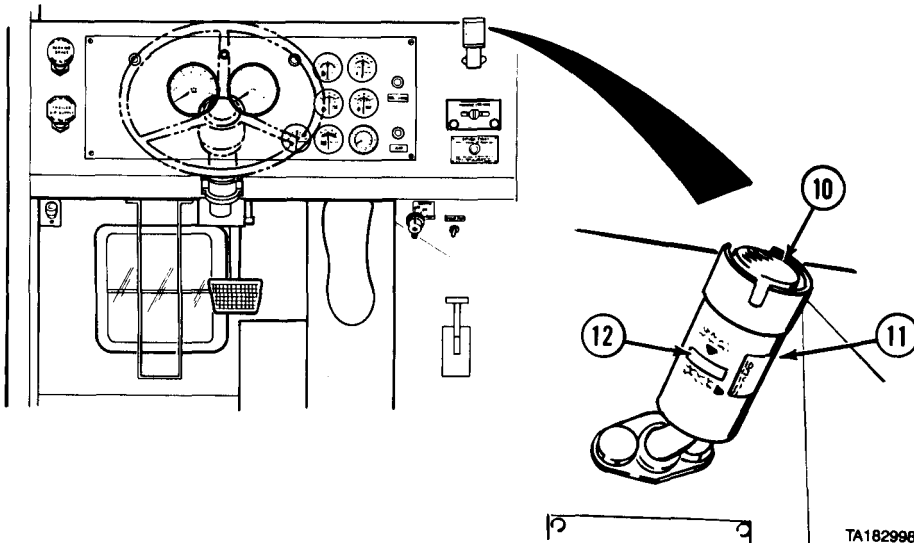
Operators Maintenance (Cont)

3-8. SERVICE AIR CLEANER ELEMENT (CONT).



TA182997

- (4) Put cover (6) on top of air cleaner canister (2).
- (5) Put three latches (7) in cover groove (8).
- (6) Push three levers (9) down to secure cover (6).
- (7) Start engine (para 2-11a or 2-11b).



TA182998

- (8) Push button (10) to reset air cleaner restriction indicator (11). If indicator window (12) shows yellow and VACUUM INCHES H₂O window shows below 18, continue with vehicle operation but notify organizational maintenance as soon as possible. If indicator window shows yellow and above 18, notify organizational maintenance.

Operators Maintenance (Cont)

3-9. SERVICE TIRES.

MODELS: All

TOOLS: Gage, tire pressure
Hose, tire inflation

SUPPLIES: None

PERSONNEL REQUIRED: MOS 64C10, Heavy vehicle driver

a. Check Tire Pressure.

WARNING

Failure to comply with these procedures may result in faulty positioning of the tire and/or rim parts, and cause the assembly to burst with explosive force, sufficient to cause serious physical injury or death. Never mount or use damaged tires or rims.

NOTE

There are two types of air pressure gages. Model A is a separate hand held gage used on vehicle serial number 51130 and below. Model B is a combined pressure gage/inflation hose used on vehicle serial number 51131 and above.

- (1) Check tire air pressure with tire pressure gage (para 3-9b).
- (2) Use Table 3-3 to make sure tires have right air pressure for road conditions and driving speed.

Table 3-3. Tire Pressure

	TIRE PRESSURES			
	<u>Highway</u>	<u>Cross Country-Dry</u>	<u>Cross Country-Wet</u>	<u>Sandy Terrain</u>
Front (all models)				
Standard Tire	60 psi (414 kPa)	35 psi (241 kPa)	20 psi (138 kPa)	30 psi (207 kPa)
Sand Tire	60 psi (414 kPa)	NA	NA	25 psi (172 kPa)
Rear				
M977,M978,M983				
Standard Tire	70 psi (483 kPa)	40 psi (276 kPa)	30 psi (207 kPa)	35 psi (241 kPa)
Sand Tire	70 psi (483 kPa)	NA	NA	30 psi (207 kPa)
M984E1				
Standard Tire	100 psi (690 kPa)	100 psi (690 kPa)	100 psi (690 kPa)	30 psi (207 kPa)
Sand Tire	100 psi (690 kPa)	NA	NA	25 psi (172 kPa)

Operators Maintenance (Cont)

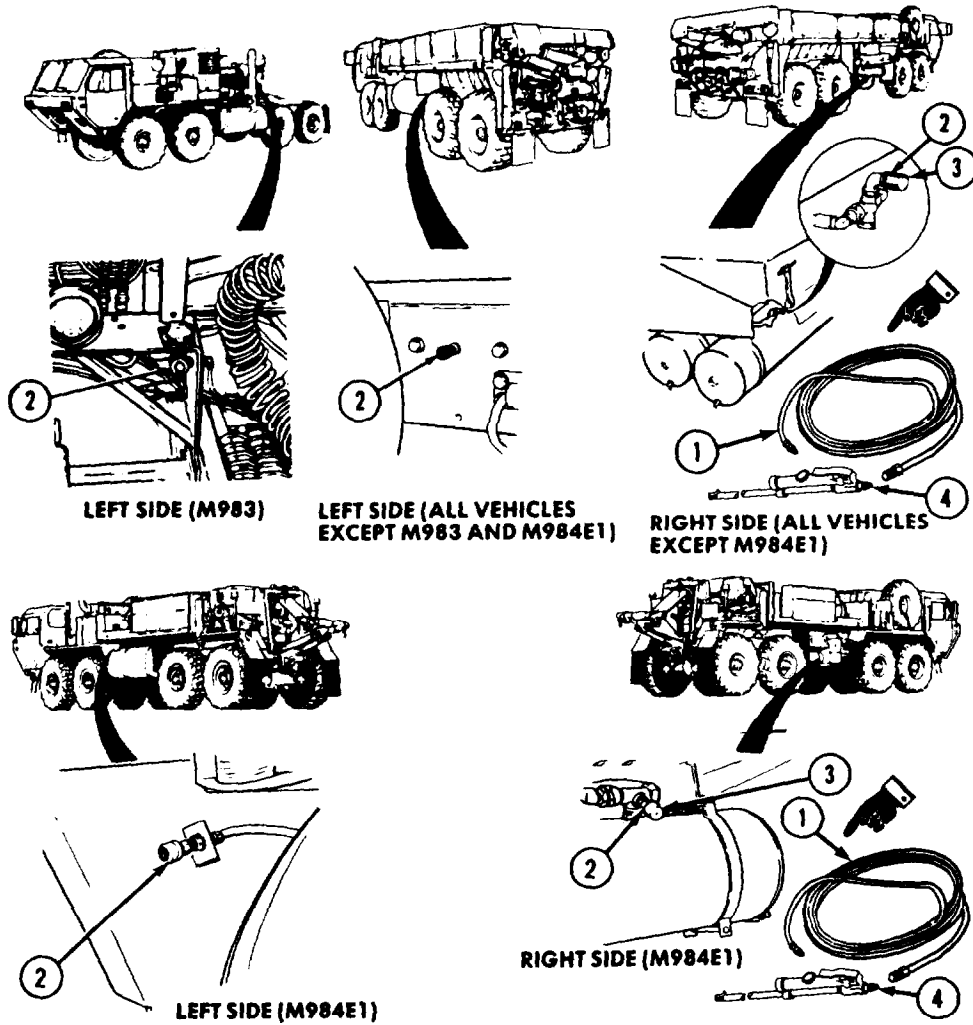
3-9. SERVICE TIRES (CONT)

Table 3-3. Tire Pressure (Cont)

	TIRE PRESSURES			
	<u>Highway</u>	<u>Cross Country-Dry</u>	<u>Cross Country-Wet</u>	<u>Sandy Terrain</u>
M984E1 (when towing another vehicle)				
Standard Tire	100 psi (690 kPa)	100 psi (690 kPa)	100 psi (690 kPa)	80 psi (552 kPa)
Sand Tire	100 psi (690 kPa)	NA	NA	80 psi (552 kPa)
M985				
Standard Tire	90 psi (621 kPa)	50 psi (345 kPa)	40 psi (276 kPa)	40 psi (276 kPa)
Sand Tire	100 psi (690 kPa)	NA	NA	40 psi (276 kPa)
Spare Tire (all models)				
Standard Tire	100 psi (690 kPa)	100 psi (690 kPa)	100 psi (690 kPa)	100 psi (690 kPa)
Sand Tire	100psi (690 kPa)	NA	NA	100 psi (690 kPa)
	OPERATING SPEEDS			
	<u>Highway</u>	<u>Cross Country-Dry</u>	<u>Cross Country-Wet</u>	<u>Sandy Terrain</u>
Maximum Speed (all models)				
Standard Tire	55mph (88 kmh)	40mph (64 kmh)	20mph (32 kmh)	20mph (32 kmh)
Sand Tire	55mph (88kmh)	NA	NA	20mph (32kmh)
M984E1 (when towing another vehicle)				
Standard Tire	15mph (24 kmh)*	15mph (24kmh)	15mph (24kmh)	15mph (24kmh)
Sand Tire	15 mph (24 kmh)*	NA	NA	15 mph (24 kmh)
	* Operation at speeds over 15 mph (24 kmh) on paved road can be achieved when the operator determines that the vehicle being towed and the terrain allow for safe operation. Under no condition can speeds exceed 35 mph (55 kmh) on paved roads and 15 mph (24 kmh) off paved roads.			

Operators Maintenance (Cont)

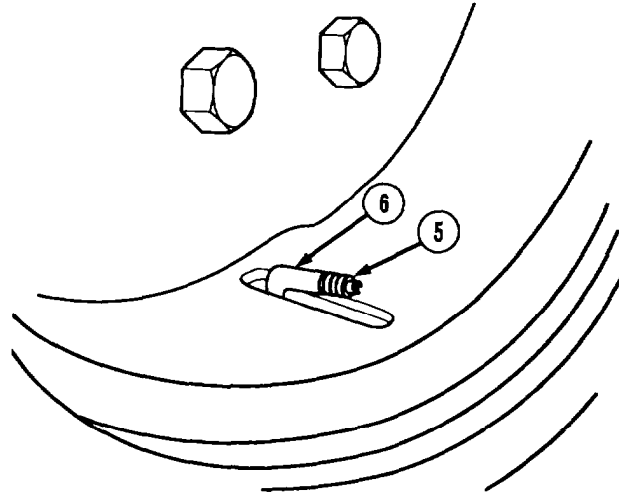
b. Inflate Tire



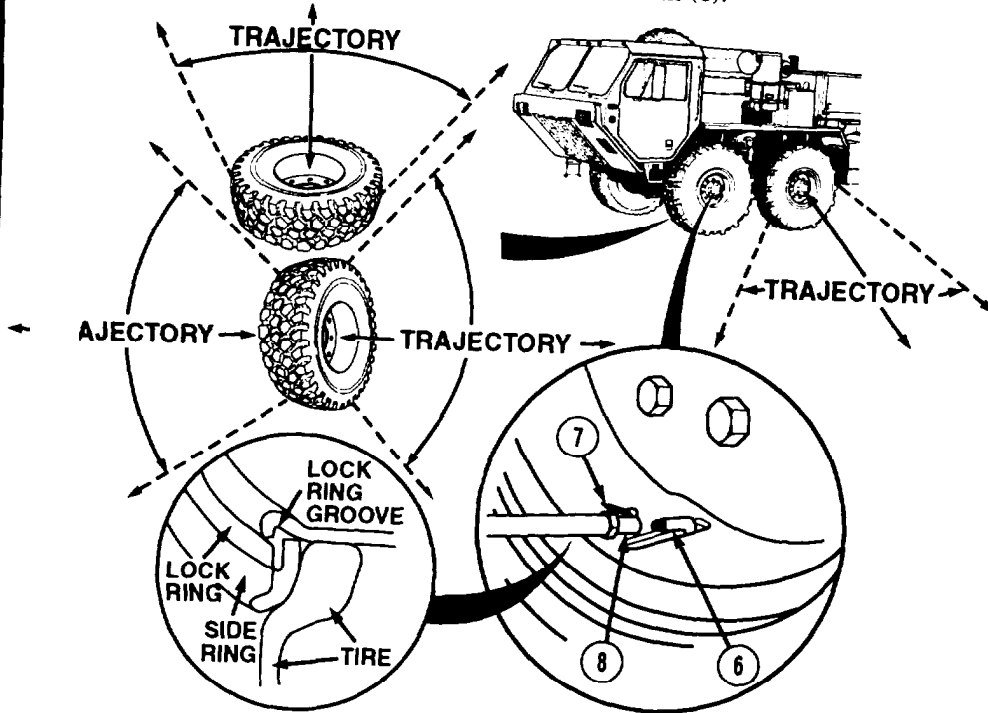
- (1) Remove air hose (1) from stowage and connect air hose to quick-disconnect coupling (2) by pushing back sleeve (3).
- (1.1) Connect inflator/deflator tire gage (4) to airhose (1).
- (2) Start engine (para 2-11a or 2-11b).

Operators Maintenance (Cont)

3-9. SERVICE TIRES (CONT).



(3) Remove valve stem cap (5) from valve stem (6).



Operators Maintenance (Cont)**WARNING**

- While changing tires or while performing tire maintenance stay out of the trajectory as shown by the area indicated. Failure to follow proper procedures may result in injury or death to personnel.
- Under some circumstances, the trajectory may deviate from its expected path. Failure to follow proper procedures may result in injury or death to personnel.
- Never inflate a tire without checking to ensure that the side ring is still properly seated in the locking groove. Ensure that the side ring, locking and locking groove are not damaged. The side ring and locking may blow off during inflation/deflation resulting in injury or death to personnel.
- Improperly seated lockrings and side rings may blow off during inflation. Never attempt to seat a locking or side ring during or after inflation. Serious injury or death may result.
- When inflating tires mounted on the vehicle, all personnel must remain out of the trajectory of the side ring and locking as shown by the areas indicated. Failure to follow proper procedures may result in serious injury or death to personnel.

NOTE

- Trajectory area as shown applies to all wheel/tire assemblies.
 - Air chuck must clamp securely with no leaks or air pressure gage readings will be inaccurate.
 - There are two types of air pressure gages. Model A is a separate hand held gage used on vehicle serial number 51130 and below. Model B is a combined pressure gage/inflation hose used on vehicle serial number 51131 and above.
- (4) Bush latch handle (7) inward, while pushing air chuck (8) onto valve stem (6). Release latch handle and immediately step out of the trajectory area, read tire air pressure gage and compare to Table 3-4.

Operators Maintenance (Cont)

3-9. SERVICE TIRES (CONT).

Table 3-4. Unsafe Inflation Pressures

WARNING

If tire has been run flat, or is over- or underinflated when tire pressure is measured and operating terrain is compared to Table 3-4, or if wheel/tire assembly has obvious or suspected damage, it is not safe to adjust tire pressure. Completely deflate tire according to para 3-9, and remove the tire from the axle. Failure to follow these procedures may result in serious personal injury or death.

	Spare Tire is:	Spare Tire is:	Front Tires are: (All models)	Front Tires are: (All models)
	Overinflated. tire pressure measured is 25% or more above the standard tire pressure. Do not adjust pressure if above pressure shown below.	Underinflated. Tire pressure measured is 80% or less than the standard tire pressure. Do not adjust pressure if below pressure shown below.	Overinflated. Tire pressure measured is 25% or more above the standard tire pressure. Do not adjust pressure if above pressure shown below.	Underinflated. Tire pressure measured is 80% or less than the standard tire pressure. Do not adjust pressure if below pressure shown below.
<u>Highway</u>				
Standard Tire	125 psi (862 kPa)	80 psi (552 kPa)	75 psi (517 kPa)	48 psi (331 kPa)
Sand Tire	125 psi (862 kPa)	80 psi (552 kPa)	75 psi (517 kPa)	48 psi (331 kPa)
<u>Cross Country-Dry</u>				
Standard Tire	125 psi (862 kPa)	80 psi (552 kPa)	44 psi (303 kPa)	28 psi (193 kPa)
Sand Tire	NA	NA	NA	NA
<u>Cross Country-Wet</u>				
Standard Tire	125 psi (862 kPa)	80 psi (552 kPa)	25 psi (172 kPa)	20 psi (138 kPa)
Sand Tire	NA	NA	NA	NA
<u>Sand</u>				
Standard Tire	125 psi (862 kPa)	80 psi (552 kPa)	38 psi (262 kPa)	24 psi (165 kPa)
Sand Tire	125 psi (862 kPa)	80 psi (552 kPa)	31 psi (214 kPa)	*25 psi (172 kPa)

Absolute minimum pressure.

Operators Maintenance (Cont)

Table 3-4. Unsafe Inflation Pressures (Cont)

WARNING

If tire has been run flat, or is over- or underinflated when tire pressure is measured and operating terrain is compared to Table 3-4, or if wheel/tire assembly has obvious or suspected damage, it is not safe to adjust tire pressure. Completely deflate tire according to para 3-9, and remove the tire from the axle. Failure to follow these procedures may result in serious personal injury or death.

	Rear Tires are: (M977, M978, M983)	Rear Tires are: (M977, M978, M983)	Rear Tires are: (M985)	Rear Tires are: (M985)
	Overinflated. Tire pressure measured is 25% or more above the standard tire pressure. Do not adjust pressure if above pressure shown below.	Underinflated. Tire pressure measured is 80% or less than the standard tire pressure. Do not adjust pressure if below pressure shown below.	Overinflated. Tire pressure measured is 25% or more above the standard tire pressure. Do not adjust pressure if above pressure shown below.	Under-inflated. Tire pressure measured is 80% or less than the standard tire pressure. Do not adjust pressure if below pressure shown below.
Highway				
Standard Tire	88 psi (607 kPa)	56 psi (386 kPa)	113 psi (779 kPa)	72 psi (496 kPa)
Sand Tire	88 psi (607 kPa)	56psi(386kPa) 125 psi (862 (862kPa)		80 psi (552 kPa)
Cross Country-Dry				
Standard Tire	50 psi (345 kPa)	32 psi (221 kPa)	63 psi (434 kPa)	40 psi (276 kPa)
Sand Tire	NA	NA	NA	NA
Cross Country-Wet				
Standard Tire	38 psi (262 kPa)	24 psi (166 kPa)	50 psi (345 kPa)	32 psi (221 kPa)
Sand Tire	NA	NA	NA	NA
Sand				
Standard Tire	44 psi (303 kPa)	28 psi (193 kPa)	50 psi (345 kPa)	32 psi (221 kPa)
Sand Tire	38 psi (262 kPa)	*25 psi (172 kPa)	50 psi (345 kPa)	32 psi (221 kPa)

* Absolute minimum pressure.

Operators Maintenance (Cont)

3-9. SERVICE TIRES (CONT).

Table 3-4. Unsafe Inflation Pressures (Cont)

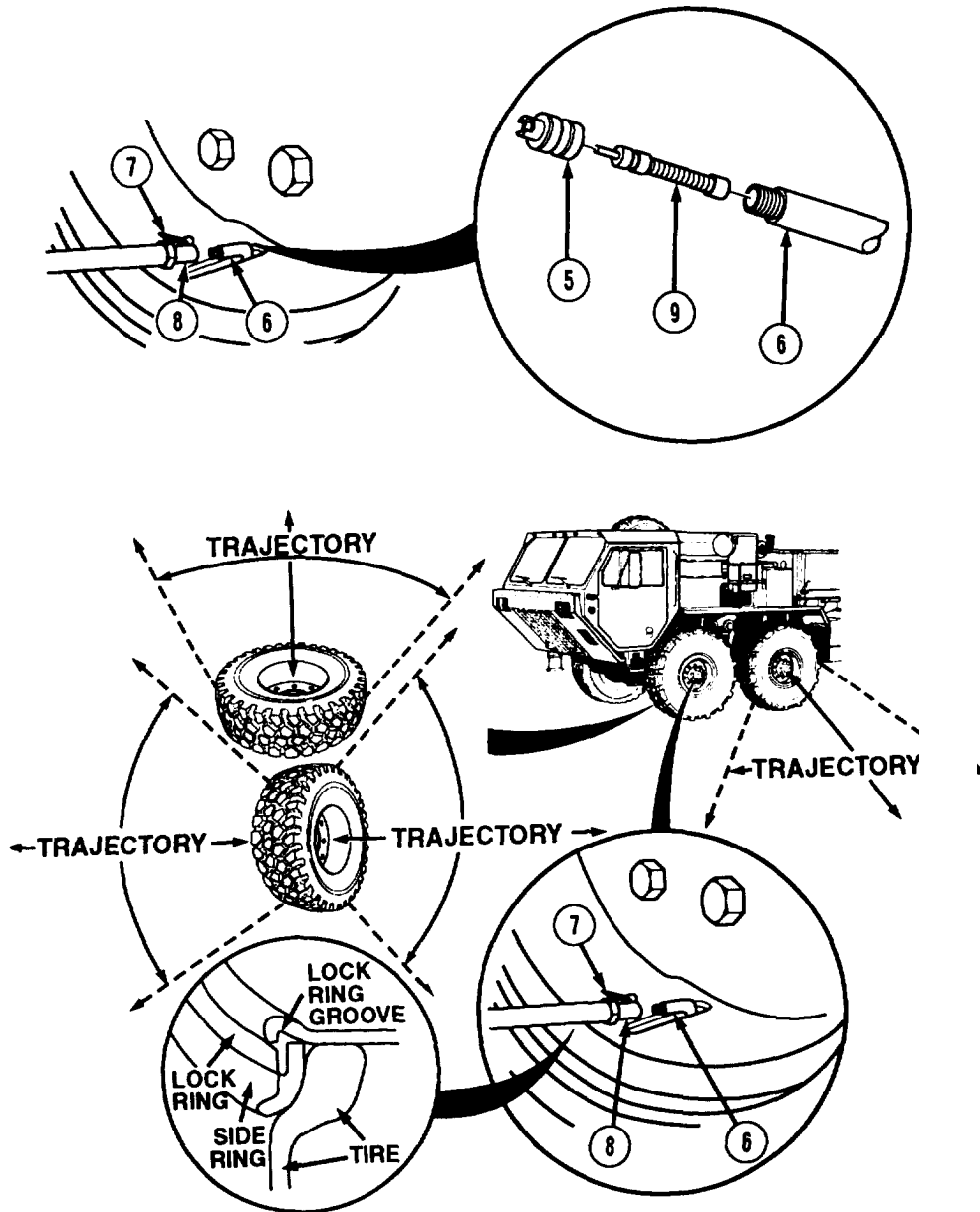
WARNING

If tire has been run flat, or is over- or underinflated when tire pressure is measured and operating terrain is compared to Table 3-4, or if wheel/tire assembly has obvious or suspected damage, it is not safe to adjust tire pressure. Completely deflate tire according to para 3-9, and remove the tire from the axle. Failure to follow these procedures may result in serious personal injury or death.

	Rear Tires are: (M984E1)	Rear Tires (M984E1)	Rear Tires are: (M984E1 when towing another vehicle)	Rear Tires are: (M984E1 when towing another vehicle)
	Overinflated. Tire pressure measured is 25% or more above the standard tire pressure. Do not adjust pressure if above pressure shown below.	Underinflated. Tire pressure measured is 80% or less than the standard tire pressure. Do not adjust pressure if below pressure shown below.	Overinflated. Tire pressure measured is 25% or more above the standard tire pressure. Do not adjust pressure if above pressure shown below.	Underinflated. Tire pressure measured is 80% or less than the standard tire pressure. Do not adjust pressure if below pressure shown below.
<u>Highway</u>				
Standard Tire	125 psi (862 kPa)	80 psi (552 kPa)	125 psi (862 kPa)	80 psi (552 kPa)
Sand Tire	125 psi (862 kPa)	80 psi (552 kPa)	125 psi (862 kPa)	80 psi (552 kPa)
<u>Cross Country-Dry</u>				
Standard Tire	125 psi (862 kPa)	80 psi (552 kPa)	125 psi (862 kPa)	80 psi (552 kPa)
Sand Tire	NA	NA	NA	NA
Standard Tire	125 psi (862 kPa)	80 psi (552 kPa)	125 psi (862 kPa)	80 psi (552 kPa)
Sand Tire	NA	NA	NA	NA
Standard Tire	38 psi (262 kPa)	24 psi (165 kPa)	99 psi (684 kPa)	64 psi (441 kPa)
Sand Tire	31 psi (215 kPa)	*25 psi (172 kPa)	99 psi (684 kPa)	64 psi (441 kPa)

Absolute minimum pressure.

Operators Maintenance (Cont)



Operators Maintenance (Cont)

3-9. SERVICE TIRES (CONT).

WARNING

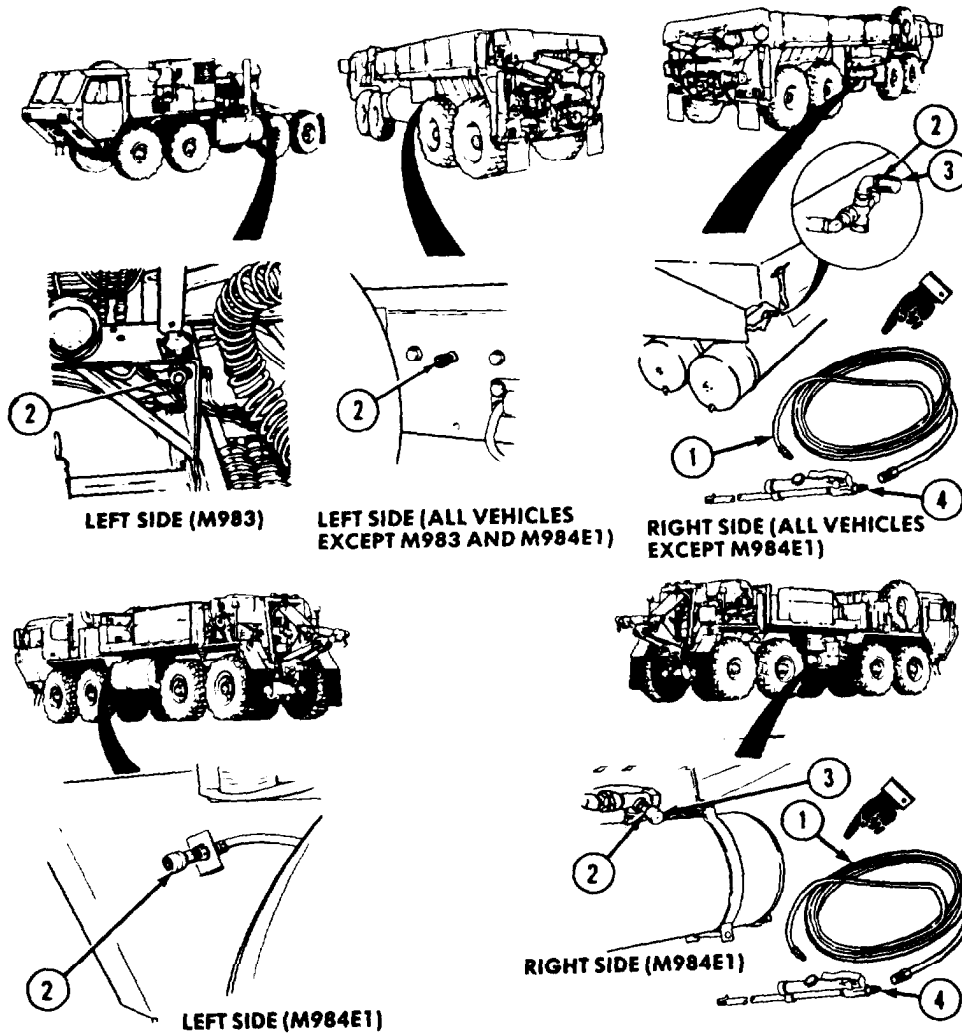
- While changing tires or while performing tire maintenance stay out of the trajectory as shown by the area indicated. Failure to follow proper procedures may result in injury or death to personnel.
- Under some circumstances, the trajectory may deviate from its expected path. Failure to follow proper procedures may result in injury or death to personnel.
- Never inflate a tire without checking to ensure that the side ring is still properly seated and the lockring is properly seated in the lockring groove. Ensure that the side ring, lockring and lockring groove are not damaged. The side ring and lockring may blow off during inflation/deflation resulting in injury or death to personnel.
- Improperly seated lockrings and side rings may blow off during inflation. Never attempt to seat a lockring or side ring during or after inflation. Serious injury or death may result.
- When inflating tires mounted on the vehicle, all personnel must remain out of the trajectory of the side ring and lockring as shown by the areas indicated. Failure to follow proper procedures may result in serious injury or death to personnel.
- If the tire has been driven on underinflated or overinflated, or there is obvious or suspected damage on the tire or wheel components, the tire must be completely deflated by removing the valve core from the valve stem before the wheel is removed from the vehicle, or personal injury or death may result.

NOTE

Trajectory as shown applies to all wheel/tire assemblies.

- (5) If tire is underinflated or overinflated or if the wheel or tire has obvious damage or is suspected of damage, remove valve core (9) from valve stem (6). When tire is completely deflated, remove from vehicle and take to Unit Maintenance for disassembly and repair and install spare tire on vehicle (para 3-6d).
- (6) If tire is not under-inflated or overinflated and the wheel or tire does not have obvious damage or is not suspected of damage, press air chuck (8) onto valve stem (6), stand out of trajectory and inflate or deflate until proper pressure is attained (see Table 3-3). Press latch handle (7) and pull air chuck (8) from valve stem (6). Install valve cap (5).
- (7) Shut off engine (para 2-11p).

Operators Maintenance (Cont)



WARNING

Hold end of air hose when disconnecting from quick-disconnect coupling. Air hose is under pressure and can fly out at fast rate of speed causing injury to personnel.

- (7.1) Remove inflator/deflator tire gage (4) from air hose (1).
- (8) Hold end of air hose (1) and push sleeve (3) back and remove air hose.
- (9) Stow air hose (1) and inflator/deflator tire gage (4).

Operators Maintenance (Cont)

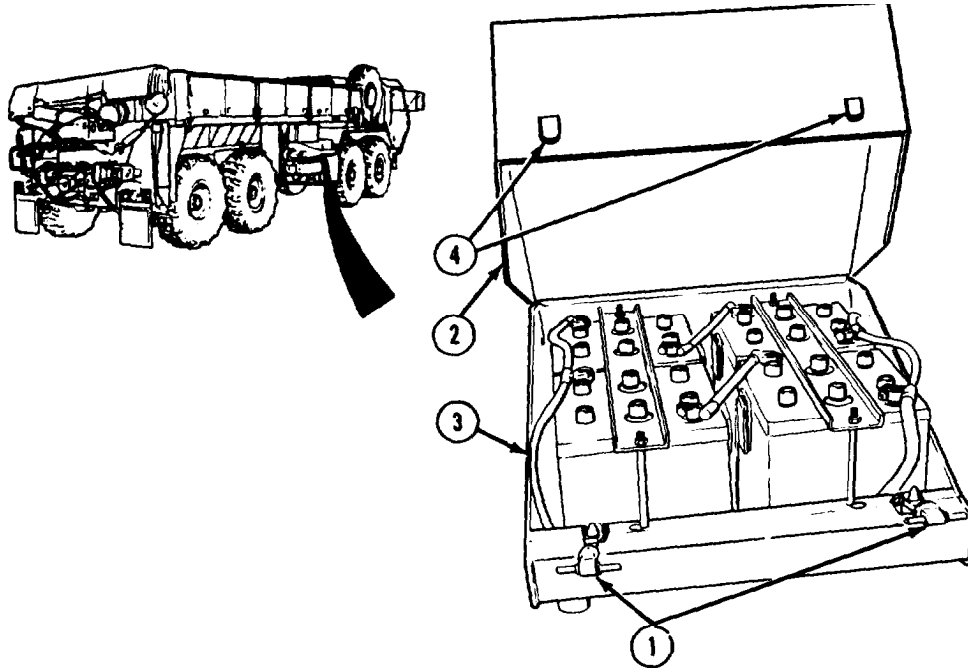
3-10. OPEN/CLOSE BATTERY BOX.

MODELS: All

TOOLS: None

SUPPLIES: None

PERSONNEL REQUIRED: MOS 88M, Motor Transport Operator

a. Open Battery Box.**WARNING**

Do not wear watches, rings, or other jewelry when working in battery box. If jewelry comes in contact with battery terminal, electrical shock and severe burn may result.

Do not smoke or have open flame near batteries. Batteries can explode. Battery acid is harmful to eyes and skin.

- (1) Disconnect two rubber hooks (1).
- (2) Slide cover (2) out and up.
- (3) Hold cover (2) in place or remove cover.

b. Close battery Box.

- (1) Slide cover (2) on battery box (3).
- (2) Align rubber hooks (1) and brackets (4).
- (3) Connect rubber hooks (1).

Operators Maintenance (Cont)

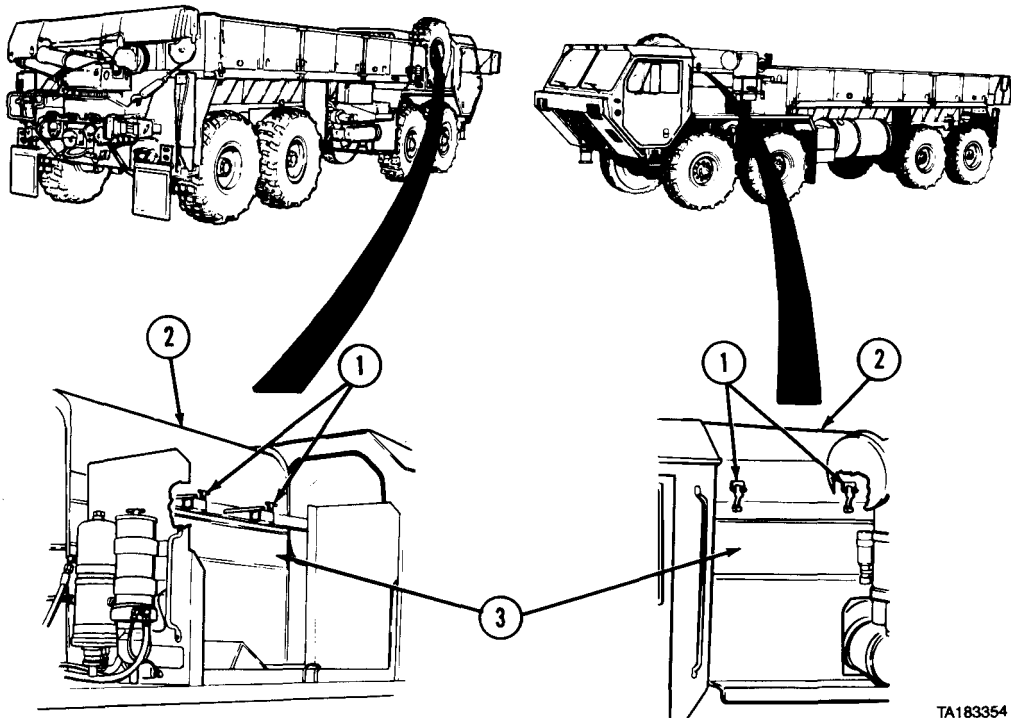
3-11. OPEN/CLOSE ENGINE COVER.

MODELS: All

TOOLS: None

SUPPLIES: None

PERSONNEL REQUIRED: MOS 64C, Heavy vehicle driver



TA183354

a. Open Engine Cover.

(1) Pull rubber hooks (1) up and out.

(2) Lift hood (2) slowly until it lays on top of engine compartment.

b. Close Engine Cover.

(1) Pull hood (2) forward.

(2) Push in side panel (3) and lower hood (2).

(3) Connect rubber hooks (1).

APPENDIX A REFERENCES

A-1. SCOPE. This appendix lists all forms, field manuals, technical manuals, and other publications referenced in this manual. Also, those publications that should be consulted for additional information about vehicle operations are listed.

A-2. PUBLICATION INDEX. The following index should be consulted frequently for latest changes or revisions and for new publications relating to material covered in this technical manual.

Consolidated Index of Army Publications and Blank Forms DA Pam 25-30 ■

A-3. FORMS The following forms pertain to this manual. Refer to DA Pamphlet 310-2 for index of blank forms.

- Standard Form 46, U.S. Government Motor Vehicle Operator's Identification Card.
- Standard Form 91, Operator's Report of Motor Vehicle Accident.
- Recommended Change to DA Publications and Blank Forms (DA Form 2020, 2028-2).
- Refer to DA PAM 738-750, The Army Maintenance Management. System (TAMMS), for instructions in the use of maintenance forms pertaining to this material.

A-4. OTHER PUBLICATIONS. The following publications contain information pertinent to the M977 series vehicles and associated equipment.

a. Safety.

- First Aid for Soldiers FM 21-11
- Safety Inspection and Testing of Lifting Devices TB 43-0142

b. Vehicle Operation.

- Aircraft Refueling FM 10-68
- Petroleum Tank Vehicle Operations FM 10-71
- Army Motor Transport Units and Operations FM 55-30
- Manual for the Wheeled Vehicle Driver FM 21-305
- Vehicle Recovery Operations FM 20-22
- Deepwater Fording of Ordnance Materiel TM 9-238
- M984 Operator's Manual TM 9-2320-354-10
- M985E1 Operator's Manual TM 9-2320-355-10
- Care, Maintenance, Repair, and Inspection of Pneumatic
Tires and Inner Tubes TM 9-2610-200-14
- Petroleum Supply Point Equipment and Operations FM 10-69 ■

References (Cont)

A-4. OTHER PUBLICATIONS (CONT).

c. Cold Weather Operation and Maintenance.

Basic Cold Weather Manual	FM 31-70
Northern Operations	FM31-71
Operation and Maintenance of Ordnance Materiel in Extreme Cold Weather (0 degrees to -65 degrees F)	FM 9-207
Purging, Cleaning, and Coating Interior Ferrous Terne Sheet Vehicle' Fuel Tanks	TB43-0212

d. Maintenance and Repair.

Lubrication Order for M977 Series Vehicles	LO 9-2320-279-21
Operator's, Unit, Direct Support and General Support Maintenance Manual for Care, Maintenance, Repair, and Inspection of Pneumatic Tires and Inner Tubes	TM 9-2610-200-14
Cooling Systems: Tactical Vehicles	TM 750-254
Use of Antifreeze Solutions and Cleaning Compounds in Engines . . . Cooling Systems	TB 750-651

e. Decontamination.

Chemical, Biological, Radiological, and Nuclear Defense	FM 21-40
---	----------

f. Operation of Auxiliary Equipment and Special Purpose Kits.

Operator's and Organizational Maintenance Manual for Radio Sets	TM 11-5820-498-12
Operator, Organizational, Direct Support, and General Support Maintenance Manual Including Repair Parts and Special Tools List for Machine Gun Mounts	TM 9-1005-245-14
Operator and Organizational Maintenance Manual for Generator Set	TM 5-6115-465-12
Lubrication Order for Generator Set	LO 5-6115-465-12

g. General.

Operator and Organizational Maintenance Manual for Chemical Alarm	TM 3-6665-225-12
Operator and Organizational Maintenance Manual Including Repair Parts and Special Tools List for Decontamination Apparatus	TM 3-4230-214-12&P
Hand Receipt Manual for M977 Series Vehicles	TM 9-2320-279-10-HR
Procedures for Destruction of Tank-Automotive Equipment to Prevent Enemy Use	TM 750-244-6
Principles of Automotive Vehicles	TM 9-8000
Camouflage	FM5-20

h. Warranty.

■ Warranty Technical Bulletin for M977 Series Vehicles	TB 9-2320-279-14
--	------------------

APPENDIX B
COMPONENTS OF END ITEM AND
BASIC ISSUE ITEMS LISTS

Section I. INTRODUCTION

B-1. SCOPE. This appendix lists components of end item and basic issue items for the M977 series vehicles to help inventory items required for safe and efficient operation.

B-2. GENERAL. The Components of End Item and Basic Issue Items Lists are divided into the following sections:

a. Section II. Components of End Item. This listing is for informational purposes only, and is not authority to requisition replacements. These items are part of the end item, but are removed and separately packaged for transportation or shipment. As part of the end item, these items must be with the end item whenever it is issued or transferred between property accounts. Illustrations are furnished to assist in identifying the items.

b. Section III. Basic Issue Items. These are the minimum essential items required to place the M977 series vehicles in operation, to operate them, and to perform emergency repairs. Although shipped separately packaged, BII must be with the vehicle during operation and whenever it is transferred between property accounts. The illustrations will assist with hard-to-identify items. This manual is the authority to request/requisition replacement BII, based on TOE/MTOE authorization of the end item.

B-3. EXPLANATION OF COLUMNS. The following provides an explanation of columns found in the tabular listings:

a. Column (1) - Illustration Number (Illus Number). This column indicates the number of the illustration in which the item is shown.

b. Column (2) - National Stock Number. Indicates the National Stock Number (NSN) assigned to the item and will be used for requisitioning purposes.

Components of End Item and Basic Issue Items Lists (Cont)

B-3. EXPLANATION OF COLUMNS (CONT).

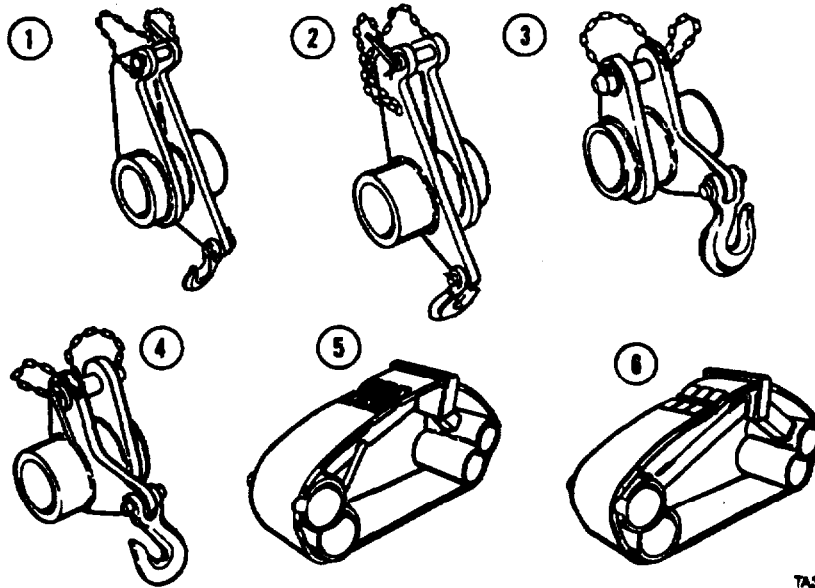
c. Column (3) - Description. Indicates the Federal item name and, if required, a minimum description to identify and locate the item. The last line for each item indicates the FSCM (in parentheses) followed by the part number. If item needed differs for different models of this equipment, the model is shown under the "Usable on Code" heading in this column. If no code is entered in this column, item is used on all models. These codes are identified as:

Code	Used On
H01	M977 Cargo w/winch
H02	M978 Tanker w/winch
H03	M983 Tractor w/winch, w/o crane
H05	M985 Cargo w/winch
H06	M977 Cargo w/o winch
H07	M978 Tanker w/o winch
H08	M983 Tractor w/winch, w/crane
H09	M985 Cargo w/o winch
H40	M984E1 Wrecker

d. Column (4) - Unit of Measure (U/M). Indicates the measure used in performing the actual operational/maintenance function. This measure is expressed by a two-character alphabetical abbreviation (es, in., pr).

e. Column (5) - Quantity Required (Qty Reqd). Indicates the quantity of the item authorized to be used with/on the equipment.

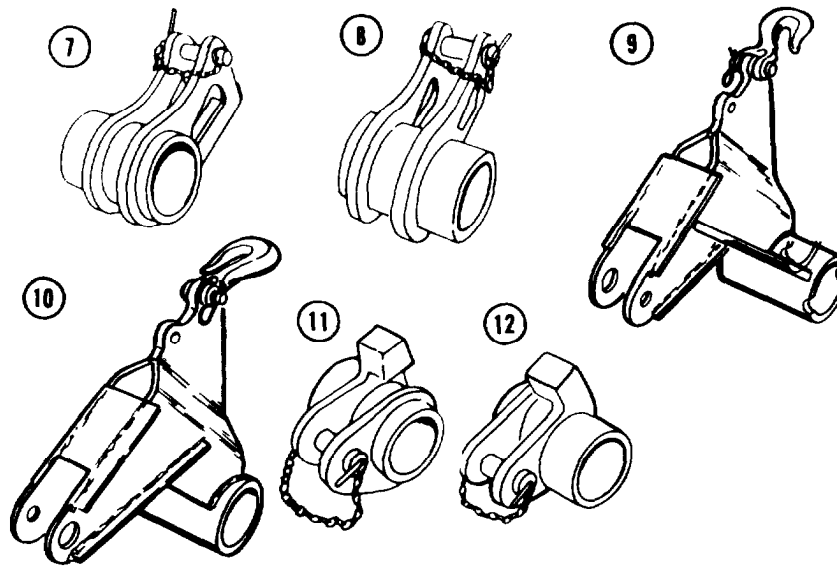
Section II. COMPONENTS OF END ITEM



7A367036

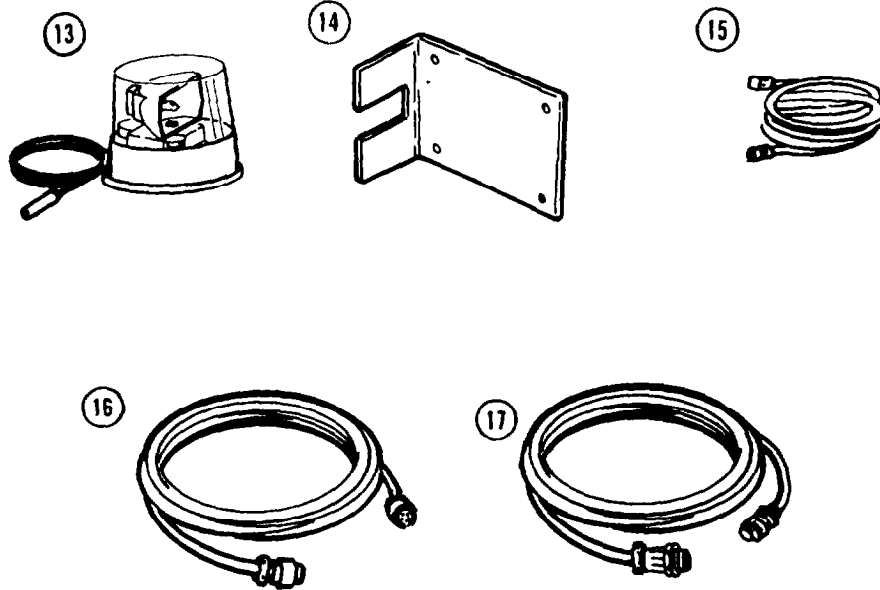
(1) Illus Number	(2) National Stock Number	(3) Description FSCM and Part Number	Usable On Code	(4) U/M	(5) Qty Reqd
1	2590-01-226-3351	ADAPTER ASSEMBLY, LIFT (LH) (in left side equipment body, on forward adapter holder) (45152) 1481890W	H40	EA	1
2	2540-01-226-3350	ADAPTER ASSEMBLY, LIFT (RH) (in left side equipment body, on forward adapter holder) (45152) 1481880W	H40	EA	1
3	2590-01-226-3349	ADAPTER ASSEMBLY, LIFT (LH) (in left side equipment body, on rear adapter holder) (45152) 1481840W	H40	EA	1
4	2540-01-226-7139	ADAPTER ASSEMBLY, LIFT (RH) (in left side equipment body, on rear adapter holder) (45152) 1481830W	H40	EA	1
5	2540-01-246-8013	ADAPTER ASSEMBLY, TOW (LH) (in left side equipment body, on forward adapter holder and support) (45152) 1531180U	H40	EA	1
6	2540-01-246-7770	ADAPTER ASSEMBLY, TOW (RH) (in left side equipment body, on forward adapter holder and support) (45152) 1531170U	H40	EA	1

Components of End Item (Cont)



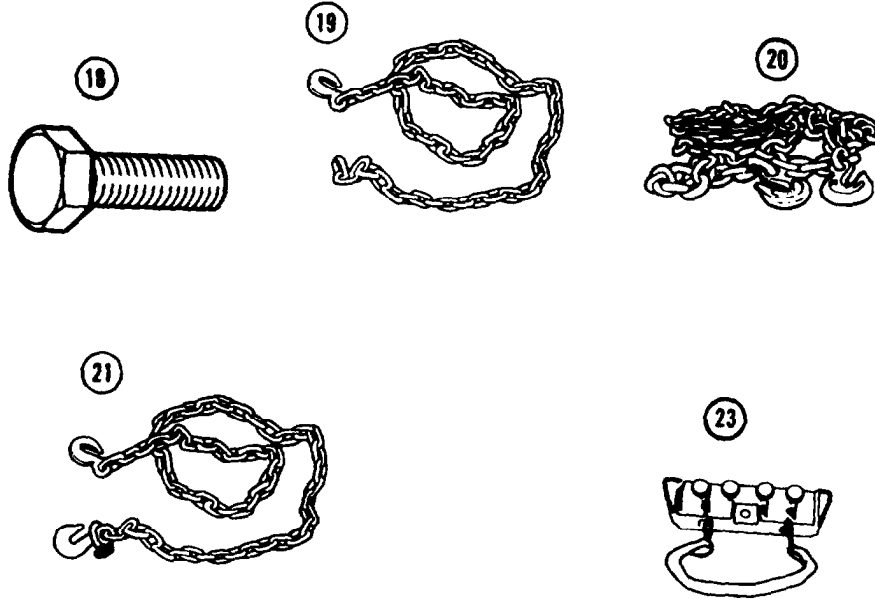
(1) Illus Number	(2) National Stock Number	(3) Description FSCM and Part Number	Usable On Code	(4) U/M	(5) Qty Reqd
7	2540-01-226-3373	ADAPTER ASSEMBLY, TOW (LH) (in left side equipment body, on center adapter holder) (45152) 1497260W	H40	EA	1
8	2540-01-226-5266	ADAPTER ASSEMBLY, TOW (RH) (in left side equipment body, on center adapter holder) (45152) 1497250W	H40	EA	1
9	2540-01-246-8012	ADAPTER ASSEMBLY, TOW (LH) (in right side equipment body, on adapter holder) (45152) 1532180W	H40	EA	1
10	2540-01-246-8012	ADAPTER ASSEMBLY, TOW (LH) (in right side equipment body, on adapter holder) (45152) 1532180W	H40	EA	1
11	2540-01-226-7138	ADAPTER ASSEMBLY, TOW (LH) (on tow crosstube) (45152) 1447200W	H40	EA	1
12	3040-01-224-5497	ADAPTER ASSEMBLY, TOW (RH) (on tow crosstube) (45152) 1447190W	H40	EA	1
12.1		Deleted			

Components of End Item (Cont)



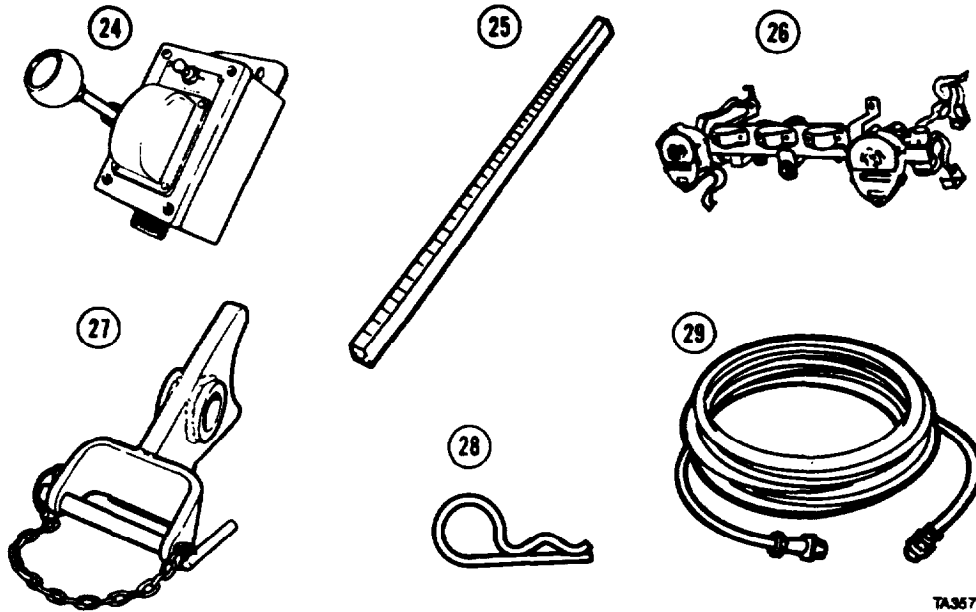
(1) Illus Number	(2) National Stock Number	(3) Description FSCM and Part Number	Usable On Code	(4) U/M	(5) Qty Reqd
13	6220-01-250-5190	BEACON, WARNING LIGHT in glove box) 45152) 1505510U	H40	EA	1
14	5340-01-211-6107	BRACKET, STEERING LOCK (right side equipment body, in bottom forward stowage box) 45152) 1358410	H40	EA	1
15	2590-01-184-1901	CABLE, REMOTE CONTROL, CRANE (stowage box, right side) (right side equipment body, in bottom rear stowage box) (12361) 2-198-6-00061	H01, 5,6,9 H40	EA EA	1 1
16	6150-01-231-6662	CABLE, REMOTE CONTROL, WINCH (right side equipment body, in bottom rear stowage box) (45152) 1491030	H40	EA	1
17	2590-01-222-5437	CABLE, TOW LIGHT (left side equipment body, in bottom forward stowage box) (16236) CS-2590-SV-0705	H40	EA	1

Components of End Item (Cont)



(1) Illus Number	(2) National Stock Number	(3) Description FSCM and Part Number	Usable On Code	(4) U/M	(5) Qty Reqd
18	5305-00-115-9526	CAPSCREW, 0.38 - 16 X 0.75 (right side equipment body, in bottom forward stowage box) (80204) B1821BH038C075D	H40	EA	4
19	4010-01-229-7769	CHAIN, 8 ft (left side equipment body, in top forward stowage box) (45152) 1340930	H40	EA	1
20	3940-01-270-3389	CHAIN, SAFETY, 16 ft (right side equipment body, in top forward stowage box) (45152) 1482010	H40	EA	2
21	4010-01-250-5428	CHAIN, 12 ft. (80535) 022-4712	H40	EA	4
22		Deleted			
23	2520-01-188-5129	CONTROL, REMOTE, W/STRAP, CRANE (stowage box, right side under cargo body) (right side equipment body, in bottom rear stowage box) (12361) 2-198-6-00053	H01,5 6,9 H40	EA EA	1 1

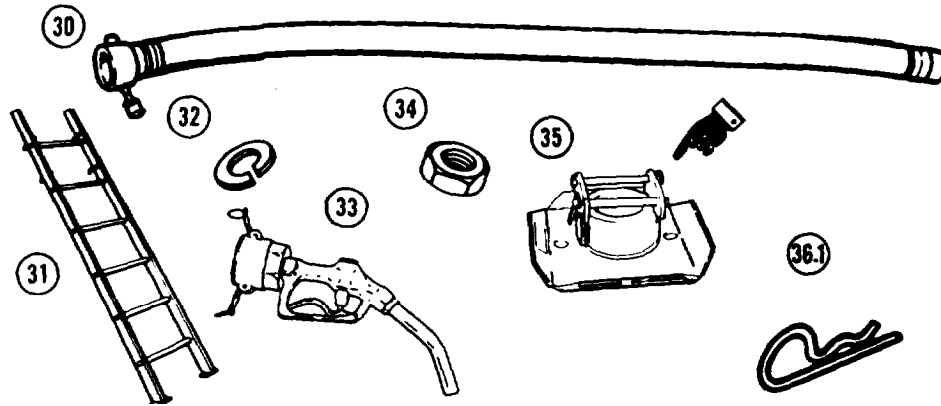
Components of End Item (Cont)



TA.957039

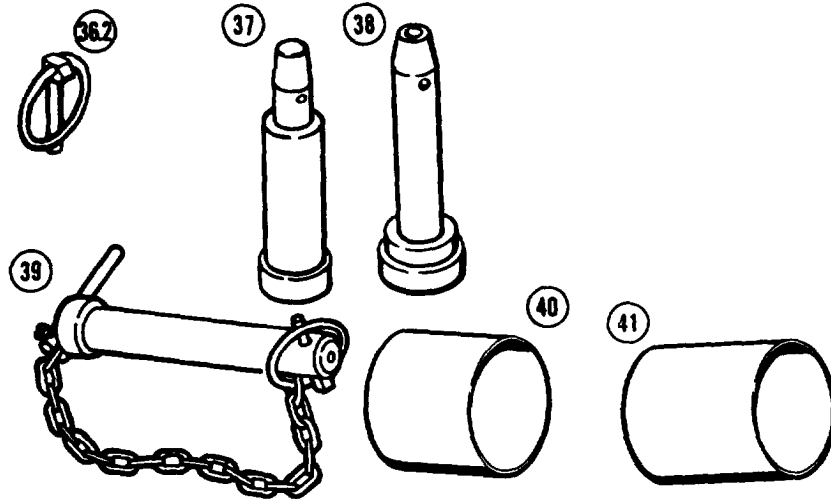
(1) Number	National Stock Number	Description FSCM and Part Number (3)	Usable On Code	(4) U/M	(5) Qty Reqd
24	2590-01-217-8317	CONTROL, REMOTE, WINCH (right side equipment body, in bottom rear stowage box) (45152) 1437940U	H40	EA	1
25	6680-01-208-4495	DIPSTICK, TANKER (45152) 1460070	H02,7	EA	1
26	6220-01-217-8316	EMERGENCY TOW LIGHTS (left side equipment body, in bottom center stowage box) (45152) 1462290U	H40	EA	1
27	2540-01-246-5218	EXTENSION, TOW ADAPTER (LH) (on tow crosstube) (45152) 1543440W	H40	EA	2
28	5315-01-161-2696	HAIRPIN, COTTER (96652) 21-08	H40	EA	4
29	6150-01-180-6035	HARNESS, WORKLAMP (left side equipment body, in bottom forward stowage box) (45152) 1419770U	H40	EA	1

Components of End Item (Cont)



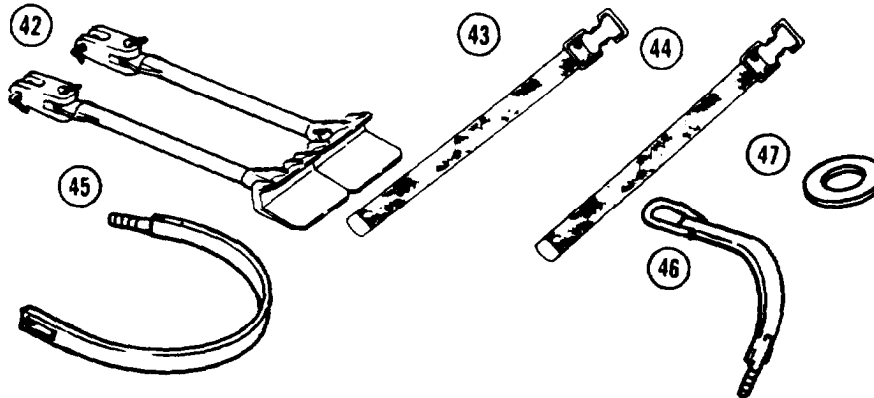
(1) Illus Number	(2) National Stock Number	(3) Description FSCM and Part Number	Usable On Code	(4) U/M	(5) Qty Reqd
30	4720-01-185-6067	HOSE ASSEMBLY: FUEL, 15 ft (right side, in tube along tank module) (45152) 1378080	H02,7	EA	1
31	2540-01-166-1384	LADDER: Vehicle (on left side over fuel tank) (on right side over batteries) (on walkway grating) (45152) 1766590W	H01,5, 6,9 H02,7,40 H03	EA EA EA	1 1 1
32	5310-00-637-9541	LOCKWASHER: (on acetylene tank straps) (on oxygen tank straps) (96906) MS35338-46	H40 H40	EA EA	2 2
33	4930-01-318-6091	NOZZLE, FUEL, 2.5 in., AUTOMOTIVE (stowage box, left front) (81718) 311AG1	H02,7	EA	2
34	5310-00-732-0558	NUT: PLAIN, HEX (on acetylene tank straps) (on oxygen tank straps) (96906) MS51967-8	H40 H40	EA EA	2 2
35	2590-01-184-1902	PAD, OUTRIGGER (on outrigger beams) (12361) 2-198-1-00028	H01,5, 6,9,40	EA	2
36		Deleted			
36.1	5315-01-259-0313	PIN, COTTER (96652) 21-07		EA	2

Components of End Item (Cont)



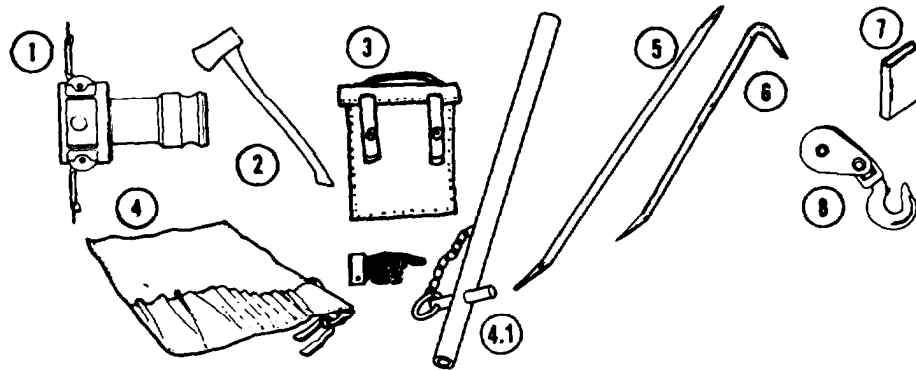
(1) IIIUS lumber	(2) National Stock Number	(3) Description FSCM and Part Number	Usable On Code	(4) U/M	(5) Qty Reqd
36.2	5315-01-258-8581	PIN, QUICK RELEASE (45152) 1536450U	H40	EA	1
37	5315-01-257-4512	PIN: TOW ADAPTER (left side equipment body in top rear stowage box) (45152) 1532880	H40	EA	2
38	5315-01-257-7802	PIN: TOW ADAPTER (right side equipment body in top rear stowage box) (45152) 1532880	H40	EA	2
39	5315-01-250-4676	PIN ASSEMBLY: EXTENSION (on extension tow adapter on crosstube) (45152) 1543800U	H40	EA	2
40	5365-01-257-4399	SPACERTUBE 4 in. long (left side equipment body in top rear stowage box) (45152) 1531110	H40	EA	2
41	5365-01-257-4400	SPACER: TUBE 5 in. long (left side equipment body in top rear stowage box) (45152) 1531120	H40	EA	1

Components of End Item (Cont)



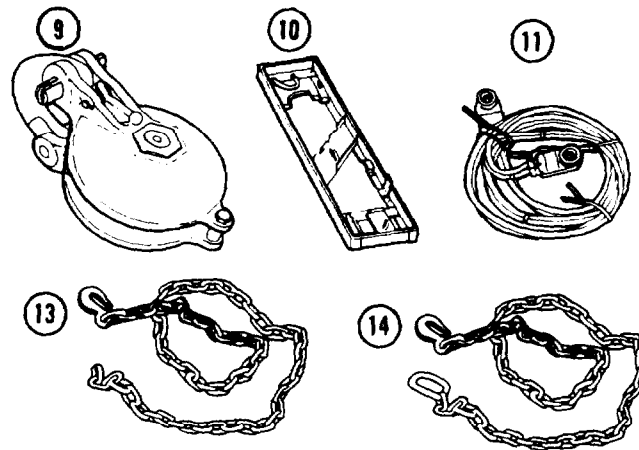
(1) Ilus Number	(2) National Stock Number	(3) Description FSCM and Part Number	Usable On Code	(4) U/M	(5) Qty Reqd
42	2540-01-217-8312	SPADE ASSEMBLY, TOW (in equipment body) (45152) 1444560U	H40	EA	1
43	5340-00-543-3398	STRAP: 1 in. x 12 in. (3 - left sides equipment body, in bottom rear stowage box) (1 -on wrecking bar, front RH fender) (19207) 8690462	H40	EA	4
44	5340-00-586-7579	STRAP: 1 in. x 16 in. (on pioneer tool bracket) (19207) 8690464	H40	EA	3
45	5340-01-236-2109	STRAP ASSEMBLY, ACETYLENE TANK (on acetylene tank, right rear) (45152) 1454420W	H40	EA	2
46	5340-01-182-9527	STRAP, RETAINING OXYGEN TANK (on oxygen tank, center rear) (45152) 1374630W	H40	EA	2
47	5310-00-080-6004	WASHER, PLAIN (on oxygen tank strap assembly) (96906) MS27183-14	H40	EA	4

Section III. BASIC ISSUE ITEMS



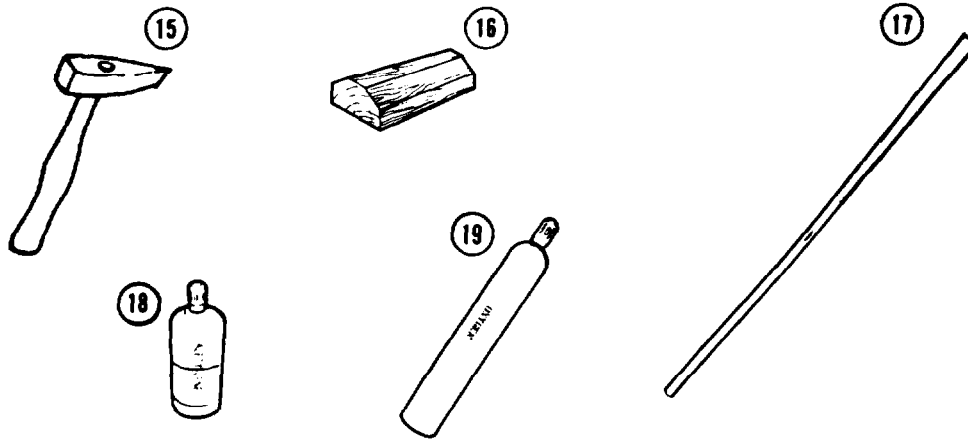
(1) IIUS Number	(2) National Stock Number	(3) Description FSCM and Part Number	Usable On Code	(4) U/M	(5) Qty Reqd
1	4730-01-222-6705	ADAPTER, REDUCER (to connect fuel nozzles) (33813) 25CX20A	H02,7	EA	2
2	5110-00-293-2336	AXE, SINGLE BIT (on pioneer tool bracket) (19207) 6150925	H02, 7,40	EA	1
3	2540-00-670-2459	BAG, PAMPHLET (cab glove box) (19207) 11676920	H40	EA	1
4	5140-01-227-9604	BAG, TOOL, WELDING KIT (right side equipment body, in top rear stowage box) (45152) 1478710	H40	EA	1
4.1	2540-01-254-5029	BAR, FAIRLEAD W/CHAIN (on retrieval system frame) (45152) 1567820W	H40	EA	1
5	5120-00-224-1372	BAR, PINCH: 36 in. (in toolbox) (19204) TDAXIA	H40	EA	1
6	5120-00-293-0665	BAR, WRECKING (in toolbox) (57068) 55-30	H40	EA	1
7	7510-00-889-3494	BINDER: LOOSE-LEAF (in cab glove box) (19207) 11677003		EA	1
8	3940-01-163-2319	BLOCK: TACKLE 20 TON (in toolbox) (left side equipment body, in top center stowage box) (75535) 8061278	H01,2, 3,5,40	EA	1

Basic issue Items (Cont)



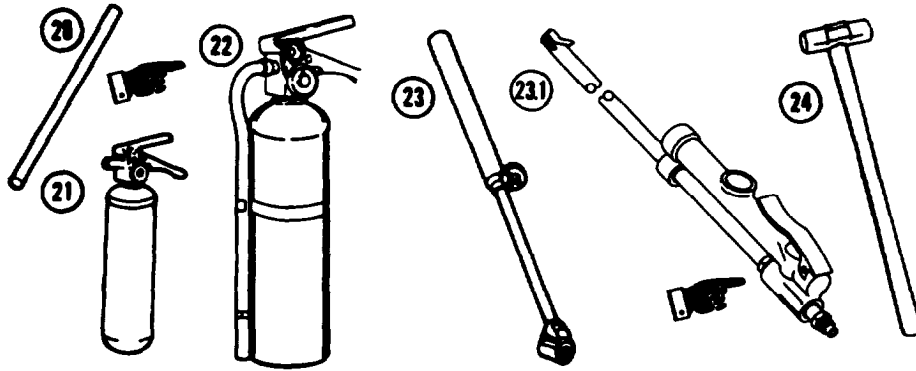
(1) illus Number	(2) National Stock Number	(3) Description FSCM and Part Number	Usable On Code	(4) U/M	(5) Qty Reqd
9	3940-01-230-0294	BLOCK: TACKLE 60 TON (left side, in equipment body) (95975) 6250-08	H40	EA	1
10	2540-00-409-8891	BRACKET ASSEMBLY: PIONEER TOOLS (left side of fuel can stowage box) (on right side equipment body stowage box) (96906) MS53053-1	H02,7 H40	EA EA	1 1
11	2590-00-148-7961	CABLE ASSEMBLY, NATO w/adapters (in toolbox) (19207) 11682379-1	H40	EA	1
12		Deleted			
13	4010-01-200-1506	CHAIN, UTILITY, 7 ft (Limp Home) (in toolbox)	H01,2,3, 5,6,7,9	EA	1
		(right side equipment body, in top forward stowage box) (45152) 1452490	H40	EA	1
14	4010-01-249-0548	CHAIN, UTILITY, 14 ft (in toolbox) (80535) 00044-9973	H01,2,3 5,6,7,9	EA	1
		(right side equipment body, in top forward stowage box) (80535) 0044-9973	H40	EA	1

Basic Issue items (Cont)



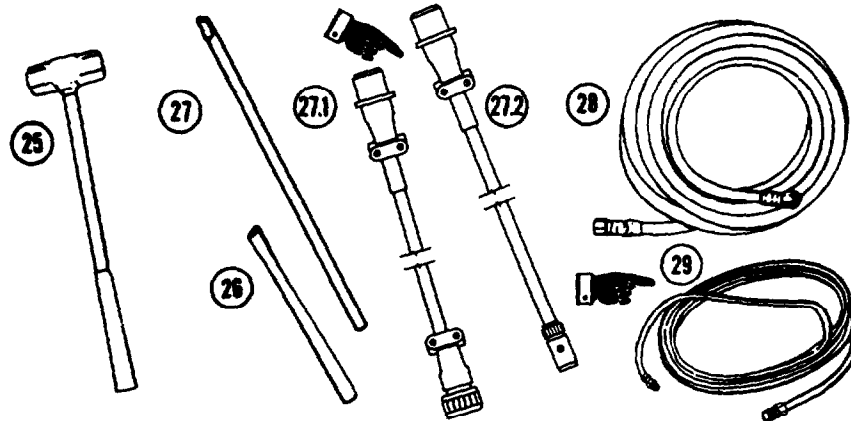
(1) IIUS Number	(2) National Stock Number	(3) Description FSCM and Part Number	Usable On Code	(4) U/M	(5) Qty Reqd
15	5110-00-221-1075	CHISEL, BLACKSMITH'S (right side equipment body, in bottom forward stowage box) (96906) MS16882-2	H40	EA	1
16	2540-01-165-6136	CHOCK:WHEEL TRAILER (under spare tire)	H01,2,3, 5,6,7,9	EA	4
		(left side equipment body, in top center stowage box)	H40	EA	4
		(under spare tire) (30966) 2279000	H40	EA	4
17	5120-00-224-1390	CROWBAR (on front RH fender) (56161) 10501985	H40	EA	1
18	8120-00-268-3360	CYLINDER COMPRESSED, ACETYLENE (vertical at right rear) (81349) MIL-C-3701-4	H40	CY	1
19	8120-00-357-7992	CYLINDER: COMPRESSED, OXYGEN (horizontal at center rear) (81348) C901/1-35	H40	CY	1

Basic issue Items (Cont)



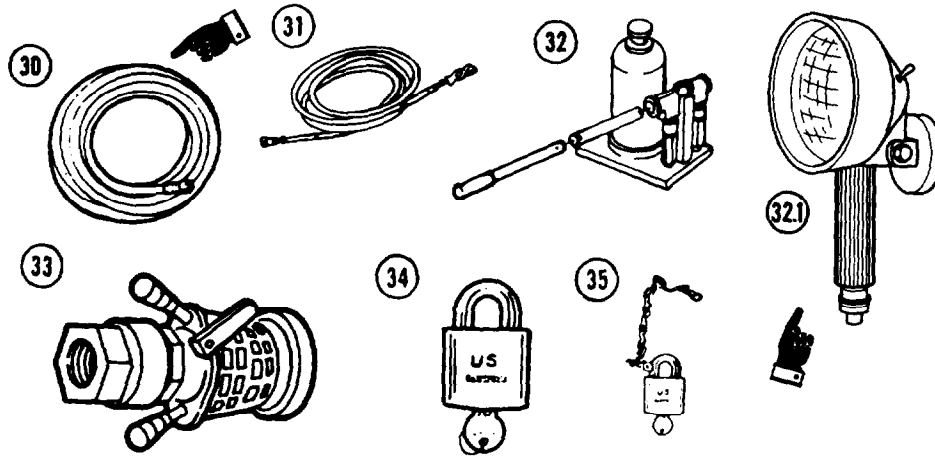
(1) IIUS Number	(2) National Stock Number	(3) Description FSCM and Part Number	Usable On Code	(4) U/M	(5) Qty Reqd
20	5340-01-209-7841	EXTENSION, HANDLE (for lug wrench, in toolbox)	H01,2,3, 5,6,7,9 H40	EA	1
		(right side equipment body, in bottom forward stowage box) (45152) 1347720		EA	1
21	4120-01-133-9053	EXTINGUISHER: FIRE, 2.7 lb (in cab right of driver's seat)	H01,2,3,6, 40	EA	1
		(on toolbox) (03670) 79734	H05,9	EA	2
22	4210-00-165-4703	EXTINGUISHER: FIRE, 5 lb (on toolbox)	H01,3,4,5, 6,9,40	EA	1
		(on battery box) (58536) A-A-393	H02,7	EA	2
23	4910-01-003-9599	GAGE, TIRE PRESSURE (in cab glove box) (94894) 976		EA	2
23.1	4910-01-386-4300	GAGE, TIRE PRESSURE (in cab glove box) (63900) I-405M		EA	2
24	5120-00-265-7462	HAMMER: HAND, 6 LB (in toolbox)	H02,7	EA	1
		(in right side equipment body, bottom forward stowage box) (90172) 41796	H40	EA	1

Basic Issue items (Cont)



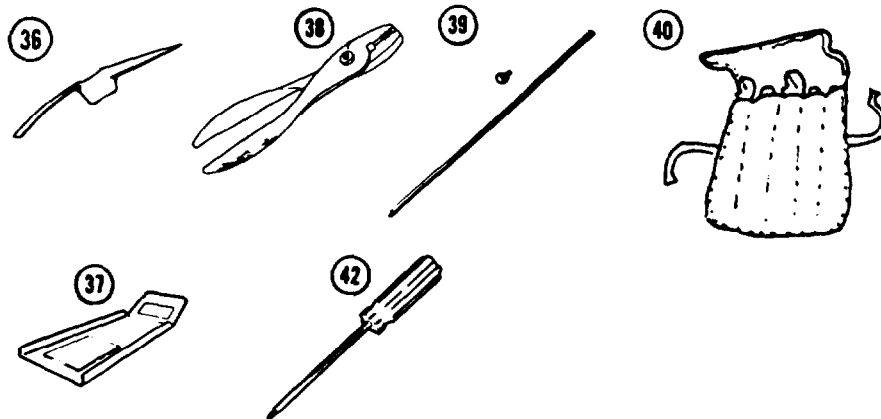
(1) Illus Number	(2) National Stock Number	(3) Description FSCM and Part Number	Usable On Code	(4) U/M	(5) Qty Reqd
25	5120-00-293-0887	HAMMER: SLEDGE, 12 lb (right side equipment body, in bottom forward stowage box) (34871) FAC1038	H40	EA	1
26	5120-00-288-6574	HANDLE: PICK MATTOCK (on left side of stowage box) (on pioneer tool bracket) (56161) 10501973	H02,7 H40	EA EA	1 1
27	5120-01-233-9508	HANDLE; WRENCH, wheel lugnut (in toolbox)	H01,2,3, 5,7,8,9 H40	EA EA	1 1
27.1	6150-10-130-6035	HARNESS, WORKLAMP (in stowage box) (45152) 141977OU	H01,5,6,9	EA	1
27.2	6150-01-320-0719	HARNESS, WORKLAMP (in stowage box) (45152) 177153OW	H01,5,6,9	EA	1
28	4720-00-356-8571	HOSE: ACETYLENE (right side equipment body, in top rear stowage box) (55681) 5600FR	H40	EA	1
29		HOSE, AIR, PNEUMATIC: 50 ft (in toolbox) (45152) 2155210U		EA	2

Basic Issue Items (Cont)



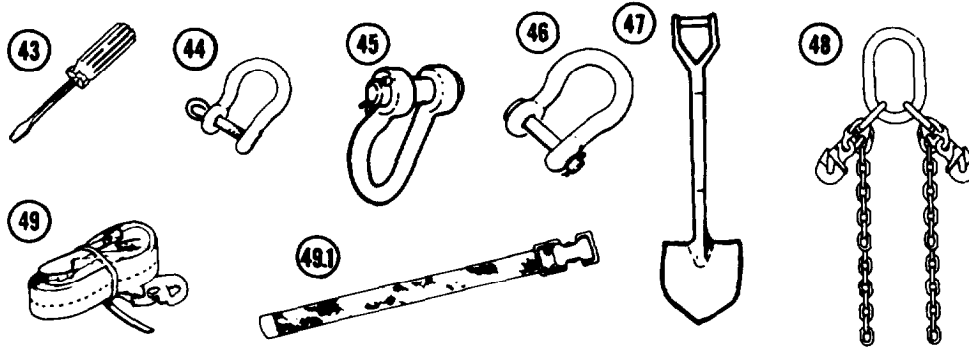
(1) IIUS Number	(2) National Stock Number	(3) Description FSCM and Part Number	Usable On Code	(4) U/M	(5) Qty Reqd
30	4720-00-356-8572	HOSE, OXYGEN (right side equipment body, in top rear stowage box) (81348) ZZ-H-461	H40	EA	1
31	4720-01-254-0189	HOSES: AIR, INTERVEHICULAR (in toolbox) (96906) MS39325-9-140-8	H03,40	SE	1
32	5120-01-146-8096	JACK: 12 TON, WITH HANDLE (in toolbox) (26952) JH-12		EA	1
32.1		LAMP, WORK (78422) 1401182	H01,5,6,9	EA	1
33	4930-00-051-3194	NOZZLE: D1 (79318) F116AV7T	H02,7	EA	1
34	5340-00-158-3805	PADLOCK: WITHOUT CHAIN (for steering column) (in stowage box) (for pump module door) (for D1 nozzle stowage box) (96906) MS35647-10	H01,2,3, 5,6,7, 9,40 H02,7 H02,7	EA EA EA	1 1 1
35	5340-00-158-3807	PADLOCK: WITH CHAIN (for stowage boxes) (96906) MS35647-9	H03 H01,2, 5,6,7,9 H40	EA EA EA	3 5

Basic issue items (Cont)



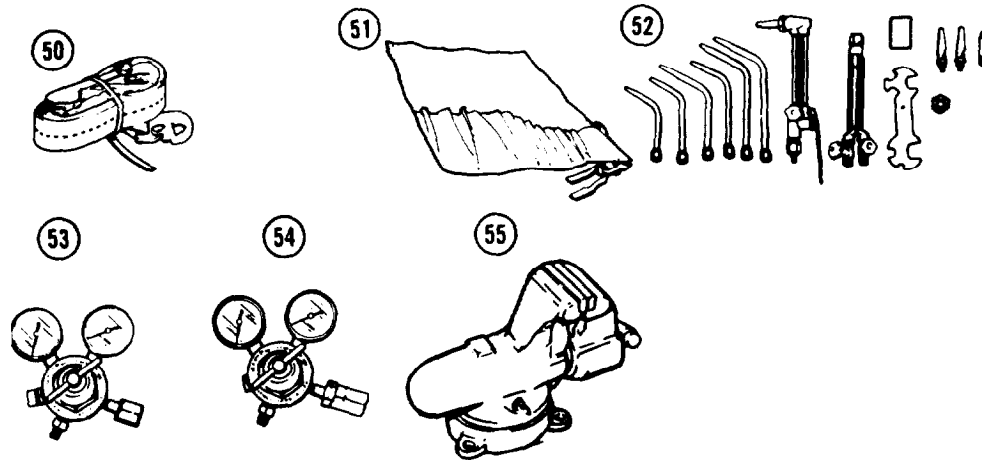
(1) Illus Number	(2) National Stock Number	(3) Description FSCM and Part Number	Usable On Code	(4) U/M	(5) Qty Reqd
36	5120-00-243-2395	PICK: MATTOCK (left side stowage box) (on pioneer tool bracket) (19207) 11677022	H02,7 H40	EA EA	1 1
37	2540-01-165-5987	PLATE: BASE, JACK (in toolbox) (45152) 1350610W		EA	1
38	5120-00-223-7398	PLIERS: SLIP JOINT, 10 in., adjustable (in toolbag) (81348) GGGP 471	H01,2,3,5 6,7,9	EA	1
		(right side equipment body, bottom forward stowage box)	H40	EA	1
39	5975-00-878-3791	ROD, GROUNDING: 30 in. with connector (in fuel can stowage) (82370) A104	H02,7	EA	6
40	5140-01-167-1541	ROLL: TOOLS AND ACCESSORIES (right side equipment body, in bottom forward stowage box) (45152) 1350190		EA	1
41		Deleted			
42	5120-00-234-8912	SCREWDRIVER: CROSS TIP, 6 in. (in toolbag) (80204) B107.15TY2DEASZ3		EA	1

Basic issue items (Cont)



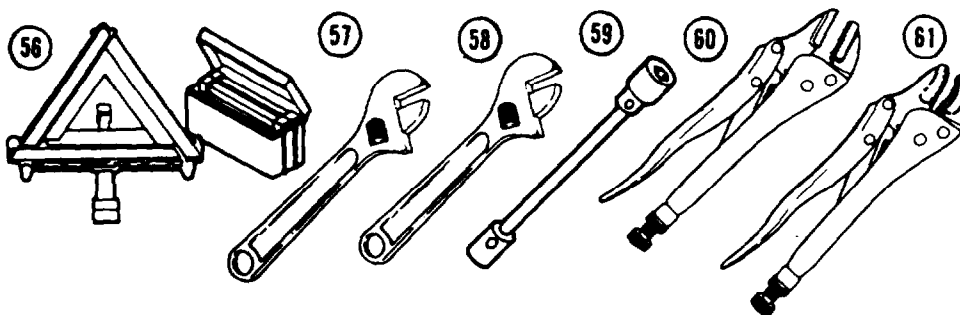
(1) Illus Number	(2) National Stock Number	(3) Description FSCM and Part Number	Usable On Code	(4) U/M	(5) Qty Reqd
43	5120-00-234-8910	SCREWDRIVER: FLAT TIP, NO.6 (in toolbag) (right side equipment body, bottom forward storage box) (72368) 2143-6	H01,2,3, 5,6,9 H40	EA EA	1 1
44	4030-01-377-1397	SHACKLE: ANCHOR, LIMP HOME (in toolbox) (5N506) G-209		EA	1
45	4030-01-197-2334	SHACKLE:SLINGING (on rear towing eyes) (45152) 1451750	H02,7	EA	2
46		SHACKLE, TOWING: (on towing eyes) (90202) M366	H01,3,5,6, 9,40 H02,7	EA EA	4 2
47	5120-00-293-3336	SHOVEL: HAND (on pioneer tool bracket) (19207) 11655784	H02,7, 40	EA	1
48	3940-01-209-6008	SLING ASSEMBLY (stowage box right side) (left side equipment body, in top forward stowage box) (45152) 1385750	H01,6 H40	EA EA	1 1
49	5340-01-204-3009	STRAP: WEBBING (in toolbox) (19200) 9392419	H05,9	EA	8
49.1	5340-00-753-3744	STRAP: WEBBING 1 in. x 36 in. (19207) 8690473	H40	EA	8

Basic Issue Items (Cont)



(1) Illus Number	(2) National Stock Number	(3) Description FSCM and Part Number	Usable On Code	(4) U/M	(5) Qty Reqd
50	1670-00-725-1437	TIEDOWN, CARGO (81349) MIL-T-27260 type C GUIB	H01,6	EA	24
51	5180-00-754-0661	TOOL KIT: WELDERS (19099) SC5180-90-N39	H40	EA	1
52	3433-00-294-6743	TORCH SET (right side equipment body, in top rear stowage box) (81349) (MIL-T-13880), type 2	H40	EA	1
53	4820-00-641-3519	VALVE REGULATING (oxygen) (right side equipment body, in top rear stowage box) (81349) MIL-R-13877, type VI	H40	EA	1
54	4820-00-551-1094	VALVE: REGULATOR, ACETYLENE (right side equipment body, in top rear stowage box) (17941) (RVT8011)	H40	EA	1
55	5120-00-243-9072	WISE: 6 in., swivel base (on frame under self-recovery winch) (81348) GGG-V-410, type IV, 6 in. jaw	H40	EA	1

Basic Issue items (Cont)



(1) Illus Number	(2) National Stock Number	(3) Description FSCM and Part Number	Usable On Code	(4) U/M	(5) Qty REQD
56	9905-00-148-9546	WARNING DEVICE SET: TRIANGULAR (under glove box in cab) (19207) 11669000		SE	1
57	5120-00-240-5328	WRENCH, 8 in., adjustable (in toolbag)	H01,2,3,5, 6,7,9	EA	1
		(right side equipment body, in bottom forward stowage: box) (96508)D78	H40	EA	1
58	5120-00-264-3796	WRENCH: 12 in., adjustable (in toolbag)	H01,2,3, 5,6,7,9	EA	1
		(right side equipment body, in bottom forward stowage box) (19207) 5323324	H40	EA	1
59	5120-01-070-8386	WRENCH: wheel nut (in toolbag)	H01,2,3, 5,6,7,9	EA	1
		(right side equipment body, in bottom forward stowage box) (45152) 1048-TR	H40	EA	1
60	5120-00-277-4244	WRENCH, PLIER: 8 1/2-in., flat (in toolbox) (81348) GGG-W-00649 TY1CLISTA	H40	EA	1
61	5120-00-494-1911	WRENCH, PLIER: 8 1/2-in., curved jaw (in toolbox) (81348) GGG-W-00649 TY1CL2STB	H40	EA	1

APPENDIX C

ADDITIONAL AUTHORIZATION LIST

Section I. INTRODUCTION

C-1. SCOPE. This appendix lists additional items that are authorized for the support of the M977 series vehicles.

C-2. GENERAL. The list identifies items that do not have to accompany the M977 series vehicles and that do not have to be turned in with it. These items are all authorized for use by CTA, MTOE, TDA, or JTA.

C-3. EXPLANATION OF LISTING. National stock numbers, descriptions, and quantities are provided to help to identify and request the additional items required to support this equipment. The items are listed in alphabetical sequence by item name under the type document (CTA, MTOE, TDA, or JTA) which authorizes the item(s) to you. If item required differs for different models of this equipment, the model is shown under the "Usable On Code" heading in this column. If no code is entered in this column, item is used on all models. These codes are identified as:

Code Used On

HO1	M977	Cargo	w/winch
HO2	M978	Tanker	w/winch
HO3	M983	Tractor	w/winch, w/crane
HO5	M985	Cargo	w/winch
HO6	M977	Cargo	w/o winch
HO7	M978	Tanker	w/o winch
HO9	M985	Cargo	w/o winch
H40	M984E1	Wrecker	

Section II. ADDITIONAL AUTHORIZATION LIST

(1) National Stock Number	(2) Description FSCM & Part Number Usable On Code	(3) U/M	(4) Qty Auth
4930-00-516-0839	ADAPTER FOR NOZZLE H02,7 (79326) CCA 107/02	EA	4
8415-00-250-2531	APRON, WELDERS H40 (81348) KK-C-450	EA	1
5110-00-293-2336	AXE, SINGLE BIT H01,3,5,6,9 (19207) 6150925	EA	1
4910-00-347-9703	BAR ASSEMBLY, HOISTING H01,2,3,5, (19204) 7551058 6,7,9,40	EA	1
6220-01-250-5190	BEACON, WARNING LIGHT H01,2,3,5,6,7,9 (45152) 1505510U	EA	1
2540-00-409-8891	BRACKET, MOUNTING H01,3,5,6,9 pioneer tool (96906) MS53053-1	EA	1
2590-00-148-7961	CABLE ASSEMBLY, NATO H01,2,3,5,6,7,9 w/adapters (56161) 10502786	EA	1
3940-01-270-3389	CHAIN, SAFETY: 16 ft used with towbar, 10 ton (45152) 1482010	EA	1
2540-01-152-7813	CHAINS, TIRE (80535) 16.00.00 x 20/2624	SE	2
3439-00-270-6047	CLEANER SET: welding H40 (81349) MIL-C-17223	SE	1
4030-01-234-0032	CLEVIS GRAB HOOK H40 (80535) 450-3815	EA	2
2540-01-198-7409	COVER, CARGO BODY H01,5,6,9 (45152) 2178120U	EA	1
4230-01-220-3221	DECONTAMINATION APPARATUS (19207) 5705588	EA	1
4210-00-257-5343	EXTINGUISHER, 15 LB H02,7 (03670) 14351	EA	4

Additional Authorization List (Cont)

(1) National Stock Number	(2) Description FSCM & Part Number Usable On Code	(3) U/M	(4) Qty Auth
7240-00-222-3084	FUEL CAN H40 (58536) A-A-1702	EA	1
8415-00-634-4658	GLOVES, LEATHER (90142) 37G2940	PR	2
2510-00-741-7585	GROUND JACK BOARD H01, 5, 6, 9, 40 (19207) 7417585	EA	2
5975-01-050-5707	GROUNDING ROD H02,7 (97403) 13219E0462	EA	4
4930-01-028-1442	GUN, GREASE H40 (10001) 3133414	EA	1
5120-00-288-6574	HANDLE: PICK, MATTOCK H01,3,5,6,9 (56161) 10501973	EA	1
2990-01-369-1295	HEATER, ARCTIC H01,2,3,5,6,7,40 (45152) 1970090U	EA	1
1055-01-137-4441	HOIST ASSEMBLY: launch pad H05,9,40 container, MLRS only (18876) 11508999	EA	1
3940-01-247-3682	HOISTING BEAM, DOUBLE H06 (28620) AC200000364	EA	1
3940-01-247-3681	HOISTING BEAM, SINGLE H06 (28620) AC200000354	EA	1
	HOSE ASSEMBLY, ARCTIC H02,7 hand actuated valve (17566) 45A254-P5	EA	1
4720-01-254-0189	HOSE, AIR, INTERVEHICULAR H01,2,3,5, (96906) MS39325-9-140-86,7,9	SE	1
4720-00-083-0048	HOSE, DISCHARGE, 3 in. x 50 ft. H02,7 (81349) M11588-09-F-LT-50FT	EA	1
	HOSE, DISCHARGE, 2 in. x 50 ft. H02,7 (97403) 13219E0503	EA	10
	KIT, CHEMICAL ALARM (19207) 5705589	KT	1
4240-01-220-6373	KIT, FILTER UNIT, GAS PARTICULATE (45152) 3SK663	KT	1
6545-00-922-1200	KIT: FIRST AID (64616) SC C-6545-IL VOL 2	EA	1
2590-01-220-6377	KIT, MOUNTING, MACHINE GUN (19207) 5705587	KT	1
1005-01-266-1233	KIT, MOUNTING, RIFLE (19207) 5705590	EA	1

Additional Authorization List (Cont)

(1) National Stock Number	(2) Description FSCM & Part Number Usable On Code	(3) U/M	(4) Qty Auth
2910-01-388-6870	KIT, SEVERE DUTY TANK REINFORCEMENT (45152) 35K800	H02,7	EA 1
2910-01-428-3166	KIT, VAPOR RECOVERY (088A2) 45D016	H02,7	KT 1
	LENS: RED (used with work lamp) (78422) 4429000	H01, 5,6,9	EA 1
2510-01-281-1116	LIFT ASSEMBLY ADAPTER (LH) (45152) 1481990W (GOER recovery only)	H40	EA 1
2510-01-281-1115	LIFT ASSEMBLY ADAPTER (RH) (45152) 1481980W (GOER recovery only)	H40	EA 1
5120-00-892-5709	MIRROR, INSPECTION (11676) UH1487		EA 1
4930-00-117-4726	NOZZLE (79326) CCN 101/14	H02,7	EA 4
4930-00-051-3194	NOZZLE, D-1 (ODT23) 64349CDK	H02,7	EA 2
5120-00-243-2395	PICK, MATTOCK (19207) 11677022	H01, 3,5,6,9	EA 1
5315-01-281-3901	PIN (45152) 1482000 (GOER recovery only)	H40	EA 8
5315-01-280-6178	PIN (45152) 1390070 (GOER recovery only)	H40	EA 2
5315-01-215-7505	PIN, QUICK RELEASE (96652) 63-02 (GOER recovery only)	H40	EA 8
7240-00-177-6154	POURING SPOUT (09647) 838A7511	H40	EA 1
4910-00-402-9623	PUMP, PRIMER (33287) J5956	H02,7	EA 1
5120-00-197-9473	PUNCH: 17 IN (81348) GGG-T-00563	H40	EA 1
4730-00-951-3294	REDUCER: 3 in. MALE TO 2 in. FEMALE (96906) MS49000-3	H02,7	EA 1

Additional Authorization List (Cont)

(1) National Stock Number	(2) Description FSCM & Part Number Usable On Code	(3) U/M	(4) Qty Auth
	SHACKLE, TOWING (used with towbar, 10 ton) (90202) M366	EA	2
4230-00-540-0623	SHIELD: FACE (58536) A-A-1994	H40 EA	1
5120-00-293-3336	SHOVEL: HAND (19207) 11655784	H01,3,5,6,9 EA	1
8415-00-164-0513	SLEEVES: WELDER'S (81348) KK-C-450	H40 PR	1
3940-00-040-2297	SLING ASSEMBLY (19207) 8330151	H01,40 EA	1
3940-01-209-6008	SLING ASSEMBLY (45152) 1385750	H01,40 EA	1
1398-01-083-9313	SLING ASSEMBLY (91796) SW71M	H06 EA	1
3940-01-241-7400	SLING ASSEMBLY (28620) AC200000332	H06 EA	1
	SLING: HOISTING BEAM, first stage, PII only (18876) 11500281-009	H03 EA	1
	SLING: HOISTING BEAM, second stage, PII only (18876) 11500280-009	H03 EA	1
	STOP: ARTICULATING ROLL (45152) 1536230 (GOER recovery only)	H40 EA	2
	STRAP: RUBBER (45152) 53059AX (GOER recovery only)	H40 EA	1
5340-01-204-3009	STRAP, WEBBING (19200) 9392419	H01,6,40 EA	8
1670-00-725-1437	TIEDOWN, CARGO (81349) MIL-T-27260, type C, GUIB	H05,9 EA	24
	TIRE, SAND (12195) 16R20XS	EA	9
	TIRE INFLATION, KIT (45152) 4SK201	H40 EA	2
5210-01-220-6381	TOOL, RELEASE, FIFTH WHEEL (19207) 12343468	H03 EA	1
2540-00-378-2012	TOW BAR: 10 ton (19207) 8383802	EA	1

Additional Authorization List (Cont)

(1) National Stock Number	(2) Description FSCM & Part Number UsableOn Code	(3) U/M	(4) Qty Auth
4710-01-281-1033	TUBE: LIFT (45152) 1481940 (GOER recovery only)	H40 EA	1
2510-01-281-1039	TUBE SUPPORT ASSEMBLY (451521 1481930W GOER recovery only)	H40 EA	1
	WATER CAN (19207) 11655980	H40 EA	1
5120-00-423-6728	WRENCH, ADJUSTABLE: 15 in. (19207) 6187328	H40 EA	1
5102-00-449-8084	WRENCH, ADJUSTABLE: 24 in. (72368) AC124	H40 EA	1
5120-00-277-1462	WRENCH, PIPE: 24 in. (19204) TKCX1D	H40 EA	1
4730-01-068-5070	WYE ASSEMBLY (9H113) 319K-2	HOZ, 7 EA	3

APPENDIX D

EXPENDABLE SUPPLIES AND MATERIALS LIST

Section I. INTRODUCTION

D-1. SCOPE. This appendix lists expendable supplies and materials that are needed to operate and maintain the M977 series vehicles. These items are authorized by CTA 50-970. This appendix includes expendable items (except Medical, Class V, Repair Parts, and Heraldic Items) and consumable materials.

D-2. EXPLANATION OF COLUMNS.

a. Column (1) - Item Number. This number is assigned to the entry in the listing and is referenced in the narrative instructions to identify the material (e.g., "Use cleaning compound, Item 5, Appendix D.").

b. Column (2) - Level. This column identifies the lowest level of maintenance that requires the listed item.

- C - Operator/Crew
- O - Organizational Maintenance
- F - Direct Support Maintenance
- H - General Support Maintenance

c. Column (3) - National Stock Number. This is the national stock number assigned to the item; use it to request or requisition the item.

d. Column (4) - Description. Indicates the Federal item name and, if required, a description to identify the item. Where applicable, the last line for each item indicates the Federal Supply Code for Manufacturer (FSCM) in parentheses followed by the part number.

e. Column (5) - Unit of Measure (U/M). Indicates the measure used in performing the actual maintenance function. This measure is expressed by a two-character alphabetical abbreviation (e.g., ea, in., pr). If the unit of measure differs from the unit of issue, requisition the *lowest* unit of issue that will satisfy the requirement.

Section II. EXPENDABLE SUPPLIES AND MATERIALS LIST

(1) Item Number	(2) Level	(3) Notional Stock Number	(4) Description	(5) U/M
1	O		Antifreeze, Arctic Type MIL-A-11755	
		6850-00-174-1806	55-gal drum	gl
2	O		Antifreeze, Permanent, Glycol, Inhibited (81349) MIL-A-46153	gl
		6850-00-181-7929	1-gal container	gl
		6850-00-181-7933	5-gal container	gl
		6850-00-181-7940	55-gal drum	gl
3	O		Compound, Cleaning Windshield (81348) O-C-1901	
		6850-00-926-2275	1-pt can	pt
4	C		Grease, Automotive and Artillery GAA (98308) MILG-10924	
		9150-00-065-0029	2-1/2 oz tube	oz
		9150-00-935-1017	14-oz cartridge	oz
		9150-00-190-0904	1-lb can	lb
		9150-00-190-0905	5-lb can	lb
		9150-00-190-0907	35-lb can	lb
5	C		Oil, Fuel, Diesel DF-1 Winter (81348) VV-F-800	
		9140-00-286-5286	Bulk	gl
		9140-00-286-5287	5-gal can	gl
		9140-00-286-5288	55-gal drum, 16 gage	gl
		9140-00-286-5289	55-gal drum, 16 gage	gl
6	C		Oil, Fuel, Diesel DF-2 Regular (81348) VV-F-800	
		9140-00-286-5294	Bulk	gl
		9140-00-286-5295	5-gal can	gl
		9140-00-286-5296	55-gal drum, 16 gage	gl
		9140-00-286-5297	55-gal drum, 18 gage	gl
7	O		Oil, Lubricating Gear, GO 75 MIL-L-2105C	
		9150-01-035-5390	1-qt can	qt
		9150-01-035-5391	5-gal drum	gl
		9150-01-035-5393	55-gal drum	gl
8	O		Oil, Lubricating Gear GO 80/90 MIL-L-2105C	
		9150-00-577-5844	5-gal drum	gl

Expendable Supplies and Materials List (cont)

(1) Item Number	(2) Level	(3) National Stock Number	(4) Description	(5) U/M
9	C		Oil, Lubricating OEA Ice, Subzero (52195) MIL-L-46167	
		9150-00-402-4478	1-qt can	qt
		9150-00-402-2372	5-gal drum	gal
10	C	9150-00-491-7197	55-gal drum, 16 gage	gal
			Oil, Lubricating OE/HDO 10 (98308) MIL-L-2104	
		9150-00-183-7807	Bulk	gal
		9150-00-189-6727	1-qt can	qt
		9150-00-186-6668	5-gal drum	gal
			55-gal drum, 18 gage	gal
11	C	9150-00-191-2772	55-gal drum, 16 gage	gal
			Oil, Lubricating OE/HDO 30 (SAE 30) (16958) MIL-L-2104	
		9150-00-183-7808	Bulk	gal
		9150-00-186-6681	1-qt can	qt
		9160-00-265-9436	5-gal drum	gal
		9160-00-188-9859	55-gal drum, 16 gage	gal
12	O	9150-00-189-6729	55-gal drum, 18 gage	gal
			Oil, Lubricating OE/HDO SO (98308) MIL-L-2104	
		9150-00-188-9864	1-qt can	qt
		9150-00-188-9865	5-gal drum	gal
		9160-00-188-9866	55-gal drum, 16 gage	gal
		4020-00-968-1357	Rope, Fibrous (81349) MIL-R-17343	ft
14	O		Solvent, Dry Cleaning, SD P-D-680 (81348)	
		6850-00-664-5685	1-qt can	qt
		6860-00-281-1985	1-gal can	gal

APPENDIX E PREPARATION FOR TRANSPORT AND OPERATION

Section I. INTRODUCTION

E-1. SCOPE. This appendix lists tasks which are to be done by the operator/crew of a vehicle in preparation for movement by ship, train, or aircraft, and tasks which must be done to prepare the vehicle for operation.

E-2. GENERAL. Tasks to be done to prepare vehicle for transport and for operation are divided into the following sections:

- a. Section II. preparation for transport Task List. This table lists tasks to be done before transporting vehicle.
- b. Section III. Preparation for Operation Task List. This table lists tasks to be done after transport before operating vehicle.

E-3. EXPLANATION OF COLUMNS.

- a. Model. This is the vehicle model to which tasks listed in the second column apply.
- b. Task. This column describes the task to be completed.
- c. Reference/Paragraph. The paragraph reference given is for the procedure in this manual to be used to perform the listed task. If no reference exists elsewhere in this manual, the task procedure is given in a paragraph of this appendix. The removal and installation procedures for the vent rollover rails, for example, are not written elsewhere in this manual, but are given in paragraph E-6.

Contents	Para	Page
Position Side Mirrors for Transport.....	E-4.a.	E-3
Position Side Mirrors for Operation.....	E-4.b.	E-3
Remove Pump Module Handrail.....	E-5.a.	E-4
Install Pump Module Handrail.....	E-5.b.	E-8
Remove Vent Rollover Rails.....	E-6.a.	E-12
Install Vent Rollover Rails.....	E-6.b.	E-13
Position Manhole Cover for Transport.....	E-7.a.	E-15
Position Manhole Cover for Operation.....	E-7.b.	E-17
RemoveVentHood.....	E-8.a.	E-19
InstallVentHood.....	E-8.b.	E-20

Preparation for Transport and Operation (Cont)

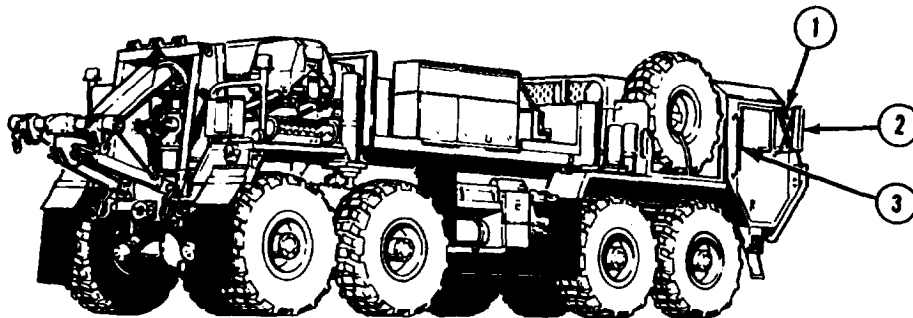
Section III. PREPARATION FOR OPERATION TASK LIST

(1) MODEL	(2) TASK	(3) REFERENCE/PARAGRAPH
All	Position both side mirrors for operation.	E-12b
All	Stow spare tire on carrier.	3-6 (Vol. 1)
M984E1	Install equipment body.	E-13b

Section IV. PROCEDURES TO PREPARE VEHICLE FOR TRANSPORT

E-12. POSITION SIDE MIRRORS FOR TRANSPORT/OPERATION.

a. Position Side Mirrors for Transport.



NOTE

Before folding back mirror frame, mirror must be rotated until it is flat with mirror frame with reflective part of mirror facing cab.

- (1) Hold mirror frame (1).
- (2) Push backward until mirror (2) is against side of cab (3).
- (3) Position mirror on other side of vehicle by repeating steps (1) and (2).

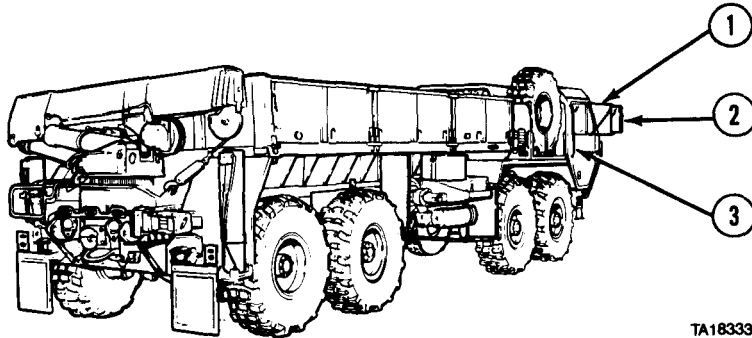
b. Position Side Mirrors for Operation.

- (1) Hold mirror frame (1).
- (2) Pull out until mirror (2) is in position for driving.
- (3) Adjust position of mirror (2) as needed.
- (4) Position mirror on other side of vehicle by repeating steps (1) through (3).

Section IV. PROCEDURES TO PREPARE VEHICLE
FOR TRANSPORT

E-4. POSITION SIDE MIRRORS FOR TRANSPORT/OPERATION.

a. Position Side Mirrors for Transport.



TA183332

- (1) Hold mirror frame (1).
- (2) Push backward until mirror (2) is against side of cab (3).
- (3) Position mirror on other side of vehicle by repeating steps (1) and (2).

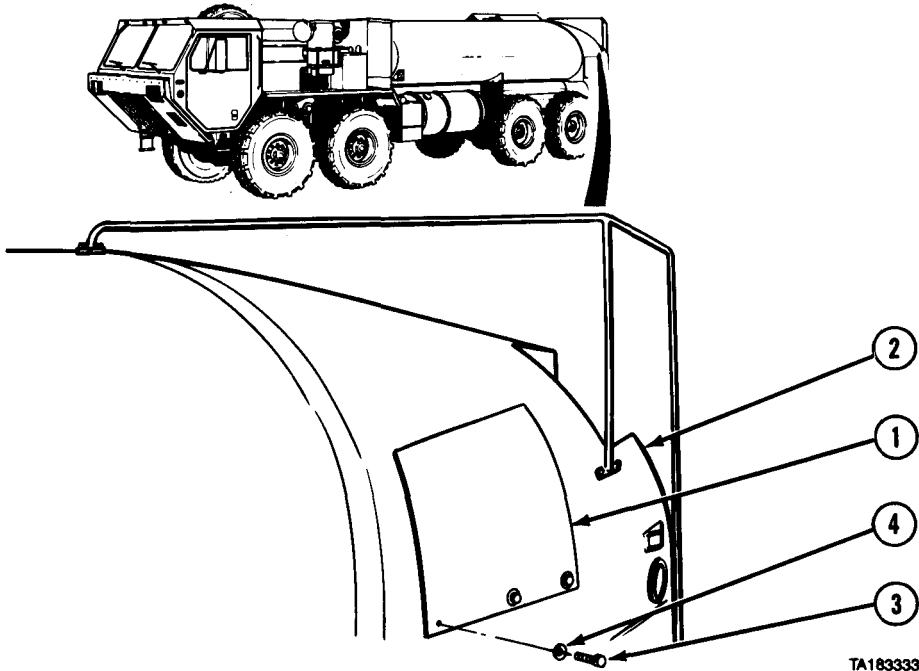
b. Position Side Mirrors for Operation.

- (1) Hold mirror frame (1).
- (2) Pull out until mirror (2) is in position for driving.
- (3) Adjust position of mirror (2) as needed.
- (4) Position mirror on other side of vehicle by repeating steps (1) through (3).

Preparation for Transport and Operation

E-5. REMOVE/INSTALL PUMP MODULE HANDRAIL.

a. Remove Handrail.



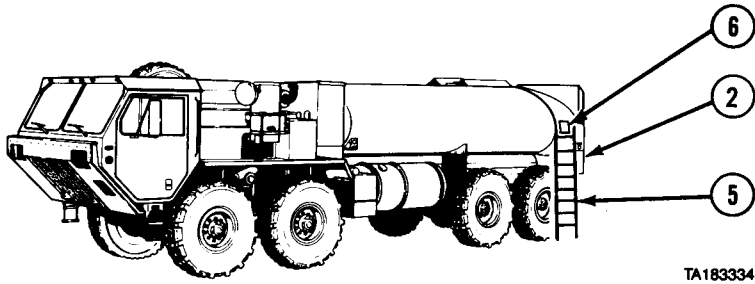
TA183333

WARNING

Push access panel tight against pump module while removing screws. If panel is not held in place, it may fall and injure personnel when last screw is removed.

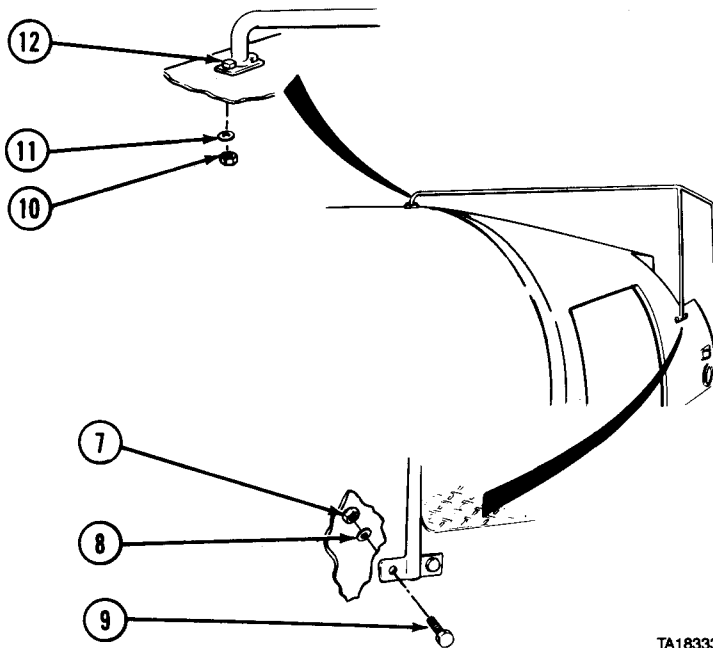
- (1) Hold access panel (1) against pump module (2).
- (2) Remove three screws (3) and washers (4).
- (3) Remove access panel (1).

Preparation for Transport and Operation (Cont)



TA183334

- (4) Remove ladder (5) from stowage (para 2-15a).
- (5) Place ladder (5) against pump module (2) in position to work through access opening (6).

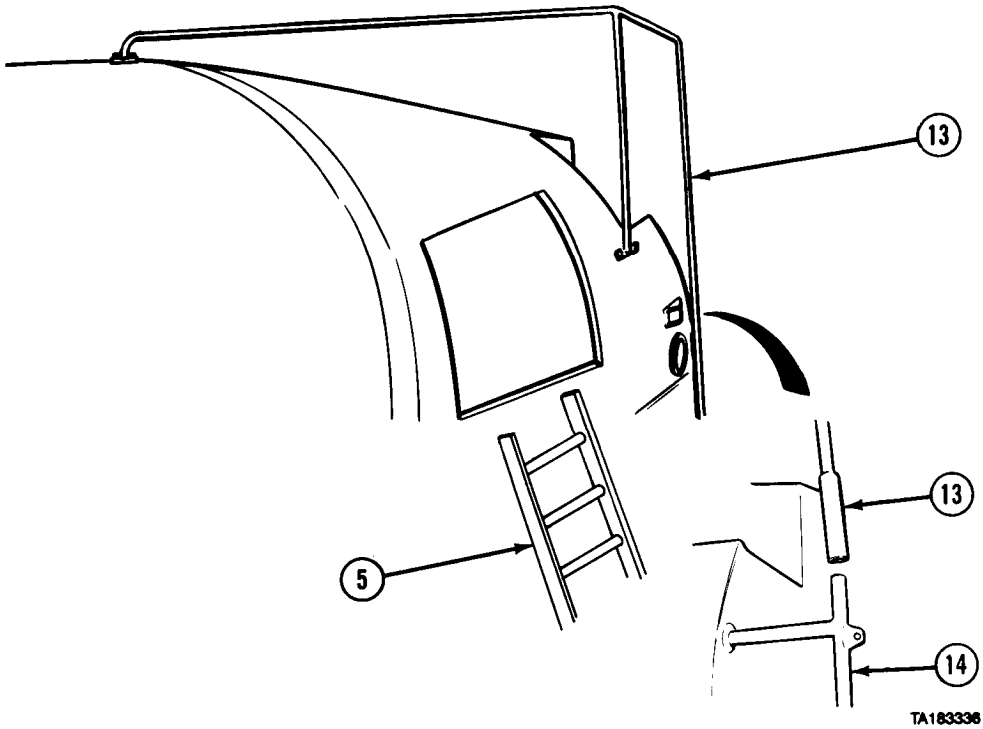


TA183335

- (6) Remove two nuts (7), washers (8), and screws (9).
- (7) Remove two nuts (10), washers (11), and screws (12).

Preparation for Transport and Operation (Cont)

E-5. REMOVE/INSTALL PUMP MODULE HANDRAIL (CONT).



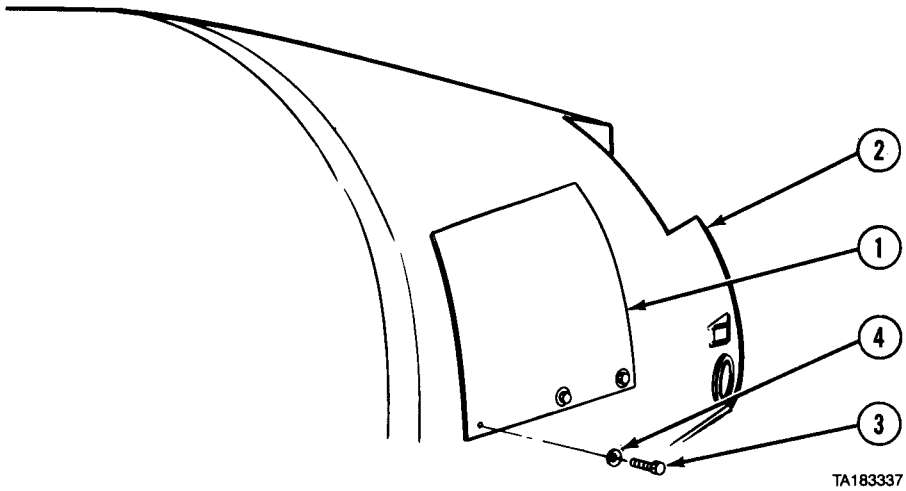
(8) Lift handrail (13) from ladder extension (14).

NOTE

Secure nuts, screws, and washers on handrail before stowing.

- (9) Stow ladder (5) (para 2-15b).
- (10) Stow handrail (13) for transport as instructed by loadmaster.

Preparation for Transport and Operation (Cont)

**WARNING**

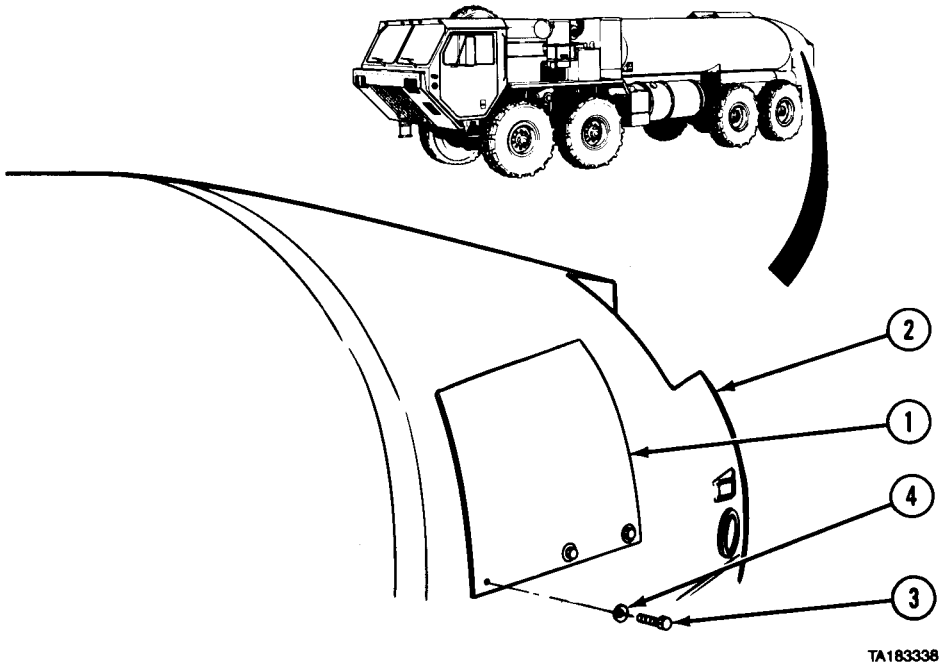
Push access panel tight against pump module while installing screws. If panel is not held in place, it may fall and injure personnel.

- (11) Hold access panel (1) against pump module (2).
- (12) Aline and install three screws (3) and washers (4).

Preparation for Transport and Operation (Cont)

E-5. REMOVE/INSTALL PUMP MODULE HANDRAIL (CONT).

b. Install Handrail.

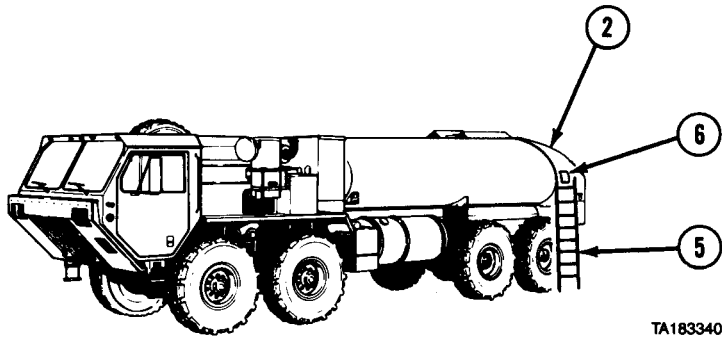


WARNING

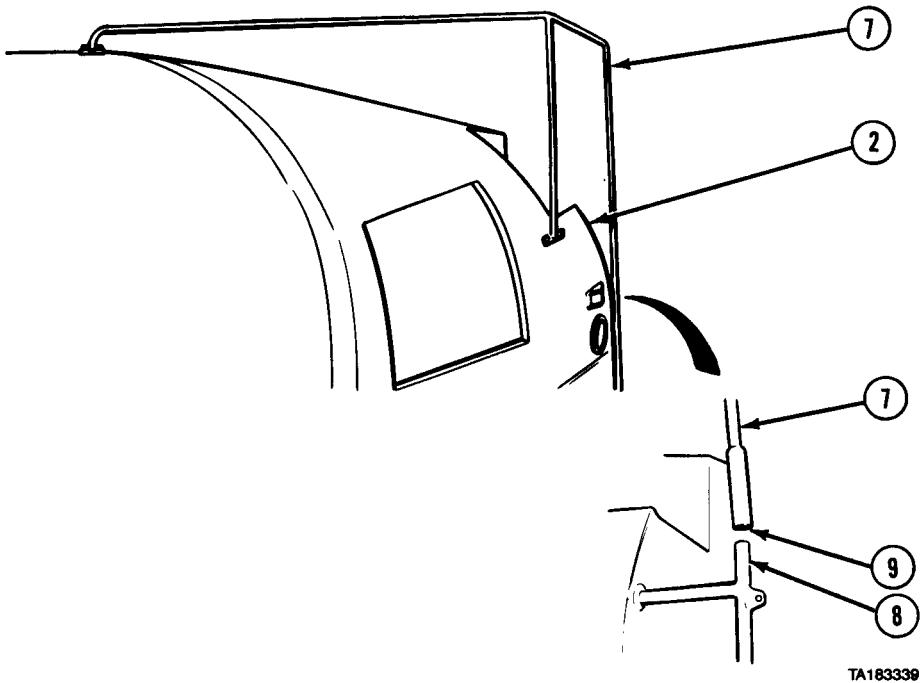
Push access panel tight against pump module while removing screws. If panel is not held in place, it may fall and injure personnel when last screw is removed.

- (1) Hold access panel (1) against pump module (2).
- (2) Remove three screws (3) and washers (4).
- (3) Remove access panel (1).

Preparation for Transport and Operation (Cont)



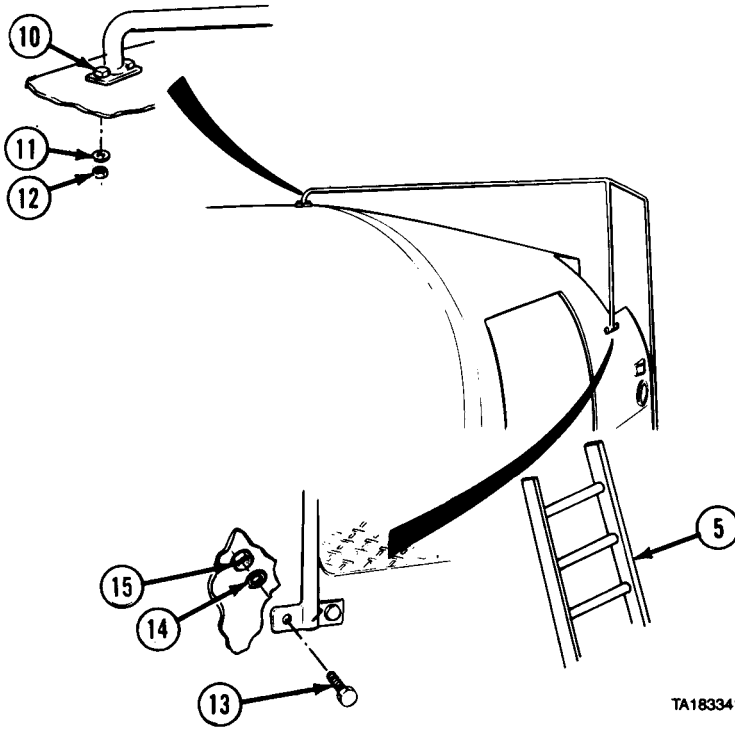
- (4) Remove ladder (5) from stowage (para 2-15a).
- (5) Place ladder (5) against pump module (2) in position to work through access opening (6).



- (6) Remove handrail (7) from stowage.
- (7) Position handrail (7) on pump module (2) so ladder extension (8) fits into socket (9).

Preparation for Transport and Operation (Cont)

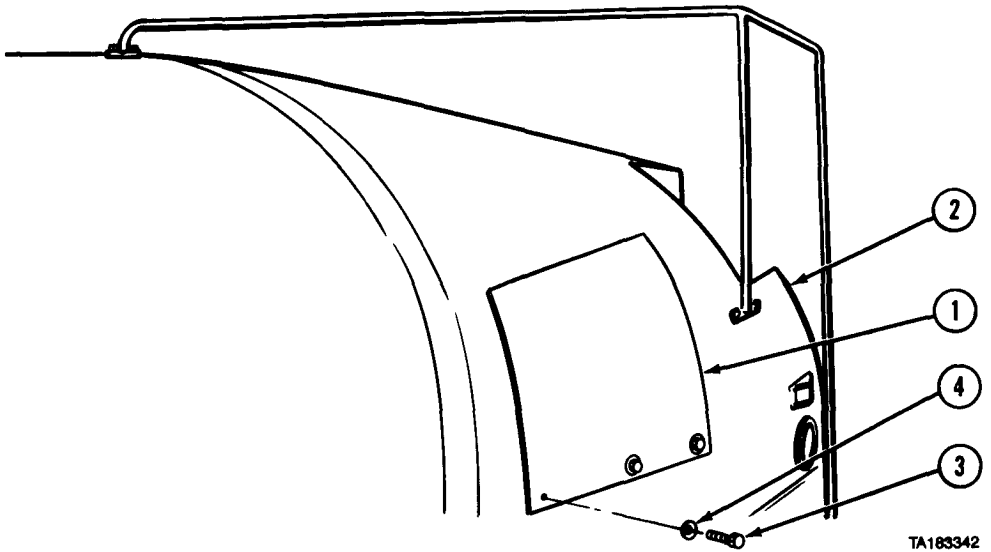
E-5. REMOVE/INSTALL PUMP MODULE HANDRAIL (CONT).



TA183341

- (8) Aline holes and install two screws (10), washers (11), and nuts (12).
- (9) Aline holes and install two screws (13), washers (14), and nuts (15).
- (10) Stow ladder (5) (para 2-15b).

Preparation for Transport and Operation (Cont)

**WARNING**

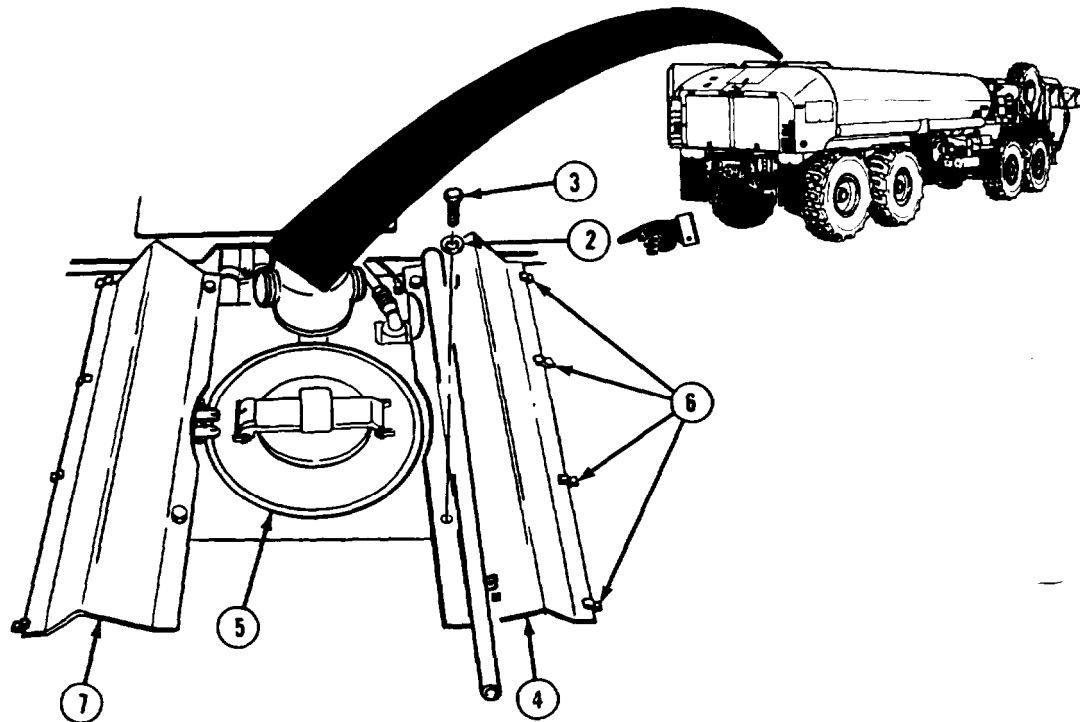
Push access panel tight against pump module while installing screws. If panel is not held in place, it may fall and injure personnel.

- (11) Hold access panel (1) against pump module (2).
- (12) Aline and install three screws (3) and washers (4).

Preparation for Transport and Operation (Cont)

E-6. REMOVE/INSTALL VENT ROLLOVER RAILS.

a. Remove Vent Rollover Rails.



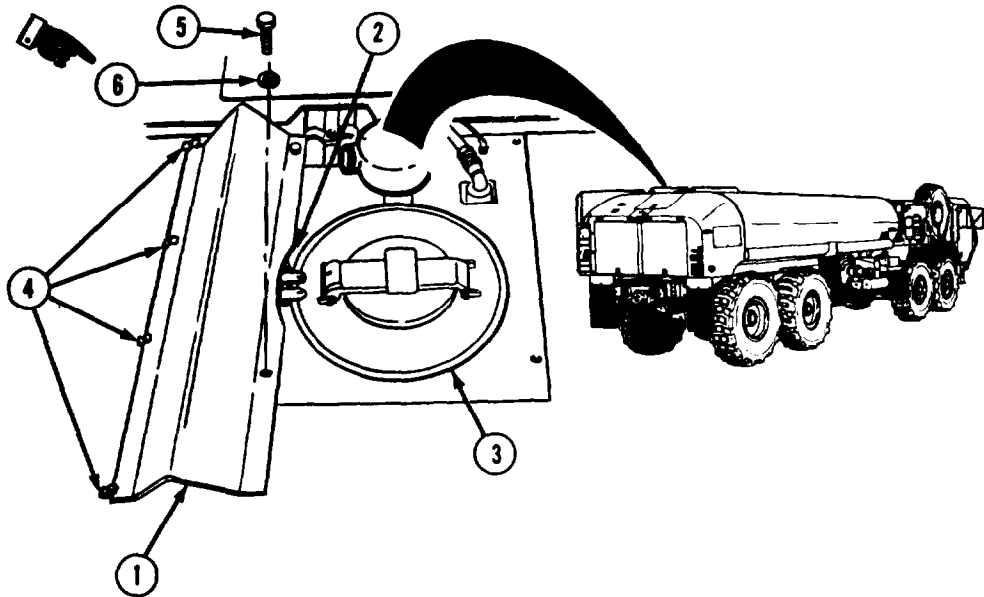
WARNING

Wet metal surfaces are slippery. Use extreme care when climbing on tank or injury could result from a fall.

- (1) Remove two screws (3) and washers (2) from vent rollover rail (4).
- (2) Pull vent rollover rail (4) toward manhole cover (5) until it is clear of retainers (6).
- (3) Secure washers (2) and screws (3) to vent rollover rail (4).
- (4) Remove vent rollover rail (4) from vehicle.
- (5) Remove other vent rollover rail (7) by repeating steps (1) through (4).
- (6) Stow vent rollover rails (4 and 7) for transport as instructed by loadmaster.

Preparation for Transport and Operation (Cont)

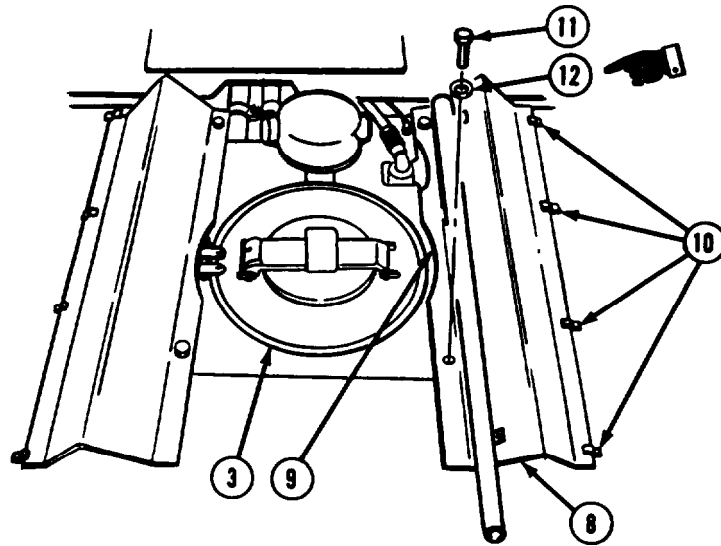
b. Install Vent Rollover Rails.



- (1) Position vent rollover rail (1) on tanker with notched edge (2) by manhole cover (3).
- (2) Slide other edge of vent rollover rail (1) under retainers (4).
- (3) Aline holes and install two screws (5) and washers (6).

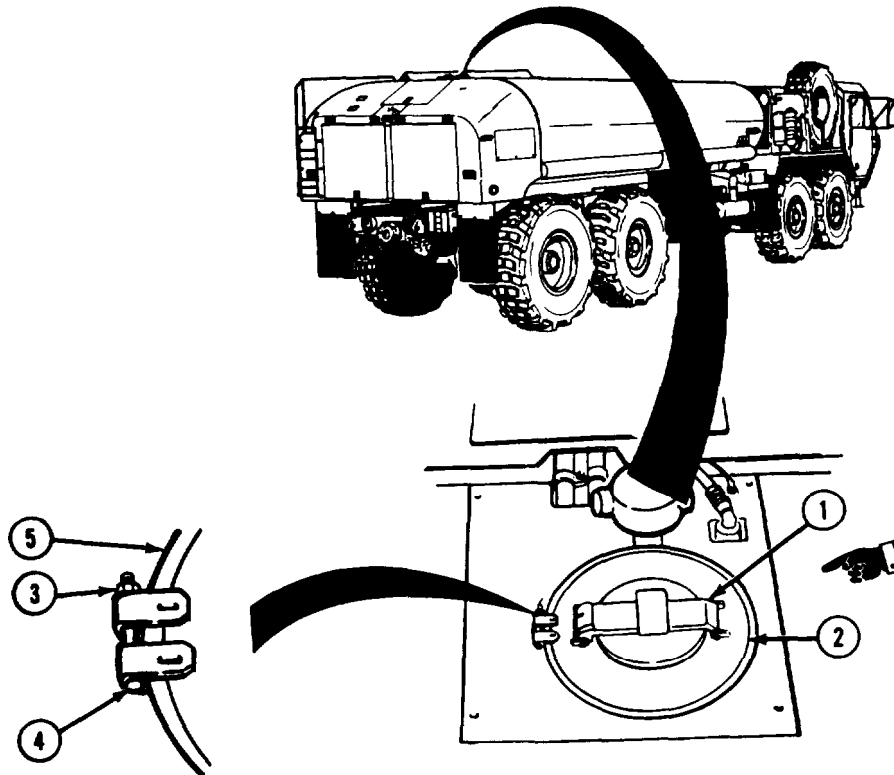
Preparation for Transport and Operation (Cont)

E-6. REMOVE/INSTALL VENT ROLLOVER RAILS (CONT).



- (4) Position vent rollover rail (8) on tanker with notched edge (9) by manhole cover (3).
- (5) Slide other edge of vent rollover rail (8) under retainers (10).
- (6) Aline holes and install two screws (11) and washers (12).

Preparation for Transport and Operation (Cont)

E-7. POSITION MANHOLE COVER FOR TRANSPORT/OPERATION.a. *Position Manhole Cover for Transport,***WARNING**

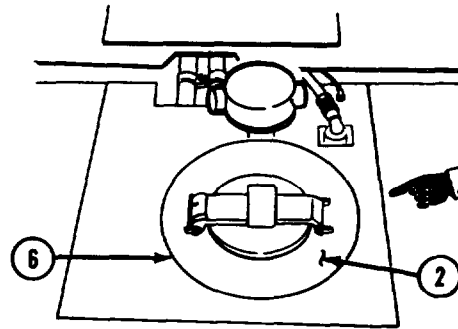
- Wet metal surfaces are slippery. Use extreme care when climbing on tank or injury could result from a fall.
- To prevent explosion caused by electrostatic charge, ground self and equipment before opening manhole cover.
- Open manhole cover slowly to relieve pressure. If there is pressure buildup, personnel may be injured.

- (1) Lift latch (1) and open manhole cover (2) enough to allow pressure to escape.
- (2) Remove nut (3) and screw (4).
- (3) Remove clamp (5).

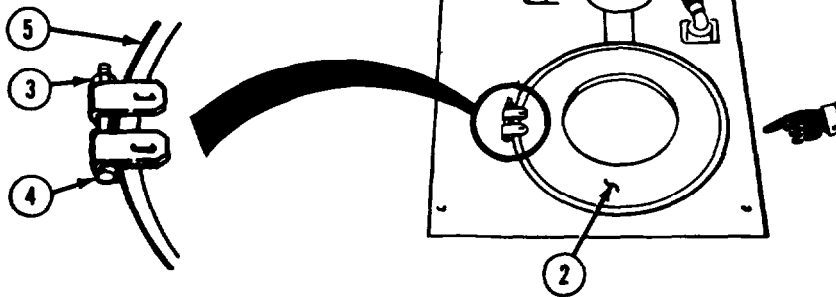
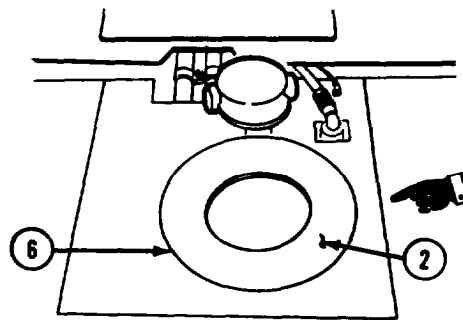
Preparation for Transport and Operation (Cont)

E-7. POSITION MANHOLE COVER FOR TRANSPORT/OPERATION (CONT).

- (4) Remove manhole cover (2) and gasket (6).



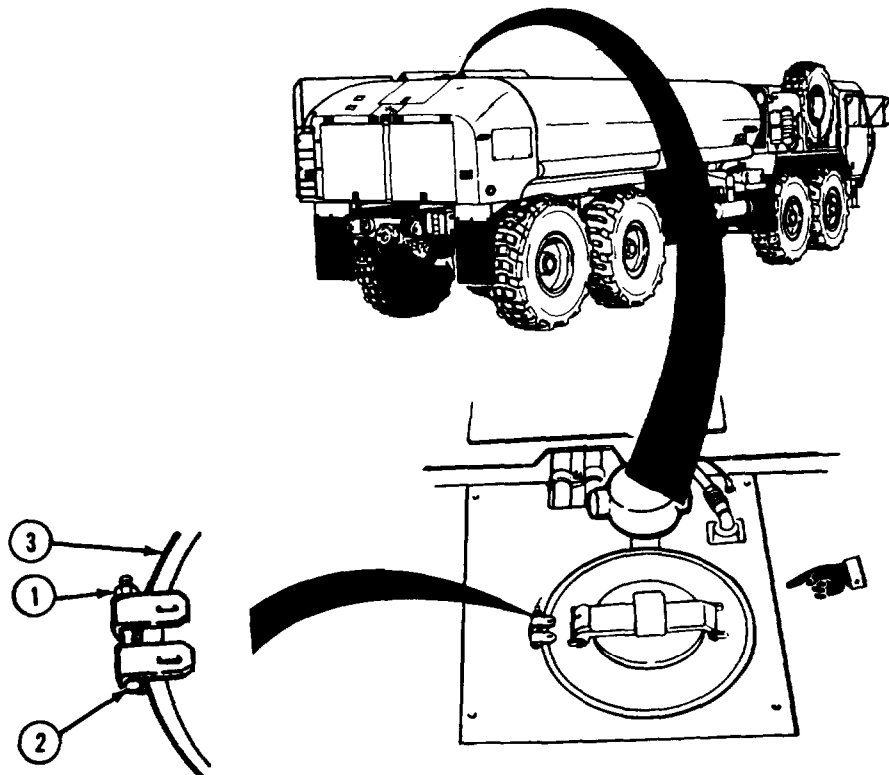
- (5) Install gasket (6).
- (6) Turn manhole cover (2) upside down and position on tanker.



- (7) Aline and install clamp (5) on manhole cover (2).
- (8) Aline and install screw (4) and nut (3).

Preparation for Transport and Operation (Cont)

b. *Position Manhole Cover for Operation.*



WARNING

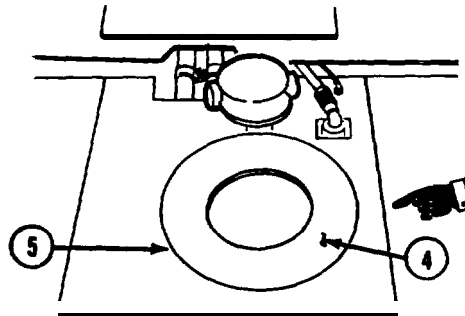
Wet metal surfaces are slippery. Use extreme care when climbing on tank or injury could result from a fall.

- (1) Remove nut (1) and screw (2).
- (2) Remove clamp (3).

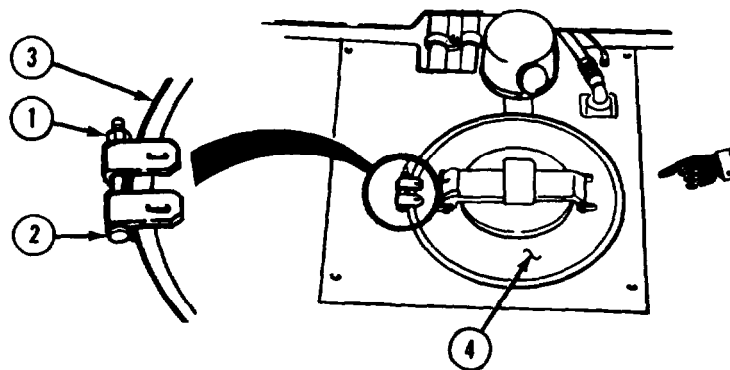
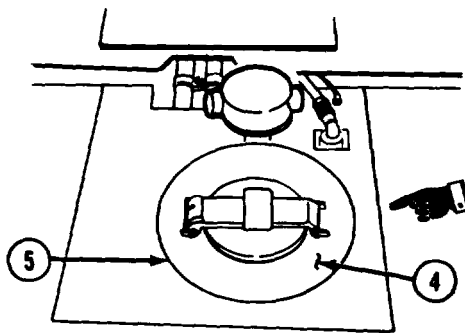
Preparation for Transport and Operation (Cont)

E-7. POSITION MANHOLE COVER FOR TRANSPORT/OPERATION (CONT).

- (3) Remove manhole cover (4) and gasket (5).

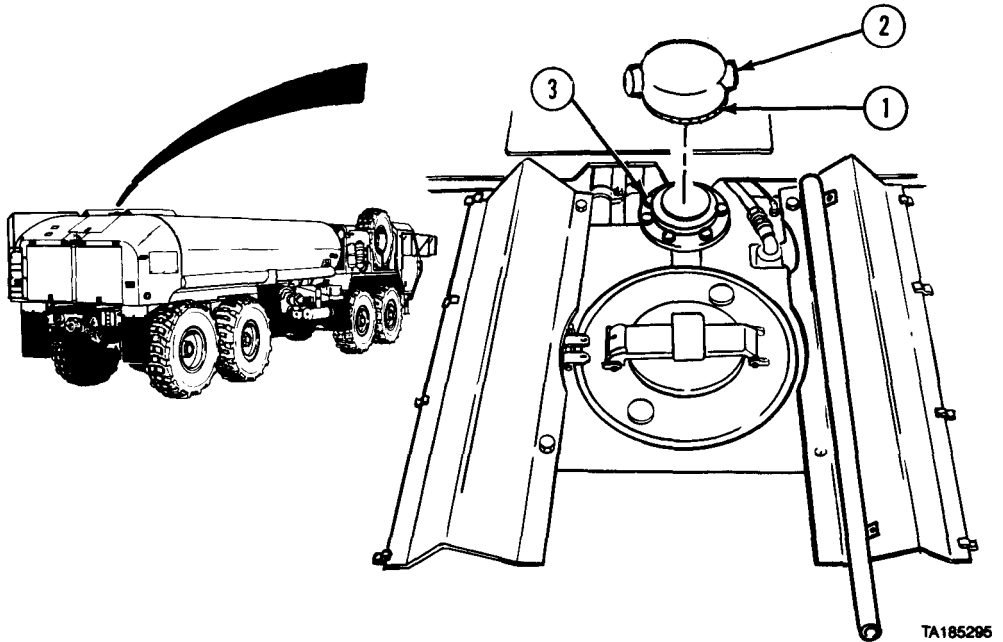


- (4) Install gasket (5).
- (5) Turn manhole cover (4) over and position on tanker.



- (6) Install clamp (3) on manhole cover (4).
- (7) Install screw (2) and nut (1).

Preparation for Transport and Operation (Cont)

E-8. REMOVE/INSTALL VENT HOOD.**a. Remove Vent Hood.**

TA185295

WARNING

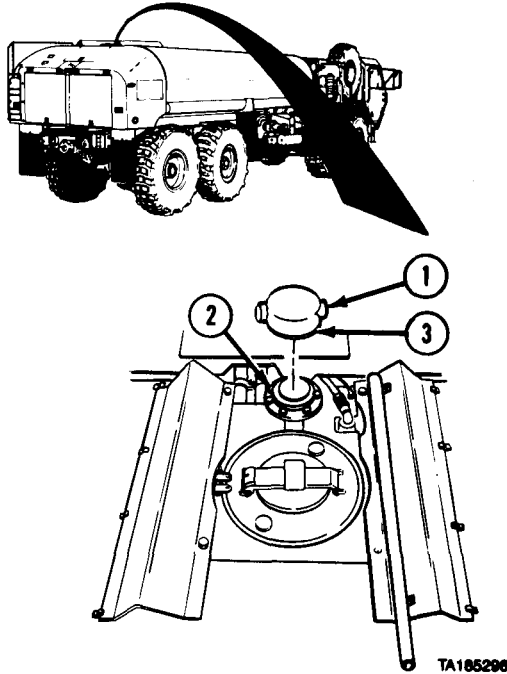
Wet metal surfaces are slippery. Use extreme care when climbing on tanker. Falling from tanker may cause personal injury or death.

- (1) Loosen clamp (1) note position and remove vent hood (2) from V13 vent valve (3).
- (2) Stow vent hood (2) for transport as instructed by loadmaster.

Preparation for Transport and Operation (Cont)

E-8. REMOVE/INSTALL VENT HOOD (CONT).

b. Install Vent Hood.



WARNING

Wet metal surfaces are slippery. Use extreme care when climbing on tanker. Falling from tanker may cause personal injury or death.

- (1) Remove vent hood (1) from stowage.
- (2) Position vent hood (1) on V13 vent valve (2) and tighten clamp (3).

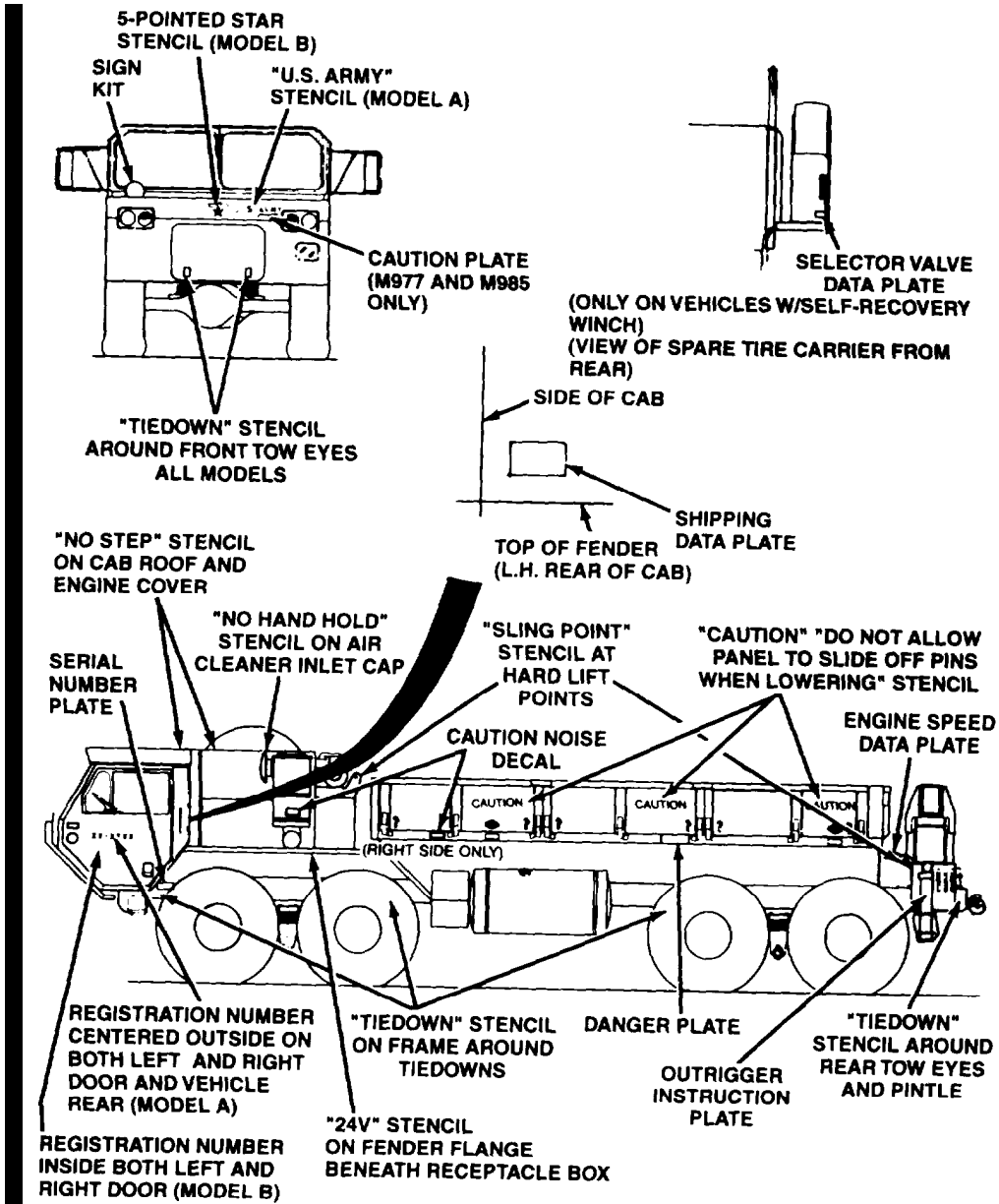
APPENDIX F STOWAGE AND SIGN GUIDE

F-1. SCOPE. This appendix shows locations for data plates, decals, and stencils that are to be in place on the M977 series vehicles.

F-2. GENERAL. The figures on the next pages show the location of metal signs, decals, and stencils used on the vehicle. Most of these signs and stencils contain cautions or information needed to operate the vehicle safely. For stowage locations of Components of End Items (COEI) and Basic Issue Items (BII), refer to Appendix B.

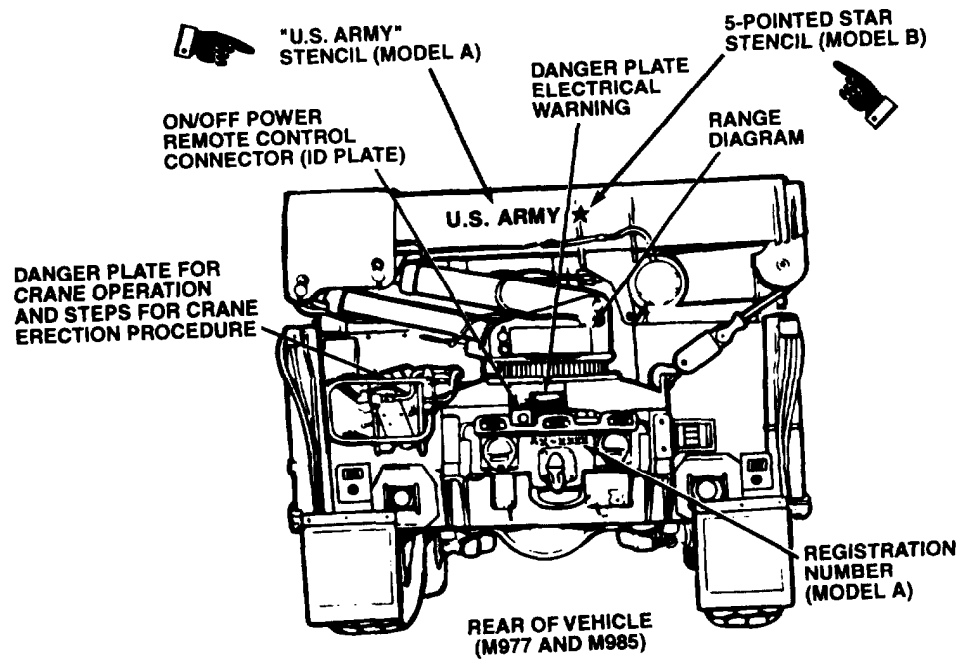
The differences between Model A and Model B as depicted here were implemented at various times during the HEMTT production cycle. Therefore, any individual HEMTT may have some markings depicted as Model A and some as Model B.

Stowage and Sign Guide (Cont)



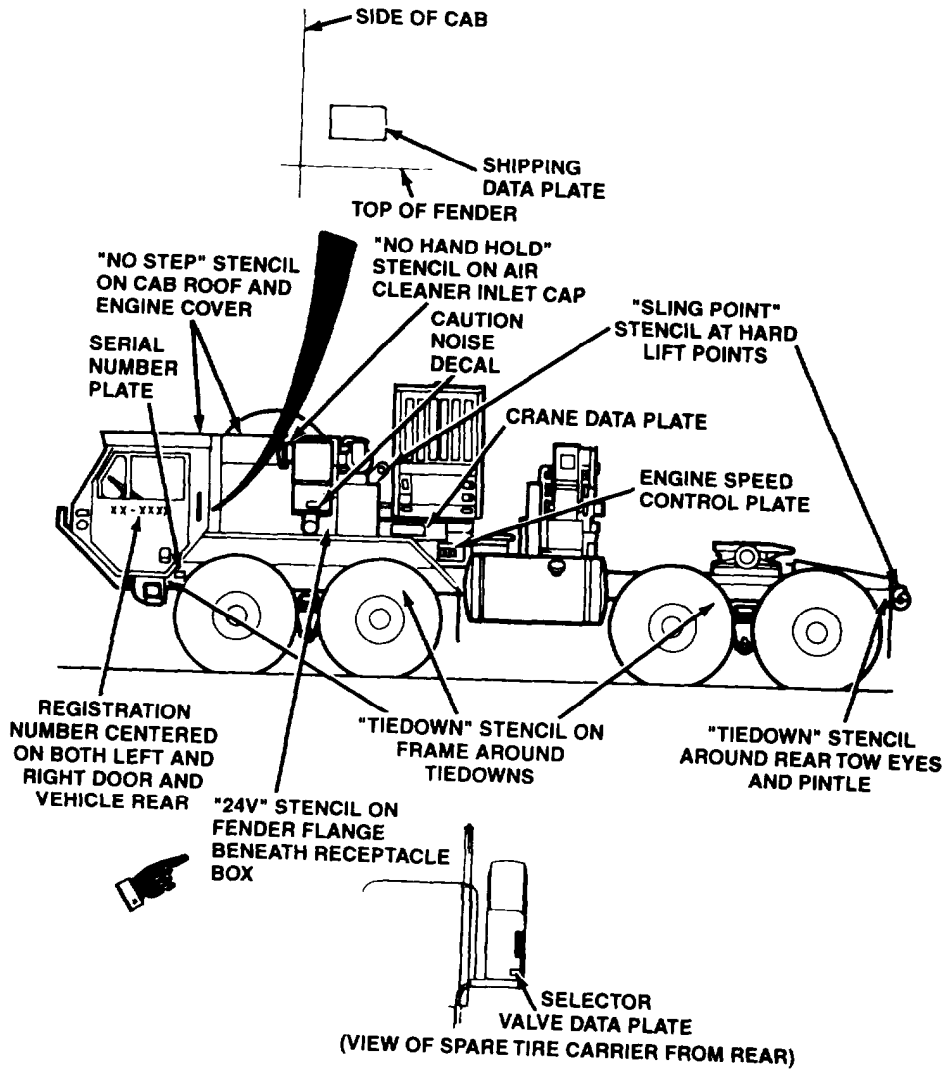
M977 and M985 Cargo Vehicles

Stowage and Sign Guide (Cont)



M977 and M985 Cargo Vehicles (Cont)

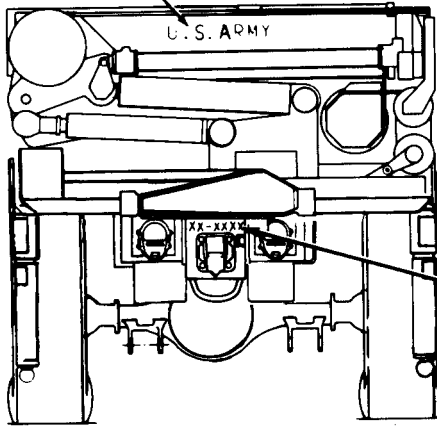
Stowage and Sign Guide (Cont)



M983 Tractor Vehicle With Crane

Stowage and Sign Guide (Cont)

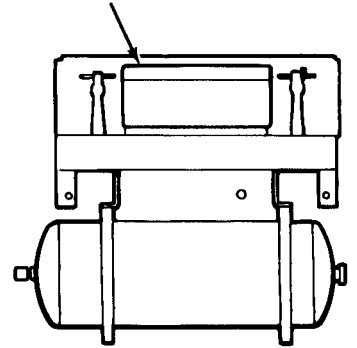
"U.S. ARMY" STENCIL



(REAR VIEW OF VEHICLE)

REGISTRATION
NUMBER

CRANE DATA PLATE

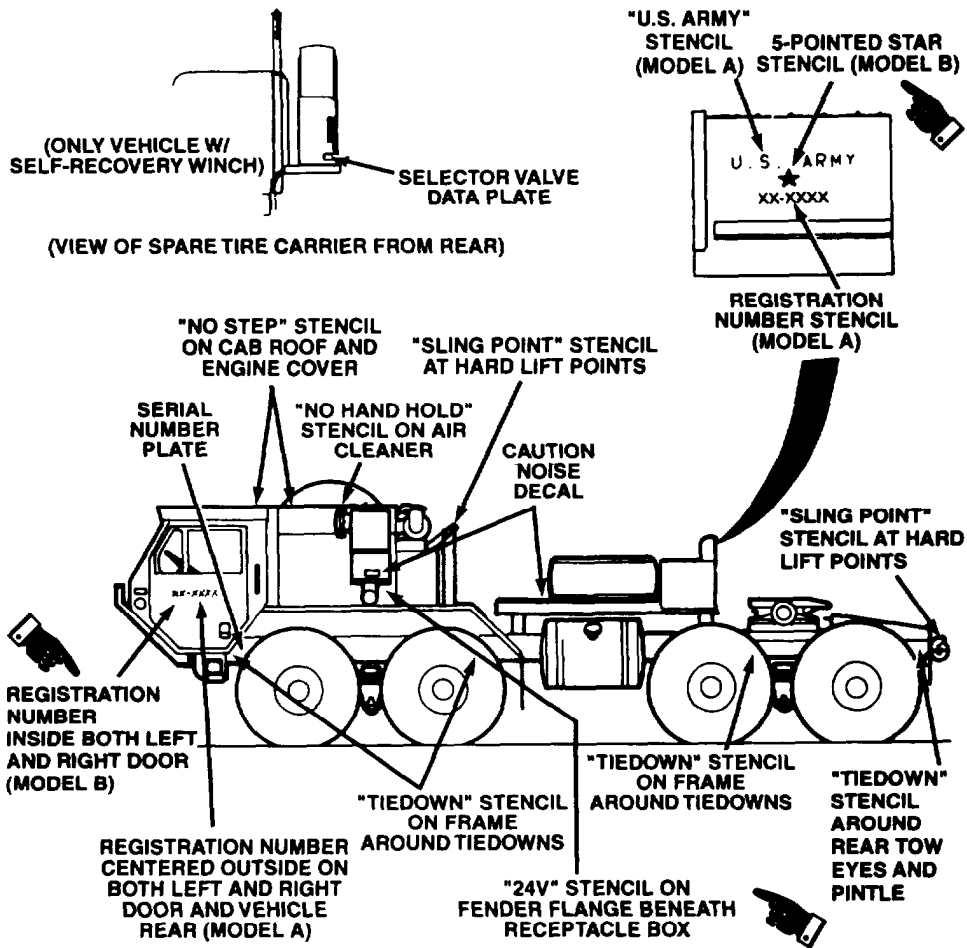


(BATTERY BOX)

TA184596

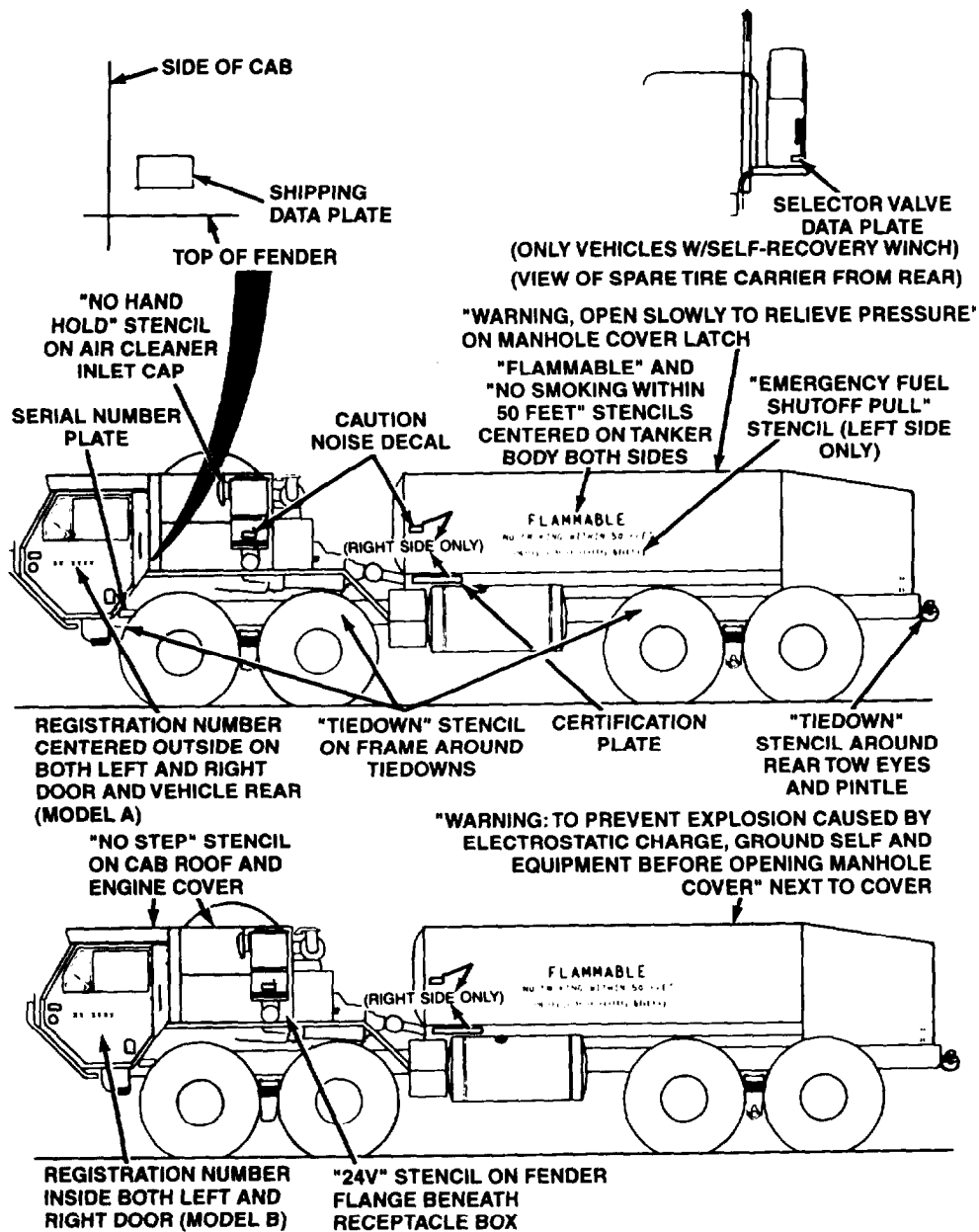
M983 Tractor Vehicle With Crane (Cont)

Stowage and Sign Guide (Cont)



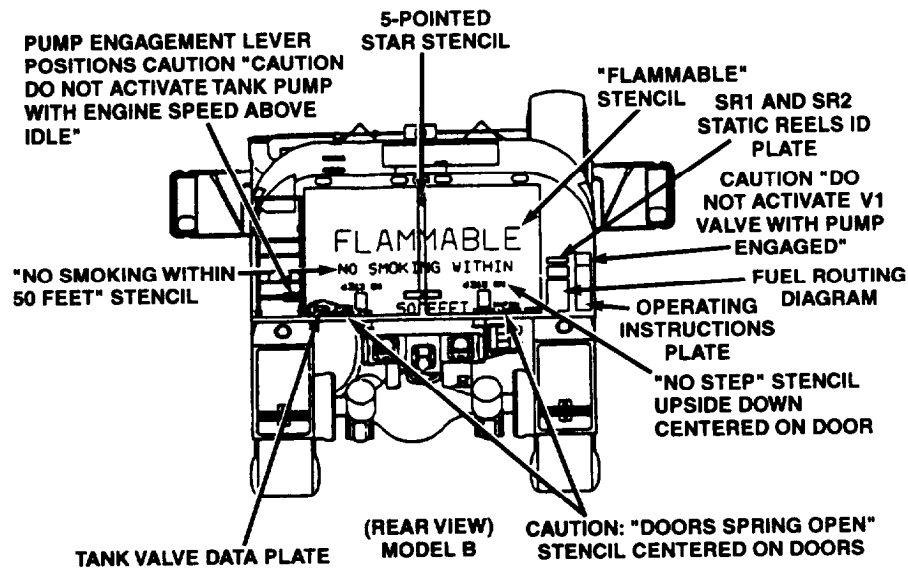
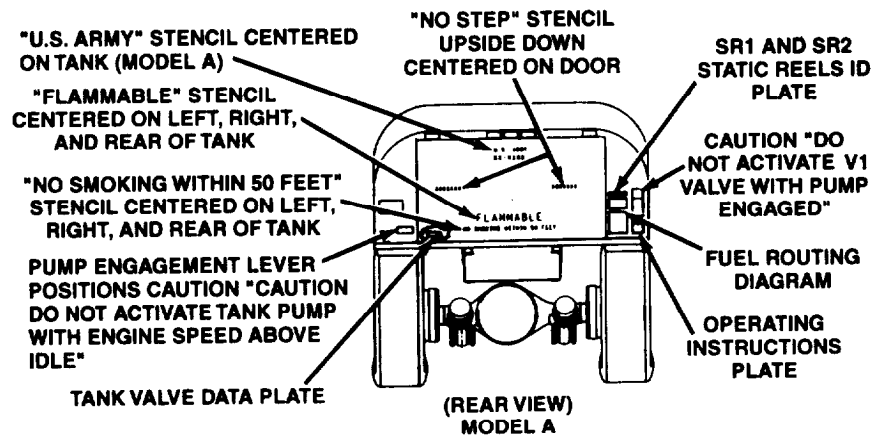
M983 Tractor Vehicle Without Crane

Stowage and Sign Guide (Cont)



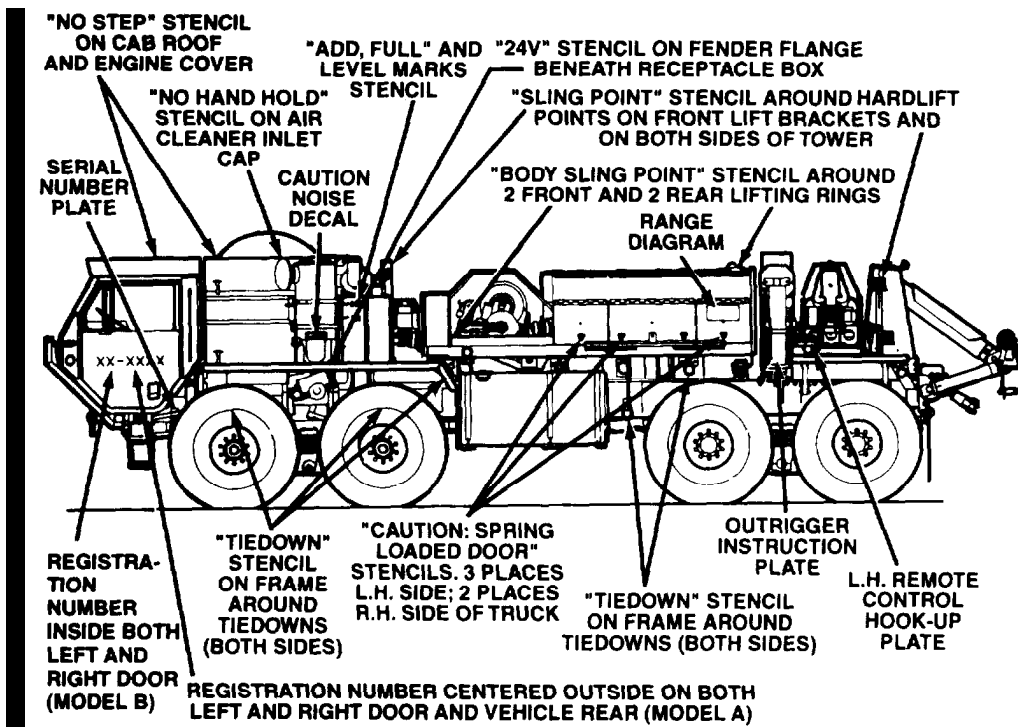
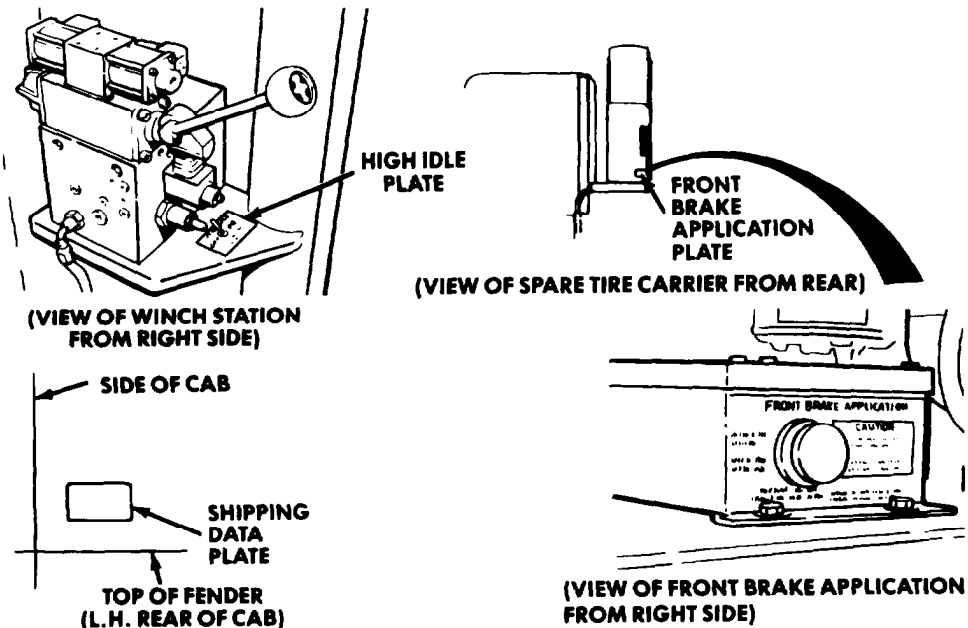
M978 Tanker Vehicle

Stowage and Sign Guide (Cont)



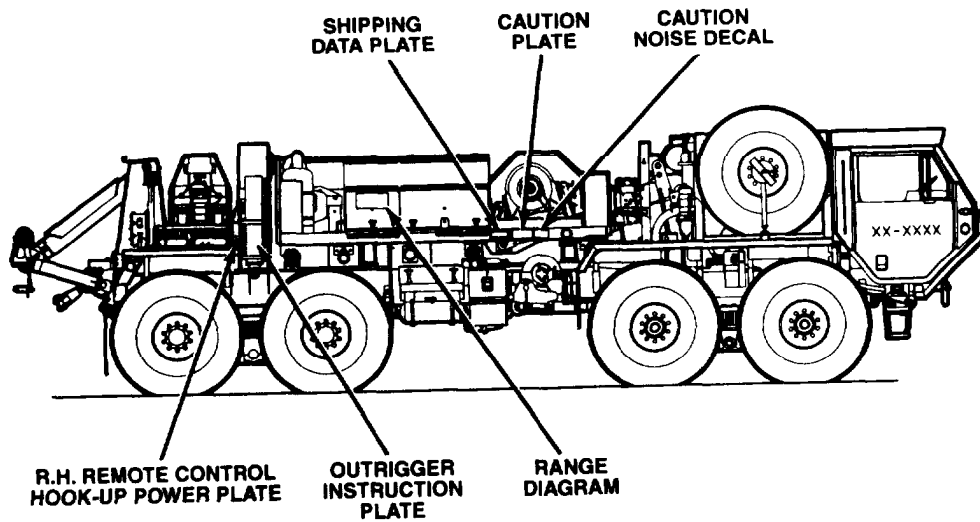
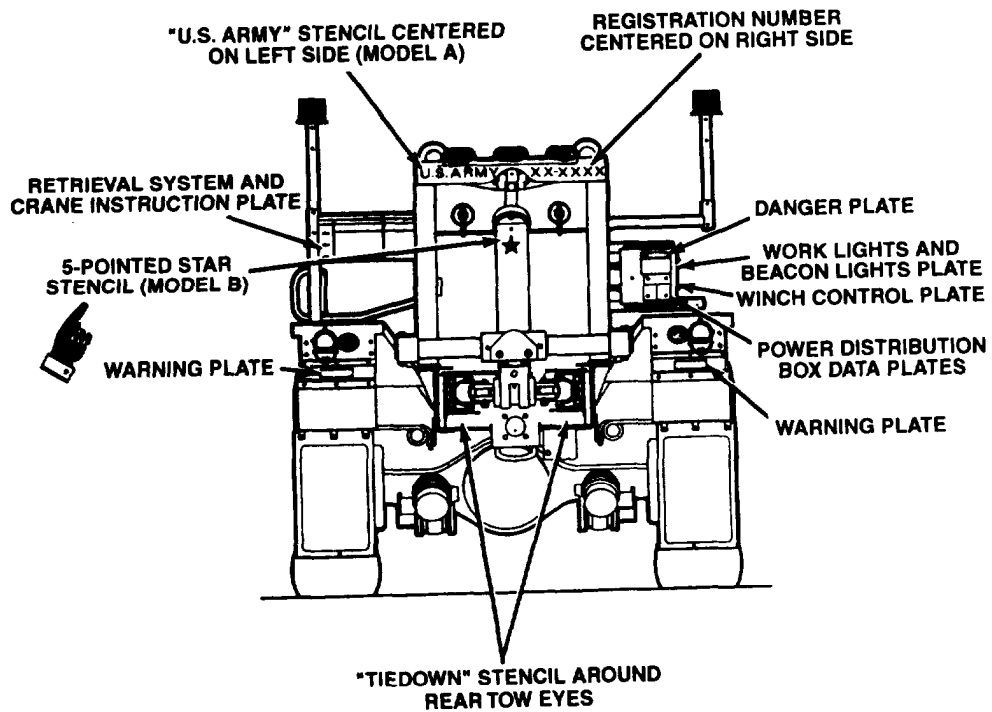
M978 Tanker Vehicle (Cont)

Stowage and Sign Guide (Cont)



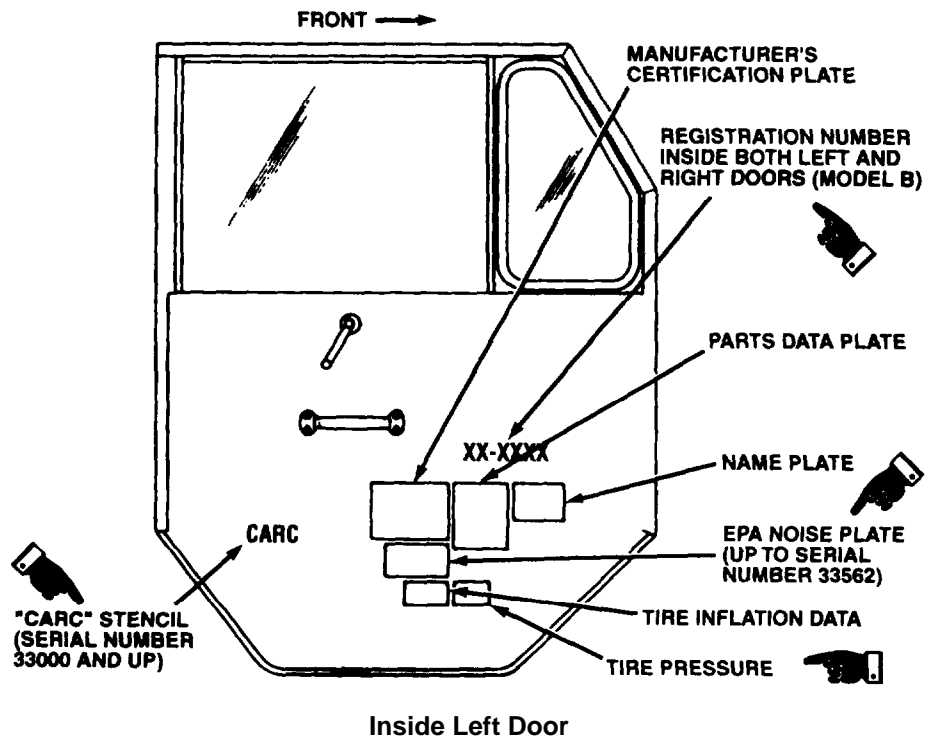
M984 Wrecker-Recovery Vehicle

Stowage and Sign Guide (Cont)

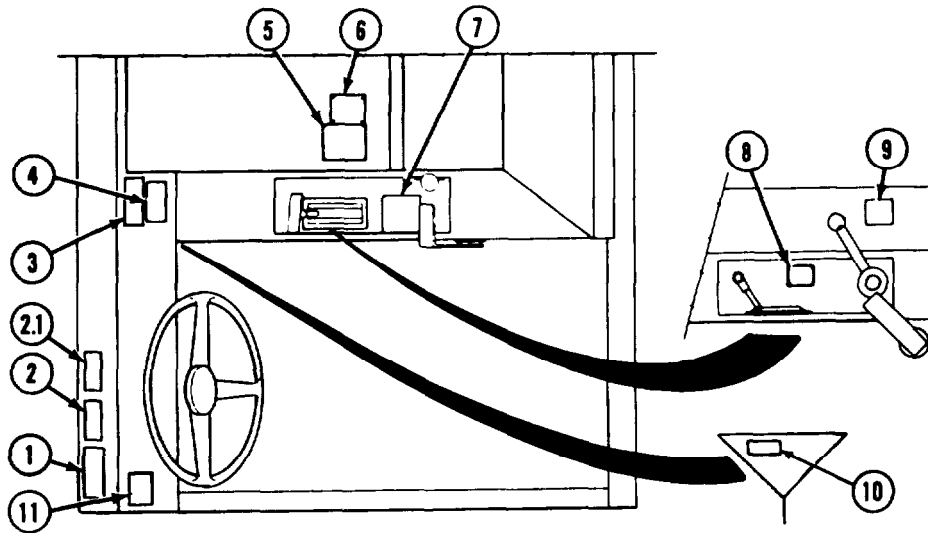


M964E1 Wrecker-Recovery Vehicle (Cont)

Stowage and Sign Guide (Cont)

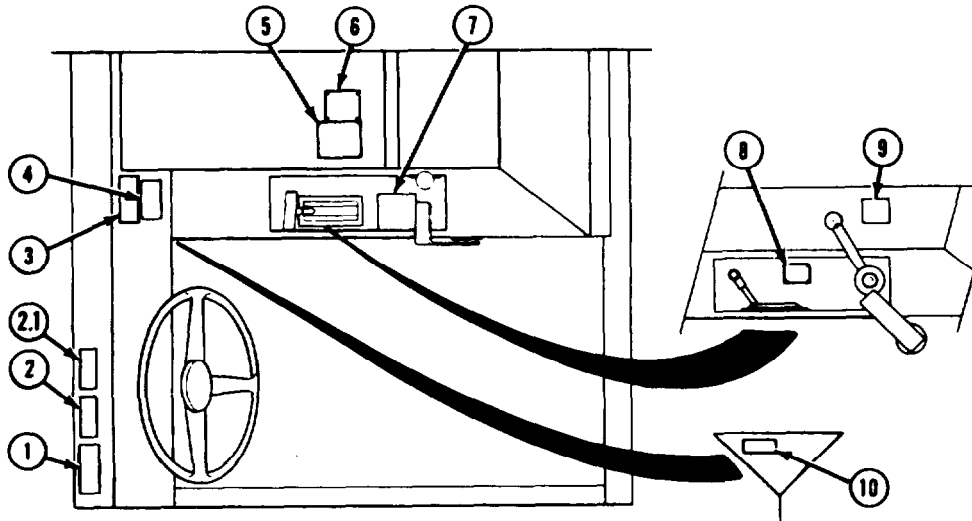


Stowage and Sign Guide (Cont)



Index Number	M977/M985 With Winch	M977/M985 Without Winch	M978 With Winch	M978 Without Winch
1	WARRANTY DECAL	WARRANTY DECAL	WARRANTY DECAL	WARRANTY DECAL
2	RUSTPROOFING DECAL	RUSTPROOFING DECAL	RUSTPROOFING DECAL	RUSTPROOFING DECAL
2.1 (S/N 33563 and up)	NOISE EXEMPTION DECAL	NOISE EXEMPTION DECAL	NOISE EXEMPTION DECAL	NOISE EXEMPTION DECAL
3	TRACTION CONTROL	TRACTION CONTROL	TRACTION CONTROL	TRACTION CONTROL
4	ETHER START	ETHER START	ETHER START	ETHER START
5	CRANE DATA	CRANE DATA	TANKER INSTRUCTIONS	TANKER INSTRUCTIONS
6	NOT USED	NOT USED	NOT USED	NOT USED
7	SELF-RECOVERY WINCH DATA	NOT USED	SELF-RECOVERY WINCH DATA	NOT USED
8	VEHICLE DATA PLATE	VEHICLE DATA PLATE	VEHICLE DATA PLATE	VEHICLE DATA PLATE
9	TRANSFER CASE DATA	TRANSFER CASE DATA	TRANSFER CASE DATA	TRANSFER CASE DATA
10	ENGINE ON-OFF DECAL	ENGINE ON-OFF DECAL	ENGINE ON-OFF DECAL	ENGINE ON-OFF DECAL
11	NOT USED	NOT USED	CAUTION DECAL	CAUTION DECAL

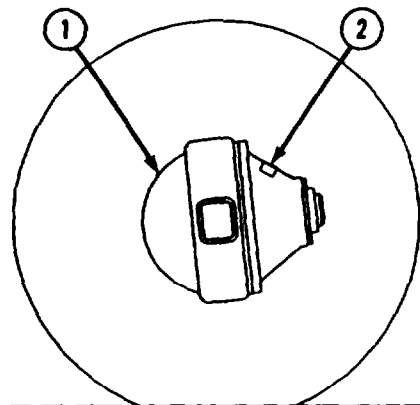
Stowage and Sign Guide (Cont)



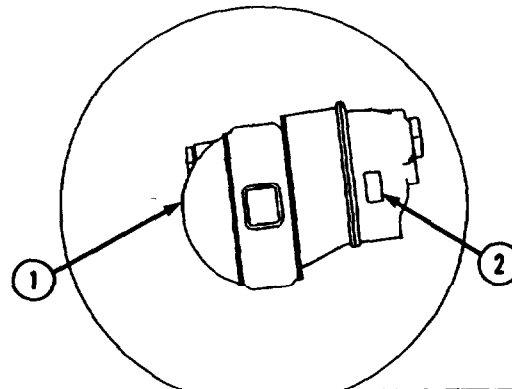
Index Number	M983	M983 Without Crane	M984E1
1	WARRANTY DECAL	WARRANTY DECAL	WARRANTY DECAL
2	RUSTPROOFING DECAL	RUSTPROOFING DECAL	RUSTPROOFING DECAL
2.1 (S/N 33563 and up)	NOISE EXEMPTION DECAL	NOISE EXEMPTION DECAL	NOISE EXEMPTION DECAL
3	TRACTION CONTROL	TRACTION CONTROL	TRACTION CONTROL
4	ETHER START	ETHER START	ETHER START
5	CRANE DATA	NOT USED	CRANE DATA
6	NOT USED	NOT USED	HEAVY-DUTY WINCH DATA
7	SELF-RECOVERY WINCH DATA	SELF-RECOVERY WINCH DATA	SELF-RECOVERY WINCH DATA
8	VEHICLE DATA PLATE	VEHICLE DATA PLATE	VEHICLE DATA PLATE
9	TRANSFER CASE DATA	TRANSFER CASE DATA	TRANSFER CASE DATA
10	ENGINE ON-OFF DECAL	ENGINE ON-OFF DECAL	ENGINE ON-OFF DECAL

Stowage and Sign Guide (Cont)

Index No.	Decal Located On	M977		M978		M983	M984E1	M985	
		w/ winch	w/o winch	w/ winch	w/o winch	w/o crane		w/ winch	w/o winch
1	Axle Housing	4	4	4	4	4	4	4	4
2	Carrier	4	4	4	4	4	4	4	4
3	Transfer Case	1	1	1	1	1	1	1	1
4	Engine	1	1	1	1	1	1	1	1
5	Transmission	1	1	1	1	1	1	1	1
6	Self-Recovery Winch	1	0	1	0	1	1	1	0
7	Heavy Duty Winch	0	0	0	0	0	1	0	0
Total No. of Decals per Vehicle		12	11	12	11	12	13	12	11



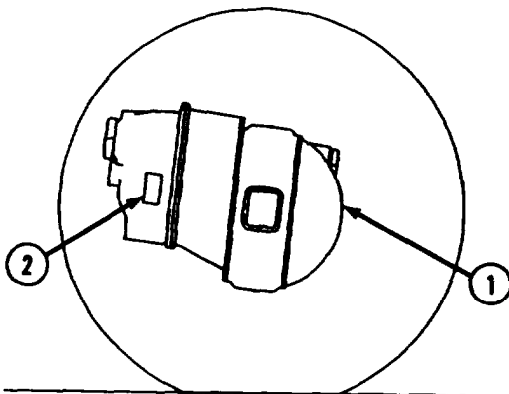
NO. 1 AXLE



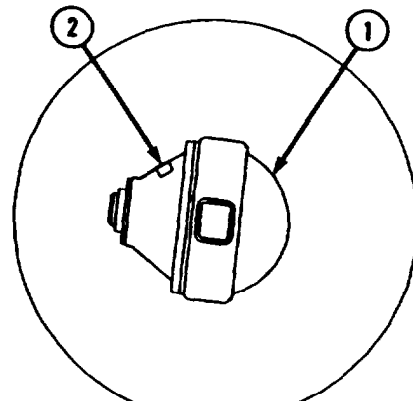
NO. 2 AXLE

Component Warranty Decal Location

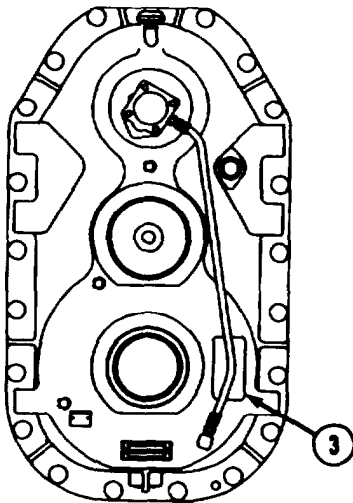
Stowage and Sign Guide (Cont)



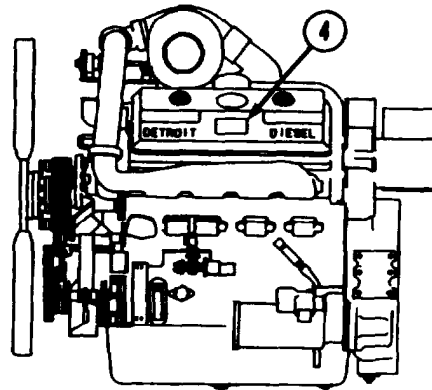
NO. 3 AXLE



NO. 1 AXLE



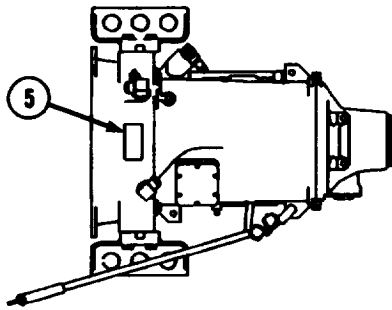
REAR VIEW OF TRANSFER CASE



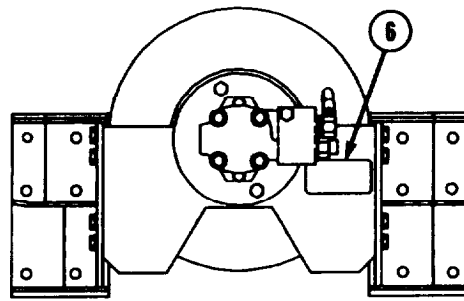
LEFT SIDE VIEW OF ENGINE

Component Warranty Decal Location (Cont)

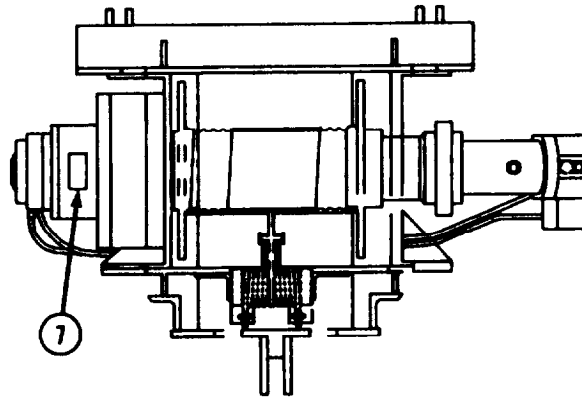
Stowage and Sign Guide (Cont)



TOP VIEW OF TRANSMISSION



FRONT VIEW OF SELF-RECOVERY WINCH



TOP VIEW OF HEAVY DUTY WINCH
(M984E1 ONLY)

Component Warranty Decal Location (Cont)

I N D E X

Subject	Paragraph, Figure, Table, Number
A	
Abbreviations	1-8
Access ladder, install/stow...	2-15
Additional authorization list (AAL)	C-1
Adjust seat	2-9
Air cleaner element, service/remove/install/clean	3-8
Air dryer, PMCS checkT 2-1
Aircraft overwing fuel servicing, or land vehicle (M978)	
Fuel servicing	2-23
Prepare vehicle	2-23
Air reservoirs, PMCS checkT 2-1
Air system	
Immediate action for loss of air system pressure	2-48
Principles of operation	1-15
Troubleshooting	3-3
Alarm, chemical (M-8), operate	2-31
Appendix	
A, References	A-1
B, Components of end item (COEI) and basic issue item (BII) lists	B-1
C, Additional authorization lists (AAL)	C-1
D, Expendable supplies and materials lists	D-1
E, Preparation for transport and operation	E-1
F, Stowage and sign guides	F-1
Apply service brakes	2-11
Arctic engine heater controls and indicators	F 2-19
Arctic engine heater, operate.	2-31
Attach snatch block to self-recovery winch cable	2-42
Auxiliary equipment data.....T 1-2
Auxiliary equipment, operate	
Chemical alarm (M-8)	2-31
Connect auxiliary hydraulic equipment	2-31
Decontamination unit (M-13).....	2-31
Disconnect auxiliary hydraulic equipment	2-31
Engine arctic heater	2-31
Gas particulate filter unit	2-31
Generator set	2-31
M-8 chemical alarm	2-31
M-13 decontamination unit	2-31
Machine gun mount	2-31
Radio	2-31
Rifle, remove from stowage mount	2-31

INDEX (CONT)

Subject	Paragraph, Figure Table, Number
A	
Auxiliary equipment, operate (Cont)	
Rifle, stow in stowage mount	2-31
Auxiliary pump, use to perform fuel servicing (M978)	2-48
Axles, data	T 1-2
B	
Basic issue items (BII)	B-1
Batteries PMCS	T 2-1
Battery box	
Close	3-10
Install fire extinguisher (M978)	2-14
Open	3-10
Remove fire extinguisher (M978).	2-14
Beacon light, remove/install.	2-30
Blackout drive lights, turn on/off	2-10
Blackout markers, turn on/off.	2-10
Bolts, nuts, and screws (PMCS)	2-6
Boom	
Raise to operating position (M977 and M985)	2-18
Raise to operating position (M983)	2-28
Rotate and telescope, manual controls (M977 and M985)	2-18
Rotate and telescope, remote controls (M977 and M985)	2-19
Bottom load fuel tank (M978)	
With exterior pump	2-22
With tanker pump	2-22
Box, battery, open/close	3-10
Brake, Jacobs [®] , engine	2-11
Brake system data	T 1-2
Brakes	
Manually release vehicle spring brakes	2-47
Operate parking brakes	2-11
Operate service brakes	2-11
Operate trailer brakes	2-11
Perform immediate action for loss of air supply system pressure	2-48
Bulk unloading, fuel (M978)	
Filtered bulk unloading	2-25
Unfiltered bulk unloading	2-25
Unfiltered gravity bulk unloading	2-25
C	
Cab	
Data	T 1-2
Install fire extinguisher in cab	2-14
Interior, PMCS	T 2-1
Remove fire extinguisher from cab	2-14
Cab-mounted foot controls and indicators	F 2-1
Cab-mounted hand controls and indicators	F 2-2
Capabilities of equipment	1-9

INDEX (CONT)

Subject	Paragraph, Figure, Table, Number
C	
Capacities	
Cooling system	T 1-2
Engine oil	T 1-2
Front tandem - front axle (No. 1)	T 1-2
Front tandem - rear axle (No. 2)	T 1-2
Fuel tank	T 1-2
Hydraulic reservoir with filters	T 1-2
Operating temperature with arctic kit	T 1-2
Operating temperature without arctic kit	T 1-2
Rear tandem - front axle (No. 3)	T 1-2
Rear tandem - rear axle (No. 4)..	T 1-2
Transfer case	T 1-2
Transmission	T 1-2
Windshield washer fluid	T 1-2
Cargo body side panels	
Install side panels (M977 and M985)	2-17
Lower all at one time (M977 and M985)	2-17
Lower one at a time (M977 and M985)	2-17
Raise and secure all at one time (M977 and M985)	2-17
Raise and secure one at a time (M977 and M985)	2-17
Remove side panels (M977 and M985)	2-17
Cargo body, M977 and M985 cargo vehicle, PMCS	T 2-2
Cargo cover kit (M977 and M985), remove/install	2-17
Chains, tire, remove/install	2-39
Change to different fuel or fuel grade (M978)	2-26
Change vehicle weight indicator	2-9
Change wheel and tire assembly	
Install spare tire/wheel	3-6
Prepare vehicle	3-6
Remove flat tire/wheel	3-6
Remove spare tire	3-6
Stow flat tire	3-6
Stow tire davit winch	3-6
Characteristics of equipment.	1-9
Check tank fuel level (M978)	2-21
Check tire pressure	3-9
Checks and services, preventive maintenance (PMCS)	2-5
Chemical alarm (M-8), controls and indicators	F 2-23
Chemical alarm (M-8), operate.	2-31
City traffic, drive in	2-11
Class I, II, and III fluid leakage, definition of	2-7
Clean air cleaner element	3-8
Classification, load	T 1-3
Clean fuel tank strainer, remove/install/clean	3-7
Clean vehicle	3-5
Cleanliness (PMCS), general maintenance procedures	2-6

INDEX (Cont)

Subject	Paragraph, Figure, Table, Number
C	
Clearance lamps, turn on/off.	2-10
Close	
Batterybox..	3-10
Enginecover	3-10
Cold engine, start vehicle	2-11
Cold environment (32°F, 0°C to -25°F, -32°C), operate vehicle in	
Brakes slip after driving through slush or water	2-36
Drive on mud, snow, ice, and slippery surfaces	2-36
Parkvehicle	2-36
Bear of vehicle skids	2-36
Vehicle becomes stuck	2-36
Vehicle starts to slide while climbing hill	2-36
Cold environment, extreme (-26°F, -32°C to -65°F, -54°C)	
operate vehicle in	
General instructions	2-37
Warm up before operating crane	2-37
Warm up before performing fuel handling operation (M978 only)	2-37
Components of end item and basic issue items (COEI and BII)	B-1
Components, major, location and description of.	1-10
Connect	
Auxiliary hydraulic equipment	2-31
Remote control unit to forward outlet	2-19
Remote control unit to rear outlet	2-19
Self-recovery winch cable to another vehicle	2-43
Tow bar	2-46
Tow bar (M1977-CBT)	2-46.1
Semitrailer to M983	2-27
Trailer (M977 and M985)	2-16
Control panel, crane (M983)	
Main, controls and indicators	F 2-15
Secondary, controls and indicators	F 2-16
Controls and indicators	
Description and use of operator's controls and indicators	2-1
Figure index	2-2
Location and use of controls and indicators	2-2
Controls, tanker, position	2-20
Cooling system data	T 1-2
Cover, cargo, kit (M977 and M985), remove/install	2-17
Cover, engine, open/close	3-11
Crane (M977 and M985)	
Connect remote control unit to forward outlet	2-19
Connect remote control unit to rear outlet	2-19
Control panel	F 2-8
Crane electrical power fails, perform emergency hydraulic operation	2-48
Crane remote control unit	F 2-9
Disconnect remote control unit from forward outlet	2-19

INDEX (CONT)

Subject	Paragraph, Figure, Table, Number
C	
Crane (M977 and M985) (Cont)	
Disconnect remote control unit from rear outlet	2-19
Prepare crane for use	2-18
Raise and lower load (manual controls)	2-18
Raise and lower load (remote controls)	2-19
Raise boom to operating position	2-18
Rotate and telescope boom (manual controls)	2-18
Rotate and telescope boom (remote controls)	2-19
Set up outriggers	2-18
Set up remote control unit	2-19
Shut down crane	2-18
Shut off switches	2-19
Stow outriggers	2-18
Crane (M983)	
Main control panel, controls and indicators	F 2-15
Operate crane using left-side controls	2-28
Operate crane using remote control panel	2-29
Operate crane using right-side controls	2-28
Prepare for use	2-28
Raise boom to operating position	2-28
Remote control panel, controls and indicators	F 2-17
Secondary control panel, controls and indicators	F 2-16
Set up outriggers	2-28
Set up remote control panel	2-29
Shut down and return crane to transport position - (manual controls)	2-28
Shut down and return crane to transport position - (remote controls)	2-29
Stow outriggers	2-28
Cross-reference list, nomenclature	1-8
D	
Damage, definition of	2-6
Dash panel controls and indicatorsF 2-5
Data, equipment	
AxlesT 1-2
Auxiliary equipmentT 1-2
Brake systemT 1-2
CabT 1-2
CapacitiesT 1-2
Center of gravityT 1-2
Cooling systemT 1-2
DimensionsT 1-2
Electrical systemT 1-2
EngineT 1-2
Fifth wheelT 1-2
Fuel systemT 1-2
Ground clearanceT 1-2

INDEX (CONT)

Subject	Paragraph, Figure Table, Number
D	
Data, equipment (Cont)	
Operating speeds	T 1-2
PerformanceT 1-2
PintleT 1-2
Recovery winchT 1-2
Self-recovery winchT 1-2
Steering systemT 1-2
Tire pressuresT 1-2
TiresT 1-2
Towing eyesT 1-2
Transfer caseT 1-2
TransmissionT 1-2
Turning circleT 1-2
WeightT 1-2
Weight distributionT 1-2
WheelbaseT 1-2
WheelsT 1-2
Data plates, locations for	F-1
Decals, locations for	F-1
Decontamination unit (M-13), controls and indicators	F 2-24
Decontamination unit (M-13), operate	2-31
Defrost, windshield, operate.	2-22
Description and location of major components	1-10
Description and use of operator's controls and indicators	
Introduction	2-1
Location and use of controls and indicators	2-2
Description of M977 series vehicles	1-1
Desert environment, operate vehicle in	2-35
Differences between modelsT 1-1
Different fuel or fuel grade, change to (M978)	2-26
Dimensions of vehicles	1-12
Disconnect	
Auxiliary hydraulic equipment	2-31
Remote control from forward outlet (M977 and M985 crane)	2-19
Remote control from rear outlet (M977 and M985 crane)	2-19
Self-recovery winch cable from another vehicle	2-41
Semitrailer from vehicle (M983)	2-27
Trailer (M977 and M985)	2-16
Distribution of weight, data...T 1-2
Domelight, turn on/off	2-10
Drain existing fuel (M978)	2-26
Drive vehicle	
Down steep grades	2-11
Forward	2-11
In city traffic	2-11
In off-road conditions	2-11
In reverse	2-11

INDEX (CONT)

Subject	Paragraph, Figure, Table, Number
D	
Drive vehicle (Cont)	
In slippery conditions	2-11
On highway	2-11
On mud, snow, ice, and slippery surfaces	2-36
Operate service brakes	2-11
Operate trailer brakes	2-11
Operate transmission/transfer case	2-11
Park	2-11
Shut off engine	2-11
Start cold engine	2-11
Start warm engine	2-11
Up steep grades	2-11
Use engine brake	2-11
Dust, extreme, operate vehicle in	2-33
E	
Electric wires and connectors (PMCS)	T 2-1
Electrical generator assembly (M983 equipped with generator), PMCS	T 2-4
Electrical power fails, perform emergency hydraulic operation, crane (M977 and M985 cranes)	2-48
Electrical system	
Data	T 1-2
Principles of operation	1-13
Troubleshooting	3-3
Element, air cleaner, remove/install/clean	3-8
Emergency flashers, turn on/off	2-44
Emergency hydraulic operation	
Perform when crane electrical power fails (M977 and M985 cranes)	2-48
Perform when hydraulic power fails (M983)	2-48
Emergency marker kit, highway	
Place on divided highway	2-44
Place on undivided highway.	2-44
Set up/secure	2-44
Emergency procedures	
Limp home/flat tire with no spare	2-49
Perform emergency hydraulic operation when electrical power fails (M977 and M985 cranes)..	2-48
Perform emergency hydraulic operation when hydraulic power fails (M983)	2-48
Perform fuel servicing using auxiliary pump (M978)	2-48
Perform immediate action for loss of air supply system pressure	2-48
Perform immediate action for loss of hydraulic system	2-48
Slave start vehicle	2-48
Engine	
Arctic heater, operate	2-31
Cover open/close	3-11

Index (Cont)

Subject	Paragraph, Figure, Table, Number
E	
Engine (Cont)	
Data	T 1-2
Shut off	2-11
Slave start	2-48
Start cold engine	2-11
Start warm engine	2-11
Troubleshooting	3-3
Engine brake, operate	2-11
Engine cover, open/close	3-11
Engine heater, arctic, operate	2-31
Equipment	
Capabilities	1-9
Characteristics	1-9
Data	1-12
Features	1-9
Equipment, auxiliary, hydraulic	
Connect	2-31
Disconnect	2-31
Equipment, auxiliary, operate	2-31
Equipment data, typical	1-12
Equipment description	
Equipment characteristics, capabilities, and features	1-9
Location and description of major components	1-10
Equipment improvement report and maintenance digest (EIR MD) and equipment improvement report and maintenance summary (EIR MS)	1-3
Expendable supplies and materials list	D-1
Exterior of vehicle, clean.	3-5
Exterior pump, bottom load tank (M978)	2-22
Extinguish fire	2-14
Extinguisher, fire	
Install on battery box (M978)	2-14
Install in cab	2-14
Install on stowage box	2-14
Operate	2-14
Remove from battery box (M978).	2-14
Remove from cab	2-14
Remove from stowage box.	2-14
Extreme cold environment (-26°F, -32°C to -65°F, -54°C), operate vehicle in.....	2-37
Extreme dust, operate vehicle in	2-33
Extreme heat, operate vehicle in	2-32
F	
Features of equipment	1-9
Fifth wheel	
Data	T 1-2
Without trailer coupled, PMCS	T 2-4

INDEX (CONT)

Subject	Paragraph, Figure, Table, Number
F	
Fifth wheel (Cont)	
With trailer coupled, PMCS	T 2-4
Figure index, controls and indicators	2-2
Filter unit, gas particulate, operate	2-31
Filtered bulk unloading, yyyyyy Äuel (M978).	2-25 .
Fire, extinguish	2-14
Fire extinguisher, install	
In cab	2-14
On battery box (M978)	2-14
On stowage box	2-14
Fire extinguisher, remove	
From battery box (M978 only).	2-14
From cab	2-14
From stowage box	2-14
Fire extinguisher, preventive maintenance checks and services	
M977 and M985 cargo vehicles	T 2-2
M978 tanker vehicle	T 2-3
Flat left front tire (no spare)	2-49
Flat right front or rear tire (no spare)	2-49
Flat tire/wheel, remove/stow.	3-6
Fluid leakage	2-7
Foot rest install/stow	2-9
Ford water obstacle	2-40
Forest, operate vehicle in	2-38
Forms	A-3
Forms and records, maintenance	1-2
Forward, drive vehicle	2-11
Forward outlet (M977 and M985)	
Connect remote control unit to	2-19
Disconnect remote control unit from	2-19
Front and rear panels, cargo body, remove/install (M977 and M985) . .	2-17
Fuel (M978)	
Bottom load with tanker yyyyyy Äuel pump	2-22 .
Change to different fuel or uel grade	2-26
Drain existing	2-26
Load through manhole	2-22
Recirculate	2-24
Unload filtered bulk	2-25
Unload unfiltered bulk	2-26
Unload unfiltered gravity bulk	2-25
Fuel level, check (M978)	2-21
Fuel pump, bottom load with tanker	2-22
Fuel servicing	
Land vehicle or aircraft overwing fueling (M978)	2-23
Using auxiliary pump (M978)	2-48
Fuel svstem	
Data	T 1-2

INDEX (CONT)

Subject	Paragraph, Figure, Table, Number
F	
Fuel system (Cont)	
PMCS	T 2-1
Fuel tank strainer, remove/install/clean	3-7
Fuel tank, PMCS	T 2-1
Fueling, land vehicle or aircraft overwing (M978)	2-23
G	
Gas particulate filter unit	
Operate	2-31
PMCS	T 2-5
Gas particulate filter unit, controls and indicators	F 2-20
General information	
Abbreviations	1-8
Differences between models.	T 1-1
Equipment data	1-12
Equipment improvement report and maintenance digest (EIR MD) and equipment improvement report and maintenance summary (EIR MS)	1-3
Hand receipt (HR) manuals	1-4
Maintenance forms and records	1-2
Metric system	1-7
Nomenclature cross-reference list	1-8
Preventive maintenance checks and services (PMCS)	2-5
Reference information	1-8
Scope	1-1
Submitting quality deficiency reports (QDR)	1-5
Warranty information	1-6
General maintenance procedures	2-6
Bolts, nuts, and screws	2-6
Cleanliness	2-6
Damage, defined	2-6
Electrical wires and connectors	2-6
Hydraulic lines and fittings	2-6
Welds	2-6
Generator set	
Operate (M983)	2-31
PMCS	T 2-5
Gravity bulk unloading, fuel	2-25
Guide, stowage and sign	F-1
H	
Handrail, pump module, remove/install	E-5
Hand receipt (HR) manuals	1-4
Heat, extreme, operate vehicle in	2-32
Heater, operate	
Engine, arctic	2-31
Personnel	2-13
Heater compartment controls and indicators	F 2-6

INDEX (Cont)

Subject	Paragraph, Figure, Table, Number
H	
Highway, drive on	2-11
Highway emergency marker kit	
Place on divided highway	2-44
Place on undivided highway	2-44
Setup/secure	2-44
Hook, pintle	
Connect trailer	2-16
Disconnect trailer	2-16
Hydraulic equipment, auxiliary	
Connect	2-31
Disconnect	2-31
Hydraulic lines and fittings, general maintenance procedures	2-6
Hydraulic system	
Immediate action for loss of hydraulic system	2-48
Main hydraulic system, principles of operation (all models except M984E1)	1-16
Main hydraulic system, principles of operation (M984E1)	1-17
PMCS	2-1
Power steering, principles of operation	1-18
Troubleshooting..	3-3
I	
Ice, drive on..	2-36
Immediate action	
For loss of air supply system pressure	2-48
For loss of hydraulic system	2-48
Index	
Figure, controls and indicators	2-2
Symptom, troubleshooting	3-3
Indicator, vehicle weight, change	2-9
Indicators, description and use of operator's controls and	2-1
Indicators, location and use of controls and	2-2
Inflatetire	3-9
Information	
Reference	1-8
Warranty	1-6
Install	
Accessladder	2-15
Air cleaner element	3-8
Beaconlight	2-30
Cargo cover kit	2-17
Drain plug	2-15.1
Fire extinguisher in cab	2-14
Fire extinguisher on battery box (M978)	2-14
Fire extinguisher on stowage box	2-14
Footrest	2-9
Front panels, cargo body (M977 and M985)	2-17
Fuel tank strainer	3-7

INDEX (Cont)

Subject	Paragraph, Figure, Table, Number
I	
Install (Cont)	
Handrail	E-5
Bear panels, cargo body (M977 and M985)	2-17
Side panels, cargo body (M977 and M985)	2-17
Spare tire/wheel	3-6
Tirechains	2-39
Vent hood, remove/install	E-8
Vent roll over rails	E-6
Worklamp	2-15.2
Instrument panel controls and indicators	F 2-5
Interior of vehicle, clean	3-5
Introduction	
Equipmentdescription	1-9
General information	1-1
Operation under usual conditions	2-9
Technical principles of operation	1-13
J	
Jewelry, wearing of, warning	c
K	
Kit, cargo cover (M977 and M985), remove/install	2-17
Kit, highway emergency marker	
Place on divided highway	2-44
Place on undivided highway	2-44
Secure	2-44
Setup	2-44
L	
Ladder, access, install/stow	2-15
Leakage, fluid	2-7
Left front tire flat (no spare tire)	2-49
Left-side controls, operate crane using (M983)	2-28
Lights, operate	
Beacon light, install	2-30
Beacon light, remove	2-30
Blackout drive lights, turn on/off	2-10
Blackout markers, turn on/off	2-10
Clearance lamps, turn on/off	2-10
Domelight, turn on/off	2-10
Panel lights, turn on/off	2-10
Parking lights, turn on/off	2-10
Service drive lights, turn on/off	2-10
Stoptlights, turn on/off	2-10
Tanker module lights, turn on/off	2-10
Work lights, turn on/off	2-10
Limp home/flat tire with no spare	2-49
List, expendable supplies and materials	D-1
List, nomenclature cross-reference	1-8
Loadclassification	T 1-3
Load fuel through manhole (M978)	2-22

INDEX (CONT)

Subject	L	Paragraph, Figure, Table, Number
Load, raise and lower (M977, M985)		
Manual controls		2-18
Remote controls		2-19
Load tanker with fuel (M978)		
Bottom load with exterior pump		2-22
Bottom load with tanker fuel pump		2-22
Load through manhole		2-22
Load vehicle with crane (M983)		
Using left-side controls		2-28
Using remote control panel		2-29
Using right-side controls		2-28
Location and description of major components		1-10
Location and use of controls and indicators		2-2
Loss of air supply system pressure, perform immediate action		2-48
Loss of hydraulic system, perform immediate action		2-48
Lower cargo body side panels (M977 and M985)		
All at one time		2-17
One at a time		2-17
Lubrication instructions, general		3-1
	M	
M-8 chemical alarm		
Controls and indicators		F 2-23
Operate		2-31
PMCS		T 2-5
M-13 decontamination unit		
Controls and indicators		F 2-24
Operate		2-31
PMCS		T 2-5
M977 cargo vehicle		F 1-1
M977, description of		1-1
M978, description of		1-1
M978 tanker vehicle		F 1-2
M983, description of		1-1
M983 tractor w/crane		F 1-3
M983 tractor w/o crane		F 1-4
M984, description of		1-1
M984 wrecker-recovery vehicle		F 1-5
M984E1, description of.....		1-1
M984E1 wrecker-recovery vehicle		F 1-6
M985 cargo vehicle		F 1-7
M985, description of		1-2
M985E1 cargo vehicle		F 1-8
M985E1, description of.....		1-1
M977 and M985 cargo vehicle crane control panel		F 2-8
M977 and M985 cargo vehicle crane remote control unit		F 2-9

INDEX (CONT)

Subject	Paragraph, Figure, Table, Number
M	
M977 and M985 cargo vehicle operating procedures	
Connect trailer	2-16
Disconnect trailer	2-16
Install cargo cover kit	2-17
Install front and rear panels	2-17
Install side panels	2-17
Lower cargo body side panels all at one time	2-17
Lower cargo body side panels one at a time	2-17
Operate crane (manual controls)	2-18
Operate crane (remote controls)	2-19
Raise and secure cargo side panels all at onetime	2-17
Raise and secure cargo side panels one at a time	2-17
Remove cargo cover kit	2-17
Remove front and rear panels	2-17
Remove side panels	2-17
M978 tanker controls, left side of vehicle	F 2-14
M978 tanker module controls	
Center	F 2-11
Far right and left	F 2-10
Near left	F 2-13
Near right	F 2-12
M978 tanker vehicle	F 1-2
M978 tanker vehicle operating procedures	
Bottom load tank with exterior pump	2-22
Bottom load tank with tanker fuel pump	2-22
Changing to a different fuel or fuel grade	2-26
Check tank fuel level	2-21
Fuel servicing	2-23
Load tank through manhole	2-22
Prepare tanker for operation	2-20
Recirculate fuel	2-24
Unload fuel (bulk)	2-25
M983 crane controls and indicators	
Main control panel	F 2-15
Remote control panel	F 2-17
Secondary control panel	F 2-16
M983 tractor vehicle operating procedures	
Connect semitrailer to vehicle	2-27
Disconnect semitrailer from vehicle	2-27
Crane operation, manual controls	2-28
Crane operation, remote controls	2-29
M983 tractor vehicle with crane	F 1-3
M983 tractor vehicle with out crane	F 1-4
M984 wrecker-recovery vehicle	F 1-5
M984E1 wrecker-recovery vehicle	F 1-6

INDEX (CONT)

Subject	Paragraph, Figure, Table, Number
M	
Machine gun mount	
Controls and indicators	F 2-22
Operate	2-31
PMCS	T 2-5
Main control panel, crane, controls and indicators (M983)	T 2-15
Main hydraulic system, principles of operation (all models except M984E1)	1-16
Main hydraulic system, principles of operation (M984E1)	1-17
Maintenance	
Forms and records (PMCS)	2-4
General maintenance procedures	2-6
Preventive, checks and services	2-3
Maintenance forms and records	1-2
Maintenance instructions	
Lubrication instructions	3-1
Maintenance procedures	3-4
Troubleshooting procedures.	3-2
Maintenance procedures	
Change wheel and tire assembly	3-6
Clean fuel tank strainer	3-7
Clean vehicle	3-5
Introduction	3-4
Open/close battery box	3-10
Open/close engine cover....	3-11
Service air cleaner element.	3-8
Service tires	3-9
Major components, location and description of	1-10
Manhole, load tanker through.	2-22
Manhole cover, position for transport/operation (M978)	E-7
Manual controls, crane operation (M977 and M985)	
Prepare for use	2-18
Raise and lower load	2-18
Raise boom to operating position	2-18
Rotate and telescope boom	2-18
Set up outriggers	2-18
Shut down crane	2-18
Stow outriggers	2-18
Manual controls, crane operation (M983)	
Operate using left-side controls	2-28
Operate using right-side controls	2-28
Prepare for use	2-28
Raise boom to operating position	2-28
Set up outriggers	2-28
Shut down and return to transport position	2-28
Stow outriggers	2-28
Manually release vehicle spring brakes	2-47

INDEX (Cont)

Subject	Paragraph, Figure, Table, Number
M	
Marker, kit, highway emergency	2-44
Place on divided highway	2-44
Place on undivided highway	2-44
Secure	2-44
Set up	2-44
Material handling cranes, data	
Grove	T 1-2
Hiab	T 1-2
Material handling cranes, troubleshooting (M977 and M985)	3-3
Material handling cranes, walk-around PMCS check	
M977 and M985 cargo vehicles	T 2-2
M983 tractor vehicle (equipped with crane)	T 2-4
Materials list, expendable supplies	D-1
Metricsystem	1-7
Mired vehicle	
Self-recover, forward, using self-recovery winch	2-41
Self-recover, to the rear, using self-recovery winch	2-41
Mirrors, side, position for transport/operation	E-4
Models, differences between	1-11
Models, vehicle description of	1-1
Move vehicle in sand or mud	2-34
Mud, operate vehicle in	2-34
Mud, snow, ice, and slippery surfaces, drive on	2-36
N	
Nomenclature cross-reference list	1-8
Number plates, change vehicle weight indicator	2-9
O	
Off-road condition, drive in	2-11
Open	
Battery box	3-10
Enginecover	3-11
Operate	
Beaconlight	2-30
Brakes, service	2-11
Brakes, trailer	2-11
Chemical alarm (M-8)	2-31
Crane, manual controls (M977 and M985)	2-18
Crane, manual controls (M983)	2-28
Crane, remote control panel	2-29
Crane, remote controls (M977 and M985)	2-19
Crane, remote controls (M983)	2-29
Crane, using left-side controls (M983)	2-28
Crane, using right-side controls (M983)	2-28
Decontamination unit (M-13)	2-31
Drain plug.	2-15.1
Engine arctic heater	2-32
Enginebrake	2-11

INDEX (Cont)

Subject	Paragraph, Figure, Table, Number
0	
Operate (Cont)	
Fireextinguisher	2-14
Gas particulate filter unit	2-31
Generator set (M983)	2-31
Heater, personnel	2-13
Lights	2-10
Machine gun mount	2-31
Parkingbrakes	2-11
Personnel heater	2-13
Radio	2-31
Rifle stowage mount	2-31
Seatbelt	2-9
Servicebrakes	2-11
Traction control lever	2-11
Trailer brakes	2-11
Transmission and transfer case	2-11
Vehicle, prepare to	2-9
Windshield defrost	2-13
Windshield washer/wipers	2-12
Work lamp	2-15.2
Operate crane (M977 and M985)	
Manual controls	2-18
Remote controls	2-19
Operate crane (M983)	
Manual controls	2-28
Remotcontrols..	2-29
Operate lights	
Beacon light, install	2-30
Beacon light, remove	2-30
Blackout drive lights, turn on/off	2-10
Blackout markers, turn on/off	2-10
Clearance lamps, turn on/off	2-10
Domelight, turn on/off	2-10
Panel lights, turn on/off.	2-10
Parking lights, turn on/off	2-10
Service drive lights, turn on/off	2-10
Stoptlights, turn on/off	2-10
Tanker module lights, turn on/off	2-10
Work lights, turn on/off	2-10
Operate vehicle	
In cold environment (32°F, 0°C to -25°F, -32°C)	2-36
In desert environment	2-35
In extreme cold environment (-26°F, -32°C to -65°F, -54°C)	2-37
In extreme dust	2-33
In extreme heat	2-32
In sand or mud	2-34
In forest or rocky terrain	2-38

INDEX (CONT)

Subject	Paragraph, Figure, Table, Number
O	
Operate vehicle, prepare to	
Adjust seat	2-9
Change vehicle weight indicator	2-9
Install footrest	2-9
Operate seatbelt	2-9
Stow footrest	2-9
Operating instructions	
Description and use of operator's controls and indicators	2-1
Operation under unusual conditions	2-32
Operation under usual conditions	2-9
PMCS	2-3
Operating procedures	
Emergency procedures	2-48
Ford water obstacle	2-40
Install/remove tire chains	2-39
Manually release vehicle spring brakes	2-47
Operate vehicle in cold environment (32°F, 0°C to -25°F, -32°C)	2-36
Operate vehicle in desert environment	2-35
Operate vehicle in extreme cold environment (-26°F, -32°C to -65°F, -54°C)	2-37
Operate vehicle in extreme dust	2-33
Operate vehicle in extreme heat	2-32
Operate vehicle in sand or mud	2-34
Operate vehicle in forest or rocky terrain	2-38
Self-recover vehicle using self-recovery winch	2-41
Set up/secure highway emergency marker kit	2-44
Tow disabled vehicle	2-45
Operating speeds	1-12
Operation references	A-1
Operation under unusual conditions	
Emergency procedures	2-48
Ford water obstacle	2-40
Install tire chains	2-39
Limp home/flat tire with no spare	2-49
Manually release vehicle spring brakes	2-47
Operate vehicle in cold environment	2-36
Operate vehicle in desert environment	2-36
Operate vehicle in extreme cold environment	2-37
Operate vehicle in extreme dust environment	2-33
Operate vehicle in extreme heat	2-32
Operate vehicle in sand or mud	2-34
Operate vehicle in forest or rocky terrain	2-38
Remove tire chains	2-39
Self-recover vehicle using self-recovery winch	2-41
Set up/secure highway emergency marker kit	2-44

INDEX (CONT)

Subject	O	Paragraph, Figure, Table, Number
Operation under unusual conditions (Cont)		
Tow disabled vehicle		2-45
Operation under usual conditions		
Auxiliary equipment operating procedures		2-31
M977 and M985 cargo body operations		2-17
M977 and M985 crane operation (manual controls)		2-18
M977 and M985 crane operation (remote controls)		2-19
M983 crane operation (manual controls)		2-28
M983 crane operation (remote controls)		2-29
Operator/crew seat adjustment controls	F	2-7
Operator/crew preventive maintenance checks and services (PMCS) tables		2-8
Operator's controls and indicators, description and use of		2-2
Outriggers (M977 and M985)		
Set up		2-18
Stow		2-18
	P	
Panel lights, turn on/off		2-10
Panels, side, cargo body (M977 and M985)		
Install front and rear panels		2-17
Install side panels		2-17
Lower all at one time		2-17
Lower one at a time		2-17
Raise and secure all at one time		2-17
Raise and secure one at a time		2-17
Remove front and rear panels.		2-17
Remove side panels		2-17
Park vehicle		2-11
Park vehicle, unusual conditions		2-36
Parking brakes, operate		2-11
Parking lights, turn on/off		2-10
Perform emergency hydraulic operation when crane electrical power fails (M977 and M985 cranes)		2-48
Perform emergency hydraulic operation when hydraulic power fails (M983)		2-48
Perform fuel servicing using auxiliary pump (M978)		2-48
Perform immediate action for loss of air supply system pressure		2-48
Perform immediate action for loss of hydraulics system		2-48
Performance data, M977 through M985	T	2-1
Personnel heater		
Turn heater on/off		2-13
Turn windshield defrost on/off.		2-13
Pintle hook		
Connect trailer using pintle hook		2-16

INDEX (CONT)

Subject	P	Paragraph, Figure, Table, Number
Pintle hook (Cont)		
Data		T 2-5
Position manhole cover for transport		E-7
Position side mirrors for transport		E-4
Power fails, crane electrical		
Perform emergency hydraulic operation (M977 and M985 cranes)		2-48
Power fails, hydraulic		
Perform emergency hydraulic operation (M983)		2-48
Power steering hydraulic system, principles of operation		1-18
Preparation for operation after transport		
Install pump module handrail		E-5
Install vent hood		E-8
Install vent rollover rails		E-6
Position manhole covers		E-7
Position side mirrors		E-4
Preparation for transport		
Position manhole covers		E-7
Position side mirrors		E-4
Remove pump module handrail		E-5
Remove vent hood		E-8
Remove vent rollover rails		E-6
Prepare crane for use (M977 and M985)		2-18
Prepare crane for use (M983)		2-28
Prepare tanker for operation (M978)		2-20
Prepare to operate vehicle		
Adjust seat		2-9
Change vehicle weight indicator		2-9
Install footrest		2-9
Operate seatbelt		2-9
Stow footrest		2-9
Pressure, tire, check		3-9
Preventive maintenance checks and services (PMCS)		
Fluid leakage		2-7
General maintenance procedures		2-6
Introduction		2-3
Maintenance forms and records		2-4
Operator/crew preventive maintenance checks and services tables		2-8
Preventive maintenance checks and services (PMCS) walk-around checks, M977 through M985		
Air dryer		T 2-1
Air reservoirs		T 2-1
Batteries		T 2-1
Cab Interior		T 2-1
Engine compartment		T 2-1
Exterior of vehicle		T 2-1
Fuel system		T 2-1

INDEX (CONT)

Subject	Paragraph, Figure, Table, Number
P	
Preventive maintenance checks and services (PMCS) walk-around checks, M977 through M985 (Cont)	
Hydraulic system	1
T 2-	1
Transmission fluid level	T 2-1
UndercarriageT 2-1
Wheels and tiresT 2-1
Preventive maintenance checks and services (PMCS) walk-around checks, M977 and M985	
Cargo bodyT 2-2
Fire extinguisherT 2-2
Material handling craneT 2-2
Stowage boxT 2-2
Preventive maintenance checks and services (PMCS) walk-around checks, M978	
Fire extinguisherT 2-3
Fuel tankT 2-3
Pump moduleT 2-3
Stowage boxesT 2-3
Preventive maintenance checks and services (PMCS) walk-around checks, M983	
Electrical generator assembly (M983 equipped with generator)	T 2-4
Fifth wheel with trailer coupled	T 2-4
Fifth wheel without trailer coupledT 2-4
Material handling crane (vehicles equipped with crane)	T 2-4
Stowage boxesT 2-4
Tire carrier (vehicles equipped with tire carrier)	T 2-4
Trailer air brake hoses and electrical cable	T 2-4
Work lampsT 2-4
Preventive maintenance checks and services (PMCS) walk-around checks, auxiliary equipment	
Engine arctic heater kit	T 2-5
Gas particulate filter unitT 2-5
Generator SetT 2-5
M-8 chemical alarmT 2-5
M-13 decontamination unitT 2-5
Machine gun mount	T 2-5
RadioT 2-5
Rifle stowage mountT 2-5
Self-recovery winch	T 2-5
Principal differences between models	T 2-5
Principles of operation	
Air system	1-15
Electrical system	1-14
Main hydraulic system (all models except M984E1)	1-16
Main hydraulic system (M984E1)	1-17
Power steering hydraulic system	1-18

INDEX (CONT)

Subject	Paragraph, Figure, Table, Number
P	
Principles of operation (Cont)	
Systems introduction	1-13
Publication indexes	A-2
Publication, references, pertinent to M977 series vehicles and associated equipment	A-4
Cold weather operation and maintenance	A-4
Decontamination	A-4
General	A-4
Maintenance and repairs	A-4
Operation of auxiliary equipment and special purpose kits	A-4
Safety	A-4
Vehicle operation	A-4
Warranty	A-4
Pump, auxiliary, use to perform fuel servicing (M978)	2-48
Pump module handrail, remove/install	E-5
Pump module, PMCS (M978)	T 2-3
Q	
Quality deficiency reports (QDR), submitting	1-5
R	
Radio	
Operate	2-31
PMCS	T 2-5
Radio installation, controls and indicators	F 2-25
Rails, vent rollover remove/install (M978)	E-6
Raise and lower load, crane (M977 and M985)	
Manual controls	2-18
Remote controls	2-19
Raise and secure cargo body side panels (M977 and M985)	
All at one time	2-17
One at a time	2-17
Raise boom to operating position (M977 and M985)	2-18
Raise boom to operating position (M983)	2-28
Rear and front panels, cargo body, remove/install (M977 and M985)	2-17
Rear of vehicle skids	2-36
Rear tire flat, no spare	2-49
Recirculate fuel (M978)	2-24
Prepare vehicle	2-24
Recirculate fuel	2-24
Shut down recirculation	2-24
Receipt, hand (HR), manuals.	1-4
Recovery winch (M984E1)	T 1-2
Reference information	1-8
References	A-1
Release vehicle spring brakes manually	2-47
Remote control panel (M983)	
Operate crane using	2-29

INDEX (Cont)

Subject	Paragraph, Figure, Table, Number
R	
Remote control panel (M983) (Cont.)	
Set up	2-29
Remote control unit, crane (M977 and M985)	
Connect to forward outlet	2-19
Connect to rear outlet	2-19
Disconnect from forward outlet	2-19
Disconnect from rear outlet	2-19
Setup	2-19
Shutoffswitches..	2-19
Remote controls, crane (M983)	
Operate crane using	2-29
Shut down and return crane to transport position	2-29
Remove	
Air cleaner element (for service)	3-8
Beaconlight	2-30
Cargo cover kit	2-17
Drain plug	2-15.1
Fire extinguisher from battery box (M978 only)	2-14
Fire extinguisher from cab	2-14
Fire extinguisher from stowage box	2-14
Flat tire/wheel	3-6
Front and rear panels, cargo body, (M977 and M985)	2-17
Fuel tank strainer	3-7
Pump module handrail	E-5
Rifle from stowage mount	2-31
Side panels, cargo body (M977 and M985)	2-17
Snatch block from self-recovery winch cable	2-42
Sparetire	3-6
Tirechains	2-39
Vent roll over rails	E-6
Vent hood	E-8
Work lamp	2-15.2
Return crane to transport position - manual controls (M983)	2-28
Return crane to transport position - remote controls (M983)	2-29
Reverse, drive vehicle in	2-11
Rifle	
Remove from stowage mount	2-31
Stow in stowage mount	2-31
Stowage mount, controls and indicators	F 2-21
Stowage mount, PMCS check	T 2-5
Right front or any rear tire flat (no spare)	2-49
Right-side controls, operate crane using (M983)	2-28
Rocky terrain, operate vehicle in	2-38
Rollover rails, vent remove/install (M978)	E-6
Rotate and telescope boom (M977 and M985)	
Manual controls	2-18
Remote controls	2-19

INDEX (CONT)

Subject	Paragraph, Figure, Table, Number
R	
Routing diagram, preventive maintenance checks and services (PMCS)	
Auxiliary equipment	T 2-5
M977 through M985	T 2-1
M977 and M985	T 2-2
M978	T 2-3
M983	T 2-4
S	
Safety references	A-4
Sand, operate vehicle in	2-34
Scope, general information	1-1
Seat, adjust	2-9
Seatbelt, operate	2-9
Secure	
Highway emergency marker kit	2-44
Select transfer case position.	2-11
Self-recover vehicle using self-recovery winch	
Attach snatch block to self-recovery winch cable	2-42
Connect self-recovery winch cable to another vehicle	2-43
Disconnect self-recovery winch cable from another vehicle	2-43
Remove snatch block from self-recovery winch cable	2-42
Winch mired vehicle forward	2-41
Winch mired vehicle to the rear	2-41
Self-recovery winch	
Data	T 1-2
PMCS	T 2-5
Troubleshooting	3-3
Self-recovery winch cable	
Connect to another vehicle	2-43
Disconnect from another vehicle	2-43
Semitrailer	
Connect to vehicle (M983)	2-27
Disconnect from vehicle (M983)	2-27
Service brakes, operate	2-11
Service drive lights, turn on/off	2-10
Service	
Air cleaner element	3-8
PMCS	2-5
Tires	3-9
Servicing, land vehicle or air craft overwing fueling (M978)	2-23
Set up/secure highway emergency marker kit	2-44
Set up	
Highway emergency marker kit	2-44
Outriggers (M977 and M985)	2-18
Outriggers (M983)	2-28
Remote control panel (M983)	2-29

INDEX (CONT)

Subject	Paragraph, Figure, Table, Number
S	
Set up (Cent)	
Remote control unit, crane (M977 and M985)	2-19
Shift lever, transfer case	
Set for highway driving	2-11
Set for off-road driving	2-11
Shut down arctic engine heater.	2-31
Shut down crane (M977 and M985).	2-18
Shut down crane - return to transport position (M983)	
Manual controls	2-28
Remote controls	2-29
Shut down recirculation, fuel (M978)	2-24
Shut off engine	2-11
Shut off switches, remote control, crane (M977 and M985)	2-19
Side mirrors, position for transport/operation	E-4
Side panels, cargo body	
Install (M977 and M985)	2-17
Lower all at one time (M977 and M985)	2-17
Lower one at a time (M977 and M985)	2-17
Raise and secure all at one time (M977 and M985)	2-17
Raise and secure one at a time (M977 and M985)	2-17
Remove (M977 and M985)	2-17
Sign guide	F-1
Skidding vehicle, control	2-36
Slave start vehicle	2-48
Slides, vehicle, while climbing hill	2-36
Slippery conditions, drive in	2-11
Slippery surfaces, drive on	2-36
Snatch block	
Attach to self-recovery winch cable	2-42
Remove from self-recovery winch cable.	2-42
Snow, drive on	2-36
Spare tire, remove/install	3-6
Special purpose kits operation references	A-4
Spring brakes, release manually	2-47
Start engine	
Cold engine	2-11
Slave start	2-48
Warm engine	2-11
Start up arctic engine heater	2-31
Steep grades, drive on	2-11
Steering	
Column mounted controls	F 2-3

INDEX (CONT)

Subject	Paragraph, Figure, Table, Number
S	
Steering (Cont)	
System, data	T 1-2
Troubleshooting	3-3
Stoplights, turn on/off	2-10
Stow	
Access ladder	2-15
Flat tire	3-6
Footrest	2-9
Outriggers (M977 and M985)	2-18
Outriggers (M983)	2-28
Rifle, stow in stowage mount	2-31
Tire davit winch	3-6
Stowage and sign guide	F-1
Stowage boxes, PMCS	
M977 and M985 cargo vehicles	T 2-2
M978 tanker vehicle	T 2-3
M983 tractor vehicle	T 2-4
Stowage mount, remove rifle from	2-31
Strainer, fuel tank, remove/install/clean	3-7
Stuck vehicle, move	2-36
Supplies, expendable, and materials list	D-1
Symptom index, troubleshooting	3-3
System, metric	1-7
System, principles of operation	
Air	1-15
Electrical	1-14
Main hydraulic (all models except M984E1)	1-16
Main hydraulic (M984E1)	1-17
Power steering hydraulic	1-18
T	
Tables	
Equipment data	T 1-2
Operator/crew preventive maintenance checks and service (PMCS)	2-8
Principle differences between models	T 1-1
Symptom index	T 3-1
Tire pressure (PSI)	T 3-3
Troubleshooting	T 3-2
Tables, PMCS routing diagram	
Auxiliary equipment	T 2-5
M977 through M985	T 2-1
M977 and M985	T 2-2
M978	T 2-3
M983	T 2-4
Tables, V7 and V8 reel valves	
Fueling delivery rate	T 2-6

INDEX (Cont)

Subject	Paragraph, Figure, Table, Number
T	
Tables, self-recovery winch pull capacity (Cont)	T 2-7
Forward	T 2-8
Rear	3-7
Tank, fuel, strainer, remove/install/clean	
Tank, load (M978)	2-22
Bottom load with exterior pump	2-22
Bottom load with tanker fuel pump	2-22
load through manhole	
Tanker	2-21
Fuel level, check	2-10
Module lights on/off	2-20
Prepare to operate	3-3
Troubleshooting	
Technical principles of operation	1-15
Air system	1-14
Electrical system	1-16
Main hydraulic system (all models except M984E1)	1-18
Main hydraulic system (M984E1)	
Power steering hydraulic system	1-13
System introduction	
Telescope boom, rotate (M977 and M985)	2-18
Manual controls	2-19
Remote controls	T 2-4
Tire carrier, PMCS (vehicles equipped with tire carrier)	2-39
Tire chains, install/remove	3-6
Tire, change	3-6
Tire davit winch, stow	3-9
Tire, inflate	3-9
Tire pressure, check	T 1-2
Tire pressure data	
Tires, service	3-9
Check tire pressure	3-9
Inflate tire	2-22
Top load fuel tank through manhole (M978)	2-46
Tow bar, connect/disconnect	2-46.1
Tow bar, connect/disconnect (M1977-CBT)	2-45
Tow disabled vehicle	T 1-2
Towing eye data	2-11
Traction control, operate	2-11
Traffic, city, drive in	
Trailer	T 2-4
Airbrake hoses and electrical cable, PMCS	2-11
Connect/disconnect	
Trailer brakes operate	
Transfer case	T 1-2
Data	2-11
Select position	

INDEX (CONT)

Subject	Paragraph, Figure, Table, Number
T	
Transmission and transfer case (Cont)	
Operate	2-11
Troubleshooting	3-3
Transmission data	T 1-2
Transmission fluid level, PMCS	T 2-1
Transport, preparation for	E-1
 Troubleshooting procedures	
Introduction	3-2
Symptom index	3-3
Tunnel panel controls and indicators	F 2-4
Turn on/off	
Blackout drive lights	2-10
Blackout markers	2-10
Clearance lamps	2-10
Domelight	2-10
Panel lights	2-10
Parking lights	2-10
Service drive lights	2-10
Stoplights	2-10
Tanker module lights	2-10
Work lights	2-10
U	
Undercarriage, PMCS	T 2-1
Unfiltered bulk unloading, (M978)	2-25
Unfiltered gravity bulk unloading, (M978)	2-25
Unload fuel (bulk) (M978)	
Filtered bulk unloading	2-25
Unfiltered bulk unloading	2-25
Unfiltered gravity bulk unloading	2-25
Unload vehicle with crane (M983)	
Using left-side controls	2-28
Using remote control panel	2-29
Using right-side controls	2-28
Unusual conditions, operate under	
Emergency procedures	2-48
Ford water obstacle	2-40
Install tire chains	2-39
Limp home/flat tire with no spare	2-49
Manually release vehicle spring brakes	2-47
Operate vehicle in cold environment	2-36
Operate vehicle in desert environment	2-35
Operate vehicle in extreme cold environment	2-37
Operate vehicle in extreme dust	2-33
Operate vehicle in extreme heat	2-32
Operate vehicle in sand or mud	2-34
Operate vehicle in forest or rocky terrain	2-38

INDEX (CONT)

Subject	Paragraph, Figure, Table, Number
U	
Unusual conditions, operate under (Cont)	
Remove tire chains	2-39
Self-recover vehicle using self-recovery winch	2-41
Set up/secure highway emergency marker kit	2-44
Tow disabled vehicle	2-45
Usual conditions, operate under	
Auxiliary equipment operating procedures	2-31
M977 and M985 cargo body operations	2-17
M977 and M985 crane operation (manual controls)	2-18
M977 and M985 crane operation (remote controls)	2-19
M983 crane operation (manual controls)	2-28
M983 crane operation (remote controls)	2-29
V	
Vehicle	
Clean exterior	3-5
Clean interior	3-5
Dimensions, dataT 1-2
Disabled, tow	2-45
Models description	1-1
Performance, dataT 1-2
Weight, dataT 1-2
Vehicle, drive	
Down steep grades	2-11
Forward	2-11
In city traffic	2-11
In off-road conditions	2-11
In reverse	2-11
In slippery conditions	2-11
On highway	2-11
On mud, snow, ice, and slippery surfaces	2-36
Operate service brakes	2-11
Operate trailer brakes	2-11
Operate transmission/transfer case	2-11
Park	2-11
Select transfer case position	2-11
Shut off engine	2-11
Start cold engine	2-11
Start warm engine	2-11
Up steep grades	2-11
Use engine brake	2-11
Vehicle, operate in	
Cold environment	2-36
Desert environment	2-35
Extreme cold environment	2-37
Extreme dust	2-33
Extreme heat	2-32
Forest or rocky terrain	2-38

INDEX (Cont)

Subject	Paragraph, Figure, Table, Number
V	
Vehicle, operate in (Cont)	
Sand or mud	2-34
Vehicle, prepare to operate	
Adjust seat	2-9
Change vehicle weight indicator	2-9
Install footrest	2-9
Operate seatbelt	2-9
Stow footrest	2-9
Vehicle weight indicator, change	2-9
Vent hood, remove/install	E-8
Vent rollover rails, remove/install (M978)	E-6
W	
Warm engine, start	2-11
Warranty information	1-6
Washer, windshield, operate	2-12
Water obstacle, ford	2-40
Weight distribution data	T 1-2
Weight indicator, vehicle, change	2-9
Weight of vehicles data.	T 1-2
Welds (PMCS)	2-6
Wheel and tire assembly	
Install spare tire/wheel	3-6
Prepare vehicle to change tire	3-6
Remove flat tire/wheel	3-6
Remove spare tire	3-6
Stow flat tire	3-6
Stow tire davit winch	3-6
Wheels and tires, PMCS	T 2-1
Wheels, data	T 1-2
Wheels, tires, and hubs, troubleshooting	3-3
Winch cable, self-recovery	
Attach snatch block	2-42
Connect to another vehicle	2-43
Disconnect from another vehicle	2-43
Remove snatch block	2-42
Winch mired vehicle with self-recovery winch	
Forward	2-41
To the rear	2-41
Winch, recovery, data (M984E1)	T 1-2
Winch, self-recovery data	T 1-2
Windshield defrost, turn on/off	2-13
Windshield washer, operate	2-12
Windshield wipers, turn on/off	2-12
Work lamps, M983 tractor vehicle, PMCS	T 2-4
■ Work lamp, operate	2-15.2
Work lights turn on/off	2-10

By Order of the Secretary of the Army:

JOHN A. WICKHAM, JR.
General, United States Army
Chief of Staff

Official:

R.L. DILWORTH
Brigadier General, United States Army
The Adjutant General

Distribution:

To be distributed in accordance with DA Form 12-38-R, Truck, Cargo, 10-ton 8x8, Heavy Expanded Mobility Tactical Truck, HEMTT, M977, M978, M983, M984, M985.

★U.S. GOVERNMENT PRINTING OFFICE: 1987 742-019/60114

RECOMMENDED CHANGES TO EQUIPMENT PUBLICATIONS



THEN - JOT DOWN THE INFO ON THIS FORM---TEAR OUT THIS PAGE---FOLD IT---AND DROP IT IN THE MAIL!

SOMETHING WRONG WITH THIS PUBLICATION?

FROM: (IMPRINT YOUR UNIT'S COMPLETE ADDRESS)

HQ & HQ CO.
46TH TRANS. BN.
FT. CARSON, CO

DATE SENT: 5 JAN. 1997

PUBLICATION NUMBER
TM 9-2320-279-10

PUBLICATION DATE
NOVEMBER 1986

PUBLICATION TITLE
OPERATOR'S MANUAL
M977 Series Vehicles

BE EXACT...PINPOINT WHERE IT IS

PAGE NO.	PARA-GRAPH	FIGURE NO.	TABLE NO.
2-9	2-2	2-5	NA

IN THIS SPACE, TELL WHAT IS WRONG AND WHAT SHOULD BE DONE ABOUT IT:

Item 17 - Does not read as labeled on truck switch.

Should read "ENGINE STOP" because that is what is on label.

SAMPLE

TEAR ALONG PERFORATED LINE

PRINTED NAME, GRADE OR TITLE, AND TELEPHONE NUMBER

ALBERT RAND, 55G, 226-5644

SIGN HERE:


Albert Rand

DA FORM 2028-2
1 JUL 79

PREVIOUS EDITIONS ARE OBSOLETE.

P.S. IF YOUR OUTFIT WANTS TO KNOW ABOUT YOUR RECOMMENDATION, MAKE A CARBON COPY OF THIS AND GIVE IT TO YOUR HEADQUARTERS.

RECOMMENDED CHANGES TO EQUIPMENT PUBLICATIONS



THEN - JOT DOWN THE INFO ON THIS FORM---TEAR OUT THIS PAGE---FOLD IT---AND DROP IT IN THE MAIL

SOMETHING WRONG WITH THIS PUBLICATION?

FROM: (IMPRINT YOUR UNIT'S COMPLETE ADDRESS)

DATE SENT:

PUBLICATION NUMBER
TM 9-2320-279-10

PUBLICATION DATE
NOVEMBER 1986

PUBLICATION TITLE
OPERATOR'S MANUAL
M977 Series Vehicles

BE EXACT...PINPOINT WHERE IT IS				IN THIS SPACE, TELL WHAT IS WRONG AND WHAT SHOULD BE DONE ABOUT IT:
PAGE NO.	PARA-GRAPH	FIGURE NO.	TABLE No.	

PRINTED NAME, GRADE OR TITLE, AND TELEPHONE NUMBER

SIGN HERE:

TEAR ALONG PERFORATED LINE

DA FORM 2028-2
1 JUL 79

PREVIOUS EDITIONS ARE OBSOLETE.

P.S. IF YOUR OUTFIT WANTS TO KNOW ABOUT YOUR RECOMMENDATION, MAKE A CARBON COPY OF THIS AND GIVE IT TO YOUR HEADQUARTERS.

FILL IN YOUR
UNIT'S ADDRESS



DEPARTMENT OF THE ARMY



OFFICIAL BUSINESS

BUSINESS REPLY MAIL

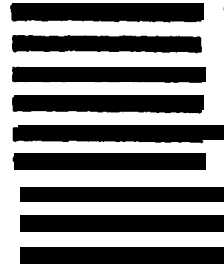
FIRST CLASS

PERMIT NO. 82

ROCK ISLAND IL

POSTAGE WILL BE PAID BY ROCK ISLAND ARSENAL

NO POSTAGE
NECESSARY
IF MAILED
IN THE
UNITED STATES



TEAR ALONG PERFORATED LINE

DIRECTOR
ARMAMENT AND CHEMICAL ACQUISITION
AND LOGISTICS ACTIVITY
ATTN: AMSTA-AC-NML
ROCK ISLAND, IL 61201-9948



THE METRIC SYSTEM AND EQUIVALENTS

LINEAR MEASURE

Centimeter = 10 Millimeters = 0.01 Meters = 0.3937 Inches
 Meter = 100 Centimeters = 1000 Millimeters = 39.37 Inches
 Kilometer = 1000 Meters = 0.621 Miles

EIGHTS

Gram = 0.001 Kilograms = 1000 Milligrams = 0.035 Ounces
 Kilogram = 1000 Grams = 2.2 Lb
 Metric Ton = 1000 Kilograms = 1 Megagram = 1.1 Short Tons

LIQUID MEASURE

Milliliter = 0.001 Liters = 0.0338 Fluid Ounces
 Liter = 1000 Milliliters = 33.82 Fluid Ounces

SQUARE MEASURE

1 Sq Centimeter = 100 Sq Millimeters = 0.155 Sq Inches
 1 Sq Meter = 10,000 Sq Centimeters = 10.76 Sq Feet
 1 Sq Kilometer = 1,000,000 Sq Meters = 0.386 Sq Miles

CUBIC MEASURE

1 Cu Centimeter = 1000 Cu Millimeters = 0.06 Cu Inches
 1 Cu Meter = 1,000,000 Cu Centimeters = 35.31 Cu Feet

TEMPERATURE

$5/9 (^{\circ}\text{F} - 32) = ^{\circ}\text{C}$
 212^o Fahrenheit is equivalent to 100^o Celsius
 90^o Fahrenheit is equivalent to 32.2^o Celsius
 32^o Fahrenheit is equivalent to 0^o Celsius
 $9/5 \text{ C}^{\circ} + 32 = \text{F}^{\circ}$

APPROXIMATE CONVERSION FACTORS

<u>TO CHANGE</u>	<u>TO</u>	<u>MULTIPLY BY</u>
Inches	Centimeters	2.540
Feet	Meters	0.305
Yards	Meters	0.914
Miles	Kilometers	1.609
Square Inches	Square Centimeters	6.451
Square Feet	Square Meters	0.093
Square Yards	Square Meters	0.836
Square Miles	Square Kilometers	2.590
Acres	Square Hectometers	0.405
Cubic Feet	Cubic Meters	0.028
Cubic Yards	Cubic Meters	0.765
Fluid Ounces	Milliliters	29.573
Pints	Liters	0.473
Quarts	Liters	0.946
Gallons	Liters	3.785
Ounces	Grams	28.349
Pounds	Kilograms	0.454
Short Tons	Metric Tons	0.907
Pound-Feet	Newton-Meters	1.356
Pounds per Square Inch	Kilopascals	6.895
Miles per Gallon	Kilometers per Liter	0.425
Miles per Hour	Kilometers per Hour	1.609

<u>TO CHANGE</u>	<u>TO</u>	<u>MULTIPLY BY</u>
Centimeters	Inches	0.394
Meters	Feet	3.280
Meters	Yards	1.094
Kilometers	Miles	0.621
Square Centimeters	Square Inches	0.155
Square Meters	Square Feet	10.764
Square Meters	Square Yards	1.196
Square Kilometers	Square Miles	0.386
Square Hectometers	Acres	2.471
Cubic Meters	Cubic Feet	35.315
Cubic Meters	Cubic Yards	1.308
Milliliters	Fluid Ounces	0.034
Liters	Pints	2.113
Liters	Quarts	1.057
Liters	Gallons	0.264
Grams	Ounces	0.035
Kilograms	Pounds	2.205
Metric Tons	Short Tons	1.102
Newton-Meters	Pound-Feet	0.738
Kilopascals	Pounds per Square Inch	0.145
Kilometers per Liter	Miles per Gallon	2.354
Kilometers per Hour	Miles per Hour	0.621

