

**TECHNICAL MANUAL
 MAINTENANCE INSTRUCTIONS
 DIRECT SUPPORT AND GENERAL SUPPORT**

**M977 SERIES 8 x 8 HEAVY
 EXPANDED MOBILITY
 TACTICAL TRUCKS (HEMTT)**

MODEL	NSN
TRUCK, CARGO, WITH WINCH M977	2320-01-097-0260
TRUCK, CARGO, WITHOUT WINCH M977	2320-01-099-6426
TRUCK, TANK, FUEL, WITH WINCH M978	2320-01-097-0249
TRUCK, TANK, FUEL, WITHOUT WINCH M978	2320-01-100-7672
TRUCK, TRACTOR, WITH WINCH, WITHOUT CRANE M983	2320-01-097-0247
TRUCK, TRACTOR, WITH WINCH, WITH CRANE M983	2320-01-099-6421
TRUCK, WRECKER-RECOVERY M984	2320-01-097-0248
TRUCK, WRECKER-RECOVERY M984E1	2320-01-195-7641
TRUCK, CARGO, WITH WINCH M985	2320-01-097-0261
TRUCK, CARGO, WITHOUT WINCH M985	2320-01-100-7873
TRUCK, CARGO, WITH WINCH M985E1	2320-01-194-7032
TRUCK, CARGO, WITHOUT WINCH M985E1	2320-01-194-7031

Approved for public release; distribution is unlimited.

HEADQUARTERS, DEPARTMENT OF THE ARMY

**TABLE OF CONTENTS
 PAGE i**

**AXLES NO. 3 AND NO. 4
 MAINTENANCE
 PAGE 10-1**

**BRAKE SYSTEM
 MAINTENANCE
 PAGE 11-1**

**STEERING SYSTEM
 MAINTENANCE
 PAGE 12-1**

**FRAME MAINTENANCE
 PAGE 13-1**

**SUSPENSION
 MAINTENANCE
 PAGE 14-1**

**CAB AND BODY
 MAINTENANCE
 PAGE 15-1**

**WINCH MAINTENANCE
 PAGE 16-1**

**ALPHABETICAL
 INDEX
 PAGE INDEX 1**

CHANGE

HEADQUARTERS
DEPARTMENT OF THE ARMY

NO. 2

Washington, D. C., 15 December 1998

TECHNICAL MANUAL

MAINTENANCE INSTRUCTIONS

DIRECT SUPPORT AND GENERAL SUPPORT

M977 SERIES, 8 X 8 HEAVY EXPANDED MOBILITY
TACTICAL TRUCKS (HEMTT)

MODEL	NSN
TRUCK, CARGO, WITH WINCH, M977	2320-01-097-0260
TRUCK, CARGO, WITHOUT WINCH, M977	2320-01-099-6426
TRUCK, TANK, FUEL, WITH WINCH, M978	2320-01-097-0249
TRUCK, TANK, FUEL, WITHOUT WINCH, M978	2320-01-100-7672
TRUCK, TRACTOR, WITH WINCH, WITHOUT CRANE, M983	2320-01-097-0247
TRUCK, TRACTOR, WITH WINCH, WITH CRANE, M983	2320-01-099-6421
TRUCK, WRECKER-RECOVERY, M984	2320-01-097-0248
TRUCK, WRECKER-RECOVERY, M984E1	2320-01-195-7641
TRUCK, CARGO, WITH WINCH, M985	2320-01-097-0261
TRUCK, CARGO, WITHOUT WINCH, M985	2320-01-100-7673
TRUCK, CARGO, WITH WINCH, M985E1	2320-01-194-7032
TRUCK, CARGO, WITHOUT WINCH, M985E1	2320-01-194-7031

Approved for public release; distribution is unlimited.

TM 9-2320-279-34-2, 3 June 1987, is changed as follows:

1. Remove old pages and insert new pages as indicated below.
2. New or changed material is indicated by a vertical bar in the margin of the page.
3. Minor changes to illustrations are indicated by a miniature pointing hand.
4. Illustrations that are new or that have major revisions are indicated by a vertical bar adjacent to the illustration.
5. Changes on cover are: Removed VOLUME NO. 2, deleted destruction notice, and changed distribution statement.

Remove Pages

c/(d blank)
i and ii
10-13 thru 10-16
10-19 and 10-20
10-25 thru 10-28
10-41 and 10-42

Insert Pages

c/(d blank)
i and ii
10-13 thru 10-16
10-19 and 10-20
10-25 thru 10-28
10-41 and 10-42

Remove Pages

11-1 thru 11-10
11-29 and 11-30
11-31 and 11-32
none
12-9 thru 12-18
none
12-29 and 12-30
12-39 and 12-40
12-48.3 and 12-48.4
12-48.13/(12-48.14blank)
12-49 thru 12-56
13-25 and 13-26
13-31 and 13-32
none
13-33 and 13-34
13-41 and 13-42
13-42.1 and 13-42.2
none
13-61 thru 13-68
13-71 and 13-72
13-75 and 13-76
13-76.1 and 13-76.2
13-77 and 13-78
13-90.1 thru 13-90.6
13-90.15 and 13-90.16
13-90.19/(13-90.20blank)
14-5 thru 14-8
14-11 thru 14-14
14-31/(14-3 blank)
15-1 and 15-2
15-21 and 15-22
15-25 and 15-26
15-33 thru 15-38
15-47 thru 15-50
15-55 and 15-56
15-63 thru 15-66
none
15-69 and 15-70
15-73 thru 15-76
16-1 and 16-2
16-53 and 16-54
16-54.1 thru 16-54.4
Index 3 and Index 4
Index 9/(Index 10 blank)
DA 2028 sample F & B
DA 2028 F & B
DA 2028 F & B
DA 2028 F & B
DA 2028 F & B
Cover

Insert Pages

11-1 thru 11-10
11-29/(11-30 blank)
none
11-45 thru 11-58
12-9 thru 12-18
12-18.1 and 12-18.2
12-29 and 12-30
12-39 and 12-40
12-48.3 and 12-48.4
12-48.13/(12-48.14blank)
12-49 thru 12-56
13-25 and 13-26
13-31 and 13-32
13-32.1 and 13-32.2
13-33 and 13-34
13-41 and 13-42
13-42.1 and 13-42.2
13-42.3/(13-42.4blank)
13-61 thru 13-68
13-71 and 13-72
13-75 and 13-76
13-76.1 and 13-76.2
13-77 and 13-78
13-90.1 thru 13-90.6
13-90.15 and 13-90.16
13-90.19/(13-90.20blank)
14-5 thru 14-8
14-11 thru 14-14
14-31/(14-32blank)
15-1 and 15-2
15-21 and 15-22
15-25 and 15-26
15-33 thru 15-38
15-47 thru 15-50
15-55 and 15-56
15-63 thru 15-66
15-68.1/(15-68.2blank)
15-69 and 15-70
15-73 thru 15-76
16-1 and 16-2
16-53 and 16-54
16-54.1 thru 16-54.17/(16-54.18blank)
Index 3 and Index 4
Index 9/(Index 10 blank)
DA 2028 sample F & B
DA 2028 F & B
DA 2028 F & B
DA 2028 F & B
DA 2028 F & B
Cover

File this change sheet in front of the publication for reference purposes.

By Order OF the Secretary of the Army:

DENNIS J. REIMER
General, United States Army
Chief of Staff

Official:



Handwritten signature of Joel B. Hudson in black ink.

JOEL B. HUDSON

Administrative Assistant to the
Secretary of the Army
05638

DISTRIBUTION: To be distributed in accordance with the Initial Distribution Number (IDN) 380653, requirements for TM 9-2320-279-34-2.

CHANGE

NO. 1

HEADQUARTERS
DEPARTMENT OF THE ARMY
Washington, D.C., 15 April 1989

TECHNICAL MANUAL
MAINTENANCE INSTRUCTIONS
DIRECT SUPPORT AND GENERAL SUPPORT
M977 SERIES, 8 X 8 HEAVY EXPANDED MOBILITY
TACTICAL TRUCKS (HEMTT)

MODEL	NSN
TRUCK, CARGO, WITH WINCH, M977	2320-01-097-0260
TRUCK, CARGO, WITHOUT WINCH, M977	2320-01-099-6426
TRUCK, TANK, FUEL, WITH WINCH, M978	2320-01-097-0249
TRUCK, TANK, FUEL, WITHOUT WINCH, M978	2320-01-100-7672
TRUCK, TRACTOR, WITH WINCH, WITHOUT CRANE, M983	2320-01-097-0247
TRUCK, TRACTOR, WITH WINCH, WITH CRANE, M983	2320-01-099-6421
TRUCK, WRECKER-RECOVERY, M984	2320-01-097-0248
TRUCK, WRECKER-RECOVERY, M964E1	2320-01-195-7641
TRUCK, CARGO, WITH WINCH, M965	2320-01-0974261
TRUCK, CARGO, WITHOUT WINCH, M965	2320-01-100-7673
TRUCK, CARGO, WITH WINCH, M965E1	2320-01-194-7032
TRUCK, CARGO, WITHOUT WINCH, M985E1	2320-01-194-7031

TM 9-2320-279-34-2,3 June 1987, is changed as follows:

1. Remove old pages and insert new pages as indicated below.
2. New or changed material is indicated by a vertical bar in the margin of the page.
3. Minor changes to illustrations are indicated by a miniature pointing hand.
4. Illustrations that are new or that have major revisions are indicated by a vertical bar adjacent to the illustration identification number.

Remove Pages

10-15 and 10-16
10-31 and 10-32
11-1 and 11-2
11-35 and 11-36
13-90.3 and 13-90.4
15-69 and 15-70
16-24.9 and 16-24.10

Insert Pages

10-15 and 10-16
10-31 and 10-32
11-1 and 11-2
11-35 and 11-36
13-90.3 and 13-90.4
15-69 and 15-70
16-24.9 and 16-24.10

Remove Pages

16-24.15 and 16-24.16
16-63 and 16-64
Index 3 thru Index 8

Insert Pages

16-24.15 and 16-24.16
16-63 and 16-64
Index 3 thru Index 8

File this change sheet in front of the publication for reference purposes.

By Order of the Secretary of the Army:

Official:

CARL E. VUONO
General, United States Army
Chief of Staff

WILLIAM J. MEEHAN II
Brigadier General United States Army
The Adjutant General

Distribution:

To be distributed in accordance with DA Form 12-38-R, Direct Support and General Support maintenance requirements for Truck, Cargo, 10-Ton, 8X8, Heavy Expanded Mobility Tactical Truck, HEMTT: M977, M978, M983, M984, M985.

WARNING

CARBON MONOXIDE (EXHAUST GAS) CAN CAUSE DEATH.

Carbon monoxide is without color or smell, but, can cause death. Breathing air with carbon monoxide produces symptoms of headache, dizziness, loss of muscular control, a sleepy feeling, and coma. Brain damage or death can result from heavy exposure. Carbon monoxide occurs in the exhaust fumes of fuel-burning heaters and internal combustion engines. Carbon monoxide can become dangerously concentrated under conditions of no ventilation. Precautions must be followed to ensure crew safety when the arctic engine heater or engine of any vehicle is operated for any purpose.

1. DO NOT operate arctic engine heater or engine of vehicle in a closed place without proper ventilation.
2. DO NOT drive any vehicle with inspection plates, cover plates, or engine compartment covers removed unless necessary for maintenance purposes.
3. BE ALERT at all times during vehicle operation for exhaust odors and exposure symptoms. If either are present, IMMEDIATELY VENTILATE personnel compartments. If symptoms persist, remove affected crew to fresh air and keep warm. DO NOT PERMIT PHYSICAL EXERCISE. If necessary, give artificial respiration and get immediate medical attention. For artificial respiration, refer to FM 21-11.
4. BE AWARE that the gas particulate filter unit or the field protection mask for nuclear-biological-chemical protection WILL NOT offer safety from carbon monoxide poisoning.

THE BEST DEFENSE AGAINST CARBON MONOXIDE POISONING IS GOOD VENTILATION.

WARNING

Adhesives, solvents, and sealing compounds can burn easily, can give off harmful vapors, and are harmful to skin and clothing. To avoid injury or death, keep away from open fire and use in well-ventilated area. If adhesive, solvent, or sealing compound gets on skin or clothing, wash immediately with soap and water.

WARNING

Never use the parking brake for normal braking or wheels will lock up causing severe skid. Skidding vehicle could result in serious injury or death.

WARNING

Fuel is very flammable and can explode easily. To avoid serious injury or death, keep fuel away from open fire and keep fire extinguisher within easy reach when working with fuel. Do not work on fuel system when engine is hot. Fuel can be ignited by hot engine. When working with fuel, post signs that read NO SMOKING WITHIN 50 FEET of vehicle.

WARNING

Remove rings, bracelets, wristwatches, neck chains, and any other jewelry before working around vehicle. Jewelry can catch on equipment and cause injury, or may short across an electrical circuit and cause severe burns or electrical shock.

WARNING

The radiator is very hot and pressurized during vehicle operation. Let radiator cool before removing cap. Failure to do so can result in serious burns.

WARNING

The exhaust pipe and muffler can become very hot during vehicle operation. Be careful not to touch these parts with bare hands, or allow body to come in contact with pipe or muffler. Exhaust system parts can become hot enough to cause serious burns.

WARNING

Do not use trailer brakes as parking brake. Trailer brakes may not hold a loaded vehicle and trailer on a grade. A runaway vehicle may cause severe personal injury or death.

WARNING

Always use seatbelts when operating vehicle. Failure to use seatbelt can result in serious injury in case of accident.

WARNING

Avoid quick, jerking, winch operation. Keep other personnel well away from vehicles involved in winching operations. A snapped cable or shifting load can cause serious injury or death.

WARNING

Always wear heavy gloves when handling winch cables. Never let cable run through hands; frayed cables can cut. Never operate winch with less than five wraps of cable on winch drum.

WARNING

If operating crane under powerlines, do not allow vehicle to contact high-voltage connections. Death on contact can result. If possible, keep one hand away from equipment to reduce the hazard of current flowing through vital organs of the body.

WARNING

When working inside the vehicle with power off, be sure to ground every capacitor likely to hold a dangerous voltage potential.

WARNING

Never work on electronic equipment unless there is another person nearby who is familiar with the operation and hazards of the equipment.

WARNING

Be careful when working on or with electrical equipment. Do not be misled by the term "low voltage". Voltages as low as 50 volts may cause death. For artificial respiration, refer to FM 21-11.

WARNING

Be careful not to short out battery terminals. Do not smoke or use open flame near batteries. Batteries may explode from a spark. Battery acid is harmful to skin and eyes.

WARNING

Brake shoes may be coated with dust. Breathing this dust may be harmful to your health. Do not use compressed air to clean brake shoes. Wear a filter mask approved for use against brake dust. Failure to comply may result in injury or death to personnel.

WARNING

Starting fluid is toxic and flammable. Do not store in cab and do not breathe fumes. Do not puncture or burn containers. Dispose of container following manufacturer's recommendations on the container.

WARNING

Compressed air used for cleaning purposes will not exceed 30 psi (207 kPa). Use only with effective chip guarding and personal protective equipment, goggles, shield, and gloves.

WARNING

After Nuclear, Biological, or Chemical (NBC) exposure of vehicle, all air filters shall be handled with extreme caution. Unprotected personnel can experience injury or death if residual toxic agents or radioactive material are present. If vehicle is exposed to chemical or biological agents, servicing personnel shall wear protective mask, hood, protective overgarments, and chemical protective gloves and boots in accordance with TM 10-277. All contaminated air filters shall be placed in double-lined plastic bags and moved swiftly to a segregation area away from the worksite. The same procedure applies for radioactive dust contamination. The Company NBC team should measure the radiation prior to filter removal to determine the extent of safety procedures required per the NBC Annex to the unit Standard Operating Procedures (SOP). The segregation area in which the contaminated air filters are temporarily stored shall be marked with appropriate NBC placards. Final disposal of contaminated air filters shall be in accordance with local SOP. Decontamination operation shall be in accordance with TM 3-220 and local SOP.

WARNING

DO NOT grind or sand painted equipment without high-efficiency air purifying respirators in use.

WARNING

Adhesives, solvents, and sealing compounds can burn easily, can give off harmful vapors, and are harmful to skin and clothing. To avoid injury or death, keep away from open fire and use in well-ventilated area. If adhesive, solvent, or sealing compound gets on skin or clothing, wash immediately with soap and water.

WARNING

Use extreme care when removing or installing spring retainers. Spring retainers are under tension and can act as projectiles when released suddenly. Ensure proper eye protection is worn to prevent injury to personnel.

WARNING

Use extreme care when compressing, releasing, removing, or installing springs. Springs are under tension and can act as projectiles when released. Ensure proper eye protection is worn to prevent injury to personnel.

TECHNICAL MANUAL

HEADQUARTERS
DEPARTMENT OF THE ARMY
Washington, DC, 3 June 1987

No. 9-2320-279-34-2

MAINTENANCE INSTRUCTIONS
DIRECT SUPPORT AND GENERAL SUPPORT
M977 SERIES, 8 X 8 HEAVY EXPANDED MOBILITY
TACTICAL TRUCKS (HEMTT)

MODEL	NSN
TRUCK, CARGO, WITH WINCH, M977	2320-01-097-0260
TRUCK, CARGO, WITHOUT WINCH, M977	2320-01-099-6426
TRUCK, TANK, FUEL, WITH WINCH, M978	2320-01-097-0249
TRUCK, TANK, FUEL, WITHOUT WINCH, M978	2320-01-100-7672
TRUCK, TRACTOR, WITH WINCH, WITHOUT CRANE, M983	2320-01-097-0247
TRUCK, TRACTOR, WITH WINCH, WITH CRANE, M983	2320-01-099-6421
TRUCK, WRECKER-RECOVERY, M984	2320-01-097-0248
TRUCK, WRECKER-RECOVERY, M984E1	2320-01-195-7641
TRUCK, CARGO, WITH WINCH, M985	2320-01-097-0261
TRUCK, CARGO, WITHOUT WINCH, M985	2320-01-100-7673
TRUCK, CARGO, WITH WINCH, M985E1	2320-01-194-7032
TRUCK, CARGO, WITHOUT WINCH, M985E1	2320-01-194-7031

Approved for public release; distribution is unlimited.

REPORTING ERRORS AND RECOMMENDING IMPROVEMENTS

You can help improve this Technical Manual. If you find any mistakes or if you know of a way to improve the procedures, please let us know. Mail a letter or your DA Form 2028 (Recommended Changes to Publications and Blank Forms) directly to: Commander, U.S. Army Tank-automotive and Armaments Command, ATTN: AMSTA-AC-NML, Rock Island, IL 61299-7630. You can also provide information to TACOM via datafax or e-mail. TACOM's datafax number is: DSN 793-0726 or (309) 782-0726. E-mail address: amsta-ac-nml@ria-emh1.army.mil

M983 with crane and M985E1 without winch are no longer in the fleet. Ignore all references to these vehicles. The M984E1 and M984A1 are the same vehicle. All references to M984E1 shall be interpreted as the M984A1 model.

TABLE OF CONTENTS

	Page
CHAPTER 10 AXLES NO. 3. AND NO. 4 MAINTENANCE	10-1
Section I Introduction	10-1
Section II Axle Assemblies	10-1
Section III Differential Carriers	10-15

TABLE OF CONTENTS (CONT)

CHAPTER 11	BRAKE SYSTEM MAINTENANCE	11-1
Section1	Introduction	11-1
Section11	Service Brakes	11-1
Section III	Air Brake System	11-5
SectionIV	Air Compressor	11-18
Section V	Trailer Brake System	11-33
CHAPTER 12	STEERING SYSTEM MAINTENANCE	12-1
Section1	Introduction	12-1
Section II	Steering Linkage and Gearbox	12-1
Section III	Steering Gear and Slave	12-19
SectionIV	Steering Pump	12-42
Section V	Steering System Adjustments	12-48
CHAPTER13	FRAME MAINTENANCE..	13-1
Section1	Introduction	13-1
Section11	Frame Assembly	13-2
Section III	Fifth Wheel Assembly	13-91
CHAPTER 14	SUSPENSION MAINTENANCE	14-1
Section1	Introduction	14-1
Section II	Spring Assembly	14-2
Section III	Lateral Torque Rod and Equalizer Beams	14-11
CHAPTER 15	CABAND BODY MAINTENANCE	15-1
Section1	Introduction	15-1
Section II	Cab Assembly	15-1
Section III	Pump Module, Tank, and Cargo Bodies ..	15-26
CHAPTER 16	WINCH MAINTENANCE..	16-1
Section I	Introduction	16-1
Section II	Self-Recovery Winch	16-2
Section III	Heavy-Duty Winch	16-22
INDEX	Index- 1

CHAPTER 10 AXLES NO. 3 AND NO. 4 MAINTENANCE

Contents	Para	Page
General	10-1	10-1
Axle No.3 (Axle Models 480 and 580) Removal/Installation	10-2	10-1
Axle No.3 (Axle Model 650) Removal/Installation	10-2.1	10-6
Axle No.4 (Axle Models 480 and 580) Removal/Installation	10-3	10-6.4
Axle No.4 (Axle Model 650)Removal/Installation	10-3.1	10-8
Axle Housing Cover Assembly, Axle No.3 Removal/Repair/Installation	10-4	10-8.3
Axle Housing Cover, Axle No. 4 (Axle Models 580 and 650) Removal/Repair/Installation (M984, M984E1)	10-5	10-11
Yoke and Oil Seal (Axle Models 480 and 580) Removal/Installation	10-6	10-13
Differential Carrier Cover, Axle No. 3 Removal/Repair/Installation	10-7	10-15
Deleted	10-8	
Differential Carrier, Axle No. 3 Removal/Installation	10-9	10-28
Differential Carrier, Axle No. 3 (Axle Models 480 and 580) Repair	10-10	10-32
Differential Carrier, Axle No. 4 Removal/Installation	10-11	10-61
Differential Carrier, Axle No. 4 (Axle Models 480 and 580) Repair	10-12	10-62

Section I. INTRODUCTION

10-1. GENERAL. This chapter contains maintenance instructions for removal, installation, and repair of axles No. 3 and No. 4 at the direct support and general support maintenance levels. Subassemblies and parts which must be removed before the axles and their components can be removed are referenced to other paragraphs of this manual or in TM 9-2320-279-20.

Section II. AXLE ASSEMBLIES Axles No. 3 and No. 4 Maintenance Instructions

This task covers:	
a. Removal	c. Follow-on Maintenance
b. Installation	
INITIAL SETUP	
<i>Models</i>	<i>Equipment Condition</i>
All	<i>TM or Para</i> <i>Condition Description</i>
<i>Test Equipment</i>	LO 9-2320-279-12 Axle lubrication drained.
None	TM 9-2320-279-20 Propeller shafts removed from front and rear of axle.
<i>Special Tools</i>	Para 10-6 Yokes loosened.
None	TM 9-2320-279-20 Brake shoes removed.
<i>Supplies</i>	TM 9-2320-279-20 Air chambers removed.
Oil, lubricating, Item 47, Appendix C	TM 9-2320-279-20 Slack adjusters removed.
Preventive, rust, Item 53, Appendix C	Para 14-4 Lateral torque rod removed.
<i>Personnel Required</i>	TM 9-2320-279-20 Shock absorbers removed.
MOS 63W, Wheel vehicle repairer (2)	TM 9-2320-279-20 Axle shafts removed.
<i>References</i>	<i>Special Environmental Conditions</i>
None	None
	<i>General Safety Instructions</i>
	Front wheels chocked.
	<i>Level of Maintenance</i>
	Direct Support

Axles No. 3 and No. 4 Maintenance Instructions (Cont)

10-2. AXLE NO. 3 (AXLE MODELS 480 AND 580) REMOVAL/INSTALLATION (CONT).

a. Removal.

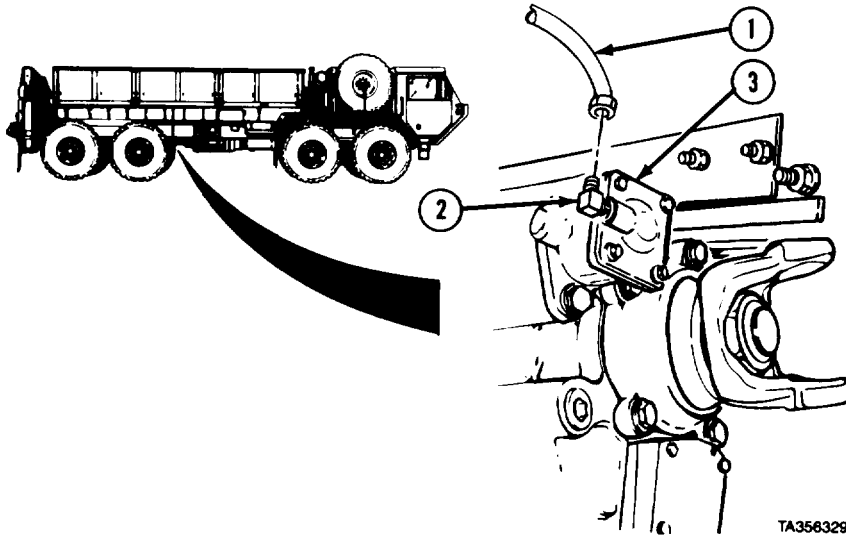

- (1) Remove power divider lockout air line (1).
- (2) Remove fitting (2) from lockout air chamber (3).

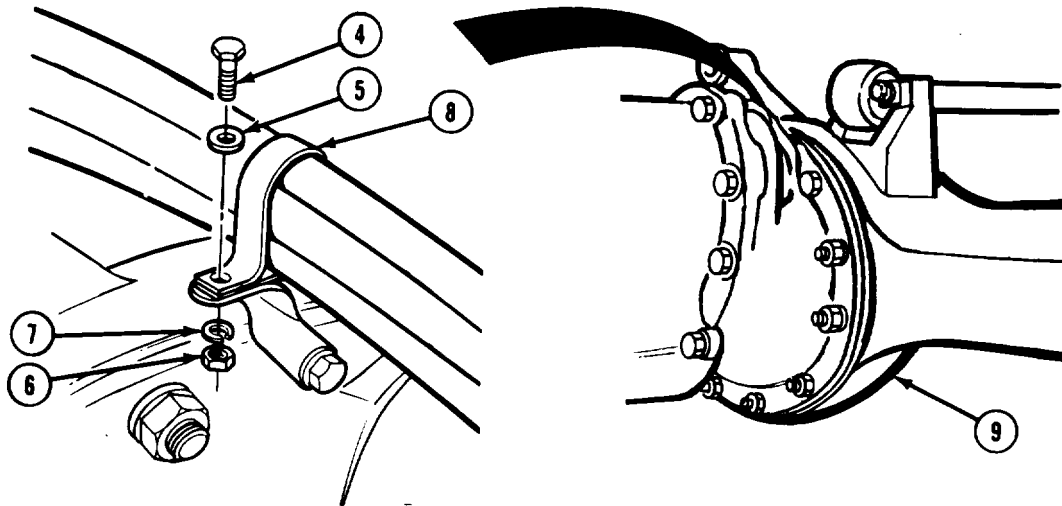

- (3) Remove screw (4), washer (5), nut (6), lockwasher (7), and clamp (8).

CAUTION

Model 480 axle weighs approximately 1100 lb (499 kg). Model 580 axle weighs approximately 1400 lb (636 kg). Be sure the lifting device used for this task is adequate.

- (4) Support axle (9) with suitable lifting device.

Axles No. 3 and No. 4 Maintenance Instructions (Cont)

- (5) Remove two nuts (10), four washers (11), and two screws (12) from torque rod (13) and axle mounting bracket (14).
- (6) Move torque rod (13) aside.

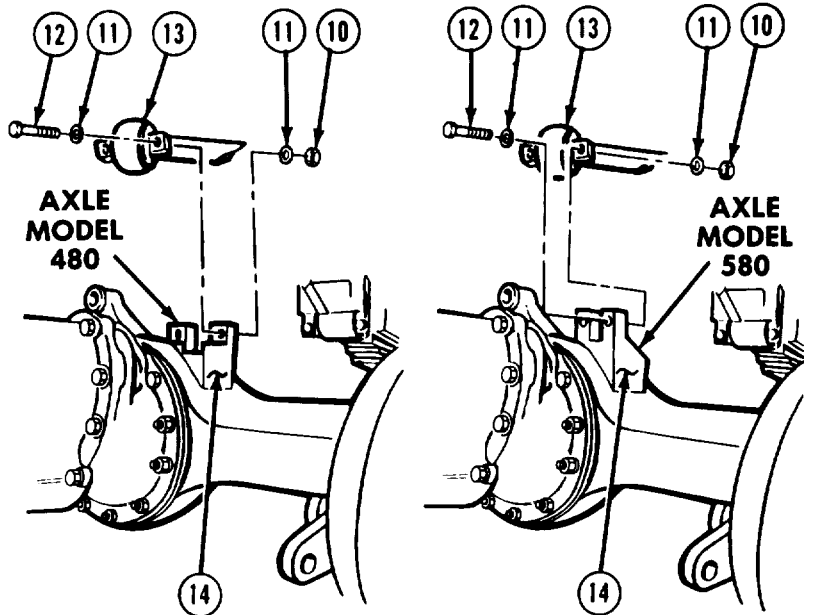

TA191195

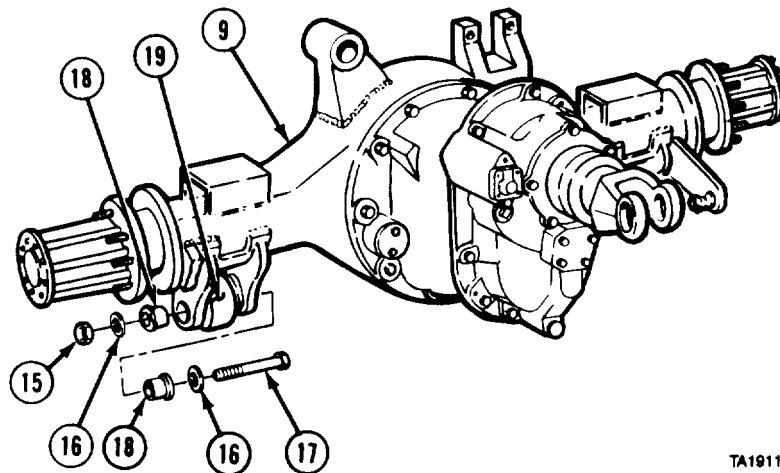

TA191194

NOTE

Screw and washer will come out with inner beam end adapter.

- (7) Remove nut (15), two washers (16), screw (17), and two beam end adapters (18) from equalizer beams (19) on each side of axle (9).

WARNING

Axle is very heavy. Keep out from under heavy parts. Falling parts may cause serious injury or death.

- (8) Soldier A and Soldier B remove axle (9).

Axles No. 3 and No. 4 Maintenance Instructions (Cont)

10-2. AXLE NO. 3 (AXLE MODELS 480 AND 580) REMOVAL/INSTALLATION (CONT)

b. Installation.

- (1) Support axle (1) with suitable lifting device.
- (2) Soldier A and Soldier B install axle (1) and align holes in two axle beam hanger brackets (2) with holes in two equalizer beams (3).

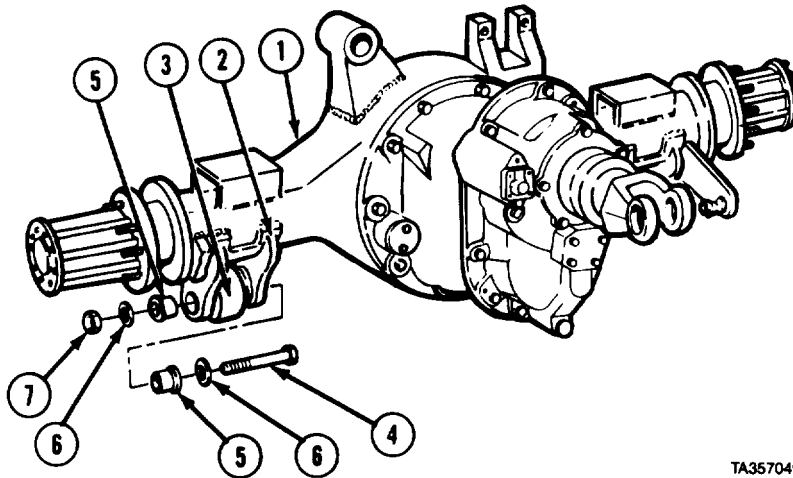

TA357049

NOTE

Screws and washers are installed with inner beam end adapters.

- (3) Lubricate threads of two screws (4) with oil and four beam end adapters (5) with rust preventive.
- (4) Install four beam end adapters (5) in axle beam hanger brackets (2).
- (5) Install two screws (4), four washers (6), and two nuts (7) loosely.

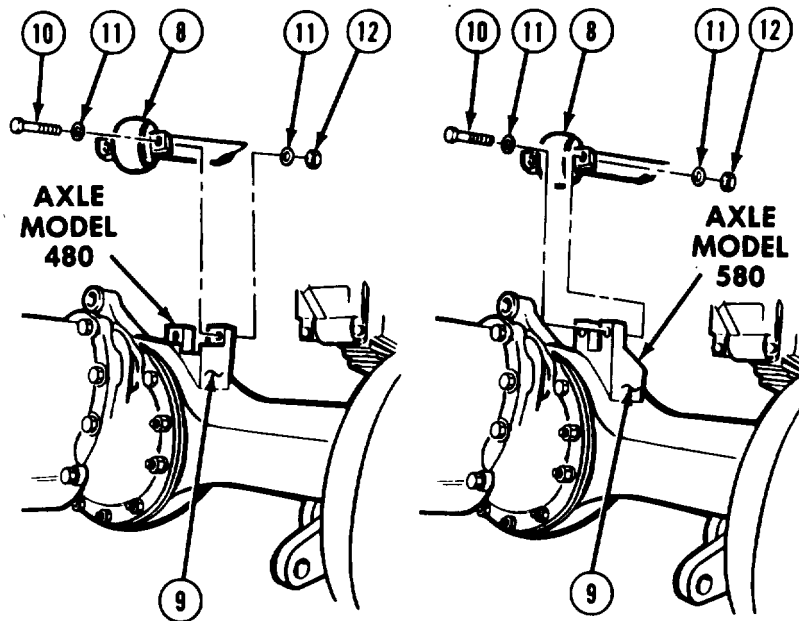

TA357047

- (6) Lower torque rod (8) on axle mounting bracket (9). Lubricate two screws (10) with oil and install screws, four washers (11), and two nuts (12).
- (7) Tighten two nuts (12) to 175 to 225 lb-ft (237 to 305 N•m).

Axles No. 3 and No. 4 Maintenance Instructions (Cont)

- (8) Tighten two screws (4) and nuts (7) to 210 to 240 lb-ft (285 to 325 N•m).
- (9) Remove lifting device from axle (1).

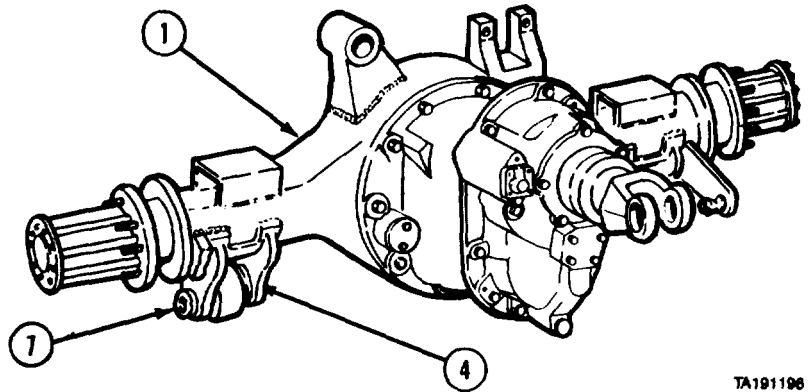

TA191196

- (10) Install clamp (13) with screw (14), washer (15), lockwasher (16), and nut (17).

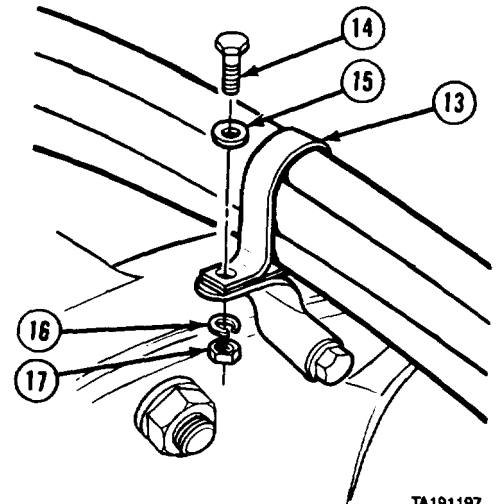

TA191197

- (11) Install fitting (18) to lockout air chamber (19).
- (12) Connect power divider lockout air line (20) to fitting (18).

c. Follow-on Maintenance.

- (1) Install axle shafts (TM 9-2320-279-20).
- (2) Install axle lateral torque rod (para 14-4).
- (3) Tighten yokes (para 10-6).
- (4) Install propeller shafts to front and rear of axle (TM 9-2320-279-20).
- (5) Install shock absorbers (TM 9-2320-279-20).
- (6) Install air chambers (TM 9-2320-279-20).
- (7) Install slack adjusters (TM 9-2320-279-20).
- (8) Install brake shoes (TM 9-2320-279-20).
- (9) Aline No. 3 axle, rear tandem suspension (para 14-7).
- (10) Fill axle to proper level with lubrication oil (LO 9-2320-279-12).

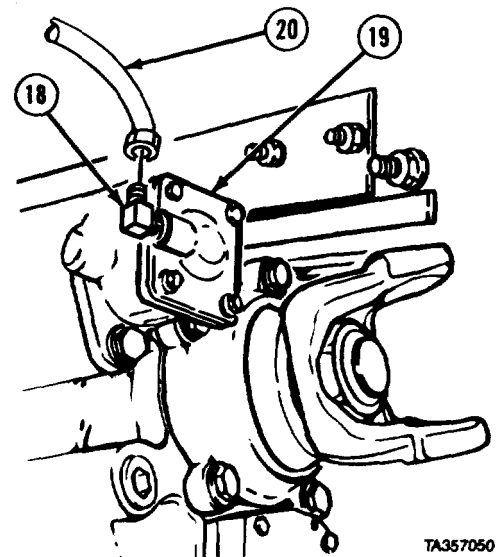

TA357050

END OF TASK

Axles No. 3 and No. 4 Maintenance Instructions (Cont)

10-2.1. AXLE NO. 3 (AXLE MODEL 650) REMOVAL/INSTALLATION (M984E1).	
This task covers:	
a. Removal b. Installation	c. Follow-on Maintenance
INITIAL SETUP	
<i>Models</i> M984E1	<i>Equipment Condition</i>
<i>Test Equipment</i> None	<i>TM or Para</i> LO 9-2320-279-12 Axle lubrication drained. Para 10-6 Yokes loosened.
<i>Special Tools</i> None	TM 9-2320-279-20 Rear brake chambers removed.
<i>Supplies</i> Oil, lubricating, Item 46, Appendix C Rust preventive, Item 54, Appendix C Ties, Cable, Plastic, Item 65, Appendix C	TM 9-2320-279-20 Shock absorbers removed. TM 9-2320-279-20 Rear brake shoes removed. TM 9-2320-279-20 Rear brake camshaft and slack adjusters removed.
<i>Personnel Required</i> MOS 63W, Wheel vehicle repairer (2)	Para 14-2 Lateral torque rod removed from No. 3 axle.
<i>References</i> None	<i>Special Environmental Conditions</i> None
	<i>General Safety Instructions</i> None
	<i>Level of Maintenance</i> Direct Support

a. Removal.

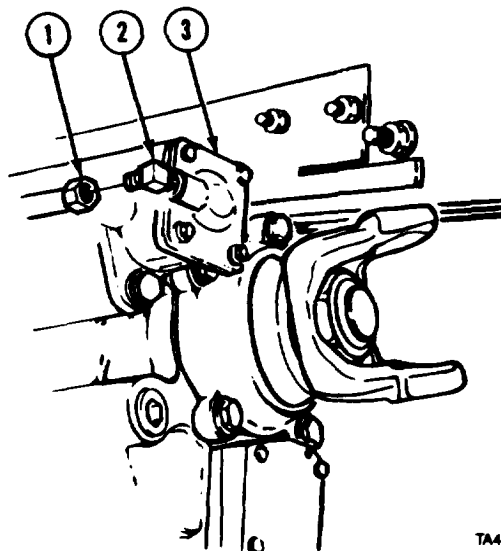
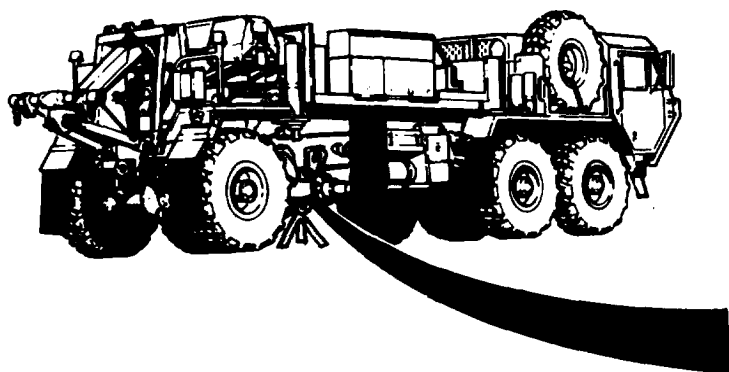

TA476433

- (1) Remove power divider lockout air line (1).
- (2) Remove fitting (2) from lockout air chamber (3).

Axles No. 3 and No. 4 Maintenance Instructions (Cont)

- (3) Remove screw (4), washer (5), locknut (6), and clamp (7).

CAUTION

Model 650 axle weighs approximately 1400 lbs. (650 kg). Be sure lifting device used for this task is adequate.

- (4) Soldier A and Soldier B secure axle (8) to suitable lifting device.

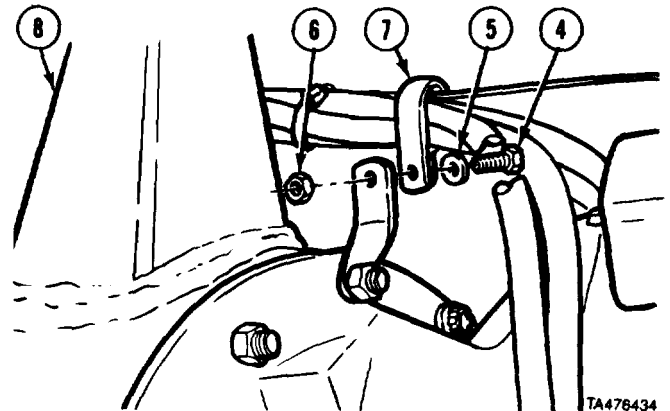

TA476434

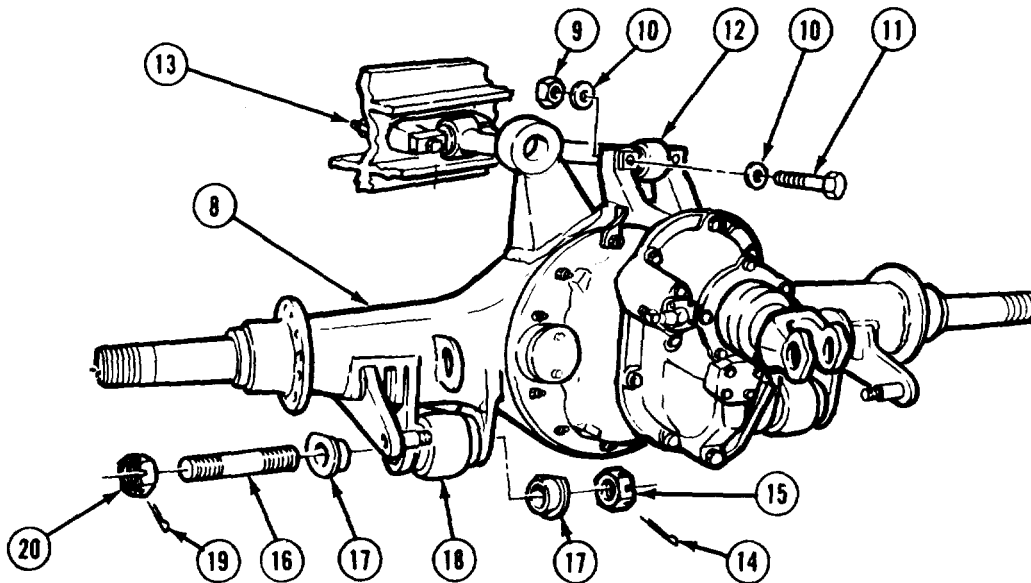

TA476435

NOTE

Remove tie wraps and clamps as necessary.

- (5) Remove two nuts (9), washers (10), and screws (11) from torque rod (12).
 (6) Loosen two nuts (13).

NOTE

Mark beam end adapters removed from short side of axle housing.

- (7) Remove two cotter pins (14), nuts (15), shafts (16), and four beam end adapters (17) from two equalizer beams (18).
 (8) Remove cotter pins (19), and nuts (20) from shafts (16).

WARNING

Axle is very heavy. Keep out from under heavy parts. Falling parts can cause serious injury or death.

- (9) Soldier A and Soldier B remove axle (8).

Axles No. 3 and No. 4 Maintenance Instructions (Cont)

10-2.1. AXLE NO. 3 (AXLE MODEL 650) REMOVAL/INSTALLATION (M984E1) (CONT).

b. Installation.

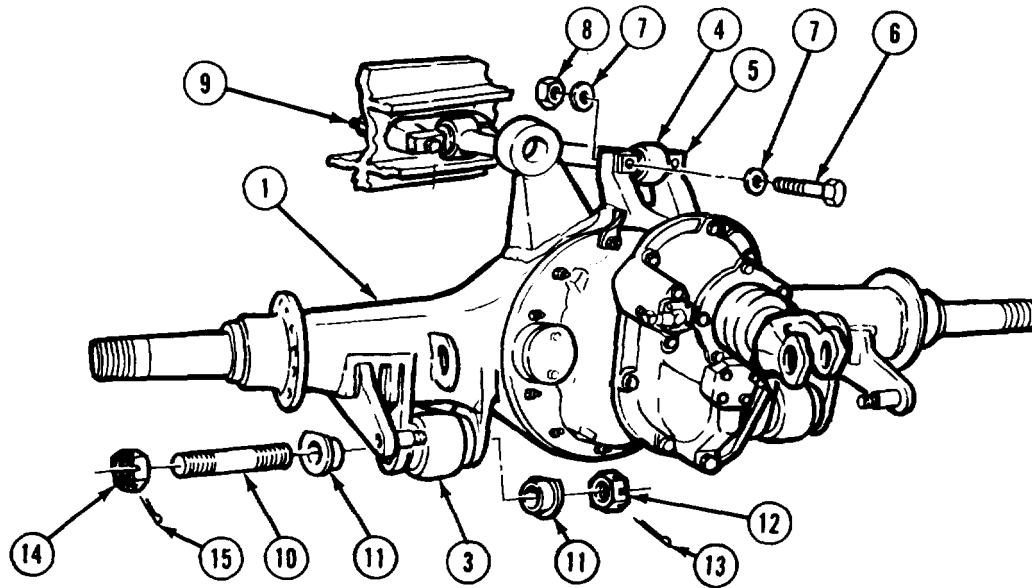

TA476436

WARNING

Axle is very heavy, Keep out from under heavy parts. Falling parts can cause serious injury or death.

- (1) Soldier A and Soldier B position axle (1) on suitable lifting device.
- (2) Soldier A and Soldier B install axle (1) and align holes in each axle beam hanger bracket (2) with holes in equalizer beam (3).
- (3) Install torque rod (4) on axle mounting bracket (5).
- (4) Lubricate two screws (6) with oil and install screws, four washers (7), and two locknuts (8). Tighten locknuts to 460 lb-ft (624 N•m).
- (5) Tighten two locknuts (9) to 460 lb-ft (624 N•m).
- (6) Lubricate threads of two shafts (10) with oil and four beam end adapters (11) with rust preventive.

NOTE

It may be necessary to loosen beam end adapter nuts on axle No. 4 equalizer beams in order to install beam end adapters in No. 3 axle equalizer beams.

- (7) Install two inner beam end adapters (11), then two outer beam end adapters (11) in axle beam hanger brackets (2) and equalizer beams (3).
- (8) Install shafts (10) through axle beam hanger brackets (2) and equalizer beams (3).
- (9) Install nuts (12) on shafts (10) until three threads show on end of shaft.
- (10) Install cotter pins (13) in nuts (12) and shafts (10).

NOTE

If beam end adapter nuts on No. 4 axle equalizer beams were loosened, tighten nuts and install cotter pins as in steps (11) and (12).

- (11) Install nuts (14) on shafts (10) and tighten to 600 to 800 lb-ft (815 to 1085 N•m).
- (12) Install cotter pins (15) in nuts (14), and shafts (10).
- (13) Remove lifting device from axle (1).

Axles No. 3 and No. 4 Maintenance Instructions (Cont)

NOTE

Use plastic ties as required to secure wires.

- (14) Install clamp (16) with screw (17), washer (18), and locknut (19).

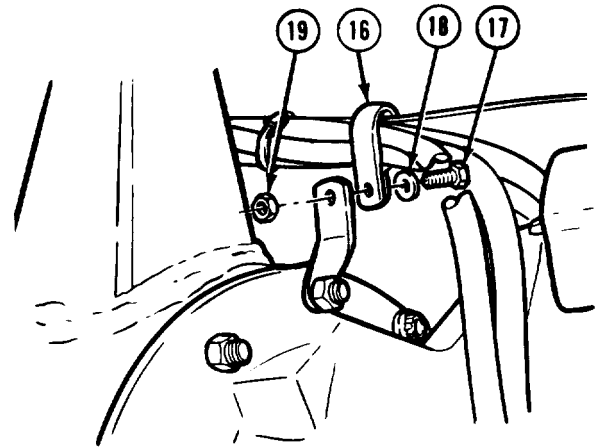

TA476437

- (15) Install fitting (20) to lockout air chamber (21).
 (16) Connect power divider lockout air line (22) to fitting (20).

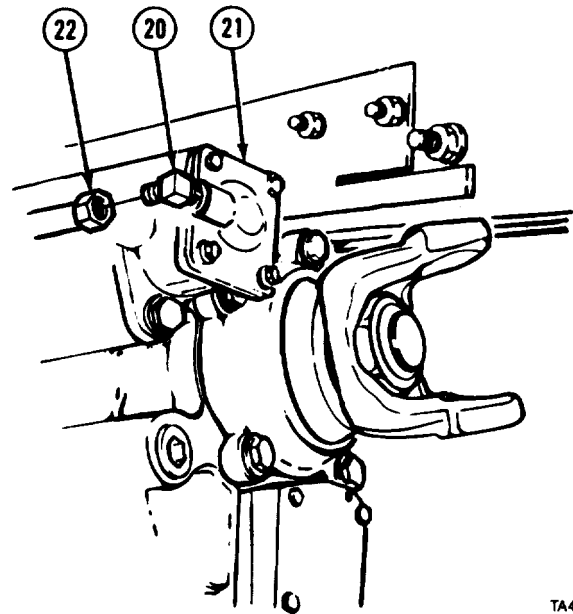

TA476438

c. Follow-on Maintenance.

- (1) Install lateral torque rod (para 14-2).
- (2) Tighten yokes (para 10-6).
- (3) Install propeller shafts to front and rear of axle (TM 9-2320-279-20).
- (4) Install shock absorbers (TM 9-2320-279-20).
- (5) Install rear brake air chambers (TM 9-2320-279-20).
- (6) Install rear brake camshaft and slack adjusters (TM 9-2320-279-20).
- (7) Install rear brake shoes (TM 9-2320-279-20).
- (8) Aline axles No. 3 and No. 4 (para 10-5).

END OF TASK

Axles No. 3 and No. 4 Maintenance Instructions (Cont)

10-3. AXLE NO. 4 (AXLE MODELS 480 AND 580) REMOVAL/INSTALLATION.	
This task covers:	
a. Removal b. Installation	c. Follow-on Maintenance
INITIAL SETUP	
<i>Models</i> All except M984E1	<i>Equipment Condition</i>
<i>Test Equipment</i> None	<i>TM or Para</i> <i>Condition Description</i>
<i>Special Tools</i> None	TM 9-2320-279-20 Axle lubrication drained. TM 9-2320-279-20 Rear brake camshaft and slack adjusters removed.
<i>Supplies</i> Oil, lubricating, Item 47, Appendix C Preventive, rust, Item 53, Appendix C	TM 9-2320-279-20 Shock absorbers removed. Para 10-6 Yokes loosened. TM 9-2320-279-20 Rear brakeshoes removed.
<i>Personnel Required</i> MOS 63W, Wheel vehicle repairer (2)	<i>Special Environmental Conditions</i> None
<i>References</i> None	<i>General Safety Instructions</i> Front wheels chocked.
	<i>Level of Maintenance</i> Direct Support

a. Removal.

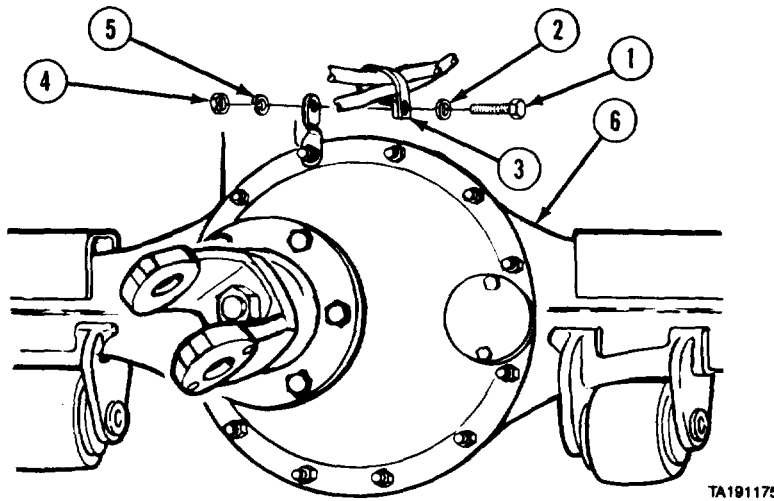

(1) Remove screw (1), washer (2), clamp (3), nut (4), and lockwasher (5).

CAUTION

Model 480 axle weighs approximately 900 lb (409 kg). Model 580 axle weighs approximately 1200 lb (545 kg). Be sure the lifting device used for this task is adequate.

(2) Position lifting device under axle No. 4 (6).

Axles No. 3 and No. 4 Maintenance Instructions (Cont)

- (3) Remove two nuts (7), four washers (8), and two screws (9) from torque rod (10) and mounting bracket (11).
- (4) Move torque rod (10) aside.

NOTE

Screw and washer will come out with inner beam end adapter.

- (5) Remove nut (12), two washers (13), two beam end adapters (14), and screw (15) from each equalizer beam (16).

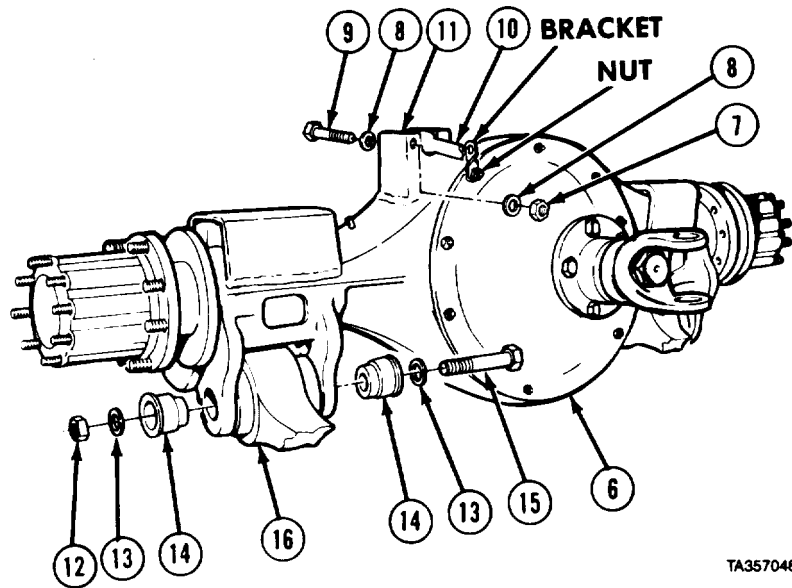

TA357048

WARNING

Axle is very heavy. Keep out from under heavy parts. Falling parts may cause serious injury or death.

NOTE

It may be necessary to loosen nut and move bracket aside to gain clearance when removing axle.

- (6) Soldier A and Soldier B remove axle (6).

b. Installation.

WARNING

Axle is very heavy. Keep out from under heavy parts. Falling parts may cause serious injury or death.

- (1) Soldier A and Soldier B position axle (1) on suitable lifting device.
- (2) Move torque rod (2) out of way.
- (3) Soldier A and Soldier B install axle (1) and align holes in two axle beam hanger brackets (3) with holes in equalizer beams (4).
- (4) Lubricate threads of two screws (5) with oil and four beam end adapters (6) with rust preventive.
- (5) Install four beam end adapters (6) in axle beam hanger brackets (3).

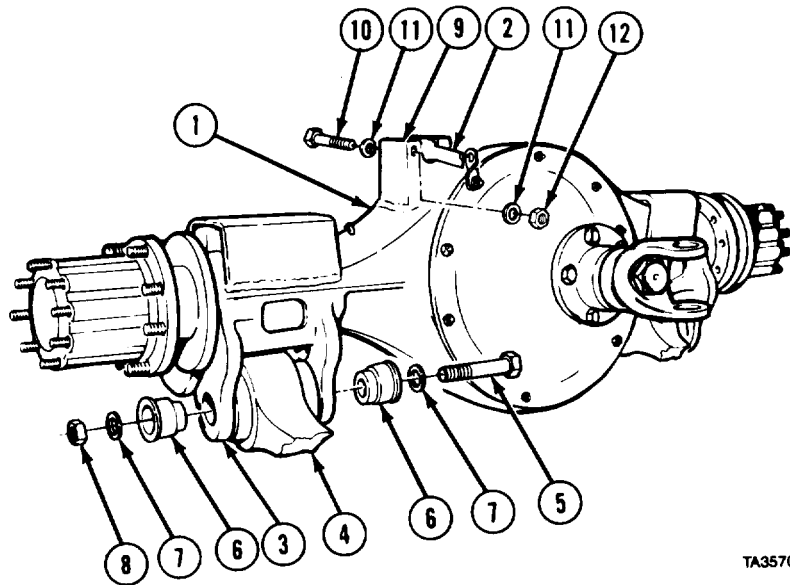

TA357051

Axles No. 3 and No. 4 Maintenance Instructions (Cont)

10-3. AXLE NO. 4 (AXLE MODELS 480 AND 580) REMOVAL/INSTALLATION (CONT).

- (6) Install two screws (5), four washers (7), and two nuts (8) loosely.
- (7) Lower and install torque rod (2) in mounting bracket (9) with two screws (10), four washers (11), and two nuts (12).
- (8) Tighten nuts (12) to 175 to 225 lb-ft (237 to 305 N•m).
- (9) Tighten nuts (8) to 210 to 240 lb-ft (285 to 325 N•m).
- (10) Remove lifting device from axle (1).

- (11) Install clamp (13) with nut (14), lockwasher (15), washer (16), and screw (17).
- (12) If nut (18) was loosened, tighten to 220 to 240 lb-ft (298 to 325 N•m).

- c. Follow-on Maintenance.
- (1) Tighten yokes (para 10-6),
 - (2) Install shock absorbers (TM 9-2320-279-20).
 - (3) Install rear brake camshaft and slack adjusters (TM 9-2320-279-20).
 - (4) Install rear brakeshoes (TM 9-2320-279-20).
 - (5) Lubricate axle No. 4 (LO 9-2320-279-12).

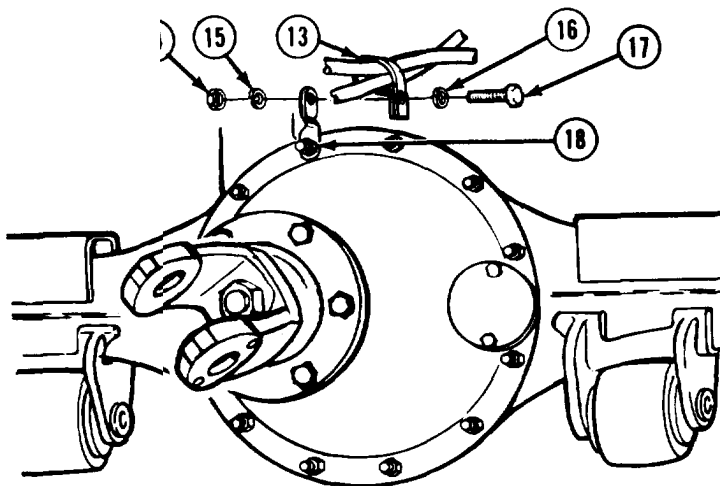

TA357046

END OF TASK

10-3.1. AXLE NO. 4 (AXLE MODEL 650) REMOVAL/INSTALLATION (M984E1).	
This task covers:	
a. Removal	c. Follow-on Maintenance
b. Installation	
INITIAL SETUP	
<i>Models</i>	<i>Equipment Condition</i>
M984E1	
<i>Test Equipment</i>	TM or Para Condition Description
None	LO 9-2320-279-12 Axle lubrication drained.
<i>Special Tools</i>	Para 10-6 Yoke loosened.
None	TM 9-2320-279-20 Rear brake shoes removed.
<i>Supplies</i>	TM 9-2320-279-20 Rear brake camshaft and slack adjusters removed.
Oil, lubricating, Item 46, Appendix C	TM 9-2320-279-20 Shock absorbers removed.
Rust preventive, Item 54, Appendix C	<i>Special Environmental Conditions</i>
<i>Personnel Required</i>	None
MOS 63W, Wheel vehicle repairer (2)	<i>General Safety Instructions</i>
<i>References</i>	Front wheels chocked,
None	<i>Level of Maintenance</i>
	Direct Support

Axles No. 3 and No. 4 Maintenance Instructions (Cont)

a. Removal.

- (1) Remove screw (1), washer (2), lockwasher (3), nut (4), and clamp (5).

CAUTION

Model 650 axles weigh approximately 1200 lbs (545 kg). Be sure lifting device used for this task is adequate.

- (2) Position suitable lifting device under axle No. 4 (6).

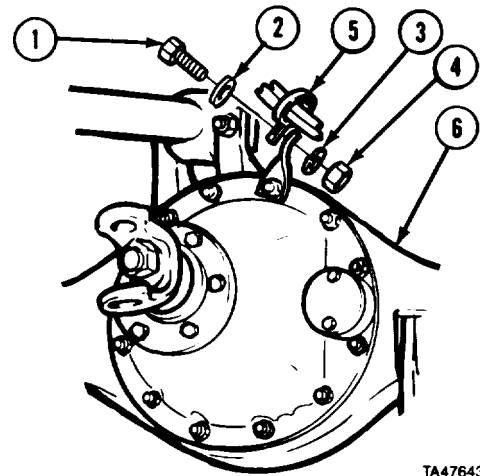

TA476439

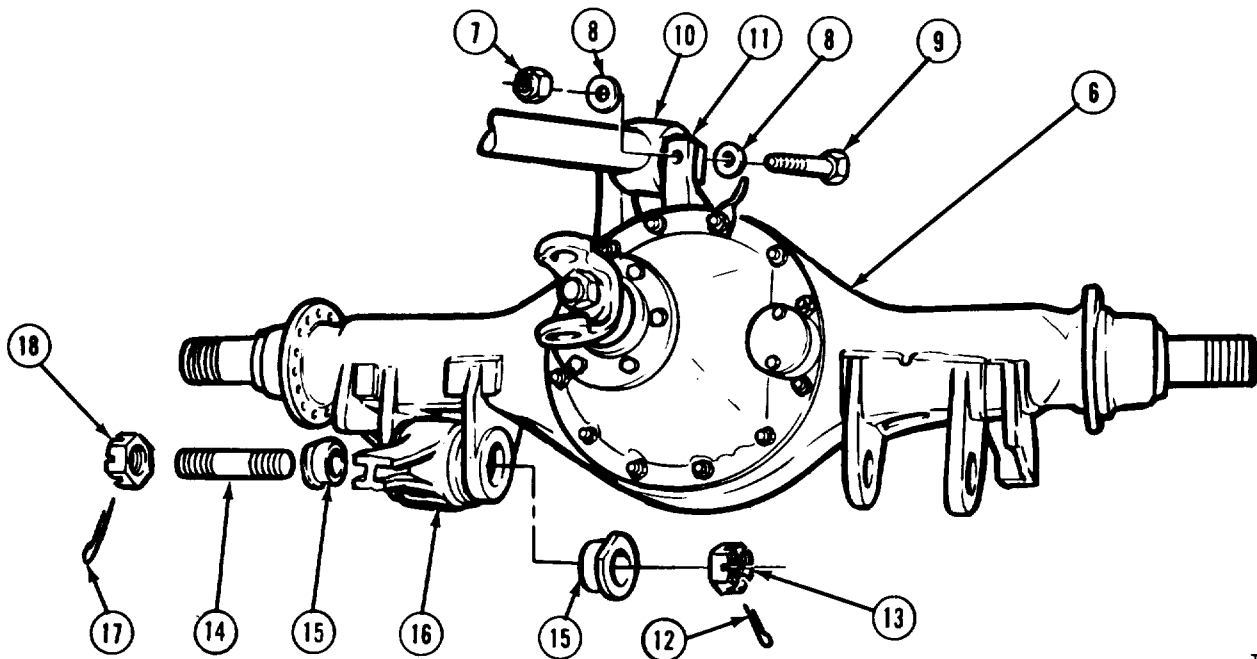

TA476440

- (3) Remove two locknuts (7), four washers (8), two screws (9), and torque rod (10) from axle bracket (11).
- (4) Remove two cotter pins (12), nuts (13), shafts (14), and four beam end adapters (15) from two equalizer beams (16).
- (5) Remove cotter pins (17) and nuts (18) from shafts (14).

WARNING

Axle is very heavy. Keep out from under heavy parts. Falling parts can cause injury or death.

- (6) Solider A and Solider B remove axle (6).

Axles No. 3 and No. 4 Maintenance Instructions (Cont)

10-3.1. AXLE NO. 4 (AXLE MODEL 650) REMOVAL/INSTALLATION (M984E1) (CONT).

b. Installation.

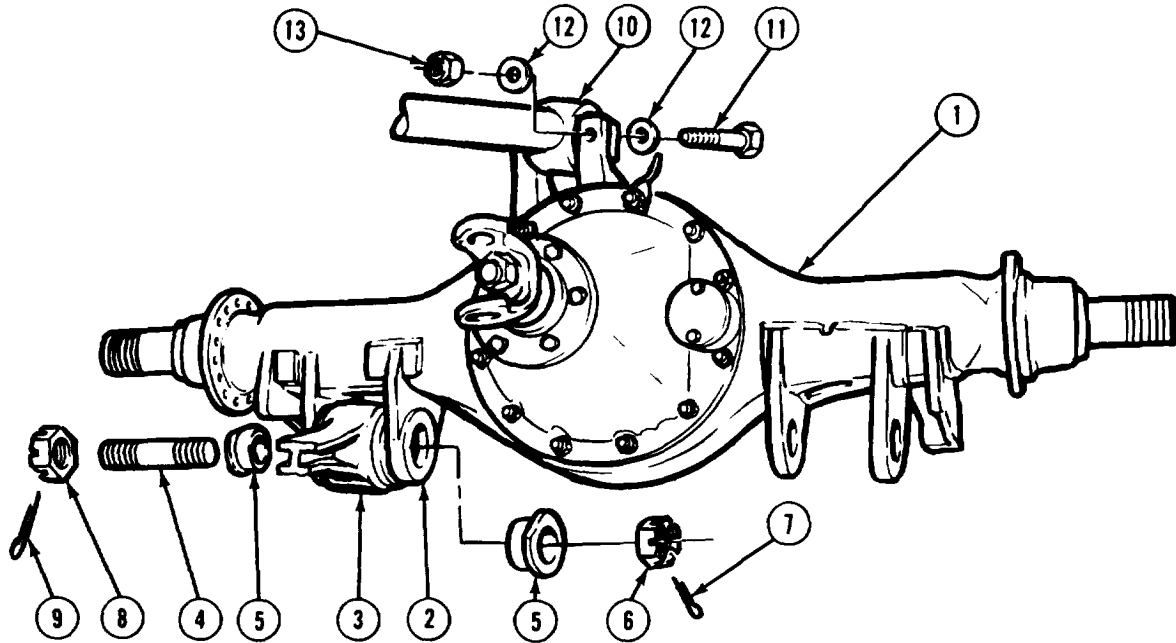

TA476441

WARNING

Axle is very heavy. Keep out from under heavy parts. Falling parts can cause serious injury or death.

- (1) Soldier A and Soldier B position axle (1) on suitable lifting device.
- (2) Soldier A and Soldier B install axle (1) and line holes in each axle beam hanger bracket (2) with holes in equalizer beams (3).
- (3) Lubricate threads of two shafts (4) with oil and four beam end adapters (5) with rust preventive.

NOTE

It may be necessary to loosen beam end adapter nuts on axle No. 3 equalizer beams in order to install beam end adapters in No. 4 axle equalizer beams.

- (4) Install two inner beam end adapters (5) in axle beam hanger brackets (2).
- (5) Install shafts (4) through beam hanger brackets (2) and equalizer beams (3).
- (6) Install nuts (6) on shafts (4) until three threads show on end of shaft.
- (7) Install cotter pin (7) in nut (6) and shaft (4).

NOTE

If beam end adapters on No. 3 axle equalizer beams were loosened, tighten nuts and install cotter pins as in steps (8) and (9).

- (8) Install nuts (8) on shafts (4) and tighten to 600 to 800 lb-ft (815 to 1085 N•m).
- (9) Install cotter pins (9) in nuts (8).
- (10) Install torque rod (10) with two screws (11), four washers (12) and locknuts (13). Tighten locknuts to 460 lb-ft (624 N•m).

Axles No. 3 and No. 4 Maintenance Instructions (Cont)

(11) Install clamp (14) with screw (15), washer (16), lockwasher (17), and nut (18).

c. Follow-on Maintenance.

- (1) Tighten yoke (para 10-6).
- (2) Install shock absorbers (TM 9-2320-279-20).
- (3) Install rear brake camshaft and slack adjusters (TM 9-2320-279-20).
- (4) Install brake shoes (TM 9-2320-279-20).
- (5) Lubricate No. 4 axle (LO 9-2320-279-12).

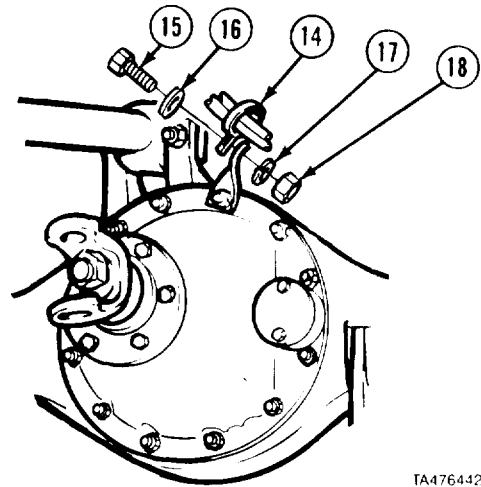

TA476442

END OF TASK

10-4. AXLE HOUSING COVER ASSEMBLY, AXLE NO. 3 REMOVAL/REPAIR/INSTALLATION.	
This task covers:	
a. Removal	d. Assembly
b. Disassembly	e. Installation
c. Cleaning/Inspection	f. Follow-on Maintenance
INITIAL SETUP	
<i>Model</i>	<i>References</i>
All	None
<i>Test Equipment</i>	<i>Equipment Condition</i>
None	<i>TM or Para</i> <i>Condition Description</i>
<i>Special Tools</i>	LO 9-2320-279-12 Axle drained.
None	Para 10-6 Yoke and oil seal removed.
<i>Supplies</i>	<i>Special Environmental Conditions</i>
Grease, automotive and artillery, Item 34, Appendix C	None
Solvent, dry cleaning, Item 57, Appendix C	<i>General Safety Instructions</i>
Adhesive-sealant, silicone, Item 6, Appendix C	None
Oil, lubricating, Item 47, Appendix C	<i>Level of Maintenance</i>
<i>Personnel Required</i>	Direct Support
MOS 63W, Wheel vehicle repairer	

Axles No. 3 and No. 4 Maintenance Instructions (Cont)

10-4. AXLE HOUSING COVER ASSEMBLY, AXLE NO. 3 REMOVAL/REPAIR/INSTALLATION (CONT).

a. *Removal.*

- (1) Remove screw (1) and lockwasher (2).
- (2) Remove 11 nuts (3), lockwashers (4), and four dowel bushings (5).
- (3) Remove cover (6).

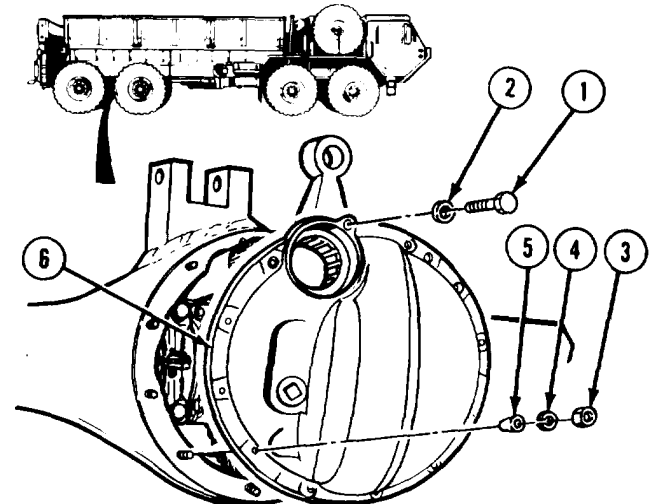

(AXLE MODEL 480 SHOWN ALL AXLES SIMILAR)

TA356121

b. *Disassembly.*

- (1) Remove pipe plug (1) and magnetic plug (2) from cover (3).
- (2) Remove retaining ring (4).
- (3) Remove roller bearing (5).

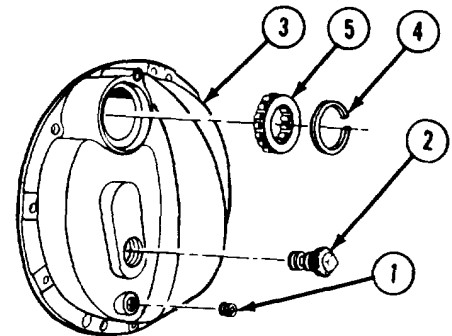

TA356123

- (4) Remove bearing sleeve (7).

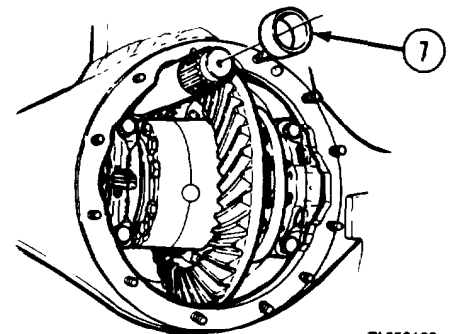

TA356122

Axles No. 3 and No. 4 Maintenance Instructions (Cont)

10-4. AXLE HOUSING COVER ASSEMBLY, AXLE NO. 3 REMOVAL/REPAIR/INSTALLATION (CONT).

c. Cleaning/Inspection.

WARNING

Adhesives, solvents, and sealing compounds can burn easily, can give off harmful vapors, and are harmful to skin and clothing. To avoid injury or death, keep away from open fire and use in well-ventilated area. If adhesive, solvent, or sealing compound gets on skin or clothing, wash immediately with soap and water.

- (1) Clean all metal parts with dry cleaning solvent.

WARNING

Compressed air used for cleaning purposes will not exceed 30 psi (207 kPa). Use only with effective chip guarding and personal protective equipment, goggles, shield, and gloves.

- (2) Dry metal parts, except bearings, with compressed air.
- (3) Allow bearings to air dry.
- (4) Inspect metal parts for breaks, cracks, and sharp edges.
- (5) Inspect machined parts for nicks and burrs.
- (6) Inspect bearings for loose rollers or cracked and broken races.
- (7) Coat bearings with lubricating oil.
- (8) Inspect dowel pins and mounting studs for cracks, breaks, and damaged threads.
- (9) Replace all damaged parts.

d. Assembly.

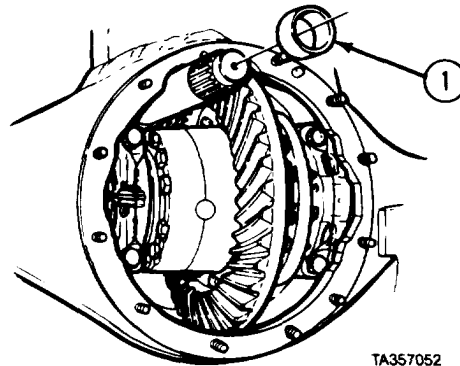

TA357052

- (1) Install bearing sleeve (1).
- (2) Pack roller bearing (2) with grease.
- (3) Install roller bearing (2) in cover (3).
- (4) Install retaining ring (4).
- (5) Install magnetic plug (5) and pipe plug (6).

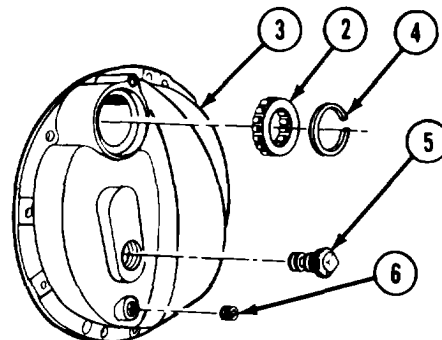

TA357307

Axles No. 3 and No. 4 Maintenance Instructions (Cont)

e. *Installation.*

WARNING

Adhesives, solvents, and sealing compounds can burn easily, can give off harmful vapors, and are harmful to skin and clothing. To avoid injury or death, keep away from open fire and use in well-ventilated area. If adhesive, solvent, or sealing compound gets on skin or clothing, wash immediately with soap and water.

(1) Apply silicone adhesive-sealant to housing and install cover (1) with four dowel bushings (2), 11 lockwashers (3), and nuts (4). Tighten nuts to 110 to 130 lb-ft (149 to 176 N•m).

(2) Install lockwashers (5) and screw (6). Tighten screw to 75 to 85 lb-ft (101 to 115 N•m).

f. *Follow-on Maintenance.*

(1) Install yoke and oil seal (para 10-6).
 (2) Lubricate axle (LO 9-2320-279-12).

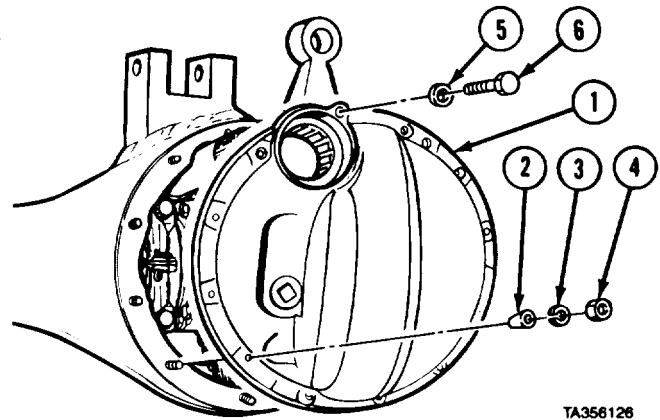

TA356126

END OF TASK

10-5. AXLE HOUSING COVER, AXLE NO. 4 (AXLE MODELS 580 AND 650) REMOVAL/REPAIR/INSTALLATION (M984, M984E1).							
This task covers:							
a. Removal	c. Installation						
b. Cleaning/Inspection	d. Follow-on Maintenance						
INITIAL SETUP							
<i>Models</i> M984, M984E1	<i>References</i> None						
<i>Test Equipment</i> None	<i>Equipment Condition</i>						
<i>Special Tools</i> None	<table border="0"> <tr> <td><i>TM or Para</i></td> <td><i>Condition</i></td> <td><i>Description</i></td> </tr> <tr> <td>LO 9-2320-279-12</td> <td>Axle drained.</td> <td></td> </tr> </table>	<i>TM or Para</i>	<i>Condition</i>	<i>Description</i>	LO 9-2320-279-12	Axle drained.	
<i>TM or Para</i>	<i>Condition</i>	<i>Description</i>					
LO 9-2320-279-12	Axle drained.						
<i>Supplies</i> Solvent, dry cleaning, Item 57, Appendix C Adhesive-sealant, silicone, Item 6, Appendix C	<i>Special Environmental Conditions</i> None						
<i>Personnel Required</i> MOS 63W, Wheel vehicle repairer	<i>General Safety Instructions</i> None						
	<i>Level of Maintenance</i> Direct Support						

Axles No. 3 and No. 4 Maintenance Instructions (Cont)

10-5. AXLE HOUSING COVER, AXLE NO. 4 (AXLE MODELS 580 AND 650)
REMOVAL/REPAIR/INSTALLATION (M984, M984E1) (CONT).

a. Removal.

- (1) Remove screw (1) and lockwasher (2).
- (2) Remove 11 nuts (3), lockwashers (4), and cover (5).
- (3) Remove magnetic plug (6) and pipe plug (7).

b. Cleaning/Inspection.

WARNING

Adhesives, solvents, and sealing compounds can burn easily, can give off harmful vapors, and are harmful to skin and clothing. To avoid injury or death, keep away from open fire and use in well-ventilated area. If adhesive, solvent, or sealing compound gets on skin or clothing, wash immediately with soap and water,

- (1) Clean all metal parts with dry cleaning solvent.

WARNING

Compressed air used for cleaning purposes will not exceed 30 psi (207 kPa). Use only with effective chip guarding and personal protective equipment, goggles, shield, and gloves.

- (2) Dry metal parts with compressed air.
- (3) Inspect metal parts for breaks, cracks, burrs, and sharp edges.
- (4) Inspect dowel pins and mounting studs for cracks, breaks, and damaged threads.
- (5) Replace all damaged parts.

c. Installation.

WARNING

Adhesives, solvents, and sealing compounds can burn easily, can give off harmful vapors, and are harmful to skin and clothing. To avoid injury or death, keep away from open fire and use in well-ventilated area. If adhesive, solvent, or sealing compound gets on skin or clothing, wash immediately with soap and water.

- (1) Apply silicone adhesive-sealant to the housing and install cover (5) to housing (8) with 11 lockwashers (4) and nuts (3). Tighten nuts to 110 to 130 lb-ft (149 to 176 N•m).
- (2) Install screw (1) and lockwasher (2). Tighten screw to 75 to 85 lb-ft (101 to 115 N•m).
- (3) Install pipe plug (7) and magnetic plug (6).

d. **Follow-on Maintenance.** Fill axle (LO 9-2320-279-12).

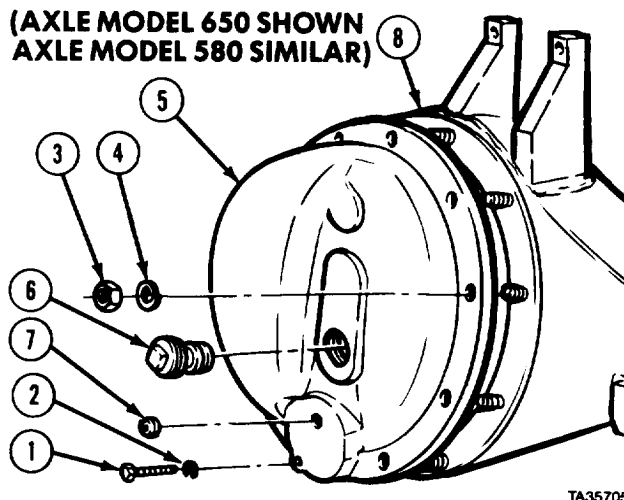

END OF TASK

Axles No. 3 and No. 4 Maintenance Instructions (Cont)

10-6. YOKE AND OIL SEAL (AXLE NO. 3 AND NO. 4) REMOVAL/INSTALLATION.

This task covers:

- a. Yoke and Oil Seal Axle No. 3, Front, Removal
- b. Yoke and Oil Seal Axle No. 3, Front, Installation
- c. Yoke and Oil Seal Axle No. 3, Rear, and Axle No. 4 Removal
- d. Yoke and Oil Seal Axle No. 3, Rear, and Axle No. 4 Installation
- e. Follow-on Maintenance

INITIAL SETUP

Models
All

Test Equipment
None

Special Tools
None

Supplies
Oil, lubricating, Item 47, Appendix C

Personnel Required
MOS 63W, Wheel vehicle repairer

References
None

Equipment Condition
TM or Para
TM 9-2320-279-20 Propeller shaft removed.

Special Environmental Conditions
None

General Safety Instructions
None

Level of Maintenance
Direct Support

a. Yoke and Oil Seal Axle No. 3, Front, Removal.

NOTE

Manufacture 2-7/8 in. socket in accordance with Appendix B, Figure 16.

- (1) Using 2-7/8 in. fabricated socket, remove nut (1) and washer (2).
- (2) Remove yoke (3).
- (3) Remove spacer (4).
- (4) Remove oil seal (5).

b. Yoke and Oil Seal Axle No. 3, Front, Installation.

- (1) Lubricate oil seal (5) with oil. Install oil seal.
- (2) Install spacer (4).
- (3) Install yoke (3) on differential shaft (6).
- (4) Install washer (2) and nut (1) on differential shaft (6).

NOTE

To tighten yoke nut, use torque multiplier and 250 lb-ft (339 N•m) capacity ratchet end torque wrench.

- (5) Using 2-7/8 in, fabricated socket, tighten nut (1) to 840 to 1020 lb-ft (1 139 to 1 383 N•m).

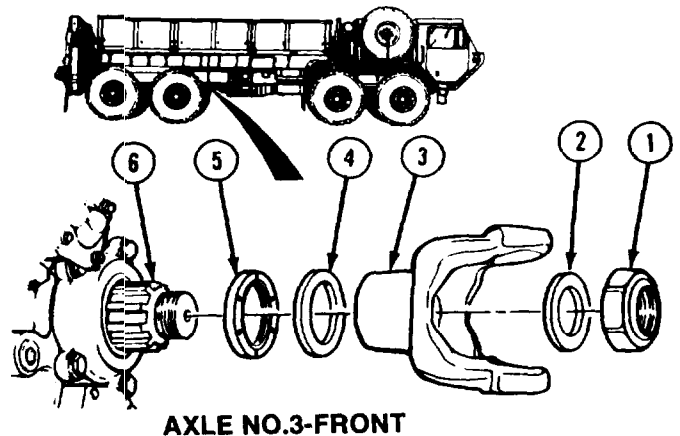

Axles No. 3 and No. 4 Maintenance Instructions (Cont)

10-6. YOKE AND OIL SEAL (AXLE NO. 3 AND NO. 4) REMOVAL/INSTALLATION (CONT).

c. Yoke and Oil Seal Axle No. 3, Rear, and Axle No. 4 Removal.

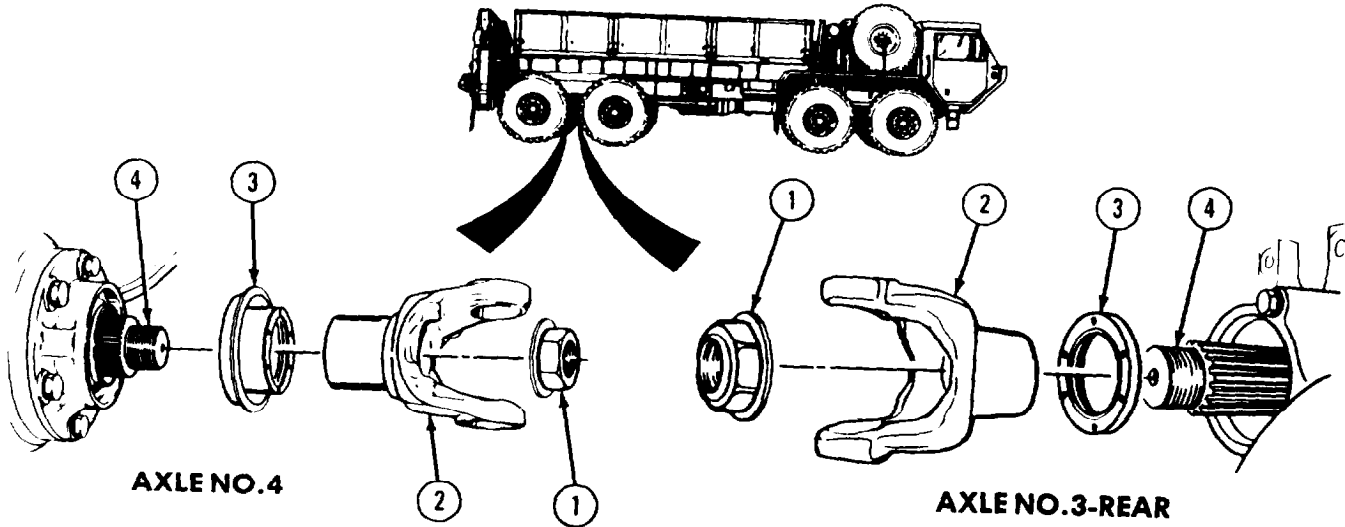

NOTE

Manufacture 2-1/4 in. socket in accordance with Appendix B, Figure 17.

- (1) Using 2-1/4 in. fabricated socket, remove flanged nut (1).
- (2) Remove yoke (2).
- (3) Remove oil seal (3).

d. Yoke and Oil Seal Axle No. 3, Rear, and Axle No. 4 Installation.

- (1) Lubricate oil seal (3) with oil. Install oil seal.
- (2) Install yoke (2) on differential shaft (4).
- (3) Install flanged nut (1) on differential shaft (4).

NOTE

To tighten yoke nut use torque multiplier and 250 lb-ft (339 N•m) capacity ratchet end torque wrench.

- (4) Using 2-1/4 in. fabricated socket, tighten flanged nut (1) to 840 to 1020 lb-ft (1 139 to 1 393 N•m).

e. Follow-on Maintenance. Install propeller shaft (TM 9-2320-270-20).

END OF TASK

Axles No. 3 and No. 4 Maintenance Instructions (Cont)

Section III. DIFFERENTIAL CARRIERS

10-7. DIFFERENTIAL CARRIER COVER, AXLE NO. 3 REMOVAL/REPAIR/INSTIATION.	
This task covers:	
a. Removal	d. Assembly
b. Disassembly	e. Installation
c. Cleaning/Inspection	f. Follow-on Maintenance
INITIAL SETUP	
<i>Models</i> All	<i>References</i> None
<i>Test Equipment</i> Indicator, dial	<i>Equipment Condition</i>
<i>Special Tools</i> Socket, 2-7/8 in., 2BF707	<i>TM or Para</i> <i>Condition Description</i>
<i>Supplies</i> Solvent, dry cleaning, Item 57, Appendix C Adhesive-sealant, silicone, Item 6, Appendix C Compound, sealing and thread locking, Item 25, Appendix C Oil, lubricating, gear, Item 44, Appendix C Tags, identification, Item 60, Appendix C	LO 9-2320-279-12 Axle lubrication drained. TM 9-2320-279-20 Propeller shaft removed. TM 9-2320-279-10 Air system drained.
<i>Personnel Required</i> MOS 63W Wheel vehicle repairer (2)	<i>Special Environmental Conditions</i> None
	<i>General Safety Instructions</i> None
	<i>Level of Maintenance</i> Direct Support

a. Removal.

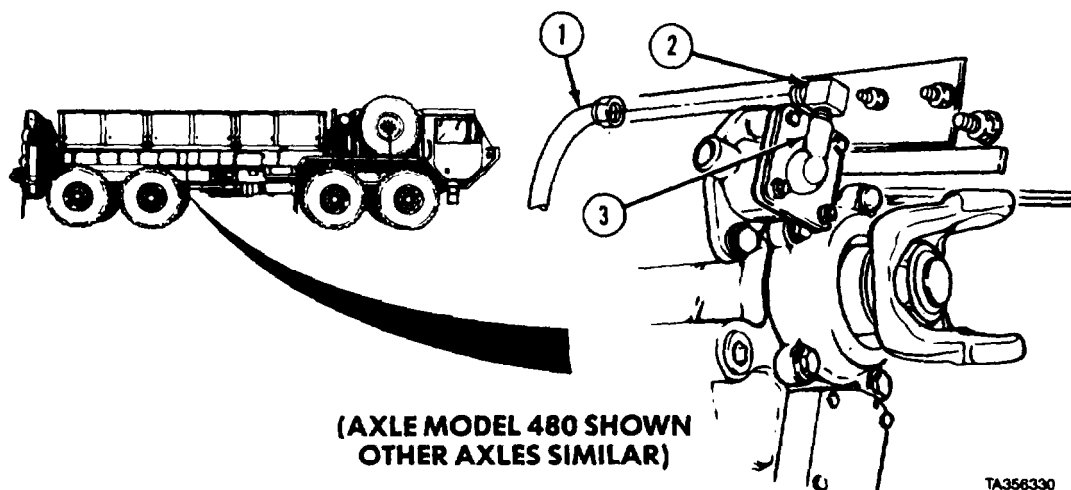

NOTE

- If axle removed from vehicle, go to step (5).
- Tag and mark air lines before disconnecting.

- (1) Remove power divider lockout air line (1).
- (2) Remove fitting (2) from lockout air chamber (3).

Axles No. 3 and No. 4 Maintenance Instructions (Cont)

10-7. DIFFERENTIAL CARRIER COVER, AXLE NO. 3 REMOVAL/REPAIR/INSTALLATION (CONT).

NOTE

Manufacture 2-7/8 in. socket in accordance with Appendix B, Figure 16.

- (3) Using 2-7/8 in. fabricated socket, loosen, but do not remove, nut (4) on yoke (5).
- (4) Support differential carrier cover (6).

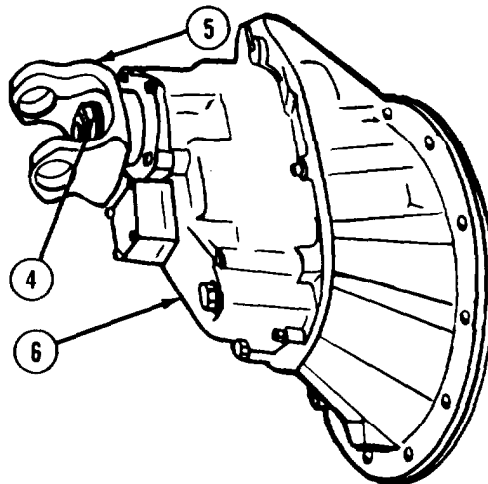

- (5) Matchmark and remove screw (7) and lockwasher (8) from differential carrier cover (6).
- (6) Matchmark and remove screw (9) and lockwasher (8) from differential carrier cover (6).
- (7) Remove eight screws (10) and lockwashers (8) from differential carrier cover (6).

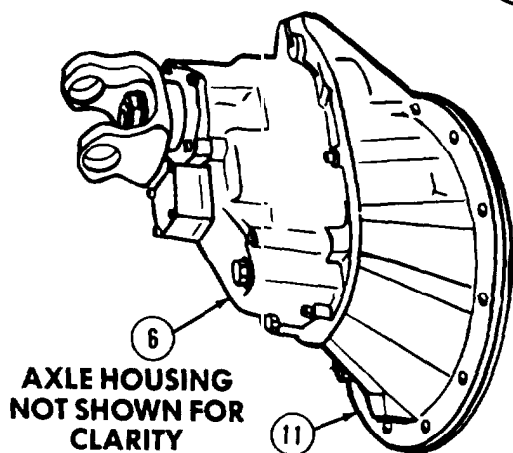
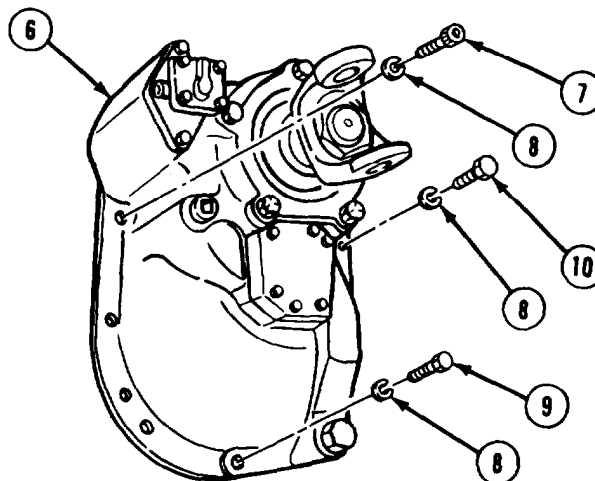

- (8) Soldier A supports differential carrier cover (6) with suitable lifting device while Soldier B guides cover from differential carrier (11).

Axles No. 3 and No. 4 Maintenance Instructions (Cont)

b. Disassembly.

WARNING

Wear safety glasses to protect eyes from possible injury or blindness while removing retaining ring.

- (1) Remove retaining ring (1) and helical side gear (2) from input shaft (3).

NOTE

Thrust washer and D-washer may come off with helical side gear.

- (2) Remove thrust washer (4) and D-washer (5) from input shaft (3).
- (3) Remove two bushings (6) from helical side gear (2).

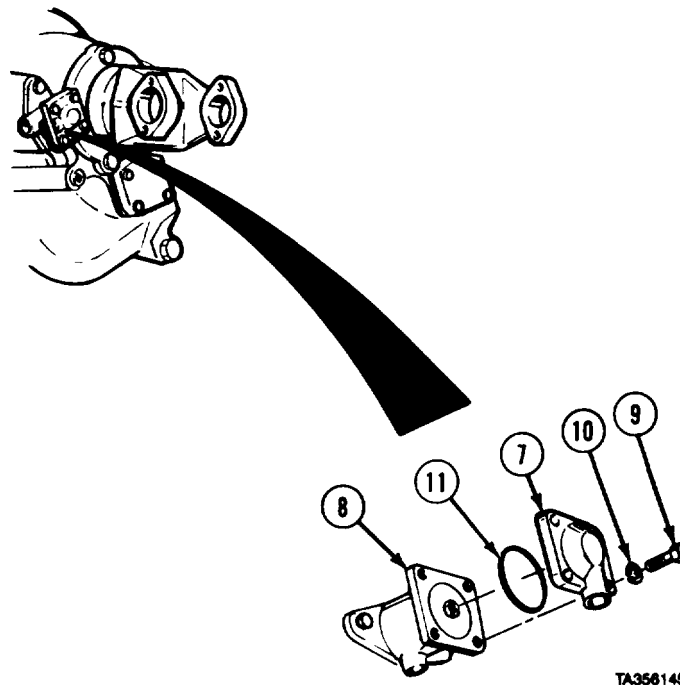
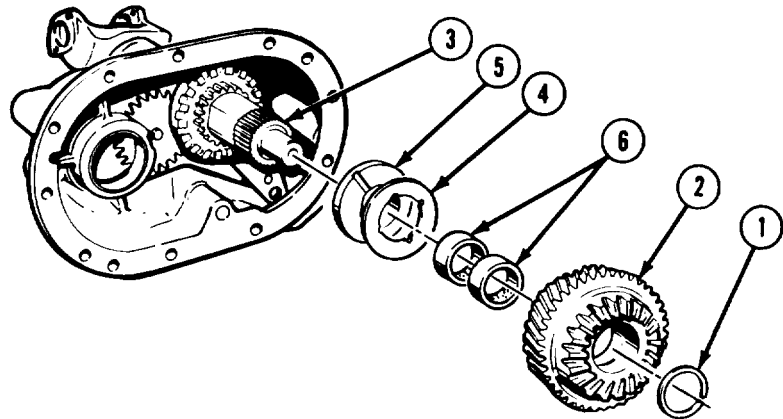

- (4) Matchmark lockout cover (7) and lockout body (8).
- (5) Remove four screws (9), lockwashers (10), and lockout cover (7).
- (6) Remove preformed packing (11) from lockout cover (7).

Axles No. 3 and No. 4 Maintenance Instructions (Cont)

10-7. DIFFERENTIAL CARRIER COVER, AXLE NO. 3 REMOVAL/REPAIR/INSTALLATION (CONT).

- (7) Remove nut (12) and washer (13).
- (8) Remove two screws (14), lockwashers (15), lockout body (8), and spring (16) from lockout fork (17).
- (9) Remove piston (18) from lockout body (8).
- (10) Remove two felt oilers (19), preformed packing (20), and preformed packing (21) from piston (18).

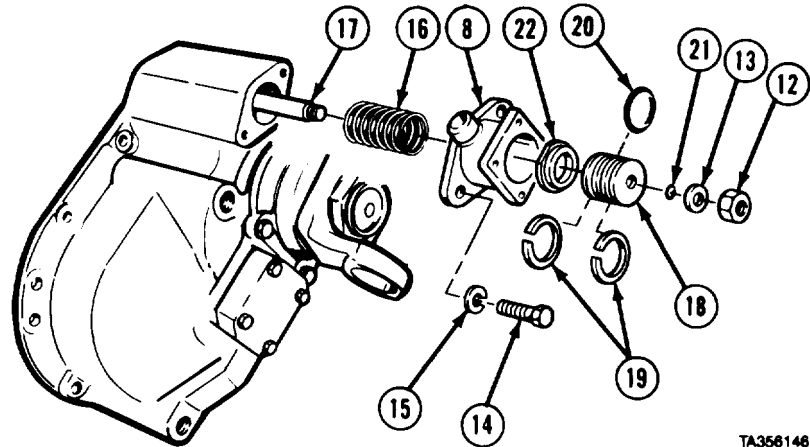

TA356146

NOTE

M984E 1 does not have piston stop in lockout body.

- (11) Remove piston stop (22) from lockout body (8).

- (12) Remove lockout fork (17) and lockout sliding clutch (23) from input shaft (3).
- (13) Remove locknut (24) and pump drive gear (25) from differential carrier cover (26).

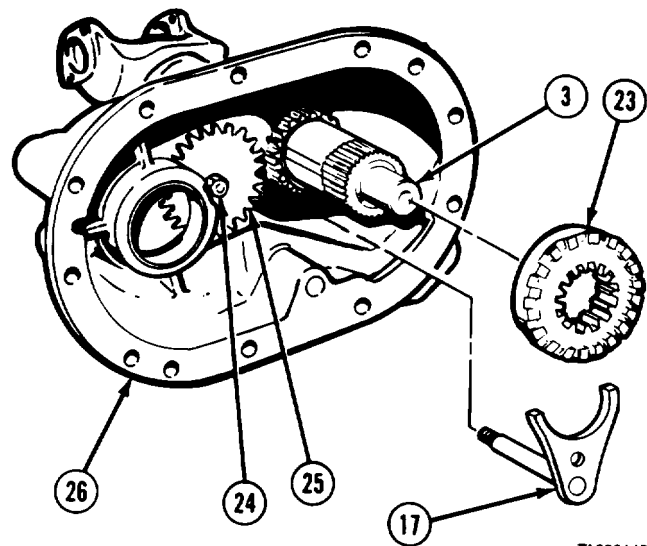

TA356146

- (14) Remove four screws (27), lockwashers (28), and pump cover (29).
- (15) Remove preformed packing (30) from pump cover (29).

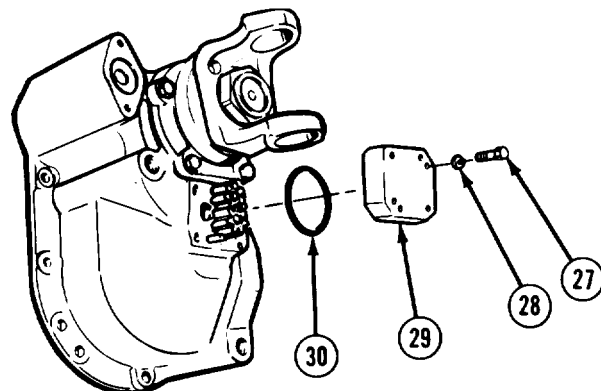

TA356149

Axles No. 3 and No. 4 Maintenance Instructions (Cont)

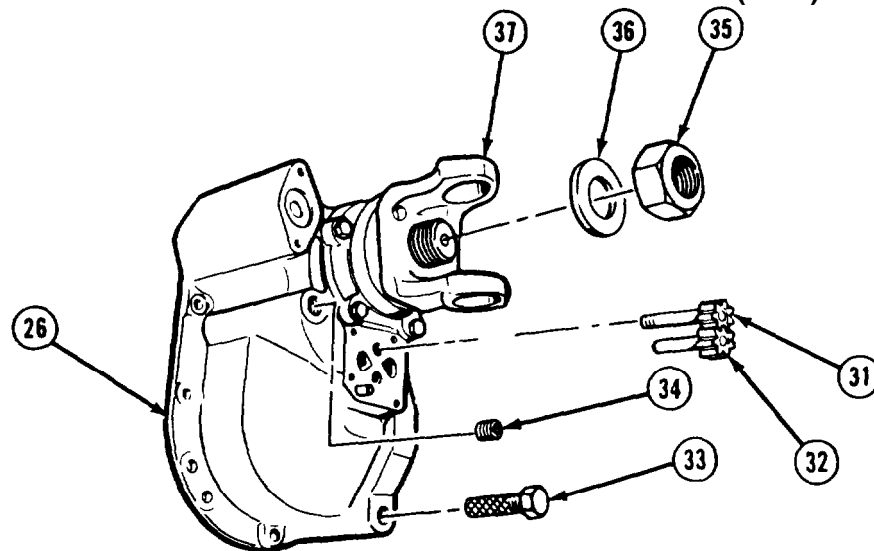

- (16) Remove threaded shaft (31) and shaft (32) from differential carrier cover (26).
- (17) Remove filter screen (33) and pipe plug (34) from differential carrier cover (26).
- (18) Using 2-7/8 in. fabricated socket, remove locknut (35), washer (36), and yoke (37).

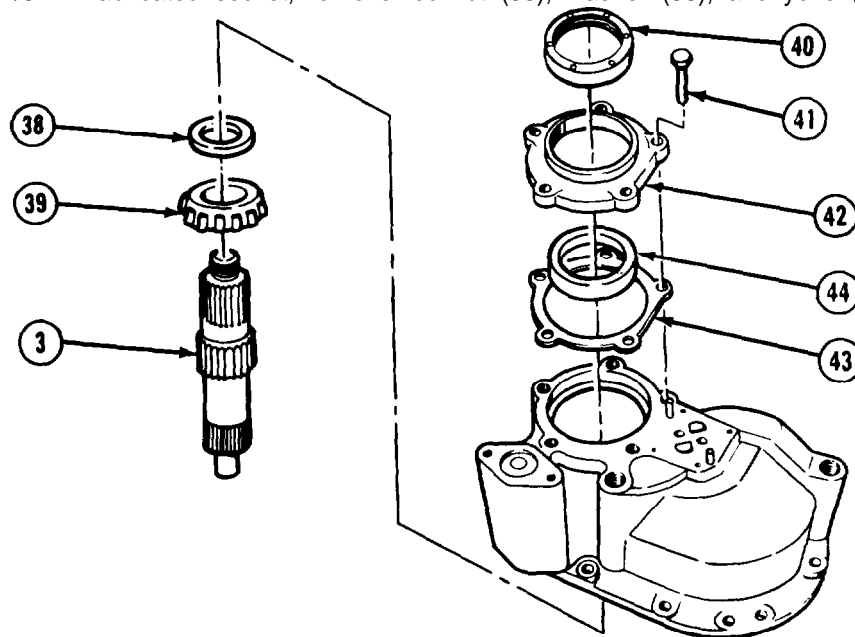

- (19) Remove input shaft (3).
- (20) Remove spacer (38) and bearing (39) from input shaft (3).
- (21) Remove oil seal (40).

NOTE

Record number of shims for assembly.

- (22) Remove five screws (41), bearing cover (42) and shims (43).
- (23) Remove bearing **cup** (44) from bearing cover (42).

Axles No. 3 and No. 4 Maintenance Instructions (Cont)

1 0-7. DIFFERENTIAL CARRIER COVER, AXLE NO. 3 REMOVAL/REPAIR/INSTALLION (CONT)-

WARNING

Wear safety glasses while removing retaining ring to protect eyes from possible injury or blindness.

NOTE

Support bearing and bearing race are provided as a set. Replace support bearing (para 10-12) whenever replacing bearing race.

- (24) Remove retaining ring (45) and bearing race (46) from inside differential carrier cover (26).

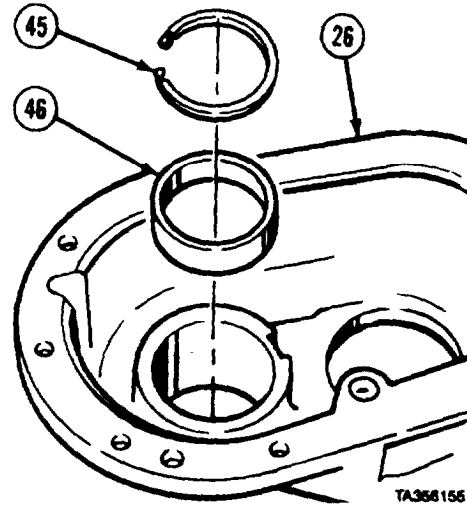

c. Cleaning/Inspection.

- (1) Scrape old sealant from differential carrier cover and differential carrier.

WARNING

Adhesives, solvents, and sealing compounds can burn easily, can give off harmful vapors, and are harmful to skin and clothing. To avoid injury or death, keep away from open fire and use in well-ventilated area. If adhesive, solvent, or sealing compound gets on skin or clothing, wash immediately with soap and water.

- (2) Use brush and dry cleaning solvent to clean all parts.
- (3) Allow bearings to air dry, then coat with lubricating oil.

WARNING

Compressed air used for cleaning purposes will not exceed 30 psi (207 kPa). Use only with effective chip guarding and personal protective equipment, goggles, shield, and gloves.

- (4) Use clean cloth or compressed air to dry all metal parts.
- (5) Inspect all metal parts for breaks, cracks, nicks, burrs, and sharp edges.
- (6) Inspect bearings for loose rollers and cracked or broken races.
- (7) Replace thrust washer removed from input shaft.
- (8) Replace two bushings removed from side gear
- (9) Replace all damaged parts.
- (10) Inspect dowel pins for cracks and breaks. Replace if damaged.
- (11) Inspect expansion plugs for damage and signs of leaks. Replace if damaged or if there is evidence of leakage.

Axles No. 3 and No. 4 Maintenance Instructions (Cont)

d. Assembly.

WARNING

While installing retaining ring, wear safety glasses to protect eyes from possible injury or blindness.

- (1) Install bearing race (1) and retaining ring (2) in differential carrier cover (3).

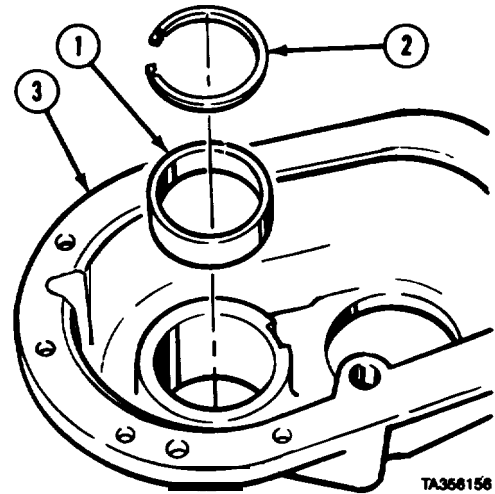

- (2) Install pipe plug (4) in differential carrier cover (3). Tighten to 40 to 60 lb-ft (54 to 81 N•m).
- (3) Install filter screen (5) in differential carrier cover (3). Tighten to 40 to 60 lb-ft (54 to 81 N•m).

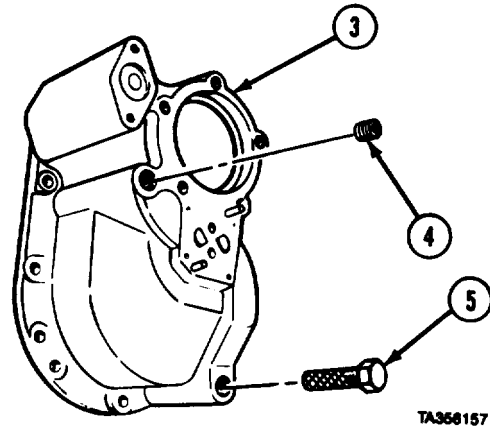

- (4) Install preformed packing (6) in pump cover (7).
- (5) Lubricate and install threaded shaft (8) in differential carrier cover (3).
- (6) Lubricate and install shaft (9) on differential carrier cover (3).
- (7) Install pump cover (7), four screws (10), and lockwashers (11) on differential carrier cover (3). Tighten screws to 85 to 105 lb-in (115 to 142 N•m).
- (8) Install pump drive gear (12) over threaded end of shaft (8).
- (9) Install nut (13) to hold pump drive gear (12) in place. Do not tighten.

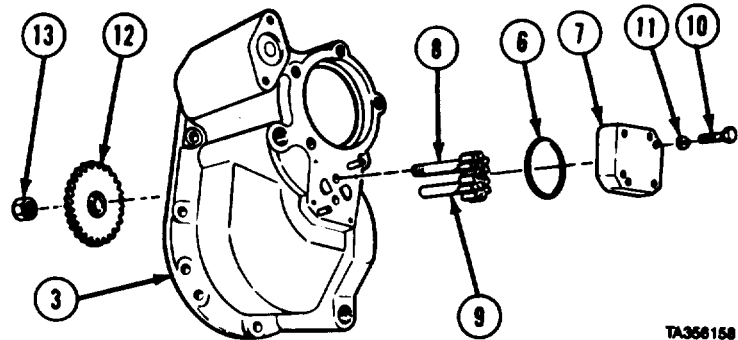

Axles No. 3 and No. 4 Maintenance Instructions (Cont)

10-7. DIFFERENTIAL CARRIER COVER, AXLE NO. 3 REMOVAL/REPAIR/INSTALLATION (CONT).

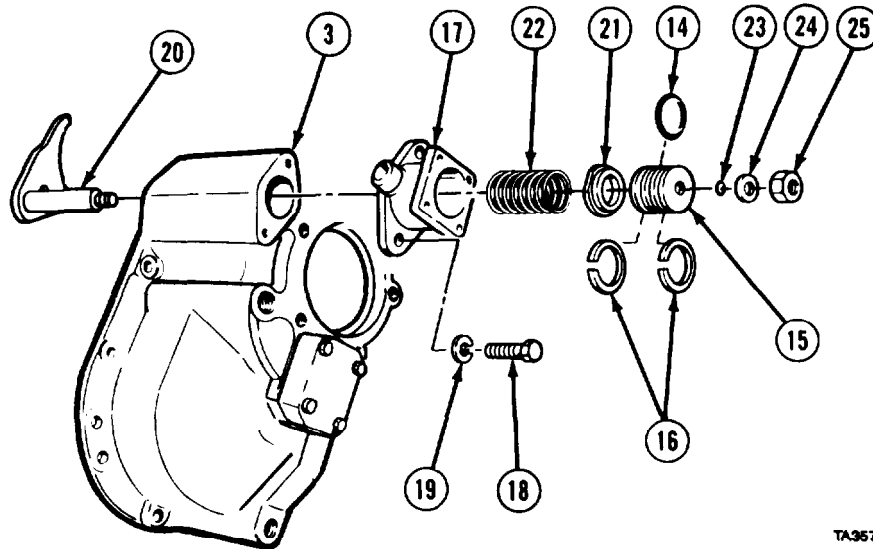

TA357058

- (10) Install preformed packing (14) on piston (15).
- (11) Soak two felt oilers (16) in lubricating oil and install on piston (15).

WARNING

Adhesives, solvents, and sealing compounds can burn easily, can give off harmful vapors, and are harmful to skin and clothing. To avoid injury or death, keep away from open fire and use in well-ventilated area. If adhesive, solvent, or sealing compound gets on skin or clothing, wash immediately with soap and water.

- (12) Apply adhesive-sealant on differential carrier cover (3) around mounting hole and screw holes for lockout body (17).
- (13) Install lockout body (17), two screws (18), and lockwashers (19) on differential carrier cover (3). Tighten screws to 48 to 56 lb-ft (65 to 76 N•m).
- (14) Install lockout fork (20) through back side of differential carrier cover (3) in lockout body (17).

NOTE

Do not install piston stop in lockout body on M984E1 (Model 650 axle).

- (15) Install piston stop (21) and spring (22) on lockout fork (20).
- (16) Push piston (15) against spring (22). Install preformed packing (23), washer (24), and nut (25) on end of lockout fork (20). Tighten nut to 20 to 25 lb-ft (27 to 34 N•m).
- (17) Install preformed packing (26) in lockout cover (27).
- (18) Install lockout cover (27), four screws (28), and lockwashers (29) on lockout body (17). Tighten screws to 105 lb-in (142 N•m).

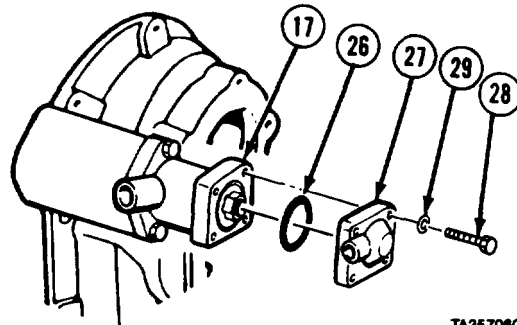

TA357060

Axles No. 3 and No. 4 Maintenance Instructions (Cont)

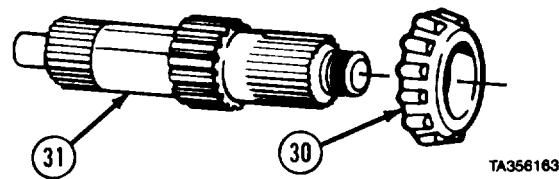

(19) Lubricate and install bearing (30) on input shaft (31).

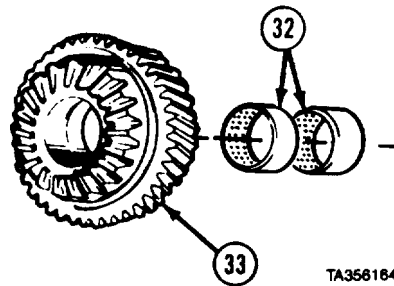

(20) Install two bushings (32) in helical side clutch (33).

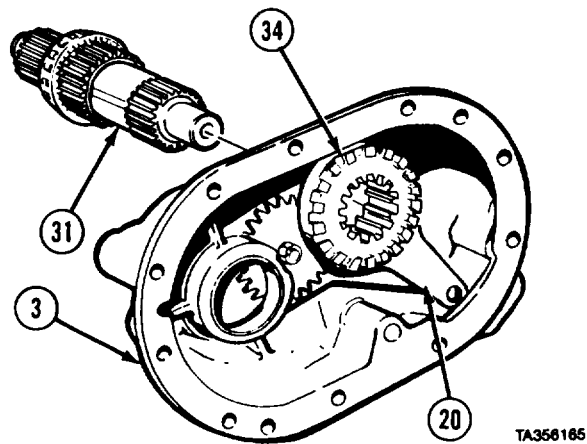

(21) Install lockout sliding clutch (34) to engage lockout fork (20) inside differential carrier cover (3).
 (22) Install input shaft (31) through front of differential carrier cover (3) in lockout sliding clutch (34).

Axles No. 3 and No. 4 Maintenance Instructions (Cont)

10-7. DIFFERENTIAL CARRIER COVER, AXLE NO. 3 REMOVAL/REPAIR/INSTALLATION (CONT).

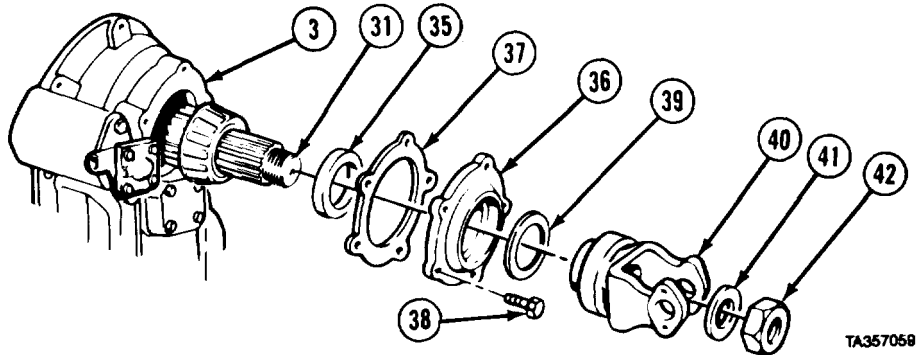

(29) Install bearing cup (35) in bearing cover (36) and apply sealing compound to bearing cover.

NOTE

Use recorded number of shims.

(24) Aline holes in shims (37) with holes in bearing cover (36) and install five screws (38), bearing cover, and shims on differential carrier cover (3). Tighten screws to 75 to 85 lb-ft (102 to 115 N•m) and apply sealing compound to outside diameter of bearing cover.

(25) Install washer (39), yoke (40), washer (41), and locknut (42) on input shaft (31). Tighten locknut finger-tight.

(26) Tighten nut (13) to 35 to 45 lb-ft (47 to 61 N•m).

(27) Install D-washer (43) on base of input shaft (31) inside differential carrier cover (3).

(28) Install thrust washer (44) on input shaft (31) against D-washer (43).

(29) Lubricate bushings (32) and install helical side gear (33) on input shaft (31).

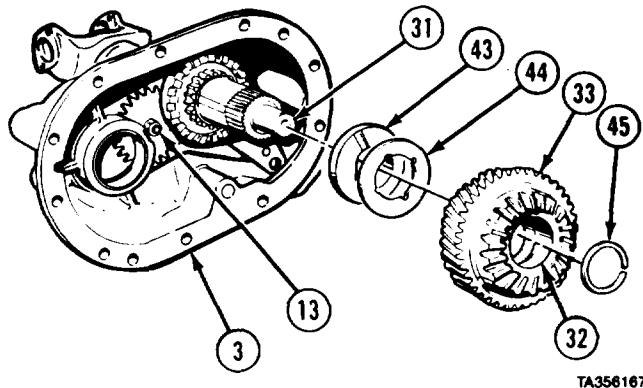

WARNING

Wear safety glasses to protect eyes from possible injury or blindness, while installing retaining ring.

(30) Install retaining ring (45) on input shaft (31).

Axles No. 3 and No. 4 Maintenance Instructions (Cont)

e. Installation.

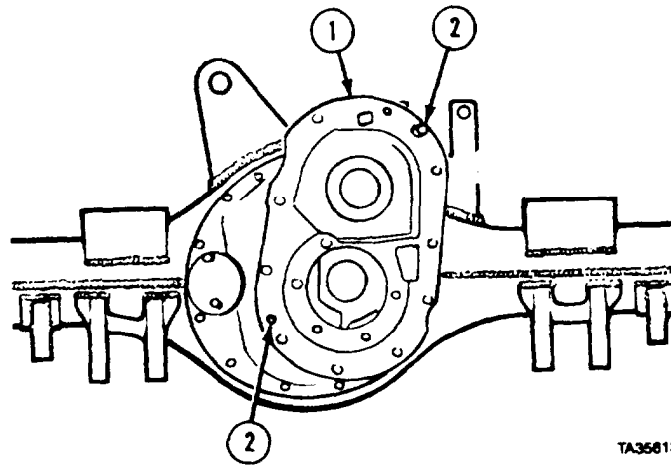

WARNING

Adhesives solvents, and sealing compounds can burn easily, can give off harmful vapors, and are harmful to skin and clothing. To avoid injury or death, keep away from open fire and use in well-ventilated area. If adhesive, solvent, or sealing compound gets on skin or clothing, wash immediately with soap and water.

- (1) Apply silicone adhesive-sealant on differential carrier (1) mounting surface and outside of two dowel pins (2).

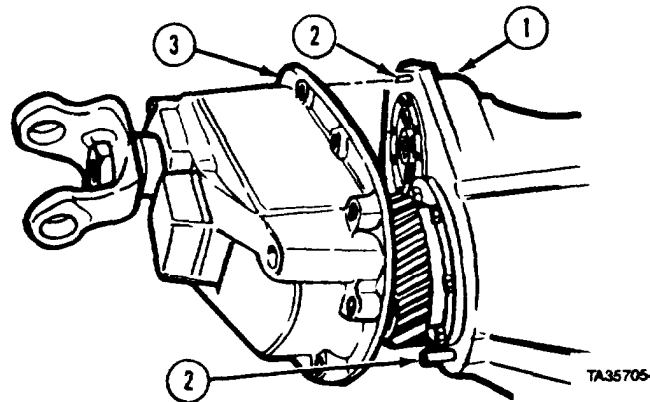

- (2) Attach lifting device to differential carrier cover (3).

NOTE

It may be necessary to turn gear to mesh with differential carrier cover.

- (3) Soldier A installs differential carrier cover (3) on differential carrier (1) and aligns cover with two dowel pins (2) while Soldier B operates lifting device.

Axles No. 3 and No. 4 Maintenance Instructions (Cont)

10-7. DIFFERENTIAL CARRIER COVER, AXLE NO. 3 REMOVAL/REPAIR/INSTALLATION (CONT).

- (4) Apply oil to threads of screw (4) and install screw and lockwasher (5) in differential carrier cover (3). Tighten screw finger-tight.
- (5) Apply oil to threads of screw (6) and install screw and lockwasher (5) in differential carrier cover (3). Tighten screw finger-tight.
- (6) Apply oil to threads of eight screws (7) and install screws and lockwashers (5) in differential carrier cover (3). Tighten screws finger-tight.
- (7) Remove lifting device from differential carrier cover (3).
- (8) Tighten screw (4,6, and 7) evenly, then tighten to 115 to 125 lb-ft (155 to

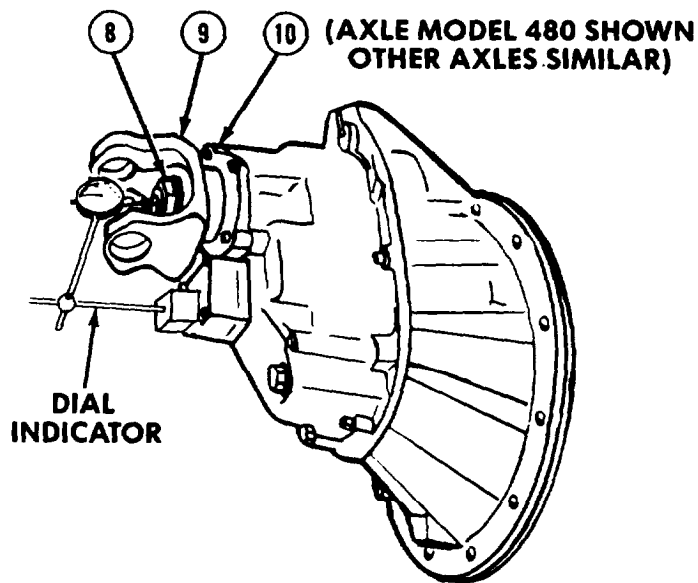
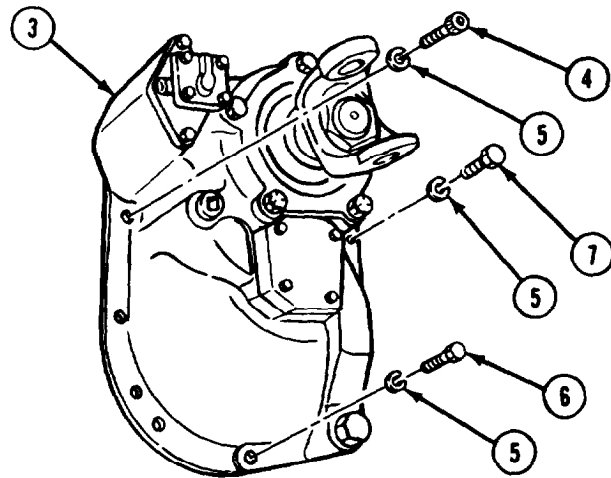

NOTE

To tighten yoke nut, use torque multiplier and 250 lb-ft. (339 N•m) ratchet end torque wrench.

- (9) Using 2-7/8 in. fabricated socket, tighten nut (8) to 840 to 1020 lb-ft (1 139 to 1 383 N•m).
- (10) Attach dial indicator to yoke (9).
- (11) Push yoke (9) in, then pry yoke away from bearing cover (10), and read amount of end play on dial indicator. Allowable end play is 0.003 to 0.007 in. (0.076 to 0.178 mm).
- (12) Remove dial indicator from yoke (9).

Axles No. 3 and No. 4 Maintenance Instructions (Cont)

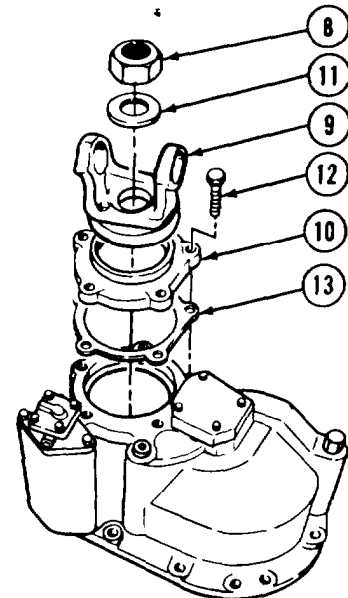
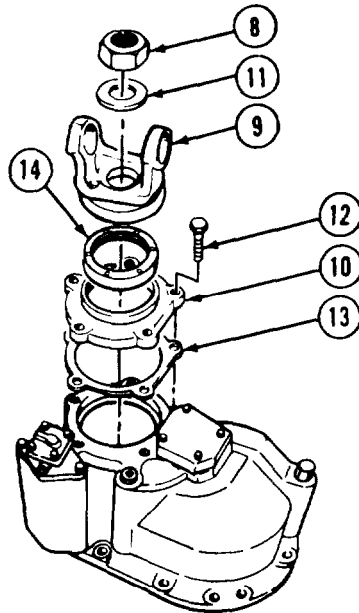

- (13) Using 2-7/8 in fabricated socket, remove nut (8), washer (11), and yoke (9).
- (14) If end play is correct, go to step (20). If end play is not correct, continue with step (15).
- (15) Remove five screws (12) from bearing cover (10).
- (16) Remove bearing cover (10).

NOTE

If measured end play is more than allowable amount, shims must be removed. If measured end play is less than allowable amount, shims must be added.

- (17) Add or remove shims (13) as necessary.
- (18) Install bearing cover (10) over shims (13).
- (19) Install five screws (12). Tighten screws to 75 to 85 lb-ft (101 to 115 N•m).
- (20) Apply light coat of lubricating oil to inside of seal (14) and install seal on bearing cover (10).
- (21) Install yoke (9), washer (11), and nut (8).
- (22) Using 2-7/8 in. fabricated socket, tighten nut (8) to 840 to 1020 lb-ft (1 139 to 1 383 N•m).
- (23) Install fitting (15) to lockout air chamber (16).
- (24) Connect power divider lockout air line (17) to lockout air chamber (16).

f. Follow-on Maintenance.

- (1) Install propeller shaft (TM 9-2320-279-20).
- (2) Lubricate axle (LO 9-2320-279-12).
- (3) Start engine and check for air leaks (TM 9-2320-279-10).

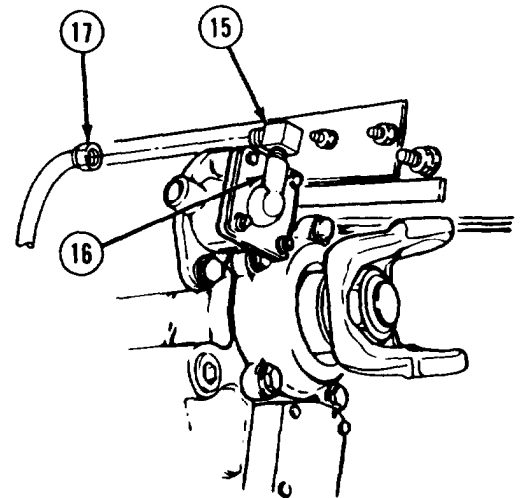

END OF TASK

10-8. DELETED.

Axles No. 3 and No. 4 Maintenance Instructions (Cont)

10-9. DIFFERENTIAL CARRIER, AXLE NO. 3 REMOVAL/INSTALLATION.

This task covers:

- a. Removal
- b. Cleaning/Inspection
- c. Installation
- d. Follow-on Maintenance

INITIAL SETUP

Models

All

Test Equipment

None

Special Tools

Adapter, torque SRES20

Supplies

Adhesive-sealant, silicone, Item 6, Appendix C

Solvent, dry cleaning, Item 57, Appendix C

Personnel Required

MOS 63W, Wheel vehicle repairer (2)

References

None

Equipment Condition

TM or Para

Para 10-7

Para 10-4

Condition Description

Differential carrier cover, axle No. 3, removed.

Axle housing cover assembly removed.

Axle on clean work surface.

Special Environmental Conditions

None

General Safety Instructions

None

Level of Maintenance

General Support

a. Removal.

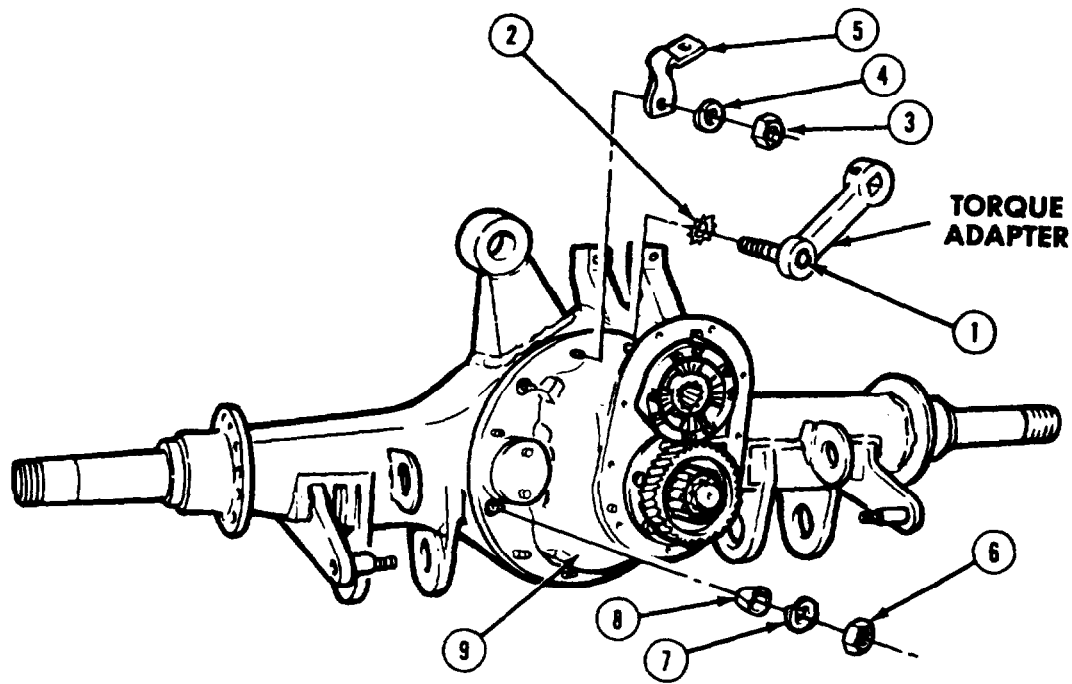

Axles No. 3 and No. 4 Maintenance Instructions (Cont)

- (1) Mark and remove two screws (1) and lock washers (2) with torque adapter.
- (2) Remove nut (3), lockwasher (4), and bracket (5).
- (3) Remove nine nuts (6) and lockwashers (7).
- (4) Remove four tapered locks (8).

WARNING

Keep out from under differential carrier. Serious injury may result if differential carrier falls from lifting device.

NOTE

Do not strike differential carrier to loosen. Tap around edge of flange to avoid damage.

- (5) Attach lifting device to differential carrier (9).
- (6) Soldier A removes differential carrier (9) while Soldier B operates lifting device.
- (7) Mount differential carrier (9) on stand and fasten in place. Remove lifting device.

b. Cleaning/Inspection.

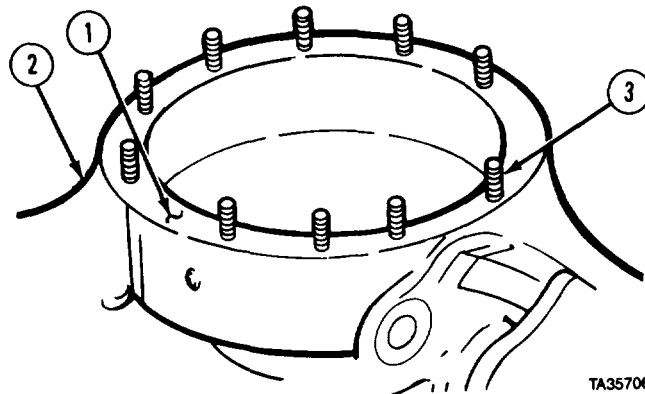

- (1) Scrape dirt and old sealant from mounting surface (1) on axle housing (2).

WARNING

Adhesives, solvents, and sealing compounds can burn easily, can give off harmful vapors, and are harmful to skin and clothing. To avoid injury or death, keep away from open fire and use in well-ventilated area. If adhesive, solvent, or sealing compound gets on skin or clothing, wash immediately with soap and water.

- (2) Use dry cleaning solvent to clean axle housing (2).
- (3) Use clean lint free cloth to wipe dry.
- (4) Inspect mounting studs (3) for cracks, breaks, and damaged threads. Replace if damaged.
- (5) Inspect axle housing (2) for cracks or damage. Replace if damaged.

Axles No. 3 and No. 4 Maintenance Instructions (Cont)

10-9. DIFFERENTIAL CARRIER, AXLE NO. 3 REMOVAL/INSTALLATION (CONT.)

c. Installation.

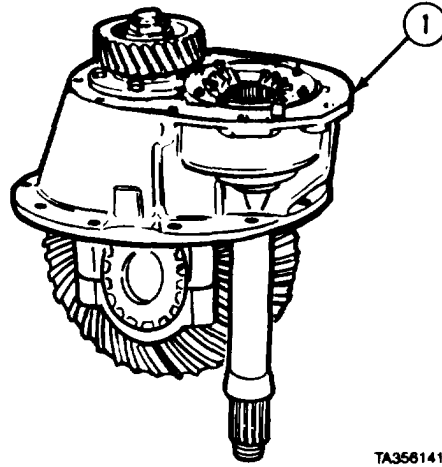

TA356141

WARNING

Keep out from under differential carrier. Serious injury may result if differential carrier falls from lifting device.

- (1) Attach lifting device to differential carrier (1).
- (2) Soldier A removes differential carrier (1) from stand while Soldier B operates lifting device.

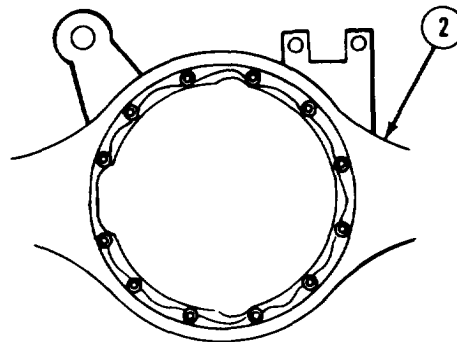

TA357063

WARNING

Adhesives, solvents, and sealing compounds can burn easily, can give off harmful vapors, and are harmful to skin and clothing. To avoid injury or death, keep away from open fire and use in well-ventilated area. If adhesive, solvent, or sealing compound gets on skin or clothing, wash immediately with soap and water.

- (3) Apply silicone adhesive-sealant on inside edge of axle housing (2) mounting surface.

Axles No. 3 and No. 4 Maintenance Instructions (Cont)

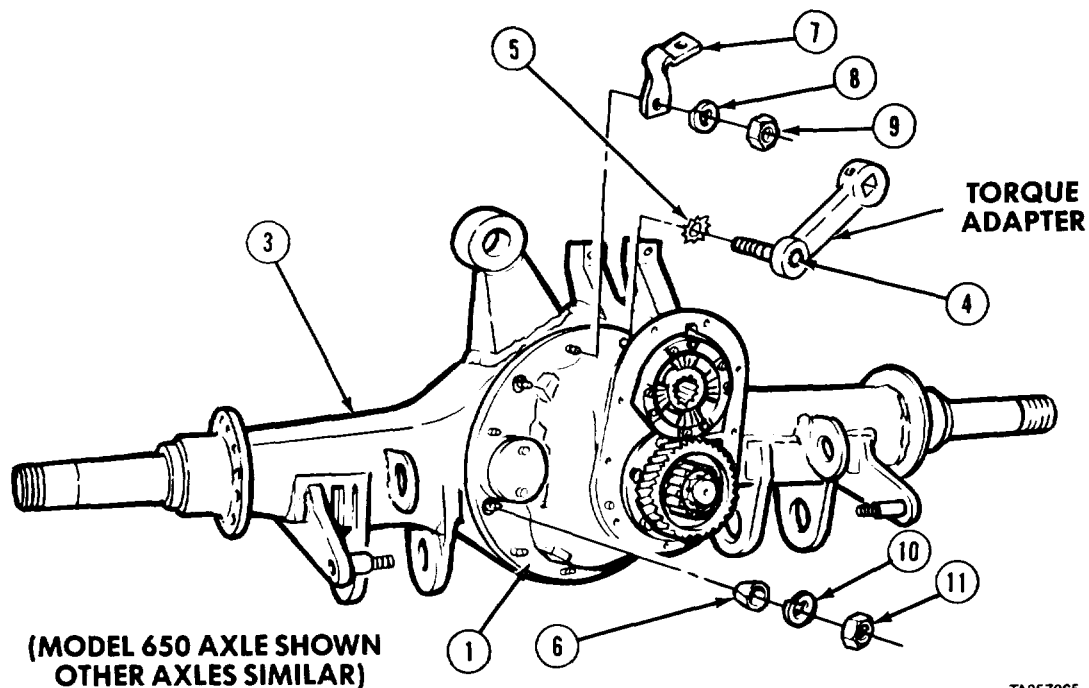

- (4) Soldier A installs differential carrier (1) on axle (3) while Soldier B operates lifting device. Remove lifting device.
- (5) Install two screws (4) and lockwashers (5).
- (6) Install four tapered locks (6).
- (7) Install bracket (7), lockwasher (8), and nut (9).
- (8) Install nine lockwashers (1) and nuts (11).
- (9) Tighten screws (4) to 210 to 230 lb-ft (285 to 312 N•m) using torque adapter and torque wrench.
- (10) Tighten nuts (11) to 150 to 170 lb-ft (203 to 230 N•m).

d. Follow-on Maintenance.

- (1) Install axle housing cover assembly (para 10-4).
- (2) Install differential carrier cover, axle No. 3 (para 10-7).

END OF TASK

10-10. DIFFERENTIAL CARRIER, AXLE NO. 3 (AXLE MODELS 480, 580, AND 650) REPAIR.	
This task covers:	
a. Disassembly	c. Assembly
b. Cleaning/Inspection	d. Follow-on Maintenance
INITIAL SETUP	
<i>Models</i>	<i>Personnel Required</i>
All	MOS 63W, Wheel vehicle repairer (2)
<i>Test Equipment</i>	<i>References</i>
Indicator, dial J3001 -3	None
Scale, spring, and attaching wire J8129	<i>Equipment Condition</i>
<i>Special Tools</i>	<i>TM or Para</i>
None	Para 10-9
<i>Supplies</i>	<i>Condition Description</i>
Adhesive-sealant, silicone, Item 6, Appendix C	Differential carrier, axle
Dye, prussian blue, Item 32, Appendix C	No. 3 removed.
Lockwire, Item 39, Appendix C	<i>Special Environmental Conditions</i>
Oil, lubricating, gear, Item 43, Appendix C	None
Solvent, dry cleaning, Item 57, Appendix C	<i>General Safety Instructions</i>
	None
	<i>Level of Maintenance</i>
	General Support

a. Disassembly.

WARNING

Edges of inner-axle differential are sharp. Wear gloves to avoid personal injury.

- (1) Remove inter-axle differential (1).
- (2) Remove output shaft (2) and assembled parts from carrier (3).

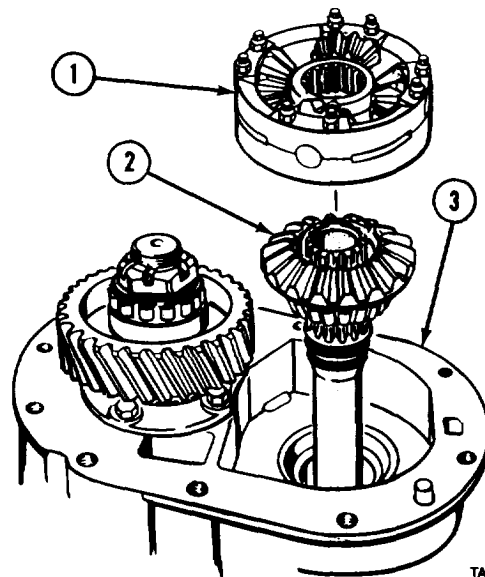

TA476354

Axles No. 3 and No. 4 Maintenance Instructions (Cont)

- (3) Matchmark inter-axle differential case halves (4 and 5).
- (4) Remove eight screws (6) and locknuts (7).
- (5) Separate two case halves (4 and 5).
- (6) Remove four thrust washers (8), side pinions (9), and bushings (10) from spider (1 1).

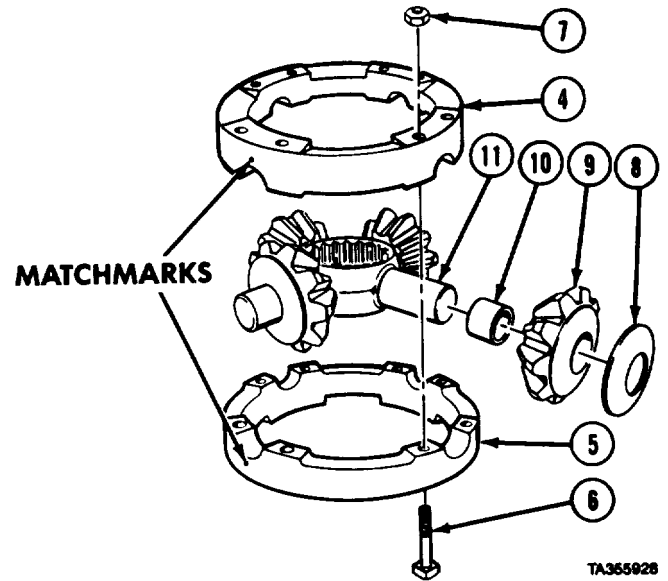

WARNING

Wear safety glasses while removing retaining rings to protect eyes from possible injury or blindness.

- (7) Remove retaining ring (12), side gear (13), and bearing cone (14) from output shaft (2).
- (8) Remove bearing cone (14) from side gear (13).
- (9) Remove two preformed packings (15) from output shaft (2).
- (10) Remove bushing (16) from output shaft (2).

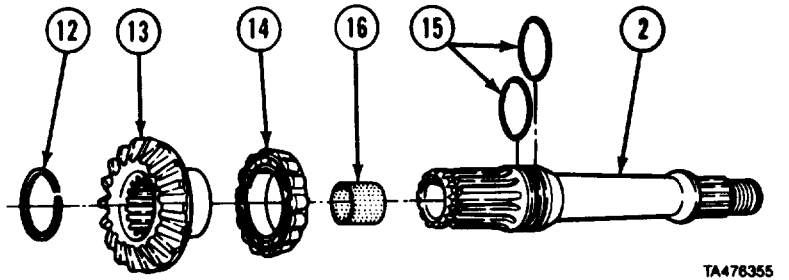

NOTE

Axle 580 has no roll pin.

- (11) Remove roll pin (17).
- (12) Loosen locknut (18).
- (13) Remove bearing CUP (19) from carrier (3).

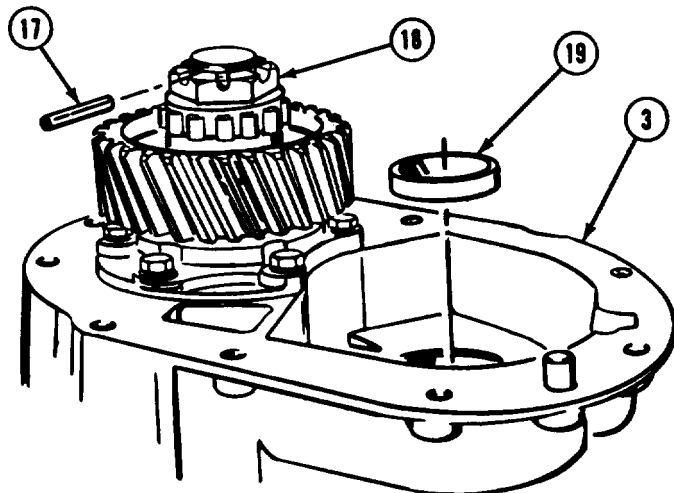

78356

Axles No. 3 and No. 4 Maintenance. Instructions (Cont)

10-10. DIFFERENTIAL CARRIER, AXLE NO. 3 (AXLE MODELS 480, 580, AND 650) REPAIR (CONT).

- (14) Check ring gear (20) backlash with dial indicator. Move ring gear back and forth to measure backlash. Record backlash.

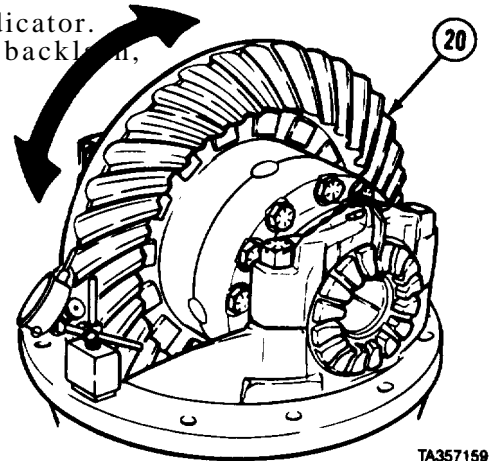

TA357159

- (15) Check tooth contact pattern. Paint one-third of teeth on ring gear (20) with prussian blue dye. Roll ring gear forward and backward to set pattern in dye. Record ring gear tooth pattern.

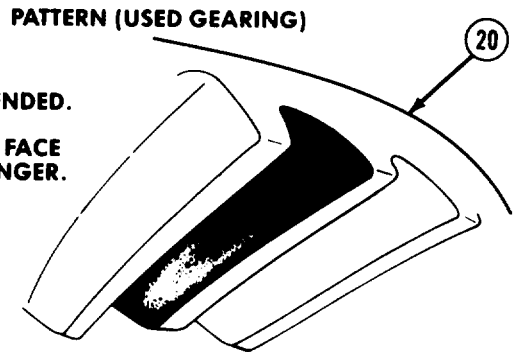

- POCKET MAY BE EXTENDED.
- PATTERN ALONG THE FACE WIDTH COULD BE LONGER.

TA357128

- (16) Remove lockwire from two screws (21).
 (17) Remove two screws (21) and adjuster lock (22).
 (18) Remove lockwire from two screws (23).
 (19) Mark center of bearing cap and remove two screws (23), washers (24), and bearing cap (25).

NOTE

Do step (20) for 480 and 580 axles only.

- (20) Remove two bushings (26).

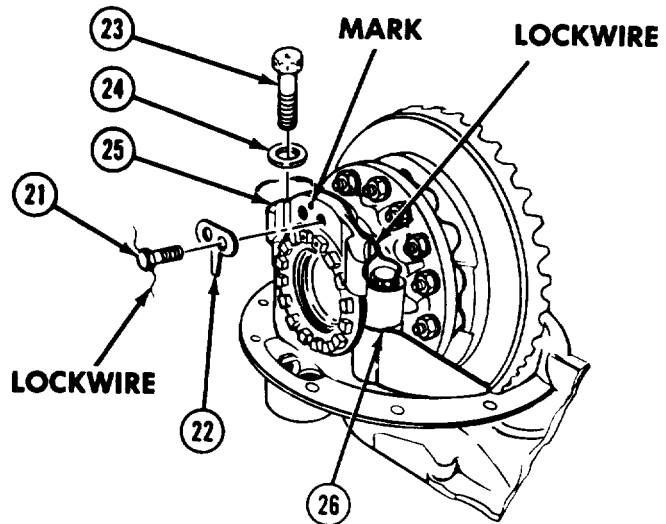

TA355987

Axles No. 3 and No. 4 Maintenance Instructions (Cont)

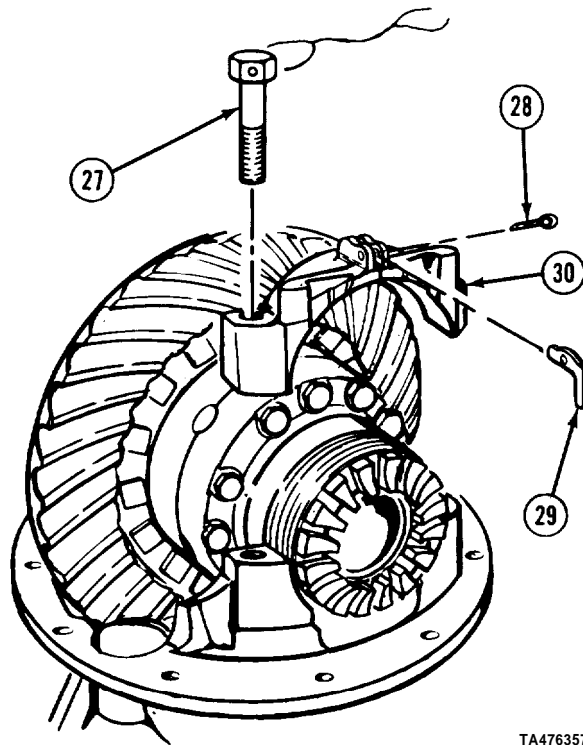

TA476357

NOTE

Gear rotation on axle 650 is opposite of 480 and 580. Axle 650 will be shown throughout entire task.

- (21) Remove lockwire from two screws (27).
- (22) Remove cotter pin (28) and adjuster lock (29) from bearing cap (30).
- (23) Mark center of bearing cap (30) and remove two screws (27) and bearing cap.

NOTE

Side of ring gear away from gear teeth must be lifted first to prevent gear from catching on differential carrier casting.

- (24) Soldier A removes ring gear (20) and differential (31) as an assembly from differential carrier (32) while Soldier B operates lifting device. Place ring gear, teeth up, on clean work surface and remove lifting device.
- (25) Remove two bearing adjusters (33 and 34) and bearing cups (35 and 36).

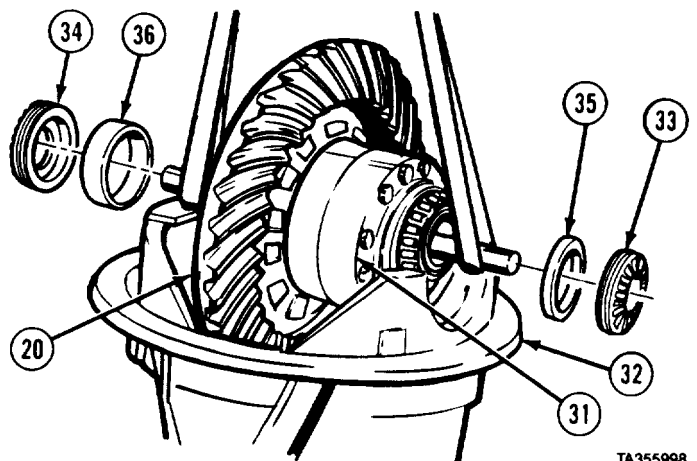

TA355998

Axles No. 3 and No. 4 Maintenance Instructions (Cont)

10-10. DIFFERENTIAL CARRIER, AXLE NO. 3 (AXLE MODELS 480,580, AND 650) REPAIR
(CONT).

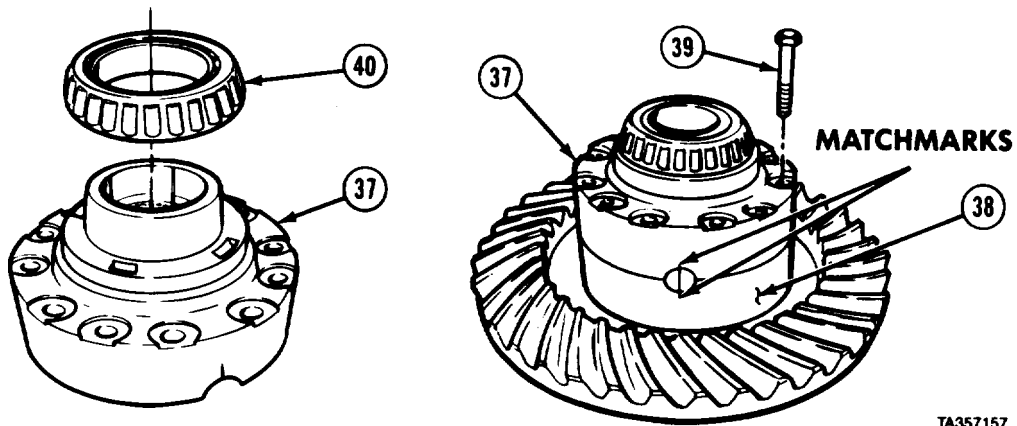

TA357157

- (26) Position ring gear (20), teeth up, on clean work surface.
- (27) Matchmark differential case plain half (37) and differential case flanged half (38)
- (28) Remove 12 screws (39) and differential case plain half (37).
- (29) Remove bearing cone (40) from differential case plain half (37).

- (30) Remove thrust washer (41) and side gear (42) from spider (43).

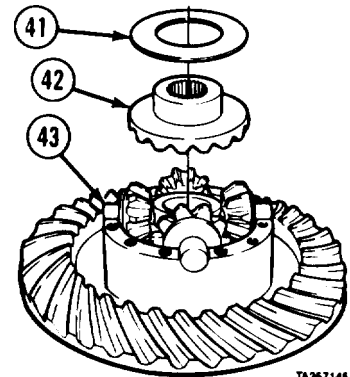

TA357145

- (31) Remove spider (43) from differential case flanged half (38),

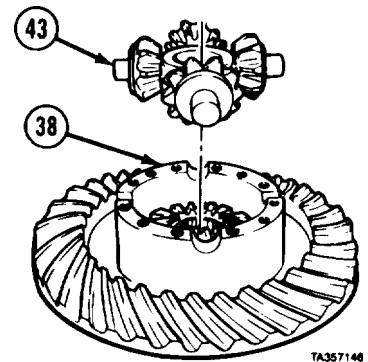

TA357146

Axles No. 3 and No. 4 Maintenance Instructions (Cont)

- (32) Remove four thrust washers (44) and side pinions (45) from spider (43).

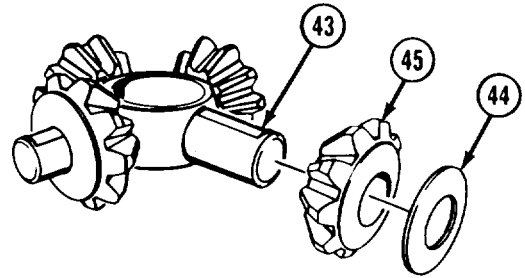

TA357116

- (33) Remove side gear (46) and thrust washer (47) from differential case flanged half (38).

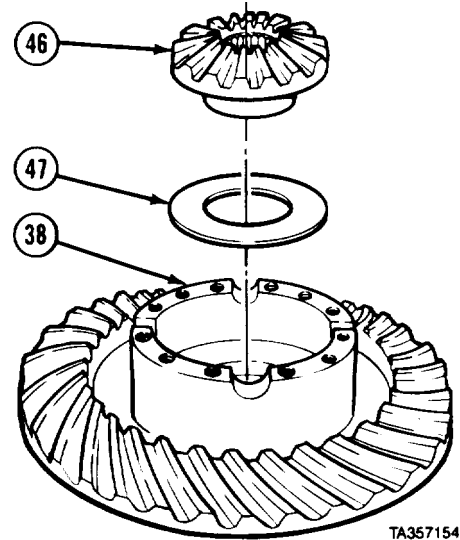

TA357154

CAUTION

Differential case cover is under spring tension. Differential case cover must be held down while nuts are removed, then released slowly to prevent damage to screw threads.

- (34) Remove 16 nuts (48) and screws (49).
 (35) Remove differential case cover (50).

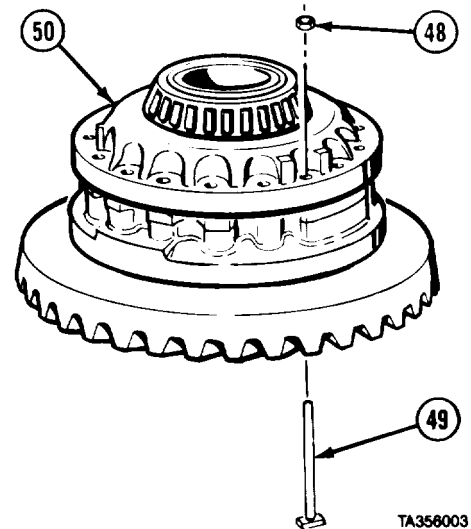

TA358003

Axles No. 3 and No. 4 Maintenance Instructions (Cont)

10-10. DIFFERENTIAL CARRIER, AXLE NO. 3 (AXLE MODELS 480, 580, AND 650) REPAIR (CONT).

(36) Remove 12 springs (51).

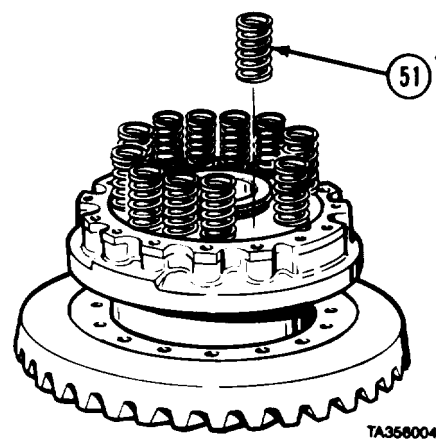

(37) Remove bearing cone (52) from differential case cover (50).

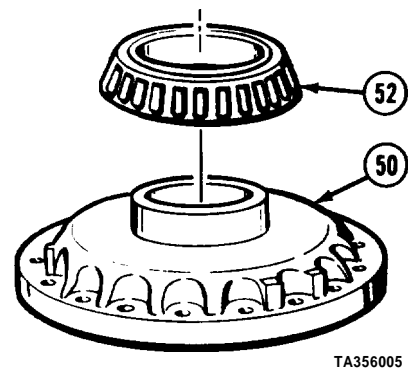

(38) Remove friction plate driver (53) and assembled parts from differential case flanged half (38).

(39) Remove differential case flanged half (38) from ring gear (20).

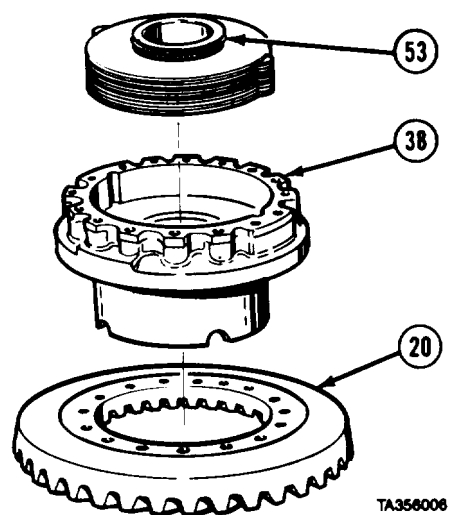

Axles No. 3 and No. 4 Maintenance Instructions (Cont)

- (40) Remove two retaining rings (54 and 55) and pressure plate (56) from friction plate driver (53).

NOTE

Do step (41) for axle Model 480 only.

- (41) Remove 11 tangled friction plates (57) and 10 splined friction plates (58) from friction plate driver (53).

NOTE

Do step (42) for axle Model 580 only.

- (42) Remove 13 tangled friction plates (57) and 12 splined friction plates (58) from friction plate driver (53).

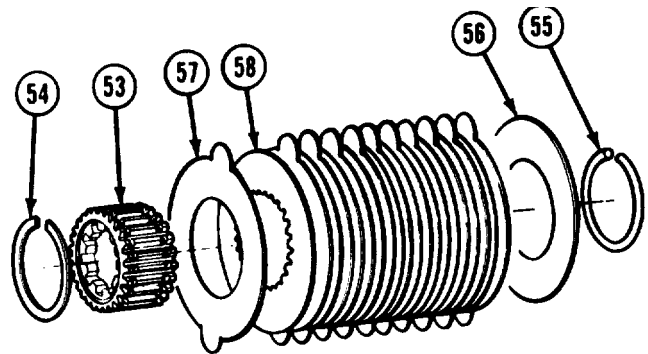

TA357152

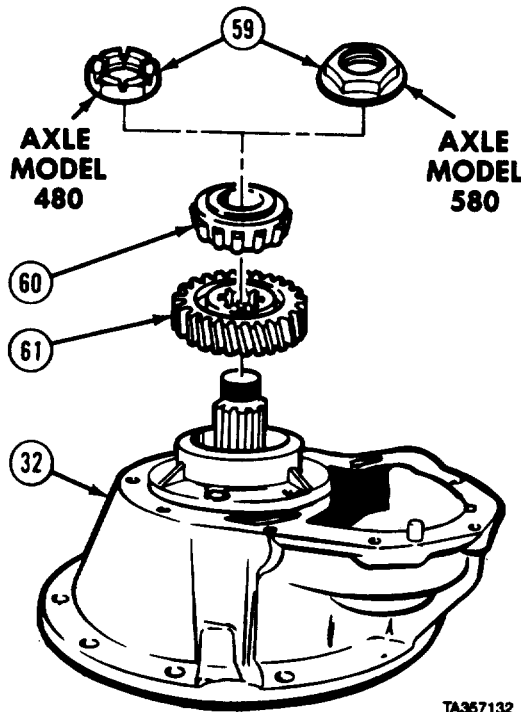

TA357132

- (43) Remove slotted nut (59).

- (44) Remove support bearing (60) and pinion gear (61) from differential carrier (32).

Axles No. 3 and No. 4 Maintenance Instructions (Cont)

10-10. DIFFERENTIAL CARRIER, AXLE NO. 3 (AXLE MODELS 480,580, AND 650) REPAIR (CONT).

- (45) Remove six screws (62) and lockwashers (63) from bearing cage (64).
- (46) Remove bearing cage (63) and attached parts from differential carrier (32).
- (47) Remove shims (65) from differential carrier (32) and bearing cage (64). Record number and size of shims.

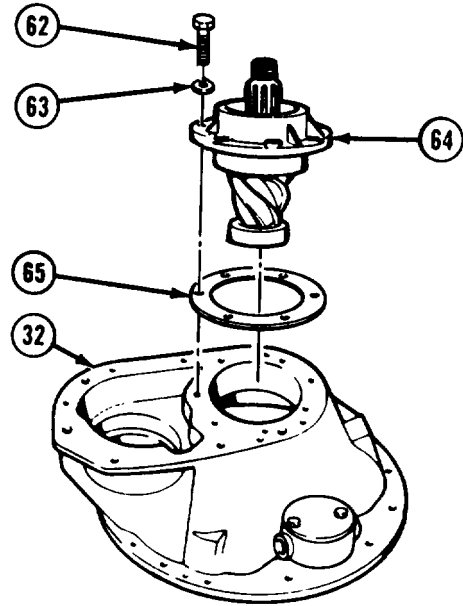

- (48) Press pinion (66) from bearing cage (64).

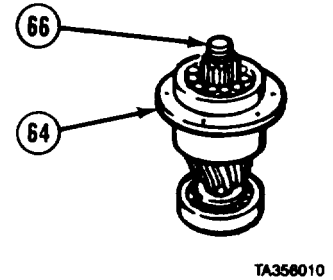

- (49) Remove bearing cone (67) and bearing cups (68 and 69) from bearing cage (64).

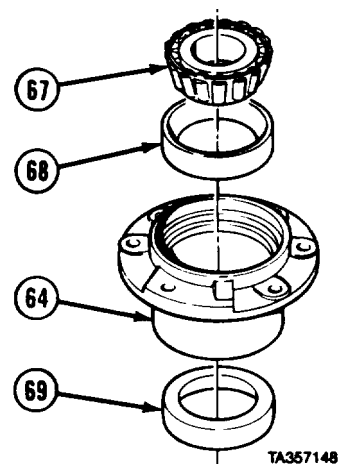

Axles No. 3 and No. 4 Maintenance Instructions (Cont)

NOTE

Axle Model 480 does not have spacer washer.

- (50) Remove spacer (70) and spacer washer (71) from pinion (66).
- (51) Remove inner bearing cone (72) and pilot bearing (73) from pinion (66).
- (52) Remove pipe plug (74) from differential carrier (32).
- (53) Remove two screws (75), lockwashers (76), and cover (77).

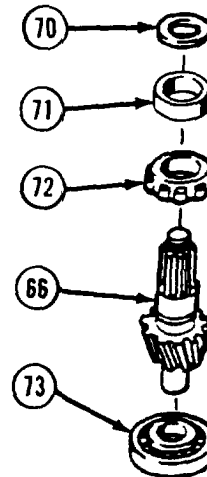

b. Cleaning/Inspection.

NOTE

If differential carrier housing must be replaced, the new housing will come as part of a kit. This kit contains parts not required in this application. Refer to TM 9-2320-279-24P for proper identification of parts.

- (1) Scrape old sealant from differential carrier.

WARNING

Adhesives, solvents, and sealing compounds can burn easily, can give off harmful vapors, and are harmful to skin and clothing. To avoid injury or death, keep away from open fire and use in well-ventilated area. If adhesive, solvent, or sealing compound gets on skin or clothing, wash immediately with soap and water.

- (2) Clean all metal parts with drycleaning solvent.

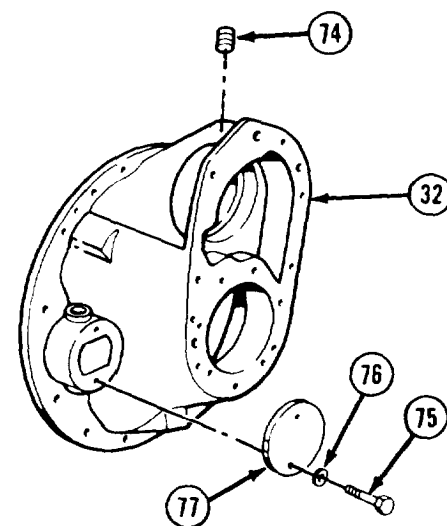

WARNING

Compressed air used for cleaning purposes will not exceed 30 psi (207 kPa). Use only with effective chip guarding and personal protective equipment, goggles, shield, and gloves.

- (3) Use clean, lint-free cloth or compressed air to dry metal parts, except bearings. Allow bearings to air dry.
- (4) Inspect all metal parts for breaks, cracks, and sharp edges. Replace if damaged.
- (5) Inspect bearings for loose rollers or cracked or broken races. Coat bearings with oil.
- (6) Inspect dowel pins for cracks and breaks. Replace if damaged.
- (7) Inspect internally splined friction plate embossing. If embossing is completely worn off, replace friction plate.
- (8) Inspect friction plates for warping, cracks, breaks, and excessive oxidation (varnish) on plates. If friction plates are warped, cracked, broken, or oxidized, replace individual friction plates as necessary. If more than half the friction plates are oxidized, replace entire set of friction plates.
- (9) If drive pinion or ring gear is bad, replace both as matched set.
- (10) Replace springs if there are signs of overheating, wear due to rubbing against other parts, or if length is less than 1.34 in. (34 mm) under 200-lb (91 kg) load. If three or more springs must be replaced, replace entire set of springs.

Axles No. 3 and No. 4 Maintenance Instructions (Cont)

10-10. DIFFERENTIAL CARRIER, AXLE NO. 3 (AXLE MODELS 480,580, AND 650) REPAIR (CONT).

- (11) Replace differential output shaft bushing.
- (12) Inspect spider for visible steps and grooves on shafts created by wear. Replace worn spider.
- (13) Inspect spider gears for chipped teeth, cracks, discoloration and out of round holes.
- (14) Inspect expansion plugs for damage or signs of leakage. Replace if **damaged** or if there is evidence of leakage.

c. Assembly.

- (1) Install pipe plug (1) in differential carrier (2).

WARNING

Adhesives, solvents, and sealing compounds can burn easily, can give off harmful vapors, and are harmful to skin and clothing. To avoid injury or death, keep away from open fire and use in well-ventilated area. If adhesive, solvent, or sealing compound gets on skin or clothing, wash immediately with soap and water.

- (2) Apply silicone adhesive-sealant to cover (3) and install with two lockwashers (4) and screws (5).
- (3) Tighten screws (5) to 35 to 45 lb-ft (47 to 61 N•m).

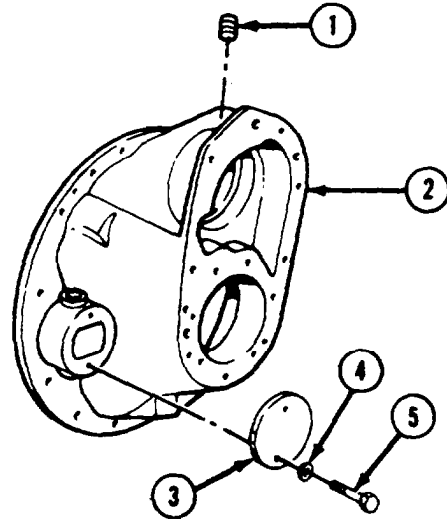

TA360027

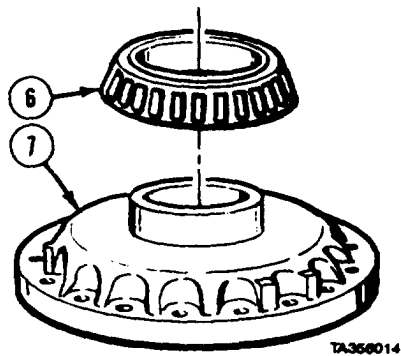

TA360014

- (4) Install bearing cone (6) on differential case cover (7).

Axles No. 3 and No. 4 Maintenance Instructions (Cont)

(5) Install bearing cone (8) on differential case plain half (9):

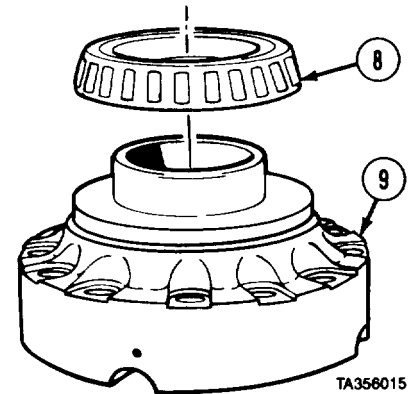

- (6) Position ring gear (10), teeth down, on suitable wooden blocks.
- (7) Position differential case flanged half (11) in ring gear (10).

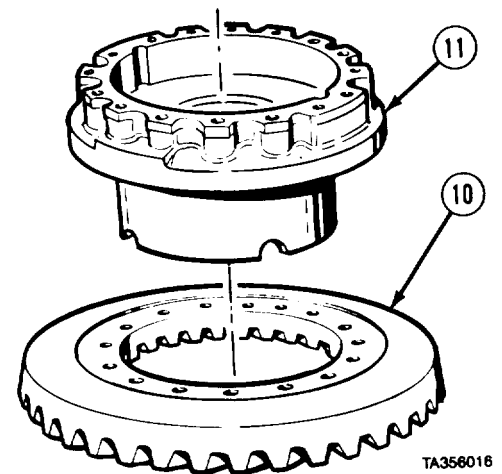

(8) Install retaining ring (12) on friction plate driver (13).

NOTE

Do step (9) for axle Model 480 only.

(9) Install 11 tanged friction plates (14) and 10 splined friction plates (15) alternately. Apply lubricating oil to last tanged friction plate installed.

NOTE

Do step (10) for axle Model 580 only.

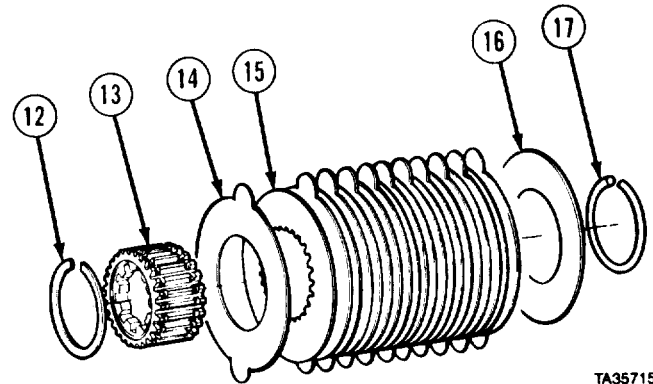

- (20) Install 13 tanged friction plates (14) and 12 splined friction plates (15) alternately. Apply lubricating oil to last friction plate installed.
- (11) Install pressure plate (16) on friction plate driver (13).
- (12) Install second retaining ring (17) on friction plate driver (13).

Axles No. 3 and No. 4 Maintenance Instructions (Cont)

10-10. DIFFERENTIAL CARRIER, AXLE NO. 3 (AXLE MODELS 480 AND 580) REPAIR (CONT).

(13) Aline and install tanged friction plates (14) as an assembly in differential case flanged half (11).

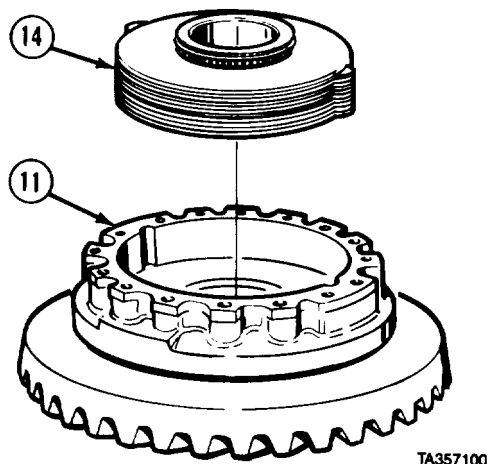

(14) Install 12 springs (18) around friction plate driver (13).

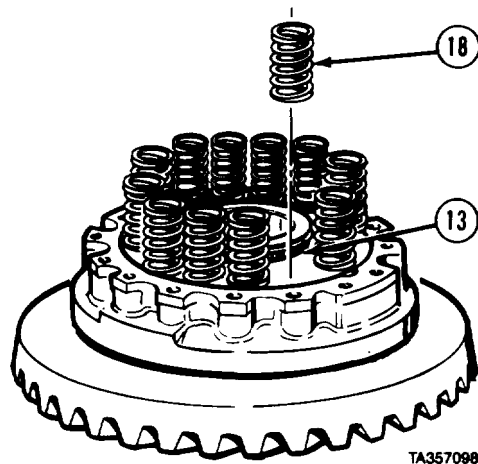

(15) Position differential case cover (7) over springs (18).
 (16) Clamp differential case cover (7) to ring gear (10).

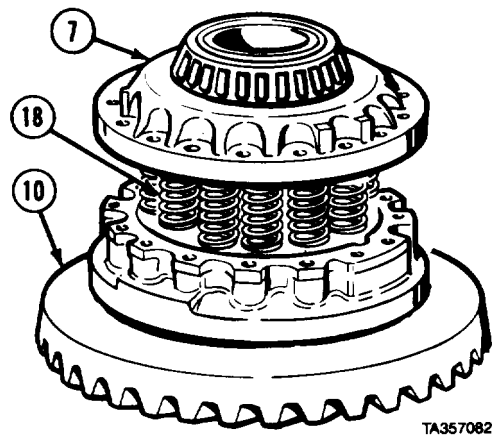

Axles No. 3 and No. 4 Maintenance Instructions (Cont)

CAUTION

Square heads of screws must be seated in machined groove of ring gear otherwise ring gear or screws may be damaged.

- (17) Install 16 screws (19) and nuts (20).
- (18) Tighten nuts (20) to 180 to 220 lb-ft (244 to 298 N-m).

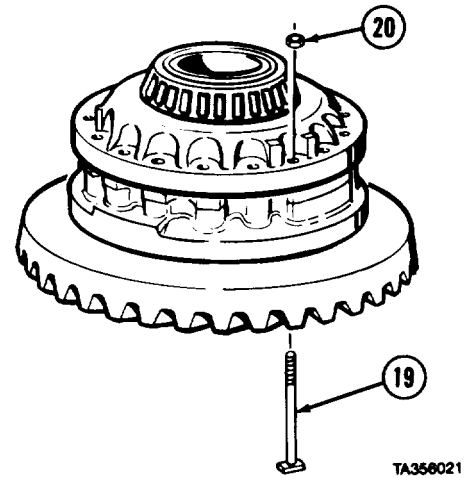

- (29) Lubricate and install thrust washer (21) and side gear (22) in differential case flanged half (11).

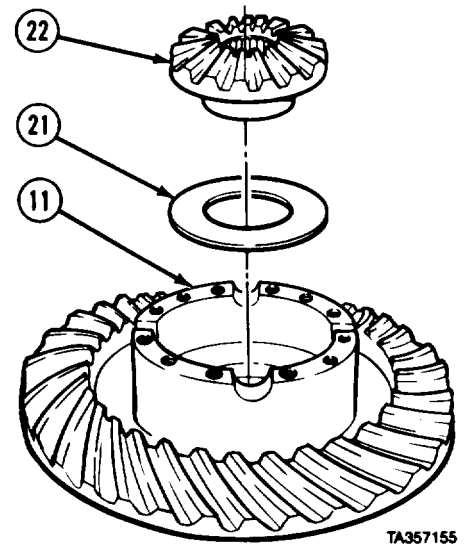

- (20) Lubricate spider (23) and install four side pinions (24) and thrust washers (25).

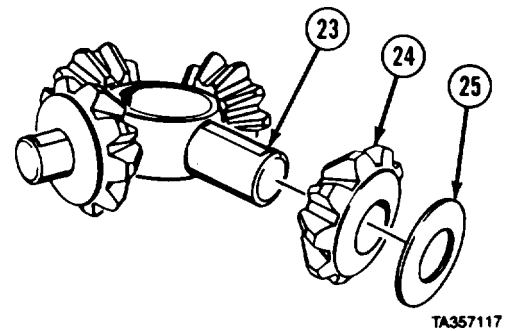

Axles No. 3 and No. 4 Maintenance Instructions (Cont)

10-10. DIFFERENTIAL CARRIER, AXLE NO. 3 (AXLE MODELS 480, 580, AND 650) REPAIR (CONT).

(21) Install spider (23) and assembled parts in differential case flanged half (11).

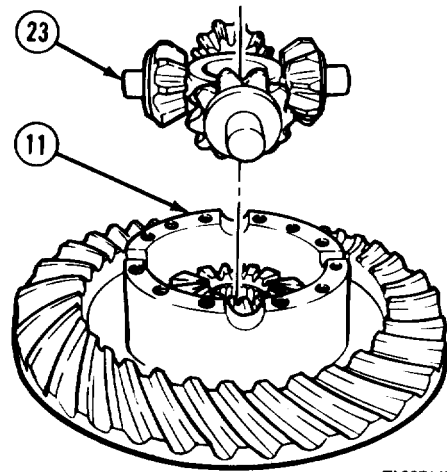

TA357147

(22) Lubricate and install side gear (26) and thrust washer (27) on top of four side pinions (24).

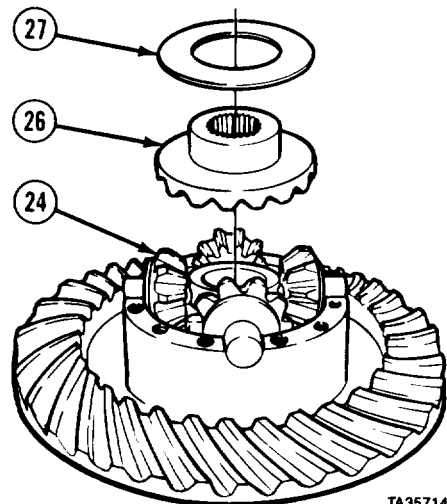

TA357144

(23) Aline matchmarks and install differential case plain half (9) on differential case flanged half (11).

NOTE

Put differential carrier in holding device before tightening screws.

(24) Install 12 screws (28) in differential case plain half (9). Tighten screws equally to 165 to 195 lb-ft (224 to 264 N·m).

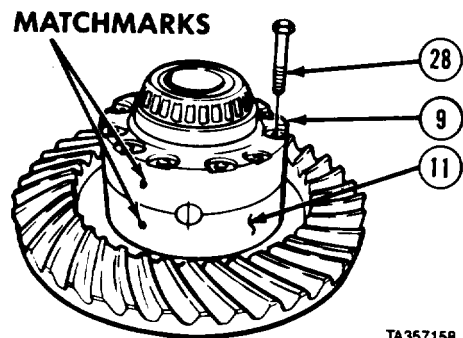

TA357158

Axles No. 3 and No. 4 Maintenance Instructions (Cont)

(25) Install inner bearing cup (29) in bearing cage (30).

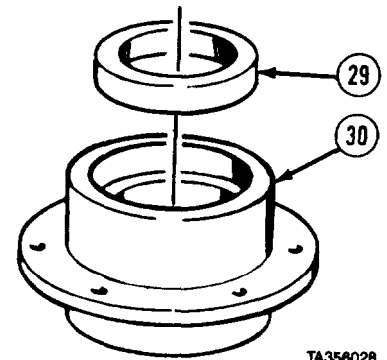

TA356028

(26) Turn bearing cage (30) over. Install outer bearing cup (31) in bearing cage.

(27) Lubricate and install inner bearing cone (32).

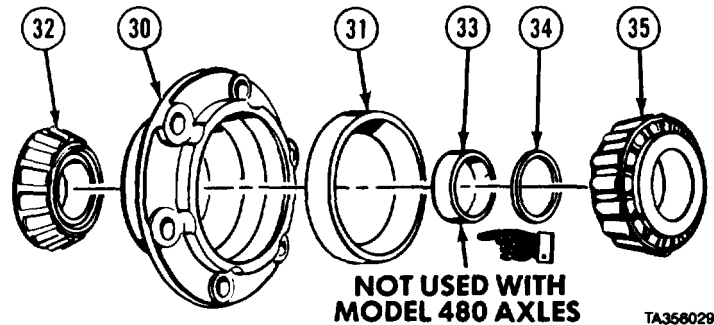

TA356029

NOTE

- Use 0.185-in. (4.70 mm) bearing cage spacer.
- Model 480 axle does not use spacer washer.

(28) Install spacer washer (33) and spacer (34) in bearing cage (30).

(29) Lubricate and install outer bearing cone (35) in outer bearing cup (31).

(30) Position bearing cage (30) in press so outer bearing cone (35) is on top.

CAUTION

- Turn bearing cage back and forth while applying pressure to be sure bearings and bearing cups are well lubricated.
- If bearing cage becomes hard to turn while applying pressure, STOP! Bearings can be damaged if too much pressure is applied. Get next larger spacer and repeat step (31).

(31) Lower press ram for load of 18.0 to 20.0 tons (16.3 to 18 metric tons).

(32) Wrap soft wire around bearing cage (30) twice and fasten one end of wire in bearing cage screw hole. Fasten other end of wire to spring scale.

(33) Pull on spring scale until bearing cage (30) begins to turn. Check that spring scale reads 3 to 7 lbs (2 to 3 kgs). If spring scale reading is correct, go to step (39). If reading is too low, go to step (37). If reading is too high, continue with step (34).

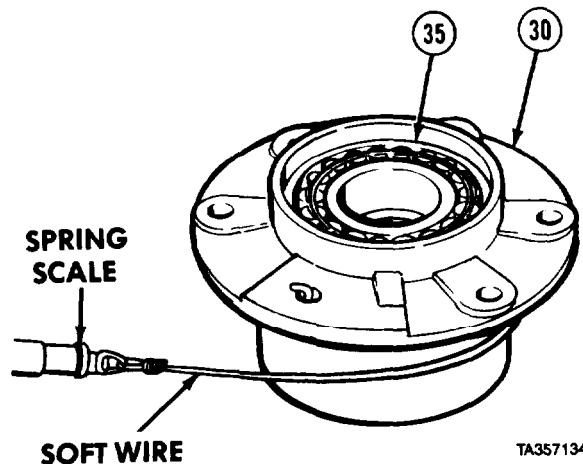

TA357134

Axles No. 3 and No. 4 Maintenance Instructions (Cont)

10-10. DIFFERENTIAL CARRIER, AXLE NO. 3 (AXLE MODELS 480,580, AND 650) REPAIR (CONT).

- (34) Remove outer bearing cone (35) and spacer (34) from bearing cage (30).
- (35) Use 0.001-in. (0.03 mm) thicker spacer (34) and install spacer and outer bearing cone (35) in bearing cage (30).
- (36) Repeat steps (30) through (33).
- (37) Remove outer bearing cone (35) and spacer (34). Use 0.001-in. (0.03 mm) thinner spacer and install spacer and outer bearing cone in bearing cage (30).
- (38) Repeat steps (30) through (33).

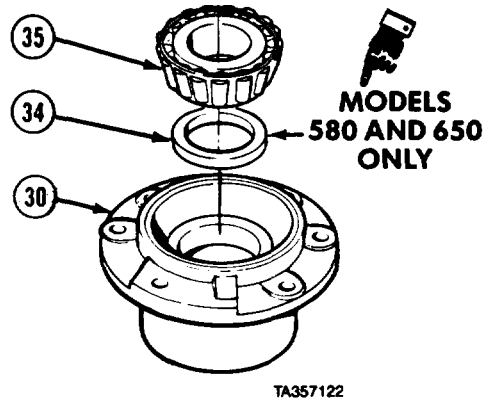

- (39.) Remove outer bearing cone (35), spacer (34), spacer washer (33), and inner bearing cone (32) from bearing cage (30).
- (40) Get spacer (34) 0.001-in. (0.03 mm) thicker than last spacer used and set aside for later installation.

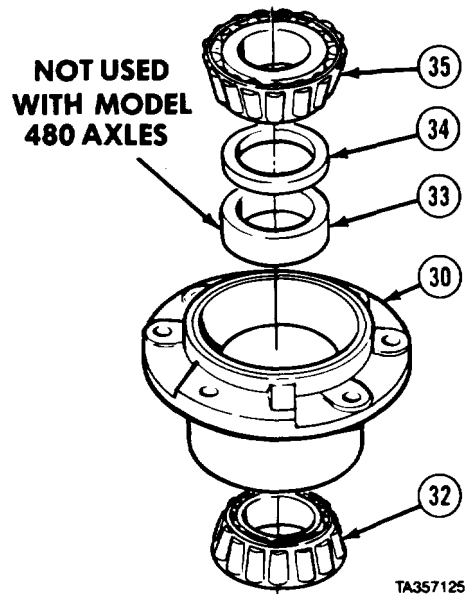

- (41) Lubricate and install pilot bearing (36) on pinion (37).
- (42) Stake pilot bearing (36) and pinion (37) as shown in pattern.

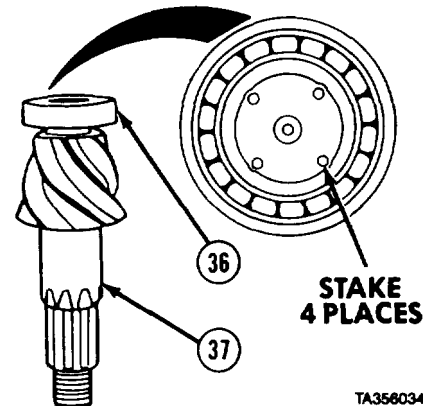

Axles No. 3 and No. 4 Maintenance Instructions (Cont)

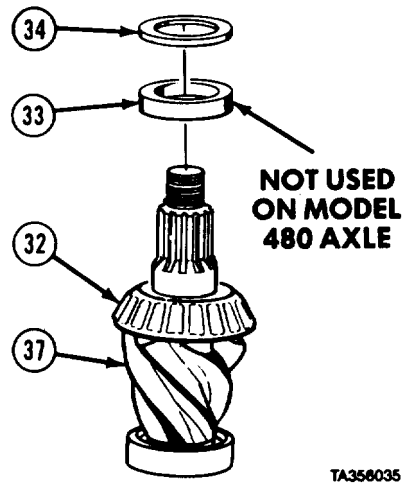

- (43) Lubricate and install inner bearing cone (32) on pinion (37).
- (44) Install spacer washer (33) and spacer (34) on pinion (37).

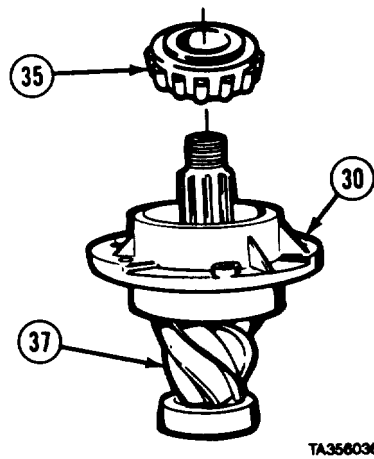

- (45) Install bearing cage (30) on pinion (37).
- (46) Lubricate and install outer bearing cone (35) on pinion (37).

Axles No. 3 and No. 4 Maintenance Instructions (Cont)

10-10. DIFFERENTIAL CARRIER, AXLE NO. 3 (AXLE MODELS 480, 580, AND 650) REPAIR (CONT).

NOTE

- To change spacer, remove pinion from bearing cage and outer bearing from pinion.
 - Turn bearing cage back and forth while applying pressure to be sure bearings are well lubricated.
- (47) Install pinion gear (38) on pinion (37). Position pinion in press and apply 1 to 2 tons load to pinion gear.
- (48) Turn bearing cage (30) by hand to make sure bearings are not binding. If bearings are binding, release pressure, then reapply pressure.

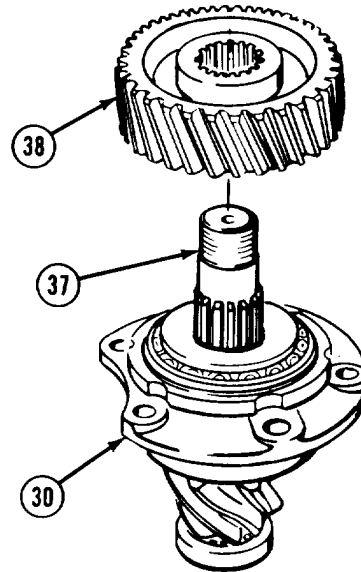

TA476358

- (49) Lower press ram for load of 18 to 20 tons (16.3 to 18.2 metric tons).
- (50) Measure pinion bearing preload. Wrap soft wire around bearing cage (30) twice and fasten one end of wire in bearing cage screw hole. Fasten other end of wire to spring scale.
- (51) Pull on spring scale until bearing cage (30) begins to turn. Check that spring scale reads 5 to 12 lbs (2.25 to 5.5 kg). If spring scale reading is correct, go to step (58). If reading is too low, go to step (55). If reading is too high, continue with step (52).

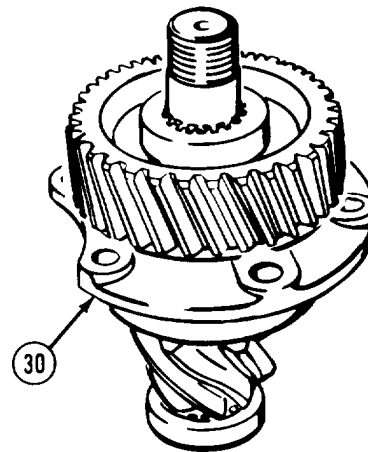

TA476359

Axles No. 3 and No. 4 Maintenance Instructions (Cont)

- (52) Remove pinion (37) from bearing cage (30), pinion gear (38), and outer bearing cone (35).
- (53) Use 0.001-in. (0.25 mm) thicker spacer (34) and install bearing cage (30), spacer, and outer bearing cone (35) on pinion (37).
- (54) Repeat steps (47) through (51).
- (55) Remove pinion (37) from bearing cage (30), pinion gear (38), and outer bearing cone (35).
- (56) Use 0.001-in. (0.25 mm) thinner spacer (34) and install bearing cage (30), spacer, and outer bearing cone (35) on pinion (37).
- (57) Repeat steps (47) through (51).
- (58) Remove pinion gear (38) from pinion (37).

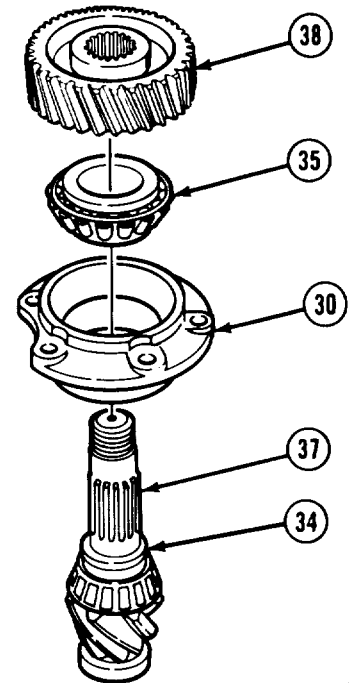

TA476360

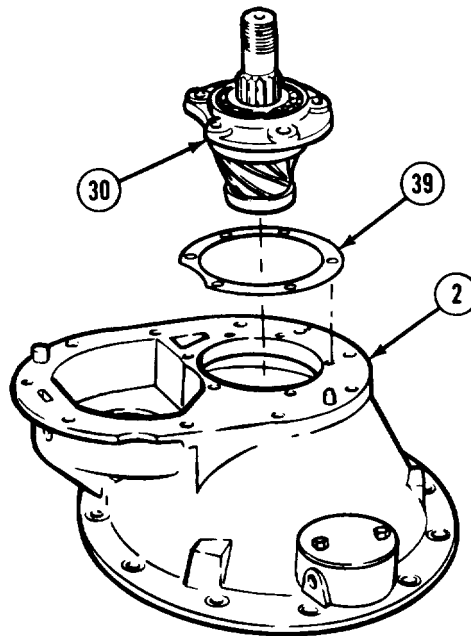

TA476361

- (59) Install same number and size of shims (39) recorded in disassembly step (46).
- (60) Install bearing cage (30) on carrier (2).

Axles No. 3 and No. 4 Maintenance Instructions (Cont)

10-10. DIFFERENTIAL CARRIER, AXLE NO. 3 (AXLE MODELS 480, 580, AND 650) REPAIR (CONT).

- (61) Install six screws (40) and lockwashers (41).
Tighten screws to 155 to 175 lb-ft (210 to 237 N·m).
- (62) Install pinion gear (38) on pinion (37).

NOTE

Support bearing and bearing race are provided as a set. Replace support bearing race (para 10-8) whenever support bearing is replaced.

- (63) Install support bearing (42) and locknut (43).
Tighten locknut to 980 lb-ft (1329 N·m).

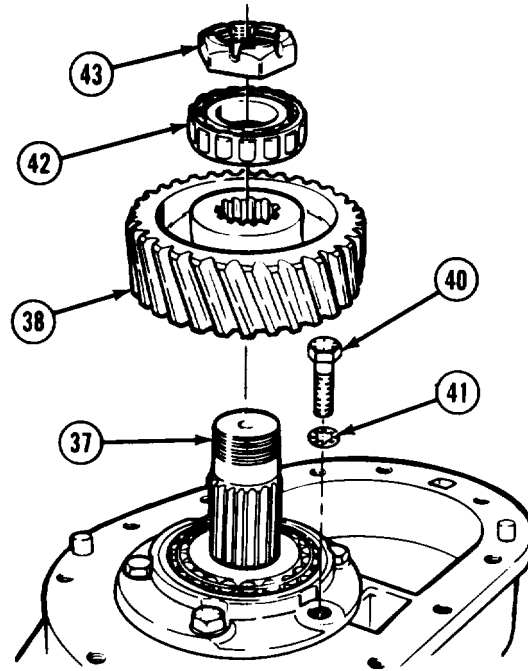

TA476362

- (64) Install two bushings (44) in carrier (2).
- (65) Lubricate bearing cones (6 and 8) with oil and position bearing cups (45 and 46) on bearing cones.
- (66) Attach suitable lifting device to assembled ring gear and differential (47).

NOTE

Ring gear must be tilted to clear casting inside carrier.

- (67) Soldier A installs assembled ring gear and differential (47) into carrier (2) while Soldier B operates lifting device.
- (68) Remove lifting device from assembled ring gear and differential (47).

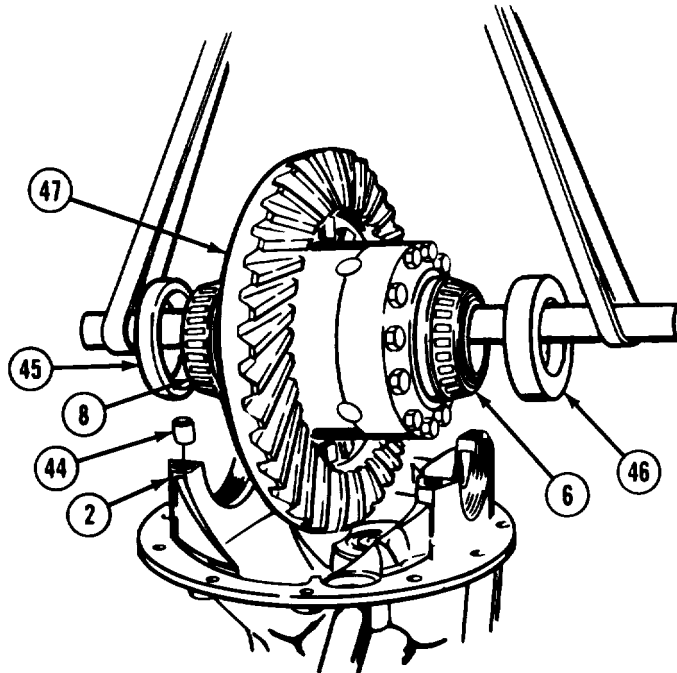

TA476363

Axles No. 3 and No. 4 Maintenance Instructions (Cont)

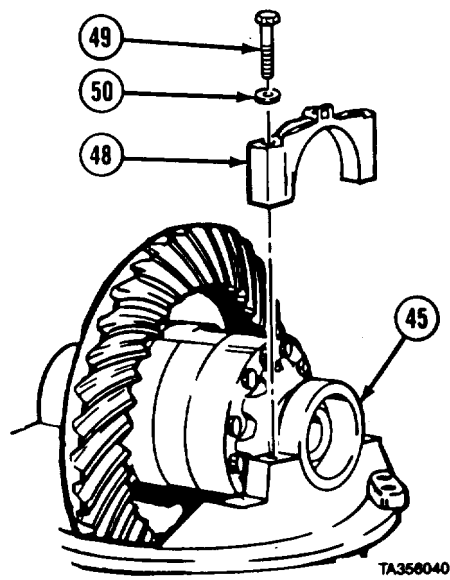

- (69) Install bearing cap (48) over bearing cup (45).
- (70) Install two screws (49) and washers (50) finger-tight.

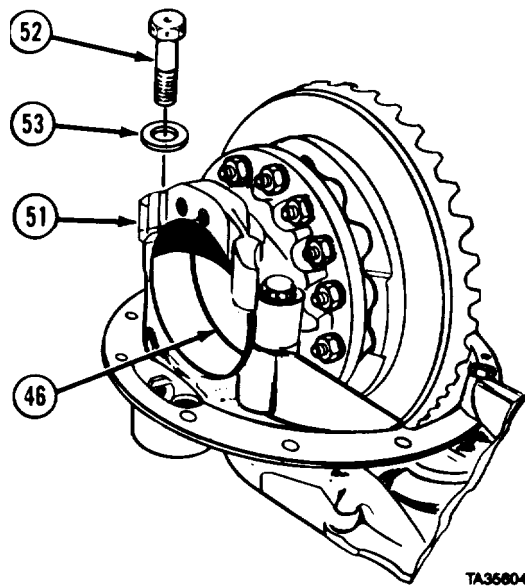

- (71) Install bearing cap (51) over bearing cup (46).
- (72) Install two screws (52) and washers (53) finger-tight.

Axles No. 3 and No. 4 Maintenance Instructions (Cont)

10-10. DIFFERENTIAL CARRIER, AXLE NO. 3 (AXLE MODELS 480, 580, AND 650) REPAIR (CONT).

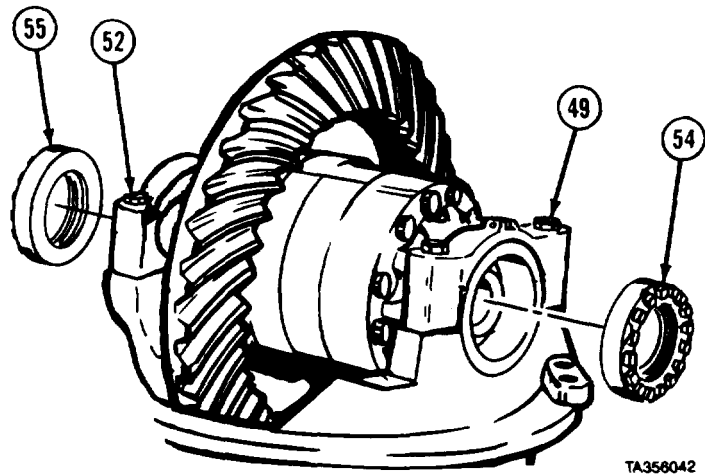

TA358042

- (73) Install bearing adjuster (54) finger-tight.
- (74) Install bearing adjuster (55) finger-tight.
- (75) Tighten four screws (49 and 52) to 40 to 50 lb-ft (54 to 68 N·m).

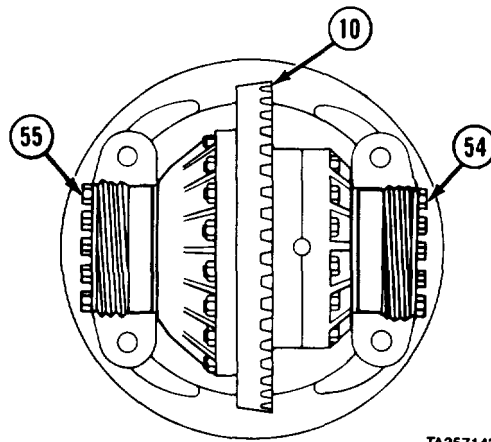

TA357143

NOTE

Aline notch in bearing adjusters with mark on bearing caps.

- (76) Tighten bearing adjuster (54) until one thread shows.
- (77) Turn bearing adjuster (55) until ring gear (10) cannot be rocked back and forth toward two bearing adjusters (54 and 55) and there is no backlash.
- (78) Rotate ring gear (10) and check for bind. If ring gear binds, turn bearing adjuster (54), then retighten until ring gear does not bind.
- (79) Tighten bearing adjuster (55) until it contacts bearing cup or resists turning.
- (80) Tighten bearing adjuster (54) two or three notches until ring gear (10) has backlash.

Axles No. 3 and No. 4 **Maintenance** Instructions (Cont)

NOTE

- . If old pinion and ring gear are used, backlash should be the same as recorded in disassembly step (14) .
 - If new pinion and ring gear are used, backlash should be 0.006 to 0.016 in. (0.152 to 0.406 mm).
 - It may be necessary to install yoke to obtain proper measurement.
- (81) Move ring gear (10) back and forth to measure backlash. If backlash is correct, go to step (90). If there is too much backlash, go to step (86). If there is not enough backlash, continue with step (82).

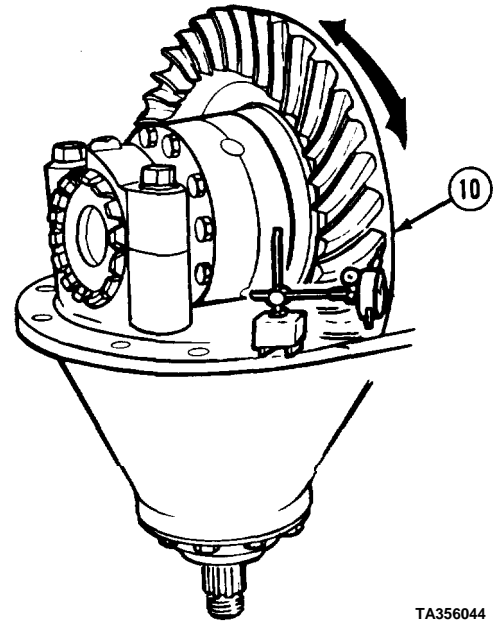

TA356044

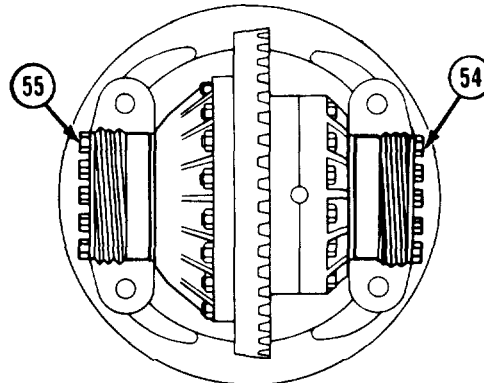

TA356045

- (82) To add backlash, loosen bearing adjuster (54) two or three notches.
 (83) Loosen bearing adjuster (55) one notch.
 (84) Tighten bearing adjuster (54) until it resists movement, then tighten two or three notches.
 (85) Repeat step (81).
 (86) To remove backlash, loosen bearing adjuster (54) two or three notches.
 (87) Tighten bearing adjuster (55) one notch.
 (88) Tighten bearing adjuster (54) until it resists movement, then tighten two or three more notches.
 (89) Repeat step (81).

Axles No. 3 and No. 4 Maintenance Instructions (Cont)

10-10. DIFFERENTIAL CARRIER, AXLE NO. 3 (AXLE MODELS 480,580, AND 650) REPAIR (CONT).

- (90) Paint one-third of teeth on ring gear (10) with prussian blue dye.
- (91) Roll ring gear (10) one-third turn, then rock ring gear forward and backward to set pattern in dye.

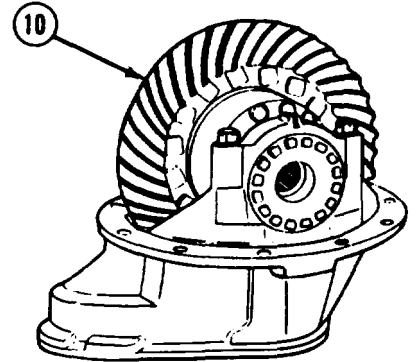

TA356046

NOTE

- A correct gear pattern for a used pinion and ring gear is clear of the toe and centers evenly along the face of gear tooth, but can be any length and shape and is acceptable as long as pattern does not run off gear tooth at any point.
- If gear pattern was correct at disassembly, then gear pattern after assembly should be the same.
- If pattern is not the same, review steps (79) through (82) and adjust backlash as required until pattern that was recorded at disassembly is reached.
- If pattern was incorrect (pattern runs off gear tooth) at disassembly then, after assembly, review steps (79) through (82) and adjust backlash as required until correct gear pattern (pattern does not run off gear teeth) is reached.
- Remember, a correct gear pattern for a used pinion and ring gear does not have to match PATTERN A (correct pattern for new gearing).

NOTE

If new pinion and ring gear are used, tooth pattern should be like correct pattern A. If tooth pattern does not look like A, check pattern B through E to find one that looks close to ring gear tooth pattern, then do step that follows incorrect pattern.

- (92) If tooth contact is like pattern A, do not adjust. Go to step (97).

CORRECT PATTERN (NEW GEARING)

- COULD VARY IN LENGTH. PATTERN SHOULD COVER 1/2 TOOTH OR MORE (FACE WIDTH).
- PATTERN SHOULD BE EVENLY CENTERED BETWEEN TOOTH TOP LAND AND ROOT.
- PATTERN SHOULD BE CLEAR OF TOOTH TOE.

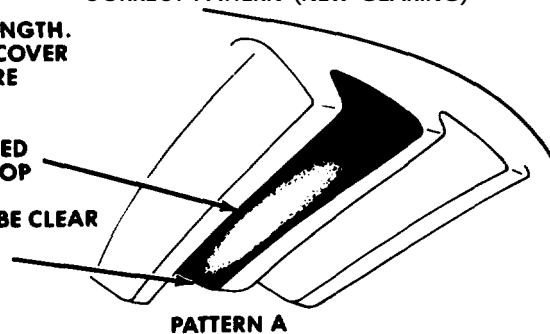

TA357120

Axles No. 3 and No. 4 Maintenance Instructions (Cont)

3) If tooth contact is like pattern B, add backlash, steps (82) through (85).

INCORRECT PATTERN

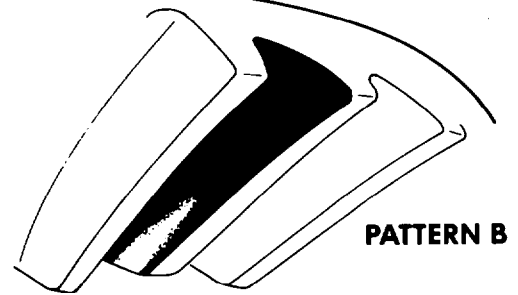

• PATTERN TOO CLOSE TO EDGE OF TOOTH TOE.

TA357142

(94) If tooth contact pattern is like pattern C, remove backlash, steps (86) through (89). Repeat step (81).

INCORRECT PATTERN

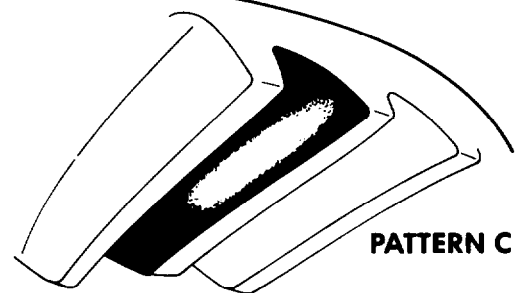

• PATTERN TOO FAR ALONG TOOTH TOWARD TOOTH HEEL.

TA357139

NOTE

To add or remove shims in steps (95) and (96), remove ring gear and differential assembly (steps (3) through (14) in Disassembly) and pinion (steps (33) through (36) in Disassembly). Add or remove shims and install pinion. Remove ring gear and differential assembly, steps (76.) through (94).

(95) If tooth contact is like pattern D, move pinion closer to ring gear (10) by removing shims, then repeat steps (81) through (92).

INCORRECT PATTERN

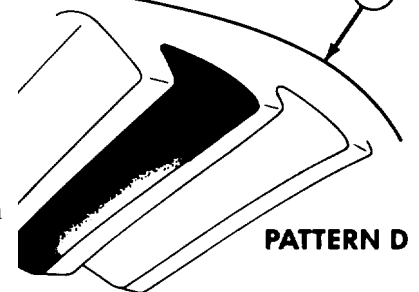

• PATTERN TOO CLOSE TO TOOTH TOP LAND AND OFF CENTER.

Axles No. 3 and No. 4 Maintenance Instructions (Cont)

10-10. DIFFERENTIAL CARRIER, AXLE NO. 3 (AXLE MODELS 480, 580, AND 650) REPAIR (CONT).

(96) If tooth contact is like pattern E, move pinion away from ring gear (10) by adding shims, then repeat steps (81) through (92).

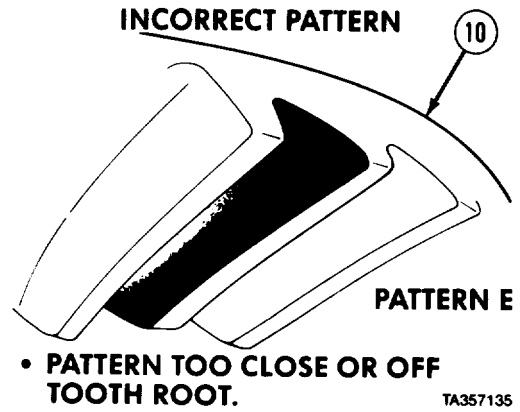

(97) Tighten four screws evenly (49 and 52) to 370 to 430 lb-ft (502 to 583 N·m).

NOTE

Bearing adjuster may be turned slightly to aline adjuster locks.

(98) Install adjuster lock (56) and cotter pin (57) on bearing cap (48).

(99) Install lockwire on two screws (49).

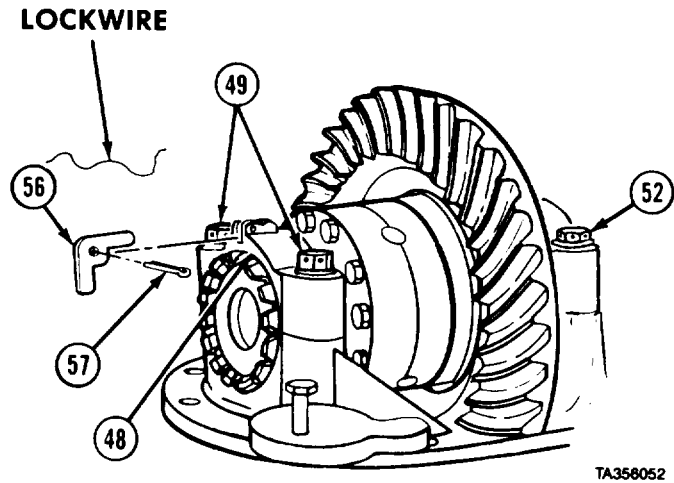

(100) Install adjuster lock (58) with two screws (59). Tighten screws evenly to 160 to 176 lb-ft (217 to 239 N·m).

(101) Install lockwire on two screws (59).

(102) Install lockwire on two screws (52).

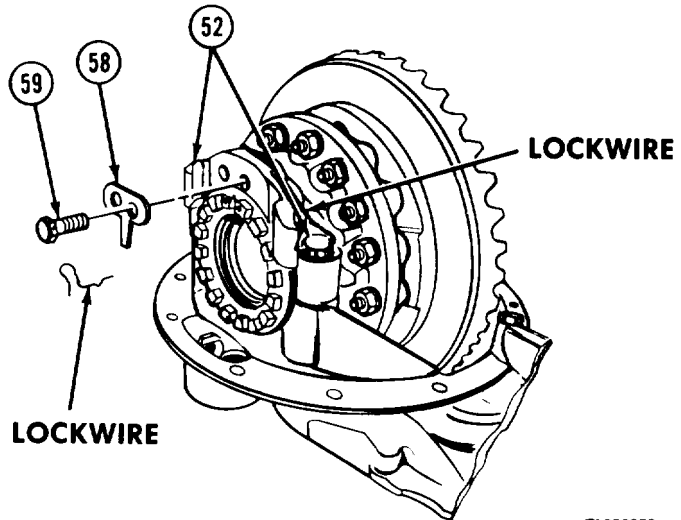

Axles No. 3 and No. 4 Maintenance Instructions (Cont)

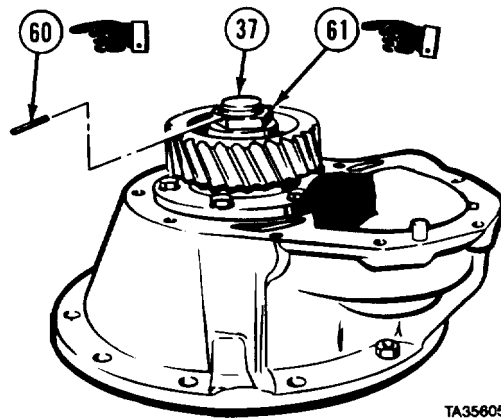

NOTE

• Do step (103) for axle Model 480 only.

Ž Tighten slotted nut until roll pin can be installed.

(103) Install roll pin (60) through slotted nut (61) and pinion (37).

(104) Lubricate and install bearing (62) on side gear (63).

(105) Install bushing (64) in end of output shaft (65).

(106) Apply lubricating oil to two preformed packings (66) and install on output shaft (65).

(107) Install side gear (63) and assembled parts on output shaft (65).

WARNING

Wear safety glasses while installing retaining rings to protect eyes from possible injury or blindness.

(108) Install retaining ring (67) on end of output shaft (65).

(109) Install bearing cup (68) in differential carrier (2).

(110) Install output shaft (65) and assembled parts in differential carrier (2).

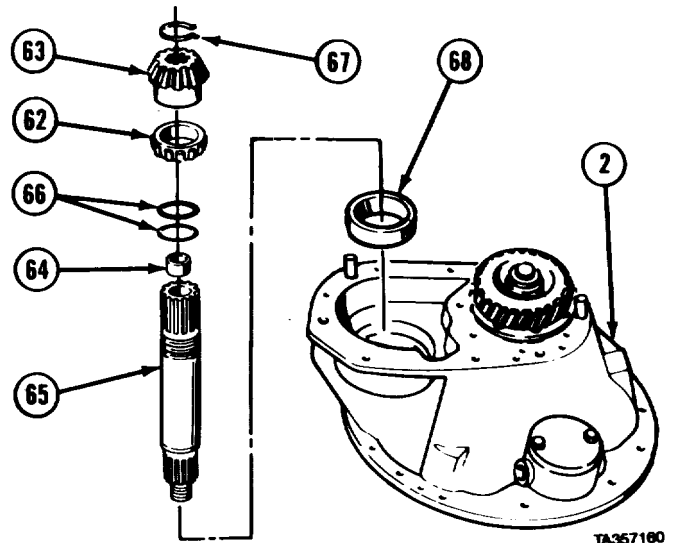

Axles No. 3 and No. 4 Maintenance Instructions (Cont)

10-10. DIFFERENTIAL CARRIER, AXLE NO. 3 (AXLE MODELS 480,580, AND 650) REPAIR (CONT).

(111) Lubricate and install four bushings (69), side pinions (70), and thrust washers (71) on spider (72).

WARNING

Edges of inter-axle differential are sharp. Wear gloves to avoid personal injury.

(112) Aline matchmarks and install inter-axle differential case halves (73 and 74) on spider (72) with assembled parts.

(113) Install eight screws (75) and locknuts (76) in two inter-axle differential case halves (73 and 74). Tighten locknuts evenly to 17 to 23 lb-ft (23 to 31 N·m).

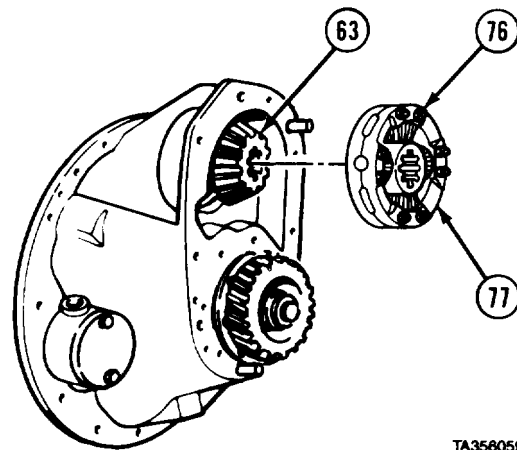
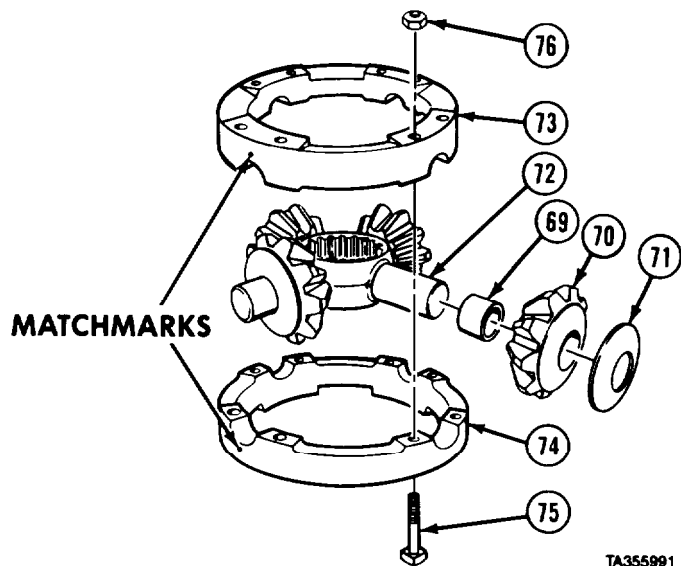

(114) Install assembled inter-axle differential (77) on side gear (63) so eight nuts (76) show.

CAUTION

Inter-axle differential and output shaft are not secured in carrier and can fall out and be damaged if carrier is tipped over.

d. Follow-on Maintenance. Install differential carrier (para 10-9).

END OF TASK

Axles No. 3 and No. 4 Maintenance Instructions (Cont)

10-11. DIFFERENTIAL CARRIER, AXLE NO. 4 REMOVAL/INSTALLATION.	
This task covers:	
a. Removal	c. Installation
b. Cleaning/Inspection	d. Follow-on Maintenance
INITIAL SETUP	
Models	References
All	None
Test Equipment	Equipment Condition
None	TM or Para Condition Description
Special Tools	Axle on clean work surface.
None	Special Environmental Conditions
Supplies	None
Adhesive-sealant, silicone, Item 6, Appendix C	General Safety Instructions
Solvent, dry cleaning, Item 57, Appendix C	None
Personnel Required	Level of Maintenance
MOS 63W, Wheel vehicle repairer (2)	General Support

- a. Removal.
- (1) Remove 12 nuts (1), lockwashers (2), and bracket (3).
 - (2) Attach lifting device to differential carrier (4).
 - (3) Soldier A removes differential carrier (4) while Soldier B operates lifting device.
 - (4) Mount differential carrier (4) on stand and fasten in place. Remove lifting device.
- b. Cleaning/Inspection.
- (1) Scrape dirt and old sealant from mounting surface on axle housing.

WARNING

Adhesives, solvents, and sealing compounds can burn easily, can give off harmful vapors, and are harmful to skin and clothing. To avoid injury or death, keep away from open fire and use in well-ventilated area. If adhesive, solvent, or sealing compound gets on skin or clothing, wash immediately with soap and water.

- (2) Use dry cleaning solvent to clean axle housing.
- (3) Use clean cloth to wipe dry.
- (4) Inspect axle housing for cracks or damage. Replace if damaged.
- (5) Inspect mounting studs for cracks, breaks, and damaged threads. Replace if damaged.

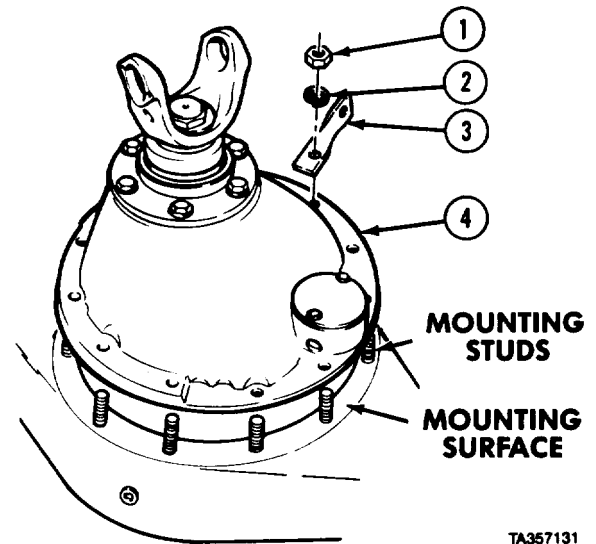

TA357131

Axles No. 3 and No. 4 Maintenance Instructions (Cont)

10-11. DIFFERENTIAL CARRIER, AXLE NO. 4 REMOVAL/INSTALLATION (CONT).

c. Installation.

WARNING

Adhesives, solvents, and sealing compounds can burn easily, can give off harmful vapors, and are harmful to skin and clothing. To avoid injury or death, keep away from open fire and use in well-ventilated area. If adhesive, solvent, or sealing compound gets on skin or clothing, wash immediately with soap and water.

- (1) Attach lifting device to differential carrier (1).
- (2) Soldier A removes differential carrier (1) from stand while Soldier B operates lifting device.
- (3) Apply silicone adhesive-sealant to housing mounting surface.
- (4) Soldier A positions differential carrier(1) in axle (2) while Soldier B operates lifting device.
- (5) Install bracket (3), 12 lockwashers (4), and nuts (5).
- (6) Tighten nuts (5) to 220 to 240 lb-ft (298 to 325 N·m).

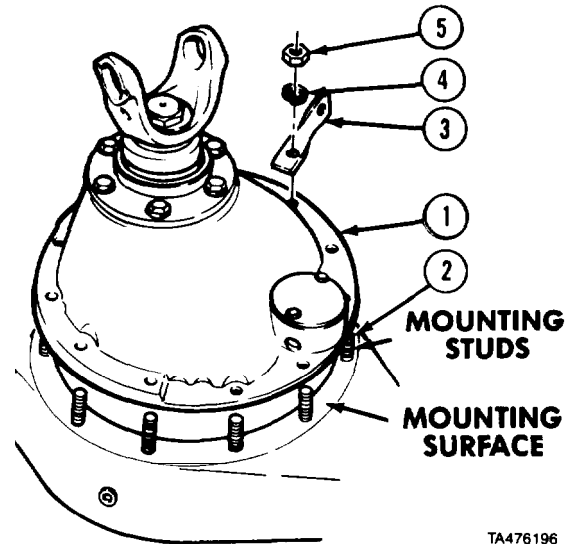

TA476196

d. Follow-on Maintenance. None.

END OF TASK

10-12. DIFFERENTIAL CARRIER, AXLE NO. 4 (AXLE MODELS 480 AND 580) REPAIR.		
This task covers:		
a. Disassembly	c. Assembly	
b. Cleaning/Inspection	d. Follow-on Maintenance	
INITIAL SETUP		
Models	Personnel Required	
All	MOS 63W, Wheel vehicle repairer (2)	
Test Equipment	References	
Scale, spring, and attaching wire J8129	None	
Indicator, dial J8001-3	Equipment Condition	
Special Tools	TM or Para	Condition Description
None		Differential carrier, axle No. 4, on clean work surface.
Supplies	Special Environmental Conditions	
Adhesive-sealant, silicone, Item 6, Appendix C	None	
Compound, sealing, Item 28, Appendix C	General Safety Instructions	
Compound, sealing and thread locking, Item 25, Appendix C	None	
Dye, prussian blue, Item 32, Appendix C	Level of Maintenance	
Lockwire, Item 39, Appendix C	General Support	
Oil, lubricating, gear, Item 43, Appendix C		
Solvent, dry cleaning, Item 57, Appendix C		

Axles No. 3 and No. 4 Maintenance Instructions (Cont)

a. *Disassembly.*

- (1) Check ring gear (1) backlash with dial indicator. Move ring gear back and forth to measure backlash. Record backlash.

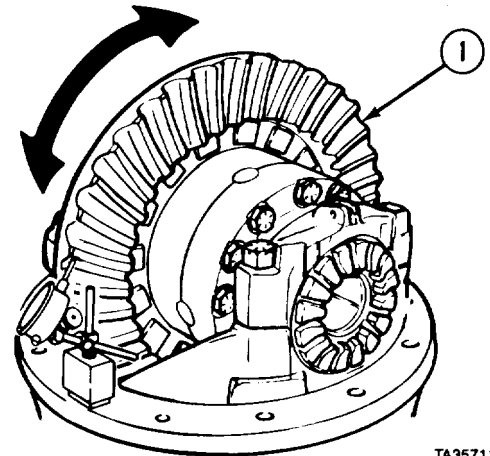

TA357115

- (2) Check tooth contact pattern. Paint one-third of teeth ring gear (1) with prussian blue dye. Roll ring gear one-third turn, then rock ring gear forward and backward to set pattern in dye. Record ring gear tooth pattern.

PATTERN (USED GEARING)

**POCKET MAY BE EXTENDED.
PATTERN ALONG THE FACE
WIDTH COULD BE LONGER.**

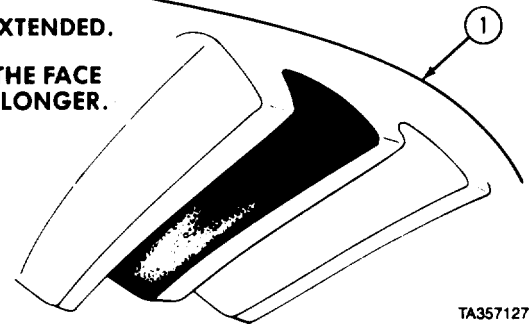

TA357127

- (3) Remove lockwire from two screws (2).
- (4) Remove cotter pin (3) and adjuster lock (4) from bearing cap (5). Matchmark center of bearing cap.
- (5) Remove two screws (2), washers (6), and bearing cap (5).

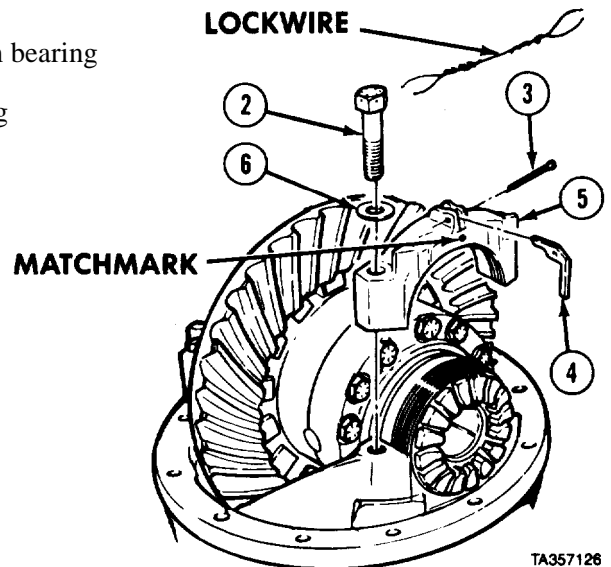

TA357126

Axles No. 3 and No. 4 Maintenance Instructions (Cont)

10-12. DIFFERENTIAL CARRIER, AXLE NO. 4 (AXLE MODELS 480 AND 580) REPAIR (CONT).

- (6) Remove lockwire from two screws (7).
- (7) Remove two screws (7) and adjuster lock (8).
- (8) Remove lockwire from two screws (9). Matchmark center of bearing cap (10).

NOTE

Only Model 650 on M984E1 has two bushings under bearing cap.

- (9) Remove two screws (9), washers (11), bearing cap (10), and two bushings (12).

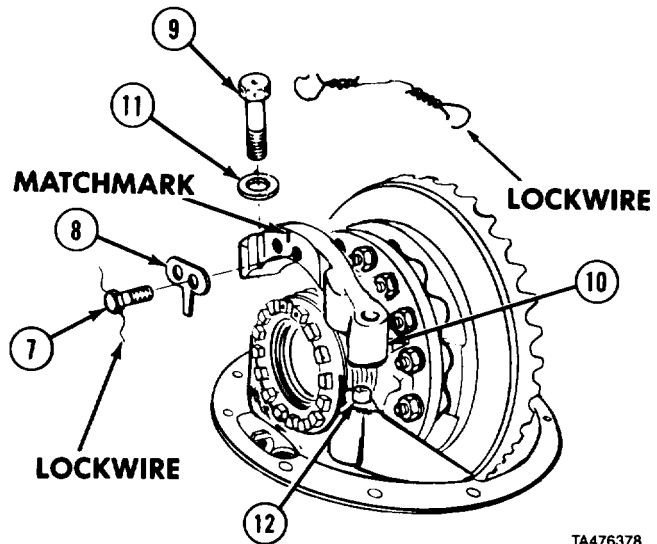

TA476378

NOTE

Ring gear must be tilted to clear casting inside carrier.

- (10) Attach lifting device to ring gear (1).
- (11) Soldier A removes ring gear (1) and assembled parts from differential carrier (13) while Soldier B operates lifting device.
- (12) Place ring gear (1) on clean work surface and remove lifting device.
- (13) Remove bearing adjusters (14 and 15) and bearing cups (16 and 17).
- (14) Soldier A and Soldier B place ring gear (1), teeth up, on clean work surface.

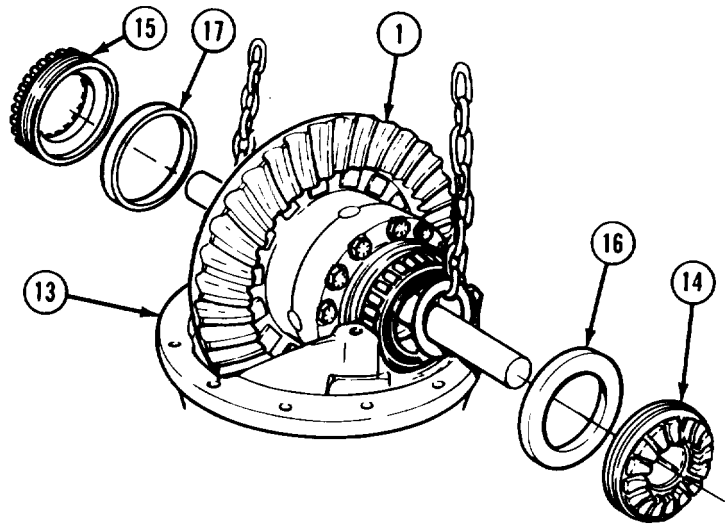

TA357113

- (15) Matchmark differential case plain half (18) and differential case flanged half (19).
- (16) Remove 12 screws (20) and differential case plain half (18).

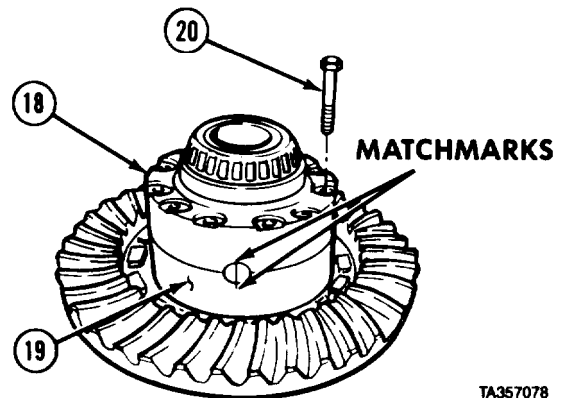

TA357078

Axles No. 3 and No. 4 Maintenance Instructions (Cont)

- (17) Remove bearing cone (21) from differential case plain half (18).

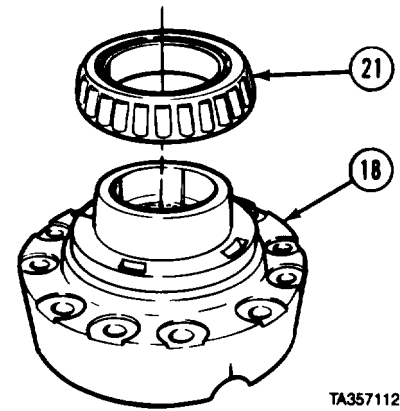

- (18) Remove thrust washer (22) and side gear (23) from spider (24).

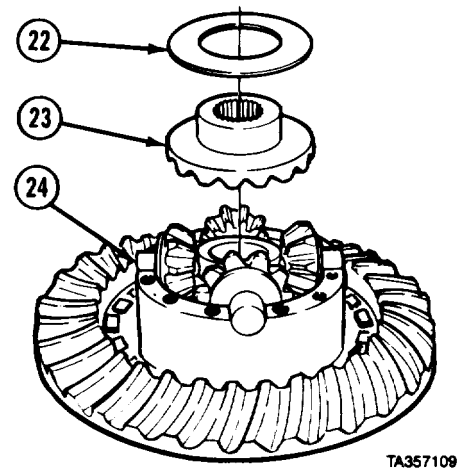

- (19) Remove spider (24) from differential case flanged half (19).

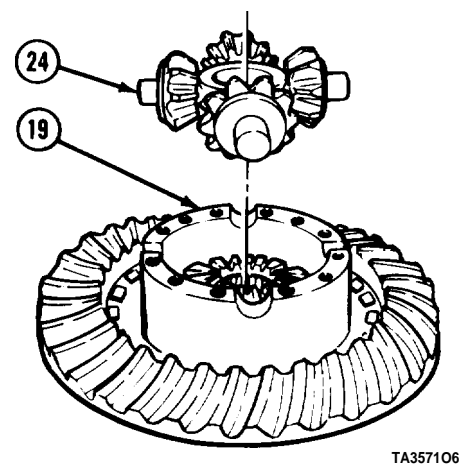

Axles No. 3 and No. 4 Maintenance Instructions (Cont)

10-12. DIFFERENTIAL CARRIER, AXLE NO. 4 (AXLE MODELS 480 AND 580) REPAIR (CONT).

- (20) Remove four thrust washers (25) and side pinions (26) from spider (24).

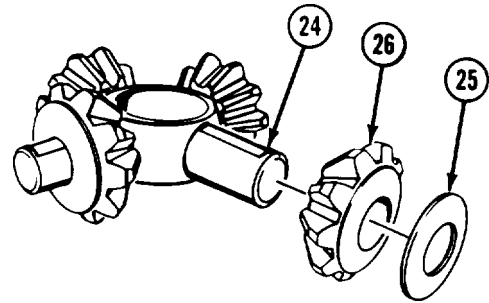

TA357119

- (21) Remove side gear (27) and thrust washer (28) from differential case flanged half (19).

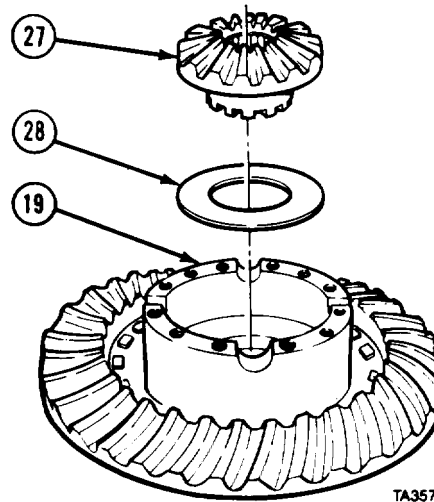

TA357107

CAUTION

Gear support case cover is under spring tension. Hold down to remove nuts then release slowly to prevent damage to screw threads.

- (22) Remove 16 nuts (29) and screws (30).
- (23) Remove gear support case cover (31).

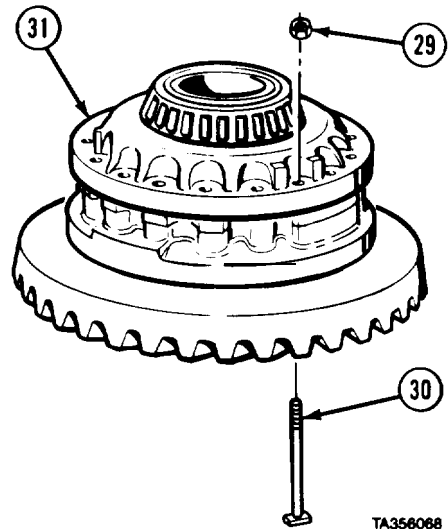

TA356068

Axles No. 3 and No. 4 Maintenance Instructions (Cont)

(24) Remove 12 springs (32).

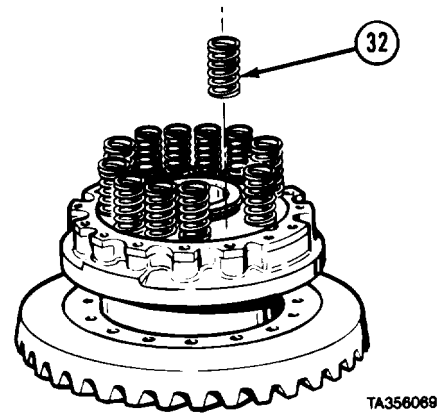

(25) Remove bearing cone (33) from gear support case cover (31).

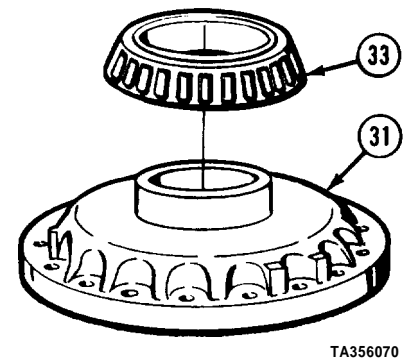

(26) Remove friction plate driver (34) and assembled parts from differential case flanged half (19).
 (27) Remove differential case flanged half (19) from ring gear (1).

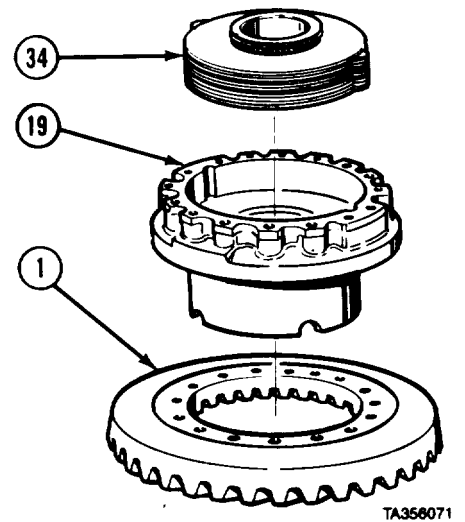

Axles No. 3 and No. 4 Maintenance Instructions (Cont)

10-12. DIFFERENTIAL CARRIER, AXLE NO. 4 (AXLE MODELS 480 AND 580) REPAIR (CONT).

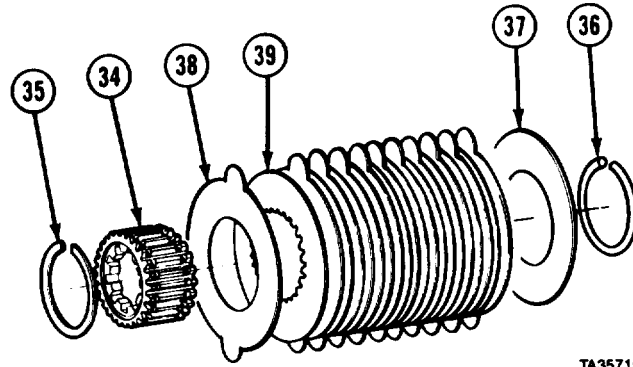

(28) Remove two retaining rings (35 and 36) and pressure plate (37) from friction plate driver (34).

NOTE

Do step (29) for axle Models 480 and 650 only.

(29) Remove 11 tangential friction plates (38) and 10 splined friction plates (39) from friction plate driver (34).

NOTE

Do step (30) for axle Model 580 only.

(30) Remove 13 tangential friction plates (38) and 12 splined friction plates (39) from friction plate driver (34).

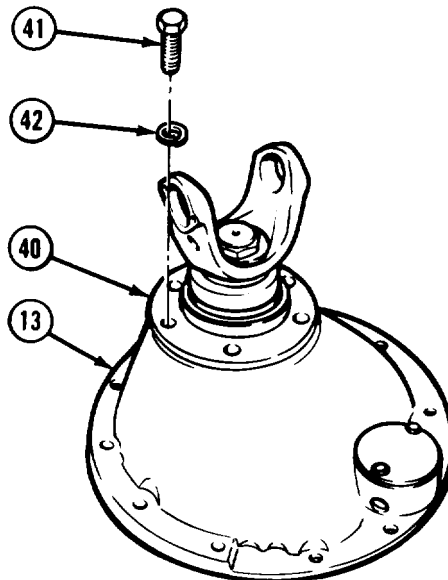

(31) Matchmark bearing cage (40) and differential carrier (13).

(32) Remove six screws (41) and lockwashers (42) from bearing cage (40).

Axles No. 3 and No. 4 Maintenance Instructions (Cont)

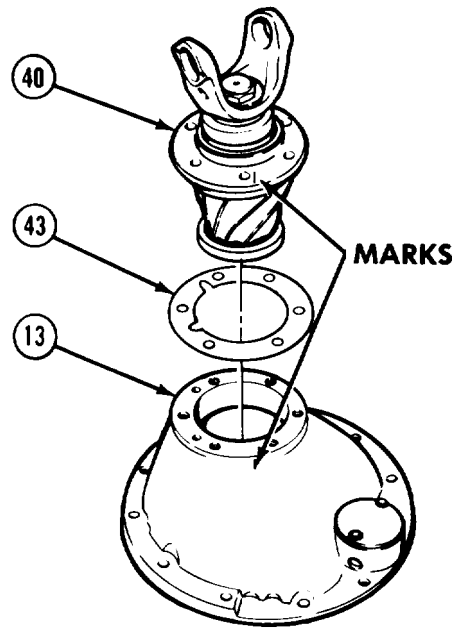

TA357092

- (33) Remove bearing cage (40) and assembled parts from differential carrier (13).
- (34) Remove shims (43) from differential carrier (13). Record number and size of shim pack.

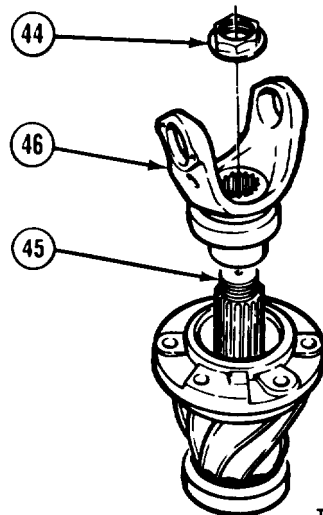

TA357094

- (35) Remove locknut (44) from pinion (45),
- (36) Remove yoke (46) from pinion (45).

Axles No. 3 and No. 4 Maintenance Instructions (Cont)

10-12. DIFFERENTIAL CARRIER, AXLE NO. 4 (AXLE MODELS 480 AND 580) REPAIR (CONT).

- (37) Remove oil seal (47).
- (38) Press pinion (45) from bearing cage (40).

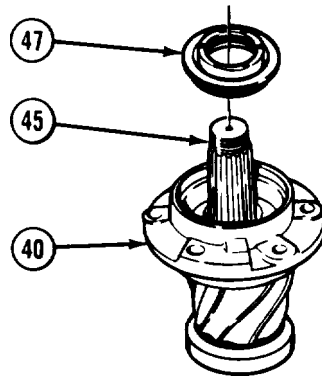

TA357104

- (39) Remove outer bearing cone (48), outer bearing cup (49), and inner bearing cup (50) from bearing cage (40).

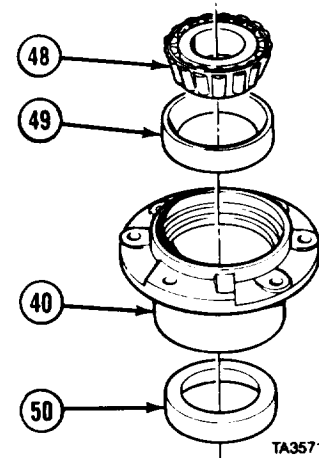

TA357149

NOTE

Axle Model 480 does not have spacer washer.

- (40) Remove spacer (51), spacer washer (52), and inner bearing cone (53) from pinion (45).
- (41) Remove pilot bearing (54) from pinion (45).

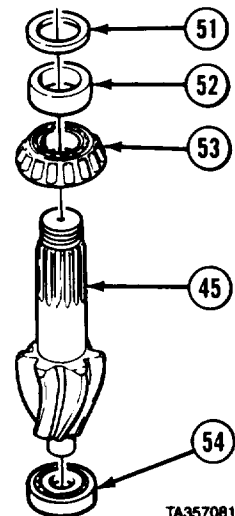

TA357081

Axles No. 3 and No. 4 Maintenance Instructions (Cent)

- (42) Remove two screws (55), lockwashers (56), and cover (57) from differential carrier (13).

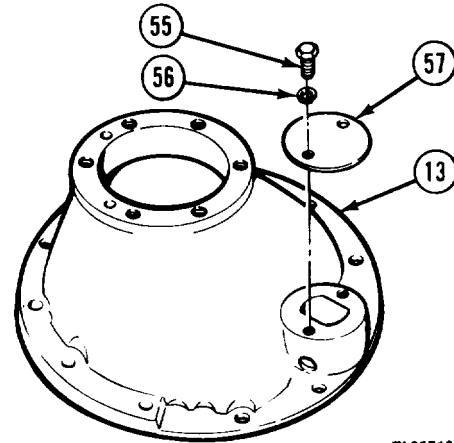

TA357103

b. Cleaning/Inspection.

- (1) Scrape old sealant from differential carrier.

WARNING

Adhesives, solvents, and sealing compounds can burn easily, can give off harmful vapors, and are harmful to skin and clothing. To avoid injury or death, keep away from open fire and use in well-ventilated area. If adhesive, solvent, or sealing compound gets on skin or clothing, wash immediately with soap and water.

- (2) Clean all metal parts with dry cleaning solvent.

WARNING

Compressed air used for cleaning purposes will not exceed 30 psi (207 kPa). Use only with effective chip guarding and personal protective equipment, goggles, shield, and gloves.

- (3) Use clean lint free cloth or compressed air to dry all metal parts, except bearings. Allow bearings to air dry.
- (4) Inspect all metal parts for breaks, cracks, and sharp edges. Replace if damaged.
- (5) Inspect bearings for loose rollers or cracked or broken races. Coat bearings with lubricating oil.
- (6) Inspect dowel pins for cracks and breaks. Replace if damaged.
- (7) Inspect internally splined friction plate embossing. If embossing is completely worn off, replace friction plate.
- (8) Inspect friction plates for warpage, cracks, breaks, and excessive oxidation on friction plates. Replace individual friction plates as necessary. If more than half the friction plates are oxidized, replace entire set of friction plates.
- (9) If pinion or ring gear is bad, replace both as a matched set.
- (10) Replace springs if there are signs of overheating, wear due to rubbing against other parts, or if length is less than 1.34 in. (34 mm) under 200 lb (91 kg) load. If three or more springs must be replaced, replace entire set of springs.
- (11) Inspect spider for visible steps and grooves on shafts created by wear. Replace worn spider.
- (12) Inspect spider gears for chipped teeth, cracks, discoloration, and out of round holes. Replace damaged spider gears.
- (13) Inspect expansion plugs for damage or signs of leakage. Replace if damaged or if there is evidence of leakage.

Axles No. 3 and No. 4 Maintenance Instructions (Cont)

10-12. DIFFERENTIAL CARRIER, AXLE NO. 4 (AXLE MODELS 480 AND 580) REPAIR (CONT).

c. Assembly.

WARNING

Adhesives, solvents, and sealing compounds can burn easily, can give off harmful vapors, and are harmful to skin and clothing. To avoid injury or death, keep away from open fire and use in well-ventilated area. If adhesive, solvent, or sealing compound gets on skin or clothing, wash immediately with soap and water.

- (1) Apply adhesive-sealant and install cover (1) on differential carrier (2).
- (2) Install two screws (3) and lockwashers (4). Tighten screws to 35 to 45 lb-ft (47 to 61 N-m).

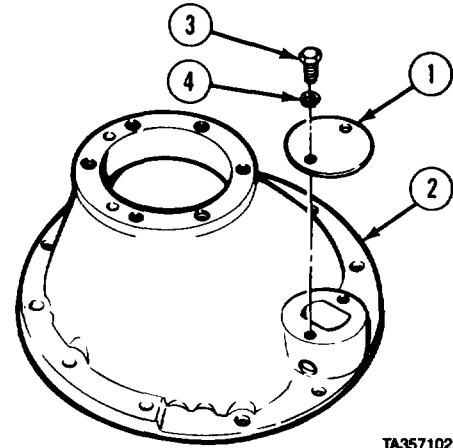

TA357102

NOTE

Lubricate bearings before installing.

- (3) Install bearing cone (5) on gear support case cover (6).

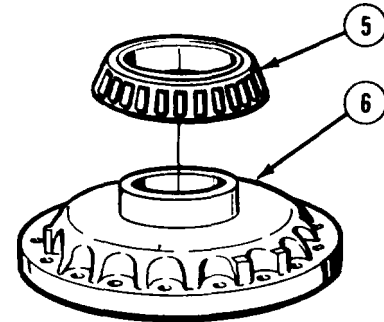

TA356078

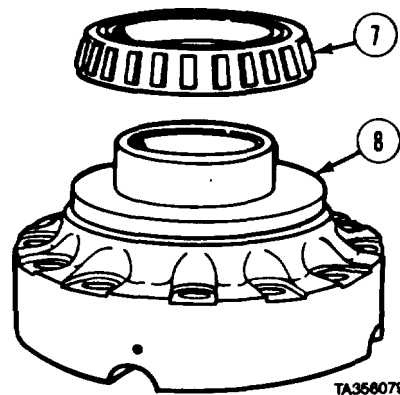

TA356079

- (4) Install bearing cone (7) on differential case plain half (8).

Axles No. 3 and No. 4 Maintenance Instructions (Cont]

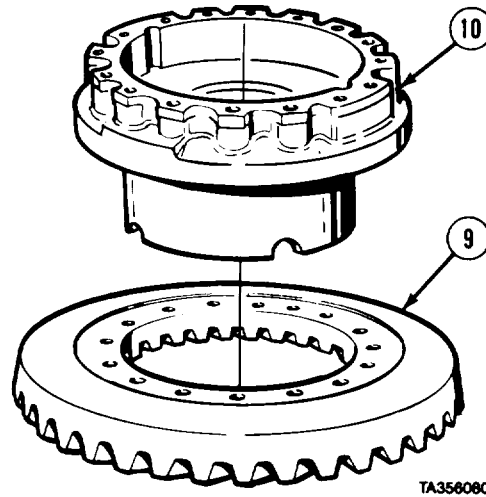

- (5) Position ring gear (9), teeth down, on suitable wooden blocks.
- (6) Aline and position differential case flanged half (10) in ring gear (9).
- (7) Install retaining ring (11) on friction plate driver (12).

NOTE

Do step (8) for axle Models 480 and 650 only.

- (8) Install 11 tanged friction plates (13) and ten splined friction plates (14) alternately. Apply lubricating oil to last tanged friction plate (13) installed.

NOTE

Do step (9) for axle Model 580 only.

- (9) Install 13 tanged friction plates (13) and twelve splined friction plates (14) alternately. lubricating oil to last tanged friction plate (13) installed.
- (10) Install pressure plate (15) on friction plate driver (12).
- (11) Install second retaining ring (16) on friction plate driver (12).
- (12) Aline and install tanged friction plates (13) as an assembly in differential case flanged half (10) with pressure plate side up.

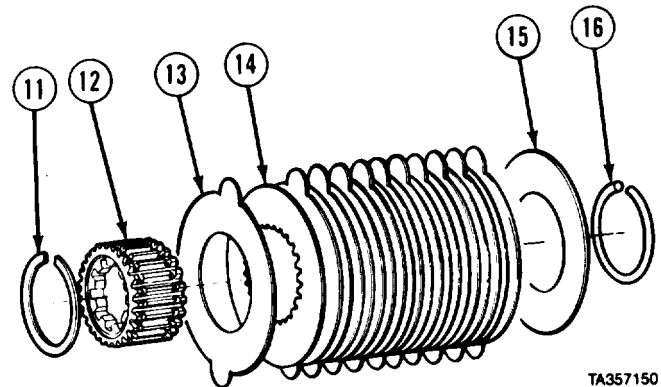

TA357150

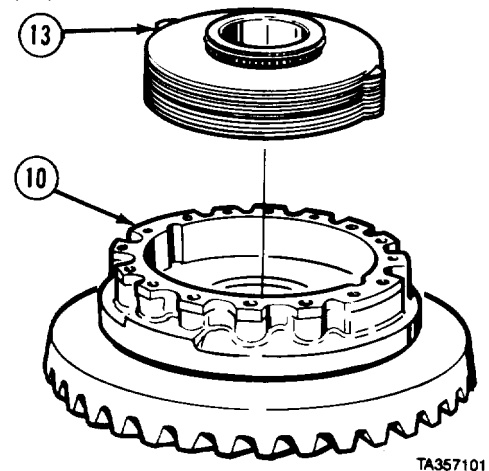

TA357101

Axles No. 3 and No. 4 Maintenance Instructions (Cont)

10-12. DIFFERENTIAL CARRIER, AXLE NO. 4 (AXLE MODELS 480 AND 580) REPAIR (CONT).

- (13) Install 12 springs (17) around friction plate driver (12).

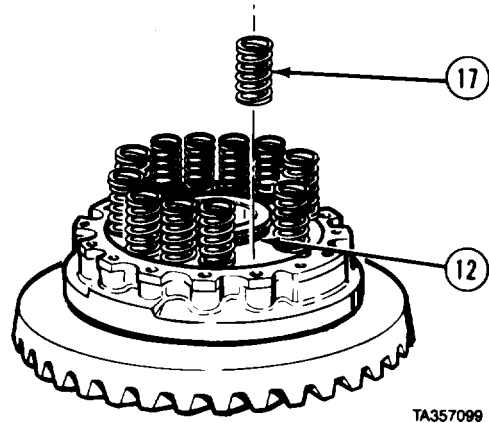

- (14) Align and position gear support case cover (6) over springs (17).
- (15) Clamp differential case cover (6) to ring gear (9).

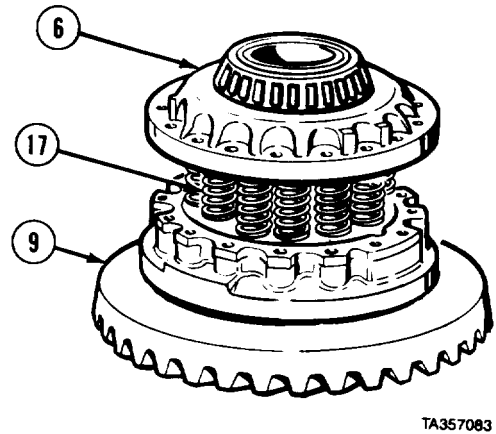

CAUTION

Square heads of screws must be seated in machined groove of ring gear otherwise ring gear or screws may be damaged.

- (16) Install 16 screws (18) and nuts (19).
- (17) Tighten nuts (19) to 180 to 220 lb-ft (244 to 298 N·m).

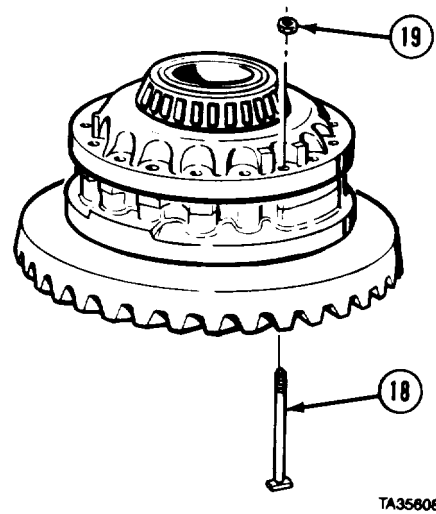

Axles No. 3 and No. 4 Maintenance Instructions (Cont)

- (18) Lubricate and install thrust washer (20) and side gear (21) in differential case flanged half (10).

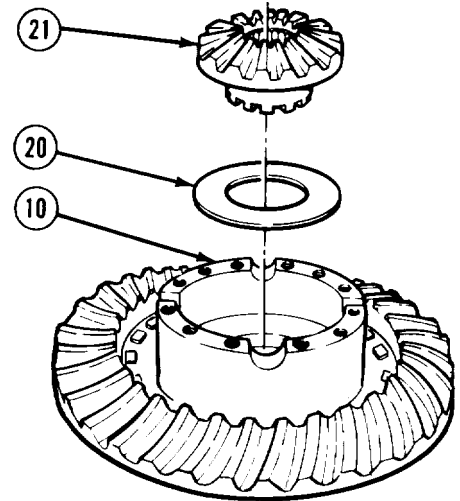

TA357108

- (19) Lubricate spider (22) and install four side pinions (23) and thrust washers (24) on spider.

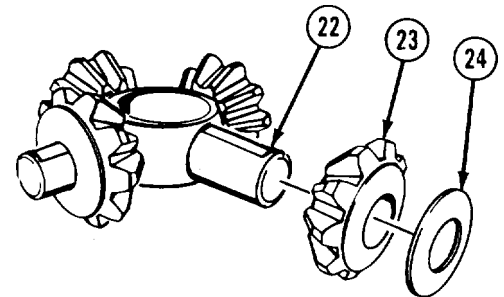

TA357118

- (20) Install spider (22) and assembled parts in differential case flanged half (10).

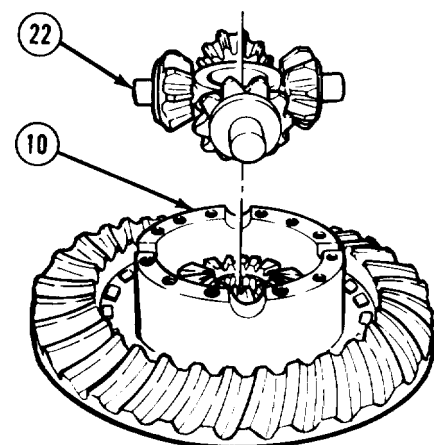

TA357105

Axles No. 3 and No. 4 Maintenance Instructions (Cont)

10-12. DIFFERENTIAL CARRIER, AXLE NO. 4 (AXLE MODELS 480 AND 580) REPAIR (CONT).

(21) Install side gear (25) and lube and instal] thrust washer (26) on side pinions (23).

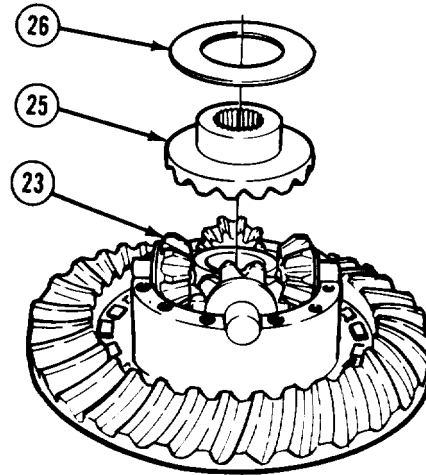

TA357110

(22) Aline matchmarks and install differential case plain half (8) on differential case flanged half (10).

NOTE

Put differential carrier in holding device before tightening screws.

(23) Install 12 screws (27) in differential case plain half (8). Tighten screws equally to 165 to 195 lb-ft (224 to 264 N·m).

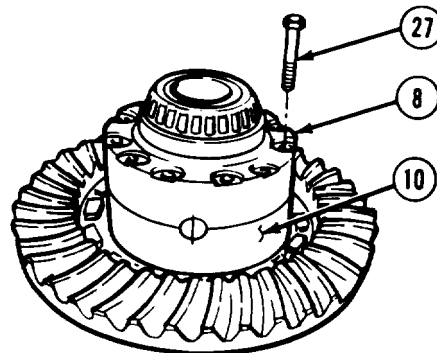

TA357077

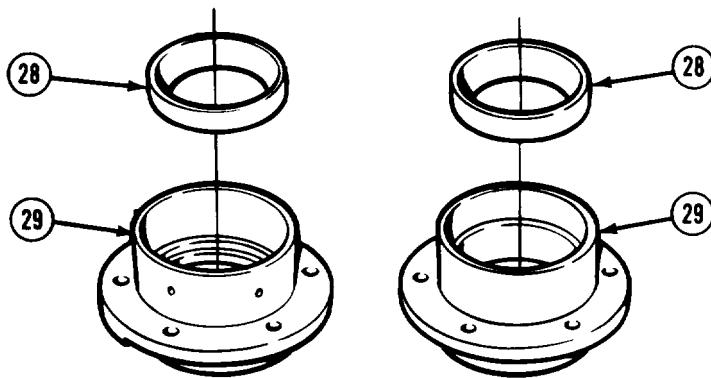

TA476669

(24) Install inner bearing cups (28) in bearing cages (29).

Axles No. 3 and No. 4 Maintenance Instructions (Cont)

- (25) Turn bearing cage (29) over.
- (26) Install outer bearing cup (30) in bearing cage (29).
- (27) Lubricate and install inner bearing cone (31).

NOTE

Model 480 axle does not use spacer washer.

- (28) Install spacer washer (32) and 0.185-in. (4.7 mm) spacer (33) in bearing cage (29).
- (29) Lubricate and install outer bearing cone (34) in outer bearing cup (30).

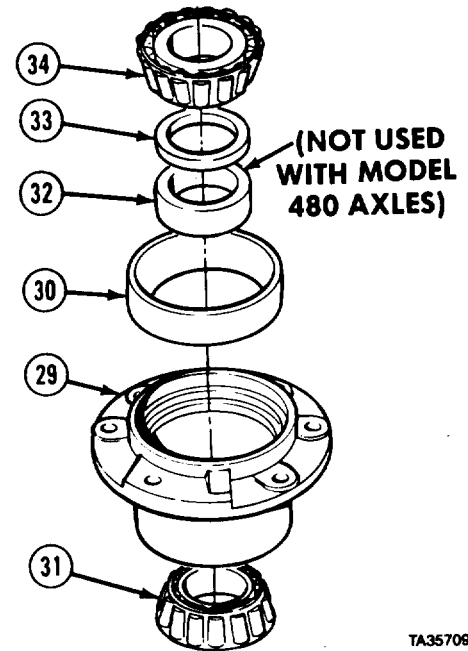

- (30) Position bearing cage (29) in press so outer bearing cone (34) is on top.

CAUTION

- Turn bearing cage back and forth while applying pressure to be sure bearings and bearing cups are well lubricated.
- If bearing cage becomes hard to turn while applying pressure, STOP! Bearings can be damaged if too much pressure is applied. Get next larger spacer and repeat step (31).

- (31) Lower press ram for load of 18.0 to 20.0 tons (16.3 to 18 metric tons).
- (32) Wrap soft wire around bearing cage (29) twice and fasten one end of wire in bearing cage screw hole. Fasten other end of wire to spring scale.
- (33) Pull on spring scale until bearing cage (29) begins to turn. Check that spring scale reads 3 to 7 lbs (2 to 3 kgs). If spring scale reading is correct, go to step (39). If reading is too low, go to step (37). If reading is too-high, continue with step (34).

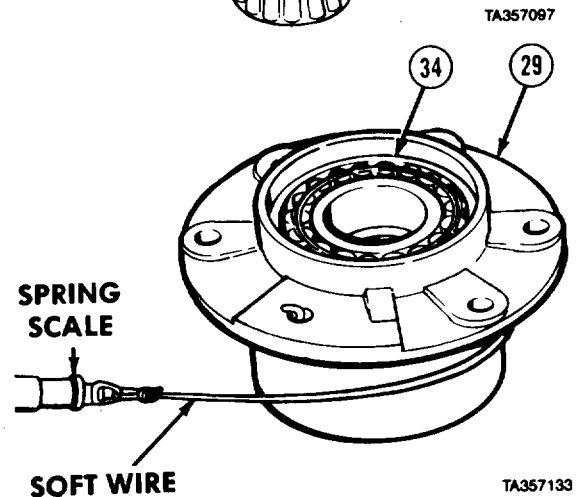

- (34) Remove outer bearing cone (34) and spacer (33) from bearing cage (29).
- (35) Use 0.001-in. (0.03 mm) thicker spacer (33) and install spacer and outer bearing cone (34) in bearing cage (29).
- (36) Repeat steps (30) through (33).
- (37) Remove outer bearing cone (34) and spacer (33). Use 0.001 -in. (0.03 mm) thinner spacer and install spacer and outer bearing cone in bearing cage (29).
- (38) Repeat steps (30) through (33).

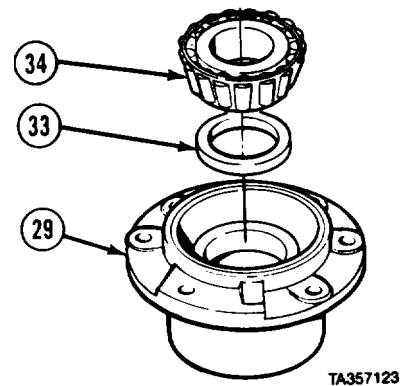

Axles No. 3 and No. 4 Maintenance Instructions (Cont)

10-12. DIFFERENTIAL CARRIER, AXLE NO. 4 (AXLE MODELS 480 AND 580) REPAIR (CONT).

NOTE

Axle Model 480 does not have spacer washer.

- (39) Remove outer bearing cone (34), spacer (33), spacer washer (32), and inner bearing cone (31) from bearing cage (29).
- (40) Get spacer (33) 0.001-in. (0.03 mm) thicker than last spacer used and set aside for later installation.

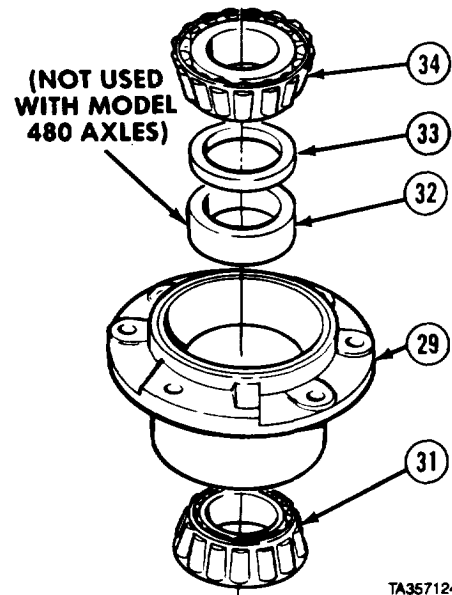

- (41) Lubricate and press pilot bearing (35) on pinion (36).
- (42) Stake pilot bearing (35) and pinion (36) as shown in pattern.

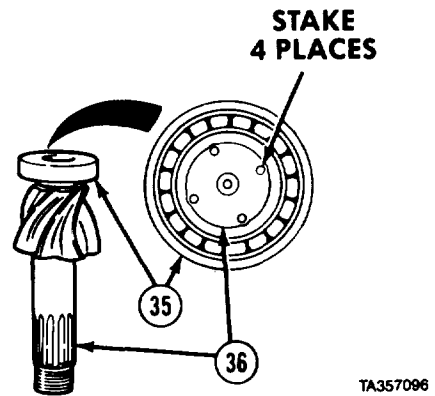

- (43) Lubricate and press inner bearing cone (31) on pinion (36).

NOTE

Axle Model 480 does not have spacer washers.

- (44) Install spacer washer (32) and spacer (33) on pinion (36).

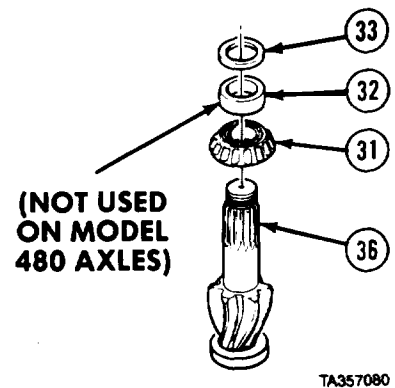

Axles No. 3 and No. 4 Maintenance Instructions (Cont)

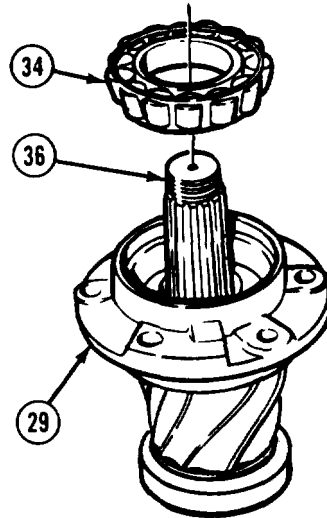

TA357095

- (45) Install bearing cage (29) on pinion (36).
- (46) Lubricate and press outer bearing cone (34) on pinion (36).

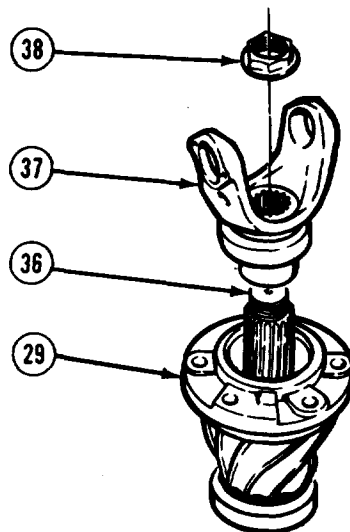

TA357093

- (47) Install yoke (37) and locknut (38) on pinion (36). Tighten locknut to 840 to 1020 lb-ft (1 139 to 1383 N·m).
- (48) Measure pinion bearing preload with yoke (37) in vise. Wrap soft wire around bearing cage (29) twice and fasten one end of wire in bearing cage screw hole. Fasten other end of wire to spring scale.
- (49) Pull on spring scale until bearing cage (29) begins to turn. Check that spring scale reads 5 to 12 lbs (2.25 to 5.5 kg).
- (50) Remove locknut (38) and yoke (37). If reading is correct, go to step (61). If reading is too low, go to step (56). If reading is too high, continue with step (51).

Axles No. 3 and No. 4 Maintenance Instructions (Cont)

10-12. DIFFERENTIAL CARRIER, AXLE NO. 4 (AXLE MODELS 480 AND 580) REPAIR (CONT).

- (51) Remove pinion (36) from bearing cage (29).
- (52) Remove outer bearing cone (34) and spacer (33).
- (53) Install pinion (36) in bearing cage (29).
- (54) Use 0.001 -in. (0.03 mm) thicker spacer (33) and install spacer and outer bearing cone (34) on pinion (36).
- (55) Repeat steps (47) through (50).
- (56) Remove pinion (36) from bearing cage (29).
- (57) Remove outer bearing cone (34) and spacer (33).
- (58) Install pinion (36) in bearing cage (29).
- (59) Use 0.001-in. (0.03 mm) thinner spacer (33) and install spacer and outer bearing cone (34) on pinion (36).
- (60) Repeat steps (47) through (50).
- (61) Install oil seal (39), yoke (37), and locknut (38) on pinion (36). Tighten locknut to 840 to 1020 lb-ft (1 139 to 1383 N-m).

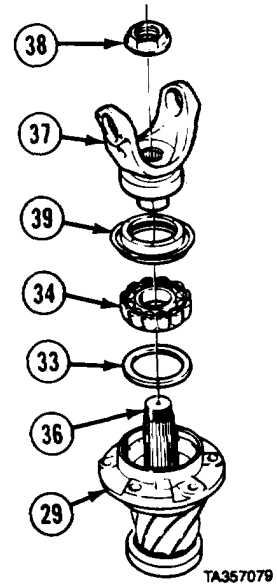

WARNING

Adhesives, solvents, and sealing compounds can burn easily, can give off harmful vapors, and are harmful to skin and clothing. To avoid injury or death, keep away from open fire and use in well-ventilated area. If adhesive, solvent, or sealing compound gets on skin or clothing, wash immediately with soap and water.

- (62) Apply sealing compound to flange of cage (29) and differential carrier (2).

NOTE

If gear set is reused, install same size shim pack as removed. If new gasket is used, install 0.023-in. (0.6 mm) shim pack.

- (63) Install shims (40) on differential carrier (2).
- (64) Aline matchmarks and install bearing cage (29) on differential carrier (2).

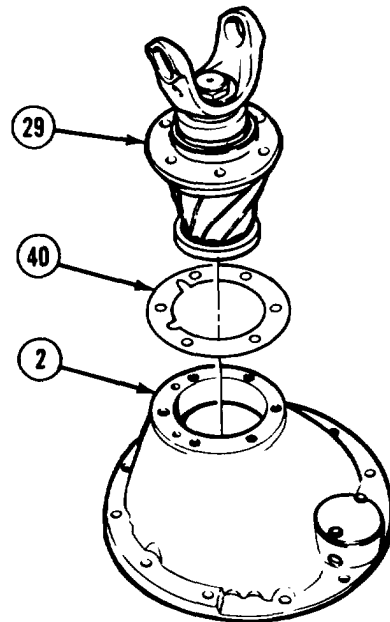

Axles No. 3 and No. 4 Maintenance Instructions (Cont)

NOTE

Model 650 axle on M984E1 does not use lockwashers.

- (65) Apply thread locking compound and install six screws (41) and lockwashers (42) to differential carrier (2). Tighten screws to 160 to 176 lb-ft (217 to 239 N·m).
- (66) Apply coat of sealing compound all the way around outside edge of shims (40).

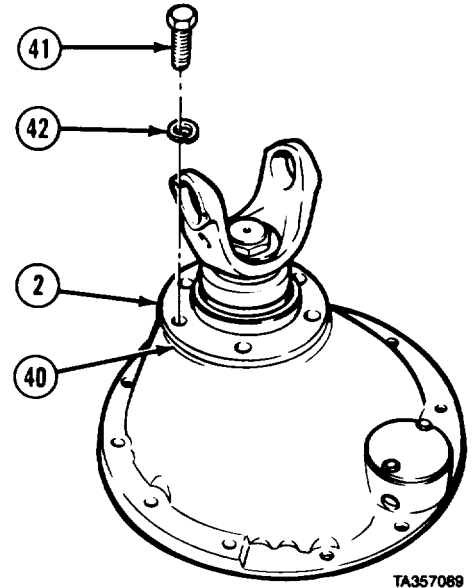

- (67) Lubricate bearing cones (5 and 7) with oil and install bearing cups (43 and 44) on bearings.

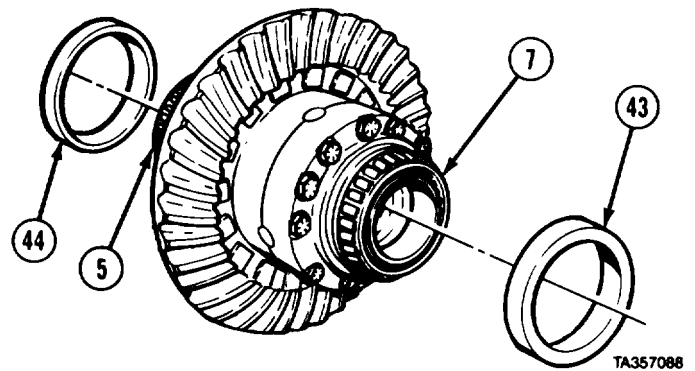

NOTE

Ring gear must be tilted to clear casting inside carrier.

- (68) Attach suitable lifting device to ring gear (9).
- (69) Soldier A guides assembled ring gear (9) in differential carrier (2) until ring gear teeth mesh with pinion inside carrier while Soldier B operates lifting device.
- (70) Remove lifting device.

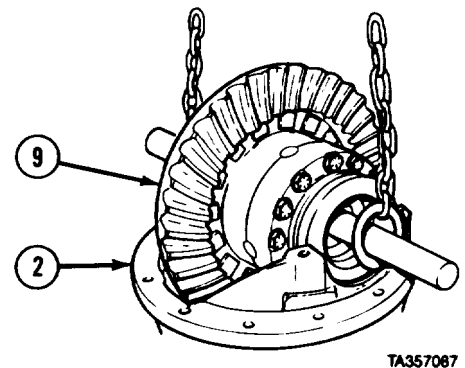

Axles No. 3 and No. 4 Maintenance Instructions (Cont)

10-12. DIFFERENTIAL CARRIER, AXLE NO. 4 (AXLE MODELS 480 AND 580) REPAIR (CONT).

NOTE

When installing bearing caps, it may be necessary to tap caps with hammer. Be sure cap is fully seated and threads aligned.

(71) Aline and seat bearing cap (45), two washers (46), and screws (47) on differential carrier (2). Tighten screws finger-tight.

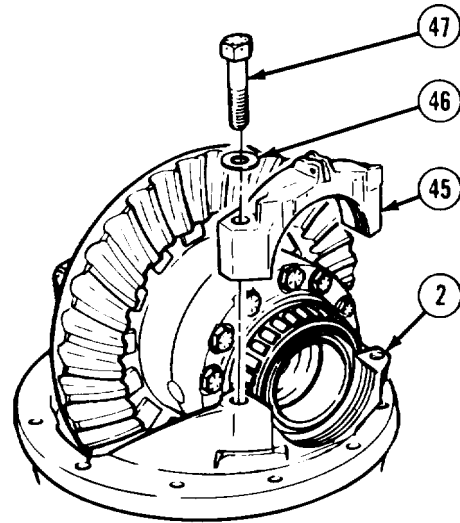

TA357084

(72) Install and seat two bushings (48), bearing cap (49), two screws (50), and washers (51).

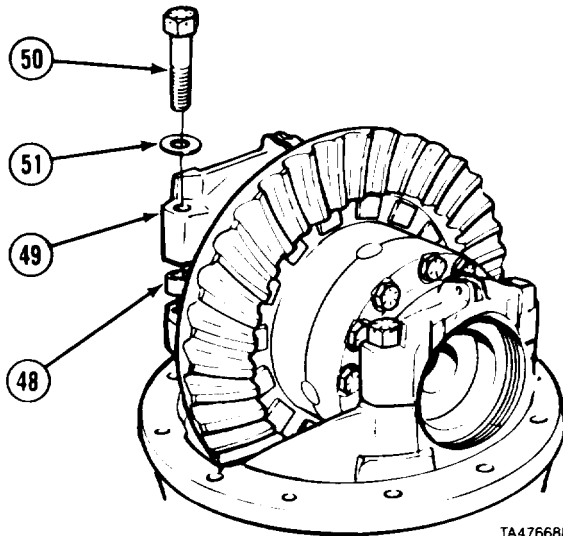

TA476688

CAUTION

Threads on bearing adjusters may be damaged if bearing adjusters are not installed carefully.

(73) Install bearing adjuster (52) finger-tight.

(74) Install bearing adjuster (53) finger-tight.

(75) Tighten four screws (47 and 50) to 40 to 50 lb-ft (54 to 68 N·m).

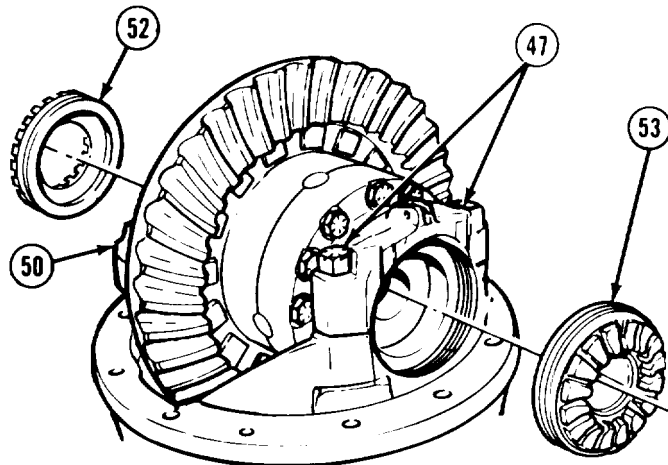

TA357086

Axles No. 3 and No. 4 Maintenance Instructions (Cont)

NOTE

Align notch in bearing adjusters with mark on bearing caps.

- (76) Tighten bearing adjuster (53) until one thread shows.
- (77) Tighten bearing adjuster (52) until ring gear (9) cannot be rocked back and forth toward two bearing adjusters (53 and 52) and there is no backlash.
- (78) Rotate ring gear (9) and check for bind. If ring gear binds, loosen bearing adjuster (52) then retighten until ring gear does not bind.
- (79) Tighten bearing adjuster (53) until it contacts bearing cup or resists turning.
- (80) Tighten bearing adjuster (53) two or three notches until ring gear (9) has backlash,

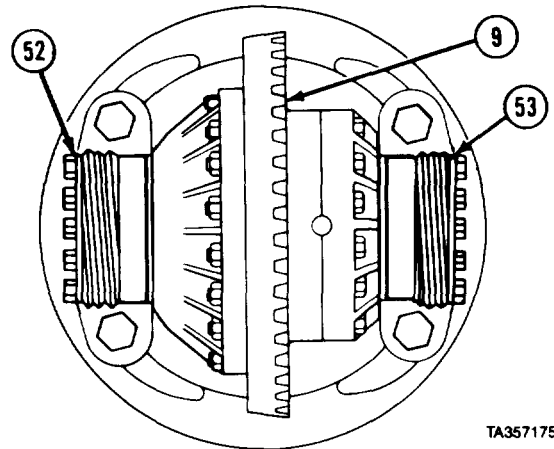

TA357175

NOTE

If old pinion and ring gear are used, backlash should be the same as recorded in disassembly step (1). If new pinion and ring gear are used, backlash should be 0.008 to 0.018 inch (0.203 to 0.457 mm).

- (81) Move ring gear (9) back and forth to measure backlash. If backlash is correct, go to step (90). If there is too much backlash, go to step (86). If there is not enough backlash, continue with step (82).

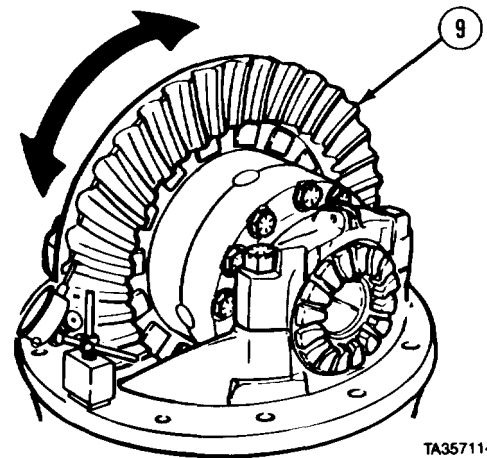

TA357114

- (82) To add backlash, loosen bearing adjuster (53) five or six notches.
- (83) Loosen bearing adjuster (52) one notch.
- (84) Tighten bearing adjuster (53) until it resists movement, then tighten two or three more notches.
- (85) Repeat step (81).
- (86) To remove backlash, loosen bearing adjuster (53) five or six notches.
- (87) Tighten bearing adjuster (52) one notch.
- (88) Tighten bearing adjuster (53) clockwise until it resists movement, then tighten two or three more notches.
- (8.9) Repeat step (81).

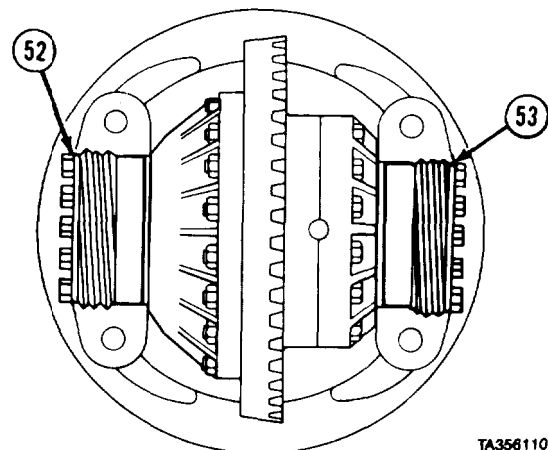

TA356110

Axles No. 3 and No. 4 Maintenance Instructions (Cont)

10-12. DIFFERENTIAL CARRIER, AXLE NO. 4 (AXLE MODELS 480 AND 580) REPAIR (CONT).

- (90) Paint one-third of teeth on ring gear (9) with prussian blue dye.
- (91) Roll ring gear (9) one-third turn, then rock ring gear forward and backward to set pattern in dye.

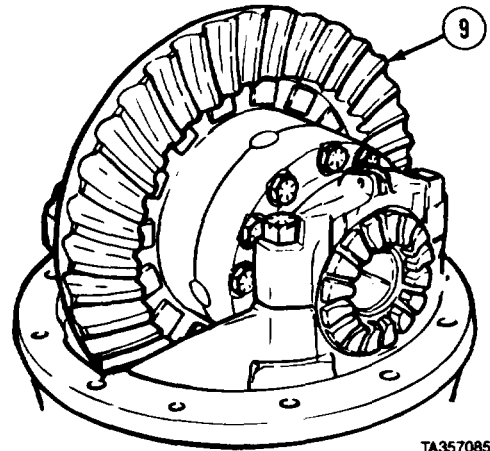

TA357085

NOTE

- A correct gear pattern for a used pinion and ring gear is clear of the toe and centers evenly along the face of gear tooth, but can be any length and shape and is acceptable as long as pattern does not run off gear tooth at any point.
- If gear pattern was correct at disassembly, then gear pattern after assembly should be the same.
- If pattern is not the same, review steps (93) through (96) and adjust backlash as required until pattern that was recorded at disassembly is reached.
- If pattern was incorrect (pattern runs off gear tooth) at disassembly then, after assembly, review steps (93) through (96) and adjust backlash as required until correct gear pattern (pattern does not run off gear teeth) is reached.
- Remember, a correct gear pattern for a used pinion and ring gear does not have to match PATTERN A (correct pattern for new gearing).

NOTE

If new pinion and ring gear are used, tooth pattern should be like correct pattern A. If tooth pattern does not look like A, check patterns B through E to find one that looks close to ring gear tooth pattern, then do step that follows incorrect pattern.

- (92) If tooth contact is like pattern A, do not adjust. Go to step (97).

CORRECT PATTERN (NEW GEARING)

- **COULD VARY IN LENGTH. PATTERN SHOULD COVER 1/2 TOOTH OR MORE (FACE WIDTH).**
- **PATTERN SHOULD BE EVENLY CENTERED BETWEEN TOOTH TOP LAND AND ROOT.**
- **PATTERN SHOULD BE CLEAR OF TOOTH TOE.**

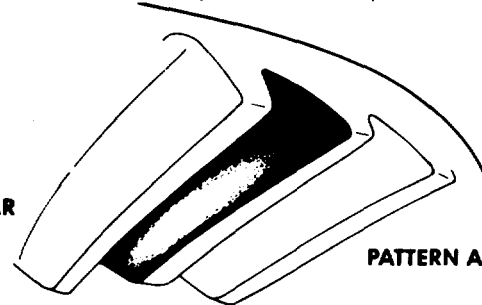

PATTERN A

TA357121

Axles No. 3 and No. 4 Maintenance Instructions (Cont)

(93) If tooth contact is like pattern B, add backlash, steps (82) through (85). Repeat steps (90) and (91).

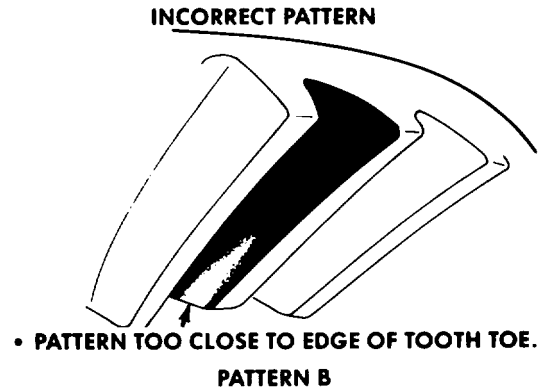

TA357141

(94) If tooth contact pattern is like pattern C, remove backlash, steps (86) through (89). Repeat steps (90) and (91).

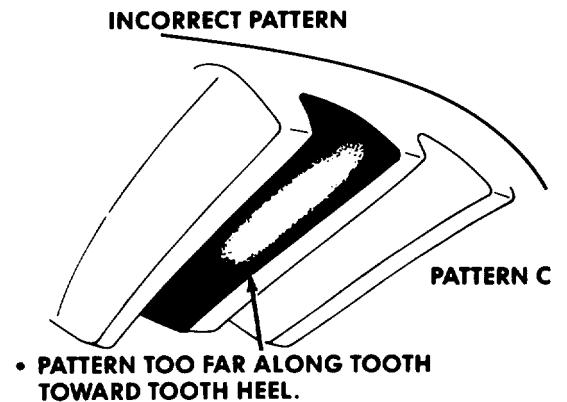

TA357140

NOTE

To add or remove shims in steps (95) and (96), remove ring gear and differential assembly (steps (4) through (14) in Disassembly) and pinion (steps (31) through (34) in Disassembly). Add or remove shims, then install pinion and ring gear and differential assembly (steps (62) through (80)).

(95) If tooth contact is like pattern D, move pinion closer to ring gear (9) by removing shims, then repeat steps (81) through (92).

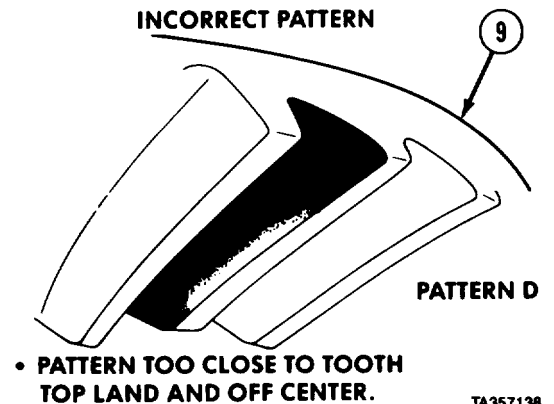

TA357138

Axles No. 3 and No. 4 Maintenance Instructions (Cont)

10-12. DIFFERENTIAL CARRIER, AXLE NO. 4 (AXLE MODELS 480 AND 580) REPAIR (CONT).

(96) If tooth contact is like pattern E, move pinion away from ring gear (9) by adding shims, then repeat steps (81) through (92).

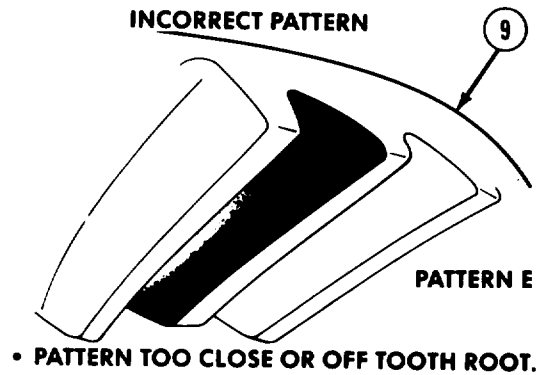

TA357136

(97) Tighten four screws (47 and 50) to 370 to 430 lb-ft (502 to 583 N•m).

NOTE

Check that both adjuster locks aline with bearing adjusters.

(98) Install adjuster lock (54) and cotter pin (55) on bearing cap (45).

(99) Install lockwire on two screws (47).

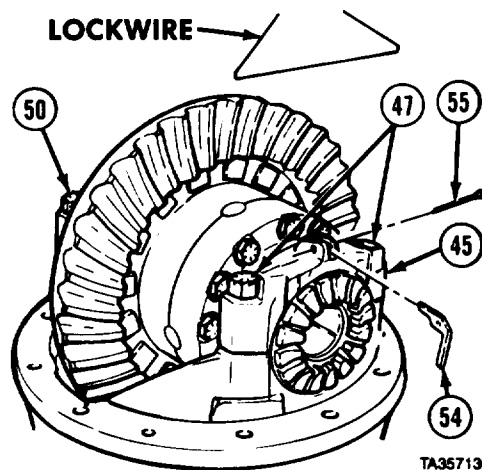

TA357130

(100) Install adjuster lock (56) with two screws (57). Tighten screws to 160 to 176 lb-ft (217 to 239 N•m).

(101) Install lockwire on two screws (57).

(102) Install lockwire on two screws (50).

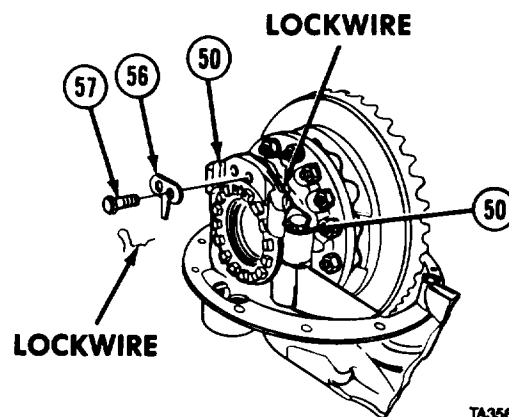

TA356118

d. Follow-on Maintenance Install differential carrier (para 10-11).

END OF TASK

CHAPTER 11 BR AKES

Contents	Para	Page
General.....	11-1	11-1
Brakeshoe Repair.....	11-2	11-1
Brakedrum Inspection and Repair.....	11-3	11-4
Rear Brake Chamber and Arctic Brake Chamber Repair.....	11-4	11-5
Brake Relay Valve Repair.....	11-5	11-9
Spring Brake Valve Repair.....	11-6	11-12
Parking Brake Valve Repair.....	11-7	11-15
Check Valve Repair.....	11-8	11-17
Air Compressor Repair.....	11-9	11-18
Deleted	11-10	
Trailer Supply Valve Repair.....	11-11	11-33
Trailer Brake Hand Control Valve Repair.....	11-12	11-36
Tractor Protection Valve Repair.....	11-13	11-41
Brake Needle Valve Repair.....	11-14	11-45

Section I. INTRODUCTION

WARNING

Caged spring in rear chamber is under 2500 lb (1 135 kg) tension. Use extreme care when handling, storing, or working around caged springs. If caged spring is released it can cause injury or death.

11-1. GENERAL. This chapter contains maintenance instructions for repair of the brake system at the direct support maintenance level.

Section II. SERVICE BRAKES

Brake System Maintenance Instructions

11-2. BRAKESHOE REPAIR.

This task covers:

- | | |
|------------------------|--------------------------|
| a. Disassembly | c. Assembly |
| b. Cleaning/Inspection | d. Follow-on Maintenance |

INITIAL SETUP

Models
All

References
None

Test Equipment
None

Equipment Condition
TM or Para *Condition Description*
Brakeshoes on clean work surface.

Special Tools
None

Special Environmental Conditions
None

Supplies
Solvent, drycleaning, Item 57, Appendix C
Tags, identification, Item 60, Appendix C

General Safety Instructions
None

Personnel Required
MOS 63W, Wheel vehicle repairer

Level of Maintenance
Direct Support

Brake System Maintenance Instructions (Cont)

11-2. BRAKESHOE REPAIR (CONT).

a. Disassembly.

WARNING

Brake shoes may be covered with dust. Breathing this dust may be harmful to your health. Do not use compressed air to clean brake shoes. Wear a filter mask approved for use against brake dust. Failure to comply may result in injury or death to personnel.

NOTE

Front brake linings each have 20 rivets, rear brake linings each have 28 rivets. Front and rear linings are disassembled in the same manner.

- (1) Remove rivets (1) from brake linings (2 and 3).
- (2) Remove brake linings (2 and 3) from brakeshoe (4)

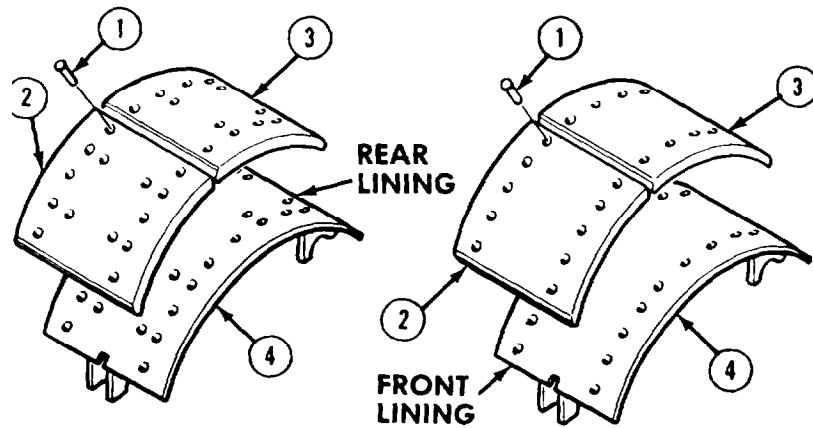

NOTE

Tag and mark front and rear brakeshoes.

b. Cleaning/Inspection.

WARNING

Adhesives, solvents, and sealing compounds can burn easily, can give off harmful vapors, and are harmful to skin and clothing. To avoid injury or death, keep away from open fire and use in well-ventilated area. If adhesive, solvent, or sealing compound gets on skin or clothing, wash immediately with soap and water.

- (1) Clean brakeshoes with drycleaning solvent.
- (2) Inspect shoes for warpage and cracks.
- (3) Check shoe span to detect sprung shoes. Measure from A to B. If distance is more than 13-9/16 in. (344 mm), shoe must be replaced.

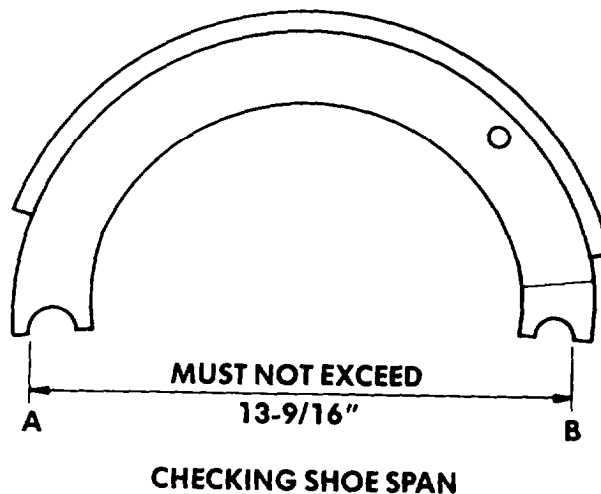

Brake System Maintenance Instructions (Cont)

c. Assembly.

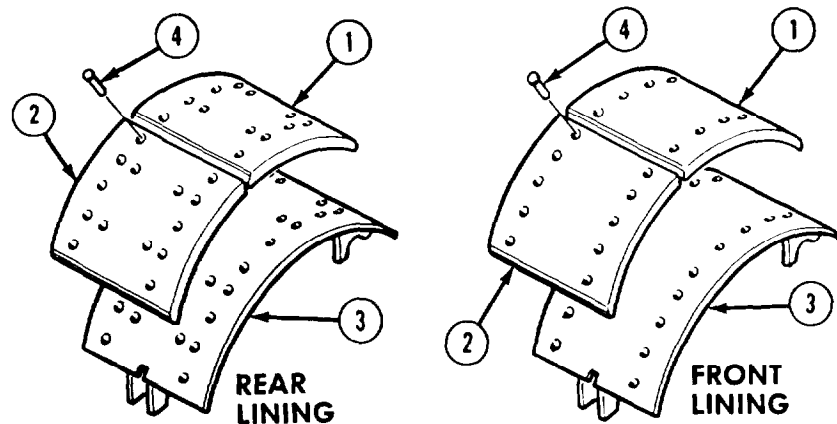

WARNING

Brake shoes may be covered with dust. Breathing this dust may be harmful to your health. Do not use compressed air to clean brake shoes. Wear a filter mask approved for use against brake dust. Failure to comply may result in injury or death to personnel.

NOTE

Front brake linings each have 20 rivets, rear brake linings each have 28 rivets. Front and rear linings are assembled in the same manner.

- (1) Install two brake linings (1 and 2) on brakeshoe (3) with rivets (4).
- (2) Using 0.008-in. (0.2 mm) feeler gage, check clearance between two brake linings (1 and 2) and brakeshoe (3). If gage cannot be inserted, brake linings are assembled right.

NOTE

Tag and mark relined brakeshoes as either top front, bottom front, or rear brakeshoes.

d. Follow-on Maintenance. None.

END OF TASK

Brake System Maintenance Instructions (Cont)

11-3. BRAKEDRUM INSPECTION AND REPAIR.		
This task covers:		
a. Inspection and Repair		
b. Follow-on Maintenance		
INITIAL SETUP		
<i>Models</i>	<i>References</i>	
All	None	
<i>Test Equipment</i>	<i>Equipment Condition</i>	
None	TM or Para	<i>Condition Description</i>
<i>Special Tools</i>	Brakedrum on clean work surface.	
None		
<i>Supplies</i>	<i>Special Environmental Conditions</i>	
Paper, abrasive, garnet (emery cloth), Item 51, Appendix C	None	
<i>Personnel Required</i>	<i>General Safety Instructions</i>	
MOS 44E, Machinist	None	
	<i>Level of Maintenance</i>	
	Direct Support	

a. Inspection and Repair.

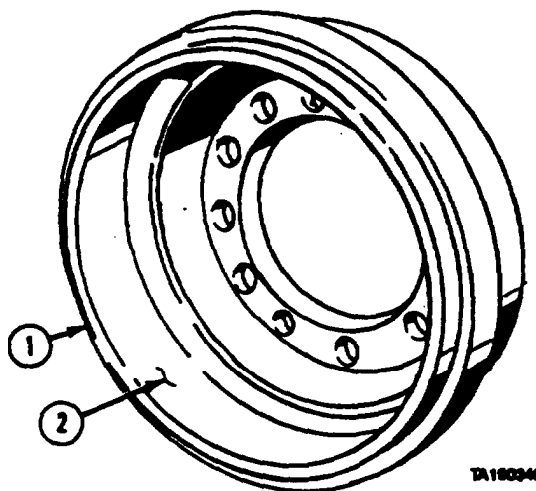

- (1) Brakedrum (1) must be round within 0.003 in. (0.076 mm). If drum is out-of-round, go to step (3).
- (2) Check brakedrum (1) for badly scored finish. If drum is scored, machine drum, go to step (3).
- (3) inside diameter of new drum is 16.51 in. (419.36 mm). Drum may be machined 0.080 in. (2.032 mm) to a maximum inside diameter of 16.59 in. (421.36 mm).
- (4) Check drum surface (2) for glossy or heat spots. If glossy or heat spots are visible, clean with emery cloth.

b. Follow-on Maintenance. None.

END OF TASK

Brake System Maintenance Instructions (Cont)

Section III. AIR BRAKE SYSTEM

11-4. REAR BRAKE CHAMBER AND ARCTIC BRAKE CHAMBER REPAIR.

This task covers:

- a. Disassembly
- b. Cleaning/Inspection
- c. Assembly
- d. Follow-on Maintenance

INITIAL SETUP

Models

All

Test Equipment

None

Special Tools

None

Supplies

Solvent, drycleaning, Item 57, Appendix C
Grease, automotive and artillery, Item 34, Appendix C

Personnel Required

MOS 63W, Wheel vehicle repairer (2)

References

None

Equipment Condition

TM or Para

TM 9-2320-279-10

Condition Description

Rear chamber spring caged.

Rear brake chamber or arctic brake chamber on work surface.

Special Environmental Conditions

None

General Safety Instructions

Do not attempt to disassemble or repair the rear chamber of the air brake chamber assembly.

Level of Maintenance

Direct Support

Brake System Maintenance Instructions (Cont)

11-4. REAR BRAKE CHAMBER AND ARCTIC BRAKE CHAMBER REPAIR (CONT).

a. Disassembly.

NOTE

- There are two types of rear brake chambers; Model A and Model B. Refer to TM 9-2320-279-24P for proper part identification if chambers must be repaired or replaced.
- Model A brake chamber and arctic brake chamber are disassembled the same way. Rear brake chamber is shown.
- Model A brake chamber diaphragm is made of rubber. Arctic brake chamber diaphragm is made of neoprene.

- (1) Remove yoke (1).
- (2) Remove two nuts (2), screws (3), and clamps (4).

WARNING

Spring is under tension. Release spring slowly to avoid personal injury,

- (3) Remove jamnut (5) from top brake chamber (6) to release spring.

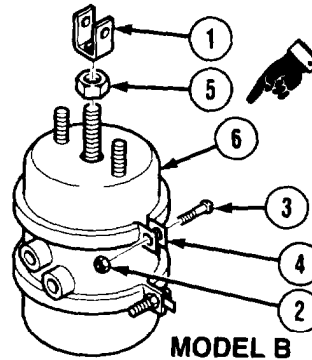
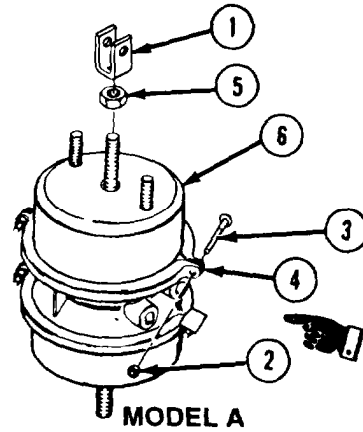

Brake System Maintenance Instructions (Cont)

NOTE

Matchmark brake assembly.

- (4) Remove top brake chamber (6).
- (5) Remove spring (7) and plunger (8).
- (6) Remove diaphragm (9) from center brake chamber (10).

Steps (7) through (11) are deleted.

b. *Cleaning/Inspection.*

WARNING

Adhesives, solvents, and sealing compounds can burn easily, can give off harmful vapors, and are harmful to skin and clothing. To avoid injury or death, keep away from open fire and use in well-ventilated area. If adhesive, solvent, or sealing compound gets on skin or clothing, wash immediately with soap and water.

- (1) Wash parts thoroughly in drycleaning solvent.
- (2) Inspect parts for damage or wear. Replace if necessary.

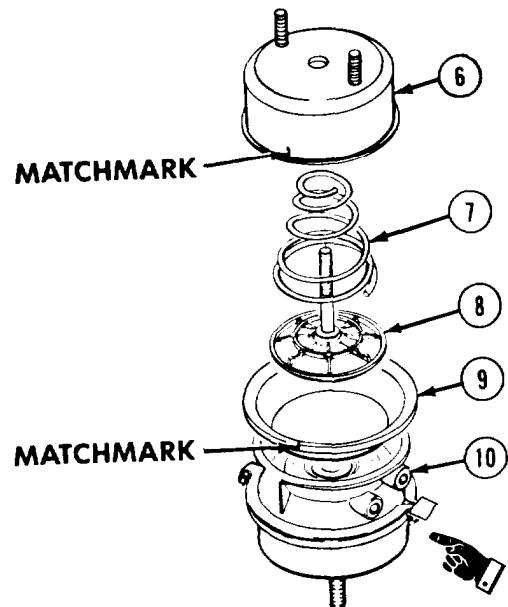

Brake System Maintenance Instructions (Cont)

11-4. REAR BRAKE CHAMBER AND ARCTIC BRAKE CHAMBER REPAIR (CONT.)

c. Assembly.

WARNING

Caged spring in rear chamber is under 2500 lb (1 135 kg) tension. Use extreme care when handling or storing caged spring. If caged spring is released it can cause injury or death.

CAUTION

Use care when closing holding device, so device does not press directly on caged spring retainer or damage edges of center brake chamber.

NOTE

- There are two types of rear brake chambers: Model A and Model B. Refer to TM 9-2320-279-24P for proper identification of parts if chambers must be repaired or replaced.
- Rear brake chamber and arctic brake chamber are assembled the same way. Rear brake chamber is shown.

Steps (1) through (7) were deleted.

- (8) Install diaphragm (1), plunger (2), and spring (3) in center brake chamber (4).

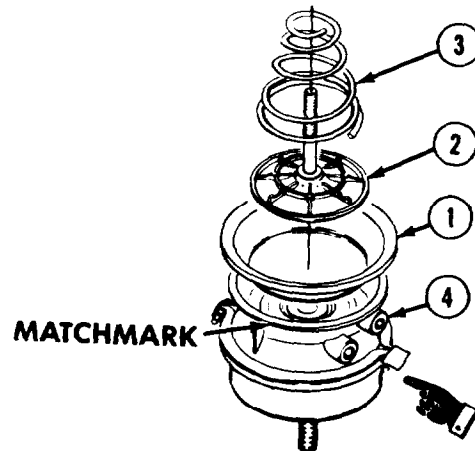

Brake System Maintenance Instructions (Cont)

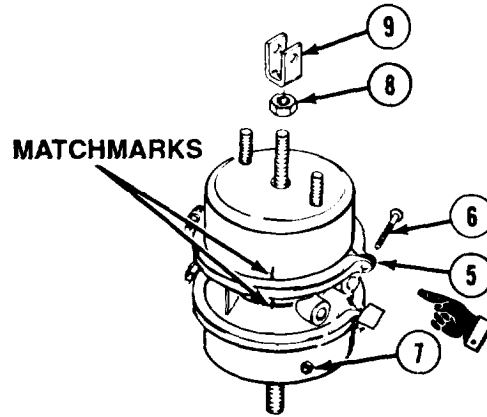

- (9) Soldier A installs and holds two clamps (5) while Soldier B installs two screws (6) and nuts (7).

NOTE

Tighten nut on Model B clamps to 25 lb ft. (34 N•m).

- (10) Rap clamps (5) with hammer and tighten two nuts (7) to 40 lb-ft (54 N•m). Release holding device.

NOTE

Install yoke until threads of stud just come through yoke.

- (11) Install jamnut (8) and yoke (9). Tighten jamnut against yoke.

d. Follow-on Maintenance. None.

END OF TASK

11-5. BRAKE RELAY VALVE REPAIR.

This task covers:

- a. Disassembly
- b. Cleaning/Inspection
- c. Assembly
- d. Follow-on Maintenance

INITIAL SETUP

Models
All

Test Equipment
None

Special Tools
None

Supplies
Grease, lithium base, Item 35, Appendix C
Solvent, drycleaning, Item 57, Appendix C

Personnel Required
MOS 63W, Wheel vehicle repairer

References
None

Equipment Condition
TM or Para
Condition Description
Brake relay valve on work surface.

Special Environmental Conditions
None

General Safety instructions
None

Level of Maintenance
Direct Support

Brake System Maintenance Instructions (Cont)

11-5. BRAKE RELAY VALVE REPAIR (CONT).

a. Disassembly.

- (1) Remove retaining ring (1) while holding down exhaust cover assembly (2).
- (2) Allow exhaust cover assembly (2) to rise slowly until spring (3) is fully extended.
- (3) Remove exhaust cover assembly (2) and preformed packings (4 and 5) from exhaust cover assembly.
- (4) Remove spring (3), inlet/exhaust valve (6), and valve retainer (7) from body (8).

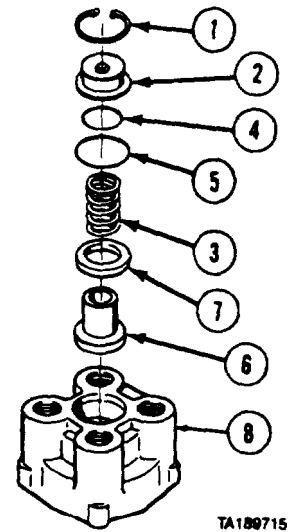

- (5) Matchmark cover (9) and body (8).

NOTE

Rear relay valve will not have mounting bracket attached.

- (6) Mount unit in vise with soft jaws. Remove four screws (JO), lockwashers (11), mounting bracket (12), cover (9), and sealing ring (13).
- (7) Remove piston (14) and preformed packing (15) from body (8).

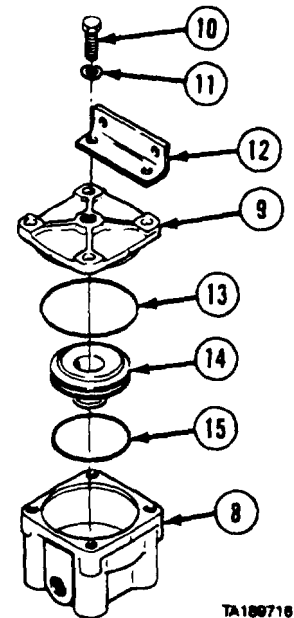

b. Cleaning/Inspection.

WARNING

Adhesives, solvents, and sealing compounds can burn easily, can give off harmful vapors, **and** are harmful to skin and clothing. To avoid injury or death, keep away from open fire and use in well-ventilated area. If adhesive, solvent, or sealing compound gets on skin or clothing, wash immediately with soap and water.

- (1) Clean all metal parts in dry cleaning solvent.
- (2) Inspect all parts for damage, cracks, breaks, or deterioration.
- (3) Replace unserviceable parts.

Brake System Maintenance Instructions (Cont)

c. Assembly.

- (1) Coat body (1), piston (2), preformed packing (3), and sealing ring (4) with light coat of grease.
- (2) Install preformed packing (3) on piston (2).
- (3) Install piston (2) in body (1).
- (4) Install sealing ring (4) on cover (5).

NOTE

Rear relay valve will not have mounting bracket attached.

- (5) Aline matchmarks and install cover (5) on body (1).
- (6) Install mounting bracket (6) with four screws (7), and lockwashers (8). Tighten screws to 80 to 120 lb-in (9 to 14 N•m).

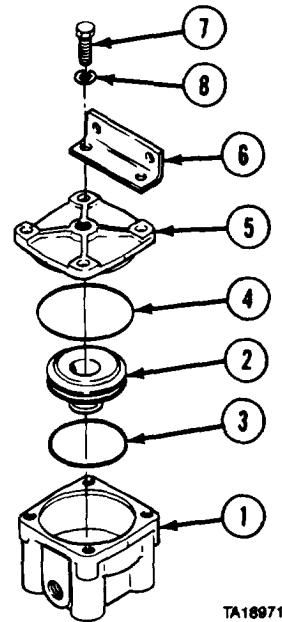

TA189717

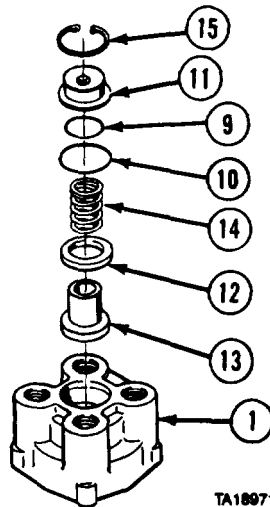

TA189716

- (7) Mount body (1) in vise with soft jaws, cover down.
- (8) Coat preformed packings (9 and 10) and exhaust cover assembly (11) with light coat of grease and install preformed packings in exhaust cover assembly.
- (9) Coat valve retainer (12) and inlet/exhaust valve (13) with light coat of grease. Install valve retainer on inlet/exhaust valve and install in body (1).
- (10) Install spring (14) in body (1).
- (11) Install exhaust cover assembly (11).
- (12) Depress exhaust cover assembly (11) and install retaining ring (15). Make sure retaining ring is seated in groove in body (1).

d. Follow-on Maintenance. None.

END OF TASK

Brake System Maintenance Instructions (Cont)

11-6. SPRING BRAKE VALVE REPAIR.		
This task covers:		
a. Disassembly	c. Assembly	
b. Cleaning/Inspection	d. Follow-on Maintenance	
INITIAL SETUP		
Models	References	
All	None	
Test Equipment	Equipment Condition	
None	TM or Para	Condition Description
Special Tools		Spring brake valve on clean work surface.
None		
Supplies	Special Environmental Conditions	
Solvent, dry cleaning, Item 57, Appendix C	None	
Compound, sealing, pipe thread, Item 29, Appendix C	General Safety Instructions	
Oil, lubricating, Item 46, Appendix C	None	
Personnel Required	Level of Maintenance	
MOS 63W. Wheel vehicle repairer	Direct Support	

a. Disassembly.

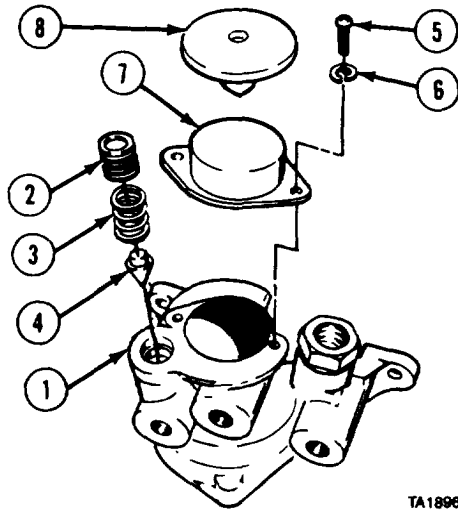

TA189679

- (1) Position valve body (1) in vise.
- (2) Remove plug (2), spring (3), and check valve (4).
- (3) Remove two screws (5), lockwashers (6), and cover (7).
- (4) Remove diaphragm (8) from cover (7).

Brake System Maintenance Instructions (Cont)

- (5) Remove retaining ring (9), valve guide (10), preformed packings (11 and 12), spring (13), and inlet/exhaust assembly (14) from valve body (1).
- (6) Remove valve retainer (15) from inlet/exhaust assembly (14).
- (7) Remove capnut (16), preformed packing (17), valve stop (18), spring (19), and valve (20).
- (8) Turn valve body (1) over in vise,

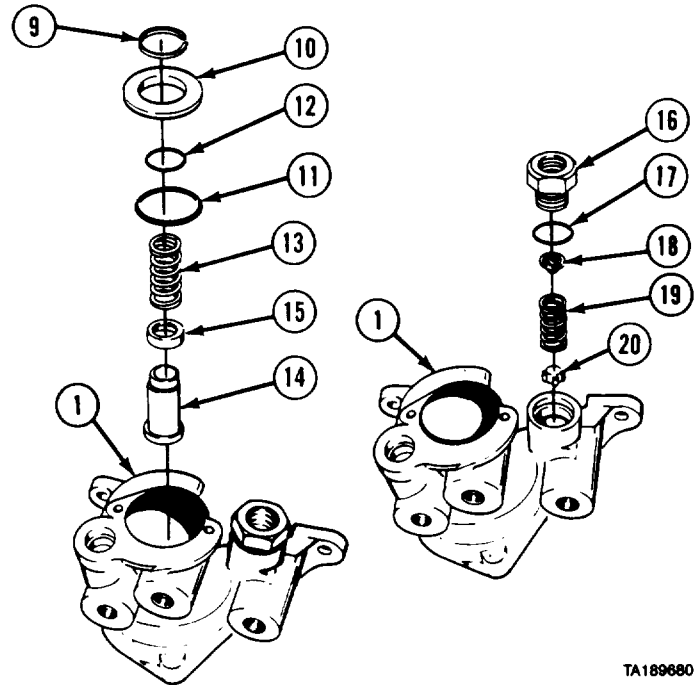

TA189680

WARNING

Cover is under spring pressure. Hold cover down while removing screws to prevent personal injury.

- (9) Hold cover (21) down and remove four screws (22) and lockwashers (23). Remove cover.
- (10) Remove springs (24, 25, and 26).
- (11) Remove piston (27) and preformed packings (28 and 29).
- (12) Remove piston (30) and preformed packings (31 and 32) from valve body (1).

b. Cleaning/Inspection.

WARNING

Adhesives, solvents, and sealing compounds can burn easily, can give off harmful vapors, and are harmful to skin and clothing. To avoid injury or death, keep away from open fire and use in well-ventilated area. If adhesive, solvent, or sealing compound gets on skin or clothing, wash immediately with soap and water.

- (1) Clean metal parts in dry cleaning solvent.
- (2) Inspect all parts for damage, cracks, breaks, or deterioration.
- (3) Inspect springs for cracks or corrosion.
- (4) Replace unserviceable parts.

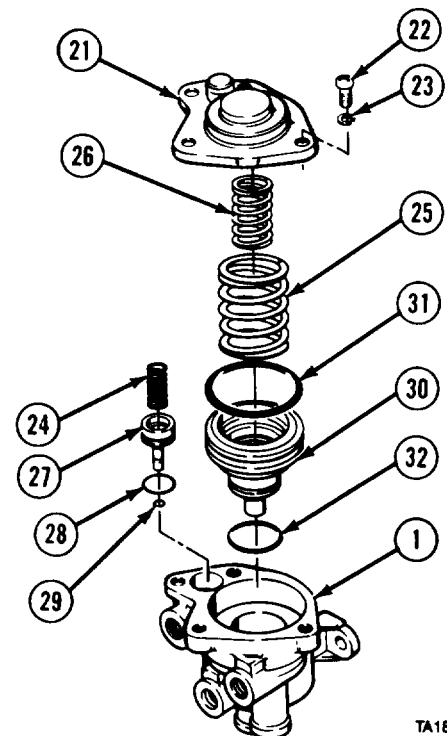

TA189682

Brake System Maintenance Instructions (Cont)

11-6. SPRING BRAKE VALVE REPAIR (CONT).

c. Assembly.

- (1) Position valve body (1) in vise.
- (2) Coat preformed packings (2 and 3) with lubricating oil and install on piston (4).
- (3) Install piston (4) in valve body (1).
- (4) Coat preformed packings (5 and 6) with lubricating oil and install on piston (7).
- (5) Install piston (7) in valve body (1).
- (6) Install springs (8 and 9) on piston (7).
- (7) Install spring (10) on piston (4).
- (8) Install and press down on cover (11). Install four screws (12) and lockwashers (13). Tighten screws to 50 to 80 lb-in. (6 to 9 N•m).
- (9) Turn valve body (1) over in vise.

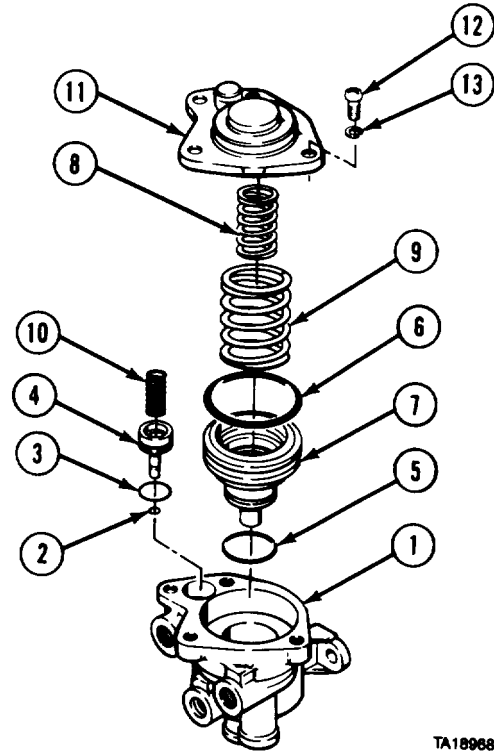

TA189683

- (10) Install valve (14), spring (15), and valve stop (16) in valve body (1).
- (11) Coat preformed packing (17) with lubricating oil and install on capnut (18).
- (12) Install capnut (18) and tighten to 100 to 125 lb-in. (11 to 14 N•m).
- (13) Coat preformed packings (19 and 20) with lubricating oil and install on valve guide (21).
- (14) Install valve retainer (22), spring (23), valve guide (21), and retaining ring (24) on inlet/exhaust valve (25) and install in valve body (1).

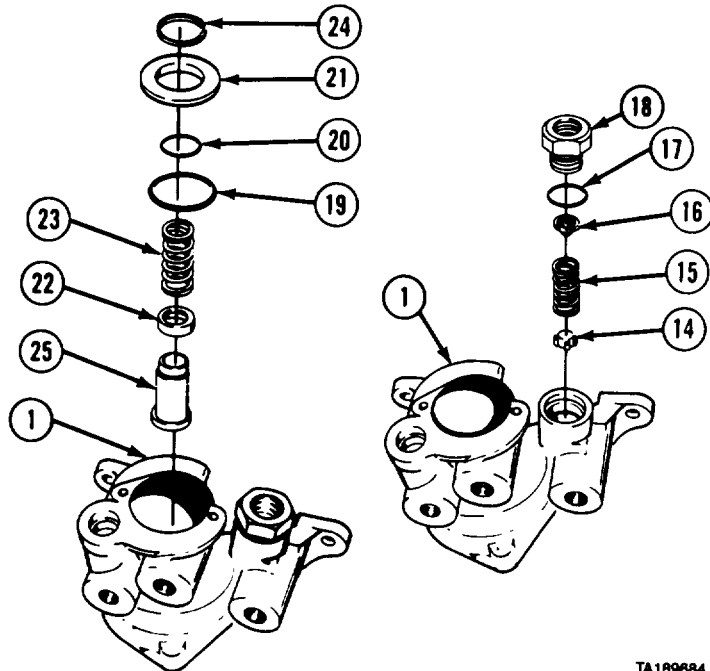

TA189684

Brake System Maintenance Instructions (Cont)

- (15) Install cover (26) with two screws (27), and lockwashers (28). Tighten screws to 20 to 30 lb-in. (2 to 3 N•m).
- (16) Install diaphragm (29) on cover (26).
- (17) Install check valve (30) and spring (31).

WARNING

Adhesives, solvents, and sealing compounds can burn easily, can give off harmful vapors, and are harmful to skin and clothing. To avoid injury or death, keep away from open fire and use in well-ventilated area. If adhesive, solvent, or sealing compound gets on skin or clothing, wash immediately with soap and water.

- (18) Coat plug (32) with pipe thread sealing compound and install.

cf. Follow-on Maintenance. None.

END OF TASK

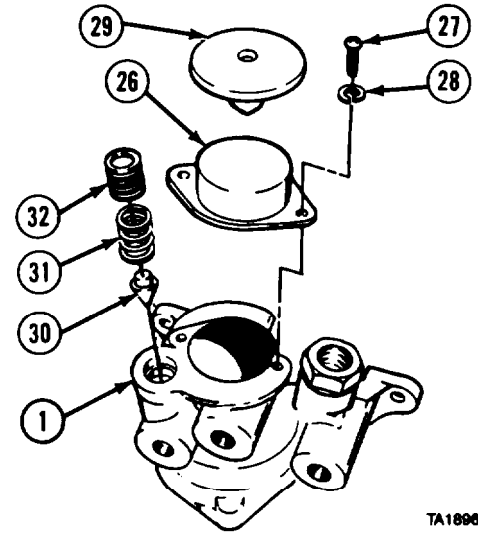

TA189686

11-7. PARKING BRAKE VALVE REPAIR.	
This task covers:	
a. Disassembly	c. Assembly
b. Cleaning/Inspection	d. Follow-on Maintenance
INITIAL SETUP	
Models	Equipment Condition
All	TM or Para
Test Equipment	Condition Description
None	Parking brake valve on clean work surface.
Special Tools	Special Environmental Conditions
None	None
Supplies	General Safety Instructions
Solvent, dry cleaning, Item 57, Appendix C	None
Oil, lubricating, Item 46, Appendix C	Level of Maintenance
Personnel Required	Direct Support
MOS 63W, Wheel vehicle repairer	
References	
None	

Brake System Maintenance Instructions (Cont)

11-7. PARKING BRAKE VALVE REPAIR (CONT).

a. Disassembly.

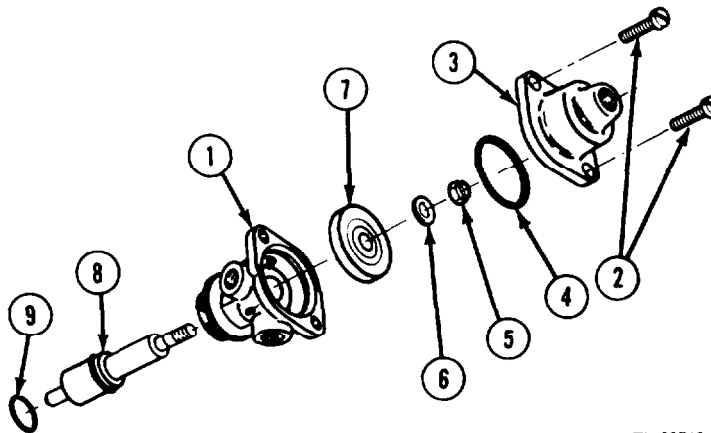

TA189713

- (1) Mount valve body (1) in vise with soft jaws.
- (2) Remove two screws (2) and end cap (3).
- (3) Remove seal (4).
- (4) Remove locknut (5), washer (6), and poppet (7).
- (5) Remove stem (8) and preformed packing (9).

b. Cleankg/inspection.

WARNING

Adhesives, solvents, and sealing compounds can burn easily, can give off harmful vapors, and are harmful to skin and clothing. To avoid injury or death, keep away from open fire and use in well-ventilated area. If adhesive, solvent, or sealing compound gets on skin or clothing, wash immediately with soap and water.

- (1) Clean all metal parts in dry cleaning solvent.
- (2) Inspect end cap and valve body for damage.
- (3) Replace damaged parts.

c. Assembly.

- (1) Mount valve body (1) in vise with soft jaws.
- (2) Coat preformed packing (9) with lubricating oil and install on stem (8).
- (3) Insert stem (8) in valve body (1) and install poppet (7), washer (6), and locknut (5).
- (4) Coat seal (4) with lubricating oil and install in valve body (1).
- (5) Install end cap (3) and two screws (2).

d. Follow-on Maintenance. None.

END OF TASK

Brake System Maintenance Instructions (Cent)

11-8. CHECK VALVE REPAIR.

This task covers:

- a. Disassembly
- b. Cleaning/Inspection
- c. Assembly
- d. Follow-on Maintenance

INITIAL SETUP

Models

All

Test Equipment

None

Special Tools

None

Supplies

Solvent, dry cleaning, Item 57, Appendix C

Personnel Required

MOS 63W, Wheel vehicle repairer

References

None

Equipment Condition

TM or Para

Condition Description

Check valve on clean work surface.

Special Environmental Conditions

None

General Safety Instructions

None

Level of Maintenance

Direct Support

NOTE

This task covers repair of Throttle Air Solenoid Check Valve, Front Double Check Valves, and Transfer Case Lockup Valve.

- a. Disassembly.
 - (1) Remove two screws (1), washer (2), and tags (3 and 4) from cap (5).
 - (2) Remove cap (5) from body (6).
 - (3) Remove valve (7) and guide (8) from body (6).
 - (4) Remove preformed packing (9) from cap (5).
- b. Cleaning/Inspection.

WARNING

Adhesives, solvents, and sealing compounds can burn easily, can give off harmful vapors, and are harmful to skin and clothing. To avoid injury or death, keep away from open fire and use in well-ventilated area. If adhesive, solvent, or sealing compound gets on skin or clothing, wash immediately with soap and water.

- (1) Clean all metal parts in dry cleaning solvent.
- (2) Inspect body and cap for damage.
- (3) Replace damaged parts.

- c. Assembly.
 - (1) Install preformed packing (9) in cap (5).
 - (2) Install guide (8) and valve (7) in body (6).
 - (3) Install cap (5) on body (6) with screw (1), tag (4), screw (1), washer (2), and tag (3).

cf. Follow-on Maintenance. None.

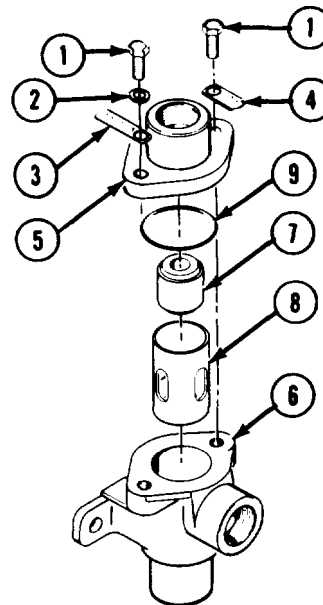

TA189689

END OF TASK

Brake System Maintenance Instructions (Cont)

Section IV. AIR COMPRESSOR

11-9. AIR COMPRESSOR REPAIR.		
This task covers:		
a. Disassembly	c. Assembly	
b. Cleaning/Inspection	d. Follow-on Maintenance	
INITIAL SETUP		
Models	Personnel Required	
All	MOS 63W, Wheel vehicle repairer	
Test Equipment	References	
None	None	
Special Tools	Equipment Condition	
None	TM or Para	Condition Description
Fabricated Tools		Air compressor on clean work surface.
Unloader bore bushing removal tool 2BF829, Figure B-9, Appendix B	Special Environmental Conditions	
Air compressor cylinder head removal tool 2AH762	None	
Supplies	General Safety Instructions	
Solvent, dry cleaning, Item 57, Appendix C	None	
Oil, lubricating, Item 46, Appendix C	Level of Maintenance	
	Direct Support	

a. Disassembly.

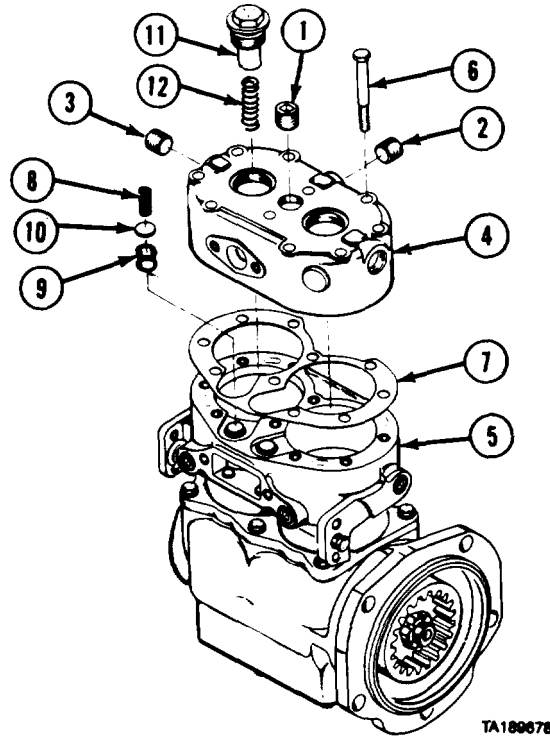

Broke System Maintenance Instructions (Cent)

- (1) Remove three plugs (1, 2, and 3).
- (2) Matchmark cylinder head (4) and cylinder block (5).
- (3) Remove 10 screws (6) and tap cylinder head (4) to break gasket seal.
- (4) Remove cylinder head (4).
- (5) Remove head gasket (7).
- (6) Remove two springs (8), inlet valve guides (9), and inlet valves (10).
- (7) Place cylinder head (4) in vise with soft jaws.
- (8) Remove two discharge valve capnuts (11) and springs (12).
- (9) Using air compressor cylinder head removal tool, remove two discharge valve seats (13).
- (10) Remove discharge valve plug (14) and discharge valve (15) from two discharge valve seats (13).

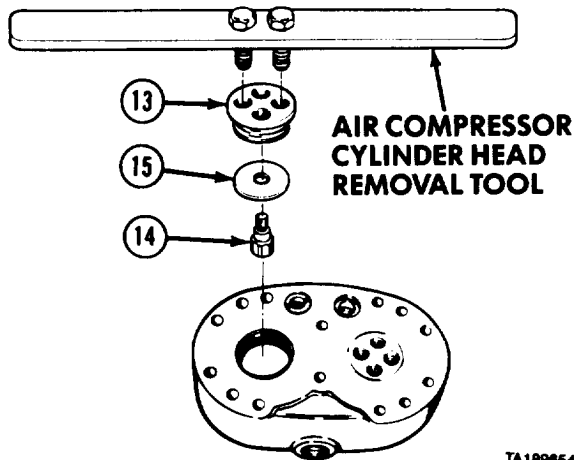

TA189654

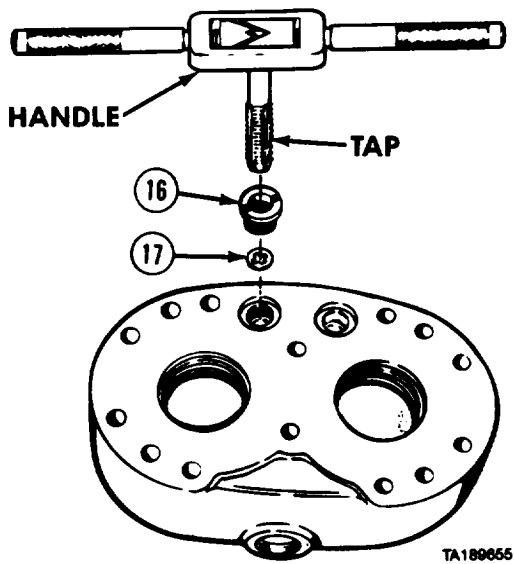

TA189655

- (11) Remove inlet valve spring bushing (16) and inlet valve spring seat (17) with tap and handle.

Brake System Maintenance Instructions (Cont)

11-9. AIR COMPRESSOR REPAIR (CONT).

- (12) Mark position of cover (18) and remove five screws (19), lockwashers (20), screw (21), cover, and gasket (22).

NOTE

Repeat steps (14) through (16) to remove second connecting rod.

- (13) Matchmark each connecting rod (23) and bearing cap (24).
- (14) Remove two screws (25) and bearing cap (24) with bearing insert (26).
- (15) Push piston (27) with connecting rod (23) and bearing insert (28) out of cylinder block (5).
- (16) Remove bearing inserts (26 and 28) from bearing cap (24) and connecting rod (23).

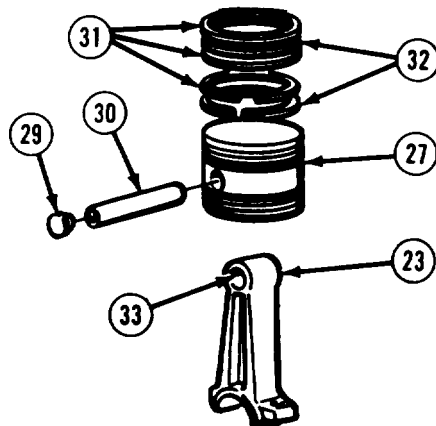
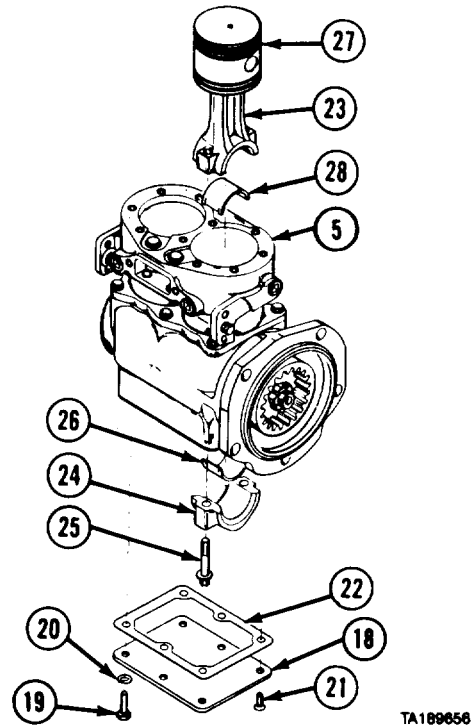

- (17) Remove two wrist pin plugs (29) and wrist pin (30) from piston (27) and connecting rod (23).
- (18) Remove piston rings (31 and 32) only if rings must be replaced.
- (19) Check inside diameter of wrist pin bushing (33). It must not exceed 0.54 in. (13.7 mm). If diameter is larger, replace wrist pin bushing.

Brake System Maintenance Instructions (Cont)

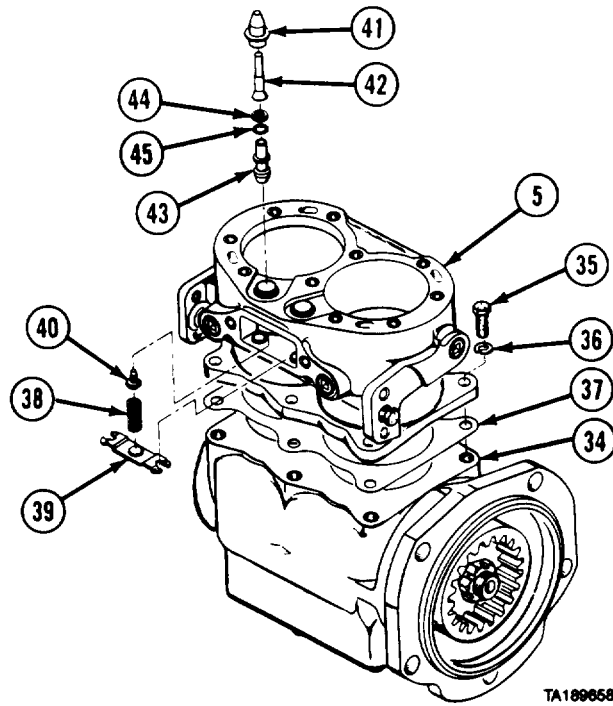

- (20) Matchmark cylinder block (5) and crankcase (34).
- (21) Remove six screws (35), lockwashers (36), and cylinder block (5).
- (22) Remove gasket (37) from cylinder block (5).
- (23) Remove unloader spring (38), spring saddle (39), and unloader spring seat (40).
- (24) Remove two guides (41), plungers (42), and pistons (43).
- (25) Remove backup ring (44) and preformed packing (45) from pistons (43).

- (26) Remove four plugs (46) from cylinder block (5).
- (27) Remove plug (47).

NOTE

Bushings are removed only if damaged.

- (28) Remove two unloader bore bushings (48) and valve seats (49).

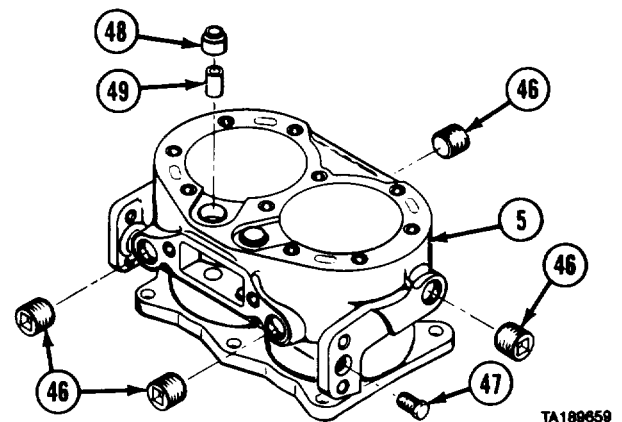

TA189659

Brake System Maintenance Instructions (Cont)

11-9. AIR COMPRESSOR REPAIR (CONT)..

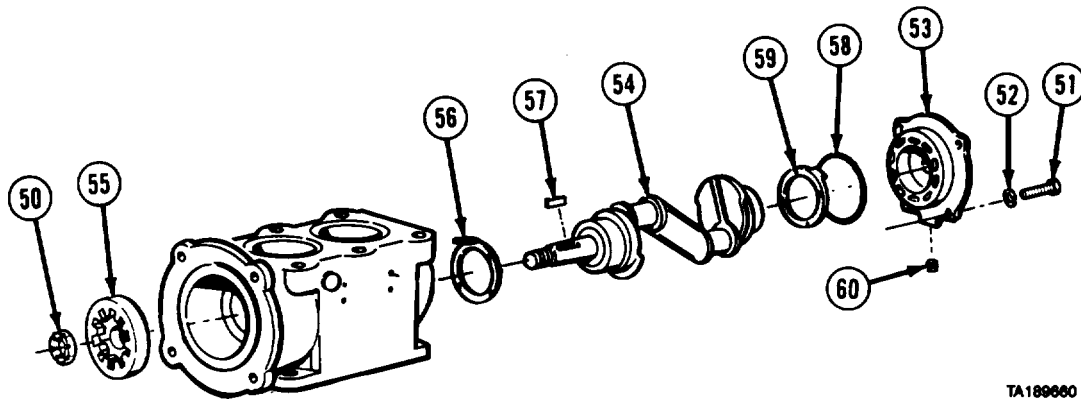

TA189060

- (29) Remove nut (50).
- (30) Remove four screws (51), lockwashers (52), and end cover (53).
- (31) Remove crankshaft (54), drive plate (55), and thrust washer (56).
- (32) Remove key (57).
- (33) Remove preformed packing (58).
- (34) Remove thrust washer (59).
- (35) Remove pipe plug (60).

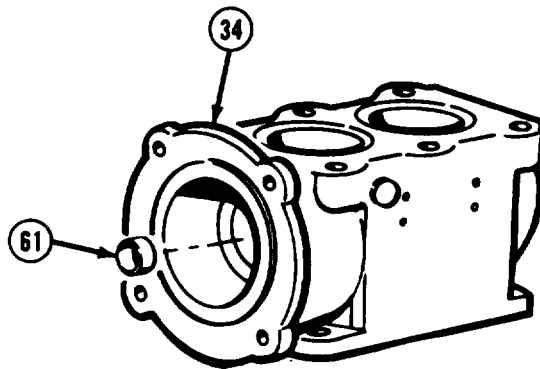

TA189061

- (36) Check inside diameter of crankcase bushing (61).
- (37) If bushing diameter is more than 0.005 in. (0.12 mm) larger than crankshaft diameter, remove bushing (61) from crankcase (34).

Brake System Maintenance Instructions (Cont)

- (38) Check inside diameter of end cover bushing (62).
- (39) If bushing diameter is more than 0.005 in. (0.12 mm) larger than crankshaft diameter, remove end cover bushing (62) from end cover.

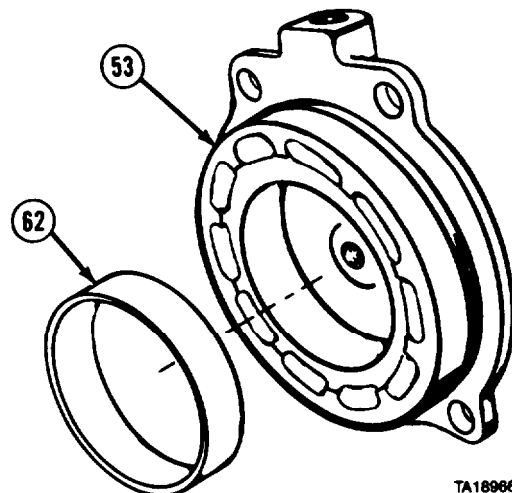

TA189662

NOTE

Remove unloader bore bushings only if damaged.

- (40) Using unloader bore bushing removal tool, remove two unloader bore bushings (48).
- (41) Remove two valve seats (49).
- (42) Install unloader bore bushings (48) in cylinder block (5).
- (43) Ream unloader bore bushings (48) inside diameter to 0.3750 in. (9.5 mm).
- (44) Install valve seats (49) in cylinder block (5).

b. Cleanhg/inspection.

WARNING

Adhesives, solvents, and sealing compounds can burn easily, can give off harmful vapors, and are harmful to skin and clothing. To avoid injury or death, keep away from open fire and use in well-ventilated area. If adhesive, solvent, or sealing compound gets on skin or clothing, wash immediately with soap and water.

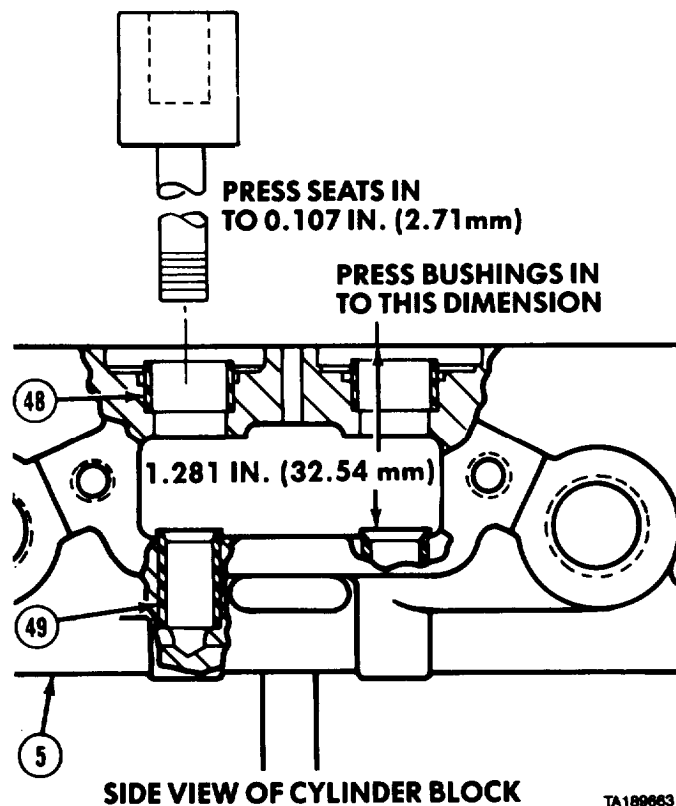

TA189663

- (1) Clean all metal parts with dry cleaning solvent.
- (2) Remove rust and scale from cavities in cylinder head and crankcase.
- (3) Clean oil passages through crankshaft, crankcase, and end cover.
- (4) Inspect all metal parts for cracks and damage.
- (5) Inspect pistons for damage and enlarged ring grooves.
- (6) Replace unserviceable parts.

Brake System Maintenance Instructions (Cont)

11-9. AIR COMPRESSOR REPAIR (CONT).

- (7) Check fit of piston rings in piston grooves.
- (8) Check ring gap with rings installed in cylinder bores.
- (9) Compare piston outside diameter with cylinder inside diameter. Piston clearance must not exceed 0.004 in. (0.10 mm).
- (10) Measure crankshaft journals. Journal diameters must be between 1.124 and 1.125 in. (28.55 and 28.57 mm).
- (11) Replace all parts that are damaged or out of tolerance.

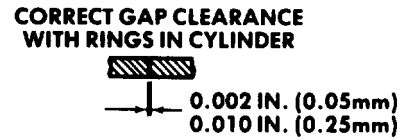
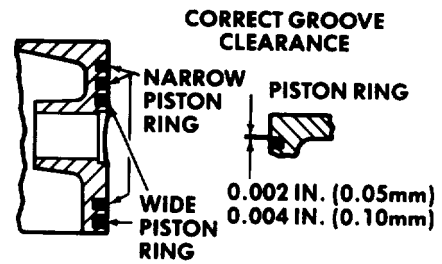

TA189064

c. Assembly.

- (1) Install crankcase bushing (1) in crankcase (2).

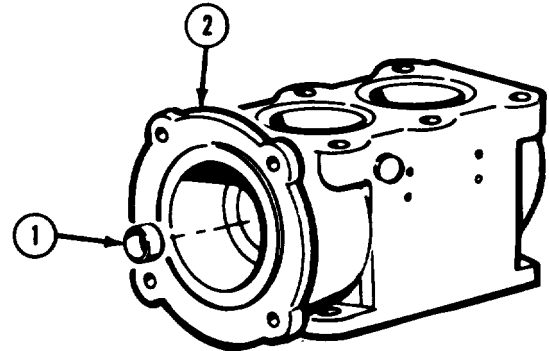

TA189065

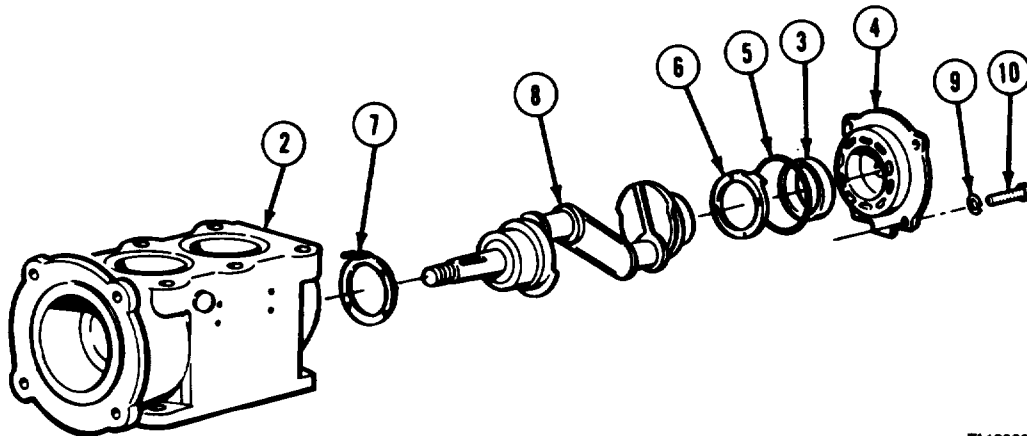

TA189066

- (2) Install end cover bushing (3) in end cover (4),

Brake System Maintenance Instructions (Cont)

NOTE

Make sure bent tang on thrust washer fits in slot of end cover.

- (3) Install preformed packing (5) and thrust washer (6) on end cover (4).
- (4) Place crankcase (2) on end.
- (5) Install thrust washer (7) in crankcase (2) with bent tang in slot in crankcase.
- (6) Install crankshaft (8) in crankcase (2).
- (7) Install end cover (4) with four lockwashers (9), and screws (10). Tighten screws to 15 to 20 lb-ft (20 to 27 N•m).

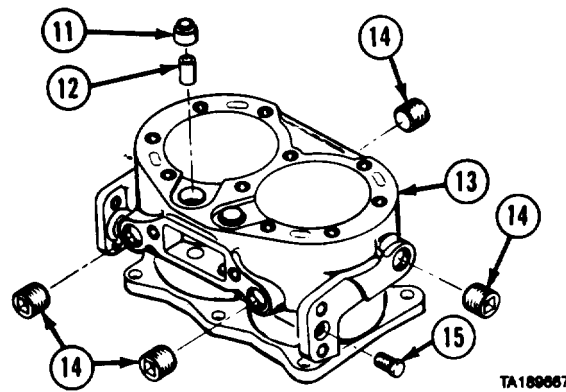

- (8) Install two unloader valve seats (11) and two bushings (12) in cylinder block (13).
- (9) Install four plugs (14).
- (10) Install plug (15).

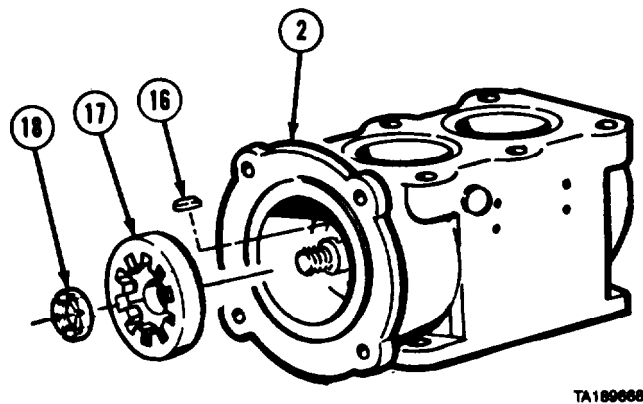

- (11) Place crankcase (2) on base and install key (16), drive plate (17), and nut (18). Tighten nut to 120 lb-ft (163 N•m).

Brake System Maintenance Instructions (Cont)

11-9. AIR COMPRESSOR REPAIR (CONT).

- (12) Install two plungers (19) in guides (20).
- (13) Install preformed packing (21) and backup ring (22) on pistons (23).
- (14) Install pistons (23) on guides (20).
- (15) Install pistons (23), guides (20), and plungers (19) in unloader valve seats (11).
- (16) Install unloader spring seat (24) in small hole in cylinder block inlet cavity,
- (17) Position spring saddle (25) between guides so forks are centered on guides.
- (18) Install unloader spring (26), making sure it seats over unloader spring seat (24) and seats on spring saddle (25).
- (19) Align matchmarks and install gasket (27) and cylinder block (13) on crankcase (2).
- (20) Install six lockwashers (28) and screws (29).

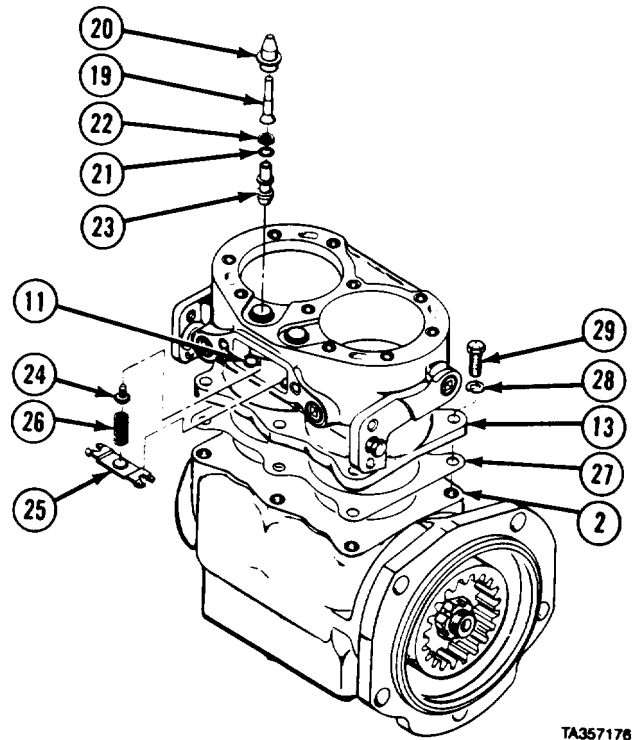

TA357176

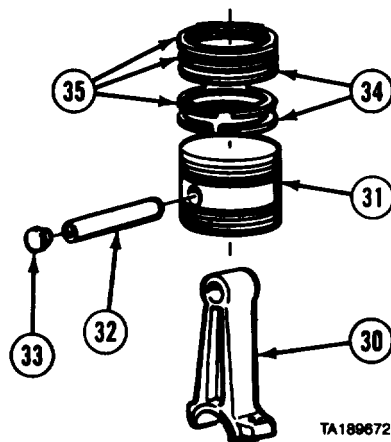

TA189672

- (21) Install connecting rod (30) in piston (31) with wrist pin (32) and two wrist pin plugs (33).

NOTE

Do step (22) only if rings were removed.

- (22) Install first wide ring (34), narrow ring (35), second wide ring (34), and two narrow rings (35) on piston (31). Punchmarks on rings must be toward top of piston, and ring gaps must be staggered.

Brake System Maintenance Instructions (Cont)

- (23) Lubricate piston (31), rings (34 and 35), and bearing inserts (36) with lubricating oil.
- (24) Place crankcase (2) and cylinder block (13) on its side.
- (25) Turn crankshaft (8) so one connecting rod journal is down.
- (26) Insert connecting rod (30) with piston (31) through cylinder block (13) until connecting rod is seated on crankshaft journal.
- (27) Install two bearing inserts (36), bearing cap (37), and two screws (38). Tighten screws evenly to 125 to 140 lb-in (14 to 16 N•m).
- (28) Repeat steps (24) through (28) to install second connecting rod.

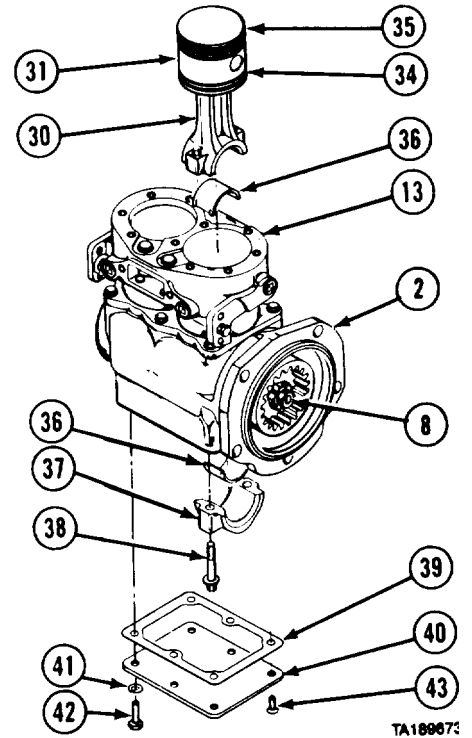

NOTE

Be sure to install screw and cover in proper position.

- (29) Install gasket (39), cover (40), five lockwashers (41), screws (42), and one screw (43).

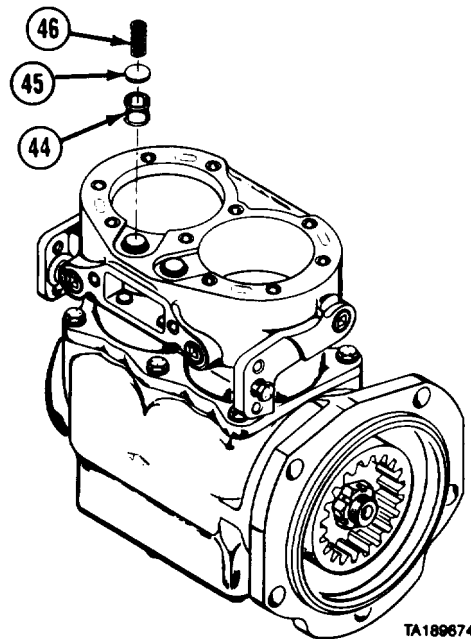

- (30) Install two inlet valve guides (44) and inlet valves (45).
- (31) Install two springs (46).

Brake System Maintenance Instructions (Cont)

11-9. AIR COMPRESSOR REPAIR (CONT).

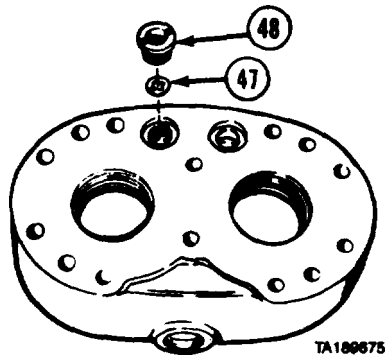

(32) Install inlet valve spring seat (47) and inlet valve spring bushing (48).

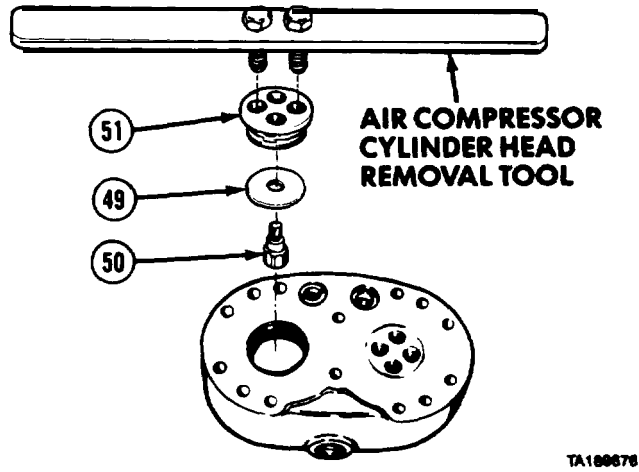

(33) Install two discharge valves (49) and discharge valve plugs (50) in discharge valve seats (51).
(34) Using air compressor cylinder head removal tool, install two discharge valve seats (51).

Brake System Maintenance Instructions (Cont)

- (35) Place head gasket (52) on cylinder block (13).
- (36) Aline cylinder head (53) on cylinder block (13) and install 10 screws (54). Tighten screws to 14 to 18 lb-ft (19 to 24 N•m).
- (37) Install two springs (55) and discharge valve capnuts (56).
- (38) Install two plugs (57) and plug (58).

d. Follow-on Maintenance. None.

END OF TASK

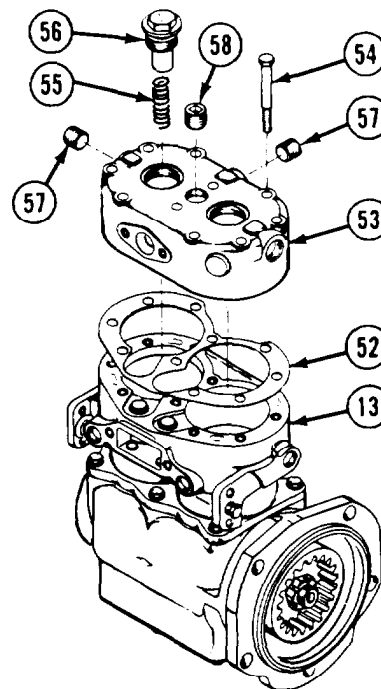

11-10. DELETED.

Pages 11-31 through 11-32 have been deleted.

Brake System Maintenance Instructions (Cent)

Section V. TRAILER BRAKE SYSTEM

11-11. TRAILER SUPPLY VALVE REPAIR.	
This task covers:	
a. Disassembly	c. Assembly
b. Cleaning/Inspection	d. Follow-on Maintenance
INITIAL SETUP	
Models All	References None
Test Equipment None	Equipment Condition <i>TM or Para</i> Condition Description Trailer supply valve on clean work surface.
Special Tools None	Special Environmental Conditions None
Supplies Oil, lubricating, Item 46, Appendix C Solvent, dry cleaning, Item 57, Appendix C	General Safety Instructions None
Personnel Required MOS 63W, Wheel vehicle repairer	Level of Maintenance Direct Support

- a. Disassembly.
 - (1) Matchmark upper valve body (1) and lower valve body (2).
 - (2) Remove two screws (3), lockwashers (4), and end plate (5).
 - (3) Separate lower valve body (2) from upper valve body (1). Set lower valve body aside.
 - (4) Remove sealing ring (6).

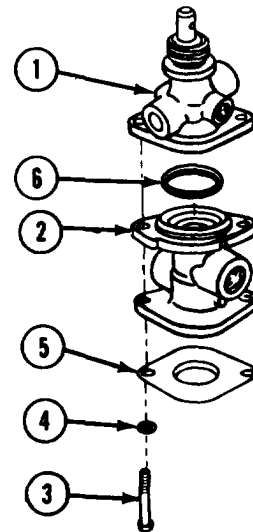

TA189695

Brake System Maintenance Instructions (Cont)

11-11. TRAILER SUPPLY VALVE REPAIR (CONT).

- (5) Remove locknut (7), washer (8), and valve (9).
- (6) Remove plunger (10) and spring (11) from upper valve body (1).
- (7) Remove preformed packing (12) from plunger (10).

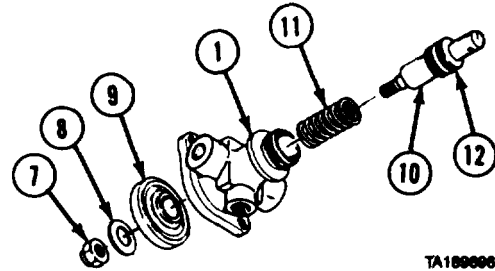

TA100006

- (8) Remove preformed packing (13).
- (9) Remove piston (14) and spring (15).
- (10) Remove preformed packings (16 and 17) from piston (14).
- (11) Remove plug (18).

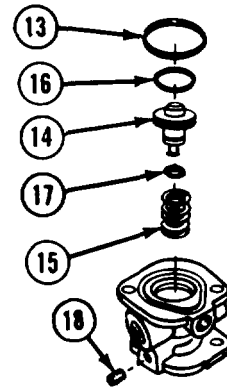

TA100007

- (12) Remove retaining ring (19) from lower valve body (2).
- (13) Remove retainer (20) and preformed packing (21).
- (14) Remove spring (22) and control valve (23).

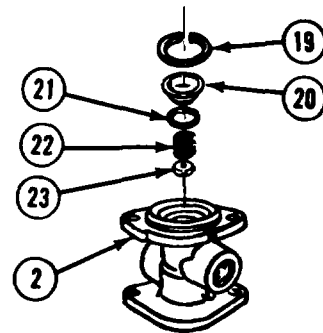

TA100008

b. Cleaning/Inspection

WARNING

Adhesives, solvents, and sealing compounds can burn easily, can give off harmful vapors, and are harmful to skin and clothing. To avoid injury or death, keep away from open fire and use in well-ventilated area. If adhesive, solvent, or sealing compound gets on skin or clothing, wash immediately with soap and water.

- (1) Clean all metal parts with dry cleaning solvent.
- (2) Inspect plunger and piston bores for damage and corrosion.
- (3) Replace unserviceable parts.

Brake System Maintenance Instructions Cont)

c. Assembly.

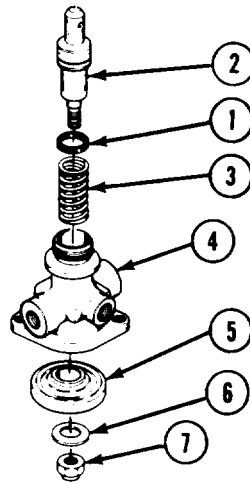

TA189699

- (1) Coat preformed packing (1) with lubricating oil and install on plunger (2).
- (2) Install spring (3) and plunger (2) in upper valve body (4).
- (3) Depress plunger (2) and install valve (5), washer (6), and locknut (7).
- (4) Hold plunger (2) in vise. Tighten nut (7) to 30 to 40 lb-in. (3 to 5 N•m).

- (5) Install control valve (8) and spring (9).
- (6) Coat preformed packing (10) with lubricating oil and install preformed packing, packing retainer (11), and retaining ring (12) in lower valve body (13).

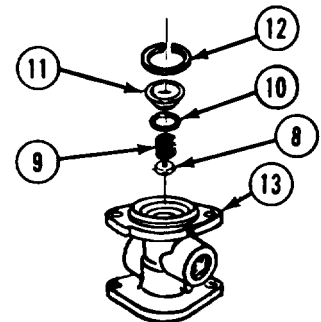

TA189700

- (7) Coat preformed packing (14) with lubricating oil and install in lower valve body (13).
- (8) Coat preformed packings (15 and 16) with lubricating oil and install on piston (17).
- (9) Install plug (18).

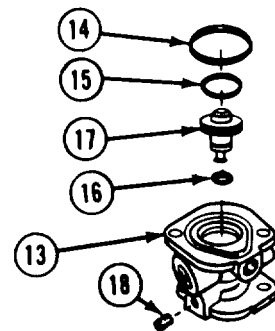

TA189701

Brake System Maintenance Instructions (Cont)

11-11. TRAILER SUPPLY VALVE REPAIR (CONT).

- (10) Install upper valve body (4) in vise.
- (11) Place lower valve body (13) on upper valve body (4) and align matchmarks.
- (12) Install spring (19) and piston (17) in lower valve body (13).
- (13) Install end plate (20) and secure with two screws (21) and lockwashers (22). Tighten screws to 30 to 40 lb-in (3 to 5 N•m).

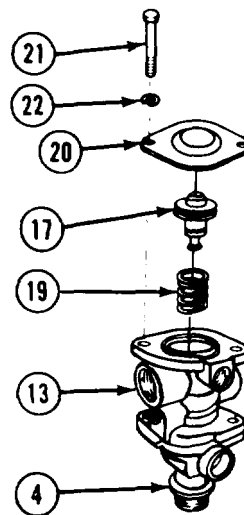

TA189702

d. Follow-on Maintenance. None.

END OF TASK

11-12. TRAILER BRAKE HAND CONTROL VALVE REPAIR.		
This task covers:		
a. Disassembly	c. Assembly	
b. Cleaning/Inspection	d. Follow-on Maintenance	
INITIAL SETUP		
Models	Equipment Condition	
All	TM or Para	Condition Description
Test Equipment		Trailer brake pressure regulator valve on clean work surface.
None		
Special l'lets	Special En vironmental Conditions	
None	None	
Supplies	General Safety Instructions	
Solvent, dry cleaning, Item 57, Appendix C	None	
Oil, lubricating, Item 46, Appendix C		
Personnel Required	Level of Ma intenance	
MOS 63W, Wheel vehicle repairer	Direct Support	
References		
None		

Brake System Maintenance Instructions (Cont)

a. Disassembly.

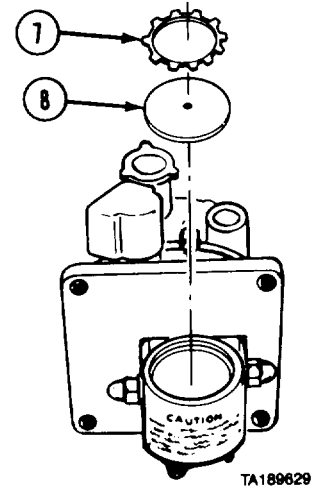
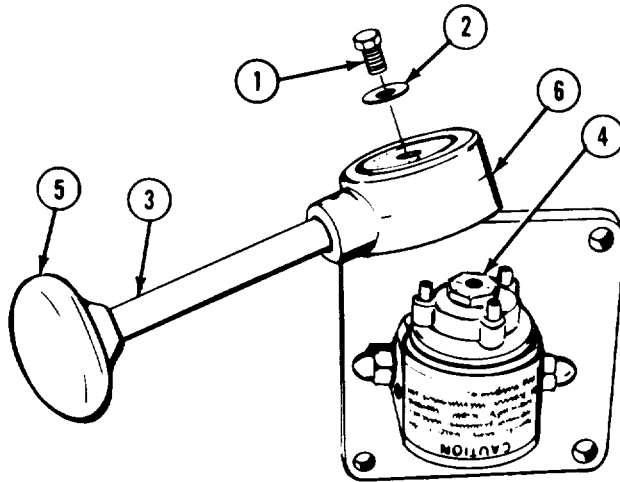

- (1) Remove screw (1), washer (2), and valve handle (3) from cam housing (4).
- (2) Remove knob (5) and valve handle (3) from control lever (6).
- (3) Remove retaining ring (7) and closure plate (8).

- (4) Remove cam retainer screw (9), cam retainer (10), and friction plate (11).
- (5) Remove three setscrews (12) from cam retainer (10).
- (6) Remove non-metallic disk (13) and outer friction disk (14).

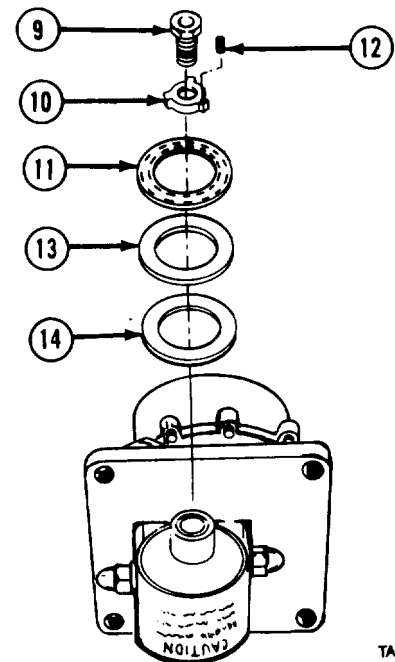

TA18963'

Brake System Maintenance Instructions (Cont)

11-12. TRAILER BRAKE HAND CONTROL VALVE REPAIR (M983) (CONT).

- (7) Scribe matchmarks on outlet housing (15) and inlet housing (16). Remove six screws (17).
- (8) Separate outlet housing (15) from inlet housing (16) and remove preformed packing (18).
- (9) Remove exhaust breather (19).
- (10) Remove plug (20)

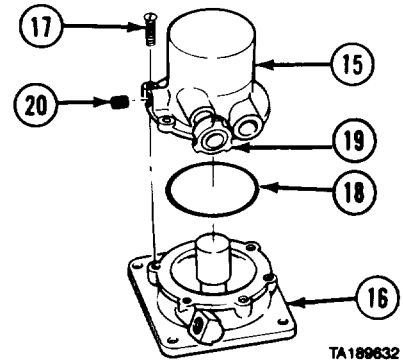

- (11) Tap outlet housing (15) to jar loose balance piston (21). Remove balance piston and spring (22) from outlet housing.
- (12) Remove U-cup (23), thrust ring (24), and two spacers (25) from balance piston (21).

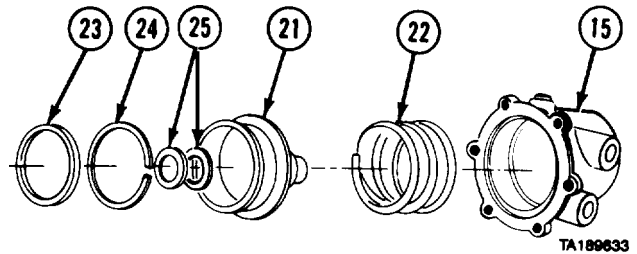

- (13) Remove cartridge assembly (26) from inlet housing (16).
- (14) Remove preformed packing (27).

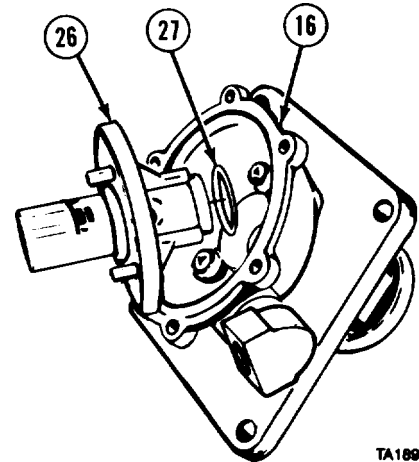

- (15) Scribe matchmarks on inlet housing (16), mounting plate (28), and cam housing (4). Remove four screws (29) and sealing washers (30) to separate inlet housing, mounting plate, and cam housing.
- (16) Remove brass fitting (31).
- (17) Grasp tip of cam follower (32) and pull out of cam housing (4).
- (18) Push out roller pin (33) and remove roller (34).

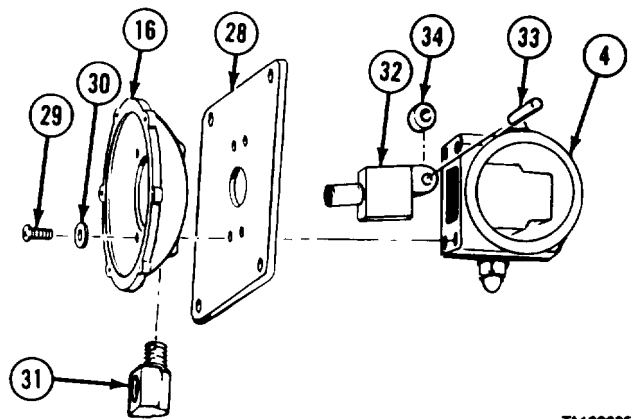

Brake System Maintenance Instructions (Cont)

- (19) Remove cam guide (35) from cam housing (4).
- (20) Remove capnut (36), washer (37), and maximum pressure stop (38).
- (21) Remove capnut (39), washer (40), insert (41), and screw (42).

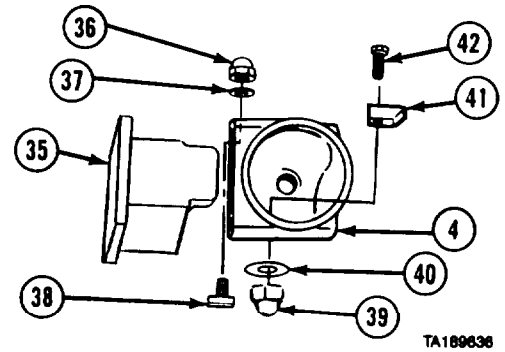

- (22) Remove actuating cam (43) and inner friction disk (44) from cam housing (4).

b. Cleanhg/inspection.

WARNING

Adhesives, solvents, and sealing compounds can burn easily, can give off harmful vapors, and are harmful to skin and clothing. To avoid injury or death, keep away from open fire and use in well-ventilated area. If adhesive, solvent, or sealing compound gets on skin or clothing, wash immediately with soap and water.

- (1) Clean all metal parts in dry cleaning solvent.
- (2) Inspect all metal parts for wear or damage.
- (3) Replace damaged parts.

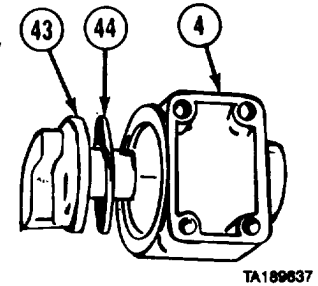

c. Assembly.

- (1) Install friction disk (1) on actuating cam (2) and install actuating cam in cam housing (3).

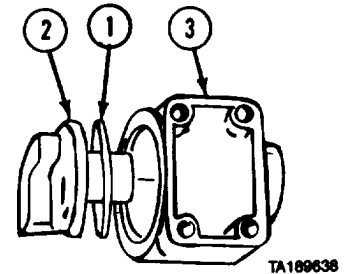

- (2) Install insert (4), screw (5), washer (6), and capnut (7). Tighten capnut finger-tight.
- (3) Install maximum pressure stop (8), washer (9), and capnut (10). Tighten capnut finger-tight.
- (4) Push cam guide (11) in cam housing (3).

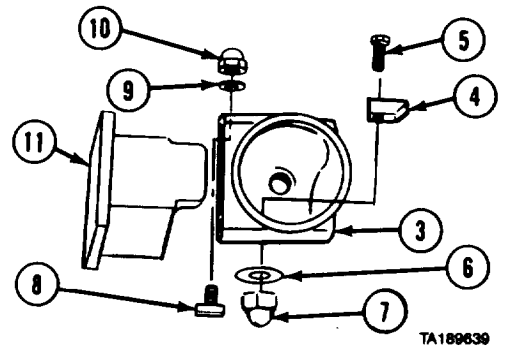

Brake System Maintenance Instructions (Cent)

11-12. TRAILER BRAKE HAND CONTROL VALVE REPAIR (M983) (CONT).

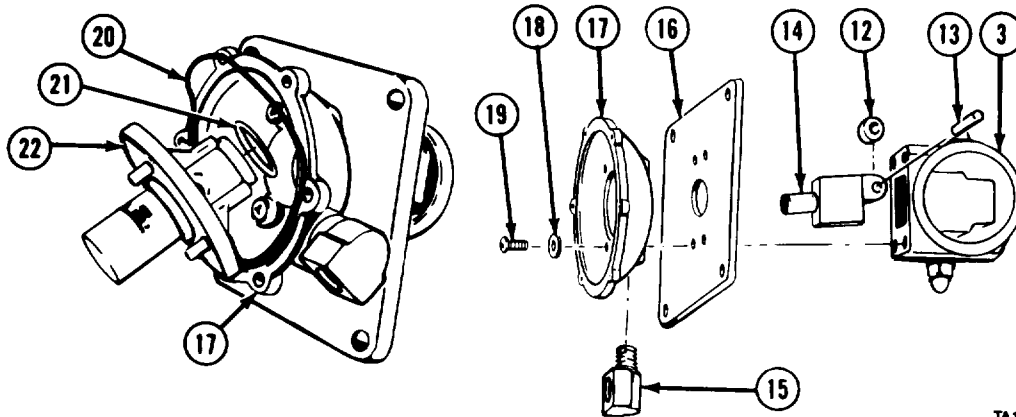

TA189840

- (5) Install roller (12) and roller pin (13) on cam follower (14), and install cam follower in cam housing (3).
- (6) Install brass fitting (15).
- (7) Aline mounting plate (16), inlet housing (17), and cam housing (3). Install four sealing washers (18) and screws (19).
- (8) Coat preformed packings (20 and 21) with lubricating oil and install in inlet housing (17).
- (9) Install cartridge assembly (22) in inlet housing (17).

- (10) Install spring (23) in outlet housing (24).
- (11) Install thrust ring (25), U-cup (26), and two spacers (27) on balance piston (28).
- (12) Install balance piston (28) in outlet housing (24).

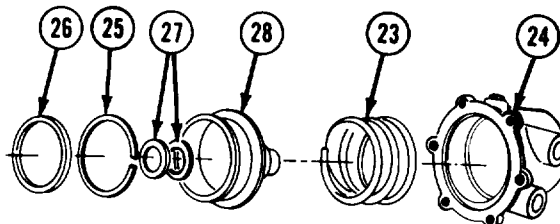

TA189842

- (13) Aline inlet housing (17), and outlet housing (24), and install six screws (29).
- (14) Install exhaust breather (30).
- (15) Install plug (31).
- (16) Install closure plate (32) and retaining ring (33).

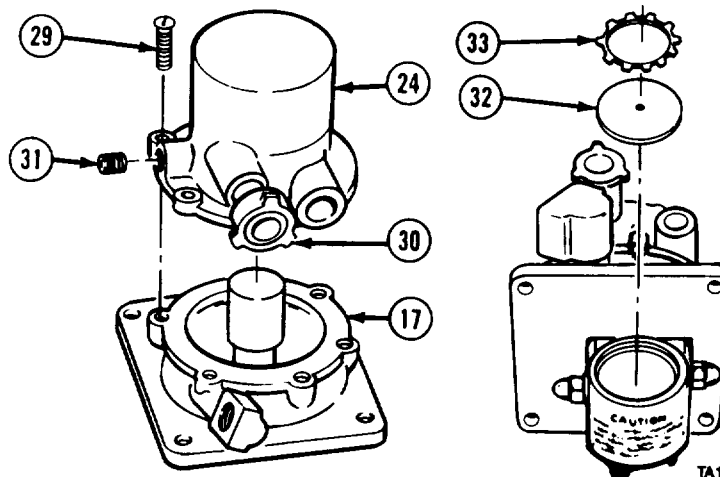

TA189843

Brake System Maintenance Instructions (Cont)

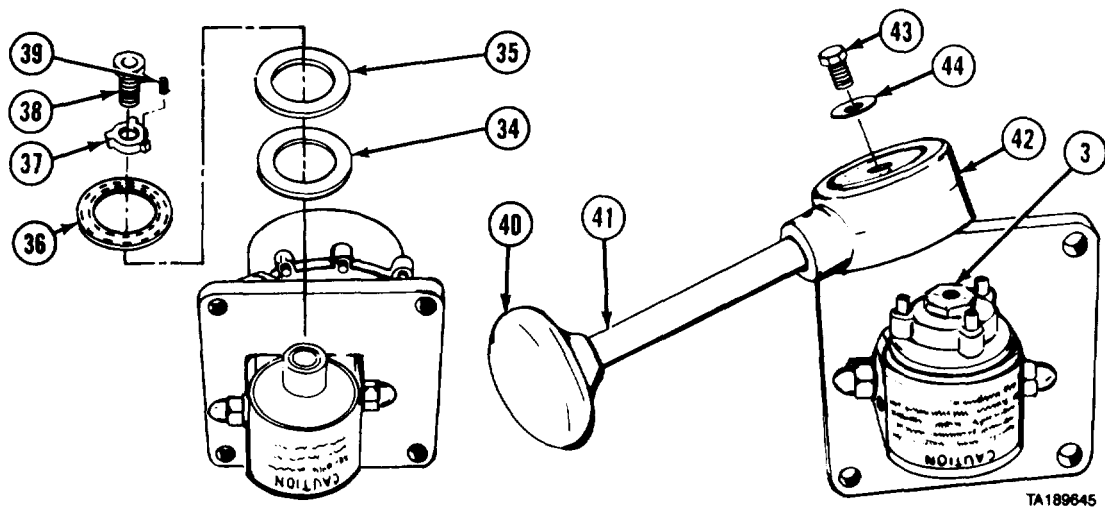

- (17) Install outer friction disk (34), non-metallic disk (35), friction plate (36), cam retainer (37), and cam retainer screw (38).
- (18) Install three setscrews (39) in cam retainer (37). Tighten each setscrew same number of turns.
- (19) Install knob (40) on valve handle (41). Install valve handle and control lever (42) on cam housing (3) with screw (43) and washer (44).

d. Follow-on Maintenance None.

END OF TASK

11-13. TRACTOR PROTECTION VALVE REPAIR.		
This task covers:		
a. Disassembly	c. Assembly	
b. Cleaning/Inspection	d. Follow-on Maintenance	
INITIAL SETUP		
Models	Equipment Condition	
All	TM or Para	Condition Description
Test Equipment		Tractor protection valve on clean work surface.
None		
Special Tools	Special Environmental Conditions	
None	None	
supplies	General Safety Instructions	
Oil, lubricating, Item 46, Appendix C	None	
Solvent, dry cleaning, Item 57, Appendix C	Level of Maintenance	
Personnel Required	Direct Support	
MOS 63W, Wheel vehicle repairer		
References		
None		

Brake System Maintenance Instructions (Cont)

11-13. TRACTOR PROTECTION VALVE REPAIR (CONT).

a. Disassembly.

- (1) Mount body (1) in vise with soft jaws.
- (2) Remove retaining ring (2) and washer (3) while holding down diaphragm seat assembly (4).

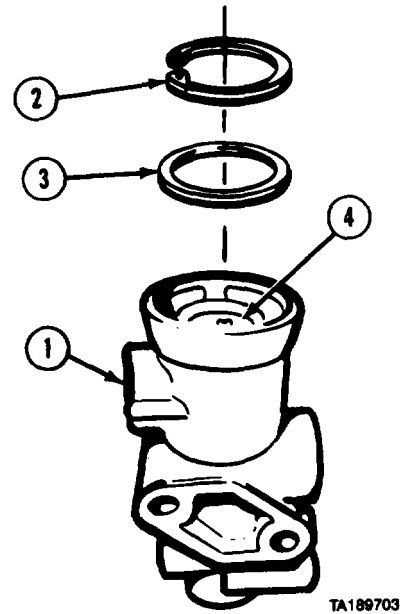

- (3) Allow diaphragm seat assembly (4) to rise slowly until spring (5) is fully extended.
- (4) Remove diaphragm seat assembly (4), spring (5), and plunger (6) from body (1).

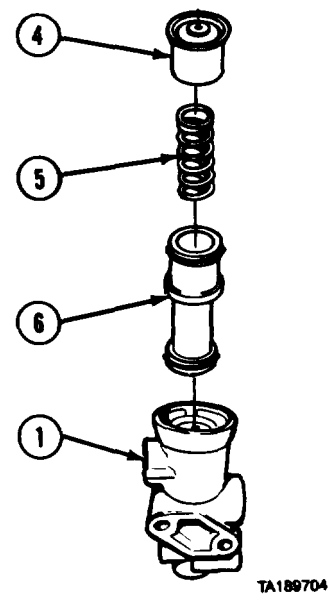

- (5) Remove preformed packing (7) from diaphragm seat assembly (4).

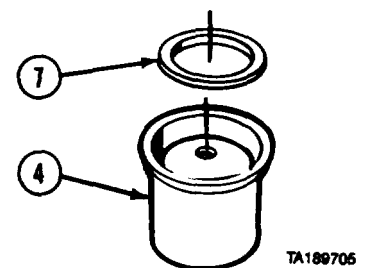

Brake System Maintenance Instructions (Cont)

- (6) Remove screw (8), washer (9), and diaphragm (10) from seat (11).

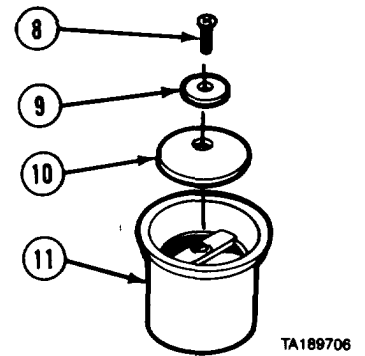

- (7) Remove retaining ring (12), valve retainer (13), valve seal (14), and preformed packings (15 and 16) from plunger (6).

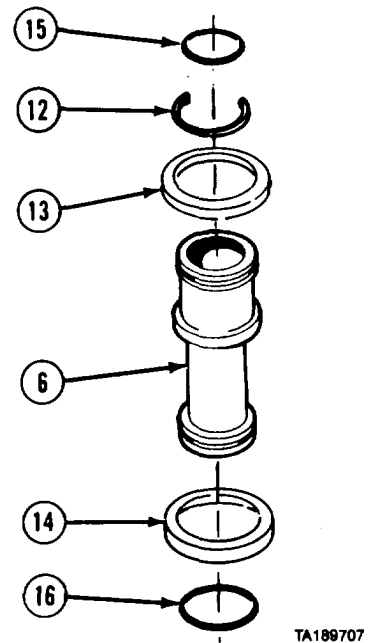

b. Cleaning/Inspection.

WARNING

Adhesives, solvents, and sealing compounds can burn easily, can give off harmful vapors, and are harmful to skin and clothing. To avoid injury or death, keep away from open fire and use in well-ventilated area. If adhesive, solvent, or sealing compound gets on skin or clothing, wash immediately with soap and water.

- (1) Clean all metal parts in dry cleaning solvent.
- (2) Inspect seat in body for damage.
- (3) Check spring for distortion.
- (4) Replace damaged parts.

c. Assembly.

- (1) Install valve seal (1) on plunger (2).
- (2) Install valve retainer (3) over valve seal (1).
- (3) Install retaining ring (4) beneath valve retainer (3).
- (4) Coat two preformed packings (5 and 6) with lubricating oil and install in two grooves (7) on plunger (2).

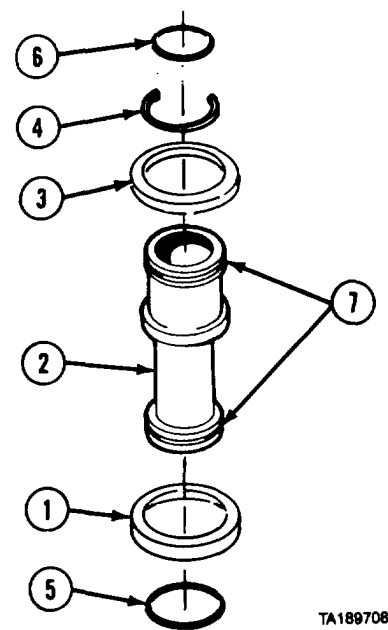

Brake System Maintenance Instructions (Cont)

11-13. TRACTOR PROTECTION VALVE REPAIR (CONT).

(5) Install diaphragm (8), washer (9), and screw (10) in seat (1 1).

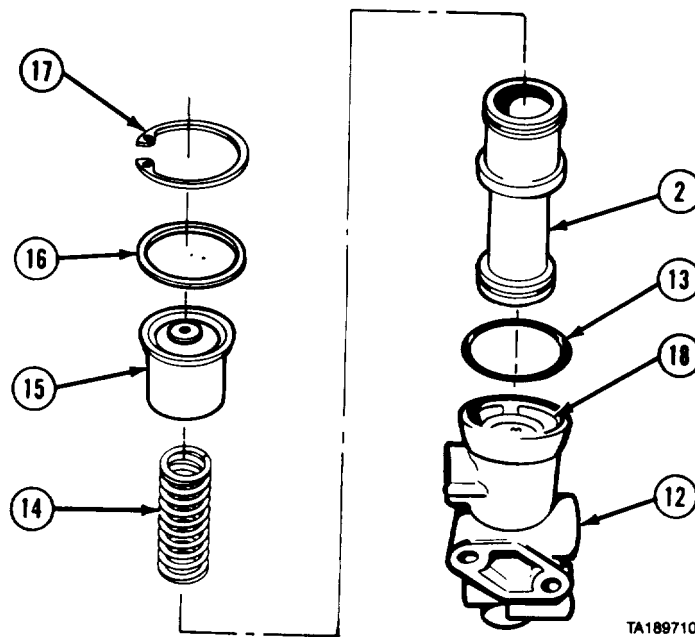
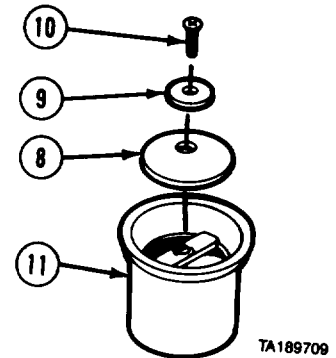

- (6) Mount body (12) in vise with soft jaws.
- (7) Coat preformed packing (13) with lubricating oil and install in body (12),
- (8) Install plunger (2) in body (12).
- (9) Install spring (14) **in plunger** (2).
- (10) Position diaphragm seat assembly (15) over spring (14) and force diaphragm seat assembly in body (12).
- (11) Install washer (16).
- (12) Install retaining ring (17) on inner groove (18) in body (12).

d. *Follow-on Maintenance.* None.

END OF TASK

Brake System Maintenance Instructions (Cont)

11-14. BRAKE TREADLE VALUE REPAIR.

This task covers:

- | | |
|------------------------|--------------------------|
| a. Disassembly | d. Testing |
| b. Cleaning/Inspection | e. Follow-on Maintenance |
| c. Assembly | |

INITIAL SETUP

Models
All

References
None

Test Equipment
None

Equipment Condition

<i>TM or Para</i>	<i>Condition Description</i>
TM 9-2320-279-20	Brake treadle and pedal removed.

Special Tools
None

Special Environmental Conditions
None

Supplies
 Adhesive-sealant, Item 8.1, Appendix C
 Chips, soap, Item 14, Appendix C
 Cloth, crocus, Item 16, Appendix C
 Compound, sealing, pipe thread, Item 29, Appendix C
 Solvent, drycleaning, Item 57, Appendix C

General Safety Instructions
None

Level of Maintenance
Direct Support

Personnel Required
MOS 62W, Wheel vehicle repairer (2)

Brake System Maintenance Instructions (Cont)

11-14. BRAKE TREADLE VALVE REPAIR (CONT).

Disassembly.

- (1) Remove nut (1) and stop button (2) from cover (3).
- (2) Remove three screws (4) with captive lockwashers (5), and cover (3) from housing (6).
- (3) Remove sleeve (7) from housing (6).

NOTE

Three tabs must be pried out to remove retaining plate.

- (4) Remove retaining plate (8) from housing (6).

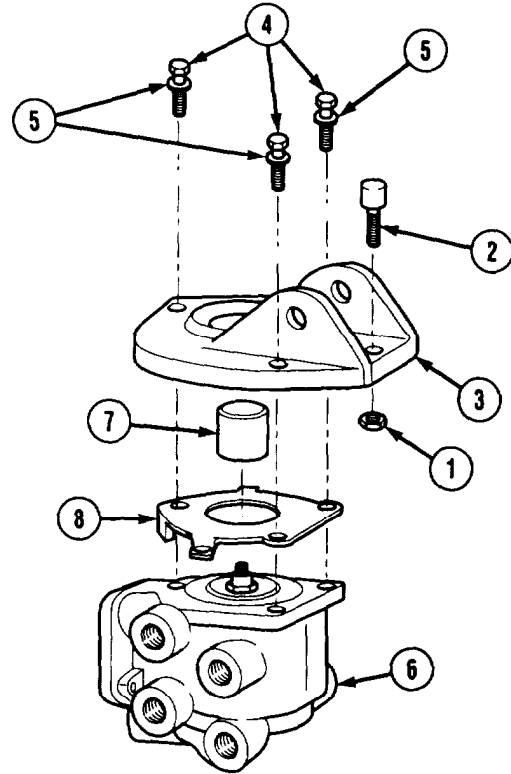

- (5) Remove lower static piston assembly (9) from housing (6).

NOTE

Upper static piston can be removed by tapping housing on wooden block.

- (6) Remove upper static piston (10) from housing (6).
- (7) Remove preformed packing (11) and preformed packing (12) from piston (10).

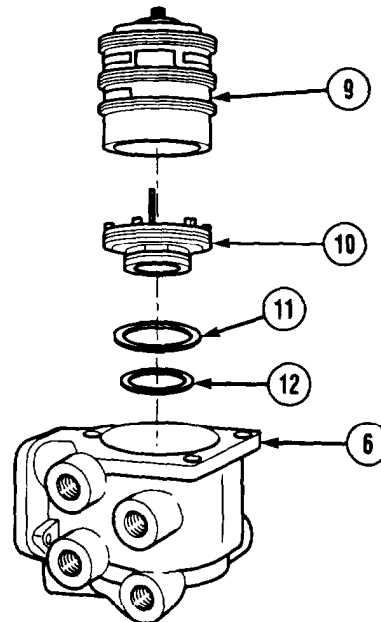

Brake System Maintenance Instructions (Cont)

WARNING

Wear eye protection and use care when removing retaining rings. Retaining rings are under spring tension and can act as projectiles when released, causing severe eye injury.

- (8) Remove retaining ring (13) from piston (10).
- (9) Remove inlet cartridge (14) from piston (10).

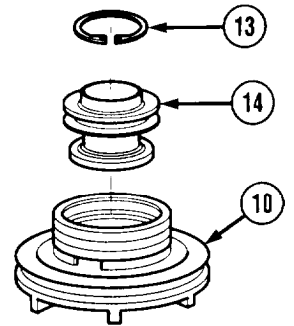

WARNING

Internal pistons are under moderate spring tension. Keep pistons compressed when removing locknut. Failure to comply may result in injury to personnel.

- (10) Compress pistons (15 and 16) and remove locknut (17), guide (18), and spring (19) from stem bolt (20).

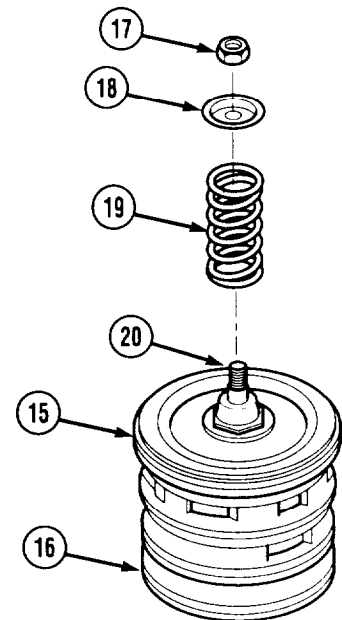

Brake System Maintenance Instructions (Cont)

11-14. BRAKE TREADLE VALVE REPAIR (CONT).

NOTE

Thin gage spring is located on relay piston side of lower static piston housing.

- (11) Remove lower piston (15), spring (21), spring (22), and relay piston (16) from lower static piston body (23).

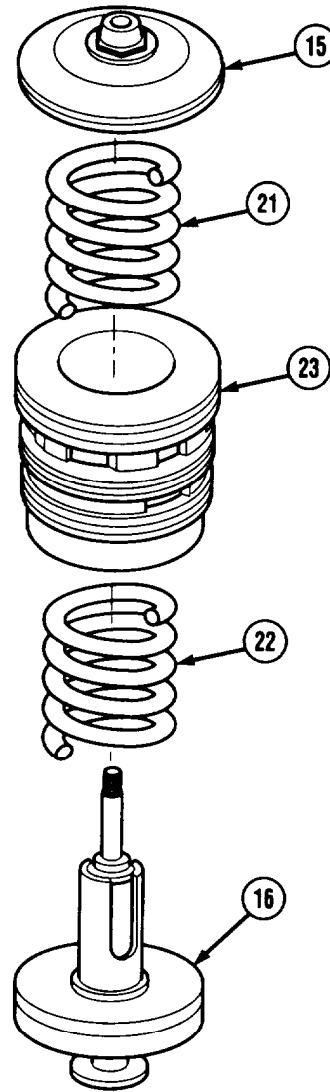

- (12) Remove stem bolt (20) from relay piston (16).
- (13) Remove preformed packing (24) and preformed packing (25) from relay piston (16).

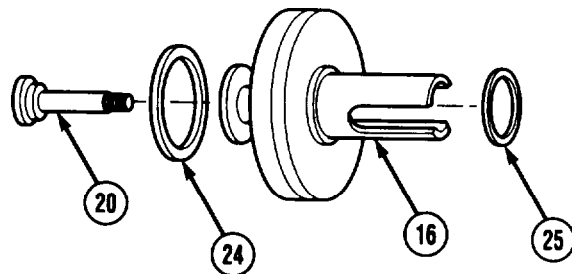

Brake System Maintenance Instructions (Cont)

- (14) Remove preformed packing (26) from lower piston (15).

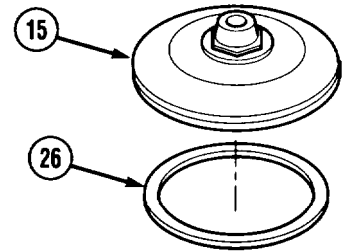

- (15) Remove nut (27), spring seat (28), and resilient mount (29) from lower piston (15).

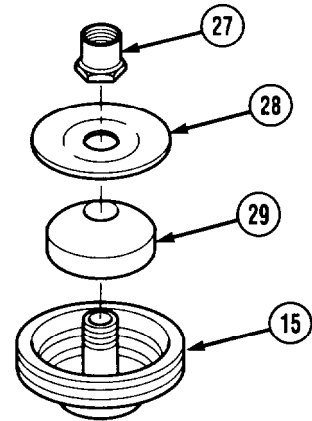

- (16) Remove preformed packing (30) and two preformed packings (31) from lower static piston body (23).

WARNING

Wear eye protection and use care when removing retaining rings. Retaining rings are under spring tension and can act as projectiles when released, causing severe eye injury.

- (17) Remove retaining ring (32) from lower static piston body (23).

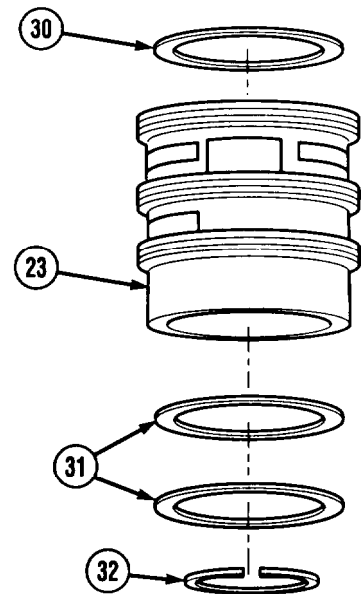

Brake System Maintenance Instructions (Cont)

11-14. BRAKE TREADLE VALVE REPAIR (CONT).

- (18) Remove retaining ring (33) from lower static piston body (23).
- (19) Remove valve stem guide (34) from lower static piston body (23).

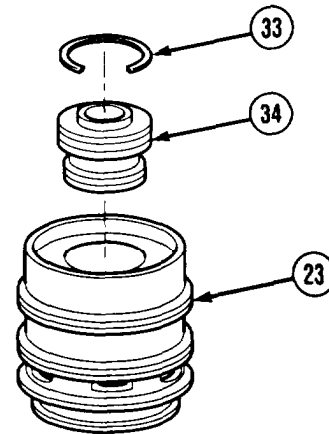

- (20) Remove screw (35), retainer (36), and diaphragm (37) from housing (6).
- (21) Remove pipe plug (38) from housing (6).

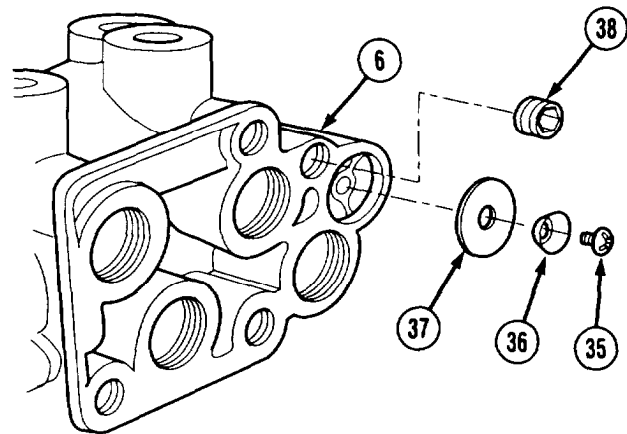

b. Cleaning/Inspection.

WARNING

Adhesives, solvents, and sealing compounds can burn easily, can give off harmful vapors, and are harmful to skin and clothing. To avoid injury or death, keep away from open fire and use in well-ventilated area. If adhesive, solvent, or sealing compound gets on skin or clothing, wash immediately with soap and water.

- (1) Clean metal parts in drycleaning solvent.
- (2) Inspect parts for damage, cracks, breaks, or deterioration.
- (3) Inspect rubber parts for cracks or deterioration.
- (4) Inspect machined surfaces for deep scratches.
- (5) Remove small nicks or burrs from pistons and housings with crocus cloth.
- (6) Replace unserviceable parts.

Brake System Maintenance Instructions (Cont)

c. Assembly.

WARNING

Adhesives, solvents, and sealing compounds can burn easily, can give off harmful vapors, and are harmful to skin and clothing. To avoid injury or death, keep away from open fire and use in well-ventilated area. If adhesive, solvent, or sealing compound gets on skin or clothing, wash immediately with soap and water.

- (1) Coat threads of pipe plug (1) with pipe thread sealing compound.
- (2) Install pipe plug (1) in housing (2).
- (3) Install diaphragm (3), retainer (4), and screw (5) in housing (2).

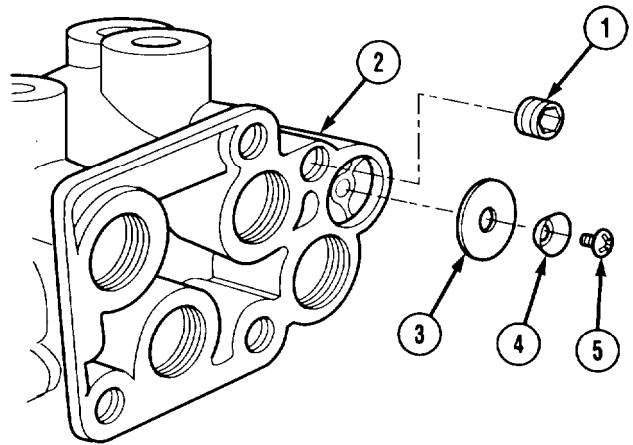

CAUTION

Lubricate all preformed packings, bores, and mating surfaces with silicone lubricant before assembly. Failure to comply may result in damage to equipment.

- (4) Install valve stem guide (6) in lower static piston body (7).

WARNING

Wear eye protection and use care when installing retaining rings. Retaining rings are under spring tension and can act as projectiles when released, causing severe eye injury.

- (5) Install retaining ring (8) in lower static piston body (7).
- (6) Install two preformed packings (9) and preformed packing (10) on lower static piston body (7).

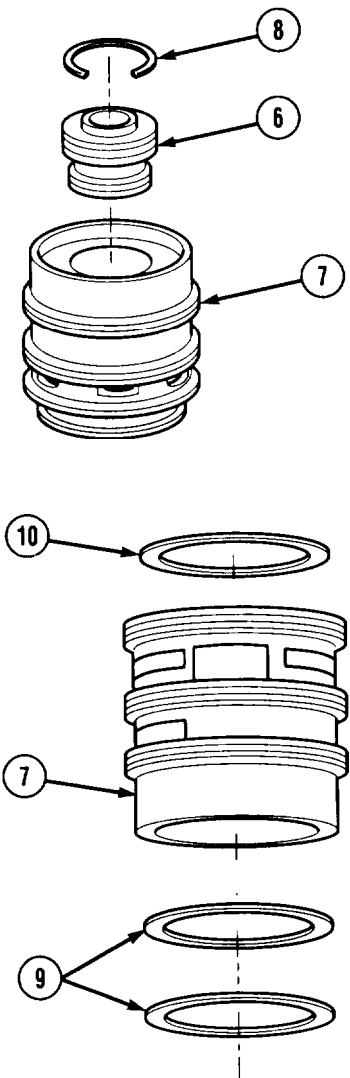

Brake System Maintenance Instructions (Cont)

11-14. BRAKE TREADLE VALVE REPAIR (CONT).

WARNING

Adhesives, solvents, and sealing compounds can burn easily, can give off harmful vapors, and are harmful to skin and clothing. To avoid injury or death, keep away from open fire and use in well-ventilated area. If adhesive, solvent, or sealing compound gets on skin or clothing, wash immediately with soap and water.

- (7) Coat threads of nut (11) with adhesive-sealant.

NOTE

Do not lubricate resilient mount.

- (8) Install resilient mount (12), spring seat (13), and nut (11) on lower piston (14).
- (9) Install preformed packing (15) on lower piston (14).

- (10) Install preformed packing (16) and preformed packing (17) on relay piston (18).

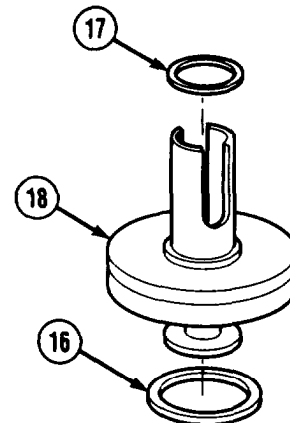
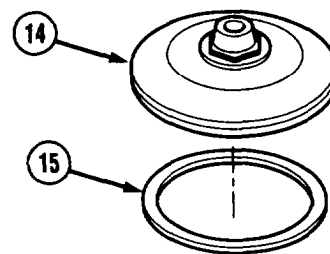
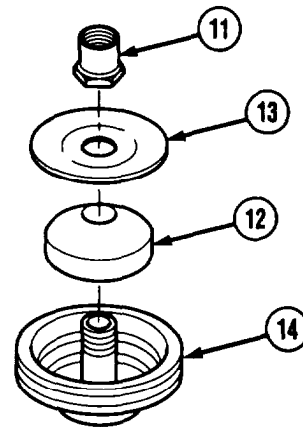

Brake System Maintenance Instructions (Cont)

NOTE

Thin gage spring is located on relay piston side of lower static piston housing.

- (11) Install spring (19) and relay piston (18) in bottom of lower static piston body (7).
- (12) Install spring (20) and lower piston (14) in top of lower static piston body (7).
- (13) Install stem bolt (21) in relay piston (18).
- (14) Position pistons (14 and 18) in soft-jawed vise.

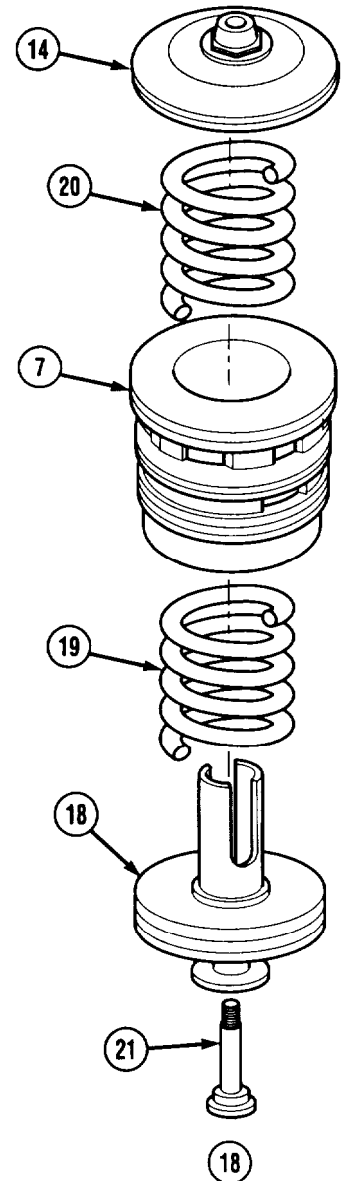

WARNING

Internal pistons are under moderate spring tension. Keep pistons compressed when installing locknut. Failure to comply may result in injury to personnel.

- (15) Soldier A compresses pistons (14 and 18) using vise while Soldier 13 installs spring (22), guide (231), and locknut (24) on stem bolt (21). Tighten to 20 to 30 lb-in. (2.3 to 3.4 N•m).

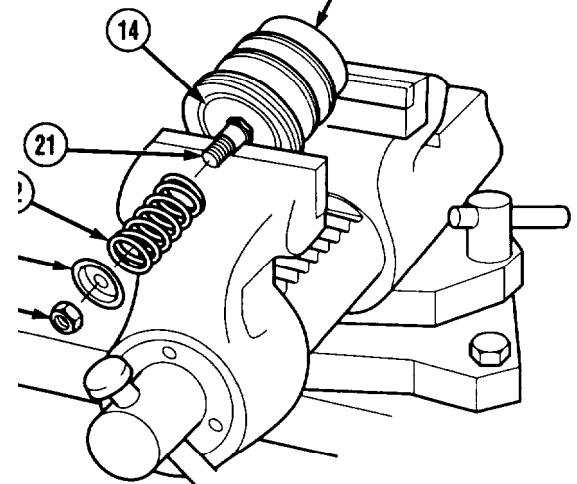

Brake System Maintenance Instructions (Cont)

11-14. BRAKE TREADLE VALVE REPAIR (CONT).

- (16) Install inlet cartridge (25) in upper static piston (26).

WARNING

Wear eye protection and use care when installing retaining rings. Retaining rings are under spring tension and can act as projectiles when released, causing severe eye injury.

- (17) Install retaining ring (27) in upper static piston (26).

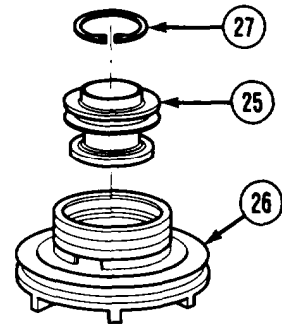

- (18) Install preformed packing (28) and preformed packing (29) on upper static piston (26).
- (19) Install upper static piston (26) in housing (2).
- (20) Install lower static piston body (7) in housing (2).

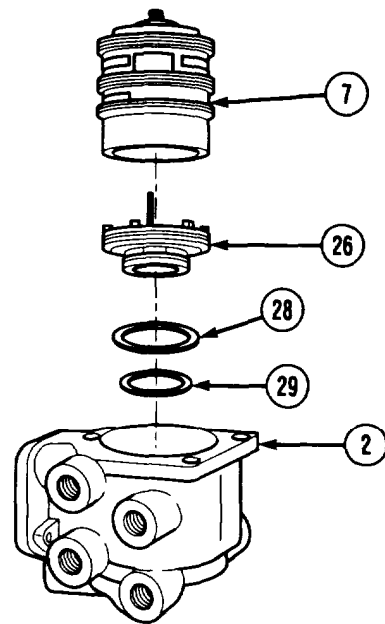

Brake System Maintenance Instructions (Cont)

NOTE

Three tabs on retainer must lock on housing.

- (21) Install retaining plate (30) on housing (2).
- (22) Install sleeve (31) on housing (2).
- (23) Install cover (32) and three screws (33) with captive lockwashers (34) on housing (2).

NOTE

Plunger must be in contact with spring seat. Adjust stop button so rollers and plunger contact each other. Poller must turn freely by hand.

- (24) Install stop button (35) and nut (36) on cover (32).

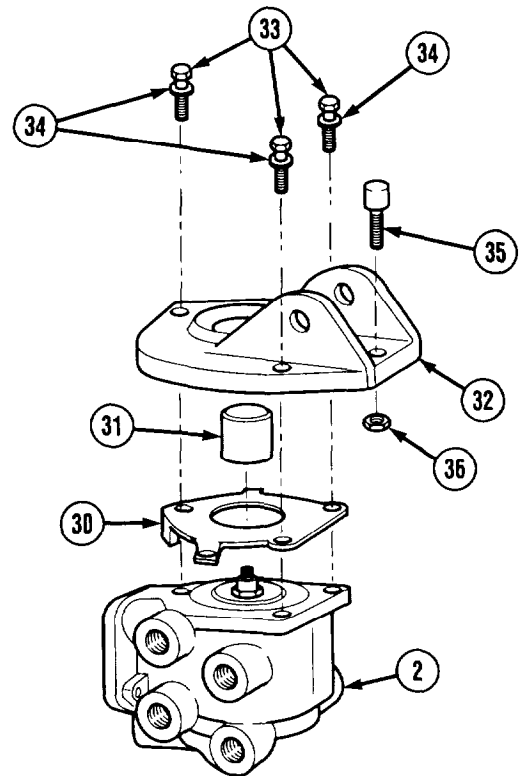

d. Testing.

- (1) Install eight pipe plugs (1) in four ports (2) on each side of treadle valve (3).
- (2) Install two pipe plugs (4) in upper ports (5 and 6) on backside of treadle valve (3).
- (3) Install air pressure gage (7) in lower delivery port (8) on backside of treadle valve (3).
- (4) Install air supply fitting (9) in lower supply port (10) on backside of treadle valve (3).

NOTE

Air pressure should be from 80 to 120 psi (552 to 827 kPa).

- (5) Install air supply line (11) on air supply fitting (9).

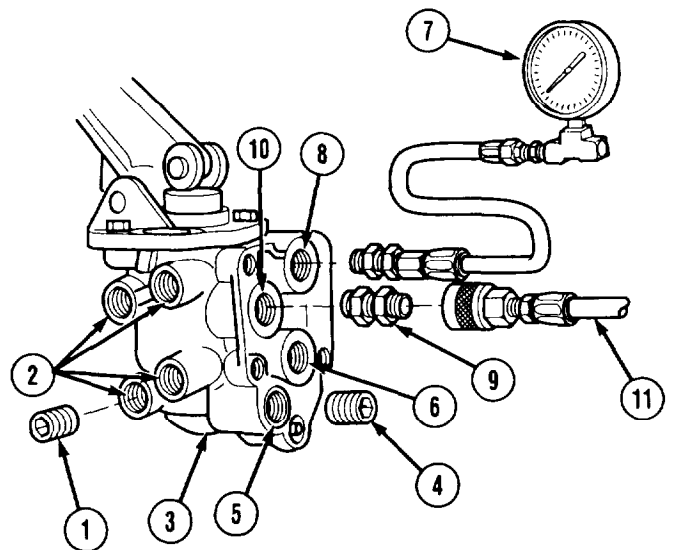

Brake System Maintenance Instructions (Cont)

11-14. BRAKE TREADLE VALVE REPAIR (CONT).

- (6) Press pedal (12) to several positions between fully released and fully applied. Delivered pressure on gage (7) should vary proportionately with movement of pedal (12).
- (7) Press pedal (12) until treadle valve (3) is fully applied. Reading on gage (7) should fall off to zero when pedal (12) is released.

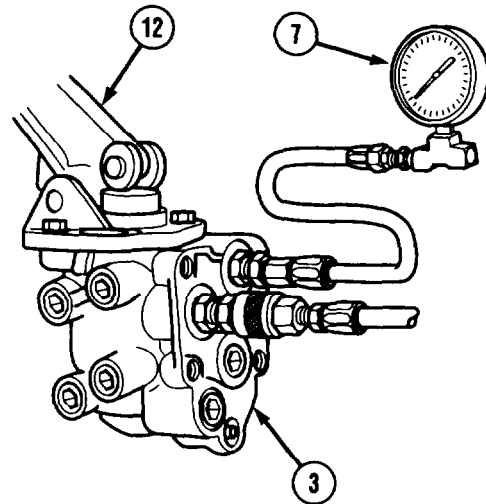

- (8) Remove air supply line (11) from air supply fitting (9).
- (9) Remove two pipe plugs (4) from upper ports (5 and 6) on backside of treadle valve (3).
- (10) Remove air pressure gage (7) from lower delivery port (8) on backside of treadle valve (3).
- (12) Remove air supply fitting (9) from lower supply port (10) on backside of treadle valve (3).

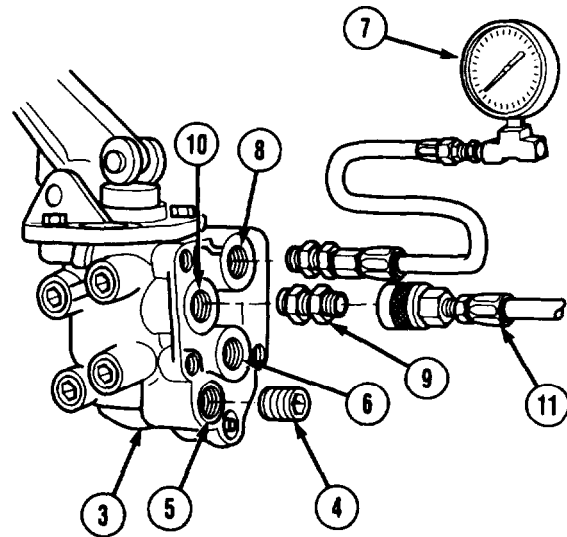

Brake System Maintenance Instructions (Cont)

- (12) Install two pipe plugs (4) in lower ports (8 and 10) on backside of treadle valve (3).
- (13) Install air pressure gage (7) in upper delivery port (6) on backside of treadle valve (3).
- (14) Install air supply fitting (9) in upper supply port (5) on backside of treadle valve (3).
- (15) Install air supply line (11) on air supply fitting (9).

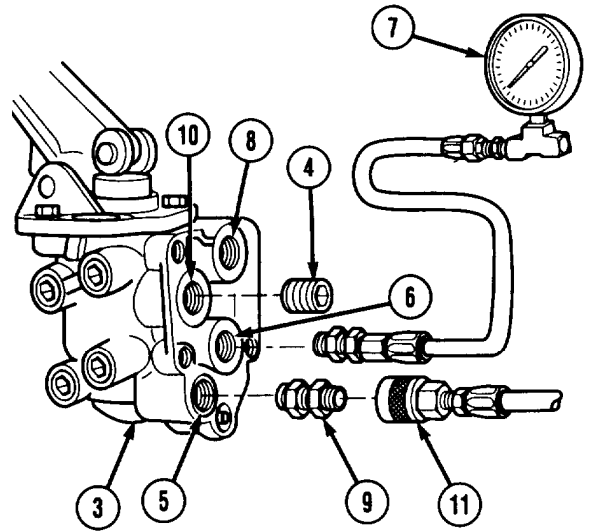

- (16) Press pedal (12) to several positions between fully released and fully applied. Delivered pressure on gage (7) should vary proportionately with movement of pedal (12).
- (17) Press pedal (12) until treadle valve (3) is fully applied. Reading on gage should fall off to zero when pedal (12) is released.
- (18) Press and hold pedal (12) with treadle valve (3) fully applied.

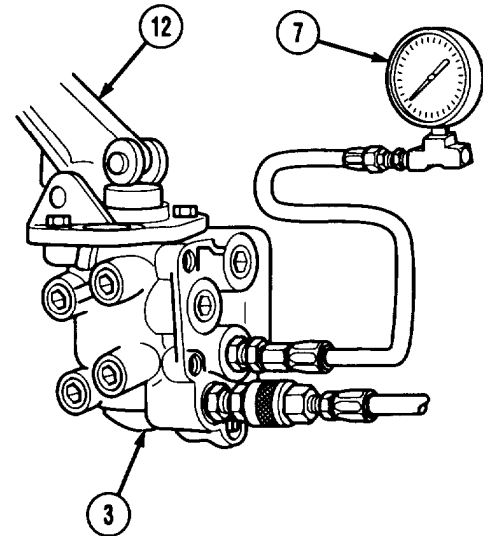

Brake System Maintenance Instructions (Cont)

11-14. BRAKE TREADLE VALVE REPAIR (CONT).

- (19) Coat exhaust port (13) and body of treadle valve (3) with soap solution.
- (20) Air leakage of exhaust port (13) must not exceed 1 in. (2.5 cm) bubble in 3 seconds in both applied and released positions.
- (21) Remove air supply line (11) from air supply fitting (9).
- (22) Remove air supply fitting (9) from upper supply port (5) on backside of treadle valve (3).
- (23) Remove air pressure gage (7) from upper delivery port (6) on backside of treadle valve (3).
- (24) Remove two pipe plugs (4) from lower ports (8 and 10) on backside of treadle valve (3).
- (25) Remove eight pipe plugs (1) from four ports (2) on each side of treadle valve (3).

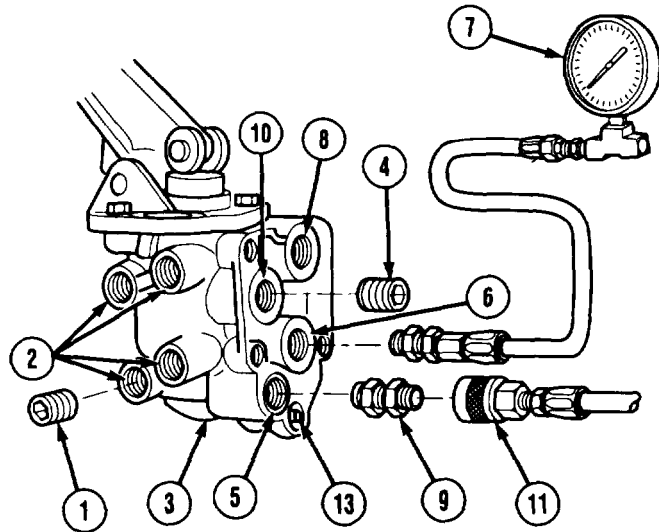

e. **Follow on Maintenance.** Install brake treadle (TM 9-2320-279-20).

END OF TASK

CHAPTER 12

STEERING SYSTEM MAINTENANCE

Contents	Para	Page
General	12-1	12-1
Steering Column Removal/Installation	12-2	12-1
Intergear Link Removal/Installation	12-3	12-6
900 Gearbox Removal/Repair/Installation.	12-4	12-11
Steering Gear and Pitman Arm Removal/Repair/Installation	12-5	12-19
Slave Steering Gear and Pitman Arm Removal/Repair/Installation	12-6	12-32
Steering Pump Removal/Repair/Installation	12-7	12-42
Steering Pump Removal/Repair/Installation (M984E1)	12-7.1	12-48
Steering/Tensioner Manifold and Bracket Removal/Repair/Installation (M984E1)	12-7.2	12-48.7
Steering Gear Adjustment	12-8	12-48.13
Steering Toe-in Adjustment	12-9	12-49
Steering System Alinement	12-10	12-53

Section I. INTRODUCTION

12-1. GENERAL. This chapter contains maintenance instructions for removal, installation, and repair of the steering system at the direct support maintenance level. The subassemblies and parts which must be removed before the steering components can be removed will be referenced to other paragraphs of this manual or TM 9-2320-279-20.

Section II. STEERING LINKAGE AND GEARBOX

Steering System Maintenance Instructions

12-2. STEERING COLUMN REMOVAL/INSTALLATION.	
This task covers:	
a. Removal	c. Follow-on Maintenance
b. Installation	
INITIAL SETUP	
Models	Equipment Condition
All	TM or Para Condition Description
Test Equipment	TM 9-2320-279-10 Shut off engine.
None	TM 9-2320-279-20 Horn switch contact roller removed.
Special Tools	TM 9-2320-279-20 Turn signal and flasher removed.
None	
Supplies	Special Environmental Conditions
None	None
Personnel Required	General Safety Instructions
MOS 63W, Wheel vehicle repairer	Wheels chocked.
References	Level of Maintenance
None	Direct Support

Steering System Maintenance Instructions (Cont)

12-2. STEERING COLUMN REMOVAL/INSTALLATION (CONT).

a. Removal.

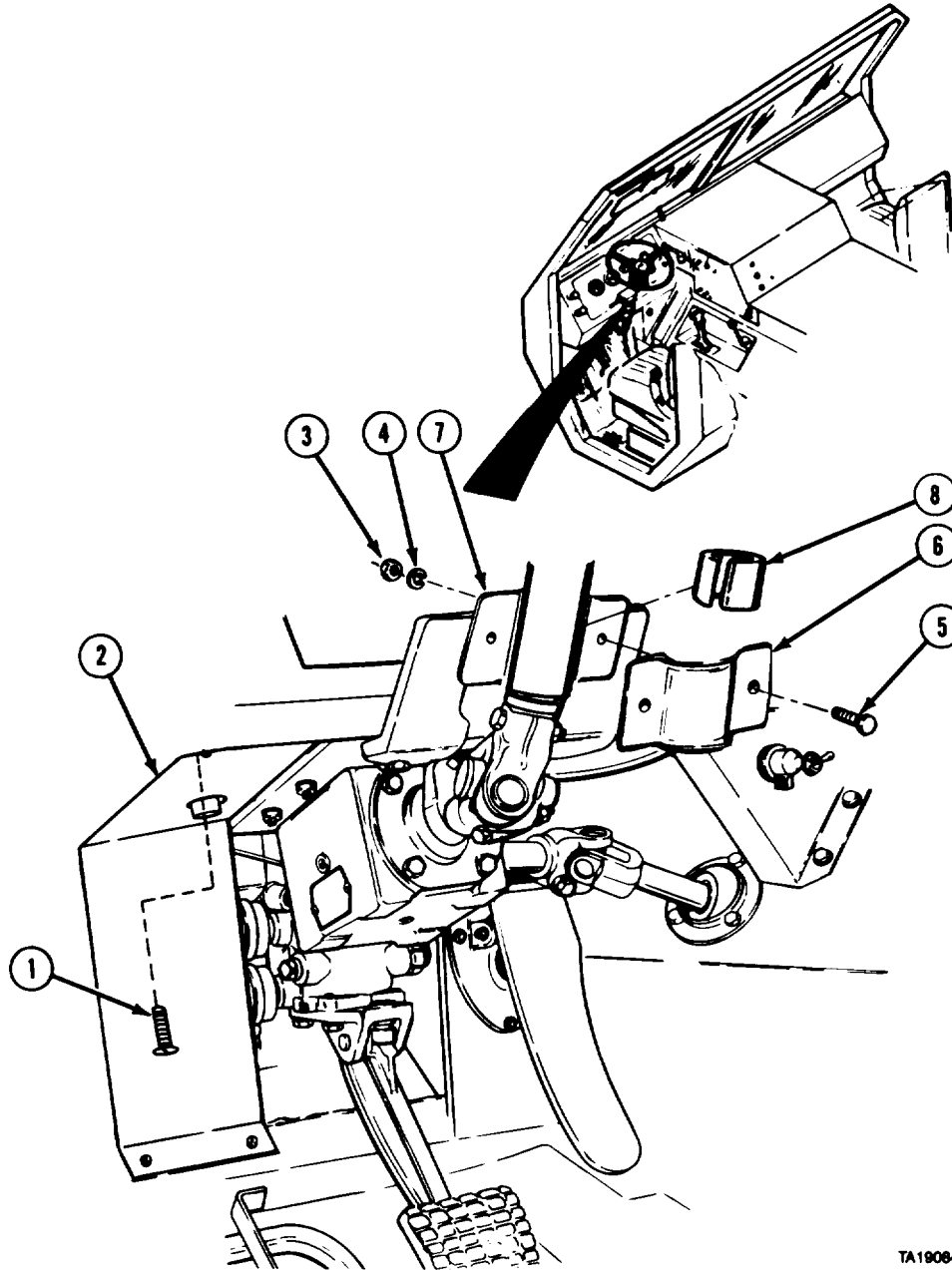

TA190845

- (1) Remove four screws (1) and headlight guard (2).
- (2) Remove two nuts (3), lockwashers (4), and screws (5).
- (3) Remove bottom collar (6), top collar (7), and grommet (8).

Steering System Maintenance Instructions (Cont)

- (4) Remove spacer (9), retaining ring (10), and steering column (11).
- (5) Remove screw (12) and locknut (13).

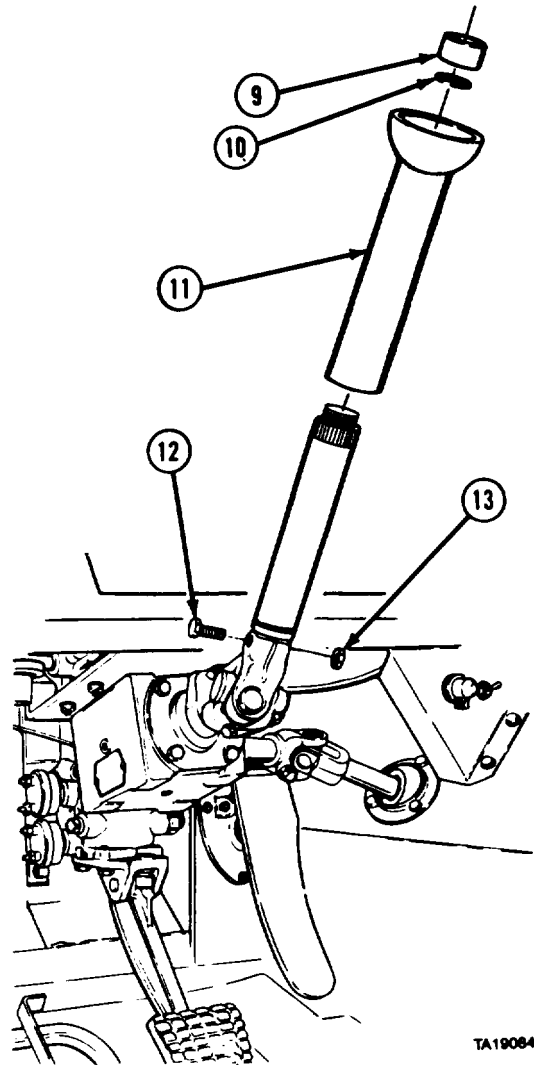

- (6) Remove two nuts (14), lockwashers (15), screws (16), and brackets (17).

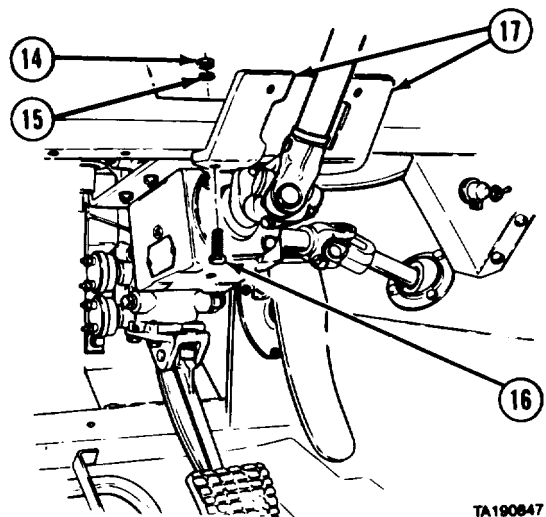

Steering System Maintenance Instructions (Cont)

12-2. STEERING COLUMN REMOVAL/INSTALLATION (CONT).

- (7) Remove steering shaft (18), retaining ring (19), spring (20), and cap (21).
- (8) Remove screw (22), locknut (23), and steering knuckle (24).

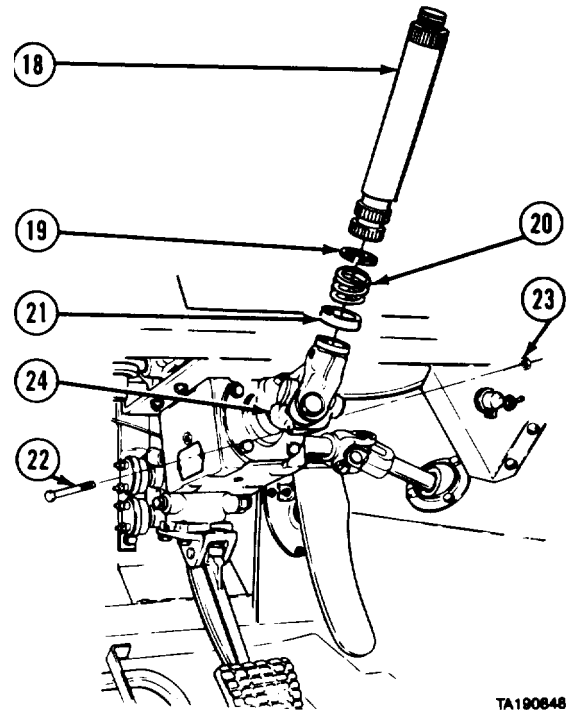

TA190648

b. Installation.

- (1) Install steering knuckle (1) with screw (2) and locknut (3).
- (2) Install retaining ring (4), spring (5), and cap (6) on bottom of steering shaft (7).

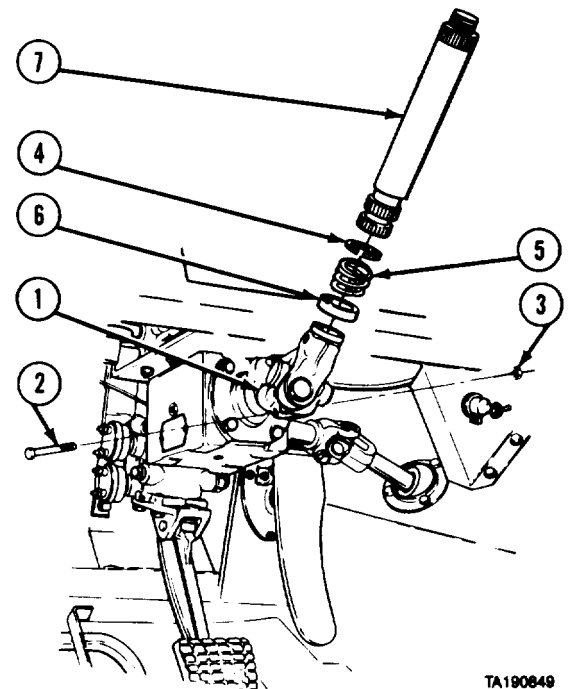

TA190649

Steering System Maintenance Instructions (Cont)

NOTE

Steering column slot must face toward dashboard for horn wire installation.

- (3) Install steering shaft (7) in steering knuckle (1) with screw (8) and locknut (9).
- (4) Install steering column (10), retaining ring (11), and spacer (12) on steering shaft (7).

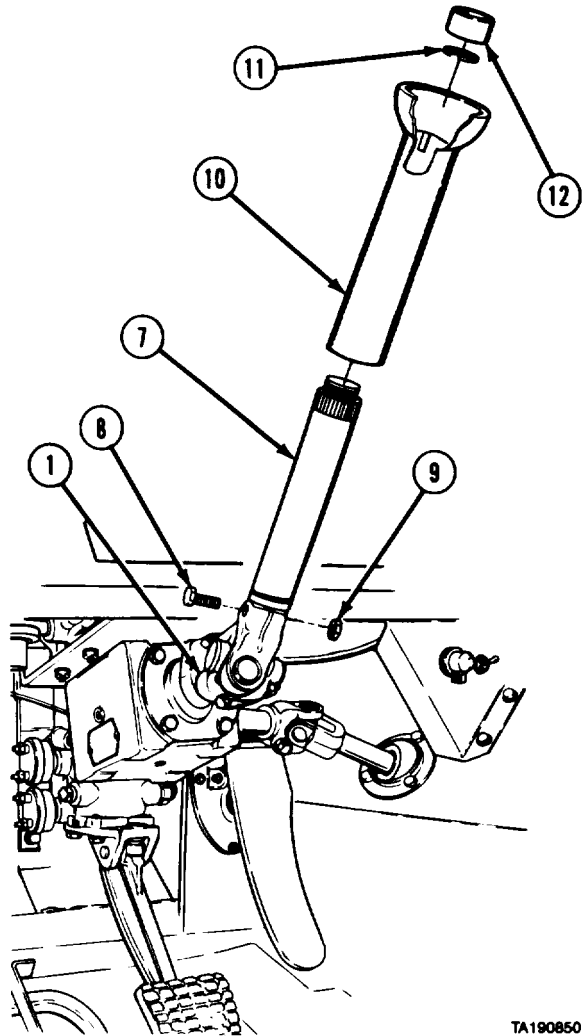

TA190850

- (5) Install two brackets (13) with screws (14), lockwashers (15), and nuts (16).

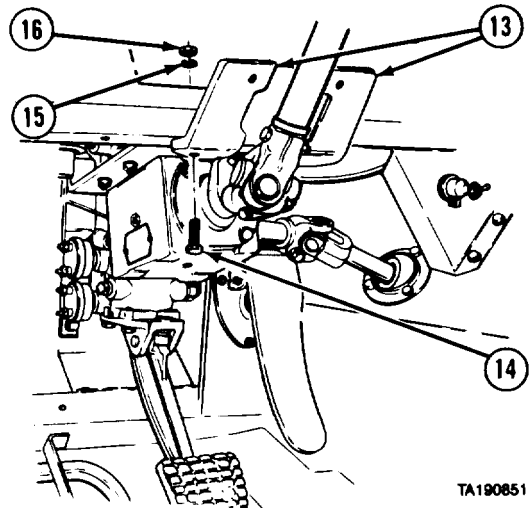

TA190851

Steering System Maintenance Instructions (Cont)

12-2. STEERING COLUMN REMOVAL/INSTALLATION (CONT).

- (6) Install grommet (17) on steering column (10).
- (7) Install top collar (18) and bottom collar (19) with two screws (20), lockwashers (21), and nuts (22).
- (8) Install headlight guard (23) with four screws (24).

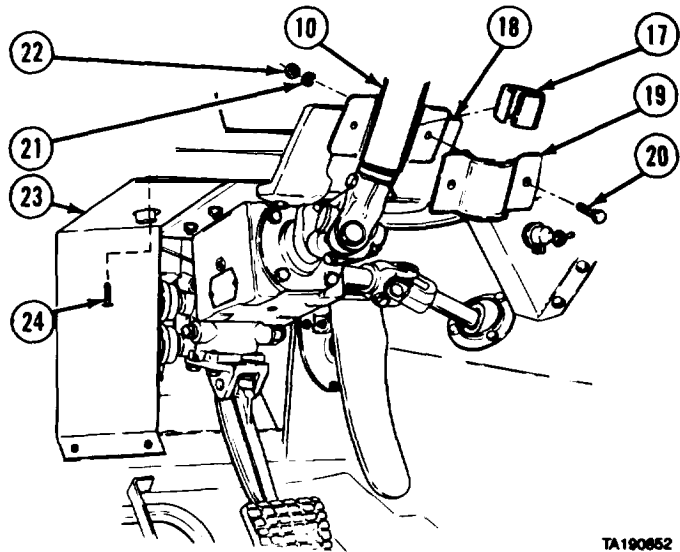

TA190852

c. Follow-on Maintenance.

- (1) Install horn switch contact roller (TM 9-2320-279-20).
- (2) Install turn signal and flasher (TM 9-2320-279-20).

END OF TASK

12-3. INTERGEAR LINK REMOVAL/INSTALLATION.

This task covers:

- a. Removal
- b. Installation
- c. Follow-on Maintenance

INITIAL SETUP

Models
All

Test Equipment
None

Special Tools
None

Supplies
None

Personnel Required
MOS 63W, Wheel vehicle repairer (2)

References
None

Equipment Condition

TM or Pam	Condition Description
TM 9-2320-279-10	Shut off engine.
TM 9-2320-279-10	Engine cover opened.
TM 9-2320-279-10	Engine side panel removed.
TM 9-2320-279-20	Batteries disconnected.

Special Environmental Conditions

None

General Safety Instructions

None

Level of Maintenance

Direct Support

Steering System Maintenance Instructions (Cont)

a. Removal.

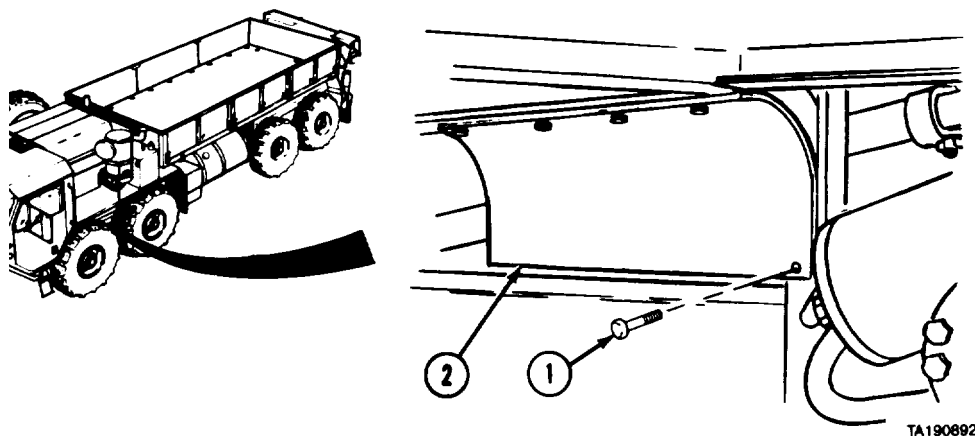

(1) Remove five screws (1) and front splash guard (2).

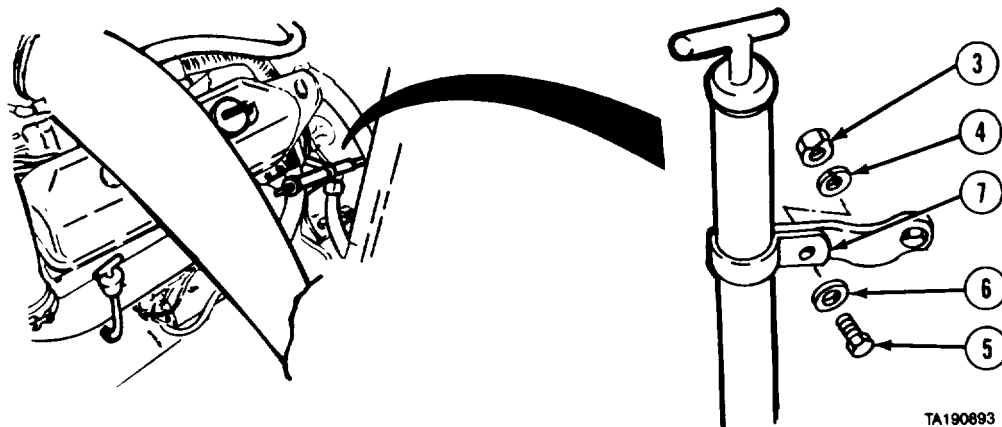

(2) Remove nut (3), lockwasher (4), screw (5), and washer (6) from clamp (7).

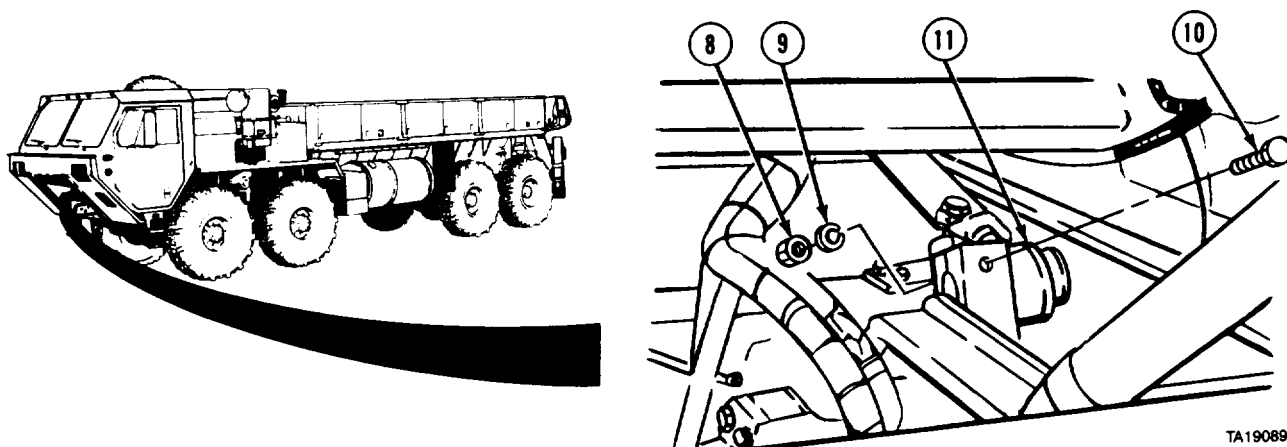

(3) Remove nut (8), lockwasher (9), screw (10), and intergear link end connector (11).

Steering System Maintenance Instructions (Cont)

12-3. INTERGEAR LINK REMOVAL/INSTALLATION (CONT).

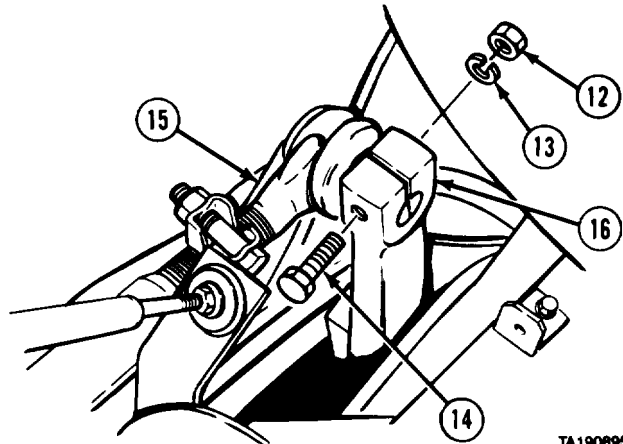
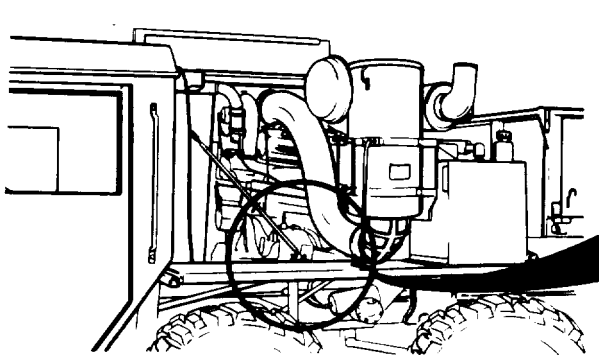

TA190895

(4) Remove nut (12), lockwasher (13), screw (14), and intergear link end connector (15) from slave steering gear pitman arm (16).

(5) Soldier A and Soldier B remove intergear link (17) by sliding intergear link back, then forward through splash guard opening (18).

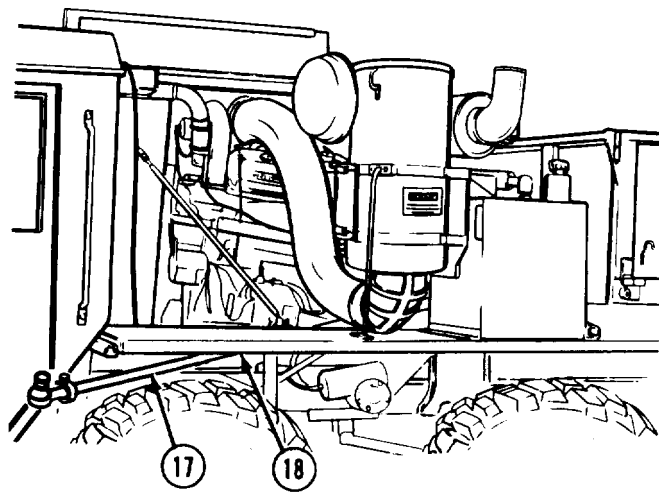

TA190896

b. Installation.

- (1) Loosen nut (1).
- (2) Adjust center-to-center distance of intergear link end connectors (2 and 3) on intergear link (4) to 68.20 in. (1 732.3 mm). Tighten two nuts (1) to 90 lb-ft (122 N•m).

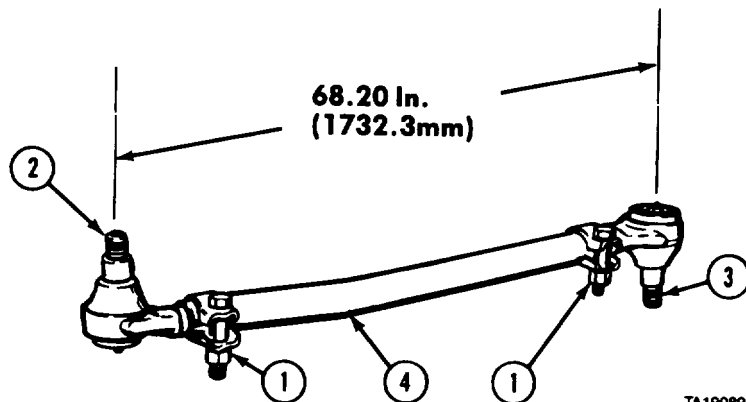

TA190897

Steering System Maintenance Instructions (Cont)

- (3) Soldier A and Soldier B position intergear link (4) through splash guard opening (5), back over starter and top of transmission, then forward under cab.

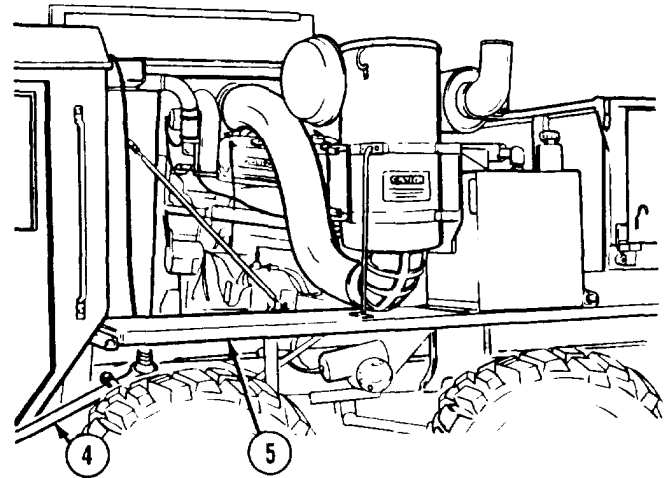

- (4) Soldier A and Soldier B install intergear link end connector (3) in slave steering gear pitman arm (6).
 (5) Install screw (7), lockwasher (8), and nut (9). Tighten nut to 90 lb-ft (122 N•m).

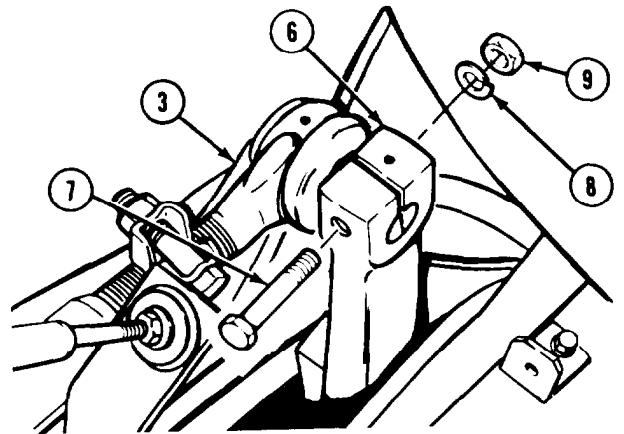

- (6) Install intergear link end connector (2) in main steering gear pitman arm (10).
 (7) Install screw (11), lockwasher (12), and nut (13). Tighten nut to 90 lb-ft (122 N•m).

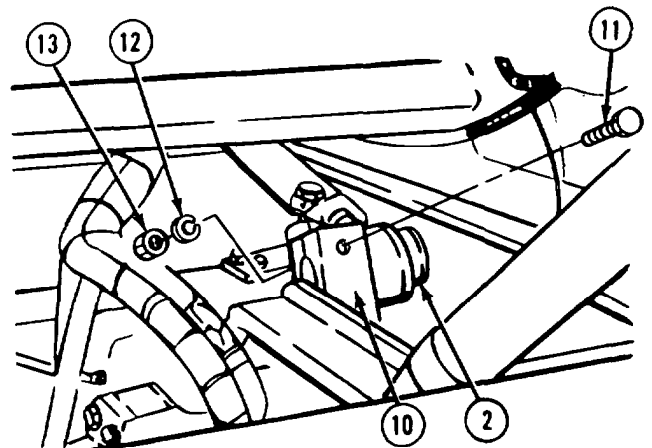

Steering System Maintenance Instructions (Cont)

12-3. INTERGEAR LINK REMOVAL/INSTALLATION (CONT).

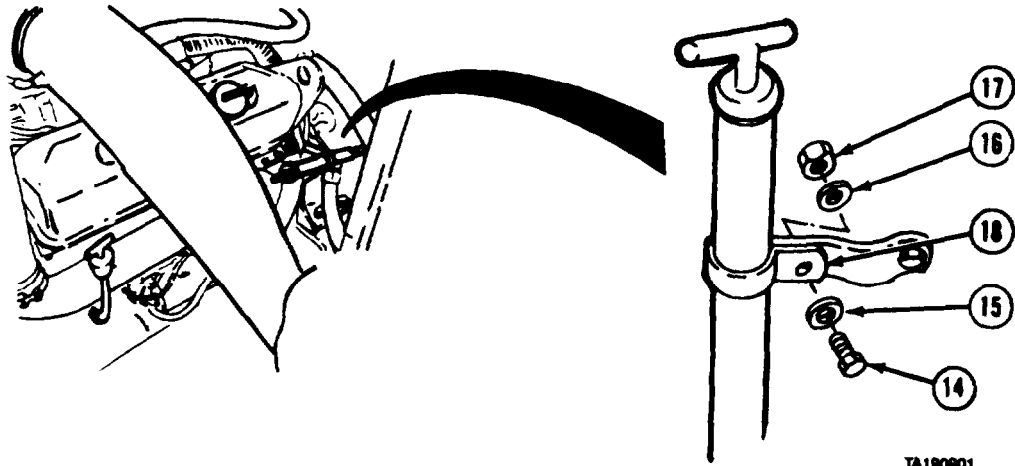

TA180801

- (8) Install screw (14), washer (15), lockwasher (16), and nut (17) to clamp (18).
- (9) Loosen two nuts (1) and turn intergear link (4) so curved area is down and away from radiator (19). Tighten nuts to 90 lb-ft (122 N•m).

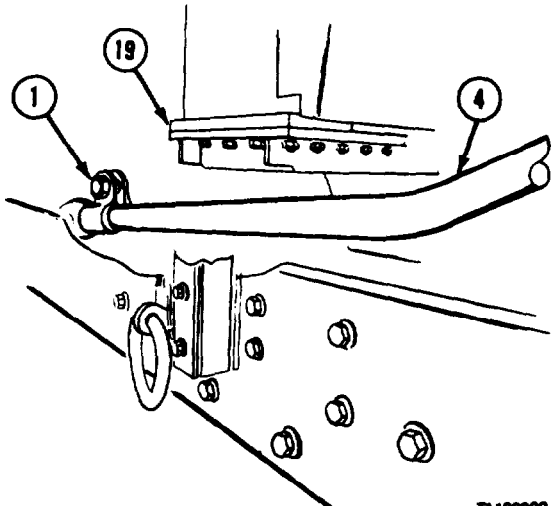

TA180802

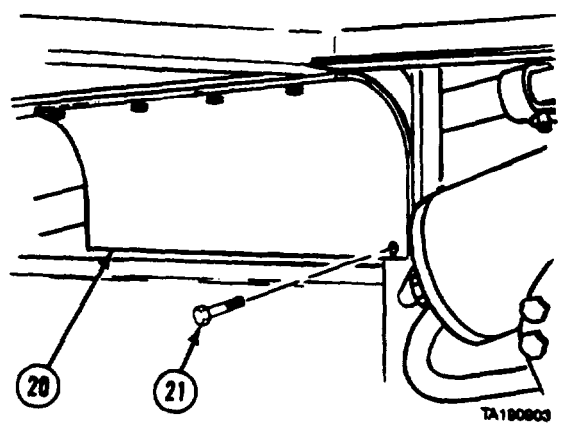
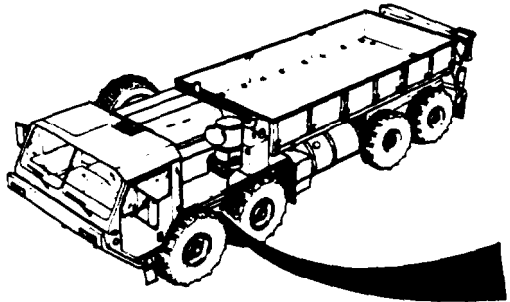

TA180803

- (10) Install front splash guard (20) with five screws (21).

Steering System Maintenance Instructions (Cont)

c. Follow-on Maintenance.

- (1) Install engine side panel (TM 9-2320-279-10)
- (2) Connect batteries (TM 9-2320-279-20).
- (3) Close engine cover (TM 9-2320-279-10).

END OF TASK

12-4. 90° GEARBOX REMOVAL/REPAIR/INSTALLATION.							
This task covers:							
a. Removal	d. Assembly						
b. Disassembly	e. Installation						
c. Cleaning/Inspection	f. Follow-on Maintenance						
INITIAL SETUP							
<i>Models</i> All	<i>Personnel Required</i> MOS 63W, Wheel vehicle repairer						
<i>Test Equipment</i> None	<i>References</i> None						
<i>Special Tools</i> None	<i>Equipment Condition</i> <table border="0"> <tr> <td><i>TM or Para</i></td> <td><i>Condition Description</i></td> </tr> <tr> <td>TM 9-2320-279-20</td> <td>Instrument panel removed.</td> </tr> <tr> <td>Para 12-2</td> <td>Steering column removed.</td> </tr> </table>	<i>TM or Para</i>	<i>Condition Description</i>	TM 9-2320-279-20	Instrument panel removed.	Para 12-2	Steering column removed.
<i>TM or Para</i>	<i>Condition Description</i>						
TM 9-2320-279-20	Instrument panel removed.						
Para 12-2	Steering column removed.						
<i>Supplies</i> Adhesive-Sealant, Item 8, Appendix C Grease, general purpose, lithium base, Item 36, Appendix C Oil, lubricating, Item 46, Appendix C Solvent, drycleaning, Item 57, Appendix C Compound, sealing, lubricating, Item 25, Appendix C compound, sealing, pipe thread, Item 29, Appendix C Cloth, crocus, Item 16, Appendix C Tags, identification, Item 60, Appendix C	<i>Special Environmental Conditions</i> None						
	<i>General Safety Instructions</i> None						
	<i>Level of Maintenance</i> Direct Support						

Steering System Maintenance Instructions (Cont)

12-4. 90° GEARBOX REMOVAL/REPAIR/INSTALLATION (CONT).

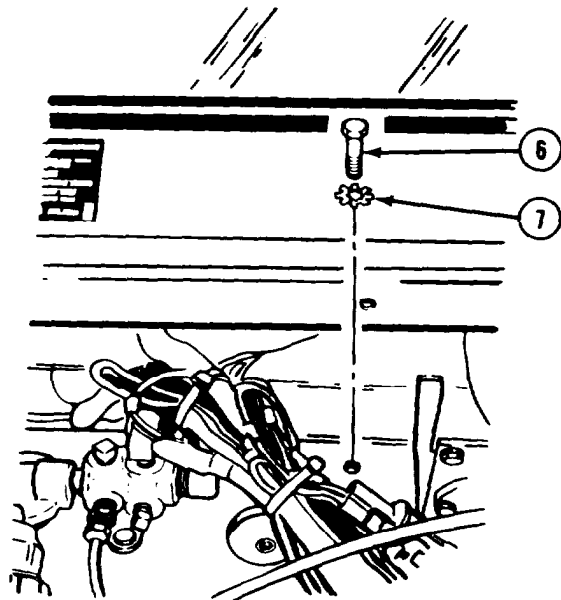
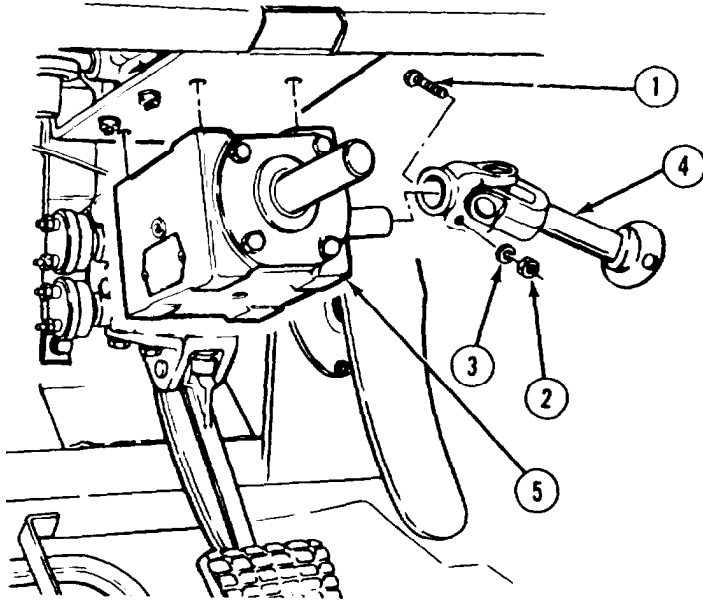

a. Removal.

- (1) Remove screw (1), nut (2), and lockwasher (3).
- (2) Remove steering shaft (4) from gearbox (5).
- (3) Support gearbox (5) and remove four screws (6) and lockwashers (7).
- (4) Remove gearbox (5).

b. Disassembly,

NOTE

Some gearboxes will have a third pipe plug in place of the reducer bushing and vent. Remove plug and install reducer bushing and vent during reassembly.

- (1) Remove two pipe plugs (1) from housing (2).
- (2) Remove vent (3) and reducer bushing (4) from housing (2).

NOTE

There are two models of gearboxes. Model A uses paper gaskets for sealing and bearing and gear backlash adjustment. Model B uses plastic shims and preformed packing for same purposes. Model A paper gaskets are no longer available and are replaced with Model B components. Do step (3) for Model A. Do steps (3.1) and (3.2) for Model B.

- (3) Remove four screws (5), pinion housing (6), paper gasket (7), and pinion shaft (8) from housing (2).
- (3.1) Remove four screws (5), pinion housing (6), plastic shims (7.1) and pinion shaft (8) from housing (2).
- (3.2) Remove preformed packing (7.2) from pinion housing (6).

Steering System Maintenance Instructions (Cont)

- (4) Remove bracket (9) and yoke key (10).
- (5) Matchmark housing (2) and open end cap (11).
- (6) Remove four screws (12), open end cap (11), and output shaft (13).
- (7) Matchmark housing (2) and closed end cap (14).

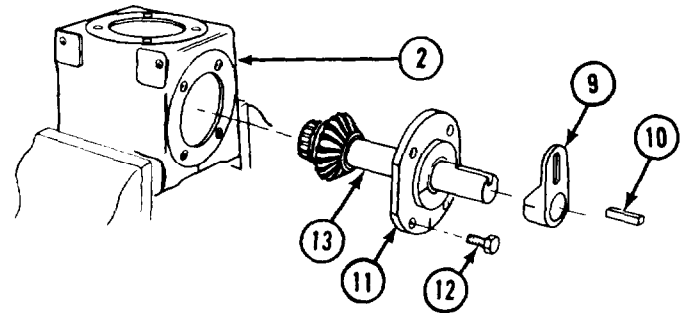

NOTE

There are two models of gearboxes. Model A uses paper gaskets. Model B uses plastic shims and preformed packing. Do step (8) for Model A. Do steps (8.1) and (8.2) for Model B.

- (8) Remove four screws (15), closed end cap (14), and paper gasket (16).
- (8.1) Remove four screws (15), closed end cap (14), and plastic shim (16.1).
- (8.2) Remove preformed packing (16.2) from closed end cap (14).

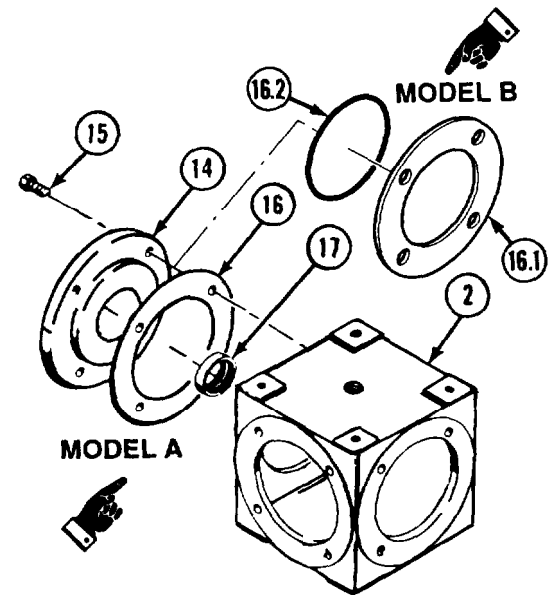

NOTE

Tag all bearing cups and cone bearings.

- (9) Remove bearing cup (17) from closed end cap (14).

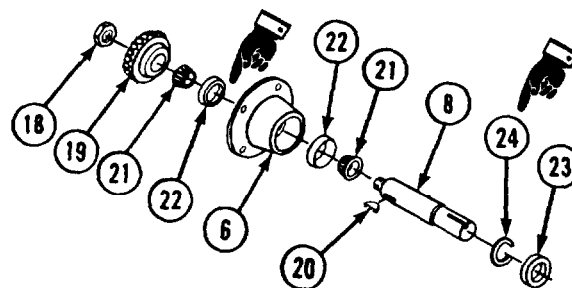

- (10) Remove crimped pinion nut (18), straight bevel gear (19), woodruff key (20), and pinion housing (6) from pinion shaft (8).
- (11) Remove two cone bearings (21) and bearing cups (22).
- (12) Remove oil seal (23) and retaining ring (24) from pinion shaft (8).

Steering System Maintenance Instructions (Cont)

12-4. 90° GEARBOX REMOVAL/REPAIR/INSTALLATION (CONT).

- (13) Remove open end cap (11), with oil seal (25) and bearing cup (26) from output shaft (13).

NOTE

There are two types of output shafts. Model A has two retaining rings. Model B does not have retaining rings. On Model B, disregard references to retaining rings.

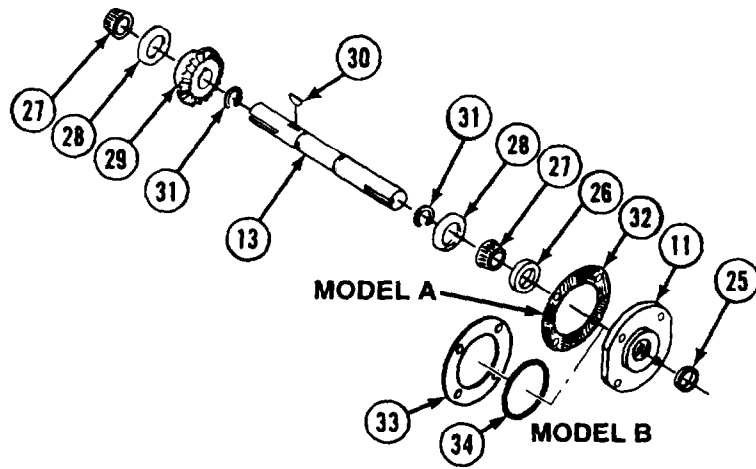

- (14) Remove two cone bearings (27), two spring washers (28), straight bevel gear (29), woodruff key (30), and two retaining rings (31) from output shaft (13).

NOTE

There are two models of gear boxes. Model A uses paper gaskets. Model B uses plastic shims and preformed packing. Do step (15) for Model A. Do step (16) for Model B.

- (15) Remove bearing cup (26), paper gasket (32), and oil seal (25) from open end cap (11).
- (16) Remove bearing cup (26), plastic shims (33), preformed packing (34), and oil seal (25) from open end cap (11).

c. **Cleaning/Inspection.**

WARNING

Adhesives, solvents, and sealing compounds can burn easily, can give off harmful vapors, and are harmful to skin and clothing. To avoid injury or death, keep away from open fire and use in well-ventilated area. If adhesive, solvent, or sealing compound gets on skin or clothing, wash immediately with soap and water.

CAUTION

Dirt and foreign material in steering system will cause damage and steering problems.

- (1) Clean old gasket material from housing and/or caps.
- (2) Clean sealant residue from threaded holes with dry cleaning solvent.

CAUTION

Do not wash machined parts together to avoid damage from parts bumping together.

- (3) Wash parts in drycleaning solvent.
- (4) Remove all small nicks or burrs with crocus cloth.
- (5) Coat all parts with light coating of lubricating oil.
- (6) Inspect housing and caps for damage.
- (7) Inspect all parts with machined surfaces for deep scratches or wear grooves.
- (8) Replace unserviceable parts.

Steering System Maintenance Instructions (Cont)

d. Assembly.

NOTE

There are two types of output shafts. Model A has retaining rings (1). Model B does not have any retaining rings. Omit step (1) when assembling Model B.

- (1) Install two retaining rings (1) on output shaft (2).
- (2) Install woodruff key (3) and straight bevel gear (4) on output shaft (2).
- (3) Install two spring washers (5) on output shaft (2).
- (4) Pack two cone bearings (6) with grease and install on output shaft (2).
- (5) Install two bearing cups (7) in pinion housing (8).

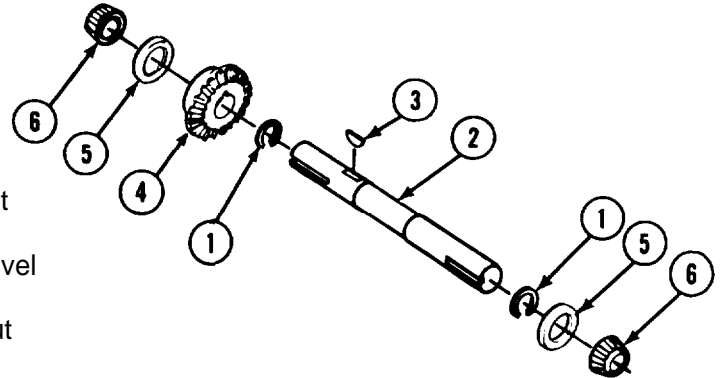

- (6) Install retaining ring (9) on pinion shaft (10).
- (7) Pack cone bearings (11 and 12) with grease.
- (8) Install cone bearing (11), pinion housing (8), and cone bearing (12) on pinion shaft (10).

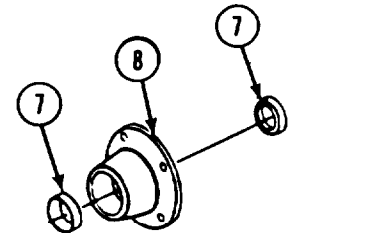

- (9) Install woodruff key (13) and straight bevel gear (14) on pinion shaft (10).
- (10) Install crimped pinion nut (15) and tighten until cone bearings (11 and 12) bind. Back crimped pinion nut (15) off about 1/4 turn and hit nut end of pinion shaft (10) sharply to free bearings.
- (11) Install bearing cup (16) in closed end cap (17).

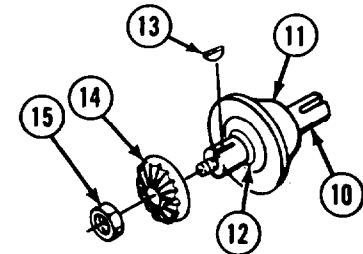
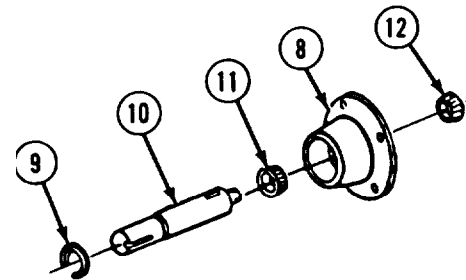

NOTE

There are two models of gearboxes. Model A uses paper gaskets for sealing and bearing and gear backlash adjustment. Model A paper gaskets are no longer available and are replaced with Model B components. Model B uses preformed packing for sealing and plastic shims for bearing and gear backlash adjustment.

- (12) Aline matchmarks and install closed end cap (17) on housing (18) with preformed packing (19), three plastic shims (19.1), and four screws (20).

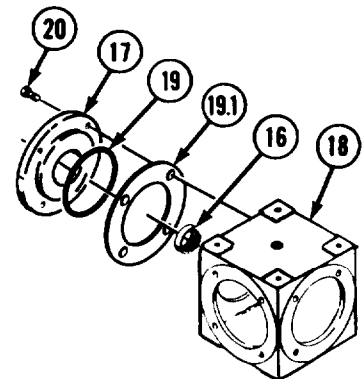

Steering System Maintenance Instructions (Cont)

12-4. 90° GEARBOX REMOVAL/REPAIR/INSTALLATION (CONT).

- (13) Install bearing cup (21) in open end cap (22).
- (14) Install output shaft (2) in housing (18).
- (15) Deleted.
- (16) Align matchmarks and install open end cap (22) on housing (18) with preformed packing (19), three plastic shims (19.1), and four screws (23).
- (17) Remove four screws (20), closed end cap (17), four screws (23), and open end cap (22) from housing (18).

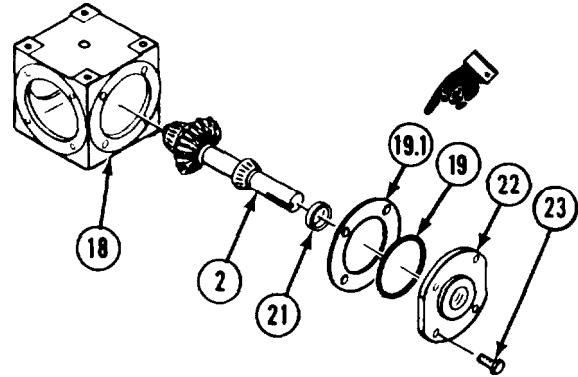

NOTE

- When making adjustments install and remove screws for end caps, as necessary, until adjustments are complete.
 - Screws for end caps must be tightened securely to make proper adjustments.
 - When adjusting bearings, make sure the number of plastic shims on each end cap does not differ from the other end cap by more than one.
- (18) Add or remove plastic shims (19.1) from closed end cap (17) and open end cap (22) until cone bearings (6) just bind when turning output shaft (2) by hand.
 - (19) Add plastic shims (19.1), one at a time, to closed end cap (17) and open end cap (22) until output shaft (2) rotates freely with no end play.

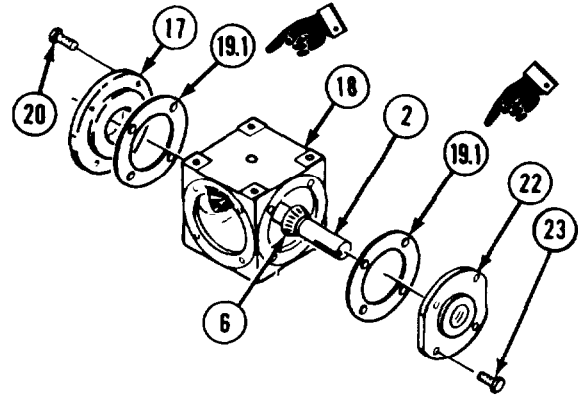

Steering System Maintenance Instructions (Cont)

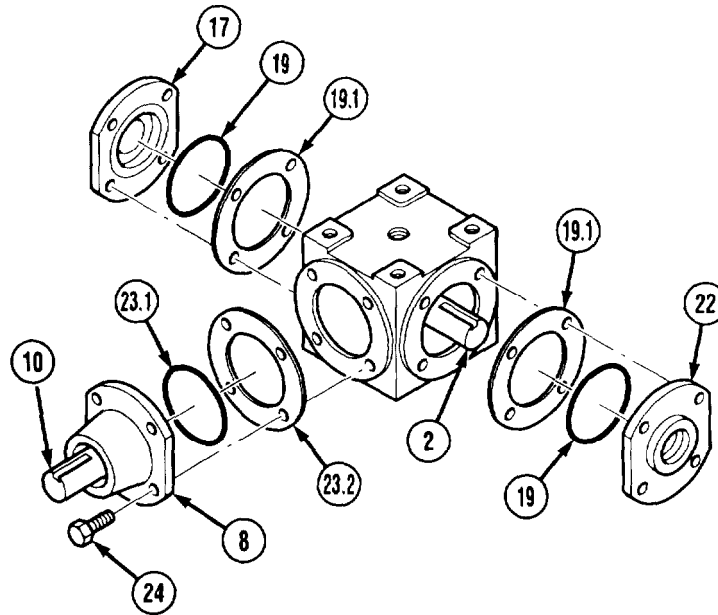
**NOTE**

Make sure gear teeth mesh as parts are assembled.

(20) Deleted.

WARNING

Adhesives, solvents, and sealing compounds can burn easily, can give off harmful vapors, and are harmful to skin and clothing. To avoid injury or death, keep away from open fire and use in well-ventilated area. If adhesive, solvent, or sealing compound gets on skin or clothing, wash immediately with soap and water.

NOTE

If installing plastic shims without preformed packing, adhesive-sealant must be applied to mating surface to ensure proper seal.

- (21) If installing plastic shims (23.2) without preformed packing (23.1), apply adhesive-sealant to mating surfaces of pinion housing (8) and housing (18). If using preformed packing, continue to step (22).
- (22) Install pinion housing (8) with preformed packing (23.1), three plastic shims (23.2), and four screws (24) and align keyways in output shaft (2) and pinion shaft (10).
- (23) Move plastic shims (19.1) one at a time from closed end cap (17) to open end cap (22) until pinion shaft (10) and output shaft (2) rotate freely with no backlash.

Steering System Maintenance Instructions (Cont)

12-4. 90° GEARBOX REMOVAL/REPAIR/INSTALIATION (CONT).

WARNING

Adhesives, solvents, and sealing compounds can burn easily, can give off harmful vapors, and are harmful to skin and clothing. To avoid injury or death, keep away from open fire and use in well-ventilated area. If adhesive, solvent, or sealing compound gets on skin or clothing, wash immediately with soap and water.

NOTE

If installing plastic shims without preformed packing, adhesive-sealant must be applied to mating surfaces to ensure proper seal.

- (24) If installing plastic shims (19.1) without preformed packing (19), apply adhesive-sealant to mating surfaces of end caps (17 and 22) and housing (18). If using preformed packing, continue to step (25).

NOTE

Gears will be properly adjusted when two plastic shims are moved to closed end cap.

- (25) Move two plastic shims (19.1) from open end cap (22) to closed end cap (17).

NOTE

If there are not enough plastic shims left in open end cap to permit moving plastic shims to closed end cap, further adjustment must be made by removing two plastic shims from between pinion housing and housing. Then repeat steps (12) and (15) through (25).

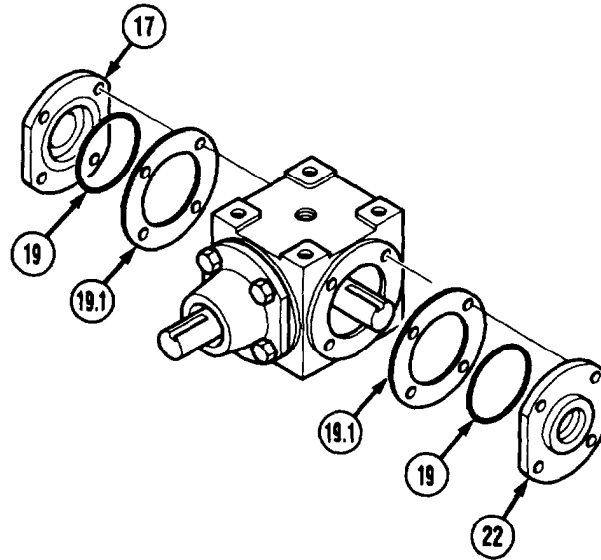

Steering System Maintenance Instructions (Cont)

WARNING

Adhesives, solvents, and sealing compounds can burn easily, can give off harmful vapors, and are harmful to skin and clothing. To avoid injury or death, keep away from open fire and use in well-ventilated area. If adhesive, solvent, or sealing compound gets on skin or clothing, wash immediately with soap and water.

- (26) Remove 12 screws (20) and clean threads and screw holes with drycleaning solvent.
- (27) Coat threads of 12 screws (20) with lubricating sealing compound and install in housing (18). Tighten screws to 15 lb-ft (20 N•m).
- (28) Install oil seal (25) on pinion shaft (10).
- (29) Install oil seal (26) on open end cap (22).
- (30) Coat threads of plug (27) with pipe thread sealing compound and install plug in bottom of housing (18).
- (31) Fill housing (18) about two-thirds full of grease.
- (32) Coat threads of remaining plug (27), used to check lubricant level, with pipe thread sealing compound and install plug in side of housing (18).
- (33) Coat threads of reducer bushing (28) and vent (29) with pipe thread sealing compound and install bushing and vent in housing (18).

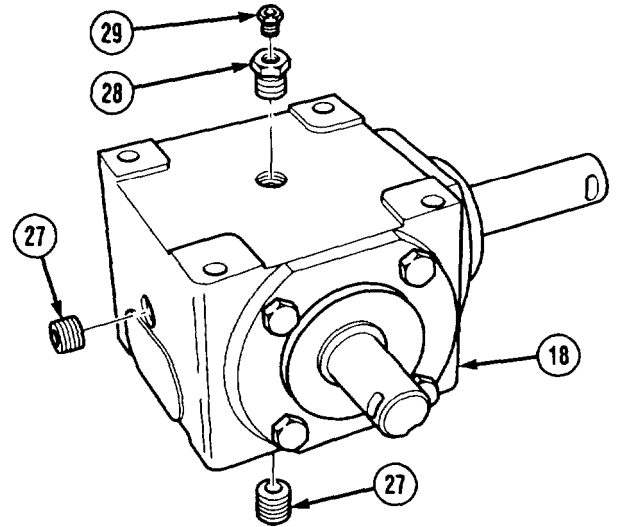
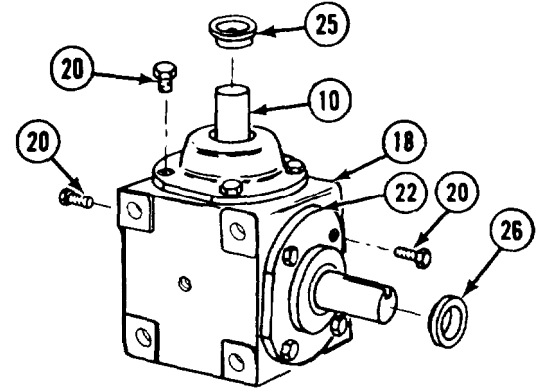

Steering System Maintenance Instructions (Cont)

124. 90° GEARBOX REMOVAL/REPAIR/INSTALLATION (CONT).

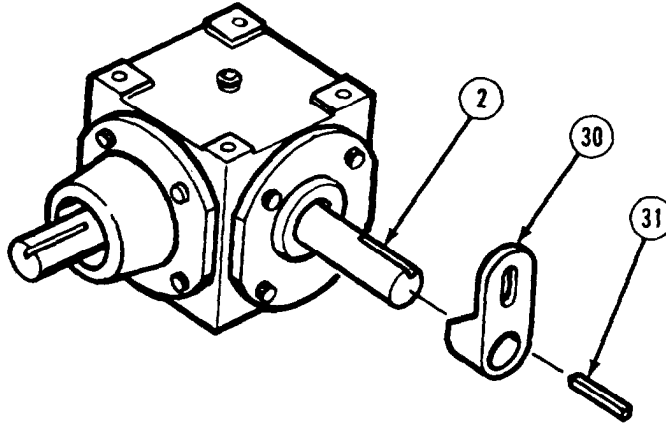

(34) Install bracket (30) and yoke key (31) on output shaft (2).

e. Installation.

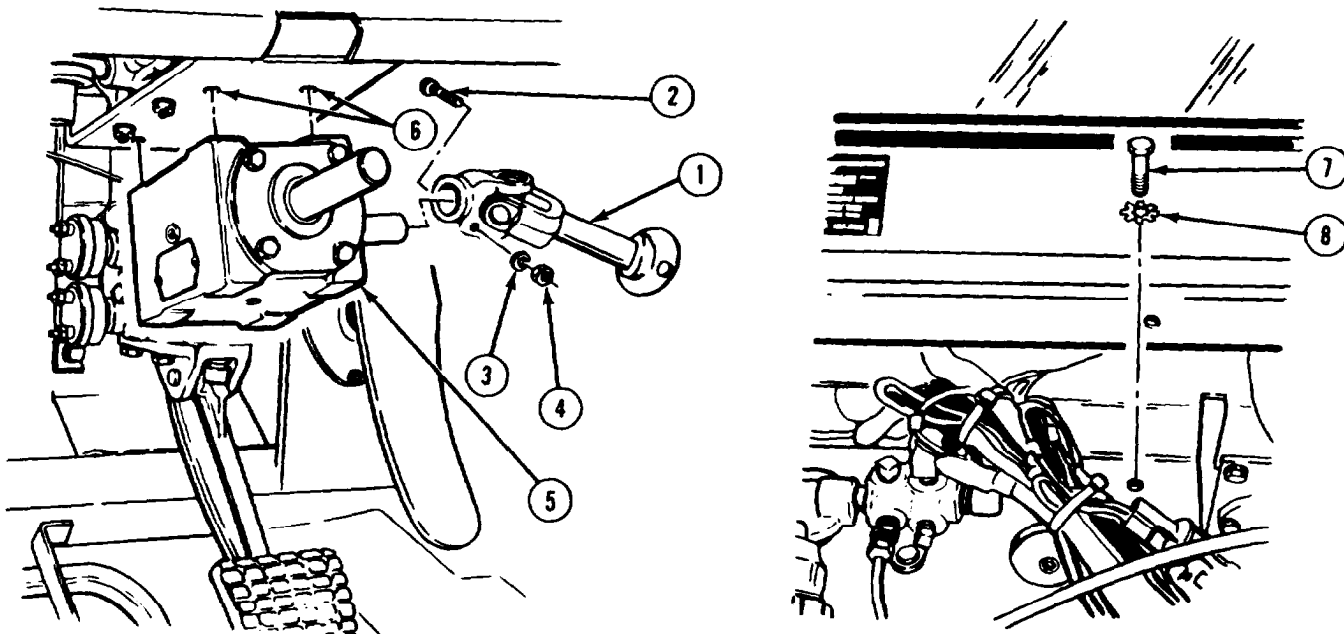

- (1) Install steering shaft (1), screw (2), lockwasher (3), and nut (4).
- (2) Align gearbox (5) with top mounting holes (6).
- (3) Install four screws (7) and lockwashers (8).

f. Follow-on Maintenance.

- (1) Install steering column (para 12-2).
- (2) Install instrument panel (TM 9-2320-279-20).

END OF TASK

Steering System Maintenance Instructions (Cont)

Section III. STEERING GEAR AND SLAVE

12-5 STEERING GEAR AND PITMAN ARM REMOVAL/REPAIR/INSTALLATION.							
This task covers:							
a. Removal	e. Assembly						
b. Disassembly	f. Installation						
c. Cleaning/Inspection	g. Follow-on Maintenance						
d. Repair							
INITIAL SETUP							
Models All	Personnel Required MOS 63W, Wheel vehicle repairer (3)						
Test Equipment None	References None						
Special Tools None	Equipment Condition						
Supplies Compound, antiseize, Item 17, Appendix C Compound, sealing, pipe thread, Item 29, Appendix C Grease, automotive and artillery, Item 34, Appendix C Oil, lubricating, Item 46, Appendix C Solvent, dry cleaning, Item 57, Appendix C Tags, identification, Item 60, Appendix C	<table border="0"> <tr> <td>TM or Para</td> <td>Condition Description</td> </tr> <tr> <td>TM 9-2320-279-10</td> <td>Shut off engine.</td> </tr> <tr> <td>LO 9-2320-279-12</td> <td>Hydraulic reservoir drained.</td> </tr> </table>	TM or Para	Condition Description	TM 9-2320-279-10	Shut off engine.	LO 9-2320-279-12	Hydraulic reservoir drained.
TM or Para	Condition Description						
TM 9-2320-279-10	Shut off engine.						
LO 9-2320-279-12	Hydraulic reservoir drained.						
	Special Environmental Conditions None						
	General Safety Instructions None						
	Level of Maintenance Direct Support						

a. Removal.

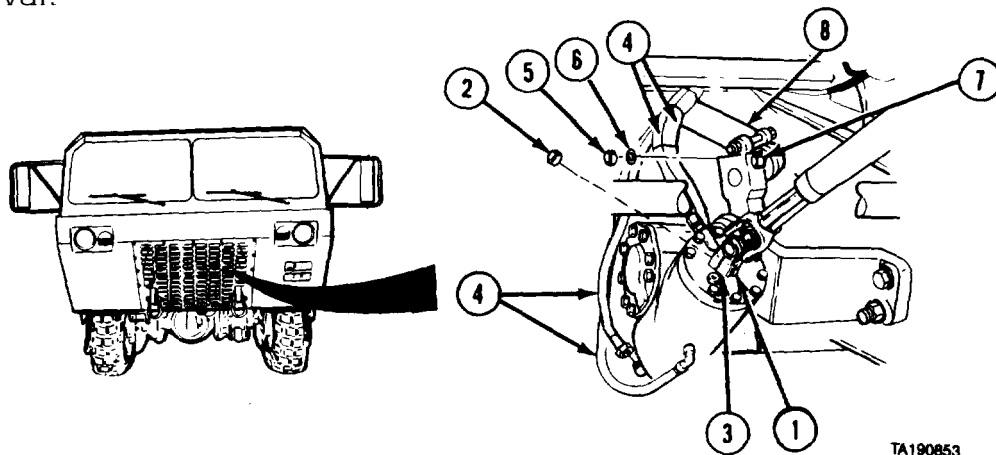

(1) Remove screw (1), locknut (2), and end yoke (3).

NOTE

Tag and mark hydraulic hoses before disconnecting.

(2) Disconnect four hydraulic hoses (4).

(3) Remove nut (5), lockwasher (6), and screw (7) and loosen intergear link end (8).

Stowing System Maintenance Instructions (Cont)

12-5. STEERING GEAR AND PITMAN ARM REMOVAL/REPAIR/INSTALLATION (CONT).

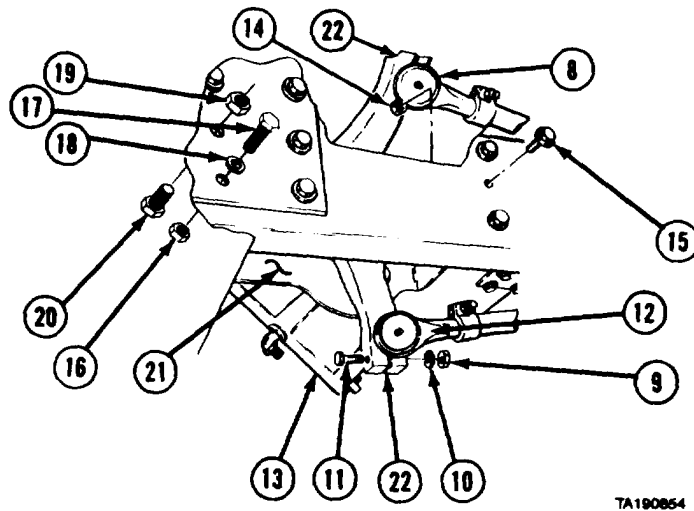

- (4) Remove nut (9), lockwasher (10), screw (11), and front drag link end (12).

WARNING

Steering gear and mounting bracket are heavy and could cause serious injury if dropped.

- (5) Soldier A and Soldier B support steering gear (13) while Soldier C removes four nuts (14) and screws (15).
 (6) Remove nut (16), screw (17), and washer (18).
 (7) Remove nut (19) and screw (20).
 (8) Soldier A and Soldier B lower steering gear (13) and bracket (21) to floor while Soldier C removes intergear link end (8) from pitman arm (22).

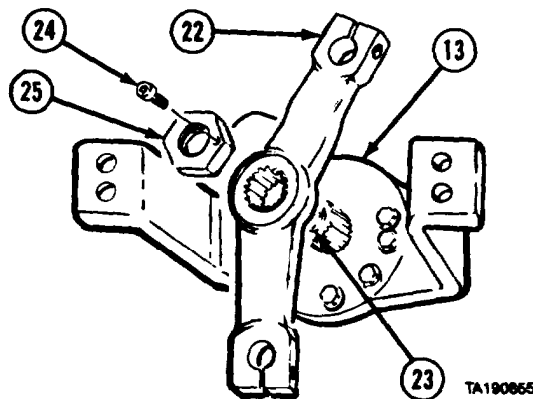

- (9) Clamp steering gear (13) in vise with soft jaws.
 (10) Make matchmarks on pitman arm (22) and steering gear shaft (23).
 (11) Remove lock screw (24) and nut (25).
 (12) Pull pitman arm (22) from steering gear shaft (23).

Steering System Maintenance Instructions (Cont)

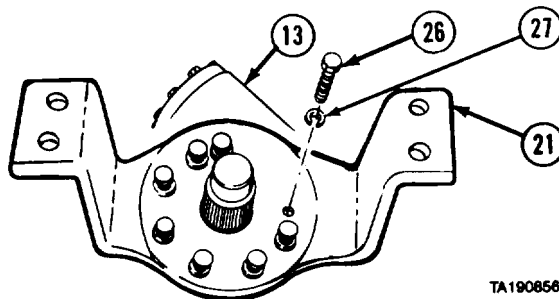

NOTE

Note position of steering gear on bracket.

(13) Remove eight screws (26), lockwashers (27), and bracket (21) from steering gear (13).

b. Disassembly.

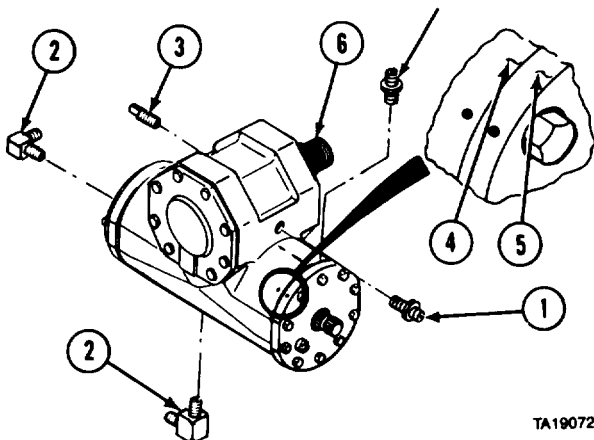

- (1) Remove two straight fittings (1), elbows (2), and pipe plug (3).
- (2) Make matchmarks on housing (4) and cylinder head (5).
- (3) Wipe output shaft (6) clean.

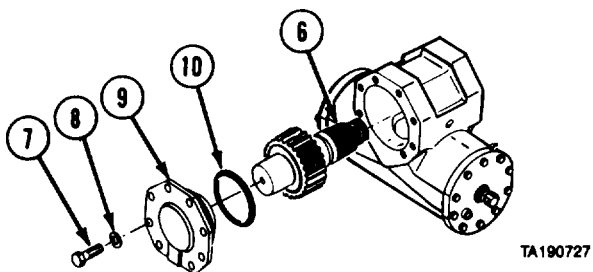

- (4) Remove eight screws (7) and lockwashers (8).
- (5) Remove housing cover (9) and output shaft (6).
- (6) Remove preformed packing (10).

Steering System Maintenance Instructions (Cont)

12-5. STEERING GEAR AND PITMAN ARM REMOVAL/REPAIR/INSTALLATION (CONT).

- (7) Remove valve (11) and preformed packing (12).
- (8) Remove 10 screws (13) and lockwashers (14).
- (9) Turn cylinder head (5) counterclockwise and remove with actuating shaft assembly (15).
- (10) Remove preformed packing (16).

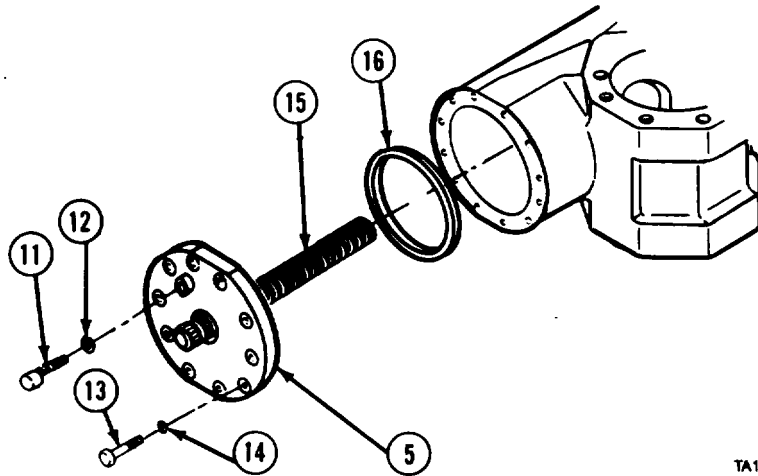

TA190728

- (11) Turn housing (4) around.
- (12) Remove preformed packing (17) from inside housing (4).
- (13) Remove valve (18) and preformed packing (19).
- (14) Remove 10 screws (20) and lockwashers (21).

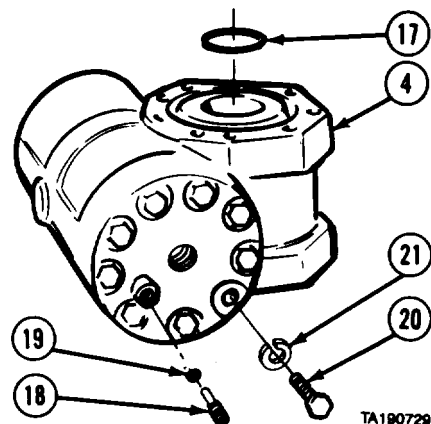

TA190729

- (15) Remove cylinder head (22) and preformed packing (23).

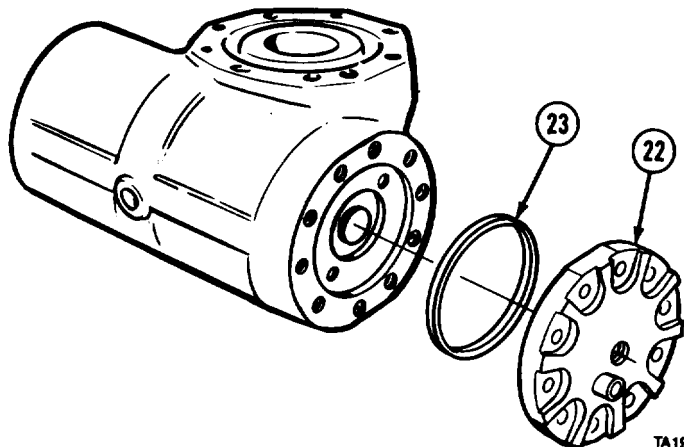

TA190730

Steering System Maintenance Instructions (Cont)

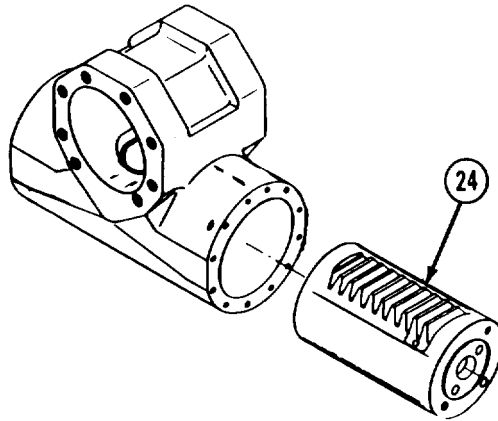

(16) Remove piston (24).

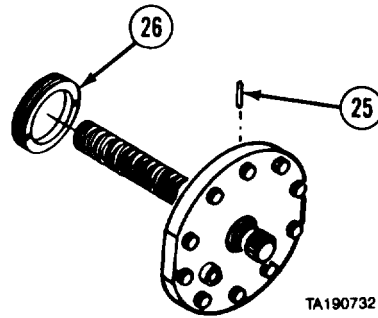

TA190732

(27) Drill out locking pin (25).
 (18) Remove retaining nut (26).

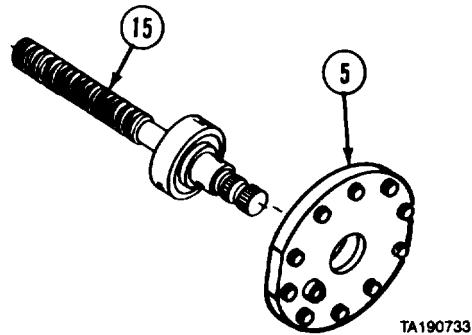

TA190733

(19) Remove actuating shaft assembly (15) from cylinder head (5).

Steering System Maintenance Instructions (Cont)

12-5. STEERING GEAR AND PITMAN ARM REMOVAL/REPAIR/INSTALLATION (CONT).

NOTE

Seals and backup washer can be removed by pressing all three seals toward inside of cylinder head.

- (20) Remove seal (27), backup washer (28), dirt seal (29), and salt seal (30) from cylinder head (5).

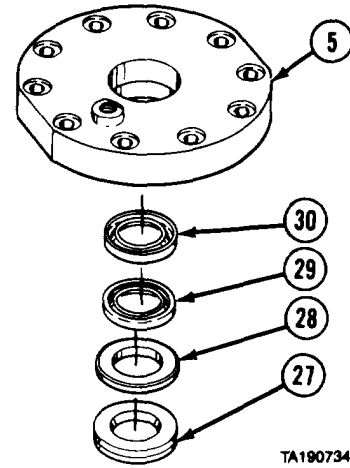

CAUTION

Do not drill more than 1.625 in. (41.27 mm) from top of output shaft gear teeth into retaining pin or damage to output shaft will result.

- (21) Remove roll pin (31) and drill out retaining pin (32).

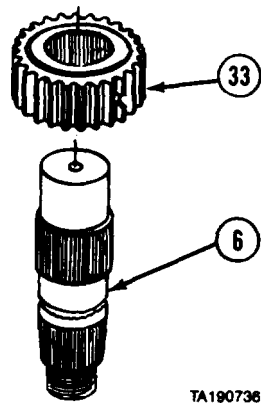
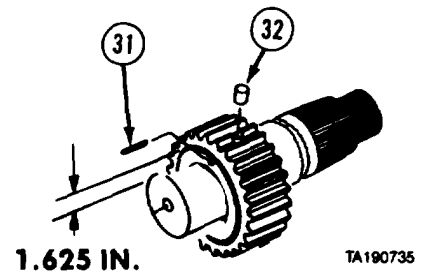

- (22) Separate output shaft (6) and output shaft gear (33).

Steering System Maintenance Instructions (Cont)

- (23) Measure inside diameter of bearing (34). If bearing is more than 0.010 in. (0.25 mm) out of round, do step, (24).
- (24) Remove bearing (34) from housing cover (9).

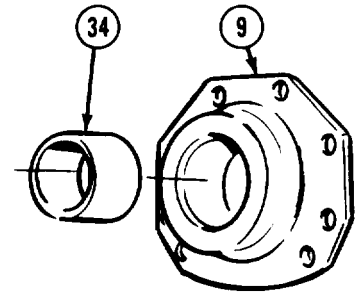

TA190737

- (25) Measure inside diameter of bearing (35). If bearing is more than 0.010 in. (0.25 mm) out of round, do step (26).
 - (26) Remove bearing (35) from housing (4).
- c. Cleaning/Inspection.

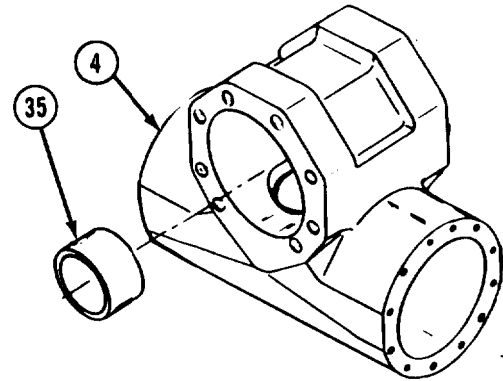

TA190738

WARNING

Adhesives, solvents, and sealing compounds can burn easily, can give off harmful vapors, and are harmful to skin and clothing. To avoid injury or death, keep away from open fire and use in well-ventilated area. If adhesive, solvent, or sealing compound gets on skin or clothing, wash immediately with soap and water.

CAUTION

Dirt and foreign material in steering system will cause damage and steering problems. Clean machined parts individually to avoid damage due to bumping together.

- (1) Clean metal parts in dry cleaning solvent.
 - (2) Inspect parts for damage.
 - (3) Replace damaged parts.
 - (4) Coat all parts with light coating of lubricating oil.
- d. Repair.
- (1) Remove all small nicks and burrs.
 - (2) Polish minor scoring to allow free movement of mating parts.
 - (3) Coat all parts with light coating of lubricating oil.
- e. Assembly.
- (1) Install bearing (1) flush with inner face of housing (2).
 - (2) Coat inner surface of bearing (1) with grease.

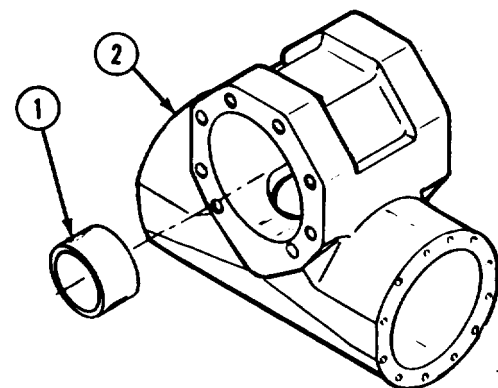

TA190739

Steering System Maintenance Instructions (Cont)

12-5. STEERING GEAR AND PITMAN ARM REMOVAL/REPAIR/INSTALLATION (CONT).

- (3) Install bearing (3) into rear of housing cover (4) about 1/4 in. (6.4 mm) below inside face of housing cover.
- (4) Coat inner surface of bearing (3) with grease.

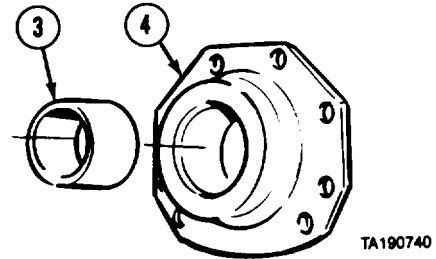

- (5) Aline arrow on output shaft (5) between two punchmarks on gear (6).
- (6) Install output shaft (5) in gear (6).

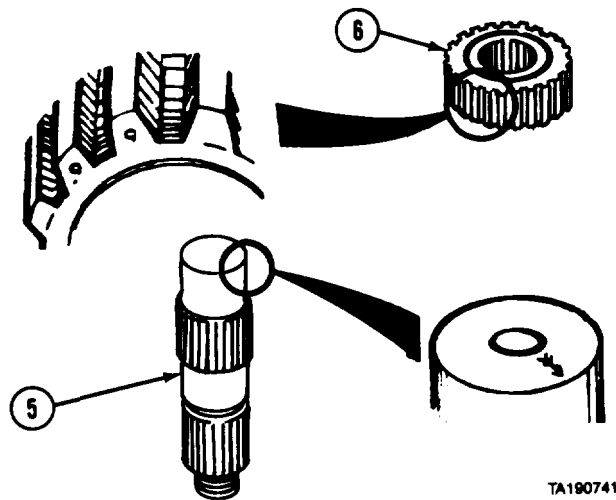

- (7) Install retaining pin (7).
- (8) Install roll pin (8).

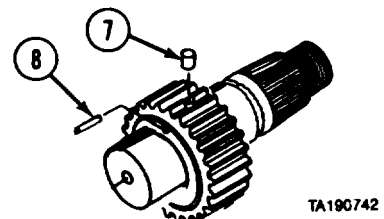

CAUTION

Backup washer must be properly seated to prevent oil leakage when steering gear is pressurized. Oil leakage will cause damage to equipment.

- (9) Install backup washer (9) in large end of cylinder head (10) until seated.

Steering System Maintenance Instructions (Cont)

- (11) Support backup washer (9).
- (11) Install dirt seal (11) in cylinder head (10) lip out, until seal rests against backup washer (9). Apply grease to dirt seal.
- (12) Install salt seal (12) lip out, so it is flush with top of cylinder head (10). Apply grease to salt seal.

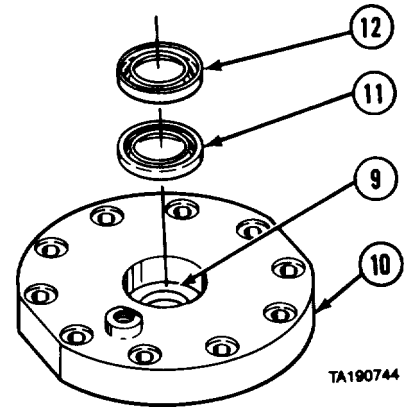

- (13) Install seal (13) evenly, garter spring up, until it rests against backup washer (9). Apply grease to seal.

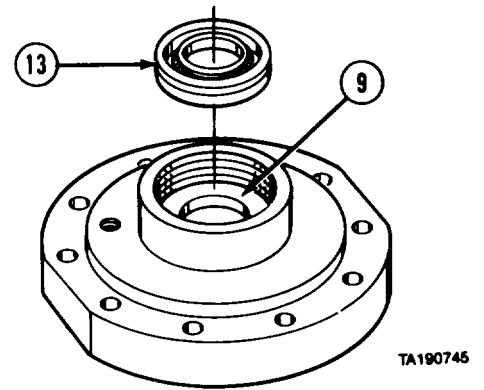

- (14) Install actuating shaft assembly (14) in cylinder head (10).

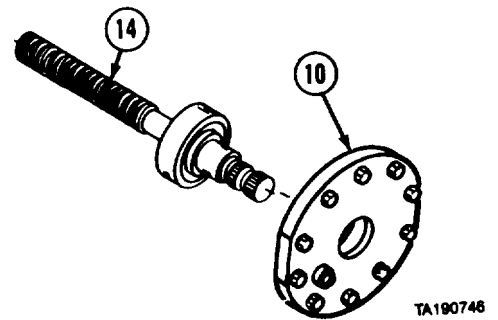

NOTE

If installing new nut, drill 3/32-in. (2.4 mm) hole for lock pin. Use lock pin hole as guide when drilling.

- (15) Install bearing retaining nut (15).
- (16) Install lock pin (16).

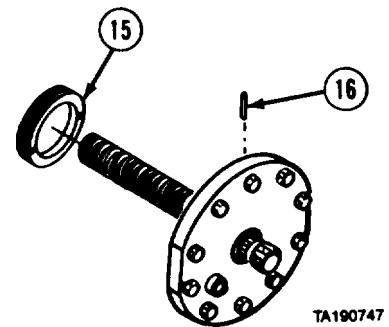

Steering System Maintenance Instructions (Cont)

12-5. STEERING GEAR AND PITMAN ARM REMOVAL/REPAIR/INSTALLATION (CONT).

(17) Install piston (17) in housing (2).

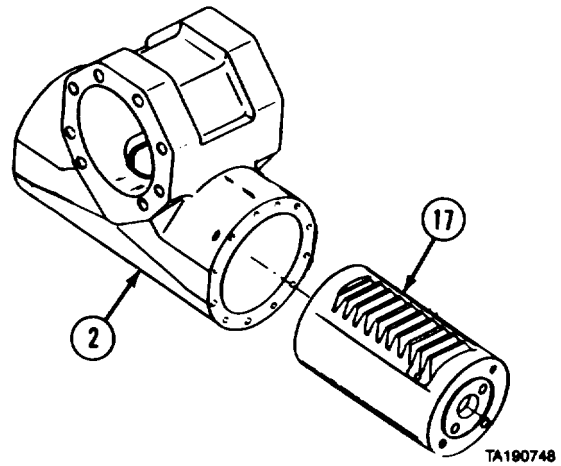

(18) Install preformed packing (18) and cylinder head (19) on housing (2).

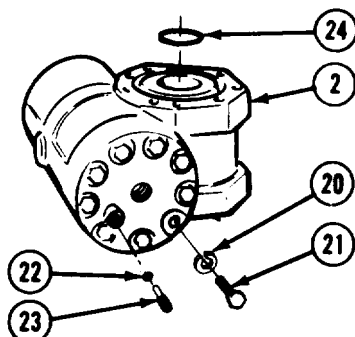
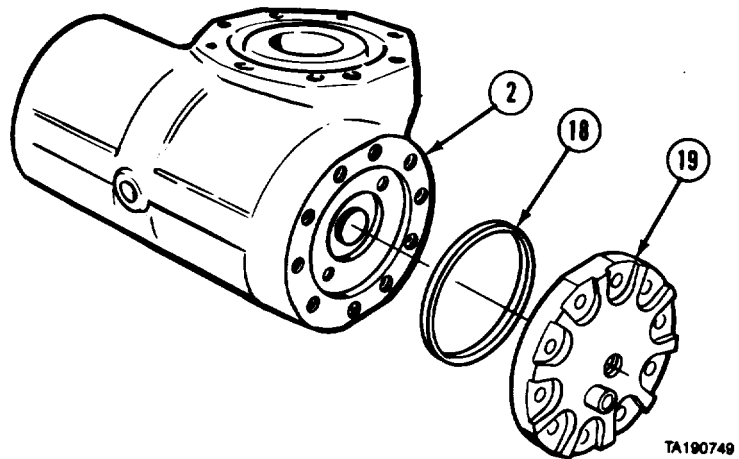

- (29) Install 10 lockwashers (20) and screws (21). Tighten screws to 20 lb-ft (27 N•m).
- (20) Install preformed packing (22) on valve (23).
- (21) Install valve (23) and turn six turns.
- (22) Install preformed packing (24) in housing (2).
- (23) Apply grease to preformed packing (24).

Steering System Maintenance Instructions (Cont)

Turn housing (2) around.
Install preformed
packing (25).

NOTE

When installing actuating
shaft, turn shaft by hand until
cap comes into place on end
of cylinder.

- (26) Thread actuating shaft
assembly (14) into piston
inside housing (2).
- (27) Align matchmarks on
cylinder head (10) and
housing (2).
- (28) Install cylinder head (10) on
housing (2) with
10 lockwashers (26) and
screws (27). Tighten screws
to 20 lb-ft (27 N•m).
- (29) Install preformed
packing (28) on valve (29).
Install valve and turn valve
six turns.

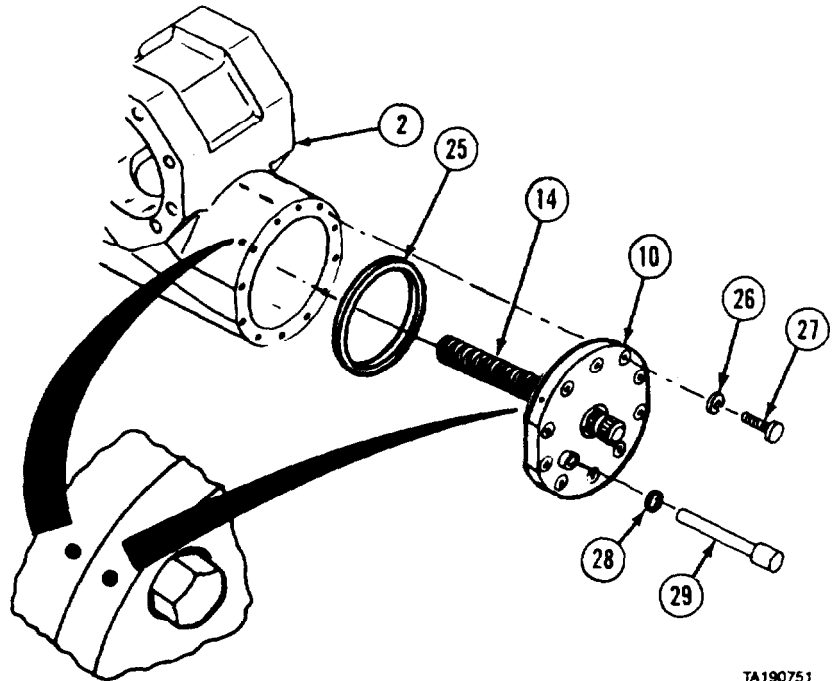

TA190751

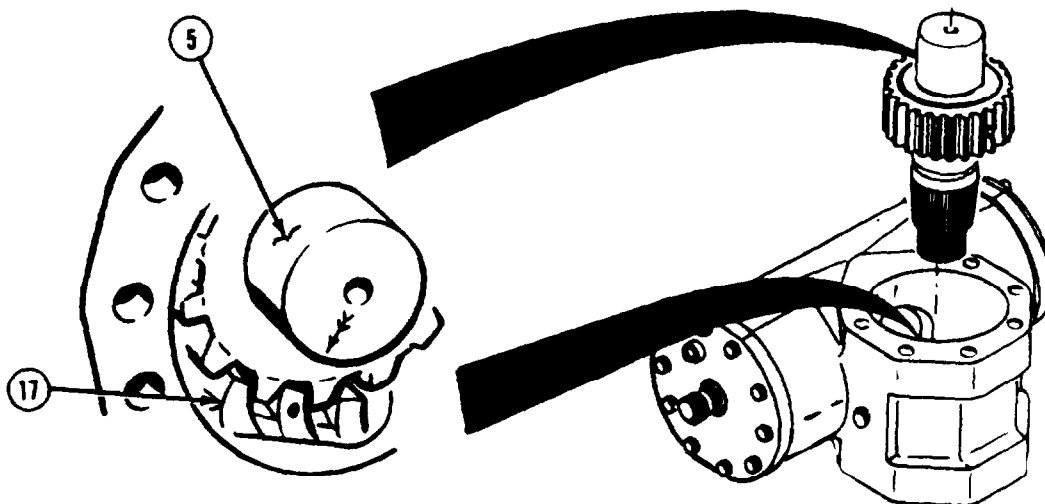

TA190752

- (30). Align arrow on output shaft (6) with scribe mark on piston (17).

Steering System Maintenance Instructions (Cont)

12-5. STEERING GEAR AND PITMAN ARM REMOVAL/REPAIR/INSTALLATION

- (31) Install output shaft (5) in housing (2).
- (32) Install preformed packing (30).
- (33) Install housing cover (4) with eight lockwashers (31) and screws (32). Tighten screws to 55 lb-ft (74 N•m).

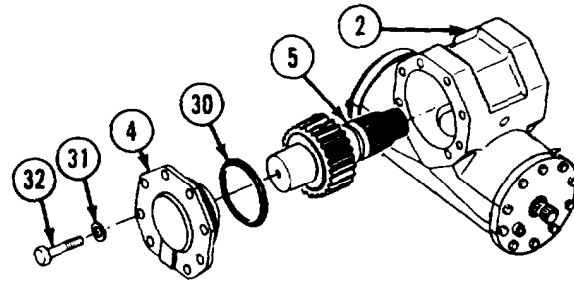

WARNING

Adhesives, solvents, and sealing compounds can burn easily, can give off harmful vapors, and are harmful to skin and clothing. To avoid injury or death, keep away from open fire and use in well-ventilated area. If adhesive, solvent, or sealing compound gets on skin or clothing, wash immediately with soap and water.

- (34) Coat threads of two straight fittings (33), two elbows (34), and one pipe plug (35) with pipe thread sealing compound and install.

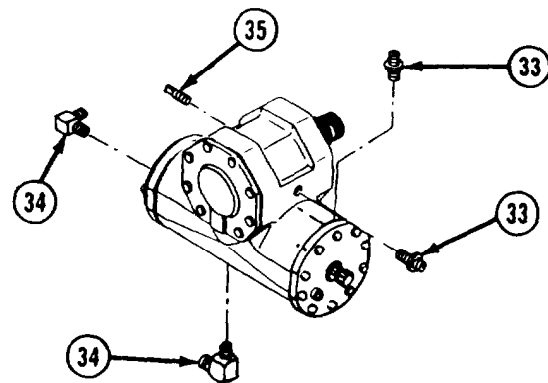

f. Installation.

CAUTION

Mating surfaces of bracket and steering gear must be free of paint and oil. If surfaces are not prepared correctly, steering gear could loosen from bracket causing damage to bracket and steering gear.

- (1) Install bracket (1) on steering gear (2) with eight screws (3) and lockwashers (4). Tighten screws to 155 lb-ft (210 N•m).

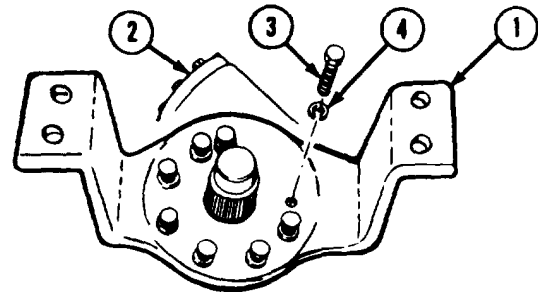

WARNING

Adhesives, solvents, and sealing compounds can burn easily, can give off harmful vapors, and are harmful to skin and clothing. To avoid injury or death, keep away from open fire and use in well-ventilated area. If adhesive, solvent, or sealing compound gets on skin or clothing, wash immediately with soap and water.

- (2) Coat threads and underside of nut (5) and splines of pitman arm (6) with antiseize compound.
- (3) Align matchmarks on pitman arm (6) and steering gear shaft (7).
- (4) Install pitman arm (6) and nut (5). Tighten nut to 675 lb-ft (915 N•m).
- (5) Install lock screw (8). Tighten screw to 12 to 15 lb-ft (16 to 20 N•m).

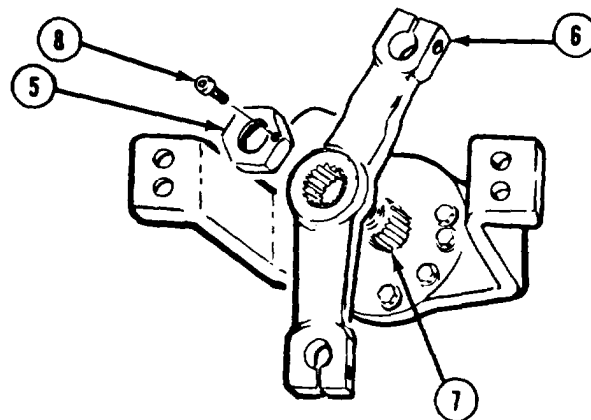

Steering System Maintenance Instructions (Cont)

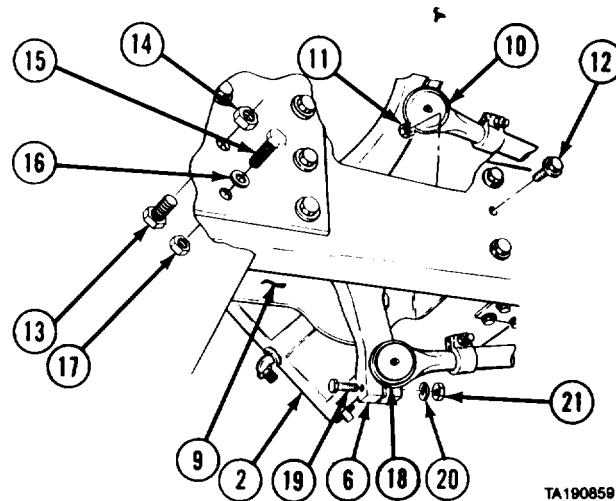

- (6) Soldier A and Soldier B support steering gear (2) and bracket (9) while Soldier C guides intergear link end (10) in top of pitman arm (6).
- (7) Install steering gear (2) and bracket (9) with four nuts (11) and screws (12). Tighten to 50 lb-ft (68 N•m).
- (8) Install screw (13) and nut (14).
- (9) Install screw (15), washer (16), and nut (17).
- (10) Install front drag link end (18) in pitman arm (6). Secure with screw (19), lockwasher (20), and nut (21). Tighten to 90 lb-ft (122 N•m).

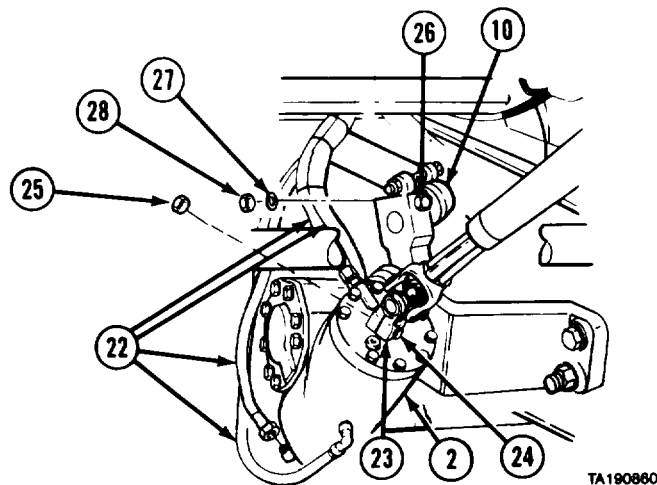

- (11) Connect four hydraulic hoses (22).
- (12) Install end yoke (23) onto steering gear (2) with screw (24) and locknut (25).
- (13) Install screw (26), lockwasher (27), and nut (28) in intergear link end (10). Tighten nut to 90 lb-ft (122 N•m).
- g. Follow-on Maintenance.
- (1) Fill hydraulic reservoir (LO 9-2320-279-12).
- (2) Start engine and turn steering wheel stop-to-stop three times to bleed air out of system (TM 9-2320-279-10).
- (3) Adjust steering gear (para 12-7).

END OF TASK

Steering System Maintenance Instructions (Cont)

12-6. SLAVE STEERING GEAR AND PITMAN ARM REMOVAL/REPAIR/INSTALLATION.

This task covers:

- | | |
|------------------------|--------------------------|
| a. Removal | e. Assembly |
| b. Disassembly | f. Installation |
| c. Cleaning/Inspection | g. Follow-on Maintenance |
| d. Repair | |

INITIAL SETUP

Models

All

Test Equipment

None

Special Tools

None

Supplies

- Compound, antiseize, high temperature, Item 17, Appendix C
- Compound, sealing, pipe thread, Item 29, Appendix C
- Grease, automotive and artillery, Item 34, Appendix C
- Oil, lubricating, Item 46, Appendix C
- Solvent, dry cleaning, Item 57, Appendix C

Personnel Required

MOS 63W, Wheel vehicle repairer (2)

References

None

Equipment Condition

- | TM or Para | Condition Description |
|------------------|----------------------------|
| TM 9-2320-279-10 | Shut off engine. |
| TM 9-2320-279-10 | Engine side panel removed. |
| LO 9-2320-279-12 | Hydraulic system drained. |

Special Environmental Conditions

None

General Safety Instructions

None

Level of Maintenance

Direct Support

a. Removal.

- (1) Remove nut (1), lockwasher (2), and screw (3).
- (2) Remove intergear link (4) from pitman arm (5).
- (3) Remove nut (6), lockwasher (7), and screw (8).

NOTE

Steering may have to be turned for clearance to remove intergear link.

- (4) Remove drag link (9) from pitman arm (5).

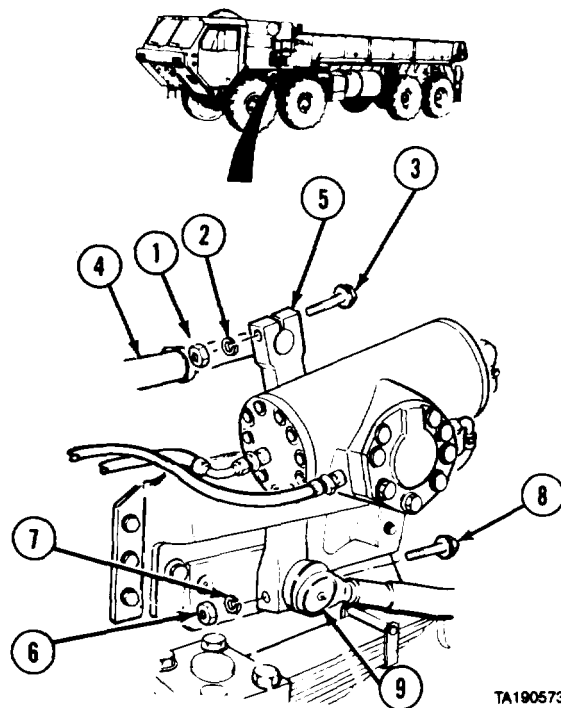

TA190573

Steering System Maintenance Instructions (Cont)

- (5) Disconnect four hoses (10 and 11).
- (6) Support slave steering gear (12).

WARNING

Slave steering gear and mounting bracket are heavy and could cause serious injury if dropped.

- (7) Soldier A and Soldier B remove six nuts (13) and screws (14).
- (8) Soldier A and Soldier B remove slave steering gear (12) and bracket (15).

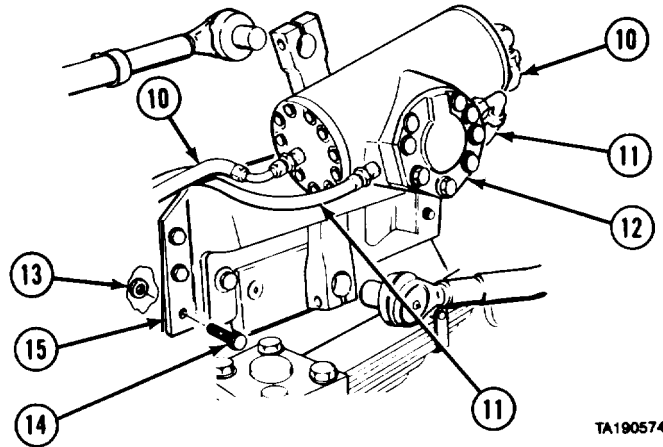

- (9) Clamp slave steering gear (12) in vise with soft jaws.
- (10) Make matchmarks on pitman arm (5) and steering gear shaft (16).
- (11) Remove lock screw (17) and nut (18).
- (12) Pull pitman arm (5) from steering gear shaft (16).

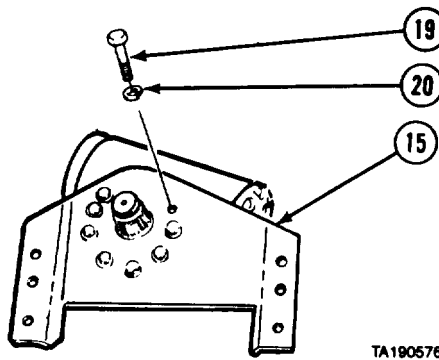
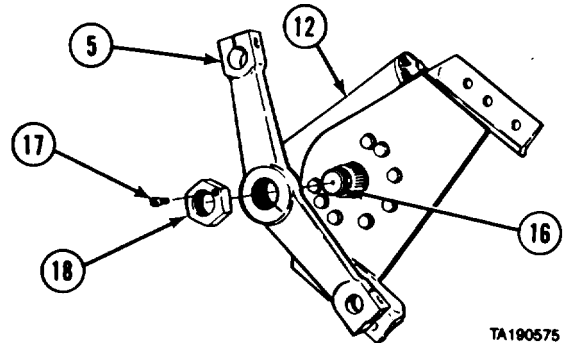

- (13) Remove eight screws (19) and lockwashers (20).
- (14) Remove bracket (15).

Steering System Maintenance Instructions (Cont)

12-6. SLAVE STEERING GEAR AND PITMAN ARM REMOVAL/REPAIR/INSTALLATION (CONT).

b. Disassemble.

- (1) Remove three straight adapters (1).
- (2) Remove elbow fitting (2) and reducer bushing (3).
- (3) Remove plug (4).
- (4) Make matchmarks on cylinder head (5) and housing (6).
- (5) Wipe output shaft (7) clean.

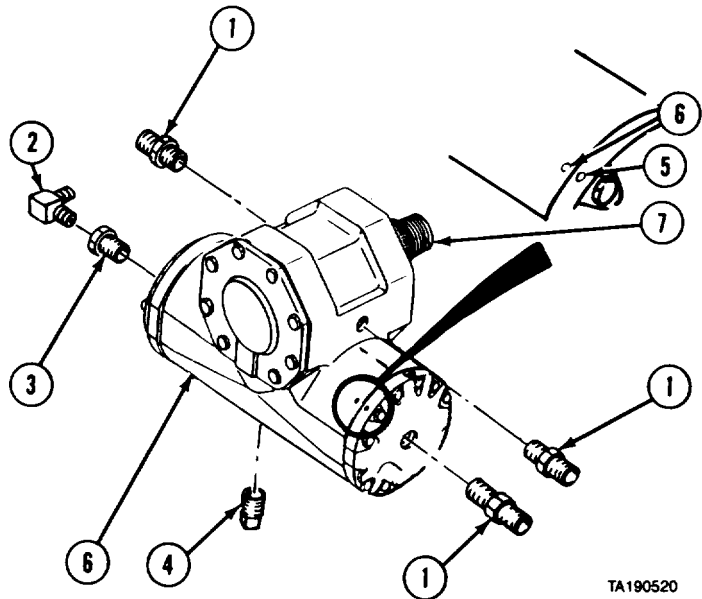

- (6) Remove eight screws (8) and lockwashers (9).
- (7) Remove housing cover (10) and output shaft (7).
- (8) Remove preformed packing (11).

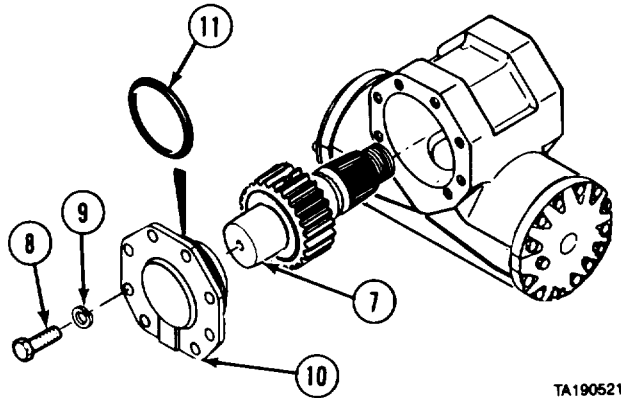

- (9) Remove 10 screws (12) and lockwashers (13).
- (10) Remove cylinder head (5).
- (11) Remove preformed packing (14).

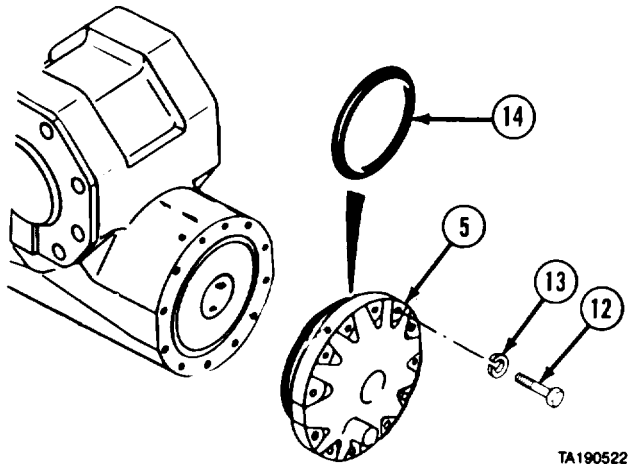

Steering System Maintenance Instructions (Cont)

- (12) Position housing (6) as shown.
- (13) Remove preformed packing (15).
- (14) Make matchmarks on housing (6) and cylinder head (16).
- (15) Remove 10 screws (17) and lockwashers (18).

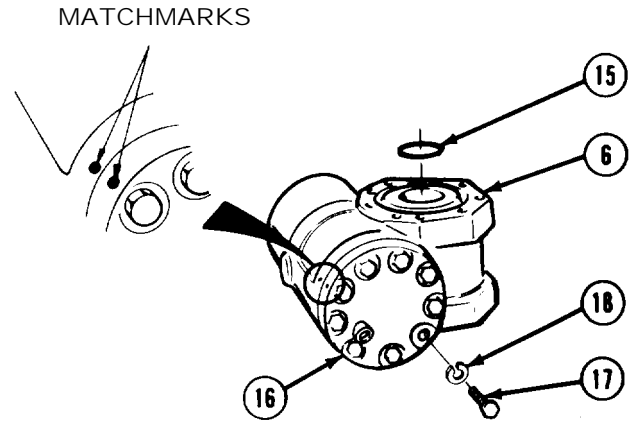

TA190523

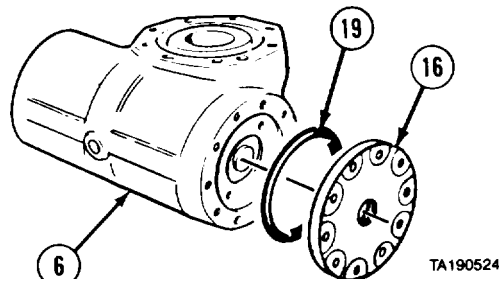

TA190524

- (16) Remove cylinder head (16) from housing (6).
- (17) Remove preformed packing (19).

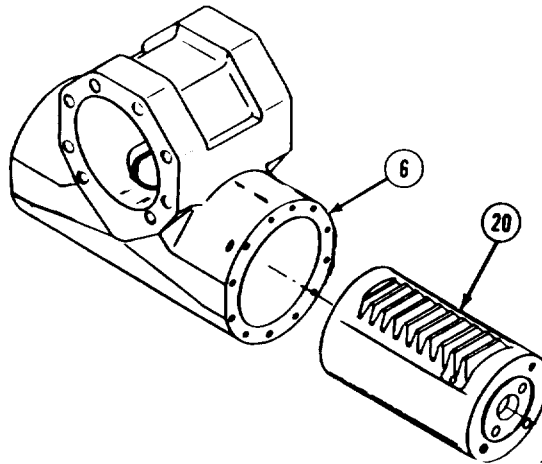

TA190525

- (18) Remove piston (20) from housing (6).

Steering System Maintenance Instructions (Cont)

12-6. SLAVE STEERING GEAR AND PITMAN ARM REMOVAL/REPAIR/INSTALLATION (CONT).

CAUTION

When removing retaining pin, do not drill more than 1.625 in. (41.27 mm) from top of output shaft gear teeth into retaining pin or damage to output shaft will result.

- (19) Remove roll pin (21) and drill out retaining pin (22) from output shaft (7).

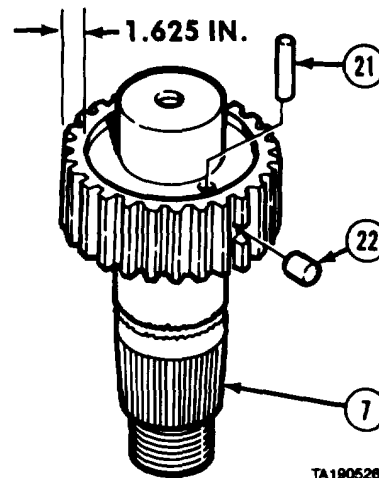

- (20) Separate output shaft (7) and output shaft gear (23).

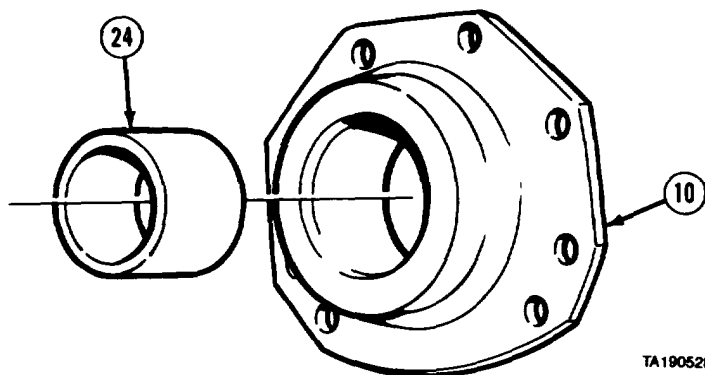
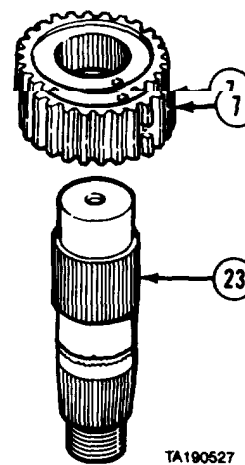

- (21) Measure inside diameter of bearing (24). If bearing is more than 0.010 in. (0.25 mm) out of round, do step (22).
- (22) Remove bearing (24) from housing cover (10).

Steering System Maintenance Instructions (Cont)

- (23) Measure inside diameter of bearing (25). If bearing is more than 0.010 in. (0.25 mm) out of round, do step (24).
- (24) Remove bearing (25) from housing (6).

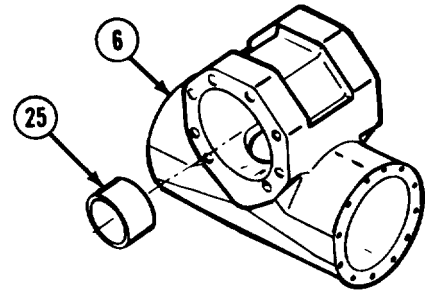

TA190529

c. Cleaning/Inspection.

WARNING

Adhesives, solvents, and sealing compounds can burn easily, can give off harmful vapors, and are harmful to skin and clothing. To avoid injury or death, keep away from open fire and use in well-ventilated area. If adhesive, solvent, or sealing compound gets on skin or clothing, wash immediately with soap and water.

CAUTION

Dirt and foreign material in steering system will cause damage and steering problems.

- (1) Clean metal parts in dry cleaning solvent.
- (2) Inspect parts for damage.
- (3) Replace damaged parts.
- (4) Coat all parts with light coat of lubricating oil.

d. Repair.

- (1) Remove all small nicks or burrs.
- (2) Polish minor scoring to allow free movement of mating parts.
- (3) Coat all parts with light coat of lubricating oil.

e. Assembly.

- (1) Install bearing (1) flush with inner face of housing (2).
- (2) Coat inner surface of bearing (1) with grease.

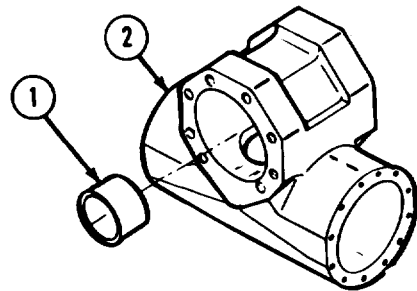

TA190530

- (3) Install bearing (3) into rear of housing cover (4). Recess bearing about 1/4 in. (6.4 mm) below inside face of housing cover.
- (4) Coat inner surface of bearing (3) with grease.

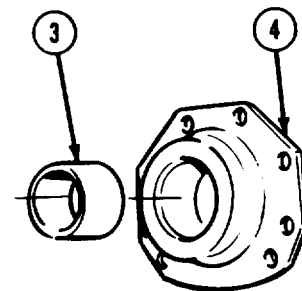

TA190531

Steering System Maintenance Instructions (Cont)

12-6. SLAVE STEERING GEAR AND PITMAN ARM REMOVAL/REPAIR/INSTALLATION (CONT).

- (5) Aline arrow on output shaft (5) between two matchmarks on output shaft gear (6).
- (6) Install output shaft (5) on output shaft gear (6).

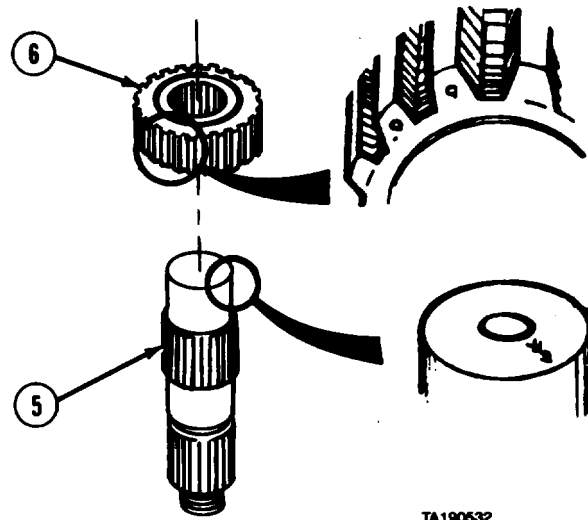

- (7) Install retaining pin (7).
- (8) Install roll pin (8).

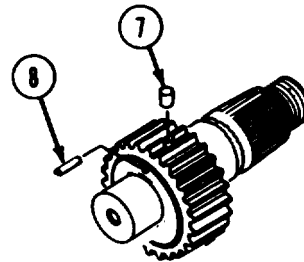

NOTE

When installing piston, be sure that end with five holes is on the correct side of housing.

- (9) Install piston (9) in housing (2).

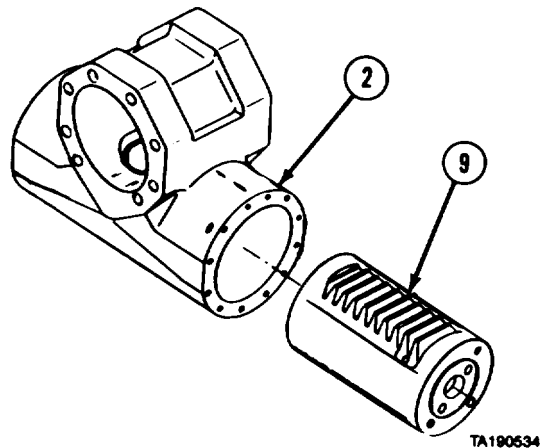

Steering System Maintenance Instructions (Cont)

- (10) Install preformed packing (10) on cylinder head (11).
- (11) Aline matchmarks on cylinder head (11) and housing (2) and install cylinder head.

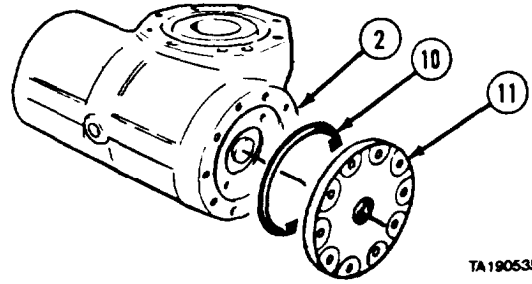

TA190535

- (12) Install 10 screws (12) with lockwashers (13). Tighten screws to 55 lb-ft (75 N•m).
- (13) Coat preformed packing (14) with grease and install in housing (2).

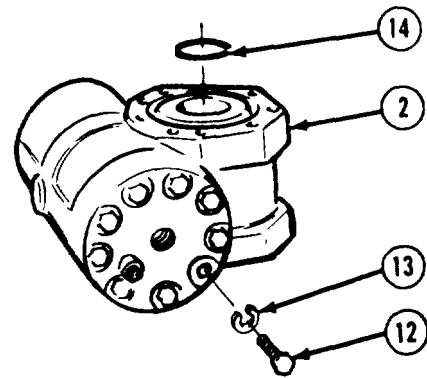

TA190536

NOTE

Be sure timing mark on piston rack is alined with center of output shaft gear on output shaft.

- (14) Aline arrow on output shaft (5) with matchmark on piston (7).
- (15) Install output shaft (6).
- (16) Install preformed packing (15) on housing cover (4).
- (17) Install housing cover (4).
- (18) Install eight screws (16) with lo&washers (17). Tighten screws to 55 lb-ft (75 N•m).

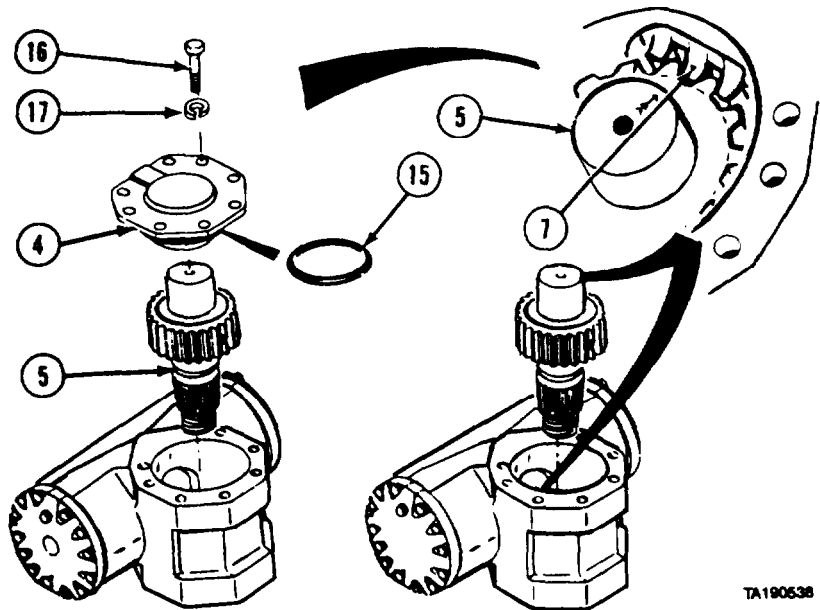

TA190538

Steering System Maintenance Instructions (Cont)

12-6. SLAVE STEERING GEAR AND PITMAN ARM REMOVAL/REPAIR/INSTALLATION (CONT).

- (19) Install preformed packing (18) on cylinder head (19).
- (20) Aline matchmark on cylinder head (19) with matchmark on housing (2) and install cylinder head.
- (21) Install 10 lockwashers (20) and screws (21). Tighten screws to 55 lb-ft (75 N•m).

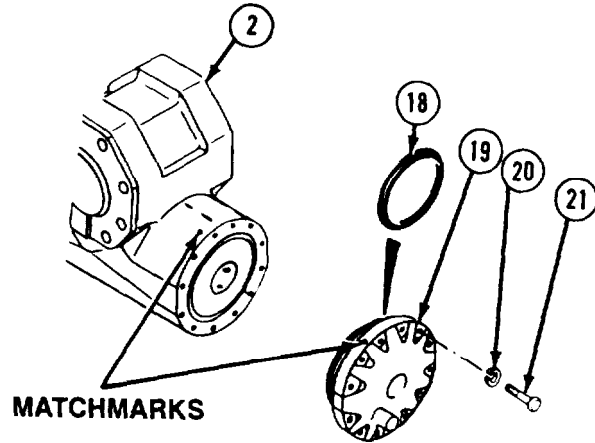

WARNING

Adhesives, solvents, and sealing compounds can burn easily, can give off harmful vapors, and are harmful to skin and clothing. To avoid injury or death, keep away from open fire and use in well-ventilated area. If adhesive, solvent, or sealing compound gets on skin or clothing, wash immediately with soap and water.

- (22) Coat threads of reducer bushing (22), three adapters (23), elbow (24), and plug (25) with pipe thread sealing compound and install.

f. Installation.

- (1) Install bracket (1) on slave steering gear housing (2) with eight screws (3) and lockwashers (4). Tighten screws to 155 lb-ft (210 N•m).

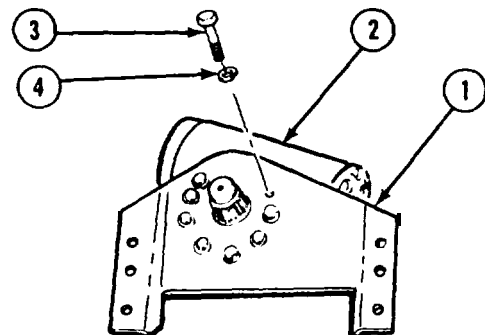

Steering System Maintenance Instructions (Cont)

WARNING

Adhesives, solvents, and sealing compounds can burn easily, can give off harmful vapors, and are harmful to skin and clothing. To avoid injury or death, keep away from open fire and use in well-ventilated area. If adhesive, solvent, or sealing compound gets on skin or clothing, wash immediately with soap and water.

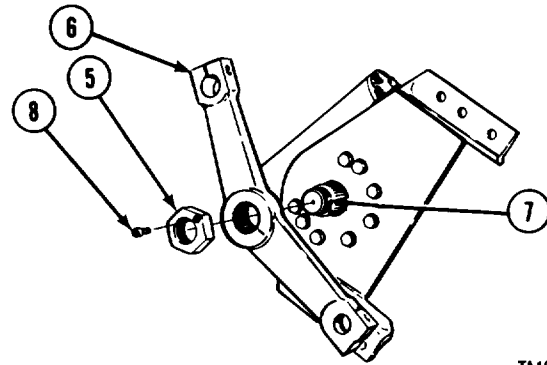

TA190578

- (2) Coat threads and underside of nut (5) and splines of pitman arm (6) with antiseize compound.
- (3) Aline matchmarks on pitman arm (6) and steering gear shaft (7).
- (4) Install pitman arm (6) and nut (5). Tighten nut to 675 lb-ft (915 N•m).
- (5) Install lock screw (8). Tighten screw to 15 lb-ft (20 N•m).

WARNING

Slave steering gear and mounting bracket are heavy and could cause serious injury if dropped.

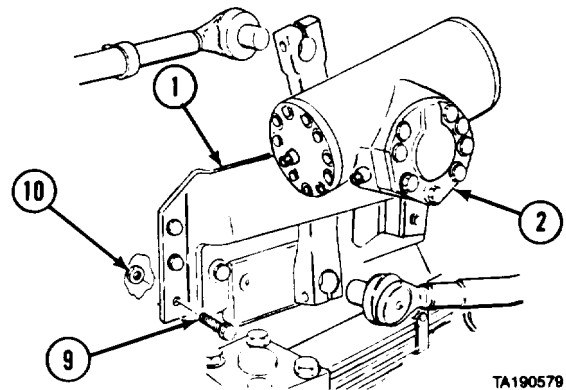

TA190579

- (6) Lift slave steering gear (2) and bracket (1) with suitable lifting device.
 - (7) Soldier A and Soldier B install slave steering gear (2) with six screws (9) and locknuts (10). Tighten to 200 lb-ft (271 N•m).
 - (8) Install intergear link (11) into pitman arm (6).
 - (9) Install screw (12), lockwasher (13), and nut (14). Tighten nut to 75 lb-ft (102 N•m).
 - (10) Install drag link (15) into pitman arm (6).
 - (11) Install screw (16), lockwasher (17), and nut (18). Tighten nut to 75 lb-ft (102 N•m).
 - (12) Connect four hoses (19 and 20).
- g. Follow-on Maintenance.
- (1) Fill hydraulic reservoir (LO 9-2320-279-12).
 - (2) Start engine and turn steering wheel stop-to-stop three times to bleed air out of system (TM 9-2320-279-10).
 - (3) Install engine side panel (TM 9-2320-279-10).

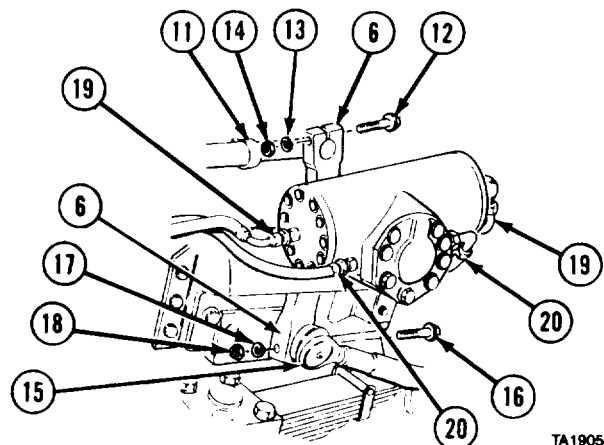

TA190580

END OF TASK

Steering System Maintenance Instructions (Cont)
Section IV. STEERING PUMP

12.7 STEERING PUMP REMOVAL /REPAIR/INSTALLATION.	
This task covers:	
a. Removal	d. Assembly
b. Disassembly	e. Installation
c. Cleaning/Inspection	f. Follow-on Maintenance
INITIAL SETUP	
Models All	Personnel Required MOS 63W, Wheel vehicle repairer
Test Equipment None	References None
Special Tools None	Equipment Condition <i>TM or Para</i> <i>Condition Description</i> LO 9-2320-279-12 Hydraulic reservoir drained.
Supplies Adhesive-sealant, silicone, Item 6, Appendix C Compound, sealing, pipe thread, Item 29, Appendix C Oil, lubricating, Item 46, Appendix C Solvent, dry cleaning, Item 57, Appendix C Tags, identification, Item 60, Appendix C	Special Environmental Conditions None General Safety Instructions None Level of Maintenance Direct Support

a. Removal.

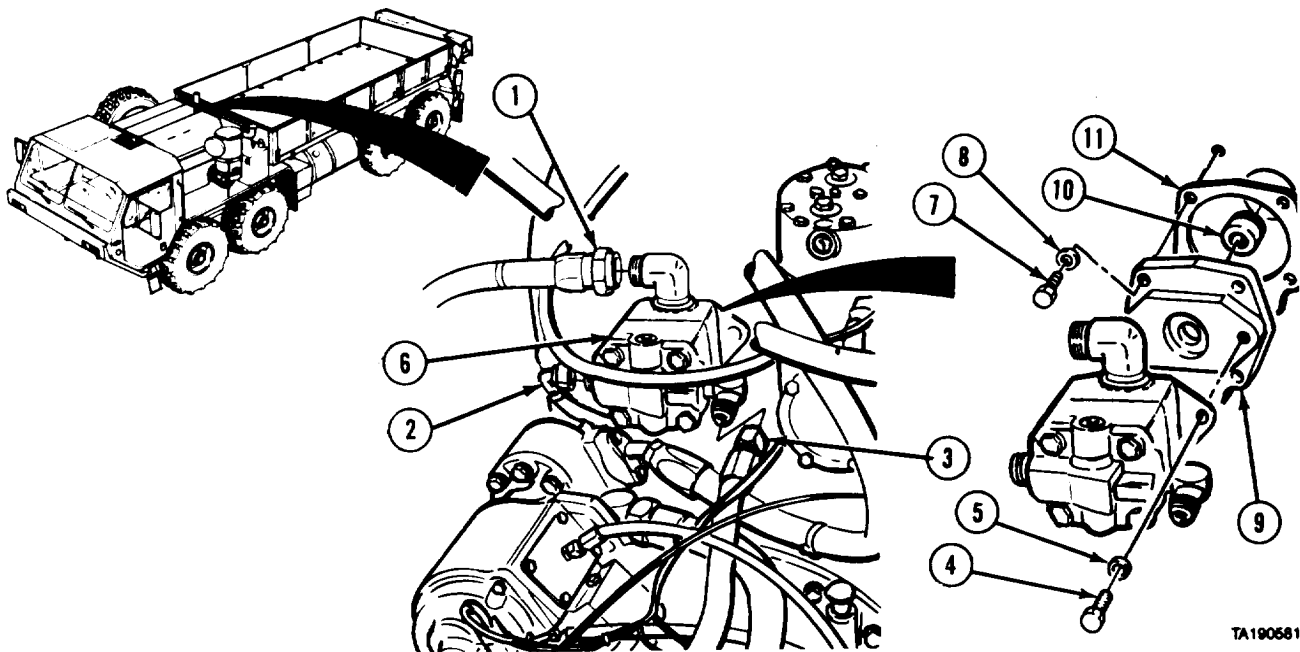

TA190581

Steering System Maintenance Instructions (Cont)

NOTE

Tag and mark hoses before disconnecting.

- (1) Disconnect hoses (1, 2, and 3).

NOTE

Coupling may come out with pump or stay in housing.

- (2) Remove two screws (4), lockwashers (5), and steering pump (6).
- (3) Remove five screws (7), lockwashers (8), plate (9), coupling (10), and gasket (11).
- (4) Remove elbows (12 and 13).
- (5) Remove fitting (14) and preformed packing (15).
- (6) Remove gasket (16) from steering pump (6).

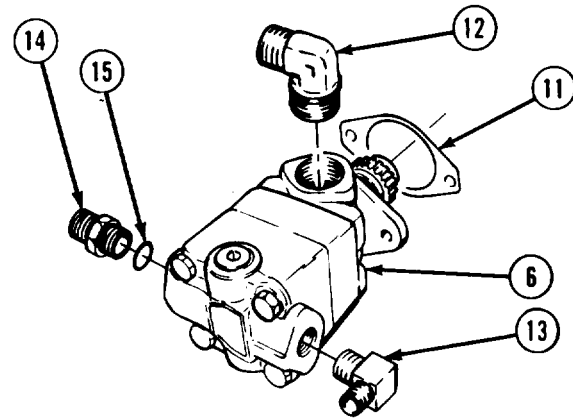

TA190582

b. Disassembly.

CAUTION

Do not disassemble valve. Valve could malfunction if disassembled.

NOTE

Make matchmarks on housings.

- (1) Remove two plugs (1), spring (2), and valve (3).
- (2) Remove retaining ring (4).
- (3) Remove four screws (5).

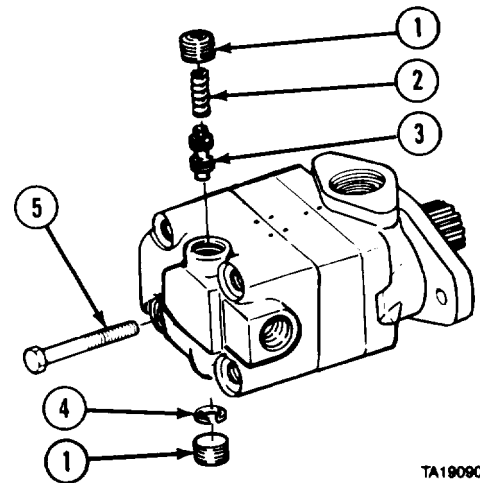

TA190904

- (4) Remove cover (6) and preformed packing (7) from ring (8).
- (5) Remove spring (9) and pressure plate (10).
- (6) Remove bushing (11) from pressure plate (10).

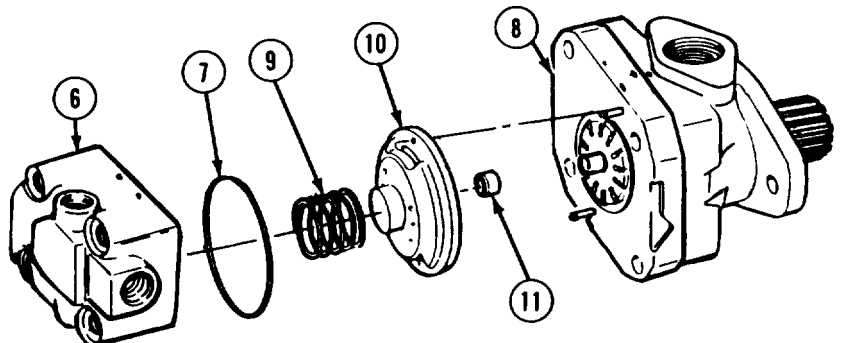

TA190905

Steering System Maintenance Instructions (Cont)

12-7. STEERING PUMP REMOVAL/REPAIR/INSTALLATION (CONT).

- (7) Remove rotor (12) and 12 vanes (13).
- (8) Remove ring (8), preformed packing (14), and two pins (15) from body (16).

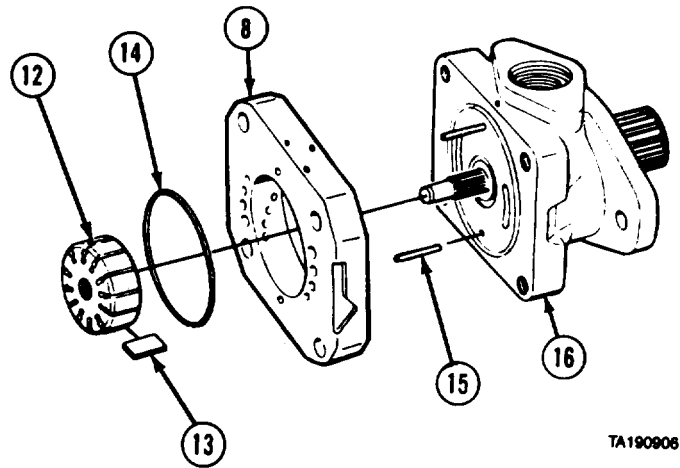

- (9) Remove retaining ring (17).
- (10) Remove nut (18) and lockwasher (19).
- (11) Press shaft (20) from body (16).

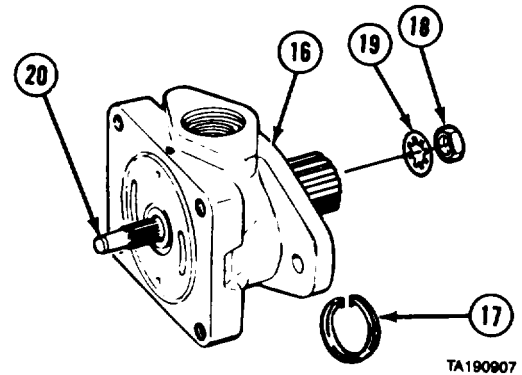

- (12) Remove seal (21) from body (16).

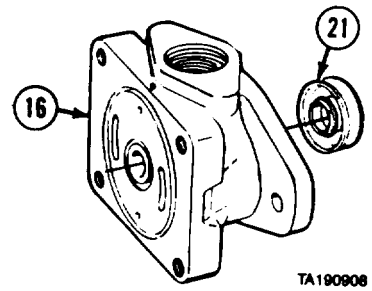

- (13) Remove retaining ring (22).
- (14) Press bearing (23) from shaft (20).
- (15) Press gear (24) from shaft (20).
- (16) Remove key (25).

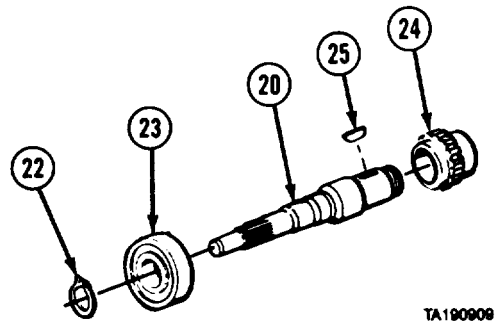

Steering System Maintenance Instructions (Cont)

c. Cleaning/Inspection.

WARNING

Adhesives, solvents, and sealing compounds can burn easily, can give off harmful vapors, and are harmful to skin and clothing. To avoid injury or death, keep away from open fire and use in well-ventilated area. If adhesive, solvent, or sealing compound gets on skin or clothing, wash immediately with soap and water.

- (1) Clean all parts in dry cleaning solvent.
- (2) Inspect and replace damaged parts.
- (3) Coat all parts with lubricating oil.

d. Assembly.

- (1) Install key (1) on shaft (2).
- (2) Press gear (3) and bearing (4) onto shaft (2).
- (3) Install retaining ring (5).

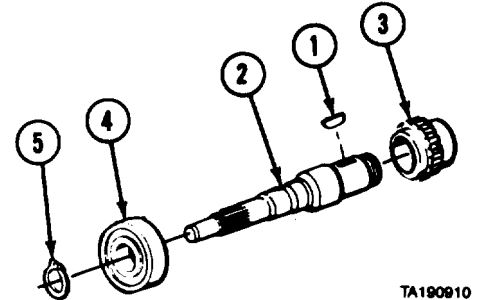

- (4) Press seal (6) into body (7).

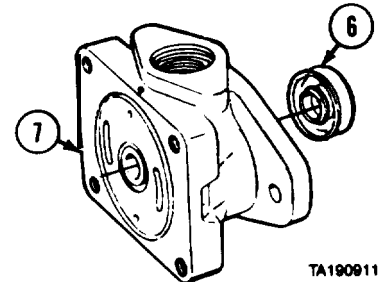

- (5) Press shaft (8) into body (7).
- (6) Install retaining ring (9).
- (7) Install lockwasher (10) and nut (11).

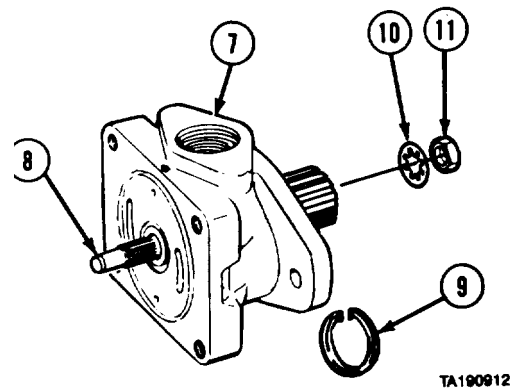

Steering System Maintenance Instructions (Cont)

12-7. STEERING PUMP REMOVAL/REPAIR/INSTALLATION (CONT).

NOTE

The rounded edges of vanes should be installed facing outward.

- (8) Install preformed packing (12) and two pins (13) in body (7).
- (9) Install 12 vanes (14) in rotor (15).
- (10) Install rotor (15) and ring (16).

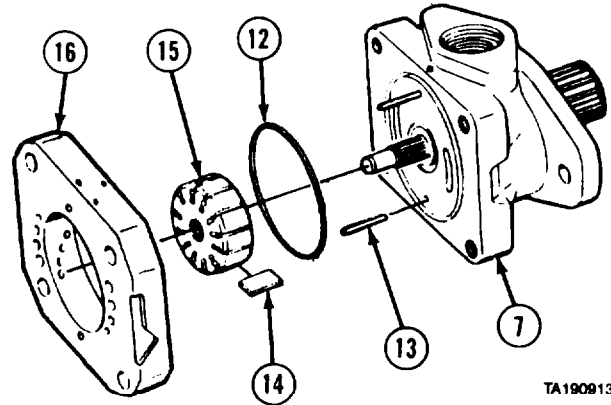

TA190913

- (11) Press bushing (17) into pressure plate (18).
- (12) Aline pressure plate (18) with pins (13) and install on ring (16).
- (13) Install spring (19).
- (14) Install preformed packing (20) on cover (21).
- (15) Install cover (21) with four screws (22). Tighten screws to 75 to 85 lb-ft (102 to 115 N•m).

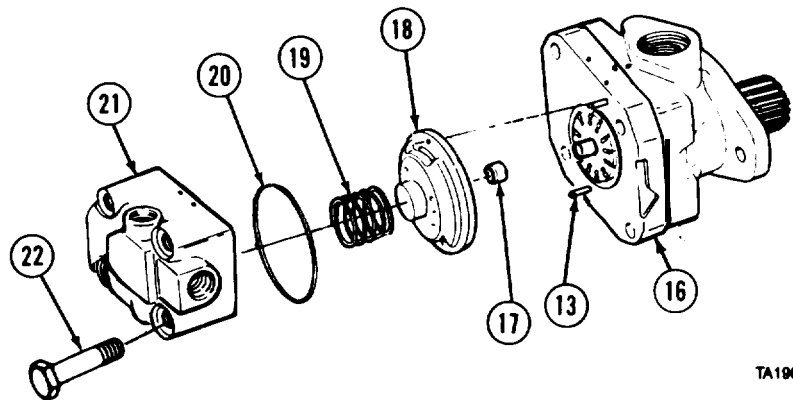

TA190914

- (16) Install retaining ring (23) in cover (21).

NOTE

Nut end of valve points out.

- (17) Install valve (24) and spring (25).
- (18) Install two plugs (26).

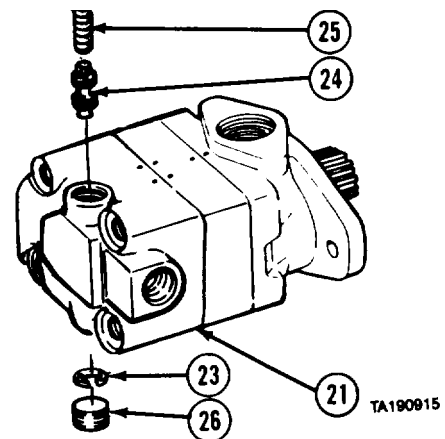

TA190915

Steering System Maintenance Instructions (Cont)

Installation.

- (1) Install preformed packing (1) and fitting (2).

WARNING

Adhesives, solvents, and sealing compounds can burn easily, can give off harmful vapors, and are harmful to skin and clothing. To avoid injury or death, keep away from open fire and use in well-ventilated area. If adhesive, solvent, or sealing compound gets on skin or clothing, wash immediately with soap and water.

- (2) Apply pipe thread sealing compound to elbows (3 and 4) and install on steering pump (5).
- (3) Coat both surfaces of gasket (6) with silicone adhesive-sealant and install on steering pump (5).

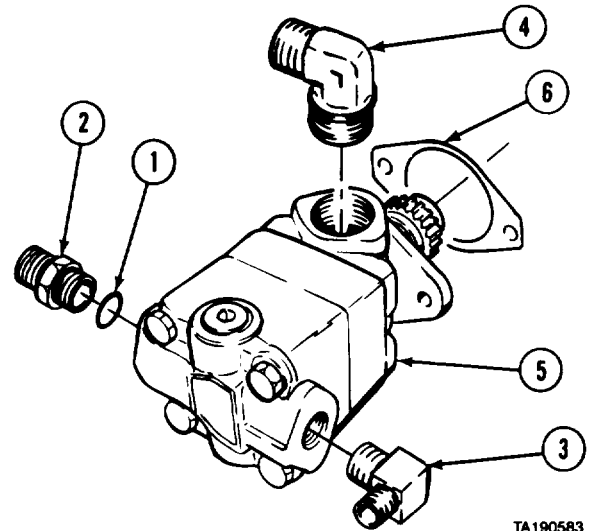

TA190583

- (4) Install gasket (7), coupling (8), plate (9), lockwashers (10), and five screws (11).
- (5) Aline gears and install steering pump (5) with two screws (12) and lockwashers (13).
- (6) Connect hoses (14, 15, and 16).

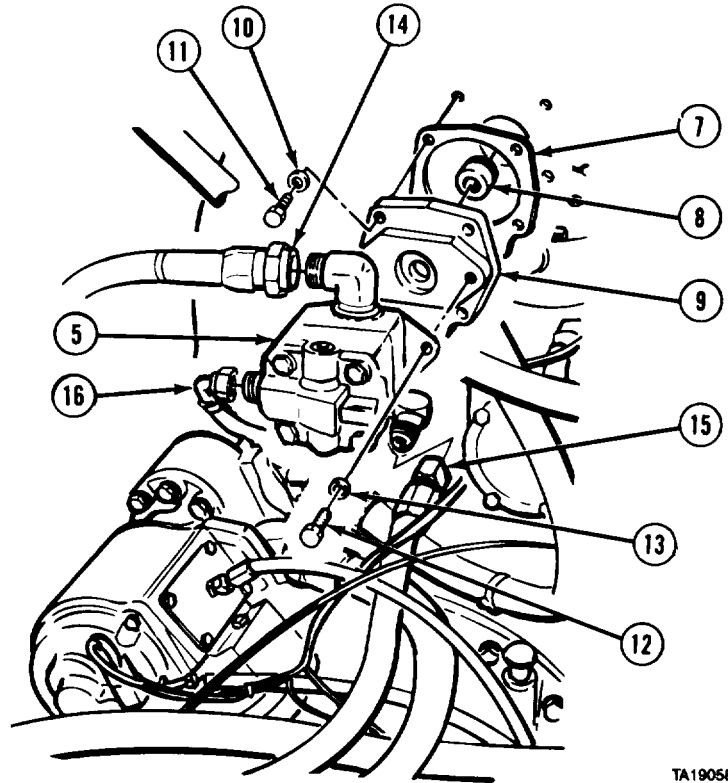

TA190584

f. Follow-on Maintenance.

- (1) Fill hydraulic reservoir (LO 9-2320-279-12).
- (2) Start engine and turn steering wheel stop-to-stop three times to bleed air out of system (TM 9-2320-279-10).

END OF TASK

Steering System Maintenance Instructions (Cont)

12-7.1. STEERING PUMP REMOVAL/REPAIR/INSTALLATION (M984E 1).

This task covers:

- a. Removal
- b. Disassembly
- c. Cleaning/Inspection
- d. Assembly
- e. Installation
- f. Follow-on Maintenance

INITIAL SETUP

Models

M984E 1

Test Equipment

None

Special Tools

None

Supplies

Tags, identification, Item 47, Appendix C
 Solvent, dry cleaning, Item 56, Appendix C
 Oil, lubricating, Item 46, Appendix C

Personnel Required

MOS 63S, Heavy wheel vehicle mechanic

References

None

Equipment Condition

TM or Para

Para 13-8

Condition Description

Hydraulic reservoir drained.

Special Environmental Conditions

None

General Safety Instructions

None

Level of Maintenance

Direct Support

a. Removal.

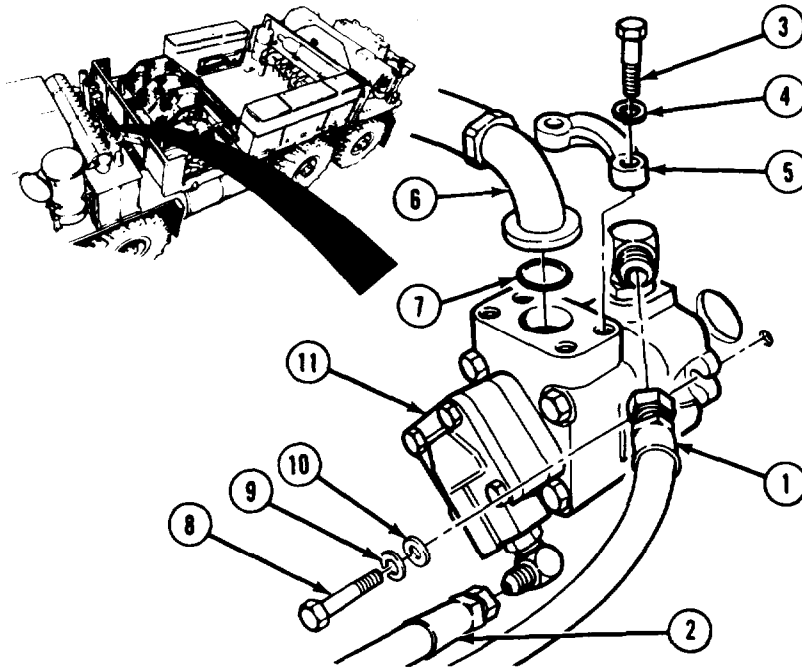

TA476364

Steering System Maintenance Instructions (Cent)

- (1) Tag, mark, and disconnect two hoses (1 and 2).
- (2) Remove four screws (3), lockwashers (4), two clamp halves (5), hose (6), and preformed packing (7).

NOTE

Splined coupling between steering/tensioner pump and engine may come off pump or stay on engine. If it comes off with pump, install on engine.

- (3) Remove two screws (8), lockwashers (9), washers (10), and steering/tensioner pump (11).

NOTE

Gasket may stay on adapter housing.

- (4) Remove gasket (12) from steering/tensioner pump (11).
- (5) Remove two fittings (13 and 14) and preformed packings (15 and 16).

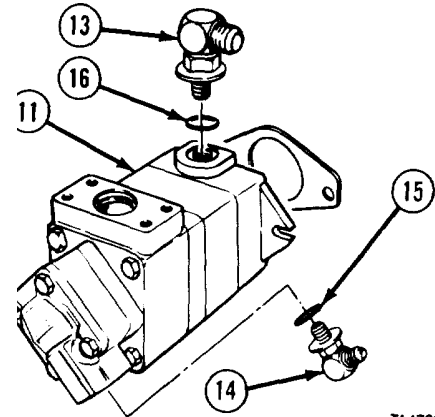

TA476365

b. Disassembly.

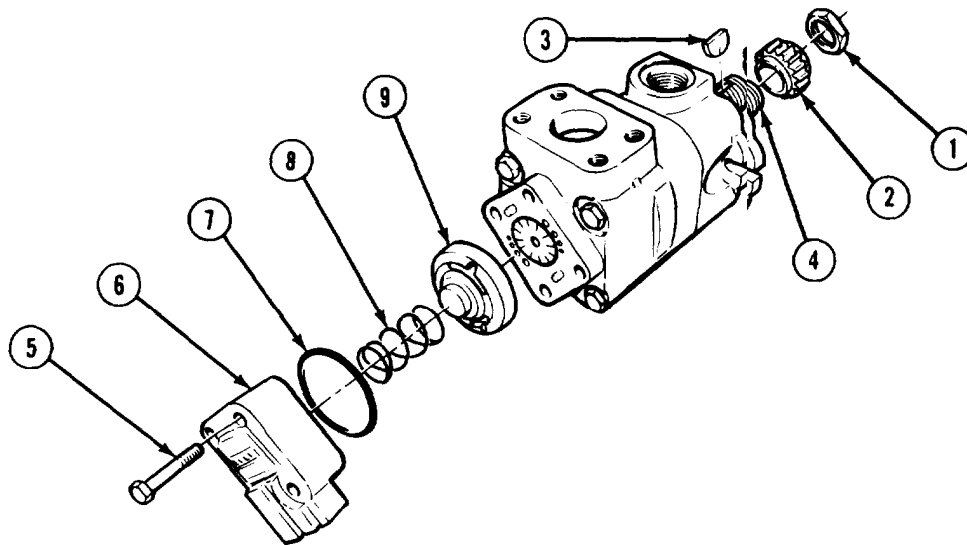

TA476366

CAUTION

Parts are under spring pressure. Use care when removing cover to prevent loss of parts.

NOTE

Matchmark pump housing before beginning disassembly.

- (1) Remove nut (1), gear (2), and key (3) from shaft (4).
- (2) Remove four screws (5), cover (6), and preformed packing (7).
- (3) Remove spring (8) and pressure plate (9).

Steering System Maintenance Instructions (Cont)

12-7.1. STEERING PUMP REMOVAL/REPAIR/INSTALLATION (M984E1) (CONT).

NOTE

Vanes will fall out of rotor when ring is removed.

- (4) Remove two pins (10), ring (11), 12 vanes (12), rotor (13), and preformed packing (14).

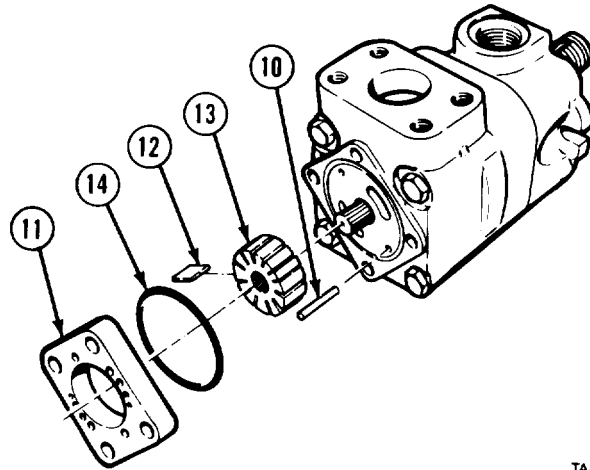

TA476367

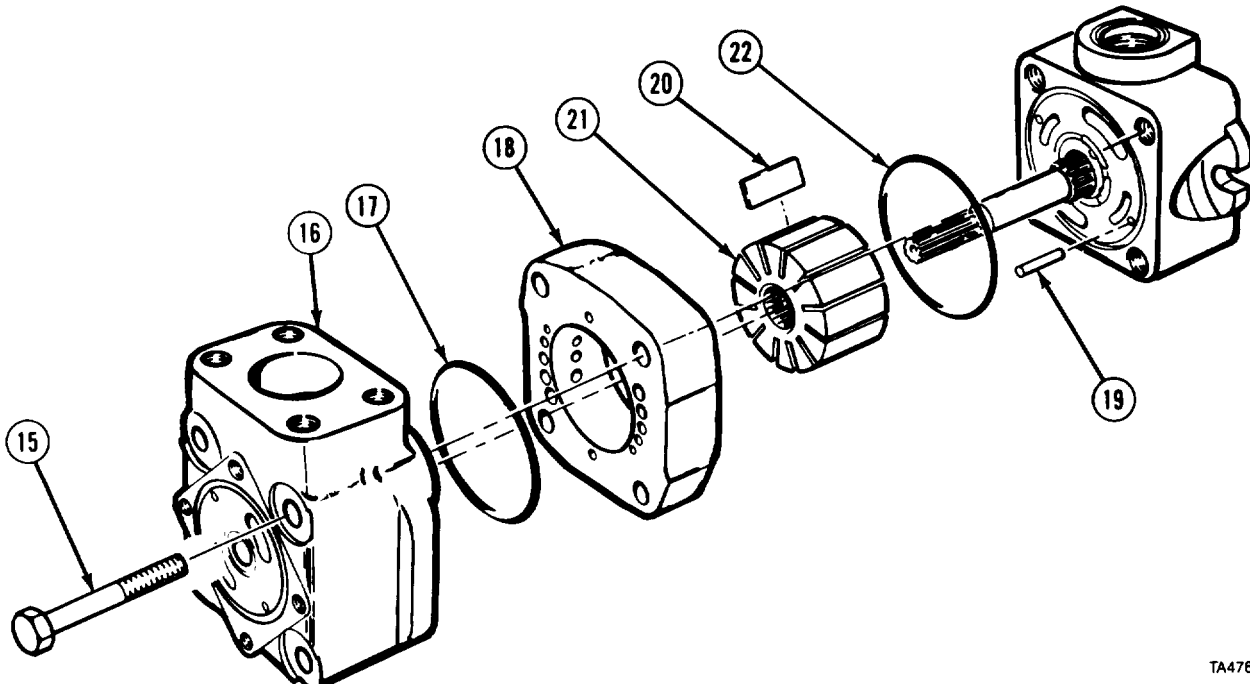

TA476368

- (5) Remove four screws (15), inlet body (16), and preformed packing (17) from ring (18).

- (6) Remove ring (18), two pins (19), 12 vanes (20), rotor (21), and preformed packing (22).

Steering System Maintenance Instructions (Cont)

NOTE

- Because of oil suction, it may be necessary to turn body over and tap end of shaft on wooden block to remove pressure plate.
 - There are two models of pumps. Model A uses a coil spring, a pressure plate with 0.0595 in. (1.5 mm) diameter holes and body with extended hub. Model B uses a wave spring, pressure plate with 0.312 in. (8 mm) diameter holes and body with a short hub. Procedures are the same. Refer to TM 9-2320-279-24P when ordering parts.
- (7) Remove pressure plate (23) and spring (24) from body (25).
 - (8) Remove preformed packing (26) from pressure plate (23).

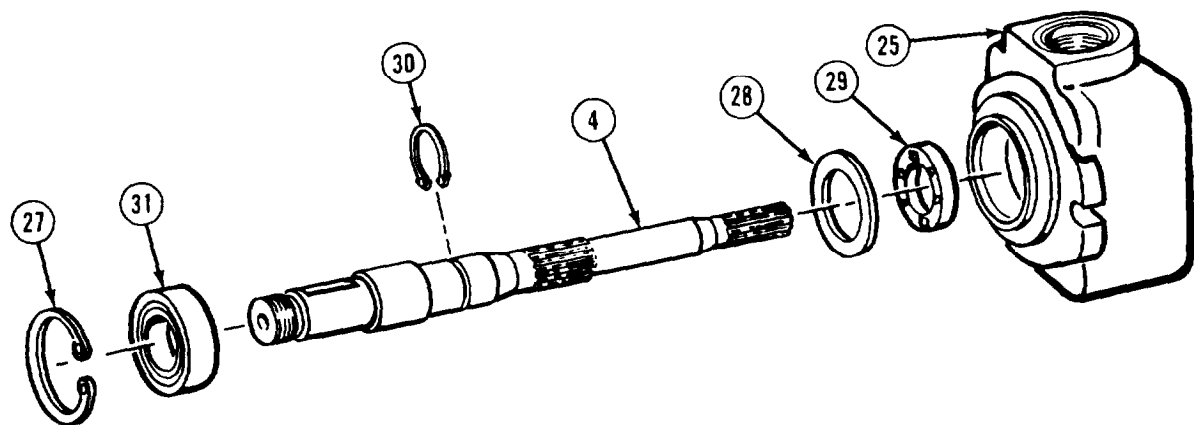
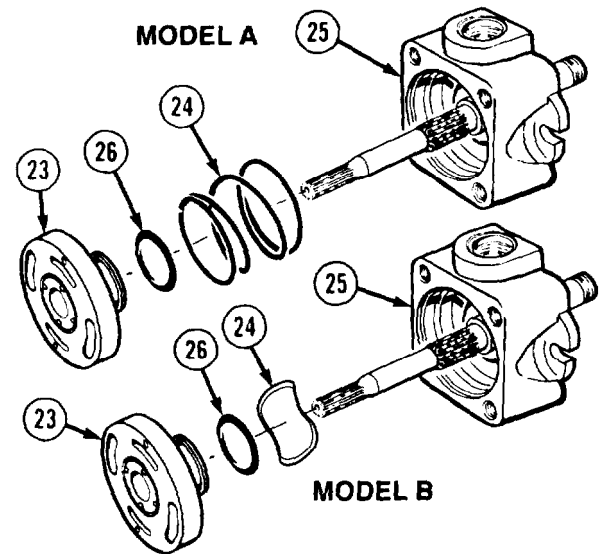

- (9) Remove retaining ring (27). Remove shaft (4) and spacer (28) from body (25).
 - (10) Remove seal (29) from body (25).
 - (11) Remove retaining ring (30) and bearing (31) from shaft (4).
- c. *Cleaning/Inspection.*

WARNING

Adhesives, solvents, and sealing compounds can burn easily, can give off harmful vapors, and are harmful to skin and clothing. To avoid injury or death, keep away from open fire and use in well-ventilated area. If adhesive, solvent, or sealing compound gets on skin or clothing, wash immediately with soap and water.

- (1) Clean all metal parts with drycleaning solvent.
- (2) Inspect and replace damaged parts.
- (3) Inspect springs for breaks or discoloration. Replace springs if broken or discolored.
- (4) Inspect face of pressure plates for grooves. Replace plates if grooved.
- (5) Inspect shaft for grooves at seal end. Replace shaft if grooved.
- (6) Replace rotors, vanes and ring at each pump rebuild.
- (7) Coat all parts with lubricating oil.

Steering System Maintenance Instructions (Cont)

12-7.1. STEERING PUMP REMOVAL/REPAIR/INSTALLATION (M984E1) (CONT).

d. Assembly.

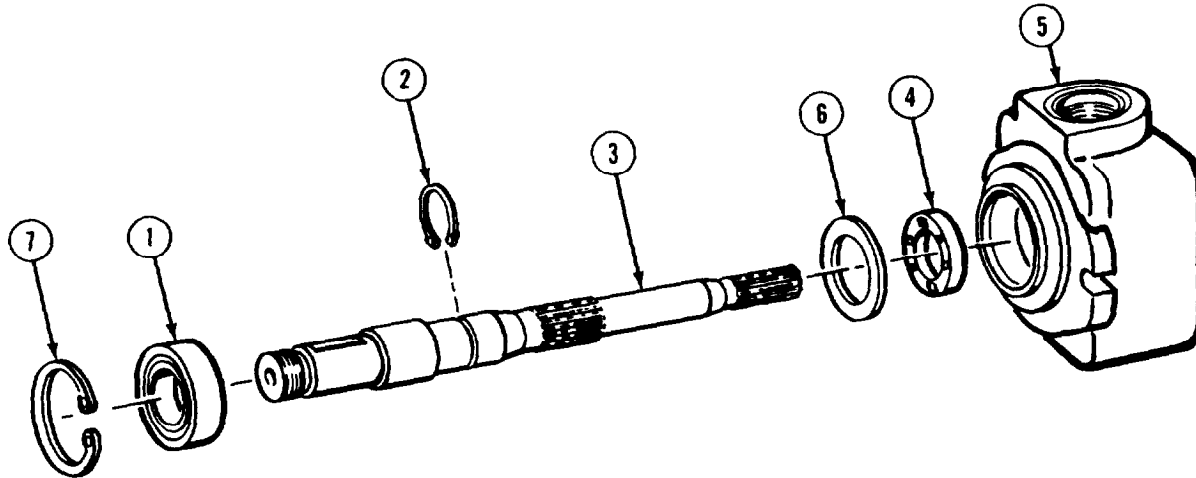

- (1) Install bearing (1) and retaining ring (2) on shaft (3).
- (2) Install seal (4) in body (5).
- (3) Install spacer (6) and shaft (3) in body (5).
- (4) Install retaining ring (7) in body (5).

NOTE

- There are two models of pumps. Model A uses a coil spring, a pressure plate with 0.0595 in. (1.5 mm) diameter holes and body with extended hub. Model B uses a wave spring, pressure plate with 0.312 in. (8 mm) diameter holes and body with a short hub. Procedures are the same. Refer to TM 9-2320-279-24P when ordering parts.

- For Model A install spring with large end toward body.

- (5) Install spring (8) in body (5).
- (6) Install preformed packing (9) on pressure plate (10).
- (7) Install pressure plate (10) in body (5).

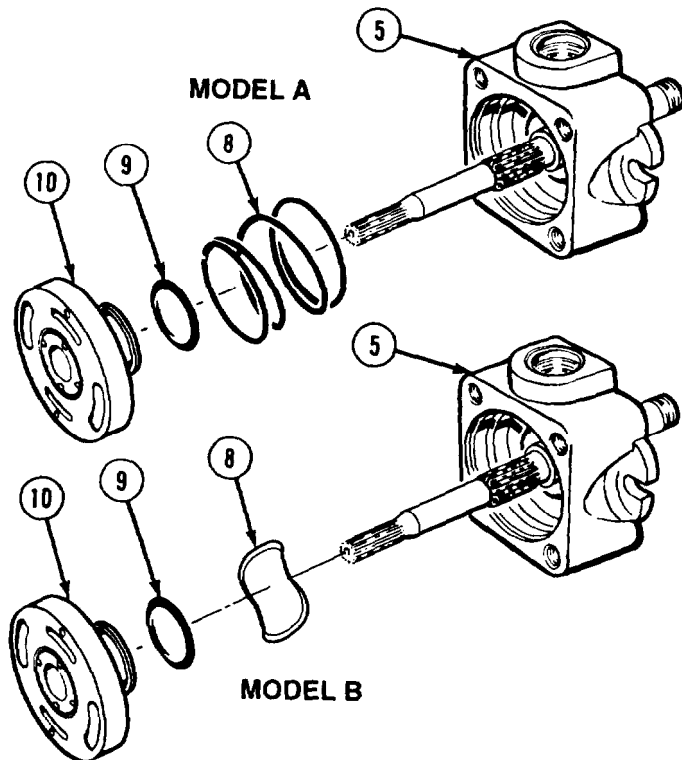

Steering System Maintenance Instructions (Cont)

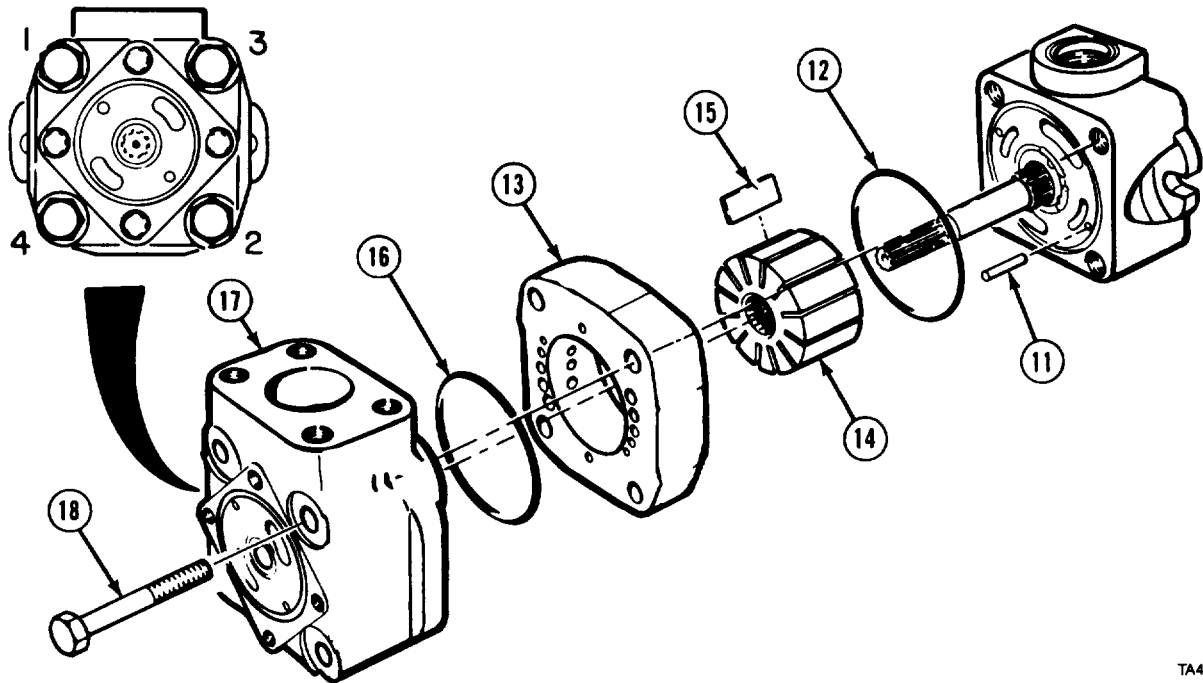

TA476373

- (8) Install two long dowel pins (11).
- (9) Install preformed packing (12) and ring (13).

NOTE

Vanes are installed with round edge against ring.

- (10) Install rotor (14) and 12 vanes (15).
- (11) Install preformed packing (16), inlet body (17), and four screws (18). Tighten screws to 75 to 85 lb-ft (102 to 115 NŹm) evenly, in 1-2-3-4 order.
- (12) Install two short dowel pins (19).
- (13) Install preformed packing (20) and ring (21).

NOTE

Vanes are installed with round edge against ring.

- (14) Install rotor (22) and 12 vanes (23).

Steering System Maintenance Instructions (Cont)

12-7.1. STEERING PUMP REMOVAL/REPAIR/INSTALLATION (M984E1) (CONT).

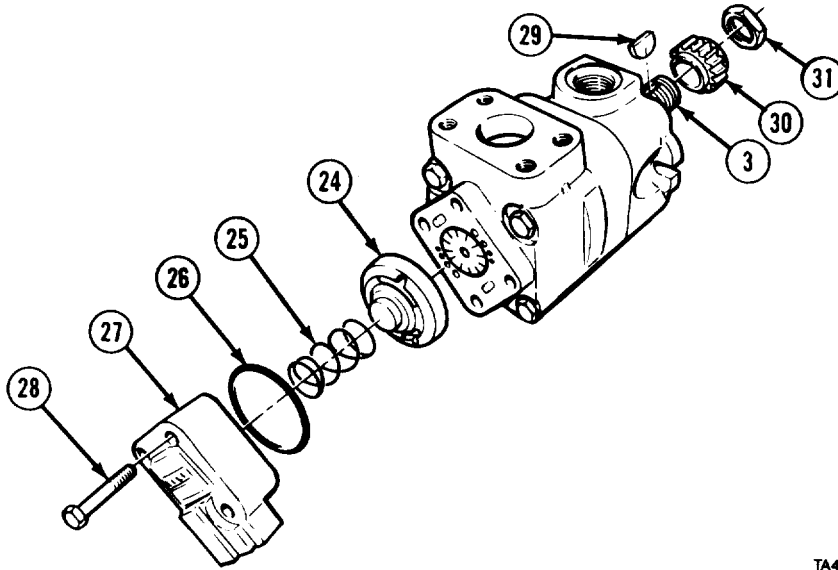

TA476375

- (15) Install pressure plate (24) and spring (25).
- (16) Install preformed packing (26), cover (27), and four screws (28). Tighten screws to 35 to 45 lb-ft (47.4 to 61.0 NŹm).
- (17) Install key (29), gear (30), and nut (31) on shaft (3). Tighten nut to 90 to 110 lb-ft (122 to 149 NŹm).
- (18) Check shaft (3) for binding.

e. Installation.

- (1) Install two preformed packings (1 and 2) on elbows (3 and 4).
- (2) Install elbows (3 and 4) in steering/tensioner pump (5) but do not tighten nuts (6).
- (3) Install gasket (7) on steering/tensioner pump (5).

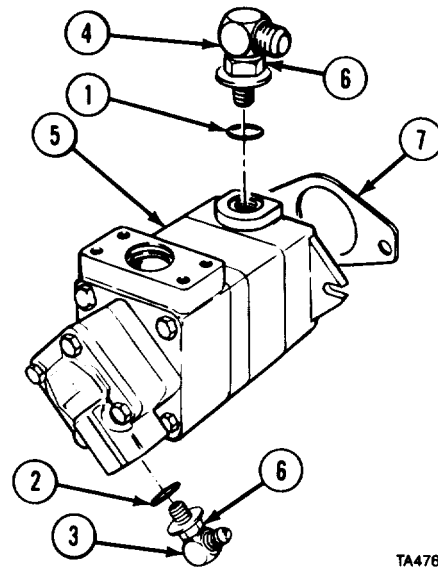

TA476376

Steering System Maintenance Instructions (Cont)

- (4) Install steering/tensioner pump (5), two washers (8), lockwashers (9), and screws (10).
- (5) Install preformed packing (11), hose (12), two clamp halves (13), four lockwashers (14), and screws (15).
- (6) Connect two hoses (16 and 17) and tighten nuts (6).

f. Follow-on Maintenance.

- (1) Fill hydraulic reservoir (para 13-8).
- (2) Start engine and turn steering wheel stop-to-stop three times to bleed air out of system.
- (3) Check for leaks.

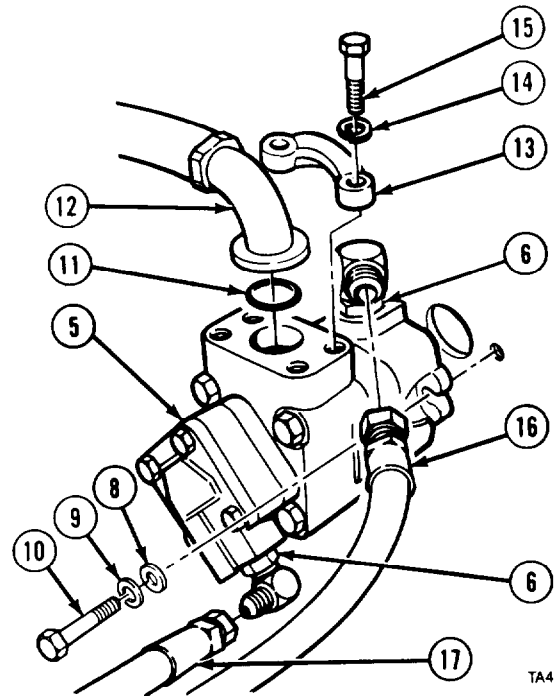

END OF TASK

12-7.2. STEERING/TENSIONER MANIFOLD AND BRACKET REMOVAL/REPAIR/INSTALLATION (M984E1).	
This task covers:	
a. Removal	d. Assembly
b. Disassembly	e. Installation
c. Cleaning/Inspection	f. Follow-on Maintenance
INITIAL SETUP	
<i>Models</i>	<i>Equipment Condition</i>
M984E1	<i>TM or Para</i> <i>Condition Description</i>
<i>Test Equipment</i>	TM 9-2320-279-20 Steering/tensioner manifold hoses and fittings removed from manifold.
None	
<i>Special Tools</i>	<i>Special Environmental Conditions</i>
None	None
<i>Supplies</i>	<i>General Safety Instructions</i>
None	None
<i>Personnel Required</i>	<i>Level of Maintenance</i>
MOS 63W, Wheel vehicle repairer (2)	Direct support
<i>References</i>	
None	

Steering System Maintenance Instructions (Cont)

**12-7.2. STEERING/TENSIONER MANIFOLD AND BRACKET
REMOVAL/REPAIR/INSTALLATION (M984E1) (CONT).**

a. Removal.

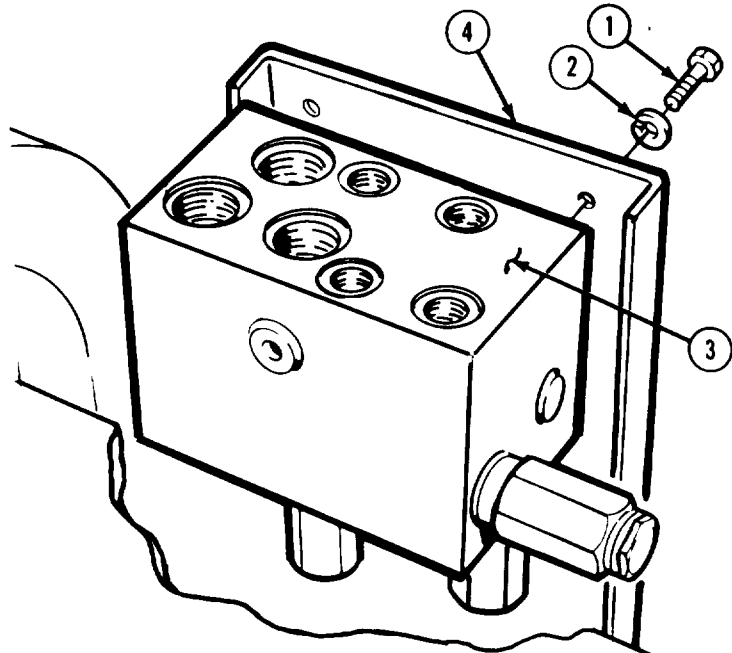
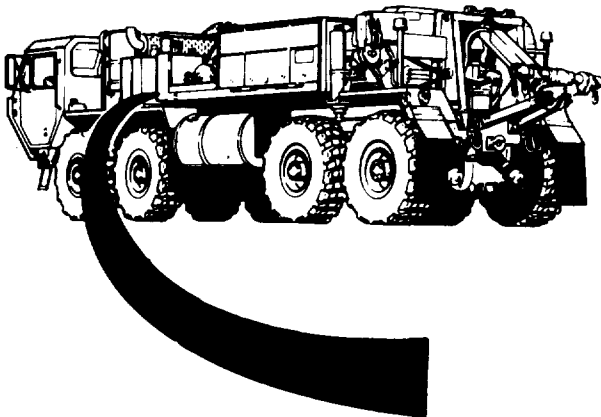

TA476569

- (1) Remove three screws (1), lockwashers (2), and manifold (3) from manifold bracket (4).
- (2) Soldier A removes four screws (5) and manifold bracket (6) while Soldier B removes four nuts (7).

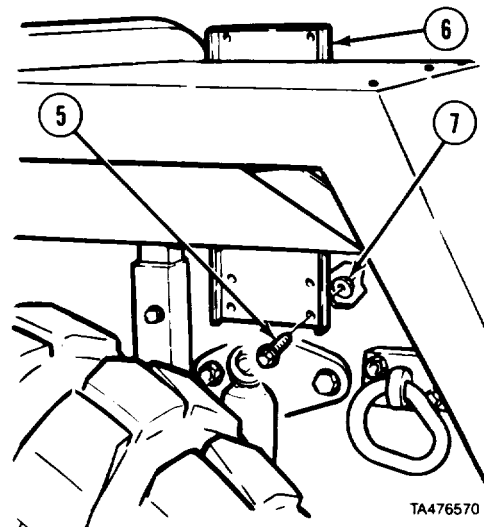

TA476570

Steering System Maintenance Instructions (Cont)

b. Disassembly.

- (1) Remove sensing valve (1). Remove two packing retainers (2 and 3) and three preformed packings (4, 5, and 6).

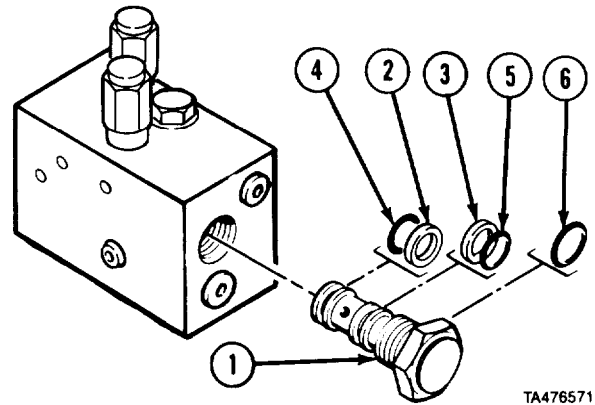

TA476571

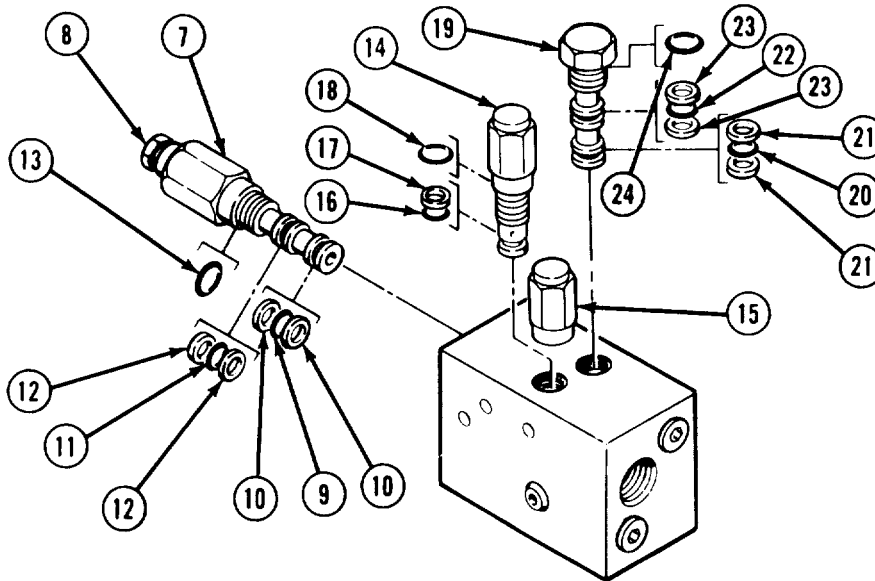

TA476572

- (2) Remove directional valve (7). Remove preformed packing (8). Remove preformed packing (9), two packing retainers (10), preformed packing (11), two packing retainers (12) and preformed packing (13).

NOTE

Relief valves look the same, but pressure settings are different. Mark position of two valves.

- (3) Remove two relief valves (14 and 15). Remove preformed packing (16), packing retainer (17) and preformed packing (18) from each valve.
- (4) Remove cartridge (19). Remove preformed packing (20), two packing retainers (21), preformed packing (22), two packing retainers (23), and preformed packing (24).

Steering System Maintenance Instructions (Cont)

**12-7.2. STEERING/TENSIONER MANIFOLD AND BRACKET
REMOVAL/REPAIR/INSTALLATION (M984E1) (CONT)**

- (5) Remove three plugs (25, 26, and 27). Remove preformed packings (28, 29, and 30).
- (6) Remove four plugs (31, 32, 33, and 34). Remove preformed packings (35, 36, 37, and 38).

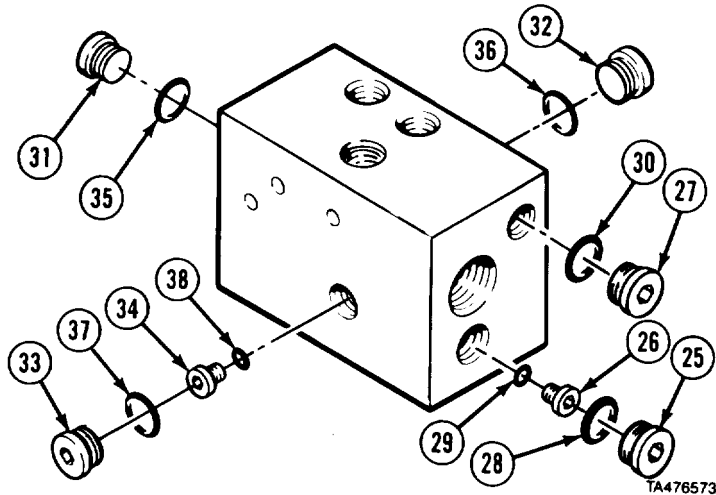

c. Cleaning/Inspection.

WARNING

Adhesives, solvents, and sealing compounds can burn easily, can give off harmful vapors, and are harmful to skin and clothing. To avoid injury or death, keep away from open fire and use in well-ventilated area. If adhesive, solvent, or sealing compound gets on skin or clothing, wash immediately with soap and water.

- (1) Clean all metal parts in dry cleaning solvent.
- (2) Inspect all threads for burrs and damage. Repair damaged threads.
- (3) Coat plugs and manifold bores with oil.

d. Assembly.

- (1) Install four preformed packings (1, 2, 3, and 4) on plugs (5, 6, 7, and 8). Install plugs.
- (2) Install preformed packings (9, 10, and 11) on three plugs (12, 13, and 14). Install plugs.

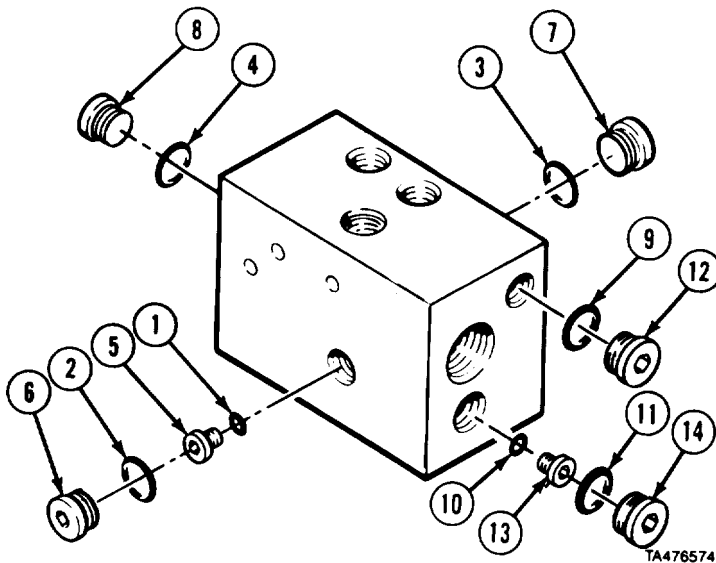

Steering System Maintenance Instructions (Cont)

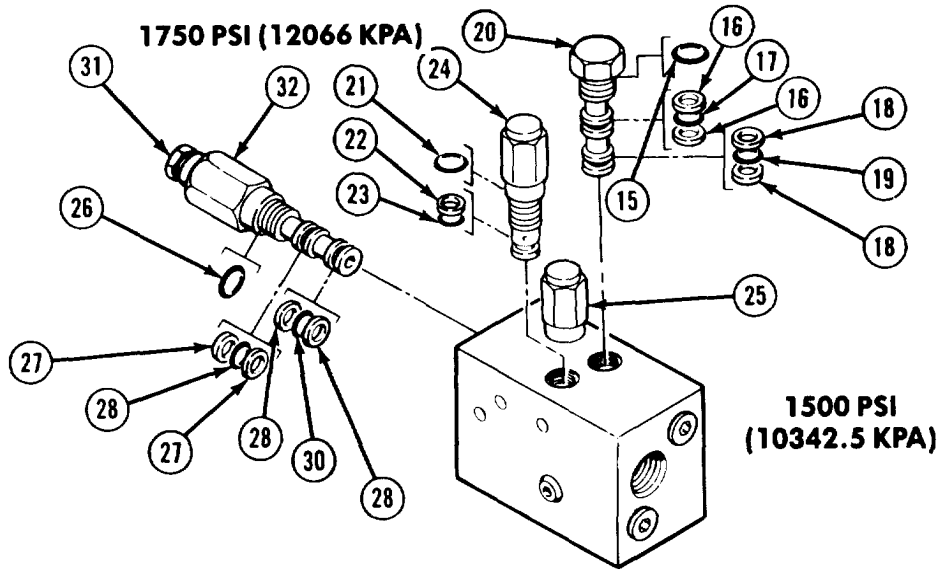

TA476575

- (3) Install preformed packing (15), two packing retainers (16), preformed packing (17), two packing retainers (18), and preformed packing (19) on cartridge (20), Install cartridge.

CAUTION

Valves are identified to specific psi rating. Be sure valves are installed in correct position. If valves are installed incorrectly steering of vehicle may be affected while standing and in OFF road condition.

- (4) Installed preformed packing (21), packing retainer (22), and preformed packing (23) on two relief valves (24 and 25).
- (5) Install preformed packing (26), two packing retainers (27), preformed packing (28), two backup rings (29), and preformed packing (30 and 31) on relief valve (32). Install relief valve.
- (6) Install preformed packing (33), preformed packing (34), packing retainer (35), preformed packing (36), and packing retainer (37) on sensing valve (38). Install sensing valve in manifold (39).

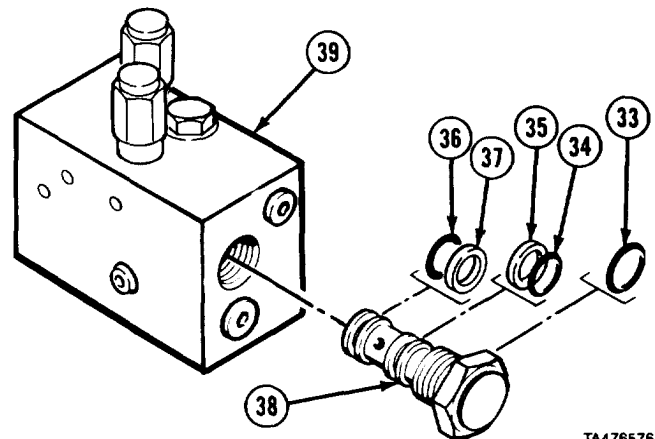

TA476576

Steering System Maintenance Instructions (Cont)

**12-7.2. STEERING/TENSIONER MANIFOLD AND BRACKET
REMOVAL/REPAIR/INSTALLATION (M984E1) (CONT).**

e. Installation.

- (1) Soldier A installs manifold bracket (1) and four screws (2) while Soldier B installs four nuts (3).

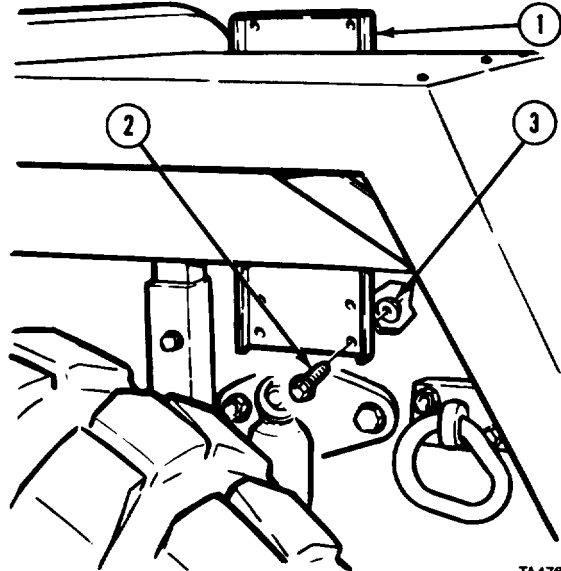

TA478577

- (2) Install manifold (4), three lockwashers (5), and screws (6) on manifold bracket (1).

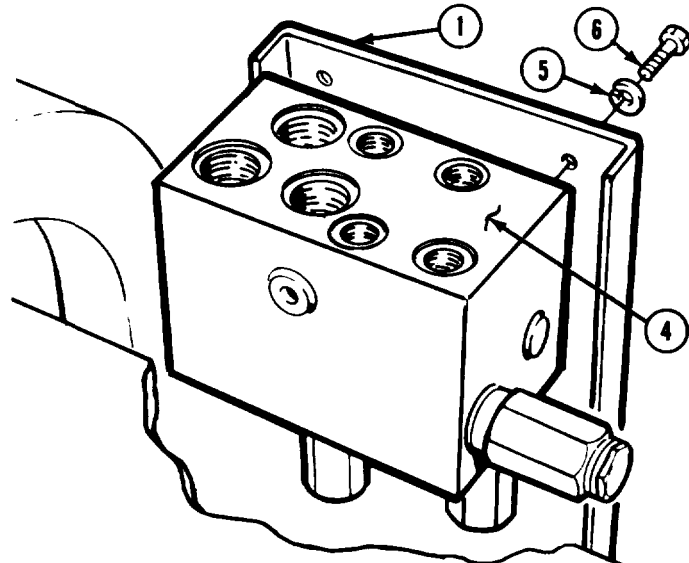

TA478578

- f. Follow-on Maintenance.* Install steering tensioner hoses and fittings on manifold (TM 9-2320-279-20).

END OF TASK

Steering System Maintenance Instructions (Cont)

Section V. STEERING SYSTEM ADJUSTMENTS

12-8. STEERING GEAR ADJUSTMENT.**This task covers:**

- a. Adjustment
- b. Follow-on Maintenance

INITIAL SETUP*Models*

All

Test Equipment

None

Special Tools

None

Supplies

Grease, GAA, Item 34, Appendix C

Personnel Required

MOS 63W, Wheel vehicle repairer (2)

References

None

Equipment Condition

TM or Para

Condition Description

None

Special Environmental Conditions

None

General Safety Instructions

Wheels chocked.

Level Maintenance

Direct support

a. Adjustment.**NOTE**

Turning plunger counterclockwise will decrease gap between walking beam and tire. Turning clockwise will increase gap.

- (1) Start engine (TM 9-2320-279-10).
- (2) Soldier A turns steering wheel full left while Soldier B checks gap between walking beam (1) and tire (2) of No. 1 axle. Gap should measure 1/4 in. (6 mm).
- (3) Soldier A releases steering wheel while Soldier B adjusts top plunger (3) to decrease gap or increase gap.
- (4) Soldier A turns steering wheel straight then back to full left while Soldier B checks gap between walking beam (1) and tire (2) of No. 1 axle.
- (5) Repeat steps (3) and (4) until gap measurement is correct.
- (6) Apply grease to outside of plunger (3).

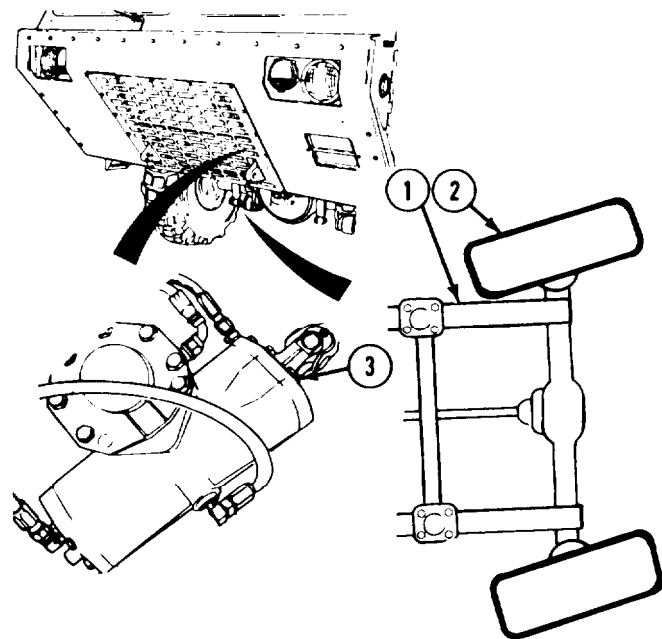

Steering System Maintenance Instructions (Cont)

- (7) Soldier A turns steering wheel full right while Soldier B checks gap between walking beam (4) and tire (5) of No. 1 axle. Gap should measure 1/4 in. (6 mm).
- (8) Soldier A releases steering wheel while Soldier B adjusts bottom plunger (6) to decrease gap or increase gap.
- (9) Soldier A turns steering wheel straight then back to full right while Soldier B checks gap between walking beam (4) and tire (5) of No. 1 axle.
- (10) Repeat steps (6) through (8) until measurement is correct.
- (11) Apply grease to outside of plunger (6).
- (12) Shut off engine (TM 9-2320-279-10).

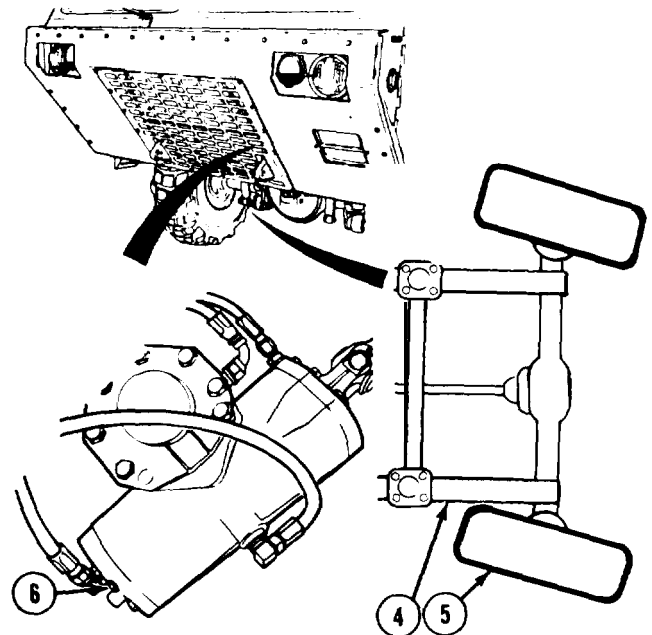

b. Follow-on Maintenance. None.

END OF TASK

12-9. STEERING TOE-IN ADJUSTMENT.	
This task covers:	
<ol style="list-style-type: none"> a. Adjustment b. Follow-on Maintenance 	
INITIAL SETUP	
<i>Models</i> All	<i>Equipment Condition</i> TM or Para
<i>Test Equipment</i> None	<i>Condition Description</i> None
<i>Special Tools</i> None	<i>Special Environmental Conditions</i> None
<i>Supplies</i> None	<i>General Safety Instructions</i> None
<i>Personnel Required</i> MOS 63W, Wheel vehicle repairer (2)	<i>Level of Maintenance</i> Direct support
<i>References</i> None	

Steering System Maintenance Instructions (Cont)

12-9. STEERING TOE-IN ADJUSTMENT (CONT).

a. Adjustment.

NOTE

Do steps (1) through (1.3) for tires without mold line. Go to step (1.4) for tires with mold line.

- (1) Chock wheels on axle No. 3.
- (1.1) Jack up axles and position jackstands under each side of suspension beams.

NOTE

- A sharpened piece of steel stock will be used as a marking device and a jackstand will make the marking device stationary. Use a clamp to hold steel stock to jackstand. The marking device must be able to make a visible mark on the tire.
- A visible mark must be made as close to the centerline of the tire as possible.

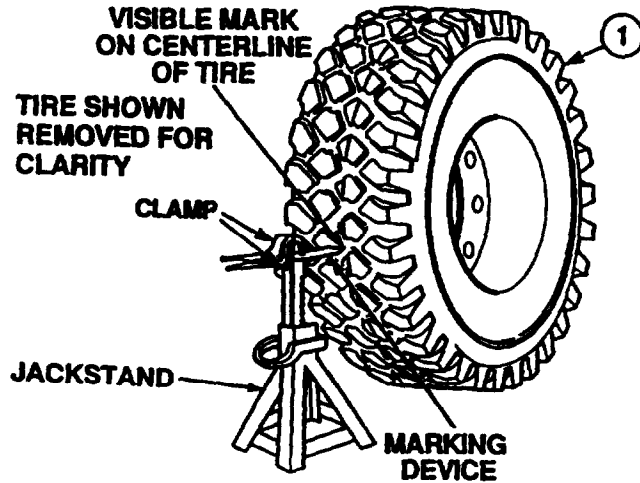

- (1.2) Soldier A spins tire (1). Soldier B holds steel stock in place at centerline of tire. Soldier A continues turning tire until a visible mark is made around entire diameter of tire.
- (1.3) Lower axles and remove chock blocks.

- (1.4) Drive vehicle straight back and then straight forward a few feet (TM 9-2320-279-10).
- (2) Stop vehicle and turn steering wheel straight ahead (TM 9-2320-279-10).
- (3) Set parking brake (TM 9-2320-279-10).
- (4) Soldier A and Solder B measure and mark all four front tires (1) 15 in. (381 mm) above ground on front and rear of each tire.

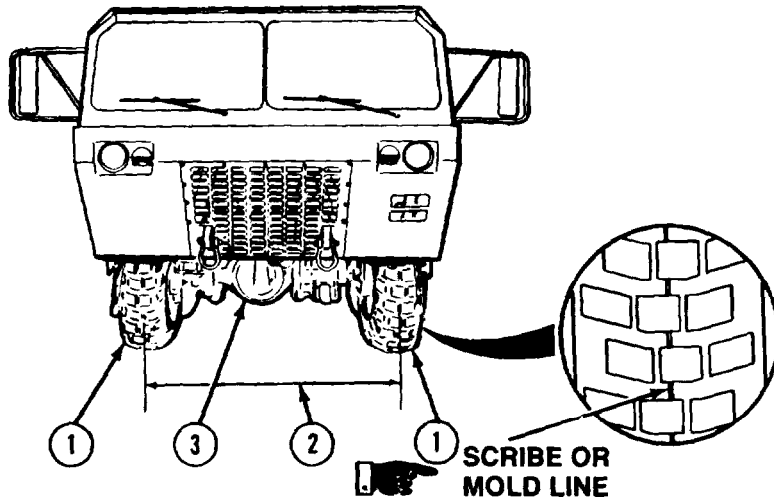

NOTE

Center of each tire is indicated by scribe or mold line down the middle of tire. Measurement is taken from line.

- (5) Measure and record front and rear distances (2) between centers of tires (1) on axle No. 1 (3).
- (6) Repeat step (5) for axle No. 2.

Steering System Maintenance Instructions (Cont)

- (7) Check that distance (4) between centers of front of tires (1) is $1/16$ to $1/8$ -in. (1.6 to 3.2 mm) less than distance (5) between centers of rear of tires on axles No. 1 and No. 2.

NOTE

If distances are correct, toe-in adjustment is complete. If distances are not correct on axle No. 1, continue with step (8). If distances are not correct for axle No. 2 only, go to step (18).

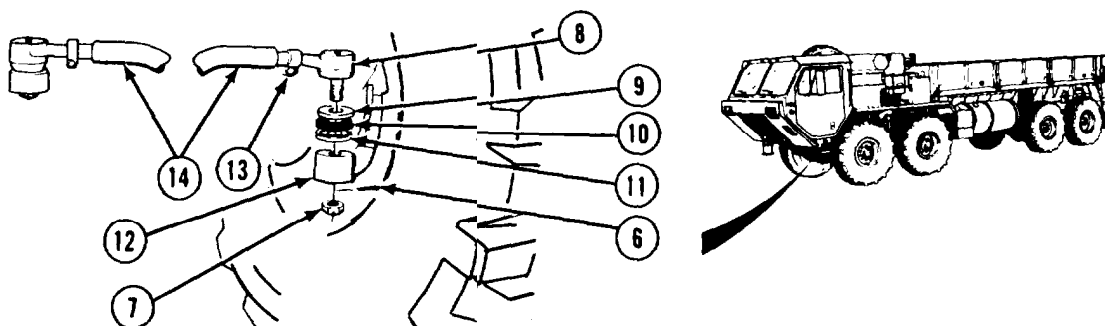
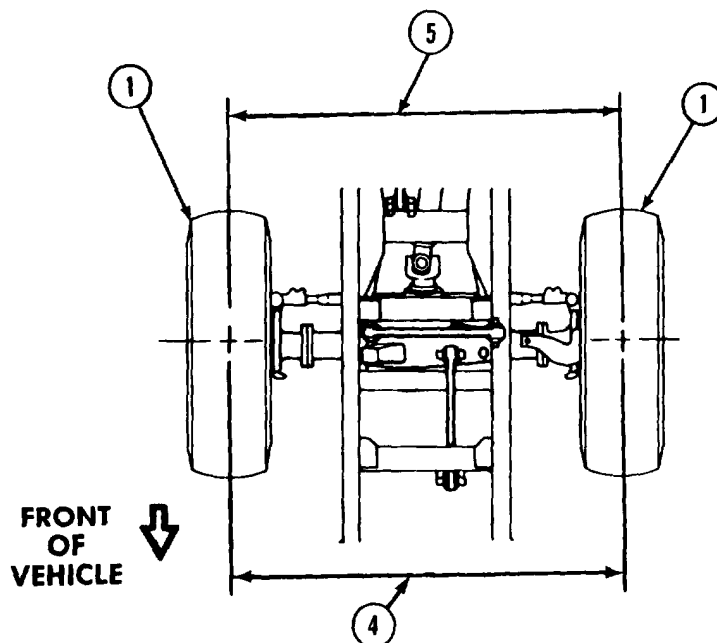

NOTE

Steps (8) through (17) are for adjustment of axle No. 1 toe-in. Shortening tie rod will increase front measurement. Lengthening tie rod will decrease front measurement. Left tie rod has coarse threads, right tie rod has fine thread. To make small adjustments, disconnect and adjust right side tie rod end. For large adjustments, disconnect and adjust left side tie rod end.

- (8) Remove cotter pin (6) and nut (7) from one tie rod end (8).
 (9) Remove tie rod end (8), washer (9), bushing (10), and washer (11) from steering arm (12).

NOTE

When adjusting tie rod ends, be sure threaded area stays within slotted area of steering arm.

- (10) Loosen nut (13) on disconnected tie rod end (8).
 (11) Turn tie rod end (8) to shorten or lengthen tie rod (14).
 (12) Tighten nut (13) after adjusting tie rod (14).
 (13) Position washer (11), bushing (10), and washer (9) on steering arm (12).
 (14) Install tie rod end (8) on steering arm (12).
 (15) Install nut (7) and tighten to 160 to 180 lb-ft (217 to 244 N•m).
 (16) Install cotter pin (6).
 (17) Repeat steps (1) through (5) and (7).

Steering System Maintenance Instructions (Cont)

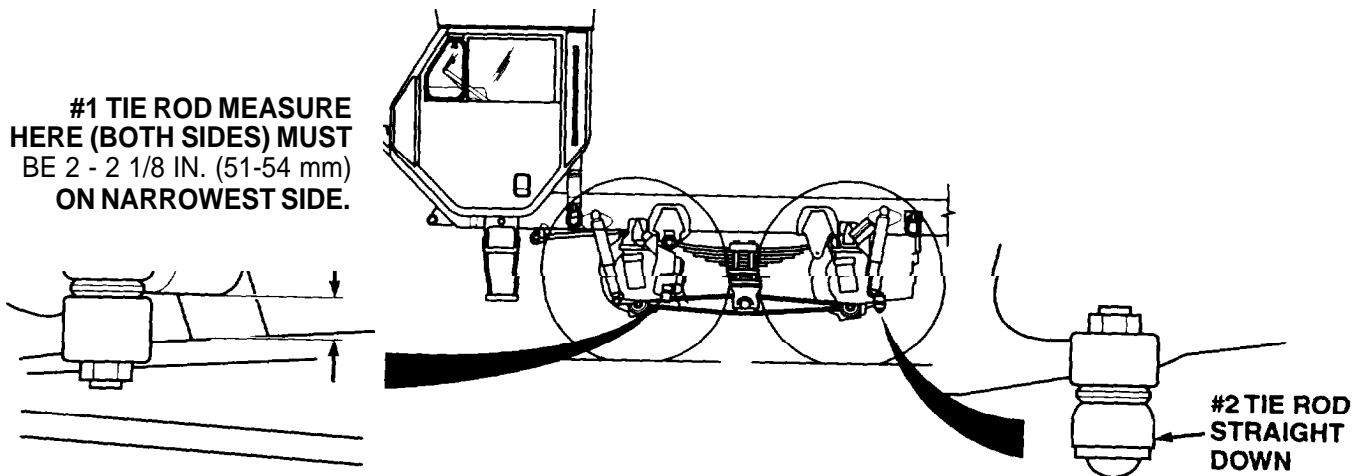

(17.1) When toe-in is set, loosen nuts (13), and push or pull tie rod (14) until 2 - 2 1/8 in. (51-54 mm) is measured between tie rod and equalizer beam (14.1) on narrowest side. Then tighten nuts.

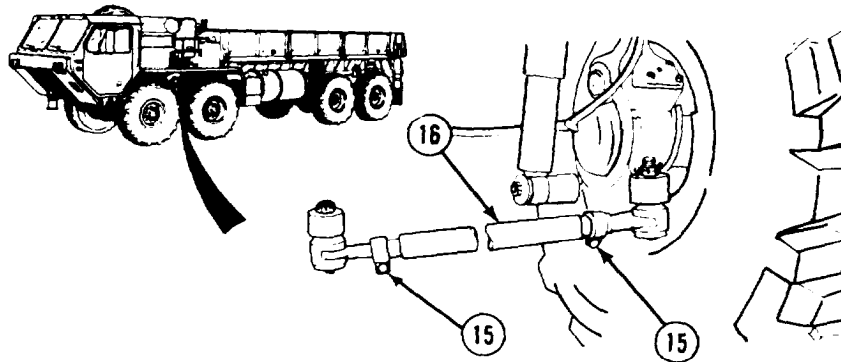

NOTE

Steps (18) through (21) are for adjustment of axle No. 2 toe-in.

(18) Loosen two nuts (15) on axle No. 2 tie rod (16).

NOTE

Shortening tie rod will increase distance measured at front of tires on axle No. 2. Lengthening tie rod will decrease distance measured at front of tires.

(19) Turn tie rod (16) to shorten or lengthen as needed.

CAUTION

- Tie rod clamps on axle No. 2 must be positioned so nuts and screws are positioned on bottom of tie rod. If they are not, damage can result from clamps striking shock absorber mount during vehicle operation.
- No. 2 tie rod has a slight bend. This should be straight down when adjustment is complete or damage to tie rod could result.

(20) Tighten two nuts (15) after adjusting tie rod (16).

(21) Repeat steps (1) through (7).

b. Follow-on Maintenance. None

END OF TASK

Steering System Maintenance Instructions (Cont)

12-10. STEERING SYSTEM ALINEMENT.

This task covers:

- a. Alinement
- b. Follow-on Maintenance

INITIAL SETUP

Models
All

References
None

Test Equipment
None

Equipment Condition
TM or Para

Condition Description
Vehicle parked on hard level surface.

Special Tools
None

Special Environmental Conditions
None

Supplies
Chalk, Item 13, Appendix C
Stock bar, metal, 0.125 x 1.00 in. (3.18 x 25.4 mm), Item 58, Appendix C

General Safety Instructions
Wheels chocked

Personnel Required
MOS 63W, Wheel vehicle repairer (2)

Level of Maintenance
Direct support

Steering System Maintenance Instructions (Cont)

12-10. STEERING SYSTEM ALINEMENT (CONT).

a. Alinement.

- (1) Adjust steering toe-in (para 12-9).
- (2) Move vehicle straight ahead about 15 feet (5 m) to remove flex from tires and tension on suspension.

NOTE

Do steps (2.1) through (2.4) for tires without mold line. Go to step (3) for tires with mold line.

- (2.1) Chock wheels on axle No. 3.
- (2.2) Jack up axles and position jackstands under each side of suspension beams.

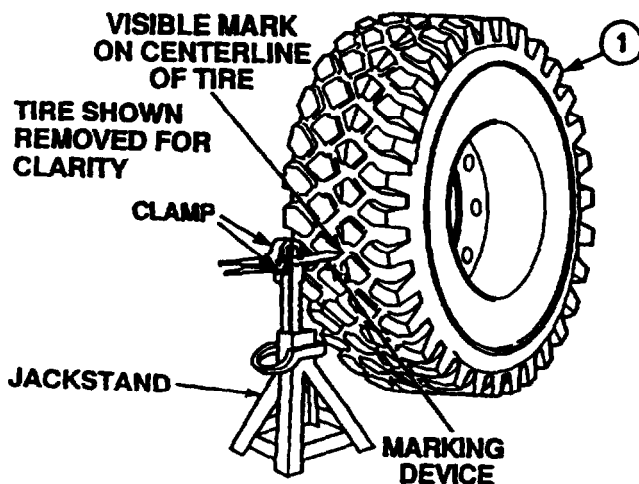

- . A sharpened piece of steel stock will be used as a marking device and a jackstand will make the marking device stationary. Use a clamp to hold steel stock to jackstand. The marking device must be able to make a visible mark on the tire.
 - . A visible mark must be made as close to the centerline of the tire as possible.
- (2.3) Soldier A spins tire (1). Soldier B holds steel stock in place at centerline of tire. Soldier A continues turning tire until a visible mark is made around entire diameter of tire.
 - (2.4) Lower axles and remove chock blocks.

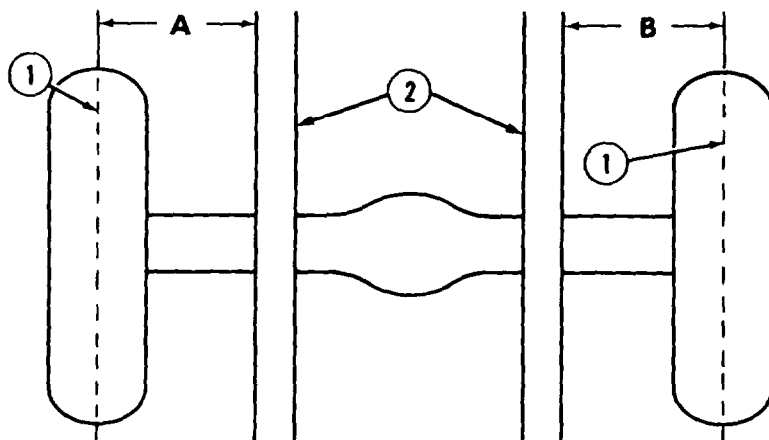

NOTE

- . Scribe or mold line is center of tire.
 - . Distance A is always taken from the side of vehicle where the lateral torque rod is attached. Driver's side for axle No. 1; passenger's side for axle No. 2.
- (3) Measure and record distance from center of axle No. 1 tire (1) to outside of rear frame rail (2) and label distance (A).
 - (4) Repeat step (3) for other tire and label distance (B).
 - (5) Subtract smaller number from larger number. If answer is 1/4 in. (6 mm) or less, go to step (11). If answer is larger than 1/4 in. (6 mm), continue with step (6).

Steering System Maintenance Instructions (Cont)

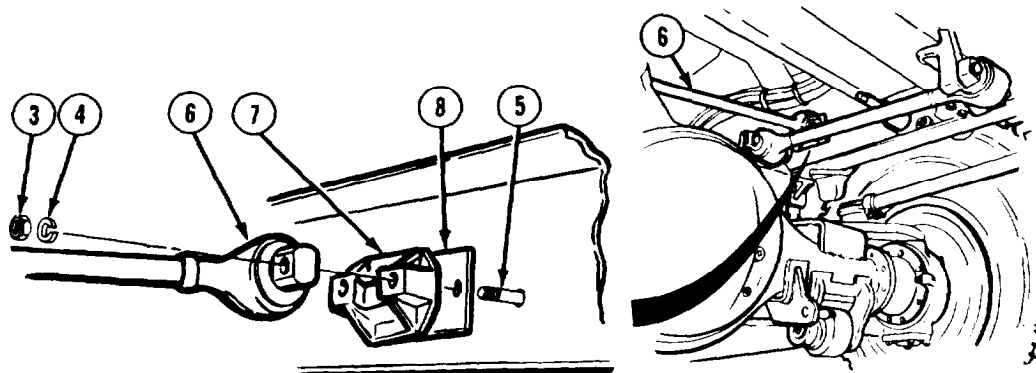

- (6) Remove two nuts (3), lockwashers (4), and screws (5).
- (7) Push lateral torque rod (6) up and remove bracket (7).

NOTE

Spacers are 1/8-in. (3 mm) thick.

- (6) Add spacers (8) if (A) is larger than (B). Remove spacers (8) if (B) is larger than (A). Distance (A) must come within 1/4 in. (6 mm) of distance (B).
- (9) Install bracket (7), lateral torque rod (6), two screws (5), lockwashers (4), and nuts (3). Tighten nuts finger-tight.
- (10) Repeat steps (3) through (5).
- (11) Tighten nuts (3) to 95 to 130 lb-ft (129 to 176 N•m).

NOTE

Procedure is the same for both front axles except lateral torque rod attaches to right side frame rail on axle No. 2.

- (12) Repeat steps (3) through (11) for axle No. 2.

Steering System Maintenance Instructions (Cont)

12-10. STEERING SYSTEM ALINEMENT (CONT.)

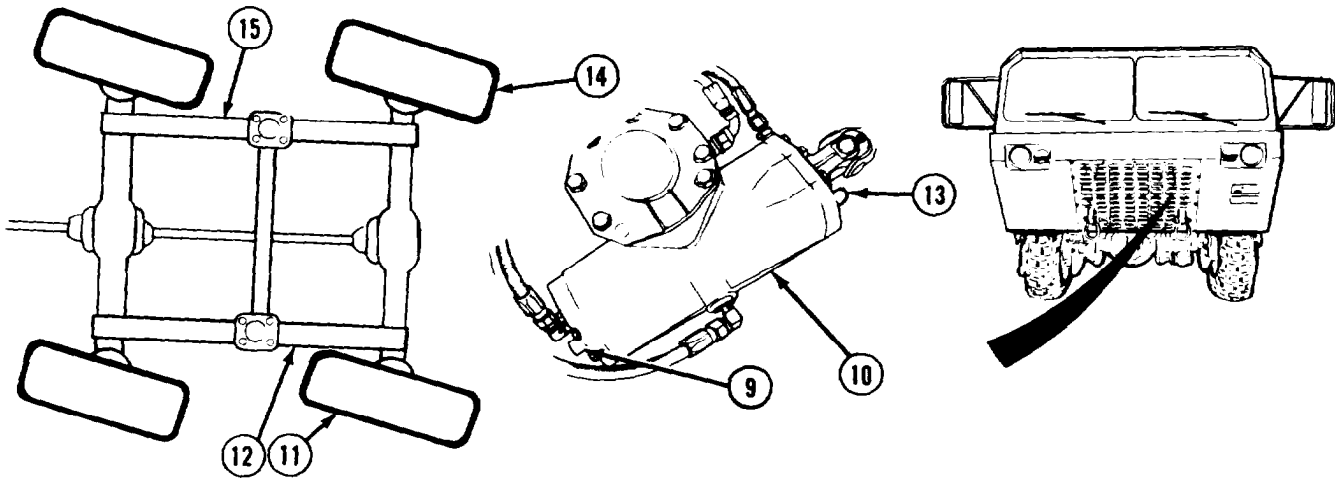

NOTE

- Axle stop bolts should be turned in to prevent interference with relief plunger adjustment.
- Each time relief plunger is adjusted, wheels must be turned toward center and then back to stops to obtain full steering relief. Plunger on bottom of steering gear regulates right turns and plunger on top regulates left turns.

- (13) Soldier A adjusts plunger (9) on steering gear (10) to obtain 3/4 in. (19 mm) clearance between tire (111) and equalizer beam (12).
- (14) Soldier A adjusts plunger (13) on steering gear (10) to obtain 3/4 in. (19 mm) clearance between tire (14) and equalizer beam (15).

NOTE

Axle stop bolts should be turned in to prevent interference with relief plunger adjustment.

- (15) Turn wheels all the way to the right,
- (16) Set 1/8-in. (3 mm) gap between stop bolt (16) and ball (17) on left end of axle No. 2 and right end of axle No. 1 by loosening nut (18) and turning stop bolt.
- (17) Tighten nut (18) on both axles.
- (18) Turn-wheels all the way to the left.
- (19) Set 1/8-in. (3 mm) gap between stop bolt (16) and ball (17) on right end of axle No. 2 and left end of axle No. 1 by loosening nut (18) and turning stop bolt.
- (20) Tighten nut (18) on both axles.

b. Follow-on Maintenance. None.

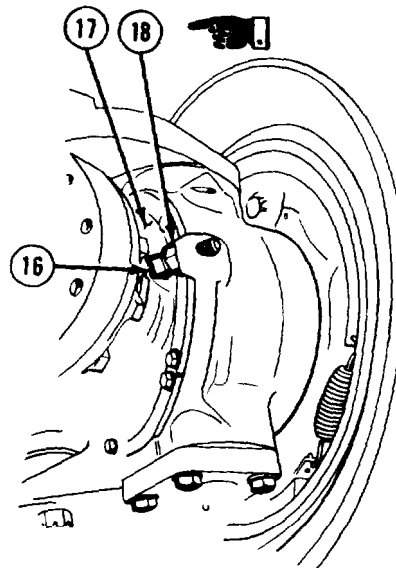

END OF TASK

CHAPTER 13

FRAME MAINTENANCE

Contents	Para	Page
General	13-1	13-1
Towing Eye Removal/Installation	13-2	13-2
Front Cab Supports Removal/Installation	13-3	13-3
Radiator Support Removal/Installation	13-4	13-5
Engine Support Removal/Installation	13-5	13-8
Lift Bracket Assemblies Removal/Installation	13-6	13-13
Transmission Support Removal/Installation	13-7	13-16
Transfer Case Support Assembly Removal/Installation	13-8	13-20
Spring Hanger Removal/Installation	13-9	13-23
Front Crossmember Removal/Installation	13-10	13-27
Front Tandem Crossmember Removal/Installation	13-11	13-31
Front Tandem Gussets Removal/Installation	13-12	13-33
Front Intermediate Crossmember Removal/Installation (M977, M978, M984, M985) ..	13-13	13-38
Front Intermediate Crossmember Removal/Installation (M983)	13-14	13-40
Front Intermediate Gussets Removal/Installation (M983)	13-15	13-41
Front Intermediate Crossmember Removal/Installation (M984E1)	13-15.1	13-42.1
Rear Intermediate Crossmember Removal/Installation (M977, M978, M984, M985, M985E1)	13-16	13-42.4
Rear Intermediate Crossmember Removal/Installation (M983)	13-17	13-44
Rear Intermediate Crossmember Removal/Installation (M984E1)	13-17.1	13-44.1
Rear Tandem Crossmember Removal/Installation	13-18	13-45
Rear Tandem Crossmember Removal/Installation (M984E1)	13-18.1	13-52
Rear Tandem Gussets Removal/Installation (M977, M978, M985, M985E1)	13-19	13-52.2
Rear Tandem Gussets Removal/Installation (M983)	13-20	13-55
Rear Tandem Gussets Removal/Installation (M984)	13-21	13-59
Rear Crossmember Removal/Installation (M977, M985)	13-22	13-62
Rear Crossmember Removal/Installation (M978)	13-23	13-64
Rear Crossmember Removal/Installation (M983, M984)	13-24	13-70
Rear Crossmember Removal/Installation (M984E1)	13-24.1	13-76.1
Pump Support Assembly Removal/Installation (M978)	13-25	13-77
2500 Gallon Tank Mount Removal/Installation (M978)	13-26	13-79
Crane Mounting Brackets Removal/Installation (M977, M985)	13-27	13-81
Crane Mounting Supports Removal/Installation (M983)	13-28	13-83
Crane Mounting Supports Removal/Installation (M984)	13-29	13-88
Crane Mounting Brackets Removal/Installation (M985E1)	13-30	13-89
Retriever Towing Support Assembly Removal/Installation (M984E1)	13-30.1	13-90.1
Retriever Lift Cylinder Removal/Installation (M984E1)	13-30.2	13-90.7
Retriever Lift Cylinder Repair (M984E1)	13-30.3	13-90.10
Retriever Tow Cylinder and Pivot Brackets Removal/Installation (M984E1)	13-30.4	13-90.14
Retriever Tow Cylinder Repair (M984E1)	13-30.5	13-90.16
Plate Assembly 2-Inch (51mm) Kingpin Removal/Installation (M983)	13-31	13-91
Plate Assembly 3.5-Inch (89 mm) Kingpin Removal/Installation (M983)	13-32	13-92
Plate Assembly Repair (M983)	13-33	13-94
Fifth Wheel Repair-2-Inch (51 mm) Kingpin (M983)	13-34	13-97
Fifth Wheel Repair-3.5-Inch (89 mm) Kingpin (M983)	13-35	13-103

Section 1. INTRODUCTION

13-1. GENERAL. This chapter contains maintenance instructions for removal, repair, and installation of frame and fifth wheel components at direct support and general support maintenance levels. Subassemblies and parts which must be removed before frame and fifth wheel components can be removed or repaired are referenced to other paragraphs of this manual or TM 9-2320-279-20.

Section II. FRAME ASSEMBLY MAINTENANCE

Frame Maintenance Instructions

13-2. TOWING EYE REMOVAL/INSTALLATION.	
This task covers:	
a. Removal	c. Follow-on Maintenance
b. Installation	
INITIAL SETUP	
<i>Models</i>	<i>Equipment Condition</i>
All	TM or Para
<i>Test Equipment</i>	Para 12-5
None	Condition Description
<i>Special Tools</i>	Steering gear removed (left side only).
None	TM 9-2320-279-20 Skid plate grille removed.
<i>Supplies</i>	<i>Special Environmental Conditions</i>
None	None
<i>Personnel Required</i>	<i>General Safety Instructions</i>
MOS 63W, Wheel vehicle repairer (2)	None
<i>References</i>	<i>Level of Maintenance</i>
None	Direct Support

a. Removal.

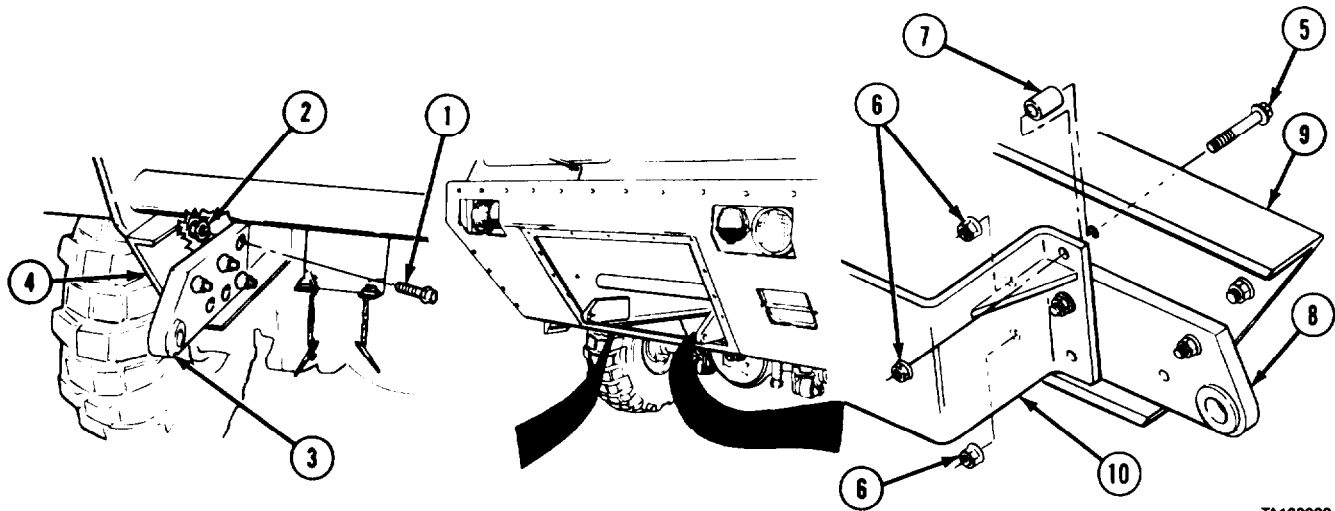

TA188903

- (1) Soldier A and Soldier B remove six screws (1), nuts (2), and right side towing eye bracket (3) from right frame (4).
- (2) Soldier A and Soldier B remove five screws (5), nuts (6), spacer (7), and left side towing eye bracket (8) from left frame (9) and steering gear bracket (10).

Frame Maintenance Instructions (Cont)

b. Installation.

- (1) Soldier A and Soldier B install left side towing eye bracket (8) and spacer (7) on left frame (9) and steering gear bracket (10) with five screws (5) and nuts (6).
- (2) Soldier A and Soldier B install right side towing eye bracket (3) on right frame (4) with six screws (1) and nuts (2).

c. Follow-on Maintenance.

- (1) Install steering gear (para 12-5).
- (2) Install skid plate grille (TM 9-2320-279-20).

END OF TASK

13-3. FRONT CAB SUPPORTS REMOVAL/INSTALLATION.	
This task covers:	
a. Removal	c. Follow-on Maintenance
b. Installation	
INITIAL SETUP	
<i>Models</i>	<i>Equipment Condition</i>
All	TM or Para Condition Description
<i>Test Equipment</i>	TM 9-2320-279-20 Blackout light removed.
None	TM 9-2320-279-20 Front cable guide removed.
<i>Special Tools</i>	Para 15-2 Cab removed.
None	Para 13-2 Towing eyes removed.
<i>Supplies</i>	<i>Special Environmental Conditions</i>
None	None
<i>Personnel Required</i>	<i>General Safety Instructions</i>
MOS 63W, Wheel vehicle repairer	None
<i>References</i>	<i>Level of Maintenance</i>
None	Direct Support

Frame Maintenance Instructions (Cont)

13-3. FRONT CAB SUPPORTS REMOVAL/INSTALLATION (CONT).

a. Removal.

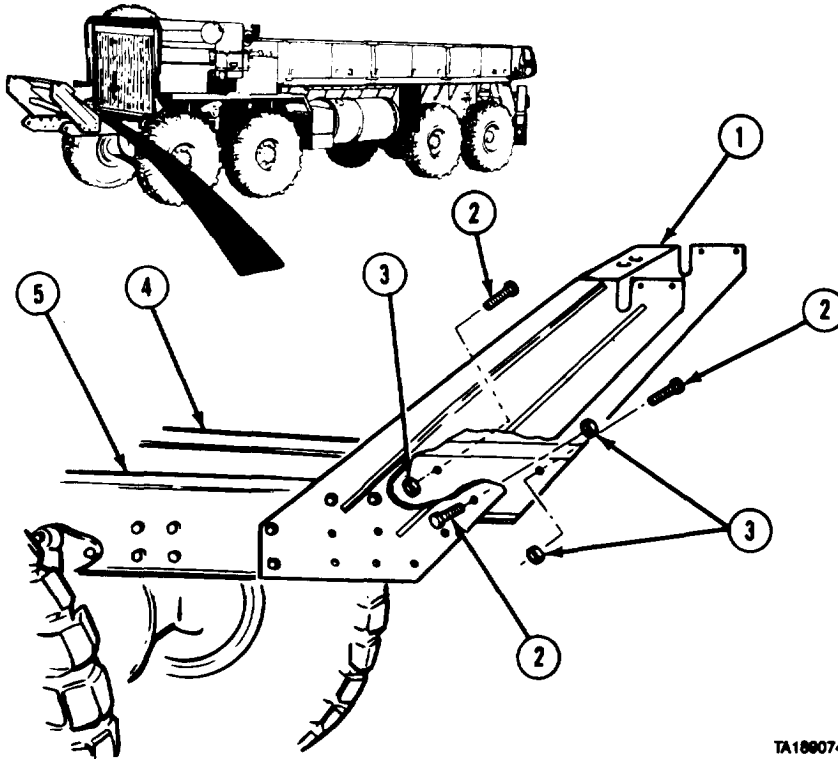

- (1) Support front cab support (1) with suitable lifting device.
- (2) Remove three screws (2) and nuts (3) from front cab support (1).
- (3) Remove three screws (2) and nuts (3) from left side of front cab support (1).
- (4) Remove front cab support (1) from left and right frame members (4 and 5).

b. Installation.

- (1) Install front cab support (1) on left and right frame members (4 and 5) with suitable lifting device.
- (2) Install three screws (2) and nuts (3) on right side and three screws and nuts on left side of front cab support (1).
- (3) Remove lifting device.

c. Follow-on Maintenance.

- (1) Install towing eyes (para 13-2).
- (2) Install front cable guide (TM 9-2320-279-20).
- (3) Install cab (para 15-2).
- (4) Install blackout light (TM 9-2320-279-20).

END OF TASK

Frame Maintenance Instructions (Cont)

13-4. RADIATOR SUPPORT REMOVAL/INSTALLATION.	
This task covers:	
a. Removal	c. Follow-on Maintenance
b. Installation	
INITIAL SETUP	
<i>Models</i>	<i>Equipment Condition</i>
All	<i>TM or Para</i>
<i>Test Equipment</i>	Para 12-5
None	TM 9-2320-279-20
<i>Special Tools</i>	Para 13-2
None	Para 13-3
<i>Supplies</i>	TM 9-2320-279-20
None	TM 9-2320-279-20
<i>Personnel Required</i>	TM 9-2320-279-20
MOS 63W, Wheel vehicle repairer (2)	Para 13-10
<i>References</i>	TM 9-2320-279-20
None	
<i>Equipment Condition</i>	<i>Special Environmental Conditions</i>
<i>TM or Para</i>	None
<i>Condition Description</i>	<i>General Safety Instructions</i>
TM 9-2320-279-10 Air system drained.	None
Para 15-2 Cab removed.	<i>Level of Maintenance</i>
TM 9-2320-279-20 Fan removed.	Direct Support
TM 9-2320-279-20 Radiator removed.	

a. Removal.

- (1) Soldier A removes four screws (1) from right side of radiator support (2) while Soldier B removes four nuts (3).
- (2) Remove hose clamp (4), nut (5), and screw (6).

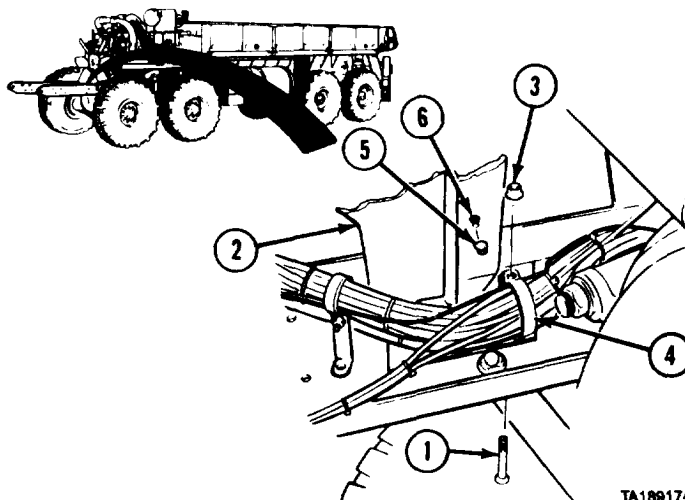

TA189174

Frame Maintenance Instructions (Cont)

13-4. RADIATOR SUPPORT REMOVAL/INSTALLATION (CONT).

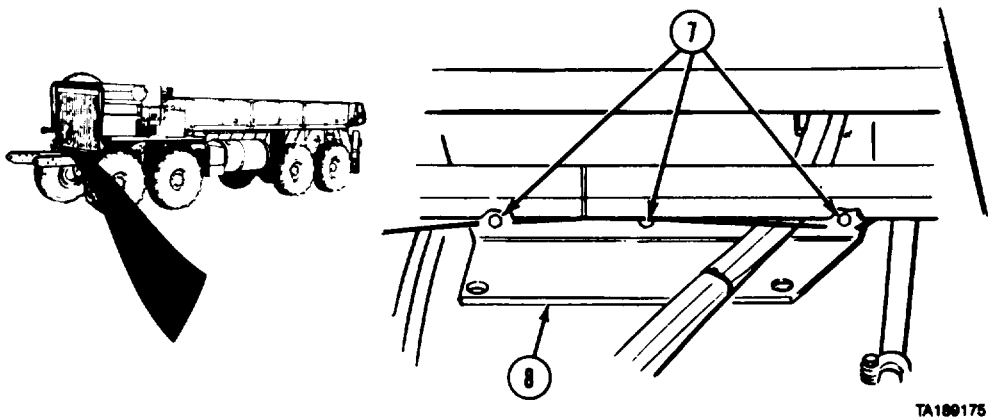

(3) Remove three screws (7) and baffle (8).

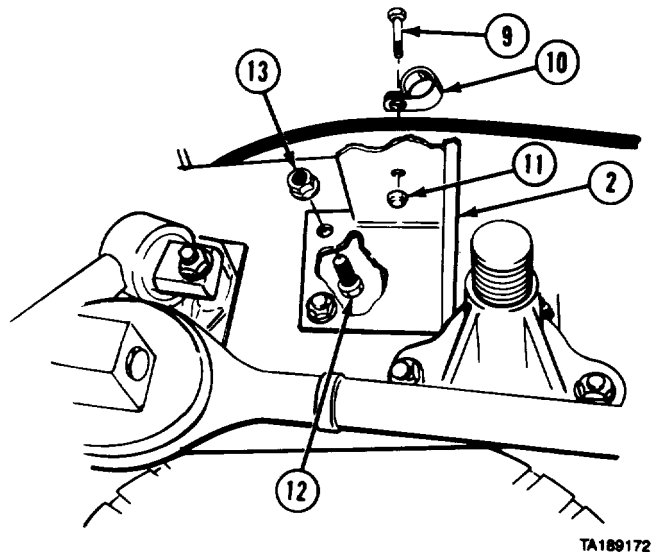

- (4) Remove screw (9), hose clamp (10), and nut (11).
- (5) Soldier A removes four screws (12) from left side of radiator support (2) while Soldier B removes four nuts (13).
- (6) Soldier A and Soldier B spread frame and remove radiator support (2) through front of vehicle.

Frame Maintenance Instructions (Cont)

b. Installation.

- (1) Soldier A and Soldier B spread frame and install radiator support (1) through front of vehicle.
- (2) Soldier A installs four screws (2) while Soldier B installs four nuts (3).
- (3) Install hose clamp (4), screw (5), and nut (6).

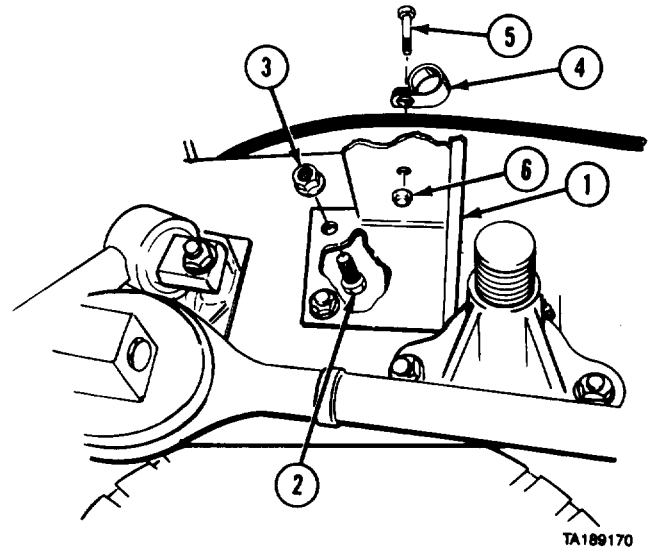

- (4) Soldier A installs four screws (7) while Soldier B installs four nuts (8).
- (5) Install hose clamp (9), screw (10), and nut (11).

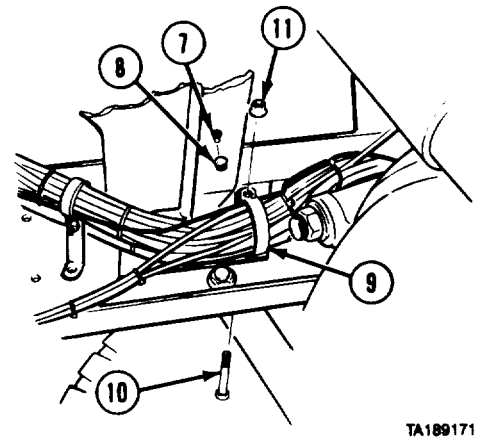

- (6) Install baffle (12) with three screws (13).

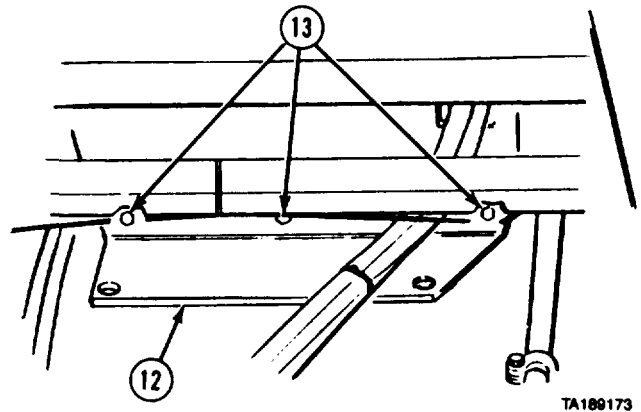

Frame Maintenance Instructions (Cont)

13-4. RADIATOR SUPPORT REMOVAL/INSTALLATION (CONT).

c. Follow-on Maintenance.

- (1) Install forward fender support screws (TM 9-2320-279-20).
- (2) Install front crossmember (para 13-10).
- (3) Install front torque rod (TM 9-2320-279-20).
- (4) Install double check valve mounting plate (TM 9-2320-279-20).
- (5) Install rear cab supports (TM 9-2320-279-20).
- (6) Install front cab supports (TM 9-2320-279-20).
- (7) Install towing eyes (para 13-2).
- (8) Install No. 1 axle shock absorbers (TM 9-2320-279-20).
- (9) Install main steering gear and bracket (para 12-5).
- (10) Install radiator (TM 9-2320-279-20).
- (11) Install fan (TM 9-2320-279-20).
- (12) Install cab (para 15-2).
- (13) Fill cooling system (TM 9-2320-279-20).
- (14) Start engine and build normal air pressure (TM 9-2320-279-10).
- (15) Check for leaks.
- (16) Shut off engine (TM 9-2320-279-10),

END OF TASK

13-5. ENGINE SUPPORT REMOVAL/INSTALLATION.	
This task covers:	
a. Removal	c. Follow-on Maintenance
b. Installation	
INITIAL SETUP	
<i>Models</i>	<i>Equipment Condition</i>
All	TM or Para
<i>Test Equipment</i>	Condition Description
None	TM 9-2320-279-20 Batteries disconnected.
<i>Special Tools</i>	TM 9-2320-279-10 Spare tire removed.
None	TM 9-2320-279-10 Engine side panels removed.
<i>supplies</i>	TM 9-2320-279-20 Engine cover removed.
Ties, cable, plastic, Item 65, Appendix C	TM 9-2320-279-20 Splash guards removed.
<i>Personnel Required</i>	TM 9-2320-279-20 Starter relay removed.
MOS 63W, Wheel vehicle repairer (2)	Para 12-6 Pitman arm removed.
<i>References</i>	<i>Special Environmental Conditions</i>
None	None
	<i>General Safety Instructions</i>
	None
	<i>Level of Maintenance</i>
	Direct Support

Frame Maintenance Instructions (Cont)

a. Removal.

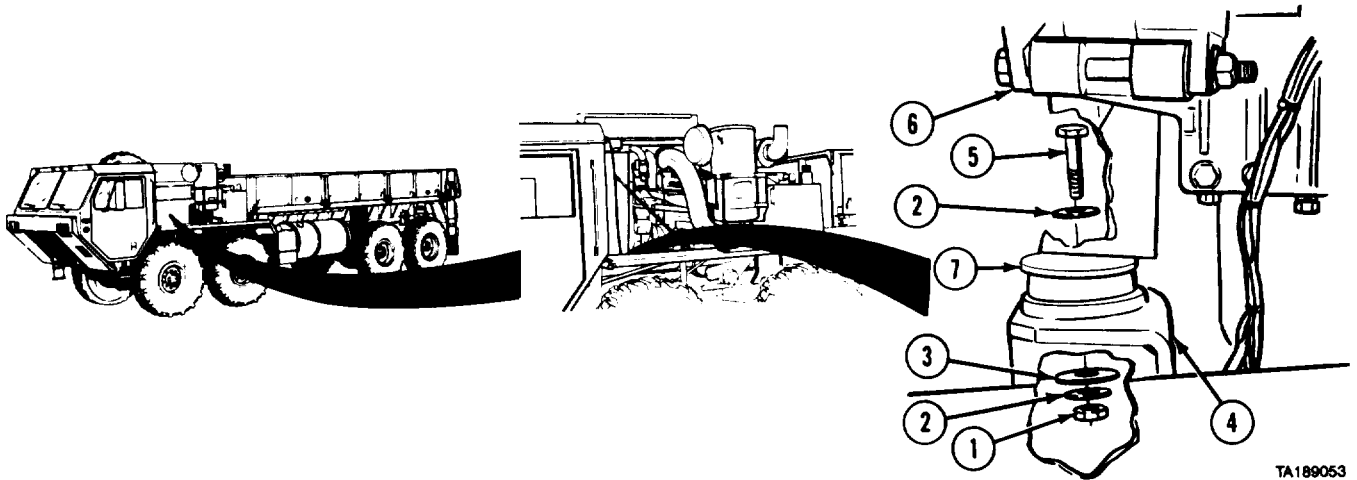

- (1) Soldier A removes nut (1) and two washers (2 and 3) from each side of engine support (4) while Soldier B removes screw (5) and washer (2).

WARNING

Keep out from under engine supported by hoist to prevent personal injury.

NOTE

When removing spacers, lift engine only enough to clear engine support.

- (2) Install suitable lifting device and raise engine (6) from engine support (4). Install suitable blocking to support engine.
- (3) Remove spacer (7) from each side of engine support (4).

NOTE

Remove hose clips and plastic cable ties as required.

- (4) Soldier A removes three nuts (8) on left side of front engine support (4) while Soldier B removes two screws (9) and screw (10).

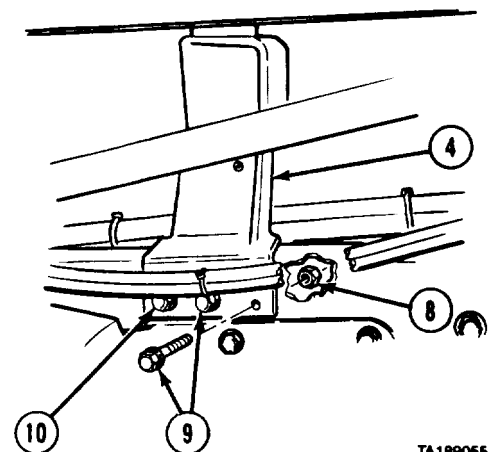

TA189055

Frame Maintenance Instructions (Cont)

13-5. ENGINE SUPPORT REMOVAL/INSTALLATION (CONT).

- (5) Soldier A removes three locknuts (11) on right side of front engine support (4) while Soldier B removes two screws (12) and screw (13).

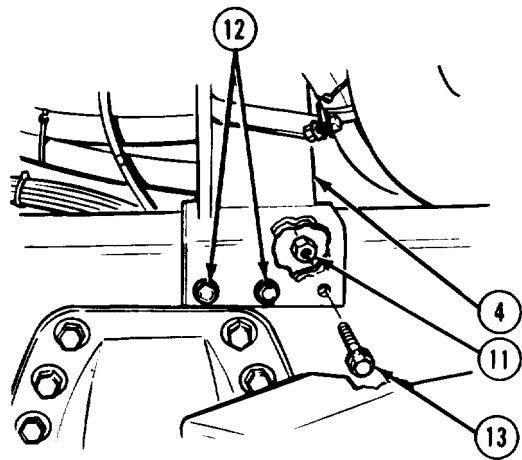

TA189056

- (6) Soldier A and Soldier B lay front engine support (4) on its side and remove from left side of vehicle.

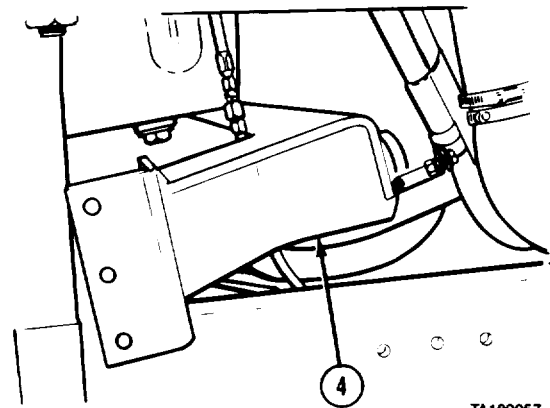

TA189057

- (7) Remove rubber biscuit (14) from each side of front engine support (4).

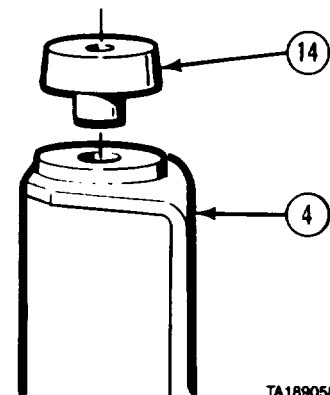

TA189058

Frame Maintenance Instructions (Cont)

b. Installation.

- (1) Install rubber biscuit (1) in each side of front engine support (2).

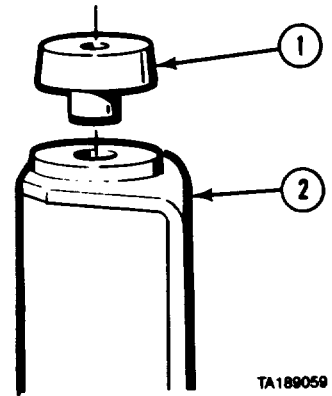

TA189059

- (2) Soldier A and Soldier B lay front engine support (2) on its side and install on left side of vehicle.

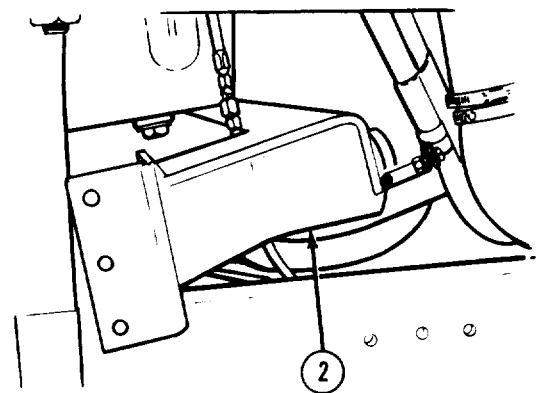

TA189060

NOTE

Install hose clips and plastic cable ties as required.

- (3) Soldier A installs and tightens screw (3) and two screws (4) in right side of front engine support (2) while Soldier B installs three locknuts (5).

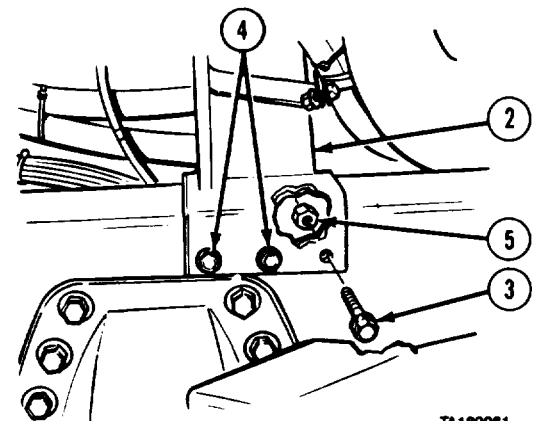

TA189061

Frame Maintenance Instructions (Cont)

13-5. ENGINE SUPPORT REMOVAL/INSTALLATION (CONT).

- (4) Soldier A installs and tightens two screws (6) and screw (7) in left side of front engine support (2) while Soldier B installs three nuts (8).

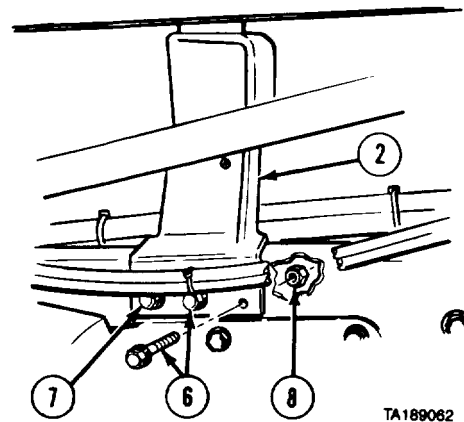

- (5) Install spacer (9) on each rubber biscuit (1).
 (6) Raise engine (10) with suitable lifting device, remove blocking, and lower engine to engine support (2).
 (7) Soldier A installs and tightens screw (11) and washer (12) on each side of engine support (2) while Soldier B installs two washers (12 and 13) and nut (14) on screw (11).

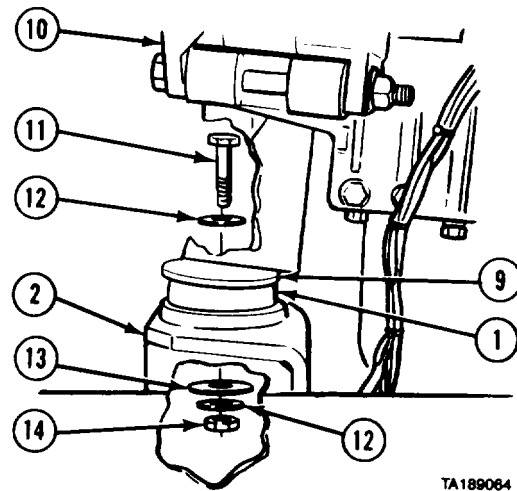

c. Follow-on Maintenance.

- (1) Install pitman arm (para 12-6).
 (2) Install starter relay (TM 9-2320-279-20).
 (3) Install splash guards (TM 9-2320-279-20).
 (4) Install engine side panels (TM 9-2320-279-10).
 (5) Install engine cover (TM 9-2320-279-20),
 (6) Connect batteries (TM 9-2320-279-20).
 (7) Install spare tire (TM 9-2320-279-10).

END OF TASK

Frame Maintenance Instructions (Cont)

13.6 LIFT BRACKET ASSEMBLIES REMOVAL/INSTALLATION.	
This task covers:	
a. Removal b. Installation	c. Follow-on Maintenance
INITIAL SETUP	
<i>Models</i> All	<i>Equipment Condition</i> <i>TM or Para</i> <i>Condition Description</i>
<i>Test Equipment</i> None	TM 9-2320-279-10 Wheels and tires removed from No. 2 axle.
<i>Special Tools</i> None	TM 9-2320-279-10 Tire winch hoist arm and extension removed.
<i>Supplies</i> None	TM 9-2320-279-20 Batteries disconnected. TM 9-2320-279-20 Splash guards removed. TM 9-2320-279-20 Propeller shaft removed from No. 1 and No. 2 axle.
<i>Personnel Required</i> MOS 63W, Wheel vehicle repairer (2)	<i>Special Environmental Conditions</i> None
<i>References</i> None	<i>General Safety Instructions</i> Do not work under vehicle unless vehicle is supported with jackstands.
	<i>Level of Maintenance</i> Direct Support

a. Removal.

NOTE

Left and right lift bracket assemblies are removed the same way. Right side is shown.

- (1) Remove two screws (1), lockwashers (2), wedge washers (3), spacers (4), and tube brace (5).
- (2) Attach suitable lifting device to lift bracket assembly (6 or 7).

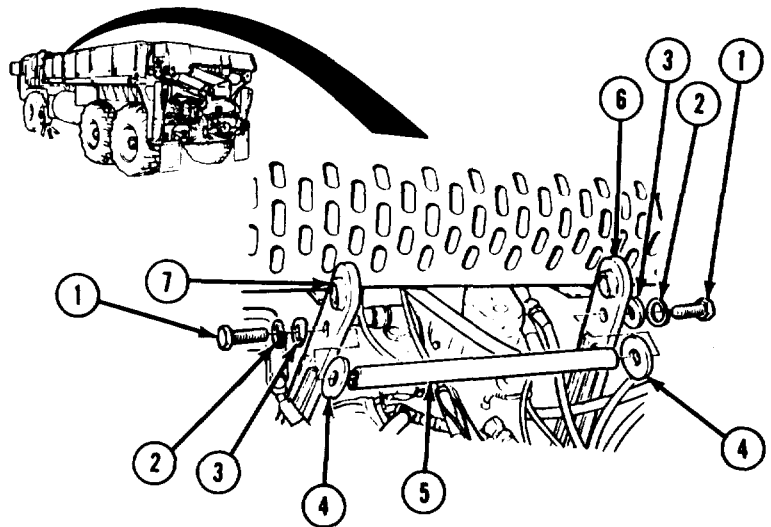

TA169065

Frame Maintenance Instructions (Cont)

13-6. LIFT BRACKET ASSEMBLIES REMOVAL/INSTALLATION (CONT).

- (3) Soldier A removes four screws (8) while Soldier B removes four nuts (9).

NOTE

Bracket is on right side only.

- (4) Soldier A removes two screws (10) while Soldier B removes two nuts (11) and bracket (12).

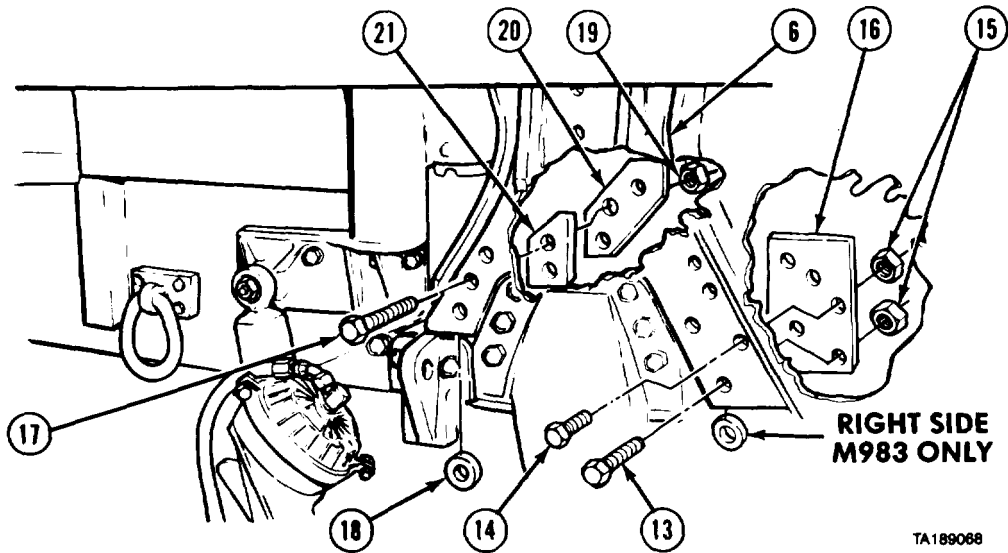
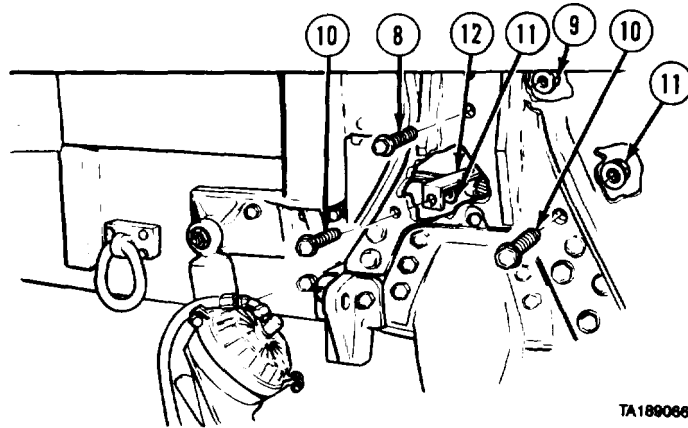

NOTE

M983 vehicle has round spacer at bottom hole of lift bracket. One screw is shorter on right side only.

- (5) Soldier A removes three screws (13) and screw (14) while Soldier B removes four nuts (15) and spacer (16).

NOTE

Round spacer is found on all vehicles except M983.

- (6) Soldier A removes two screws (17) and round spacer (18) while Soldier B removes two nuts (19) and spacers (20 and 21).
- (7) Soldier A operates lifting device and lowers lift bracket (6) from vehicle while Soldier B guides bracket.

Frame Maintenance Instructions (Cont)

b. Installation.

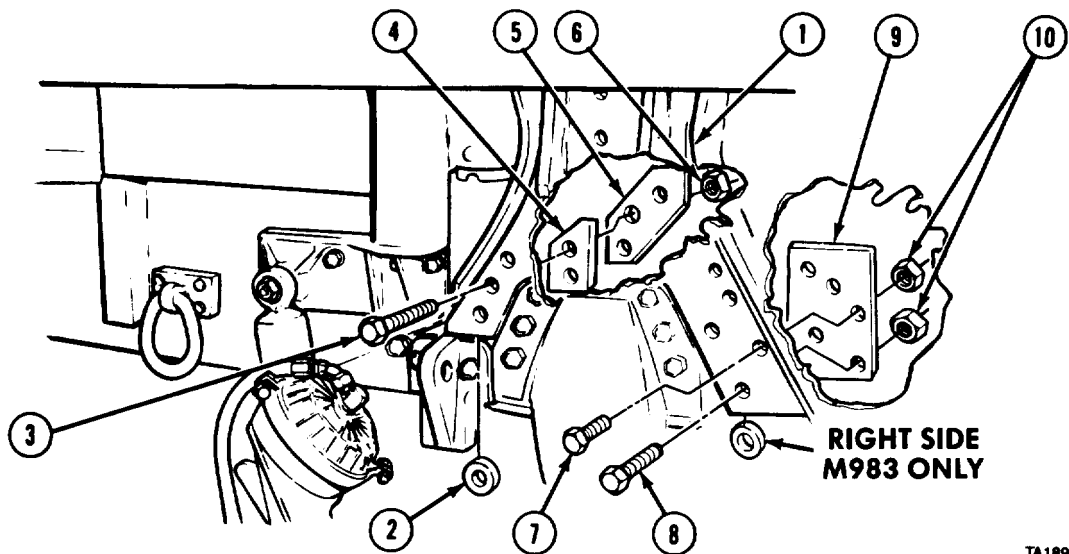

TA189070

NOTE

Left and right lift bracket assemblies are installed the same way.

- (1) Soldier A operates lifting device and positions lift bracket (1) on vehicle while Soldier B guides bracket and aligns holes.

NOTE

Do not install round spacer on M983 vehicles.

- (2) Soldier A installs round spacer (2) and two screws (3) while Soldier B installs two spacers (4 and 5) and nuts (6).

NOTE

Install round spacer at bottom hole of lift bracket on M983 only.

- (3) Soldier A installs screw (7) and three screws (8) while Soldier B installs spacer (9) and four nuts (10).

- (4) Install four screws (11) and nuts (12).
- (5) Soldier A installs two screws (13) while Soldier B installs bracket (14) and two nuts (15).

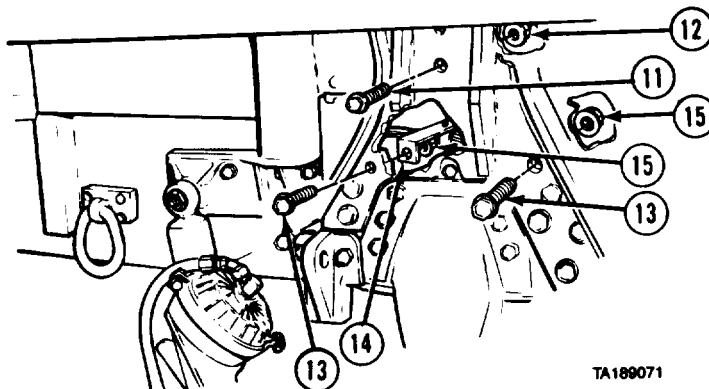

TA189071

Frame Maintenance Instructions (Cont)

13-6. LIFT BRACKET ASSEMBLIES REMOVAL/INSTALLATION (CONT.)

- (6) Install tube brace (16), two spacers (17), wedge washers (18), lockwashers (19), and screws (20).
- (7) Remove lifting device from lift bracket (1 or 21).

c. Follow-on Maintenance.

- (1) Install propeller shaft on No. 1 and No. 2 axle (TM 9-2320-279-20).
- (2) Install splash guards (TM 9-2320-279-20).
- (3) Connect batteries (TM 9-2320-279-20).
- (4) Install wheels and tires on No. 2 axle (TM 9-2320-279-10).
- (5) Install winch hoist arm and extension (TM 9-2320-279- 10).

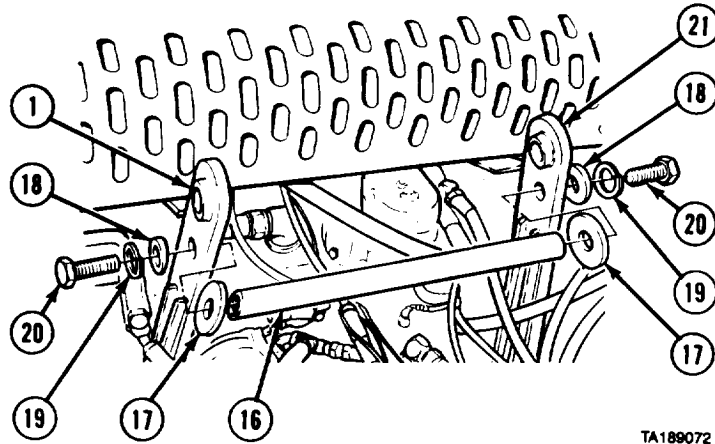

TA189072

END OF TASK

13-7. TRANSMISSION SUPPORT REMOVAL/INSTALLATION.	
This task covers:	
a. Removal	c. Follow-on Maintenance
b. Installation	
INITIAL SETUP	
<i>Models</i>	<i>Equipment Condition</i>
All	<i>TM or Para</i>
<i>Test Equipment</i>	<i>Condition Description</i>
None	TM 9-2320-279-20 Fuel can stowage box removed (M978).
<i>Special Tools</i>	Para 15-9 Cargo body floor hatch removed (M977, M985).
None	TM 9-2320-279-20 Engine cover removed.
<i>Supplies</i>	TM 9-2320-279-10 Engine side panels removed.
Oil, lubricating, Item 48, Appendix C	TM 9-2320-279-20 Splash guards removed.
<i>Personnel Required</i>	TM 9-2320-279-20 Generator removed (M983).
MOS 63W, Wheel vehicle repairer (2)	Para 13-6 Lift bracket assemblies removed.
<i>References</i>	<i>Special Environmental Conditions</i>
None	None
<i>Equipment Condition</i>	<i>General Safety Instructions</i>
TM or Para	None
Condition Description	<i>Level of Maintenance</i>
TM 9-2320-279-10 Shut off engine.	Direct Support
TM 9-2320-279-10 Cargo body front panel removed (M977, M985).	

Frame Maintenance Instructions (Cont)

a. Removal.

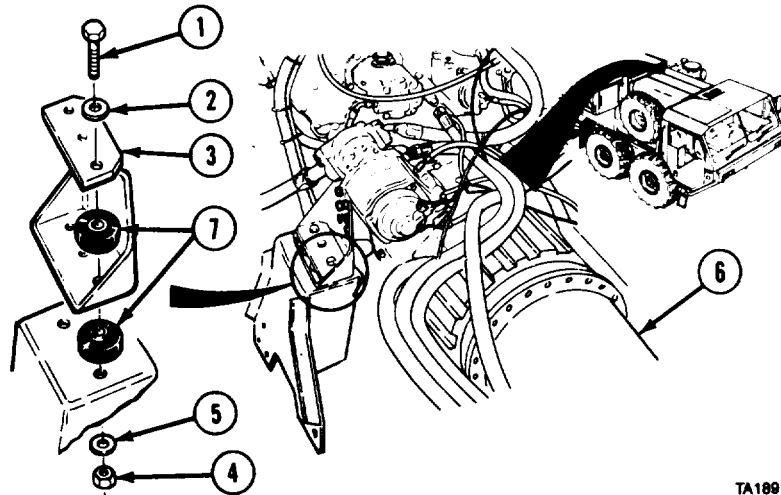

TA189169

NOTE

Left and right transmission supports are removed the same way.

- (1) Soldier A removes three screws (1), washers (2), and plate (3) while Soldier B removes locknuts (4) and washers (5).

NOTE

Transmission should be lifted just enough to take weight off supports and provide clearance for removing rubber mounts.

- (2) Support transmission (6) with suitable lifting device.
- (3) Remove six rubber mounts (7).

NOTE

Steps (4) and (5) apply to left transmission support.

- (4) Remove two screws (8), nuts (9), and lockwashers (10).
- (5) Pull manifold block (11) away from transmission support (12).

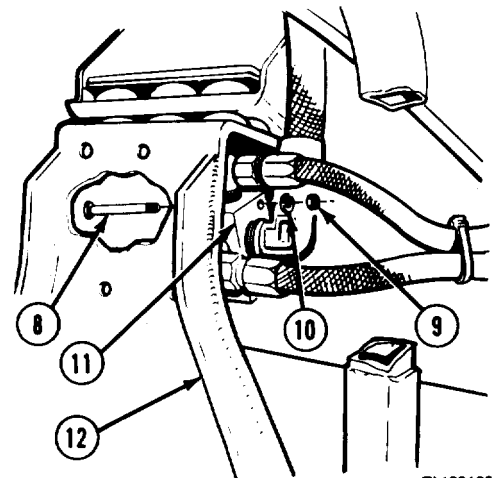

TA189168

Frame Maintenance Instructions (Cont)

13-7. TRANSMISSION SUPPORT REMOVAL/INSTALLATION (CONT).

NOTE

- M983 vehicle has only round spacers.
 - Spacers may drop from frame rail as soon as transmission support is loosened.
- (6) Remove one locknut (13), screw (14), and two spacers (15 and 16).
- (7) Remove transmission support (12) from vehicle.

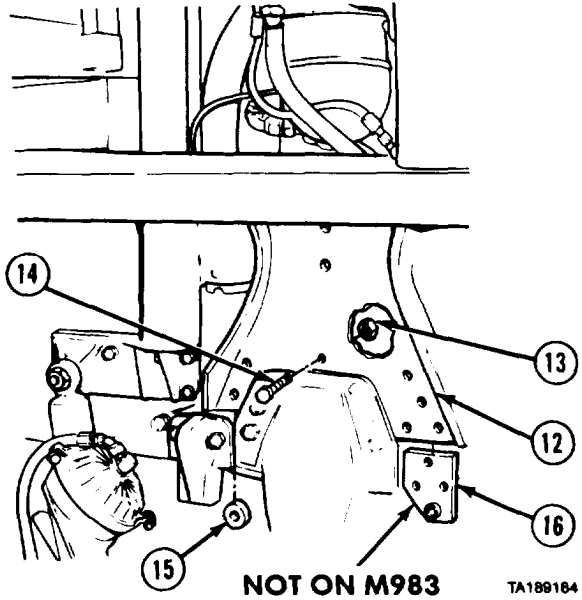

b. Installation.

NOTE

- Left and right transmission supports are installed the same way.
 - Install hose clips and tie wraps as required.
 - It may be necessary to wait to install spacers until vehicle lift bracket assemblies are installed (para 13-6).
- (1) Install transmission support (1) with one screw (2), locknut (3), and two spacers (4 and 5).

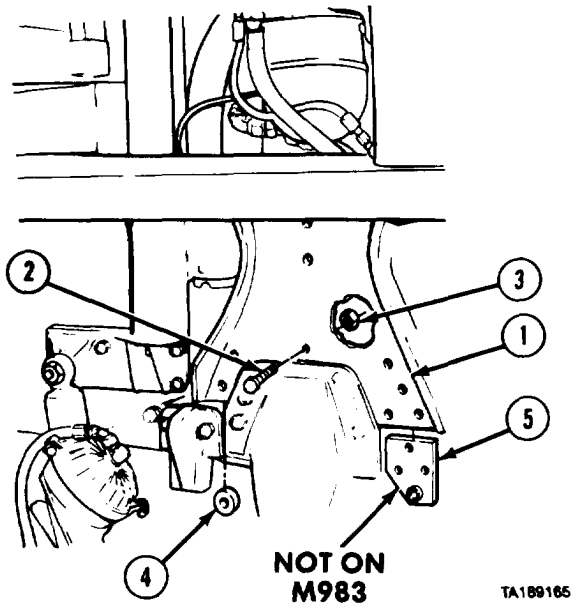

Frame Maintenance Instructions (Cont)

- (2) Install six rubber mounts (6) and plate (7).
- (3) Soldier A operates suitable lifting device while Soldier B guides transmission (8) into position over transmission support (9).
- (4) Soldier A lowers transmission (8) into position guided by Soldier B.
- (5) Lubricate three screws (10) with oil and install with washers (11).
- (6) Install three washers (12) and locknuts (13).
- (7) Tighten screws (10) to 170 lb-ft (231 N.m).

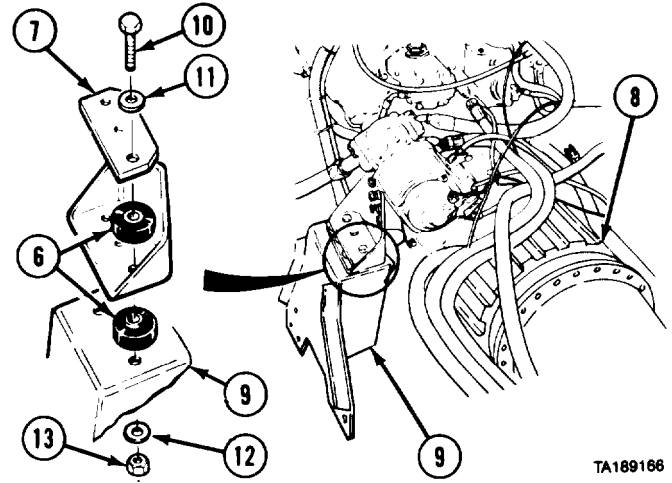

- (8) Aline holes in manifold block (14) with holes in transmission support (9).
- (9) Install two screws (15), lockwashers (16), and nuts (17).

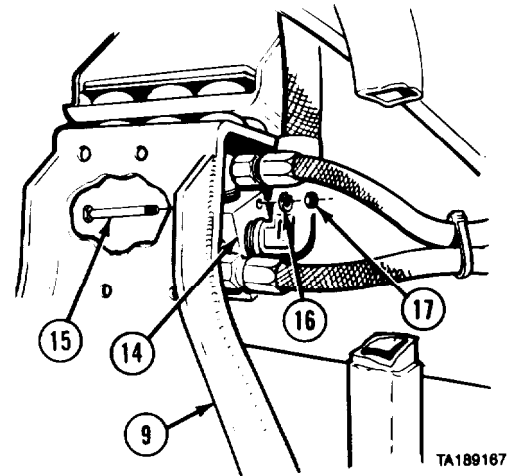

c. Follow-on Maintenance.

- (1) Install lift bracket assemblies (para 13-6).
- (2) Install generator (M983) (TM 9-2320-279-20).
- (3) Install splash guards (TM 9-2320-279-20).
- (4) Install engine side panels (TM 9-2320-279-10).
- (5) Install engine cover (TM 9-2320-279-20).
- (6) Install cargo body floor hatch (M977, M985) (para 15-9).
- (7) Install fuel can stowage box (M978) (TM 9-2320-279-20).
- (8) Install cargo body front panel (M977, M985) (TM 9-2320-279-10).

END OF TASK

Frame Maintenance Instructions (Cont)

13-8. TRANSFER CASE SUPPORT ASSEMBLY REMOVAL/INSTALLATION.	
This task covers:	
a. Removal	c. Follow-on Maintenance
b. Installation	
INITIAL SETUP	
<i>Models</i>	<i>Equipment Condition</i>
All	TM or Para
<i>Test Equipment</i>	Condition Description
None	TM 9-2320-279-10 Shut off engine.
	TM 9-2320-279-20 Fuel tank removed.
<i>Special Tools</i>	<i>Special Environmental Conditions</i>
None	None
<i>Supplies</i>	<i>General Safety Instructions</i>
None	None
<i>Personnel Required</i>	<i>Level of Maintenance</i>
MOS 63W, Wheel vehicle repairer (2)	Direct Support
<i>References</i>	
None	

a. Removal.

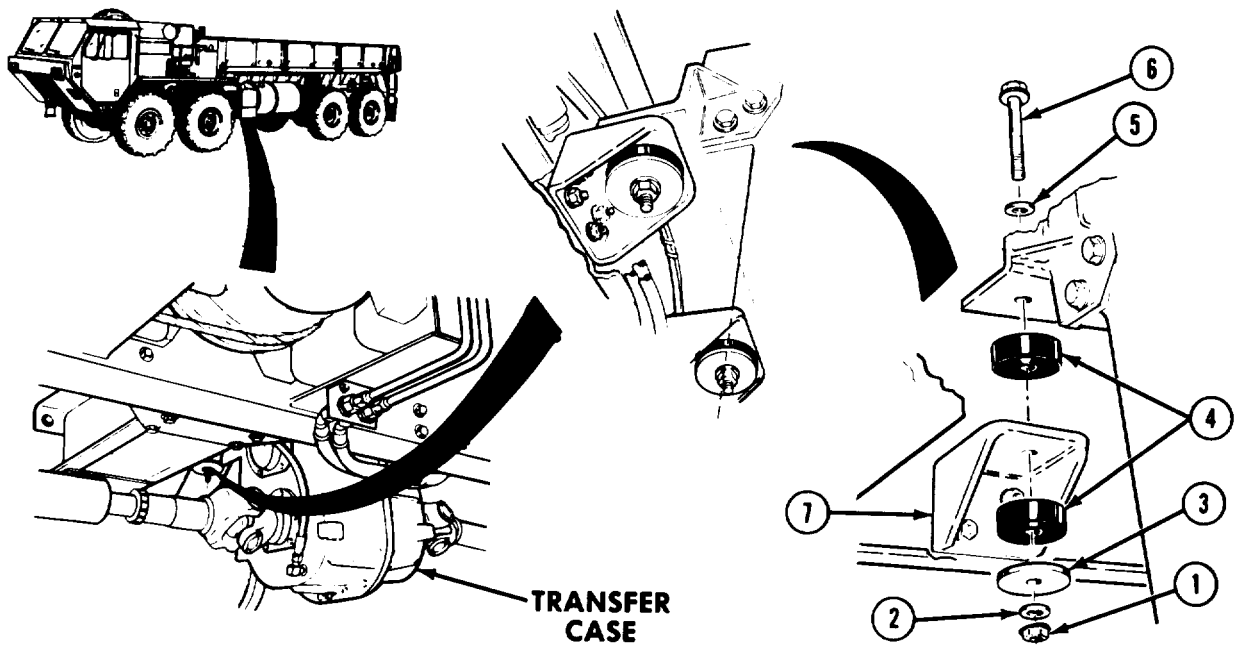

TA189075

- (1) Soldier A and Soldier B support transfer case with suitable lifting device.
- (2) Remove nut (1), washer (2), spacers (3), two biscuits (4), washer (5), and screw (6) each from two left side transfer case support assemblies (7).

Frame Maintenance Instructions (Cont)

- (3) Remove two nuts (8), washers (9), plate (10), four biscuits (11), two washers (12), and two screws (13) from right side transfer case support assembly (14).

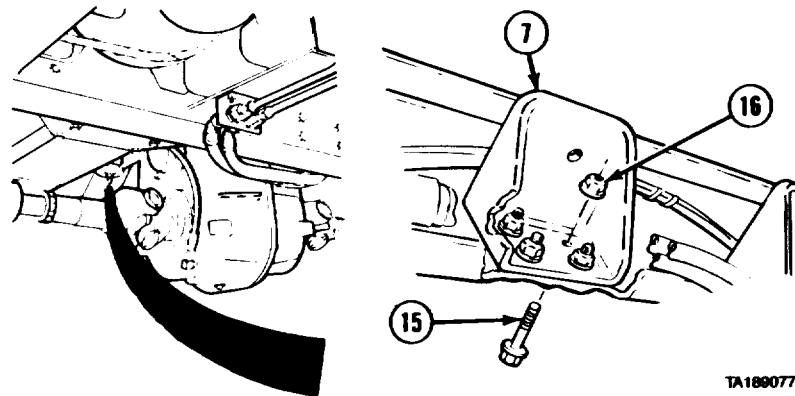
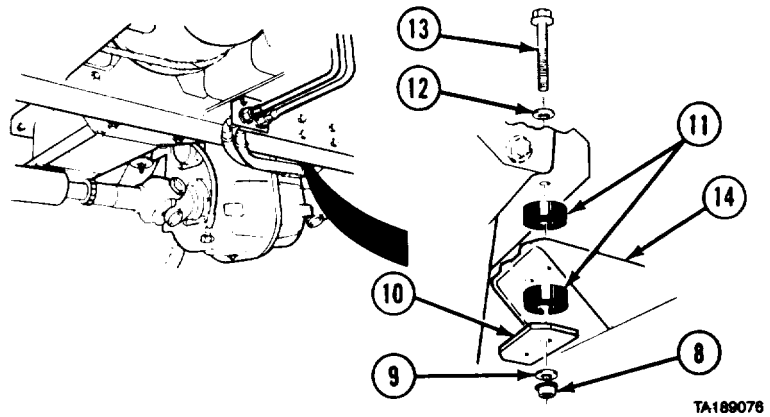

- (4) Soldier A removes eight screws (15) from two left side transfer case support assemblies (7), while Soldier B removes eight nuts (16) and transfer case support assemblies.
- (5) Soldier A removes four screws (17) while Soldier B removes four nuts (18) and right side transfer case support assembly (14).

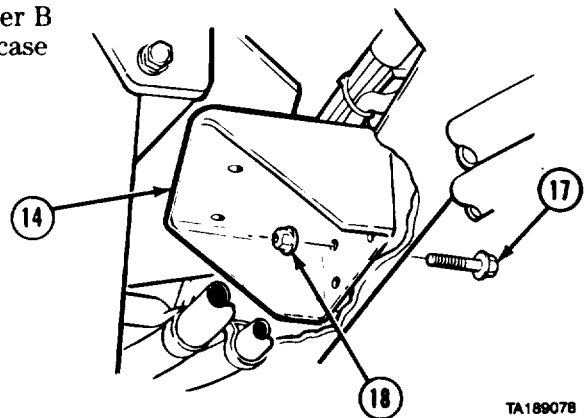

Frame Maintenance Instructions (Cont)

13-8. TRANSFER CASE SUPPORT ASSEMBLY REMOVAL/INSTALLATION (CONT.)

b. Installation.

- (1) Soldier A installs right side transfer case support assembly (1) and holds four nuts (2) while Soldier B installs four screws (3).

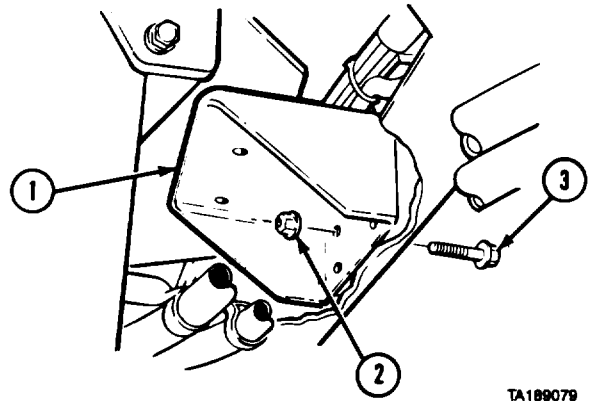

TA189079

- (2) Soldier A installs two left side transfer case support assemblies (4) and four nuts (5) while Soldier B installs four screws (6).

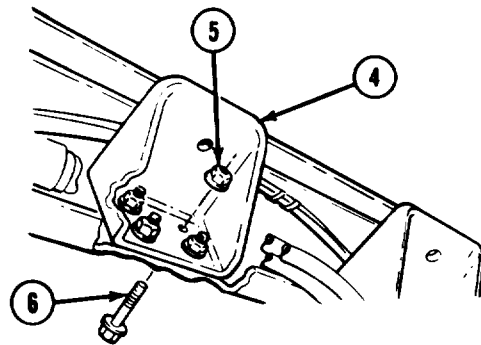

TA189080

- (3) Install two screws (7), two washers (8), four biscuits (9), plate (10), two washers (11), and two nuts (12) through transfer case (13) and right side transfer case support assembly (1).

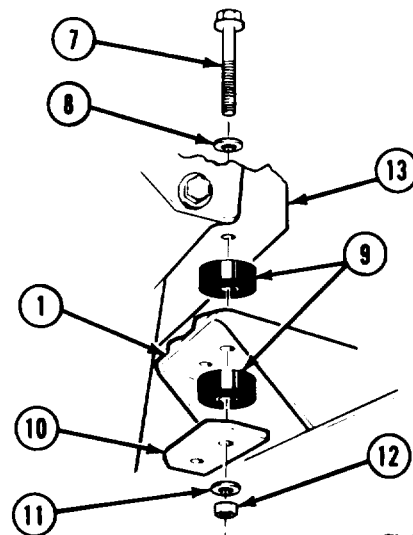

TA189081

Frame Maintenance Instructions (Cont)

- (4) Install screw (14) with washer (15), two biscuits (16), spacer (17), washer (18), and nut (19) each in two left side transfer case support assemblies (4).

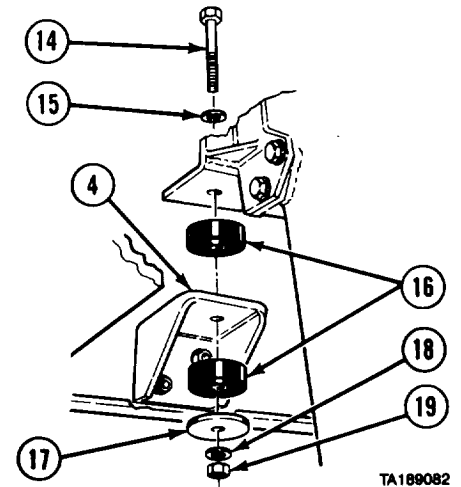

- c. *Follow-on Maintenance.* Install fuel tank (TM 9-2320-279-20).

END OF TASK

13-9. SPRING HANGER REMOVAL/INSTALLATION.	
his task covers:	
<ul style="list-style-type: none"> a. Front Tandem Spring Hangers Removal b. Front Tandem Spring Hangers Installation c. Rear Tandem Spring Hangers Removal 	<ul style="list-style-type: none"> d. Rear Tandem Spring Hangers Installation e. Follow-on Maintenance
INITIAL SETUP	
<i>Models</i>	<i>Equipment Condition</i>
All	<i>TM or Para</i>
<i>Test Equipment</i>	Para 14-2
None	<i>Condition Description</i>
<i>Special Tools</i>	Spring removed.
None	<i>Special Environmental Conditions</i>
<i>Supplies</i>	None
None	<i>General Safety Instructions</i>
<i>Personnel Required</i>	Wheels chocked.
MOS 63W, Wheel vehicle repairer (2)	<i>Level of Maintenance</i>
<i>References</i>	Direct Support
None	

Frame Maintenance Instructions (Cont)

13-9. SPRING HANGER REMOVAL/INSTALLATION (CONT.)

a. Front Tandem Spring Hangers Removal.

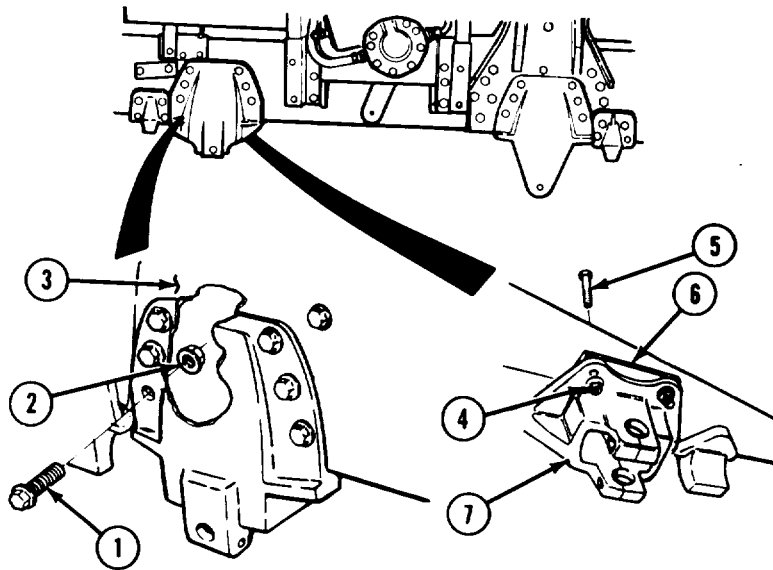

TA357312

- (1) Soldier A removes six screws (1) while Soldier B removes nuts (2) on inside of frame (3).
- (2) Soldier A removes two nuts (4) and screws (5) while Soldier B removes spacer (6) and hanger (7).

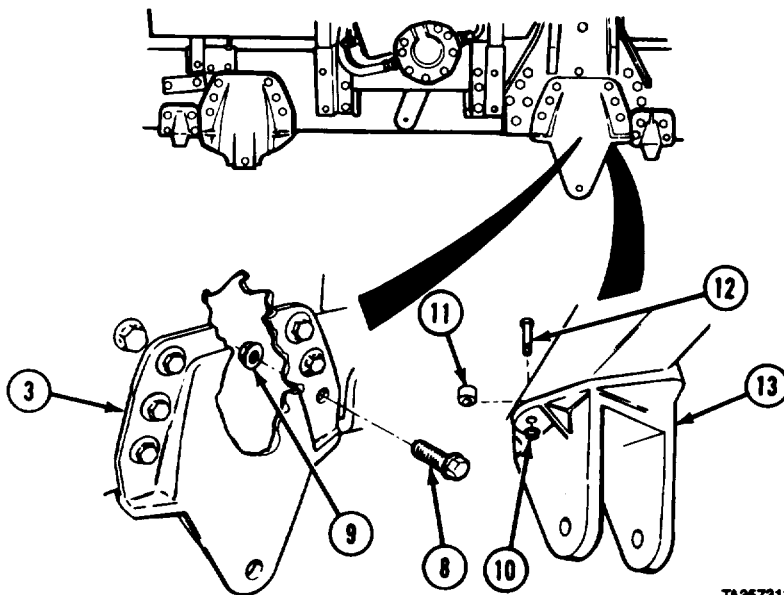

TA367313

- (3) Soldier A removes six screws (8) while Soldier B removes nuts (9) on inside of frame (3),
- (4) Soldier A removes nut (10), spacer (11), and screw (12) while Soldier B removes spring hanger (13).

Frame Maintenance Instructions (Cont)

b. Front tandem Spring Hangers Installation.

- (1) Soldier A installs nuts (1) on back of frame (2) while Soldier B installs spring hanger (3) with six screws (4). Do not tighten screws.
- (2) Install spacer (5), screw (6) and nut (7).
- (3) Soldier A and Soldier B tighten nuts (1 and 7) and screws (4 and 6).

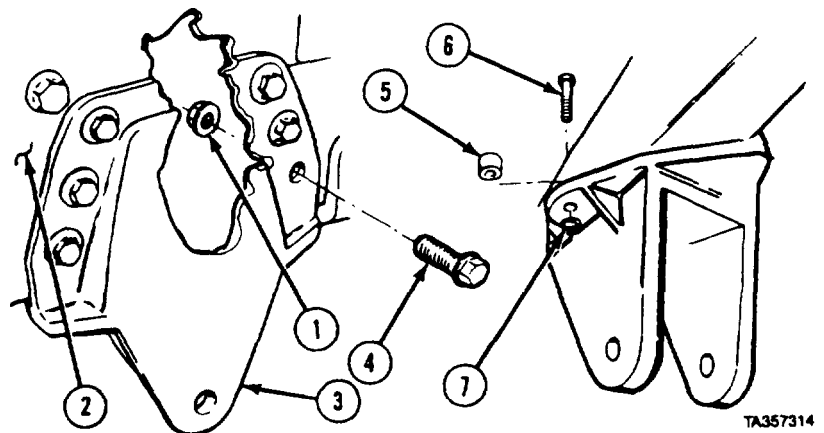

TA357314

- (4) Soldier A installs six nuts (8) while Soldier B installs hanger (9) with six screws (10). Do not tighten screws.
- (5) Install spacer (11), two screws (12), and nuts (13).
- (6) Soldier A and Soldier B tighten nuts (8 and 13) and screws (10 and 12).

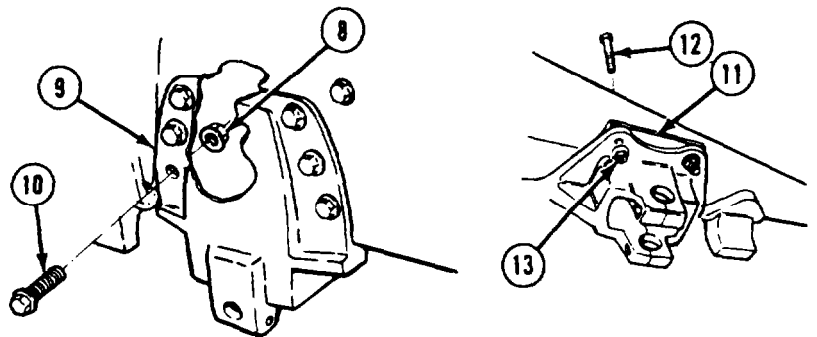

TA357315

c. Rear Tandem Spring Hangers Removal.

NOTE

Only M984E1 has bracket and air line.

- (1) Soldier A removes six screws (1) while Soldier B removes nuts (2) and moves bracket and air line (3) aside.
- (2) Soldier A removes two nuts (4), screws (5), and spacers (6) while Soldier B removes hanger (7).

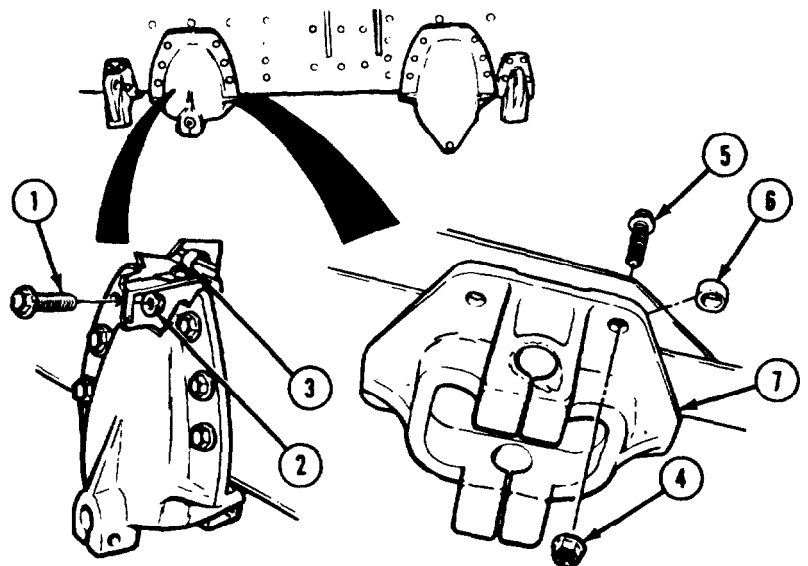

M984E1 LEFT SPRING HANGER-SHOWN.
ALL MODELS SIMILAR.

TA357316

Frame Maintenance Instructions (Cont)

13-9. SPRING HANGER REMOVAL/INSTALLATION (CONT).

NOTE

- M978 left rear spring hanger and M984E1 right rear spring hanger have bracket.
 - M984E1 may have a bracket on each right side spring hanger.
- (3) Soldier A removes six screws (8) while Soldier B removes nuts (9) and bracket (10).
 - (4) Soldier A removes two nuts (11), screws (12), and spacers (13) while Soldier B removes spring hanger (14).

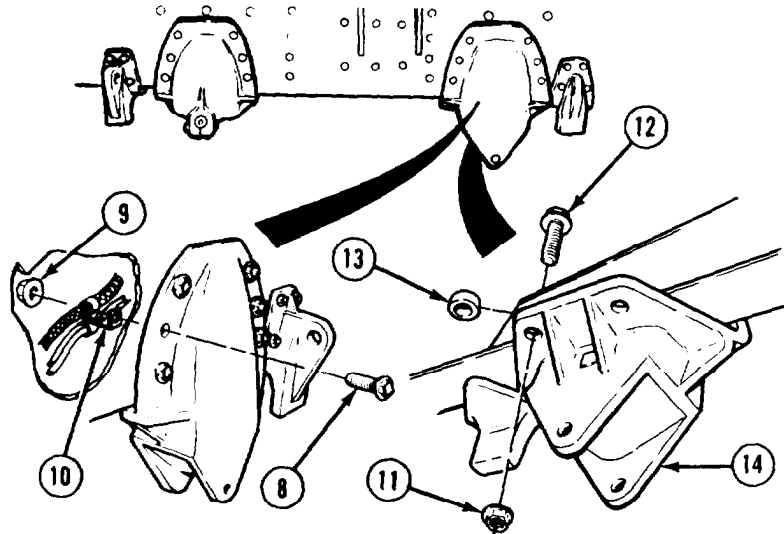

LEFT REAR SPRING HANGER SHOWN

d. Rear Tandem Spring Hangers Installation.

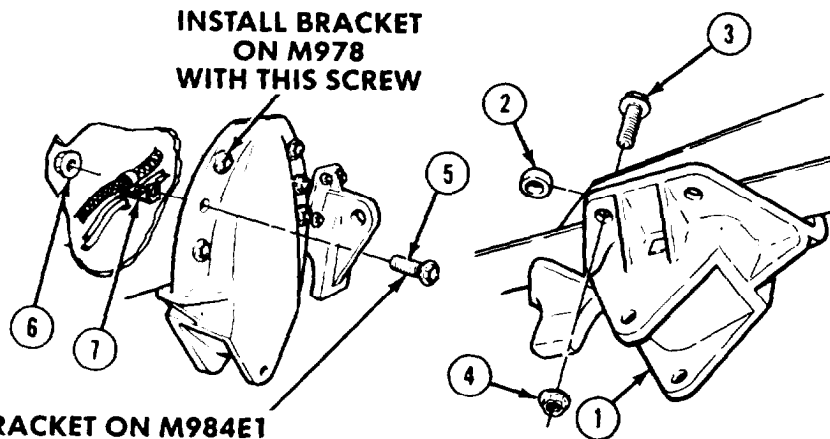

INSTALL BRACKET ON M978 WITH THIS SCREW

INSTALL BRACKET ON M984E1 WITH THIS SCREW

LEFT REAR SPRING HANGER SHOWN

- (1) Soldier A installs spring hanger (1) while Soldier B installs two spacers (2), screws (3), and nuts (4). Do not tighten screws.

NOTE

- M978 left rear spring hanger and M984E1 right rear spring hanger have bracket.
 - M984E1 may have a bracket on each right side spring hanger.
- (2) Soldier A installs six screws (5) while Soldier B installs bracket (7) and nuts (6). Do not tighten nuts.
 - (3) Soldier A and Soldier B tighten eight screws (3 and 5) and nuts (4 and 8).

Frame Maintenance Instructions (Cont)

- (5) Soldier A installs spring hanger (8) while Soldier B installs two spacers (9), screws (10), and nuts (11). Do not tighten nuts.
- (6) Soldier A installs six screws (12) while Soldier B installs bracket and air line (13) and six nuts (14). Do not tighten nuts.
- (7) Soldier A and Soldier B tighten eight screws (10 and 12) and nuts (11 and 14).

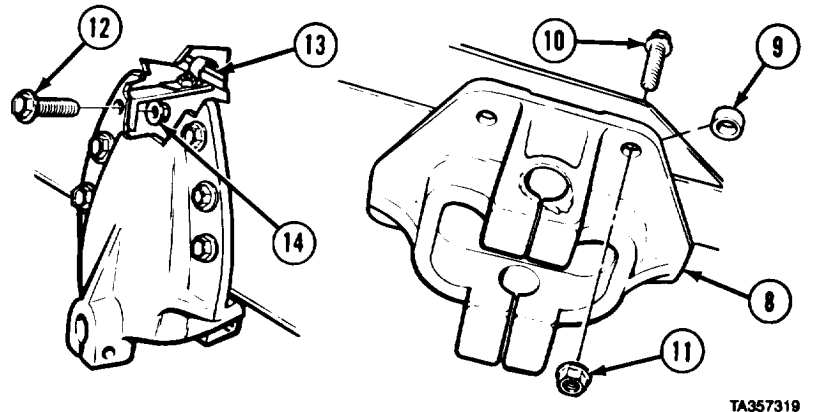

e. Follow-on Maintenance. Install springs (para 14-2)

END OF TASK

13-10. FRONT CROSSMEMBER REMOVAL/INSTALLATION.	
This task covers:	
<ul style="list-style-type: none"> a. Removal b. Installation 	<ul style="list-style-type: none"> c. Follow-on Maintenance
INITIAL SETUP	
<i>Models</i>	<i>Equipment Condition</i>
All	<i>TM or Para</i> <i>Condition Description</i>
<i>Test Equipment</i>	TM 9-2320-279-10 Air system drained.
None	TM 9-2320-279-20 (M984E1) Quick release valve removed.
<i>Special Tools</i>	<i>Special Environmental Conditions</i>
None	None
<i>Supplies</i>	<i>General Safety Instructions</i>
Tags, identification, Item 60, Appendix C	None
<i>Personnel Required</i>	<i>Level of Maintenance</i>
MOS 63W, Wheel vehicle repairer	Direct Support
<i>References</i>	
None	

Frame Maintenance Instructions (Cont)

13-10. FRONT CROSSMEMBER REMOVAL/INSTALLATION (CONT).

a. Removal.

NOTE

Tag and mark air lines before disconnecting.

- (1) Disconnect two air lines (1).
- (2) Remove four screws (2), lockwashers (3), lockwashers (4), four nuts (5), bracket (6), and ground wire (7).

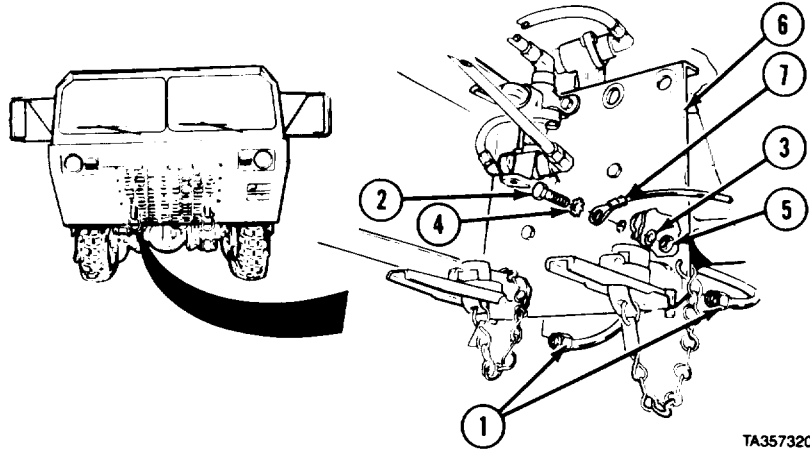

TA357320

- (3) Remove four nuts (8), screws (9), and eight washers (10).
- (4) Remove torque rod (11).

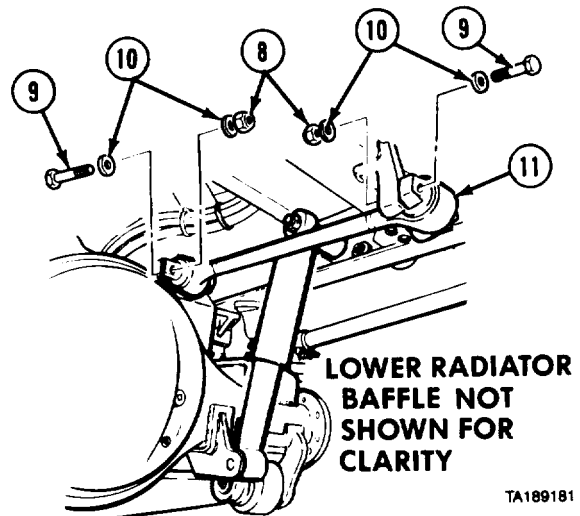

TA189181

- (5) Remove two screws (12) from radiator baffle (13) and top of crossmember (14).

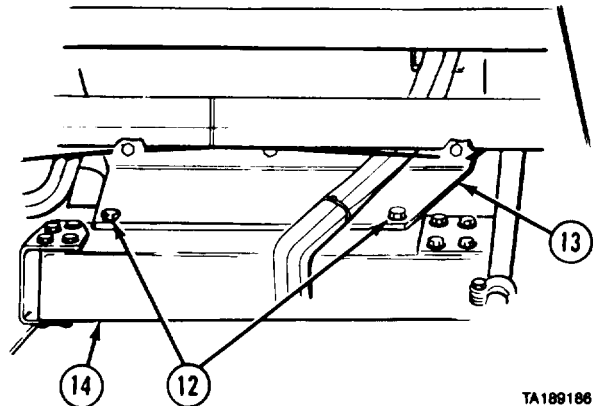

TA189186

Frame Maintenance Instructions (Cont)

- (6) Remove 16 locknuts (15) and screws (16) from top and bottom of crossmember (14).
- (7) Remove crossmember (14).
- (8) Remove eight screws (17), nuts (18), and two crossmember brackets (19).

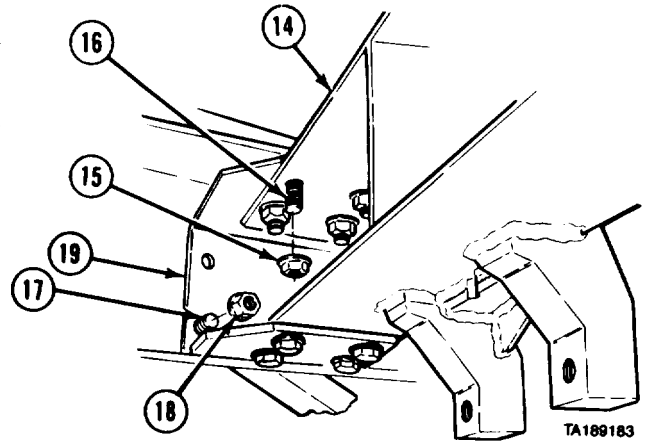

b. Installation.

NOTE

Chamfered side of bracket faces rear of vehicle.

- (1) Install two crossmember brackets (1) with eight screws (2) and locknuts (3). Do not tighten.
- (2) Install crossmember (4) with 16 screws (5) and locknuts (6).
- (3) Tighten nuts (3) on two crossmember brackets (1).

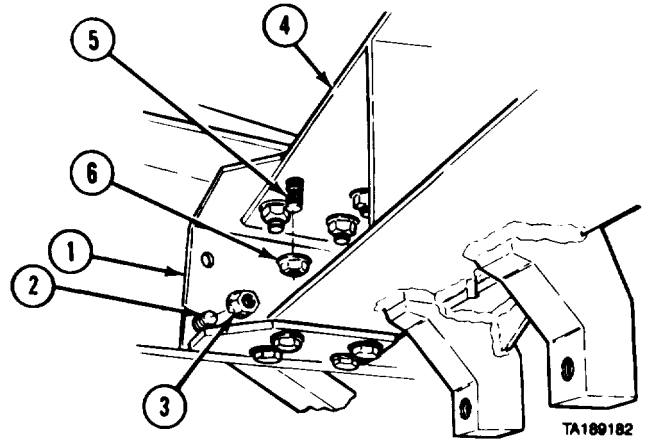

NOTE

- Tighten nuts on M984 to 280 lb-ft (379 N.m).
- Tighten nuts on M984E1 to 460 lb-ft (623 N.m).
- Tighten nuts on all other vehicles to 170 lb-ft (230 N.m).
- (4) Install torque rod (7) with four screws (8), eight washers (9), and four nuts (10).

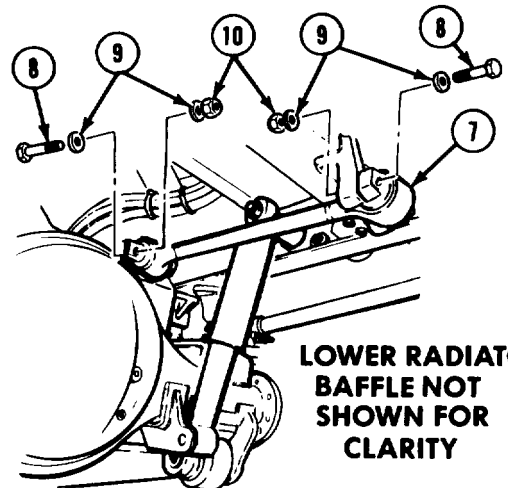

**LOWER RADIATOR
BAFFLE NOT
SHOWN FOR
CLARITY**

TA189180

Frame Maintenance Instructions (Cont)

13-10. FRONT CROSSMEMBER REMOVAL/INSTALLATION (CONT).

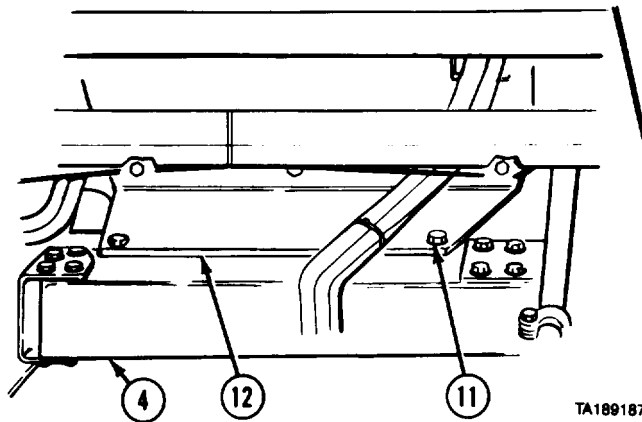

TA189187

(5) Install two screws (11) in radiator baffle (12) and crossmember (4).

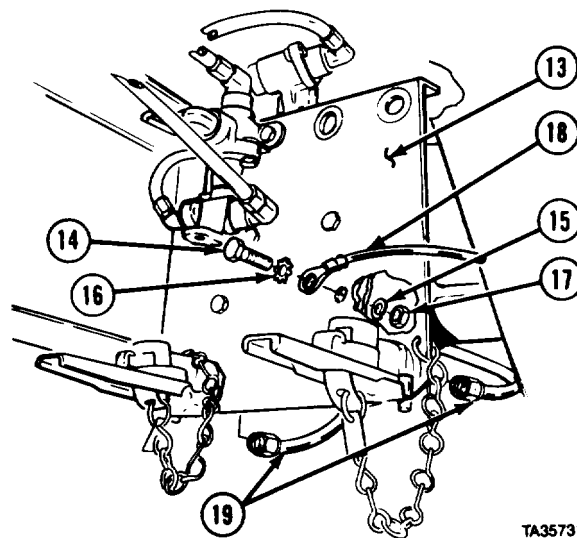

TA357311

- (6) Install bracket (13) with four screws (14), lockwashers (15), lockwasher (16), four nuts (17), and ground wire (18).
- (7) Connect two air lines (19).

c. Follow-on Maintenance.

- (1) (M984E1) Install quick release valve (TM 9-2320-279-20).
- (2) Start engine, build up air pressure, and check for air leaks (TM 9-2320-279-10).

END OF TASK

Frame Maintenance Instructions (Cont)

13-11. FRONT TANDEM CROSSMEMBER REMOVAL/INSTALLATION.

This task covers:

- a. Removal
- b. Installation
- c. Follow-on Maintenance

INITIAL SETUP

<p><i>Models</i> All</p> <p><i>Test Equipment</i> None</p> <p><i>Special Tools</i> None</p> <p><i>Supplies</i> Oil, lubricating, Item 31, Appendix C Ties, cable, plastic, Item 65, Appendix C</p> <p><i>Personnel Required</i> MOS 63W, Wheel vehicle repairer (2)</p> <p><i>References</i> None</p>	<p><i>Equipment Condition</i> TM or Para <i>Condition Description</i> TM 9-2320-279-20 Front brake relay valve removed.</p> <p>TM 9-2320-279-20 Front cable tensioner removed. (Optional on M977, M978, and M985).</p> <p>TM 9-2320-279-20 Front propeller shaft removed.</p> <p>TM 9-2320-279-20 Batteries disconnected.</p> <p><i>Special Environmental Conditions</i> None</p> <p><i>General Safety Instruction</i> None</p> <p><i>Level of Maintenance</i> Direct Support</p>
---	--

a. Removal.

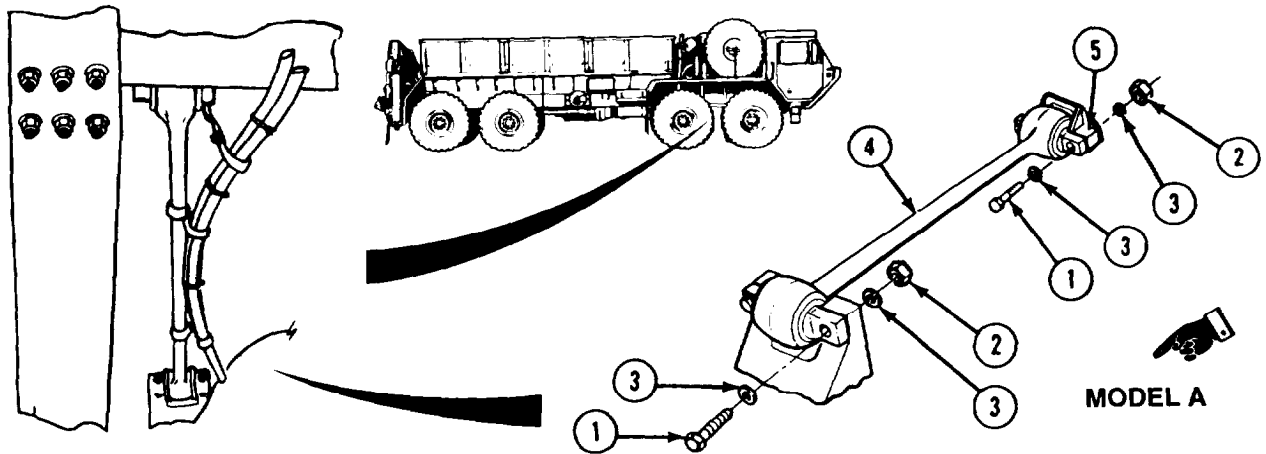

NOTE

Remove hose brackets, clips, and plastic cable ties as required.

There are two models of vehicles. Model A contains a torque rod with no spacers. Model B uses spacers for torque rod installation. Do steps (1) and (2) for Model A. Do steps (2.1) thru (2.3) for Model B.

- (1) Remove four screws (1), four locknuts (2), and eight washers (3) from torque rod (4).
- (2) Remove torque rod (4) and front mounting plate (5).

Frame Maintenance Instructions (Cont)

13-11. FRONT TANDEM CROSSMEMBER REMOVAL/INSTALLATION (CONT).

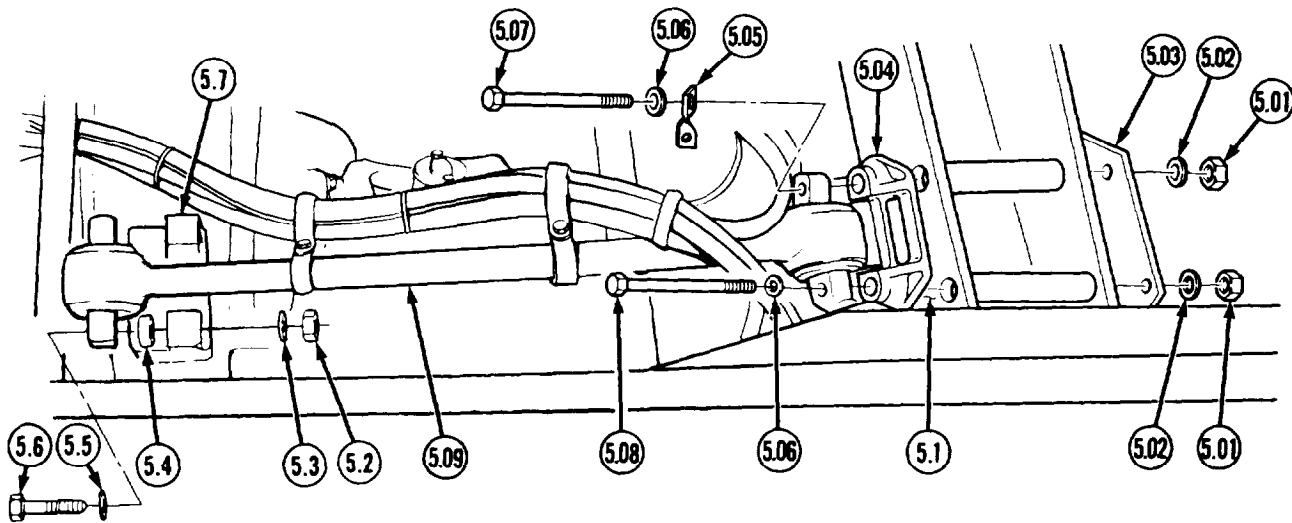

NOTE

Some crossmembers have welded spacers. Others have spacers that are held in by the screws.

- (2.1) Remove two locknuts (5.01), two washers (5.02), plate (5.03), bracket (5.04) one twist bracket (5.05), two washers (5.06), and two screws (5.07 and 5.08) from No. 2 torque rod (5.09) and crossmember (5.1).
- (2.2) Remove two locknuts (5.2), two washers (5.3), two spacers (5.4), two washers (5.5), and two screws (5.6) from torque rod (5.09) and No. 2 axle (5.7).
- (2.3) Remove torque rod (5.09) from axle (5.7).

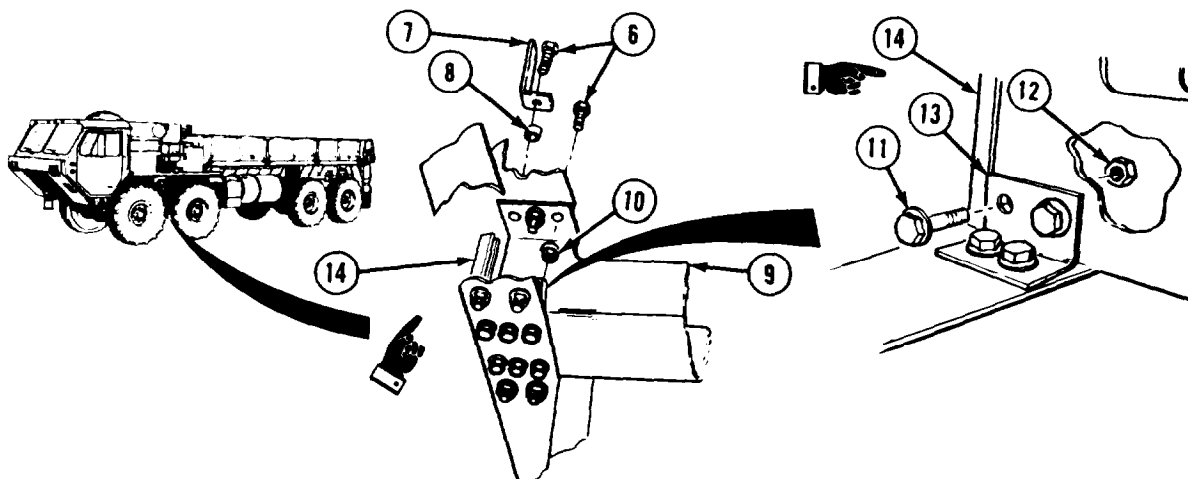

- (3) Soldier A removes screws (6), bracket (7), and spacer (8) from crossmember (9) while Soldier B removes 24 locknuts (10).
- (4) Remove 16 screws (11), nuts (12), and four support brackets (13).
- (5) Soldier A and Soldier B remove crossmember (9).

NOTE

Some vehicles have quickedge on outer right side of crossmember. Do step (6) for these vehicles.

- (6) If damaged, remove two quickedges (14) from crossmember (9).

Frame Maintenance Instructions (Cont)

b. Installation.

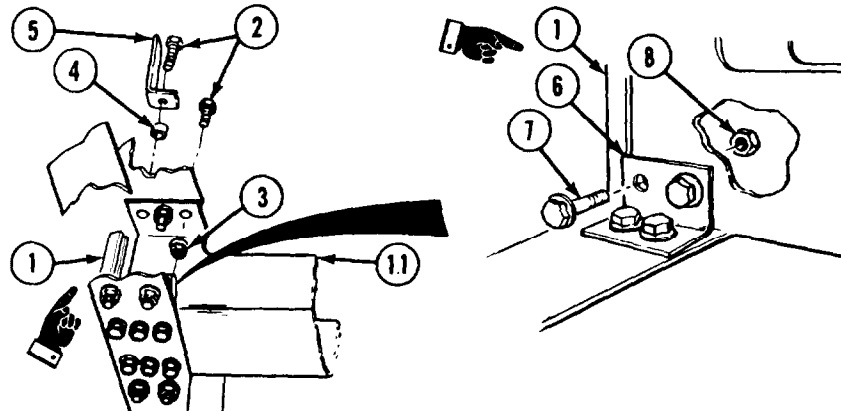

- (1) If removed or not previously installed, install two quickedges (1) on crossmember (1.1).
- (1.1) Soldier A and Soldier B install crossmember (1.1) with 23 screws (2) and locknuts (3). Do not tighten.
- (2) Install spacer (4) and bracket (5) with one screw (2) and locknut (3).
- (3) Soldier A holds 23 screws (2) while Soldier B tightens 23 locknuts (3).
- (4) Install four support brackets (6) with 16 screws (7) and nuts (8).

NOTE

- Install hose brackets, clips, and plastic cable ties as required.
- Tighten nuts on all vehicles to 170 lb-ft (230 N•m).
- There are two models of vehicles. Model A contains a torque rod with no spacers. Model B uses spacers for torque rod installation. Do step (5) for Model A. Do steps (6) through (9) for Model B.
- (5) Install front mounting plate (9) and torque rod (10) with four screws (11), eight washers (12), and four locknuts (13).

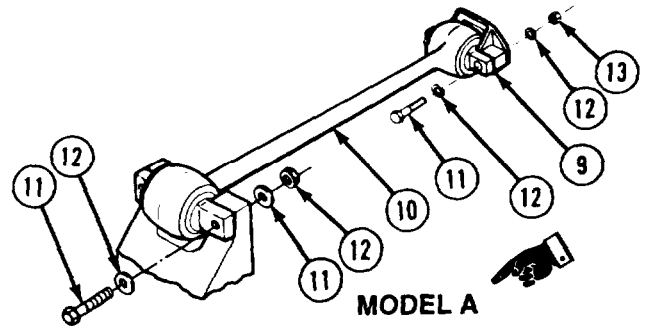

Frame Maintenance Instructions (Cont)

13-11. FRONT TANDEM CROSSMEMBER REMOVAL/INSTALLATION (CONT).

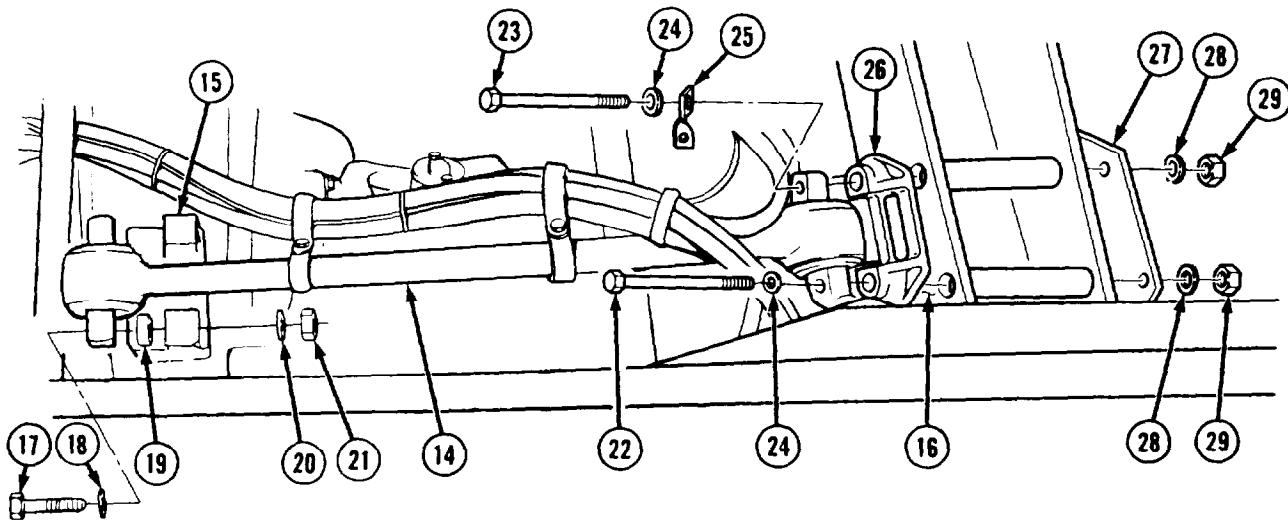

- (6) Position torque rod (14) on No. 2 axle (15) and align torque rod with holes in crossmember (16).
- (7) Lubricate two screws (17) with lubricating oil and install screws, two washers (18), two spacers (19), two washers (20), and two locknuts (21) on axle end of torque rod (14). Do not tighten nuts.

NOTE

Some crossmembers have welded spacers. Others have spacers that are held in by the screws.

- (8) Lubricate two screws (22 and 23) with lubricating oil and install screws, two washers (24), twist bracket (25), bracket (26), plate (27), two washers (28), and two locknuts (29).
- (9) Tighten four locknuts (21 and 29) to 170 lb-ft (230 N•m).

c. Follow-on Maintenance.

- (1) Install front brake relay valve (TM 9-2320-279-20).
- (2) Install front propeller shaft (TM 9-2320-279-20).
- (3) Install front cable tensioner (TM 9-2320-279-20).
- (4) Connect batteries (TM 9-2320-279-20).

END OF TASK

Frame Maintenance Instructions (Cont)

13-12. FRONT TANDEM GUSSETS REMOVAL/INSTALLATION.

This task covers:

- | | |
|------------------------------------|------------------------------------|
| a. Lower Left Gusset Removal | f. Lower Right Gusset Installation |
| b. Lower Left Gusset Installation | g. Upper Right Gusset Removal |
| c. Upper Left Gusset Removal | h. Upper Right Gusset Installation |
| d. Upper Left Gusset Installation | i. Follow-on Maintenance |
| e. Lower Right Gusset Installation | |

INITIAL SETUP

Models

All

Test Equipment

None

Special Tools

None

Supplies

Ties, cable, plastic, Item 65, Appendix C

Personnel Required

MOS 63W, wheel vehicle repairer (2)

References

None

Equipment Condition

TM or Para

Para 13-11

Condition Description

Front tandem crossmember removed.

TM 9-2320-279-20 Front cable tensioner removed.

Special Environmental Conditions

None

General Safety Instructions

None

Level of Maintenance

Direct Support

Frame Maintenance Instructions (Cont)

13-12. FRONT TANDEM GUSSETS REMOVAL/INSTALLATION (CONT).

a. Lower Left Gusset Removed.

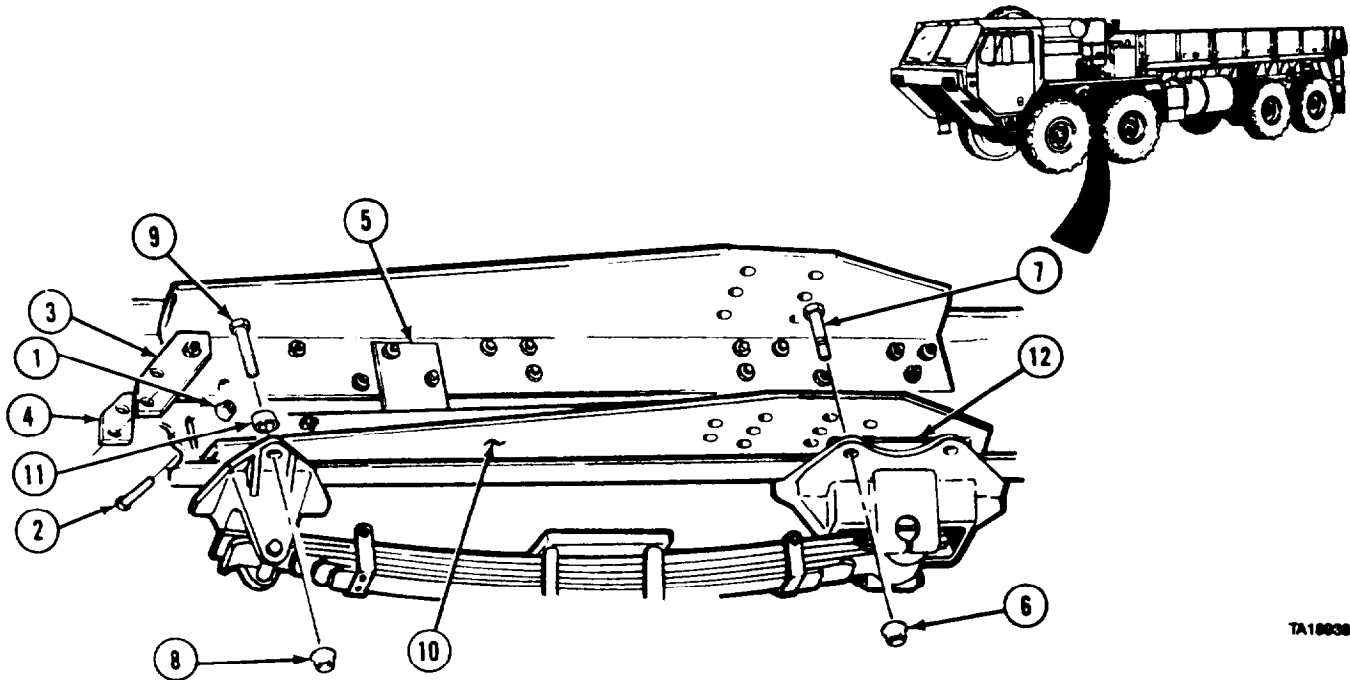

TA189384

WARNING

Do not remove upper and lower gussets at the same time. If both gussets are removed, slave steering gear will fall and cause serious personal injury.

NOTE

Remove hose brackets, clips, and plastic cable ties as required.

- (1) Soldier A and Soldier B remove 24 locknuts (1), screws (2), and three spacers (3, 4, and 5).
- (2) Remove two locknuts (6) and screws (7).
- (3) Remove locknut (8) and screw (9).
- (4) Remove lower left gusset (10) and two spacers (11 and 12).

b. Lower Left Gusset Installation.

NOTE

If upper left gusset is to be removed, do not install spacers on inside of gussets until upper left gusset is installed.

- (1) Soldier A and Soldier B install lower left gusset (10) and three spacers (3, 4, and 5) with 24 screws (2) and locknuts (1).
- (2) Install spacer (12), two screws (7), and locknuts (6).

NOTE

Install hose brackets, clips, and plastic cable ties as required.

- (3) Install spacer (11), screw (9) and locknut (8).

Frame Maintenance Instructions (Cont)

c. Upper Left Gusset Removal.

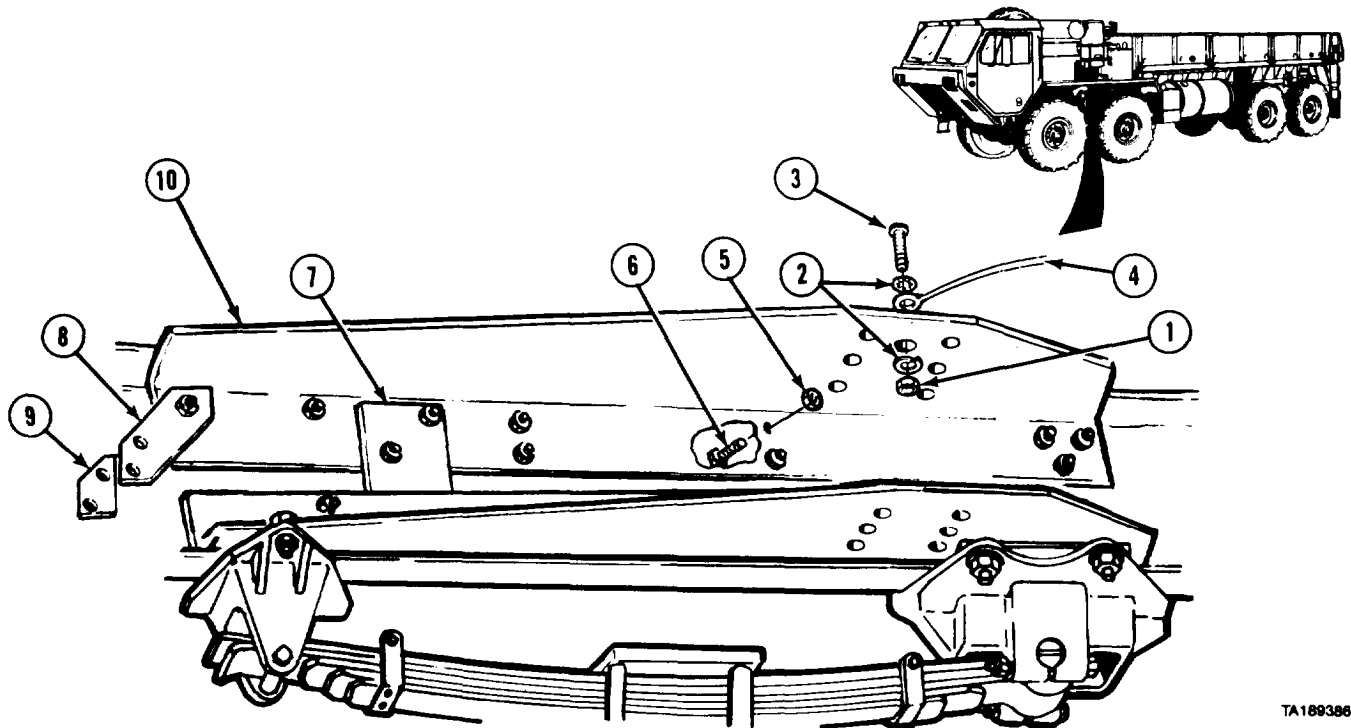

TA189386

- (1) Remove nut (1), two lockwashers (2), screw (3), and ground wire (4).

WARNING

Install lower left gusset before removing upper left gusset to prevent slave steering gear falling and causing serious personal injury.

NOTE

If lower left gusset was removed and installed, no spacers and only 16 screws and locknuts are left to be removed from upper left gusset. Mark position of spacers if not removed.

- (2) Soldier A and Soldier B remove 23 locknuts (5), screws (6), and three spacers (7, 8, and 9) with upper left gusset (10).

d. Upper Left Gusset Installation.

- (1) Soldier A and Soldier B install upper left gusset (10) with 16 screws (6) and locknuts (5).
 (2) Install three spacers (7, 8, and 9) with seven screws (6) and locknuts (5).
 (3) Install ground wire (4) with screw (3), two lockwashers (2), and nut (1).

Frame Maintenance Instructions (Cont)

13-12. FRONT TANDEM GUSSETS REMOVAL/INSTALLATION (CONT).

e. Lower Right Gusset Removal.

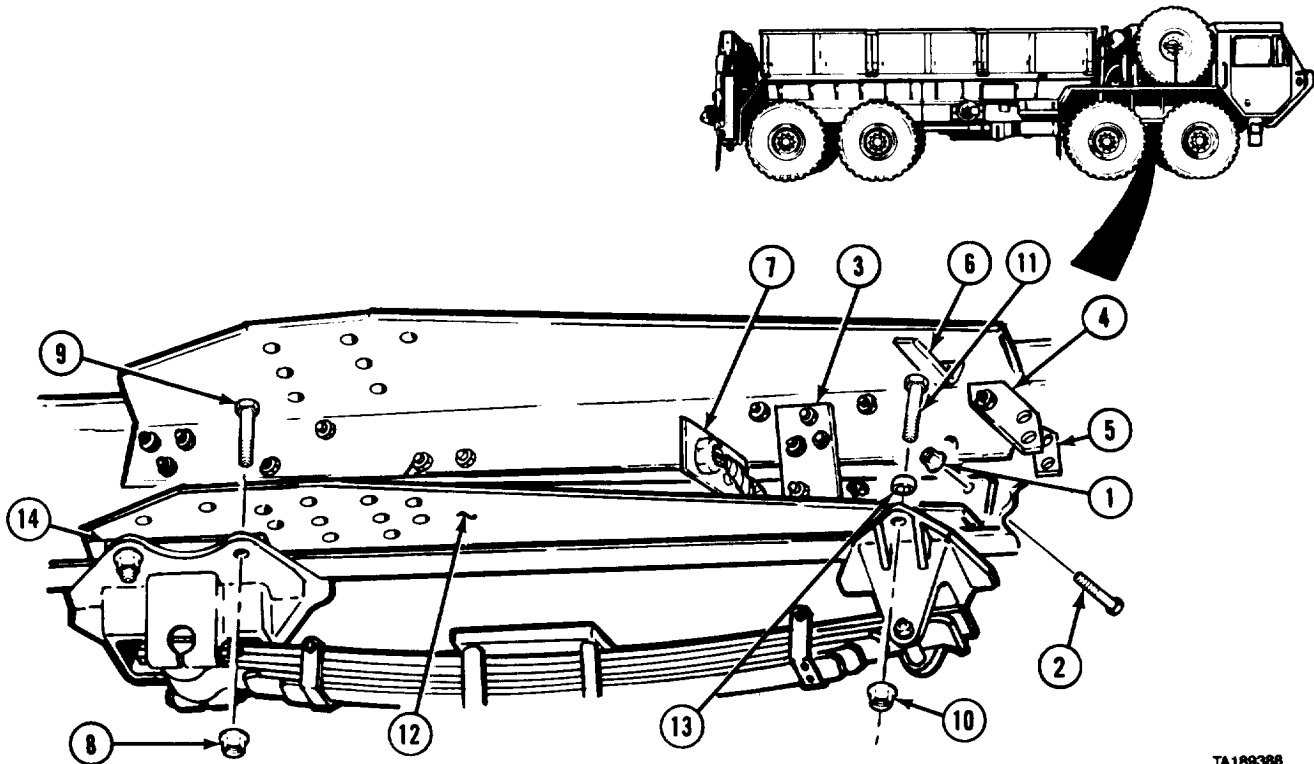

TA189388

CAUTION

Do not remove upper and lower right gussets at the same time. If both gussets are removed, vehicle parts may shift and be damaged.

- (1) Soldier A and Soldier B remove 23 locknuts (1), screws (2), three spacers (3, 4, and 5), bracket (6), and engine electrical connector bracket (7).
- (2) Remove two locknuts (8) and screws (9).
- (3) Remove locknut (10) and screw (11).
- (4) Remove lower right gusset (12) and two spacers (13 and 14).

f. Lower Right Gusset Installation.

NOTE

If upper right gusset is to be removed, do not install spacers on inside of gussets until upper right gusset is installed.

- (1) Soldier A and Soldier B install lower right gusset (12), three spacers (3, 4, and 5), bracket (6), and engine electrical connector bracket (7) with 23 screws (2) and locknuts (1).
- (2) Install spacer (14), two screws (9), and locknuts (8).
- (3) Install spacer (13), screw (11), and locknut (10).

Frame Maintenance Instructions (Cont)

g. Upper Right Gusset Removal.

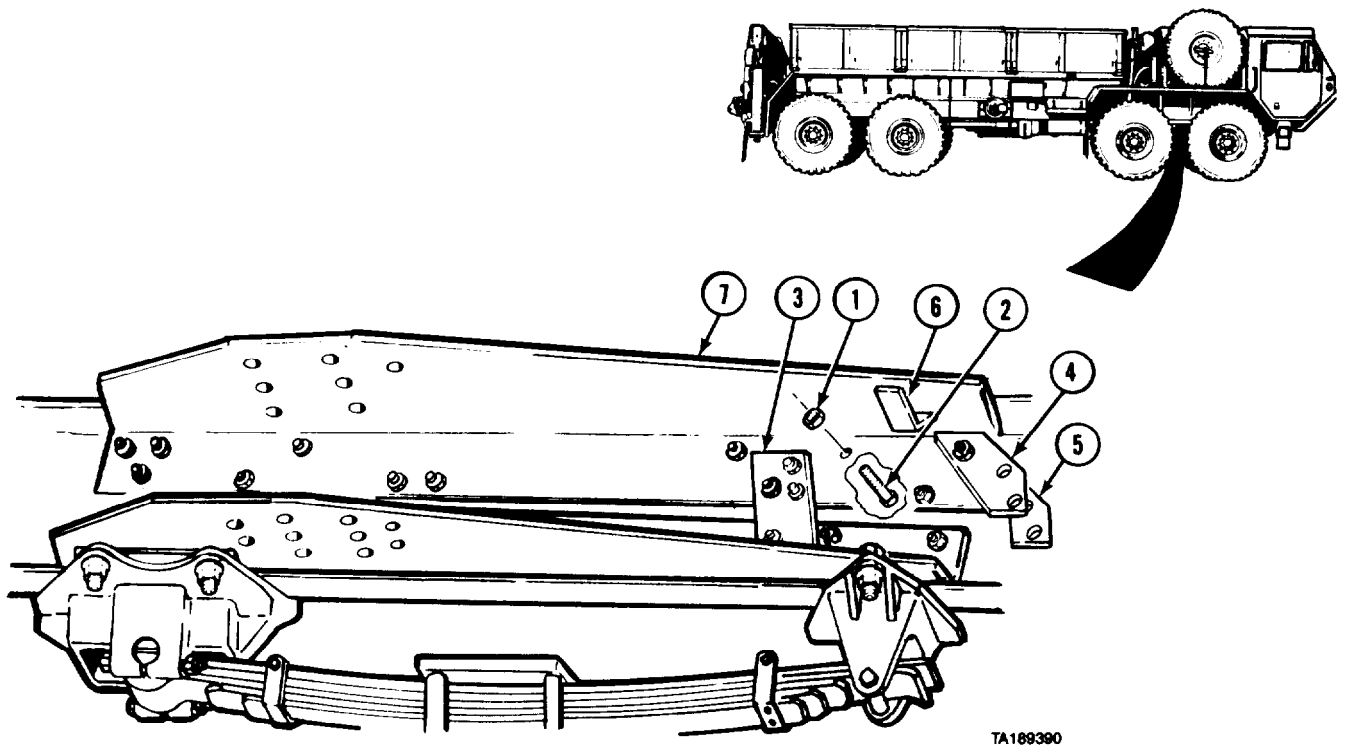

TA189390

CAUTION

Install lower right gusset before removing upper right gusset to prevent vehicle parts from shifting and being damaged.

NOTE

If lower right gusset was removed and installed, no spacers and only 12 screws and locknuts are left to be removed from upper right gusset. Mark position of spacers if not removed.

- (1) Remove seven locknuts (1), screws (2), three spacers (3, 4, and 5), and bracket (6).
- (2) Soldier A and Soldier B remove 12 locknuts (1), screws (2), and upper right gusset (7).

h. Upper Right Gusset Installation.

CAUTION

Install upper gussets before removing lower gussets to prevent vehicle parts from shifting and being damaged.

- (1) Soldier A and Soldier B install upper right gusset (7) with 12 screws (2) and locknuts (1).
- (2) Install three spacers (3, 4, and 5) with seven screws (2), locknuts (1), and bracket (6).

i. Follow-on Maintenance.

- (1) Install front tandem crossmember (para 13-11).
- (2) Install front cable tensioner (TM 9-2320-279-20).

END OF TASK

Frame Maintenance Instructions (Cont)

3-13. FRONT INTERMEDIATE CROSSMEMBER REMOVAL/INSTALLATION (M977, M978, M984, M985).	
This task covers:	
a. Removal b. Installation	c. Follow-on Maintenance
INITIAL SETUP	
Models M977, M978, M984, and M985	References None
Test Equipment None	Equipment Condition <i>TM or Para</i> <i>Condition Description</i> TM 9-2320-279-10 Shut off engine.
Special Tools None	Special Environmental Conditions None
Supplies None	General Safety Instructions None
Personnel Required MOS 63W, Wheel vehicle repairer	Level of Maintenance Direct Support

a. Removal.

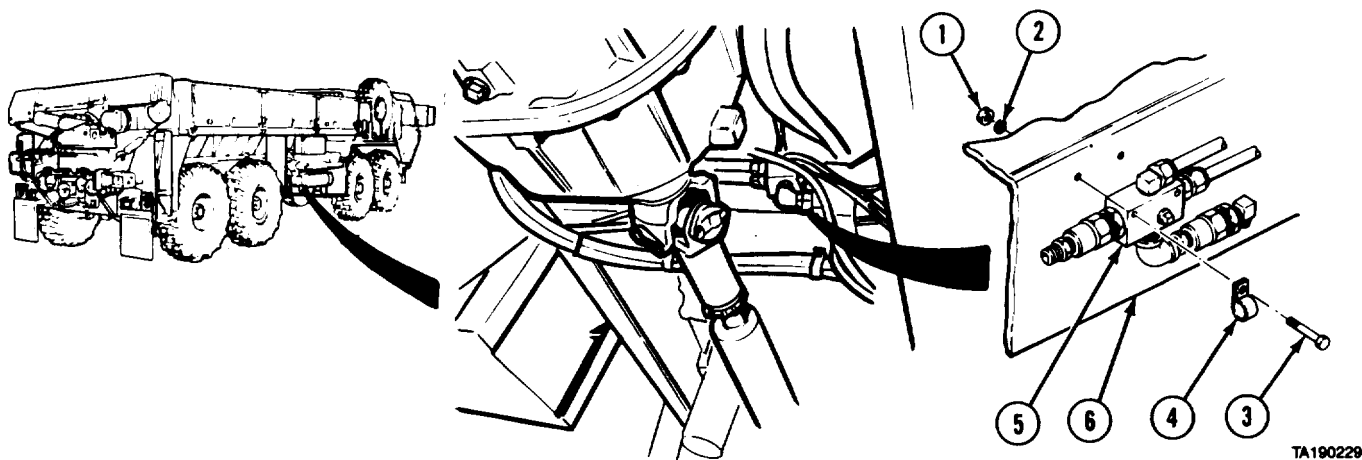

- (1) Remove two nuts (1), lockwashers (2), screws (3), and cushion clip (4).
- (2) Move air manifold (5) away from crossmember (6).

TA190229

Frame Maintenance Instructions (Cont)

- (3) Remove 16 locknuts (7) and screws (8) from crossmember (9).
- (4) Remove crossmember (9).

NOTE

To remove screws from left bracket, stowage box must be removed. To remove screws from right bracket, battery box must be removed (TM 9-2320-279-20).

- (5) Remove eight locknuts (10), screws (11), and two brackets (12).

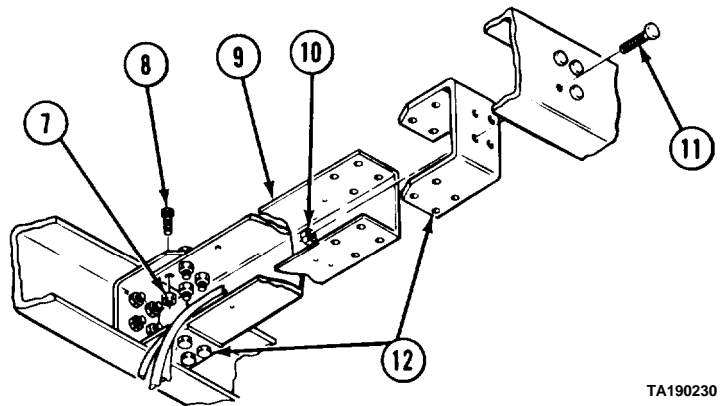

TA190230

b. Installation.

NOTE

After installing screws on left side, stowage box must be installed. After installing screws on right side, battery box must be installed (TM 9-2320-279-20).

- (1) Install two brackets (1) and eight screws (2).
- (2) Install, but do not tighten, eight locknuts (3).

NOTE

When installing crossmember, air manifold mounting holes go on right side.

- (3) Install crossmember (4) in brackets (1) with 16 screws (5) and locknuts (6).
- (4) Tighten eight locknuts (3).

- (5) Install air manifold (7) and cushion clip (8) on crossmember (9), with two screws (10), lockwashers (11), and nuts (12).

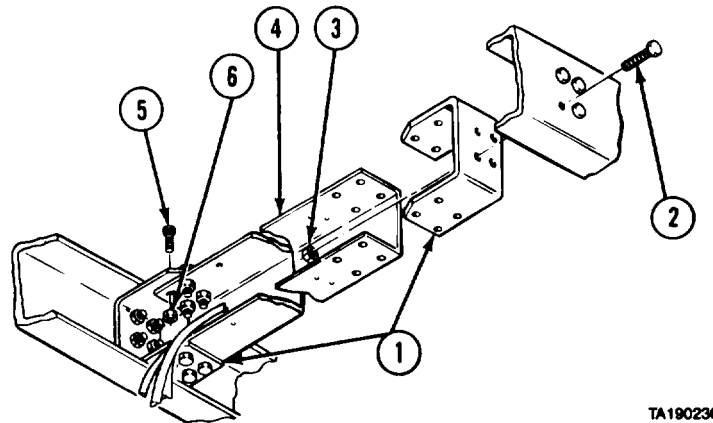

TA190230

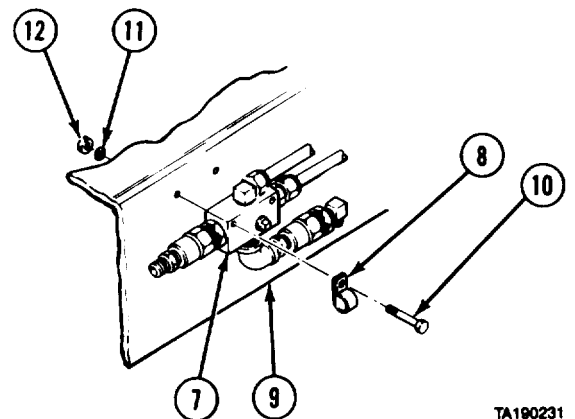

TA190231

c. Follow-on Maintenance. None.

END OF TASK

Frame Maintenance Instructions (Cont)

13-14. FRONT INTERMEDIATE CROSSMEMBER REMOVAL/INSTALLATION (M983).	
This task covers:	
a. Removal	c. Follow-on Maintenance
b. Installation	
INITIAL SETUP	
Models	Equipment Condition
M983	<i>TM or Para</i> <i>Condition Description</i>
Test Equipment	TM 9-2320-279-10 Shut off engine.
None	TM 9-2320-279-20 No. 4 air reservoir removed.
Special Tools	TM 9-2320-279-20 Battery box removed.
None	TM 9-2320-279-20 Propeller shaft between transfer case and No. 2 axle removed.
Supplies	TM 9-2320-279-20 No. 1 air manifold removed.
None	
Personnel Required	Special Environmental Conditions
MOS 63W, Wheel vehicle repairer (2)	None
References	General Safety Instructions
None	Wheels chocked.
	Level of Maintenance
	Direct Support

a. Removal.

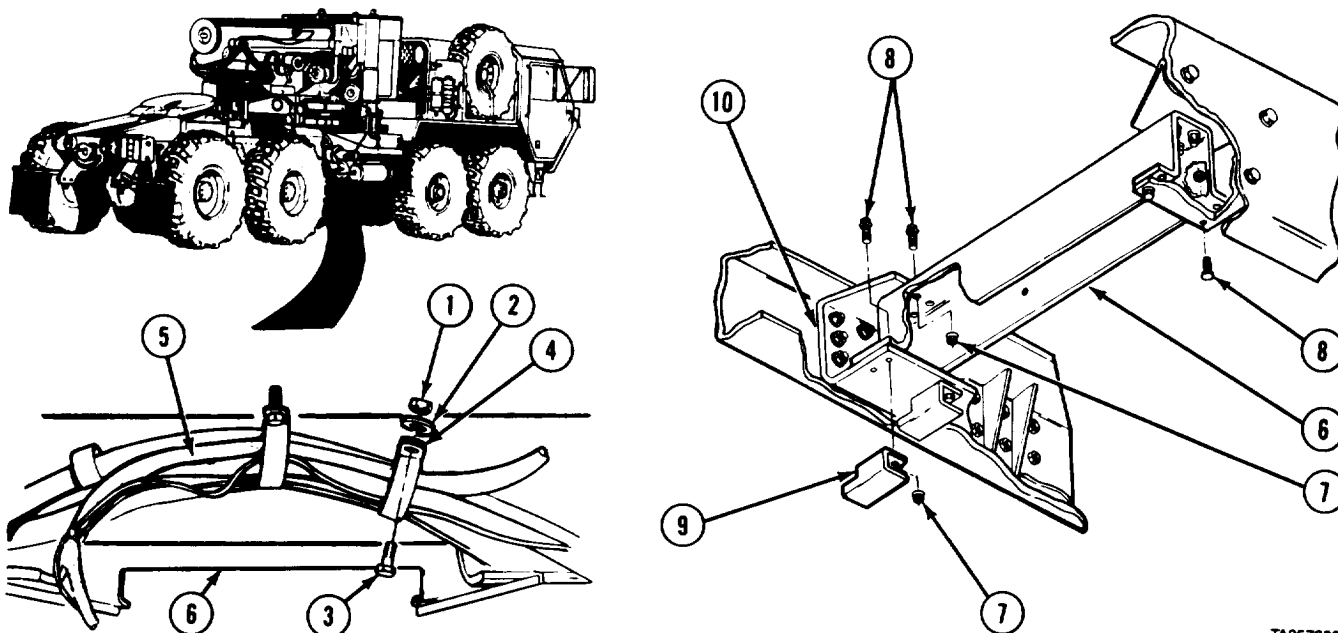

TA357306

- (1) Remove two nuts (1), lockwashers (2), screws (3), and clamps (4).
- (2) Slide wiring harness (5) away from crossmember (6).
- (3) Soldier A and Soldier B remove 16 locknuts (7), screws (8), and two brackets (9) from gussets (10).

Frame Maintenance Instructions (Cont)

NOTE

If crossmember is held tight between gussets, loosen gusset locknuts to remove crossmember.

- (4) Remove crossmember (6) from gussets (10).

b. Installation.

NOTE

It may be necessary to loosen locknuts on gussets for installation of crossmember.

- (1) Soldier A and Soldier B position crossmember (6) in gussets (10).

NOTE

Install hose clips and plastic ties as required. Tighten all loose locknuts.

- (2) Soldier A and Soldier B install 16 screws (8), two brackets (9), and 16 locknuts (7).
- (3) Install two clamps (4), screws (3), lockwashers (2), and nuts (1).

c. Follow-on Maintenance.

- (1) Install No. 4 air reservoir (TM 9-2320-279-20).
- (2) Install battery box (TM 9-2320-279-20).
- (3) Install propeller shaft between transfer case and No. 2 axle (TM 9-2320-279-20).
- (4) Install No. 1 air manifold (TM 9-2320-279-20).

END OF TASK

13-15. FRONT INTERMEDIATE GUSSETS REMOVAL/INSTALLATION (M983).		
This task covers:		
a. Removal	c. Follow-on Maintenance	
b. Installation		
INITIAL SETUP		
<i>Models</i>	<i>Equipment Condition</i>	
M983	<i>TM or Para</i>	<i>Condition Description</i>
<i>Test Equipment</i>	TM 9-2320-279-10	Shut off engine.
None	Para 13-14	Front intermediate crossmember removed.
<i>Special Tools</i>	<i>Special Environmental conditions</i>	
None	None	
<i>Supplies</i>	<i>General Safety Instructions</i>	
None	None	
<i>Personnel Required</i>	<i>Level of Maintenance</i>	
MOS 63W, Wheel vehicle repairer (2)	Direct Support	
<i>References</i>		
None		

Frame Maintenance Instructions (Cont)

13-15. FRONT INTERMEDIATE GUSSETS REMOVAL/INSTALLATION (M983) (CONT).

a. Removal.

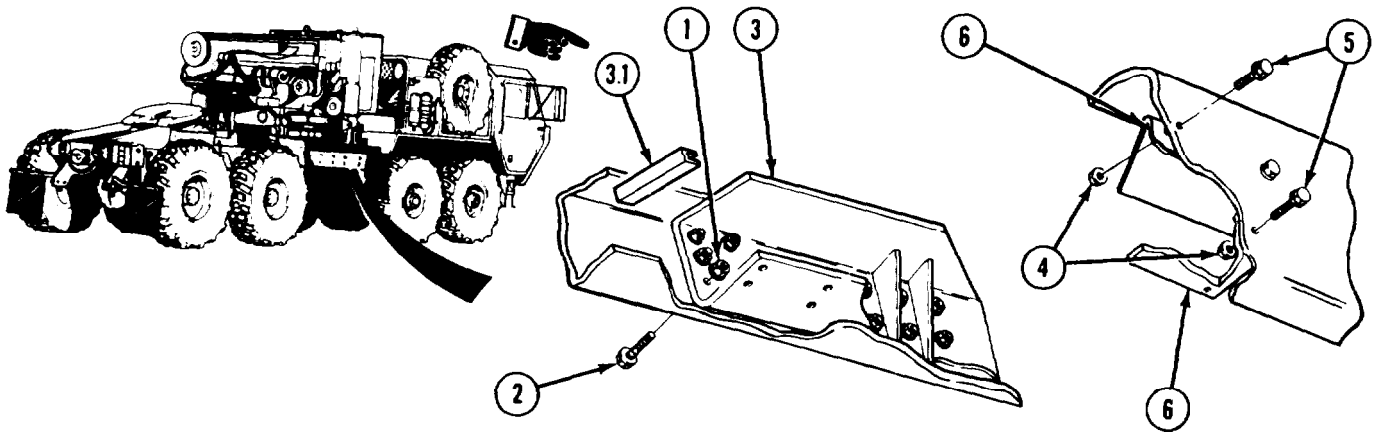

- (1) Soldier A and Soldier B remove eight locknuts (1) and screws (2).

NOTE

Pulling device may be required if gusset is difficult to remove.

- (2) Soldier A and Soldier B remove right gusset (3).

NOTE

Some vehicles have quickedge on rear edge of right gusset. Do step (2.1) for these vehicles.

- (2.1) If damaged, remove quickedge (3.1) on right gusset (3).

- (3) Soldier A and Soldier B remove four locknuts (4), screws (5), and two left gussets (6).

b. Installation.

- (1) Soldier A and Soldier B install two left gussets (6) with four screws (5) and locknuts (4).

- (1.1) If removed or not previously installed, install quickedge (3.1) on right gusset (3).

- (2) Soldier A and Soldier B install right gusset (3) with eight screws (2) and locknuts (1).

- c. Follow-on Maintenance.** Install front intermediate crossmember (para 13-14).

END OF TASK

Frame Maintenance Instructions (Cont)

13-15.1. FRONT INTERMEDIATE CROSSMEMBER REMOVAL/INSTALLATION (M984E1).

This task covers:

- a. Removal
- b. Installation

c. Follow-on Maintenance

INITIAL SETUP

Models

M984E1

Test Equipment

None

Special Tools

None

Supplies

Tags, identification, Item 60, Appendix C

Personnel Required

MOS 63W, Wheel vehicle repairer

References

None

Equipment Condition

TM or Para	Condition Description
TM 9-2320-279-10	Equipment body removed.
TM 9-2320-279-10	Drain air from air reservoirs.
TM 9-2320-279-10	Batteries disconnected.
TM 9-2320-279-20	Vise, vise mount, and tube support removed.
TM 9-2320-279-20	Self recovery winch removed.
TM 9-2320-279-20	Transfer Case to No. 2 axle propshaft removed.

Special Environmental Conditions

None

General Safety Instructions

None

Level of Maintenance

Direct Support

a. Removal.

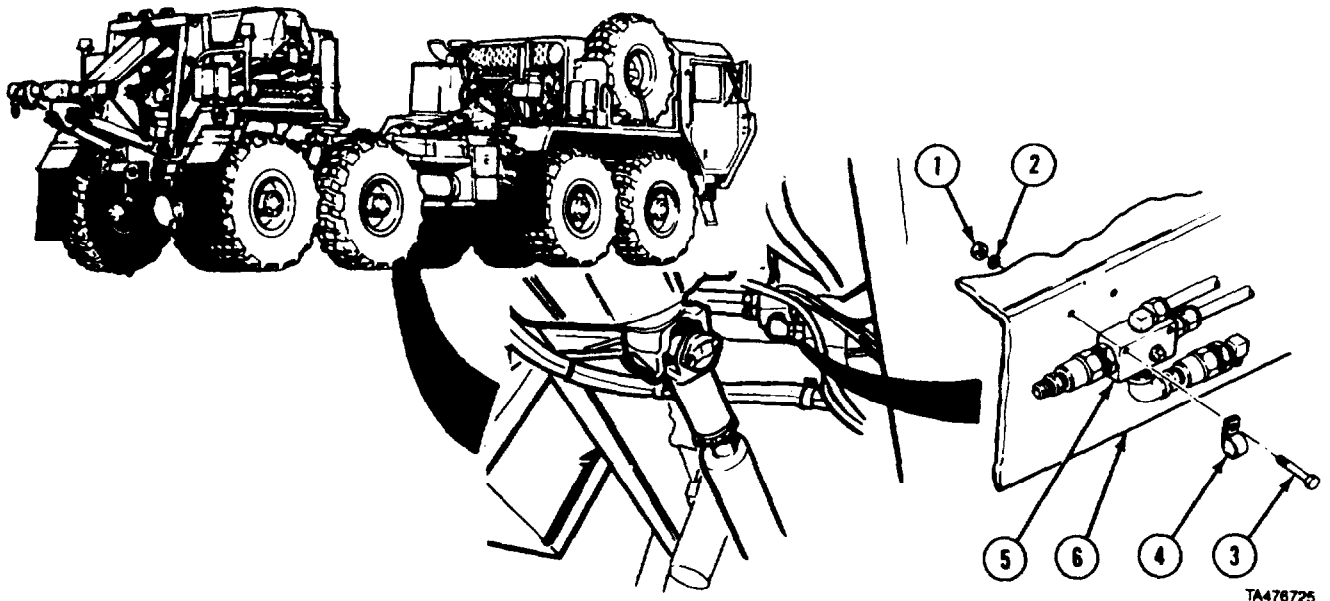

NOTE

Remove hose and clamps as required.

- (1) Remove two nuts (1), lockwashers (2), screws (3) and cushion clip (4).
- (2) Move air manifold (5) away from crossmember (6).

Frame Maintenance Instructions (Cont)

13-15.1. Front INTERMEDIATE CROSSMEMBER REMOVAL/INSTALLATION (M984E1)

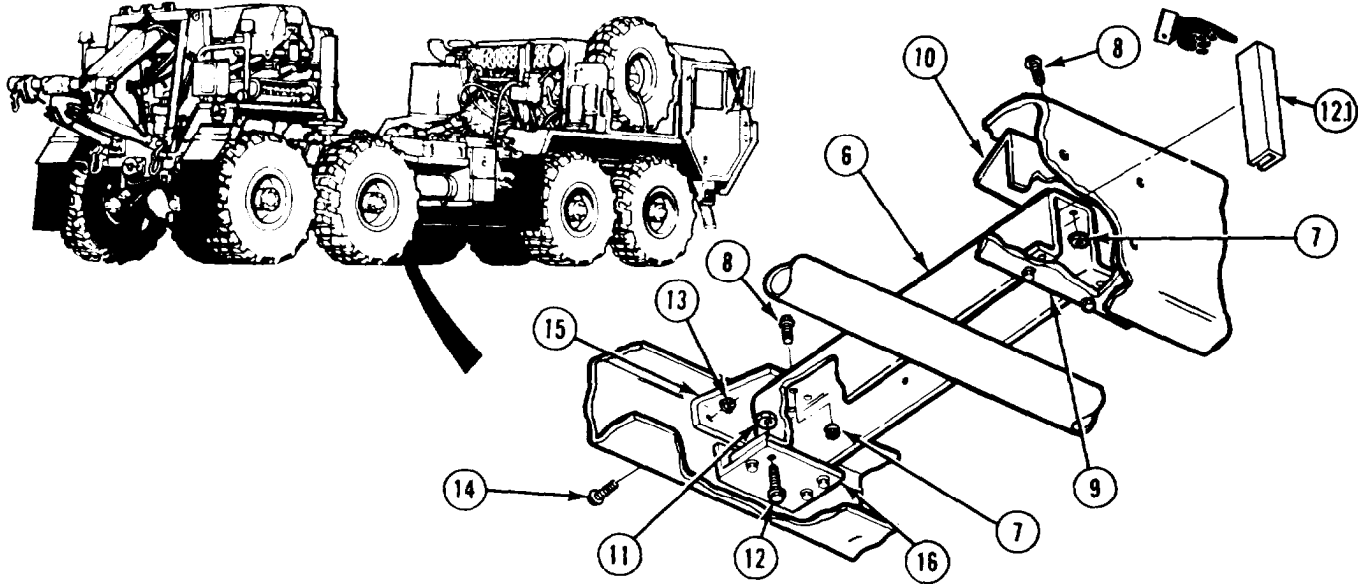

WARNING

When the four locknuts and screws are removed from the right side, both gussets will be loose. If gussets fall from frame, personal injury could result.

- (3) Remove eight locknuts (7) and screws (8).
- (4) Remove right side lower and upper gussets (9 and 10).
- (5) Support crossmember (6).

NOTE

Some vehicles have quickedge on outer right side of crossmember. Do step (6.1) for these vehicles.

- (6) Remove four locknuts (11), screws (12), and crossmember (6).
- (6.1) If damaged, remove two quickedges (12.1) from crossmember (6).
- (7) Remove four locknuts (13), screws (14), and gussets (15 and 16).

Frame Maintenance Instructions (Cont)

b. Installation.

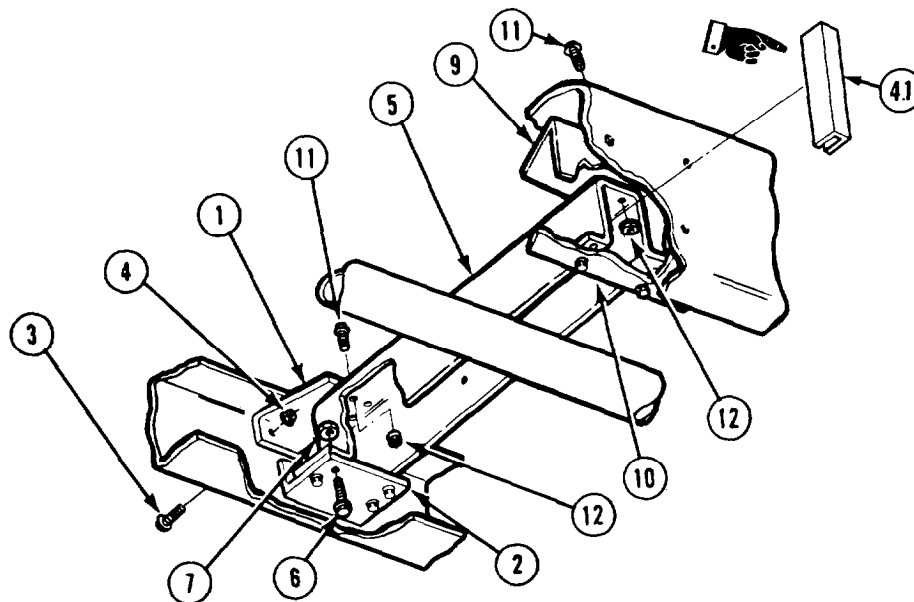

NOTE

Install hoses and clamps as required.

- (1) Install gussets (1 and 2) with four screws (3) and locknuts (4).
- (1.1) If removed or not previously installed, install two quickedges (4.1) on crossmember (5).
- (2) Lift and support crossmember (5) in place.
- (3) Install four screws (6) and locknuts (7).

WARNING

Until the locknuts and screws are installed in the right side, both gussets will be loose. If gussets fall from frame, personal injury could result.

- (4) Install right side upper and lower gussets (9 and 10).
- (5) Install eight screws (11) and locknuts (12).

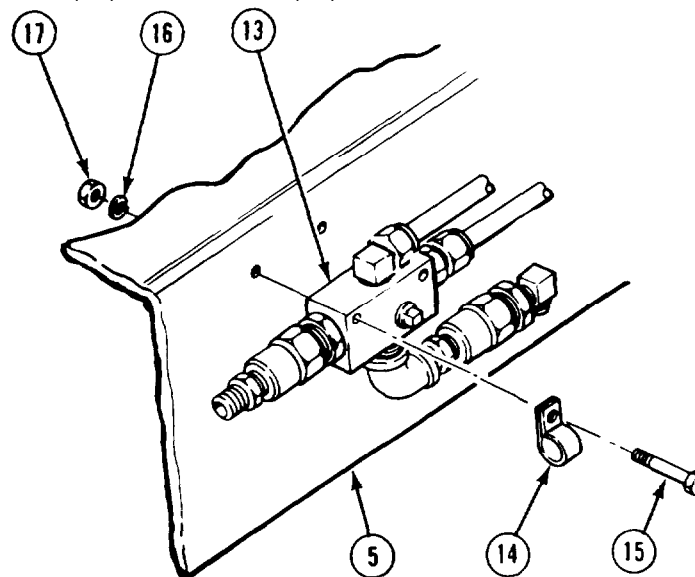

- (6) Move air manifold (13) against crossmember (5).
- (7) Install cushion clips (14) and air manifold (13) with two screws (15), lockwashers (16) and nuts (17).

Frame Maintenance Instructions (Cont)

13-15.1. FRONT INTERMEDIATE CROSSMEMBER REMOVAL/INSTALLATION (M984E1) (CONT).

c. Follow-on Maintenance.

- (1) Install transfer case to No. 2 axle propshaft (TM 9-2320-279-20).
- (2) Install self recovery winch (TM 9-2320-279-20).
- (3) Install vise, vise mount and tube support (TM 9-2320-279-20).
- (4) Install equipment body (TM 9-2320-279-10).
- (5) Connect batteries (TM 9-2320-279-10).
- (6) Start engine, build up air pressure, and check for air leaks (TM 9-2320-279-10).

END OF TASK

13-16. REAR INTERMEDIATE CROSSMEMBER REMOVAL/INSTALUTION (M977, M978, M984, M985, M985E1).					
This task covers:					
<ul style="list-style-type: none"> a. Removal b. Installation 	<ul style="list-style-type: none"> c. Follow-on Maintenance 				
INITIAL SETUP					
<p><i>Models</i> M977, M978, M984, M985, and M985E1</p> <p><i>Test Equipment</i> None</p> <p><i>Special Tools</i> None</p> <p><i>Supplies</i> None</p> <p><i>Personnel Required</i> MOS 63W, Wheel vehicle repairer (2)</p>	<p><i>References</i> None</p> <p><i>Equipment Condition</i></p> <table style="width: 100%; border: none;"> <tr> <td style="text-align: center;"><i>TMorPara</i></td> <td style="text-align: center;"><i>Condition Description</i></td> </tr> <tr> <td style="text-align: center;">TM 9-2320-279-10</td> <td style="text-align: center;">Shut off engine.</td> </tr> </table> <p><i>Special Environmental Conditions</i> None</p> <p><i>General Safety Instructions</i> None</p> <p><i>Level of Maintenance</i> Direct Support</p>	<i>TMorPara</i>	<i>Condition Description</i>	TM 9-2320-279-10	Shut off engine.
<i>TMorPara</i>	<i>Condition Description</i>				
TM 9-2320-279-10	Shut off engine.				

Frame Maintenance Instructions (Cont)

a. Removal.

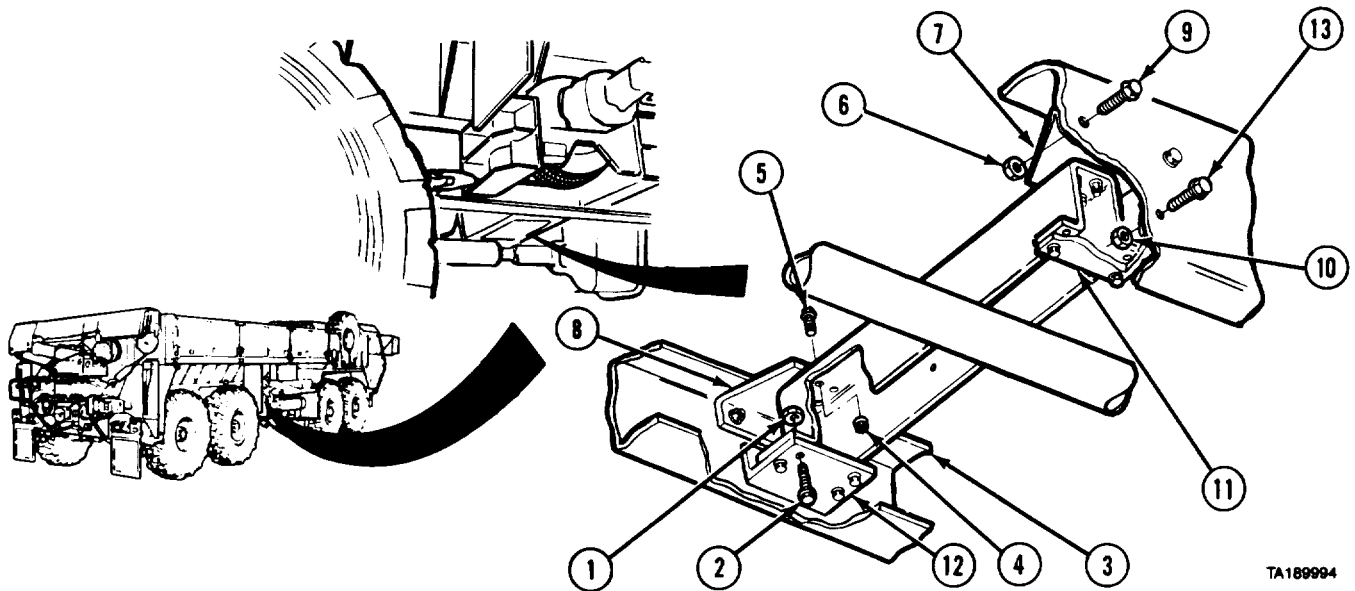

TA189994

NOTE

Remove hoses and clamps as required.

- (1) Remove eight locknuts (1) and screws (2) from bottom of crossmember (3).
- (2) Remove eight locknuts (4) and screws (5) from top of crossmember (3).
- (3) Soldier A removes six locknuts (6) and two upper gussets (7 and 8), while Soldier B removes four screws (9).
- (4) Soldier A and Soldier B remove crossmember (3).
- (5) Soldier A removes five locknuts (10) and two lower gussets (11 and 12), while Soldier B removes four screws (13).

b. Installation.

NOTE

Install hoses and clamps as required.

- (1) Soldier A installs two lower gussets (11 and 12) and five locknuts (10) while Soldier B installs four screws (13).
- (2) Soldier A and Soldier B install crossmember (3).
- (3) Soldier A installs two upper gussets (7 and 8) and six locknuts (6), while Soldier B installs four screws (9). Do not tighten locknuts.
- (4) Install eight screws (5) and locknuts (4) in top of crossmember (3).
- (5) Soldier A tightens six locknuts (6) while Soldier B holds screws (9).
- (6) Install eight screws (2) and locknuts (1) in bottom of crossmember (3).

c. Follow-on Maintenance. None.

END OF TASK

Frame Maintenance Instructions (Cont)

13-17. REAR INTERMEDIATE CROSSMEMBER REMOVAL/INSTALLATION (M983).	
This task covers:	
a. Removal	c. Follow-on Maintenance
b. Installation	
INITIAL SETUP	
<i>Models</i>	<i>Equipment Condition</i>
M983	<i>TM or Para</i> <i>Condition Description</i>
<i>Test Equipment</i>	TM 9-2320-279-10 Shut off engine.
None	TM 9-2320-279-20 Rear decking removed.
<i>Special Tools</i>	<i>Special Environmental Conditions</i>
None	None
<i>Supplies</i>	<i>General Safety Instructions</i>
Ties, cable, plastic, Item 65, Appendix C	None
<i>Personnel Required</i>	<i>Level of Maintenance</i>
MOS 63W, Wheel vehicle repairer	Direct Support
<i>References</i>	
None	

a. Removal.

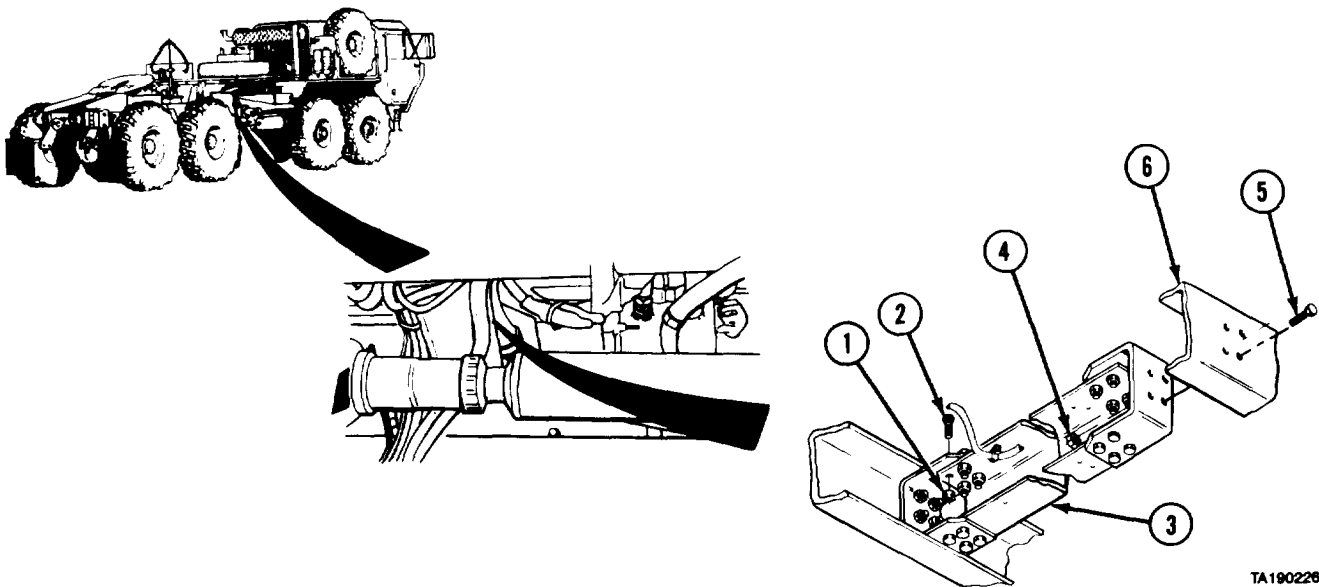

TA190226

NOTE

Remove hoses, clamps, and plastic cable ties as required.

- (1) Remove eight nuts (1) and screws (2) from both ends of crossmember (3).
- (2) Remove crossmember (3).
- (3) Remove four nuts (4), screws (5), and two crossmember brackets (6).

Frame Maintenance Instructions (Cont)

b. Installation.

- (1) Install two crossmember brackets (6) with four screws (5) and nuts (4). Do not tighten.
- (2) Attach both ends of crossmember (3) to brackets (6) with eight screws (2) and nuts (1) at each end.

NOTE

Install hoses, clamps, and plastic cable ties.

- (3) Tighten nuts (4) to 212 lb-ft (287 N·m).

c. Follow-on Maintenance. Install rear decking (TM 9-2320-279-20).

END OF TASK

13-17.1. REAR INTERMEDIATE CROSSMEMBER REMOVAL/INSTALLATION (M984E1).									
This task covers:									
<ul style="list-style-type: none"> a. Removal b. Installation 	<ul style="list-style-type: none"> c. Follow-on Maintenance 								
INITIAL SETUP									
<p>Models M984E1</p> <p>Test Equipment None</p> <p>Special Tools None</p> <p>Supplies Tags, identification, Item 60, Appendix C</p> <p>Personnel Required MOS 63W, Wheel vehicle repairer (2)</p> <p>References N o n e</p>	<p>Equipment Condition</p> <table border="0"> <tr> <td style="text-align: center;"><i>TM or Para</i></td> <td style="text-align: center;"><i>Condition Description</i></td> </tr> <tr> <td>TM 9-2320-279-10</td> <td>Equipment body removed.</td> </tr> <tr> <td>TM 9-2320-279-10</td> <td>Drain air from air reservoirs</td> </tr> <tr> <td>TM 9-2320-279-10</td> <td>Batteries disconnected</td> </tr> </table> <p>Special Environmental Conditions None</p> <p>General Safety Instructions None</p> <p>Level of Maintenance Direct Support</p>	<i>TM or Para</i>	<i>Condition Description</i>	TM 9-2320-279-10	Equipment body removed.	TM 9-2320-279-10	Drain air from air reservoirs	TM 9-2320-279-10	Batteries disconnected
<i>TM or Para</i>	<i>Condition Description</i>								
TM 9-2320-279-10	Equipment body removed.								
TM 9-2320-279-10	Drain air from air reservoirs								
TM 9-2320-279-10	Batteries disconnected								

Frame Maintenance Instructions (Cont)

13-17.1. REAR INTERMEDIATE CROSSMEMBER REMOVAL/INSTALLATION (M984E1)
(CONT).

a. Removal.

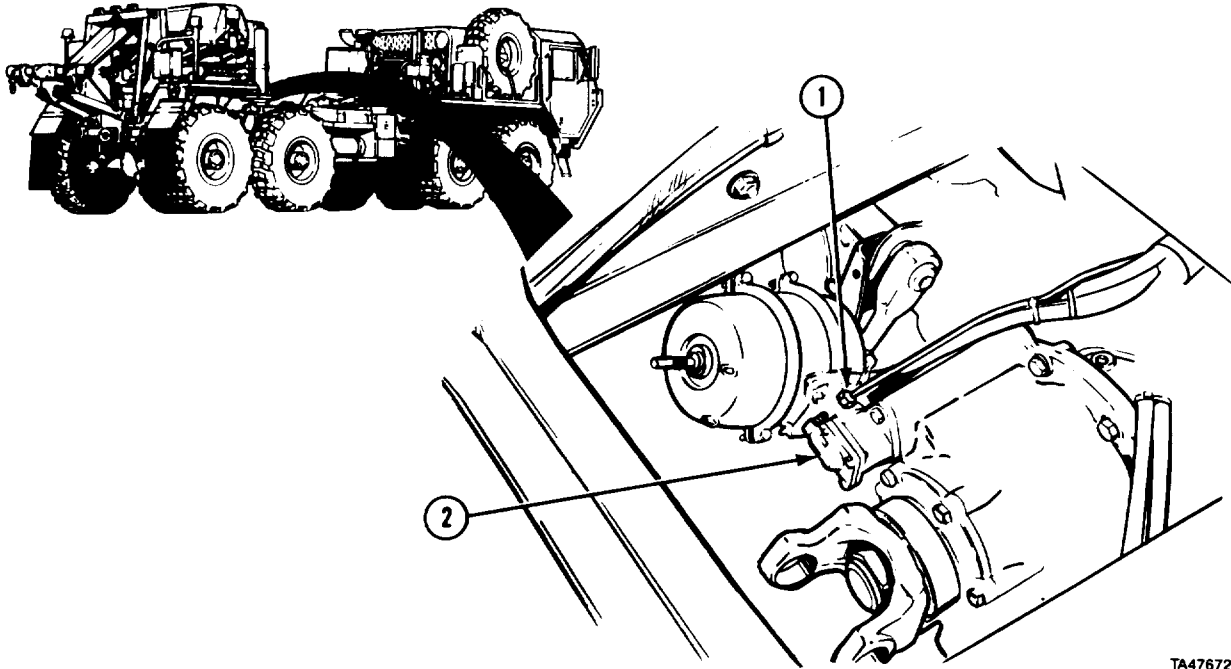

TA476729

NOTE

- Tag and mark air lines and electrical connectors before disconnecting.
- Remove clips, clamps and plastic cable ties as required. Mark location when removing.

(1) Disconnect air line (1) from axle No. 3 differential lockout valve (2).

(2) Disconnect two air lines (3 and 4) from rear double check valve (5).

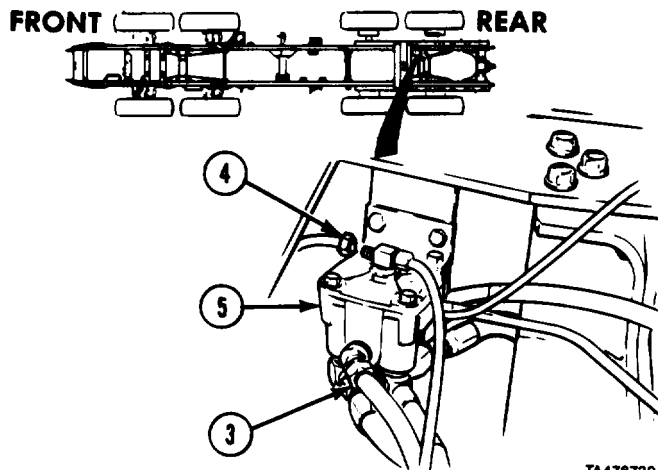

TA476730

Frame Maintenance Instructions (Cont)

- (3) Disconnect two air lines (6 and 7) from left rear brake relay valve (8).

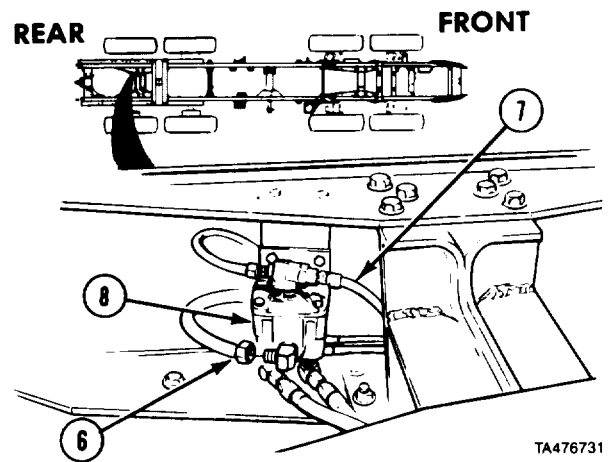

- (4) Disconnect two air lines (9) from tractor protection valve (10).

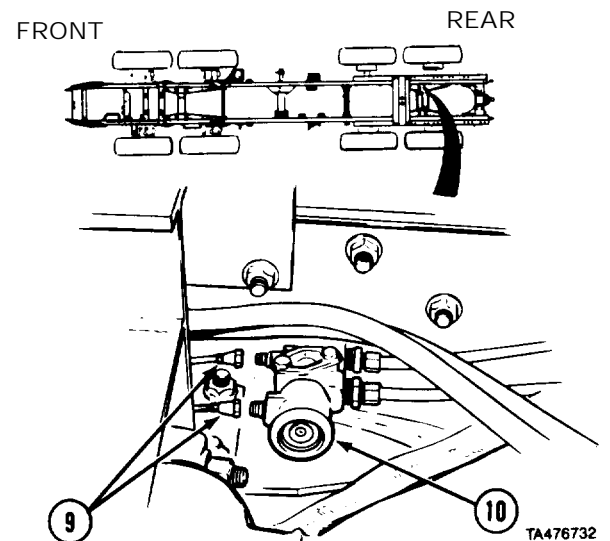

NOTE

Do steps (5) through (8) for taillight wiring on both rear fenders.

- (5) Remove three nuts (11), lockwashers (12), screws (13) and cover (14).
- (6) Disconnect connector (15) and remove from cover (14).
- (7) Disconnect four connectors (16).
- (8) Remove grommet (17) and chassis wiring harness (18) from fender (19).

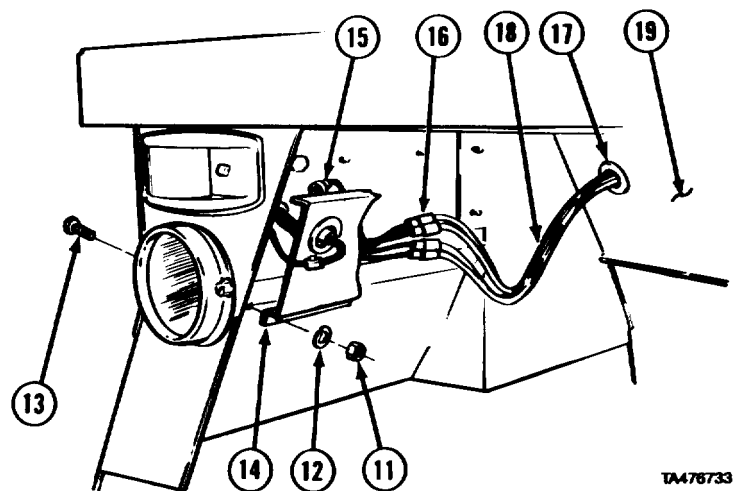

TA476733

Frame Maintenance Instructions (Cont)

**13-17.1. REAR INTERMEDIATE CROSSMEMBER REMOVAL/INSTALLATION (M984E1)
(CONT).**

- (9) Remove three nuts (20), lockwashers (21), and screws (22).
- (10) Remove nut (23), two lockwashers (24), wire (25), screw (26), cover (27), and trailer electrical connector (28) from mounting bracket (29).

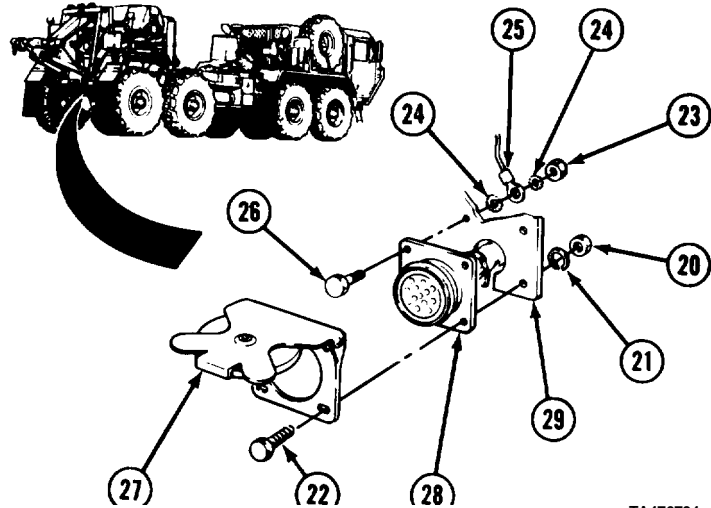

TA476734

- (11) Disconnect connector (30) from high idle control assembly (31).

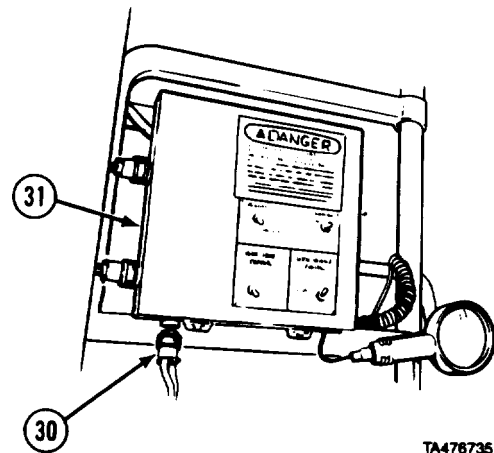

TA476735

- (12) Remove nut (32), two lockwashers (33) and three wires (34) at No. 4 axle stop (35).

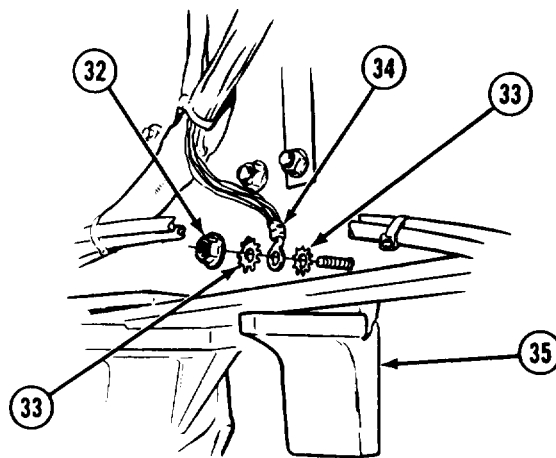

RIGHT SIDE AXLE STOP

TA476736

Frame Maintenance Instructions (Cont)

- (13) Soldier A and Soldier B remove chassis wiring harness (16) and air line bundle (36) from crossmembers (37).
- (14) Remove air line (38) from crossmembers (37).

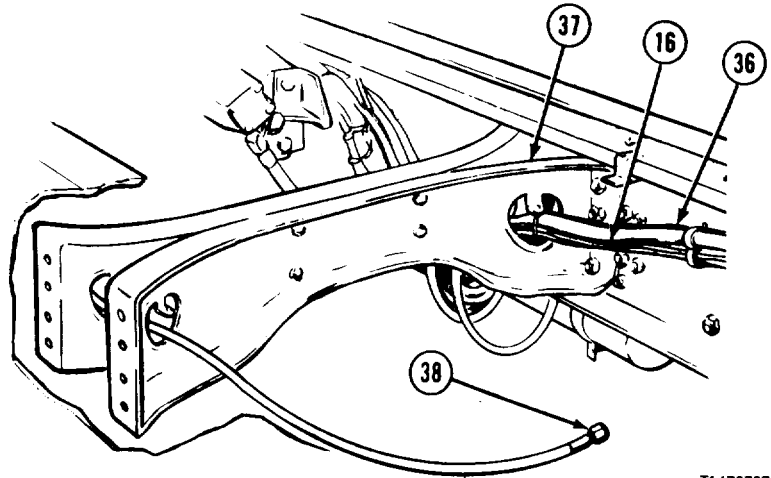

TA476737

- (15) Remove two screws (39) and nuts (40).
- (16) Remove 16 screws (41) and nuts (42).
- (17) Remove four screws (43) and nuts (44). Move clip bracket (45) aside.

NOTE

Mark position of crossmembers.

- (18) Remove crossmembers (37) and spacers (46).
- (19) Remove four strips of edging (47) from two crossmembers (37).

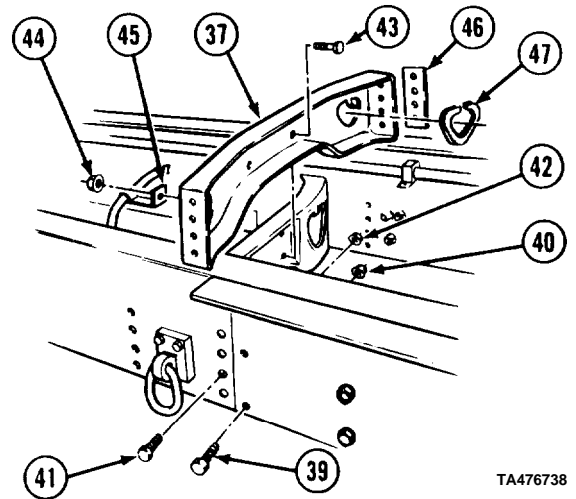

TA476738

b. Installation.

- (1) Install four strips of edging (1) on two crossmembers (2).

NOTE

Install flat side of crossmembers on top of frame.

- (2) Install two spacers (3), crossmembers (2), 16 screws (4), and nuts (5). Do not tighten.
- (3) Install clip bracket (6), four screws (7) and nuts (8). Tighten nuts (5 and 8).
- (4) Install two screws (9) and nuts (10).

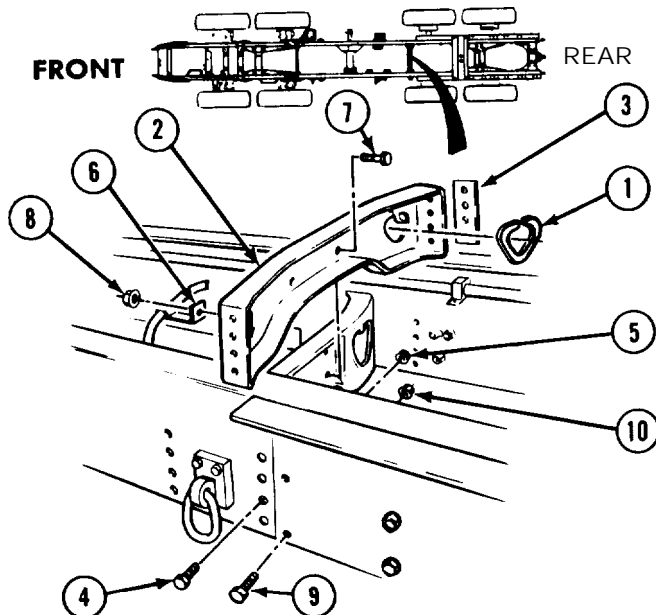

TA476739

Frame Maintenance Instructions (Cont)

13-17.1. REAR INTERMEDIATE CROSSMEMBER REMOVAL/INSTALMTION (M984E1)
(CONT).

- (5) Install air line (11) through crossmembers (2).
- (6) Soldier A and Soldier B install air line bundle (12) and chassis wiring harness (13) through crossmembers (2).

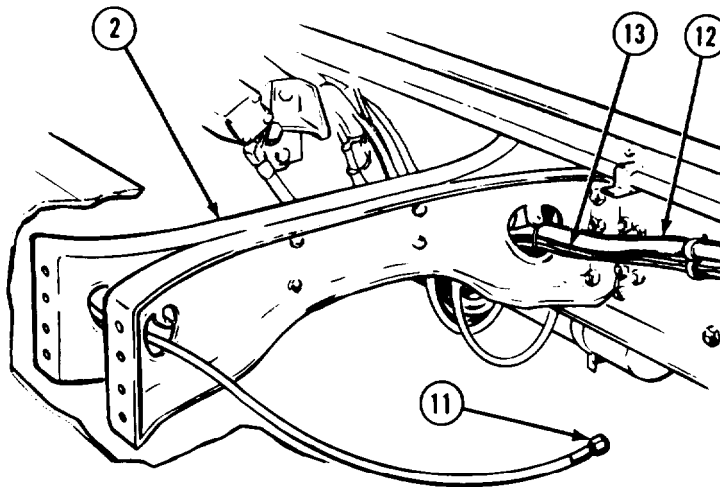

TA476740

- (7) Install lockwasher (14), three wires (15), lockwasher (14), and nut (16) at No. 4 axle stop (17).

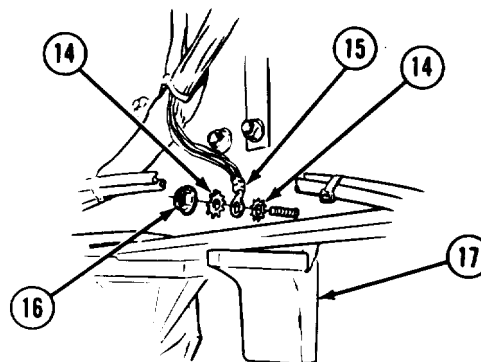

RIGHT SIDE AXLE STOP TA476741

- (8) Connect connector (18) to high idle control assembly (19),

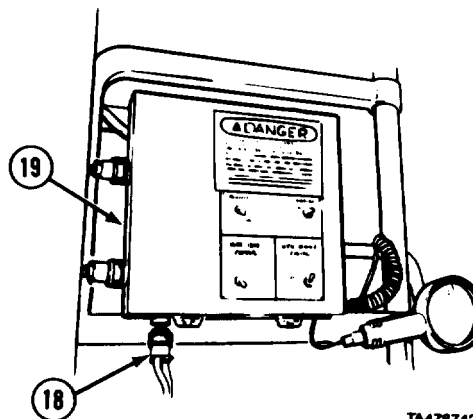

TA476742

Frame Maintenance Instructions (Cont)

- (9) Install trailer electrical connector (20), cover (21), three screws (22), lockwashers (23), and nuts (24).
- (10) Install screw (25), lockwashers (26), wire (27), lockwasher (28), and nut (29).

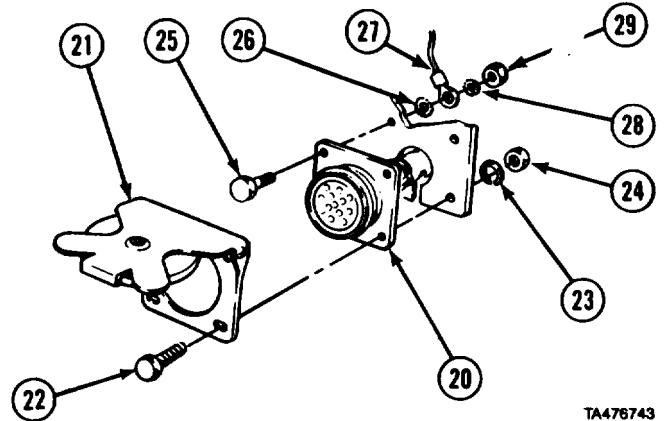

TA476743

NOTE

Do steps (11) through (14) for taillight wiring on both rear fenders.

- (11) Install chassis wiring harness (13) and grommet (30) to rear fender (31).
- (12) Connect four connectors (32).
- (13) Install clearance light connector (33) through outside of cover (34) and connect to connector (35).
- (14) Install cover (34), three screws (36), lockwashers (37), and nuts (38).
- (15) Connect two air lines (39) to tractor protection valve (40).

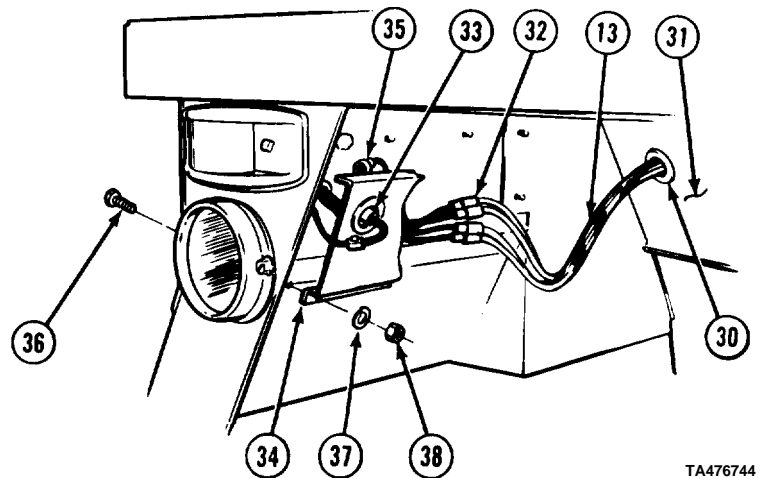

TA476744

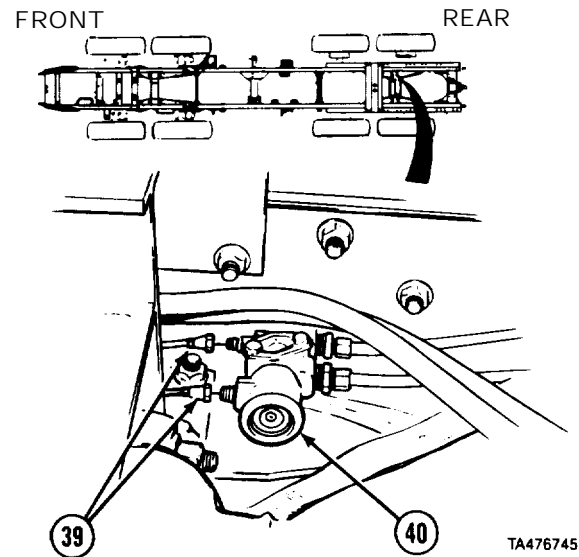

TA476745

Frame Maintenance Instructions (Cont)

**13-17.1. REAR INTERMEDIATE CROSSMEMBER REMOVAL/INSTALLATION (M984E1)
(CONT).**

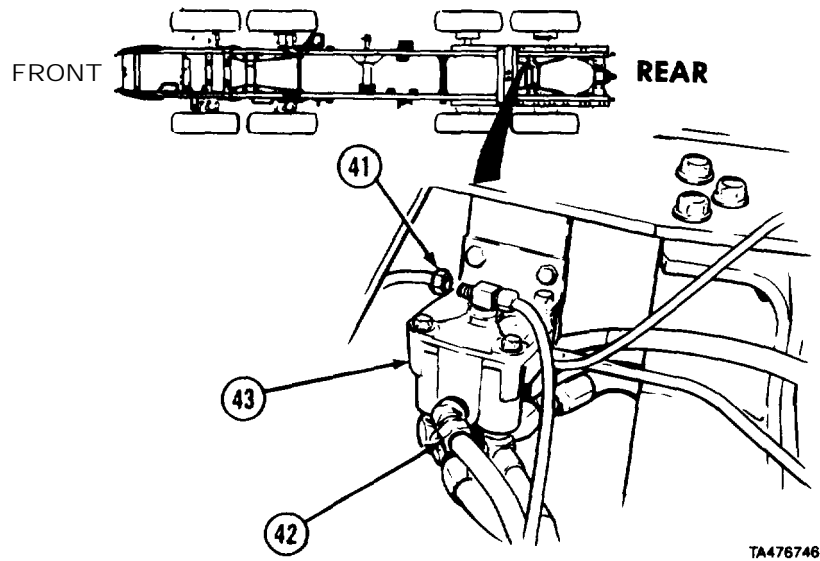

(16) Connect two air lines (41 and 42) to rear double check valve (43).

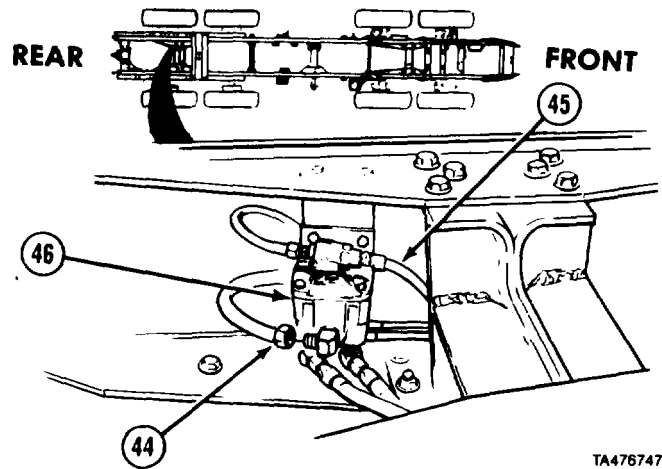

(17) Connect two airlines (44 and 45) to left rear brake relay valve (46).

Frame Maintenance Instructions (Cont)

- (18) Connect air line (47) to axle No. 3 differential lockout valve (48).

NOTE

Install clips, clamps and plastic cable ties as required.

C. Follow-on Maintenance.

- (1) Connect batteries (TM 9-2320-279-10),
- (2) Start engine (TM 9-2320-279-10). Check for air leaks.
- (3) Install equipment body (TM 9-2320-279-10).
- (4) Check vehicle operations (TM 9-2320-279-20).

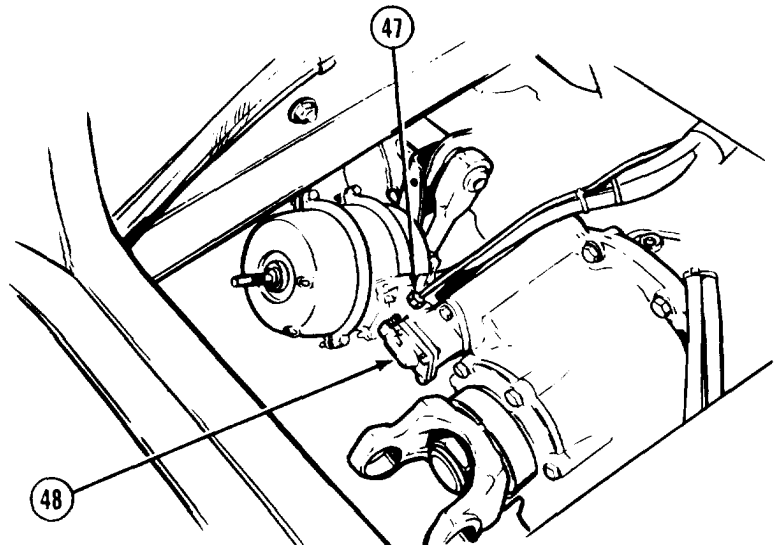

END OF TASK

13-18. REAR TANDEM CROSSMEMBER REMOVAL/INSTALLATION.													
This task covers:													
<ul style="list-style-type: none"> a. Removal b. Installation 	<ul style="list-style-type: none"> c. Follow-on Maintenance 												
INITIAL SETUP													
Models	Equipment Condition												
All except M984E1	<table border="0"> <thead> <tr> <th>TM or Para</th> <th>Condition Description</th> </tr> </thead> <tbody> <tr> <td>TM 9-2320-279-20</td> <td>Cable tensioner removed.</td> </tr> <tr> <td>TM 9-2320-279-20</td> <td>Right and left rear brake relay valves removed.</td> </tr> <tr> <td>TM 9-2320-279-20</td> <td>Trailer protection valve removed.</td> </tr> <tr> <td>TM 9-2320-279-20</td> <td>Taillights removed.</td> </tr> <tr> <td>Para 14-4</td> <td>Rear lateral torque rods removed.</td> </tr> </tbody> </table>	TM or Para	Condition Description	TM 9-2320-279-20	Cable tensioner removed.	TM 9-2320-279-20	Right and left rear brake relay valves removed.	TM 9-2320-279-20	Trailer protection valve removed.	TM 9-2320-279-20	Taillights removed.	Para 14-4	Rear lateral torque rods removed.
TM or Para	Condition Description												
TM 9-2320-279-20	Cable tensioner removed.												
TM 9-2320-279-20	Right and left rear brake relay valves removed.												
TM 9-2320-279-20	Trailer protection valve removed.												
TM 9-2320-279-20	Taillights removed.												
Para 14-4	Rear lateral torque rods removed.												
Test Equipment	Special Environmental Conditions												
None	None												
Special Tools	General Safety Instructions												
None	None												
Supplies	Level of Maintenance												
Tags, identification, Item 60, Appendix C	Direct Support												
Personnel Required													
MOS 63W, Wheel vehicle repairer (2)													
References													
None													
Equipment Condition													
<table border="0"> <thead> <tr> <th>TM or Para</th> <th>Condition Description</th> </tr> </thead> <tbody> <tr> <td>TM 9-2320-279-10</td> <td>Air tanks drained.</td> </tr> <tr> <td>TM 9-2320-279-20</td> <td>Rear axle propeller shaft removed.</td> </tr> </tbody> </table>	TM or Para	Condition Description	TM 9-2320-279-10	Air tanks drained.	TM 9-2320-279-20	Rear axle propeller shaft removed.							
TM or Para	Condition Description												
TM 9-2320-279-10	Air tanks drained.												
TM 9-2320-279-20	Rear axle propeller shaft removed.												

Frame Maintenance Instructions (Cont)

13-18. REAR TANDEM CROSSMEMBER REMOVAL/INSTALLATION (CONT).

a. Removal.

- (1) Soldier A and Soldier B remove eight screws (1) and nuts (2) from left frame rail (3).

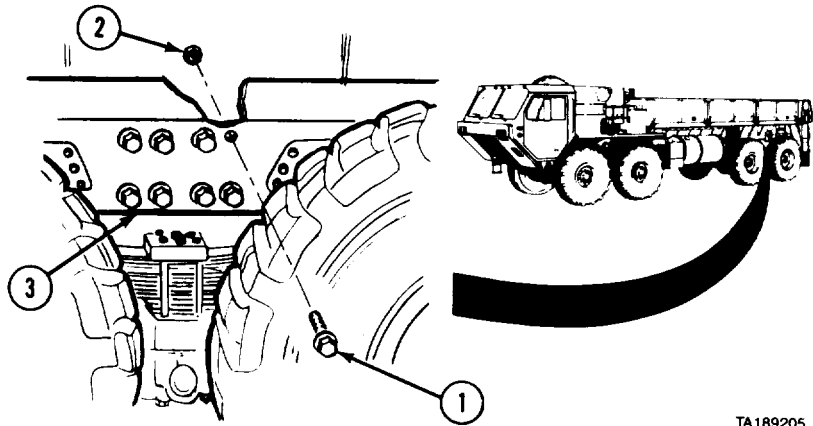

TA189205

NOTE

There are five additional screws and nuts to remove on vehicles with self-recovery winch.

- (2) Soldier A and Soldier B remove eight screws (4) and nuts (5) from right frame rail (6).

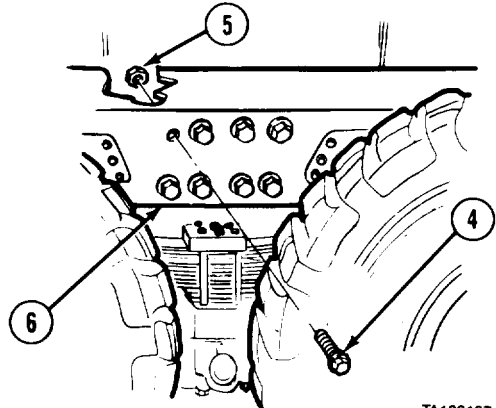

TA189197

NOTE

Do step (3) for M977 and M985 vehicles only.

- (3) Disconnect crane marker light connector (7).

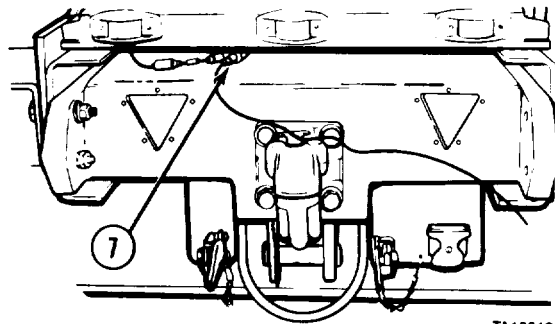

TA189191

Frame Maintenance Instructions (Cont)

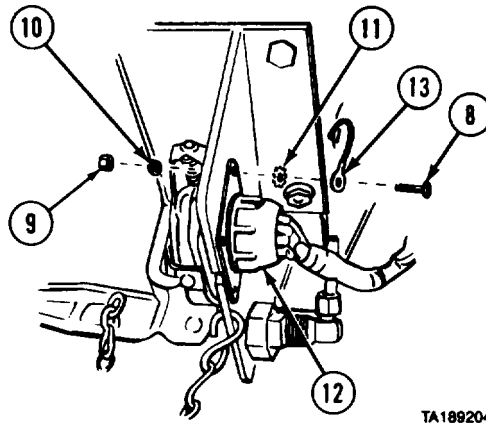

- (4) Remove four screws (8), nuts (9), and lockwashers (10 and 11).
- (5) Disconnect trailer connector (12) and ground wire (13).

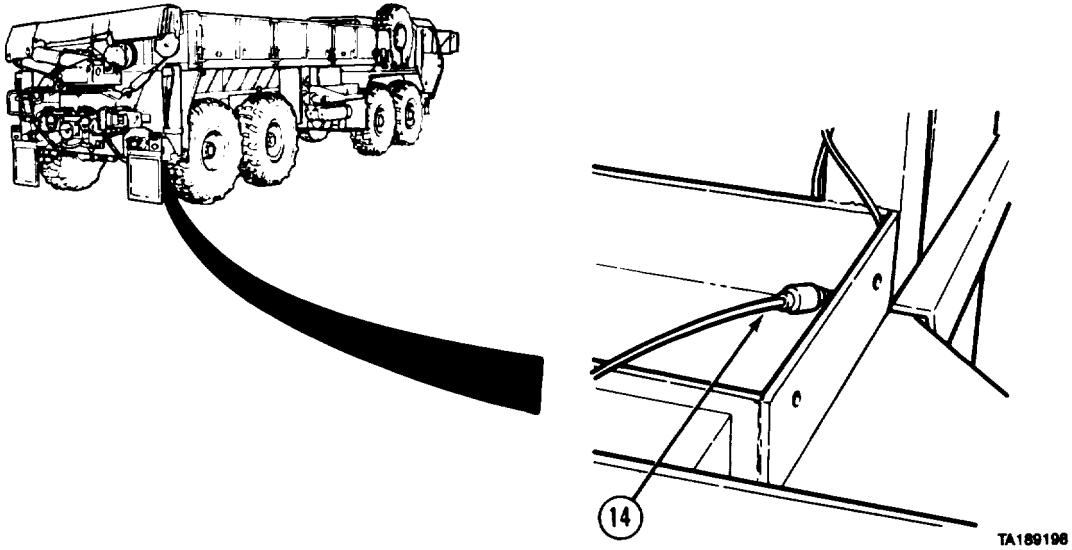

NOTE

Do step (6) for M977 and M985 vehicles.

- (6) Disconnect cargo body clearance light connector (14).

Frame Maintenance Instructions (Cont)

13-18. REAR TANDEM CROSSMEMBER REMOVAL/INSTALLATION (CONT).

NOTE

- Tag and mark wire harness and air lines.
- Remove air line and electric wire clips and brackets as required,
- (7) Pull wire harness (15) and air lines (16) through two rear tandem crossmembers (17 and 18).
- (9) Remove two grommets (19) from crossmembers (17 and 18).
- (9) Remove 24 screws (20) and nuts (21) from crossmembers (17 and 18) and gussets (22).

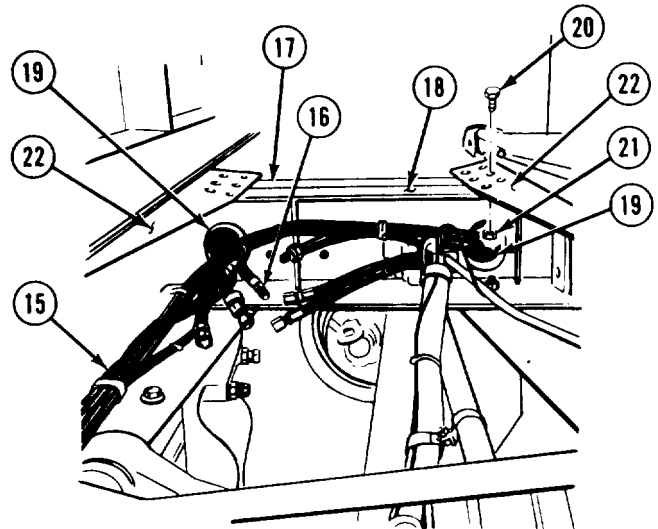

TA189200

- (10) Remove screw (23) and nut (24) on right side rear spring hanger bracket (25).

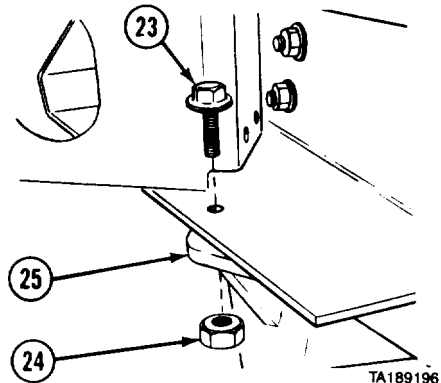

TA189196

CAUTION

Do not apply excessive force to spread frame rails or frame could be damaged.

- (11) Use hydraulic jack (26) to spread frame rails (3 and 6).
- (12) Slide right ends of crossmembers (17 and 18) to rear of vehicle and remove.

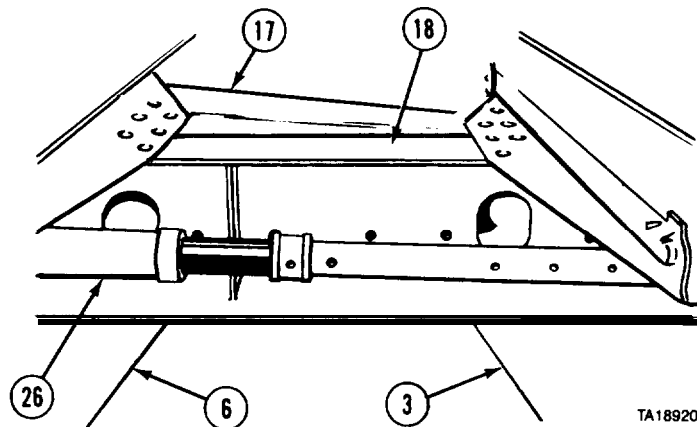

TA189203

Frame Maintenance Instructions (Cont)

b. Installation.

- (1) Soldier A and Soldier B install left end of front crossmember (1) against left frame rail (2) and slide right end in place.
- (2) Soldier A and Soldier B install left end of rear crossmember (3) against left frame rail (2) and slide right end in place.
- (3) Remove hydraulic jack (4).
- (4) Install 24 screws (5) and nuts (6) through crossmembers (1 and 3) and gussets (7). Do not tighten.

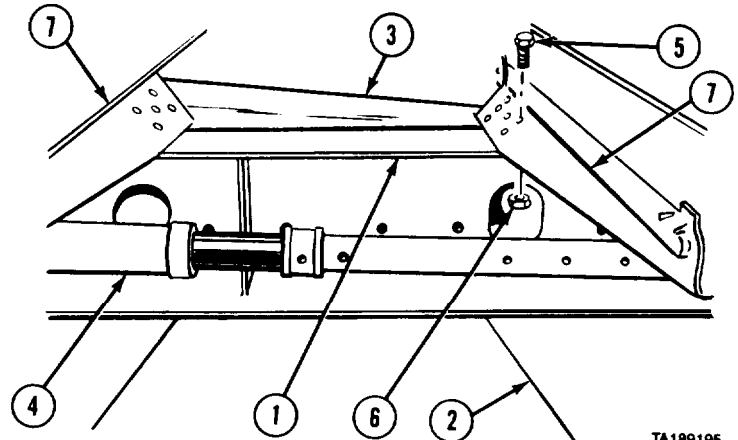

- (5) Install screw (8) and nut (9).

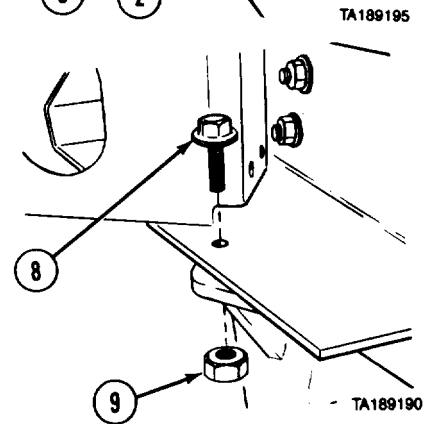

NOTE

There are five additional screws to install on vehicles with self-recovery winch.

- (6) Soldier A and Soldier B install eight screws (10) and nuts (11) in right frame rail (12). Do not tighten.

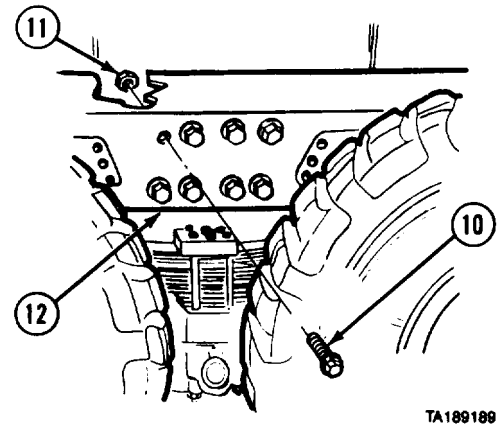

Frame Maintenance Instructions (Cont)

13-18. REAR TANDEM CROSSMEMBER REMOVAL/INSTALLATION (CONT.)

- (7) Soldier A and Soldier B install eight screws (13) and nuts (14) in left frame rail (2).
- (8) Tighten nuts and screws installed in steps (4), (6), and (7).

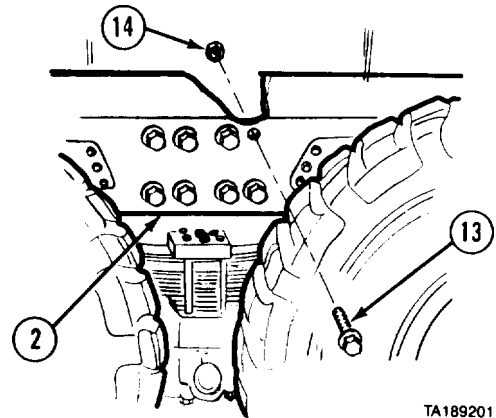

TA189201

- (9) Install wire harness (15) and air lines (16) through rear tandem crossmembers (1 and 3).
- (10) Install grommets (17) in crossmembers (1 and 3).

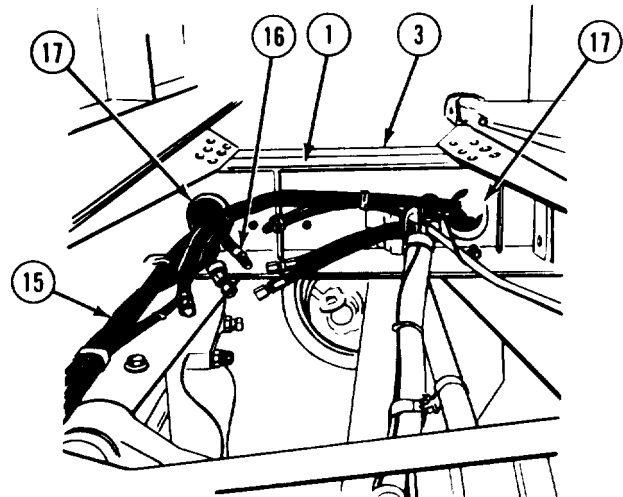

TA189199

NOTE

Do step (11) for M977 and M985 vehicles.

- (11) Connect cargo body clearance light connector (18).

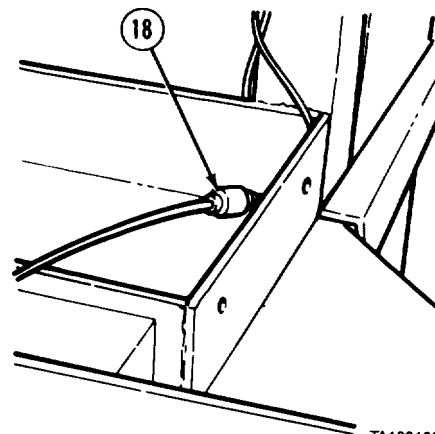

TA189192

Frame Maintenance Instructions (Cont)

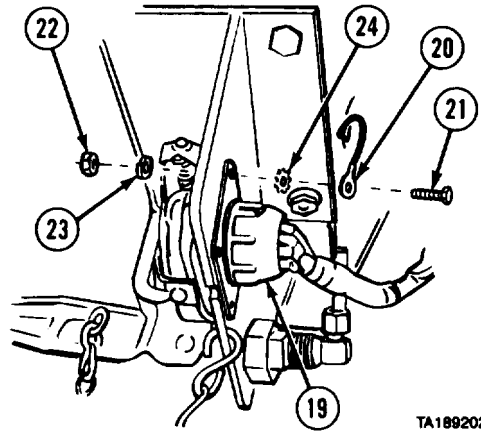

- (12) Connect trailer connector (19) and ground wire (20) with four screws (21), nuts (22), and lockwashers (23 and 24).

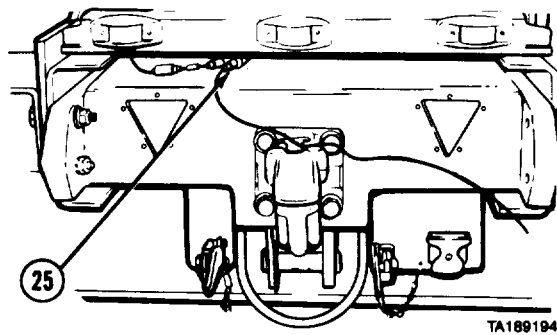

NOTE

Do step (13) for M977 and M985 vehicles only.

- (13) Connect crane marker light connector (25).

c. Follow-on Maintenance.

- (1) Install tail lights (TM 9-2320-279-20).
- (2) Install rear lateral torque rods (para 14-4).
- (3) Install trailer protection valve (TM 9-2320-279-20).
- (4) Install right and left rear brake relay valves (TM 9-2320-279-20).
- (5) Install cable tensioner (TM 9-2320-279-20).
- (6) Install rear axle propeller shaft (TM 9-2320-279-20).

END OF TASK

Frame Maintenance Instructions (Cont)

13-18.1. REAR TANDEM CROSSMEMBER REMOVAL/INSTALLATION (M984E1).		
This task covers:		
a. Removal	c. Follow-on Maintenance	
b. Installation		
INITIAL SETUP		
Models	Equipment Condition	
M984E1	TM or Para	Condition Description
Test Equipment	TM 9-2320-279-20	Left rear brake relay valve removed.
None	Para 17-3.1	Crane removed.
Special Tools		
None		
Supplies		
None		
Personnel Required		
MOS 63W, Wheel vehicle repairer (2)		
References		
None		
Equipment Condition	Special Environmental Conditions	
TM or Para	Condition Description	
TM 9-2320-279-20	Rear fenders removed.	
TM 9-2320-279-20	Torque rods removed from No. 3 and No. 4 axles.	
TM 9-2320-279-20	Tractor protection valve removed.	
	General Safetg Instructions	
	Wheels chocked	
	Level of Maintenance	
	Direct Support	

NOTE
 . For ease of removal and installation, the following equipment condition may be used, but is not necessary.
 • TM 9-2320-279-10 Wheels and tires removed from No. 3 and No. 4 axles.

a. Removal.

- (1) Remove eight screws (1) and nuts (2)

NOTE

Mark position of each bracket on removal.

- (2) Soldier A removes 16 screws (3) while Soldier B removes nuts (4) and four crossmember brackets (5) from gussets (6).

NOTE

. It may be necessary to spread gussets to remove crossmembers.

- Mark position of clip brackets before removal.

- (3) Remove 24 screws (7), nuts (8) and four clip brackets (9).
- (4) Soldier A attaches and operates suitable lifting device while Soldier B removes two crossmembers (10 and 11).

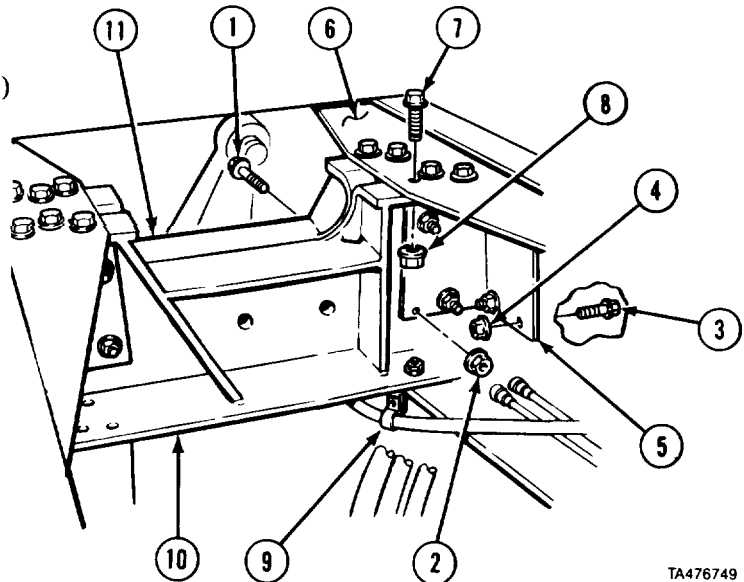

TA476749

Frame Maintenance Instructions (Cont)

b. Installation.

NOTE

Install all screws and nuts before tightening.

- (1) Install crossmember bracket (1), four screws (2) and nuts (3).

NOTE

It may be necessary to lift gussets to install crossmembers.

- (2) Install crossmember (4) on gussets (5). Aline holes in gussets and crossmember.
- (3) Install crossmember (6) on gussets (5). Aline holes in gussets and crossmember (4 and 6).

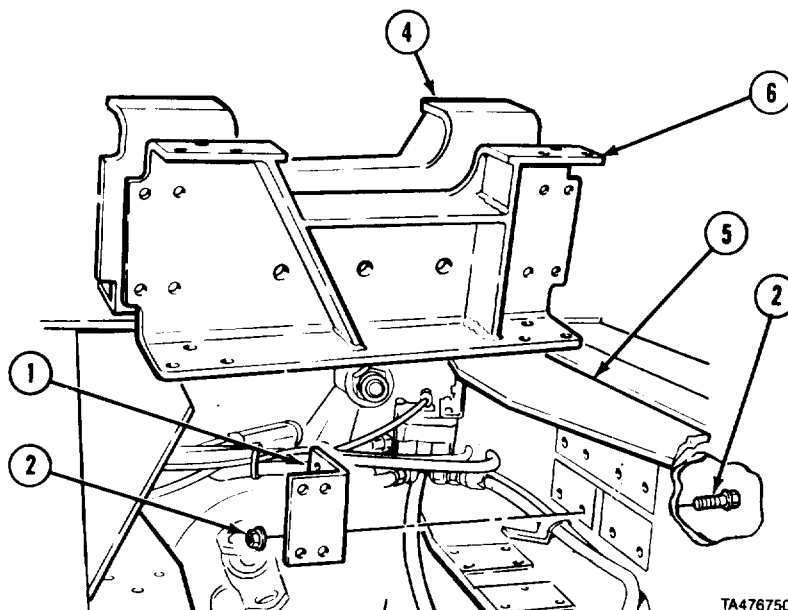

TA476750

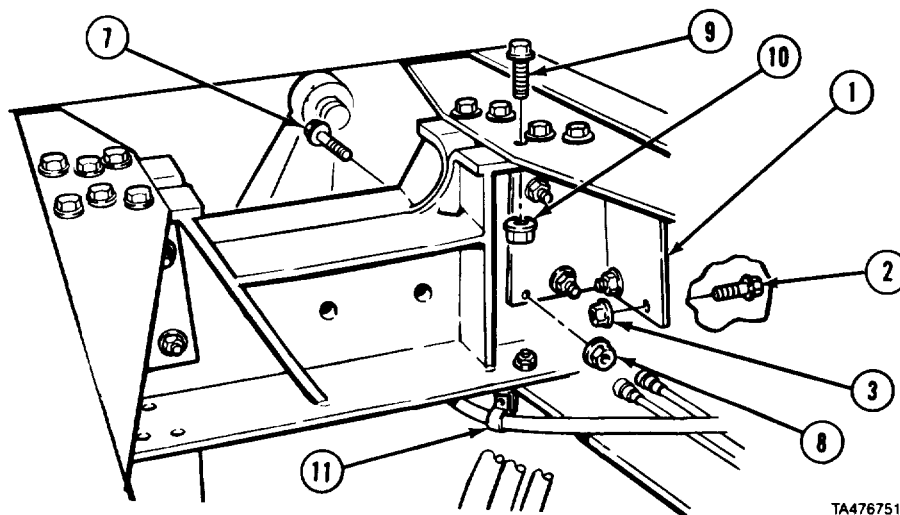

TA476751

- (4) Install three crossmember brackets (1), eight screws (7) and nuts (8).
- (5) Soldier A installs 12 screws (2) while Soldier B installs nuts (3). Do not tighten nuts.
- (6) Install 24 screws (9), nuts (10) and four clip brackets (11).
- (7) Soldier A tightens 48 nuts (3, 8 and 10) while Soldier B holds screws (2, 7, and 9).

c. Follow-on Maintenance.

- (1) Install crane (para 17-3.1).
- (2) Install left rear brake relay valve (TM 9-2320-279-20).
- (3) Install tractor protection valve (TM 9-2320-279-20).
- (4) Install torque rods on No. 3 and No. 4 axles (TM 9-2320-279-20).
- (5) Install rear fenders (TM 9-2320-279-20).

NOTE

Install wheels and tires on No. 3 and No. 4 axles if removed (TM 9-2320-279-10).

END OF TASK

Frame Maintenance Instructions (Cont)

13-19. REAR TANDEM GUSSETS REMOVAL/INSTALLATION (M977, M985, M985E1 , M978).

This task covers:

- | | |
|-----------------------------------|------------------------------------|
| a. Lower Left Gusset Removal | f. Lower Right Gusset Installation |
| b. Lower Left Gusset Installation | g. Upper Right Gusset Removal |
| c. Upper Left Gusset Removal | h. Upper Right Gusset Installation |
| d. Upper Left Gusset Installation | i. Follow-on Maintenance. |
| e. Lower Right Gusset Removal | |

INITIAL SETUP

Models

M977, M985, M985E1 , M978

Test Equipment

None

Special Tools

None

Supplies

Ties, cable, plastic, Item 65, Appendix C

Personnel Required

MOS 63W, Wheel vehicle repairer (2)

References

None

Equipment Condition

TM or Para

Para 13-18

Condition Description

Rear tandem crossmember removed.
Left and right rear brake relay valves removed.
Tractor protection valve removed.

Special Environmental Conditions

None

General Safety Instructions

None

Level of Maintenance

Direct Support

a. Lower Left Gusset Removal.

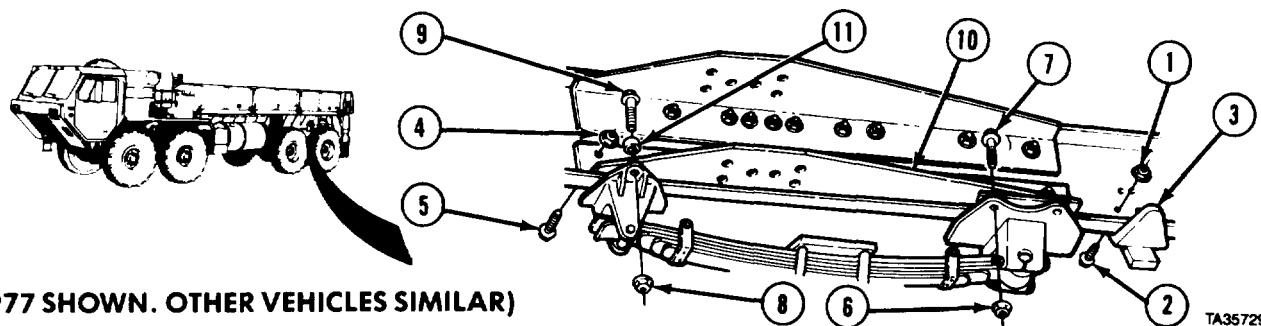

NOTE

- Remove and install hose brackets, clips, and plastic cable ties as required.
- Ž Mark position of screws before removing.

- (1) Remove two locknuts (1), screws (2), and No. 3 axle stop (3).
- (2) Soldier A and Soldier B remove 17 locknuts (4) and screws (5).
- (3) Remove two locknuts (6) and screws (7).
- (4) Remove locknut (8) and screw (9).
- (5) Remove lower left gusset (10) and two spacers (11 and 12).

b. Lower Left Gusset Installation.

- (1) Soldier A and Soldier B install lower left gusset (10), 17 screws (5), and locknuts (4).
- (2) Install spacer (12), two screws (9), and locknuts (6).
- (3) Install spacer (11), screw (9), and locknut (8).
- (4) Install No. 3 axle stop (3), two screws (2), and locknuts (1).

Frame Maintenance Instructions (Cont)

c. Upper Left Gusset Removal.

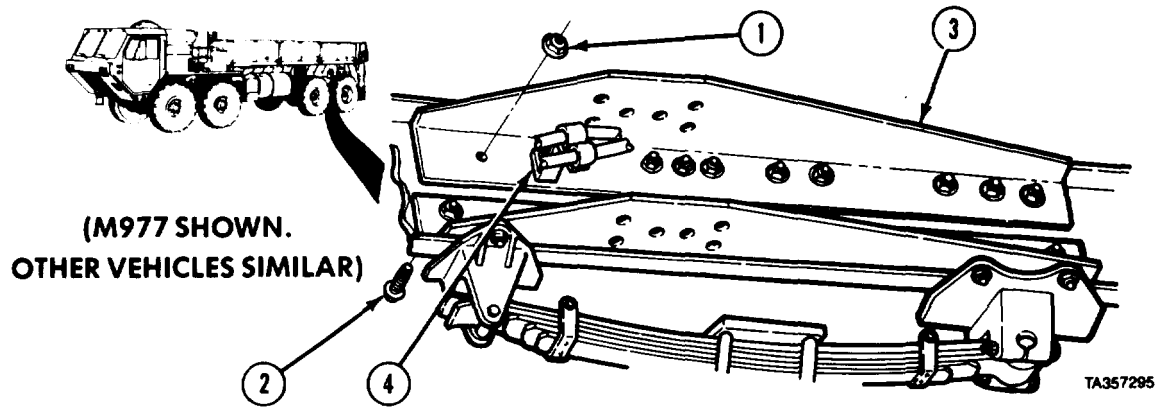

NOTE

- . Mark location of screws and bracket before removing.
- Do step (2) for M978.

(1) Soldier A and Soldier B remove 11 locknuts (1), screws (2), and upper left gusset (3).

(2) Soldier A and Soldier B remove 11 locknuts (1), screws (2), upper left gusset (3), and bracket (4).

d. Upper Left Gusset Installation.

(1) Soldier A and Soldier B install upper left gusset (3) with 11 screws (2) and locknuts (1).

NOTE

Do steps (2) and (3) for M978.

(2) Soldier A and Soldier B install upper left gusset (3) with 10 screws (2) and locknuts (1).

(3) Soldier A and Soldier B install bracket (4) to upper left gusset (3) with one screw (2) and locknut (1).

Frame Maintenance Instructions (Cont)

13-19. REAR TANDEM GUSSETS REMOVAL/INSTALLATION (M977, M985, M985E1, M978)
(CONT).

e. Lower Right Gusset Removal.

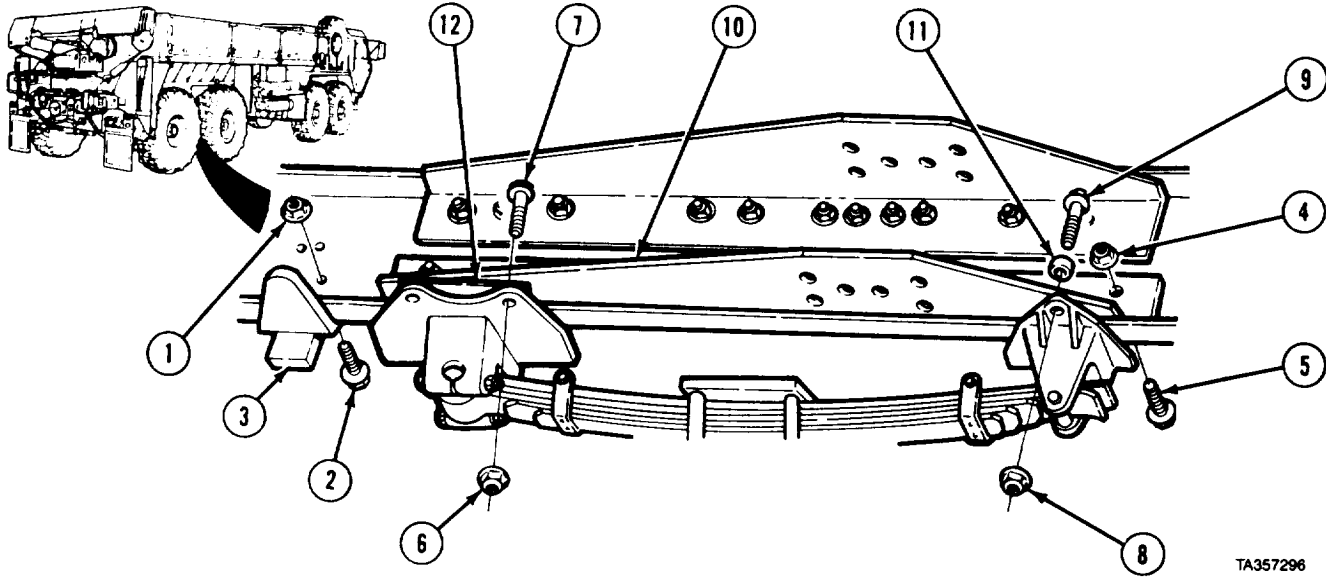

TA357296

NOTE

- Remove and install hose brackets, and plastic cables ties as required.
- Mark location of screws before removing.

- (1) Remove two locknuts (1), screws (2), and No. 3 axle stops (3).
- (2) soldier A and soldier B remove 17 locknuts (4) and screws (5).
- (3) Remove two locknuts (6) and screws (7).
- (4) Remove locknut (8) and screw (9).
- (5) Remove lower right gusset (10) and two spacers (11 and 12).

f. Lower Right Gusset Installation.

- (1) Soldier A and Soldier B install lower right gusset (10), 17 screws (5), and locknuts (4).
- (2) Install spacer (12) two screws (7), and locknuts (6).
- (3) Install spacer (11), screw (9), and locknut (8).
- (4) Install No. 3 axle stop (3), two screws (2), and locknuts (1).

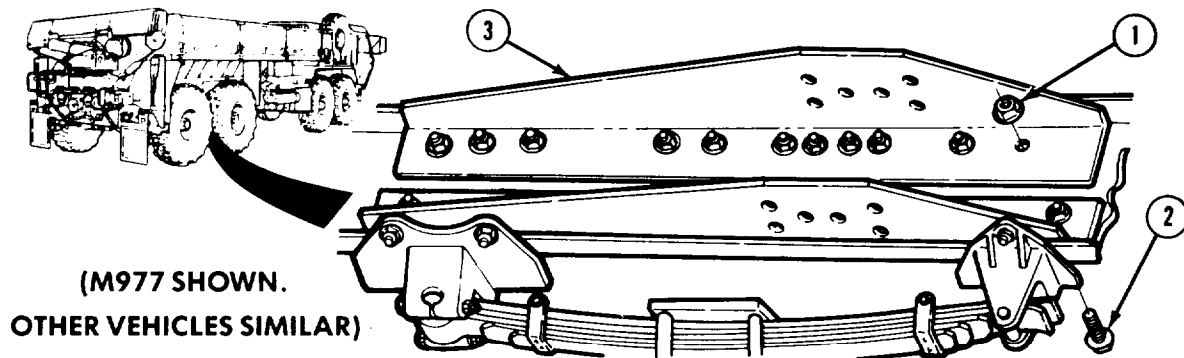

TA357297

Frame Maintenance Instructions (Cont)

NOTE

Mark location of screws before removing.

g. Upper Right Gusset Removal. Soldier A and Soldier B remove 11 locknuts (1), screws (2), and upper right gusset (3).

h. Upper Right Gusset Installation. Soldier A and Soldier B install upper right gusset (3) with 11 screws (2) and locknuts (1).

i. Follow-on Maintenance.

(1) Install rear tandem crossmember (para 13-18).

(2) Install tractor protection valve (TM 9-2320-29-20).

(3) Install left and right rear brake relay valves (TM 9-2320-279-20).

END OF TASK

3-20. REAR TANDEM GUSSETS REMOVAL/INSTALLATION (M983).		
This task covers:		
a. Lower Left Gusset Removal	f. Lower Right Gusset Installation	
b. Lower Left Gusset Installation	g. Upper Right Gusset Removal	
c. Upper Left Gusset Removal	h. Upper Right Gusset Installation	
d. Upper Left Gusset Installation	i. Follow-on Maintenance.	
e. Lower Right Gusset Removal		
INITIAL SETUP		
<i>Model.s</i>	<i>Equipment Condition</i>	
M983	<i>TM or Para</i>	<i>Condition Description</i>
<i>Test Equipment</i>	Para 13-18	Rear tandem crossmember removed.
None	TM 9-2320-279-20	Wheel chock stowage box removed (lower left gusset (M983).
<i>Special Tools</i>	TM 9-2320-279-20	Left and right rear brake relay valves removed.
None		
<i>Supplies</i>		
Ties, cable, plastic, Item 65, Appendix C		
<i>Personnel Required</i>	<i>Special Environmental Conditions</i>	
MOS 63W, Wheel vehicle repairer (2)	None	
<i>References</i>	<i>General Safety Instructions</i>	
None	None	
	<i>Level of Maintenance</i>	
	Direct Support	

Frame Maintenance Instructions (Cont)

13-20. REAR TANDEM GUSSETS REMOVAL/INSTALLATION (M983) (CONT).

a. Lower Left Gusset Removal.

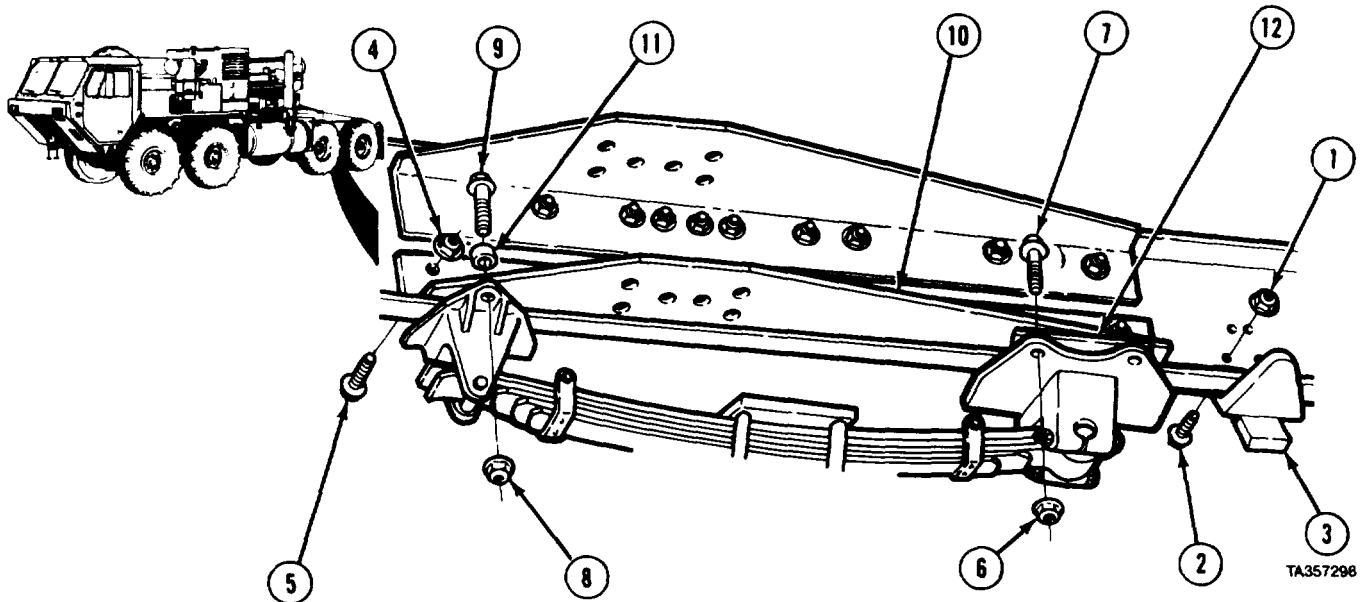

NOTE

- . Remove hose brackets, clips, and plastic cable ties as required.
- . Mark location of screws before removal.

- (1) Remove two locknuts (1), screws (2), and No. 3 axle stop (3).
- (2) Soldier A and Soldier B remove 14 locknuts (4) and screws (5).
- (3) Remove two locknuts (6) and screws (7).
- (4) Remove locknut (8) and screw (9).
- (5) Remove lower left gusset (10) and two spacers (11 and 12).

b. Lower Left Gusset Installation.

- (1) Soldier A and Soldier B install lower left gusset (10), 14 screws (5), and locknuts (4).
- (2) Install spacer (12), two screws (7), and locknuts (6).

NOTE

Install hose brackets, clips, and plastic cable ties as required.

- (3) Install spacer (11), screw (9), and locknut (8).
- (4) Install No. 3 axle stop (3), two screws (2), and locknuts (1).

Frame Maintenance Instructions (Cont)

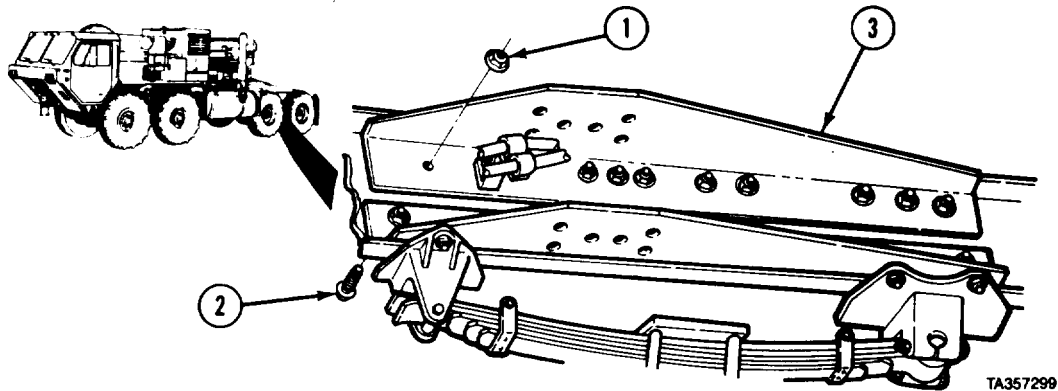

c. Upper Left Gusset Removal. Soldier A and Soldier B remove 11 locknuts (1), screws (2), and upper left gusset (3).

d. Upper Left Gusset Installation.

(1) Soldier A and Soldier B install upper left gusset (3), 11 screws (2), and locknuts (1).

e. Lower Right Gusset Removal.

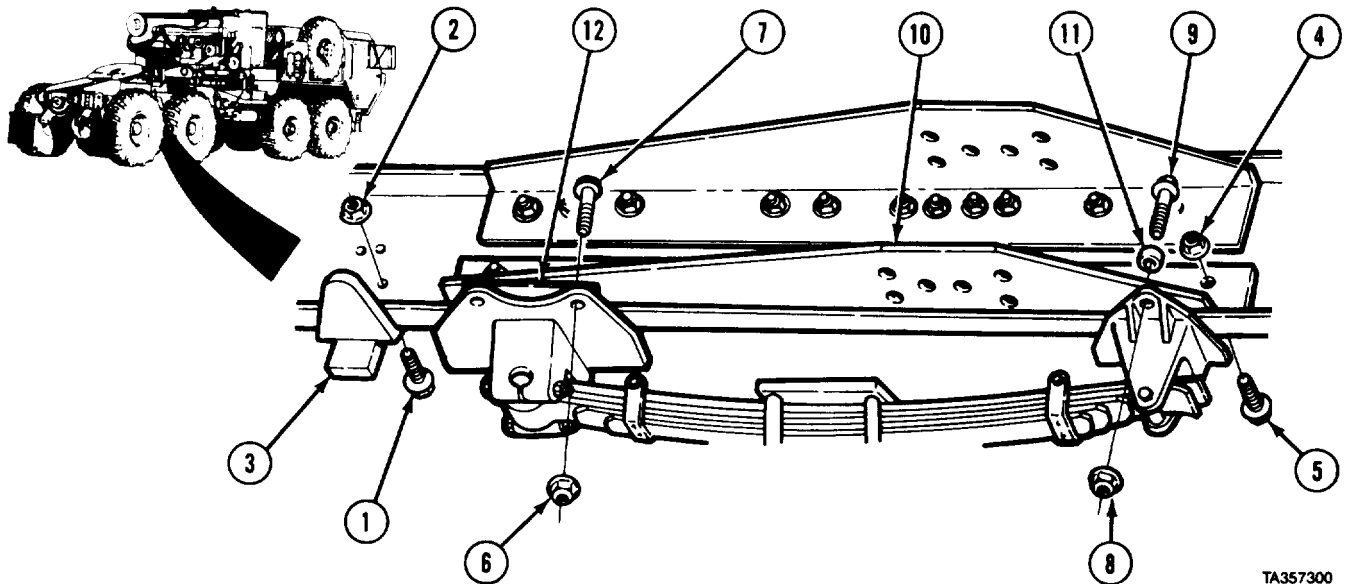

NOTE

Mark location of screws before removing.

- (1) Remove two screws (1), locknuts (2), and No. 3 axle stop (3).
- (2) Soldier A and Soldier B remove 16 locknuts (4) and screws (5).
- (3) Remove two locknuts (6) and screws (7).
- (4) Remove locknut (8) and screw (9).
- (5) Remove lower right gusset (10) and two spacers (11 and 12).

f. Lower Right Gusset Installation.

- (1) Soldier A and Soldier B install lower right gusset (10), 16 screws (5), and locknuts (4).
- (2) Install spacer (12), two screws (7), and locknuts (6).
- (3) Install spacer (11), screw (9), and locknut (8).
- (4) Install No. 3 axle stop (3), two screws (1), and locknuts (2).

Frame Maintenance Instructions (Cont)

13-20. REAR TANDEM GUSSETS REMOVAL/INSTALLATION (M983) (CONT).

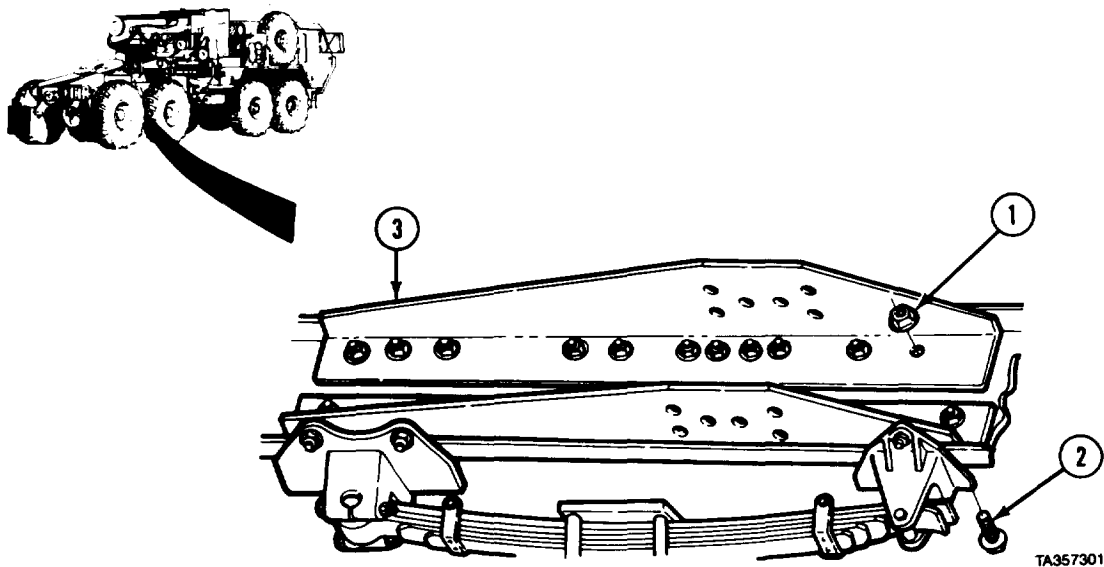

NOTE

Mark location of screws before removing.

g. Upper Right Gusset Removal. Soldier A and Soldier B remove 11 locknuts (1), screws (2), and upper right gusset (3).

h. Upper Right Gusset Installation. Soldier A and Soldier B install upper right gusset (3) with 11 screws (2) and locknuts (1).

i. Follow-on Maintenance.

- (1) Install rear tandem crossmember (para 13-18).
- (2) Install left and right rear brake relay valves (TM 9-2320-279-20).
- (3) Install wheel chock stowage box (M983) (TM 9-2320-279-20).

END OF TASK

Frame Maintenance Instructions (Cont)

13-21. REAR TANDEM GUSSETS REMOVAL/INSTALLATION (M984).

This task covers:

- | | |
|---|--|
| <ul style="list-style-type: none"> a. Lower Left Gusset Removal b. Lower Left Gusset Installation c. Upper Left Gusset Removal d. Upper Left Gusset Installation e. Lower Right Gusset Removal | <ul style="list-style-type: none"> f. Lower Right Gusset Installation g. Upper Right Gusset Removal h. Upper Right Gusset Installation i. Follow-on Maintenance. |
|---|--|

INITIAL SETUP

Models

M984

Test Equipment

None

Special Tools

None

Supplies

Ties, cable, plastic, Item 65, Appendix C

Personnel Required

MOS 63W, Wheel vehicle repairer (2)

References

None

Equipment Condition

TM or Para

Para 13-18

Condition Description

Rear tandem crossmember removed.

TM 9-2320-279-20

Left and right rear brake relay valves removed.

Equipment Condition

TM or Para

TM 9-2320-279-20

Condition Description

Tractor protection valve removed.

TM 9-2320-279-20

Rear fenders removed.

NOTE

If removing upper and lower gussets, do the following procedure.

Para 13-29

Crane mounting supports removed.

Special Environmental Conditions

None

General Safety Instructions

None

Level of Maintenance

Direct Support

Frame Maintenance Instructions (Cont)

13-21. REAR TANDEM GUSSETS REMOVAL/INSTALLATION (M984) (CONT).

a. Lower Left Gusset Removal.

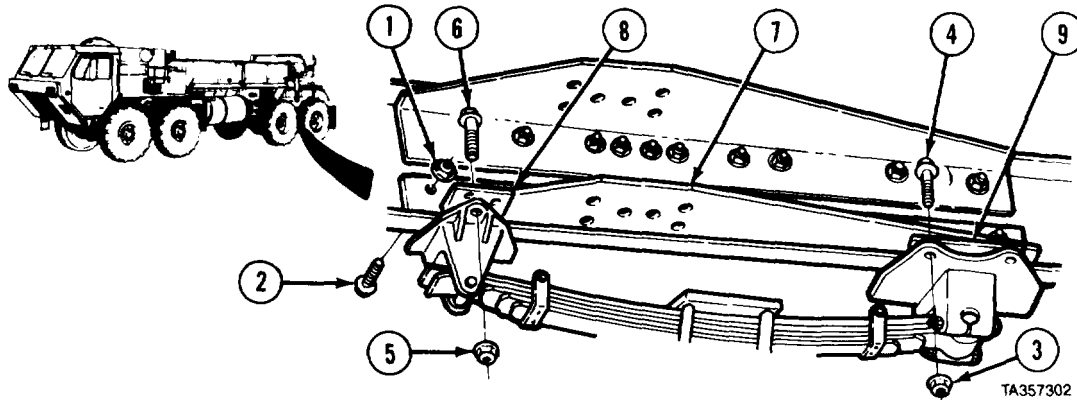

NOTE

- Remove hose brackets, clips, and plastic cable ties as required.
- Mark location of screws before removal.

- (1) Soldier A and, Soldier B remove 13 locknuts (1) and screws (2).
- (2) Remove two locknuts (3) and screws (4).
- (3) Remove two locknuts (5) and screws (6).
- (4) Remove lower left gusset (7) and two spacers (8 and 9)

b. Lower Left Gusset Installation.

- (1) Soldier A and Soldier B install lower left gusset (7), 13 screws (2), and locknuts (1).
- (2) Install spacer (9), two screws (4), and locknuts (3).

NOTE

Install hose brackets, clips, and plastic cable ties as required.

- (3) Install spacer (8), two screws (5), and locknuts (6).

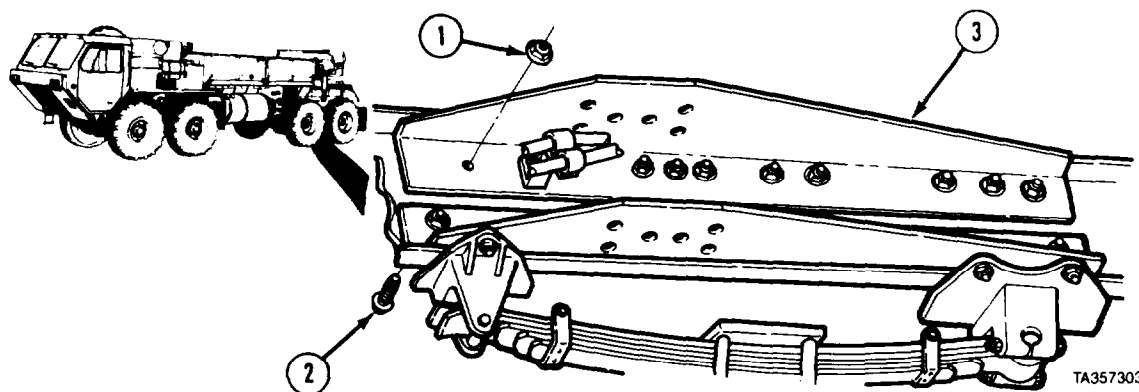

c. Upper Left Gusset Removed. Soldier A and Soldier B remove 10 locknuts (1), screws (2), and upper left gusset (3).

d. Upper Left Gusset Installation.

- (1) Soldier A and Soldier B install upper left gusset (3), 10 screws (2), and locknuts (1).

Frame Maintenance Instructions (Cont)

e. Lower Right Gusset Removal.

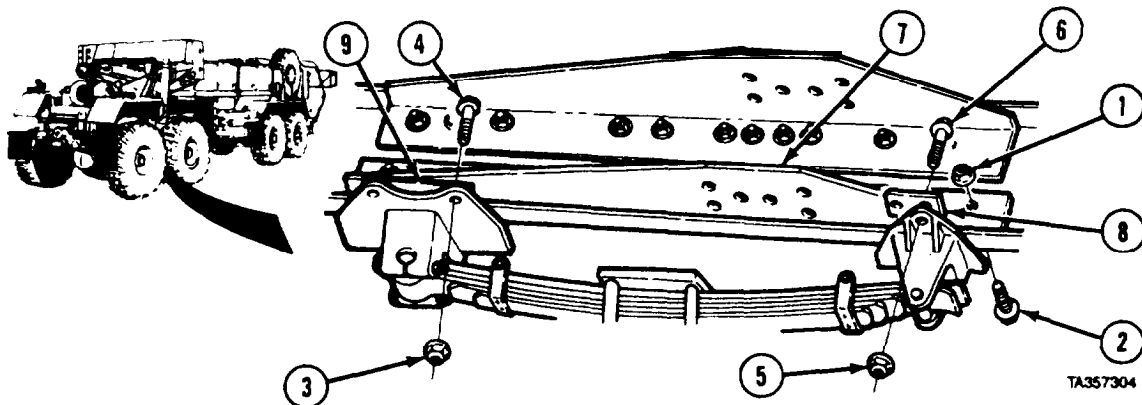

- (1) Soldier A and Soldier B remove 13 locknuts (1) and screws (2).
- (2) Remove two locknuts (3) and screws (4).
- (3) Remove two locknuts (5) and screws (6).
- (4) Remove lower right gusset (7) and two spacers (8 and 9).

f. Lower Right Gusset Installation.

- (1) Soldier A and Soldier B install lower right gusset (7) 13 screws (2), and locknuts (1).
- (2) Install spacer (9), two screws (4), and locknuts (3).
- (3) Install spacer (8), two screws (6), and locknut (5).

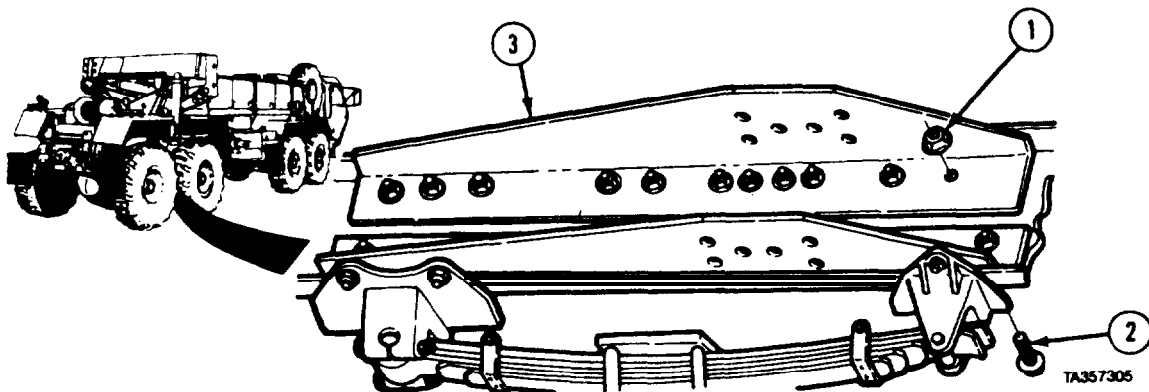

g. Upper Right Gusset Removal. Soldier A and Soldier B remove 10 locknuts (1), screws (2), and upper right gusset (3).

h. Upper Right Gusset Installation. Soldier A and Soldier B install upper right gusset (3) with 10 screws (2) and locknuts (1).

Frame Maintenance Instructions (Cont)

13-21. REAR TANDEM GUSSETS REMOVAL/INSTALLATION (M984) (CONT).

i. Follow-on Maintenance.

- (1) Install rear tandem crossmember (para 13-18).

NOTE

If upper and lower gussets were removed, do the following procedure.

- (2) Install crane mounting supports (para 13-29).
- (3) Install left and right rear brake relay valves (TM 9-2320-279-20).
- (4) Install tractor protection valve (TM 9-2320-279-20).
- (5) Install rear fenders (TM 9-2320-279-20).

END OF TASK

13-22. REAR CROSSMEMBER REMOVAL/INSTALLATION (M977, M985).

This task covers:

- a. Removal
- b. Installation
- c. Follow-on Maintenance

INITIAL SETUP

Models
M977, M985

Equipment Condition
TM or Para
Para 13-27
Condition Description
Crane mounting brackets removed

Test Equipment
None

Special Environmental Conditions
None

Special Tools
None

General Safety Instructions
None

Supplies
None

Level of Maintenance
Direct Support

Personnel Required
MOS 63W, Wheel vehicle repairer (2)

References
None

a. Removal.

- (1) Remove two screws (1), nuts (2), and lockwashers (3) holding bracket (4) to rear crossmember (5).

NOTE

Not all models have star-shaped lockwashers. Star-shaped lockwashers are only on screw closest to pintle.

- (2) Remove two screws (6), nuts (7), lockwashers (7.1), and lockwashers (8) holding bracket (9) to rear crossmember (5).
- (3) Soldier A and Soldier B remove rear crossmember (5) from frame (10) using suitable lifting device.

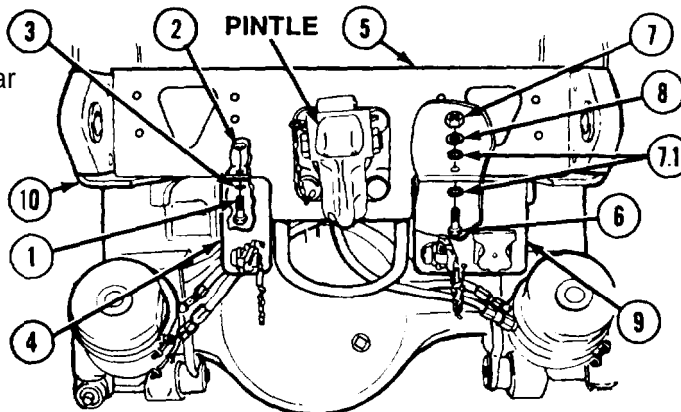

Frame Maintenance Instructions (Cont)

- (4) Remove four nuts (11), lockwashers (12), washers (13), screws (14), and pintle (15) from rear crossmember (5).
- (5) Remove four locknuts (16), lockwashers (16.1) screws (17), and two cross braces (18) from rear crossmember (5).
- (6) Remove lifting device.

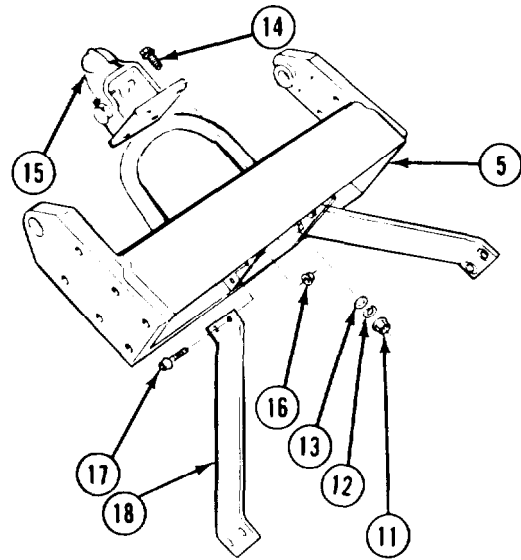

b. Installation.

- (1) Install pintle (1) on rear crossmember (2) with four screws (3), washers (4), lockwashers (5), and nuts (6).
- (2) Install two cross braces (7) on rear crossmember (2) with four screws (8) and locknuts (9).

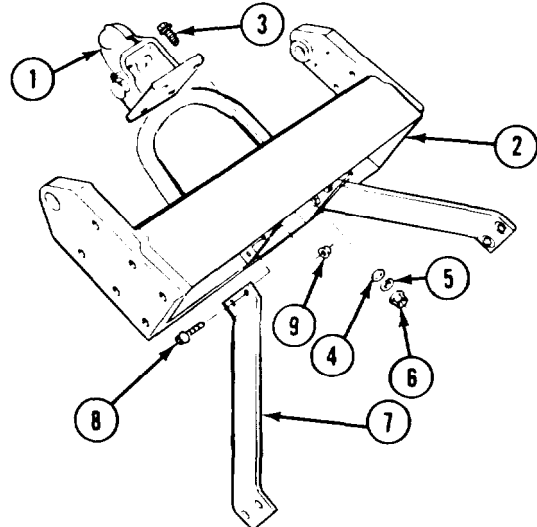

- (3) Soldier A and Soldier B install rear crossmember (2) in frame (10) with suitable lifting device. Remove lifting device.
- (4) Install bracket (11) to rear crossmember (2) with two screws (12), lockwashers (13), and nuts (14).

NOTE

Not all models have star-shaped lockwashers. Star-shaped lockwashers are only on screw closest to pintle.

- (5) Install bracket (15) to rear crossmember (2) with two screws (16), lockwashers (16.1), lockwashers (17), and nuts (18).

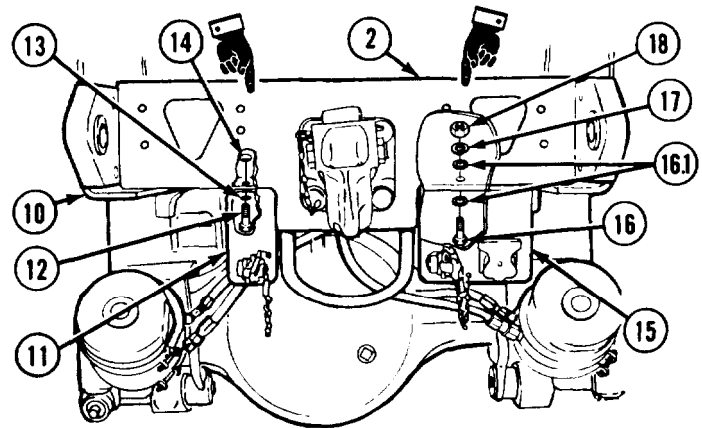

- c. Follow-on Maintenance.** Install crane mounting brackets (para 13-27).
- END OF TASK**

Frame Maintenance instructions (Cont)

13-23. REAR CROSSMEMBER REMOVAL/INSTALLATION (M978).	
This task covers:	
a. Removal	c. Follow-on Maintenance
b. Installation	
INITIAL SET UP	
Models M978	Equipment Condition TM or Para Condition Description TM 9-2320-279-20 Rear composite light assemblies removed.
Test Equipment None	Special Environmental Conditions None
Special Tools None	General Safety Instructions None
Supplies None	Level of Maintenance Direct Support
Personnel Required MOS 63W, Wheel vehicle repairer (2)	
References None	

a. Removal.

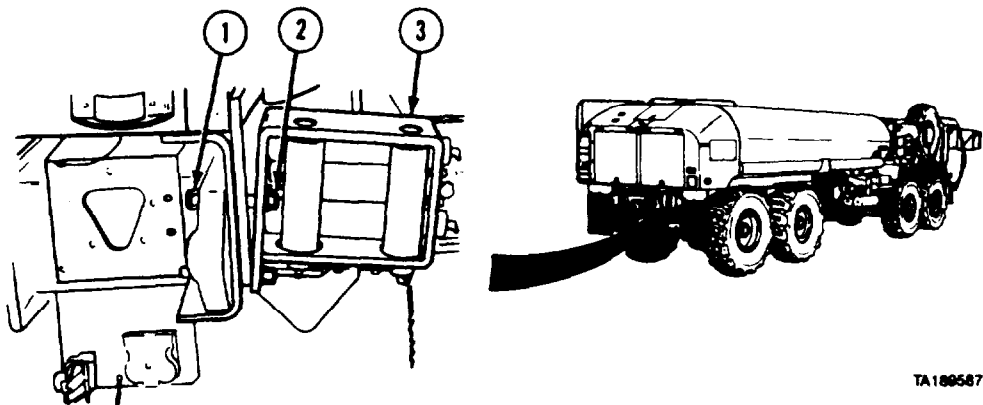

WARNING

Fuel is very flammable and can explode easily. To avoid serious injury or death, keep fuel away from open fire and keep fire extinguisher within easy reach when working with fuel. Do not work on fuel system when engine is hot. Fuel can be ignited by hot engine. When working with fuel, post signs that read NO SMOKING WITHIN 50 FEET of vehicle.

NOTE

M978 vehicles without self-recovery winch do not have rear cable guide. Do step (1) for vehicles without self-recovery winch. Do step (2) for vehicles with self-recovery winch.

- (1) Remove four nuts (1) and screws (2).
- (2) Remove four nuts (1), screws (2), and rear cable guide (3).

Frame Maintenance Instructions (Cont)

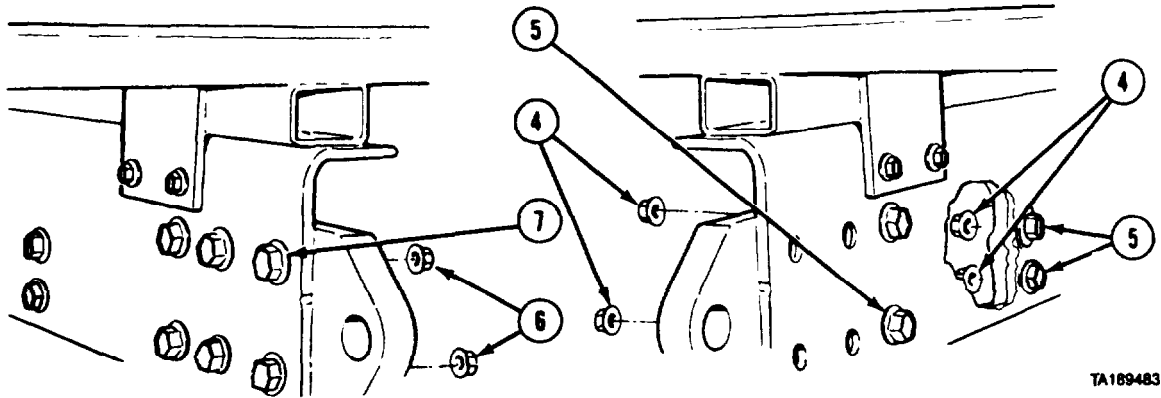

- (3) Remove four nuts (4) and screws (5).
- (4) Remove eight nuts (6) and screws (7).

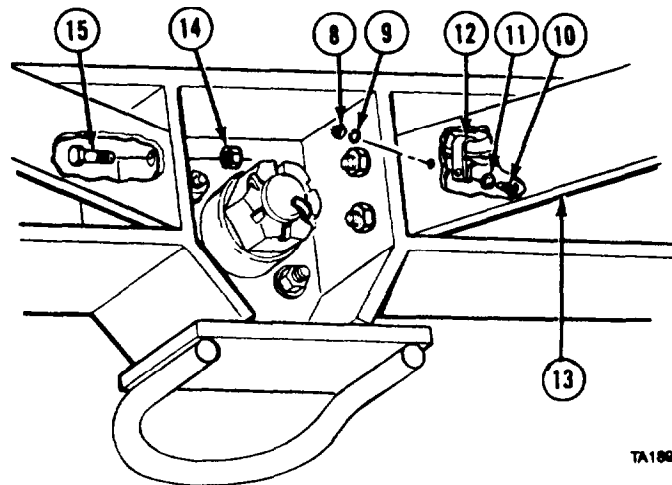

- (5) Remove two nuts (8), lockwashers (9), screws (10), and washers (11) from clamps (12) and cross braces (13).
- (6) Remove four nuts (14), screws (15), and two cross braces (13).

- (7) Remove two screws (16), nuts (17), and lockwashers (18).

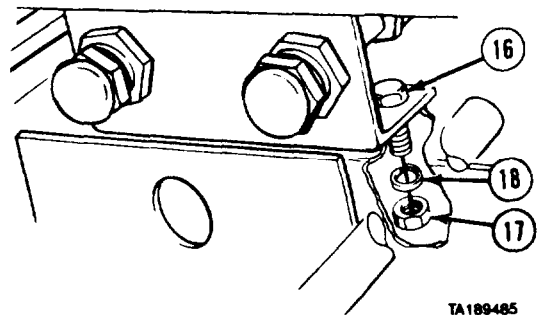

Frame Maintenance Instructions (Cont)

13-23. REAR CROSSMEMBER REMOVAL/INSTALLATION (M978) (CONT).

- (8) Remove two screws (19), nuts (20), lockwashers (21), and trailer connection bracket (22).

NOTE

Not all models have star-shaped lockwashers. Star-shaped lockwashers are only on screw closest to pintle.

- (9) Remove two screws (23), nuts (24), lockwashers (24.1), lockwashers (25), and trailer connection bracket (26).
- (10) Install suitable lifting device to rear crossmember (27).
- (11) Soldier A guides rear crossmember (27) while Soldier B operates lifting device to remove rear crossmember.
- (12) Remove lifting device from rear crossmember (27).
- (13) Remove four nuts (28), eight washers (29), four screws (30), and pintle (31).

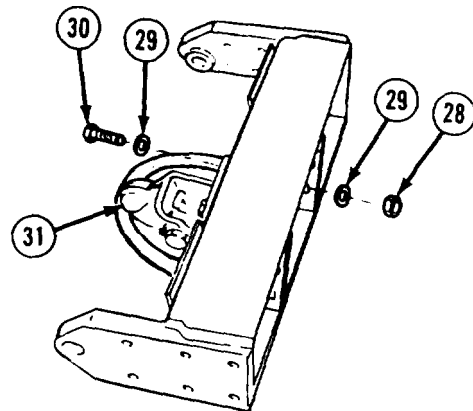
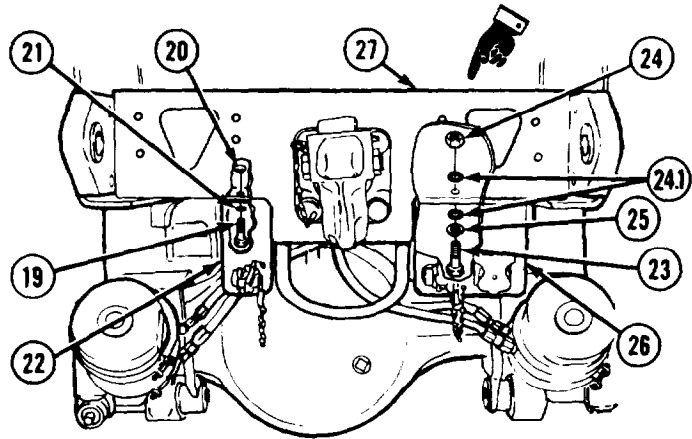

b. Installation.

- (1) Install pintle (1) to rear crossmember (2) with four screws (3), eight washers (4), and four nuts (5).

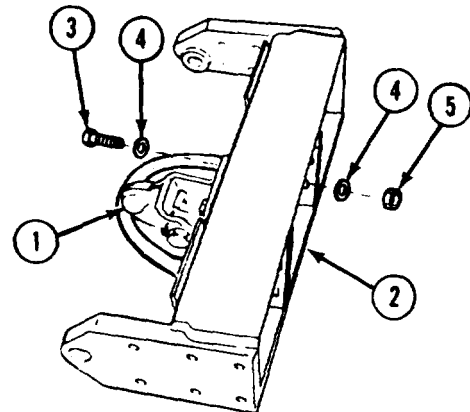

Frame Maintenance Instructions (Cont)

- (2) Install suitable lifting device on rear crossmember (2).
- (3) Soldier A operates lifting device while Soldier B guides rear crossmember (2) on frame (6).
- (4) Remove lifting device from rear crossmember (2).

NOTE

Not all models have star-shaped lockwashers. Star-shaped lockwashers are only on screw closest to pintle.

- (5) Install trailer brake connection bracket (7) to crossmember (2) with two screws (8), lockwashers (8.1), lockwashers (9), and nuts (10).

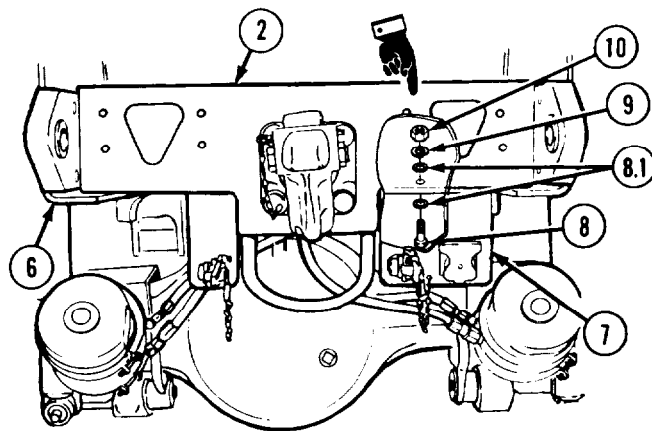

NOTE

Position wiring harness over top of cross braces.

- (6) Install two cross braces (11) with four screws (12) and nuts (13).
- (7) Install two clamps (14) to cross braces (11) with two screws (15), washers (16), lockwashers (17), and nuts (18).

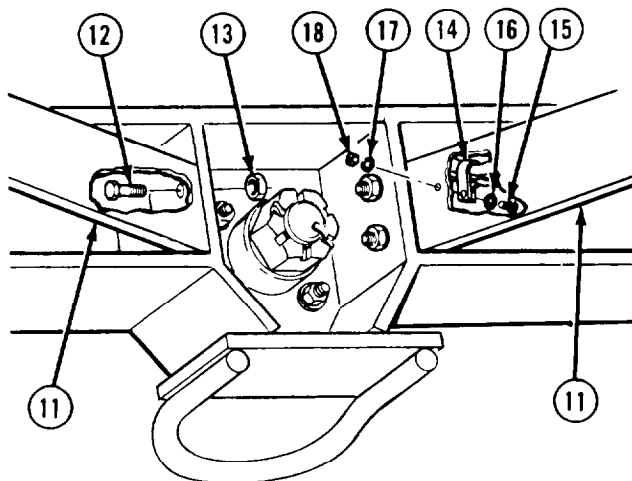

- (8) Install two screws (19) through frame (6) and crossmember (2).
- (9) Install two nuts (20). Do not tighten.
- (10) Install two screws (21) and nuts (22). Do not tighten.

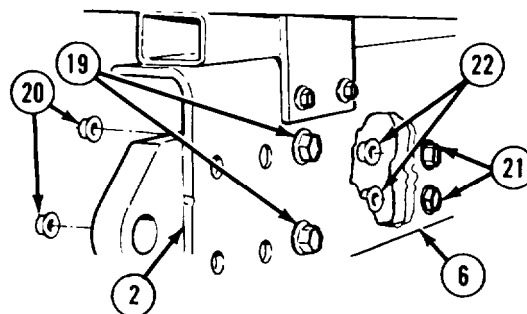

Frame Maintenance Instructions (Cont)

13-23. REAR CROSSMEMBER REMOVAL/INSTALLATION (M978) (CONT).

NOTE

M978 vehicles without self-recovery winch do not have rear cable guide. Do step (11) for vehicles without self-recovery winch. Do steps (12) and (13) for vehicles with self-recovery winch.

- (11) Install four screws (23) and nuts (24). Do not tighten.
- (12) Hold rear cable guide (25) in position.
- (13) Install four screws (23) and nuts (24). Do not tighten.

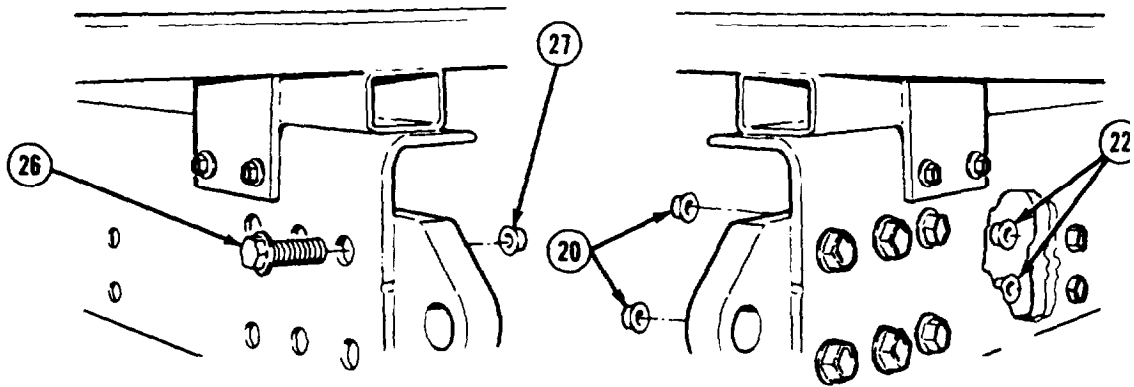
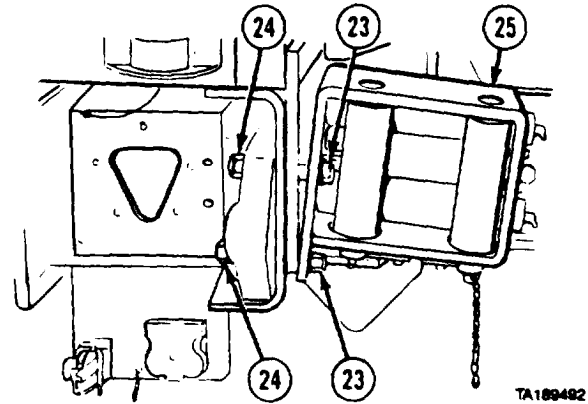

- (14) Install eight screws (26) and nuts (27).
- (15) Tighten two nuts (20) and two nuts (22).
- (16) Tighten four nuts (24).

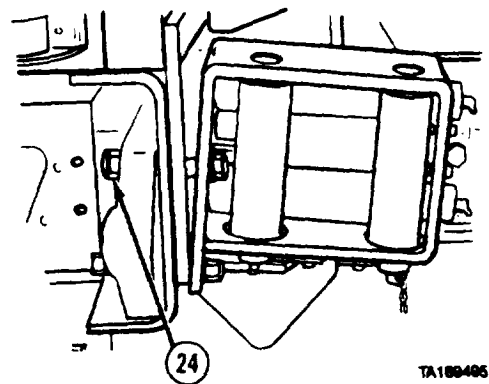

Frame Maintenance Instructions (Cont)

(17) Tighten eight nuts (27).

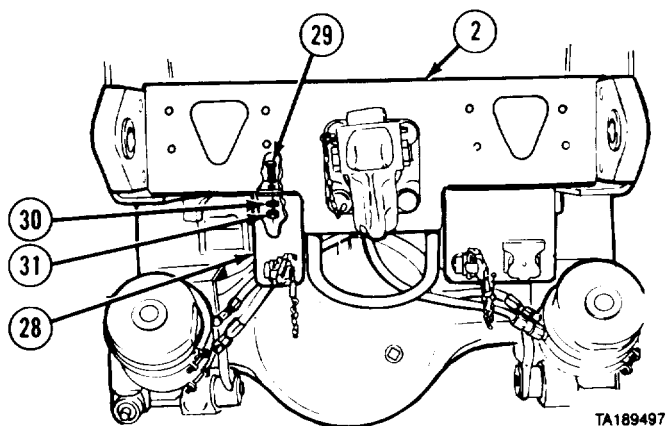
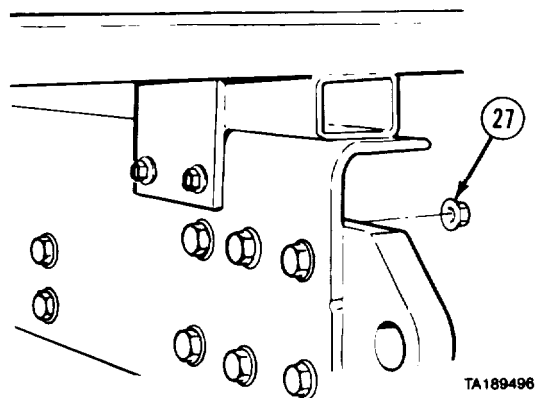

(18) Install trailer brake connection bracket (28) to rear crossmember (2) with two screws (29), lockwashers (30), and nuts (31).

(19) Install auxiliary hydraulic bracket (32) on rear crossmember (2) with two screws (33), lockwashers (34), and nuts (35).

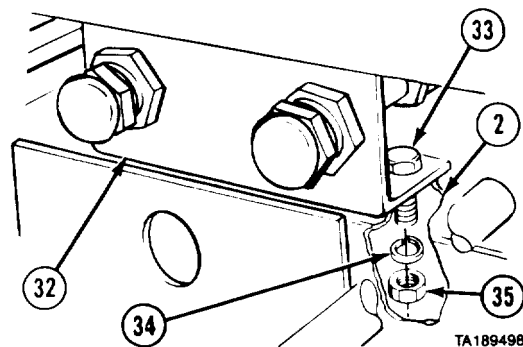

c. Follow-on Maintenance. Install rear composite light assemblies (TM 9-2320-279-20).

END OF TASK

Frame Maintenance Instructions (Cont)

13-24. REAR CROSSMEMBER REMOVAL/INSTALLATION (M983, M984).	
This task covers:	
a. Removal b. Installation	c. Follow-on Maintenance
INITIAL SETUP	
Models M983, M984	Equipment Condition
Test Equipment None	TM or Para Condition Description TM 9-2320-279-20 Rear composite light assemblies removed. TM 9-2320-354-10 Tow bar removed (M984).
Special Tools None	Special Environmental Conditions None
Supplies Ties, cable, plastic, Item 65, Appendix C	General Safety Instructions None
Personnel Required MOS 63W, Wheel vehicle repairer (2)	Level of Maintenance Direct Support
References None	

a. Removal.

NOTE

Left and right rear mudflap and bracket assemblies are removed in a similar manner. M984 shown.

- (1) Remove cotter pin (1).
- (2) Loosen two screws (2) and nuts (3).
- (3) Remove mounting bar and mud flap assembly (4).
- (4) Remove two screws (5), nuts (6), and mounting bracket (7).

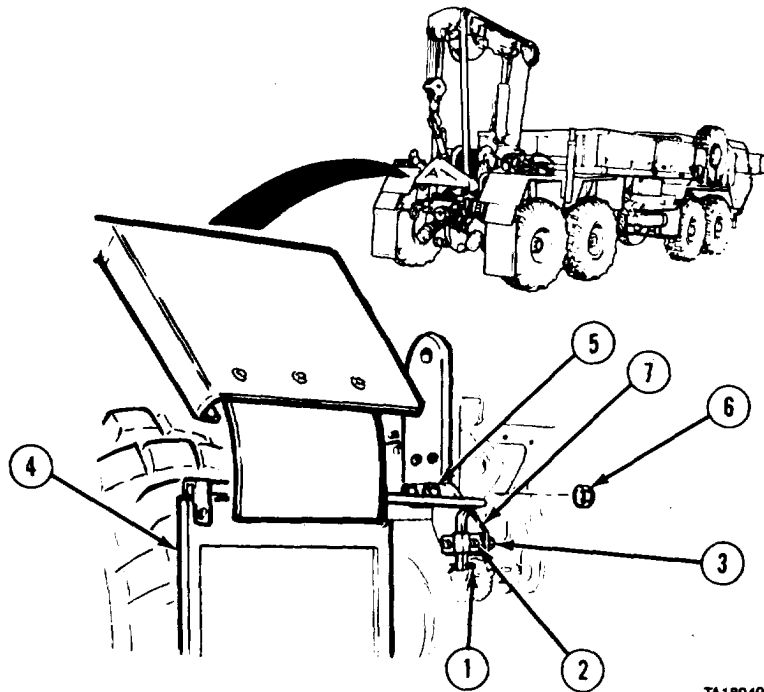

TA188499

Frame Maintenance Instructions (Cont)

NOTE

M984 vehicles have tow bar mounting bracket between cable guide and frame. Do step (6) for M984 vehicles and step (7) for M983 vehicles.

- (5) Remove four nuts (8) screws (9), and cable guide (10).
- (6) Soldier A removes two nuts (8) while Soldier B removes screws (9), cable guide (10), and tow bar mounting bracket (11).

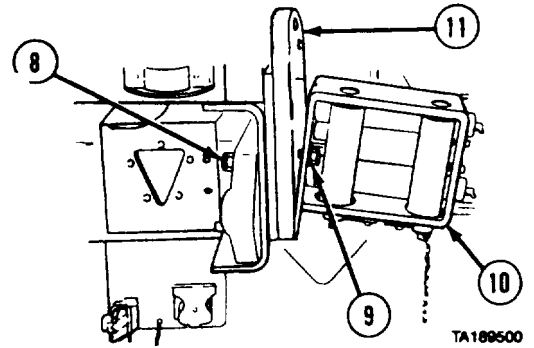

- (7) Remove two nuts (12) and screws (13).
- (8) Remove two nuts (14) and screws (15).

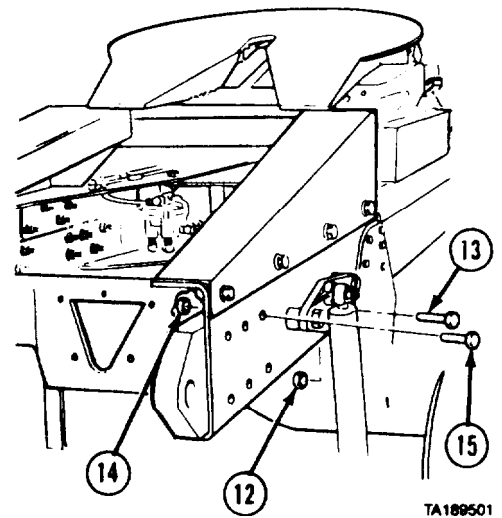

NOTE

Tow bar mounting bracket is on M984 vehicles only.

- (9) Remove two screws (16), nuts (17), and tow bar mounting bracket (18).
- (10) Remove six screws (19) and nuts (20).

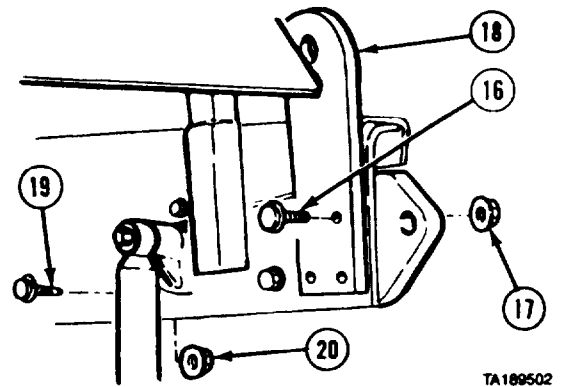

Frame Maintenance Instructions (Cont)

13-24. REAR CROSSMEMBER REMOVAL/INSTALIATION (M983) (M984) (CONT).

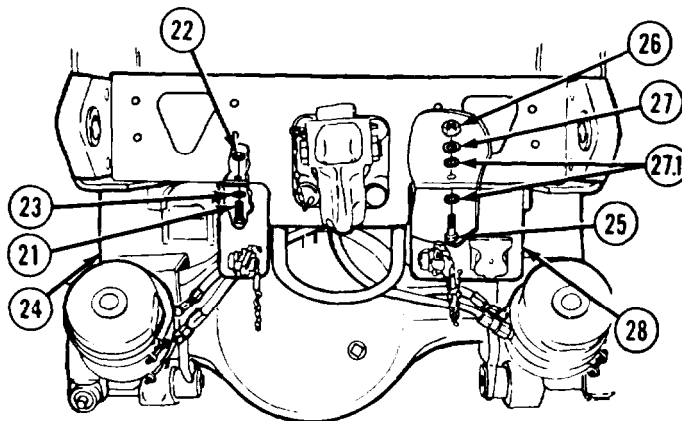

- (11) Remove two screws (21), nuts (22), washers (23), and trailer connection bracket (24).

NOTE

Not all models have star-shaped lockwashers. Star-shaped lockwashers are only on screw closest to pintle.

- (12) Remove two screws (25), nuts (26), washers (27), lockwashers (27.1), and trailer connection bracket (28).

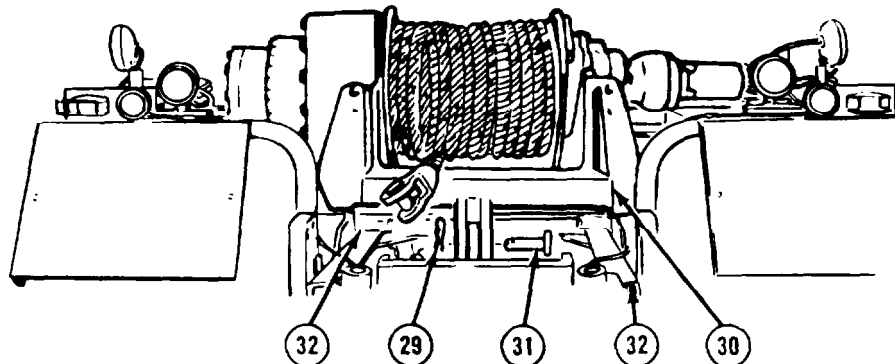

WARNING

Winch is heavy. Keep hands out from under and away from winch at all times. Winch could drop, causing serious injury.

NOTE

Steps (14) through (22) apply to M984 vehicles only.

- (13) Remove safety pin.
 (14) Soldier A raises winch (30) slightly using suitable lifting device while Soldier B removes pin (31).
 (15) Soldier A raises winch (30) using suitable lifting device while Soldier B positions suitable blocking on both sides of frame (32) under winch.
 (16) Lower winch (30) on blocking.

Frame Maintenance Instructions (Cont)

- (17) Remove lifting device.
- (18) Remove two nuts (33), washers (34), and screws (35) on both ends of winch support (36).
- (19) Move light bracket (37) off crossmember (38).
- (20) Remove four nuts (39) and screws (40).
- (21) Remove winch support (36).

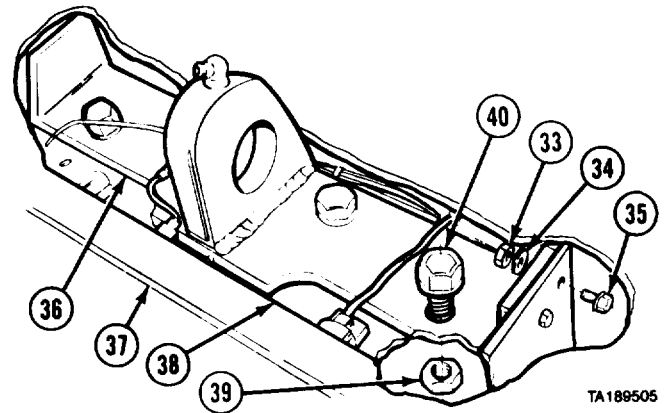

- (22) Soldier A and Soldier B remove rear crossmember (38) with suitable lifting device.

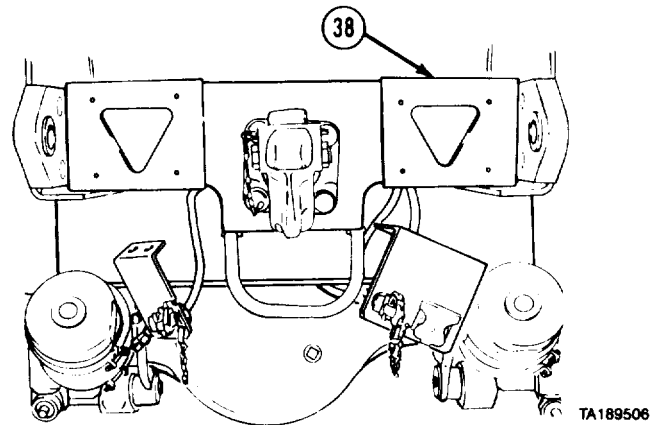

- (23) Remove four screws (41), nuts (42), washers (43), and pintle (44).

NOTE

Remove plastic cable ties, clips, and brackets as required.

- (24) Remove four screws (45), nuts (46), and two cross braces (47).
- (25) Remove lifting device.

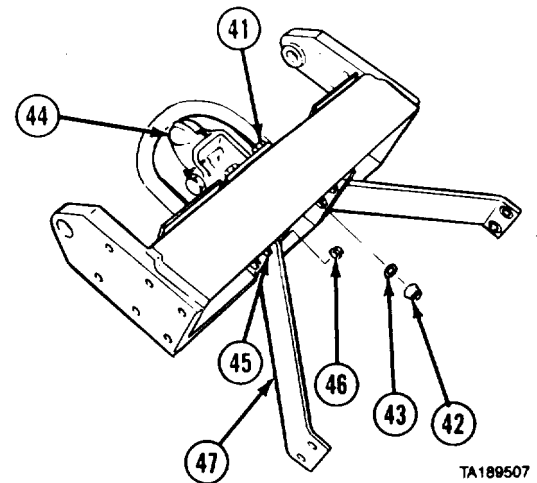

Frame Maintenance Instructions (Cont)

13-24. REAR CROSSMEMBER REMOVAL/INSTALLATION (M983, M984) (CONT).

b. Installation.

NOTE

Aline holes in crossmember with holes in frame.

- (1) Soldier A and Soldier B install rear crossmember (1) in frame (2) with suitable lifting device.

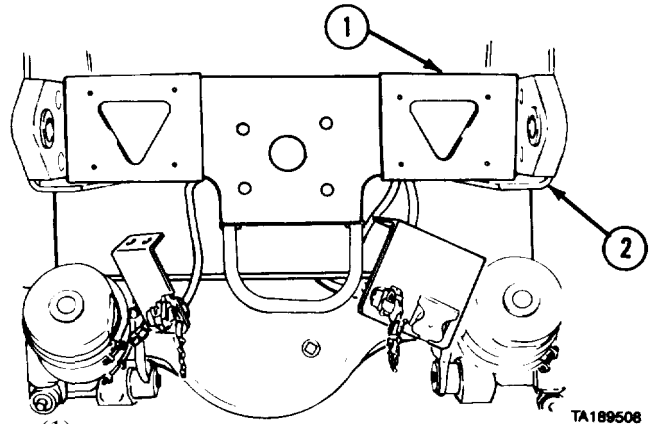

- (2) Install two cross braces (3) to rear crossmember (1) with four screws (4) and nuts (5).
- (3) Install pintle (6) to rear crossmember (1) with four screws (7), washers (8), and nuts (9).

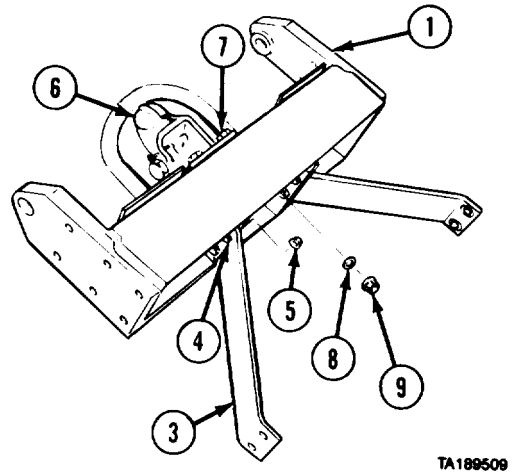

NOTE

Do not tighten nuts in steps (4) through (12) until step (12) is completed.

- (4) Install two screws (10) and nuts (11) through frame (2) and crossmember (1),
- (5) Install two screws (12) and nuts (13).

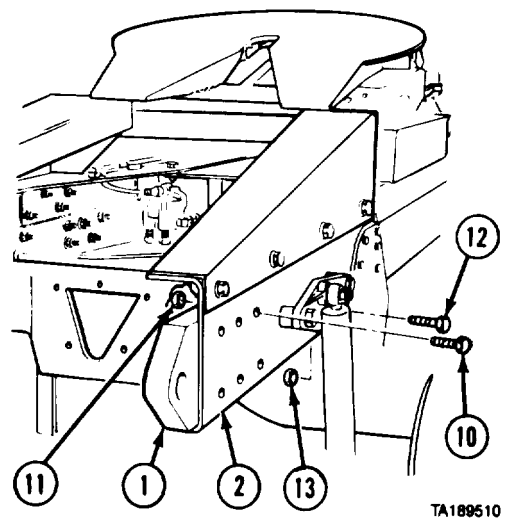

Frame Maintenance Instructions (Cont)

NOTE

Do step (6) for M983 vehicles. Do steps (7) and (8) for M984 vehicles.

- (6) Install cable guide (14) with four screws (15) and nuts (16).
- (7) Position tow bar mounting bracket (17) with cable guide (14).
- (8) Soldier A positions bracket (17) and cable guide (14) on crossmember (1), while Soldier B installs two nuts (16).
- (9) Install two screws (18), mounting bracket (19), and nuts (20).

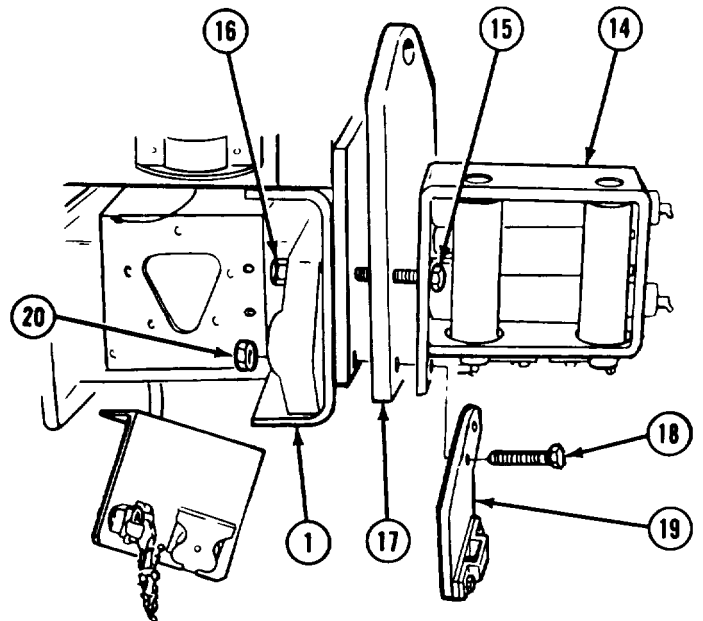

NOTE

Install tow bar mounting bracket on M984 vehicles only.

- (10) Install six screws (21), nuts (22), and tow bar mounting bracket (23).
- (11) Install two screws (24), mounting bracket (25), and two nuts (26).
- (12) Install two screws (27) and nuts (28).
- (13) Install trailer connection bracket (29) to rear crossmember (1) with two screws (30), washers (31), and nuts (32).

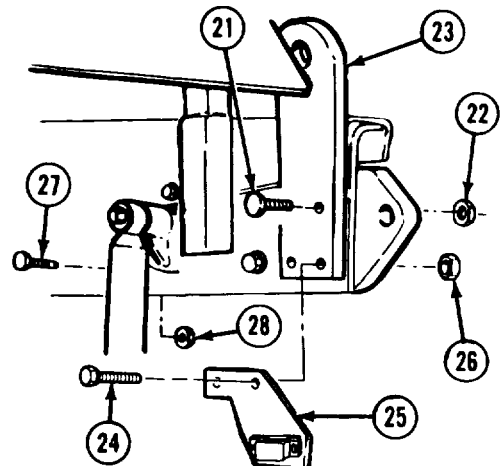

NOTE

Not all models have star-shaped lockwashers. Star-shaped lockwashers are only in screws closest to pintle.

- (14) Install trailer connection bracket (33) to rear crossmember (1) with two screws (34), lockwashers (34.1), washers (35), and nuts (36).

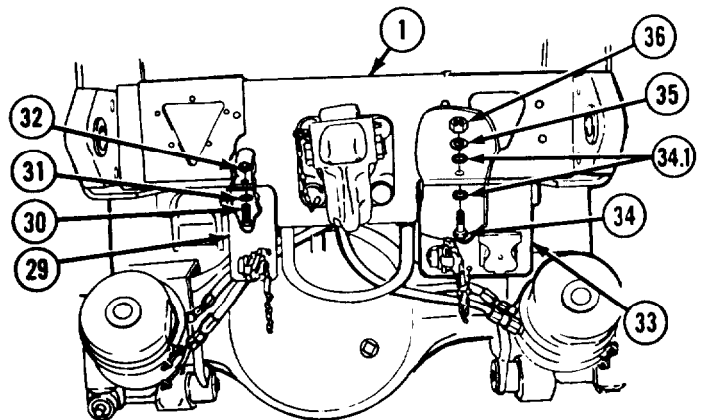

Frame Maintenance Instructions (Cont)

13-24. REAR CROSSMEMBER REMOVAL/INSTALLATION (M983, M984) (CONT).

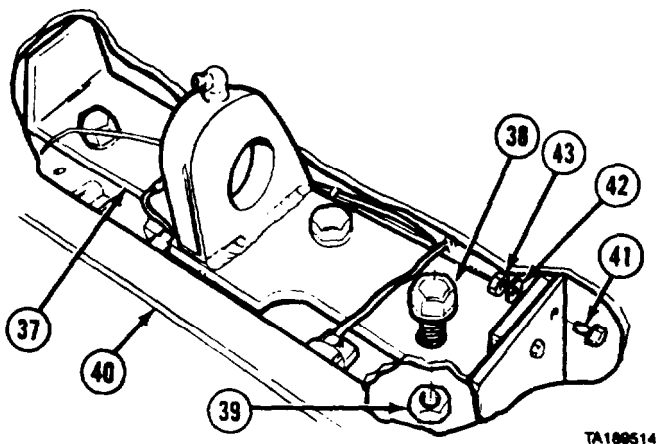

NOTE

Steps (15) through (19) apply to M984 vehicles only.

- (15) Install winch support (37) with four screws (38) and nuts (39).
- (16) Install light bracket (40) with two screws (41), washers (42), and nuts (43) through both ends of support (37).

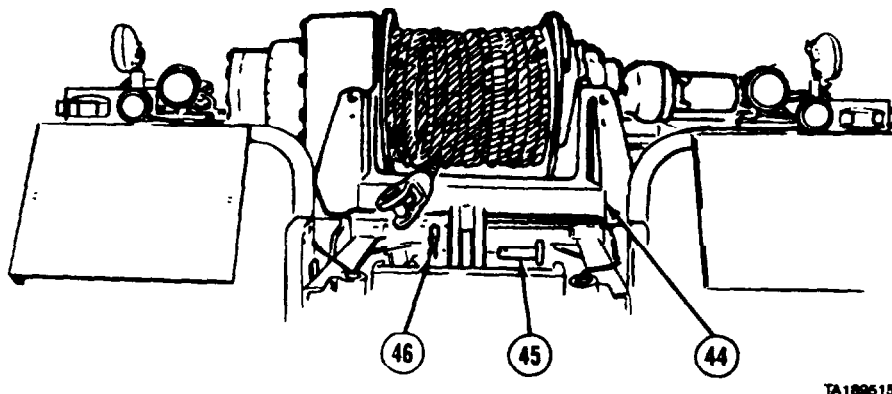

WARNING

Winch is heavy. Keep hands out from under and away from winch at all times. Winch could drop, causing serious injury.

- (17) Soldier A raises winch (44) with lifting device, while Soldier B removes blocking.
- (18) Soldier A slowly lowers winch (44) while Soldier B installs pin (45).
- (19) Install safety pin (46).

Frame Maintenance Instructions (Cont)

NOTE

Left and right rear mud flap and bracket assemblies are installed in a similar manner.

- (20) Install mounting bar and mud flap assembly (47).
- (22) Install cotter pin (48).
- (22) Tighten two screws (49) and nuts (50).
- (23) Remove lifting device.

c. Follow-on Maintenance.

- (1) Install rear composite light assemblies (TM 9-2320-279-20).
- (2) Install tow bar (TM 9-2320-354-10).

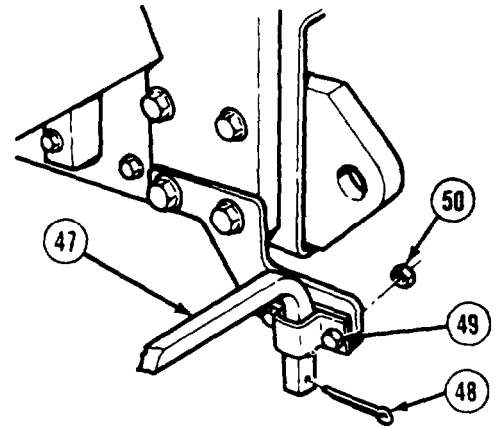

TA189516

END OF TASK

13-24.1. REAR CROSSMEMBER REMOVAL/INSTALLATION (M984E1).	
This task covers:	
a. Removal	c. Follow-on Maintenance
b. Installation	
INITIAL SETUP	
<i>Models</i>	<i>Equipment Condition</i>
M984E1	<i>TM or Para</i>
<i>Test Equipment</i>	Para 13-30.3
None	Para 13-30.5
<i>Special Tools</i>	TM 9-2320-279-20
None	
<i>Supplies</i>	
None	
<i>Personnel Required</i>	
MOS 63W, Wheel vehicle repairer (2)	
<i>References</i>	
None	TM 9-2320-279-10
Equipment Condition	Special Environmental Conditions
<i>TM or Para</i>	<i>Condition Description</i>
TM 9-2320-279-10	Towing shackles removed from rear of vehicle.
Para 16-10.3	Fairlead tensioner removed.
TM 9-2320-279-20	Mudflap mounting brackets removed.
TM 9-2320-279-20	Rear fenders removed.
	<i>General Safety Instruction</i>
	None
	<i>Level of Maintenance</i>
	Direct Support
	NOTE
	For ease of removal and installation, the following equipment condition may be used, but is not necessary.
	TM 9-2320-279-10
	Wheels and tires removed from No. 4 axle.

13-24. REAR CROSSMEMBER REMOVAL/INSTALLATION (M984E1) (CONT).

a. Removal

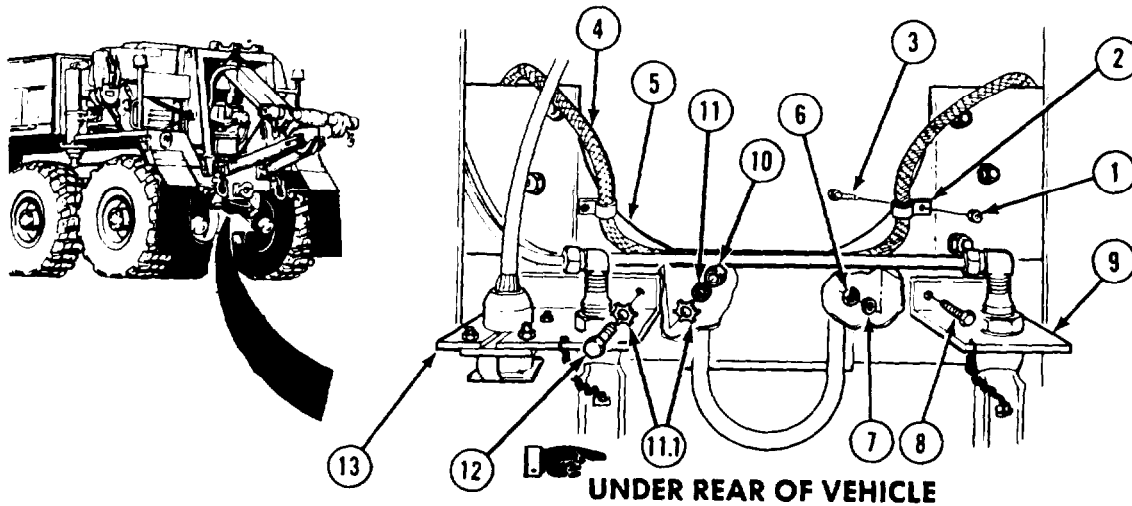

- (1) Remove two locknuts (1), clamps (2), and screws (3). Move wire harness (4) away from rear crossmember (6).
- (2) Remove two nuts (6), lockwashers (7), and screws (8). Move emergency towing gladhand bracket (9) aside.

NOTE

Not all models have star-shaped lockwashers. Star-shaped lockwashers are only on screw closest to pintle.

- (3) . Remove two nuts (10), lockwashers (11), lockwashers (11.1) and screws (12). Move service towing gladhand bracket (13) aside.

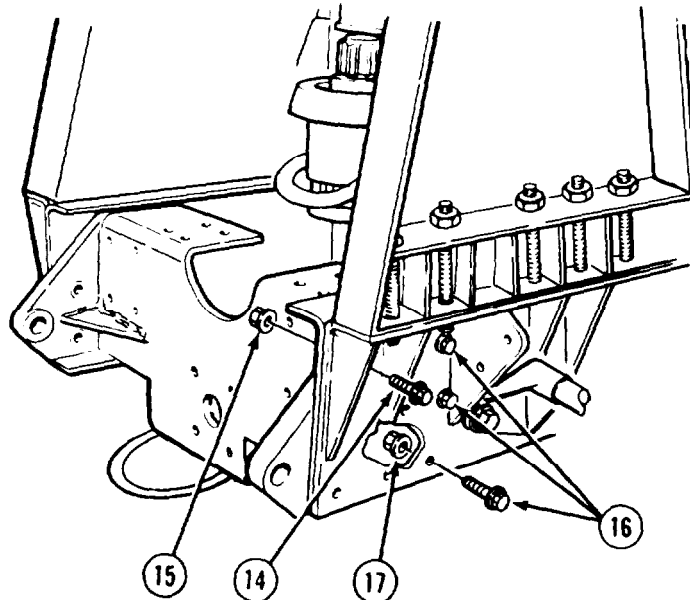

NOTE

Do steps (4) through (9) on both sides of frame.

- (4) Remove screw (14) and nut (15).
- (5) Soldier A removes three screws (16) while Soldier B removes nuts (17).

Frame Maintenance Instructions (Cont)

- (6) Soldier A removes three nuts (18) while Soldier B removes screws (19).
- (7) Remove locknut (20) and washer (21) from stud (22). Remove stud.
- (8) Soldier A removes four nuts (23) while Soldier B removes screws (24).
- (9) Attach suitable lifting device to rear crossmember (5).

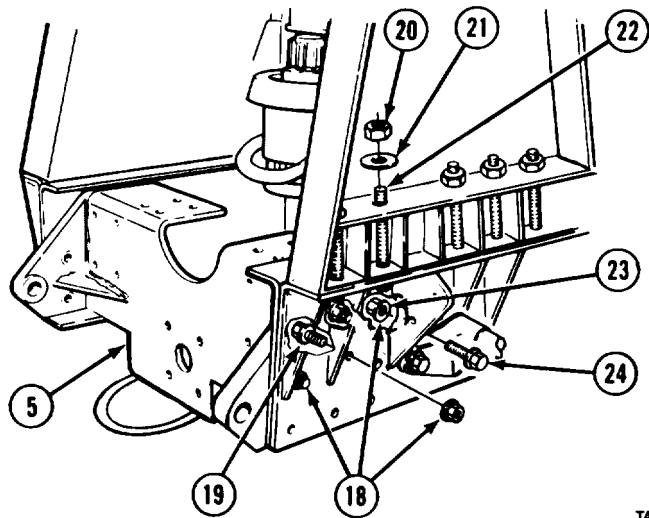

TA476754

NOTE

It may be necessary to spread frame to remove rear crossmember.

- (10) Soldier A and Soldier B remove rear crossmember (5).
- (11) Remove three nuts (25), screws (26), and two angles (27) from each side of rear crossmember (5).

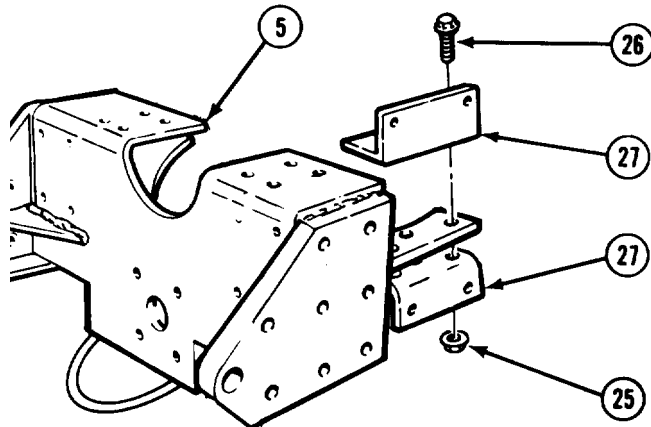

TA476755

b. Installation.

- (1) Install two angles (1), three screws (2), and nuts (3) on each side of rear crossmember (4). Do not tighten nuts.

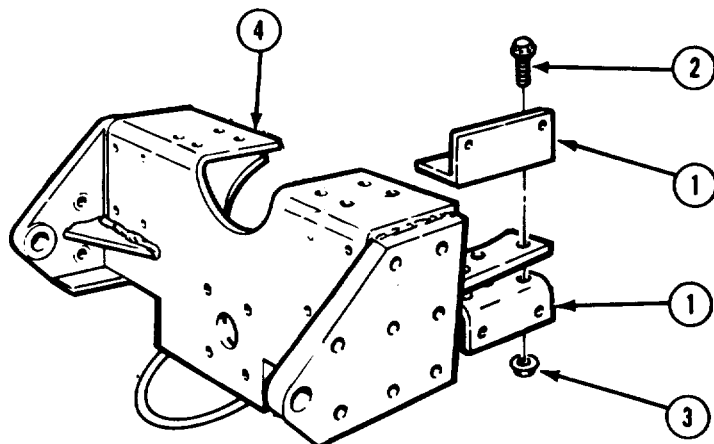

TA476756

Frame Maintenance Instructions (Cont)

13-24.1. REAR CROSSMEMBER REMOVAL/INSTALLATION (M984E1) (CONT).

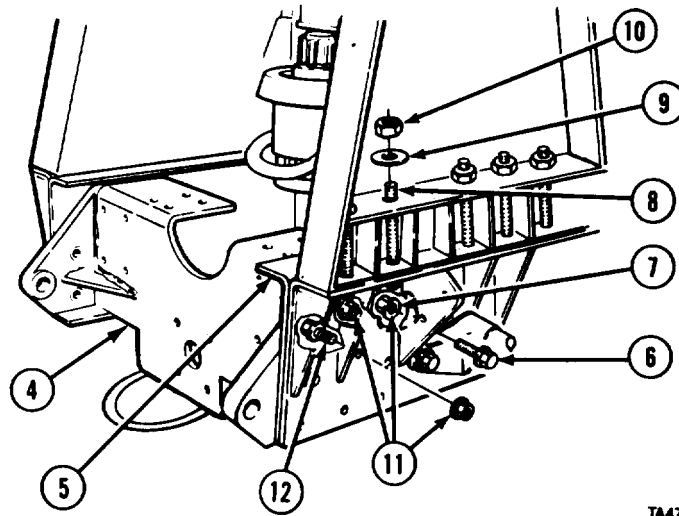

TA476757

NOTE

It may be necessary to spread frame to install rear crossmember.

- (2) Soldier A attaches and operates suitable lifting device while Soldier B installs rear crossmember (4) in frame (5).

NOTE

- . Do steps (3) through (7) for both side of frame.
- . Do not tighten nuts in steps (3), (5) or (6).

- (3) Soldier A installs four screws (6) while Soldier B installs nuts (7).
- (4) Install stud (8), washer (9), and locknut (10).
- (5) Soldier A installs three nuts (11) while Soldier B installs screws (12).
- (6) Soldier A installs three screws (13) while Soldier B installs nuts (14).
- (7) Install screw (15) and nut (16).
Tighten all nuts installed in steps (1) through (7).

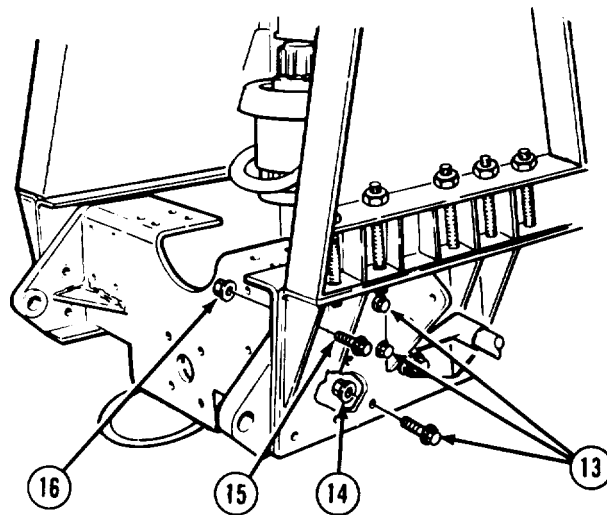

TA476758

Frame Maintenance Instructions (Cont)

NOTE

Not all models have star-shaped lockwashers. Star-shaped lockwashers are only on screw closest to pintle.

- (8) Install service towing gladhand bracket (17), two screws (18), lockwashers (19), lockwashers (19.1) and nuts.
- (9) Install emergency towing gladhand bracket (21), two screws (22), lockwashers (23), and nuts (24).
- (10) Install harness (25), two clamps (26), screws (27), and locknuts (28).

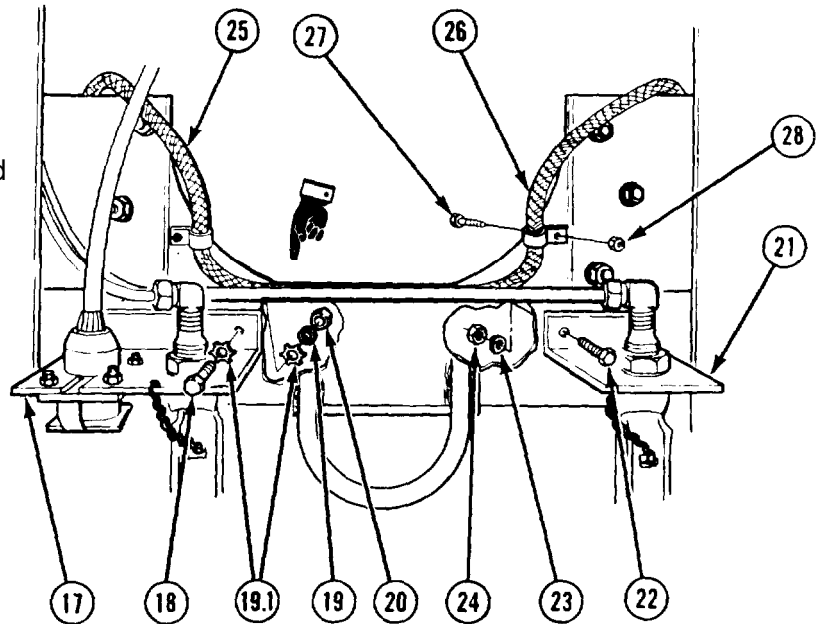

C. Follow-on Maintenance.

- (1) Install pintle hitch (TM 9-2320-279-20).
- (2) Install fairlead tensioner (para 16-10.3).
- (3) Install retriever tow cylinders (para 13-30.4).
- (4) Install retriever lift cylinders (para 13-30.2).
- (5) Install rear fenders (TM 9-2320-279-20).
- (6) Install mudflap mounting brackets (TM 9-2320-279-20).
- (7) Install towing shackles (TM 9-2320-279-10).

NOTE

Install wheels and tires (TM 9-2320-279-10) if removed.

END OF TASK

13-25. PUMP SUPPORT ASSEMBLY REMOVAL/INSTALLATION (M978).

This task covers:

- a. Removal
- b. Installation
- c. Follow-on Maintenance

INITIAL SETUP

Models
M978

Test Equipment
None

Special Tools
None

Supplies
None

Personnel Required
MOS 63W, Wheel vehicle repairer

References
None

Equipment Condition

TM or Para Condition Description
TM 9-2320-79-10 Shut off engine.

Special Environmental Conditions
None

General Safety Instructions

No smoking, flame, sparks, and hot or glowing objects within 50 ft (15 m) of vehicle.

Level of Maintenance

Direct Support

Frame Maintenance Instructions (Cont)

13-25. PUMP SUPPORT ASSEMBLY REMOVAL/INSTALLATION (M978) (CONT).

a. Removal.

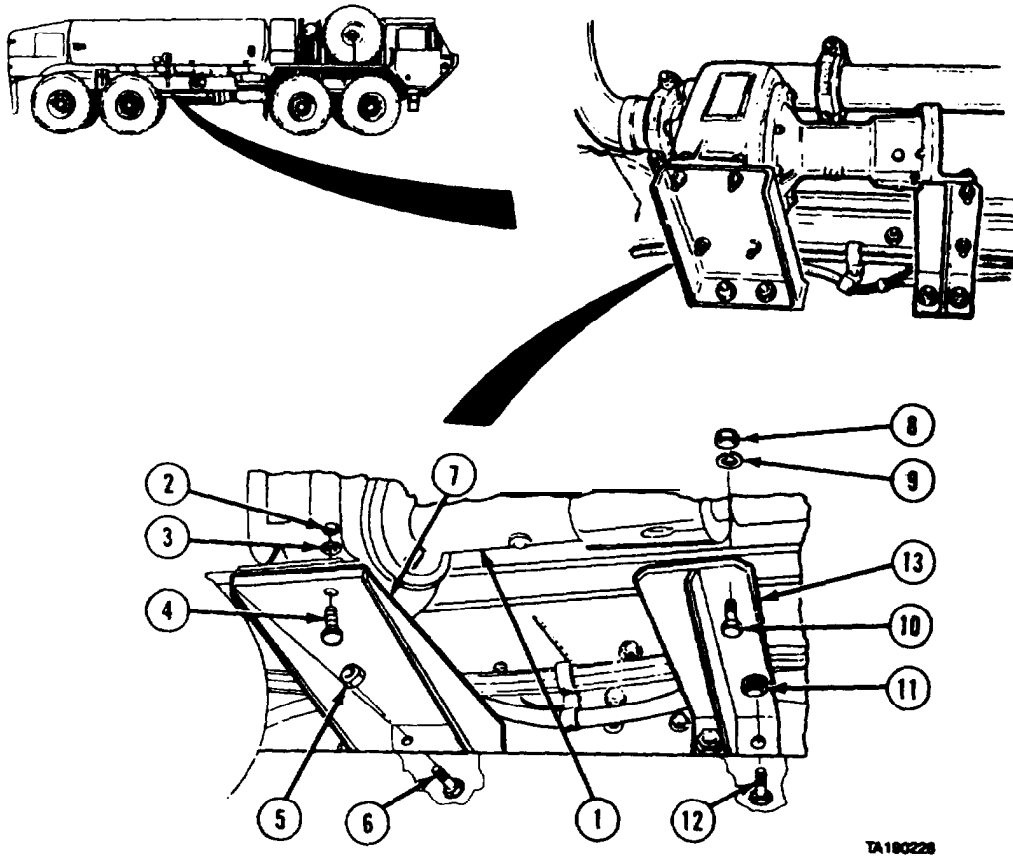

TA100228

WARNING

Fuel is very flammable and can explode easily. To avoid serious injury or death keep fuel away from open fire and keep fire extinguisher within easy reach when working with fuel. Do not work on fuel system when engine is hot. Fuel can be ignited by hot engine. When working with fuel, post signs that read NO SMOKING WITHIN 50 FEET of vehicle.

- (1) Support hydraulic fuel pump (1) with suitable device.
- (2) Remove four nuts (2), lockwashers (3), and screws (4).
- (3) Remove four locknuts (5), screws (6), and pump support (7).
- (4) Remove two nuts (8) lockwashers (9), and screws (10).
- (5) Remove two locknuts (11), screws (12), and support (13).

Frame Maintenance Instructions (Cont)

- b. Installation.
 - (1) Install support (13) with two screws (12) and locknuts (11).
 - (2) Install two screws (10), lockwashers (9), and nuts (8).
 - (3) Install pump support (7) with four screws (6) and locknuts (5).
 - (4) Install four screws (4), lockwashers (3), and nuts (2).
 - (5) Remove supporting device from hydraulic fuel pump (1).
- c. Follow-on Maintenance. None.

END OF TASK

13-26. 2500 GALLON TANK MOUNT REMOVAL/INSTALLATION (M978).	
This task covers:	
a. Removal	c. Follow-on Maintenance
b. Installation	
INITIAL SETUP	
Models	Equipment Condition
M978	<i>TM or Para</i> <i>Condition Description</i>
Test Equipment	TM 9-2320-279-20 2500 gallon tank drained.
None	Special Environmental Conditions
Special Tools	None
None	General Safety Instructions
Supplies	No smoking, flame, sparks, and hot or glowing objects within 50 ft (15 m) of vehicle.
None	Level of Maintenance
Personnel Required	Direct Support
MOS 63W, Wheel vehicle repairer (2)	
References	
None	

Frame Maintenance Instructions (Cont)

13-26. 2500 GALLON TANK MOUNT REMOVAL/INSTALLATION (M978) (CONT).

a. Removal.

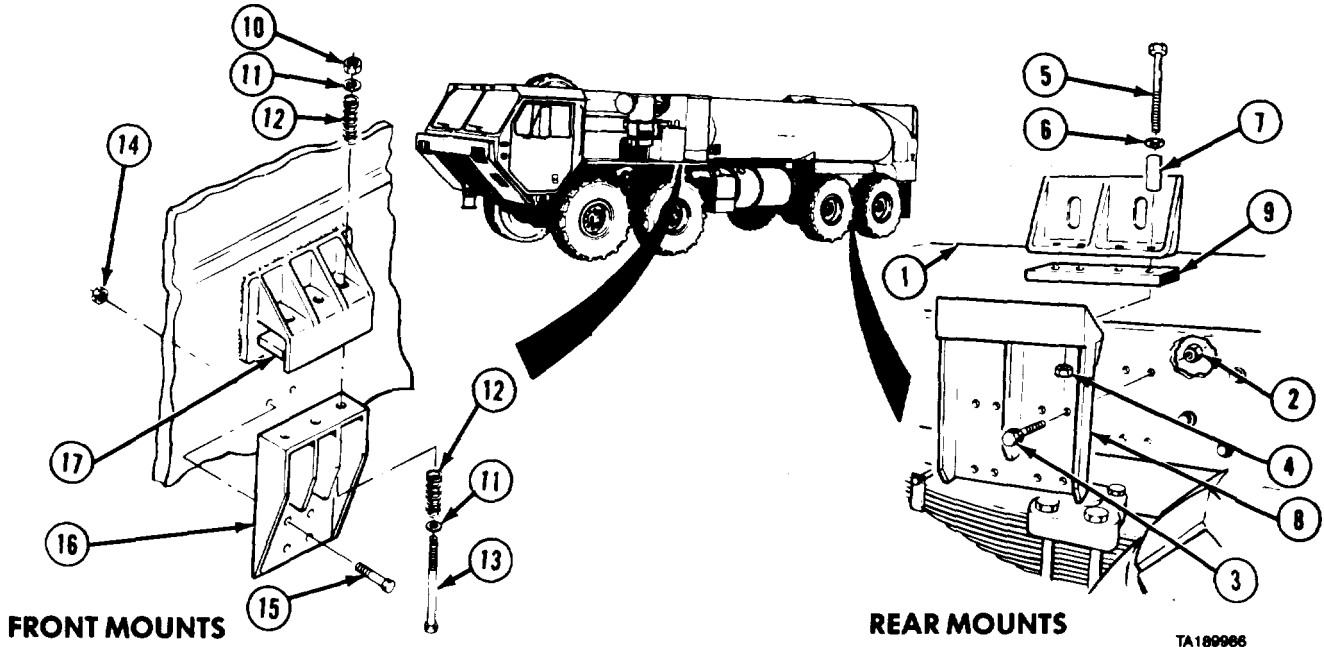

CAUTION

Remove one tank mount at a time. Be sure tank has proper support when removing mounts or it will drop, causing damage to tank and frame.

NOTE

- Left and right tank mounts are removed and installed the same way.
- Rear cable tensioner must be removed (TM 9-2320-279-20) before removal of right rear tank mount.
- Fuel tank must be removed (TM 9-2320-279-20) before removing left front tank mount.

- (1) Support tank (1) with suitable support.
- (2) Soldier A and Soldier B remove eight locknuts (2) and screws (3).
- (3) Remove four locknuts (4), screws (5), washers (6), and spacers (7).
- (4) Remove rear mount (8) and pad (9).
- (5) Remove three locknuts (10), six washers (11), springs (12), and three screws (13).
- (6) Remove seven locknuts (14) and screws (15).
- (7) Remove front mount (16) and pad (17).

b. Installation.

- (1) Soldier A and Soldier B install rear mount (8) with eight screws (3), locknuts (2), and pad (9). Do not tighten locknuts.
- (2) Install four spacers (7), washers (6), screws (5), and locknuts (4).
- (3) Tighten four locknuts (2).
- (4) Install front mount (16) with three screws (13), six washers (11), springs (12), pad (17), and locknuts (10). Do not tighten locknuts.
- (5) Install seven screws (15) and locknuts (14).
- (6) Tighten three locknuts (10) to ends of threads on screws (13).

Frame Maintenance Instructions (Cont)

- c. Follow-on Maintenance.
 - (1) Install rear cable tensioner (TM 9-2320279-20).
 - (2) Install fuel tank (TM 9-2320- 279-20).

END OF TASK

13-27. CRANE MOUNTING BRACKETS REMOVAL/INSTALLATION (M977, M985).	
This task covers:	
a. Removal b. Installation	c. Follow-on Maintenance
INITIAL SETUP	
Models M977, M985	Equipment Condition
Test Equipment None	<i>TM or Para</i> Para 17-35 Para 17-3 TM 9-2320279-20 TM 9-2320-279-20
Special Tools None	<i>Condition Description</i> Outrigger removed. Crane removed. Winch cable guide removed. Taillights removed.
Supples None	<i>Specia l En viron men tal Condit ions</i> None
Personnel Required MOS 63W, Wheel vehicle repairer (2)	<i>General Safety Instructions</i> None
References None	<i>Level of Ma intena nce</i> Direct Support

- a. Removal.

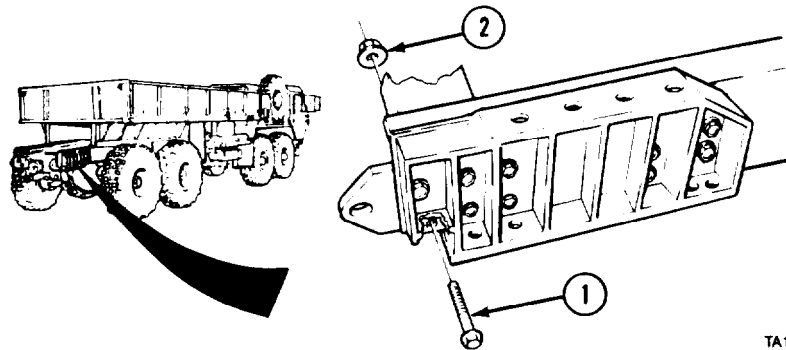

TA190439

NOTE

- Right and left side brackets are removed the same way.
- (1) Soldier A removes screw (1) while Soldier B removes nut (2).

Frame Maintenance Instructions (Cont)

13-27. CRANE MOUNTING BRACKETS REMOVAL/INSTALLATION (M977, M985) (CONT).

- (2) Soldier A removes four screws (1) while Soldier B removes four nuts (2), two spacers (3), and two spacers (4).

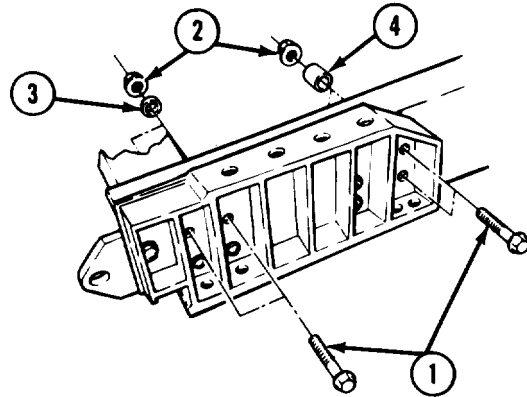

TA190442

- (3) Soldier A removes three screws (5) and one spacer (6) while Soldier B removes three nuts (2), two spacers (4), bracket (7), and mounting bracket (8).

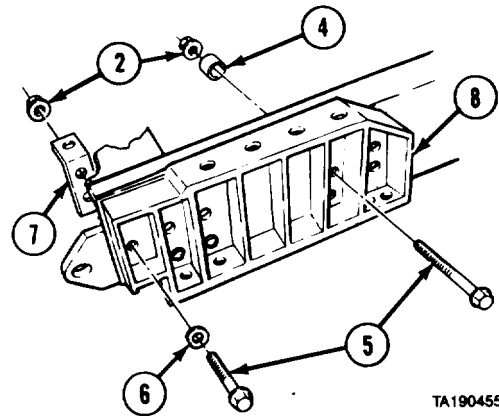

TA190455

b. Installation.

NOTE

Right and left side brackets are installed the same way.

- (1) Soldier A installs mounting bracket (1) with three screws (2) and spacer (3) while Soldier B installs two spacers (4), bracket (5), and three nuts (6).

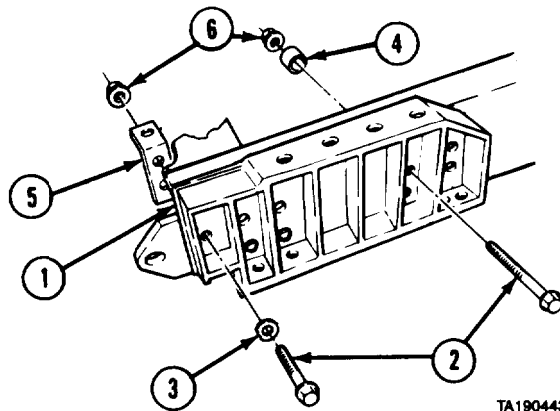

TA190443

Frame Maintenance Instructions (Cont)

- (2) Soldier A installs four screws (7) while Soldier B installs two spacers (4), two spacers (8), and four nuts (6).

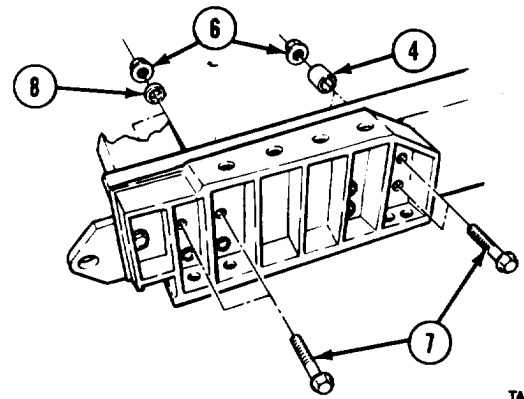

TA190444

- (3) Soldier A installs screw (7) while Soldier B installs nut (6).

c. Follow-on Maintenance.

- (1) Install outrigger (para 17-35).
- (2) Install crane (para 17-3).
- (3) Install winch cable guide (TM 9-2320-279-20).
- (4) Install taillights (TM 9-2320-279-20).

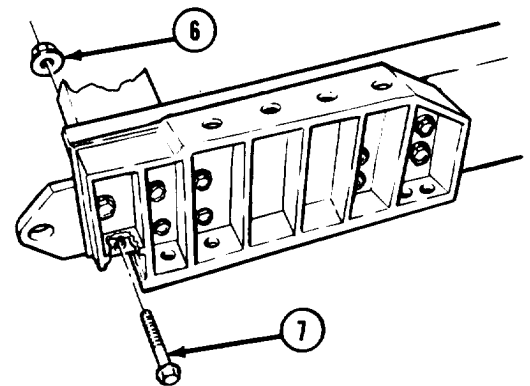

TA190445

END OF TASK

13-28. CRANE MOUNTING SUPPORTS REMOVAL/INSTALLATION (M983).									
This task covers:									
<ul style="list-style-type: none"> a. Removal b. Installation 	<ul style="list-style-type: none"> c. Follow-on Maintenance 								
INITIAL SETUP									
<p>Models 9 8 3</p> <p>Test Equipment None</p> <p>Special Tools None</p> <p>Supplies None</p> <p>Personnel Required MOS 63W, Wheel vehicle repairer</p> <p>References None</p>	<p>Equipment Condition</p> <table border="0"> <tr> <td><i>TM or Para</i></td> <td><i>Condition Description</i></td> </tr> <tr> <td>Para 18-2</td> <td>Crane removed.</td> </tr> <tr> <td>TM 9-2320-279-20</td> <td>Fuel tank removed.</td> </tr> <tr> <td>TM 9-2320-279-20</td> <td>Battery box removed.</td> </tr> </table> <p>Special Environmental Conditions None</p> <p>General Safety Instructions None</p> <p>Level of Maintenance Direct Support</p>	<i>TM or Para</i>	<i>Condition Description</i>	Para 18-2	Crane removed.	TM 9-2320-279-20	Fuel tank removed.	TM 9-2320-279-20	Battery box removed.
<i>TM or Para</i>	<i>Condition Description</i>								
Para 18-2	Crane removed.								
TM 9-2320-279-20	Fuel tank removed.								
TM 9-2320-279-20	Battery box removed.								

Frame Maintenance Instructions (Cont)

13-28. CRANE MOUNTING SUPPORTS REMOVAL/INSTALLATION (M983) (CONT).

a. Removal.

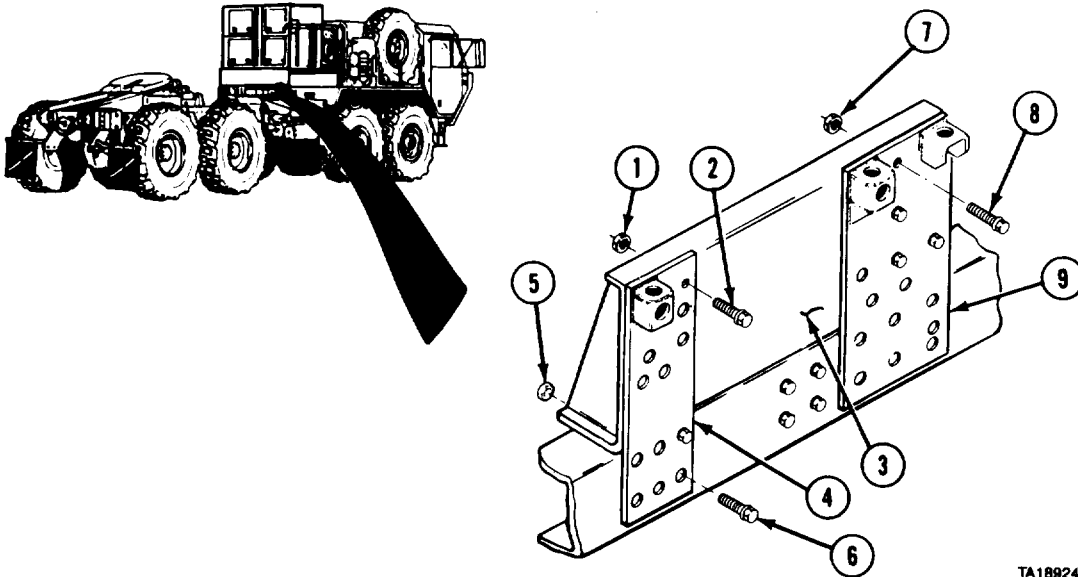

TA189243

- (1) Remove five nuts (1) and screws (2) from right pedestal support (3) and rear fishplate (4).
- (2) Remove two nuts (5), screws (6), and rear fishplate (4).
- (3) Remove seven nuts (7), screws (8), and front fishplate (9).

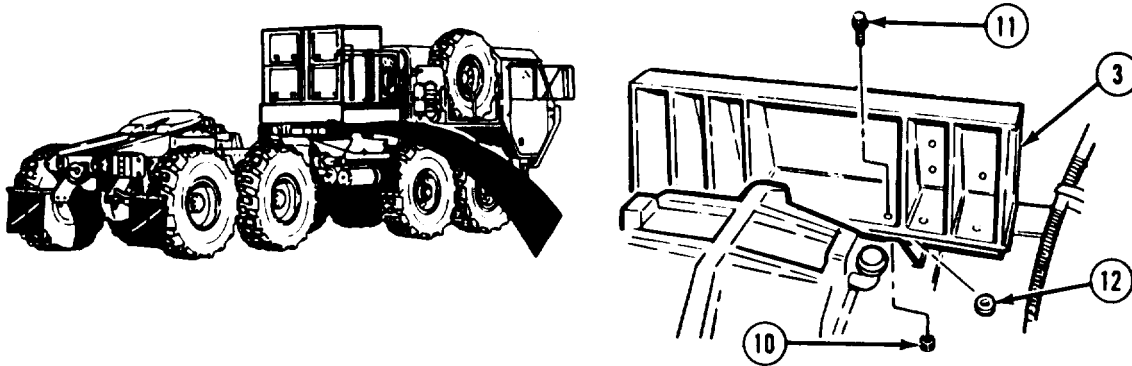

TA189247

- (4) Remove six nuts (10) and screws (11) from right pedestal support (3)
- (5) Remove right pedestal support (3) and six spacers (12).

Frame Maintenance Instructions (Cont)

- (6) Remove three nuts (13) and screws (14) from left pedestal support (15), rear fishplate (16), and front fishplate (17).
- (7) Remove nine nuts (18) and screws (19) from left pedestal support (15) and front fishplate (17).
- (8) Loosen three screws (20).

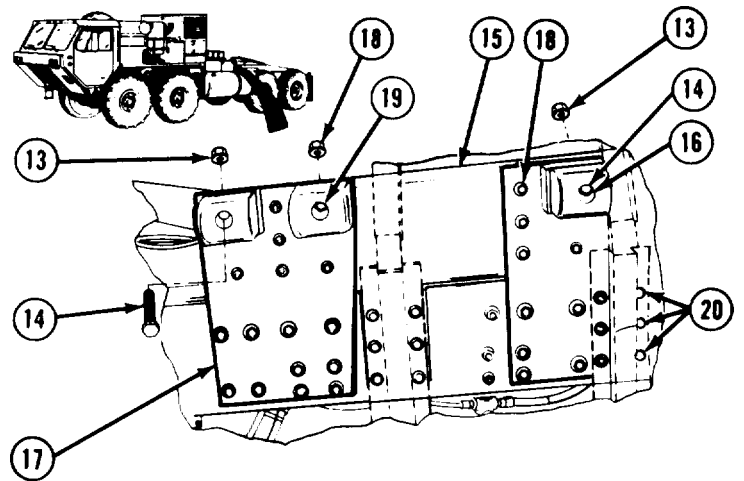

TA189250

- (9) Remove three nuts (21) and screws (22).
- (10) Remove five nuts (23), screws (24), rear fishplate (16), and inside support (25).
- (11) Remove 10 nuts (26), screws (27), front fishplate (17), and inside support (28).

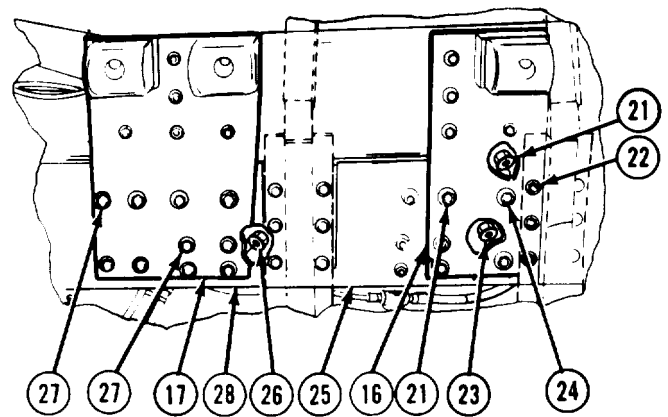

TA189242

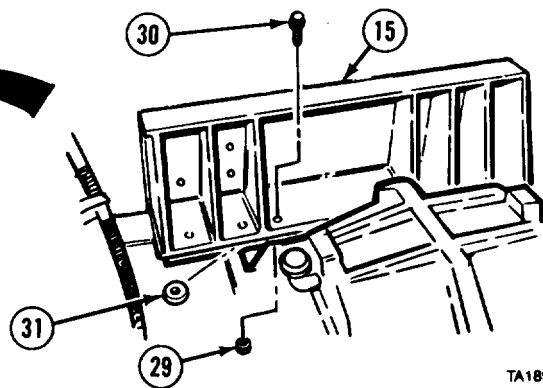
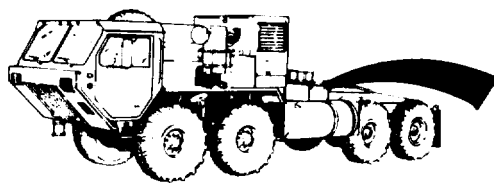

TA189246

- (12) Remove six nuts (29) and screws (30) from left pedestal support (15).
- (13) Remove left pedestal support (15) and six spacers (31).

Frame Maintenance Instructions (Cont)

13-28. CRANE MOUNTING SUPPORTS REMOVAL/INSTALLATION (M983) (CONT).

b. Installation.

NOTE

Do not tighten nuts until all screws are installed,

- (1) Install six spacers (1) and left pedestal support (2) with six screws (3) and nuts (4).

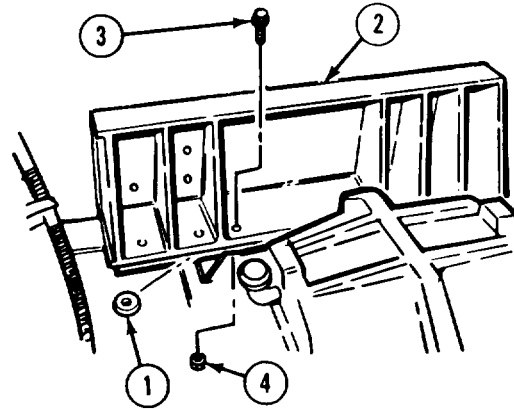

TA189245

- (2) Install inside support (5) and front fishplate (6) with 10 screws (7) and nuts (8).
- (3) Install inside support (9) and rear fishplate (10) with three screws (11), nuts (12), five screws (13), and nuts (14).

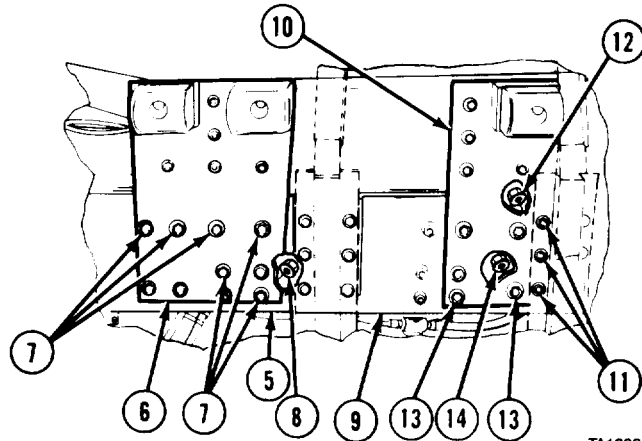

TA189241

- (4) Tighten three screws (15) on fuel tank mount.
- (5) Install 12 screws (16) and nuts (17).

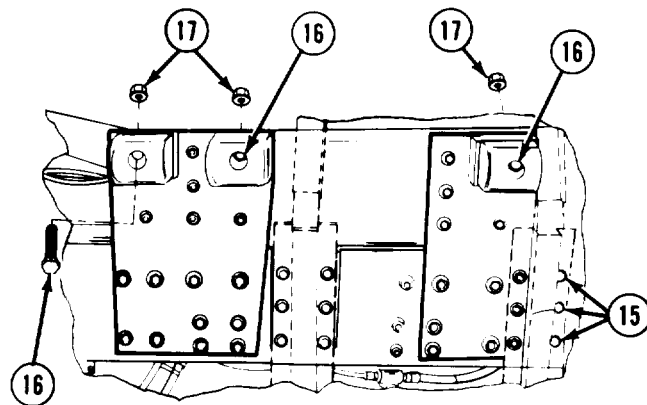

TA189249

Frame Maintenance Instructions (Cont)

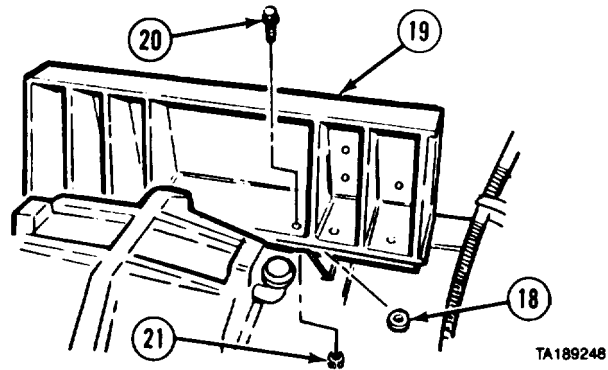

NOTE

Do not tighten nuts until all screws are installed.

- (6) Install six spacers (18) and right pedestal support (19) with six screws (20) and nuts (21).

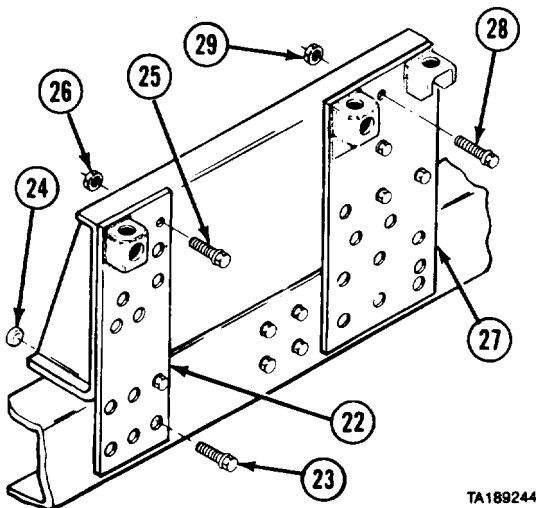

- (7) Install rear fishplate (22) with two screws (23) and nuts (24).
- (8) Install five screws (25) and nuts (26).
- (9) Install front fishplate (27) with seven screws (28) and nuts (29).

c. Follow-on Maintenance.

- (1) Install battery box (TM 9-2320-279-20).
- (2) Install fuel tank (TM 9-2320-279-20).
- (3) Install crane (para 18-2).

END OF TASK

Frame Maintenance Instructions (Cont)

13-29. CRANE MOUNTING SUPPORTS REMOVAL/INSTALLATION (M984).	
This task covers:	
a. Removal b. Installation	c. Follow-on Maintenance
INITIAL SETUP	
Models M984	Equipment Condition
Test Equipment None	<i>TM or Para</i> <i>Condition Description</i>
Special Tools None	TM 9-2320-354-24&P Crane removed.
Supplies Tags, identification, Item 60, Appendix C	TM 9-2320-279-20 Left intermediate fender removed.
Personnel Required MOS 63W, Wheel vehicle repairer (2)	TM 9-2320-279-20 Right intermediate fender removed.
References None	TM 9-2320-279-20 Rear cable tensioner removed.
	TM 9-2320-279-20 Rear fenders removed,
	Special Environmental Conditions None
	General Safety Instructions None
	Level of Maintenance Direct Support

a. Removal.

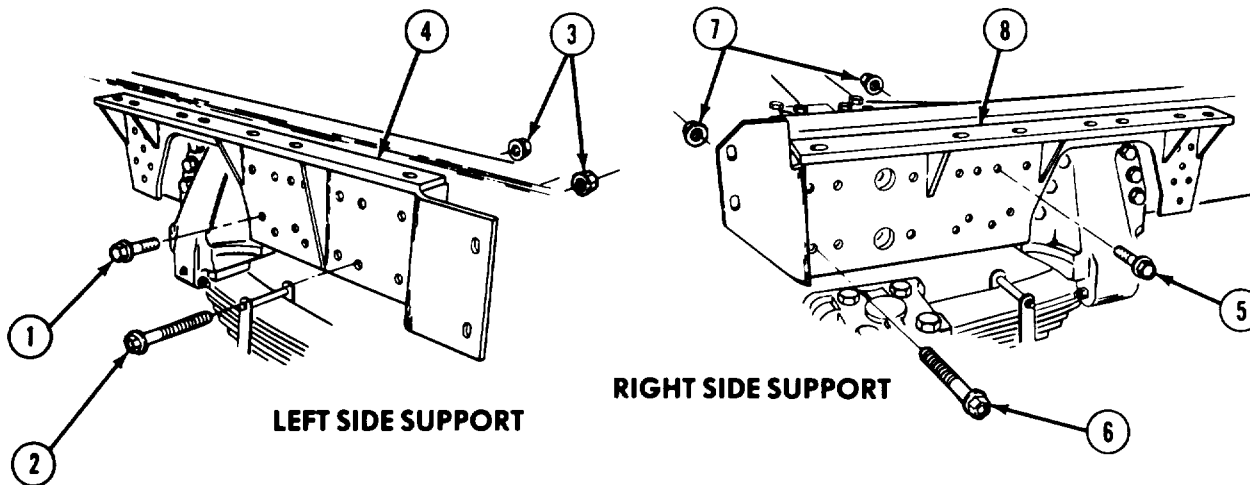

TA189238

Frame Maintenance Instructions (Cont)

- (1) Tag and mark 14 screws (1) and eight screws (2) for position. Soldier A removes 14 screws and eight screws while Soldier B removes 22 nuts (3).
- (2) Remove left crane mount support (4).
- (3) Soldier A removes 14 screws (5) and four screws (6) while Soldier B removes 18 nuts (7).
- (4) Remove right crane mount support (8).
- b. Installation.
 - (1) Soldier A installs right crane mount support (8) with 14 screws (5) and four screws (6) while Soldier B installs 18 nuts (7).
 - (2) Soldier A installs left crane mount support (4) with 14 screws (1) and eight screws (2) while Soldier B installs 22 nuts (3).
- c. Follow-on Maintenance.
 - (1) Install rear fenders (TM 9-2320-279-20).
 - (2) Install rear cable tensioner (TM 9-2320-279-20).
 - (3) Install right intermediate fender (TM 9-2320-279-20).
 - (4) Install left intermediate fender (TM 9-2320-279-20).
 - (5) Install crane (TM 9-2320-354-24&P).

END OF TASK

13.30. CRANE MOUNTING BRACKETS REMOVAL/INSTALLATION (M985E1).	
This task covers:	
a. Removal	c. Follow-on Maintenance
b. Installation	
INITIAL SETUP	
<i>Models</i>	<i>Equipment Condition</i>
M985E1	TM or Para <i>Condition Description</i>
<i>Test Equipment</i>	TM 9-2320-355- Crane removed.
None	24&P
<i>Special Tools</i>	TM 9-2320-279-20 Rear fenders removed.
None	<i>Special Environmental Conditions</i>
<i>Supplies</i>	None
None	<i>General Safety Instructions</i>
<i>Personnel Required</i>	None
MOS 63W, Wheel vehicle repairer (2)	<i>Level of Maintenance</i>
<i>References</i>	Direct Support
None	

Frame Maintenance Instructions (Cont)

13-30. CRANE MOUNTING BRACKETS REMOVAL/INSTALLATION (M985E1) (CONT).

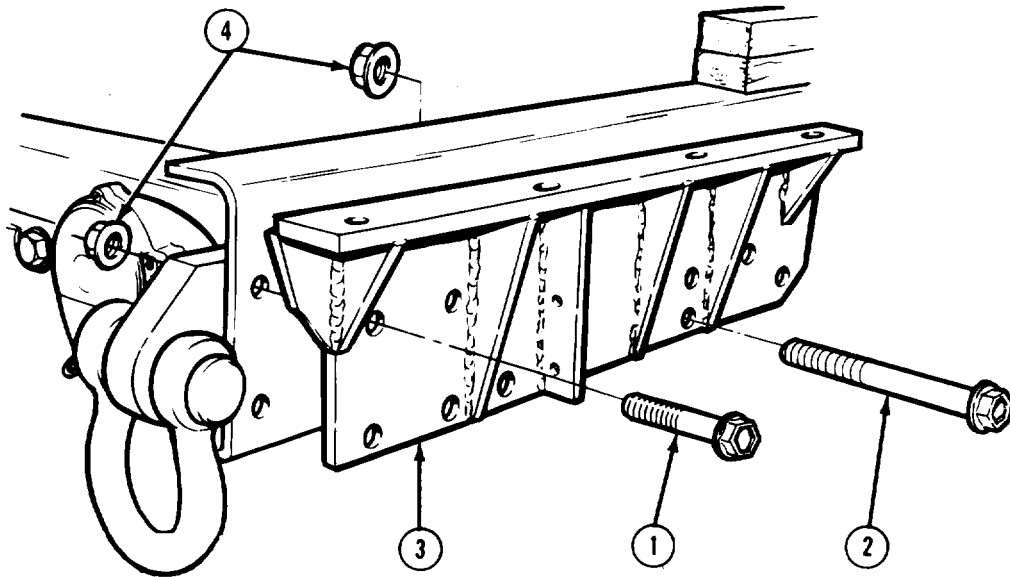

TA189236

NOTE

- . Mark position of all screws before removing.
- Right and left brackets are removed the same way,

a. Removal. Soldier A removes six screws (1), five screws (2), and bracket (3) while Soldier B removes 11 nuts (4).

b. Installation. Soldier A installs bracket (3) with six screws (1) and five screws (2) while Soldier B installs 11 nuts (4).

c. Follow-on Maintenance.

- (1) Install crane (TM 9-2320-355-24&P),
- (2) Install rear fenders (TM 9-2320-279-20).

END OF TASK

Frame Maintenance Instructions (Cont)

13-30.1 RETRIEVER TOWING SUPPORT ASSEMBLY REMOVAL/INSTALLATION (M984E1).	
This task covers:	
a. Removal	b. Installation
c. Follow-on Maintenance	
INITIAL SETUP	
<i>Models</i>	<i>Equipment Condition (cont)</i>
M984E1	<i>TM or Para</i> Condition Description
<i>Test Equipment</i>	TM 9-2320-279-20 Fixed work lamps removed.
None	TM 9-2320-279-20 Beacon support brackets removed.
<i>Special Tools</i>	TM 9-2320-279-20 Rear clearance marker lights and bracket removed.
None	TM 9-2320-279-20 Fairlead/Tensioner liftbar support removed.
<i>Supplies</i>	TM 9-2320-279-20 Para 13-30.2 Retriever lift cylinder removed.
Plastic, anti-friction, Item 52.1, Appendix C	Para 13-30.4 Retriever tow cylinders removed.
Tape, acrylic foam double backed, Item 60.1, Appendix C	
<i>Personnel Required</i>	<i>Special Environmental Conditions</i>
MOS 63W, Wheel vehicle repairer (2)	None
<i>References</i>	<i>General Safety Instructions</i>
None	None
<i>Equipment Condition</i>	<i>Level of Maintenance</i>
TM or Para Condition Description	Direct Support
TM 9-2320-279-20 Rear fenders removed.	
TM 9-2320-279-20 Snatch block bar and pin removed.	

a. Removal.

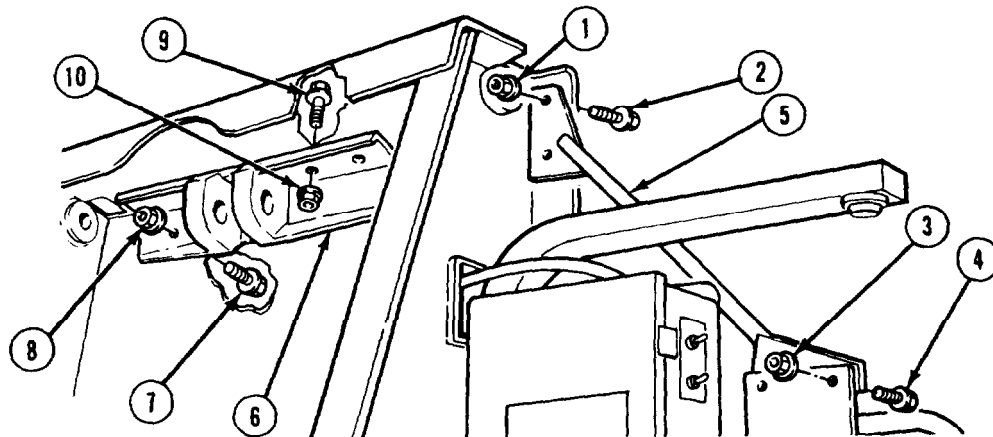

WARNING

Lift cylinder bracket is very heavy. Keep out from under heavy parts. Make sure lifting device is around center of balance of part being moved. Falling parts may cause serious injury or death.

- (1) Remove two nuts (1) and screws (2).
- (2) Remove two nuts (3), screws (4), and brace (5).
- (3) Attach suitable lifting device to lift cylinder bracket (6).
- (4) Soldier A removes six screws (7) while Soldier B removes nuts (8).
- (5) Soldier A removes four screws (9) while Soldier B removes nuts (10) and lifts cylinder bracket (6).

Frame Maintenance Instructions (Cont)

13-30.1 RETRIEVER TOWING SUPPORT ASSEMBLY REMOVAL/INSTALLATION (M984E1) (CONT).

NOTE

Some vehicles have a winch clevis tiedown. Do steps (5.1) through (5.3) for these vehicles.

- (5.1) Loosen ratchet (10.1) and remove hook (10.2) from eye bolt (10.3).
- (5.2) Remove nut (10.4), ratchet end of tiedown (10.5), eyebolt (10.3) and spacer (10.6).
- (5.3) If damaged, remove plastic (10.7) and adhesive (10.8).

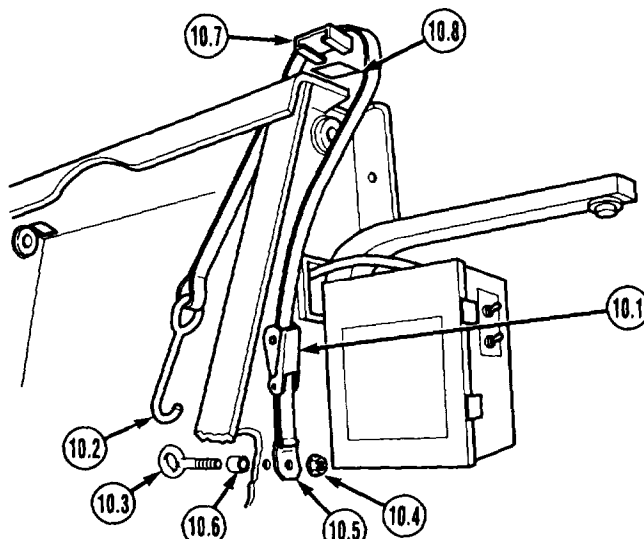

NOTE

Remove wire clips and plastic cable ties as necessary.

- (6) Remove six hydraulic lines (11 and 12) from bulkhead adapters (13 and 14).
- (7) Remove nut (15), screw (16), washer (17), and clamp (18).
- (8) Remove strobe and work lamp wiring harness (19) from towing support (20).
- (9) Remove grommet (21).
- (10) Remove hydraulic line (22) from crane control valve fitting (23).
- (11) Remove three hydraulic lines (24) from three bulkhead adapters (13).
- (12) Remove three hydraulic lines (25) from bulkhead adapters (14).

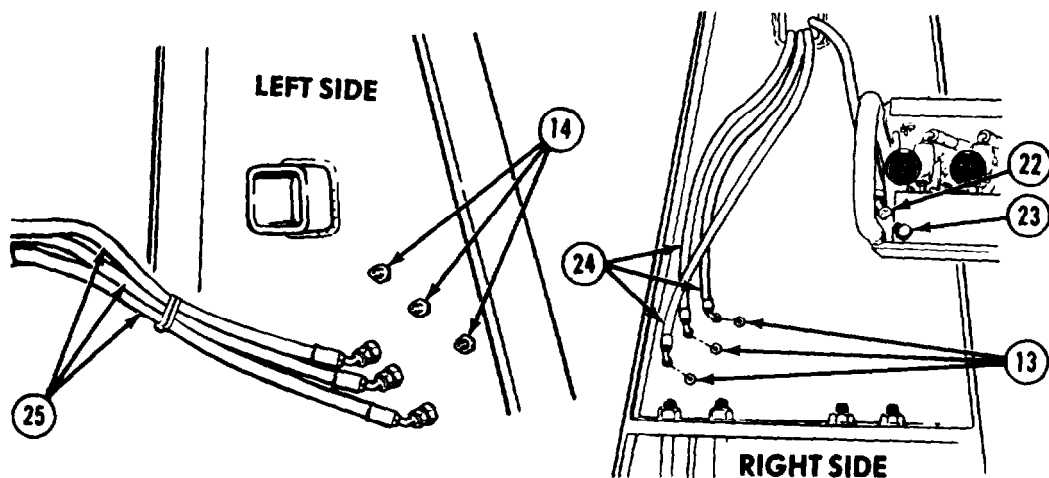
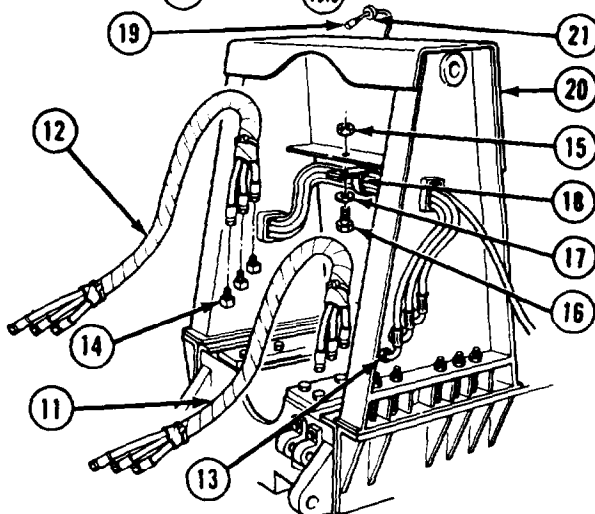

Frame Maintenance Instructions (Cont)

- (13) Remove four nuts (26), lockwashers (27) and screws (28). Move hydraulic filter and bracket (29) aside.
- (14) Pull fairlead motor hydraulic Line (30) from towing support (20).

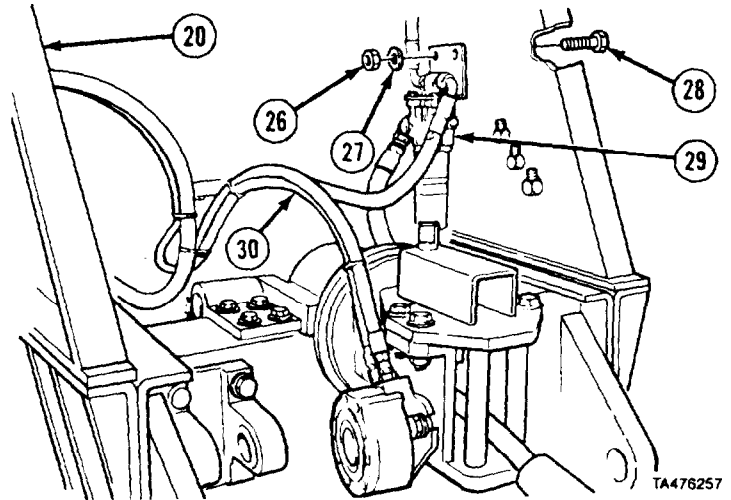

- (15) Remove six nuts (31) and bulkhead adapters (13 and 14).
- (16) Attach suitable lifting device to towing support (20).
- (17) Remove ten locknuts (32), washers (33), and studs (34). Remove ten locknuts and washers from studs.

WARNING

Towing support is very heavy. Keep out from under heavy parts. Heavy parts can fall and cause injury or death.

- (18) Soldier A operates lifting device while Soldier B guides towing support (20).

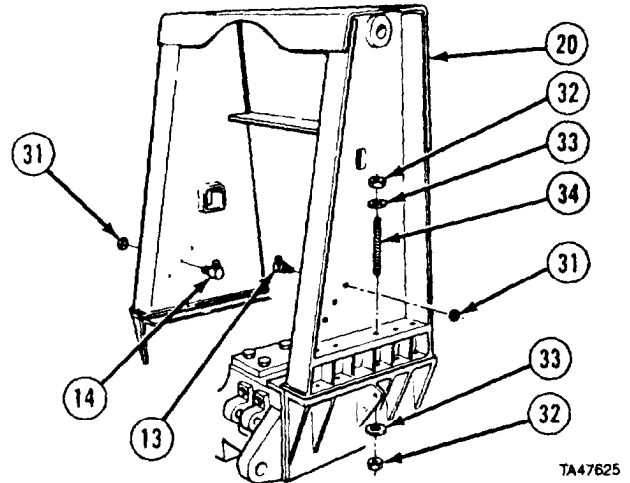

b. Installation.

WARNING

Towing support is very heavy. Keep out from under heavy parts. Heavy parts can fall and cause injury or death.

NOTE

Install locknuts on studs so studs are evenly installed.

- (1) Attach suitable lifting device to towing support (1). Soldier A installs towing support (1) with ten studs (2), 20 washers (3) and 20 locknuts (4) while Soldier B operates lifting device. Tighten nuts to 300 lb-ft (407 N-m).
- (2) Install six bulkhead adapters (5 and 6) and nuts (7).

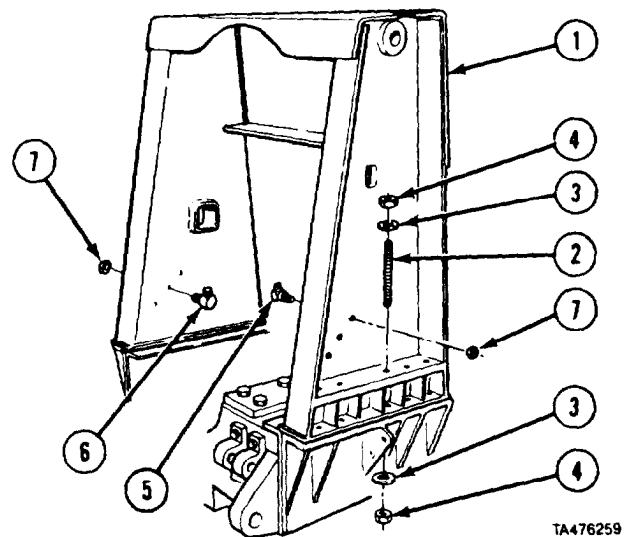

Frame Maintenance Instructions (Cont)

13-30.1 RETRIEVER TOWING SUPPORT ASSEMBLY REMOVAL/INSTALLATION (M984E1) (CONT).

- (3) Install hydraulic filter and bracket (8) with four screws (9), lockwashers (10), and nuts (11).
- (4) Install fair-lead motor hydraulic line (12) in left side of towing support (1).

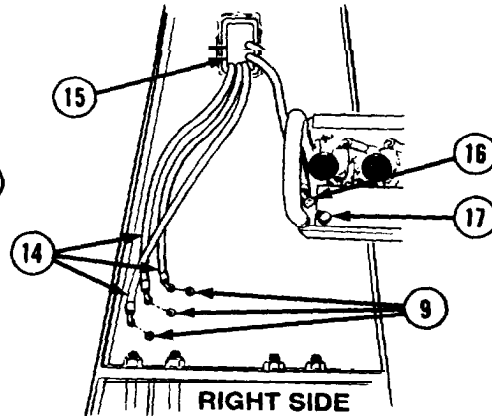
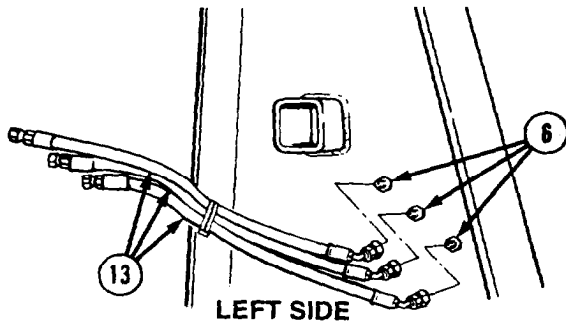
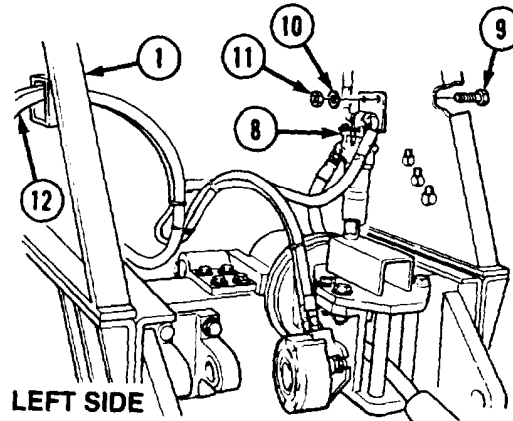

- (5) Install three hydraulic lines (13) on bulkhead adapters (6).
- (6) Install three hydraulic lines (14) on bulkhead adapters (9) and install through conduit (15)
- (7) Install hydraulic line (16) on crane control valve fitting (17) and install through conduit (15).

Frame Maintenance Instructions (Cont)

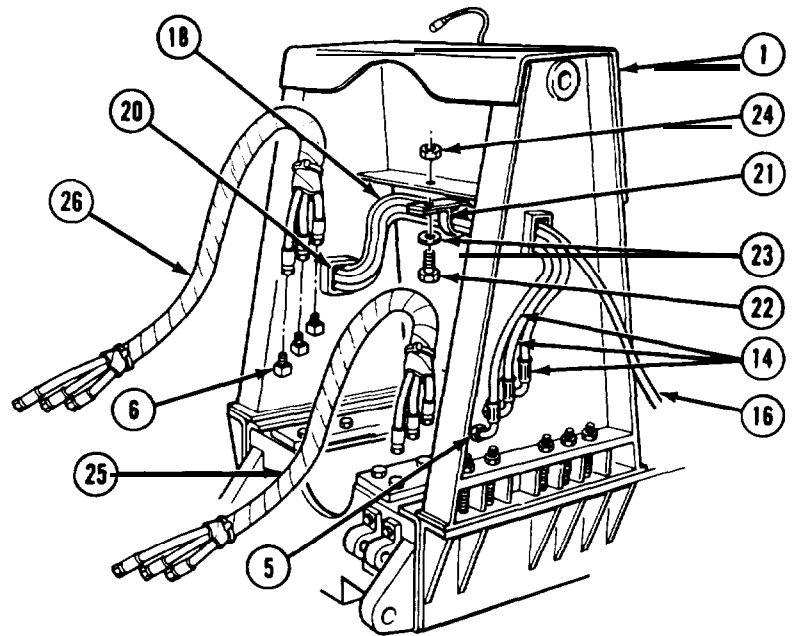
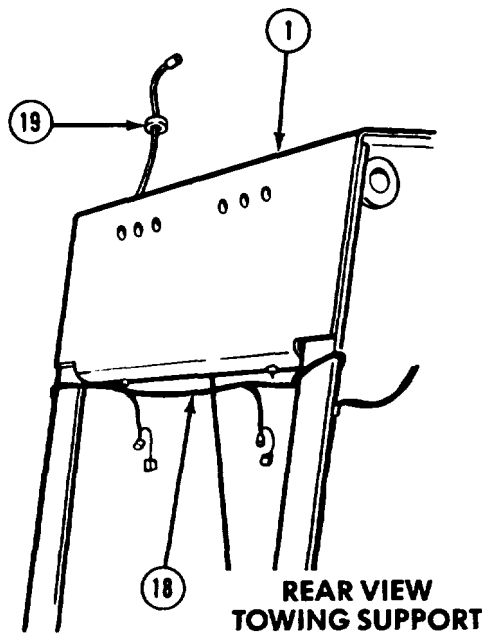

NOTE

Install wire clips and plastic cable ties as necessary.

- (8) Install strobe and worklamp wiring harness (18) to towing support (1).
- (9) Install grommet (19) in towing support (1).
- (10) Install hydraulic lines (14 and 16) through conduit (20).
- (11) Install clamp (21) over lines (14 and 16) and wiring harness (18).
- (12) Install screw (22), washer (23), and nut (24).
- (13) Install six hydraulic lines (25 and 26) on bulkhead adapters (5 and 6).

NOTE

Some vehicles have a winch clevis tie down. Do steps (13.1) through (13.5) for these vehicles.

- (13.1) Install adhesive tape (26.1) and plastic (26.2).
- (13.2) Install eyebolt (26.3), spacer (26.4), ratchet and tiedown (26.5), and nut (26.6).
- (13.3) Route tiedown (26.5) over plastic (26.2) and through opening in top to wing support (1).
- (13.4) Install hook (26.7) in eyebolt (26.3).
- (13.5) Use ratchet (26.8) to tighten tiedown (26.5) in stowed position.

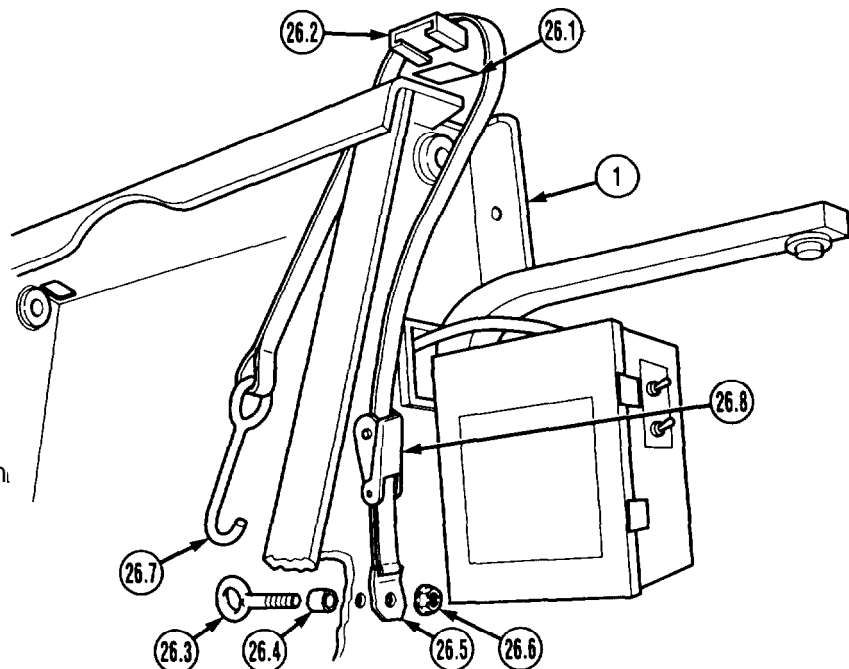

Frame Maintenance Instructions (Cont)

**13-30.1. RETRIEVER TOWING SUPPORT ASSEMBLY REMOVAL/INSTALLATION (M984E1)
(CONT).**

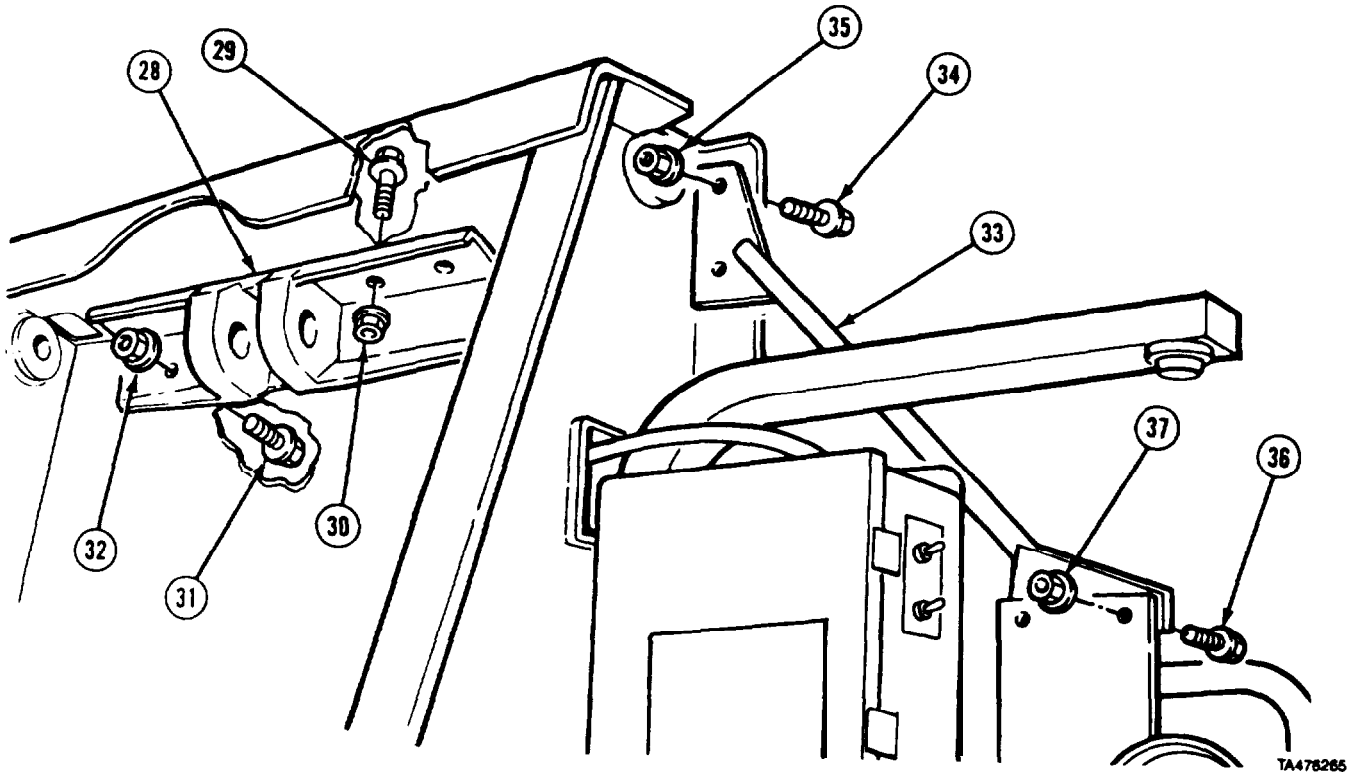

WARNING

Lift cylinder bracket is very heavy. Keep out from under heavy parts. Make sure lifting device is around center of balance of part being moved. Falling parts may cause serious injury or death.

- (14) Attach suitable lifting device to lift cylinder bracket (28).
- (15) Soldier A installs four screws (29) while Soldier B installs lift cylinder bracket (28) and four nuts (30). Do not tighten.
- (16) Soldier A installs six screws (31) while Soldier B installs nuts (32). Tighten nuts (30 and 32).
- (17) Install brace (33) with two screws (34) and nuts (35). Do not tighten,
- (18) Install two screws (36) and nuts (37).
- (19) Tighten nuts (35 and 37).

c. Follow-on Maintenance.

- (1) Install rear valve body brace (TM 9-2320-279-20).
- (2) Install beacon support brackets (TM 9-2320-279-20).
- (3) Install rear fenders (TM 9-2320-279-20).
- (4) Install snatch block bar and pin (TM 9-2320-279-20).
- (5) Install fairlead/tensioner lift bar support (TM 9-2320-279-20).
- (6) Install rear clearance marker lights and bracket (TM 9-2320-279-20).
- (7) Install lift cylinder (para 13-30.2).
- (8) Install retriever tow cylinders (para 13-30.4).
- (9) Install fixed work lamps (TM 9-2320-279-20)
- (10) Start engine, engage PTO (TM 9-2320-279-10). Check for hydraulic leaks. Check retriever lift and tow cylinder operation.

END OF TASK

Frame Maintenance Instructions (Cont)

13-30.2. RETRIEVER LIFT CYLINDER REMOVAL/INSTALLATION (M984E1).

This task covers:

- a. Removal
- b. Installation

Follow-on Maintenance

INITIAL SETUP

Models

M984E1

Test Equipment

None

Special Tools

None

Supplies

Compound, antiseize, Item 17, Appendix C

Personnel Required

MOS 63W, Wheel vehicle repairer (2)

References

None

Equipment Condition

TM or Para

TM 9-2320-279-20
Para 13-30.4

Condition Description

Engine shut down.
Retriever tow cylinders removed.
Retriever crosstube assembly removed.

Special Environmental Conditions

None

General Safety Instructions

None

Level of Maintenance

Direct Support

a. Removal.

- (1) Remove two screws (1), lockwashers (2), and cover (3) from retriever cylinder (4).

NOTE

Tag and mark all lines before removal.

- (2) Disconnect two hydraulic lines (5) from fittings (6).
- (3) Attach suitable lifting device to towbar center assembly (7).
- (4) Attach suitable lifting device to lift cylinder (4).

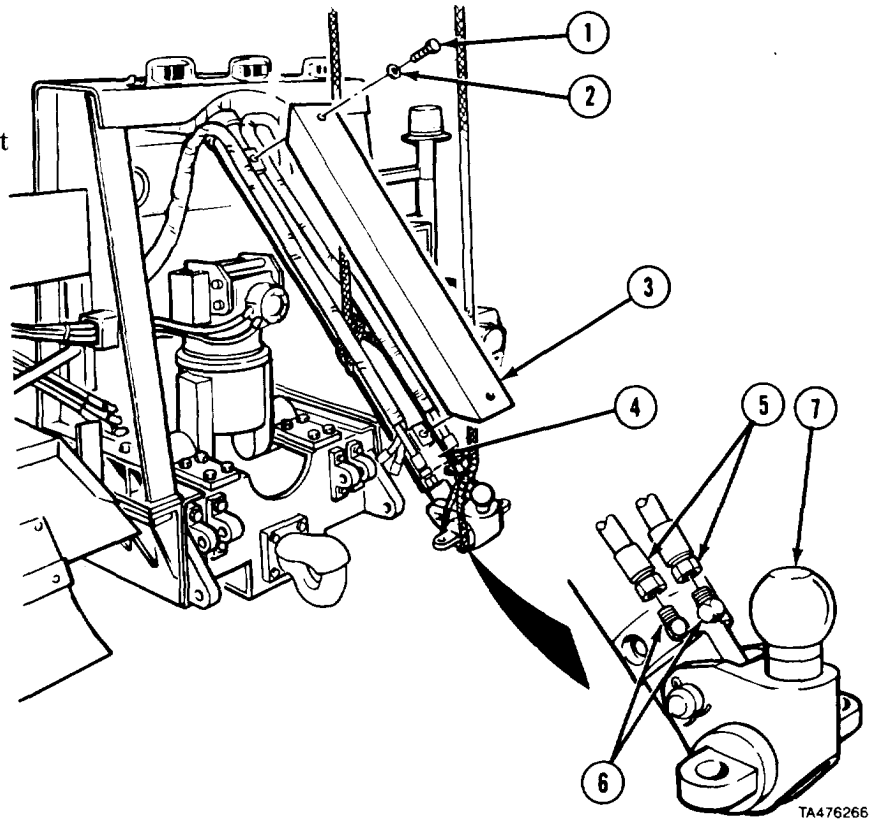

Frame Maintenance Instructions (Cont)

13-30.2. RETRIEVER LIFT CYLINDER REMOVAL/INSTALLATION (M984E1) (CONT).

- (5) Remove two spacers (8) and center pin (9) from towbar center assembly (7).
- (6) Soldier A removes two cotter pins (10), pin (11), and towbar center assembly (7) while Soldier B operates lifting device.

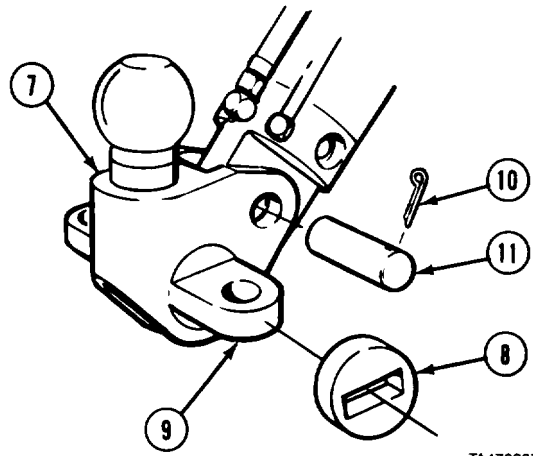

TA476267

- (7) Soldier A removes two cotter pins (12), pin (13), spacer washers (14), and lift cylinder (4) while Soldier B operates lifting device.

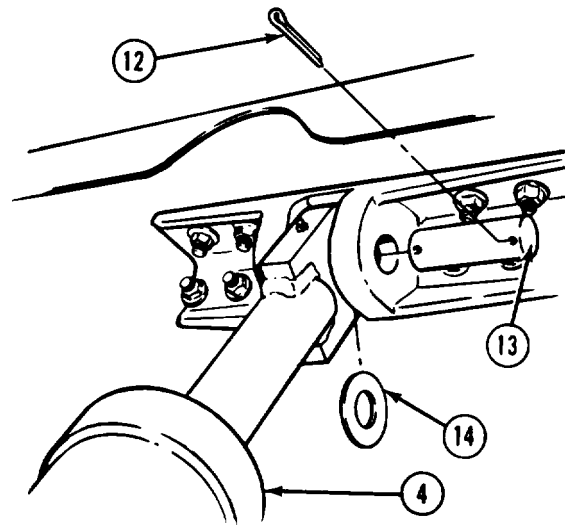

TA476268

- (8) Remove grease fitting (15).
- (9) Remove two fittings (16) and preformed packings (17).
- (10) Remove check valve (18) and thermal check valve (19).

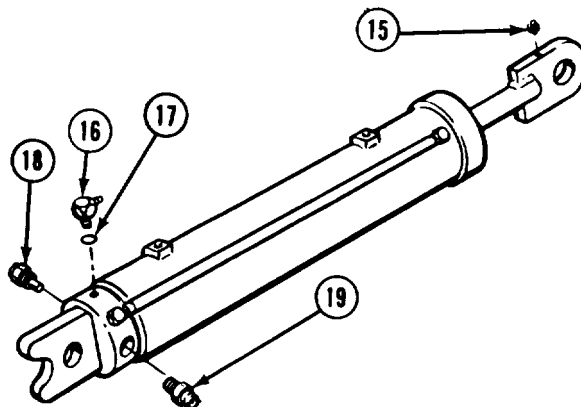

TA476269

Frame Maintenance Instructions (Cont)

b. Installation.

- (1) Install thermal check valve (1) and check valve (2) in lift cylinder (3).
- (2) Install two preformed packings (4) and fittings (5).
- (3) Install grease fitting (6).

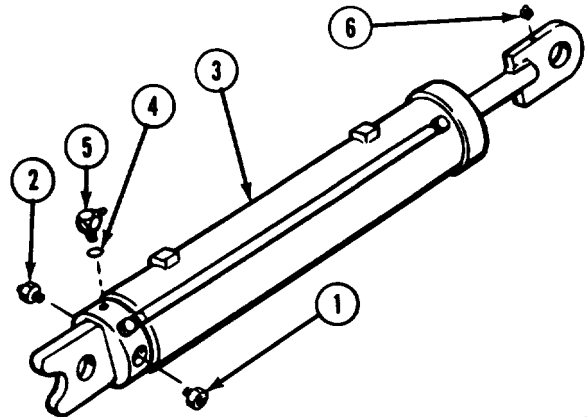

TA476270

WARNING

Keep out from under heavy parts. Falling parts may cause serious injury or death.

- (4) Attach suitable lifting device to lift cylinder (3).
- (5) Soldier A installs lift cylinder to cylinder bracket (7) with pin (8), two spacer washers (9), and two cotter pins (10) while Soldier B operates lifting device.

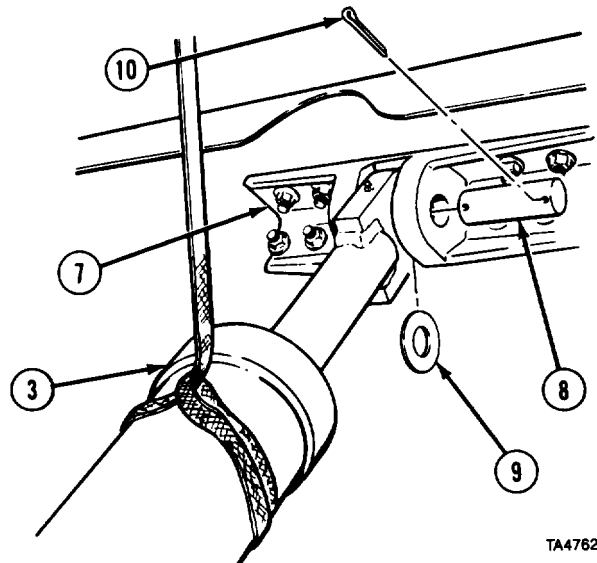

TA476271

- (6) Soldier A installs towbar center assembly (11), pin (12), and two cotter pins (13) on lift cylinder (3) while Soldier B operates lifting device.
- (?) Install center pin (14) and two spacers (15).

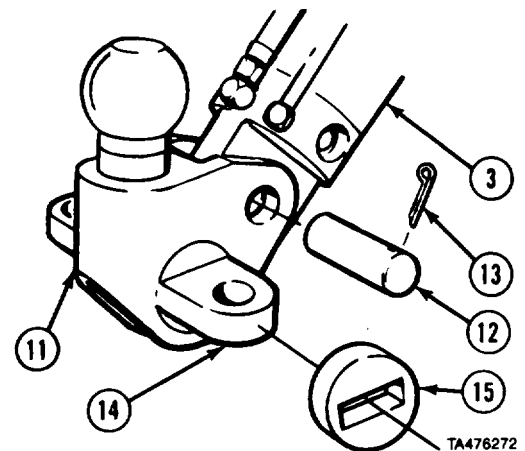

TA476272

Frame Maintenance Instructions (Cont)

13-30.2. RETRIEVER LIFT CYLINDER REMOVAL/INSTALLATION (M984E1) (CONT).

- (8) Connect two hydraulic lines (16) to fittings (5).
- (9) Install cover (17), two lockwashers (18), and screws (19).

c. Follow-on Maintenance.

- (1) Install retriever tow cylinders (para 13-30.4).
- (2) Install retriever crosstube assembly (TM 9-2320-279-20).
- (3) Check and fill hydraulic reservoir (LO 9-2320-279-12).
- (4) Check for leaks.
- (5) Check operation of retriever system lift cylinder.

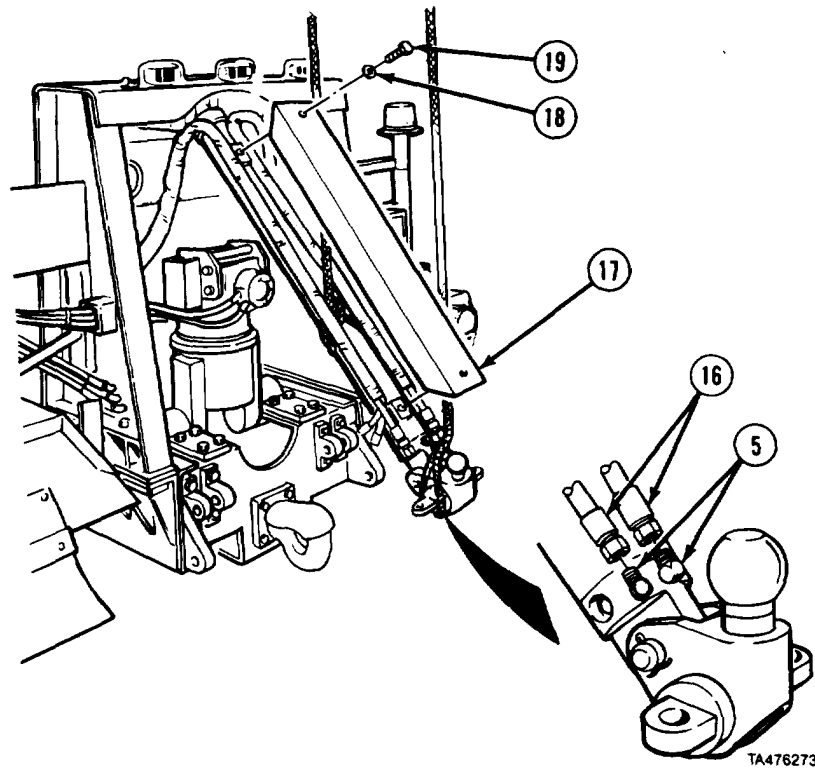

END OF TASK

13-30.3. RETRIEVER LIFT CYLINDER REPAIR (M984E1).

This task covers:

- a. Disassembly
- b. Cleaning/Inspection
- c. Assembly
- d. Follow-on Maintenance

INITIAL SETUP

Models

M984E1

Test Equipment

None

Special Tools

None

Supplies

Solvent, dry cleaning, Item 57, Appendix C
Oil, lubricating, Item 46, Appendix C

Personnel Required

MOS 63W, Wheel vehicle repairer (2)

References

None

Equipment Condition

TM or Para

Para 13-30.2

Condition Description

Retriever lift cylinder removed.

Special Environmental Conditions

None

General Safety Instructions

None

Level of Maintenance

Direct Support

Frame Maintenance Instructions (Cont)

a. Disassembly.

- (1) Remove bushing(1).
- (2) Remove setscrew (2) and plug (3) from end cap (4).
- (3) Remove end cap (4) from cylinder (5).
- (4) Soldier A and Soldier B remove piston rod assembly (6) from cylinder (5).

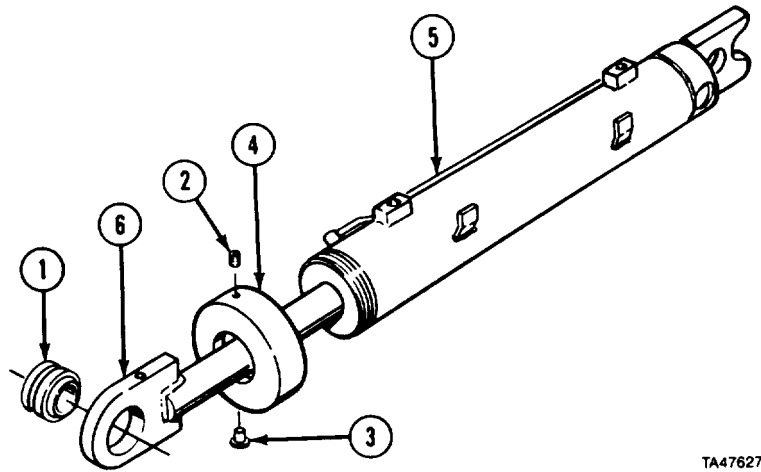

TA476274

- (5) Remove nut (7), piston (8), head (9), and end cap (4) from piston rod (6).

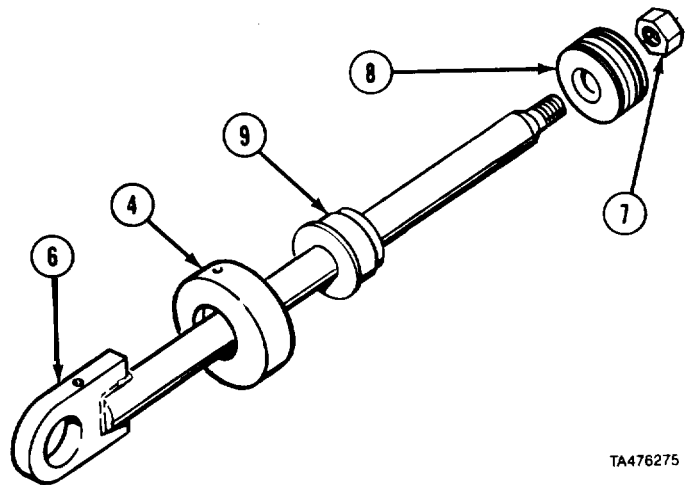

TA476275

- (6) Remove two backup rings (10), seals (11), and wear ring (12) from piston (8).
- (7) Remove preformed packing (13).

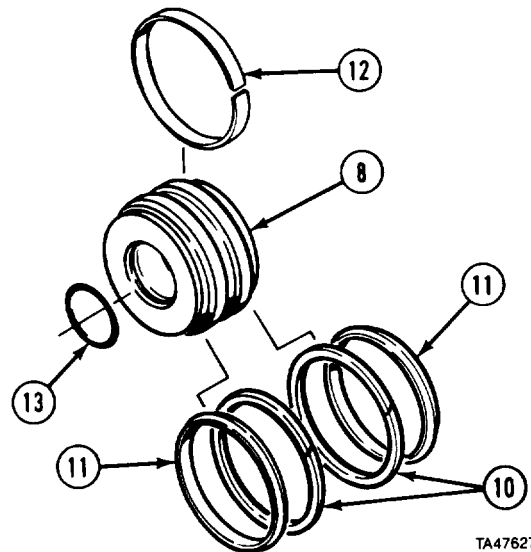

TA476276

Frame Maintenance Instructions (Cont)

13-30.3. RETRIEVER LIFT CYLINDER REPAIR (M984E1) (CONT).

- (8) Remove wiper seals (14), backup ring (15), and seal (16) from head (9).
- (9) Remove preformed packing (17) and backup ring (18).

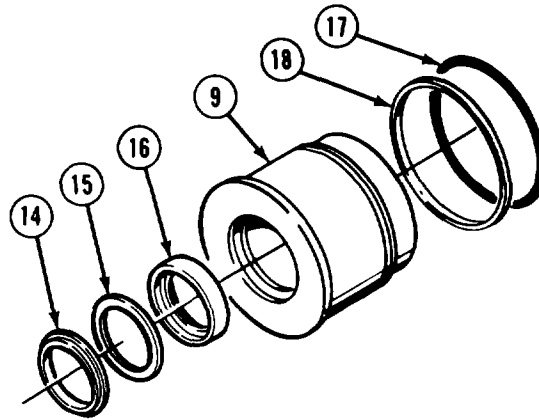

TA476289

b. Cleaning and Inspection

WARNING

Adhesives, solvents, and sealing compounds can burn easily, can give off harmful vapors, and are harmful to skin and clothing. To avoid injury or death, keep away from open fire and use in well-ventilated area. If adhesive, solvent, or sealing compound gets on skin or clothing, wash immediately with soap and water.

- (1) Clean all metal parts with dry cleaning solvent.
- (2) Inspect threads of end cap and cylinder for nicks and burrs.
- (3) Inspect cylinder for grooves on inside wall.
- (4) Inspect head and piston for nicks and gouges.
- (5) Remove nicks and burrs with crocus cloth. Clean up threads with thread chasing tool.
- (6) Lubricate piston rod, head, piston, and inside of cylinder with oil.
- (7) Replace piston rod if scored, pitted, bent or damaged,
- (8) Replace bushing if inside diameter is out of round more than 0.005 in. (0.127 mm) or inside diameter is greater than 3.007 in. (76.37 mm).

c. Assembly.

- (1) Install backup ring (1) and preformed packing (2) on head (3).
- (2) Install seal (4), backup ring (5), and wiper seal (6).

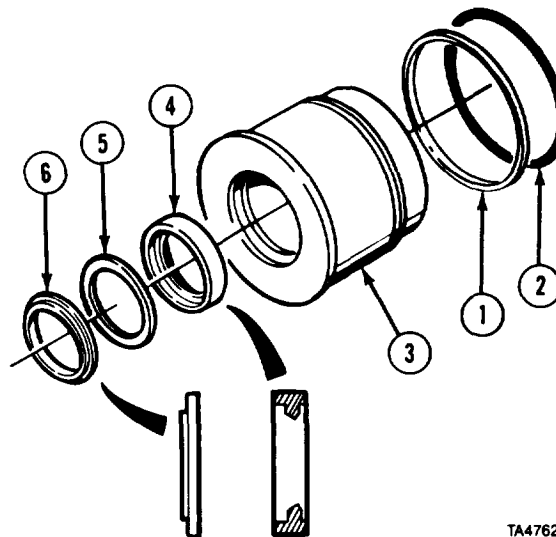

TA476278

Frame Maintenance Instructions (Cont)

NOTE

Seals face in different directions.

- (3) Install wear ring (7), two seals (8), and backup rings (9) on piston (10).
- (4) Install preformed packing (11).

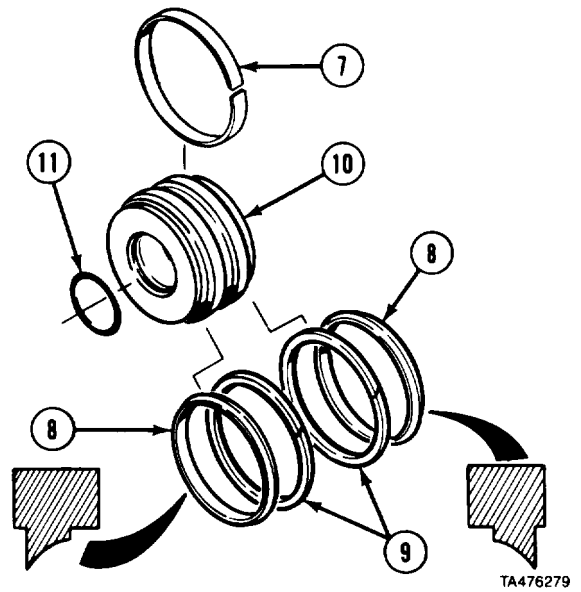

- (5) Install end cap (12), head (3), piston (9), and nut (13) on piston rod (14).
- (6) Tighten nut (13) to 800 lb-ft (1 084 N•m).

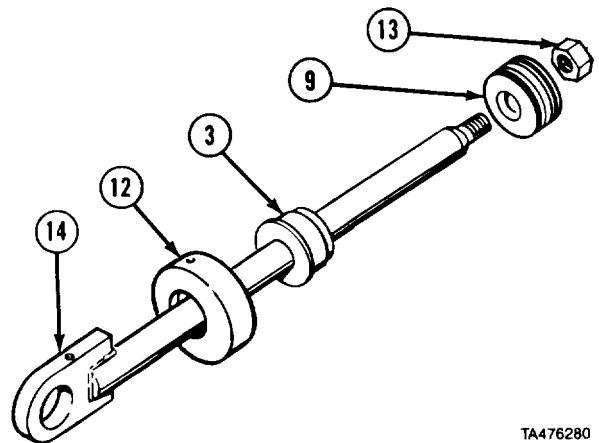

- (7) Soldier A and Soldier B install piston rod (14) in cylinder (15). Tighten end cap (16) and install setscrew (17) and plug (18).
- (8) Install bushing (19).

- d. Follow-on Maintenance.
 - (1) Install lift cylinder (para 13-30.2)
 - (2) Check operation (TM 9-2320-279-10).

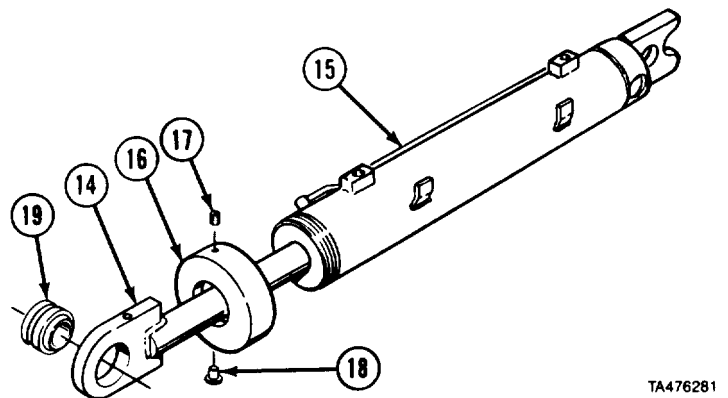

END OF TASK

Frame Maintenance Instructions (Cont)

13-30.4. RETRIEVER TOW CYLINDERS AND PIVOT BRACKETS REMOVAL/INSTALLATION (M984E1).	
This task covers:	
a. Removal b. Installation	c. Follow-on Maintenance
INITIAL SETUP	
Models M984E1	References None
Test Equipment None	Equipment Condition TM or Para Condition Description TM 9-2320-279-10 Engine shut down.
Special Tools None	Special Environmental Conditions None
Supplies Compound, antiseize, Item 17, Appendix C Oil, lubricating, Item 46, Appendix C	General Safety Instructions None
Personnel Required MOS 63W, Wheel vehicle repairer (2)	Level of Maintenance Direct Support

a. Removal.

WARNING

If both tow cylinders are removed lift cylinder must be supported to avoid personal injury or death.

NOTE

- Right and left cylinders are removed the same.
- Tag and mark hydraulic lines and fittings.

- (1) Remove centering spring (1).
- (2) Remove two hydraulic lines (2) from fittings (3).
- (3) Remove two fittings (3) and preformed packings (4).
- (4) Remove check valve (5) and thermal check valve (6).
- (5) Support towing cylinder (7) with suitable lifting device.
- (6) Remove cotter pin (8), washer (9), and pin (10).
- (7) Remove screw (11) and washer (12) from pivot bracket (13).
- (8) Soldier A removes sleeve (14), two washers (15), and cylinder (7) while Soldier B operates lifting device.
- (9) Remove grease fittings (16).

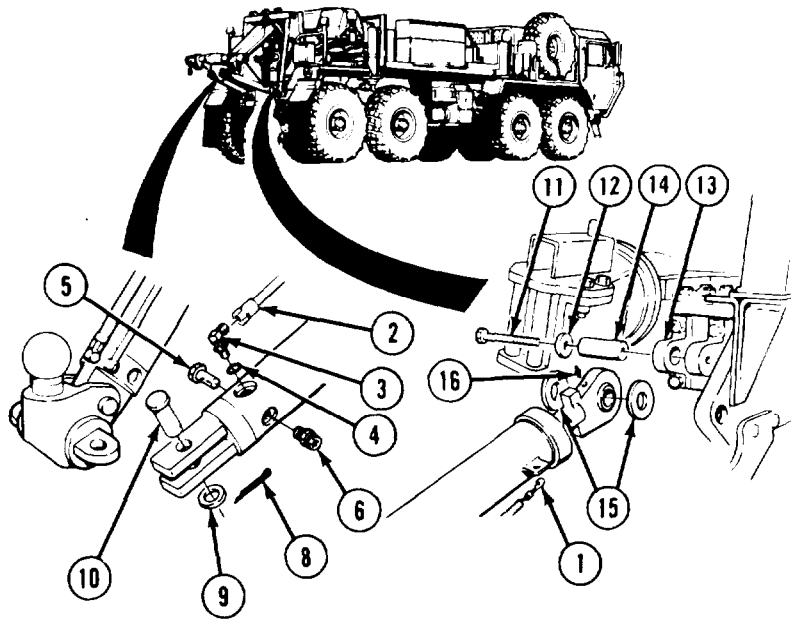

**CROSS TUBE
REMOVED FOR CLARITY**

TA476282

Frame Maintenance Instructions (Cont)

- (10) Soldier A removes four screws (17) and pivot bracket (13) while Soldier B removes four nuts (18).

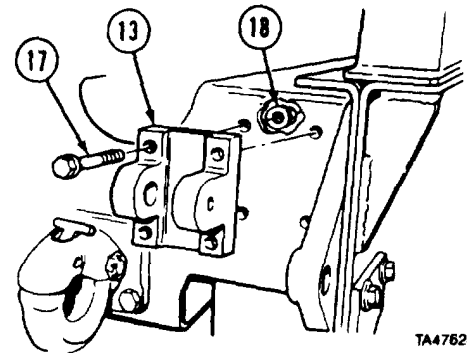

b. Installation.

- (1) Soldier A installs pivot bracket (1) with four screws (2) while Soldier B installs four nuts (3).

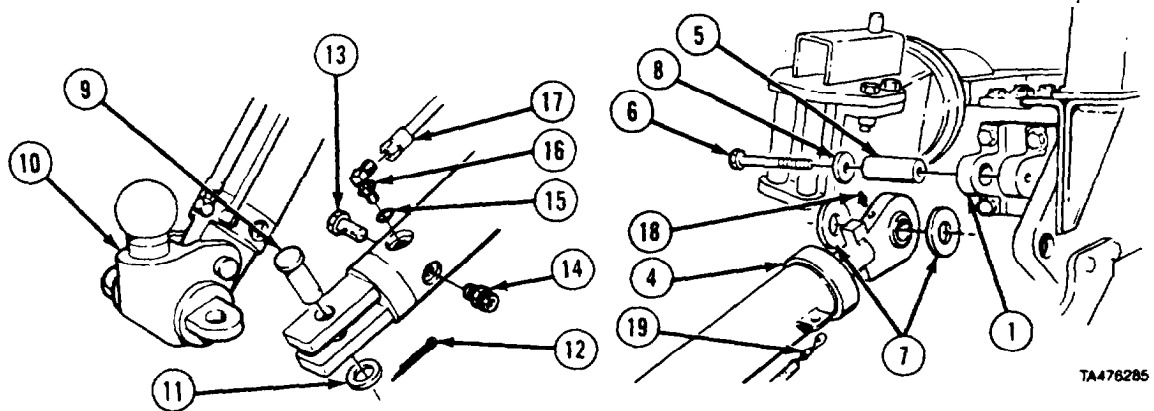
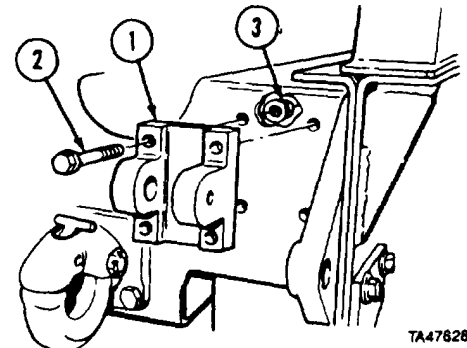

- (2) Attach suitable lifting device to towing cylinder (4).
 (3) Apply antiseize compound to sleeve (5) and oil to threads of screw (6).
 (4) Soldier A installs cylinder (4) on pivot bracket (1) with sleeve (5), two washers (7), washer (8), and screw (6) and tightens screw to 55 lb-ft (75 N•m) while Soldier B operates lifting device.
 (5) Apply antiseize compound to pin (9).
 (6) Soldier A installs cylinder (4) on towbar center assembly (10) with pin (9), washer (11) and cotter pin (12) while Soldier B operates lifting device.
 (7) Install check valve (13) and thermal check valve (14) on cylinder (4).
 (8) Install two preformed packings (15) and fittings (16).
 (9) Connect two hydraulic Lines (17) to fittings (16).
 (10) Install grease fitting (18).
 (11) Install centering spring (19).

c. Follow-on Maintenance.

- (1) Check and fill hydraulic reservoir (LO 9-2320-279-12).
 (2) Check for leaks.

END OF TASK

Frame Maintenance Instructions (Cont)

13-30.5 RETRIEVER TOW CYLINDER REPAIR (M984E1).

This task covers:

- | | |
|------------------------|--------------------------|
| a. Disassembly | c. Assembly |
| b. Cleaning/Inspection | d. Follow-on Maintenance |

INITIAL SETUP

Models

M984E1

References

None

Test Equipment

None

Equipment Condition

TM or Para	Condition Description
Para 13-30.4	Retriever tow cylinder removed.

Special Tools

None

Special Environmental Conditions

None

Supplies

Solvent, drycleaning, Item 57, Appendix C
Oil, lubricating, Item 46, Appendix C

General Safety Instructions

None

Personnel Required

MOS 63W, Wheel vehicle repairer (2)

Level of Maintenance

Direct Support

a. Disassembly

- (1) Remove bushing (1).
 - (2) Remove setscrew (2) and plug (3) from end cap (4).
 - (3) Remove end cap (4) from cylinder (5).
 - (4) Remove piston rod assembly (6) and end cap (4) from cylinder (5).
-
- (5) Remove locknut (7), piston (8), head (9), and end cap (4) from piston rod assembly (6).

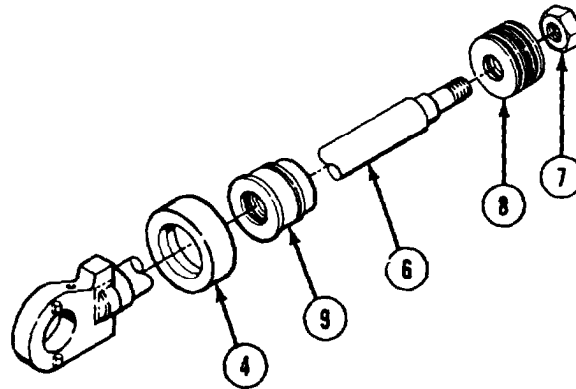
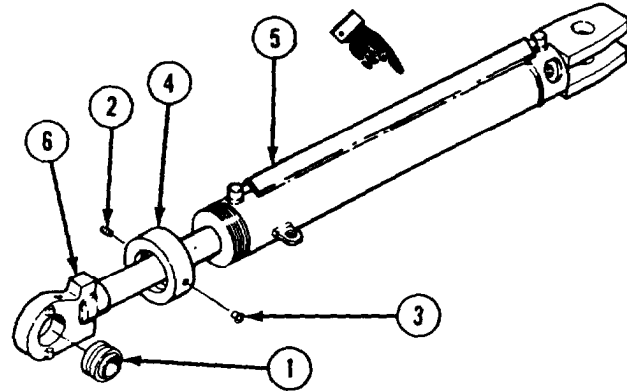

Frame Maintenance Instructions (Cont)

- (6) Remove two backup rings (10), seals (11), and wear ring (12) from piston (8).
- (7) Remove preformed packing (13).

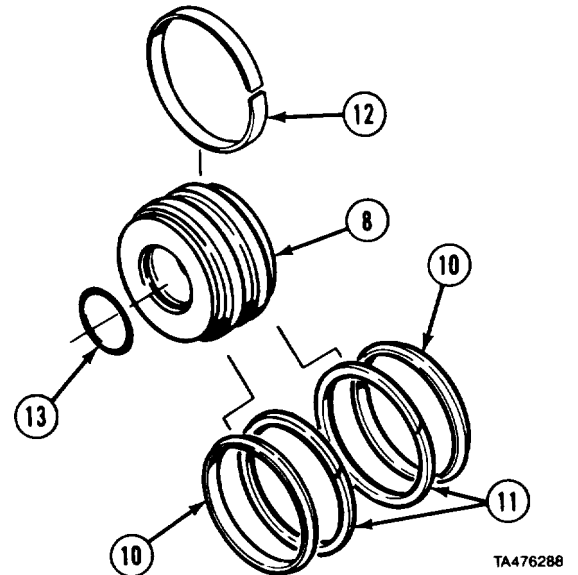

- (8) Remove seal (14), backup ring (15), and seal (16) from head (9).
- (9) Remove preformed packing (17) and backup ring (18).

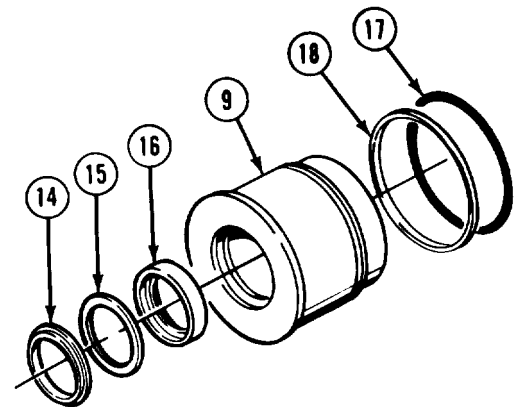

b. Cleaning and Inspection

WARNING

Adhesives, solvents, and sealing compounds can burn easily, can give off harmful vapors, and are harmful to skin and clothing. To avoid injury or death, keep away from open fire and use in well-ventilated area. If adhesive, solvent, or sealing compound gets on skin or clothing, wash immediately with soap and water.

- (1) Clean all metal parts with dry cleaning solvent.
- (2) Inspect threads of end cap and cylinder for nicks and burrs.
- (3) Inspect cylinder for grooves on inside wall.
- (4) Inspect head and piston for nicks and gouges.
- (5) Remove nicks and burrs with crocus cloth. Clean up threads with thread chasing tool.
- (6) Lubricate piston rod, head, piston, and inside of cylinder with oil.
- (7) Replace piston rod if scored, pitted, bent or damaged.
- (8) Replace bushing if inside diameter is out of round more than 0.005 in. (0.127 mm) or inside diameter is greater than 2.007 in. (50.97 mm).

Frame Maintenance Instructions (Cont)

13-30.5. RETRIEVER TOW CYLINDER REPAIR (M984E1) (CONT).

c. Assembly.

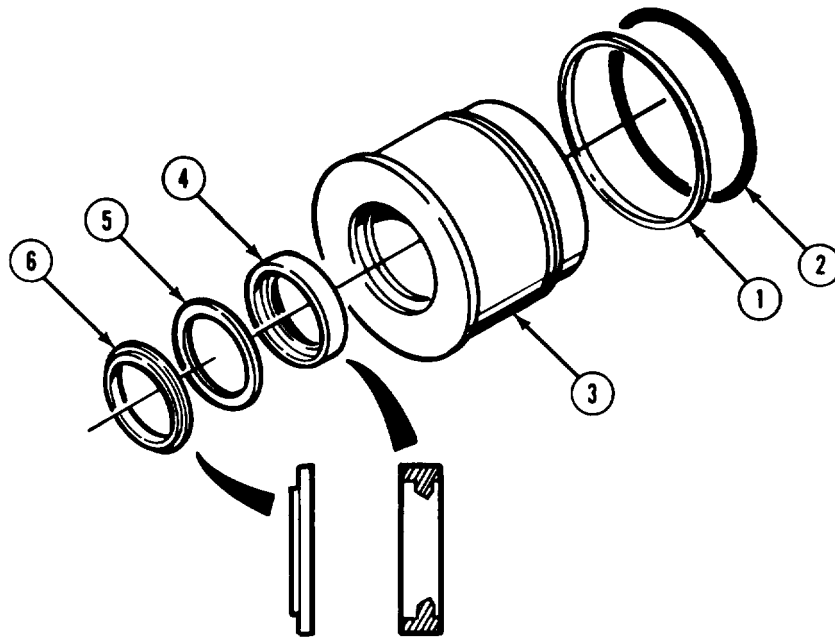

TA476290

- (1) Install backup ring (1) and preformed packing (2) on head (3).
- (2) Install seal (4), backup ring (5), and seal (6).
- (3) Install wear ring (6), two seals (7), and backup rings (8) on piston (9).
- (4) Install preformed packing (10).

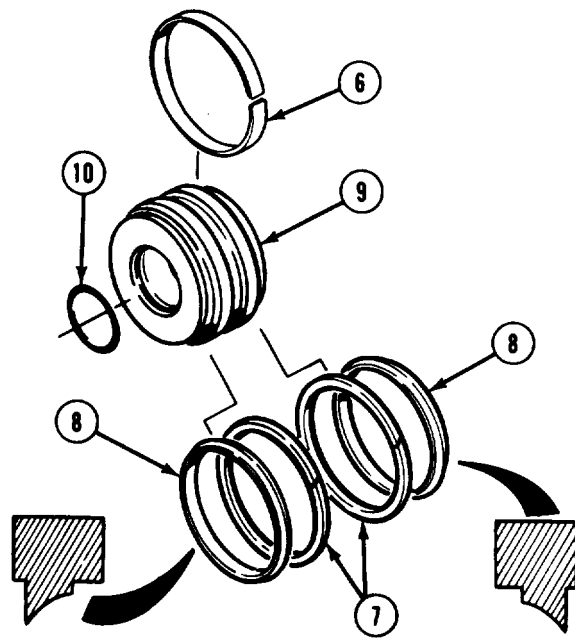

TA476291

Frame Maintenance Instructions (Cont)

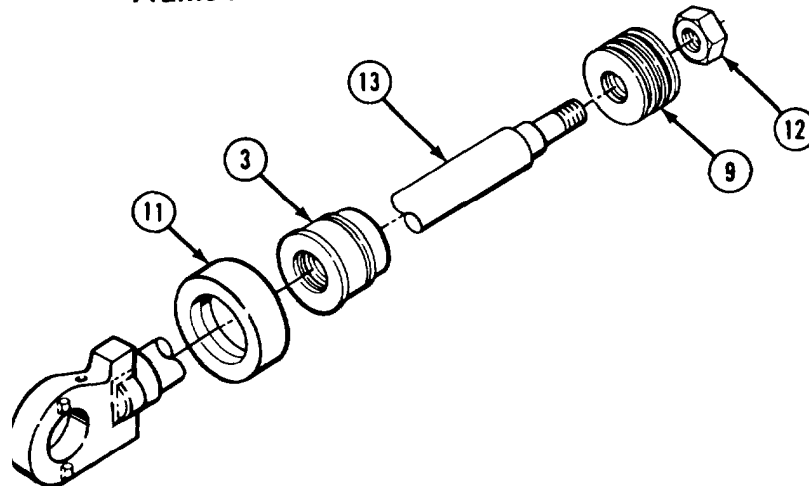

- (5) Install end cap (11), head (3), piston (9), and locknut (12) on piston (13).
- (6) Tighten locknut (12) to 300 lb-ft (406.8 N•m).

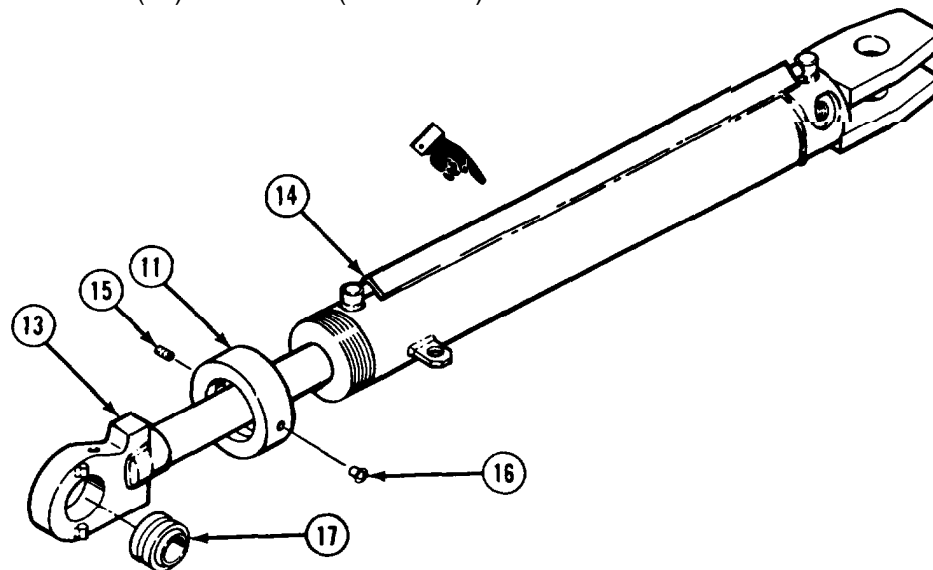

- (7) Install piston rod (13) in cylinder (14). Tighten end cap (11) and install setscrew (15) and plug (16).
- (8) Install bushing (17).

d. Follow-on Maintenance

- (1) Check operation (TM 9-2320-279-10).
- (2) Install retriever tow cylinder (para 13-30.4)

END OF TASK

Frame Maintenance Instructions (Cent)

Section III. FIFTH WHEEL ASSEMBLY

13-31. PLATE ASSEMBLY 2-INCH (51 MM) KINGPIN REMOVAL/INSTALLATION (M983).		
This task covers:		
a. Removal	c. Follow-on Maintenance	
b. Installation		
INITIAL SETUP		
Models	References	
M983 with crane	None	
Test Equipment	Equipment Condition	
None	TM or Para	Condition Description
Special Tools	None	
None	Special Environmental Conditions	
Supplies	None	
None	General Safety Instructions	
Personnel Required	None	
MOS 63W, Wheel vehicle repairer (2)	Level of Maintenance	
	Direct Support	

a. Removal.

- (1) Soldier A and Soldier B rotate rear of plate assembly (1) upward.
- (2) Remove roll pin (2) from hinge pin (3).
- (3) Drive hinge pin (3) halfway through plate (4) and shoe (5). Repeat procedure for opposite side.
- (4) Install suitable lifting device to support plate assembly (1).

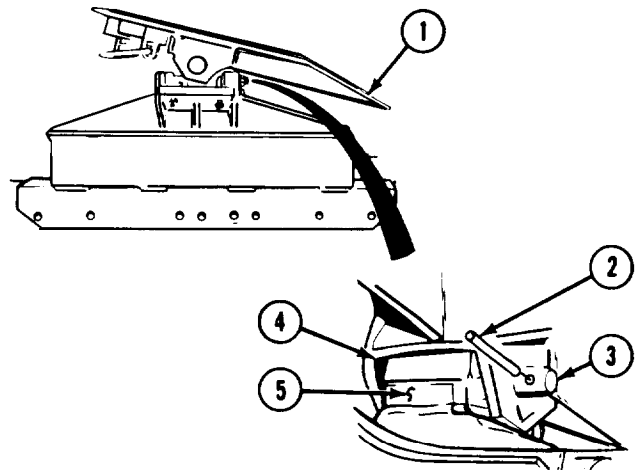

NOTE

Plate assembly must have balanced support. Do not lift plate assembly more than necessary to remove pin. Plate assembly can jam on removal if not balanced.

- (5) Remove hinge pin (3) from both sides of plate (4).
- (6) Soldier A operates lifting device and removes plate assembly (1) guided by Soldier B.
- (7) Remove lifting device from plate assembly (1).

TA189231

Frame Maintenance Instructions (Cont)

13-31. PLATE ASSEMBLY 2-INCH (51 MM) KINGPIN REMOVAL/INSTALLATION (M983)

b. Installation.

- (1) Install suitable lifting device to plate assembly (1).
- (2) Soldier A operates lifting device and moves plate assembly (1) over compensator assembly (2) guided by Soldier B.
- (3) Soldier A operates lifting device while Soldier B aligns shoes (3) with slots on both sides of plate (4).
- (4) Install two hinge pins (5) through plate (4) and shoes (3) until hole in each pin shows.
- (5) Install roll pin (6) in hole of each hinge pin (5).
- (6) Remove lifting device.

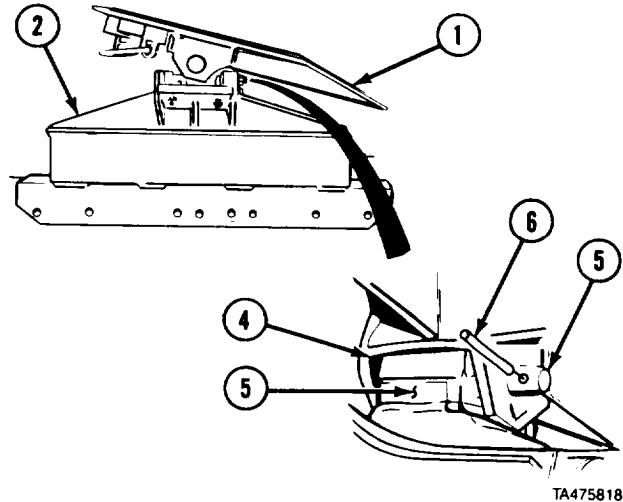

c. Follow-on Maintenance. Lubricate fifth wheel (LO 9-2320-279-12).

END OF TASK

13-32. PLATE ASSEMBLY 3.5-INCH (89 MM) KINGPIN REMOVAL/INSTALLATION (M983).

This task covers:

- | | |
|---|--|
| <ol style="list-style-type: none"> a. Removal b. Installation | <ol style="list-style-type: none"> c. Follow-on Maintenance |
|---|--|

INITIAL SETUP

Models
M983 without crane

Test Equipment
None

Special Tools
None

Supplies
None

Personnel Required
MOS 63W, Wheel vehicle repairer (2)

References
None

Equipment Condition

<i>TM or Para</i>	<i>Condition Description</i>
	None

Special Environmental Conditions
None

General Safety Instructions
None

Level of Maintenance
General Support

Frame Maintenance Instructions (Cont)

a. Removal.

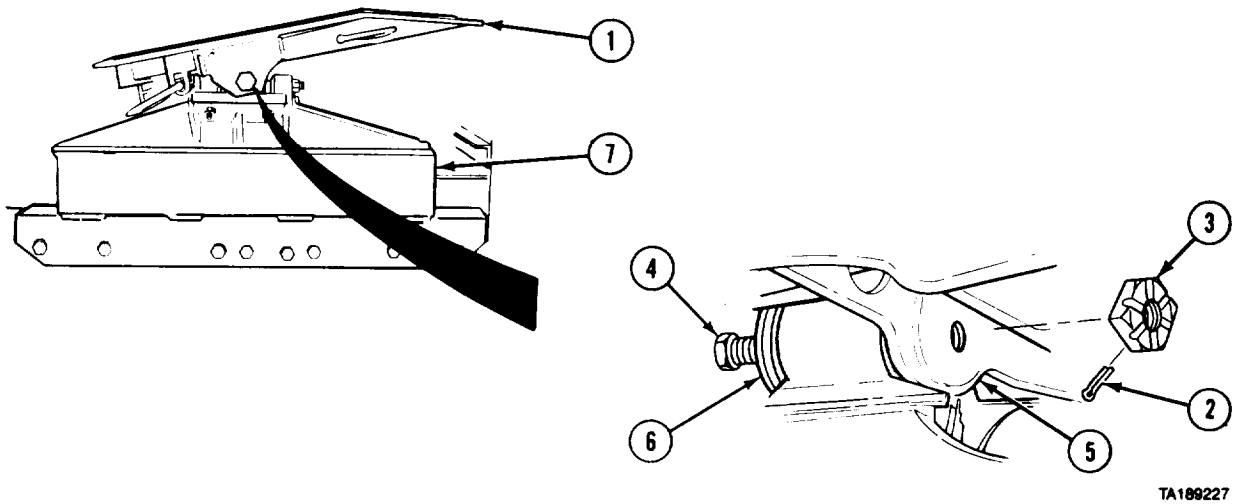

- (1) Soldier A and Soldier B rotate rear of plate assembly (1) upward.
- (2) Remove cotter pin (2) and nut (3).
- (3) Move screw (4) halfway through plate (5) and shoe (6). Repeat same procedure for opposite side.

NOTE

Plate assembly must have balanced support. Do not lift plate assembly more than necessary to remove screw. Plate assembly can jam on removal if not balanced.

- (4) Attach suitable lifting device to support plate assembly (1).
 - (5) Remove screws (4) from both sides of plate (5).
 - (6) Soldier A operates lifting device and removes plate assembly (1) guided by Soldier B.
 - (7) Remove lifting device from plate assembly (1).
- b. Installation.
- (1) Attach suitable lifting device to plate assembly.
 - (2) Soldier A operates lifting device and moves plate assembly (1) over compensator assembly (7) . guided by Soldier B.
 - (3) Soldier A operates lifting device while Soldier B aligns shoes (6) with slots on both sides of plate (5).
 - (4) Install two screws (4) through plate (5) and shoes (6).
 - (5) Install two nuts (3) on screws (4).
 - (6) Secure nuts (3) with two cotter pins (2) through screws (4).
 - (7) Remove lifting device from plate assembly.

- c. Follow-on Maintenance. Lubricate fifth wheel (LO 9-2320-279-12).

END OF TASK

Frame Maintenance Instructions (Cont)

13-33. PLATE ASSEMBLY COMPENSATOR REPAIR (M983).	
This task covers:	
a. Disassembly	c. Assembly
b. Cleaning/Inspection	d. Follow-on Maintenance
INITIAL SETUP	
Models M983	References None
Test Equipment None	Equipment Condition
Special Tools None	TM or Para Para 13-31 Plate assembly removed (2-inch kingpin). Para 13-32 Plate assembly removed (3.5-inch kingpin).
Supplies Grease, automotive and artillery, Item 34, Appendix C Solvent, dry cleaning, Item 57, Appendix C	Special Environmental Conditions None
Personnel Required MOS 63W, Wheel vehicle repairer	General Safety Instructions None
	Level of Maintenance General Support

a. Disassembly.

- (1) Remove shoe (1) from each side of compensator bracket (2).
- (2) Remove cushion (3) and grease fitting (4) from each shoe (1).
- (3) Remove cushion (5), two washers (6 and 7), and spring (8) from one side of tie rod (9).
- (4) Remove tie rod (9) from compensator bracket (2).
- (5) Repeat step (3) for other side of tie rod (9).

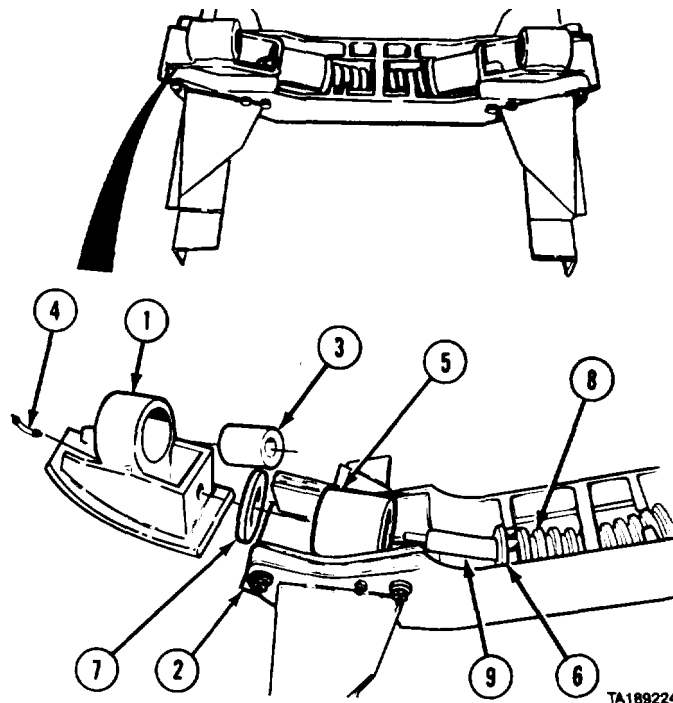

Frame Maintenance Instructions (Cont)

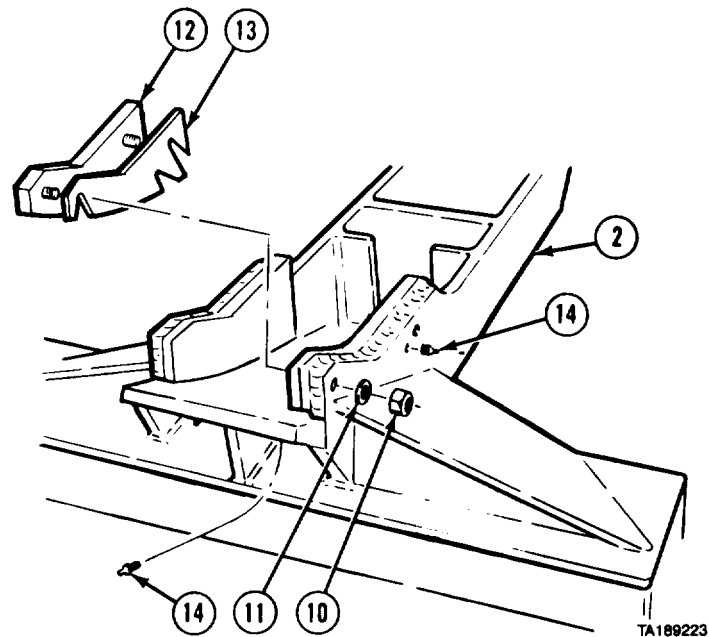

- (6) Remove four nuts (10), lockwashers (11), two adjusting plates (12), and shims (13) from compensator bracket (2).

NOTE

There are 10 grease fittings on 3.5-inch (89 mm) fifth wheel bracket and eight grease fittings on 2-inch (51 mm) fifth wheel bracket.

- (7) Remove grease fittings (14) from compensator bracket (2).

b. Cleaning/Inspection.

WARNING

Adhesives, solvents, and sealing compounds can burn easily, can give off harmful vapors, and are harmful to skin and clothing. To avoid injury or death, keep away from open fire and use in well-ventilated area. If adhesive, solvent, or sealing compound gets on skin or clothing, wash immediately with soap and water.

- (1) Clean all metal parts in dry cleaning solvent.
- (2) Inspect both edges of each shoe (1), Edge thickness must be 0.3-in. (7 mm) or greater. If less, replace shoe.
- (3) Inspect all parts for damage.
- (4) Replace all damaged parts.

0.3 INCH OR MORE

TA1S9226

13-33. PLATE ASSEMBLY COMPENSATOR REPAIR (M983) (CONT).

c. Assembly.

NOTE

Lubricate moving parts before assembly (LO 9-2320-279-12). There are 10 grease fittings on 3.5-inch (89 mm) fifth wheel bracket and eight grease fittings on 2-inch (51 mm) fifth wheel bracket.

- (1) Install grease fittings (1) in compensator bracket (2).
- (2) Install two adjusting plates (3) and shims (4) with four lockwashers (5) and nuts (6). Do not tighten.

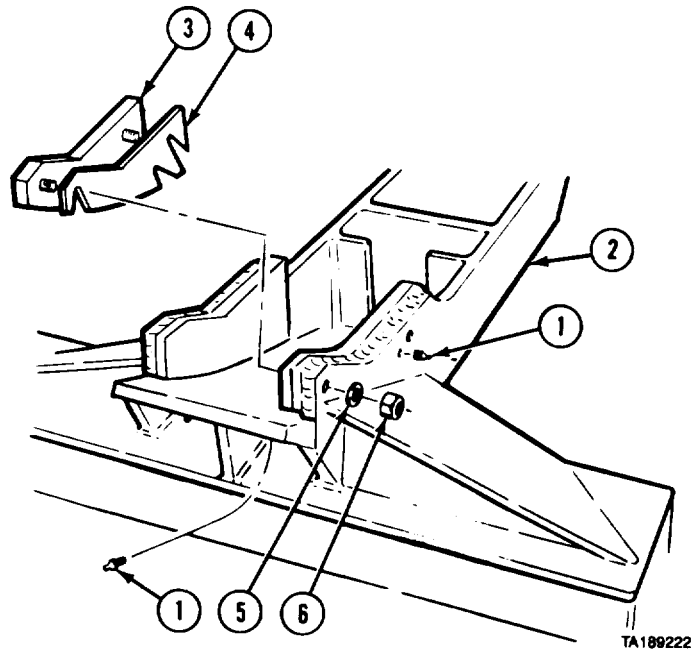

- (3) Install cushion (7) in shoe (8).
- (4) Install grease fitting (9) in shoe (8).
- (5) Install spring (10), two washers (11 and 12), cushion (13), and shoe (8) with cushion (7) on one end of tie rod (14).
- (6) Install tie rod (14) in center of compensator bracket (2).
- (7) Repeat step (5) for other end of tie rod (14).
- (8) Install second shoe (8) and cushion (7) on tie rod (14).

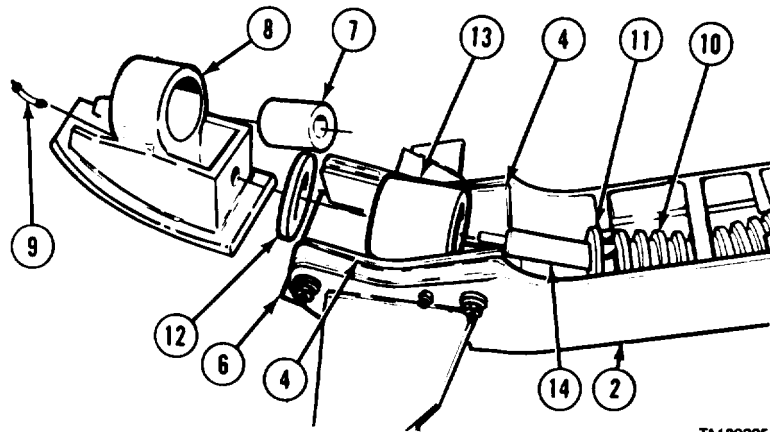

NOTE

Some free lateral movement of shoe should exist after shimming.

- (9) Measure front and back movement of each shoe (8) in compensator bracket (2). Add shims (4) if movement exceeds 0.06 in. (2 mm).
- (10) Tighten nuts (6).
- (11) Clamp one shoe (8) on compensator bracket (2).
- (12) Pry other shoe (8) up from compensator bracket (2). If upward movement exceeds 0.5-in. (13 mm), compensator bracket or shoe must be replaced.

d. Follow-on Maintenance. Install fifth wheel plate assembly (para 13-31 for 2-inch kingpin or para 13-32 for 3.5-inch kingpin).

END OF TASK

Frame Maintenance Instructions (Cent)

13-34. FIFTH WHEEL REPAIR - 2-INCH (51 MM) KINGPIN (M983).							
<p>b This task covers:</p> <p>a. Disassembly b. Cleaning/Inspection c. Assembly d. Follow-on Maintenance</p>							
<p>INITIAL SETUP</p> <table border="0"> <tr> <td style="vertical-align: top;"> <p>Models M983</p> <p>Test Equipment Lock Tester - 2-Inch TFTLN- 1000</p> <p>Special Tools None</p> <p>Supplies Solvent, dry cleaning, Item 57, Appendix C Compound, antiseize, Item 17, Appendix C</p> <p>Personnel Required MOS 63W, Wheel vehicle repairer (2)</p> </td> <td style="vertical-align: top;"> <p>References None</p> <p>Equipment Condition</p> <table border="0"> <tr> <td>TM or Para</td> <td>Condition Description</td> </tr> <tr> <td></td> <td>Fifth wheel plate assembly on clean work surface.</td> </tr> </table> <p>Special Environmental Conditions None</p> <p>General Safety Instructions None</p> <p>Level of Maintenance General Support</p> </td> </tr> </table>		<p>Models M983</p> <p>Test Equipment Lock Tester - 2-Inch TFTLN- 1000</p> <p>Special Tools None</p> <p>Supplies Solvent, dry cleaning, Item 57, Appendix C Compound, antiseize, Item 17, Appendix C</p> <p>Personnel Required MOS 63W, Wheel vehicle repairer (2)</p>	<p>References None</p> <p>Equipment Condition</p> <table border="0"> <tr> <td>TM or Para</td> <td>Condition Description</td> </tr> <tr> <td></td> <td>Fifth wheel plate assembly on clean work surface.</td> </tr> </table> <p>Special Environmental Conditions None</p> <p>General Safety Instructions None</p> <p>Level of Maintenance General Support</p>	TM or Para	Condition Description		Fifth wheel plate assembly on clean work surface.
<p>Models M983</p> <p>Test Equipment Lock Tester - 2-Inch TFTLN- 1000</p> <p>Special Tools None</p> <p>Supplies Solvent, dry cleaning, Item 57, Appendix C Compound, antiseize, Item 17, Appendix C</p> <p>Personnel Required MOS 63W, Wheel vehicle repairer (2)</p>	<p>References None</p> <p>Equipment Condition</p> <table border="0"> <tr> <td>TM or Para</td> <td>Condition Description</td> </tr> <tr> <td></td> <td>Fifth wheel plate assembly on clean work surface.</td> </tr> </table> <p>Special Environmental Conditions None</p> <p>General Safety Instructions None</p> <p>Level of Maintenance General Support</p>	TM or Para	Condition Description		Fifth wheel plate assembly on clean work surface.		
TM or Para	Condition Description						
	Fifth wheel plate assembly on clean work surface.						

- a. Disassembly.
- (1) Remove two cotter pins (1).
 - (2) Remove pin (2) from plate (3).
 - (3) Remove tension spring (4) and lock guard (5) from plate (3).

NOTE

Kingpin jaws must be in locked position.

- (4) Remove screw (6), two washers (7), and roller (8) from yoke (9).
- (5) Remove nut (10), screw (11), two washers (12), and roller (13).
- (6) Unhook cam plate (14) from release handle (15) and remove cam plate.

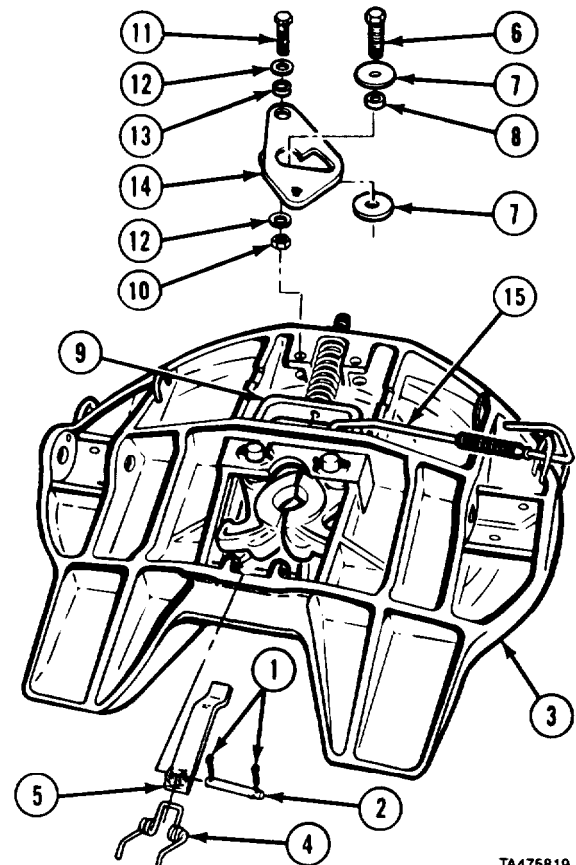

TA475819

Frame Maintenance Instructions (Cont)

113-34. FIFTH WHEEL REPAIR- 2-INCH (51 MM) KINGPIN (M983) (CONT). I

- (7) Remove release handle (15).
- (8) Remove washer (16), spring (17), and washer (18) from release handle (15).

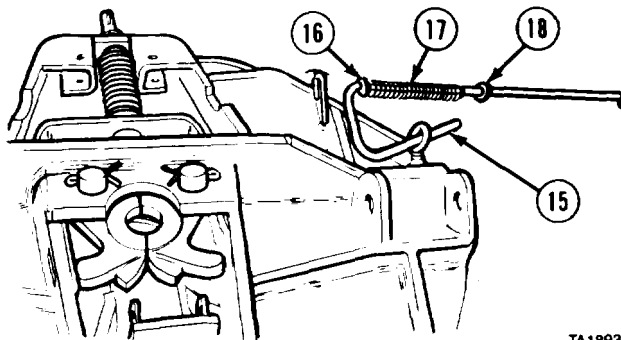

TA189394

- (9) Remove nut (19), washer (20), rubber block (21), and yoke shank (22).

WARNING

Spring is under compression. Remove carefully to prevent personal injury.

- (10) Remove spring (23).
- (11) Remove roll pin (24), secondary locking lever (25), and spring (26) from plate (3).
- (12) Remove yoke (9).
- (13) Remove two cotter pins (27), lockpins (28), and lockjaws (29).
- (14) Remove two grease fittings (30) from plate (3).

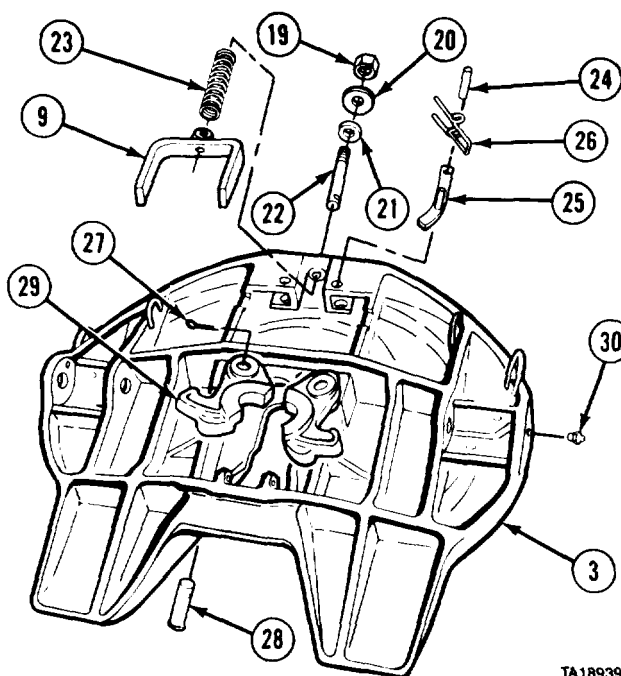

TA189395

b. Cleaning/Ispection.

WARNING

Adhesives, solvents, and sealing compounds can burn easily, can give off harmful vapors, and are harmful to skin and clothing. To avoid injury or death, keep away from open fire and use in well-ventilated area. If adhesive, solvent, or sealing compound gets on skin or clothing, wash immediately with soap and water.

- (1) Clean all parts with dry cleaning solvent.
- (2) Remove corrosion from bare metal.
- (3) Inspect top of plate for cracks or distortion. Replace plate if damaged.
- (4) Inspect lockpin holes in plate. New pins must fit tightly. Replace plate if new pins are not tight.
- (5) Inspect all parts for breaks, cracks, bends, or other damage.
- (6) Replace all damaged parts.

Frame Maintenance Instructions (Cont)

c. Assembly.

- (1) Install one grease fitting (1) in each side of plate (2).

WARNING

Adhesives, solvents, and sealing compounds can burn easily, can give off harmful vapors, and are harmful to skin and clothing. To avoid injury or death, keep away from open fire and use in well-ventilated area. If adhesive, solvent, or sealing compound gets on skin or clothing, wash immediately with soap and water.

- (2) Apply antiseize compound to lockpin holes in plate (2).
- (3) Position lockjaws (3) in plate (2) with large recessed diameter facing plate.
- (4) Soldier A and Soldier B install lockpins (4) through plate (2) and lock jaws (3) from top surface
- (5) Install two cotter pins (5) in lockpins (4).
- (6) Place 2-in. (51 mm) diameter locktester plug (6) in lockjaws (3).
- (7) Install yoke (7) in plate (2) around lockjaws (3). Ends of yoke must come to ends of lockjaws.
- (8) Remove locktester plug (6).

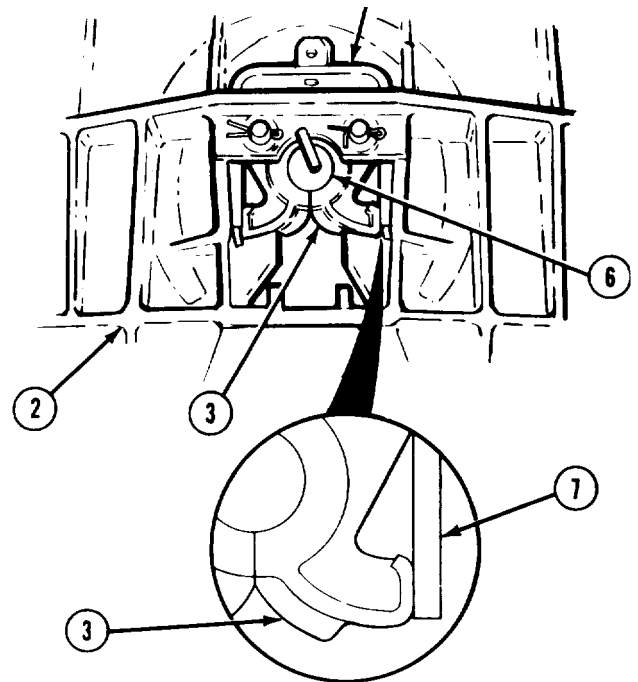
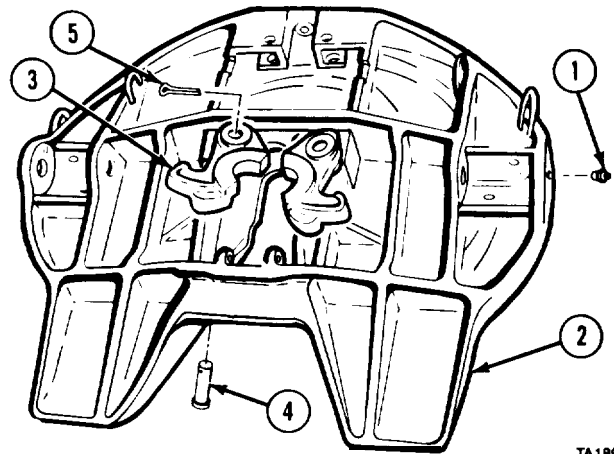

Frame Maintenance Instructions (Cont)

13-34. FIFTH WHEEL REPAIR - 2-INCH (51 MM) KINGPIN (M983) (CONT).

- (9) Install spring (8), secondary release lever (9), and roll pin (10).
- (10) Install spring (11) on yoke (7).
- (11) Insert yoke shank (12) through plate (2) and spring (11) with recess in yoke shank alined with hole in yoke (7).
- (12) Install rubber block (13), washer (14), and nut (15) on end of yoke shank (12). Do not tighten nut.

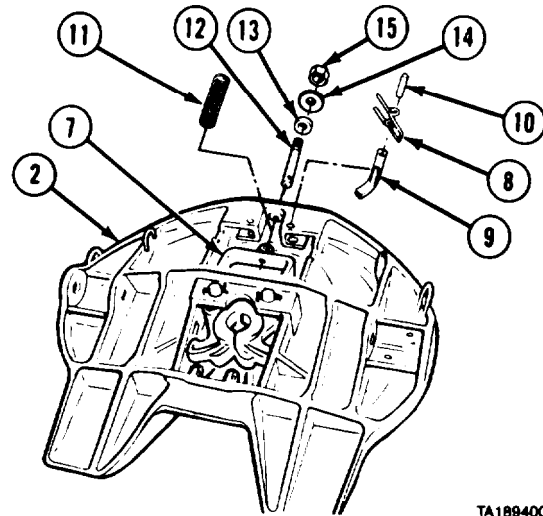

- (13) Install washer (16), spring (17), and washer (18) on release handle (19).
- (14) Install release handle (19) in hole in plate (2), handle end first.

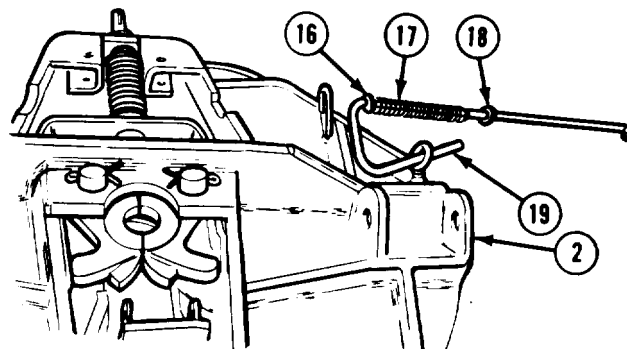

- (15) Install end of release handle (19) in cam plate (20).
- (16) Install washer (21) under cam plate (20).
- (17) Install roller (22) in cam plate (20) on washer (21).
- (18) Install washer (23) on screw (24).
- (19) Install screw (24) through roller (22) and washer (21) and into yoke (7). Do not tighten.

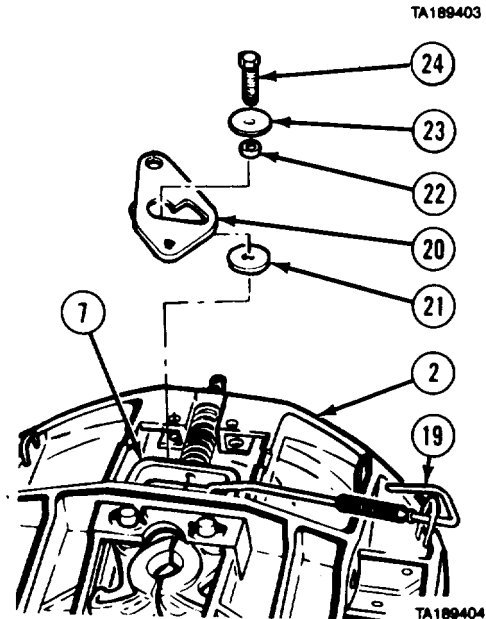

Frame Maintenance Instructions (Cont)

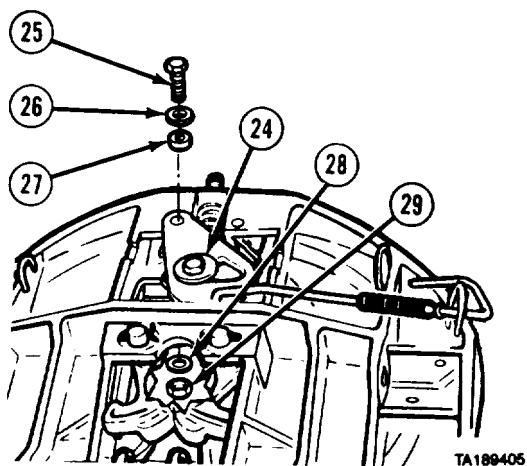

NOTE

Cam plate pivots on plate from front left mounting hole.

- (20) Install screw (25), washer (26), roller (27), washer (28), and nut (29).
- (21) Tighten screw (24) and nut (29).

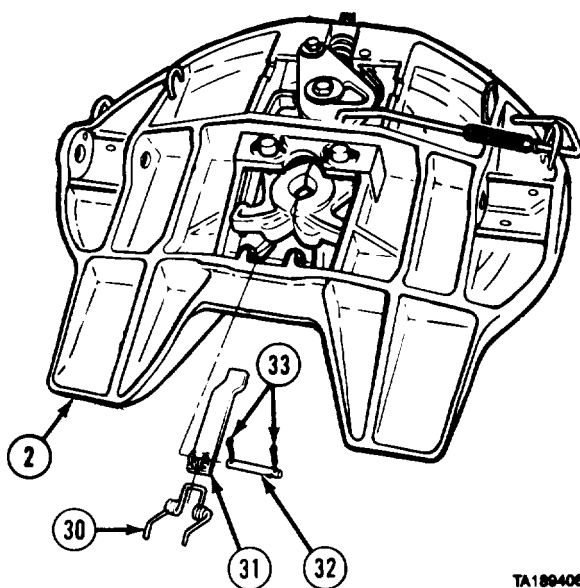

- (22) Attach tension spring (30) to lock guard (31) with bend toward top surface of plate (2).
- (23) Install pin (32) through plate (2) and lock guard (31).
- (24) Install two cotter pins (33).

Frame Maintenance Instructions (Cent)

[13-34. FIFTH WHEEL REPAIR - 2-INCH (51 MM) KINGPIN (M983) (CONT). {

- (25) Soldier A and Soldier B turn plate (2) over.
- (26) Place kingpin (34) of lock tester in open lockjaws (3).
- (27) Place lever (35) over front of plate (2).
- (28) Push down on kingpin (34) and pull lever (35) to lock fifth wheel.
- (29) Check that ends of yoke (7) are flush with ends of lockjaws (3).

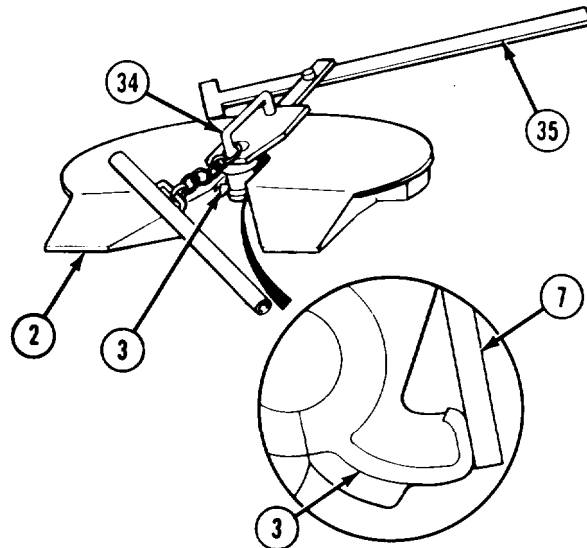

TA189407

- (30) Tighten or loosen nut (15) until rubber washer (14) seats snugly against fifth wheel when lockjaws (3) are closed on kingpin (34) of lock tester.
- (31) Turn nut (15) counterclockwise to allow yoke (7) to move in and tighten lockjaws (3) on kingpin (34).
- (32) Turn nut (15) clockwise to pull yoke (7) out of loosened lockjaws (3).

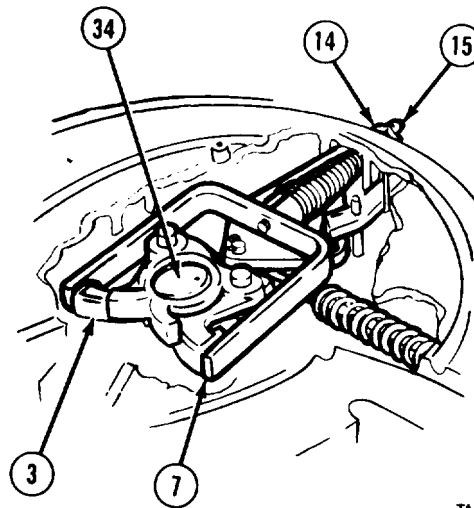

TA189408

- (33) Position bar (36) against fifth wheel cross tie (37) and pry toward rear to open lockjaws (3) and release kingpin (34).
- (34) Repeat steps (25) through (32) to verify adjustment.

d. Follow-on Maintenance. None.

END OF TASK

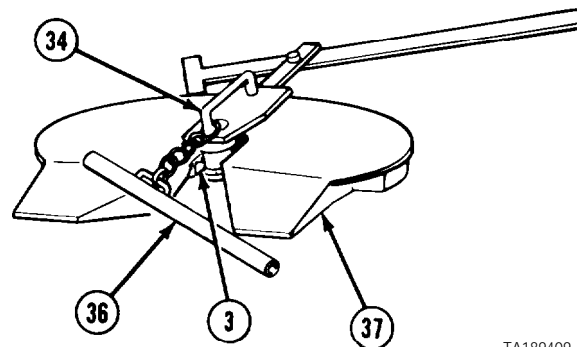

TA189409

Frame Maintenance Instructions (Cont)

13-35. FIFTH WHEEL REPAIR – 3.5-INCH (89 MM) KINGPIN (M983).		
This task (covers:		
a. Disassembly	c. Assembly	
b. Cleaning/Inspection	d. Follow-on Maintenance	
INITIAL SETUP		
MODELS M983 without crane	References None	
Test Equipment None	Equipment Conditions	
Special Tools Lock Tester 3.5-Inch TFTLN 1500	TM or Para	Condition Description Fifth wheel on clean work surf ace.
Supplies Solvent, dry cleaning, Item 57, Appendix C Compound, antiseize, Item 17, Appendix C	Special Environmental Conditions None	
Personnel Required MOS 63W, Wheel vehicle repairer (2)	General Safety Instructions None	
	Level Maintenance General Support	

a. Disassembly.

- (1) Move jaws to closed position.
- (2) Remove cotter pin (1) and secondary lock release handle (2) from plate (3).
- (3) Remove cotter pin (4), lockpin (5), secondary jaw (6), and spring (7) from plate (3).
- (4) Remove cotter pin (8), lockpin (9), hinged lock (10), and U-spring (11) from center of plate (3).

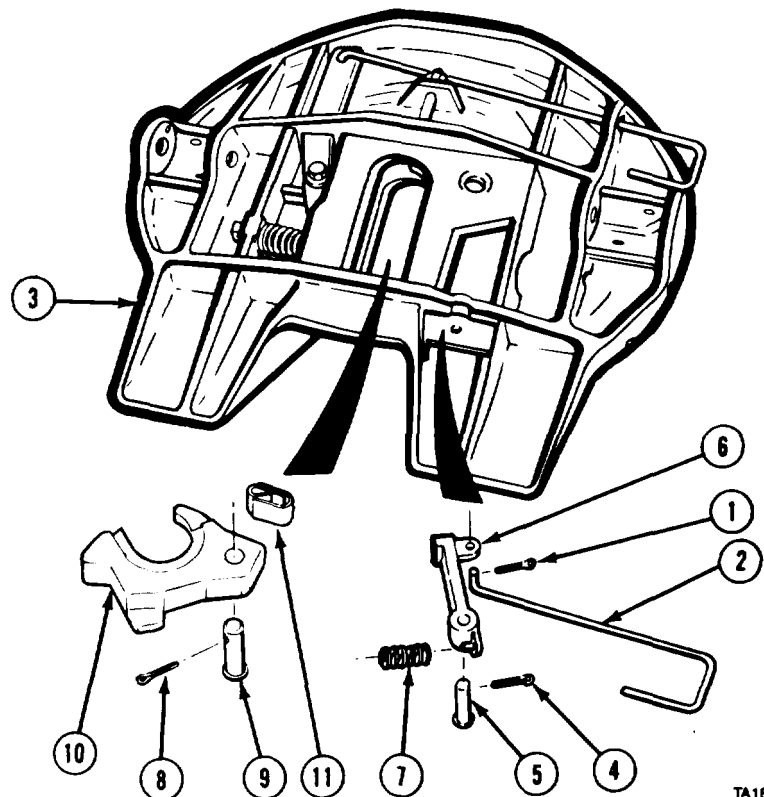

TA189353

Frame Maintenance Instructions (Cent)

[13-35. FIFTH WHEEL REPAIR - 3.5-INCH (89 MM) KINGPIN (M983) (CONT). I

- (5) Wedge plunger (12) in held-back position.
- (6) Remove screw (13), two washers (14), nut (15), release lever (16), and release handle (17).

WARNING

Spring and plunger are under tension. Release slowly to prevent personal injury.

- (7) Remove plunger (12) and spring (18).
- [8] Remove screw (19), spring (20), adjusting wedge (21), and locknut (22) from plate (3).
- (9) Remove nut (23) and stationary jaw (24) from plate (3).
- (10) Remove grease fitting (25) from each side of plate (3).

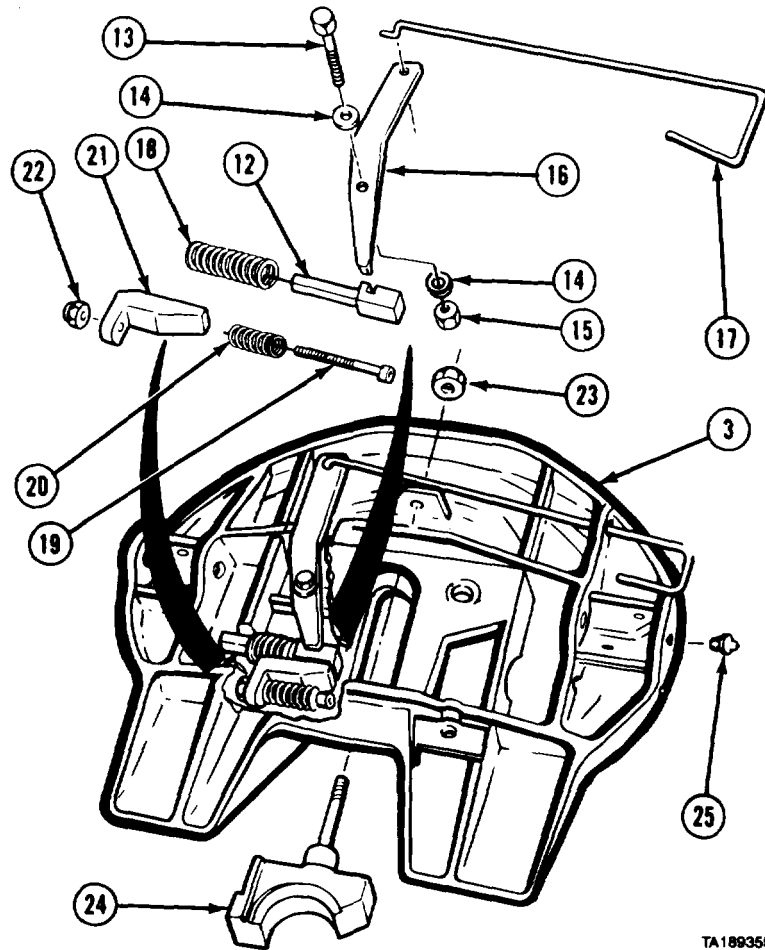

TA189355

b. Cleaning/Inspection.

WARNING

Adhesives, solvents, and sealing compounds can burn easily, can give off harmful vapors, and are harmful to skin and clothing. To avoid injury or death, keep away from open fire and use in well-ventilated area. If adhesive, solvent, or sealing compound gets on skin or clothing, wash immediately with soap and water.

- (1) Clean all metal parts with dry cleaning solvent.
- (2) Remove corrosion from bare metal.
- (3) Inspect top of plate for cracks or distortion.
- (4) Inspect lockpin holes in plate, New pins must fit tightly. Replace plate if new pins are not tight.
- (5) Inspect all parts for damage.
- (6) Replace all damaged parts.

Frame Maintenance Instructions (Cont)

c. Assembly.

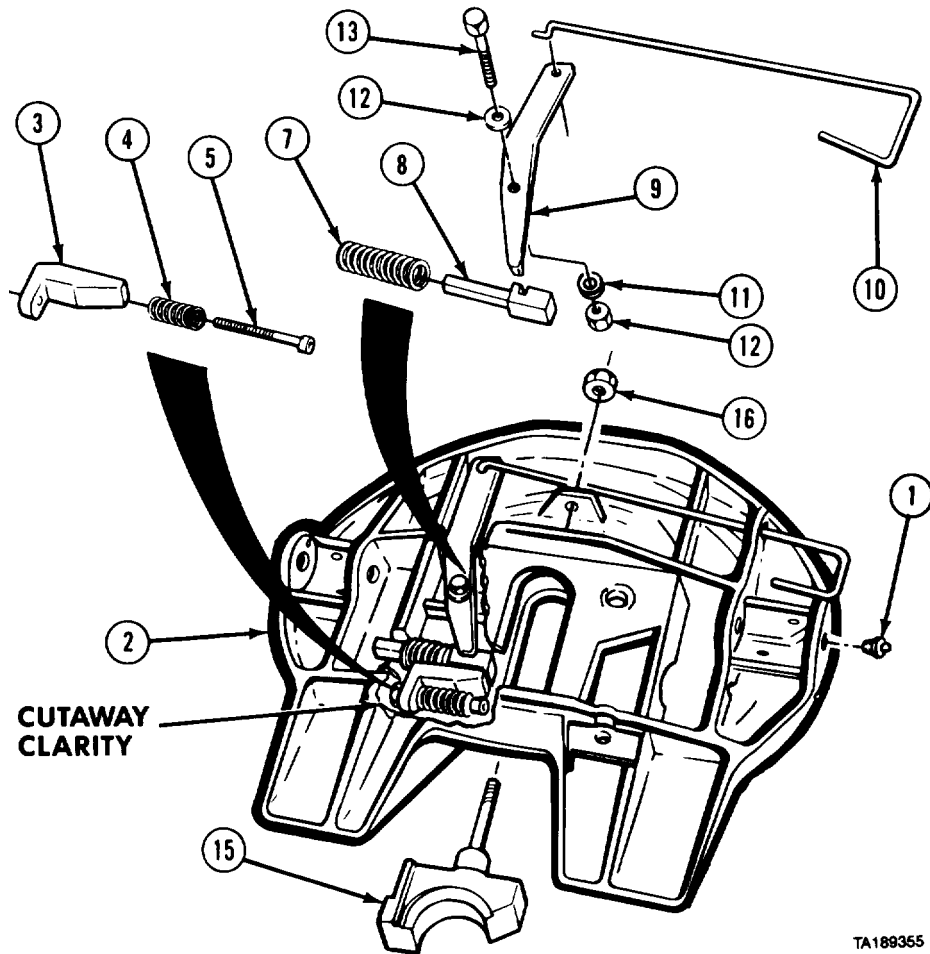

TA189355

- (1) Install one grease fitting (1) in each side of plate (2).
- (2) Install adjusting wedge (3), spring (4), screw (5), and locknut (6). Tighten shows out of locknut.

WARNING

Spring and plunger are under tension. Handle carefully to avoid personal injury.

- (3) Soldier A and Soldier B install spring (7) and plunger (8).
- (4) Install release handle (9) in plate (2).
- (5) Install release lever (10) on release handle (9).

NOTE

Release lever must move freely. Do not overtighten.

- (6) Install washer (11) between release lever (10) and plate (2).
- (7) Install release lever (10) into slot in plunger (8).
- (8) Install washer (12) on screw (13) and insert through release lever (10) into hole in plate (2).
- (9) Install nut (14) on screw (13).
- (10) Install stationary jaw (15) in center of plate (2).
- (11) Install nut (16) on stationary jaw (15).
- (12) Soldier A and Soldier B turn plate (2) over.

Frame Maintenance Instructions (Cont)

13-35. FIFTH WHEEL REPAIR — 3.5-INCH (89 MM) KINGPIN (M983) (CONT).

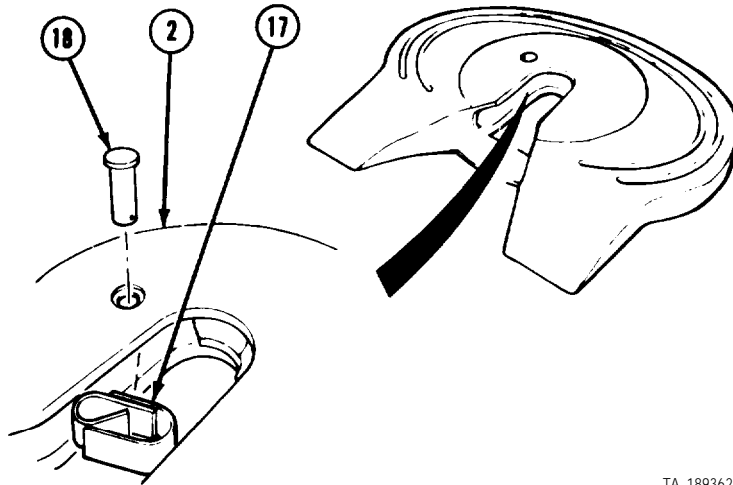

TA 189362

(13) Install U-spring (17) in center of plate (2).

WARNING

Adhesives, solvents, and sealing compounds can burn easily, can give off harmful vapors, and are harmful to skin and clothing. To avoid injury or death, keep away from open fire and use in well-ventilated area. If adhesive, solvent, or sealing compound gets on skin or clothing, wash immediately with soap and water.

(14) Apply antiseize compound to lockpin hole in plate (2).

(15) Start lockpin (18) in hole in plate (2).

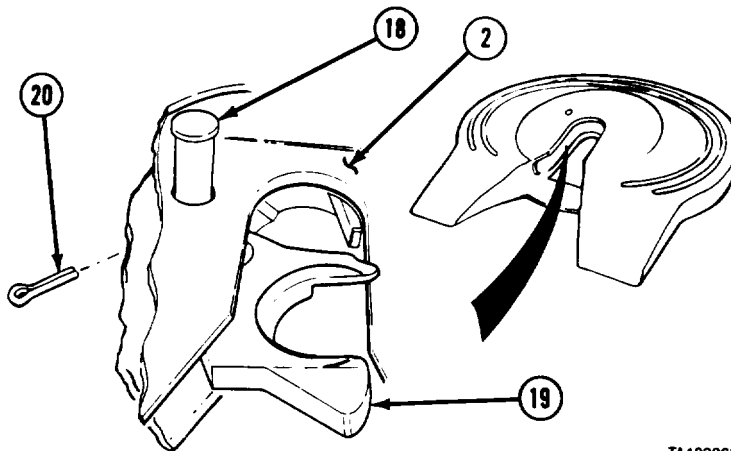

TA 189363

(16) Install hinged lock (19) in center of plate (2).

(17) Soldier A and Soldier B install lockpin (18) through hinged jaw (19) and plate (2).

(18) Soldier A and Soldier B turn plate on edge and install cotter pin (20) in lockpin (18).

Frame Maintenance Instructions (Cont)

- (19) Install release handle (21) in plate (2) and apply antiseize compound to secondary lockpin hole.
- (20) Install secondary lock (22) on release handle (21).
- (21) Install cotter pin (23) in release handle (21).
- (22) Install secondary lockpin (24) and cotter pin (25).
- (23) Soldier A and Soldier B lay plate (2) upside down.
- (24) Lock hinged jaw (19) with secondary lock (22).
- (25) Compress and install spring (26) in plate (2).

WARNING

Improper adjustment can cause improper locking of the mechanism and result in personal injury.

- (26) Soldier A and Soldier B turn plate (2) right side UP, or on edge as needed, to make adjustment.

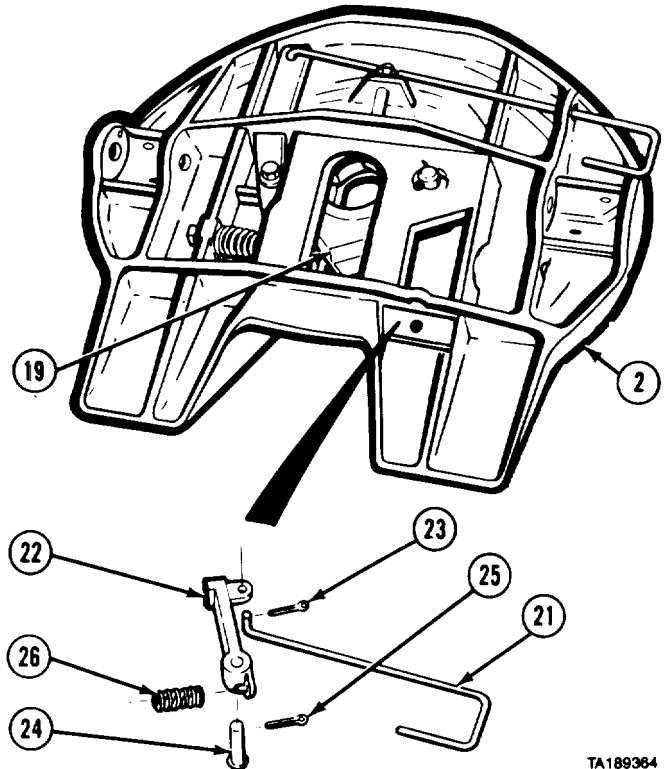

TA189364

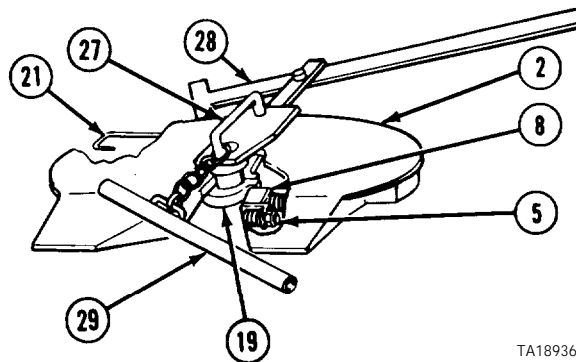

TA189366

- (27) Place kingpin (27) of lock tester in open jaw.
- (28) Place lever (28) over front of plate (2).
- (29) Push down on kingpin (27) and pull lever (28) to lock fifth wheel.
- (30) Tighten or loosen screw (5) to provide 0.040-in. (1 mm) clearance between plunger (8) and hinged jaw (19).
- (31) Place bar (29) against fifth wheel cross tie. While prying toward rear with bar to open hinged jaw (19), pull release handle (21) and remove jaw tester.

d. Follow-on Maintenance. None.

END OF TASK

CHAPTER 14 SUSPENSION MAINTENANCE

Contents	Para	Page
General	14-1	14-1
Spring Removal/Repair/Installation	14-2	14-1
Deleted	14-3	
Lateral Torque Rod Removal/Installation	14-4	14-11
Equalizer Beam Assembly (Front Tandem) Removal/Repair/Installation	14-5	14-14
Equalizer Beam Assembly (Rear Tandem) Removal/Repair/Installation	14-6	14-20
Equalizer Beam Assembly (Rear Tandem) Removal/Installation (M984E1)	14-6.1	14-23
Equalizer Beam Assembly (Rear Tandem) Repair (M984E1)	14-6.2	14-25
Rear Tandem Suspension Alinement	14-7	14-30

Section I. INTRODUCTION

14-1. GENERAL. {This chapter contains maintenance instructions for removal, installation, and repair of the suspension components at the direct support and general support maintenance level. Subassemblies and parts which must be removed before suspension components can be removed are referenced to other paragraphs of this manual or TM 9-2320-279-20.

Section II. SPRING ASSEMBLY

Suspension Maintenance Instructions

14-2. SPRING REMOVAL/REPAIR/INSTALLATION.	
This task covers:	
<ul style="list-style-type: none"> a. Front Spring Removal b. Rear Spring Removal (M984E1) c. Front and Rear Spring Disassembly d. Cleaning/Inspection 	<ul style="list-style-type: none"> e. Front and Rear Spring Assembly f. Front Spring Installation g. Rear Spring Installation (M984E1) h. Follow-on Maintenance
INITIAL SETUP	
<i>Models</i>	<i>Equipment Condition</i>
All	<i>TM or Para</i>
<i>Test Equipment</i>	<i>Condition Description</i>
None	TM 9-2320-279-10 Wheel assemblies removed.
<i>Specials Tools</i>	TM 9-2320-279-20 Axle No. 4 shock absorbers removed (when removing rear springs only).
None	<i>Special Environmental Conditions</i>
<i>Supplies</i>	None
Oil, lubricating, Item 46, Appendix C	<i>General Safety Instructions</i>
Preventive, rust, Item 53, Appendix C	Wheels chocked
Solvent, dry cleaning, Item 57, Appendix C	<i>Level of Maintenance</i>
<i>Personnel Required</i>	Direct Support
MOS 63W, Wheel vehicle repairer (2)	
<i>References</i>	
None	

Suspension Maintenance Instructions (Cont)

14-2. SPRING REMOVAL/REPAIR/INSTALLATION (CONT).

a. Front Spring Removal.

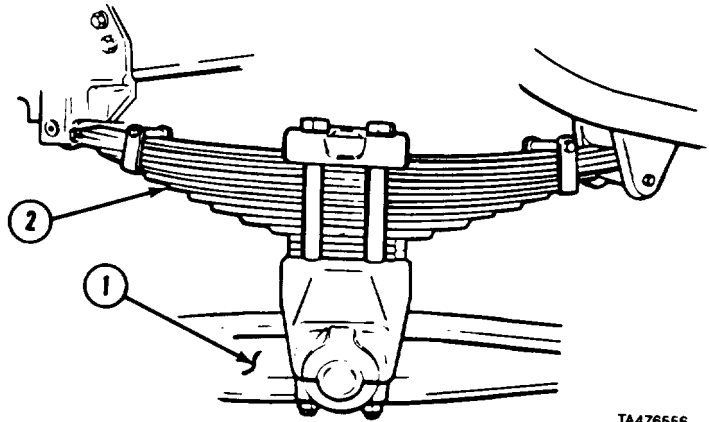
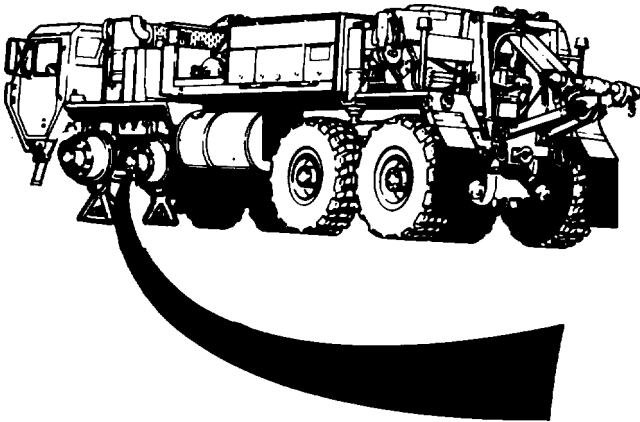

TA476556

WARNING

Make sure vehicle is securely supported before removing springs. If vehicle falls, serious personal injury or death may result.

NOTE

Front and rear springs are removed the same on all models except for M984E 1. Front spring is shown.

- (1) Raise vehicle with suitable lifting device so there is at least 40 in. (102 cm) clearance between frame and ground.
- (2) Position supports under frame.
- (3) Lower vehicle on supports.
- (4) Position lifting device under equalizer beam (1).
- (5) Raise lifting device until weight is off spring (2).

- (6) Remove two locknuts (3), four washers (4), and two screws (5).
- (7) Remove grease fitting (6).
- (8) Remove pin (7).
- (9) Remove locknut (8), screw (9), and spacer (10).

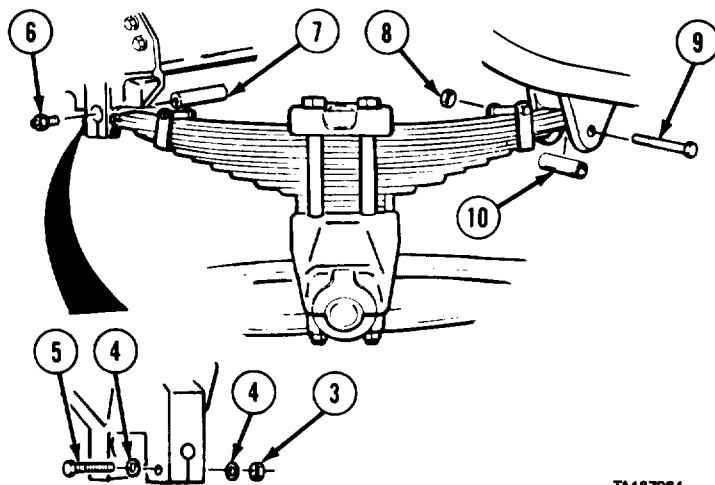

TA187964

Suspension Maintenance Instructions (Cont)

- (10) Loosen two nuts (11) and remove two screws (12), nuts (11) and lockwashers (13).
- (11) Soldier A removes four nuts (14) and washers (15) while Soldier B holds four screws (16).
- (12) Position supports under each end of equalizer beam (1) to allow equalizer beam to be lowered.
- (13) Lower equalizer beam (1) on supports.
- (14) Remove four screws (16), washers (17) and saddle cap (18).
- (15) Soldier A and Soldier B remove spring (2).

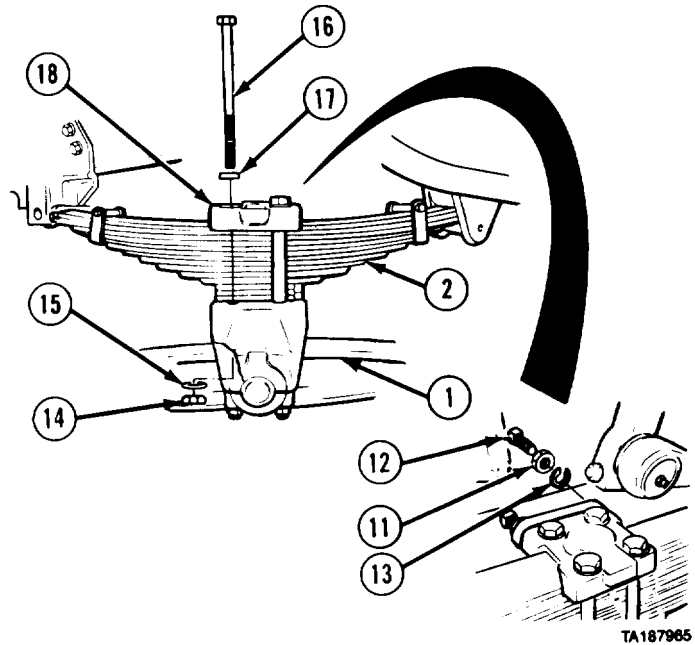

TA187965

b. Rear Spring Removal (M984EI).

WARNING

Make sure vehicle is securely supported before removing springs. If vehicle falls, it will cause serious injury or death.

- (1) Raise vehicle with suitable lifting device until weight is off springs (1).
- (2) Remove two locknuts (2), four washers (3), and two screws (4).
- (3) Remove grease fitting (5).
- (4) Remove pin (6).
- (5) Remove locknut (7), screw (8), and spacer (9).

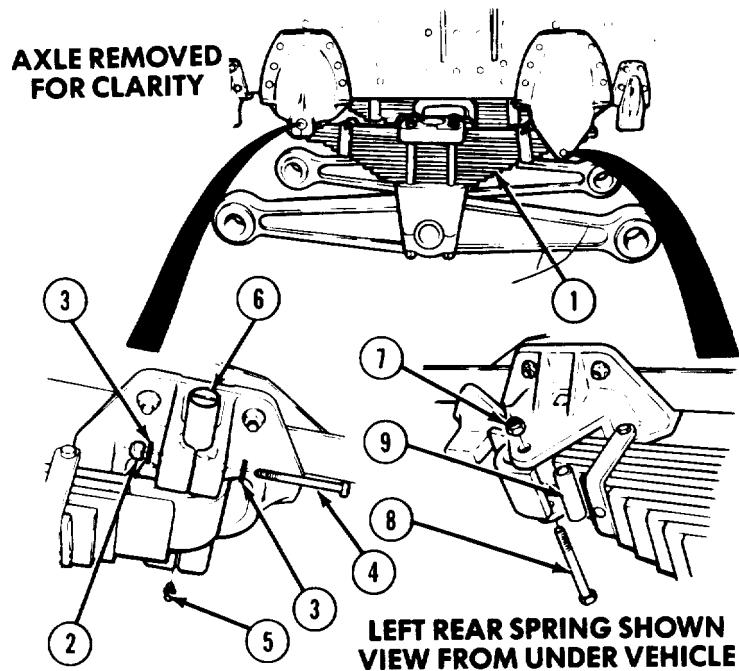

LEFT REAR SPRING SHOWN VIEW FROM UNDER VEHICLE

TA476203

Suspension Maintenance Instructions (Cont)

14-2. SPRING REMOVAL/REPAIR/INSTALLATION(CONT.)

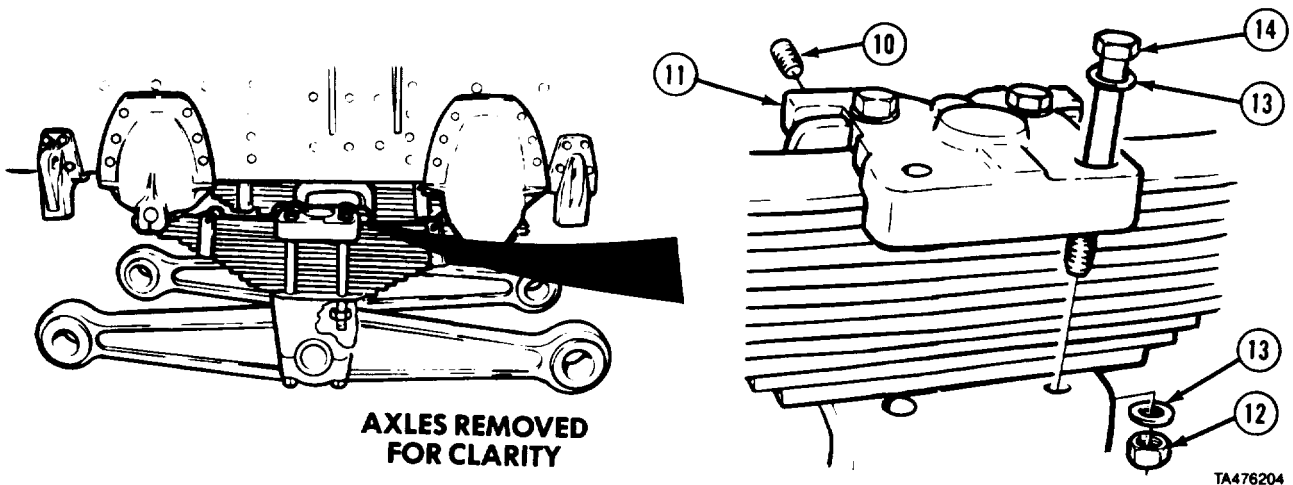

- (6) Remove two setscrews (10) from saddle cap (11).
- (7) Soldier A removes four nuts (12) and washers (13) while Soldier B holds four screws (14). Remove two screws and washers from saddle cap (11).

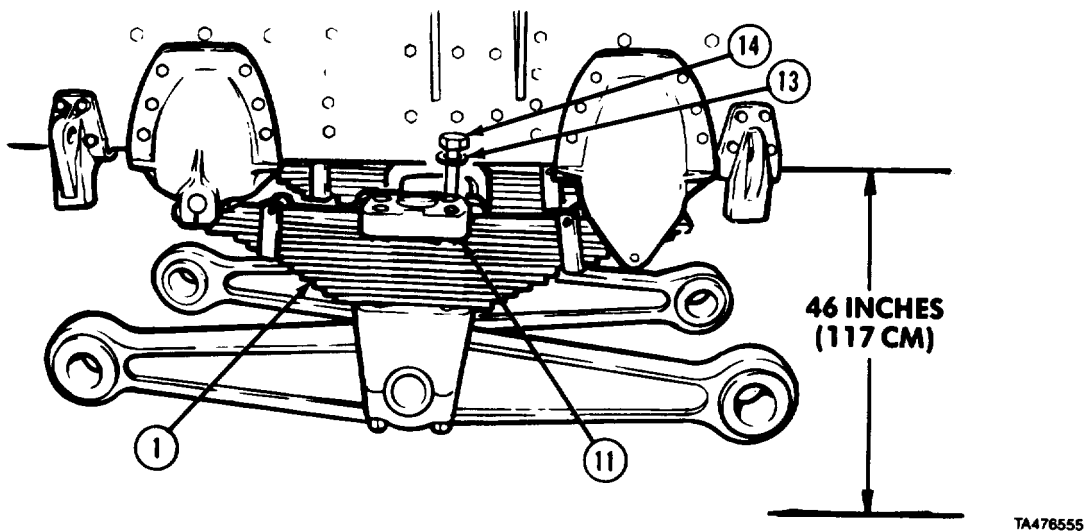

WARNING

Make sure vehicle is sufficiently supported before removing springs. If vehicle falls, it will cause serious injury or death.

- (8) Raise vehicle with suitable lifting device so there is at least 46 in. (117 cm) clearance between frame and ground.
- (9) Position supports under frame.
- (10) Lower vehicle onto supports.
- (11) Attach suitable lifting device to spring (1).
- (12) Soldier A and Soldier B remove spring (1).
- (13) Remove saddle cap (11), two screws (14) and washers (13) from spring (1).

Suspension Maintenance Instructions (Cont)

c. Front and Rear Spring Disassembly

NOTE

Spring for M977 shown. Other springs similar. M1977-CBT rear springs do not have clips,

- (1) Remove two nuts (1), screws (2), and spacers (3).

WARNING

Spring is compressed under pressure and could cause injury if not disassembled carefully

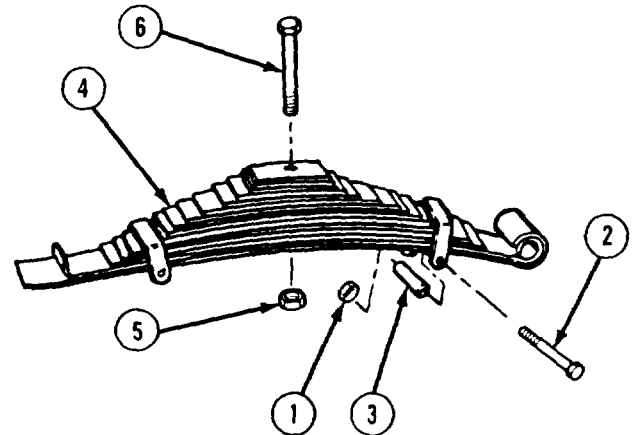

NOTE

Some spring assemblies have screws with round heads.

- (2) Compress spring (4), remove nut (5), and screw (6).
- (3) Disassemble spring (4) and lay out all plates.
- (4) Remove main plate (7) from wrapper plate (8).

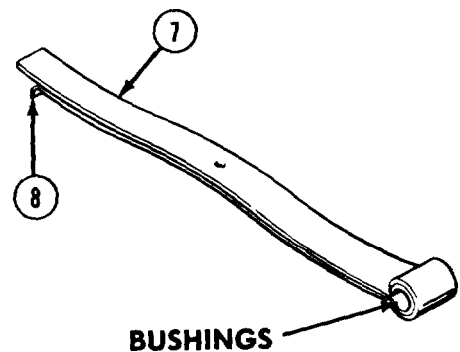

d. Cleaning/Inspection.

- (1) Inspect screws and nuts for damaged threads. Inspect screws for wear on shaft. Replace screws and nuts if worn or damaged.

WARNING

Adhesives, solvents, and sealing compounds can burn easily, can give off harmful vapors, and are harmful to skin and clothing. To avoid injury or death, keep away from open fire and use in well-ventilated area. If adhesive, solvent, or sealing compound gets on skin or clothing, wash immediately with soap and water.

- (2) Clean spring plates with drycleaning solvent and cloth.
- (3) Inspect spring plates for cracks and breaks. If any plates other than main, wrapper, or No. 3 spring plates are cracked or broken, replace entire spring assembly.
- (4) Inspect spring eye bushings for breaks or worn-out condition. If bushings are broken or worn-out, replace main plate.
- (5) Replace all cracked or broken parts.

Suspension Maintenance Instructions (Cont)

14-2. SPRING REMOVAL/REPAIR/INSTALLATION (CONT).

e. Front and Rear Spring Assembly.

NOTE

Coat all plates with rust preventive.

- (1) Install main plate (1) on wrapper plate (2).

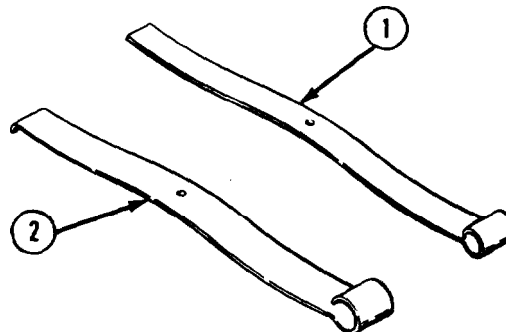

- (2) Turn spring plates (1 and 2) over.

NOTE

No. 6 plate on M984E1 rear springs has clips.
 No. 7 plate on M985 and M985E1 rear springs has clips. M1977-CBT rear springs do not have clips. After installing plates and clips, do step (4).

- (3) Position spring plates (3 and 4) and plate and clip (5) on plates (1 and 2).
- (4) Aline holes in spring plates (1, 2, 3,4, and 5) so screw (6) can be inserted and taken out easily.
- (5) Remove screw (6).

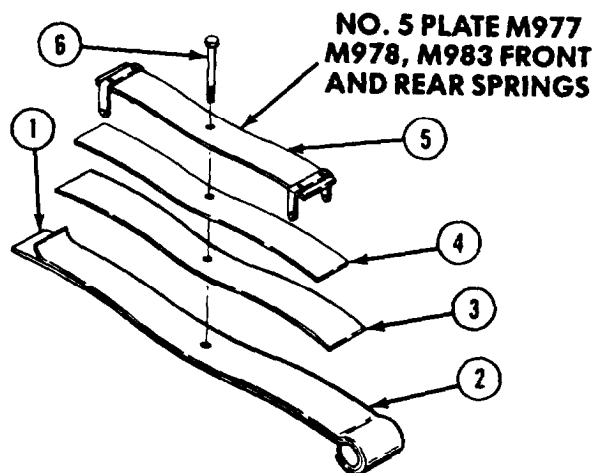

Suspension Maintenance Instructions (Cont)

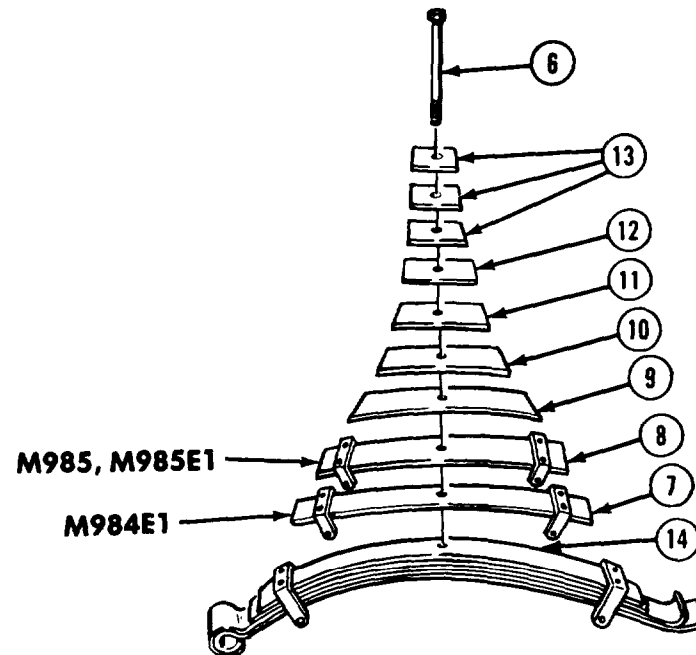

NOTE

- M977, M978, and M983 have 11 spring leaves and 3 spacer plates.
 - M1977-CBT has 10 spring leaves and no spacer plates.
 - M984, M985 and M985E1 have 12 spring plates and 3 spacer plates.
 - M984E1 has 12 spring plates.
- (6) Position spring plates (7,8,9,10,11, and 12) and three spacer plates (13) on spring assembly (14).
 - (7) Align holes in spring assembly (14), spring plates (7 through 12), and spacer plates (13) and install screw (6).
 - (8) Compress spring assembly (14). Install nut (15) and tighten to 65 to 75 lb-ft (88 to 102 N•m).
 - (9) Install two spacers (16), screws (17), and nuts (18).

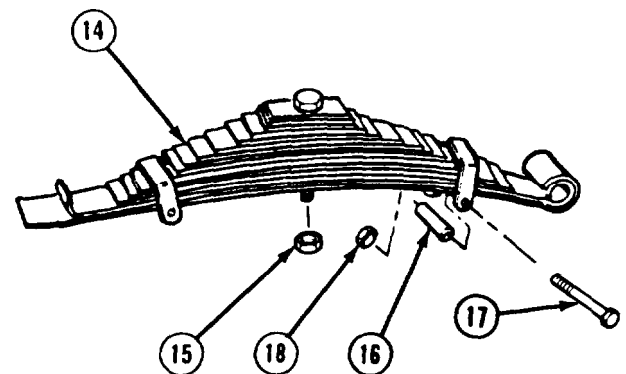

Suspension Maintenance Instructions (Cont)

14-2. SPRING REMOVAL/REPAIR/INSTALLATION (CONT).

f. Front Spring Installation.

NOTE

Front and rear springs are installed the same on all models except M984E1. Front spring is shown

- (1) Soldier A and Soldier B install spring (1).
- (2) Coat threads of four screws (2) with lubricating oil. Install saddle cap (3), four screws, and washers (4).
- (3) Install four washers (5) and nuts (6). Do not tighten nuts.
- (4) Coat threads of two screws (7) with lubricating oil. Install two locknuts (8) and lockwashers (9) on screws. Install and tighten screws to 150 lb-ft (203 N•m). Tighten locknuts.

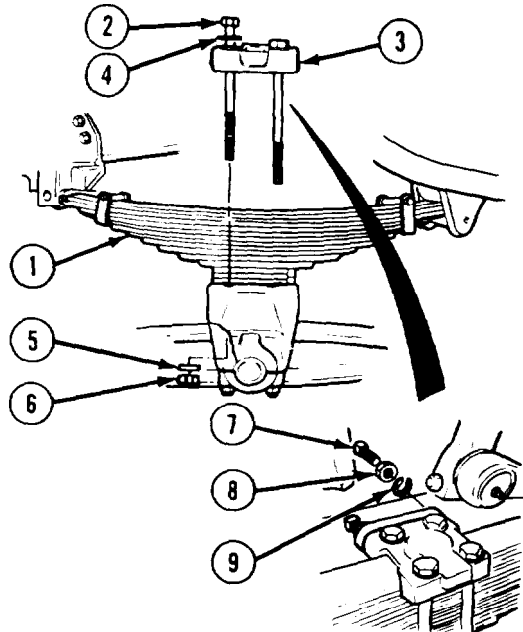

- (5) Install screw (10), spacer (11), and locknut (12).
- (6) Install pin (13).
- (7) Install two screws (14), four washers (15), and two locknuts (16).
- (8) Install grease fitting (17).
- (9) Soldier A and Soldier B tighten screws (2) and nuts (6) to 300 lb-ft (407 N•m).

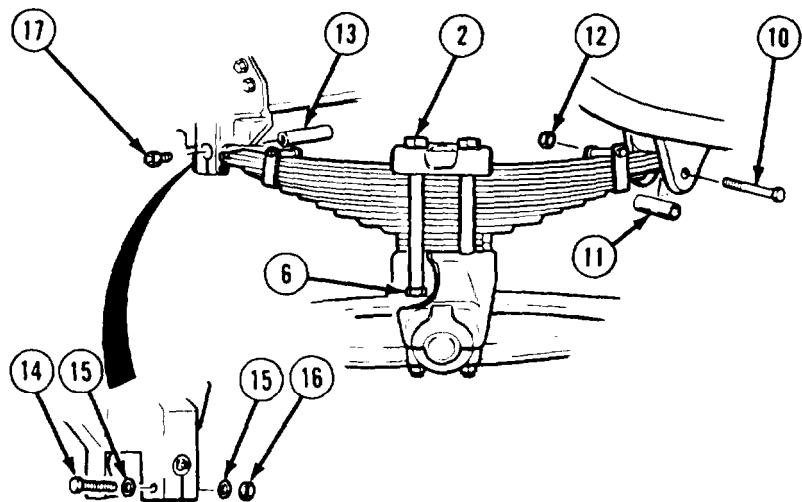

Suspension Maintenance Instructions (Cont)

- (10) Raise lifting device under equalizer beam (18) enough to allow removal of supports under frame.

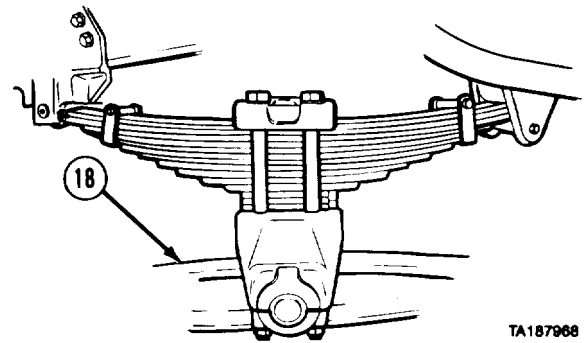

TA187968

9. Rear Spring Installation (M984E1).

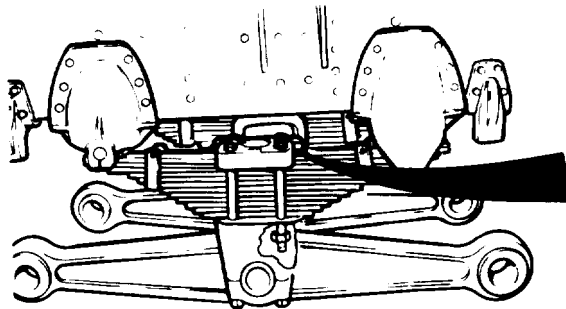

AXLES REMOVED
FOR CLARITY

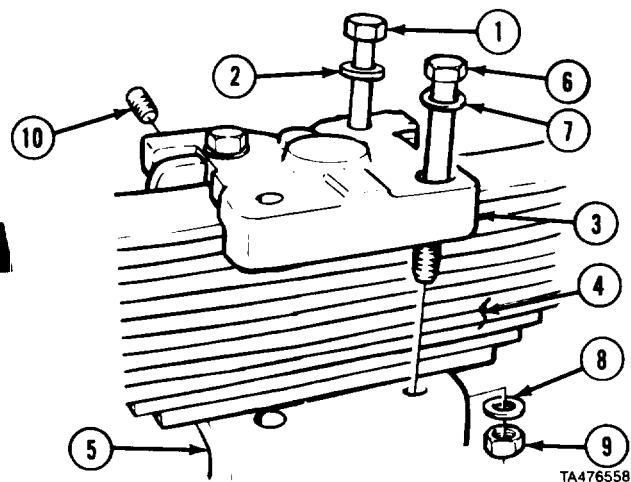

TA476558

- (1) Coat threads of two screws (1) with lubricating oil. Install screws and two washers (2) in saddle cap (3).
- (2) Position saddle cap (3) and screws (1) on spring (4).
- (3) Attach suitable lifting device to spring (4).
- (4) Soldier A and Soldier B position spring (4) on saddle (5).
- (5) Coat threads of two screws (6) with lubricating oil. Install screws and two washers (7) in saddle cap (3) and saddle (5).
- (6) Soldier A installs four washers (8) and nuts (9) on screws (1 and 6) while Soldier B holds screws. Do not tighten.
- (7) Coat threads of two setscrews (10) with lubricating oil. Install setscrews. Tighten setscrews to 150 lb-ft (203 N-m).

Suspension Maintenance Instructions (Cont)

I 14-2. SPRING REMOVAL/REPAIR/INSTALLATION (CONT). I

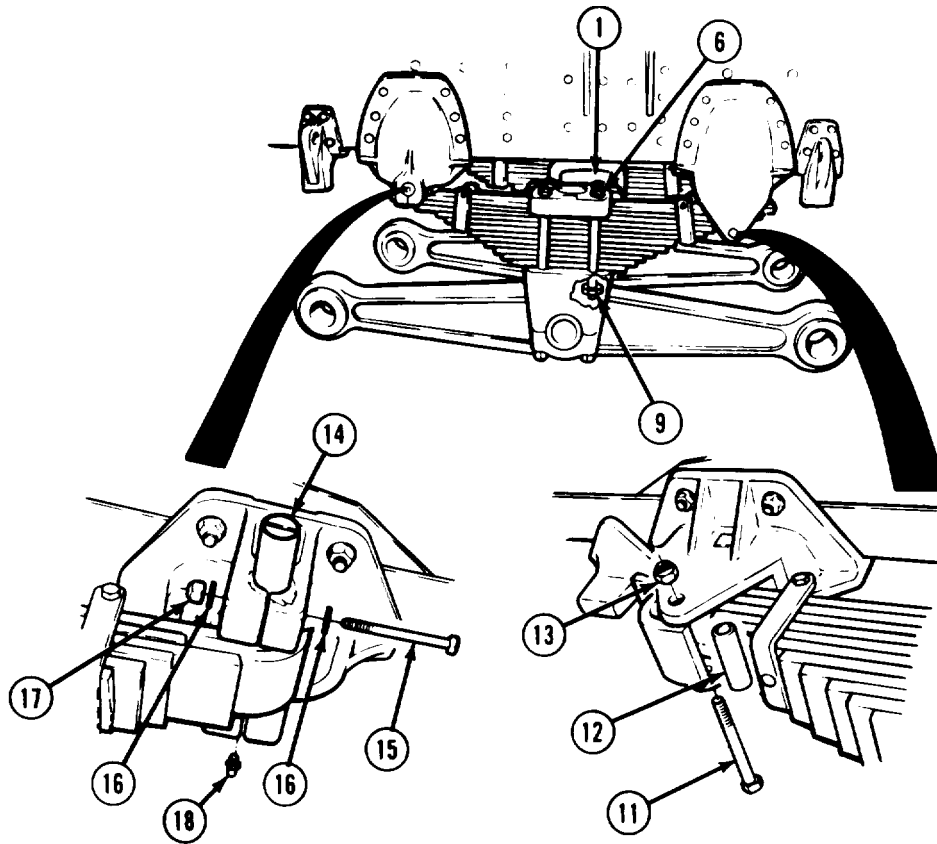

TA476560

(8) Install screw (11), spacer (12), and locknut (13).

NOTE

Slot in pin faces down.

(9) Install pin(14).

(10) Install two screws (15), four washers (16), and two locknuts (17).

(11) Install grease fitting (18).

NOTE

Use cross pattern when tightening screws.

(12) Soldier A and Soldier B tighten screws (land 6)and nuts (9)to300 lb-ft(406Nm).

(13) Remove lifitng device.

h. Follow-on Maintenance.

(1) Install wheel assemblies (TM 9-2320-279-10).

(2) Remove wheel chocks (TM 9-2320-279-10).

(3) Install shock absorbers (TM 9-2320-279-20).

END OF TASK

I 14-3. DELETED. I

Suspension Maintenance Instructions (Cont)

Section III. LATERAL TORQUE ROD AND EQUALIZER BEAMS

14-4. LATERAL TORQUE ROD REMOVAL/INSTALLATION.	
This task covers:	
a. Removal b. Installation	c. Follow-on Maintenance
INITIAL SETUP	
Models All	References None
Test Equipment None	Equipment Condition
Special Tools None	TM or Para Condition Description TM 9-2320-279-10 Shut off engine.
Supplies Oil, lubricating, Item 47, Appendix C Tags, identification, Item 60, Appendix C	Special Environmental Conditions None
Personnel Required MOS 63W, Wheel vehicle repairer	General Safety Instructions None
	Level of Maintenance Direct Support

a. Removal.

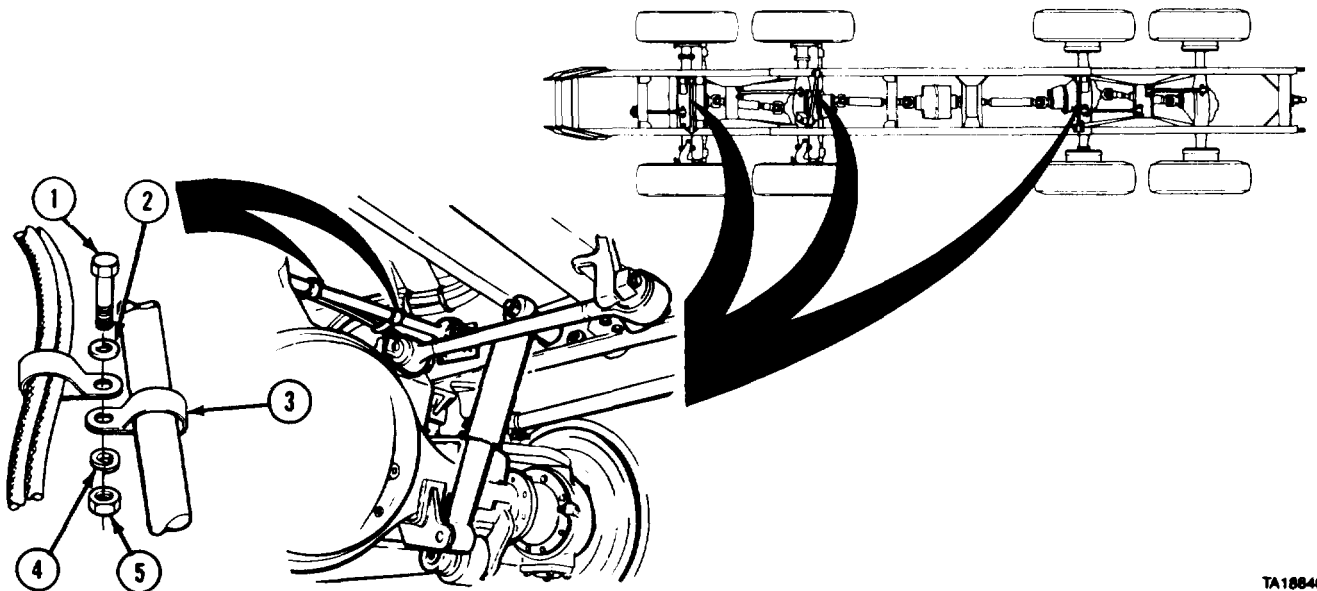

TA188404

NOTE

There are three lateral torque rods. Front lateral torque rod is shown. Step (1) applies to front lateral torque rod only.

- (1) Remove two screws (1), washers (2), clamps (3), lockwashers (4), and nuts (5).

Suspension Maintenance Instructions (Cont)

Section III. LATERAL TORQUE ROD AND EQUALIZER BEAMS

14-4. LATERAL TORQUE ROD REMOVAL/INSTALLATION.

This task covers:

- a. Removal
- b. Installation
- c. Follow-on Maintenance

INITIAL SETUP

Models
All

Test Equipment
None

Special Tools
None

Supplies
Oil, lubricating, Item 47, Appendix C
Tags, identification, Item 60, Appendix C

Personnel Required
MOS 63W, Wheel vehicle repairer

References
None

Equipment Condition
TM or Para Condition Description
TM 9-2320-279-10 Shut off engine.

Special Environmental Conditions
None

General Safety Instructions
None

Level of Maintenance
Direct Support

a. Removal.

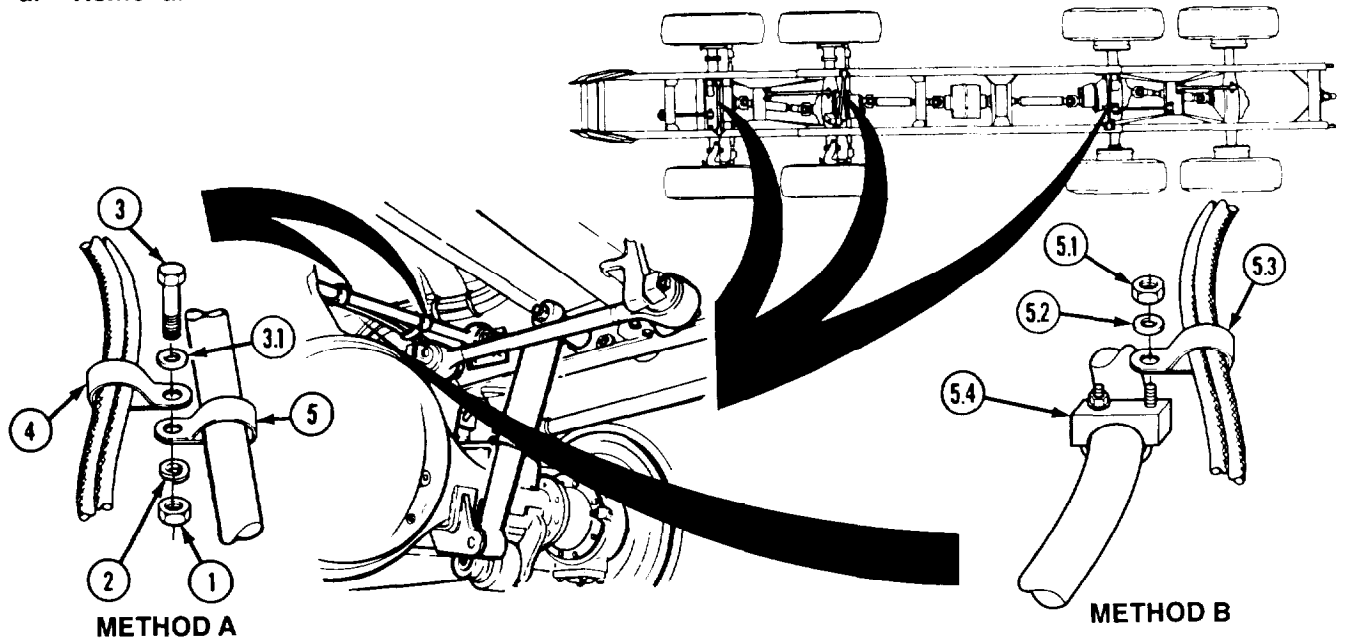

NOTE

- There are three lateral torque rods. Front lateral torque rod is shown
- There are two methods of attaching hoses to the front lateral torque rod. Do step (1) for method A. Do step (1.1) for method B.

(1) Remove two nuts (1), lockwashers (2), screws (3), washer (3.1), hose clips (4), and clamp (5).

(1.1) Remove four nuts (5.1), lockwashers (5.2), two hose clips (5.3), and clamps (5.4).

Suspension Maintenance Instructions (Cont)

14-4. LATERAL TORQUE ROD REMOVAL/INSTALLATION (CONT).

NOTE

M984E1 does not use washer.

- (2) Remove locknut (6) and washer (7) from stud (8).
- (3) Remove two locknuts (9) and washers (10).

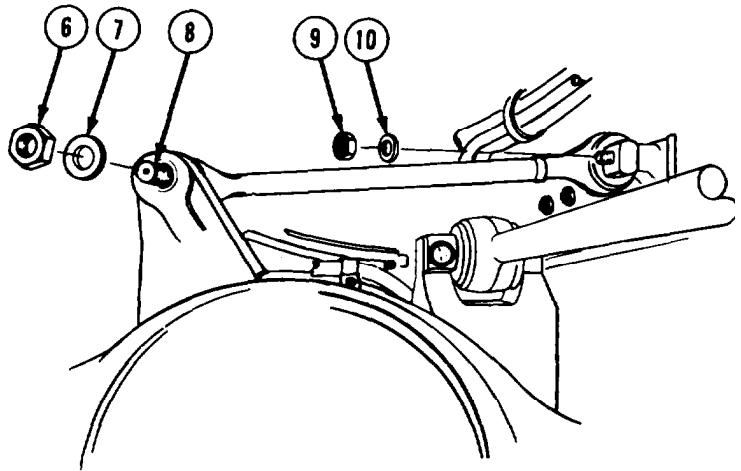

NOTE

- Second lateral torque rod has plate on M983 only.
- M984 and M984E1 do not use plate on third torque rod.
- Tag and mark shims and screws.

- (4) Remove screw (11), screw (12), washers (13), plate (14), bracket (15), and shims (16).

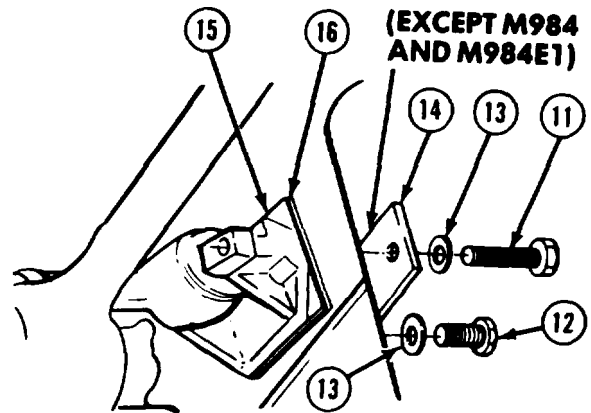

- (5) Remove lateral torque rod (17).

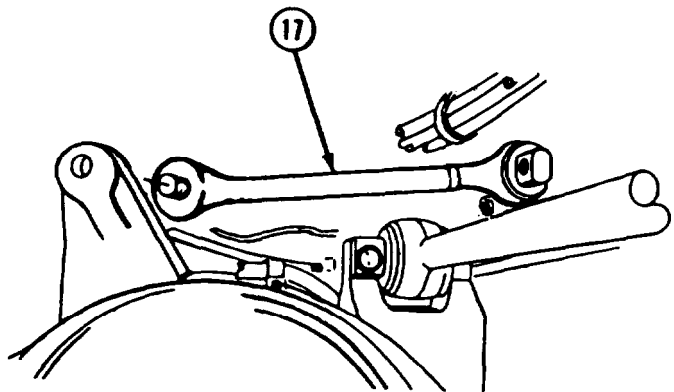

Suspension Maintenance Instructions (Cont)

b. Installation.

NOTE

- Second lateral torque rod has plate on M983 only.
 - M984 and M984E1 do not use plate on third torque rod.
- (1) Install shims (1), bracket (2), and plate (3) with two washers (4) and screws (5 and 6).

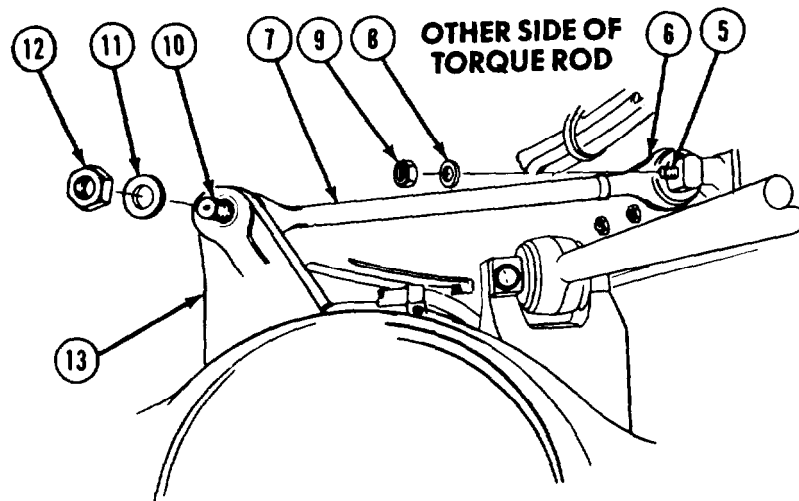
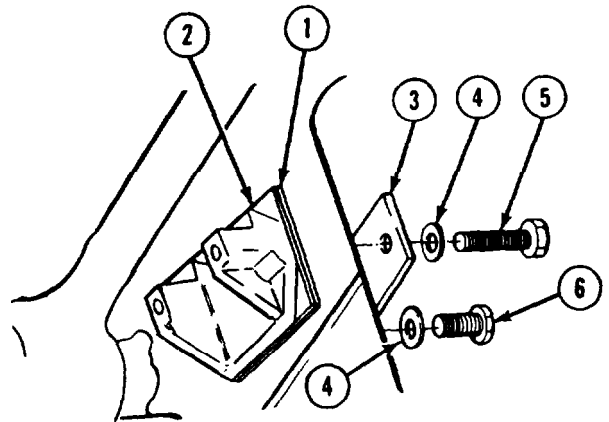

- (2) Install lateral torque rod (7).
- (3) Lubricate threads of two screws (5 and 6) with oil and install two washers (8) and locknuts (9) on screws. Do not tighten nuts.

NOTE

M984E1 does not use washer.

- (4) Lubricate threads of stud (10) with oil and install washer (11) and locknut (12) on stud. Tighten between 175 and 225 lb-ft (238 and 305 N•m).

NOTE

Axle bracket must be rapped with hammer to seat lateral torque rod.

- (5) Rap torque rod axle bracket (13) with hammer. Tighten locknut (12) between 175 and 225 lb-ft (238 and 305 N•m).
- (6) Tighten two locknuts (9).

Suspension Maintenance Instructions (Cont)

14-4. LATERAL TORQUE ROD REMOVAL/INSTALLATION (CONT).

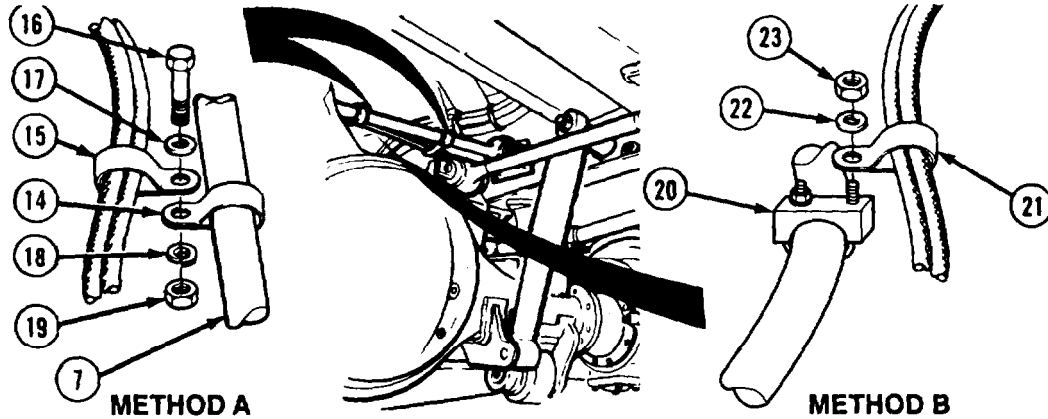

NOTE

- There are two methods of attaching hoses to the front lateral torque rod. Do step (7) for method A. Do step (8) for method B.
- Steps (7) and (8) apply to both methods.

(7) Install two clamps (14) and two hose clips (15) with two screws (16), washers (17), lockwashers (18), and nuts (19).

(8) Install two clamps (20) and two hose clips (21) with four lockwashers (22) and nuts (23).

c. Follow-on Maintenance. Aline all axles (para 14-7).

END OF TASK

14-5. EQUALIZER BEAM ASSEMBLY (FRONT TANDEM) REMOVAL/REPAIR/INSTALLATION.

This task covers:

- | | |
|------------------------|--------------------------|
| a. Removal | d. Assembly |
| b. Disassembly | e. Installation |
| c. Cleaning/Inspection | f. Follow-on Maintenance |

INITIAL SETUP

Models

All

Test Equipment

None

Special Tools

- Adapter, center bushing, removing Y-861
- Adapter, center bushing, installing Y-862
- Adapter, end bushing, replacing Y-855-A
- Clamp, adapter, end bushing Y-856

Supplies

- Grease, automotive and artillery, Item 34, Appendix C
- Solvent, drycleaning, Item 57, Appendix C
- Preventive, rust, Item 53, Appendix C
- Paper, abrasive, garnet (emery cloth), Item 51, Appendix C

Personnel Required

MOS 63W, Wheel vehicle repairer (2)

References

None

Equipment Condition

TM or Para	Condition Description
	Vehicle on level surface.

Special Environmental Conditions

None

General Safety Instructions

Wheels chocked.

Level of Maintenance

Direct Support

Suspension Maintenance Instructions (Cont)

a. Removed.

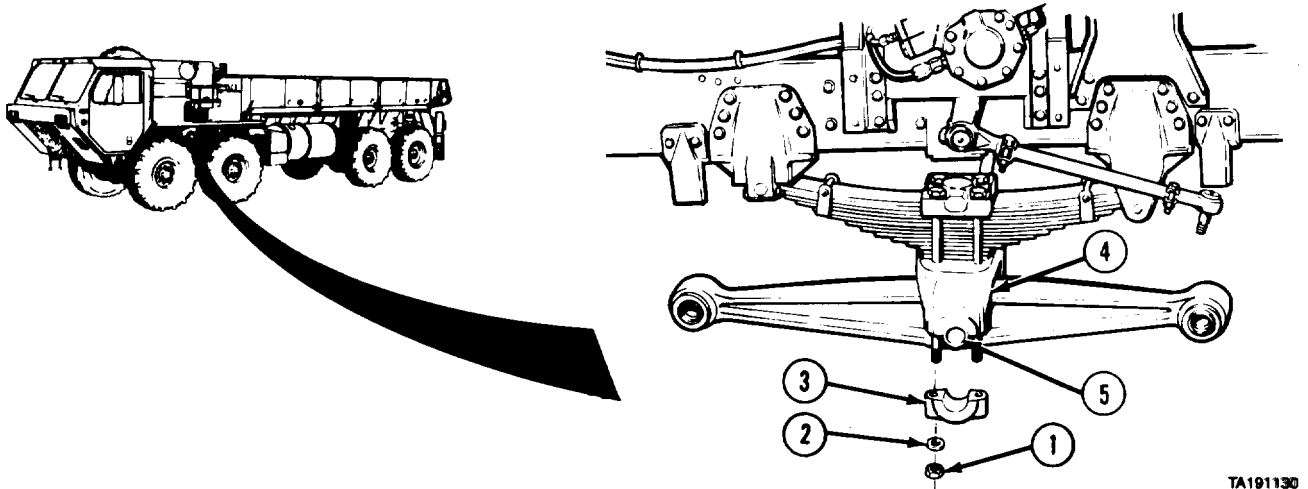

NOTE

. Left and right sides are removed in the same way. Left side is shown. Axles not shown for clarity.

Ž Center lifting device under center of cross tube so both equalizer beams can be lowered evenly.

(1) Remove four nuts (1), washers (2), and two saddle caps (3).

NOTE

Tires must touch ground after vehicle frame is supported.

(2) Raise front of vehicle with suitable lifting device until gap of approximately 1/4 in. (6 mm) appears between saddle (4) and center bushing (5).

(3) Support front of vehicle with two jackstands.

Suspension Maintenance Instructions (Cont)

T4-5. EQUALIZER BEAM ASSEMBLY (FRONT TANDEM) REMOVAL/REPAIR/INSTALLATION (CONT).

- (4) Support each equalizer beam (6) with suitable lifting device.

NOTE

Screw on axle No. 1 right side and axle No. 2 left side can only be removed with beam end adapter.

- (5) Remove two nuts (7), screws (8), and four washers (9) from each equalizer beam (6).
- (6) Remove four beam end adapters (10) from each equalizer beam (6).
- (7) Lower lifting devices and remove equalizer beams (6).
- (8) Remove two intermediate tubes (11) from each equalizer beam (6).
- (9) Remove center cross tube (12) from equalizer beams (6).

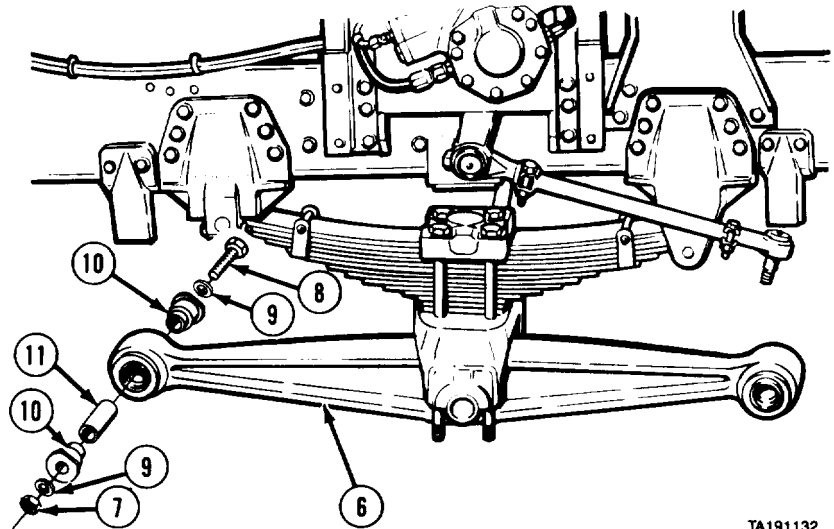

TA191132

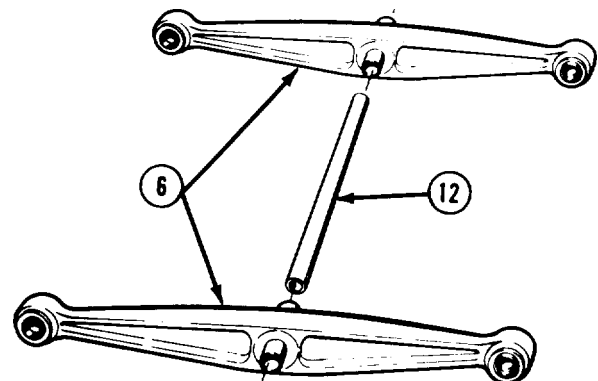

TA191133

Suspension Maintenance Instructions (Cont)

b. Disassembly.

WARNING

Force required to remove end bushings may exceed 30 tons. Use care when pressing out bushings to prevent serious personal injury or death. Always wear eye protection to prevent injury when operating press.

- (1) Use end bushing remover to press two beam end bushings (1) out of equalizer beam (2).
- (2) Use center bushing remover to press beam center housing (3) out of equalizer beam (2).

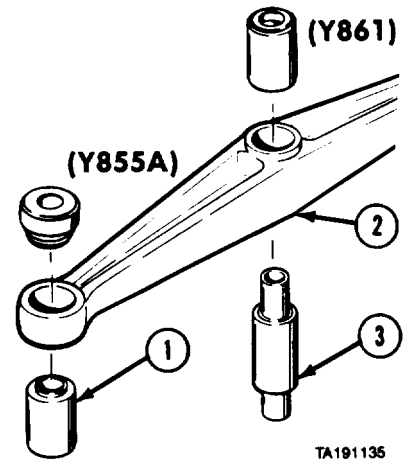

c. Cleaning/inspection.

WARNING

Adhesives, solvents, and sealing compounds can burn easily, can give off harmful vapors, and are harmful to skin and clothing. To avoid injury or death, keep away from open fire and use in well-ventilated area. If adhesive, solvent, or sealing compound gets on skin or clothing, wash immediately with soap and water.

- (1) Clean equalizer beam and parts with dry cleaning solvent.
- (2) Clean equalizer beam bushing bores with emery cloth or cylinder hone to remove all scale, rust, and corrosion.
- (3) Inspect equalizer beam for cracks and damage.
- (4) Replace equalizer beam if cracked or damaged.

Suspension Maintenance Instructions (Cont)

14-5. EQUALIZER BEAM ASSEMBLY (FRONT TANDEM) REMOVAL/REPAIR/INSTALLATION (CONT).

d. Assembly.

- (1) Lubricate two beam end bushings (1), beam center bushing (2), and three bores in equalizer beam (3) with grease.
- (2) Use end bushing installer and press two beam end bushings (1) into equalizer beam (3) so bushings are centered in beam.
- (3) Use center bushing installer and press beam center bushing (2) into equalizer beam (3) so that closed end extends 2 1/2 in. (63.5 mm) from straight side of equalizer beam.
- (4) Coat both ends of beam center bushing (2) with rust preventive.

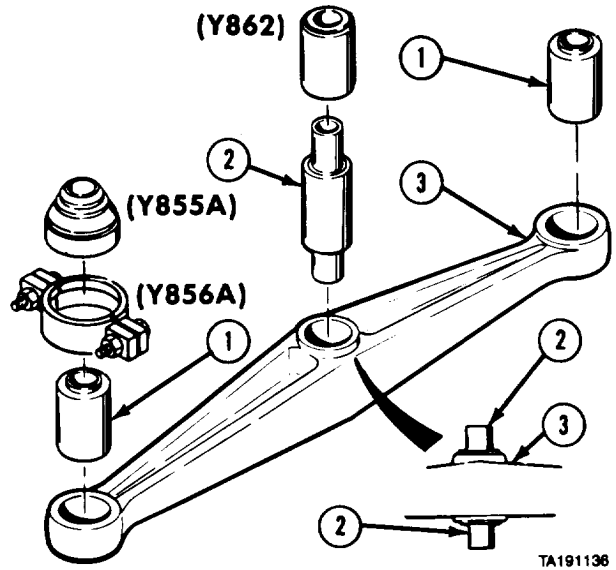

e. Installation.

- (1) Apply rust preventive to both ends of center cross tube (1).
- (2) Soldier A and Soldier B install two equalizer beams (2) on center cross tube (1).

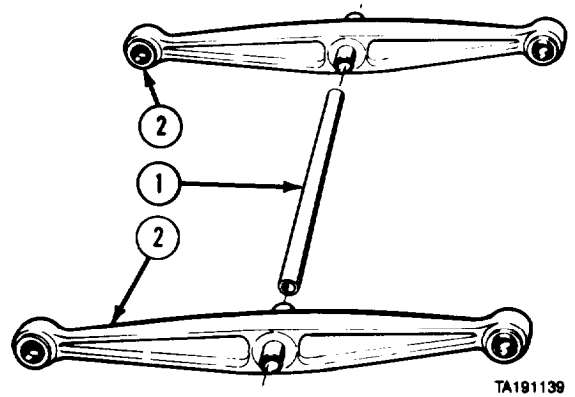

Suspension Maintenance Instructions (Cont)

NOTE

Left and right sides are installed in the same way. Left side is shown. Axles are not shown for clarity.

- (3) Install two intermediate tubes (3) in each equalizer beam (2).
- (4) Raise equalizer beams (2) into position with suitable lifting devices.

NOTE

Screw on axle No. 1 right side and axle No. 2 left side must be installed with beam end adapter.

- (5) Install four beam end adapters (4) in each equalizer beam (2).
- (6) Install four washers (5), two screws (6), and nuts (7) in each equalizer beam (2). Tighten to 210 to 240 lb-ft (285 to 325 N-m).

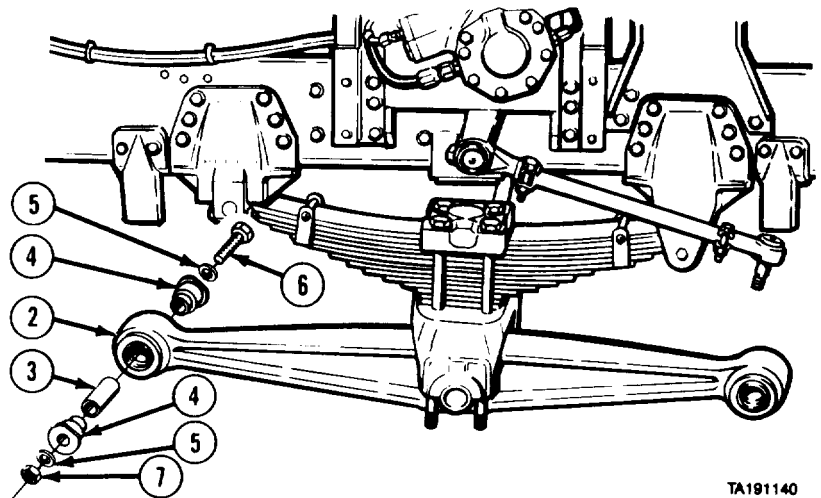

TA191140

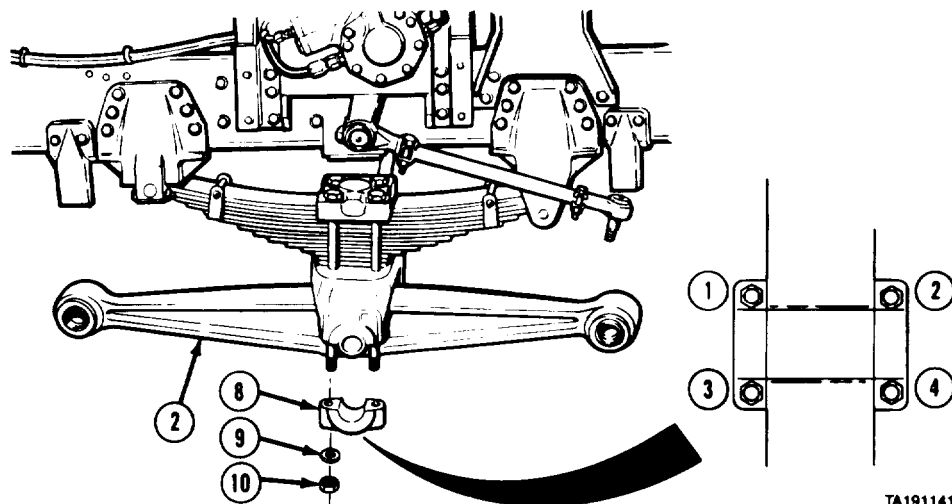

TA191141

- (7) Install two saddle caps (8), four washers (9), and nuts (10) on each equalizer beam (2). Tighten nuts in 1-4-3-2 order, to 225 to 275 lb-ft (305 to 373 N-m).
- (8) Remove lifting device from under each equalizer beam (2).
- (9) Raise front of vehicle, remove jackstands, and lower front of vehicle.

f. Follow-on Maintenance. Aline steering system (para 12- 10).

END OF TASK

Suspension Maintenance Instructions (Cont)

14-6. Equalizer BEAM ASSEMBLY (REAR TANDEM) REMOVAL/REPAIR/INSTALMTION.

This task covers:

- a. Removal
- b. Installation
- c. Follow-on Maintenance

INITIAL SETUP

ModeIs

All

Yest Equipment

None

Special Tools

M984, M985

- Adapter, end bushing, replacing Y855A
- Clamp, adapter, end bushing Y856
- Adapter, center bushing, removing, Y861
- Adapter, center bushing, installing, Y862

M977, M978, M983

- Adapter, center bushing, removing Y852
- Adapter, center bushing, installation Y853
- Adapter, end bushing, replacing Y855A
- Clamp, adapter, end bushing Y856

Supplies

- Grease, molybdenum disulfide, Item 38, Appendix C
- Preventive, rust, Item 53, Appendix C
- Solvent, dry cleaning, Item 57, Appendix C

Supplies

- Oil, lubricating, Item 47, Appendix C
- Tags, identification, Item 60, Appendix C
- Paper, abrasive, garnet (emery cloth), Item 51, Appendix C

Personnel Required

MOS 63W, Wheel vehicle repairer (2)

References

None

Equipment Condition

<i>TM or Para</i>	<i>Condition Description</i>
	Vehicle on level surface

Special Environmental Conditions

None

General Safetey Instructions

Front wheels chocked.

Level of Maintenance

Direct Support

Suspension Maintenance Instructions (Cont)

a. Removal.

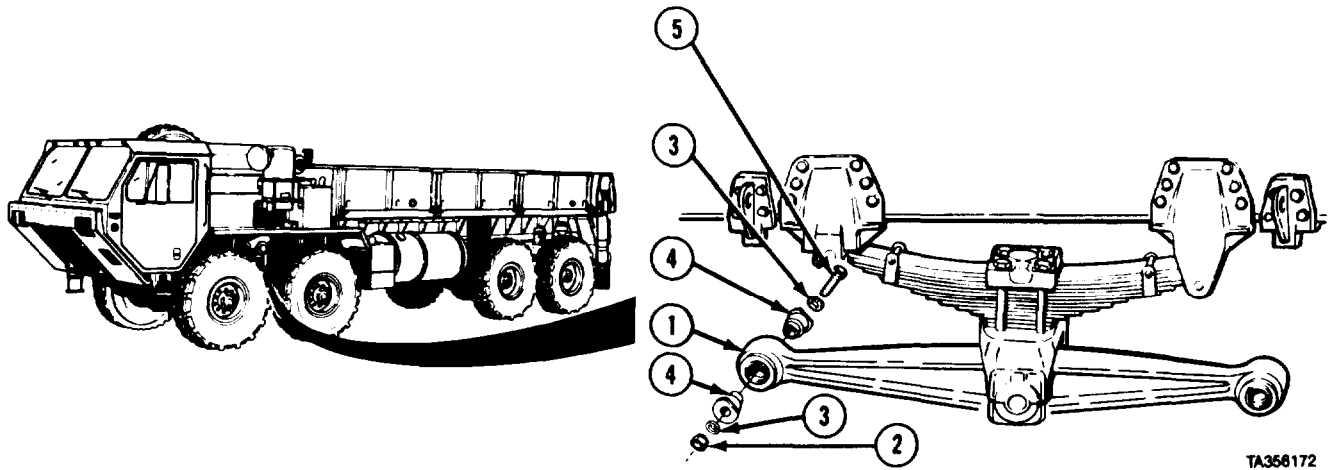

TA356172

NOTE

- Axles not shown for clarity.
- Center lifting device under center of cross tube so both equalizer beams can be lowered evenly.
- M984 equalizer beams are slightly offset. Tag or mark TOP, RIGHT, and LEFT side before removing. Mark INSIDE of equalizer beam.

- (1) Support equalizer beams (1) with suitable lifting device.
- (2) Remove nut (2) and washer (3) from each end of both equalizer beams (1).

NOTE

Screw will come out with inner beam end adapter.

- (3) Remove two beam end adapters (4), screw (5), and washer (3) from each end of equalizer beams (1).
- (4) Support rear of vehicle with two jackstands.

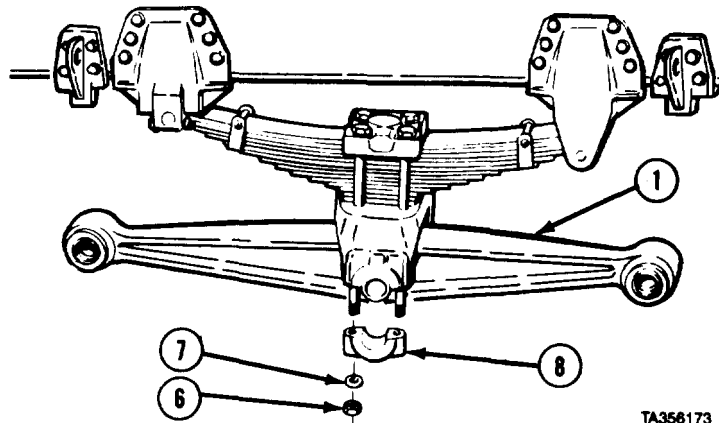

TA356173

- (5) Remove four nuts (6), washers (7), and two saddle caps (8) from both sides of vehicle.
- (6) Soldier A and Soldier B lower lifting device and remove equalizer beams(1) from vehicle.

Suspension Maintenance Instructions (Cont)

14-6. Equalizer BEAM ASSEMBLY (REAR TANDEM) REMOVAL/REPAIR/INSTALLATION (CONT).

b. Installation.

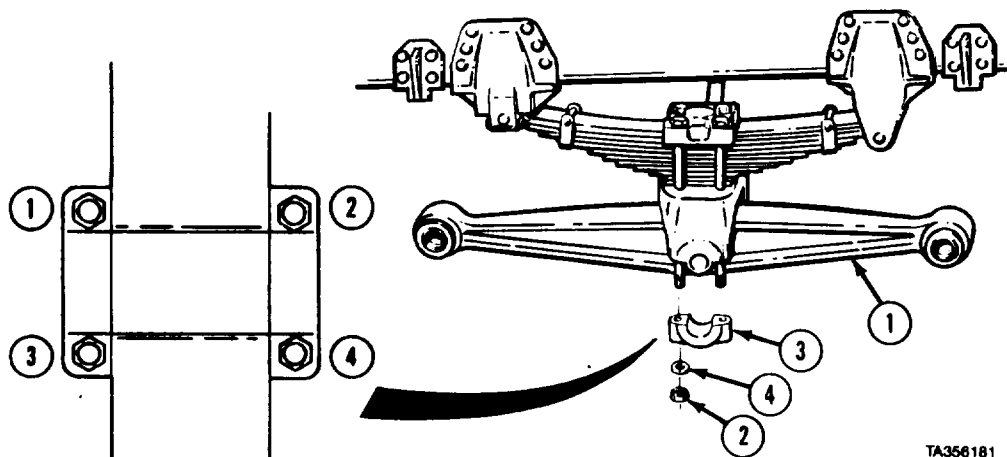
**NOTE**

Axles are not shown for clarity. Equalizer beams are installed the same way. Left side is shown.

Center lifting device under center of cross tube so both equalizer beams can be raised evenly.

- (1) Raise both equalizer beams (1) in position with suitable lifting device.
- (2) Lubricate four nuts (2) with oil. Install two saddle caps (3), four washers (4), and nuts on each equalizer beam (1).
- (3) Tighten nuts (2) in 1-4-3-2 order to 275 to 300 lbft (373 to 407 N-m).
- (4) Coat four beam end adapters (5 and 6) with rust preventive.
- (5) Install two beam end adapters (5) in each equalizer beam (1).
- (6) Lubricate threads of two screws (7) with oil and install four washers (8), two beam end adapters (6), screws, and nuts (9) in each equalizer beam (1). Tighten nuts to 210 to 240 lb-ft (285 to 325 N-m).
- (7) Remove lifting device from under each equalizer beam (1).
- (8) Raise rear of vehicle, remove jackstands, and lower rear of vehicle.

c. Follow-on Maintenance. Aline rear tandem suspension (para 14-7).

END OF TASK

Suspension Maintenance Instructions (Cont)

14-6.1. EQUALIZER BEAM ASSEMBLY (REAR TANDEM) (MODEL 650) REMOVAL/INSTALLATION (M984E1).	
This task covers:	
a. Removal b. Installation	c. Follow-on Maintenance
INITIAL SETUP	
Models M984E1	Equipment Condition
Test Equipment None	TM or Para Para 10-2.1 Para 10-3.1
Special Tools None	Condition Description Axle No. 3 (Axle Model 650) removed. Axle No. 4 (Axle Model 650) removed.
Supplies Oil Lubricating, Item 46, Appendix C	Special Enviromental Conditions None
Personnel Required MOS 63W, Wheel vehicle repairer (2)	General Safety Instructions Front Wheels chocked
References None	Level Of Maintenance Direct Support

a. Removal.

NOTE

- Removal steps are the same for both sides. Left side shown.
- Support equalizer beams with suitable lifting device.
 - (1) Remove four nuts (1), washer (2) and saddle caps (3) from both sides of vehicle.
 - (2) Solder A and Soldier B lower lifting device and remove equalizer beams (4) from vehicle.

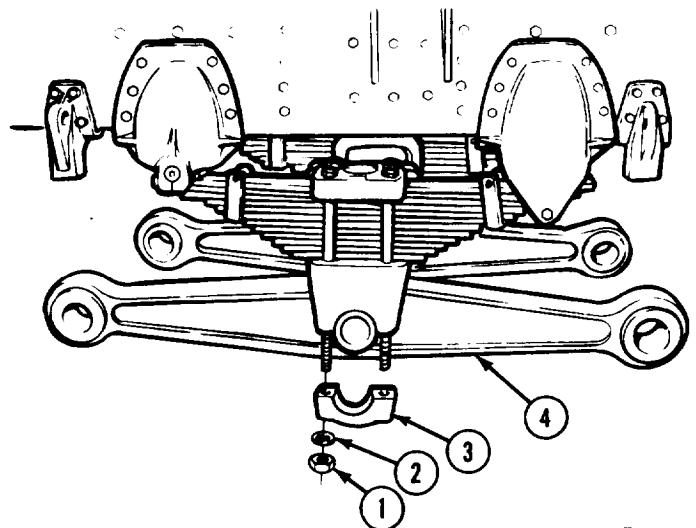

TA476561

Suspension Maintenance Instructions (Cont)

14-6.1. EQUALIZER BEAM ASSEMBLY (REAR TANDEM) (MODEL 650)
REMOVAL/INSTALLATION (M984E1) (CONT).

b. Installation.

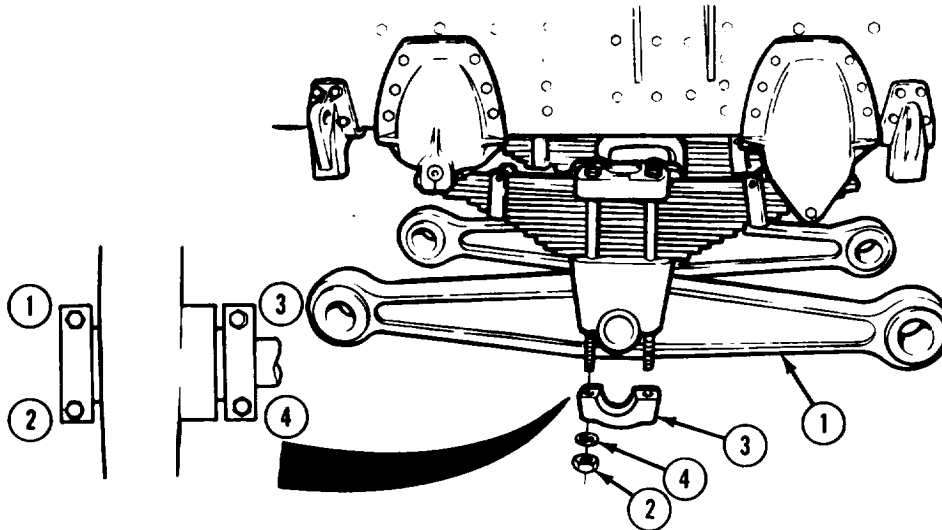

TA476562

NOTE

- Installation steps are the same for both sides. Left side shown.
- Center suitable lifting device under center of cross tube so both equalizer beams can be raised evenly.

- (1) Raise both equalizer beams (1) into position with lifting device.
- (2) Lubricate eight nuts (2) with oil. Install two saddle caps (3), four washers (4) and nuts (2) on each equalizer beam (1).
- (3) Tighten eight nuts (2) in 1-2-3-4 order, 275 to 300 lb-ft (373 to 406 N-m).
- (4) Remove lifting device from under equalizer beams (1).

c. Follow-on Maintenance.

- (1) Install Axle No. 3 (Axle Model 650) (para 10-2. 1).
- (2) Install Axle No. 4 (Axle Model 650) (para 10-3. 1).

END OF TASK

Suspension Maintenance Instructions (Cont)

14-6.2. EQUALIZER BEAM ASSEMBLY (REAR TANDEM) REPAIR.

This task covers:

- a. Disassembly
- b. Cleaning/Inspection
- c. Assembly
- d. Follow-on Maintenance

INITIAL SETUP

Models
All

Test Equipment
None

Special Tools

M984, M985, M985E1

- Adapter, end bushing, replacing Y855A
- Clamp, adapter, end bushing Y856
- Adapter, center bushing removing, Y861
- Adapter, center bushing installing, Y862

M984E1

- Tooling Set, Y840A
- Adapter, end bushing replacing Y844A
- Clamp, adapter, end bushing Y843A
- Adapter, center bushing replacing Y842

M977, M978, M983

- Adapter, center bushing, removing Y852
- Adapter, center bushing, installing Y853
- Adapter, end bushing, replacing Y855A
- Clamp, adapter, end bushing Y856

Supplies

- Grease, automotive and artillery, Item 34, Appendix C
- Preventive, rust, Item 53, Appendix C
- Solvent, dry cleaning, Item 57, Appendix C
- Oil, lubricating, Item 46, Appendix C
- Paper, abrasive, garnet (emery cloth), Item 51, Appendix C

Personnel Required

MOS 63W, Wheel vehicle repairer (2)

References

None

Equipment Condition

TM or Para

Para 10-6 or 10-6.1

Condition Description

Equalizer beams removed.

Special Environmental Conditions

None

General Safety Instructions

Front wheels chocked

Level of Maintenance

Direct Support

Suspension Maintenance Instructions (Cont)

14-6.2. EQUALIZER BEAM ASSEMBLY (REAR TANDEM) REPAIR.

a. Disassembly

NOTE

M984E1 does not have spacers in equalizer beams.

- (1) Remove two spacers (1) from each equalizer beam (2).

WARNING

Keep hands and feet away from heavy parts. If equalizer beams fall from cross tube, personnel can be injured.

NOTE

Tag and mark TOP and INSIDE of equalizer beams before removing from cross tube.

- (2) Soldier A and Soldier B remove two equalizer beams (2) from cross tube (3) with suitable lifting device

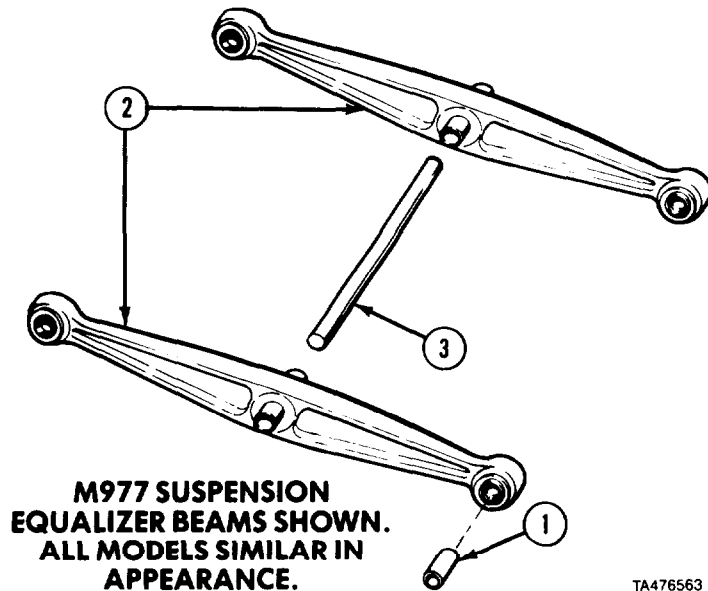

TA476563

WARNING

Force required to remove center and end bushings on all vehicles, except M984, M985, and M984E1, may exceed 30 tons (27 metric tons). M984 and M985 center and end bushings may require more than 75 tons (68 metric tons) force. Use of a press of 100-ton (90 metric tons) capacity or more is required to remove and install center and end bushings on M984E1 equalizer beams. Use care when pressing out bushings to prevent serious personal injury or death. Always wear eye protection to prevent injury when operating press.

M984E1 ONLY

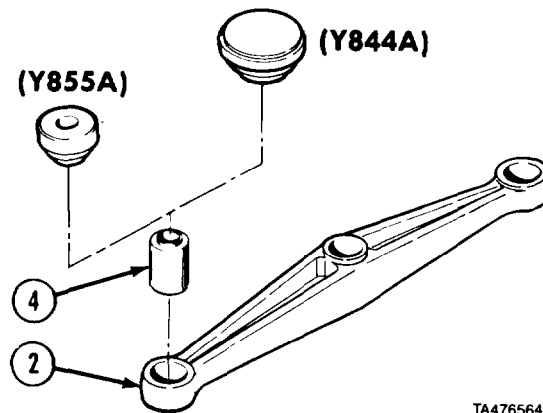

TA476564

- (3) Use end bushing adapter to press two beam end bushings (4) out of equalizer beam (2).

Suspension Maintenance Instructions (Cont)

- (4) Use center bushing removing adapter to press beam center bushing (5) out of equalizer beam (2).

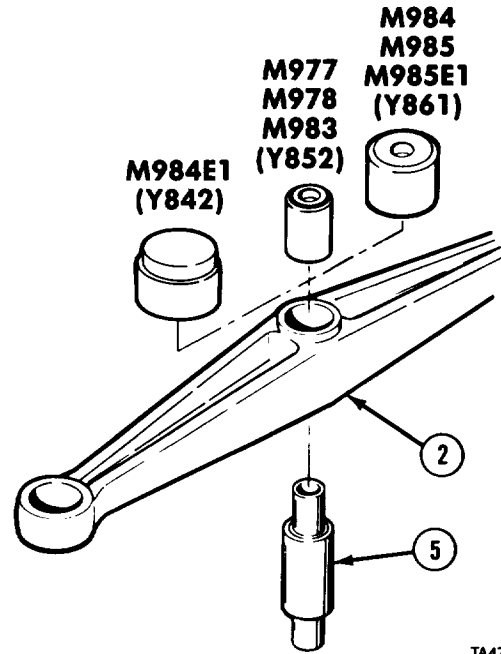

TA476565

b. Cleaning/Inspection

WARNING

Adhesives, solvents, and sealing compounds can burn easily, can give off harmful vapors, and are harmful to skin and clothing. To avoid injury or death, keep away from open fire and use in well-ventilated area. If adhesive, solvent, or sealing compound gets on skin or clothing, wash immediately with soap and water.

- (1) Clean all metal parts in dry cleaning solvent.
- (2) Clean equalizer beam bushing bores with emery cloth or cylinder hone to remove all corrosion.
- (3) Inspect equalizer beam for cracks and damage.
- (4) Replace equalizer beam if cracked or damaged.
- (5) Inspect cross tube for bends and breaks. Replace cross tube if bent or broken.

c. Assembly.

- (1) Lubricate two beam end bushings (1), beam center bushing (2), and three bores of equalizer beam (3) with grease.

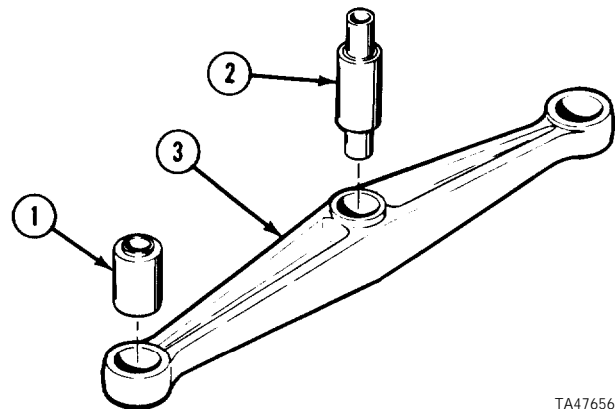

TA476566

Suspension Maintenance Instructions (Cont)

14-6.2. EQUALIZER BEAM ASSEMBLY (REAR TANDEM) REPAIR (CONT).

- (2) Install end bushing adapter into clamp, tighten clamp, and press two beam end bushings (1) into equalizer beam (3) so bushings are centered in beam. Bushings are seated when clamp touches equalizer beam.

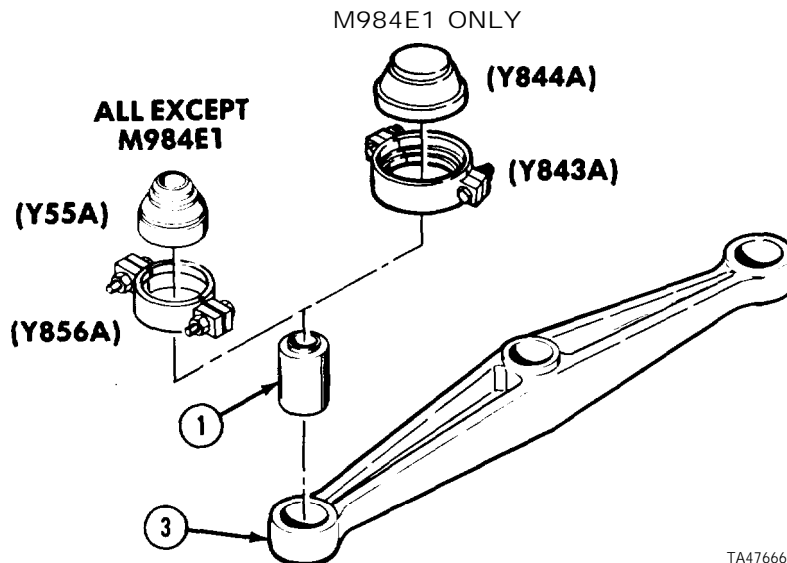

- (3) Position center bushing (2) in equalizer beam (3) with open end to INSIDE of beam.

NOTE

- On M984E1, use clamp and center bushing adapter.

Ž Plugged end of bushing points away from vehicle.

- (4) Use center bushing adapter and press beam center bushing (2) into equalizer beam (3) until center bushing adapter bottoms on equalizer beam.

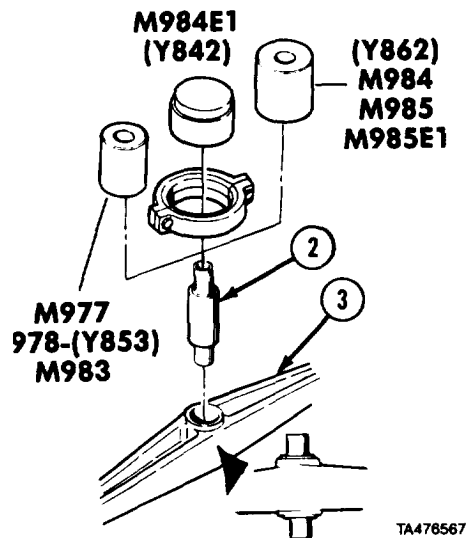

Suspension Maintenance Instructions (Cont)

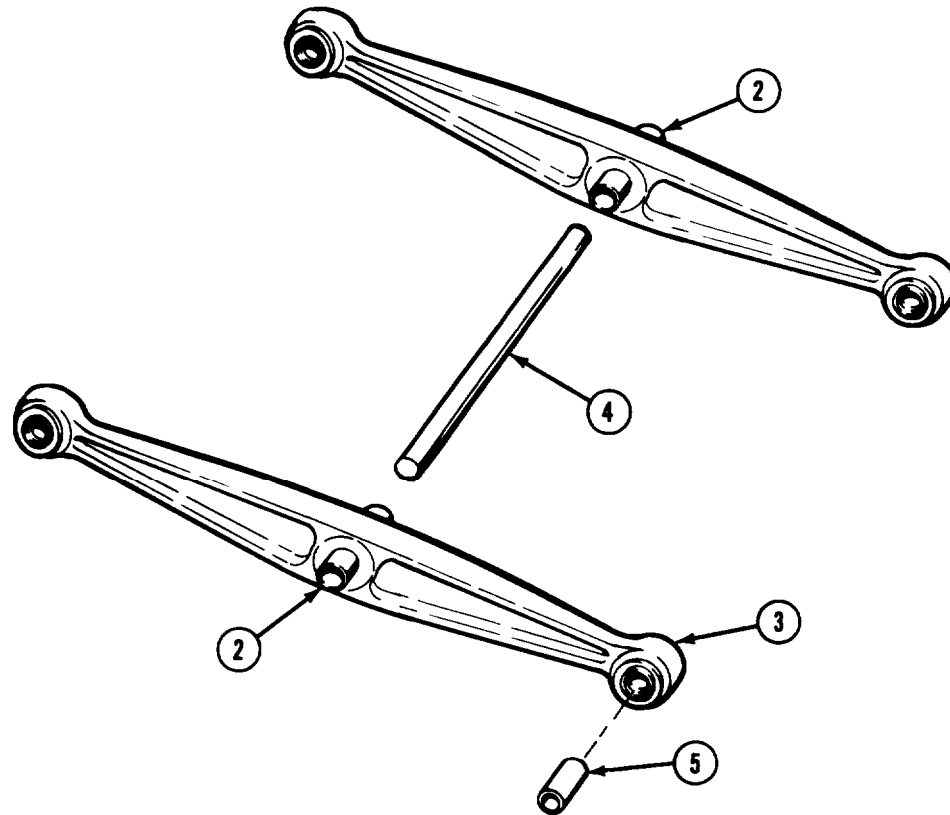

TA476568

- (5) Apply rust preventive to both ends of center bushings (2).
- (6) Apply rust preventive to both ends of center cross tube (4).

WARNING

Keep hands and feet away from heavy parts while lifting. Equalizer beam can cause injury to personnel if dropped.

- (7) Soldier A and Soldier B install two equalizer beams (3) on center cross tube (4) with suitable lifting device.

CAUTION

Spacers must be centered in equalizer beam. Damage to spacers can result if not centered when positioning equalizer beams on axle.

NOTE

M984E1 does not use spacers in equalizer beams.

- (8) Install two spacers (5) in each equalizer beam (3).

d. Follow-on Maintenance. Install equalizer beams (para 10-6 or 10-6.1).

END OF TASK

Suspension Maintenance Instructions (Cont)

14-7. REAR TANDEM SUSPENSION ALINEMENT.

This task covers:

- a. Alinement
- b. Follow-on Maintenance

INITIAL SETUP

Models

All

Test Equipment

None

Special Tools

None

Supplies

Oil, lubricating, Item 46, Appendix C

Personnel Required

MOS 63W, Wheel vehicle repairer

References

None

Equipment Condition

TM or Para

Condition Description

None

Special Environmental Conditions

None

General Safety Instructions

None

Level of Maintenance

Direct Support

a. Alhiement.

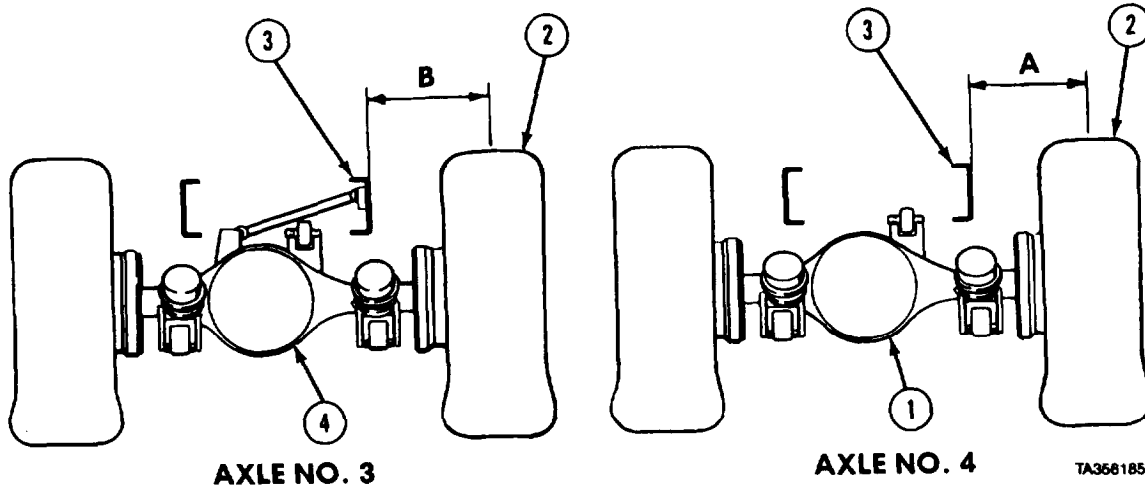

NOTE

Drive vehicle straight ahead then back 10 ft (3 m) and coast to a stop before taking any measurements.

- (1) At axle No. 4 (1), measure horizontal distance (A) from center of tire (2) to frame (3).
- (2) At axle No. 3 (4), check that horizontal distance (B) from center of tire (2) to frame (3) is not more than 0.25 in. (6.35 mm) different than measurement (A).

Suspension Maintenance Instructions (Cont)

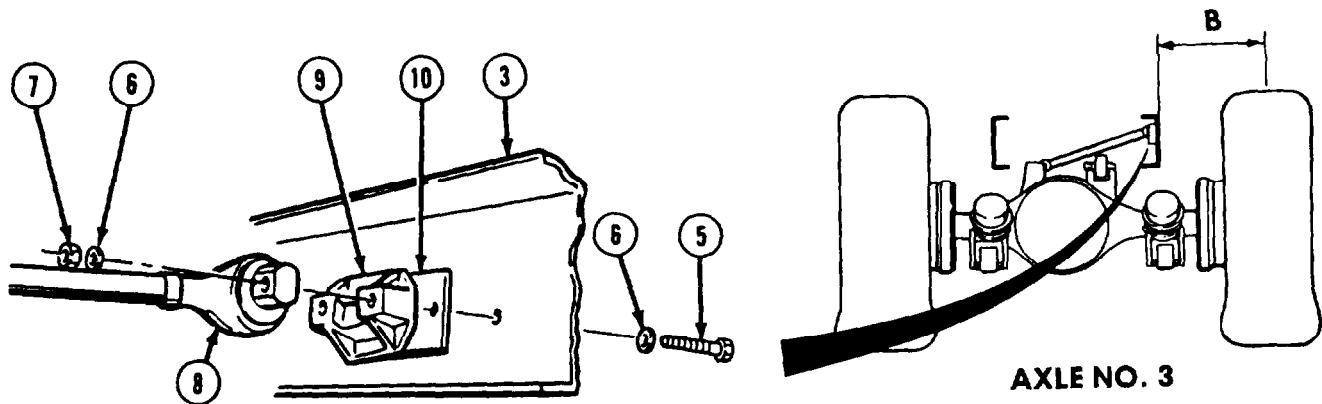
**NOTE**

Raise chassis to raise axles from ground to aid in adding or removing shims,

- (3) If conditions of step (2) are not met, remove two screws (5), four washers (6), and two locknuts (7) from lateral torque rod (8) and bracket (9).

NOTE

Adding shims will decrease measurement taken in step (2). Subtracting shims will increase measurement.

- (4) Remove or add shims (10) between bracket (9) of axle No. 3 and frame (3) so measurement (B) is within 0.25 in. (6.35 mm) of measurement (A), taken on axle No. 4.
- (5) After proper number of shims (10) has been determined, lubricate threads of two screws (5) with oil.
- (6) Install two screws (5), four washers (6), shims (10), bracket (9), and two locknuts (7) to secure lateral torque rod (8) to frame (3).
- (7) Tighten two locknuts (7).

NOTE

On M984E1, tighten locknuts to 300 lb-ft (407 N•m). All other vehicles locknuts are tightened to 170 lb-ft (231 N•m).

b. Follow-on Maintenance. None.

END OF TASK

CHAPTER 15 CAB AND BODY MAINTENANCE

Contents	Para	Page
General.....	15-1	15-1
Cab Removal/Installation	15-2	15-1
Defroster Plenum Removal/Installation	15-3	15-15
Defroster Nozzle Removal/Installation	15-4	15-19
Insulation Removal/Installation	15-5	15-21
Static Ground Reel Repair (M978)	15-6	15-26
H1 and H2 Fuel Transfer Hose Reel Repair (M978)	15-7	15-34
HAV HAND ACTUATED CONTROL VALVE Hose Reel Repair (M978)	15-8	15-39
Cargo Body Floor Hatch Removal/Installation (M977, M985)	15-9	15-46
Cargo Body Removal/Installation (M977, M985, MP85E1)	15-10	15-48
Cargo Body Mounting Brackets Removal/Installation (M977, M985)	15-11	15-51
Wood Sill Removal/Installation (M977, M985)	15-12	15-54
Pump Module Removal/Installation (M978)	15-13	15-55
2500 Gallon Tank Removal/Installation (M978)	15-14	15-65
Tank Vent Removal/Installation (M978)	15-15	15-73
Wrecker Body Removal/Installation (M984)	15-16	15-75
Wrecker Body Mounting Brackets Removal/Installation (M984)	15-17	15-78
Wood Sill Removal/Installation (M984)	15-18	15-79

Section I. INTRODUCTION

15-1. GENERAL. This chapter contains maintenance instructions for removal, installation, and repair of cab and body components at direct support and general support maintenance levels. Subassemblies and Darts which must be removed before cab and body components can be removed are referenced to other paragraphs of this manual or in TM 9-2320-279-20.

Section II. CAB ASSEMBLY Cab and Body Maintenance Instructions

15-2. CAB REMOVAL/INSTALLATION.	
This task covers:	
a. Removal	c. Follow-on Maintenance
b. Installation	
INITIAL SETUP	
<i>Models</i>	<i>Equipment Condition</i>
All	<i>TM or Para</i> <i>Condition Description</i>
<i>Test Equipment</i>	TM 9-2320-279-10 Shut off engine.
None	TM 9-2320-279-10 Spare tire removed.
<i>Special Tools</i>	TM 9-2320-279-10 Air system drained.
None	TM 9-2320-279-20 Batteries disconnected.
<i>Supplies</i>	TM 9-2320-279-20 Cooling system drained.
Connector, electrical, butt, Item 31, Appendix C	TM 9-2320-279-20 Skid plate grille removed.
Tags, identification, Item 60, Appendix C	TM 9-2320-279-20 Skid plate removed.
Ties, cable, plastic, Item 65, Appendix C	TM 9-2320-279-20 Top center console cover removed.
<i>Personnel Required</i>	TM 9-2320-279-20 Electric horns removed.
MOS 63W, Wheel vehicle repairer (2)	<i>Special Environmental Conditions</i>
<i>References</i>	None
TC 9-510 Metal Body Repair & Related Operations	<i>General Safety Instructions</i>
	None
	<i>Level of Maintenance</i>
	General Support

Cab and Body Maintenance Instructions (Cont)

15-2. CAB REMOVAL/INSTALLATION (CONT).

a. Removal

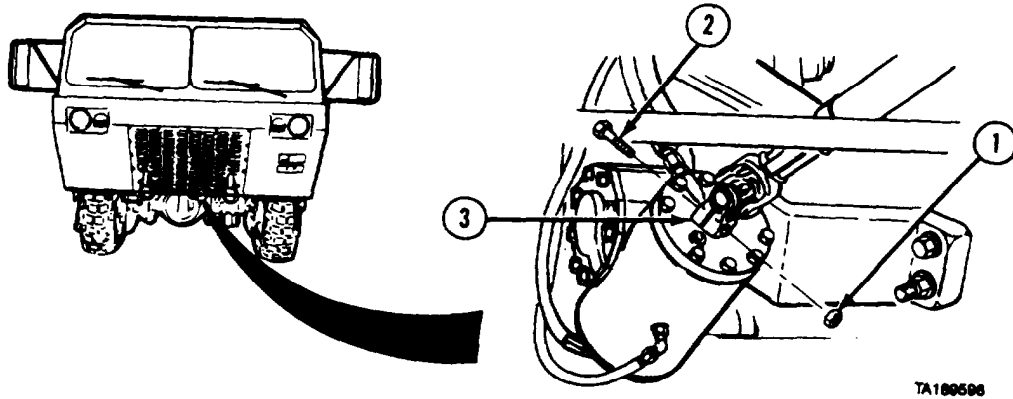

(1) Remove locknut (1), screw (2), and end yoke (3).

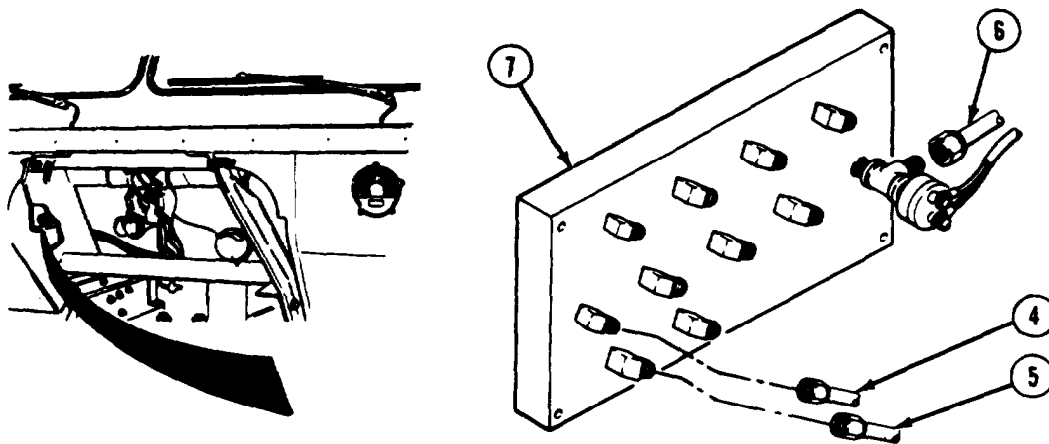

NOTE

- Remove plastic cable ties as necessary.
- Tag and mark air lines before disconnecting.

(2) Disconnect two air lines (4), eight air lines (5), and air line (6) from No. 4 air manifold (7).

Cab and Body Maintenance Instructions (Cont)

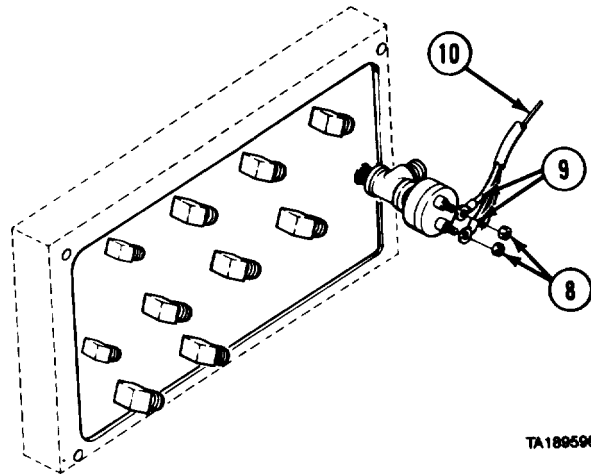

- (3) Remove two nuts (8) and wires (9).
- (4) Cut wire (10).

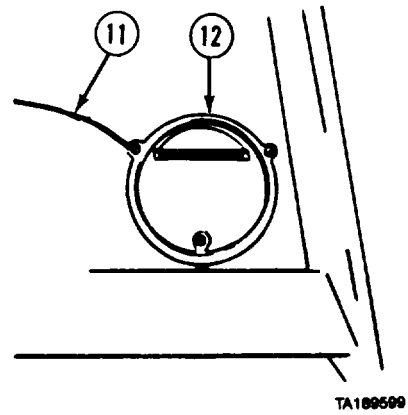
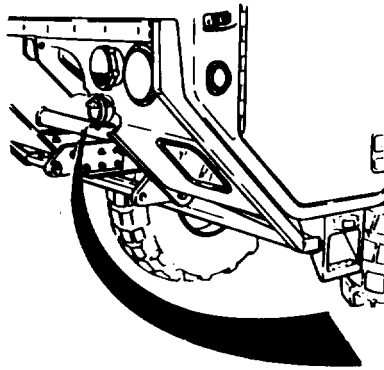

- (5) Disconnect wire (11) from blackout light (12).

Cob and Body Maintenance Instructions (Cont)

15-2. CAB REMOVAL/INSTALLATION (CONT).

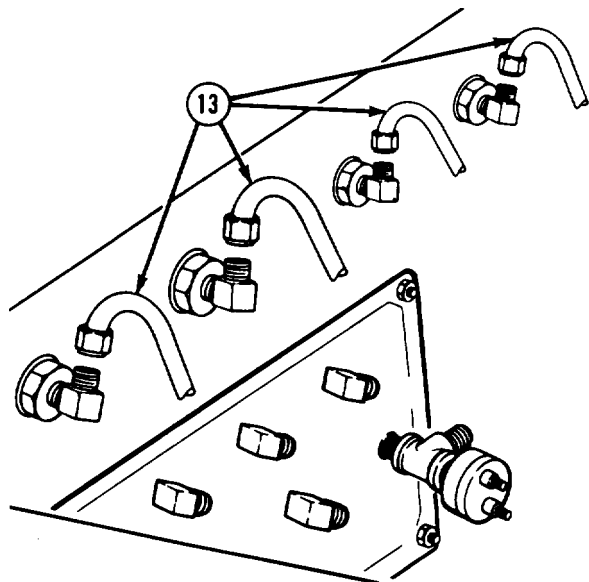

TA189800

(6) Disconnect four air lines (13),

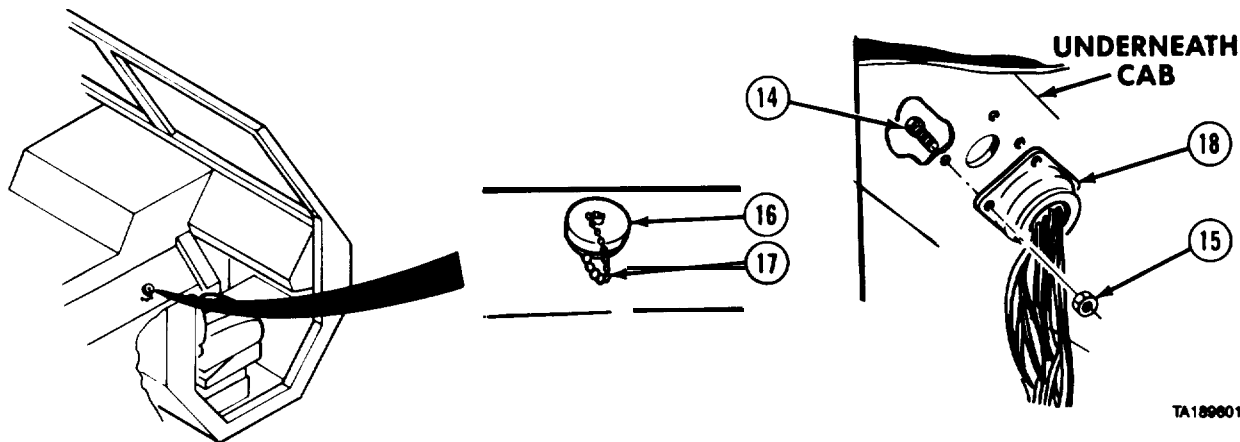

TA189801

(7) Soldier A removes four screws (14) while Soldier B removes locknuts (15).

(8) Soldier A removes cap (16) and chain (17) while Soldier B removes STE/ICE connector (18).

Cab and Body Maintenance Instructions (Cont)

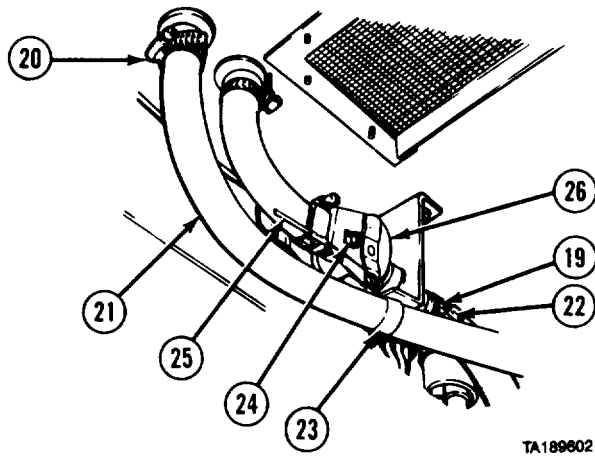

- (9) Loosen clamps (19 and 20).
- (10) Disconnect heater hoses (21 and 22).
- (11) Loosen clamp (23) and remove heater hose (21).
- (12) Loosen screw (24) and disconnect heater control cable (25) from heater control valve (26).

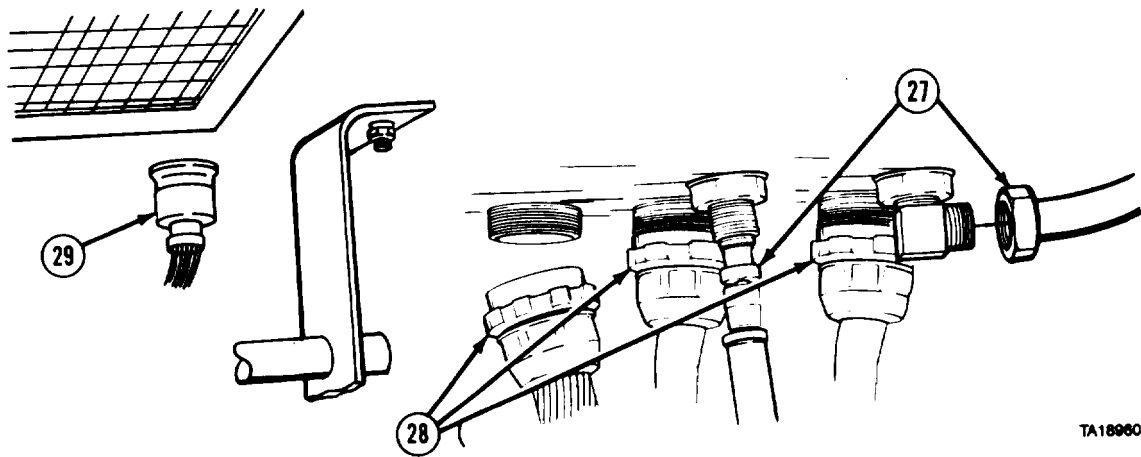

- (13) Disconnect two air lines (27).
- (14) Disconnect three electrical connectors (28).
- (15) Disconnect electrical connector (29).

Cab and Body Maintenance Instructions (Cont)

15-2. CAB REMOVAL/INSTALLATION (CONT).

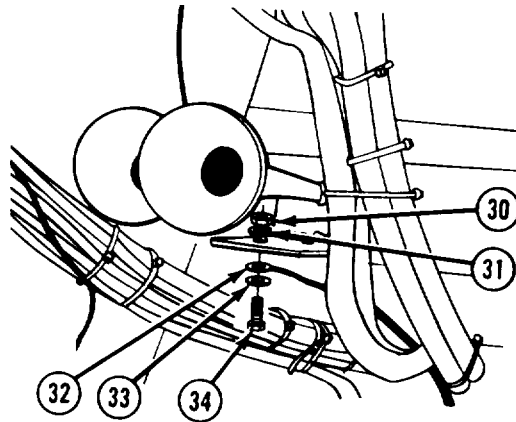

TA189804

(16) Remove nut (30), lockwasher (31), wire (32), washer (33), and screw (34).

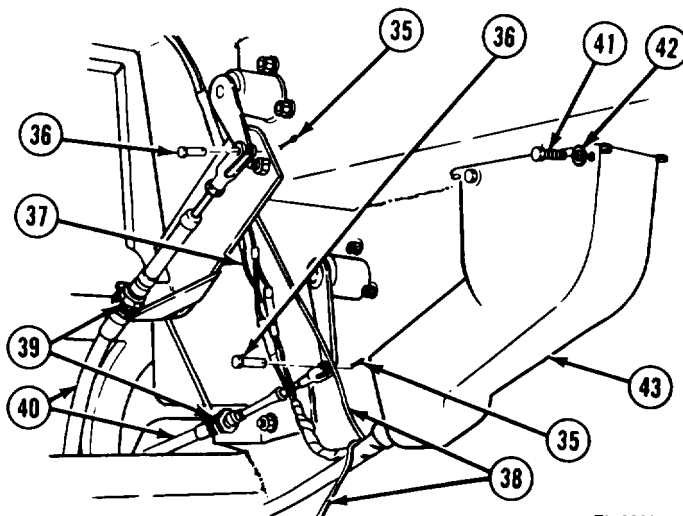

TA189805

- (17) Remove two cotter pins (35) and pins (36).
- (18) Disconnect three wires (37).
- (19) Cut two wires (38).
- (20) Loosen two nuts (39) and remove two cables (40).
- (21) Remove four screws (41) and washers (42).
- (22) Slide boot (43) down.

Cab and Body Maintenance Instructions (Cont]

- (23) Remove cotter pin (44) and washer (45).
- (24) Remove two screws (46), nuts (47), and bracket (48).
- (25) Remove shift cable (49).
- (26) Remove four wires (37 and 38) and shift cable (49) through boot (43).

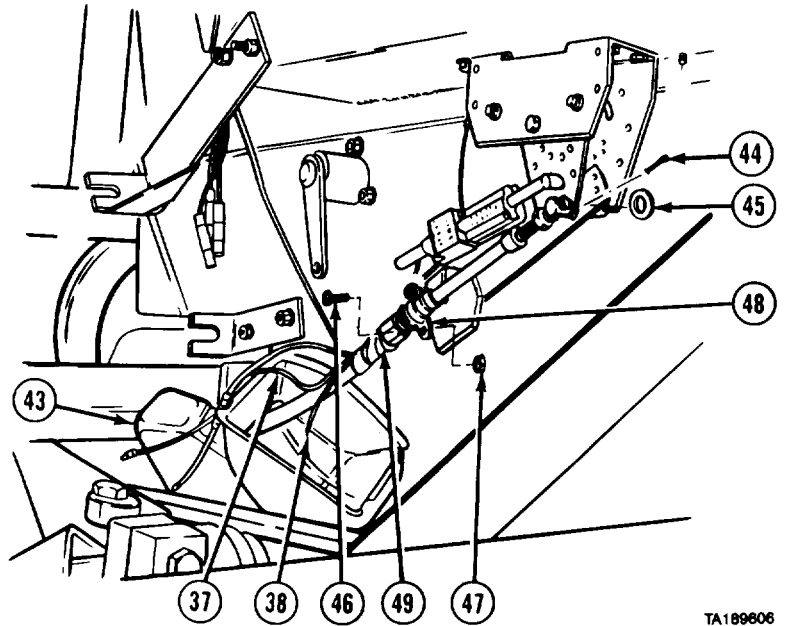

TA189606

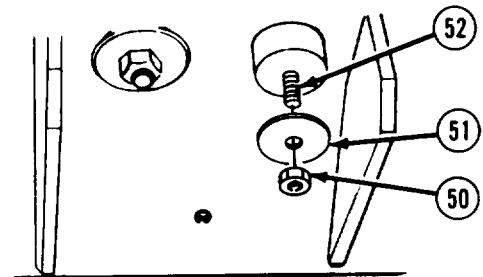
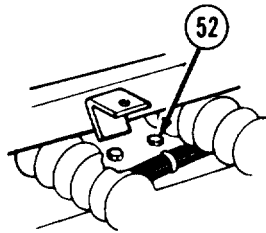
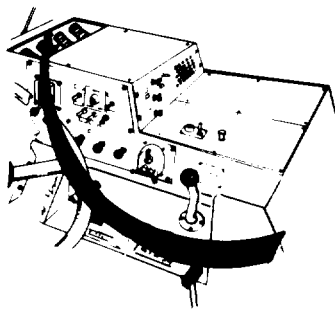

TA189607

- (27) Soldier A removes two nuts (50) and washers (51) while Soldier B removes two screws (52).

- (28) Soldier A moves suitable lifting device in position over cab (53) while Soldier B attaches lifting device to each side of cab.

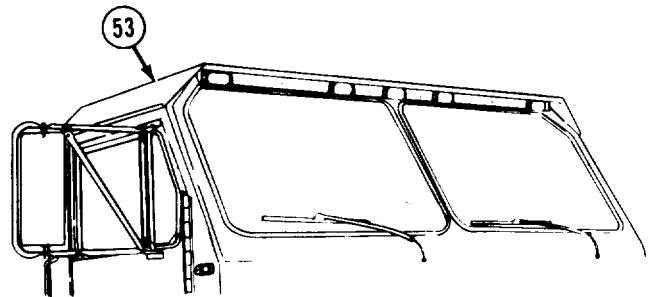

TA189608

Cab and Body Maintenance Instructions (Cont)

15-2. CAB REMOVAL/INSTALLATION (CONT).

(29) Soldier A removes nuts (54) from both sides of cab while Soldier B removes screws (55) and washers (56).

WARNING

Stay clear of cab while lifting and moving. If cab falls, serious injury or death could result.

- (30) Lift cab (53) from vehicle using suitable lifting device.
- (31) Remove cushions (57) from both side supports (58).

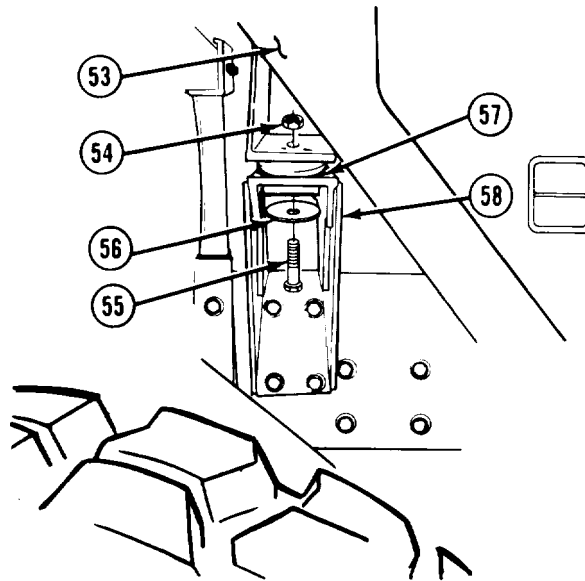

TA189609

(32) Remove two cushions (59) from cab support (60).

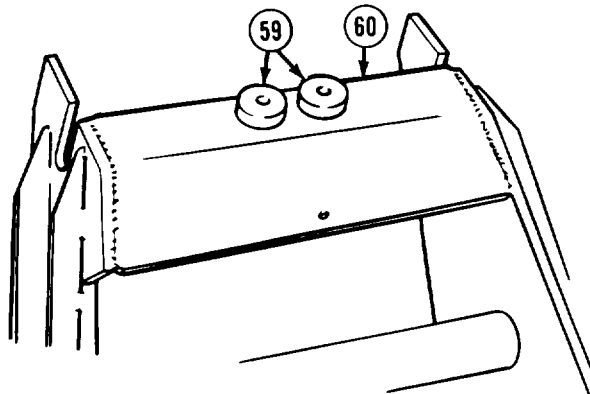

TA189611

6. Installation.

(1) Install two cushions (1) in cab support (2).

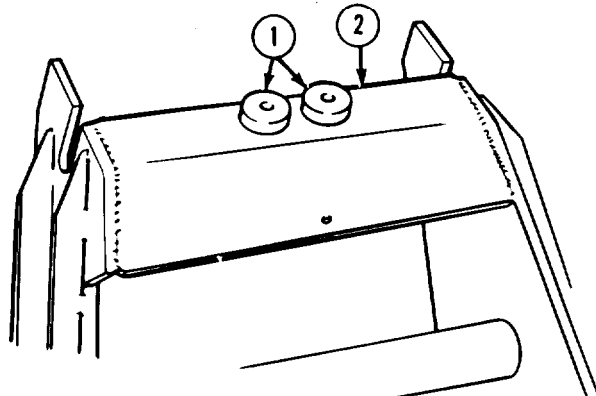

TA189612

Cab and Body Maintenance Instructions (Cont)

(2) Install cushion (3) on both side supports (4).

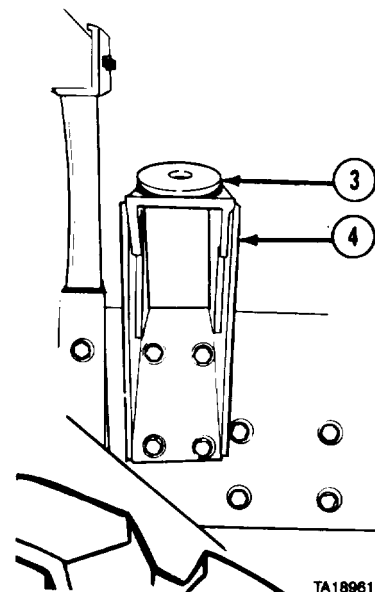

(3) Soldier A operates suitable lifting device and moves lifting device over cab (5) while Soldier B attaches lifting device to each side of cab.

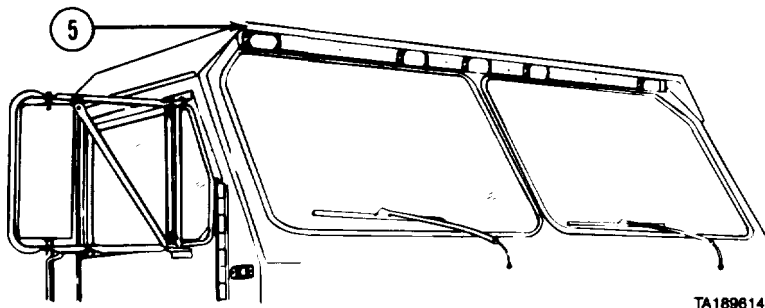

WARNING

Stay clear of cab while lifting and transporting. If cab falls, serious injury or death could result.

(4) Soldier A operates lifting device to lift and move cab (5) while Soldier B guides cab to position on frame supports (6).

NOTE

If cab and supports do not line up, it may be necessary to loosen cab support screws.

(5) Install screws (7), washers (8), and nuts (9) on both sides of cab (5).

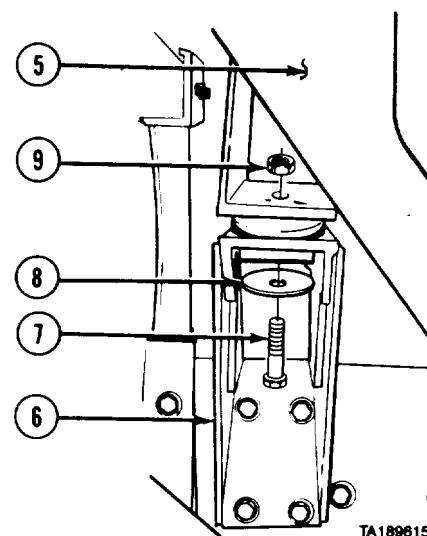

Cab and Body Maintenance Instructions (Cont)

15-2. CAB REMOVAL/INSTALLATION (CONT).

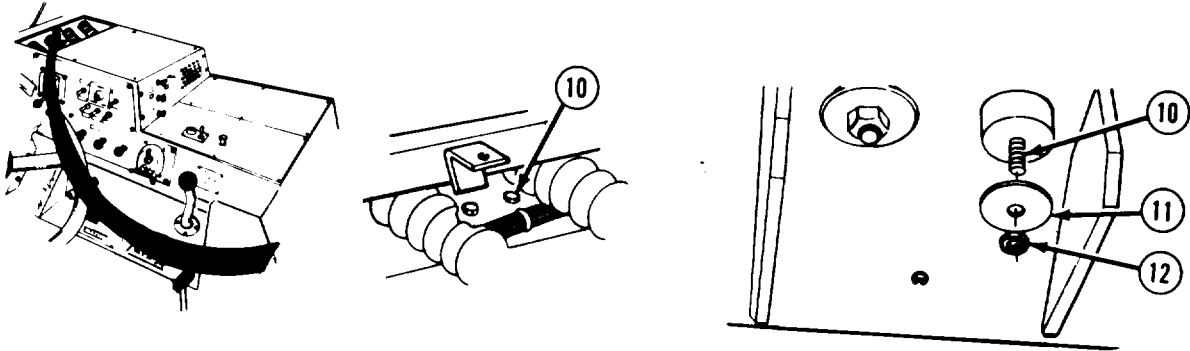

(6) Soldier A installs and holds two screws (10) while Soldier B installs two washers (11) and nuts (12) on screws.

(7) Install shift cable (13) and four wires (14 and 15) through boot (16).

(8) Install shift cable (13) and bracket (17) with two screws (18) and nuts (19).

(9) Adjust shift cable (13) (TM 9-2320-279-20).

(10) Install washer (20) and cotter pin (21).

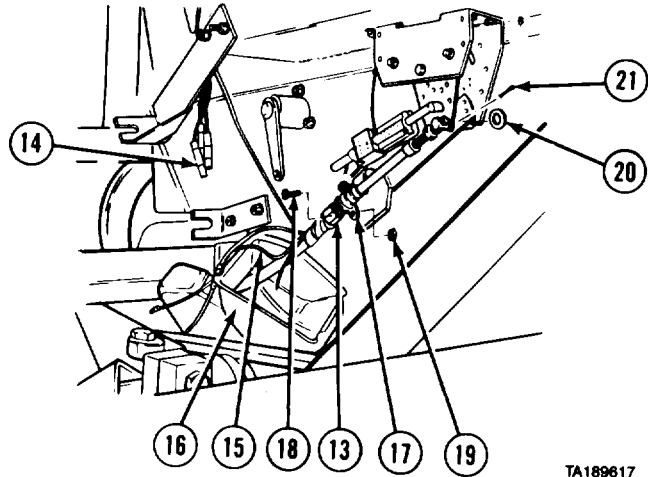

TA189617

(11) Slide boot (16) up into position with one cut wire (15) out of bottom of boot.

(12) Connect three wires (14).

(13) Connect two cut wires (15) with electrical butt connector.

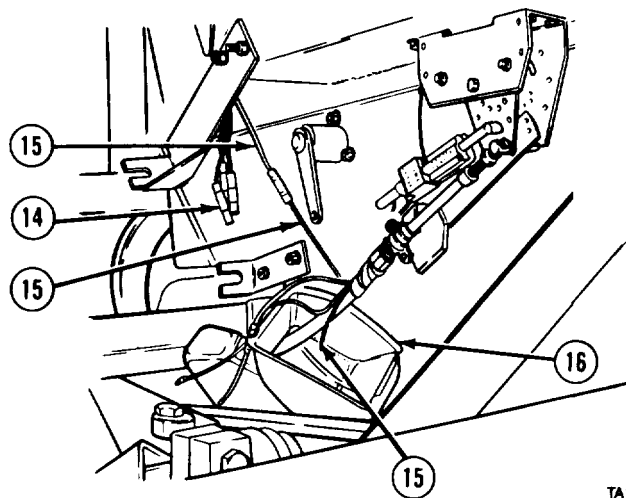

TA189618

Cab and Body Maintenance Instructions (Cont)

- (14) Install four screws (22) and washers (23).
- (15) Install two cables (24). Tighten two nuts (25).
- (16) Install two pins (26) and cotter pins (27).

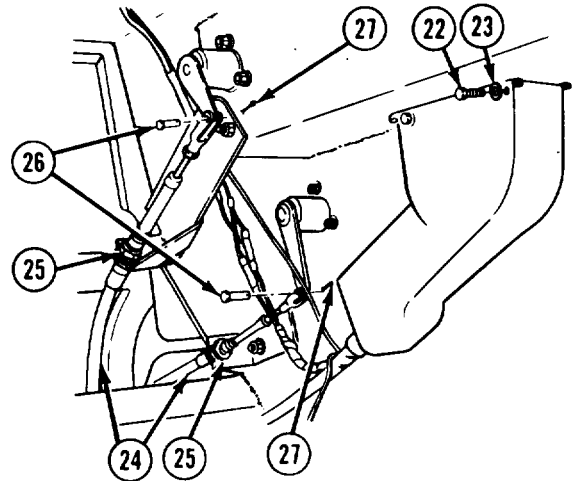

TA189619

- (17) Install screw (28), washer (29), wire (30), lockwasher (31), and nut (32).

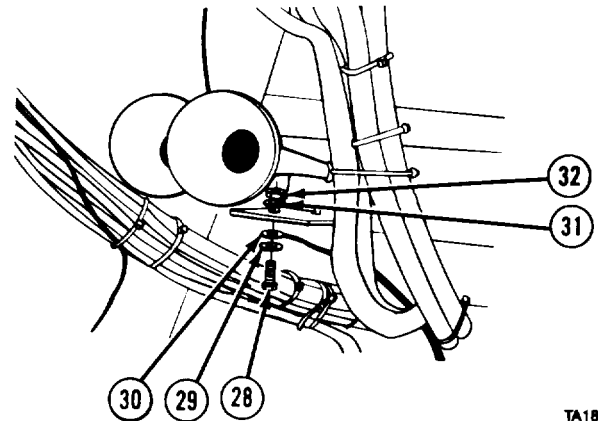

TA189620

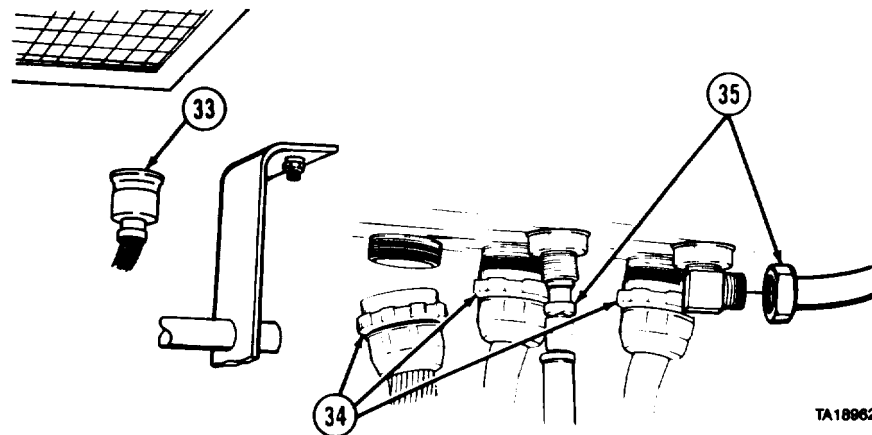

TA189621

- (18) Install electrical connector (33).
- (19) Install three electrical connectors (34).
- (20) Install two air lines (35).

Cab and Body Maintenance Instructions (Cont)

15-2. CAB REMOVAL/INSTALLATION (CONT).

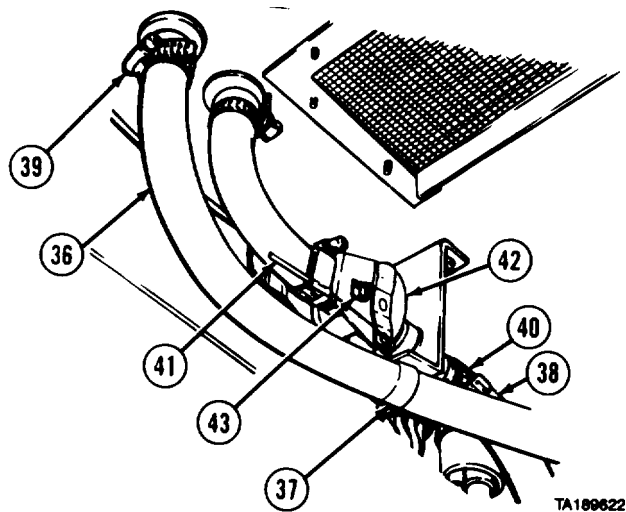

- (21) Install hose (36) through clamp (37). Tighten clamp.
- (22) Connect two hoses (36 and 38).
- (23) Tighten clamps (39 and 40).
- (24) Connect heater cable (41) to heater control valve (42).
- (25) Tighten screw (43),

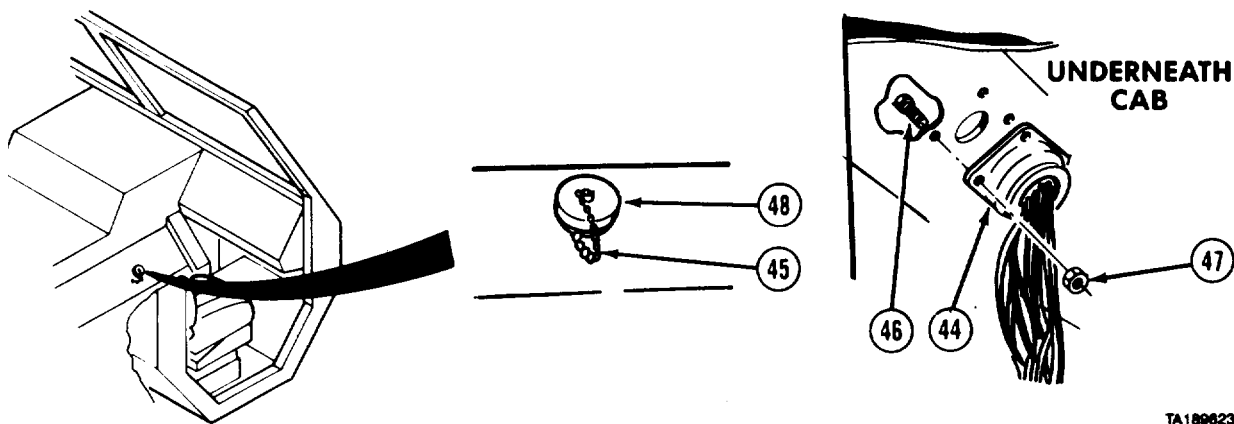

- (26) Aline STE/ICE connector (44).
- (27) Soldier A installs chain (45) and four screws (46) while Soldier B installs four locknuts (47).
- (28) Install cap (48).

Cob and Body Maintenance Instructions (Cont)

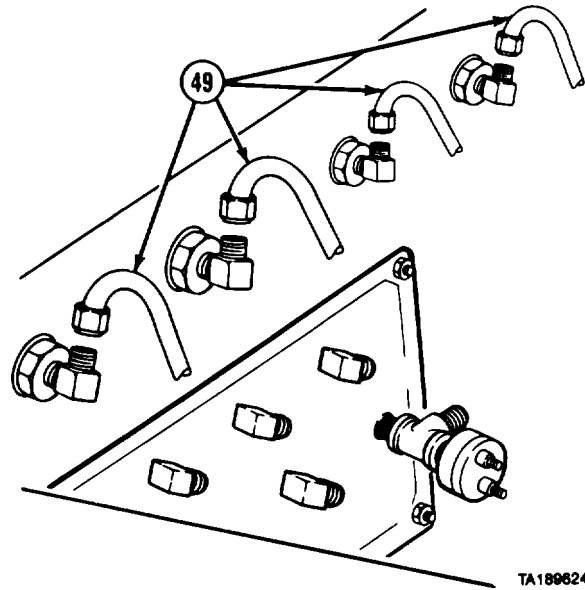

(29) Install four air lines (49).

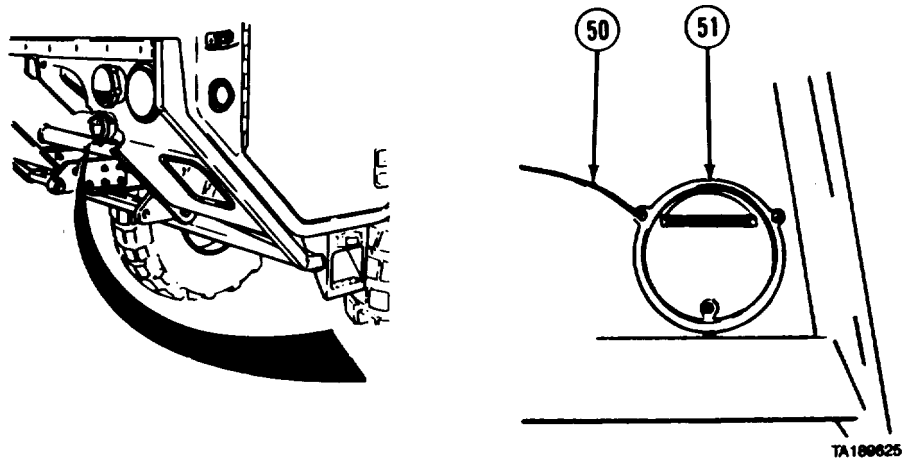

(30) Connect wire (50) to blackout light (51).

Cab and Body Maintenance Instructions (Cont)

15-2. CAB REMOVAL/INSTALLATION (CONT).

- (31) Connect two wires (52) to trailer stoplight pressure switch (53) with two nuts (54).
- (32) Connect end of wire (55) with electrical butt connector.

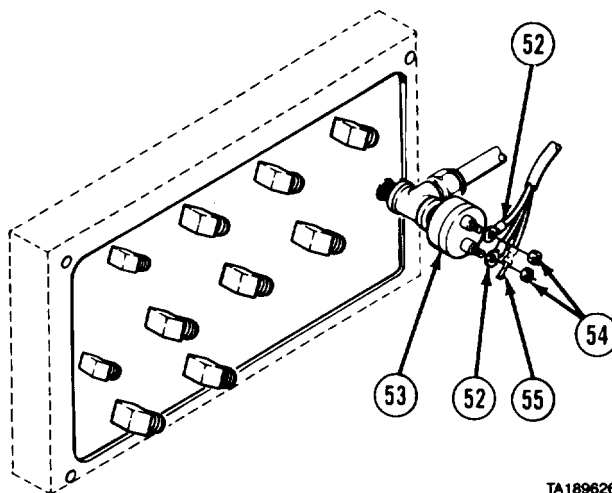

TA189626

NOTE

Install plastic cable ties as needed to secure air lines.

- (33) Connect eight air lines (56), two air lines (57), and air line (58) to No. 4 manifold (59).

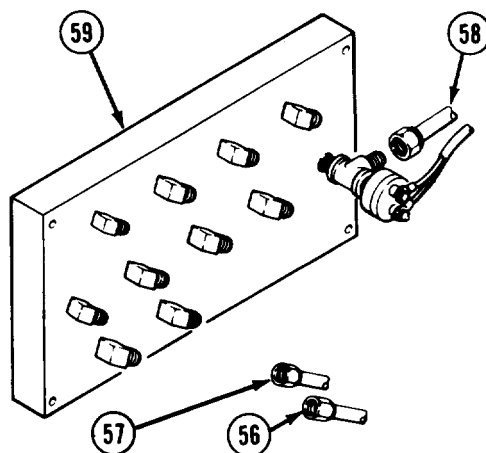

TA189627

- (34) Install end yoke (60) with screw (61) and locknut (62).

c. Follow-on Maintenance

- (1) Adjust transfer case linkage (TM 9-2320-279-20).
- (2) Install skid plate (TM 9-2320-279-20).
- (3) Install skid plate grille (TM 9-2320-279-20).
- (4) Install top center console cover (TM 9-2320-279-20).
- (5) Fill cooling system (TM 9-2320-279-20).
- (6) Connect batteries (TM 9-2320-279-20).
- (7) Stow spare tire (TM 9-2320-279-20).
- (8) Close air drains (TM 9-2320-279-20).
- (9) Install electric horns (TM 9-2320-279-20).

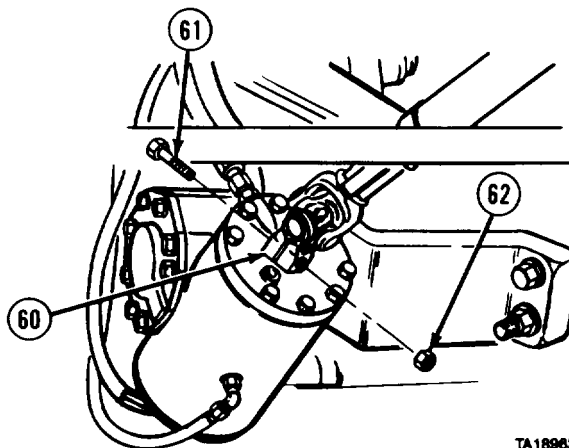

TA189628

END OF TASK

Cab and Body Maintenance Instructions (Cont)

15-3. DEFROSTER PLENUM REMOVAL/INSTALLATION		
This task covers:		
a. Removal	c. Follow-on Maintenance	
b. Installation		
INITIAL SETUP		
Models	References	
All	None	
Test Equipment	Equipment Condition	
None	TM or Para	Condition Description
Special Tools	TM 9-2320-279-20	Instrument panel removed.
None	Special Environmental Conditions	
Suppl ies	None	
Ties, cable, plastic, Item 65, Appendix C	General Safety Instructions	
Adhesive-sealant, silicone, Item 6, Appendix C	None	
Personnel Required	Level of Maintenance	
MOS 63W, Wheel vehicle repairer	Direct Support	

a. Removal.

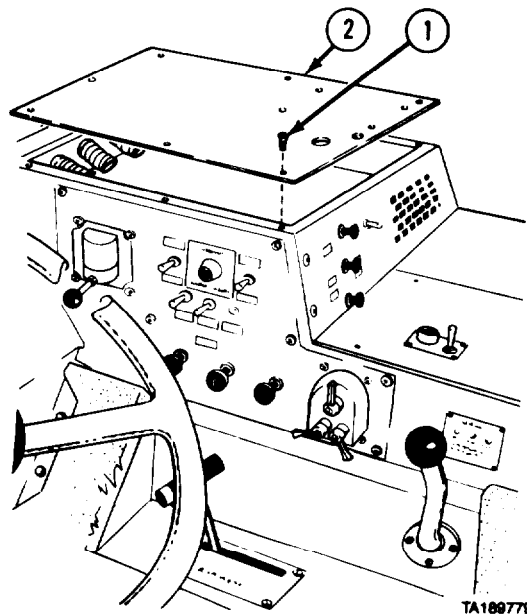

(1) Remove eight screws (1) and heater compartment cover (2).

Cob and Body Maintenance Instructions (Cont)

15-3. DEFROSTER PLENUM REMOVAL/INSTALLATION (CONT).

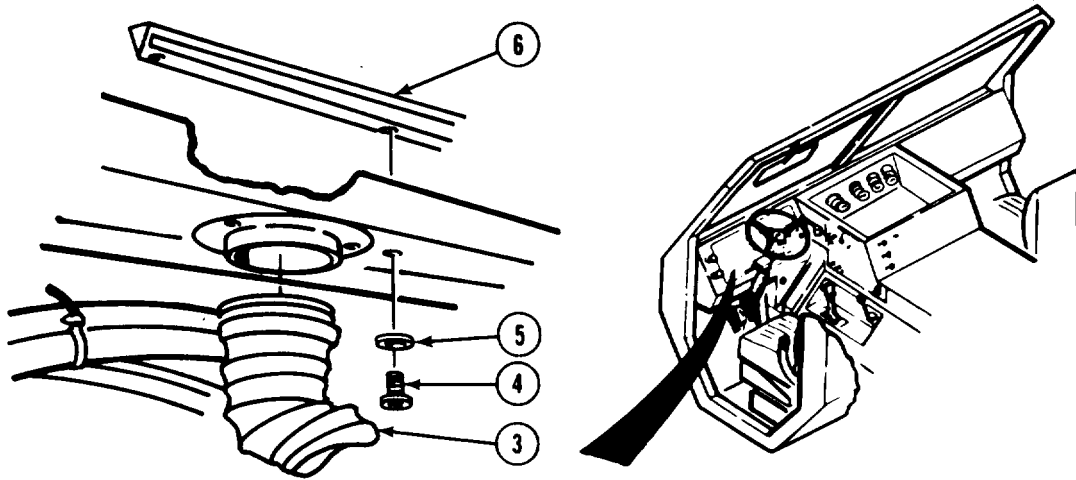

TA189780

NOTE

- Plenums are installed with silicone adhesive-sealant and may be difficult to remove.

Ž Remove plastic cable ties as necessary.

- (2) Remove defroster hose (3).
- (3) Remove three screws (4) and washers (5).
- (4) Remove left defroster plenum (6).

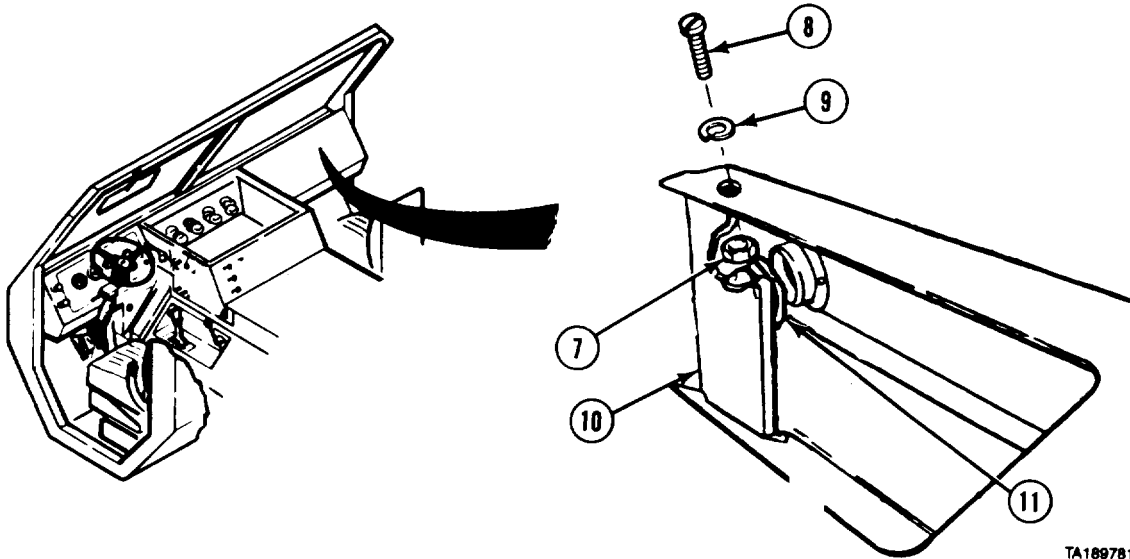

TA189781

- (5) Remove nut (7), screw (8), and lockwasher (9).
- (6) Remove defroster guard (10),
- (7) Remove defroster hose (11).

Cab and Body Maintenance Instructions (Cont)

- (8) Remove three screws (12) and washers (13).
- (9) Remove right defroster plenum (14).

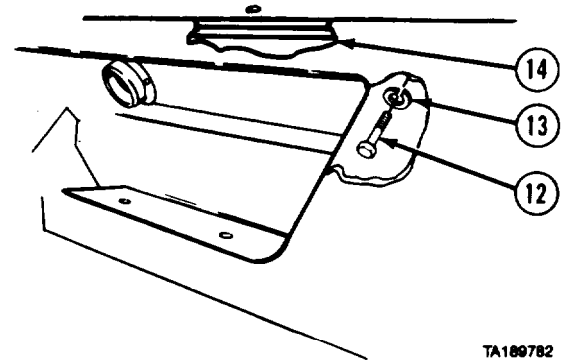

TA189782

b. Installation.

WARNING

Adhesives, solvents, and sealing compounds can burn easily, can give off harmful vapors, and are harmful to skin and clothing. To avoid injury or death, keep away from open fire and use in well-ventilated area. If adhesive, solvent, or sealing compound gets on skin or clothing, wash immediately with soap and water.

- (1) Coat right defroster plenum (1) with silicone adhesive-sealant and position right defroster plenum.
- (2) Install right defroster plenum (1) with three washers (2) and screws (3).

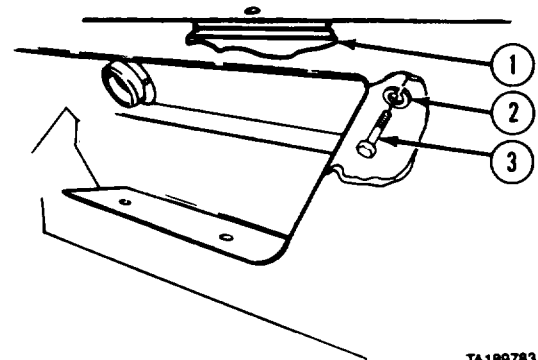

TA189783

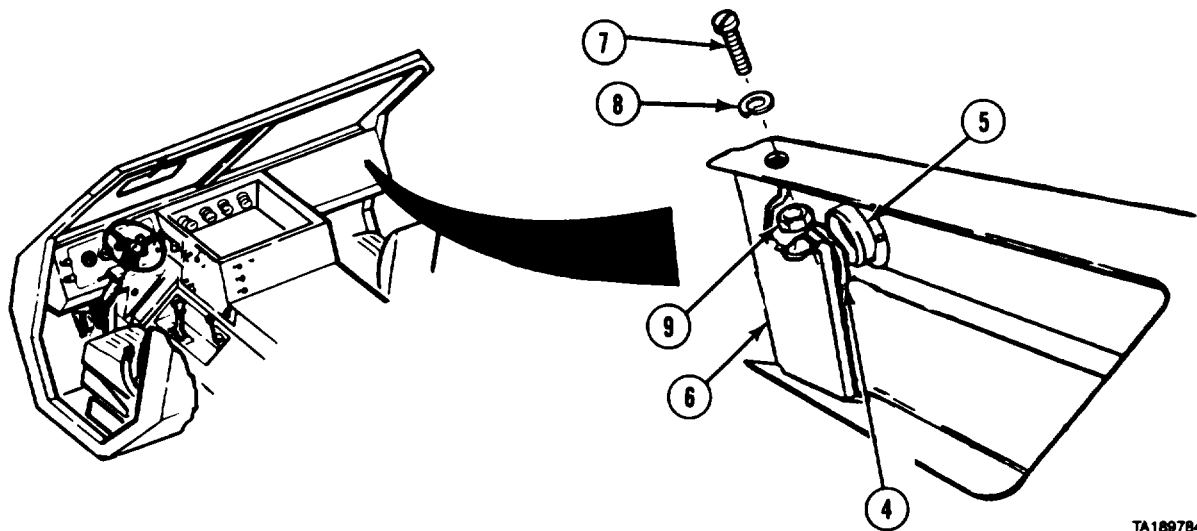

TA189784

NOTE

Install plastic cable ties as necessary.

- (3) Install defroster hose (4) on defroster nozzle (5).
- (4) Install defroster guard (6) with screw (7), lockwasher (8), and nut (9).

Cab and Body Maintenance Instructions (Cont)

15-3. DEFROSTER PLENUM REMOVAL/INSTALLATION [CONT].

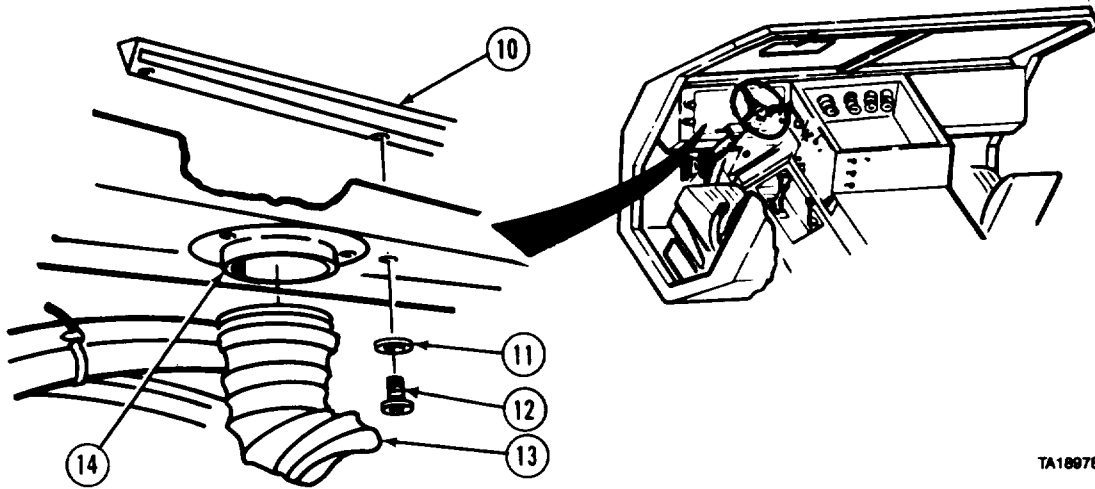

- (5) Coat left defroster plenum (10) with silicone adhesive-sealant and position left defroster plenum,
- (6) Install left defroster plenum (10) with three washers (11) and screws (12).
- (7) Install defroster hose (13) on defroster nozzle (14).

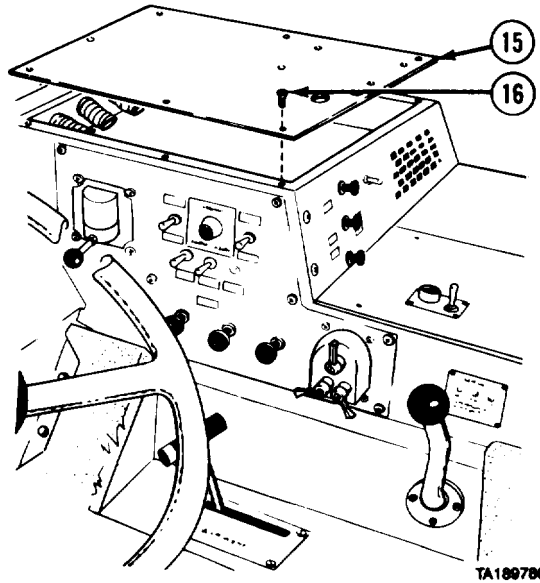

- (8) Install heater compartment cover (15) with eight screws (16).

c. Follow-on Maintenance. Install instrument panel (TM 9-2320-279-20).

END OF TASK

Cab and Body Maintenance Instructions (Cont)

15-4. DEFROSTER NOZZLE REMOVAL/INSTALLATION.	
This task covers:	
a. Removal b. Installation	c. Follow-on Maintenance
INITIAL SETUP	
Models All	References None
Test Equipment None	Equipment Condition
Special Tools None	TM or Para Condition Description TM 9-2320-279-10 Shut off engine. Para 15-3 Defroster plenum removed.
Supplies Ties, cable, plastic, Item 65, Appendix C Adhesive-sealant, silicone, Item 6, Appendix C	Special Environmental Conditions None
Personnel Required MOS 63W, Wheel vehicle repairer	General Safety Instructions None
	Level of Maintenance Direct Support

a. Removal.

NOTE

Remove plastic cable ties as necessary.

- (1) Remove defroster hoses (1).
- (2) Remove two rivets (2) each from two defroster nozzles (3).

NOTE

Nozzles are installed with silicone adhesive-sealant and may be difficult to remove.

- (3) Remove two defroster nozzles (3).
- (4) Repeat steps (1), (2), and (3) for right side.

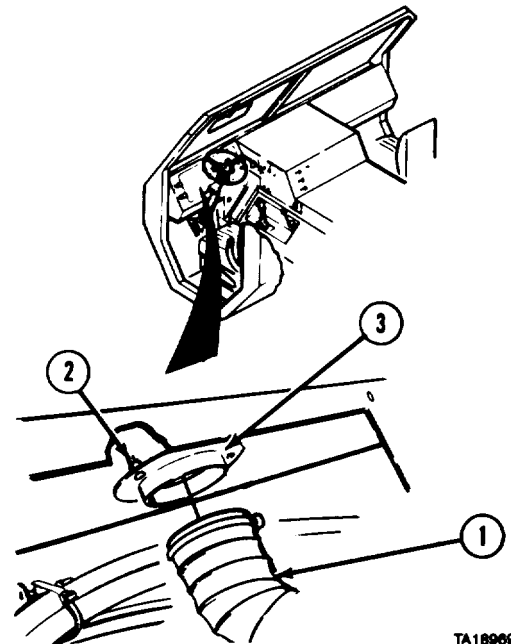

Cab and Body Maintenance Instructions (Cont)

15-4. DEFROSTER NOZZLE REMOVAL/INSTALLATION (CONT).

b. Installation

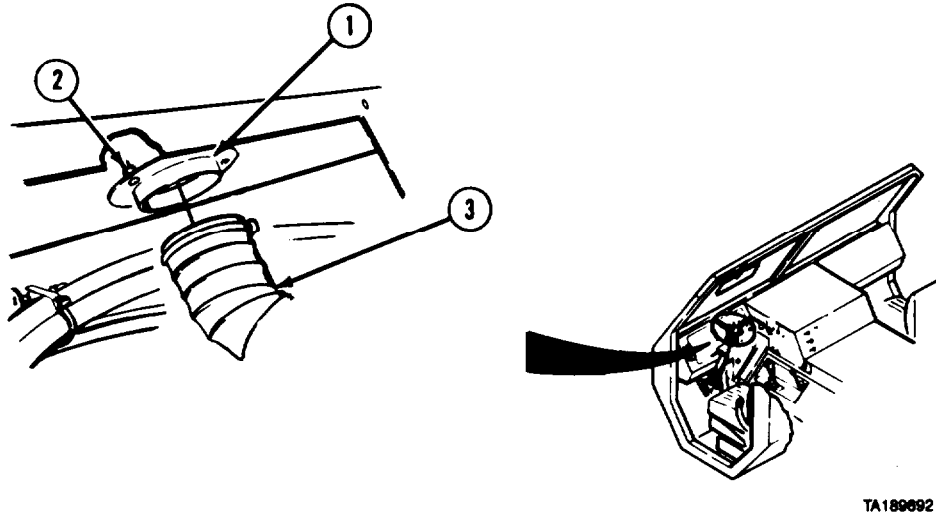

WARNING

Adhesives, solvents, and sealing compounds can burn easily, can give off harmful vapors, and are harmful to skin and clothing. To avoid injury or death, keep away from open fire and use in well-ventilated area. If adhesive, solvent, or sealing compound gets on skin or clothing, wash immediately with soap and water.

- (1) Apply silicone adhesive-sealant to two defroster nozzles (1).
- (2) Install two defroster nozzles (1) with two rivets (2) each.

NOTE

Install plastic cable ties as necessary.

- (3) Install two defroster hoses (3).
- (4) Repeats steps (1), (2), and (3) for right side.

c. Follow-on Maintenance. Install defroster plenum (para 15-3).

END OF TASK

Cab and Body Maintenance Instructions (Cont)

15-5. INSULATION REMOVAL/INSTALLATION.

This task covers:

- a. Removal
- b. Installation
- c. Follow-on Maintenance

INITIAL SETUP

Models
All

Test Equipment
None

Special Tools
None

Supplies
Adhesive, Item 5.1, Appendix C
Adhesive, Item 5.2, Appendix C

Personnel Required
MOS 63W, Wheel vehicle repairer (2)

References
None

Equipment Condition

TM or Para	Condition	Description
TM 9-2320-279-10	Shut off	engine.
TM 9-2320-279-10	Cab fire extinguisher	removed.

Equipment Condition (cont)

<i>TM or Para</i>	<i>Condition</i>	<i>Description</i>
TM 9-2320-279-10	Windshield washer bottle	removed.
TM 9-2320-279-20	Recovery winch handle	removed.
TM 9-2320-279-20	Recovery winch cable bracket	removed.
TM 9-2320-279-20	Engine switch bracket	removed.
TM 9-2320-279-20	Seats removed (to replace side and back (insulation).	

Special Environmental Conditions
None

General Safety Instructions
None

Level of Maintenance
Direct Support

a. Removal.

NOTE

Remove only insulation necessary to perform specific replacement or repair.

- (1) Remove cab roof insulation (1, 2, 3, and 4).
- (2) Remove cab side insulation (5).

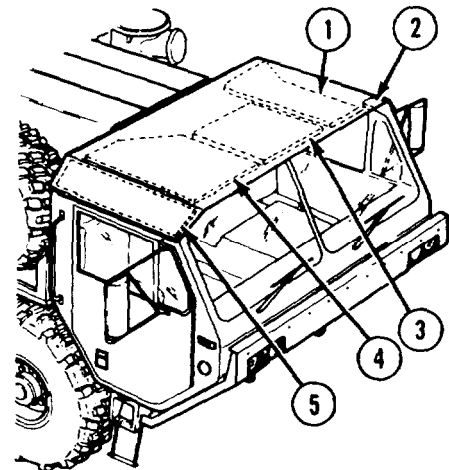

Cab and Body Maintenance Instructions (Cont)

15-5. INSULATION REMOVAL/INSTALLATION (CONT).

- (3) Remove four nuts (6), lockwashers (7), washers (8), screws (9), and two handles (10) from both sides of cab (11).
- (4) Remove insulation (12, 13 and 14) from both sides of cab (11).

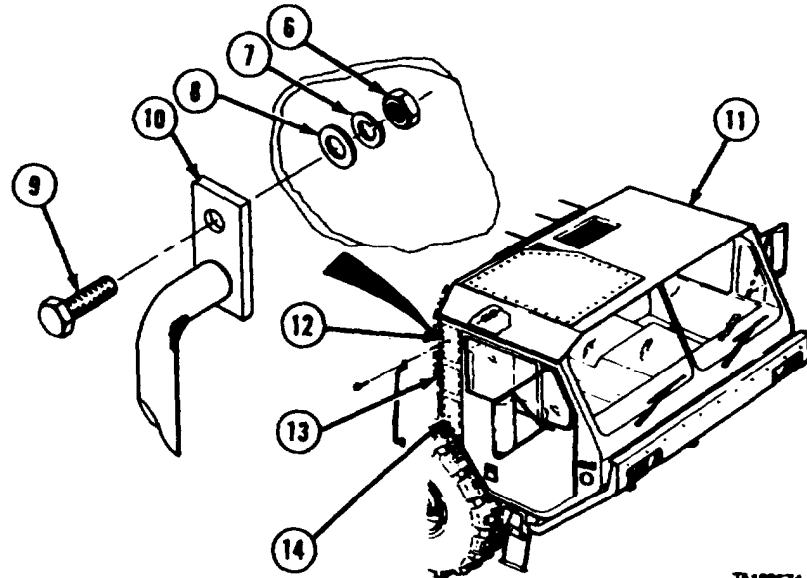

TA188674

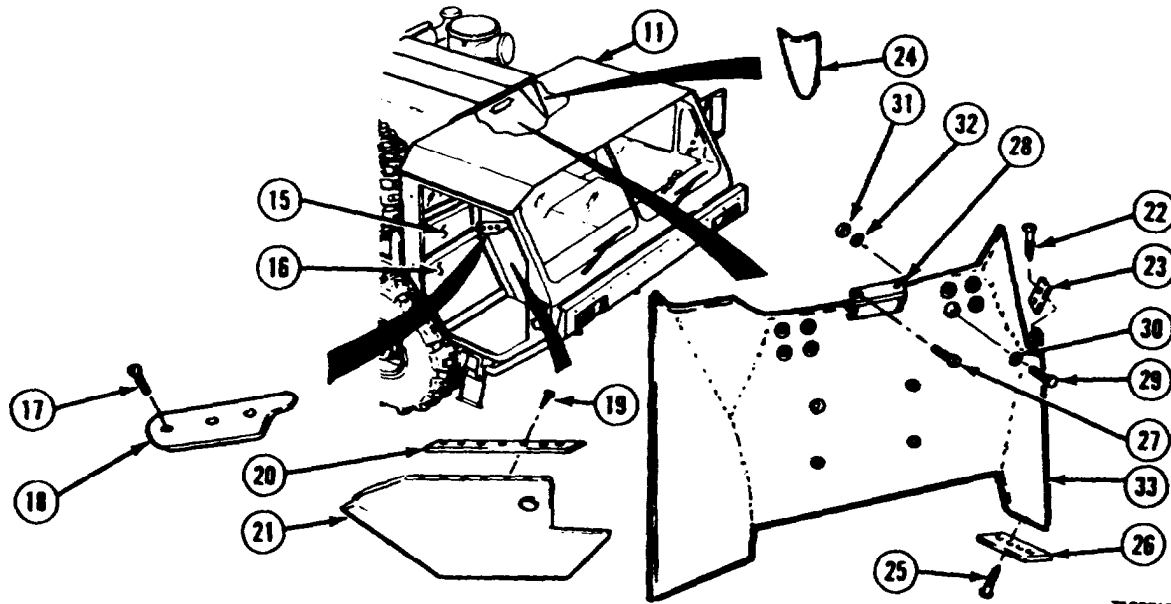

TA827104

- (5) Remove insulation (15 and 16) from both sides of cab (11).
- (6) Remove three screws (17) and plate (18).
- (7) Remove seven screws (19) and retaining strip (20).
- (8) Remove insulation (21).
- (9) Remove two screws (22) and retaining strip (23).
- (10) Remove insulation (24).
- (11) Remove four screws (26) and retaining strip (26).
- (12) Remove two screws (27) and light assembly (28).
- (13) Soldier 5 and Soldier B remove 12 screws (29), washers (30), nuts (31), and lockwashers (32).
- (14) Remove insulation (33).

Cab and Body Maintenance Instructions (Cont)

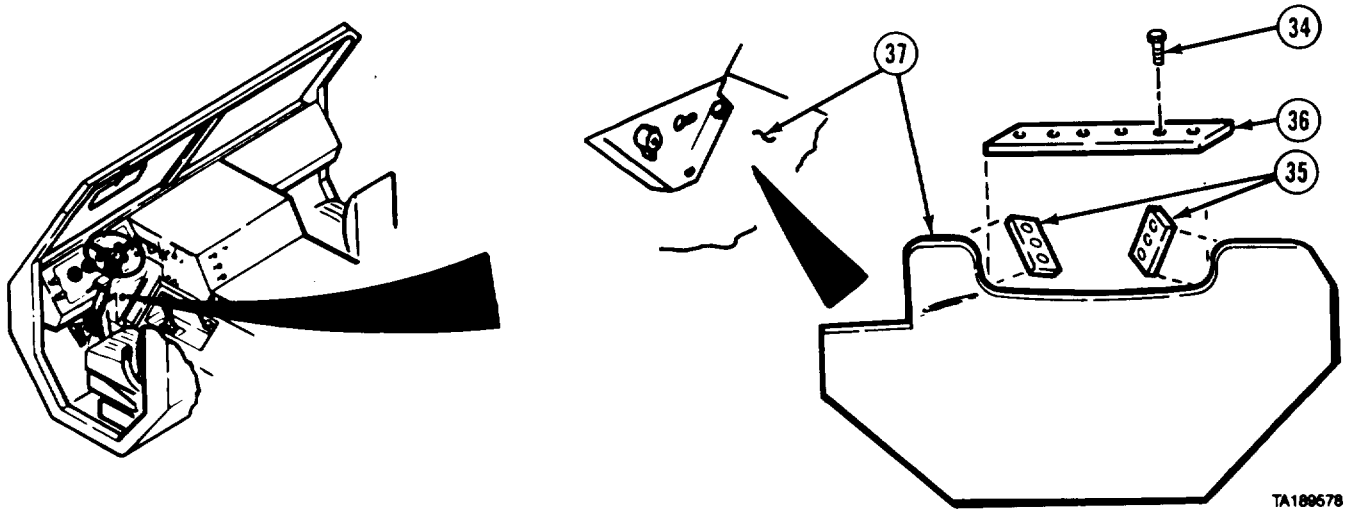

- (15) Remove 12 screws (34) and three retaining strips (35 and 36)
- (16) Remove insulation (37).

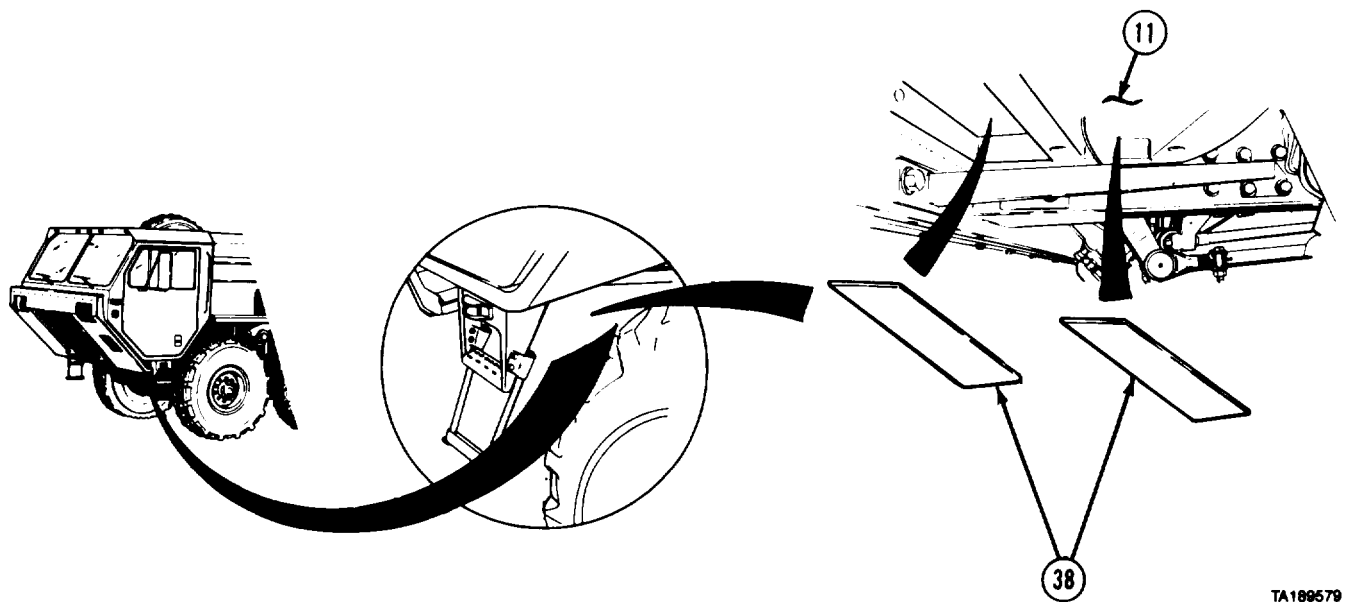

- (17) Remove insulation (38) from both sides of cab (11).

Cab and Body Maintenance Instructions (Cont)

15-5. INSULATION REMOVAL/INSTALLATION (CONT).

b. Installation.

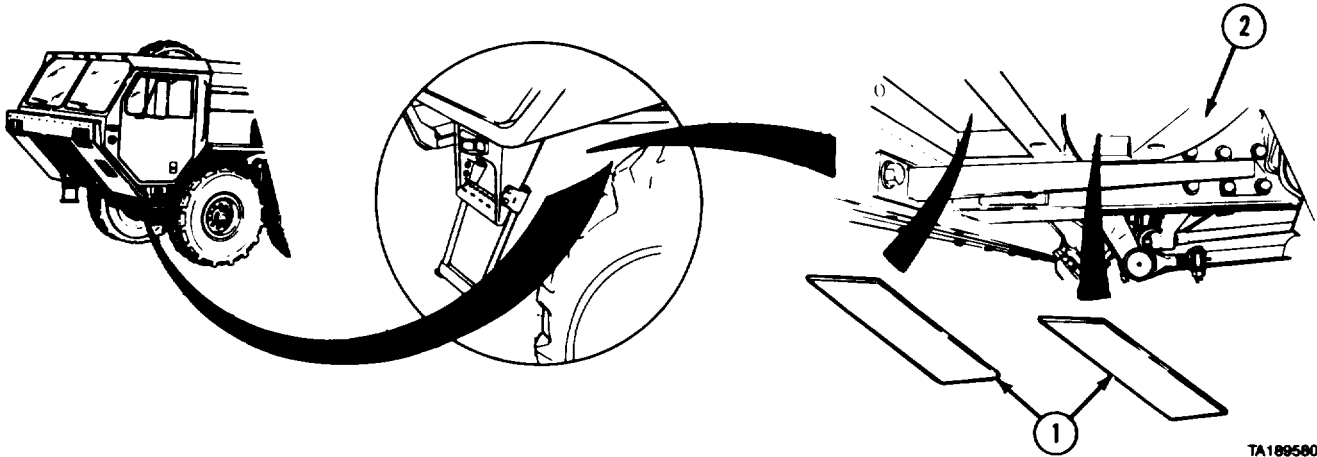

TA189580

WARNING

Adhesives, solvents, and sealing compounds can burn easily, can give off harmful vapors, and are harmful to skin and clothing. To avoid injury or death, keep away from open fire and use in well-ventilated area. If adhesive, solvent, or sealing compound gets on skin or clothing, wash immediately with soap and water.

NOTE

Apply adhesive on back of each insulation piece.

(1) Install insulation (1) on both sides of cab (2).

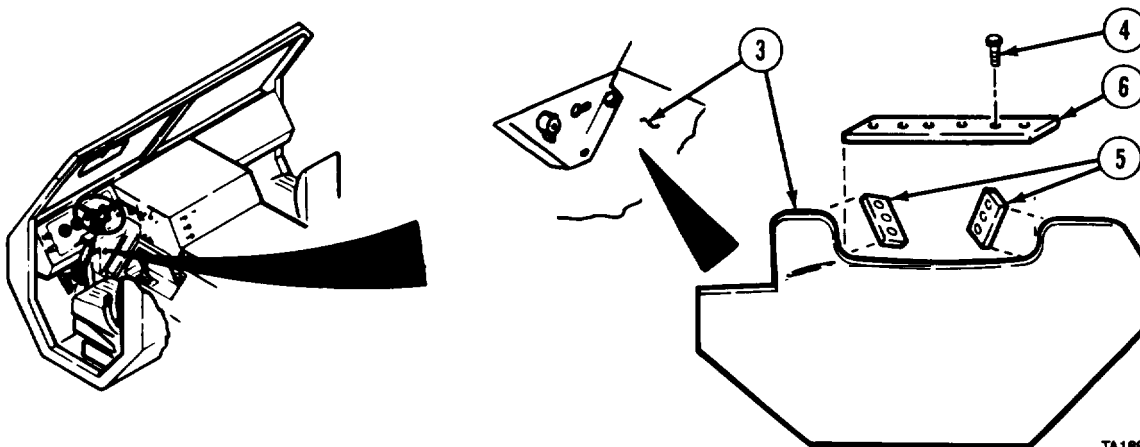

TA189581

- (2) Install insulation (3).
- (3) Install 12 screws (4) and three retaining strips (5 and 6).

Cab and Body Maintenance Instructions (Cont)

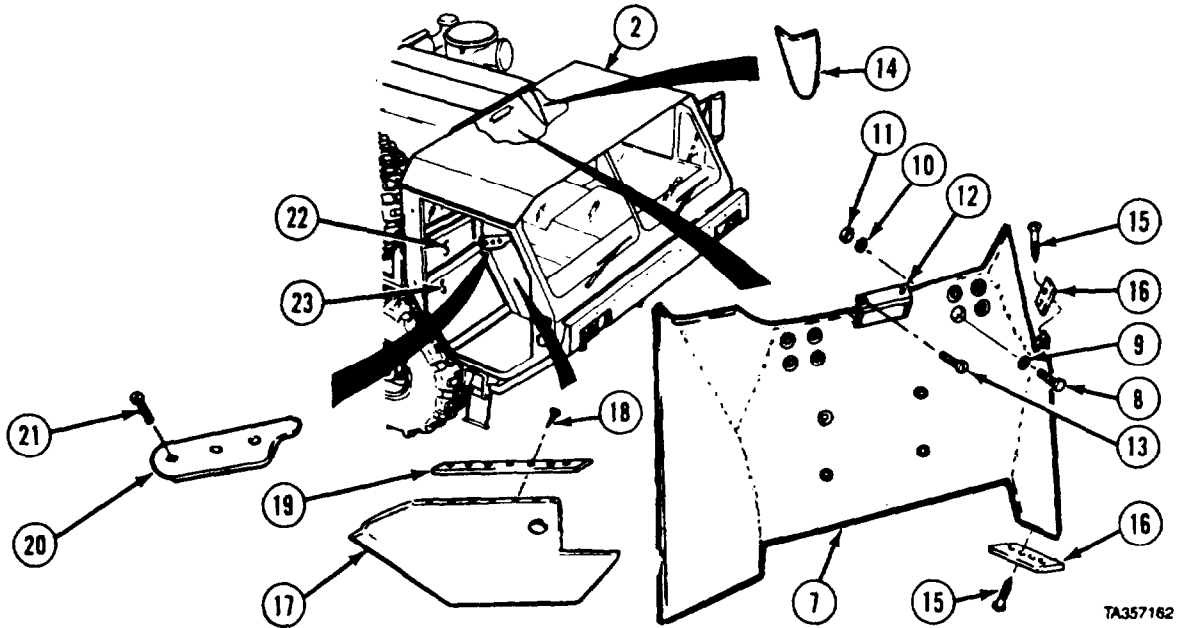

TA357162

- (4) Install insulation (7).
- (5) Soldier A and Soldier B install 12 screws (8), washers (9), lockwashers (10), and nuts (11).
- (6) Install light assembly (12) with two screws (13).
- (7) Install insulation (14).
- (8) Install six screws (15) and two retaining strips (16).
- (9) Install insulation (17).
- (10) Install seven screws (18) and retaining strip (19).
- (11) Install plate (20) with three screws (21).
- (12) Install insulation (22 and 23) on both sides of cab (2).

- (13) Install insulation (24, 25, and 26) on both sides of cab (2).
- (14) Install two handles (27) with four screws (28), washers (29), lockwashers (30) and nuts (31) on both sides of cab (2).

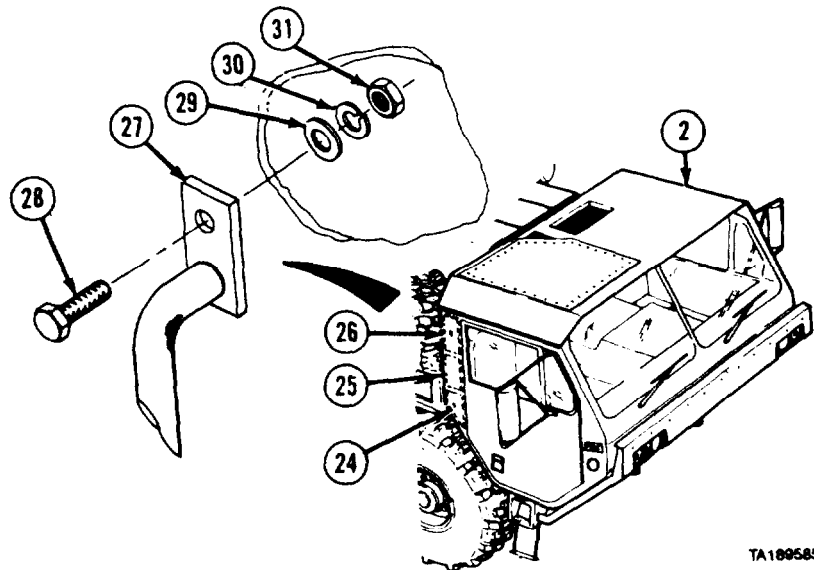

TA189585

Cab and Body Maintenance Instructions (Cont)

15-5. INSULATION REMOVAL/INSTALLATION (CONT).

- (15) Install cab side insulation (32).
- (16) Install cab roof insulations (33,34, 35, and 36).

C. Follow-on Maintenance.

- (1) Install cab fire extinguisher (TM 9-2320-279-10).
- (2) Install windshield washer bottle (TM 9-2320-279-10).
- (3) Install engine switch bracket (TM 9-2320-279-20).
- (4) Install recovery winch cable bracket (TM 9-2320-279-20).
- (5) Install recovery winch handle (TM 9-2320-279-20).

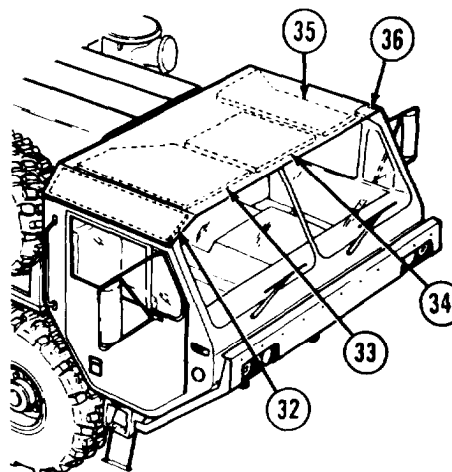

END OF TASK

Section III. PUMP MODULE, TANK, AND CARGO BODIES

15-6. STATIC GROUND REEL REPAIR (M978).	
This task covers:	
<ul style="list-style-type: none"> a. Disassembly b. Cleaning/Inspection 	<ul style="list-style-type: none"> c. Assembly d. Follow-on Maintenance
INITIAL SETUP	
<i>Models</i> M978	<i>Equipment Condition</i> TM or Para
<i>Test Equipment</i> None	<i>Condition Description</i> Static ground reel on clean work surface.
<i>Special Tools</i> None	<i>Special Environmental Conditions</i> None
<i>Supplies</i> Oil, lubricating, Item 46, Appendix C	<i>General Safety Instructions</i> None
<i>Personnel Required</i> MOS 63W, Wheel vehicle repairer	<i>Level of Maintenance</i> Direct Support
<i>References</i> None	

Cab and Body Maintenance Instructions (Cont)

a. Disassembly.

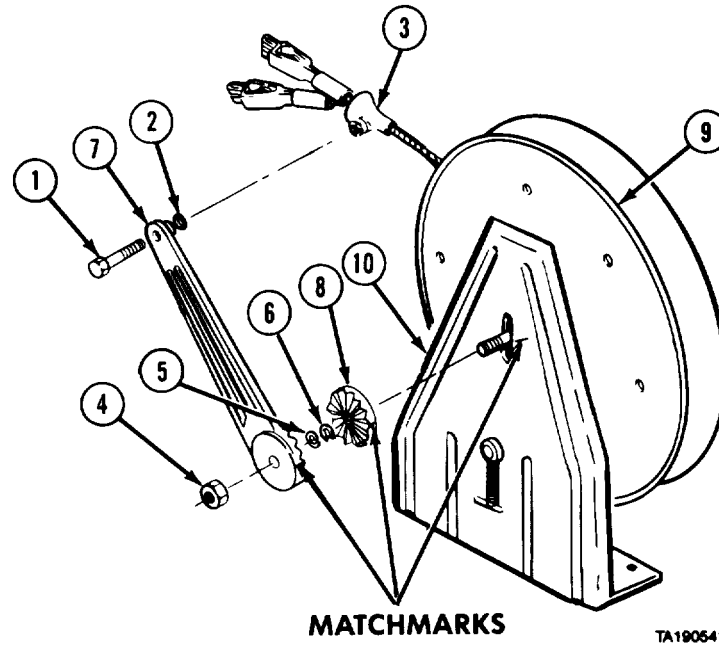

NOTE

Matchmark frame, guide arm, and arm positioner before removal.

- (1) Remove screw (1), washer (2), and cable guide (3).
- (2) Remove nut (4), lockwasher (5), lockwasher (6), guide arm (7), and arm positioner (8).
- (3) Remove reel (9) from frame (10).

- (4) Remove spring (11) from frame (10) and cotter pin (12).

WARNING

Wear safety glasses while removing retaining rings to protect eyes from injury or blindness.

- (5) Remove cotter pin (12) and retaining ring (13) from pawl (14).

CAUTION

Needle bearings may fall out when removing bearing.

- (6) Remove pawl (14) and needle bearing (15) from frame (10).

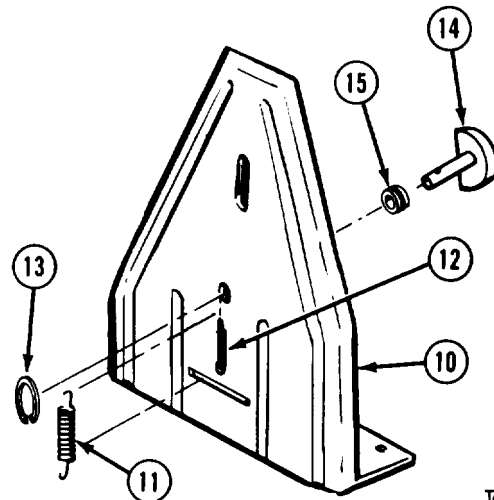

TA190542

Cab and Body Maintenance Instructions (Cont)

15-6. STATIC GROUND REEL REPAIR (M978) (CONT).

NOTE

Number of shims may vary from reel to reel.

- (7) Remove shim spacers (16).
- (8) Remove six screws (17) and front disk assembly (18) from back disk assembly (19).
- (9) Remove spacer (20).

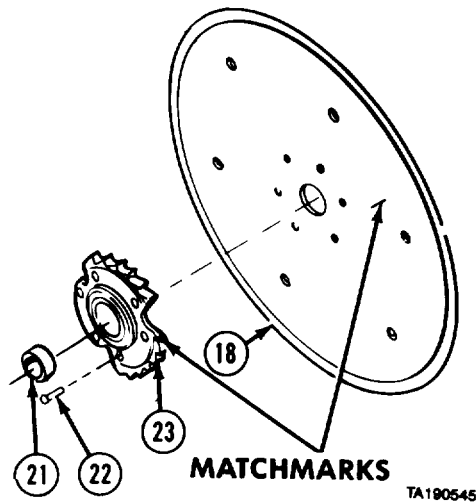
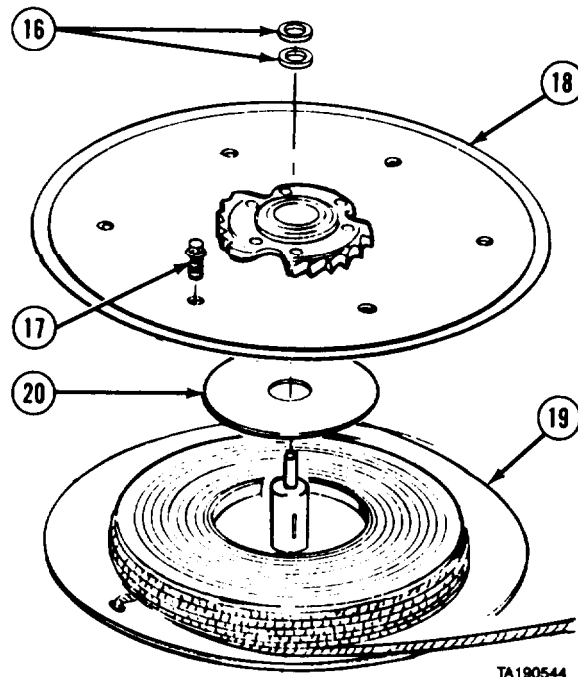

NOTE

Matchmark ratchet position.

- (10) Press out roller bearing (21).
- (21) Remove six rivets (22) and ratchet (23) from front disk assembly (18).

Cab and Body Maintenance Instructions (Cont)

WARNING

Spring is tightly wound and must be tied together to contain spring coils. If spring is not tied together when removed, spring will unwind with force causing injury to personnel.

- (12) Tie spring (24) together and remove spring from back disk assembly (19).

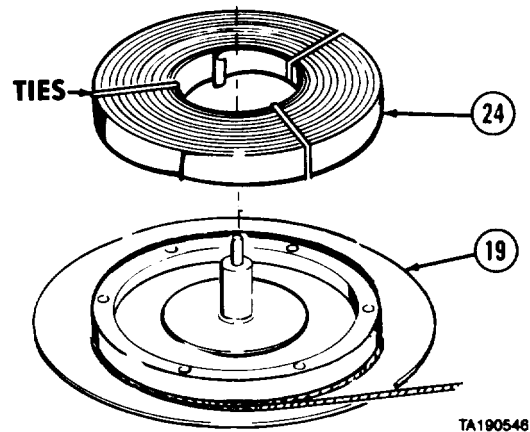

TA190546

- (13) Separate coated cable (25) from back disk assembly (19).
- (14) Remove screw (26) and coated cable (25).
- (15) Remove cable terminal (27) from coated cable (25).
- (16) Remove setscrew (28) from hub collar (29).

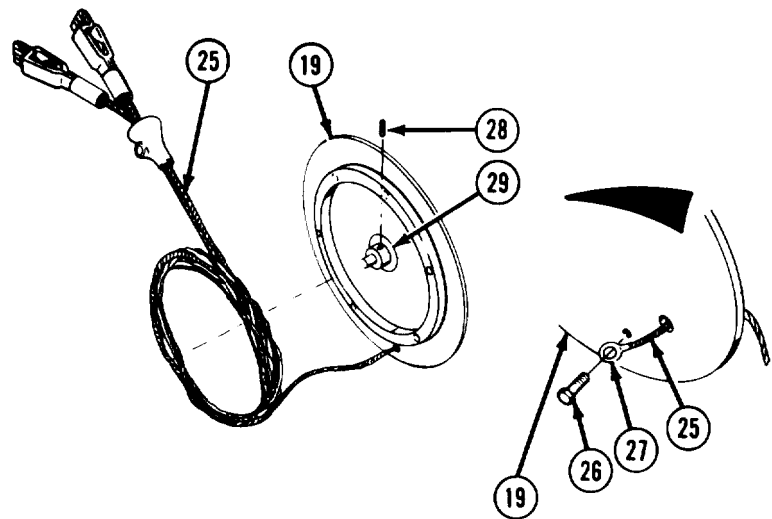

TA190547

WARNING

Wear safety glasses while removing retaining rings to protect eyes from possible injury or blindness.

NOTE

Number of shim spacers may vary from reel to reel.

- (17) Remove retaining ring (30) and shim spacers (31).
- (18) Matchmark and press out hub collar (29) and hub shaft (32).
- (19) Remove spacer (33).
- (20) Press out roller bearing (34) through back disk assembly (19).
- (21) Remove key (35) from hub shaft (32).

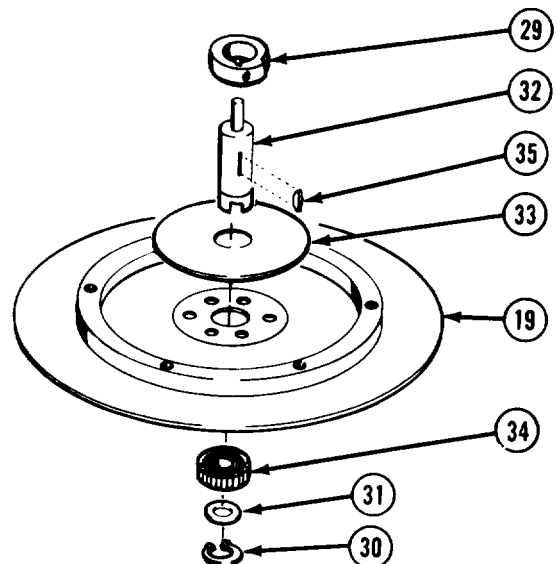

TA190548

Cab and Body Maintenance Instructions (Cont)

15-6. STATIC GROUND REEL REPAIR (M978) (CONT).

NOTE

Matchmark reel drum and back disk assembly before removal.

- (22) Remove five screws (36) and reel drum (37) from back disk assembly (19).
- (23) Remove six rivets (38) and washer (39).

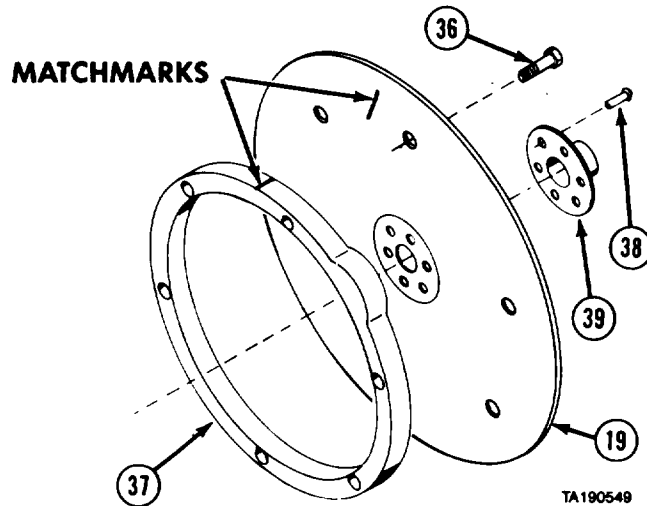

NOTE

Both cable clamps are removed the same way.

- (24) Remove screw (40) and cable clamp (41).
- (25) Remove cable terminal (42), rubber bumper (43), and cable guide (3) from coated cable (25).

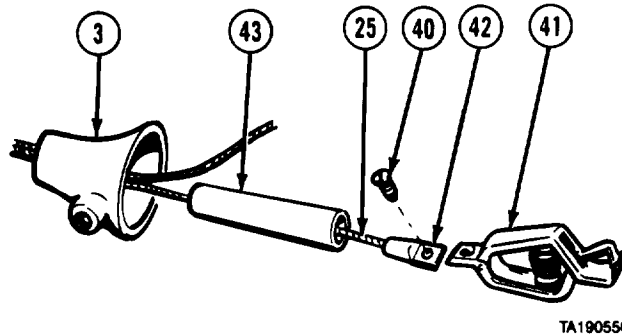

b. Cleaning/Inspection.

WARNING

Adhesives, solvents, and sealing compounds can burn easily, can give off harmful vapors, and are harmful to skin and clothing. To avoid injury or death, keep away from open fire and use in well-ventilated area. If adhesive, solvent, or sealing compound gets on skin or clothing, wash immediately with soap and water.

- (1) Clean all metal components of static ground reel with dry cleaning solvent.
- (2) Inspect all parts for damage and replace damaged parts as necessary.
- (3) Inspect cable clamp for proper operation.
- (4) Inspect coated cable for kinks and broken strands.

Cab and Body Maintenance Instructions (Cont)

c. Assembly.

NOTE

Both cable clamps are installed the same way.

- (1) Slide cable guide (1) over two coated cables (2).
- (2) Slide rubber bumper (3) over each coated cable (2).
- (3) Install cable terminal (4) on end of each coated cable (2).
- (4) Install cable clamp (5) on each cable terminal (4) with screw (6).
- (5) Install washer (7) on back disk assembly (8) with six rivets (9).
- (6) Install roller bearing (10) in washer (7).
- (7) Align reel drum (11) with matchmarks on back disk (8) and install with five screws (12).

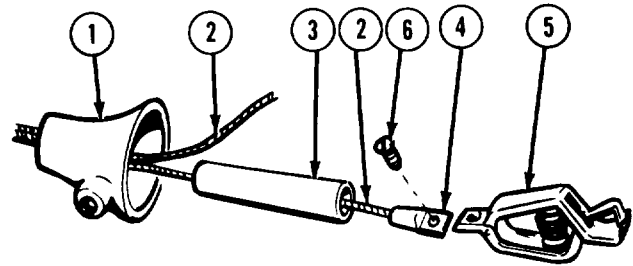

TA190551

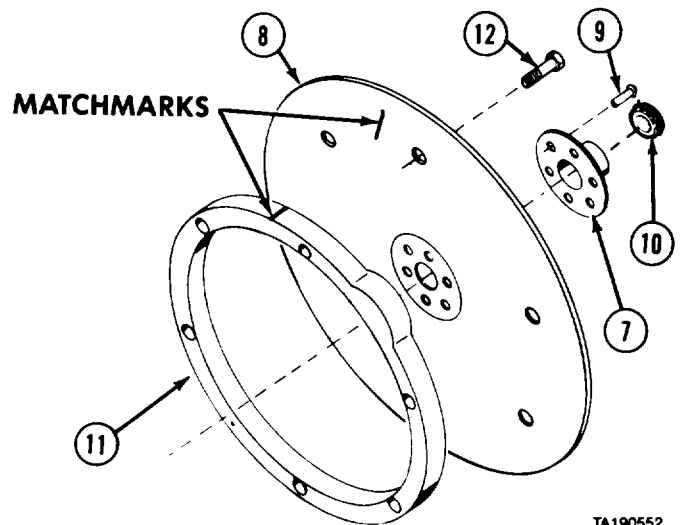

TA190552

- (8) Install key (13) in hub shaft (14).
- (9) A line and install hub collar (15) on hub shaft (14).
- (10) Install spacer (16), hub shaft (14), and hub collar (15) through back disk assembly (8).
- (11) Install shim spacer (17) and retaining ring (18).
- (12) Install setscrew (19) in hub collar (15).

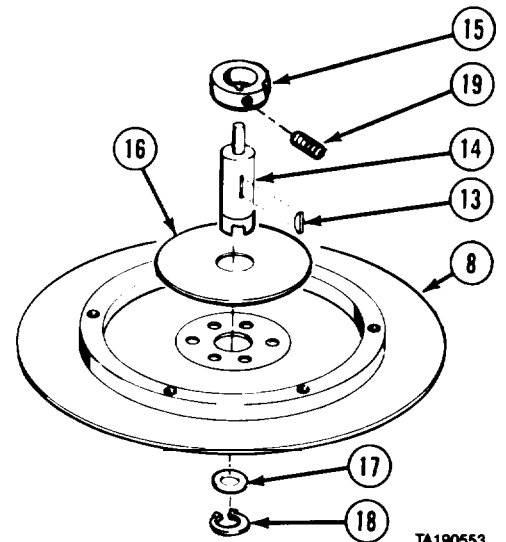

TA190553

Cab and Body Maintenance Instructions (Cont)

15-6. STATIC GROUND REEL REPAIR (M978) (CONT).

- (13) Route other end of coated cable (2) through hole in back disk assembly (8).
- (14) Install cable terminal (20) on coated cable (2).
- (15) Install cable terminal (20) on back disk assembly (8) with screw (21).

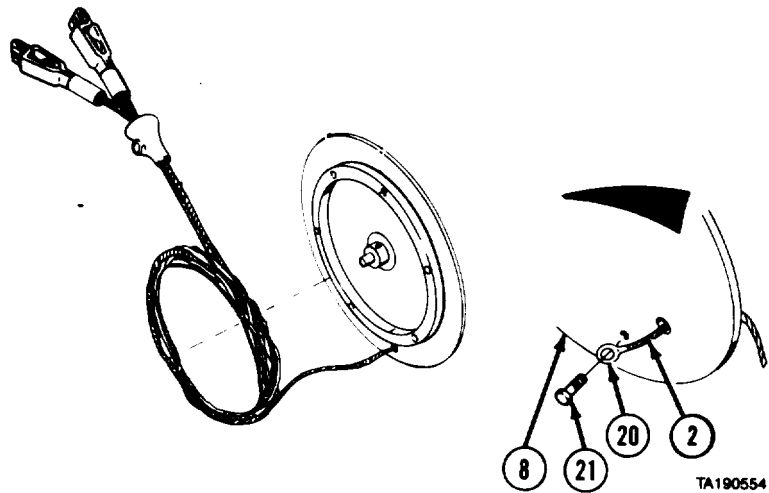

WARNING

Do not untie spring until spring is securely installed in back disk assembly. Spring is tightly wound. If spring is released before it is installed, spring will unwind causing injury to personnel.

- (16) Position spring (22) in back disk assembly (8) so hooked ends of spring are installed in cut-outs on reel drum (11) and hub collar (15).
- (17) Remove ties from spring (22).

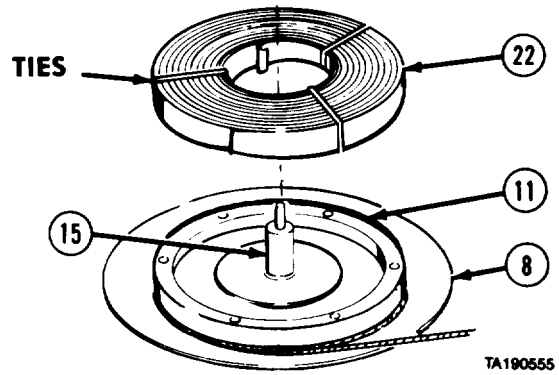

- (18) Install roller bearing (23) in ratchet (24).
- (19) Aline ratchet (24) with matchmarks on front disk assembly (25) and install with six rivets (26).

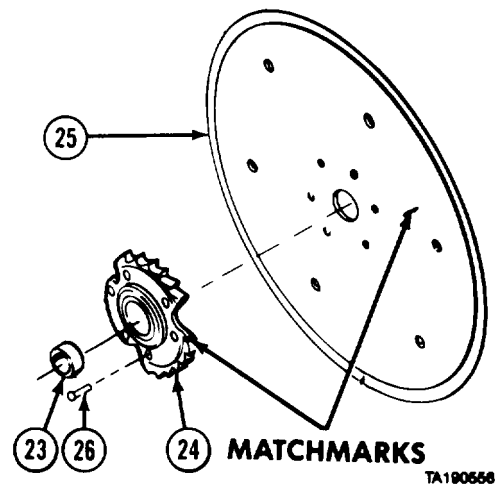

Cab and Body Maintenance Instructions (Cont)

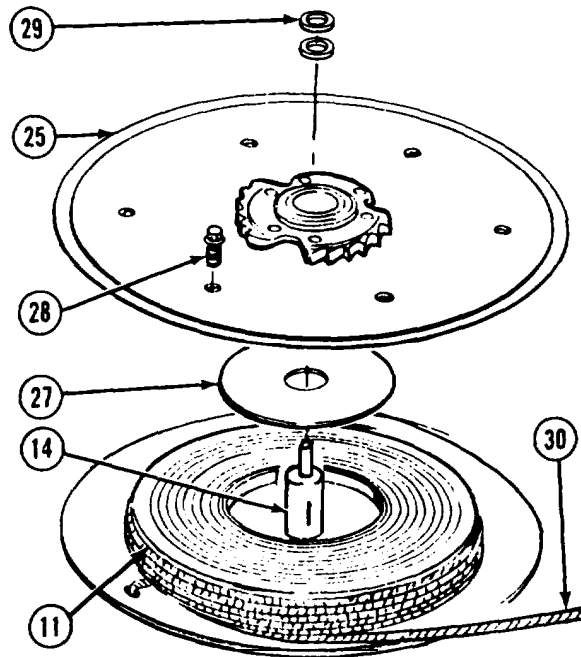

- (20) Install spacer (27) on hub shaft (14).
- (21) Mine front disk assembly (25) on reel drum (11) and install with six screws (28).
- (22) Install shim spacer (29).
- (23) Install cable (30) on reel drum (11).
- (23.1) Apply light coating of oil to needle bearing (31) and shaft of Pawl (32).
- (24) Install needle bearing (31) and pawl (32) in frame (33).
- (25) Install retaining ring (34).

NOTE

Pawl must be point up when installing cotter pin to ensure proper operation of ratchet.

- (26) Install cotter pin (35) in pawl (32).
- (27) Install spring (36) in cotter pin (35) and frame (33).

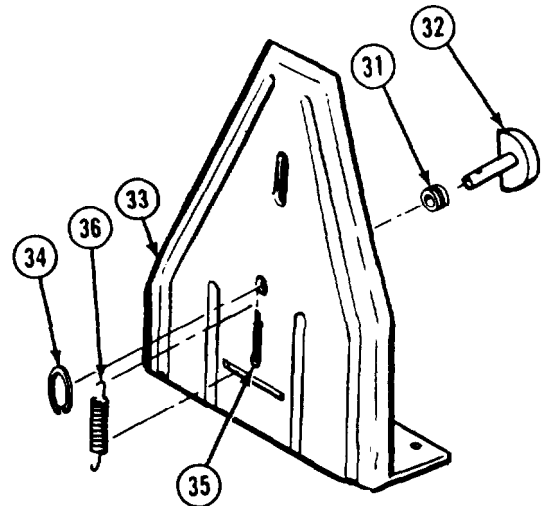

Cab and Body Maintenance Instructions (Cont)

15-6. STATIC GROUND REEL REPAIR (M978) (CONT).

- (28) Install reel (37) on frame (33).
- (29) Install arm positioner (38), guide arm (39), lockwasher (40), and lockwasher (41). Aline guide arm with matchmarks on frame (33) and install nut (42).
- (30) Install screw (43) and washer (44) through guide arm (39) and cable guide (1).
- (31) Check measurement from top of cable guide (1) to bottom of frame (33). Measurement should be 17.0 in. (431.8 mm).
- (32) Check measurement from center of pawl (32) to center of reel.
- (33) If measurements in steps (31) and/or (32) are incorrect, disassemble reel and correct.

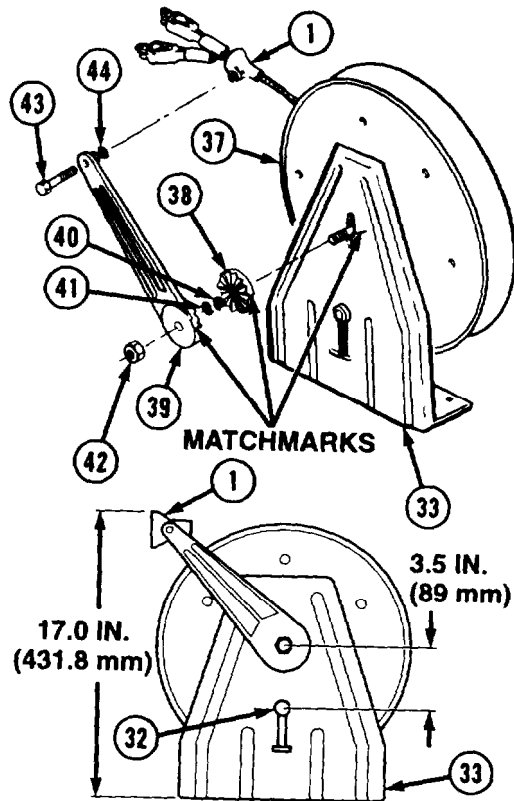

d. Follow-on Maintenance. None.

END OF TASK

15-7. H1 AND H2 FUEL TRANSFER HOSE REEL REPAIR (M978)

This task covers:

- a. Disassembly
- b. Cleaning/Inspection
- c. Assembly
- d. Follow-on Maintenance

INITIAL SETUP

Models

M978

Test Equipment

None

Special Tools

None

Supplies

Adhesive-sealant, silicone, Item 6, Appendix C
 Compound, sealing, pipe thread, Item 29, Appendix C
 Solvent, drycleaning, Item 57, Appendix C

Personnel Required

MOS 63W, Wheel vehicle repairer

References

None

Equipment Condition

TM or Para

Condition Description
 H1 or H2 fuel transfer hose reel on clean work surface.

Special Environmental Conditions

None

General Safety Instructions

No smoking, flame, sparks, and hot or glowing objects within 50 ft (15 m) of fuel transfer hose reel.

Level of Maintenance

Direct Support

Cab and Body Maintenance Instructions (Cont)

a. Disassembly.

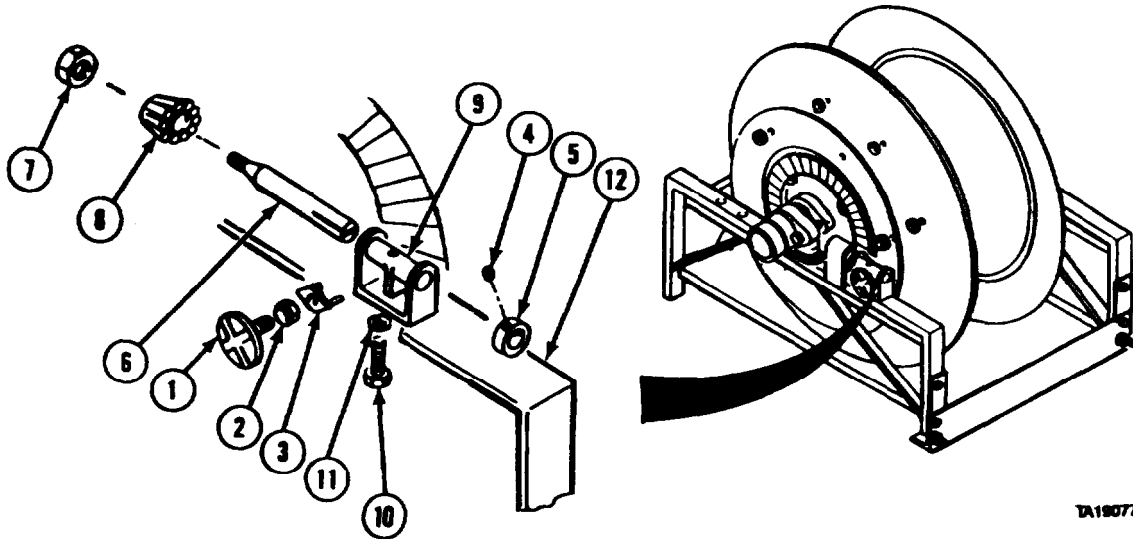

TA180775

NOTE

H1 and H2 fuel transfer hose reels are disassembled the same way. H2 fuel transfer hose reel is shown.

- (1) Remove brake wheel (1), brake spring (2), and brake pad (3).
- (2) Loosen setscrew (4) and remove collar (5) from pinion shaft (6).
- (3) Remove nut (7).
- (4) Remove pinion gear (8) and pinion shaft (6) from pinion bearing (9).
- (5) Remove two screws (10), lockwashers (11), and pinion bearing (9) from front frame (12).

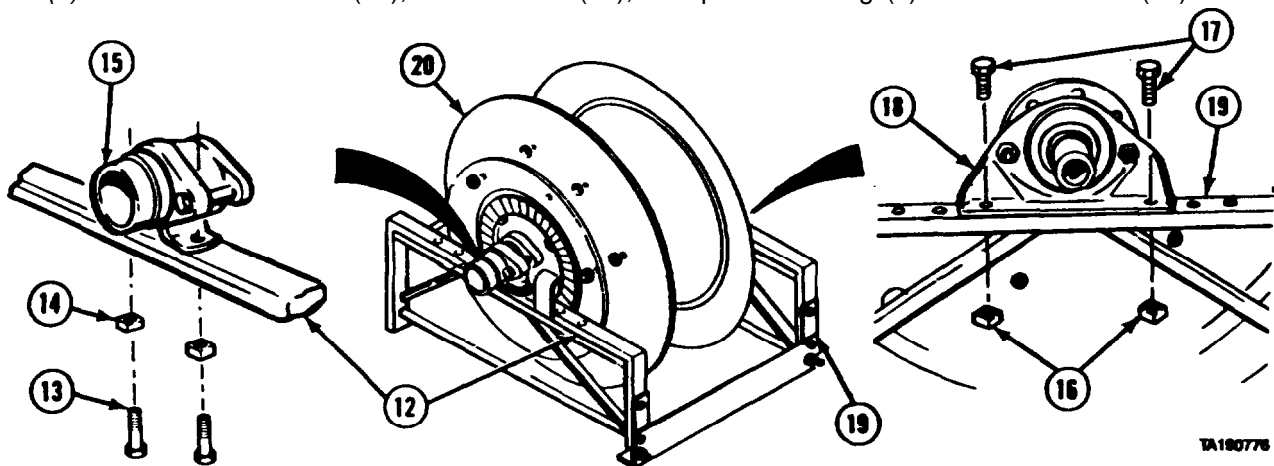

TA180776

- (6) Remove two screws (13) and spacers (14) from packing gland (15) and front frame (12).
- (7) Remove two nuts (16) and screws (17) from pillow block (18) and back frame (19).
- (8) Remove reel (20) from front and back frames (12 and 19).

Cab and Body Maintenance Instructions (Cont)

15-7. H1 AND H2 FUEL TRANSFER HOSE REEL REPAIR (M978) (CONT).

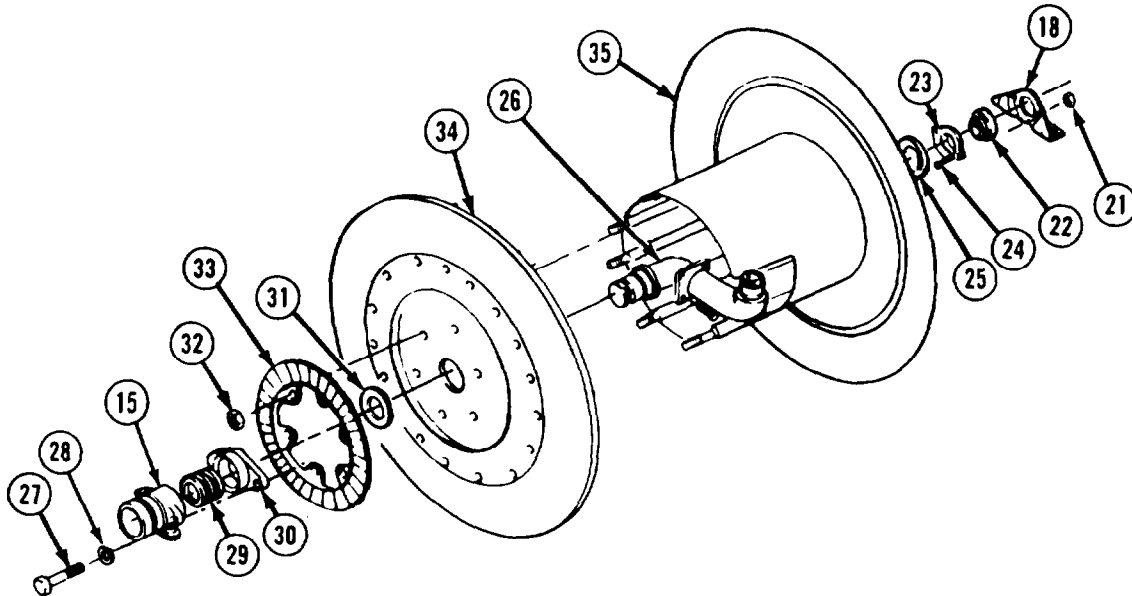

- (9) Remove two nuts (21), pillow block (18), ball bearing (22), bearing holder (23), screws (24), and washer (25) from hub assembly (26).
- (10) Remove two screws (27), lockwashers (28), packing gland (15), packing (29), follower (30), and washer (31) from hub assembly (26).
- (11) Remove six nuts (32), ring gear (33), and front disk (34) from back disk (35).
- (12) Remove hub assembly (26) from back disk (35).
- (13) Remove four screws (36), flanged riser (37), and gasket (38) from hub assembly (26).

NOTE

If nipple is not 2.5 in. (63.5 mm) long, replace with standard nipple (P/N MS 51593-171).

- (14) Remove nipple (39) from flanged riser (37).
- (15) Remove drum (40), six spacer pipes (41), and six bolts (42).

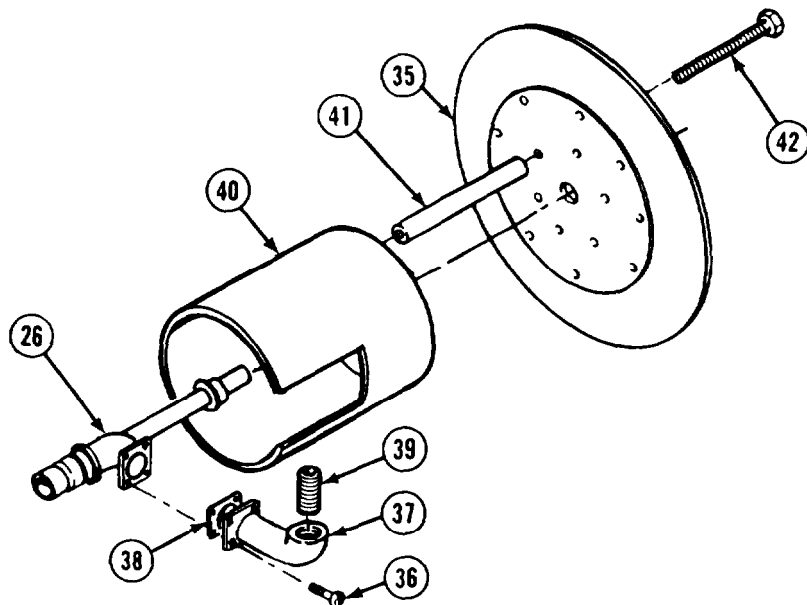

Cab and Body Maintenance Instructions (Cont)

b. Cleaning/Inspection.

WARNING

Adhesives, solvents, and sealing compounds can burn easily, can give off harmful vapors, and are harmful to skin and clothing. To avoid injury or death, keep away from open fire and use in well-ventilated area. If adhesive, solvent, or sealing compound gets on skin or clothing, wash immediately with soap and water.

- (1) Clean all metal parts of hose reel with drycleaning solvent.
- (2) Inspect parts for damage.
- (3) Replace all damaged parts.

c. Assembly.

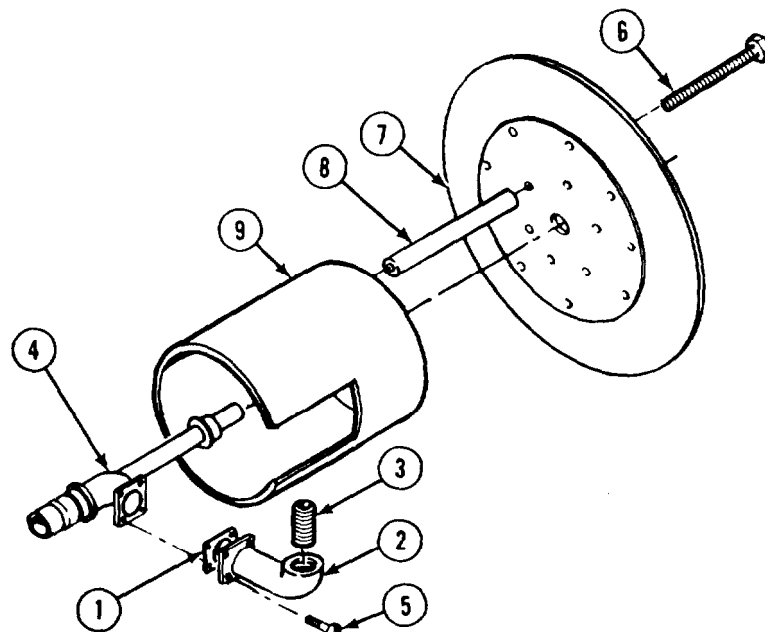

WARNING

Adhesives, solvents, and sealing compounds can burn easily, can give off harmful vapors, and are harmful to skin and clothing. To avoid injury or death, keep away from open fire and use in well-ventilated area. If adhesive, solvent, or sealing compound gets on skin or clothing, wash immediately with soap and water.

NOTE

- H1 and H2 fuel transfer hose reels are assembled the same way. H2 fuel transfer hose reel is shown.
- Ensure nipple is 2.5 in. (63.5 mm) long. If length is not correct, replace with standard nipple (P/N MS 51593-171).

- (1) Apply silicone adhesive-sealant to gasket (1) and install on flanged riser (2).
- (2) Apply pipe thread sealing compound and install nipple (3) in flanged riser (2).
- (3) Install flanged riser (2) on hub assembly (4) with four screws (5).
- (4) Insert six screws (6) through inner holes of back disk (7).
- (5) Position spacer pipes (8) over each screw (6) and place drum (9) over screws and spacer pipes.
- (6) Install flanged riser (2) and hub assembly (4) in center hole of back disk (7) so flanged riser fits in gap of drum (9).

Cab and Body Maintenance Instructions (Cont)

15-7. H1 AND H2 FUEL TRANSFER HOSE REEL REPAIR (M978) (CONT).

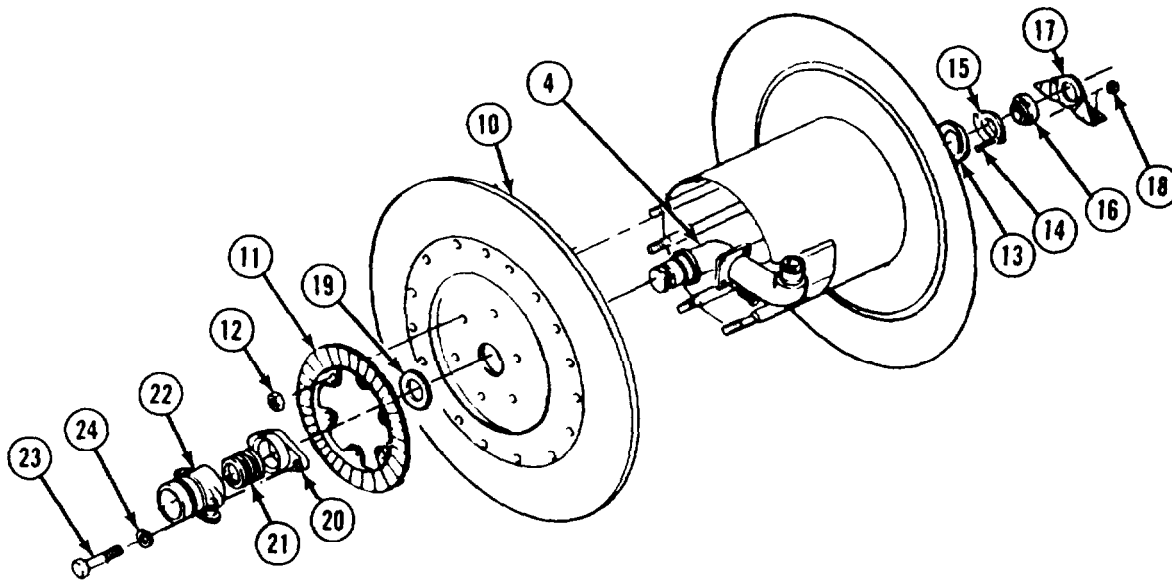

- (7) Position front disk (10) on hub assembly (4) and install ring gear (11) and six nuts (12).
- (8) Install washer (13), two screws (14), bearing holder (15), ball bearing (16), pillow block (17), and nuts (18).

NOTE

The packing style joint assembly requires occasional tightening for proper sealing. The two screws should be tightened alternately and evenly until the lockwashers are flattened and/or there is no evidence of leakage. Care should be taken to alternately tighten each screw in 1/4 turn increments. Do not completely tighten one screw and then the other.

- (9) Install washer (19), follower (20), packings (21), packing gland (22), two screws (23), and lockwashers (24) on hub assembly (4) and front disk (10).

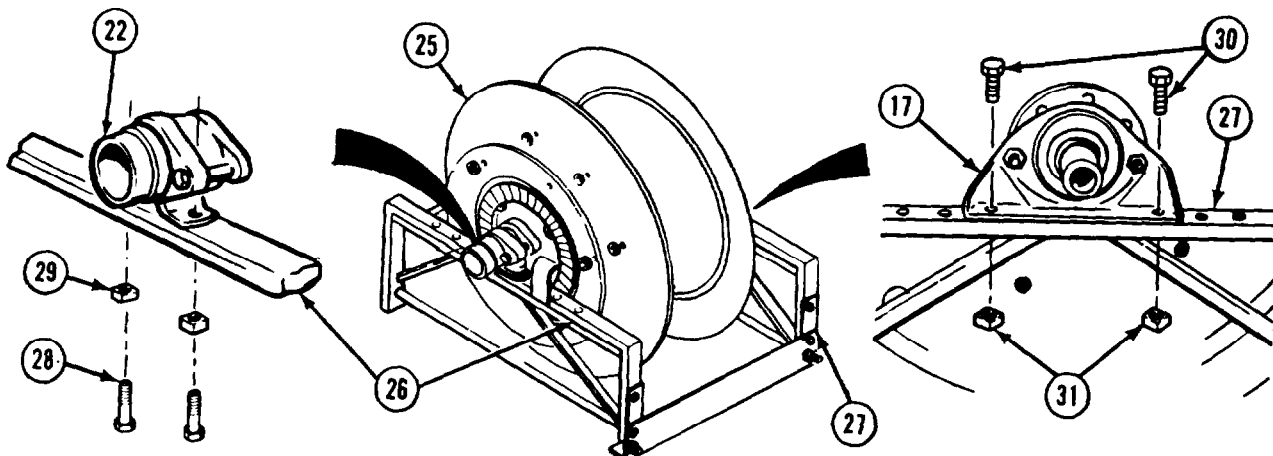

- (10) Install reel (25) in front frame (26) and back frame (27).
- (11) Install two screws (28) and spacers (29) through front frame (26) into packing gland (22)
- (12) Install two screws (30) through pillow block (17) and rear frame (27) and install two nuts (31).

Cab and Body Maintenance Instructions (Cont)

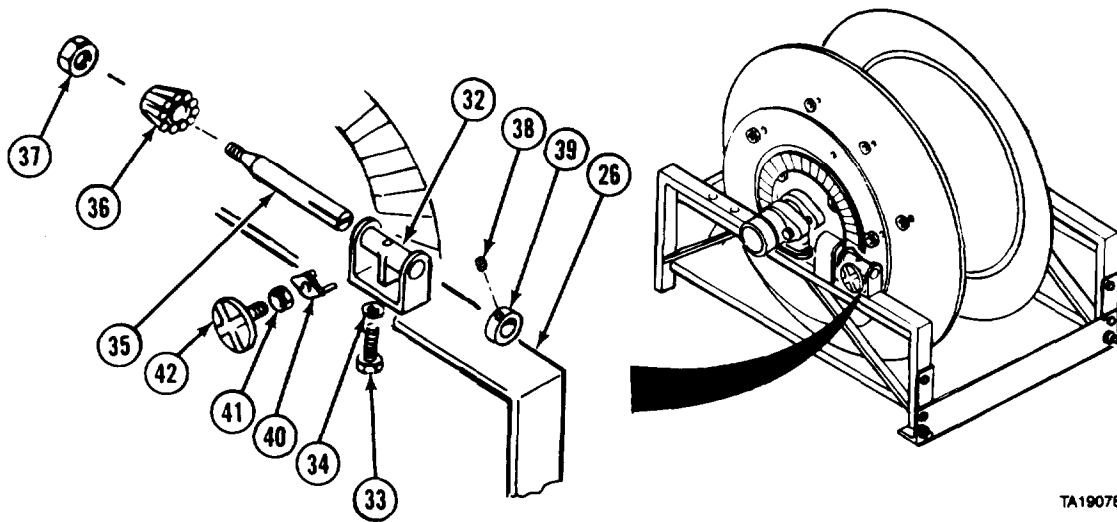

TA190782

- (13) Position pinion bearing (32) on front frame (26) and install screws (33) and lockwashers (34).
- (14) Insert threaded end of pinion shaft (35) through pinion bearing (32) and install pinion gear (36) and nut (37) on pinion shaft.
- (15) Loosen setscrew (38) in pinion shaft collar (39). Install pinion shaft collar on pinion shaft (35) and tighten setscrew.
- (16) Install brake pad (40), brake spring (41), and brake wheel (42) on pinion bearing (32).

d. Follow-on Maintenance. None.

END OF TASK

15-8. HAV HAND ACTUATED CONTROL VALVE HOSE REEL REPAIR (M978).	
This task covers:	
a. Disassembly	c. Assembly
b. Cleaning/Inspection	d. Follow-on Maintenance
INITIAL SETUP	
Models M978	References None
Test Equipment None	Equipment Condition
Special Tools None	TM or Para Condition Description HAV control hose reel on clean work surface.
Supplies Compound, sealing, pipe thread, Item 29, Appendix C Solvent, dry cleaning, Item 57, Appendix C	Special Environmental Conditions None
Personnel Required MOS 63W, Wheel vehicle repairer	General Safety Instructions None
	Level of Maintenance Direct Support

Cab and Body Maintenance Instructions (Cont)

15-8. HAV HAND ACTUATED CONTROL VALVE HOSE REEL REPAIR (M978) (CONT).

a. Disassembly.

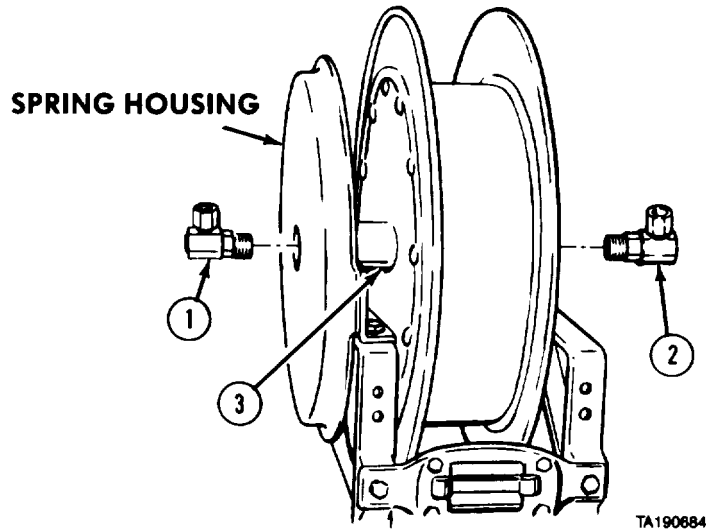

WARNING

Be careful when removing swivel joints. Spring housing may unwind when swivel joints are removed causing injury to personnel.

- (1) Remove two swivel joints (1 and 2) from dual outlet hub (3).
- (2) Remove two nuts (4), screws (5), and front mount (6).
- (3) Remove two nuts (7), screws (8), and rear mount (9).

NOTE

Relieve tension on spring before removing spring housing.

- (4) Remove four nuts (10), screws (11), and spring housing (12) from two brackets (13).

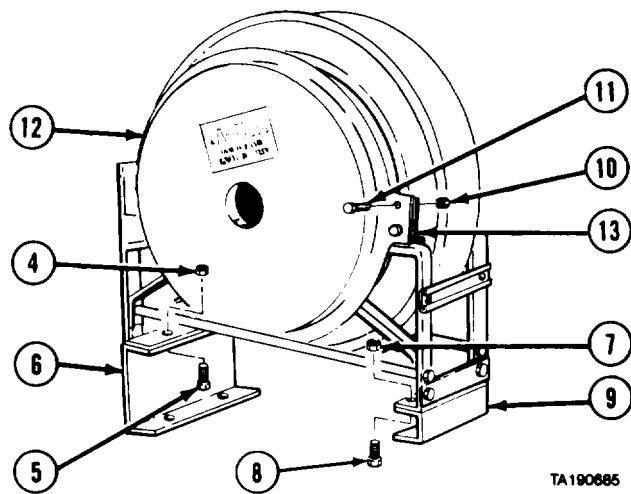

Cab and Body Maintenance Instructions (Cont)

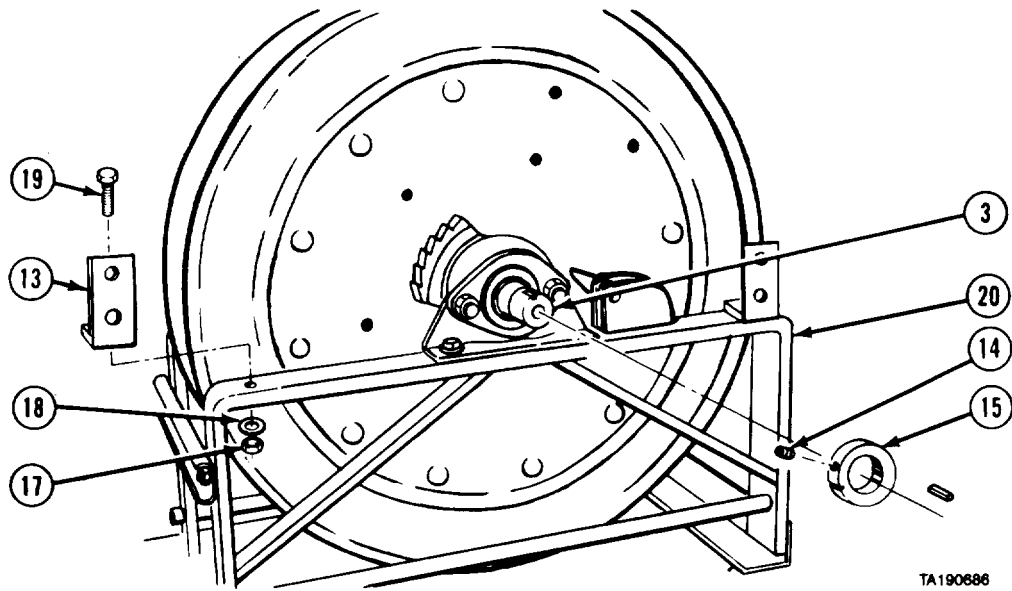

NOTE

Match mark spring arbor and hub before removal,

- (5) Remove setscrew (14), spring arbor (15), and key (16) from dual outlet hub (3).
- (6) Remove two nuts (17), washers (18), screws (19), and brackets (13) from stand (20).
- (7) Remove two nuts (21), screws (22), and ratchet mechanism (23) from stand (20).
- (8) Remove two locknuts (24), screws (25), bearing holder (26), and shim (27) from stand (20) and dual outlet hub (3).
- (9) Repeat step (8) for other side.
- (10) Remove hose reel (28) from stand (20).

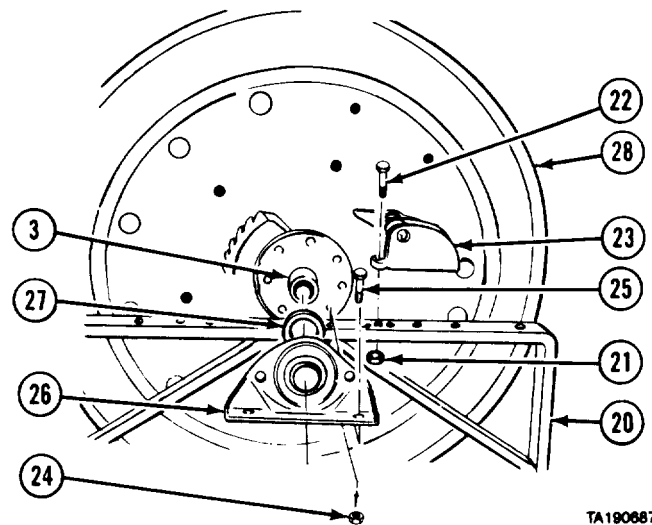

Cab and Body Maintenance Instructions (Cont)

15-8. HAV HAND ACTUATED CONTROL VALVE HOSE REEL REPAIR (M978) (CONT).

NOTE

Right and left bearing holders are disassembled the same way.

- (11) Remove two locknuts (29) and screws (30) from pillow block (31) and bearing holder (26).
- (12) Remove bearing (32) from bearing holder (26).

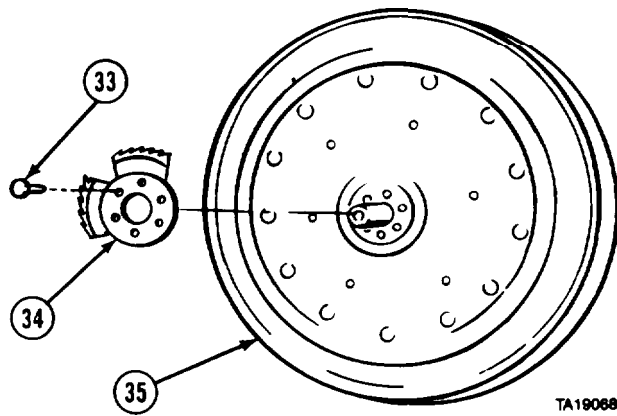
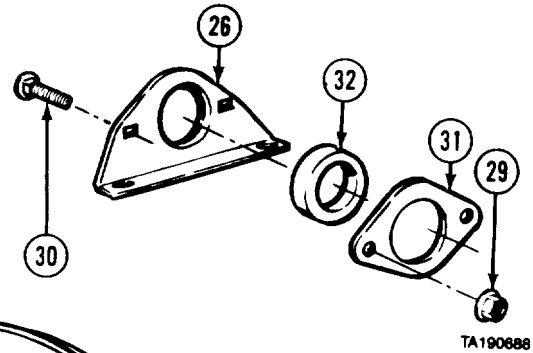

- (13) Remove six rivets (33) and ratchet wheel (34) from front disk (35).

- (14) Remove 10 nuts (36), screws (37), and front disk (35) from back disk (38).

- (15) Remove drum (39) and 10 spacer pipes (40).

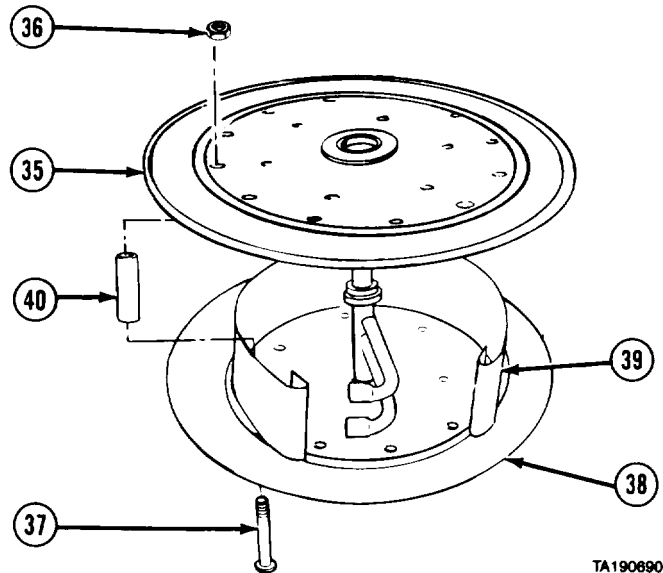

Cab and Body Maintenance Instructions (Cont)

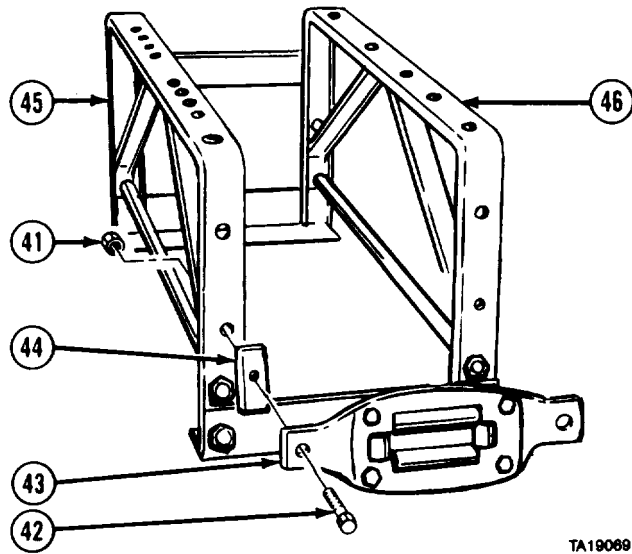

(16) Remove two nuts (41), screws (42), roller (43), and spacers (44) from front frame (45) and back frame (46).

b. Cleaning/Inspection.

WARNING

Adhesives, solvents, and sealing compounds can burn easily, can give off harmful vapors, and are harmful to skin and clothing. To avoid injury or death, keep away from open fire and use in well-ventilated area. If adhesive, solvent, or sealing compound gets on skin or clothing, wash immediately with soap and water.

- (1) Clean all metal parts in dry cleaning solvent.
- (2) Inspect all parts for damage.
- (3) Replace all damaged parts.

c. Assembly.

(1) Install two spacers (1) and roller (2) on front frame (3) and back frame (4) with two screws (5) and nuts (6).

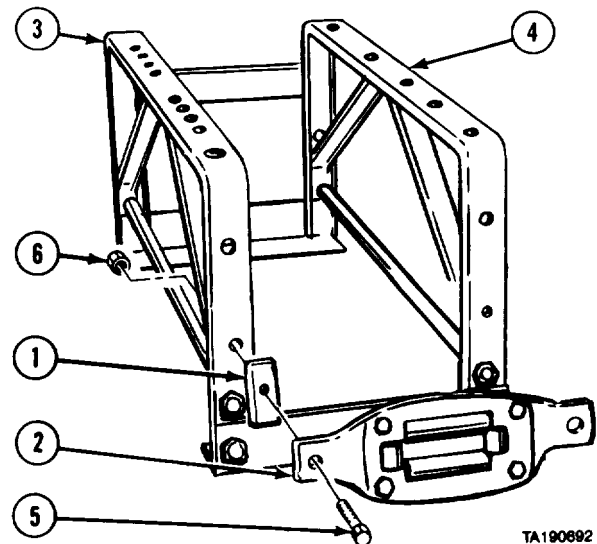

Cab and Body Maintenance Instructions (Cont)

15-8. HAV HAND ACTUATED CONTROL VALVE HOSE REEL REPAIR (M978) (CONT).

- (2) Install front disk (7) and drum (8) on back disk (9) with ten screws (10), spacer pipes (11) and nuts (12).

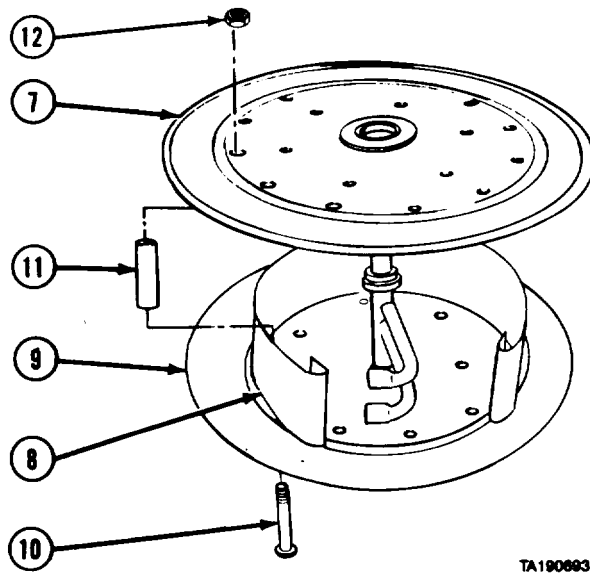

TA190693

- (3) Install ratchet wheel (13) on front disk (7) with six rivets (14).

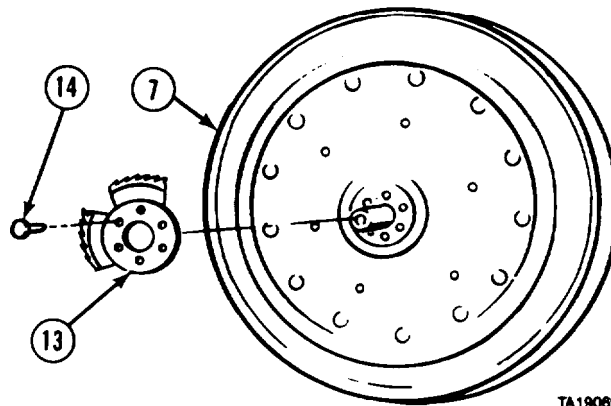

TA190694

NOTE

Right and left bearing holders are assembled the same way.

- (4) Install bearing (15) and pillow block (16) on bearing holder (17) with two screws (18) and locknuts (19).

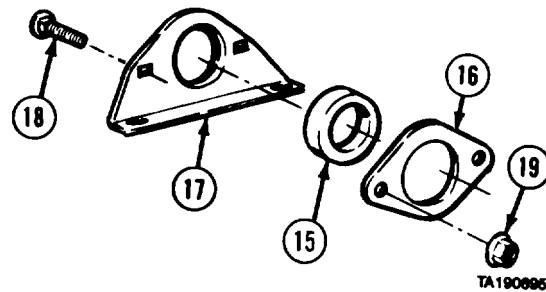

TA190695

Cab and Body Maintenance Instructions (Cont)

- (5) Position hose reel (20) in stand (21).
- (6) Install shim (22) on end of dual outlet hub (23).
- (7) Install bearing holder (24) on end of dual outlet hub (23) and stand (21) with two screws (25) and locknuts (26).
- (8) Repeat step (7) for other side.
- (9) Install ratchet mechanism (27) on stand (21) with two screws (28) and locknuts (29).

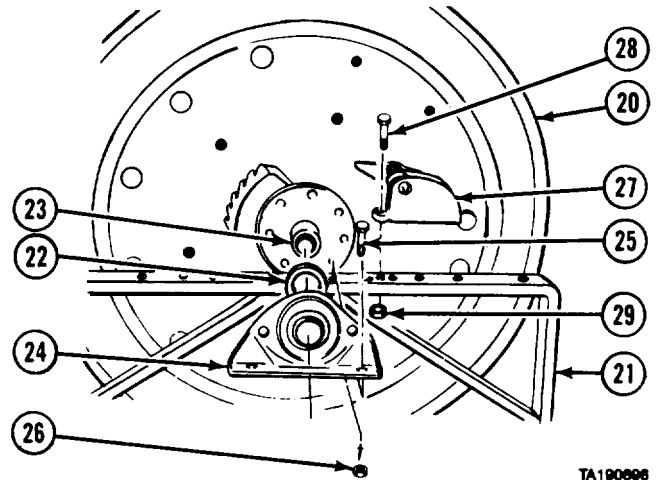

- (10) Install two brackets (30) on stand (21) with two screws (31), washers (32), and nuts (33).
- (11) Install key (34), spring arbor (35), and setscrew (36) on dual outlet hub (23).

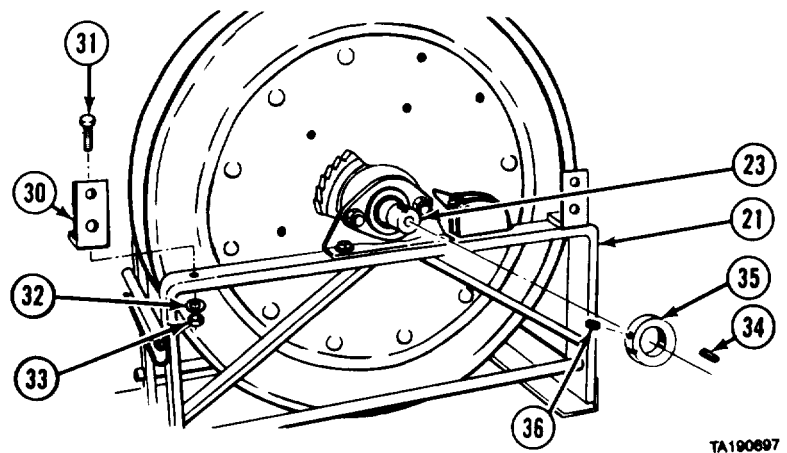

- (12) Install spring housing (37) on two brackets (30) with four screws (38) and nuts (39).
- (13) Install rear mount (40) with two screws (41) and nuts (42).
- (14) Install front mount (43) with two screws (44) and nuts (45).

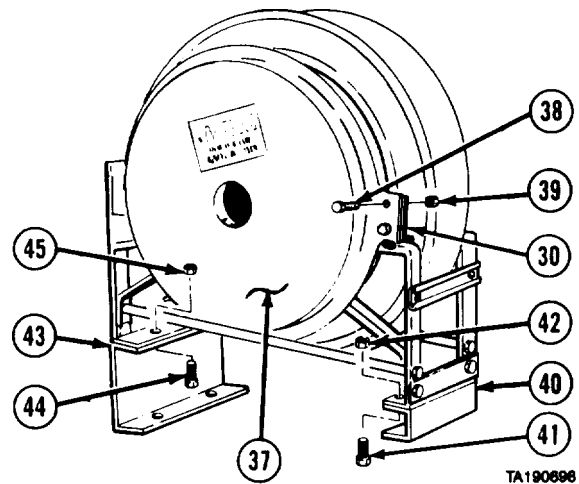

Cab and Body Maintenance Instructions (Cont)

15-8. HAV HAND ACTUATED CONTROL VALVE HOSE REEL REPAIR (M978) (CONT).

WARNING

Adhesives, solvents, and sealing compounds can burn easily, can give off harmful vapors, and are harmful to skin and clothing. To avoid injury or death, keep away from open fire and use in well-ventilated area. If adhesive, solvent, or sealing compound gets on skin or clothing, wash immediately with soap and water.

(15) Apply pipe thread sealing compound to threads of two swivel joints (46 and 47) and install in ends of dual outlet hub (23).

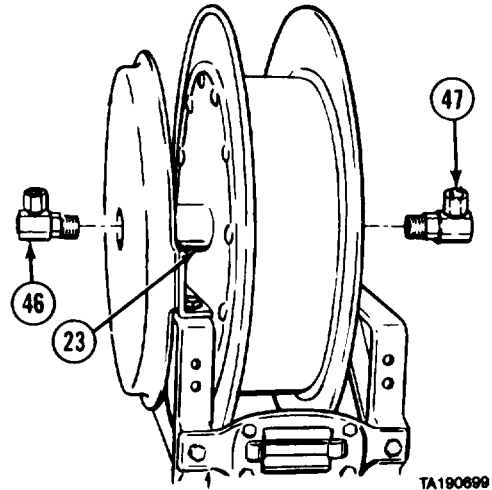

TA190699

d. Follow-on Maintenance. None.

END OF TASK

5-9. CARGO BODY FLOOR HATCH REMOVAL/INSTALLATION (M977, M985).

this task covers:

- a. Removal
- b. Installation
- c. Follow-on Maintenance

INITIAL SETUP

Models

M977, M985

Test Equipment

None

Special Tools

None

Supplies

None

Personnel Required

MOS 63W, Wheel vehicle repairer

References

None

Equipment Condition

TM or Para	Condition Description
TM 9-2320-279-10	Shut off engine.
TM 9-2320-279-10	Cargo body front panel removed.

Special Environmental Conditions

None

General Safety Instructions

None

Level of Maintenance

Direct Support

Cob and Body Maintenance Instructions (Cont)

a. Removal.

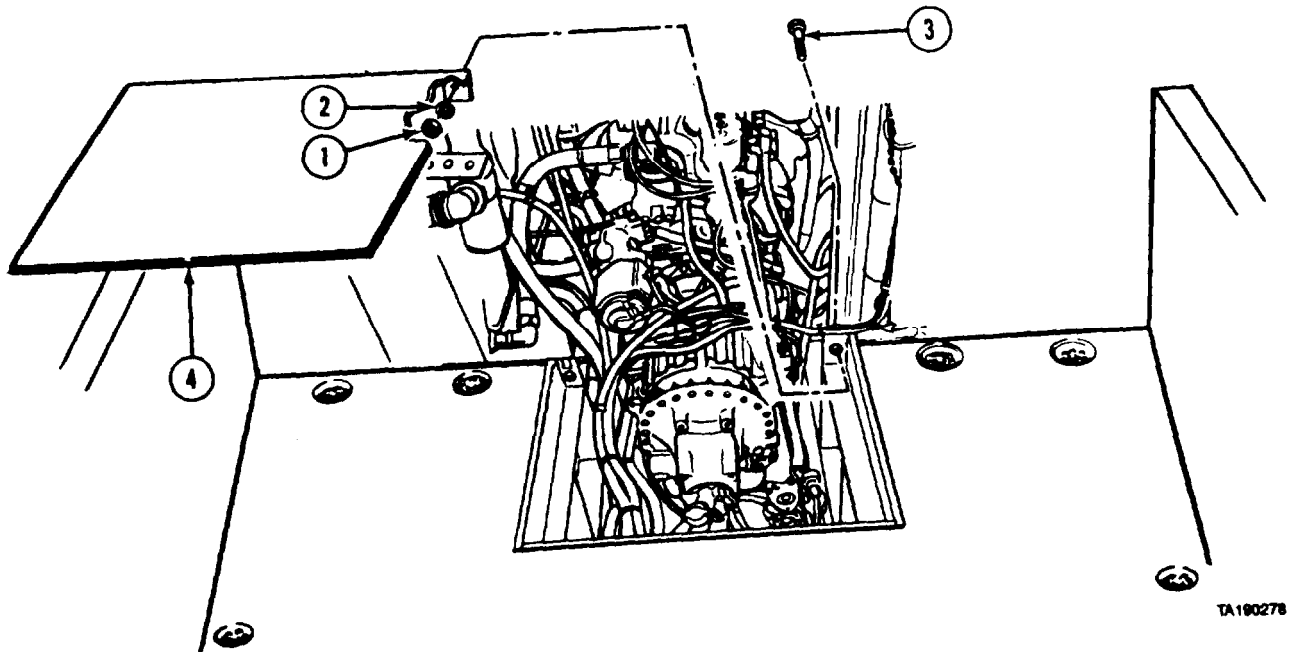

- (1) Remove two nuts (1), lockwashers (2), and screws (3).
- (2) Slide hatch (4) forward and remove.

b. Installation.

- (1) Position hatch (4) over hole and slide back.
- (2) Install two screws (3), lockwashers (2), and nuts (1).

c. Follow-on Maintenance. Install cargo body front panel (TM 9-2320-279-10).

END OF TASK

Cab and Body Maintenance Instructions (Cont)

15-10. CARGO BODY REMOVAL/INSTALLATION (M977, M985, M985E1)

This task covers:

- a. Removal
- b. Installation
- c. Follow-on Maintenance

INITIAL SETUP

Models

M977, M985, M985E1

Test Equipment

None

Special Tools

None

Supplies

Compound, walking, Item 29.1, Appendix C
Ties, cable, plastic, Item 65, Appendix C

Personnel Required

MOS 63W, Wheel vehicle repairer (2)

References

None

Equipment Condition

TM or Para *Condition Description*
TM 9-2320-279-10 Shut off engine.
TM 9-2320-279-10 Ladder and straps removed.
TM 9-2320-355-10 Crane outrigger base plates removed (M985E1 only).

Equipment Condition (cont)

TM or Para *Condition Description*
TM 9-2320-279-20 Reflectors removed.
TM 9-2320-279-20 Marker lights removed.
TM 9-2320-279-20 Crane remote control stowage box removed.
TM 9-2320-279-20 Rear splash guards removed.
TM 9-2320-279-20 Center mud flaps removed.
TM 9-2320-279-20 Crane stowage box removed.
TM 9-2320-279-10 Cargo body side, front, and rear panels removed.

Special Environmental Conditions
None

General Safety Instructions
None

Level of Maintenance
Direct Support

a. Removal.

NOTE

The following steps apply to brackets on both sides of vehicle. Passenger side is shown.

- (1) Remove two locknuts (1) and washers (2).
- (2) Remove two screws (3), washers (4), sleeves (5), springs (6), and washers (7) from bracket (8).

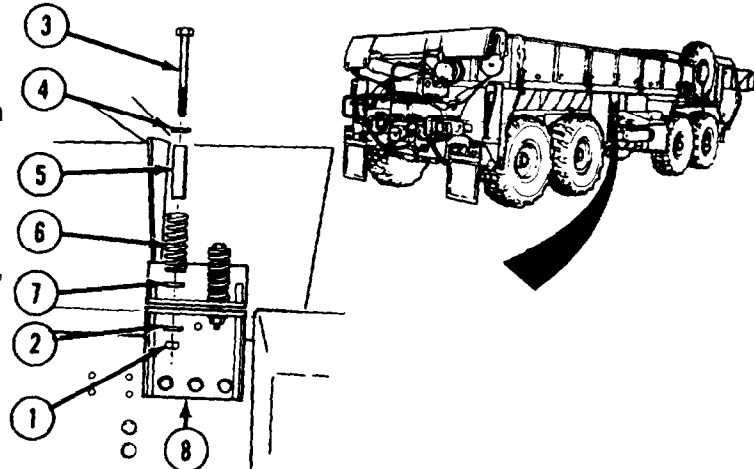

Cab and Body Maintenance Instructions (Cont)

- (3) Remove three locknuts (9) and screws (10).
- (4) Remove spacer (11).

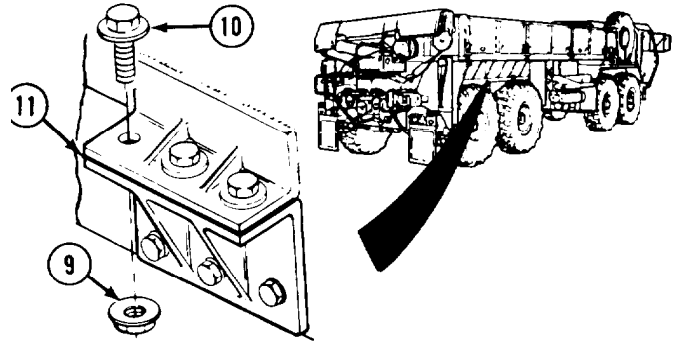

- (5) Remove two nuts (12) and screws (13) from bracket (14).

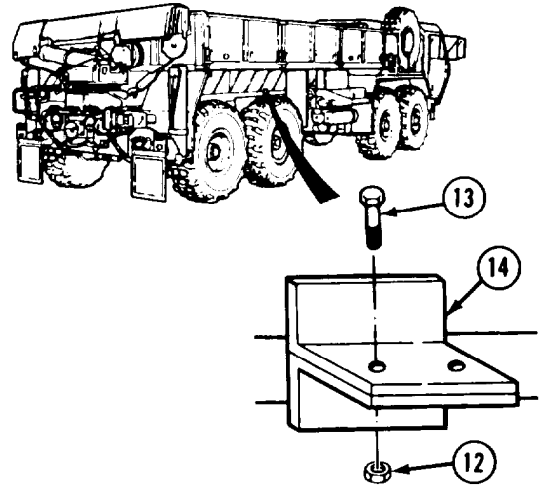

- (6) Soldier A operates hoist and moves lifting device over cargo body (15) while Soldier B attaches lifting device to fourth and sixth tiedowns (16 and 17) on each side of cargo body.

WARNING

Stay clear of cargo body while lifting and moving. If cargo body falls, serious injury or death could result.

- (7) Soldier A operates hoist and lifts cargo body (15) off vehicle while Soldier B guides cargo body to work area.

6. Installation.

NOTE

Do not apply walking compound within the 10 by 27 in. (254 by 686 mm) area for pod retainers (four places) (M985 only).

- (1) Apply walking compound, as necessary, to deck area of cargo body (1).
- (1.1) Operate hoist and move lifting device over cargo body (1).
- (2) Attach lifting device to fourth and sixth tiedowns (2 and 3) on each side of cargo body (1).

WARNING

Stay clear of cargo body while lifting and moving. If cargo body falls, serious injury or death could result.

- (3) Soldier A operates hoist to lift and move cargo body (1) while Soldier B guides cargo body to position on vehicle.

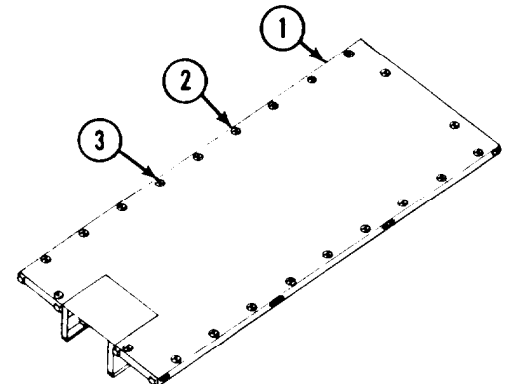
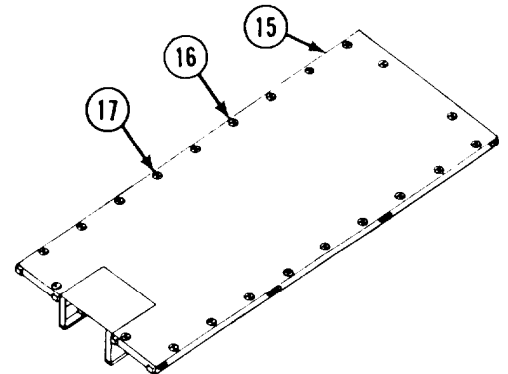

Cab and Body Maintenance Instructions (Cont)

15-10. CARGO BODY REMOVAL/INSTALLATION (M977, M985, M98SE1) (CONT).

NOTE

The following steps apply to brackets on both sides of vehicle. Passenger side is shown.

- (4) Install spacer (4) in bracket (5).
- (5) Install three screws (6) and locknuts (7) in bracket (5). Do not tighten.

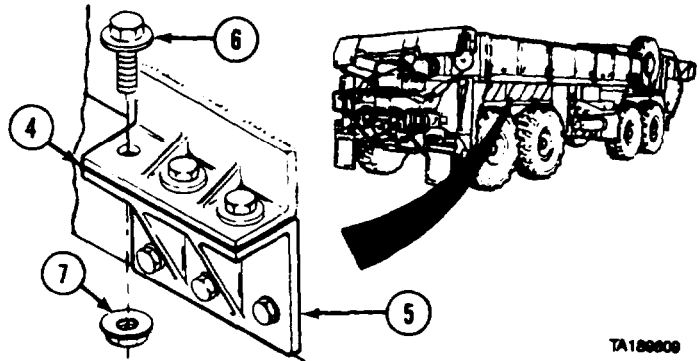

- (6) Install two screws (8) and nuts (9) in bracket (10). Do not tighten.

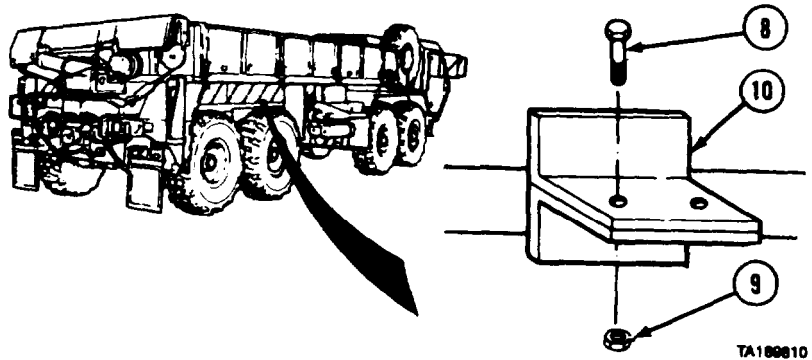

- (7) Install two washers (11), springs (12) and sleeves (13) with two washers (14), screws (15), washers (16) and locknuts (17).
- (8) Tighten locknuts (17) until springs (12) are compressed to 3-5/8 in. (92 mm).

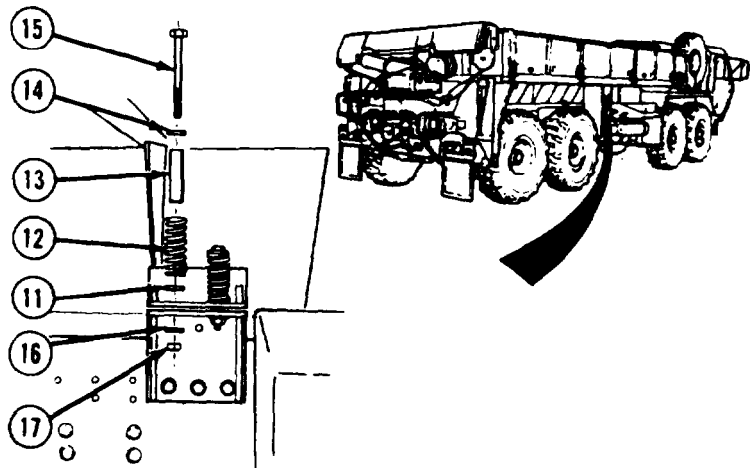

Cab and Body Maintenance Instructions (Cont)

- (9) Tighten three screws (6) and two screws (8) on each side of vehicle.

c. Follow-on Maintenance.

- (1) Install cargo body side, front, and rear panels (TM 9-2320-279-10).
- (2) Install crane stowage box (TM 9-2320-279-20).
- (3) Install center mud flaps (TM 9-2320-279-20).
- (4) Install rear splash guards (TM 9-2320-279-20).
- (5) Install crane remote control stowage box (TM 9-2320-279-20).
- (6) Install marker lights (TM 9-2320-279-20).
- (7) Install reflectors (TM 9-2320-279-20).
- (8) Install crane outrigger base plates (TM 9-2320-355-10) (M985E1 only).
- (9) Install ladder and straps (TM 9-2320-279-10).

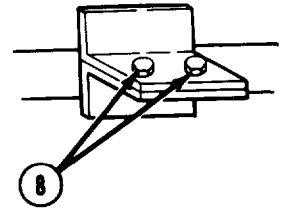
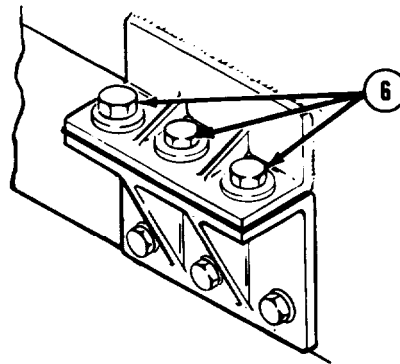

TA180812

END OF TASK

15-11. CARGO BODY MOUNTING BRACKETS REMOVAL/INSTALLATION (M977, M985).	
This task covers:	
a. Removal	c. Follow-on Maintenance
b. Installation	
INITIAL SETUP	
<i>Models</i>	<i>Equipment Condition</i>
M977, M985	TM or Para
<i>Test Equipment</i>	<i>Condition Description</i>
None	TM 9-2320-279-10 Shut off engine.
<i>Special Tools</i>	TM 9-2320-279-10 Vehicle unloaded.
None	TM 9-2320-279-20 Fuel tank removed (when removing left front bracket),
<i>Supplies</i>	<i>Special Environmental Conditions</i>
None	None
<i>Personnel Required</i>	<i>General Safety Instructions</i>
MOS 63W, Wheel vehicle repairer	None
<i>References</i>	<i>Level of Maintenance</i>
None	Direct Support

Cab and Body Maintenance Instructions (Cont)

15-11. CARGO BODY MOUNTING BRACKETS REMOVAL/INSTALLATION (M977, M985)
(CONT).

a. Removal.

NOTE

- Top bracket is welded in place.
- Remove one bracket at a time. The following steps apply to both sides of vehicle.

- (1) Remove two locknuts (1), four washers (2 and 3), two springs (4), sleeves (5), washers (6), and screws (7).
- (2) Remove three locknuts (8) and screws (9).
- (3) Remove screw (10), washer (11), nut (12), and bracket (13).

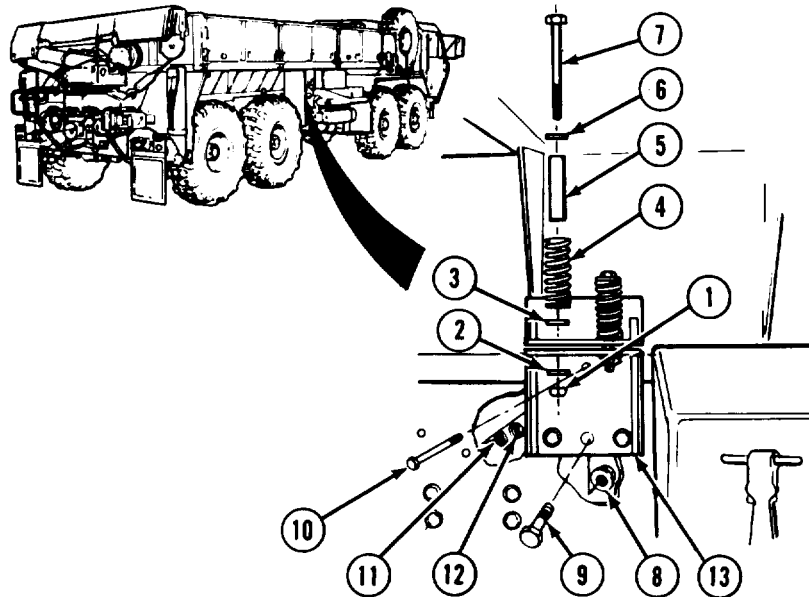

TA189982

- (4) Remove three nuts (14) and screws (15).
- (5) Remove three locknuts (16) and screws (17).
- (6) Remove screw (18), washer (19), locknut (20), bracket (21), and spacer (22).

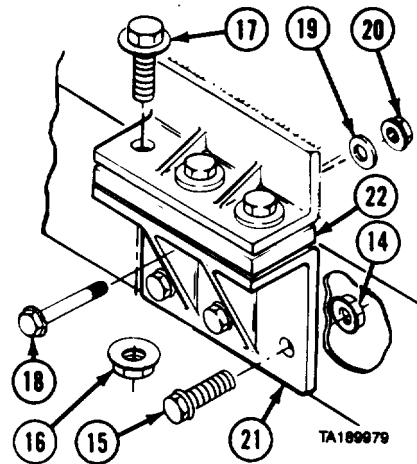

TA189979

- (7) Remove two screws (23), nuts (24), and lockwasher (25).
- (8) Remove screw (26), washer (27), locknut (28), and bracket (29).

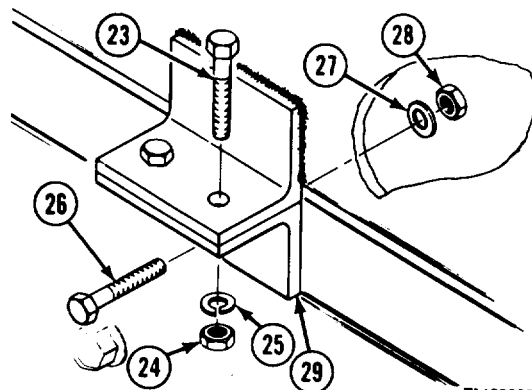

TA189980

Cab and Body Maintenance Instructions (Cont)

b. Installation.

NOTE

The following steps apply to both sides of vehicle. Passenger side is shown.

- (1) Install bracket (1) and spacer (2) with screw (3), washer (4), and locknut (5).
- (2) Install three screws (6) and locknuts (7). Do not tighten.
- (3) Install three screws (8) and nuts (9). Tighten nuts to 375 lb-ft (509 N·m).
- (4) Tighten locknuts (7).

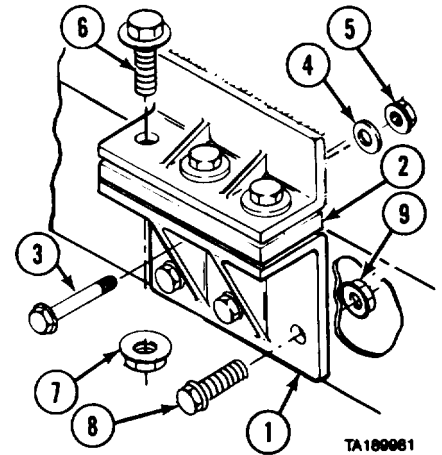

- (5) Install bracket (10), screw (11), washer (12), and nut (13).
- (6) Install three screws (14) and locknuts (15).
- (7) Install two screws (16), washers (17), sleeves (18), springs (19), four washers (20 and 21), and two locknuts (22).
- (8) Tighten each locknut (22) until each spring (19) is compressed to 3-5/8 in. (92 mm).

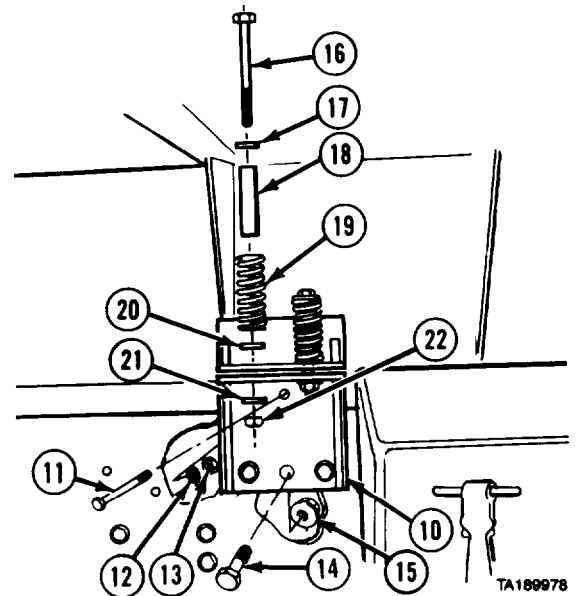

- (9) Install bracket (23), screw (24), washer (25), and locknut (26).
- (10) Install two screws (27), lockwashers (28), and nuts (29).

c. Follow-on Maintenance. Install fuel tank (when left front bracket is removed) (TM 9-2320-279-20).

END OF TASK

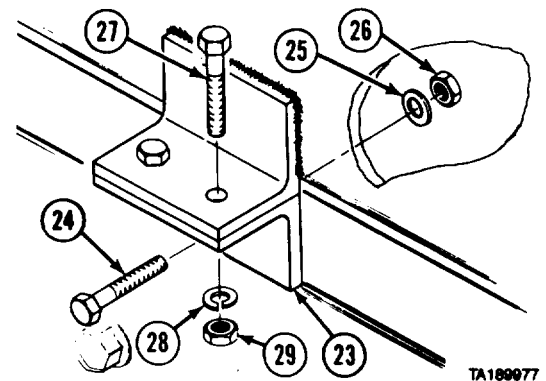

Cab and Body Maintenance Instructions (Cont)

15-12. WOOD SILL REMOVAL/INSTALLATION (M977, M985).		
This task covers:		
a. Removal	c. Follow-on Maintenance	
b. Installation		
INITIAL SETUP		
Models M977, M985	References None	
Test Equipment None	Equipment Condition	
Special Tools None	TM or Para Para 15-10	Condition Description Cargo body removed.
Supplies None	Special Environmental Conditions None	
Personnel Required MOS 63W, Wheel vehicle repairer	General Safety Instructions None	
	Level of Maintenance Direct Support	

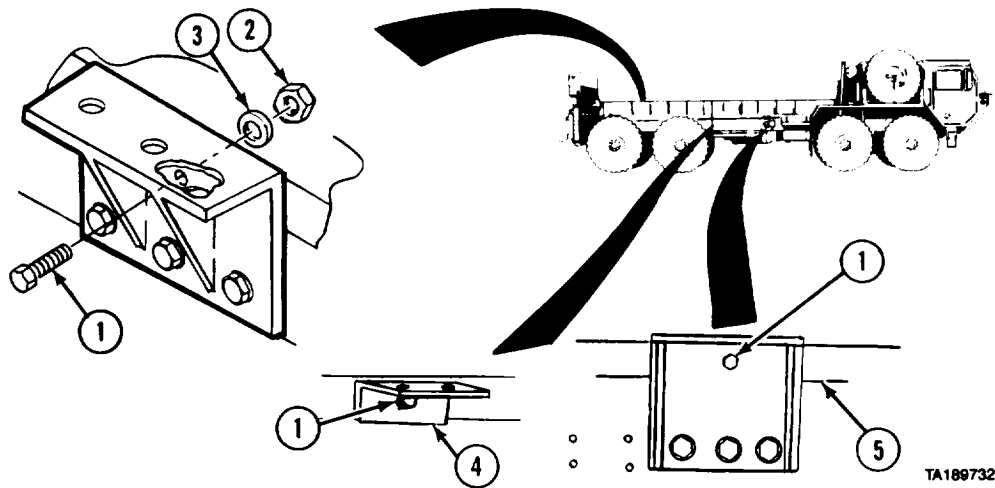

- a. Removal. Remove six screws (1), locknuts (2), washers (3), two brackets (4), and four wood sills (5).
- b. Installation. Install four wood sills (5) and two brackets (4) with six screws (1), washers (3), and locknuts (2).
- c. Follow-on Maintenance. Install cargo body (para 15-10).

END OF TASK

Cab and Body Maintenance Instructions (Cont)

15-13. PUMP MODULE REMOVAL/INSTALLATION (M978).	
This task covers:	
a. Removal	c. Follow-on Maintenance
b. Installation	
INITIAL SETUP	
<i>Models</i> M978	<i>Equipment Condition (cont)</i> TM or Para Condition Description
<i>Test Equipment</i> None	TM 9-2320-279-20 Pump module top door removed.
<i>Special Tools</i> Insert-removal tool 114010	TM 9-2320-279-20 Rear mud flaps/splash guards removed.
<i>Supplies</i> Tags, identification, Item 60, Appendix C	TM 9-2320-279-20 Rear cable guide removed.
<i>Personnel Required</i> MOS 63W, Wheel vehicle repairer (2)	TM 9-2320-279-20 Batteries disconnected.
<i>References</i> None	TM 9-2320-279-20 Hard lift point access panel removed.
<i>Equipment Condition</i> TM or Para Condition Description	TM 9-2320-279-20 Hose cover removed.
TM 9-2320-279-20 2500 gallon tank drained.	<i>Special Environmental Conditions</i> None
TM 9-2320-279-10 Air system drained.	<i>General Safety Instructions</i> None
TM 9-2320-355-10 Rear access doors opened.	<i>Level of Maintenance</i> Direct Support

a. Removal.

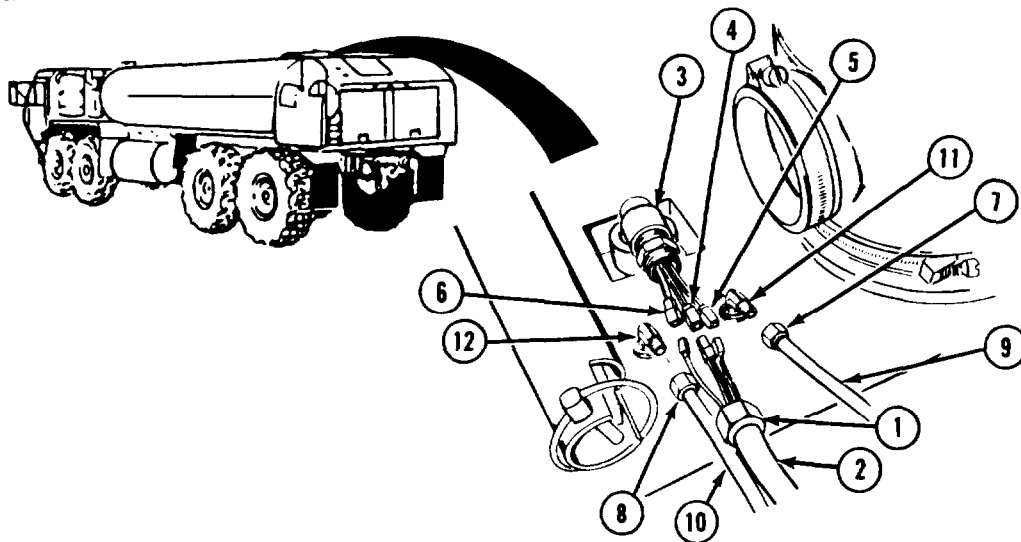

NOTE

- Tag and mark all piping, tubes, and electrical conduit tubing before removal.
- (1) Remove nut (1) and hose (2) from tank level sensor (3).
 - (2) Disconnect three connectors (4, 5, and 6).
 - (3) Remove two nuts (7 and 8) and tubes (9 and 10) from elbows (11 and 12).

Cab and Body Maintenance Instructions (Cont)

15-13. PUMP MODULE REMOVAL/INSTALLATION (M978) (CONT)

- (4) Remove two nuts (13) screws (14) and coupling halves (15) from coupling gasket (16).
- (5) Push coupling gasket (16) onto pipe (17).

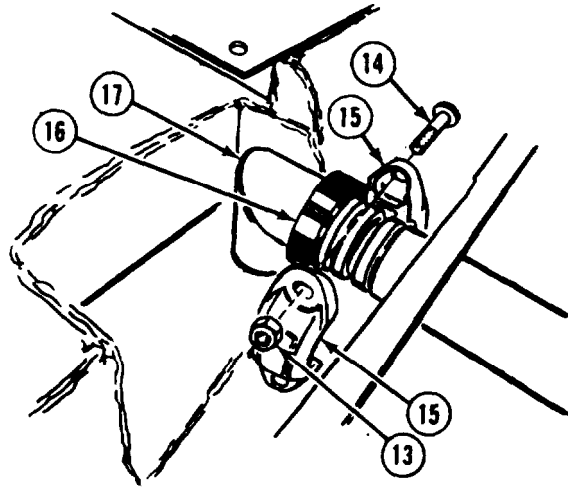

TA190805

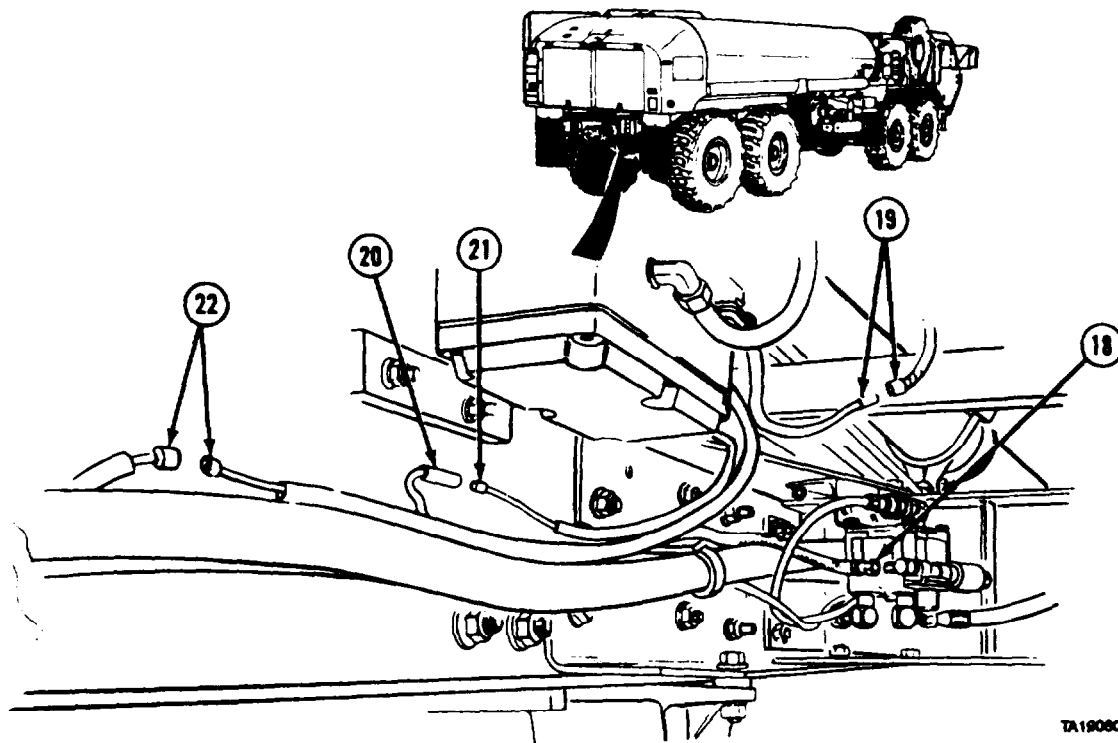

TA190804

NOTE

Hose is located above and forward of fourth axle on parking brake relay valve. Wire and connectors are located on inside of left chassis rail above and behind fourth axle.

- (6) Disconnect hose (18).
- (7) Disconnect connectors (19).
- (8) Disconnect connector (20) and connector (21) using insert removal tool.
- (9) Disconnect connectors (22).

Cab and Body Maintenance Instructions (Cont)

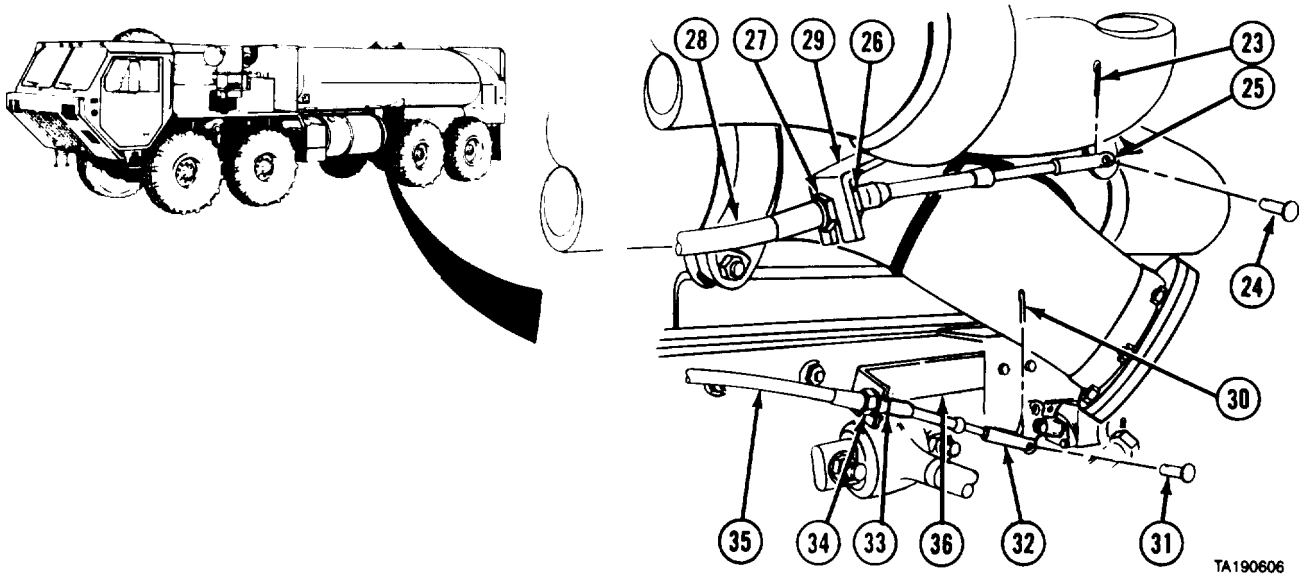

CAUTION

Linkage must not be connected or tangled with piping or other parts that will be removed with tank or linkage and module may be damaged.

- (10) Remove cotter pin (23) and pin (24) from clevis (25).
- (11) Loosen two nuts (26 and 27) and remove cable (28) from bracket (29).
- (12) Remove cotter pin (30) and pin (31) from clevis (32).
- (13) Loosen two nuts (33 and 34) and remove cable (35) from bracket (36).

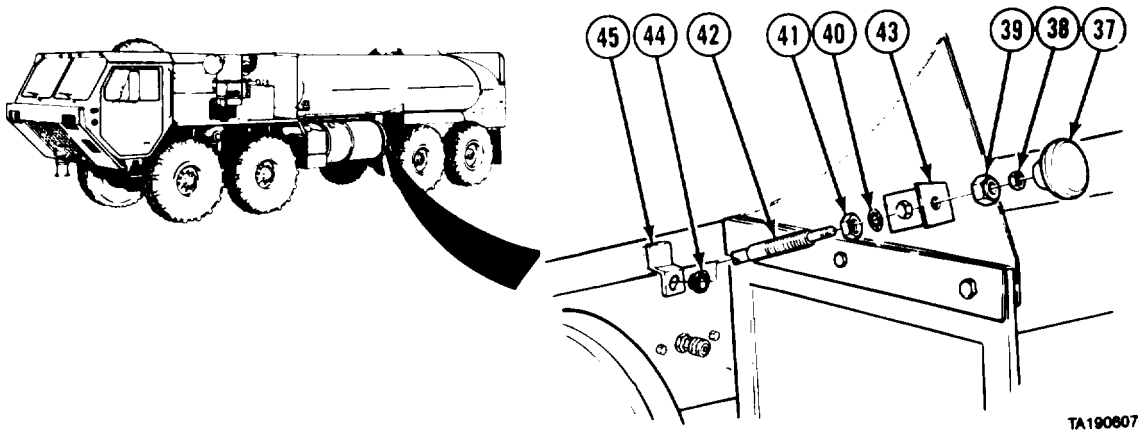

- (14) Remove knob (37), nut (38), nut (39), lockwasher (40), nut (41), and cable (42) from bracket (43).
- (15) Remove cable (42) and grommet (44) from bracket (45).

Cab and Body Maintenance Instructions (Cont)

15-13. PUMP MODULE REMOVAL/INSTALLATION (M978) (CONT).

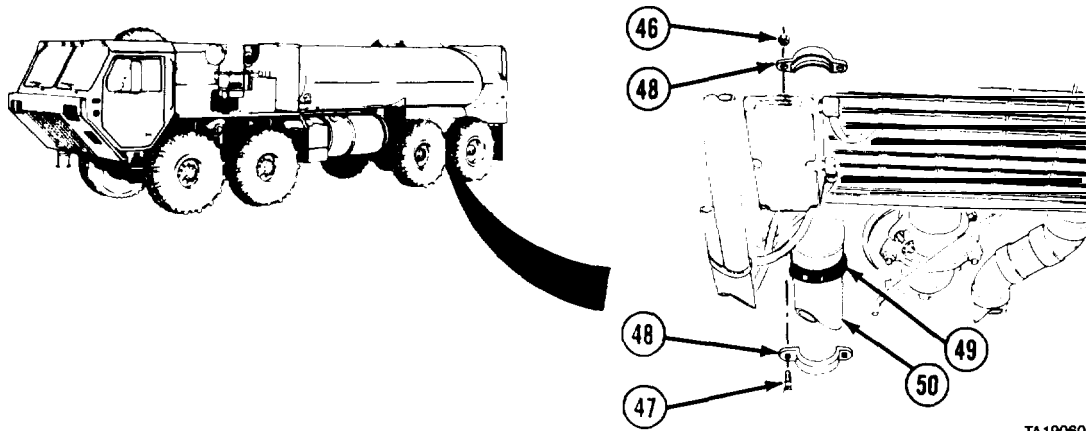

WARNING

Fuel will drain from piping when coupling is removed. Contact with fuel can irritate eyes and skin. Do not let fuel get into eyes. If fuel comes in contact with eyes, immediately rinse eyes with clear water. Wash fuel off skin with soap and water as soon as possible after contact to avoid serious injury.

- (16) Remove two nuts (46), screws (47), and coupling halves (48) from coupling gasket (49).
- (17) Push coupling gasket (49) onto pipe (50).

- (18) Remove two nuts (51), screws (52), and coupling halves (53) from coupling gasket (54).
- (19) Push coupling gasket (54) onto pipe (55).

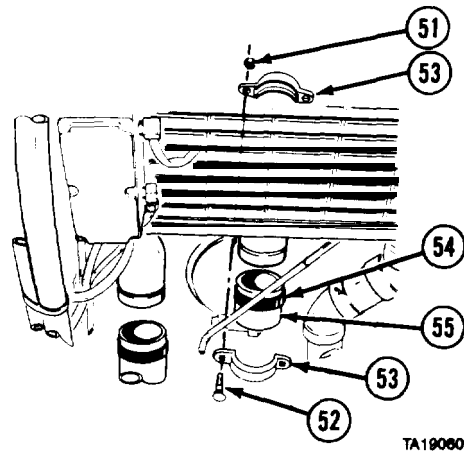

WARNING

Fuel will drain from piping when coupling is removed. Contact with fuel can irritate eyes and skin. Do not let fuel get into eyes. If fuel comes in contact with eyes, immediately rinse eyes with clear water. Wash fuel off skin with soap and water as soon as possible after contact to avoid serious injury.

- (20) Remove two nuts (56), screws (57), and coupling halves (58) from coupling gasket (59).
- (21) Push coupling gasket (59) onto pipe (60).

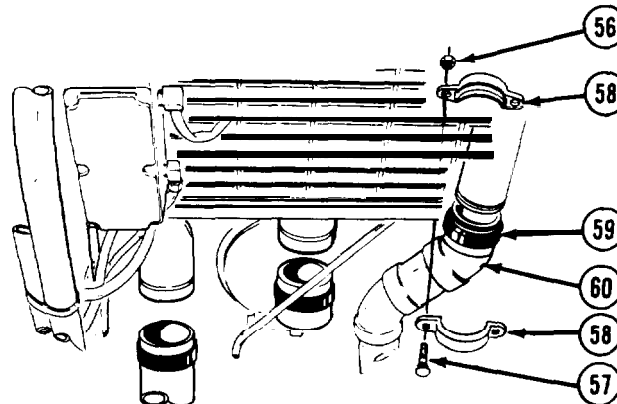

Cab and Body Maintenance Instructions (Cent)

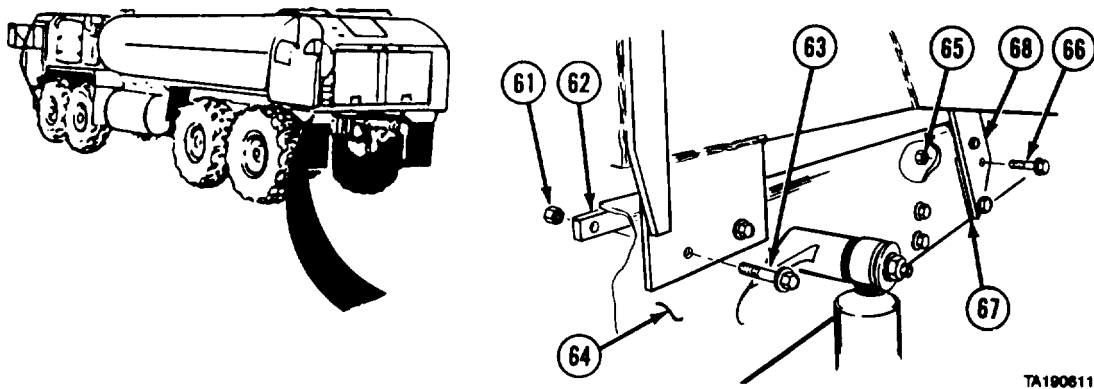

TA190611

NOTE

Left and right side pump module mounting brackets are removed the same way. Left side is shown.

- (22) Soldier A removes two nuts (61) and plate (62) while Soldier B holds and removes two screws (63) from chassis rail (64).
- (23) Soldier A removes four nuts (65) while Soldier B holds and removes four screws (66) and plate (67) from under hard lift point (68).

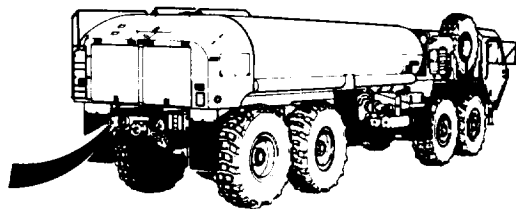
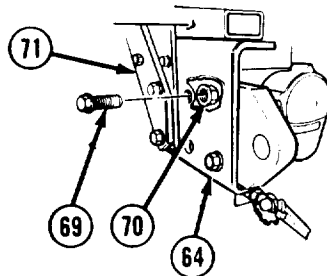

TA190612

- (24) Remove two screws (69) and nuts (70) from left chassis rail (64).
- (25) Attach suitable lifting device to pump module (71).

WARNING

Do not get under module while supported by lifting device. Module could fall causing personal injury or death.

CAUTION

Module must be lifted slowly and carefully while Soldier B makes sure no wires, hoses, or linkages, are caught during removal causing damage to module parts.

- (26) Soldier A operates lifting device while Soldier B guides and clears pump module (71) from vehicle.
- (27) Soldier A lowers module (71) onto suitable blocking while Soldier B guides module.
- (28) Disconnect lifting device from module (71).

Cab and Body Maintenance Instructions (Cont)

15-13. PUMP MODULE REMOVAL/INSTALLATION (M978) (CONT).

b. Installation.

WARNING

Do not get under module while supported by lifting device. Module could fall causing personal injury or death.

CAUTION

Module must be lowered slowly and carefully into place while Soldier B makes sure no wires, hoses, or linkages are caught beneath module causing damage to module parts.

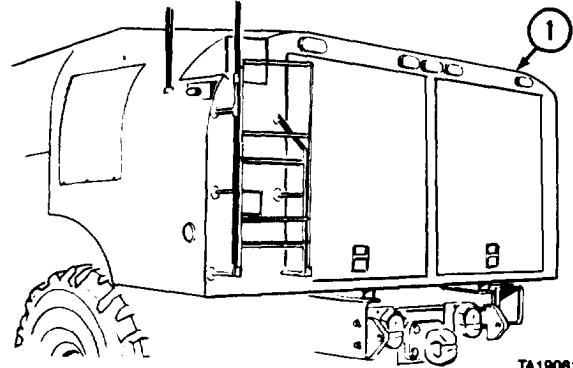

TA190813

- (1) Attach suitable lifting device to pump module (1).
- (2) Soldier A operates lifting device while Soldier B guides pump module (1) onto vehicle.

NOTE

Left and right side pump module mounting brackets are installed the same way. Left side is shown.

- (3) Soldier A installs and holds plate (2) on left chassis rail (3) under hard lift point (4) and four screws (5) while Soldier B installs nuts (6). Do not tighten.
- (4) Soldier A installs and holds two screws (7) while Soldier B installs plate (8) and two nuts (9).
- (5) Tighten nuts (6 and 9).
- (6) Remove lifting device from pump module (1).
- (7) Loosen four nuts (10).

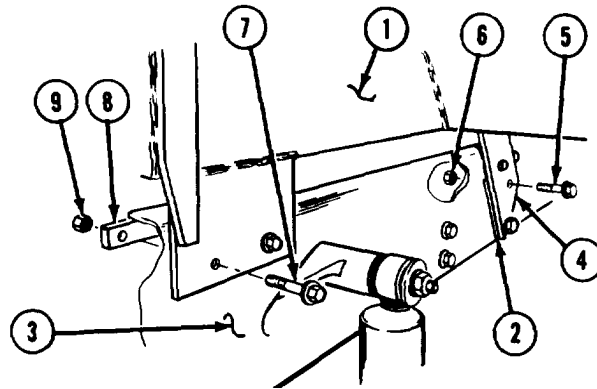

TA190814

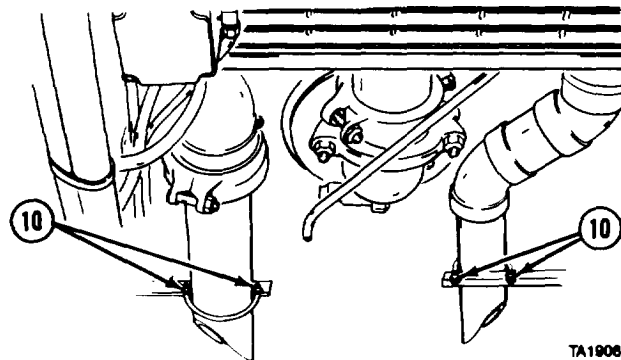

TA190815

Cab and Body Maintenance Instructions (Cont)

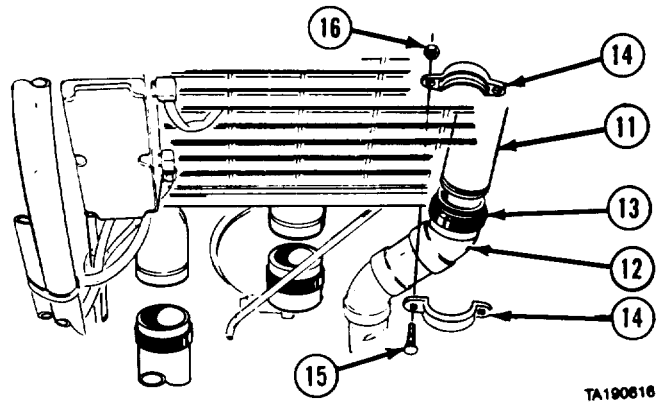

CAUTION

- . Do not tear or otherwise damage coupling gaskets during installation. If damaged coupling gasket is used, piping connection will leak.
- . Do not pinch or pull coupling gaskets off center when coupling halves are installed. If gasket is damaged or moved out of position, piping connection will leak.

- (8) Aline pipes (11 and 12) and install coupling gasket (13) over connections of pipes.
 (9) Install two coupling halves (14) on coupling gasket (13) with two screws (15) and nuts (16).

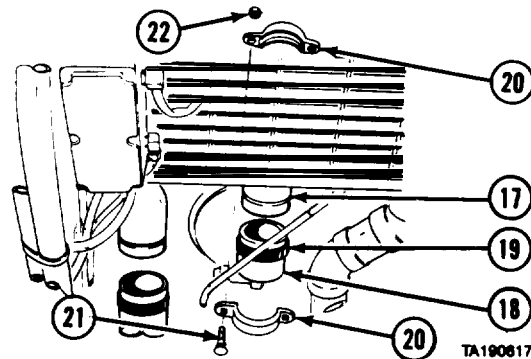

- (10) Aline pipes (17 and 18) and install coupling gasket (19) over connections of pipes.
 (11) Install two coupling halves (20) on coupling gasket (19) with two screws (21) and nuts (22).

Cab and Body Maintenance Instructions (Cont)

15-13. PUMP MODULE REMOVAL/INSTALLATION (M978) (CONT).

- (12) Aline pipes (23 and 24) and install coupling gasket (25) over connections of pipes.
- (13) Install two coupling halves (26) on coupling gasket (25) with two screws (27) and nuts (28).

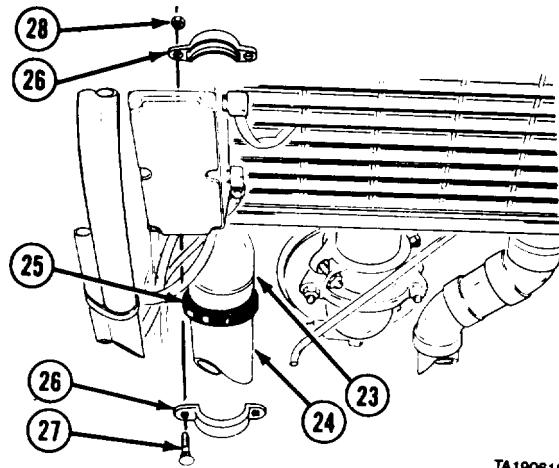

TA190618

- (14) Tighten four nuts (10).

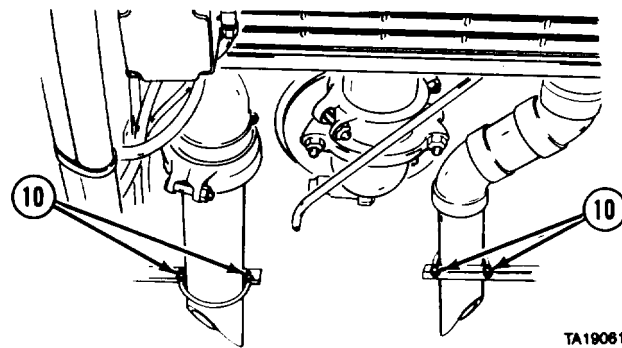

TA190619

- (15) Install cable (29) and grommet (30) in bracket (31).
- (16) Install nut (32) and lockwasher (33) on cable (29).
- (17) Install cable (29) in bracket (34) and install nut (35), nut (36), and knob (37).

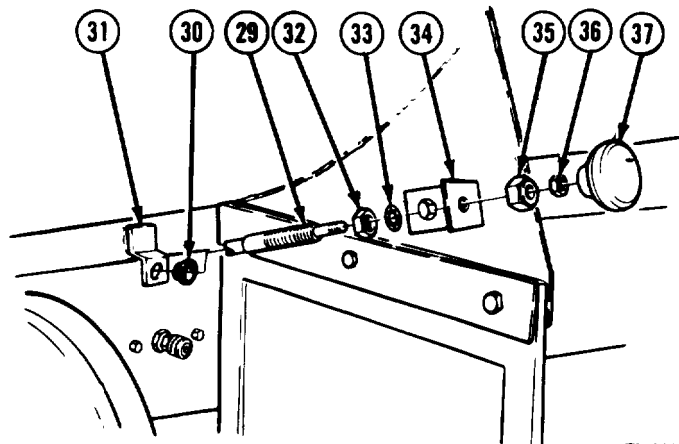

TA190620

Cab and Body Maintenance Instructions (Cont)

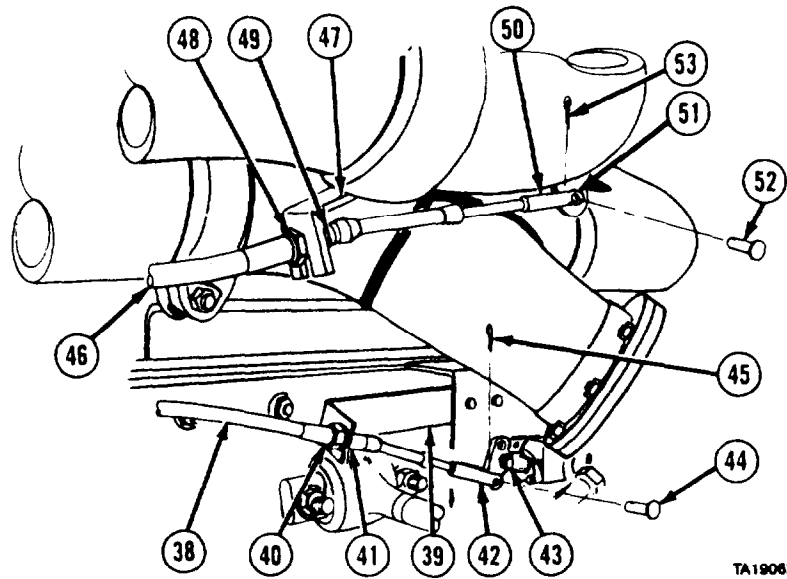

- (18) Install cable (38) in bracket (39) and tighten two nuts (40 and 41).
- (19) Install clevis (42) on lever (43) with pin (44) and cotter pin (45).
- (20) Install cable (46) in bracket (47) and tighten two nuts (48 and 49).
- (21) Install clevis (50) on lever (51) with pin (52) and cotter pin (53).

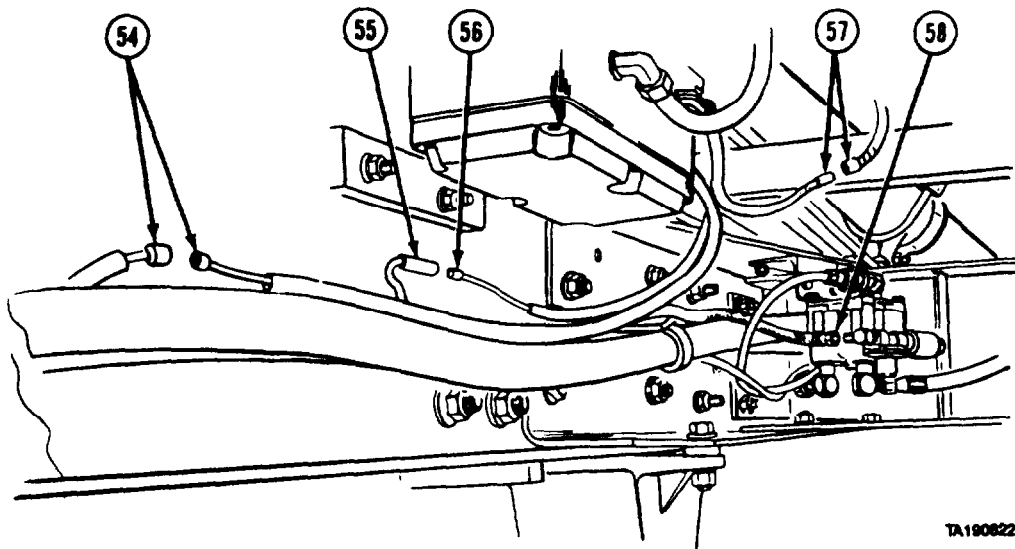

- (22) Connect connectors (54).
- (23) Connect connector (55) to connector (56) using insert removal tool.
- (24) Connect connectors (57).
- (25) Connect hose (58).

Cab and Body Maintenance Instructions (Cont)

15-13. PUMP MODULE REMOVAL/INSTALLATION (M978) (CONT).

CAUTION

Do not tear or otherwise damage coupling gaskets during installation. If damaged coupling gasket is used, piping connection will leak.

- (26) Position coupling gasket (59) over connections of pipes (60 and 61).

CAUTION

Do not pinch or pull coupling gasket off center when coupling halves are installed. If gasket is damaged or moved out of position, piping connection will leak.

- (27) Install two coupling halves (62) on coupling gasket (59) with two screws (63) and nuts (64).
- (28) Install two screws (65) and nuts (66) in left chassis rail (3).

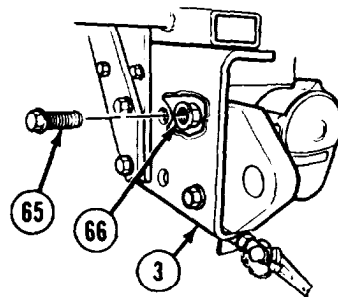
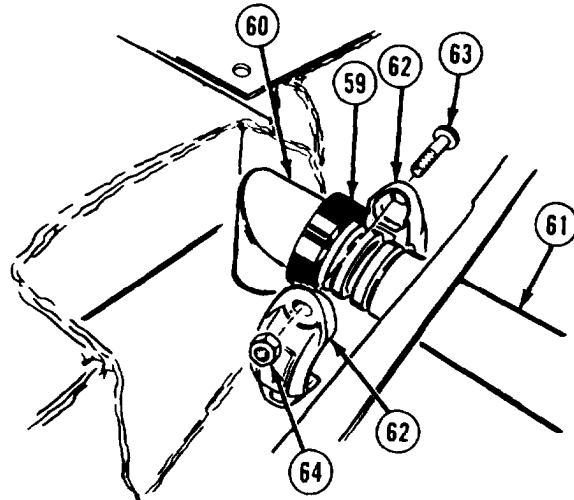

- (29) Install two tubes (67 and 68) on elbows (69 and 70) with nuts (71 and 72).
- (30) Connect three connectors (73, 74, and 75).
- (31) Install hose (76) on tank level sensor (77) with nut (78).

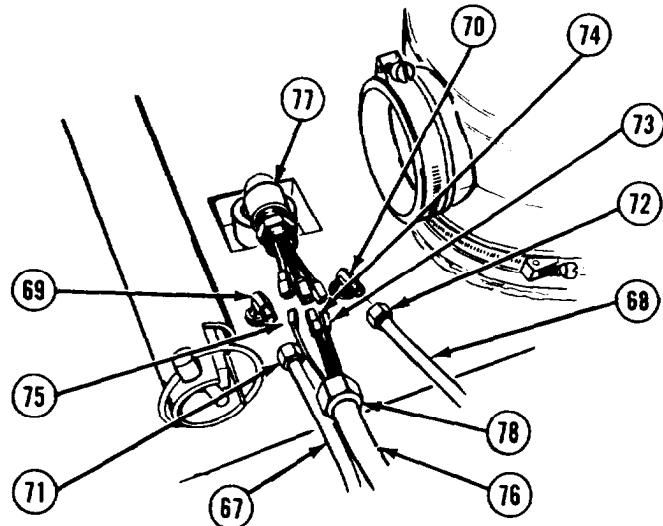

C. Follow-on Maintenance.

- (1) Connect batteries (TM 9-2320-279-20).
- (2) Install rear mud flaps and splash guards (TM 9-2320-279-20).
- (3) Install rear cable guide (TM 9-2320-279-20).
- (3.1) Install hose cover (TM 9-2320-279-20) (for left side only) (some models only).
- (4) Start engine, build up air pressure (TM 9-2320-279-10).
- (5) Install hard lift point access panel (TM 9-2320-279-20).
- (6) Prepare tanker for operation (TM 9-2320-279-10).
- (7) Fill tank with fuel by performing bottom loading (TM 9-2320-279-10).
- (8) Recirculate fuel (TM 9-2320-279-10).

Cab and Body Maintenance Instructions (Cont)

- (9) Inspect pump module and piping connections for leaks and proper operation.
- (10) Install pump module top access door (TM 9-2320-279-20).
- (11) Close rear access doors (TM 9-2320-279-10).

END OF TASK

15-14. 2500 GALLON TANK REMOVAL/INSTALLATION (M978).

This task covers:

- a. Removal
- b. Installation
- c. Follow-on Maintenance

INITIAL SETUP

Models

M978

Test Equipment

None

Special Tools

None

Supplies

Compound, walking, Item 29.1, Appendix C

Personnel Required

MOS 63W, Wheel vehicle repairer (3)

References

None

Equipment Condition

TM or Para

TM 9-2320-279-10 Ladder removed.
 Para 15-15 Tank vent removed.
 TM 9-2320-279-20 Fuel tank removed.
 TM 9-2320-279-20 Center mud flaps removed.
 TM 9-2320-279-20 Stowage box B removed.
 TM 9-2320-279-20 Dipstick tube removed.
 TM 9-2320-279-20 Vent rollover guards removed.
 TM 9-2320-279-20 Fuel level sensor removed.
 TM 9-2320-279-20 Side clearance light removed.
 TM 9-2320-279-20 Side clearance light wiring removed.
 TM 9-2320-279-20 Side reflectors removed.
 TM 9-2320-279-20 Stowage tube removed.
 TM 9-2320-279-20 Emergency valve outlet piping removed.

Equipment Condition (cont)

TM or Para

Condition Description
 TM 9-2320-279-20 Line strainer piping removed.
 TM 9-2320-279-20 V3 suction line valve removed.
 TM 9-2320-279-20 V3 suction line valve to primary pump piping removed.
 TM 9-2320-279-20 Primary pump removed
 TM 9-2320-279-20 Primary pump to flow limiting valve piping removed.
 TM 9-2320-279-20 V1 emergency valve cable removed.
 TM 9-2320-279-20 Emergency shut-off cable removed.
 TM 9-2320-279-20 V19 jet level sensor removed.
 TM 9-2320-279-20 V10 bottom load valve removed.
 TM 9-2320-279-20 V13 vent valve remove'

Special Environmental Conditions

None

General Safety Instructions

No smoking, flame, sparks, and hot or glowing objects within 50 ft (15 m) of vehicle.
 Work in well-ventilated area.

Level of Maintenance

Direct Support

Cab and Body Maintenance Instructions (Cont)

15-14. 2500 GALLON TANK REMOVAL/INSTALLATION (M978) (CONT)

a. Removal.

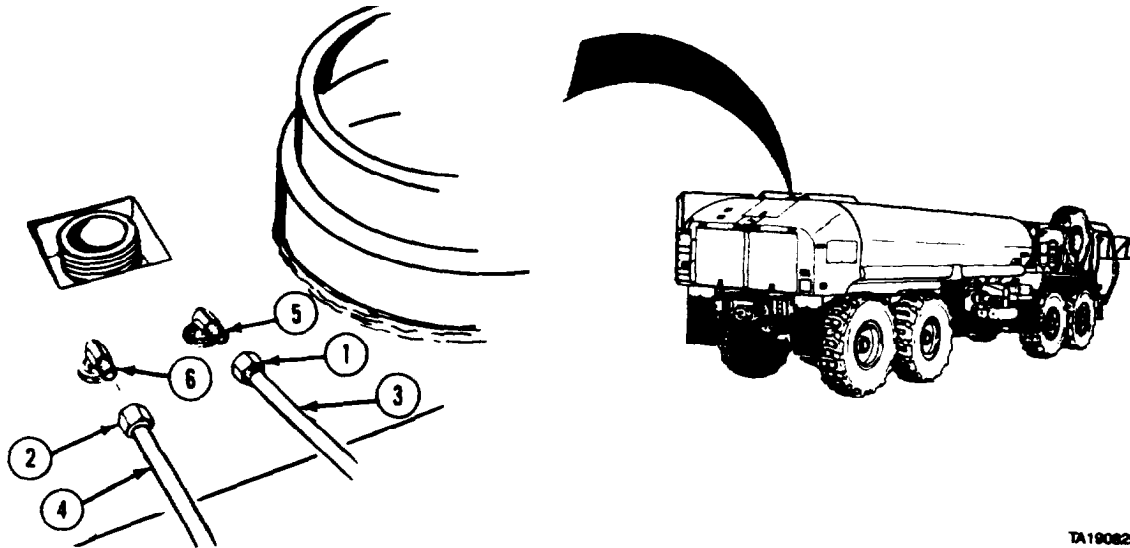

TA190825

NOTE

Tags and mark tubes and lines before removal.

(2) Remove two nuts (1 and 2), tubes (3 and 4), and elbows (5 and 6).

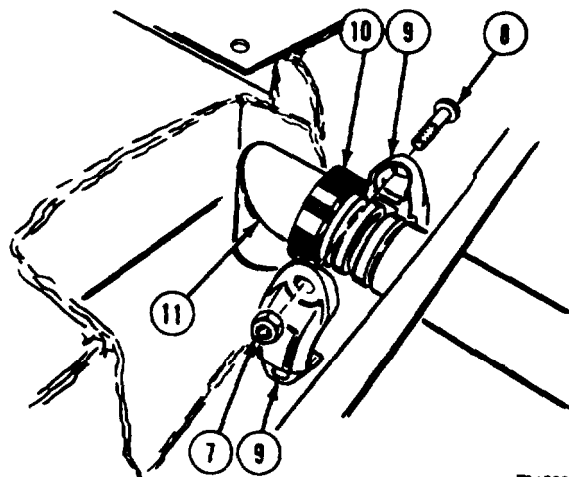

TA190825

(2) Remove two nuts (7), screws (8), and coupling halves (9) from coupling gasket (10).
(3) Push coupling gasket (10) onto pipe (11).

Cab and Body Maintenance Instructions (Cont)

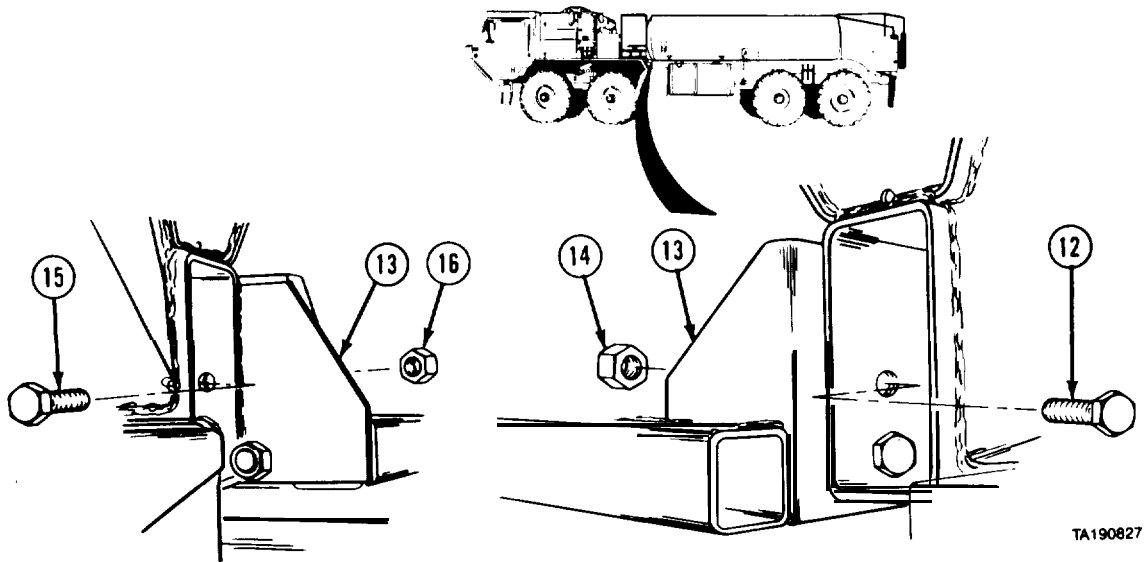

TA190827

NOTE

Screws are inside tank mounting rail.

- (4) Soldier A removes two screws (12) from left side of tank front crossmember (13) while Soldier B holds and removes locknuts (14).
- (5) Soldier A removes three screws (15) from right side of tank front crossmember (13) while Soldier B holds and removes locknuts (16).
- (6) Soldier A and Soldier B remove tank front crossmember (13) from vehicle.

NOTE

Both left and right front tank mounts are removed the same way.

- (7) Remove three locknuts (17), screws (18), six washers (19), and springs (20) from front tank mounting bracket (21) and frame mounting bracket (22).

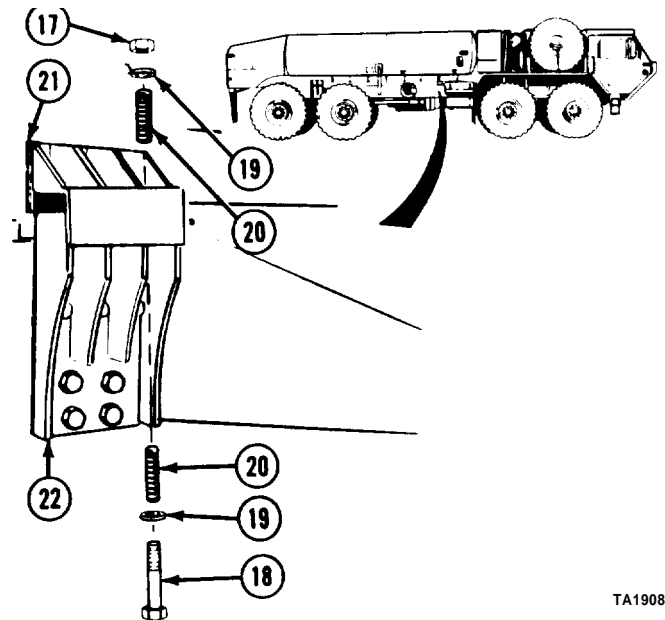

TA190826

Cab and Body Maintenance Instructions (Cont)

15-14. 2500 GALLON TANK REMOVAL/INSTALLATION (M978) (CONT).

NOTE

Both left and right rear tank mounts are removed the same way.

- (8) Remove four locknuts (23), washers (24), screws (25), washers (26), and spacers (27) from rear tank mounting bracket (28) and frame mounting bracket (29).

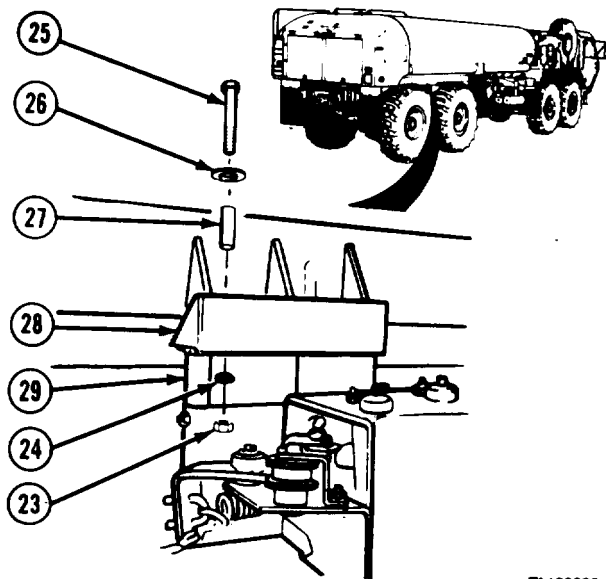

TA190830

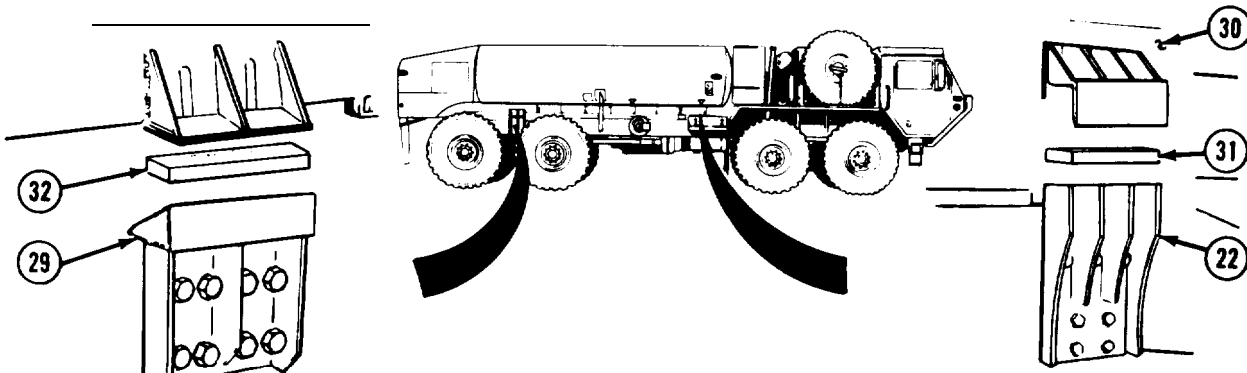

WARNING

Do not get under tank while it is supported by lifting device. Tank could fall, causing personal injury or death.

CAUTION

Tank must be lifted slowly and carefully. Make sure no wires, hoses, or linkages are caught during removal, or severe damage to tank and chassis will result.

NOTE

Rubber pads may fall out of front mounting brackets when tank is lifted.

- (9) Attach suitable lifting device to tank (30).
- (10) Soldier A operates lifting device while Soldier B and Soldier C guide tank (30) from vehicle.
- (11) Soldier A lowers tank (30) onto suitable blocking, while Soldier B and Soldier C guide tank.
- (12) Remove lifting device from tank (30).
- (13) Remove four rubber pads (31 and 32) from front and rear frame mounting brackets (22 and 29).

Cab and Body Maintenance Instructions (Cont)

b. Installation.

- (1) Apply walking compound as required around filler area and approach area. Touch up paint as necessary.

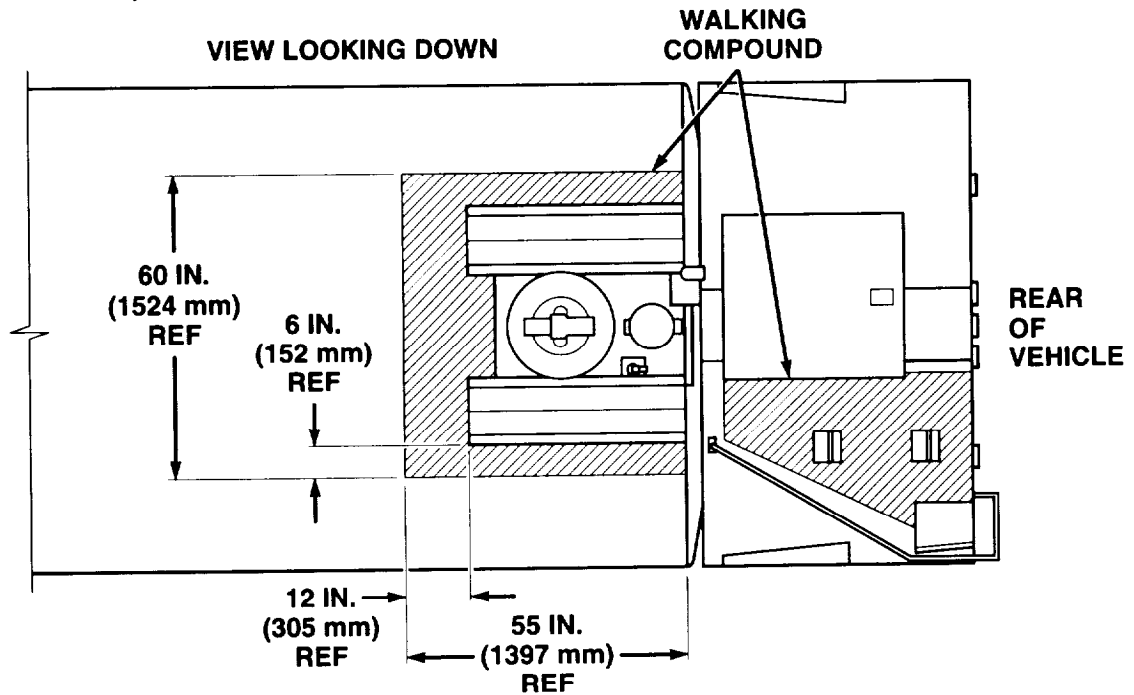

Cab and Body Maintenance Instructions (Cont)

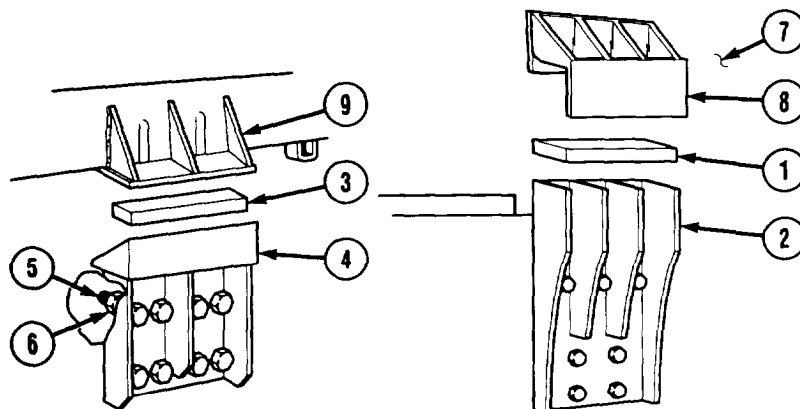

- (1.1) Install two rubber pads (1) on two front frame mounting brackets (2).
- (2) Install two rubber pads (3) on two rear frame mounting brackets (4).
- (3) Soldier A holds eight screws (5) on two rear frame mounting brackets (4) while Soldier B loosens nuts (6).

WARNING

Do not get under tank while supported by lifting device. Tank could fall causing personal injury or death.

CAUTION

Tank must be lowered slowly and carefully into place while Soldier B and Soldier C make sure tank does not collide with module or other vehicle components causing damage to tank, module, or other vehicle components.

- (4) Attach suitable lifting device to tank (7).
- (5) Soldier A operates lifting device while Soldier B and Soldier C guide tank (7) so front tank mounting brackets (8) and rubber pads (1) aline with front frame mounting brackets (2), and rear tank mounting brackets (9) and rubber pads (3) aline with rear frame mounting brackets (4).

NOTE

Both left and right mounts are installed the same way.

- (6) Install six springs (10), washers (11), three screws (12), and locknuts (13) in front tank mounting bracket (8) and frame mounting bracket (2).

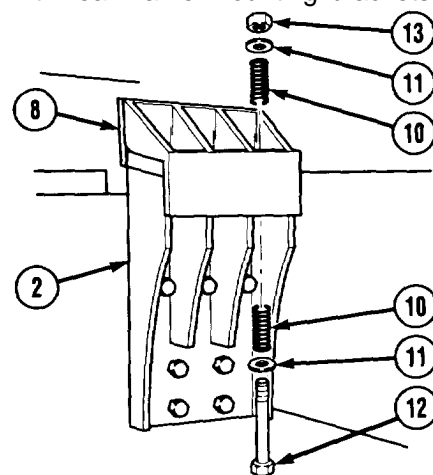

Cab and Body Maintenance Instructions (Cont)

15-14. 2500 GALLON TANK REMOVAL/INSTALLATION (M978) (CONT).

NOTE

Both left and right mounts are installed the same way.

- (7) Install four spacers (14), washers (15), screws (16), washers (17), and locknuts (18) in rear tank mounting bracket (9) and frame mounting bracket (4). Do not tighten locknuts.

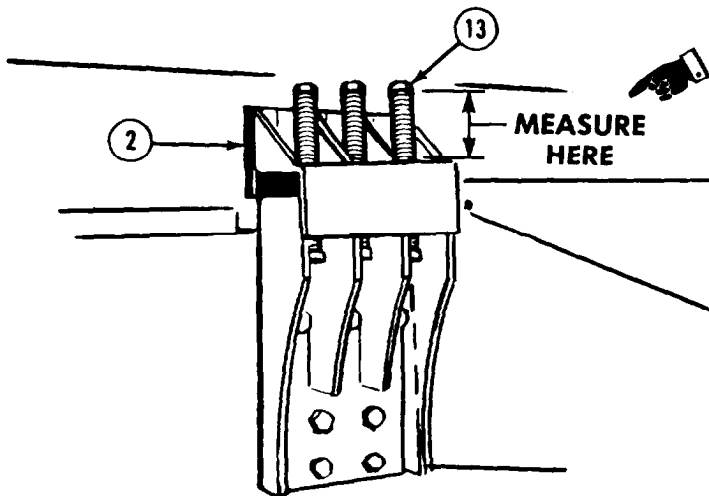
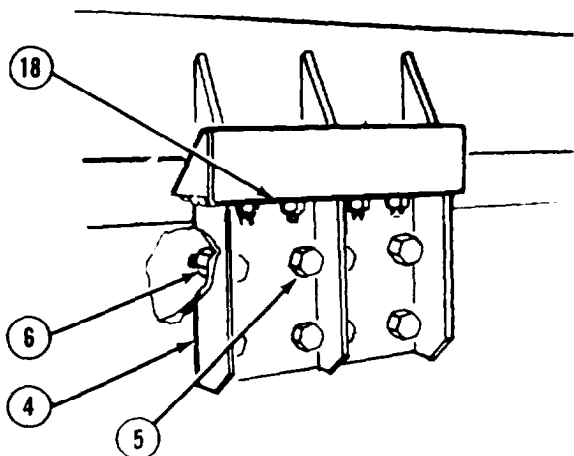
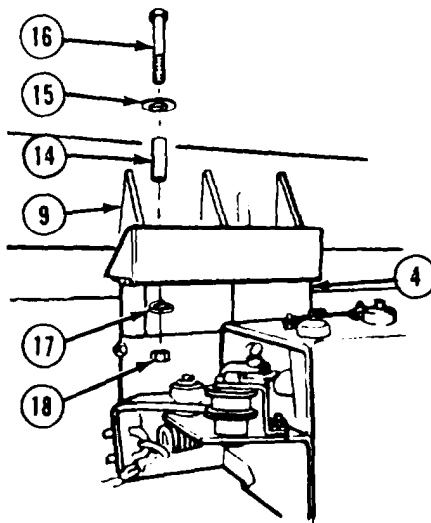

NOTE

Compress springs on both left and right front tank mounts 3-5/8 in. ± 1/8 in. (92 mm ± 3 mm).

- (8) Tighten three locknuts (13) on front tank mounting brackets (2).
- (9) Tighten four locknuts (18) on rear frame mounting brackets (4). Torque to 150 lb-ft (203 N•m).
- (10) Soldier A holds eight screws (5) while Soldier B tightens nuts (6) behind rear frame mounting bracket (4).

Cab and Body Maintenance Instructions (Cont)

- (11) Soldier A and Soldier B position tank front crossmember (19) on vehicle.
- (12) Soldier A installs three screws (20) in right side of tank front crossmember (19) while Soldier B installs and holds nuts (21).

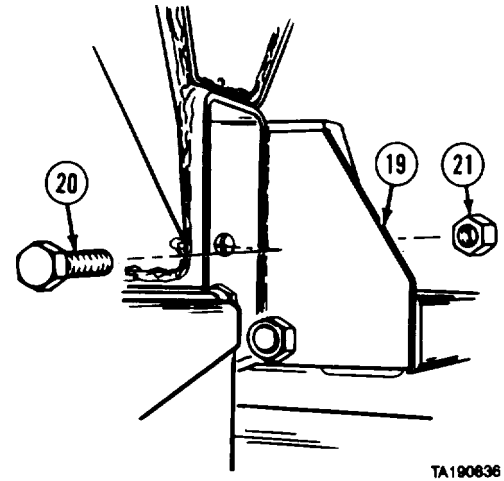

- (13) Soldier A installs two screws (22) in left side of tank front crossmember (19) while Soldier B installs and holds nuts (23).

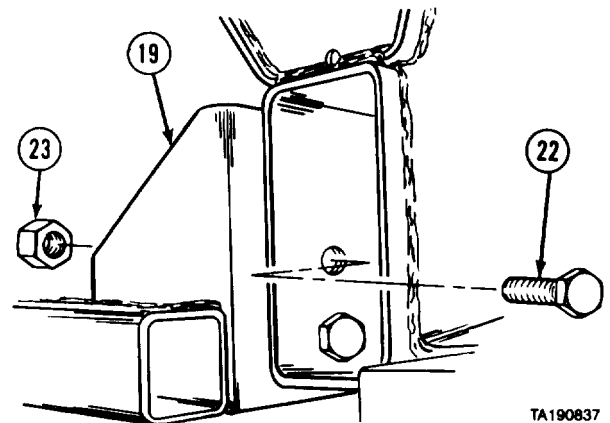

- (14) Position coupling gasket (24) over connection of pipes (25 and 26).

CAUTION

Do not pinch or pull coupling gasket off center when coupling halves are installed. If gasket is damaged or moved out of position, piping connection will leak.

- (15) Install two coupling halves (27) on coupling gasket (24) with two screws (28) and nuts (29).

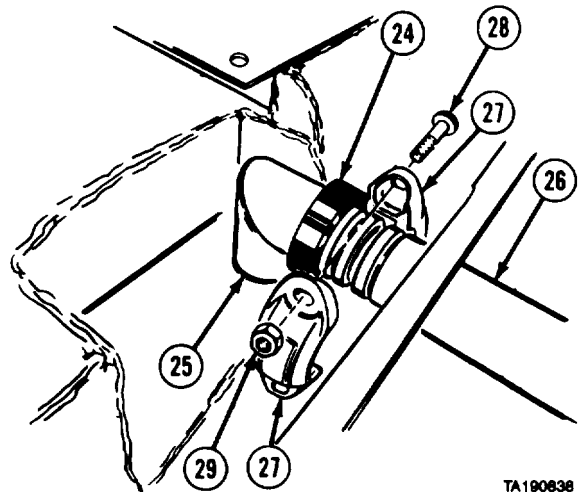

Cab and Body Maintenance Instructions (Cont)

15-14. 2500 GALLON TANK REMOVAL/INSTALLATION (M978) (CONT).

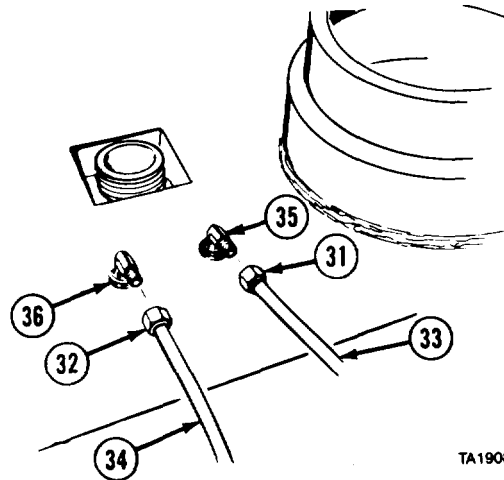

(16) Install two nuts (31 and 32) and tubes (33 and 34) on elbows (35 and 36).

c. Follow-on Maintenance.

- (1) Install tank vent (para 15-15).
- (2) Install V13 vent valve (TM 9-2320-279-20).
- (3) Install V10 bottom load valve (TM 9-2320-279-20).
- (4) Install V19 jet level sensor (TM 9-2320-279-20).
- (5) Install V1 emergency valve cable (TM 9-2320-279-20).
- (6) Install emergency shut-off cable (TM 9-2320-279-20).
- (7) Install primary pump to flow limiting valve piping (TM 9-2320-279-20).
- (8) Install primary pump (TM 9-2320-279-20).
- (9) Install V3 suction line valve to primary pump piping (TM 9-2320-279-20).
- (10) Install V3 suction line valve (TM 9-2320-279-20).
- (11) Install line strainer piping (TM 9-2320-279-20).
- (12) Install emergency valve outlet piping (TM 9-2320-279-20).
- (13) Install stowage tube (TM 9-2320-279-20).
- (14) Install side reflectors (TM 9-2320-279-20).
- (15) Install side clearance light wiring (TM 9-2320-279-20).
- (16) Install side clearance lights (TM 9-2320-279-20).
- (17) Install fuel level sensor (TM 9-2320-279-20).
- (18) Install vent rollover guards (TM 9-2320-279-20).
- (19) Install dipstick tube (TM 9-2320-279-20).
- (20) Install stowage box B (TM 9-2320-279-20).
- (21) Install center mud flaps (TM 9-2320-279-20).
- (22) Install ladder (TM 9-2320-279-10).
- (23) Prepare tanker for operation (TM 9-2320-279-10).
- (24) Fill tank with fuel by performing bottom loading (TM 9-2320-279-10).
- (25) Recirculate fuel (TM 9-2320-279-10).
- (26) Inspect pump module and piping connection for leaks and proper operation.

END OF TASK

Cab and Body Maintenance Instructions (Cont)

15-15. TANK VENT REMOVAL/INSTALLATION (M978).

This task covers:

- a. Removal
- b. Installation
- c. Follow-on Maintenance

INITIAL SETUP

Models

M978

Test Equipment

None

Special Tools

None

Supplies

Tape, antiseize, tetrafluoroethylene, Item 61, Appendix C

Personnel Required

MOS 63W, Wheel vehicle repairer

References

FM 10-20

FM 10-71

Equipment Condition

TM or Para	Condition Description
TM 9-2320-279-20	2500 gallon tank drained.
FM 10-20	Tank purged.
TM 9-2320-279-20	Tank vent drain removed.

Special Environmental Conditions

None

General Safety Instructions

No smoking, flame, sparks, and hot or glowing objects within 50 ft (15 m) of vehicle.

Level of Maintenance

Direct Support

a. Removal

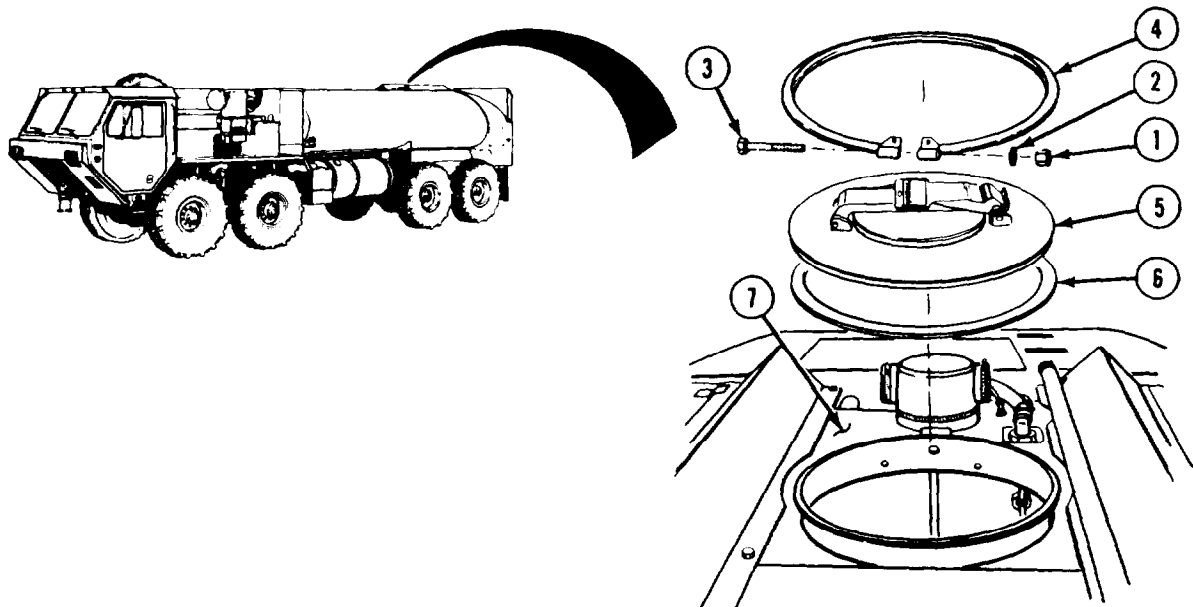

- (1) Remove nut (1), lockwasher (2), and screw (3) from clamp (4).
- (2) Remove clamp (4) from manhole cover (5).
- (3) Remove manhole cover (5) and gasket (6) from tank (7).

Cob and Body Maintenance Instructions (Cont)

15-15. TANK VENT REMOVAL/INSTALLATION (M978) (CONT).

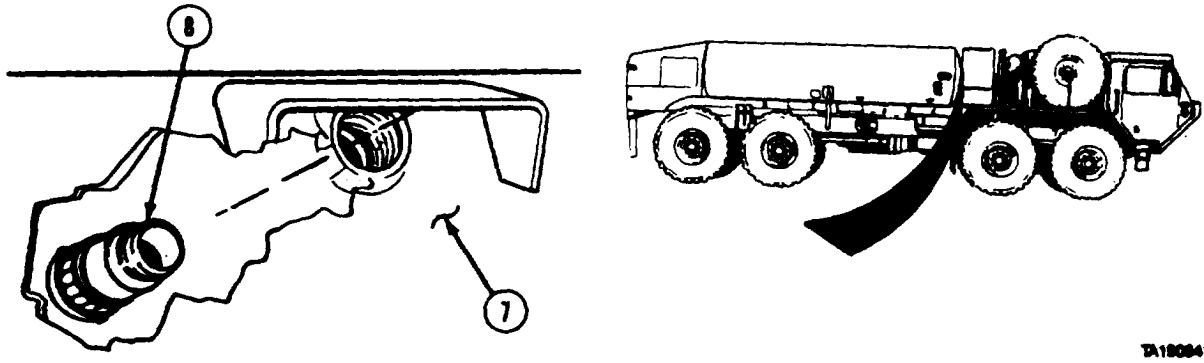

TA190841

WARNING

Before entering tank be sure to read and follow all safety precautions in FM 10-71 and FM 10-20. Liquids and vapors in the M978 tanker are flammable and toxic and can cause injury or death.

NOTE

Tank vent must be removed from inside tank and can be reached only by entering manhole and crawling to front of tank.

(4) Remove tank vent (8) from tank (7).

b. Installation.

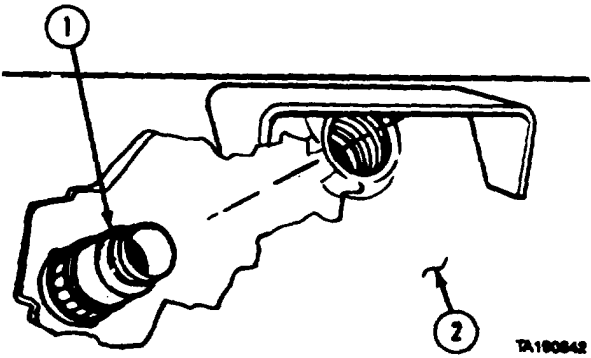

TA190842

WARNING

Before entering tank be sure to read and follow all safety precautions in FM 10-71 and FM 10-20. Liquids and vapors in the M978 tanker are flammable and toxic and can cause injury or death.

(1) Apply antiseize tape to threads of vent (1) and install in tank (2).

Cab and Body Maintenance Instructions (Cont)

- (2) Position gasket (3) and manhole cover (4) on tank (2).
- (3) Install clamp (5) on manhole cover (4).
- (4) Install screw (6), lockwasher (7), and nut (8) on clamp (5).

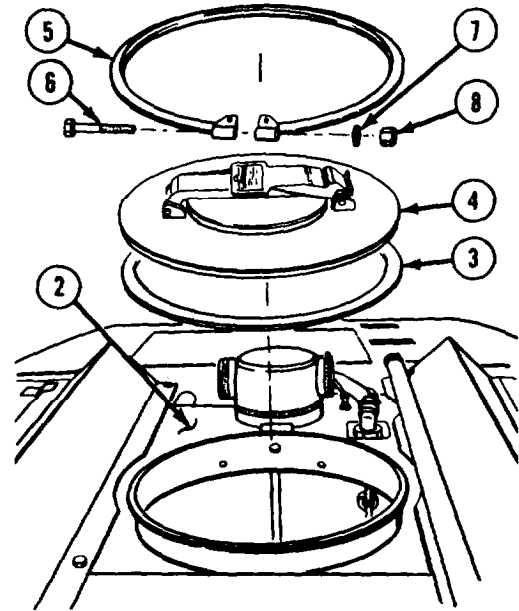

- c. **Follow-on Maintenance.** Install tank vent drain (TM 9-2320-279-20).

END OF TASK

15-16. WRECKER BODY REMOVAL/INSTALLATION (M984).	
This task covers:	
a. Removal	c. Follow-on Maintenance
b. Installation	
INITIAL SETUP	
<i>Models</i> M984	<i>Equipment Condition</i> TM or Para Condition Description TM 9-2320-279-10 Shut off engine. TM 9-2320-279-20 Reflectors removed. TM 9-2320-354-10 BII material removed. TM 9-2320-279-20 Marker lights removed. TM 9-2320-279-20 Rear mud flaps removed.
<i>Test Equipment</i> None	<i>Special Environmental Conditions</i> None
<i>Special Tools</i> None	<i>General Safety Instructions</i> Wheels chocked.
<i>Supplies</i> None	<i>Level of Maintenance</i> Direct Support
<i>Personnel Required</i> MOS 63W, Wheel vehicle repairer (2)	
<i>References</i> None	

Cob and Body Maintenance Instructions (Cont)

15-16. WRECKER BODY REMOVAL/INSTALLATION (M984) (CONT).

a. Removal.

NOTE

Step (1) applies to both rear mounting brackets. Right side is shown.

- (1) Remove two nuts (1), washers (2), and screws (3).

NOTE

Step (2) applies to both front mounting brackets. Right side is shown.

- (2) Soldier A keeps nuts (4) from turning while Soldier B removes two screws (5), springs (6), sleeves (7), washers (8), and nuts.

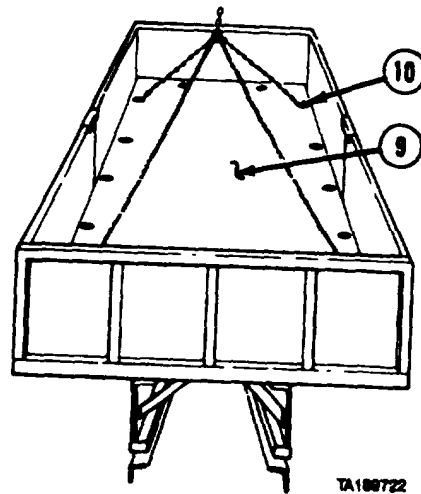
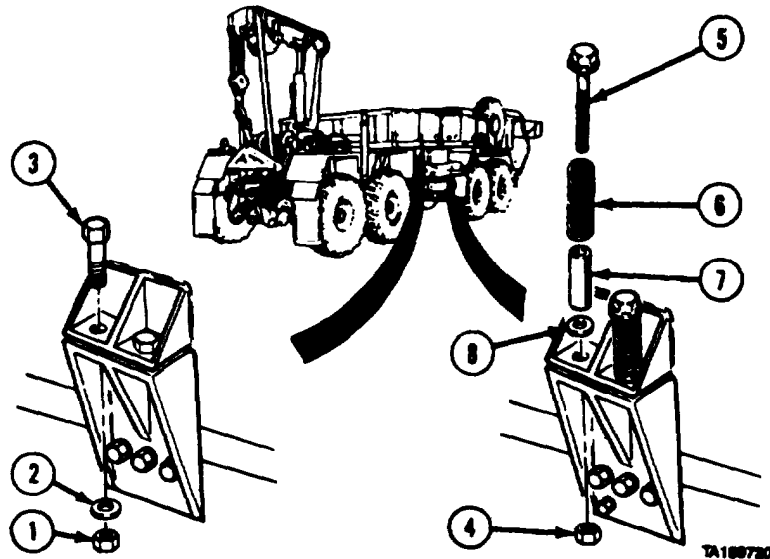

- (3) Operate hoist and move lifting device over cargo box (9).
- (4) Attach lifting device to four corner tiedowns (10).

WARNING

Keep out from under heavy parts. Falling parts can cause serious injury or death.

- (5) Soldier A operates hoist, lifts cargo body (9) off vehicle, and moves to work area while Soldier B guides cargo body.
- (6) Remove wrecker body side panels (TM 9-2320-354-10).

Cab and Body Maintenance Instructions (Cont)

b. Installation.

- (1) Install wrecker body side panels (TM 9-2320-354-10).
- (2) Attach lifting device to four corner tiedowns (1).

WARNING

Keep out from under heavy parts. Falling parts can cause serious injury or death.

- (3) Soldier A guides cargo body (2) while Soldier B operates hoist to lift and position cargo body on vehicle.

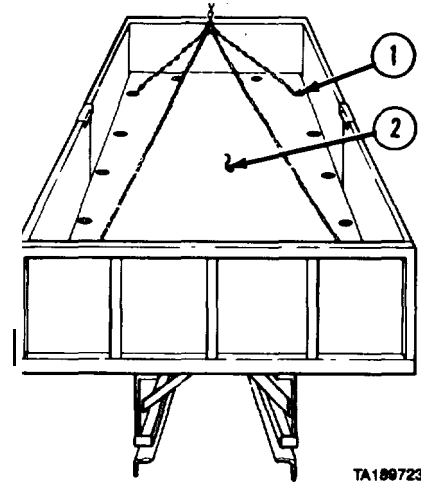

NOTE

Steps (4) and (5) apply to both front mounting brackets. Right side is shown.

- (4) Soldier A installs two screws (3), springs (4), sleeves (5), and washers (6) while Soldier B keeps two nuts (7) from turning.
- (5) Tighten nuts (7) until springs (4) are compressed to 3 7/8 in. (98 mm).
- (6) Repeat step (4) for front bracket on left side of vehicle.

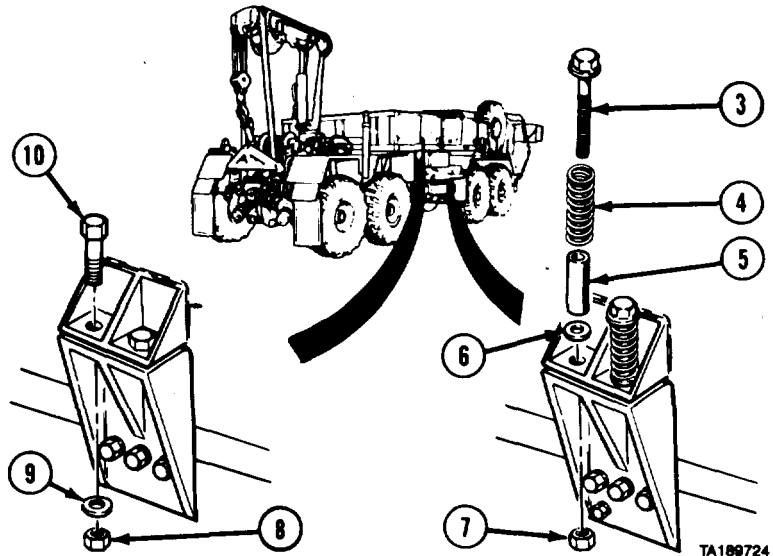

NOTE

Steps (7) and (8) apply to both rear mounting brackets. Right side is shown.

- (7) Install two nuts (8), washers (9) and screws (10).
- (8) Repeat step (7) for rear bracket on left side of vehicle.

c. Follow-on Maintenance.

- (1) Install BII material (TM 9-2320-354-10).
- (2) Install rear mud flaps (TM 9-2320-279-20).
- (3) Install marker lights (TM 9-2320-279-20).
- (4) Install reflectors (TM 9-2320-279-20).

END OF TASK

Cab and Body Maintenance Instructions (Cont)

15-17. WRECKER BODY MOUNTING BRACKETS REMOVAL/INSTALLATION (M984).

his task covers:

- a. Removal
- b. Installation
- c. Follow-on Maintenance

INITIAL SETUP

Models

M984

Test Equipment

None

Special Tools

None

Supplies

None

Personnel Required

MOS 63W, Wheel vehicle repairer (2)

References

None

Equipment Condition

TM or Para

Condition Description

- TM 9-2320-279-10 Shut off engine.
- TM 9-2320-279-20 Fuel tank removed (left front side only).
- TM 9-2320-279-20 Battery box removed (right front side only).

Special Environmental Conditions

None

General Safety Instructions

None

Level of Maintenance

Direct Support

a. Removal.

NOTE

Both rear mounting brackets are removed and installed in the same manner. Right side is shown.

- (1) Remove two nuts (1), washers (2), and screws (3).
- (2) Soldier A removes three nuts (4) while Soldier B removes three screws (5) and rear mounting bracket (6).
- (3) Soldier A removes two nuts (7) while Soldier B removes two screws (8), springs (9), sleeves (10), and washers (11).
- (4) Soldier A removes four nuts (12) while Soldier B removes four screws (13) and front mounting bracket (14).

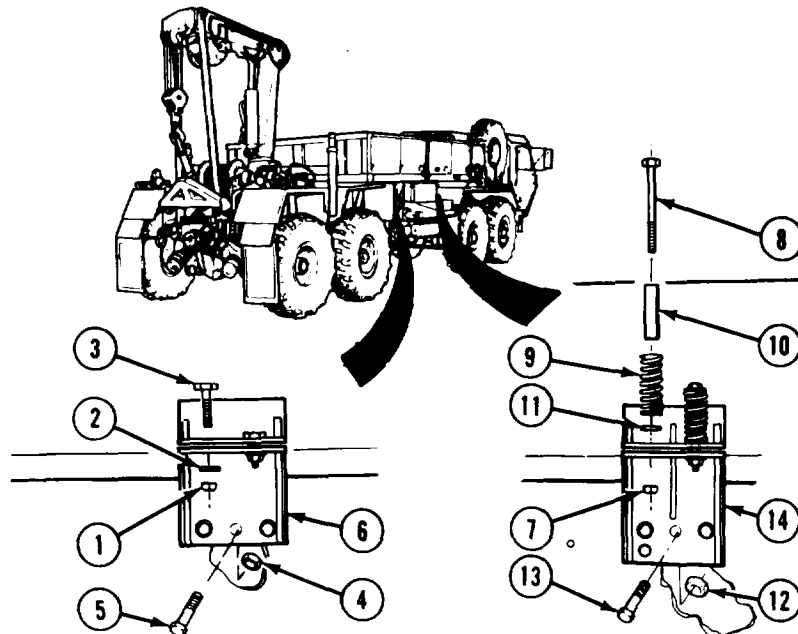

TA190224

Cab and Body Maintenance Instructions (Cont)

b. Installation.

- (1) Soldier A installs front mounting bracket (14) and four screws (13) while Soldier B installs four nuts (12).
- (2) Soldier A installs two washers (11), sleeves (10), springs (9), and screws (8) while Soldier B installs two nuts (7).
- (3) Repeat steps (1) and (2) to install front mounting bracket (14) on left side of vehicle.
- (4) Soldier A installs rear mounting brackets (6) and three screws (5) while Soldier B installs three nuts (4).
- (5) Install two screws (3), washers (2), and nuts (1).

c. Follow-on Maintenance.

- (1) Install fuel tank (TM 9-2320-279-20).
- (2) Install battery box (TM 9-2320-279-20).

END OF TASK

15-18. WOOD SILL REMOVAL/INSTALLATION (M984).		
This task covers:		
a. Removal	c. Follow-on Maintenance	
b. Installation		
INITIAL SETUP		
Models	References	
M984	None	
Test Equipment	Equipment Condition	
None	TM or Para	Condition Description
Special Tools	Para 15-16	Wrecker body removed.
Driver, Torx Head FTX30A2	Special Environmental Conditions	
Supplies	None	
Wood, Item 68, Appendix C	General Safety Instructions	
Personnel Required	None	
MOS 63W, Wheel vehicle repairer	Level of Maintenance	
	Direct Support	

Cab and Body Maintenance Instructions (Cont)

15-18. WOOD SILL REMOVAL/INSTALLATION (M984) (CONT.)

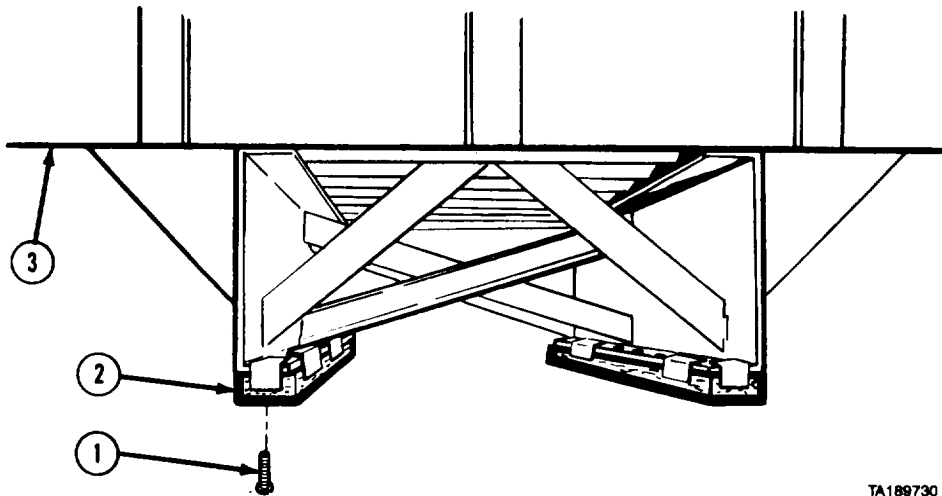

a. Removal. Using torx head driver, remove 10 screws (1) and two wood sills (2) from wrecker body (3).

b. Installation. Using torx head driver, install two wood sills (2) with 10 screws (1) on wrecker body (3).

c. Follow-on Maintenance. Install wrecker body (para 15-16).

END OF TASK

CHAPTER 16 WINCH MAINTENANCE

Contents	Para	Page
General.....	16-1	16-1
Self-Recover Winch Drum Repair	16-2	16-2
Self-Recover Winch Hydraulic Motor Removal/Installation	16-3	16-8
Self-Recover Winch Hydraulic Motor Repair	16-4	16-9
Self-Recover Winch Counterbalance Valve Removal/Installation	16-5	16-14
Self-Recover Winch Counterbalance Valve Repair	16-6	16-15
Self-Recover Winch Brake Removal/Installation	16-7	16-15
Self-Recover Winch Brake Repair	16-8	16-18
Heavy-Duty Winch Supports Removal/Installation (M984)	16-9	16-22
Heavy-Duty Winch Removal/Installation (M984)	16-10	16-24
Heavy-Duty Winch Cable Sheave Removal/Repair/Installation	16-10.1	16-24.1
Heavy-Duty Winch and Brackets Removal/Installation	16-10.2	16-24.6
Fairlead Tensioner Assembly Removal/Repair/Installation and Adjustment	16-10.3	16-24.9
Heavy-Duty Winch Repair (M984)	16-11	16-25
Heavy-Duty Winch Repair (M984E1)	16-11.1	16-38.1
Heavy-Duty Winch Drum Repair (M984)	16-12	16-38.2
Heavy-Duty Winch Hydraulic Motor Removal/Installation (M984)	16-13	16-45
Heavy-Duty Winch Hydraulic Motor Removal/Installation	16-13.1	16-46
Heavy-Duty Winch Hydraulic Motor Repair (M984)	16-14	16-47
Heavy-Duty Winch Hydraulic Motor Repair (P/N 73077) (M984E1)	16-14.1	16-54
Heavy-Duty Winch Hydraulic Motor (P/N V12-80TSSHS 000 A080/031 ACI011-096/050-000) Repair	16-14.2	16-54.5
Heavy-Duty Winch Counterbalance Valve Removal/Repair/Installation (M984)	16-15	16-55
Heavy-Duty Winch Counterbalance Valve Removal/Repair/Installation	16-15.1	16-58
Heavy-Duty Winch Brake Removal/Repair/Installation (M984)	16-16	16-58.4
Heavy-Duty Winch Brake Removal/Repair/Installation (M984E1)	16-17	16-63
Fairlead/Tensioner Motor Removal/Repair/Installation (M984E1)	16-18	16-69

Section I. INTRODUCTION

16-1. GENERAL. This chapter contains maintenance instructions for removal, installation, and repair of self-recovery and heavy-duty winches at the direct support and general support maintenance levels. Subassemblies and parts which must be removed before winch components can be removed are referenced to other paragraphs of this manual or TM 9-2320-279-20.

**Section II. SELF-RECOVERY WINCH
Winch Maintenance Instructions**

16-2. SELF-RECOVERY WINCH DRUM REPAIR.

This task covers:

- | | |
|------------------------|--------------------------|
| a. Disassembly | c. Assembly |
| b. Cleaning/Inspection | d. Follow-on Maintenance |

INITIAL SETUP

Models

All

References

None

Test Equipment

None

Equipment Condition

TM or Para

Condition Description

Self-recovery winch drum on clean work surface.

Special Tools

None

Supplies

Solvent, dry cleaning, Item 57, Appendix C
Grease, ball bearing, lithium, Item 35, Appendix C

Special Environmental Conditions

None

General Safety Instructions

None

Personnel Required

MOS 63W, Wheel vehicle repairer

Level of Maintenance

General Support

a. Disassembly.

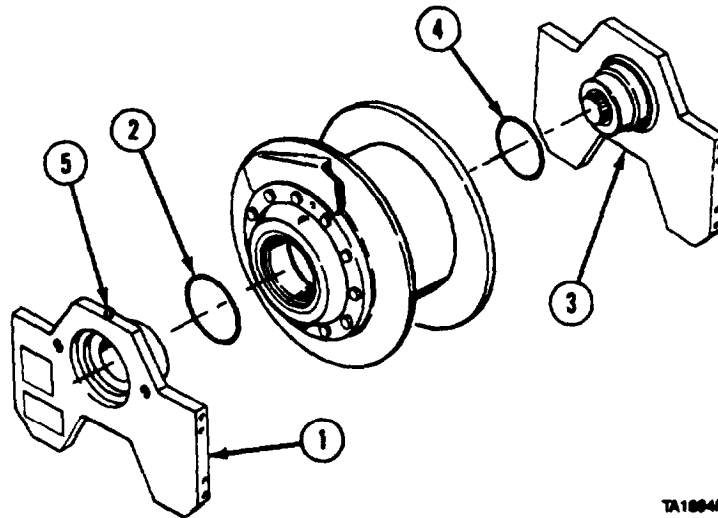

TA100450

- (1) Remove motor end support (1) and preformed packing (2).
- (2) Remove gear end support (3) and preformed packing (4).
- (3) Remove poppet valve (5).

Winch Maintenance Instructions (Cont)

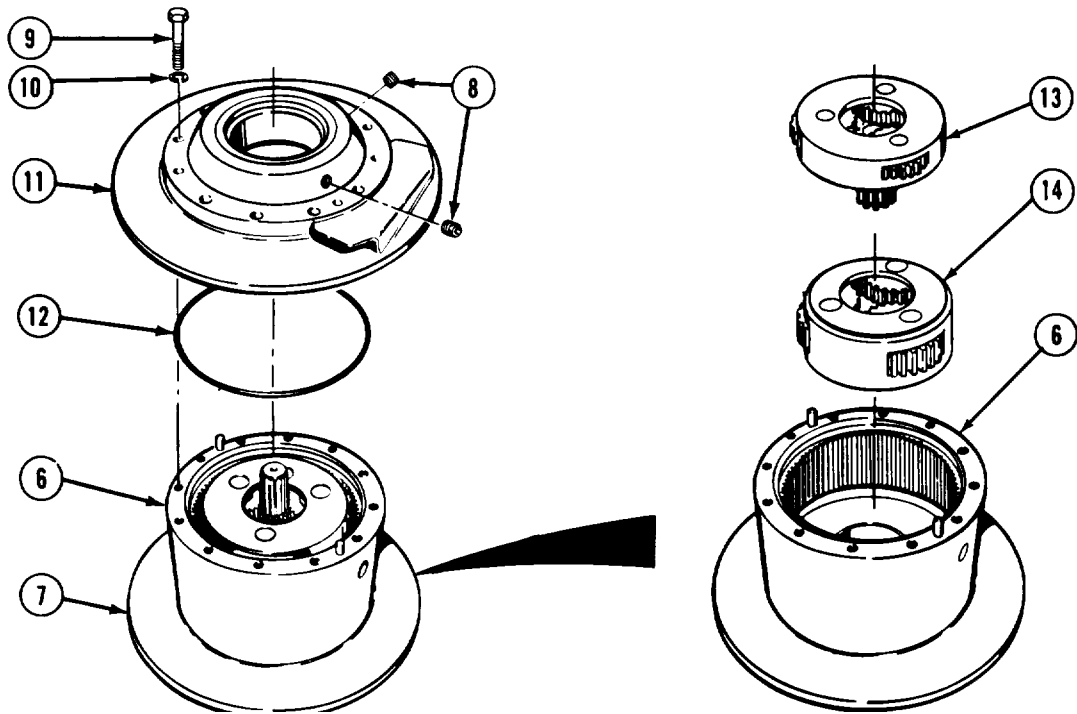

TA476353

- (4) Position drum (6), gear end drum hub (7) down.
- (5) Remove two plugs (8).
- (6) Remove 12 screws (9), lockwashers (10), motor end drum hub (11), and preformed packing (12).
- (7) Remove primary carrier assembly (13) from drum (6).
- (8) Remove secondary carrier assembly (14) from drum (6).
- (9) Turn drum (6) over and remove 12 screws (15) and lockwashers (16).
- (10) Remove gear end drum hub (7) and preformed packing (17).

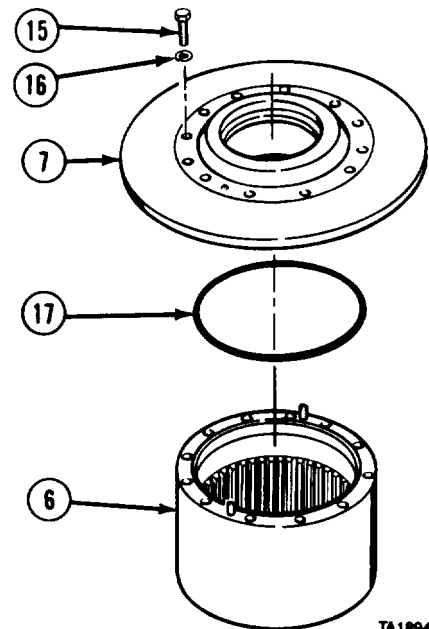

TA189462

Winch Maintenance Instructions (Cont)

16-2. SELF-RECOVERY WINCH DRUM REPAIR (CONT).

- (11) Remove seal (18) from motor end drum hub (11) and seal from gear end drum hub (7).
- (12) Press one sleeve bearing (19) from each drum hub (7 and 11).

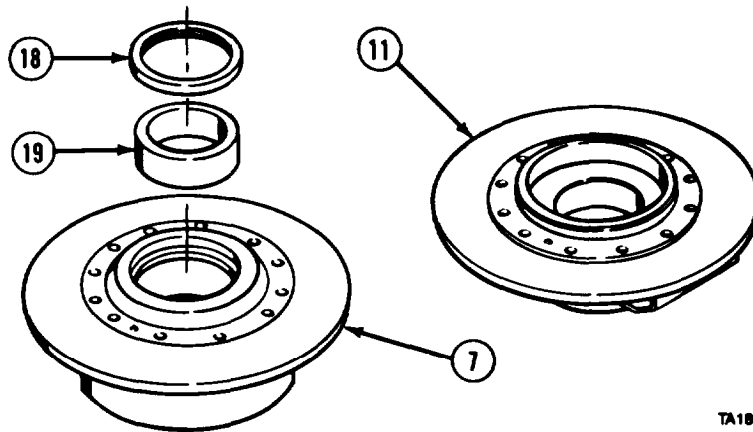

- (13) Remove retaining ring (20) from primary carrier assembly (13).
- (14) Remove secondary sun gear (21).
- (15) Remove retaining ring (22).

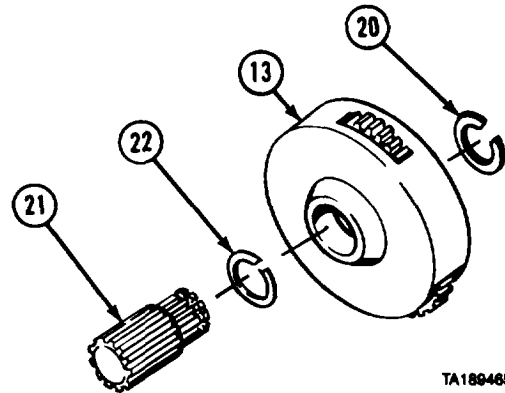

b. Cleaning/Inspection.

WARNING

Adhesives, solvents, and sealing compounds can burn easily, can give off harmful vapors, and are harmful to skin and clothing. To avoid injury or death, keep away from open fire and use in well-ventilated area. If adhesive, solvent, or sealing compound gets on skin or clothing, wash immediately with soap and water.

- (1) Clean metal parts in dry cleaning solvent.
- (2) Inspect all machined surfaces for damage.
- (3) Inspect threaded parts for crossed or stripped threads.
- (4) Replace primary or secondary planetary carrier thrust washers if planetary gear end play is 0.040 in. (1.02 mm) or more. Thrust washers must not be re-used if thinner than 0.045 in. (1.14 mm).
- (5) Replace sleeve bearings if inside diameter exceeds 4.552 in. (115.62 mm) or if deeply scored or out-of-round.
- (6) Replace all damaged parts.

Winch Maintenance Instructions (Cont)

c. Assembly.

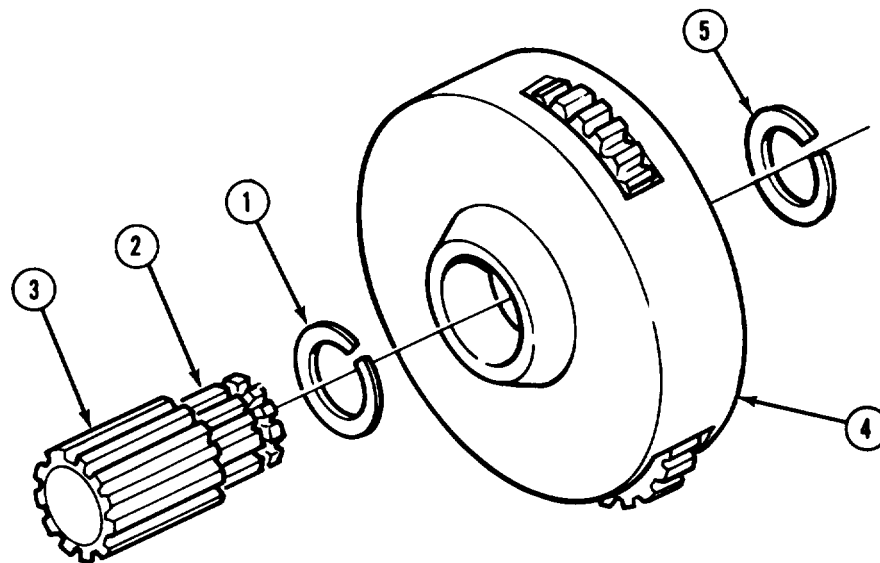

TA356171

- (1) Install retaining ring (1) and seat on shoulder (2) of secondary sun gear (3).
- (2) Install secondary sun gear (3) in primary carrier assembly (4).
- (3) Install retaining ring (5) on secondary sun gear (3).

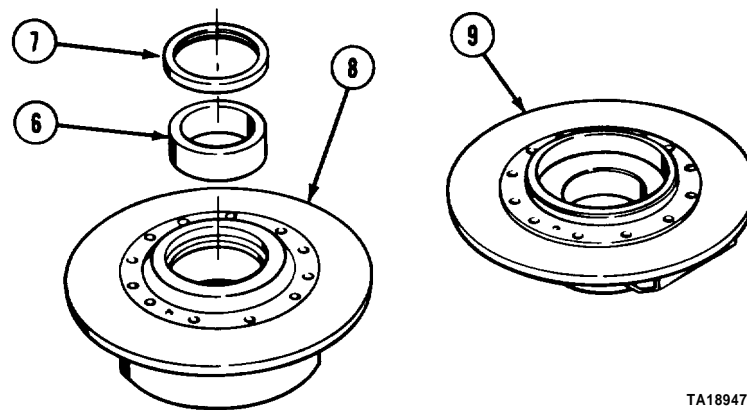

TA18947o

- (4) Press one sleeve bearing (6) and one seal (7) in each drum hub (8 and 9).

Winch Maintenance Instructions (Cont)

16-2. SELF-RECOVERY WINCH DRUM REPAIR (CONT).

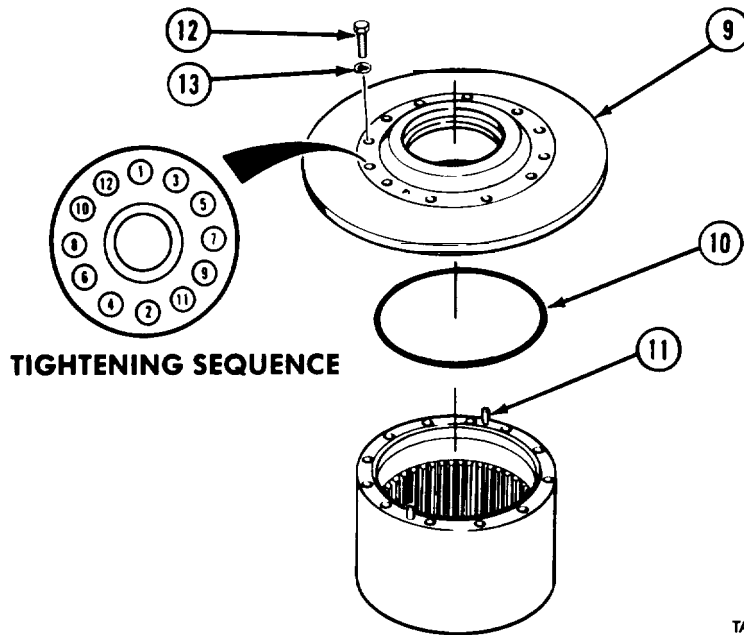

TA189471

- (5) Install preformed packing (10) on gear end drum hub (9).
- (6) Aline gear end drum hub (9) with pins (11) and install with 12 screws (12) and lockwashers (13).
- (7) Tighten screws (12) to 90 to 95 lb-ft (122 to 129 N·m) in sequence shown.

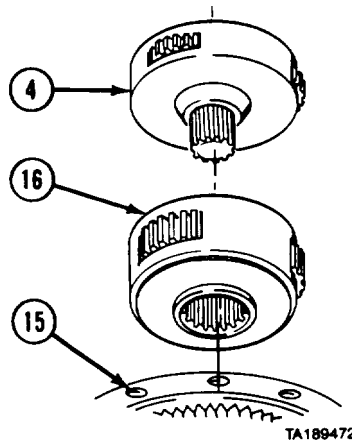

TA189472

- (8) Turn drum (15) over and install secondary carrier assembly (16).
- (9) Aline gears and install primary carrier assembly (4).

Winch Maintenance Instructions (Cont)

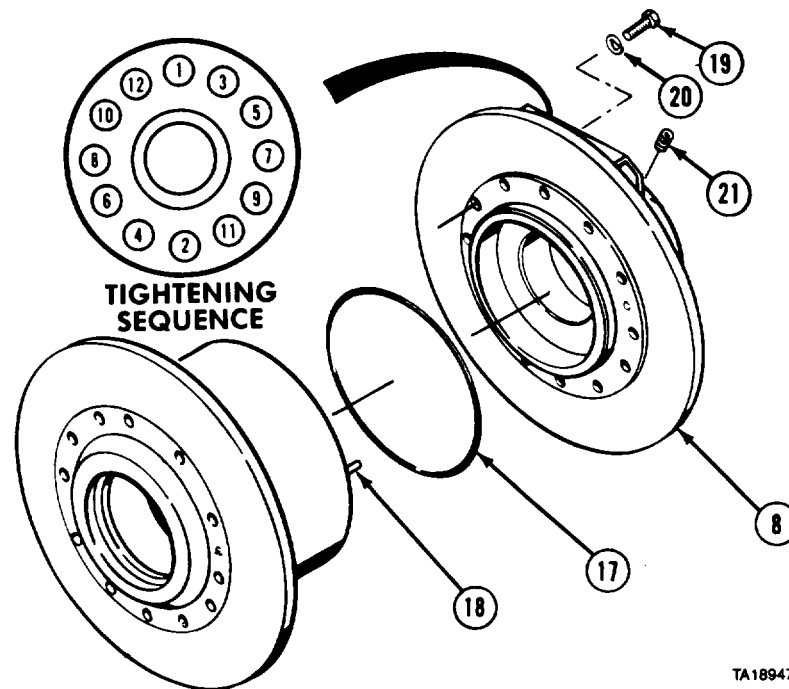

- (10) Install preformed packing (17) on motor end drum hub (8).
- (11) Aline motor end drum hub (8) with pins (18) and install with 12 screws (19) and lockwashers (20).
- (12) Tighten screws (19) to 90 to 95 lb-ft (122 to 129 N-m) in sequence shown.
- (13) Install two plugs (21).

- (14) Install two preformed packings (22).
- (15) Support drum (15) with suitable lifting device and install gear end support (23) and motor end support (24).
- (16) Install poppet valve (25).
- (17) Remove lifting device.

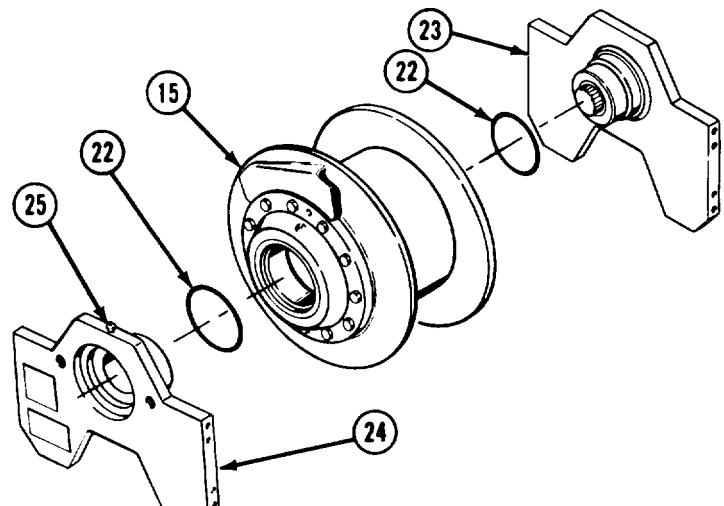

d. Follow-on Maintenance. None.

END OF TASK

Winch Maintenance Instructions (Cont)

16-3. SELF-RECOVERY WINCH HYDRAULIC MOTOR REMOVAL/INSTALLATION.		
This task covers:		
a. Removal	c. Installation	
b. Cleaning/Inspection	d. Follow-on Maintenance	
INITIAL SETUP		
Models	Equipment Condition	
All	TM or Para	Condition Description
Test Equipment	Para 16-5	Self-recovery winch counterbalance valve removed.
None	Special Environmental Conditions	
Special Tools	None	
None	General Safety Instructions	
Supplies	None	
Solvent, dry cleaning, Item 57, Appendix C	Level of Maintenance	
Adhesive-sealant, silicone, Item 6, Appendix C	Direct Support	
Personnel Required		
MOS 63W, Wheel vehicle repairer		
References		
None		

- a. Removal.
 - (1) Place suitable container under hydraulic motor (1) to catch oil.
 - (2) Remove two screws (2), lockwashers (3), hydraulic motor (1), and gasket (4) from winch brake (5).

b. Cleaning/Inspection.

WARNING

Adhesives, solvents, and sealing compounds can burn easily, can give off harmful vapors, and are harmful to skin and clothing. To avoid injury or death, keep away from open fire and use in well-ventilated area. If adhesive, solvent, or sealing compound gets on skin or clothing, wash immediately with soap and water.

- (1) Clean all metal parts in dry cleaning solvent.
- (2) Inspect all mating surfaces for scratches and burrs.
- (3) Replace all scratched or damaged parts.

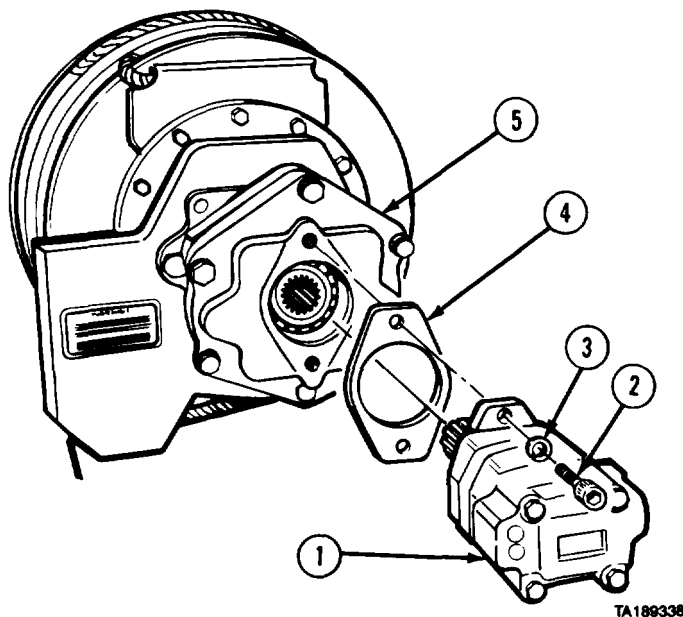

Winch Maintenance Instructions (Cont)

c. Installation.

WARNING

Adhesives, solvents, and sealing compounds can burn easily, can give off harmful vapors, and are harmful to skin and clothing. To avoid injury or death, keep away from open fire and use in well-ventilated area. If adhesive, solvent, or sealing compound gets on skin or clothing, wash immediately with soap and water.

- (1) Coat both sides of gasket (1) with silicone adhesive-sealant and install gasket on hydraulic motor (2).
- (2) Install hydraulic motor (2) on winch brake (3) with two screws (4) and lockwashers (5).

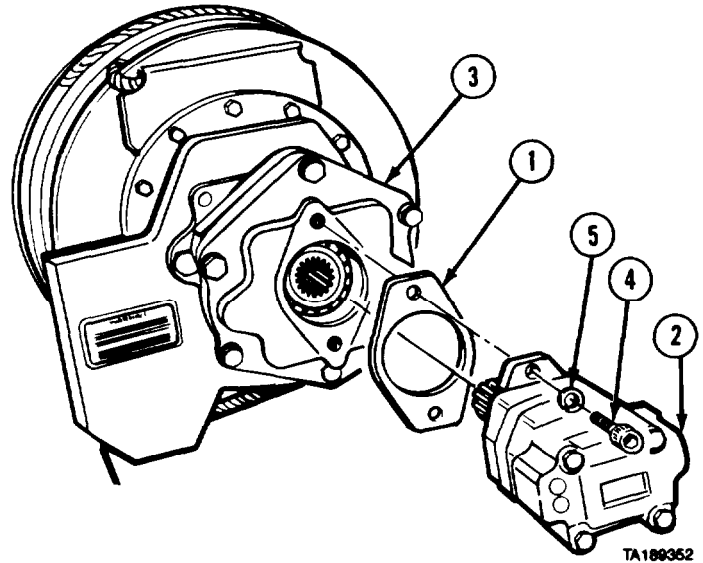

d. Follow-on Maintenance. Install self-recovery winch counterbalance valve (para 16-5).

END OF TASK

16-4. SELF-RECOVERY WINCH HYDRAULIC MOTOR REPAIR.	
This task covers:	
a. Disassembly	c. Assembly
b. Cleaning/Inspection	d. Follow-on Maintenance
INITIAL SETUP	
Models	Equipment Condition
All	<i>TM or Para</i>
Test Equipment	<i>Condition Description</i>
None	Self-recovery winch hydraulic motor on clean work surface.
Special Tools	Special Environmental Conditions
None	None
Supplies	General Safety Instructions
Solvent, dry cleaning, Item 57, Appendix C Grease, ball bearing, lithium base, Item 35, Appendix C	None
Personnel Required	Level of Maintenance
MOS 63W, Wheel vehicle repairer	General Support
References	
None	

Winch Maintenance Instructions (Cont)

16-4. SELF-RECOVERY WINCH HYDRAULIC MOTOR REPAIR (CONT).

a. Disassembly.

NOTE

Matchmark four sections of motor housing.

- (1) Clamp hydraulic motor (1), shaft end down, in vise with soft jaws.
- (2) Remove four screws (2) and valve housing (3) from hydraulic motor (1).
- (3) Remove two springs (4) and pins (5).

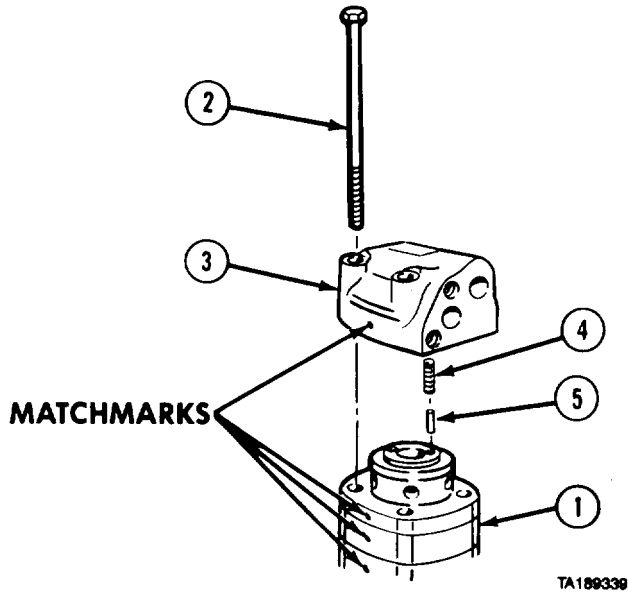

- (4) Remove seals (6 and 7).
- (5) Remove two check plugs (8), preformed packings (9), springs (10), and steel balls (11) from valve housing (3).
- (6) Remove plug (12) and preformed packing (13) from valve housing (3).

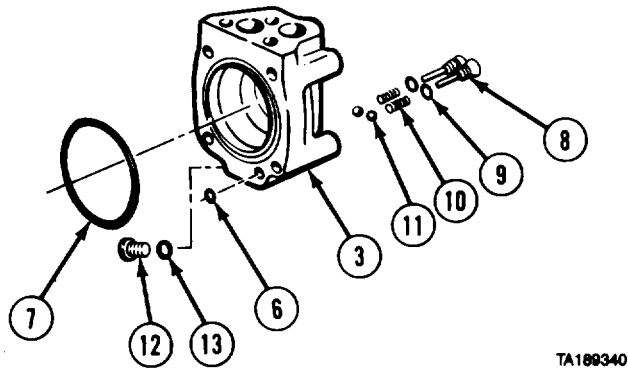

- (7) Remove balance ring (14).
- (8) Remove inner and outer face seals (15 and 16) from balance ring (14).
- (9) Remove valve (17).
- (10) Remove valve plate (18) from bearing housing (19).
- (11) Remove two seals (20 and 21).
- (12) Remove valve drive (22).

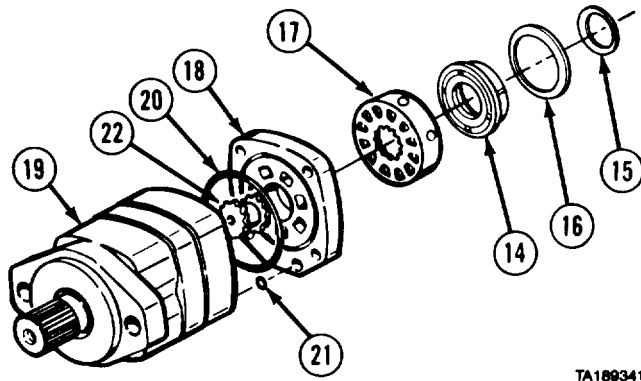

Winch Maintenance Instructions (Cont)

NOTE

Hub and pins of geroler are a matched set.

- (13) Remove geroler (23).
- (14) Remove drive (24), two seals (25 and 26), and wear plate (27).
- (15) Remove shaft face seal (28) and seal (29).

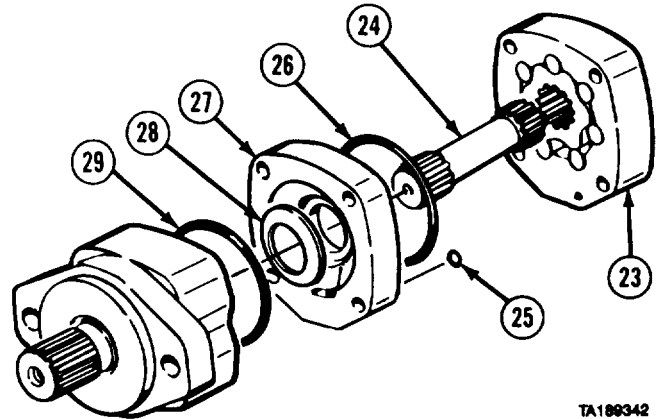

TA189342

- (16) Remove bearing housing (19) from vise.
- (17) Press shaft and bearing assembly (30) from bearing housing (19).

CAUTION

Do not press seals out together or bearing housing will be damaged.

- (18) Remove dust seal (31) from bearing housing (19).
- (19) Remove shaft seal (32) from bearing housing (19).

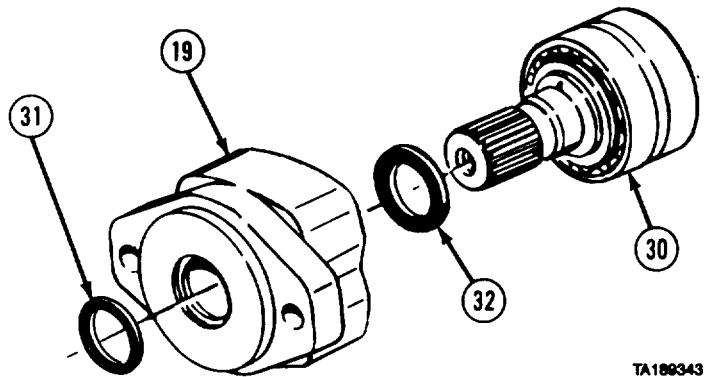

TA189343

b. Cleaning/Inspection.

WARNING

Adhesives, solvents, and sealing compounds can burn easily, can give off harmful vapors, and are harmful to skin and clothing. To avoid injury or death, keep away from open fire and use in well-ventilated area. If adhesive, solvent, or sealing compound gets on skin or clothing, wash immediately with soap and water.

- (1) Clean all metal parts in dry cleaning solvent.
- (2) Inspect all mating surfaces for scratches and burrs.
- (3) Replace all scratched or damaged parts.

c. Assembly.

- (1) Coat shaft seal (1) and dust seal (2) with grease.
- (2) Install shaft seal (1) in bearing housing (3) with lip up.
- (3) Install dust seal (2) in bearing housing (3).
- (4) Place bearing housing (3) in press
- (5) Press shaft and bearing assembly (4) in bearing housing (3).
- (6) Clamp bearing housing (3), shaft end down, in vise with soft jaws.

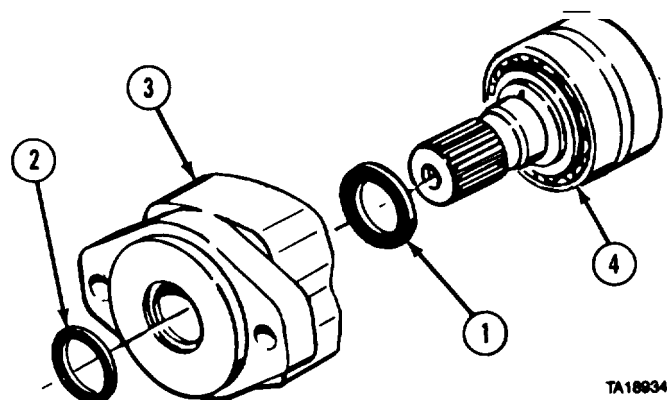

TA189344

Winch Maintenance Instructions (Cont)

16-4. SELF-RECOVERY WINCH HYDRAULIC MOTOR REPAIR (CONT).

- (7) Coat seal (5) with grease and install seal in bearing housing (3).
- (8) Coat shaft face seal (6) with grease and install in wear plate (7).
- (9) Install wear plate (7) on bearing housing (3).
- (10) Coat two seals (8 and 9) with grease and install in wear plate (7).
- (11) Install drive (10) in bearing housing (3).

NOTE

Keep rollers in outer ring of geroler if rollers are loose.

- (12) Aline case drain hole in geroler (11) with case drain hole in wear plate (7).
- (13) Install geroler (11) on wear plate (7).

NOTE

Do steps (14) through (18) to time hydraulic motor for maximum power.

- (14) Find largest open pocket in geroler (11)
Mark location on outside of geroler.
- (15) Install valve drive (12) in geroler (11).
- (16) Coat seals (13 and 14) with grease and install in valve plate (15).
- (17) Install valve plate (15) on geroler(11).
- (18) Aline timing mark on valve (16) with matchmark on outside of geroler (11) and install valve on valve plate (15).

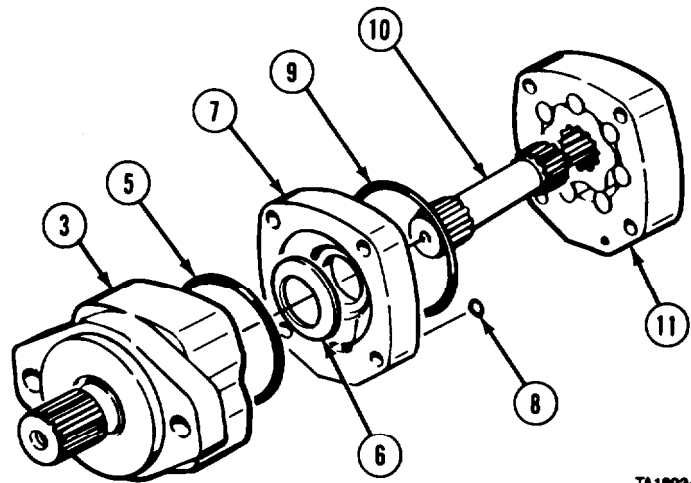

TA189346

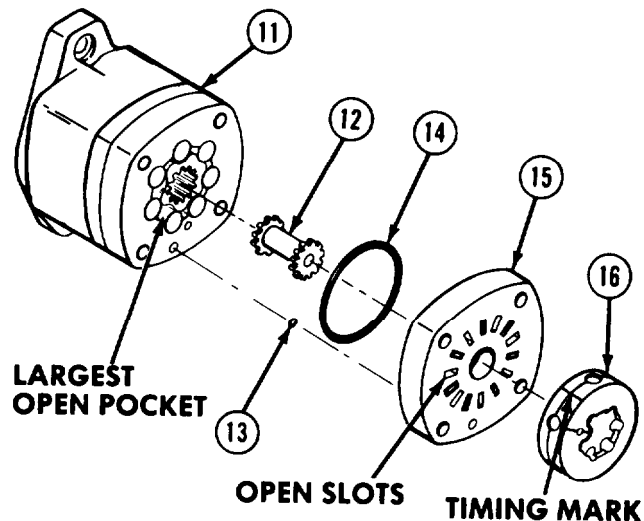

TA189346

- (19) Install two springs (17) and two pins (18) in holes of valve housing (19).
- (20) Coat two seals (20 and 21) with grease and install seals in valve housing (19).

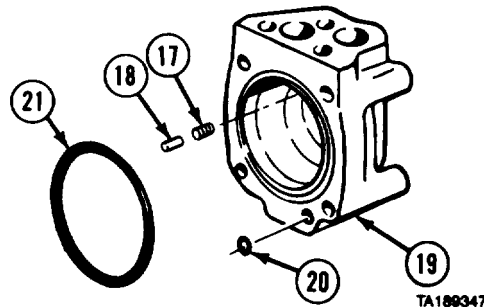

TA189347

Winch Maintenance Instructions (Cont)

- (21) Coat inner and outer face seals (22 and 23) with grease and install seals on balance ring (24).

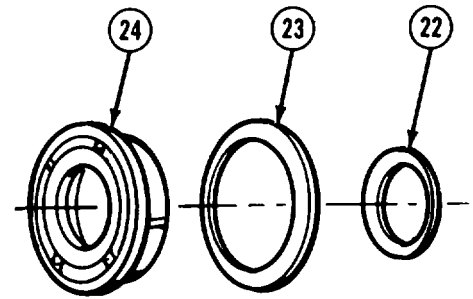

TA189348

- (22) Align pin grooves in balance ring (24) with two pins (18) in valve housing (19).
- (23) Install balance ring (24) in valve housing (19).

NOTE

Insert knife through hole in valve housing to keep balance ring in place during installation.

- (24) Apply pressure to side of balance ring (24) to hold in place.

HOLE IN VALVE

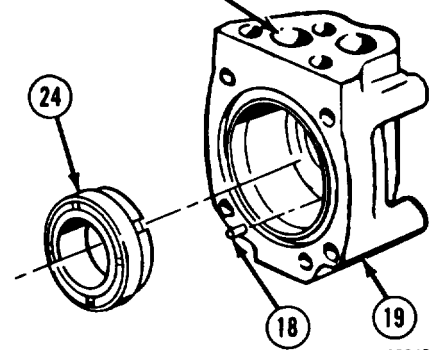

TA189349

- (25) Install valve housing (19) on valve plate (15).

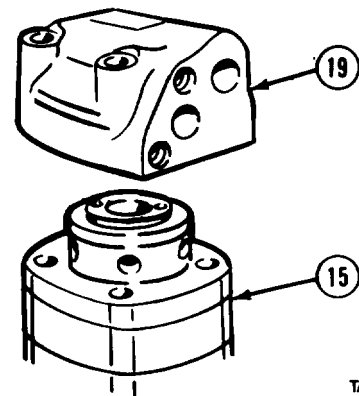

TA189350

- (26) Install four screws (25) and tighten alternately to 35 to 40 lb-ft (47 to 54 N·m).
- (27) Install two steel balls (26), springs (27), preformed packings (28), and check plugs (29) in valve housing (19).
- (28) Coat seal (30) with grease and install seal on plug (31).
- (29) Install plug (31) in valve housing (19). Tighten to 4 lb-ft (5 N·m).

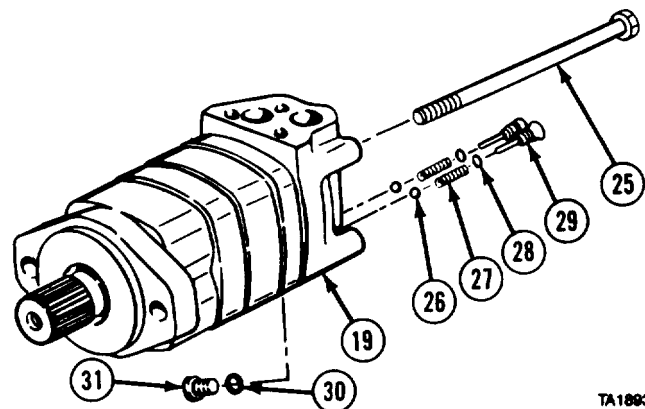

TA189351

d. Follow-on Maintenance. None.

END OF TASK

Winch Maintenance Instructions (Cont)

16-5. SELF-RECOVERY WINCH COUNTERBALANCE VALVE REMOVAL/INSTALLATION.	
This task covers:	
a. Removal b. Installation	c. Follow-on Maintenance
INITIAL SETUP	
Models All	Equipment Condition <i>TM or Para</i> <i>Condition Description</i> TM 9-2320-279-20 Self-recovery winch and brackets removed.
Test Equipment None	
Special Tools None	Special Environmental Conditions None
Supplies None	General Safety Instructions None
Personnel Required MOS 63W, Wheel vehicle repairer	Level of Maintenance Direct Support
References None	

a. Removal.

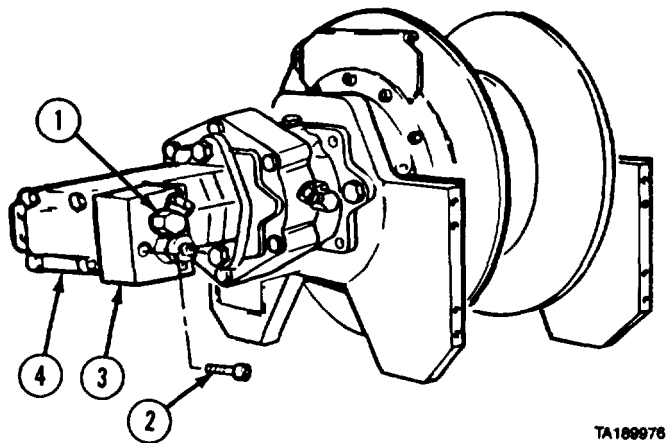

- (1) Loosen fitting (1).
- (2) Remove three screws (2) and counterbalance valve (3) from hydraulic motor (4).

b. Installation.

- (1) Install counterbalance valve (3) and three screws (2) on hydraulic motor (4).
- (2) Tighten three screws (2).
- (3) Tighten fitting (1).

c. Follow-on Maintenance. Install self-recovery winch and brackets (TM 9-2320-279-20).

END OF TASK

Winch Maintenance Instructions (Cont)

16-6. SELF-RECOVERY WINCH COUNTERBALANCE VALVE REPAIR.		
This task covers:		
a. Disassembly	c. Assembly	
b. Cleaning/Inspection	d. Follow-on Maintenance	
INITIAL SETUP		
Models	Equipment Condition	
All	<i>TM or Para</i>	Condition Description
Test Equipment		Self-recovery winch counterbalance valve on clean work surface.
None		
Special Tools	Special Environmental Conditions	
None	None	
Supplies	General Safety Instructions	
Oil, lubricating, Item 46, Appendix C	None	
Solvent, dry cleaning, Item 57, Appendix C		
Personnel Required	Level of Maintenance	
MOS 63W, Wheel vehicle repairer	General Support	
References		
None		

- a. Disassembly.
- (1) Remove two preformed packings (1) from counterbalance valve (2).
 - (2) Remove valve cartridge (3) from counterbalance valve body (2).
 - (3) Remove preformed packing (4), backup ring (5), backup ring (6), preformed packing (7), preformed packing (8), and backup ring (9) from valve cartridge (3).
 - (4) Remove swivel adapter (10) and preformed packing (11).

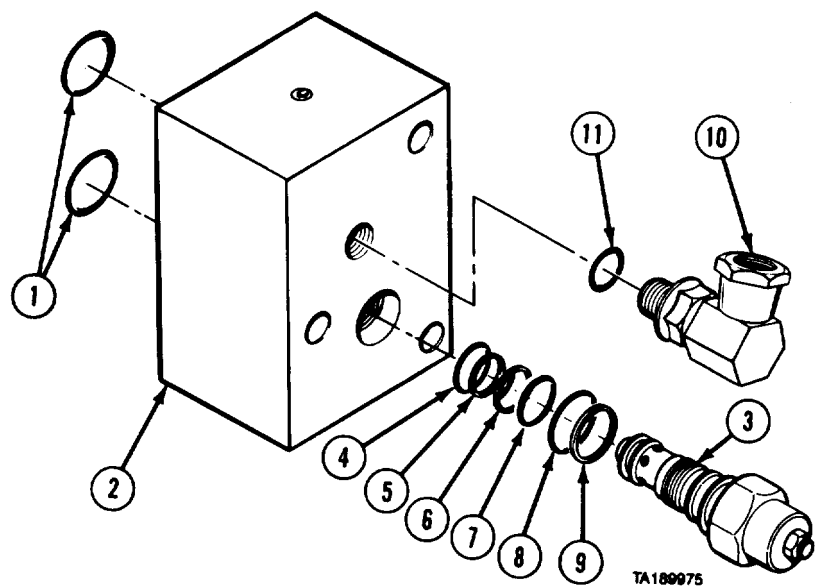

Winch Maintenance Instructions (Cont)

16-6. SELF-RECOVERY WINCH COUNTERBALANCE VALVE REPAIR (CONT).

b. Cleaning/Inspection.

WARNING

Adhesives, solvents, and sealing compounds can burn easily, can give off harmful vapors, and are harmful to skin and clothing. To avoid injury or death, keep away from open fire and use in well-ventilated area. If adhesive, solvent, or sealing compound gets on skin or clothing, wash immediately with soap and water.

- (1) Clean valve cartridge and valve body in dry cleaning solvent.
- (2) Inspect valve cartridge and valve body for damage.
- (3) Replace all damaged parts.

c. Assembly.

- (1) Install preformed packing (11) on swivel adapter (10) and install swivel adapter. Do not tighten,
- (2) Coat preformed packings (8, 7, and 4) with lubricating oil.
- (3) Install backup ring (9) and preformed packing (8) in top groove of valve cartridge (3).
- (4) Install preformed packing (7) and backup ring (6) in middle groove of valve cartridge (3).
- (5) Install backup ring (5) and preformed packing (4) in bottom groove of valve cartridge (3).
- (6) Install valve cartridge (3) in counterbalance valve body (2).
- (7) Install two preformed packings (1).

d. Follow-on Maintenance. None.

END OF TASK

16-7. SELF-RECOVERY WINCH BRAKE REMOVAL/INSTALLATION.		
This task covers:		
a. Removal	c. Follow-on Maintenance	
b. Installation		
INITIAL SETUP		
Models	Equipment Condition	
All	<i>TM or Para</i>	<i>Condition Description</i>
Test Equipment	Para 16-3	Self-recovery winch
None		hydraulic motor removed.
Special Tools	Special Environmental Conditions	
None	None	
Supplies	General Safety Instructions	
Oil, lubricating, Item 46, Appendix C	None	
Adhesive-sealant, silicone, Item 6, Appendix C	Level of Maintenance	
Personnel Required	Direct Support	
MOS 63W, Wheel vehicle repairer		
References		
None		

Winch Maintenance Instructions (Cont)

a. Removal.

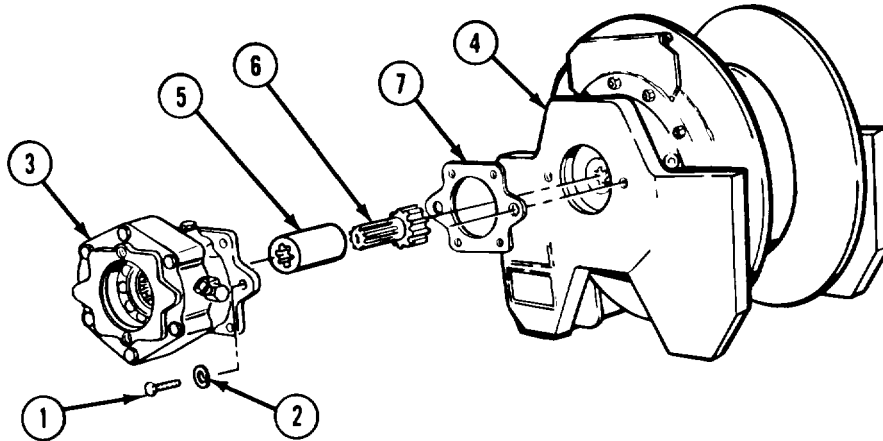

TA169368

- (1) Remove two screws (1), lockwashers (2), and winch brake (3) from motor end support (4).

NOTE

Primary sun gear may stay in spline coupling or motor end support.

- (2) Remove spline coupling (5) and primary sun gear (6).
 (3) Remove gasket (7).

b. Installation.

- (1) Coat spline coupling (5) with lubricating oil and install spline coupling on winch brake (3).
 (2) Install primary sun gear (6).

WARNING

Adhesives, solvents, and sealing compounds can burn easily, can give off harmful vapors, and are harmful to skin and clothing. To avoid injury or death, keep away from open fire and use in well-ventilated area. If adhesive, solvent, or sealing compound gets on skin or clothing, wash immediately with soap and water.

- (3) Apply silicone adhesive-sealant to both sides of gasket (7) and install.
 (4) Install winch brake (3) on motor end support (4) with two screws (1) and lockwashers (2).

c. Follow-on Maintenance. Install self-recovery winch hydraulic motor (para 16-3).

END OF TASK

Winch Maintenance Instructions (Cont)

16-8. SELF-RECOVERY WINCH BRAKE REPAIR.		
This task covers:		
a. Disassembly	c. Assembly	
b. Cleaning/Inspection	d. Follow-on Maintenance	
INITIAL SETUP		
Models	Equipment Condition	
All	<i>TM or Para</i>	Condition Description
Test Equipment		Self-recovery winch brake on clean work surface.
None		
Special Tools	Special Environmental Conditions	
None	None	
Supplies	General Safety Instructions	
Solvent, dry cleaning, Item 57, Appendix C	None	
Oil, lubricating, Item 46, Appendix C	Level of Maintenance	
Personnel Required	General Support	
MOS 63W, Wheel vehicle repairer		
References		
None		

- a. Disassembly.
 (1) Remove swivel fitting (1) and preformed packing (2).

NOTE

- Matchmark cover and housing.
 (2) Remove six screws (3) and lockwashers (4).
 (3) Remove cover (5) from housing (6).
 (4) Remove preformed packing (7).
 (5) Remove bearing (8).

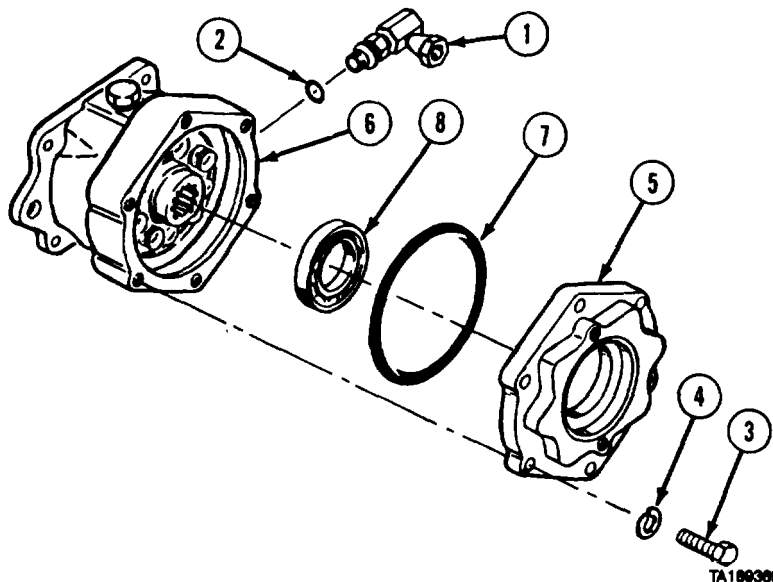

Winch Maintenance Instructions (Cont)

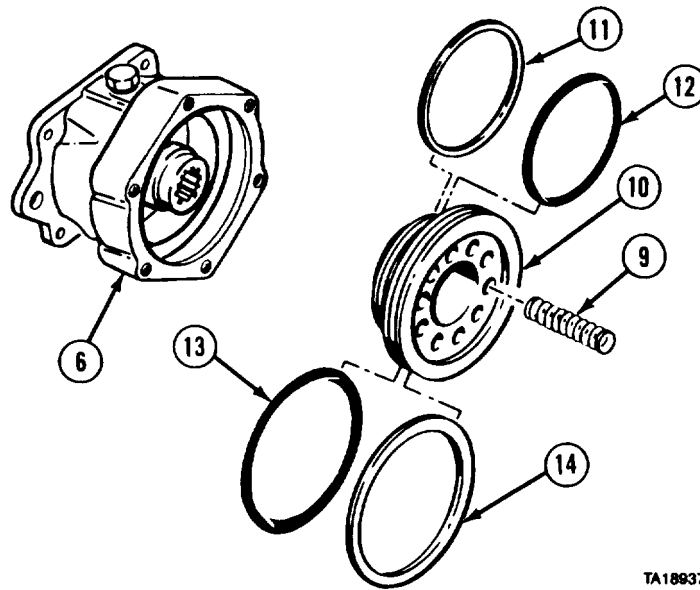

TA189370

- (6) Remove 10 springs (9) from piston (10).

NOTE

There are two threaded screw holes in piston.

- (7) Insert two screws in piston (10) and tighten evenly to remove piston from housing (6). Remove two screws.
- (8) Remove backup ring (11), preformed packing (12), preformed packing (13), and backup ring (14) from piston (10).

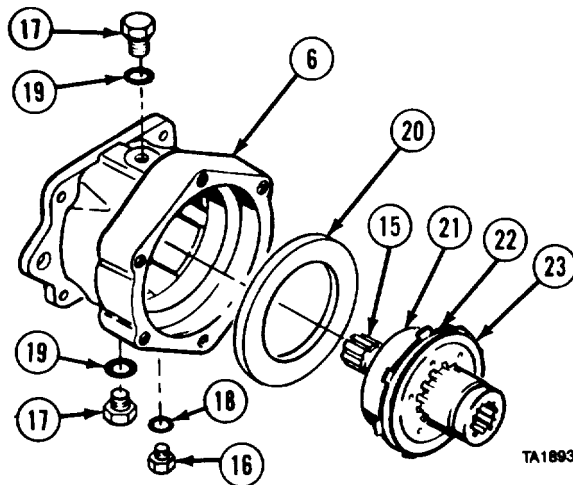

TA189371

- (9) Push on closed end of shaft (15) and remove shaft from housing (6).
- (10) Remove plug (16) and two plugs (17) from housing (6).
- (11) Remove preformed packing (18) from plug (16) and two preformed packings (19) from plugs (17).
- (12) Remove spacer (20).
- (13) Press bearing (21) from shaft (15) and remove 10 friction plates (22) and nine steel plates (23).

Winch Maintenance Instructions (Cont)

16-8. SELF-RECOVERY WINCH BRAKE REPAIR (CONT). [

b. Cleaning/Inspection.

WARNING

Adhesives, solvents, and sealing compounds can burn easily, can give off harmful vapors, and are harmful to skin and clothing. To avoid injury or death, keep away from open fire and use in well-ventilated area. If adhesive, solvent, or sealing compound gets on skin or clothing, wash immediately with soap and water.

- (1) Clean all metal parts with dry cleaning solvent.
- (2) Inspect all threaded parts for crossed and stripped threads.
- (3) Inspect all machined parts for damage.
- (4) Check housing and cover for cracks or damage.
- (5) Replace friction plates when worn to 0.077 in. (1.95 mm).
- (6) Replace steel plates only if warped, cracked, deeply grooved, or discolored by heat.
- (7) Replace springs when springs can be compressed to 2 in. (50 mm) with a load of 180 lb (82 kg).
- (8) Replace all damaged parts.

c. Assembly.

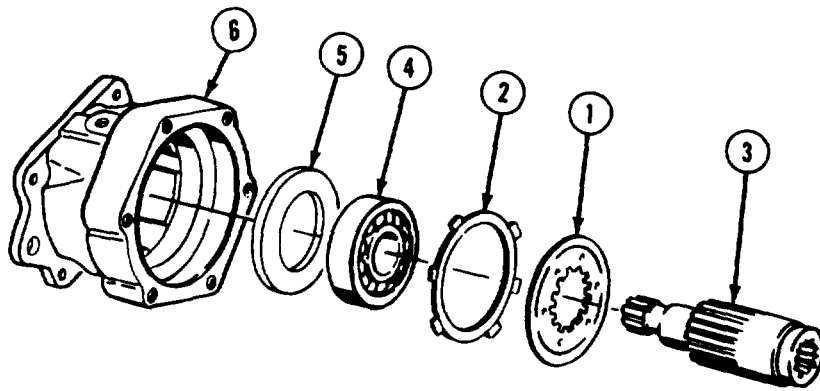

TA100372

- (1) Starting with one steel plate (1), alternate nine steel plates and 10 friction plates (2) on shaft (3).
- (2) Press bearing (4) on closed end of shaft (3).
- (3) Install spacer (5) in housing (6).
- (4) Aline tabs of friction plates (2) with slots in housing (6).
- (5) Install shaft (3), closed end first, in housing (6).
- (6) Push shaft (3) in housing (6) until bearing (4) seats on bottom of housing.

Winch Maintenance Instructions (Cont)

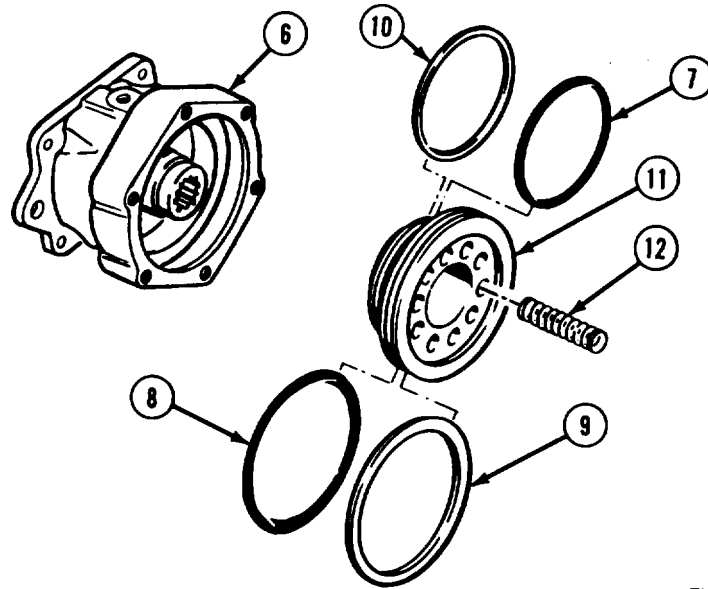

TA186373

- (7) Coat two preformed packings (7 and 8) with lubricating oil.
- (8) Install two preformed packings (7 and 8) and two backup rings (9 and 10) on piston (11).
- (9) Install piston (11) in housing (6).
- (10) Install 10 springs (12) in piston (11).

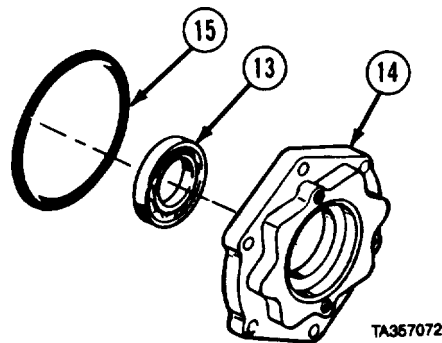

TA357072

- (11) Press bearing (13) in cover (14).
- (12) Coat preformed packing (15) with lubricating oil and install on cover (14).



Winch Maintenance Instructions (Cont)

16-8. SELF-RECOVERY WINCH BRAKE REPAIR (CONT).

- (13) Position cover (14) on springs (12). Install six screws (16) and lockwashers (17) through cover in housing (6).
- (14) Tighten screws (16) evenly.
- (15) Coat preformed packings (18 and 19) with lubricating oil and install on two plugs (20) and plug (21).
- (16) Install plug (21) and two plugs (20).
- (17) Install preformed packing (22) on swivel fitting (23),
- (18) Install swivel fitting (23) on housing (6).

d. Follow-on Maintenance. None.

END OF TASK

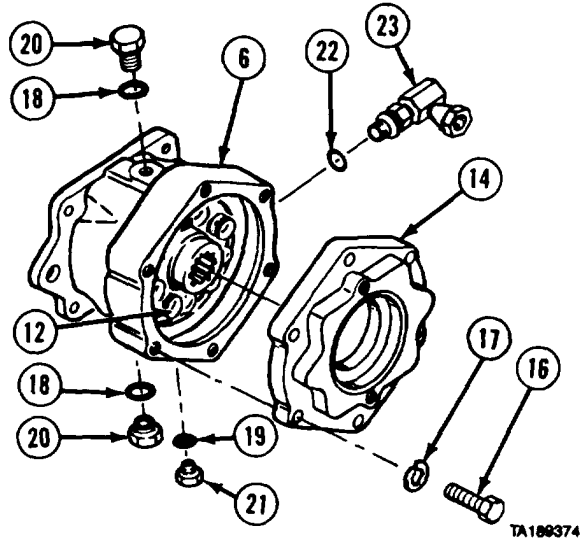

Section III. HEAVY-DUTY WINCH

16-9. HEAVY-DUTY WINCH SUPPORTS REMOVAL/INSTALLATION (M984).	
This task covers:	
a. Removal	c. Follow-on Maintenance
b. Installation	
INITIAL SETUP	
Models	Equipment Condition
M984	<i>TM or Para</i>
Test Equipment	Para 16-10
None	Condition Description
Special Tools	Heavy-duty winch removed.
None	Special Environmental Conditions
Supplies	None
None	General Safety Instructions
Personnel Required	None
MOS 63W, Wheel vehicle repairer	Level of Maintenance
References	Direct Support
None	

Winch Maintenance Instructions (Cont)

a. Removal.

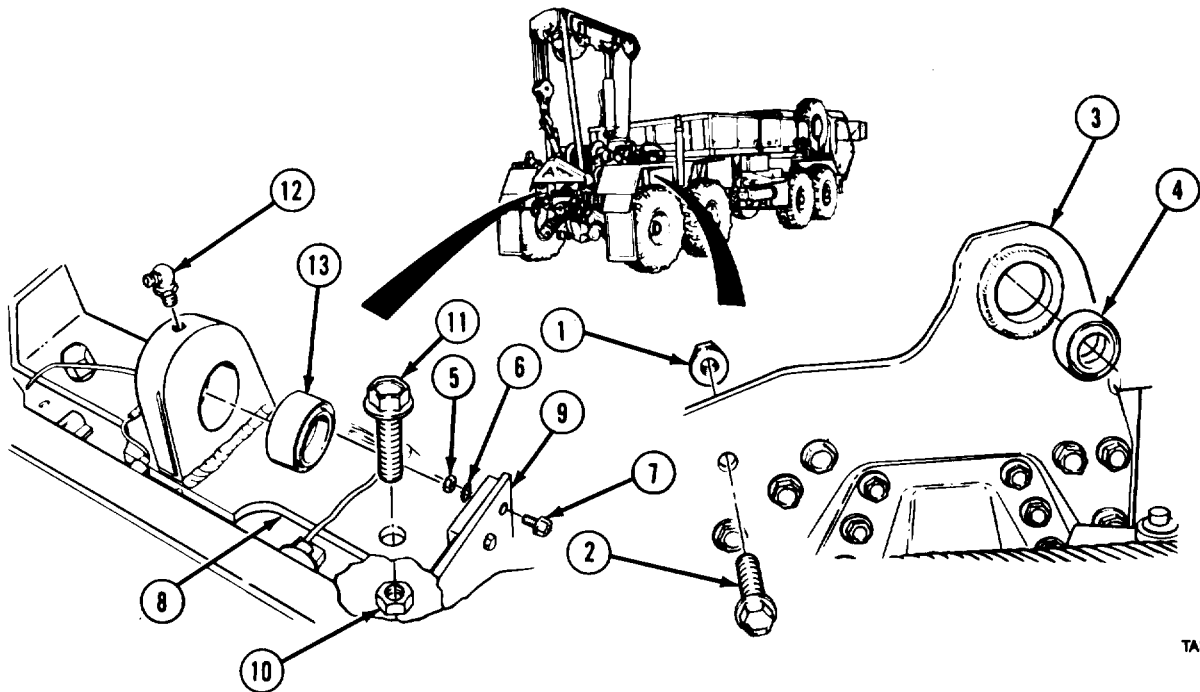

TA357074

NOTE

Right and left winch brackets are removed and installed the same way.

- (1) Remove seven nuts (1) and screws (2) from winch bracket (3).
- (2) Remove winch bracket (3).
- (3) Remove bushing (4).
- (4) Remove two nuts (5), washers (6), and screws (7) from both ends of support (8). Move light bracket (9) out of way.
- (5) Remove four nuts (10) and screws (11).
- (6) Remove support (8).
- (7) Remove grease fitting (12).
- (8) Remove bushing (13).

b. Installation.

- (1) Install bushing (13) in support (8).
- (2) Install support (8) with four screws (11) and nuts (10).
- (3) Install light bracket (9) with two screws (7), washers (6), and nuts (5) on both ends of support (8).
- (4) Install grease fitting (12).
- (5) Install bushing (4) in winch bracket (3).
- (6) Install winch bracket (3) with seven screws (2) and nuts (1).

c. Follow-on Maintenance. Install heavy-duty winch (para 16-10).

END OF TASK

Winch Maintenance Instructions (Cont)

16-10. HEAVY-DUTY WINCH REMOVAL/INSTALLATION (M984).		
This task covers:		
a. Removal	c. Follow-on Maintenance	
b. Installation		
INITIAL SETUP		
<i>Models</i>	<i>Equipment Condition</i>	
M984	<i>TM or Para</i>	<i>Condition Description</i>
<i>Test Equipment</i>	TM 9-2320-279-20	Winch cable removed.
None	TM 9-2320-279-20	Heavy-duty winch and auxiliary hydraulic relief valve and bracket removed (M984).
<i>Special Tools</i>	<i>Special Environmental Conditions</i>	
None	None	
<i>Supplies</i>	<i>General Safety Instructions</i>	
None	None	
<i>Personnel Required</i>	<i>Level of Maintenance</i>	
MOS 63W, Wheel vehicle repairer (2)	Direct Support	
<i>References</i>		
None		

a. Removal.

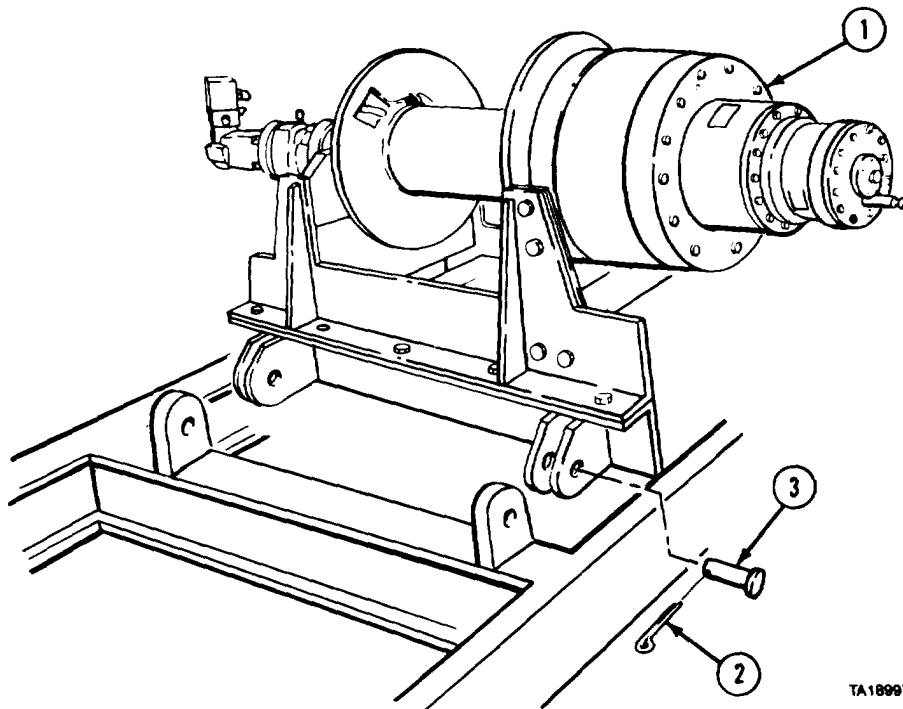

Winch Maintenance Instructions (Cont)

WARNING

Stand clear of winch when winch is being lifted or moved to avoid personal injury.

- (1) Attach suitable lifting device to winch (1).
- (2) Soldier A removes three cotter pins (2) and pins (3) while Soldier B supports winch (1) with lifting device.
- (3) Soldier A guides winch (1) from vehicle while Soldier B operates lifting device.
- (4) Remove lifting device.

b. Installation.

- (1) Attach suitable lifting device to winch (1).

WARNING

Stand clear of winch when winch is being lifted or moved to avoid personal injury.

- (2) Soldier A guides winch (1) in position on vehicle while Soldier B operates lifting device.
- (3) Soldier A aligns mounting lugs and installs three pins (3) and cotter pins (2).

c. Follow-on Maintenance.

- (1) Install heavy-duty winch and auxiliary hydraulic relief valve and bracket (TM 9-2320-279-20).
- (2) Install winch cable (TM 9-2320-279-20).

END OF TASK

16-10.1. HEAVY-DUTY WINCH CABLE SHEAVE REMOVAL/REPAIR/INSTALLATION.	
This task covers:	
a. Removal	d. Assembly
b. Disassembly	e. Installation
c. Cleaning/Inspection	f. Follow-on Maintenance
INITIAL SETUP	
<i>Models</i>	<i>Equipment Condition</i>
M984E1	<i>TM or Para</i> <i>Condition Description</i>
<i>Test Equipment</i>	TM 9-2320-279-20 Heavy duty winch cable removed.
None	TM 9-2320-279-20 No. 3 prop shaft removed.
<i>Special Tools</i>	TM 9-2320-279-20 Left middle mud flap removed.
None	
<i>Supplies</i>	<i>Special Environmental Conditions</i>
None	None
<i>Personnel Required</i>	<i>General Safety Instructions</i>
MOS 63S, Heavy wheel vehicle mechanic (2)	None
<i>References</i>	<i>Level of Maintenance</i>
None	Direct Support

Winch Maintenance Instructions (Cont)

16-10.1. HEAVY-DUTY WINCH CABLE SHEAVE REMOVAL/REPAIR/INSTALLATION (CONT).

a. Removal.

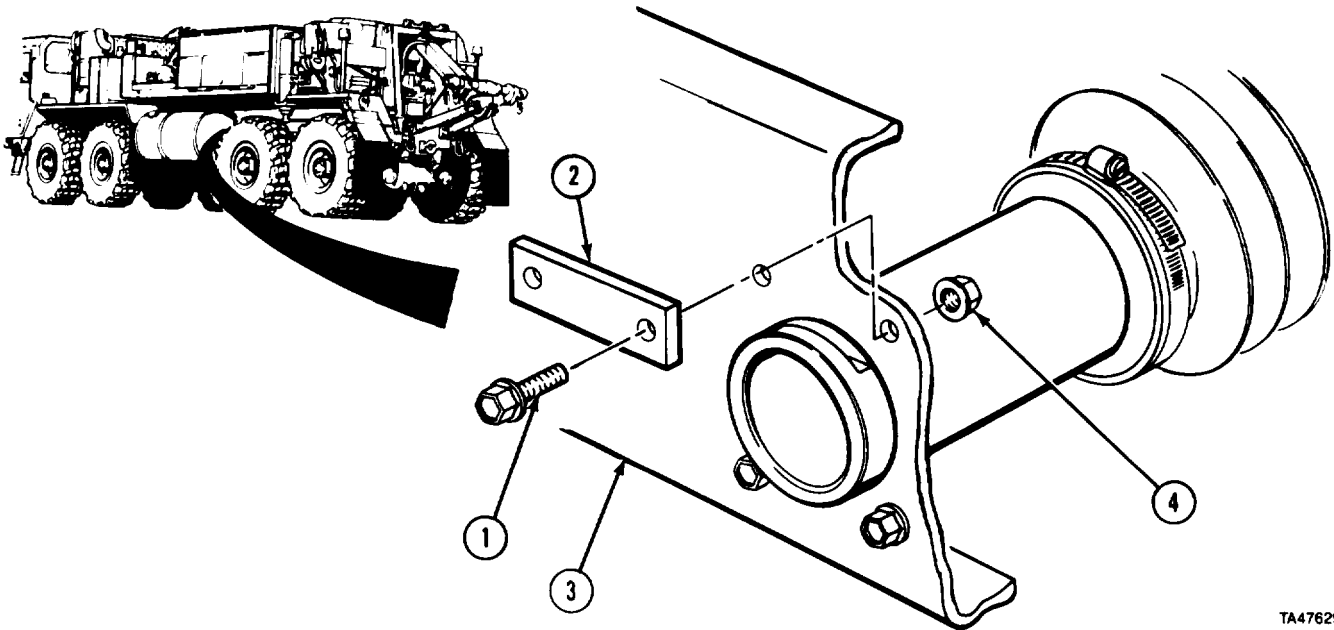

TA476294

(1) Soldier A removes two screws (1) and lockplate (2) from equipment body (3) while Soldier B holds nuts (4).

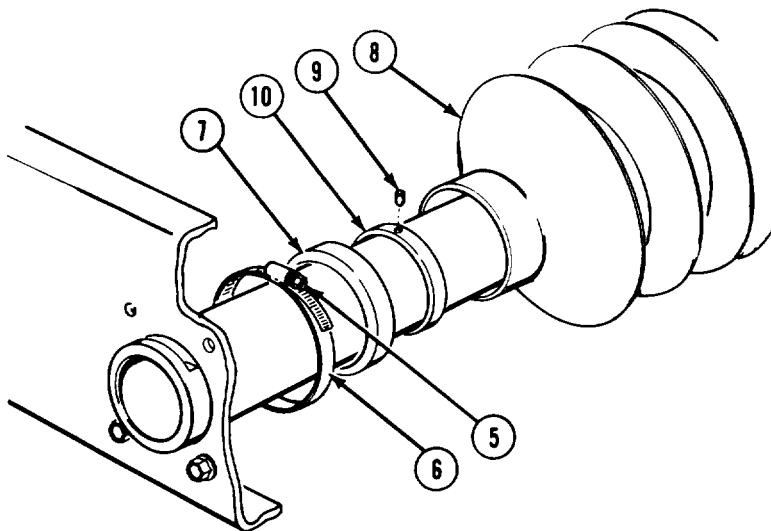

TA476295

(2) Loosen two clamp screws (5) and slide clamps (6) clear of ring (7) and boot (8).
 (3) Slide boot (8) back and remove setscrew (9) from locking (10).
 (4) Repeat steps (2) and (3) for other side.

Winch Maintenance Instructions (Cont)

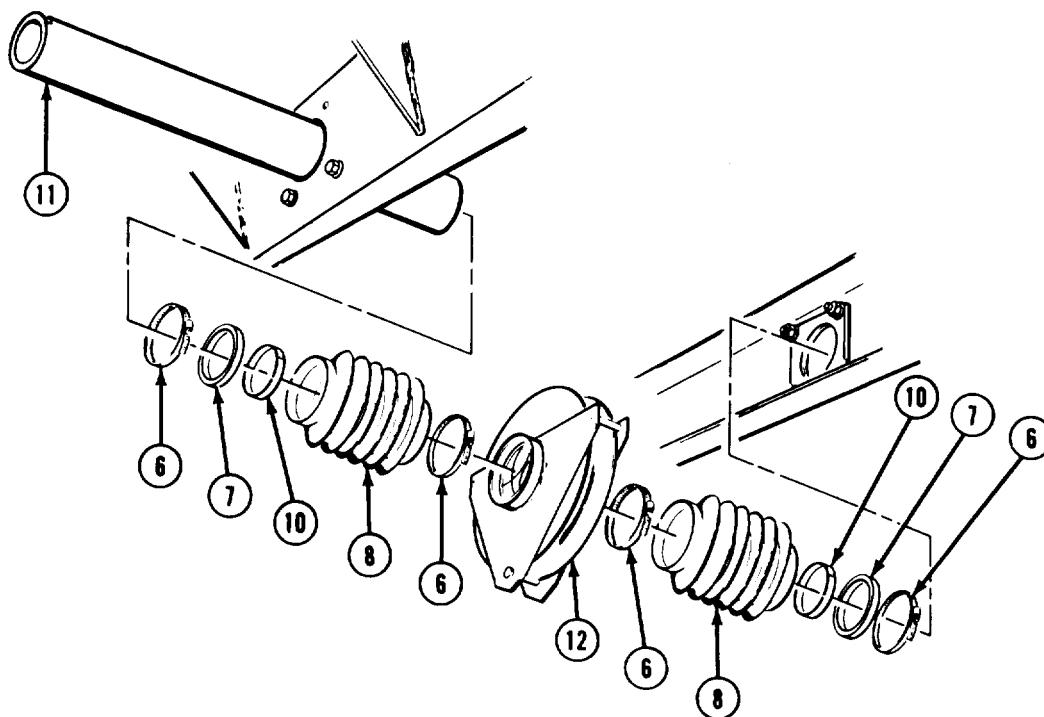

TA476296

- (5) Soldier A removes shaft (11) halfway while Soldier B removes clamp (6), ring (7), boot (8), locking (10), clamp (6), and sheave (12).
- (6) Remove clamp (6), boot (8), locking (10), ring (7), clamp (6), and shaft (11).
- (7) Soldier A removes six screws (1) while Soldier B holds nuts (4). Soldier B removes two plates (13) and nuts (4).

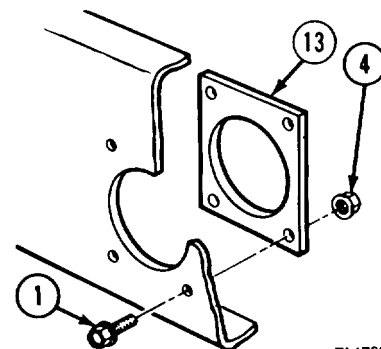

TA476297

b. Disassembly.

- (1) Remove cotter pin (1) and pin (2) from cable guide (3).
- (2) Remove sheave (4) from cable guide (3).
- (3) Remove bushing (5) from sheave (4).

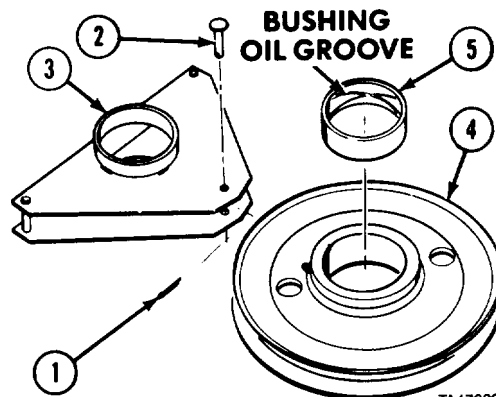

TA476298

Winch Maintenance Instructions (Cont)

16-10.1. HEAVY-DUTY WINCH CABLE SHEAVE REMOVAL/REPAIR/INSTALLATION (CONT).

c. Cleaning/Inspection.

WARNING

Adhesives, solvents, and sealing compounds can burn easily, can give off harmful vapors, and are harmful to skin and clothing. To avoid injury or death, keep away from open fire and use in well-ventilated area. If adhesive, solvent, or sealing compound gets on skin or clothing, wash immediately with soap and water.

- (1) Clean all metal parts in dry cleaning solvent.
- (2) Inspect all parts for damage.
- (3) Replace damaged parts.
- (4) Replace bushing when any part of bushing oil groove is worn smooth.

d. Assembly.

- (1) Install bushing (1) in sheave (2).
- (2) Install sheave (2) in cable guide (3) with pin (4) and cotter pin (5).

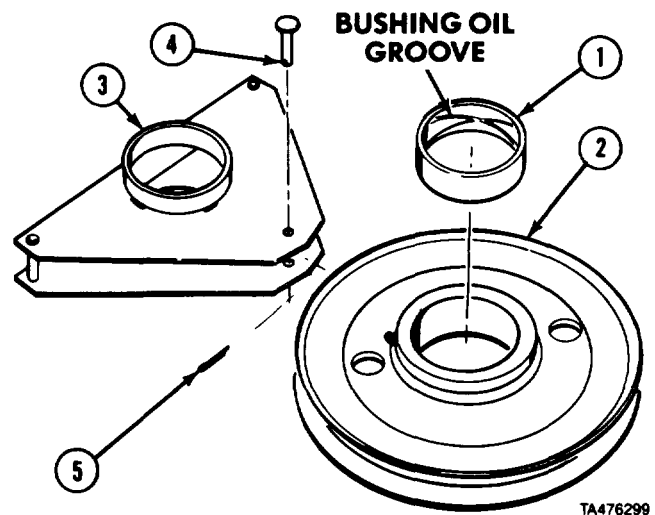

e. Installation.

- (1) While Soldier A installs six screws (1), Soldier B holds nuts (2). Soldier B installs two plates (3) and nuts (2).

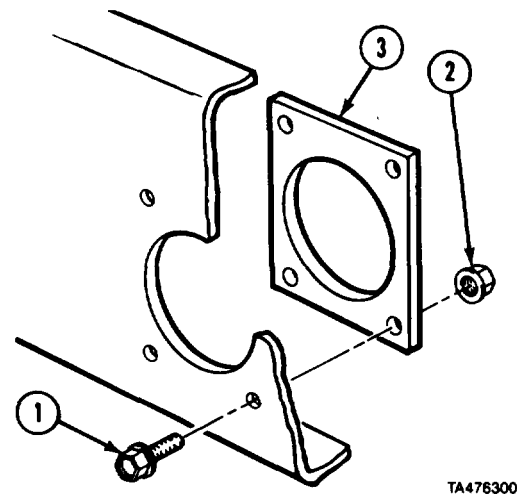

Winch Maintenance Instructions (Cont)

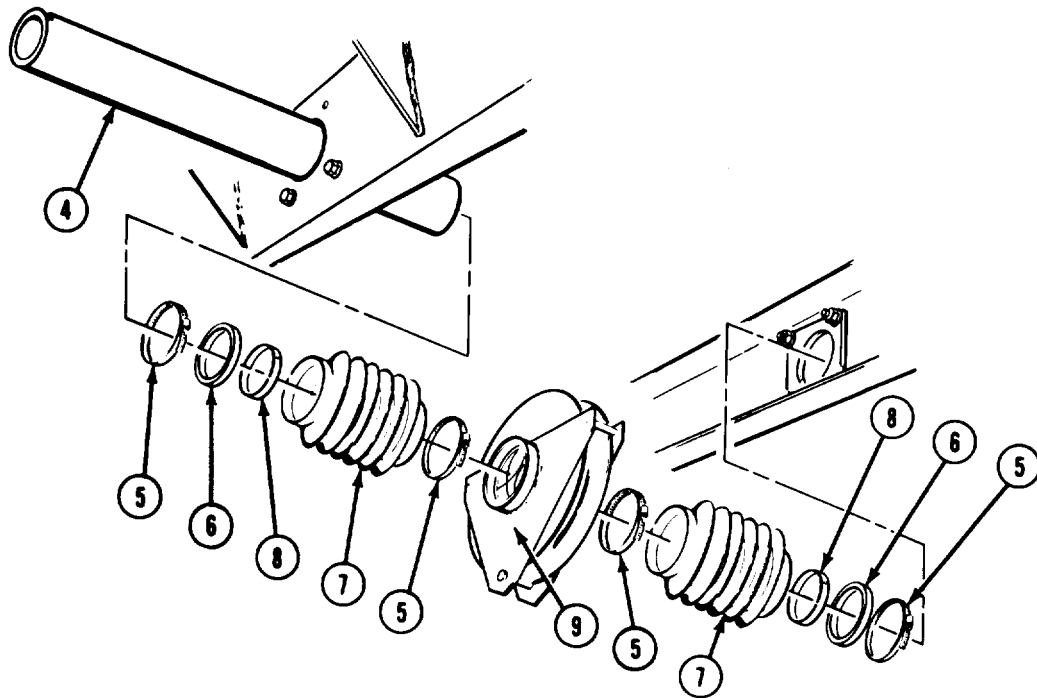

TA476301

NOTE

Install shaft with lock slot in proper position.

- (2) Soldier A installs shaft (4) halfway while Soldier B installs clamp (5), ring (6), boot (7), lockring (8), clamp (5), and sheave (9).
- (3) Install clamp (5), boot (7), lockring (8), ring (6), and clamp (5).
- (4) Position shaft (4) to align lockplate groove.

NOTE

Distance between inner surface of frame and inside edge of lockring is 7 in. (17.5 cm).

- (5) Align lockrings (8) and install two setscrews (10).

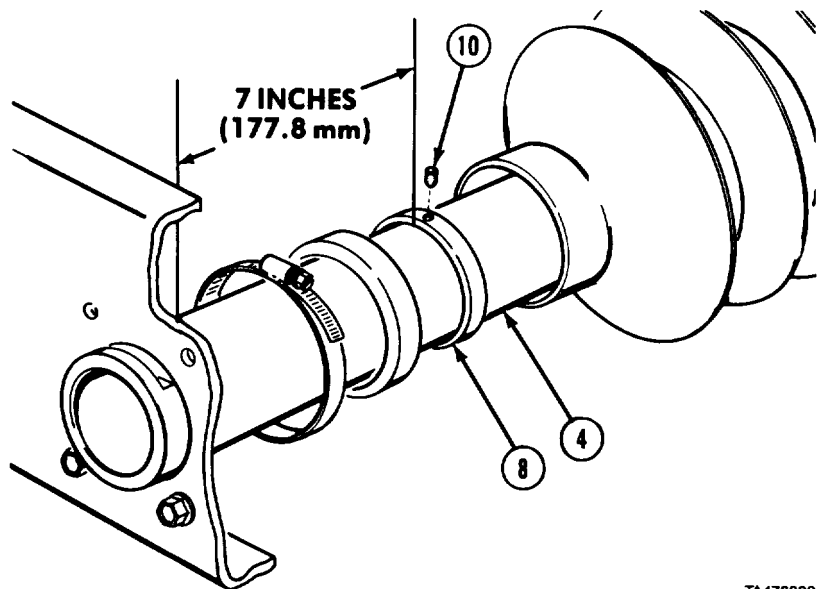

TA476302

Winch Maintenance Instructions (Cont)

16-10.1. HEAVY-DUTY WINCH CABLE SHEAVE REMOVAL/REPAIR/INSTALLATION (CONT).

- (6) Position rings (6), boots (7) and install clamps (5).
- (7) Tighten four clamp screws (11).
- (8) Install lockplate (12) with two screws (2) and nuts (13).

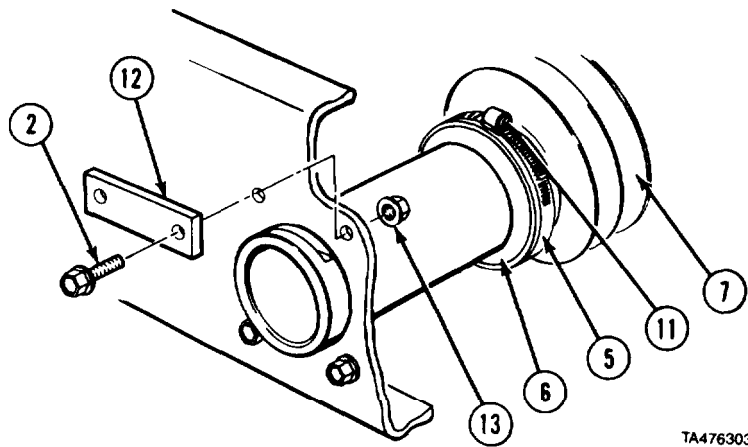

TA476303

f. Follow-on Maintenance.

- (1) Heavy duty winch cable installed (TM 9-2320-279-20).
- (2) No. 3 prop shaft installed (TM 9-2320-279-20).
- (3) Left middle mud flap installed (TM 9-2320-279-20).
- (4) Check for proper movement of cable guide.

END OF TASK

16-10.2. HEAVY DUTY WINCH AND BRACKETS REMOVAL/INSTALLATION.	
This task covers:	
a. Removal	c. Follow-on Maintenance
b. Installation	
INITIAL SETUP	
Models	Equipment Condition
M984E1	<i>TM or Para</i> <i>Condition Description</i>
Test Equipment	TM 9-2320-279-10 Spade extensions removed.
None	TM 9-2320-279-20 Heavy duty winch cable removed.
Special Tools	Special Environmental Conditions
None	None
Supplies	General Safety Instructions
None	None
Personnel Required	Level of Maintenance
MOS 63W, Wheel vehicle repairer (2)	Direct Support
References	
None	

Winch Maintenance Instructions (Cont)

a. Removal.

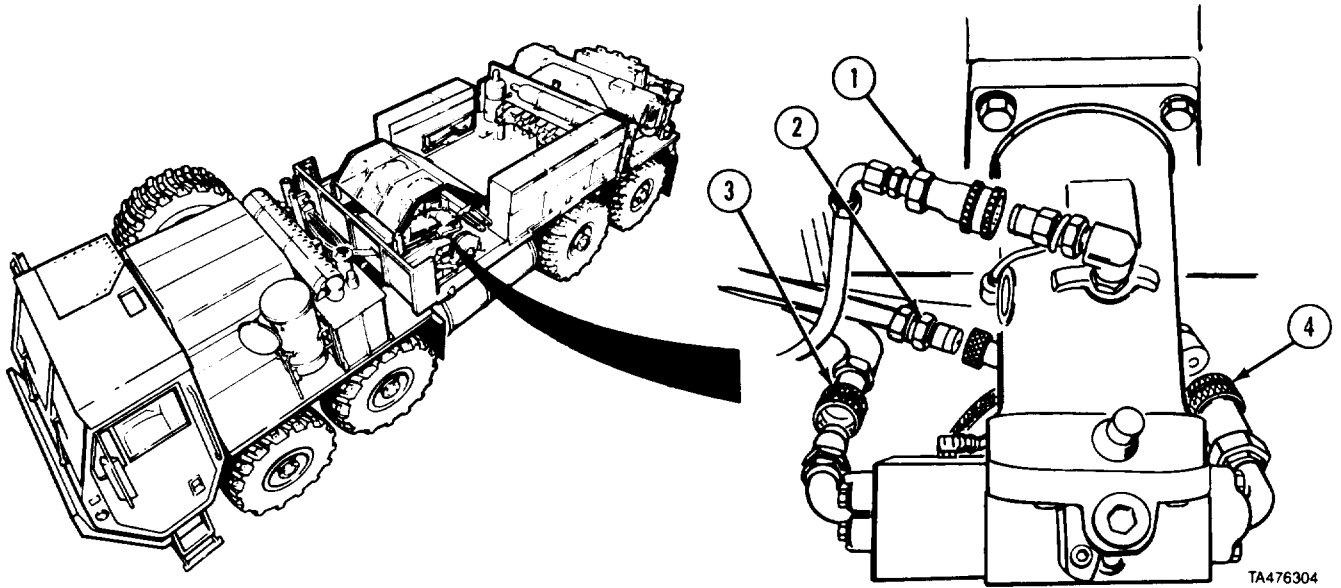

(1) Disconnect four hydraulic hoses (1, 2, 3, and 4).

WARNING

Keep out from under heavy parts. Make sure lifting strap is around center of balance of part being moved. Falling parts may cause serious injury or death.

- (2) Attach suitable lifting device to winch (5).
- (3) Soldier A removes three quick pins (6) and pins (7) from two brackets (8) and bracket (9), starting at bracket (9), while Soldier B supports winch (5) with lifting device.
- (4) Soldier A guides winch (5) while Soldier B operates lifting device.

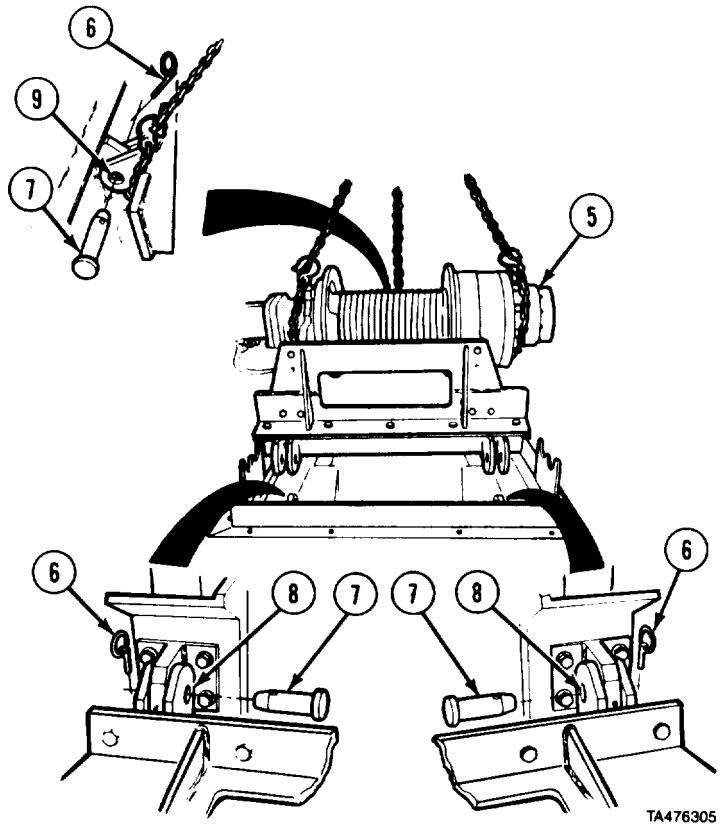

TA476305

Winch Maintenance Instructions (Cont)

16-10.2. HEAVY DUTY WINCH AND BRACKETS REMOVAL/INSTALLATION (CONT).

NOTE

Left and right brackets are removed the same way.

- (5) Soldier A removes four screws (10) while Soldier B removes nuts (11).
- (6) Remove bracket (8).
- (7) Remove grease fitting (12) and bearing (13) from bracket (8).

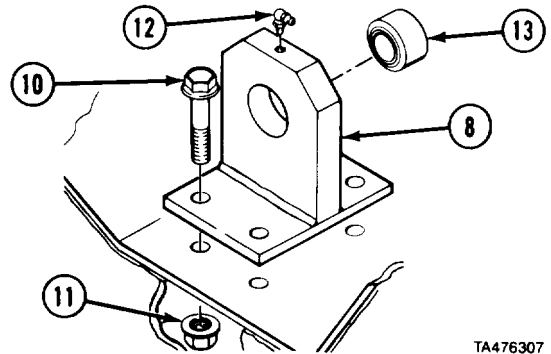

TA476307

b. Installation.

NOTE

Left and right brackets are installed the same way.

- (1) Install bearing (1) and grease fitting (2) in bracket (3).
- (2) Soldier A installs and holds bracket (3) and four screws (4) while Soldier B installs four nuts (5).

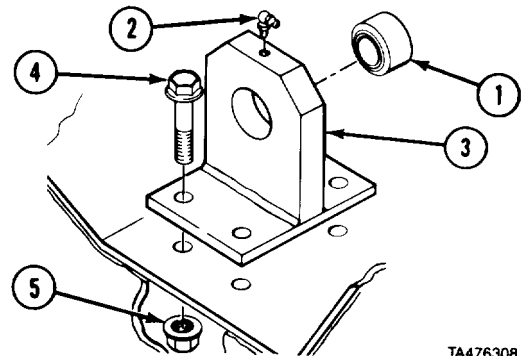

TA476308

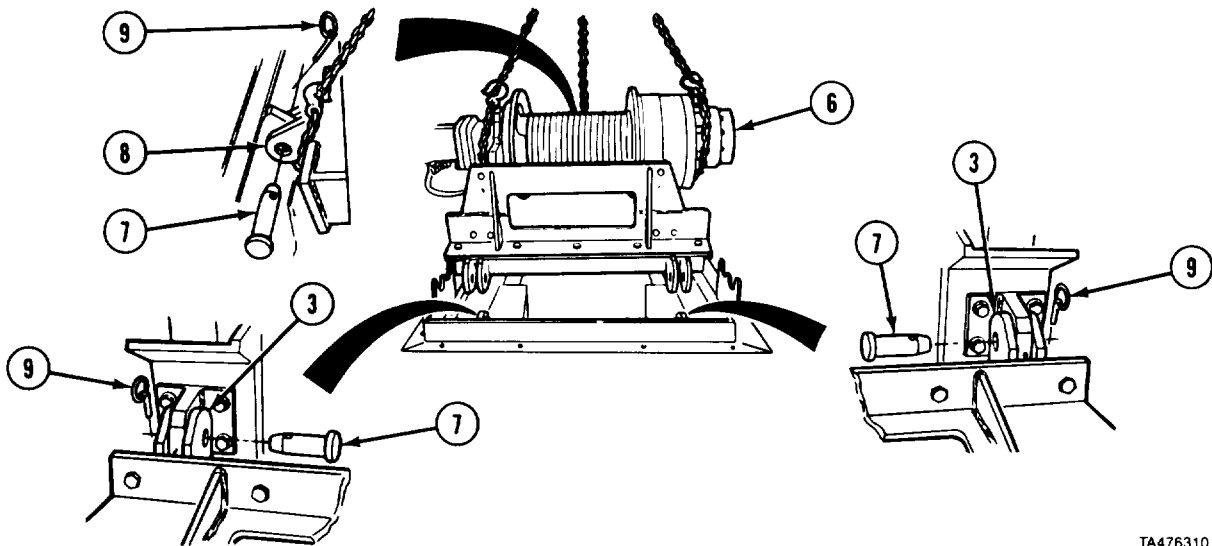

TA476310

WARNING

Keep out from under heavy parts. Make sure lifting strap is around center of balance of part being moved. Falling parts may cause serious injury or death.

- (3) Soldier A guides winch (6) into position on vehicle while Soldier B operates lifting device.
- (4) Aline mounting lugs and install three pins (7) in two brackets (3) and bracket (8) with quick pins (9).

Winch Maintenance Instructions (Cont)

(5) Connect four hydraulic hoses (10,11,12, and 13).

c. Follow-on Maintenance.

- (1) Heavy-duty winch cable installed (TM 9-2320-279-20).
- (2) Spade extension installed (TM 9-2320-279-10).

END OF TASK

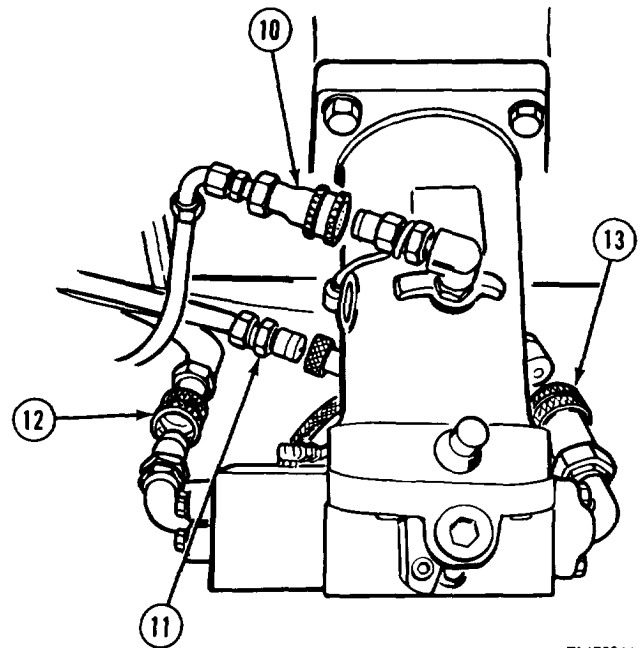

TA476311

16-10.3. FAIRLEAD TENSIONER ASSEMBLY REMOVAL/REPAIR/INSTALLATION AND ADJUSTMENT.					
This task covers:					
<ul style="list-style-type: none"> a. Removal b. Disassembly c. Cleaning/Inspection d. Assembly 	<ul style="list-style-type: none"> e. Installation f. Adjustment g. Follow-on Maintenance 				
INITIAL SETUP					
<p>Models M984E1</p> <p>Test Equipment None</p> <p>Special Tools None</p> <p>Supplies Grease, automotive and artillery, Item 34, Appendix C</p> <p>Personnel Required MOS 63W, Heavy wheel vehicle mechanic (2)</p>	<p>References None</p> <p>Equipment Condition</p> <table border="1"> <thead> <tr> <th>TM or Para</th> <th>Condition Description</th> </tr> </thead> <tbody> <tr> <td>Para 16-18</td> <td>Fairlead motor removed.</td> </tr> </tbody> </table> <p>Special Environmental Conditions None</p> <p>General Safety Instructions None</p> <p>Level of Maintenance Direct Support</p>	TM or Para	Condition Description	Para 16-18	Fairlead motor removed.
TM or Para	Condition Description				
Para 16-18	Fairlead motor removed.				

Winch Maintenance Instructions (Cont)

16-10.3. FAIRLEAD TENSIONER ASSEMBLY REMOVAL/REPAIR/INSTALLATION AND ADJUSTMENT (CONT).

a. Removal.

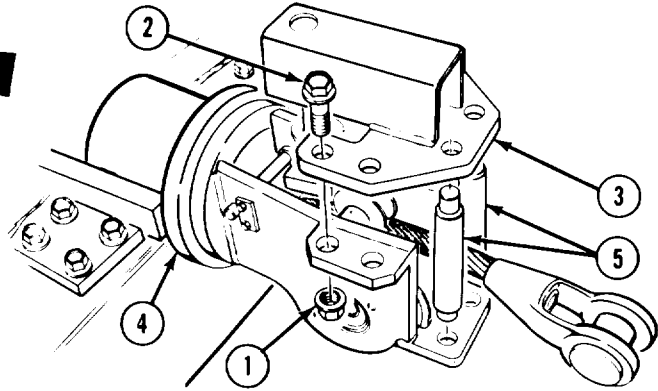
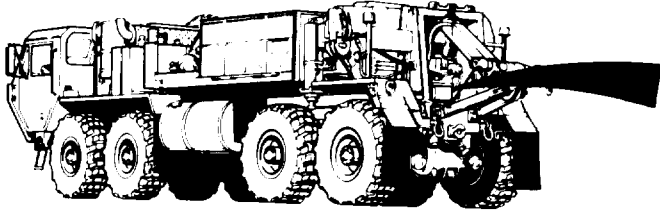

TA476312

- (1) Remove four nuts (1), screws (2), and plate (3) from fairlead (4),
- (2) Remove two rollers (5).

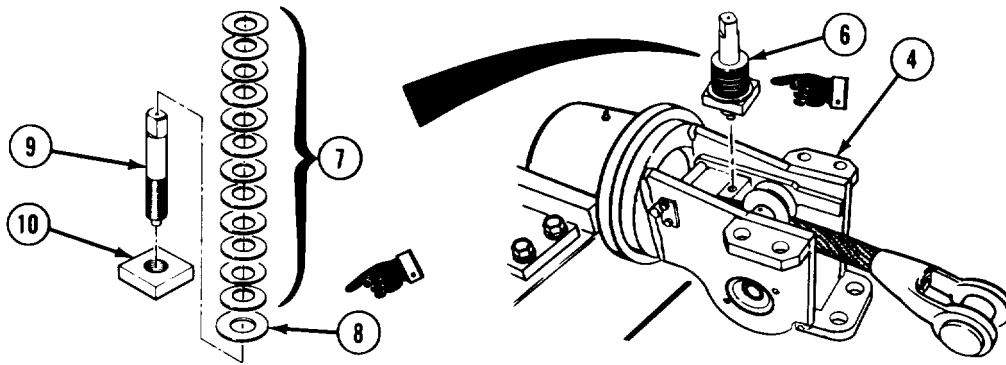

TA500292

- (3) Remove tensioner assembly (6) from fairlead (4).
- (4) Remove 12 washers (7) and washer (8) from shaft (9).
- (5) Remove shaft (9) from block (10).

- (6) Remove two screws (11), lockwashers (12), and lockplate (13).
- (7) Remove pin (14) and pivot arm (15) from fairlead (4).
- (8) Remove cotter pin (16) and pin (17) from clevis (18).
- (9) Remove clevis and cable (18) from fairlead (4).

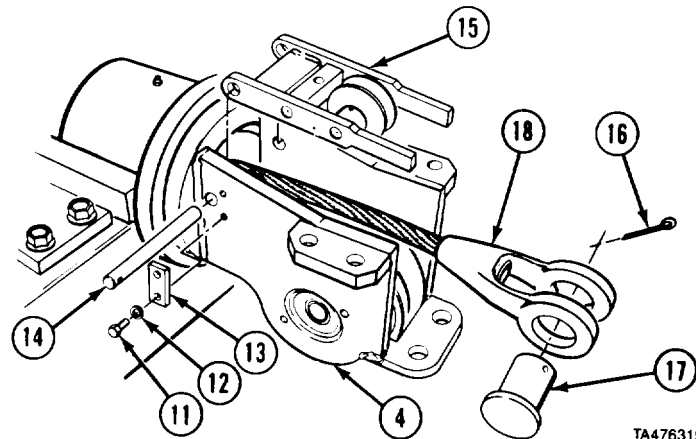

TA476315

Winch Maintenance Instructions (Cont)

- (10) Remove two setscrews (19), pin (20), and sheave (21) from pivot arm (15).
- (11) Remove bearing (22) from sheave (21).

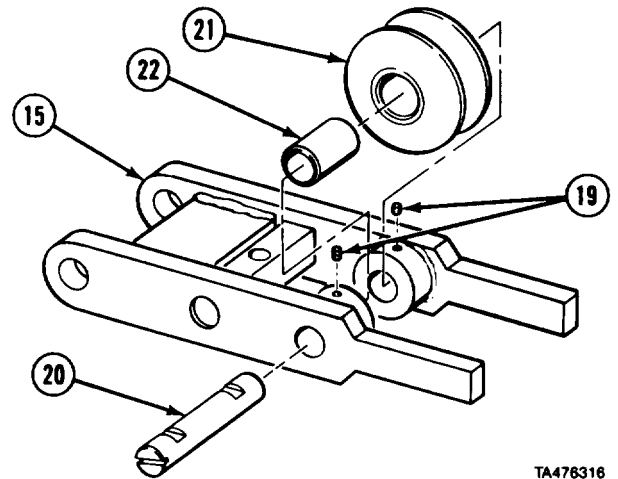

TA476316

- (12) Attach suitable lifting device to fairlead (4).
- (13) Remove eight screws (23) and nuts (24).
- (14) Soldier A removes fairlead (4) while Soldier B operates lifting device.

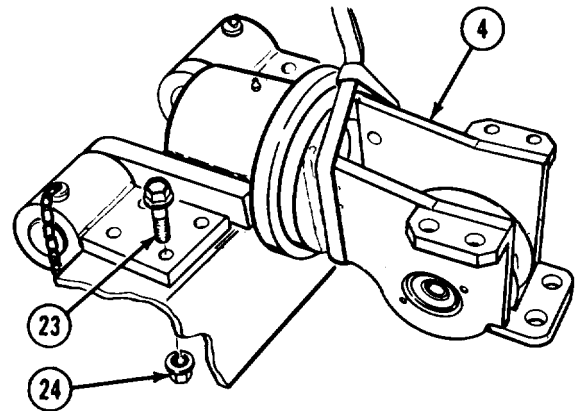

TA476317

NOTE

Left and right brackets are removed the same way.

- (15) Remove quick pin (25), pin (26), and bracket (27) from trunnion (28).
- (16) Remove grease fitting (29) from drum (30).
- (17) Remove four screws (31), lockwashers (32), and plate (33).
- (18) Remove drum (30) from fairlead (4).

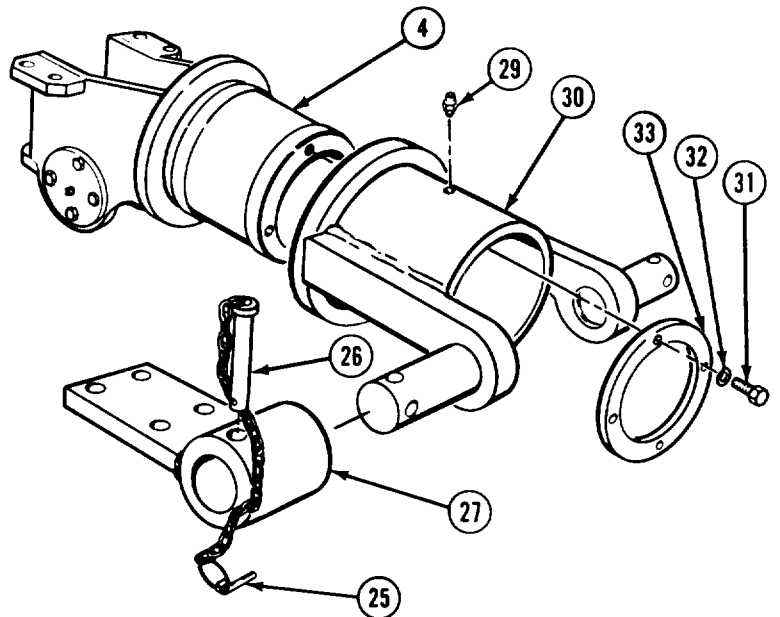

TA476319

Winch Maintenance Instructions (Cont)

16-10.3. FAIRLEAD TENSIONER ASSEMBLY REMOVAL/REPAIR/INSTALLATION AND ADJUSTMENT (CONT).

b. Disassembly.

NOTE

Position wood block under fairlead.

- (1) Remove four screws (1), lockwasher (2), and plate (3) from fairlead (4).
- (2) Remove shaft (5) from sleeve (6).
- (3) Remove pin (7).

NOTE

Note position of washers.

- (4) Remove sheave (8) and two washers (9 and 10) from fairlead (4).
- (5) Remove key (11) from sheave (8).

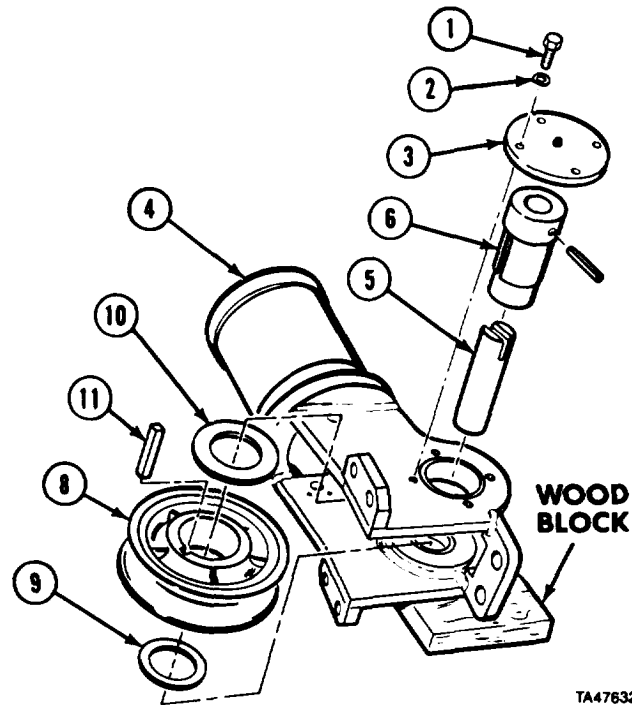

- (6) Remove two bearings (12 and 13) from fairlead (4).
- c. Cleaning/Inspection.

WARNING

Adhesives, solvents, and sealing compounds can burn easily, can give off harmful vapors, and are harmful to skin and clothing. To avoid injury or death, keep away from open fire and use in well-ventilated area. If adhesive, solvent, or sealing compound gets on skin or clothing, wash immediately with soap and water.

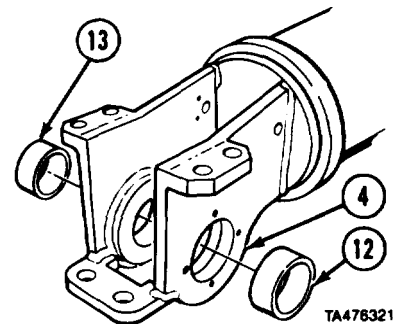

- (1) Clean all metal parts in dry cleaning solvent.
- (2) Inspect each part for damage.
- (3) Replace damaged parts.
- (4) Inspect shaft diameters. Small end must be no smaller than 2.993 in. (75.83 mm). Large end must be no smaller than 2.493 in. (63.13 mm). If either diameter is smaller, replace shaft.
- (5) Inspect sheave bearing. Diameter must not exceed .763 in. (19.45 mm). If diameter is larger, replace bearing.
- (6) Inspect sheave washers. If washers are thinner than .088 in. (2.25 mm), replace washers.
- (7) Inspect fairlead bearings. Large bearing must not exceed 3.017 in. (76.3 mm). Small bearing must not exceed 3.010 in. (76.2 mm). If either bearing exceeds wear limits, replace bearing.

Winch Maintenance Instructions (Cont)

d. Assembly.

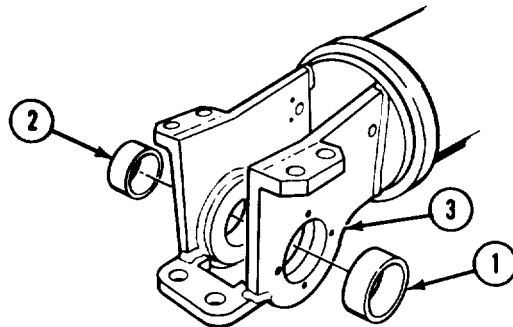

TA476322

(1) Install two bearings (1 and 2) in fairlead (3).

NOTE

Position wood block under fairlead.

- (2) Install pin (4) and shaft (5) in sleeve (6).
- (3) Install key (7) in sheave (8).
- (4) Install sheave (8) with two washers (9 and 10), shaft (5), and sleeve (6).
- (5) Install plate (11) with four lockwashers (12) and screws (13) on fairlead (3).

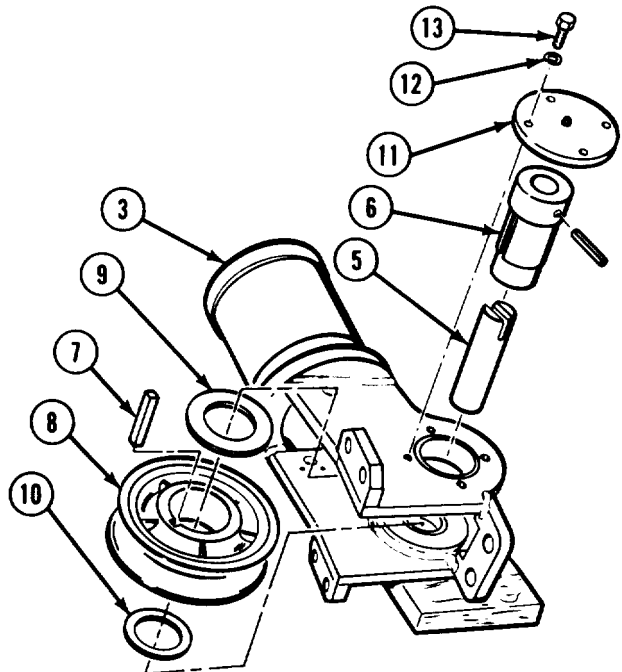

TA476323

e. Installation.

- (1) Apply coating of grease to shaft of fairlead (1).
- (2) Install drum (2) on fairlead (1).
- (3) Install plate (3) with four lockwashers (4) and screws (5).
- (4) Install grease fitting (6) in drum (2).

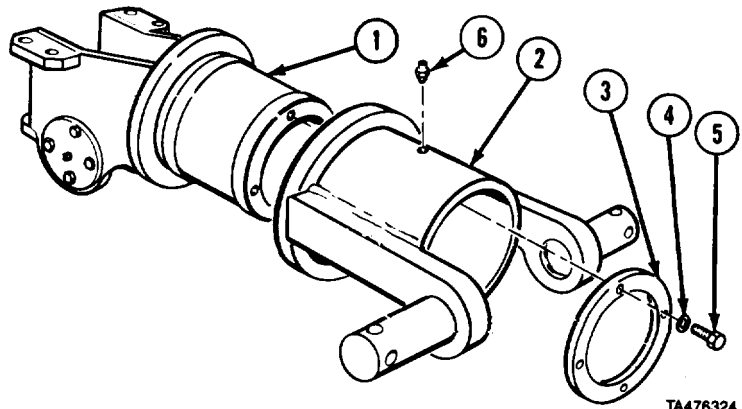

TA476324

Winch Maintenance Instructions (Cont)

16-10.3. FAIRLEAD Tensioner ASSEMBLY REMOVAL/REPAIR/INSTALLATION AND ADJUSTMENT (CONT).

NOTE

Left and right brackets are installed the same way.

- (5) Install bracket (7) on trunnion (8) with pin (9) and quick pin (10).

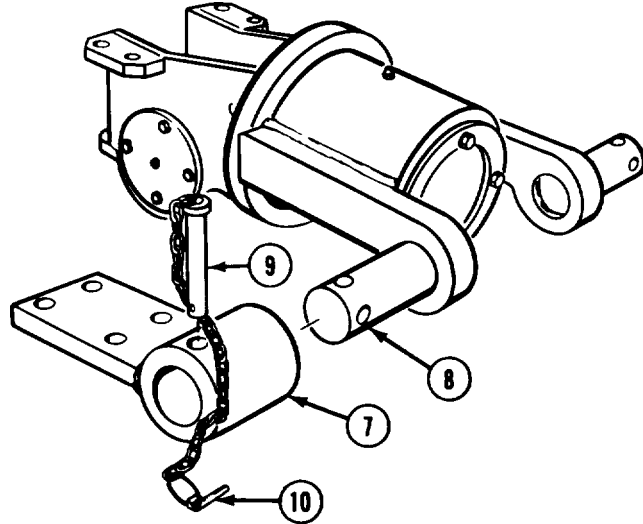

TA476325

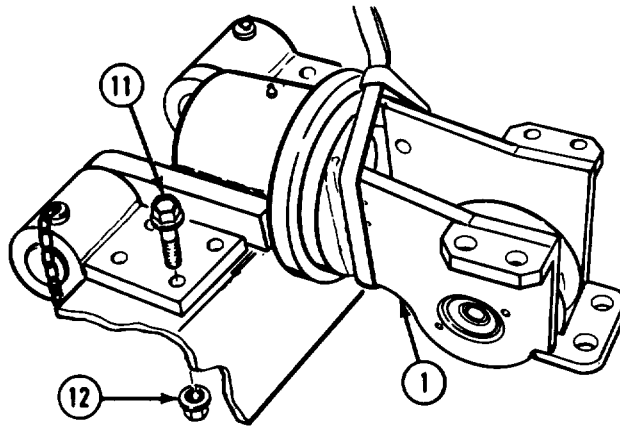

TA476326

- (6) Attach suitable lifting device to fairlead (1).
- (7) Soldier A installs fairlead (1) with eight screws (11) and nuts (12) while Soldier B operates suitable lifting device.

Winch Maintenance Instructions (Cont)

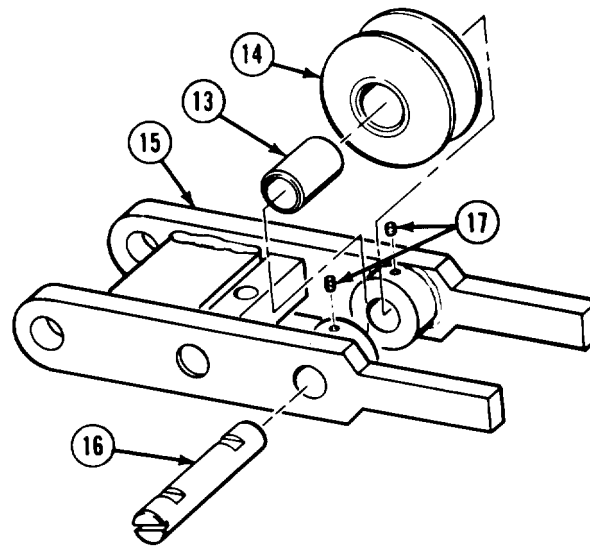

TA476327

NOTE

Shaft is installed with slots up.

- (8) Install bearing (13) in sheave (14).
- (9) Install sheave (14) in pivot arm (15) with shaft (16) and two setscrews (17).

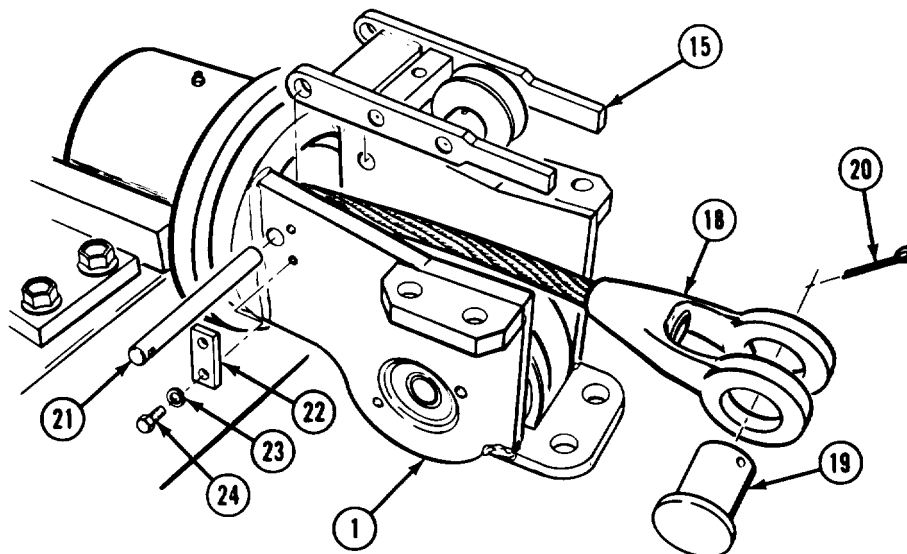

TA476328

- (10) Install cable and clevis (18) in fairlead (1).
- (11) Install pin (19) and cotter pin (20) in clevis (18).
- (12) Install pivot arm (15) with pin (21), lockplate (22), two lockwashers (23), and screws (24).

Winch Maintenance Instructions (Cont)

16-10.3. FAIRLEAD TENSIONER ASSEMBLY REMOVAL/REPAIR/INSTALLATION AND ADJUSTMENT (CONT).

NOTE

Washers are installed starting with beveled side up, the next beveled side down. Continue alternating until all washers are installed.

- (13) Install shaft (25) in block (26).
- (14) Install washer (27) and 12 washers (28) on shaft (25).

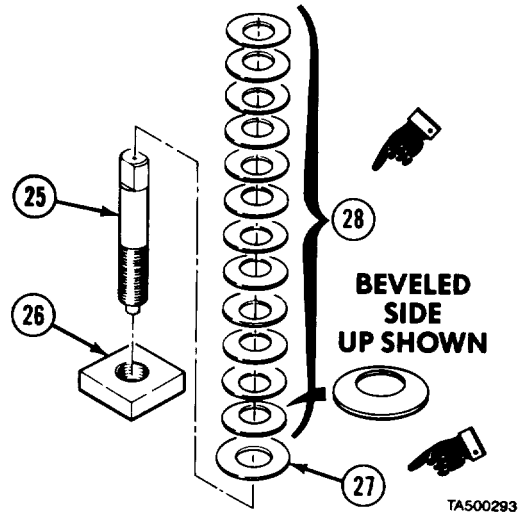

TA500293

- (15) Install tensioner assembly (29) in pivot arm (15).

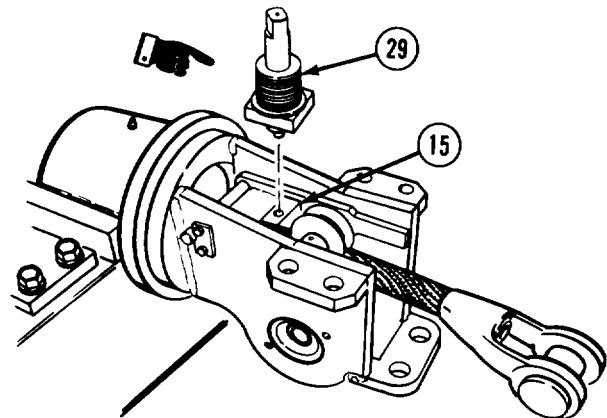

TA500294

- (16) Install two rollers (30) and plate (31) on fairlead (1) with four screws (32) and nuts (33).

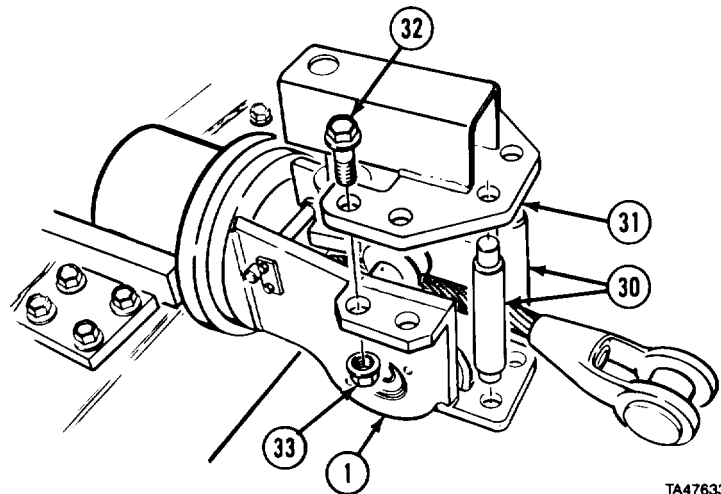

TA476331

Winch Maintenance Instructions (Cont)

- f. Adjustment.
 - (1) Turn stud (1) counterclockwise until roller (2) does not contact cable (3).
 - (2) Turn stud (1) clockwise until roller (2) just contacts cable (3) then turn stud clockwise eight more turns.
- g. Follow-on Maintenance.
 - (1) Lubricate fairlead (LO 9-2320-279-12).
 - (2) Install fairlead motor (TM 9-2320-279-20).

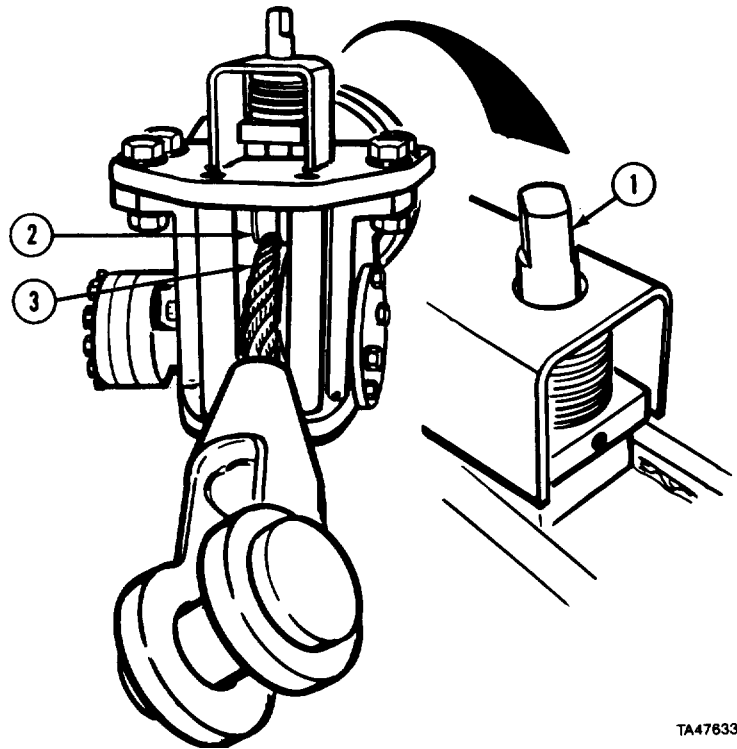

TA476332

END OF TASK

16-11. HEAVY-DUTY WINCH REPAIR (M984).		
This task covers:		
a. Disassembly	c. Assembly	
b. Cleaning/Inspection	d. Follow-on Maintenance	
INITIAL SETUP		
Models M984	Personnel Required MOS 63W, Wheel vehicle repairer (2)	
Test Equipment None	References None	
Special Tools None	Equipment Condition	
Fabricated Tools Detent ball compression tool, Item 3, Appendix B	TM or Para Para 16-10 Para 16-16	Condition Description Heavy-duty winch removed. Heavy-duty winch brake installed.
Supplies Oil, lubricating, Item 46, Appendix C Solvent, dry cleaning, Item 57, Appendix C Adhesive-sealant, silicone, Item 6, Appendix C Grease, general purpose, lithium base, Item 36, Appendix C	Special Environmental Conditions None	
	General Safety Instructions None	
	Level of Maintenance General Support	

Winch Maintenance Instructions (Cont)

16-11. HEAVY-DUTY WINCH REPAIR (M984) (CONT).

a. Disassembly.

NOTE

Matchmark all housings.

- (1) Remove pipe plugs (1 and 2) and drain oil from winch (3).

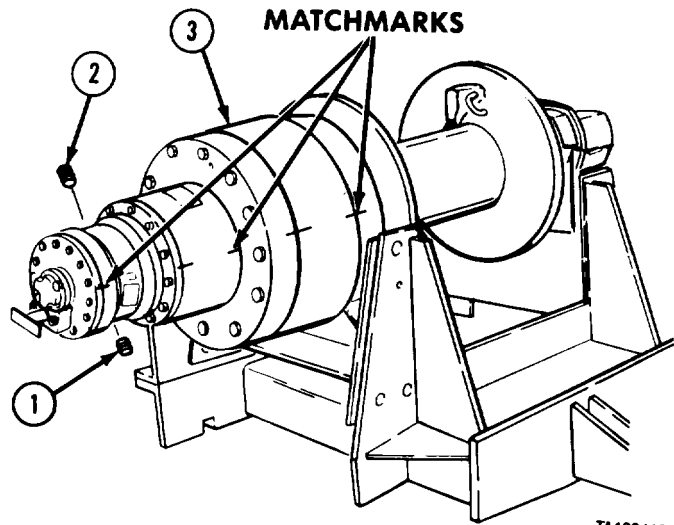

TA189410

- (2) Remove four screws (4), lockwashers (5), cover (6), and gasket (7).
- (3) Remove retaining ring (8).
- (4) Remove 10 screws (9) and lockwashers (10).

NOTE

Winch brake must be installed when doing step (5).

- (5) Using wheel puller on input shaft (11), loosen end cover (12), and turn end cover away from shaft.

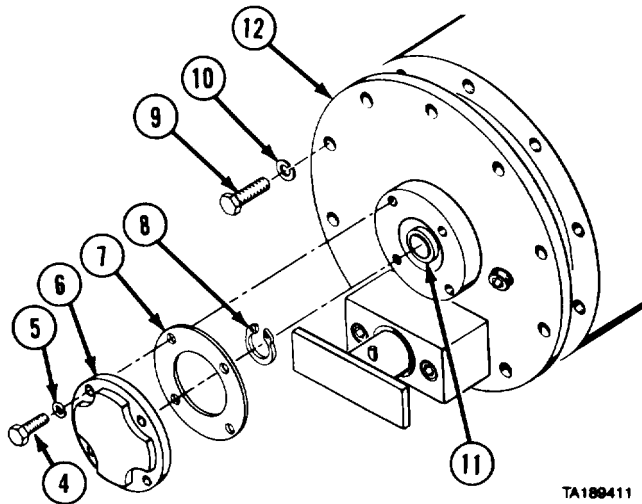

TA189411

- (6) Remove spacer (13) and drive sleeve (14).

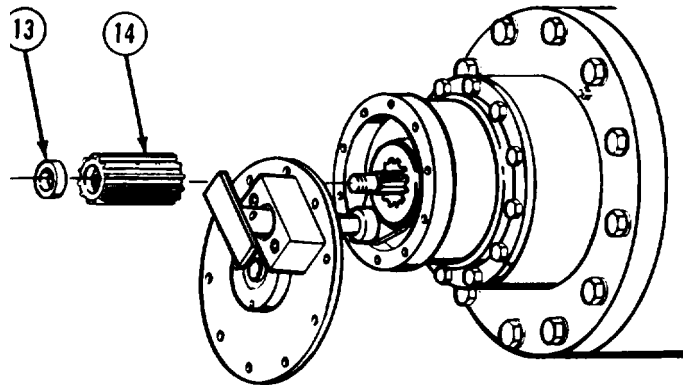

TA189412

Winch Maintenance Instructions (Cont)

- (7) Turn and remove drive hub (15) and end cover (12).
- (8) Remove primary sun gear (16).

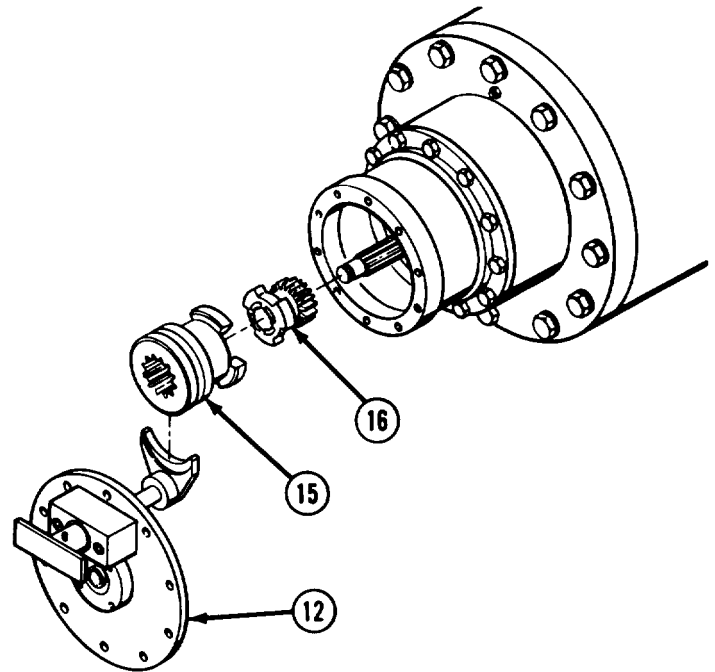

TA189413

- (9) Remove roll pin (17) and shifter T-handle (18).
- (10) Remove two screws (19) and shifter housing (20).
- (11) Remove oil seal (21) from shifter housing (20).
- (12) Remove retaining ring (22) and shifter (23).
- (13) Without pushing on shifter shaft (24), remove bushing (25) and shifter shaft from end cover (12).
- (14) Remove retaining ring (26).
- (15) Remove bearing (27).
- (16) Remove pipe plug (28).

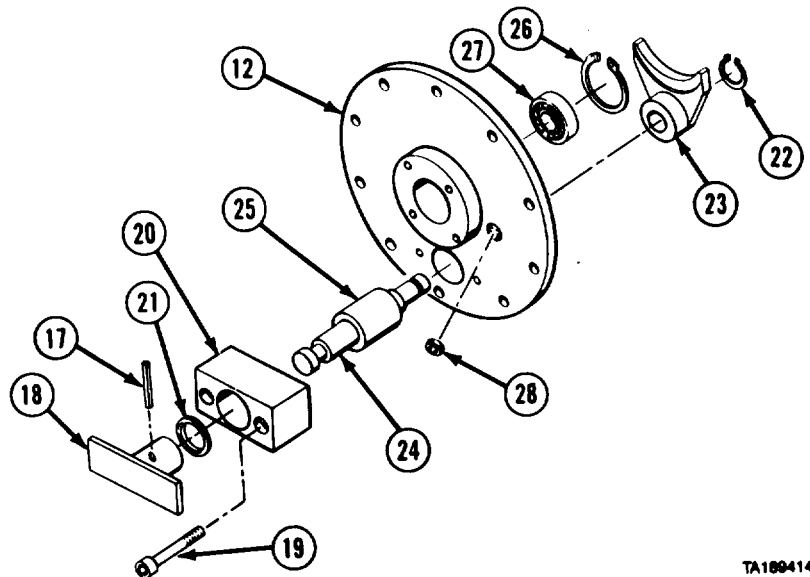

TA189414

Winch Maintenance Instructions (Cont)

16-11. HEAVY-DUTY WINCH REPAIR (M984) (CONT).

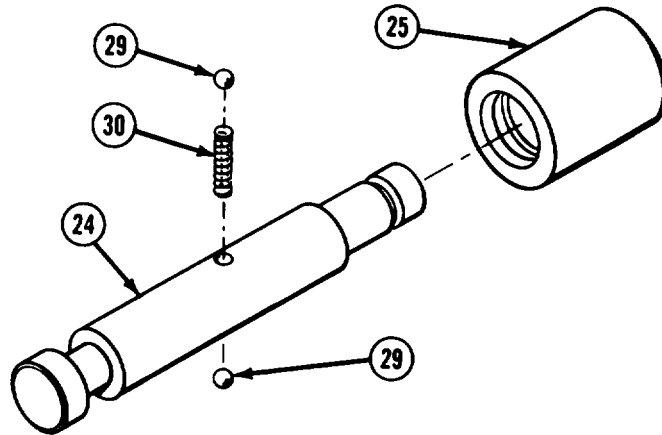

TA100415

WARNING

Two detent balls are spring loaded. Be careful when removing to avoid serious personal injury.

NOTE

Remove bushing carefully so detent balls are not lost.

(17) Place cloth around shifter shaft (24) and remove bushing (25), two balls (29), and spring (30).

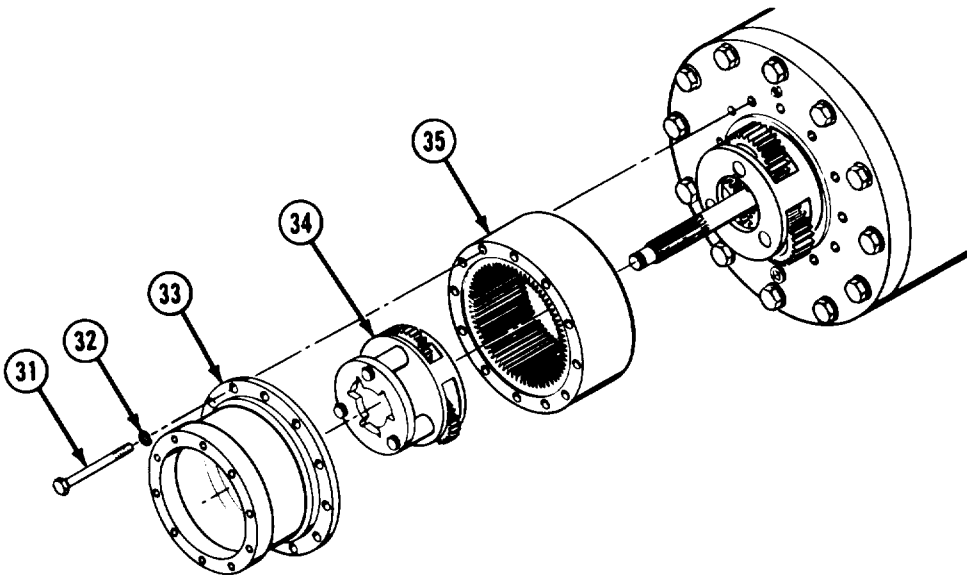

TA100416

(18) Remove 12 screws (31), lockwashers (32), gear end housing (33), primary carrier assembly (34), and ring gear (35).

Winch Maintenance Instructions (Cont)

- (19) Remove two retaining rings (36) and secondary sun gear (37).

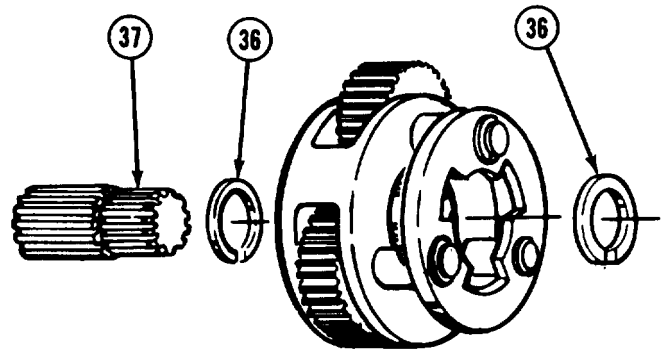

TA189417

- (20) Remove input shaft (11).
 (21) Remove secondary carrier housing (38).

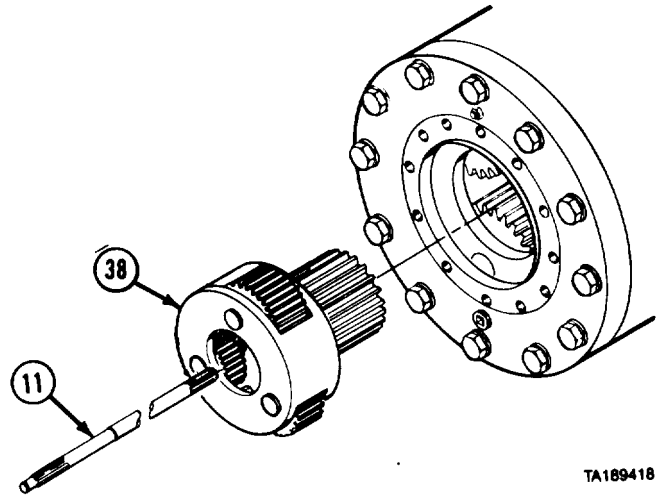

TA189418

- (22) Remove sun gear (39).
 (23) Spread retaining ring (40) and slide retaining ring down on output shaft (41).
 (24) Push output shaft (41) up in secondary carrier housing (38) and remove retaining ring (42).
 (25) Remove output shaft (41).
 (26) Remove retaining ring (40) and two retaining rings (43).

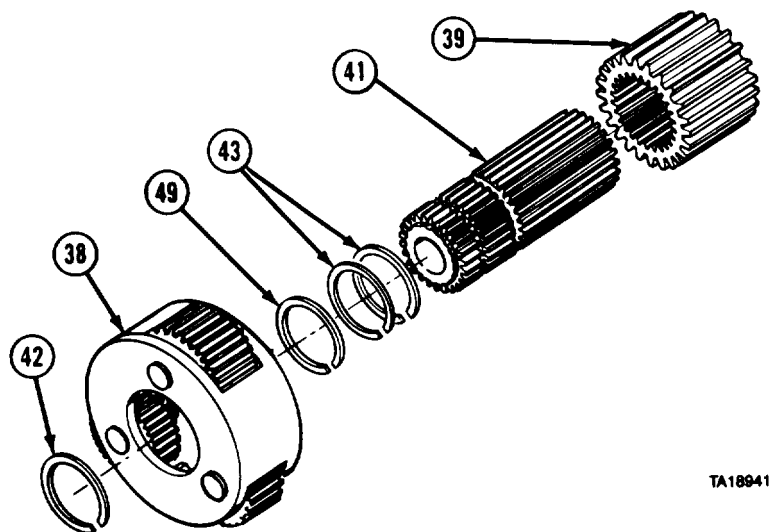

TA189419

Winch Maintenance Instructions (Cont)

16-11. HEAVY-DUTY WINCH REPAIR (M984) (CONT).

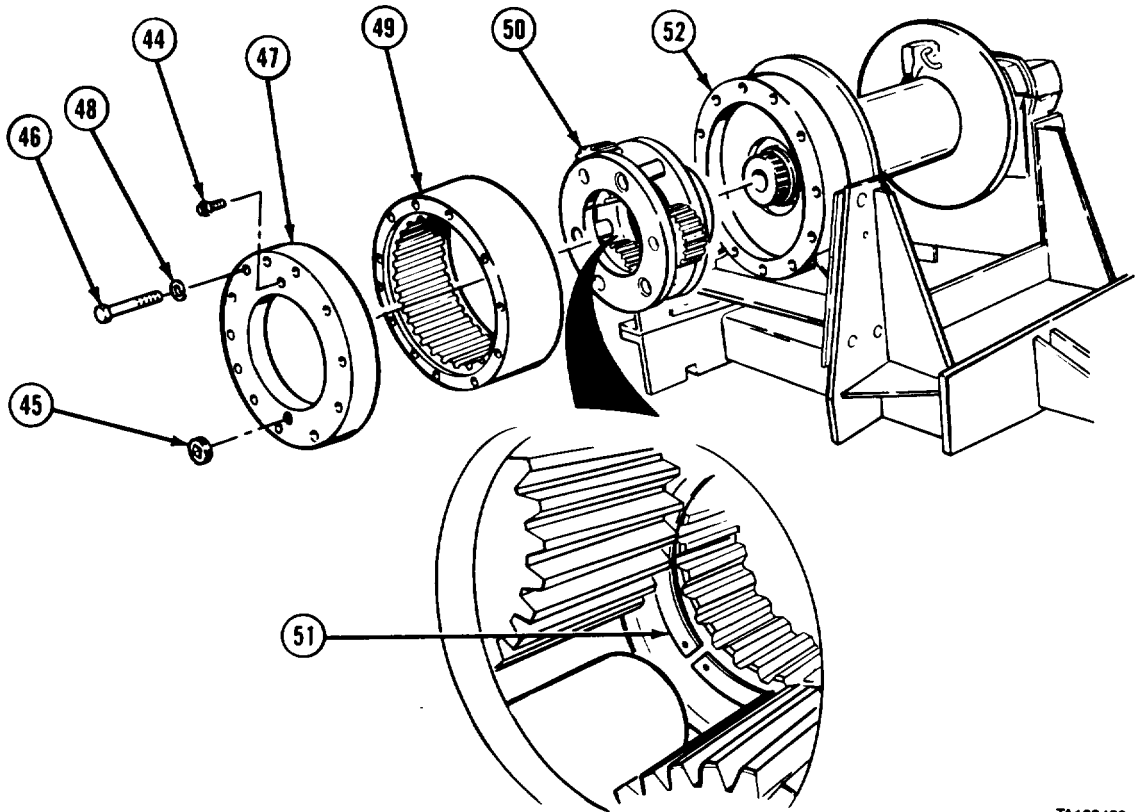

TA189420

- (27) Remove air vent (44).
- (28) Remove plug (45).
- (29) Loosen 12 screws (46) and adapter cover (47).
- (30) Remove 12 screws (46), lockwashers (48), and adapter cover (47).
- (31) Remove ring gear (49).
- (32) Support third planetary carrier assembly (50) with suitable lifting device. Loosen retaining ring (51) inside third planetary carrier.
- (33) Soldier A guides third planetary carrier assembly (50) away from gear end support (52) while Soldier B operates lifting device.

Winch Maintenance Instructions (Cont)

- (34) Remove retaining ring (51) from third planetary carrier assembly (50).

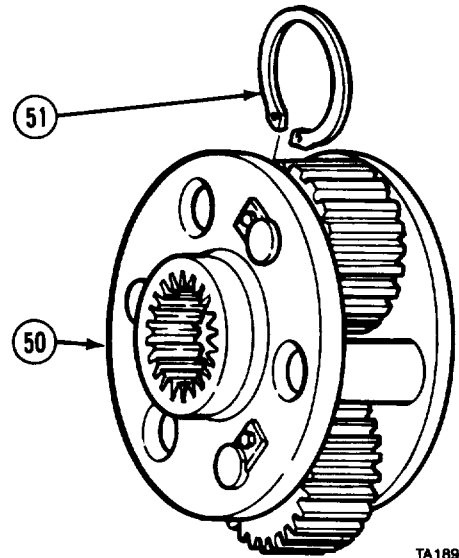

TA189421

b. Cleaning/Inspection.

WARNING

Adhesives, solvents, and sealing compounds can burn easily, can give off harmful vapors, and are harmful to skin and clothing. To avoid injury or death, keep away from open fire and use in well-ventilated area. If adhesive, solvent, or sealing compound gets on skin or clothing, wash immediately with soap and water.

- (1) Clean all metal parts in dry cleaning solvent.
- (2) Inspect all parts for damage.
- (3) Bushing must be replaced if inside diameter is 1.04 in. (26.42 mm) or greater.
- (4) Maximum clearance between bushing and shifter shaft is 0.007 in. (0.178 mm).
- (5) Minimum thickness of shifter wear surface is 0.25 in. (6.35 mm).
- (6) Replace damaged parts.

c. Assembly.

- (1) Install retaining ring (1) in output end of third planetary carrier assembly (2).

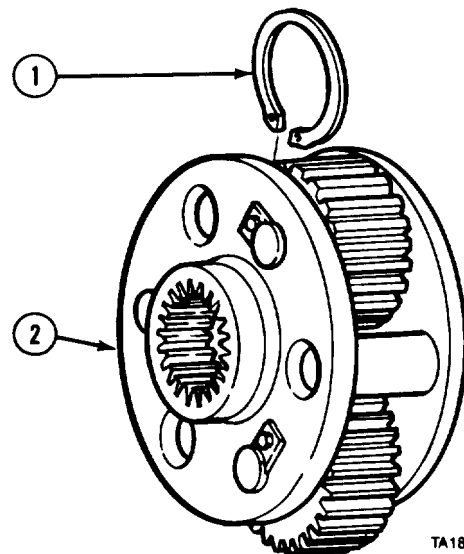

TA189424

Winch Maintenance Instructions (Cont)

16-11. HEAVY-DUTY WINCH REPAIR (M984) (CONT).

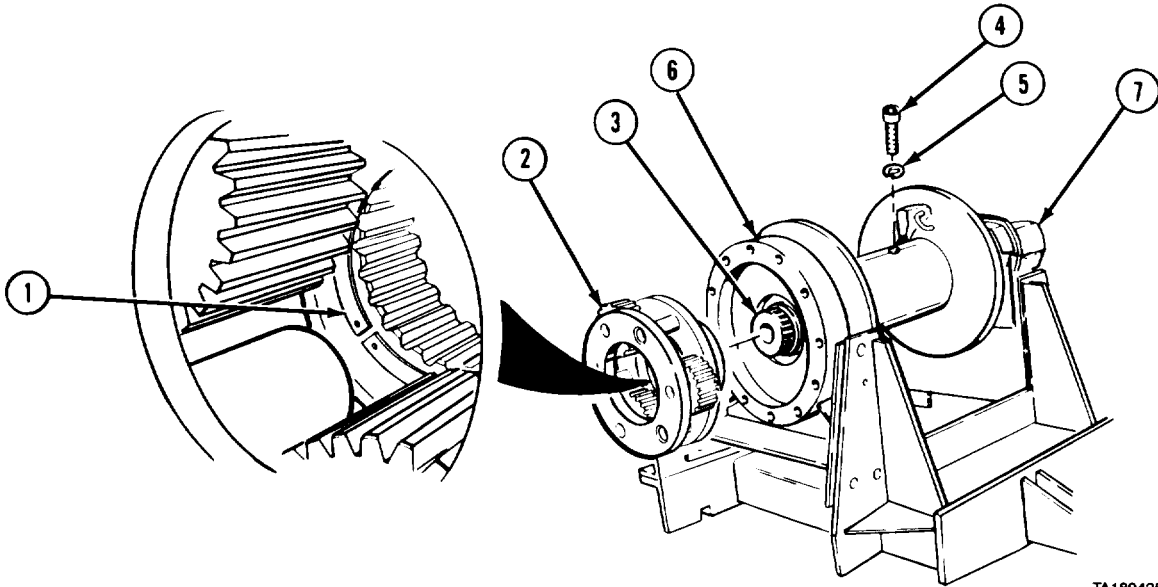

TA189425

- (2) Attach lifting device to third planetary carrier assembly (2).
- (3) Soldier A places third planetary carrier assembly (2) on output shaft (3) and spreads retaining ring (1) inside planetary carrier to seat planetary carrier against output shaft while Soldier B operates lifting device.
- (4) Remove heavy-duty winch brake (para 16-16).
- (5) Remove two screws (4) and lockwashers (5).
- (6) Drive output shaft (3) towards gear end (6).
- (7) Soldier A installs retaining ring (1) while Soldier B operates lifting device.
- (8) Remove lifting device.
- (9) Drive output shaft (3) towards winch brake (7).
- (10) Install two screws (4) and lockwashers (5).
- (11) Install heavy-duty winch brake (para 16-16).

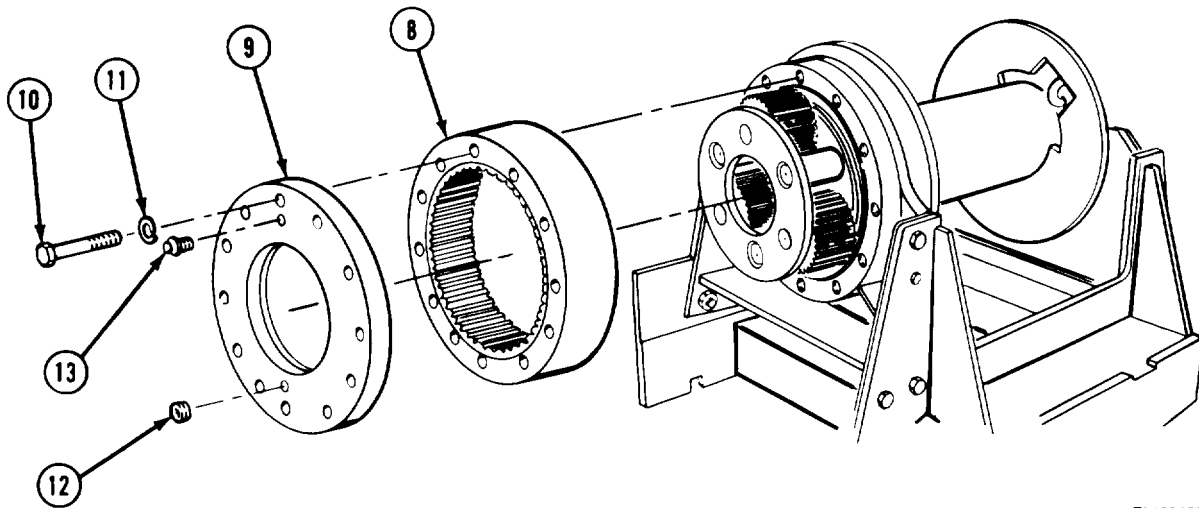

TA189426

Winch Maintenance Instructions (Cont)

WARNING

Adhesives, solvents, and sealing compounds can burn easily, can give off harmful vapors, and are harmful to skin and clothing. To avoid injury or death, keep away from open fire and use in well-ventilated area. If adhesive, solvent, or sealing compound gets on skin or clothing, wash immediately with soap and water.

- (12) Apply silicone adhesive-sealant to both mounting surfaces of ring gear (8) and install.
- (13) Install adapter cover (9) with 12 screws (10) and lockwashers (11).
- (14) Install plug (12).
- (15) Install air vent (13).
- (16) Install two retaining rings (14) in groove (15).
- (17) Install third retaining ring (16) on output shaft (3) between two grooves (15 and 17).
- (18) Push output shaft (3) in secondary carrier housing (18) and install retaining ring (19) in groove (20).
- (19) Pull output shaft (3) out and install retaining ring (16) in groove (17).

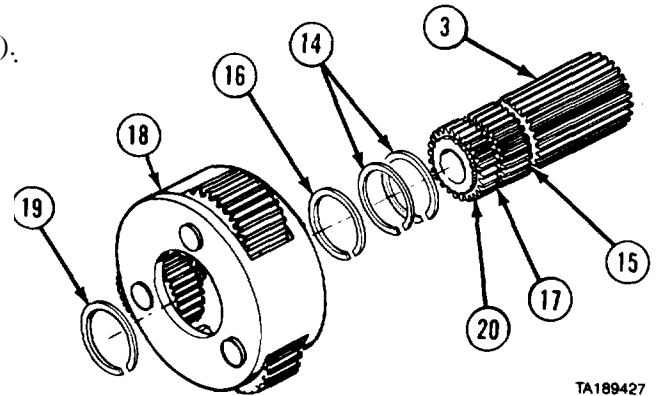

TA189427

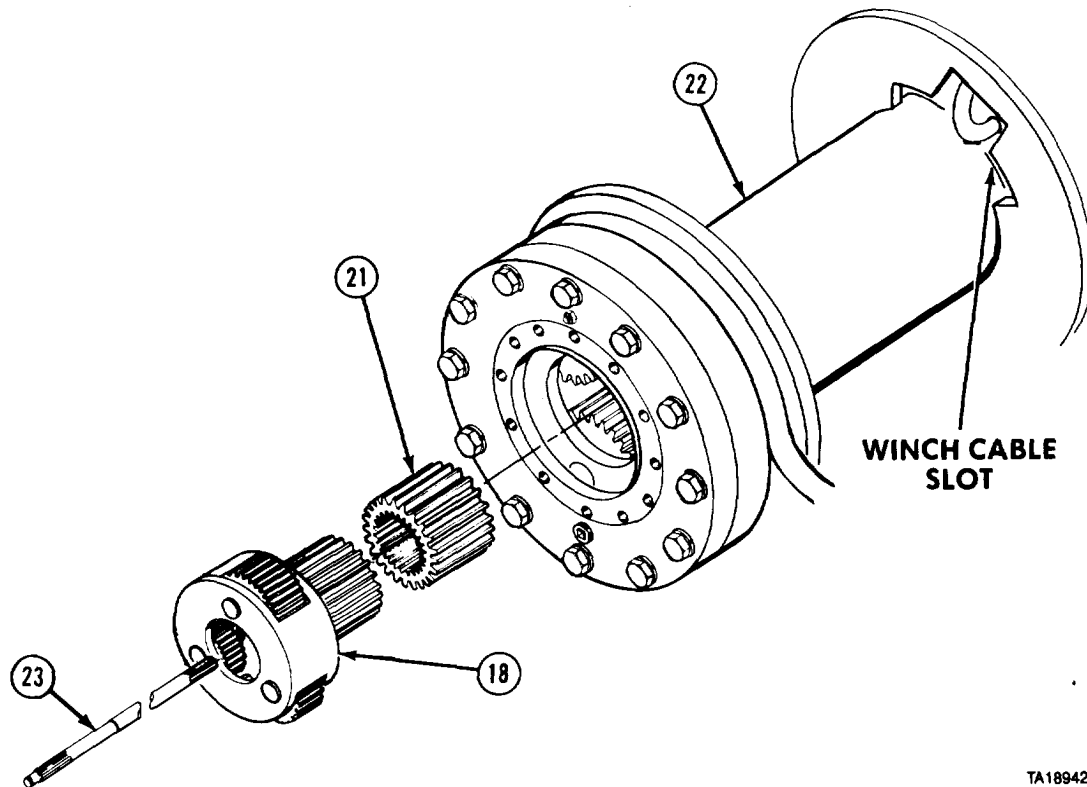

TA189428

- (20) Soldier A installs sun gear (21) while Soldier B turns winch drum (22) with crowbar in winch cable slot.
- (21) Install secondary carrier housing (18).
- (22) Install input shaft (23).

Winch Maintenance Instructions (Cont)

16-11. HEAVY-DUTY WINCH REPAIR (M984) (CONT).

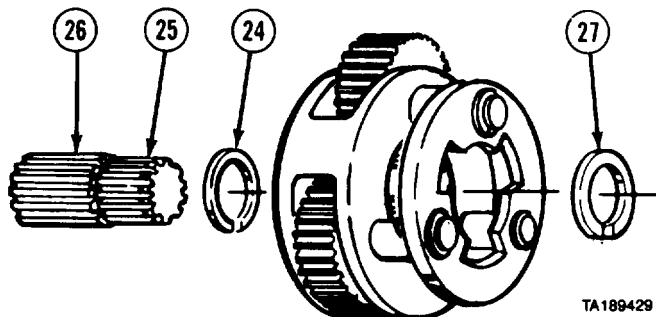

TA189429

- (23) Install retaining ring (24) and seat against shoulder (25).
- (24) Install secondary sun gear (26) and retaining ring (27).

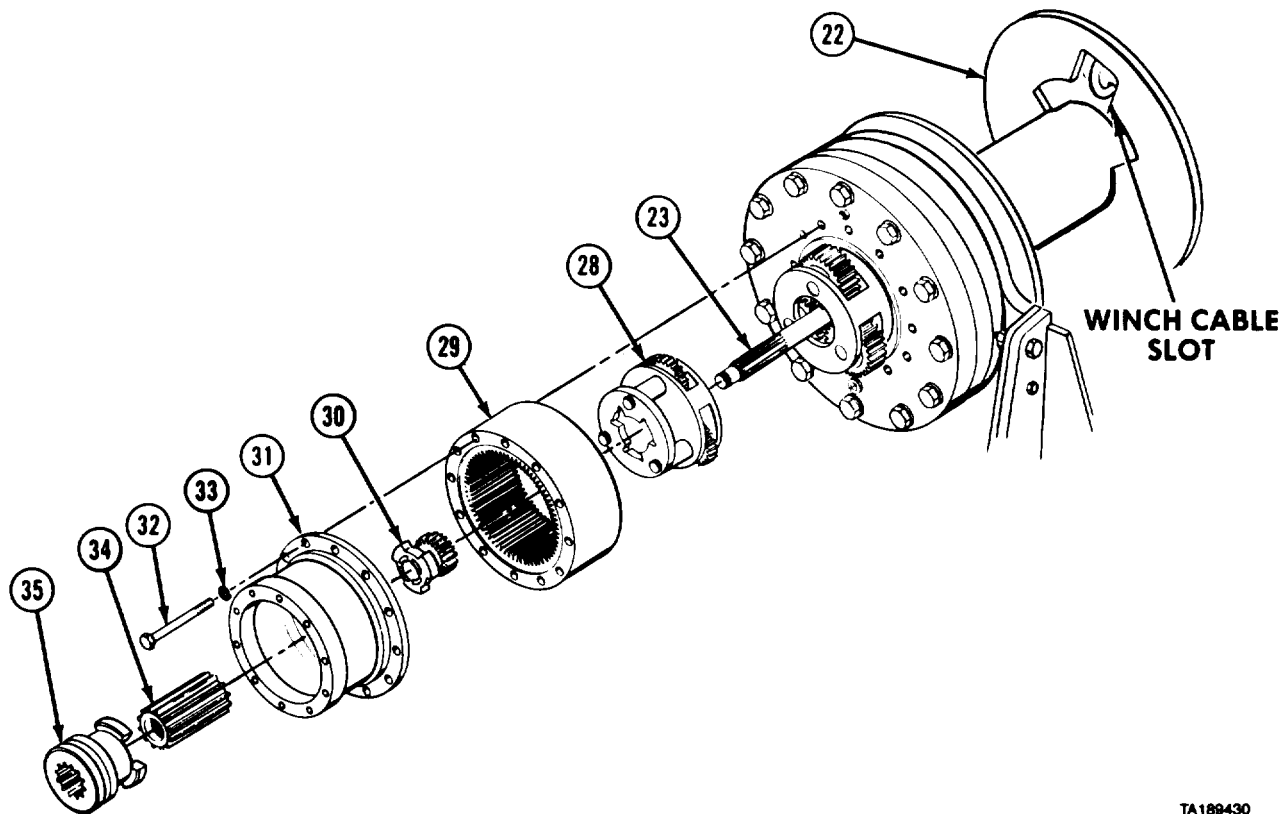

TA189430

Winch Maintenance Instructions (Cont)

- (25) Install primary carrier assembly (28) on input shaft (23).

WARNING

Adhesives, solvents, and sealing compounds can burn easily, can give off harmful vapors, and are harmful to skin and clothing. To avoid injury or death, keep away from open fire and use in well-ventilated area. If adhesive, solvent, or sealing compound gets on skin or clothing, wash immediately with soap and water.

- (26) Apply silicone adhesive-sealant to both mounting surfaces of ring gear (29) and install.
 (27) Soldier A installs primary sun gear (30) while Soldier B turns winch drum (22) with crowbar in winch cable slot.
 (28) Apply silicone adhesive-sealant to both mounting surfaces of gear end housing (31) and install with 12 screws (32) and lockwashers (33).
 (29) Install drive sleeve (34).
 (30) Soldier A aligns drive hub (35) with slots on primary carrier assembly (28) and installs drive hub on drive sleeve (34) while Soldier B turns winch drum (32) with crowbar in winch cable slot.

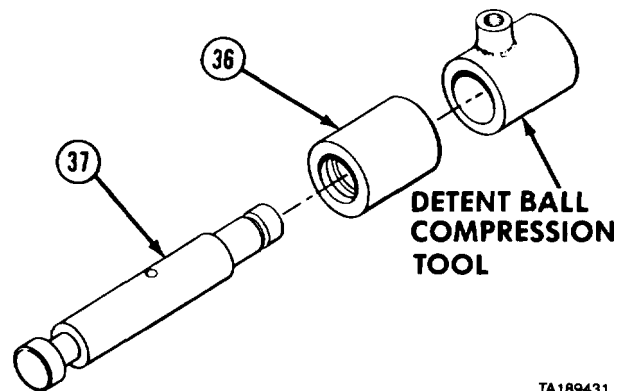

- (31) Install bushing (36) on shifter shaft (37).
 (32) Install detent ball compression tool on shifter shaft (37) and align holes.

Winch Maintenance Instructions (Cont)

16-11. HEAVY-DUTY WINCH REPAIR (M984) (CONT).

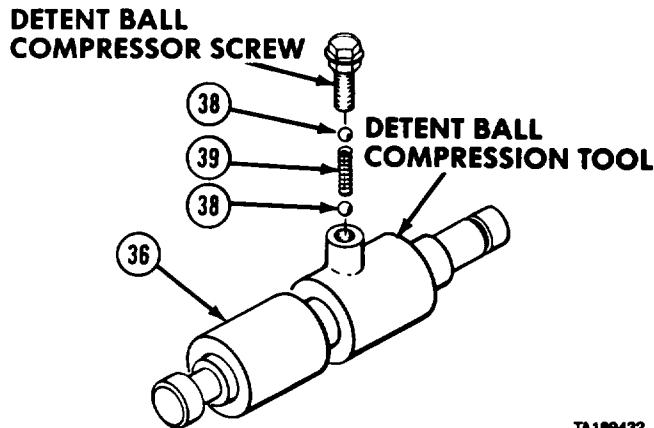

TA189432

- (33) Install two balls (38) and one spring (39).
- (34) Compress balls (38) and spring (39) with detent ball compressor screw.
- (35) Keeping bushing (36) and detent ball compression tool together, slide bushing over balls (38) and spring (39).
- (36) Remove detent ball compressor screw and detent ball compression tool.

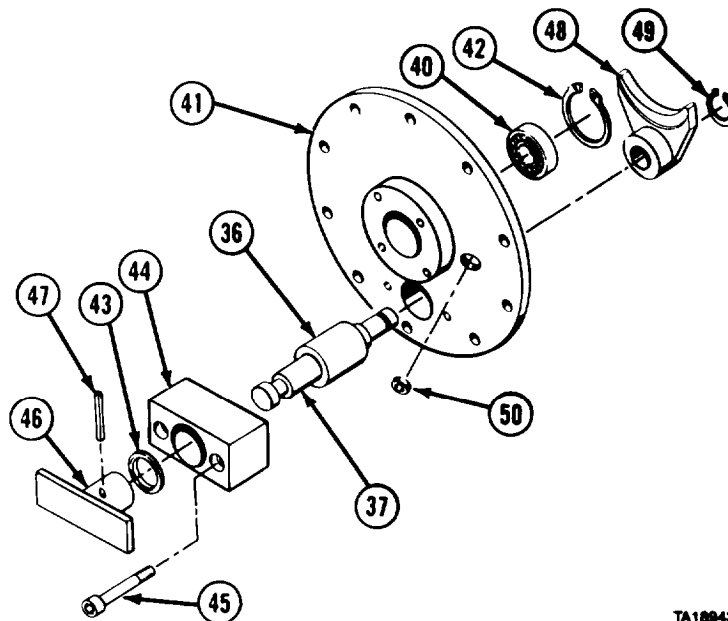

TA189433

- (37) Press bearing (40) in end cover (41).
- (38) Install retaining ring (42).
- (39) Install bushing (36) and shifter shaft (37) in end cover (41). Do not push on shifter shaft.
- (40) Install oil seal (43) in shifter housing (44).
- (41) Install shifter housing (44) with two screws (45).
- (42) Install shifter T-handle (46) with roll pin (47).
- (43) Install shifter (48) and retaining ring (49).
- (44) Install pipe plug (50).

Winch Maintenance Instructions (Cont)

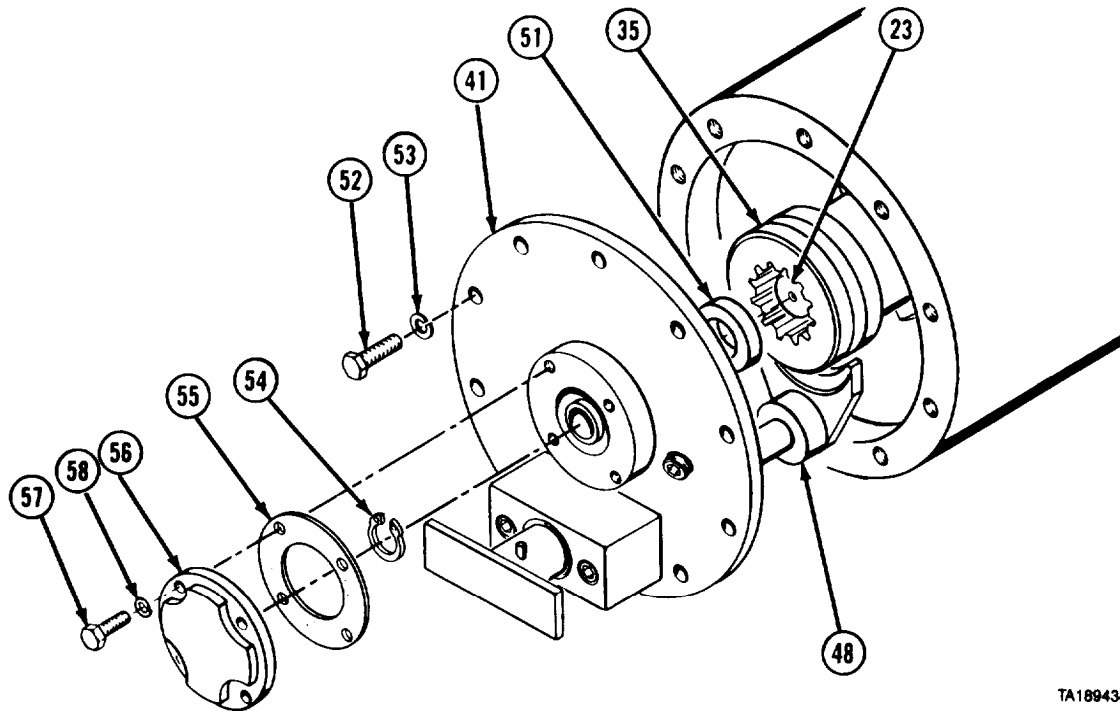

TA189434

- (45) Install spacer (51), flat side out, on input shaft (23).

WARNING

Adhesives, solvents, and sealing compounds can burn easily, can give off harmful vapors, and are harmful to skin and clothing. To avoid injury or death, keep away from open fire and use in well-ventilated area. If adhesive, solvent, or sealing compound gets on skin or clothing, wash immediately with soap and water.

NOTE

Coat both sides of end cover with silicone adhesive-sealant.

- (46) Install end cover (41) on input shaft (23) making sure shifter (48) engages slot on drive hub (35)
 (47) Install 10 screws (52) and lockwashers (53).
 (48) Remove heavy-duty winch brake (para 16-16).
 (49) Drive input shaft (23) out to clear retaining ring groove.
 (50) Install retaining ring (54).
 (51) Coat both surfaces of gasket (55) with silicone adhesive-sealant and install.
 (52) Install cover (56) with four screws (57) and lockwashers (58).

Winch Maintenance Instructions (Cont)

16-11. HEAVY-DUTY WINCH REPAIR (M984) (CONT).

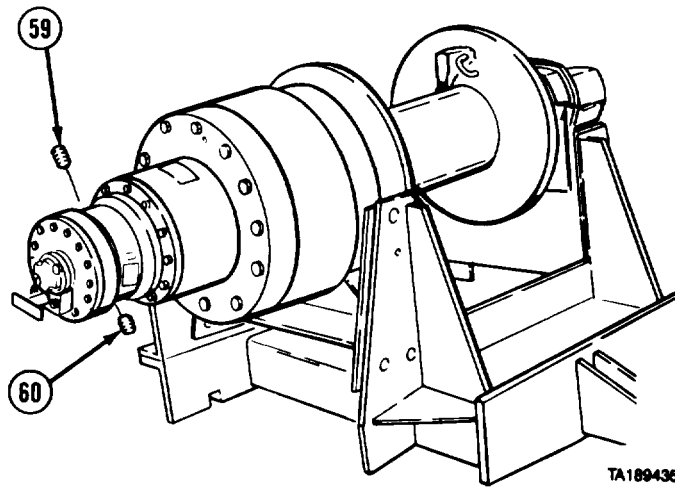

TA189436

(53) Install two pipe plugs (59 and 60).

d. Follow-on Maintenance.

- (1) Install heavy-duty winch (para 16-10).
- (2) Install heavy-duty winch brake (para 16-16).
- (3) Install heavy-duty winch hydraulic motor (para 16-13).
- (4) Install heavy-duty winch counterbalance valve (para 16-15).
- (5) Fill winch with oil (LO 9-2320-279-12).

END OF TASK

Winch Maintenance Instructions (Cont)

16-11.1. HEAVY-DUTY WINCH REPAIR (M984E1).	
This task covers:	
a. Disassembly	c. Assembly
b. Cleaning/Inspection	d. Follow-on Maintenance
INITIAL SETUP	
Models M984E1	Equipment Condition
Test Equipment Indicator, dial J8001-3	TM or Para TM 9-2320-279-20 Para 16-13.1
Special Tools None	Condition Description Cable removed. Heavy-duty winch motor removed. Heavy-duty winch brake removed.
Supplies Adhesive-sealant, silicone, Item 6, Appendix C	Para 16-17 TM 9-2320-279-20 Para 16-10.2
Personnel Required MOS 63W, Wheel vehicle repairer (2)	Heavy-duty winch tensioner removed. Heavy-duty winch removed from truck.
References None	Special Environmental Conditions None
	General Safety Instructions None
	Level of Maintenance General Support

a. Disassembly.

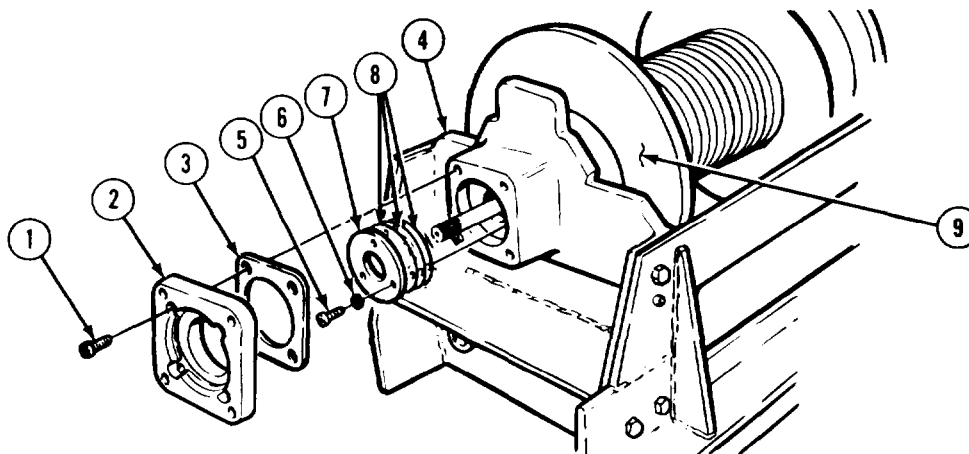

TA476333

(1) Remove four screws (1), adapter (2), and gasket (3) from frame (4).

NOTE

Number of shims may vary.

(2) Remove three screws (5), lockwashers (6), plate (7), and shims (8) from winch (9).

Winch Maintenance Instructions (Cont)

16-11.1. HEAVY-DUTY WINCH REPAIR (M984E1) (CONT).

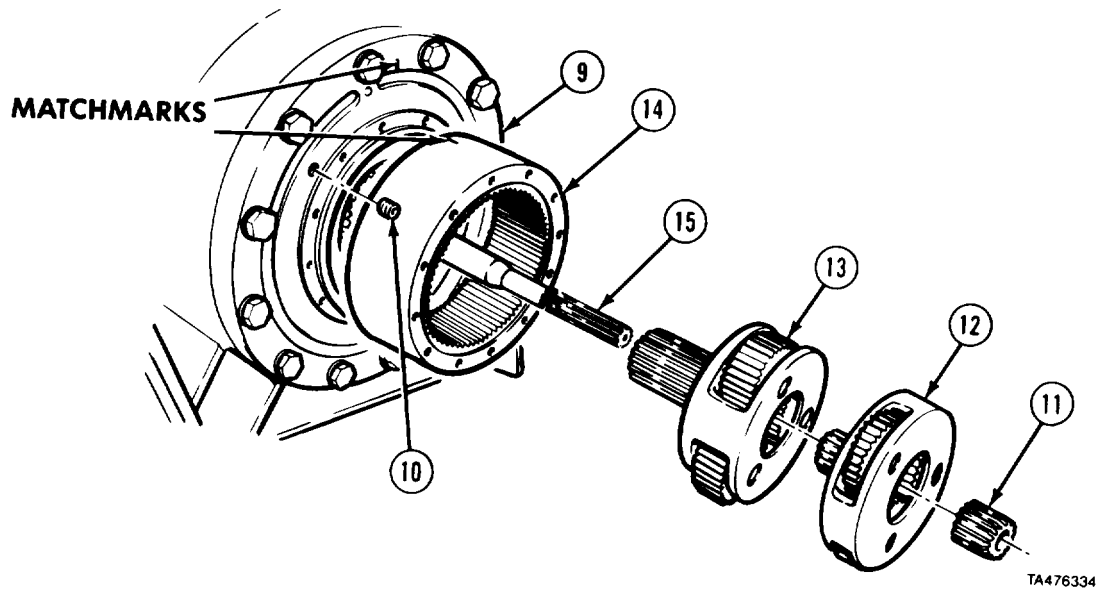

NOTE

Two brake screws may be used to hold ring gear in position. Matchmark ring gear to winch.

- (3) Remove two plugs (10) and drain oil.
- (4) Remove sun gear (11).
- (5) Remove primary carrier (12) and secondary carrier (13) from ring gear (14).
- (6) Remove ring gear (14) from winch (9).
- (7) Remove shaft (15).

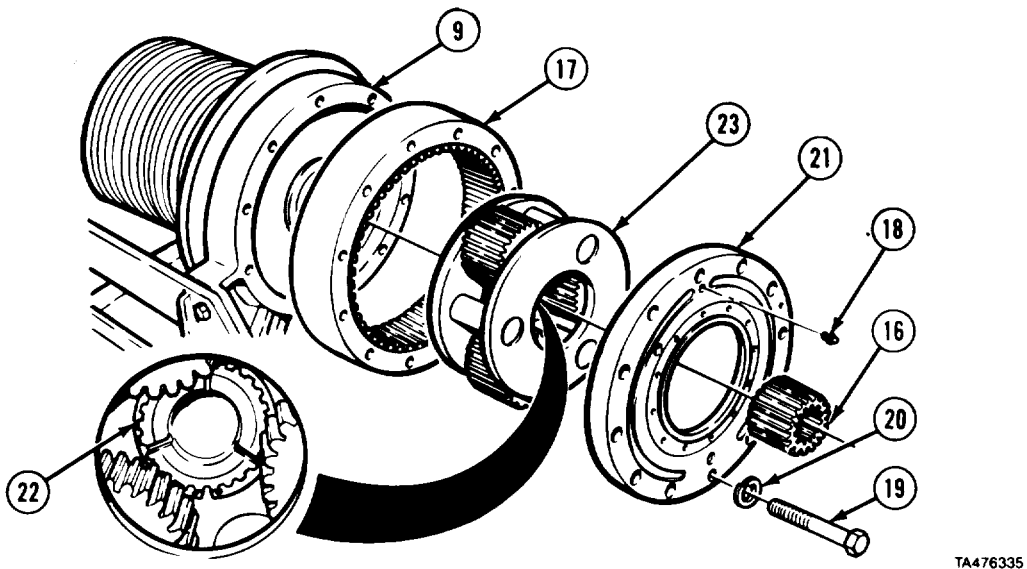

- (8) Remove sun gear (16)

Winch Maintenance Instructions (Cont)

NOTE

Two ring screws may be used to support ring gear.

- (9) Support ring gear (17).
- (10) Remove air vent (18), 12 screws (19), lockwashers (20), and cover (21).
- (11) Loosen snap ring (22).
- (12) Remove third carrier (23) from ring gear (17).
- (13) Remove ring gear (17) from winch (9).

NOTE

All three gears are repaired the same.

- (14) Remove screw (24), lockwasher (25), lock tab (26), and pin (27) from third carrier (23).
- (15) Remove gear (28), two washers (29), and snap ring (22).

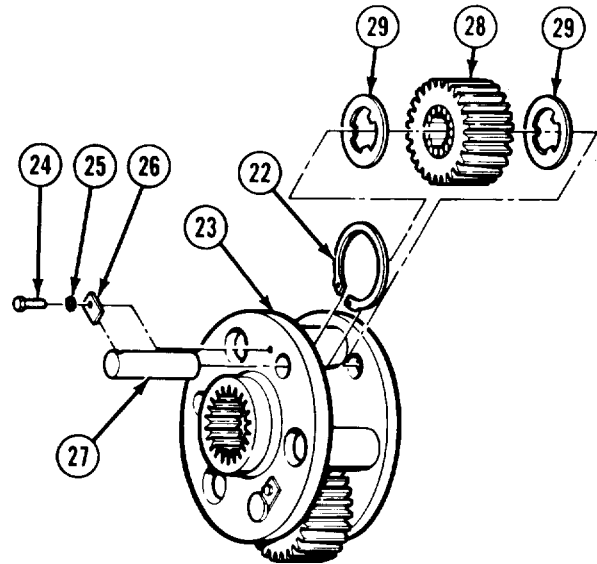

- (16) Remove 22 rollers (30), spacer (31), 22 rollers (30), spacer (31), and 22 rollers (30) from gear (28).

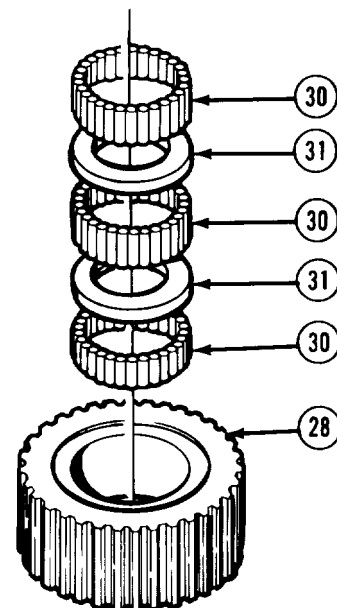

TA476337

Winch Maintenance Instructions (Cont)

16-11.1. HEAVY-DUTY WINCH REPAIR (M984E1) (CONT).

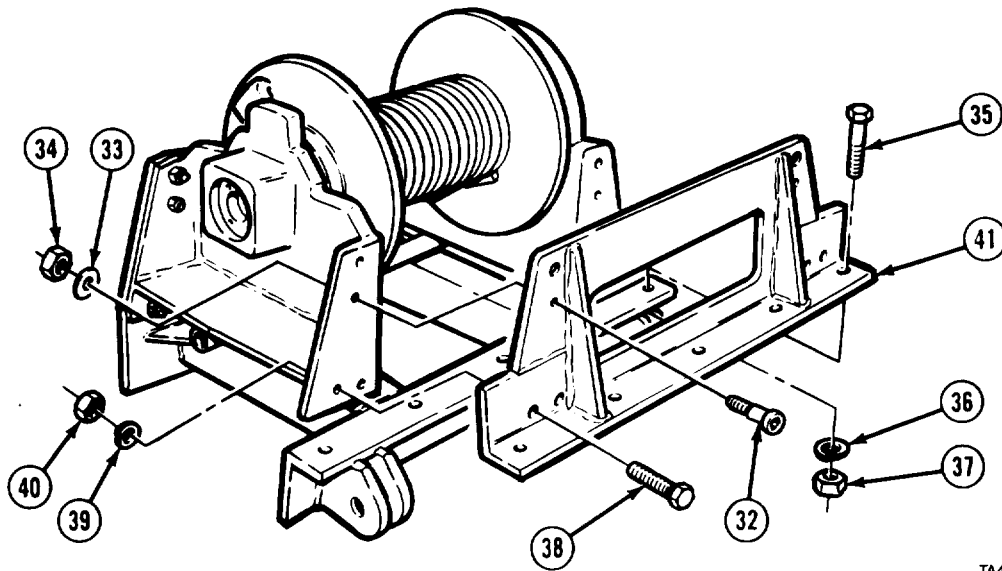

TA476338

- (17) Remove two screws (32), washers (33), and nuts (34).
- (18) Remove five screws (35), lockwashers (36), and nuts (37).
- (29) Remove six screws (38), lockwashers (39), nuts (40), and bracket (41).

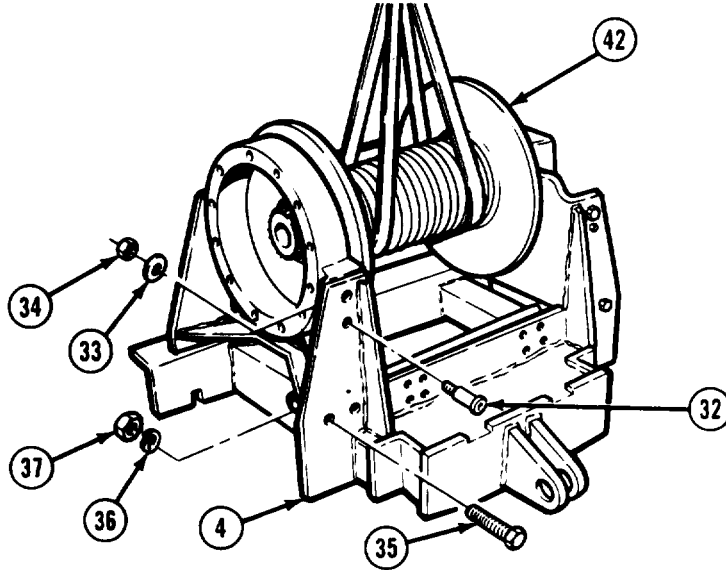

TA476339

WARNING

Keep out from under heavy parts. Falling parts may cause serious injury or death.

- (20) Attach suitable lifting device to drum (42).
- (21) Remove screw (32), washer (33), and nut (34).
- (22) Remove three screws (35), lockwashers (36), and nuts (37) from frame (4).

Winch Maintenance Instructions (Cont)

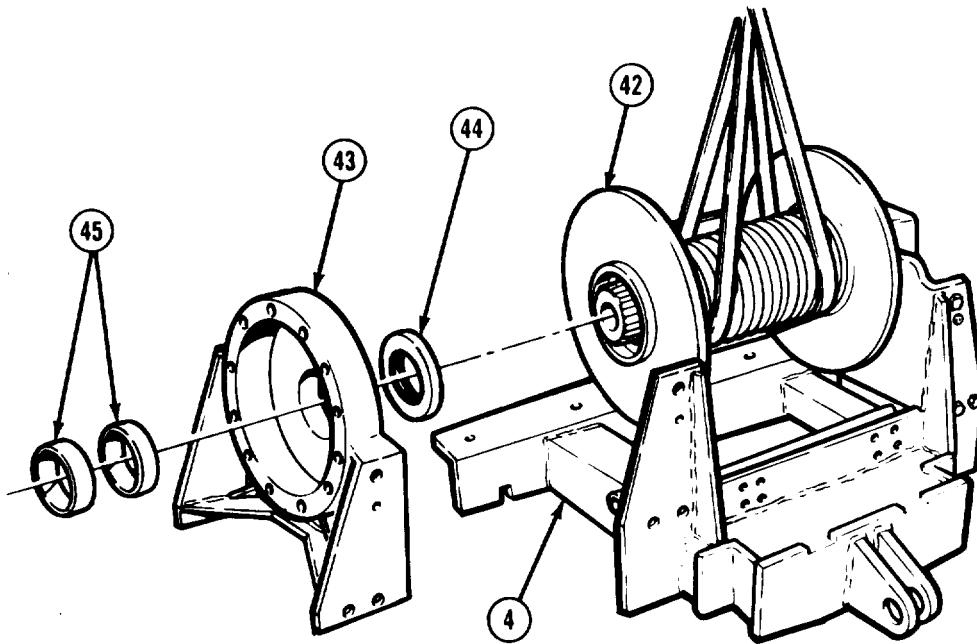

TA476340

- (23) Soldier A and Soldier B remove gear-end support (43) from drum (42) and frame (4).
- (24) Remove oil seal (44) and press two bushings (45) from gear-end support (43).

- (25) Soldier A removes drum (42) from frame (4) while Soldier B operates lifting device.
- (26) Remove two screws (46), lockwashers (47), output shaft (48), and two keys (49).
- (27) Remove screw (32), washer (33), and nut (34).
- (28) Remove three screws (38), lockwashers (39), and nuts (40).
- (29) Remove motor end support (50) from frame (4).
- (30) Remove oil seal (44) and press out two bushings (45).

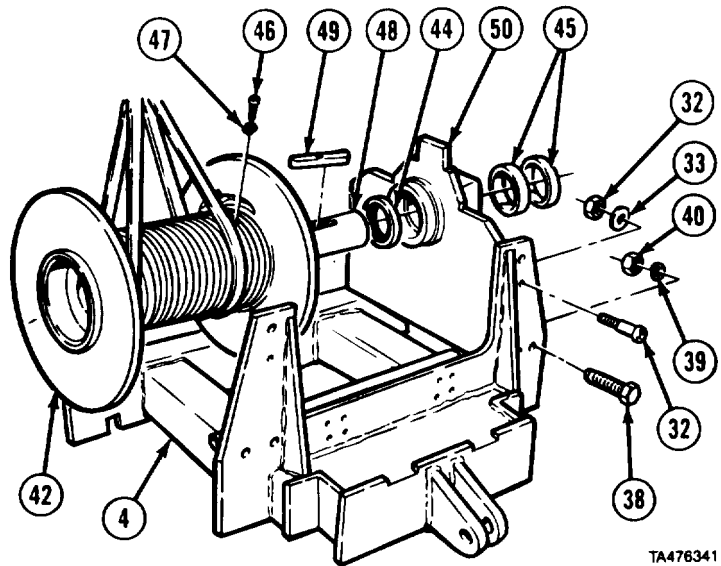

TA476341

Winch Maintenance Instructions (Cont)

16-11.1. HEAVY-DUTY WINCH REPAIR (M984E1) (CONT).

b. Cleaning/Inspection.

WARNING

Adhesives, solvents, and sealing compounds can burn easily, can give off harmful vapors, and are harmful to skin and clothing. To avoid injury or death, keep away from open fire and use in well-ventilated area. If adhesive, solvent, or sealing compound gets on skin or clothing, wash immediately with soap and water.

- (1) Clean all metal parts in dry cleaning solvent.
- (2) Inspect all parts for damage.
- (3) Maximum inside diameter of bushings is 4.552 in. (115.62 mm).
- (4) All planetary thrust washers may not be reused if thinner than 0.045 in. (1.115 mm).

c. Assembly.

- (1) Install two bushings (1) and oil seal (2) in motor end support (3).
- (2) Install motor end support (3) with screw (4), washer (5), and nut (6).
- (3) Install three screws (7), lockwashers (8), and nuts (9).
- (4) Install two keys (10) in output shaft (11).
- (5) Install output shaft (11) in drum (12) with two lockwashers (13) and screws (14).
- (6) Install drum (12) in motor end support (3).

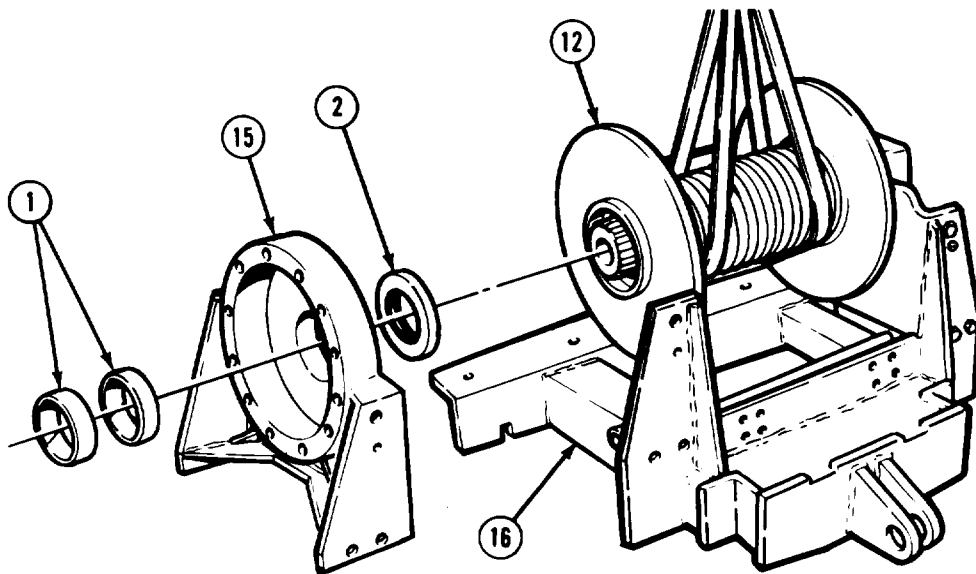
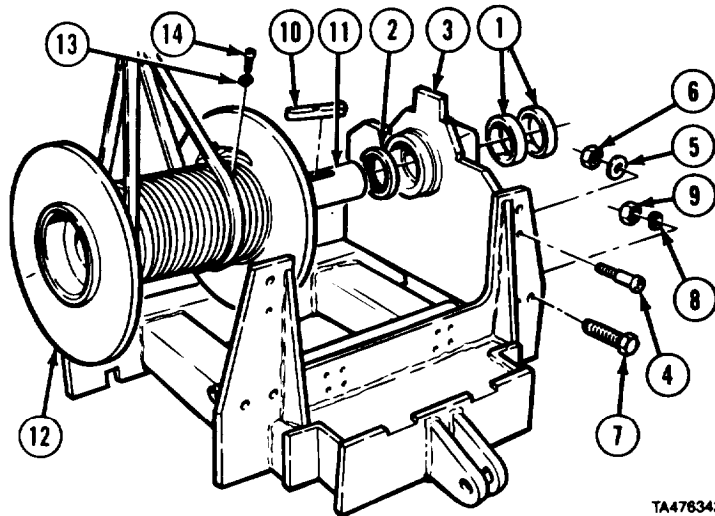

- (7) Install two bushings (1) and oil seal (2) in gear end support (15).
- (8) Install gear end support (15) on drum (12) and frame (16).

Winch Maintenance Instructions (Cont)

- (9) Install screw (4), washer (5), and nut (6) in frame (16).
- (10) Install three screws (7), lockwashers (8), and nuts (9).

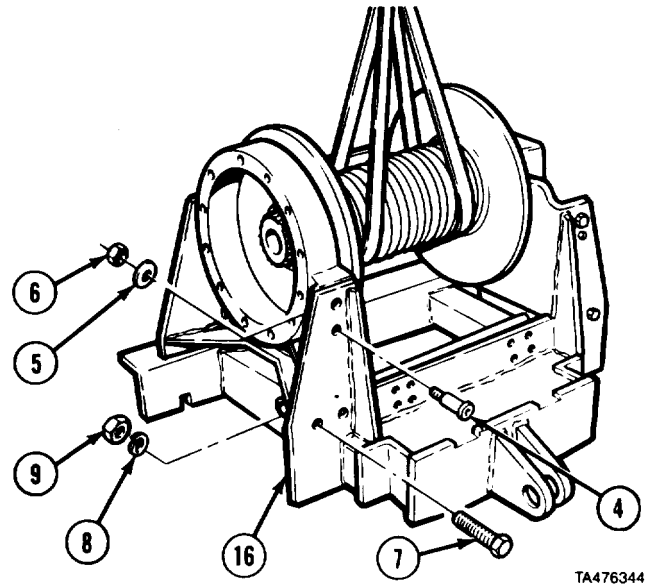

TA476344

- (11) Install bracket (17) with two screws (4), washers (5), and nuts (6).
- (12) Install six screws (7), lockwashers (8), and nuts (9).
- (13) Install five screws (18), lockwashers (19), and nuts (20).

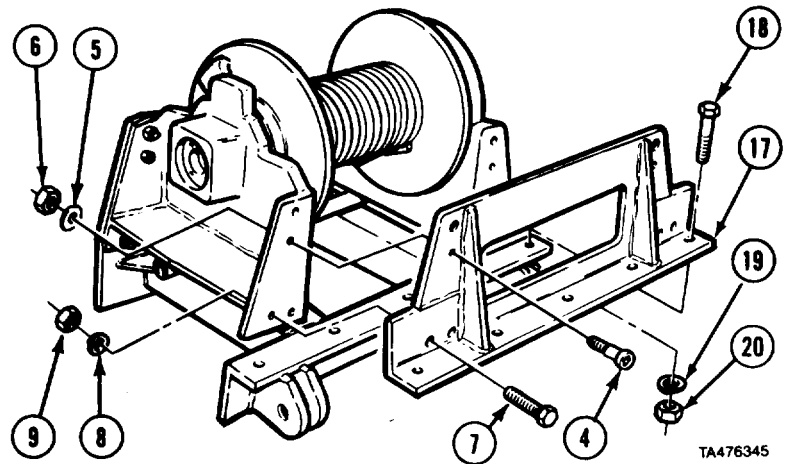

TA476345

- (14) Install 22 rollers (21), spacer (22), 22 rollers (21), spacer (22), and 22 rollers (21) in gear (23).

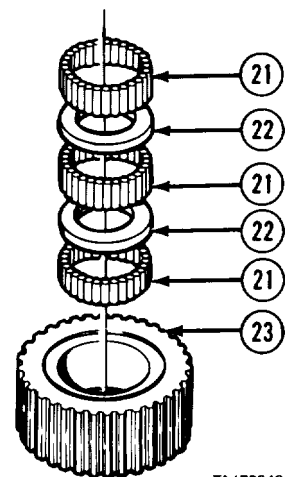

TA476346

Winch Maintenance Instructions (Cont)

16-11.1. HEAVY-DUTY WINCH REPAIR (M984E1) (CONT).

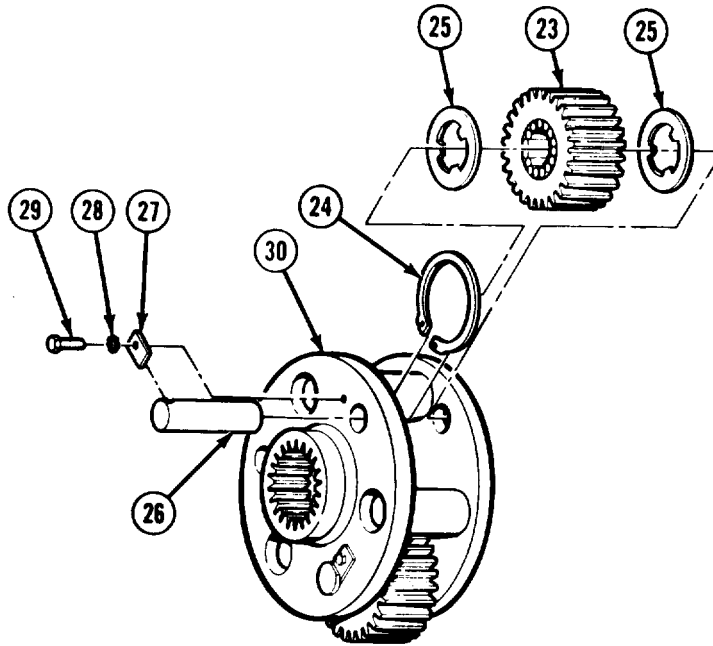

TA476347

NOTE

All three gears are installed the same.

- (15) Position snap ring (24), two washers (25), and gear (23).
- (16) Install pin (26), lock tab (27), lockwasher (28), and screw (29) in third carrier (30).

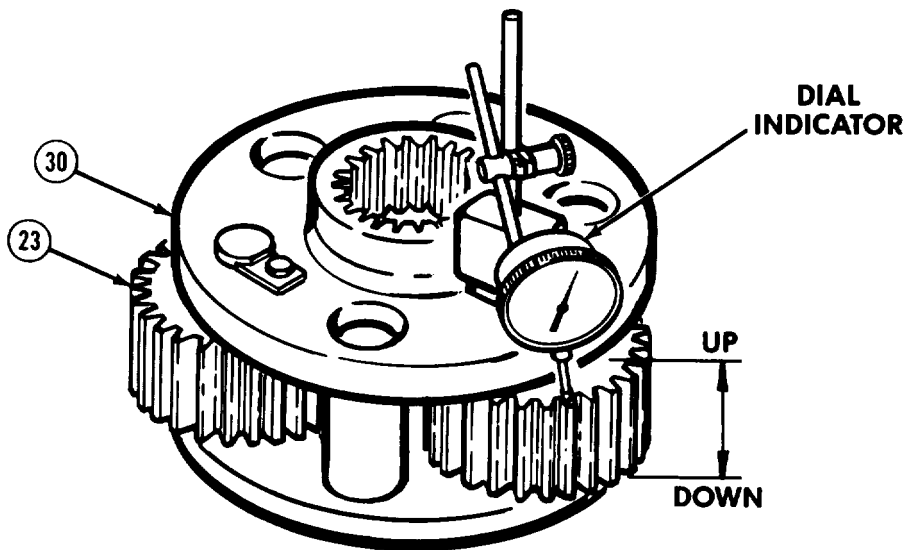

TA476348

- (17) Attach dial indicator to third carrier (30).

NOTE

Replace third carrier washers if gear end play is 0.55 in. (1.4 mm) or more.

- (18) Move gears (23) down then up and read amount of end play on dial indicator.

Winch Maintenance Instructions (Cont)

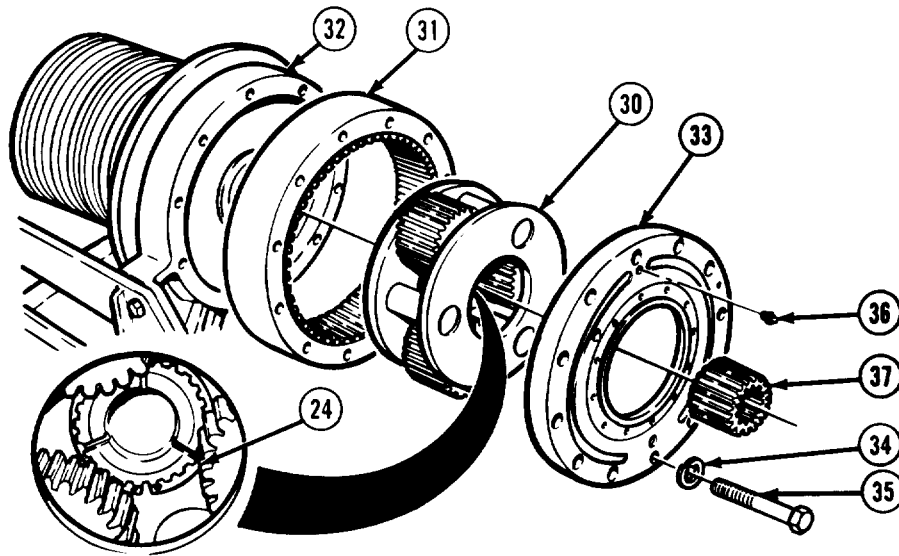

TA476349

NOTE

Two ring screws may be used to support ring gear.

- (19) Soldier A applies sealant while Soldier B positions and supports ring gear (31) on winch (32).
- (20) Install third carrier (30) in ring gear (31).
- (21) Install snap ring (24).
- (22) Apply sealant and install cover (33) with 12 lockwashers (34) and screws (35).
- (23) Install air vent (36) and sun gear (37).

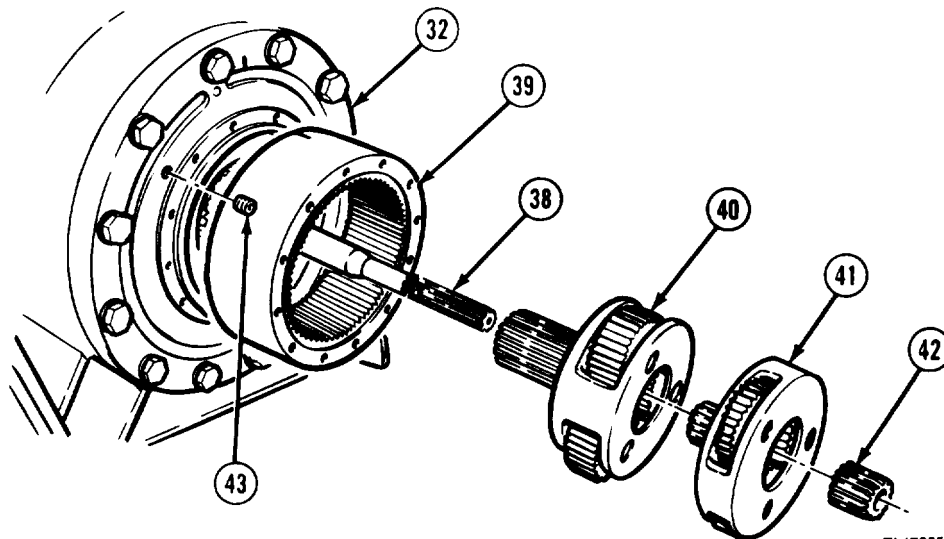

TA476350

- (24) Install shaft (38) in winch (32).
- (25) Apply sealant and position ring gear (39).
- (26) Install secondary carrier (40) and primary carrier (41) in ring gear (39).
- (27) Install sun gear (42) and two plugs (43).

Winch Maintenance Instructions (Cont)

16-11.1. HEAVY-DUTY WINCH REPAIR (M984E1) (CONT).

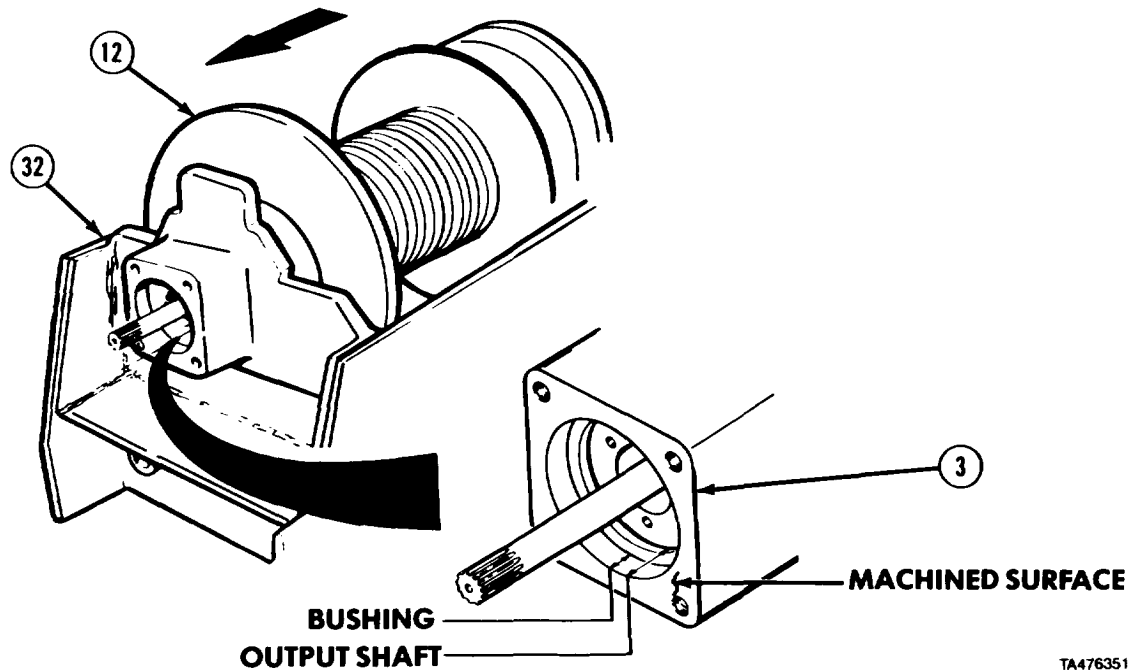

- (28) Move drum (12) fully to motor end of winch (32).

NOTE

Measurement for steps (29) and (30) must be made from same area on machined surface.

- (29) Measure distance from machined surface of motor end support (3) and output shaft and record measurement.
 (30) Measure distance from machined surface of motor end support (3) and bushing and record measurement.
 (31) Subtract measurement recorded in step (30) from measurement recorded in step (29) and record answer.

NOTE

Example of measurement of step (31) was 0.004 in. (0.10 mm). Use a 0.010 in. (0.25 mm) shim. If measurement was 0.080 in. (2.05 mm) combine different size shims to get 0.090 in. (2.3 mm). Always go to next highest thickness.

- (32) Round off answer in step (31) to next highest 0.010 in. (0.25 mm). This will be size of shims required in step (33).

Winch Maintenance Instructions (Cont)

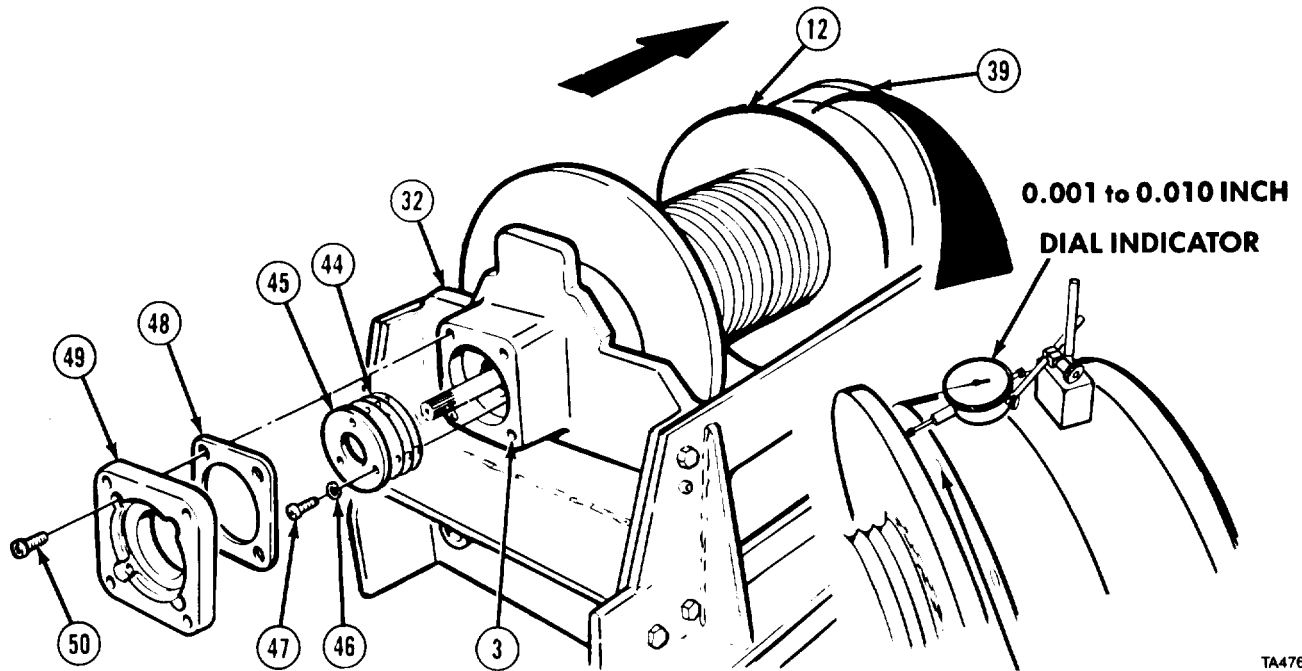

TA476352

NOTE

Shims are available in different thickness 0.010 in. (0.25 mm), 0.020 in. (0.5 mm), and 0.060 in. (1.55 mm) mix to obtain shimming thickness required.

- (33) Install shim (44) and plate (45) with three lockwashers (46) and screws (47) to winch (32).
- (34) Attach dial indicator on winch (32).

NOTE

End play should read between 0.001 and 0.010 in.

- (35) Move drum (12) fully toward ring gear (39) end of winch (32) and read amount of end play on dial indicator.
- (36) Install gasket (48) and adapter (49) with four screws (50) to motor end support (3).

d. Follow-on Maintenance.

- (1) Install heavy-duty winch brake (para 16-17).
- (2) Install heavy-duty winch motor (para 16-13.1).
- (3) Install tensioner (TM 9-2320-279-20).
- (4) Install winch on vehicle (TM 9-2320-279-20).
- (5) Install cable (TM 9-2320-279-20).
- (6) Fill with oil (LO 9-2320-279-12).
- (7) Check operation of heavy duty winch (TM 9-2320-279-10).

END OF TASK

Winch Maintenance Instructions (Cont)

16-12. HEAVY-DUTY WINCH DRUM REPAIR (M984).		
This task covers:		
a. Disassembly	c. Assembly	
b. Cleaning/Inspection	d. Follow-on Maintenance	
INITIAL SETUP		
Models	Equipment Condition	
M984	TM or Para	Condition Description
Test Equipment	Para 16-16	Heavy-duty winch brake removed.
None	Para 16-11	Heavy-duty winch disassembled.
Special Tools	Special Environmental Condition-s	
None	None	
Supplies	General Safety Instructions	
Solvent, dry cleaning, Item 57, Appendix C	None	
Personnel Required	Level of Maintenance	
MOS 63W, Wheel vehicle repairer (2)	General Support	
References		
None		

Winch Maintenance Instructions (Cont]

a. Disassembly.

WARNING

Stand clear of heavy parts when being lifted or moved with hoist or crane to avoid personal injury.

- (1) Attach lifting device to drum (1). Take up slack on sling.
- (2) Remove six screws (2), lockwashers (3), and nuts (4).
- (3) Remove two screws (5), lockwashers (6), and nuts (7).

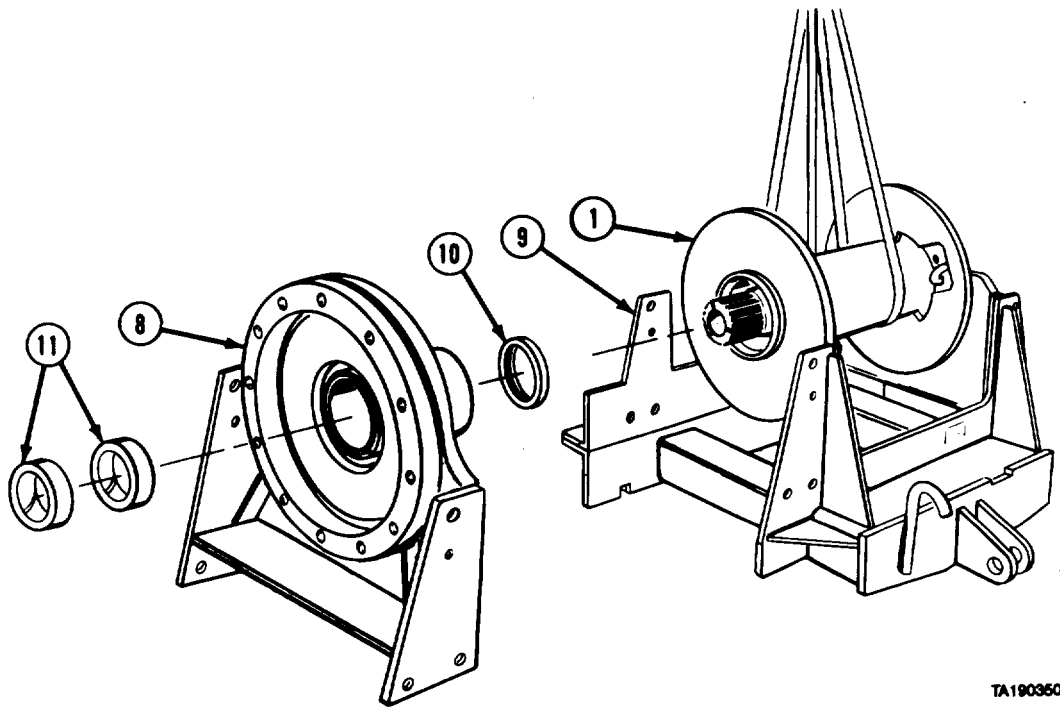
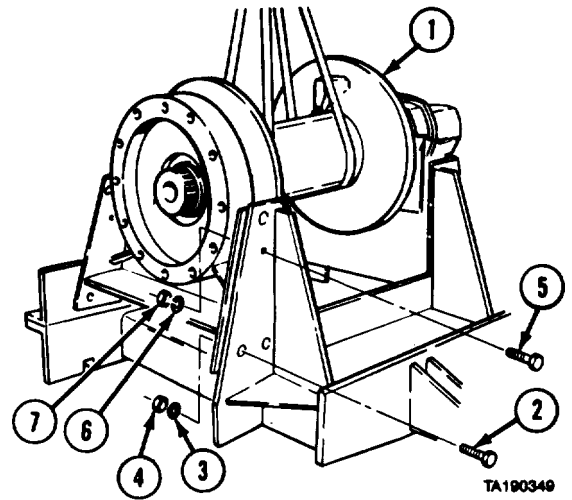

- (4) Soldier A and Soldier B remove gear end support (8) from drum (1) and frame (9).
- (5) Remove oil seal (10) and press two bronze bushings (11) from gear end support (8).

Winch Maintenance Instructions (Cont)

16-12. HEAVY-DUTY WINCH DRUM REPAIR (M984) (CONT).

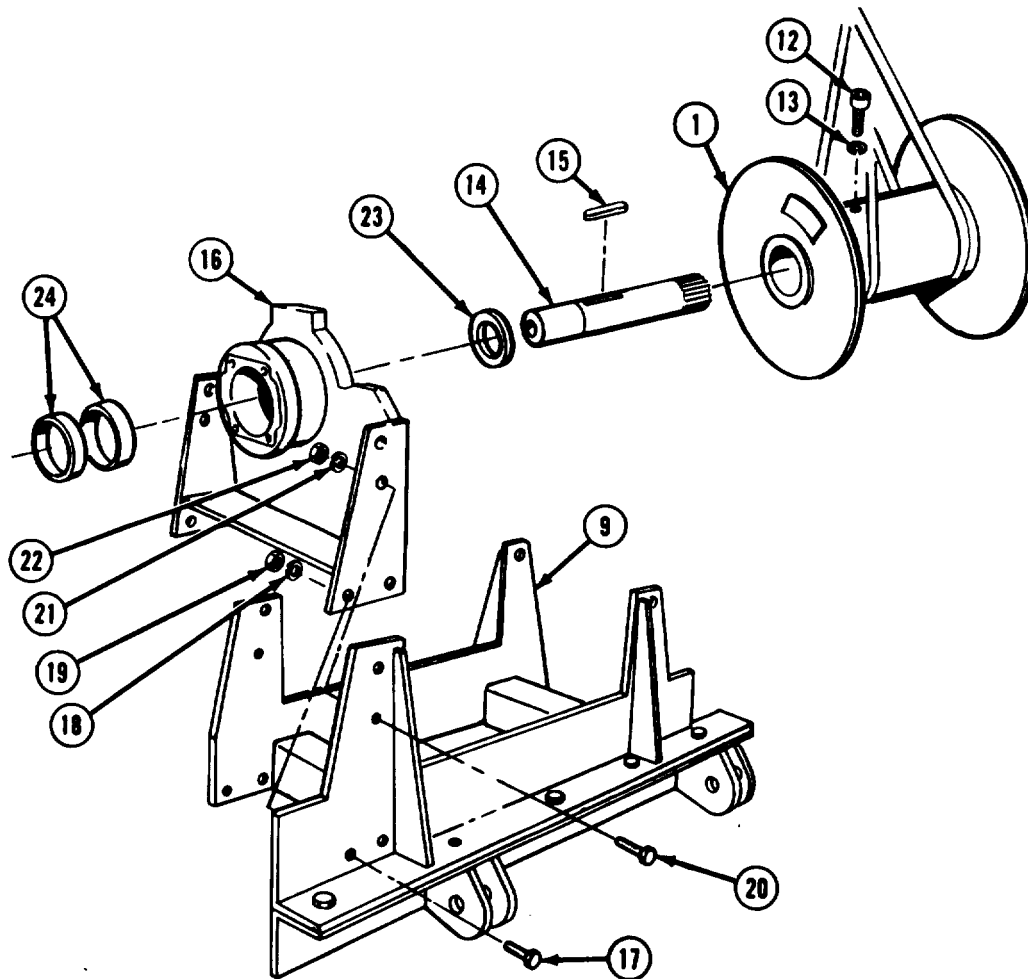

TA190351

- (6) Soldier A removes drum (1) from frame (9) while Soldier B operates lifting device.
- (7) Remove two screws (12), lockwashers (13), output shaft (14), and two keys (15).
- (8) Support motor end support (16) with suitable lifting device and remove six screws (17), lockwashers (18), and nuts (19).
- (9) Remove two screws (20), lockwashers (21), and nuts (22).
- (10) Soldier A removes motor end support (16) from frame (9) while Soldier B operates lifting device.
- (11) Remove oil seal (23) and press out two bronze bushings (24).

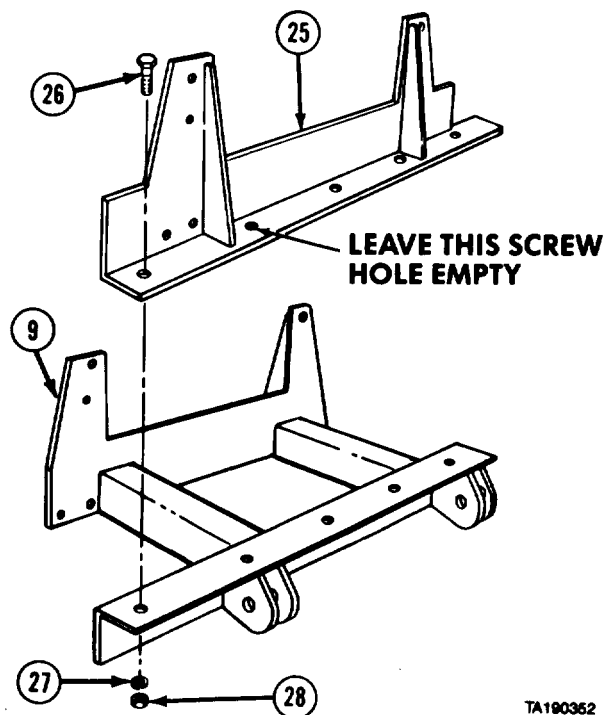
Winch Maintenance Instructions (Cont)

- (12) Support forward frame (25) with suitable lifting device.
 (13) Remove four screws (26), lockwashers (27), and nuts (28).
 (14) Soldier A guides forward frame (25) away from frame (9) while Soldier B operates lifting device.
 (15) Remove lifting device from forward frame (25).

b. Cleaning/Inspection.

WARNING

Adhesives, solvents, and sealing compounds can burn easily, can give off harmful vapors, and are harmful to skin and clothing. To avoid injury or death, keep away from open fire and use in well-ventilated area. If adhesive, solvent, or sealing compound gets on skin or clothing, wash immediately with soap and water.

- (1) Clean all metal parts in dry cleaning solvent.
- (2) Maximum inside diameter of bushings is 4.552 in. (115.62 mm).
- (3) Inspect all parts for damage.
- (4) Replace damaged parts.

Winch Maintenance Instructions (Cont)

16-12. HEAVY-DUTY WINCH DRUM REPAIR (M984) (CONT).

c. Assembly.

- (1) Attach suitable lifting device to forward frame (1).
- (2) Soldier A guides forward frame (1) in place on frame (2) while Soldier B operates lifting device.
- (3) Install four screws (3), lockwashers (4), and nuts (5).
- (4) Remove lifting device from forward frame (1).

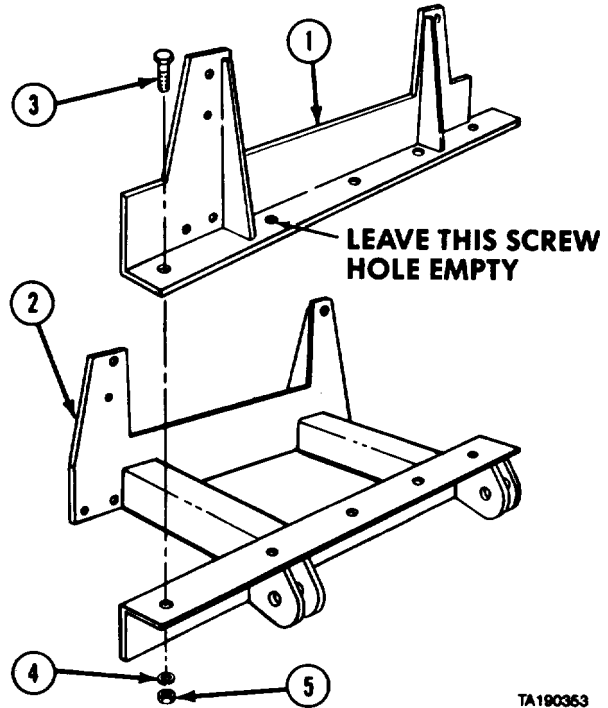

TA190363

- (5) Press two bronze bushings (6) and oil seal (7) in motor end support (8).
- (6) Install sling through motor end support (8) and support with lifting device.
- (7) Soldier A installs motor end support (8) on frame (2) while Soldier B operates lifting device.

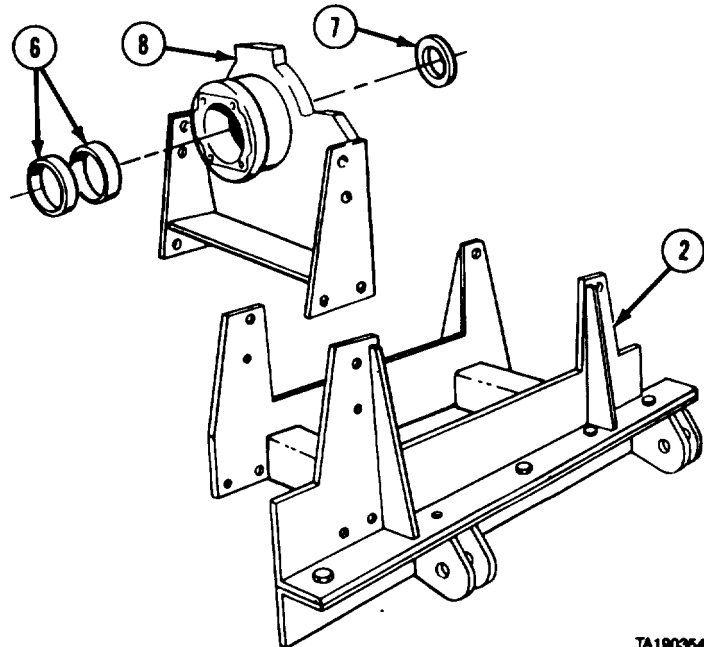

TA190364

Winch Maintenance Instructions (Cont)

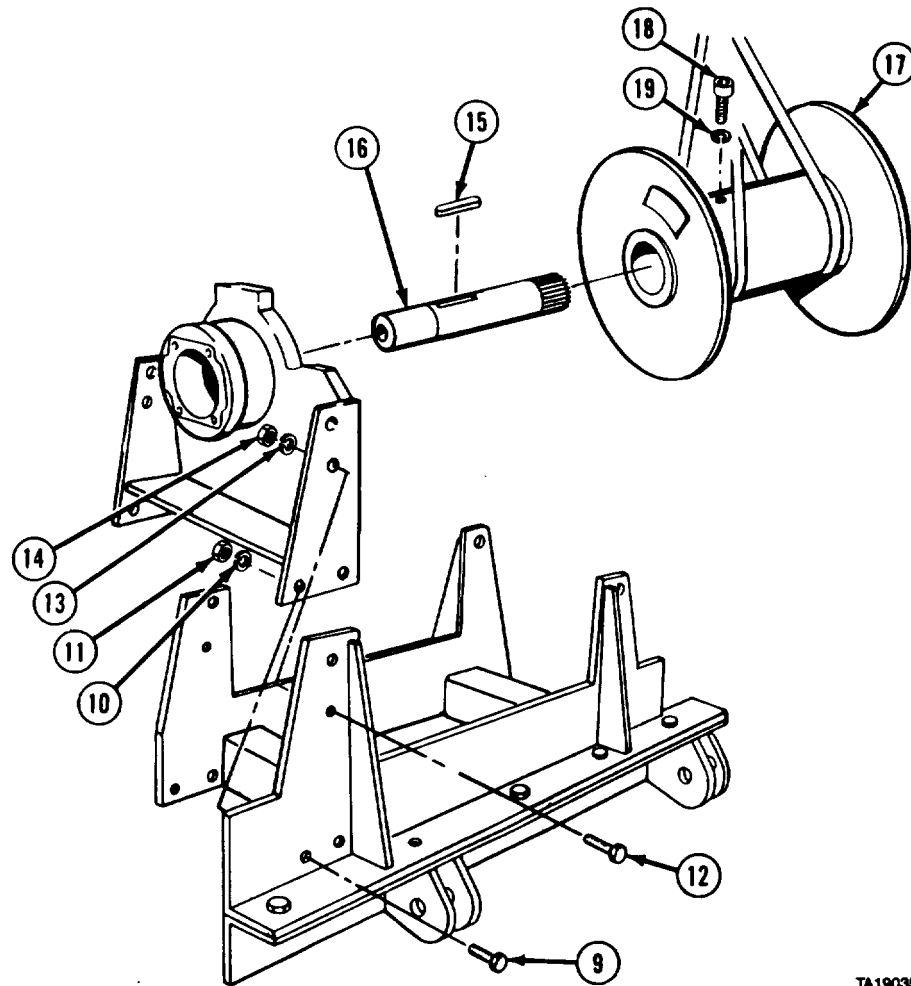

TA190355

- (8) Soldier A installs six screws (9), lockwashers (10), nuts (11), two screws (12), lockwashers (13), and nuts (14) while Soldier B operates lifting device.
- (9) Remove lifting device.
- (10) Install two keys (15) on output shaft (16).
- (11) Install output shaft (16) in drum (17).
- (12) Install two screws (18) and lockwashers (19).
- (13) Attach suitable lifting device to drum (17).

Winch Maintenance Instructions (Cont)

16-12. HEAVY-DUTY WINCH DRUM REPAIR (M984) (CONT).

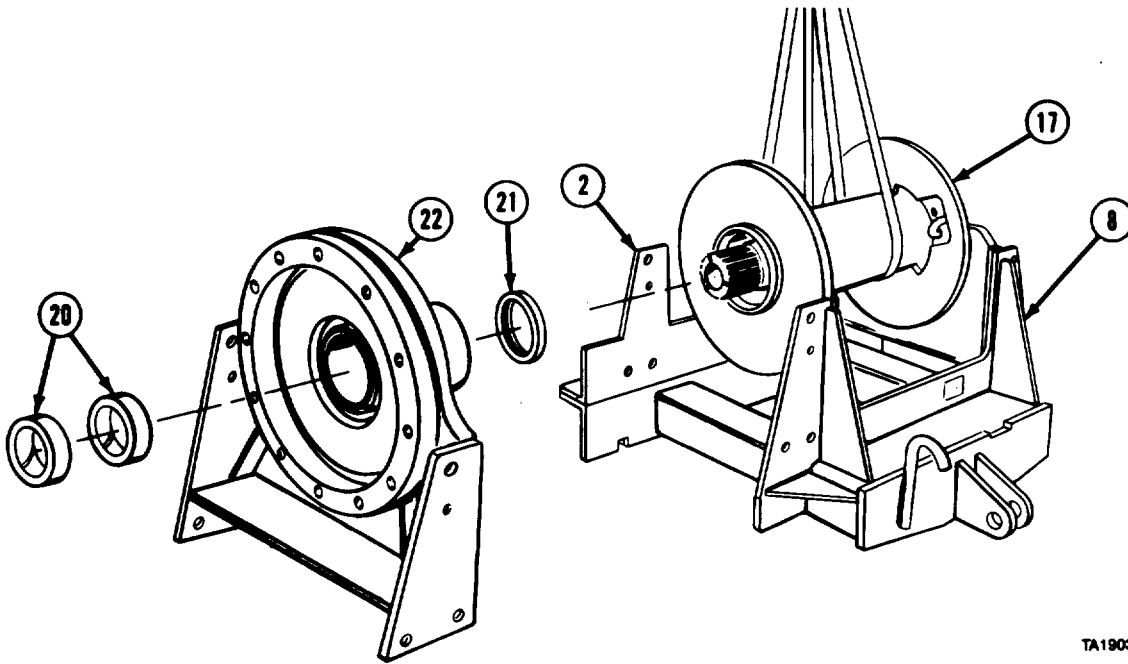

TA190356

- (14) Soldier A installs drum (17) on motor end support (8) while Soldier B operates lifting device.
- (15) Press two bronze bushings (20) and install oil seal (21) in gear end support (22).
- (16) Soldier A and Soldier B install gear end support (22) on frame (2).

- (17) Install six screws (23), lockwashers (24), nuts (25), two screws (26), lockwashers (27), and nuts (28) to frame (2) and gear end support (22).
- (18) Remove lifting device.

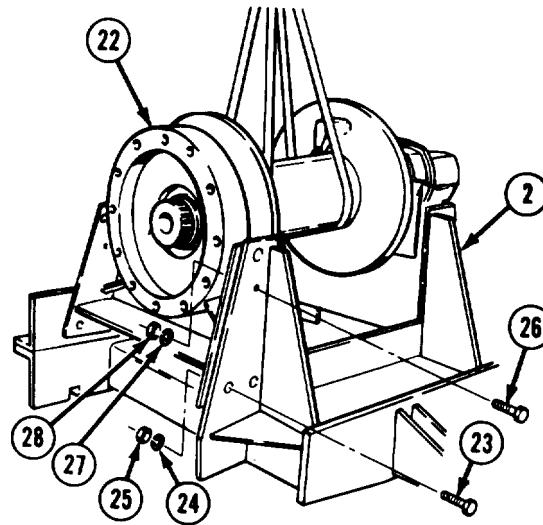

TA190357

d. Follow-on Maintenance. Assemble heavy-duty winch (para 16-11).

END OF TASK

Winch Maintenance Instructions (Cont)

16-13. HEAVY-DUTY WINCH HYDRAULIC MOTOR REMOVAL/INSTALLATION (M984).		
This task covers:		
a. Removal	c. Follow-on Maintenance	
b. Installation		
INITIAL SETUP		
<i>Models</i>	<i>Equipment Condition</i>	
M984	<i>TM or Para</i>	<i>Condition Description</i>
<i>Test Equipment</i>	Para 16-15	Heavy-duty winch counterbalance valve removed.
None		
<i>Special Tools</i>	<i>Special Environmental Conditions</i>	
None	None	
<i>Supplies</i>	<i>General Safety Instructions</i>	
None	None	
<i>Personnel Required</i>	<i>Level of Maintenance</i>	
MOS 63W, Wheel vehicle repairer	Direct Support	
<i>References</i>		
None		

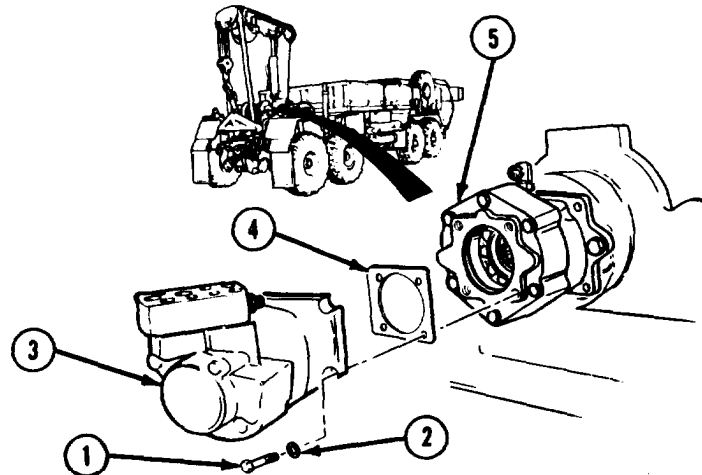

TA106436

- a. Removal.** Remove four screws (1), washers (2), hydraulic motor (3), and gasket (4) from brake (5).
- b. Installation.** Install gasket (4) and hydraulic motor (3) on brake (5) with four washers (2) and screws (1).
- c. Follow-on Maintenance.** Install heavy-duty winch counterbalance valve (para 16-15).

END OF TASK

Winch Maintenance Instructions (Cont)

16-13.1. HEAVY-DUTY WINCH HYDRAULIC MOTOR REMOVAL/INSTALLATION.

This task covers:

- a. Removal
- b. Installation
- c. Follow-on Maintenance

INITIAL SETUP

Models

M984E1

Test Equipment

None

Special Tools

None

Supplies

None

Personnel Required

MOS 63W, Heavy wheel vehicle mechanic

References

None

Equipment Condition

<i>TM or Para</i>	<i>Condition Description</i>
Para 16-12	Counterbalance valve removed.

Special Environmental Conditions

None

General Safety Instructions

None

Level of Maintenance

Direct Support

a. Removal.

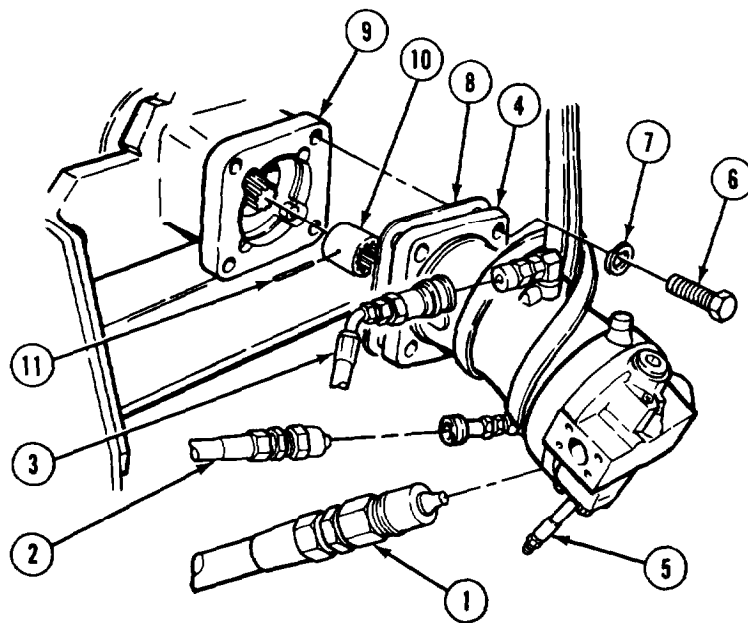
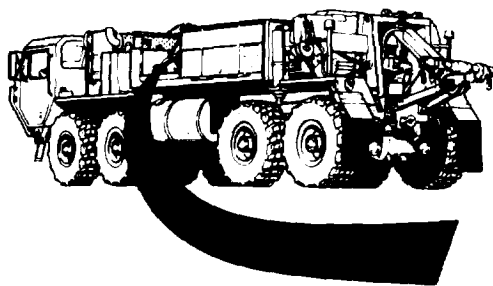

TA476215

- (1) Disconnect three hydraulic lines (1, 2, and 3) from motor (4).
- (2) Remove hydraulic line (5) from motor (4).
- (3) Attach suitable lifting device to motor (4).
- (4) Remove four screws (6), lockwashers (7), motor (4), and gasket (8) from winch (9).
- (5) Remove coupling (10).
- (6) Remove pin (11) from coupling (10).

Winch Maintenance Instructions (Cont)



(7) Remove four screws (12), lockwashers (13), two clamp halves (14), connector assembly (15), and preformed packing (16) from motor (4).

(8) Remove connector (17) and preformed pack (18) from elbow (19).

(9) Remove two connectors (20 and 21) from fittings (22).

(10) Remove cap (23) and two fittings (22).

(11) Remove two elbows (24) and preformed packings (25) from motor (4).

(12) Remove fitting (26) and preformed packing (27).

(13) Remove plug (28) and preformed packing (29).

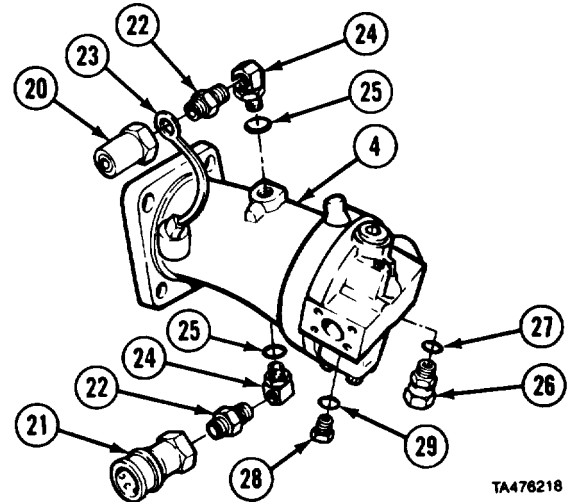

b. Installation.

(1) Install preformed packing (1) and plug (2).

(2) Install preformed packing (3) and fitting (4).

(3) Install two preformed packings (5), elbows (6), fittings (7) on motor (8).

(4) Install cap (9), connector (10), and connector (11).

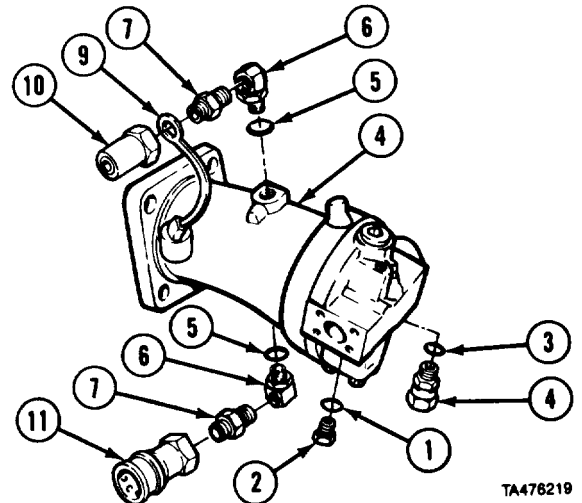

Winch Maintenance Instructions (Cont)

16-13.1. HEAVY-DUTY WINCH HYDRAULIC MOTOR REMOVAL/INSTALLATION (CONT).

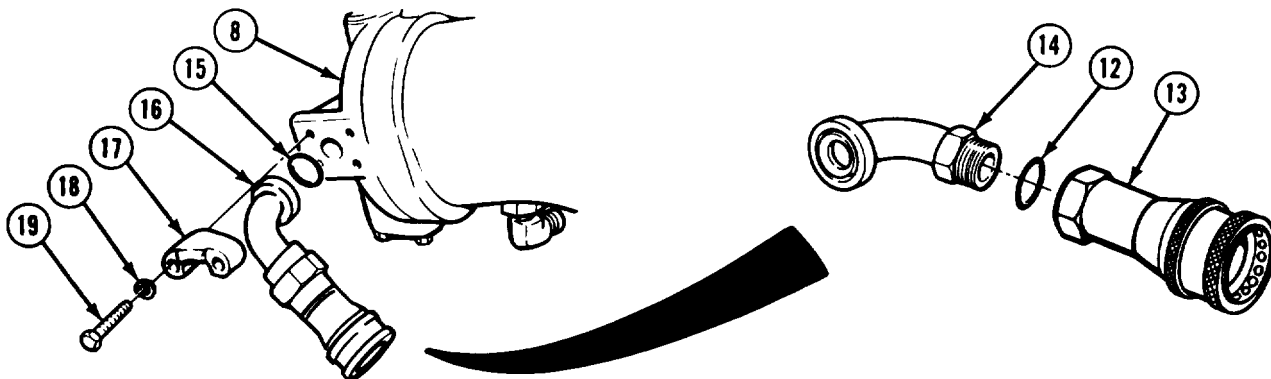

TA476220

- (5) Install preformed packing (12) and connector (13) on elbow (14).
- (6) Install preformed packing (15) and connector assembly (16) with two clamp halves (17), four lockwashers (18), and screws (19) to motor (8).

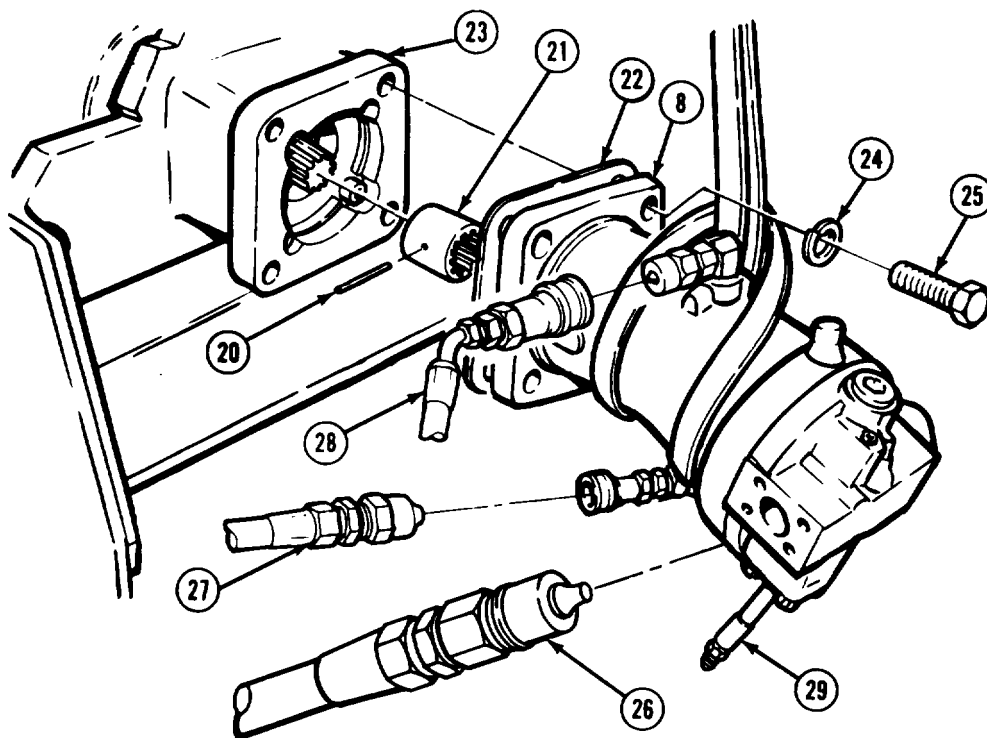

TA476222

- (7) Install pin (20) in coupling (21).
- (8) Attach suitable lifting device to motor (8).
- (9) Install coupling (21), gasket (22), and motor (8) on winch (23) with four lockwashers (24) and screws (25).
- (10) Connect three hydraulic lines (26, 27, and 28) to motor (8).
- (11) Connect hydraulic line (29) to motor (8).

c. Follow-on Maintenance. Counterbalance valve installed (para 16-12).

END OF TASK

Winch Maintenance Instructions (Cont)

16-14. HEAVY-DUTY WINCH HYDRAULIC MOTOR REPAIR (M984).

This task covers:

- a. Disassembly
- b. Cleaning/Inspection
- c. Assembly
- d. Follow-on Maintenance

INITIAL SETUP

Models

M984

Test Equipment

None

Special Tools

None

Supplies

Solvent, dry cleaning, Item 57, Appendix C
 Grease, automotive and artillery, Item 34, Appendix C
 Oil, lubricating, Item 46, Appendix C
 Compound, sealing, pipe thread, Item 29, Appendix C

Personnel Required

MOS 63W, Wheel vehicle repairer

References

None

Equipment Condition

TM or Para

Condition Description

Heavy-duty winch hydraulic motor on clean work surface.

Special Environmental Conditions

None

General Safety Instructions

None

Level of Maintenance

General Support

a. Disassembly.

NOTE

Mark valve body adapter and hydraulic motor.

- (1) Remove four screws (1) and valve body adapter (2) from hydraulic motor (3).
- (2) Remove two preformed packings (4) from valve body adapter (2).
- (3) Remove preformed packing (5), preformed packing (6), plug (7), and ball (8).
- (4) Remove straight fitting (9) from valve body adapter (2).
- (5) Remove fitting (10).

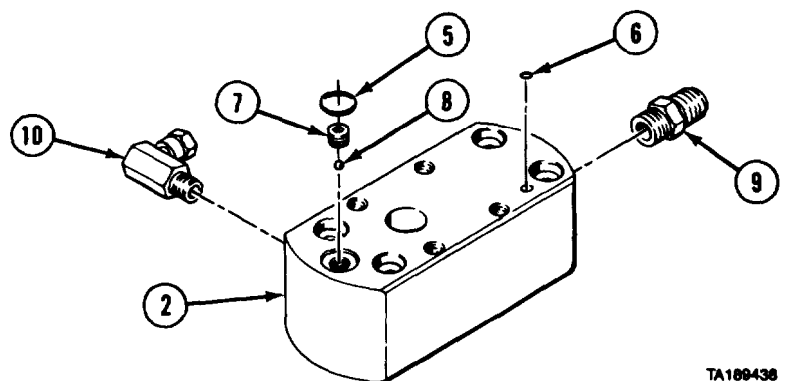
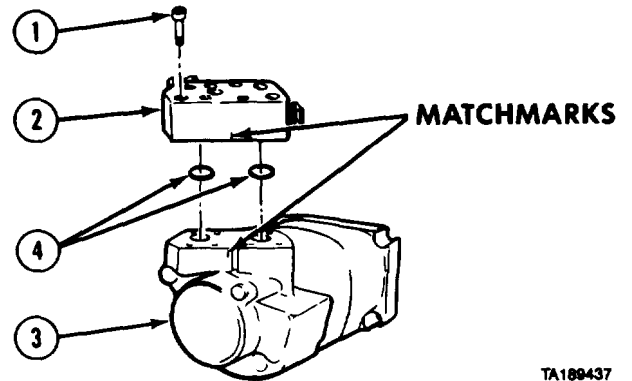

TA189437

TA189438

Winch Maintenance Instructions (Cont)

16-14. HEAVY-DUTY WINCH HYDRAULIC MOTOR REPAIR (M984) (CONT).

- (6) Clamp hydraulic motor (3), shaft end down, in soft jaw vise.

NOTE

Matchmark complete housing.

- (7) Remove four screws (11) and lift valve housing (12) from hydraulic motor (3).

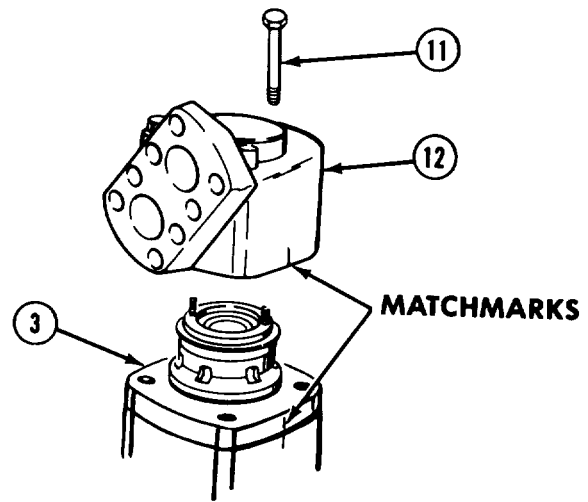

TA189439

- (8) Remove two preformed packings (13 and 14) from valve housing (12).
- (9) Remove two check plugs (15), preformed packings (16), springs (17), and steel balls (18) from valve housing (12).
- (10) Remove plug (19) and preformed packing (20) from valve housing (12).

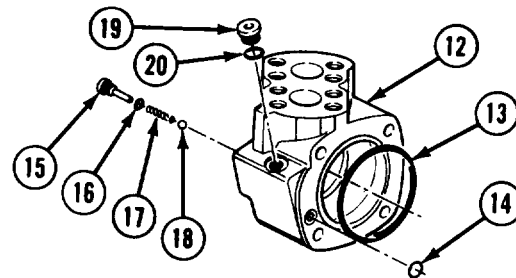

TA189440

- (11) Remove two springs (21) from balance ring (22).
- (12) Remove balance ring (22).
- (13) Remove inner face seal (23) and outer face seal (24) from balance ring (22).
- (14) Remove valve (25) from valve plate (26).

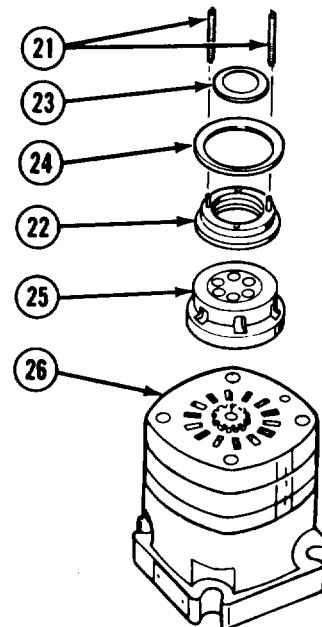

TA189441

Winch Maintenance Instructions (Cont)

- (15) Remove valve plate (26).
- (16) Remove preformed packing (27) from valve plate (26).
- (17) Remove valve drive (28) from geroler (29).

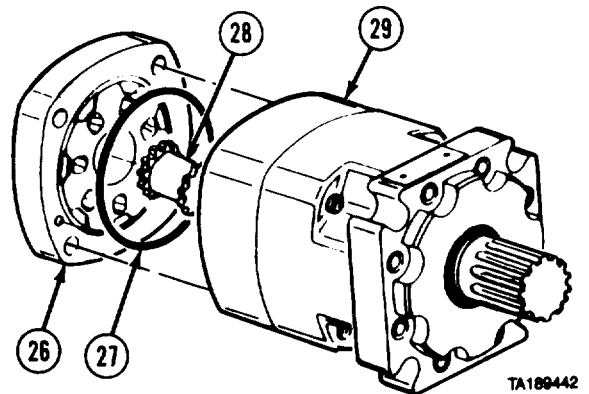

NOTE

Hub and pins in geroler are a matched set. Be careful hub and pins do not fall out.

- (18) Remove geroler (29), drive (30), and preformed packings (31 and 32) from bearing housing (33).
- (19) Turn bearing housing (33) over in vise.
- (20) Remove eight screws (34) and front retainer (35).

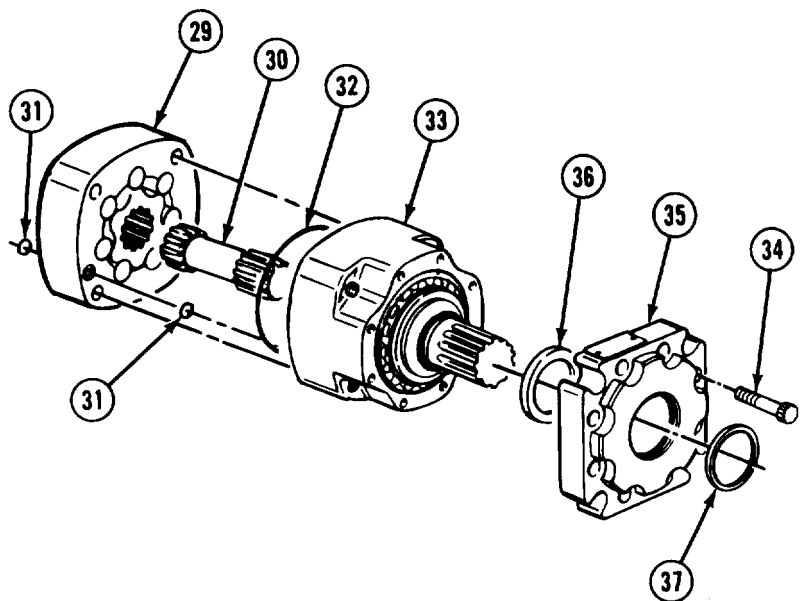

CAUTION

Do not try to remove both seals at same time or damage to mounting flange will result.

- (21) Remove shaft seal (36) from front retainer (35).
- (22) Remove dust seal (37).
- (23) Remove preformed packing (38) from bearing housing (33).
- (24) Press shaft and bearings (39) out of bearing housing (33).
- (25) Remove shaft face seal (40) from bearing housing (33).

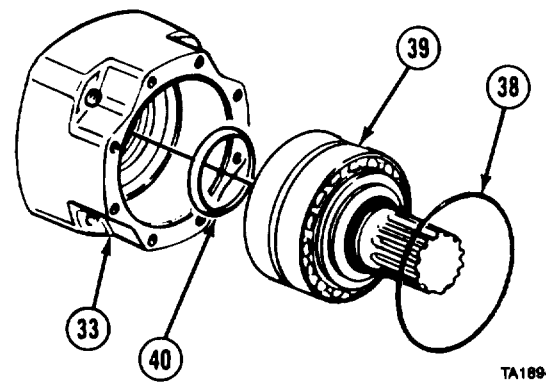

Winch Maintenance Instructions (Cont)

16-14. HEAVY-DUTY WINCH HYDRAULIC MOTOR REPAIR (M984) (CONT).

b. Cleaning/Inspection.

WARNING

Adhesives, solvents, and sealing compounds can burn easily, can give off harmful vapors, and are harmful to skin and clothing. To avoid injury or cleat h, keep away from open fire and use in well-ventilated area. If adhesive, solvent, or sealing compound gets on skin or clothing, wash immediately with soap and water.

- (1) Clean all metal parts in dry cleaning solvent.
- (2) Inspect all mating surfaces for scratches and burrs.
- (3) Replace all scratched or damaged parts.
- (4) If any one bearing or shaft is damaged, replace as a set.

c. Assembly.

- (1) Place bearing housing (1) on clean work surface with large opening up.
- (2) Coat shaft face seal (2) with grease and install in bearing housing (1) with wide opening down.
- (3) Press shaft and bearing assembly (3) in bearing housing (1).
- (4) Coat preformed packing (4) with grease and install in bearing housing (1).

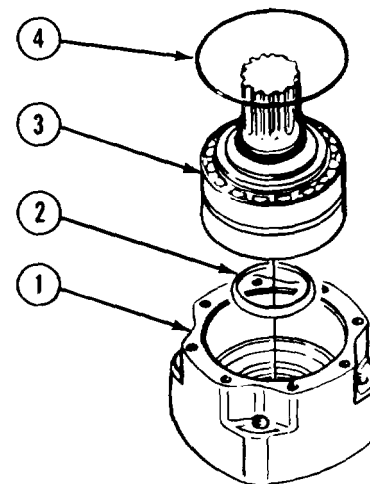

TA189446

- (5) Install dust seal (5) in front retainer (6) with metal side of dust seal toward front retainer.
- (6) Install shaft seal (7) in front retainer (6) with smooth side toward retainer.
- (7) Coat dust seal (.5) and shaft seal (7) with grease.
- (8) Install front retainer (6) on shaft and bearing assembly (3).
- (9) Coat threads of eight screws (8) with lubricating oil and install. Do not tighten screws.

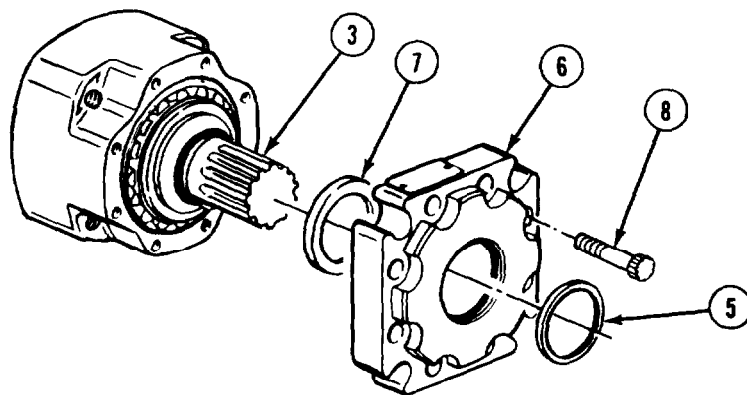

TA189447

- (10) Position bearing housing (1) in vise with soft jaws.
- (11) Tighten screws (8) to 21 lb-ft (28 N.m) in sequence shown.
- (12) Position bearing housing (1) in vise with output shaft down.

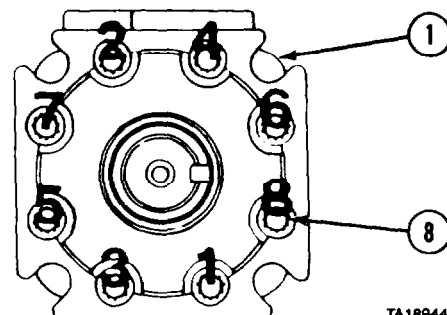

TA189448

Winch Maintenance Instructions (Cont)

- (13) Pour small amount of lubricating oil inside bearing housing (1).
- (14) Coat preformed packing (9) with grease and install in groove of bearing housing (1).
- (15) Install drive (10) in shaft and bearing assembly (3).
- (16) Coat two preformed packings (11) with grease and install in geroler (12).
- (17) Install geroler (12) on bearing housing (1).

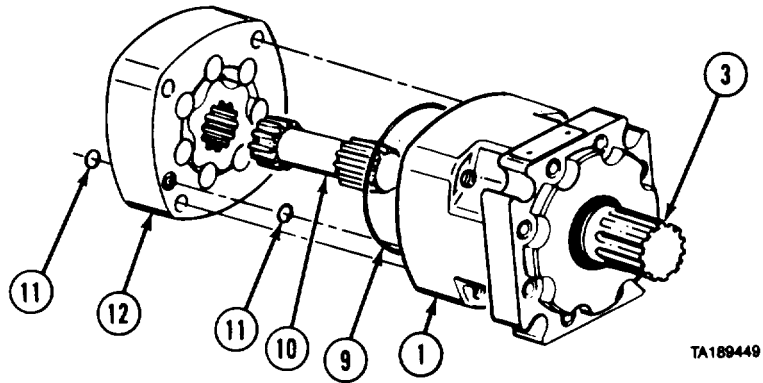

TA189449

NOTE

- Aline case drain holes.
- Do steps (18) through (22) to time hydraulic motor for maximum power.
- (18) Find largest open pocket in geroler (12). Mark location on outside of geroler.
- (19) Install valve drive (13) in geroler (12).
- (20) Coat preformed packing (14) with grease and install in valve plate (15).
- (21) Install valve plate (15) on geroler (12).
- (22) Aline timing mark on valve (16) with matchmark on outside of geroler (12) and install valve on valve plate (15).

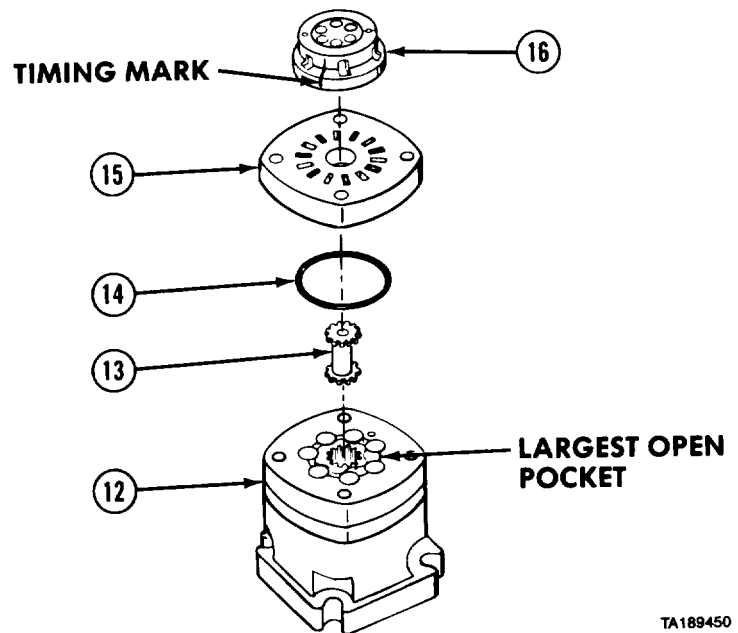

TA189450

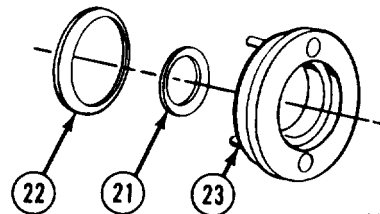
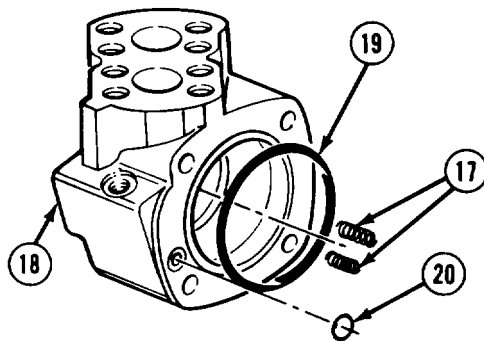

TA189452

- (23) Install two springs (17) inside valve housing (18).
- (24) Coat preformed packings (19 and 20) with grease and install in valve housing (18).
- (25) Coat inner face seal (21) and outer face seal (22) with grease and install on balance ring (23).

Winch Maintenance Instructions (Cont)

16-14. HEAVY-DUTY WINCH HYDRAULIC MOTOR REPAIR (M984) (CONT).

- (26) Install balance ring (23) in spring holes of valve housing (18).
- (27) Apply pressure to side of balance ring (23) to hold in place.

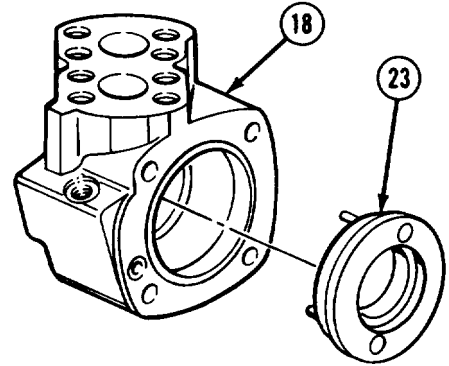

TA189453

NOTE

Insert knife through hole in valve housing to keep balance ring in place.

- (28) Install valve housing (18) against valve plate (15).

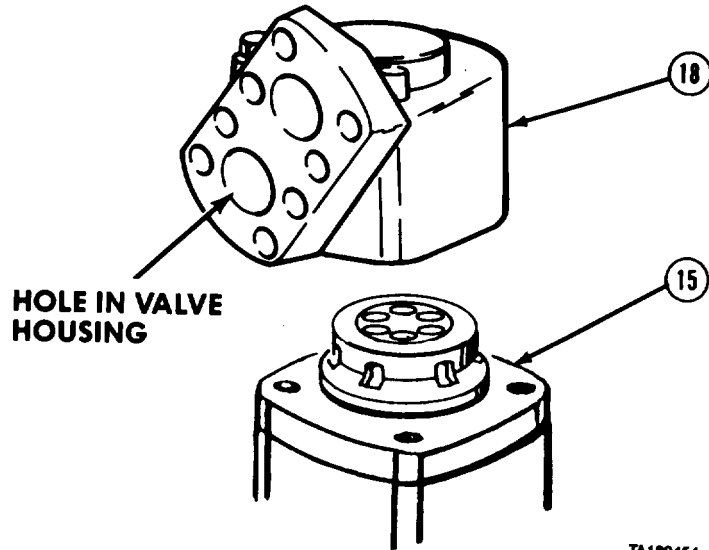

TA189454

- (29) Install four screws (24). Tighten screws to 50 lb-ft (68 N.m) in sequence shown.
- (30) Install two steel balls (25), springs (26), preformed packings (27), and check plugs (28) in valve housing (18).
- (31) Coat preformed packing (29) with grease and install on plug (30).
- (32) Install plug (30) in valve housing (18).

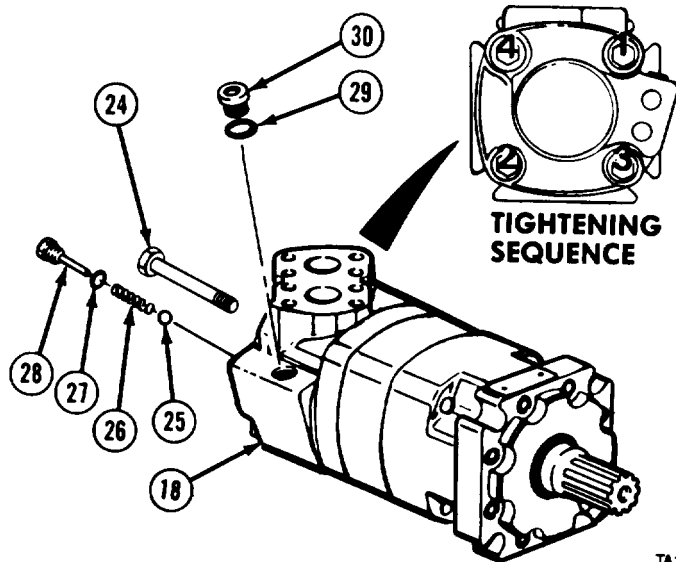

TA189455

Winch Maintenance Instructions (Cont)

WARNING

Adhesives, solvents, and sealing compounds can burn easily, can give off harmful vapors, and are harmful to skin and clothing. To avoid injury or death, keep away from open fire and use in well-ventilated area. If adhesive, solvent, or sealing compound gets on skin or clothing, wash immediately with soap and water.

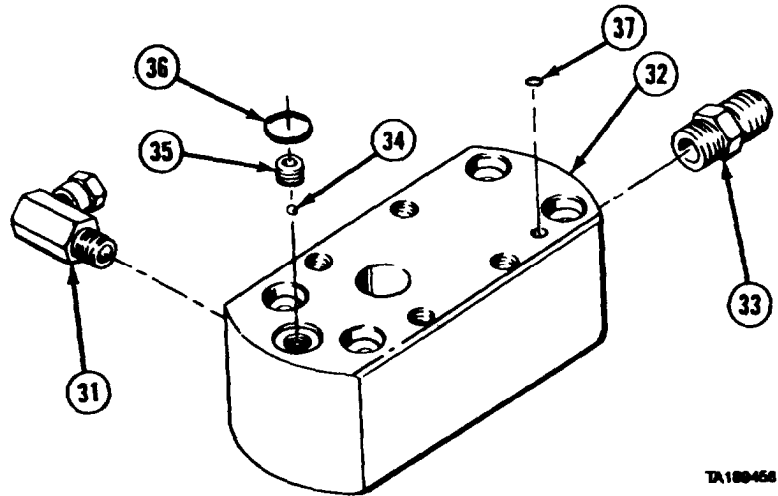

TA188456

- (33) Apply pipe thread sealing compound to threads of fitting (31) and install on valve body adapter (32).
- (34) Apply pipe thread sealing compound to threads of straight fitting (33) and install.
- (35) Install ball (34), plug (35), and two preformed packings (36 and 37).
- (36) coat two preformed packings (38) with lubricating oil and install in valve body adapter (32).
- (37) Install four screws (39) to attach valve body adapter (32) to hydraulic motor (40).
- (38) Remove hydraulic motor (40) from vise.

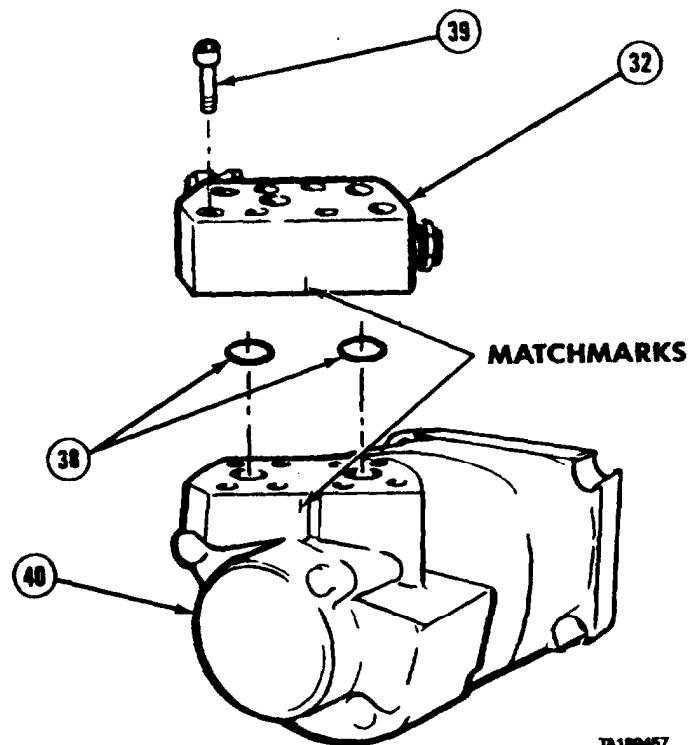

TA188457

d. Follow-on Maintenance. None.

END OF TASK

Winch Maintenance Instructions (Cont)

16-14.1 HEAVY-DUTY WINCH HYDRAULIC MOTOR (P/N 73077) REPAIR		
This task covers:		
a. Disassembly	c. Assembly	
c. Cleaning/Inspection	d. Follow-on Maintenance	
INITIAL SETUP		
<i>Models</i> M984E1	<i>References</i> None	
<i>Test Equipment</i> None	<i>Equipment Condition</i> <i>TM or Para</i> Para 16-13 <i>Condition Description</i> Heavy-duty winch motor removed.	
<i>Special Tools</i> None	<i>Special Environmental Conditions</i> None	
<i>Supplies</i> None	<i>General Safety Instructions</i> None	
<i>Personnel Required</i> MOS 63W, Heavy wheel vehicle mechanic (2)	<i>Level of Maintenance</i> General Support	

a. Disassembly

NOTE

There are two models of hydraulic motors. Model B is smaller in size but equal in functional performance and fully interchangeable with Model A. Internal parts are not interchangeable.

WARNING

Wear safety glasses when removing snap ring. Ring may come off causing personal injury

NOTE

- Do steps (1) and (2) for Model A. Do steps (2.1) through (2.3) for Model B.
 - Keep shims with cover during disassembly.
- (1) Remove snap ring (1), cover (2), preformed packing (3), and shims (4) from motor (5).
- (2) Remove seal (6) from cover (2).

Winch Maintenance Instructions (Cont)

- (2.1) Remove four screws (6.1).
- (2.2) Carefully pry flange (6.2) off motor (5).
- (2.3) Remove preformed packing (6.3) and seal ring (6.4) from flange (6.2).

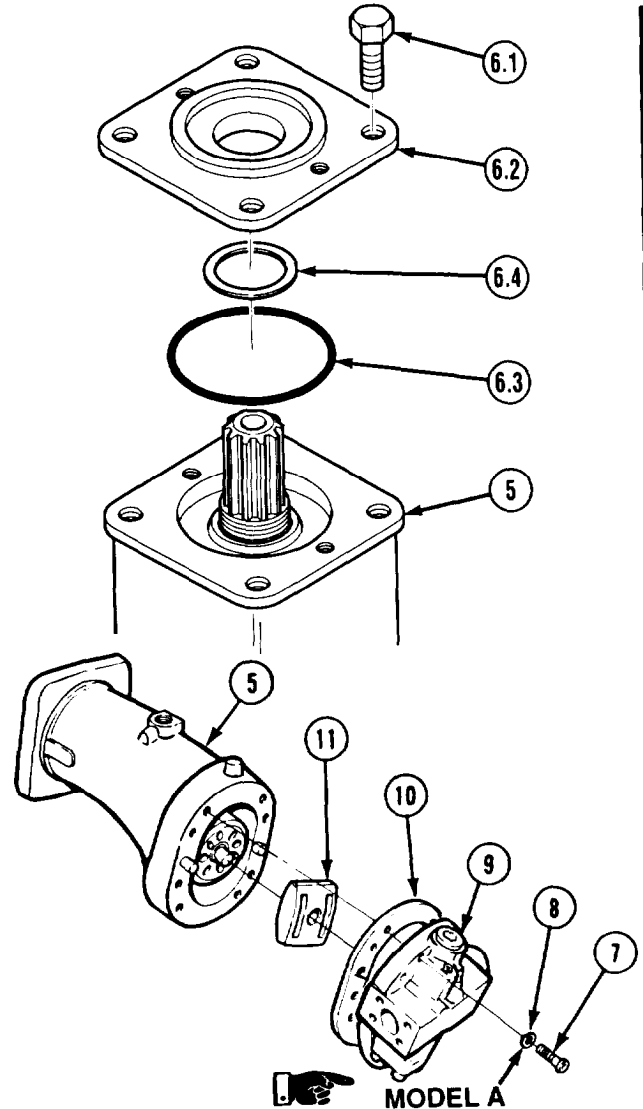

CAUTION

Motor is factory set. Do not remove setscrews or jamnuts.

NOTE

Lockwashers are only used on Model A.

- (3) Remove eight screws (7), lockwashers (8), plate (9), gasket (10), and lens (11) from motor (5).

NOTE

Do steps (4) through (7) for Model A. Do steps (7.1) through (7.3) for Model B.

- (4) Remove two plugs (12) and preformed packings (13).
- (5) Remove four screws (14), lockwashers (15), plate (16), and two preformed packings (17).

NOTE

Use care when removing subassembly to prevent from coming apart.

- (6) Remove subassembly (18) from plate (9).
- (7) Remove preformed packing (19) from subassembly (18).

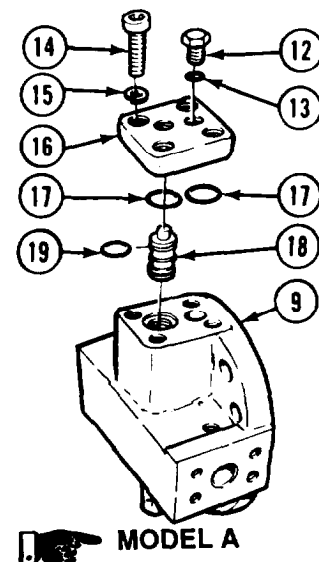

Winch Maintenance Instructions (Cont)

16-14.1 HEAVY-DUTY WINCH HYDRAULIC MOTOR (P/N 73077) REPAIR (CONT).

- (7.1) Remove four screws (12.1) and control housing (13.1).
- (7.2) Remove preformed packing (14.1) from control housing (13.1).
- (7.3) Remove subassembly (15.1), spring (16.11, bushing (17.11, and spring (18.1) from port of control (19.1).

CAUTION

To disassemble Model A, a clamp must be used to hold cylinder assembly to bearing assembly to avoid damage to parts.

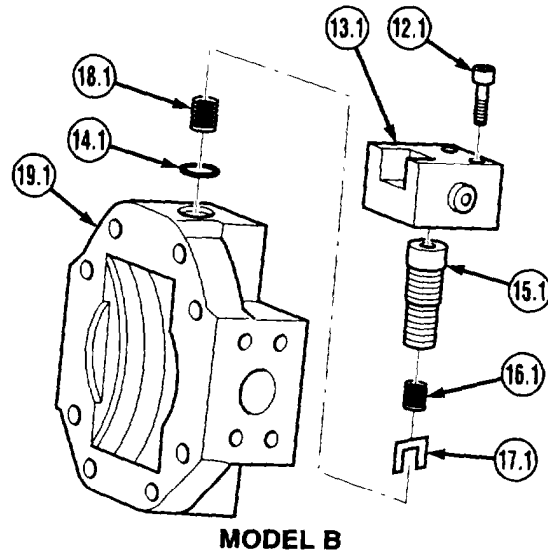

NOTE

No further disassembly of Model B is possible. Do step (8) for Model A only.

- (8) Soldier A removes bearing assembly (20) from motor (5) while Soldier B guides bearing assembly.

b. Cleaning/Inspection.

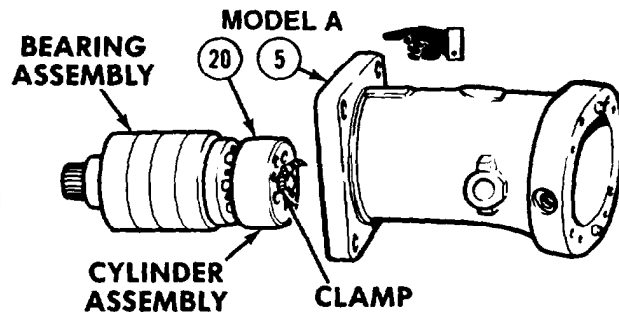

WARNING

Adhesives, solvents, and sealing compounds can burn easily, can give off harmful vapors, and are harmful to skin and clothing. To avoid injury or death, keep away from open fire and use in well-ventilated area. If adhesive, solvent, or sealing compound gets on skin or clothing, wash immediately with soap and water.

- (1) Clean all metal parts in drycleaning solvent.
- (2) Inspect each part for damage.
- (3) Replace damaged parts.

c. Assembly.

NOTE

- To assemble Model A, a clamp must be used to hold cylinder assembly to bearing assembly to avoid damage to parts.
- Do step (1) for Model A only.
- (1) Soldier A installs bearing assembly (1) in motor (2) while Soldier B aligns bearing assembly and removes clamp.

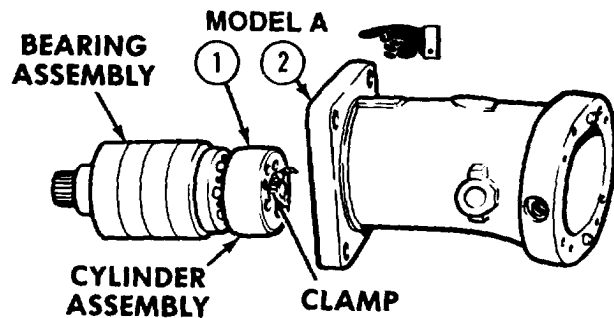

Winch Maintenance Instructions (Cont)

NOTE

Do steps (2) through (5) for Model A. Do steps (5.1) through (5.3) for Model B.

- (2) Install preformed packing (3) on subassembly (4).
- (3) Install subassembly (4) in plate (5).
- (4) Install two preformed packings (6), plate (7) with four lockwashers (8) and screws (9).
- (5) Install two preformed packings (10) and plugs (11) in plate (7).
- (5.1) Install spring (3.1), bushing (4.1), spring (5.1), and subassembly (6.1) in port of control (7.1).
- (5.2) Install preformed packing (8.1) on control housing (9.1).
- (5.3) Install control housing (9.1) with four screws (10.1).

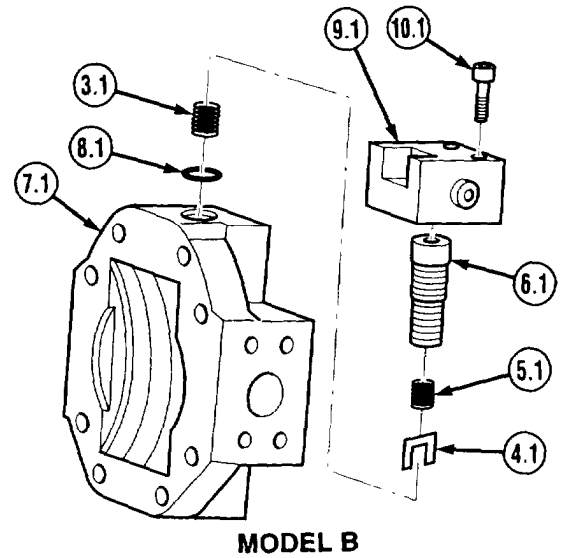
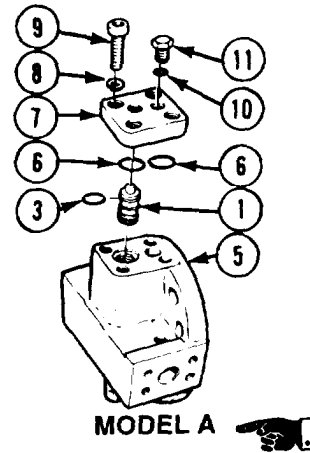

Winch Maintenance Instructions (Cont)

16-14.1 HEAVY-DUTY WINCH HYDRAULIC MOTOR (P/N 73077) REPAIR (CONT).

NOTE

Lockwashers are only used on Model A.

- (6) Install lens (12), gasket (13), and plate (5) with eight lockwashers (14) and screws (15).

NOTE

- Use same shims removed during disassembly. If replacement is necessary, use shim pack provided with motor.
- Do steps (7) through (9) for Model A. Do steps (10) and (11) for Model B.
- (7) Install shims (16) and preformed packing (17) in motor (2).
- (8) Install seal (18) in cover (19).

WARNING

Wear safety glasses when installing snap ring. Ring may come off causing personal injury

- (9) Install cover (19) and snap ring (20).

- (10) Install seal ring (16.1) and preformed packing (17.1) in flange (18.1).
- (11) Install flange (18.1) on motor (19.1) with four screws (20.1).

d. **Follow-on Maintenance.** Check operation of motor,

END OF TASK

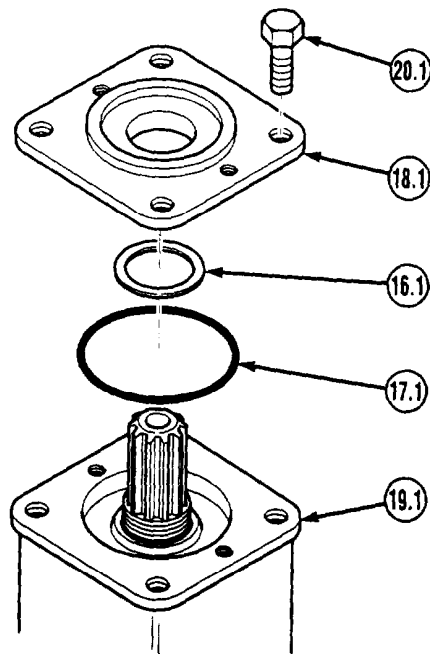
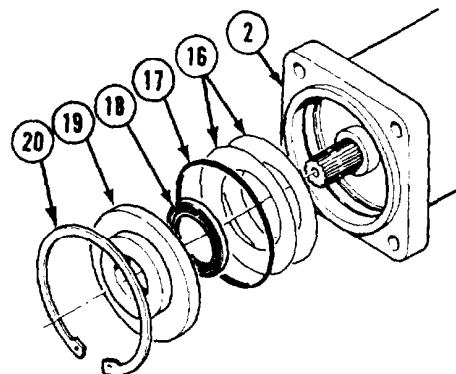
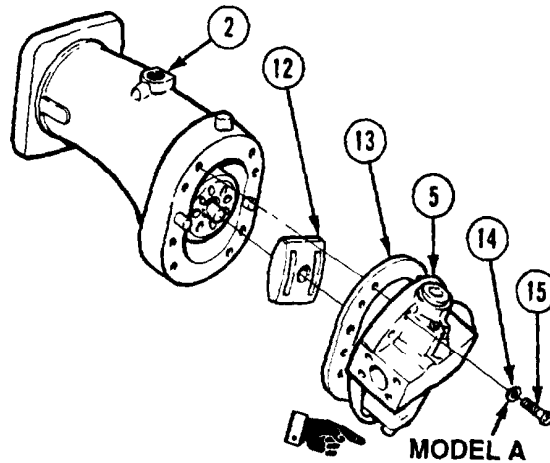

Winch Maintenance Instructions (Cont)

16-14.2 HEAVY-DUTY WINCH HYDRAULIC MOTOR (P/N V12-80TSSHS 000 A080/031 AC1011-096/050-000) REPAIR.

This task covers:

- | | | |
|------------------------|---------------|--------------------------|
| a. Disassembly | c. Assembly | e. Test |
| b. Cleaning/Inspection | d. Adjustment | f. Follow-on Maintenance |

INITIAL SETUP*Models*

M984E1

References

None

Test Equipment

Hydraulic Pump

Hydraulic Brake

Equipment Condition

TM or Para

Para 16-13.1

Condition Description

Heavy-duty winch motor removed.

Special Tools

Gages

Special Environmental Conditions

None

Supplies

Solvent, drycleaning, Item 57, Appendix C

Grease, automotive and artillery, Item 34, Appendix C

Appendix C

Oil, lubricating, Item 46, Appendix C

Compound, sealing, pipe thread, Item 29, Appendix C

Appendix C

General Safety Instructions

None

Level of Maintenance

General Support

Personnel Required

MOS 632, Wheel vehicle repairer

a. Disassembly.

- (1) Remove retaining ring (1) from hydraulic motor (2).
- (2) Remove seal carrier (3) from hydraulic motor (2).
- (3) Remove preformed packing (4) from seal carrier (3).
- (4) Remove shaft seal (5) from hydraulic motor (2).

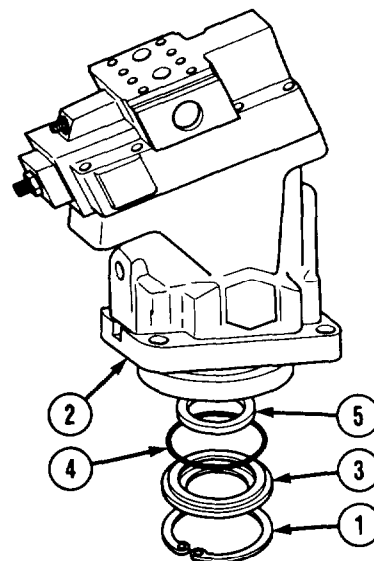

Winch Maintenance Instructions (Cont)

16-14.2 HEAVY-DUTY WINCH HYDRAULIC MOTOR (P/N V12-80TSSHS 000 A080/031 ACI011-096/050-000) REPAIR (CONT).

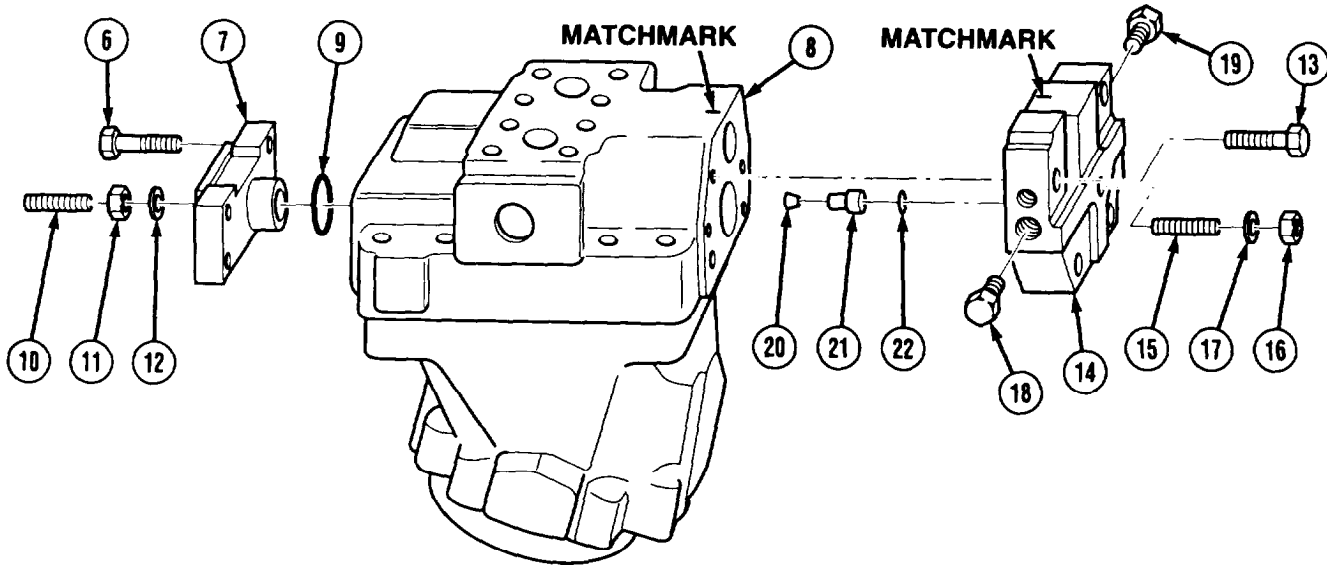

- (5) Clamp hydraulic motor (2), shaft end down, in soft jaw vise.
- (6) Remove four screws (6) and cover (7) from end cap (8).
- (7) Remove preformed packing (9), setscrew (10), nut (11), and seal washer (12) from cover (7).

NOTE

Matchmark control cover assembly and end cap.

- (8) Remove four screws (13) and control cover assembly (14) from end cap (8).
- (9) Remove setscrew (15), nut (16), seal washer (17), two hex plug assemblies (18 and 19), two valve cones (20), two valve guides (21), and preformed packings (22) from control cover assembly (14).

Winch Maintenance Instructions (Cont)

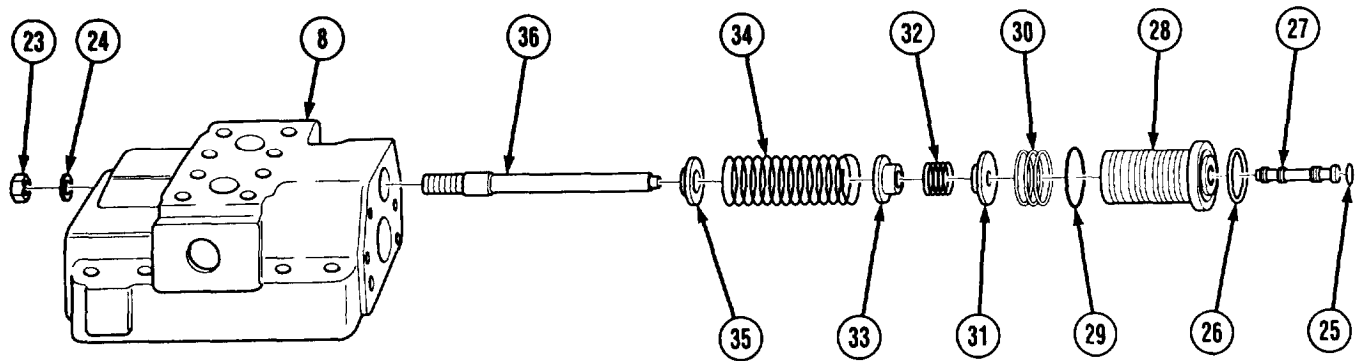

- (10) Remove seal nut (23) and seal washer (24) from end cap (8).
- (11) Remove preformed packing (25), support ring (26), valve spool (27), valve sleeve (28), preformed packing (29), nine piston rings (30), spring seat (31), compression spring (32), spring seat (33), compression spring (34), spring guide (35), and adjusting screw (36) from end cap (8).
- (12) Remove expanding plug (37), setscrew (38), expanding plug (39), and performed packing (40) from end cap (8).

NOTE

Matchmark end cap and bearing housing assembly.

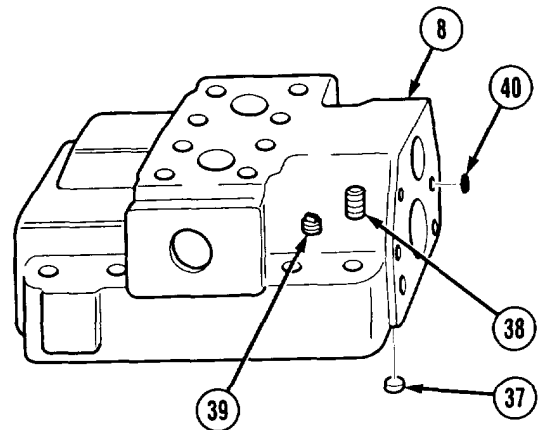

- (13) Remove eight screws (41) and end cap (8) from bearing housing assembly (42).

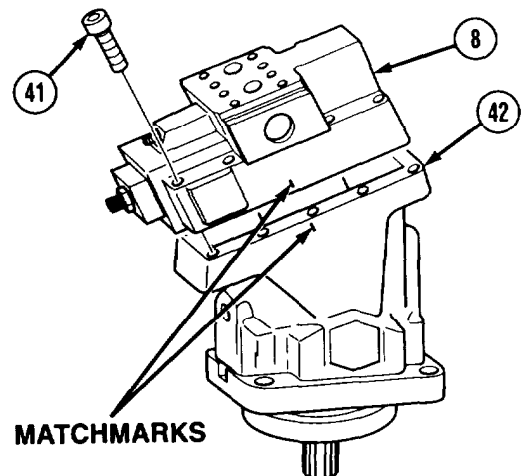

Winch Maintenance Instructions (Cont)

16-14.2 HEAVY-DUTY WINCH HYDRAULIC MOTOR (P/N V12-80TSSHS 000 A080/031 ACI011-096/050-000) REPAIR (CONT).

- (14) Remove setscrew (43), setscrew (44), setting piston (45), companion pin (46), and preformed packing (47) from end cap (8).

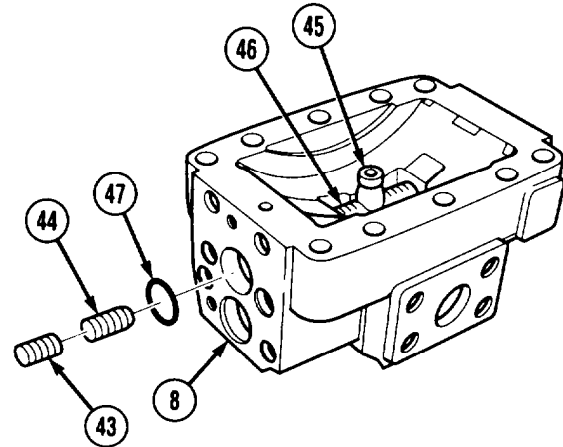

- (15) Remove valve assembly (48), sliding plate (49), needle bearing (50), and guide pin (51) from cylinder barrel (52).
 (16) Remove cylinder barrel (52) and gasket (53) from bearing housing assembly (42).

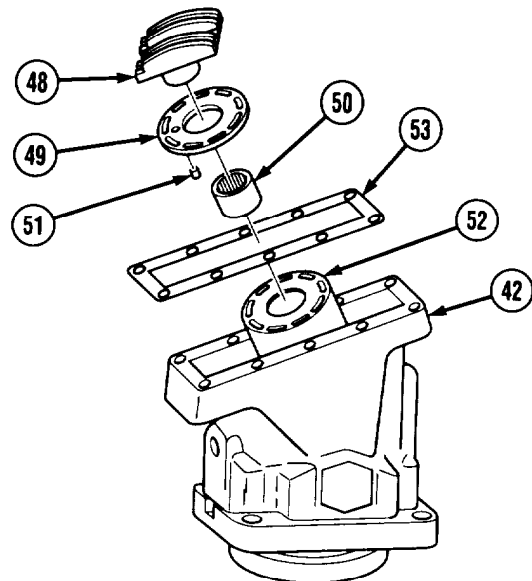

- (17) Remove joint shaft (54), six rollers (55), and two support pins (56) from bearing housing assembly (42).

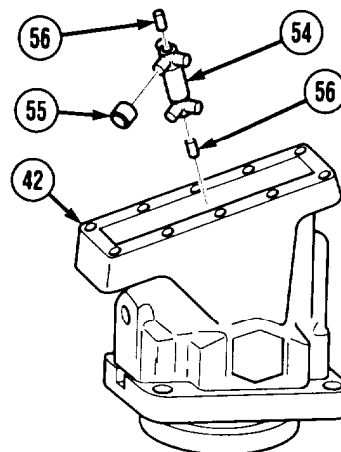

Winch Maintenance Instructions (Cont)

- (18) Remove retaining ring (57), joint coupling (58), three pins (59), three spring pins (60), guide pin (61), and compression spring (62) from bearing housing assembly (42).
- (19) Remove nine piston assemblies (63) from bearing housing assembly (42).
- (20) Remove three piston rings (64) from each of nine piston assemblies (63).

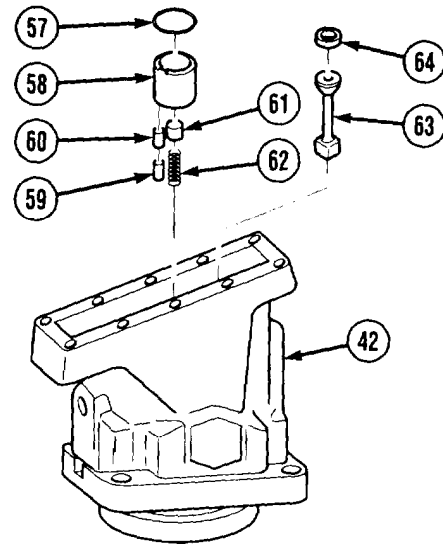

NOTE

Matchmark bearing housing assembly and flange.

- (21) Remove eight screws (65) and bearing housing assembly (42) from flange (66).

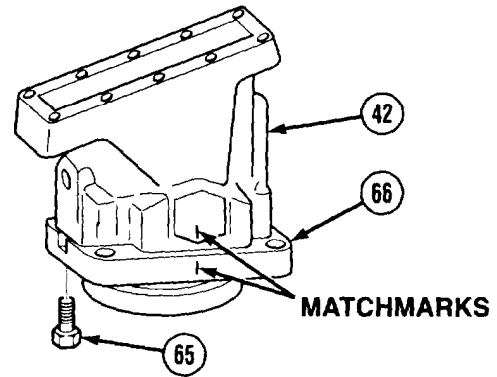

Winch Maintenance Instructions (Cont)

16-14.2 HEAVY-DUTY WINCH HYDRAULIC MOTOR (P/N V12-80TSSHS 000 A080/031 ACI011-096/050-000) REPAIR (CONT).

NOTE

Record thickness of spacer washers to aid in assembly.

- (22) Remove retaining ring (67) and two spacer washers (68 and 69) from flange (66).
- (23) Remove shaft (70) from flange (66) using plastic mallet.
- (24) Remove cylinder bearing (71) and bearing (72) from flange (66) using a drift.
- (25) Remove gasket (73) from flange (66).

b. Cleaning/Inspection.

WARNING

Adhesives, solvents, and sealing compounds can burn easily, can give off harmful vapors, and are harmful to skin and clothing. To avoid injury or death, keep away from open fire and use in well-ventilated area. If adhesive, solvent, or sealing compound gets on skin or clothing, wash immediately with soap and water.

- (1) Clean all metal parts in drycleaning solvent.
- (2) Inspect all mating surfaces for scratches and burrs.
- (3) Replace all scratched or damaged parts.

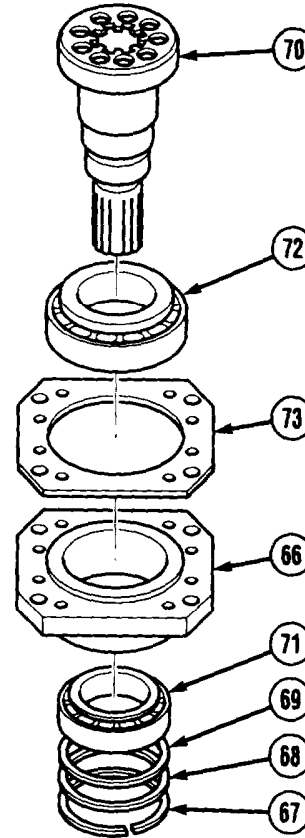

Winch Maintenance Instructions (Cont)**c. Assembly.**

- (1) Install cylinder bearing (1) and cylinder bearing (2) in flange (3).

NOTE

- Install thickest spacer washer with text facing bearing.
 - Select spacer washers (5) based on thickness recorded at disassembly.
- (2) Install shaft (4), two spacer washers (5 and 6) and retaining ring (7) in flange (3).
- (3) Inspect clearance between cylinder bearing (1) and spacer washer (5). Clearance should be 0.000-0.003 inch (0.0-0.1 mm). Correct if necessary by selecting alternate thickness of spacer washer (5).
- (4) Install gasket (8) on flange (3).

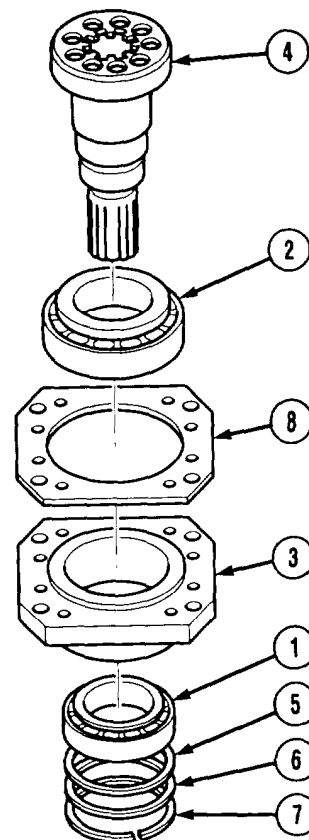

Winch Maintenance Instructions (Cont)

16-14.2 HEAVY-DUTY WINCH HYDRAULIC MOTOR (P/N V12-80TSSHS 000 A080/031 ACI011-096/050-100) REPAIR (CONT).

- (5) Install three piston rings (9) on each of nine pistons (10) and install piston assemblies in shaft (4).
- (6) Install compression spring (11), guide pin (12), three spring pins (13), three pins (14), joint coupling (15), and retaining ring (16) in shaft (4).
- (7) Install one support pin (17) in shaft (4).
- (8) Install six rollers (18) on joint shaft (19) and install joint shaft assembly in shaft (4).
- (9) Position flange (3) in soft jaw vise with spline of shaft (4) down.

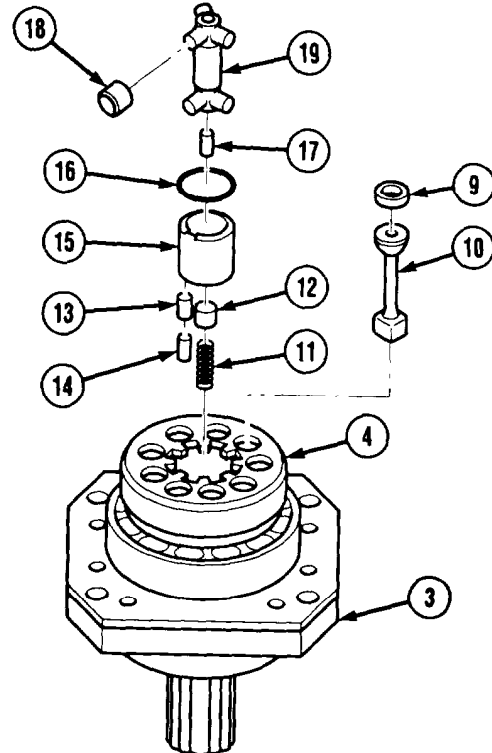

- (10) Install remaining support pin (17) in cylinder barrel (20) and secure it using grease.

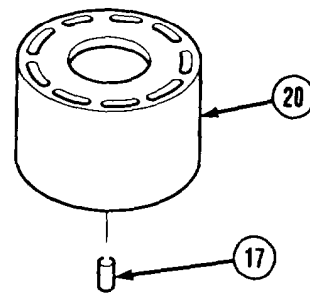

- (11) Install cylinder barrel (20) on shaft (4).

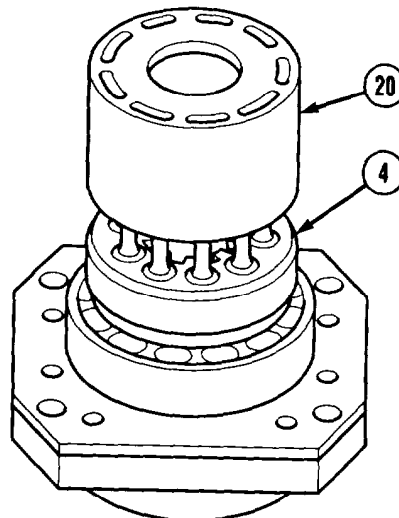

Winch Maintenance Instructions (Cont)

- (12) Aline matchmarks and install bearing housing assembly (21) on flange (3) using eight screws (22). Tighten screws to 44 lb-ft (60 N•m).

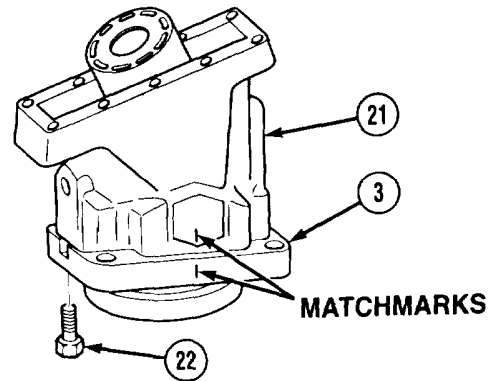

- (13) Install gasket (23) on bearing housing assembly (21).
- (14) Install guide pin (24), needle bearing (25), sliding plate (26), and valve assembly (27) in cylinder barrel (20).

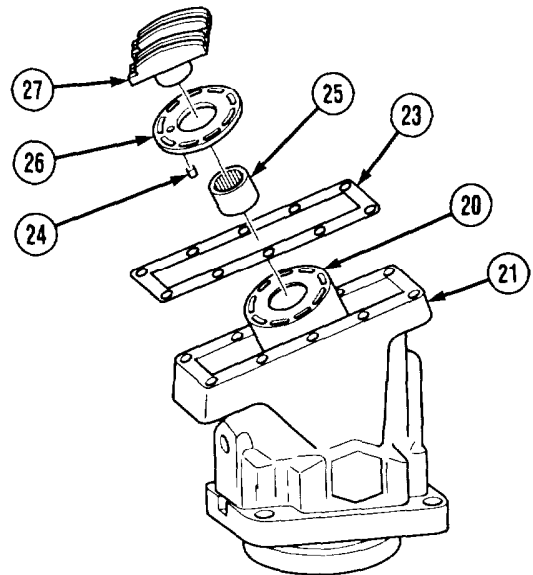

- (15) Install setting piston (28) and companion pin (29) in end cap (30).
- (16) Install setscrew (31) in setting piston (28) and tighten setscrew to 11 lb-ft (15 N•m).
- (17) Install setscrew (32) in setting piston (28) and tighten setscrew to 18.5 lb-ft (25 N•m).

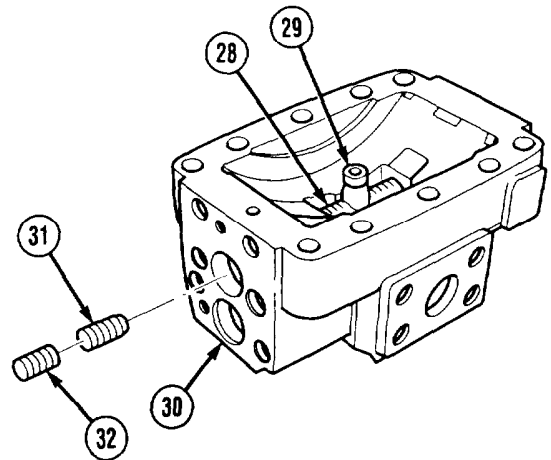

Winch Maintenance Instructions (Cont)

16-14.2 HEAVY-DUTY WINCH HYDRAULIC MOTOR (P/N V12-80TSSHS 000 A080/031 ACI011-096/050-000) REPAIR (CONT).

- (18) Align matchmarks and install end cap (30) on bearing housing assembly (21) using eight screws (31). Tighten screws to 44 lb-ft (60 N•m).

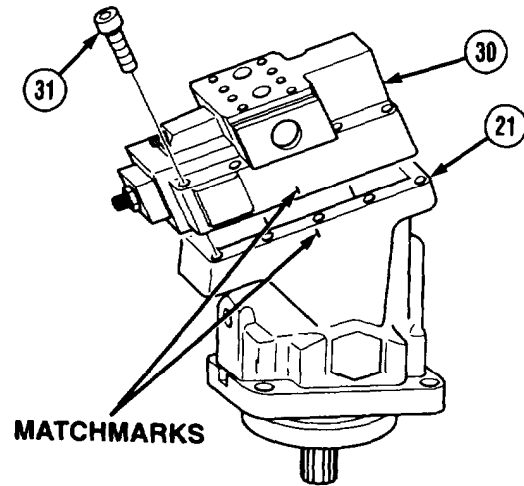

- (19) Coat three preformed packings (32) with grease and install packing in end cap (30).
- (20) Install two expanding plugs (33 and 34) and setscrew (35) in end cap (30).

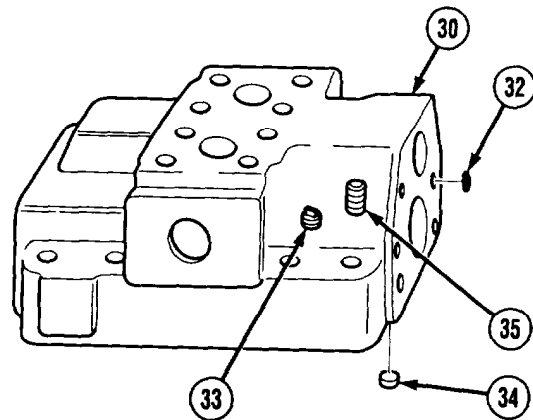

Winch Maintenance Instructions (Cont)

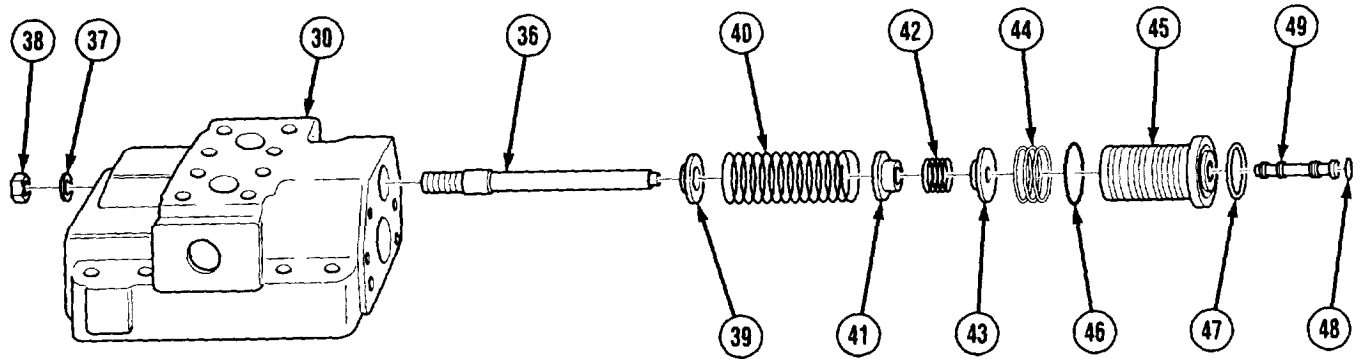

- (21) Install adjusting screw (36) in end cap (30) and secure using seal washer (37) and seal nut (38).
- (22) Install spring guide (39), compression spring (40), spring seat (41), compression spring (42), and spring seat (43) on adjusting screw (36).
- (23) Install nine piston rings (44) on valve sleeve (45).
- (24) Coat preformed packing (46) with grease and install on valve sleeve (45).
- (25) Apply small amount of lubricating oil to valve sleeve (45) and install in end cap (30).
- (26) Install support ring (47) on valve sleeve (45).
- (27) Coat preformed packing (48) with grease and install packing on valve spool (49).
- (28) Install valve spool (49) in valve sleeve (45).

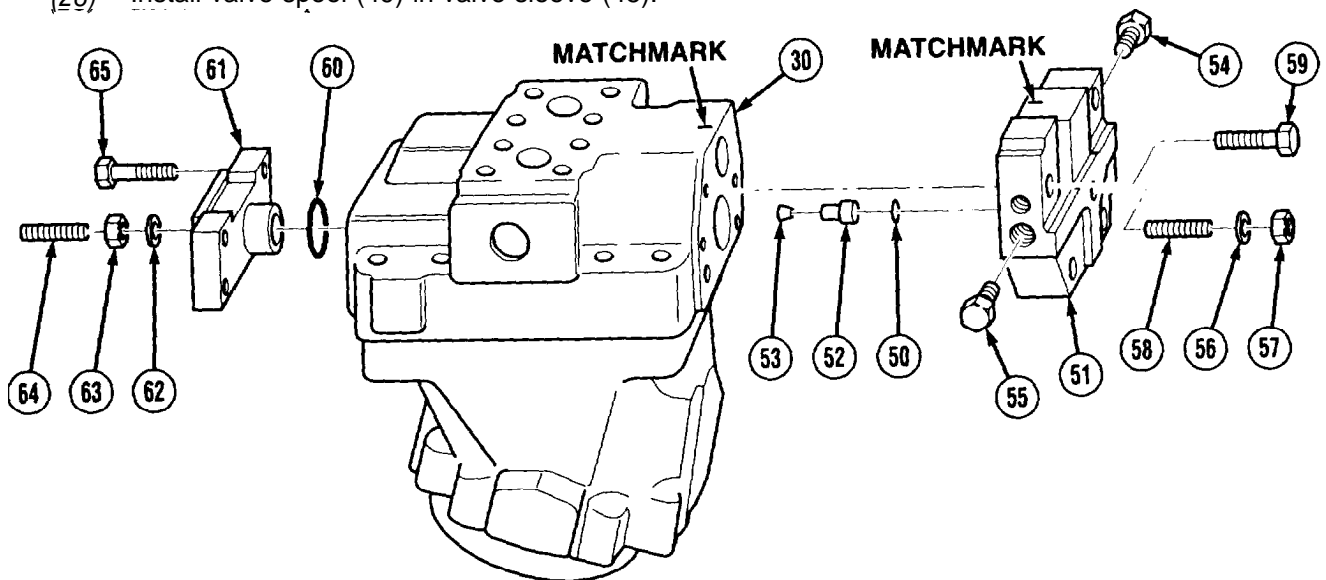

- (29) Coat four preformed packings (50) with grease and install in control cover assembly (51).
- (30) Install two valve guides (52), two valve cones (53), and two hex plug assemblies (54 and 55) in control cover assembly (51).
- (31) Install seal washer (56) and nut (57) on setscrew (58).
- (32) Install setscrew (58) in control cover assembly (51).
- (33) Align matchmarks and install control cover assembly (51) on end cap (30) using four screws (59). Tighten screws to 44 lb-ft (60 N•m).
- (34) Coat preformed packing (60) with grease and install packing on cover (61).
- (35) Install seal washer (62) and nut (63) on setscrew (64).
- (36) Install setscrew (64) in cover (61).
- (37) Install cover (61) on end cap (30) using four screws (65). Tighten screws to 44 lb-ft (60 N•m).

Winch Maintenance Instructions (Cont)

16-14.2 HEAVY-DUTY WINCH HYDRAULIC MOTOR (P/N V12-80TSSHS 000 A080/031 ACI011-096/050-000) REPAIR (CONT).

- (38) Position hydraulic motor (66) in soft jaw vise with spline of shaft up.
- (39) Pour small amount of lubricating oil inside hydraulic motor (66).
- (40) Install shaft seal (67) in hydraulic motor (66).
- (42) Coat preformed packing (68) with grease and install packing on seal carrier (69).
- (42) Install seal carrier (69) and retaining ring (70) in hydraulic motor (66).

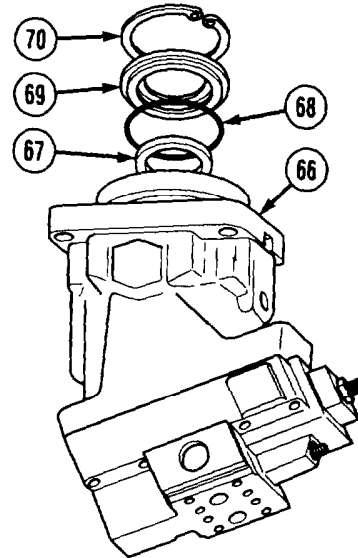

HYDRAULIC CIRCUIT

- 1. Variable motor
- 2. Servo piston
- 3. Not used
- 4. Check valves
- 5. 4/3-way servo valve
- 6. Servo pressure supply
- 7. Threshold spring
- 8. Modulating spring
- 9. Orifice pressure drain from setting piston side 1
- 10. Orifice pressure drain from setting piston side 2
- 11. Damping orifice (for restricting the servo pressure supply)

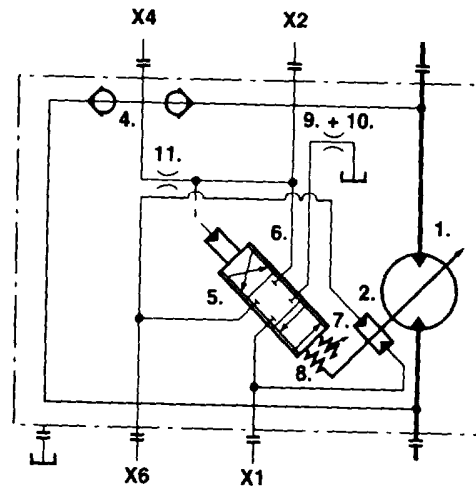

Winch Maintenance Instructions (Cont)

d. Adjustment.

- (1) Fill hydraulic motor (1) with lubricating oil.
- (2) Connect hydraulic motor (1) to pump supplying about 7.92 gallons/min (30 liters/min).
- (3) Install two 0-8500 psi (0-600 bar) gages in ports X4 and X6.
- (4) Loosen nut (2) and turn adjusting screw (3) counterclockwise to ensure that threshold spring is unloaded.
- (5) Increase system pressure until gage at port X4 reads 1392 psi (96 bar).
- (6) Turn adjusting screw (3) clockwise until pressure on gage at port X6 starts to increase.
- (7) Tighten nut (2).

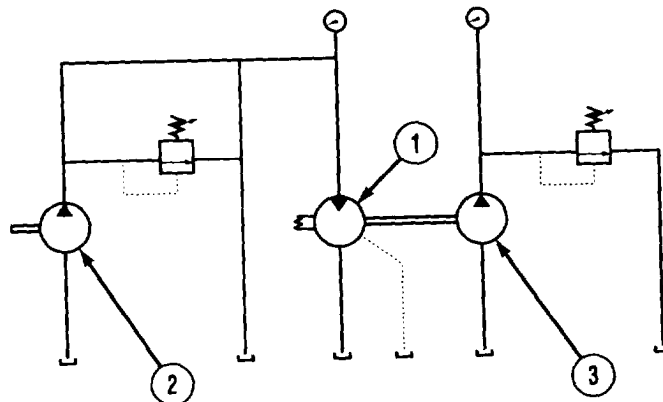
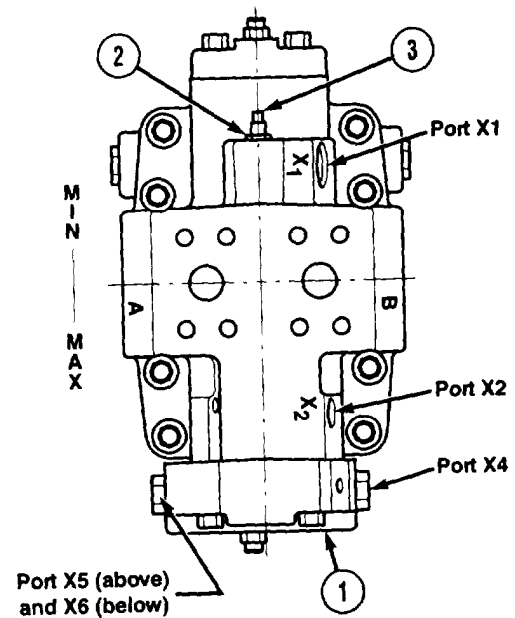

e. Test.

- (1) Connect hydraulic motor (1) to pump (2) supplying about 7.92 gallons/min (30 liters/min).
- (2) Connect brake pump (3) to hydraulic motor (1).
- (3) Increase pressure from brake pump (3) to brake hydraulic motor (1) until inlet pressure reaches 2900 psi (200 bar).
- (4) Check drain flow. Drain flow should be 0.8 gallons/min (3.0 liters/min).
- (5) If drain flow is excessive, correct fault and retest hydraulic motor (1).

f. Follow-on Maintenance. None.

END OF TASK

Winch Maintenance Instructions (Cont)

16-15. HEAVY-DUTY WINCH COUNTERBALANCE VALVE REMOVAL/REPAIR/INSTALLATION (M984).

This task covers:

- | | |
|------------------------|--------------------------|
| a. Removal | d. Assembly |
| b. Disassembly | e. Installation |
| c. Cleaning/Inspection | f. Follow-on Maintenance |

INITIAL SETUP

<i>Models</i>	<i>Equipment Condition</i>
M984	<i>TM or Para</i> <i>Condition Description</i>
<i>Test Equipment</i>	TM 9-2320-279-20 Heavy-duty winch hydraulic tubes removed.
None	
<i>Special Tools</i>	<i>Special Environmental Conditions</i>
None	None
<i>Supplies</i>	<i>General Safety Instructions</i>
Solvent, dry cleaning, Item 57, Appendix C	None
Oil, lubricating, Item 46, Appendix C	<i>Level of Maintenance</i>
<i>Personnel Required</i>	Direct Support
MOS 63W, Wheel vehicle repairer	
<i>References</i>	
None	

a. Removal.

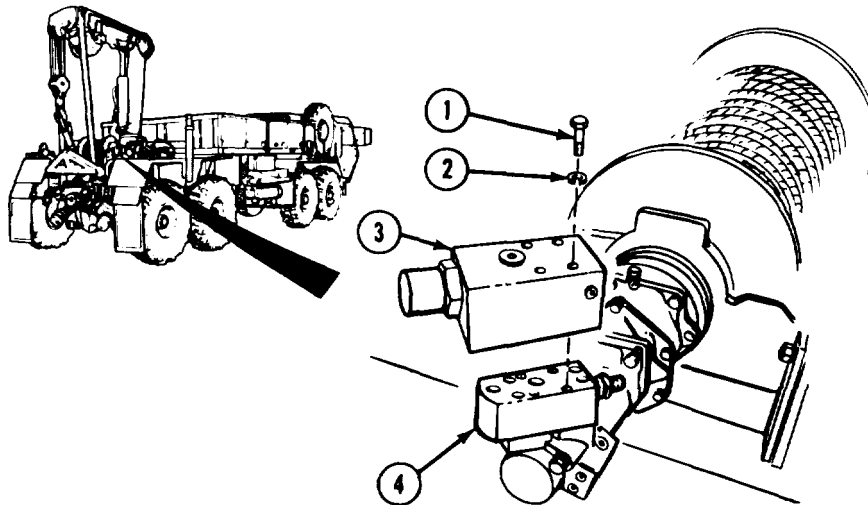

TA189963

- (1) Remove four screws (1), lockwashers (2), and counterbalance valve (3) from valve body adapter (4).
- (2) Cover valve body adapter (4).

Winch Maintenance Instructions (Cont)

16-15. HEAVY-DUTY WINCH COUNTERBALANCE VALVE REMOVAL/REPAIR/INSTALLATION (M984) (CONT).

b. Disassembly.

NOTE

Mark elbow fittings,

- (1) Remove preformed packing (1).
- (2) Remove elbow fitting (2) and remove preformed packing (3) from elbow fitting.
- (3) Remove spool plug (4), spool spring (5), washer (6), and spool (7).
- (4) Remove spool orifice plug (8) from spool (7).
- (5) Remove preformed packing (9) from spool plug (4).
- (6) Remove poppet plug (10) and preformed packing (11).
- (7) Remove pipe plug (12) and poppet orifice plug (13) from counterbalance valve body (14).
- (8) Remove plug (15) and preformed packing (16) from counterbalance valve body (14).
- (9) Remove poppet plug (17), preformed packing (18), compression spring (19), poppet spring (20), and poppet (21) from counterbalance valve body (14).

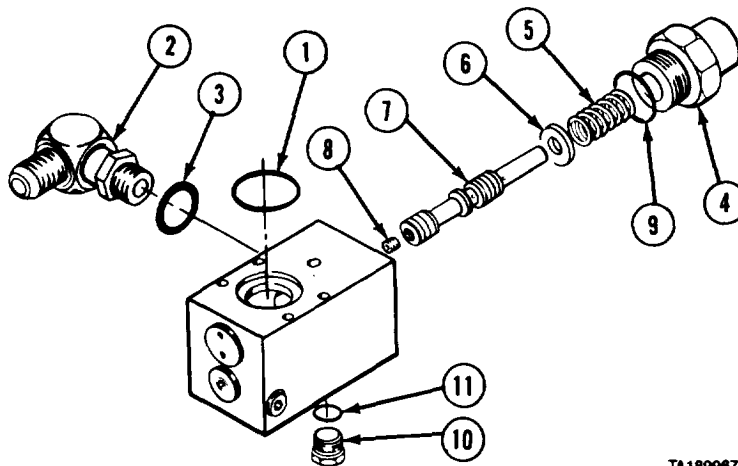

TA189987

c. Cleaning/Inspection.

WARNING

Adhesives, solvents, and sealing compounds can burn easily, can give off harmful vapors, and are harmful to skin and clothing. To avoid injury or death, keep away from open fire and use in well-ventilated area. If adhesive, solvent, or sealing compound gets on skin or clothing, wash immediately with soap and water.

- (1) Clean all metal parts in dry cleaning solvent.
- (2) Inspect all parts for damage.
- (3) Compression spring, poppet spring, and spool spring must be replaced if load-height specifications as listed in Table 16-1 are not met.
- (4) Check valve body for cracks.
- (5) Replace damaged parts.

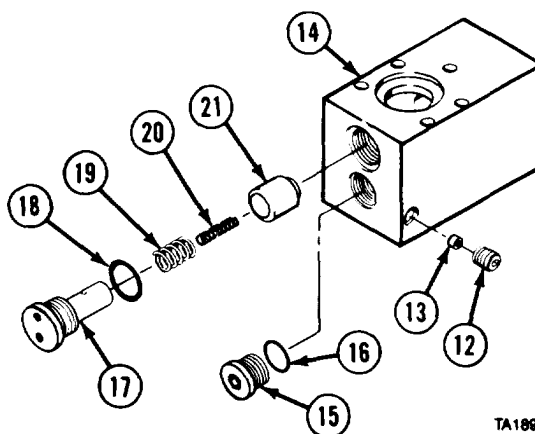

TA189986

Winch Maintenance Instructions (Cont)

Table 16-1. Compression Spring, Popp et Spring, and Spool Spring Load-Height Specifications.

Spring	Length Without Load in. (mm)	Length Under Load in. (mm)	Load Ibs (kg)
Compression	1.00 ± 0.015 (25.4 ± 0.38)	0.75 (19.05)	135 - 165 (61 - 75)
Poppet	1.25 ± 0.01 (31.75 ± 0.25)	0.66 (16.94)	6.3 - 6.9 (2.86 - 3.13)
Spool	2.0 ± 0.018 (50.8 ± 0.46)	1.73 (43.94)	204 - 242 (93 - 110)

d. Assembly.

- (1) Install poppet (1), poppet spring (2), and compression spring (3) in counterbalance valve body (4).
- (2) Coat preformed packing (5) with lubricating oil and install on poppet plug (6).
- (3) Install poppet plug (6) in counterbalance valve body (4).
- (4) Coat preformed packing (7) with lubricating oil and install on plug (8).
- (5) Install plug (8) in counterbalance valve body (4).
- (6) Install poppet orifice plug (9) and pipe plug (10) in counterbalance valve body (4).

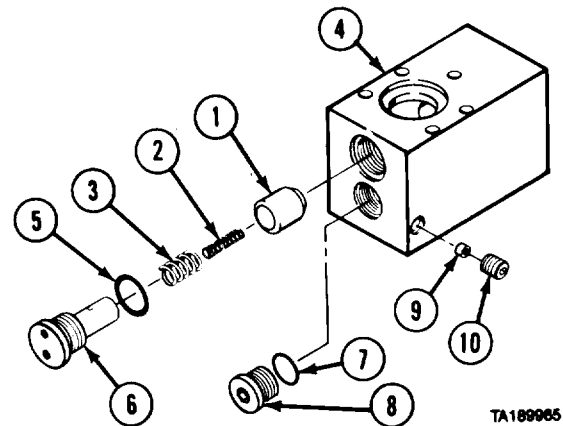

- (7) Install spool orifice plug (11) in spool (12).
- (8) Install spool (12), washer (13), and spool spring (14) in counterbalance-valve body (4).
- (9) Coat preformed packing (15) with lubricating oil and install on spool plug (16).
- (10) Put spool plug (16) over spool spring (14) and install spool plug in counterbalance valve body (4).
- (11) Coat preformed packing (17) with lubricating oil and install on poppet plug (18).
- (12) Install poppet plug (18) in counterbalance valve body (4).
- (13) Coat preformed packing (19) with lubricating oil and install on elbow fitting (20).
- (14) Install elbow fitting (20).
- (15) Coat preformed packing (21) with lubricating oil and install in counterbalance valve body (4).

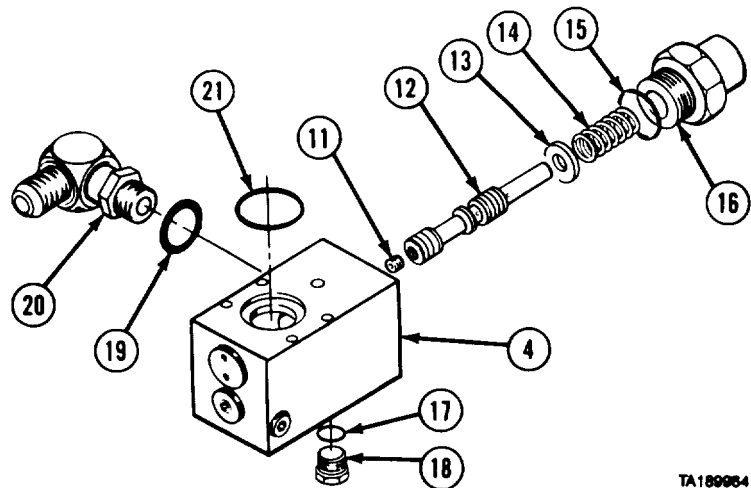

Winch Maintenance Instructions (Cont)

16-15. HEAVY-DUTY WINCH COUNTERBALANCE VALVE REMOVAL/REPAIR/INSTALLATION (M984) (CONT).

e. Installation.

- (1) Remove covering from valve body adapter (1).
- (2) Install counterbalance valve (2) on valve body adapter (1) with four screws (3) and lockwashers (4).

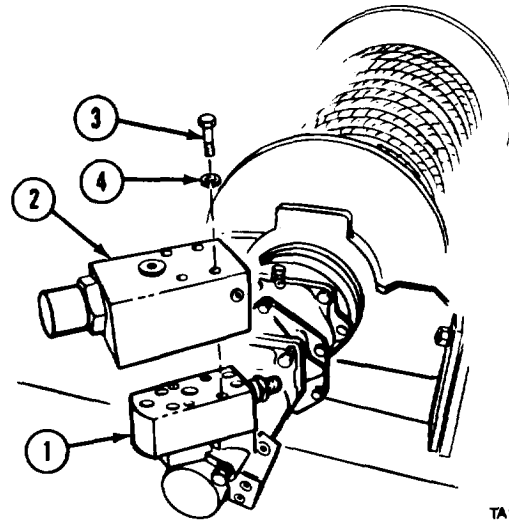

TA189968

- f. Follow-on Maintenance.** Install heavy-duty winch hydraulic tubes (TM 9-2320-279-20).

END OF TASK

16-15.1. HEAVY-DUTY WINCH COUNTERBALANCE VALVE REMOVAL/REPAIR/INSTALLATION.

This task covers:

- a. Removal
- b. Disassembly
- c. Cleaning/Inspection
- d. Assembly
- e. Installation
- f. Follow-on Maintenance

INITIAL SETUP

Models

M984E1

Test Equipment

None

Special Tools

None

Supplies

Oil, lubricating, Item 47, Appendix C
Solvent, dry cleaning, Item 57, Appendix C

Personnel Required

MOS 63S, Heavy wheel vehicle mechanic

References

None

Equipment Condition

<i>TM or Para</i>	<i>Condition Description</i>
TM 9-2320-279-10	Shut off engine.

Special Environmental Conditions

None

General Safety Instructions

None

Level of Maintenance

Direct Support

Winch Maintenance Instructions (Cont)

a. Removal.

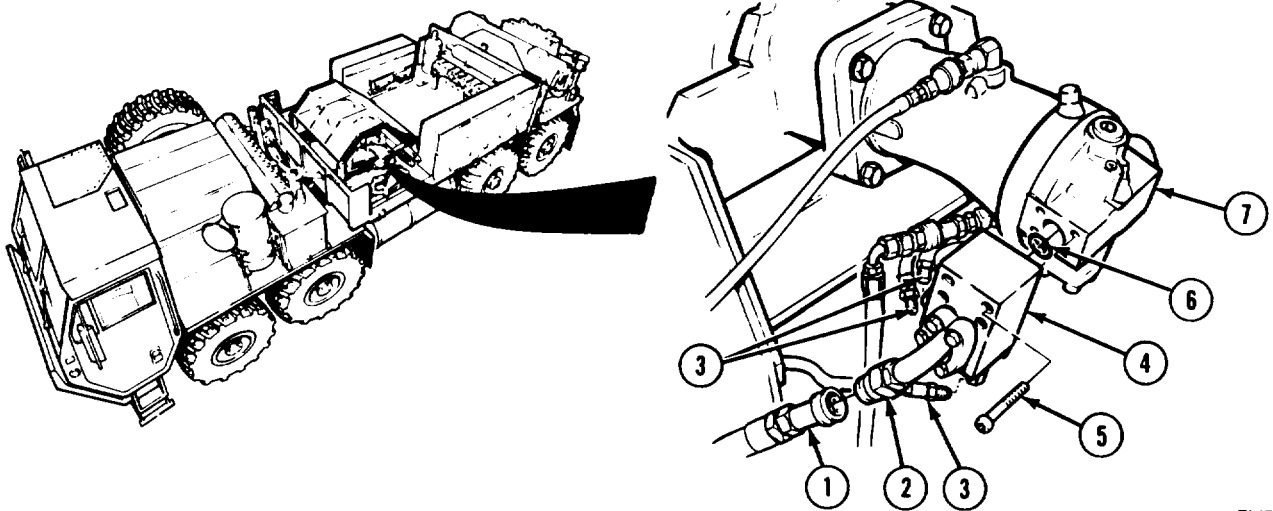

TA476205

NOTE

Tag and mark all lines.

- (1) Disconnect hydraulic hose (1) from coupling (2).
- (2) Disconnect three hoses (3) from valve body (4).
- (3) Remove four screws (5), valve body (4), and preformed packing (6) from motor (7).
- (4) Remove four screws (8), lockwashers (9), two flange halves (10), coupling (2), elbow (11), and preformed packing (12) from valve body (4).

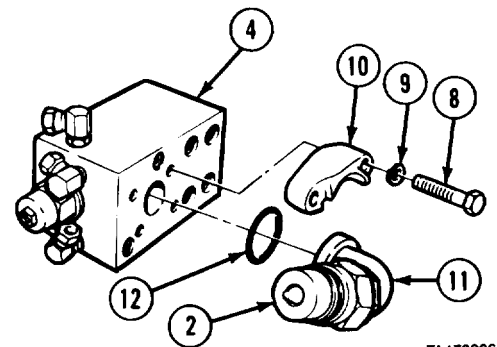

TA476206

- (5) Remove valve (13) from valve body (4).
- (6) Remove three elbows (14) and preformed packings (15).

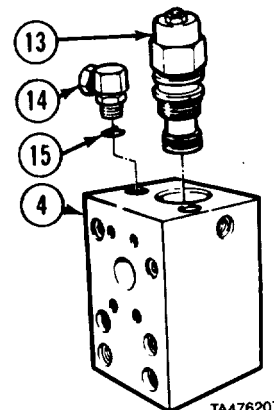

TA476207

Winch Maintenance Instructions (Cont)

16-15.1. HEAVY-DUTY WINCH COUNTERBALANCE VALVE REMOVAL/REPAIR/INSTALLATION (CONT).

b. Disassembly.

- (1) Remove two packing retainers (1), preformed packing (2), packing retainer (3), preformed packing (4), preformed packing (5), and packing retainer (6) from valve (7).

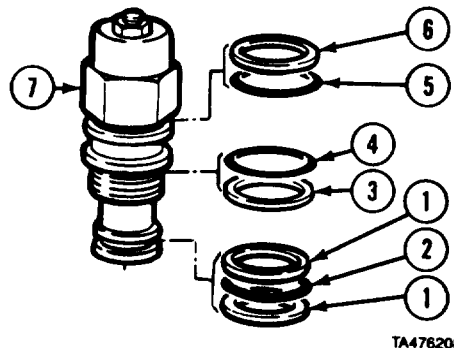

- (2) Remove plug (8) and preformed packing (9) from valve body (10).
- (3) Remove plug (11), preformed packing (12), setscrew (13), and ball (14).
- (4) Remove two plugs (15), preformed packings (16), springs (17), balls (18), and pin (19).

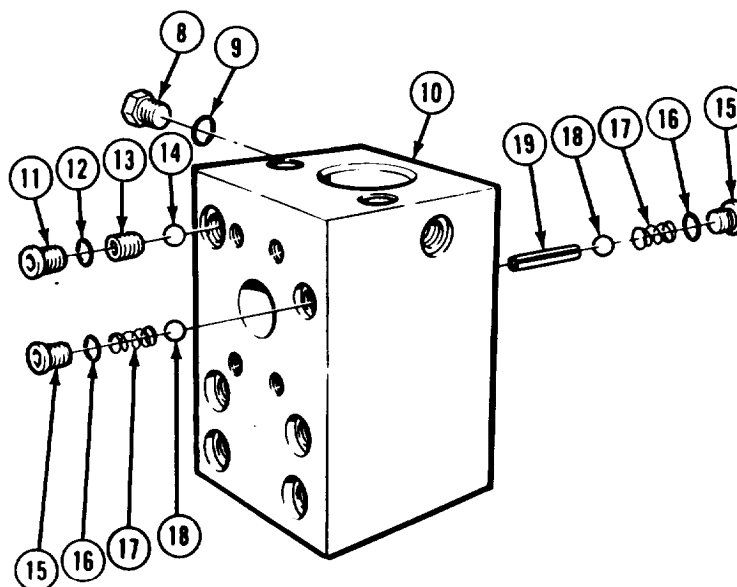

c. Cleaning/Inspection.

WARNING

Adhesives, solvents, and sealing compounds can burn easily, can give off harmful vapors, and are harmful to skin and clothing. To avoid injury or death, keep away from open fire and use in well-ventilated area. If adhesive, solvent, or sealing compound gets on skin or clothing, wash immediately with soap and water.

- (1) Clean all metal parts in dry cleaning solvent.
- (2) Inspect each part for damage.
- (3) Replace damaged parts.
- (4) Replace springs if broken or if free length is less than 0.180 in. (0.45 mm).

Winch Maintenance Instructions (Cont)

d. Assembly.

NOTE

Lubricate preformed packings before installing.

- (2) Install packing retainer (1), preformed packing (2), preformed packing (3), packing retainer (4), preformed packing (5), and two packing retainers (6) on valve (7).

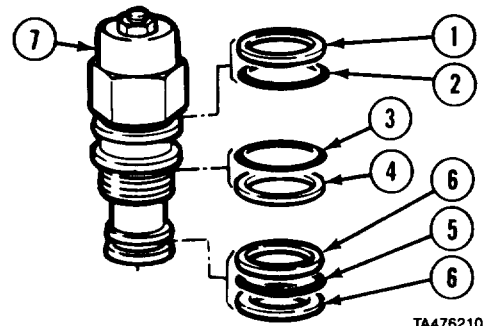

TA476210

- (2) Install pin (8), two balls (9), springs (10), preformed packings (11), and plugs (12) in valve body (13).
- (3) Install ball (14), setscrew (15), preformed packing (16), and plug (17).
- (4) Install preformed packing (18) and plug (19).

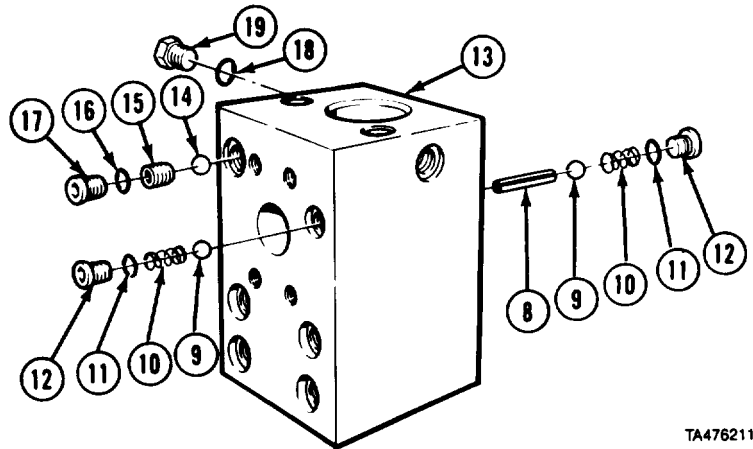

TA476211

e. Installation.

NOTE

Lubricate preformed packings before installing.

- (1) Install three preformed packings (1) and elbows (2) in valve body (3).
- (2) Install valve (4) and tighten to 65 lb-ft (88 N·m).

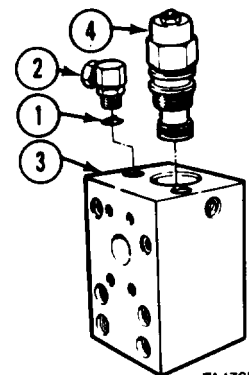

TA476212

- (3) Install preformed packing (5) and coupling and elbow (6) on valve body (3) with two flange halves (7), four lockwashers (8), and screws (9).

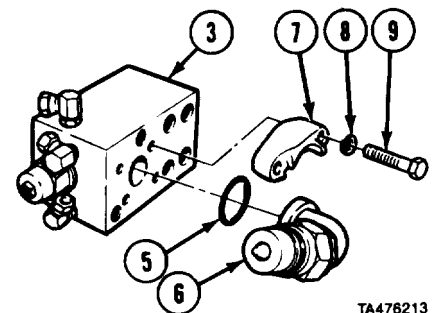

TA476213

Winch Maintenance Instructions (Cont)

16-15.1. HEAVY-DUTY WINCH COUNTERBALANCE VALVE REMOVAL/REPAIR/INSTALLATION (CONT).

- (4) Install preformed packing (10) and valve body (3) with four screws (11) to motor (12).
- (5) Connect three hoses (13) to elbows (2).
- (6) Connect hose (14) to coupling and elbow (6).

f. Follow-on Maintenance.

- (1) Check and fill hydraulic reservoir (LO 9-2320-279-12).
- (2) Operate heavy-duty winch, check for leaks (TM 9-2320-279-10).

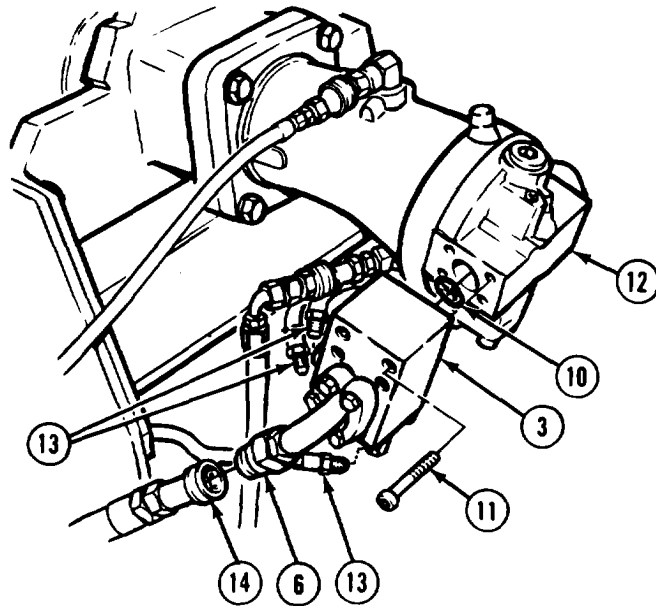

TA478214

END OF TASK

16-16. HEAVY-DUTY WINCH BRAKE REMOVAL/REPAIR/INSTALLATION (M984).

This task covers:

- a. Removal
- b. Disassembly
- c. Cleaning/Inspection
- d. Assembly
- e. Installation
- f. Follow-on Maintenance

INITIAL SETUP

Models
M984

Test Equipment
None

Special Tools
None

Supplies
Solvent, dry cleaning, Item 57, Appendix C
Oil, lubricating, Item 46, Appendix C

Personnel Required
MOS 63W, Wheel vehicle repairer

References

Equipment Condition

<i>TM or Para</i>	<i>Condition Description</i>
Para 16-13	Heavy-duty winch hydraulic motor removed.

Special Environmental Conditions

None

General Safety Instructions

None

Level of Maintenance

Direct Support

Winch Maintenance Instructions (Cont)

a. Removal.

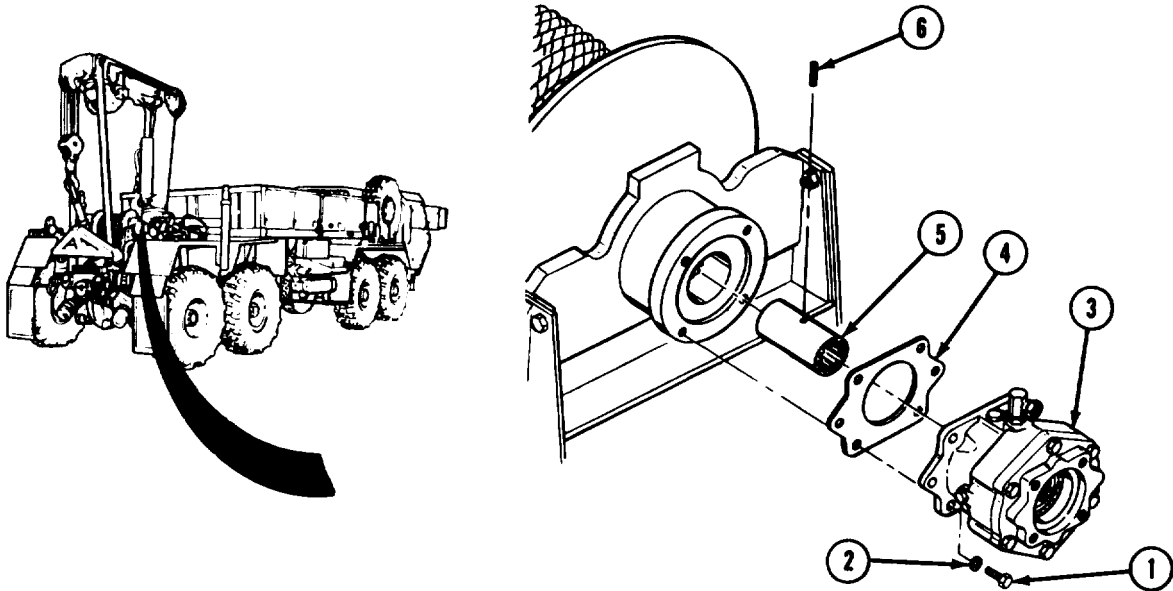

TA189330

- (1) Remove four screws (1) and lockwashers (2) from winch brake (3).
- (2) Remove winch brake (3), gasket (4), and coupling (5).
- (3) Remove roll pin (6) from coupling (5).

b. Disassembly.

- (1) Remove two plugs (1), one plug (2), and three preformed packings (3) from housing (4).
- (2) Remove fitting (5) and preformed packing (6).
- (3) Remove six screws (7) and lockwashers (8).
- (4) Position housing (4) in press.
- (5) Hold shaft (9) down with press and pry cover (10) loose from housing (4).
- (6) Remove housing (4) from press.
- (7) Remove cover (10) from housing (4).
- (8) Remove preformed packing (11) from cover (10).
- (9) Press bearing (12) from cover (10).

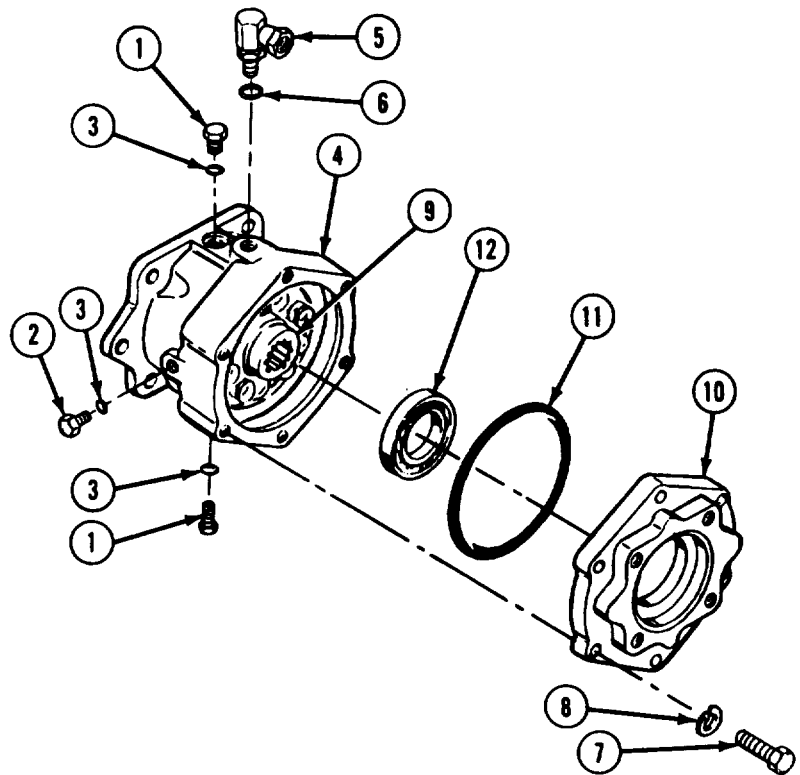

TA189331

Winch Maintenance Instructions (Cont)

16-16. HEAVY-DUTY WINCH BRAKE REMOVAL/REPAIR/INSTALLATION (M984) (CONT).

(10) Remove 10 springs (13) from piston (14).

NOTE

There are two threaded holes in piston. Insert two screws and tighten to remove piston.

- (11) Remove piston (14) from housing (4).
- (12) Remove backup ring (15), preformed packing (16), backup ring (17), and preformed packing (18) from piston (14).

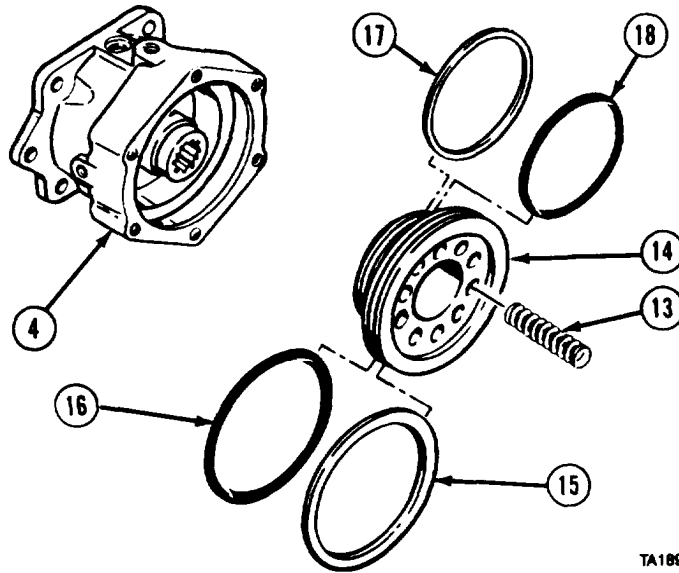

TA189332

- (13) Press on closed end of shaft (19) and remove from housing (4).
- (14) Press bearing (20) from shaft (19) and remove 10 friction plates (21) and nine steel plates (22).
- (15) Remove spacer (23).

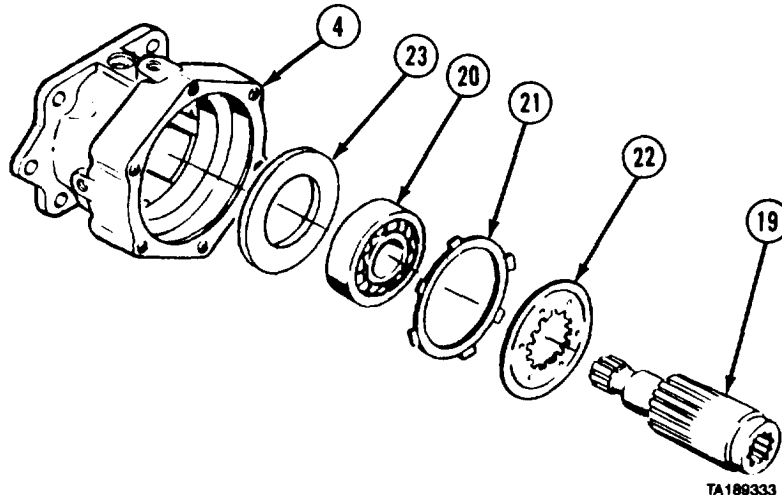

TA189333

c. Cleaning/Inspection.

WARNING

Adhesives, solvents, and sealing compounds can burn easily, can give off harmful vapors, and are harmful to skin and clothing. To avoid injury or death, keep away from open fire and use in well-ventilated area. If adhesive, solvent, or sealing compound gets on skin or clothing, wash immediately with soap and water.

- (1) Clean all metal parts with dry cleaning solvent.
- (2) Inspect all threaded parts for crossed and stripped threads.
- (3) Inspect all parts for damage or cracks.
- (4) Measure and record thickness of each friction plate. Replace any friction plate worn to 0.077 in. (1.95 mm) or less.
- (5) Measure and record thickness of new plate if used.

Winch Maintenance Instructions (Cont)

- (6) Add measurements of all 10 friction plates. If total is less than 0.776 in. (19.7 mm), replace friction plates, starting with thinnest plate, until total measurement of 10 friction plates is 0.776 in. (19.7 mm) or-more.
- (7) Replace steel plates only if warped, cracked, deeply grooved, or discolored by heat.
- (8) Spring length without load must be at least 2.43 in. (61.7 mm) ± 0.018 in. (0.46 mm). Spring length with load of 180 lb (81.7 kg) must be more than 1.949 in. (49.5 mm).
- (9) Replace all damaged parts.

d. Assembly.

- (1) Starting with one steel plate (1), alternate nine steel plates and 10 friction plates (2) on shaft (3),
- (2) Press bearing (4) on closed end of shaft (3).
- (3) Install spacer (5) in housing (6).
- (4) Aline tabs of friction plates (2) with slots in housing (6).
- (5) Install shaft (3), closed end first, in housing (6).
- (6) Press shaft (3) in housing (6) until bearing (4) is seated on bottom of housing.

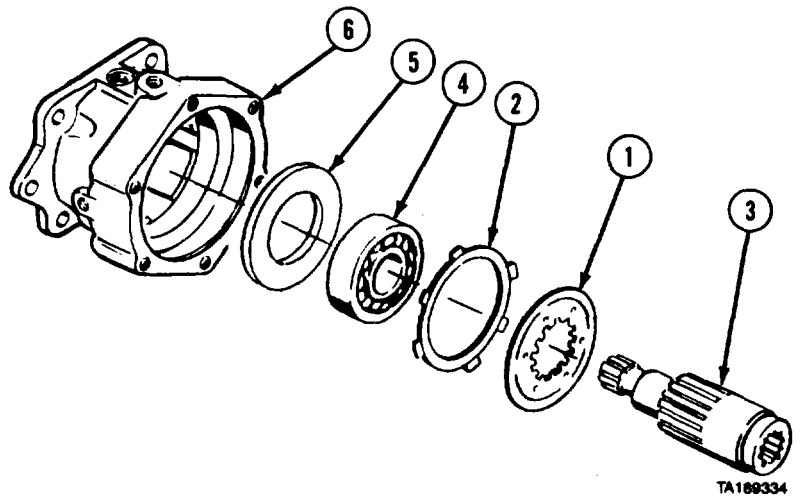

- (7) Coat two preformed packings (7 and 8) with lubricating oil.
- (8) Install preformed packing (7), backup ring (9), preformed packing (8), and backup ring (10) on piston (11).
- (9) Install piston (11) in housing (6).
- (10) Install 10 springs (12) in piston (11).

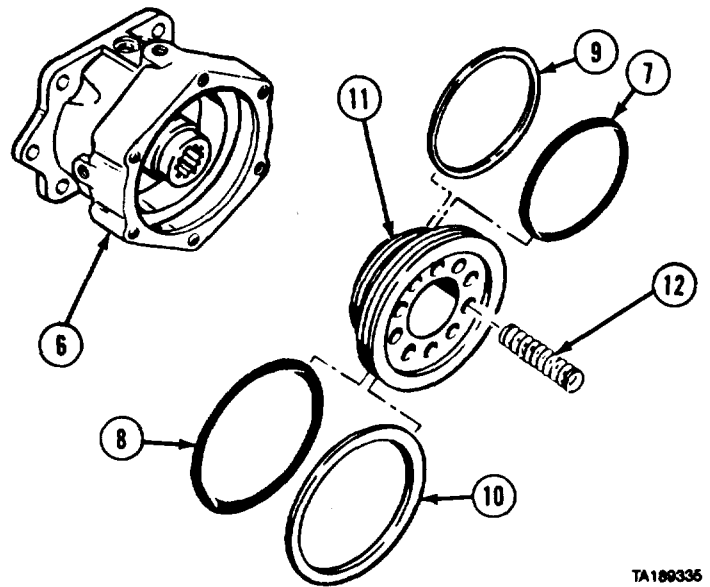

TA189335

Winch Maintenance Instructions (Cont)

16-16. HEAVY-DUTY WINCH BRAKE REMOVAL/REPAIR/INSTALLATION (M984) (CONT).

- (11) Press bearing (13) in cover (14).
- (12) Coat preformed packing (15) with lubricating oil and install packing on cover (14).
- (13) Position cover (14) on springs (12).
- (14) Install six screws (16) and lockwashers (17). Tighten screws evenly.
- (15) Coat preformed packing (18) with lubricating oil and install preformed packing on fitting (19).
- (16) Install fitting (19).
- (17) Install two preformed packings (20) and two plugs (21).
- (18) Install preformed packing (22) and plug (23),

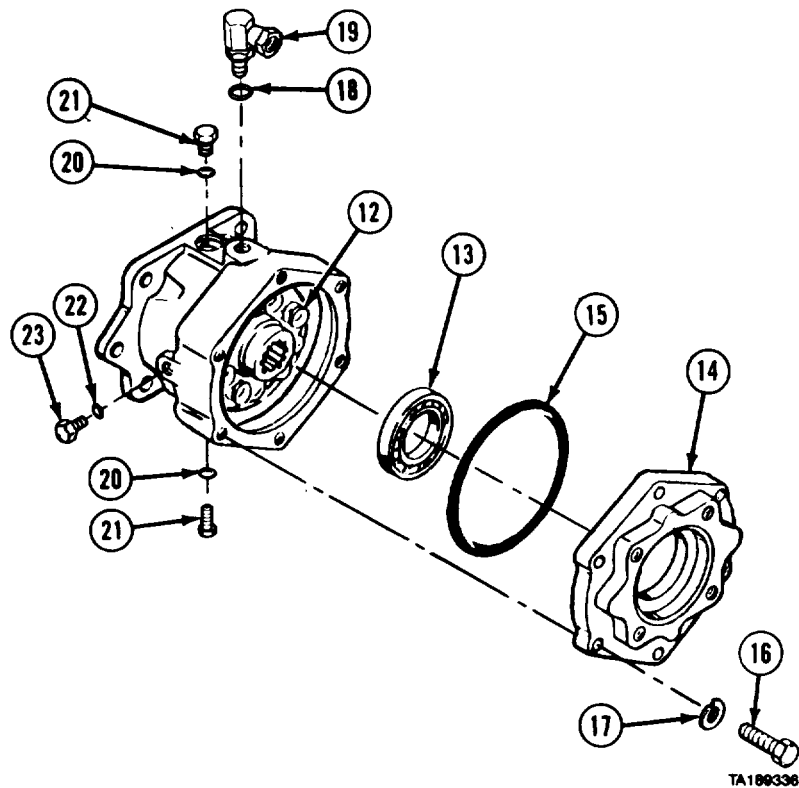

TA169336

e. Installation.

- (1) Install roll pin (1) in coupling (2).
- (2) Install coupling (2), gasket (3), and winch brake (4) on motor end support (5) with four screws (6) and lockwashers (7).

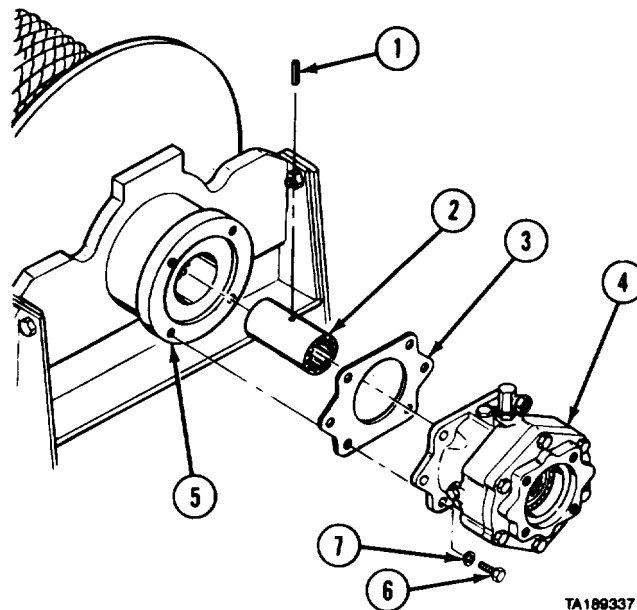

TA169337

f. Follow-on Maintenance. Install heavy-duty winch hydraulic motor (para 16-13).

END OF TASK

Winch Maintenance Instructions (Cont)

16-17. HEAVY-DUTY WINCH BRAKE REMOVAL/REPAIR/INSTALLATION.

This task covers:

- | | |
|------------------------|--------------------------|
| a. Removal | d. Assembly |
| b. Disassembly | e. Installation |
| c. Cleaning/Inspection | f. Follow-on Maintenance |

INITIAL SETUP

Models

M984E1

Test Equipment

None

Special Tools

None

Supplies

- Adhesive-Sealant, silicone, Item 6, Appendix C
- Compound, sealing, pipe thread, Item 29, Appendix C
- Solvent, dry cleaning, Item 58, Appendix C
- Tags, identification, Item 61, Appendix C

Personnel Required

MOS 63W, Wheel vehicle repairer

References

None

Equipment Condition

<i>TM or Para</i>	<i>Condition Description</i>
TM 9-2320-279-10	Shut off engine.
TM 9-2320-279-10	Heavy-duty winch cover raised.
LO 9-2320-279-12	Heavy-duty winch oil drained.

Special Environmental Conditions

None

General Safety Instructions

None

Level of Maintenance

Direct Support

a. Removal.

NOTE

- Place suitable container under brake to catch oil.
- Matchmark brake housing, adapter and ring gear.

(1) Remove plug (1).

NOTE

Tag and mark hydraulic lines and fittings before removal.

- (2) Disconnect two hydraulic lines (2).
- (3) Remove elbow (3), preformed packing (4), elbow (5), and preformed packing (6) from brake (7).
- (4) Remove 12 screws (8), lockwashers (9), and brake (7).

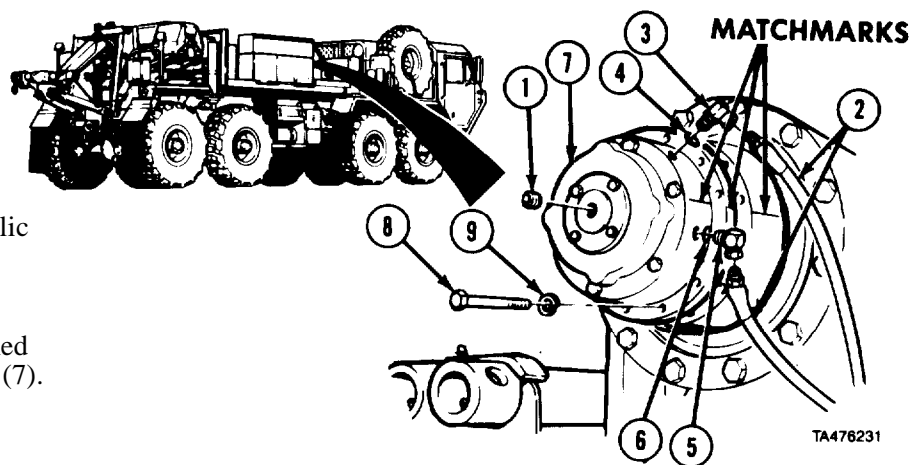

Winch Maintenance Instructions (Cont)

16-17. HEAVY-DUTY WINCH BRAKE REMOVAL/REPAIR/INSTALLATION (CONT).

b. Disassembly.

(1) Remove four screws (1), lockwashers (2), and cover (3).

CAUTION

Loosen screws evenly. Housing is under 2500 lbs (1135 kg) spring loading. Equipment can be damaged if screws are not loosened evenly.

NOTE

Matchmark housing and adapter.

(2) Remove six screws (4), lockwashers (5), housing (6), and preformed packing (7) from adapter (8).

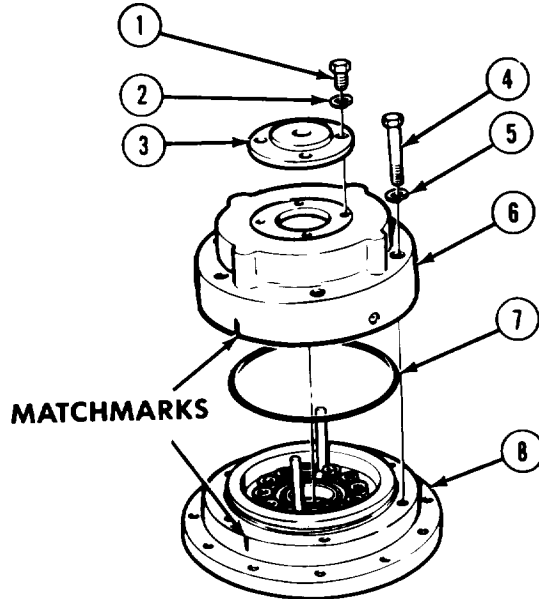

TA476232

NOTE

- If necessary, tap housing on firm surface to loosen piston suet ion.
 - Bearing could remain in housing or stay on shaft.
- (3) Remove piston (9), shaft (10), and bearing (11) from housing (6).
 (4) Remove shaft (10) from piston (9).
 (5) Remove bearing (11).

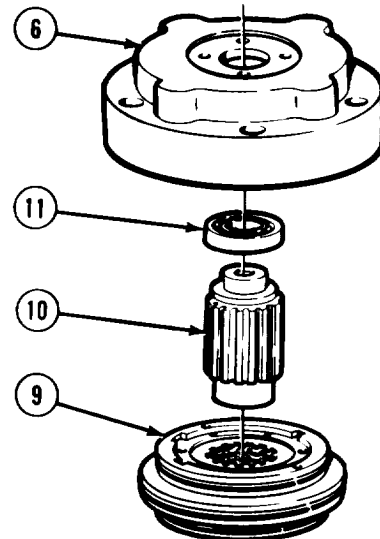

TA476233

Winch Maintenance Instructions (Cont)

- (6) Remove five friction plates (12) and four drive plates (13).
- (7) Remove spacer (14) from piston (9).
- (8) Remove packing retainer (15), preformed packing (16), preformed packing (17), packing retainer (18), and preformed packing (16) from piston (9).

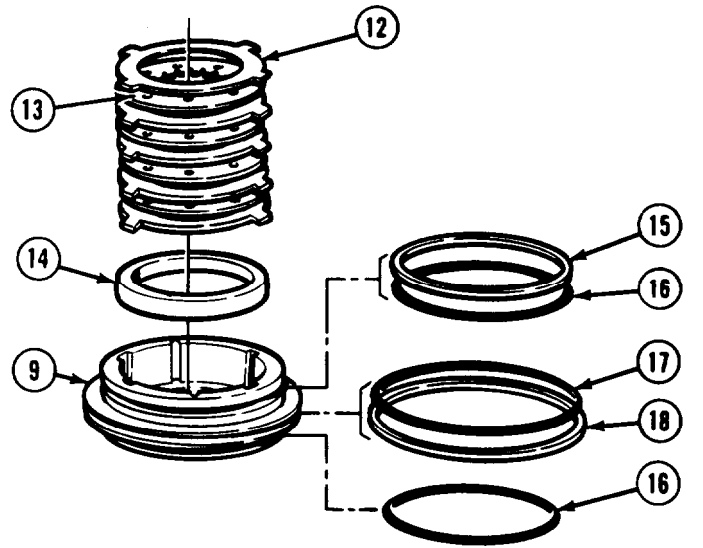

TA476234

- (9) Remove 12 springs (19) and two pins (20) from adapter (8).
- (10) Remove bearing (21) from adapter (8).

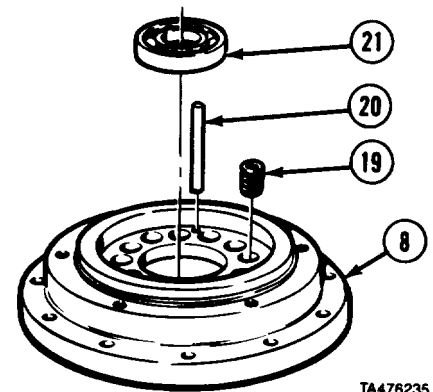

TA476235

c. Cleaning/Inspection.**WARNING**

Adhesives, solvents, and sealing compounds can burn easily, can give off harmful vapors, and are harmful to skin and clothing. To avoid injury or death, keep away from open fire and use in well-ventilated area. If adhesive, solvent, or sealing compound gets on skin or clothing, wash immediately with soap and water.

- (1) Clean all metal parts with dry cleaning solvent.
- (2) Inspect all threaded parts for crossed and stripped threads. Repair damaged threads.
- (3) Inspect all parts for damage or cracks. Replace damaged or cracked parts.
- (4) Replace any friction plate if warped, discolored by heat or worn to 0.078 in. (1.95 mm) or less.
- (5) Replace any drive plate if warped, discolored by heat or worn to 0.054 in. (1.37 mm) or less.
- (6) Replace all springs if any spring is broken, discolored by heat, or if free length of any one spring is less than 0.093 in. (23.5 mm).
- (7) Replace all damaged parts.

Winch Maintenance Instructions (Cont)

16-17. HEAVY-DUTY WINCH BRAKE REMOVAL/REPAIR/INSTALLATION (CONT).

d. Assembly.

- (1) Install bearing (1) in adapter (2).
- (2) Install shaft (3) in adapter (2).
- (3) Install two pins (4) tapered side up.
- (4) Install 12 springs (5) in holes in adapter (2).

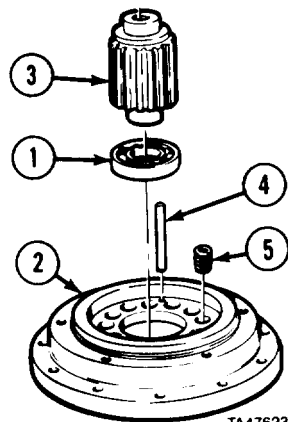

TA476236

- (5) Install preformed packing (6), packing retainer (7), preformed packing (8), preformed packing (9), and packing retainer (10) on piston (11).
- (6) Install piston (11) in adapter (2).

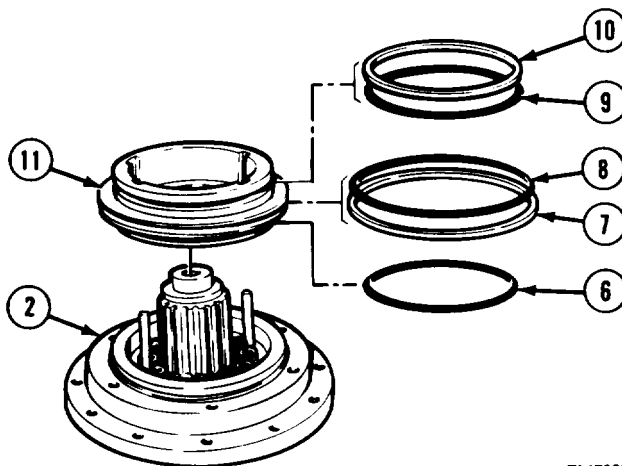

TA476237

- (7) Install spacer (12) in piston (11).
- (8) Alternately, install five friction plates (13) and four drive plates (14).

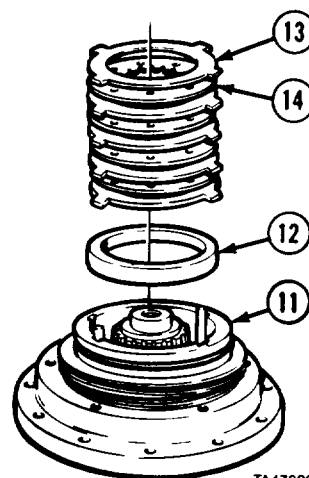

TA476238

Winch Maintenance Instructions (Cont)

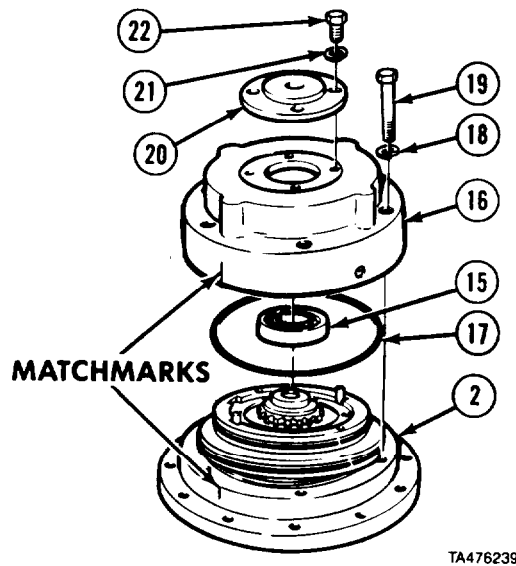

- (9) Install bearing (15) in housing (16).
- (10) Install preformed packing (17) on adapter (2).

CAUTION

Preformed packing can be damaged if housing screws are not tightened evenly to draw housing and adapter together.

- (11) Aline matchmarks and install housing (16) on adapter (2) with six lockwashers (18) and screws (19). tighten screws to 45 lb-ft (61 N.m).

WARNING

Adhesives, solvents, and sealing compounds can burn easily, can give off harmful vapors, and are harmful to skin and clothing. To avoid injury or death, keep away from open fire and use in well-ventilated area. If adhesive, solvent, or sealing compound gets on skin or clothing, wash immediately with soap and water.

- (12) Apply adhesive-sealant to inside edges of cover (20) and install with four lockwashers (21) and screws (22).

Winch Maintenance Instructions (Cont)

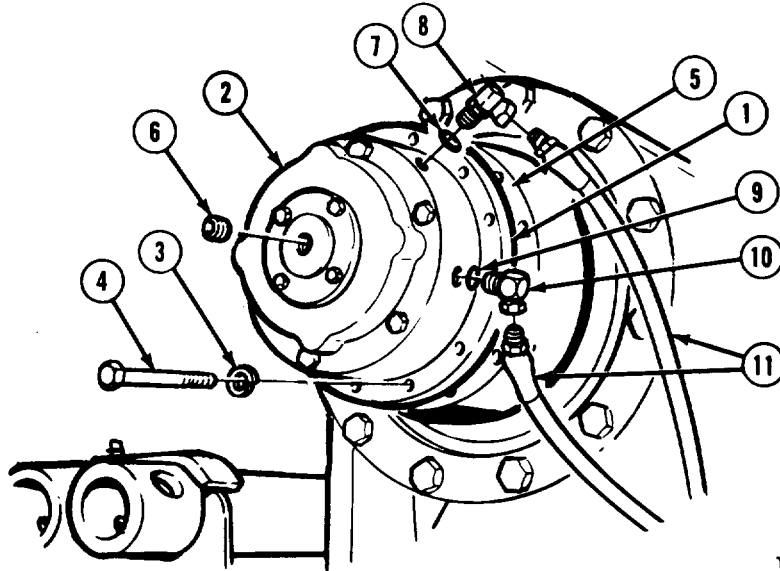
16-17. HEAVY-DUTY WINCH BRAKE REMOVAL/REPAIR/INSTALLATION (CONT).**e. Installation.**

TA476240

WARNING

Adhesives, solvents, and sealing compounds can burn easily, can give off harmful vapors, and are harmful to skin and clothing. To avoid injury or death, keep away from open fire and use in well-ventilated area. If adhesive, solvent, or sealing compound gets on skin or clothing, wash immediately with soap and water.

- (1) Apply adhesive-sealant to mating surface of adapter (1).
- (2) Install brake assembly (2) with 12 lockwashers (3) and screws (4) to ring gear (5). Tighten screws to 30 lb-ft (40.7 N.m).
- (3) Apply pipe thread sealing compound and install plug (6).
- (4) Install preformed packing (7), elbow (8), preformed packing (9), and elbow (10).
- (5) Connect two hydraulic lines (11).

f. Follow-on Maintenance.

- (1) Fill heavy-duty winch (LO 9-2320-279-12).
- (2) Lower heavy-duty winch cover (TM 9-2320-279-10).
- (3) Check operation of heavy-duty winch (TM 9-2320-279-10).

END OF TASK

Winch Maintenance Instructions (Cont)

16-18. FAIRLEAD/TENSIONER MOTOR REMOVAL/REPAIR/INSTALLATION (M984E1).	
This task covers:	
a. Removal	d. Assembly
b. Disassembly	e. Installation
c. Cleaning/Inspection	f. Follow-on Maintenance
INITIAL SETUP	
<i>Models</i>	<i>References</i>
M984E1	None
<i>Test Equipment</i>	<i>Equipment Condition</i>
None	<i>TM or Para</i> <i>Condition Description</i>
<i>Special Tools</i>	TM 9-2320-279-10 Fairlead lowered.
None	<i>Special Environmental Conditions</i>
<i>Supplies</i>	None
None	<i>General Safety Instructions</i>
<i>Personnel Required</i>	None
MOS 63W, Heavy wheel vehicle mechanic	<i>Level of Maintenance</i>
	Direct Support

a. Removal.

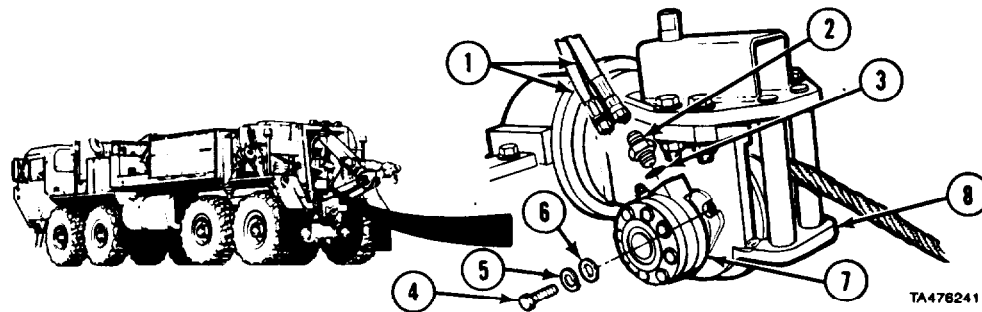

NOTE

Tag and mark all lines.

- (1) Disconnect two hydraulic hoses (1).
- (2) Remove two fittings (2) and preformed packings (3).
- (3) Remove two screws (4), lockwashers (5), washers (6), and motor (7) from fairlead (8).

b. Disassembly.

- (1) Remove plug (1) and preformed packing (2) from cover (3).

NOTE

Matchmark cover, ring, and motor.

- (2) Remove eight screws (4), washers (5), cover bearing assembly (3), and preformed packing (6) from IGR assembly (7).

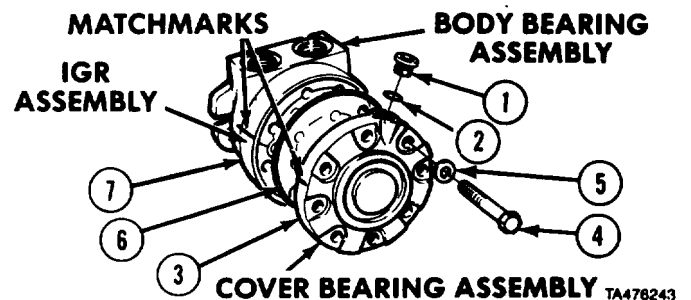

Winch Maintenance Instructions (Cont)

16-18. FAIRLEAD/TENSIONER MOTOR REMOVAL/REPAIR/INSTALLATION (M984E1) (CONT).

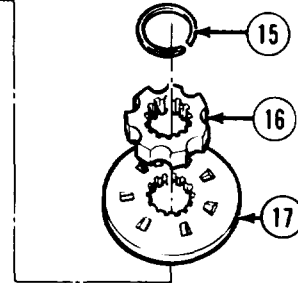
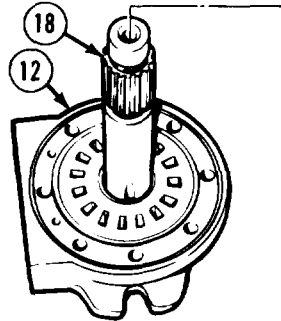
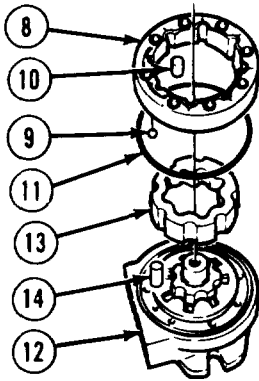

TA476245

NOTE

Shorter rollers are in ring. Long rollers are in geroler.

- (3) Remove ring (8), two balls (9), eight rollers (10), and preformed packing (11) from body bearing assembly (12).
- (4) Remove outer geroler (13) and seven rollers (14).
- (5) Remove retaining ring (15), inner geroler (16), and rotary valve (17) from shaft (18).
- (6) Remove shaft (18) from body bearing assembly (12).
- (7) Remove dust seal (19), packing retainer (20), and quad ring (21) from body bearing assembly (12).

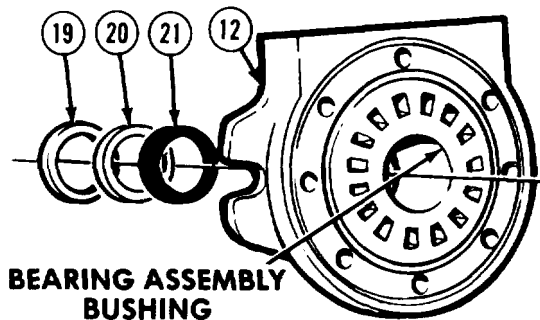

TA476247

c. Cleaning/Inspection.

WARNING

Adhesives, solvents, and sealing compounds can burn easily, can give off harmful vapors, and are harmful to skin and clothing. To avoid injury or death, keep away from open fire and use in well-ventilated area. If adhesive, solvent, or sealing compound gets on skin or clothing, wash immediately with soap and water.

- (1) Clean all metal parts in dry cleaning solvent.
- (2) Inspect each part for damage.
- (3) Replace damaged parts.
- (4) Coat all parts with lubricating oil.
- (5) If any area of shaft is pitted, grooved or bent, replace shaft and end cover bearing assembly.
- (6) If bushing is worn more than 0.005 in (0.15 mm) out of round replace body bearing assembly.
- (7) If body rollers are worn smaller than 0.370 in, (9.4 mm) replace IGR assembly.
- (8) If geroler rollers are worn smaller than 0.395 in. (9.92 mm) replace IGR assembly.
- (9) If any machined surfaces are grooved or pitted replace.

Winch Maintenance Instructions (Cont)

d. Assembly.

- (1) Install quad ring seal (1), packing retainer (2), and dust seal (3) in body bearing assembly (4).

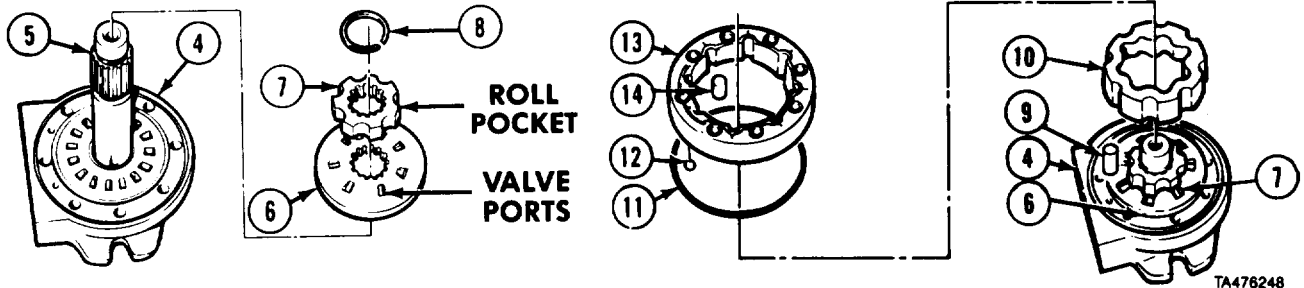
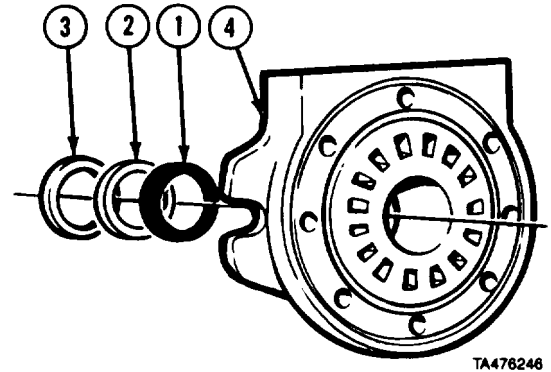

- (2) Install shaft (5) in body bearing assembly (4).

NOTE

T shaped slots face down on shaft spline.

- (3) Install valve (6) on shaft (5).

NOTE

Roll pockets on inner geroler go between valve posts.

- (4) Install inner geroler (7) and retaining ring (8) on shaft (5).

NOTE

Short rollers are installed in ring. Long rollers are installed in geroler.

- (5) Install seven rollers (9) on inner geroler (7).
 (6) Install outer geroler (10) on valve (6).
 (7) Install preformed packing (11) in body (4).
 (8) Install two balls (12) in small holes of IGR assembly (13).
 (9) Aline matchmarks and install IGR assembly (13) and eight rollers (14).

Winch Maintenance Instructions (Cont)

16-18. FAIRLEAD/TENSIONER MOTOR REMOVAL/REPAIR/INSTALLATION (M984E1) (CONT).

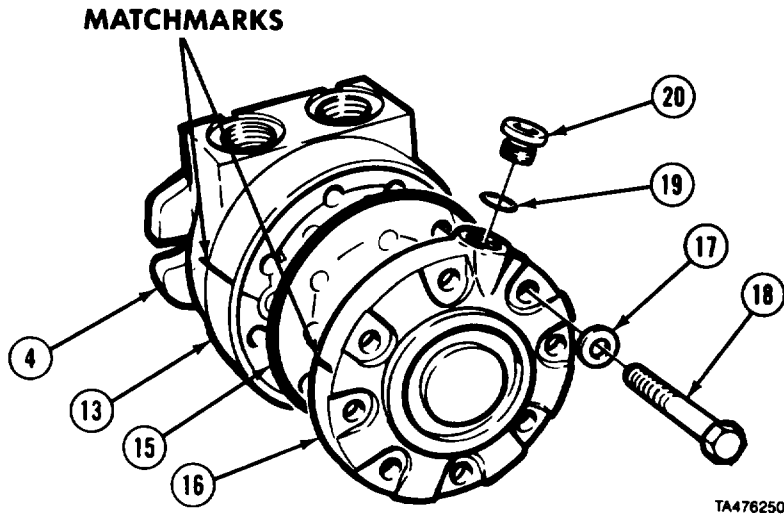

TA476250

- (10) Install preformed packing (15) in cover bearing assembly (16).
- (11) Aline matchmarks and install cover (16) on IGR assembly (13) and body bearing assembly (4) with eight washers (17) and screws (18).
- (12) Install preformed packing (19) and plug (20) in cover bearing assembly (16).

e. Installation.

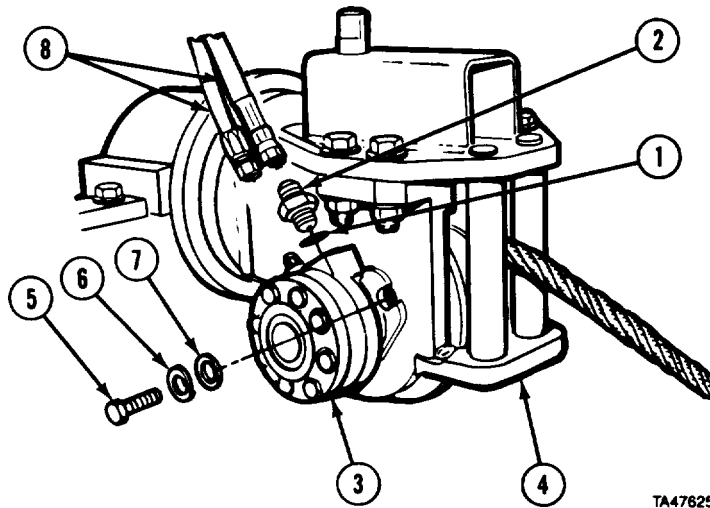

TA476251

- (1) Install two preformed packings (1) and fittings (2).
- (2) Intall motor (3) on fairlead (4) with two screws (5), lockwashers (6), and washers (7).
- (3) Connect two hydraulic hoses (8).

f. Follow-on Maintenance.

- (1) Check operation (TM 9-2320-279-10).
- (2) Fairlead raised (TM 9-2320-279-10).
- (3) Check for leaks.

END OF TASK

INDEX

Subject	Paragraph, Figure, Table Number
A	
ACTUATED CONTROL VALVE, HAV HAND, air hose reel (M978) repair	15-8
Air compressor repair	11-9
Air governor repair	11-10
Air solenoid check valve, throttle (M984) repair	11-8
Arctic brake chamber and rear brake chamber repair	11-4
Arm, pitman, and steering gear removal/repair/installation	12-5
Arm, pitman, and slave gear removal/repair/installation	12-6
Asbestos warning	c
Axle housing cover assembly, axle No. 3 removal/repair/installation	10-4
Axle housing cover, axle No.4 (models 580 and 650) (M984, M984E1) removal/repair/ installation	10-5
Axle No. 3 (models 480 and 580) removal/installation	10-2
Axle No. 3 and No. 4, front oil seal and yoke removal/installation	10-6
Axle No. 3 (model 650) (M984E1) removal/installation	10-2.1
Axle No. 3, differential carrier	
Removal/Installation	10-9
Repair	10-10
Axle No. 3, differential carrier cover removal/repair/installation	10-7
Axle No. 3, housing cover assembly removal/installation	10-4
Axle No. 4 (models 480 and 580) removal/installation	10-3
Axle No. 4 (model 650) (M984E1) removal/installation	10-3.1
Axle No. 4 and No. 3, front oil seal and yoke removal/installation	10-6
Axle No. 4, differential carrier	
Removal/Installation	10-11
Repair	10-12
Axle No. 4, axle housing cover (models 580 and 650) (M984, M984E1) removal/repair/ installation	10-5
B	
Batteries, terminals, and cables warning.	c
Beam assembly, equalizer, (front tandem) removal/repair/installation	14-5
Beam assembly, equalizer, (rear tandem) removal/repair/installation	14-6
Body, cargo (M977, M985, M985E1) removal/installation.	15-10
Body, cargo, mounting brackets (M977, M985) removal/installation	15-11
Body cargo, floor hatch (M977, M985) removal/installation.	15-9
Body, wrecker (M984) removal/installation	15-16
Body, wrecker, mounting brackets (M984) removal/installation	15-17
Box, gear (90°), steering removal/repair/installation	12-4
Bracket and steering/tensioner manifold (M984E1) removal/repair/installation	12-7.2
Bracket assemblies, lift removal/installation	13-6
Brackets and heavy-duty winch removal/installation.	16-10.2
Brackets, mounting, wrecker body (M984) removal/installation	15-17
Brackets, mounting, cargo body (M977, M985) removal/installation	15-11
Brackets, mounting, crane (M977, M985) removal/installation	13-27
Brackets, mounting, crane (M985E1) removal/installation	13-30
Brackets, pivot, and tow cylinder, retriever (M984E1) removal/installation	13-30.4
Brake chamber, arctic, and rear brake chamber repair	11-4
Brake chamber, rear, antarctic brake chamber repair	11-4
Brake drum inspection and repair	11-3
Brake, heavy-duty winch (M984) removal/repair/installation	16-16
Brake, heavy-duty winch (M984E1) removal/repair/installation	16-17
Brake, pressure regulator valve, trailer (M983) repair	11-13

INDEX (CONT)

Subject	Paragraph, Figure, Table Number
Brake relay valve repair	11-5
Brake, self-recovery winch	
Removal/Installation	16-7
Repair	16-8
Brakeshoe repair	11-2
Brake valve, parking repair.	11-7
Brake valve, spring repair.	11-6
Bulk fuel tank mount (M978) removal/installation	13-26
C	
Cab removal/installation	15-2
Cab supports, front removal/installation	13-3
Cable sheave, heavy-duty winch removal/repair/installation	16-10.1
Carbon monoxide (exhaust gas) warning	a
Cargo body (M977, M985, M985E1) removal/installation	15-10
Cargo body floor hatch (M977, M985) removal/installation	15-9
Cargo body mounting brackets (M977, M985) removal/installation	15-11
Carrier cover, differential, axle No. 3 removal/repair/installation	10-7
Carrier, differential, axle No. 3	
Removal/Installation.	10-9
Repair	10-10
Carrier, differential, axle No. 4 (models 480 and 580)	
Removal/Installation	10-11
Repair	10-12
Case, transfer, lockup valve repair	8-12
Case, transfer, support assembly removal/installation	13-8
Chamber, arctic brake, and rear brake chamber repair	11-4
Chamber, rear brake, antarctic brake chamber repair	11-4
Check valve, front double repair	11-8
Check valve, throttle air solenoid (M984) repair	11-8
Column, steering removal/installation	12-2
Compressed air warning	c
Compressor, air repair	11-9
Control valve, reel hose, HAV hand actuated repair (M978)	15-8
Counterbalance valve, heavy-duty winch (M984) removal/repair/installation	16-15
Counterbalance valve, heavy-duty winch removal/repair/installation	16-15.1
Counterbalance valve, self-recovery winch	
Removal/Installation	16-5
Repair	16-6
Cover assembly, axle housing, axle No. 3 removal/repair/installation.	10-4
Cover, axle housing, axle No. 4 (models 580 and 650) (M984, M984E1) removal/repair/ installation	10-5
Cover, differential carrier, axle No. 3 removal/repair/installation	10-7
Crane mounting brackets (M977, M985) removal/installation	13-27
Crane mounting brackets (M985E1) removal/installation.	13-30
Crane mounting supports (M983) removal/installation	13-28
Crane mounting supports (M984) removal/installation	13-29
Crossmember, front removal/installation	13-10
Crossmember, front intermediate (M977, M978, M984, M985) removal/installation	13-13
Crossmember, front intermediate (M983) removal/installation	13-14
Crossmember, front intermediate (M984E1) removal/installation	13-15.1
Crossmember, front tandem removal/installation	13-11
Crossmember, rear (M977, M985) removal/installation	13-22
Crossmember, rear (M978) removal/installation	13-23

INDEX (CONT)

Subject	Paragraph, Figure, Table Number
Crossmember, rear (M983, M984) removal/installation	13-24
Crossmember, rear (M984E1) removal/installation	13-24.1
Crossmember, rear intermediate (M977, M978, M984, M985, M985E1) removal/installation	13-16
Crossmember, rear intermediate (M983) removal/installation	13-17
Crossmember, rear tandem removal/installation.	13-18
Crossmember, rear tandem (M984E1) removal/installation	13-18.1
Cylinder, lift, retriever (M984E1)	
Removal/Installation	13-30.2
Repair	13-30.3
Cylinder, tow, and pivot brackets, retriever (M984E1) removal/installation	13-30.4
Cylinder, tow, retriever (M984E1) repair.	13-30.5
D	
Defroster nozzle removal/installation.	15-4
Defroster plenum removal/installation.	15-3
Differential carrier, axle No. 3	
Removal/Installation	10-9
Repair	10-10
Differential carrier, axle No. 4	
Removal/Installation	10-11
Repair	10-12
Differential carrier cover, axle No. 3 removal/repair/installation	10-7
Double check valve, front repair	11-8
Drum, heavy-duty winch (M984) repair.	16-12
Drum, self-recovery winch repair.	16-2
E	
Engine support removal/installation	13-5
Equalizer beam assembly (front tandem) removal/repair/installation.	14-6
Equalizer beam assembly (rear tandem) removal/repair/installation.	14-6
Eye, towing removal/installation	13-2
F	
Fairlead tensioner assembly removal/repair/installation and adjustment.	16-10.3
Fairlead tensioner motor (M984E1) removal/repair/installation	16-18
Fifth wheel, 2-Inch (51 mm) kingpin (M983) repair	13-34
Fifth wheel, 3.5-inch (89 mm) kingpin (M983) repair.	13-35
Floor hatch, cargo body (M977, M985) removal/installation	16-9
Front cab supports removal/installation	13-3
Front crossmember removal/installation	13-10
Front double check valve repair.	11-8
Front intermediate crossmember (M977, M978, M984, M986) removal/installation.	13-13
Front intermediate crossmember (M983) removal/installation.	13-14
Front intermediate crossmember (M984E1) removal/installation	13-15.1
Front intermediate gussets (M983) removal/installation.	13-15
Front tandem crossmember removal/installation	13-11
Front tandem, equalizer beam assembly removal/repair/installation	14-5
Front tandem gussets removal/installation	13-12
Fuel transfer hose reel, H1 and H2 (M978) repair.	15-7
Fuel warning.	a
G	
Gear, slave steering, and pitman arm removal/repair/installation.	12-6
Gear, steering adjustment	12-8
Gear, steering, and pitman arm removal/repair/installation.	12-5
Gearbox (90 °) removal/repair/installation	12-4
Governor, air repair.	11-10

INDEX (CONT)

Subject	Paragraph, Figure, Table Number
Ground reel, static (M978) repair	15-6
Gussets, front intermediate (M983) removal/installation	13-15
Gussets, front tandem removal/installation	13-12
Gussets, rear tandem (M977, M978, M985, M985E1) removal/installation	13-19
Gussets, rear tandem (M983) removal/installation	13-20
Gussets, rear tandem (M984) removal/installation	13-21
H	
H1 and H2 fuel transfer hose reel (M978) repair	15-7
HAND ACTUATED CONTROL VALVE, HAV, hose reel repair	15-8
Hand control valve, trailer brake repair	11-12
Hanger, spring removal/installation	13-9
Hatch, cargo body, floor (M977, M98.5) removal/installation	15-9
HAV HAND ACTUATED CONTROL VALVE airhose reel (M978) repair	15-8
Heavy-duty winch	
Removal/Installation (M984)	16-10
Repair (M984)	16-11
Repair (M984E1)	16-11.1
Heavy-duty winch and brackets removal/installation	16-10.2
Heavy-duty winch brake (M984) removal/repair/installation	16-16
Heavy-duty winch brake (M984E1) removal/repair/installation	16-17
Heavy-duty winch cable sheave removal/repair/installation	16-10.1
Heavy-duty winch counterbalance valve (M984) removal/repair/installation	16-15
Heavy-duty winch counterbalance valve removal/repair/installation	16-15.1
Heavy-duty winch drum (M984) repair	16-12
Heavy-duty winch hydraulic motor	
Removal/Installation (M984)	16-13
Removal/Installation	16-13.1
Repair (M984)	16-14
Repair	16-14.1
Heavy-duty winch supports (M984) removal/installation	16-9
High voltage warning	b
Hose reel, H1 and H2 fuel transfer (M978) repair	15-7
Hose reel, HAV HAND ACTUATED CONTROL VALVE (M978) repair	15-8
Hot exhaust pipe/muffler warning	b
Hot radiator warning	b
Housing cover assembly, axle No. 3 removal/repair/installation	10-4
Housing cover, axle No. 4 (models 580 and 650) (M984, M984E1) removal/repair/installation	10-5
Hydraulic motor, heavy-duty winch	
Removal/Installation (M984)	16-13
Removal/Installation	16-13.1
Repair (M9X4)	16-14
Repair PN 73077	16-14.1
Repair PN V12-80TSSHS000A080/031ACI01I-096/050-000	16-14.2
Hydraulic motor, self-recovery winch	
Removal/Installation	16-3
Repair	16-4
I	
Insulation removal/installation	15-5
Intergear link removal/installation	12-3
Intermediate crossmember, front (M977, M978, M984, M985) removal/installation	13-13
Intermediate crossmember, front (M983) removal/installation	13-14
Intermediate crossmember, front (M984E1) removal/installation	13-15.1
Intermediate crossmember, rear (M977, M978, M984, M98.5, M985E1) removal/installation	13-16
Intermediate crossmember, rear (M983) removal/installation	13-17

INDEX (CONT)

Subject	Paragraph, Figure, Table Number
Intermediate crossmember, rear (M984E1) removal/installation	13-17.1
Intermediate gussets, front (M983) removal/installation	13-15
J	
.Jewelry, wearing, warning	a
K	
Kingpin, 2-inch (51 mm), fifth wheel (M983) repair	13-34
Kingpin, 2-inch (51 mm), plate assembly (M983) removal/installation	13-31
Kingpin, 3.5-inch (89 mm), fifth wheel (M983) repair	13-35
Kingpin, 3.5-inch (89 mm), plate assembly (M983) removal/installation.	13-32
L	
Lateral torque rod removal/installation	14-4
Lift bracket assemblies removal/installation	13-6
Lift cylinder, retriever (M984E1)	
Removal/Installation	13-30.2
Repair	13-30.3
Link, intergear removal/installation.	12-3
Lockup valve, transfer case repair.	8-12
Low voltage warning	b
M	
Manifold, steering/tensioner, and bracket (M984E1) removal/repair/installation	12-7.2
Module, pump (M978) removal/installation	15-13
Motor, fairlead/tensioner (M984E1) removal/repair/installation	16-18
Motor, heavy-duty winch hydraulic	
Removal/Installation (M984).....	16-13
Removal/Installation	16-13.1
Repair (M984)	16-14
Repair	16-14.1
Motor, self-recovery winch hydraulic	
Removal/Installation	16-3
Repair	16-4
Mount, 2500 gallon tank (M978) removal/installation.	13-26
Mounting brackets, cargo body (M977, M985) removal/installation	15-11
Mounting brackets, crane (M977, M985) removal/installation	13-27
Mounting brackets, crane (M985E1) removal/installation	13-30
Mounting brackets, wrecker body (M984) removal/installation.	15-17
Mounting supports, crane (M983) removal/installation.	13-28
Mounting supports, crane (M984) removal/installation.	13-29
N	
No. 3 and No. 4 axle, yoke and oil seal removal/installation	10-6
No. 3 axle (models 480 and 580) removal/installation	10-2
No. 3 axle, differential carrier	
Removal/Installation	10-9
Repair	10-10
No. 3 axle, differential carrier cover removal/repair/installation	10-7
No. 3 axle housing cover assembly removal/repair/installation.	10-4
No. 4 and No. 3 axle, yoke and oil seal removal/installation	10-6
No. 4 axle (models 480 and 580) removal/installation	10-3
No. 4 axle, differential carrier	
Removal/Installation	10-11
Repair	10-12
No. 4 axle housing cover (models 580 and 650) (M984, M984E1) removal/repair/installation	10-5
Nozzle, defroster removal/installation	15-4
Nuclear, biological, or chemical exposure warning.	c

INDEX (CONT)

Subject	Paragraph, Figure, Table Number
O	
Oil seal and yoke (axle No. 3 and No. 4) removal/installation	10-6
P	
Parking brake, incorrect use of, warning	a
Parking brake valve repair.	11-7
Pitman arm and slave steering gear removal/repair/installation	12-6
Pitman arm and steering gear removal/repair/installation	12-5
Plate assembly, 2-inch (51 mm) kingpin (M983) removal/installation	13-31
Plate assembly, 3.5-inch (89 mm) kingpin (M983) removal/installation.	13-32
Plate assembly (M983) repair.	13-33
Plenum, defroster removal/installation	15-3
Pressure regulator valve, trailer brake repair	11-12
Protection valve, tractor repair.	11-13
Pump module (M978) removal/installation	15-13
Pump, steering removal/repair/installation	12-7
Pump, steering (M984E1) removal/repair/installation	12-7.1
Pump support assembly (M978) removal/installation	13-25
R	
Radiator support removal/installation	13-4
Rear brake chamber and arctic brake chamber repair	11-4
Rear crossmember (M977, M985) removal/installation	13-22
Rear crossmember (M978) removal/installation.	13-23
Rear crossmember (M983, M984) removal/installation.	13-24
Rear crossmember (M984E1) removal/installation	13-24.1
Rear intermediate crossmember (M977, M978, M984, M985, M985E1) removal/installation	13-16
Rear intermediate crossmember (M983) removal/installation	13-17
Rear intermediate crossmember (M984E1) removal/installation	13-17.1
Rear tandem crossmember removal/installation	13-18
Rear tandem crossmember (M984E1) removal/installation	13-18.1
Rear tandem, equalizer beam assembly removal/repair/installation	14-6
Rear tandem gussets (M977, M978, M985, M985E1) removal/installation.	13-19
Rear tandem gussets (M983) removal/installation.	13-20
Rear tandem gussets (M984) removal/installation.	13-21
Rear tandem suspension alinement	14-7
Reel, fuel transfer hose, H1 and H2 (M978) repair	15-7
Reel, HAV HAND ACTUATED CONTROL VALVE air hose (M978) repair	15-8
Reel, static ground (M978) repair	15-6
Regulator valve, trailer brake pressure repair	11-12
Relay valve, brake repair	11-5
Retriever lift cylinder (M984E1) Removal/Installation	13-30.2
Repair	13-30.3
Retriever tow cylinder and pivot brackets (M984E1) removal/installation.	13-30.4
Retriever tow cylinder (M984E1) repair	13-30.5
Retriever towing support assembly (M984E1) removal/installation	13-30.1
Rod, lateral torque removal/installation	14-4
S	
Seal, oil, and yoke (axle No. 3 and No. 4 removal/installation.	10-6
Seatbelts use warning	b
Self-recovery winch brake Removal/Installation	16-7
Repair	16-8
Self-recovery winch counterbalance valve Removal/Installation	16-5

INDEX (CONT)

Subject	Paragraph, Figure, Table Number
Self-recovery winch counterbalance valve (Cont)	
Repair	16-6
Self-recovery winch drum repair	16-2
Self-recovery winch hydraulic motor	
Removal/Installation	16-3
Repair	16-4
Sheave, cable, heavy-duty winch removal/repair/installation.	16-10.1
Sill, wood (M977, M985) removal/installation	15-12
Sill, wood (M984) removal/installation	15-18
Slave steering gear and pitman arm removal/repair/installation	12-6
Solenoid check valve, throttle air (M984) repair	11-8
Spring	
Removal/Installation	14-2
Repair	14-3
Spring brake valve repair.	11-6
Spring hanger removal/installation.	13-9
Starting fluid warning	c
Static ground reel repair	15-6
Steering column removal/installation.	12-2
Steering gear adjustment	12-8
Steering gear and pitman arm removal/repair/installation.	12-5
Steering gear, slave, and pitman arm removal/repair/installation	12-6
Steering gearbox (90°) removal/repair/installation	12-4
Steering pump removal/repair/installation	12-7
Steering pump (M984E1) removal/repair/installation	12-7.1
Steering system alinement	12-10
Steering/tensioner manifold and bracket (M984E1) removal/repair/installation	12-7.2
Steering toe-in adjustment	12-9
Supply valve, trailer repair.	11-11
Support assembly, pump (M978) removal/installation.	13-25
Support assembly, retriever towing (M984E1) removal/installation	13-30.1
Support assembly, transfer case removal/installation.	13-8
Support, engine removal/installation	13-5
Support, radiator removal/installation	13-4
Support, transmission removal/installation	13-7
Supports, cab, front removal/installation	13-3
Supports, heavy-duty winch (M984) removal/installation	16-9
Supports, mounting, crane (M983) removal/installation.	13-28
Supports, mounting, crane (M984) removal/installation.	13-29
Suspension, rear tandem, alinement	14-7
T	
Table of contents	i
Tandem crossmember, front removal/installation.,	13-11
Tandem crossmember, rear removal/installation	13-18
Tandem crossmember, rear (M984E1) removal/installation	13-18.1
Tandem, equalizer beam assembly, front removal/repair/installation	14-5
Tandem, equalizer beam assembly, rear removal/repair/installation	14-6
Tandem, gussets, front removal/installation	13-12
Tandem, gussets, rear (M977, M978, M985, M985E1) removal/installation.	13-19
Tandem, gussets, rear (M983) removal/installation	13-20
Tandem, gussets, rear (M984)	13-21
Tandem, suspension, rear, alinement	14-7
Tank, 2500 gallon (M978) removal/installation	15-14

INDEX (CONT)

Subject	Paragraph, Figure, Table Number
Tank mount, 2500 gallon (M978) removal/installation	13-26
Tank vent (M978) removal/installation.	15-15
Tensioner assembly, fairlead removal/repair/installation and adjustment.	16-10.3
Tensioner/fairlead motor (M984E1) removal/repair/installation	16-18
Tensioner/steering manifold and bracket (M984E1) removal/repair/installation	12-7.2
Throttle air solenoid check valve (M984) repair	11-8
Toe-in, steering adjustment	12-9
Torque rod, lateral removal/installation.	14-4
Tow cylinder and pivot brackets, retriever (M984E1) removal/installation	13-30.4
Tow cylinder, retriever (M984E1) repair	13-30.5
Towing eye removal/installation	13-2
Towing support assembly, retriever (M984E1) removal/installation	13-30.1
Tractor protection valve repair.	11-13
Trailer brake hand control valve repair	11-12
Trailer brake warning	b
Trailer supply valve repair	11-11
Transfer case lockup valve repair.	12-8
Transfer hose reel, fuel, H1 and H2 (M978) repair	15-7
Transfer case support assembly removal/installation	13-8
Transmission support removal/installation	13-7
V	
Valve, brake, parking repair.	11-7
Valve, brake, spring repair.	11-6
Valve, brake check repair.	11-8
Valve, check, front double repair	11-8
Valve, check, throttle air solenoid (M984) repair	11-8
Valve, control, HAV HAND ACTUATED, hose reel (M978) repair	15-8
Valve, lockup, transfer case	12-8
Valve, counterbalance, heavy-duty winch (M984) removal/repair/installation	16-15
Valve, counterbalance, heavy-duty winch removal/repair/installation.	16-15.1
Valve, counterbalance, self-recovery winch Removal/Installation	16-5
Repair	16-6
Valve, parking brake repair.	11-7
Valve, hand control, trailer brake repair	11-12
Valve, relay, brake repair.	11-5
Valve, spring brake repair.	11-6
Valve, throttle air solenoid check (M984)	11-8
Valve, tractor protection repair	11-13
Valve, trailer brake pressure regulator repair	11-12
Valve, trailer supply repair.	11-11
Valve, transfer case lockup repair	12-8
Vent, tank (M978) removal/installation	15-15
W	
Warnings	
Adhesives and solvents	a
Asbestos in brake linings.	c
Batteries, terminals, and cables	c
Carbon monoxide (exhaust gas)	a
Compressed air	c
Crane operation under powerlines.	b

INDEX (CONT)

Subject	Paragraph, Figure, Table Number
Warnings (cont)	
Fuel	a
High voltage	b
Hot exhaust pipe/muffler	b
Hotradiator	b
Jewelry, wearing of	a
"Low" voltage	b
Nuclear, biological, or chemical (NBC) exposure	c
Parking brake, incorrect use of	a
Seatbelts, use of	b
Starting fluid.	c
Trailer brakes	b
Winch cable, handling of	b
Winch operation	b
Wheel, fifth, 2-inch (51 mm) kingpin repair	13-34
Wheel fifth, 3.5-inch (89 mm) kingpin repair	13-35
Winch brake heavy-duty (M984) removal/repair/installation.	16-16
Winch brake, heavy-duty (M984E1) removal/repair/installation	16-17
Winch brake, self-recovery	
Removal/Installation	16-7
Repair	16-8
Winch counterbalance valve, heavy-duty (M984) removal/repair/installation	16-15
Winch counterbalance valve, heavy-duty removal/repair/installation.	16-15.1
Winch counterbalance valve, self-recovery	
Removal/Installation	16-5
Repair	16-6
Winch drum, heavy-duty (M984) repay	16-12
Winch drum, self-recovery repair	16-2
Winch, heavy-duty	
Removal/Installation (M984)	16-10
Repair (M984)	16-11
Repair (M984E1)	16-11.1
Winch heavy-duty, and brackets removal/installation	16-10.2
Winch: heavy-duty, cable sheave removal/repair/installation	16-10.1
Winch hydraulic motor heavy-duty	
Removal/Installation (M984)	16-13
Removal/Installation	16-13.1
Repair (M984)	16-14
Repair PN 73077	16-14.1
Repair PN V12-80TSSHS000A080/031ACI011-096/050-000	16-14.2
Winch hydraulic motor, self-recovery	
Removal/Installation	16-3
Repair	16-4
Winch maintenance	16-1
Winch, self-recovery, drum repair	16-2
Winch supports, heavy-duty (M984) removal/installation	16-9
Wood sill (M977,M985) removal/installation	15-12
Woodsill	15-18
Wrecker body (M984) removal/installation.	15-16
Wrecker body mounting brackets (M984) removal/installation	15-16
Y	
Yoke and oil seal (axle No. 3 and No. 4) removal/installation	10-6

By Order of the Secretary of the Army:

JOHN A. WICKHAM, JR.
General, United States Army
Chief of Staff

Official:

R.L. DILWORTH
Brigadier General United States Army
The Adjutant General

Distribution

To be distributed in accordance with DA Form 12-38, Direct and General Support Maintenance requirements for Truck, Cargo, 10-Ton, 8x8, Heavy Expanded Mobility, Tactical Truck, HEMTT, m977, M9778, M983, M984, and M985.

RECOMMENDED CHANGES TO EQUIPMENT PUBLICATIONS



SOMETHING WRONG

WITH THIS PUBLICATION?

THEN - JOT DOWN THE INFO ON THIS FORM---TEAR OUT THIS PAGE---FOLD IT---AND DROP IT IN THE MAIL!

FROM: (IMPRINT YOUR UNIT'S COMPLETE ADDRESS)

HQ & HQ CO.
46TH TRANS. BN.
FT. CARSON, CO

DATE SENT: 5 JAN., 1997

PUBLICATION NUMBER TM 9-2320-279-34	PUBLICATION DATE 3 JUNE 1987	PUBLICATION TITLE DIRECT SUPPORT AND GENERAL SUPPORT MAINTENANCE MANUAL M977 Series Vehicles
--	---------------------------------	--

BE EXACT...PINPOINT WHERE IT IS				IN THIS SPACE, TELL WHAT IS WRONG AND WHAT SHOULD BE DONE ABOUT IT:
PAGE NO.	PARA-GRAPH	FIGURE NO.	TABLE NO.	
21-8	21-2	NA	NA	<p><i>In para 21-2.c, Assembly, step (1) user is not cautioned about touching commutator.</i></p> <p><i>Add caution to not touch commutator of armature during assembly so oils from skin will not damage it.</i></p>

SAMPLE

PRINTED NAME, GRADE OR TITLE, AND TELEPHONE NUMBER ALBERT RAND, SSG, 226-5644	SIGN HERE: <i>Albert Rand</i>
--	----------------------------------

TEAR ALONG PERFORATED LINE

RECOMMENDED CHANGES TO EQUIPMENT PUBLICATIONS



SOMETHING WRONG

WITH THIS PUBLICATION?

FROM: (IMPRINT YOUR UNIT'S COMPLETE ADDRESS)

DATE SENT:

THEN - JOT DOWN THE INFO ON THIS FORM---TEAR OUT THIS PAGE---FOLD IT---AND DROP IT IN THE MAIL!

PUBLICATION NUMBER TM 9-2320-279-34-2	PUBLICATION DATE 3 JUNE 1987	PUBLICATION TITLE DIRECT SUPPORT AND GENERAL SUPPORT MAINTENANCE MANUAL M977 Series Vehicles
---	--	---

BE EXACT...PINPOINT WHERE IT IS				IN THIS SPACE, TELL WHAT IS WRONG AND WHAT SHOULD BE DONE ABOUT IT:
PAGE NO.	PARA-GRAPH	FIGURE NO.	TABLE NO.	

PRINTED NAME, GRADE OR TITLE, AND TELEPHONE NUMBER

SIGN HERE:

TEAR ALONG PERFORATED LINE

FILL IN YOUR
UNIT'S ADDRESS



FOLD BACK

DEPARTMENT OF THE ARMY



OFFICIAL BUSINESS

NO POSTAGE
NECESSARY
IF MAILED
IN THE
UNITED STATES

BUSINESS REPLY MAIL
FIRST CLASS BRM PERMIT NO. 82 ROCK ISLAND, IL

POSTAGE WILL BE PAID BY ROCK ISLAND ARSENAL

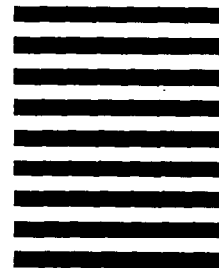

Director
Armament and Chemical Acquisition
and Logistics Activity
ATTN: AMSTA-AC-NML
Rock Island, IL 61201-9948

TEAR ALONG PERFORATED LINE



THE METRIC SYSTEM AND EQUIVALENTS

LINEAR MEASURE

1 Centimeter = 10 Millimeters = 0.01 Meters = 0.3937 Inches
 1 Meter = 100 Centimeters = 1000 Millimeters = 39.37 Inches
 1 Kilometer = 1000 Meters = 0.621 Miles

WEIGHTS

1 Gram = 0.001 Kilograms = 1000 Milligrams = 0.035 Ounces
 1 Kilogram = 1000 Grams = 2.2 Lb
 1 Metric Ton = 1000 Kilograms = 1 Megagram = 1.1 Short Tons

LIQUID MEASURE

1 Milliliter = 0.001 Liters = 0.0338 Fluid Ounces
 1 Liter = 1000 Milliliters = 33.82 Fluid Ounces

SQUARE MEASURE

1 Sq Centimeter = 100 Sq Millimeters = 0.155 Sq Inches
 1 Sq Meter = 10,000 Sq Centimeters = 10.76 Sq Feet
 1 Sq Kilometer = 1,000,000 Sq Meters = 0.386 Sq Miles

CUBIC MEASURE

1 Cu Centimeter = 1000 Cu Millimeters = 0.06 Cu Inches
 1 Cu Meter = 1,000,000 Cu Centimeters = 35.31 Cu Feet

TEMPERATURE

$5/9 (^{\circ}\text{F} - 32) = ^{\circ}\text{C}$
 212^o Fahrenheit is equivalent to 100^o Celsius
 90^o Fahrenheit is equivalent to 32.2^o Celsius
 32^o Fahrenheit is equivalent to 0^o Celsius
 $9/5 \text{ C}^{\circ} + 32 = \text{F}^{\circ}$

APPROXIMATE CONVERSION FACTORS

<u>TO CHANGE</u>	<u>TO</u>	<u>MULTIPLY BY</u>
Inches	Centimeters	2.540
Feet	Meters	0.305
Yards	Meters	0.914
Miles	Kilometers	1.609
Square Inches	Square Centimeters	6.451
Square Feet	Square Meters	0.093
Square Yards	Square Meters	0.836
Square Miles	Square Kilometers	2.590
Acres	Square Hectometers	0.405
Cubic Feet	Cubic Meters	0.028
Cubic Yards	Cubic Meters	0.765
Fluid Ounces	Milliliters	29.573
Pints	Liters	0.473
Quarts	Liters	0.946
Gallons	Liters	3.785
Ounces	Grams	28.349
Pounds	Kilograms	0.454
Short Tons	Metric Tons	0.907
Pound-Feet	Newton-Meters	1.356
Pounds per Square Inch	Kilopascals	6.895
Miles per Gallon	Kilometers per Liter	0.425
Miles per Hour	Kilometers per Hour	1.609

<u>TO CHANGE</u>	<u>TO</u>	<u>MULTIPLY BY</u>
Centimeters	Inches	0.394
Meters	Feet	3.280
Meters	Yards	1.094
Kilometers	Miles	0.621
Square Centimeters	Square Inches	0.155
Square Meters	Square Feet	10.764
Square Meters	Square Yards	1.196
Square Kilometers	Square Miles	0.386
Square Hectometers	Acres	2.471
Cubic Meters	Cubic Feet	35.315
Cubic Meters	Cubic Yards	1.308
Milliliters	Fluid Ounces	0.034
Liters	Pints	2.113
Liters	Quarts	1.057
Liters	Gallons	0.264
Grams	Ounces	0.035
Kilograms	Pounds	2.205
Metric Tons	Short Tons	1.102
Newton-Meters	Pound-Feet	0.738
Kilopascals	Pounds per Square Inch	0.145
Kilometers per Liter	Miles per Gallon	2.354
Kilometers per Hour	Miles per Hour	0.621

