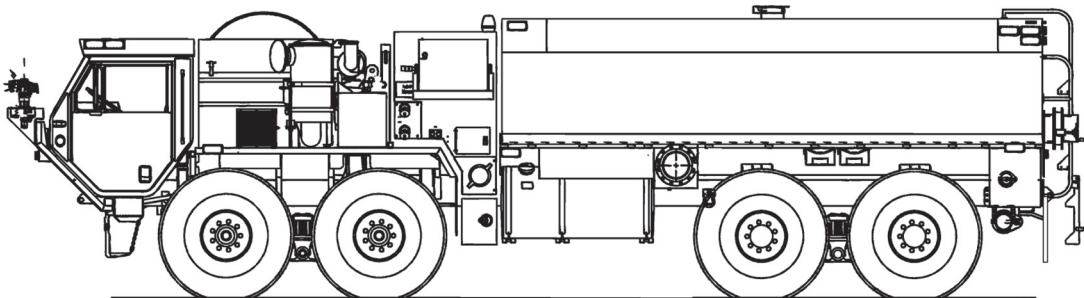


# \* TM 9-2320-328-13&P-2

---

TECHNICAL MANUAL  
OPERATOR'S AND FIELD LEVEL  
MAINTENANCE MANUAL  
(INCLUDING REPAIR PARTS AND SPECIAL TOOLS LIST)  
FOR  
HEMTT-BASED WATER TENDER (HEWATT)  
MODEL M1158  
NSN 2320-01-528-6294



\* **SUPERSEDURE NOTICE:** This manual supersedes TM 9-2320-328-13&P-2 dated 30 April 2008.

**DISTRIBUTION STATEMENT A:** Approved for public release; distribution is unlimited.

---

**HEADQUARTERS, DEPARTMENT OF THE ARMY**

**15 MARCH 2009**



---

**WARNING SUMMARY**

---

This list summarizes critical warnings in this technical manual. They are repeated here to let you know how important they are. Study these warnings carefully. They can save your life and the lives of personnel you work with. If there is any doubt about handling tools, materials, equipment, and procedures, see TB 43-0216, Safety and Hazard Warnings for Operation and Maintenance of TACOM Equipment.

**FOR INFORMATION ON FIRST AID, REFER TO FM 4-25.11.**

**OPERATION HAZARDS****WARNING**

- **CARBON MONOXIDE (EXHAUST GAS) CAN CAUSE DEATH**
- **Carbon monoxide is without color or smell, but can cause death. Breathing air with carbon monoxide produces symptoms of headache, dizziness, loss of muscular control, a sleepy feeling, and coma. Brain damage or death can result from heavy exposure. Carbon monoxide occurs in the exhaust fumes of fuel-burning heaters and internal combustion engines. Carbon monoxide can become dangerously concentrated under conditions of no ventilation. Precautions must be followed to ensure crew safety when the personnel heater or engine of any vehicle is operated for any purpose.**
- **DO NOT operate personnel heater or engine of vehicle in a closed place without proper ventilation.**
- **DO NOT drive any vehicle with inspection plates, cover plates, or engine compartment covers removed unless necessary for maintenance purposes.**
- **BE ALERT at all times during vehicle operation for exhaust odors and exposure symptoms. If either are present, IMMEDIATELY VENTILATE personnel compartments. If symptoms persist, remove affected crew to fresh air and keep warm. DO NOT PERMIT PHYSICAL EXERCISE. If necessary, give artificial respiration and get immediate medical attention. For artificial respiration, refer to FM 4-25.11.**
- **BE AWARE that the gas particulate filter unit or field protection mask for nuclear-biological-chemical protection WILL NOT offer safety from carbon monoxide poisoning.**
- **THE BEST DEFENSE AGAINST CARBON MONOXIDE POISONING IS GOOD VENTILATION.**

**WARNING**



Personnel hearing can be **PERMANENTLY DAMAGED** if exposed to constant high noise levels of 85 dB or greater. Wear approved hearing protection devices when working in high noise level areas. Hearing loss occurs gradually, but becomes permanent over time.

**WARNING**



Diesel fuel compartment heaters come on automatically when truck engine is running and air temperature is below 39°F (4°C). **CARBON MONOXIDE (EXHAUST GAS) CAN KILL YOU.** Carbon monoxide is a colorless, odorless, **DEADLY POISONOUS** gas and when breathed, deprives body of oxygen and causes **SUFFOCATION**. Breathing air with carbon monoxide produces symptoms of headache, dizziness, loss of muscular control, a sleepy feeling, and coma. **Permanent BRAIN DAMAGE or DEATH** can result from severe exposure. Precautions **MUST** be followed to ensure personnel are safe whenever compartment heaters or engine are operated for any purpose. Injury to personnel may result.

**WARNING**



**DO NOT** operate compartment heaters or engine of truck in enclosed area without adequate ventilation. **BE ALERT** at all times whenever **BATTERY** switch is **ON**, truck engine is running, and air temperature is below 39°F (4°C) for exhaust symptoms. If either are present, **IMMEDIATELY EVACUATE AND VENTILATE** the area. Affected personnel treatment shall be: expose to fresh air; keep warm; **DO NOT PERMIT PHYSICAL EXERCISE**; if necessary, give artificial respiration as described in FM 4-25.11 and get medical attention. **BE AWARE**; neither the gas particulate filter unit nor field protection mask for nuclear-biological-chemical protection will protect you from carbon monoxide poisoning. **THE BEST DEFENSE AGAINST CARBON MONOXIDE POISONING IS GOOD VENTILATION.**

## MODIFICATION HAZARD

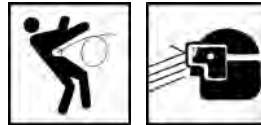
### WARNING



Unauthorized modifications to, alterations to, or installations of this equipment are prohibited and are in violation of AR 750-10. Any unauthorized modifications, alterations, or installations could result in injury or death to personnel or damage to equipment.

## HIGH-PRESSURE HYDRAULIC SYSTEM

### WARNING



- Hydraulic systems can cause serious injury if high-pressure lines or equipment fails.
- Never work on hydraulic systems or equipment unless there is another person nearby who is familiar with the operation and hazards of the equipment and can give first aid.
- Be sure to wear proper eye protection to prevent injury or death. Never disconnect any hydraulic hose or part while the engine is running. Allow several minutes to elapse after shutting off engine, to allow pressure to relieve itself, before attempting to remove hoses. Failure to comply may result in injury to personnel.

## ELECTRICAL SYSTEM

### WARNING



- Remove all jewelry, such as rings, dog tags, bracelets, etc. If jewelry or tools contact electrical circuits, a direct short may result. Damage to equipment or death to personnel may occur.
- Do not smoke, use open flame, make sparks or other ignition sources around batteries. A battery giving off gas could explode and cause injury to personnel.

**SOLVENT CLEANING COMPOUND****WARNING**

Solvent cleaning compound MIL-PRF-680 Type II and III may be irritating to the eyes and skin. Use protective gloves and goggles. Use in well-ventilated areas. Use respirator as needed. Accidental ingestion can cause irritation of digestive tract and respiratory tract, may cause lung and central nervous system damage. Can be fatal if swallowed. Inhalation of high/massive concentrations can cause coma or be fatal. First aid for ingestion: do not induce vomiting. Seek immediate medical attention. First aid for skin contact: remove contaminated clothing. Wash skin thoroughly with soap and water. If symptoms persist, seek medical attention. First aid for eye contact: flush with water for 15 minutes or until irritation subsides. If symptoms persist, seek medical attention. First aid for inhalation: move to fresh air. If not breathing, provide artificial respiration. If symptoms persist, seek medical attention. Keep away from open flames and other sources of ignition. Failure to follow this warning may result in injury or death to personnel.

- The flashpoint for Type II solvent cleaning compound is 141 to 198°F (61 to 92°C) and Type III is 200 to 241°F (93 to 116°C).
- Improper cleaning methods and use of unauthorized cleaning solvents may injure personnel and damage equipment.
- Fire extinguishers should be placed nearby when using solvent cleaning compound. Failure to follow this warning may result in injury or death.
- Cloths or rags saturated with solvent cleaning compound must be disposed of IAW authorized facility's procedures. Failure to follow this warning may result in injury.
- Eye shields must be worn when cleaning with a wire brush. Flying rust and metal particle may cause injury.

**ADHESIVE****WARNING**

Adhesives, solvents, and sealing compounds can burn easily, can give off harmful vapors, and are harmful to skin and clothing. To avoid injury or death, keep away from open fire and use in well-ventilated area. If adhesive, solvent, or sealing compound gets on skin or clothing, wash immediately with soap and water.

**FLAMMABLE LIQUID AND COMBUSTIBLE VAPOR**

**WARNING**



Gasoline, fuel oil, lubricating oil, grease, paint, paint thinner, cleaning solvents, and other combustible liquids present a serious fire hazard. Always store combustible liquids in approved containers and in their designated compartments or deck storage locations. Ensure exhaust and ventilation fans are operating while using cleaning solvents or paint products. Never store or charge batteries in a confined space without ventilation or near electrical equipment.

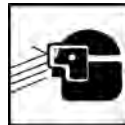
**WARNING**



Fuel is very flammable and can explode easily. To avoid serious injury or death, keep fuel away from open fire and keep fire extinguisher within easy reach when working with fuel. Do not work on fuel system when engine is hot. Fuel can be ignited by hot engine. While working with fuel, post signs that read **NO SMOKING WITHIN 50 FEET OF VEHICLE**.

**PARTS UNDER PRESSURE**

**WARNING**



Wear safety goggles and use caution when removing or installing springs, snap rings, retaining rings, and other parts under spring tension. These parts can act as projectiles, resulting in serious injury to personnel.





CHANGE  
NO. 1

HEADQUARTERS  
DEPARTMENT OF THE ARMY  
WASHINGTON, D.C., 20 JUNE 2012

**TECHNICAL MANUAL**  
**OPERATOR'S AND FIELD LEVEL**  
**MAINTENANCE MANUAL**  
**(INCLUDING REPAIR PARTS AND SPECIAL TOOLS LIST**

**FOR**  
**HEMTT-BASED WATER TENDER (HEWATT)**

**MODEL M1158**

**NSN 2320-01-528-6294**

**DISTRIBUTION STATEMENT A:** Approved for public release; distribution is unlimited.

TM 9-2320-328-13&P-2, dated 15 March 2009, is updated as follows:

1. File this sheet in front of the manual for reference.
2. This change is a result of a configuration change to the vehicle.
3. New or updated text and illustrations are indicated by a vertical bar in the outer margin of the page.
4. Remove old pages and insert new pages as indicated below:

**Remove Pages**

A thru C/(D blank)

i thru xi/(xii blank)

INDEX-1 thru INDEX-25/(26 blank)

----

**Insert Pages**

A thru C/(D blank)

i thru xii

INDEX-1 thru INDEX-26

2028s

5. Replace the following work packages with their revised version.

**Work Package Number**

WP 0113	WP 0211
WP 0114	WP 0212
WP 0116	WP 0217
WP 0117	WP 0227
WP 0119	WP 0229
WP 0121	WP 0237
WP 0123	WP 0245
WP 0125	WP 0246
WP 0126	WP 0250
WP 0129	WP 0259
WP 0131	WP 0266
WP 0175	WP 0267
WP 0184	WP 0268
WP 0188	WP 0283
WP 0190	WP 0286
WP 0193	WP 0288
WP 0194	WP 0292
WP 0196	WP 0298
WP 0205	WP 0311
WP 0210	

6. Add the following new work packages.

**Work Package Number**

WP 0124.1  
WP 0131.1  
WP 0237.1  
WP 0305.1  
WP 0305.2

By order of the Secretary of the Army:

RAYMOND T. ODIERNO  
*General, United States Army*  
*Chief of Staff*

Official:



JOYCE E. MORROW  
*Administrative Assistant to the*  
*Secretary of the Army*  
1213005

Distribution: To be distributed in accordance with the initial distribution number (IDN) 381179 requirements for TM 9-2320-328-13&P-2.



## LIST OF EFFECTIVE PAGES/WORK PACKAGES

NOTE: This manual supersedes TM 9-2320-328-13&P-2 dated 30 April 2008. Zero in the "Change No." column indicates an original page or work package.

Date of issue for the original manual is:

Original 15 March 2009

Change 1 20 June 2012

**TOTAL NUMBER OF VOLUMES IS 3, TOTAL NUMBER OF PAGES  
FOR FRONT AND REAR MATTER IS 198 AND TOTAL NUMBER OF  
WORK PACKAGES IS 408, CONSISTING OF THE FOLLOWING:**

Page/WP No.	Change No.	Page/WP No.	Change No.
<b>VOLUME 2</b>			
Cover . . . . .	1	WP 0137 (8 pgs) . . . . .	0
Warning Summary (6 pgs) . . . . .	0	WP 0138 (8 pgs) . . . . .	0
i/(ii blank) . . . . .	1	WP 0139 (2 pgs) . . . . .	0
iii thru xii. . . . .	1	WP 0140 (2 pgs) . . . . .	0
Chp 3 Title Cont. page . . . . .	0	WP 0141 (10 pgs) . . . . .	0
WP 0113 (10 pgs) . . . . .	1	WP 0142 (10 pgs) . . . . .	0
WP 0114 (10 pgs) . . . . .	1	WP 0143 (6 pgs) . . . . .	0
WP 0115 (10 pgs) . . . . .	0	WP 0144 (2 pgs) . . . . .	0
WP 0116 (24 pgs) . . . . .	1	WP 0145 (2 pgs) . . . . .	0
WP 0117 (18 pgs) . . . . .	1	WP 0146 (2 pgs) . . . . .	0
WP 0118 (10 pgs) . . . . .	0	WP 0147 (2 pgs) . . . . .	0
WP 0119 (8 pgs) . . . . .	1	WP 0148 (12 pgs) . . . . .	0
WP 0120 (32 pgs) . . . . .	0	WP 0149 (2 pgs) . . . . .	0
WP 0121 (18 pgs) . . . . .	1	WP 0150 (2 pgs) . . . . .	0
WP 0122 (12 pgs) . . . . .	0	WP 0151 (8 pgs) . . . . .	0
WP 0123 (10 pgs) . . . . .	1	WP 0152 (14 pgs) . . . . .	0
WP 0124 (6 pgs) . . . . .	0	WP 0153 (12 pgs) . . . . .	0
WP 0124.1 (4 pgs) . . . . .	1	WP 0154 (2 pgs) . . . . .	0
WP 0125 (12 pgs) . . . . .	1	WP 0155 (4 pgs) . . . . .	0
WP 0126 (6 pgs) . . . . .	1	WP 0156 (2 pgs) . . . . .	0
WP 0127 (26 pgs) . . . . .	0	WP 0157 (2 pgs) . . . . .	0
Chp 4 Title page . . . . .	0	WP 0158 (20 pgs) . . . . .	0
WP 0128 (6 pgs) . . . . .	0	WP 0159 (4 pgs) . . . . .	0
WP 0129 (36 pgs) . . . . .	1	WP 0160 (4 pgs) . . . . .	0
Chp 5 Title page . . . . .	0	WP 0161 (4 pgs) . . . . .	0
WP 0130 (12 pgs) . . . . .	0	WP 0162 (4 pgs) . . . . .	0
WP 0131 (4 pgs) . . . . .	1	WP 0163 (4 pgs) . . . . .	0
WP 0131.1 (8 pgs) . . . . .	1	WP 0164 (2 pgs) . . . . .	0
WP 0132 (6 pgs) . . . . .	0	WP 0165 (6 pgs) . . . . .	0
WP 0133 (2 pgs) . . . . .	0	WP 0166 (4 pgs) . . . . .	0
WP 0134 (10 pgs) . . . . .	0	WP 0167 (2 pgs) . . . . .	0
WP 0135 (2 pgs) . . . . .	0	WP 0168 (4 pgs) . . . . .	0
WP 0136 (2 pgs) . . . . .	0	WP 0169 (6 pgs) . . . . .	0
		WP 0170 (2 pgs) . . . . .	0

Page/WP No.	Change No.	Page/WP No.	Change No.
WP 0171 (6 pgs)	0	WP 0221 (2 pgs)	0
WP 0172 (2 pgs)	0	WP 0222 (2 pgs)	0
WP 0173 (4 pgs)	0	WP 0223 (4 pgs)	0
WP 0174 (4 pgs)	0	WP 0224 (8 pgs)	0
WP 0175 (2 pgs)	1	WP 0225 (4 pgs)	0
WP 0176 (2 pgs)	0	WP 0226 (6 pgs)	0
WP 0177 (6 pgs)	0	WP 0227 (4 pgs)	1
WP 0178 (4 pgs)	0	WP 0228 (2 pgs)	0
WP 0179 (2 pgs)	0	WP 0229 (4 pgs)	1
WP 0180 (4 pgs)	0	WP 0230 (6 pgs)	0
WP 0181 (8 pgs)	0	WP 0231 (2 pgs)	0
WP 0182 (4 pgs)	0	WP 0232 (2 pgs)	0
WP 0183 (8 pgs)	0	WP 0233 (2 pgs)	0
WP 0184 (2 pgs)	1	WP 0234 (4 pgs)	0
WP 0185 (4 pgs)	0	WP 0235 (4 pgs)	0
WP 0186 (6 pgs)	0	WP 0236 (4 pgs)	0
WP 0187 (2 pgs)	0	WP 0237 (8 pgs)	1
WP 0188 (8 pgs)	1	WP 0237.1 (6 pgs)	1
WP 0189 (2 pgs)	0	WP 0238 (6 pgs)	0
WP 0190 (2 pgs)	1	WP 0239 (6 pgs)	0
WP 0191 (4 pgs)	0	WP 0240 (4 pgs)	0
WP 0192 (4 pgs)	0	WP 0241 (4 pgs)	0
WP 0193 (10 pgs)	1	WP 0242 (2 pgs)	0
WP 0194 (14 pgs)	1	WP 0243 (2 pgs)	0
WP 0195 (2 pgs)	0	WP 0244 (2 pgs)	0
WP 0196 (6 pgs)	1	WP 0245 (2 pgs)	1
WP 0197 (4 pgs)	0	WP 0246 (2 pgs)	1
WP 0198 (2 pgs)	0	WP 0247 (12 pgs)	0
WP 0199 (2 pgs)	0	WP 0248 (4 pgs)	0
WP 0200 (2 pgs)	0	WP 0249 (4 pgs)	0
WP 0201 (2 pgs)	0	WP 0250 (4 pgs)	1
WP 0202 (2 pgs)	0	WP 0251 (4 pgs)	0
WP 0203 (2 pgs)	0	WP 0252 (4 pgs)	0
WP 0204 (18 pgs)	0	WP 0253 (2 pgs)	0
WP 0205 (32 pgs)	1	WP 0254 (4 pgs)	0
WP 0206 (4 pgs)	0	WP 0255 (2 pgs)	0
WP 0207 (2 pgs)	0	WP 0256 (8 pgs)	0
WP 0208 (4 pgs)	0	WP 0257 (6 pgs)	0
WP 0209 (4 pgs)	0	WP 0258 (2 pgs)	0
WP 0210 (6 pgs)	1	WP 0259 (4 pgs)	1
WP 0211 (4 pgs)	1	WP 0260 (4 pgs)	0
WP 0212 (4 pgs)	1	WP 0261 (2 pgs)	0
WP 0213 (2 pgs)	0	WP 0262 (2 pgs)	0
WP 0214 (2 pgs)	0	WP 0263 (2 pgs)	0
WP 0215 (4 pgs)	0	WP 0264 (4 pgs)	0
WP 0216 (4 pgs)	0	WP 0265 (8 pgs)	0
WP 0217 (6 pgs)	1	WP 0266 (4 pgs)	1
WP 0218 (4 pgs)	0	WP 0267 (4 pgs)	1
WP 0219 (2 pgs)	0	WP 0268 (8 pgs)	1
WP 0220 (2 pgs)	0	WP 0269 (2 pgs)	0

Page/WP No.	Change No.	Page/WP No.	Change No.
WP 0270 (12 pgs)	0	WP 0299 (6 pgs)	0
WP 0271 (6 pgs)	0	WP 0300 (2 pgs)	0
WP 0272 (4 pgs)	0	WP 0301 (2 pgs)	0
WP 0273 (4 pgs)	0	WP 0302 (32 pgs)	0
WP 0274 (6 pgs)	0	WP 0303 (34 pgs)	0
WP 0275 (2 pgs)	0	WP 0304 (4 pgs)	0
WP 0276 (4 pgs)	0	WP 0305 (4 pgs)	0
WP 0277 (4 pgs)	0	WP 0305.1 (4 pgs)	1
WP 0278 (6 pgs)	0	WP 0305.2 (4 pgs)	1
WP 0279 (16 pgs)	0	WP 0306 (4 pgs)	0
WP 0280 (12 pgs)	0	WP 0307 (8 pgs)	0
WP 0281 (8 pgs)	0	WP 0308 (4 pgs)	0
WP 0282 (6 pgs)	0	WP 0309 (4 pgs)	0
WP 0283 (4 pgs)	1	WP 0310 (4 pgs)	0
WP 0284 (4 pgs)	0	WP 0311 (4 pgs)	1
WP 0285 (4 pgs)	0	WP 0312 (2 pgs)	0
WP 0286 (12 pgs)	1	WP 0313 (2 pgs)	0
WP 0287 (4 pgs)	0	WP 0314 (8 pgs)	0
WP 0288 (6 pgs)	1	WP 0315 (6 pgs)	0
WP 0289 (6 pgs)	0	WP 0316 (4 pgs)	0
WP 0290 (6 pgs)	0	WP 0317 (2 pgs)	0
WP 0291 (8 pgs)	0	WP 0318 (2 pgs)	0
WP 0292 (20 pgs)	1	WP 0319 (4 pgs)	0
WP 0293 (4 pgs)	0	WP 0320 (16 pgs)	0
WP 0294 (4 pgs)	0	WP 0321 (6 pgs)	0
WP 0295 (4 pgs)	0	WP 0322 (6 pgs)	0
WP 0296 (4 pgs)	0	WP 0323 (2 pgs)	0
WP 0297 (4 pgs)	0	WP 0324 (6 pgs)	0
WP 0298 (20 pgs)	1	INDEX-1 thru INDEX-26.	1





HEADQUARTERS  
DEPARTMENT OF THE ARMY  
WASHINGTON, D.C., 15 MARCH 2009

**TECHNICAL MANUAL**  
**OPERATOR'S AND FIELD LEVEL**  
**MAINTENANCE MANUAL**  
**(INCLUDING REPAIR PARTS AND SPECIAL TOOLS LIST)**  
**FOR**  
**HEMTT-BASED WATER TENDER (HEWATT)**  
**MODEL M1158**  
**NSN 2320-01-528-6294**

**REPORTING ERRORS AND RECOMMENDING IMPROVEMENTS**

You can help improve this publication. If you find any errors, or if you would like to recommend any improvements to the procedures in this publication, please let us know. The preferred method is to submit your DA Form 2028 (Recommended Changes to Publications and Blank Forms) through the Internet on the TACOM Unique Logistics Support Applications (TULSA) Web site. The Internet address is <https://tulsa.tacom.army.mil>. Access to all applications requires CAC authentication, and you must complete the Access Request form the first time you use it. The DA Form 2028 is located under the TULSA Applications on the left-hand navigation bar. Fill out the form and click on SUBMIT. Using this form on the TULSA Web site will enable us to respond more quickly to your comments and to better manage the DA Form 2028 program. You may also mail, e-mail, or fax your comments or DA Form 2028 directly to the U.S. Army TACOM Life Cycle Management Command. The postal mail address is U.S. Army TACOM Life Cycle Management Command, ATTN: AMSTA-LCL-MPP/ TECH PUBS, MS 727, 6501 E. 11 Mile Road, Warren, MI 48397-5000. The e-mail address is [tacomlcmc.daform2028@us.army.mil](mailto:tacomlcmc.daform2028@us.army.mil). The fax number is DSN 786-1856 or Commercial (586) 282-1856. A reply will be furnished to you.

\* **SUPERSEDURE NOTICE:** This manual supersedes TM 9-2320-328-13&P-2 dated 30 April 2008.

**DISTRIBUTION STATEMENT A:** Approved for public release; distribution is unlimited.



**TABLE OF CONTENTS**

	<u>Page No.</u>	<u>WP Sequence No.</u>
<b>VOLUME 2</b>		
<b>CHAPTER 3 TROUBLESHOOTING PROCEDURES (CONTINUED)</b>		
<b>MISCELLANEOUS ELECTRICAL COMPONENTS</b>		
12-Volt Handheld Radio Charger(s) Does Not Operate . . . . .	WP 0113	
12-Volt Streamlight Charger(s) Does Not Operate . . . . .	WP 0114	
24-Volt Battery Charger Does Not Operate Properly. . . . .	WP 0115	
Clearance and/or Directional Light(s) Does Not Operate . . . . .	WP 0116	
Driver Side Stowage Compartment Striplight(s) Does Not Operate . . . . .	WP 0117	
Foam/Water Level Gauge(s) Does Not Illuminate. . . . .	WP 0118	
Two-Way Radio Does Not Operate Properly. . . . .	WP 0119	
Intercom and Headsets Do Not Operate Properly. . . . .	WP 0120	
Passenger Side Stowage Compartment Striplight(s) Does Not Operate . . . . .	WP 0121	
Pump House or Pump Operator's Panel Striplight(s) Does Not Operate . . . . .	WP 0122	
Rear Step Buzzer Audio Alarm Does Not Operate . . . . .	WP 0123	
SINCGARS Do Not Operate Properly . . . . .	WP 0124	
SINCGARS Vehicle Remote Control Unit (VRCU) Does Not Operate Properly . . . . .	WP 0124.1	
Siren Does Not Operate Properly . . . . .	WP 0125	
Shoreline Inlet Receptacle Does Not Operate Properly . . . . .	WP 0126	
<b>HEATER, VEHICULAR COMPARTMENT</b>		
Pump House Heater Does Not Operate Properly . . . . .	WP 0127	
<b>CHAPTER 4 PREVENTIVE MAINTENANCE CHECKS AND SERVICES (PMCS)</b>		
Preventive Maintenance Checks and Services (PMCS) Introduction . . . . .	WP 0128	
Preventive Maintenance Checks and Services (PMCS), Including Lubrication Instructions . . . . .	WP 0129	
Table 1. Preventive Maintenance Checks and Services. . . . .	0129-2	
Table 2. Lubricating Chart. . . . .	0129-35	
<b>CHAPTER 5 MAINTENANCE INSTRUCTIONS</b>		
Maintenance General Introduction . . . . .	WP 0130	
Table 1. Tire Pressures. . . . .	0130-2	
Table 2. Recommended Flats Rotation. . . . .	0130-10	
Figure 1. General Tightening Sequences. . . . .	0130-11	

**TABLE OF CONTENTS (CONTINUED)**

	<u>Page No.</u>	<u>WP Sequence No.</u>
<b>ADJUSTMENTS AND ALIGNMENTS</b>		
Stowage Compartment Door Latch Striker Adjustment . . . . .		WP 0131
Static Pump Idle Pressure Adjustment . . . . .		WP 0131.1
Bumper Turret Adjustment . . . . .		WP 0132
<b>FIRE PUMP SYSTEM</b>		
Hydraulic Heat Exchanger Fan(s) Switch Replacement . . . . .		WP 0133
Hydraulic Heat Exchanger Replacement . . . . .		WP 0134
Hydraulic Heat Exchanger Bottom Shroud Panel Replacement . . . . .		WP 0135
Hydraulic Heat Exchanger Fan(s) Replacement . . . . .		WP 0136
Hydraulic Heat Exchanger Shroud Replacement . . . . .		WP 0137
Hydraulic Hose Replacement . . . . .		WP 0138
Table 1. Hydraulic Reservoir Hoses. . . . .	0138-3	
Table 2. Hydrostatic Charge Pump Hoses. . . . .	0138-4	
Table 3. Hydraulic Override Manifold Hoses. . . . .	0138-5	
Table 4. Hydraulic Oil Filter Base Hoses. . . . .	0138-6	
Table 5. Hydrostatic Pump Motor. . . . .	0138-6	
Table 6. Hydraulic Pressure Control Hoses. . . . .	0138-7	
Table 7. Hydraulic Heat Exchanger. . . . .	0138-8	
Hydraulic Oil Drain Mounting Bracket Replacement . . . . .		WP 0139
Hydraulic Oil Filter Replacement . . . . .		WP 0140
Hydraulic Oil Filter Base Replacement. . . . .		WP 0141
Hydraulic Override Manifold Replacement. . . . .		WP 0142
Hydraulic Pressure Control Replacement . . . . .		WP 0143
Hydraulic Reservoir Breather Replacement . . . . .		WP 0144
Hydraulic Reservoir Drain/Fill . . . . .		WP 0145
Hydraulic Reservoir Fluid Level Gauge Replacement . . . . .		WP 0146
Hydraulic Reservoir Fluid Level Switch Replacement . . . . .		WP 0147
Hydraulic Reservoir and Bracket Replacement . . . . .		WP 0148
Hydraulic Reservoir Strainer Replacement . . . . .		WP 0149
Hydraulic Reservoir Temperature Sensor Replacement . . . . .		WP 0150
Hydrostatic Pump Motor Replacement. . . . .		WP 0151
Hydrostatic Charge Pump Replacement . . . . .		WP 0152
Power Take Off (PTO) Replacement . . . . .		WP 0153

**TABLE OF CONTENTS (CONTINUED)**

	<u>Page No.</u>	<u>WP Sequence No.</u>
Power Take Off (PTO) Drive Shaft Replacement . . . . .		WP 0154
Power Take Off (PTO) Solenoid and Pressure Switch Replacement . . . . .		WP 0155
Water Pump Dipstick Assembly Replacement . . . . .		WP 0156
Water Pump Gear Case Drain/Fill . . . . .		WP 0157
Water Pump Replacement . . . . .		WP 0158
<b>RELIEF VALVE ASSEMBLY</b>		
Passenger Side Auxiliary Inlet Drain Valve Replacement . . . . .		WP 0159
Driver Side Auxiliary Inlet Drain Valve Replacement. . . . .		WP 0160
No. 1 Driver Side Discharge Drain Valve Replacement . . . . .		WP 0161
No. 2 Passenger Side Discharge Drain Valve Replacement. . . . .		WP 0162
Thermal Relief Valve Replacement . . . . .		WP 0163
<b>PRIMER PUMP ASSEMBLY</b>		
Manual Primer Handle Replacement. . . . .		WP 0164
Primer Pump Replacement . . . . .		WP 0165
Primer Tank and Bracket Replacement. . . . .		WP 0166
Primer Valve Cable Replacement . . . . .		WP 0167
Primer Valve Control Solenoid Replacement . . . . .		WP 0168
Primer Valve Replacement . . . . .		WP 0169
<b>DRAIN VALVE ASSEMBLY</b>		
Bumper Turret Auto Drain Valve Replacement . . . . .		WP 0170
Foam Tank Drain Valve Replacement. . . . .		WP 0171
Water Tank Drain Valve Replacement . . . . .		WP 0172
<b>FOAM SYSTEM ASSEMBLY</b>		
Bumper Turret Foam Metering Valve and Orifice Replacement . . . . .		WP 0173
Under Truck Nozzles Foam Metering Valve and Orifice Replacement . . . . .		WP 0174
Foam Tank Level Probe Replacement . . . . .		WP 0175
Foam System Shutoff Valve Replacement . . . . .		WP 0176
Foam System Eductor Replacement. . . . .		WP 0177
Foam System Eductor Valve Replacement. . . . .		WP 0178
Foam System Flush Valve Replacement. . . . .		WP 0179
Foam System Inlet Check Valve Replacement. . . . .		WP 0180
Foam System Manual Metering Valve Replacement. . . . .		WP 0181
Foam System Service Valve Replacement . . . . .		WP 0182

**TABLE OF CONTENTS (CONTINUED)**

	<u>Page No.</u>	<u>WP Sequence No.</u>
Foam System Strainer(s) Replacement . . . . .		WP 0183
Foam Tank Pressure/Vacuum/Vent Replacement . . . . .		WP 0184
Foam Tank Fill Port Extension and Cover Replacement . . . . .		WP 0185
<b>WATER TANK ASSEMBLY</b>		
Inlet Valve Replacement. . . . .		WP 0186
Tank-To-Pump Check Valve Replacement . . . . .		WP 0187
Manual Bray Dump Valve(s) Replacement . . . . .		WP 0188
Foam/Water Tank Level Probe Cover Replacement . . . . .		WP 0189
Water Tank Level Probe Replacement. . . . .		WP 0190
Water Tank Fill & Re-Circulating Line Valve Replacement . . . . .		WP 0191
Water Tank Vent Fill Tower Replacement . . . . .		WP 0192
Water Tank Replacement. . . . .		WP 0193
Water Tank Cradle Replacement . . . . .		WP 0194
<b>INSTRUMENT PANEL ASSEMBLY</b>		
CHECK FOR OPEN COMPARTMENT DOOR WHEN LIGHT IS ON Indicator Replacement . . . . .		WP 0195
Warning Light and CHECK FOR OPEN COMPARTMENT DOOR WHEN LIGHT IS ON Flasher Unit(s) Replacement . . . . .		WP 0196
Cab Pressure Governor Control Replacement. . . . .		WP 0197
Cab Panel Indicator Replacement . . . . .		WP 0198
Cab Rocker Switch Replacement. . . . .		WP 0199
Cab Water and/or Foam Level Gauge(s) Replacement . . . . .		WP 0200
Cab 1-2-3 Signal Indicator Lamp Holder Replacement . . . . .		WP 0201
Cab 1-2-3 Signal Indicator Lamp Replacement . . . . .		WP 0202
Warning Buzzer (Cab and Pump Operator's Panel) Replacement. . . . .		WP 0203
Cab Instrument Panel Assembly Replacement . . . . .		WP 0204
Cab Instrument Panel Replacement. . . . .		WP 0205
Pump Operator's Panel Cover Replacement . . . . .		WP 0206
Pump Operator's Panel Open/Close . . . . .		WP 0207
Pump Operator's Panel Replacement . . . . .		WP 0208
Pump Operator's Panel Electric Valve Control Replacement. . . . .		WP 0209
Pump Operator's Panel Electric Valve Control Meter Replacement and Calibration . . . . .		WP 0210
Pump Operator's Panel Foam Level Gauge Replacement and Calibration . . . . .		WP 0211

**TABLE OF CONTENTS (CONTINUED)**

	<u>Page No.</u>	<u>WP Sequence No.</u>
Pump Operator's Panel Water Level Gauge Replacement and Calibration . . . . .		WP 0212
Pump Operator's Panel Indicator Replacement . . . . .		WP 0213
Pump Operator's Panel Indicator Lamp Replacement . . . . .		WP 0214
Striplight Replacement . . . . .		WP 0215
Pump Operator's Panel Pressure Governor Control Replacement . . . . .		WP 0216
Cab High Idle Switch and Indicator Replacement . . . . .		WP 0217
Pump Operator's Panel Overheat Test Button and Indicator Replacement . . . . .		WP 0218
Pump Operator's Panel Driver Main Inlet Primer Button Replacement . . . . .		WP 0219
Pump Operator's Panel Toggle Switch (Two-Position) Replacement . . . . .		WP 0220
Pump Operator's Panel Toggle Switch (Three-Position) Replacement . . . . .		WP 0221
Pump Primer Motor Diode Pack Replacement . . . . .		WP 0222
<b>WARNING LIGHT ASSEMBLY</b>		
Cab Clearance Lights and Bracket Replacement . . . . .		WP 0223
Cab Front Lightbar Replacement . . . . .		WP 0224
Cab Side Lightbar Replacement . . . . .		WP 0225
Cab Lightbar Repair . . . . .		WP 0226
Lower Rear Marker Lights and Bracket Replacement . . . . .		WP 0227
Rear Marker/Clearance Directional LED Replacement . . . . .		WP 0228
Rear Marker/Clearance LED Replacement . . . . .		WP 0229
Roof Mounted Clearance Light(s) Replacement . . . . .		WP 0230
Warning Light(s) Replacement . . . . .		WP 0231
Overhead Warning Beacon Replacement . . . . .		WP 0232
<b>SPOTLIGHTS</b>		
Scene Light(s) Replacement . . . . .		WP 0233
Step Light(s) Replacement . . . . .		WP 0234
<b>DOME AND ENGINE LIGHT ASSEMBLY</b>		
Dome Light Replacement . . . . .		WP 0235
<b>MISCELLANEOUS ELECTRICAL COMPONENTS</b>		
Battery Disconnect Switch Replacement . . . . .		WP 0236
24-Volt 10 AMP Per Bank Battery Charger and Bracket Replacement . . . . .		WP 0237
24-Volt 15 AMP Per Bank Battery Charger Removal/Installation . . . . .		WP 0237.1
Battery Box and Bracket Replacement . . . . .		WP 0238
120-Volt Receptacle Replacement . . . . .		WP 0239

**TABLE OF CONTENTS (CONTINUED)**

	<u>Page No.</u>	<u>WP Sequence No.</u>
Blackout Relay(s) Replacement . . . . .	WP 0240	WP 0240
Terminal Block (Pass-Through) Replacement . . . . .	WP 0241	WP 0241
Cab Power Distribution Block Circuit Breaker Replacement . . . . .	WP 0242	WP 0242
Cab Power Distribution Block Diode Replacement . . . . .	WP 0243	WP 0243
Cab Power Distribution Block Relay(s) Replacement . . . . .	WP 0244	WP 0244
Discharge Pressure Transducer Replacement. . . . .	WP 0245	WP 0245
Door Switch Replacement . . . . .	WP 0246	WP 0246
Hose Reel Replacement. . . . .	WP 0247	WP 0247
Electrically-Operated Ball Valve Electric Motor and Drive Assembly Replacement . . . . .	WP 0248	WP 0248
Electrically-Operated Ball Valve Seats and Preformed Packing Replacement . . . . .	WP 0249	WP 0249
Flow Sensor Replacement . . . . .	WP 0250	WP 0250
High Amperage Cable(s) Replacement . . . . .	WP 0251	WP 0251
Hose Reel Circuit Breaker Replacement . . . . .	WP 0252	WP 0252
Reel Rewind Switch Replacement . . . . .	WP 0253	WP 0253
Hose Reel Solenoid Replacement . . . . .	WP 0254	WP 0254
Inline Fuse Replacement . . . . .	WP 0255	WP 0255
Intercom Replacement . . . . .	WP 0256	WP 0256
Intercom Cables and Connectors Replacement. . . . .	WP 0257	WP 0257
Intercom Headset Hangers Replacement . . . . .	WP 0258	WP 0258
Portable Handheld Radio and Charger Replacement . . . . .	WP 0259	WP 0259
Power Cable Assembly Replacement (SINCGARS) . . . . .	WP 0260	WP 0260
Streamlight and Charger Replacement . . . . .	WP 0261	WP 0261
Pump House Power Distribution Block Circuit Breaker Replacement . . . . .	WP 0262	WP 0262
Pump House Power Distribution Block Relay Replacement . . . . .	WP 0263	WP 0263
Pump House Power Distribution Box Replacement . . . . .	WP 0264	WP 0264
Pump Input and Discharge Pressure Transducers Replacement . . . . .	WP 0265	WP 0265
Rear Step Buzzer Button and Cable Replacement . . . . .	WP 0266	WP 0266
Rear Step Buzzer Button Compartment Replacement. . . . .	WP 0267	WP 0267
Shoreline Inlet Receptacle Replacement . . . . .	WP 0268	WP 0268
Shutoff Control Valve Diode Replacement. . . . .	WP 0269	WP 0269
Shutoff Control Valve Manifold Replacement. . . . .	WP 0270	WP 0270
Shutoff Control Valve Replacement . . . . .	WP 0271	WP 0271
Cover, Door, and Electronic Mounting Base Replacement (SINCGARS) . . . . .	WP 0272	WP 0272



**TABLE OF CONTENTS (CONTINUED)**

	<u>Page No.</u>	<u>WP Sequence No.</u>
Speaker Replacement . . . . .		WP 0273
Terminal Block Replacement . . . . .		WP 0274
Thermal Relief Valve Switch Replacement . . . . .		WP 0275
Two-Way Radio Replacement . . . . .		WP 0276
Windshield Deluge Motor Replacement . . . . .		WP 0277
Bumper Turret Wire Harness Replacement . . . . .		WP 0278
Cab Instrument Panel Wire Harness Replacement . . . . .		WP 0279
Cab Power Distribution Wire Harness and Block Replacement . . . . .		WP 0280
Cab Pump Control Wire Harness Replacement . . . . .		WP 0281
Cab Roof Wire Harness Replacement . . . . .		WP 0282
Direct Tank Fill Valve Wire Harness Replacement . . . . .		WP 0283
Discharge Valve Control Wire Harness Replacement . . . . .		WP 0284
Driver Side Auxiliary Inlet Valve Control Wire Harness Replacement . . . . .		WP 0285
Driver Side Body Wire Harness Replacement . . . . .		WP 0286
Lightbar Flasher Unit Replacement . . . . .		WP 0287
Pressure Governor ECU Replacement . . . . .		WP 0288
Intercom Wire Harness Replacement . . . . .		WP 0289
Lightbar Cable Assembly Branch Replacement . . . . .		WP 0290
Lightbar Cable Assembly Replacement . . . . .		WP 0291
Main Wire Harness Replacement . . . . .		WP 0292
No. 1 Driver Side Flow Sensor Wire Harness Replacement . . . . .		WP 0293
No. 1 Driver Side Pressure Transducer Wire Harness Replacement . . . . .		WP 0294
No. 2 Passenger Side Flow Sensor Wire Harness Replacement . . . . .		WP 0295
Passenger Side Auxiliary Inlet Valve Control Wire Harness Replacement . . . . .		WP 0296
No. 2 Passenger Side Pressure Transducer Wire Harness Replacement . . . . .		WP 0297
Passenger Side Body Wire Harness Replacement . . . . .		WP 0298
Pump House Power Distribution Wire Harness and Block Replacement . . . . .		WP 0299
Primer Pump Control Solenoid Replacement . . . . .		WP 0300
Pump House B+ Stud Replacement . . . . .		WP 0301
Pump House Wire Harness Replacement . . . . .		WP 0302
Pump Operator's Panel Wire Harness Replacement . . . . .		WP 0303
Water Tank Fill & Re-Circulating Line Valve Control Wire Harness Replacement . . . . .		WP 0304
Waterproof Splice Box Replacement . . . . .		WP 0305

**TABLE OF CONTENTS (CONTINUED)**

	<u>Page No.</u>	<u>WP Sequence No.</u>
Hydraulic Override Manifold Solenoid and Proportioning Valve Replacement . . . . .	WP 0305.1	
VRCU Cable and Bracket Replacement. . . . .	WP 0305.2	
<b>HEATER, VEHICULAR COMPARTMENT</b>		
Pump House Heater Test Switch Replacement . . . . .	WP 0306	
Pump House Heater Diagnostic and Thermal Switch(es) Replacement . . . . .	WP 0307	
Heater Fuel Pump Replacement . . . . .	WP 0308	
Heater Fuel Tank Pickup Replacement . . . . .	WP 0309	
Pump House Heater Replacement. . . . .	WP 0310	
<b>PIPING, WATER AND FOAM</b>		
Direct Tank Fill Valve Replacement . . . . .	WP 0311	
Bumper Turret Valve Replacement . . . . .	WP 0312	
Coupling Replacement . . . . .	WP 0313	
No. 1 Driver Side Discharge Valve Replacement. . . . .	WP 0314	
No. 2 Passenger Side Discharge Valve Replacement. . . . .	WP 0315	
Hose Reel Hose Replacement . . . . .	WP 0316	
Hose Reel Discharge Valve Replacement . . . . .	WP 0317	
Piping Assembly (Pipe Thread Sealing Compound) . . . . .	WP 0318	
Pump Cooler (Dump-To-Ground) Valve Replacement. . . . .	WP 0319	
Plumbing, Hoses, and Piping Replacement . . . . .	WP 0320	
Figure 1. Water Intake System. . . . .	0320-2	
Figure 2. Foam and Water Tank Fill Systems. . . . .	0320-4	
Figure 3. Side and Hose Reel Discharge System. . . . .	0320-6	
Figure 4. Pump Cooler (Dump-To-Ground) and Bumper Turret System. . . . .	0320-8	
Figure 5. Under Truck Nozzles and Thermal Relief System. . . . .	0320-10	
Figure 6. Windshield Deluge System. . . . .	0320-12	
Figure 7. Priming and Pump Drain Systems. . . . .	0320-14	
Pump Drain Valve Replacement . . . . .	WP 0321	
Tank-To-Pump Valve Replacement . . . . .	WP 0322	
Under Truck Nozzles Valve Replacement . . . . .	WP 0323	
Windshield Deluge Automatic Drain Valve Replacement. . . . .	WP 0324	
<b>ALPHABETICAL INDEX . . . . .</b>		INDEX-1

---

## HOW TO USE THIS TECHNICAL MANUAL

This manual is designed to help operate and maintain the HEMTT-Based Water Tender (HEWATT). This technical manual should be used in conjunction with the TM 9-2320-422-10 and TM 9-2320-325-14&P series manuals. Listed below are some of the features included in this manual to help locate and use the needed information:

- Warnings, cautions, subject headings, and other essential information are printed in bold type, making them easier to see.
- In addition to text, there are illustrations showing how to take a component off and put it back on. Cleaning and inspection criteria are also included where necessary.

This manual is subdivided into three volumes containing the following:

### Volume 1

- Chapter 1 of this manual supplements the TM 9-2320-422-10 manual and it describes the HEWATT specific components. Equipment data is also provided.
- Chapter 2 of this manual supplements the TM 9-2320-422-10 manual and provides HEWATT Operating Instructions.
- Chapter 3 of this manual supplements the TM 9-2320-325-14&P manual and provides HEWATT Operator and Field Level Troubleshooting Procedures for Fire Pump System, Foam Proportioner System, Water Tank Assembly, Instrument Housing Assembly, Warning Light Assembly, Spotlights, and Dome and Engine Light Assembly.

### Volume 2

- Chapter 3 (continued) of this manual supplements the TM 9-2320-325-14&P manual and provides HEWATT Field Level Troubleshooting Procedures for Miscellaneous Electrical Components and Heater, Vehicular Compartment.
- Chapter 4 of this manual supplements the TM 9-2320-325-14&P manual and provides HEWATT Preventive Maintenance Checks and Services (PMCS) and Lubrication Instructions.
- Chapter 5 of this manual supplements the TM 9-2320-325-14&P manual and provides Field Level Maintenance Instructions for Adjustments and Alignments on the HEWATT, as well as Removal/Installation Instructions for Fire Pump System, Relief Valve Assembly, Primer Pump Assembly, Drain Valve, Foam System Assembly, Water Tank Assembly, Instrument Panel Assembly, Warning Light Assembly, Spotlights, Dome and Engine Light Assembly, Miscellaneous Electrical Components, Heater, Vehicular Components, and Piping, Water and Foam.

### Volume 3

- Chapter 5 (continued) of this manual supplements the TM 9-2320-325-14&P manual and provides Removal/Installation Instructions for Special Purpose Body, Mounting Brackets, Fuel Tank, and Air Reservoir, and Fixed Firefighting Equipment. An Illustrated List of Manufactured Items and Torque Limits are provided at the rear of this chapter.
- Chapter 6 of this manual supplements the TM 9-2320-325-14&P manual and provides Repair Parts and Special Tools List (RPSTL) for the HEWATT.
- Chapter 7 of this manual supplements the TM 9-2320-325-14&P manual and provides References, Two-Level Maintenance Allocation Chart (MAC), Components of End Item (COEI) and Basic Issue Items (BII) Lists, and Expendable and Durable Items List.

A complete Alphabetical Index is provided at the rear of each volume to help locate items in the text.

The vehicles referenced in the TM 9-2320-422-10 and TM 9-2320-325-14&P manuals are similar, but not identical to the vehicle referenced in the supplemental manual. HEWATT vehicle procedures that are common to the M985 can be found in the TM 9-2320-422-10 or TM 9-2320-325-14&P manual. Configuration differences can be determined by visually inspecting the vehicle prior to maintenance.

Follow these guidelines when using the manual:

- Read all WARNINGS and CAUTIONS before performing any procedure.
- The operator must read this technical manual along with TM 9-2320-422-10 manual and become familiar with the content of each manual before attempting to operate the vehicle.
- Maintenance personnel must read this technical manual along with TM 9-2320-325-14&P manual and become familiar with the content of each manual before performing any maintenance to the vehicle.

## **CHAPTER 3**

### **TROUBLESHOOTING PROCEDURES (CONTINUED)**



**FIELD LEVEL MAINTENANCE**

**12-VOLT HANDHELD RADIO CHARGER(S) DOES NOT OPERATE**

**INITIAL SETUP:**

**Tools and Special Tools**

Tool Kit, General Mechanic's: Automotive  
(WP 0398, Item 17)

**References**

TM 9-2320-325-14&P  
WP 0004  
WP 0007  
WP 0119  
WP 0205  
Deleted  
WP 0242

**References (continued)**

Deleted  
WP 0255  
WP 0259  
WP 0280  
Deleted

**Equipment Conditions**

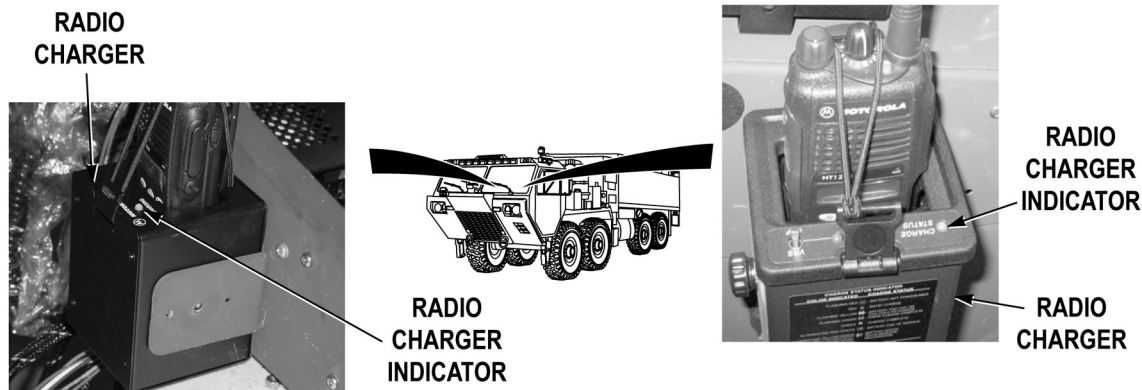
Engine OFF (TM 9-2320-422-10)  
Wheels chocked (TM 9-2320-422-10)

**MALFUNCTION**

**TEST OR INSPECTION**

**CORRECTIVE ACTION**

**12-VOLT HANDHELD RADIO CHARGER(S) DOES NOT OPERATE**



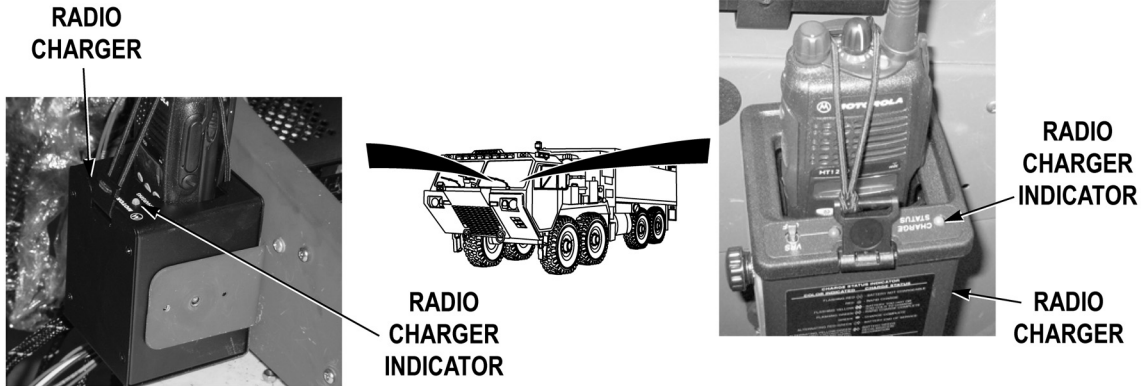
**NOTE**

Battery, or radio with battery, must be fully seated in radio charger before charger indicator will illuminate. The red indicator will illuminate when radio battery pack is charging, and green indicator will illuminate when radio battery pack is fully charged.

Step 1. Push battery disconnect switch to on position (WP 0007). With handheld radios seated in radio chargers, check if both radio charger indicators illuminate.

If both radio charger indicators illuminate, fault corrected.

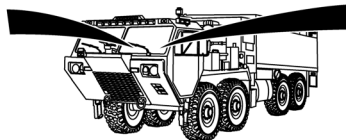
MALFUNCTION	TEST OR INSPECTION	CORRECTIVE ACTION
-------------	--------------------	-------------------



Step 2. With handheld radios seated in radio chargers, check if either radio charger indicators illuminate.

If both radio charger indicators do not illuminate, go to Step 13.

RLN5233A MODEL RADIO CHARGER



NNTN7618A MODEL RADIO CHARGER

**NOTE**

Model RLN5233A radio charger has been replaced by model NNTN7618A radio charger.

- Step 3. Determine which model of 12-volt handheld charger is installed.
- a. If model RLN5233A radio charger is installed, go to Step 4.
  - b. If model NNTN7618A radio charger is installed, go to Step 7.

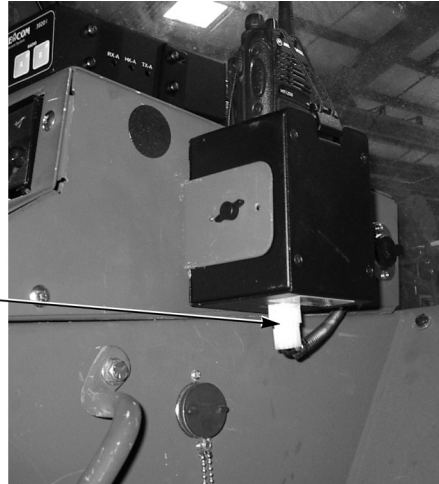


---

**MALFUNCTION****TEST OR INSPECTION****CORRECTIVE ACTION**

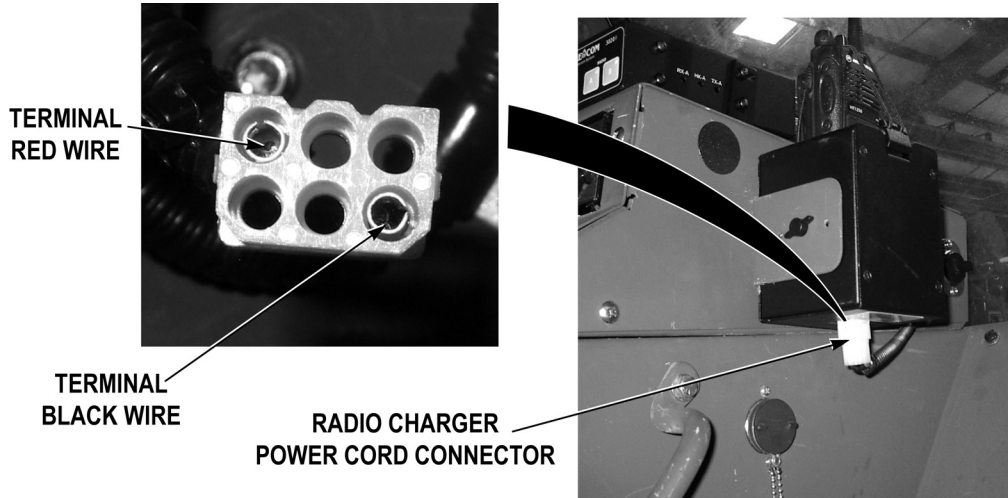
---

**RADIO CHARGER  
POWER CORD CONNECTOR**



- Step 4. Check if radio charger power cord connector is securely connected on non-operating radio charger.
- If power cord is not securely connected, reconnect power cord (WP 0259).

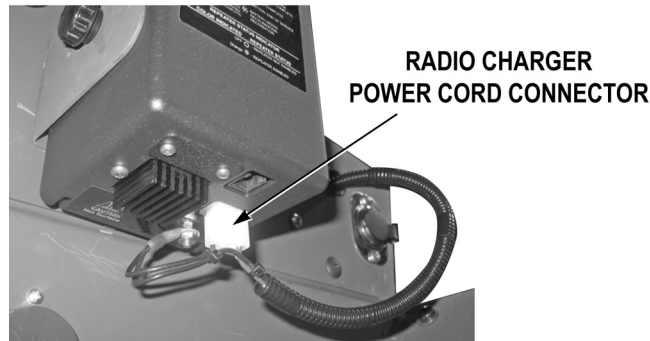
MALFUNCTION	TEST OR INSPECTION	CORRECTIVE ACTION
-------------	--------------------	-------------------

**WARNING**

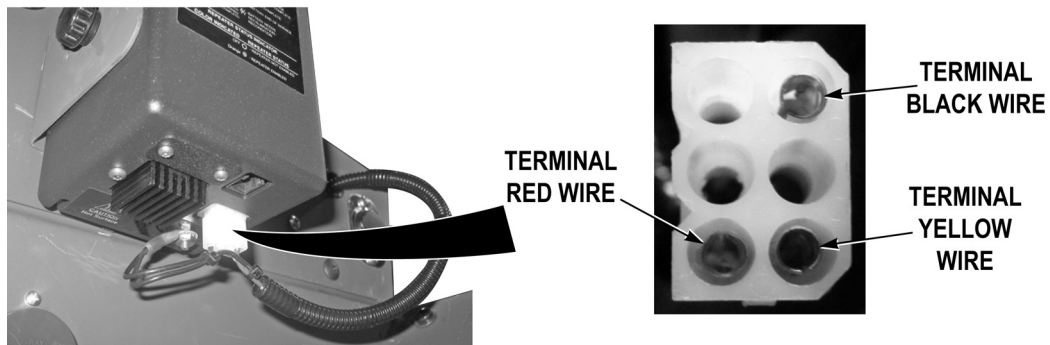
Remove rings, wristwatches, neck chains, and any other jewelry before working around vehicle. Jewelry can catch on equipment and cause serious injury. Jewelry and tools may short across electrical circuits and cause damage to equipment, or severe burns or electrical shock to personnel.

- Step 5. Disconnect radio charger power cord connector from non-operating radio charger. Check for 10 to 14 VDC between red wire at radio charger power cord connector and a known good ground.
- If 10 to 14 VDC are not present, repair red wire in radio charger power cord if repairable (TM 9-2320-325-14&P).
- Step 6. Pull battery disconnect switch to off position (WP 0007). Check for continuity across radio charger power cord connector black wire at radio battery charger power cord connector to a known good ground.
- a. If there is continuity, replace non-operating battery charger (WP 0259).
  - b. If there is no continuity, repair black wire in radio charger power cord if repairable (TM 9-2320-325-14&P).

MALFUNCTION	TEST OR INSPECTION	CORRECTIVE ACTION
-------------	--------------------	-------------------



- Step 7. Check if radio charger power cord connector is securely connected on non-operating radio charger.  
 If power cord is not securely connected, reconnect power cord (WP 0259).



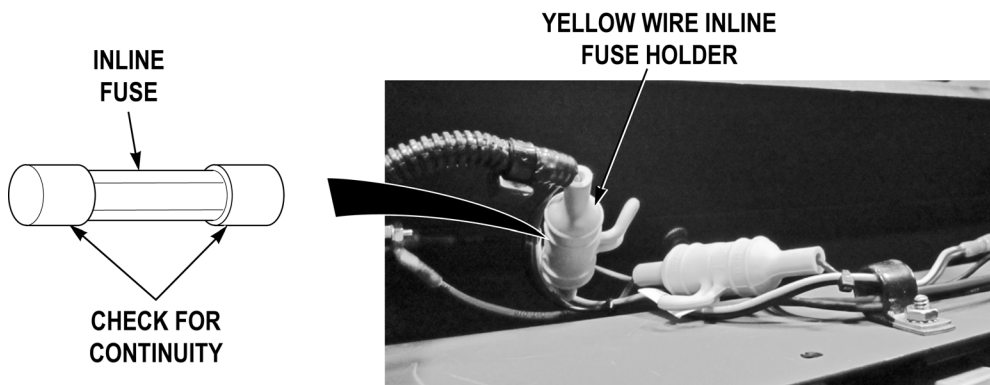
**WARNING**



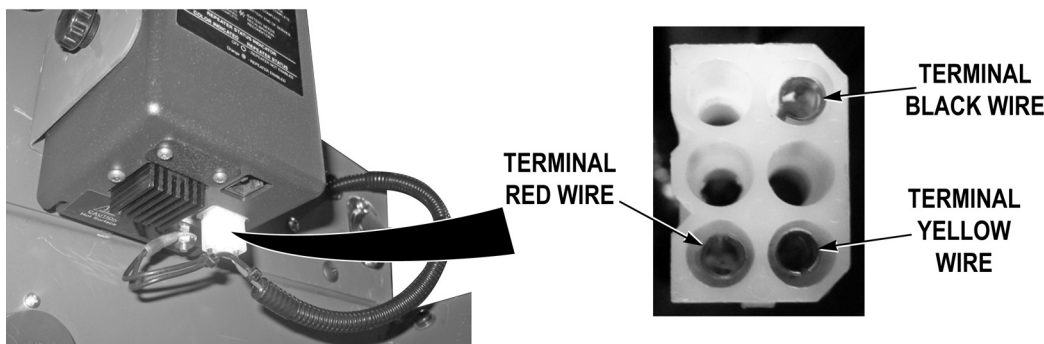
**Remove rings, wristwatches, neck chains, and any other jewelry before working around vehicle. Jewelry can catch on equipment and cause serious injury. Jewelry and tools may short across electrical circuits and cause damage to equipment, or severe burns or electrical shock to personnel.**

- Step 8. Disconnect radio charger power cord connector from non-operating radio charger. Check for 10 to 14 VDC between yellow wire at radio charger power cord connector and a known good ground.  
 If 10 to 14 VDC are present, go to Step 10.

MALFUNCTION	TEST OR INSPECTION	CORRECTIVE ACTION
-------------	--------------------	-------------------



- Step 9. Remove cab instrument panel A (WP 0205). Remove inline fuse from yellow wire inline fuse holder (WP 0255). Check for continuity across fuse.
- If there is continuity, repair yellow wire in radio charger power cord if repairable (TM 9-2320-325-14&P).
  - If there is no continuity, replace fuse (WP 0255).



**WARNING**

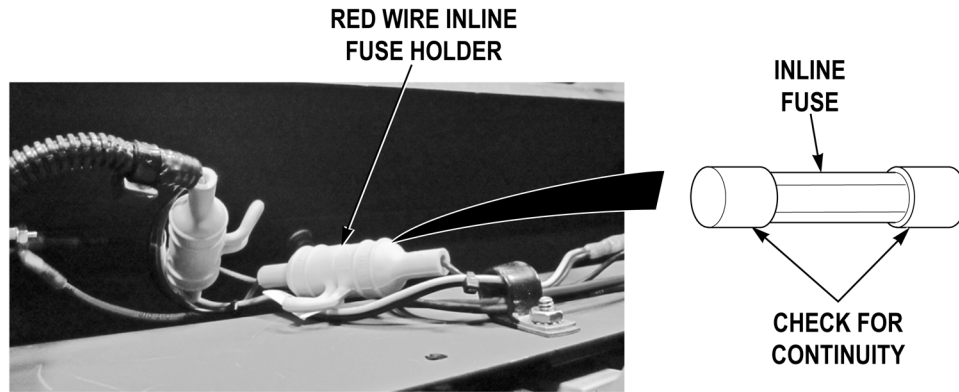


Remove rings, wristwatches, neck chains, and any other jewelry before working around vehicle. Jewelry can catch on equipment and cause serious injury. Jewelry and tools may short across electrical circuits and cause damage to equipment, or severe burns or electrical shock to personnel.

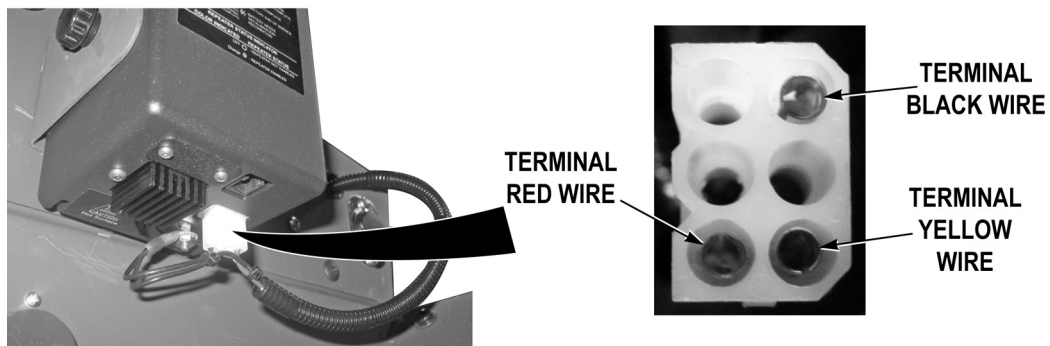
- Step 10. Check for 10 to 14 VDC between red wire at radio battery charger power cord connector and a known good ground.

If 10 to 14 VDC are present, go to Step 12.

MALFUNCTION	TEST OR INSPECTION	CORRECTIVE ACTION
-------------	--------------------	-------------------



- Step 11. Remove cab instrument panel A (WP 0205). Remove inline fuse from red wire inline fuse holder (WP 0255). Check for continuity across fuse.
- a. If there is no continuity, replace fuse (WP 0255).
  - b. If there is continuity, repair red wire in radio charger power cord if repairable (TM 9-2320-325-14&P).



- Step 12. Pull battery disconnect switch to off position (WP 0007). Check for continuity across black wire at radio battery charger power cord connector to a known good ground.
- a. If there is continuity, replace non-operating battery charger (WP 0259).
  - b. If there is no continuity, repair black wire in radio charger power cord if repairable (TM 9-2320-325-14&P).

MALFUNCTION	TEST OR INSPECTION	CORRECTIVE ACTION
-------------	--------------------	-------------------



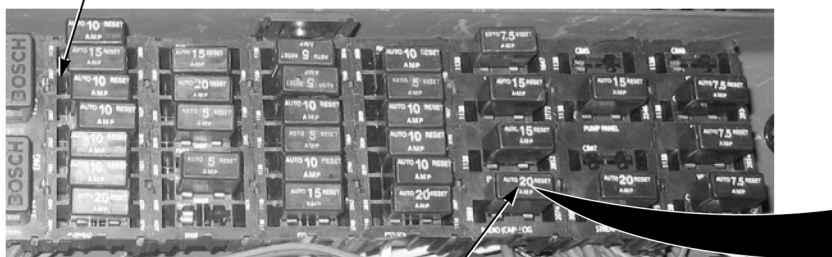
**NOTE**

Two-way radio is turned on by pressing and releasing volume control knob.

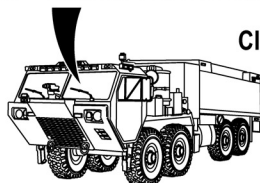
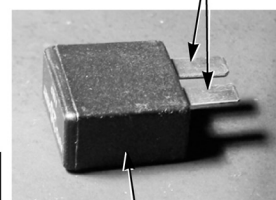
Step 13. Push battery disconnect switch to on position (WP 0007). Push two-way radio volume control knob to on position (WP 0004). Check if two-way radio display illuminates.

If two-way radio display does not illuminate, troubleshoot Two-Way Radio Does Not Operate Properly (WP 0119).

**CAB POWER DISTRIBUTION BLOCK**



**TERMINAL CONNECTORS**



**CIRCUIT BREAKER 4**

**CIRCUIT BREAKER 4**

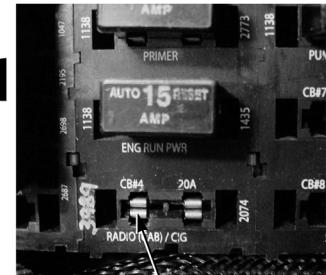
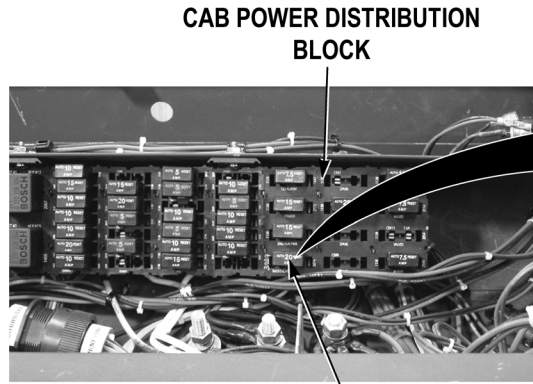
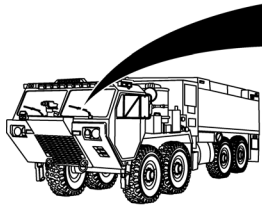
Step 14. Remove cab instrument panel A (WP 0205). Remove circuit breaker 4 (WP 0242). Check for continuity across circuit breaker.

If there is no continuity, replace circuit breaker 4 (WP 0242).

---

<b>MALFUNCTION</b>	<b>TEST OR INSPECTION</b>	<b>CORRECTIVE ACTION</b>
--------------------	---------------------------	--------------------------

---



- Step 15. Check for 10 to 14 VDC between circuit breaker 4 terminal connector wire 3989 (yellow) at cab power distribution block, to a known good ground.
- a. If 10 to 14 VDC are present, repair wire 2074 in cab power distribution wire harness if repairable (TM 9-2320-325-14&P), or replace cab power distribution wire harness and block (WP 0280).
  - b. If 10 to 14 VDC are not present, repair wire 3989 in cab power distribution wire harness if repairable (TM 9-2320-325-14&P), or replace cab power distribution wire harness and block (WP 0280).

**END OF TASK**

**FOLLOW-ON MAINTENANCE**

Remove wheel chocks (TM 9-2320-422-10)

**END OF TASK**

**END OF WORK PACKAGE**





**FIELD LEVEL MAINTENANCE**

**12-VOLT STREAMLIGHT CHARGER(S) DOES NOT OPERATE**

**INITIAL SETUP:**

**Tools and Special Tools**

- Lead Set, Test (WP 0398, Item 14)
- Tool Kit, General Mechanic's: Automotive (WP 0398, Item 17)

**References**

- TM 9-2320-325-14&P
- WP 0007
- WP 0113
- WP 0242

**References (continued)**

- WP 0261
- WP 0280
- WP 0292
- WP 0298

**Equipment Conditions**

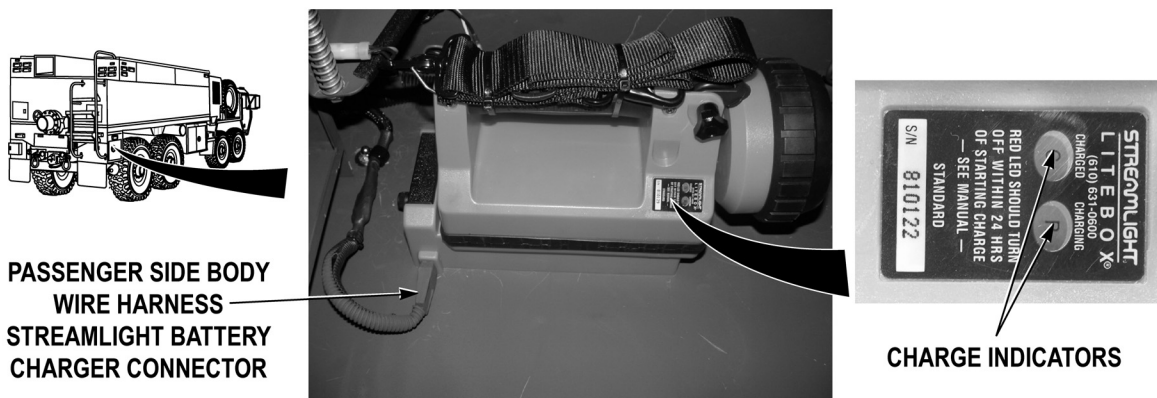
- Engine OFF (TM 9-2320-422-10)
- Wheels chocked (TM 9-2320-422-10)

**MALFUNCTION**

**TEST OR INSPECTION**

**CORRECTIVE ACTION**

**12-VOLT STREAMLIGHT CHARGER(S) DOES NOT OPERATE**



**NOTE**

Streamlight assembly must be fully seated in streamlight charger before charge indicator on streamlight assembly will illuminate. Red indicator will illuminate when streamlight battery pack is charging, and green indicator will illuminate when streamlight battery pack is fully charged.

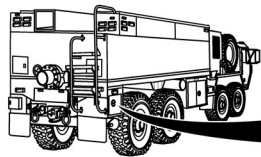
- Step 1. Push battery disconnect switch to on position (WP 0007). With streamlights seated in streamlight chargers, check if both streamlight charge indicators illuminate.

If neither streamlight charge indicator illuminates, go to Step 7.

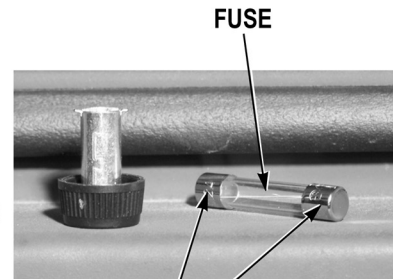
- Step 2. Check if passenger side body wire harness streamlight battery charger connector is fully connected on non-operating streamlight charger.

If power cord in not fully connected, reconnect power cord (WP 0261).

MALFUNCTION	TEST OR INSPECTION	CORRECTIVE ACTION
-------------	--------------------	-------------------



FUSE CAP



FUSE

CHECK FOR CONTINUITY

**WARNING**

Remove rings, wristwatches, neck chains, and any other jewelry before working around vehicle. Jewelry can catch on equipment and cause serious injury. Jewelry and tools may short across electrical circuits and cause damage to equipment, or severe burns or electrical shock to personnel.

Step 3. Remove fuse from base of streamlight battery charger (WP 0261). Check for continuity across fuse.

If there is no continuity, replace fuse (WP 0261).

Step 4. Install fuse in base of streamlight battery charger. Swap streamlight at non-operating streamlight charger with a known good streamlight. Check if streamlight charge indicator illuminates.

If streamlight charge indicator illuminates, replace non-operating streamlight (WP 0261).

MALFUNCTION	TEST OR INSPECTION	CORRECTIVE ACTION
-------------	--------------------	-------------------



- Step 5. Disconnect passenger side body wire harness streamlight battery charger connector from non-operating streamlight charger. With a test lead set, check for 10 to 14 VDC between wire 2075 (red) at passenger side body wire harness streamlight battery charger connector and a known good ground.

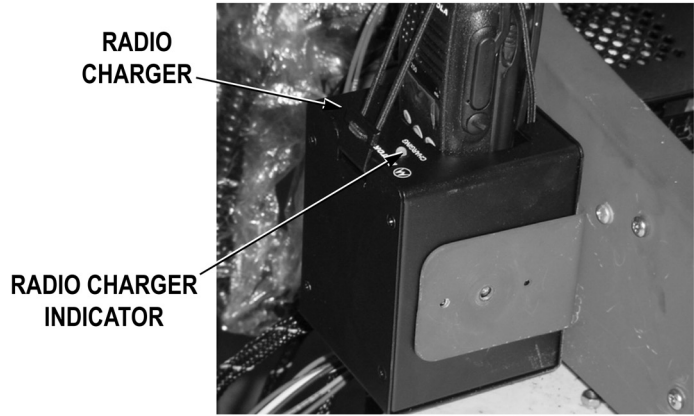
If 10 to 14 VDC are not present, repair wire 2075 in passenger side body wire harness if repairable (TM 9-2320-325-14&P), or replace passenger side body wire harness (WP 0298).

- Step 6. Pull battery disconnect switch to off position (WP 0007). With a test lead set, check for continuity across passenger side body wire harness wire 2740 (black) from passenger side body wire harness streamlight battery charger connector to a known good ground.
- If there is no continuity, repair wire 2740 in passenger side body wire harness if repairable (TM 9-2320-325-14&P), or replace passenger side body wire harness (WP 0298).
  - If there is continuity, replace non-operating streamlight battery charger (WP 0261).

---

<b>MALFUNCTION</b>	<b>TEST OR INSPECTION</b>	<b>CORRECTIVE ACTION</b>
--------------------	---------------------------	--------------------------

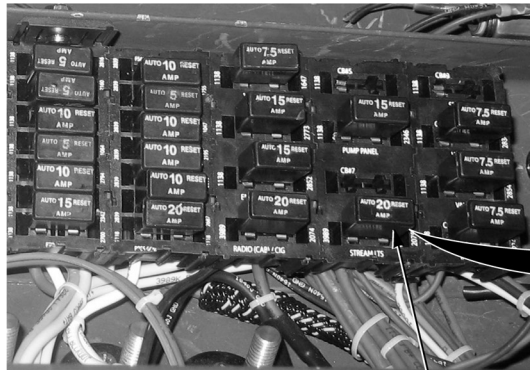
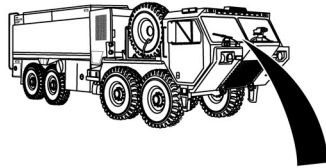
---



Step 7. With handheld radios seated in radio chargers, check if radio charger indicators illuminate.

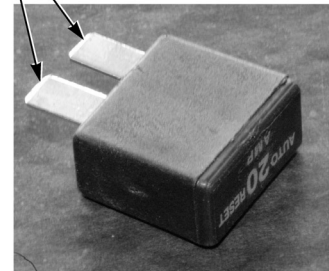
If radio charger indicators do not illuminate, troubleshoot 12-Volt Handheld Radio Charger(s) Does Not Operate (WP 0113).

MALFUNCTION	TEST OR INSPECTION	CORRECTIVE ACTION
-------------	--------------------	-------------------



**CIRCUIT BREAKER  
CB8**

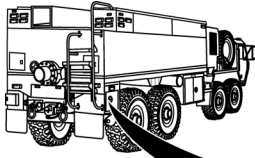
**TERMINAL  
CONNECTORS**



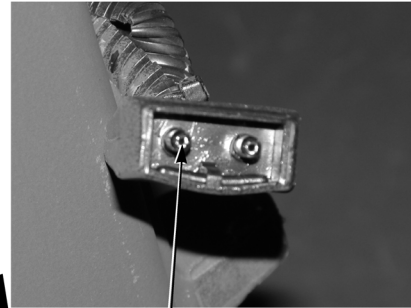
Step 8. Pull battery disconnect switch to off position (WP 0007). Remove circuit breaker CB 8 (WP 0242). Check for continuity across circuit breaker CB 8 terminal connectors.

If there is no continuity, replace circuit breaker CB 8 (WP 0242).

MALFUNCTION	TEST OR INSPECTION	CORRECTIVE ACTION
-------------	--------------------	-------------------



PASSENGER SIDE BODY  
WIRE HARNESS  
STREAMLIGHT BATTERY  
CHARGER CONNECTOR



TERMINAL  
WIRE 2075

**WARNING**



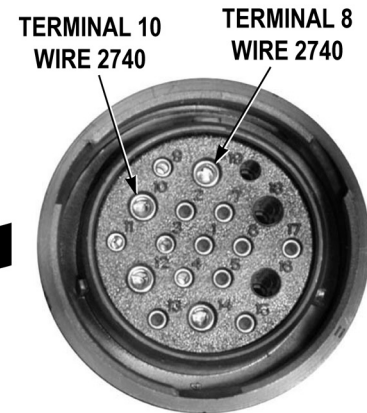
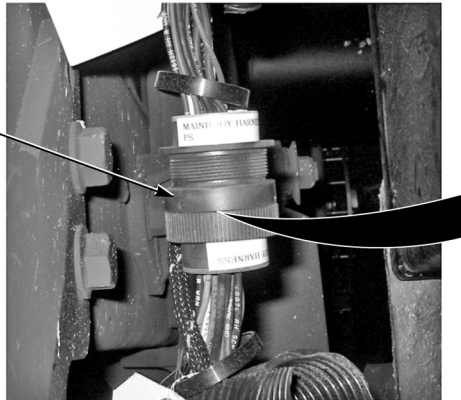
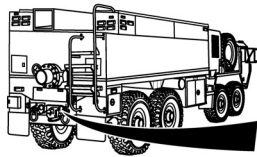
Remove rings, wristwatches, neck chains, and any other jewelry before working around vehicle. Jewelry can catch on equipment and cause serious injury. Jewelry and tools may short across electrical circuits and cause damage to equipment, or severe burns or electrical shock to personnel.

- Step 9. Install circuit breaker CB 8 (WP 0242). Disconnect passenger side body wire harness streamlight battery charger connector. Push battery disconnect switch to on position (WP 0007). With a test lead set, check for 10 to 14 VDC at wire 2075 (red) from passenger side body wire harness streamlight battery charger connector to a known good ground.

If 10 to 14 VDC are not present, go to Step 11.

MALFUNCTION	TEST OR INSPECTION	CORRECTIVE ACTION
-------------	--------------------	-------------------

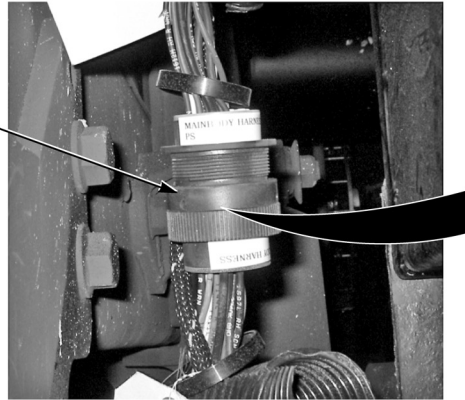
MAIN WIRE HARNESS  
PASSENGER SIDE BODY WIRE  
HARNESS CONNECTOR



- Step 10. Disconnect main wire harness passenger side body wire harness connector. With a test lead set, check for continuity across main wire harness wire 2740 (black) from main wire harness passenger side body wire harness connector, terminals 8 and 10 to a known good ground.
- If there is continuity at both terminals, repair wire 2740 in passenger side body wire harness if repairable (TM 9-2320-325-14&P), or replace passenger side body wire harness (WP 0298).
  - If there is no continuity at either terminal, repair wire 2740 in main wire harness if repairable (TM 9-2320-325-14&P), or replace main wire harness (WP 0292).

**MALFUNCTION****TEST OR INSPECTION****CORRECTIVE ACTION**

**MAIN WIRE HARNESS  
PASSENGER SIDE BODY WIRE  
HARNESS CONNECTOR**



**TERMINAL 7  
WIRE 1615**

**WARNING**

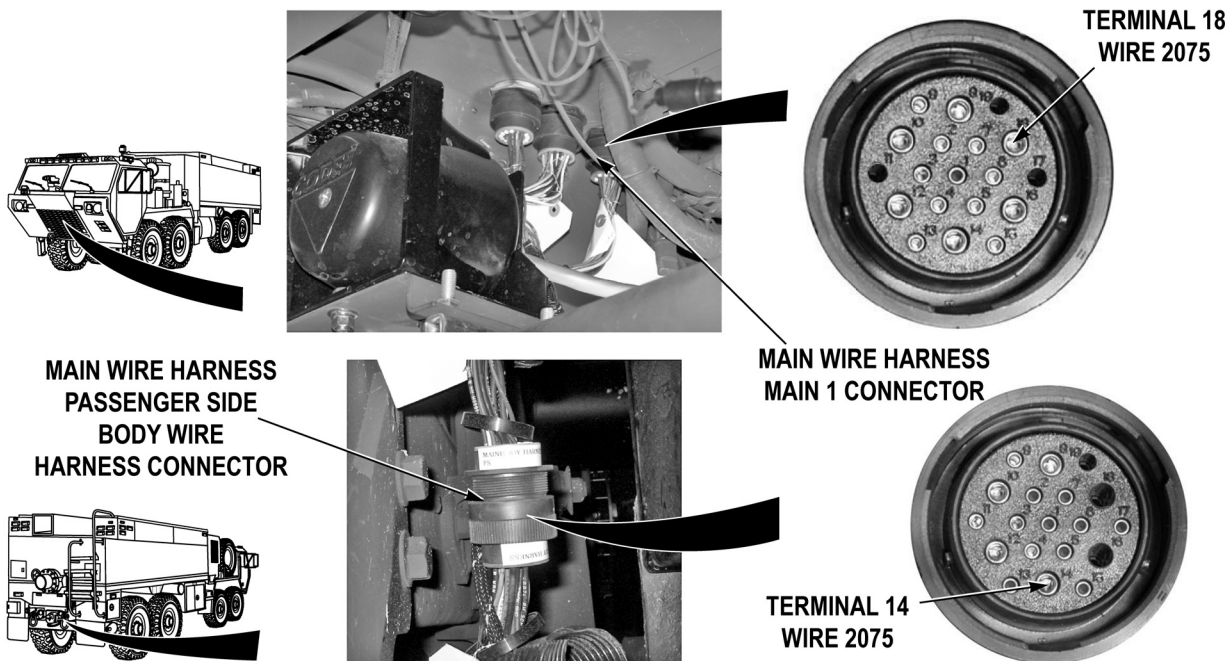
**Remove rings, wristwatches, neck chains, and any other jewelry before working around vehicle. Jewelry can catch on equipment and cause serious injury. Jewelry and tools may short across electrical circuits and cause damage to equipment, or severe burns or electrical shock to personnel.**

- Step 11. Pull battery disconnect switch to off position (WP 0007). Disconnect main wire harness passenger side body wire harness connector. Push battery disconnect switch to on position (WP 0007). With a test lead set, check for 10 to 14 VDC between wire 2075 (red) from main wire harness passenger side body wire harness connector, terminal 14 to a known good ground.

If 10 to 14 VDC are not present, repair wire 2075 in passenger side body wire harness if repairable (TM 9-2320-325-14&P), or replace passenger side body wire harness (WP 0298).



**MALFUNCTION**  
**TEST OR INSPECTION**  
**CORRECTIVE ACTION**



- Step 12. Pull battery disconnect switch to off position (WP 0007). Disconnect main wire harness main 1 connector. With a test lead set, check for continuity across wire 2075 (red) from main wire harness main 1 connector, terminal 18 to main wire harness passenger side body wire harness connector, terminal 14.
- a. If there is continuity, repair wire 2075 in cab power distribution wire harness if repairable (TM 9-2320-325-14&P), or replace cab power distribution wire harness and block (WP 0280).
  - b. If there is no continuity, repair wire 2075 in main wire harness if repairable (TM 9-2320-325-14&P), or replace main wire harness (WP 0292).

**END OF TASK**

**FOLLOW-ON MAINTENANCE**

Remove wheel chocks (TM 9-2320-422-10)

**END OF TASK**

**END OF WORK PACKAGE**



## FIELD LEVEL MAINTENANCE

## 24-VOLT BATTERY CHARGER DOES NOT OPERATE PROPERLY

## INITIAL SETUP:

**Tools and Special Tools**

Lead Set, Test (WP 0398, Item 14)  
 Tool Kit, General Mechanic's: Automotive  
 (WP 0398, Item 17)

**References**

TM 9-2320-325-14&P  
 TM 9-6140-200-14  
 WP 0004  
 WP 0008  
 WP 0030

**References (continued)**

WP 0237  
 WP 0239  
 WP 0268  
 WP 0305  
 WP 0339

**Equipment Conditions**

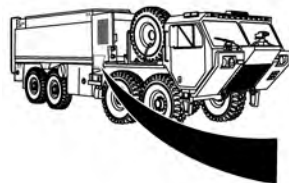
Engine OFF (TM 9-2320-422-10)  
 Wheels chocked (TM 9-2320-422-10)

## MALFUNCTION

## TEST OR INSPECTION

## CORRECTIVE ACTION

## 24-VOLT BATTERY CHARGER DOES NOT OPERATE PROPERLY



24-VOLT BATTERY CHARGER

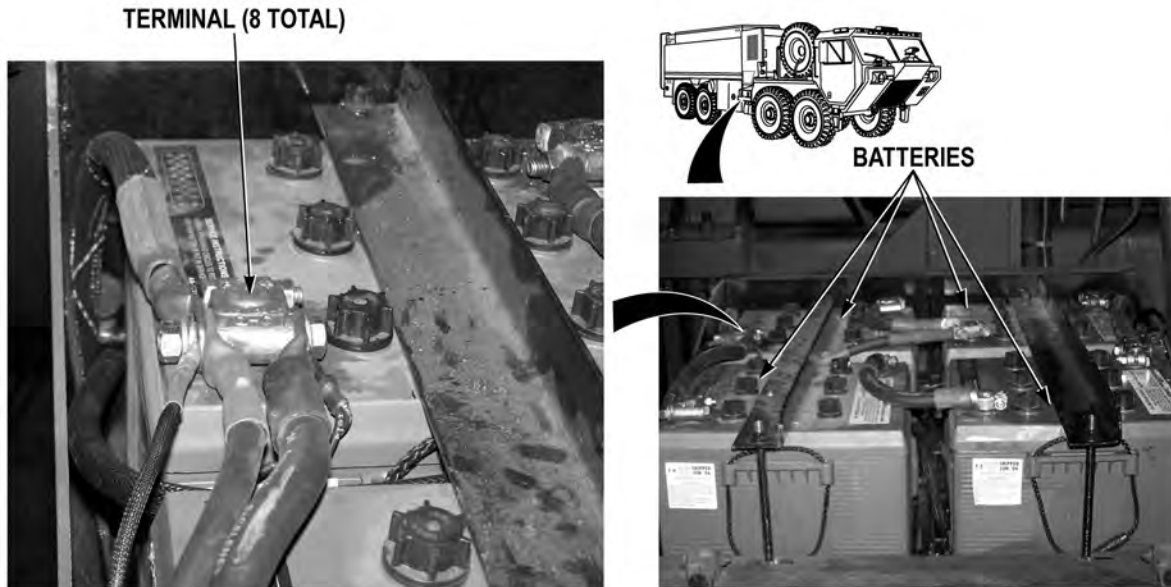
- Step 1. Connect shoreline inlet power cord between SHORELINE INLET receptacle and 110 VAC power source (WP 0030). Open passenger side pump house control access door (WP 0008). Check if 24-volt battery charger LEDs illuminate.

If 24-volt battery charger LEDs do not illuminate, go to Step 6.

**MALFUNCTION**

**TEST OR INSPECTION**

**CORRECTIVE ACTION**



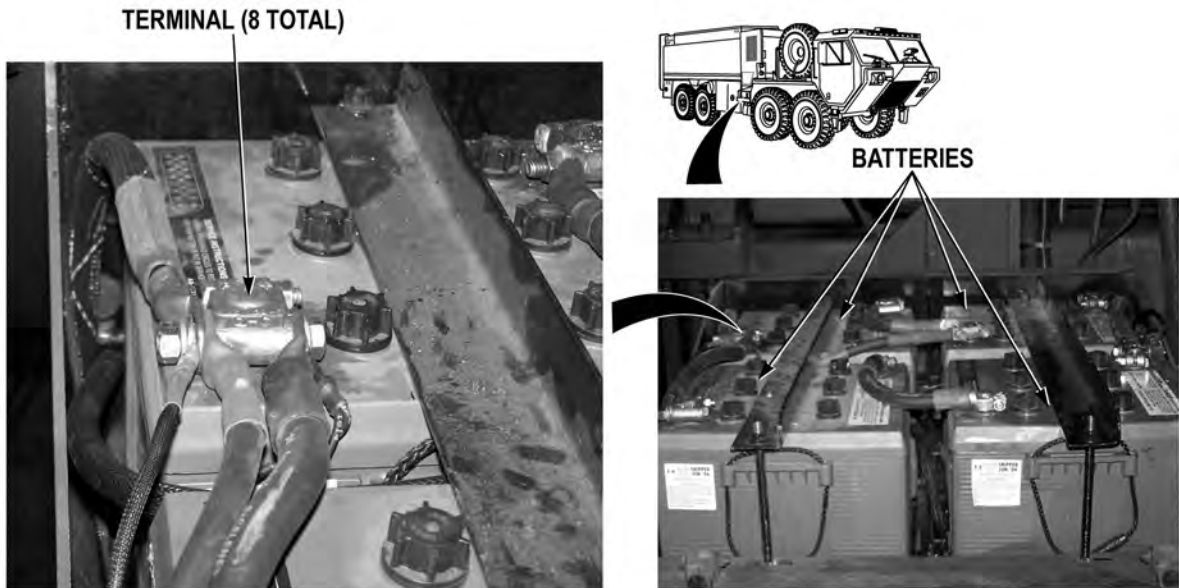
**WARNING**



**Wear proper eye protection when working around batteries. Do not allow smoking, flames, or hot objects around batteries. If battery is giving off gases, it can explode. Failure to comply may result in injury or death to personnel.**

Step 2. Open battery box (TM 9-2320-325-14&P) Inspect all batteries for dirt, corrosion, and loose battery terminals.

If battery terminals are dirty, corroded, or loose, clean and service batteries (TM 9-6140-200-14).

**MALFUNCTION****TEST OR INSPECTION****CORRECTIVE ACTION****WARNING**

**Wear proper eye protection when working around batteries. Do not allow smoking, flames, or hot objects around batteries. If battery is giving off gases, it can explode. Failure to comply may result in injury or death to personnel.**

- Step 3. Charge batteries (TM 9-2320-325-14&P) Disconnect battery terminals and cables (TM 9-2320-325-14&P) Check condition of each battery by performing a specific gravity test (TM 9-6140-200-14).

If any battery fails specific gravity test, replace each individual failed battery (TM 9-2320-325-14&P)

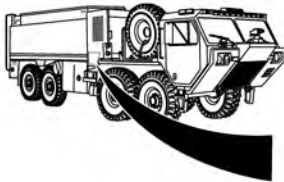
- Step 4. Check each individual battery by performing a battery load test (TM 9-6140-200-14). Reconnect batteries (TM 9-2320-325-14&P)

If any battery fails load test, replace each individual failed battery (TM 9-2320-325-14&P)

---

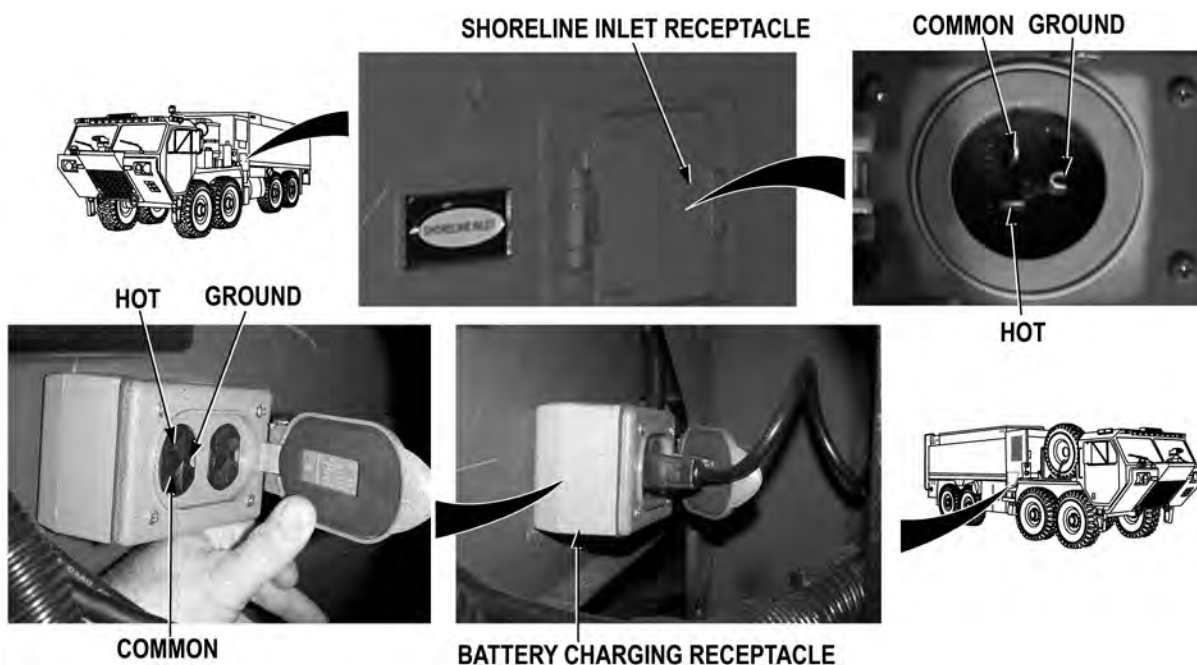
**MALFUNCTION****TEST OR INSPECTION****CORRECTIVE ACTION**

---

**24-VOLT BATTERY CHARGER**

- Step 5. Operate 24-volt battery charger for a minimum of sixteen hours. Check if 24-volt battery charger green LEDs illuminate, indicating a full charge.
- a. If 24-volt battery charger green LEDs illuminate, problem corrected.
  - b. If 24-volt battery charger green LEDs do not illuminate, replace 24-volt battery charger (WP 0237).

**MALFUNCTION**  
**TEST OR INSPECTION**  
**CORRECTIVE ACTION**



**WARNING**



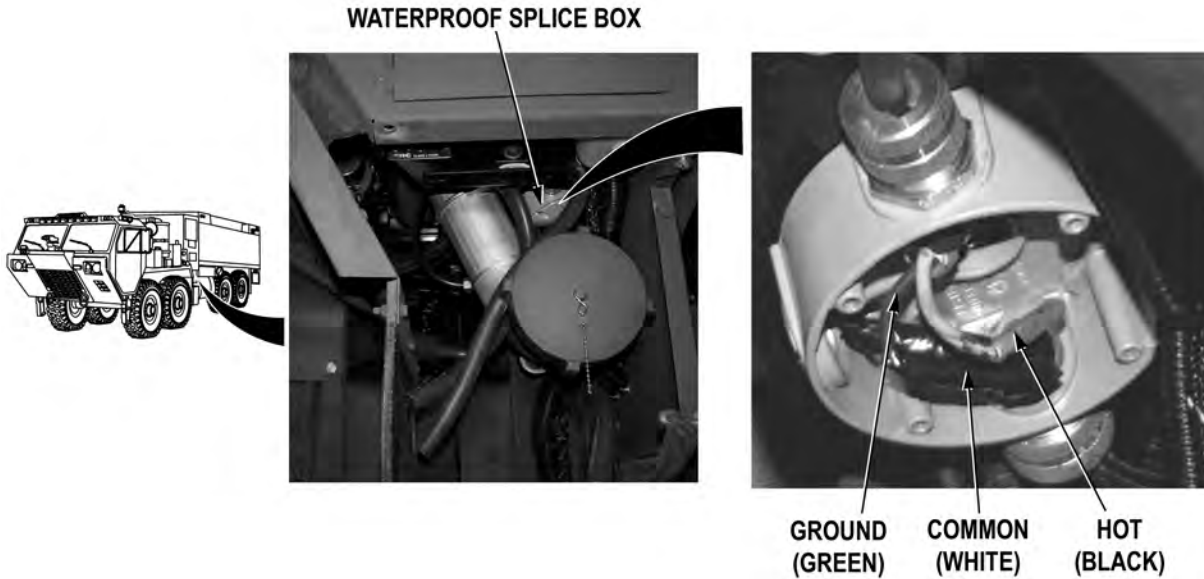
**110 Volt AC power is potentially lethal. Do not work on AC wiring when it is connected to a power source. Failure to comply may cause injury or death to personnel.**

**NOTE**

SHORELINE INLET receptacle plunger must be fully engaged for continuity to be observed for Step 6.

- Step 6. Remove pump house panel B (WP 0339). Disconnect shoreline inlet power cord from SHORELINE INLET receptacle and 110 VAC power source (WP 0030). Disconnect 24-volt battery charger power cord from 120-volt receptacle. With a test lead set, check for continuity across shoreline power cord hot wire, from SHORELINE INLET receptacle hot terminal to 120-volt receptacle hot terminal. Continue continuity check across common wire and ground wire.

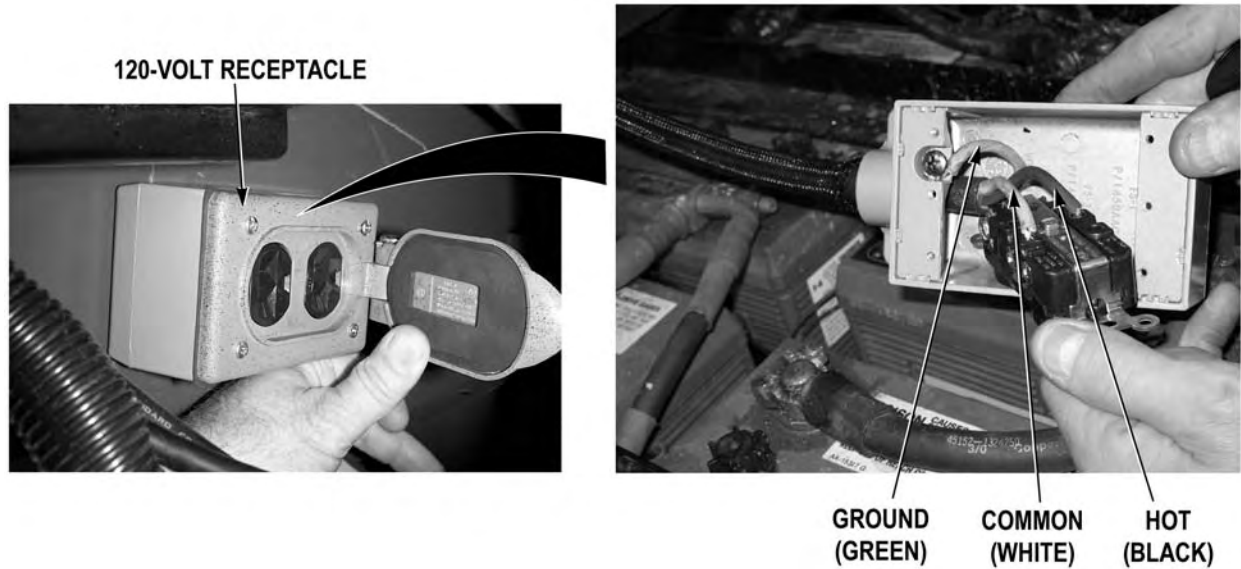
If there is continuity at all wires, go to Step 9.

**MALFUNCTION****TEST OR INSPECTION****CORRECTIVE ACTION**

- Step 7. Remove waterproof splice box cover from waterproof splice box (WP 0305). Remove shoreline inlet power cord wire connectors from hot wire (black), common wire (white), and ground wire (green) (WP 0305). Check for continuity across shoreline power cord from 120-volt receptacle hot terminal to shoreline power cord termination (black) at waterproof splice box. Continue continuity checks across common wire (white) and ground wire (green).

If there is continuity across all wires, replace SHORELINE INLET receptacle (WP 0268).



**MALFUNCTION****TEST OR INSPECTION****CORRECTIVE ACTION**

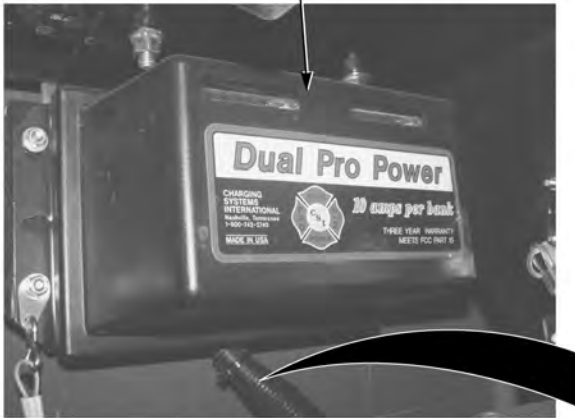
- Step 8. Remove 120-volt receptacle (WP 0239). Check for continuity across shoreline power cord from 120-volt receptacle hot wire termination (black) to termination (black) at waterproof splice box. Continue continuity checks across common wire (white) and ground wire (green).
- a. If there is continuity across all wires, replace 120-volt receptacle (WP 0239).
  - b. If there is no continuity across any wire, replace shoreline power cord (WP 0239).

**MALFUNCTION**

**TEST OR INSPECTION**

**CORRECTIVE ACTION**

24-VOLT BATTERY CHARGER



POWER CORD



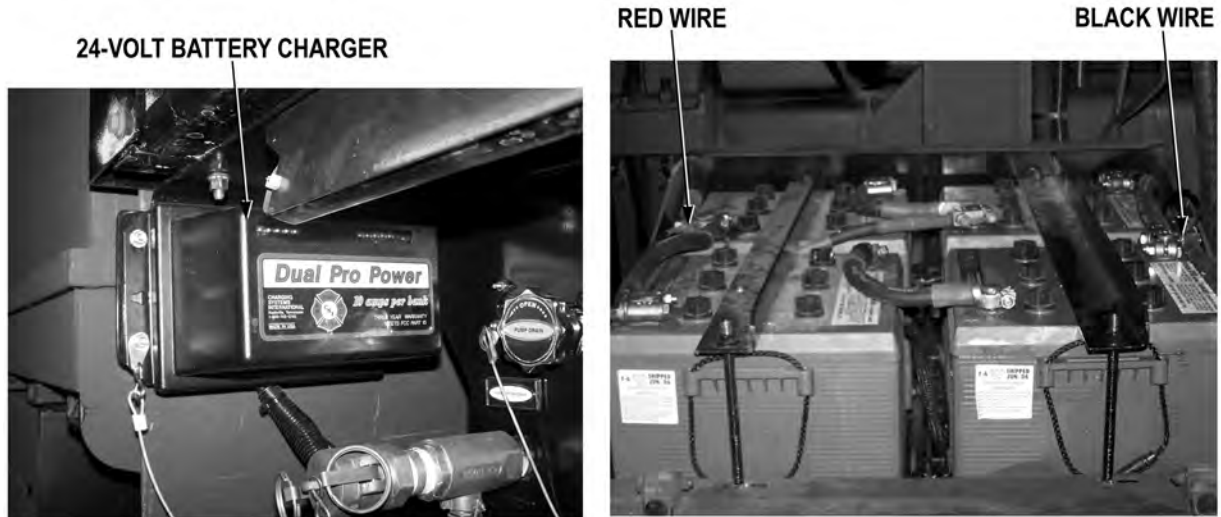
**WARNING**



**Do not disassemble 24-volt battery charger. Incorrect reassembly may result in risk of electrical shock or fire. Failure to comply may result in injury or death to personnel or damage to equipment.**

Step 9. Check if 24-volt battery charger and power cord are free from excessive wear and damage.

If 24-volt battery charger or power cord are not free from damage, replace 24-volt battery charger (WP 0237).

**MALFUNCTION****TEST OR INSPECTION****CORRECTIVE ACTION****WARNING**

**Wear proper eye protection when working around batteries. Do not allow smoking, flames, or hot objects around batteries. If battery is giving off gases, it can explode. Failure to comply may result in injury or death to personnel**

- Step 10. Disconnect batteries (TM 9-2320-325-14&P) Inspect 24-volt battery charger red and black wires from 24-volt battery charger to battery terminations.

If 24-volt battery charger red or black wire are damaged, repair wires if repairable (TM 9-2320-325-14&P), or replace 24-volt battery charger (WP 0237).

---

**MALFUNCTION****TEST OR INSPECTION****CORRECTIVE ACTION**

---

**POSITIVE TERMINAL****SERIES CONNECTED  
BATTERIES****NEGATIVE TERMINAL**

- Step 11. Reconnect batteries (TM 9-2320-325-14&P) Check for at least 10 VDC between series connected batteries from positive terminal to negative terminal.
- a. If at least 10 VDC are present, replace 24-volt battery charger (WP 0237).
  - b. If there is less than 10 VDC, replace batteries (TM 9-2320-325-14&P)

**END OF TASK****FOLLOW-ON MAINTENANCE**

Remove wheel chocks (TM 9-2320-422-10)

**END OF TASK****END OF WORK PACKAGE**

**FIELD LEVEL MAINTENANCE**

**CLEARANCE AND/OR DIRECTIONAL LIGHT(S) DOES NOT OPERATE**

**INITIAL SETUP:**

**Tools and Special Tools**

Lead Set, Test (WP 0398, Item 14)  
 Tool Kit, General Mechanic's: Automotive  
 (WP 0398, Item 17)

**References**

TM 9-2320-325-14&P  
 WP 0007  
 WP 0205  
 WP 0227  
 WP 0228  
 WP 0229  
 WP 0242

**References (continued)**

WP 0244  
 WP 0279  
 WP 0280  
 WP 0286  
 WP 0292  
 WP 0298  
 WP 0335

**Equipment Conditions**

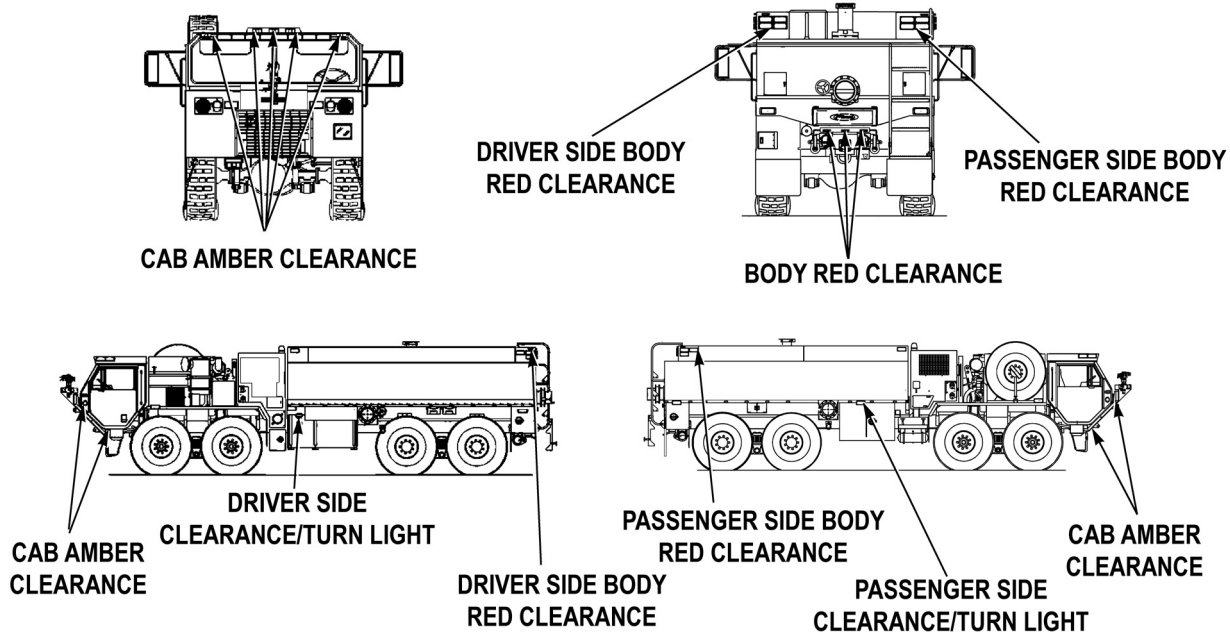
Engine OFF (TM 9-2320-422-10)  
 Wheels chocked (TM 9-2320-422-10)

**MALFUNCTION**

**TEST OR INSPECTION**

**CORRECTIVE ACTION**

**CLEARANCE AND/OR DIRECTIONAL LIGHT(S) DOES NOT OPERATE**



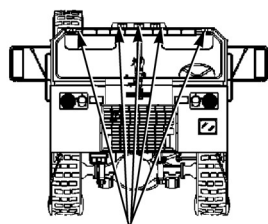
Step 1. Push battery disconnect switch to on position (WP 0007). Turn Service Drive Lights On (TM 9-2320-422-10). Turn On Clearance Lamps (TM 9-2320-422-10). Check if all clearance lights on body operate.

If all clearance lights on body operate, go to Step 28.

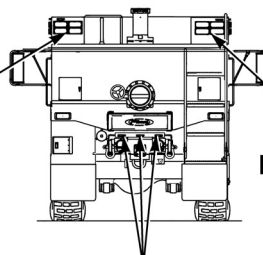
**MALFUNCTION**

**TEST OR INSPECTION**

**CORRECTIVE ACTION**



**CAB AMBER CLEARANCE**



**DRIVER SIDE BODY  
RED CLEARANCE**

**PASSENGER SIDE BODY  
RED CLEARANCE**

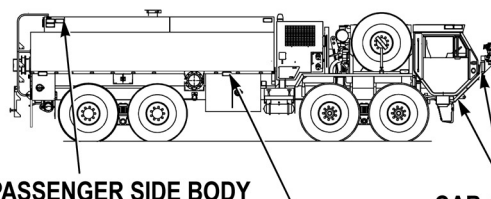
**BODY RED CLEARANCE**



**CAB AMBER  
CLEARANCE**

**DRIVER SIDE  
CLEARANCE/TURN LIGHT**

**DRIVER SIDE BODY  
RED CLEARANCE**



**PASSENGER SIDE BODY  
RED CLEARANCE**

**PASSENGER SIDE  
CLEARANCE/TURN LIGHT**

**CAB AMBER  
CLEARANCE**

Step 2. Check if cab clearance lights operate.

If cab clearance lights do not operate, troubleshoot Clearance and Side Markers Do Not Operate (TM 9-2320-325-14&P).

Step 3. Check if at least one clearance light on body operates.

If all clearance lights on body do not operate, go to Step 20.

**WARNING**



Remove rings, wristwatches, neck chains, and any other jewelry before working around vehicle. Jewelry can catch on equipment and cause serious injury. Jewelry and tools may short across electrical circuits and cause damage to equipment, or severe burns or electrical shock to personnel.

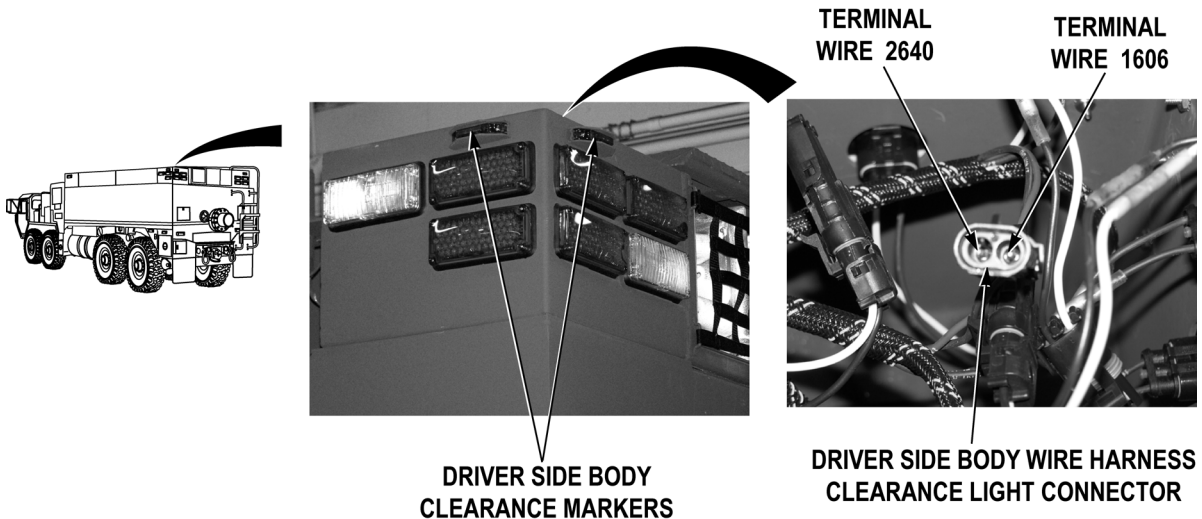
Step 4. Check if non-operating clearance light is located on driver side of body.

If non-operating clearance light is not located on driver side, go to Step 11.

Step 5. Check if at least one driver side clearance light operates.

If both driver side clearance lights do not operate, go to Step 8.

MALFUNCTION	TEST OR INSPECTION	CORRECTIVE ACTION
-------------	--------------------	-------------------



- Step 6. Remove driver side rear light bezel cover (WP 0335). Disconnect driver side body wire harness clearance light connector. With a test lead set, check for 22 to 28 VDC between wire 1606 (green) at lower driver side body wire harness clearance light connector, terminals and a known good ground.

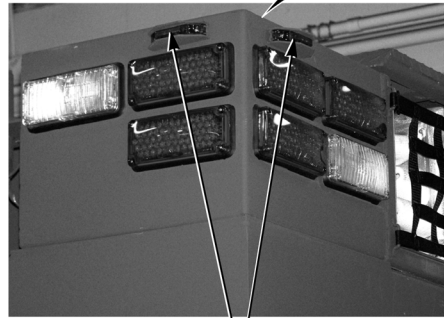
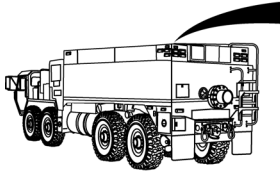
If 22 to 28 VDC are not present, repair wire 1606 in lower driver side body wire harness if repairable (TM 9-2320-325-14&P), or replace driver side body wire harness (WP 0286).

- Step 7. Turn Off Clearance Lamps (TM 9-2320-422-10). Turn Service Drive Lights Off (TM 9-2320-422-10). Pull battery disconnect switch to off position (WP 0007). With a test lead set, check for continuity across wire 2640 (black) from driver side body wire harness clearance light connector, terminals to a known good ground.
- If there is continuity, replace non-operating clearance light (WP 0229).
  - If there is no continuity, repair wire 2640 in lower driver side body wire harness if repairable (TM 9-2320-325-14&P), or replace driver side body wire harness (WP 0286).

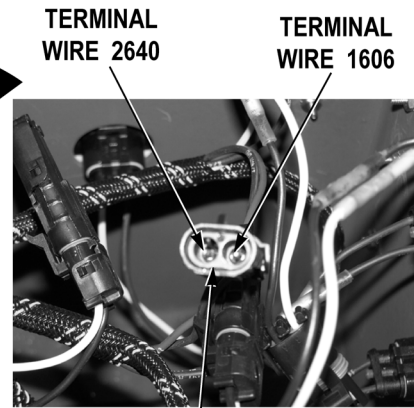
---

**MALFUNCTION**  
**TEST OR INSPECTION**  
**CORRECTIVE ACTION**

---



**DRIVER SIDE BODY  
 CLEARANCE MARKERS**



**DRIVER SIDE BODY WIRE HARNESS  
 CLEARANCE LIGHT CONNECTOR**

**WARNING**

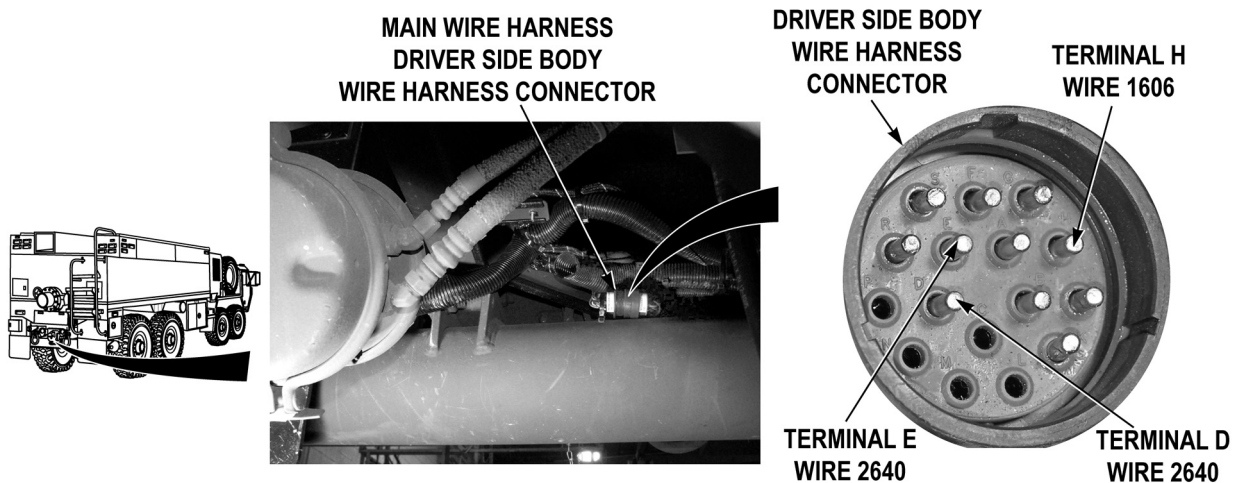


**Remove rings, wristwatches, neck chains, and any other jewelry before working around vehicle. Jewelry can catch on equipment and cause serious injury. Jewelry and tools may short across electrical circuits and cause damage to equipment, or severe burns or electrical shock to personnel.**

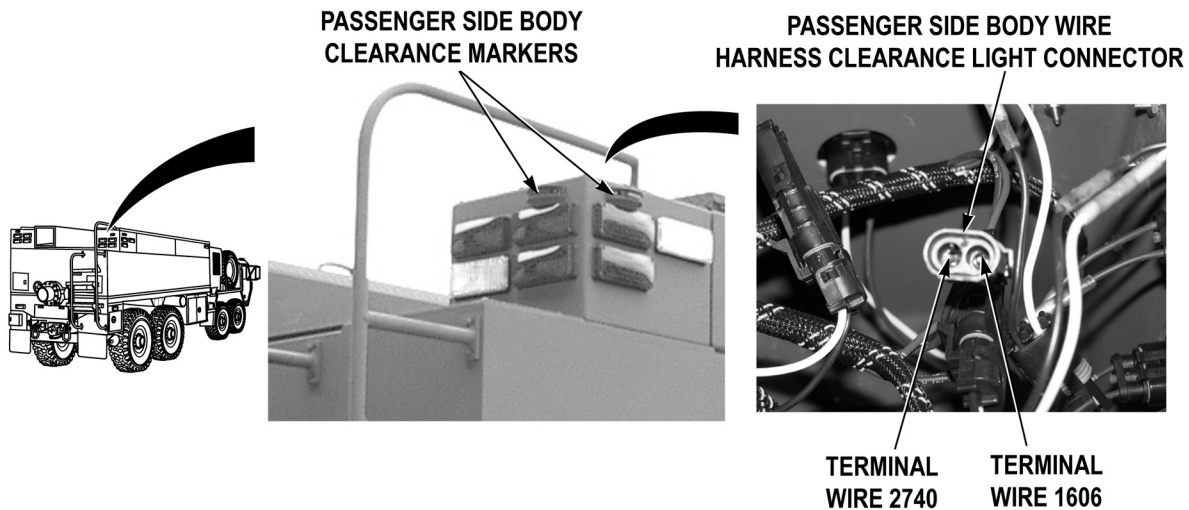
- Step 8. Remove driver side rear light bezel cover (WP 0335). Disconnect driver side body wire harness clearance light connector. With a test lead set, check for 22 to 28 VDC between wire 1606 (green) at driver side body wire harness clearance light connector terminal and a known good ground.

If 22 to 28 VDC are not present, go to Step 10.



**MALFUNCTION****TEST OR INSPECTION****CORRECTIVE ACTION**

- Step 9. Turn Off Clearance Lights (TM 9-2320-422-10). Turn Service Drive Lights Off (TM 9-2320-422-10). Pull battery disconnect switch to off position (WP 0007). Disconnect main wire harness driver side body wire harness connector. With a test lead set, check for continuity across main wire harness wire 2640 (black) from main wire harness driver side body wire harness connector, terminals D and E to a known good ground.
- If there is continuity at both terminals, repair wire 2640 in driver side body wire harness if repairable (TM 9-2320-325-14&P), or replace driver side body wire harness (WP 0286).
  - If there is no continuity, repair wire 2640 in main wire harness if repairable (TM 9-2320-325-14&P), or replace main wire harness (WP 0292).
- Step 10. Disconnect main wire harness driver side body wire harness connector. With a test lead set, check for 22 to 28 VDC between wire 1606 (green) at main wire harness driver side body wire harness connector, terminal H and a known good ground.
- If 22 to 28 VDC are present, repair wire 1606 in driver side body wire harness if repairable (TM 9-2320-325-14&P), or replace driver side body wire harness (WP 0286).
  - If 22 to 28 VDC are not present, repair wire 1606 in main wire harness if repairable (TM 9-2320-325-14&P), or replace main wire harness (WP 0292).
- Step 11. Check if non-operating clearance lights are located on passenger side of body.
- If non-operating clearance light is not located on passenger side, go to Step 18.
- Step 12. Check if at least one passenger side clearance light operates.
- If both passenger side clearance lights do not operate, go to Step 15.

**MALFUNCTION****TEST OR INSPECTION****CORRECTIVE ACTION****WARNING**

**Adhesives, solvents, and sealing compounds can burn easily, can give off harmful vapors, and are harmful to skin and clothing. To avoid injury or death, keep away from open fire and use in well-ventilated area. If adhesive, solvent, or sealing compound gets on skin or clothing, wash immediately with soap and water.**

- Step 13. Remove passenger side light bezel cover (WP 0335). Disconnect passenger side body wire harness clearance light connector. Check for 22 to 28 VDC between wire 1606 (green) at passenger side body wire harness clearance light connector, terminal and a known good ground.

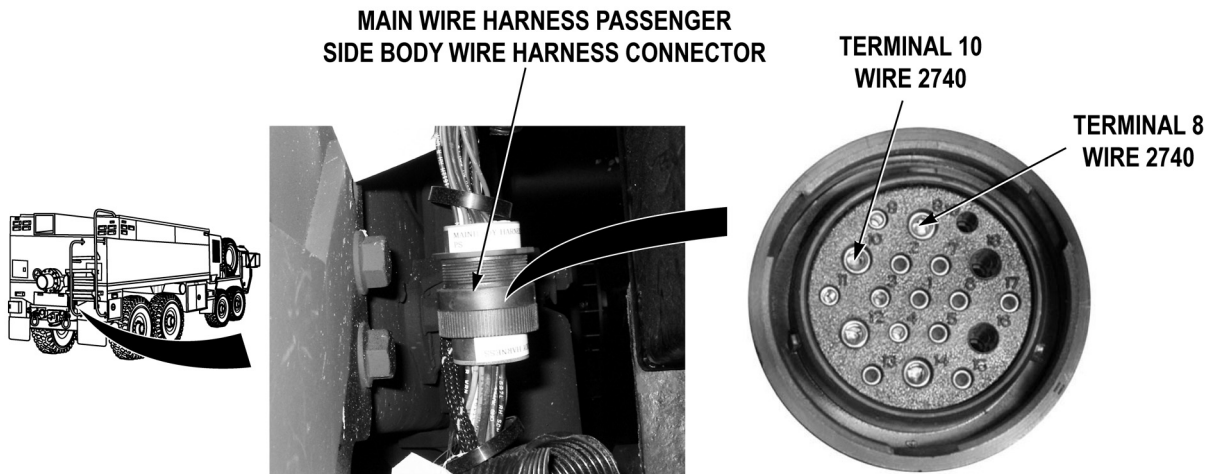
If 22 to 28 VDC are not present, repair wire 1606 in passenger side body wire harness if repairable (TM 9-2320-325-14&P), or replace passenger side body wire harness (WP 0298).

- Step 14. Turn Off Clearance Lamps (TM 9-2320-422-10). Turn Service Drive Lights Off (TM 9-2320-422-10). Pull battery disconnect switch to off position (WP 0007). With a test lead set, check for continuity across wire 2740 (black) from lower passenger side body wire harness at passenger side body wire harness clearance light connector to a known good ground.
- a. If there is continuity, replace non-operating clearance light (WP 0229).
  - b. If there is no continuity, repair wire 2740 in passenger side body wire harness if repairable (TM 9-2320-325-14&P), or replace passenger side body wire harness (WP 0298).

**MALFUNCTION****TEST OR INSPECTION****CORRECTIVE ACTION**

- Step 15. Remove passenger side light bezel cover (WP 0335). Disconnect passenger side body wire harness clearance light connector at non-operating clearance marker. Check for 22 to 28 VDC between wire 1606 (green) at passenger side body wire harness clearance marker terminal and a known good ground.

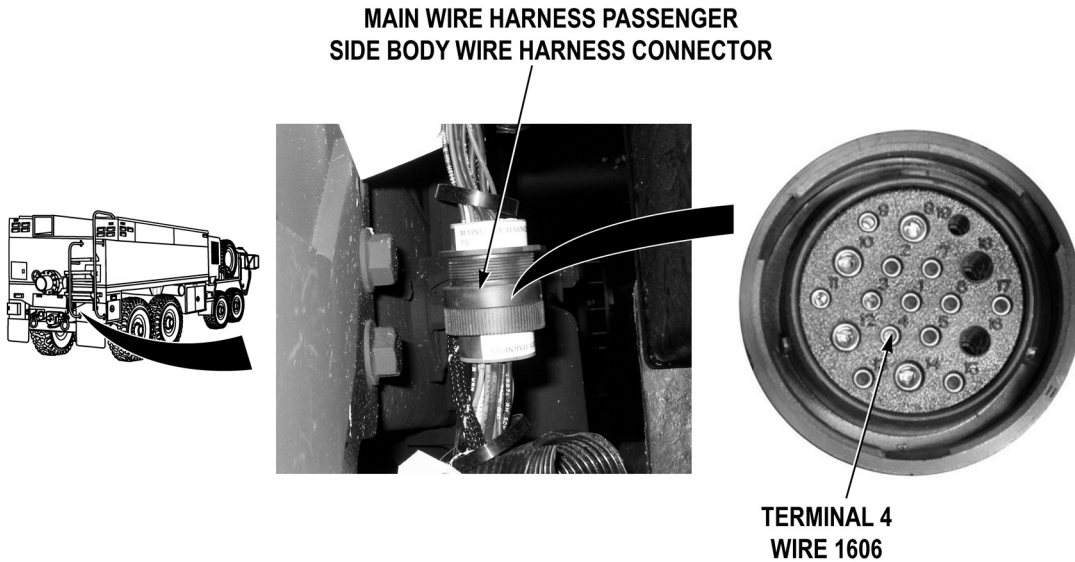
If 22 to 28 VDC are present, go to Step 17.

**WARNING**

**Remove rings, wristwatches, neck chains, and any other jewelry before working around vehicle. Jewelry can catch on equipment and cause serious injury. Jewelry and tools may short across electrical circuits and cause damage to equipment, or severe burns or electrical shock to personnel.**

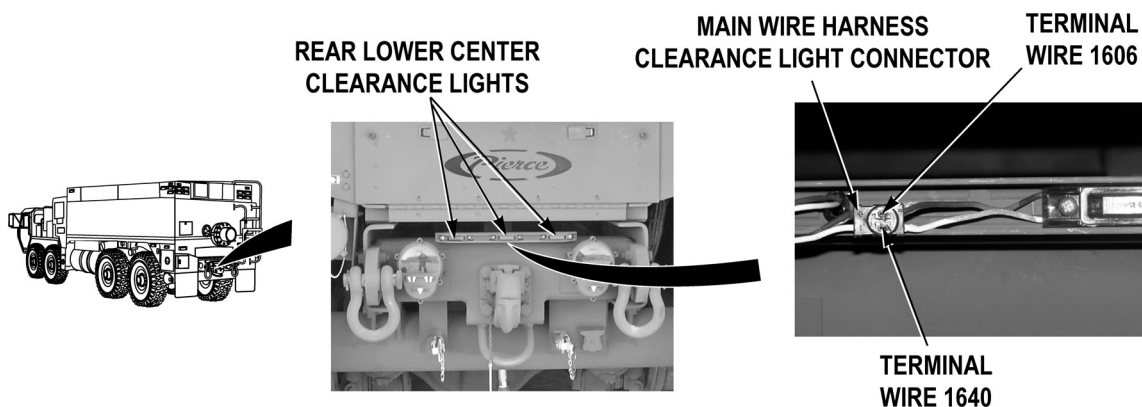
- Step 16. Turn Off Clearance Lamps (TM 9-2320-422-10). Turn Service Drive Lights Off (TM 9-2320-422-10). Pull battery disconnect switch to off position (WP 0007). Disconnect main wire harness passenger side body wire harness connector. With a test lead set, check for continuity across main wire harness wire 2740 (black) from main wire harness passenger side body wire harness connector, terminals 8 and 10 to a known good ground.
- If there is continuity at both terminals, repair wire 2740 in passenger side body wire harness if repairable (TM 9-2320-325-14&P), or replace passenger side body wire harness (WP 0298).
  - If there is no continuity at either terminal, repair wire 2740 in main wire harness if repairable (TM 9-2320-325-14&P), or replace main wire harness (WP 0292).

MALFUNCTION	TEST OR INSPECTION	CORRECTIVE ACTION
-------------	--------------------	-------------------

**WARNING**

Remove rings, wristwatches, neck chains, and any other jewelry before working around vehicle. Jewelry can catch on equipment and cause serious injury. Jewelry and tools may short across electrical circuits and cause damage to equipment, or severe burns or electrical shock to personnel.

- Step 17. Disconnect main wire harness passenger side body wire harness connector. With a test lead set, check for 22 to 28 VDC between wire 1606 (green) at main wire harness passenger side body wire harness connector, terminal H and a known good ground.
- a. If 22 to 28 VDC are present, repair wire 1606 in passenger side body wire harness if repairable (TM 9-2320-325-14&P), or replace passenger side body wire harness (WP 0298).
  - b. If 22 to 28 VDC are not present, repair wire 1606 in main wire harness if repairable (TM 9-2320-325-14&P), or replace main wire harness (WP 0292).

**MALFUNCTION****TEST OR INSPECTION****CORRECTIVE ACTION****WARNING**

Remove rings, wristwatches, neck chains, and any other jewelry before working around vehicle. Jewelry can catch on equipment and cause serious injury. Jewelry and tools may short across electrical circuits and cause damage to equipment, or severe burns or electrical shock to personnel.

- Step 18. Remove non-operating rear lower center clearance light (WP 0227). With a test lead set, check for 22 to 28 VDC between terminal wire 1606 (black) at main wire harness clearance light connector terminal and a known good ground.

If 22 to 28 VDC are not present, repair wire 1606 in main wire harness if repairable (TM 9-2320-325-14&P), or replace main wire harness (WP 0292).

**NOTE**

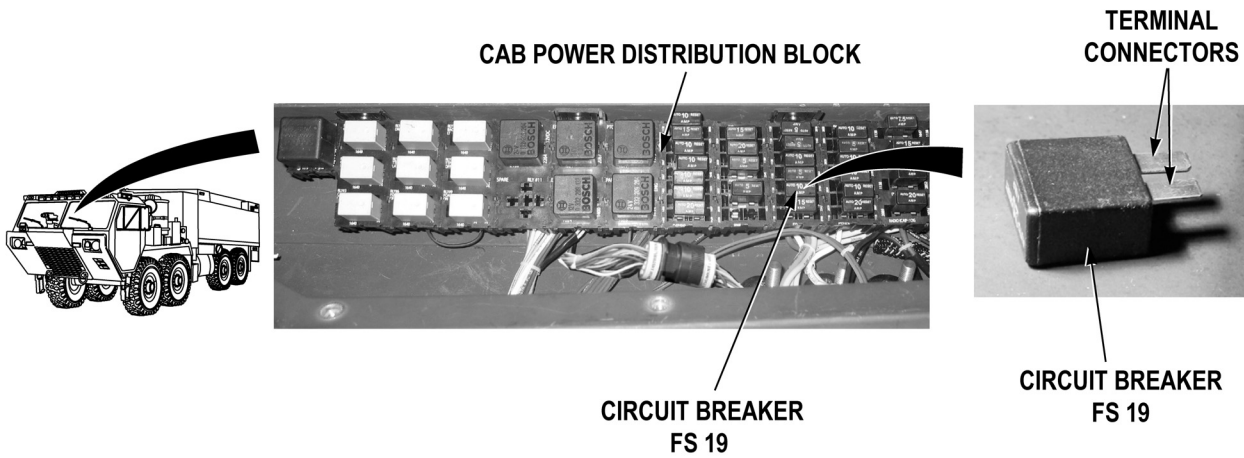
Lower center rear clearance marker LED light assembly must be inserted into connector so + marking on light assembly align with black wire. LED lights will not function if installed in reversed position.

- Step 19. Turn Off Clearance Lamps (TM 9-2320-422-10). Turn Service Drive Lights Off (TM 9-2320-422-10). Pull battery disconnect switch to off position (WP 0007). With a lead test set, check for continuity across main wire harness wire 1640 (white) from main wire harness clearance light connector terminal and a known good ground.
- a. If there is continuity, replace non-operating clearance light (WP 0227).
  - b. If there is no continuity, repair wire 1640 in main wire harness if repairable (TM 9-2320-325-14&P), or replace main wire harness (WP 0292).

MALFUNCTION	TEST OR INSPECTION	CORRECTIVE ACTION
-------------	--------------------	-------------------

Step 20. Check if clearance lights at side clearance/turn lights operate.

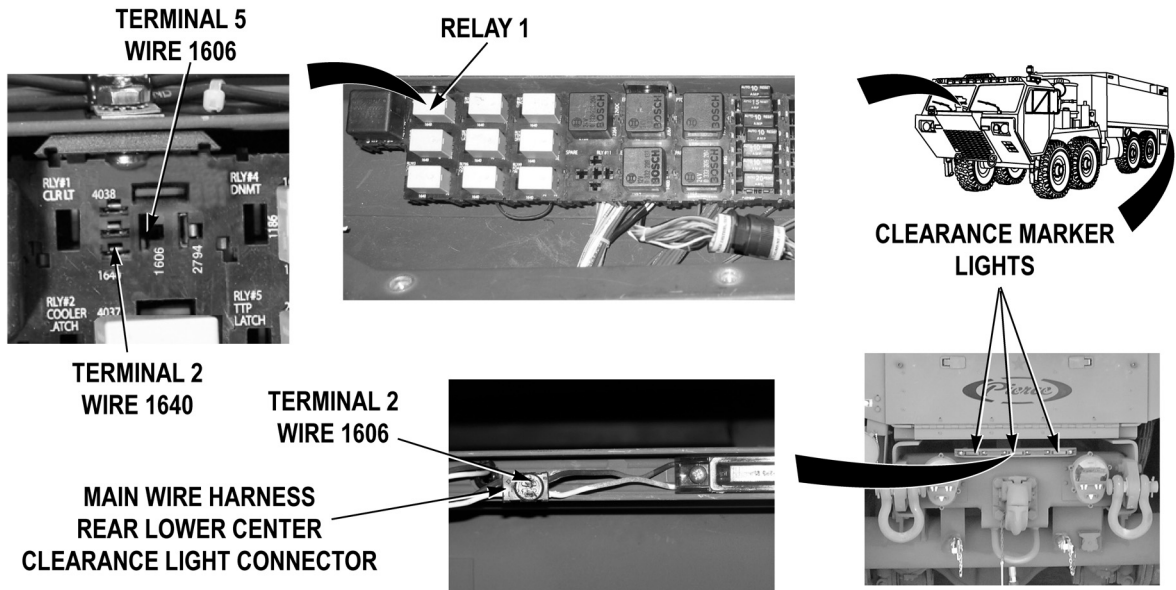
If clearance lights at side clearance/turn lights do not operate, repair wire H012 (white) in cab instrument panel wire harness (TM 9-2320-325-14&P), or replace cab instrument panel wire harness (WP 0279).



Step 21. Turn Service Drive Lights Off (TM 9-2320-422-10). Pull battery disconnect switch to off position (WP 0007). Remove cab instrument panel A (WP 0205). Remove circuit breaker FS 19 (WP 0242). With a test lead set, check for continuity across circuit breaker.

If there is no continuity, replace circuit breaker FS 19 (WP 0242).

MALFUNCTION	TEST OR INSPECTION	CORRECTIVE ACTION
-------------	--------------------	-------------------



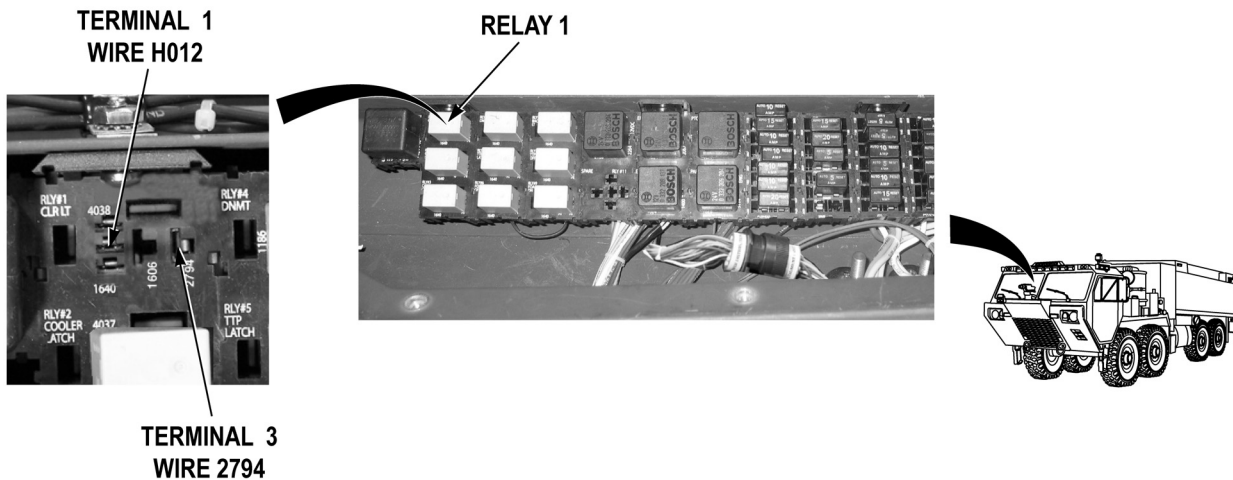
Step 22. Install circuit breaker FS 19 (WP 0242). Remove relay 1 (WP 0244). Remove one rear lower center clearance light (WP 0229). With a test lead set, check for continuity across wire 1606 (green) from cab power distribution block relay 1 connector, terminal 5 to rear lower center clearance light connector terminal.

If there is no continuity, go to Step 27.

Step 23. With a test lead set, check for continuity across cab power distribution wire harness wire 1640 (black) from relay 1 connector, terminal 2 to a known good ground.

If there is no continuity, replace cab power distribution wire harness and block (WP 0280).

MALFUNCTION	TEST OR INSPECTION	CORRECTIVE ACTION
-------------	--------------------	-------------------

**WARNING**

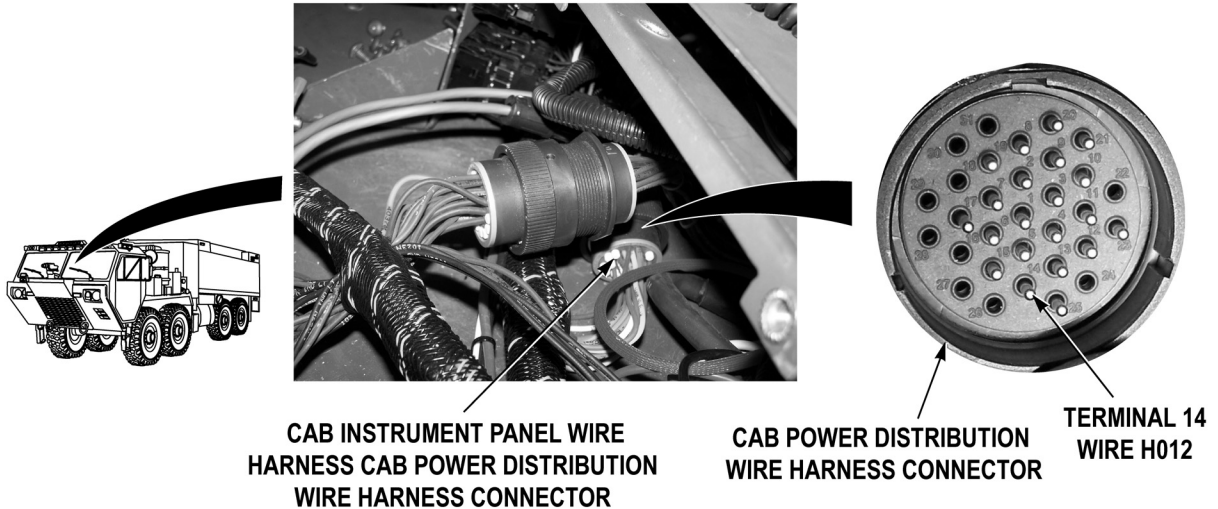
Remove rings, wristwatches, neck chains, and any other jewelry before working around vehicle. Jewelry can catch on equipment and cause serious injury. Jewelry and tools may short across electrical circuits and cause damage to equipment, or severe burns or electrical shock to personnel.

- Step 24. Push battery disconnect switch to on position (WP 0007). Turn Service Drive Lights On (TM 9-2320-422-10). Turn On Clearance Lamps (TM 9-2320-422-10). With a test lead set, check for 22 to 28 VDC between cab power distribution wire harness wire H012 (white) at relay 1 connector, terminal 1 and a known good ground.

If 22 to 28 VDC are not present, go to Step 26.

- Step 25. With a test lead set, check for 22 to 28 VDC between cab power distribution wire harness wire 2794 (red) at relay 1 connector, terminal 3 and a known good ground.
- If 22 to 28 VDC are present, replace relay 1 (WP 0244).
  - If 22 to 28 VDC are not present, replace cab power distribution wire harness and block (WP 0280).

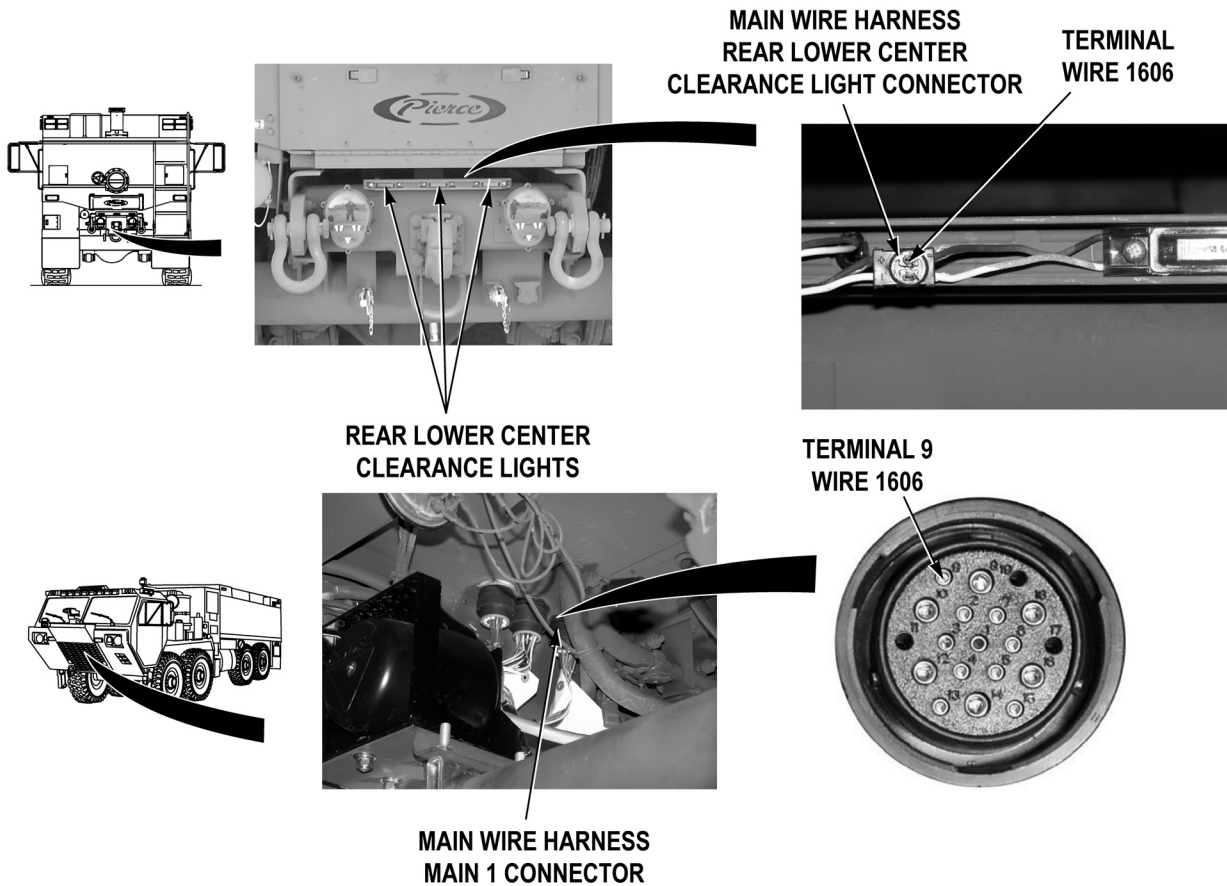


**MALFUNCTION****TEST OR INSPECTION****CORRECTIVE ACTION****WARNING**

Remove rings, wristwatches, neck chains, and any other jewelry before working around vehicle. Jewelry can catch on equipment and cause serious injury. Jewelry and tools may short across electrical circuits and cause damage to equipment, or severe burns or electrical shock to personnel.

- Step 26. Disconnect cab instrument panel wire harness cab power distribution wire harness connector. With a test lead set, check for 22 to 28 VDC between cab instrument panel wire harness wire H012 (white) at cab power distribution wire harness connector, terminal 14 and a known good ground.
- a. If 22 to 28 VDC are present, repair wire H012 in cab power distribution wire harness if repairable (TM 9-2320-325-14&P), or replace cab power distribution wire harness and block (WP 0280).
  - b. If 22 to 28 VDC are not present, repair wire H012 in cab instrument panel wire harness if repairable (TM 9-2320-325-14&P), or replace cab instrument panel wire harness (WP 0279).

MALFUNCTION	TEST OR INSPECTION	CORRECTIVE ACTION
-------------	--------------------	-------------------

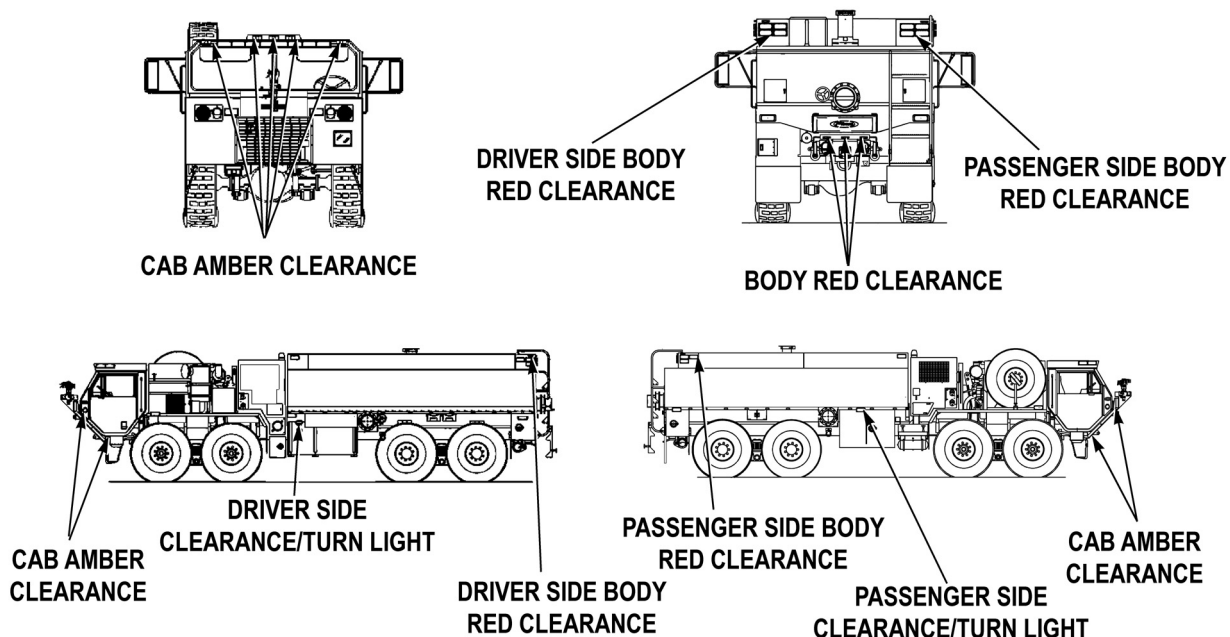


- Step 27. Remove skid plate grille (WP 0349). Disconnect main wire harness main 1 connector. With a test lead set, check for continuity across wire 1606 (green) from main wire harness main 1 connector, terminal 9 to rear center lower clearance light connector terminal.
- a. If there is continuity, repair wire 1606 in cab power distribution wire harness if repairable (TM 9-2320-325-14&P), or replace cab power distribution wire harness and block (WP 0280).
  - b. If there is no continuity, repair wire 1606 in main wire harness if repairable (TM 9-2320-325-14&P), or replace main wire harness (WP 0292).

**MALFUNCTION**

**TEST OR INSPECTION**

**CORRECTIVE ACTION**



**WARNING**



Remove rings, wristwatches, neck chains, and any other jewelry before working around vehicle. Jewelry can catch on equipment and cause serious injury. Jewelry and tools may short across electrical circuits and cause damage to equipment, or severe burns or electrical shock to personnel.

Step 28. Check if clearance light(s) at side clearance/turn lights operate.

If clearance light(s) at side clearance/turn lights do not operate, go to Step 37.

**NOTE**

Operation of vehicle with malfunctioning turn signals may violate AR 385-55.

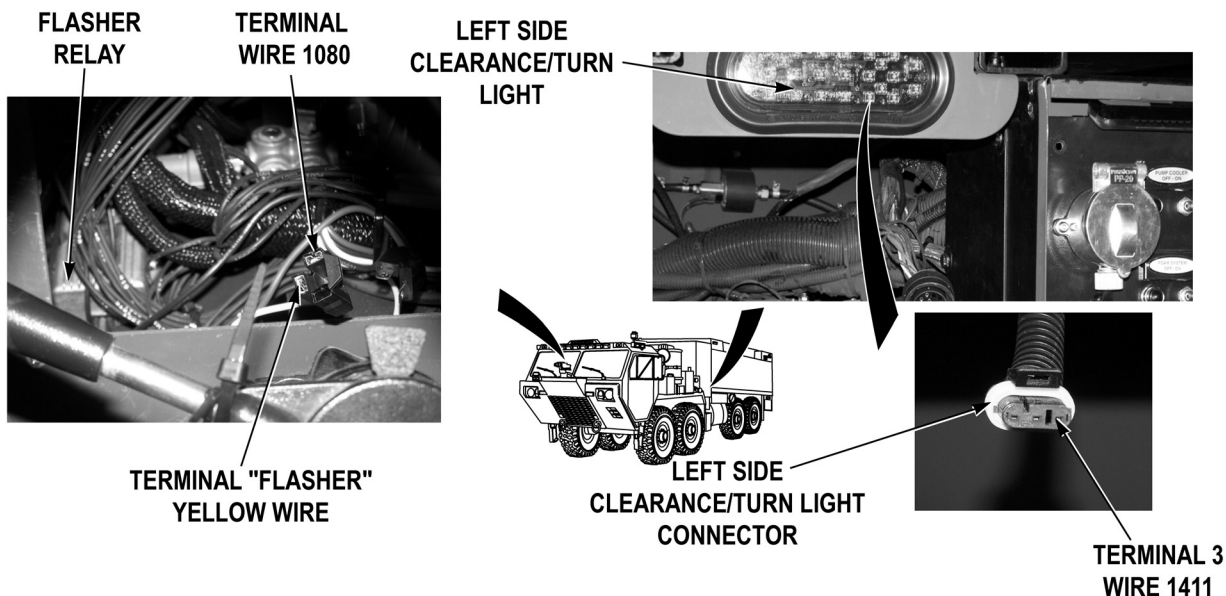
Step 29. Turn Off Clearance Lamps (TM 9-2320-422-10). Turn left turn signal on (TM 9-2320-422-10). Check if left side clearance/turn light flashes.

If left side clearance/turn light flashes, go to Step 33.

Step 30. Check if left front turn light flashes.

If left front turn signal does not flash, troubleshoot Left Front Turn Signal Does Not Operate (TM 9-2320-325-14&P).

MALFUNCTION	TEST OR INSPECTION	CORRECTIVE ACTION
-------------	--------------------	-------------------



**WARNING**

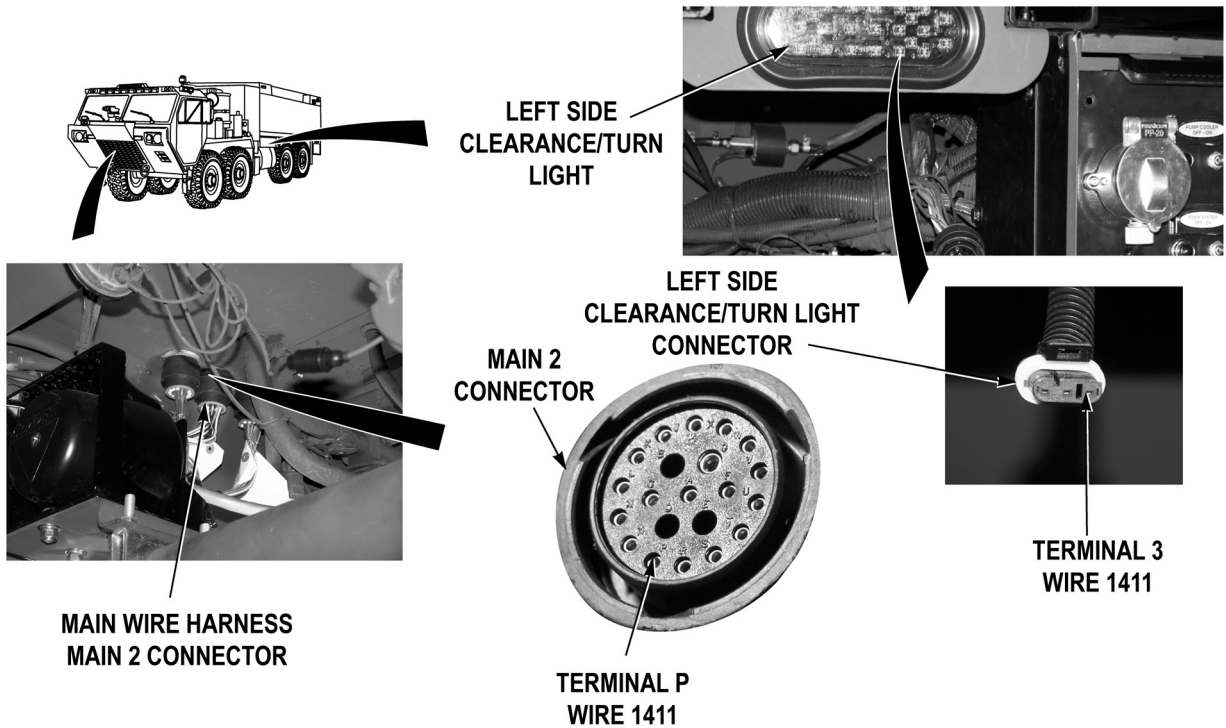


Remove rings, wristwatches, neck chains, and any other jewelry before working around vehicle. Jewelry can catch on equipment and cause serious injury. Jewelry and tools may short across electrical circuits and cause damage to equipment, or severe burns or electrical shock to personnel.

Step 31. Pull battery disconnect switch to off position (WP 0007). Remove six screws holding sunscreen and place instrument panel in service position (TM 9-2320-325-14&P). Remove flasher relay (TM 9-2320-325-14&P). Install a test lead set between cab wire harness flasher relay connector terminals wire 1080 and turn signal 'Flasher' yellow wire. Remove left side clearance/turn light (WP 0228). Push battery disconnect switch to on position (WP 0007). Turn Service Drive Lights On (TM 9-2320-422-10). Turn left turn signal on (TM 9-2320-325-14&P). With a test lead set, check for 22 to 28 VDC between main wire harness wire 1411 (yellow) at left side clearance/turn light connector, terminal 3 and a known good ground.

If 22 to 28 VDC are present, replace left side clearance/turn light (WP 0228).

MALFUNCTION	TEST OR INSPECTION	CORRECTIVE ACTION
-------------	--------------------	-------------------

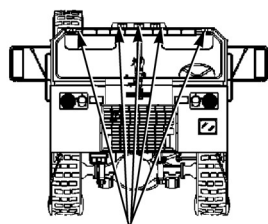


- Step 32. Remove skid plate grille (WP 0349). Pull battery disconnect switch to off position (WP 0007). Disconnect main wire harness main 2 connector. With a test lead set, check for continuity across wire 1411 (yellow) from main wire harness main 2 connector, terminal P to left side clearance/turn connector, terminal 3.
- If there is continuity, repair wire 1411 in cab instrument panel wire harness if repairable (TM 9-2320-325-14&P), or replace cab instrument panel wire harness (WP 0279).
  - If there is no continuity, repair wire 1411 in main wire harness if repairable (TM 9-2320-325-14&P), or replace main wire harness (WP 0292).

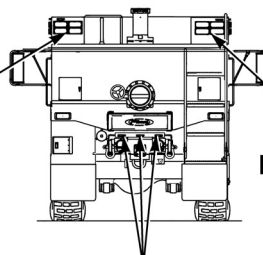
**MALFUNCTION**

**TEST OR INSPECTION**

**CORRECTIVE ACTION**



**CAB AMBER CLEARANCE**



**DRIVER SIDE BODY  
RED CLEARANCE**

**PASSENGER SIDE BODY  
RED CLEARANCE**

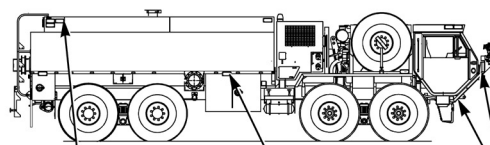
**BODY RED CLEARANCE**



**CAB AMBER  
CLEARANCE**

**DRIVER SIDE  
CLEARANCE/TURN LIGHT**

**DRIVER SIDE BODY  
RED CLEARANCE**



**PASSENGER SIDE BODY  
RED CLEARANCE**

**PASSENGER SIDE  
CLEARANCE/TURN LIGHT**

**CAB AMBER  
CLEARANCE**

**WARNING**



Remove rings, wristwatches, neck chains, and any other jewelry before working around vehicle. Jewelry can catch on equipment and cause serious injury. Jewelry and tools may short across electrical circuits and cause damage to equipment, or severe burns or electrical shock to personnel.

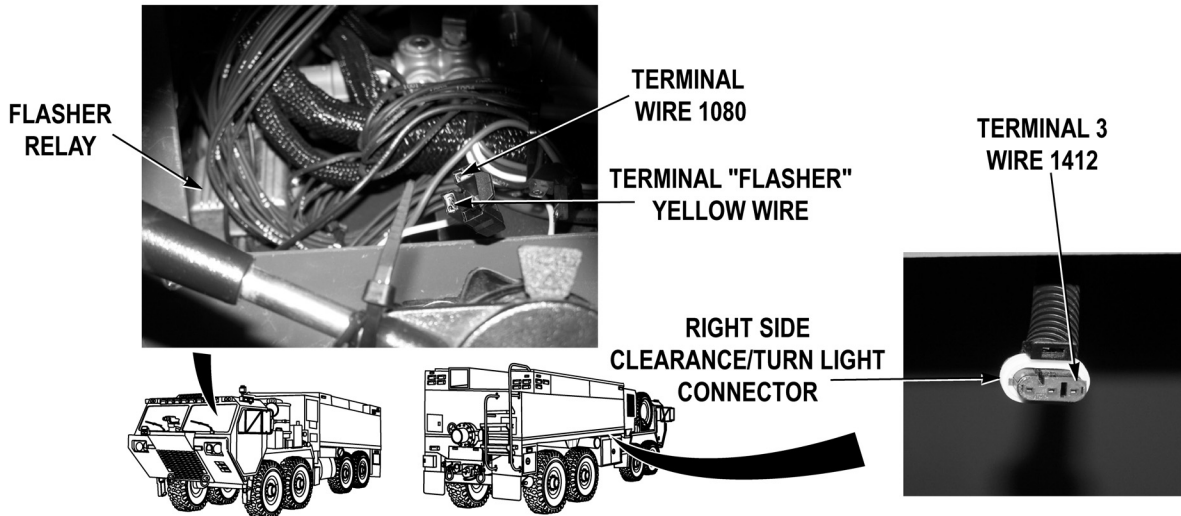
Step 33. Turn right turn signal on (TM 9-2320-422-10). Check if right side clearance/turn light flashes.

If right side clearance/turn light flashes, fault has been corrected.

Step 34. Check if right front turn light flashes.

If right front turn light does not flash, troubleshoot Right Front Turn Signal Does Not Operate (TM 9-2320-325-14&P)

MALFUNCTION	TEST OR INSPECTION	CORRECTIVE ACTION
-------------	--------------------	-------------------



**WARNING**

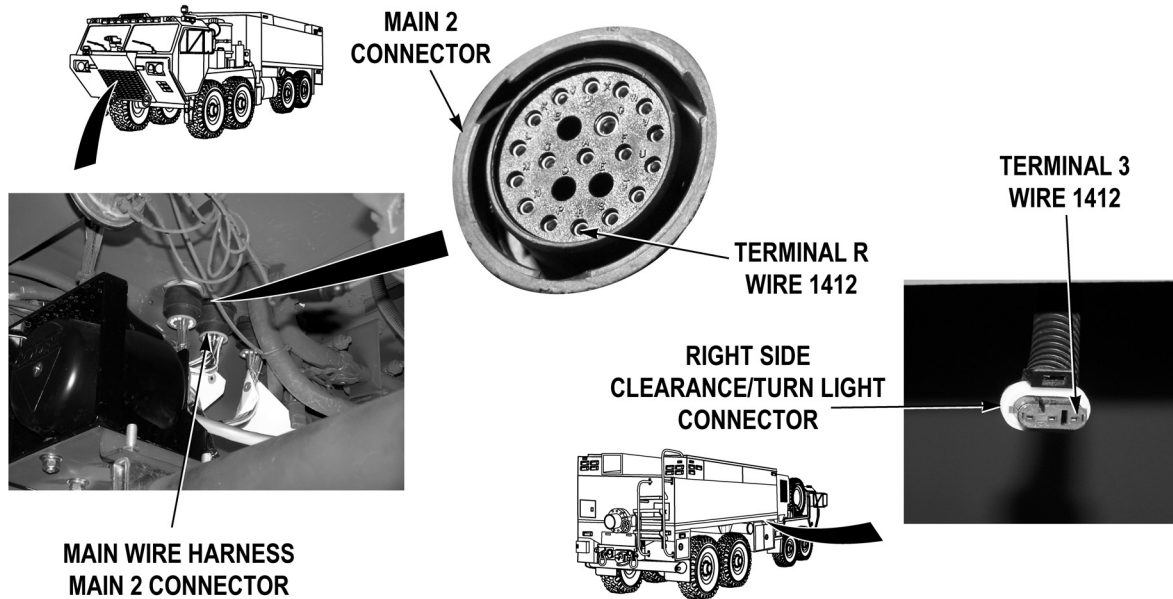


Remove rings, wristwatches, neck chains, and any other jewelry before working around vehicle. Jewelry can catch on equipment and cause serious injury. Jewelry and tools may short across electrical circuits and cause damage to equipment, or severe burns or electrical shock to personnel.

Step 35. Pull battery disconnect switch to off position (WP 0007). Remove six screws holding sunscreen, and place instrument panel in service position (TM 9-2320-325-14&P). Remove flasher relay (TM 9-2320-325-14&P). Install test lead set between cab wire harness flasher relay connector terminals wire 1080 and turn signal "Flasher" yellow wire. Disconnect main wire harness from right side clearance/turn light connector (WP 0228). Push battery disconnect switch to on position (WP 0007). Turn Service Drive Lights On (TM 9-2320-422-10). Turn right turn signal on (TM 9-2320-422-10). With a test lead set, check for 22 to 28 VDC between main wire harness wire 1412 (green) at right side clearance/turn light connector, terminal 3 and a known good ground.

If 22 to 28 VDC are present, replace right side clearance/turn light (WP 0228).

MALFUNCTION	TEST OR INSPECTION	CORRECTIVE ACTION
-------------	--------------------	-------------------



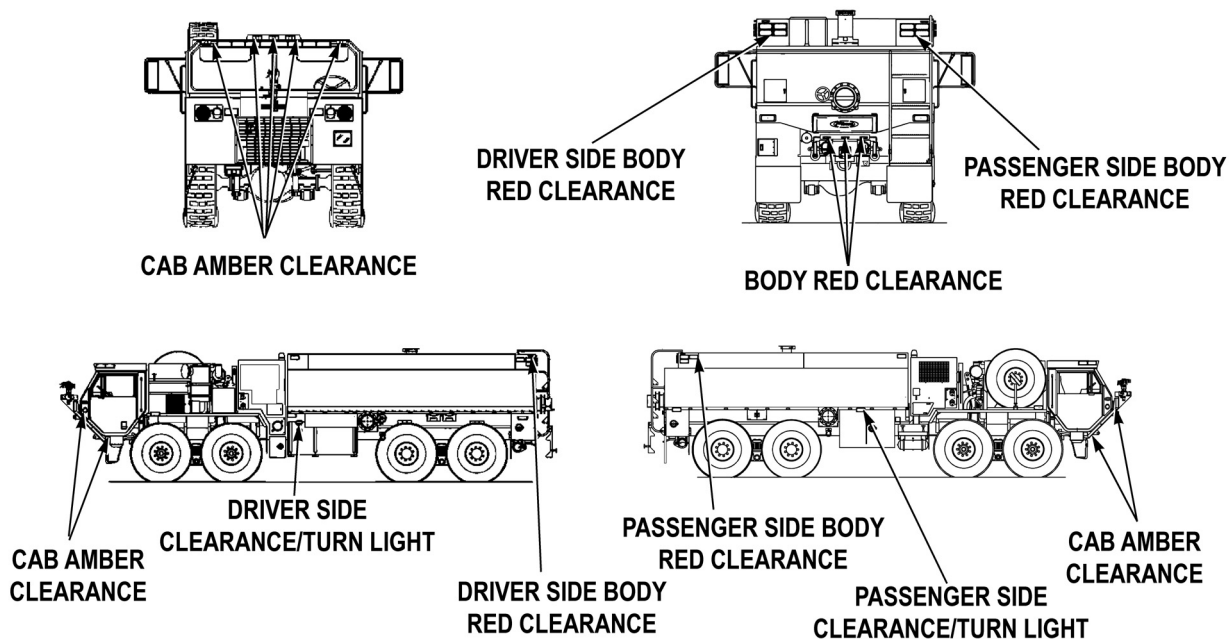
- Step 36. Remove skid plate grille (WP 0349). Pull battery disconnect switch to off position (WP 0292). Disconnect main wire harness main 2 connector. With a test lead set, check for continuity across wire 1412 (green) from main wire harness main 2 connector, terminal R to right side clearance/turn connector terminal 3.
- If there is continuity, repair wire 1412 in cab instrument panel wire harness if repairable (TM 9-2320-325-14&P), or replace cab instrument panel wire harness (WP 0279).
  - If there is no continuity, repair wire 1412 in main wire harness if repairable (TM 9-2320-325-14&P), or replace main wire harness (WP 0292).



**MALFUNCTION**

**TEST OR INSPECTION**

**CORRECTIVE ACTION**



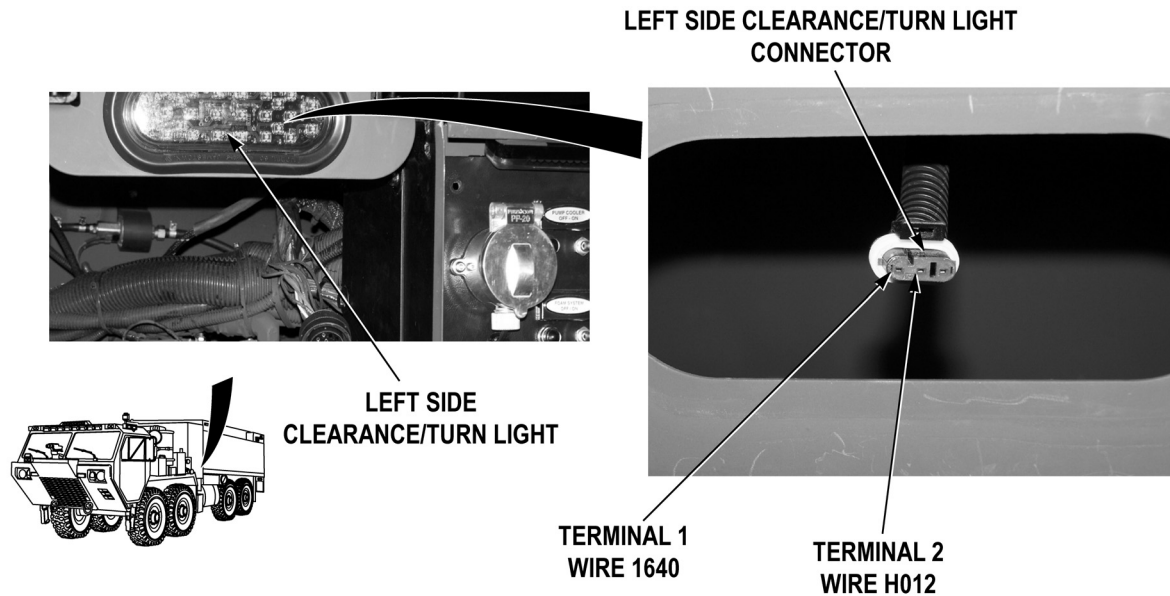
**WARNING**



Remove rings, wristwatches, neck chains, and any other jewelry before working around vehicle. Jewelry can catch on equipment and cause serious injury. Jewelry and tools may short across electrical circuits and cause damage to equipment, or severe burns or electrical shock to personnel.

Step 37. Check if at least one clearance light(s) at side clearance/turn lights operate.

If both clearance lights at side clearance/turn lights do not operate, go to Step 40.

**MALFUNCTION****TEST OR INSPECTION****CORRECTIVE ACTION**

- Step 38. Disconnect main wire harness from non-operating side clearance/turn light connector (WP 0228). With a test lead set, check for 22 to 28 VDC between wire H012 (white) at main wire harness side clearance/turn light connector, terminal 2 and a known good ground.

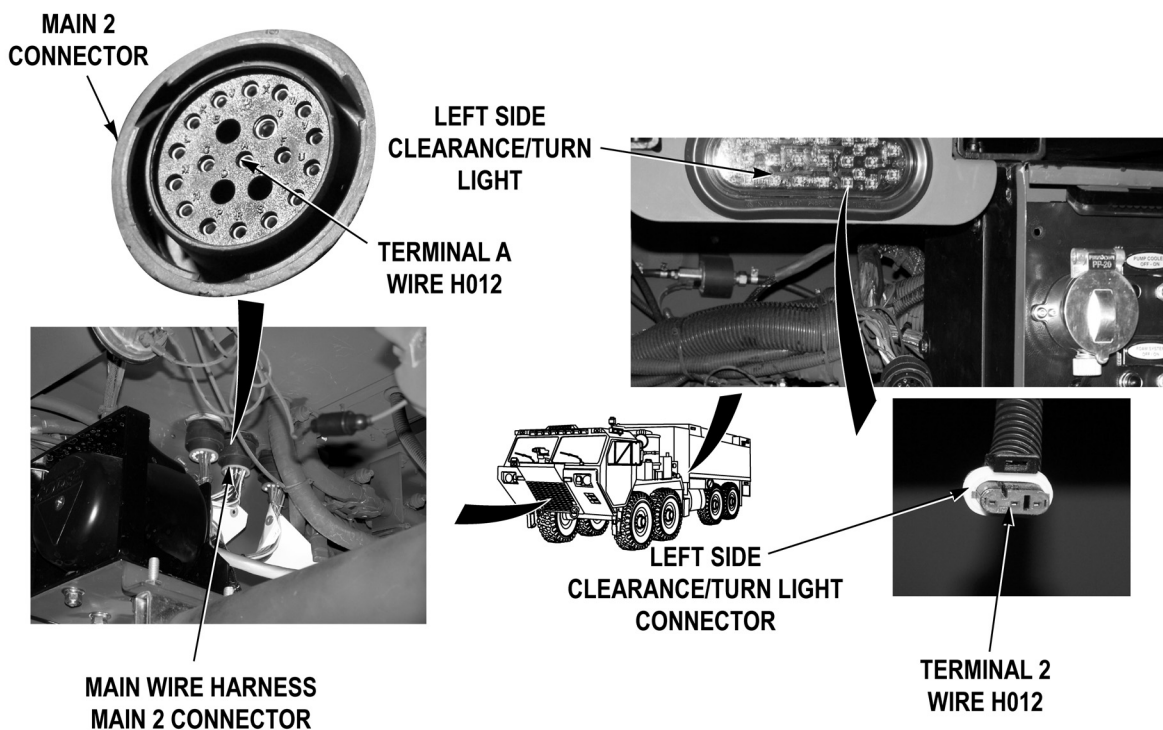
If 22 to 28 VDC are not present, repair wire H012 in main wire harness (TM 9-2320-325-14&P), or replace main wire harness (WP 0292).

- Step 39. Turn Service Drive Lights Off (TM 9-2320-422-10). Pull battery disconnect switch to off position (WP 0007). With a test lead set, check for continuity across main wire harness wire 1640 (black) from main wire harness side clearance/turn light connector, terminal 1 and a known good ground.
- a. If there is continuity, replace non-operating side clearance/turn light (WP 0228).
  - b. If there is no continuity, repair wire 1640 in main wire harness if repairable (TM 9-2320-325-14&P), or replace main wire harness (WP 0292).

- Step 40. Remove one non-operating side clearance/turn light (WP 0228). With a test lead set, check for 22 to 28 VDC between wire H012 (white) at main wire harness side clearance/turn light connector, terminal 2 and a known good ground.

If 22 to 28 VDC are present, repair wire 1640 if repairable (TM 9-2320-325-14&P), or replace main wire harness (WP 0292).

MALFUNCTION	TEST OR INSPECTION	CORRECTIVE ACTION
-------------	--------------------	-------------------



Step 41. Remove skid plate grille (WP 0349). Turn Service Drive Lights Off (TM 9-2320-422-10). Pull battery disconnect switch to on position (WP 0007). Disconnect main wire harness main 2 connector. With a test lead set, check for continuity across wire H012 (white) from main wire harness main 2 connector, terminal A to side clearance/turn light connector, terminal 2.

- If there is continuity, repair wire H012 in main wire harness if repairable (TM 9-2320-325-14&P), or replace main wire harness (WP 0292).
- If there is no continuity, repair wire H012 in cab instrument panel wire harness if repairable (TM 9-2320-325-14&P), or replace cab instrument panel wire harness (WP 0279).

**END OF TASK**

**FOLLOW-ON MAINTENANCE**

Remove wheel chocks (TM 9-2320-422-10)

**END OF TASK**

**END OF WORK PACKAGE**



**FIELD LEVEL MAINTENANCE**

**DRIVER SIDE STOWAGE COMPARTMENT STRIPLIGHT(S) DOES NOT OPERATE**

**INITIAL SETUP:**

**Tools and Special Tools**

- Lead Set, Test (WP 0398, Item 14)
- Tool Kit, General Mechanic's: Automotive (WP 0398, Item 17)

**References**

- TM 9-2320-325-14&P
- WP 0004
- WP 0007
- WP 0008
- WP 0102

**References (continued)**

- WP 0215
- WP 0242
- WP 0246
- WP 0280
- WP 0286
- WP 0292
- WP 0349

**Equipment Conditions**

- Engine OFF (TM 9-2320-422-10)
- Wheels chocked (TM 9-2320-422-10)

**MALFUNCTION**

**TEST OR INSPECTION**

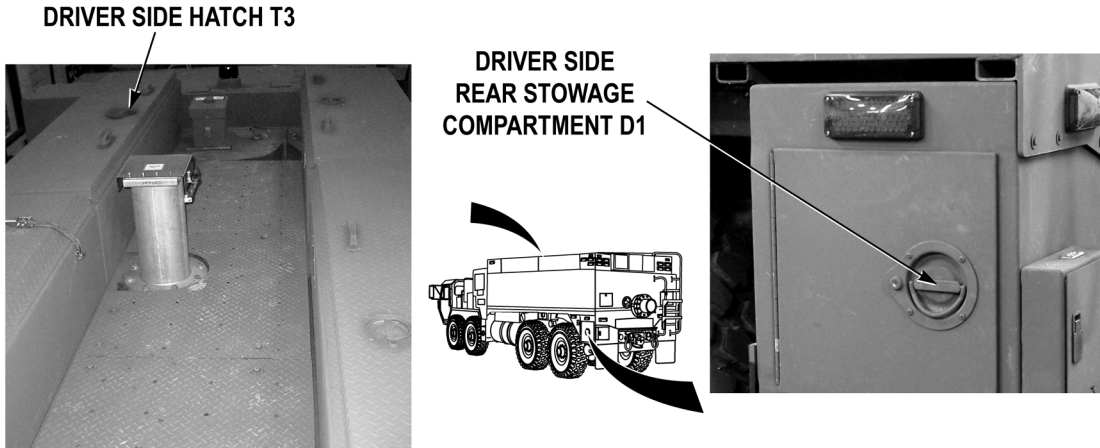
**CORRECTIVE ACTION**

**DRIVER SIDE STOWAGE COMPARTMENT STRIPLIGHT(S) DOES NOT OPERATE**

---

MALFUNCTION	TEST OR INSPECTION	CORRECTIVE ACTION
-------------	--------------------	-------------------

---



- Step 1. Push battery disconnect switch to on position (WP 0007). Turn Service Drive Lights On (TM 9-2320-422-10). Open driver side rear storage compartment D1 door and driver side storage hatch T3 (WP 0008). Check if driver side storage compartment striplights operate.
- If driver side rear storage compartment D1 striplight does not operate, go to Step 16.
  - If driver side storage hatch T3 striplights does not operate, go to Step 8.
  - If driver side storage compartment D1 and driver side storage hatch T3 striplights do not operate, go to Step 2.

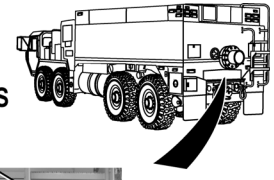
---

MALFUNCTION	TEST OR INSPECTION	CORRECTIVE ACTION
-------------	--------------------	-------------------

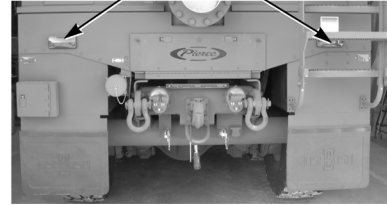
---



FRONT LOWER  
WARNING LIGHTS



REAR LOWER  
WARNING LIGHTS



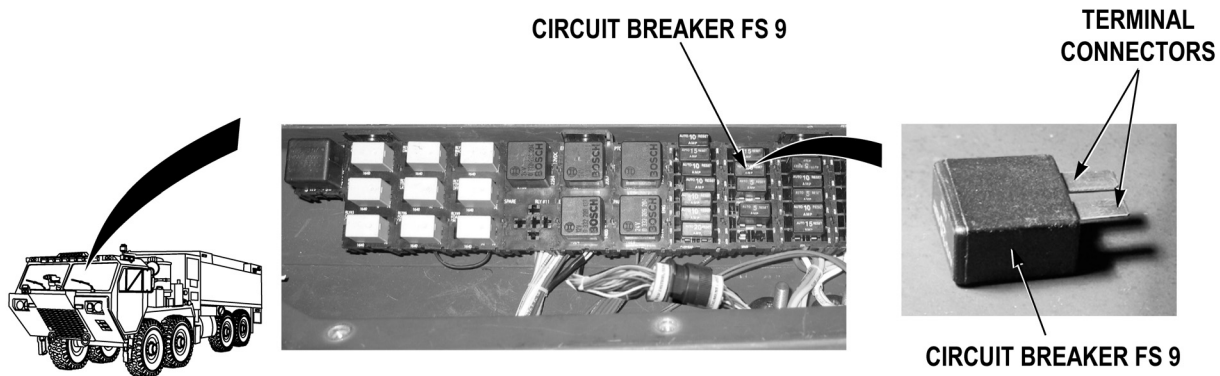
- Step 2. Put EMERG MASTER and F/R LOWER WARNING switches to on position (WP 0004). Check if front and rear warning lights operate.

If front and rear warning lights do not operate, troubleshoot Warning Lights (All) Do Not Operate (WP 0102).

---

<b>MALFUNCTION</b>	<b>TEST OR INSPECTION</b>	<b>CORRECTIVE ACTION</b>
--------------------	---------------------------	--------------------------

---

**WARNING**

Remove rings, wristwatches, neck chains, and any other jewelry before working around vehicle. Jewelry can catch on equipment and cause serious injury. Jewelry and tools may short across electrical circuits and cause damage to equipment, or severe burns or electrical shock to personnel.

- Step 3. Put EMERG MASTER and F/R LOWER WARNING switches to off position (WP 0004). Turn Service Drive Lights Off (TM 9-2320-422-10). Pull battery disconnect switch to off position (WP 0007). Remove circuit breaker FS 9 (WP 0242). Check for continuity across circuit breaker terminal connectors.

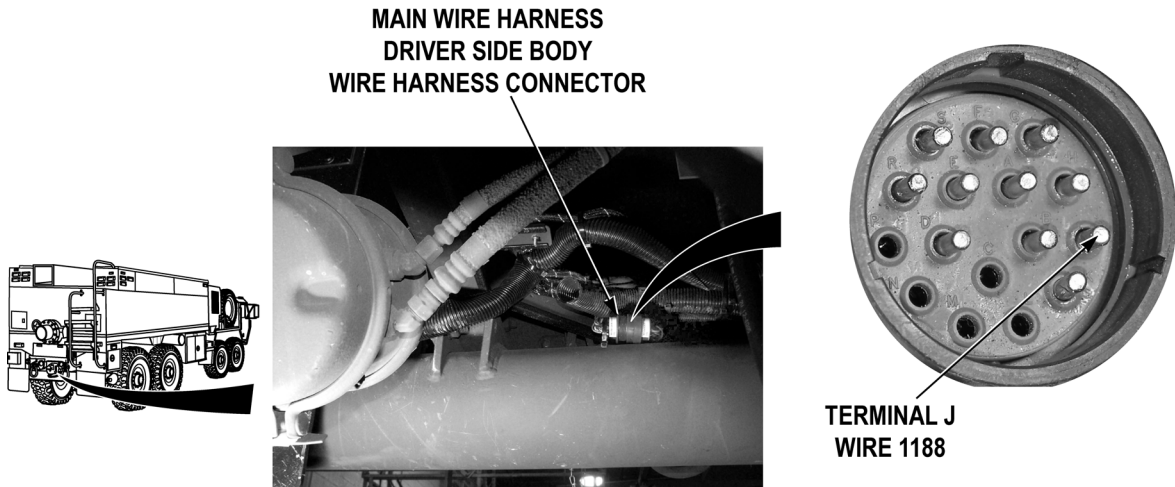
If there is no continuity, replace circuit breaker FS 9 (WP 0242).



---

<b>MALFUNCTION</b>	<b>TEST OR INSPECTION</b>	<b>CORRECTIVE ACTION</b>
--------------------	---------------------------	--------------------------

---

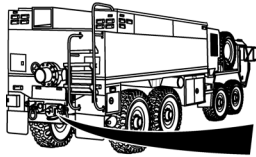
**WARNING**

Remove rings, wristwatches, neck chains, and any other jewelry before working around vehicle. Jewelry can catch on equipment and cause serious injury. Jewelry and tools may short across electrical circuits and cause damage to equipment, or severe burns or electrical shock to personnel.

- Step 4. Install circuit breaker FS 9 (WP 0242). Disconnect main wire harness driver side body wire harness connector. Push battery disconnect switch to on position (WP 0007). Turn Service Drive Lights On (TM 9-2320-422-10). With a test lead set, check for 22 to 28 VDC between wire 1188 (red) at main wire harness driver side body wire harness connector, terminal J and a known good ground.

If 22 to 28 VDC are not present, go to Step 7.

MALFUNCTION	TEST OR INSPECTION	CORRECTIVE ACTION
-------------	--------------------	-------------------



MAIN WIRE HARNESS  
DRIVER SIDE BODY  
WIRE HARNESS CONNECTOR



TERMINAL E  
WIRE 2640



TERMINAL D  
WIRE 2640

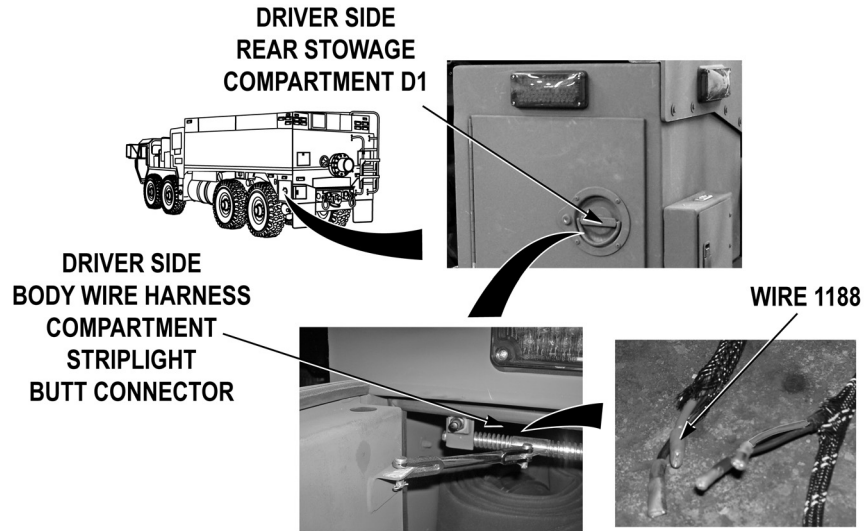
- Step 5. Turn Service Drive Lights Off (TM 9-2320-422-10). Pull battery disconnect switch to off position (WP 0007). With a test lead set, check for continuity across wire 2640 (black) from main wire harness driver side body wire harness connector, terminals D and E to a known good ground.

If there is no continuity at either terminal, repair wire 2640 in main wire harness if repairable (TM 9-2320-325-14&P), or replace main wire harness (WP 0292).

---

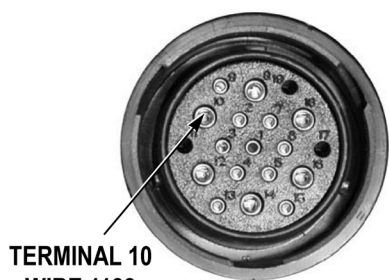
<b>MALFUNCTION</b>	<b>TEST OR INSPECTION</b>	<b>CORRECTIVE ACTION</b>
--------------------	---------------------------	--------------------------

---



- Step 6. Connect main wire harness driver side body wire harness connector. Cut driver side body wire harness stowage compartment striplight butt splice connector wire 1188 (red). Push battery disconnect switch to on position (WP 0007). Turn Service Drive Lights On (TM 9-2320-422-10). Check for 22 to 28 VDC between wire 1188 (red) at driver side body wire harness stowage compartment striplight connector and a known good ground.
- a. If 22 to 28 VDC are present, repair wire 2640 in driver side body wire harness if repairable (TM 9-2320-325-14&P), or replace driver side body wire harness (WP 0286).
  - b. If 22 to 28 VDC are not present, repair wire 1188 in driver side body wire harness if repairable (TM 9-2320-325-14&P), or replace driver side body wire harness (WP 0286).

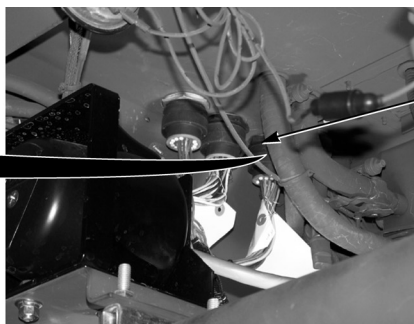
MALFUNCTION	TEST OR INSPECTION	CORRECTIVE ACTION
-------------	--------------------	-------------------



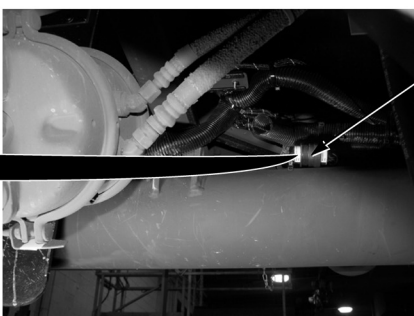
TERMINAL 10  
WIRE 1188



TERMINAL J  
WIRE 1188



MAIN WIRE HARNESS  
MAIN 1 CONNECTOR



MAIN WIRE HARNESS  
DRIVER SIDE BODY  
WIRE HARNESS  
CONNECTOR

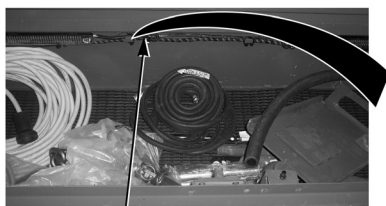
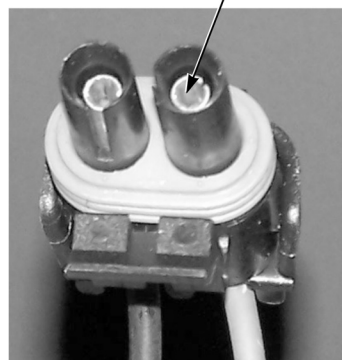


Step 7. Turn Service Drive Lights Off (TM 9-2320-422-10). Pull battery disconnect switch to off position (WP 0007). Remove skid plate grille (WP 0349). Disconnect main wire harness main 1 connector. With a lead test set, check for continuity across main wire harness wire 1188 (red) from main wire harness main 1 connector, terminal 10 to main wire harness driver side body wire harness connector, terminal J.

- a. If there is continuity, repair wire 1188 in cab power distribution wire harness if repairable (TM 9-2320-325-14&P), or replace cab power distribution wire harness and block (WP 0280).
- b. If there is no continuity, repair wire 1188 in main wire harness if repairable (TM 9-2320-325-14&P), or replace main wire harness (WP 0292).

Step 8. Check if both driver side stowage hatch T3 striplight operate.

If both driver side stowage hatch T3 lights do not operate, go to Step 11.

**MALFUNCTION****TEST OR INSPECTION****CORRECTIVE ACTION****DRIVER SIDE HATCH T3****TERMINAL A  
WIRE 1188****DRIVER SIDE BODY WIRE HARNESS  
DRIVER SIDE HATCH  
STRIPLIGHT CONNECTOR****WARNING**

Remove rings, wristwatches, neck chains, and any other jewelry before working around vehicle. Jewelry can catch on equipment and cause serious injury. Jewelry and tools may short across electrical circuits and cause damage to equipment, or severe burns or electrical shock to personnel.

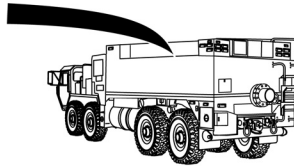
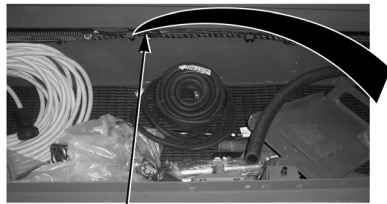
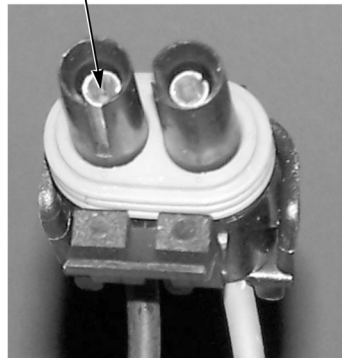
- Step 9. Turn Service Drive Lights Off (TM 9-2320-422-10). Pull battery disconnect switch to off position (WP 0007). Disconnect non-operating driver side stowage hatch T3 striplight. Turn Service Drive Light ON (TM 9-2320-279-10). Push battery disconnect switch to on position (WP 0007). With a test lead set, check for 22 to 28 VDC between wire 1188 at driver side body wire harness driver side hatch striplight connector, terminal A to a known good ground.

If 22 to 28 VDC are not present, repair wire 1188 in upper driver side body wire harness if repairable (TM 9-2320-325-14&P), or replace driver side body wire harness (WP 0286).

---

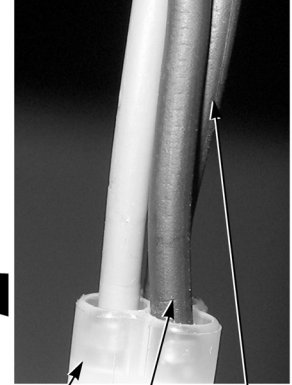
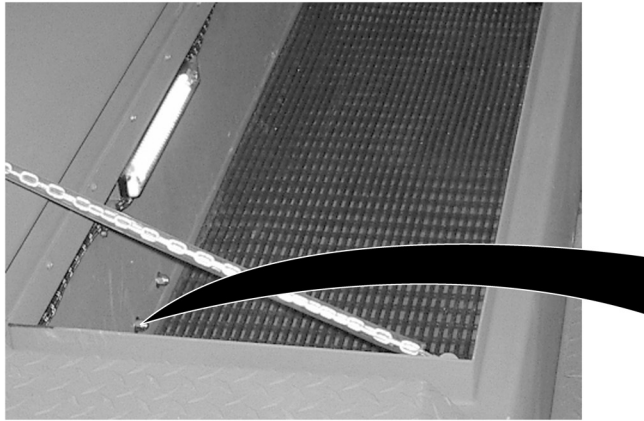
<b>MALFUNCTION</b>		
	<b>TEST OR INSPECTION</b>	
		<b>CORRECTIVE ACTION</b>

---

**DRIVER SIDE HATCH T3****TERMINAL B  
WIRE 1474****DRIVER SIDE BODY WIRE HARNESS  
DRIVER SIDE HATCH  
STRIPLIGHT CONNECTOR**

- Step 10. Turn Service Drive Light Off (TM 9-2320-422-10). Pull battery disconnect switch to off position (WP 0007). With a test lead set, check for continuity across wire 1474 from driver side body wire harness driver side hatch striplight connector, terminal B to a known good ground.
- a. If there is continuity, replace non-operating driver side stowage hatch striplight (WP 0215).
  - b. If there is no continuity, repair wire 1474 in upper driver side body wire harness if repairable (TM 9-2320-325-14&P), or replace driver side body wire harness (WP 0286).

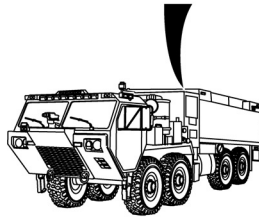
MALFUNCTION	TEST OR INSPECTION	CORRECTIVE ACTION
-------------	--------------------	-------------------



DRIVER SIDE  
STOWAGE HATCH  
DOOR SWITCH

WIRE  
1474

WIRE  
2460



### NOTE

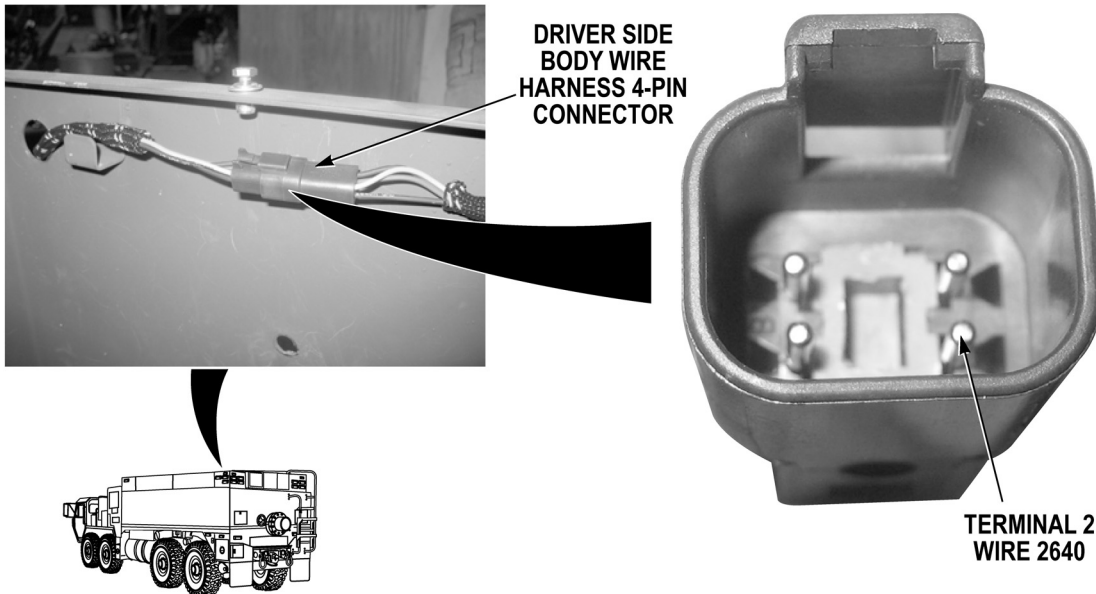
If wire 1474 cannot be identified at door switch, measure continuity across both black wire terminals to ground. Continuity should be measured between all terminals, when switch is closed (door switch is not pressed).

- Step 11. Turn Service Drive Light Off (TM 9-2320-422-10). Pull battery disconnect switch to off position (WP 0007). Remove door switch from driver side stowage hatch T3 (WP 0246). Do not disconnect wires. With a test lead set, check for continuity between door switch terminal wire 1474 (black) and a known good ground when switch is closed (door switch is not pressed).

If there is continuity, go to Step 14.

- Step 12. Check for continuity across door switch between terminal wire 1474 and terminal wire 2460.

If there is no continuity, replace door switch (WP 0246).

**MALFUNCTION****TEST OR INSPECTION****CORRECTIVE ACTION**

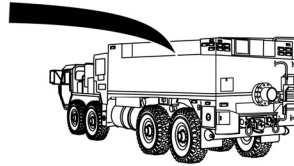
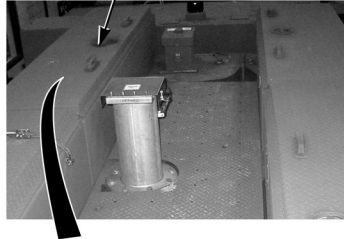
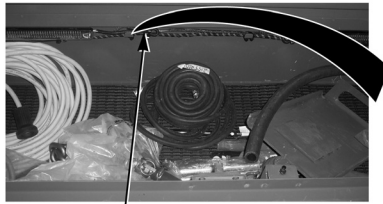
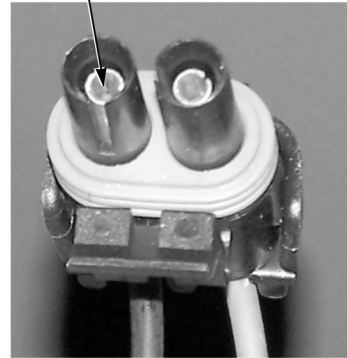
- Step 13. Disconnect driver side wire harness 4-pin connector (WP 0246). With a test lead set, check for continuity across wire 2460 (black) from driver side wire harness 4-pin connector, terminal 12 to a known good ground.
- a. If there is continuity, repair wire 2640 in upper driver side body wire harness if repairable (TM 9-2320-325-14&P), or replace driver side wire harness (WP 0286).
  - b. If there is no continuity, repair wire 2640 in lower driver side body wire harness if repairable (TM 9-2320-325-14&P), or replace driver side wire harness (WP 0286).



---

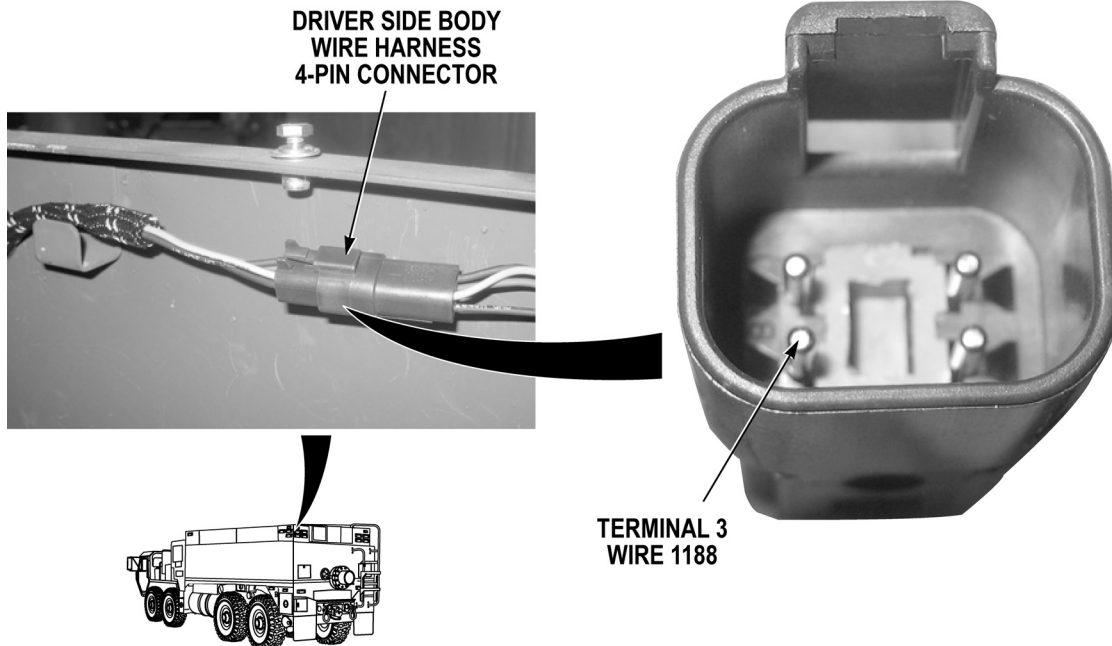
<b>MALFUNCTION</b>	<b>TEST OR INSPECTION</b>	<b>CORRECTIVE ACTION</b>
--------------------	---------------------------	--------------------------

---

**DRIVER SIDE HATCH T3****TERMINAL B  
WIRE 1474****DRIVER SIDE BODY WIRE HARNESS  
DRIVER SIDE HATCH  
STRIPLIGHT CONNECTOR**

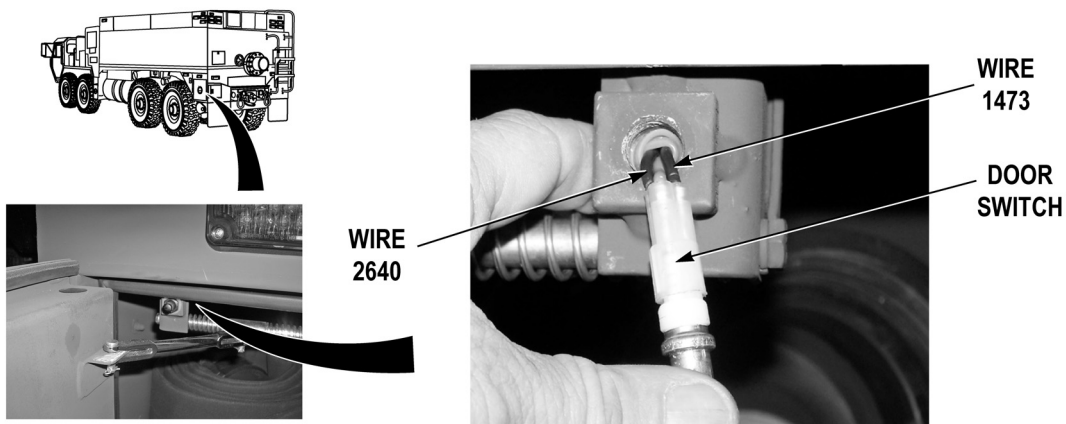
- Step 14. Disconnect either driver side body wire harness driver side hatch T3 striplight connector. With a test lead set, check for continuity across driver side body wire harness wire 1474 from driver side hatch switch to driver side body wire harness driver side hatch striplight connector, terminal B.

If there is no continuity, repair wire 1474 in driver side body wire harness if repairable (TM 9-2320-325-14&P), or replace driver side body wire harness (WP 0286).

**MALFUNCTION****TEST OR INSPECTION****CORRECTIVE ACTION****WARNING**

Remove rings, wristwatches, neck chains, and any other jewelry before working around vehicle. Jewelry can catch on equipment and cause serious injury. Jewelry and tools may short across electrical circuits and cause damage to equipment, or severe burns or electrical shock to personnel.

- Step 15. Disconnect driver side body 4-pin wire harness connector. Pull battery disconnect switch to on position (WP 0007). Turn Service Drive Light On (TM 9-2320-422-10). With a test lead set, check for 22 to 28 VDC between wire 1188 at driver side body wire harness 4-pin connector, terminal 3 to a known good ground.
- a. If 22 to 28 VDC are present, repair wire 1188 in upper driver side body wire harness if repairable (TM 9-2320-325-14&P), or replace driver side body wire harness (WP 0286).
  - b. If 22 to 28 VDC are not present, repair wire 1188 in lower driver side wire harness if repairable (TM 9-2320-325-14&P), or replace driver side body wire harness (WP 0286).

**MALFUNCTION****TEST OR INSPECTION****CORRECTIVE ACTION****NOTE**

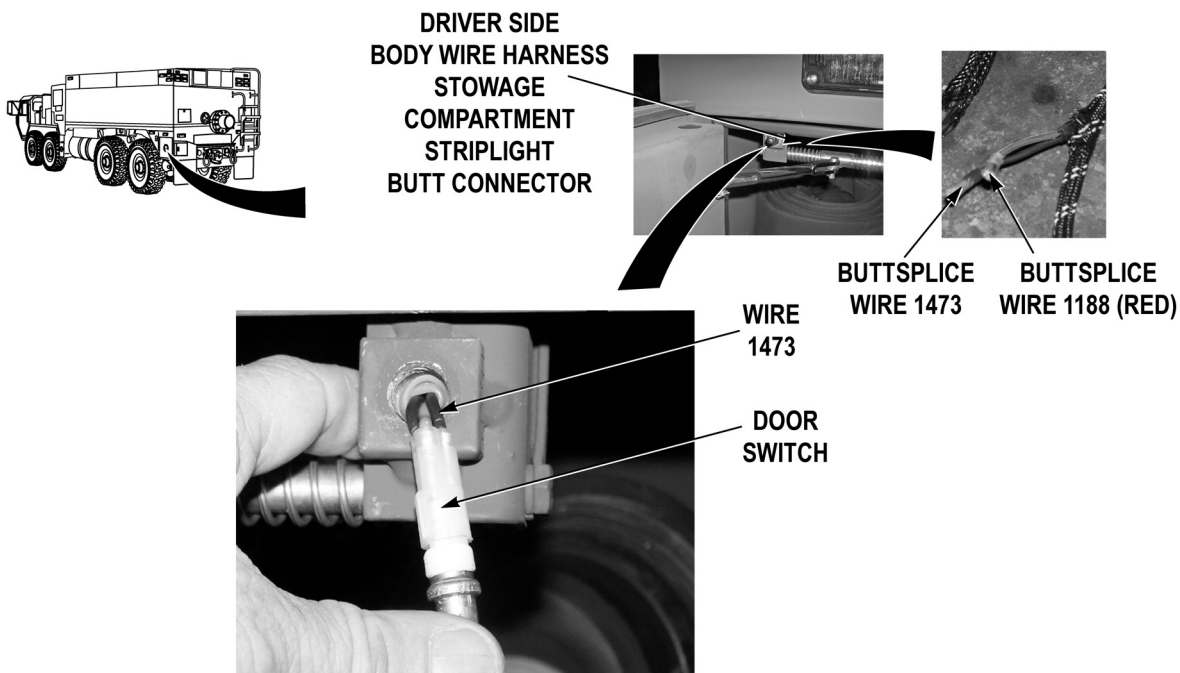
If wire 1473 cannot be identified at door switch, measure continuity across both black wire terminals to ground. Continuity should be measured between all terminals, when switch is closed (door switch is not pressed).

- Step 16. Turn Service Drive Lights OFF (TM 9-2320-422-10). Pull battery disconnect switch to off position (WP 0007). Remove door switch from driver side stowage compartment D1 (WP 0246). Do not disconnect wires. With a test lead set, check for continuity between door switch terminal wire 1473 (black) and a known good ground when switch is closed (door switch is not pressed).

If there is continuity, go to Step 18.

- Step 17. Check for continuity across door switch between terminal wire 1473 (black) and terminal wire 2640 (black).
- a. If there is continuity at both terminals, repair wire 2640 in driver side body wire harness if repairable (TM 9-2320-325-14&P), or replace driver side body wire harness (WP 0286).
  - b. If there is no continuity, replace door switch (WP 0246).

**MALFUNCTION**  
**TEST OR INSPECTION**  
**CORRECTIVE ACTION**



Step 18. Remove driver side stowage compartment D1 striplight (WP 0215). Cut driver side body wire harness stowage compartment striplight butt splice connector. Check for continuity across driver side body wire harness wire 1473 (black) from driver side stowage compartment striplight butt splice connector to driver side stowage compartment D1 door switch connector.

If there is no continuity, repair wire 1473 in driver side body wire harness if repairable (TM 9-2320-325-14&P), or replace driver side body wire harness (WP 0286).

---

**MALFUNCTION****TEST OR INSPECTION****CORRECTIVE ACTION**

---

**WARNING**

**Remove rings, wristwatches, neck chains, and any other jewelry before working around vehicle. Jewelry can catch on equipment and cause serious injury. Jewelry and tools may short across electrical circuits and cause damage to equipment, or severe burns or electrical shock to personnel.**

- Step 19. Cut driver side body wire harness stowage compartment striplight butt splice connector. Push battery disconnect switch to on position (WP 0007). Turn Service Drive Lights On (TM 9-2320-422-10). Check for 22 to 28 VDC between wire 1188 (red) at driver side body wire harness stowage compartment striplight butt splice connector and a known good ground.
- a. If 22 to 28 VDC are present, replace stowage compartment D1 striplight (WP 0215).
  - b. If 22 to 28 VDC are not present, repair wire 1188 in driver side body wire harness if repairable (TM 9-2320-325-14&P), or replace driver side body wire harness (WP 0286).

**END OF TASK****FOLLOW-ON MAINTENANCE**

1. Install skid plate grille if removed (WP 0349)
2. Remove wheel chocks (TM 9-2320-422-10)

**END OF TASK****END OF WORK PACKAGE**



---

**FIELD LEVEL MAINTENANCE**
**FOAM/WATER LEVEL GAUGE(S) DOES NOT ILLUMINATE**


---

**INITIAL SETUP:****Tools and Special Tools**

Lead Set, Test (WP 0398, Item 14)  
 Tool Kit, General Mechanic's: Automotive  
 (WP 0398, Item 17)

**References**

TM 9-2320-325-14&P  
 WP 0007  
 WP 0010  
 WP 0204  
 WP 0207  
 WP 0211  
 WP 0212

**References (continued)**

WP 0242  
 WP 0280  
 WP 0281  
 WP 0292  
 WP 0303  
 WP 0349

**Equipment Conditions**

Engine OFF (TM 9-2320-422-10)  
 Wheels chocked (TM 9-2320-422-10)

---

**MALFUNCTION****TEST OR INSPECTION****CORRECTIVE ACTION**

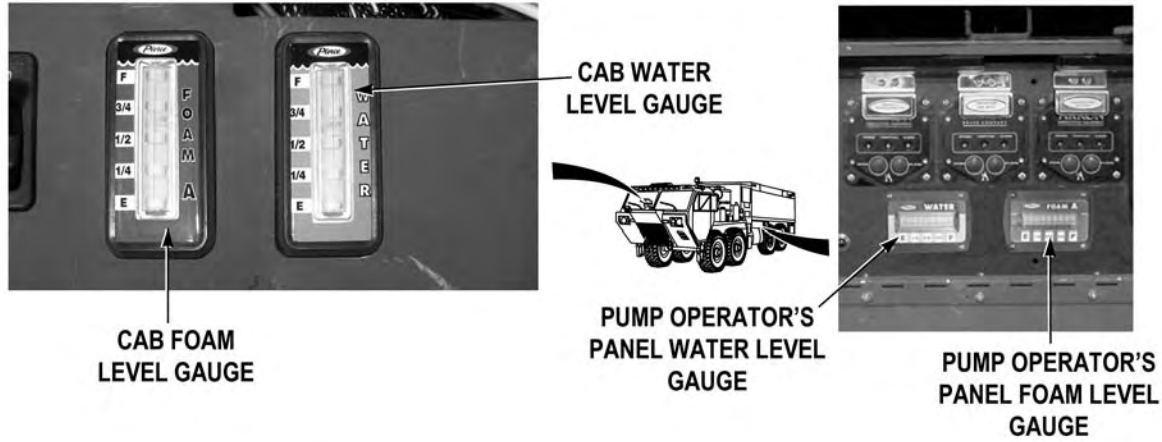

---

**FOAM/WATER LEVEL GAUGE(S) DOES NOT ILLUMINATE**

**MALFUNCTION**

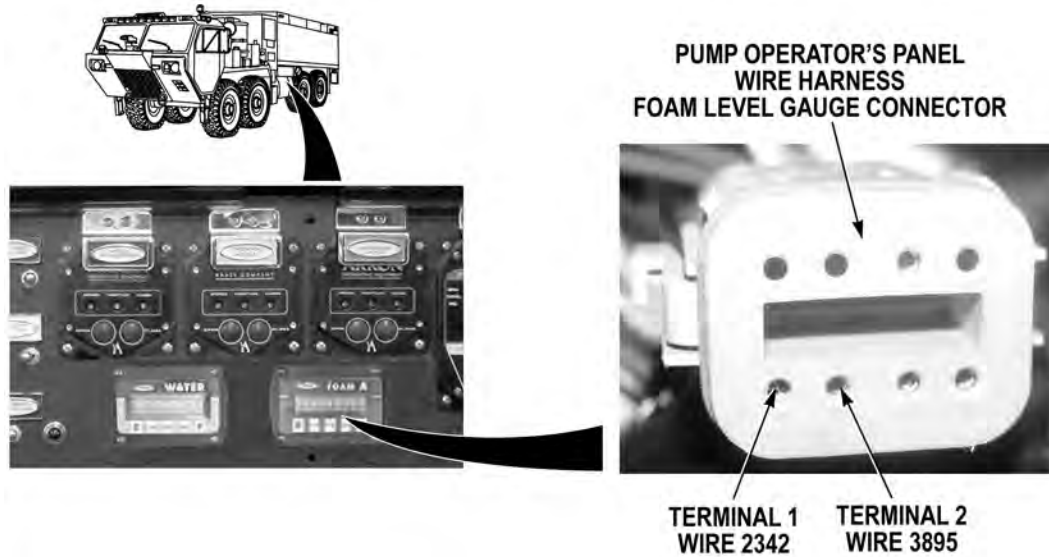
**TEST OR INSPECTION**

**CORRECTIVE ACTION**



- Step 1. Push battery disconnect switch to on position (WP 0007). Check if cab and pump operator's panel water and foam level gauges illuminate or flash.  
 If cab and pump operator's panel water and foam level gauges do not illuminate or flash, go to Step 16.
- Step 2. Check if cab water level gauges illuminate or flash.  
 If cab water level gauges do not illuminate or flash, go to Step 12.
- Step 3. Check if cab foam level gauge illuminates or flashes (WP 0004).  
 If cab foam level gauge does not illuminate or flash, go to Step 14.
- Step 4. Open pump operator's panel cover (WP 0010). Check if pump operator's panel water and foam level gauges illuminate or flash.  
 If pump operator's panel water and foam level gauges, do not illuminate or flash, go to Step 10.
- Step 5. Check if pump operator's panel water level gauge illuminates or flashes.  
 If pump operator's panel water level gauge does not illuminate or flash, go to Step 8.



**MALFUNCTION****TEST OR INSPECTION****CORRECTIVE ACTION****WARNING**

**Remove rings, wristwatches, neck chains, and any other jewelry before working around vehicle. Jewelry can catch on equipment and cause serious injury. Jewelry and tools may short across electrical circuits and cause damage to equipment, or severe burns or electrical shock to personnel.**

- Step 6. Pull battery disconnect switch to off position (WP 0007). Open pump operator's panel (WP 0207). Disconnect pump operator's panel wire harness foam level gauge connector. Push battery disconnect switch to on position (WP 0007). With a test lead set, check for 22 to 28 VDC at wire 2342 (red) from pump operator's panel wire harness foam level gauge connector, terminal 1 and a known good ground.

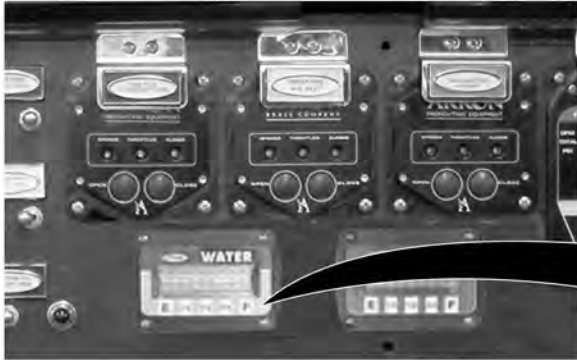
If 22 to 28 VDC are not present, repair wire 2342 in pump operator's panel wire harness if repairable (TM 9-2320-325-14&P), or replace pump operator's panel wire harness (WP 0303).

- Step 7. Pull battery disconnect switch to off position (WP 0007). With a test lead set, check for continuity across wire 3895 from pump operator's panel wire harness foam level gauge connector, terminal 2 to a known good ground.
- a. If there is continuity, replace pump operator's panel foam level gauge (WP 0211).
  - b. If there is no continuity, repair wire 3895 in pump operator's panel wire harness if repairable (TM 9-2320-325-14&P), or replace pump operator's panel wire harness (WP 0303).

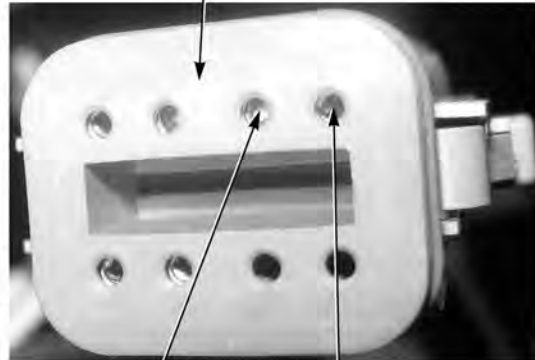
## MALFUNCTION

## TEST OR INSPECTION

## CORRECTIVE ACTION



PUMP OPERATOR'S PANEL  
WIRE HARNESS WATER  
LEVEL GAUGE CONNECTOR



TERMINAL 2  
WIRE 3855

TERMINAL 1  
WIRE 2342

**WARNING**

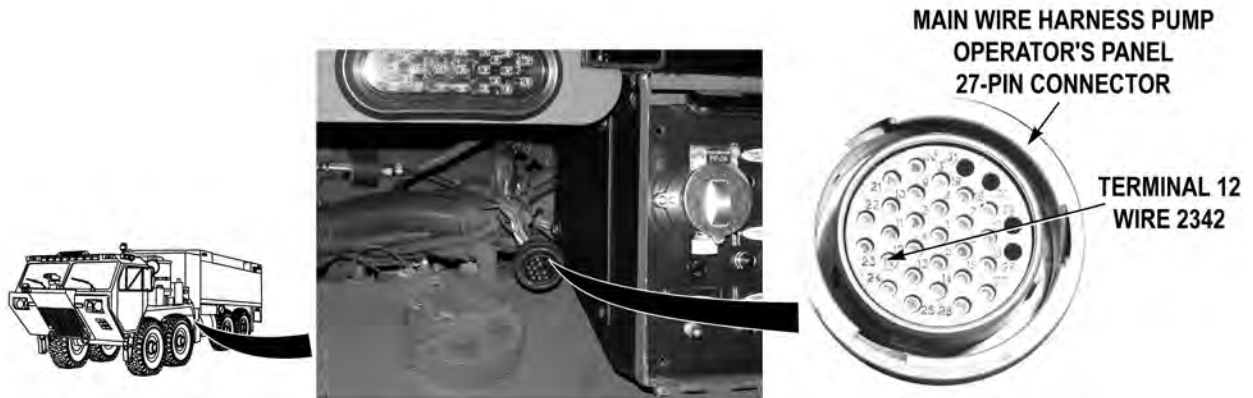
Remove rings, wristwatches, neck chains, and any other jewelry before working around vehicle. Jewelry can catch on equipment and cause serious injury. Jewelry and tools may short across electrical circuits and cause damage to equipment, or severe burns or electrical shock to personnel.

- Step 8. Pull battery disconnect switch to off position (WP 0007). Open pump operator's panel (WP 0207). Disconnect pump operator's panel wire harness water level gauge connector. Push battery disconnect switch to on position (WP 0007). With a test lead set, check for 22 to 28 VDC at wire 2342 (red) from pump operator's panel wire harness water level gauge connector, terminal 1 and a known good ground.

If 22 to 28 VDC are not present, repair wire 2342 in pump operator's panel wire harness if repairable (TM 9-2320-325-14&P), or replace pump operator's panel wire harness (WP 0303).

**MALFUNCTION****TEST OR INSPECTION****CORRECTIVE ACTION**

- Step 9. Pull battery disconnect switch to off position (WP 0007). With a test lead set, check for continuity across wire 3895 from pump operator's panel wire harness water level gauge connector, terminal 2 to a known good ground.
- If there is continuity, replace pump operator's panel water level gauge (WP 0212).
  - If there is no continuity, repair wire 3895 in pump operator's panel wire harness if repairable (TM 9-2320-325-14&P), or replace pump operator's panel wire harness (WP 0303).

**WARNING**

**Remove rings, wristwatches, neck chains, and any other jewelry before working around vehicle. Jewelry can catch on equipment and cause serious injury. Jewelry and tools may short across electrical circuits and cause damage to equipment, or severe burns or electrical shock to personnel.**

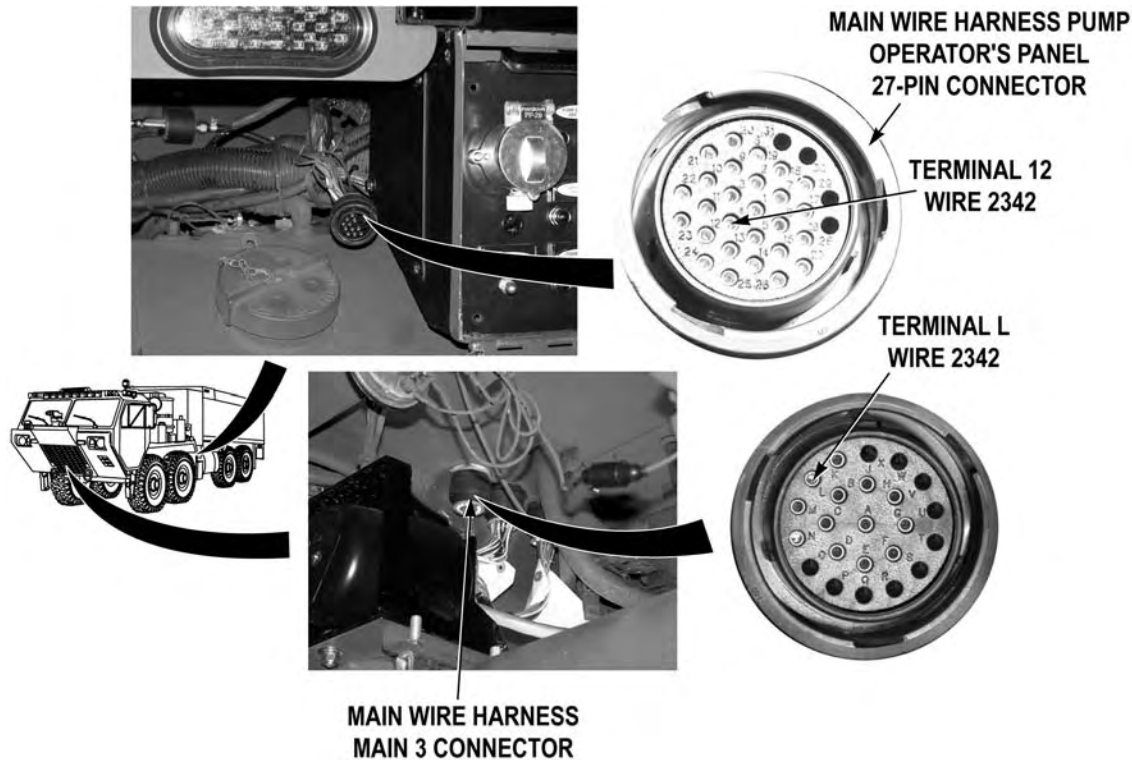
- Step 10. Pull battery disconnect switch to off position (WP 0007). Disconnect main wire harness pump operator's panel 27-pin connector. Push battery disconnect switch to on position (WP 0007). With a test lead set, check for 22 to 28 VDC at wire 2342 from main wire harness pump operator's panel 27-pin connector to a known good ground.

If 22 to 28 VDC are present repair wire 2342 in pump operator's panel wire harness if repairable (TM 9-2320-325-14&P), or replace pump operator's panel wire harness (WP 0303).

## MALFUNCTION

## TEST OR INSPECTION

## CORRECTIVE ACTION

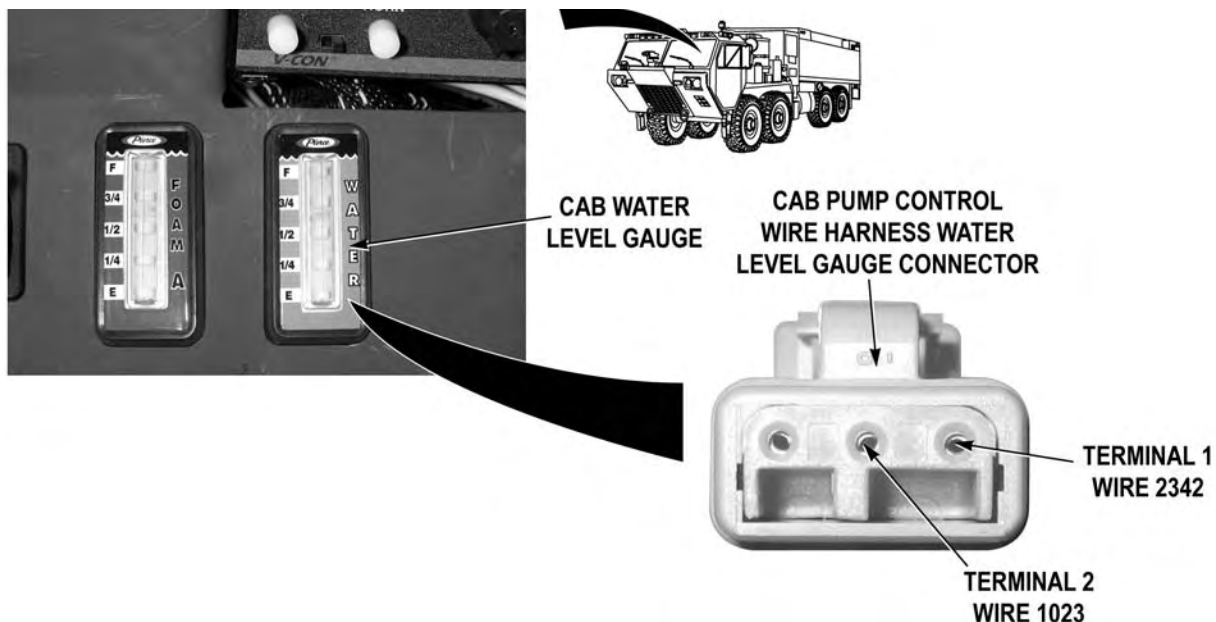


- Step 11. Pull battery disconnect switch to off position (WP 0007). Remove skid plate grille (WP 0349). Disconnect main wire harness main 3 connector. With a test lead set, check for continuity across main wire harness wire 2342 from main wire harness pump operator's panel 27-pin connector, terminal 12 to main wire harness main 3 connector, terminal L.
- a. If there is continuity, repair wire 2342 in cab pump control wire harness if repairable (TM 9-2320-325-14&P), or replace cab pump control wire harness (WP 0281).
  - b. If there is no continuity, repair wire 2342 in main wire harness if repairable (TM 9-2320-325-14&P), or replace main wire harness (WP 0292).

## MALFUNCTION

## TEST OR INSPECTION

## CORRECTIVE ACTION

**WARNING**

Remove rings, wristwatches, neck chains, and any other jewelry before working around vehicle. Jewelry can catch on equipment and cause serious injury. Jewelry and tools may short across electrical circuits and cause damage to equipment, or severe burns or electrical shock to personnel.

- Step 12. Pull battery disconnect switch to off position (WP 0007). Remove cab instrument panel B (WP 0204). Disconnect cab pump control wire harness water level gauge connector. Push battery disconnect switch to on position (WP 0007). With a test lead set, check for 22 to 28 VDC at wire 2342 (red) from cab pump control wire harness water level gauge connector, terminal 1 and a known good ground.

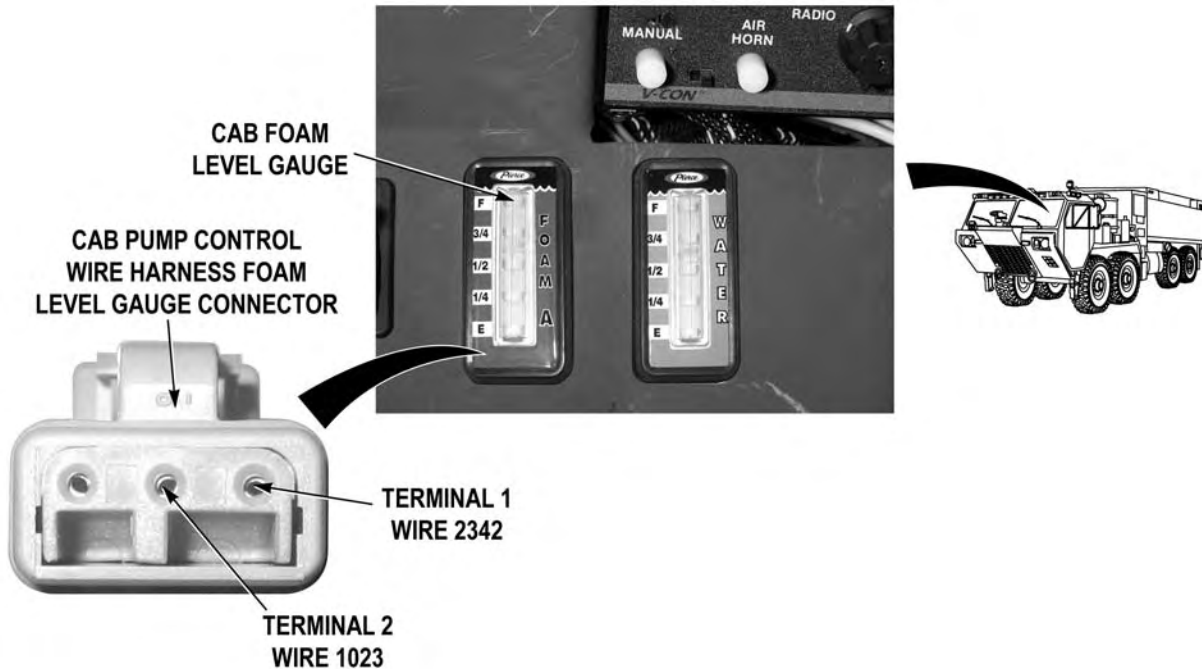
If 22 to 28 VDC are not present, repair wire 2342 in cab pump control wire harness if repairable (TM 9-2320-325-14&P), or replace cab pump control wire harness (WP 0281).

- Step 13. Pull battery disconnect switch to off position (WP 0007). With a test lead set, check for continuity across wire 1023 from cab pump control wire harness water level gauge connector, terminal 2 to a known good ground.
- If there is continuity, replace cab water level gauge (WP 0211).
  - If there is no continuity, repair wire 3895 in cab pump control wire harness if repairable (TM 9-2320-325-14&P), or replace cab pump control wire harness (WP 0281).

## MALFUNCTION

## TEST OR INSPECTION

## CORRECTIVE ACTION



- Step 14. Pull battery disconnect switch to off position (WP 0007). Remove cab instrument panel B (WP 0204). Disconnect cab pump control wire harness foam level gauge connector. Push battery disconnect switch to on position (WP 0007). With a test lead set, check for 22 to 28 VDC at wire 2342 (red) from cab pump control wire harness foam level gauge connector, terminal 1 and a known good ground.

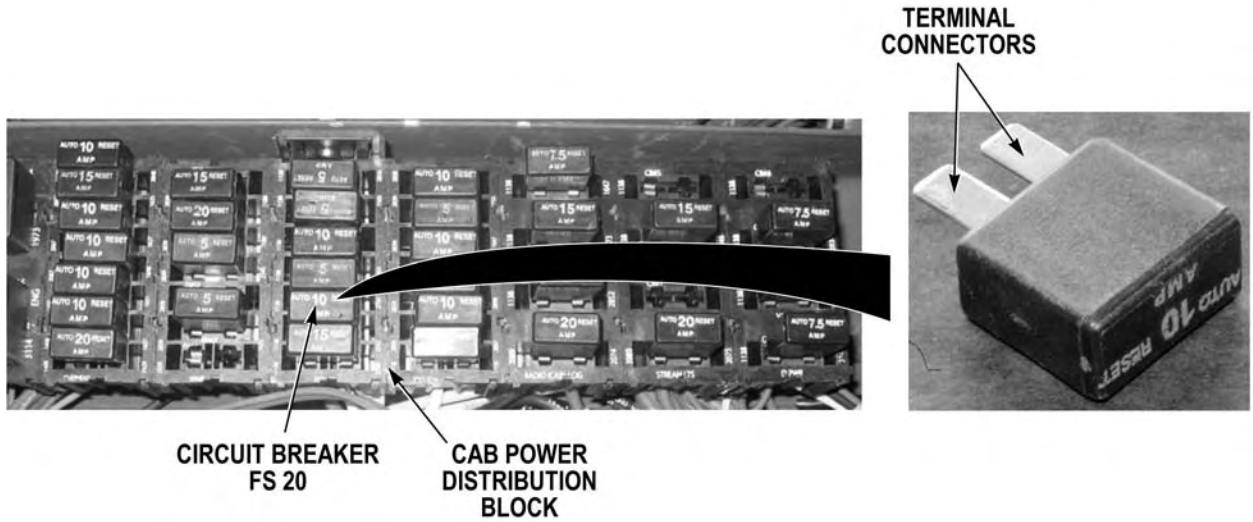
If 22 to 28 VDC are not present, repair wire 2342 in cab pump control wire harness if repairable (TM 9-2320-325-14&P), or replace cab pump control wire harness (WP 0281).

- Step 15. Pull battery disconnect switch to off position (WP 0007). With a test lead set, check for continuity across wire 1023 from cab pump control wire harness foam level gauge connector, terminal 2 to a known good ground.
- a. If there is continuity, replace cab foam level gauge (WP 0211).
  - b. If there is no continuity, repair wire 3895 in cab pump control wire harness if repairable (TM 9-2320-325-14&P), or replace cab pump control wire harness (WP 0281).

**MALFUNCTION**

**TEST OR INSPECTION**

**CORRECTIVE ACTION**



Step 16. Pull battery disconnect switch to off position (WP 0007). Remove circuit breaker FS 20 (WP 0242). Check for continuity across circuit breaker FS 20 terminal connectors.

If there is no continuity, replace circuit breaker FS 20 (WP 0242).

**MALFUNCTION****TEST OR INSPECTION****CORRECTIVE ACTION****WARNING**

**Remove rings, wristwatches, neck chains, and any other jewelry before working around vehicle. Jewelry can catch on equipment and cause serious injury. Jewelry and tools may short across electrical circuits and cause damage to equipment, or severe burns or electrical shock to personnel.**

- Step 17. Install circuit breaker FS 20 (WP 0242). Disconnect cab pump control wire harness cab power distribution wire harness connector. Push battery disconnect switch to on position (WP 0007). With a test lead set, check for 22 to 28 VDC at cab power distribution wire harness wire 2342 from cab pump control wire harness cab power distribution wire harness connector, terminal B to a known good ground.
- a. If 22 to 28 VDC are present, repair wire 2342 in cab pump control wire harness if repairable (TM 9-2320-325-14&P), or replace cab pump control wire harness (WP 0281).
  - b. If 22 to 28 VDC are not present, repair wire 2342 in cab power distribution wire harness if repairable (TM 9-2320-325-14&P), or replace cab power distribution wire harness (WP 0280).

**FOLLOW-ON MAINTENANCE**

1. Install cab instrument panel B if removed (WP 0204)
2. Install skid plate grille if removed (WP 0349)
3. Remove wheel chocks (TM 9-2320-422-10)

**END OF TASK****END OF WORK PACKAGE**



**FIELD LEVEL MAINTENANCE**

**TWO-WAY RADIO DOES NOT OPERATE PROPERLY**

**INITIAL SETUP:**

**Tools and Special Tools**

Lead Set, Test (WP 0398, Item 14)  
 Tool Kit, General Mechanic's: Automotive  
 (WP 0398, Item 17)

**References**

TM 9-2320-325-14&P  
 WP 0004  
 WP 0007  
 WP 0008  
 WP 0120

**References (continued)**

WP 0205  
 WP 0236  
 WP 0251  
 WP 0255  
 WP 0274  
 WP 0276

**Equipment Conditions**

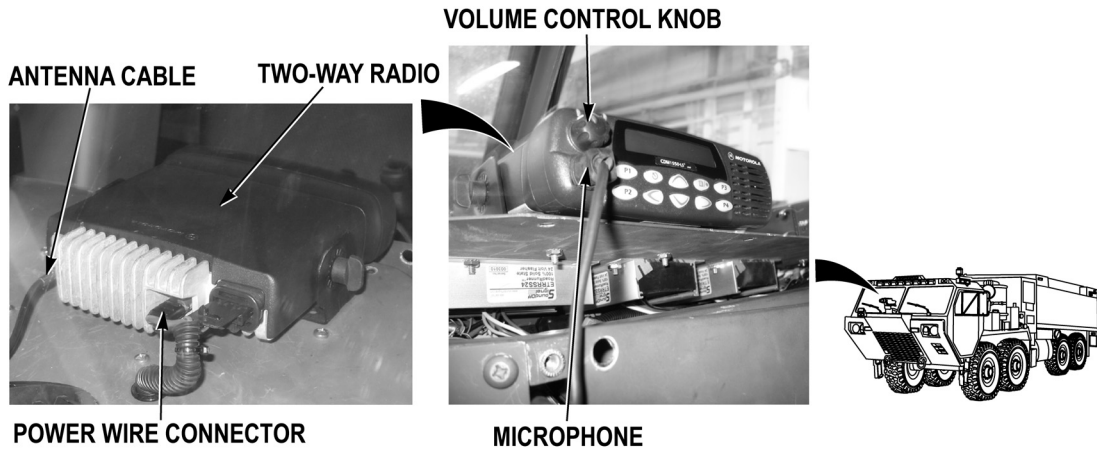
Engine OFF (TM 9-2320-422-10)  
 Wheels chocked (TM 9-2320-422-10)

**MALFUNCTION**

**TEST OR INSPECTION**

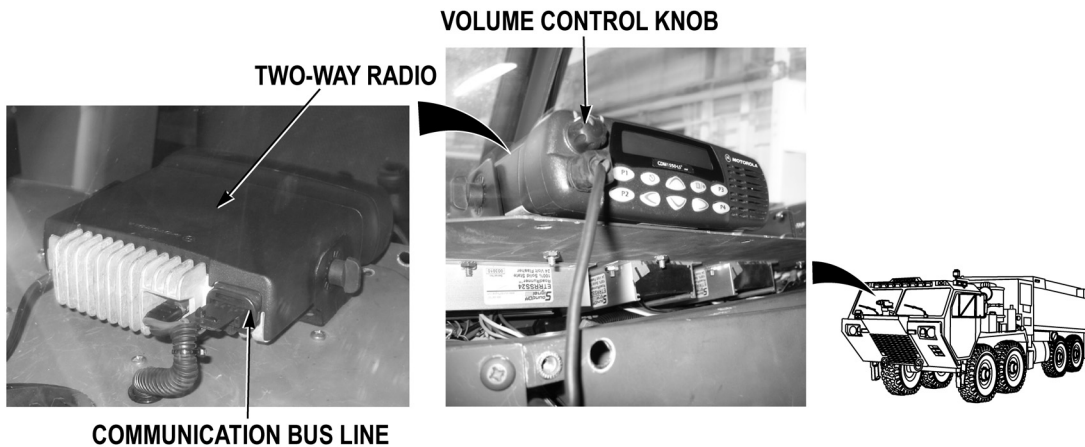
**CORRECTIVE ACTION**

**TWO-WAY RADIO DOES NOT OPERATE PROPERLY**



Step 1. Check if two-way radio antenna cable, power wire connector, and microphone are connected to two-way radio.

If two-way radio antenna cable, power wire connector, and microphone are not connected, connect disconnected connector (WP 0276).

**MALFUNCTION****TEST OR INSPECTION****CORRECTIVE ACTION****NOTE**

Two-way radio is turned on by pressing and releasing volume control knob.

- Step 2. Push battery disconnect switch to on position (WP 0007). Push two-way radio volume control knob to on position (WP 0004). Check if two-way radio display illuminates.

If two-way radio display does not illuminate, go to Step 5.

**NOTE**

Two-way radio will enter into a self test mode after power up. If power up self test is successful, you will hear two high pitch tones. If two-way radio fails to power up, you will hear a single low pitch tone.

- Step 3. Push two-way radio volume control knob to off position (WP 0004). Turn two-way radio volume control knob clockwise to full volume position (WP 0004). Push two-way radio volume control knob to on position (WP 0004). Check for audible two-way radio self test tones.

If two-way radio transmits a single low pitch tone, replace two-way radio (WP 0276).

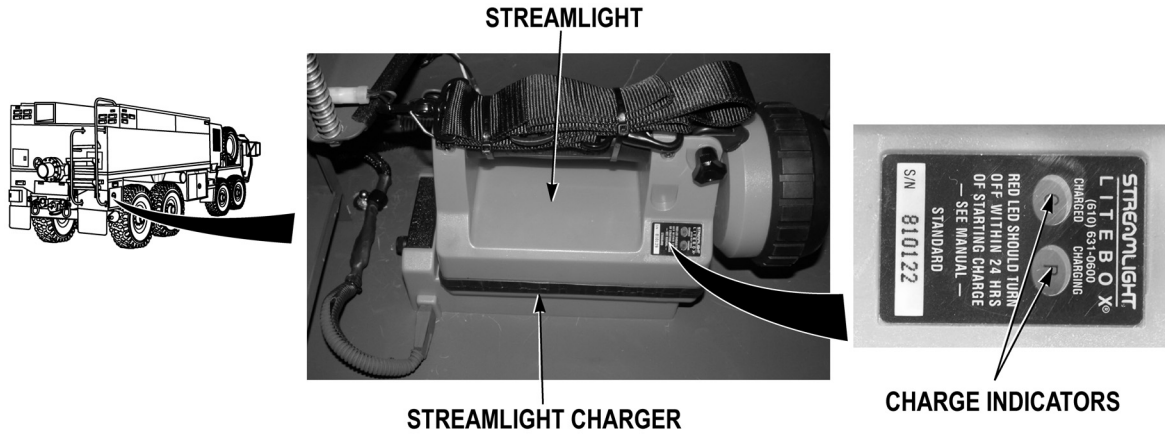
- Step 4. Disconnect communication bus line between two-way radio and intercom controller (WP 0276). Using two-way radio microphone, check if two-way radio transmits and receives to and from a handheld radio.

- a. If two-way radio does not operate properly, replace two-way radio (WP 0276).
- b. If two-way radio operates properly, troubleshoot Intercom and Headsets Do Not Operate Properly (WP 0120).

---

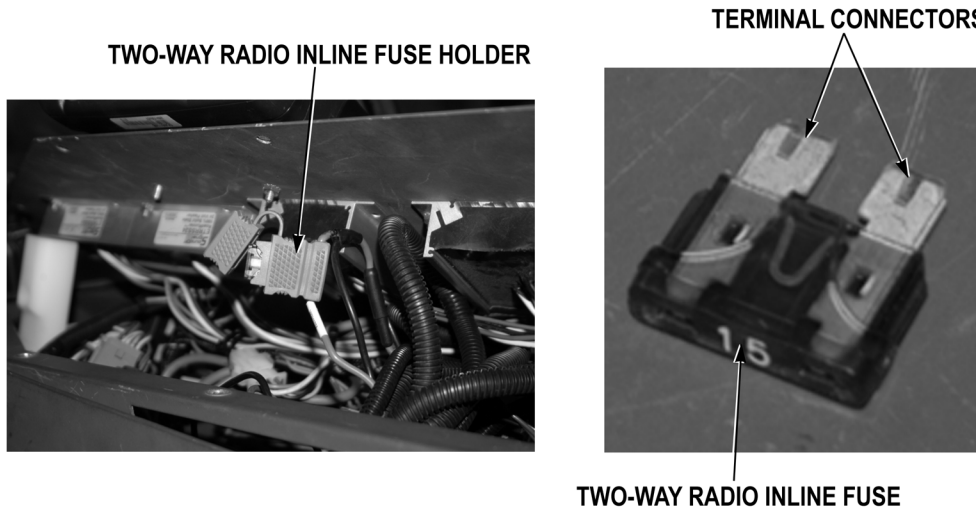
**MALFUNCTION**  
**TEST OR INSPECTION**  
**CORRECTIVE ACTION**

---



Step 5. Open passenger side stowage compartment P1 door (WP 0008). With streamlight securely fastened in streamlight charge, check if streamlight charge indicators illuminate (WP 0004).

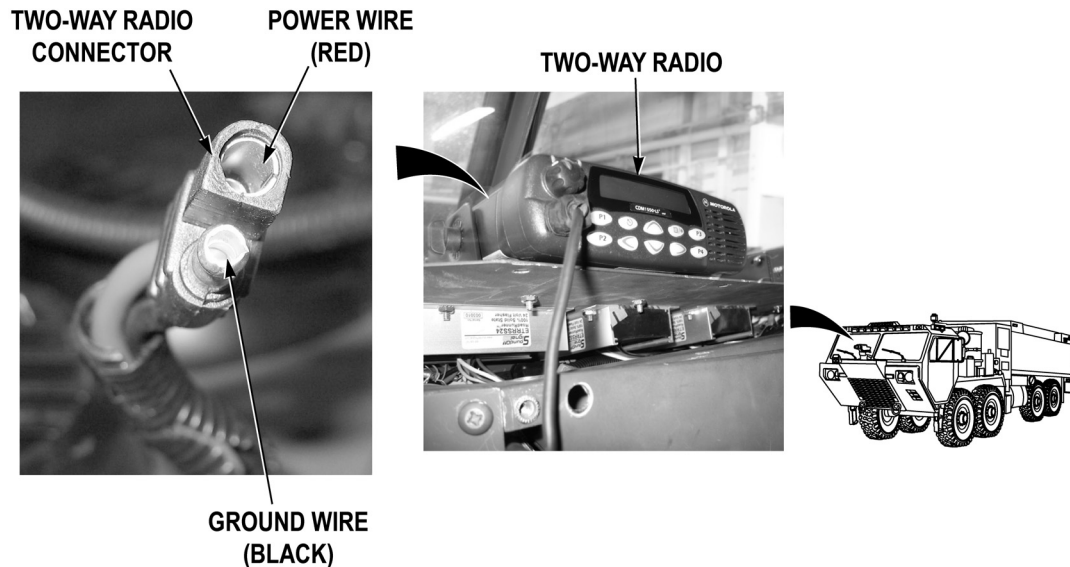
If streamlight charge indicators do not illuminate, go to Step 9.

**MALFUNCTION****TEST OR INSPECTION****CORRECTIVE ACTION****WARNING**

**Remove rings, wristwatches, neck chains, and any other jewelry before working around vehicle. Jewelry can catch on equipment and cause serious injury. Jewelry and tools may short across electrical circuits and cause damage to equipment, or severe burns or electrical shock to personnel.**

- Step 6. Pull battery disconnect switch to off position (WP 0007). Remove instrument panel A (WP 0205). Remove two-way radio inline fuse (WP 0255). Check for continuity across fuse.

If there is no continuity across fuse, replace fuse (WP 0255).

**MALFUNCTION****TEST OR INSPECTION****CORRECTIVE ACTION****WARNING**

**Remove rings, wristwatches, neck chains, and any other jewelry before working around vehicle. Jewelry can catch on equipment and cause serious injury. Jewelry and tools may short across electrical circuits and cause damage to equipment, or severe burns or electrical shock to personnel.**

Step 7. Install two-way radio inline fuse (WP 0255). Disconnect two-way radio connector from two-way radio (WP 0276). Push battery disconnect switch to on position (WP 0007). Check for 12 to 14 VDC between two-way radio power wire (red) connector and a known good ground.

If 12 to 14 VDC are not present, repair two-way radio power wire if repairable (TM 9-2320-325-14&P), or replace two-way radio (WP 0276).

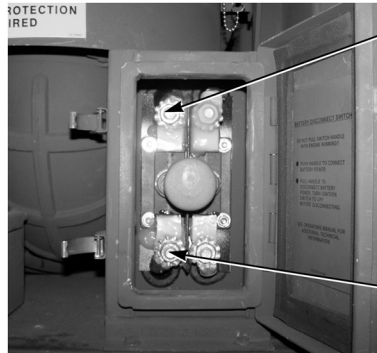
Step 8. Pull battery disconnect switch to off position (WP 0007). Check for continuity across two-way radio ground wire (black) from radio connector to a known good ground.

- a. If there is continuity, replace two-way radio (WP 0276).
- b. If there is no continuity, repair two-way radio ground wire if repairable (TM 9-2320-325-14&P), or replace two-way radio (WP 0276).

---

**MALFUNCTION**  
**TEST OR INSPECTION**  
**CORRECTIVE ACTION**

---



**BATTERY DISCONNECT  
 SWITCH 12 VDC  
 TERMINATION  
 FROM BATTERY**

**BATTERY DISCONNECT  
 SWITCH 12 VDC  
 TERMINATION**

**WARNING**



**Remove rings, wristwatches, neck chains, and any other jewelry before working around vehicle. Jewelry can catch on equipment and cause serious injury. Jewelry and tools may short across electrical circuits and cause damage to equipment, or severe burns or electrical shock to personnel.**

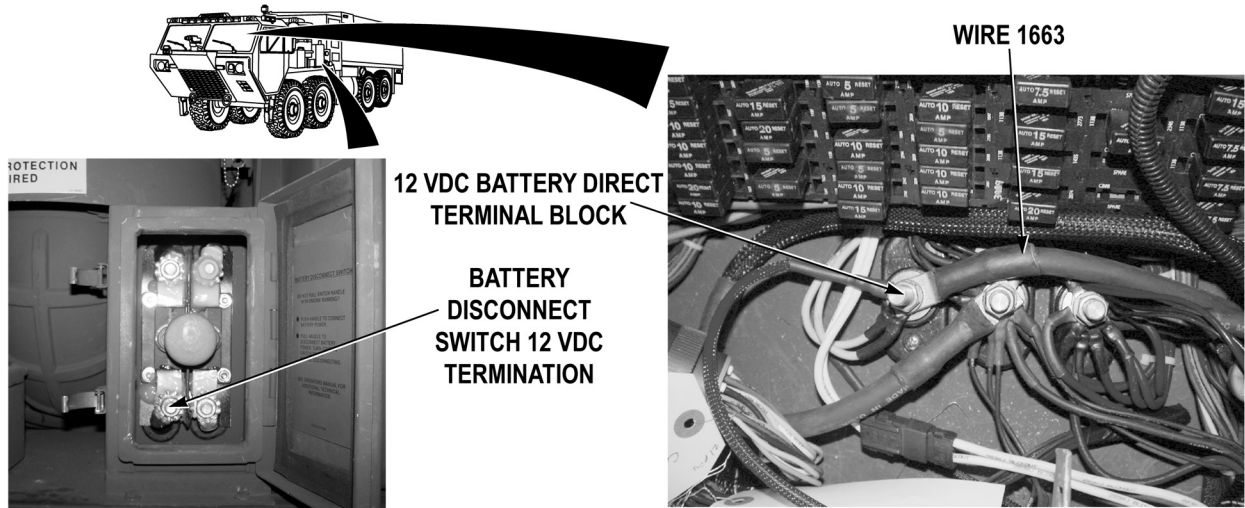
Step 9. Disconnect batteries (TM 9-2320-325-14&P) Check battery disconnect switch 12 VDC terminations for loose and corroded connections.

If connections are loose or corroded, clean and/or tighten connections or replace battery disconnect switch (WP 0236).

---

**MALFUNCTION**  
**TEST OR INSPECTION**  
**CORRECTIVE ACTION**

---



- Step 10. With test lead set, check for continuity across high amperage wire 1663 (black) from battery disconnect switch 12 VDC termination to 12 VDC cab battery direct terminal block.
- a. If there is continuity, replace 12 VDC cab battery direct terminal block (WP 0274).
  - b. If there is no continuity, repair wire 1663 if repairable (TM 9-2320-325-14&P), or replace high amperage cable (WP 0251).

**END OF TASK**

**FOLLOW-ON MAINTENANCE**

Remove wheel chocks (TM 9-2320-422-10)

**END OF TASK**

**END OF WORK PACKAGE**





---

**FIELD LEVEL MAINTENANCE****INTERCOM AND HEADSETS DO NOT OPERATE PROPERLY**

---

**INITIAL SETUP:****Tools and Special Tools**

Lead Set, Test (WP 0398, Item 14)  
Tool Kit, General Mechanic's: Automotive  
(WP 0398, Item 17)

**Personnel Required**

MOS 63B Wheeled Vehicle Mechanic (2)

**References**

TM 9-2320-325-14&P  
TM 11-5820-890-10  
WP 0004  
WP 0007

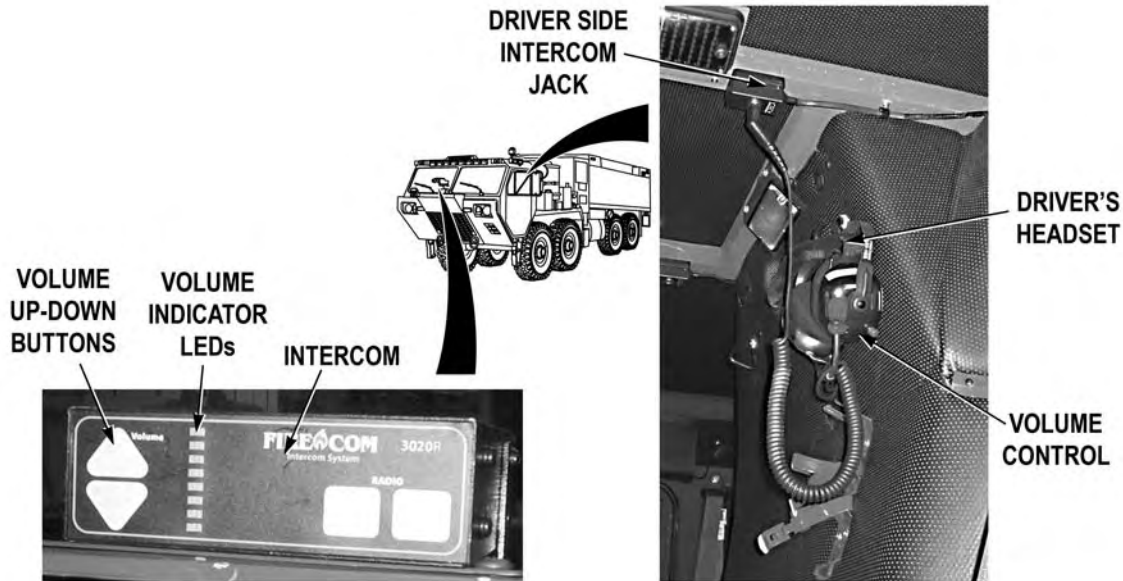
**References (continued)**

WP 0010  
WP 0256  
WP 0257  
WP 0276  
WP 0289

**Equipment Conditions**

Engine OFF (TM 9-2320-422-10)  
Wheels chocked (TM 9-2320-422-10)

---

**MALFUNCTION****TEST OR INSPECTION****CORRECTIVE ACTION****INTERCOM AND HEADSETS DO NOT OPERATE PROPERLY****⚠ CAUTION**

**Excessive intercom volume may be present. If volume is excessive, adjust headset volume control as required for safe usage. Failure to comply may result in damage to hearing.**

- Step 1. Push battery disconnect switch to on position (WP 0007). Check if at least one intercom volume indicator LEDs illuminate (WP 0004).

If volume indicator LEDs do not illuminate, go to Step 41.

**NOTE**

- When connecting headset into intercom jack, ensure headset connector is completely inserted into headset jack.
- Driver's headset (Model UH-10S) has one earphone.

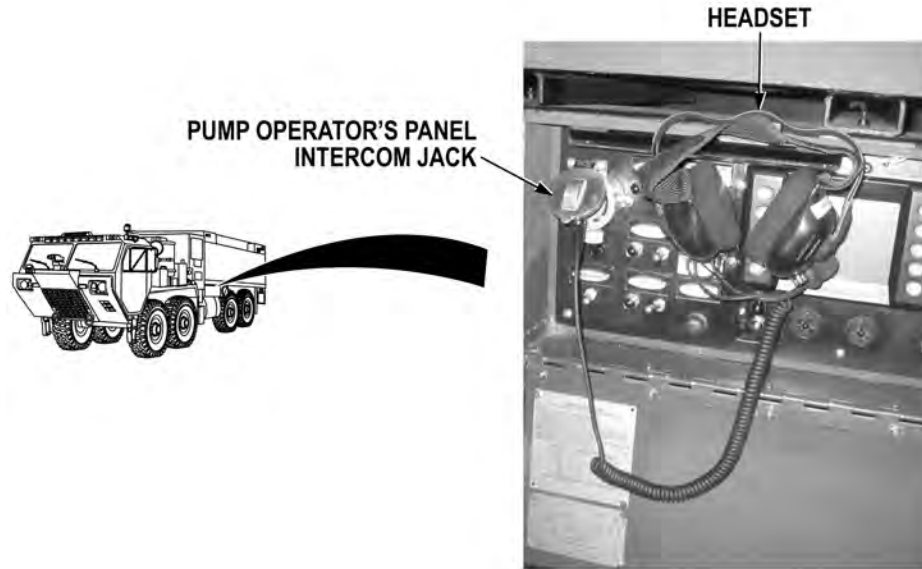
- Step 2. Press intercom volume up and down buttons until four volume indicator LEDs are illuminated (WP 0004). Connect driver's headset into driver side intercom jack (WP 0004). Put on headset and adjust for comfortable fit. Set headset volume control to low volume (counterclockwise) (WP 0004). While talking into headset microphone, (do not press push-to-talk button), check if headset microphone can be heard through headset earphone.

If driver's headset microphone can be heard through headset earphone, go to Step 4.

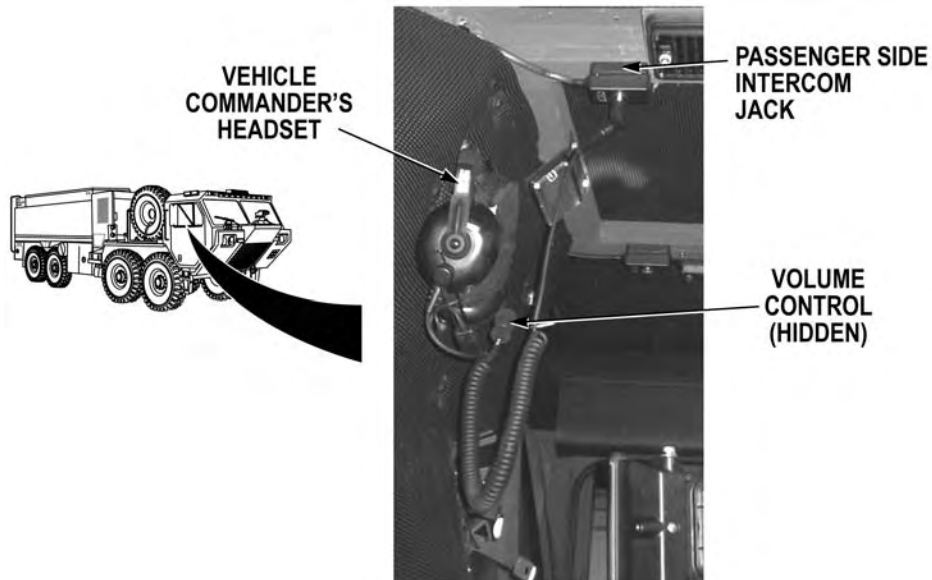
---

**MALFUNCTION****TEST OR INSPECTION****CORRECTIVE ACTION**

---



- Step 3. Disconnect driver's headset from driver side intercom jack (WP 0004). Open pump operator's panel cover (WP 0010). Connect driver's headset into pump operator's panel intercom jack (WP 0004). While talking into headset microphone, (do not press push-to-talk button), check if driver's headset microphone can be heard through headset earphone.
- a. If driver's headset microphone can be heard through headset earphone, go to Step 6.
  - b. If driver's headset microphone cannot be heard through headset earphone, replace driver's headset.

**MALFUNCTION****TEST OR INSPECTION****CORRECTIVE ACTION****NOTE**

When connecting headset into intercom jack, ensure headset connector is completely inserted in headset jack.

- Step 4. Connect vehicle commander's headset into passenger side intercom jack (WP 0004). Put on headset and adjust for comfortable fit. Set headset volume control to low volume (counterclockwise) (WP 0004). While talking into headset microphone, (do not press push-to-talk button), check if vehicle commander's headset microphone can be heard through both headset earphones.

If vehicle commander's headset microphone can be heard through both headset earphones, go to Step 9.

- Step 5. Disconnect vehicle commander's headset from passenger side intercom jack (WP 0004). Connect vehicle commander's headset into driver side intercom jack (WP 0004). While talking into vehicle commander's headset microphone, (do not press push-to-talk button), check if vehicle commander's headset microphone can be heard through both headset earphones.
- If vehicle commander's headset microphone can be heard through both headset earphones, go to Step 10.
  - If vehicle commander's headset microphone cannot be heard through both headset earphones, replace vehicle commander's headset.

**MALFUNCTION****TEST OR INSPECTION****CORRECTIVE ACTION****NOTE**

If intercom wire harness connectors are not identified at intercom, disconnect wire harness connector one at a time until correct wire harness is identified. Reconnect connector before disconnecting next intercom wire harness connector.

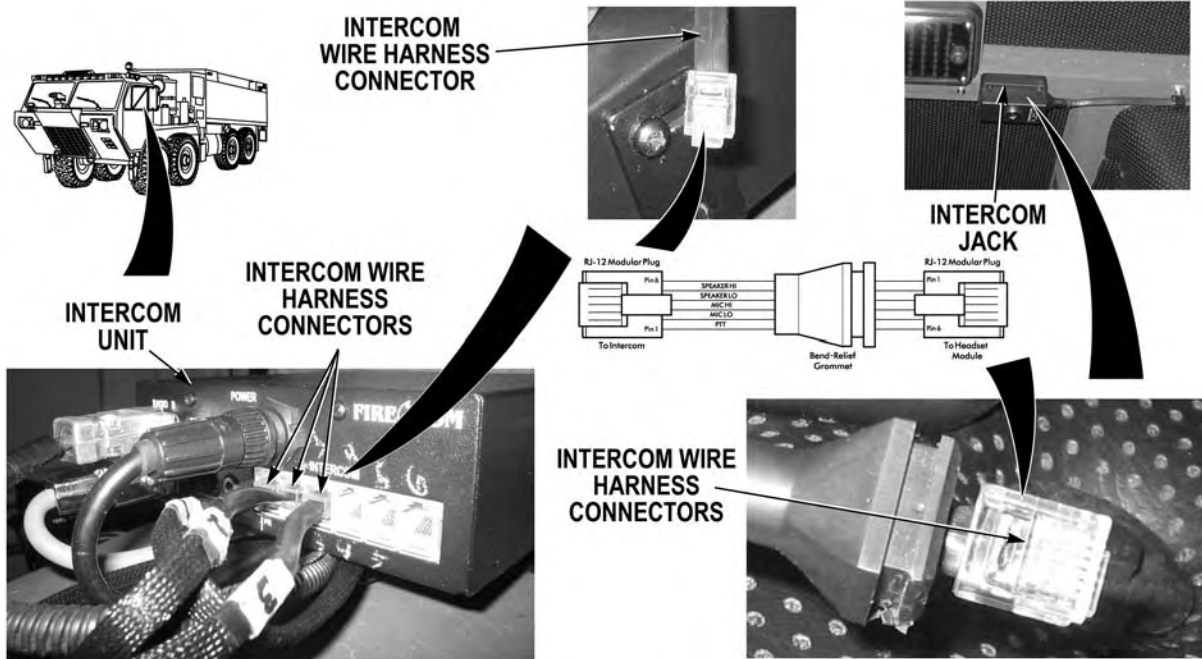
- Step 6. Disconnect driver's headset from pump operator's panel intercom jack (WP 0004). Connect driver's headset into driver side intercom jack (WP 0004). Disconnect driver side intercom cable connector from intercom (WP 0257). Disconnect passenger side intercom cable connector from intercom (WP 0257). Connect driver side intercom cable connector into passenger side intercom cable connector at intercom. While talking into driver's headset microphone, (do not press push-to-talk button), check if headset microphone can be heard through headset earphone.

If driver's headset microphone can be heard though headset earphones, replace intercom (WP 0256).

**MALFUNCTION**

**TEST OR INSPECTION**

**CORRECTIVE ACTION**



**NOTE**

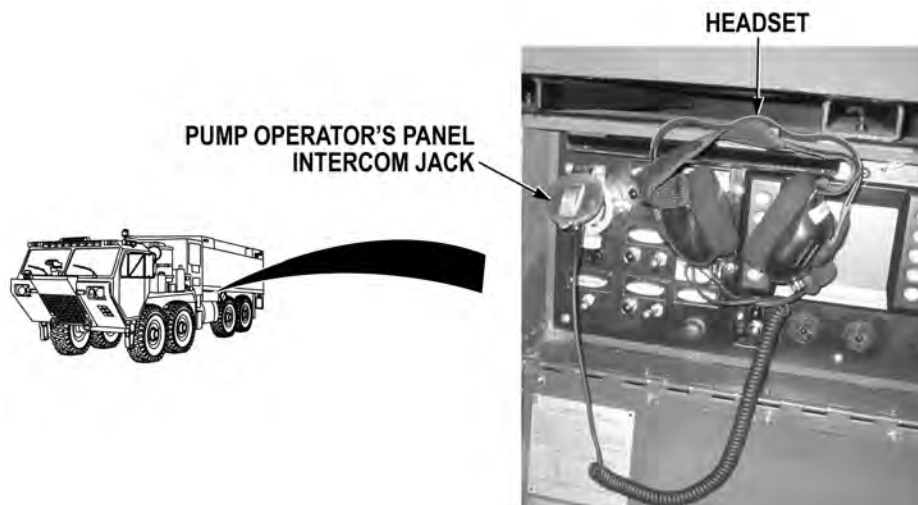
Note position of intercom jack prior to disconnect intercom cable to ensure proper installation.

- Step 7. Pull battery disconnect switch to off position (WP 0007). Disconnect driver side intercom cable connector from intercom and reconnect passenger side intercom cable connector in original position (WP 0257). Disconnect intercom cable connector from driver side intercom jack (WP 0257). Check driver side intercom cable and connectors for bent terminals and damage.

If intercom cable has bent terminals or is damaged, replace intercom cable and connector (WP 0257).

**MALFUNCTION****TEST OR INSPECTION****CORRECTIVE ACTION**

- Step 8. Turn battery disconnect switch to off position (WP 0007). Disconnect driver side intercom cable from driver side intercom headset jack. Disconnect passenger side intercom cable from passenger side intercom headset jack. Connect passenger side intercom cable to driver side intercom headset jack. Turn battery disconnect switch to ON position (WP 0007). While talking into driver side headset microphone (do not press push-to-talk button), check if driver side headset microphone can be heard through headset earphone.
- If driver side headset microphone can be heard through headset earphones, replace driver side intercom jack (WP 0257).
  - If driver side headset microphone cannot be heard through headset earphones, replace driver side intercom cable and connectors (WP 0257).



- Step 9. Disconnect vehicle commander's headset from passenger side intercom jack (WP 0004). Open pump operator's panel cover (WP 0010). Connect vehicle commander's headset into pump operator's panel intercom jack (WP 0004). While talking into vehicle commander's headset microphone, (do not press push-to-talk button), check if headset microphone can be heard through both headset earphones.
- If vehicle commander's headset microphone can be heard through both headset earphones, go to Step 13.
  - If vehicle commander's headset microphone cannot be heard through both headset earphones, replace intercom cable and connectors (WP 0257).

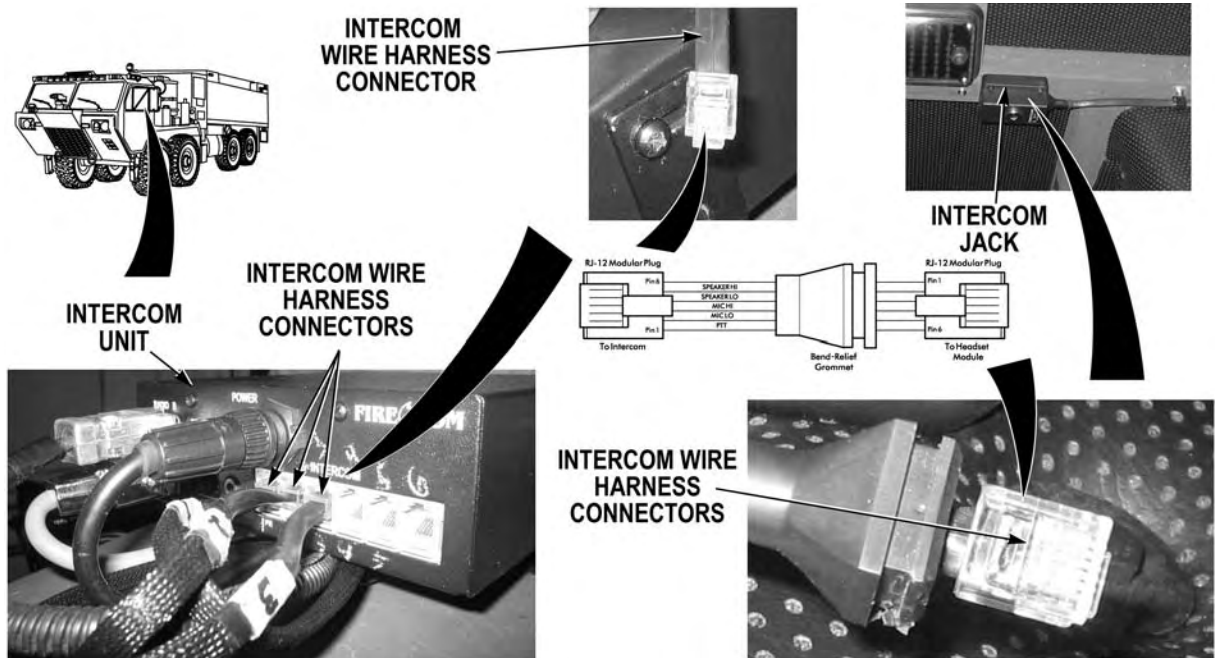
**MALFUNCTION****TEST OR INSPECTION****CORRECTIVE ACTION**

- Step 10. Disconnect vehicle commander's headset from driver side intercom jack (WP 0004). Connect vehicle commander's headset into passenger side intercom jack (WP 0004). Disconnect passenger side intercom cable connector from intercom (WP 0257). Disconnect driver side intercom cable connector from intercom (WP 0257). Connect passenger side intercom cable connector into driver side intercom cable connector at intercom. While talking into vehicle commander's headset microphone, (do not press push-to-talk button), check if headset microphone can be heard through headset earphones.

If vehicle commander's headset microphone can be heard though headset earphones, replace intercom (WP 0256).



**MALFUNCTION**  
**TEST OR INSPECTION**  
**CORRECTIVE ACTION**



**NOTE**

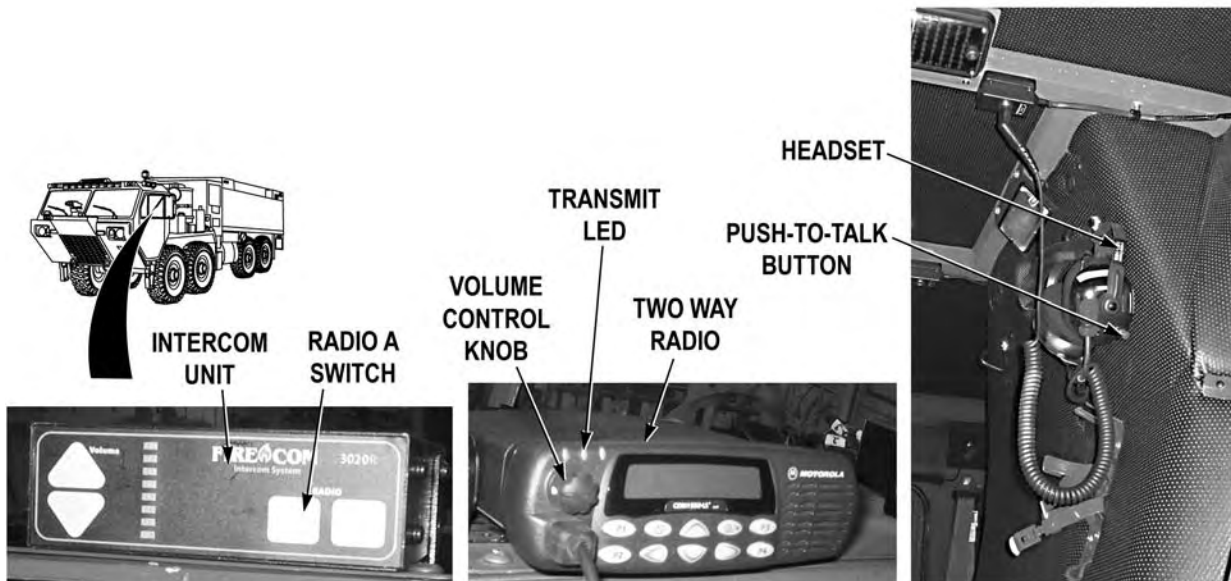
Note position of intercom jack prior to disconnecting intercom cable to ensure proper installation.

- Step 11. Pull battery disconnect switch to off position (WP 0007). Disconnect passenger side intercom cable connector from intercom and reconnect driver side intercom cable connector in original position (WP 0257). Remove passenger side intercom jack cover and disconnect intercom cable connector (WP 0257). Check passenger side intercom cable and connectors for bent terminals and damage.

If intercom cable has bent terminals or is damaged, replace intercom cable and connector (WP 0257).

**MALFUNCTION****TEST OR INSPECTION****CORRECTIVE ACTION**

- Step 12. Turn battery disconnect switch to off position (WP 0007). Disconnect passenger side intercom cable from passenger side intercom headset jack. Disconnect driver side intercom cable from driver side intercom headset jack. Connect driver side intercom cable to passenger side intercom headset jack. Turn battery disconnect switch to ON position (WP 0007). While talking into passenger side headset microphone (do not press push-to-talk button), check if passenger side headset microphone can be heard through headset earphone.
- If passenger side headset microphone can be heard through headset earphones, replace passenger side intercom jack (WP 0257).
  - If passenger side headset microphone cannot be heard through headset earphones, replace passenger side intercom cable and connectors (WP 0257).



- Step 13. Disconnect vehicle commander's headset from pump operator's panel intercom jack (WP 0004). Connect vehicle commander's headset into passenger side intercom jack (WP 0004). Press intercom RADIO A button to select two-way radio (WP 0004). Push two-way radio volume control knob to on position (WP 0004). Adjust two-way radio volume as required for normal operations. While an assistant operates two-way radio, check if two-way radio communications can be heard through headset earphones.

If two-way radio communications cannot be heard through headset earphones, go to Step 38.

**MALFUNCTION****TEST OR INSPECTION****CORRECTIVE ACTION****NOTE**

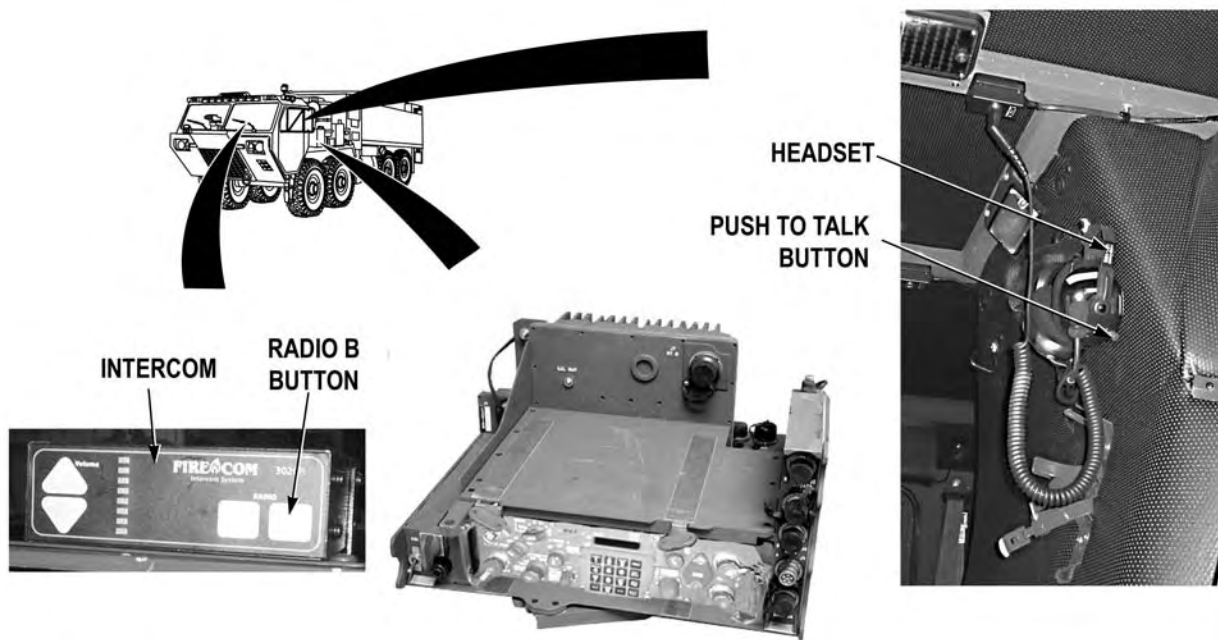
- Two-way radio transmit LED will illuminate when two-way radio keys up to transmit.
- Key up times will vary from time headset push-to-talk button is pressed until two-way radio is ready to transmit depending on intercom HK-A setting.

Step 14. While an assistant monitors two-way radio, press headset push-to-talk button and talk into microphone (WP 0004). Check if intercom keys up to transmit two-way radio.

If intercom does not key up two-way radio, go to Step 34.

Step 15. While an assistant monitors two-way radio, press headset push-to-talk button and talk into microphone (WP 0004). Check if headset communication can be heard at two-way radio.

If headset communications cannot be heard at two-way radio, go to Step 29.



Step 16. Press intercom RADIO B switch to select SINGARS radio (WP 0004). Turn SINGARS radio on (TM 9-2320-422-10). While an assistant operates SINGARS radio, check if SINGARS radio communications can be heard through vehicle commander's headset earphones.

If SINGARS radio communications can not be heard through headset earphones, go to Step 25.

---

**MALFUNCTION****TEST OR INSPECTION****CORRECTIVE ACTION**

---

**NOTE**

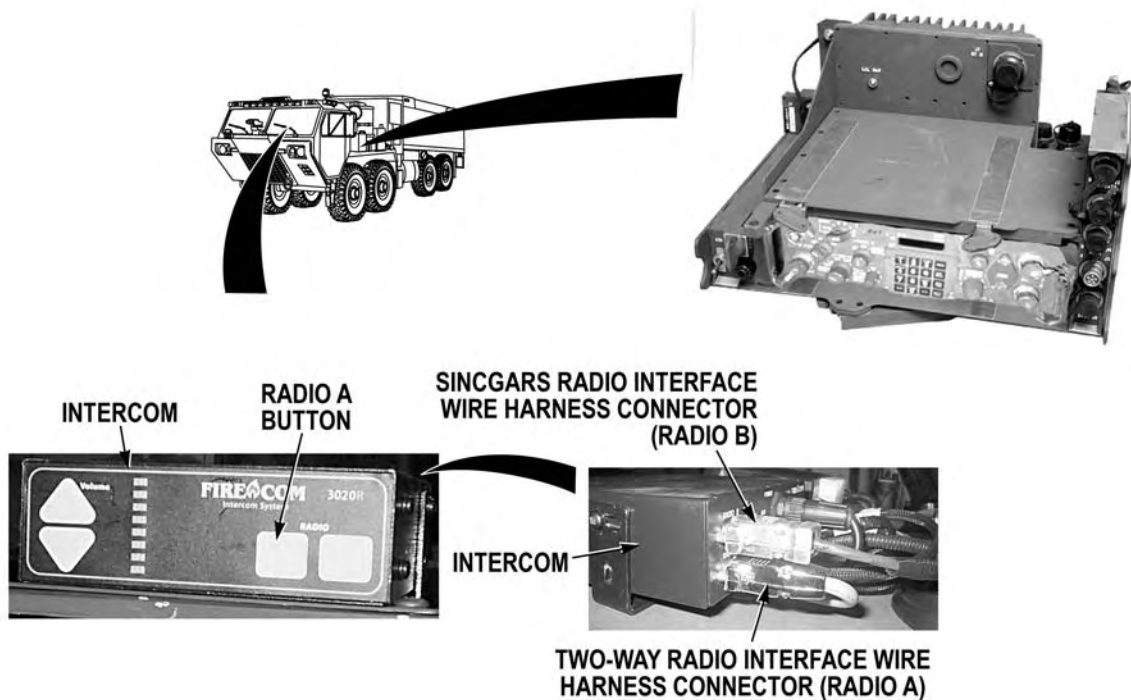
Key up times will vary from time headset push-to-talk button is pressed until SINCGARS radio is ready to transmit depending on intercom HK-B setting.

- Step 17. While an assistant monitors SINCGARS radio, press headset push-to-talk button (WP 0004). Check if intercom keys up SINCGARS radio.

If intercom does not key up SINCGARS radio, go to Step 22.

- Step 18. While an assistant monitors SINCGARS radio, press headset push-to-talk button and talk into microphone (WP 0004). Check if headset communication can be heard at SINCGARS radio.

If headset communications can be heard at SINCGARS radio, system is operating properly, notify supervisor.

**MALFUNCTION****TEST OR INSPECTION****CORRECTIVE ACTION**

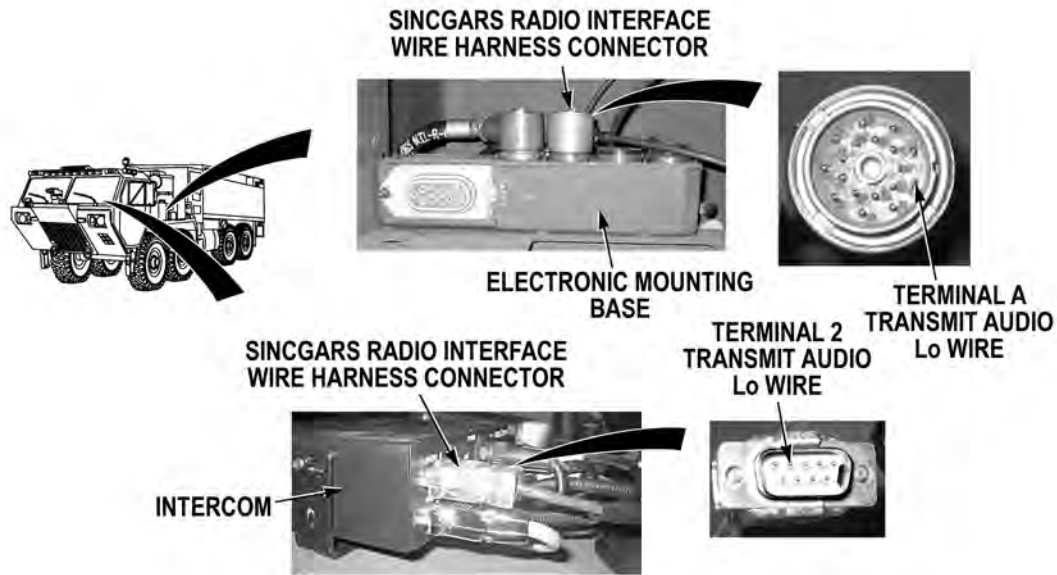
- Step 19. Pull battery disconnect switch to off position (WP 0007). Remove four screws and lift intercom away from intercom bracket (WP 0256). Disconnect SINGARS interface wire harness connector from intercom RADIO B connector (WP 0289). Disconnect two-way radio interface wire harness connector from intercom RADIO A connector (WP 0289). Connect SINGARS radio interface wire harness connector on intercom RADIO A connector. Push battery disconnect switch to on position (WP 0007). Press intercom RADIO A button (WP 0004). While an assistant operates SINGARS radio, check if SINGARS radio communications can be heard through headset earphones.

If SINGARS radio communications can be heard through headset earphones, replace intercom (WP 0256).

**MALFUNCTION**

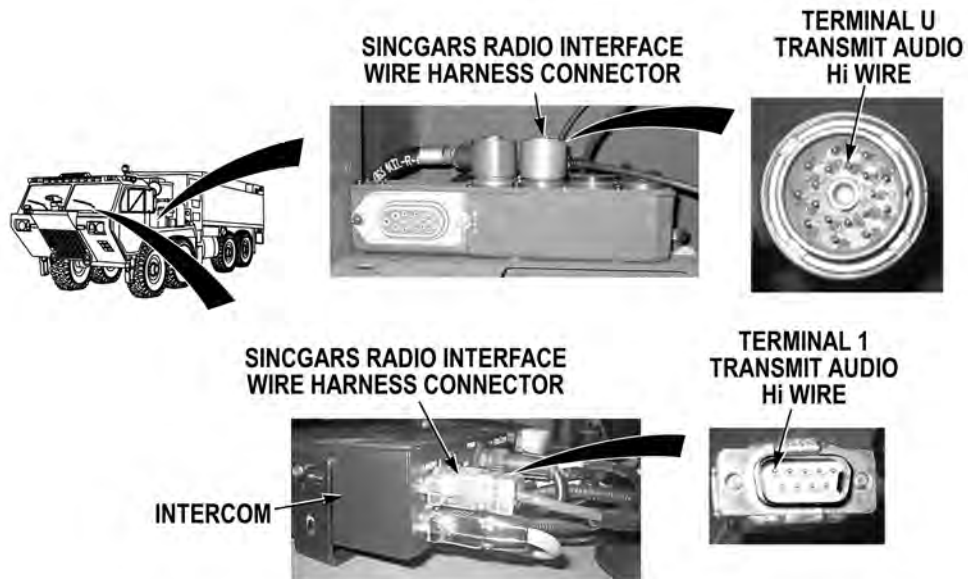
**TEST OR INSPECTION**

**CORRECTIVE ACTION**



Step 20. Remove and install SINCARS radio and two-way radio interface wire harnesses in original positions. Pull battery disconnect switch to off position (WP 0007). Remove SINCARS receiver transmitter and power adapter from electronic mounting base (TM 11-5820-890-10). Disconnect SINCARS radio interface wire harness connectors from electronics mounting base and intercom (WP 0289). With a lead test set, check for continuity across SINCARS radio interface wire harness transmit audio Lo wire (red) from intercom connector, terminal 2 to SINCARS radio connector, terminal A.

If there is no continuity, repair transmit audio Lo wire if repairable (TM 9-2320-325-14&P), or replace SINCARS radio interface wire harness (WP 0289).

**MALFUNCTION****TEST OR INSPECTION****CORRECTIVE ACTION**

- Step 21. With a lead test set, check for continuity across SINCARS radio interface wire harness transmit audio Hi wire (brown) from intercom connector, terminal 1 to SINCARS radio connector, terminal U.
- a. If there is continuity, fault is in SINCARS electronic mounting base, power adapter, or receiver transmitter, notify supervisor.
  - b. If there is no continuity, repair transmit audio Hi wire if repairable (TM 9-2320-325-14&P), or replace SINCARS radio interface wire harness (WP 0289).

**MALFUNCTION**

**TEST OR INSPECTION**

**CORRECTIVE ACTION**

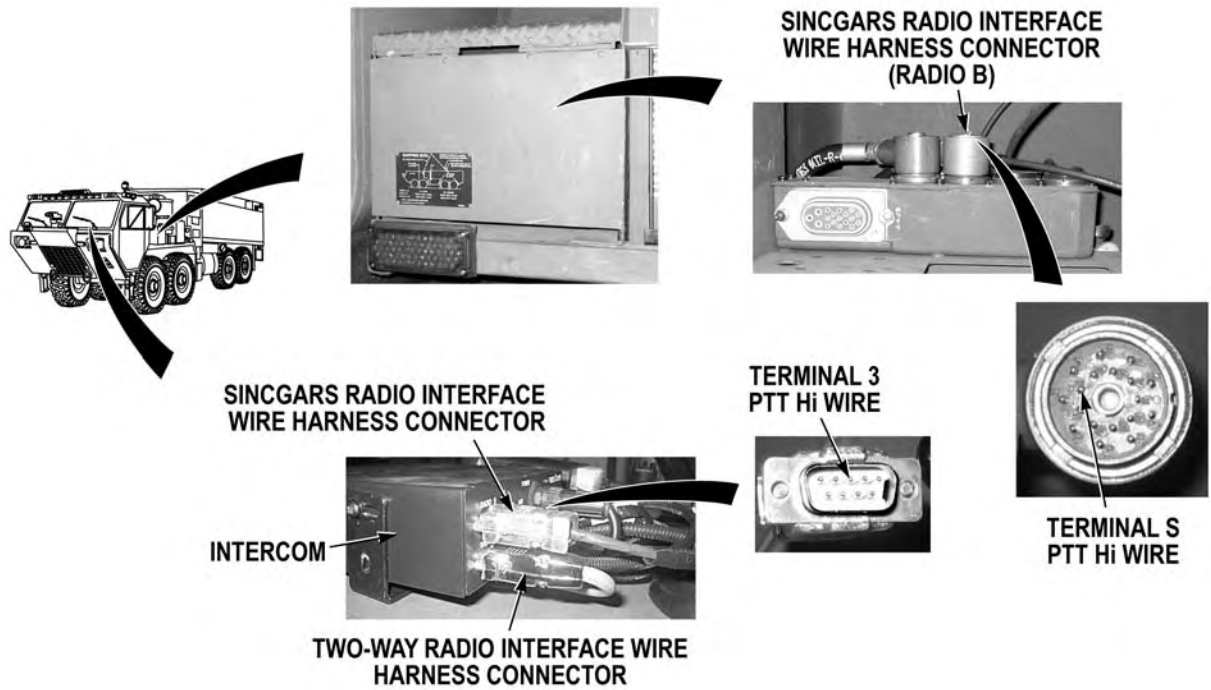


Step 22. Pull battery disconnect switch to off position (WP 0007). Remove SINGGARS receiver transmitter and power adapter from electronic mounting base (TM 11-5820-890-10). Disconnect SINGGARS radio interface wire harness connectors from electronics mounting base and intercom (WP 0289). With a lead test set, check for continuity across SINGGARS radio interface wire harness PTT Lo wire (yellow) from intercom connector, terminal 4 to SINGGARS radio connector, terminal A.

If there is no continuity, repair PTT Lo wire if repairable (TM 9-2320-325-14&P), or replace SINGGARS radio interface wire harness (WP 0289).



**MALFUNCTION**  
**TEST OR INSPECTION**  
**CORRECTIVE ACTION**



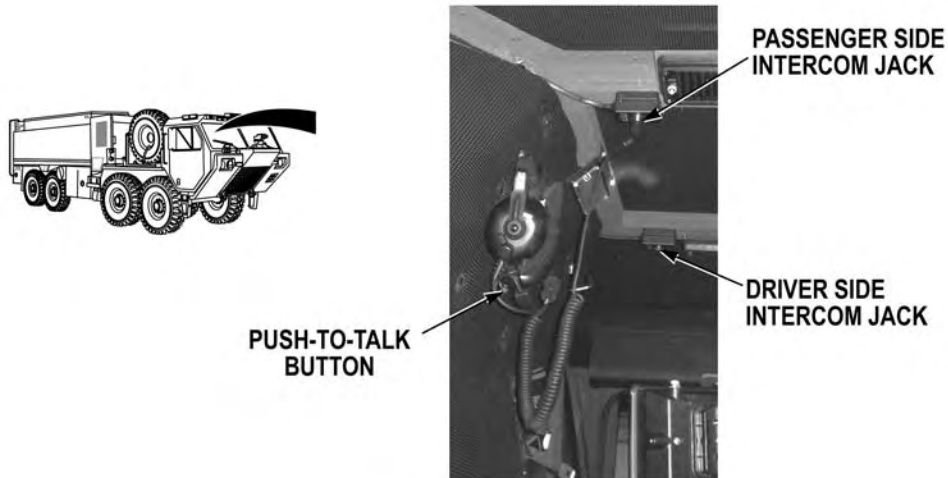
Step 23. With a lead test set, check for continuity across SINGGARS radio interface wire harness PTT Hi wire (orange) from intercom connector, terminal 3 to SINGGARS radio connector, terminal S.

If there is no continuity, repair PTT Hi wire if repairable (TM 9-2320-325-14&P), or replace SINGGARS radio interface wire harness (WP 0289).

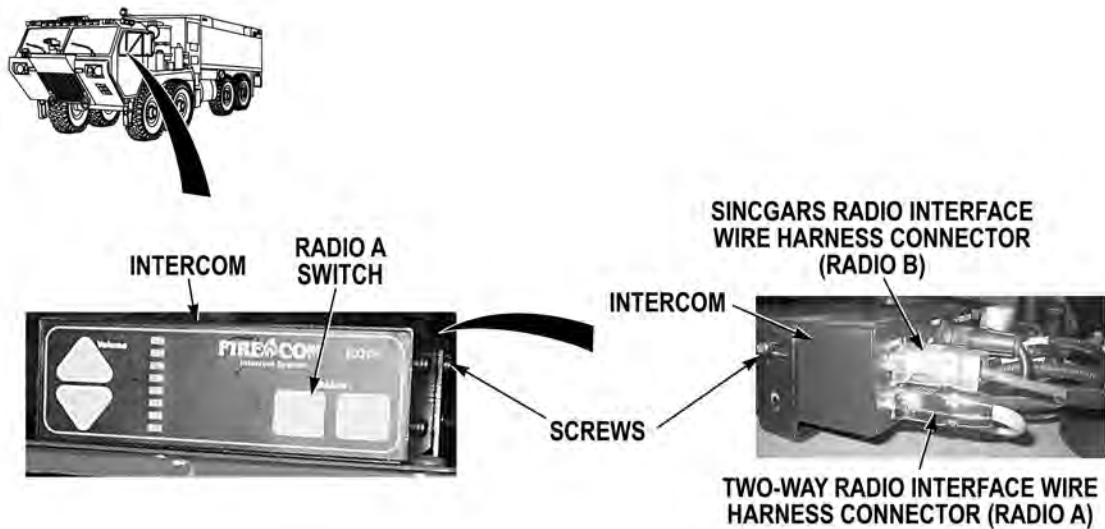
---

**MALFUNCTION****TEST OR INSPECTION****CORRECTIVE ACTION**

---



- Step 24. Connect SINGARS radio interface wire harness connectors on electronic mounting base and intercom (WP 0289). Install power adaptor and SINGARS receiver transmitter on electronic mounting base (TM 11-5820-890-10). Disconnect vehicle commander's headset from passenger side intercom jack (WP 0004). Connect vehicle commander's headset into driver side intercom jack (WP 0004). Push battery disconnect switch to on position (WP 0007). While an assistant monitors SINGARS radio, press headset push-to-talk button (WP 0004). Check if intercom keys up to transmit SINGARS radio.
- a. If intercom keys up SINGARS radio, replace intercom cables and connectors (WP 0257).
  - b. If intercom does not key up SINGARS radio, fault is in SINGARS electronic mounting base, power adaptor, or receiver transmitter, notify Supervisor.

**MALFUNCTION****TEST OR INSPECTION****CORRECTIVE ACTION**

- Step 25. Inspect SINGGARS radio interface wire harness connectors at intercom and SINGGARS electronic mounting base for loose connectors.

If SINGGARS interface wire harness connectors are loose tighten connection (WP 0289),

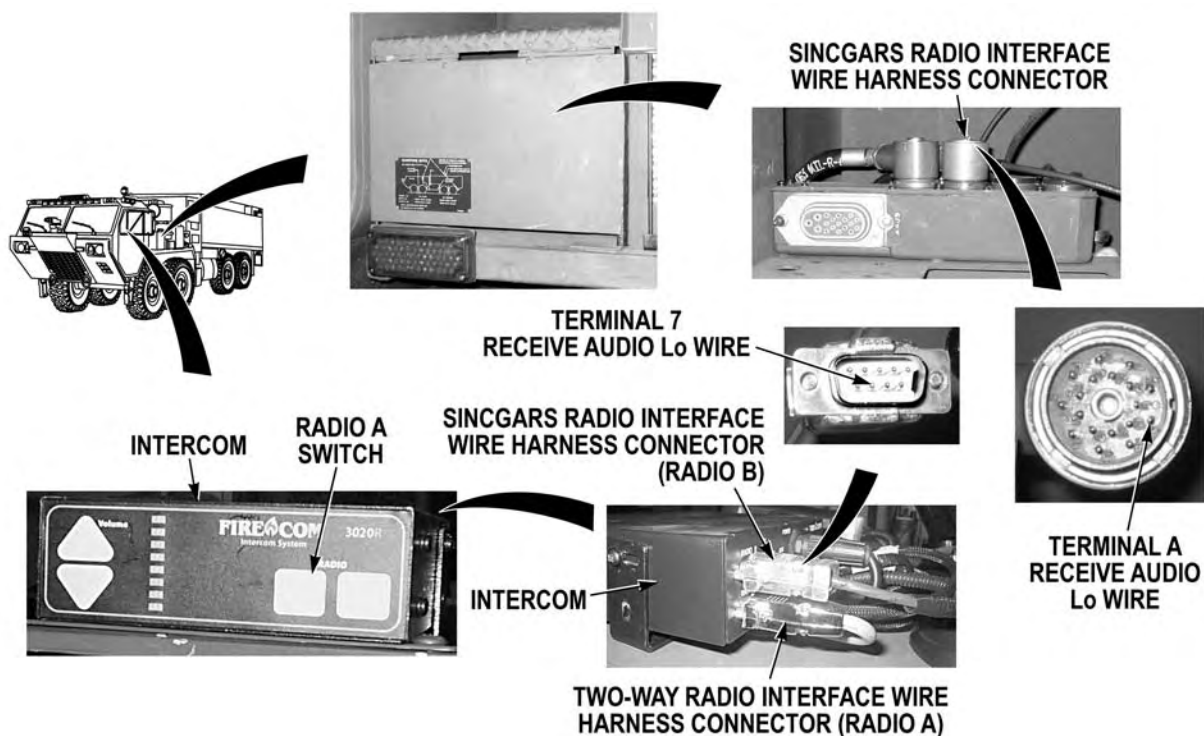
- Step 26. Remove four screws and lift intercom away from intercom bracket (WP 0256). Disconnect SINGGARS interface wire harness connector from intercom RADIO B connector (WP 0289). Disconnect two-way radio interface wire harness connector from intercom RADIO A connector (WP 0289). Connect SINGGARS radio interface wire harness connector on intercom RADIO A connector. Press intercom RADIO A button (WP 0004). While an assistant operates SINGGARS radio, check if SINGGARS radio communications can be heard through headset earphones.

If SINGGARS radio communications can be heard through headset earphones, replace intercom (WP 0256).

**MALFUNCTION**

**TEST OR INSPECTION**

**CORRECTIVE ACTION**



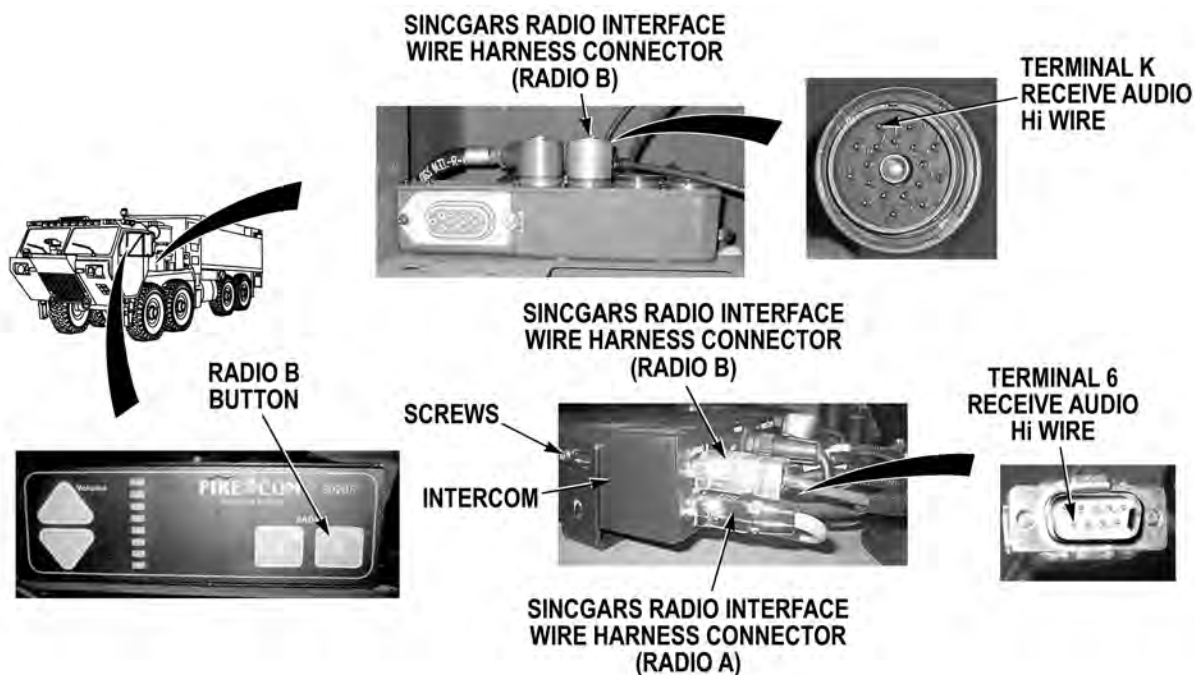
Step 27. Remove and install SINGGARS radio and two-way radio interface wire harnesses on original positions. Pull battery disconnect switch to off position (WP 0007). Remove SINGGARS receiver transmitter and power adapter from electronic mounting base (TM 11-5820-890-10). Disconnect SINGGARS radio interface wire harness connectors from electronics mounting base and intercom (WP 0289). With a lead test set, check for continuity across SINGGARS radio interface wire harness receive audio Lo wire (violet) from intercom connector, terminal 7 to SINGGARS radio connector, terminal A.

If there is no continuity, repair receive audio Lo wire if repairable (TM 9-2320-325-14&P), or replace SINGGARS radio interface wire harness (WP 0289).

## MALFUNCTION

## TEST OR INSPECTION

## CORRECTIVE ACTION



Step 28. Check for continuity across SINGGARS radio interface wire harness receive audio Hi wire (blue) from intercom connector, terminal 6 to SINGGARS radio connector, terminal K.

- a. If there is continuity, fault is in SINGGARS electronic mounting base, power adapter, or receiver transmitter, notify Supervisor.
- b. If there is no continuity, repair receive audio Hi wire if repairable (TM 9-2320-325-14&P), or replace SINGGARS radio interface wire harness (WP 0289).

Step 29. Inspect two-way radio interface wire harness connectors at intercom and two-way radio for loose connectors.

If two-way radio interface wire harness connectors are loose, tighten connection (WP 0289).

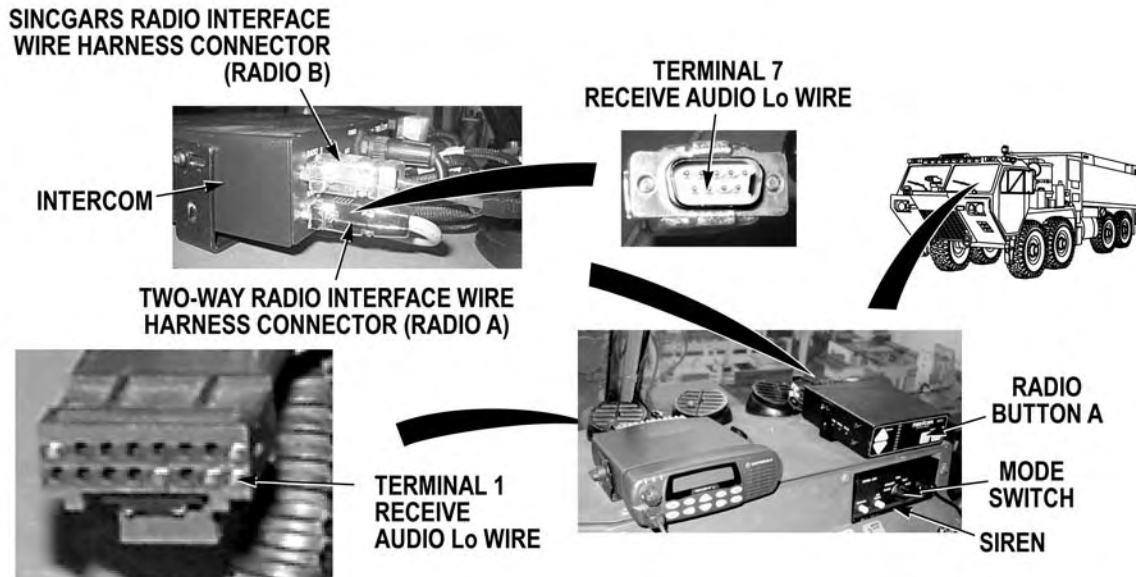
Step 30. Remove four screws and lift intercom away from intercom bracket (WP 0256). Disconnect SINGGARS interface wire harness connector from intercom RADIO B connector (WP 0289). Disconnect two-way radio interface wire harness connector from intercom RADIO A connector (WP 0289). Connect two-way radio interface wire harness connector on intercom RADIO B connector. Press intercom RADIO B button (WP 0004). While an assistant operates two-way radio, check if two-way radio communications can be heard through headset earphones.

If two-way radio communications can be heard through headset earphones, replace intercom (WP 0256).

## MALFUNCTION

## TEST OR INSPECTION

## CORRECTIVE ACTION



- Step 31. Put EMERG MASTER switch to on position (WP 0004). Turn Service Drive Lights on (TM 9-2320-422-10). Remove and install two-way radio and SINGGARS interface wire harnesses in original positions. Press intercom RADIO A button (WP 0004). Put siren mode select switch to RADIO position (WP 0004). While an assistant operates two-way radio, check if two-way radio communications can be heard through siren speaker.

If two-way radio communications can be heard through siren speaker, repair two-way radio interface wire harness if repairable (TM 9-2320-325-14&P), or replace two-way radio interface wire harness (WP 0289).

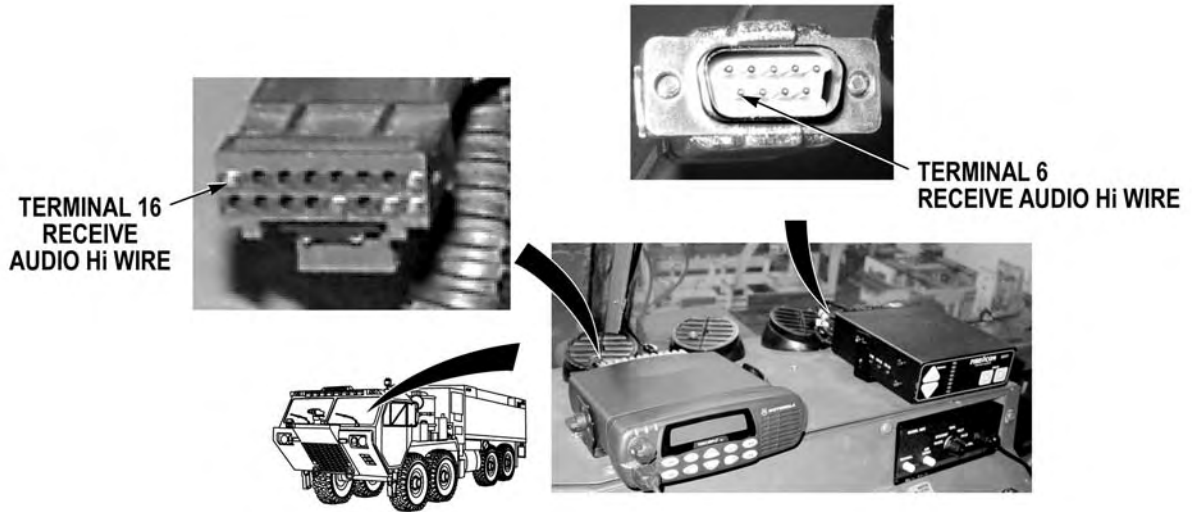
- Step 32. Pull battery disconnect switch to off position (WP 0007). Disconnect two-way radio interface wire harness connectors from two-way radio and intercom (WP 0289). With a test lead set, check for continuity across two-way radio interface wire harness receive audio Lo wire (violet) from intercom connector, terminal 7 to two-way radio connector, terminal 1.

If there is no continuity, repair receive audio Lo wire if repairable (TM 9-2320-325-14&P), or replace two-way radio interface wire harness (WP 0289).

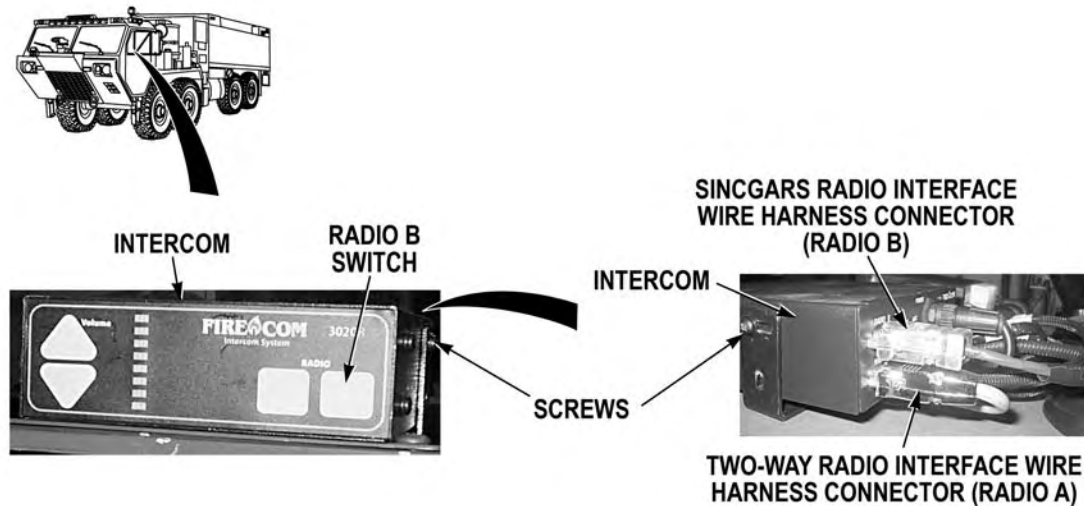
---

MALFUNCTION	TEST OR INSPECTION	CORRECTIVE ACTION
-------------	--------------------	-------------------

---



- Step 33. With a test lead set, check for continuity across two-way radio interface wire harness receive audio Hi wire (blue) from intercom connector, terminal 6 to two-way radio connector, terminal 16.
- If there is continuity, replace two-way radio (WP 0276).
  - If there is no continuity, repair receive audio Hi wire if repairable (TM 9-2320-325-14&P), or replace two-way radio interface wire harness (WP 0289).

**MALFUNCTION****TEST OR INSPECTION****CORRECTIVE ACTION**

- Step 34. Inspect two-way radio interface wire harness connectors at intercom and two-way radio for loose connectors.

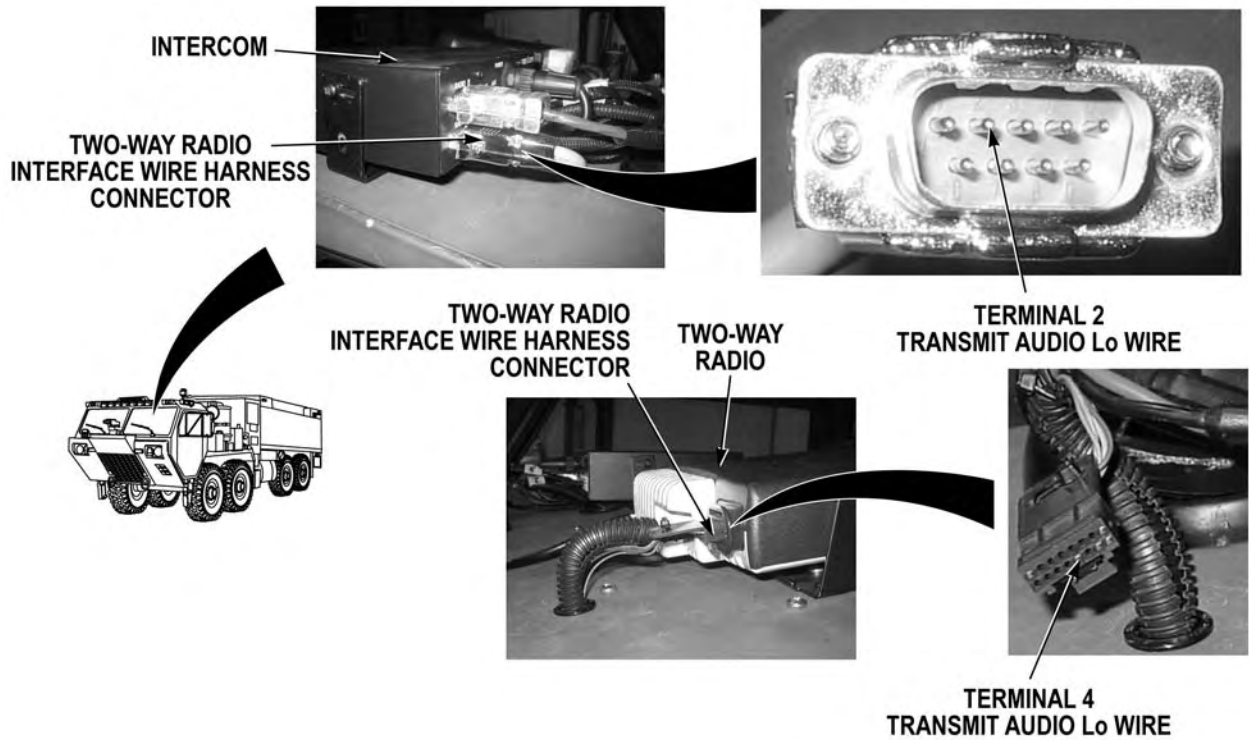
If two-way radio interface wire harness connectors are loose, tighten connection (WP 0289),

- Step 35. Remove four screws and lift intercom away from intercom bracket (WP 0256). Disconnect SINGGARS interface wire harness connector from intercom RADIO B connector (WP 0289). Disconnect two-way radio interface wire harness connector from intercom RADIO A connector (WP 0289). Connect two-way radio interface wire harness connector on intercom RADIO B connector. Press intercom RADIO B button (WP 0004). While an assistant monitors two-way radio, check if headset communications can be heard through two-way radio.

If headset communications can be heard through two-way radio, replace intercom (WP 0256).



**MALFUNCTION**  
**TEST OR INSPECTION**  
**CORRECTIVE ACTION**



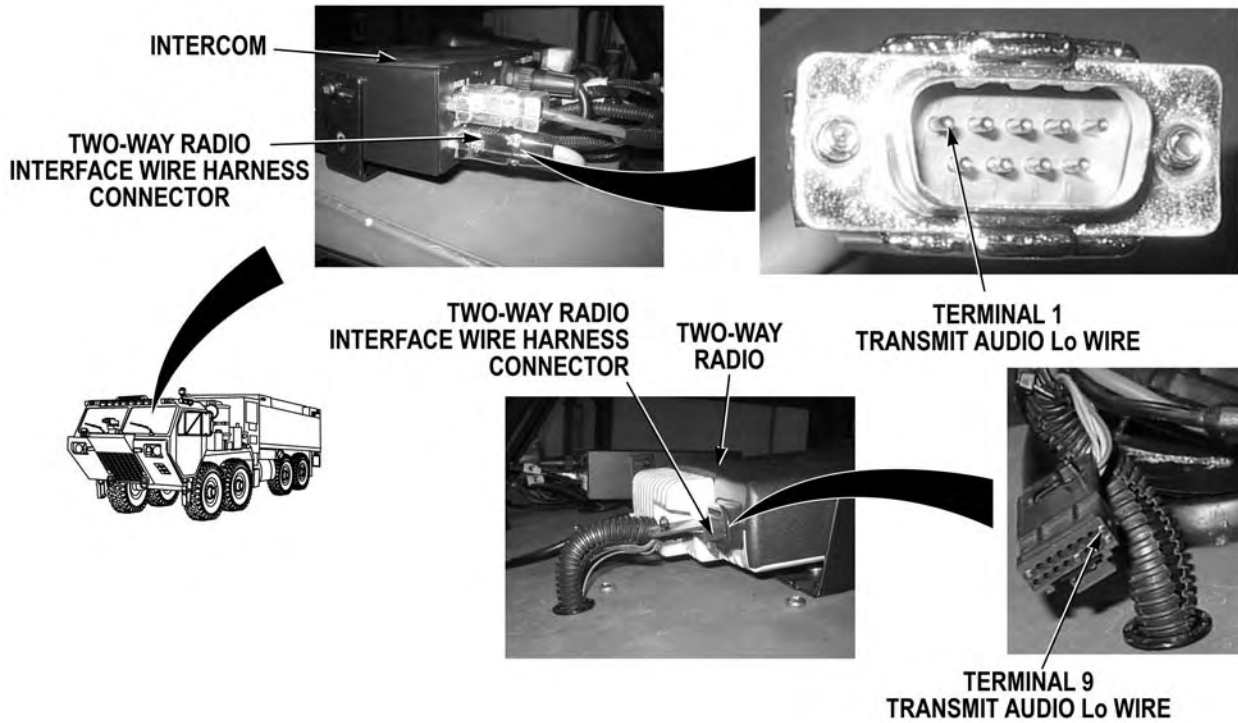
Step 36. Remove and install two-way radio and SINCGARS interface wire harnesses in original positions. Pull battery disconnect switch to off position (WP 0007). Disconnect two-way radio interface wire harness connectors from two-way radio and intercom (WP 0289). With a test lead set, check for continuity across two-way radio interface wire harness transmit audio Lo wire (red) from intercom connector, terminal 2 to two-way radio connector, terminal 4.

If there is no continuity, repair transmit audio Lo wire if repairable (TM 9-2320-325-14&P), or replace two-way radio interface wire harness (WP 0289).

## MALFUNCTION

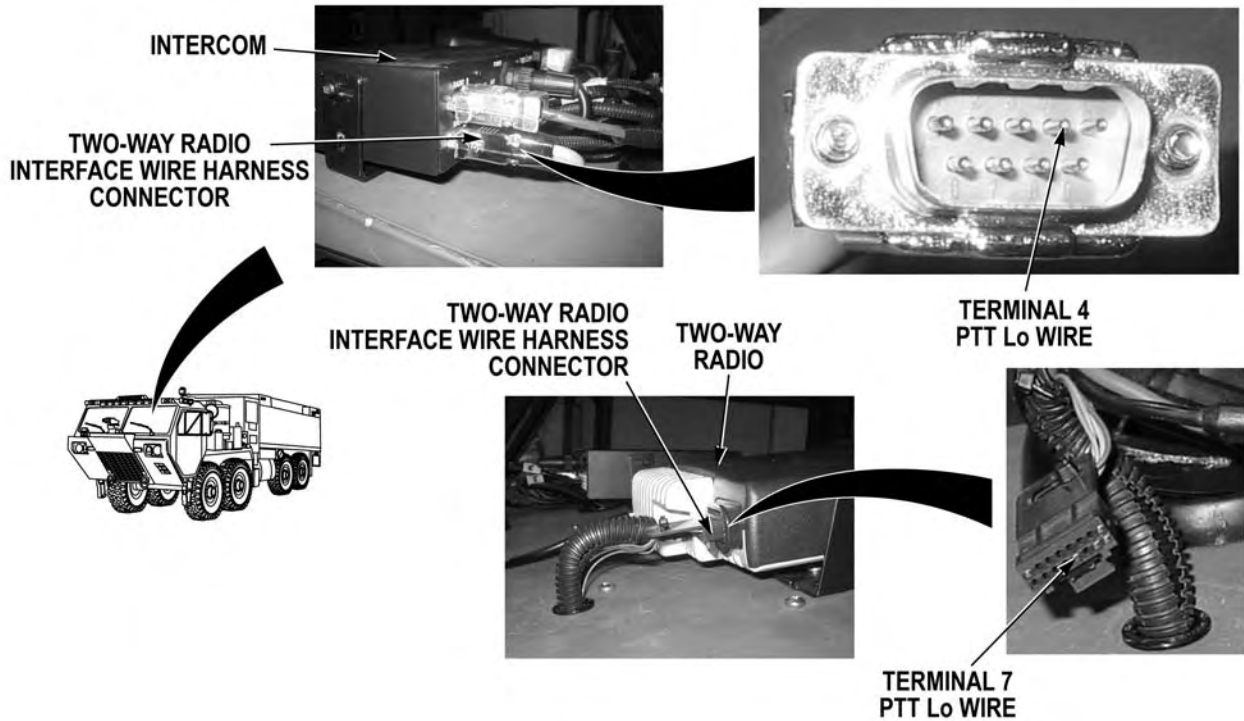
## TEST OR INSPECTION

## CORRECTIVE ACTION



- Step 37. With a test lead set, check for continuity across two-way radio interface wire harness transmit audio Hi wire (brown) from intercom connector, terminal 1 to two-way radio connector, terminal 9.
- a. If there is continuity, replace two-way radio (WP 0276).
  - b. If there is no continuity, repair transmit audio Hi wire if repairable (TM 9-2320-325-14&P), or replace two-way radio interface wire harness (WP 0289).

**MALFUNCTION**  
**TEST OR INSPECTION**  
**CORRECTIVE ACTION**



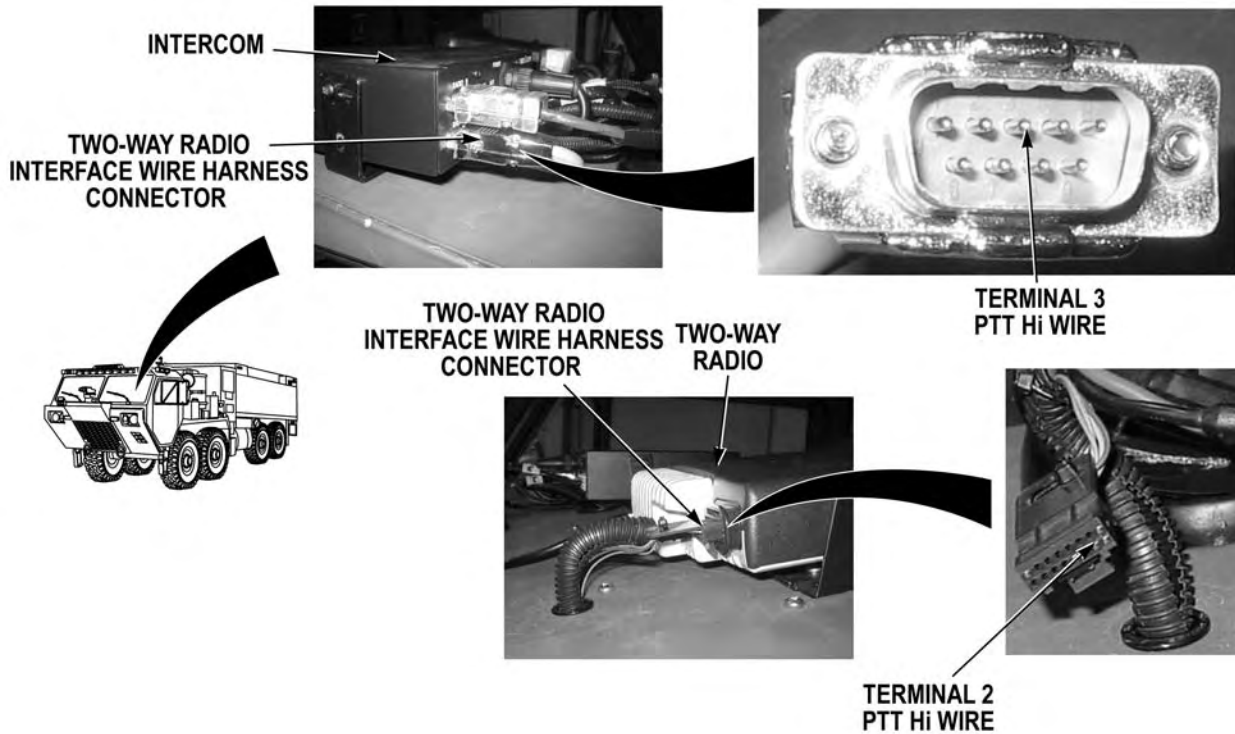
Step 38. Disconnect two-way radio interface wire harness connectors from two-way radio and intercom (WP 0289). With a test lead set, check for continuity across two-way radio interface wire harness PTT Lo wire (yellow) from intercom connector, terminal 4 to two-way radio connector, terminal 7.

If there is no continuity, repair PTT Lo wire if repairable (TM 9-2320-325-14&P), or replace two-way radio interface wire harness (WP 0289).

**MALFUNCTION**

**TEST OR INSPECTION**

**CORRECTIVE ACTION**



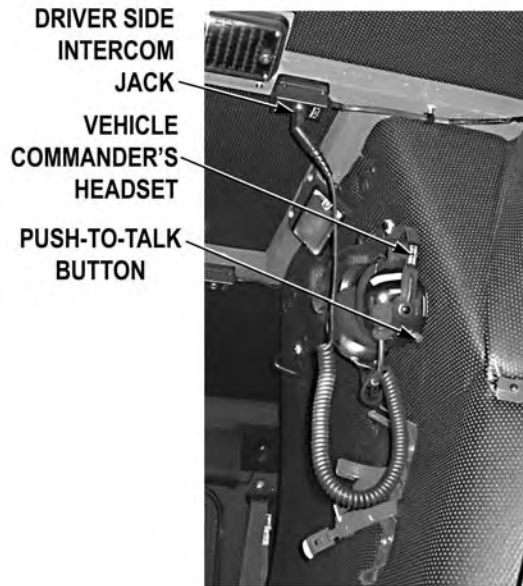
Step 39. With a test lead set, check for continuity across two-way radio interface wire harness PTT Hi wire (orange) from intercom connector, terminal 3 to two-way radio connector, terminal 2.

If there is no continuity, repair PTT Hi wire if repairable (TM 9-2320-325-14&P), or replace two-way radio interface wire harness (WP 0289).

---

MALFUNCTION	TEST OR INSPECTION	CORRECTIVE ACTION
-------------	--------------------	-------------------

---

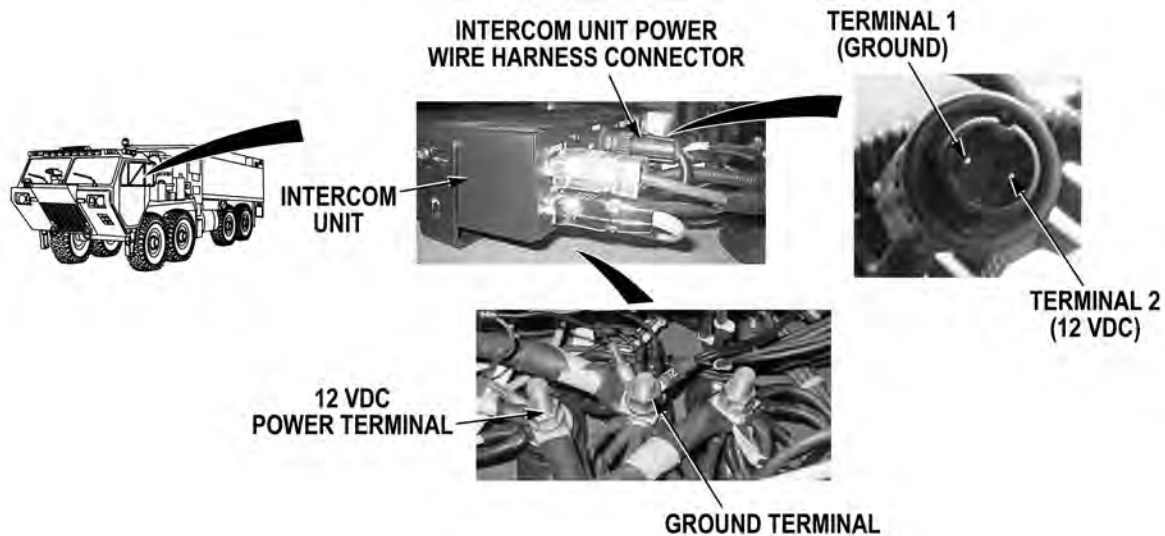


- Step 40. Connect two-way radio interface wire harness connectors on two-way radio and intercom (WP 0289). Disconnect vehicle commander's headset from passenger side intercom jack (WP 0004). Connect vehicle commander's headset into driver side intercom jack (WP 0004). While an assistant monitors two-way radio, press headset push-to-talk button (WP 0004). Check if intercom keys up to transmit two-way radio.
- If intercom keys up two-way radio, replace intercom cables and connectors (WP 0257).
  - If intercom does not key up two-way radio, replace two-way radio (WP 0276).

## MALFUNCTION

## TEST OR INSPECTION

## CORRECTIVE ACTION

**WARNING**

Remove rings, wristwatches, neck chains, and any other jewelry before working around vehicle. Jewelry can catch on equipment and cause serious injury. Jewelry and tools may short across electrical circuits and cause damage to equipment, or severe burns or electrical shock to personnel.

- Step 41. Disconnect intercom power wire harness connector. With a test lead set, check for 10 to 14 VDC between intercom power wire harness connector terminals 1 and 2.
- If 10 to 14 VDC are present, replace intercom (WP 0256).
- Step 42. Pull battery disconnect switch to off position (WP 0007). Remove cab instrument panel A (WP 0205). Check intercom power wire harness wire connections at cab power distribution block 12 VDC power and ground terminals.
- If connections are loose, tighten connections (WP 0289).
  - If connections are not loose, repair intercom power wire harness wires if repairable (TM 9-2320-325-14&P) or replace intercom (WP 0256).

END OF TASK

**FOLLOW-ON MAINTENANCE**

Remove wheel chocks (TM 9-2320-422-10)

**END OF TASK**

**END OF WORK PACKAGE**





**FIELD LEVEL MAINTENANCE**

**PASSENGER SIDE STOWAGE COMPARTMENT STRIPLIGHT(S) DOES NOT OPERATE**

**INITIAL SETUP:**

**Tools and Special Tools**

Lead Set, Test (WP 0398, Item 14)  
 Tool Kit, General Mechanic's: Automotive  
 (WP 0398, Item 17)

**References**

TM 9-2320-325-14&P  
 WP 0004  
 WP 0007  
 WP 0008  
 WP 0102

**References (continued)**

WP 0215  
 WP 0242  
 WP 0246  
 WP 0280  
 WP 0292  
 WP 0298  
 WP 0349

**Equipment Conditions**

Engine OFF (TM 9-2320-422-10)  
 Wheels chocked (TM 9-2320-422-10)

**MALFUNCTION**

**TEST OR INSPECTION**

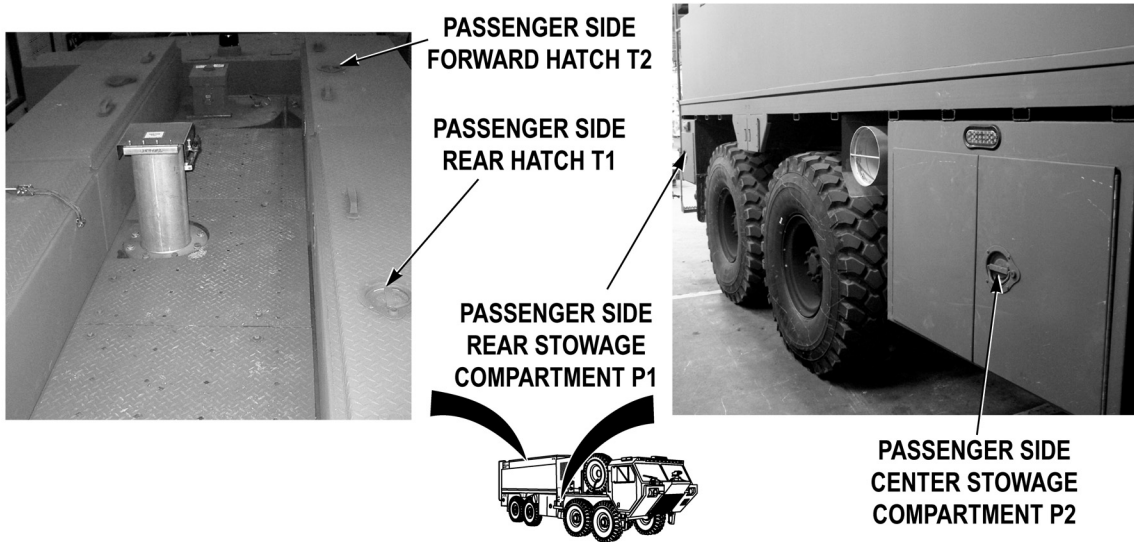
**CORRECTIVE ACTION**

**PASSENGER SIDE STOWAGE COMPARTMENT STRIPLIGHT(S) DOES NOT OPERATE**

---

**MALFUNCTION**  
**TEST OR INSPECTION**  
**CORRECTIVE ACTION**

---



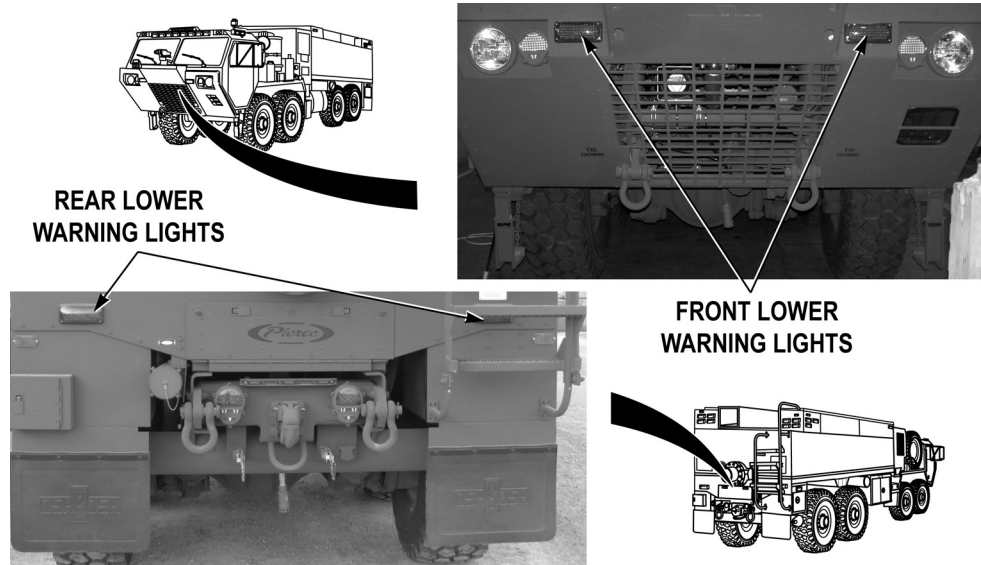
Step 1. Push battery disconnect switch to on position (WP 0007). Turn Service Drive Lights On (TM 9-2320-422-10). Open all passenger side compartment doors and hatches (WP 0008). Check if at least one passenger side stowage compartment striplight operates.

If at least one passenger side stowage compartment striplight operates, go to Step 5.

---

**MALFUNCTION**  
**TEST OR INSPECTION**  
**CORRECTIVE ACTION**

---



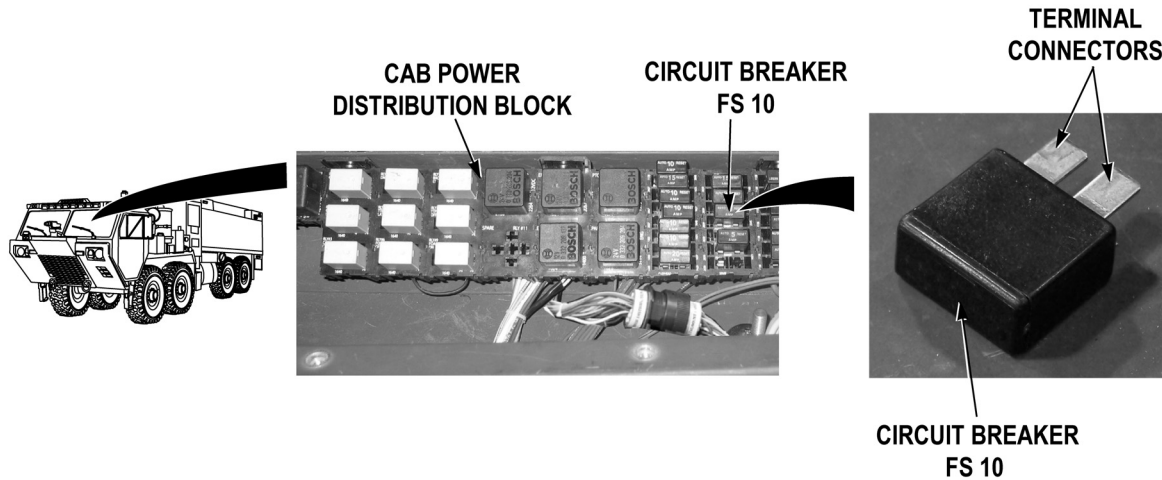
Step 2. Put EMERG MASTER and F/R LOWER WARNING switches to on position (WP 0004). Check if front and rear lower warning lights operate.

If front and rear lower warning lights do not operate, troubleshoot Warning Lights (All) Do Not Operate (WP 0102).

---

<b>MALFUNCTION</b>	<b>TEST OR INSPECTION</b>	<b>CORRECTIVE ACTION</b>
--------------------	---------------------------	--------------------------

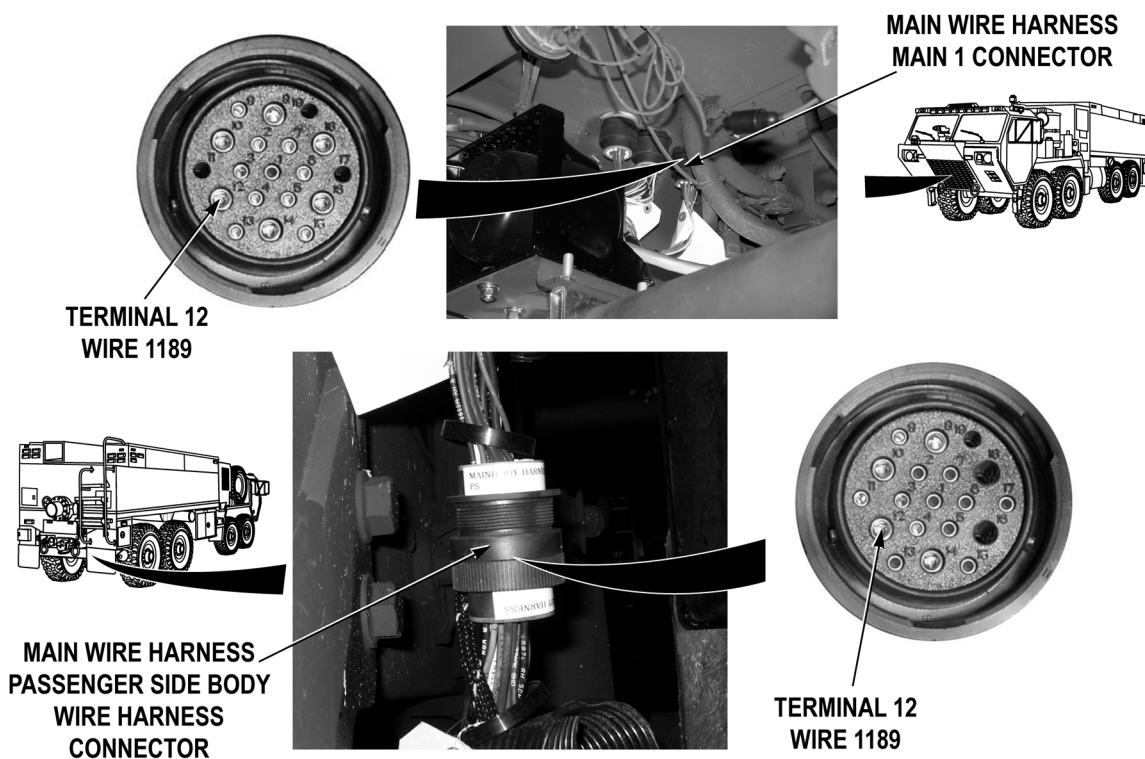
---



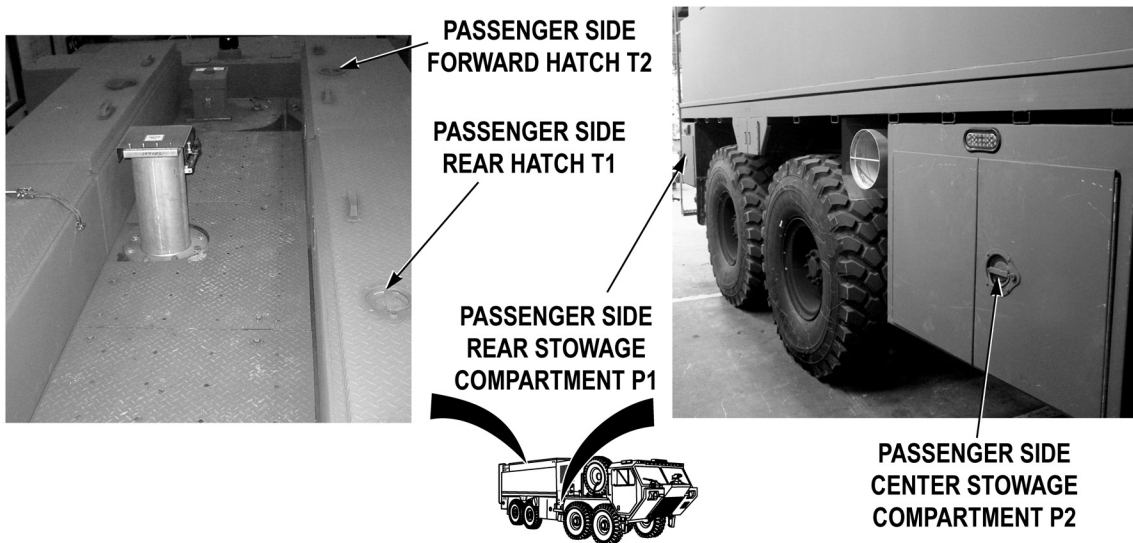
Step 3. PUT EMERG MASTER and F/R LOWER WARNING switches to off position (WP 0004). Turn Service Drive Lights Off (TM 9-2320-422-10). Pull battery disconnect switch to off position (WP 0007). Remove circuit breaker FS 10 (WP 0242). Check for continuity across circuit breaker terminal connectors.

If there is no continuity, replace circuit breaker FS 10 (WP 0242).

MALFUNCTION	TEST OR INSPECTION	CORRECTIVE ACTION
-------------	--------------------	-------------------

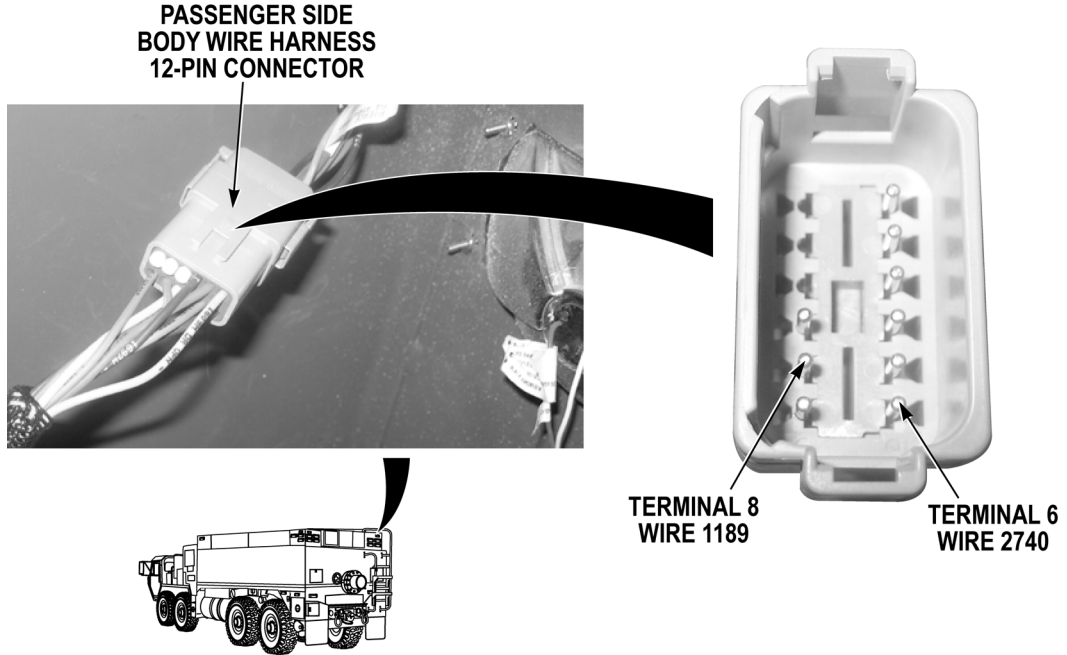


- Step 4. Turn Service Drive Lights Off (TM 9-2320-422-10). Pull battery disconnect switch to off position (WP 0007). Disconnect main wire harness passenger side body wire harness connector. Remove skid plate grille (WP 0349). Disconnect main wire harness main 1 connector. With a test lead set, check for continuity across wire 1189 (red) from main wire harness main 1 connector, terminal 12 to main wire harness passenger side body wire harness connector, terminal 12.
- a. If there is continuity, repair wire 1189 in cab power distribution wire harness if repairable (TM 9-2320-325-14&P), or replace cab power distribution wire harness and block (WP 0280).
  - b. If there is no continuity, repair wire 1189 in main wire harness if repairable (TM 9-2320-325-14&P), or replace main wire harness (WP 0292).

**MALFUNCTION****TEST OR INSPECTION****CORRECTIVE ACTION**

- Step 5. Check if non-operating storage compartment striplight is located in passenger side center storage compartment P2.
- If non-operating storage compartment striplight is located in passenger side center storage compartment P2, go to Step 22.
- Step 6. Check if non-operating storage compartment striplight is located in passenger side rear storage compartment P1.
- If non-operating storage compartment striplight is located in passenger side rear storage compartment P1, go to Step 14.
- Step 7. Check if passenger side top storage compartment striplights operate.
- If one or more passenger side top storage compartment striplights operate, go to Step 10.

MALFUNCTION	TEST OR INSPECTION	CORRECTIVE ACTION
-------------	--------------------	-------------------



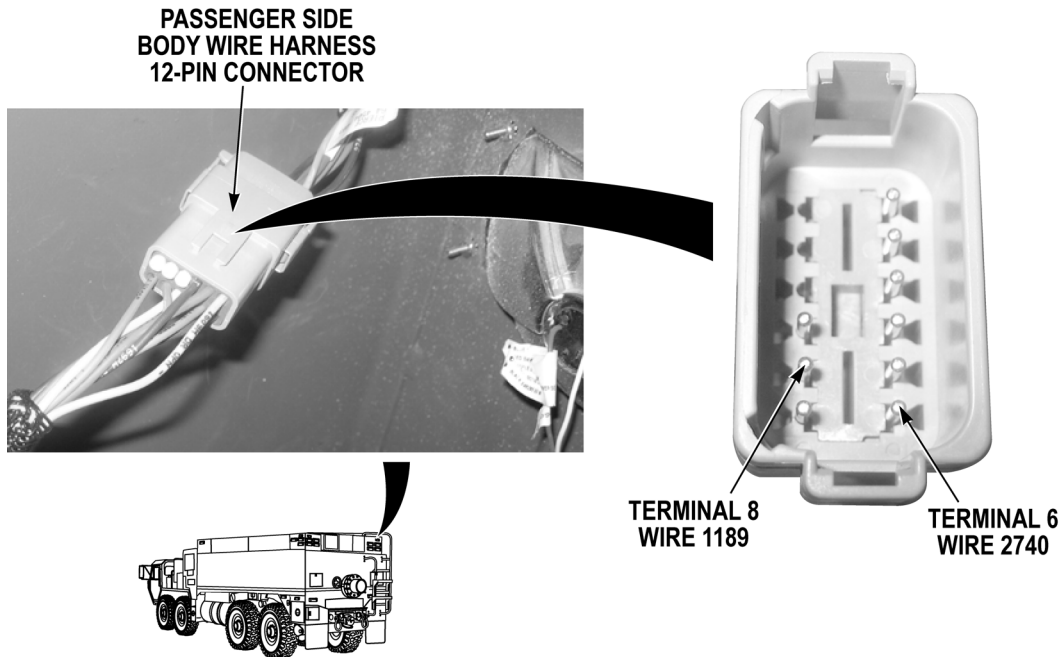
**WARNING**



Remove rings, wristwatches, neck chains, and any other jewelry before working around vehicle. Jewelry can catch on equipment and cause serious injury. Jewelry and tools may short across electrical circuits and cause damage to equipment, or severe burns or electrical shock to personnel.

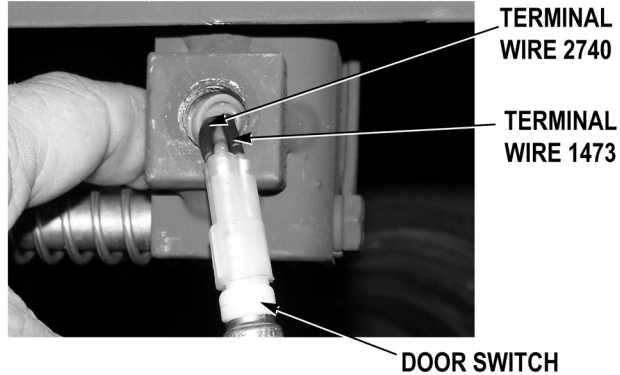
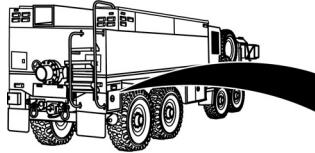
Step 8. Turn Service Drive Lights Off (TM 9-2320-422-10). Pull battery disconnect switch to off position (WP 0007). Disconnect passenger side body wire harness 12-pin connector. Push battery disconnect switch to on position (WP 0007). Turn Service Drive Lights On (TM 9-2320-422-10). With a test lead set, check for 22 to 28 VDC at wire 1189 from passenger side body wire harness 12-pin connector, terminal 8 to a known good ground.

If 22 to 28 VDC are not present, repair wire 1189 in lower passenger side body wire harness if repairable (TM 9-2320-325-14&P), or replace passenger side body wire harness (WP 0298).

**MALFUNCTION****TEST OR INSPECTION****CORRECTIVE ACTION**

- Step 9. Turn Service Drive Lights Off (TM 9-2320-422-10). Pull battery disconnect switch to off position (WP 0007). With a test lead set, check for continuity across wire 2740 from lower body wire harness 12-pin connector, terminal 6 to a known good ground.
- a. If there is continuity, repair wire 2740 in upper passenger side body wire harness if repairable (TM 9-2320-325-14&P), or replace passenger side body wire harness (WP 0298).
  - b. If there is no continuity, repair wire 2740 in lower passenger side body wire harness if repairable (TM 9-2320-325-14&P), or replace passenger side body wire harness (WP 0298).



**MALFUNCTION****TEST OR INSPECTION****CORRECTIVE ACTION****NOTE**

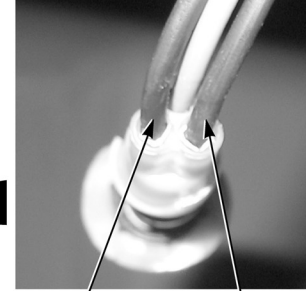
If wire 1472 or 1474 cannot be identified at door switch, measure continuity between both black wire terminals to ground. Continuity should be measured between all terminals, when switch is closed (door switch is not pressed).

- Step 10. Turn Service Drive Lights Off (TM 9-2320-422-10). Pull battery disconnect switch to off position (WP 0007). Remove door switch from passenger side top stowage compartment with non-operating striplight (WP 0246). Do not disconnect wires. Check for continuity between door switch terminal wire 1472 or 1474 (black) and a known good ground when switch is closed (door switch is not pressed).

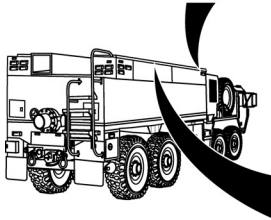
If there is continuity, go to Step 12.

- Step 11. Check for continuity across door switch between terminal wire 1472 or 1474 (black) and terminal wire 2740 (black).
- a. If there is continuity, repair wire 2740 in upper passenger side body wire harness if repairable (TM 9-2320-325-14&P), or replace passenger side body wire harness (WP 0298).
  - b. If there is no continuity, replace door switch (WP 0246).

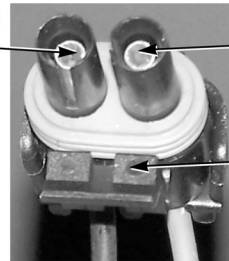
MALFUNCTION	TEST OR INSPECTION	CORRECTIVE ACTION
-------------	--------------------	-------------------



WIRE 1472 OR 1474      WIRE 2740



TERMINAL B  
WIRE 1472  
OR 1474



TERMINAL A  
WIRE 1189  
PASSENGER  
SIDE BODY  
WIRE HARNESS  
STOWAGE  
COMPARTMENT  
STRIPLIGHT  
CONNECTOR

Step 12. Disconnect non-operating passenger side body wire harness stowage compartment striplight connector. Check for continuity across upper passenger side body wire harness wire 1472 or 1474 (black) from passenger side top stowage compartment striplight connector, terminal B to non-operating passenger side top stowage compartment door switch connector.

If there is no continuity, repair wire 1472 or 1474 in upper passenger side body wire harness if repairable (TM 9-2320-325-14&P), or replace passenger side body wire harness (WP 0298).

---

**MALFUNCTION****TEST OR INSPECTION****CORRECTIVE ACTION**

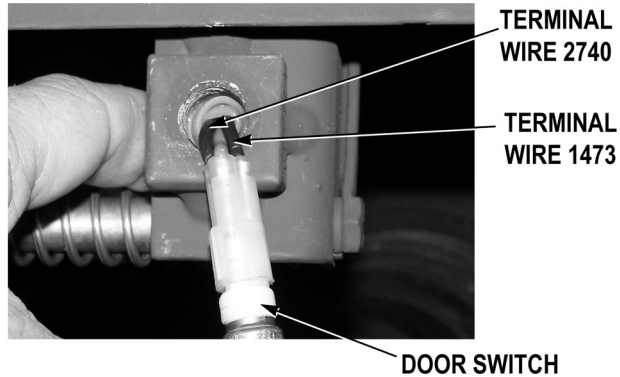
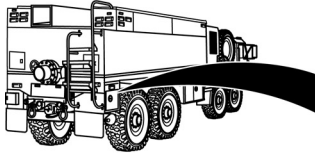
---

**WARNING**

**Remove rings, wristwatches, neck chains, and any other jewelry before working around vehicle. Jewelry can catch on equipment and cause serious injury. Jewelry and tools may short across electrical circuits and cause damage to equipment, or severe burns or electrical shock to personnel.**

- Step 13. Push battery disconnect switch to on position (WP 0007). Turn Service Drive Lights On (TM 9-2320-422-10). Check for 22 to 28 VDC between wire 1189 (red) at non-operating passenger side body wire harness stowage compartment striplight connector, terminal A and a known good ground.
- a. If 22 to 28 VDC are present, replace stowage compartment striplight (WP 0215).
  - b. If 22 to 28 VDC are not present, repair wire 1189 in upper passenger side body wire harness if repairable (TM 9-2320-325-14&P), or replace passenger side body wire harness (WP 0298).
- Step 14. Check if passenger side top stowage compartment striplights operate.
- If passenger side top stowage compartment striplights do not operate, go to Step 20.

MALFUNCTION	TEST OR INSPECTION	CORRECTIVE ACTION
-------------	--------------------	-------------------



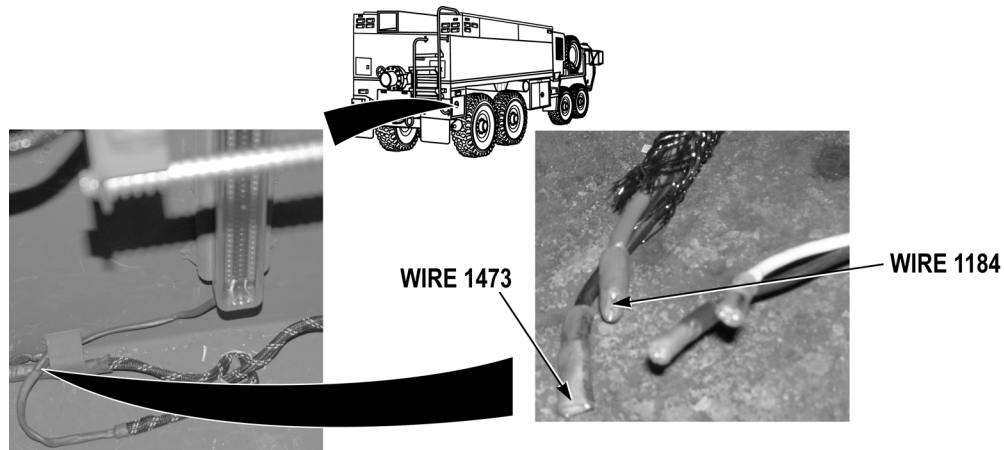
### NOTE

If wire 1473 cannot be identified at door switch, measure continuity between both black wire terminals to ground. Continuity should be measured between all terminals, when switch is closed (door switch is not pressed).

- Step 15. Turn Service Drive Lights OFF(TM 9-2320-422-10). Pull battery disconnect switch to off position (WP 0007). Remove door switch from passenger side rear stowage compartment P1 (WP 0246). Do not disconnect wires. Check for continuity between door switch terminal wire 1473 (black) and a known good ground when switch is closed (door switch is not pressed).

If there is continuity, go to Step 17.

- Step 16. Check for continuity across passenger side rear stowage compartment P1 door switch between terminal wire 1473 (black) and terminal wire 2740 (black).
- If there is continuity, repair wire 2740 in lower passenger side body wire harness if repairable (TM 9-2320-325-14&P), or replace lower passenger side body wire harness (WP 0298).
  - If there is no continuity, replace passenger side rear stowage compartment P1 door switch (WP 0246).

**MALFUNCTION****TEST OR INSPECTION****CORRECTIVE ACTION**

- Step 17. Cut passenger side body wire harness stowage compartment striplight butt splice connector wire 1473. Check for continuity across passenger side body wire harness wire 1473 (black) from passenger side rear stowage compartment striplight butt splice connector termination to passenger side rear stowage compartment P1 door switch connector.

If there is no continuity, repair wire 1473 in lower passenger side body wire harness if repairable (TM 9-2320-325-14&P), or replace lower passenger side body wire harness (WP 0298).

**WARNING**

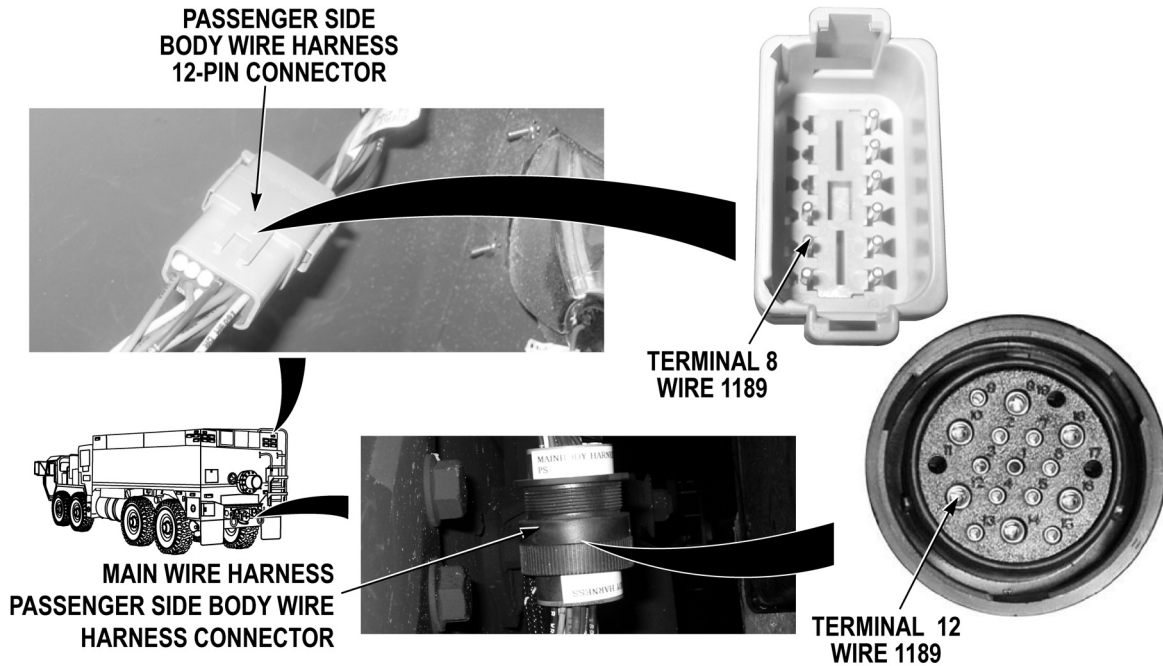
**Remove rings, wristwatches, neck chains, and any other jewelry before working around vehicle. Jewelry can catch on equipment and cause serious injury. Jewelry and tools may short across electrical circuits and cause damage to equipment, or severe burns or electrical shock to personnel.**

- Step 18. Repair passenger side body wire harness wire 1473. Cut passenger side body wire harness stowage compartment striplight butt splice connector wire 1189. Push battery disconnect switch to on position (WP 0007). Turn Service Drive Lights On (TM 9-2320-422-10). Check for 22 to 28 VDC between wire 1189 (red) at passenger side body wire harness stowage compartment P1 striplight connector termination and a known good ground.
- a. If 22 to 28 VDC are present, replace stowage compartment striplight (WP 0215).
  - b. If 22 to 28 VDC are not present, repair wire 1189 in lower passenger side body wire harness if repairable (TM 9-2320-325-14&P), or replace passenger side body wire harness (WP 0298).

**MALFUNCTION**

**TEST OR INSPECTION**

**CORRECTIVE ACTION**



**WARNING**



Remove rings, wristwatches, neck chains, and any other jewelry before working around vehicle. Jewelry can catch on equipment and cause serious injury. Jewelry and tools may short across electrical circuits and cause damage to equipment, or severe burns or electrical shock to personnel.

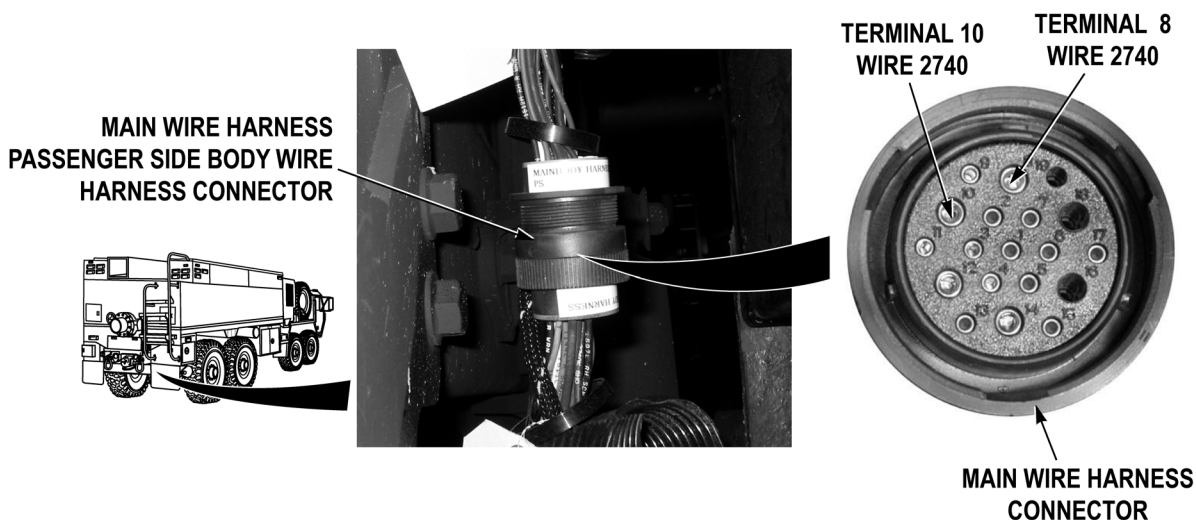
Step 19. Turn Service Drive Lights Off (TM 9-2320-422-10). Pull battery disconnect switch to off position (WP 0007). Disconnect passenger side body wire harness 12-pin connector. Pull battery disconnect switch to on position (WP 0007). Turn Service Drive Lights On (TM 9-2320-422-10). With a test lead set, check for 22 to 28 VDC between wire 1189 from passenger side body wire harness 12-pin connector, terminal 8 to a known good ground.

If 22 to 28 VDC are not, repair wire 1189 in upper passenger side body wire harness if repairable (TM 9-2320-325-14&P), or replace passenger side body wire harness (WP 0298).

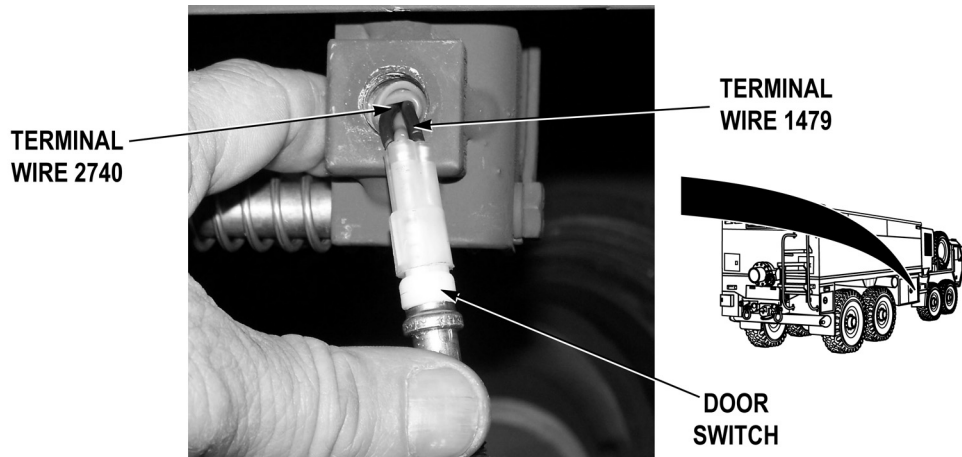
**MALFUNCTION****TEST OR INSPECTION****CORRECTIVE ACTION**

Step 20. Turn Service Drive Lights Off (TM 9-2320-422-10). Pull battery disconnect switch to off position (WP 0007). Disconnect main wire harness passenger side body wire harness connector. Pull battery disconnect switch to on position (WP 0007). Turn Service Drive Lights On (TM 9-2320-422-10). With a test lead set, check for 22 to 28 VDC between wire 1189 at main wire harness passenger side body wire harness connector, terminal 12 and a known good ground.

If 22 to 28 VDC are not present, repair wire 1189 in main wire harness if repairable (TM 9-2320-325-14&P), or replace main wire harness (WP 0292).



- Step 21. With a test lead set, check for continuity across wire 2740 from main wire harness passenger side body wire harness, terminals 8 and 10 to a known good ground.
- If there is continuity, repair wire 2740 in passenger side body wire harness if repairable (TM 9-2320-325-14&P), or replace passenger side body wire harness (WP 0298)
  - If there is no continuity, repair wire 2740 in main wire harness if repairable (TM 9-2320-325-14&P), or replace main harness (WP 0298).

**MALFUNCTION****TEST OR INSPECTION****CORRECTIVE ACTION****NOTE**

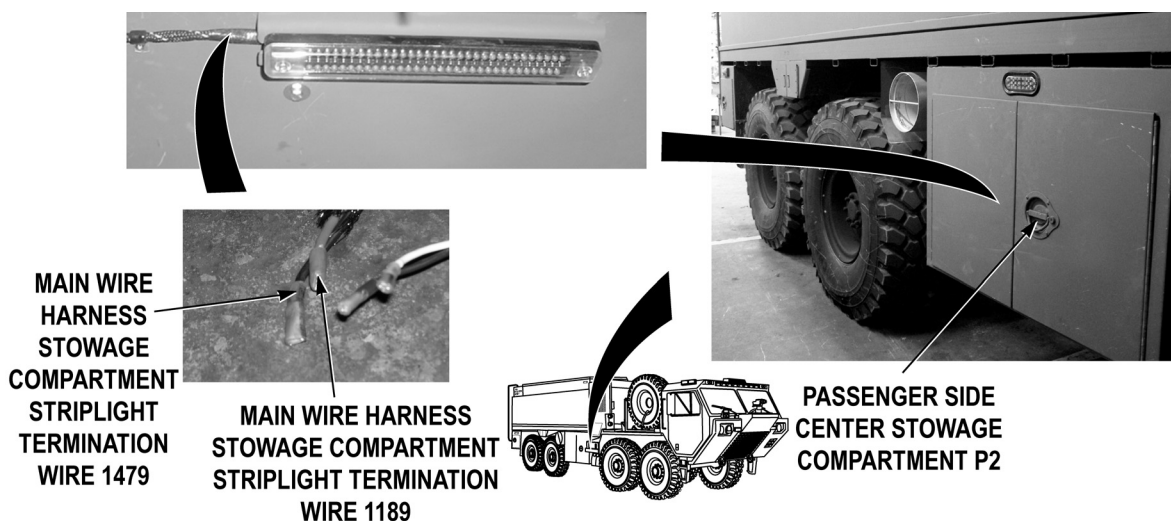
If wire 1479 cannot be identified at door switch, measure continuity between both black wire terminals to ground. Continuity should be measured between all terminals, when switch is closed (door switch is not pressed).

- Step 22. Turn Service Drive Lights Off (TM 9-2320-422-10). Pull battery disconnect switch to off position (WP 0007). Remove door switch from passenger side front stowage compartment P2 (WP 0246). Do not disconnect wires. Check for continuity between door switch terminal wire 1479 (black) and a known good ground when switch is closed (door switch is not pressed).

If there is continuity, go to Step 24.

- Step 23. Check for continuity across passenger side front stowage compartment P2 door switch between terminal wire 1479 (black) and terminal wire 2740 (black).
- a. If there is continuity, repair wire 2740 in main wire harness if repairable (TM 9-2320-325-14&P), or replace main wire harness (WP 0292).
  - b. If there is no continuity, replace passenger side front stowage compartment P2 door switch (WP 0246).



**MALFUNCTION****TEST OR INSPECTION****CORRECTIVE ACTION**

- Step 24. Cut main wire harness storage compartment striplight butt splice connector. Check for continuity across main wire harness wire 1479 (black) from main storage compartment P2 striplight connector termination to passenger side front storage compartment P2 door switch connector.

If there is no continuity, repair wire 1472 in main wire harness if repairable (TM 9-2320-325-14&P), or replace main wire harness (WP 0292).

**WARNING**

**Remove rings, wristwatches, neck chains, and any other jewelry before working around vehicle. Jewelry can catch on equipment and cause serious injury. Jewelry and tools may short across electrical circuits and cause damage to equipment, or severe burns or electrical shock to personnel.**

- Step 25. Cut main wire harness wire 1189 at non-operating passenger side storage compartment P2 striplight butt splice connector. Push battery disconnect switch to on position (WP 0007). Turn Service Drive Lights On (TM 9-2320-422-10). Check for 22 to 28 VDC between wire 1189 (red) at main wire harness storage compartment striplight connector termination and a known good ground.
- If 22 to 28 VDC are present, replace storage compartment striplight (WP 0215).
  - If 22 to 28 VDC are not present, repair wire 1189 in main wire harness if repairable (TM 9-2320-325-14&P), or replace main wire harness (WP 0292).

**END OF TASK**

**FOLLOW-ON MAINTENANCE**

Remove wheel chocks (TM 9-2320-422-10)

**END OF TASK**

**END OF WORK PACKAGE**

## FIELD LEVEL MAINTENANCE

## PUMP HOUSE OR PUMP OPERATOR'S PANEL STRIPLIGHT(S) DOES NOT OPERATE

## INITIAL SETUP:

**Tools and Special Tools**

Lead Set, Test (WP 0398, Item 14)  
 Tool Kit, General Mechanic's: Automotive  
 (WP 0398, Item 17)

**References**

TM 9-2320-325-14&P  
 WP 0004  
 WP 0007  
 WP 0010  
 WP 0205  
 WP 0207  
 WP 0215

**References (continued)**

WP 0220  
 WP 0242  
 WP 0280  
 WP 0292  
 WP 0302  
 WP 0303

**Equipment Conditions**

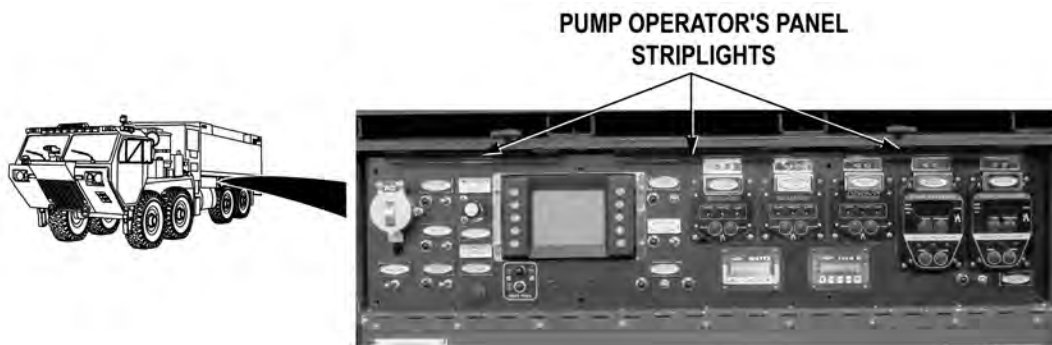
Engine OFF (TM 9-2320-422-10)  
 Wheels chocked (TM 9-2320-422-10)

## MALFUNCTION

## TEST OR INSPECTION

## CORRECTIVE ACTION

## PUMP HOUSE OR PUMP OPERATOR'S PANEL STRIPLIGHT(S) DOES NOT OPERATE

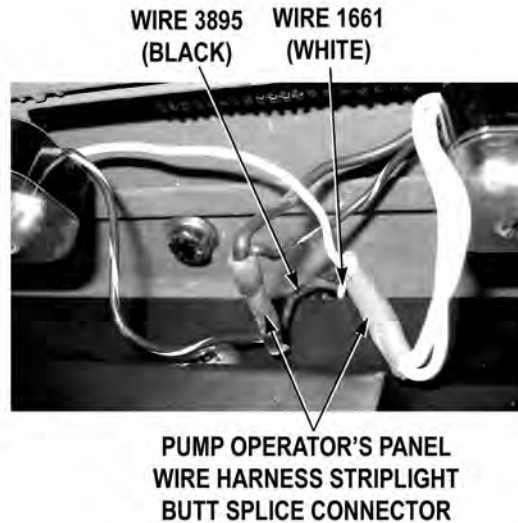


Step 1. Push battery disconnect switch to on position (WP 0007). Open pump operator's panel cover (WP 0010). Put pump operator's panel PANEL LIGHTS switch to on position (WP 0004). Check if all pump operator's panel striplights operate.

If all pump operator's panel striplights operate, go to Step 5.

Step 2. Check if any pump operator's panel striplights operate.

If all pump operator's panel striplights do not operate, go to Step 14.

**MALFUNCTION****TEST OR INSPECTION****CORRECTIVE ACTION****WARNING**

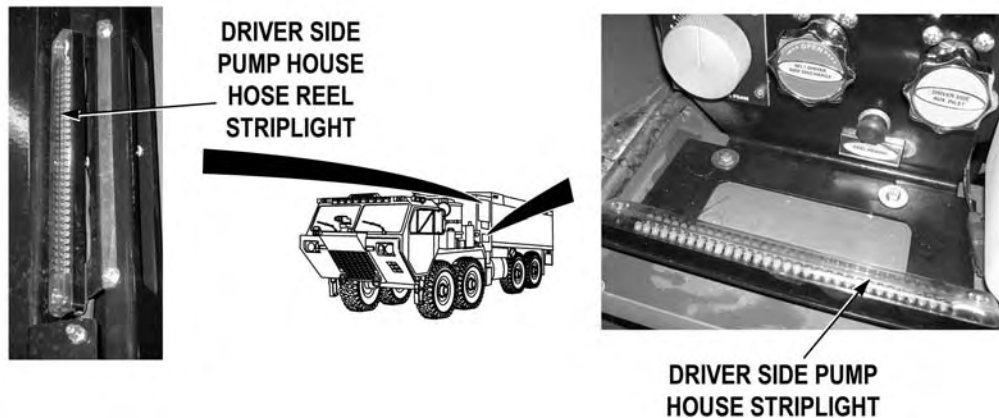
**Remove rings, wristwatches, neck chains, and any other jewelry before working around vehicle. Jewelry can catch on equipment and cause serious injury. Jewelry and tools may short across electrical circuits and cause damage to equipment, or severe burns or electrical shock to personnel.**

- Step 3. Pull battery disconnect switch to off position (WP 0007). Open pump operator's panel (WP 0207). Cut wire 1661 (black) in pump operator's panel wire harness striplight butt splice connector from non-operating pump operator's panel striplight. Push battery disconnect switch to on position (WP 0007). Check for 22 to 28 VDC between pump operator's panel wire harness wire 1661 (black) at striplight butt splice connector termination and known good ground.

If 22 to 28 VDC are not present, repair wire 1661 in pump operator's panel wire harness if repairable (TM 9-2320-325-14&P), or replace pump operator's panel wire harness (WP 0303).

**MALFUNCTION****TEST OR INSPECTION****CORRECTIVE ACTION**

- Step 4. Put pump operator's panel PANEL LIGHTS switch to off position (WP 0004). Pull battery disconnect switch to off position (WP 0007). Cut wire 3895 (black) in pump operator's panel wire harness striplight butt splice connector from non-operating pump operator's panel striplight. Check for continuity across pump operator's panel wire harness wire 3895 (black) from striplight butt splice connector termination to a known good ground.
- If there is continuity, replace non-operating pump operator's panel striplight (WP 0215).
  - If there is no continuity, repair wire 3895 in pump operator's panel wire harness if repairable (TM 9-2320-325-14&P), or replace pump operator's panel wire harness (WP 0303).



- Step 5. Open pump house access door assembly (WP 0009). Open driver side pump house control access door (WP 0008). Check if both driver side pump house striplights operate.

If driver side pump house striplights do not operate, go to Step 8.

**MALFUNCTION****TEST OR INSPECTION****CORRECTIVE ACTION**

- Step 6. Disconnect pump house wire harness passenger side striplight connector. With a test lead set, check for 22 to 28 VDC between pump house wire harness wire 1661 (black) at striplight connector, terminal A and a known good ground.

If 22 to 24 VDC are not present, repair wire 1661 in pump house wire harness if repairable (TM 9-2320-325-14&P), or replace pump house wire harness (WP 0302).

- Step 7. Put pump operator's panel PANEL LIGHTS switch to off position (WP 0004). Pull battery disconnect switch to off position (WP 0007). With a test lead set, check for continuity across pump house wire harness wire 2740 (black) from passenger side striplight connector, terminal B to a known good ground.
- a. If there is continuity, replace passenger side pump house striplight (WP 0215).
  - b. If there is no continuity, repair wire 2740 in pump house wire harness if repairable (TM 9-2320-325-14&P), or replace pump house wire harness (WP 0302).

**NOTE**

Step 8 will check if pump house wire harness is receiving power. If passenger side pump house striplight operate, Step 9 and Step 10 will assist in determining where power is lost to driver side striplights.

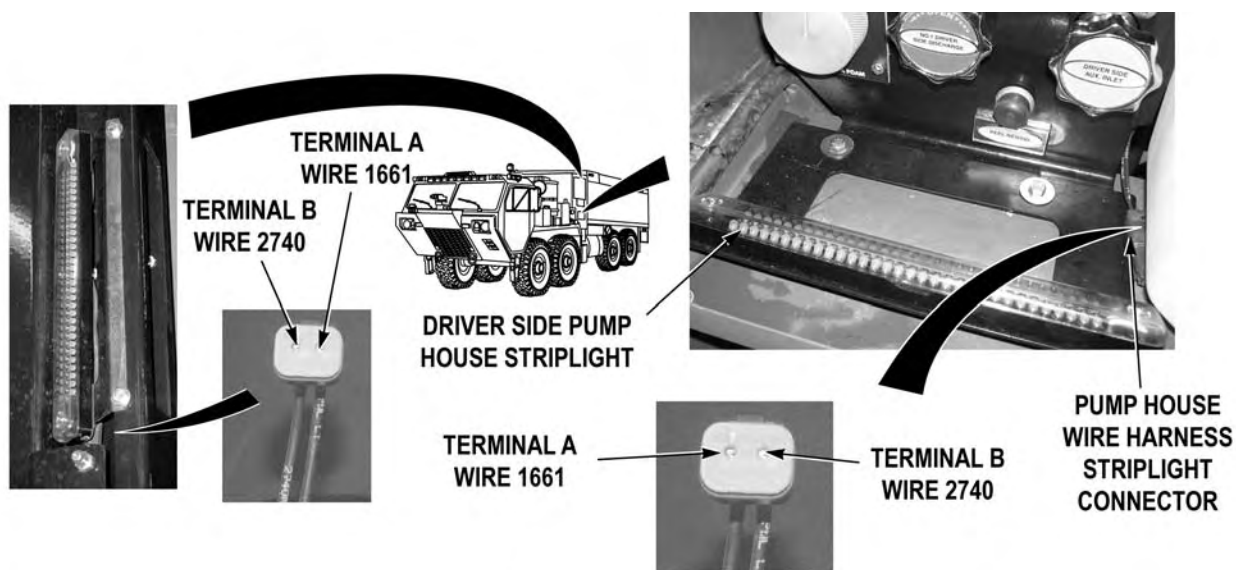
- Step 8. Open passenger side pump house control access door (WP 0008). Check if passenger side pump house striplight operates.

If passenger side pump house striplight does not operate, go to Step 11.

## MALFUNCTION

## TEST OR INSPECTION

## CORRECTIVE ACTION

**WARNING**

Remove rings, wristwatches, neck chains, and any other jewelry before working around vehicle. Jewelry can catch on equipment and cause serious injury. Jewelry and tools may short across electrical circuits and cause damage to equipment, or severe burns or electrical shock to personnel.

- Step 9. Disconnect pump house wire harness striplight connector from either driver side pump house striplight. With a test lead set, check for 22 to 28 VDC between pump house wire harness wire 1661 (black) at driver side striplight connector, terminal A and a known good ground.

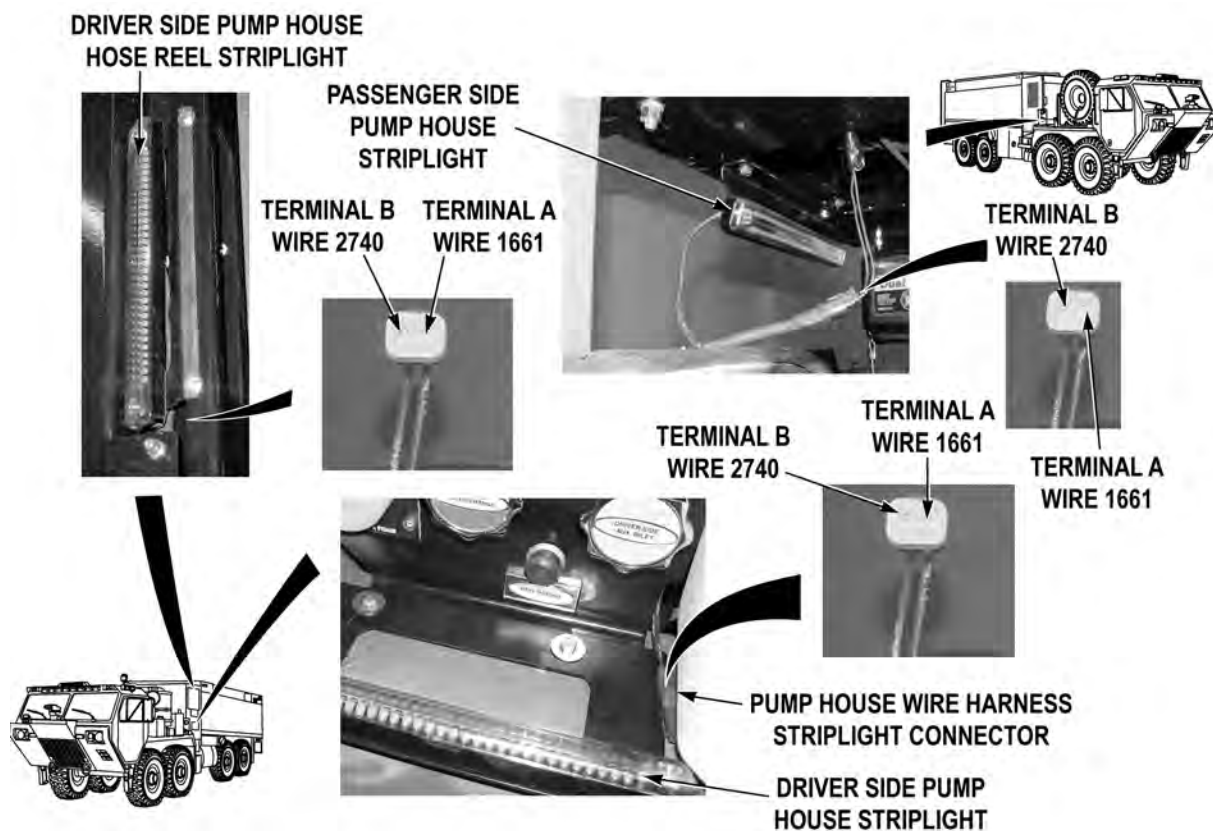
If 22 to 28 VDC are not present, repair wire 1661 in pump house wire harness if repairable (TM 9-2320-325-14&P), or replace pump house wire harness (WP 0302).

- Step 10. Put pump operator's panel PANEL LIGHTS switch to off position (WP 0004). Pull battery disconnect switch to off position (WP 0007). With a test lead set, check for continuity across pump house wire harness wire 2740 (black) from driver side striplight connector, terminal B to a known good ground.
- a. If there is continuity, replace pump house striplight (WP 0215).
  - b. If there is no continuity, repair wire 2740 in pump house wire harness if repairable (TM 9-2320-325-14&P), or replace pump house wire harness (WP 0302).

**MALFUNCTION**

**TEST OR INSPECTION**

**CORRECTIVE ACTION**



**WARNING**



**Remove rings, wristwatches, neck chains, and any other jewelry before working around vehicle. Jewelry can catch on equipment and cause serious injury. Jewelry and tools may short across electrical circuits and cause damage to equipment, or severe burns or electrical shock to personnel.**

- Step 11. Put pump operator's panel PANEL LIGHTS switch to off position (WP 0004). Pull battery disconnect switch to off position (WP 0007). Disconnect any pump house striplight connector. With a lead test set, check for continuity across pump house wire harness wire 2740 (black) from striplight connector, terminal B to a known good ground.

If there is no continuity, repair wire 2740 in pump house wire harness if repairable (TM 9-2320-325-14&P), or replace pump house wire harness (WP 0302).



**MALFUNCTION****TEST OR INSPECTION****CORRECTIVE ACTION**

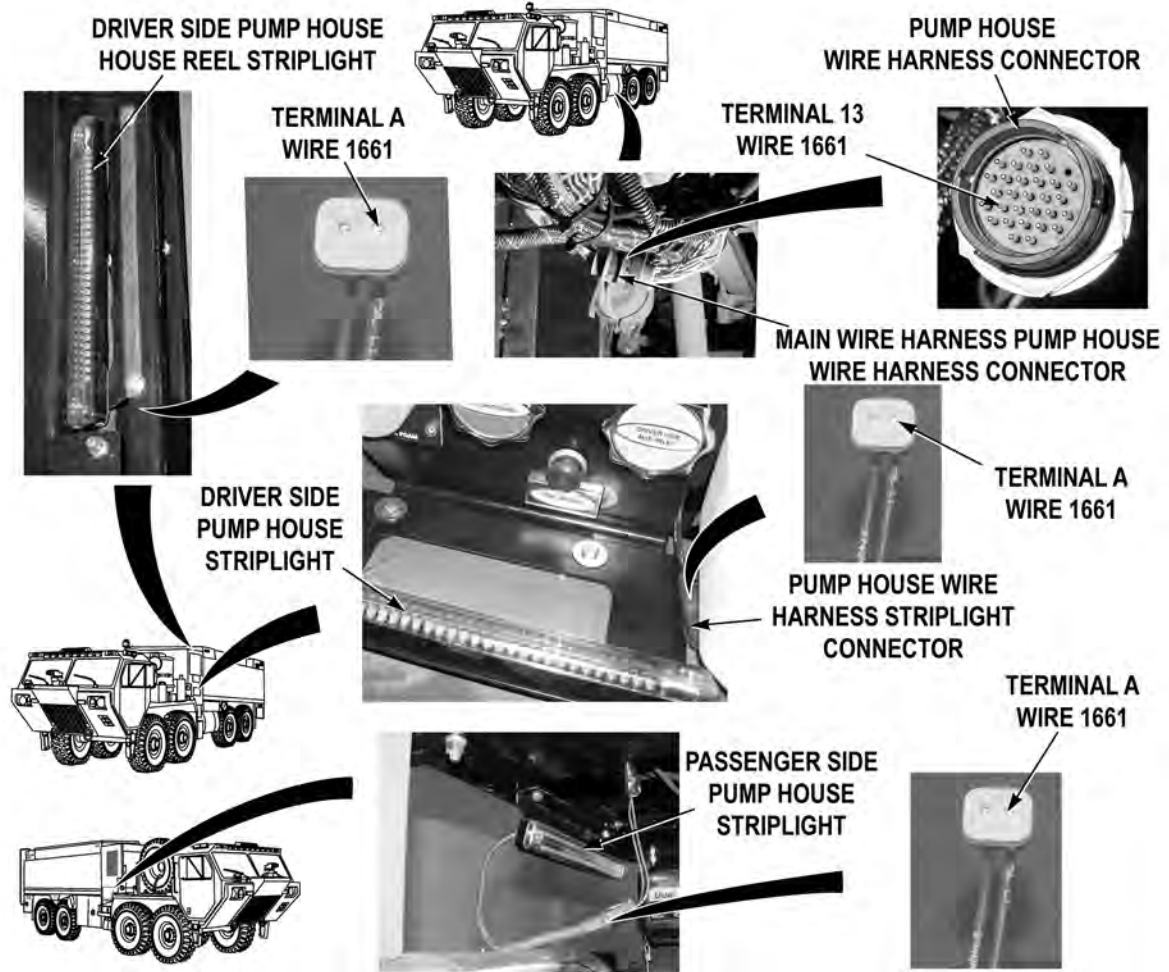
- Step 12. Disconnect main wire harness pump operator's panel 11-pin wire harness connector. With a test lead set, check for continuity across wire 1661 (black) from main wire harness pump operator's panel 11-pin wire harness connector, terminal G to disconnected pump house wire harness striplight connector, terminal A.

If there is continuity, repair wire 1661 in pump operator's panel wire harness if repairable (TM 9-2320-325-14&P), or replace pump operator's panel wire harness (WP 0303).

**MALFUNCTION**

**TEST OR INSPECTION**

**CORRECTIVE ACTION**

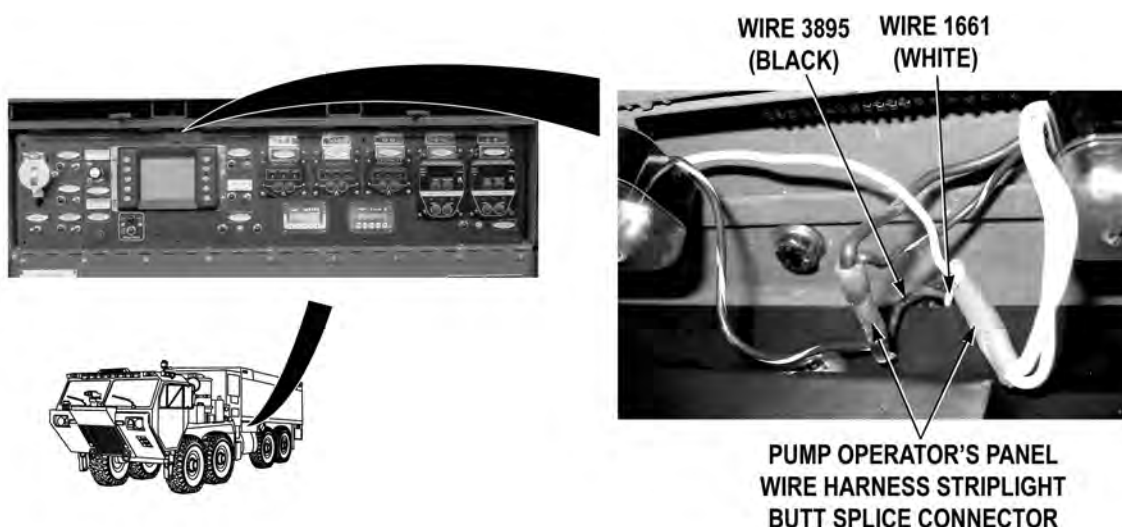


- Step 13. Disconnect main wire harness pump house wire harness connector. With a test lead set, check for continuity across pump house wire harness wire 1661 (black) from pump house wire harness connector, terminal 13 to striplight connector, terminal A.
- a. If there is continuity, repair wire 1661 in main wire harness if repairable (TM 9-2320-325-14&P), or replace main wire harness (WP 0292).
  - b. If there is no continuity, repair wire 1661 in pump house wire harness if repairable (TM 9-2320-325-14&P), or replace pump house wire harness (WP 0302).

Step 14. Check if pump house striplights operate.

If pump house striplights do not operate, go to Step 16.

**MALFUNCTION**  
**TEST OR INSPECTION**  
**CORRECTIVE ACTION**

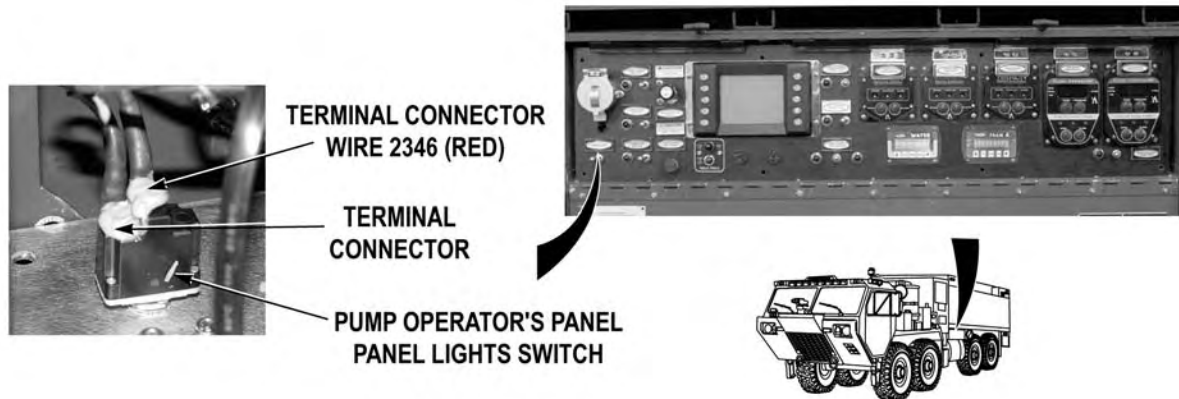


- Step 15. Put pump operator's panel PANEL LIGHTS switch to off position (WP 0004). Pull battery disconnect switch to off position (WP 0007). Open pump operator's panel (WP 0207). Disconnect pump operator's panel wire harness striplight connector. With a test lead set, check for continuity across pump operator's panel wire harness wire 3895 (black) from striplight connector terminal B, to a known good ground.
- a. If there is continuity, repair wire 1661 in pump operator's panel wire harness if repairable (TM 9-2320-325-14&P), or replace pump operator's panel wire harness (WP 0303).
  - b. If there is no continuity, repair wire 3895 in pump operator's panel wire harness if repairable (TM 9-2320-325-14&P), or replace pump operator's panel wire harness (WP 0303).



- Step 16. Pull battery disconnect switch to off position (WP 0007). Remove cab instrument panel A (WP 0205). Remove circuit breaker 6 (WP 0242). Check for continuity across circuit breaker.

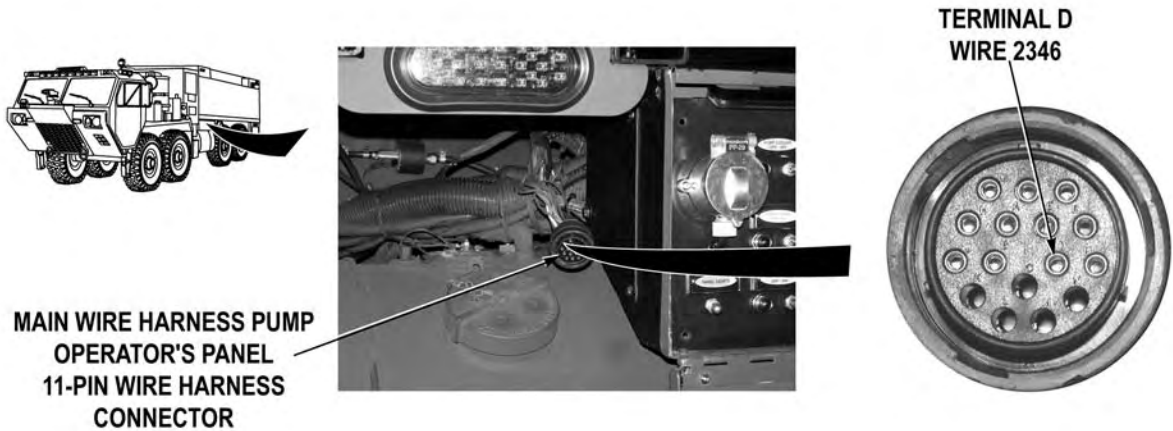
If there is no continuity, replace circuit breaker 6 (WP 0242).

**MALFUNCTION****TEST OR INSPECTION****CORRECTIVE ACTION**

- Step 17. Install circuit breaker 6 (WP 0242). Open pump operator's panel (WP 0207). Push battery disconnect switch to on position (WP 0007). Check for 22 to 28 VDC between pump operator's panel wire harness wire 2346 (red) at PANEL LIGHTS switch terminal connector, and a known good ground.

If 22 to 28 VDC are not present, go to Step 19.

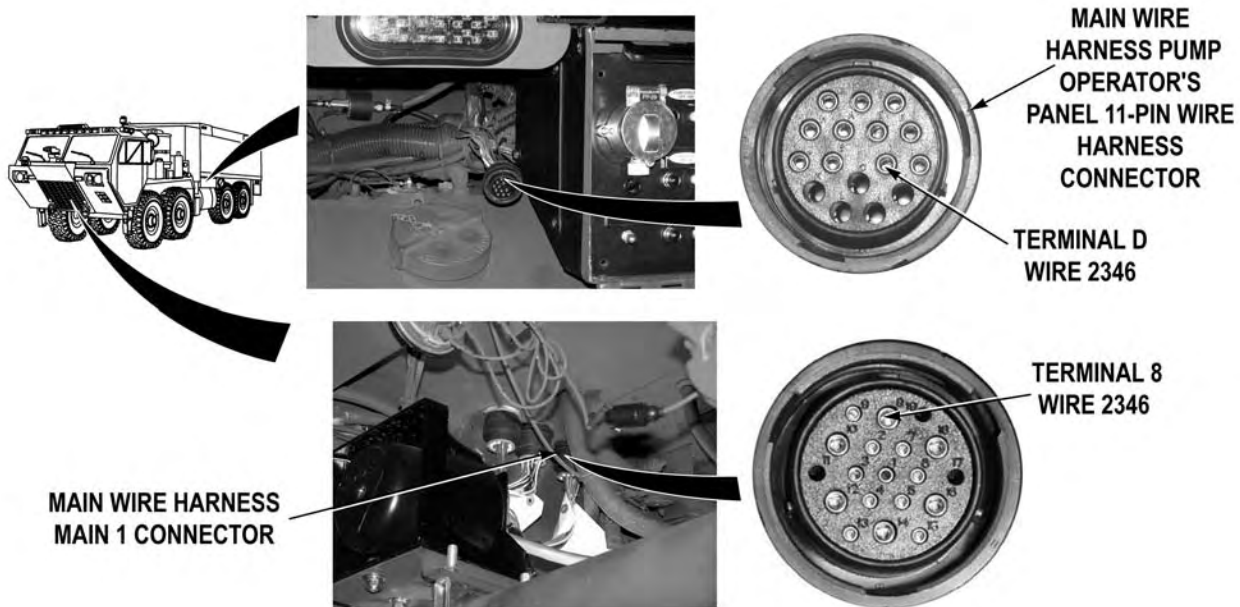
- Step 18. Pull battery disconnect switch to off position (WP 0007). Check for continuity across PANEL LIGHTS switch from terminal connector to terminal connector, when switch is put to on position.
- a. If there is continuity, repair wire 1661 in pump operator's panel wire harness if repairable (TM 9-2320-325-14&P), or replace pump operator's panel wire harness (WP 0303).
  - b. If there is no continuity, replace PANEL LIGHTS switch (WP 0220).

**MALFUNCTION****TEST OR INSPECTION****CORRECTIVE ACTION****WARNING**

**Remove rings, wristwatches, neck chains, and any other jewelry before working around vehicle. Jewelry can catch on equipment and cause serious injury. Jewelry and tools may short across electrical circuits and cause damage to equipment, or severe burns or electrical shock to personnel.**

- Step 19. Disconnect main wire harness pump operator's panel 11-pin wire harness connector. With a test lead set, check for 22 to 28 VDC between main wire harness wire 2346 (red) at main wire harness pump operator's panel 11-pin wire harness connector, terminal D and a known good ground.

If 22 to 28 VDC are present, repair wire 2346 in pump operator's panel wire harness if repairable (TM 9-2320-325-14&P), or replace pump operator's panel wire harness (WP 0303).

**MALFUNCTION****TEST OR INSPECTION****CORRECTIVE ACTION**

- Step 20. Pull battery disconnect switch to off position (WP 0007). Remove skid plate grille (WP 0349). Disconnect main wire harness main 1 connector. With a test lead set, check for continuity across main wire harness wire 2346 (red) from main 1 connector, terminal 8 to main wire harness pump operator's panel 11-pin wire harness connector, terminal D.
- a. If there is continuity, repair wire 2346 in cab power distribution wire harness if repairable (TM 9-2320-325-14&P), or replace cab power distribution wire harness and block (WP 0280).
  - b. If there is no continuity, repair wire 2346 in main wire harness if repairable (TM 9-2320-325-14&P), or replace main wire harness (WP 0292).

**END OF TASK****FOLLOW-ON MAINTENANCE**

Remove wheel chocks (TM 9-2320-422-10)

**END OF TASK****END OF WORK PACKAGE**

---

**FIELD LEVEL MAINTENANCE**
**REAR STEP BUZZER AUDIO ALARM DOES NOT OPERATE**


---

**INITIAL SETUP:****Tools and Special Tools**

Lead Set, Test (WP 0398, Item 14)  
 Tool Kit, General Mechanic's: Automotive  
 (WP 0398, Item 17)

**Personnel Required**

MOS 63B Wheeled Vehicle Mechanic (2)

**References**

TM 9-2320-325-14&P  
 WP 0004  
 WP 0007  
 WP 0201  
 WP 0202  
 WP 0203

**References (continued)**

WP 0205  
 WP 0242  
 WP 0266  
 WP 0280  
 WP 0286  
 WP 0292

**Equipment Conditions**

Engine OFF (TM 9-2320-422-10)  
 Wheels chocked (TM 9-2320-422-10)

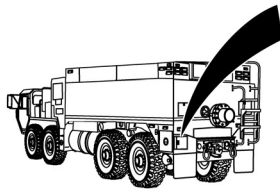
---

**MALFUNCTION****TEST OR INSPECTION****CORRECTIVE ACTION**

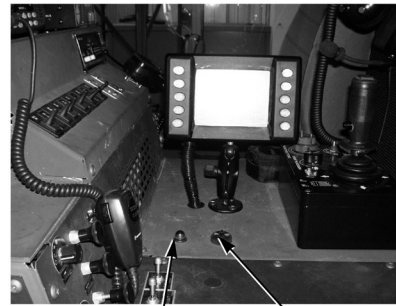

---

**REAR STEP BUZZER AUDIO ALARM DOES NOT OPERATE**

**MALFUNCTION**  
**TEST OR INSPECTION**  
**CORRECTIVE ACTION**



**REAR STEP BUZZER  
 PUSH BUTTON ASSEMBLY**



**REAR STEP BUZZER INDICATOR**  
**REAR STEP BUZZER AUDIO ALARM**

Step 1. Push battery disconnect switch to on position (WP 0007). While an assistant pushes rear step buzzer push button, check if rear step buzzer audio alarm operates (WP 0004).

If rear step buzzer alarm operates, go to Step 9.

Step 2. While an assistant pushes rear step buzzer push button, check if rear step buzzer indicator illuminates.

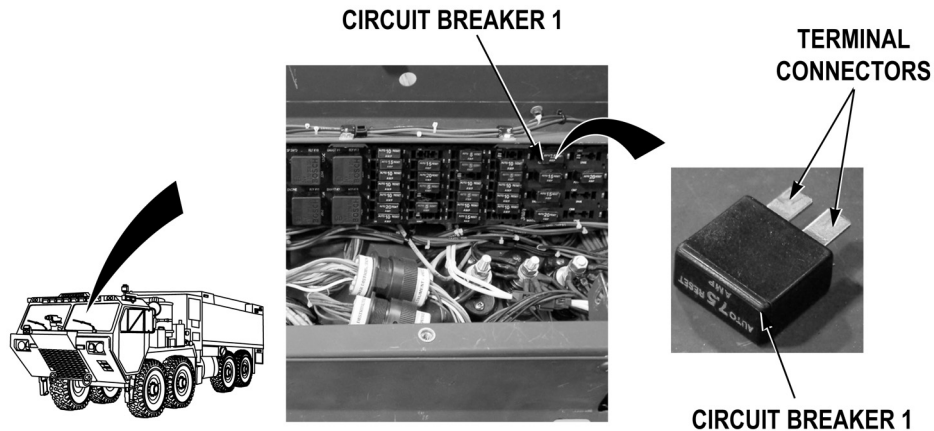
If rear step buzzer indicator illuminates go to Step 11.



---

<b>MALFUNCTION</b>	<b>TEST OR INSPECTION</b>	<b>CORRECTIVE ACTION</b>
--------------------	---------------------------	--------------------------

---

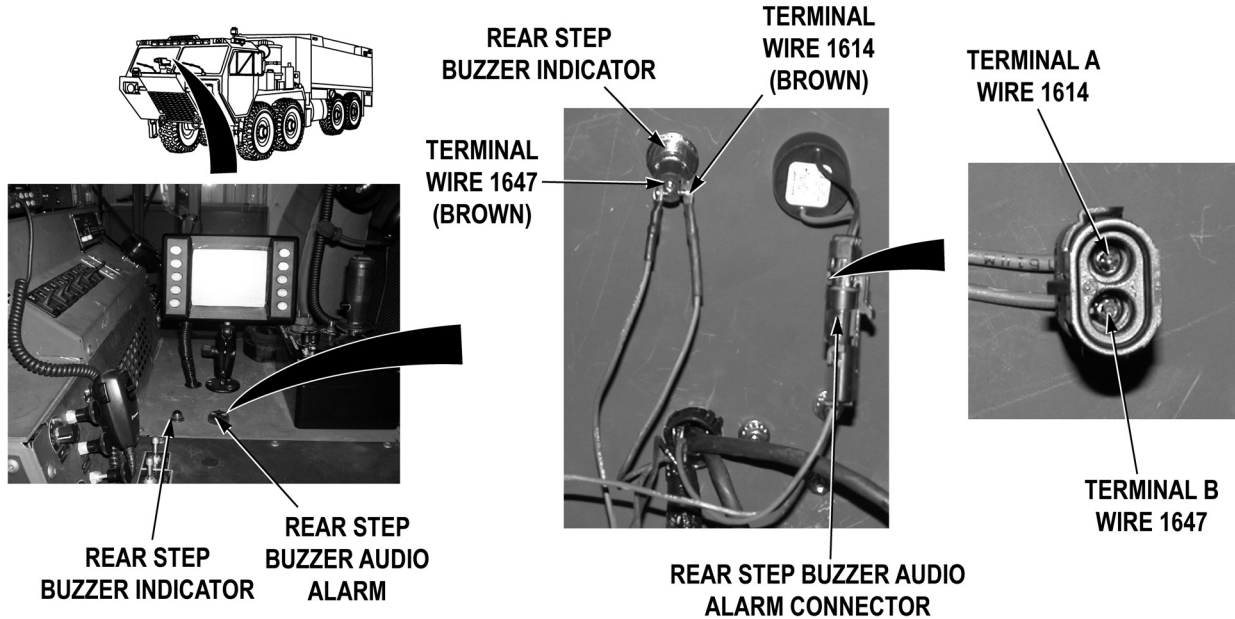
**WARNING**

Remove rings, wristwatches, neck chains, and any other jewelry before working around vehicle. Jewelry can catch on equipment and cause serious injury. Jewelry and tools may short across electrical circuits and cause damage to equipment, or severe burns or electrical shock to personnel.

- Step 3. Pull battery disconnect switch to off position (WP 0007). Remove cab instrument panel A (WP 0205). Remove circuit breaker 1 (WP 0242). Check for continuity across circuit breaker from terminal to terminal.

If there is no continuity, replace circuit breaker 1 (WP 0242).

MALFUNCTION	TEST OR INSPECTION	CORRECTIVE ACTION
-------------	--------------------	-------------------



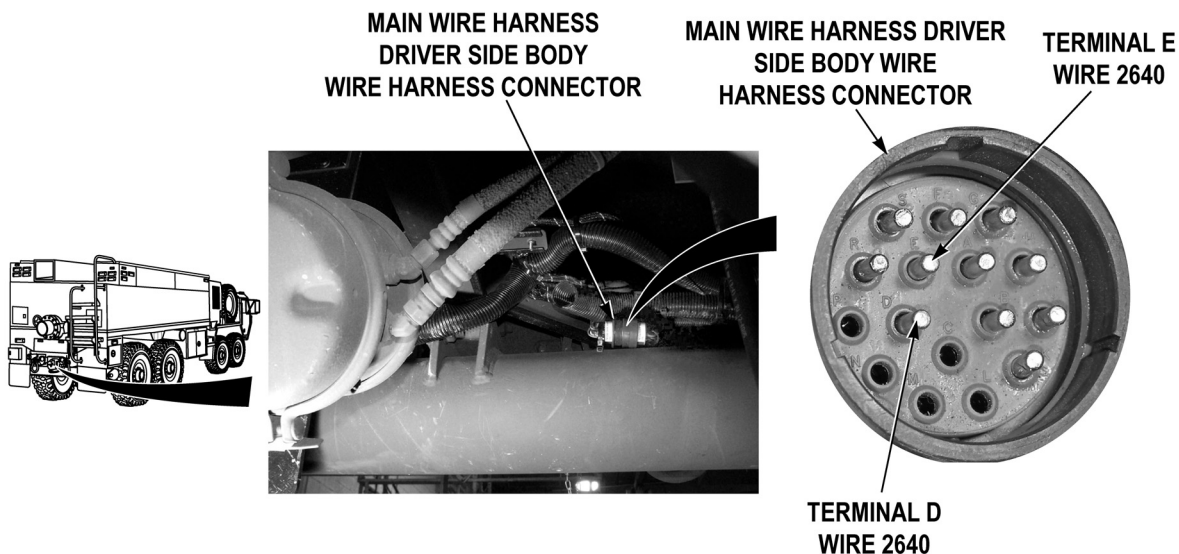
**NOTE**

Rear step buzzer indicator and audio alarm connectors are in contact with two separate wire harnesses. Wire 1647 (brown) originates at cab power distribution wire harness and introduces power into the circuit. Wire 1614 (brown) originates at main wire harness and leads to rear step buzzer push button assembly. When rear step buzzer push button assembly is pushed, a ground is applied to circuit, completing circuit.

- Step 4. Install circuit breaker 1 (WP 0242). Remove cab instrument panel D (WP 0205). Push battery disconnect switch to on position (WP 0007). Disconnect rear step buzzer audio alarm connector. With a test lead set, check for 22 to 28 VDC between cab power distribution wire harness wire 1647 (brown) at rear step buzzer audio alarm connector, terminal B and a known good ground.

If 22 to 28 VDC are not present, repair wire 1647 in cab power distribution wire harness if repairable (TM 9-2320-325-14&P), or replace cab power distribution wire harness and block (WP 0280).

MALFUNCTION	TEST OR INSPECTION	CORRECTIVE ACTION
-------------	--------------------	-------------------



Step 5. Pull battery disconnect switch to off position (WP 0007). Disconnect main wire harness driver side body wire harness connector. With a test lead set, check for continuity across main wire harness wire 2640 (black) from driver side body wire harness connector, terminals D and E to a known good ground.

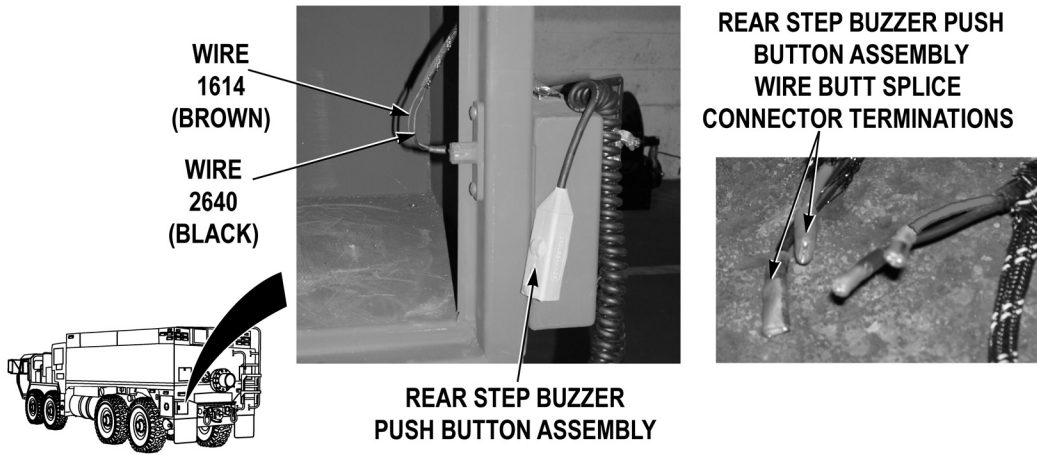
If there is no continuity at either terminal, repair wire 2640 in main wire harness if repairable (TM 9-2320-325-14&P), or replace main wire harness (WP 0292).



Step 6. While an assistant pushes rear step buzzer push button (WP 0004), with a test lead set, check for continuity between main wire harness driver side body wire harness connector, terminals B and D, and then B and E.

If there is continuity between terminals B and D or B and E, repair wire 1614 in main wire harness if repairable (TM 9-2320-325-14&P), or replace main wire harness (WP 0292).

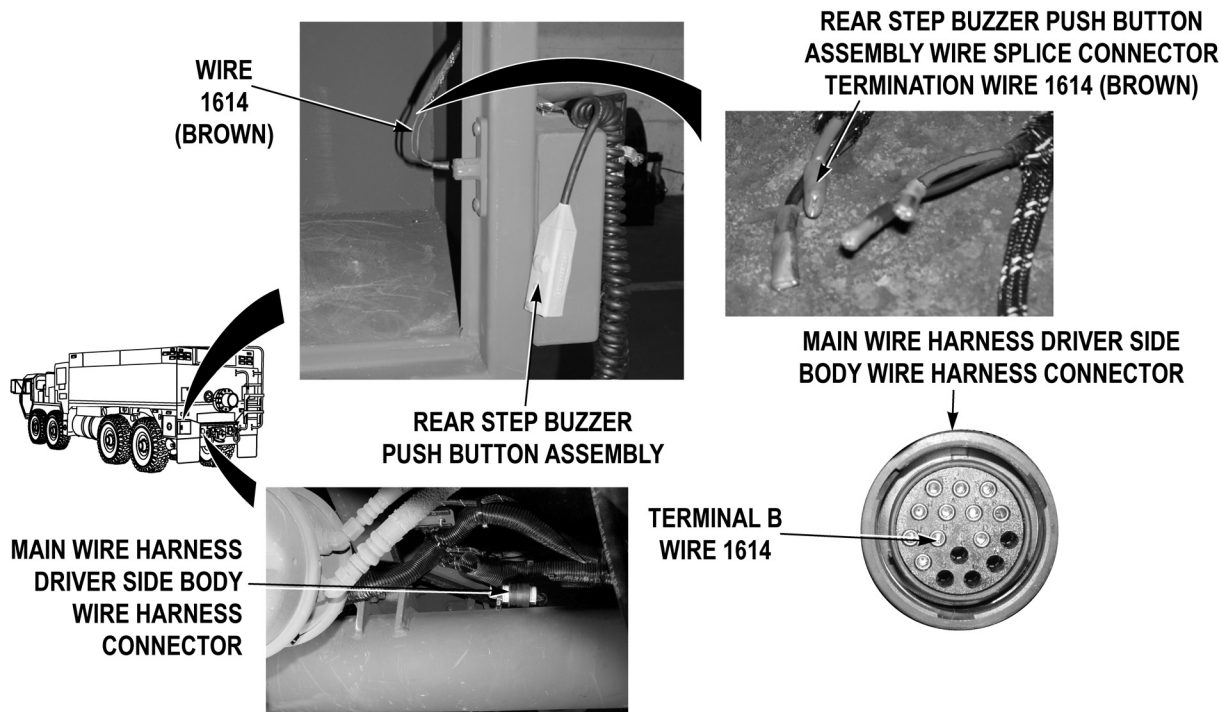
MALFUNCTION	TEST OR INSPECTION	CORRECTIVE ACTION
-------------	--------------------	-------------------



Step 7. Cut driver side body wire harness wires 1614 (brown) and 2640 (black) at rear step buzzer push button assembly wire butt splice connectors (WP 0266). While an assistant pushes rear step buzzer push button (WP 0004), check for continuity across rear step buzzer push button assembly from wire 1614 (brown) to wire 2640 (black) butt splice connector terminations.

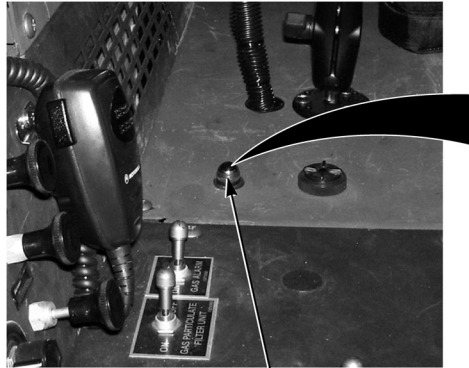
If there is no continuity, replace rear step buzzer push button assembly (WP 0266).

MALFUNCTION	TEST OR INSPECTION	CORRECTIVE ACTION
-------------	--------------------	-------------------



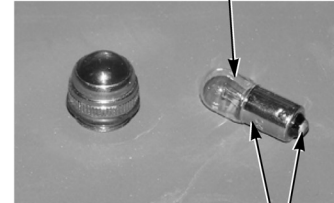
- Step 8. With a test lead set, check for continuity across driver side body wire harness wire 1614 (brown) from main wire harness driver side body wire harness connector, terminal B to rear step buzzer push button assembly wire butt splice connector termination.
- a. If there is continuity, repair wire 2640 in driver side body wire harness if repairable (TM 9-2320-325-14&P), or replace driver side body wire harness (WP 0286).
  - b. If there is no continuity, repair wire 1614 in driver side body wire harness if repairable (TM 9-2320-325-14&P), or replace driver side body wire harness (WP 0286).

MALFUNCTION	TEST OR INSPECTION	CORRECTIVE ACTION
-------------	--------------------	-------------------



REAR STEP BUZZER  
WARNING INDICATOR

REAR STEP WARNING  
INDICATOR LAMP



CHECK FOR  
CONTINUITY

**WARNING**

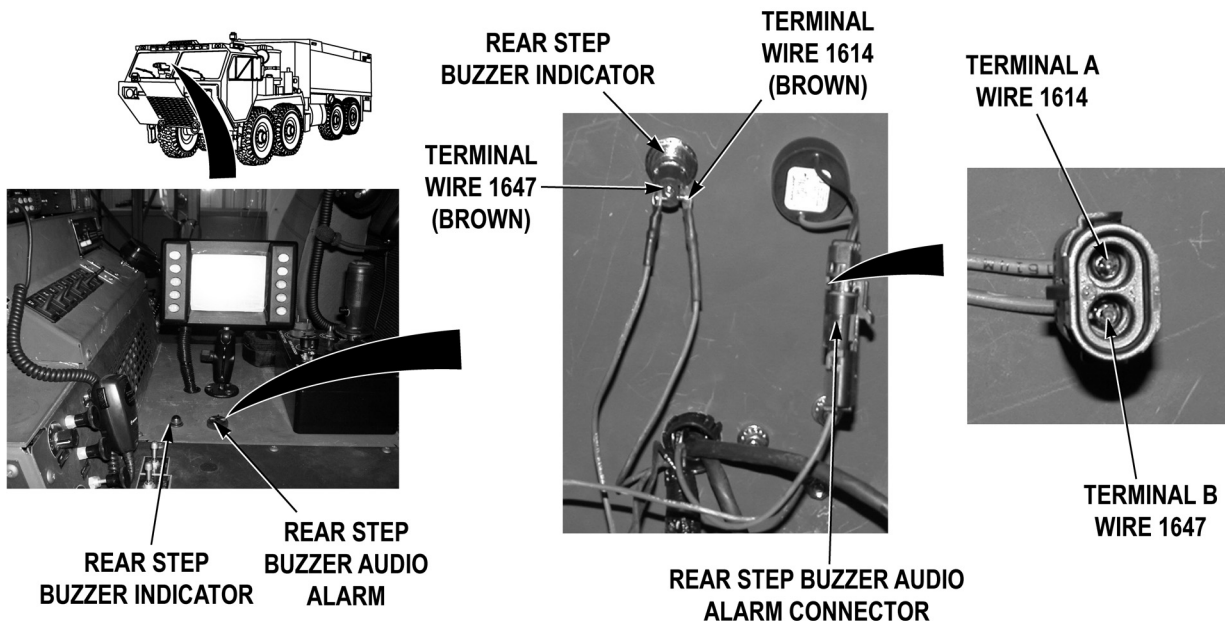


Remove rings, wristwatches, neck chains, and any other jewelry before working around vehicle. Jewelry can catch on equipment and cause serious injury. Jewelry and tools may short across electrical circuits and cause damage to equipment, or severe burns or electrical shock to personnel.

Step 9. Pull battery disconnect switch to off position (WP 0007). Remove rear step buzzer indicator lamp (WP 0202). Check for continuity across lamp.

If there is no continuity, replace lamp (WP 0202).

MALFUNCTION	TEST OR INSPECTION	CORRECTIVE ACTION
-------------	--------------------	-------------------



Step 10. Remove cab instrument panel D (WP 0205). Disconnect rear step buzzer audio alarm connector. With a test lead set, check for continuity across cab power distribution wire harness wire 1647 (brown) from rear step buzzer audio alarm connector, terminal B to rear step buzzer indicator terminal.

If there is no continuity, repair wire 1647 in cab power distribution wire harness if repairable (TM 9-2320-325-14&P), or replace cab power distribution wire harness and block (WP 0280).

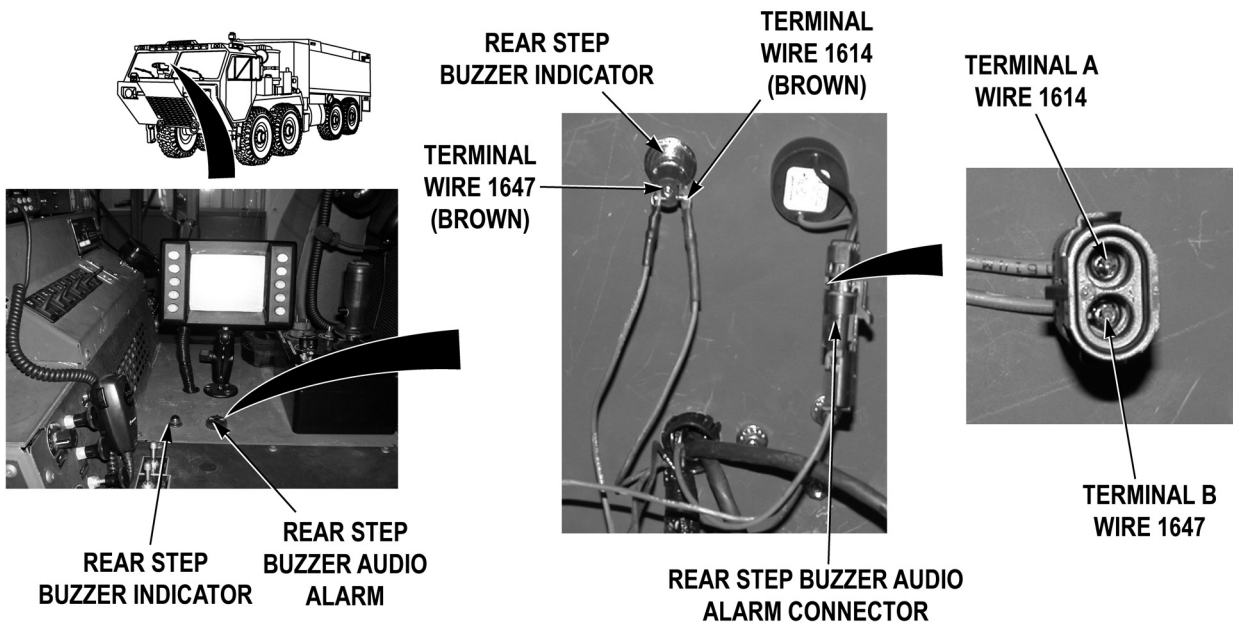
Step 11. With a test lead set, check for continuity across main wire harness wire 1614 (brown) from rear step buzzer audio alarm connector, terminal A to rear step buzzer indicator terminal.

- a. If there is continuity, replace rear step buzzer indicator (WP 0201).
- b. If there is no continuity, repair wire 1614 in main wire harness if repairable (TM 9-2320-325-14&P), or replace main wire harness (WP 0292).

**MALFUNCTION**

**TEST OR INSPECTION**

**CORRECTIVE ACTION**



Step 12. Pull battery disconnect switch to off position (WP 0007). Remove cab instrument panel D (WP 0205). Disconnect rear step buzzer audio alarm connector. With a test lead set, check for continuity across cab power distribution wire harness wire 1647 (brown) from rear step buzzer audio alarm connector, terminal B to rear step buzzer indicator terminal.

If there is no continuity, repair wire 1647 in cab distribution wire harness if repairable (TM 9-2320-325-14&P), or replace cab power distribution wire harness and block (WP 0280).

Step 13. With a test lead set, check for continuity across main wire harness wire 1614 (brown) from rear step buzzer audio alarm connector, terminal A to rear step buzzer indicator terminal.

- a. If there is continuity, replace rear step buzzer indicator (WP 0203).
- b. If there is no continuity, repair wire 1614 in main wire harness if repairable (TM 9-2320-325-14&P), or replace main harness (WP 0292).

**END OF TASK**

**FOLLOW-ON MAINTENANCE**

Remove wheel chocks (TM 9-2320-422-10)

**END OF TASK**

**END OF WORK PACKAGE**



---

**FIELD LEVEL MAINTENANCE****SINGGARS DO NOT OPERATE PROPERLY**

---

**INITIAL SETUP:****Tools and Special Tools**

Lead Set, Test (WP 0398, Item 14)  
Tool Kit, General Mechanic's: Automotive  
(WP 0398, Item 17)

**Equipment Conditions**

Engine OFF (TM 9-2320-422-10)  
Wheels chocked (TM 9-2320-422-10)

**References**

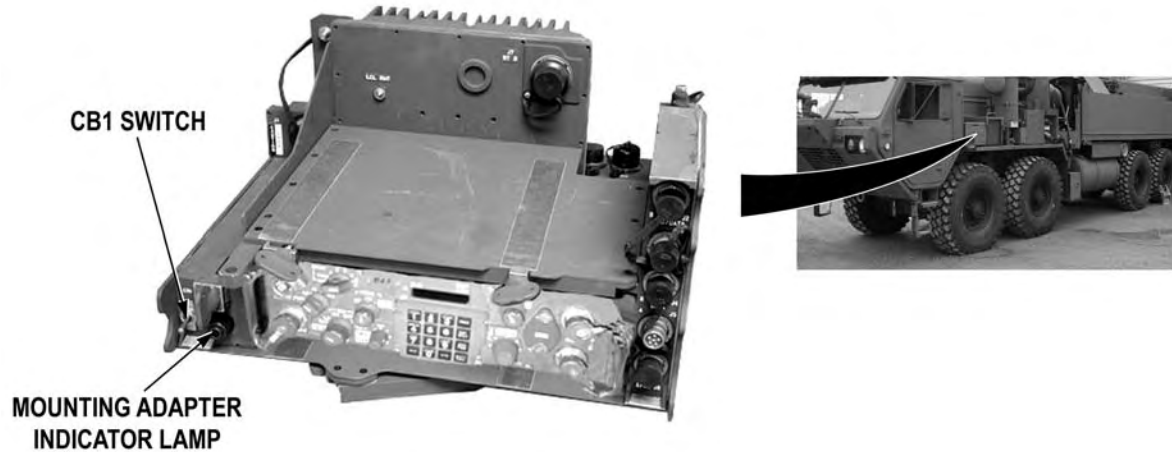
TM 11-5280-890-10  
WP 0004  
WP 0007  
WP 0120  
WP 0272

---

**MALFUNCTION****TEST OR INSPECTION****CORRECTIVE ACTION**

---

**SINGGARS DO NOT OPERATE PROPERLY**

**MALFUNCTION****TEST OR INSPECTION****CORRECTIVE ACTION****NOTE**

Make sure that mounting adapter indicator lamp is turned fully left (counterclockwise) before Step 1.

- Step 1. Push battery disconnect switch to on position (WP 0007). Put mounting adapter CB1 switch to ON position (TM 9-2320-422-10). Check if mounting adapter indicator light illuminates.

If indicator light does not illuminate, go to Step 3.

**NOTE**

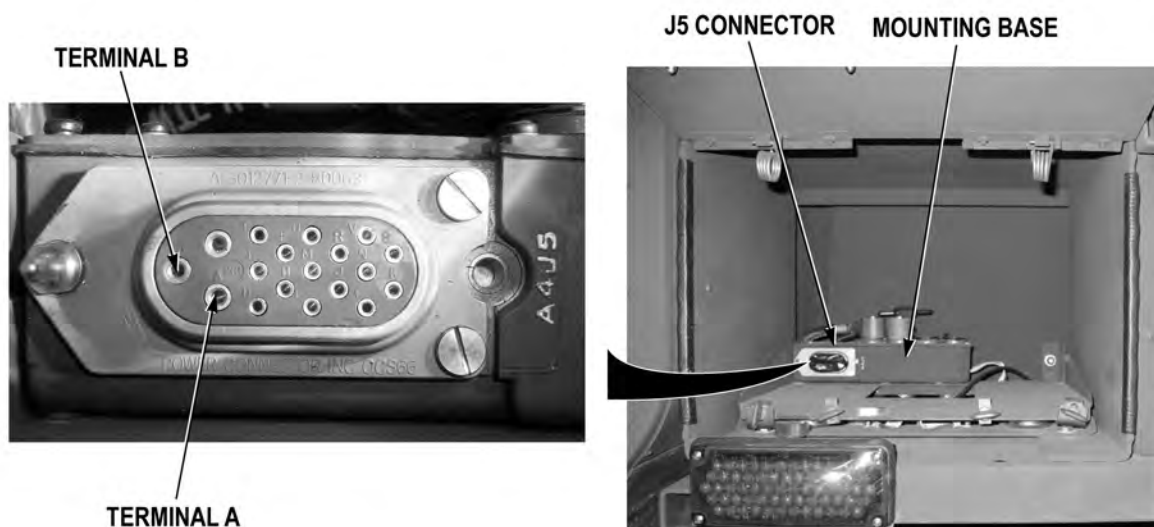
Mounting adapter indicator light will blink for approximately 3 seconds, then stay illuminated if mounting adapter is operating properly.

- Step 2. Put mounting adapter CB1 switch to OFF, then back to ON position (TM 9-2320-422-10). Check if mounting adapter indicator continues to blink after 3 seconds.
- a. If mounting adapter indicator light continues to blink after 3 seconds, notify Supervisor.
  - b. If mounting adapter indicator light illuminates and stays continuously illuminated after 3 seconds, go to Step 7.

## MALFUNCTION

## TEST OR INSPECTION

## CORRECTIVE ACTION

**WARNING**

**Remove rings, wristwatches, neck chains, and any other jewelry before working around vehicle. Jewelry can catch on equipment and cause serious injury. Jewelry and tools may short across electrical circuits and cause damage to equipment, or severe burns or electrical shock to personnel.**

- Step 3. Pull battery disconnect switch to off position (WP 0007). Put mounting adapter CB1 switch to OFF position (TM 11-5280-890-10). Remove SINCGARS receiver transmitter and mounting adapter from mounting base (WP 0272). With a test lead set, check for continuity across SINCGARS radio power cable and mounting base from mounting base J5 connector, terminal A and terminal B to a known good ground.

If there is no continuity at either terminal, go to Step 6.

- Step 4. Push battery disconnect switch to on position (WP 0007). With a test lead set, check for 22 to 28 VDC between mounting base J5 connector, terminal B and a known good ground.

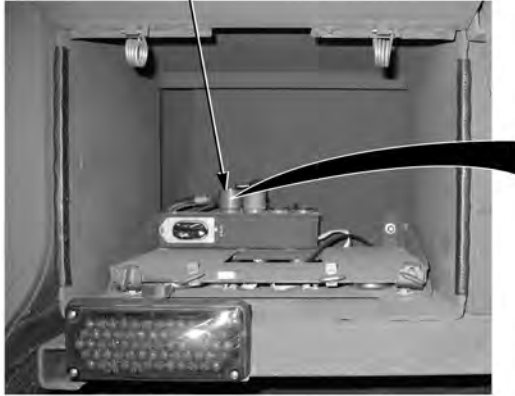
If 22 to 28 VDC are present at mounting base J5 connector, notify Supervisor.

## MALFUNCTION

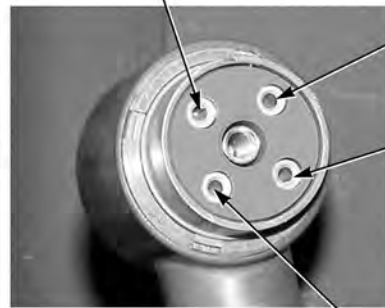
## TEST OR INSPECTION

## CORRECTIVE ACTION

SINGGARS RADIO  
POWER CABLE J1 CONNECTOR



TERMINAL A



TERMINAL D

TERMINAL C

TERMINAL B

**WARNING**

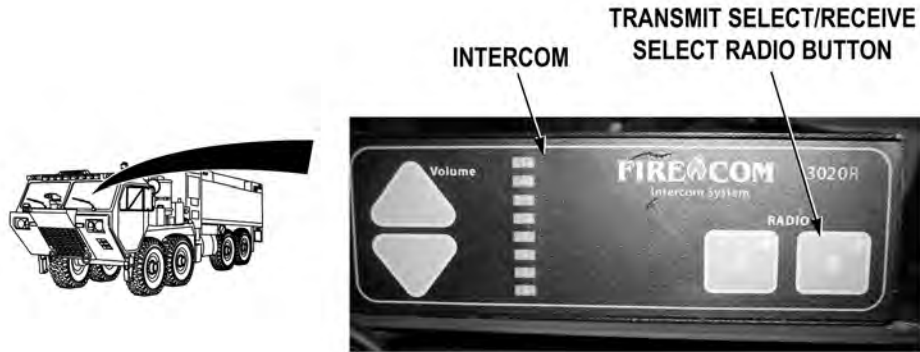
**Remove rings, wristwatches, neck chains, and any other jewelry before working around vehicle. Jewelry can catch on equipment and cause serious injury. Jewelry and tools may short across electrical circuits and cause damage to equipment, or severe burns or electrical shock to personnel.**

- Step 5. Pull battery disconnect switch to off position (WP 0007). Disconnect SINGGARS power cable J1 connector from mounting base (TM 11-5280-890-10). Push battery disconnect switch to on position (WP 0007). With a test lead set, check for 22 to 28 VDC between SINGGARS power cable assembly J1 connector, terminals A and B and a known good ground.
- a. If 22 to 28 VDC are present at both terminals, replace mounting base (WP 0272).
  - b. If 22 to 28 VDC are not present at either terminal, replace SINGGARS power cable assembly (WP 0260).
- Step 6. With a test lead set, check for continuity across SINGGARS radio power cable ground wire, from SINGGARS power cable assembly J1 connector, terminals C and D to a known good ground.
- a. If there is continuity at both terminals, replace mounting base (WP 0272).
  - b. If there is no continuity at either terminal, replace SINGGARS power cable assembly (WP 0260).

---

**MALFUNCTION**  
**TEST OR INSPECTION**  
**CORRECTIVE ACTION**

---



- Step 7. Press intercom transmit select/receive RADIO B button (WP 0004). With intercom headset connected to pump operator's panel intercom jack (WP 0004), check if intercom system sends and receives through SINGGARS radio set (WP 0004).

If intercom system sends and receives through SINGGARS radio set, fault corrected.

- Step 8. Connect handset to SINGGARS receiver transmitter (TM 11-5280-890-10). Check if SINGGARS receiver transmitter sends and receives to and from another radio set.
- a. If SINGGARS receiver transmitter sends and receives to and from another radio set, troubleshoot Intercom and Headsets Does Not Operate Properly (WP 0120).
  - b. If SINGGARS receiver transmitter does not send and receive to and from another radio set, notify Supervisor.

**END OF TASK**

**FOLLOW-ON MAINTENANCE**

Remove wheel chocks (TM 9-2320-422-10)

**END OF TASK**

**END OF WORK PACKAGE**



## FIELD LEVEL MAINTENANCE

## SINGGARS VEHICLE REMOTE CONTROL UNIT (VRCU) DOES NOT OPERATE PROPERLY

## INITIAL SETUP:

**Tools and Special Tools**

Lead Set, Test (WP 0398, Item 14)  
 Tool Kit, General Mechanic's: Automotive  
 (WP 0398, Item 17)

**Equipment Conditions**

Engine OFF (TM 9-2320-422-10)  
 Wheels chocked (TM 9-2320-422-10)

**References**

TM 11-5820-890-10  
 WP 0007  
 WP 0124  
 WP 0260

## MALFUNCTION

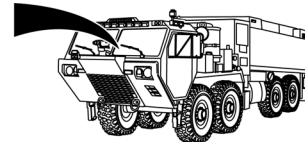
## TEST OR INSPECTION

## CORRECTIVE ACTION

## SINGGARS VEHICLE REMOTE CONTROL UNIT (VRCU) DOES NOT OPERATE PROPERLY



SINGGARS  
 VEHICLE REMOTE  
 CONTROL UNIT (VRCU)  
 DISPLAY



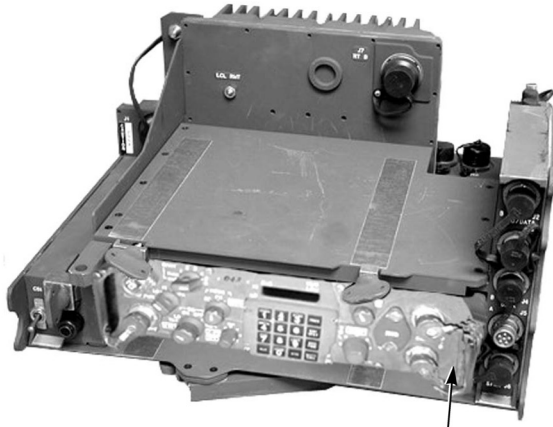
- Step 1. Push battery disconnect switch to on position (WP 0007). Put SINGGARS Vehicle Remote Control Unit (VRCU) switch to ON position (TM 11-5820-890-10). Check if SINGGARS VRCU display illuminates.

If SINGGARS VRCU display does not illuminate, go to Step 3.

---

**MALFUNCTION****TEST OR INSPECTION****CORRECTIVE ACTION**

---



**SINCGARS  
RADIO**



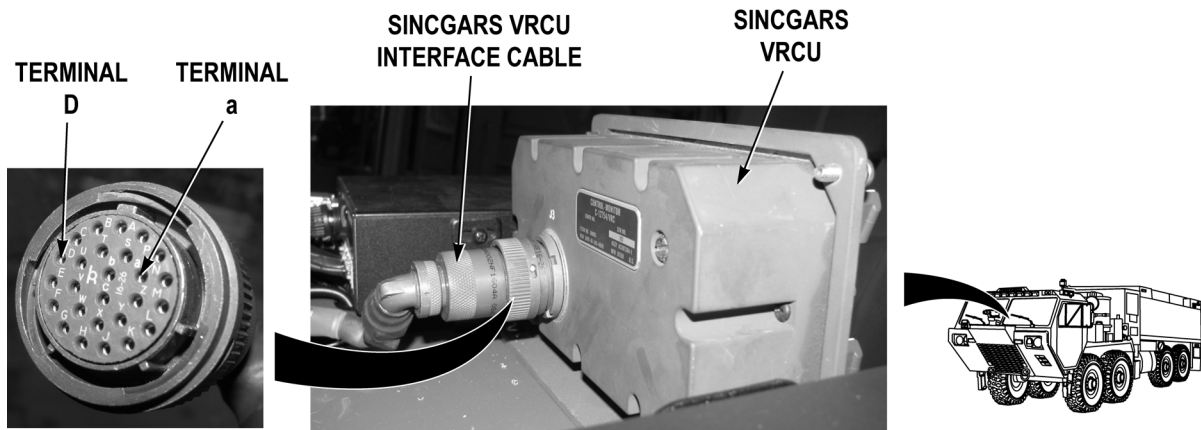
- Step 2. Connect handset to SINCGARS receiver transmitter (TM 11-5820-890-10). Check if SINCGARS receiver transmitter sends and receives to and from another radio set.
- a. If SINCGARS receiver transmitter does send and receive to and from another radio set, notify Supervisor.
  - b. If SINCGARS receiver transmitter does not send and receive to and from another radio set, troubleshoot SINCGARS Do Not Operate (WP 0124).



---

**MALFUNCTION**  
**TEST OR INSPECTION**  
**CORRECTIVE ACTION**

---



**WARNING**



**Remove rings, wristwatches, neck chains, and any other jewelry before working around vehicle. Jewelry can catch on equipment and cause serious injury. Jewelry and tools may short across electrical circuits and cause damage to equipment, or severe burns or electrical shock to personnel.**

- Step 3. Pull battery disconnect switch to OFF position (WP 0007). Disconnect SINGGARS VRCU interface cable from SINGGARS VRCU (TM 11-5820-890-10). Push battery disconnect switch to ON position (WP 0007). With a test lead set, check for 10 to 14 VDC between SINGGARS VRCU interface cable connector, terminal D and a known good ground.

If 10 to 14 VDC are not present at SINGGARS VRCU interface cable connector, terminal D, replace SINGGARS VRCU interface cable assembly (WP 0260).

- Step 4. With a test lead set, check for continuity across SINGGARS VRCU interface cable, from SINGGARS VRCU interface cable connector, terminal a to a known good ground.
- a. If there is continuity at SINGGARS VRCU interface cable connector, terminal a, notify Supervisor.
  - b. If there is no continuity at SINGGARS VRCU interface cable connector, terminal a, replace SINGGARS VRCU interface cable assembly (WP 0260).

**END OF TASK**

**FOLLOW-ON MAINTENANCE**

Remove wheel chocks (TM 9-2320-422-10)

**END OF TASK**

**END OF WORK PACKAGE**

---

**FIELD LEVEL MAINTENANCE**  
**SIREN DOES NOT OPERATE PROPERLY**

---

**INITIAL SETUP:****Tools and Special Tools**

Lead Set, Test (WP 0398, Item 14)  
Tool Kit, General Mechanic's: Automotive  
(WP 0398, Item 17)

**References**

TM 9-2320-325-14&P  
WP 0004  
WP 0007  
WP 0104  
WP 0205  
WP 0242

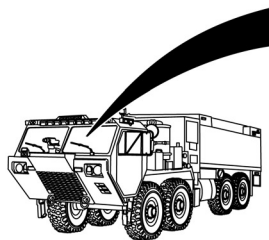
**References (continued)**

WP 0273  
WP 0280  
WP 0292  
WP 0349  
WP 0380  
WP 0400

**Equipment Conditions**

Engine OFF (TM 9-2320-422-10)  
Wheels chocked (TM 9-2320-422-10)

---

**MALFUNCTION****TEST OR INSPECTION****CORRECTIVE ACTION****SIREN DOES NOT OPERATE PROPERLY**

- Step 1. Push battery disconnect switch to on position (WP 0007). Put EMERG MASTER switch to on position (WP 0004). Put siren control selector switch to WAIL, YELP, and HI-LO (WP 0004). Check if siren operates.

If siren operates in at least one mode, but not all, replace siren control (WP 0380).

**MALFUNCTION****TEST OR INSPECTION****CORRECTIVE ACTION****NOTE**

Integrated siren amplifier will produce a faint audible signal which can be heard at siren control if siren speaker or wiring fails.

- Step 2. Put siren control selector switch to WAIL, YELP, and HI-LO (WP 0004). Check if siren output can be heard at siren control.

If siren is heard faintly at siren control, go to Step 11.

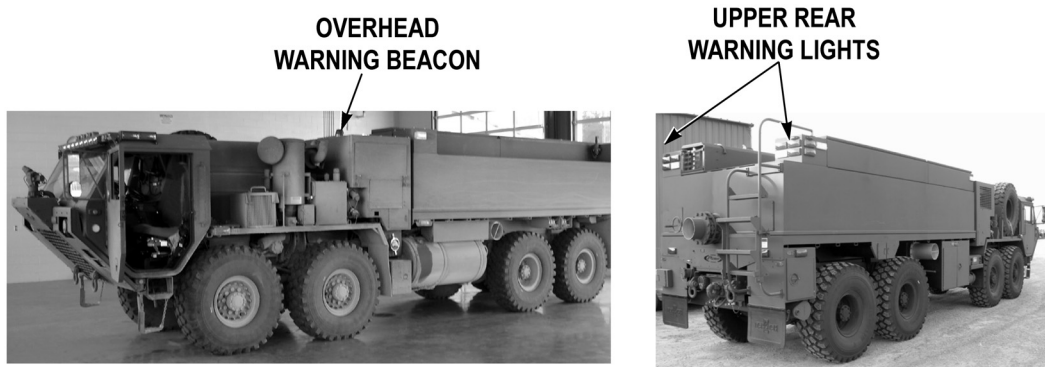
- Step 3. Check if siren speaker operates without distortion.

If siren operates with distortion, cut main wire harness wires 1052 (brown), and 1053 (yellow) at siren speaker butt splice connectors and swap wire connections, if distortion persists, replace siren speaker (WP 0400).

---

**MALFUNCTION****TEST OR INSPECTION****CORRECTIVE ACTION**

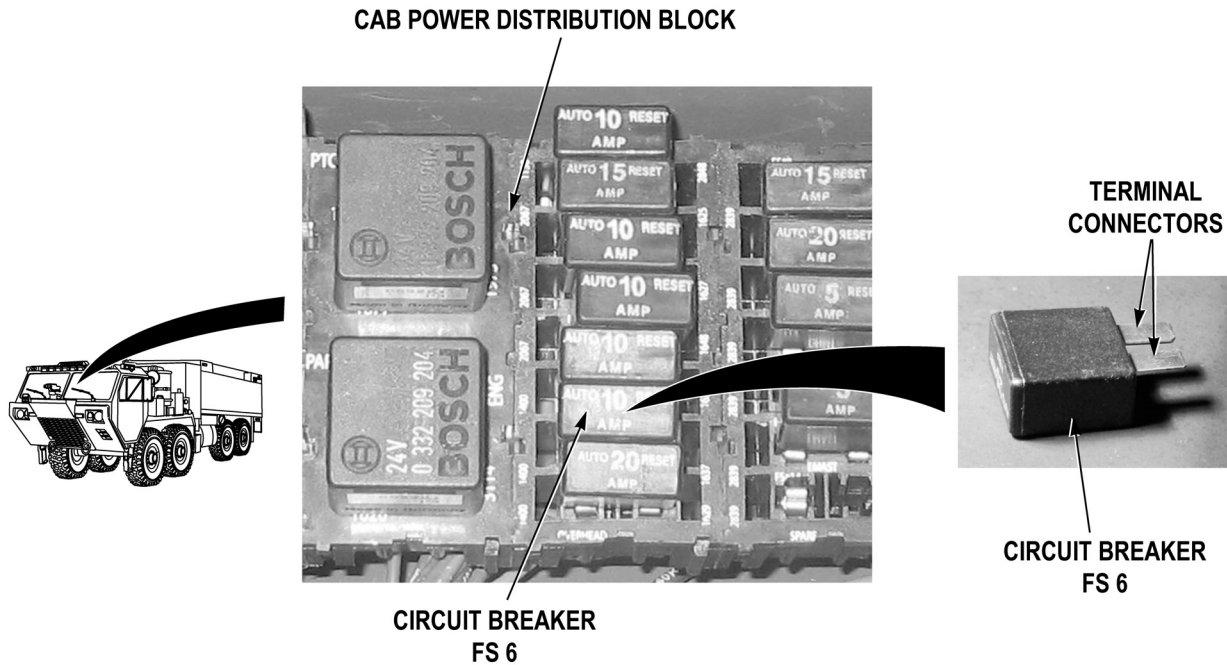
---



- Step 4. Put OVERHEAD WARNING and UPPER REAR WARNING switches to on position (WP 0004). Check if overhead warning beacon and upper rear warning lights operate.

If overhead warning beacon and upper rear warning lights do not operate, troubleshoot Warning Lights (Overhead Beacon) Do Not Operate (WP 0104).

**MALFUNCTION**  
**TEST OR INSPECTION**  
**CORRECTIVE ACTION**



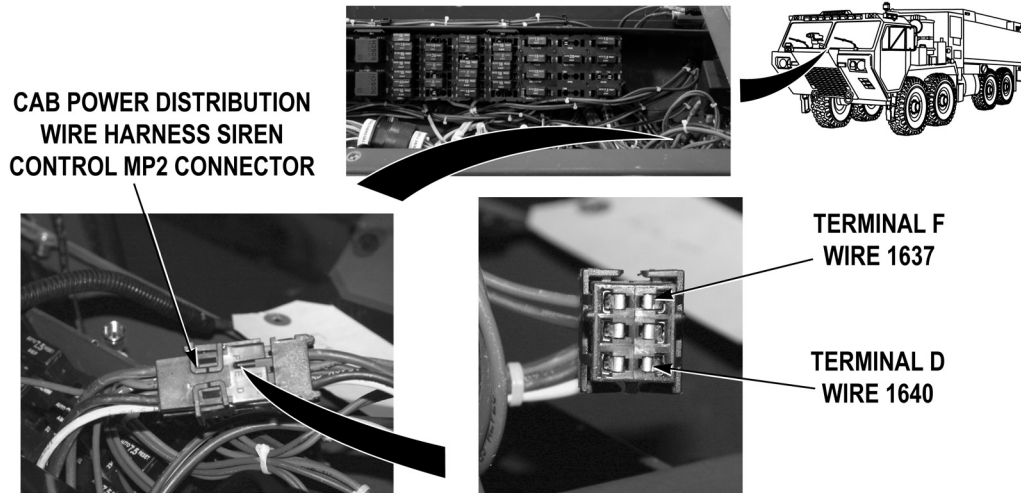
**WARNING**



Remove rings, wristwatches, neck chains, and any other jewelry before working around vehicle. Jewelry can catch on equipment and cause serious injury. Jewelry and tools may short across electrical circuits and cause damage to equipment, or severe burns or electrical shock to personnel.

Step 5. Put OVERHEAD WARNING and UPPER REAR WARNING switches to off position (WP 0004). Put EMERG MASTER switch to off position (WP 0004). Pull battery disconnect switch to off position (WP 0007). Remove cab instrument panel A (WP 0205). Remove circuit breaker FS 6 (WP 0242). Check for continuity across circuit breaker.

If there is no continuity, replace circuit breaker FS 6 (WP 0242).

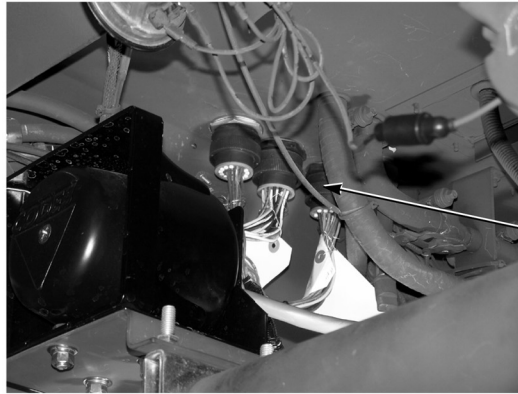
**MALFUNCTION****TEST OR INSPECTION****CORRECTIVE ACTION**

- Step 6. Install circuit breaker FS 6 (WP 0242). Disconnect cab power distribution wire harness siren control MP2 connector. Push battery disconnect switch to on position (WP 0007). Put EMERG MASTER switch to on position (WP 0004). With a test lead set, check for 22 to 28 VDC between wire 1637 (red) at cab power distribution wire harness siren control MP2 connector, terminal F and a known good ground.

If 22 to 28 VDC are not present, repair wire 1637 in cab power distribution harness if repairable (TM 9-2320-325-14&P), or replace cab power distribution harness (WP 0280).

- Step 7. Pull battery disconnect switch to off position (WP 0007). Put EMERG MASTER switch to off position (WP 0004). With a test lead set, check for continuity across cab power distribution wire harness wire 1640 (black) from cab power distribution harness siren control MP2 connector, terminal D to a known good ground.

If there is no continuity, repair wire 1640 in cab power distribution wire harness (TM 9-2320-325-14&P), or replace cab power distribution wire harness (WP 0280).

**MALFUNCTION****TEST OR INSPECTION****CORRECTIVE ACTION****MAIN WIRE HARNESS  
MAIN 1 CONNECTOR****NOTE**

Integrated siren amplifier will produce a faint audible signal which can be heard at siren control if siren speaker or wiring fails.

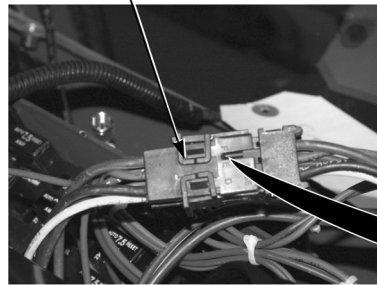
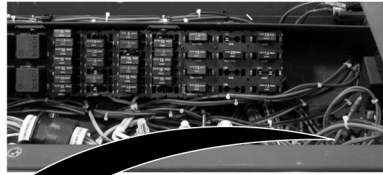
- Step 8. Reconnect cab power distribution wire harness siren control MP2 connector. Remove skid plate grille (WP 0349). Disconnect main wire harness main 1 connector. Push battery disconnect switch to on position (WP 0007). Put EMERG MASTER switch to on position (WP 0004). Put siren control selector switch to WAIL, YELP, and HI-LO (WP 0004). Check if siren output can be heard at siren control.

If siren can be heard at siren control, go to Step 15.



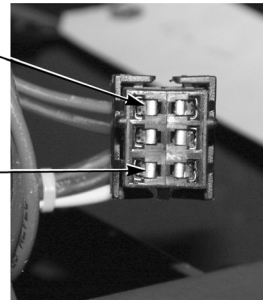
**MALFUNCTION****TEST OR INSPECTION****CORRECTIVE ACTION**

**CAB POWER DISTRIBUTION  
WIRE HARNESS SIREN  
CONTROL MP2 CONNECTOR**



**TERMINAL A  
WIRE 1052**

**TERMINAL C  
WIRE 1053**

**NOTE**

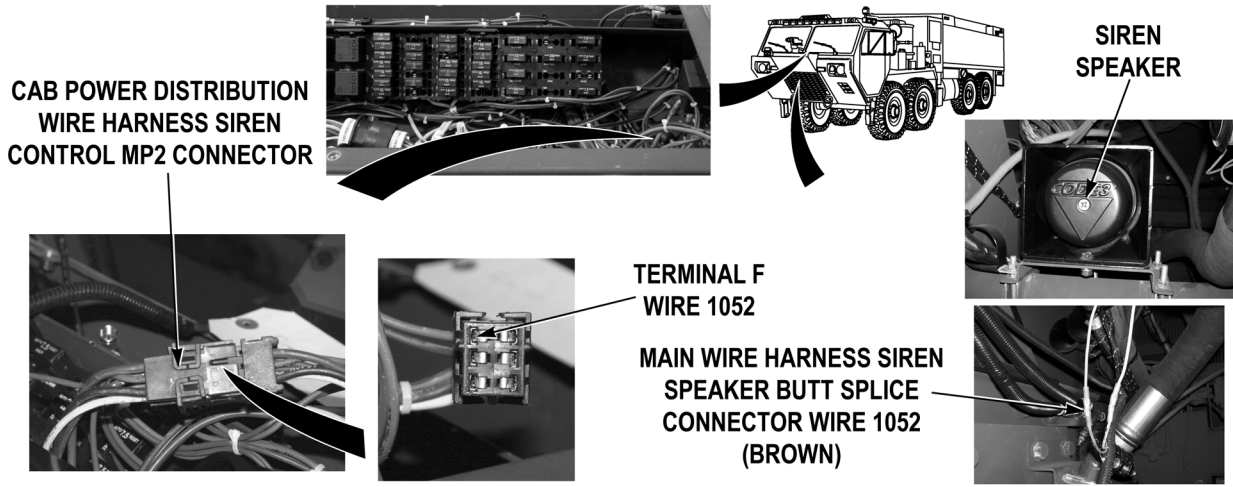
Steps 9 and 10 checks cab power distribution wire harness wires 1052 (brown) and 1053 (orange) for a short to ground.

- Step 9. Pull battery disconnect switch to off position (WP 0007). Put EMERG MASTER switch to off position (WP 0004). With a test lead set, check for continuity (short to ground) of power distribution wire harness wire 1052 (brown) from cab power distribution wire harness siren control MP2 connector, terminal A to a known good ground.

If there is continuity, repair wire 1052 in cab power distribution wire harness if repairable (TM 9-2320-325-14&P), or replace cab power distribution wire harness (WP 0280).

- Step 10. With a test lead set, check for continuity (short to ground) of power distribution wire harness wire 1053 (orange) from cab power distribution wire harness siren control MP2 connector, terminal C to a known good ground.
- a. If there is continuity, repair wire 1053 in cab power distribution wire harness if repairable (TM 9-2320-325-14&P), or replace cab power distribution wire harness (WP 0280).
  - b. If there is no continuity, replace siren control (WP 0380).

MALFUNCTION	TEST OR INSPECTION	CORRECTIVE ACTION
-------------	--------------------	-------------------



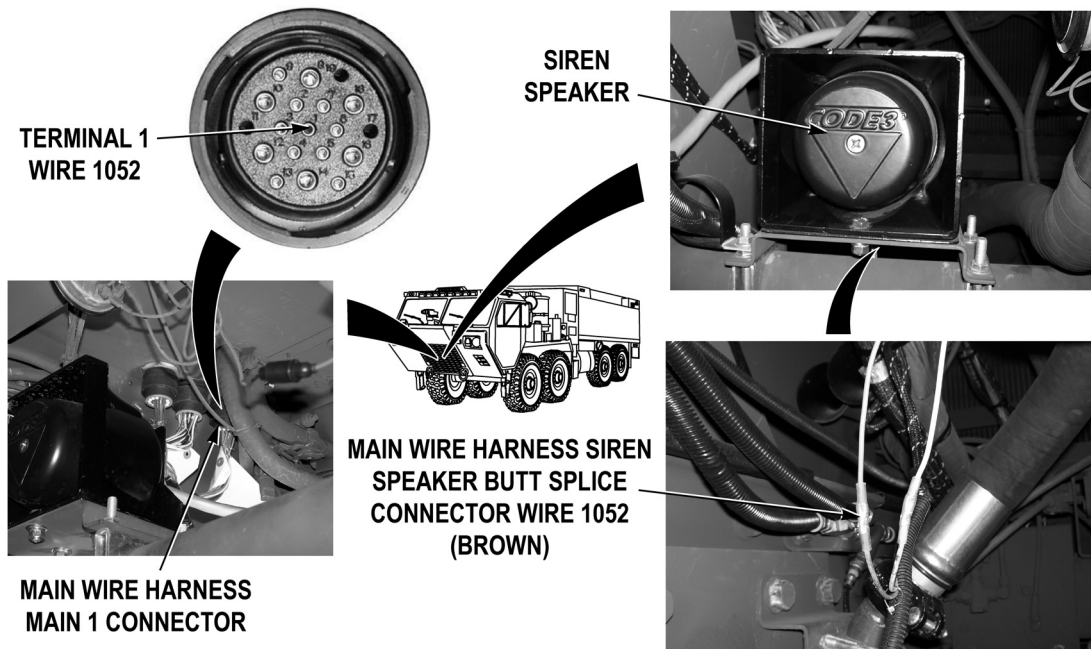
Step 11. Pull battery disconnect switch to off position (WP 0007). Put EMERG MASTER switch to off position (WP 0004). Remove skid plate grille (WP 0349). Cut main wire harness siren speaker butt splice connector wire 1052 (brown) at siren speaker. Remove cab instrument panel A (WP 0205). Disconnect cab power distribution wire harness siren control MP2 connector. With a test lead set, check for continuity across wire 1052 (brown) from main wire harness siren speaker butt splice connector, termination to cab power distribution wire harness siren control MP2 connector, terminal A.

If there is continuity, go to Step 13.

---

<b>MALFUNCTION</b>		
<b>TEST OR INSPECTION</b>		
	<b>CORRECTIVE ACTION</b>	

---

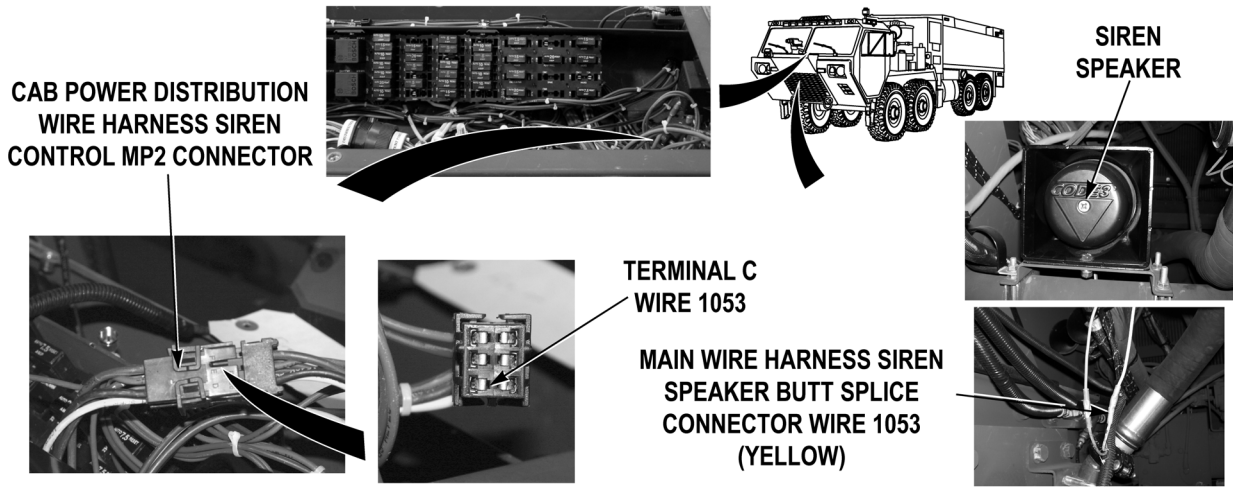


- Step 12. Disconnect main wire harness main 1 connector. With a test lead set, check for continuity across wire 1052 (brown), from main wire harness main 1 connector, terminal 1 to main wire harness siren speaker butt splice connector, termination.
- a. If there is continuity, repair wire 1052 (brown) in cab power distribution wire harness if repairable (TM 9-2320-325-14&P), or replace cab power distribution wire harness and block (WP 0280).
  - b. If there is no continuity, repair wire 1052 (brown) in main wire harness if repairable (TM 9-2320-325-14&P), or replace main wire harness (WP 0292).

---

<b>MALFUNCTION</b>		
<b>TEST OR INSPECTION</b>		
	<b>CORRECTIVE ACTION</b>	

---



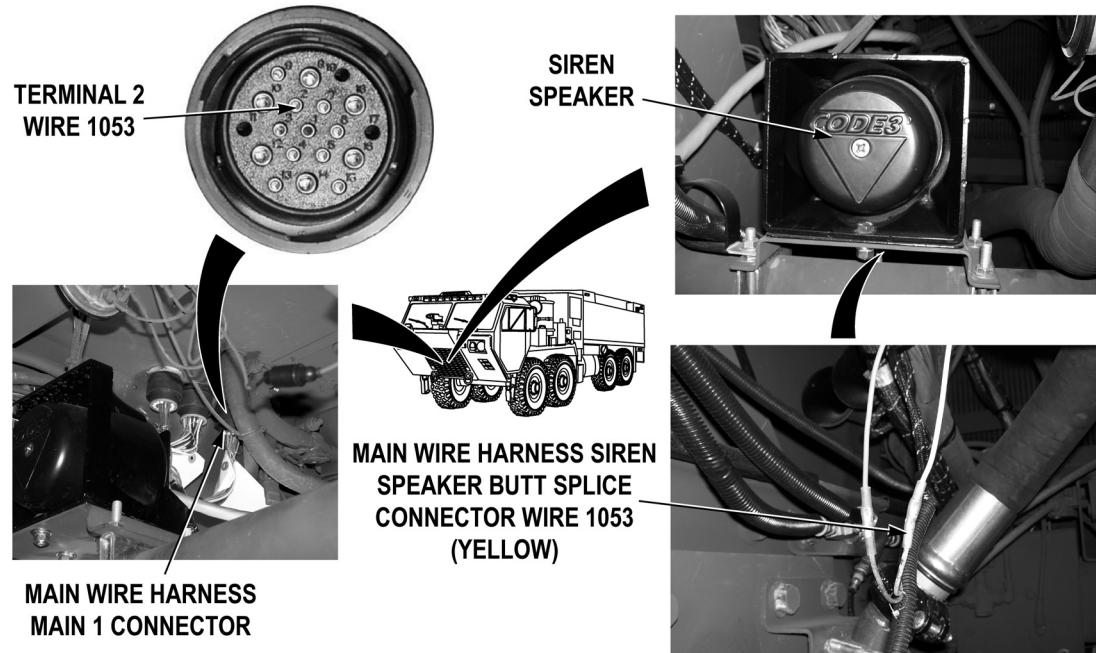
Step 13. Cut main wire harness siren speaker butt splice connector wire 1053 (yellow) at siren speaker. With a test lead set, check for continuity across wire 1053 (yellow) from main wire harness siren speaker butt splice connector, termination to cab power distribution wire harness siren control MP2 connector, terminal C.

If there is continuity, replace siren speaker (WP 0273).

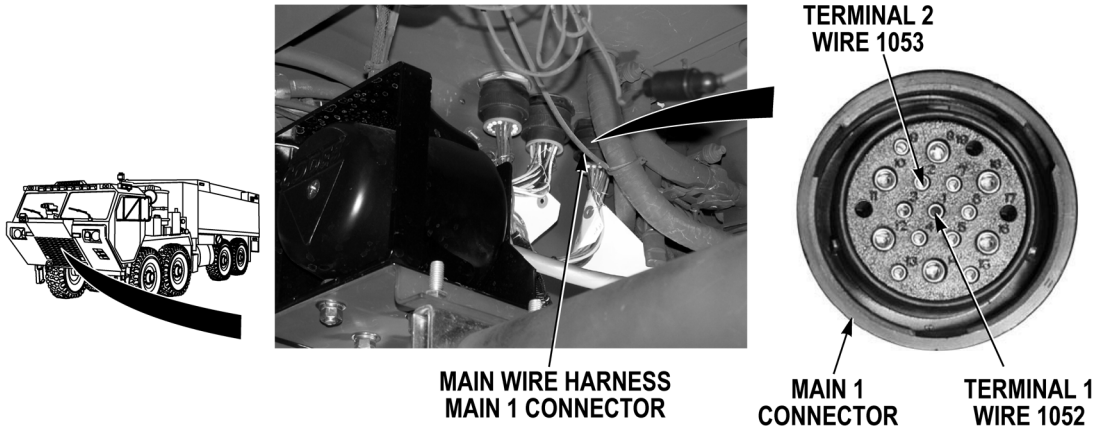
---

<b>MALFUNCTION</b>
<b>TEST OR INSPECTION</b>
<b>CORRECTIVE ACTION</b>

---



- Step 14. Disconnect main wire harness main 1 connector. With a test lead set, check for continuity across wire 1053 (yellow), from main wire harness main 1 connector, terminal 2 to main wire harness siren speaker butt splice connector, termination.
- a. If there is continuity, repair wire 1053 in cab power distribution wire harness if repairable (TM 9-2320-325-14&P), or replace cab power distribution wire harness and block (WP 0280).
  - b. If there is no continuity, repair wire 1053 in main wire harness if repairable (TM 9-2320-325-14&P), or replace main wire harness (WP 0292).

**MALFUNCTION****TEST OR INSPECTION****CORRECTIVE ACTION****NOTE**

Steps 15 and 16 check main wire harness wires 1052 (brown) and 1053 (orange) for a short to ground.

- Step 15. If battery disconnect switch is in on position, pull battery disconnect switch to off position (WP 0007). If EMERG MASTER switch is in on position, put EMERG MASTER switch to off position (WP 0007). With a test lead set, check for continuity (short to ground) of main wire harness wire 1052 (brown) from main wire harness main 1 connector, terminal 1 to a known good ground.

If there is continuity, repair wire 1052 in main wire harness if repairable (TM 9-2320-325-14&P), or replace main wire harness (WP 0292).

- Step 16. With a test lead set, check for continuity (short to ground) of main wire harness wire 1053 (orange) from main wire harness main 1 connector, terminal 2 to a known good ground.
- a. If there is continuity, repair wire 1053 in cab power distribution wire harness if repairable (TM 9-2320-325-14&P), or replace cab power distribution wire harness (WP 0280).
  - b. If there is no continuity, replace siren control (WP 0380).

**END OF TASK****FOLLOW-ON MAINTENANCE**

Remove wheel chocks (TM 9-2320-422-10)

**END OF TASK****END OF WORK PACKAGE**

---

**FIELD LEVEL MAINTENANCE**
**SHORELINE INLET RECEPTACLE DOES NOT OPERATE PROPERLY**


---

**INITIAL SETUP:****Tools and Special Tools**

Tool Kit, General Mechanic's: Automotive  
(WP 0398, Item 17)

**Equipment Conditions**

Engine OFF (TM 9-2320-422-10)  
Wheels chocked (TM 9-2320-422-10)

**References**

TM 9-2320-325-14&P  
WP 0008  
WP 0115  
WP 0268  
WP 0339

---

**MALFUNCTION****TEST OR INSPECTION****CORRECTIVE ACTION**


---

**SHORELINE INLET RECEPTACLE DOES NOT OPERATE PROPERLY****WARNING**

- **110 Volt AC power is potentially lethal. Do not work on AC wiring when it is connected to a power source. Failure to comply may cause injury or death to personnel.**
- **SHORELINE INLET receptacle discharges shoreline inlet power cord from receptacle with force. Ensure that area near vehicle is free of flammable liquids, combustible materials, or liquids that can conduct electricity. Shoreline inlet power cord is powered with 110 VAC when discharged from SHORELINE INLET receptacle. Failure to comply may result in injury or death to personnel or damage to equipment.**

**NOTE**

Periodically inspect shoreline inlet power cord rubber connector protector. Rubber connector protector covers shoreline inlet power cord female plug with 1/8" rubber to protect connector and nearby obstructions from impact damage.

---

MALFUNCTION	TEST OR INSPECTION	CORRECTIVE ACTION
-------------	--------------------	-------------------

---



SHORELINE INLET POWER CORD



SHORELINE INLET RECEPTACLE

- Step 1. Connect shoreline inlet power cord to SHORELINE INLET receptacle. Turn ENGINE switch to START position (TM 9-2320-422-10). Check if shoreline inlet power cord is discharged from SHORELINE INLET receptacle.

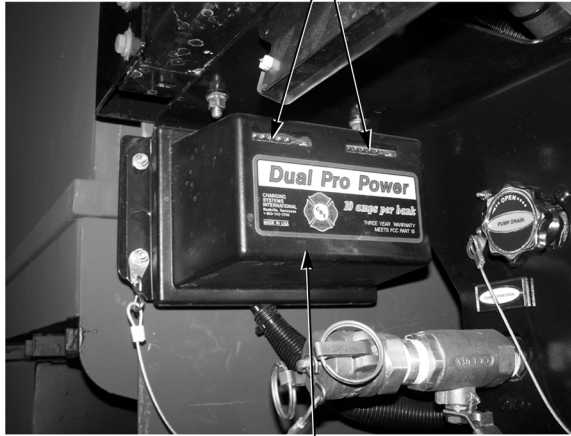
If shoreline inlet power cord does not fully discharge from SHORELINE INLET receptacle, go to Step 3.



---

<b>MALFUNCTION</b>		
	<b>TEST OR INSPECTION</b>	
		<b>CORRECTIVE ACTION</b>

---

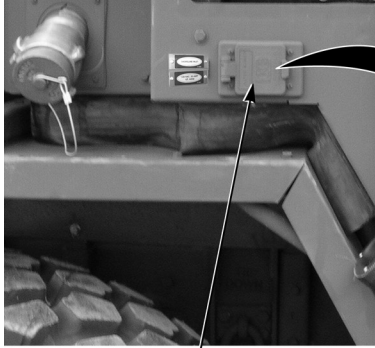
**CHARGE INDICATORS****24-VOLT BATTERY CHARGER**

- Step 2. Connect shoreline inlet power cord to SHORELINE INLET receptacle and power source. Open passenger side pump house panel controls access door (WP 0008). Check if 24-volt battery charger, charge indicators are illuminated.
- a. If 24-volt battery charger charge indicators do not illuminate, troubleshoot 24-Volt Battery Charger Does Not Operate Properly (WP 0115).
  - b. If 24-volt battery charger charge indicators are illuminated, fault corrected.

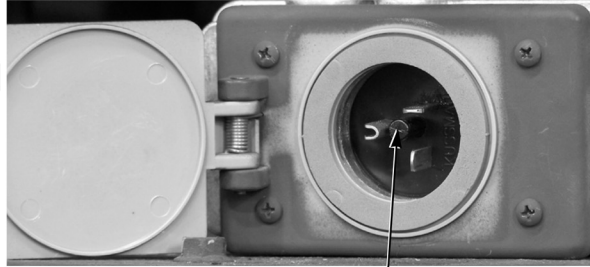
---

MALFUNCTION	TEST OR INSPECTION	CORRECTIVE ACTION
-------------	--------------------	-------------------

---



SHORELINE INLET RECEPTACLE

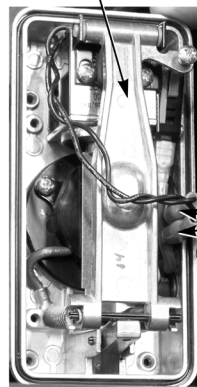


DISCHARGE PLUNGER

- Step 3. Disconnect shoreline inlet power cord from SHORELINE INLET receptacle and power source. Open SHORELINE INLET receptacle protective cover. Inspect SHORELINE INLET receptacle plastic discharge plunger for damage.

If SHORELINE INLET receptacle plunger is damaged, replace SHORELINE INLET receptacle (WP 0268).

MALFUNCTION	TEST OR INSPECTION	CORRECTIVE ACTION
-------------	--------------------	-------------------

SHORELINE INLET  
RECEPTACLESOLENOID  
TERMINAL  
CONNECTORS**WARNING**

Remove rings, wristwatches, neck chains, and any other jewelry before working around vehicle. Jewelry can catch on equipment and cause serious injury. Jewelry and tools may short across electrical circuits and cause damage to equipment, or severe burns or electrical shock to personnel.

- Step 4. Remove SHORELINE INLET receptacle from pump house panel A (WP 0339). Remove four screws from SHORELINE INLET receptacle. Remove back plate from SHORELINE INLET receptacle. Disconnect SHORELINE INLET receptacle 24 VDC solenoid connectors. While an assistant puts ENGINE switch to START position (TM 9-2320-422-10), check for 22 to 28 VDC between SHORELINE INLET receptacle solenoid from terminal connector to terminal connector while engine is being cranked.
- a. If 22 to 28 VDC are present, replace SHORELINE INLET receptacle (WP 0268).
  - b. If 22 to 28 VDC are not present, repair wires from SHORELINE INLET receptacle to HEMTT starter if repairable (TM 9-2320-325-14&P), or replace SHORELINE INLET receptacle (WP 0268).

**END OF TASK**

**FOLLOW-ON MAINTENANCE**

Remove wheel chocks (TM 9-2320-422-10)

**END OF TASK**

**END OF WORK PACKAGE**



**FIELD LEVEL MAINTENANCE**

**PUMP HOUSE HEATER DOES NOT OPERATE PROPERLY**

**INITIAL SETUP:**

**Tools and Special Tools**

- Lead Set, Test (WP 0398, Item 14)
- Tool Kit, General Mechanic's: Automotive (WP 0398, Item 17)

**Personnel Required**

- MOS 63B Wheeled Vehicle Mechanic (2)

**References**

- TM 9-2320-325-14&P
- WP 0004
- WP 0007
- WP 0009
- WP 0205
- WP 0242
- WP 0244
- WP 0262

**References (continued)**

- WP 0280
- WP 0292
- WP 0299
- WP 0302
- WP 0306
- WP 0307
- WP 0308
- WP 0310
- WP 0339

**Equipment Conditions**

- Engine OFF (TM 9-2320-422-10)
- Wheels chocked (TM 9-2320-422-10)

**MALFUNCTION**

**TEST OR INSPECTION**

**CORRECTIVE ACTION**

**PUMP HOUSE HEATER DOES NOT OPERATE PROPERLY**

## MALFUNCTION

## TEST OR INSPECTION

## CORRECTIVE ACTION

DIESEL HEATER  
DIAGNOSTIC INDICATORDIESEL HEATER  
TEST SWITCH**WARNING**

- **CARBON MONOXIDE (EXHAUST GAS) CAN CAUSE DEATH.**
- **Carbon monoxide gas is generated whenever pump house heater is operating. Do not operate pump house heater in an enclosed area without proper ventilation. Failure to comply may cause injury or death to personnel.**

Step 1. Push battery disconnect switch to on position (WP 0007). Open pump house access door assembly (WP 0009). Put DIESEL HEATER TEST switch to on position (WP 0004). Check if pump house heater operates.

If pump house heater operates, go to Step 3.

Step 2. With DIESEL HEATER TEST switch in on position (WP 0004), check if pump house heater attempts to start, does not attempt to start, or starts and shuts down.

- a. If pump house heater attempts to start or starts and shuts down, go to Step 7.
- b. If pump house heater does not attempt to start, go to Step 20.

Step 3. Check if DIESEL HEATER DIAGNOSTIC indicator illuminates (WP 0004).

If DIESEL HEATER DIAGNOSTIC indicator does not illuminate, go to Step 16.

**MALFUNCTION****TEST OR INSPECTION****CORRECTIVE ACTION**

**DIESEL HEATER  
DIAGNOSTIC SWITCH**

**DIESEL HEATER  
DIAGNOSTIC INDICATOR**

- Step 4. Put DIESEL HEATER DIAGNOSTIC switch in up position (WP 0004). Check if DIESEL HEATER DIAGNOSTIC indicator flashes.

If DIESEL HEATER DIAGNOSTIC indicator flashes, go to Step 9.

**WARNING**



- **CARBON MONOXIDE (EXHAUST GAS) CAN CAUSE DEATH**
- **Carbon monoxide gas is generated whenever pump house heater is operating. Do not operate pump house heater in an enclosed area without proper ventilation. Failure to comply may cause injury or death to personnel.**

- Step 5. Release DIESEL HEATER DIAGNOSTIC switch (WP 0004). Operate pump house heater for 10 minutes. Check if heater shuts down.

If heater shuts down, go to Step 9.

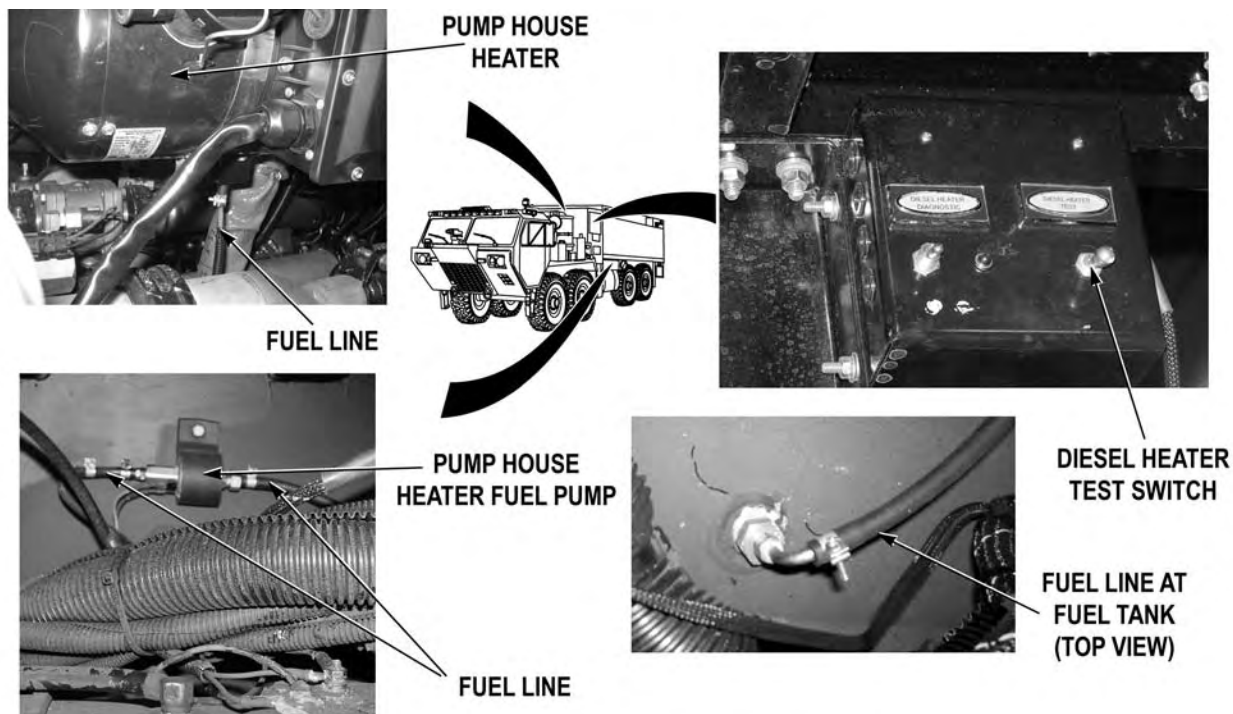
- Step 6. Put DIESEL HEATER DIAGNOSTIC switch in up position (WP 0004). Check if DIESEL HEATER DIAGNOSTIC indicator flashes.

- a. If DIESEL HEATER DIAGNOSTIC indicator flashes, go to Step 9.
- b. If DIESEL HEATER DIAGNOSTIC indicator does not flash, replace pump house heater diagnostic module thermostatic switch (WP 0307).

## MALFUNCTION

## TEST OR INSPECTION

## CORRECTIVE ACTION

**WARNING**

Fuel is very flammable and can explode easily. Keep fuel away from open fire and keep fire extinguisher within easy reach when working with fuel. When working with fuel, post signs that read NO SMOKING WITHIN 50 FEET of vehicle. Failure to comply may cause injury to death to personnel.

**NOTE**

Pump house heater fuel pump will make an audible clicking sound when operating.

Step 7. Put DIESEL HEATER TEST switch to off position (WP 0004). While an assistant puts DIESEL HEATER TEST switch to on position, check if pump house heater fuel pump operates.

If pump house heater fuel pump does not operate, go to Step 10.

Step 8. Put DIESEL HEATER TEST switch to off position (WP 0004). Pull battery disconnect switch to off position (WP 0007). Remove pump house panel G (WP 0339). Check fuel line from pump house heater to fuel tank for leaks, kinks and damage.

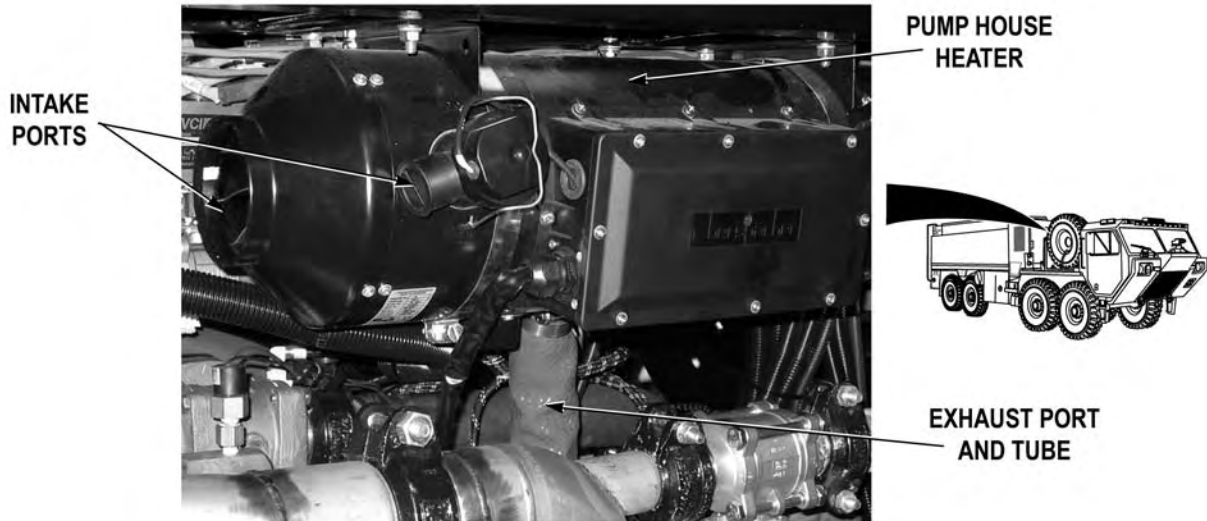
If fuel line is leaking, kinked, or damaged, replace fuel line (WP 0308).



## MALFUNCTION

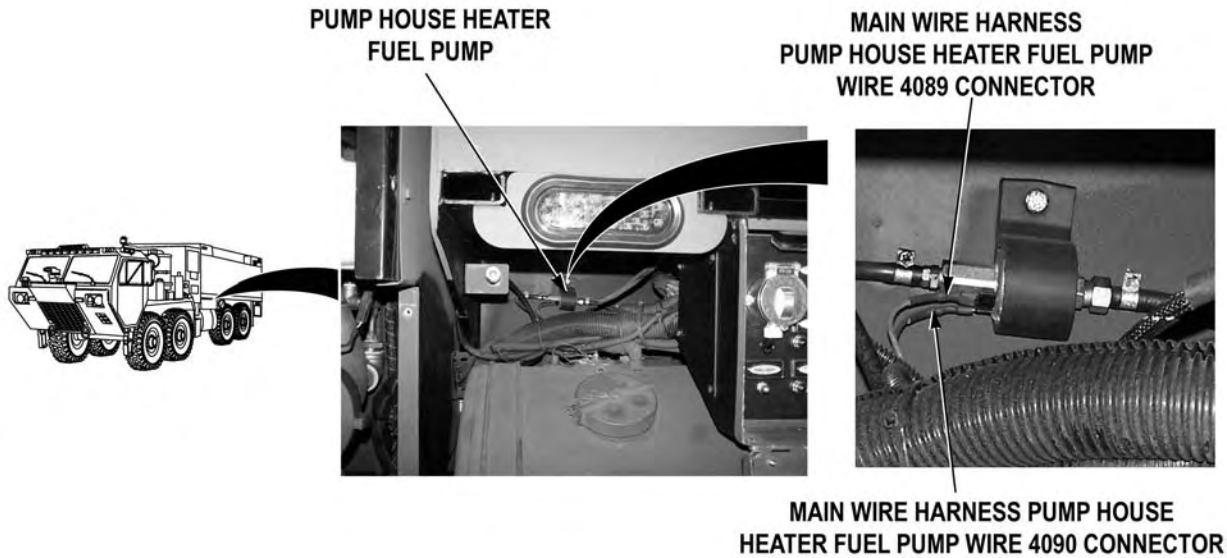
## TEST OR INSPECTION

## CORRECTIVE ACTION

**WARNING**

**Diesel heater exhaust tube becomes very hot during operation. Do not touch or allow body to come in contact with exhaust tube when hot. Allow sufficient time for diesel heater exhaust tube to cool before performing any maintenance to system. Failure to comply may cause injury or death to personnel.**

- Step 9. If on, put DIESEL HEATER TEST switch to off position (WP 0004). If on, pull battery disconnect switch to off position (WP 0007). Remove pump house panel E (WP 0339). After system cools, check pump house heater intake and exhaust ports for blockage.
- a. If pump house heater intake or exhaust ports are blocked, remove blockage.
  - b. If pump house heater intake and exhaust ports are not blocked, replace pump house heater (WP 0310).

**MALFUNCTION****TEST OR INSPECTION****CORRECTIVE ACTION**

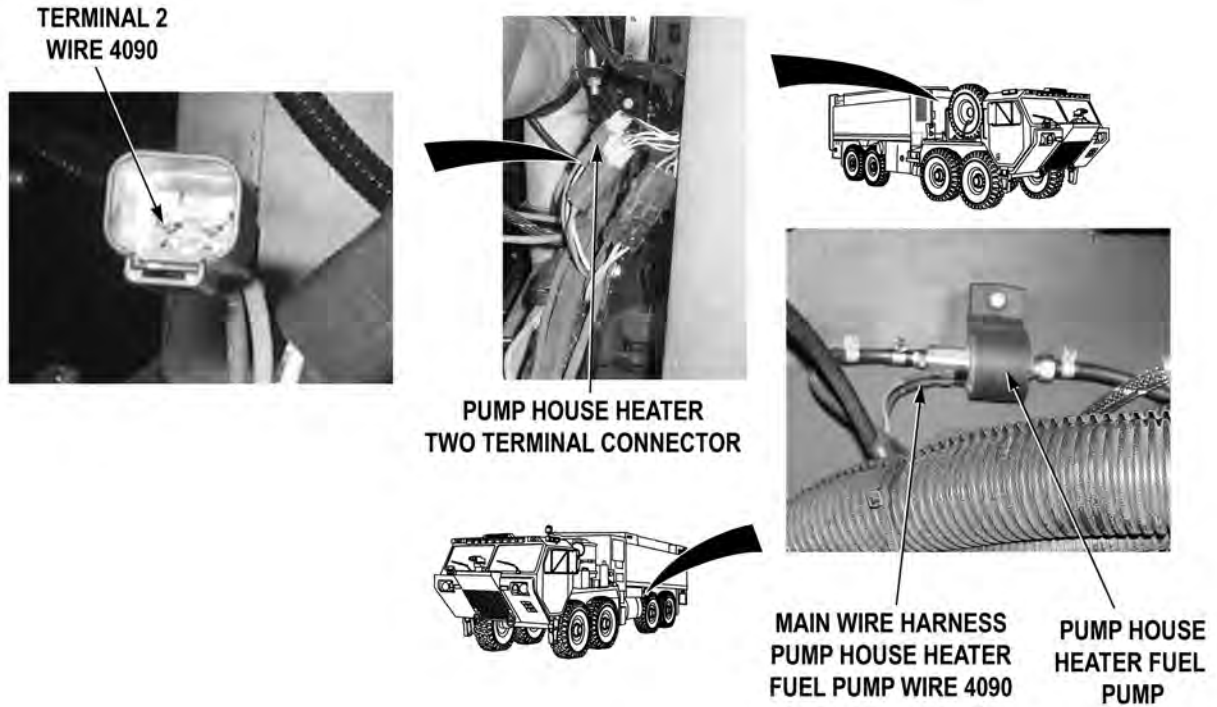
- Step 10. Put DIESEL HEATER TEST switch to off position (WP 0004). Disconnect main wire harness pump house heater fuel pump wire 4089 (green) from pump house heater fuel pump connector. Put DIESEL HEATER TEST switch to on position (WP 0004). Check for 22 to 28 VDC between main wire harness pump house heater fuel pump wire 4089 (green), terminal and a known good ground.

If 22 to 28 VDC are not present, go to Step 14.

- Step 11. Pull battery disconnect switch to off position (WP 0007). Disconnect main wire harness pump house heater fuel pump wire 4090 (purple) from pump house heater fuel pump connector. Check for continuity across wire 4090 (purple) from main wire harness pump house heater fuel pump, terminal and a known good ground.

If there is continuity, replace pump house heater fuel pump (WP 0308).

MALFUNCTION	TEST OR INSPECTION	CORRECTIVE ACTION
-------------	--------------------	-------------------



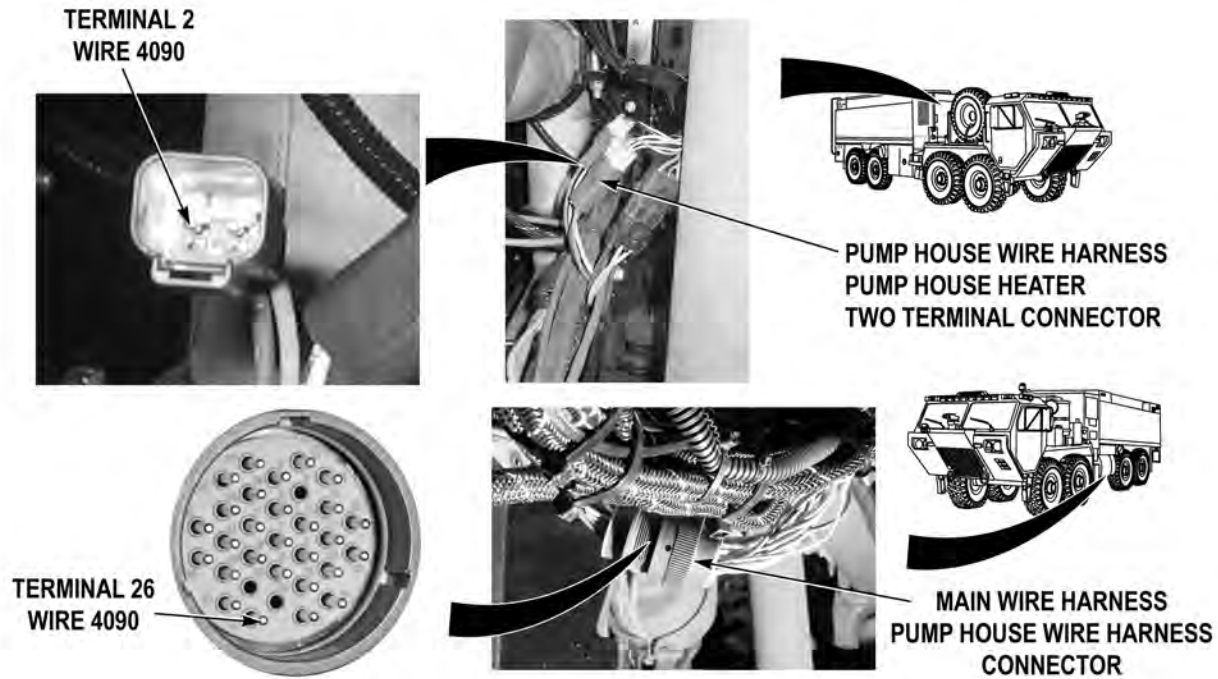
Step 12. Remove pump house panel G (WP 0339). Disconnect pump house wire harness pump house heater two terminal connector. With a test lead set, check for continuity across wire 4090 (purple) from pump house wire harness pump house heater two terminal connector, terminal 2 to main wire harness pump house heater fuel pump, terminal.

If there is continuity, replace pump house heater (WP 0310).

**MALFUNCTION**

**TEST OR INSPECTION**

**CORRECTIVE ACTION**

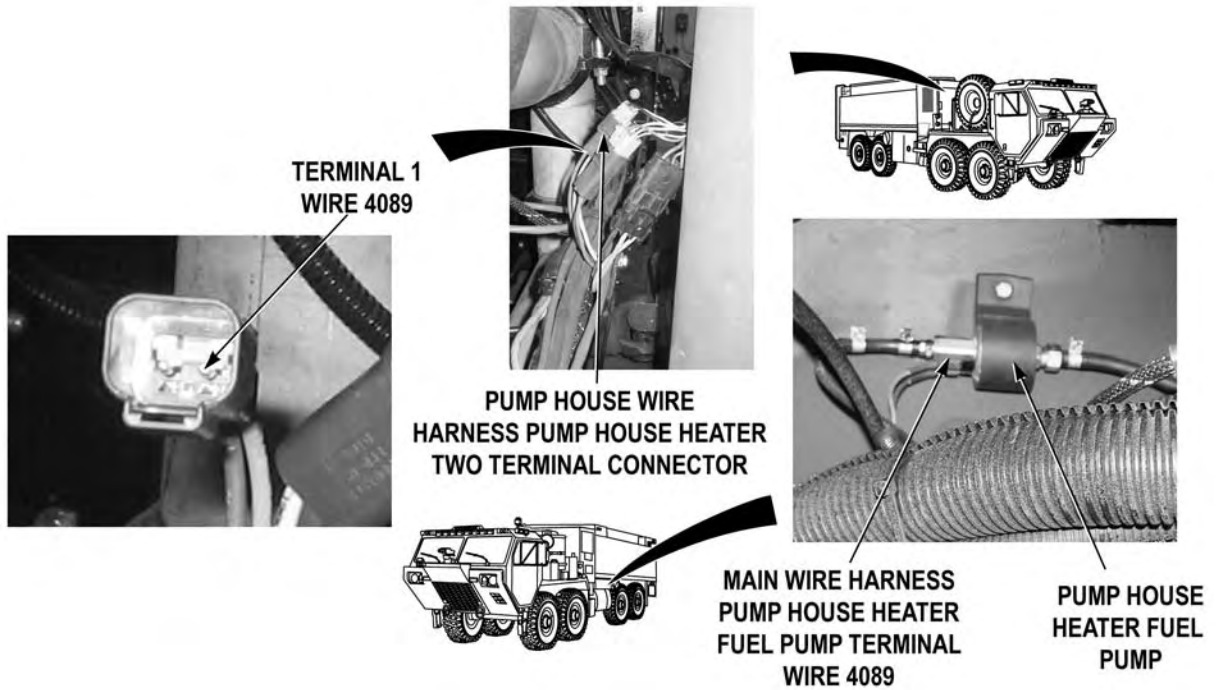


- Step 13. Disconnect main wire harness pump house wire harness connector. With a test lead set, check for continuity across pump house wire harness wire 4090 (purple) from main wire harness pump house wire harness connector, terminal 26 to pump house wire harness pump house heater two terminal connector, terminal 2.
- a. If there is continuity, repair wire 4090 in main wire harness if repairable (TM 9-2320-325-14&P), or replace main wire harness (WP 0292).
  - b. If there is no continuity, repair wire 4090 in pump house wire harness if repairable (TM 9-2320-325-14&P), or replace pump house wire harness (WP 0302).

---

**MALFUNCTION**  
**TEST OR INSPECTION**  
**CORRECTIVE ACTION**

---



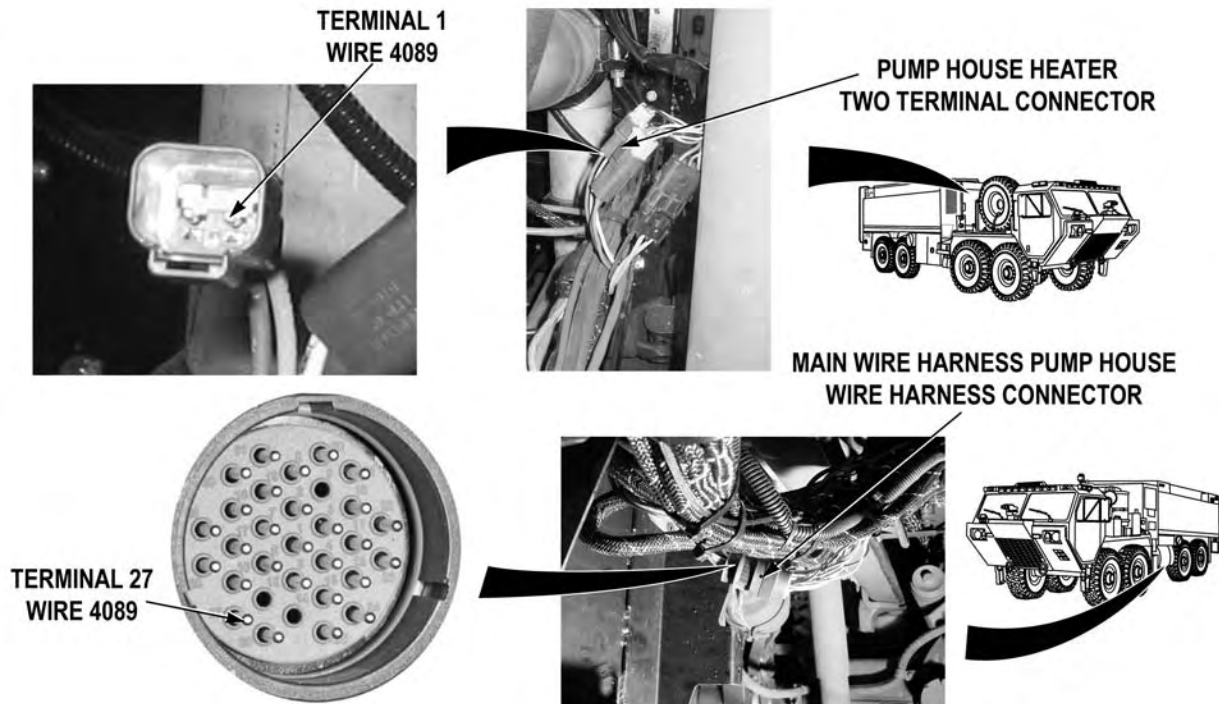
Step 14. Pull battery disconnect switch to off position (WP 0007). Remove pump house panel G (WP 0339). Disconnect pump house wire harness pump house heater two terminal connector. With a test lead set, check for continuity across wire 4089 (green) from pump house wire harness pump house heater two terminal connector, terminal 1 to main wire harness pump house heater fuel pump, terminal.

If there is continuity, replace pump house heater (WP 0310).

## MALFUNCTION

## TEST OR INSPECTION

## CORRECTIVE ACTION

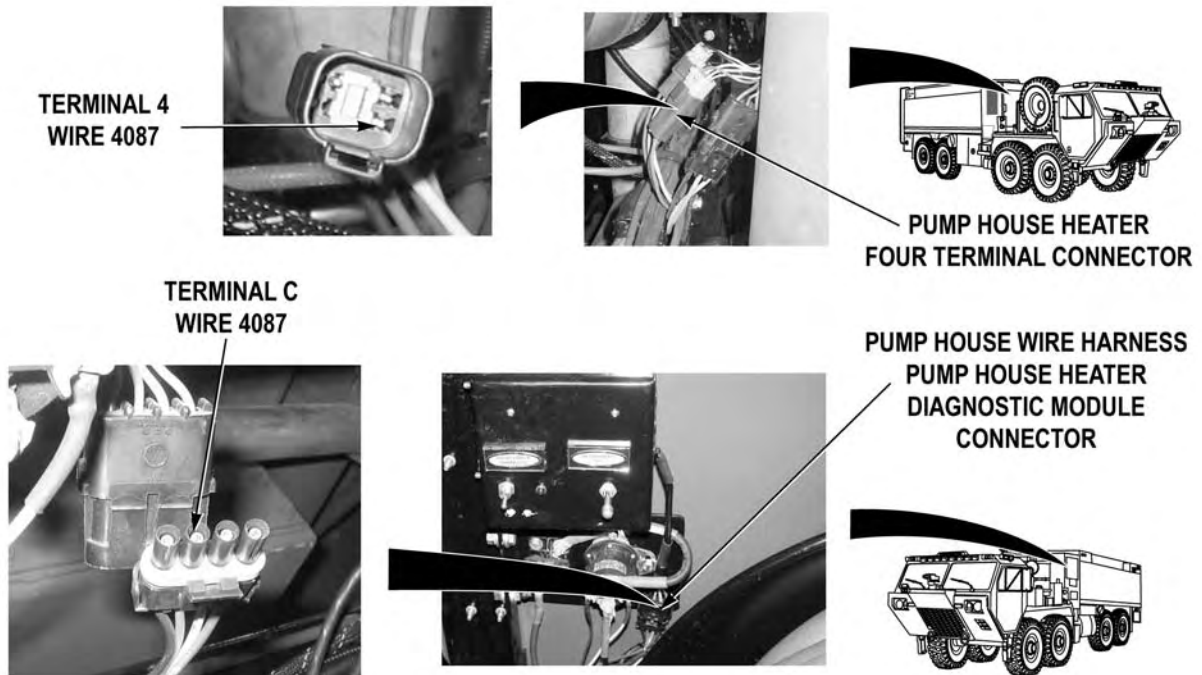


- Step 15. Disconnect main wire harness pump house wire harness connector. With a test lead set, check for continuity across pump house wire harness wire 4089 (green) from main wire harness pump house wire harness connector, terminal 27 to pump house wire harness pump house heater two terminal connector, terminal 1.
- If there is continuity, repair wire 4089 in main wire harness if repairable (TM 9-2320-325-14&P), or replace main wire harness (WP 0292).
  - If there is no continuity, repair wire 4089 in pump house wire harness if repairable (TM 9-2320-325-14&P), or replace pump house wire harness (WP 0302).

## MALFUNCTION

## TEST OR INSPECTION

## CORRECTIVE ACTION



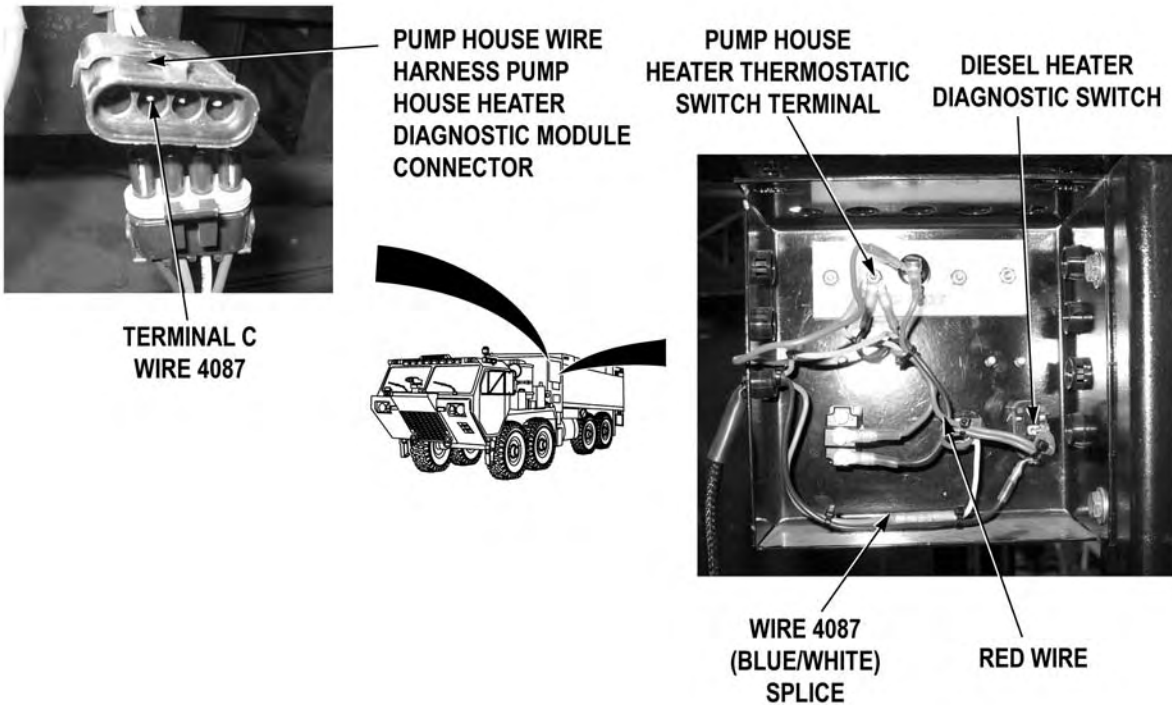
- Step 16. Put DIESEL HEATER TEST switch to off position (WP 0004). Pull battery disconnect switch to off position (WP 0007). Open pump house access door assembly (WP 0009). Disconnect pump house wire harness pump house heater diagnostic module connector. Remove pump house panel G (WP 0339). Disconnect pump house wire harness pump house heater four terminal connector. With a test lead set, check for continuity across pump house wire harness wire 4087 (blue) from pump house heater diagnostic module connector, terminal C to pump house heater four terminal connector, terminal 4.

If there is no continuity, repair wire 4087 in pump house wire harness if repairable (TM 9-2320-325-14&P), or replace pump house wire harness (WP 0302).

**MALFUNCTION**

**TEST OR INSPECTION**

**CORRECTIVE ACTION**



Step 17. Remove pump house panel E (WP 0339). Check for continuity across red wire from pump house heater thermostatic switch to DIESEL HEATER DIAGNOSTIC switch.

If there is no continuity, repair red wire if repairable (TM 9-2320-325-14&P), or replace pump house heater diagnostic module (WP 0307).

Step 18. Cut pump house heater diagnostic module wire 4087 (blue and white) at butt splice connector. Check for continuity across wire 4087 (blue) from pump house wire harness pump house heater diagnostic module connector, terminal C to pump house heater diagnostic module butt splice connector termination.

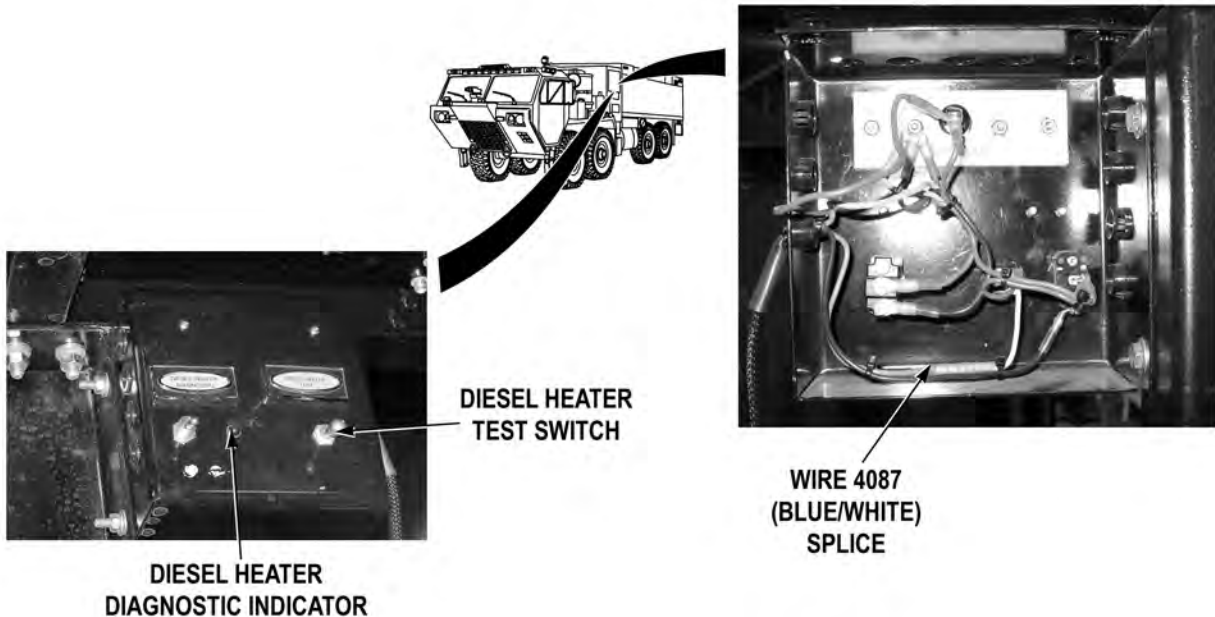
If there is no continuity, repair wire 4087 if repairable (TM 9-2320-325-14&P), or replace pump house heater diagnostic module (WP 0307).



## MALFUNCTION

## TEST OR INSPECTION

## CORRECTIVE ACTION

**WARNING**

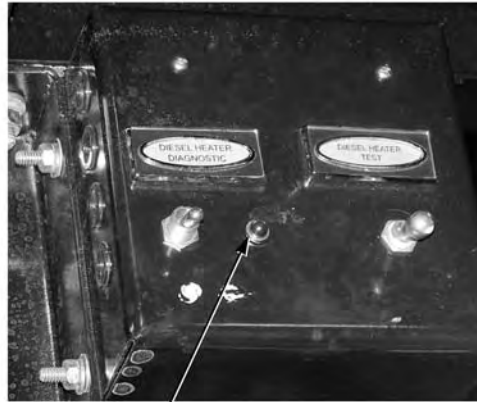
Remove rings, wristwatches, neck chains, and any other jewelry before working around vehicle. Jewelry can catch on equipment and cause serious injury. Jewelry and tools may short across electrical circuits and cause damage to equipment, or severe burns or electrical shock to personnel.

- Step 19. Connect test set lead between white wire which was cut in Step 18 and a known good ground. Connect pump house wire harness pump house heater diagnostic module connector. Connect main wire harness pump house heater four terminal connector. Push battery disconnect switch to on position (WP 0007). Put DIESEL HEATER TEST switch to on position (WP 0004). Check if DIESEL HEATER DIAGNOSTIC indicator illuminates (WP 0004).
- a. If DIESEL HEATER DIAGNOSTIC indicator illuminates, repair pump house diagnostic module wire 4087 (blue and white) (TM 9-2320-325-14&P), and replace pump house heater (WP 0310).
  - b. If DIESEL HEATER DIAGNOSTIC indicator does not illuminate, replace pump house heater diagnostic module (diagnostic indicator) (WP 0307).

---

**MALFUNCTION****TEST OR INSPECTION****CORRECTIVE ACTION**

---

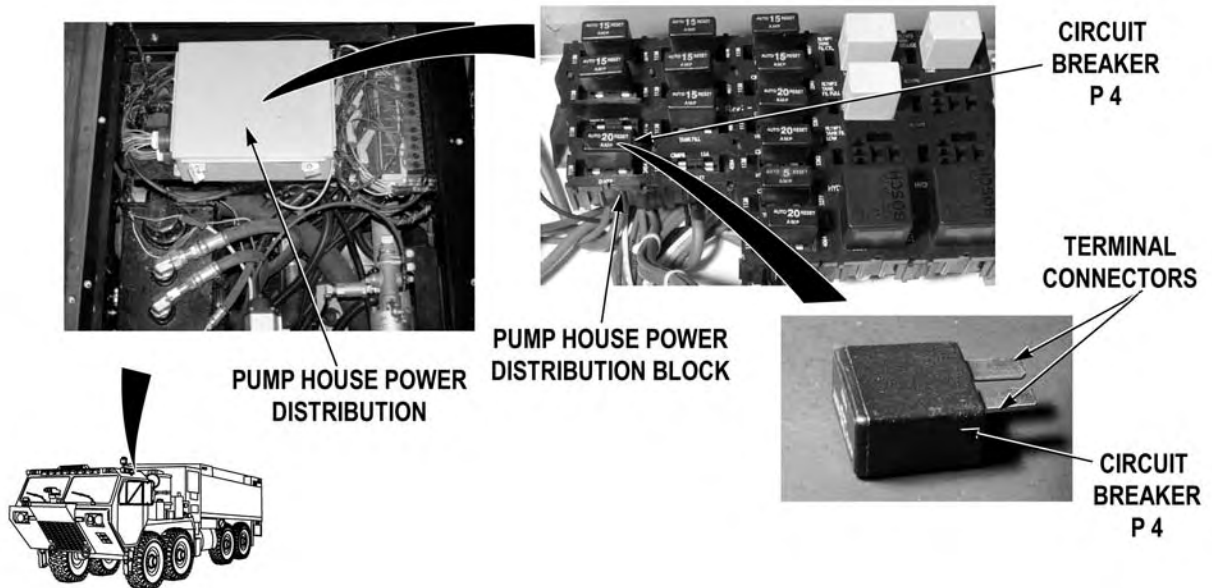


**DIESEL HEATER  
DIAGNOSTIC INDICATOR**

Step 20. Check if DIESEL HEATER DIAGNOSTIC indicator illuminates (WP 0004).

If DIESEL HEATER DIAGNOSTIC indicator does not illuminate, go to Step 26.

**MALFUNCTION**  
**TEST OR INSPECTION**  
**CORRECTIVE ACTION**



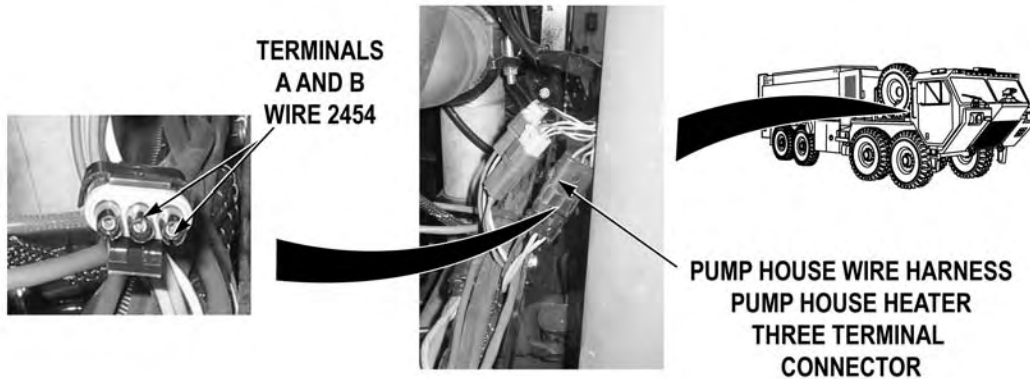
**WARNING**



**Remove rings, wristwatches, neck chains, and any other jewelry before working around vehicle. Jewelry can catch on equipment and cause serious injury. Jewelry and tools may short across electrical circuits and cause damage to equipment, or severe burns or electrical shock to personnel.**

- Step 21. Put DIESEL HEATER TEST switch to off position (WP 0004). Pull battery disconnect switch to off position (WP 0007). Remove pump house panel K (WP 0339). Open pump house power distribution box (WP 0262). Remove circuit breaker P 4 (WP 0262). Check for continuity across circuit breaker P 4.

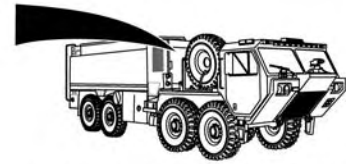
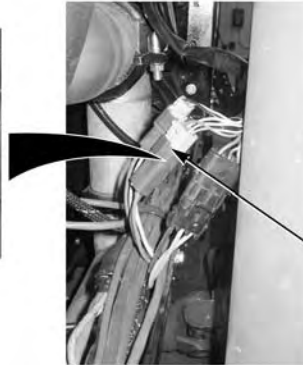
If there is no continuity, replace circuit breaker P 4 (WP 0262).

**MALFUNCTION****TEST OR INSPECTION****CORRECTIVE ACTION**

- Step 22. Install circuit breaker P 4 (WP 0262). Remove pump house panel G (WP 0339). Disconnect pump house wire harness pump house heater three terminal connector. Push battery disconnect switch to on position (WP 0007). Check for 22 to 28 VDC between wires 2454 (green) at pump house wire harness pump house heater three terminal connector, terminals A and B, and a known good ground.
- a. If 22 to 28 VDC are not present at both terminals, go to Step 25.
  - b. If 22 to 28 VDC are present at one but not both terminals, repair wire 2454 in pump house wire harness if repairable (TM 9-2320-325-14&P), or replace pump house wire harness (WP 0302).
  - c. If 22 to 28 VDC are present at both terminals, go to Step 23.

**MALFUNCTION****TEST OR INSPECTION****CORRECTIVE ACTION**

TERMINAL 2  
WIRE 4086



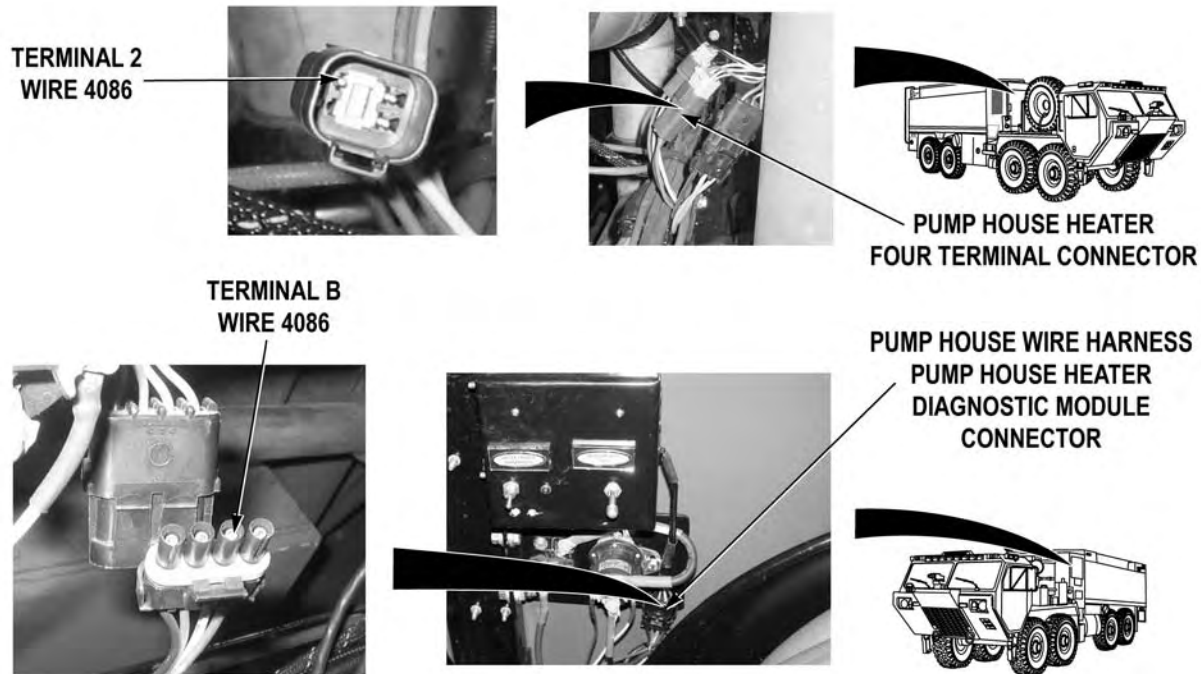
PUMP HOUSE WIRE HARNESS  
PUMP HOUSE HEATER  
FOUR TERMINAL CONNECTOR

**WARNING**

**Remove rings, wristwatches, neck chains, and any other jewelry before working around vehicle. Jewelry can catch on equipment and cause serious injury. Jewelry and tools may short across electrical circuits and cause damage to equipment, or severe burns or electrical shock to personnel.**

- Step 23. Disconnect pump house wire harness pump house heater four terminal connector. Put DIESEL HEATER TEST switch to on position (WP 0004). With a test lead set, check for 22 to 28 VDC between pump house wire harness wire 4086 (yellow) at pump house wire harness pump house heater four terminal connector, terminal 2 and a known good ground.

If 22 to 28 VDC are present, replace pump house heater (WP 0310).

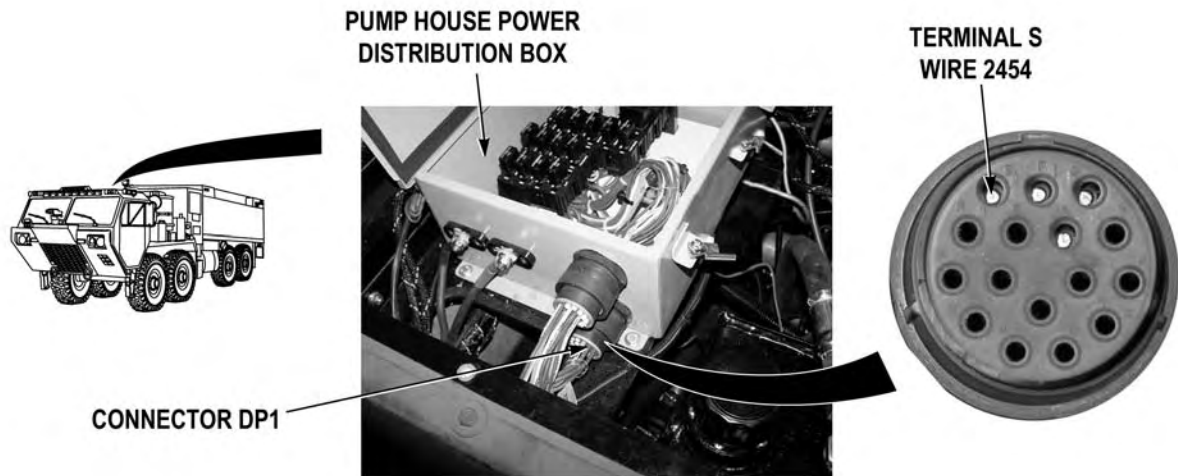
**MALFUNCTION****TEST OR INSPECTION****CORRECTIVE ACTION**

- Step 24. Put DIESEL HEATER TEST switch to off position (WP 0004). Pull battery disconnect switch to off position (WP 0007). Disconnect pump house wire harness pump house heater diagnostic module connector. With a test lead set, check for continuity across pump house wire harness wire 4086 (yellow) from pump house heater diagnostic module connector, terminal B to pump house heater four terminal connector, terminal 2.
- a. If there is continuity, repair wire 4068 in pump house heater diagnostic module wire harness if repairable (TM 9-2320-325-14&P), or replace pump house heater diagnostic module wire harness (WP 0307).
  - b. If there is no continuity, repair wire 4068 in pump house wire harness if repairable (TM 9-2320-325-14&P), or replace pump house wire harness (WP 0302).

## MALFUNCTION

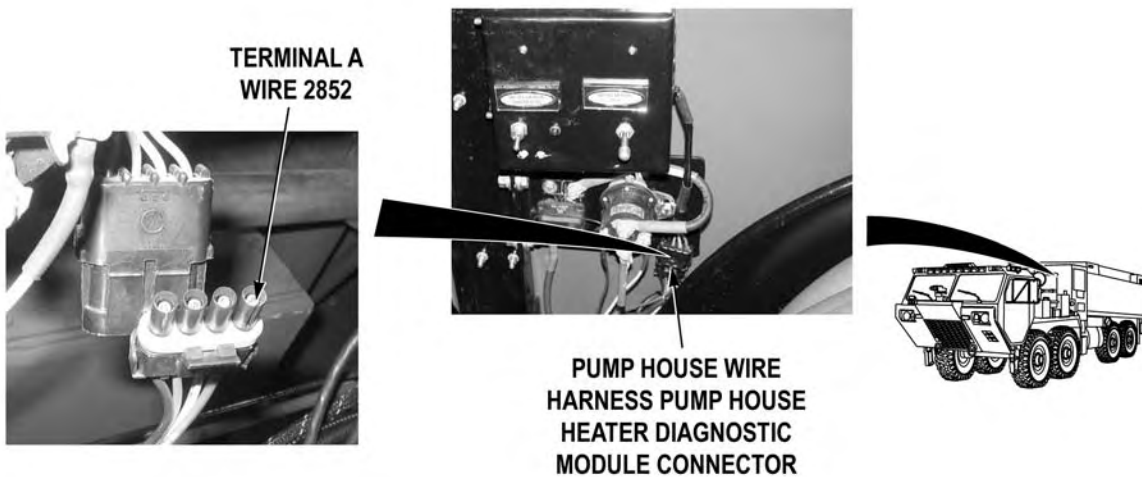
## TEST OR INSPECTION

## CORRECTIVE ACTION

**WARNING**

Remove rings, wristwatches, neck chains, and any other jewelry before working around vehicle. Jewelry can catch on equipment and cause serious injury. Jewelry and tools may short across electrical circuits and cause damage to equipment, or severe burns or electrical shock to personnel.

- Step 25. Disconnect pump house wire harness pump house power distribution connector DP1. With a test lead set, check for 22 to 28 VDC between wire 2454 (green) at pump house power distribution wire harness connector DP1, terminal S and a known good ground.
- a. If 22 to 28 VDC are not present, repair wire 2454 in pump house power distribution wire harness if repairable (TM 9-2320-325-14&P), or replace pump house power distribution wire harness and block (WP 0299).
  - b. If 22 to 28 VDC are present, repair wire 2454 in pump house wire harness if repairable (TM 9-2320-325-14&P), or replace pump house wire harness (WP 0302).

**MALFUNCTION****TEST OR INSPECTION****CORRECTIVE ACTION****WARNING**

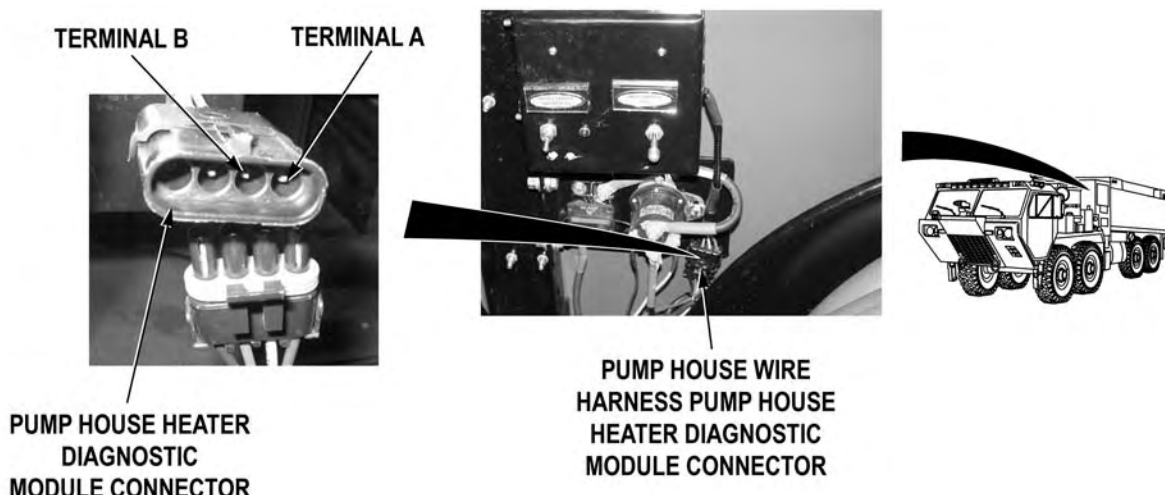
**Remove rings, wristwatches, neck chains, and any other jewelry before working around vehicle. Jewelry can catch on equipment and cause serious injury. Jewelry and tools may short across electrical circuits and cause damage to equipment, or severe burns or electrical shock to personnel.**

- Step 26. Disconnect pump house wire harness pump house heater diagnostic module connector. With a test lead set, check for 22 to 28 VDC between wire 2852 (red) at pump house wire harness pump house heater diagnostic module connector, terminal A and a known good ground.

If 22 to 28 VDC are not present, go to Step 32.

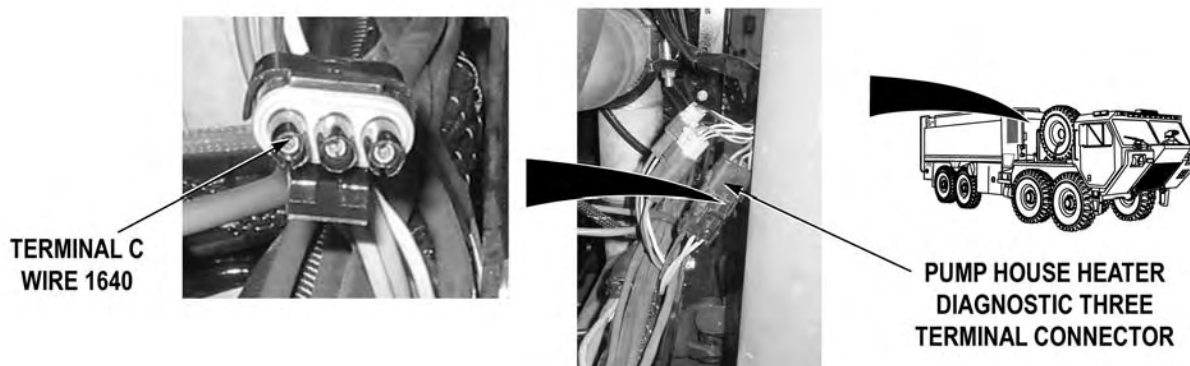


**MALFUNCTION**  
**TEST OR INSPECTION**  
**CORRECTIVE ACTION**



Step 27. Pull battery disconnect switch to off position (WP 0007). With a test lead set, check for continuity across pump house heater diagnostic module connector, terminals A and B when DIESEL HEATER TEST switch is in on position (WP 0004).

If there is no continuity, go to Step 29.



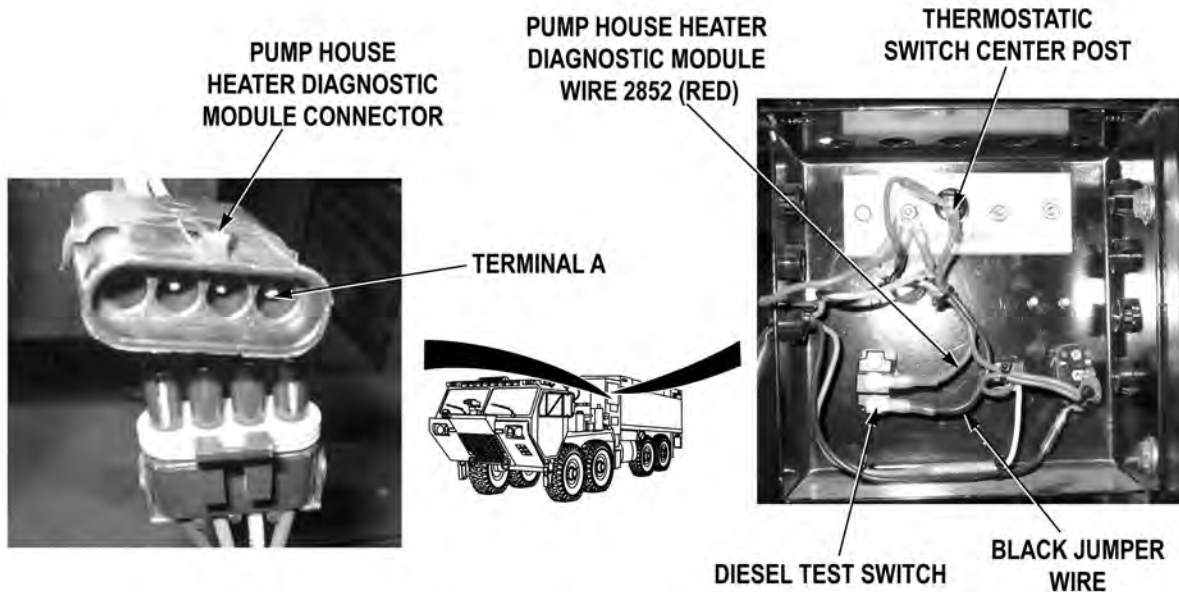
Step 28. Remove pump house panel G (WP 0339). Disconnect pump house wire harness pump house heater three terminal connector. With a test lead set, check for continuity across wire 1640 (black) from pump house wire harness pump house heater three terminal connector, terminal C to a known good ground.

- a. If there is continuity, replace pump house heater (WP 0310).
- b. If there is no continuity, repair wire 1640 in pump house wire harness if repairable (TM 9-2320-325-14&P), or replace pump house wire harness (WP 0302).

**MALFUNCTION**

**TEST OR INSPECTION**

**CORRECTIVE ACTION**



Step 29. Check for continuity across pump house heater diagnostic module wire 2852 (red) from pump house diagnostic module connector, terminal A to thermostatic switch center post (red wire) terminal.

If there is no continuity, repair wire 2852 if repairable (TM 9-2320-325-14&P), or replace pump house heater diagnostic module (WP 0307).

Step 30. Check for continuity across pump house heater diagnostic module DIESEL HEATER TEST switch when in on position (WP 0004).

If there is no continuity, replace pump house heater diagnostic module DIESEL HEATER TEST switch (WP 0306).

Step 31. Check for continuity across pump house heater diagnostic module wire 2852 (red) from thermostatic switch center post (red wire) terminal to DIESEL HEATER TEST switch.

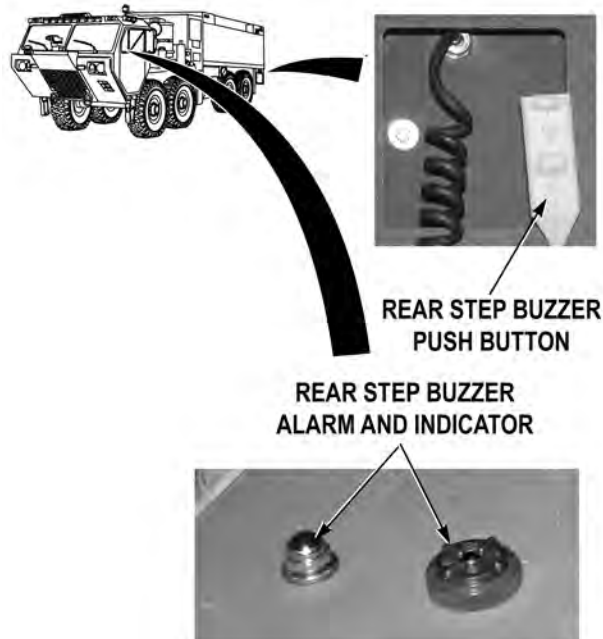
a. If there is continuity, repair black jumperwire between DIESEL HEATER TEST switch and thermostatic switch if repairable (TM 9-2320-325-14&P), or replace pump house heater diagnostic module (WP 0307).

b. If there is no continuity, repair wire 2852 if repairable (TM 9-2320-325-14&P), or replace pump house heater diagnostic module (WP 0307).

**MALFUNCTION**

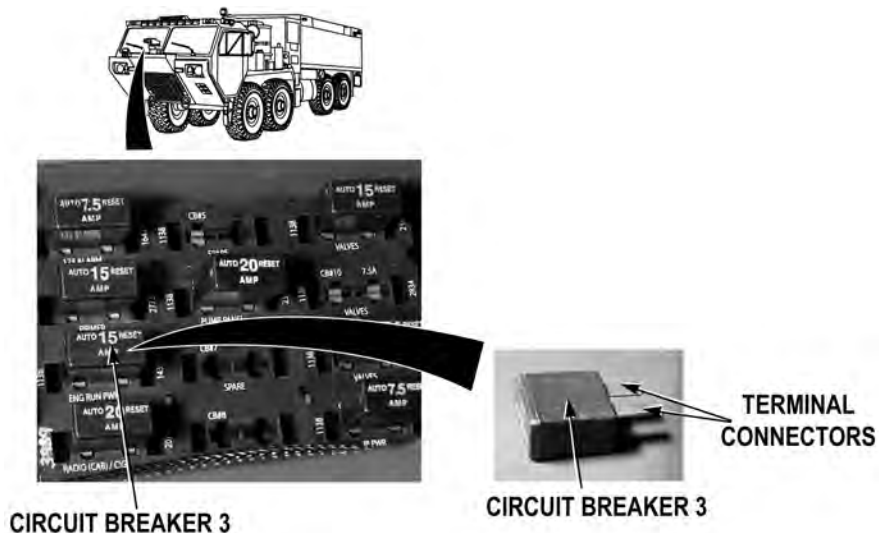
**TEST OR INSPECTION**

**CORRECTIVE ACTION**



Step 32. While an assistant pushes rear step buzzer push button (WP 0004). Check if rear buzzer alarm and indicator operates.

If rear step buzzer indicator and alarm do not operate, replace cab power distribution wire harness and block (WP 0280).



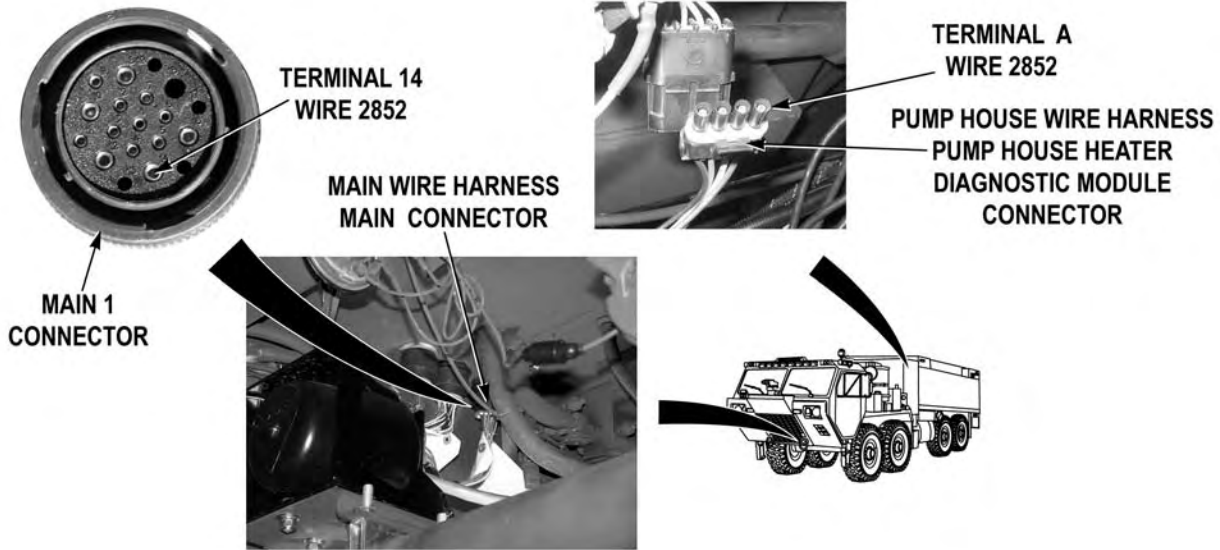
Step 33. Pull battery disconnect switch to off position (WP 0007). Remove cab instrument panel A (WP 0205). Remove circuit breaker 3 (WP 0242). Check for continuity across circuit breaker 3.

If there is no continuity, replace circuit breaker 3 (WP 0242).

**MALFUNCTION**

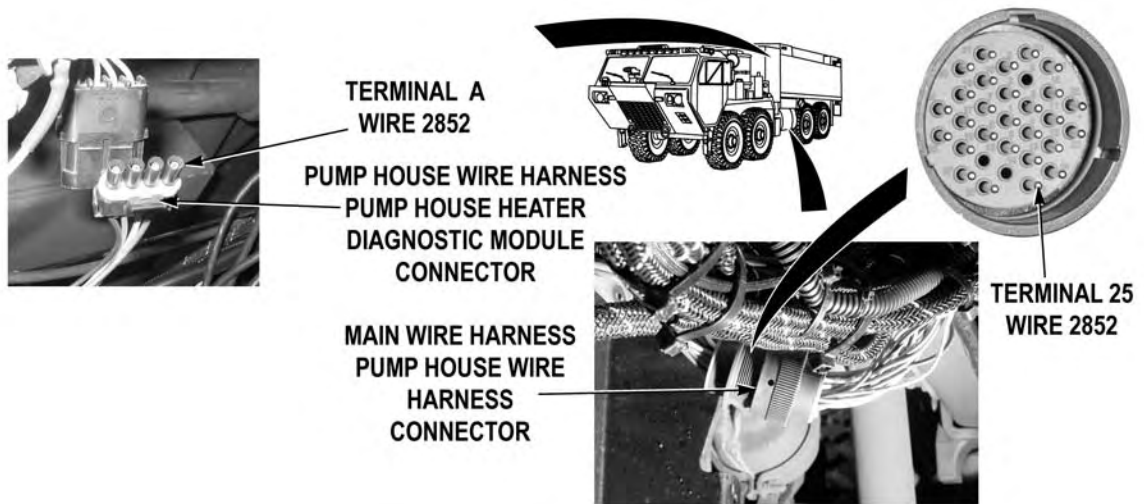
**TEST OR INSPECTION**

**CORRECTIVE ACTION**



Step 34. Remove skid plate grille (WP 0349). Disconnect main wire harness main 1 connector. With a lead test set, check for continuity across wire 2852 (red) from main wire harness main 1 connector, terminal 14 to pump house heater diagnostic module connector, terminal A.

If there is continuity, repair wire 2852 in cab power distribution wire harness if repairable (TM 9-2320-325-14&P), or replace cab power distribution wire harness and block (WP 0280).

**MALFUNCTION****TEST OR INSPECTION****CORRECTIVE ACTION**

- Step 35. Disconnect main wire harness pump house wire harness connector. With a test lead set, check for continuity across pump house wire harness wire 2852 (red) from main wire harness pump house wire harness connector, terminal 25 to pump house wire harness pump house heater diagnostic module connector, terminal A.
- a. If there is continuity, repair wire 2852 in main wire harness if repairable (TM 9-2320-325-14&P), or replace main wire harness (WP 0292).
  - b. If there is no continuity, repair wire 2852 in pump house wire harness if repairable (TM 9-2320-325-14&P), or replace pump house wire harness (WP 0302).

**END OF TASK****FOLLOW-ON MAINTENANCE**

Remove wheel chocks (TM 9-2320-422-10)

**END OF TASK****END OF WORK PACKAGE**



## **CHAPTER 4**

### **PREVENTIVE MAINTENANCE CHECKS AND SERVICES (PMCS)**





---

**FIELD LEVEL MAINTENANCE****PREVENTIVE MAINTENANCE CHECKS AND SERVICES (PMCS) INTRODUCTION**

---

**INTRODUCTION**

Preventive Maintenance Checks and Services (PMCS) are required inspections and care of your vehicle is necessary to keep it in proper working order. All instructions are mandatory. This section contains PMCS requirements for the HEWATT installed enhancements to the basic HEMTT vehicle. The PMCS table (WP 0129) contains checks and services necessary to ensure enhancements are ready for operation. Using the PMCS table, perform preventive maintenance checks and services at the specified intervals.

**WARNING**

Solvent cleaning compound MIL-PRF-680 Type II and III may be irritating to the eyes and skin. Use protective gloves and goggles. Use in well-ventilated areas. Use respirator as needed. Accidental ingestion can cause irritation of digestive tract and respiratory tract, may cause lung and central nervous system damage. Can be fatal if swallowed. Inhalation of high/massive concentrations can cause coma or be fatal. First aid for ingestion: do not induce vomiting. Seek immediate medical attention. First aid for skin contact: remove contaminated clothing. Wash skin thoroughly with soap and water. If symptoms persist, seek medical attention. First aid for eye contact: flush with water for 15 minutes or until irritation subsides. If symptoms persist, seek medical attention. First aid for inhalation: move to fresh air. If not breathing, provide artificial respiration. If symptoms persist, seek medical attention. Keep away from open flames and other sources of ignition. Failure to follow this warning may result in injury or death to personnel.

- The flashpoint for Type II solvent cleaning compound is 141 to 198°F (61 to 92°C) and Type III is 200 to 241°F (93 to 116°C).
- Improper cleaning methods and use of unauthorized cleaning solvents may injure personnel and damage equipment.
- Fire extinguishers should be placed nearby when using solvent cleaning compound. Failure to follow this warning may result in injury or death.
- Cloths or rags saturated with solvent cleaning compound must be disposed of IAW authorized facility's procedures. Failure to follow this warning may result in injury.
- Eye shields must be worn when cleaning with a wire brush. Flying rust and metal particles may cause injury.

**a. Cleanliness.**

Dirt, grease, oil, and debris only get in the way and may cover up a serious problem. Use solvent cleaning compound on metal surfaces and soapy water on rubber.

**b. Bolts, Nuts, and Screws.**

Check bolts, nuts, and screws for obvious looseness, missing, bent, or broken condition and tighten or replace as necessary. If they cannot be checked with a tool, look for chipped paint, bare metal, or rust around bolt heads.

**c. Welds.**

Look for loose or chipped paint, rust, or gaps where parts are welded together. If a cracked weld is found, notify the supervisor.

**d. Electrical Wires and Connectors.**

Look for cracked or broken insulation, exposed wires, and loose or broken connectors. Tighten loose connectors and ensure that wires are in good shape.

**e. Fluid Hoses, Tubes, and Fittings.**

Look for wear, damage, or leaks. Ensure clamps and fittings are tight. Wet spots show leaks, but a stain around a fitting or connector may also indicate a leak. If connector or fitting is loose, tighten it. If hoses, tubes, or fittings are broken or worn out, repair or replace per applicable procedure.

**f. Air System Components.**

Look for worn, damaged, or leaking components. Ensure clamps and fittings are tight. If a leak comes from a loose fitting or connector, tighten it. If component is damaged or worn out, repair or replace per applicable procedure.

**g. Damage.**

Damage is defined as any condition that affects safety or would make the truck unserviceable for mission requirements.

---

## PMCS WARNINGS AND CAUTIONS

Always observe the warnings and cautions appearing in your PMCS table. Warnings and cautions appear before applicable procedures. You must observe these warnings and cautions to prevent serious injury to yourself or prevent equipment being damaged.

## EXPLANATION OF TABLE ENTRIES

If an item or component being inspected is inoperable or damaged, either troubleshoot by following instructions in troubleshooting section of this manual or repair and/or replace as described in related maintenance task.

When doing preventive maintenance, take along tools and supplies needed to make all checks, including a clean cloth or two.

The following is a breakdown of the PMCS table:

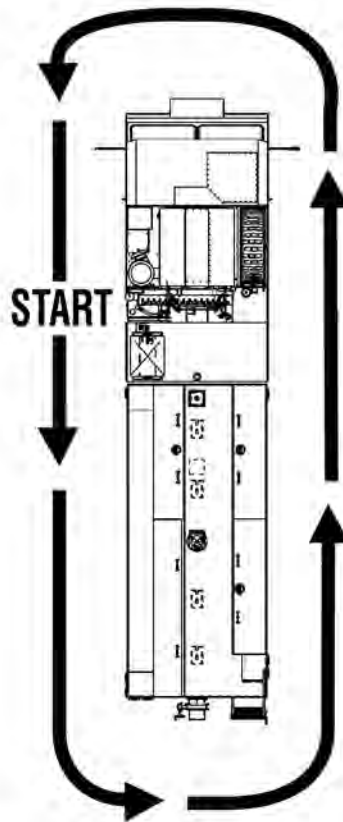
1. **Item No. Column.** Checks and services are numbered in a logical order for moving around the vehicle.
2. **Interval Column.** This column identifies when the PMCS should be performed.
  - (a) Perform (A-After Operations) checks right after operating vehicle.
  - (b) Perform (D-During Operations) checks during operation of vehicle.
  - (c) Perform (W-Weekly) checks weekly.
  - (d) Perform (M-Monthly) checks monthly.
3. **Item To Be Inspected Procedure Column.** This column identifies item to be inspected and contains all information required to do check/inspection. A digital photo is supplied to aid user in identifying items. Whenever replacement is recommended, reference is made to applicable maintenance instructions.
4. **Not Mission Capable If Column.** This column contains a brief statement of condition that would cause vehicle to be less than fully ready to perform its assigned mission.

## ROUTING DIAGRAM

**WARNING**

**Engine must be shut off and parking brake set before performing PMCS walk around. Severe injury to personnel may result.**

Refer to Preventive Maintenance Checks and Services (PMCS) for HEWATT vehicle. This routing diagram will be of help to complete the PMCS. It shows vehicle PMCS routing track that matches the sequence of PMCS to be performed.



---

## LEAKAGE CLASSIFICATION AND DEFINITION

Extreme weather conditions, periods of high use, or combat conditions may dictate that PMCS is performed more often than is required in the PMCS Table.

As PMCS is performed, look for and be aware of an unusual amount of puddles, or unusually large puddles. Excessive puddles could indicate a leakage problem.

It is necessary to know how fluid leakage affects status of fuel, oil, coolant, and hydraulic system. The following are definitions of the type/classes of leakage necessary to know in order to determine status of the enhancement. Learn, then be familiar with them and REMEMBER - WHEN IN DOUBT, NOTIFY THE SUPERVISOR.

### **CAUTION**

**Equipment operation is allowable with minor leakage (Class I or II). Consideration must be given to the capacity in item/system being checked/inspected. When in doubt, notify Supervisor. When operating with Class I or II leaks, continue to check fluid levels as required in the PMCS. Class III leaks should be repaired per applicable procedure.**

1. **Class I.** Seepage of fluid, as indicated by wetness or discoloration, not great enough to form drops.
2. **Class II.** Leakage of fluid great enough to form drops, but not enough to cause drops that fall from item being checked/inspected.
3. **Class III.** Leakage of fluid great enough to form drops that fall from item being checked/inspected.

**END OF WORK PACKAGE**



---



**FIELD LEVEL MAINTENANCE****PREVENTIVE MAINTENANCE CHECKS AND SERVICES (PMCS), INCLUDING LUBRICATION INSTRUCTIONS**

---

**PREVENTIVE MAINTENANCE CHECKS AND SERVICES****NOTE**

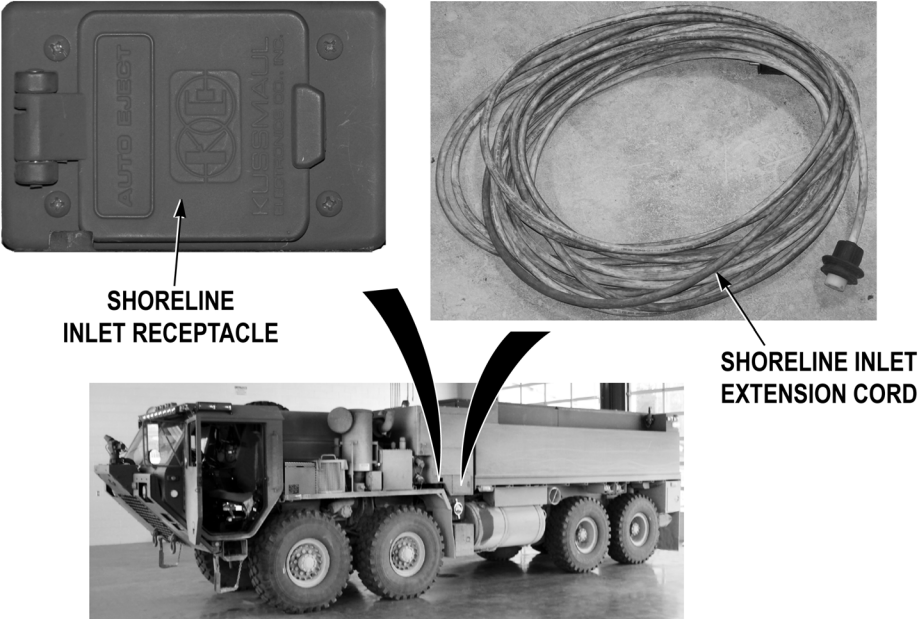
- These checks are to be performed in the order listed, within designated interval.
- Perform basic HEMTT PMCS (TM 9-2320-422-10) prior to performing PMCS in this table.
- Battery switch must be in the ON position to perform PMCS checks (TM 9-2320-422-10).
- While performing PMCS, be aware of any unusual puddles under the vehicle; this could indicate a leakage problem.
- Perform Weekly if:
  - Assigned as the operator but have not operated vehicle since last weekly inspection.
  - Operating the vehicle for the first time.

*Table 1. Preventive Maintenance Checks and Services.*

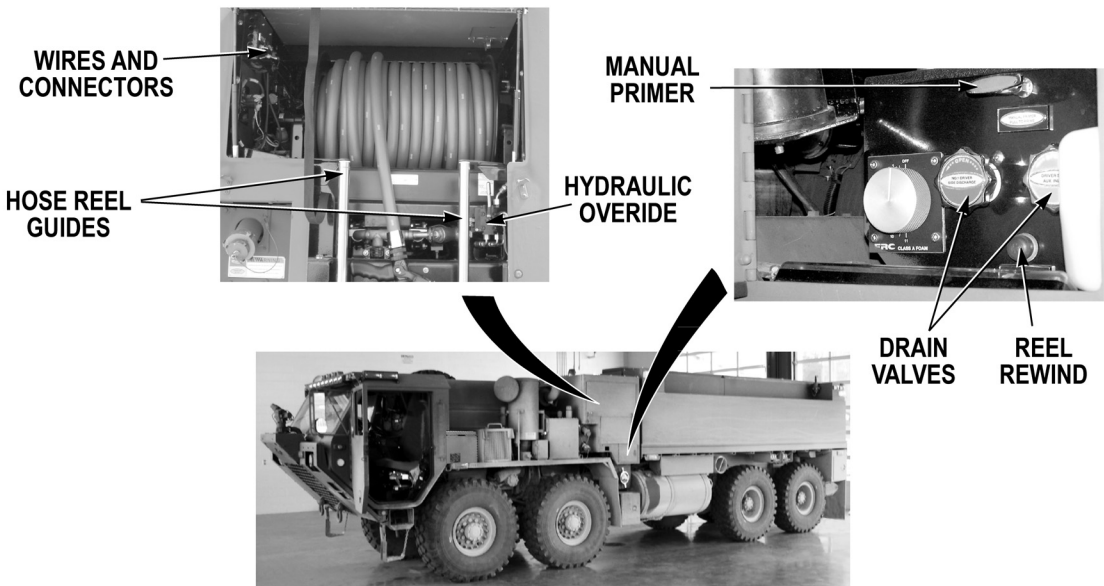
Item No.	Interval	Item To Inspect Or Service	Procedure	Not Fully Mission Capable if:
<p><b>MAKE THE FOLLOWING WALK AROUND CHECKS:</b></p> <p style="text-align: center;"><b><u>WARNING</u></b></p> <div style="text-align: center;">  </div> <p><b>Chock wheels prior to performing any After Operation, Weekly, or Monthly PMCS procedures.</b></p> <div style="text-align: center;">  <p><b>SINGGARS</b></p> </div>				
1	A	Driver Side Body	<ul style="list-style-type: none"> <li>a. Inspect SINGGARS access door and enclosure for damage and loose or missing hardware.</li> <li>b. Inspect SINGGARS for damage and/or loose connections.</li> </ul>	If SINGGARS is damaged or non-operational.



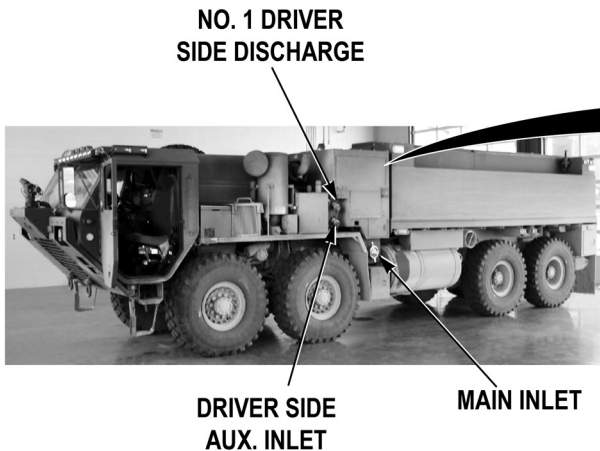
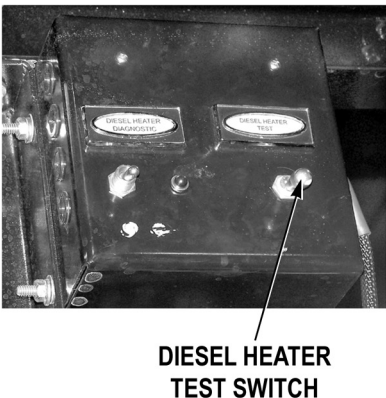
**Table 1. Preventive Maintenance Checks and Services. (Continued)**

Item No.	Interval	Item To Inspect Or Service	Procedure	Not Fully Mission Capable if:
2	A	Driver Side Pump House	<div style="text-align: center;">  <p>SHORELINE INLET RECEPTACLE</p> <p>SHORELINE INLET EXTENSION CORD</p> </div> <ol style="list-style-type: none"> <li>a. Check if pump house access panels are free from damage and loose or missing hardware.</li> <li>b. Check if shoreline inlet receptacle operates and is free from damage and loose or missing hardware.</li> <li>c. Check shoreline inlet extension cord and seals for damage or excessive wear.</li> </ol>	






**Table 1. Preventive Maintenance Checks and Services. (Continued)**

Item No.	Interval	Item To Inspect Or Service	Procedure	Not Fully Mission Capable if:
			<p>d. Examine hose reel, hose, and hose reel guide assembly for damage and loose or missing hardware. (Lubricate if required, see Table 2).</p> <p>e. Examine hose reel nozzle for damage and obstructions.</p> <p>f. Check if REEL REWIND button, MANUAL PRIMER handle, and hydraulic override controls operate and are free from damage (WP 0004).</p> <p>g. Check if NO. 1 DRIVER SIDE DISCHARGE and DRIVER SIDE AUX. INLET drain valves operate and are free from damage.</p> <p>h. Check if water piping, foam piping, hydraulic hoses, and air hoses are free from leaks, kinks, damage and loose or missing fittings.</p> <p>i. Check if wires are free from damage and loose connections.</p>	<p>If water piping, foam piping, hydraulic hoses are damaged or have loose or missing hardware.</p> <p>If wires are damaged.</p>


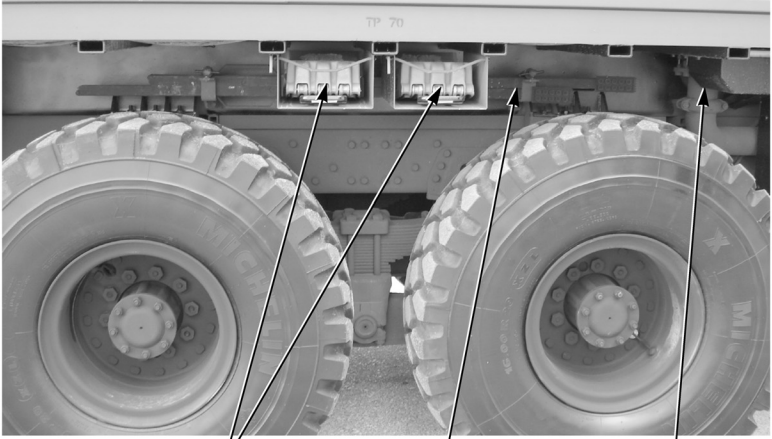

**Table 1. Preventive Maintenance Checks and Services. (Continued)**

Item No.	Interval	Item To Inspect Or Service	Procedure	Not Fully Mission Capable if:
				<ul style="list-style-type: none"> <li>j. Check if main inlet, NO. 1 DRIVER SIDE DISCHARGE, and DRIVER SIDE AUX. INLET caps operate properly and are free from damage.</li> <li>k. Check if main inlet screen is present and free from damage.</li> <li>l. Operate diesel heater test switch. Check if heater operates (WP 0004).</li> </ul>



**Table 1. Preventive Maintenance Checks and Services. (Continued)**

Item No.	Interval	Item To Inspect Or Service	Procedure	Not Fully Mission Capable if:
3	A	Driver Side Body	<div style="display: flex; justify-content: space-around; align-items: center;">   </div> <p style="text-align: center;"><b>STOWAGE COMPARTMENT D2</b></p> <p style="text-align: center;"><b><u>WARNING</u></b></p> <div style="display: flex; justify-content: center; gap: 10px;">    </div> <ul style="list-style-type: none"> <li>• <b>Items in compartments may have shifted or come loose during operations. Use caution and be aware that items may fall out while opening doors, causing injury to personnel.</b></li> <li>• <b>While parked on side slopes, items inside compartments may fall out. Use caution and be aware that items may fall out while opening doors causing injury to personnel.</b></li> </ul>	
			<ol style="list-style-type: none"> <li>a. Check if stowage compartment door D2 operates and is free from damage, debris, and loose or missing hardware. (Lubricate if required, see Table 2.)</li> <li>b. Inventory and inspect all COEI and BII items that have been used in mission for damage, missing gaskets, and proper operation (WP 0040).</li> <li>c. Inspect COEI and BII mountings for damage and loose or missing hardware.</li> <li>d. If fording operations were required, inspect D2 stowage compartment for dirt, debris, and foreign materials. Clean stowage compartment D2, COEI, and BII if required.</li> </ol>	

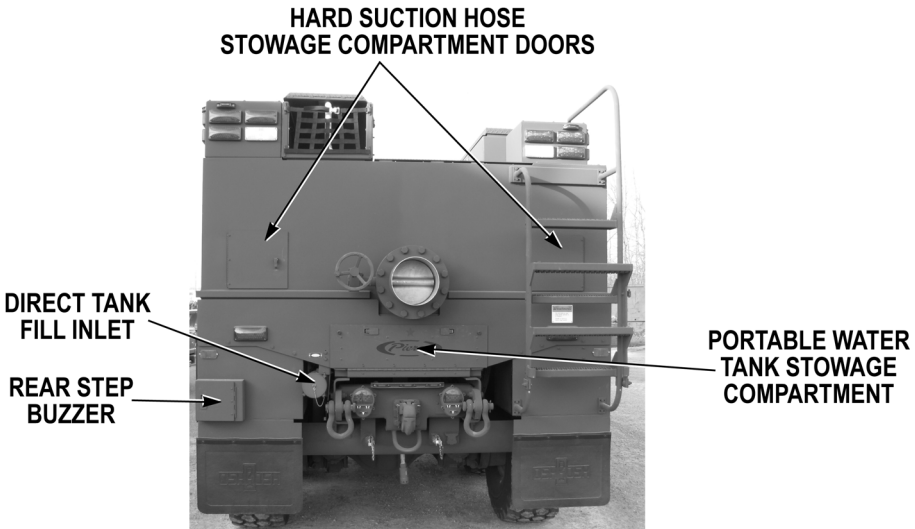
**Table 1. Preventive Maintenance Checks and Services. (Continued)**

Item No.	Interval	Item To Inspect Or Service	Procedure	Not Fully Mission Capable if:
			 <p style="text-align: center;"> <span data-bbox="776 972 954 999">WHEEL CHOCKS</span>                         <span data-bbox="1003 972 1198 999">FOLDING LADDER</span>                         <span data-bbox="1256 972 1403 1026">DIRECT TANK FILL VALVE</span> </p> <p style="text-align: center;"><b><u>WARNING</u></b></p>  <ul style="list-style-type: none"> <li>• <b>Items in compartments may have shifted or come loose during operations. Use caution and be aware that items may fall out while opening doors, causing injury to personnel.</b></li> <li>• <b>While parked on side slopes, items inside compartments may fall out. Use caution and be aware that items may fall out while opening doors causing injury to personnel.</b></li> </ul>	<p>e. Inventory wheel chocks and inspect wheel chock stowage compartment for damage and loose or missing hardware.</p> <p>f. Check folding ladder for damage and loose or missing hardware.</p> <p>g. Check DIRECT TANK FILL valve for damage and loose or missing hardware.</p>

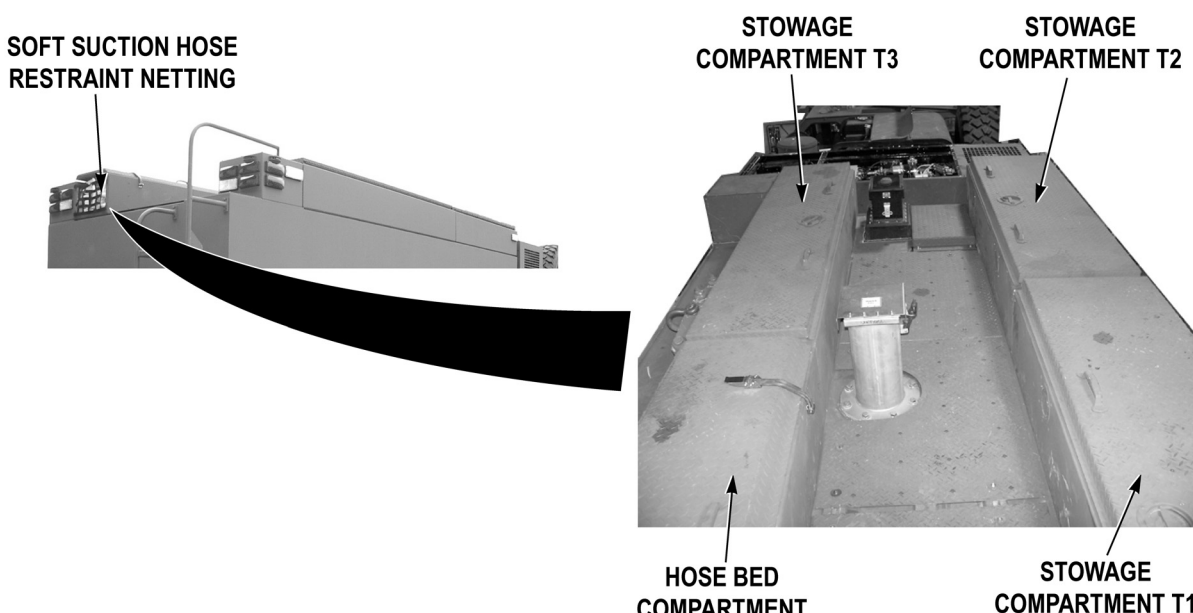

**Table 1. Preventive Maintenance Checks and Services. (Continued)**

Item No.	Interval	Item To Inspect Or Service	Procedure	Not Fully Mission Capable if:
			<div style="display: flex; justify-content: space-around; align-items: center;">   </div> <p style="text-align: center; margin-top: 10px;"><b>STOWAGE COMPARTMENT D1</b></p> <p data-bbox="570 835 1170 1184">                     h. Check if stowage compartment door D1 operates and is free from damage, debris, and loose or missing hardware. (Lubricate if required, see Table 2.)                      i. Check if stowage compartment D1 striplight operates.                      j. Inventory and inspect all COEI and BII items that have been used in mission for damage, missing gaskets, and proper operation (WP 0040).                 </p>	

**Table 1. Preventive Maintenance Checks and Services. (Continued)**

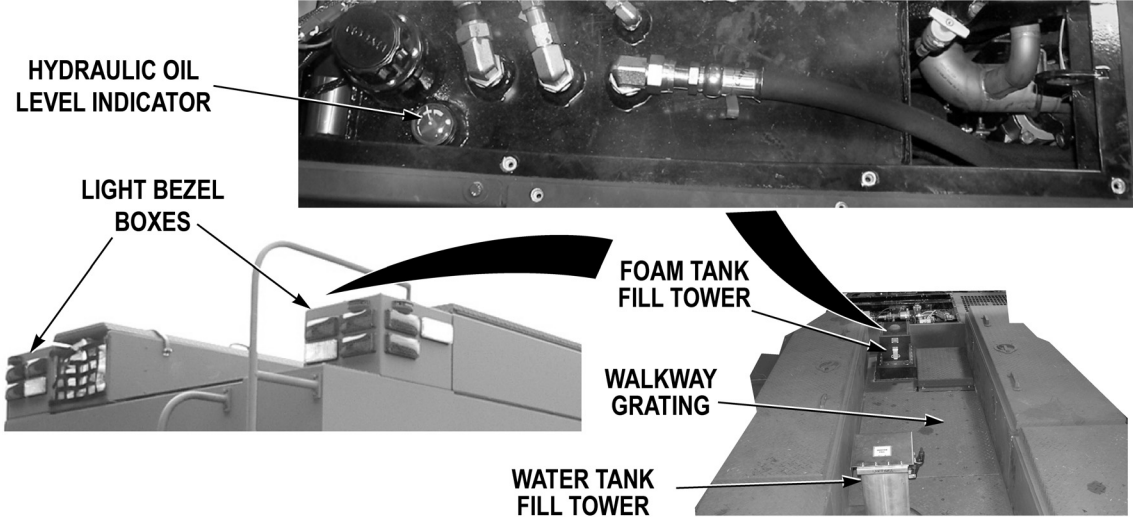
Item No.	Interval	Item To Inspect Or Service	Procedure	Not Fully Mission Capable if:
4	A	Rear Body	 <p>a. Check if REAR STEP BUZZER operates and compartment is free from damage and loose or missing hardware. Check if audible warning buzzer and indicator operate inside personnel cab.</p> <p>b. Check if hard suction hose stowage compartment doors operate and are free from damage, debris, and loose or missing hardware. (Lubricate if required, see Table 2.)</p> <p>c. Check if hard suction hoses and connections are free from damage and obstructions.</p> <p>d. Check if hard suction hose gaskets are present and free from excessive wear and damage.</p> <p>e. Check if portable water tank compartment door operates and is free from damage, debris, and loose or missing hardware. (Lubricate if required, see Table 2.)</p> <p>f. Check if DIRECT TANK FILL inlet, cap, and strainer are free from damage and loose or missing hardware.</p>	

**Table 1. Preventive Maintenance Checks and Services. (Continued)**

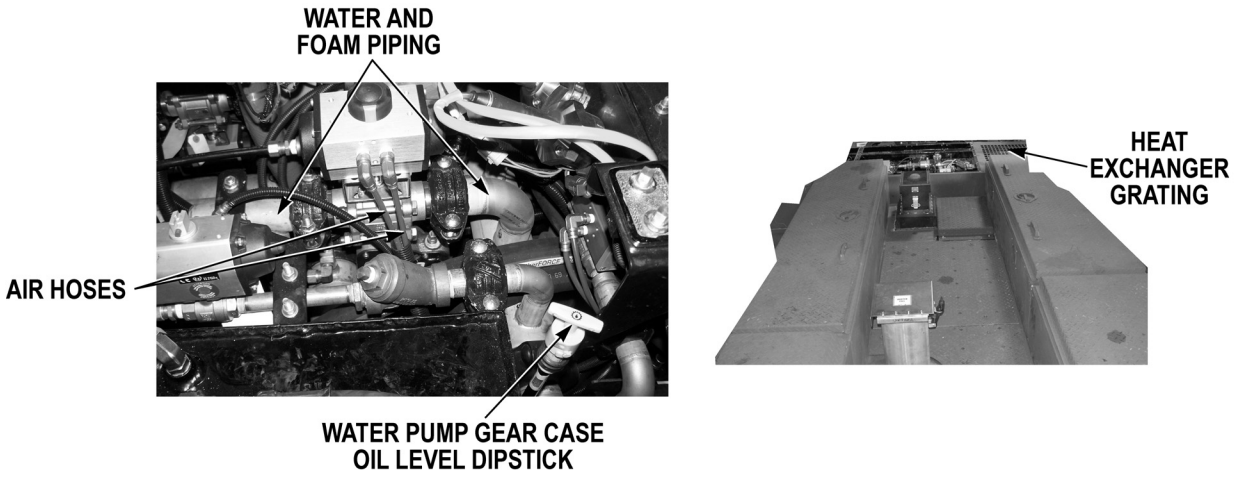
Item No.	Interval	Item To Inspect Or Service	Procedure	Not Fully Mission Capable if:
5	A	Vehicle Body Top	<div style="text-align: center;">  <p><b>WARNING</b></p>  <p><b>Compartment doors that swing up are heavy. Ensure to have a firm grip when opening. Failure to comply may result in injury to personnel.</b></p> </div> <ol style="list-style-type: none"> <li>a. Check if hose bed compartment door operates and is free from damage, debris, and loose or missing hardware. (Lubricate if required, see Table 2.)</li> <li>b. Check if hose restraint netting is free from excessive wear, tears, cuts, or burns.</li> <li>c. Check if stowage compartment doors T1, T2, and T3 operate and are free from damage, debris, and loose or missing hardware. (Lubricate if required, see Table 2.)</li> <li>d. Check if stowage compartment T1, T2, and T3 striplights operate.</li> <li>e. Inventory and inspect all COEI and BII items that have been used in mission for damage, missing gaskets, and proper operation (WP 0040).</li> </ol>	



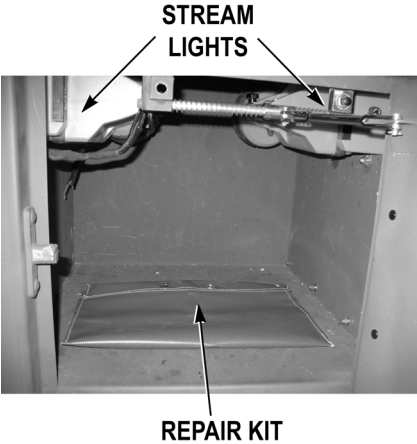
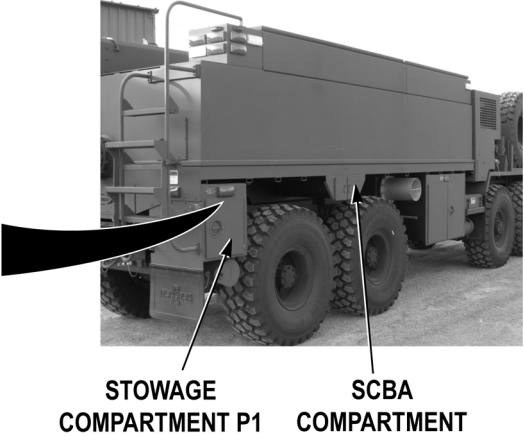

**Table 1. Preventive Maintenance Checks and Services. (Continued)**

Item No.	Interval	Item To Inspect Or Service	Procedure	Not Fully Mission Capable if:
			<p>f. Check if WATER TANK fill tower and cover operate and are free from damage and loose or missing hardware. Check water tank for contamination or debris. (Lubricate if required, refer to Table 2.)</p> <p>g. Check if FOAM TANK fill tower and cover operate and are free from damage and loose or missing hardware, Check foam tank for contamination or debris. (Lubricate if required, refer to Table 2.)</p> <p>h. Check walkway grating for damage or loose or missing hardware.</p> <p>i. Check if warning light bezel boxes are free from damage and loose or missing hardware.</p> <p>j. Check hydraulic oil reservoir oil level. If arrow is in green section, hydraulic oil level is ok. (Fill if required, refer to Table 2.)</p>	<p>If hydraulic oil level is low. If hydraulic oil appears milky or foaming.</p>

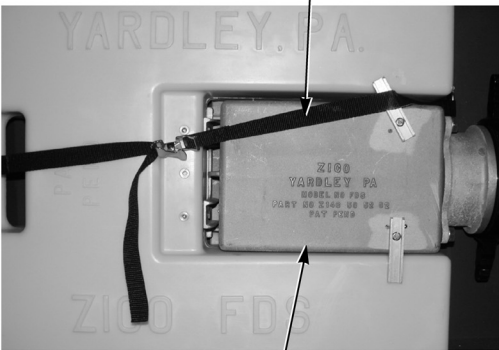




**Table 1. Preventive Maintenance Checks and Services. (Continued)**

Item No.	Interval	Item To Inspect Or Service	Procedure	Not Fully Mission Capable if:
6	A	Vehicle Body Top Pump House	<div style="text-align: center;">  <p style="text-align: center;"><b>NOTE</b></p> <p>Water pump gear case oil level may be checked either hot or cold.</p> <ol style="list-style-type: none"> <li>a. Check if water piping, foam piping, and air hoses are free from leaks, kinks, damage, and loose or missing fittings.</li> <li>b. Check water pump gear case oil level.</li> <li>c. Check if heat exchanger grating is free from blockage and debris.</li> </ol> </div>	If water pump gear case oil level is low.

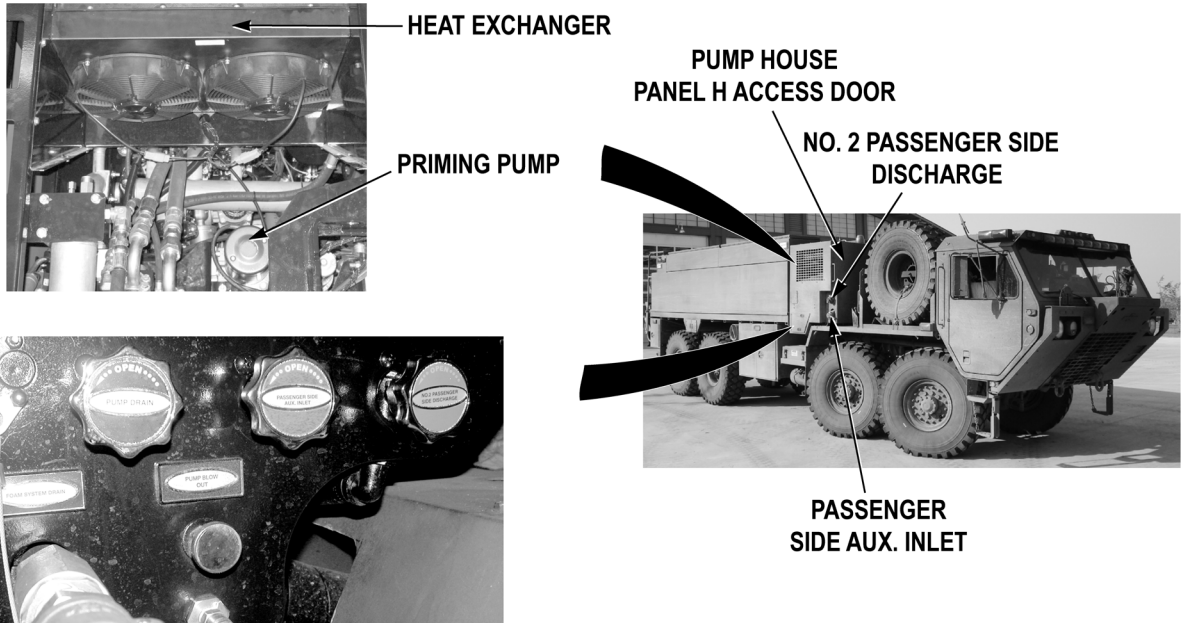
**Table 1. Preventive Maintenance Checks and Services. (Continued)**

Item No.	Interval	Item To Inspect Or Service	Procedure	Not Fully Mission Capable if:
7	A	Passenger Side Body  	 <p style="text-align: center;"><b>WARNING</b></p>  <ul style="list-style-type: none"> <li>• Items in compartments may have shifted or come loose during operations. Use caution and be aware that items may fall out while opening doors, causing injury to personnel.</li> <li>• While parked on side slopes, items inside compartments may fall out. Use caution and be aware that items may fall out while opening doors causing injury to personnel.</li> </ul> <ol style="list-style-type: none"> <li>a. Check if stowage compartment door P1 operates and is free from damage, debris, and loose or missing hardware. (Lubricate if required, see Table 2.)</li> <li>b. Check if stowage compartment P1 striplight operates.</li> <li>c. Check if streamlights and chargers operate and are free from damage. Check streamlight chargers for loose or missing hardware and loose wire connections.</li> <li>d. Inventory and inspect repair kit for portable water tank.</li> <li>e. Inventory SCBA tanks and check if SCBA stowage compartments are free from damage, debris, and loose or missing hardware. (Lubricate if required, see Table 2.)</li> </ol>	

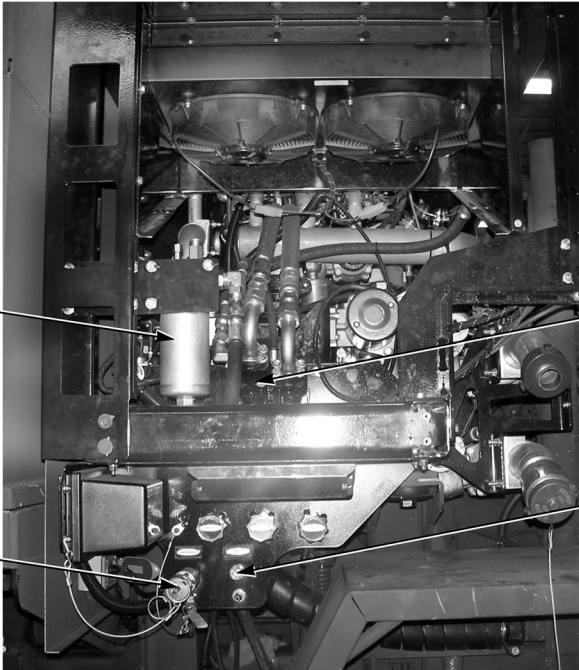
**Table 1. Preventive Maintenance Checks and Services. (Continued)**

Item No.	Interval	Item To Inspect Or Service	Procedure	Not Fully Mission Capable if:
<div style="display: flex; justify-content: space-around; align-items: center;"> <div style="text-align: center;"> <p>SUCTION HOSE STRAINER MOUNTING STRAP</p>  <p>SUCTION HOSE STRAINER</p> </div> <div style="text-align: center;"> <p>STOWAGE COMPARTMENT P2</p>  </div> </div>				
<p><b>WARNING</b></p> <div style="display: flex; justify-content: center; gap: 20px;">    </div>				
<ul style="list-style-type: none"> <li>• Items in compartments may have shifted or come loose during operations. Use caution and be aware that items may fall out while opening doors, causing injury to personnel.</li> <li>• While parked on side slopes, items inside compartments may fall out. Use caution and be aware that items may fall out while opening doors causing injury to personnel.</li> </ul>				
			<p>f. Check if stowage compartment door P2 operates and is free from damage, debris, and loose or missing hardware. (Lubricate if required, see Table 2.)</p> <p>g. Check if stowage compartment P2 striplight operates.</p> <p>h. Check if suction hose strainer mounting strap is free from excessive wear and/or damage.</p> <p>i. Check if suction hose strainer is free from damage and obstructions.</p>	

**Table 1. Preventive Maintenance Checks and Services. (Continued)**

Item No.	Interval	Item To Inspect Or Service	Procedure	Not Fully Mission Capable if:
8	A	Passenger Side Pump House	 <p>The procedure section contains seven numbered steps (a-g) detailing the inspection and service requirements for the passenger side pump house components.</p> <ol style="list-style-type: none"> <li>Check if pump house access panels are free from damage and loose or missing hardware.</li> <li>Open pump house panel H access door.</li> <li>Check heat exchanger assembly for damage and loose or missing hardware.</li> <li>Check if priming pump is free from damage and loose or missing hardware.</li> <li>Check if NO. 2 PASSENGER SIDE DISCHARGE and PASSENGER SIDE AUX. INLET and pump drain valves operate and are free from damage and loose or missing hardware.</li> <li>Check if NO. 2 PASSENGER SIDE DISCHARGE, and PASSENGER SIDE AUX. INLET caps operate properly and are free from damage. Check gaskets for tears, rips, and excessive wear.</li> <li>Check PASSENGER SIDE AUX. INLET strainer screen for damage, debris, and obstructions.</li> </ol>	

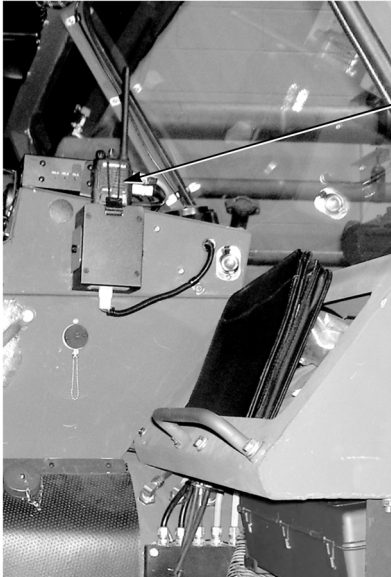
**Table 1. Preventive Maintenance Checks and Services. (Continued)**

Item No.	Interval	Item To Inspect Or Service	Procedure	Not Fully Mission Capable if:
				
			<ul style="list-style-type: none"> <li data-bbox="570 1136 1146 1226">h. Check if foam system drain valve and pump blow out operate and are free from loose or missing hardware.</li> <li data-bbox="570 1247 1146 1337">i. Check if water piping, foam piping, hydraulic hoses, and air hoses are free from leaks, kinks, damage and loose or missing fittings.</li> <li data-bbox="570 1457 1105 1509">j. Check if wires are free from damage and loose connections.</li> <li data-bbox="570 1535 1127 1625">k. Check if hydraulic oil filter assembly is free from leaks, damage, and loose or missing hardware.</li> <li data-bbox="570 1650 1138 1740">l. Check if hydraulic charge pump is free from leaks, damage, and loose or missing hardware.</li> <li data-bbox="570 1766 1105 1856">m. Check valves, valve motors, and other equipment for loose wire connections, damage, and loose or missing hardware.</li> </ul>	<p data-bbox="1195 1247 1414 1436">If water piping, foam piping, hydraulic hoses are damaged or have loose or missing hardware.</p> <p data-bbox="1195 1457 1325 1520">If wires are damaged.</p>

**Table 1. Preventive Maintenance Checks and Services. (Continued)**

Item No.	Interval	Item To Inspect Or Service	Procedure	Not Fully Mission Capable if:
9	A	Passenger Side Personnel Cab	<div data-bbox="467 472 1328 1050" data-label="Image"> </div> <ol style="list-style-type: none"> <li>a. Check if SCBA seat if free from damage and loose or missing hardware.</li> <li>b. Check if SCBA breakaway brackets are free from damage and loose or missing fittings.</li> <li>c. Check if seatbelt is free from rips, tears, and excessive wear. Check if seatbelt is free from damage and loose or missing hardware.</li> <li>d. Check that seatbelt and latch operate properly.</li> <li>e. Inventory and inspect personnel cab COEI and BII (WP 0040).</li> </ol>	

**Table 1. Preventive Maintenance Checks and Services. (Continued)**

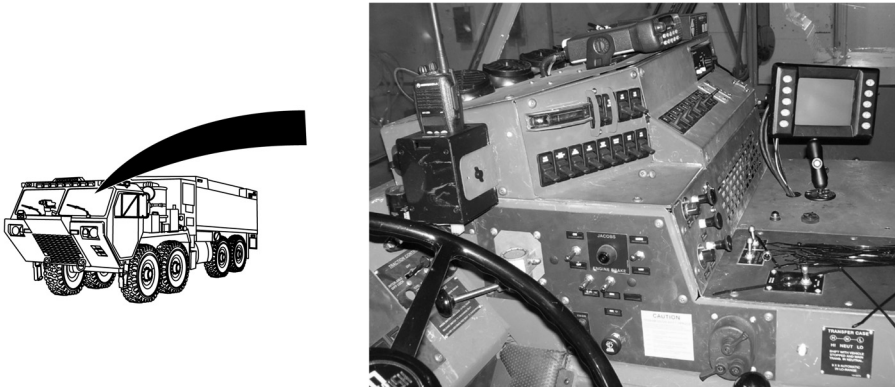
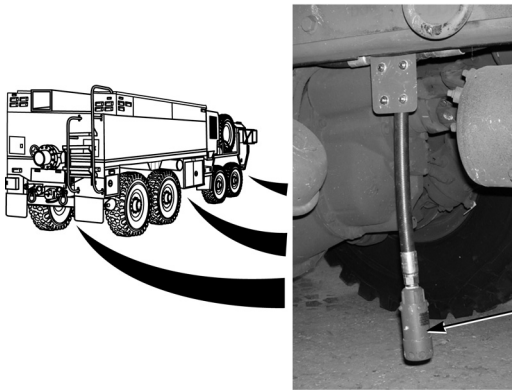
Item No.	Interval	Item To Inspect Or Service	Procedure	Not Fully Mission Capable if:
			<p>f. Check if passenger side handheld radio operates and is free from damage.</p> <p>g. Check if handheld radio base is operating and free from damage and loose or missing hardware.</p> <p>h. Check if battery charger wires and connections are free from damage and securely connected.</p>	<p>If both handheld radios do not operate properly.</p>



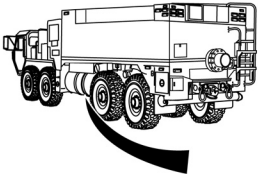
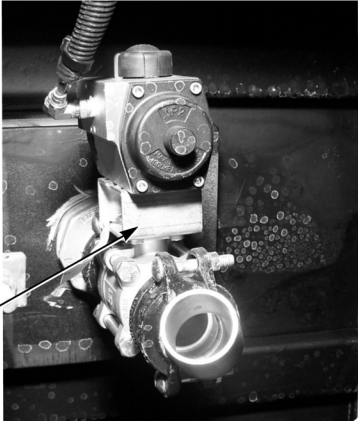

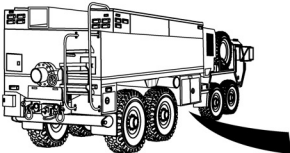

**Table 1. Preventive Maintenance Checks and Services. (Continued)**

Item No.	Interval	Item To Inspect Or Service	Procedure	Not Fully Mission Capable if:
10	A	Front Cab Body	<div data-bbox="495 420 1242 1060" data-label="Image"> </div> <ol style="list-style-type: none"> <li data-bbox="667 1165 1235 1262">a. Check bumper turret and air lines for leaks, kinks, damage, obstructions and loose or missing fittings.</li> <li data-bbox="667 1276 1263 1339">b. Check if windshield deluge nozzles and hoses are free from leaks, kinks, and damage.</li> <li data-bbox="667 1354 1252 1417">c. Check if siren is free from damage and loose or missing hardware.</li> </ol>	

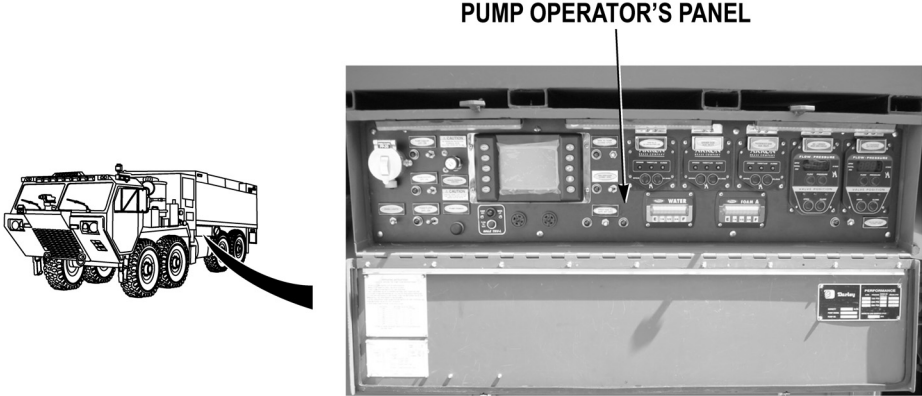
**Table 1. Preventive Maintenance Checks and Services. (Continued)**

Item No.	Interval	Item To Inspect Or Service	Procedure	Not Fully Mission Capable if:
11	A	Personnel Cab Driver Side		
12	A	Vehicle Bottom	<p>a. Check if cab instrument panel assembly is free from damage and loose or missing hardware.</p> <p>b. Check if cab instrument panel and pump control panel backlighting operates.</p> <p>c. Check cab instrument and pump control panel switches for proper operation and visible damage. Check if emergency warning lights are working on exterior of vehicle.</p>  <p style="text-align: right;"><b>UNDER TRUCK NOZZLE</b></p>	<p>If all control panel switches are inoperable.</p>
			<p>a. Check if under truck nozzles and hoses are free from leaks, damage, obstructions, and loose or missing hardware.</p>	

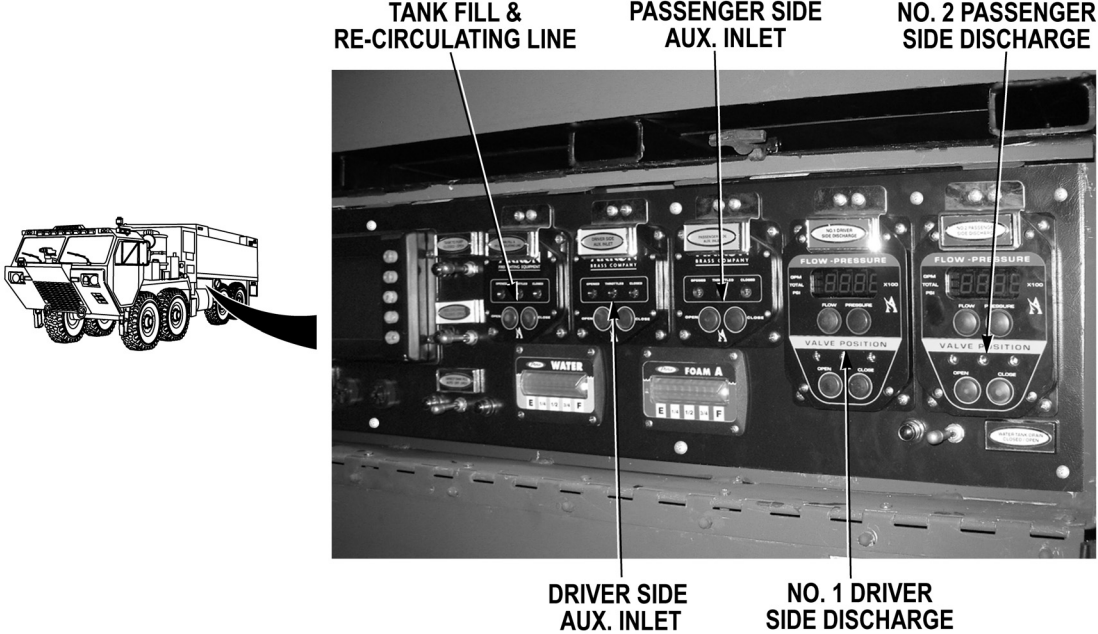
**Table 1. Preventive Maintenance Checks and Services. (Continued)**

Item No.	Interval	Item To Inspect Or Service	Procedure	Not Fully Mission Capable if:
		 <p data-bbox="618 709 764 764"><b>WATER TANK DRAIN VALVE</b></p>	 <p data-bbox="792 877 951 911"><b>WARNING</b></p>  <p data-bbox="345 1079 1289 1140"><b>Ensure personnel are clear from under vehicle before operating tank drain. Failure to comply could cause injury to personnel.</b></p> <p data-bbox="667 1159 1256 1251">b. Check if water tank drain valve operates and is free from leaks, damage, obstructions, and loose or missing hardware.</p>	
			 <p data-bbox="1252 1472 1398 1564"><b>HYDRAULIC RESERVOIR DRAIN VALVE</b></p> <p data-bbox="667 1703 1256 1795">c. Check if hydraulic oil reservoir drain valve is free from leaks, damage and loose or missing hardware.</p>	

**Table 1. Preventive Maintenance Checks and Services. (Continued)**

Item No.	Interval	Item To Inspect Or Service	Procedure	Not Fully Mission Capable if:
13	D	Pump Operator's Panel	<p style="text-align: center;"><b>PUMP OPERATOR'S PANEL</b></p>  <ol style="list-style-type: none"> <li>a. Check if pump operator's panel enclosure is free from damage and loose or missing hardware.</li> <li>b. Check if pump operator's panel, PANEL LIGHTS operate.</li> <li>c. Check pump operator's panel switches for proper operation and visible damage.</li> <li>d. Check pressure governor for proper operation and visible damage.</li> <li>e. Check all indicators for operation and visible damage.</li> <li>f. Check if all segments of water tank and foam tank level gauges illuminate when tanks are full.</li> </ol>	

**Table 1. Preventive Maintenance Checks and Services. (Continued)**

Item No.	Interval	Item To Inspect Or Service	Procedure	Not Fully Mission Capable if:
			<p>g. Check if No. 1 Driver Side DISCHARGE, DRIVER SIDE AUX. INLET, TANK FILL &amp; RE-CIRCULATING LINE, NO. 2 PASSENGER SIDE DISCHARGE, and PASSENGER SIDE AUX. INLET valve controls operate properly and are free from damage.</p>	<p>If valve control is inoperable or damaged.</p>

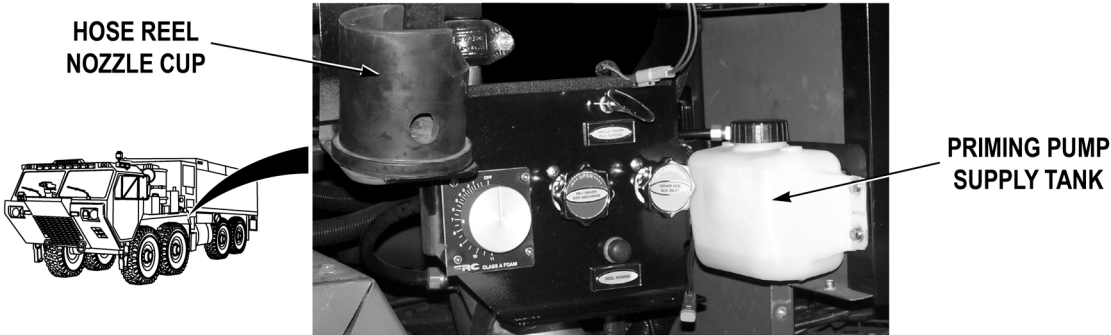

**Table 1. Preventive Maintenance Checks and Services. (Continued)**

Item No.	Interval	Item To Inspect Or Service	Procedure	Not Fully Mission Capable if:
14	D	Rear Body	<div data-bbox="505 415 1036 865" data-label="Image"> </div> <p data-bbox="696 871 967 898" style="text-align: center;"><b>PORTABLE WATER TANK</b></p> <ol style="list-style-type: none"> <li data-bbox="570 961 1166 1024">a. Check if portable water tank frame is free from damage and loose or missing hardware.</li> <li data-bbox="570 1041 1166 1104">b. Check if portable water tank is free from leaks and tears.</li> </ol> <div data-bbox="518 1178 721 1234" data-label="Caption"> <p><b>SOFT DISCHARGE HOSE</b></p> </div> <div data-bbox="570 1262 1089 1644" data-label="Image"> </div> <ol style="list-style-type: none"> <li data-bbox="570 1709 1166 1801">c. Check soft discharge hoses for wear, tears, cuts or burns. Check fittings and threads for visible damage.</li> </ol>	

**Table 1. Preventive Maintenance Checks and Services. (Continued)**

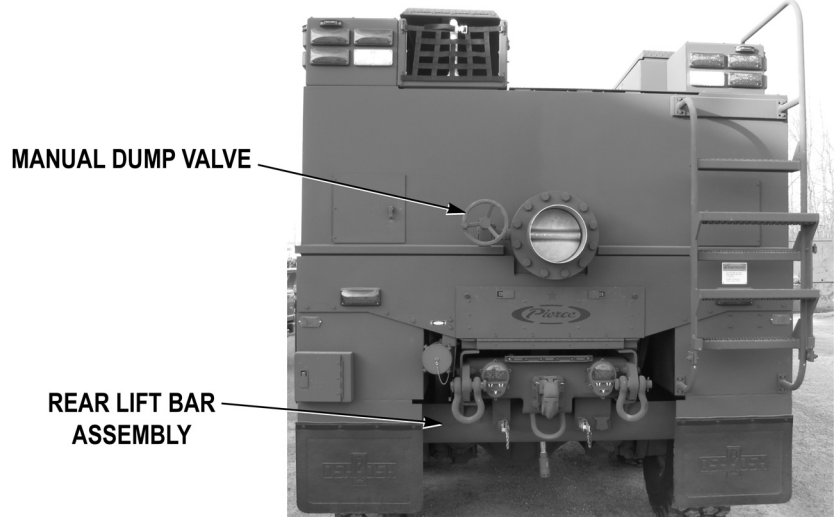
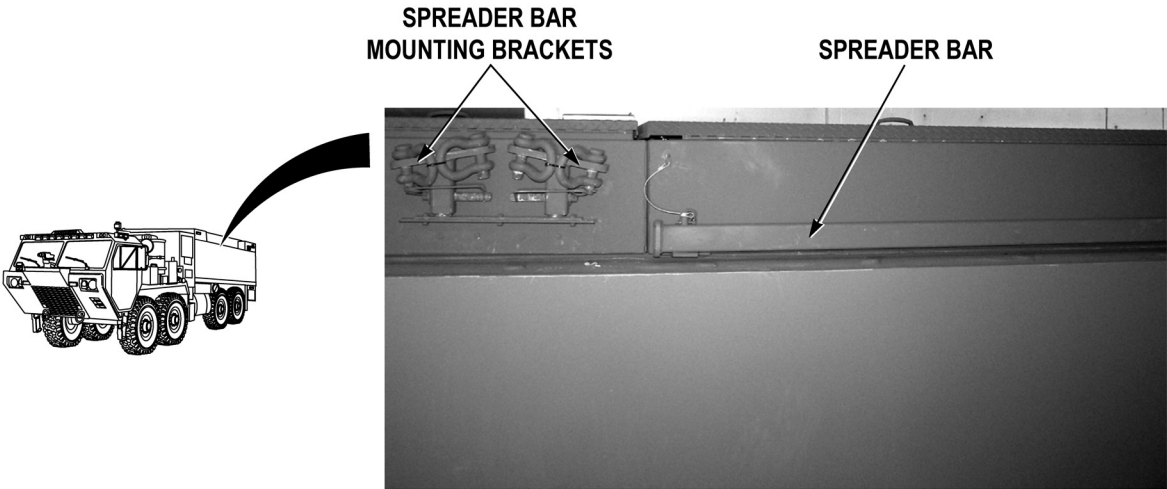
Item No.	Interval	Item To Inspect Or Service	Procedure	Not Fully Mission Capable if:
15	D	Personnel Cab Driver Side	<div data-bbox="410 554 716 751" data-label="Image"> </div> <div data-bbox="776 449 1300 835" data-label="Image"> </div> <ol style="list-style-type: none"> <li>a. Check if cab instrument panel and pump control panel backlighting operates.</li> <li>b. Check cab instrument and pump control panel switches for proper operation and visible damage. Check if emergency warning lights are working on exterior of vehicle.</li> <li>c. Check pressure governor for proper operation and visible damage (WP 0017).</li> </ol>	<p>If all control panel switches are inoperable.</p>
			<div data-bbox="337 1289 1425 1703" data-label="Image"> </div> <ol style="list-style-type: none"> <li>d. Check if all segments of water tank and foam tank level gauges illuminate when tanks are full (WP 0022).</li> </ol>	

**Table 1. Preventive Maintenance Checks and Services. (Continued)**

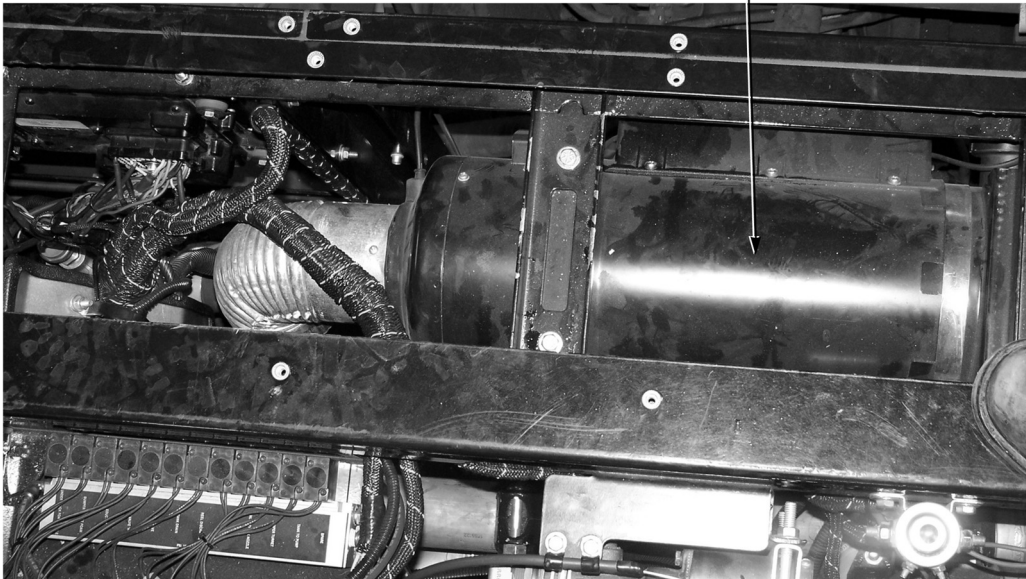
Item No.	Interval	Item To Inspect Or Service	Procedure	Not Fully Mission Capable if:
16	M	Driver Side Pump House	 <p>The diagram shows a truck with a hose reel. The close-up photo shows the pump house with labels: <b>HOSE REEL NOZZLE CUP</b> pointing to a cylindrical component, and <b>PRIMING PUMP SUPPLY TANK</b> pointing to a white plastic tank.</p>	
17	M	Driver Side Body	<p>a. Inspect hose reel nozzle cup for damage or loose or missing hardware.</p> <p>b. Refill priming pump supply tank with water. Refer to (WP 0035).</p>  <p><b>MANUAL DUMP VALVE</b></p> <p>a. Check if manual dump valve operates and is free from damage and loose or missing hardware.</p>	



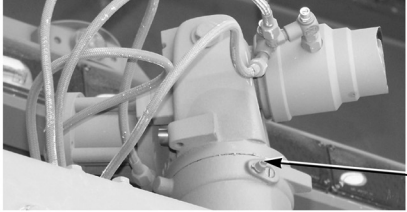



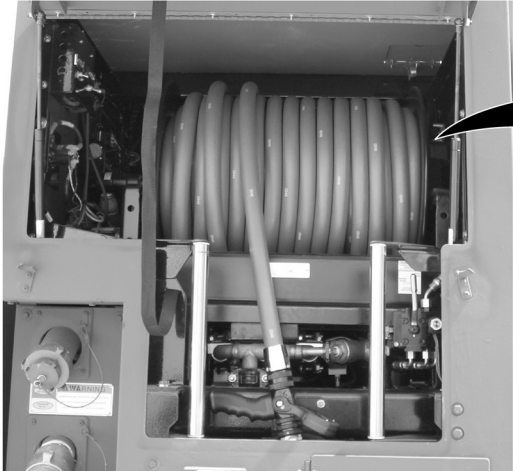
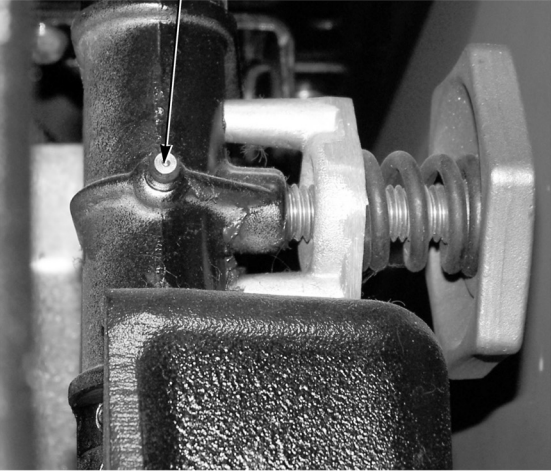
**Table 1. Preventive Maintenance Checks and Services. (Continued)**

Item No.	Interval	Item To Inspect Or Service	Procedure	Not Fully Mission Capable if:
18	M	Rear Body	 <p>a. Check if rear body is free from dents and scratches. Paint any exposed surfaces as required. Refer to TB 43-0242.</p> <p>b. Check if manual dump valve operates and is free from damage and loose or missing hardware.</p> <p>c. Check if rear lift bar is free from damage and loose or missing hardware.</p>	
19	M	Vehicle Body Top	 <p>a. Check if spreader bar, shackle assemblies, and mounting brackets are free from damage and loose or missing hardware.</p>	



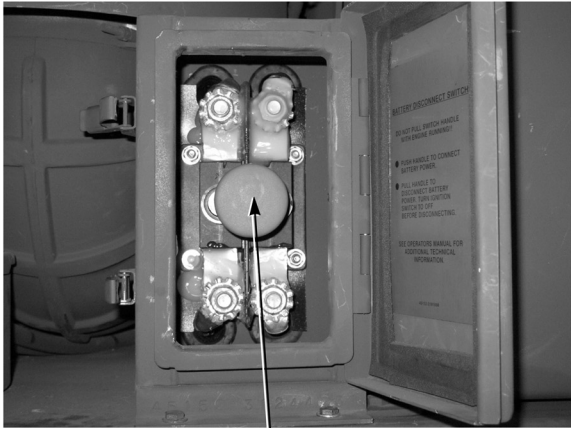
**Table 1. Preventive Maintenance Checks and Services. (Continued)**

Item No.	Interval	Item To Inspect Or Service	Procedure	Not Fully Mission Capable if:
20	M	Vehicle Body Pump House Top	<div style="text-align: center; margin-bottom: 10px;"> <p>PUMP HOUSE DIESEL HEATER</p>  </div> <ol style="list-style-type: none"> <li>a. Open pump house panel K access door (WP 0339).</li> <li>b. Check if diesel heater is free from damage and loose or missing hardware.</li> </ol>	

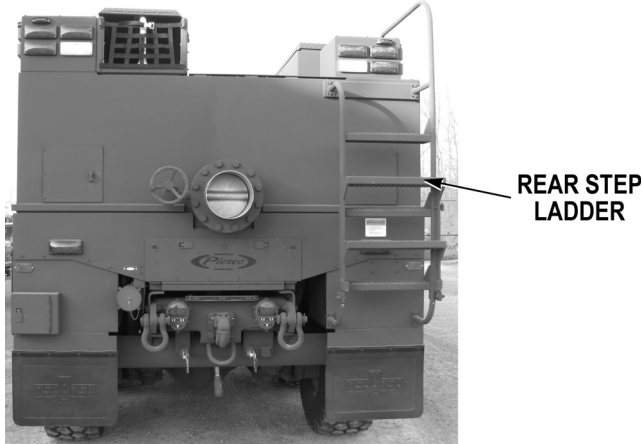
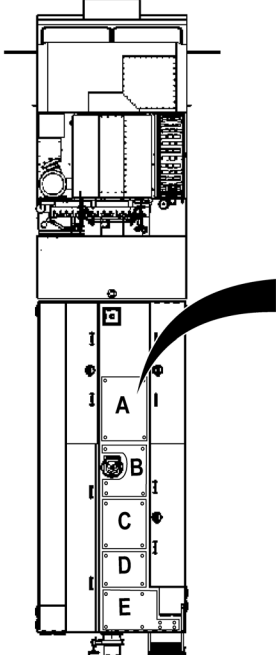

**Table 1. Preventive Maintenance Checks and Services. (Continued)**

Item No.	Interval	Item To Inspect Or Service	Procedure	Not Fully Mission Capable if:
21	M	Passenger Side Body	<div style="display: flex; justify-content: space-around;">   </div> <div style="text-align: center;">  <p><b>PTO GREASE FITTINGS</b></p> <p><b><u>WARNING</u></b></p>  <p><b>Ensure batteries are disconnected, PUMP PTO switch is in off position, and PTO shaft is not spinning, prior to performing PMCS on PTO shaft. Failure to comply may cause serious injury or death to personnel.</b></p> </div> <div style="display: flex; justify-content: space-between; margin-top: 20px;"> <div style="border-right: 1px solid black; width: 25%;"></div> <div style="border-right: 1px solid black; width: 50%;"> <ul style="list-style-type: none"> <li>a. Grease pump PTO grease fittings.</li> <li>b. Grease bumper turret grease fitting.</li> </ul> </div> <div style="width: 25%;"></div> </div> <div style="display: flex; justify-content: space-around; margin-top: 20px;">   </div> <div style="display: flex; justify-content: space-between; margin-top: 20px;"> <div style="border-right: 1px solid black; width: 25%;"></div> <div style="border-right: 1px solid black; width: 50%;"> <ul style="list-style-type: none"> <li>c. Grease hose reel grease fitting.</li> </ul> </div> <div style="width: 25%;"></div> </div>	

**Table 1. Preventive Maintenance Checks and Services. (Continued)**

Item No.	Interval	Item To Inspect Or Service	Procedure	Not Fully Mission Capable if:
22	M	Driver Side Body	<p><b>MANUAL DUMP VALVE</b></p>  <p>d. Check if manual dump valve operates and is free from damage and loose or missing hardware.</p>	
			<p><b>BATTERY DISCONNECT SWITCH</b></p>  <p>a. Inspect battery disconnect switch for damage and loose connections.</p> <p>b. Check if driver side body is free from dents and scratches. Paint any exposed surfaces as required.</p>	



**Table 1. Preventive Maintenance Checks and Services. (Continued)**

Item No.	Interval	Item To Inspect Or Service	Procedure	Not Fully Mission Capable if:
23	M	Rear Body		
24	M	Vehicle Body Top  	<p>a. Check rear step ladder for damage and loose or missing hardware. (Lubricate if required, see Table 2).</p>  <p><b>WALKWAY GRATING</b></p> <p>a. Check if walkway grating is free from damage and loose or missing hardware.</p> <p>b. Check if vehicle body top and pump house top are free from dents and scratches. Paint any exposed surfaces as required. Refer to TB 43-0242.</p>	

**Table 1. Preventive Maintenance Checks and Services. (Continued)**

Item No.	Interval	Item To Inspect Or Service	Procedure	Not Fully Mission Capable if:
25	M	Passenger Side Body	<div data-bbox="375 432 1149 798" data-label="Image"> </div> <p data-bbox="570 898 1141 995">a. Check if passenger side body is free from dents and scratches. Paint any exposed surfaces as required. Refer to TB 43-0242.</p>	

**Table 1. Preventive Maintenance Checks and Services. (Continued)**

Item No.	Interval	Item To Inspect Or Service	Procedure	Not Fully Mission Capable if:
26	M	Personnel Cab Driver Side	<div style="display: flex; justify-content: space-around; align-items: center;"> <div style="text-align: center;">  <p>HANDHELD RADIO AND CHARGER</p> </div> <div style="text-align: center;">  <p>RADIO HEADSET</p> </div> </div> <ol style="list-style-type: none"> <li>a. Check if driver side handheld radio operates and is free from damage.</li> <li>b. Check if handheld radio base is operating and free from damage and loose or missing hardware.</li> <li>c. Check if battery charger wires and connections are free from damage and securely connected.</li> <li>d. Check if radio headsets operate at all headset jacks.</li> </ol>	

## LUBRICATION INTRODUCTION

### 1. Intervals (on-condition or hardtime) and the related man-hour times are based on normal operation.

The man-hour time specified is the time needed to do all the services prescribed for a particular interval. Change the hardtime interval if lubricants are contaminated or if operating the equipment under adverse operating conditions, including longer-than-usual operating hours. The calendar interval may be extended during periods of low activity. If extended, adequate preservation precautions must be taken. Hardtime intervals must be applied during the warranty period.

### WARNING



Solvent cleaning compound MIL-PRF-680 Type II and III may be irritating to the eyes and skin. Use protective gloves and goggles. Use in well-ventilated areas. Use respirator as needed. Accidental ingestion can cause irritation of digestive tract and respiratory tract, may cause lung and central nervous system damage. Can be fatal if swallowed. Inhalation of high/massive concentrations can cause coma or be fatal. First aid for ingestion: do not induce vomiting. Seek immediate medical attention. First aid for skin contact: remove contaminated clothing. Wash skin thoroughly with soap and water. If symptoms persist, seek medical attention. First aid for eye contact: flush with water for 15 minutes or until irritation subsides. If symptoms persist, seek medical attention. First aid for inhalation: move to fresh air. If not breathing, provide artificial respiration. If symptoms persist, seek medical attention. Keep away from open flames and other sources of ignition. Failure to follow this warning may result in injury or death to personnel.

- The flashpoint for Type II solvent cleaning compound is 141 to 198°F (61 to 92°C) and Type III is 200 to 241°F (93 to 116°C).
- Improper cleaning methods and use of unauthorized cleaning solvents may injure personnel and damage equipment.
- Fire extinguishers should be placed nearby when using solvent cleaning compound. Failure to follow this warning may result in injury or death.
- Cloths or rags saturated with solvent cleaning compound must be disposed of IAW authorized facility's procedures. Failure to follow this warning may result in injury.
- Eye shields must be worn when cleaning with a wire brush. Flying rust and metal particle may cause injury.

### 2. Cleaning fittings before lubrication.

Clean parts with solvent cleaning compound (SD P-D-680) or equivalent. Dry before lubricating.

### 3. Lubrication after high-pressure washing.

After a thorough washing, lubricate all grease fittings and oil can points outside and underneath vehicle.



**WARNING**

Personnel hearing can be **PERMANENTLY DAMAGED** if exposed to constant high noise levels of 85 dB or greater. Wear approved hearing protection devices when working in high noise level areas. Hearing loss occurs gradually, but becomes permanent over time.

**NOTE**

These lubrication instructions are mandatory.

**Table 2. Lubricating Chart.**

Item No.	Interval	Item To Be Lubricated	Procedure	Type	Quantity
1	3 months 6 months	WATER PUMP Gear Case	Check gear case oil level. Replace gear case oil.	75W/90:Synthetic 75W/90:Synthetic	1 qt. (0.9 l)
2	12 months	CAB AND BODY	Lubricate doors, side panels, hood hinges, locks, latches, and other pivot points.	Cleaner, Lubricant A (MIL-L-63460)	As required
3	As required	Priming Pump Lubricant Supply Tank	Fill priming pump lubricant supply tank.	Water	1.7 qt. (1.6 l)
4	12 months	PTO Driven Hydrostatic Pump	Replace hydraulic oil in reservoir.	Hydraulic Oil, OE/HDO 10	11 gal. (41.6 l)
5	6 months	Pump PTO	Grease Fittings (2)	GAA (MIL-G-10924) Grease Automotive and Artillery	As required
6	6 months	Hose Reel	Grease Fitting	GAA (MIL-G-10924) Grease Automotive and Artillery	As required
7	12 months	Hydraulic Oil Filter	Replace	Filter Element Model 02400010 BHHC	1
8	6 months	Bumper Turret	Grease Fitting	GAA (MIL-G-10924) Grease Automotive and Artillery	As required

**END OF WORK PACKAGE**



## **CHAPTER 5**

### **MAINTENANCE INSTRUCTIONS**



---

**FIELD LEVEL MAINTENANCE**  
**MAINTENANCE GENERAL INTRODUCTION**

---

**SCOPE**

This work package supplements the M985 Series Manuals and provides general maintenance information for the HEWATT.

**STANDARD ARMY TOOLS AND EQUIPMENT**

There are standard army tools and general mechanic's tool sets required for maintenance of this vehicle. For authorizing standard army tools and equipment, refer to the Modified Table of Organization and Equipment (MTOE) applicable to the unit. General Mechanics Tool Kit (GMTK), tools from the Standard Automotive Tool Set (SATS) and tools that are considered Special Tools will be listed under Tools and Special Tools at the beginning of the maintenance task.

**SPECIAL TOOLS, TMDE, AND SUPPORT EQUIPMENT**

Special tools for Field Level Maintenance are listed in the RPSTL which is the authority for requisitioning. The Maintenance Allocation Chart (MAC) lists special tools needed for the various maintenance tasks.

**REPAIR PARTS**

Field and Sustainment level repair parts are listed and illustrated in the Repair Parts and Special Tools List covering Field Level Maintenance for this vehicle.

**INSPECTION AND SERVICE UPON RECEIPT**

- a. Upon receipt of new, used, or reconditioned vehicle, inspect all fill valves, drain valves, and dump valves to be sure they are in proper working order. Secure, clean, and correctly adjust and/or lubricate as needed (WP 0129). Check Components of End Item (COEI) and Basic Issue Items (BII) to be sure every item is there, in good condition, and properly mounted or stowed (WP 0040).
- b. Check vehicle for proper tire pressure.

**WARNING**



**Tire pressure must be checked properly or serious injury or death to personnel may occur. Refer to Table 1 for proper tire pressure check instructions.**

*Table 1. Tire Pressures.*

Tire Location	Tire Pressures			
	Highway	Cross Country-Dry	Cross Country-Wet	Sandy Terrain
Front Tire	60 psi (414 kPa)	35 psi (241 kPa)	20 psi (138 kPa)	30 psi (207 kPa)
Front Sand Tire	60 psi (414 kPa)	N/A	N/A	25 psi (172 kPa)
Rear Tire	70 psi (483 kPa)	40 psi (276 kPa)	30 psi (207 kPa)	35 psi (241 kPa)
Rear Sand Tire	70 psi (483 kPa)	N/A	N/A	30 psi (207 kPa)

- c. Perform Preventive Maintenance Checks and Services (PMCS) for the HEWATT (WP 0129).

## GENERAL MAINTENANCE PROCEDURES

### a. Cleanliness.

#### **WARNING**



Solvent cleaning compound MIL-PRF-680 Type II and III may be irritating to the eyes and skin. Use protective gloves and goggles. Use in well-ventilated areas. Use respirator as needed. Accidental ingestion can cause irritation of digestive tract and respiratory tract, may cause lung and central nervous system damage. Can be fatal if swallowed. Inhalation of high/massive concentrations can cause coma or be fatal. First aid for ingestion: do not induce vomiting. Seek immediate medical attention. First aid for skin contact: remove contaminated clothing. Wash skin thoroughly with soap and water. If symptoms persist, seek medical attention. First aid for eye contact: flush with water for 15 minutes or until irritation subsides. If symptoms persist, seek medical attention. First aid for inhalation: move to fresh air. If not breathing, provide artificial respiration. If symptoms persist, seek medical attention. Keep away from open flames and other sources of ignition. Failure to follow this warning may result in injury or death to personnel.

- The flashpoint for Type II solvent cleaning compound is 141 to 198°F (61 to 92°C) and Type III is 200 to 241°F (93 to 116°C).
- Improper cleaning methods and use of unauthorized cleaning solvents may injure personnel and damage equipment.
- Fire extinguishers should be placed nearby when using solvent cleaning compound. Failure to follow this warning may result in injury or death.
- Cloths or rags saturated with solvent cleaning compound must be disposed of IAW authorized facility's procedures. Failure to follow this warning may result in injury.
- Eye shields must be worn when cleaning with a wire brush. Flying rust and metal particle may cause injury.
- Never use fuel to clean parts. Fuel is highly flammable. Serious personal injury could result if fuel ignites during cleaning.
- Compressed air used for cleaning purposes will not exceed 30 psi (207 kPa). Use only with effective chip guarding and personal protective equipment (goggles/shield, gloves, etc). Failure to comply may result in injury to personnel.

Dirt, grease, oil, and debris only get in the way and may cover up a serious problem. Use solvent cleaning compound (WP 0400, Item 8) on metal surfaces and soapy water on rubber.

### b. Bolts, Nuts, and Screws.

Check bolts, nuts, and screws for obvious looseness, missing, bent, or broken condition and tighten or replace as necessary. If they cannot be checked with a tool, look for chipped paint, bare metal, or rust around bolt heads.

---

c. **Welds.**

Look for loose or chipped paint, rust, or gaps where parts are welded together. If a bad weld is found, notify your supervisor.

d. **Electric Wires and Connectors.**

Look for cracked or broken insulation, bare wires, and loose or broken connectors. Tighten loose connectors and ensure wires are in good shape.

e. **Fluid Hoses, Tubes, and Fittings.**

Look for wear, damage, leaks, and ensure clamps and fittings are tight. Wet spots show leaks, but a stain around a fitting or connector may also indicate a leak. If connector or fitting is loose, tighten it. If something is broken or worn out, repair or replace per applicable procedure.

f. **Damage.**

Damage is defined as any condition that affects safety or would make the vehicle unserviceable for mission requirements.

## GENERAL REMOVAL INSTRUCTIONS

a. **Work Required.**

Remove parts if replacement is required. Do not disassemble a component any further than needed.

b. **Preparation.**

Before removal of any electrical, hydraulic, or air system components, ensure system component is not energized or pressurized. Disconnect battery ground cables. Relieve air system pressure before removal of fasteners (e.g., nuts, locknuts, etc.). Remove any paint on threads to prevent binding of fasteners.

c. **Identification.**

To ease assembly and installation, tag and mark shims, connectors, wires, and mating end of lines before disconnecting them. Identify similar parts to ensure correct assembly.

d. **Position of Valves.**

Before removing valve handles, mark or diagram their position when open and closed. This will help during assembly.

e. **Location.**

Before removing cable ties, cushion clamps, hoses, tubing, wire, etc., note the location, position, and routing of each to ensure correct assembly.



## GENERAL CLEANING INSTRUCTIONS

### a. Cleaning Solvents.

#### **WARNING**



Solvent cleaning compound MIL-PRF-680 Type II and III may be irritating to the eyes and skin. Use protective gloves and goggles. Use in well-ventilated areas. Use respirator as needed. Accidental ingestion can cause irritation of digestive tract and respiratory tract, may cause lung and central nervous system damage. Can be fatal if swallowed. Inhalation of high/massive concentrations can cause coma or be fatal. First aid for ingestion: do not induce vomiting. Seek immediate medical attention. First aid for skin contact: remove contaminated clothing. Wash skin thoroughly with soap and water. If symptoms persist, seek medical attention. First aid for eye contact: flush with water for 15 minutes or until irritation subsides. If symptoms persist, seek medical attention. First aid for inhalation: move to fresh air. If not breathing, provide artificial respiration. If symptoms persist, seek medical attention. Keep away from open flames and other sources of ignition. Failure to follow this warning may result in injury or death to personnel.

- The flashpoint for Type II solvent cleaning compound is 141 to 198°F (61 to 92°C) and Type III is 200 to 241°F (93 to 116°C).
- Improper cleaning methods and use of unauthorized cleaning solvents may injure personnel and damage equipment.
- Fire extinguishers should be placed nearby when using solvent cleaning compound. Failure to follow this warning may result in injury or death.
- Cloths or rags saturated with solvent cleaning compound must be disposed of IAW authorized facility's procedures. Failure to follow this warning may result in injury.
- Eye shields must be worn when cleaning with a wire brush. Flying rust and metal particle may cause injury.
- Never use fuel to clean parts. Fuel is highly flammable. Serious personal injury could result if fuel ignites during cleaning.
- Compressed air used for cleaning purposes will not exceed 30 psi (207 kPa). Use only with effective chip guarding and personal protective equipment (goggles/shield, gloves, etc). Failure to comply may result in injury to personnel.

Use only approved cleaning solvents to clean parts. Solvent cleaning compound (WP 0400, Item 8) is commonly used. Always work in a well-ventilated area.

### b. Removing Deposits.

Soak parts in solvent cleaning compound (WP 0400, Item 8), and wash away deposits by flushing or spraying. When necessary, brush with soft bristle brush (not wire) moistened in solvent. Use compressed air to dry parts (except bearings) after cleaning. Bearings must drip and air dry.

 **CAUTION**

**Do not use wire brushes, abrasive wheels or compounds to clean parts. Failure to comply may result in damage to equipment.**

c. **Tools.**

Do not use wire brushes, abrasive wheels or abrasive compounds to clean parts unless specifically approved in the detailed procedures. Parts may be scratched or altered and a highly stressed part may weaken.

d. **Ball and Roller Bearings.**

When cleaning ball or roller bearings, place them in a basket and suspend them in a container of solvent cleaning compound (WP 0400, Item 8). If needed, use a brush to remove caked grease, chips, etc. Avoid rotating bearing before solid particles are removed to prevent damaging races and balls. When bearings have been cleaned, coat them lightly with lubricating oil (WP 0400, Item 20) to remove solvent.

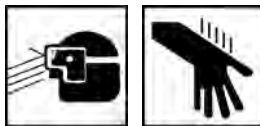
e. **Rubber Parts.**

 **CAUTION**

**Do not clean tires, lubricant seals, rubber hoses, or electrical components with solvent. Failure to comply may result in damage to equipment.**

Do not clean preformed packings or rubber parts in solvent cleaning compound. Wipe parts clean with a dry, cleaning cloth (WP 0400, Item 9).

f. **Exterior Parts.**

**WARNING**

**Steam cleaning creates hazardous noise levels and severe burn potential. Eye, skin, and ear protection is required. Failure to comply may result in injury to personnel.**

Steam clean all exterior parts thoroughly before removing. This will make inspection and disassembly easier.

g. **Degreasing Machine.**

 **CAUTION**

**To prevent corrosion, parts should be dipped in rust preventive within 2 hours of degreasing.**

A degreasing machine may be used to remove heavy grease and oil from metal parts.

h. **Passages.**

Solvent cleaning compound MIL-PRF-680 Type II and III may be irritating to the eyes and skin. Use protective gloves and goggles. Use in well-ventilated areas. Use respirator as needed. Accidental ingestion can cause irritation of digestive tract and respiratory tract, may cause lung and central nervous system damage. Can be fatal if swallowed. Inhalation of high/massive concentrations can cause coma or be fatal. First aid for ingestion: do not induce vomiting. Seek immediate medical attention. First aid for skin contact: remove contaminated clothing. Wash skin thoroughly with soap and water. If symptoms persist, seek medical attention. First aid for eye contact: flush with water for 15 minutes or until irritation subsides. If symptoms persist, seek medical attention. First aid for inhalation: move to fresh air. If not breathing, provide artificial respiration. If symptoms persist, seek medical attention. Keep away from open flames and other sources of ignition. Failure to follow this warning may result in injury or death to personnel.

- The flashpoint for Type II solvent cleaning compound is 141 to 198°F (61 to 92°C) and Type III is 200 to 241°F (93 to 116°C).
- Improper cleaning methods and use of unauthorized cleaning solvents may injure personnel and damage equipment.
- Fire extinguishers should be placed nearby when using solvent cleaning compound. Failure to follow this warning may result in injury or death.
- Cloths or rags saturated with solvent cleaning compound must be disposed of IAW authorized facility's procedures. Failure to follow this warning may result in injury.
- Eye shields must be worn when cleaning with a wire brush. Flying rust and metal particle may cause injury.

After degreasing, check all oil passages and cavities for dirt or blockage before coating with lubricating oil (WP 0400, Item 20). Run a thin, flexible wire through oil passages to ensure they are not clogged. Use a pressure spray gun and solvent cleaning compound (WP 0400, Item 8) to clean dirty passages.

i. **Electrical Parts.**

Electrical parts; such as coils, junction blocks, and switches, should not be soaked or sprayed with cleaning solutions. Clean these parts with a cleaning cloth (WP 0400, Item 9) moistened with solvent cleaning compound (WP 0400, Item 8).

j. **Hydraulic System.**

When cleaning hydraulic system parts, use solvent cleaning compound (WP 0400, Item 8). Clean and dry parts thoroughly to make sure no residue remains. If a coating preservative is required before assembly, apply a light film of hydraulic fluid (WP 0400, Item 17). If petroleum-free solvents are not available, use the same hydraulic fluid as used in vehicles system.

## GENERAL INSPECTION INSTRUCTIONS

### a. **Cleaning.**

Clean all parts before inspection. Check for defects such as physical distortion, wear, cracks, and pitting.

### b. **Sealing Surfaces.**

Inspect all surfaces in contact with gaskets, packings, or seals for nicks and burring. If any defect is found, remove it before assembly.

### c. **Tubing, Hoses, and Fittings.**

Inspect all hose surfaces for broken or frayed fabric. Check for breaks caused by sharp kinks or contact with other parts of the vehicle. Inspect fittings, tubing, mating surfaces, and threads for nicks, cracks, scratches, and other damage. Replace any defective part. After assembly and during initial vehicle operation periods, check for leaks.

### d. **Electrical Parts.**

Inspect all wiring harnesses for broken, chafed, or burned wiring. Inspect all terminal connectors for loose connections and broken parts.

## GENERAL INSTALLATION INSTRUCTIONS

### a. **Preparation.**

When unpacking items, remove all packing material, barrier paper, tape, plastic bags, protective caps, and protective grease coatings. Handle and store removed components carefully.

### b. **Sealing Compounds.**

#### **WARNING**



**Adhesives, solvents, and sealing compounds can burn easily, can give off harmful vapors, and are harmful to skin and clothing. To avoid injury or death, keep away from open fire and use in well-ventilated area. If adhesive, solvent, or sealing compound gets on skin or clothing, wash immediately with soap and water.**

#### **CAUTION**

**Use sealing compound sparingly and only on male threads. Do not apply compound on first two threads to avoid contamination of system from compound. Do not apply compound to hose connections or fittings with preformed packings. Damage to equipment may result.**

Use sealing compounds as required in each maintenance task.

### c. **Torquing.**

Tighten bolts, screws, washers, hoses, and fittings as required in WP 0387 or in each maintenance task.

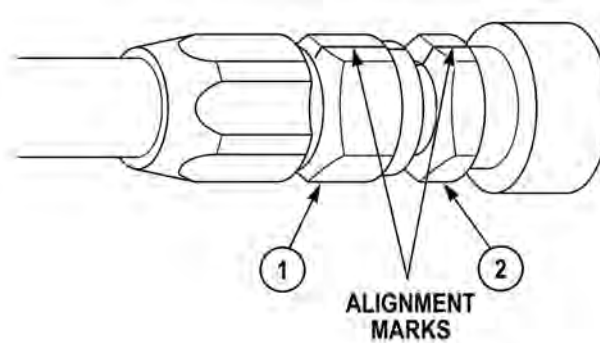
d. **Identification Tags.**

Put hoses, tubes, lines, and electrical wiring in place by matching identification tags and markings on equipment.

e. **Hoses, Air Lines, and Wiring.**

After installing hoses, air lines, and wiring, ensure that they do not contact moving parts or component edges. Secure in place, out of way, with cable ties and cushion clips.

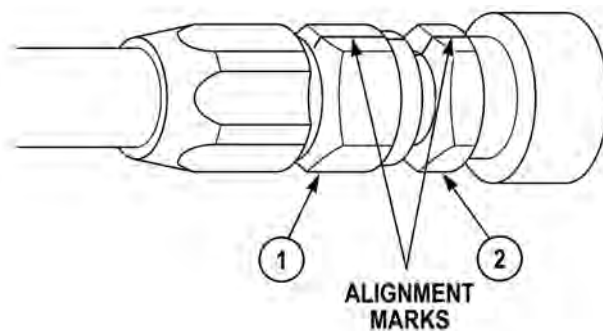
f. **Hose and Fitting Tightening Procedures.**



**NOTE**

Tighten hoses and fittings as required in WP 0387 or in each maintenance task. If a torque wrench and crowsfoot are not available or cannot be used, use the following procedure.

1. Install hose (1) on fitting (2).



**NOTE**

When turning effort increases, hose nut seat is in contact with fitting seat.

2. Tighten hose (1) until seated on fitting (2).

**NOTE**

Alignment marks allow the mechanic to count the number of flats the hose has rotated during tightening.

3. Scribe alignment mark on hose (1) and fitting (2).
4. Tighten hose nut (1) until mark on hose nut has rotated correct number of flats (refer to Table 2).

**Table 2. Recommended Flats Rotation.**

Dash No.	JIC 37-Degree Flared Hose and Fitting Machined Seat	SAE 45-Degree Flared Hose and Fitting Machined Seat	JIC 37-Degree Flared Tube
-4	1 1/2 - 1 3/4	1 - 1 1/4	2 1/4 - 2 3/4
-5	1 - 1 1/2	1 - 1 1/4	2 1/4 - 2 3/4
-6	1 - 1 1/2	3/4 - 1	2 1/4 - 2 3/4
-8	1 1/4 - 1 3/4	1 - 1 1/4	2 1/4 - 2 3/4
-10	1 1/4 - 1 3/4	1 - 1 1/4	2 - 1/2
-12	1 - 1 1/2	1 - 1 1/4	2 - 1/2
-16	3/4 - 1	----	2 1/4 - 2 3/4
-20	1/2 - 3/4	----	2 - 1/2
-24	1/2 - 3/4	----	2 - 1/2
-32	3/4	----	1 - 1 1/4

g. **Fastener Tightening Sequence Procedure.**

1. **Installation Torque.**

**NOTE**

If a component has a critical tightening sequence, it will be illustrated in that particular work package; otherwise, use the general sequence charts provided in Figure 1.

- (a) Tighten nuts twice in a crisscross pattern using a torque wrench. The first time nut is torqued, apply approximately 75% of final torque value.
- (b) Repeat sequence a second time until 100% of final torque value has been obtained for each nut.

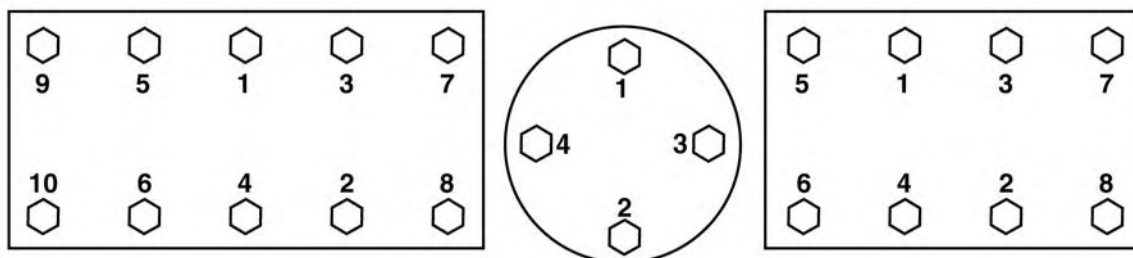


Figure 1. General Tightening Sequences.

2. **Check Torque.**

**NOTE**

When one or more screws are loose, check torque for all bolts on the component.

Tighten nuts in a crisscross pattern using a torque wrench. Apply 100% of final torque value.

h. **Pipe Thread Tightening Procedures.**

**WARNING**



Adhesives, solvents, and sealing compounds can burn easily, can give off harmful vapors, and are harmful to skin and clothing. To avoid injury or death, keep away from open fire and use in well-ventilated area. If adhesive, solvent, or sealing compound gets on skin or clothing, wash immediately with soap and water.

**CAUTION**

Use sealing compound sparingly and only on male threads. Do not apply compound on first two threads to avoid contamination of system from compound. Do not apply compound to hose connections or fittings with preformed packings. Damage to equipment may result.

- 1. Coat threads of male fitting with sealing compound, sealant, or adhesive as indicated in each work package.

2. Position male fitting on female fitting. Tighten only finger-tight.
3. Scribe alignment mark on both fittings.

**CAUTION**

- **It may be necessary to tighten fitting slightly more or less than 2 1/2 turns to match position noted prior to removal. Do not loosen fitting to arrive at proper position or a leak may occur.**
  - **Overtightening may cause pipe fitting to deform and damage to the joining fitting, flange, or component.**
4. Tighten male fitting 2 1/2 (3 maximum) full turns past hand-tight position.

**PREPARATION FOR SHIPMENT OR STORAGE**

Proper preservation of a vehicle and its individual parts for storage or shipment is vital to the life of the equipment.

- a. Perform pump and blow out procedures (WP 0033).
- b. Perform preparation for storage or shipment (WP 0032).
- c. For general preservation data as well as preservation procedures for vehicle specific parts, refer to Equipment Preservation Data Sheets (EPDS).
- d. Refer to TM 9-2320-325-14&P for preparation for shipment or storage information.
- e. Refer to TM 43-0213 Corrosion Prevention and Control (CPC) for Tactical Vehicles.
- f. Refer to TB 9-2300-281-15 for overseas shipment instructions.
- g. Refer to TB 9-2300-281-15 for Basic Issue Items (BI) packing instructions.

**END OF WORK PACKAGE**



---

**FIELD LEVEL MAINTENANCE****STOWAGE COMPARTMENT DOOR LATCH STRIKER ADJUSTMENT**

---

**INITIAL SETUP:****Tools and Special Tools**

Tool Kit, General Mechanic's: Automotive  
(WP 0398, Item 17)

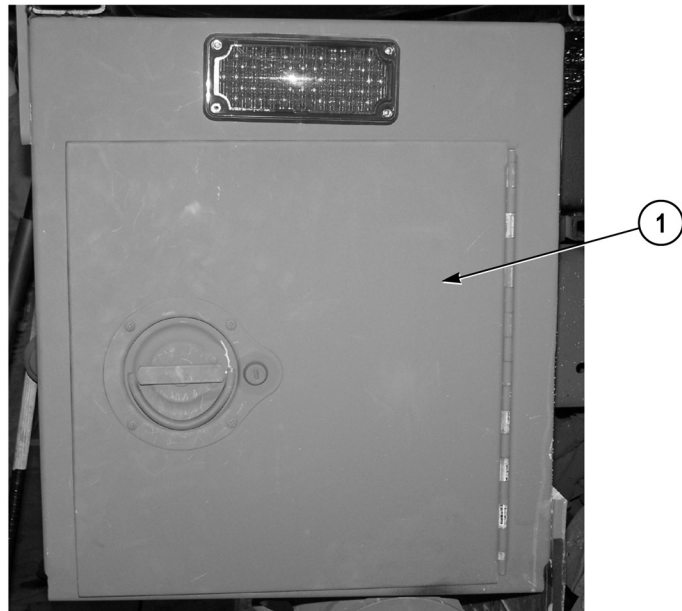
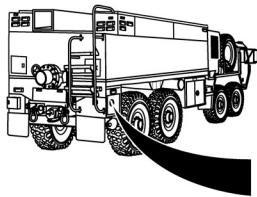
**Equipment Conditions**

Engine OFF (TM 9-2320-422-10)  
Wheels chocked (TM 9-2320-422-10)

**References**

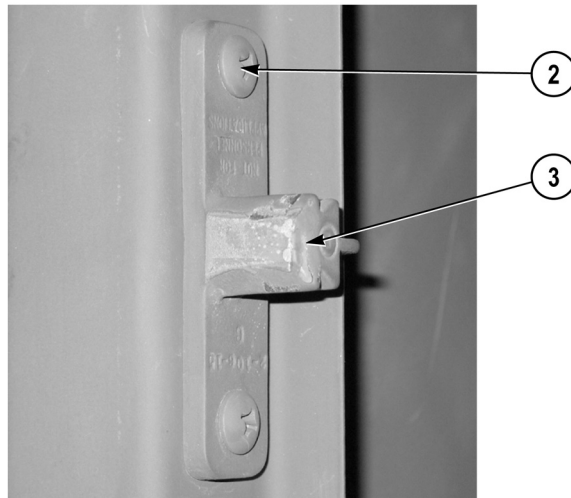
WP 0008

---

**LOWER STOWAGE COMPARTMENT DOOR LATCH STRIKER ADJUSTMENT****NOTE**

All lower stowage compartment door latch strikers are adjusted the same way. Passenger side rear stowage compartment shown.

1. Open stowage compartment door (1) (WP 0008).



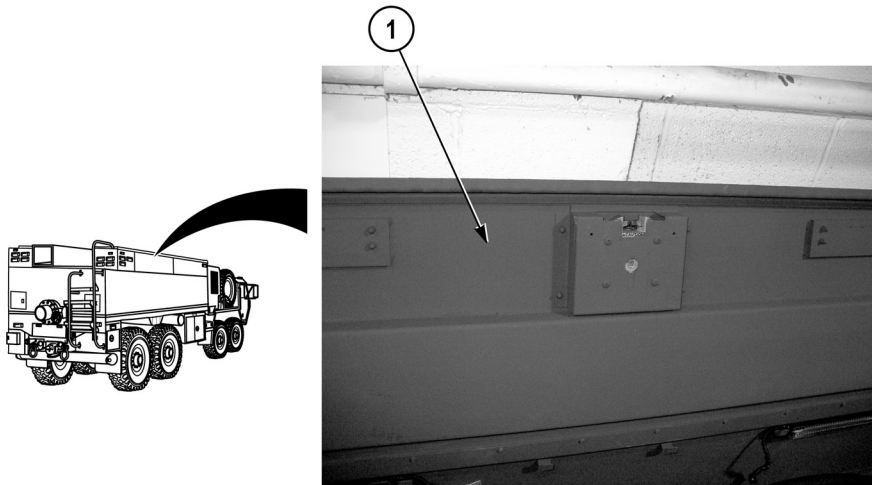
### NOTE

To adjust door latch striker, move door latch striker side to side and up and down.

2. Loosen two screws (2) on door latch striker (3) and adjust to desired position.
3. Tighten two screws (2) and close stowage compartment door (1) to check for proper adjustment (WP 0008).
4. Repeat Steps (1) through (3) until desired adjustment has been met.

### END OF TASK

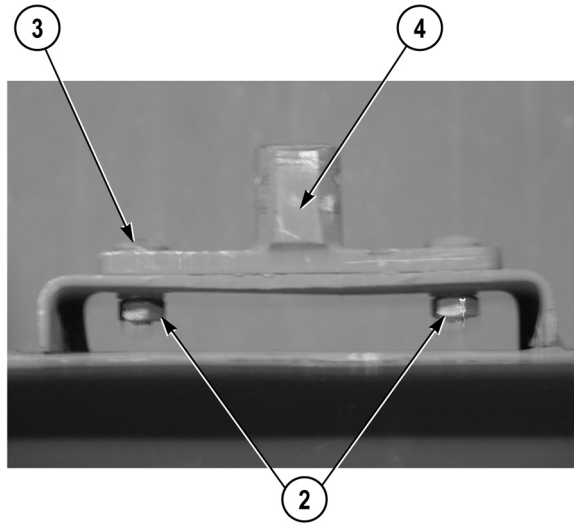
### UPPER STOWAGE COMPARTMENT DOOR LATCH STRIKER ADJUSTMENT



### NOTE

All upper stowage compartment door latch strikers are adjusted the same way. Passenger side rear stowage compartment shown.

1. Open stowage compartment door (1) (WP 0008).

**NOTE**

To adjust door latch striker, move door latch striker side to side and up and down.

2. Loosen two nuts (2) on screws (3) on door latch striker (4) and adjust to desired position.
3. Tighten two nuts (2) on screws (3) and close stowage compartment door (1) to check for proper adjustment (WP 0008).
4. Repeat Steps (1) through (3) until desired adjustment has been met.

**END OF TASK****FOLLOW-ON MAINTENANCE**

Remove wheel chocks (TM 9-2320-422-10)

**END OF TASK****END OF WORK PACKAGE**



---

**FIELD LEVEL MAINTENANCE**

**STATIC PUMP IDLE PRESSURE ADJUSTMENT**

---

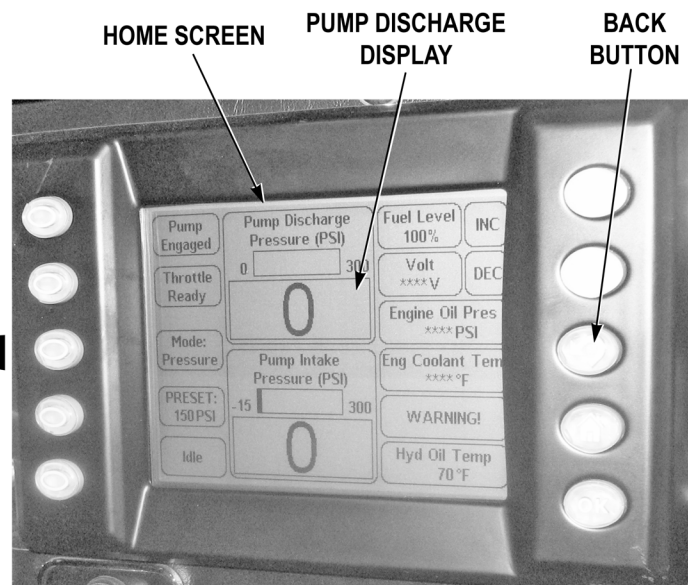
**INITIAL SETUP:**

**References**  
WP 0016

**Equipment Conditions**

Engine OFF (TM 9-2320-422-10)  
Wheels chocked (TM 9-2320-422-10)

---

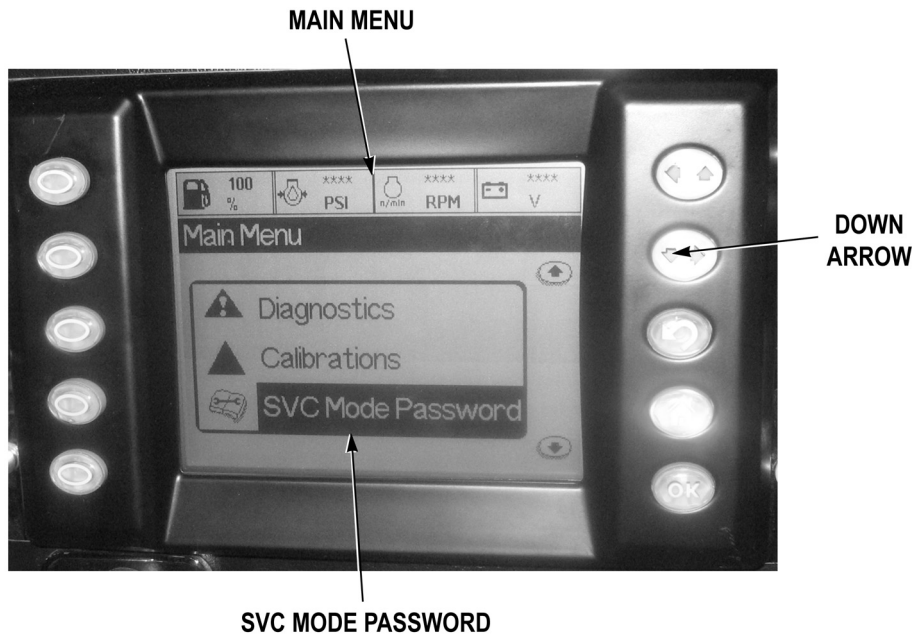
**ADJUSTMENT**

1. Prime water pump from pump operator's panel (WP 0016).
2. Observe static idle pressure on home screen Pump Discharge display.

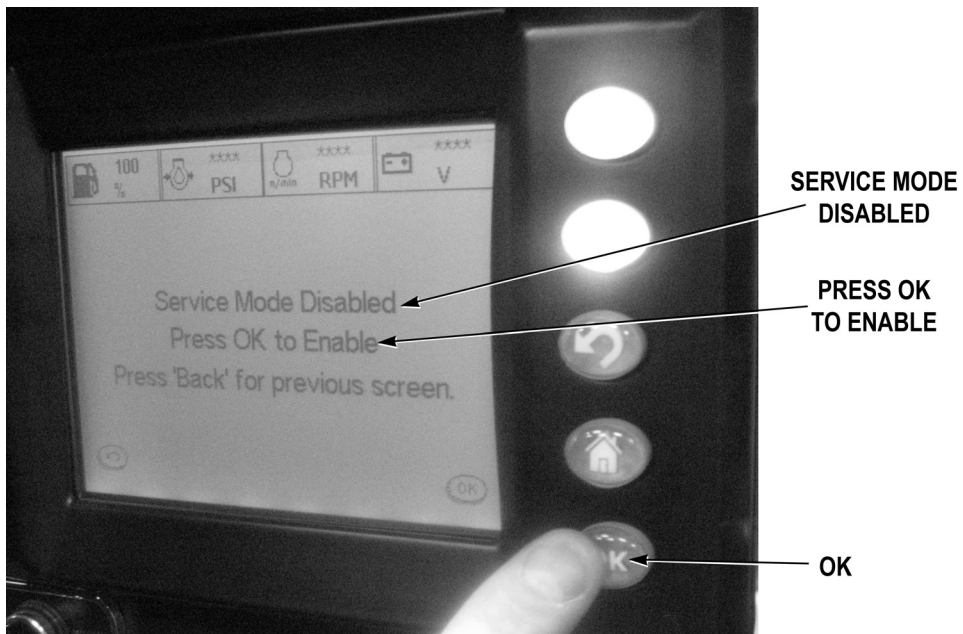
**NOTE**

Static idle pressure must be at least 30 psi (207 kPa). If static idle pressure is not at least 30 psi (207 kPa), perform Steps (3) through (16).

3. From home screen, press back button and go to Main Menu display.



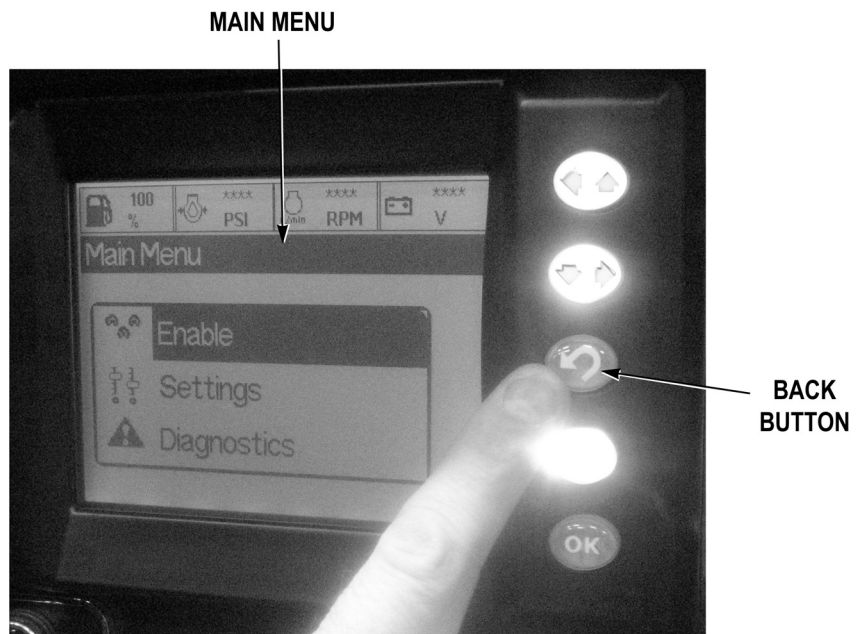
- 4. Press down arrow and go to SVC Mode Password display.



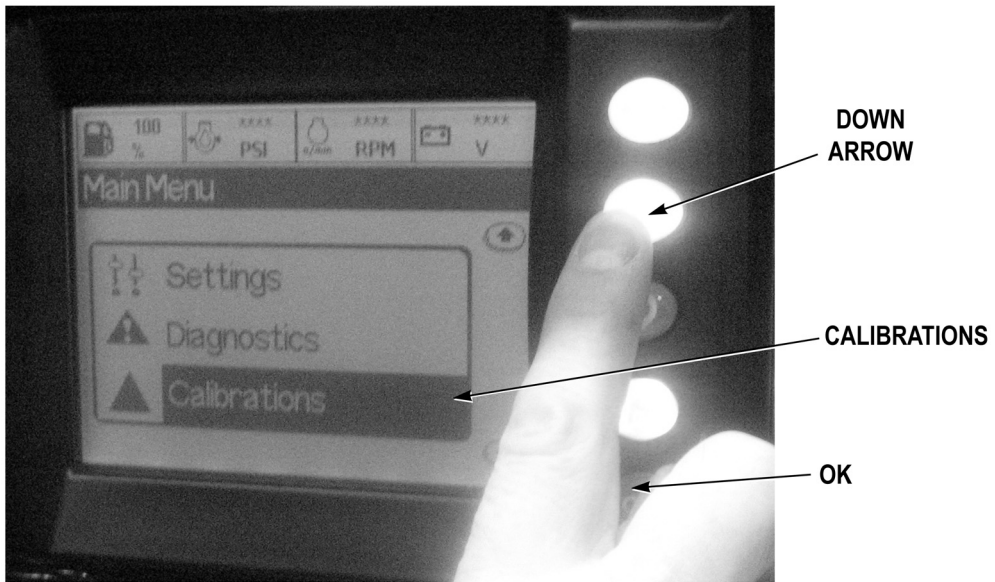
- 5. Press OK and go to Service Mode Disabled display.



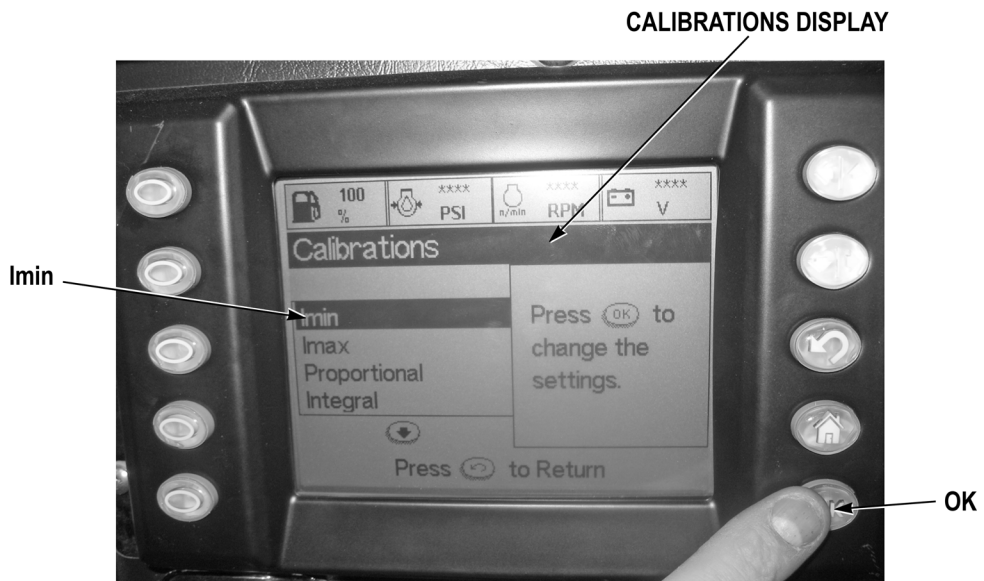
6. Press OK to Enable and go to Service Mode Enabled display.



7. Press back button to Main Menu display.



8. Press down arrow to Calibrations display.



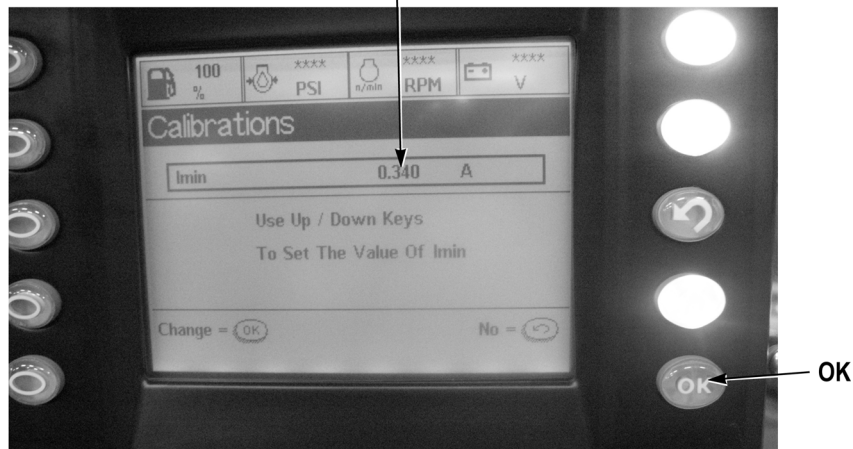
**⚠ CAUTION**

Calibrations can only be made in Imin. Changes made in any other settings will adversely affect water pump operation.

9. Press OK and Imin will be highlighted on Calibrations display.



**AMPERAGE NUMERICAL VALUE**

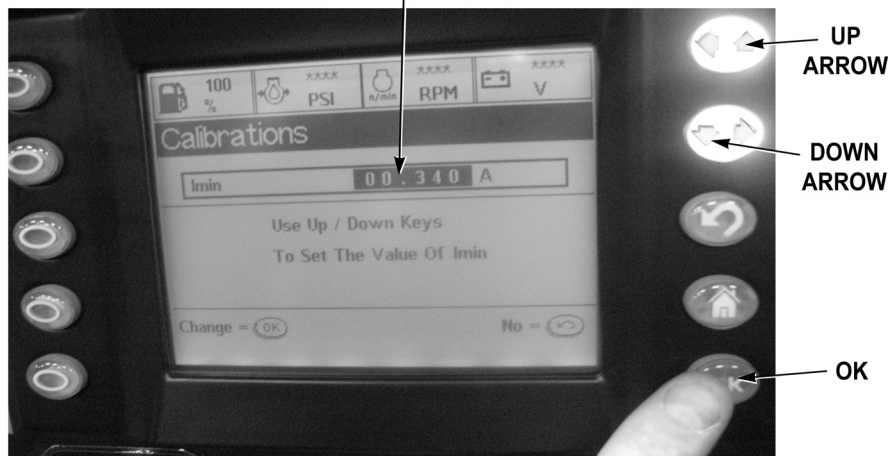


**NOTE**

Amperage numerical values will vary, 0.340 A (amp) will be used as a reference only.

10. Press OK and Imin amperage numerical value will appear.

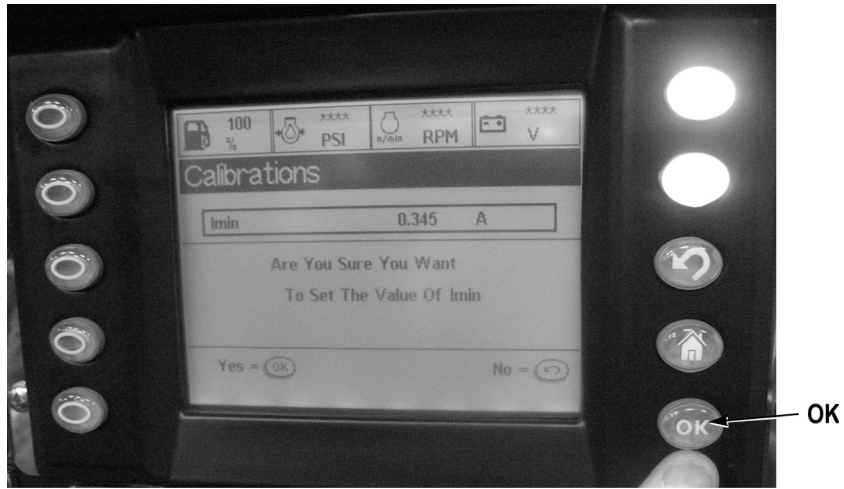
**AMPERAGE NUMERICAL VALUE HIGHLIGHTED**



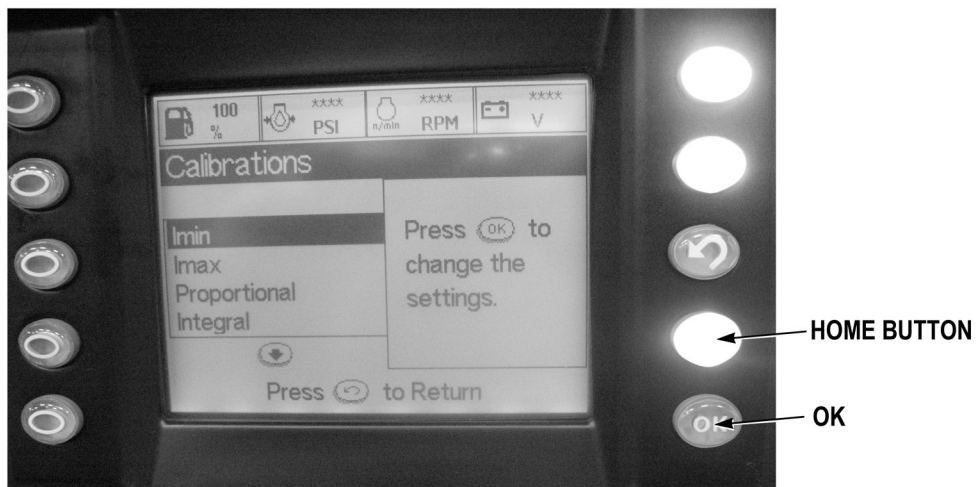
11. Press OK and amperage numerical value will be highlighted.

**NOTE**

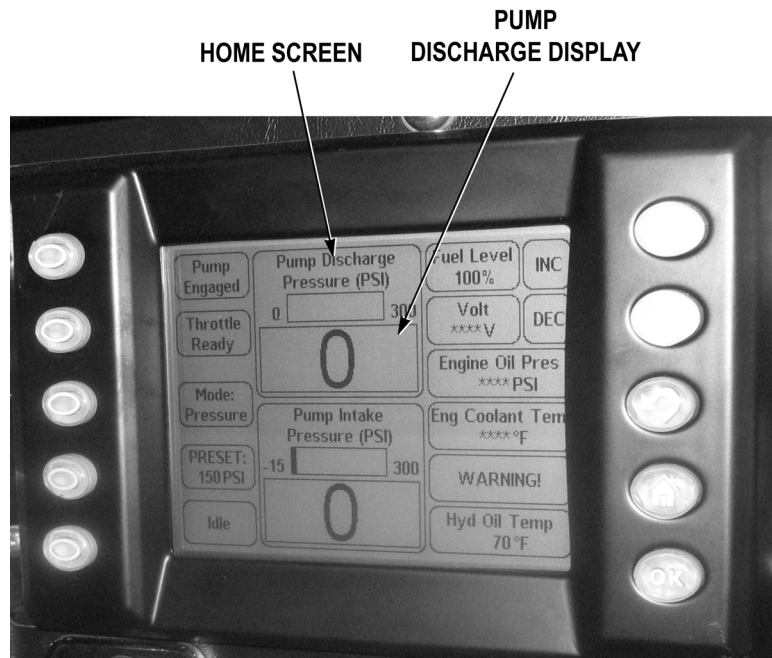
- Several adjustments may be necessary in order to correctly set static idle pressure.
  - Adjustments are made in increments of 0.005, i.e., from 0.340 A (amp) to 0.345 A (amp).
  - Adjustments are made by “tapping” up arrow, until value has increased by 0.005 A (amp).
12. Each tap up of arrow, will increase value 0.001 A (amp). If value is increased by more than 0.005 A (amp), tap down arrow to correct value.



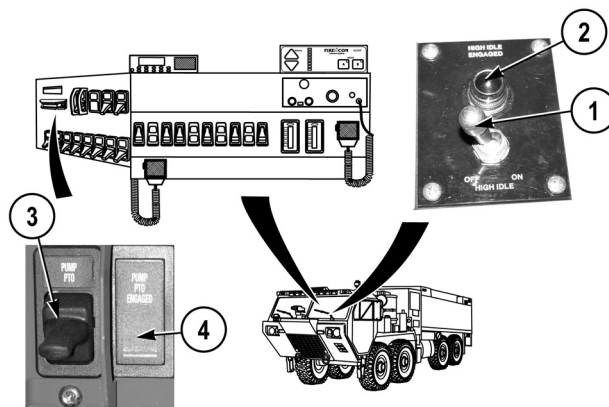
13. When correct value is displayed, press OK to set new value.
14. Press OK to store settings into memory (see illustration after this step).



15. Press home button to return to home screen (see illustration after this step).



16. Observe static idle pressure on Pump Discharge display.
17. If static idle pressure is not of correct pressure, repeat Steps (2) through (16).



18. Put HIGH IDLE switch (1) to OFF position. Indicator light (2) will go out.
19. Put PTO PUMP switch (3) to OFF position. Indicator light (4) will go out.

**END OF TASK**

**FOLLOW-ON MAINTENANCE**

1. Perform any applicable post operation procedures (WP 0030)
2. Remove wheel chocks (TM 9-2320-422-10)

**END OF TASK**

**END OF WORK PACKAGE**

---

**FIELD LEVEL MAINTENANCE**  
**BUMPER TURRET ADJUSTMENT**

---

**INITIAL SETUP:****Tools and Special Tools**

Tool Kit, General Mechanic's: Automotive  
(WP 0398, Item 17)

**References**

WP 0028  
WP 0391, Fig. 79

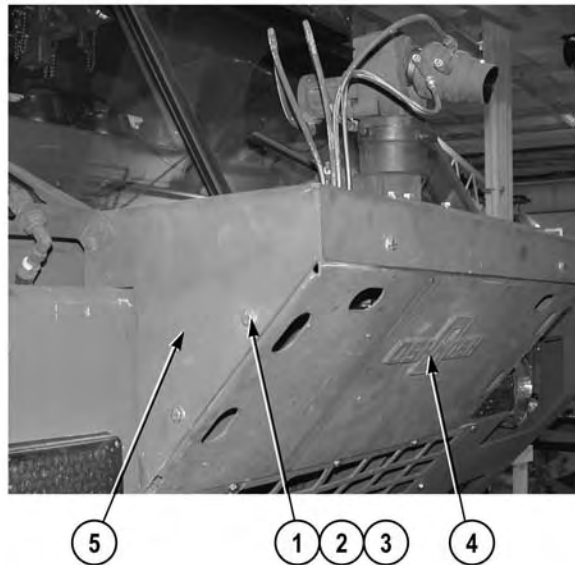
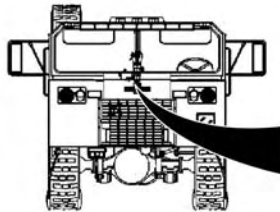
**Materials/Parts**

Locknut (6)

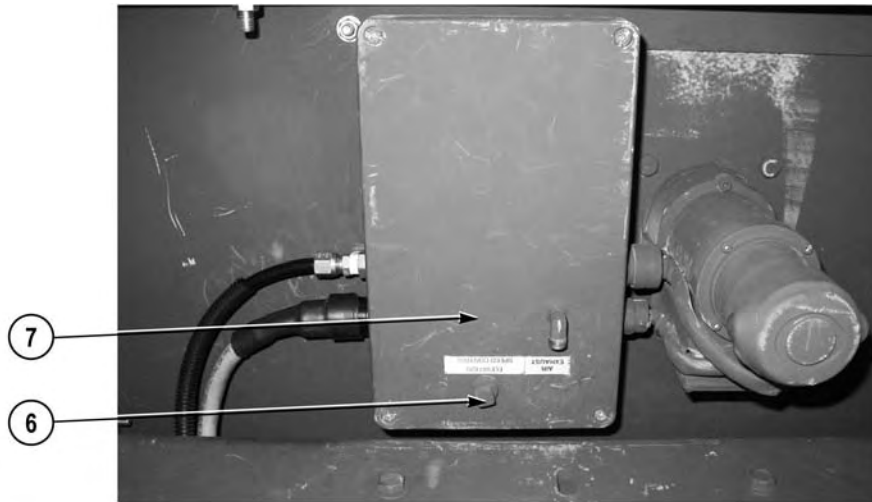
**Equipment Conditions**

Engine OFF (TM 9-2320-422-10)  
Wheels chocked (TM 9-2320-422-10)

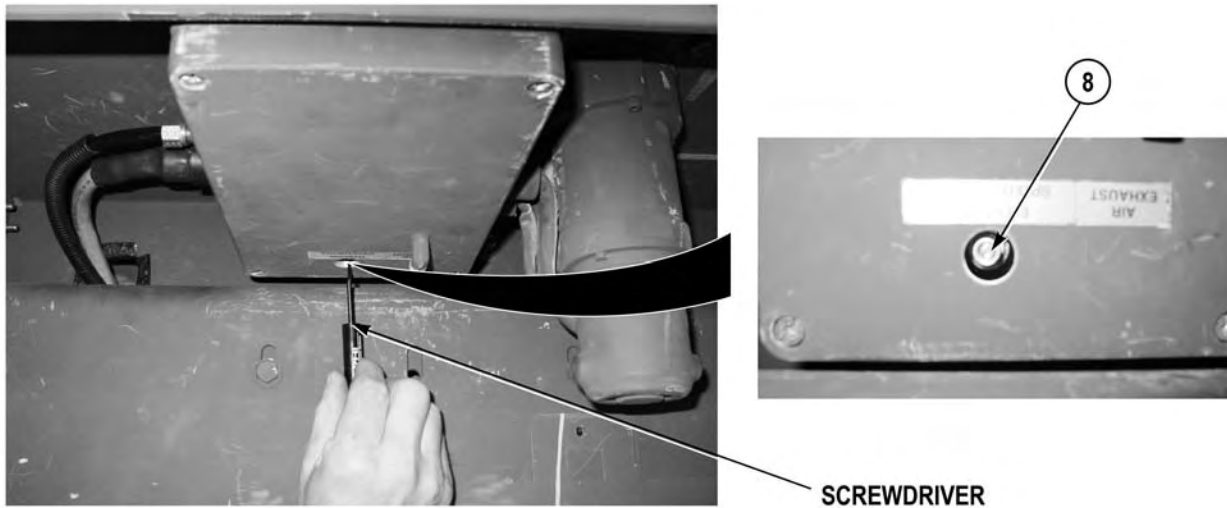
---

**BUMPER TURRET VERTICAL SPEED ADJUSTMENT**

1. Remove six locknuts (1), 12 washers (2), six screws (3), and cover (4) from bumper turret mount (5). Discard locknuts.



2. Remove plug (6) from junction box cover (7).

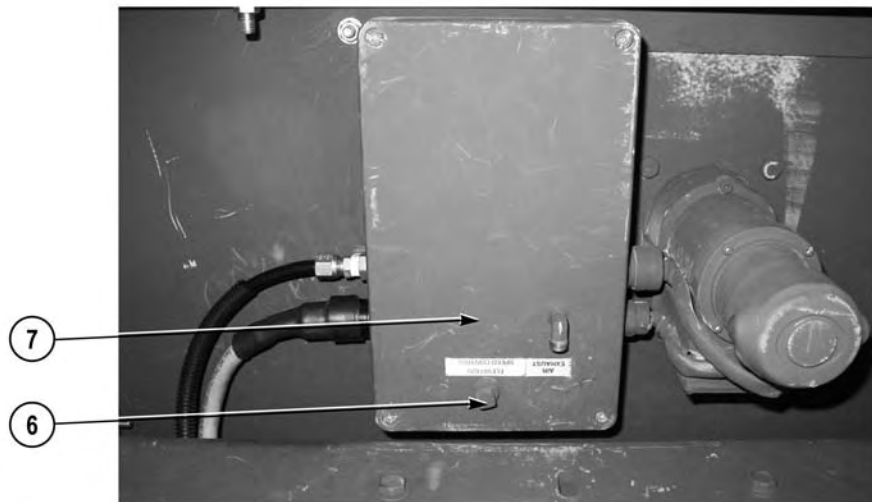


### NOTE

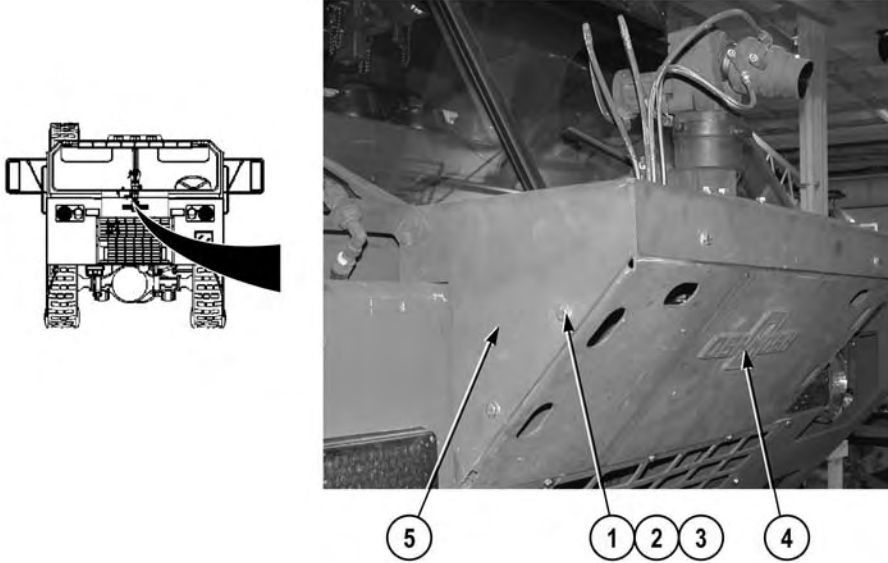
- Vertical speed control is adjusted by using screwdriver and turning needle valve clockwise or counterclockwise in increments of 1/8 of a turn.
  - To increase vertical speed, turn needle valve counterclockwise in increments of 1/8 of a turn.
  - To decrease vertical speed, turn needle valve clockwise in increments of 1/8 of a turn.
  - Maintain air pressure in normal operating range (85 to 120 psi [586 to 827 kPa]) to ensure accurate adjustment.
3. Using a small screwdriver, adjust needle valve (8).



4. Check vertical speed by operating bumper turret (9) (WP 0028).
5. Repeat Steps (3) and (4) until desired vertical speed is obtained.



6. Install plug (6) on junction box cover (7).



7. Install cover (4) on bumper turret mount (5) with six screws (3), 12 washers (2), and six locknuts (1).

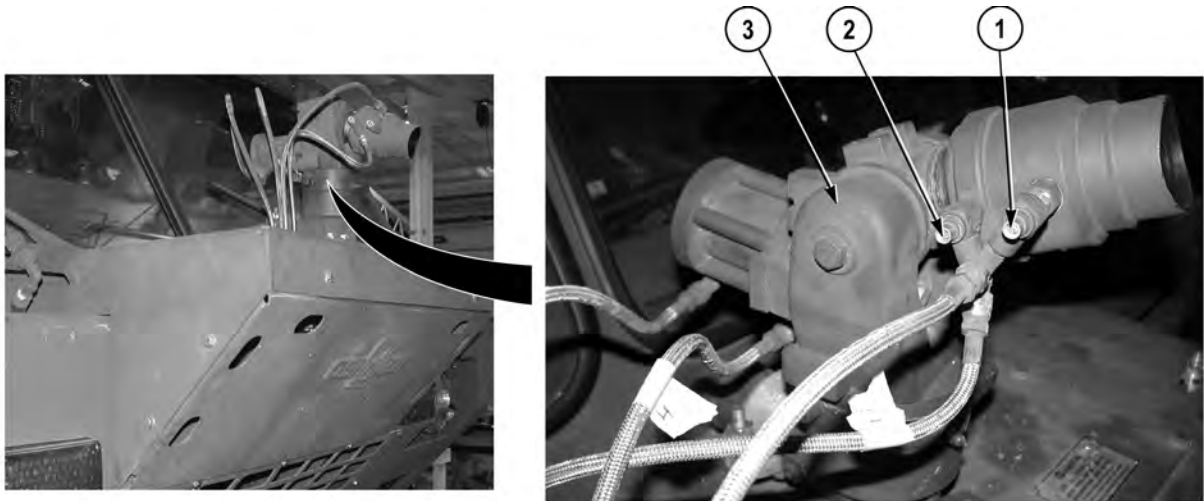
#### END OF TASK

#### BUMPER TURRET NOZZLE SPEED ADJUSTMENT

##### NOTE

- Reducing speed too much may cause erratic or incorrect shift pattern operation.
- Nozzle speed control is adjusted by using a small screwdriver and turning two needle valves clockwise or counterclockwise in increments of 1/8 of a turn.
- Both needle valves must be turned in same direction and distance. Failure to comply may result in nozzle pattern sleeve drifting when pattern control rocker switch is released on joystick.
- To increase nozzle speed, turn both needle valves counterclockwise in increments of 1/8 of a turn.
- To decrease nozzle speed, turn both needle valves clockwise in increments of 1/8 of a turn.
- Needle valve closest to nozzle discharge controls fog speed.
- Needle valve closest to air cylinders controls straight stream speed.
- Maintain air pressure in normal operating range (85 to 120 psi [586 to 827 kPa]) to ensure accurate adjustment.





1. Using a small screwdriver, adjust fog needle valve (1) and straight stream needle valve (2).
2. Check nozzle speed by operating bumper turret (3) (WP 0028).
3. Repeat Steps (1) and (2) until desired nozzle speed is obtained.

**END OF TASK**

**FOLLOW-ON MAINTENANCE**

Remove wheel chocks (TM 9-2320-422-10)

**END OF TASK**

**END OF WORK PACKAGE**



## FIELD LEVEL MAINTENANCE

## HYDRAULIC HEAT EXCHANGER FAN(S) SWITCH REPLACEMENT

## INITIAL SETUP:

**Tools and Special Tools**

Cap Set, Protective (WP 0398, Item 1)  
 Drain Pan (WP 0398, Item 4)  
 Tool Kit, General Mechanic's: Automotive  
 (WP 0398, Item 17)

**Materials/Parts**

Compound, Sealing, Pipe Thread  
 (WP 0400, Item 11)

**Materials/Parts (continued)**

Tags, Identification (WP 0400, Item 23)  
 Lockwasher (1)

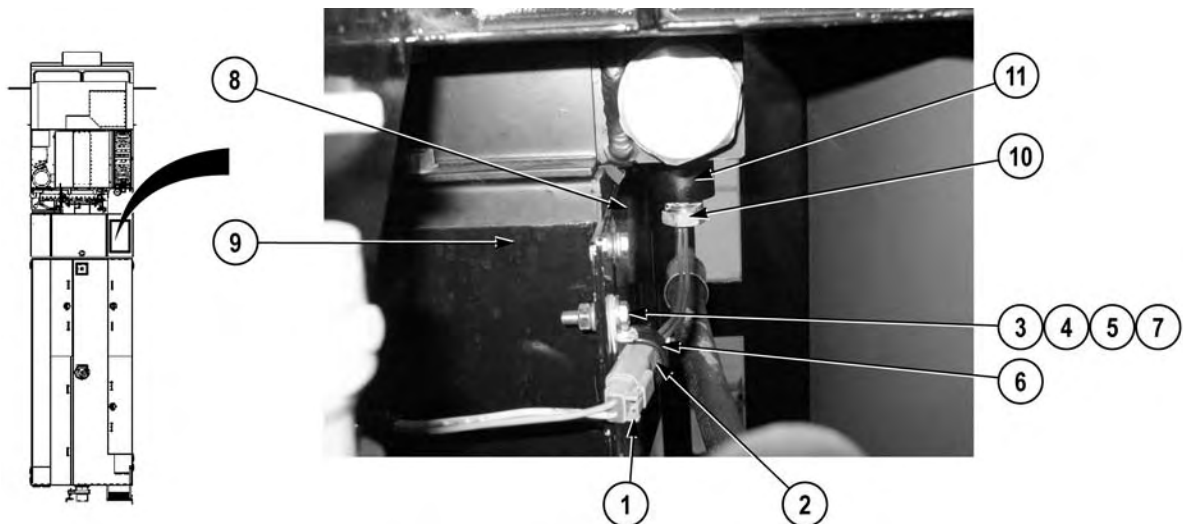
**References**

WP 0391, Fig. 8

**Equipment Conditions**

Pump house panel K removed (WP 0339)

## REMOVAL

**NOTE**

Tag and mark wires prior to removal to ensure proper installation.

1. Disconnect pump house wire harness connector (1) from fan switch connector (2).
2. Remove nut (3), lockwasher (4), two washers (5), cushion clip (6), screw (7), and fan switch connector (2) from side shroud C (8) and rear shroud B (9). Discard lockwasher.

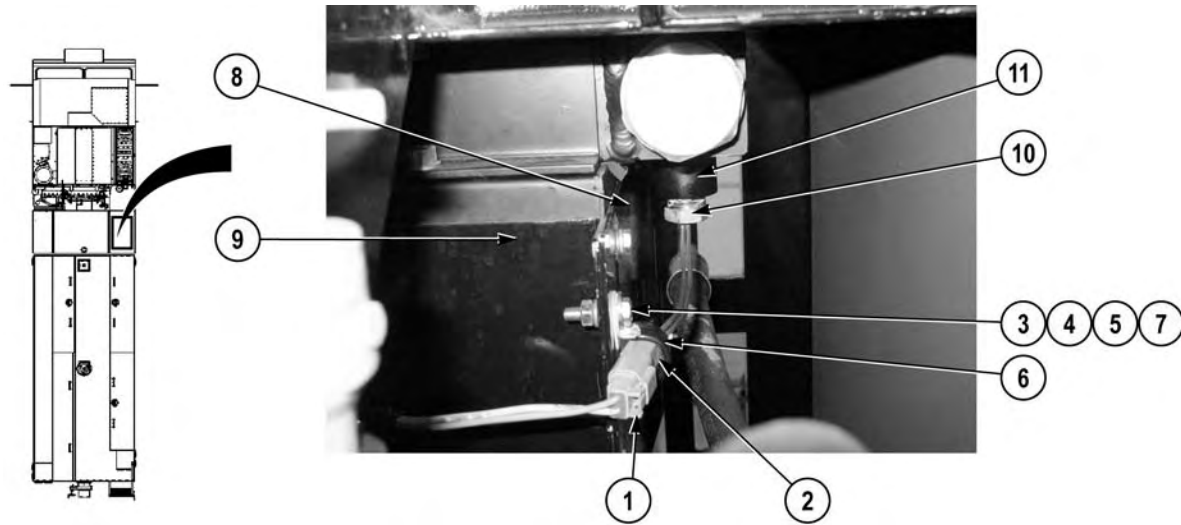
**NOTE**

Place a suitable drain pan under fan switch.

3. Remove fan switch (10) from hydraulic heat exchanger (11).

## END OF TASK

## INSTALLATION

**WARNING**

**Adhesives, solvents, and sealing compounds can burn easily, can give off harmful vapors, and are harmful to skin and clothing. To avoid injury or death, keep away from open fire and use in well-ventilated area. If adhesive, solvent, or sealing compound gets on skin or clothing, wash immediately with soap and water.**

1. Apply pipe thread sealing compound to threads of fan switch (10).
2. Install fan switch (10) on hydraulic heat exchanger (11).
3. Install fan switch connector (2) and cushion clip (6) on side shroud C (8) and rear shroud B (9) with screw (7), two washers (5), lockwasher (4), and nut (3).
4. Connect pump house wire harness connector (1) on fan switch connector (2).

**END OF TASK****FOLLOW-ON MAINTENANCE**

Install pump house panel K (WP 0339)

**END OF TASK****END OF WORK PACKAGE**

## FIELD LEVEL MAINTENANCE

## HYDRAULIC HEAT EXCHANGER REPLACEMENT

## INITIAL SETUP:

**Tools and Special Tools**

- Cap Set, Protective (WP 0398, Item 1)
- Drain Pan (WP 0398, Item 4)
- Standard Automotive Tool Set (SATS), (WP 0398, Item 15)
  - Wrench, Adjustable 18"
  - Wrench, Pipe 18"
- Tool Kit, General Mechanic's: Automotive (WP 0398, Item 17)

**Materials/Parts**

- Fluid, Hydraulic (WP 0400, Item 17)
- Tags, Identification (WP 0400, Item 23)
- Preformed Packing (1)
- Preformed Packing (2)
- Preformed Packing (1)
- Preformed Packing (1)
- Preformed Packing (1)
- Preformed Packing (1)
- Preformed Packing (1)
- Preformed Packing (1)
- Lockwasher (21)

**Personnel Required**

- MOS 63B Wheeled Vehicle Mechanic (2)

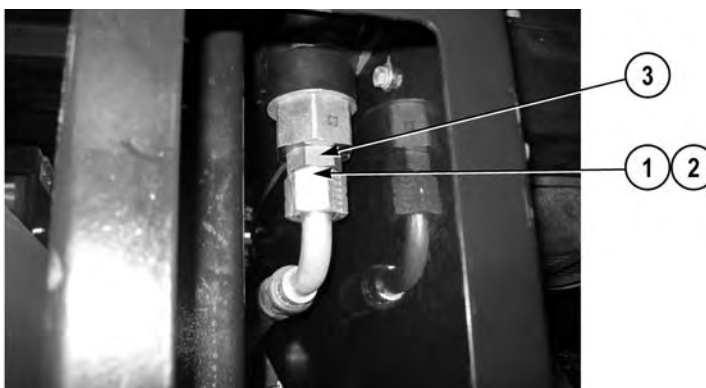
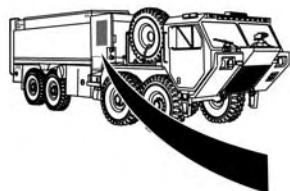
**References**

- WP 0136
- WP 0391, Fig. 7, 8, 10, 46, 71

**Equipment Conditions**

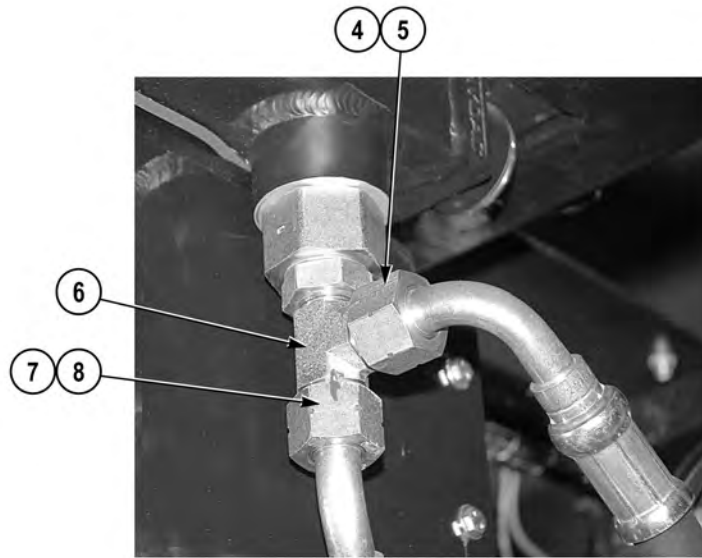
- Hydraulic heat exchanger shrouds A, B, and C removed (WP 0137)
- Hydraulic heat exchanger fans removed (WP 0136)
- Pump house panel M removed (WP 0339)
- Hydraulic reservoir drained (WP 0145)
- Hydraulic heat exchanger fan switch removed (WP 0133)

## REMOVAL

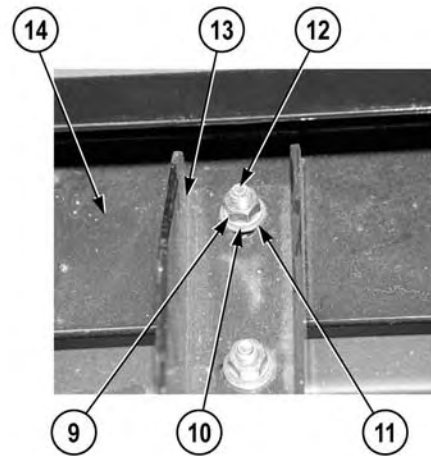
**NOTE**

- Tag and mark hoses and fittings prior to removal to ensure proper installation.
- Place suitable drain pan under hoses being removed.
- Cap and plug hoses and fittings upon removal.

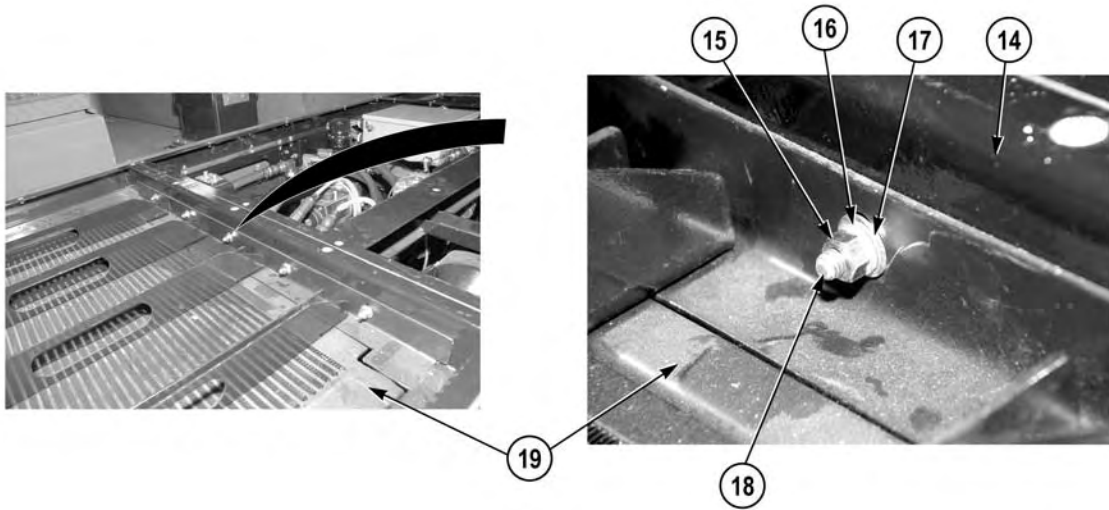
1. Remove hose 1682893 (1) and preformed packing (2) from fitting (3). Discard preformed packing.



2. Remove hose 1682884 (4) and preformed packing (5) from tee (6). Discard preformed packing.
3. Remove hose 1682886 (7) and preformed packing (8) from tee (6). Discard preformed packing.



4. Remove four nuts (9), lockwashers (10), eight washers (11), and four screws (12) from four brackets (13) and pump house frame (14). Discard lockwashers.

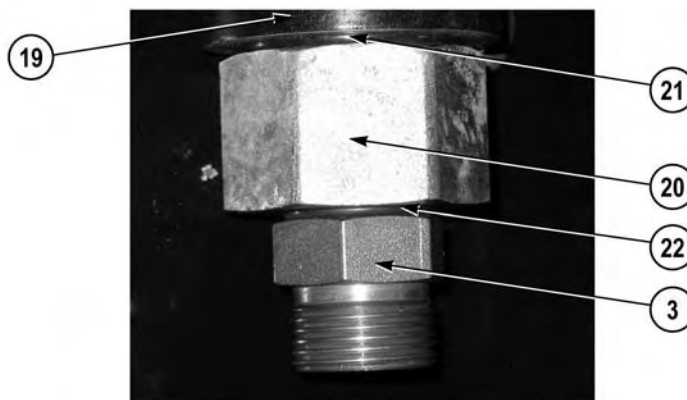


**WARNING**

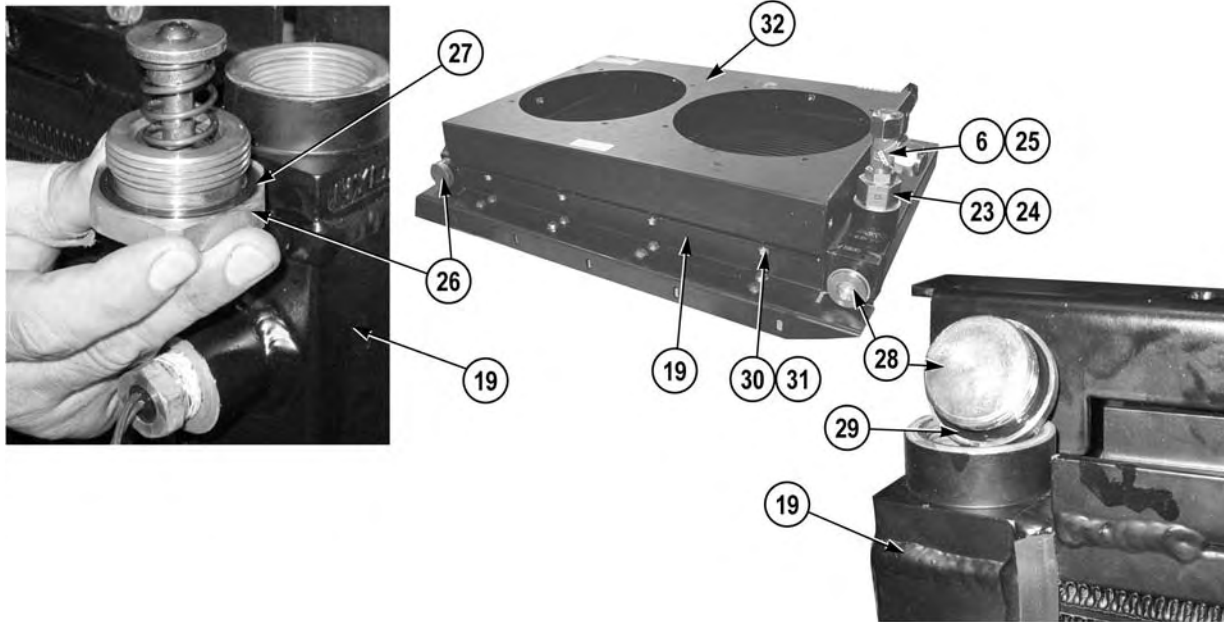


**Hydraulic heat exchanger weighs 85 lb. (38.56 kg). Do not attempt to remove hydraulic heat exchanger without the aid of an assistant and a suitable lifting device. Failure to comply may result in serious injury to personnel and damage to equipment.**

5. With the aid of an assistant and a suitable lifting device, remove five nuts (15), lockwashers (16), 10 washers (17), five screws (18), and hydraulic heat exchanger (19) from pump house frame (14). Discard lockwashers.



6. Remove fitting (20) and preformed packing (21) from hydraulic heat exchange (19). Discard preformed packing.
7. Remove fitting (3) and preformed packing (22) from fitting (20). Discard preformed packing.



### NOTE

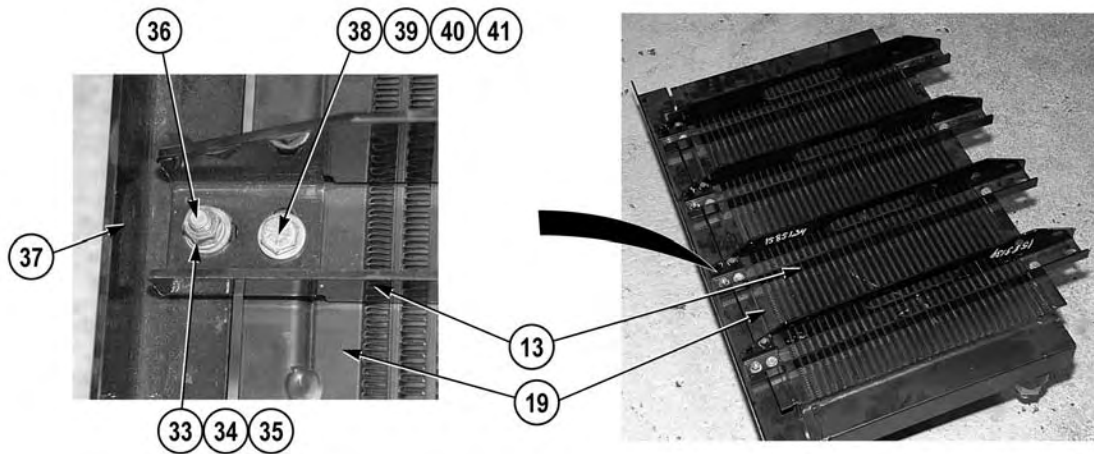
Note position of tee prior to removing fitting to ensure proper installation.

8. Remove fitting (23) and preformed packing (24) from hydraulic heat exchanger (19). Discard preformed packing.
9. Remove tee (6) and preformed packing (25) from fitting (23). Discard preformed packing.
10. Remove pressure relief valve (26) and preformed packing (27) from hydraulic heat exchanger (19). Discard preformed packing.
11. Remove plug (28) and preformed packing (29) from hydraulic heat exchanger (19). Discard preformed packing.

### NOTE

- Perform Step (12) if housing needs to be removed.
  - Note position of housing on hydraulic heat exchanger prior to removal to ensure proper installation.
12. Remove eight screws (30), washers (31), and housing (32) from hydraulic heat exchanger (19).





13. Remove four nuts (33), lockwashers (34), eight washers (35), four screws (36), and bracket (37) from four brackets (13). Discard lockwashers.

#### NOTE

Note position and orientation of brackets prior to removal to ensure proper installation.

14. Remove eight nuts (38), lockwashers (39), 16 washers (40), eight screws (41), and four brackets (13) from hydraulic heat exchanger (19). Discard lockwashers.

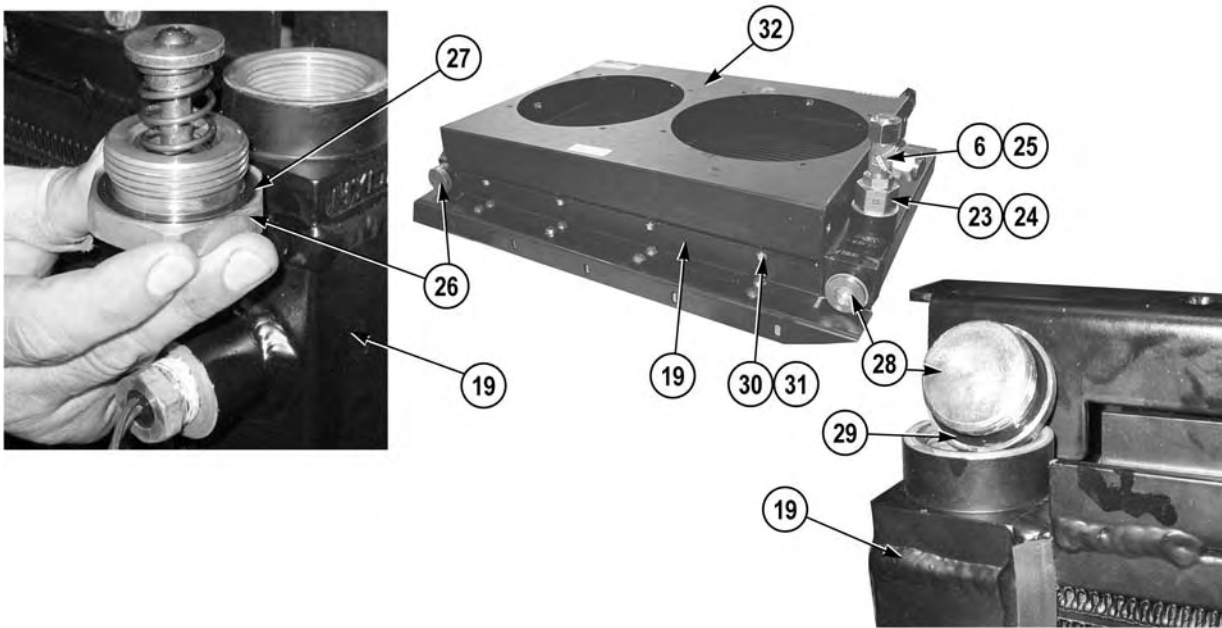
#### END OF TASK

#### INSTALLATION

#### NOTE

Install brackets on hydraulic heat exchanger as noted prior to removal.

1. Install four brackets (13) on hydraulic heat exchanger (19) with eight screws (41), 16 washers (40), eight lockwashers (39), and nuts (38).
2. Install bracket (37) on four brackets (13) with four screws (36), eight washers (35), four lockwashers (34), and nuts (33).



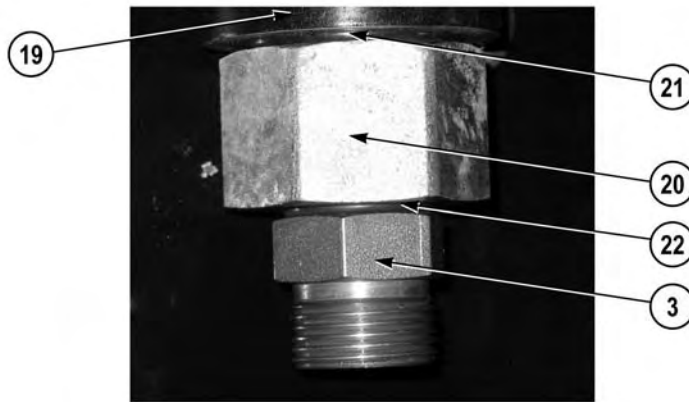
### NOTE

- Perform Step (3) if housing was removed.
  - Install housing on hydraulic heat exchanger as noted prior to removal.
3. Install housing (32) on hydraulic heat exchanger (19) with eight washers (31) and screws (30).
  4. Lightly lubricate preformed packing (29) with clean oil, and install preformed packing (29) and plug (28) on hydraulic heat exchanger (19).
  5. Lightly lubricate preformed packing (27) with clean oil, and install preformed packing (27) and pressure relief valve (26) on hydraulic heat exchanger (19).

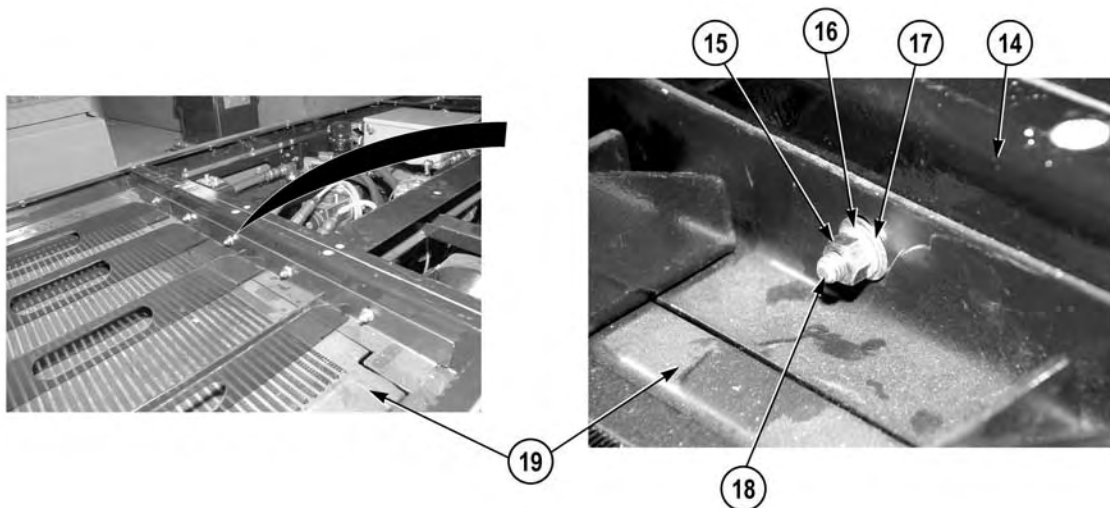
### NOTE

Install tee as noted prior to removal.

6. Lightly lubricate preformed packing (25) with clean oil, and install preformed packing (25) and tee (6) on fitting (23).
7. Lightly lubricate preformed packing (24) with clean oil, and install preformed packing (24) and fitting (23) on hydraulic heat exchanger (19).



8. Lightly lubricate preformed packing (21) with clean oil, and install preformed packing (21) and fitting (20) on hydraulic heat exchanger (19).
9. Lightly lubricate preformed packing (22) with clean oil, and install preformed packing (22) and fitting (3) on fitting (20).

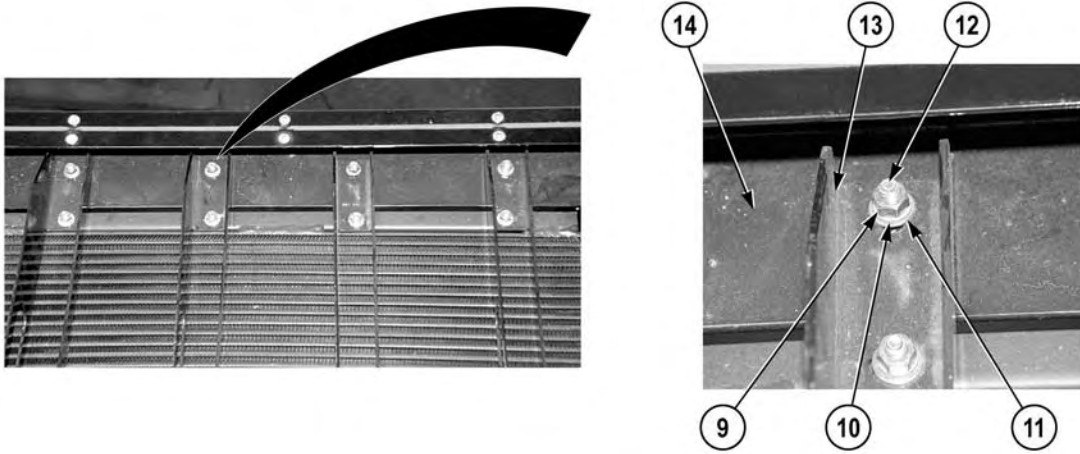


**WARNING**

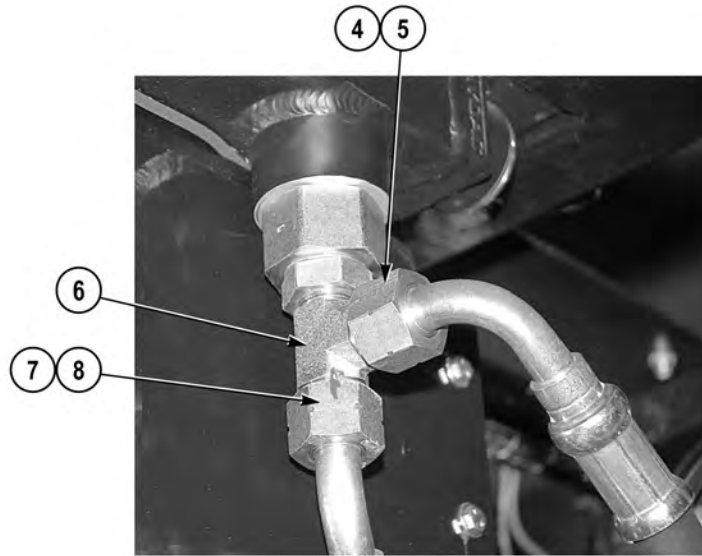


**Hydraulic heat exchanger weighs 85 lb. (38.56 kg). Do not attempt to install hydraulic heat exchanger without the aid of an assistant and a suitable lifting device. Failure to comply may result in serious injury to personnel and damage to equipment.**

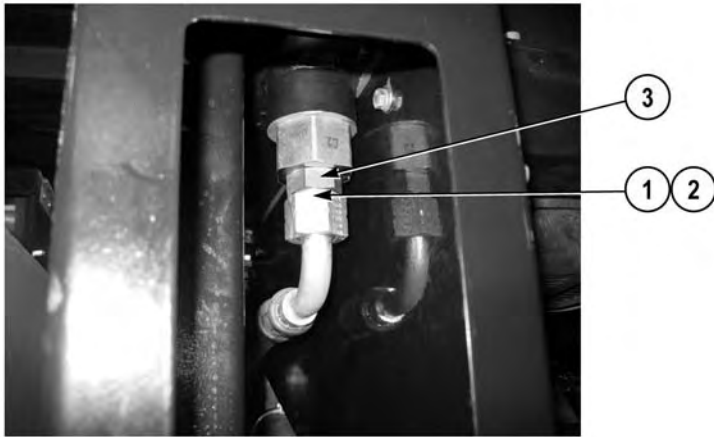
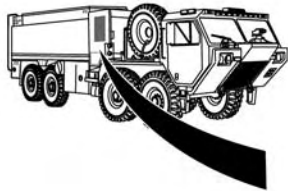
10. With the aid of an assistant and a suitable lifting device, install hydraulic heat exchanger (19) on pump house frame (14) with five screws (18), 10 washers (17), five lockwashers (16), and nuts (15).



11. Install four brackets (13) on pump house frame (14) with four screws (12), eight washers (11), four lockwashers (10), and nuts (9).



12. Lightly lubricate preformed packing (8) with clean oil, and install preformed packing (8) and hose 1682886 (7) on tee (6).
13. Lightly lubricate preformed packing (5) with clean oil, and install preformed packing (5) and hose 1682884 (4) on tee (6).



14. Lightly lubricate preformed packing (2) with clean oil, and install preformed packing (2) and hose 1682893 (1) on fitting (3).

#### END OF TASK

#### FOLLOW-ON MAINTENANCE

1. Install hydraulic heat exchanger fan switch (WP 0133)
2. Install hydraulic heat exchanger fans (WP 0136)
3. Fill hydraulic reservoir (WP 0145)
4. Install pump house panel M (WP 0339)
5. Install hydraulic heat exchanger shrouds A, B, and C (WP 0137)

#### END OF TASK

#### END OF WORK PACKAGE



## FIELD LEVEL MAINTENANCE

## HYDRAULIC HEAT EXCHANGER BOTTOM SHROUD PANEL REPLACEMENT

## INITIAL SETUP:

**Tools and Special Tools**

Tool Kit, General Mechanic's: Automotive  
(WP 0398, Item 17)

**References**

WP 0391, Fig. 8

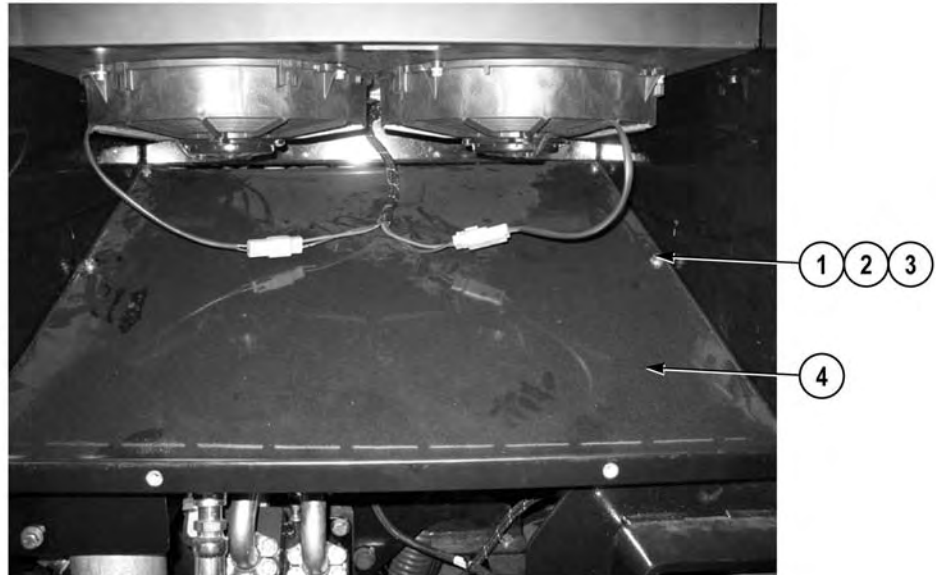
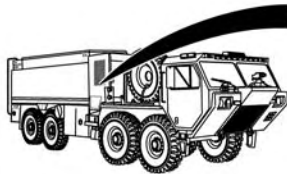
**Materials/Parts**

Lockwasher (4)

**Equipment Conditions**

Pump house panel H removed (WP 0339)

## REMOVAL



Remove four screws (1), lockwashers (2), washers (3), and hydraulic heat exchanger bottom shroud panel (4) from vehicle. Discard lockwashers.

## END OF TASK

**INSTALLATION**

Install hydraulic heat exchanger bottom shroud panel (4) on vehicle with four washers (3), lockwashers (2), and screws (1).

**END OF TASK**

**FOLLOW-ON MAINTENANCE**

Install pump house panel H (WP 0339)

**END OF TASK**

**END OF WORK PACKAGE**



---

**FIELD LEVEL MAINTENANCE**  
**HYDRAULIC HEAT EXCHANGER FAN(S) REPLACEMENT**

---

**INITIAL SETUP:****Tools and Special Tools**

Tool Kit, General Mechanic's: Automotive  
(WP 0398, Item 17)

**Materials/Parts**

Lockwasher (4)

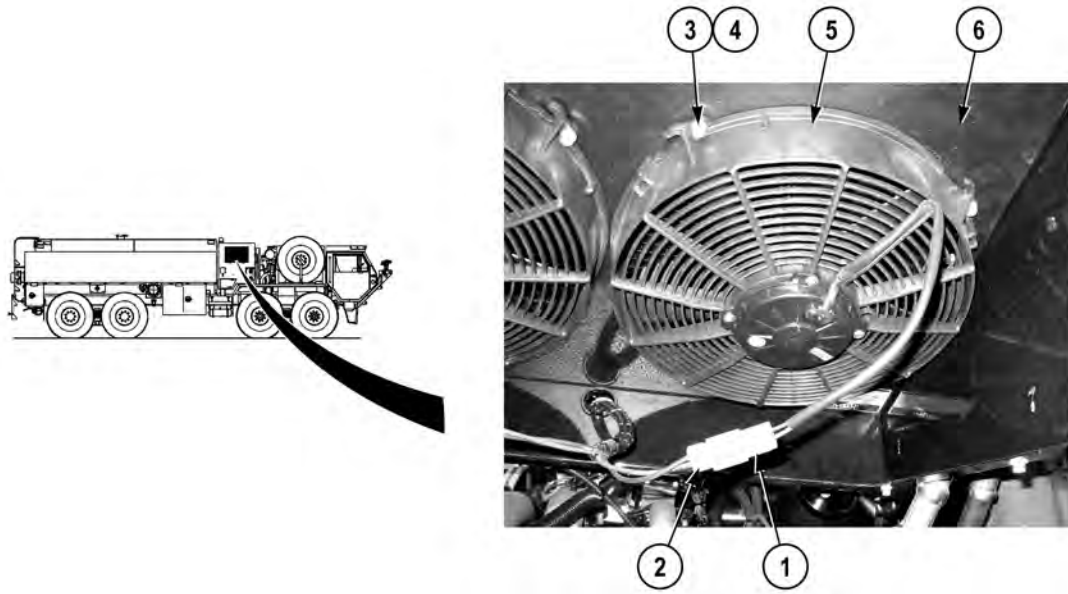
**References**

WP 0391, Fig. 8

**Equipment Conditions**

Hydraulic heat exchanger bottom shroud panel removed (WP 0135)

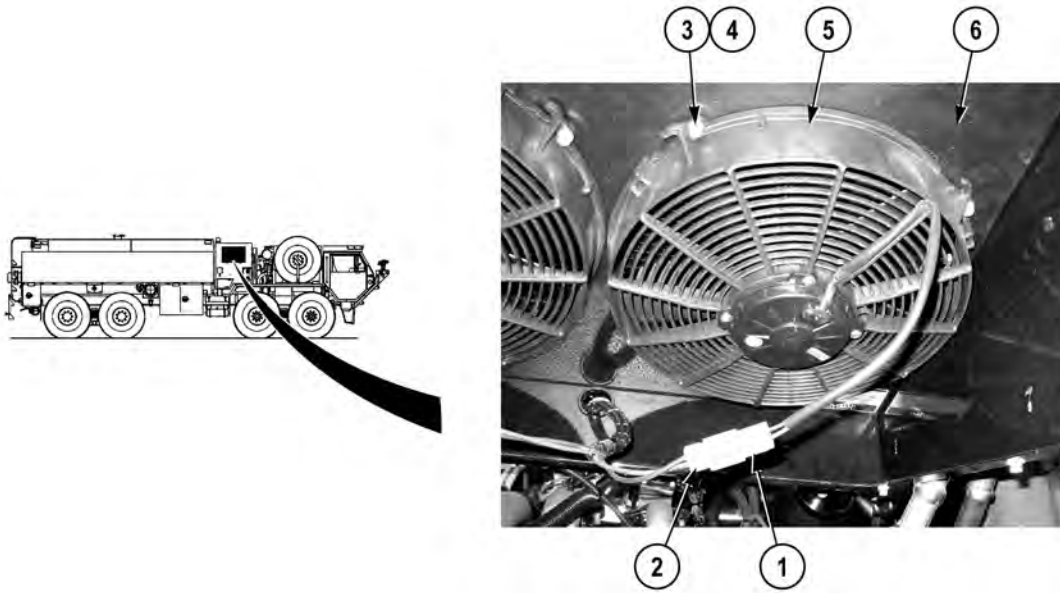
---

**REMOVAL****NOTE**

- Both hydraulic heat exchanger fans are removed the same way. Front hydraulic heat exchanger fan shown.
- Note position of hydraulic heat exchanger fans prior to removal to ensure proper installation.

1. Disconnect hydraulic heat exchanger fan connector (1) from pump house wire harness connector (2).
2. Remove four screws (3), lockwashers (4), and hydraulic heat exchanger fan (5) from bracket (6). Discard lockwashers.

**END OF TASK**

**INSTALLATION****NOTE**

- Both hydraulic heat exchanger fans are installed the same way. Front hydraulic heat exchange fan shown.
- Install hydraulic heat exchanger fans as noted prior to removal.

1. Install hydraulic heat exchanger fan (5) on bracket (6) with four lockwashers (4) and screws (3).
2. Connect pump house wire harness connector (2) to hydraulic heat exchanger fan connector (1).

**END OF TASK****FOLLOW-ON MAINTENANCE**

Install hydraulic heat exchanger bottom shroud panel (WP 0135)

**END OF TASK****END OF WORK PACKAGE**

FIELD LEVEL MAINTENANCE

HYDRAULIC HEAT EXCHANGER SHROUD REPLACEMENT

INITIAL SETUP:

**Tools and Special Tools**

Tool Kit, General Mechanic's: Automotive  
(WP 0398, Item 17)

**References**

WP 0391, Fig. 8

**Materials/Parts**

Adhesive, Thread, Locking (WP 0400, Item 6)  
Tags, Identification (WP 0400, Item 23)  
Lockwasher (18)

**Equipment Conditions**

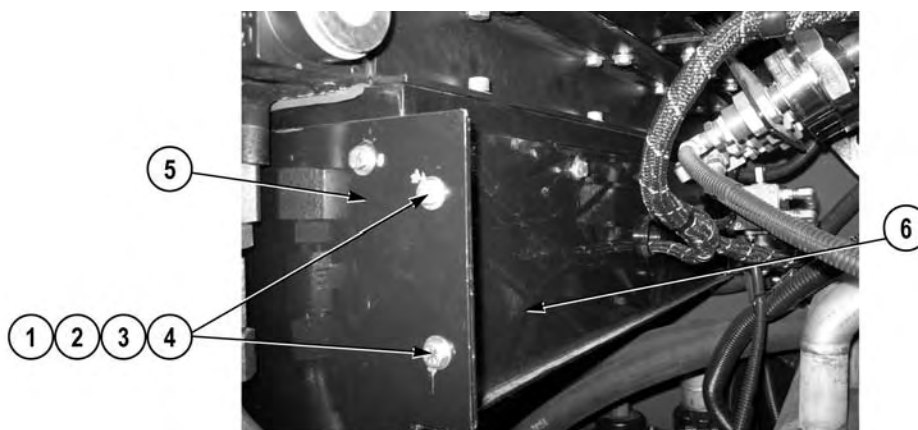
Pump house panel G removed  
(shrouds A and B) (WP 0339)  
Pump house panel K removed  
(shrouds B and C) (WP 0339)  
Hydraulic heat exchanger bottom shroud panel  
removed (WP 0135)



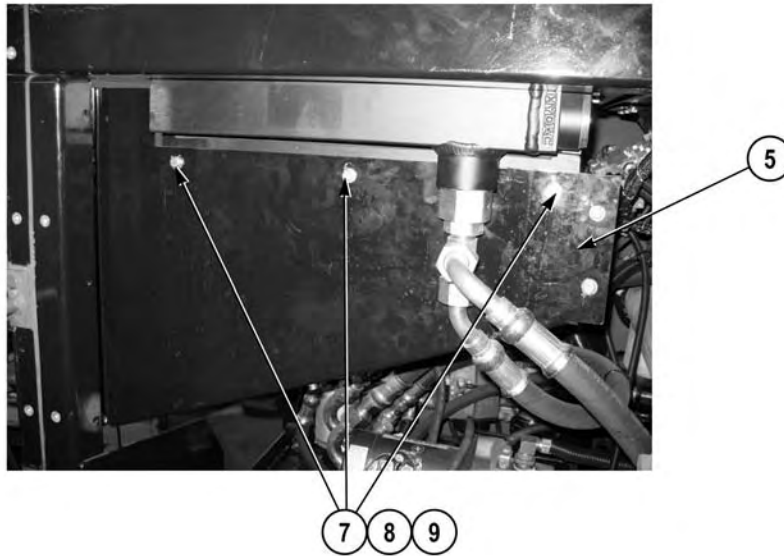
SHROUD C                  SHROUD B                  SHROUD A



SHROUD A REMOVAL



1. Remove two nuts (1), lockwashers (2), four washers (3), and two screws (4) from shroud A (5) and shroud B (6). Discard lockwashers.



2. Remove three screws (7), lockwashers (8), washers (9), and shroud A (5) from vehicle. Discard lockwashers.

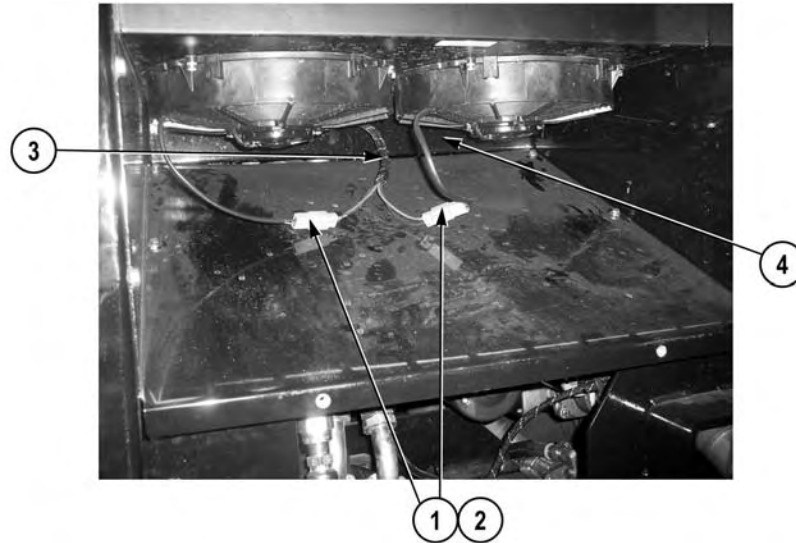
**END OF TASK**

**SHROUD A INSTALLATION**

1. Install shroud A (5) on vehicle with three washers (9), lockwashers (8), and screws (7).



2. Install shroud A (5) on shroud B (6) with two screws (4), four washers (3), two lockwashers (2), and nuts (1).

**SHROUD B REMOVAL****NOTE**

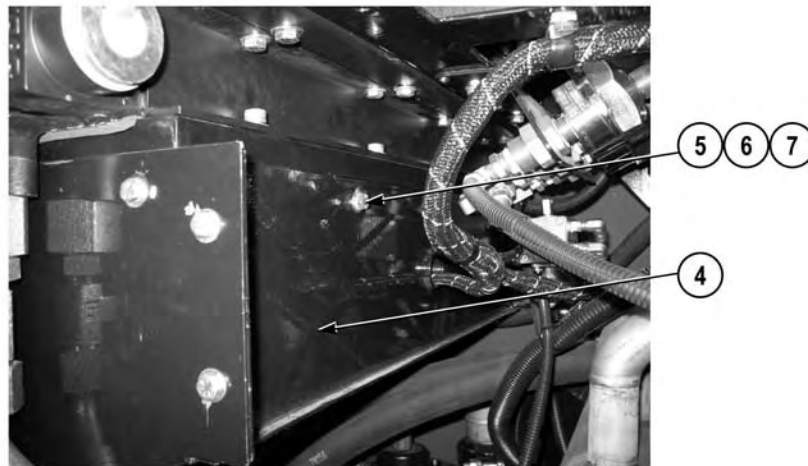
Tag and mark wires prior to removal to ensure proper installation.

1. Disconnect two pump house wire harness connectors (1) from hydraulic heat exchanger fan connectors (2).

**NOTE**

Note routing of wire harness prior to removal to ensure proper installation.

2. Remove pump house wire harness (3) from shroud B (4).

**NOTE**

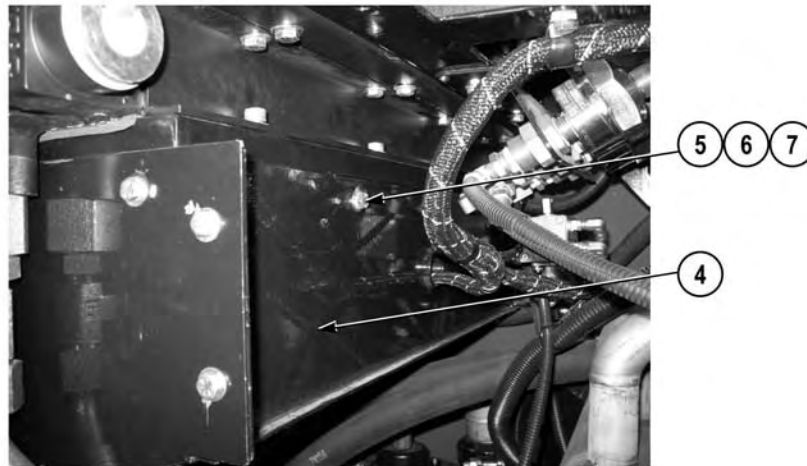
Note position and orientation of shroud B prior to removal to ensure proper installation.

3. Remove two screws (5), lockwashers (6), and washers (7) from shroud B (4) and vehicle. Discard lockwashers.

**NOTE**

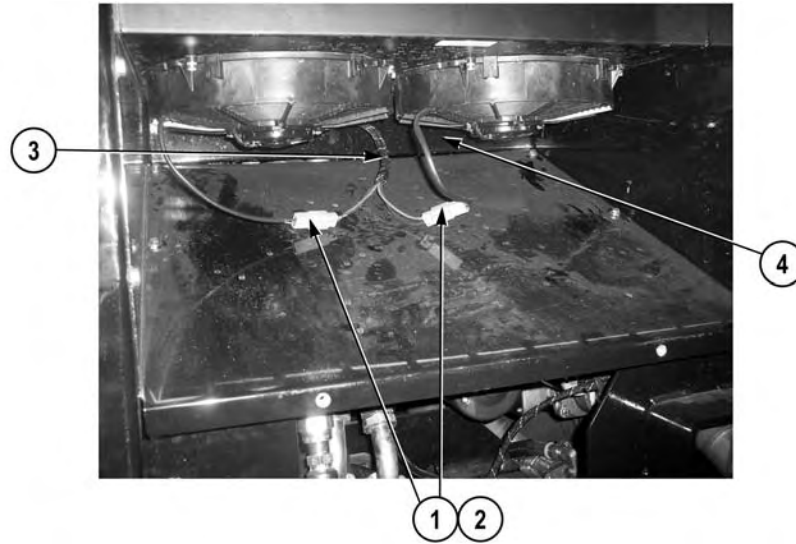
Remove cushion clips as required.

4. Remove four nuts (8), lockwashers (9), eight washers (10), four screws (11), and shroud B (4) from vehicle. Discard lockwashers.

**END OF TASK****SHROUD B INSTALLATION****NOTE**

- Install cushion clips as required.
- Install shroud B as noted prior to removal.

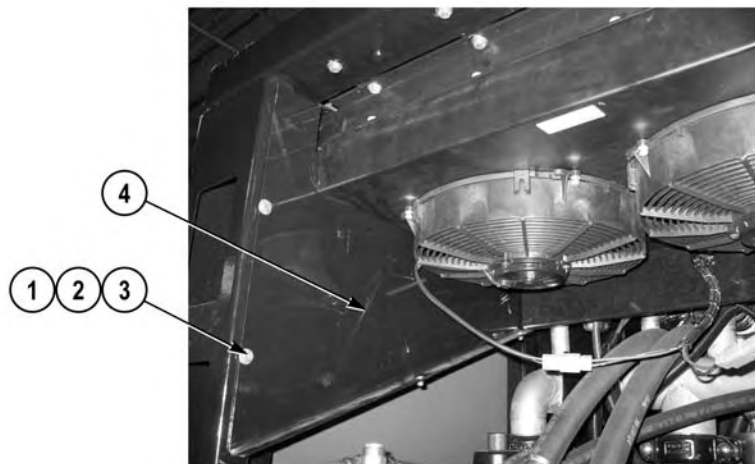
1. Install shroud B (4) on vehicle with four screws (11), eight washers (10), four lockwashers (9), and nuts (8).
2. Install two washers (7), lockwashers (6), and screws (5) on shroud B (4) and vehicle.



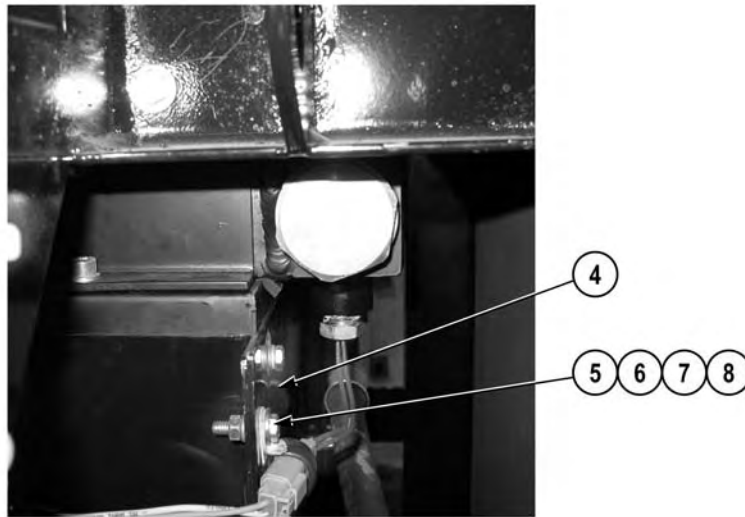
3. Install pump house wire harness (3) through shroud B (4).
4. Connect two pump house wire harness connectors (1) to heat exchanger fan connectors (2).

**END OF TASK**

#### **SHROUD C REMOVAL**



1. Remove three screws (1), lockwashers (2), and washers (3) from shroud C (4) and vehicle. Discard lockwashers.

**NOTE**

Remove cushion clips as required.

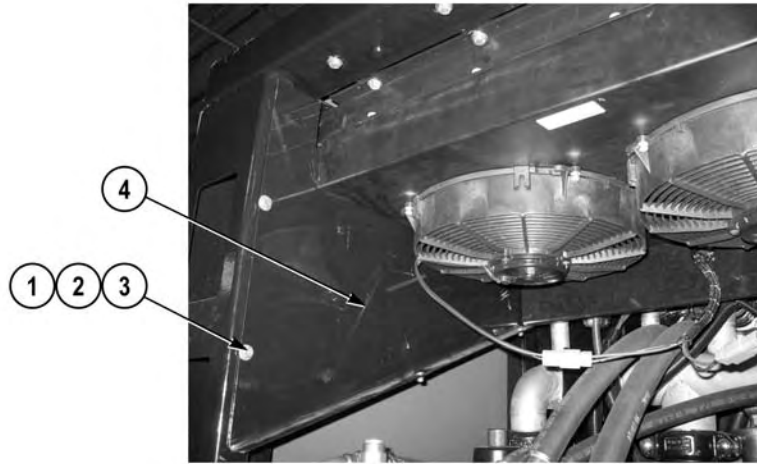
2. Remove four nuts (5), lockwashers (6), eight washers (7), four screws (8), and shroud C (4) from vehicle. Discard lockwashers.

**END OF TASK****SHROUD C INSTALLATION****NOTE**

Install cushion clips as required.

1. Install shroud C (4) on vehicle with four screws (8), eight washers (7), four lockwashers (6), and nuts (5).





2. Install three washers (3), lockwashers (2), and screws (1) on shroud C (4) and vehicle.

**END OF TASK**

**FOLLOW-ON MAINTENANCE**

1. Install hydraulic heat exchanger bottom shroud panel (WP 0135)
2. Install pump house panel K (shrouds B and C) (WP 0135)
3. Install pump house panel G (shrouds A and B) (WP 0135)

**END OF TASK**

**END OF WORK PACKAGE**



---

**FIELD LEVEL MAINTENANCE**  
**HYDRAULIC HOSE REPLACEMENT**

---

**INITIAL SETUP:****Tools and Special Tools**

Cap Set, Protective (WP 0398, Item 1)  
Tool Kit, General Mechanic's: Automotive  
(WP 0398, Item 17)

**Materials/Parts**

Fluid, Hydraulic (WP 0400, Item 17)  
Tags, Identification (WP 0400, Item 23)  
Ties, Cable, Plastic (WP 0400, Item 26)

**Materials/Parts (continued)**

Preformed Packing (Qty may vary)

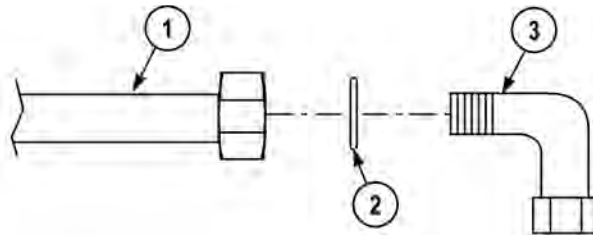
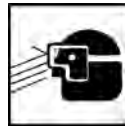
**References**

WP 0391, Fig. 7, 9, 10

**Equipment Conditions**

Hydraulic reservoir drained (WP 0145)

---

**TYPICAL HYDRAULIC HOSE REMOVAL****WARNING**

**Hydraulic hoses may retain residual pressure. Wear eye protection to prevent eye injury. Failure to comply may result in serious injury to personnel.**

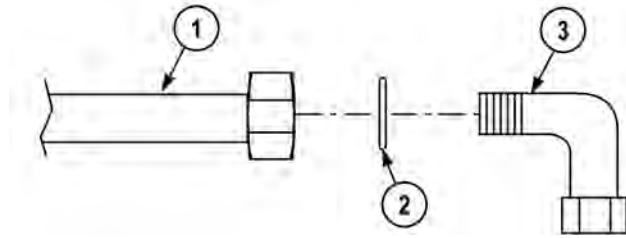
**NOTE**

- This procedure only shows location of hydraulic hoses. It will never be necessary to remove all hydraulic hoses at once.
- All hydraulic hoses are connected to fittings. Fittings from which hydraulic hoses are being removed or installed may be an elbow, tee fitting, or an adapter on a valve or other hydraulic component.
- All hoses are removed the same way. Elbow is shown.
- Tag and mark position of hydraulic hoses.
- Remove cushion clips and cable ties as required.
- Cap and plug hydraulic hoses and fittings upon removal.

Remove hose (1) and preformed packing (2) from elbow (3). Discard preformed packing.

**END OF TASK**

---

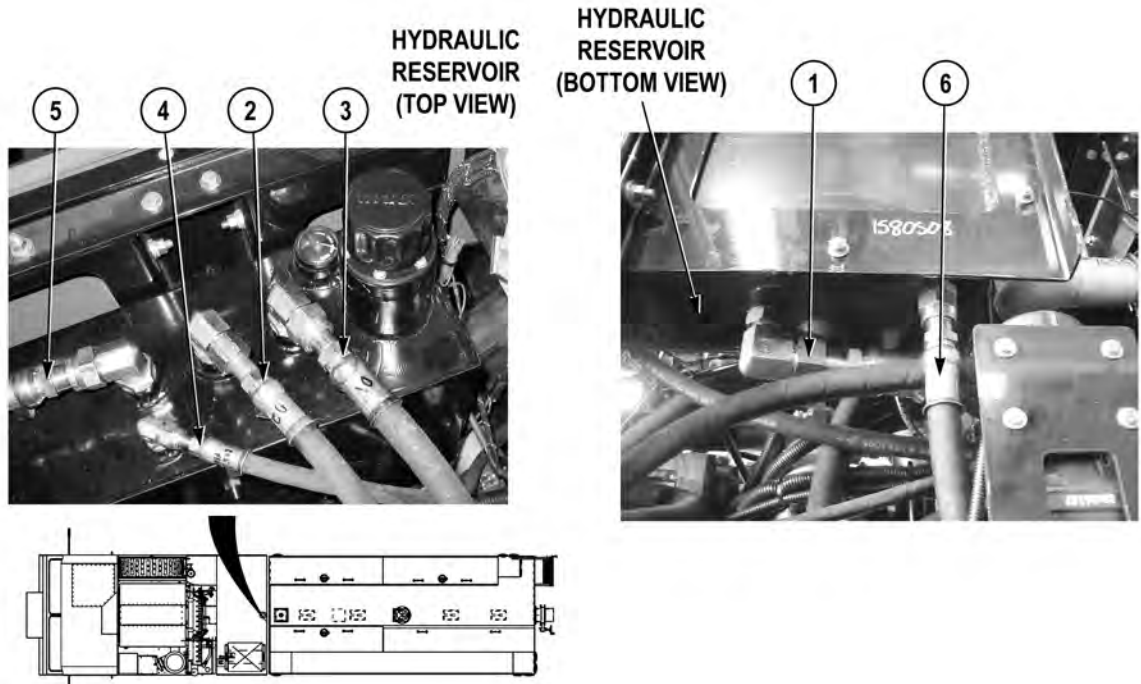
**TYPICAL HYDRAULIC HOSE INSTALLATION****NOTE**

Install cushion clips and cable ties as required.

Lightly lubricate preformed packing (2) with clean oil, and install preformed packing (2) and hose (1) on elbow (3).

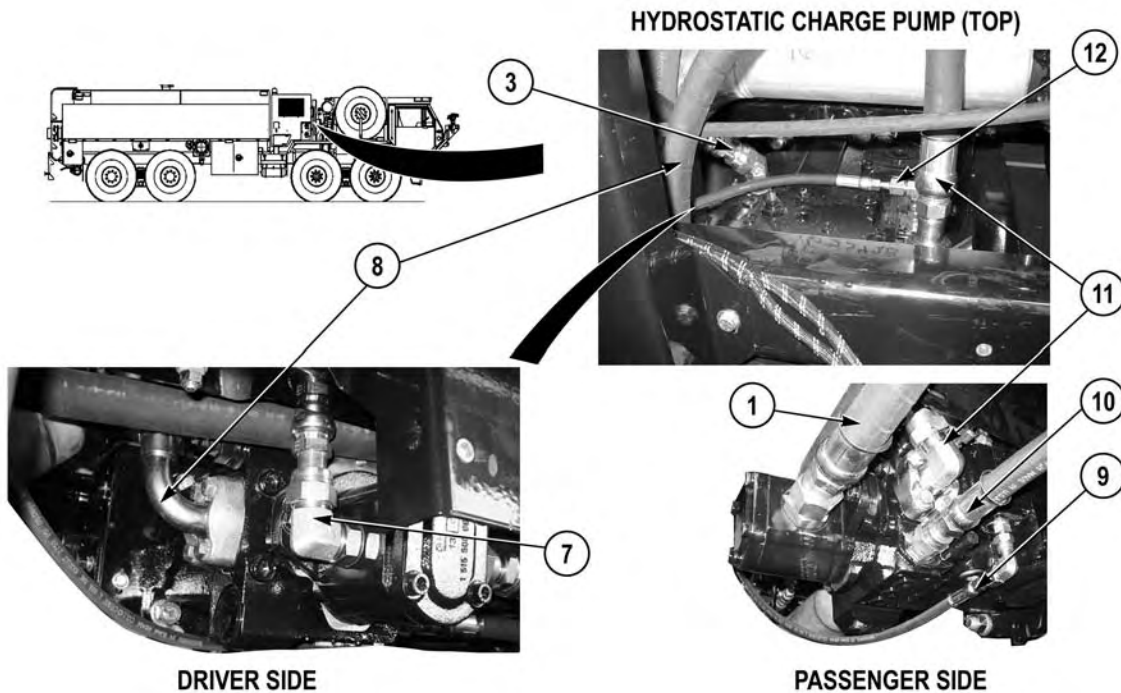
**END OF TASK**

HYDRAULIC HOSES



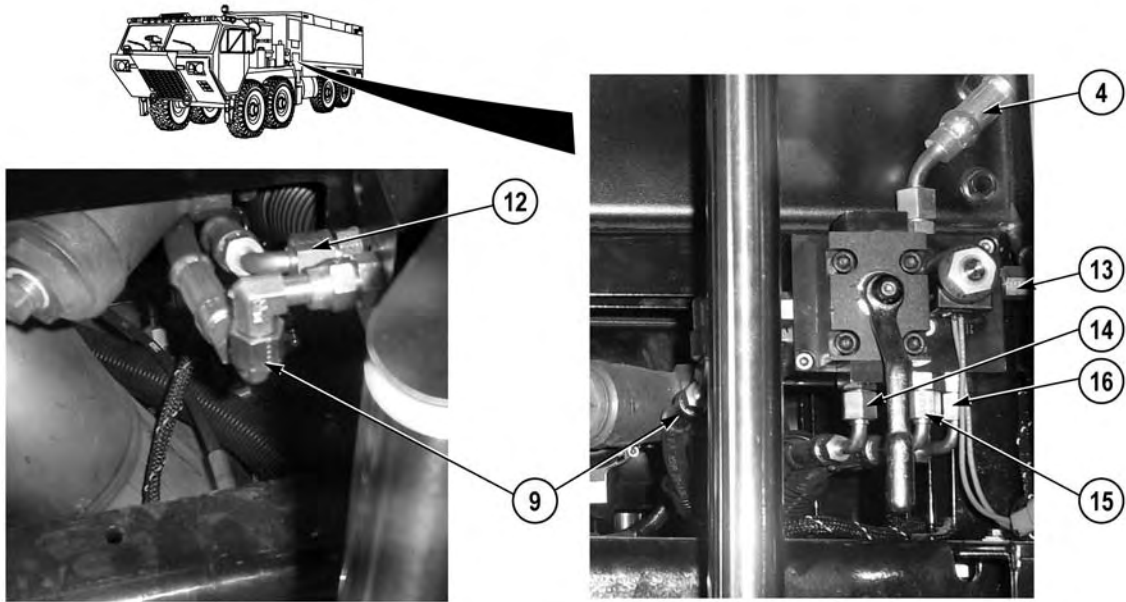
**Table 1. Hydraulic Reservoir Hoses.**

Item No.	Hose No.	From	To
1	1682838	Hydraulic reservoir	Hydrostatic charge pump (Table 2)
2	1682841	Hydraulic reservoir	Hydrostatic pump motor (Table 5) (T1)
3	1682888	Hydraulic reservoir	Hydrostatic charge pump (Table 2) (T2)
4	1682987	Hydraulic reservoir	Hydraulic override manifold (Table 4) (T1)
5	1682893	Hydraulic reservoir	Hydraulic heat exchange (Table 7)
6	1682915	Hydraulic reservoir	Drain



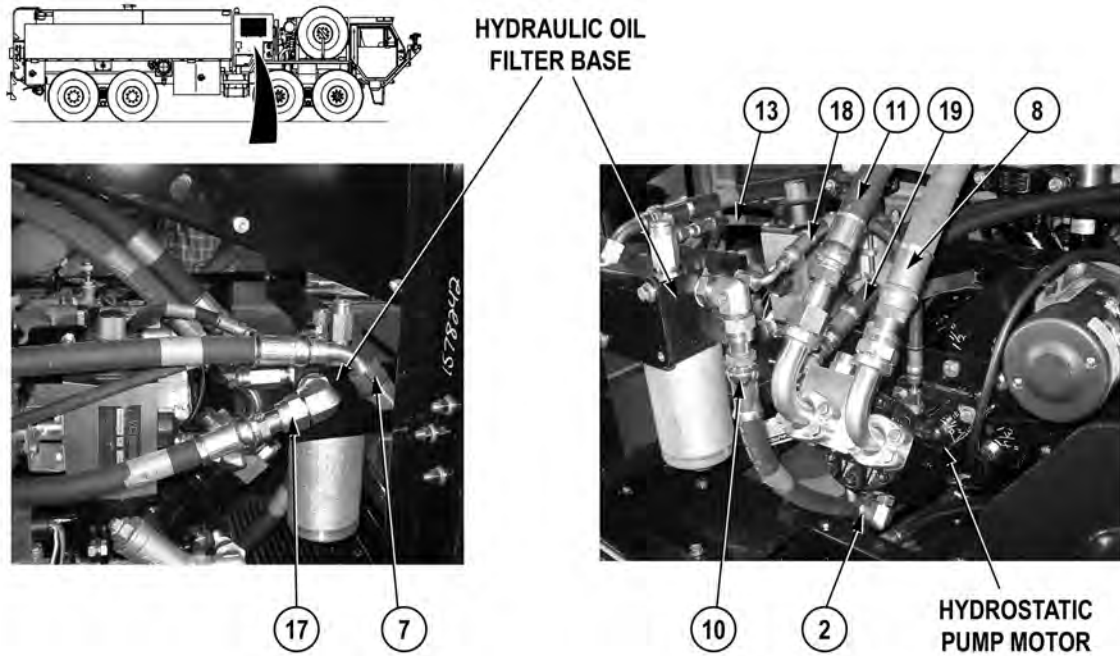
**Table 2. Hydrostatic Charge Pump Hoses.**

Item No.	Hose No.	From	To
1	1682838	Hydrostatic charge pump	Hydraulic reservoir (Table 1)
3	1682888	Hydrostatic charge pump	Hydraulic reservoir (Table 1)
7	1682901	Hydrostatic charge pump	Hydraulic oil filter base (Table 4) (P1)
8	1682839	Hydrostatic charge pump	Hydrostatic pump motor (Table 5)
9	1682912	Hydrostatic charge pump (Y1)	Hydraulic override manifold (Table 3) (Y2)
10	1682902	Hydrostatic charge pump	Hydraulic oil filter base (Table 4) (P2)
11	1682840	Hydrostatic charge pump	Hydrostatic pump motor (Table 5)
12	1682911	Hydrostatic charge pump (Y2)	Hydraulic override manifold (Table 3) (Y1)



**Table 3. Hydraulic Override Manifold Hoses.**

Item No.	Hose No.	From	To
4	1682987	Hydraulic override manifold (T1)	Hydraulic reservoir (Table 1)
13	1682910	Hydraulic override manifold (CP)	Hydraulic oil filter base (Table 4) (G)
9	1682912	Hydraulic override manifold (Y2)	Hydrostatic charge pump (Table 2) (Y2)
12	1682911	Hydraulic override manifold (Y1)	Hydrostatic charge pump (Table 2) (Y1)
14	1682914 (No. 1)	Hydraulic override manifold (MC1) (No. 1)	Hydraulic pressure control (Table 6) (Port 1)
15	1682914 (No. 2)	Hydraulic override manifold (MC2) (No. 2)	Hydraulic pressure control (Table 6) (Port 2)
16	1682914 (No. 3)	Hydraulic override manifold (MC3) (No. 3)	Hydraulic pressure control (Table 6) (Port 3)



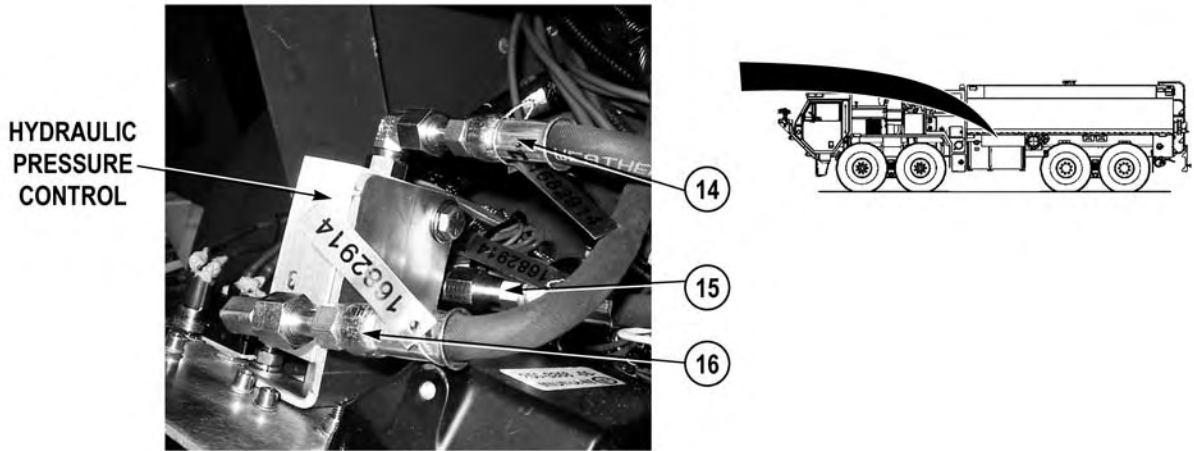
**Table 4. Hydraulic Oil Filter Base Hoses.**

Item No.	Hose No.	From	To
13	1682910	Hydraulic oil filter base (G)	Hydraulic override manifold (Table 3) (CP)
7	1682901	Hydraulic oil filter base (P1)	Hydrostatic charge pump (Table 2)
17	1682884	Hydraulic oil filter base (T1)	Hydraulic heat exchanger (Table 7)
18	1682906	Hydraulic oil filter base (T2)	Hydrostatic pump motor (Table 5) (T2)
10	1682902	Hydraulic oil filter base (P2)	Hydrostatic charge pump (Table 2)

**Table 5. Hydrostatic Pump Motor.**

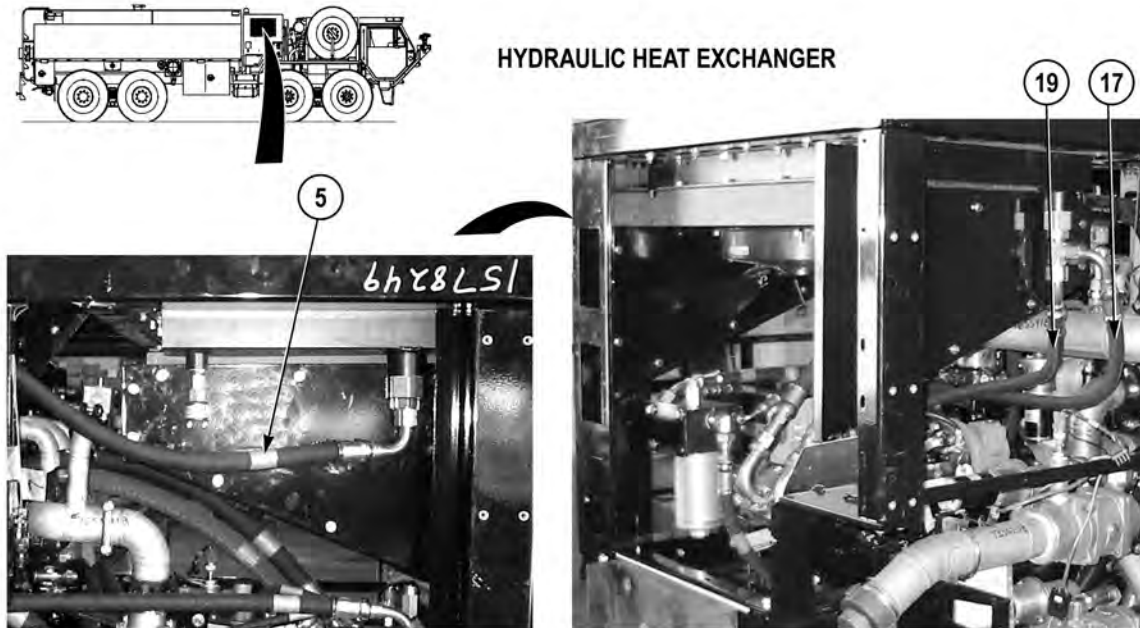
Item No.	Hose No.	From	To
8	1682839	Hydrostatic pump motor	Hydrostatic charge pump (Table 2)
11	1682840	Hydrostatic pump motor	Hydrostatic charge pump (Table 2)
18	1682906	Hydrostatic pump motor (T2)	Hydraulic oil filter base (Table 4) (T2)
19	1682886	Hydrostatic pump motor	Hydraulic heat exchanger (Table 7)
2	1682841	Hydrostatic pump motor (T1)	Hydraulic reservoir (Table 1)





**Table 6. Hydraulic Pressure Control Hoses.**

Item No.	Hose No.	From	To
14	1682914 (MC1) No. 1	Hydraulic pressure control (Port 1)	Hydraulic override manifold (MC1) No. 1 (Table 3)
15	1682914 (MC2) No.2	Hydraulic pressure control (Port 2)	Hydraulic override manifold (MC2) No. 2 (Table 3)
16	1682914 (MC3) No. 3	Hydraulic pressure control (Port 3)	Hydraulic override manifold (MC3) No. 3 (Table 3)



*Table 7. Hydraulic Heat Exchanger.*

Item No.	Hose No.	From	To
5	1682893	Hydraulic heat exchanger	Hydraulic reservoir (Table 1)
19	1682886	Hydraulic heat exchanger	Hydrostatic pump motor (Table 5)
17	1682884	Hydraulic heat exchanger	Hydraulic oil filter base (Table 4)

**END OF TASK**

**FOLLOW-ON MAINTENANCE**

Fill oil reservoir (WP 0145)

**END OF TASK**

**END OF WORK PACKAGE**

## FIELD LEVEL MAINTENANCE

## HYDRAULIC OIL DRAIN MOUNTING BRACKET REPLACEMENT

## INITIAL SETUP:

**Tools and Special Tools**

Tool Kit, General Mechanic's: Automotive  
(WP 0398, Item 17)

**References**

WP 0391, Fig. 10

**Materials/Parts**

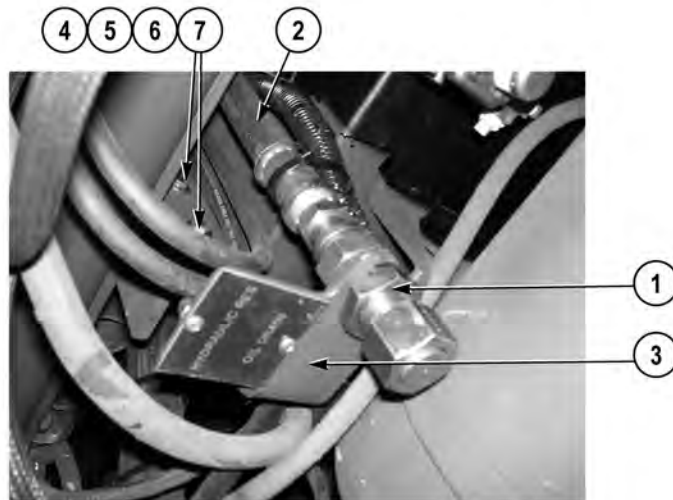
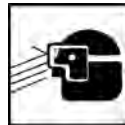
Lockwasher (2)

**Equipment Conditions**

Engine OFF (TM 9-2320-422-10)

Wheels chocked (TM 9-2320-422-10)

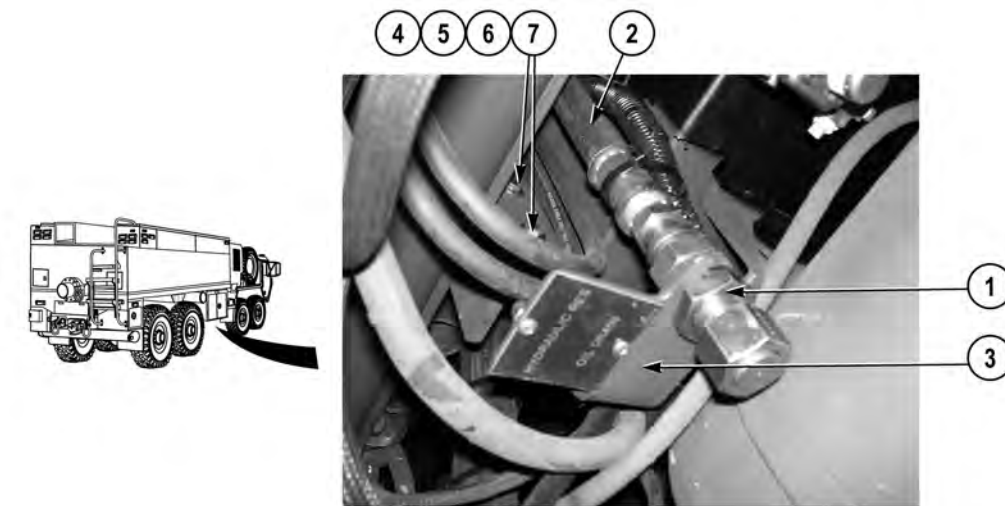
## REMOVAL

**WARNING**

**Hydraulic hoses may retain residual pressure. Wear eye protection to prevent eye injury. Failure to comply may result in serious injury to personnel.**

1. Loosen jam nut (1) on hydraulic oil drain hose (2).
2. Remove hydraulic oil drain hose (2) from hydraulic oil drain mounting bracket (3).
3. Remove two nuts (4), four washers (5), two lockwashers (6), screws (7), and hydraulic oil drain mounting bracket (3) from vehicle. Discard lockwashers.

**END OF TASK**

**INSTALLATION**

1. Install two screws (7), lockwashers (6), four washers (5), two nuts (4), and hydraulic oil drain mounting bracket (3) on vehicle.
2. Install hydraulic oil drain hose (2) on hydraulic oil drain mounting bracket (3).
3. Tighten jam nut (1) on hydraulic drain hose (2).

**END OF TASK****FOLLOW-ON MAINTENANCE**

Remove wheel chocks (TM 9-2320-422-10)

**END OF TASK****END OF WORK PACKAGE**

---

**FIELD LEVEL MAINTENANCE**  
**HYDRAULIC OIL FILTER REPLACEMENT**

---

**INITIAL SETUP:****Tools and Special Tools**

Drain Pan (WP 0398, Item 4)  
Tool Kit, General Mechanic's: Automotive  
(WP 0398, Item 17)

**Materials/Parts**

Preformed Packing (1)

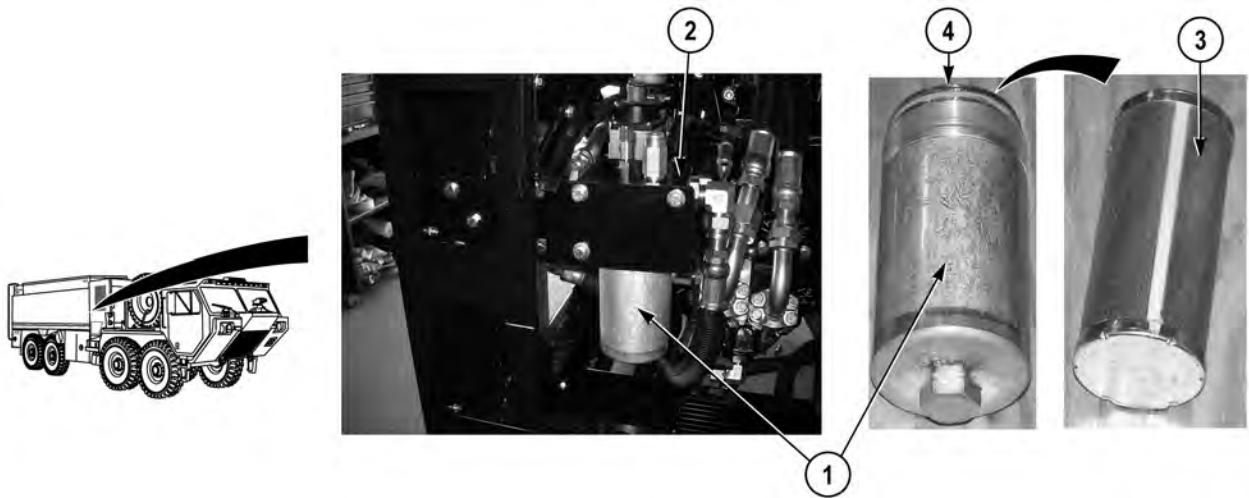
**References**

WP 0391, Fig. 46

**Equipment Conditions**

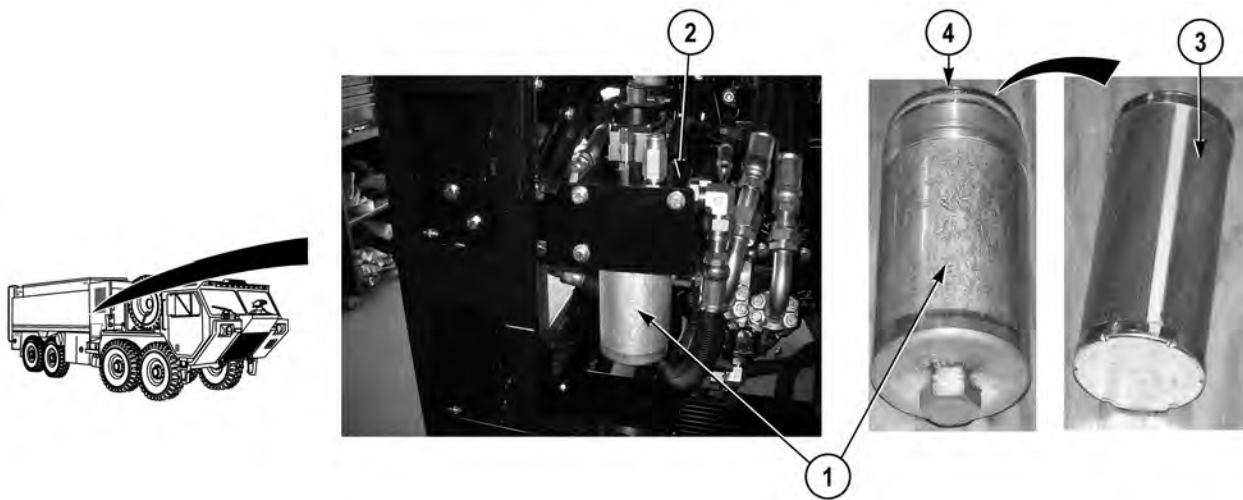
Hydraulic reservoir drained (WP 0145)  
Pump house panel H removed (WP 0339)

---

**REMOVAL**

1. Position drain pan under filter housing (1).
2. Remove filter housing (1) from manifold (2).
3. Remove filter (3) and preformed packing (4) from filter housing (1). Discard preformed packing.

**END OF TASK**

**INSTALLATION**

Lightly lubricate preformed packing (4) with clean oil, and install preformed packing (4), filter (3), and filter housing (1) on manifold (2).

**END OF TASK****FOLLOW-ON MAINTENANCE**

1. Fill hydraulic reservoir (WP 0145)
2. Install pump house panel H (WP 0339)

**END OF TASK****END OF WORK PACKAGE**

---

**FIELD LEVEL MAINTENANCE**  
**HYDRAULIC OIL FILTER BASE REPLACEMENT**

---

**INITIAL SETUP:****Tools and Special Tools**

Cap Set, Protective (WP 0398, Item 1)  
Drain Pan (WP 0398, Item 4)  
Tool Kit, General Mechanic's: Automotive  
(WP 0398, Item 17)

**Materials/Parts**

Oil, Lubricating (WP 0400, Item 20)  
Tags, Identification (WP 0400, Item 23)  
Preformed Packing (1)  
Preformed Packing (1)  
Preformed Packing (1)  
Lockwashers (3)  
Preformed Packing (1)  
Preformed Packing (1)  
Preformed Packing (1)  
Preformed Packing (1)  
Preformed Packing (1)  
Preformed Packing (1)  
Preformed Packing (1)

**Materials/Parts (continued)**

Preformed Packing (1)  
Preformed Packing (1)  
Backing Ring (2)  
Preformed Packing (1)  
Preformed Packing (1)  
Preformed Packing (1)  
Preformed Packing (1)  
Preformed Packing (1)  
Preformed Packing (1)  
Preformed Packing (1)  
Lockwasher (3)

**References**

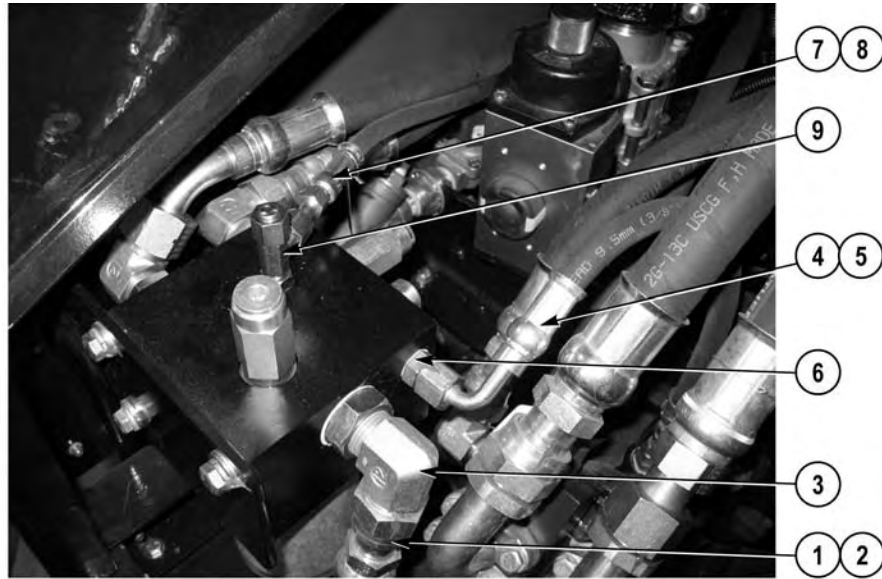
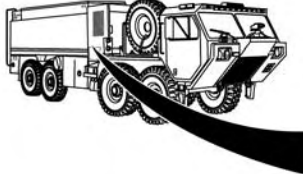
WP 0391, Fig. 4

**Equipment Conditions**

Hydraulic oil filter removed (WP 0140)  
Hydraulic heat exchanger bottom shroud panel  
removed (WP 0135)

---

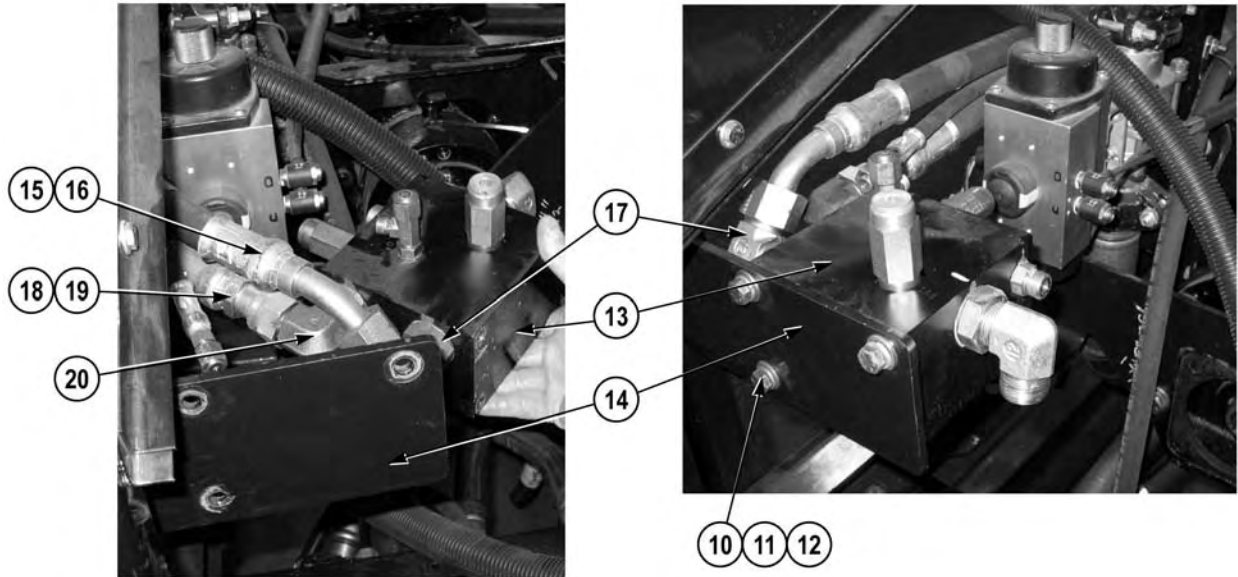
## REMOVAL

**NOTE**

- Cap and plug hoses upon removal.
- Tag and mark hoses prior to removal to ensure proper installation.
- Place suitable drain pan under hoses.

1. Remove hose 1682902 (1) and preformed packing (2) from elbow (3). Discard preformed packing.
2. Remove hose 1682906 (4) and preformed packing (5) from fitting (6). Discard preformed packing.
3. Remove hose 1682910 (7) and preformed packing (8) from tee (9). Discard preformed packing.

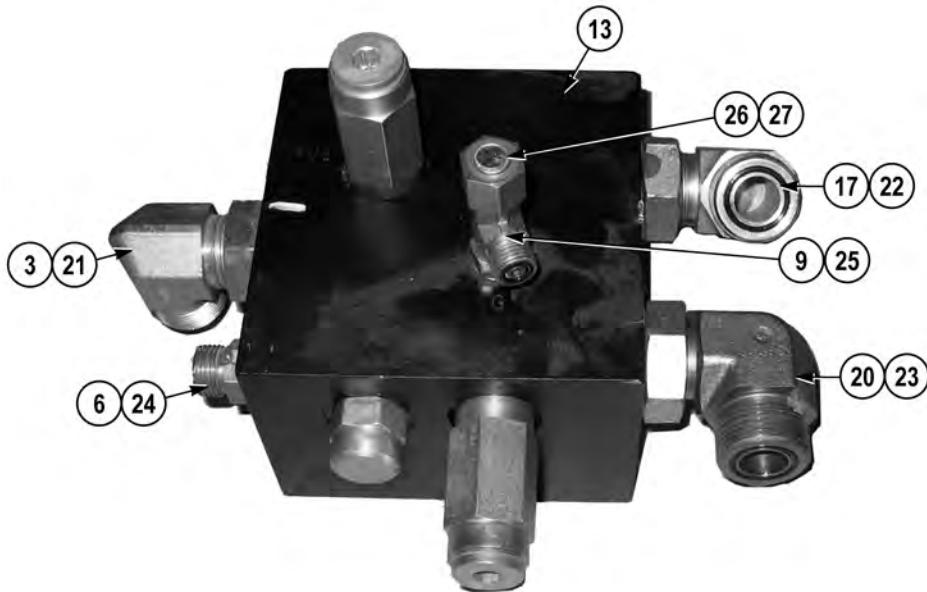




### NOTE

Manifold needs to be removed from bracket in order to remove two remaining hoses.

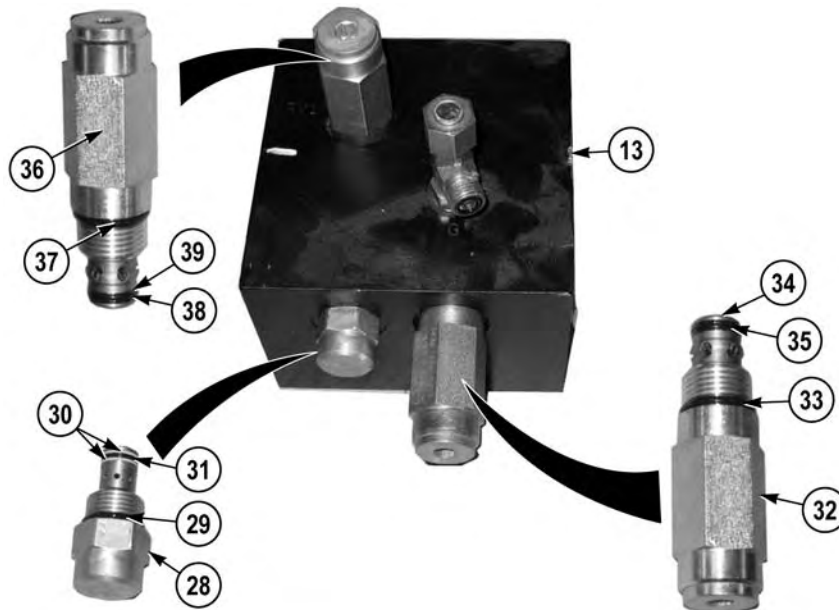
4. Remove three screws (10), lockwashers (11), washers (12), and manifold (13) from bracket (14). Discard lockwashers.
5. Remove hose 1682901 (15) and preformed packing (16) from elbow (17). Discard preformed packing.
6. Remove hose 1682884 (18) and preformed packing (19) from elbow (20) and manifold (13) from vehicle. Discard preformed packing.



### NOTE

Note position of elbows and fittings prior to removal to ensure proper installation.

7. Remove elbow (3) and preformed packing (21) from manifold (13). Discard preformed packing.
8. Remove elbow (17) and preformed packing (22) from manifold (13). Discard preformed packing.
9. Remove elbow (20) and preformed packing (23) from manifold (13). Discard preformed packing.
10. Remove fitting (6) and preformed packing (24) from manifold (13). Discard preformed packing.
11. Remove tee (9) and preformed packing (25) from manifold (13). Discard preformed packing.
12. Remove cap (26) and preformed packing (27) from tee (9). Discard preformed packing.



13. Remove flow control valve (28), preformed packing (29), two backing rings (30), and preformed packing (31) from manifold (13). Discard preformed packings and backing rings.

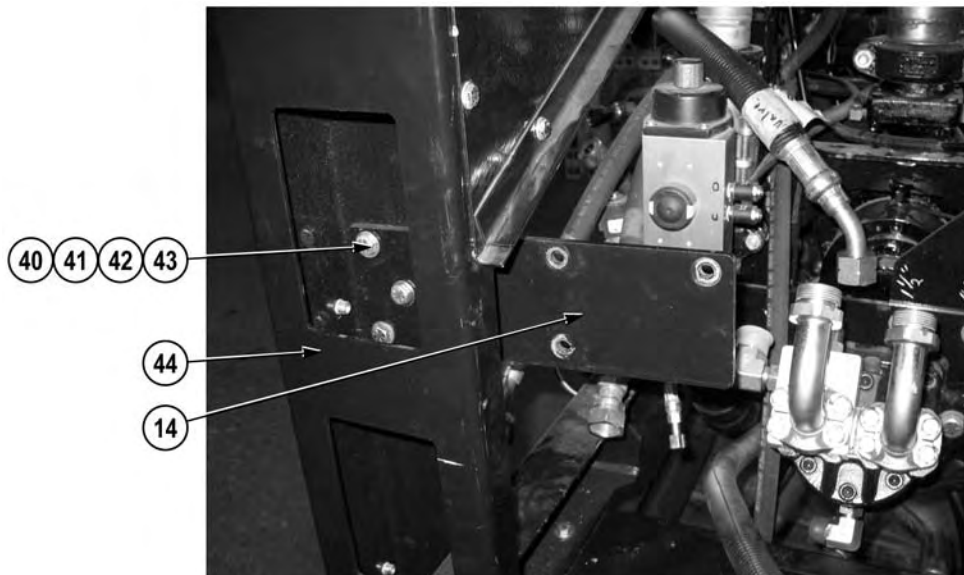
** CAUTION**

**Relief valves are not interchangeable. Note position of relief valves prior to removal to ensure proper installation. Failure to comply may cause damage to equipment.**

**NOTE**

Note position of preformed packings prior to removal to ensure proper installation.

14. Remove relief valve (32), preformed packing (33), and two preformed packings (34) and (35) from manifold (13). Discard preformed packing.
15. Remove relief valve (36), preformed packing (37), and two preformed packings (38) and (39) from manifold (13). Discard preformed packing.



### NOTE

Perform Step (16) if bracket needs to be removed.

16. Remove three nuts (40), lockwashers (41), six washers (42), three screws (43), and bracket (14) from frame rail (44). Discard lockwashers.

### END OF TASK

### INSTALLATION

### NOTE

Perform Step (1) if bracket was removed.

1. Install bracket (14) on frame rail (44) with three screws (43), six washers (42), three lockwashers (41), and nuts (40).



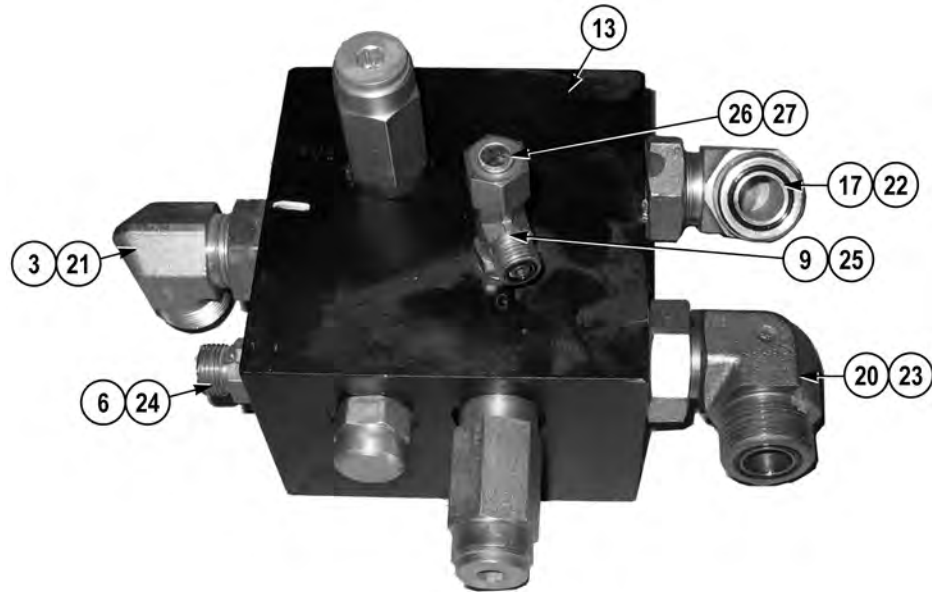
### **CAUTION**

**Relief valves are not interchangeable. Install relief valves as noted prior to removal. Failure to comply may cause damage to equipment.**

### NOTE

Install preformed packings as noted prior to removal.

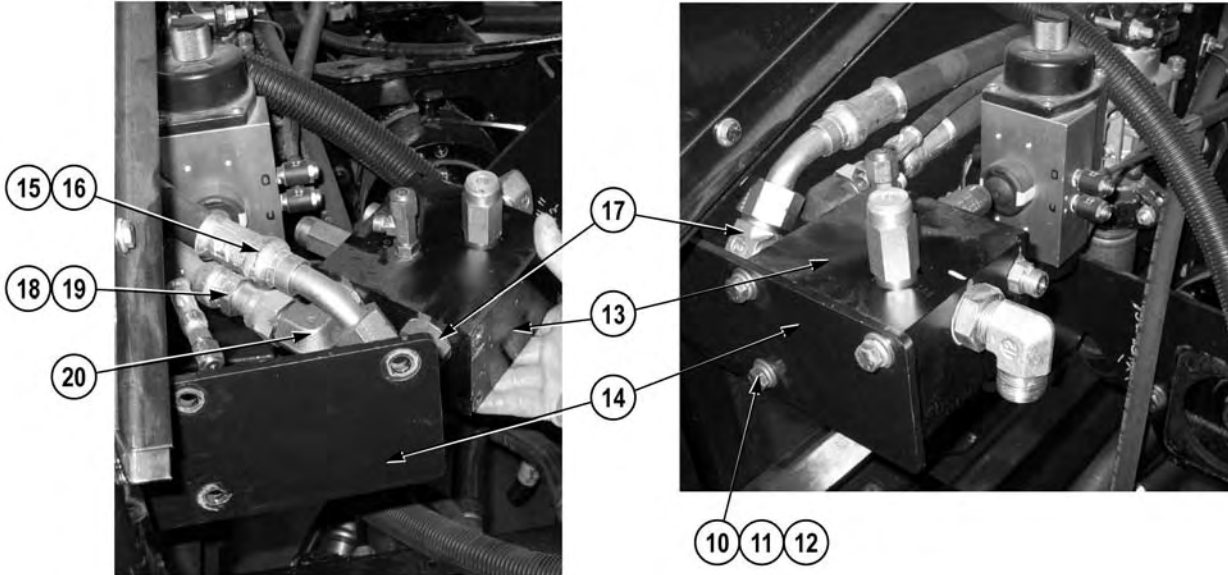
2. Lightly lubricate three preformed packings (37), (38), and (39) with clean oil, and install preformed packing (37), two preformed packings (39) and (38), and relief valve (36) on manifold (13).
3. Lightly lubricate three preformed packings (33), (34), and (35) with clean oil, and install preformed packing (33), two preformed packings (35) and (34), and relief valve (32) on manifold (13).
4. Lightly lubricate two preformed packings (29) and (31) and two backing rings (30) with clean oil, and install two preformed packings (29) and (31), backing rings (30), and flow control valve (28) on manifold (13).



### NOTE

Install elbows and fittings as noted prior to removal.

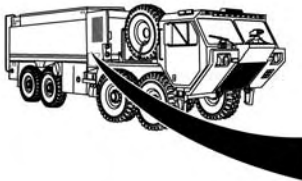
5. Lightly lubricate preformed packing (27) with clean oil, and install preformed packing (27) and cap (26) on tee (9).
6. Lightly lubricate preformed packing (25) with clean oil, and install preformed packing (25) and tee (9) on manifold (13).
7. Lightly lubricate preformed packing (24) on manifold (13) with clean oil, and install preformed packing (24) and fitting (6) on manifold (13).
8. Lightly lubricate preformed packing (23) with clean oil, and install preformed packing (23) and elbow (20) on manifold (13).
9. Lightly lubricate preformed packing (22) with clean oil, and install preformed packing (22) and elbow (17) on manifold (13).
10. Lightly lubricate preformed packing (21) with clean oil, and install preformed packing (21) and elbow (3) on manifold (13).



### NOTE

First two hoses are installed on manifold before manifold is attached to bracket.

11. Lightly lubricate preformed packing (19) with clean oil, and install preformed packing (19) and hose 1682884 (18) on elbow (20).
12. Lightly lubricate preformed packing (16) with clean oil, and install preformed packing (16) and hose 1682901 (15) on elbow (17).
13. Install manifold (13) on bracket (14) with three washers (12), lockwashers (11), and screws (10).



14. Lightly lubricate preformed packing (8) with clean oil, and install preformed packing (8) and hose 1682910 (7) on tee (9).
15. Lightly lubricate preformed packing (5) with clean oil, and install preformed packing (5) and hose 1682906 (4) on tee (6).
16. Lightly lubricate preformed packing (2) with clean oil, and install preformed packing (2) and hose 1682902 (1) on elbow (3).

#### END OF TASK

#### FOLLOW-ON MAINTENANCE

1. Install hydraulic heat exchanger bottom shroud panel installed (WP 0135)
2. Install hydraulic oil filter (WP 0140)

#### END OF TASK

#### END OF WORK PACKAGE





---

**FIELD LEVEL MAINTENANCE****HYDRAULIC OVERRIDE MANIFOLD REPLACEMENT**

---

**INITIAL SETUP:****Tools and Special Tools**

Cap Set, Protection (WP 0398, Item 1)  
Drain Pan (WP 0398, Item 4)  
Tool Kit, General Mechanic's: Automotive  
(WP 0398, Item 17)

**Materials/Parts**

Oil, Lubricating (WP 0400, Item 20)  
Tags, Identification (WP 0400, Item 23)  
Preformed Packing (1)  
Preformed Packing (1)  
Preformed Packing (1)  
Preformed Packing (1)  
Preformed Packing (1)  
Preformed Packing (1)  
Preformed Packing (1)  
Preformed Packing (1)  
Preformed Packing (1)

**Materials/Parts (continued)**

Preformed Packing (1)  
Preformed Packing (1)  
Preformed Packing (1)  
Preformed Packing (1)  
Preformed Packing (1)  
Preformed Packing (1)  
Lockwasher (2)

**References**

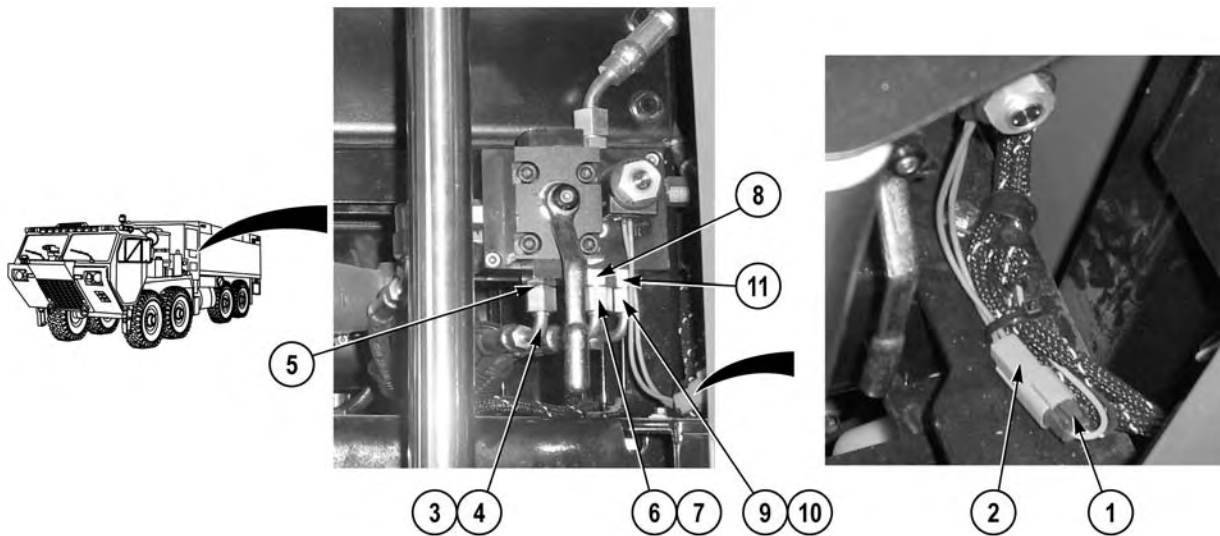
WP 0391, Fig. 39

**Equipment Conditions**

Pump house access door opened (WP 0009)  
Hydraulic reservoir drained (WP 0145)

---

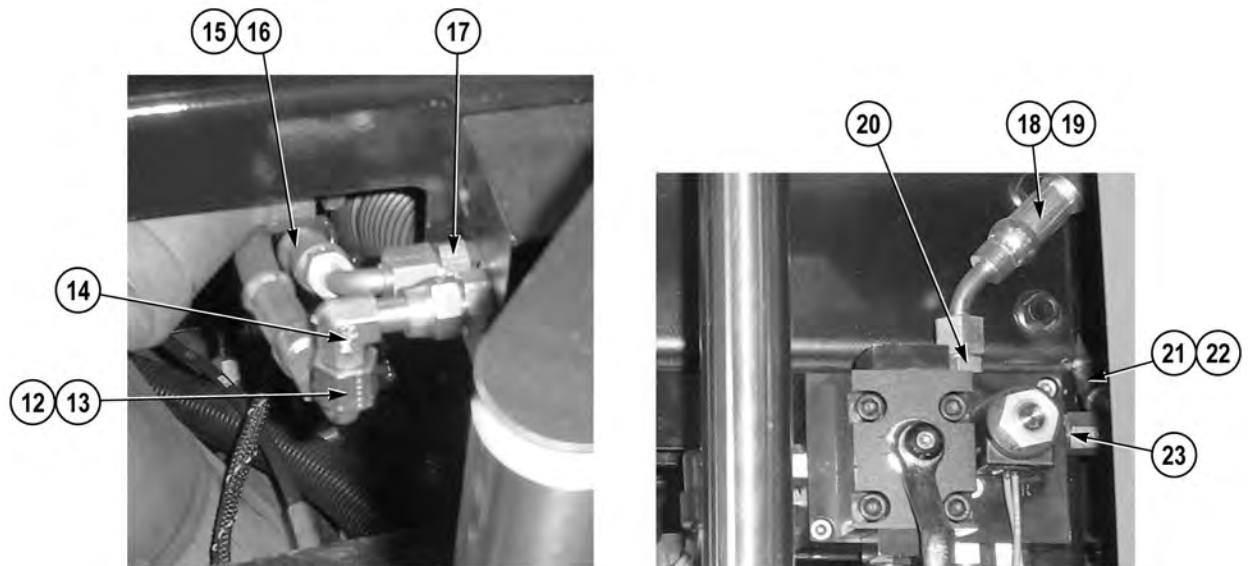
## REMOVAL



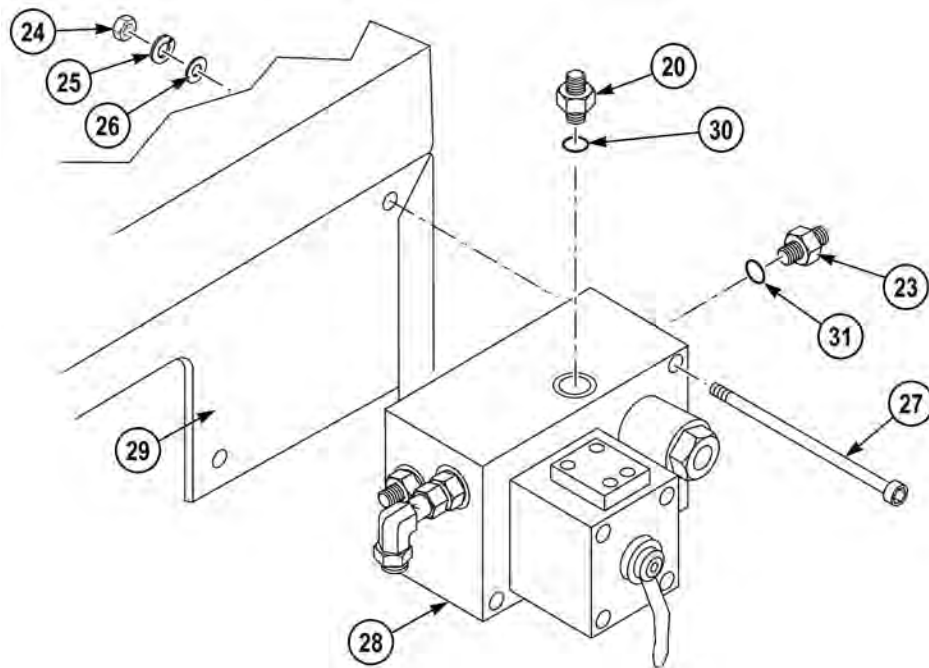
1. Disconnect pump house wire harness connector (1) from hydraulic override manifold connector (2).

**NOTE**

- Position suitable drain pan under hoses to catch hydraulic fluid.
  - Cap and plug hoses upon removal.
  - Hoses 3, 6, and 9 have the same hose number.
  - Tag and mark hoses prior to removal to ensure proper installation.
2. Remove hose 1682914 (3) and preformed packing (4) from fitting (5). Discard preformed packing.
  3. Remove hose 1682914 (6) and preformed packing (7) from fitting (8). Discard preformed packing.
  4. Remove hose 1682914 (9) and preformed packing (10) from fitting (11). Discard preformed packing.



5. Remove hose 1682912 (12) and preformed packing (13) from elbow (14). Discard preformed packing.
6. Remove hose 1682911 (15) and preformed packing (16) from fitting (17). Discard preformed packing.
7. Remove hose 1682987 (18) and preformed packing (19) from fitting (20). Discard preformed packing.
8. Remove hose 1682910 (21) and preformed packing (22) from fitting (23). Discard preformed packing.

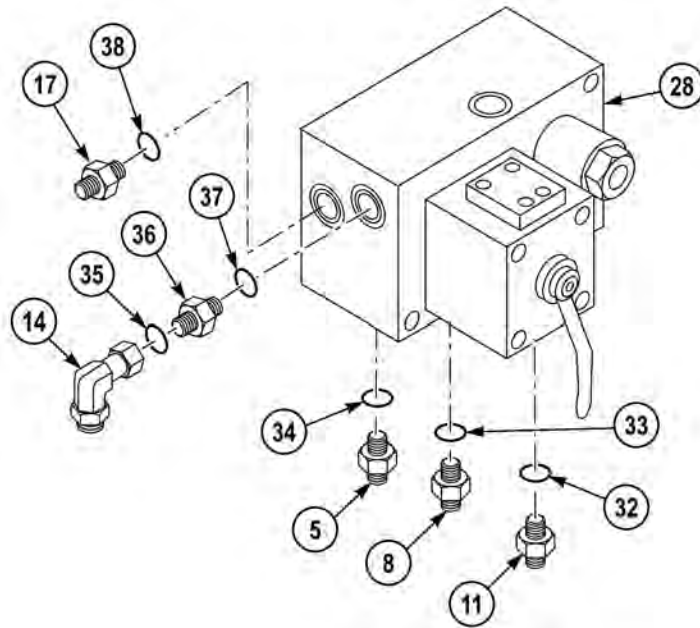


9. Remove two nuts (24), lockwashers (25), washers (26), screws (27), and manifold (28) from bracket (29). Discard lockwashers.

### NOTE

Note position of fittings and elbows prior to removal to ensure proper installation.

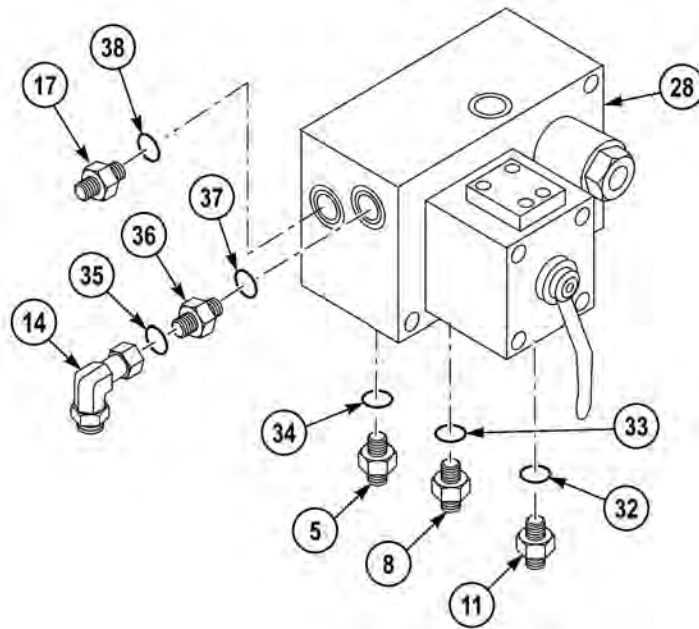
10. Remove fitting (20) and preformed packing (30) from manifold (28). Discard preformed packing.
11. Remove fitting (23) and preformed packing (31) from manifold (28). Discard preformed packing.



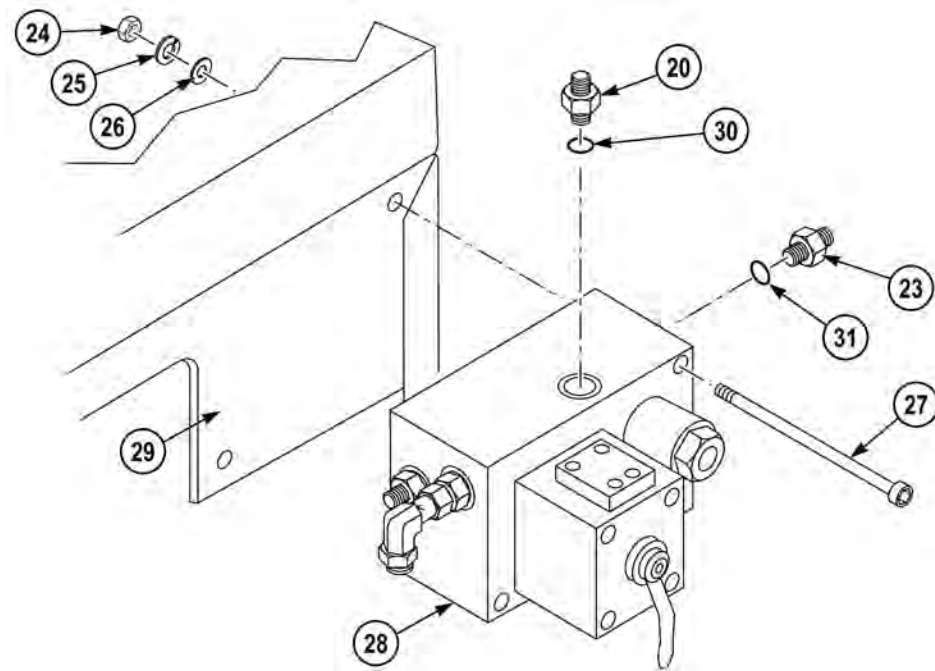
12. Remove fitting (11) and preformed packing (32) from manifold (28). Discard preformed packing.
13. Remove fitting (8) and preformed packing (33) from manifold (28). Discard preformed packing.
14. Remove fitting (5) and preformed packing (34) from manifold (28). Discard preformed packing.
15. Remove elbow (14) and preformed packing (35) from fitting (36). Discard preformed packing.
16. Remove fitting (36) and preformed packing (37) from manifold (28). Discard preformed packing.
17. Remove fitting (17) and preformed packing (38) from manifold (28). Discard preformed packing.

**END OF TASK**

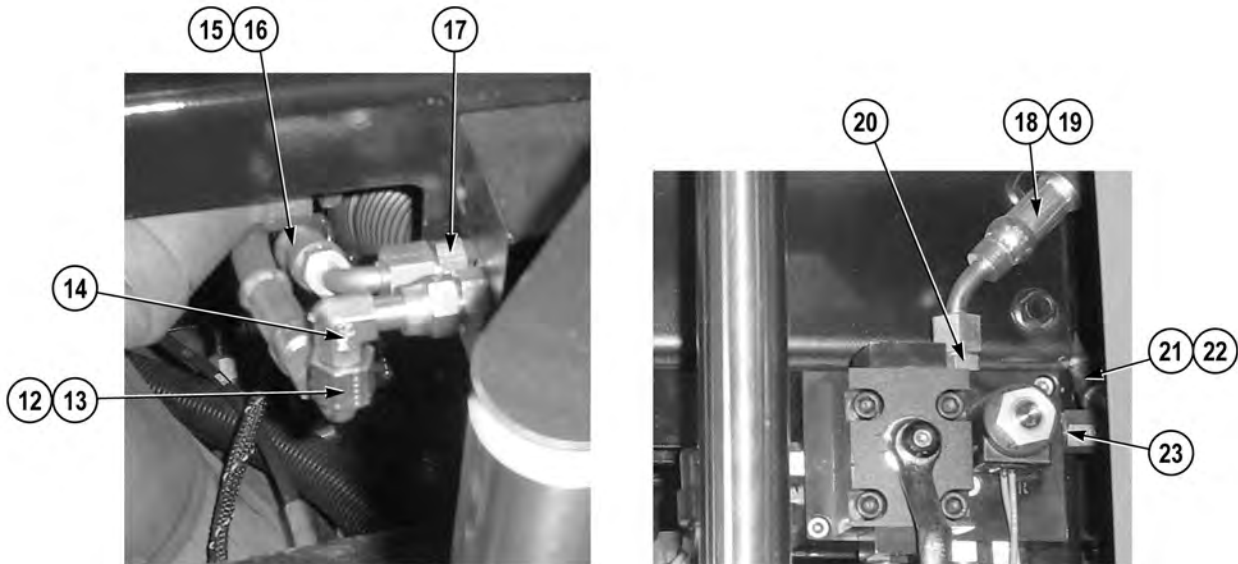
## INSTALLATION



1. Lightly lubricate preformed packing (38) with clean oil, and install preformed packing (38) and fitting (17) on manifold (28).
2. Lightly lubricate preformed packing (37) with clean oil, and install performed packing (37) and fitting (36) on manifold (28).
3. Lightly lubricate preformed packing (35) with clean oil, and install performed packing (35) and elbow (14) on fitting (36).
4. Lightly lubricate preformed packing (34) with clean oil, and install performed packing (34) and fitting (5) on manifold (28).
5. Lightly lubricate preformed packing (33) with clean oil, and install preformed packing (33) and fitting (8) on manifold (28).
6. Lightly lubricate preformed packing (32) with clean oil, and install preformed packing (32) and fitting (11) on manifold (28).

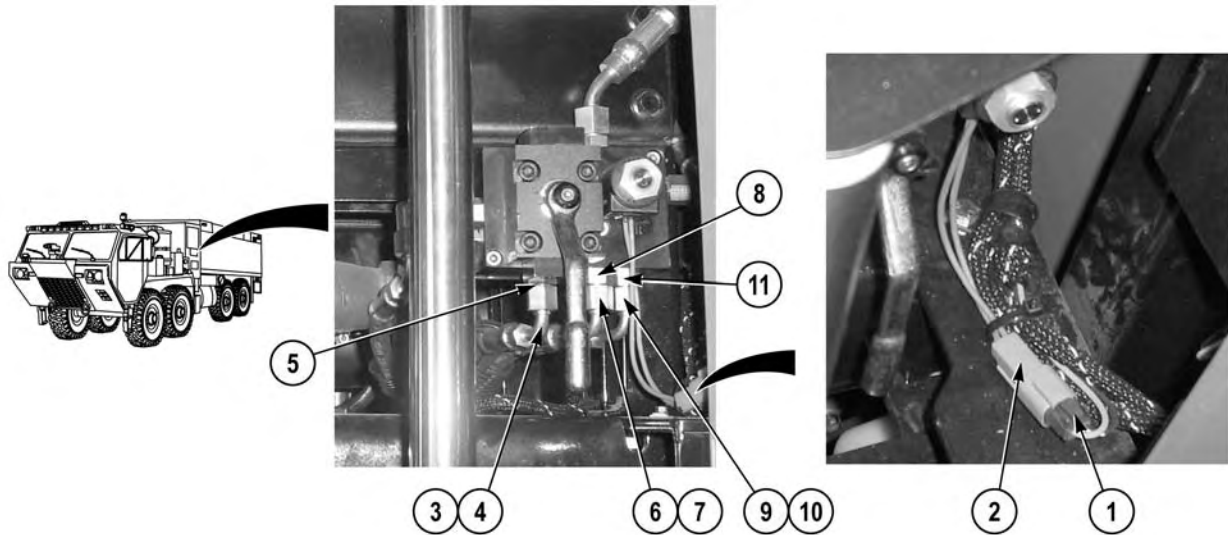


7. Lightly lubricate preformed packing (31) with clean oil, and install preformed packing (31) and fitting (23) on manifold (28).
8. Lightly lubricate preformed packing (30) with clean oil, and install preformed packing (30) and fitting (20) on manifold (28).
9. Install manifold (28) on bracket (29) with two screws (27), washers (26), lockwashers (25), and nuts (24).



10. Lightly lubricate preformed packing (22) with clean oil, and install preformed packing (22) and hose 1682910 (21) on fitting (23).
11. Lightly lubricate preformed packing (19) with clean oil, and install preformed packing (19) and hose 1682987 (18) on fitting (20).
12. Lightly lubricate preformed packing (16) with clean oil, and install preformed packing (16) and hose 1682911 (15) on fitting (17).
13. Lightly lubricate preformed packing (13) with clean oil, and install preformed packing (13) and hose 1682912 (12) on elbow (14).





14. Lightly lubricate preformed packing (10) with clean oil, and install preformed packing (10) and hose 1682914 (9) on fitting (11).
15. Lightly lubricate preformed packing (7) with clean oil, and install preformed packing (7) and hose 1682914 (6) on fitting (8).
16. Lightly lubricate preformed packing (4) with clean oil, and install preformed packing (4) and hose 1682914 (3) on fitting (5).
17. Connect hydraulic override manifold connector (2) on pump house wire harness connector (1).

#### END OF TASK

#### FOLLOW-ON MAINTENANCE

1. Fill hydraulic reservoir (WP 0145)
2. Close pump house access door (WP 0009)

#### END OF TASK

#### END OF WORK PACKAGE



---

**FIELD LEVEL MAINTENANCE**  
**HYDRAULIC PRESSURE CONTROL REPLACEMENT**

---

**INITIAL SETUP:****Tools and Special Tools**

Cap Set, Protective (WP 0398, Item 1)  
 Drain Pan (WP 0398, Item 4)  
 Tool Kit, General Mechanic's: Automotive  
 (WP 0398, Item 17)

**Materials/Parts**

Oil, Lubrication, (WP 0400, Item 20)  
 Tags, Identification (WP 0400, Item 23)  
 Preformed Packing (1)  
 Preformed Packing (1)  
 Preformed Packing (1)

**Materials/Parts (continued)**

Lockwasher (2)  
 Preformed Packing (1)  
 Preformed Packing (1)  
 Preformed Packing (1)  
 Lockwasher (2)

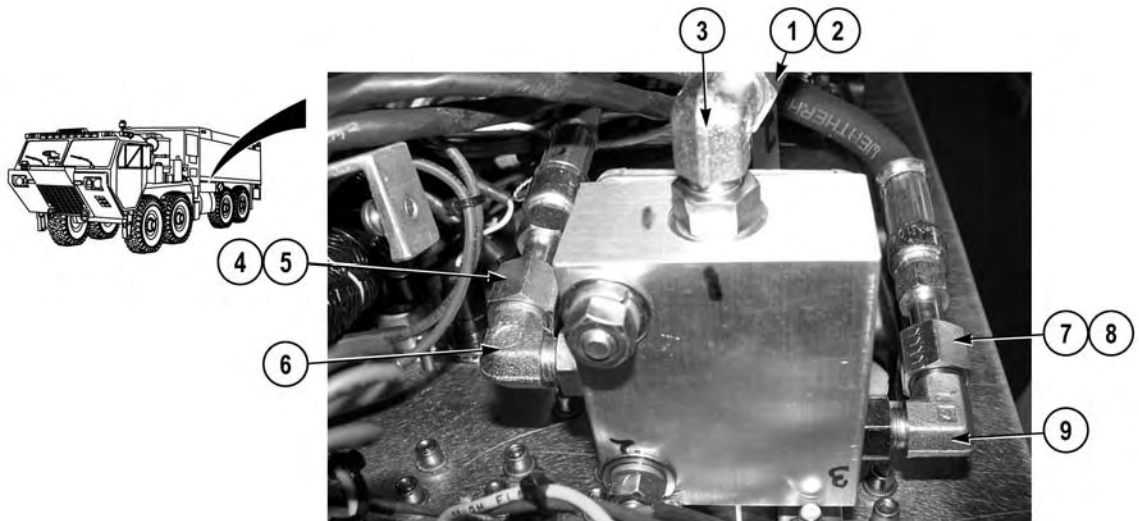
**References**

WP 0391, Fig. 15

**Equipment Conditions**

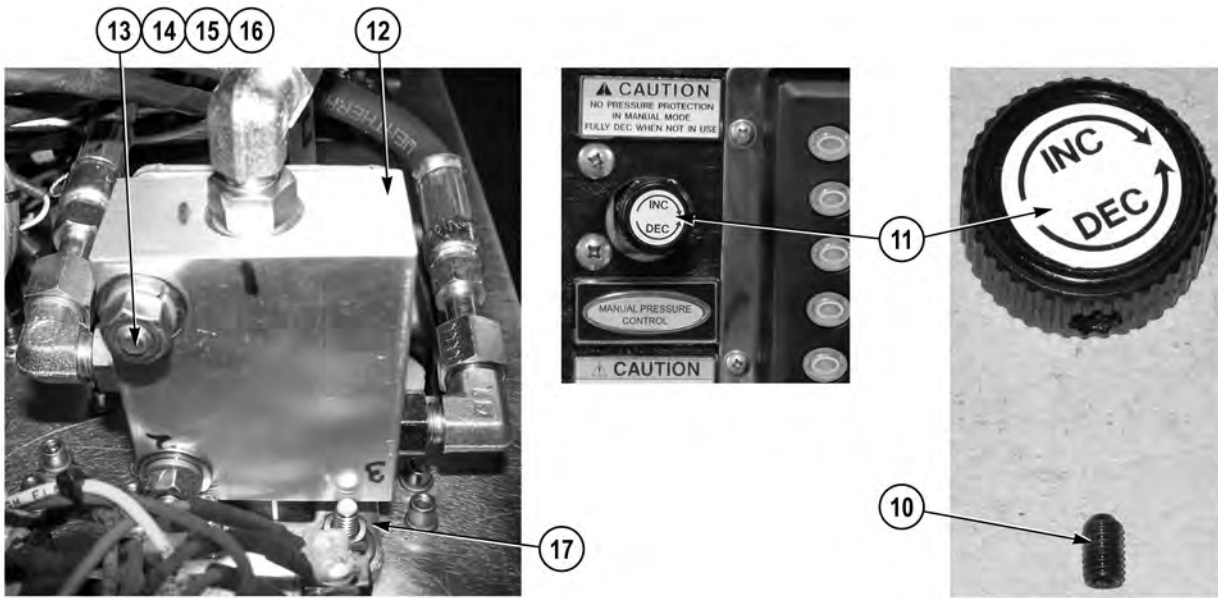
Pump operator's panel opened (WP 0207)

---

**REMOVAL****NOTE**

- Position drain pan under hoses and valve.
- Tag and mark hoses prior to removal to ensure proper installation.
- Cap and plug hoses upon removal.
- Hoses 1, 4, and 7 have same hose number.

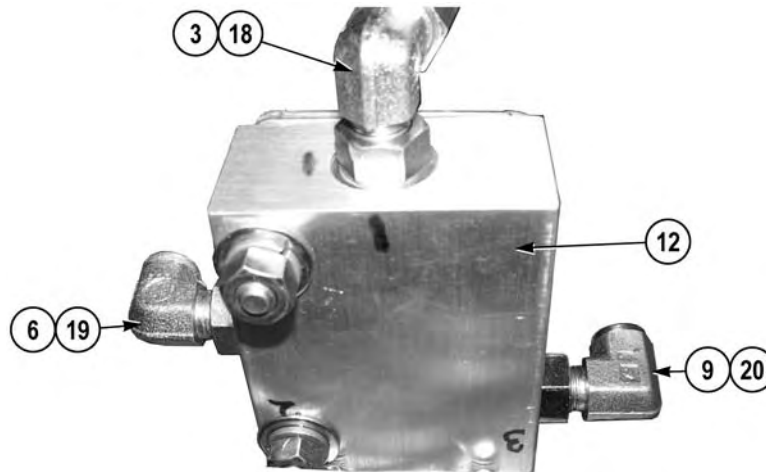
1. Remove hose 1682914 (1) and preformed packing (2) from elbow (3). Discard preformed packing.
2. Remove hose 1682914 (4) and preformed packing (5) from elbow (6). Discard preformed packing.
3. Remove hose 1682914 (7) and preformed packing (8) from elbow (9). Discard preformed packing.



**NOTE**

Note position of knob prior to removal to ensure proper installation.

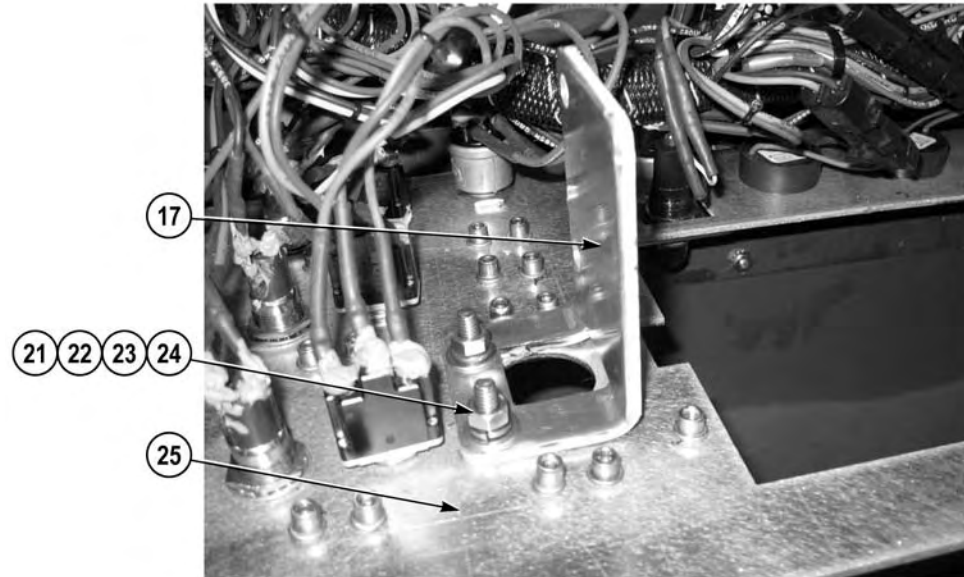
4. Remove setscrew (10) and knob (11) from valve (12).
5. Remove two nuts (13), lockwashers (14), four washers (15), two screws (16), and valve (12) from bracket (17). Discard lockwashers.



**NOTE**

Note position of elbows prior to removal to ensure proper installation.

6. Remove elbow (3) and preformed packing (18) from valve (12). Discard preformed packing.
7. Remove elbow (6) and preformed packing (19) from valve (12). Discard preformed packing.
8. Remove elbow (9) and preformed packing (20) from valve (12). Discard preformed packing.

**NOTE**

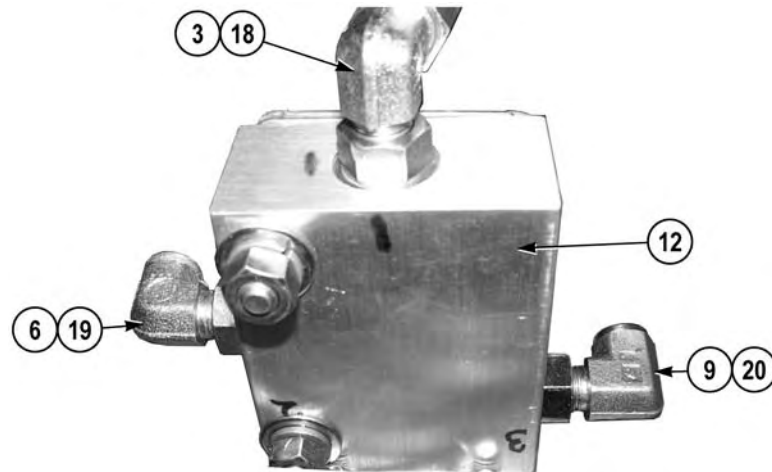
Perform Step (9) if bracket needs to be removed.

9. Remove two nuts (21), lockwashers (22), washers (23), screws (24), and bracket (17) from panel (25). Discard lockwashers.

**END OF TASK****INSTALLATION****NOTE**

Perform Step (1) if bracket was removed.

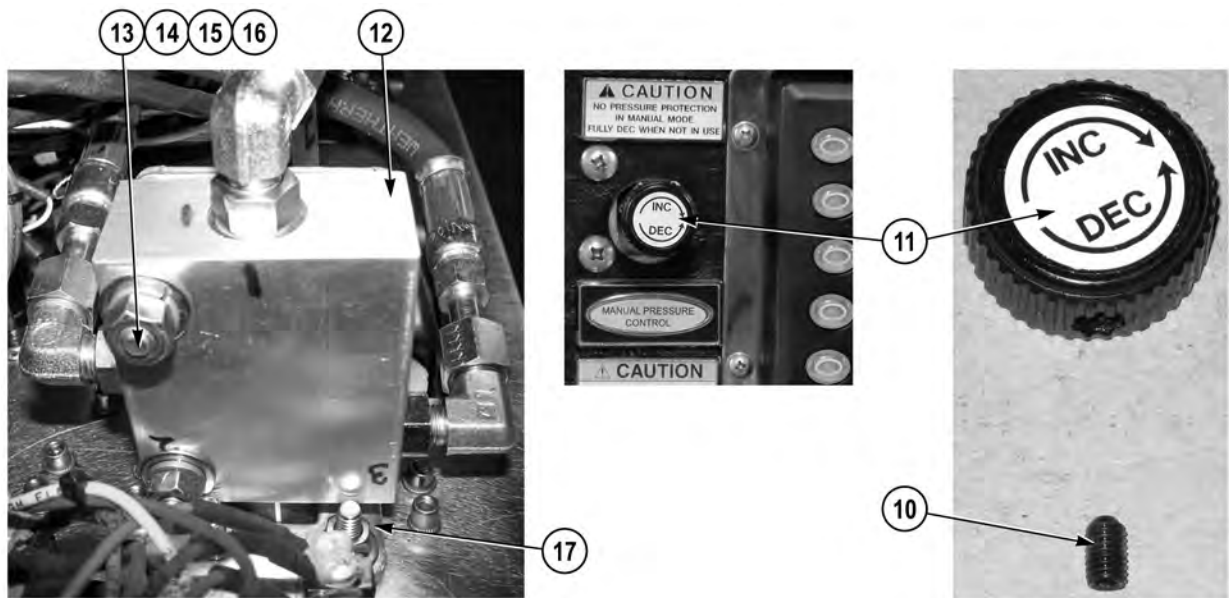
1. Install bracket (17) on panel (25) with two screws (24), washers (23), lockwashers (22), and nuts (21).



### NOTE

Install elbows as noted prior to removal.

2. Lightly lubricate preformed packing (20) with clean oil, and install preformed packing (20) and elbow (9) on valve (12).
3. Lightly lubricate preformed packing (19) with clean oil, and install preformed packing (19) and elbow (6) on valve (12).
4. Lightly lubricate preformed packing (18) with clean oil, and install preformed packing (18) and elbow (3) on valve (12).

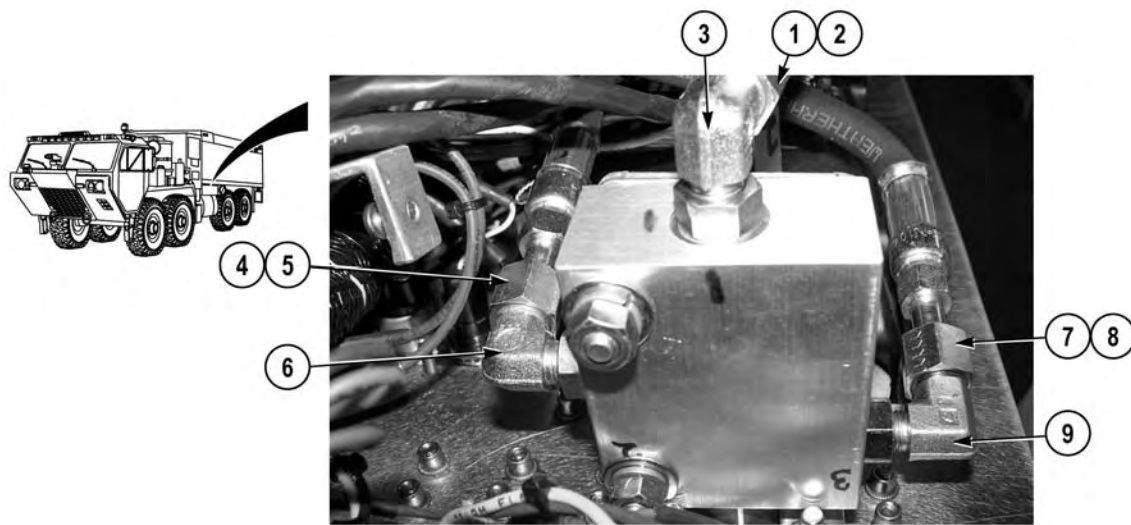


5. Install valve (12) on bracket (17) with two screws (16), four washers (15), two lockwashers (14), and nuts (13).

#### NOTE

Install knob as noted prior to removal.

6. Install knob (11) on valve (12) with setscrew (10).



7. Lightly lubricate preformed packing (8) with clean oil, and install preformed packing (8) and hose 1682914 (7) on elbow (9).
8. Lightly lubricate preformed packing (5) with clean oil, and install preformed packing (5) and hose 1682914 (4) on elbow (6).
9. Lightly lubricate preformed packing (2) with clean oil, and install preformed packing (2) and hose 1682914 (1) on elbow (3).

#### END OF TASK

#### FOLLOW-ON MAINTENANCE

Close pump operator's panel (WP 0207)

#### END OF TASK

#### END OF WORK PACKAGE



---

**FIELD LEVEL MAINTENANCE**  
**HYDRAULIC RESERVOIR BREATHER REPLACEMENT**

---

**INITIAL SETUP:****Tools and Special Tools**

Tool Kit, General Mechanic's: Automotive  
(WP 0398, Item 17)

**References**

WP 0149  
WP 0391, Fig. 10

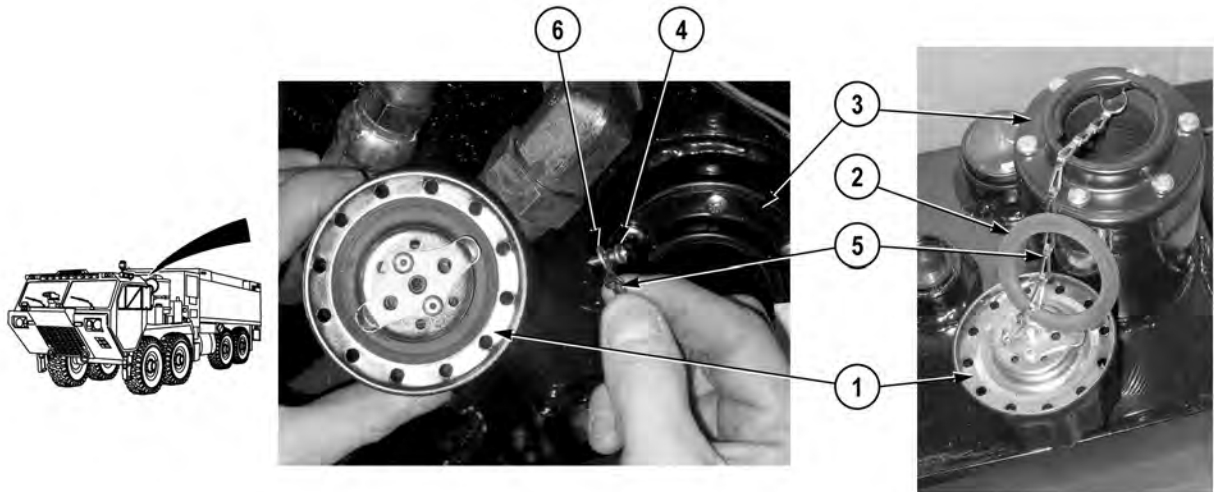
**Materials/Parts**

Fluid, Hydraulic (WP 0400, Item 17)  
Preformed Packing (1)

**Equipment Conditions**

Engine OFF (TM 9-2320-422-10)  
Wheels chocked (TM 9-2320-422-10)  
Pump house panel K access door opened  
(WP 0008)

---

**REMOVAL**

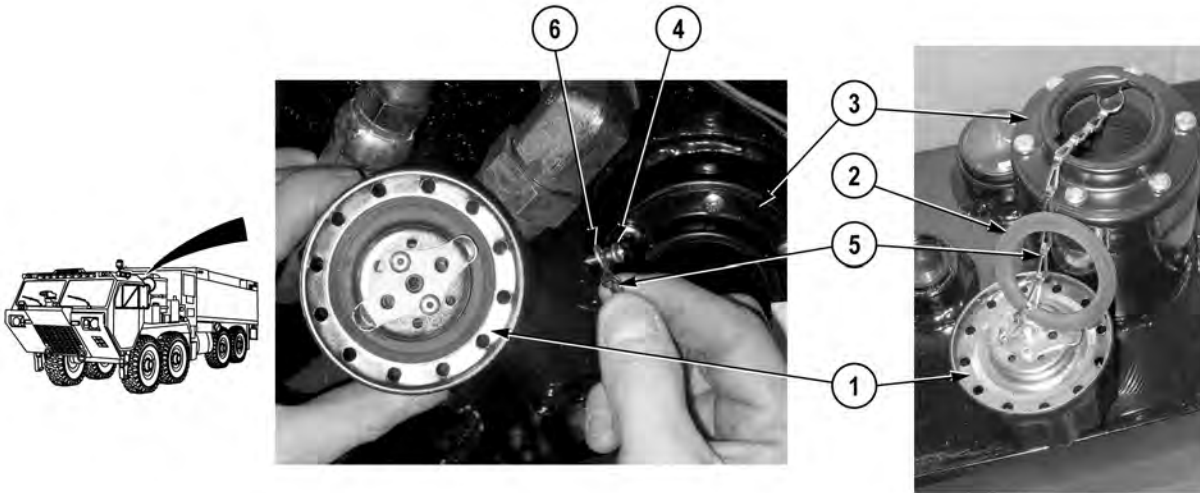
1. Remove breather (1) and preformed packing (2) from strainer collar (3).
2. Remove screw (4), chain (5), and washer (6) from breather (1).
3. Remove preformed packing (2) from breather (1). Discard preformed packing.

**NOTE**

Perform Step (4) if chain needs to be removed.

4. Remove chain (5) from strainer collar (3) (WP 0149).

**END OF TASK**

**INSTALLATION****NOTE**

Perform Step (1) if chain needs to be installed.

1. Install chain (5) on strainer collar (3) (WP 0149).

**NOTE**

Perform Step (2) if installing new preformed packing.

2. Lightly lubricate preformed packing (2) with clean oil and install preformed packing (2) on breather (1).
3. Install preformed packing (2) on breather (1).
4. Install washer (6) and chain (5) on breather (1) with screw (4).
5. Install preformed packing (2) and breather (1) on strainer collar (3).

**END OF TASK****FOLLOW-ON MAINTENANCE**

1. Close pump house panel K access door (WP 0008)
2. Remove wheel chocks (TM 9-2320-422-10)

**END OF TASK****END OF WORK PACKAGE**

---

**FIELD LEVEL MAINTENANCE**  
**HYDRAULIC RESERVOIR DRAIN/FILL**

---

**INITIAL SETUP:****Tools and Special Tools**

Drain Pan (2) (WP 0398, Item 4)  
Tool Kit, General Mechanic's: Automotive  
(WP 0398, Item 17)

**Materials/Parts**

Hydraulic Fluid, Petroleum Base  
(WP 0400, Item 17)  
Preformed Packing (1)

**Personnel Required**

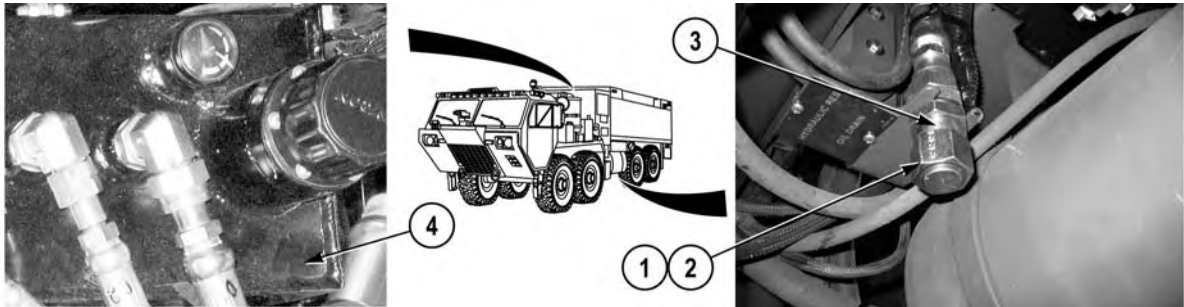
MOS 63B Wheeled Vehicle Mechanic (2)

**References**

TM 9-2320-325-14&P  
TM 9-2320-422-10  
WP 0004  
WP 0391, Fig. 10

**Equipment Conditions**

Engine OFF (TM 9-2320-422-10)  
Wheels chocked (TM 9-2320-422-10)  
Pump house panel K access door opened  
(WP 0008)

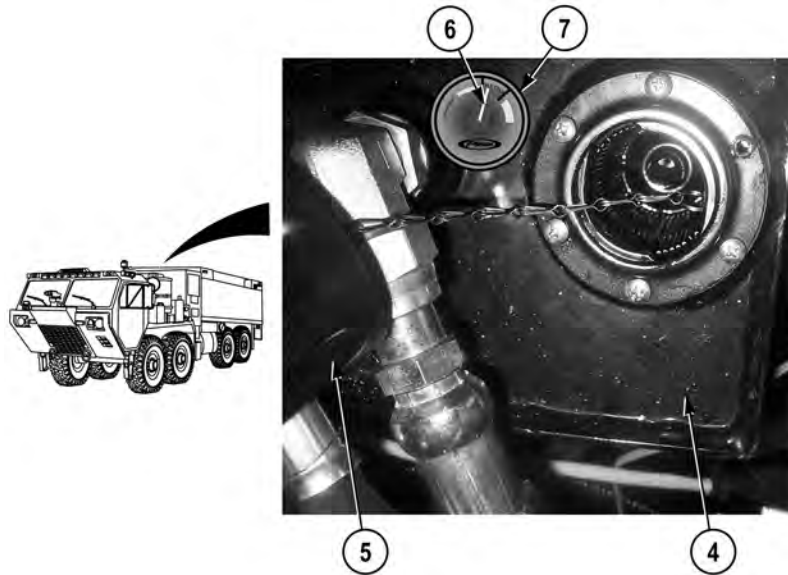
**DRAIN****WARNING**

**Hydraulic oil may be hot. Ensure hydraulic oil is cool prior to removal. Failure to comply may result in injury to personnel.**

**NOTE**

- Hydraulic reservoir contains approximately nine gallons of hydraulic fluid.
- With the aid of an assistant, alternate drain pans as required to keep drain pans from overflowing.

1. Remove cap (1) and preformed packing (2) from fitting (3). Discard preformed packing.
2. Allow oil to drain completely from hydraulic reservoir (4).
3. Lightly lubricate preformed packing (2) with clean oil, and install preformed packing (2) and cap (1) on fitting (3).

**FILL**

1. Remove hydraulic reservoir breather (5) from hydraulic reservoir (4).
2. Fill hydraulic reservoir (4) until indicator (6) on fluid level gauge (7) reaches mark on full cold.
3. Install hydraulic reservoir breather (5) on hydraulic reservoir (4).

**NOTE**

Perform Steps (4) through (9) if any hydraulic components have been removed or replaced.

4. Connect batteries (TM 9-2320-325-14&P).
5. Start engine (TM 9-2320-422-10).
6. Operate PTO for one minute (WP 0004).
7. Disconnect batteries (TM 9-2320-325-14&P).
8. Check for leaks.
9. Check indicator (6) on fluid level gauge (7) and fill hydraulic reservoir (4) until indicator (6) on fluid level gauge (7) reaches mark on full cold.

**END OF TASK****FOLLOW-ON MAINTENANCE**

1. Close pump house panel K access door (WP 0008)
2. Remove wheel chocks (TM 9-2320-422-10)

**END OF TASK****END OF WORK PACKAGE**

---

**FIELD LEVEL MAINTENANCE**  
**HYDRAULIC RESERVOIR FLUID LEVEL GAUGE REPLACEMENT**

---

**INITIAL SETUP:****Materials/Parts**

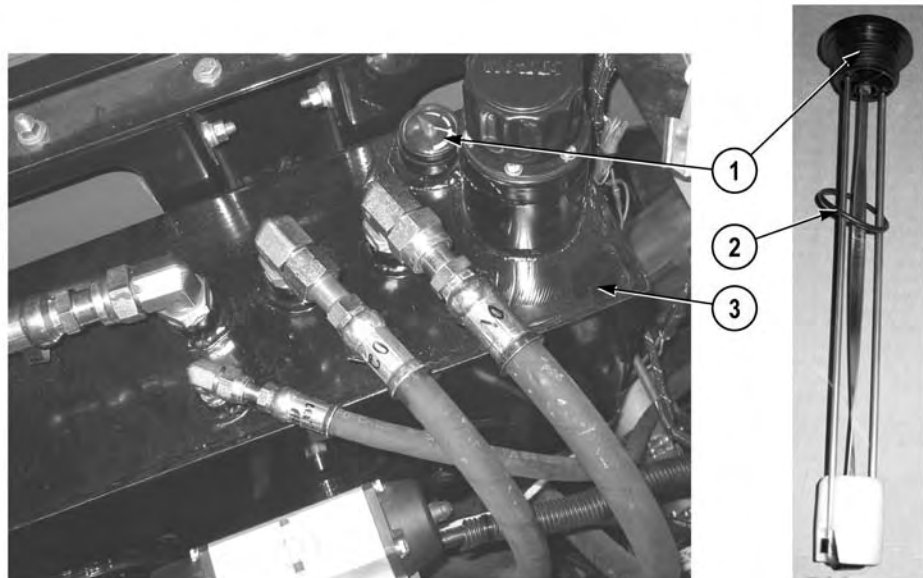
Fluid, Hydraulic (WP 0400, Item 17)  
Preformed Packing (1)

**References**

WP 0391, Fig. 10

**Equipment Conditions**

Engine OFF (TM 9-2320-422-10)  
Wheels chocked (TM 9-2320-422-10)  
Pump house panel K access door opened  
(WP 0008)

**REMOVAL**

Remove fluid level gauge (1) and preformed packing (2) from hydraulic reservoir (3). Discard preformed packing.

**END OF TASK**

**INSTALLATION**

Lightly lubricate preformed packing (2) with clean oil, and install preformed packing (2) and fluid level gauge (1) on hydraulic reservoir (3).

**END OF TASK****FOLLOW-ON MAINTENANCE**

1. Close pump house panel K access door (WP 0008)
2. Remove wheel chocks (TM 9-2320-422-10)

**END OF TASK****END OF WORK PACKAGE**

## FIELD LEVEL MAINTENANCE

## HYDRAULIC RESERVOIR FLUID LEVEL SWITCH REPLACEMENT

## INITIAL SETUP:

**Tools and Special Tools**

Tool Kit, General Mechanic's: Automotive  
(WP 0398, Item 17)

**Materials/Parts**

Tape, Teflon (WP 0400, Item 25)

**References**

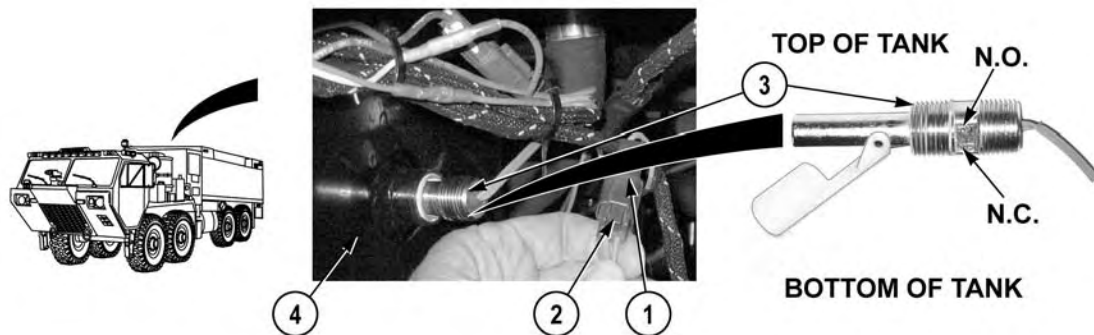
WP 0391, Fig. 10

**Equipment Conditions**

Pump house panel K access panel  
opened (WP 0008)

Hydraulic reservoir drained (WP 0145)

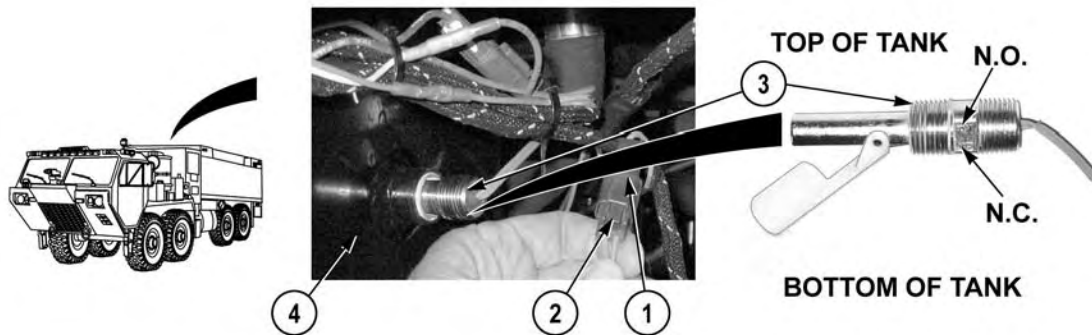
## REMOVAL

**NOTE**

- Hydraulic reservoir fluid level switch is located on driver side of hydraulic reservoir.
- Note position of switch prior to removal to ensure proper installation.

1. Disconnect pump house wire harness connector (1) from hydraulic reservoir fluid level switch connector (2).
2. Remove hydraulic reservoir fluid level switch (3) from hydraulic reservoir (4).

**END OF TASK**

**INSTALLATION****NOTE**

Install switch as noted prior to removal.

1. Apply teflon tape to threads of hydraulic reservoir fluid level switch (3).
2. Install hydraulic reservoir fluid level switch (3) in hydraulic reservoir (4).
3. Connect pump house wire harness connector (1) on hydraulic reservoir fluid level switch connector (2).

**END OF TASK****FOLLOW-ON MAINTENANCE**

Fill hydraulic reservoir (WP 0145)

**END OF TASK****END OF WORK PACKAGE**



---

**FIELD LEVEL MAINTENANCE****HYDRAULIC RESERVOIR AND BRACKET REPLACEMENT**

---

**INITIAL SETUP:****Tools and Special Tools**

- Cap Set, Protective (WP 0398, Item 1)
- Drain Pan (WP 0398, Item 4)
- Standard Automotive Tool Set (SATS),  
(WP 0398, Item 15)
  - Wrench, Adjustable 15"
- Tool Kit, General Mechanic's: Automotive  
(WP 0398, Item 17)

**Materials/Parts**

- Tags, Identification (WP 0400, Item 23)
- Ties, Cable, Plastic (WP 0400, Item 26)
- Fluid, Hydraulic (WP 0400, Item 17)
- Locknut (2)
- Preformed Packing (1)
- Preformed Packing (1)
- Preformed Packing (2)
- Preformed Packing (1)
- Preformed Packing (1)
- Preformed Packing (1)
- Preformed Packing (1)
- Preformed Packing (2)
- Preformed Packing (1)

**Materials/Parts (continued)**

- Preformed Packing (1)
- Lockwasher (2)
- Lockwasher (5)
- Lockwasher (9)
- Seal (2)

**Personnel Required**

- MOS 63B Wheeled Vehicle Mechanic (2)

**References**

- WP 0391, Fig. 10, 21, 71, 93

**Equipment Conditions**

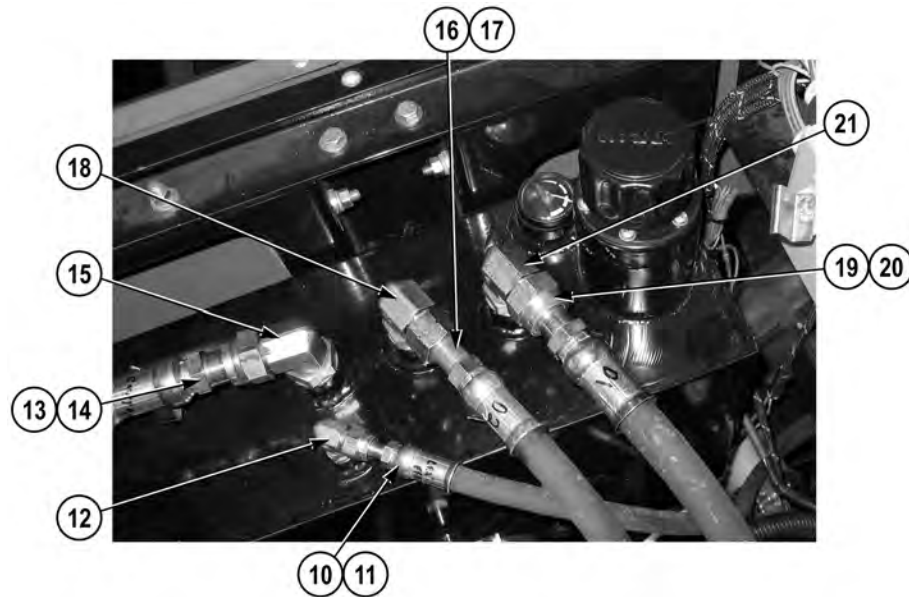
- Hydraulic reservoir drained (WP 0145)
  - Foam system eductor valve removed (WP 0178)
  - Hydraulic reservoir temperature sensor removed  
(WP 0150)
  - Hydraulic reservoir fluid level switch removed  
(WP 0147)
  - Hydraulic reservoir fluid level gauge removed  
(WP 0146)
  - Hydraulic reservoir strainer removed (WP 0149)
-

## REMOVAL

**NOTE**

- Position suitable drain pan under hoses to catch hydraulic fluid.
- Tag and mark hoses prior to removal to ensure proper installation.
- Cap and plug hoses prior to removal.
- Remove cable ties as required.
- Perform Steps (1) through (3) to provide clearance for hydraulic reservoir and hoses removal.

1. Remove two locknuts (1), cradle (2), U-bolt (3), and bracket (4) from pipe (5). Discard locknuts.
2. Remove coupling (6) (WP 0313) and pipe (5) from valve (7).
3. Remove line (8) from elbow (9).

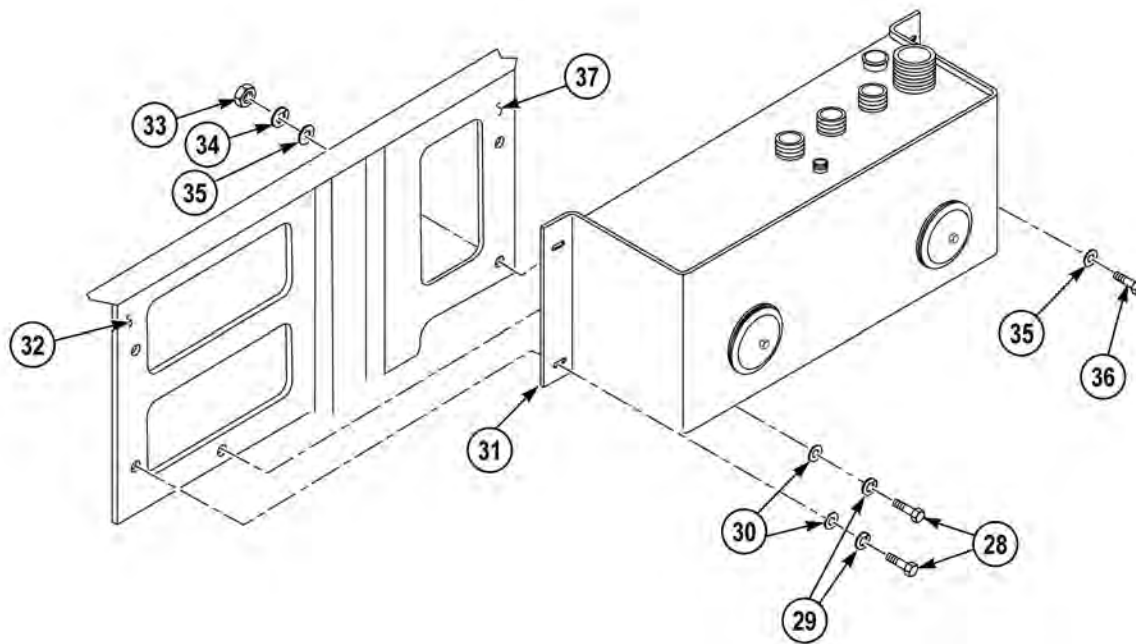


4. Remove hose 1682987 (10) and preformed packing (11) from elbow (12). Discard preformed packing.
5. Remove hose 1682893 (13) and preformed packing (14) from elbow (15). Discard preformed packing.
6. Remove hose 1682841 (16) and preformed packing (17) from elbow (18). Discard preformed packing.
7. Remove hose 1682888 (19) and preformed packing (20) from elbow (21). Discard preformed packing.



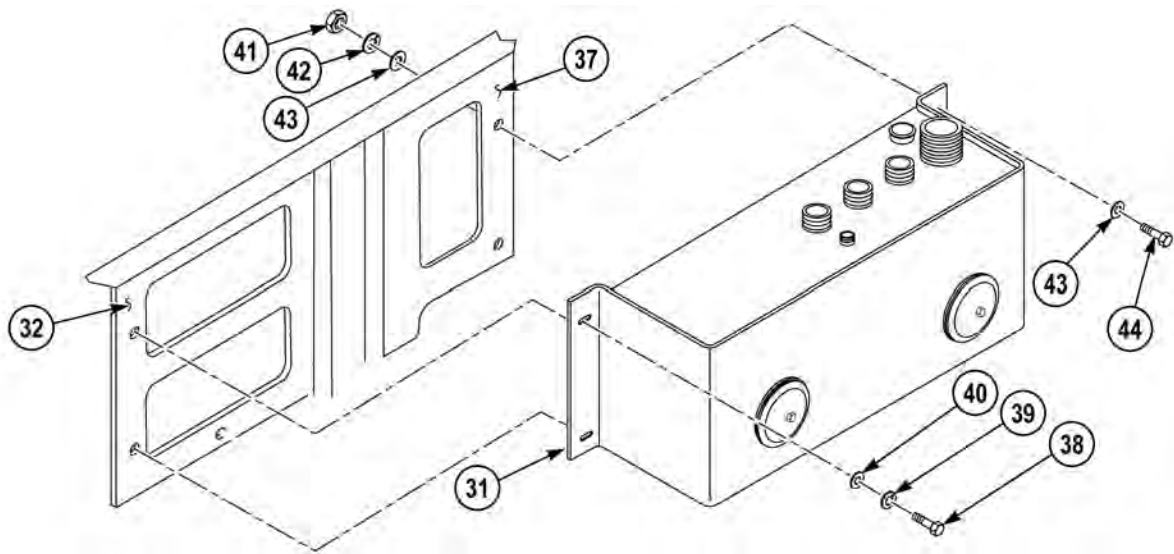
(BOTTOM OF TANK, BACK VIEW)

8. Remove hose 1682838 (22) and preformed packing (23) from elbow (24). Discard preformed packing.
9. Remove hose 1682915 (25) and preformed packing (26) from fitting (27). Discard preformed packing.

**NOTE**

Top two screws are removed last.

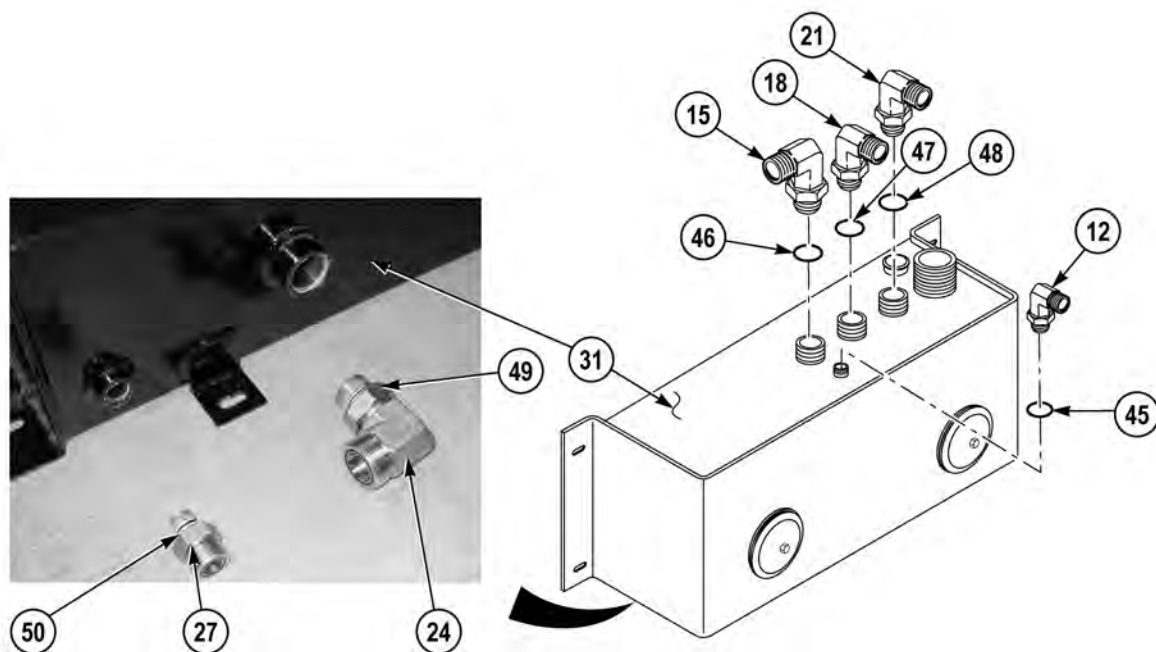
10. Remove two screws (28), lockwashers (29), and washers (30) from hydraulic reservoir (31) and bracket (32). Discard lockwashers.
11. Remove nut (33), lockwasher (34), two washers (35), and screw (36) from hydraulic reservoir (31) and bracket (37). Discard lockwasher.



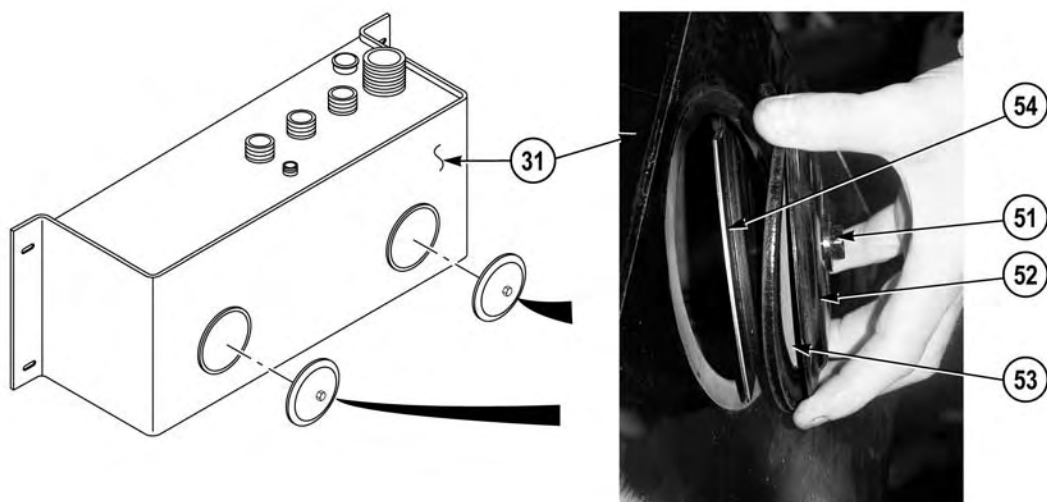
**⚠ CAUTION**

**Hydraulic reservoir is awkward and must be removed with the aid of an assistant.  
Failure to comply may cause damage to equipment.**

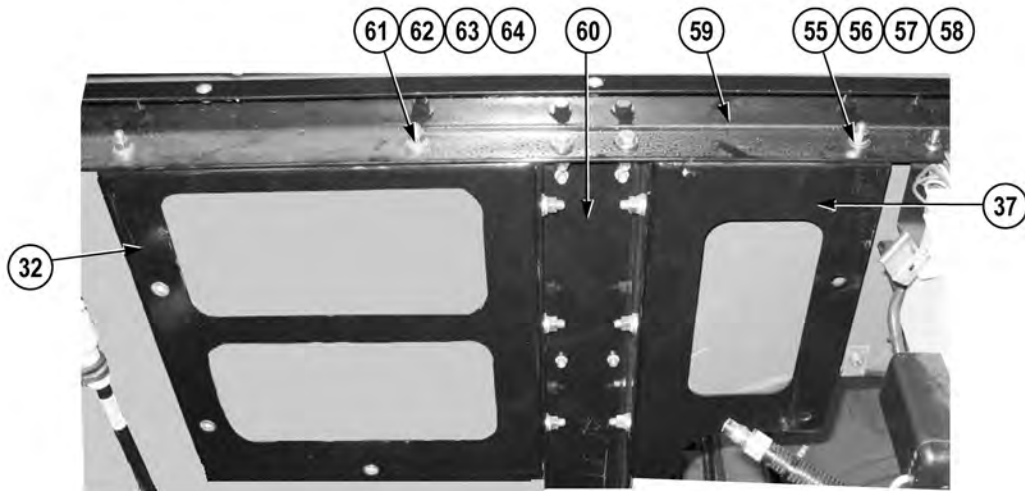
12. With the aid of an assistant, remove screw (38), lockwasher (39), washer (40), and hydraulic reservoir (31) from bracket (32). Discard lockwasher.
13. With the aid of an assistant, remove nut (41), lockwasher (42), two washers (43), screw (44), and hydraulic reservoir (31) from bracket (37) and vehicle. Discard lockwasher.



14. Remove elbow (12) and preformed packing (45) from hydraulic reservoir (31). Discard preformed packing.
15. Remove elbow (15) and preformed packing (46) from hydraulic reservoir (31). Discard preformed packing.
16. Remove elbow (18) and preformed packing (47) from hydraulic reservoir (31). Discard preformed packing.
17. Remove elbow (21) and preformed packing (48) from hydraulic reservoir (31). Discard preformed packing.
18. Remove elbow (24) and preformed packing (49) from hydraulic reservoir (31). Discard preformed packing.
19. Remove fitting (27) and preformed packing (50) from hydraulic reservoir (31). Discard preformed packing.



20. Loosen two screws (51) and remove covers (52), seals (53), and retainers (54) from hydraulic reservoir (31). Discard seals.



### NOTE

Perform Steps (21) and (22) if brackets need to be removed.

21. Remove four nuts (55), lockwashers (56), eight washers (57), four screws (58), and bracket (37) from crossmember (59) and support bracket (60). Discard lockwashers.
22. Remove five nuts (61), lockwashers (62), ten washers (63), five screws (64), and bracket (32) from crossmember (59) and support bracket (60). Discard lockwashers.

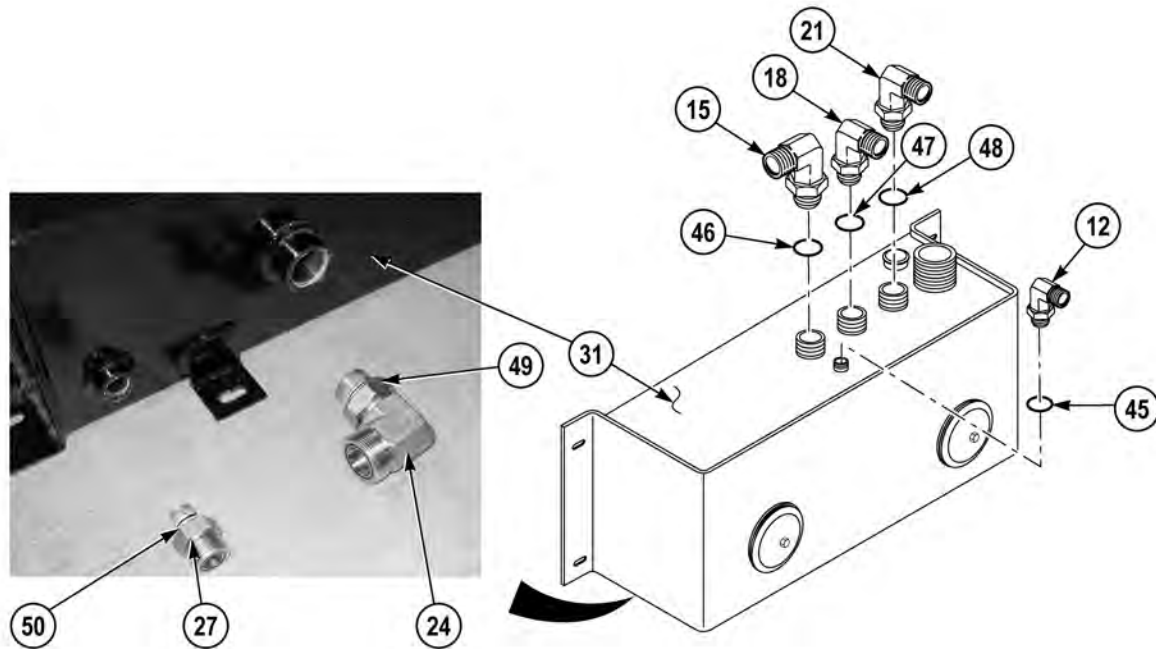
### END OF TASK

### INSTALLATION

### NOTE

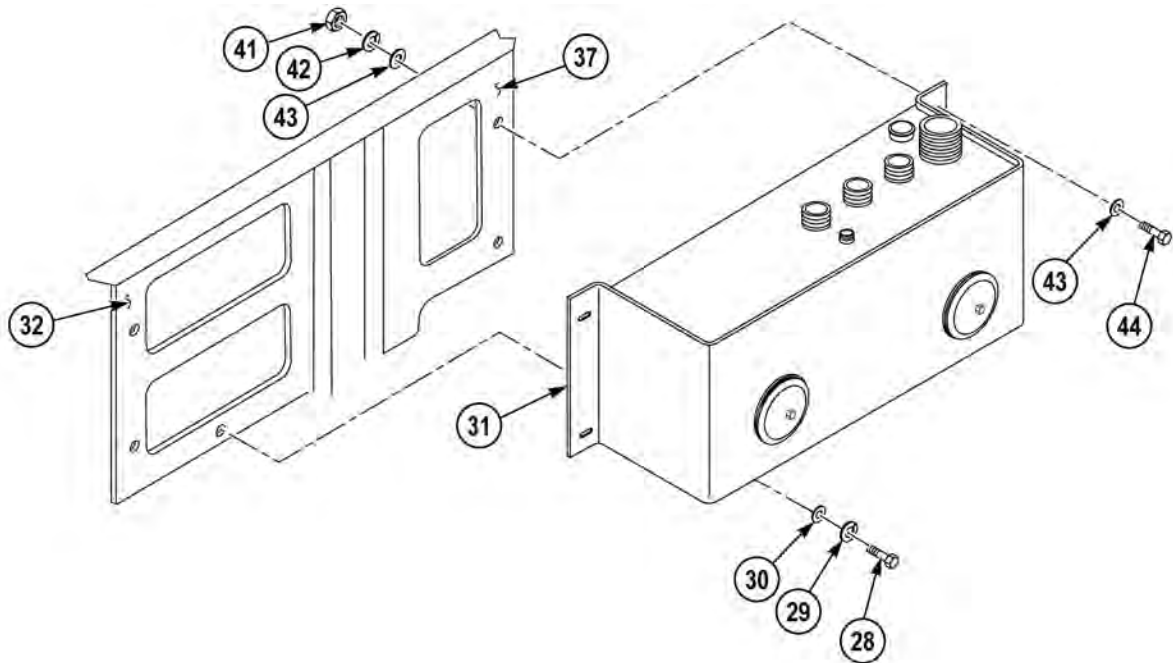
Perform Steps (1) and (2) if brackets were removed.

1. Install bracket (32) on support bracket (60) and crossmember (59) with five screws (64), ten washers (63), five lockwashers (62), and nuts (61).
2. Install bracket (37) on support bracket (60) and crossmember (59) with four screws (58), eight washers (57), four lockwashers (56), and nuts (55).
3. Lightly lubricate two seals (53) with clean oil, and install seal (53) on hydraulic reservoir (31) with two retainers (54), covers (52), and tighten screws (51).



4. Lightly lubricate preformed packing (50) with clean oil, and install preformed packing (50) and fitting (27) on hydraulic reservoir (31).
5. Lightly lubricate preformed packing (49) with clean oil, and install preformed packing (49) and elbow (24) on hydraulic reservoir (31).
6. Lightly lubricate preformed packing (48) with clean oil, and install preformed packing (48) and elbow (21) on hydraulic reservoir (31).
7. Lightly lubricate preformed packing (47) with clean oil, and install preformed packing (47) and elbow (18) on hydraulic reservoir (31).
8. Lightly lubricate preformed packing (46) with clean oil, and install preformed packing (46) and elbow (15) on hydraulic reservoir (31).
9. Lightly lubricate preformed packing (45) with clean oil, and install preformed packing (45) and elbow (12) on hydraulic reservoir (31).





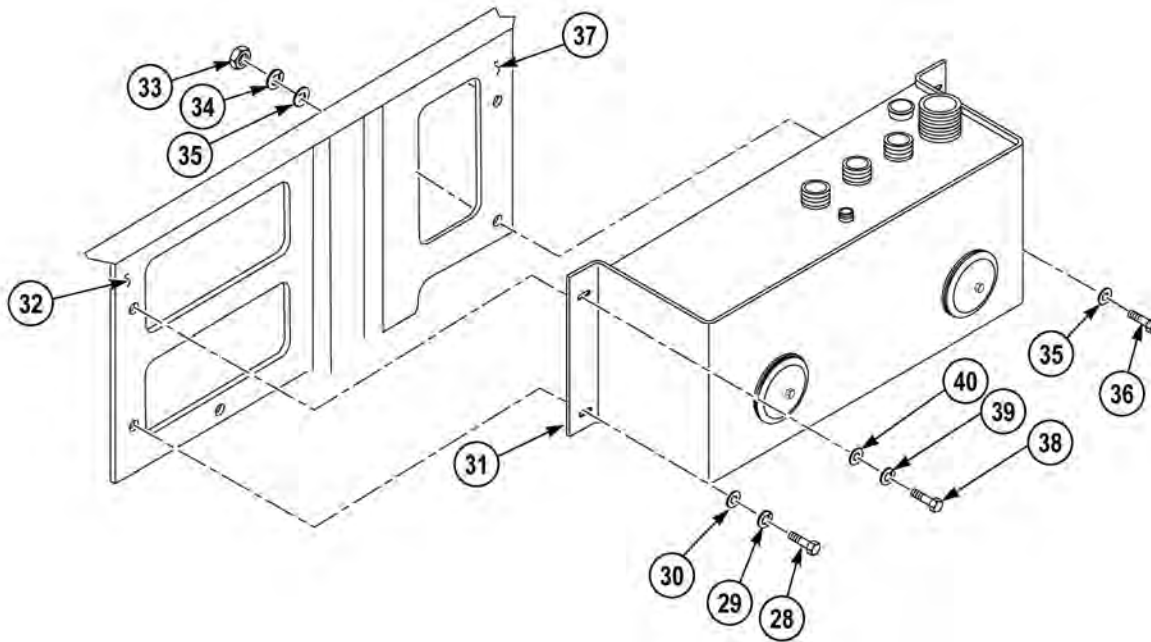
**⚠ CAUTION**

**Hydraulic reservoir is awkward and must be installed with the aid of an assistant. Failure to comply may cause damage to equipment.**

**NOTE**

Installing hydraulic reservoir on two brackets is not the reverse of removal. Installing screw on upper right hand corner first, and screw under hydraulic reservoir second allows for easier installation for hydraulic reservoir and remaining screws.

10. With the aid of an assistant, install hydraulic reservoir (31) on bracket (37) with screw (44), two washers (43), lockwasher (42), and nut (41).
11. With the aid of an assistant, install hydraulic reservoir (31) on bracket (32) with bottom washer (30), lockwasher (29), and screw (28).

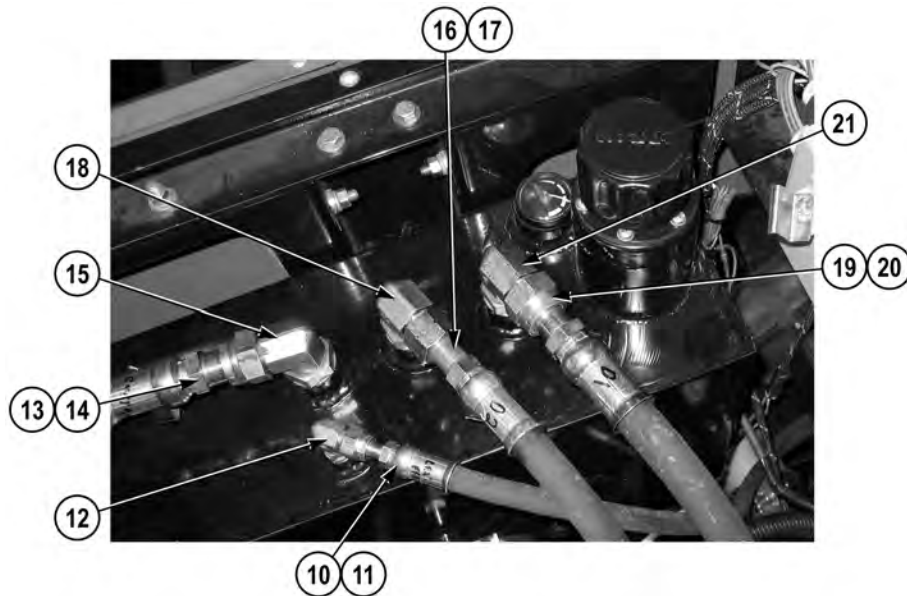


12. Install washer (40), lockwasher (39), and screw (38) on hydraulic reservoir (31) and bracket (32).
13. Install washer (30), lockwasher (29), and screw (28) on hydraulic reservoir (31) and bracket (32).
14. Install screw (36), two washers (35), lockwasher (34), and nut (33) on hydraulic reservoir (31) and bracket (37).



(BOTTOM OF TANK, BACK VIEW)

15. Lightly lubricate preformed packing (26) with clean oil, and install preformed packing (26) and hose 1682915 (25) on fitting (27).
16. Lightly lubricate preformed packing (23) with clean oil, and install preformed packing (23) and hose 1682838 (22) on elbow (24).



17. Lightly lubricate preformed packing (20) with clean oil, and install preformed packing (20) and hose 1682888 (19) on elbow (21).
18. Lightly lubricate preformed packing (17) with clean oil, and install preformed packing (17) and hose 1682841 (16) on elbow (18).
19. Lightly lubricate preformed packing (14) with clean oil, and install preformed packing (14) and hose 1682893 (13) on elbow (15).
20. Lightly lubricate preformed packing (11) with clean oil, and install preformed packing (11) and hose 1682987 (10) on elbow (12).



21. Install line (8) on elbow (9).
22. Install coupling (6) (WP 0313) and pipe (5) on valve (7).

### NOTE

Install cable ties as required.

23. Install bracket (4) on pipe (5) with U-bolt (3), cradle (2), and two locknuts (1).

### END OF TASK

### FOLLOW-ON MAINTENANCE

1. Install hydraulic reservoir strainer (WP 0149)
2. Install hydraulic reservoir fluid level gauge (WP 0146)
3. Install hydraulic reservoir fluid level switch (WP 0147)
4. Install hydraulic reservoir temperature sensor (WP 0150)
5. Install foam system eductor valve (WP 0178)
6. Fill hydraulic reservoir (WP 0145)

### END OF TASK

### END OF WORK PACKAGE

## FIELD LEVEL MAINTENANCE

## HYDRAULIC RESERVOIR STRAINER REPLACEMENT

## INITIAL SETUP:

**Tools and Special Tools**

Tool Kit, General Mechanic's: Automotive  
(WP 0398, Item 17)

**Materials/Parts**

Adhesive, Thread, Locking (WP 0400, Item 6)  
Gasket (2)

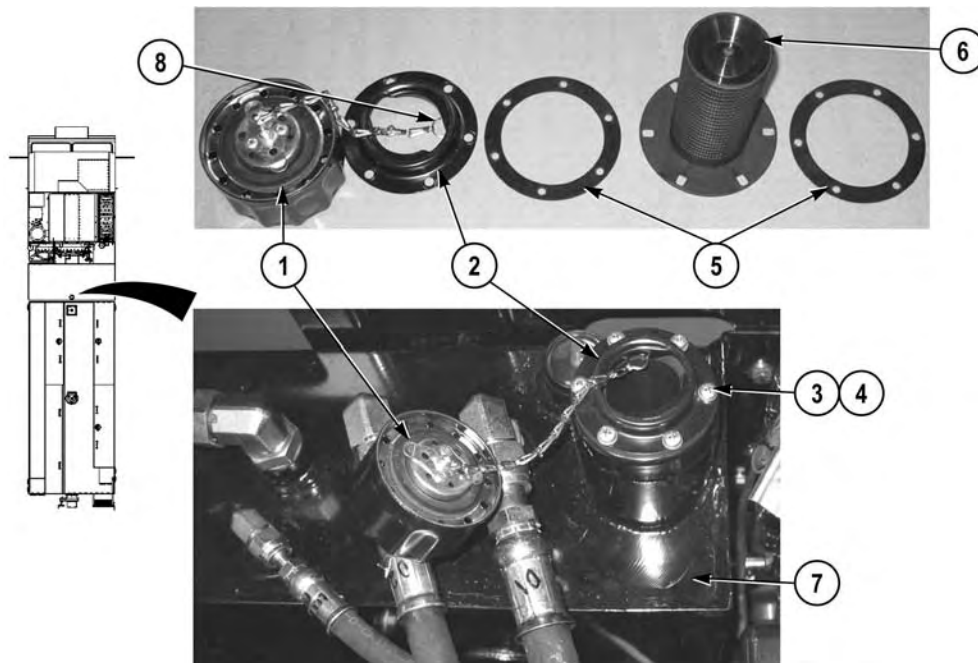
**References**

WP 0391, Fig. 10

**Equipment Conditions**

Engine OFF (TM 9-2320-422-10)  
Wheels chocked (TM 9-2320-422-10)  
Pump house panel K access door opened  
(WP 0008)

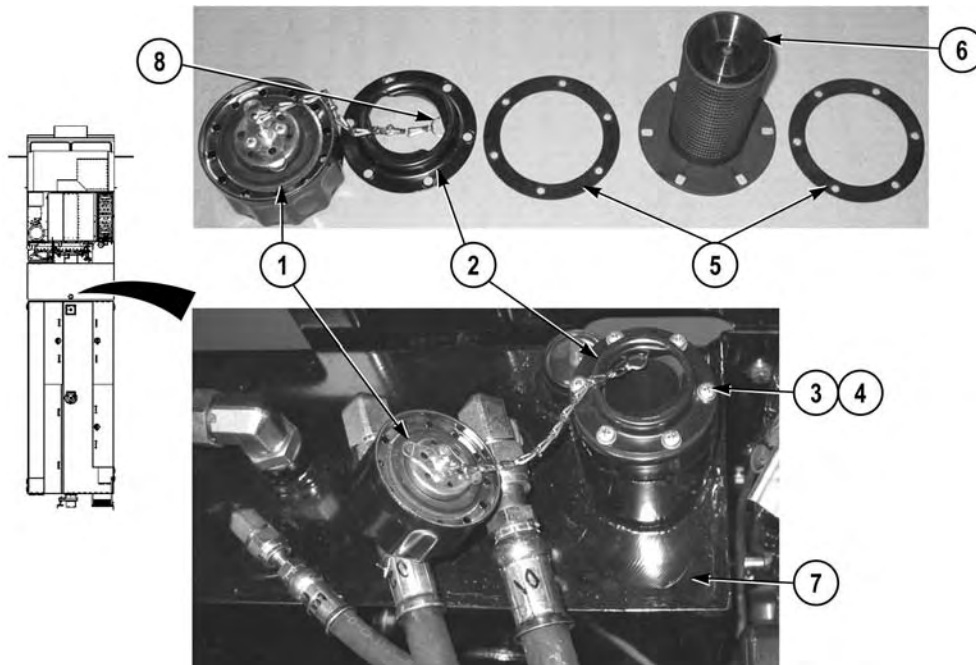
## REMOVAL



1. Remove breather (1) from strainer collar (2).
2. Remove six screws (3), washers (4), strainer collar (2), two gaskets (5), and strainer (6) from reservoir (7). Discard gaskets.
3. Remove ring (8) from strainer collar (2).

## END OF TASK

## INSTALLATION



1. Install ring (8) on strainer collar (2).

### **WARNING**



**Adhesives, solvents, and sealing compounds can burn easily, can give off harmful vapors, and are harmful to skin and clothing. To avoid injury or death, keep away from open fire and use in well-ventilated area. If adhesive, solvent, or sealing compound gets on skin or clothing, wash immediately with soap and water.**

2. Apply adhesive on threads of six screws (3).
3. Install two gaskets (5), strainer (6), and strainer collar (2) on reservoir (7) with six washers (4) and screws (3).
4. Install breather (1) on strainer collar (2).

**END OF TASK**

### **FOLLOW-ON MAINTENANCE**

1. Close pump house panel K access door (WP 0008)
2. Remove wheel chocks (TM 9-2320-422-10)

**END OF TASK**

**END OF WORK PACKAGE**

## FIELD LEVEL MAINTENANCE

## HYDRAULIC RESERVOIR TEMPERATURE SENSOR REPLACEMENT

## INITIAL SETUP:

**Tools and Special Tools**

Tool Kit, General Mechanic's: Automotive  
(WP 0398, Item 17)

**References**

WP 0391, Fig. 10

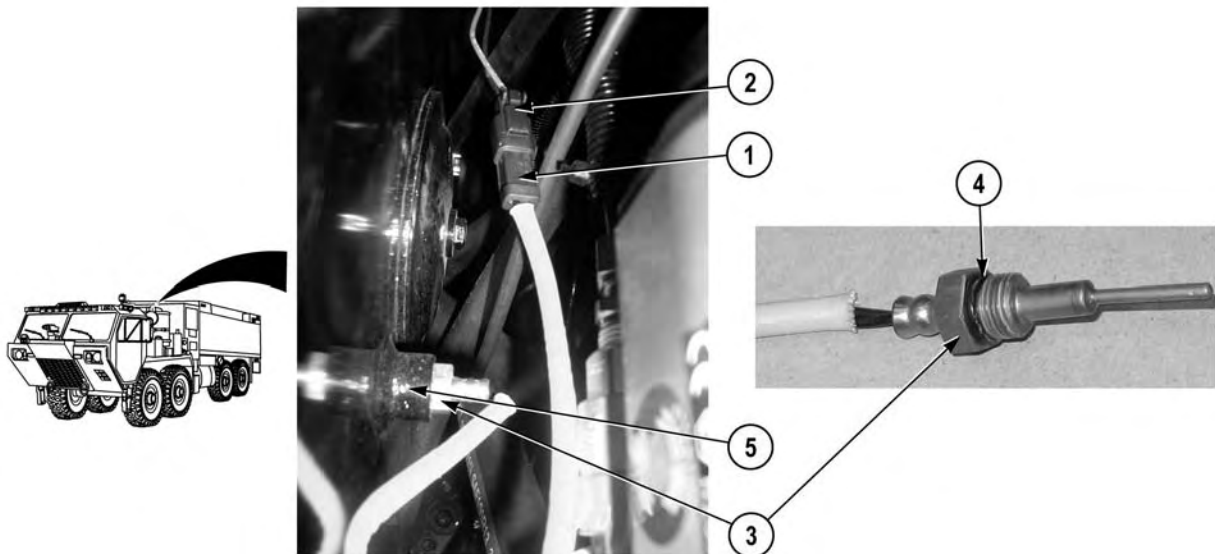
**Materials/Parts**

Fluid, Hydraulic (WP 0400, Item 17)  
Preformed Packing (1)

**Equipment Conditions**

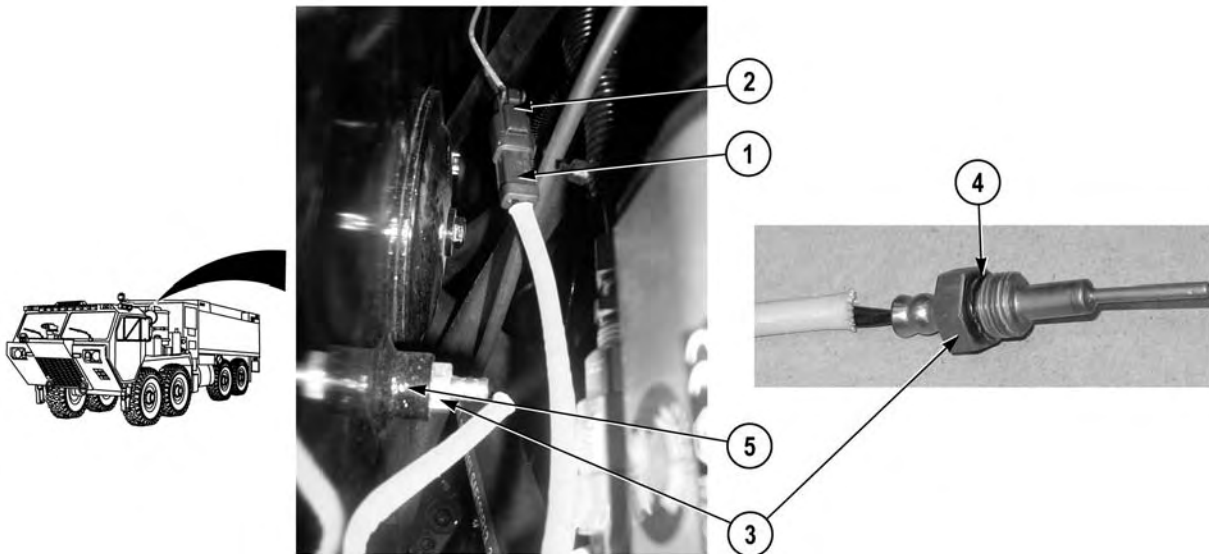
Pump house panel K access door opened  
(WP 0008)  
Hydraulic reservoir drained (WP 0145)

## REMOVAL



1. Disconnect hydraulic reservoir temperature sensor connector (1) from pump house wire harness connector (2).
2. Remove hydraulic reservoir temperature sensor (3) and preformed packing (4) from hydraulic reservoir (5). Discard preformed packing.

## END OF TASK

**INSTALLATION**

1. Lightly lubricate preformed packing (4) with clean oil, and install preformed packing (4) and hydraulic reservoir temperature sensor (3) on hydraulic reservoir (5).
2. Connect hydraulic reservoir temperature sensor connector (1) on pump house wire harness connector (2).

**END OF TASK****FOLLOW-ON MAINTENANCE**

1. Fill hydraulic reservoir (WP 0145)
2. Check for leaks (TM 9-2320-422-10)
3. Close pump house panel K access door (WP 0008)

**END OF TASK****END OF WORK PACKAGE**



---

**FIELD LEVEL MAINTENANCE**  
**HYDROSTATIC PUMP MOTOR REPLACEMENT**

---

**INITIAL SETUP:****Tools and Special Tools**

Cap Set, Protective (WP 0398, Item 1)  
Drain Pan (WP 0398, Item 4)  
Standard Automotive Tool Set (SATS),  
(WP 0398, Item 15)  
• Wrench, Adjustable 18"  
Tool Kit, General Mechanic's: Automotive  
(WP 0398, Item 17)

**Materials/Parts**

Fluid, Hydraulic (WP 0400, Item 17)  
Tags, Identification (WP 0400, Item 23)  
Ties, Cable, Plastic (WP 0400, Item 26)  
Preformed Packing (2)  
Preformed Packing (1)  
Preformed Packing (1)  
Preformed Packing (1)  
Preformed Packing (1)  
Preformed Packing (1)  
Preformed Packing (1)

**Materials/Parts (continued)**

Preformed Packing (1)  
Preformed Packing (1)  
Preformed Packing (1)  
Preformed Packing (2)  
Lockwasher (4)  
Lockwasher (8)  
Backup Ring (2)

**Personnel Required**

MOS 63B Wheeled Vehicle Mechanic (2)

**References**

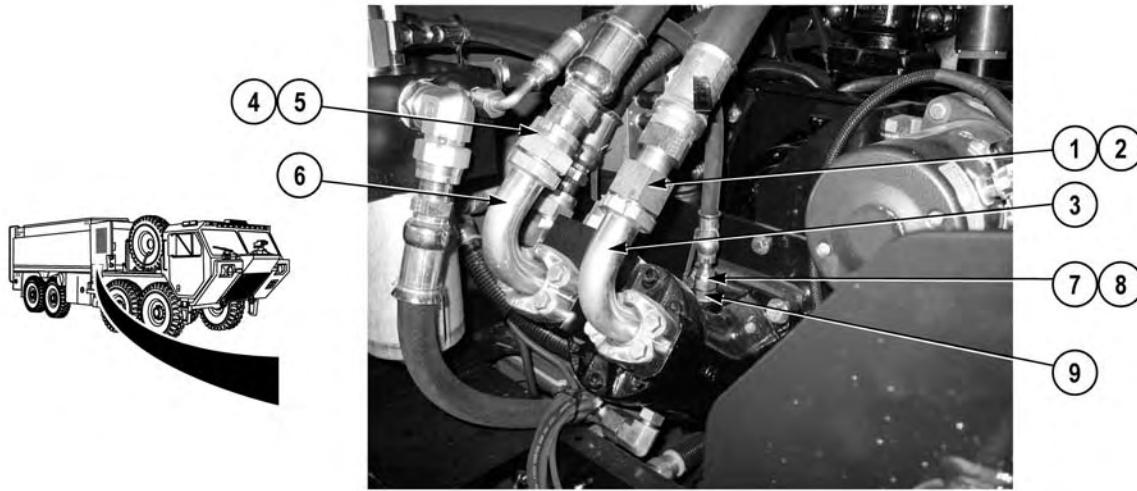
WP 0391, Fig. 7, 9, 10, 11

**Equipment Conditions**

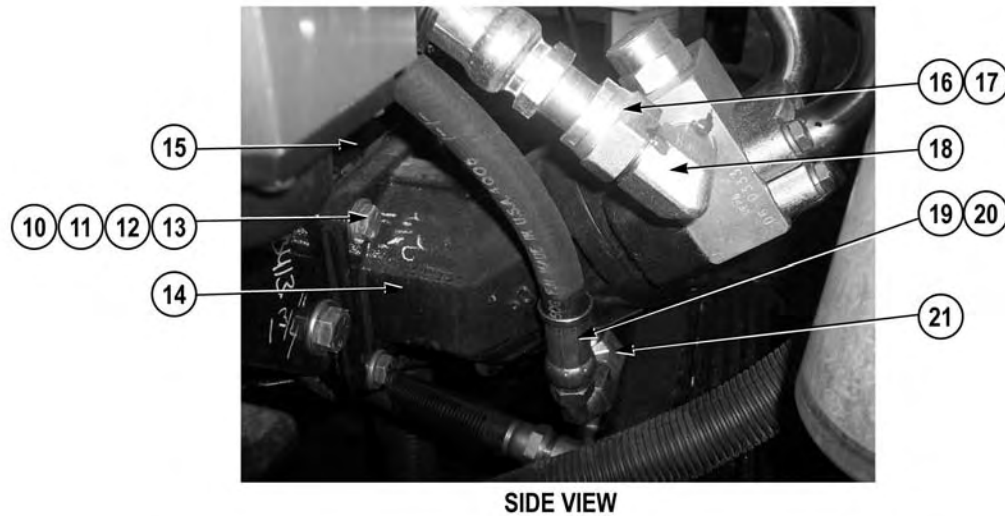
Hydraulic heat exchanger shroud panel A  
removed (WP 0137)  
Hydraulic reservoir drained (WP 0145)

---

## REMOVAL

**NOTE**

- Position drain pan under hoses.
  - Tag and mark hoses prior to removal to ensure proper installation.
  - Cap and plug hoses and fittings upon removal.
  - Remove cable ties as required.
1. Remove hose 1682839 (1) and preformed packing (2) from elbow (3). Discard preformed packing.
  2. Remove hose 1682840 (4) and preformed packing (5) from elbow (6). Discard preformed packing.
  3. Remove hose 1682906 (7) and preformed packing (8) from fitting (9). Discard preformed packing.



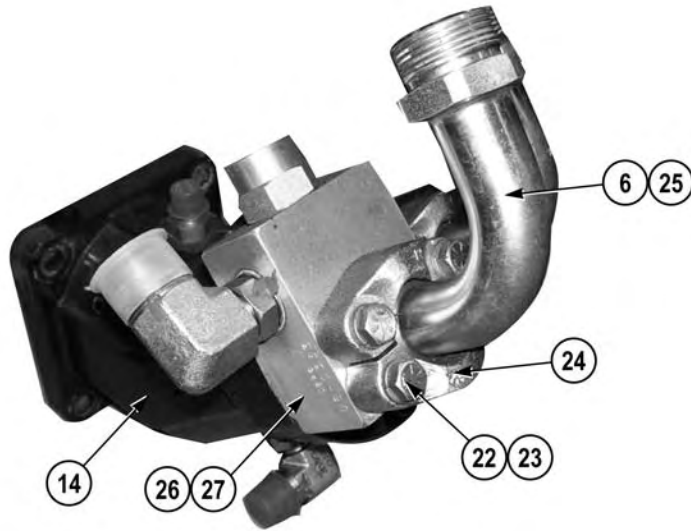
**⚠ CAUTION**

Pump motor has a splined shaft that turns water pump. Pump motor must be rotated in order to remove two remaining hoses, only pull pump motor away from water pump enough to provide clearance. Failure to comply may cause damage to equipment.

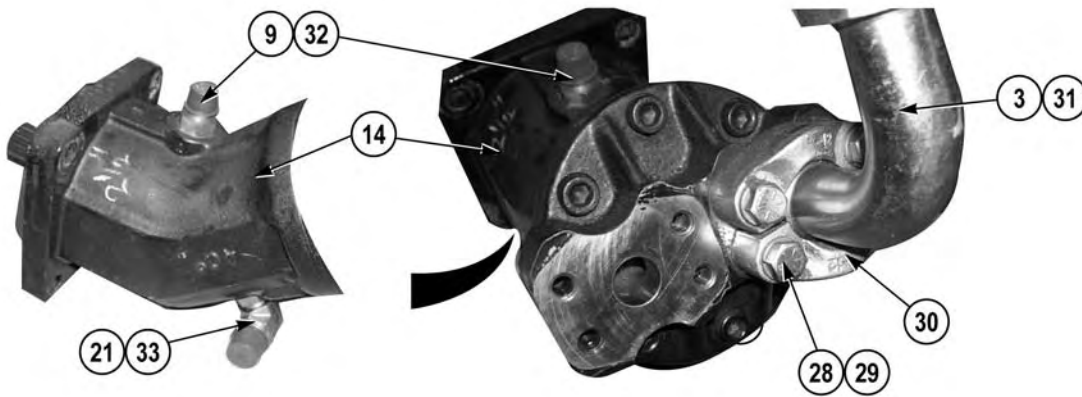
**NOTE**

Note position of elbows and fittings prior to removal to ensure proper installation.

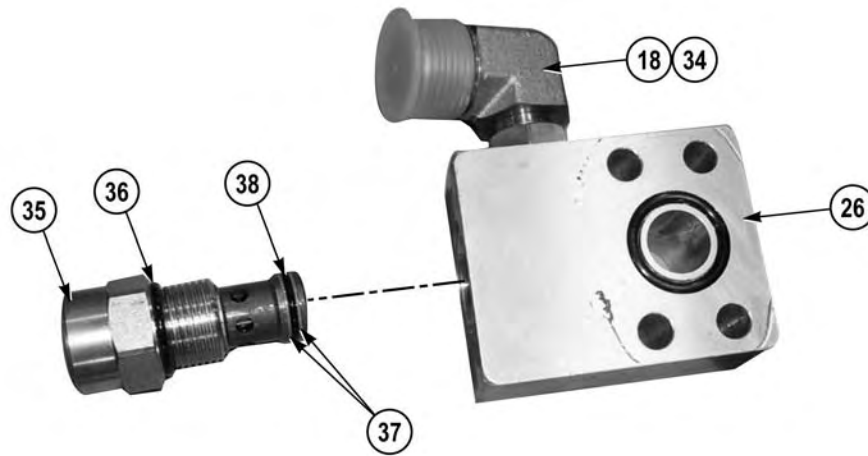
4. With the aid of an assistant, remove four nuts (10), lockwashers (11), eight washers (12), and four screws (13) from pump motor (14) and water pump (15). Discard lockwashers.
5. Pull pump motor (14) away from water pump (15) and rotate clockwise.
6. Remove hose 1682886 (16) and preformed packing (17) from elbow (18). Discard preformed packing.
7. Remove hose 1682841 (19) and preformed packing (20) from elbow (21). Discard preformed packing.
8. Remove pump motor (14) from water pump (15).



9. Remove four screws (22), lockwashers (23), two flange halves (24), elbow (6), preformed packing (25), adapter block (26), and preformed packing (27) from pump motor (14). Discard lockwashers and preformed packings.



10. Remove four screws (28), lockwashers (29), two flange halves (30), elbow (3), and preformed packing (31) from pump motor (14). Discard lockwashers and preformed packing.
11. Remove fitting (9) and preformed packing (32) from pump motor (14). Discard preformed packing.
12. Remove elbow (21) and preformed packing (33) from pump motor (14). Discard preformed packing.



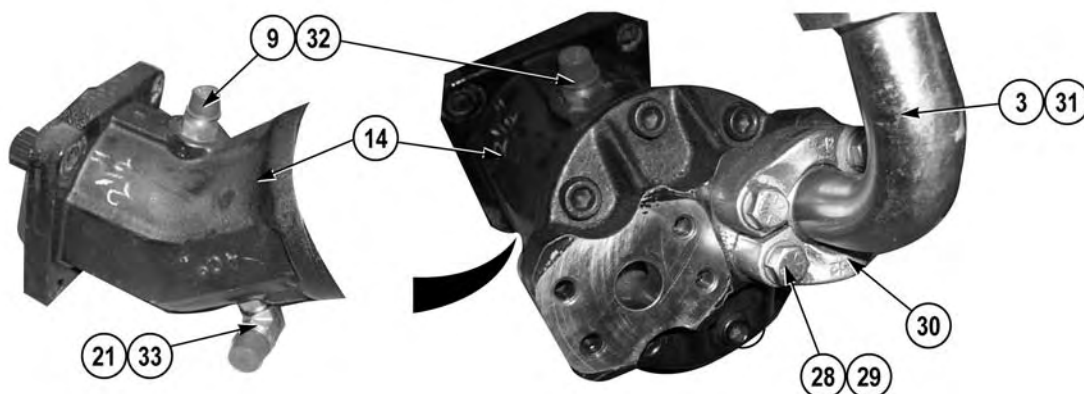
13. Remove elbow (18) and preformed packing (34) from adapter block (26). Discard preformed packing.
14. Remove valve (35) preformed packing (36), two backup rings (37), and preformed packing (38) from adapter block (21). Discard preformed packings and backup rings

#### END OF TASK

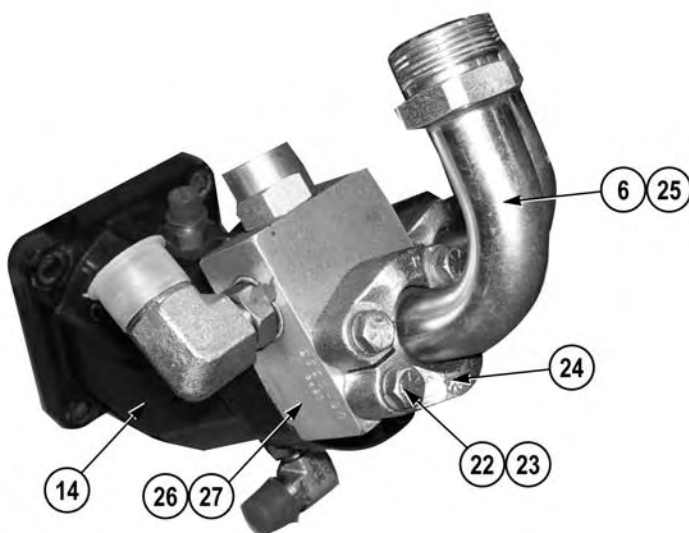
#### INSTALLATION

#### NOTE

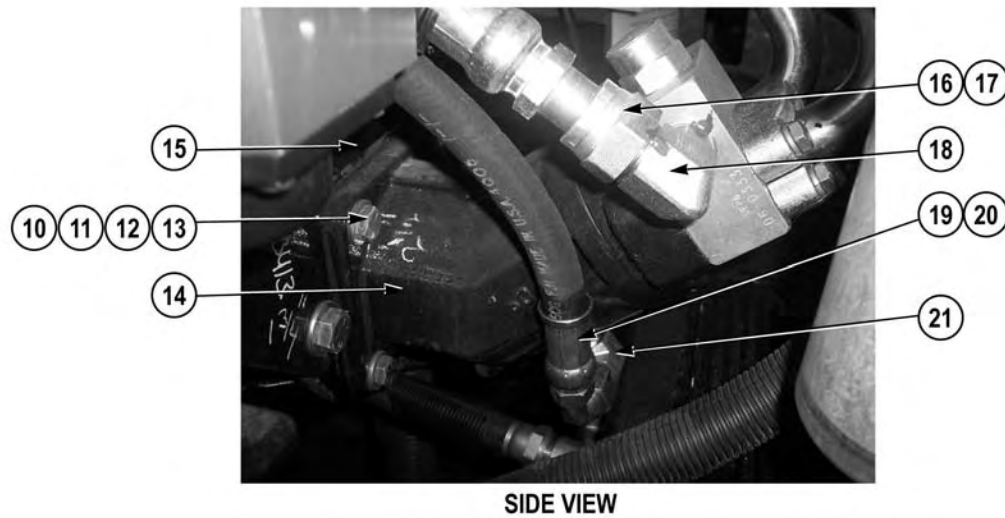
- Install elbows and fittings as noted prior to removal.
  - Install cable ties as required.
1. Lightly lubricate two backup rings (37) and preformed packings (38) and (36) with clean oil, and install preformed packings (38) and (36), backing rings (37), and valve (35) on adapter block (26).
  2. Lightly lubricate preformed packing (34) with clean oil, and install preformed packing (34) and elbow (18) on adapter block (26).



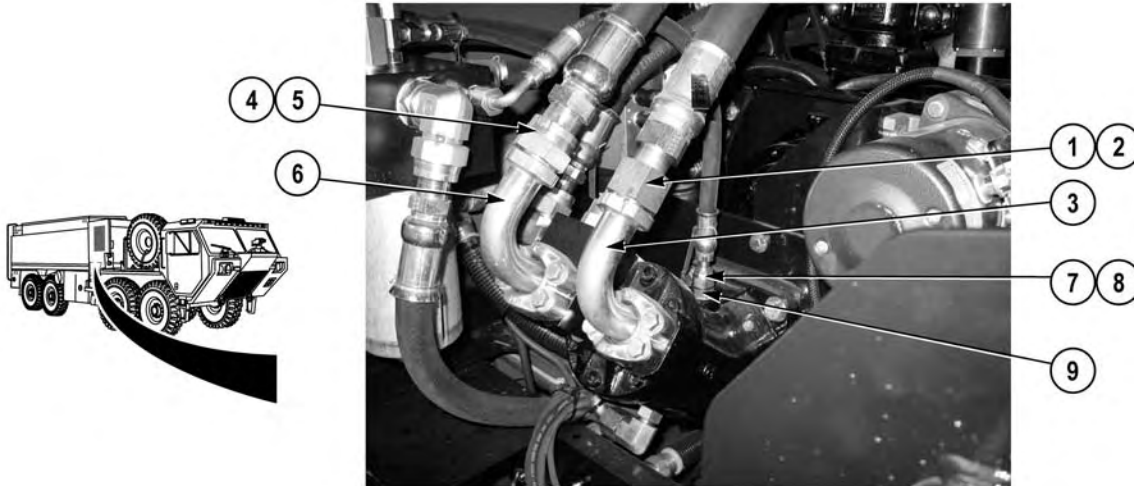
3. Lightly lubricate preformed packing (33) with clean oil, and install preformed packing (33) and elbow (21) on pump motor (14).
4. Lightly lubricate preformed packing (32) with clean oil, and install preformed packing (32) and fitting (9) on pump motor (14).
5. Lightly lubricate preformed packing (31) with clean oil, and install preformed packing (31) and elbow (3) on pump motor (14) with two flange halves (30), four lockwashers (29), and screws (28).



6. Lightly lubricate two preformed packings (27) and (25) with clean oil, and install preformed packing (27), adapter block (26), preformed packing (25) and elbow (6) on pump motor (14) with two flange halves (24), four lockwashers (23), and screws (22).



7. Position pump motor (14) on water pump (15).
8. Lightly lubricate preformed packing (20) with clean oil, and install preformed packing (20) and hose 1682841 (19) on elbow (21).
9. Lightly lubricate preformed packing (17) with clean oil, and install preformed packing (17) and hose 1682886 (16) on elbow (18).
10. With the aid of an assistant, rotate pump motor (14) counterclockwise, and install pump motor (14) on water pump (15) with four screws (13) eight washers (12), four lockwashers (11), and nuts (10).



11. Lightly lubricate preformed packing (8) with clean oil, and install preformed packing (8) and hose 1682906 (7) on fitting (9).
12. Lightly lubricate preformed packing (5) with clean oil, and install preformed packing (5) and hose 1682840 (4) on elbow (6).
13. Lightly lubricate preformed packing (2) with clean oil, and install preformed packing (2) and hose 1682839 (1) on elbow (3).

#### END OF TASK

#### FOLLOW-ON MAINTENANCE

1. Install hydraulic heat exchanger shroud panel A (WP 0137)
2. Fill hydraulic reservoir (WP 0145)

#### END OF TASK

#### END OF WORK PACKAGE



---

**FIELD LEVEL MAINTENANCE**
**HYDROSTATIC CHARGE PUMP REPLACEMENT**


---

**INITIAL SETUP:****Tools and Special Tools**

- Cap Set, Protective (WP 0398, Item 1)
- Drain Pan (WP 0398, Item 4)
- Standard Automotive Tool Set (SATS), (WP 0398, Item 15)
  - Socket, Socket Wrench, 1/2" DR, 6 PT, Regular, 1-1/16"
  - Wrench, Adjustable 18"
  - Wrench, Combination, 1-1/16"
  - Wrench, Combination, 1-1/8" (2)
  - Wrench, Adjustable, Automotive, 18"
- Tool Kit, General Mechanic's: Automotive (WP 0398, Item 17)
- Water Pump Engine Removal Kit

**Materials/Parts**

- Tags, Identification (WP 0400, Item 23)
- Ties, Cable, Plastic (WP 0400, Item 26)
- Oil, Lubrication (WP 0400, Item 20)
- Preformed Packing (1)
- Preformed Packing (1)
- Preformed Packing (1)
- Preformed Packing (1)
- Preformed Packing (1)
- Preformed Packing (1)
- Preformed Packing (1)
- Preformed Packing (1)
- Preformed Packing (1)
- Preformed Packing (1)

**Materials/Parts (continued)**

- Preformed Packing (1)
- Preformed Packing (1)
- Preformed Packing (1)
- Preformed Packing (1)
- Preformed Packing (1)
- Preformed Packing (1)
- Lockwasher (4)
- Lockwasher (4)
- Lockwasher (4)
- Lockwasher (4)

**Personnel Required**

- MOS 63B Wheeled Vehicle Mechanic (2)

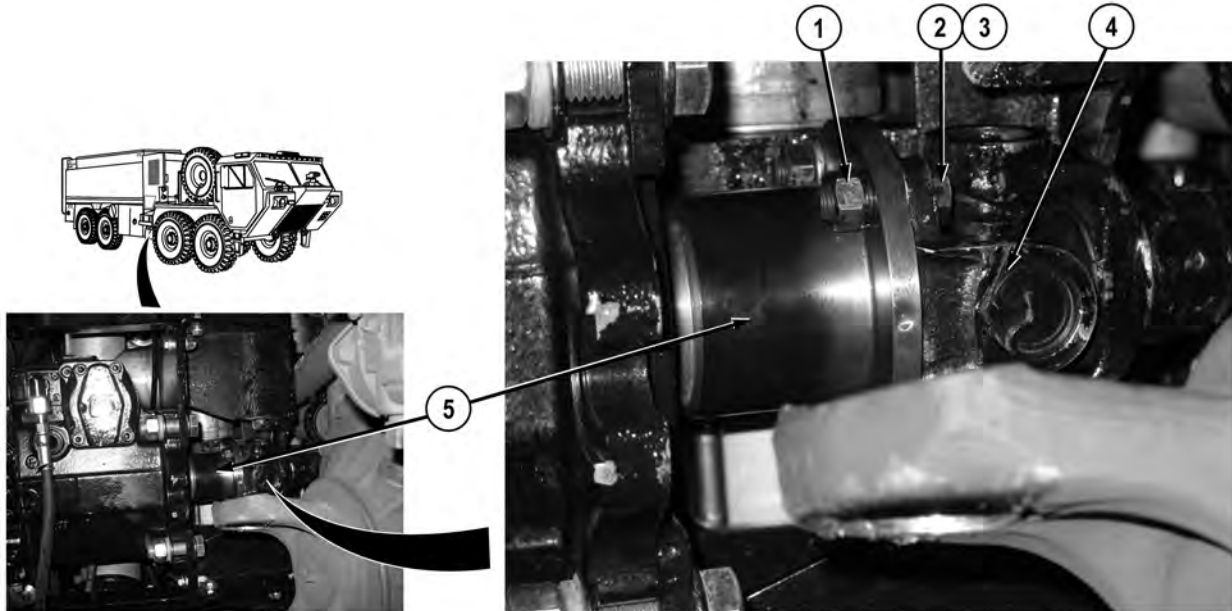
**References**

- WP 0313
- WP 0391, Fig. 6, 9, 10, 39

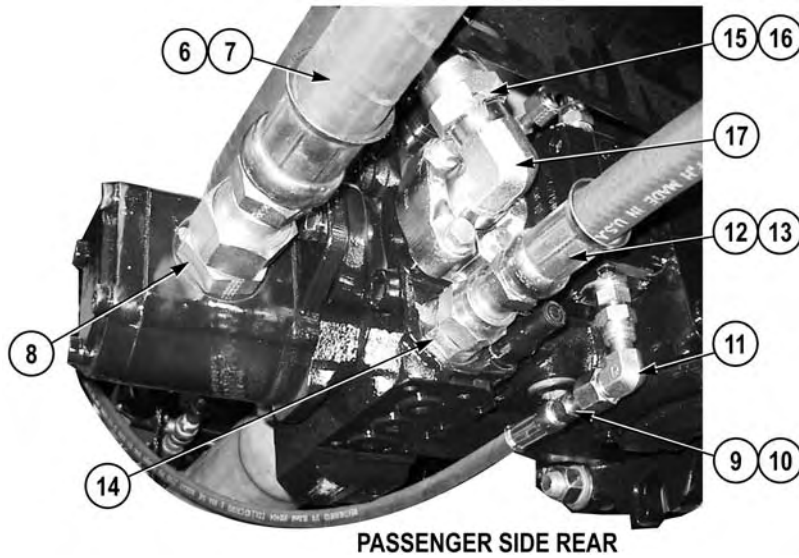
**Equipment Conditions**

- Transmission and transfer case set to neutral (TM 9-2320-422-10)
  - Hydraulic reservoir removed (WP 0148)
  - Pump house panel G removed (WP 0339)
  - Propeller shafts removed from transfer case to No. 2 axle and transmission to transfer case (TM 9-2320-325-14&P)
  - Water system drained (WP 0033)
  - Foam system drained (WP 0022)
-

REMOVAL



1. Remove four nuts (1), lockwashers (2), screws (3) and PTO yoke (4) from pump (5). Discard lockwashers.



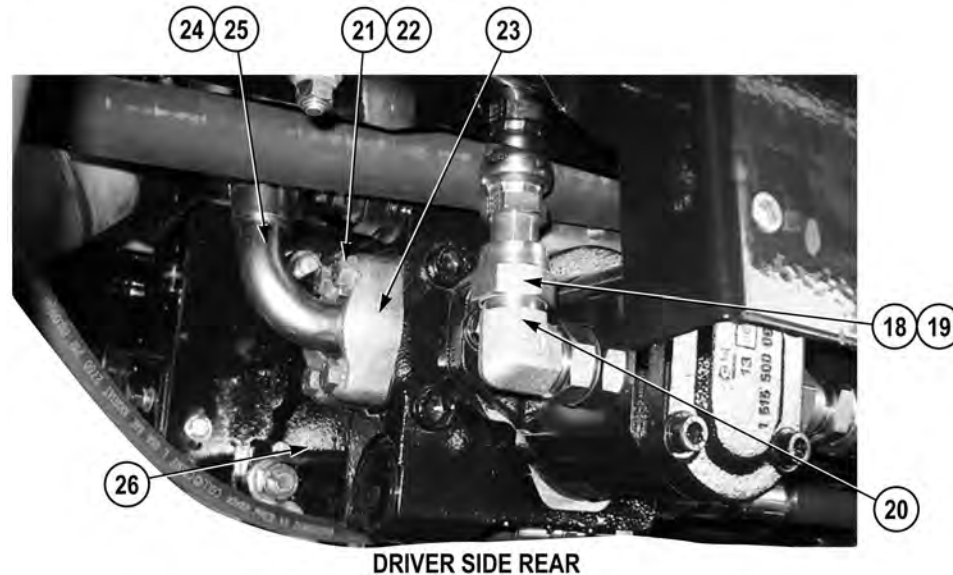
PASSENGER SIDE REAR

**NOTE**

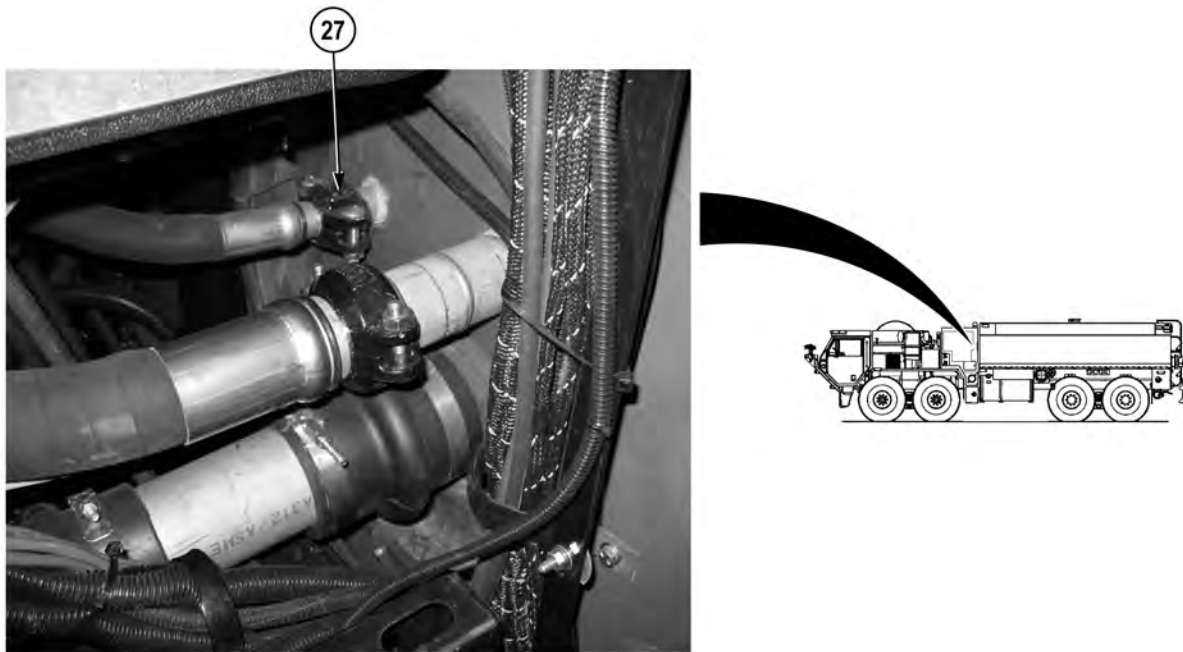
- Position drain pan under hoses being removed.
- Tag and mark hoses and fittings upon removal.
- Cap and plug hoses and fittings upon removal.
- Remove cable ties as required.

2. Remove hose 1682838 (6) and preformed packing (7) from fitting (8). Discard preformed packing.

3. Remove hose 1682912 (9) and preformed packing (10) from elbow (11). Discard preformed packing.
4. Remove hose 1682902 (12) and preformed packing (13) from fitting (14). Discard preformed packing.
5. Remove hose 1682840 (15) and preformed packing (16) from elbow (17). Discard preformed packing.



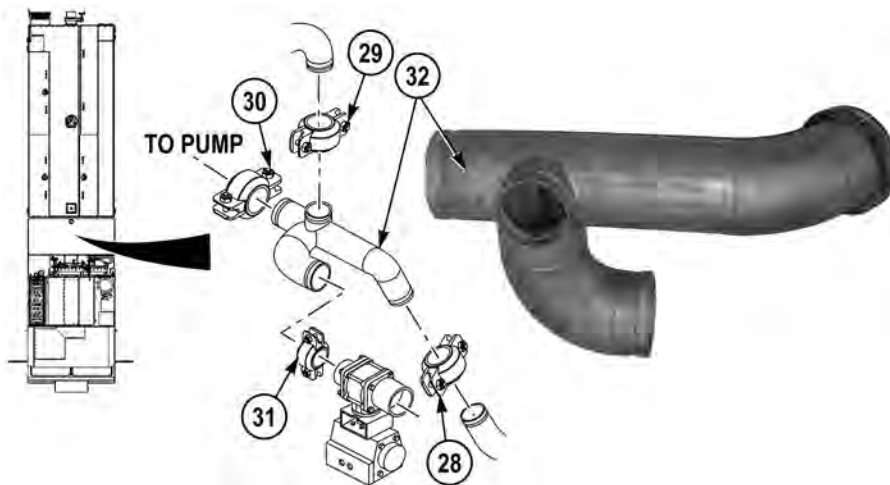
6. Remove hose 1682901 (18) and preformed packing (19) from elbow (20). Discard preformed packing.
7. Remove four screws (21), lockwashers (22), two flange halves (23), hose 1682839 (24), and preformed packing (25) from charge pump (26). Discard lockwashers and preformed packing.



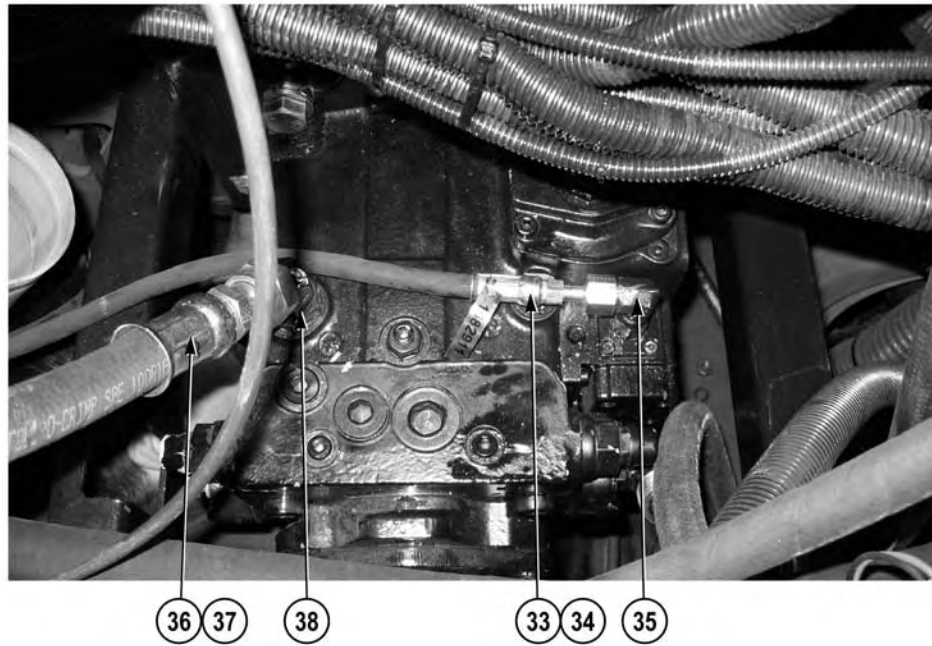
**NOTE**

Removing coupling on foam supply line is required to remove main inlet manifold.

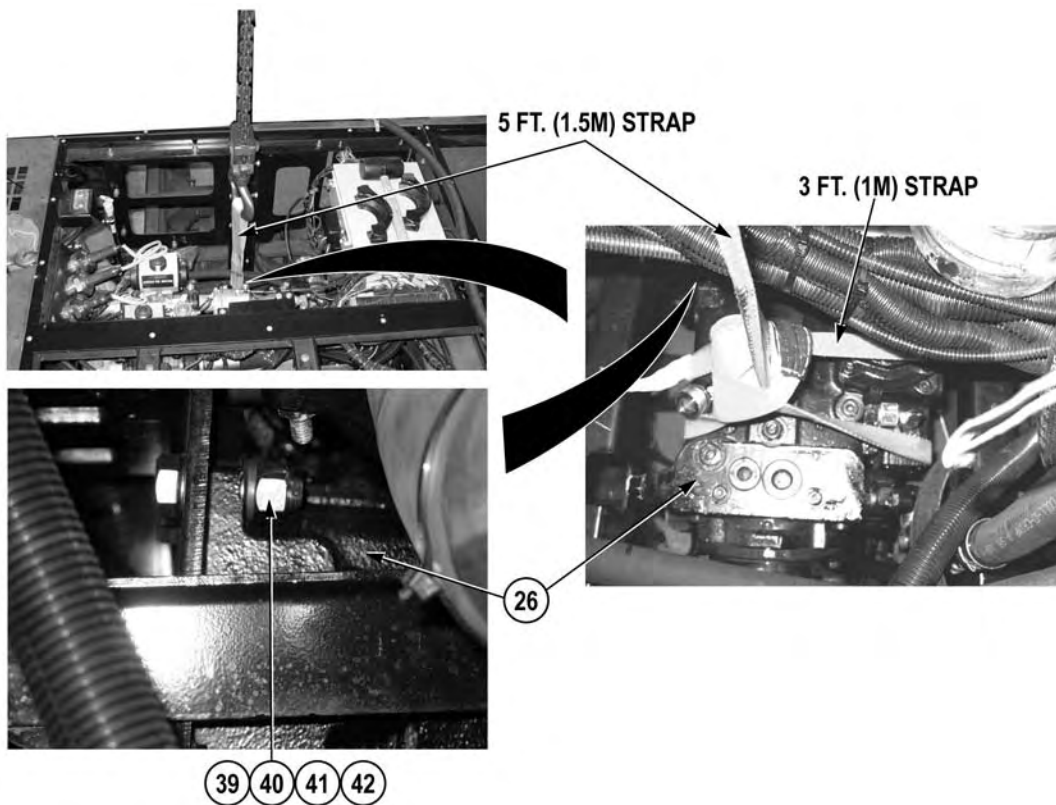
8. Remove coupling (27) from vehicle (WP 0313).



9. Remove four couplings (28), (29), (30), and (31), and main inlet manifold (32) from vehicle (WP 0313).



10. Remove hose 1682911 (33) and preformed packing (34) from elbow (35). Discard preformed packing.
11. Remove hose 1682888 (36) and preformed packing (37) from elbow (38). Discard preformed packing.

**WARNING**

**Charge pump weighs 170 lb. (77.18 kg). Do not attempt to remove hydraulic pump without the aid of an assistant, two straps and a suitable lifting device. Failure to comply may result in injury or death to personnel and damage to equipment.**

**NOTE**

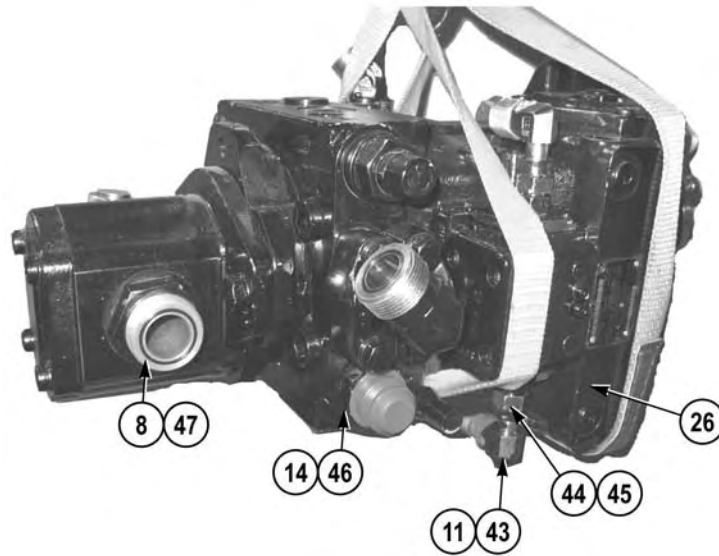
Loops are obtained from the TFFT water pump engine removal kit.

12. Loop 3 ft. (1 m) strap around charge pump (26).
13. Loop 5 ft. (1.5 m) strap through 3 ft. (1 m) strap.
14. Attach suitable lifting device to 5 ft. (1.5 m) strap.

**NOTE**

Charge pump is lowered to ground.

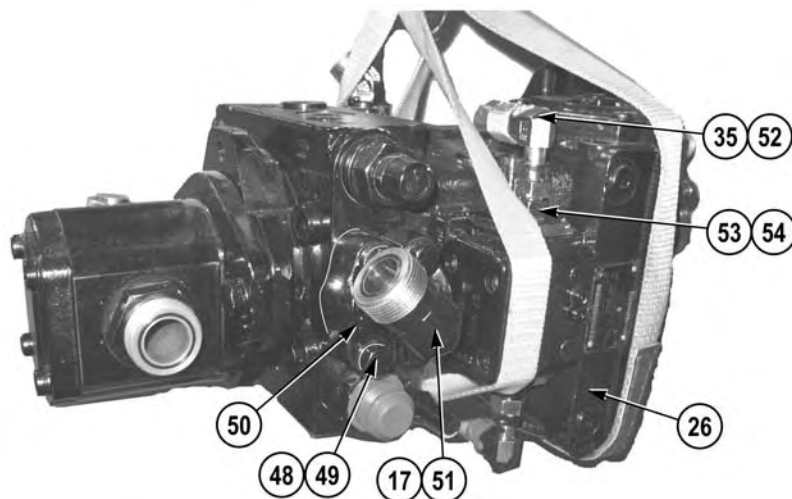
15. With the aid of an assistant and suitable lifting device, remove four nuts (39), lockwashers (40), eight washers (41), four screws (42), and charge pump (26) from vehicle. Discard lockwashers.



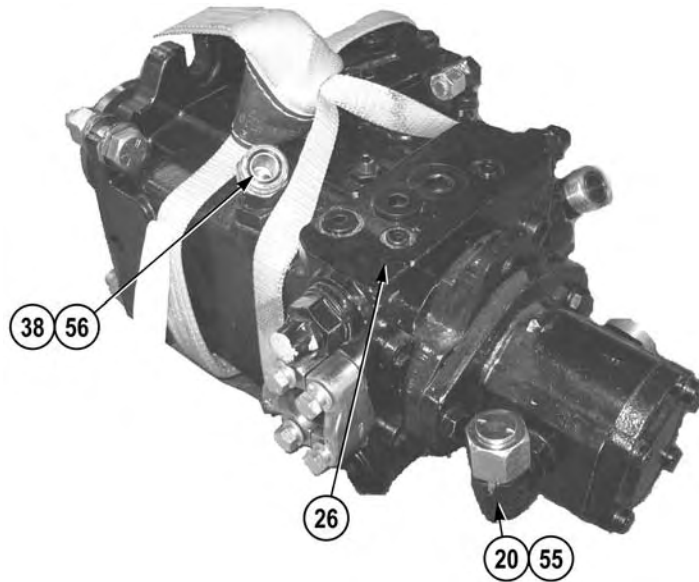
### NOTE

Note position of elbows and fittings prior to removal to ensure proper installation.

16. Remove elbow (11) and preformed packing (43) from fitting (44). Discard preformed packing.
17. Remove fitting (44) and preformed packing (45) from charge pump (26). Discard preformed packing.
18. Remove fitting (14) and preformed packing (46) from charge pump (26). Discard preformed packing.
19. Remove fitting (8) and preformed packing (47) from charge pump (26). Discard preformed packing.



20. Remove four screws (48), lockwashers (49), two flange halves (50), elbow (17), and preformed packing (51) from charge pump (26). Discard lockwashers and preformed packing.
21. Remove elbow (35) and preformed packing (52) from fitting (53). Discard preformed packing.
22. Remove fitting (53) and preformed packing (54) from charge pump (26). Discard preformed packing.



23. Remove elbow (20) and preformed packing (55) from charge pump (26). Discard preformed packing.

24. Remove elbow (38) and preformed packing (56) from charge pump (26). Discard preformed packing.

#### END OF TASK

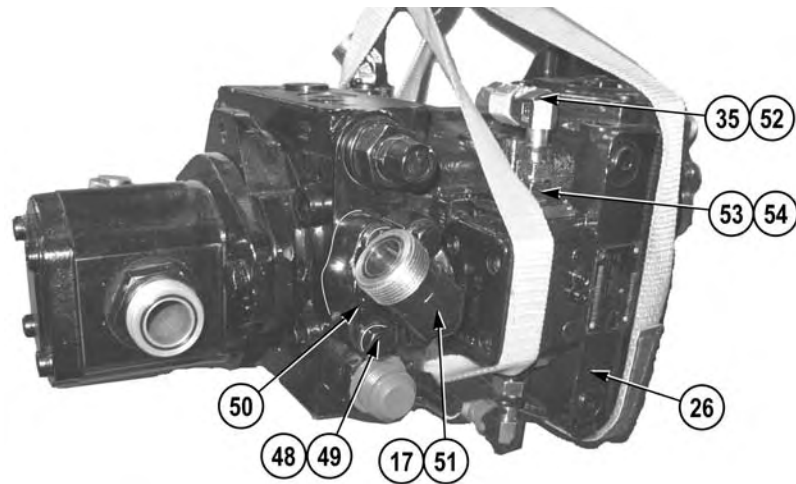
#### INSTALLATION

#### NOTE

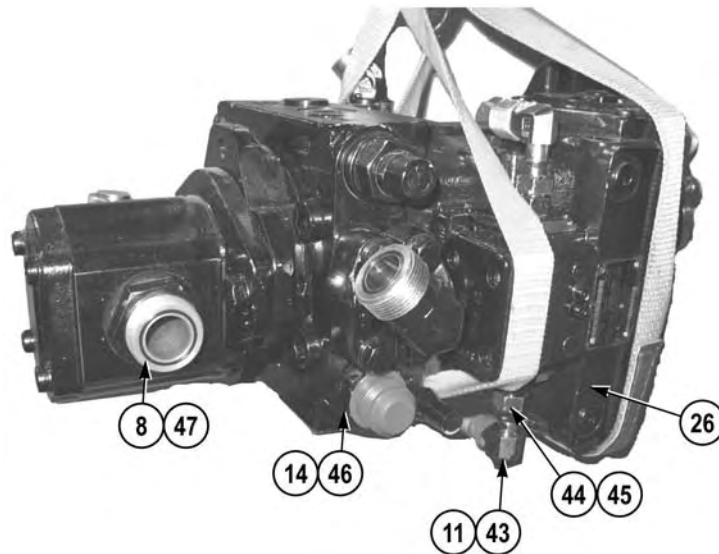
Install elbows and fittings as noted prior to removal.

1. Lightly lubricate preformed packing (56) with clean oil, and install preformed packing (56) and elbow (38) on charge pump (26).
2. Lightly lubricate preformed packing (55) with clean oil, and install preformed packing (55) and elbow (20) on charge pump (26).

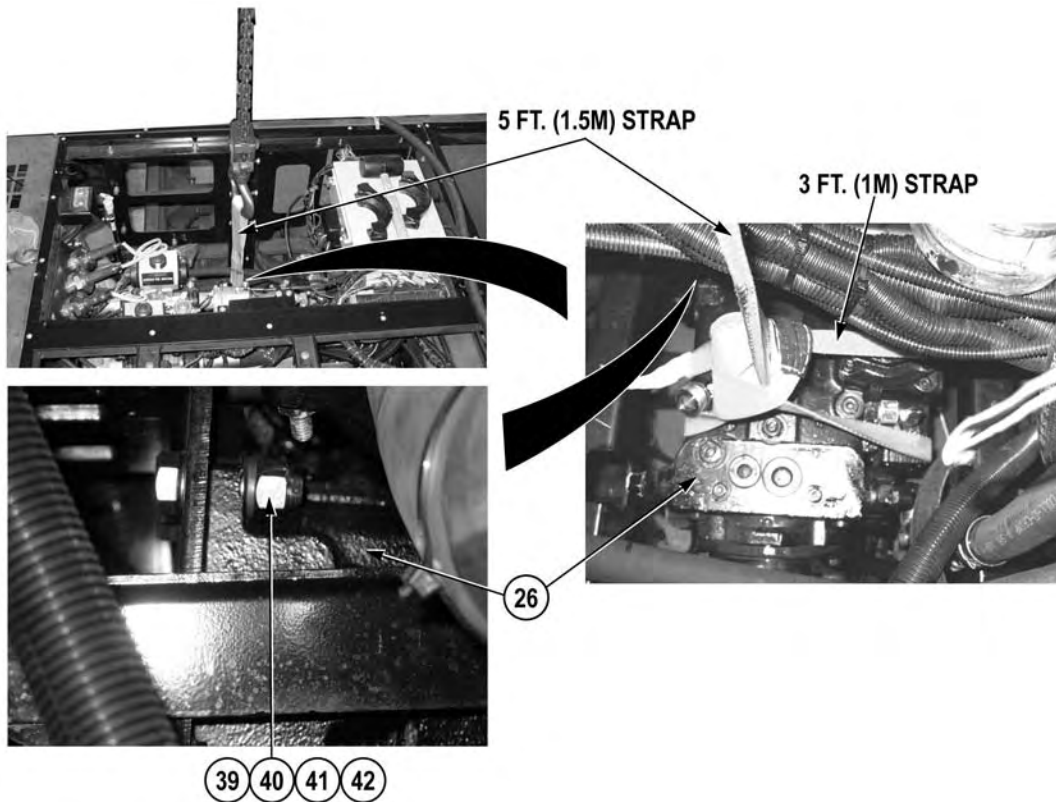




3. Lightly lubricate preformed packing (54) with clean oil, and install preformed packing (54) and fitting (53) on charge pump (26).
4. Lightly lubricate preformed packing (52) with clean oil, and install preformed packing (52) and elbow (35) on fitting (53).
5. Lightly lubricate preformed packing (51) with clean oil, and install preformed packing (51) and elbow (17) on charge pump (26) with two flange halves (50), four lockwashers (49), and screws (48).

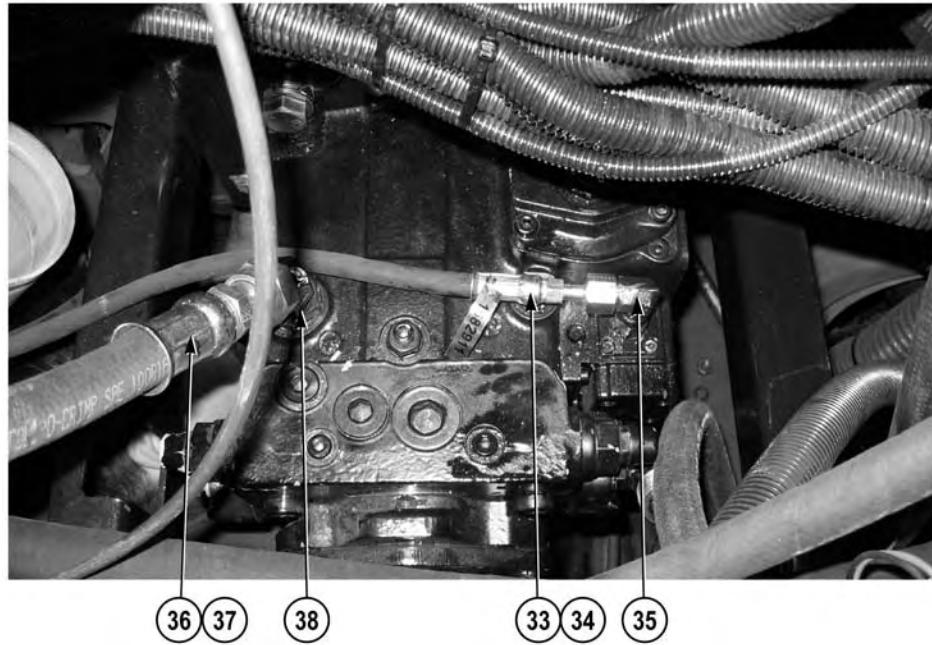


6. Lightly lubricate preformed packing (47) with clean oil, and install preformed packing (47) and fitting (8) on charge pump (26).
7. Lightly lubricate preformed packing (46) with clean oil, and install preformed packing (46) and fitting (14) on charge pump (26).
8. Lightly lubricate preformed packing (45) with clean oil, and install preformed packing (45) and fitting (44) on charge pump (26).
9. Lightly lubricate preformed packing (43) with clean oil, and install preformed packing (43) and elbow (11) on fitting (44).

**WARNING**

**Hydraulic pump weighs 170 lb. (77.18 kg). Do not attempt to install hydraulic pump without the aid of an assistant, two straps and a suitable lifting device. Failure to comply may result in injury or death to personnel and damage to equipment.**

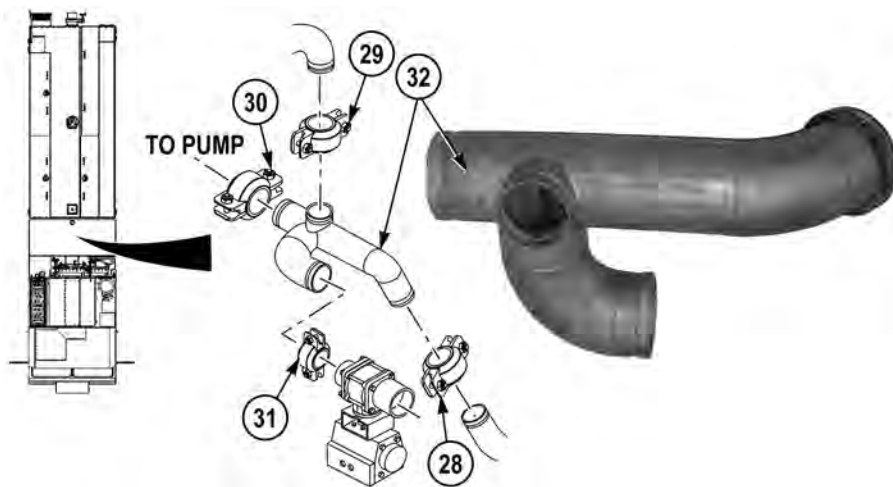
10. Loop 3 ft. (1 m) strap around charge pump (26).
11. Loop 5 ft. (1.5 m) strap through 3 ft. (1 m) strap.
12. Attach suitable lifting device to 5 ft. (2 m) strap.
13. With the aid of an assistant and suitable lifting device, install charge pump (26) on vehicle with four screws (42), eight washers (41), four lockwashers (40), and nuts (39).



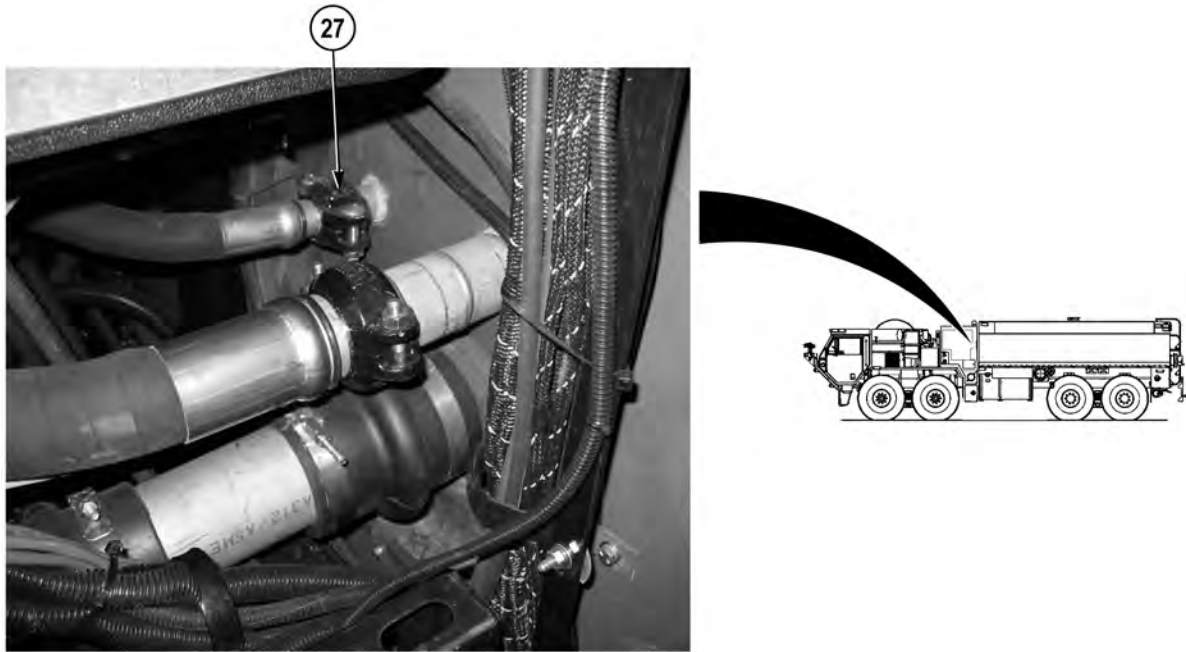
**NOTE**

Install cable ties as required.

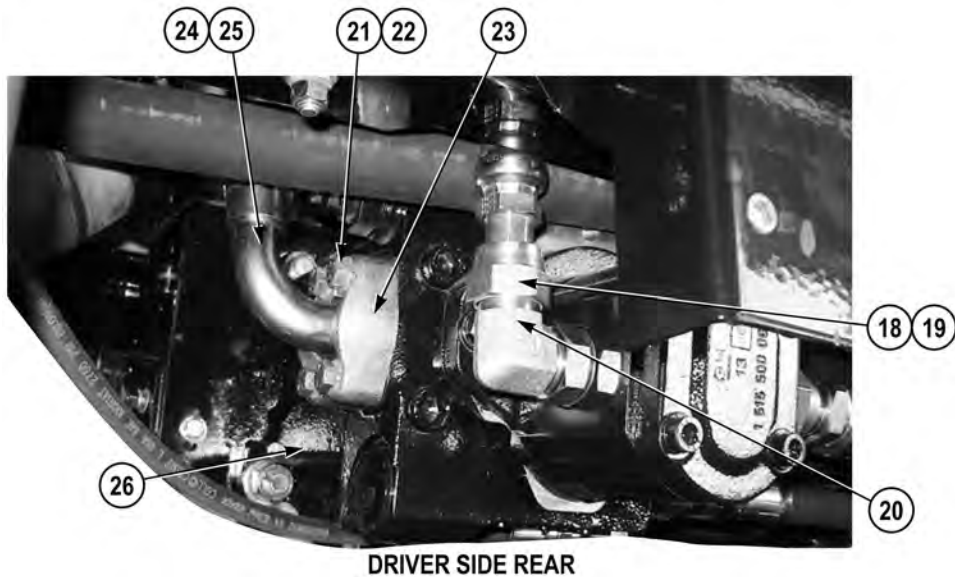
14. Lightly lubricate preformed packing (37) with clean oil, and install preformed packing (37) and hose 1682888 (36) on elbow (38).
15. Lightly lubricate preformed packing (34) with clean oil, and install preformed packing (34) and hose 1682911 (33) on elbow (35).



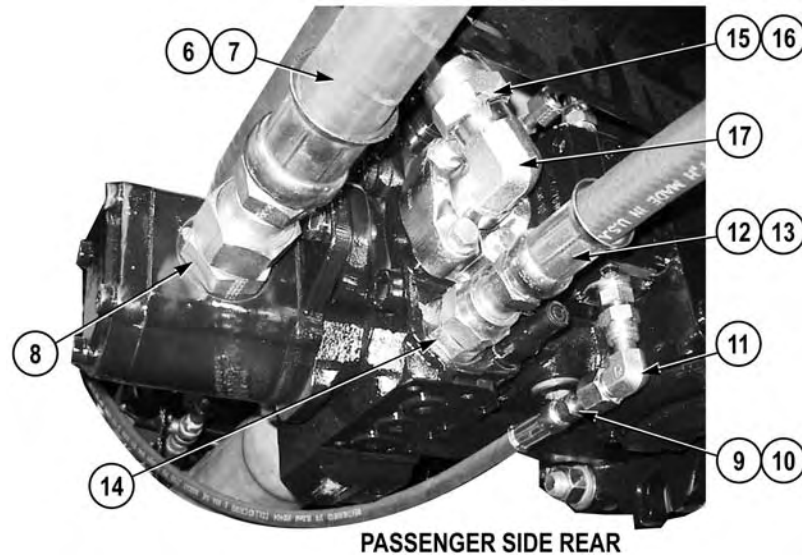
16. Install four couplings (28), (29), (30), and (31) (WP 0313) and main inlet manifold (32) on vehicle.



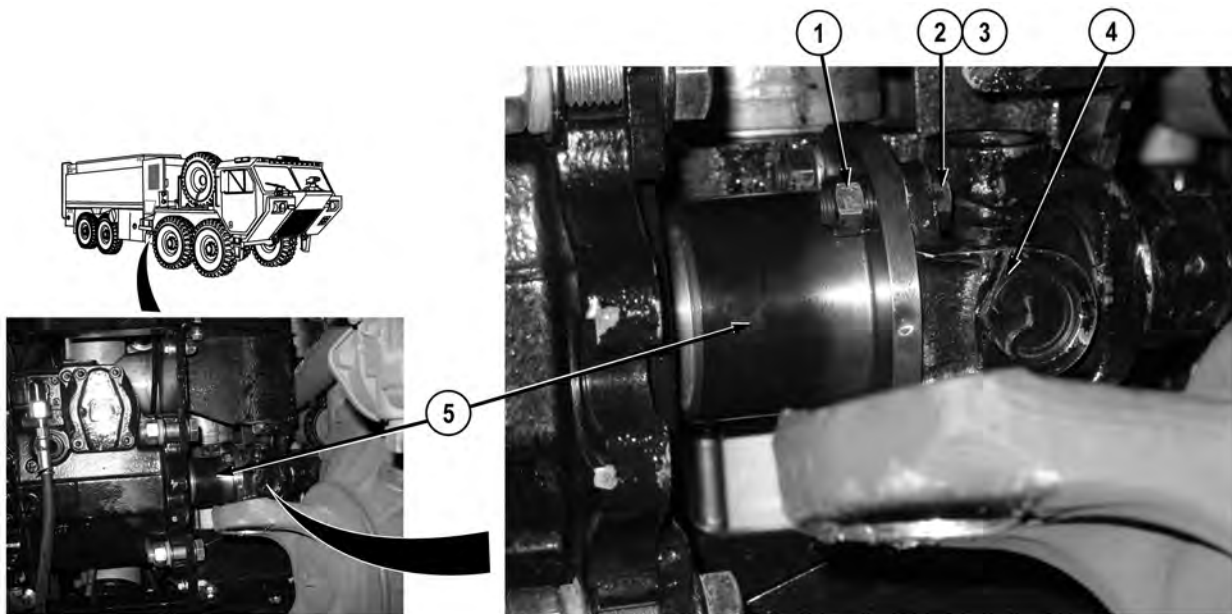
17. Install coupling (27) on vehicle (WP 0313).



- 18. Lightly lubricate preformed packing (25) with clean oil, and install preformed packing (25) and hose 1682839 (24) on charge pump (26) with two flange halves (23), four lockwashers (22), and screws (21).
- 19. Lightly lubricate preformed packing (19) with clean oil, and install preformed packing (19) and hose 1682901 (18) on elbow (20).



20. Lightly lubricate preformed packing (16) with clean oil, and install preformed packing (16) and hose 1682840 (15) on elbow (17).
21. Lightly lubricate preformed packing (13) with clean oil, and install preformed packing (13) and hose 1682902 (12) on fitting (14).
22. Lightly lubricate preformed packing (10) with clean oil, and install preformed packing (10) and hose 168212 (9) on elbow (11).
23. Lightly lubricate preformed packing (7) with clean oil, and install preformed packing (7) and hose 1682838 (6) on fitting (8).



24. Install PTO yoke (4) on pump (5) with four screws (3), lockwashers (2), and nuts (1).

**END OF TASK**

**FOLLOW-ON MAINTENANCE**

1. Install hydraulic reservoir (WP 0148)
2. Install pump house panel G (WP 0339)
3. Fill foam system (WP 0022)
4. Install propeller shafts from transmission to transfer case and transfer case to No. 2 axle (TM 9-2320-325-14&P)

**END OF TASK**

**END OF WORK PACKAGE**

---

**FIELD LEVEL MAINTENANCE**  
**POWER TAKE OFF (PTO) REPLACEMENT**

---

**INITIAL SETUP:****Tools and Special Tools**

- Cap Set, Protective (WP 0398, Item 1)
- Crows Foot, 10 mm, 0.25 in. (WP 0398, Item 3)
- Drain Pan (WP 0398, Item 4)
- Standard Automotive Tool Set (SATS), (WP 0398, Item 15)
  - Wrench, Adjustable 18"
  - Wrench, Torque, Ratcheting, 3/8" Drive, 75 ft-lb
- Tool Kit, General Mechanic's: Automotive (WP 0398, Item 17)

**Materials/Parts**

- Adhesive, Thread, Locking, (WP 0400, Item 6)
- Compound, Sealing, Pipe Thread (WP 0400, Item 11)
- Fluid, Hydraulic (WP 0400, Item 17)
- Tags, Identification (WP 0400, Item 23)

**Materials/Parts (continued)**

- Lockwasher (4)
- Gasket (1)

**Personnel Required**

- MOS 63B Wheeled Vehicle Mechanic (2)

**References**

- WP 0391, Fig. 5

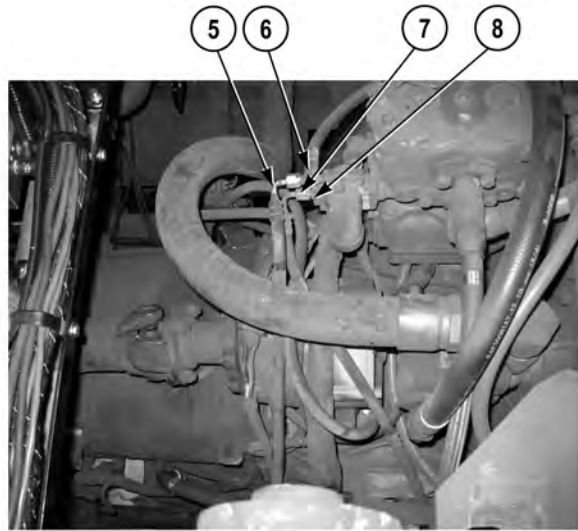
**Equipment Conditions**

- Batteries disconnected (TM 9-2320-325-14&P)
- Lifting bracket tube brace removed (TM 9-2320-325-14&P)
- Muffler removed (TM 9-2320-325-14&P)
- Air system drained (TM 9-2320-422-10)

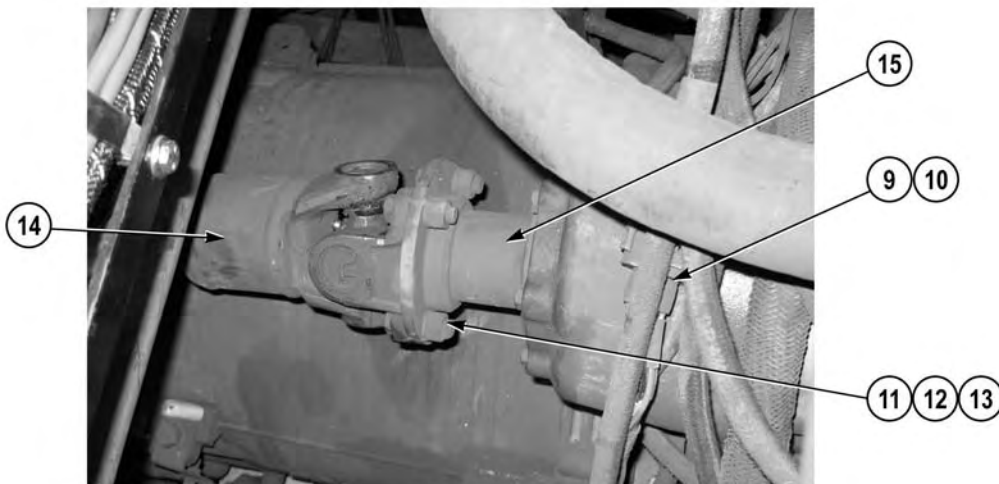
**REMOVAL****NOTE**

- Tag and mark air lines and hoses prior to removal to ensure proper installation.
- Cap and plug hoses and fittings upon removal.

1. Remove air line 2001 (1) from fitting (2).
2. Remove hose 2278 (3) from elbow (4).



3. Remove air line 2159 (5) from tee (6).
4. Remove air line 2126 (7) from fitting (8).



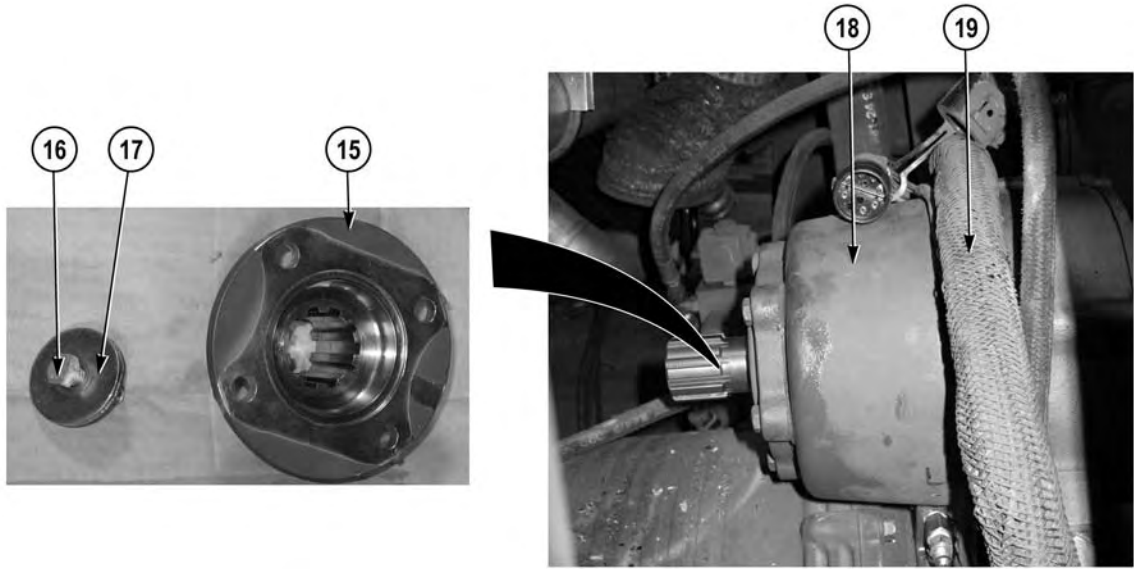
5. Disconnect connector C82 (9) from connector C82 (10).

### NOTE

An assistant rotating and holding drive shaft aids in drive shaft removal.

6. With the aid of an assistant, remove four nuts (11), lockwashers (12), screws (13), and drive shaft (14) from flange (15). Discard lockwashers.

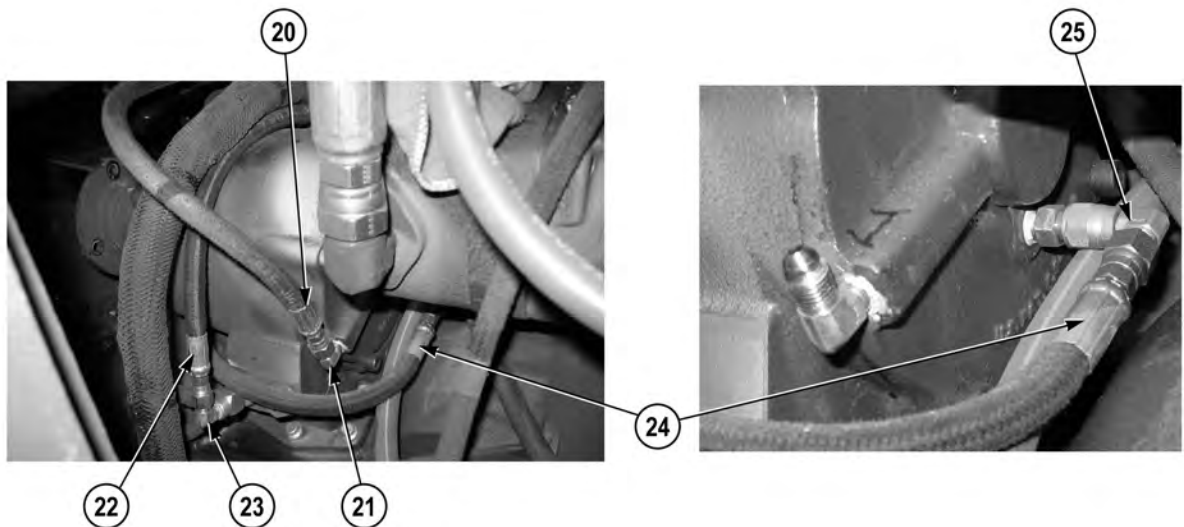




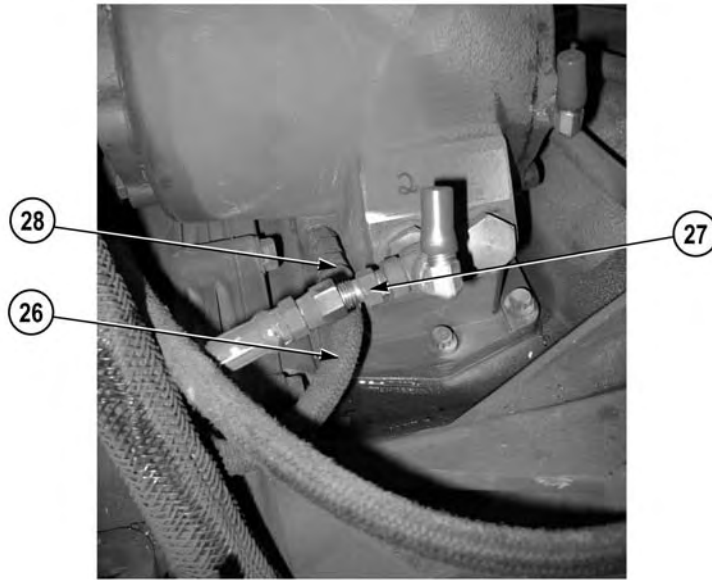
**NOTE**

Remove flange to allow repositioning of wire harness and easier removal of power take off and attaching hardware.

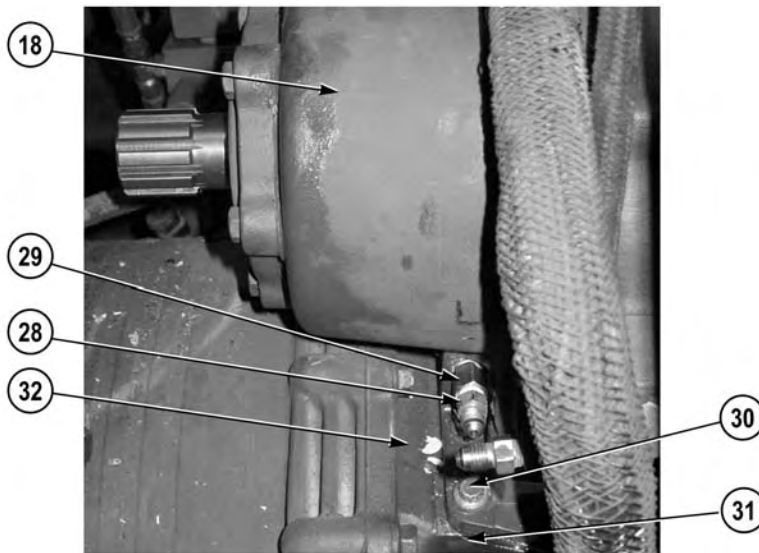
7. Remove screw (16), washer (17), and flange (15) from power take off (18).
8. Reposition main wire harness (19) from top of power take off (18) to below power take off (18).



9. Remove hose (20) from elbow (21).
10. Remove hose (22) from elbow (23).
11. Remove hose (24) from elbow (25).



12. Remove hose (26) from fitting (27).
13. Remove hose (26) from fitting (28).



**NOTE**

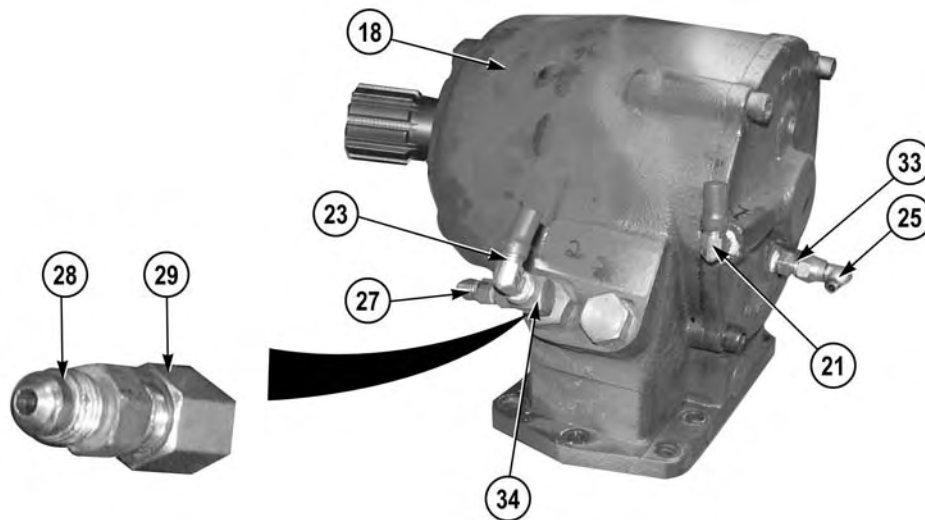
- Fitting and orifice fitting must be removed in order to provide clearance when removing screws.
- Note position of elbows and fittings prior to removal to ensure proper installation.

14. Remove orifice fitting (29) and fitting (28) from power take off (18).

**WARNING**

**Power take off weighs 72 lb. (33 kg). Do not attempt to remove power take off without the aid of an assistant. Failure to comply may result in injury to personnel and damage to equipment.**

15. With the aid of an assistant, remove eight screws (30), power take off (18), and gasket (31) from transmission (32). Discard gasket.

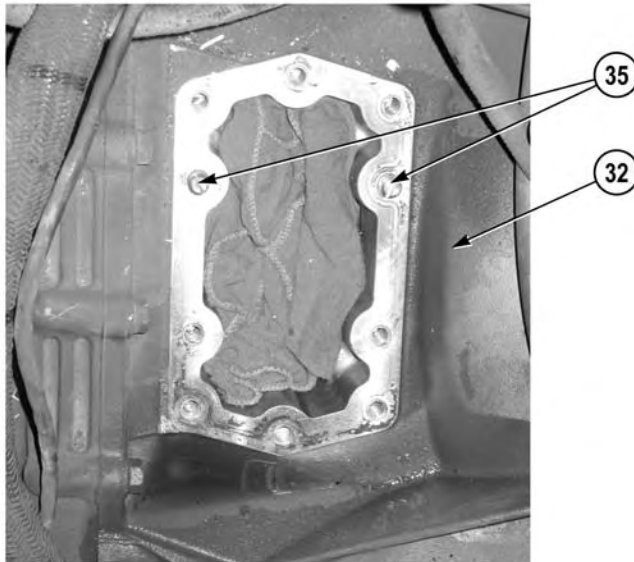


16. Remove elbow (25) from fitting (33).
17. Remove fitting (33) from power take off (18).
18. Remove elbow (21) from power take off (18).

**NOTE**

Power take off comes with tee fitting.

19. Remove elbow (23) and fitting (27) from tee (34).
20. Remove fitting (28) from orifice fitting (29).

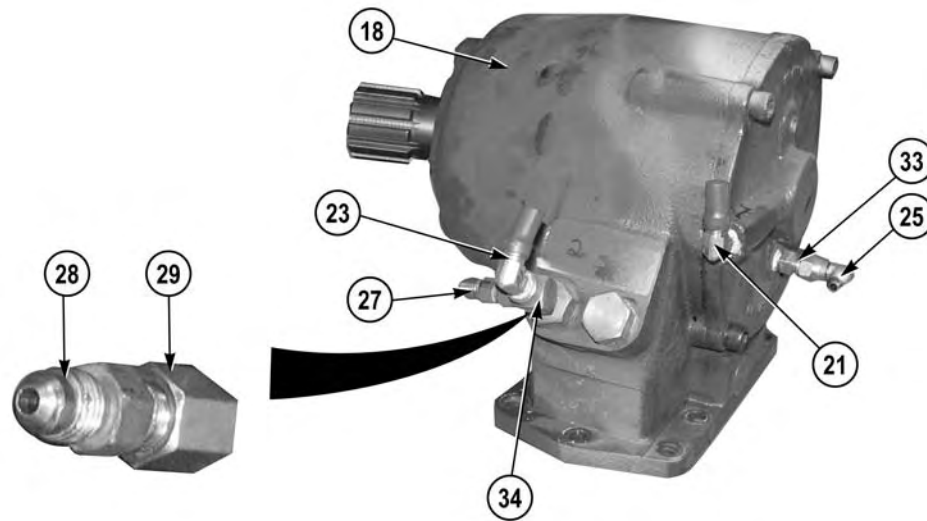


21. Remove two alignment pins (35) from transmission (32).

**END OF TASK**

**INSTALLATION**

1. Install two alignment pins (35) on transmission (32).

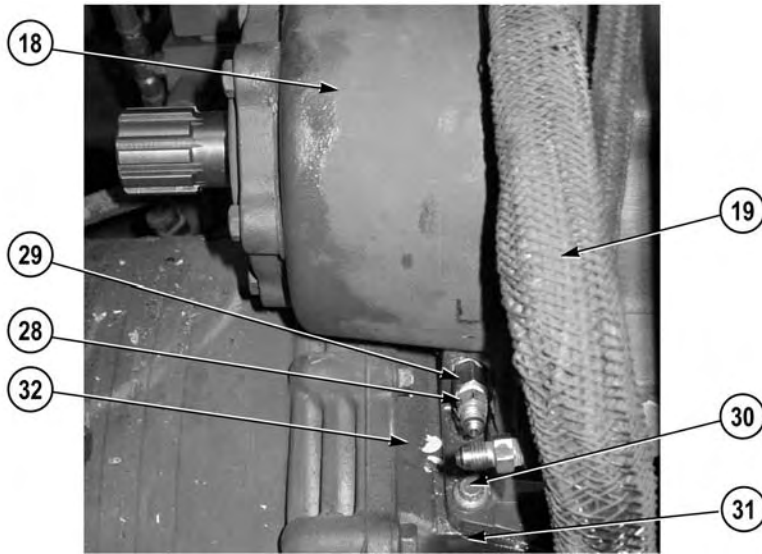


**WARNING**



**Adhesives, solvents, and sealing compounds can burn easily, can give off harmful vapors, and are harmful to skin and clothing. To avoid injury or death, keep away from open fire and use in well-ventilated area. If adhesive, solvent, or sealing compound gets on skin or clothing, wash immediately with soap and water.**

2. Apply sealing compound to threads of three fittings (27), (28), and (33) and three elbows (21), (23), and (25).
3. Install fitting (28) on orifice fitting (29).
4. Install fitting (27) and elbow (23) on tee (34).
5. Install elbow (21) on power take off (18).
6. Install fitting (33) on power take off (18).
7. Install elbow (25) on fitting (33).

**WARNING**

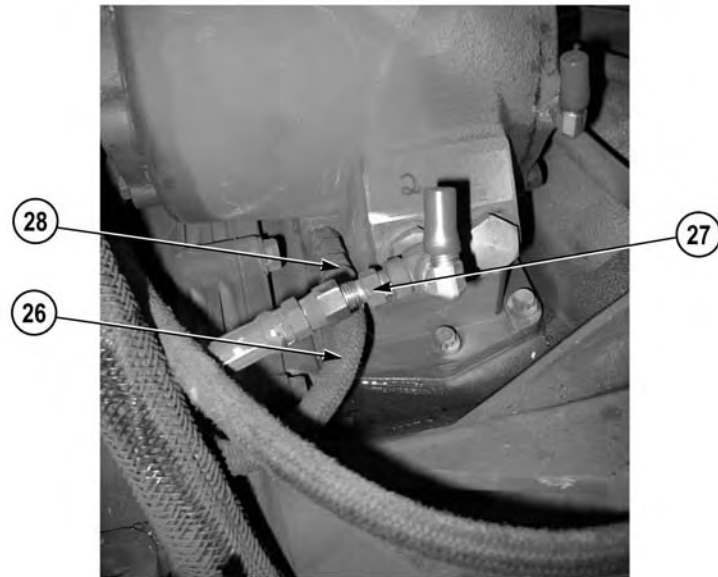
Adhesives, solvents, and sealing compounds can burn easily, can give off harmful vapors, and are harmful to skin and clothing. To avoid injury or death, keep away from open fire and use in well-ventilated area. If adhesive, solvent, or sealing compound gets on skin or clothing, wash immediately with soap and water.

8. Apply sealing compound to threads of eight screws (30).

**WARNING**

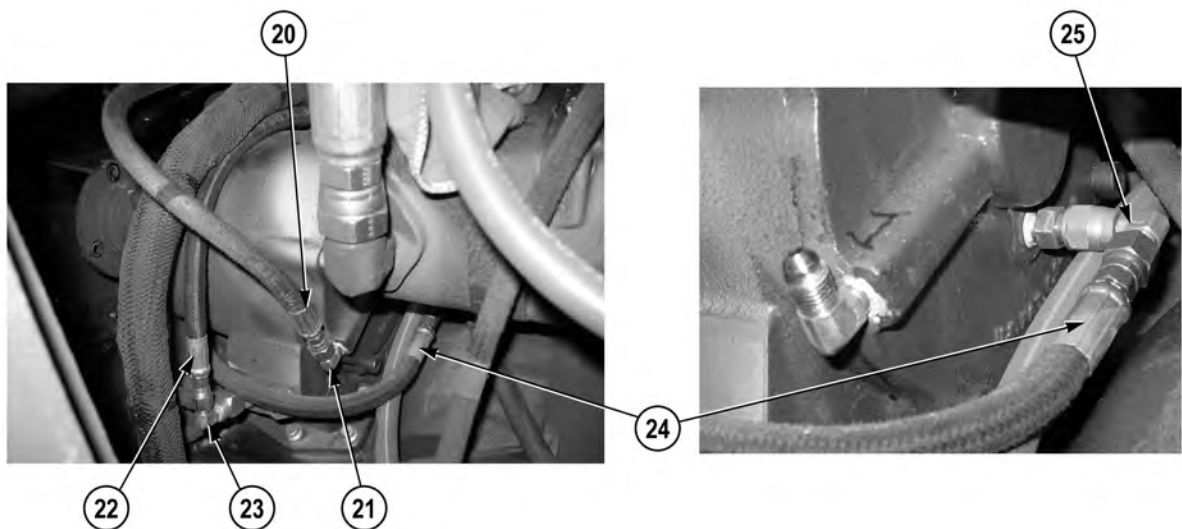
Power take off weighs 72 lb. (33 kg). Do not attempt to install power take off without the aid of an assistant. Failure to comply may result in injury to personnel and damage to equipment.

9. With the aid of an assistant, install gasket (31) and power take off (18) on transmission (32) with eight screws (30). Tighten screws to 30 to 35 lb-ft (41 to 47 N•m).
10. Apply sealing compound to threads of orifice fitting (29).
11. Install orifice fitting (29) and fitting (28) on power take off (18).
12. Reposition main wire harness (19) from bottom of power take off (18) to top of power take off (18).



13. Install hose (26) on fitting (28).

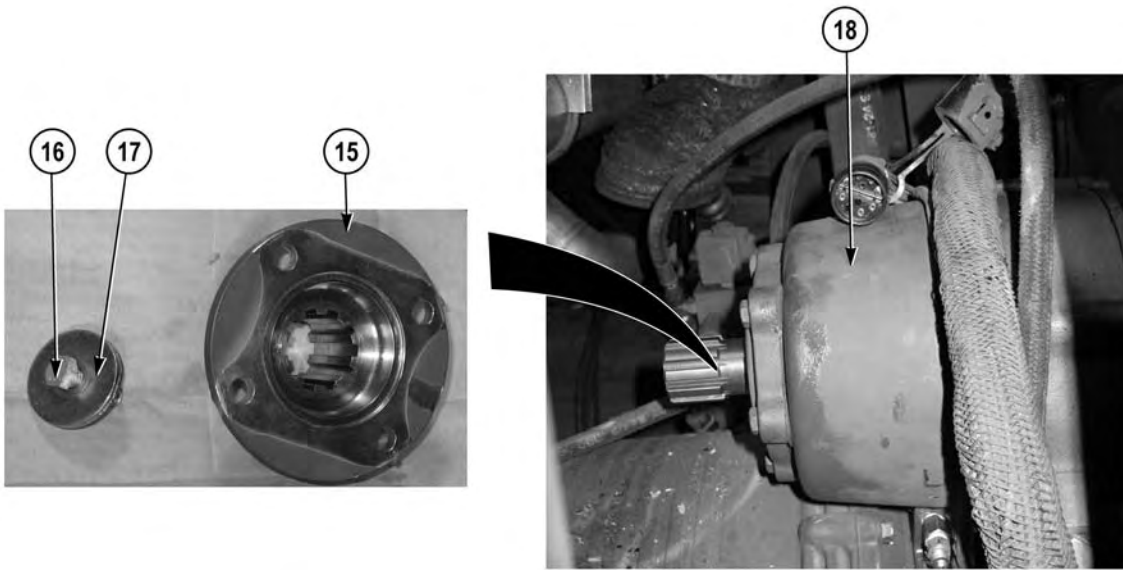
14. Install hose (26) on fitting (27).



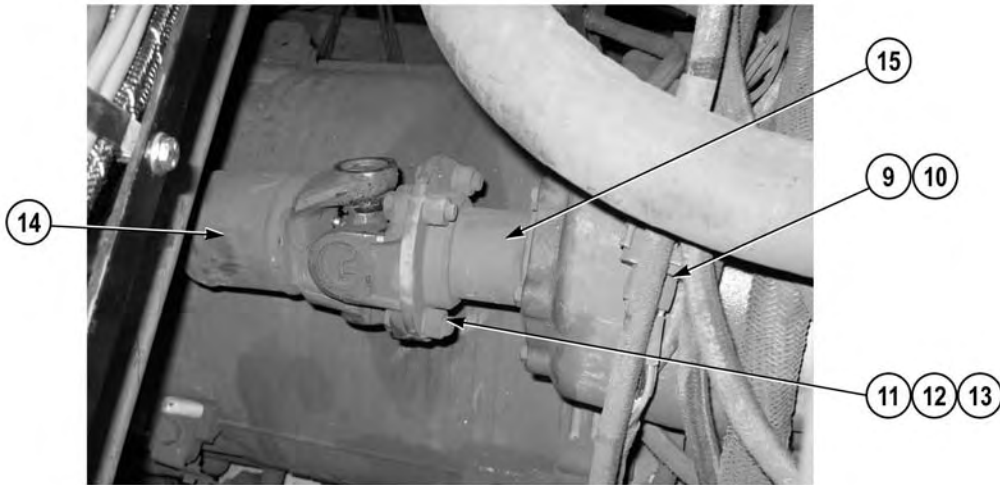
15. Install hose (24) on elbow (25).

16. Install hose (22) on elbow (23).

17. Install hose (20) on elbow (21).



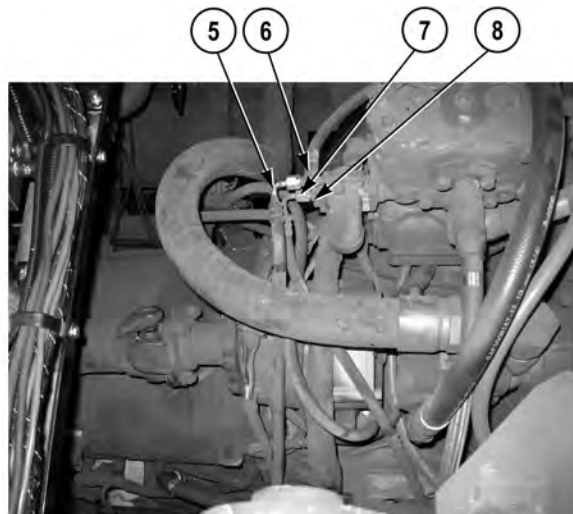
18. Install flange (15) on power take off (18) with washer (17) and screw (16). Tighten screw to 25 lb-ft (34 N•m).



19. With the aid of an assistant, install drive shaft (14) on flange (15) with four screws (13), lockwashers (12), and nuts (11).

20. Connect connector C82 (10) to connector C82 (9).





21. Install air line 2126 (7) on fitting (8).
22. Install air line 2159 (5) on tee fitting (6).



23. Install hose 2278 (3) on elbow (4).
24. Install air line 2001 (1) on fitting (2).

#### END OF TASK

#### FOLLOW-ON MAINTENANCE

1. Install muffler (TM 9-2320-325-14&P)
2. Install lifting bracket tube brace (TM 9-2320-325-14&P)
3. Connect batteries (TM 9-2320-325-14&P)

#### END OF TASK

#### END OF WORK PACKAGE



## FIELD LEVEL MAINTENANCE

## POWER TAKE OFF (PTO) DRIVE SHAFT REPLACEMENT

## INITIAL SETUP:

**Tools and Special Tools**

Tool Kit, General Mechanic's: Automotive  
(WP 0398, Item 17)

**Materials/Parts**

Lockwasher (4)  
Lockwasher (4)

**Personnel Required**

MOS 63B Wheeled Vehicle Mechanic (2)

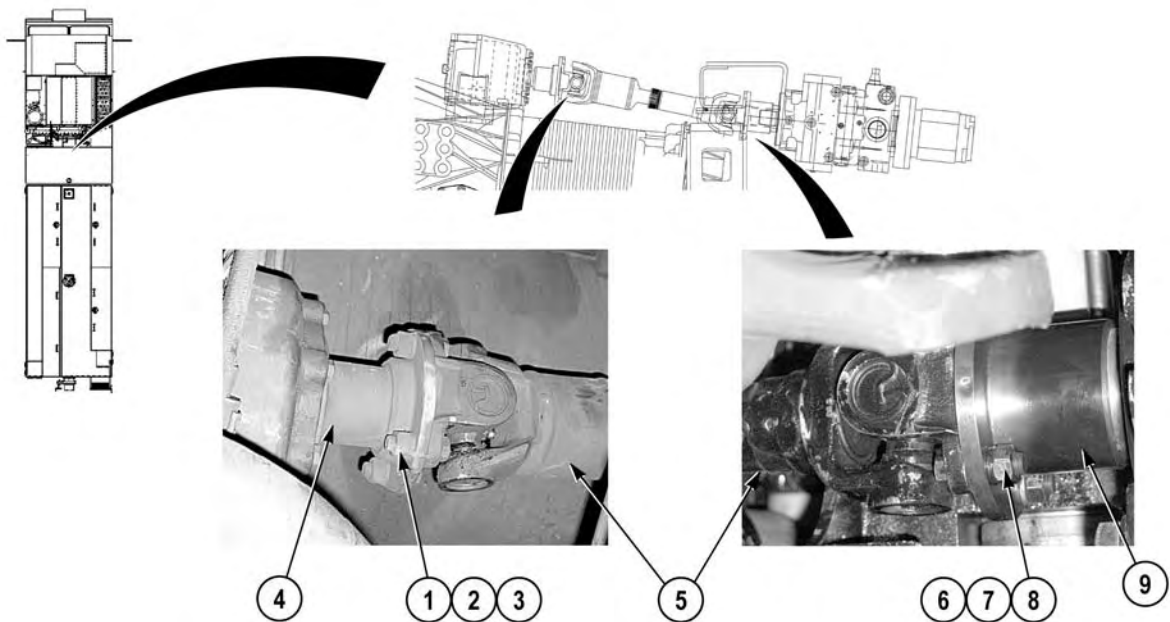
**References**

WP 0391, Fig. 5, 6

**Equipment Conditions**

Engine OFF (TM 9-2320-422-10)  
Wheels chocked (TM 9-2320-422-10)

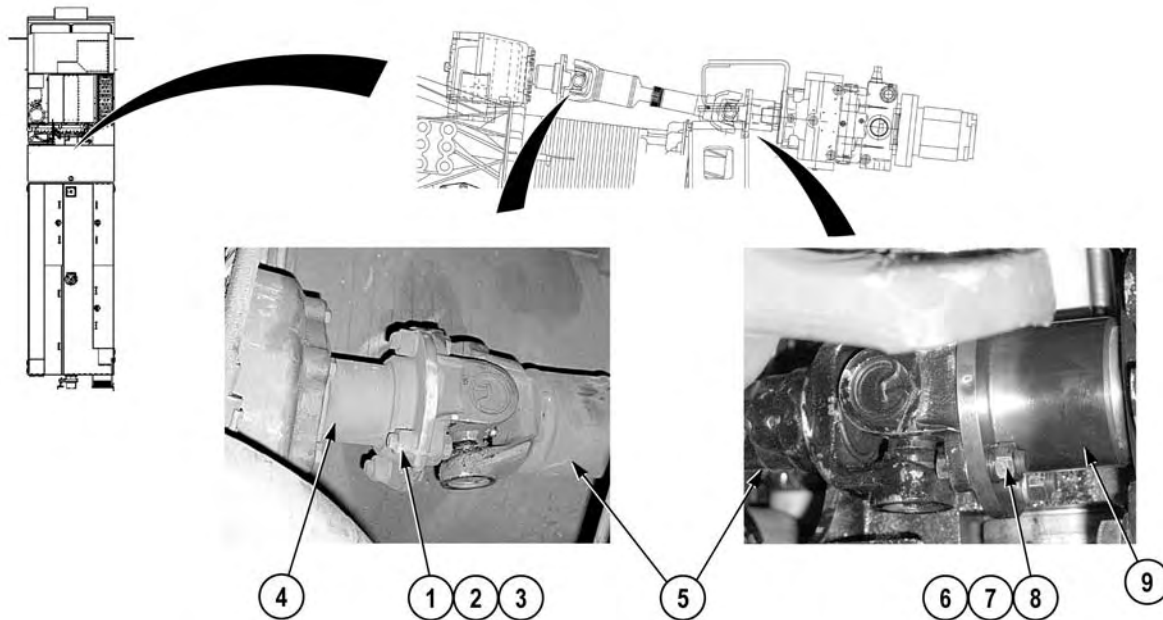
## REMOVAL

**NOTE**

An assistant rotating and holding drive shaft aids in drive shaft removal.

1. With the aid of an assistant, remove four nuts (1), lockwashers (2), and screws (3) from PTO (4) and drive shaft (5). Discard lockwashers.
2. With the aid of an assistant, remove four nuts (6), lockwashers (7), screws (8), and drive shaft (5) from pump (9). Discard lockwashers.

**END OF TASK**

**INSTALLATION****NOTE**

An assistant rotating and holding drive shaft aids in drive shaft installation.

1. With the aid of an assistant, install drive shaft (5) on pump (9) with four screws (8), lockwashers (7), and nuts (6).
2. With the aid of an assistant, install drive shaft (5) on PTO (4) with four screws (3), lockwashers (2), and nuts (1).

**END OF TASK****FOLLOW-ON MAINTENANCE**

Remove wheel chocks (TM 9-2320-422-10)

**END OF TASK****END OF WORK PACKAGE**

## FIELD LEVEL MAINTENANCE

## POWER TAKE OFF (PTO) SOLENOID AND PRESSURE SWITCH REPLACEMENT

## INITIAL SETUP:

**Tools and Special Tools**

Drain Pan (WP 0398, Item 4)  
 Tool Kit, General Mechanic's: Automotive  
 (WP 0398, Item 17)

**Materials/Parts**

Tags, Identification (WP 0400, Item 23)  
 Lockwasher (2)  
 Preformed Packing (1)

**Materials/Parts (continued)**

Preformed Packing (1)  
 Preformed Packing (1)  
 Lockwasher (1)

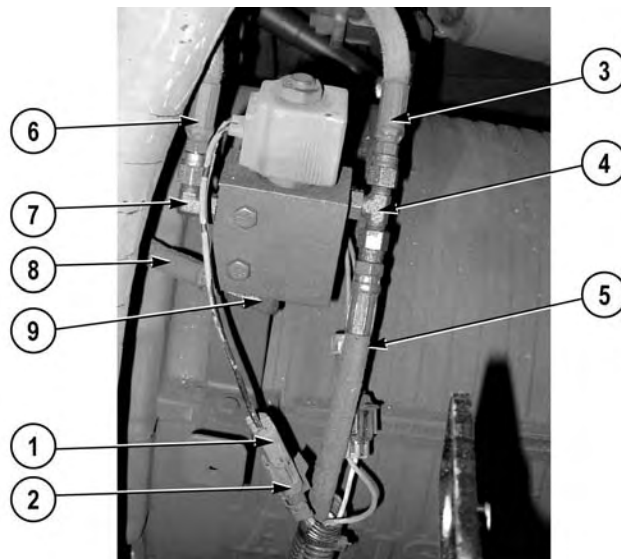
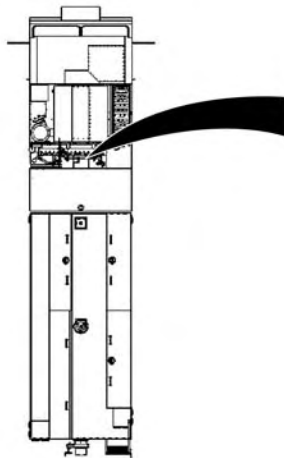
**References**

WP 0391, Fig. 5

**Equipment Conditions**

Batteries disconnected (TM 9-2320-325-14&P)

## REMOVAL

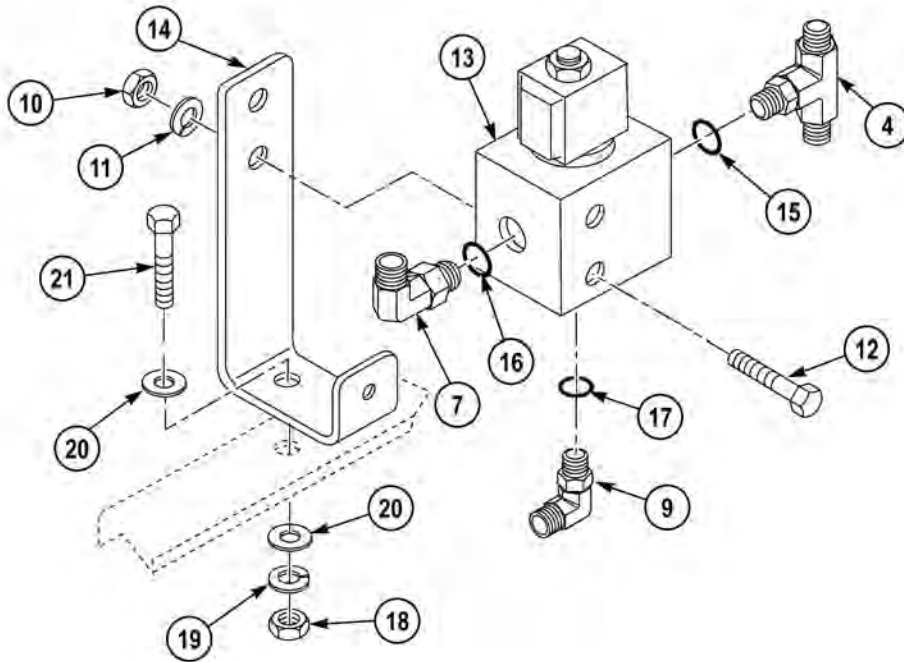


1. Disconnect solenoid connector (1) from main wire harness connector (2).

**NOTE**

- Note position of elbows prior to removal to ensure proper installation.
- Tag and mark hoses prior to removal to ensure proper installation.
- Position drain pan under hoses.

2. Remove hose (3) from tee (4).
3. Remove hose (5) from tee (4).
4. Remove hose (6) from elbow (7).
5. Remove hose (8) from elbow (9).



6. Remove two nuts (10), lockwashers (11), screws (12), and valve body (13) from bracket (14). Discard lockwashers.
7. Remove tee (4) and preformed packing (15) from valve body (13). Discard preformed packing.
8. Remove elbow (7) and preformed packing (16) from valve body (13). Discard preformed packing.
9. Remove elbow (9) and preformed packing (17) from valve body (13). Discard preformed packing.

### NOTE

Perform Step (10) if bracket needs to be removed.

10. Remove nut (18), lockwasher (19), two washers (20), screw (21), and bracket (14) from vehicle. Discard lockwashers.

### END OF TASK

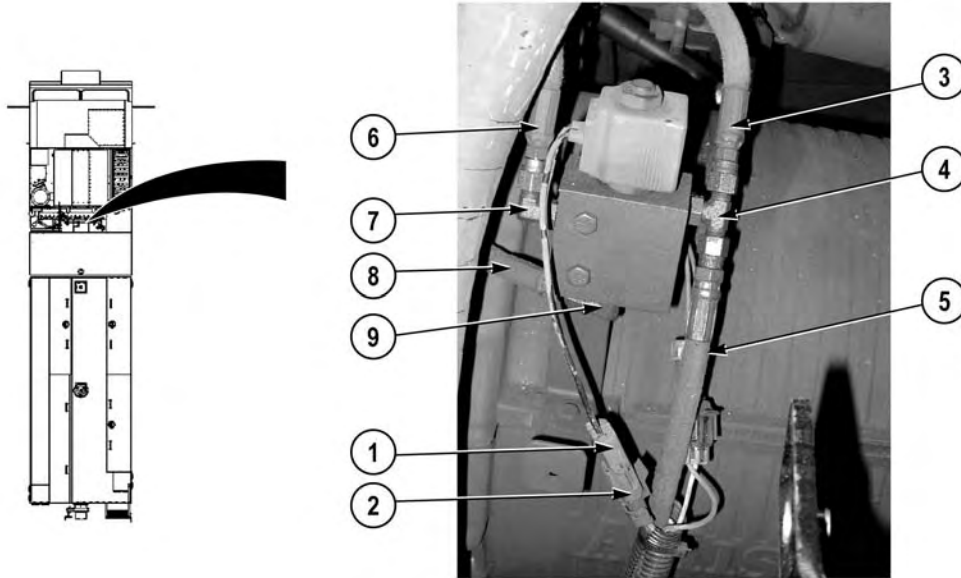
### INSTALLATION

### NOTE

Perform Step (1) if bracket was removed.

1. Install bracket (14) on vehicle with screw (21), two washers (20), lockwashers (19), and nut (18).
2. Lightly lubricate preformed packing (17) with clean oil, and install preformed packing (17) and elbow (9) on valve body (13).

3. Lightly lubricate preformed packing (16) with clean oil, and install preformed packing (16) and elbow (7) on valve body (13).
4. Lightly lubricate preformed packing (15) with clean oil, and install preformed packing (15) and tee (4) on valve body (13).
5. Install valve body (13) on bracket (14) with two screws (12), lockwashers (11), and nuts (10).



6. Install hose (8) on elbow (9).
7. Install hose (6) on elbow (7).
8. Install hose (5) on tee (4).
9. Install hose (3) on tee (4).
10. Connect main wire harness connector (2) on solenoid connector (1).

**END OF TASK**

#### **FOLLOW-ON MAINTENANCE**

Connect batteries (TM 9-2320-325-14&P)

**END OF TASK**

**END OF WORK PACKAGE**





## FIELD LEVEL MAINTENANCE

## WATER PUMP DIPSTICK ASSEMBLY REPLACEMENT

## INITIAL SETUP:

**Tools and Special Tools**

Tool Kit, General Mechanic's: Automotive  
(WP 0398, Item 17)

**References**

WP 0391, Fig. 11

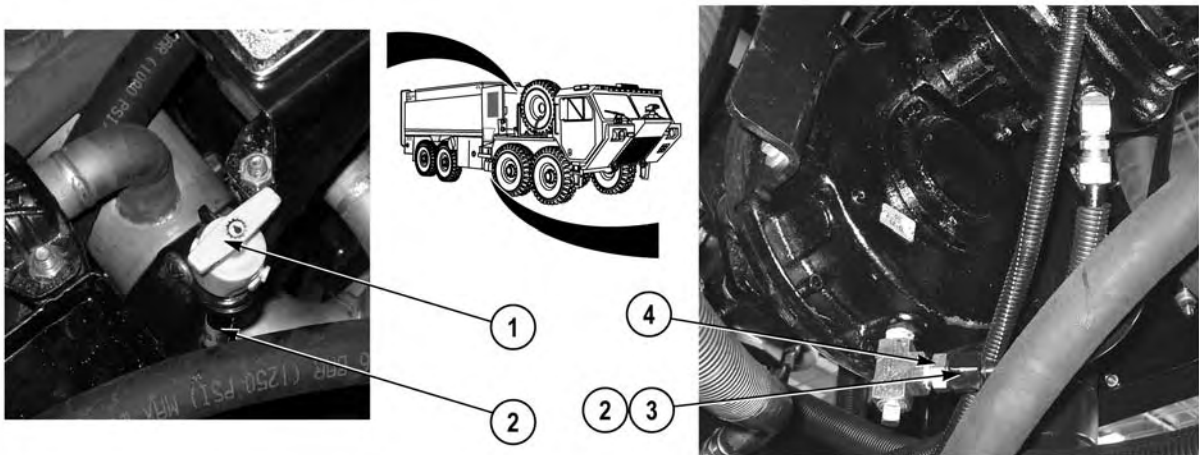
**Materials/Parts**

Preformed packing (1)  
Lockwasher (1)

**Equipment Conditions**

Pump house panel K removed (WP 0339)  
Water pump gear case drained (WP 0157)

## REMOVAL



1. Remove dipstick (1) from tube (2).
2. Remove tube (2) and preformed packing (3) from fitting (4). Discard preformed packing.

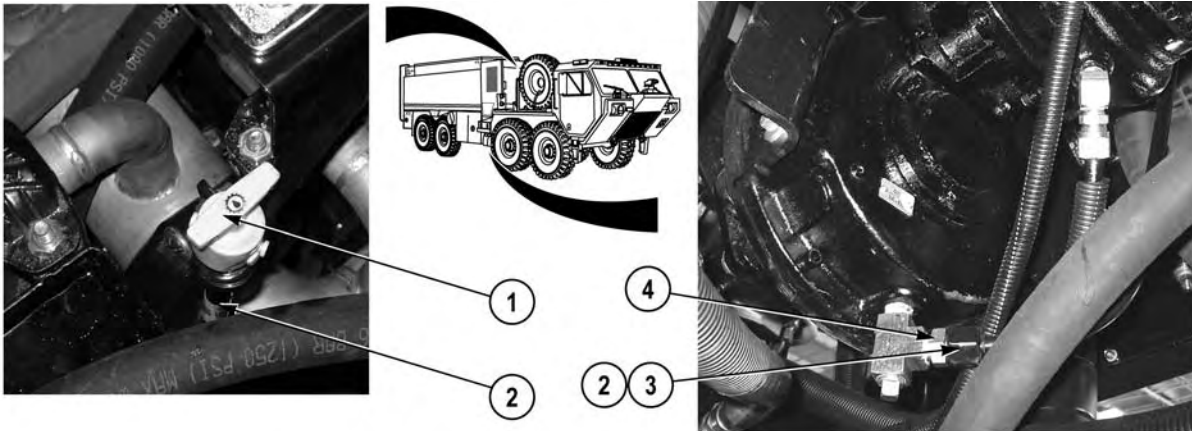


3. Remove nut (5), lockwasher (6), two washers (7), screw (8), cushion clip (9), and tube (2) from bracket (10). Discard lockwashers.

**END OF TASK**

**INSTALLATION**

1. Install tube (2) and cushion clip (9) on bracket (10) with screw (8), two washers (7), lockwasher (6) and nut (5).



2. Lightly lubricate preformed packing (3) with clean oil, and install preformed packing (3) and tube (2) on fitting (4).
3. Install dipstick (1) in tube (2).

**END OF TASK**

**FOLLOW-ON MAINTENANCE**

1. Fill water pump gear case (WP 0157)
2. Install pump house panel K (WP 0339)

**END OF TASK**

**END OF WORK PACKAGE**

---

**FIELD LEVEL MAINTENANCE**  
**WATER PUMP GEAR CASE DRAIN/FILL**

---

**INITIAL SETUP:****Tools and Special Tools**

Drain Pan (WP 0398, Item 4)  
Tool Kit, General Mechanic's: Automotive  
(WP 0398, Item 17)

**Materials/Parts**

Compound, Sealing, Pipe Thread  
(WP 0400, Item 11)  
Pump, Lubricant (WP 0400, Item 1)

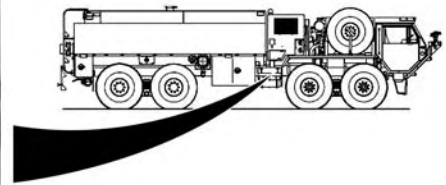
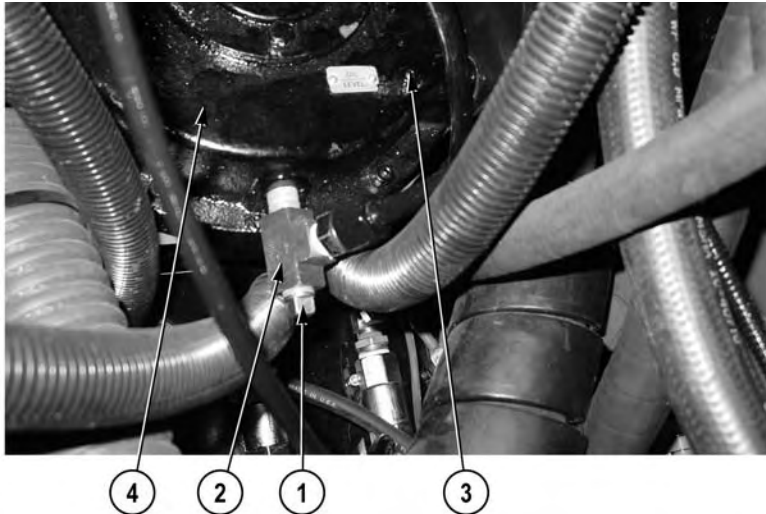
**References**

WP 0391, Fig. 11

**Equipment Conditions**

Engine OFF (TM 9-2320-422-10)  
Wheels chocked (TM 9-2320-422-10)

---

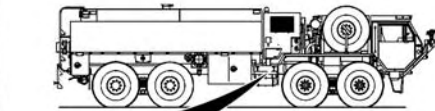
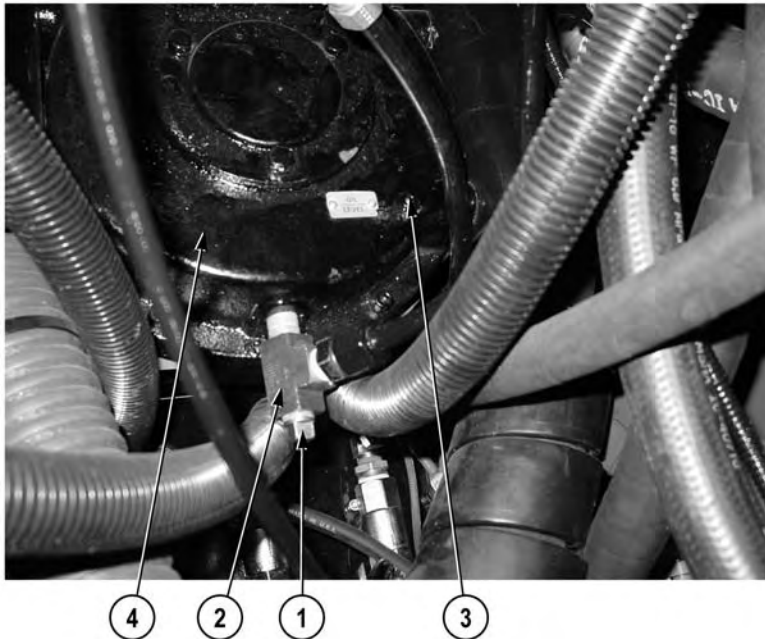
**REMOVAL****WARNING**

**Gear case oil may be hot. Ensure oil is cool prior to removal. Failure to comply may result in injury to personnel.**

1. Place drain pan under water pump gear case drain plug (1).
2. Remove water pump gear case drain plug (1) from tee (2).
3. Remove water pump gear case oil level plug (3) from water pump gear case (4).
4. Allow oil to drain completely from water pump gear case (4).

**END OF TASK**

## INSTALLATION

**WARNING**

**Adhesives, solvents, and sealing compounds can burn easily, can give off harmful vapors, and are harmful to skin and clothing. To avoid injury or death, keep away from open fire and use in well-ventilated area. If adhesive, solvent, or sealing compound gets on skin or clothing, wash immediately with soap and water.**

1. Apply sealing compound to water pump gear case oil level plug (3) and water pump gear case drain plug (1).
2. Install water pump gear case drain plug (1) in tee (2).
3. Fill water pump gear case (4) with gear lube through water pump gear case oil level opening until oil flows out opening.
4. Install water pump gear case oil level plug (3) in water pump gear case (4).

**END OF TASK**

**FOLLOW-ON MAINTENANCE**

Remove wheel chocks (TM 9-2320-422-10)

**END OF TASK**

**END OF WORK PACKAGE**

## FIELD LEVEL MAINTENANCE

## WATER PUMP REPLACEMENT

## INITIAL SETUP:

**Tools and Special Tools**

Cap Set, Protective (WP 0398, Item 1)  
 Tool Kit, General Mechanic's: Automotive  
 (WP 0398, Item 17)  
 Water Pump Engine Removal Kit

**Materials/Parts**

Compound, Sealing (WP 0400, Item 11)  
 Oil, Lubricating (WP 0400, Item 20)  
 Tags, Identification (WP 0400, Item 23)  
 Ties, Cable (WP 0400, Item 26)  
 Preformed Packing (1)  
 Lockwasher (16)  
 Lockwasher (2)  
 Lockwasher (4)  
 Gasket (1)

**Personnel Required**

MOS 63B Wheeled Vehicle Mechanic (2)

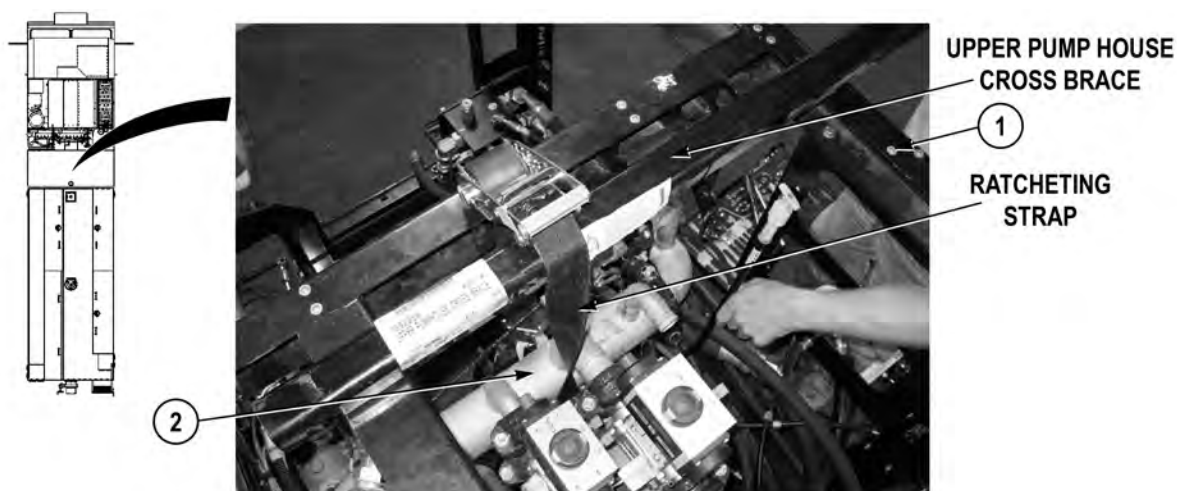
**References**

WP 0313  
 WP 0391, Fig. 11, 12

**Equipment Conditions**

Pump house panel K removed (WP 0339)  
 Hydraulic heat exchanger removed (WP 0134)  
 Water pump gear case drained (WP 0157)  
 Hydrostatic pump motor removed (WP 0151)  
 Bumper turret valve removed (WP 0312)  
 Primer pump removed (WP 0165)  
 Water tank drained (WP 0015)

## REMOVAL



**⚠ CAUTION**

Discharge manifold assembly is heavy and must be supported with ratcheting strap. Failure to comply may result in damage to equipment.

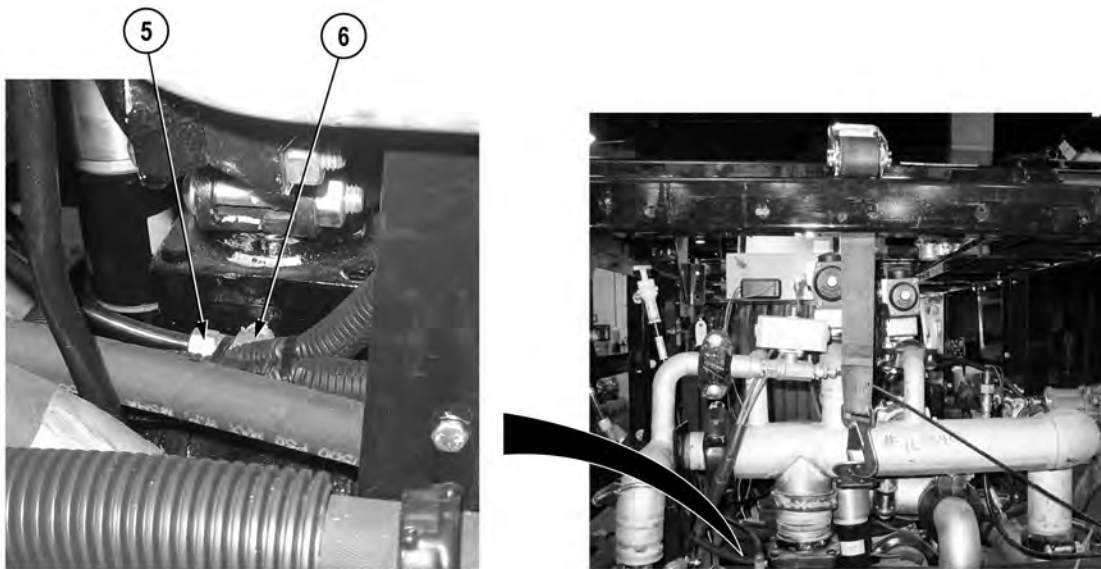
**NOTE**

Ratcheting strap is obtained from the TFFT water pump engine removal kit.

1. Position upper pump house cross brace on upper pump house frame (1).
2. Attach ratcheting strap on upper pump house cross brace and support discharge manifold assembly (2).

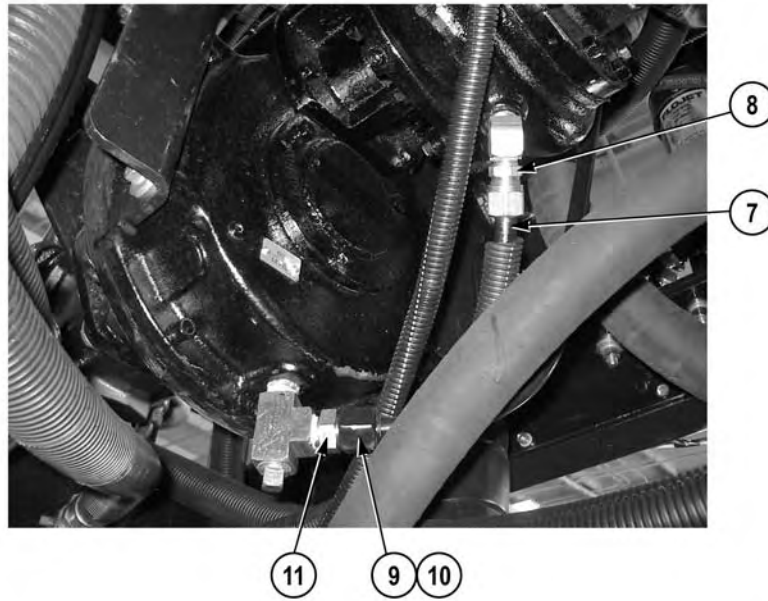


3. Remove two couplings (3) and (4) from vehicle (WP 0313).

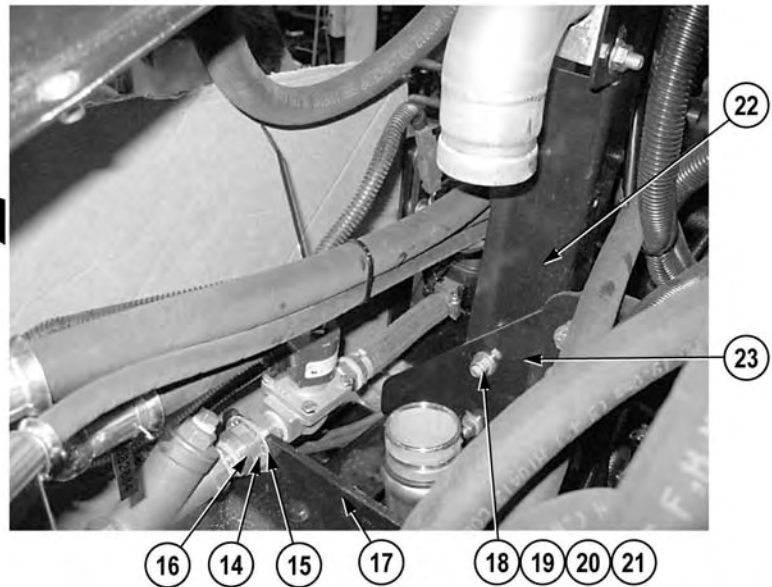


#### NOTE

- Tag and mark lines and hoses prior to removal to ensure proper installation.
  - Remove cable ties as required.
4. Remove line (5) from elbow (6).



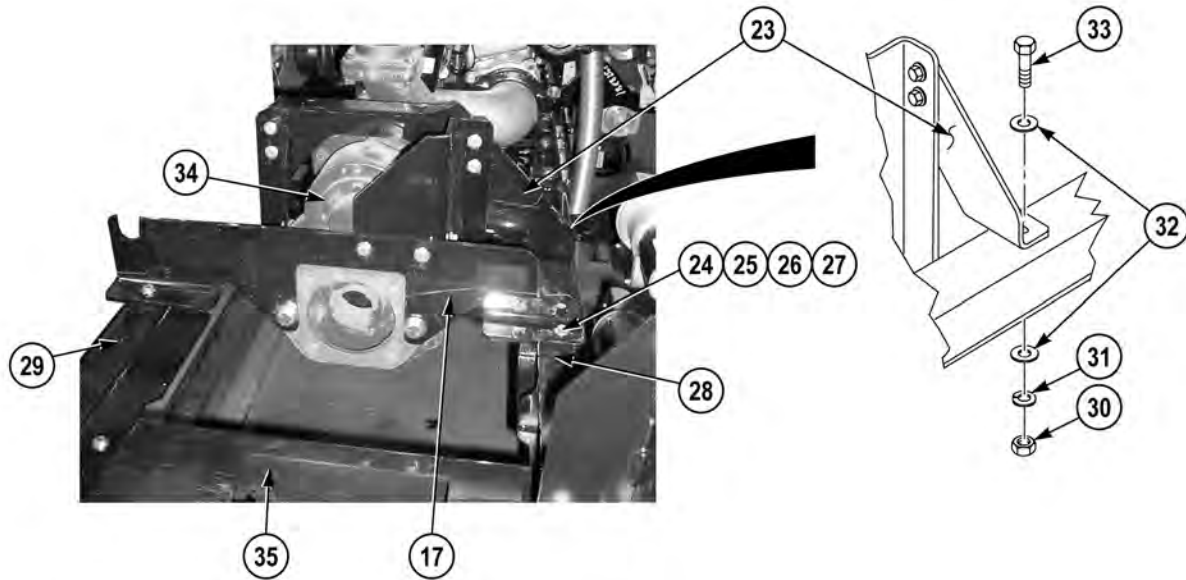
5. Remove line (7) from fitting (8).
6. Remove dipstick tube fitting (9) and preformed packing (10) from fitting (11). Discard preformed packing.



**NOTE**

Cap and plug hoses upon removal.

7. Remove hose (12) from elbow (13).
8. Loosen nut (14) and lockwasher (15), and remove bulkhead fitting (16) from bracket (17).
9. Remove two nuts (18), lockwashers (19), four washers (20), two screws (21), and bracket (22) from bracket (23). Discard lockwashers.



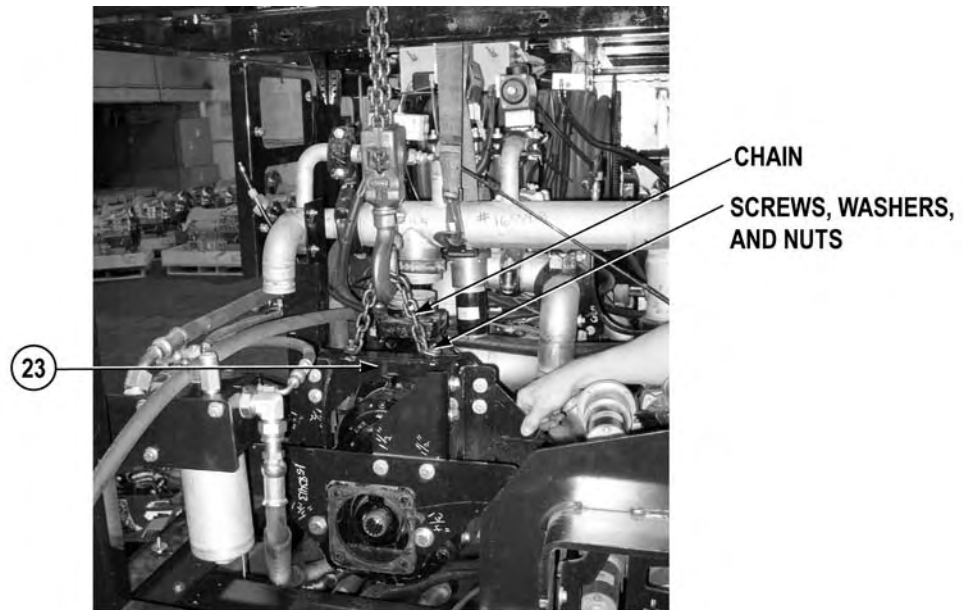
10. Remove two nuts (24), lockwashers (25), four washers (26), and two screws (27) from bracket (17) and two frame rails (28) and (29). Discard lockwashers.
11. Remove two nuts (30), lockwashers (31), four washers (32), and two screws (33) from bracket (23) and two frame rails (28) and (29). Discard lockwashers.

### NOTE

Pump and brackets need to be slid towards outside frame rail in order to attach lifting device.

12. Slide two brackets (17) and (23) and water pump (34) towards outside frame rail (35).

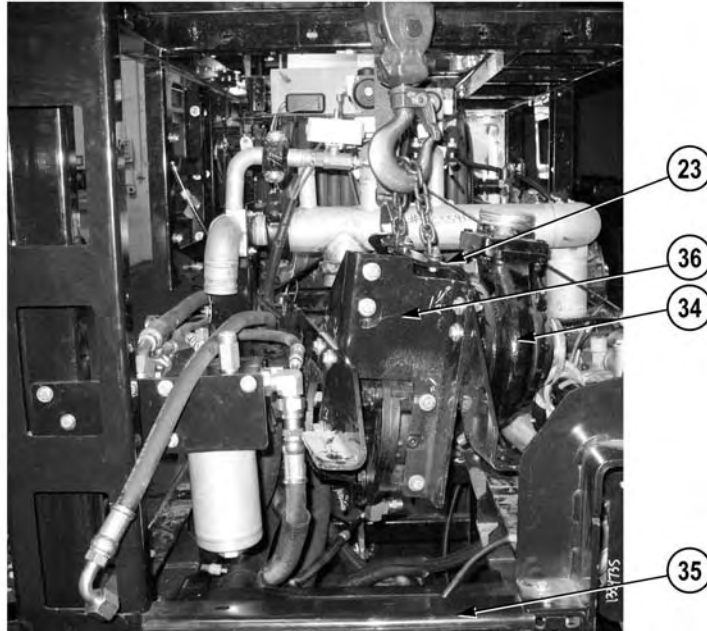




### NOTE

Chain, screws, washers, and nuts are obtained from the TFFT water pump engine removal kit.

13. Attach chain on bracket (23) with two screws, four washers and two nuts.

**WARNING**

**Water pump and brackets weigh 160 lb. (73 kg). Do not attempt to remove water pump without the aid of an assistant and a suitable lifting device. Failure to comply may result in serious injury to personnel or damage to equipment.**

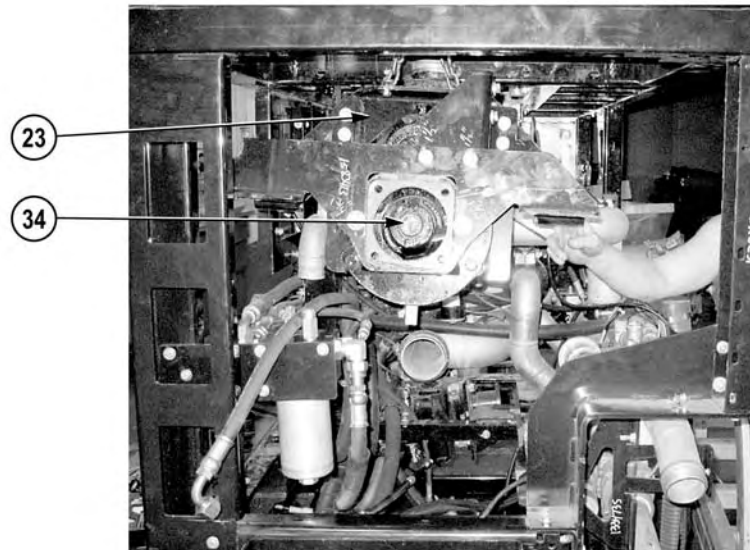
**CAUTION**

**Water pump must be lifted and rotated in order to provide clearance when removing water pump. Failure to comply may cause damage to equipment.**

**NOTE**

Water pump must be lifted approximately five inches above frame rails.

14. With the aid of an assistant and suitable lifting device, lift bracket (23) and water pump (34).
15. Rotate bracket (23) and water pump (34) so that bracket (36) faces outside frame rail (35).



16. Continue lifting bracket (23) and water pump (34), and rotate water pump (34) back to original position and remove water pump (34) from vehicle.



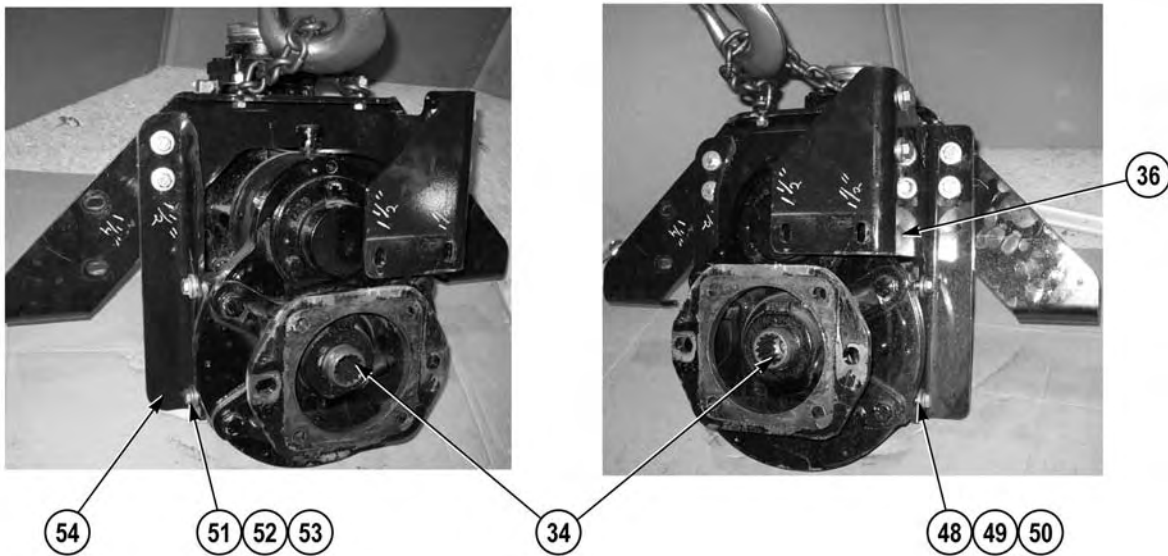
### NOTE

Note position of elbows and fittings prior to removal.

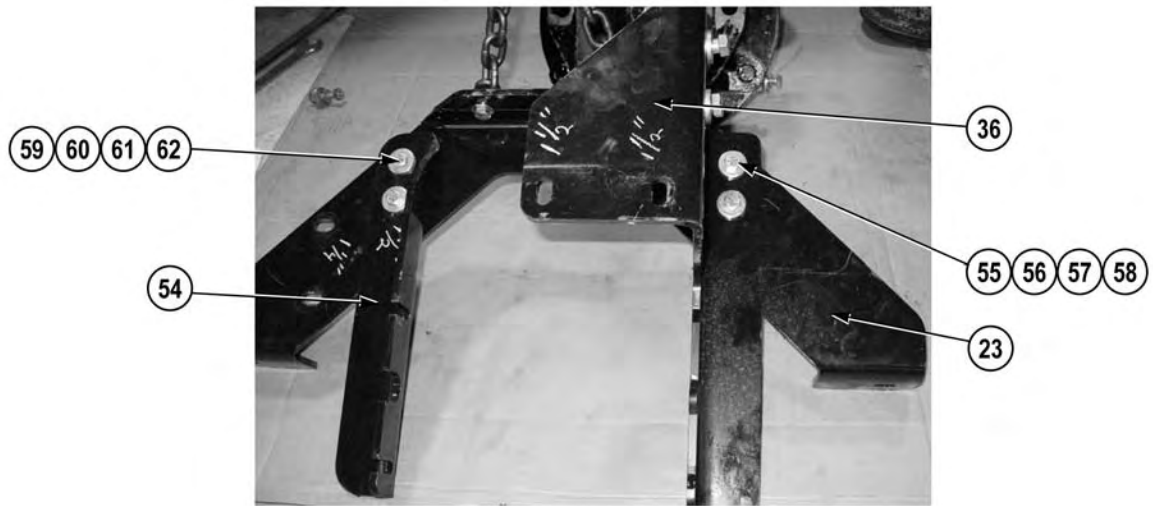
17. Remove tee (37) and nipple (38) from water pump (34).  
 18. Remove elbow (39) from water pump (34).  
 19. Remove elbow (6) from water pump (34).



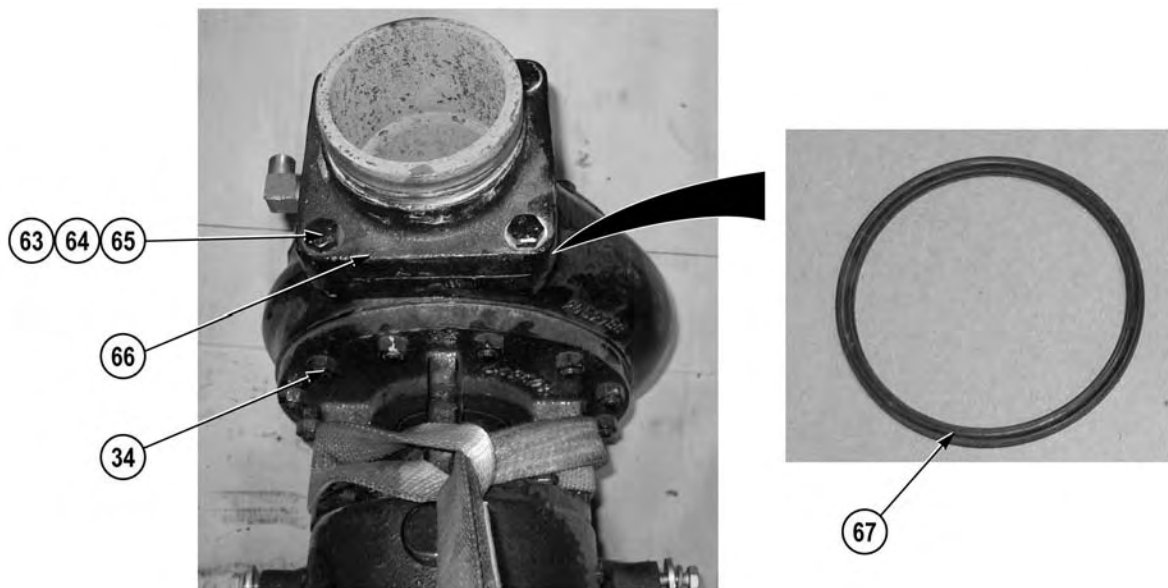
20. Remove two nuts (40), lockwashers (41), four washers (42), and two screws (43) from bracket (17) and water pump (34). Discard lockwashers.
21. Remove two nuts (44), lockwashers (45), four washers (46), two screws (47), and bracket (17) from bracket (36). Discard lockwashers.



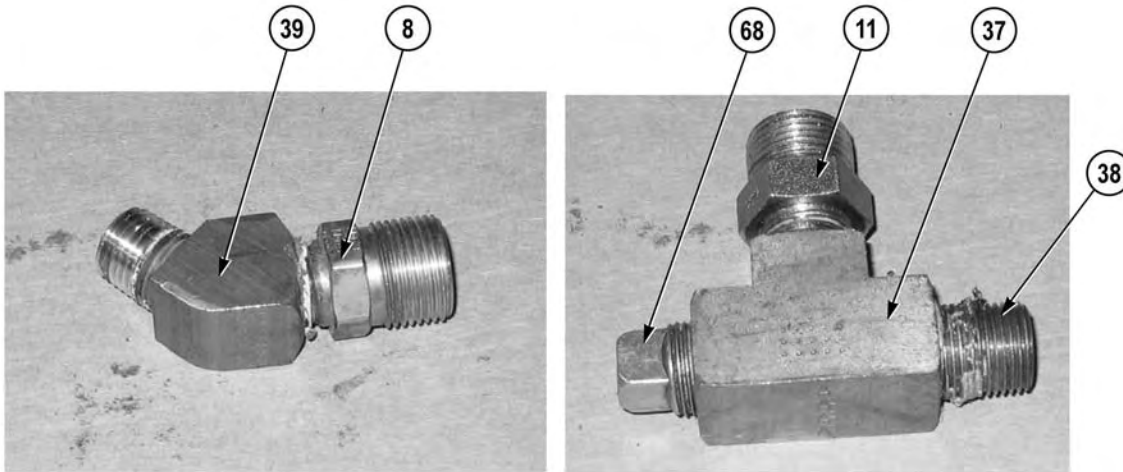
22. Remove two screws (48), lockwashers (49), and washers (50), from bracket (36), and water pump (34). Discard lockwashers.
23. Remove two screws (51), lockwashers (52), washers (53), bracket (54), and bracket (36) from water pump (34). Discard lockwashers.



24. Remove two nuts (55), lockwashers (56), four washers (57), two screws (58), and bracket (36) from bracket (23). Discard lockwashers.
25. Remove two nuts (59), lockwashers (60), four washers (61), two screws (62), and bracket (54) from bracket (23). Discard lockwashers.



26. Remove four nuts (63), lockwashers (64), screws (65), flange (66), and gasket (67) from water pump (34). Discard lockwashers and gasket.



27. Remove fitting (8) from elbow (39).
28. Remove fitting (11), plug (68), and nipple (38) from tee (37).

#### END OF TASK

#### INSTALLATION

#### WARNING



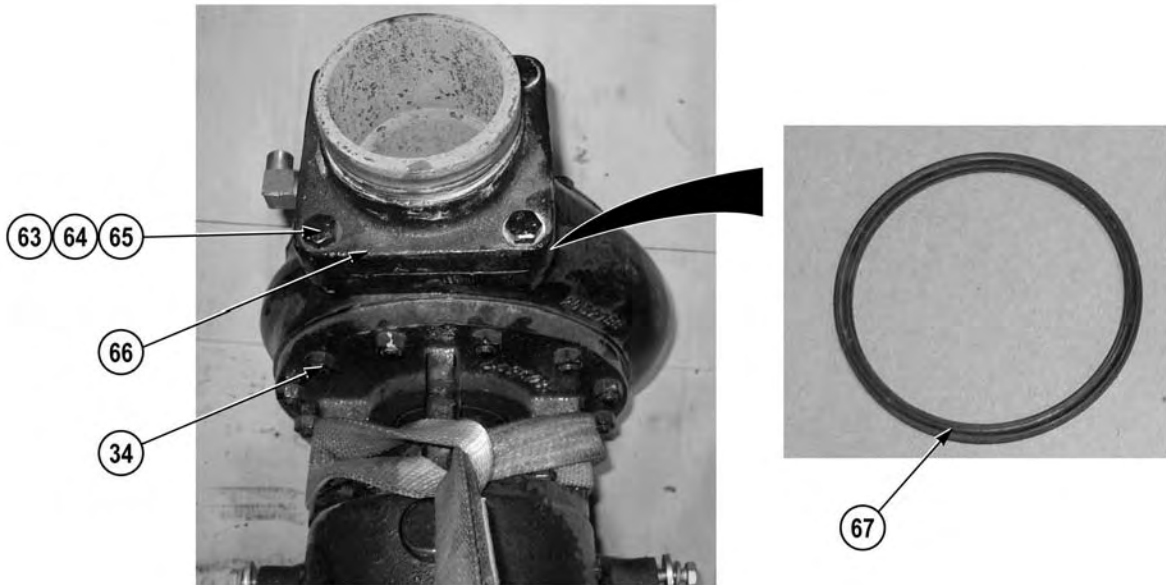
**Adhesives, solvents, and sealing compounds can burn easily, can give off harmful vapors, and are harmful to skin and clothing. To avoid injury or death, keep away from open fire and use in well-ventilated area. If adhesive, solvent, or sealing compound gets on skin or clothing, wash immediately with soap and water.**

1. Apply sealing compound to threads of two fittings (8) and (11), plug (68), and nipple (38).

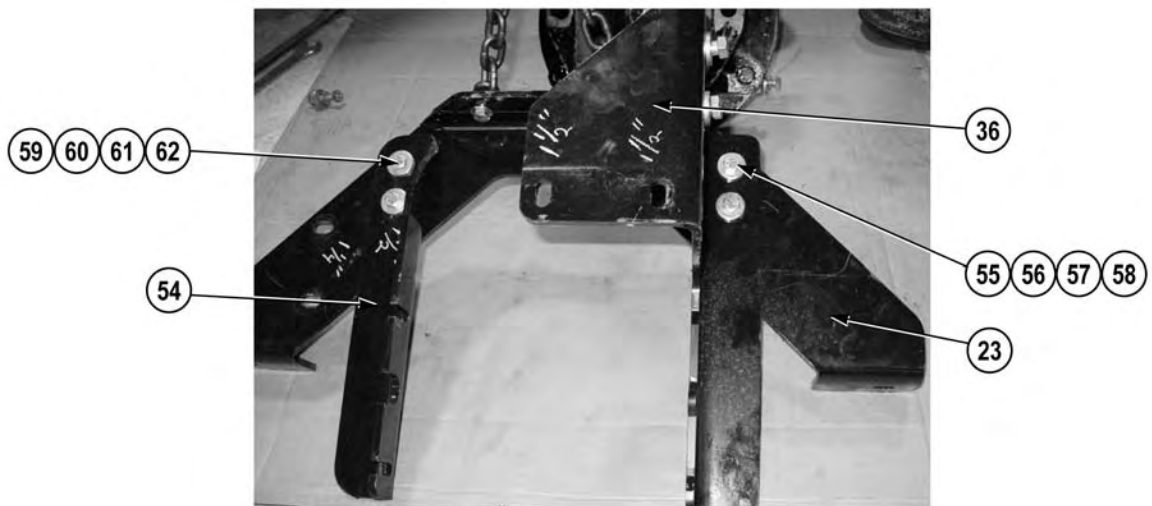
#### **NOTE**

Install elbows and fittings as noted prior to removal.

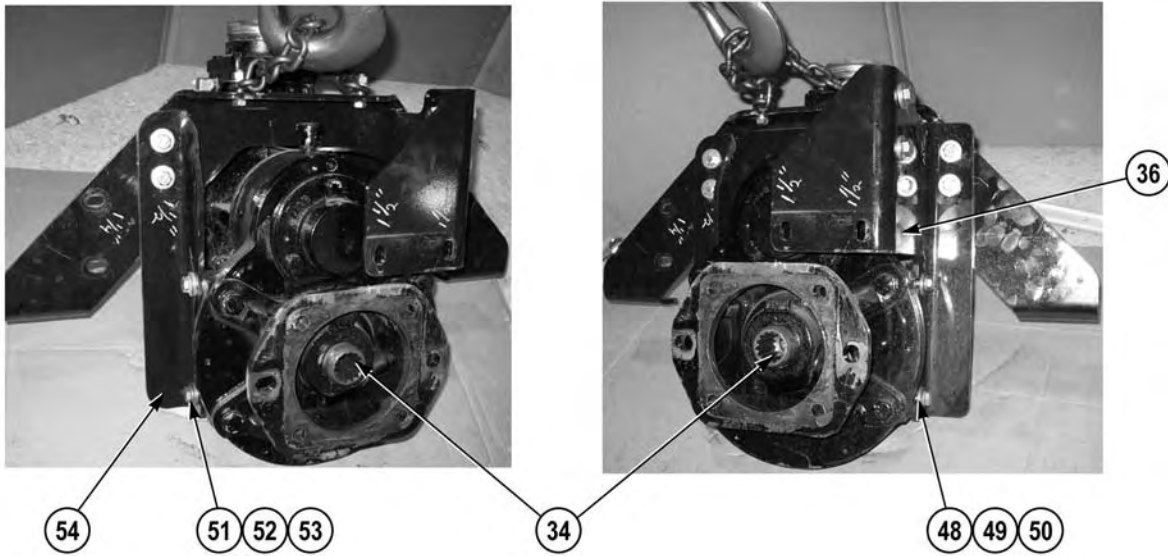
2. Install nipple (38), plug (68), and fitting (11) on tee (37).
3. Install fitting (8) on elbow (39).



4. Install gasket (67) and flange (66) on water pump (34) with four screws (65), lockwashers (64), and nuts (63).



5. Install bracket (54) on bracket (23) with two screws (62), four washers (61), two lockwashers (60), and nuts (59).
6. Install bracket (36) on bracket (23) with two screws (58), four washers (57), two lockwashers (56), and nuts (55).



7. Install bracket (54) on water pump (34) with two washers (53), lockwashers (52), and screws (51).
8. Install bracket (36) on water pump (34) with two washers (50), lockwashers (49), and screws (48).



9. Install bracket (17) on bracket (36) with two screws (47), four washers (46), two lockwashers (45), and nuts (44).
10. Install bracket (17) on water pump (34) with two screws (43), four washers (42), two lockwashers (41), and nuts (40).





### **WARNING**



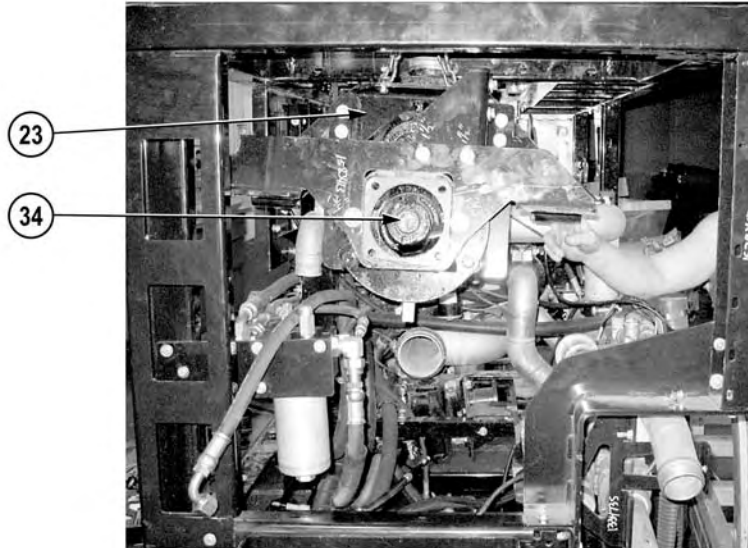
**Adhesives, solvents, and sealing compounds can burn easily, can give off harmful vapors, and are harmful to skin and clothing. To avoid injury or death, keep away from open fire and use in well-ventilated area. If adhesive, solvent, or sealing compound gets on skin or clothing, wash immediately with soap and water.**

11. Apply sealing compound to threads of two elbows (6) and (39) and nipple (38).

### **NOTE**

Install elbows and tee as noted prior to removal.

12. Install elbow (6) on water pump (34).
13. Install elbow (39) on water pump (34).
14. Install tee (37) and nipple (38) on water pump (34).

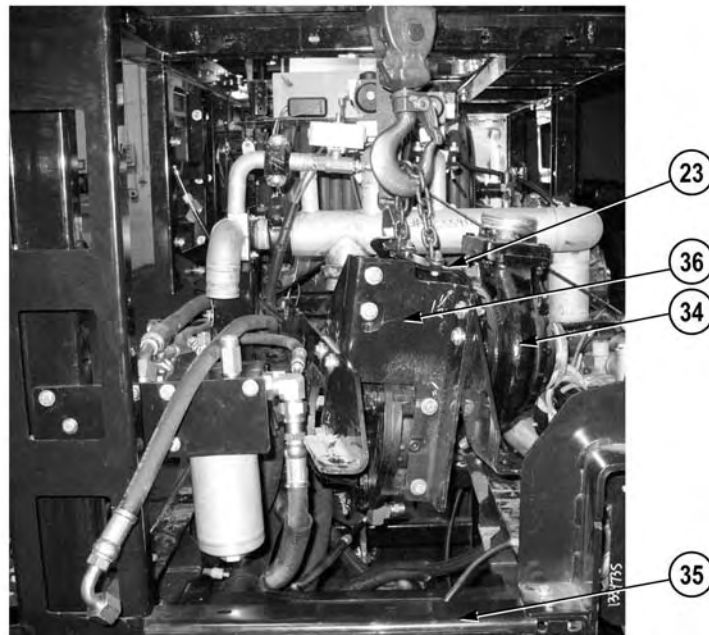
**WARNING**

Water pump and brackets weigh 160 lb. (73 kg). Do not attempt to install water pump without the aid of an assistant and a suitable lifting device. Failure to comply may result in serious injury to personnel or damage to equipment.

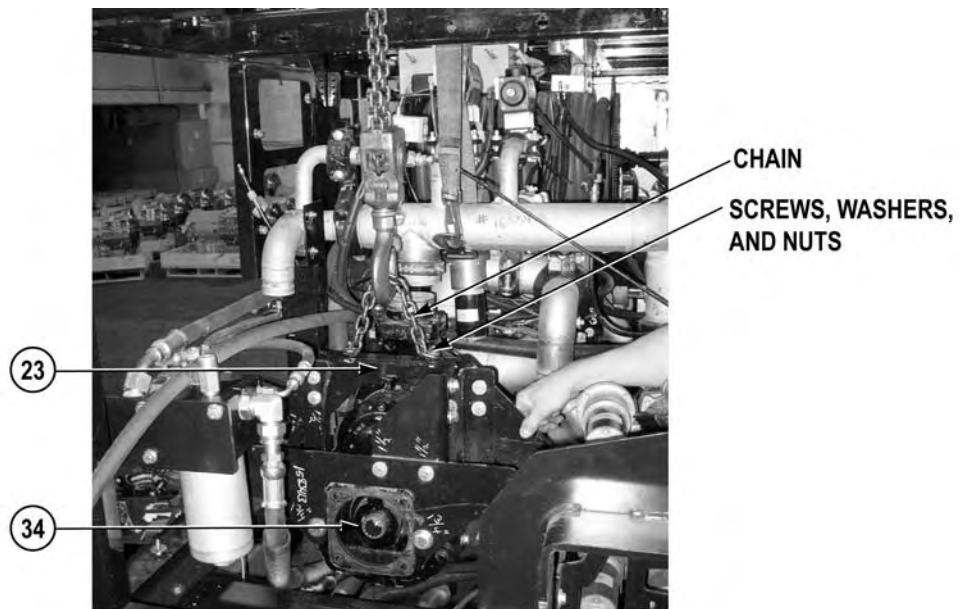
**CAUTION**

Water pump must be lowered and rotated in order to provide clearance when installing water pump. Failure to comply may cause damage to equipment.

15. Lower bracket (23) and water pump (34).

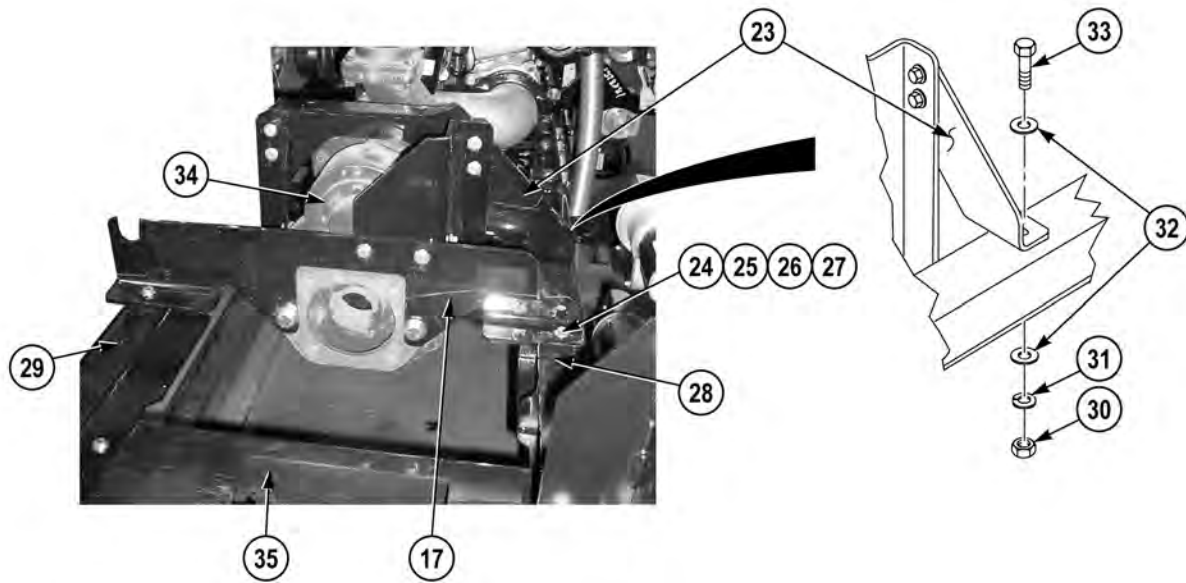


16. Rotate water pump (34) and bracket (23) so that bracket (36) faces outside frame rail (35).

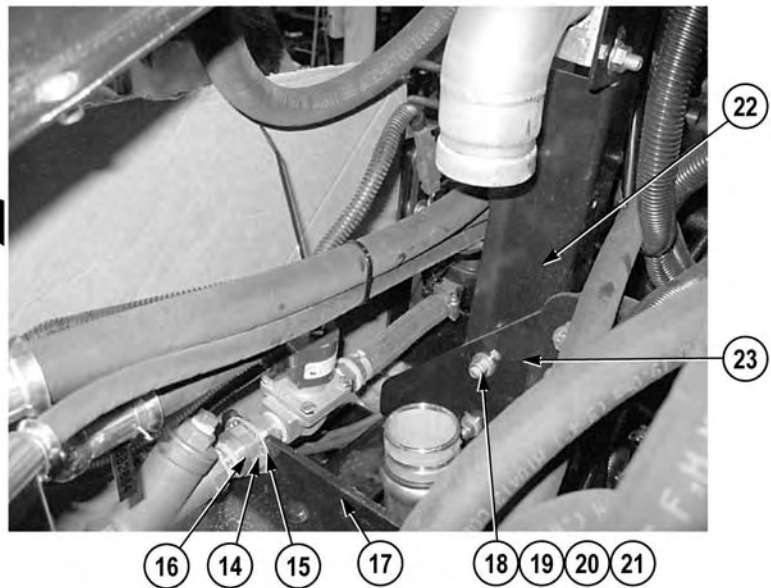
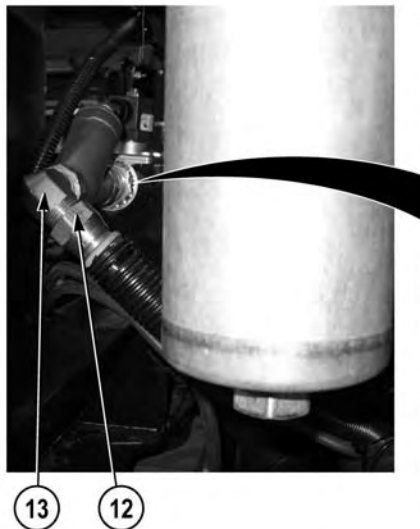


17. Rotate water pump (34) and bracket (23) and lower water pump (34) and bracket (23) on vehicle.

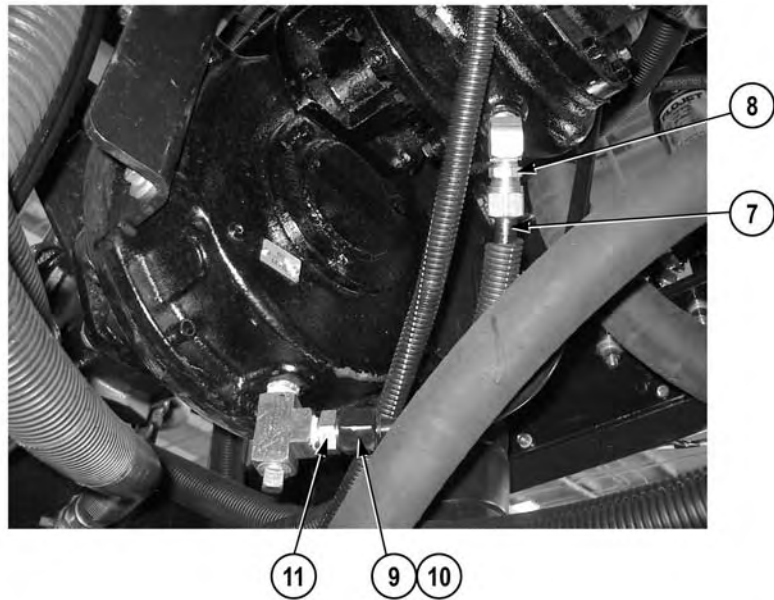
18. Remove two nuts, four washers, two screws, and chain from bracket (23).



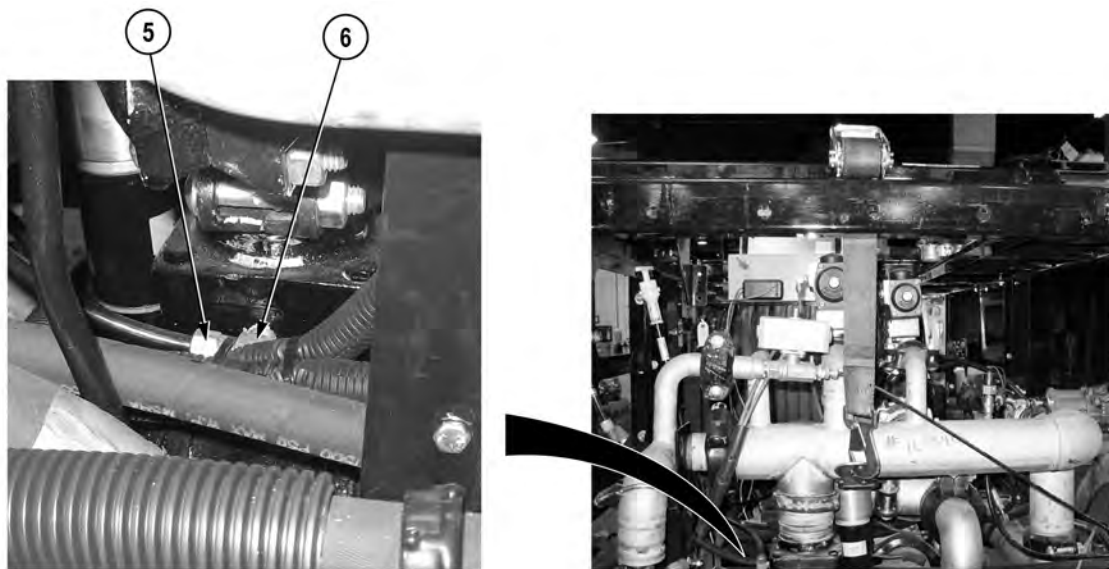
19. Slide two brackets (17) and (23) and water pump (34) into position away from outside frame rail (35).
20. Install bracket (23) on two frame rails (29) and (28) with two screws (33), four washers (32), two lockwashers (31), and nuts (30).
21. Install bracket (17) on two frame rails (28) and (29) with two screws (27), four washers (26), two lockwashers (25), and nuts (24).



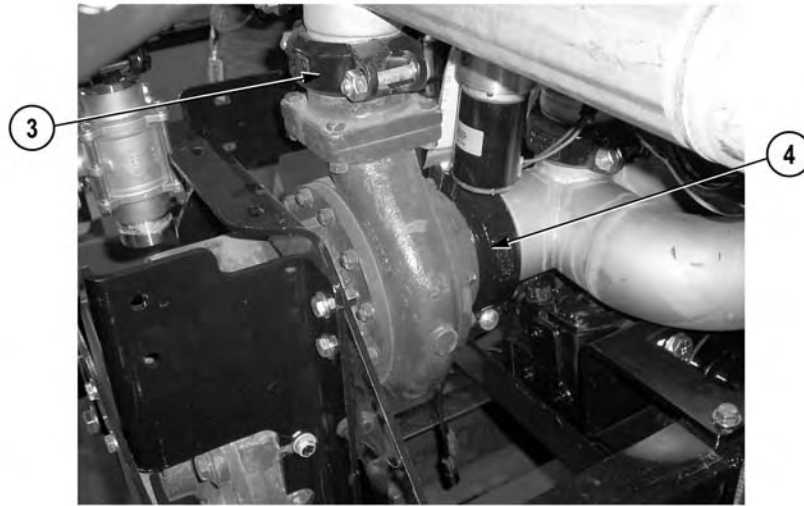
22. Install bracket (22) on bracket (23) with two screws (21), four washers (20), two lockwashers (19), and nuts (18).
23. Install bulkhead fitting (16) on bracket (17) with lockwasher (15) and nut (14).
24. Install hose (12) on elbow (13).



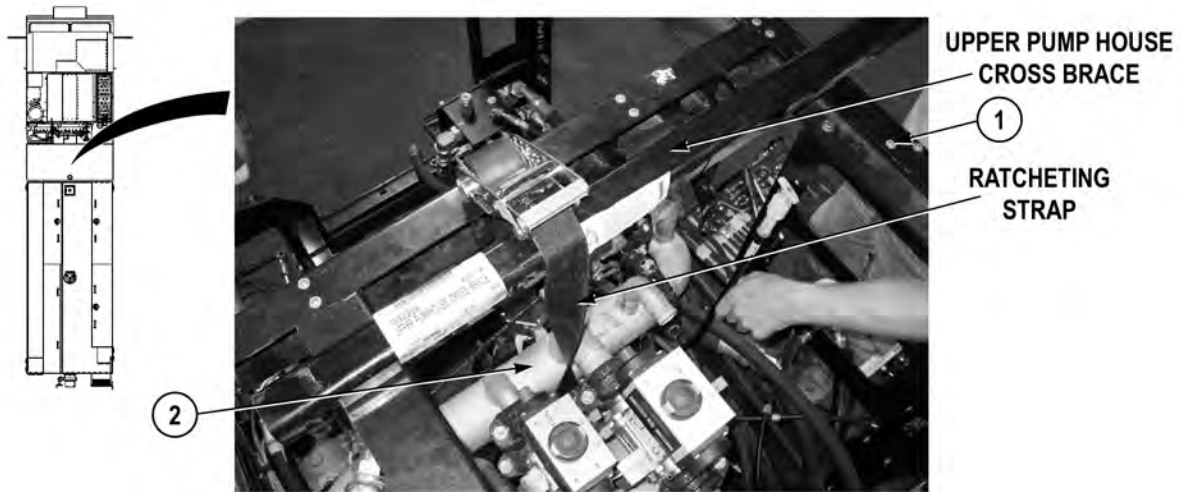
25. Lightly lubricate preformed packing (10) with clean oil, and install preformed packing (10) and dipstick tube fitting (9) on fitting (11).
26. Install line (7) on fitting (8).



27. Install line (5) on elbow (6).



28. Install two couplings (3) and (4) on vehicle (WP 0313).



29. Remove ratcheting strap from upper pump house cross brace and discharge manifold assembly (2).

30. Remove upper pump house cross brace from upper pump house frame (1).

**END OF TASK**

**FOLLOW-ON MAINTENANCE**

1. Install primer pump (WP 0165)
2. Install bumper turret valve (WP 0312)
3. Install hydrostatic pump motor (WP 0151)
4. Fill water pump gear case (WP 0157)
5. Install hydraulic heat exchanger (WP 0134)
6. Install pump house panel K (WP 0339)
7. Check for proper operation and leaks

**END OF TASK****END OF WORK PACKAGE**





---

**FIELD LEVEL MAINTENANCE****PASSENGER SIDE AUXILIARY INLET DRAIN VALVE REPLACEMENT**

---

**INITIAL SETUP:****Tools and Special Tools**

Tool Kit, General Mechanic's: Automotive  
(WP 0398, Item 17)

**Materials/Parts**

Adhesive, Spray (WP 0400, Item 5)  
Compound, Sealing, Pipe Thread  
(WP 0400, Item 11)  
Tags, Identification (WP 0400, Item 23)  
Locknut (1)

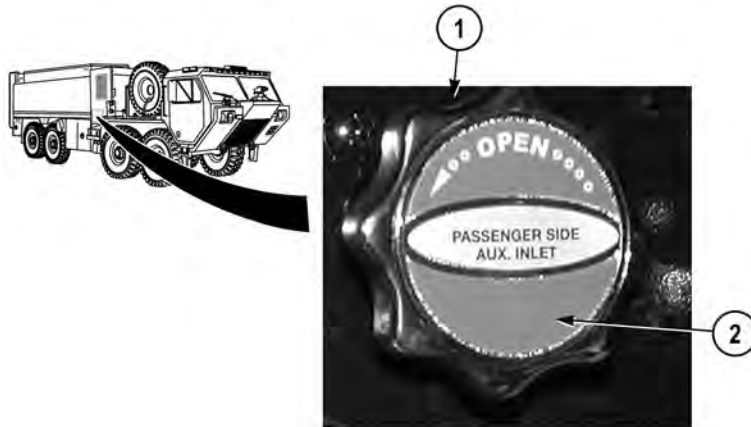
**References**

WP 0391, Fig. 14

**Equipment Conditions**

Pump house panel H access door opened  
(WP 0008)  
Pump house panel P removed (WP 0339)

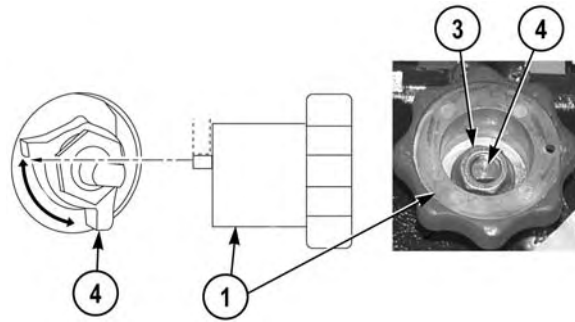
---

**REMOVAL**

1. Turn valve handle (1) clockwise to closed position.

**NOTE**

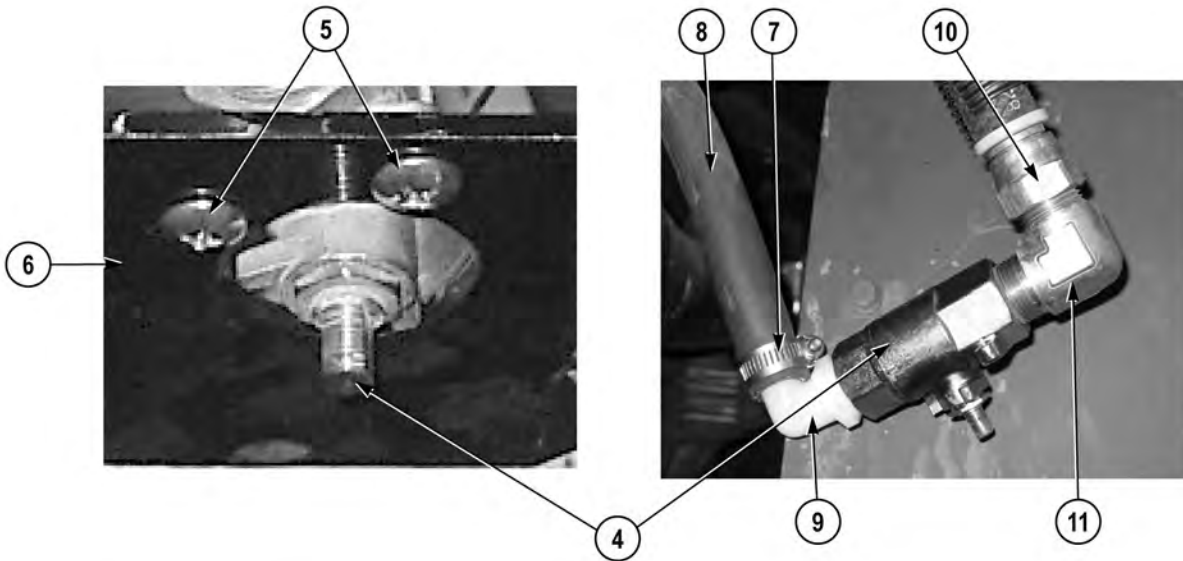
- Cover is attached to valve handle with adhesive.
  - Note position of cover prior to removal to ensure proper installation.
  - Use care when removing cover.
2. Pry cover (2) from valve handle (1).



**NOTE**

- Stop on valve handle is positioned between 90 degrees indent on valve.
- Note position of valve handle on valve prior to removal to ensure proper installation.

3. Remove locknut (3) and valve handle (1) from valve (4). Discard locknut.



4. Remove two screws (5) and valve (4) from manual valve control mounting bracket (6).

**NOTE**

Tag and mark hoses prior to removal to ensure proper installation.

5. Loosen clamp (7) and remove hose (8) from elbow (9).
6. Remove hose (10) from elbow (11).

**NOTE**

Note location of elbows prior to removal to ensure proper installation.

7. Remove elbow (9) and elbow (11) from valve (4).

**END OF TASK**

---

**INSTALLATION****WARNING**

**Adhesives, solvents, and sealing compounds can burn easily, can give off harmful vapors, and are harmful to skin and clothing. To avoid injury or death, keep away from open fire and use in well-ventilated area. If adhesive, solvent, or sealing compound gets on skin or clothing, wash immediately with soap and water.**

1. Apply sealing compound to threads of elbow (9), and elbow (11).

**NOTE**

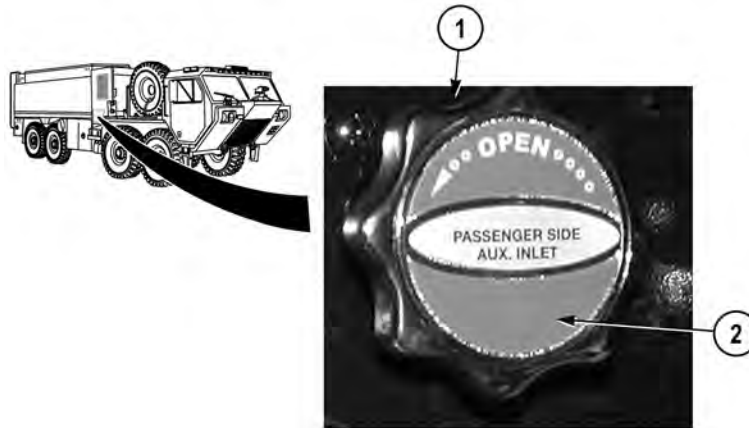
Install elbows as noted prior to removal.

2. Install elbow (11) and elbow (9) on valve (4).
3. Install hose (10) on elbow (11).
4. Install hose (8) on elbow (9) and tighten clamp (7).
5. Install valve (4) on manual valve control mounting bracket (6) with two screws (5).

**NOTE**

Install valve handle on valve as noted prior to removal.

6. Install valve handle (1) on valve (4) with locknut (3).



### **WARNING**



**Adhesives, solvents, and sealing compounds can burn easily, can give off harmful vapors, and are harmful to skin and clothing. To avoid injury or death, keep away from open fire and use in well-ventilated area. If adhesive, solvent, or sealing compound gets on skin or clothing, wash immediately with soap and water.**

7. Apply adhesive to back of cover (2).

### **NOTE**

Install cover on handle as noted prior to removal.

8. Install cover (2) on handle (1).

### **END OF TASK**

### **FOLLOW-ON MAINTENANCE**

1. Close pump house panel H access door (WP 0008)
2. Install pump house panel P (WP 0339)

### **END OF TASK**

### **END OF WORK PACKAGE**

## FIELD LEVEL MAINTENANCE

## DRIVER SIDE AUXILIARY INLET DRAIN VALVE REPLACEMENT

## INITIAL SETUP:

**Tools and Special Tools**

Tool Kit, General Mechanic's: Automotive  
(WP 0398, Item 17)

**Materials/Parts**

Adhesive, Spray (WP 0400, Item 5)  
Compound, Sealing, Pipe Thread  
(WP 0400, Item 11)  
Tags, Identification (WP 0400, Item 23)  
Locknut (1)

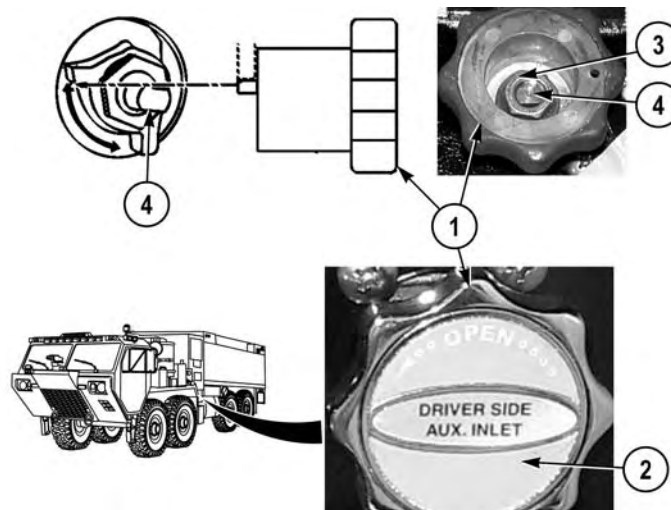
**References**

WP 0391, Fig. 14

**Equipment Conditions**

Pump house panel A access door opened  
(WP 0008)  
Pump house panel B removed (WP 0339)

## REMOVAL



1. Turn valve handle (1) clockwise to closed position.

**NOTE**

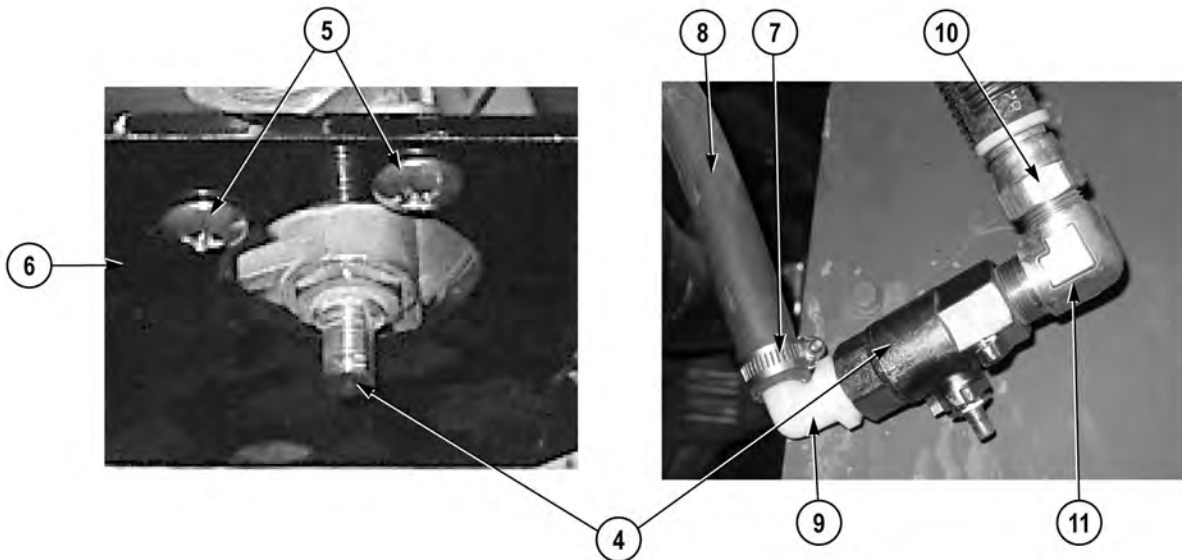
- Cover is attached to valve handle with adhesive.
- Note position of cover prior to removal to ensure proper installation.
- Use care when removing cover.

2. Pry cover (2) from valve handle (1).

**NOTE**

- Stop on valve handle is positioned between 90 degrees indent on valve.
- Note position of valve handle on valve prior to removal to ensure proper installation.

3. Remove locknut (3) and valve handle (1) from valve (4). Discard locknut.



4. Remove two screws (5) and valve (4) from manual valve control mounting bracket (6).

**NOTE**

Tag and mark hoses prior to removal to ensure proper installation.

5. Loosen clamp (7) and remove hose (8) from elbow (9).
6. Remove hose (10) from elbow (11).

**NOTE**

Note location of elbows prior to removal to ensure proper installation.

7. Remove elbow (9) and elbow (11) from valve (4).

**END OF TASK**

## INSTALLATION

### WARNING



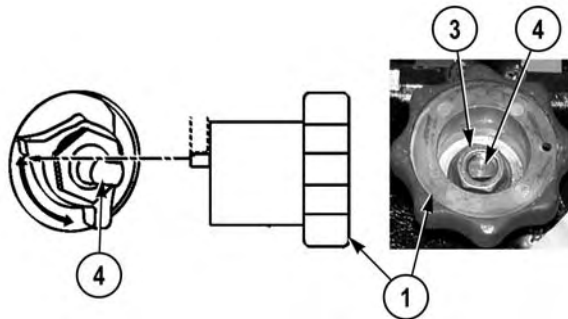
**Adhesives, solvents, and sealing compounds can burn easily, can give off harmful vapors, and are harmful to skin and clothing. To avoid injury or death, keep away from open fire and use in well-ventilated area. If adhesive, solvent, or sealing compound gets on skin or clothing, wash immediately with soap and water.**

1. Apply sealing compound to threads of elbow (9) and elbow (11).

### **NOTE**

Install elbows as noted prior to removal.

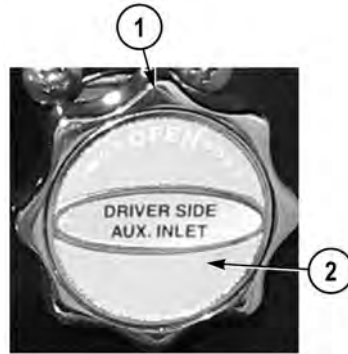
2. Install elbow (11) and elbow (9) on valve (4).
3. Install hose (10) on elbow (11).
4. Install hose (8) on elbow (9) and tighten clamp (7).
5. Install valve (4) on manual valve control mounting bracket (6) with two screws (5).



### **NOTE**

Install handle in the position as noted prior to removal.

6. Install valve handle (1) on valve (4) and locknut (3).

**WARNING**

Adhesives, solvents, and sealing compounds can burn easily, can give off harmful vapors, and are harmful to skin and clothing. To avoid injury or death, keep away from open fire and use in well-ventilated area. If adhesive, solvent, or sealing compound gets on skin or clothing, wash immediately with soap and water.

7. Apply adhesive to back of cover (2).

**NOTE**

Install cover on handle as noted prior to removal.

8. Install cover (2) on handle (1).

**END OF TASK****FOLLOW-ON MAINTENANCE**

1. Close pump house panel A access door (WP 0008)
2. Install pump house panel B (WP 0339)

**END OF TASK****END OF WORK PACKAGE**



## FIELD LEVEL MAINTENANCE

## NO. 1 DRIVER SIDE DISCHARGE DRAIN VALVE REPLACEMENT

## INITIAL SETUP:

**Tools and Special Tools**

Tool Kit, General Mechanic's: Automotive  
(WP 0398, Item 17)

**Materials/Parts**

Adhesive, Spray (WP 0398, Item 5)  
Compound, Sealing, Pipe Thread,  
(WP 0400, Item 11)  
Tags, Identification (WP 0400, Item 23)  
Locknut (1)

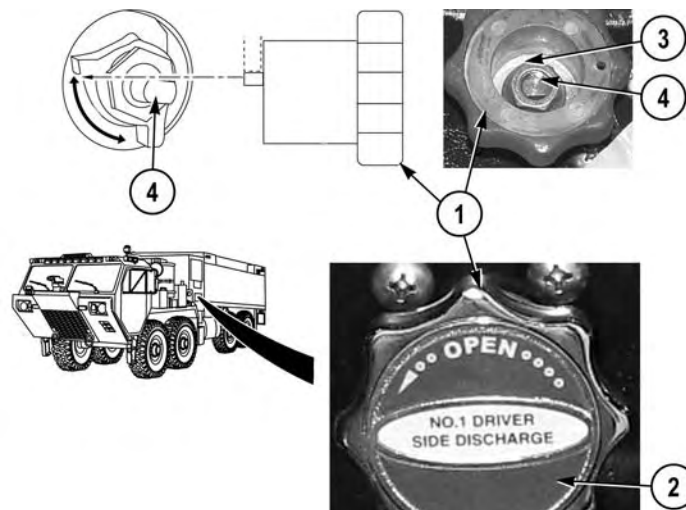
**References**

WP 0391, Fig.14

**Equipment Conditions**

Pump house panel A access door open  
(WP 0008)  
Pump house panel B removed (WP 0339)

## REMOVAL



1. Turn valve handle (1) clockwise to closed position.

**NOTE**

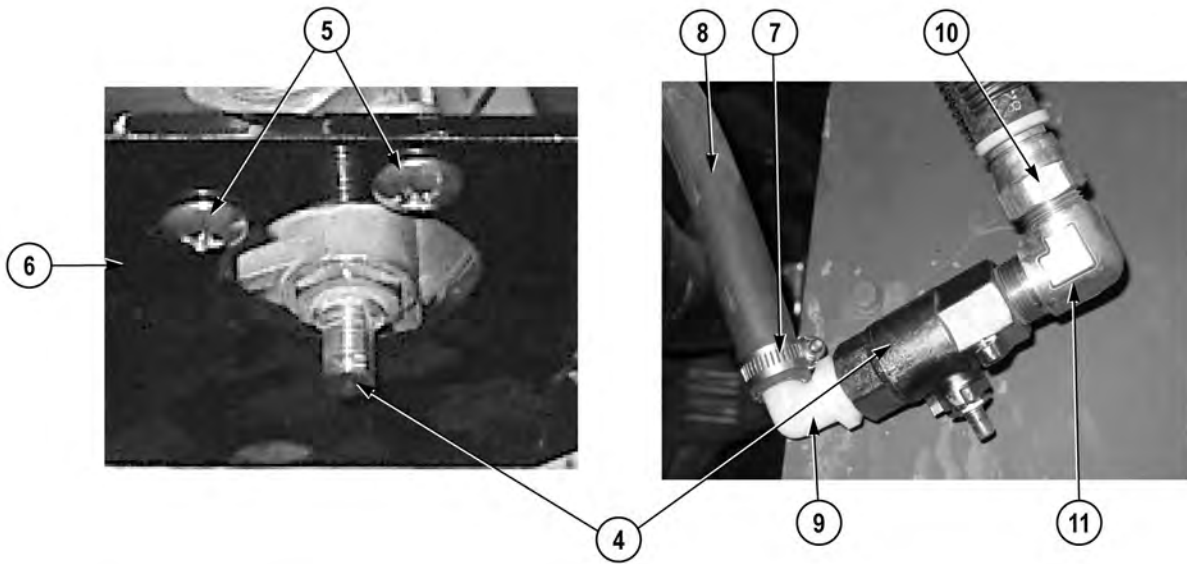
- Cover is attached to valve handle with adhesive.
- Note position of cover prior to removal to ensure proper installation.
- Use care when removing cover.

2. Pry cover (2) from valve handle (1).

**NOTE**

- Stop on valve handle is positioned between 90 degrees indent on valve.
- Note position of valve handle on valve prior to removal to ensure proper installation.

3. Remove locknut (3) and valve handle (1) from valve (4). Discard locknut.



4. Remove two screws (5) and valve (4) from manual valve control mounting bracket (6).

#### NOTE

- Tag and mark hoses prior to removal to ensure proper installation.

5. Loosen clamp (7) and remove hose (8) from elbow (9).
6. Remove hose (10) from elbow (11).

#### NOTE

Note location of elbows prior to removal to ensure proper installation.

7. Remove elbow (9) and elbow (11) from valve (4).

**END OF TASK**

## INSTALLATION

### WARNING



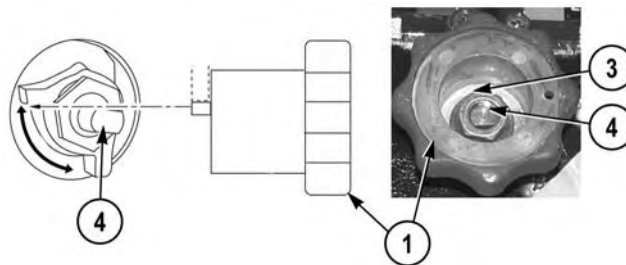
**Adhesives, solvents, and sealing compounds can burn easily, can give off harmful vapors, and are harmful to skin and clothing. To avoid injury or death, keep away from open fire and use in well-ventilated area. If adhesive, solvent, or sealing compound gets on skin or clothing, wash immediately with soap and water.**

1. Apply sealing compound to threads of elbow (9) and elbow (11).

### **NOTE**

Install elbows as noted prior to removal.

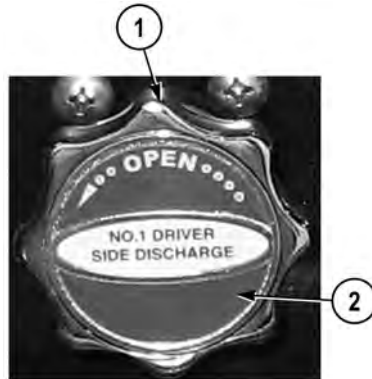
2. Install elbow (11) and elbow (9) on valve (4).
3. Install hose (10) on elbow (11).
4. Install hose (8) on elbow (9) and tighten clamp (7).
5. Install valve (4) on manual valve control mounting bracket (6) with two screws (5).



### **NOTE**

Install handle in the position as noted prior to removal.

6. Install valve handle (1) on valve (4) with locknut (3).

**WARNING**

Adhesives, solvents, and sealing compounds can burn easily, can give off harmful vapors, and are harmful to skin and clothing. To avoid injury or death, keep away from open fire and use in well-ventilated area. If adhesive, solvent, or sealing compound gets on skin or clothing, wash immediately with soap and water.

7. Apply adhesive to back of cover (2).

**NOTE**

Install cover on handle as noted prior to removal.

8. Install cover (2) on handle (1).

**END OF TASK****FOLLOW-ON MAINTENANCE**

1. Close pump house panel A access door (WP 0008)
2. Install pump house panel B (WP 0339)

**END OF TASK****END OF WORK PACKAGE**

---

**FIELD LEVEL MAINTENANCE****NO. 2 PASSENGER SIDE DISCHARGE DRAIN VALVE REPLACEMENT**

---

**INITIAL SETUP:****Tools and Special Tools**

Tool Kit, General Mechanic's: Automotive  
(WP 0398, Item 17)

**Materials/Parts**

Adhesive, Spray (WP 0398, Item 5)  
Compound, Sealing, Pipe Thread  
(WP 0400, Item 11)  
Tags, Identification (WP 0400, Item 23)  
Locknut (1)

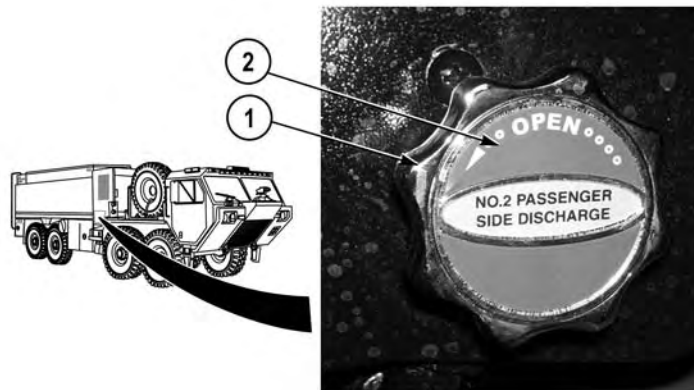
**References**

WP 0391, Fig. 14

**Equipment Conditions**

Pump house panel H access door  
opened (WP 0008)  
Pump house panel P removed (WP 0339)

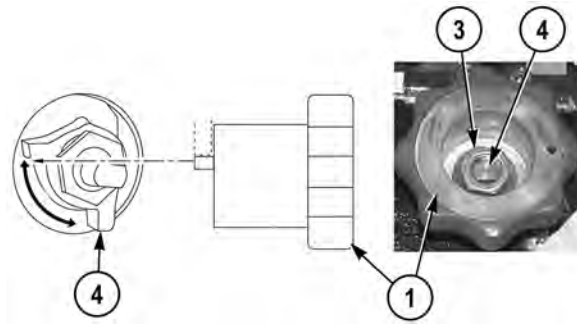
---

**REMOVAL**

1. Turn valve handle (1) clockwise to closed position.

**NOTE**

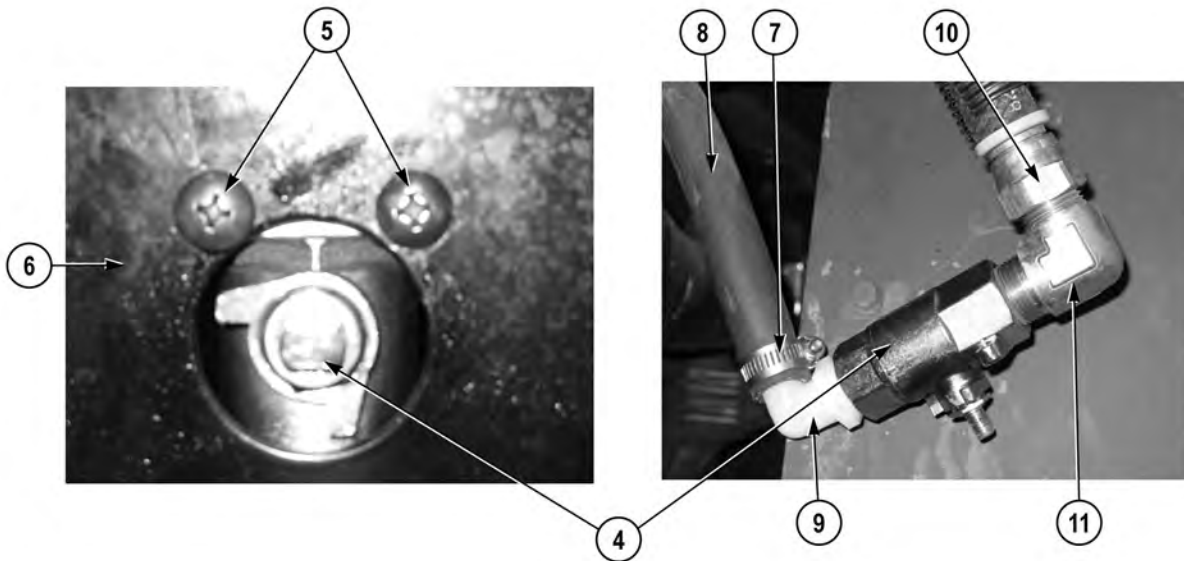
- Cover is attached to valve handle with adhesive.
  - Note position of cover prior to removal to ensure proper installation.
  - Use care when removing cover.
2. Pry cover (2) from valve handle (1).



**NOTE**

- Stop on valve handle is positioned between 90 degrees indent on valve.
- Note position of valve handle on valve prior to removal to ensure proper installation.

3. Remove locknut (3) and valve handle (1) from valve (4). Discard locknut.



4. Remove two screws (5) and valve (4) from manual valve control mounting bracket (6).

**NOTE**

Tag and mark hoses prior to removal to ensure proper installation.

5. Loosen clamp (7) and remove hose (8) from elbow (9).
6. Remove hose (10) from elbow (11).

**NOTE**

Note location of elbow prior to removal to ensure proper installation.

7. Remove elbow (9) and elbow (11) from valve (4).

**END OF TASK**

---

**INSTALLATION****WARNING**

**Adhesives, solvents, and sealing compounds can burn easily, can give off harmful vapors, and are harmful to skin and clothing. To avoid injury or death, keep away from open fire and use in well-ventilated area. If adhesive, solvent, or sealing compound gets on skin or clothing, wash immediately with soap and water.**

1. Apply sealing compound to threads of elbow (9), and elbow (11).

**NOTE**

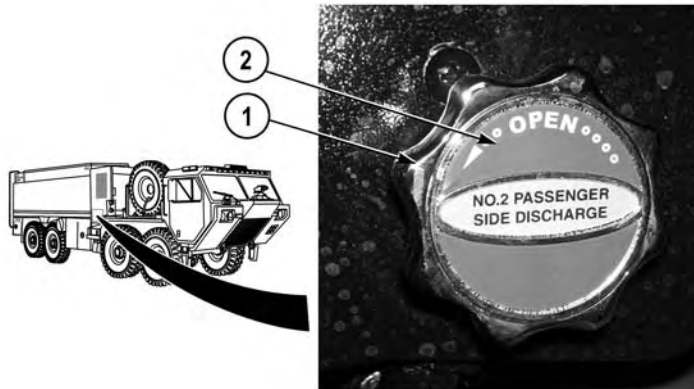
Install elbows as noted prior to removal.

2. Install elbow (11) and elbow (9) on valve (4).
3. Install hose (10) on elbow (11).
4. Install hose (8) on elbow (9) and tighten clamp (7).
5. Install valve (4) on manual valve control mounting bracket (6) with two screws (5).

**NOTE**

Install handle in the position as noted prior to removal.

6. Install valve handle (1) on valve (4) with locknut (3).

**WARNING**

Adhesives, solvents, and sealing compounds can burn easily, can give off harmful vapors, and are harmful to skin and clothing. To avoid injury or death, keep away from open fire and use in well-ventilated area. If adhesive, solvent, or sealing compound gets on skin or clothing, wash immediately with soap and water.

**NOTE**

Install cover on handle as noted prior to removal.

7. Apply adhesive to back of cover (2).
8. Install cover (2) on handle (1).

**END OF TASK****FOLLOW-ON MAINTENANCE**

1. Close pump house panel H access door (WP 0008)
2. Install pump house panel P (WP 0339)

**END OF TASK****END OF WORK PACKAGE**



---

**FIELD LEVEL MAINTENANCE**  
**THERMAL RELIEF VALVE REPLACEMENT**

---

**INITIAL SETUP:****Tools and Special Tools**

Standard Automotive Tool Set (SATS),  
(WP 0398, Item 15)  
• Wrench, Adjustable, 18"  
Tool Kit, General Mechanic's: Automotive  
(WP 0398, Item 17)

**References**

WP 0318  
WP 0391, Fig. 13

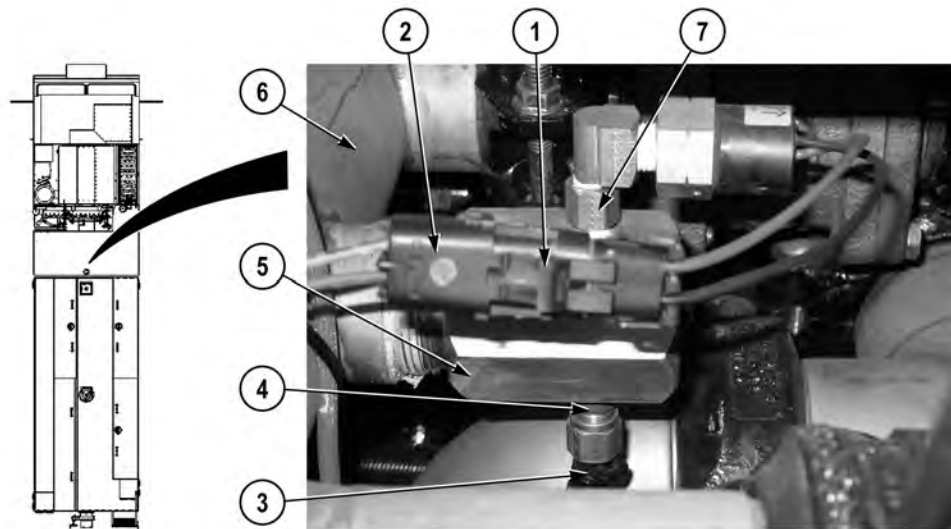
**Equipment Conditions**

Pump house panel G removed (WP 0339)

**Materials/Parts**

Compound, Sealing, Pipe Thread  
(WP 0400, Item 11)

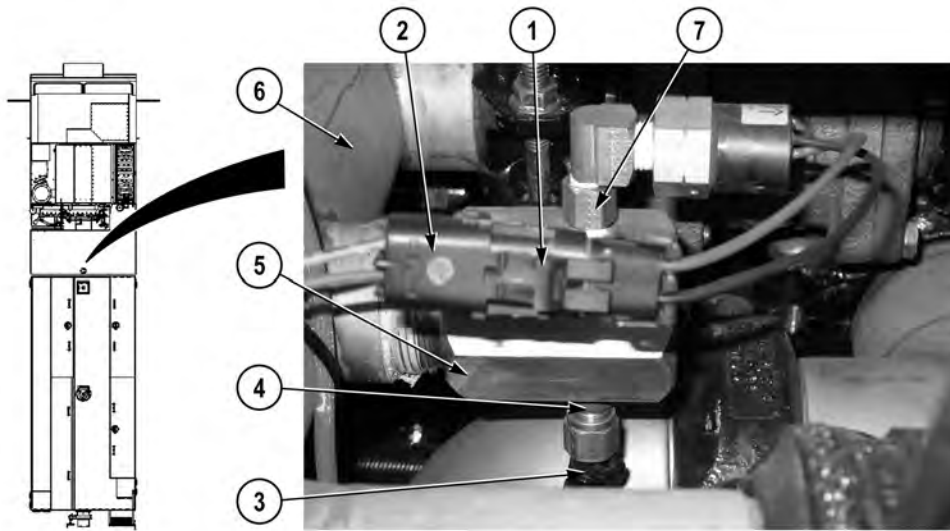
---

**REMOVAL**

1. Disconnect thermal relief valve switch connector (1) from pump house wire harness connector (2).
2. Remove drain line (3) from fitting (4).
3. Remove thermal relief valve (5) from manifold (6) (WP 0318).
4. Remove fitting (7) from thermal relief valve (5).
5. Remove fitting (4) from thermal relief valve (5).

**END OF TASK**

## INSTALLATION

**WARNING**

Adhesives, solvents, and sealing compounds can burn easily, can give off harmful vapors, and are harmful to skin and clothing. To avoid injury or death, keep away from open fire and use in well-ventilated area. If adhesive, solvent, or sealing compound gets on skin or clothing, wash immediately with soap and water.

**CAUTION**

Use pipe thread sealing compound sparingly only on pipe threads. Do not apply compound to hose connections. Failure to comply may result in damage to equipment.

1. Apply sealing compound to threads of two fittings (4) and (7).
2. Install fitting (4) on thermal relief valve (5).
3. Install fitting (7) on thermal relief valve (5).
4. Install thermal relief valve (5) on manifold (6) (WP 0318).
5. Install drain line (3) on fitting (4).
6. Connect thermal relief valve switch connector (1) on pump house wire harness connector (2).

**END OF TASK**

**FOLLOW-ON MAINTENANCE**

Install pump house panel G (WP 0339)

**END OF TASK**

**END OF WORK PACKAGE**



---

**FIELD LEVEL MAINTENANCE**  
**MANUAL PRIMER HANDLE REPLACEMENT**

---

**INITIAL SETUP:****Tools and Special Tools**

Tool Kit, General Mechanic's: Automotive  
(WP 0398, Item 17)

**Materials/Parts**

Lockwasher (2)

**References**

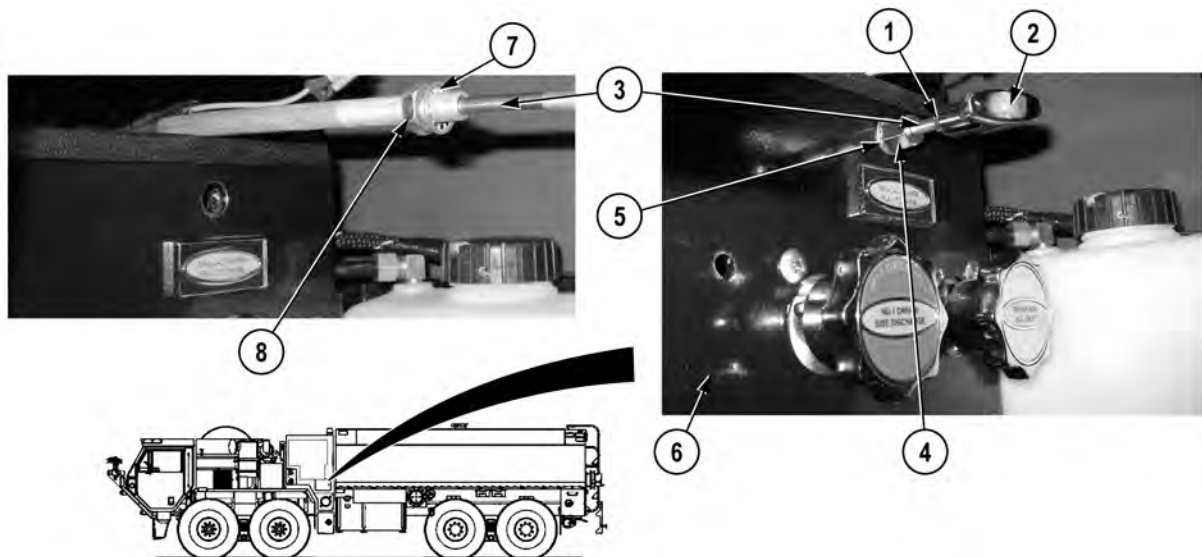
WP 0391, Fig. 18

**Equipment Conditions**

Engine OFF (TM 9-2320-422-10)

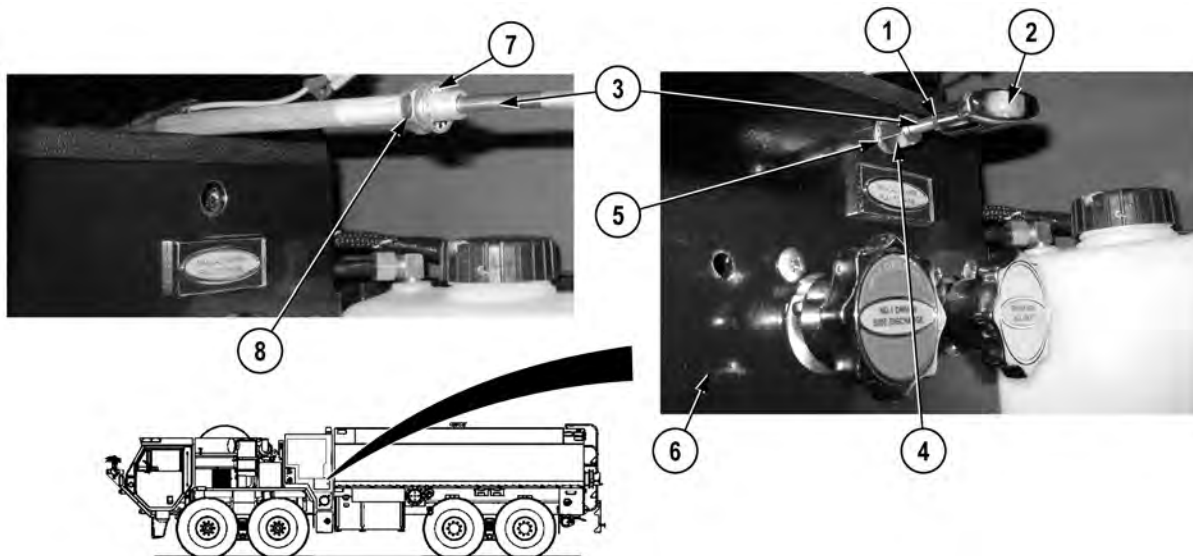
Wheels chocked (TM 9-2320-422-10)

---

**REMOVAL**

1. Loosen jam nut (1) and remove handle (2) from cable (3).
2. Remove jam nut (1) from cable (3).
3. Remove nut (4), lockwasher (5), and cable (3) from bracket (6). Discard lockwasher.
4. Remove lockwasher (7) and nut (8) from cable (3). Discard lockwasher.

**END OF TASK**

**INSTALLATION**

1. Position nut (8) and lockwasher (7) on cable (3).
2. Install cable (3) on bracket (6) with lockwasher (5) and nut (4).
3. Position jam nut (1) on cable (3).
4. Install handle (2) on cable (3) and tighten jam nut (1).

**END OF TASK****FOLLOW-ON MAINTENANCE**

Remove wheel chocks (TM 9-2320-422-10)

**END OF TASK****END OF WORK PACKAGE**

## FIELD LEVEL MAINTENANCE

## PRIMER PUMP REPLACEMENT

## INITIAL SETUP:

**Tools and Special Tools**

Tool Kit, General Mechanic's: Automotive  
(WP 0398, Item 17)

**Materials/Parts**

Compound, Sealing, Pipe Thread  
(WP 0400, Item 11)  
Tags, Identification (WP 0400, Item 23)  
Ties, Cable, Plastic (WP 0400, Item 26)  
Locknut (1)  
Locknut (1)

**Materials/Parts (continued)**

Locknut (1)  
Lockwasher (2)

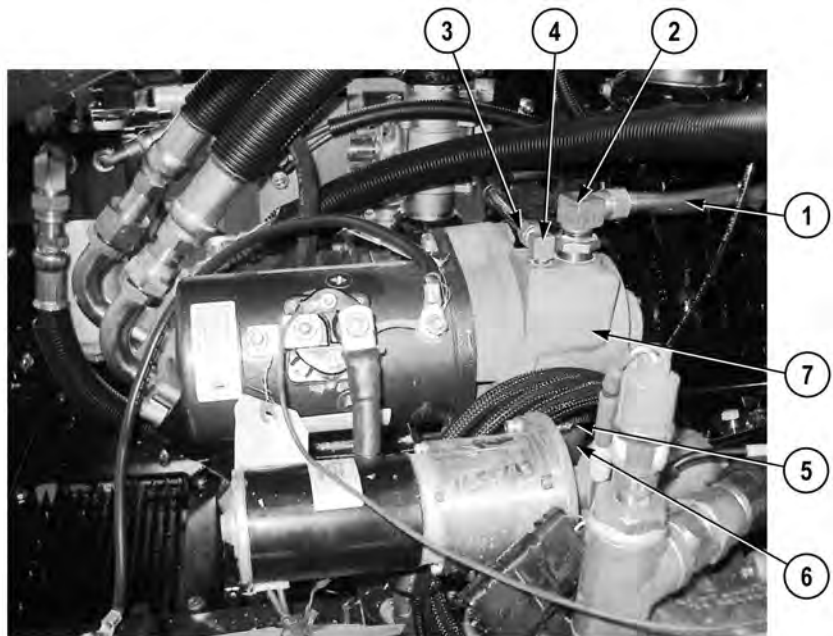
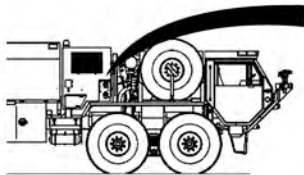
**References**

WP 0391, Fig. 17

**Equipment Conditions**

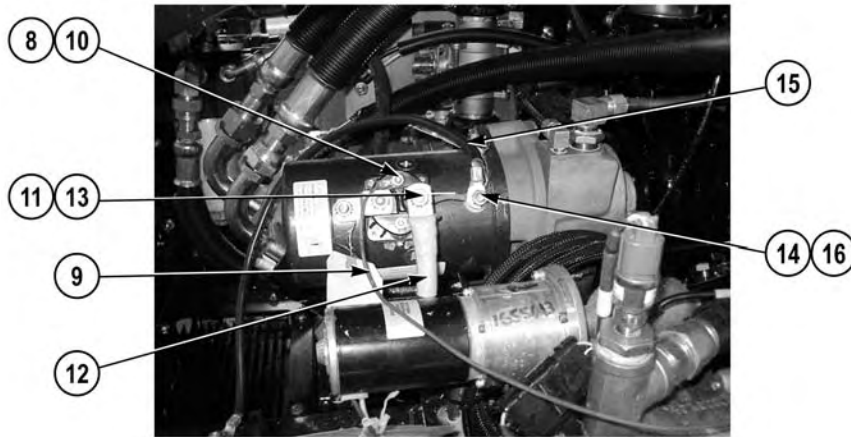
Hydraulic heat exchanger shroud panel A  
removed (WP 0137)

## REMOVAL

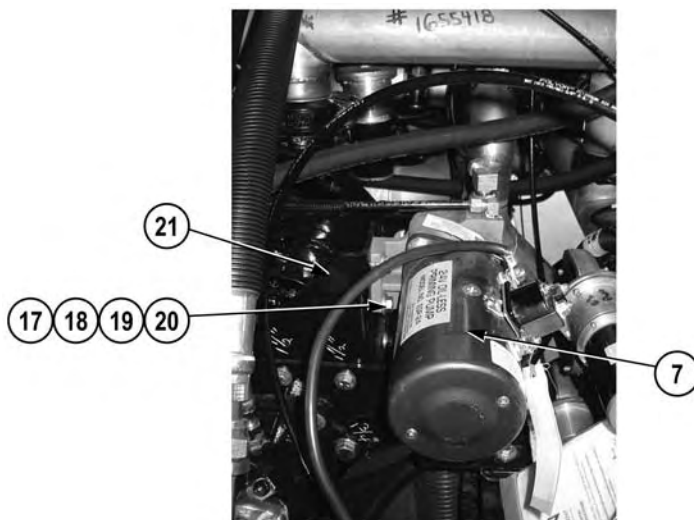
**NOTE**

- Tag and mark hoses and wires prior to removal to ensure proper installation.
- Remove cable ties as required.

1. Remove line (1) from elbow (2).
2. Remove supply line (3) from elbow (4).
3. Loosen clamp (5) and remove hose (6) from primer pump (7) and vehicle.



4. Remove locknut (8) and wire 2774 (9) from stud (10). Discard locknut.
5. Remove locknut (11) and high amperage cable (12) from stud (13). Discard locknut.
6. Remove locknut (14) and wire (15) from stud (16). Discard locknut.

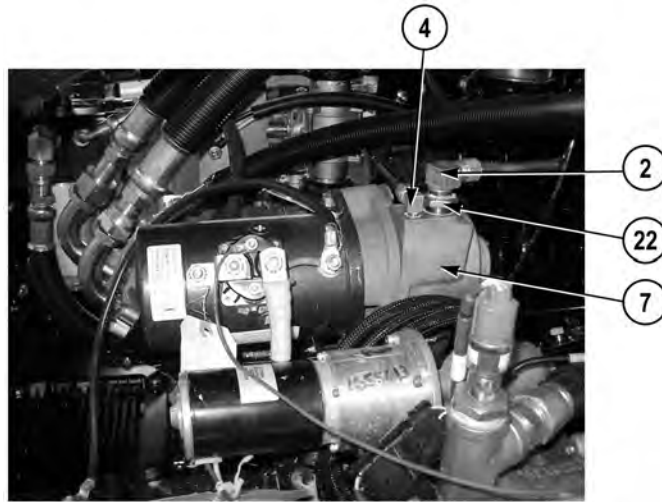


### NOTE

Note position of washers prior to removal to ensure proper installation.

7. Remove two nuts (17), lockwashers (18), four washers (19), two screws (20), and primer pump (7) from bracket (21). Discard lockwashers.





8. Remove elbow (2) and fitting (22) from primer pump (7).
9. Remove elbow (4) from primer pump (7).
10. Remove elbow (2) from fitting (22).

#### END OF TASK

#### INSTALLATION

#### WARNING



Adhesives, solvents, and sealing compounds can burn easily, can give off harmful vapors, and are harmful to skin and clothing. To avoid injury or death, keep away from open fire and use in well-ventilated area. If adhesive, solvent, or sealing compound gets on skin or clothing, wash immediately with soap and water.

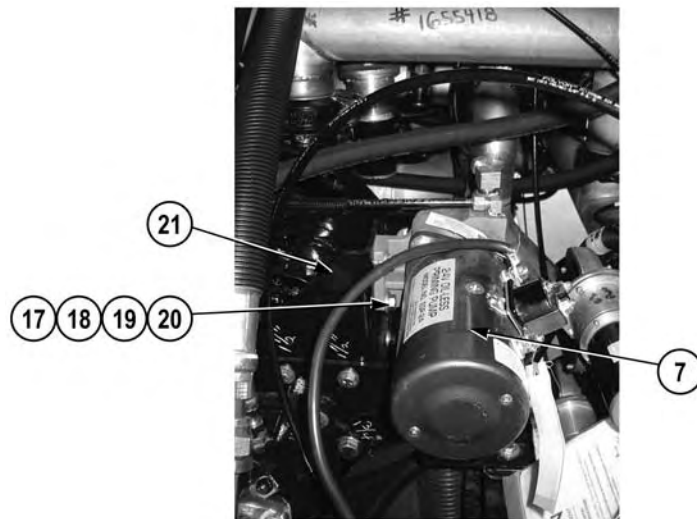
#### CAUTION

Use sealing compound sparingly only on pipe threads. Do not apply compound to hose connections. Damage to equipment may result.

#### NOTE

Install cable ties as required.

1. Apply sealing compound to threads of fitting (22) and two elbows (2) and (4).
2. Install elbow (2) on fitting (22).
3. Install fitting (22) and elbow (2) on primer pump (7).
4. Install elbow (4) on primer pump (7).



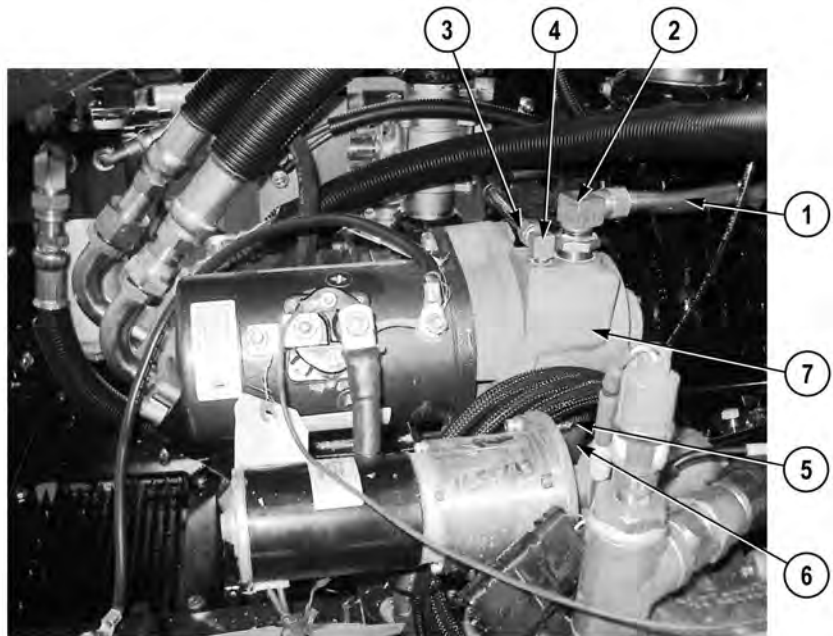
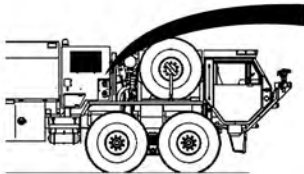
**NOTE**

Install washers as noted prior to removal.

5. Install primer pump (7) on bracket (21) with two screws (20), four washers (19), two lockwashers (18), and nuts (17).



6. Install wire (15) on stud (16) with locknut (14).
7. Install high amperage cable (12) on stud (13) with locknut (11).
8. Install wire 2774 (9) on stud (10) with locknut (8).



9. Install hose (6) on primer pump (7) and tighten clamp (5).
10. Install supply line (3) on elbow (4).
11. Install line (1) on elbow (2).

#### END OF TASK

#### FOLLOW-ON MAINTENANCE

1. Install hydraulic heat exchanger shroud panel A (WP 0137)
2. Check for proper operation and leaks

#### END OF TASK

#### END OF WORK PACKAGE



---

**FIELD LEVEL MAINTENANCE**  
**PRIMER TANK AND BRACKET REPLACEMENT**

---

**INITIAL SETUP:****Tools and Special Tools**

Tool Kit, General Mechanic's: Automotive  
(WP 0398, Item 17)

**References**

WP 0326  
WP 0391, Fig. 19

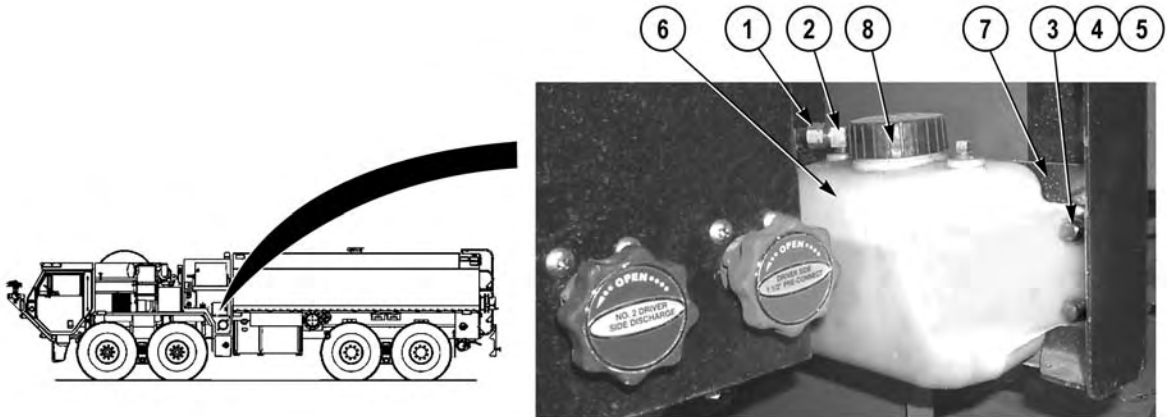
**Materials/Parts**

Compound, Sealing, Pipe Thread  
(WP 0400, Item 11)  
Lockwasher (4)  
Lockwasher (2)

**Equipment Conditions**

Pump house panels B and D removed (WP 0339)

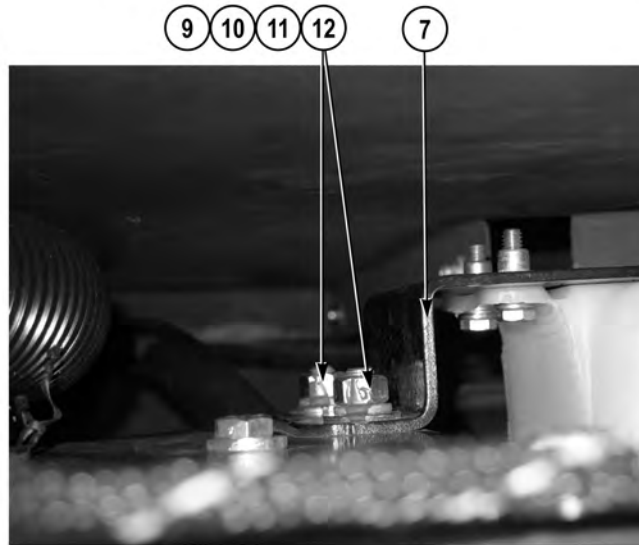
---

**REMOVAL**

1. Remove primer line (1) from elbow (2).
2. Remove four screws (3), lockwashers (4), washers (5), and primer tank (6) from bracket (7). Discard lockwashers.

**NOTE**

- Pickup tube remains attached to elbow and is removed as an assembly.
  - Note position of elbow prior to removal to ensure proper installation.
3. Remove elbow (2) from primer tank (6).
  4. Remove cap (8) from primer tank (6).

**NOTE**

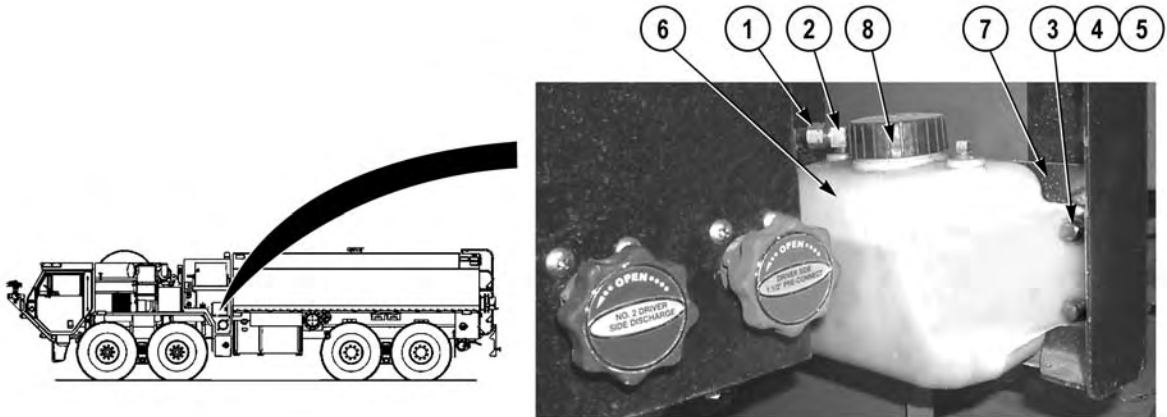
Perform Step (5) if bracket needs to be removed.

5. Remove two nuts (9), lockwashers (10), four washers (11), two screws (12), and bracket (7) from vehicle. Discard lockwashers.

**END OF TASK****INSTALLATION****NOTE**

Perform Step (1) if bracket was removed.

1. Install bracket (7) on vehicle with two screws (12), four washers (11), two lockwashers (10), and nuts (9).



2. Install cap (8) on primer tank (6).

### **WARNING**



**Adhesives, solvents, and sealing compounds can burn easily, can give off harmful vapors, and are harmful to skin and clothing. To avoid injury or death, keep away from open fire and use in well-ventilated area. If adhesive, solvent, or sealing compound gets on skin or clothing, wash immediately with soap and water.**

3. Apply sealing compound to threads of elbow (2).

### **NOTE**

Install elbow in same position as noted prior to removal.

4. Install elbow (2) on primer tank (6).
5. Install primer tank (6) on bracket (7) with four washers (5), lockwashers (4), and screws (3).
6. Install primer line (1) on elbow (2).

### **END OF TASK**

### **FOLLOW-ON MAINTENANCE**

Install pump house panels B and D (WP 0339)

### **END OF TASK**

### **END OF WORK PACKAGE**





**FIELD LEVEL MAINTENANCE**  
**PRIMER VALVE CABLE REPLACEMENT**

**INITIAL SETUP:****Tools and Special Tools**

Tool Kit, General Mechanic's: Automotive  
(WP 0398, Item 17)

**References**

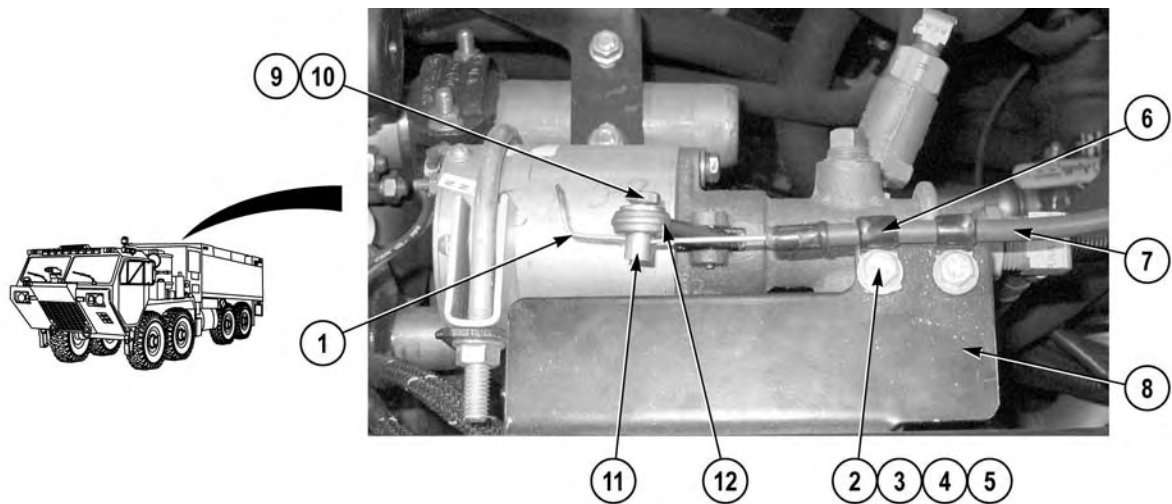
WP 0391, Fig. 18

**Materials/Parts**

Ties, Cable, Plastic (WP 0400, Item 26)  
Lockwasher (2)

**Equipment Conditions**

Manual primer handle removed (WP 0164)  
Pump house panel K removed (WP 0339)

**REMOVAL**

1. Straighten cable wire (1).

**NOTE**

Note position of cable on bracket prior to removal to ensure proper installation.

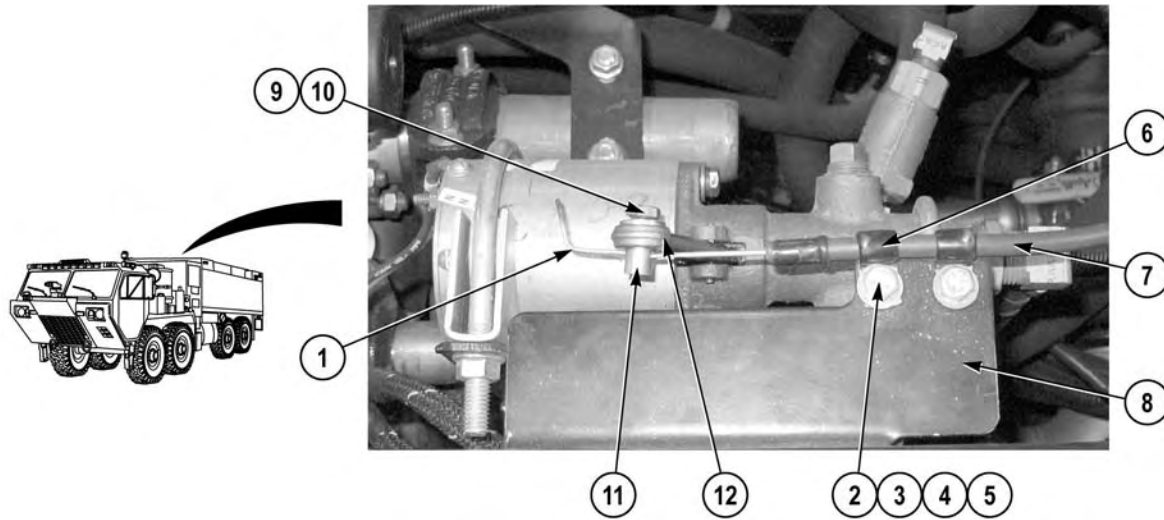
2. Remove two nuts (2), lockwasher (3), four washers (4), two screws (5), cushion clips (6), and cable (7) from bracket (8). Discard lockwashers.
3. Remove screw (9), washer (10), and retainer (11) from lever (12).
4. Remove cable wire (1) from retainer (11).

**NOTE**

- Note routing of cable in pump house prior to removal to ensure proper installation.
- Remove cable ties as required.

5. Remove cable (7) from vehicle.

**END OF TASK**

**INSTALLATION****NOTE**

- Route cable in pump house as noted prior to removal.
- Install cable ties as required.

1. Position cable wire (1) on retainer (11).
2. Install retainer (11) on lever (12) with washer (10) and screw (9). Do not tighten screw.

**NOTE**

Install cable on bracket as noted prior to removal.

3. Install cable (7) on bracket (8) with two cushion clips (6), screws (5), four washers (4), two lockwashers (3), and nuts (2).
4. Tighten screw (9).
5. Bend cable wire (1).

**END OF TASK****FOLLOW-ON MAINTENANCE**

1. Install pump house panel K (WP 0339)
2. Install manual primer handle (WP 0164)

**END OF TASK****END OF WORK PACKAGE**

---

**FIELD LEVEL MAINTENANCE**  
**PRIMER VALVE CONTROL SOLENOID REPLACEMENT**

---

**INITIAL SETUP:****Tools and Special Tools**

Tool Kit, General Mechanic's: Automotive  
(WP 0398, Item 17)

**References**

WP 0391, Fig. 17, 18

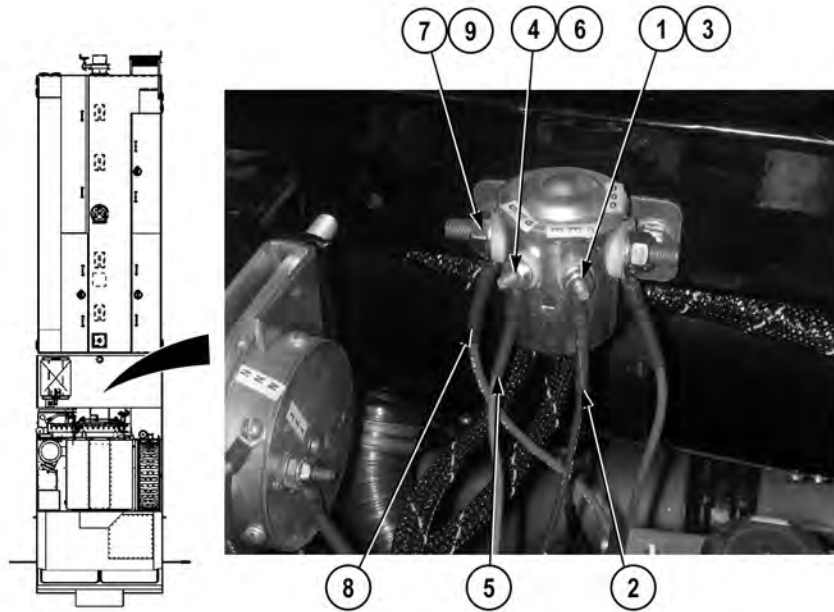
**Materials/Parts**

Compound, Sealing (WP 0400, Item 10)  
Tags, Identification (WP 0400, Item 23)  
Lockwasher (2)

**Equipment Conditions**

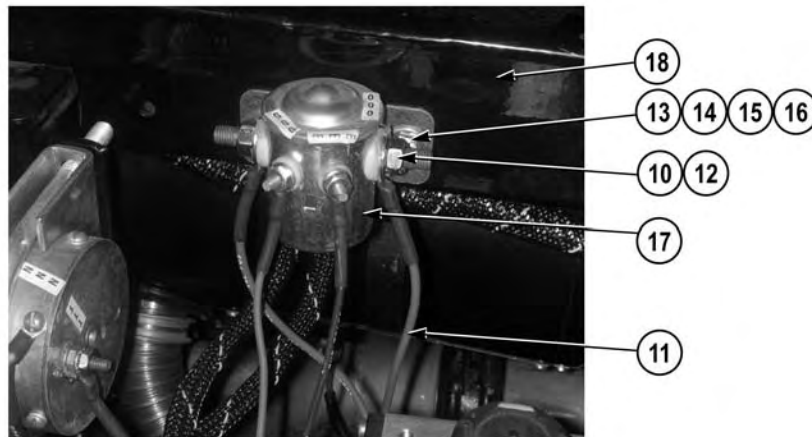
Pump house panel K removed (WP 0339)

---

**REMOVAL****NOTE**

Tag and mark wires prior to removal to ensure proper installation.

1. Remove nut (1) and wire 1640 (2) from stud (3).
2. Remove nut (4) and wire 1590 (5) from stud (6).
3. Remove nut (7) and wire 4065 (8) from stud (9).

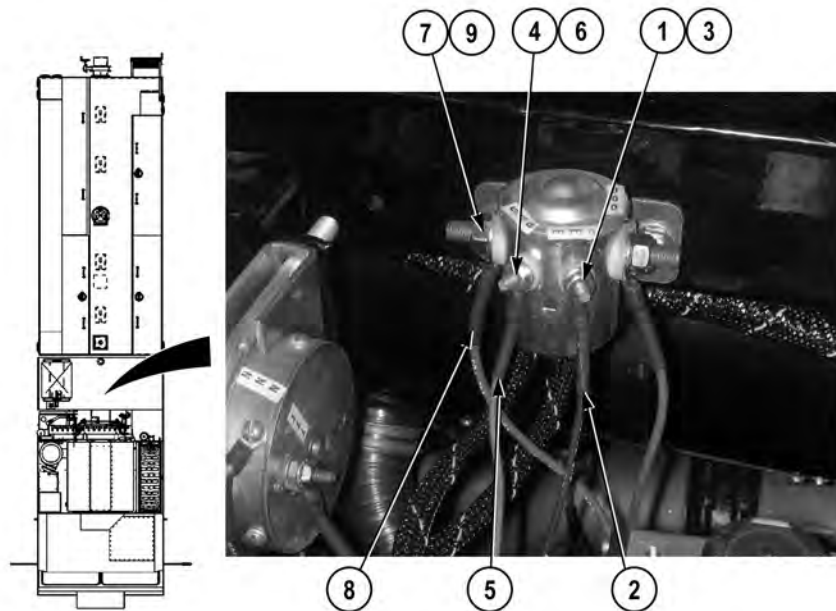


4. Remove nut (10) and wire 4064 (11) from stud (12).
5. Remove two nuts (13), lockwashers (14), four washers (15), two screws (16), and solenoid (17) from bracket (18). Discard lockwashers.

#### END OF TASK

#### INSTALLATION

1. Install solenoid (17) on bracket (18) with two screws (16), four washers (15), two lockwashers (14), and nuts (13).
2. Install wire 4064 (11) on stud (12) with nut (10).



3. Install wire 4065 (8) on stud (9) with nut (7).
4. Install wire 1590 (5) on stud (6) with nut (4).
5. Install wire 1640 (2) on stud (3) with nut (1).

### WARNING



**Adhesives, solvents, and sealing compounds can burn easily, can give off harmful vapors, and are harmful to skin and clothing. To avoid injury or death, keep away from open fire and use in well-ventilated area. If adhesive, solvent, or sealing compound gets on skin or clothing, wash immediately with soap and water.**

6. Apply sealing compound to ends of four wires (2), (5), (8), and (11), nuts (1), (4), (7), and (10), and studs (3), (6), (9), and (12).

**END OF TASK**

### **FOLLOW-ON MAINTENANCE**

Install pump house panel K (WP 0339)

**END OF TASK**

**END OF WORK PACKAGE**



## FIELD LEVEL MAINTENANCE

## PRIMER VALVE REPLACEMENT

## INITIAL SETUP:

**Tools and Special Tools**

Tool Kit, General Mechanic's: Automotive  
(WP 0398, Item 17)

**Materials/Parts**

Compound, Sealing, Pipe Thread  
(WP 0400, Item 11)  
Tags, Identification (WP 0400, Item 23)  
Locknut (1)  
Lockwasher (1)

**Materials/Parts (continued)**

Locknut (4)  
Lockwasher (2)

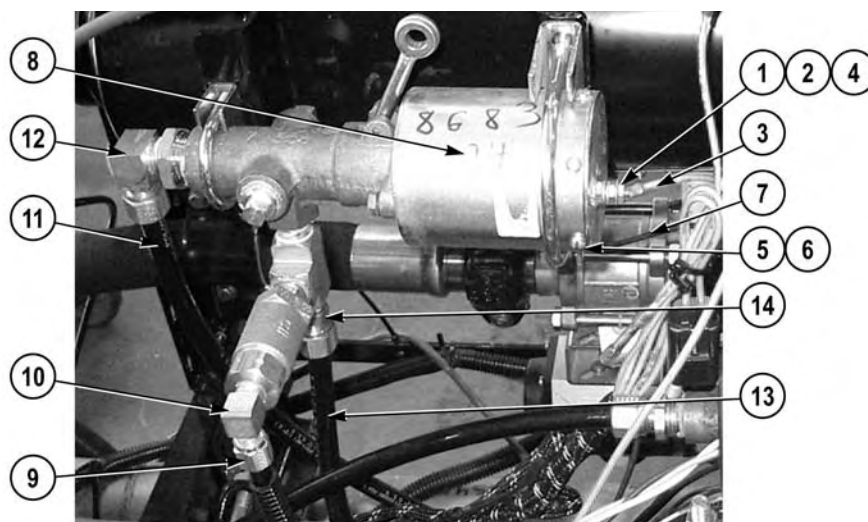
**References**

WP 0391, Fig. 18, 71

**Equipment Conditions**

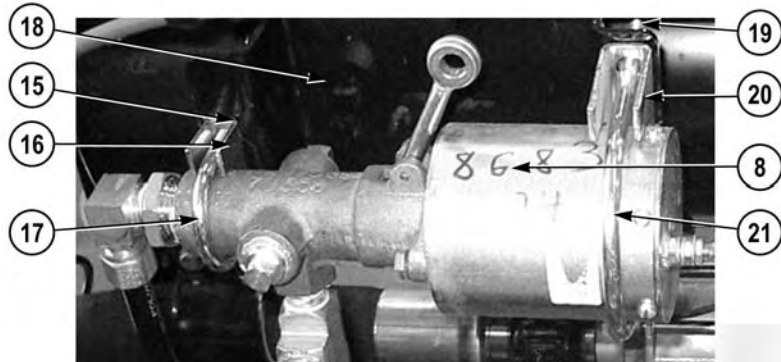
Primer valve cable removed from primer  
valve (WP 0167)

## REMOVAL

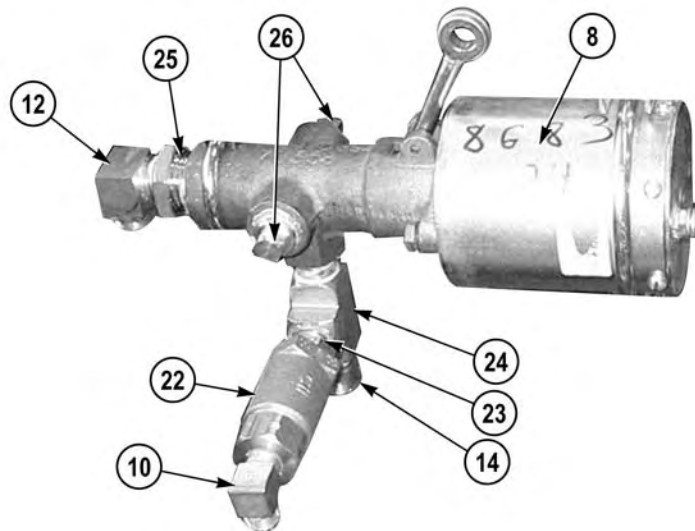
**NOTE**

Tag and mark wires and hoses prior to removal to ensure proper installation.

1. Remove locknut (1), washer (2), and wire 4065 (3) from stud (4). Discard locknut.
2. Remove screw (5), lockwasher (6), and ground wire 4068 (7) from primer valve (8). Discard lockwasher.
3. Remove line (9) from elbow (10).
4. Remove line (11) from elbow (12).
5. Remove line (13) from fitting (14).



6. Remove two locknuts (15), cradle (16), and U-bolt (17) from bracket (18) and primer valve (8). Discard locknuts.
7. Remove two locknuts (19), cradle (20), U-bolt (21), and primer valve (8) from bracket (18). Discard locknuts.

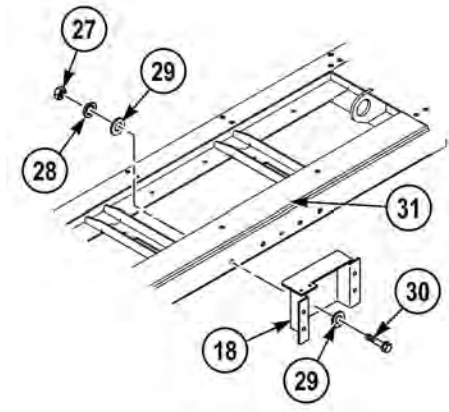


### NOTE

Note position of elbows and fittings prior to removal to ensure proper installation.

8. Remove elbow (10) from check valve (22).
9. Remove check valve (22) from fitting (23).
10. Remove two fittings (14) and (23) from tee (24).
11. Remove tee (24) from primer valve (8).
12. Remove elbow (12) from fitting (25).
13. Remove fitting (25) from primer valve (8).
14. Remove two plugs (26) from primer valve (8).



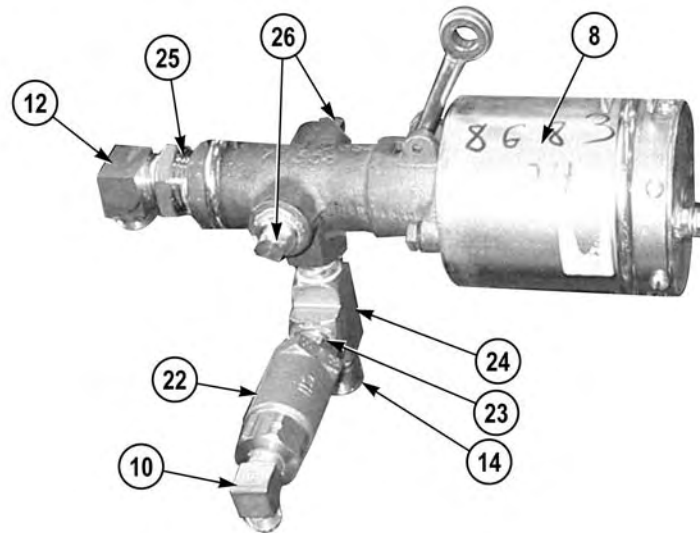


15. Remove two nuts (27), lockwashers (28), four washers (29), two screws (30), and bracket (18) from frame rail (31). Discard lockwashers.

#### END OF TASK

#### INSTALLATION

1. Install bracket (18) on frame rail (31) with two screws (30), four washers (29), two lockwashers (28), and nuts (27).



### **WARNING**

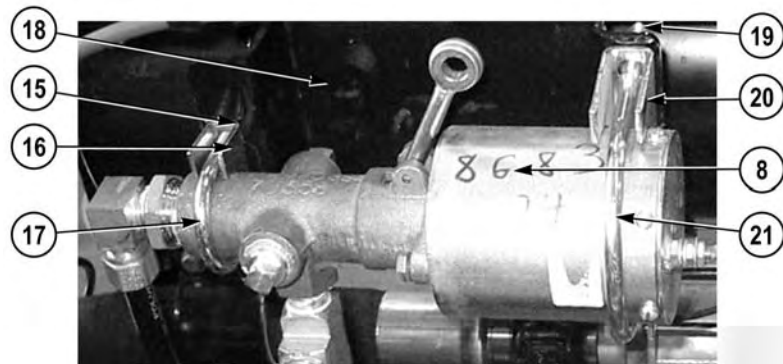


**Adhesives, solvents, and sealing compounds can burn easily, can give off harmful vapors, and are harmful to skin and clothing. To avoid injury or death, keep away from open fire and use in well-ventilated area. If adhesive, solvent, or sealing compound gets on skin or clothing, wash immediately with soap and water.**

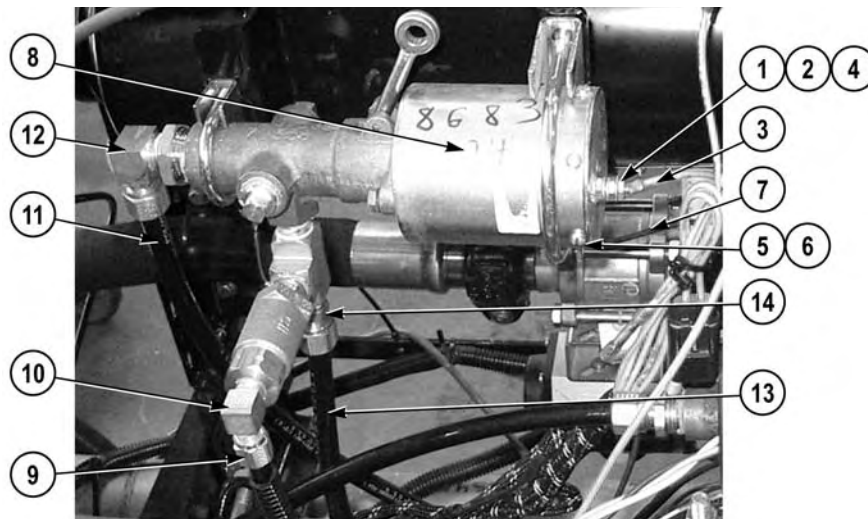
### **NOTE**

Install elbows and fittings as noted prior to removal.

2. Apply sealing compound to threads of two plugs (26), tee (24), three fittings (14), (23), and (25), and two elbows (10) and (12).
3. Install two plugs (26) on primer valve (8).
4. Install fitting (25) on primer valve (8).
5. Install elbow (12) on fitting (25).
6. Install tee (24) on primer valve (8).
7. Install two fittings (14) and (23) on tee (24).
8. Install check valve (22) on fitting (23).
9. Install elbow (10) on check valve (22).



10. Install primer valve (8) on bracket (18) with cradle (20), U-bolt (21), and two locknuts (19).
11. Install cradle (16) and U-bolt (17) on bracket (18) and primer valve (8) with two locknuts (15).



12. Install line (13) on fitting (14).
13. Install line (11) on elbow (12).
14. Install line (9) on elbow (10).
15. Install ground wire 4068 (7) on primer valve (8) with lockwasher (6) and screw (5).
16. Install wire 4065 (3) on stud (4) with washer (2) and locknut (1).

**END OF TASK**

#### **FOLLOW-ON MAINTENANCE**

Install primer valve cable on primer valve (WP 0167)

**END OF TASK**

**END OF WORK PACKAGE**



---

**FIELD LEVEL MAINTENANCE****BUMPER TURRET AUTO DRAIN VALVE REPLACEMENT**

---

**INITIAL SETUP:****Tools and Special Tools**

Tool Kit, General Mechanic's: Automotive  
(WP 0398, Item 17)

**References**

WP 0391, Fig. 64

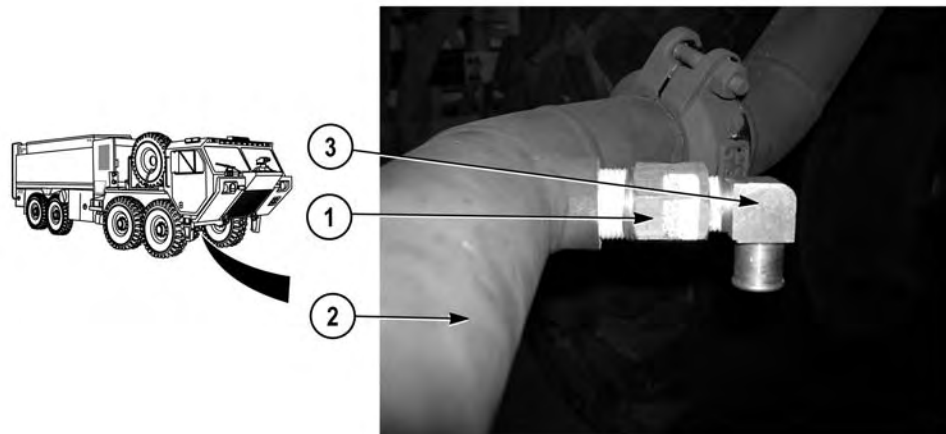
**Materials/Parts**

Compound, Sealing, Pipe Thread  
(WP 0400, Item 11)

**Equipment Conditions**

Skid plate grille removed (WP 0349)

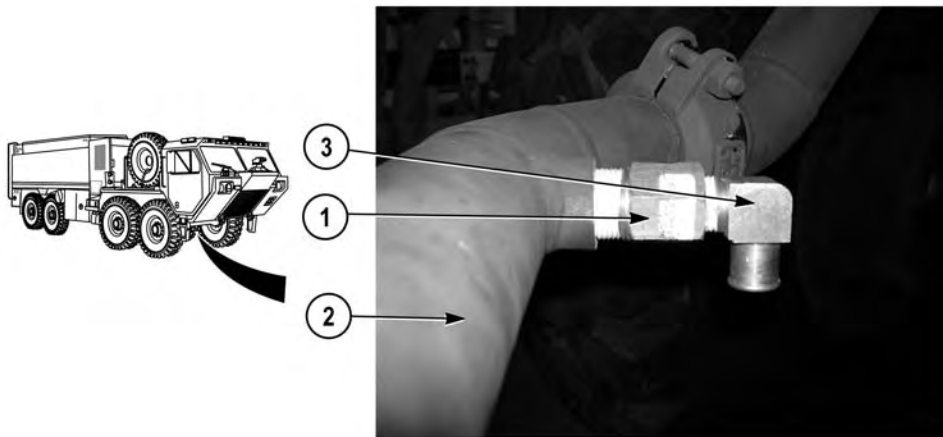
---

**REMOVAL****NOTE**

Note position of drain valve and elbow prior to removal to ensure proper installation.

1. Remove drain valve (1) from pipe (2).
2. Remove elbow (3) from drain valve (1).

**END OF TASK**

**INSTALLATION****WARNING**

**Adhesives, solvents, and sealing compounds can burn easily, can give off harmful vapors, and are harmful to skin and clothing. To avoid injury or death, keep away from open fire and use in well-ventilated area. If adhesive, solvent, or sealing compound gets on skin or clothing, wash immediately with soap and water.**

1. Apply sealing compound to threads of drain valve (1) and elbow (3).
2. Install elbow (3) on drain valve (1).

**NOTE**

Install drain valve and elbow as noted prior to removal.

3. Install drain valve (1) on pipe (2).

**END OF TASK****FOLLOW-ON MAINTENANCE**

Install skid plate grille (WP 0349)

**END OF TASK****END OF WORK PACKAGE**

---

**FIELD LEVEL MAINTENANCE**  
**FOAM TANK DRAIN VALVE REPLACEMENT**

---

**INITIAL SETUP:****Tools and Special Tools**

- Drain Pan (WP 0398, Item 4)
- Standard Automotive Tool Set (SATS),  
(WP 0398, Item 15)
  - Wrench, Adjustable, 18"
- Tool Kit, General Mechanic's: Automotive  
(WP 0398, Item 17)

**References**

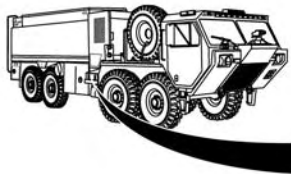
- WP 0369
- WP 0391, Fig. 21

**Equipment Conditions**

- Foam system service valve closed (WP 0004)
- Pump house panel H removed (WP 0339)

**Materials/Parts**

- Compound, Sealing, Pipe Thread  
(WP 0400, Item 11)
- Lockwasher (1)

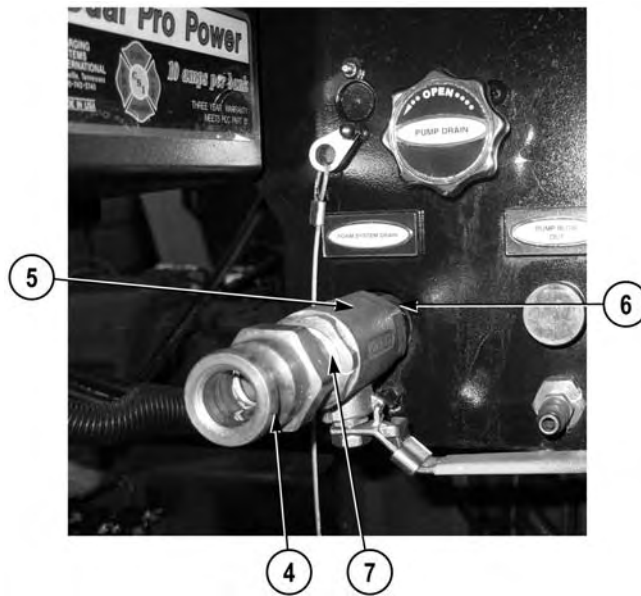
**REMOVAL**

1. Remove snap pin (1) from handle (2).
2. Remove cap (3) from adapter (4).

**NOTE**

Position drain pan under adapter to catch residual foam agent.

3. Open handle (2) on foam tank drain valve (5).

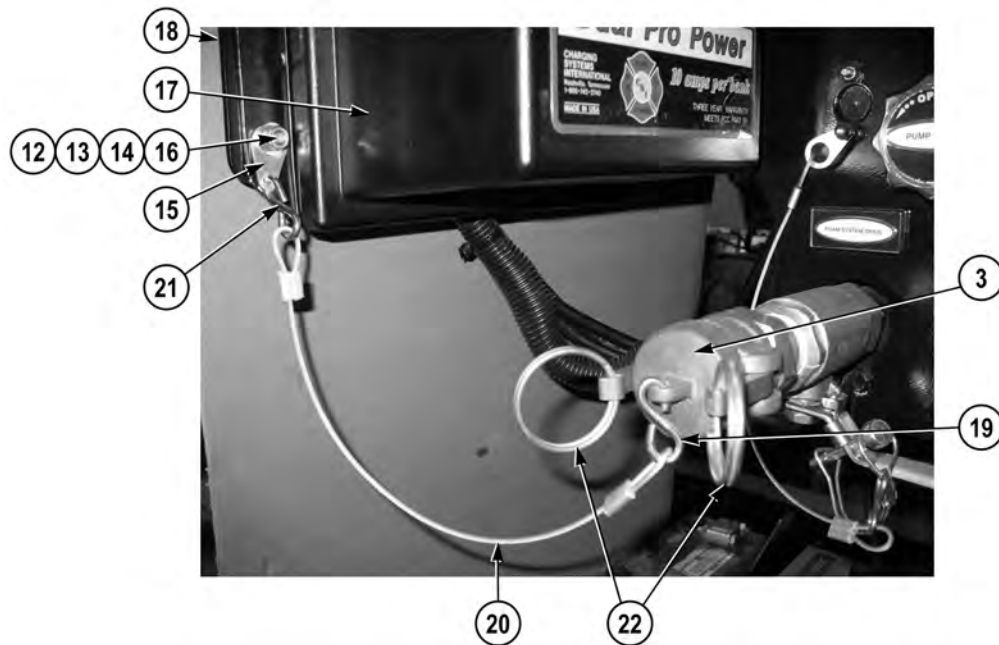


4. Remove foam tank drain valve (5) from bracket (6).
5. Remove foam tank drain valve (5) and adapter (4) from nipple (7).



6. Remove nut (8) and clip (9) from screw (10).
7. Remove wire rope (11) from clip (9) (WP 0369).





8. Remove nut (12), lockwasher (13), two washers (14), clip (15), and screw (16) from battery charger (17) and bracket (18). Discard lockwasher.
9. Remove S-hook (19) from cap (3) and wire rope (20).
10. Remove S-hook (21) from clip (15) and wire rope (20).
11. Remove two rings (22) from cap (3).

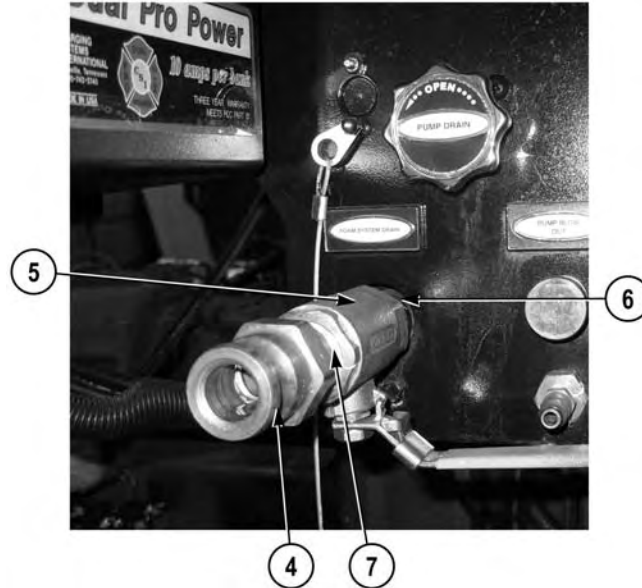
#### END OF TASK

#### INSTALLATION

1. Install two rings (22) on cap (3).
2. Install S-hook (21) on clip (15) and wire rope (20).
3. Install S-hook (19) on cap (3) and wire rope (20).
4. Install clip (15) on battery charger (17) and bracket (18) with screw (16), two washers (14), lockwasher (13), and nut (12).



5. Install wire rope (11) on clip (9) (WP 0369).
6. Install clip (9) on screw (10) with nut (8).

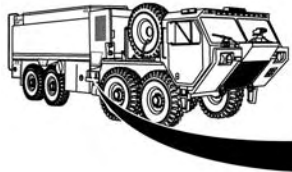


### **WARNING**



**Adhesives, solvents, and sealing compounds can burn easily, can give off harmful vapors, and are harmful to skin and clothing. To avoid injury or death, keep away from open fire and use in well-ventilated area. If adhesive, solvent, or sealing compound gets on skin or clothing, wash immediately with soap and water.**

7. Apply sealing compound to threads of nipple (7) and bracket (6).
8. Install foam tank drain valve (5) and adapter (4) on nipple (7).
9. Install foam tank drain valve (5) on bracket (6).



10. Close handle (2) on foam tank drain valve (5).
11. Install cap (3) on adapter (4).
12. Install snap pin (1) on handle (2).

#### END OF TASK

#### FOLLOW-ON MAINTENANCE

1. Open foam system service valve (WP 0004)
2. Install pump house panel H (WP 0339)

#### END OF TASK

#### END OF WORK PACKAGE

---

**FIELD LEVEL MAINTENANCE**  
**WATER TANK DRAIN VALVE REPLACEMENT**

---

**INITIAL SETUP:****Tools and Special Tools**

Tool Kit, General Mechanic's: Automotive  
(WP 0398, Item 17)

**References**

WP 0313  
WP 0391, Fig. 22

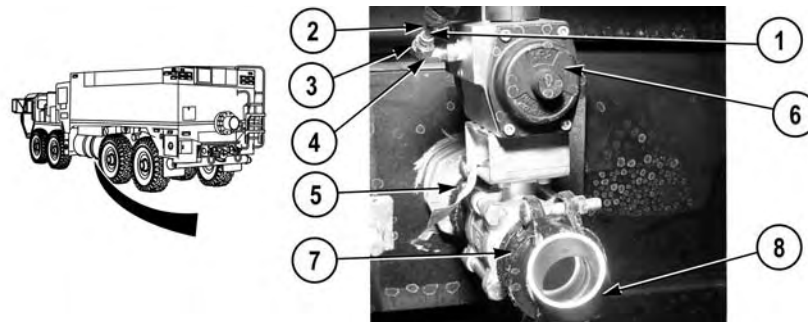
**Materials/Parts**

Compound, Sealing, Pipe Thread  
(WP 0400, Item 11)  
Tags, Identification (WP 0400, Item 23)

**Equipment Conditions**

Water tank drained (WP 0015)  
Air system drained (TM 9-2320-422-10)

---

**REMOVAL****WARNING**

**Air lines could contain residual air pressure. Air lines under pressure will move violently when removed. Ensure air system is completely drained prior to removing air lines. Failure to comply may result in serious injury to personnel.**

**NOTE**

Tag and mark air lines prior to removal to ensure proper installation.

1. Remove two air lines (1) and (2) from elbows (3) and (4).

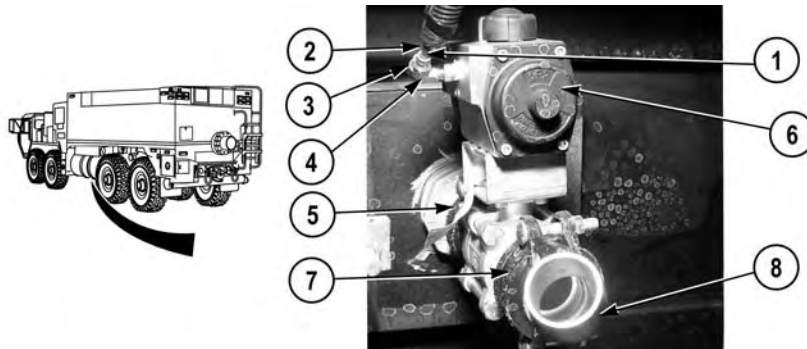
**NOTE**

Residual water may be present in valve.

2. Remove coupling (5) and valve (6) from vehicle (WP 0313).
3. Remove coupling (7) and elbow (8) from valve (6) (WP 0313).
4. Remove two elbows (3) and (4) from valve (6).

**END OF TASK**

## INSTALLATION

**WARNING**

Adhesives, solvents, and sealing compounds can burn easily, can give off harmful vapors, and are harmful to skin and clothing. To avoid injury or death, keep away from open fire and use in well-ventilated area. If adhesive, solvent, or sealing compound gets on skin or clothing, wash immediately with soap and water.

**CAUTION**

Use pipe thread sealing compound sparingly only on pipe threads. Do not apply compound to hose connections. Failure to comply may result in damage to equipment.

1. Apply sealing compound to threads of two elbows (3) and (4).
2. Install two elbows (4) and (3) on valve (6).
3. Install elbow (8) and coupling (7) on valve (6) (WP 0313).
4. Install valve (6) and coupling (5) on vehicle (WP 0313).
5. Install two air lines (2) and (1) on elbows (4) and (3).

**END OF TASK**

**END OF WORK PACKAGE**

## FIELD LEVEL MAINTENANCE

## BUMPER TURRET FOAM METERING VALVE AND ORIFICE REPLACEMENT

## INITIAL SETUP:

**Tools and Special Tools**

Tool Kit, General Mechanic's: Automotive  
(WP 0398, Item 17)

**References**

WP 0313  
WP 0391, Fig. 21

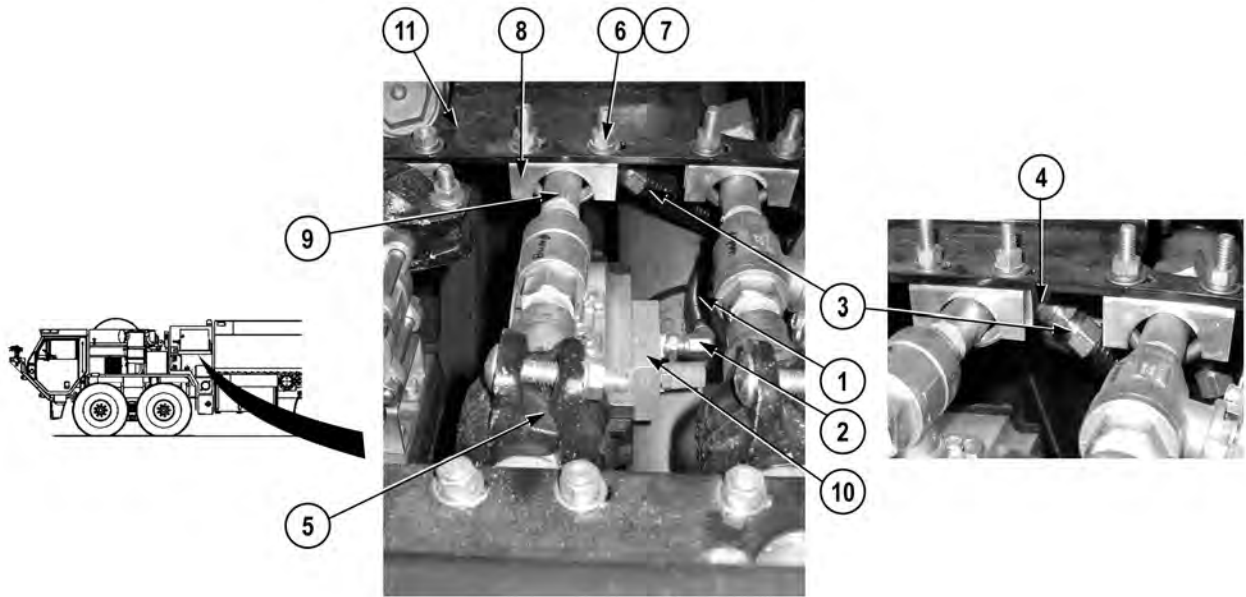
**Materials/Parts**

Compound, Sealing, Pipe Thread  
(WP 0400, Item 11)  
Tags, Identification (WP 0400, Item 23)  
Locknut (2)

**Equipment Conditions**

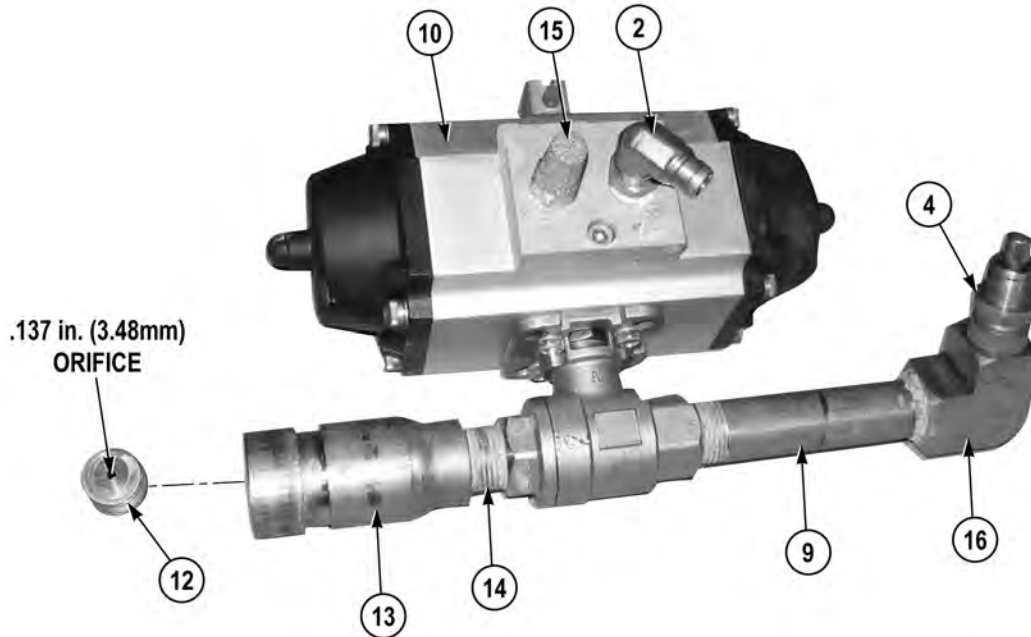
Air system drained (TM 9-2320-422-10)  
Hose reel hose removed (WP 0316)

## REMOVAL

**NOTE**

Tag and mark air line and line prior to removal to ensure proper installation.

1. Remove air line (1) from elbow (2).
2. Remove line (3) from fitting (4).
3. Remove coupling (5) from vehicle (WP 0313).
4. Remove two locknuts (6), U-bolt (7), cradle (8), pipe (9), and valve (10) from bracket (11). Discard locknuts.



5. Remove orifice fitting (12) from adapter (13).
6. Remove adapter (13) and nipple (14) from valve (10).
7. Remove pipe (9) from valve (10).
8. Remove elbow (2) and muffler (15) from valve (10).
9. Remove nipple (14) from adapter (13).
10. Remove fitting (4) and pipe (9) from elbow (16).

## INSTALLATION

### WARNING



**Adhesives, solvents, and sealing compounds can burn easily, can give off harmful vapors, and are harmful to skin and clothing. To avoid injury or death, keep away from open fire and use in well-ventilated area. If adhesive, solvent, or sealing compound gets on skin or clothing, wash immediately with soap and water.**

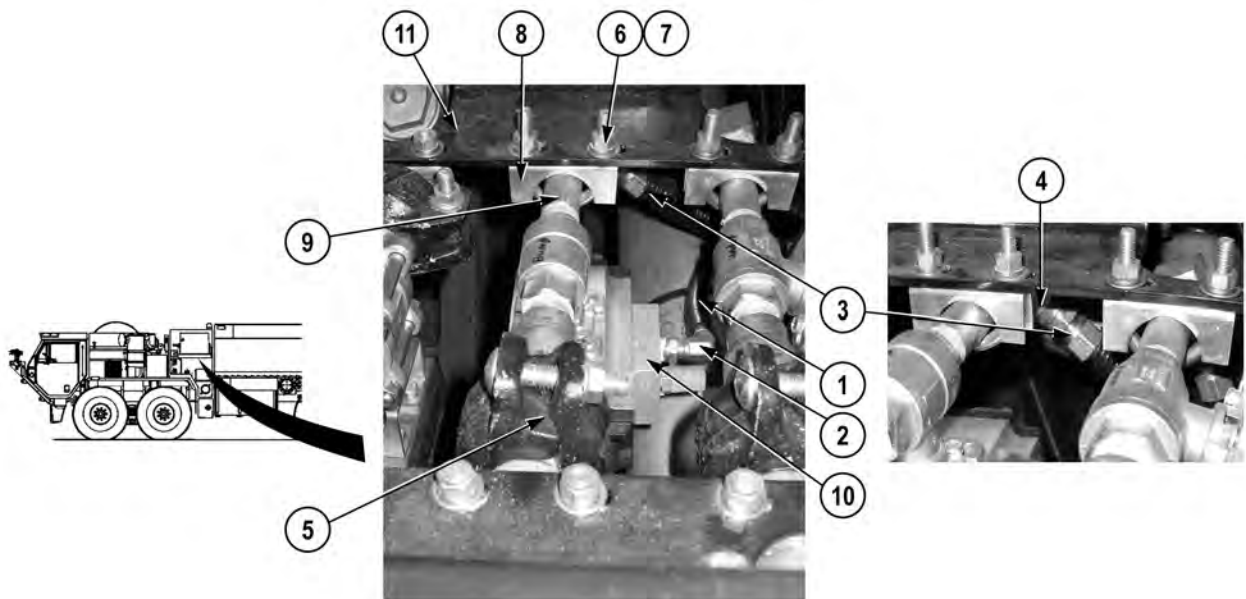
1. Apply sealing compound to threads of elbow (2), fitting (4), pipe (9), nipple (14), and muffler (15).



**NOTE**

Install elbow and fittings as noted prior to removal.

2. Install fitting (4) and pipe (9) on elbow (16).
3. Install nipple (14) on adapter (13).
4. Install elbow (2) and muffler (15) on valve (10).
5. Install pipe (9) on valve (10).
6. Install nipple (14) and adapter (13) on valve (10).
7. Install orifice fitting (12) on adapter (13).



8. Install pipe (9) and valve (10) on bracket (11) with cradle (8), U-bolt (7), and two locknuts (6).
9. Install coupling (5) on vehicle (WP 0313).
10. Install line (3) on fitting (4).
11. Install air line (1) on elbow (2).

**END OF TASK**

**FOLLOW-ON MAINTENANCE**

Install hose reel hose (WP 0316)

**END OF TASK**

**END OF WORK PACKAGE**



## FIELD LEVEL MAINTENANCE

## UNDER TRUCK NOZZLES FOAM METERING VALVE AND ORIFICE REPLACEMENT

## INITIAL SETUP:

**Tools and Special Tools**

Tool Kit, General Mechanic's: Automotive  
(WP 0398, Item 17)

**References**

WP 0313  
WP 0391, Fig. 21

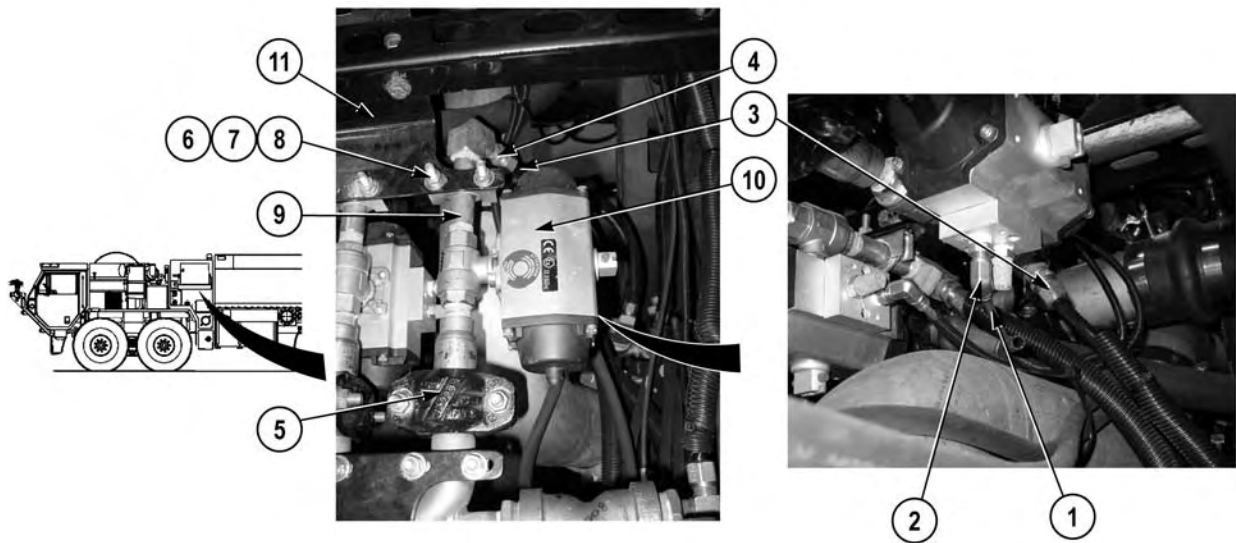
**Materials/Parts**

Compound, Sealing, Pipe Thread  
(WP 0400, Item 11)  
Tags, Identification (WP 0400, Item 23)  
Locknut (2)

**Equipment Conditions**

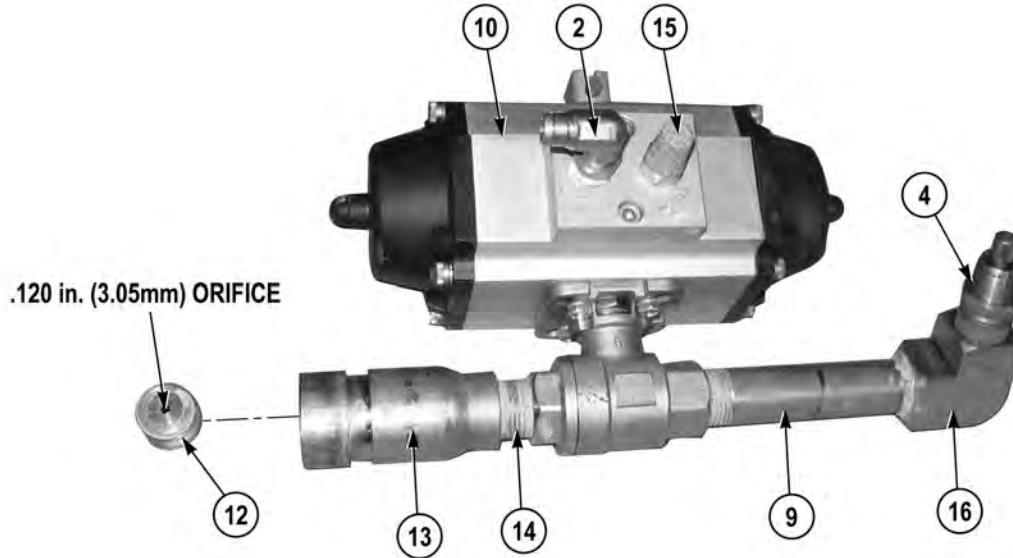
Air system drained (TM 9-2320-422-10)  
Hose reel hose removed (WP 0316)

## REMOVAL

**NOTE**

Tag and mark air line and line prior to removal to ensure proper installation.

1. Remove air line (1) from elbow (2).
2. Remove line (3) from fitting (4).
3. Remove coupling (5) from vehicle (WP 0313).
4. Remove two locknuts (6), U-bolt (7), cradle (8), pipe (9) and valve (10) from bracket (11). Discard locknuts.



### NOTE

Note position of elbow and fittings prior to removal to ensure proper installation.

5. Remove orifice fitting (12) from adapter (13).
6. Remove adapter (13) and nipple (14) from valve (10).
7. Remove pipe (9) from valve (10).
8. Remove elbow (2) and muffler (15) from valve (10).
9. Remove nipple (14) from adapter (13).
10. Remove fitting (4) and pipe (9) from elbow (16).

### END OF TASK

### INSTALLATION

#### WARNING



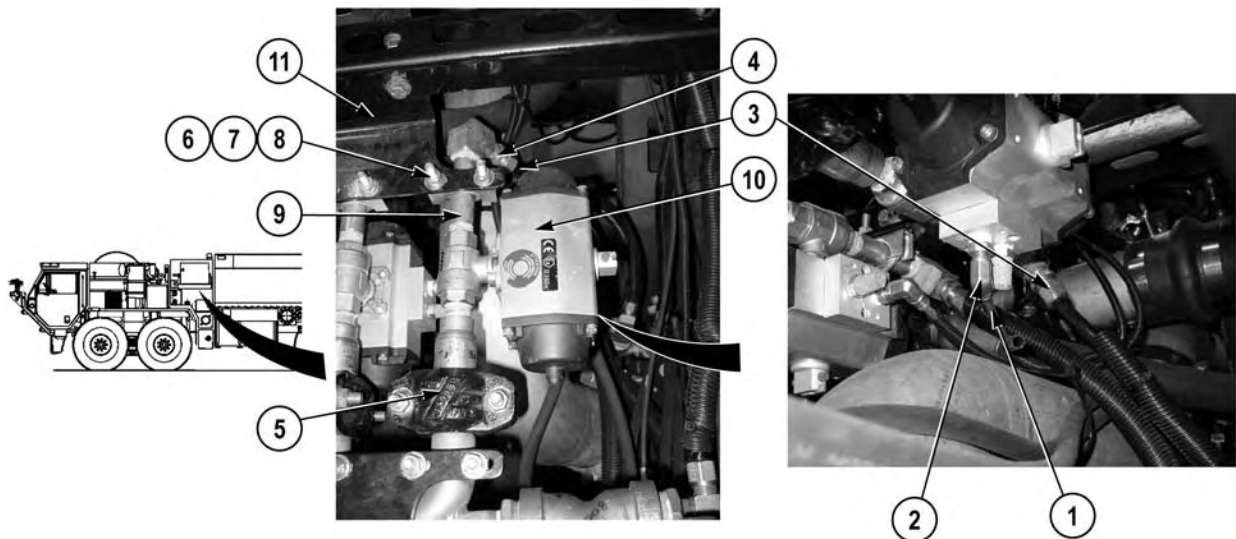
**Adhesives, solvents, and sealing compounds can burn easily, can give off harmful vapors, and are harmful to skin and clothing. To avoid injury or death, keep away from open fire and use in well-ventilated area. If adhesive, solvent, or sealing compound gets on skin or clothing, wash immediately with soap and water.**

1. Apply sealing compound to threads of elbow (2), fitting (4), pipe (9), nipple (14), and muffler (15).

**NOTE**

Install elbow and fittings as noted prior to removal.

2. Install fitting (4) and pipe (9) on elbow (16).
3. Install nipple (14) on adapter (13).
4. Install elbow (2) and muffler (15) on valve (10).
5. Install pipe (9) on valve (10).
6. Install nipple (14) and adapter (13) on valve (10).
7. Install orifice fitting (12) on adapter (13).



8. Install pipe (9) and valve (10) on bracket (11) with cradle (8), U-bolt (7), and two locknuts (6).
9. Install coupling (5) on vehicle (WP 0313).
10. Install line (3) on fitting (4).
11. Install air line (1) on elbow (2).

**END OF TASK**

**FOLLOW-ON MAINTENANCE**

Install hose reel hose (WP 0316)

**END OF TASK**

**END OF WORK PACKAGE**



**FIELD LEVEL MAINTENANCE**  
**FOAM TANK LEVEL PROBE REPLACEMENT**

**INITIAL SETUP:****Tools and Special Tools**

Tool Kit, General Mechanic's: Automotive  
(WP 0398, Item 17)

**References:**

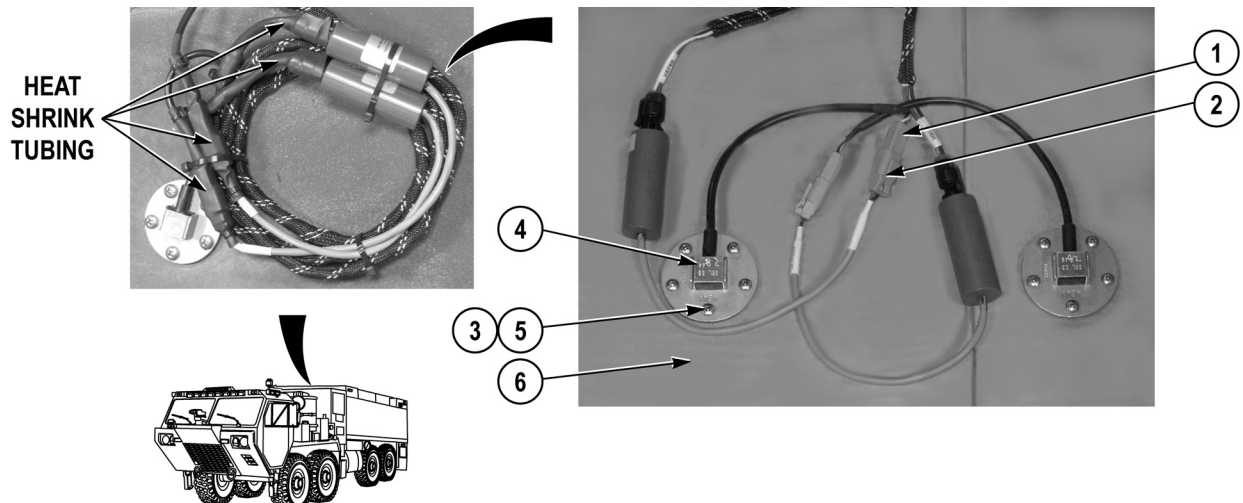
TM 9-2320-325-14&P  
WP 0022  
WP 0391, Fig. 24

**Materials/Parts**

Tags, Identification (WP 0400, Item 23)  
Ties, Cable, Plastic (WP 0400, Item 26)  
Tube, Shrink (WP 0400, Item 27)  
Gasket (1)

**Equipment Conditions**

Foam/water tank level probe cover removed  
(WP 0189)

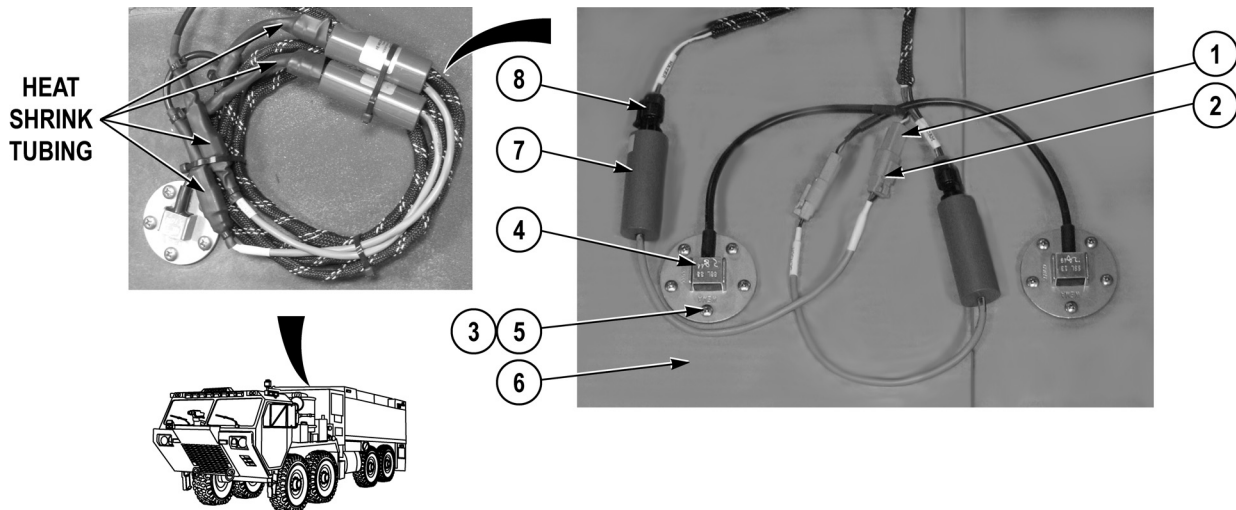
**REMOVAL**

**⚠ CAUTION**

**Both adapter connector ends must be covered with heat shrink tubing. Failure to comply will allow moisture to enter connector ends and not allow foam level gauge to function properly.**

**NOTE**

- Tag and mark connectors prior to removal to ensure proper installation.
  - Remove cable ties as required.
  - Foam level may be higher than top of probe. Perform Step (1) if foam system requires draining.
1. Drain foam tank (WP 0022).
  2. Disconnect foam level probe connector (1) from adapter connector (2).
  3. Remove five screws (3), foam level probe (4), and gasket (5) from tank (6). Discard gasket.

**NOTE**

Perform Step (4) if adapter needs to be removed.

4. Disconnect adapter connector (7) from passenger side body wire harness connector (8).

**END OF TASK****INSTALLATION****NOTE**

- Perform Step (1) if adapter was removed.
- Install cable ties as required.
- Both ends of adapter connector must be covered with heat shrink tubing before connecting adapter connector to passenger side body wire harness connector and foam level probe (TM 9-2320-325-14&P).

1. Connect passenger side body wire harness connector (8) on adapter connector (7).
2. Install gasket (5) and foam level probe (4) on tank (6) with five screws (3).
3. Connect adapter connector (2) on foam level probe connector (1).

**FOLLOW-ON MAINTENANCE**

Install foam/water tank level probe cover (WP 0189)

**END OF TASK****END OF WORK PACKAGE**



---

**FIELD LEVEL MAINTENANCE**  
**FOAM SYSTEM SHUTOFF VALVE REPLACEMENT**

---

**INITIAL SETUP:****Tools and Special Tools**

Tool Kit, General Mechanic's: Automotive  
(WP 0398, Item 17)

**References**

WP 0313  
WP 0391, Fig. 21

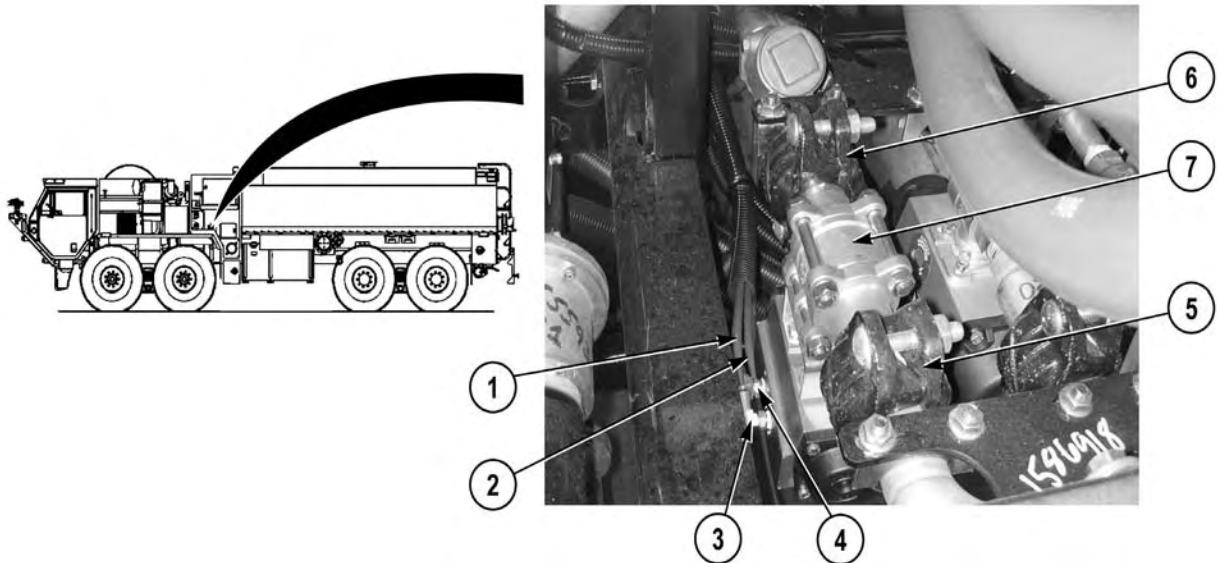
**Materials/Parts**

Tags, Identification (WP 0400, Item 23)  
Tape, Teflon (WP 0400, Item 25)  
Ties, Cable, Plastic (WP 0400, Item 26)

**Equipment Conditions**

Air system drained (TM 9-2320-422-10)  
Foam system service valve closed (WP 0004)  
Hose reel hose removed (WP 0316)

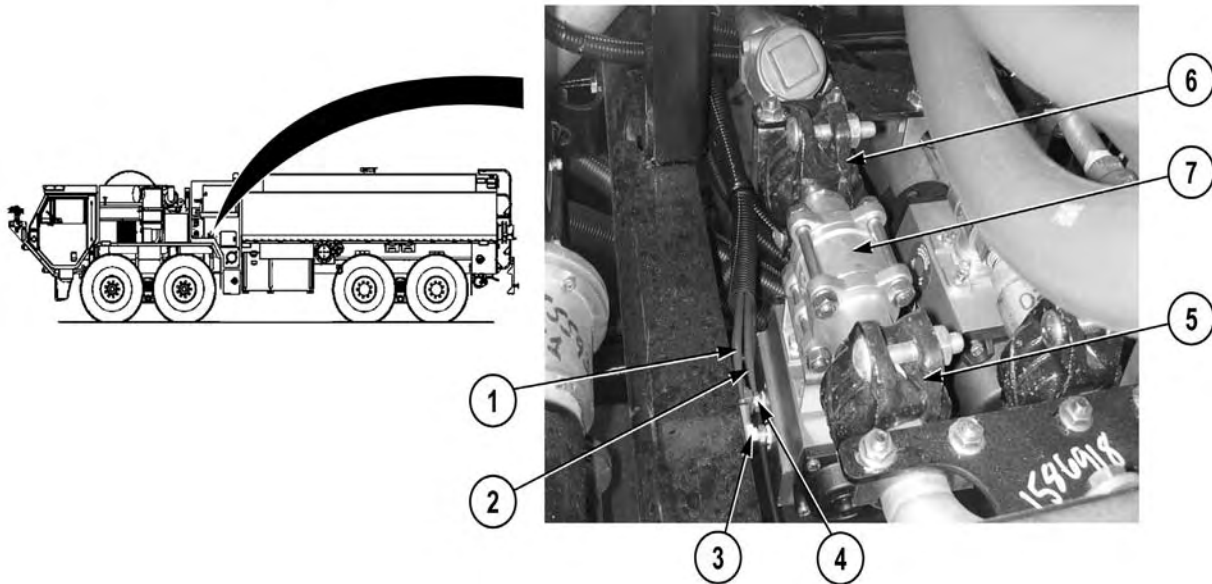
---

**REMOVAL****NOTE**

- Tag and mark air lines prior to removal to ensure proper installation.
- Remove cable ties as required.
- Note position of elbows prior to removal to ensure proper installation.

1. Remove two air lines (1) and (2) from elbows (3) and (4).
2. Remove two couplings (5) and (6) and valve (7) from vehicle (WP 0313).
3. Remove two elbows (3) and (4) from valve (7).

**END OF TASK**

**INSTALLATION**

**⚠ CAUTION**

Use teflon tape sparingly only on pipe threads. Do not apply tape to hose connections. Damage to equipment may result.

1. Apply teflon tape to threads of two elbows (3) and (4).

**NOTE**

Install elbows in same position as noted prior to removal.

2. Install two elbows (4) and (3) on valve (7).
3. Install valve (7) and two couplings (6) and (5) on vehicle (WP 0313).

**NOTE**

Install cable ties as required.

4. Install two air lines (2) and (1) on elbows (4) and (3).

**END OF TASK****FOLLOW-ON MAINTENANCE**

1. Install hose reel hose (WP 0316)
2. Open foam system service valve (WP 0004)

**END OF TASK****END OF WORK PACKAGE**

---

**FIELD LEVEL MAINTENANCE**  
**FOAM SYSTEM EDUCTOR REPLACEMENT**

---

**INITIAL SETUP:****Tools and Special Tools**

Tool Kit, General Mechanic's: Automotive  
(WP 0398, Item 17)

**References**

WP 0391, Fig. 21

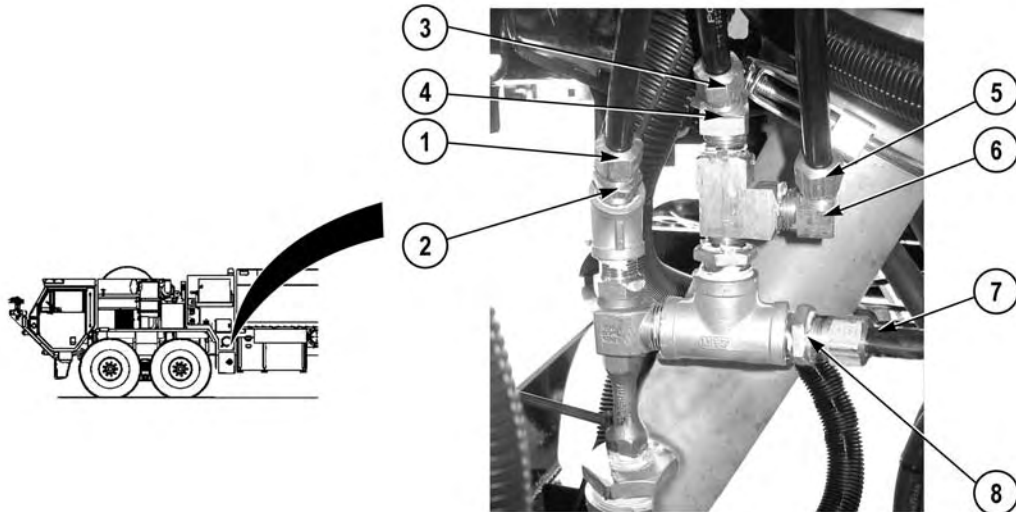
**Materials/Parts**

Compound, Sealing, Pipe Thread  
(WP 0400, Item 11)  
Tags, Identification (WP 0400, Item 23)

**Equipment Conditions**

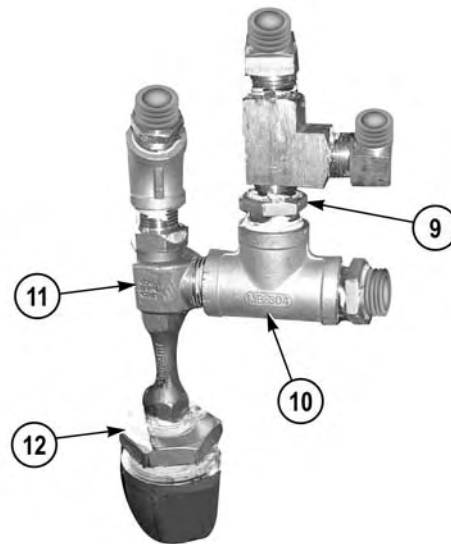
Engine OFF (TM 9-2320-422-10)  
Wheels chocked (TM 9-2320-422-10)

---

**REMOVAL****NOTE**

Tag and mark lines prior to removal to ensure proper installation.

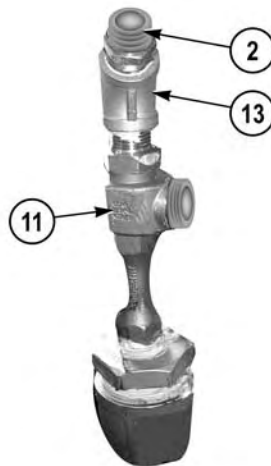
1. Remove line (1) from fitting (2).
2. Remove line (3) from elbow (4).
3. Remove line (5) from elbow (6).
4. Remove line (7) from fitting (8).



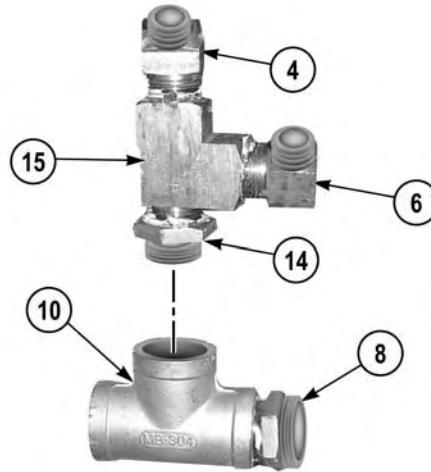
### NOTE

Note position of elbows and fittings prior to removal to ensure proper installation.

5. Remove fitting (9) from tee (10).
6. Remove tee (10) from eductor (11).
7. Remove eductor (11) from fitting (12).



8. Remove elbow (13) from eductor (11).
9. Remove fitting (2) from elbow (13).



10. Remove two elbows (4) and (6) and fitting (14) from tee (15).
11. Remove fitting (8) from tee (10).

#### END OF TASK

#### INSTALLATION

#### NOTE

Install elbows and fittings as noted prior to removal.

1. Install fitting (8) on tee (10) (WP 0318).

#### WARNING

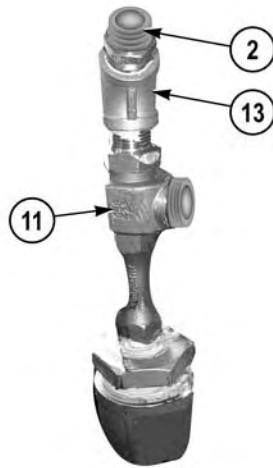


**Adhesives, solvents, and sealing compounds can burn easily, can give off harmful vapors, and are harmful to skin and clothing. To avoid injury or death, keep away from open fire and use in well-ventilated area. If adhesive, solvent, or sealing compound gets on skin or clothing, wash immediately with soap and water.**

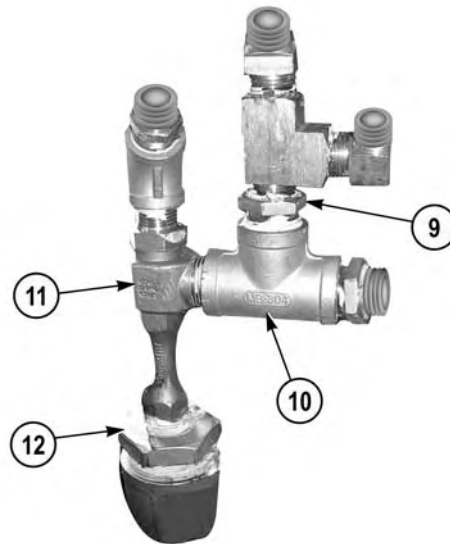
#### CAUTION

**Use pipe thread sealing compound sparingly only on pipe threads. Do not apply compound to hose connections. Damage to equipment may result.**

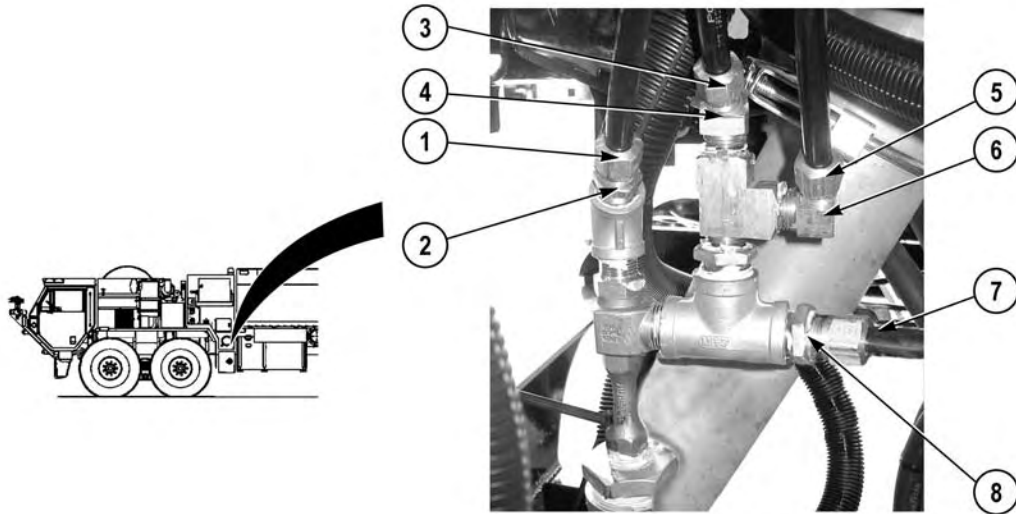
2. Apply pipe thread sealing compound to threads of two elbows (6) and (4), tee (15), and fitting (2).
3. Install two elbows (6) and (4) and fitting (14) on tee (15).



4. Install fitting (2) on elbow (13).
5. Install elbow (13) on eductor (11) (WP 0318).



6. Install eductor (11) on fitting (12) (WP 0318).
7. Install tee (10) on eductor (11) (WP 0318).
8. Install fitting (9) on tee (10) (WP 0318).



9. Install line (7) on fitting (8).
10. Install line (5) on elbow (6).
11. Install line (3) on elbow (4).
12. Install line (1) on fitting (2).

**END OF TASK**

**FOLLOW-ON MAINTENANCE**

Remove wheel chocks (TM 9-2320-422-10)

**END OF TASK**

**END OF WORK PACKAGE**





---

**FIELD LEVEL MAINTENANCE**  
**FOAM SYSTEM EDUCTOR VALVE REPLACEMENT**

---

**INITIAL SETUP:****Tools and Special Tools**

Tool Kit, General Mechanic's: Automotive  
(WP 0398, Item 17)

**References**

WP 0313  
WP 0391, Fig. 21

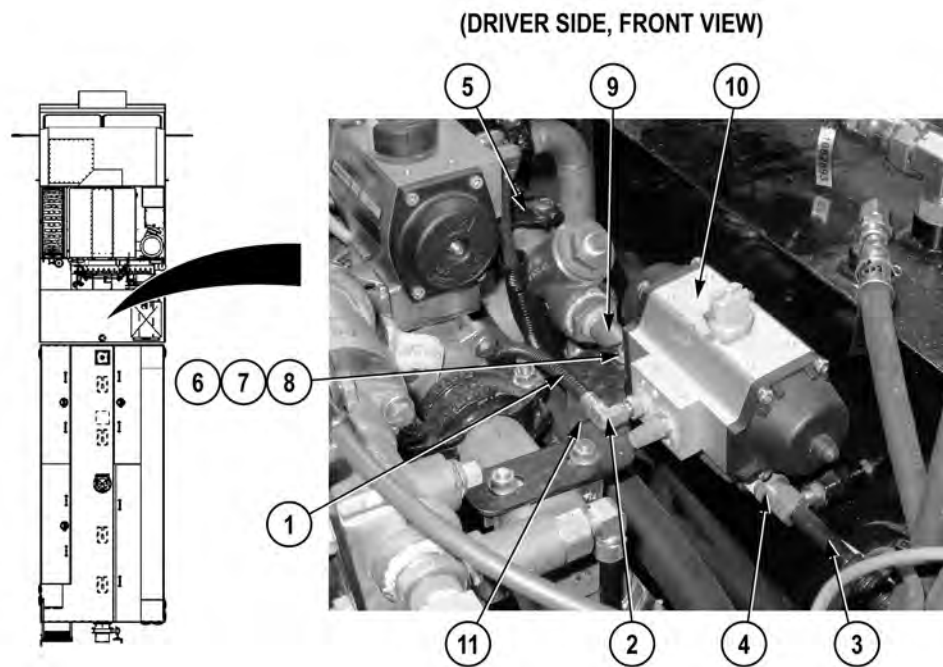
**Materials/Parts**

Compound, Sealing, Pipe Thread  
(WP 0400, Item 11)  
Locknut (2)

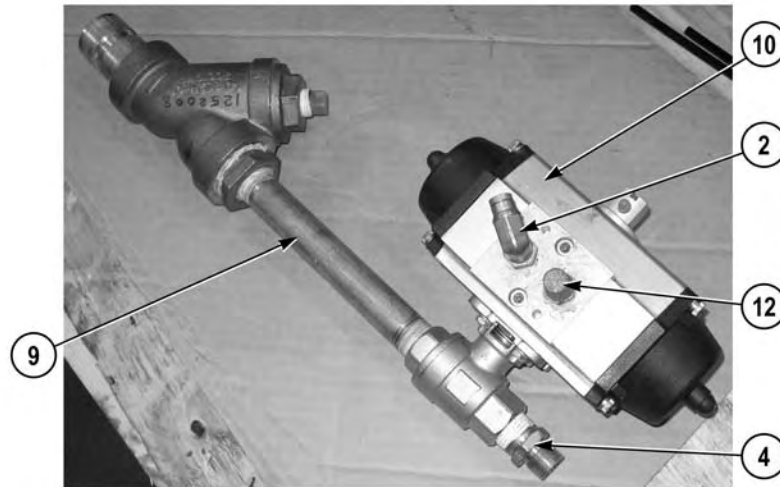
**Equipment Conditions**

Air system drained (TM 9-2320-422-10)  
Pump house panel K removed (WP 0339)

---

**REMOVAL**

1. Remove air line (1) from elbow (2).
2. Remove line (3) from fitting (4).
3. Remove coupling (5) from vehicle (WP 0313).
4. Remove two locknuts (6), U-bolt (7), cradle (8), pipe (9) and valve (10) from bracket (11). Discard locknuts.



### NOTE

Note position of elbow and muffler prior to removal to ensure proper installation.

5. Remove fitting (4) and pipe (9) from valve (10).
6. Remove elbow (2) and muffler (12) from valve (10).

### END OF TASK

### INSTALLATION

#### WARNING



Adhesives, solvents, and sealing compounds can burn easily, can give off harmful vapors, and are harmful to skin and clothing. To avoid injury or death, keep away from open fire and use in well-ventilated area. If adhesive, solvent, or sealing compound gets on skin or clothing, wash immediately with soap and water.

#### CAUTION

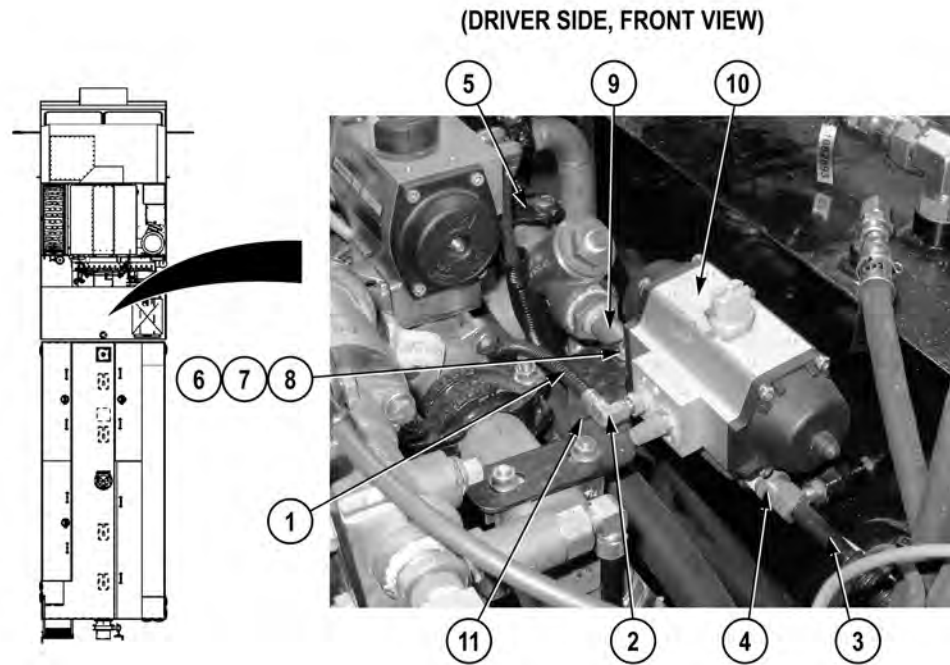
Use pipe thread sealing compound sparingly only on pipe threads. Do not apply compound to hose connections. Damage to equipment may result.

1. Apply sealing compound to threads of elbow (2) muffler (12), fitting (4), and pipe (9).

### NOTE

Install elbow and muffler as noted prior to removal.

2. Install elbow (2) and muffler (12) on valve (10).
3. Install fitting (4) and pipe (9) on valve (10).



4. Install valve (10) and pipe (9) on bracket (11) with cradle (8), U-bolt (7), and two locknuts (6).
5. Install coupling (5) on vehicle (WP 0313).
6. Install line (3) on fitting (4).
7. Install air line (1) on elbow (2).

**END OF TASK**

**FOLLOW-ON MAINTENANCE**

Install pump house panel K (WP 0339)

**END OF TASK**

**END OF WORK PACKAGE**



---

**FIELD LEVEL MAINTENANCE**  
**FOAM SYSTEM FLUSH VALVE REPLACEMENT**

---

**INITIAL SETUP:****Tools and Special Tools**

Tool Kit, General Mechanic's: Automotive  
(WP 0398, Item 17)

**References**

WP 0313  
WP 0391, Fig. 21

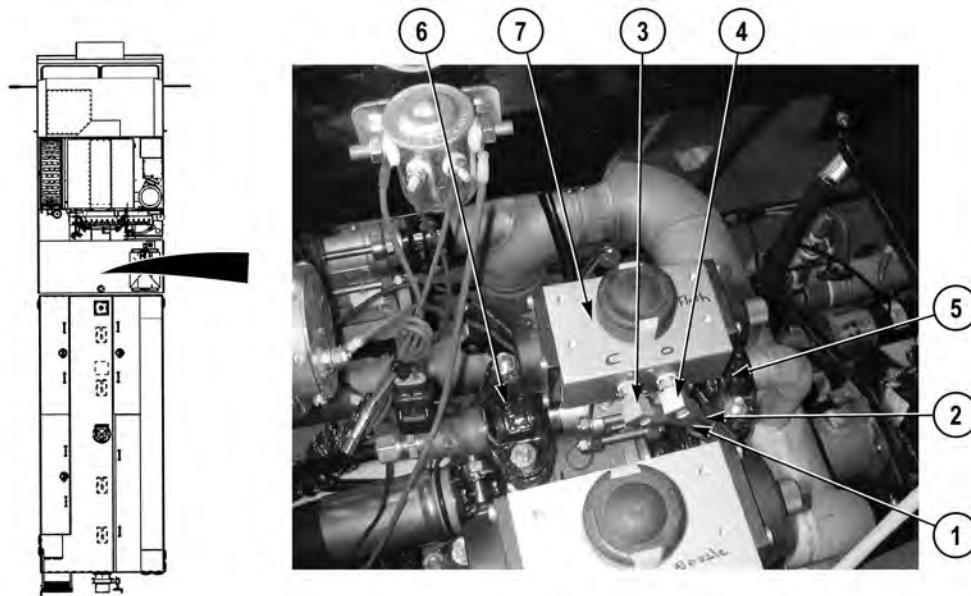
**Materials/Parts**

Compound, Sealing, Pipe Thread  
(WP 0400, Item 11)  
Tags, Identification (WP 0400, Item 23)  
Tape, Teflon (WP 0400, Item 25)

**Equipment Conditions**

Air system drained (TM 9-2320-422-10)  
Pump house panel K removed (WP 0339)

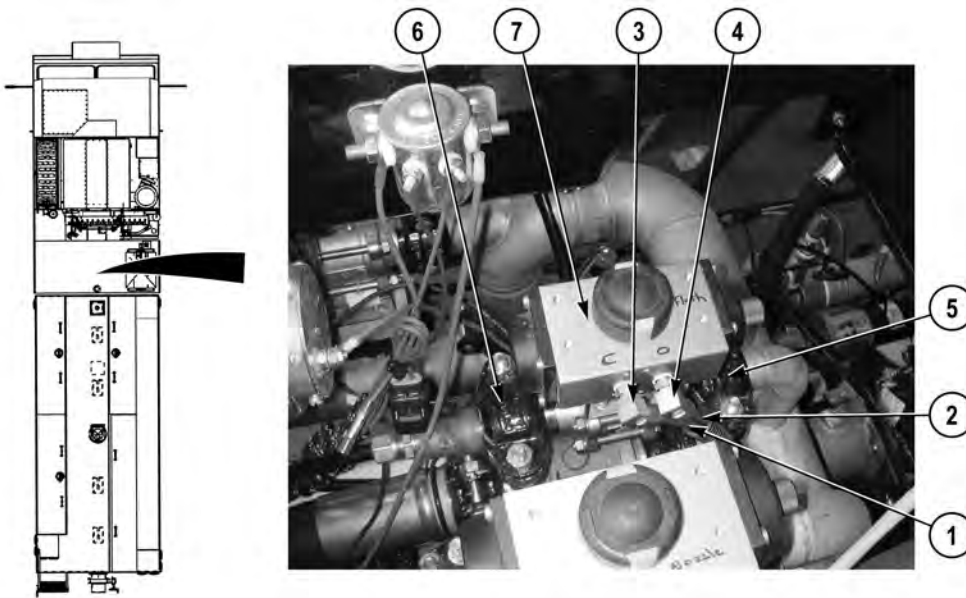
---

**REMOVAL****NOTE**

- Tag and mark air lines prior to removal.
- Note position of elbows prior to removal to ensure proper installation.

1. Remove two air lines (1) and (2) from elbows (3) and (4).
2. Remove two couplings (5) and (6) and valve (7) from vehicle (WP 0313).
3. Remove two elbows (3) and (4) from valve (7).

**END OF TASK**

**INSTALLATION**

1. Apply teflon tape to threads of two elbows (3) and (4).

**NOTE**

Install elbows in same position as noted prior to removal.

2. Install two elbows (4) and (3) on valve (7).
3. Install valve (7) on vehicle with two couplings (6) and (5) (WP 0313).
4. Install two air lines (2) and (1) on elbows (4) and (3).

**END OF TASK****FOLLOW-ON MAINTENANCE**

Install pump house panel K (WP 0339)

**END OF TASK****END OF WORK PACKAGE**

---

**FIELD LEVEL MAINTENANCE**  
**FOAM SYSTEM INLET CHECK VALVE REPLACEMENT**

---

**INITIAL SETUP:****Tools and Special Tools**

Tool Kit, General Mechanic's: Automotive  
(WP 0398, Item 17)

**References**

WP 0313  
WP 0391, Fig. 21

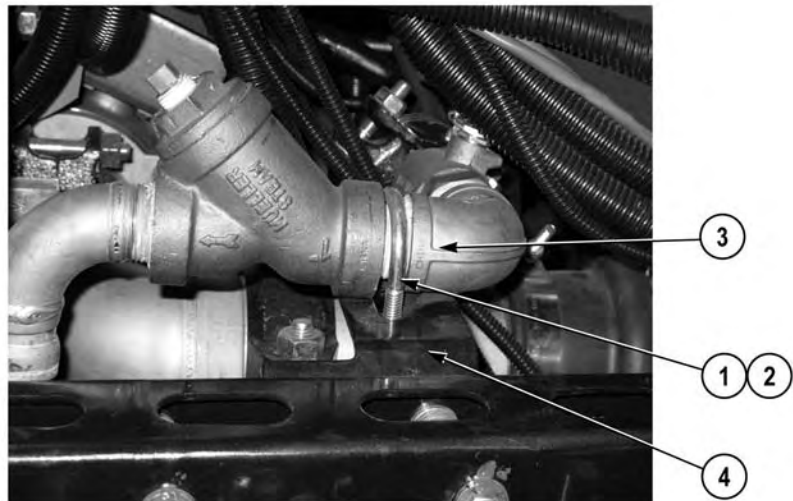
**Materials/Parts**

Compound, Sealing, Pipe Thread  
(WP 0400, Item 11)  
Locknut (2)  
Locknut (2)

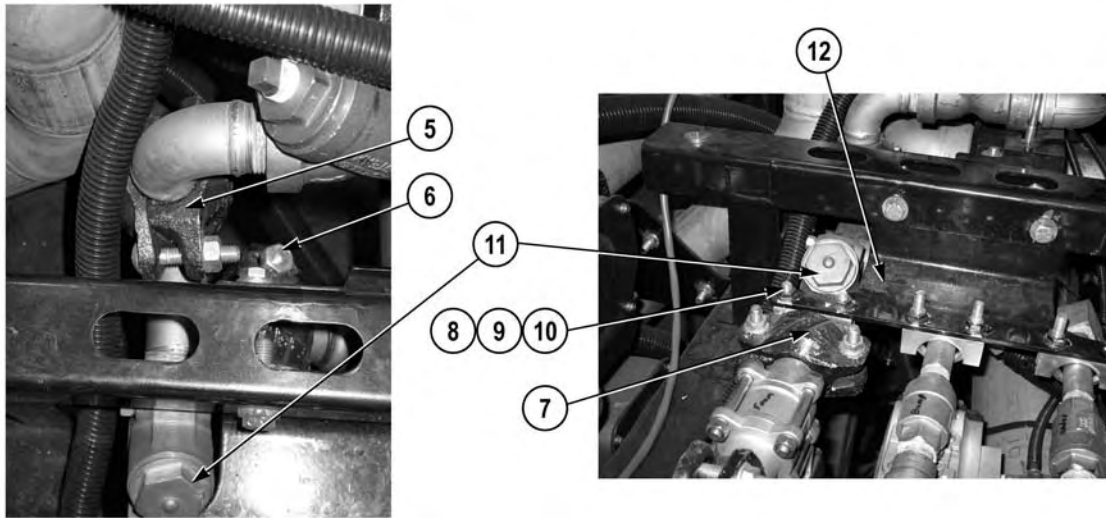
**Equipment Conditions**

Foam system service valve closed (WP 0004)  
Hose reel removed (WP 0247)

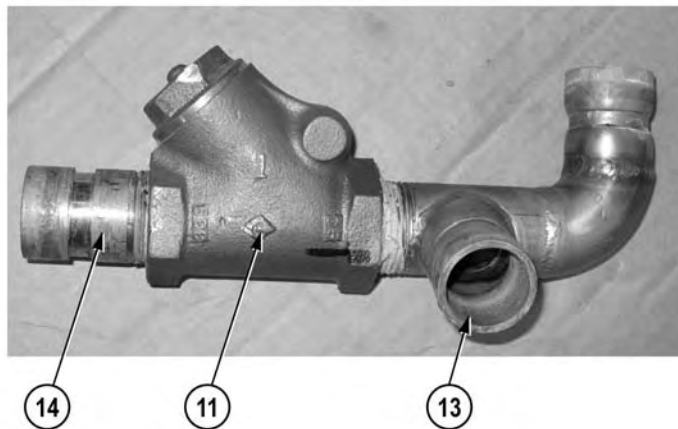
---

**REMOVAL**

1. Remove two locknuts (1) and U-bolt (2) from pipe (3) and bracket (4). Discard locknuts.



2. Remove three couplings (5), (6), and (7) from vehicle (WP 0313).
3. Remove two locknuts (8), U-bolt (9), cradle (10), and foam system inlet check valve (11) from bracket (12). Discard locknuts.



**NOTE**

Note position of supply/drain weldment on check valve prior to removal to ensure proper installation.

4. Remove supply/drain weldment (13) and nipple (14) from foam system inlet check valve (11).

**END OF TASK**



**INSTALLATION****WARNING**

Adhesives, solvents, and sealing compounds can burn easily, can give off harmful vapors, and are harmful to skin and clothing. To avoid injury or death, keep away from open fire and use in well-ventilated area. If adhesive, solvent, or sealing compound gets on skin or clothing, wash immediately with soap and water.

**NOTE**

Install supply/drain weldment on check valve as noted prior to removal.

1. Apply sealing compound to threads of supply/drain weldment (13) and nipple (14).
2. Install nipple (14) and supply/drain weldment (13) on foam system inlet check valve (11).
3. Install foam system inlet check valve (11) on bracket (12) with cradle (10), U-bolt (9), and two locknuts (8).
4. Install three couplings (7), (6), and (5) on vehicle (WP 0313).



5. Install U-bolt (2) on bracket (4) and pipe (3) with two locknuts (1).

**END OF TASK****FOLLOW-ON MAINTENANCE**

1. Open foam system service valve (WP 0004)
2. Install hose reel (WP 0247)

**END OF TASK****END OF WORK PACKAGE**



---

**FIELD LEVEL MAINTENANCE**  
**FOAM SYSTEM MANUAL METERING VALVE REPLACEMENT**

---

**INITIAL SETUP:****Tools and Special Tools**

Tool Kit, General Mechanic's: Automotive  
(WP 0398, Item 17)

**Materials/Parts**

Compound, Sealing, Pipe Thread,  
(WP 0400, Item 11)  
Preformed Packing (1)  
Lockwasher (2)  
Lockwasher (1)  
Lockwasher (2)

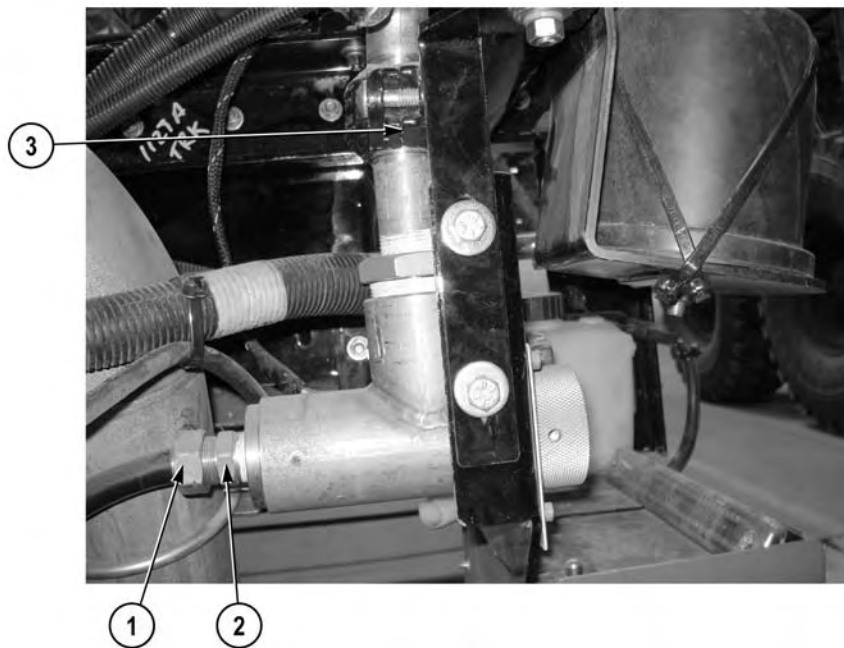
**References**

WP 0160  
WP 0161  
WP 0164  
WP 0253  
WP 0313  
WP 0391, Fig. 21, 71

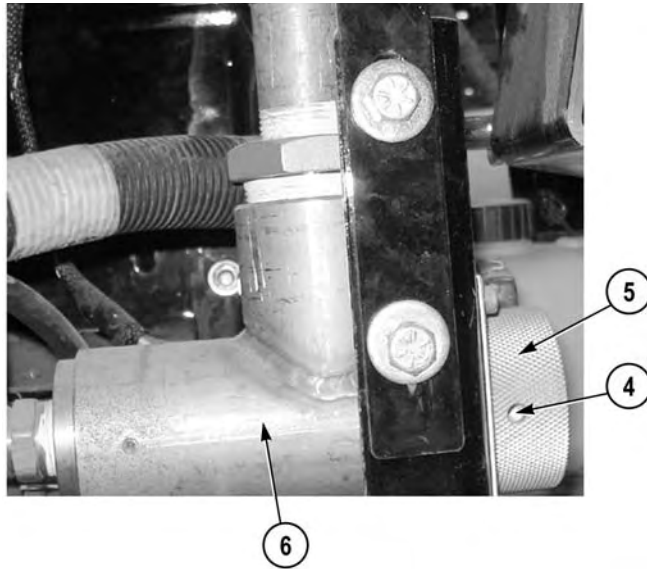
**Equipment Conditions**

Pump house panels A and B removed (WP 0339)

---

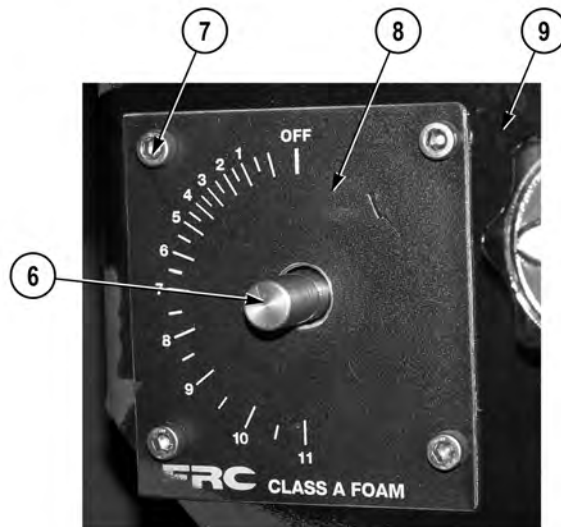
**REMOVAL**

1. Remove line (1) from fitting (2).
2. Remove coupling (3) from vehicle (WP 0313).

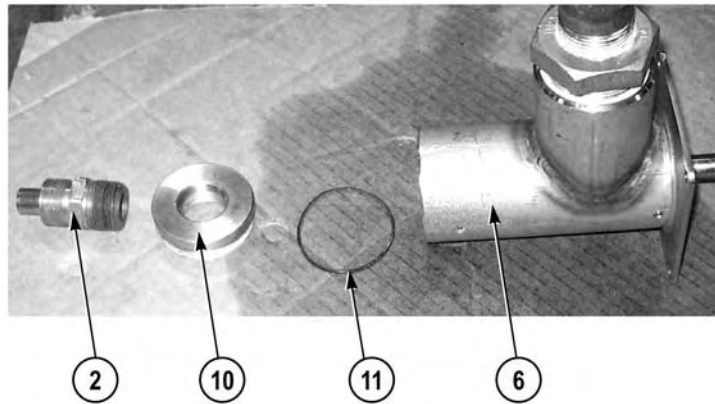
**NOTE**

Note position of valve control knob prior to removal to ensure proper installation.

3. Remove two setscrews (4) and valve control knob (5) from valve (6).



4. Remove four screws (7), data plate (8), and valve (6) from bracket (9).



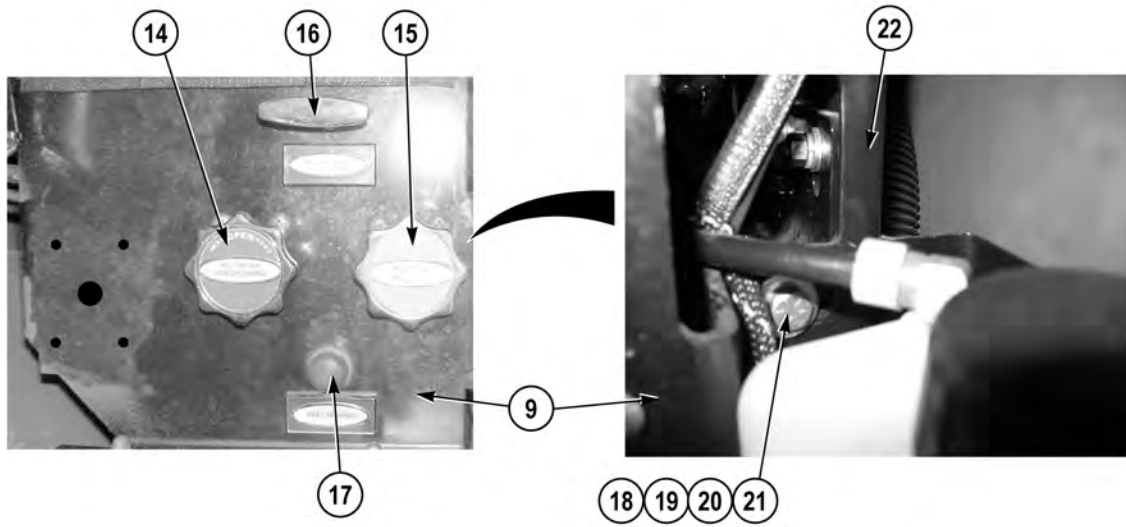
### NOTE

Note position of fitting and adapters prior to removal to ensure proper installation.

5. Remove fitting (2) from adapter (10).
6. Remove adapter (10) and preformed packing (11) from valve (6). Discard preformed packing.



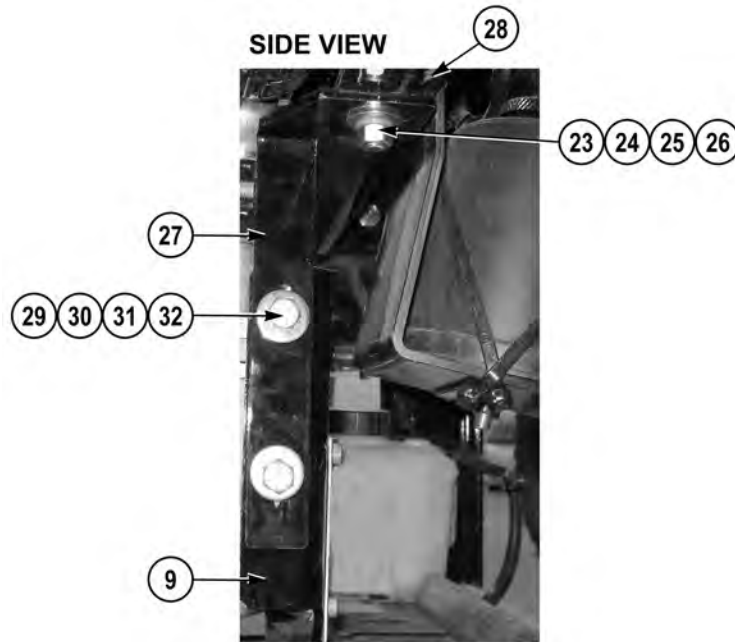
7. Remove fitting (12) from adapter (13).
8. Remove adapter (13) from valve (6).



**NOTE**

Perform Steps (9) through (15) if bracket needs to be removed.

9. Remove No. 1 driver side discharge valve (14) from vehicle (WP 0161).
10. Remove driver side auxiliary inlet drain valve (15) from vehicle (WP 0160).
11. Remove manual primer handle (16) from vehicle (WP 0164).
12. Remove reel rewind switch (17) from vehicle (WP 0253).
13. Remove two nuts (18), lockwashers (19), four washers (20), two screws (21), and bracket (9) from bracket (22). Discard lockwashers.



14. Remove nut (23), lockwasher (24), two washers (25), screw (26), and bracket (27) from frame (28). Discard lockwasher.
15. Remove two nuts (29), lockwashers (30), four washers (31), two screws (32), and bracket (27) from bracket (9). Discard lockwashers.

## END OF TASK

## INSTALLATION

### NOTE

Perform Steps (1) through (3) if bracket was removed.

1. Install bracket (27) on bracket (9) with two screws (32), four washers (31), two lockwashers (30) and nuts (29).
2. Install bracket (27) on frame (28) with screw (26), two washers (25), lockwasher (24), and nut (23).
3. Install bracket (9) on bracket (22) with two screws (21), four washers (20), two lockwashers (19), and nuts (18).
4. Install reel rewind switch (17) on vehicle (WP 0253).
5. Install manual primer handle (16) on vehicle (WP 0164).
6. Install driver side auxiliary inlet drain valve (15) on vehicle (WP 0160).
7. Install No. 1 driver side discharge valve (14) on vehicle (WP 0161).

### WARNING



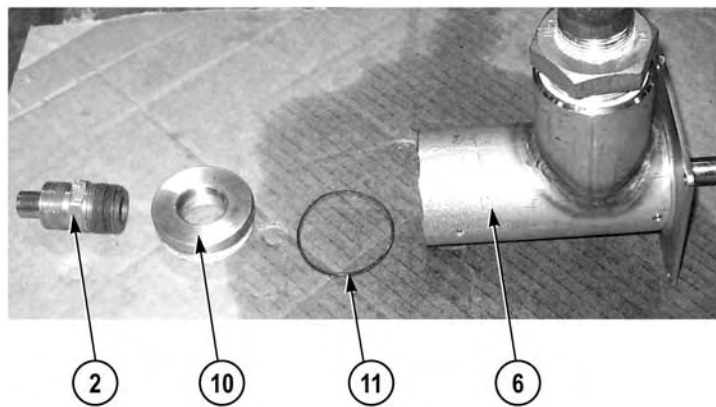
**Adhesives, solvents, and sealing compounds can burn easily, can give off harmful vapors, and are harmful to skin and clothing. To avoid injury or death, keep away from open fire and use in well-ventilated area. If adhesive, solvent, or sealing compound gets on skin or clothing, wash immediately with soap and water.**

### NOTE

- Apply sealing compound to threads of fitting (2), adapter (10), fitting (12), and adapter (13).
- Install fitting and adapters as noted prior to removal.

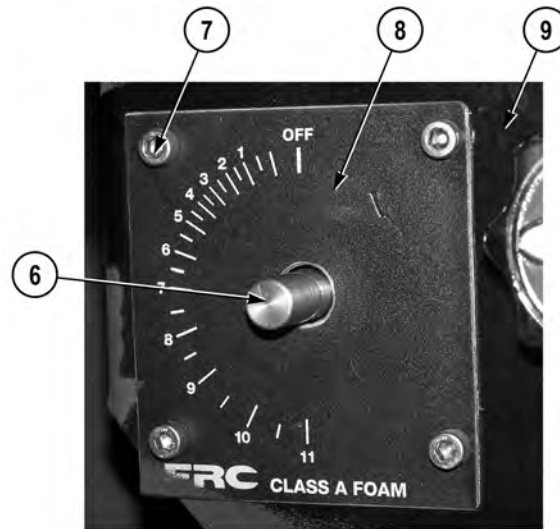


8. Install adapter (13) on valve (6).
9. Install fitting (12) on adapter (13).

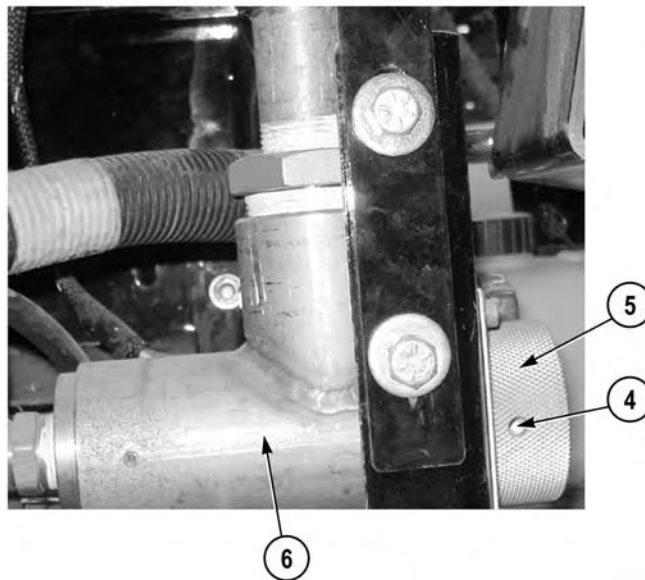


10. Install preformed packing (11) and adapter (10) on valve (6).
11. Install fitting (2) on adapter (10).





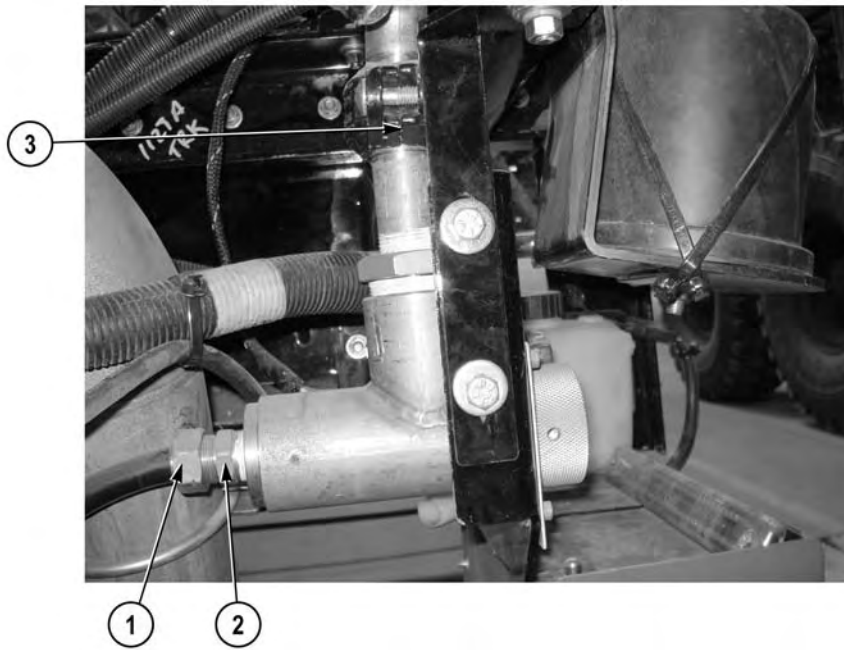
12. Install data plate (8) and valve (6) on bracket (9) with four screws (7).



**NOTE**

Install valve control knob as noted prior to removal.

13. Install valve control knob (5) on valve (6) with two setscrews (4).



14. Install coupling (3) on vehicle (WP 0313).

15. Install line (1) on fitting (2).

**END OF TASK**

**FOLLOW-ON MAINTENANCE**

Install pump house panels A and B (WP 0339)

**END OF TASK**

**END OF WORK PACKAGE**

---

**FIELD LEVEL MAINTENANCE**  
**FOAM SYSTEM SERVICE VALVE REPLACEMENT**

---

**INITIAL SETUP:****Tools and Special Tools**

Tool Kit, General Mechanic's: Automotive  
(WP 0398, Item 17)

**Reference**

WP 0313  
WP 0318  
WP 0391, Fig. 21

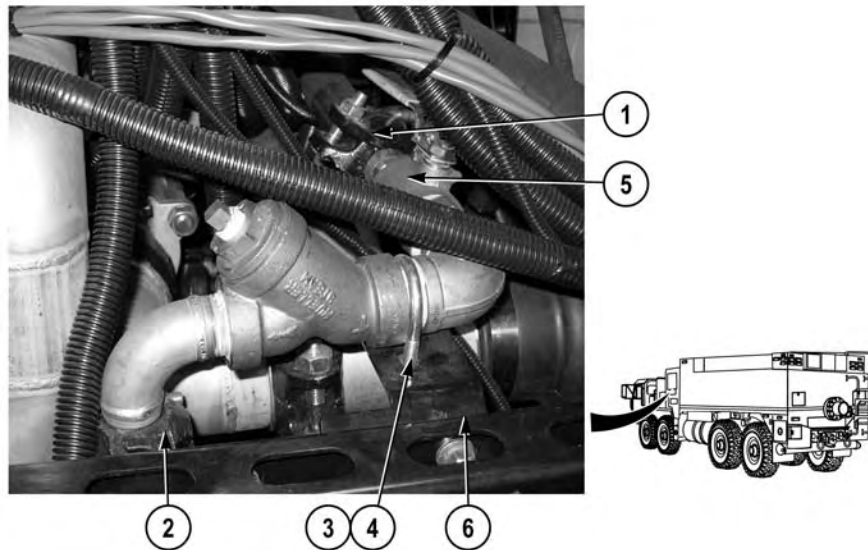
**Materials/Parts**

Compound, Sealing, Pipe Thread  
(WP 0400, Item 11)  
Locknut (2)

**Equipment Conditions**

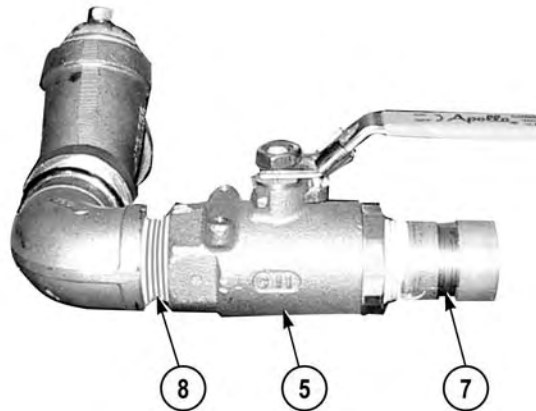
Foam system drained (WP 0022)  
Hose reel removed (WP 0247)

---

**REMOVAL****NOTE**

Foam service valve is removed as an assembly with strainer.

1. Remove two couplings (1) and (2) from vehicle (WP 0313).
2. Remove two locknuts (3), U-bolt (4), and valve (5) from bracket (6). Discard locknuts.

**NOTE**

Note position of valve prior to removal to ensure proper installation.

3. Remove fitting (7) and nipple (8) from valve (5).

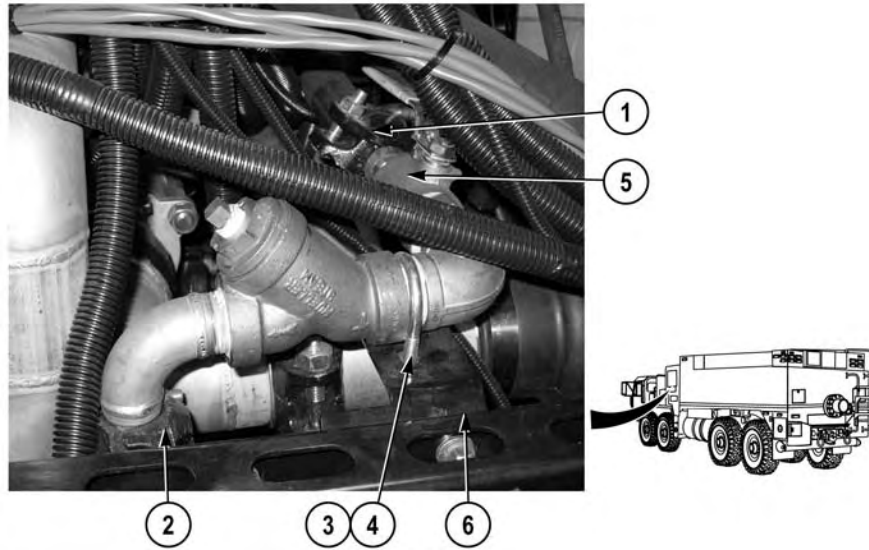
**END OF TASK****INSTALLATION****WARNING**

Adhesives, solvents, and sealing compounds can burn easily, can give off harmful vapors, and are harmful to skin and clothing. To avoid injury or death, keep away from open fire and use in well-ventilated area. If adhesive, solvent, or sealing compound gets on skin or clothing, wash immediately with soap and water.

**NOTE**

Install valve as noted prior to removal.

1. Apply sealing compound to threads of fitting (7) and nipple (8).
2. Install fitting (7) and nipple (8) on valve (5) (WP 0318).



### NOTE

- Foam service valve is installed as an assembly.
  - Valve must be installed in open position.
3. Install valve (5) on bracket (6) with U-bolt (4), and two locknuts (3).
  4. Install two couplings (1) and (2) on vehicle (WP 0313).

**END OF TASK**

### FOLLOW-ON MAINTENANCE

1. Install hose reel (WP 0247)
2. Fill foam system (WP 0022)

**END OF TASK**

**END OF WORK PACKAGE**



---

**FIELD LEVEL MAINTENANCE**  
**FOAM SYSTEM STRAINER(S) REPLACEMENT**

---

**INITIAL SETUP:****Tools and Special Tools**

Tool Kit, General Mechanic's: Automotive  
(WP 0398, Item 17)

**Materials/Parts**

Compound, Sealing, Pipe Thread  
(WP 0400, Item 11)  
Locknut (2)

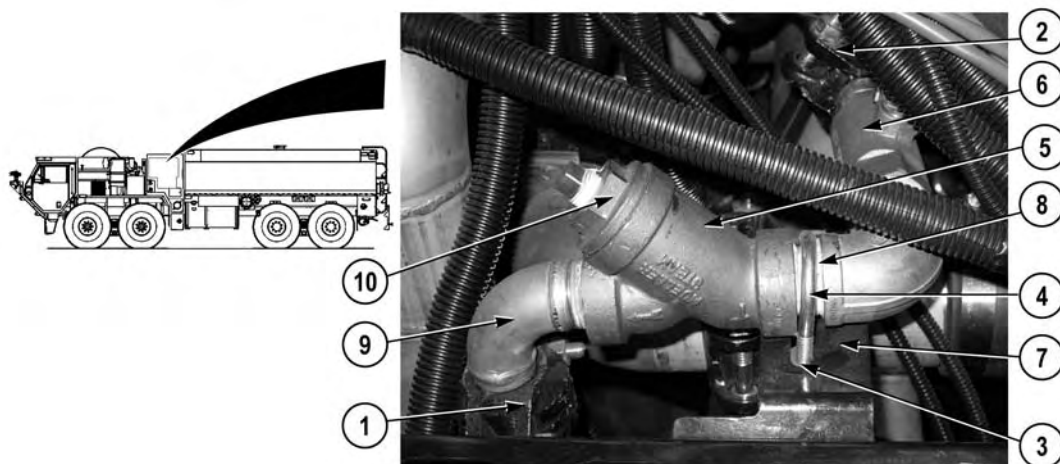
**References**

WP 0313  
WP 0318  
WP 0391, Fig. 21

**Equipment Conditions**

Foam agent drained (WP 0022)  
Hose reel removed (supply strainer and  
flush strainer) (WP 0247)  
Foam system eductor valve removed

---

**FOAM SYSTEM SUPPLY STRAINER REMOVAL****NOTE**

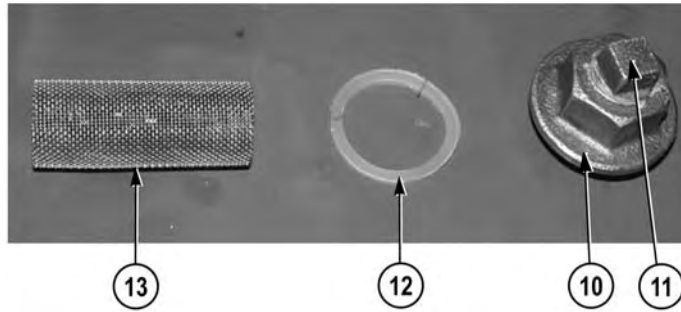
Foam system supply strainer is removed as an assembly with foam service valve.

1. Remove two couplings (1) and (2) from vehicle (WP 0313).
2. Remove two locknuts (3), U-bolt (4), strainer (5), and foam service valve (6) from bracket (7). Discard locknuts.
3. Remove strainer (5) from nipple (8).

**NOTE**

Note position of weldment prior to removal to ensure proper installation.

4. Remove weldment (9) from strainer (5).
5. Remove cap (10) from strainer (5).



6. Remove plug (11) from cap (10).
7. Remove gasket (12) and screen (13) from strainer (5).

#### END OF TASK

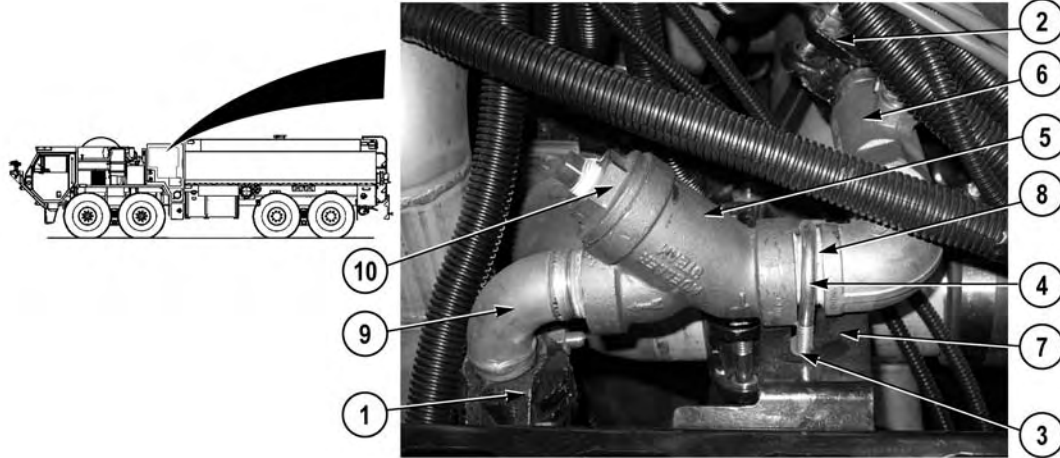
#### FOAM SYSTEM SUPPLY STRAINER INSTALLATION

#### NOTE

Strainer can be cleaned and replaced.

1. Install screen (13) and gasket (12) in strainer (5).





### **WARNING**



**Adhesives, solvents, and sealing compounds can burn easily, can give off harmful vapors, and are harmful to skin and clothing. To avoid injury or death, keep away from open fire and use in well-ventilated area. If adhesive, solvent, or sealing compound gets on skin or clothing, wash immediately with soap and water.**

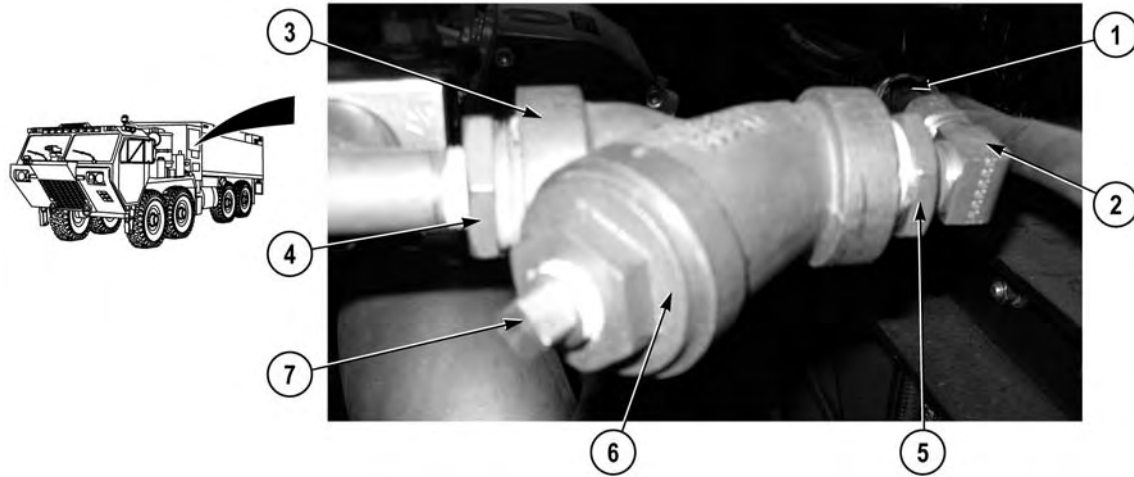
2. Apply sealing compound to threads of cap (10), weldment (9), and foam service valve (6).
3. Install plug (11) on cap (10) (WP 0318).
4. Install cap (10) on strainer (5) (WP 0318).

### **NOTE**

Install weldment in same position as noted prior to removal.

5. Install weldment (9) on strainer (5) (WP 0318).
6. Install foam service valve (6), strainer (5) and U-bolt (4) on bracket (7) with two locknuts (3).
7. Install two couplings (1) and (2) on vehicle (WP 0313).

**END OF TASK**

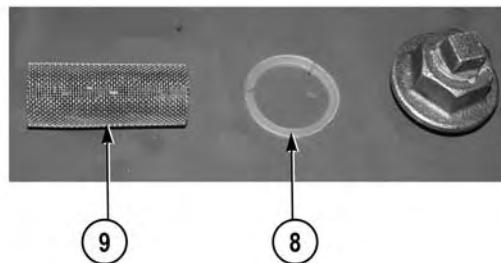
**FOAM SYSTEM FLUSH STRAINER REMOVAL**

1. Remove hose (1) from elbow (2).
2. Remove strainer (3) from fitting (4).

**NOTE**

Note position of elbow prior to removal to ensure proper installation.

3. Remove elbow (2) from fitting (5).
4. Remove fitting (5) from strainer (3).
5. Remove cap (6) from strainer (3).
6. Remove plug (7) from cap (6).



7. Remove gasket (8) and screen (9) from strainer (3).

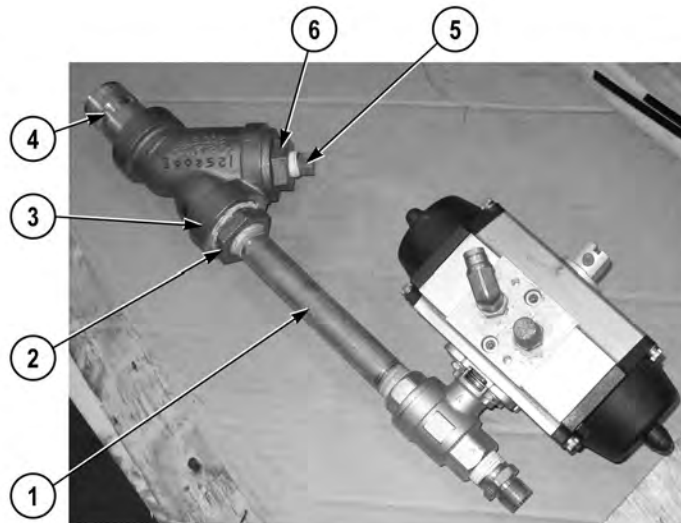
**END OF TASK****FOAM SYSTEM FLUSH STRAINER INSTALLATION**

1. Install screen (9) and gasket (8) in strainer (3).

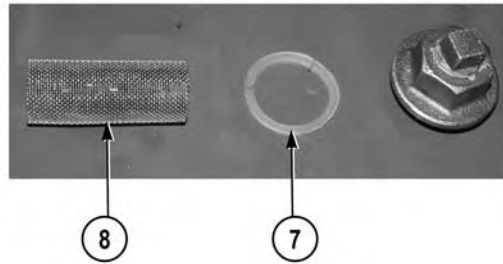
**WARNING**

**Adhesives, solvents, and sealing compounds can burn easily, can give off harmful vapors, and are harmful to skin and clothing. To avoid injury or death, keep away from open fire and use in well-ventilated area. If adhesive, solvent, or sealing compound gets on skin or clothing, wash immediately with soap and water.**

2. Apply sealing compound to threads of plug (7), cap (6), fitting (5), fitting (4), and elbow (2).
3. Install plug (7) on cap (6).
4. Install cap (6) on strainer (3).
5. Install fitting (5) on strainer (3).
6. Install elbow (2) on fitting (5).
7. Install strainer (3) on fitting (4).
8. Install hose (1) on elbow (2).

**END OF TASK****FOAM SYSTEM EDUCTOR STRAINER REMOVAL**

1. Remove pipe (1) from fitting (2).
2. Remove fitting (2) from strainer (3).
3. Remove pipe (4) from strainer (3).
4. Remove plug (5) from cap (6).
5. Remove cap (6) from strainer (3).

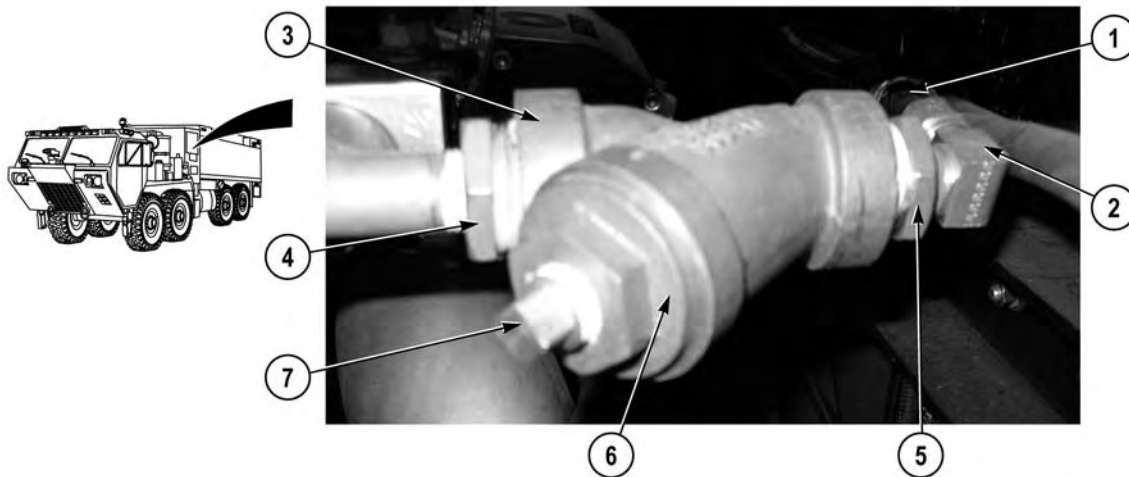


- Remove gasket (7) and screen (8) from strainer (3).

**END OF TASK**

**FOAM SYSTEM EDUCTOR STRAINER INSTALLATION**

- Install screen (8) and gasket (7) in strainer (3).

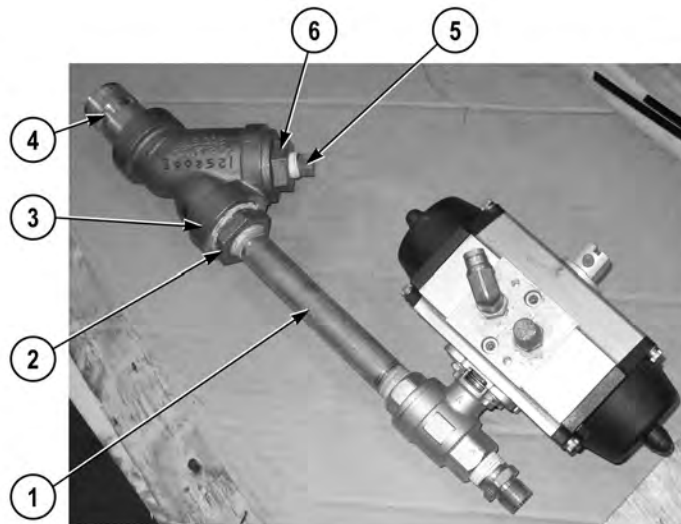


**WARNING**



**Adhesives, solvents, and sealing compounds can burn easily, can give off harmful vapors, and are harmful to skin and clothing. To avoid injury or death, keep away from open fire and use in well-ventilated area. If adhesive, solvent, or sealing compound gets on skin or clothing, wash immediately with soap and water.**

- Apply sealing compound to threads of cap (6), plug (5), pipe (4), fitting (2), and pipe (1).



3. Install cap (6) on strainer (3).
4. Install plug (5) on cap (6).
5. Install pipe (4) on strainer (3).
6. Install fitting (2) on strainer (3).
7. Install fitting (2) on pipe (1).

**END OF TASK**

**FOLLOW-ON MAINTENANCE**

1. Install hose reel (if removed) (WP 0247)
2. Install foam system eductor valve (WP 0178)

**END OF TASK**

**END OF WORK PACKAGE**



---

**FIELD LEVEL MAINTENANCE**

**FOAM TANK PRESSURE/VACUUM/VENT REPLACEMENT**

---

**INITIAL SETUP:****Tools and Special Tools**

Tool Kit, General Mechanic's: Automotive  
(WP 0398, Item 17)

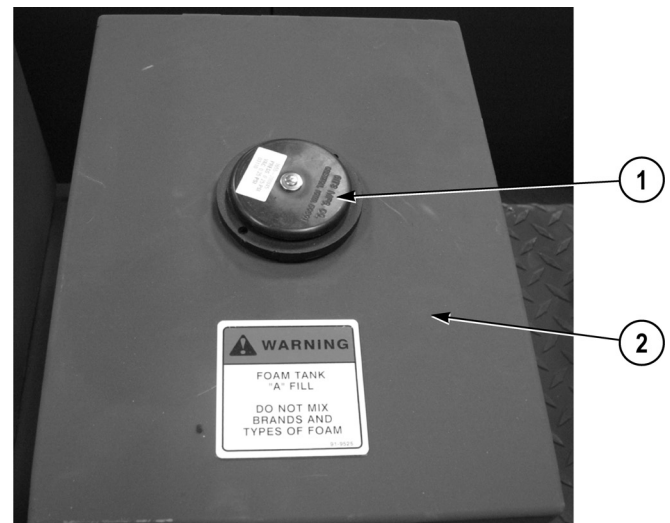
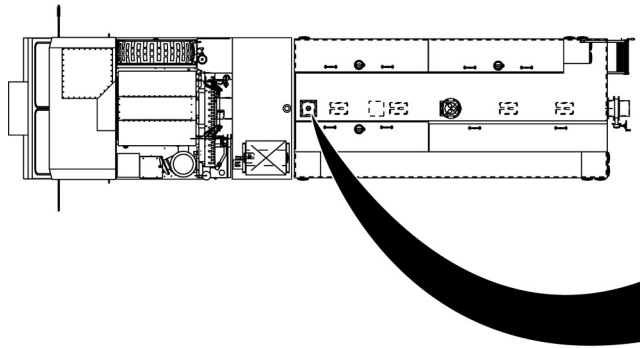
**Equipment Conditions**

Engine OFF (TM 9-2320-422-10)  
Wheels chocked (TM 9-2320-422-10)

**References**

WP 0391, Fig. 24

---

**REMOVAL**

Remove foam tank vent (1) from foam tank (2).

**END OF TASK****INSTALLATION**

Install foam tank vent (1) on foam tank (2).

**END OF TASK****FOLLOW-ON MAINTENANCE**

Remove wheel chocks (TM 9-2320-422-10)

**END OF TASK****END OF WORK PACKAGE**





## FIELD LEVEL MAINTENANCE

## FOAM TANK FILL PORT EXTENSION AND COVER REPLACEMENT

## INITIAL SETUP:

**Tools and Special Tools**

Tool Kit, General Mechanic's: Automotive  
(WP 0398, Item 17)

**References**

WP 0391, Fig. 24

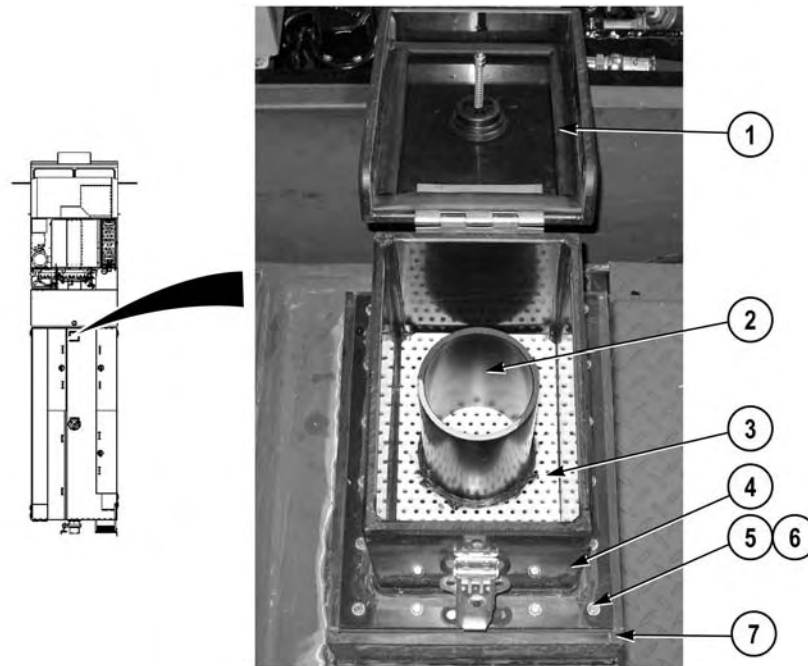
**Materials/ Parts**

Seal (1)

**Equipment Conditions**

Foam tank pressure/vacuum/vent removed  
(WP 0184)

## REMOVAL

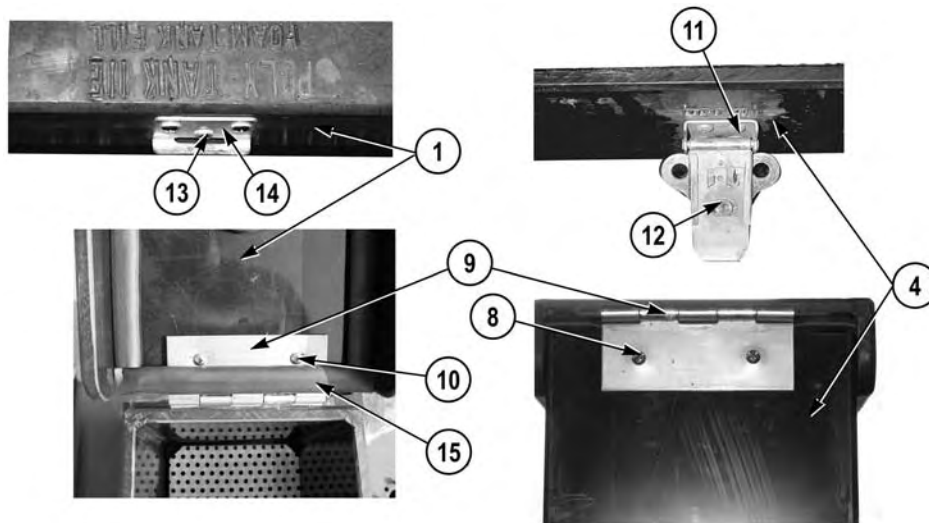


1. Open cover (1).

**NOTE**

Fill tube and strainer are removed as an assembly.

2. Remove fill tube (2) and strainer (3) from fill port extension (4).
3. Remove 18 screws (5), fill port extension (4), and rubber gasket (6) from water tank (7).

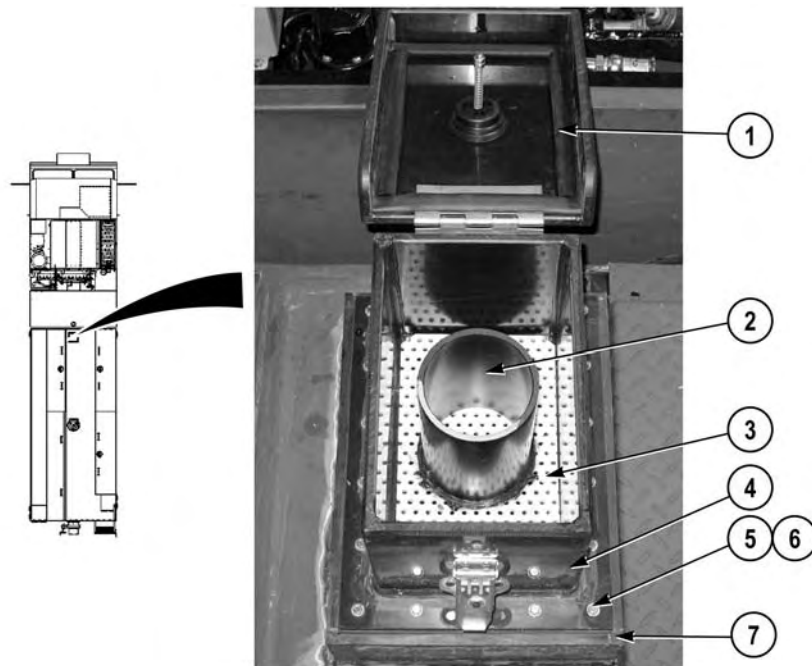


4. Remove two screws (8) and hinge (9) from fill port extension (4).
5. Remove two screws (10) and cover (1) from hinge (9).
6. Remove four screws (11) and latch (12) from fill port extension (4).
7. Remove three screws (13) and latch catch (14) from cover (1).
8. Remove and discard seal (15) from cover (1).

#### END OF TASK

#### INSTALLATION

1. Install seal (15) on cover (1).
2. Install latch catch (14) on cover (1) with three screws (13).
3. Install latch (12) on fill port extension (4) with four screws (11).
4. Install hinge (9) on cover (1) with two screws (10).
5. Install hinge (9) on fill port extension (4) with two screws (8).



6. Install rubber gasket (6) and fill port extension (4) on water tank (7) with 18 screws (5).
7. Install strainer (3) and fill tube (2) on fill port extension (4).
8. Close cover (1).

**END OF TASK**

#### **FOLLOW-ON MAINTENANCE**

Install foam tank pressure/vacuum/vent (WP 0184)

**END OF TASK**

**END OF WORK PACKAGE**



---

**FIELD LEVEL MAINTENANCE**
**INLET VALVE REPLACEMENT**


---

**INITIAL SETUP:****Tools and Special Tools**

Tool Kit, General Mechanic's: Automotive  
(WP 0398, Item 17)

**Materials/Parts**

Compound, Sealing, Pipe Thread  
(WP 0400, Item 11)  
Ties, Cable, Plastic (WP 0400, Item 26)  
Locknut (2)  
Lockwasher (2)  
Locknut (2)

**Personnel Required**

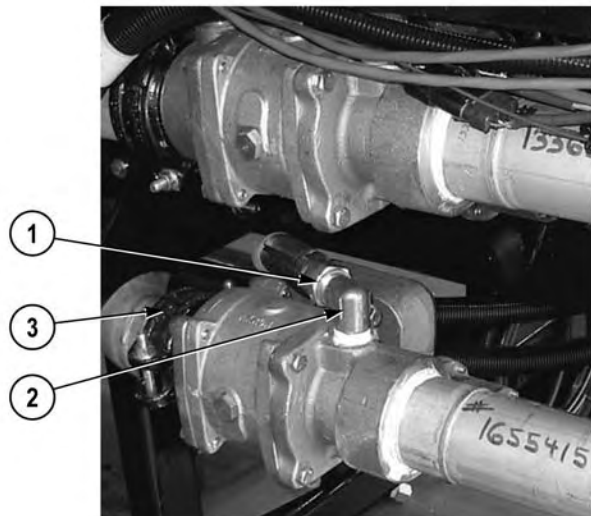
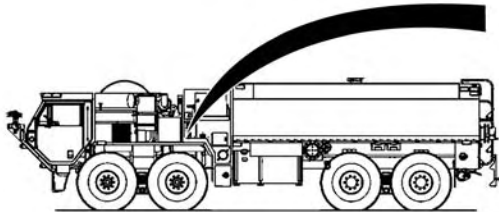
MOS 63B Wheeled Vehicle Mechanic (2)

**References**

WP 0248  
WP 0313  
WP 0318  
WP 0391, Fig. 65

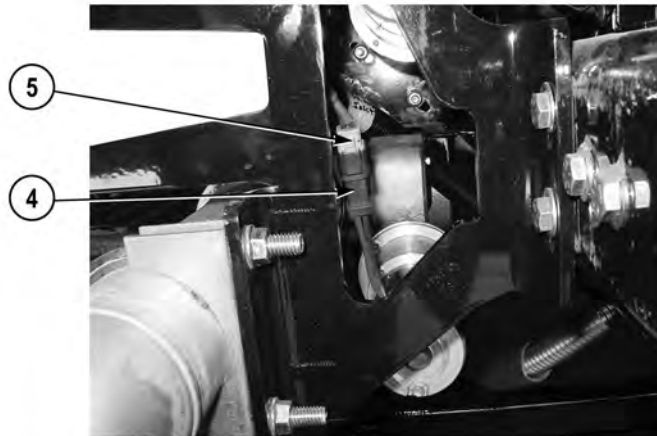
**Equipment Conditions**

Pump house panels A, C, and E removed driver side (WP 0339)  
Pump house panels H, I, and G removed passenger side (WP 0339)

**REMOVAL****NOTE**

- Both inlet valves are removed the same way. Driver side shown.
- Remove cable ties as required.

1. Remove hose (1) from elbow (2).
2. Remove coupling (3) from vehicle (WP 0313).



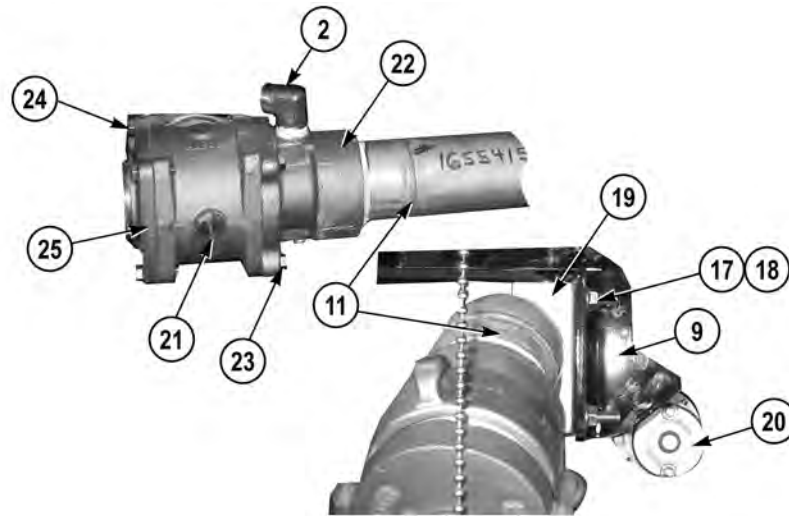
**NOTE**

- Support bracket holding inlet and discharge pipes must be removed with valve assembly to permit clearance for discharge valve replacement.
- Pipe and valve are replaced as an assembly.

3. Disconnect electric motor connector (4) from electric motor harness connector (5).



4. Remove two locknuts (6), U-bolt (7), and cradle (8) from bracket (9) and pipe (10). Discard locknuts.
5. With the aid of an assistant, support pipe (11) and remove two nuts (12), lockwashers (13), four washers (14), and two screws (15) from brackets (9) and channel bracket (16). Discard lockwasher.
6. With the aid of an assistant, remove pipe (11) and bracket (9) from vehicle.



7. Remove two locknuts (17), U-bolt (18), cradle (19), and pipe (11) from bracket (9). Discard locknuts.
8. Remove electric motor and drive assembly (20) from inlet valve (21) (WP 0248).

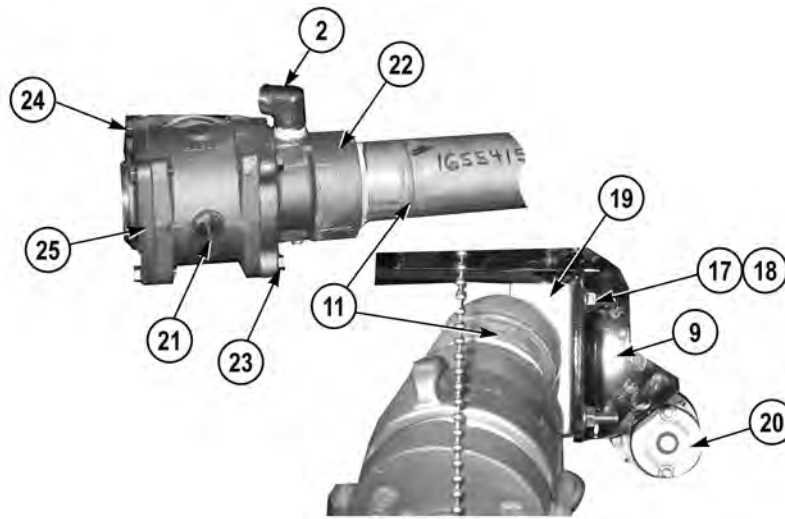
### NOTE

Note position of elbow prior to removal to ensure proper installation.

9. Remove elbow (2) from adapter (22).
10. Remove pipe (11) from adapter (22).
11. Remove four screws (23) and adapter (22) from inlet valve (21).
12. Remove four screws (24) and adapter (25) from inlet valve (21).

**END OF TASK**

## INSTALLATION



### NOTE

- Both inlet valves are installed the same way. Driver side shown.
  - Install cable ties as required.
1. Install adapter (25) on inlet valve (21) with four screws (24).
  2. Install adapter (22) on inlet valve (21) with four screws (23).

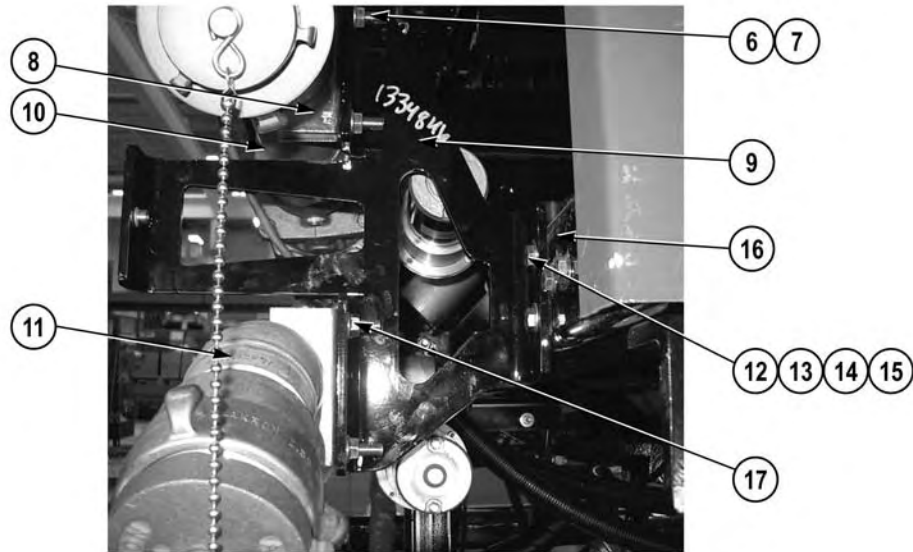
### WARNING



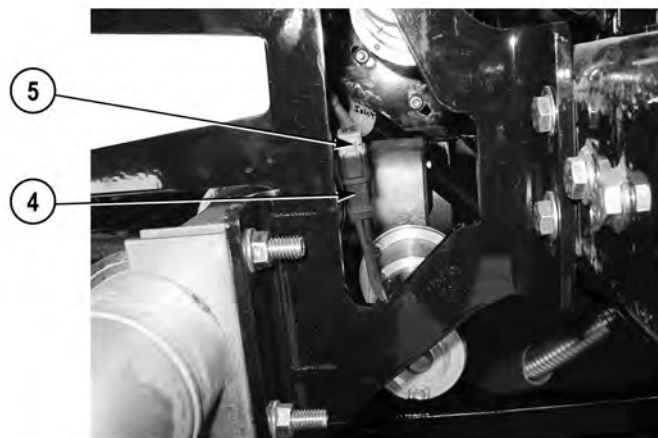
**Adhesives, solvents, and sealing compounds can burn easily, can give off harmful vapors, and are harmful to skin and clothing. To avoid injury or death, keep away from open fire and use in well-ventilated area. If adhesive, solvent, or sealing compound gets on skin or clothing, wash immediately with soap and water.**

3. Apply sealing compound to threads of pipe (11) and elbow (2)
4. Install pipe (11) on adapter (22) (WP 0318).
5. Install elbow (2) on adapter (22) (WP 0318).
6. Install electric motor and drive assembly (20) on valve (21) (WP 0248).
7. Install pipe (11) on bracket (9) with cradle (19), U-bolt (18), and two locknuts (17). Do not tighten locknuts.

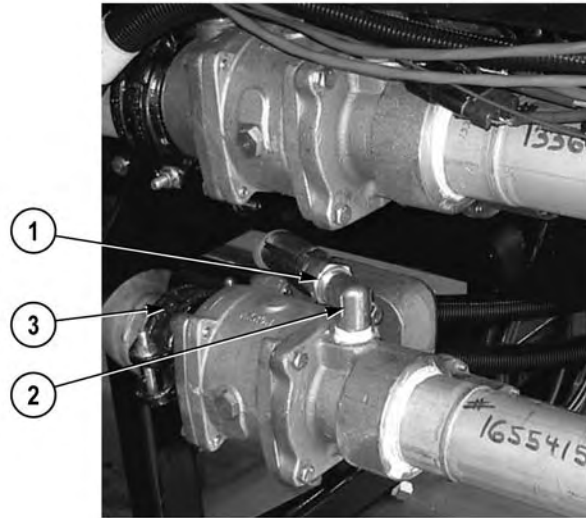
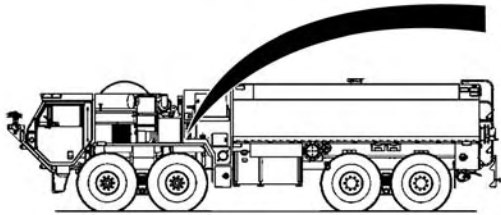




8. With the aid of an assistant, position pipe (11) and bracket (9) on vehicle.
9. With the aid of an assistant, install bracket (9) on channel bracket (16) with two screws (15), four washers (14), two lockwashers (13), and nuts (12).
10. Install bracket (9) on pipe (10) with U-bolt (7), cradle (8), and two locknuts (6).
11. Tighten two locknuts (17).



12. Connect electric motor connector (4) on electric motor harness connector (5).



13. Install coupling (3) on vehicle (WP 0313).

14. Install hose (1) on elbow (2).

#### END OF TASK

#### FOLLOW-ON MAINTENANCE

1. Install pump house panels A, C, and E driver side (WP 0339)
2. Install pump house panels H, I, and G passenger side (WP 0339)

#### END OF TASK

#### END OF WORK PACKAGE

---

**FIELD LEVEL MAINTENANCE**  
**TANK-TO-PUMP CHECK VALVE REPLACEMENT**

---

**INITIAL SETUP:****Tools and Special Tools**

Tool Kit, General Mechanic's: Automotive  
(WP 0398, Item 17)

**References**

WP 0313  
WP 0391, Fig. 20

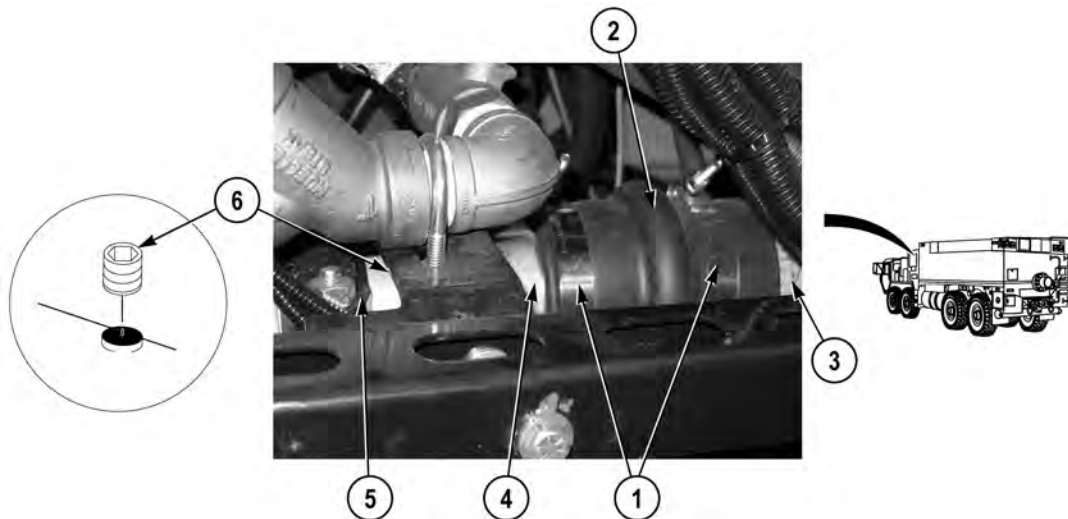
**Materials/Parts**

Compound, Sealing, Pipe Thread  
(WP 0400, Item 11)

**Equipment Conditions**

Water tank drained (WP 0015)  
Hose reel removed (WP 0247)

---

**REMOVAL**

**⚠ CAUTION**

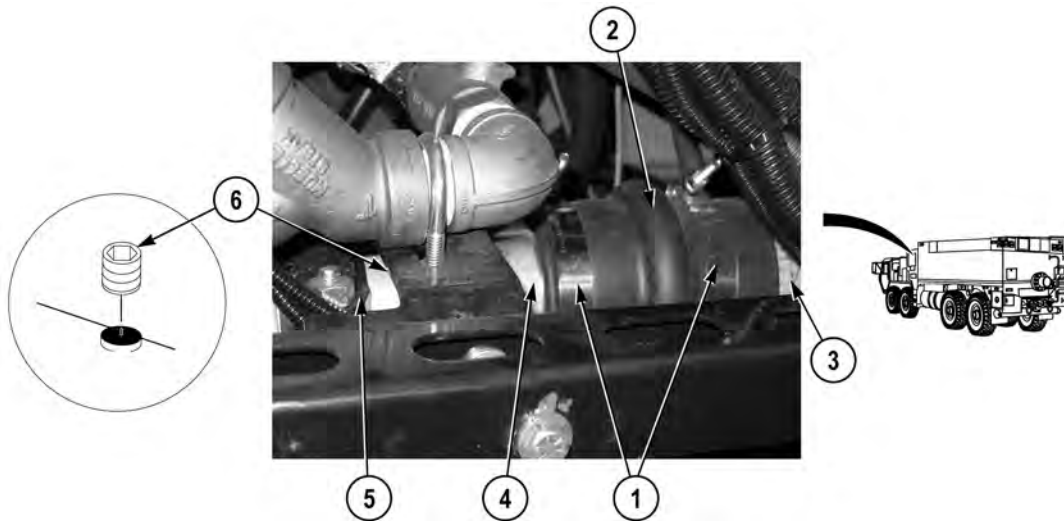
**Note position of check valve prior to removal. Failure to comply may cause damage to equipment.**

**NOTE**

Hump hose must be slid over pipe to provide clearance when removing check valve.

1. Loosen two clamps (1) and slide hump hose (2) onto pipe (3) and away from check valve (4).
2. Remove coupling (5) and check valve (4) from vehicle (WP 0313).
3. Remove plug (6) from check valve (4).

**END OF TASK**

**INSTALLATION****WARNING**

**Adhesives, solvents, and sealing compounds can burn easily, can give off harmful vapors, and are harmful to skin and clothing. To avoid injury or death, keep away from open fire and use in well-ventilated area. If adhesive, solvent, or sealing compound gets on skin or clothing, wash immediately with soap and water.**

1. Apply sealing compound to threads of plug (6).
2. Install plug (6) on check valve (4).

**NOTE**

Install check valve as noted prior to removal.

3. Install coupling (5) and check valve (4) on vehicle (WP 0313).
4. Slide hump hose (2) onto check valve (4) from pipe (3) and tighten two clamps (1).

**END OF TASK****FOLLOW-ON MAINTENANCE**

Install hose reel (WP 0247)

**END OF TASK****END OF WORK PACKAGE**

---

**FIELD LEVEL MAINTENANCE**  
**MANUAL BRAY DUMP VALVE(S) REPLACEMENT**

---

**INITIAL SETUP:****Tools and Special Tools**

Standard Automotive Tool Set (SATS),  
(WP 0398, Item 15)

- Wrench, Torque, Click, Ratcheting,  
1/2" Drive, 250 ft-lb
- Wrench, Torque, Dial, 3/8" Drive, 300 in-lb

Tool Kit, General Mechanic's: Automotive  
(WP 0398, Item 17)

**Materials/Parts**

Adhesive, Sealant (WP 0400, Item 4)  
Guide Pin, Qty 4, (WP 0386, Item a-1)  
Lockwasher (4)  
Lockwasher (8)  
Locknut (2)  
Locknut (1)

**Materials/Parts (continued)**

Locknut (12)  
Lockwasher (2)  
Locknut (14)  
Gasket (1)

**Personnel Required**

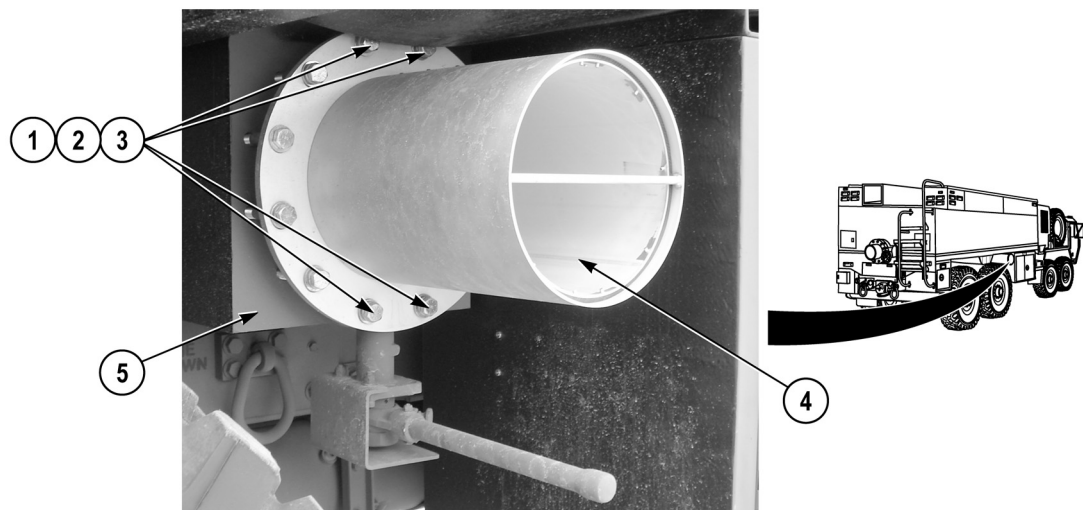
MOS 63B Wheeled Vehicle Mechanic (2)

**References**

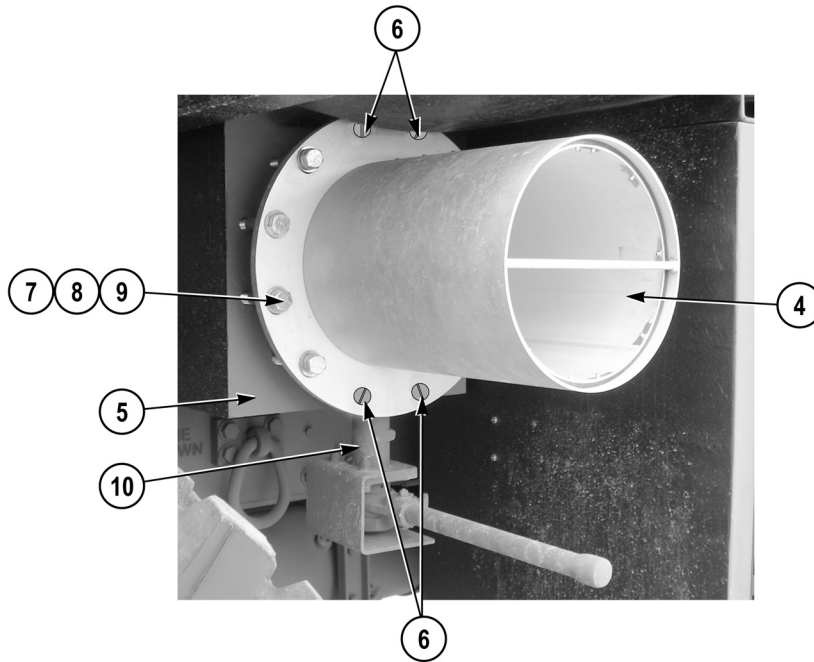
WP 0391, Fig. 16

**Equipment Conditions**

Water tank drained (WP 0015)

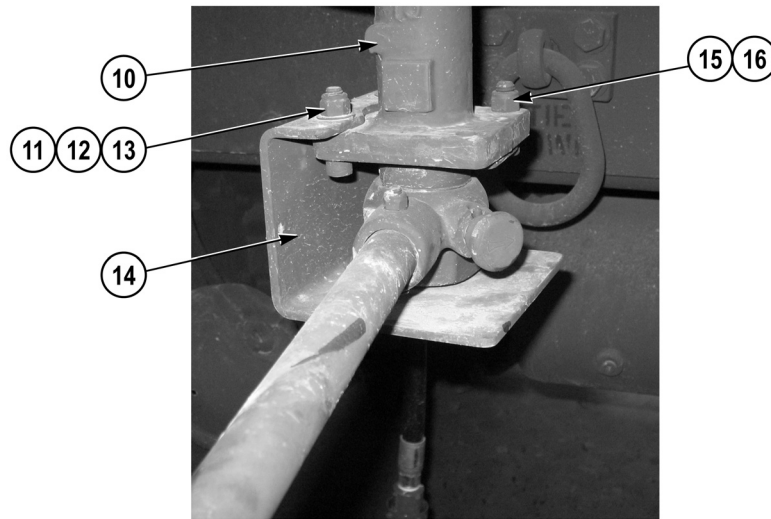
**REMOVAL****NOTE**

- Perform Steps (1) through (8) for both driver and passenger side manual bray dump valve removal.
  - Both driver and passenger side manual bray dump valves are removed the same way. Passenger side shown.
1. Remove four screws (1), lockwashers (2), and washers (3) from dump chute (4) and water tank (5). Discard lockwashers.

**WARNING**

**Dump chute weighs 50 lb (22.7 kg). Bray valve weighs 55 lb (24.9 kg). Do not attempt to lift or move dump chute or bray valve without the aid of an assistant. Failure to comply may result in injury or death to personnel.**

2. Install four guide pins (6) in dump chute (4) and water tank (5).
3. Remove eight screws (7), lockwashers (8), and washers (9) from dump chute (4) and water tank (5). Discard lockwashers.
4. Remove dump chute (4) from four guide pins (6) and vehicle.
5. With the aid of an assistant, remove manual bray dump valve (10) from four guide pins (6) and water tank (5).
6. Remove four guide pins (6) from water tank (5).

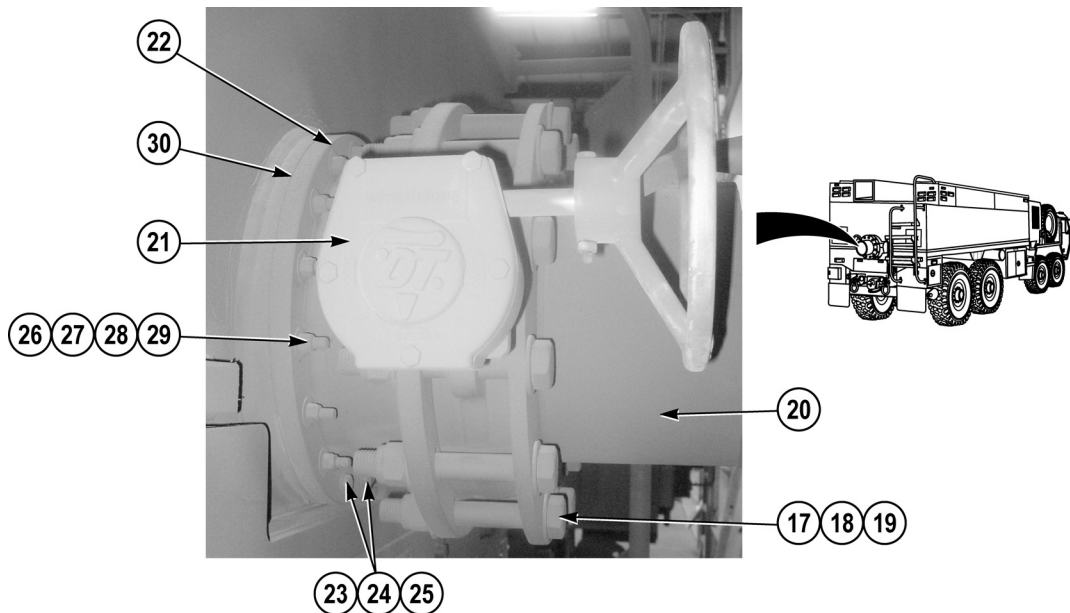


7. Remove two locknuts (11), washers (12), screws (13), and ratchet cover (14) from manual bray dump valve (10). Discard locknuts.

#### NOTE

Note position of locknut and screw prior to removal to ensure proper installation.

8. Remove locknut (15) and screw (16) from manual bray dump valve (10). Discard locknut.

**NOTE**

Perform Steps (9) through (11) for rear hand wheel dump valve removal.

9. With the aid of an assistant, remove 12 locknuts (17), 24 washers (18), 12 screws (19), dump chute (20), and rear hand wheel dump valve (21) from adapter (22). Discard locknuts.
10. Remove two screws (23), lockwashers (24), and washers (25) from adapter (22). Discard lockwashers.

**NOTE**

Note position of washers prior to removal to ensure proper installation.

11. With the aid of an assistant, remove 14 locknuts (26), washers (27), washers (28), screws (29), adapter (22), and gasket (30) from vehicle. Discard locknuts and gasket.

**END OF TASK**



---

**INSTALLATION****WARNING**

**Adhesives, solvents, and sealing compounds can burn easily, can give off harmful vapors, and are harmful to skin and clothing. To avoid injury or death, keep away from open fire and use in well-ventilated area. If adhesive, solvent, or sealing compound gets on skin or clothing, wash immediately with soap and water.**

**NOTE**

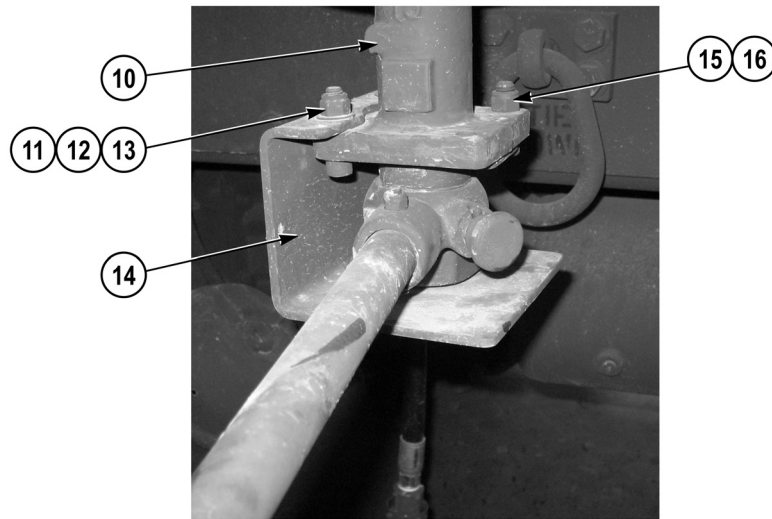
Perform Steps (1) through (4) for rear hand wheel dump valve installation.

1. Apply sealant to two washers (25) and 14 washers (27).

**NOTE**

Install washers as noted prior to removal.

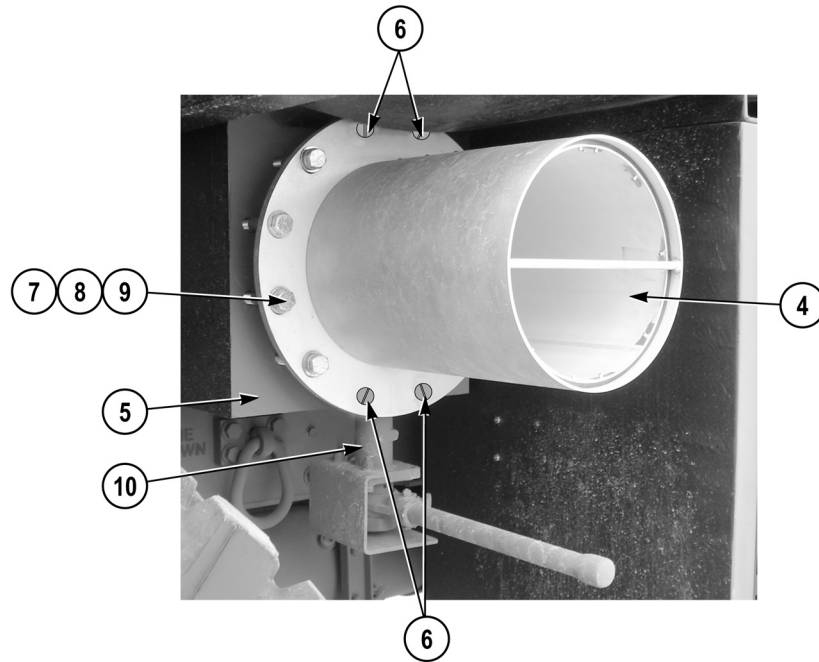
2. With the aid of an assistant, install gasket (30) and adapter (22) on vehicle with 14 screws (29), washers (28), washers (27), and locknuts (26). Tighten locknuts (26) in a criss-cross pattern until 3/8" of threads show beyond nut.
3. Install two washers (25), lockwashers (24) and screws (23) on adapter (22). Tighten screws to 60 lb-in (6.78 N•m).
4. With the aid of an assistant, install rear hand wheel dump valve (21) and dump chute (20) on adapter (22) with 12 screws (19), 24 washers (18), and 12 locknuts (17). Tighten screws in a criss-cross pattern until 3/4" of threads show beyond nuts.



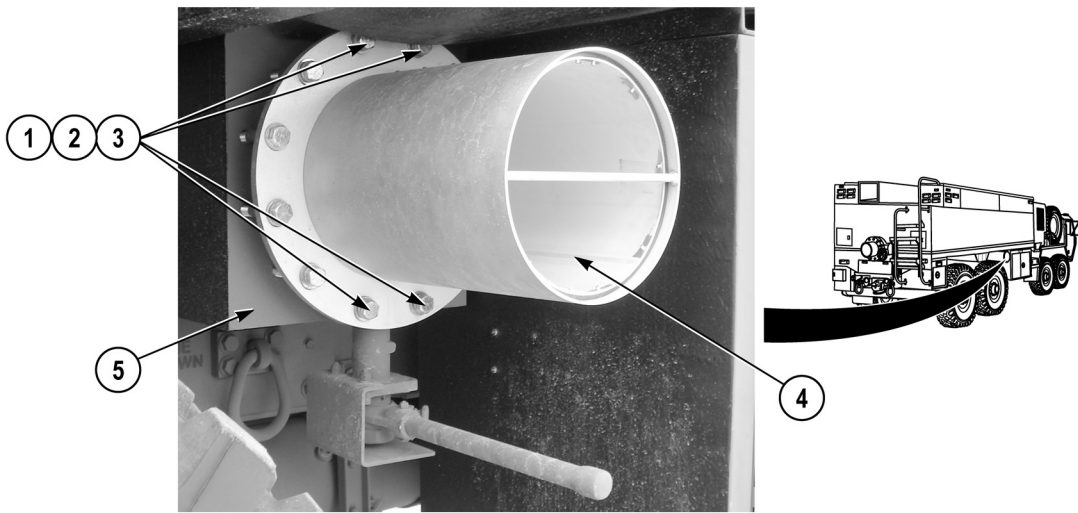
### NOTE

- Perform Steps (5) through (13) for both driver and passenger side manual dump valve installation.
- Both driver and passenger side manual bray dump valves are installed the same way. Passenger side shown.
- Install screw and locknut as noted prior to removal.

5. Install screw (16) and locknut (15) on manual bray dump valve (10).
6. Install ratchet cover (14) on manual bray dump valve (10) with two screws (13), washers (12), and locknuts (11).



7. Install four guide pins (6) on water tank (5).
8. With the aid of an assistant, install manual bray dump valve (10) on four guide pins (6) and water tank (5).
9. Position dump chute (4) on four guide pins (6).
10. Install eight washers (9), lockwashers (8), and screws (7) on dump chute (4) and water tank (5). Do not tighten screws.
11. Remove four guide pins (6) from dump chute (4) and water tank (5).



12. Install four washers (3), lockwashers (2), and screws (1) on dump chute (4) and water tank (5). Do not tighten screws.

#### NOTE

Tighten screws in a criss-cross pattern.

13. Tighten eight screws (7) and four screws (1) in a criss-cross pattern to 20 lb-ft (27.12 N•m).

**END OF TASK**

**END OF WORK PACKAGE**

---

**FIELD LEVEL MAINTENANCE**  
**FOAM/WATER TANK LEVEL PROBE COVER REPLACEMENT**

---

**INITIAL SETUP:****Tools and Special Tools**

Tool Kit, General Mechanic's: Automotive  
(WP 0398, Item 17)

**Materials/Parts**

Lockwasher (4)

**References**

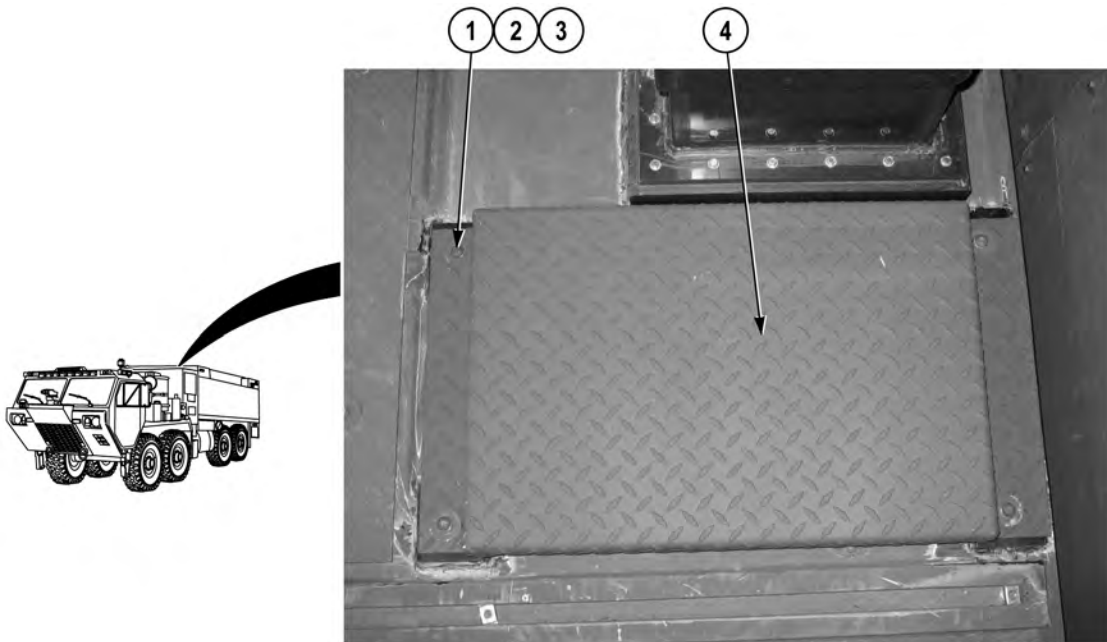
WP 0391, Fig. 24

**Equipment Conditions**

Engine OFF (TM 9-2320-422-10)

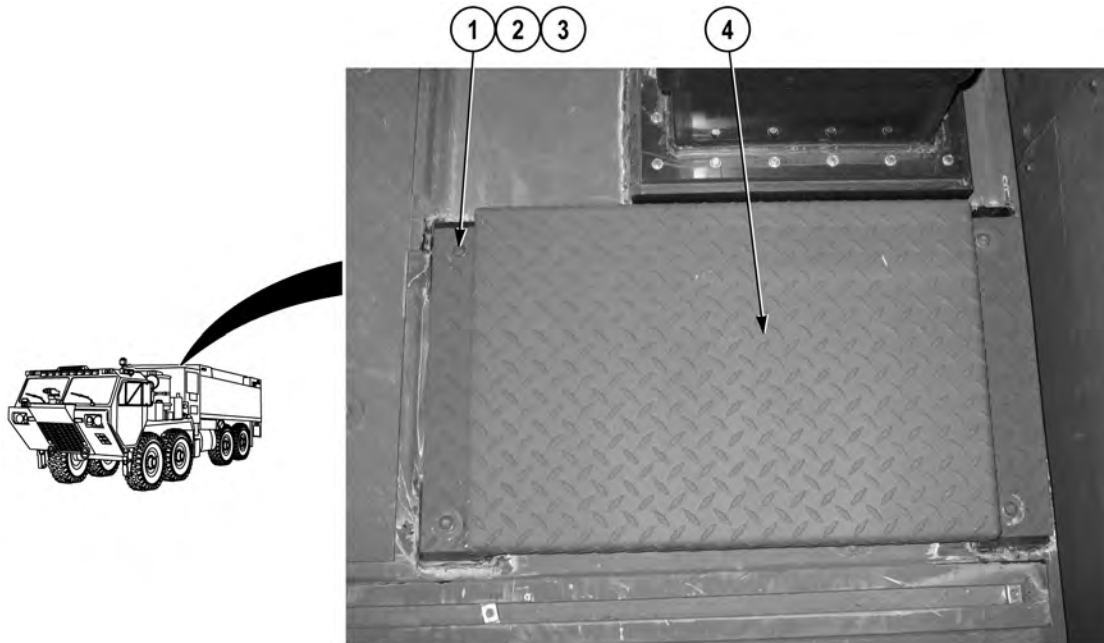
Wheels chocked (TM 9-2320-422-10)

---

**REMOVAL**

Remove four screws (1), lockwashers (2), washers (3), and foam/water tank level probe cover (4) from vehicle. Discard lockwashers.

**END OF TASK**

**INSTALLATION**

Install foam/tank level probe cover (4) on vehicle with four washers (3), lockwashers (2), and screws (1).

**END OF TASK**

**FOLLOW-ON MAINTENANCE**

Remove wheel chocks (TM 9-2320-422-10)

**END OF TASK**

**END OF WORK PACKAGE**

---

**FIELD LEVEL MAINTENANCE**  
**WATER TANK LEVEL PROBE REPLACEMENT**

---

**INITIAL SETUP:****Tools and Special Tools**

Tool Kit, General Mechanic's: Automotive  
(WP 0398, Item 17)

**References**

TM 9-2320-325-14&P  
WP 0391, Fig. 24

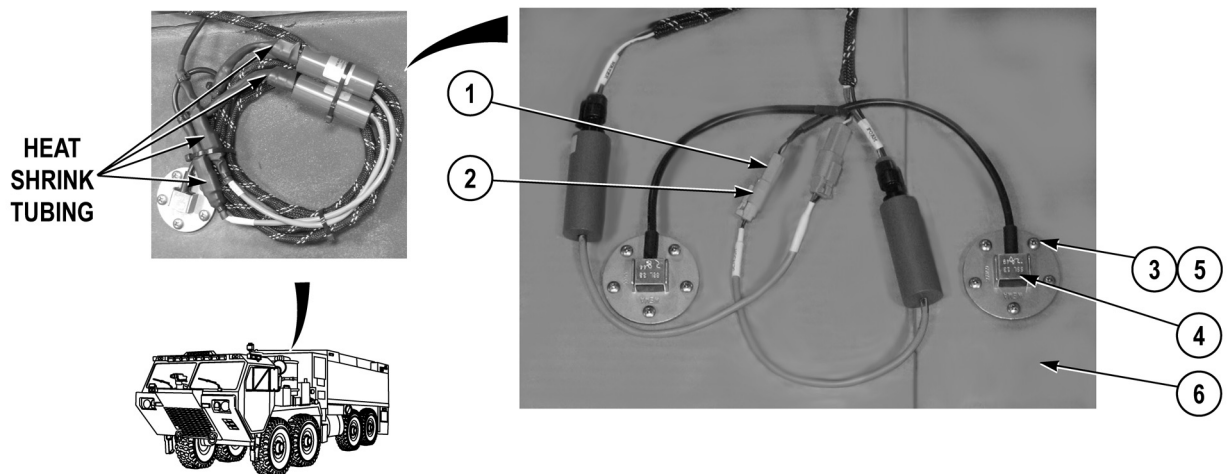
**Materials/Parts**

Tags, Identification (WP 0400, Item 23)  
Ties, Cable, Plastic (WP 0400, Item 26)  
Tube, Shrink (WP 0400, Item 27)  
Gasket (1)

**Equipment Conditions**

Foam/water tank level probe cover removed  
(WP 0189)

---

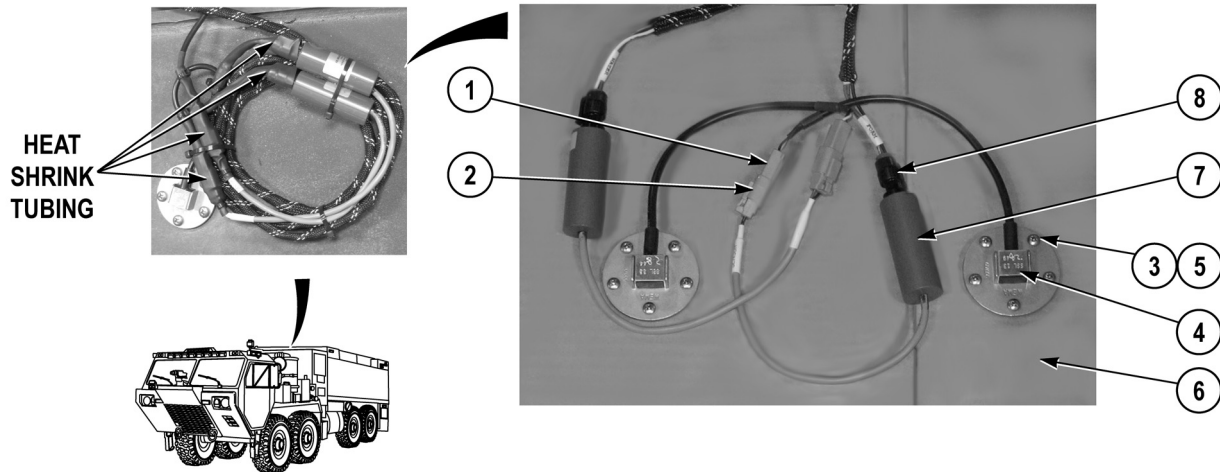
**REMOVAL**

**⚠ CAUTION**

**Both adapter connector ends must be covered with heat shrink tubing. Failure to comply will allow moisture to enter connector ends and not allow water level gauge to function properly.**

**NOTE**

- Tag and mark connectors prior to removal to ensure proper installation.
  - Remove cable ties as required.
1. Disconnect water level probe connector (1) from adapter connector (2).
  2. Remove four screws (3), water level probe (4), and gasket (5) from tank (6). Discard gasket.



**NOTE**

Perform Step (3) if adapter needs to be removed.

3. Disconnect adapter connector (7) from passenger side body wire harness connector (8).

**END OF TASK**

**INSTALLATION**

**NOTE**

- Perform Step (1) if adapter was removed.
- Install cable ties as required.
- Both ends of adapter connector must be covered with heat shrink tubing before connecting adapter connector to passenger side body wire harness connector and water tank level probe (TM 9-2320-325-14&P).

1. Connect passenger side body wire harness connector (8) on adapter connector (7).
2. Install gasket (5) and water level probe (4) on tank (6) with five screws (3).
3. Connect adapter connector (2) on water level probe connector (1).

**END OF TASK**

**FOLLOW-ON MAINTENANCE**

Install foam/water tank level probe cover (WP 0189)

**END OF TASK**

**END OF WORK PACKAGE**



---

**FIELD LEVEL MAINTENANCE****WATER TANK FILL & RE-CIRCULATING LINE VALVE REPLACEMENT**

---

**INITIAL SETUP:****Tools and Special Tools**

Tool Kit, General Mechanic's: Automotive  
(WP 0398, Item 17)

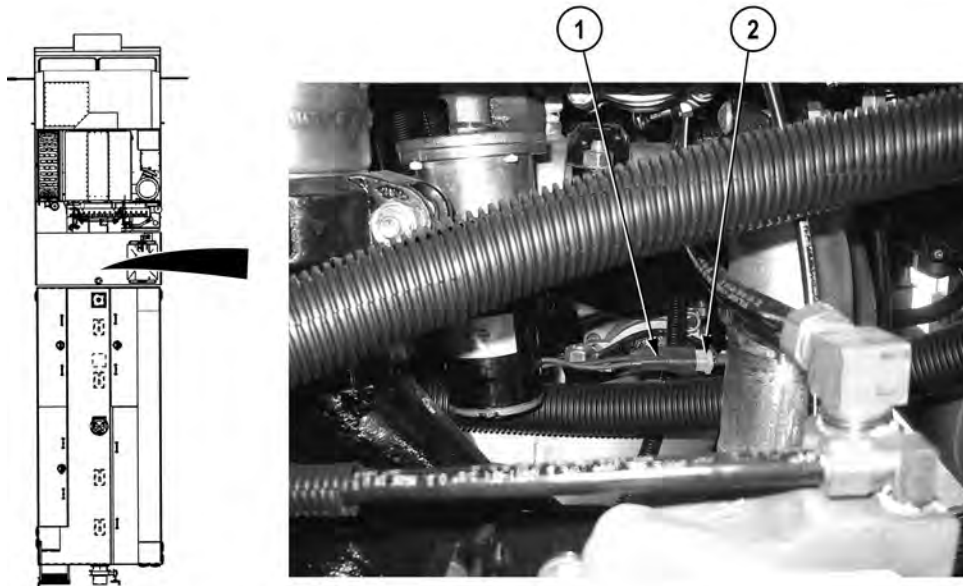
**References**

WP 0313  
WP 0391, Fig. 23

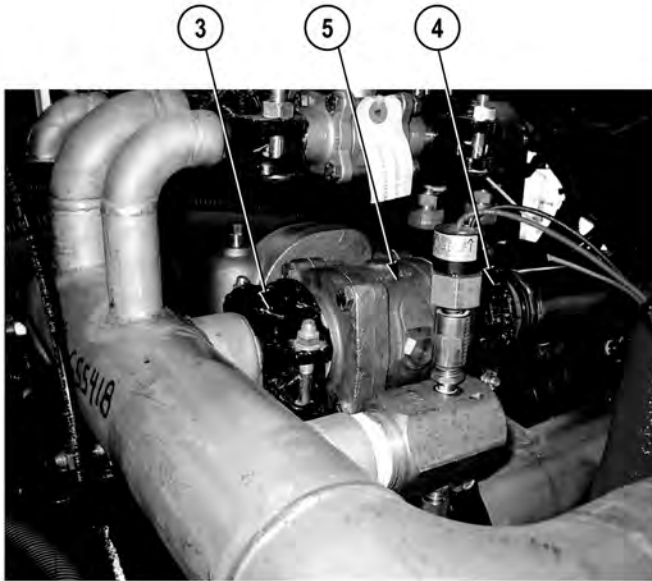
**Equipment Conditions**

Water tank drained (WP 0015)  
Foam system flush valve removed (WP 0179)  
Under truck nozzles valve removed (WP 0323)  
Pump house panel G removed (WP 0339)

---

**REMOVAL**

1. Disconnect water tank fill & re-circulating line valve connector (1) from valve control wire harness connector (2).

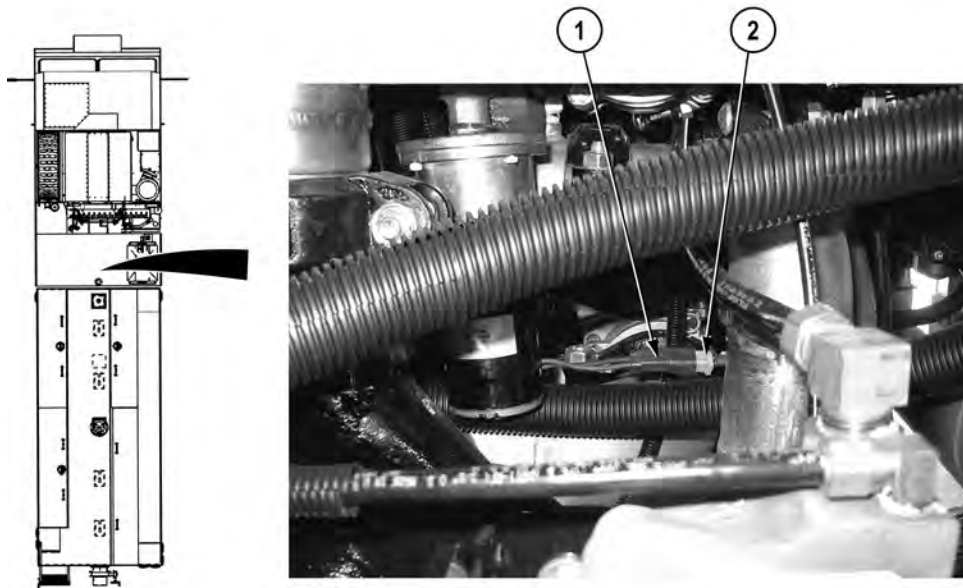


2. Remove two couplings (3) and (4) and valve (5) from vehicle (WP 0313).

#### END OF TASK

#### INSTALLATION

1. Install valve (5) and two couplings (4) and (3) on vehicle (WP 0313).



2. Connect water tank fill & re-circulating line valve connector (1) on valve control wire harness connector (2).

**END OF TASK**

**FOLLOW-ON MAINTENANCE**

1. Install under truck nozzles valve (WP 0323)
2. Install foam system flush valve (WP 0179)
3. Install pump house panel G (WP 0339)

**END OF TASK**

**END OF WORK PACKAGE**



---

**FIELD LEVEL MAINTENANCE**  
**WATER TANK VENT FILL TOWER REPLACEMENT**

---

**INITIAL SETUP:****Tools and Special Tools**

Standard Automotive Tool Set (SATS),  
(WP 0398, Item 15)  
• Wrench, Torque, Click, Ratcheting, 1/2" drive  
75 lb-ft  
Tool Kit, General Mechanic's: Automotive  
(WP 0398, Item 17)

**Materials/Parts**

Adhesive, Sealant, Silicone RTV  
(WP 0400, Item 3)  
Lockwasher (8)  
Locknut (3)

**Materials/Parts (continued)**

Lockwasher (4)  
Locknut (2)  
Locknut (1)

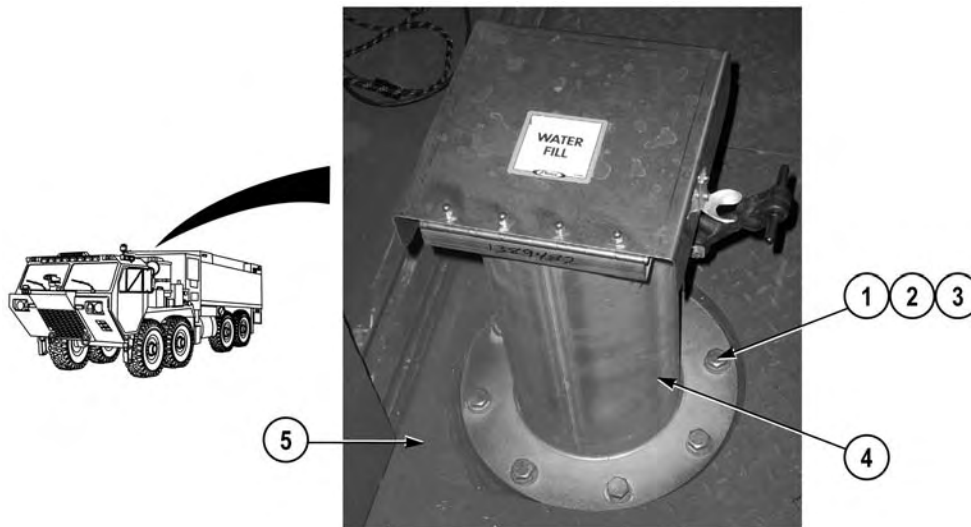
**References**

WP 0391, Fig. 66

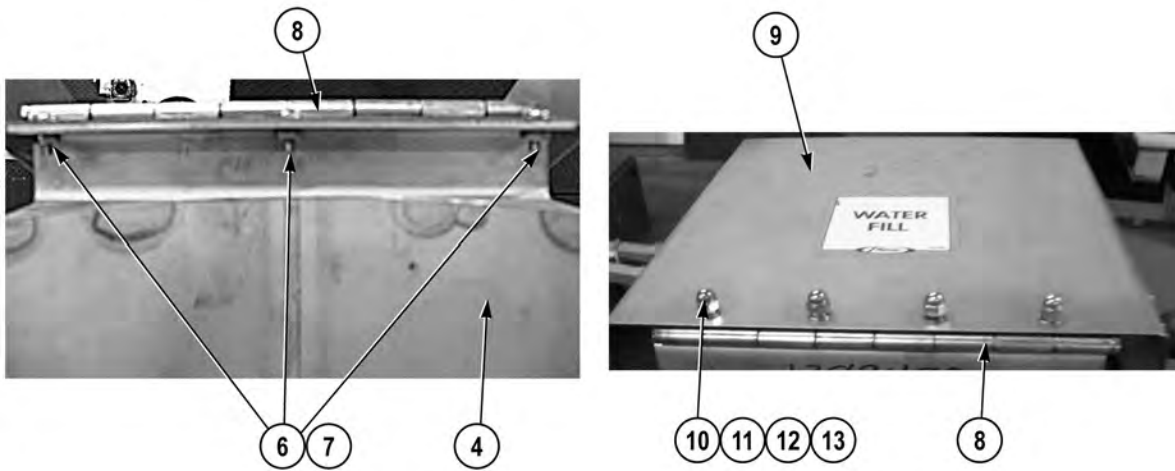
**Equipment Conditions**

Engine OFF (TM 9-2320-422-10)  
Wheels chocked (TM 9-2320-422-10)

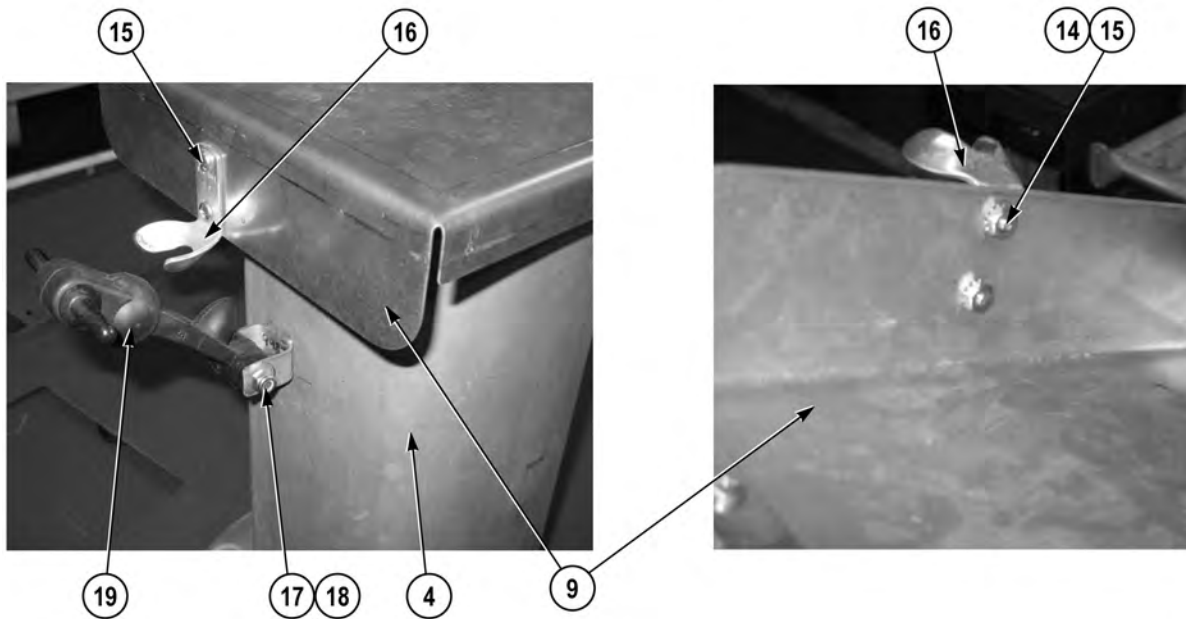
---

**REMOVAL**

1. Remove eight screws (1), lockwashers (2), washers (3), and water tank vent/fill tower (4) from water tank (5). Discard lockwashers.



2. Remove three locknuts (6), screws (7), hinge (8), and cover (9) from water tank vent/fill tower (4). Discard locknuts.
3. Remove four nuts (10), lockwashers (11), washers (12), screws (13), and hinge (8) from cover (9). Discard lockwashers.

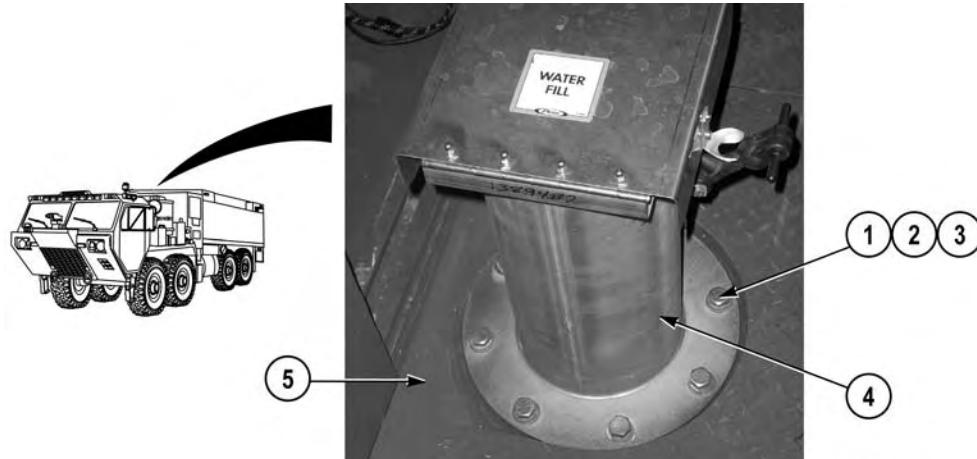


4. Remove two locknuts (14), screws (15), and bracket (16) from cover (9). Discard locknuts.
5. Remove locknut (17), screw (18), and rubber draw latch (19) from water tank vent/fill tower (4). Discard locknut.

**END OF TASK**

**INSTALLATION**

1. Install rubber draw latch (19) on water tank vent/fill tower (4) with screw (18) and locknut (17).
2. Install bracket (16) on cover (9) with two screws (15) and two locknuts (14).
3. Install hinge (8) on cover (9) with four screws (13), washers (12), lockwashers (11), and nuts (10).
4. Install hinge (8) on water tank vent/fill tower (4) with three screws (7) and locknuts (6).

**WARNING**

**Adhesives, solvents, and sealing compounds can burn easily, can give off harmful vapors, and are harmful to skin and clothing. To avoid injury or death, keep away from open fire and use in well-ventilated area. If adhesive, solvent, or sealing compound gets on skin or clothing, wash immediately with soap and water.**

**NOTE**

Sealant will be applied to mating surface of water tank vent/fill tower and water tank.

5. Apply sealant to base of water tank vent/fill tower (4).
6. Install water tank vent/fill tower (4) to water tank (5) with eight washers (3), lockwashers (2), and screws (1).
7. Tighten screws (1) to 20 lb-ft (27 N•m).

**END OF TASK****FOLLOW-ON MAINTENANCE**

Remove wheel chocks (TM 9-2320-422-10)

**END OF TASK****END OF WORK PACKAGE**





---

**FIELD LEVEL MAINTENANCE**
**WATER TANK REPLACEMENT**


---

**INITIAL SETUP:****Tools and Special Tools**

Standard Automotive Tool Set (SATS),  
 (WP 0398, Item 15)

- Wrench, Adjustable 18"
- Wrench, Pipe 18"
- Trestle, Hoist, Portable (4)
- Extension 1/2" DR, 10" Long

Tool Kit, General Mechanic's: Automotive  
 (WP 0398, Item 17)

Water Tank Lift Kit

**Materials/Parts**

Compound, Sealing, Pipe Thread  
 (WP 0400, Item 11)

Tags, Identification (WP 0400, Item 23)

**Personnel Required**

MOS 63B Wheeled Vehicle Mechanic (4)

**References**

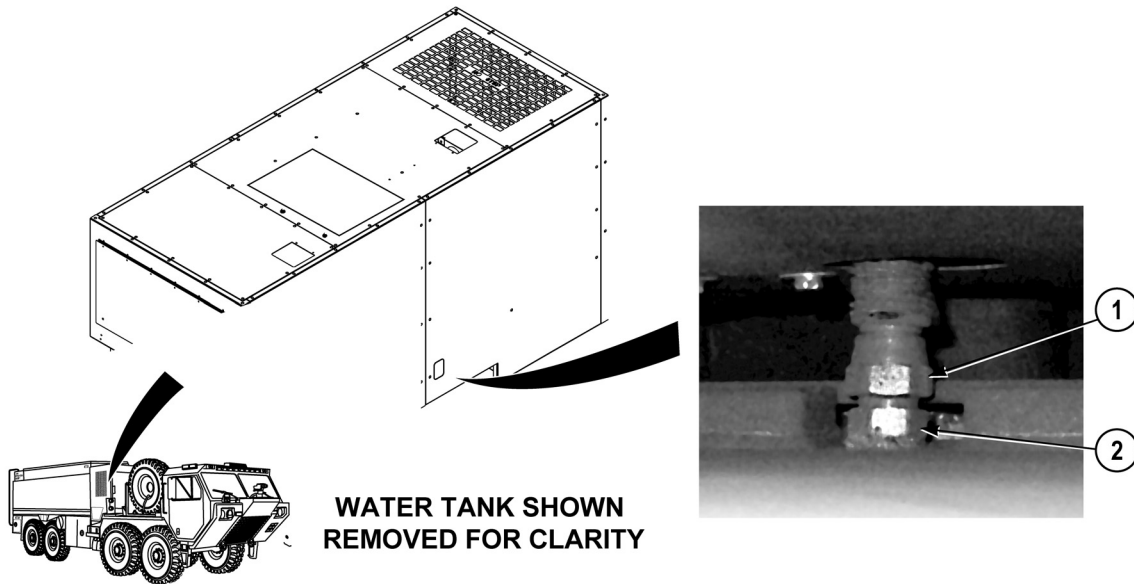
WP 0313  
 WP 0318  
 WP 0321  
 WP 0391, Fig. 24

**Equipment Conditions**

Hose reel removed (WP 0247)  
 Foam tank drained (WP 0022)  
 Water tank drain valve removed (WP 0172)  
 Direct tank fill valve removed (WP 0311)  
 Small compartment doors removed (hard suction  
 hoses) (WP 0350)

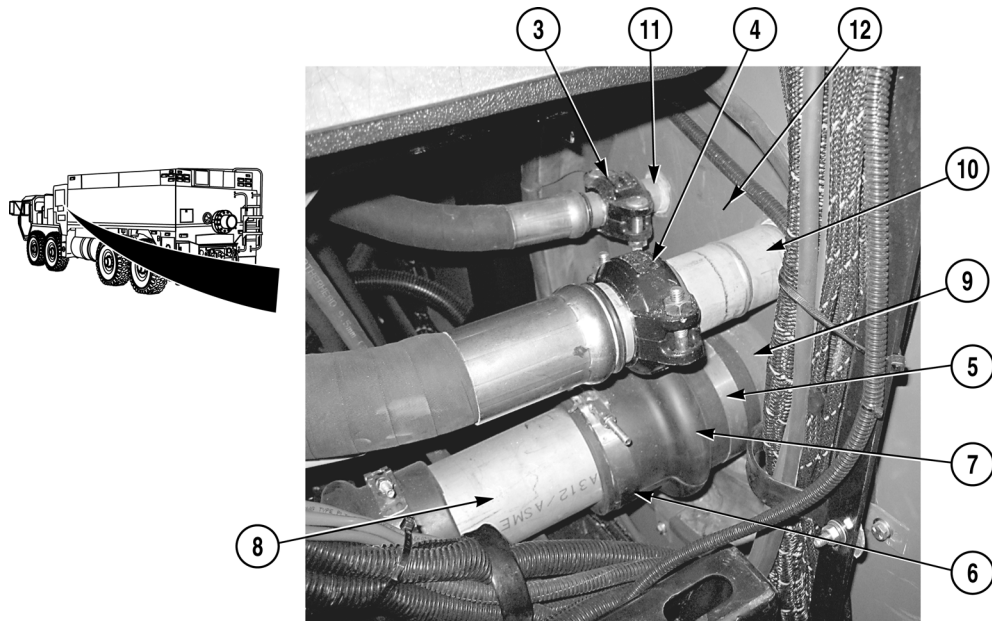
**Equipment Conditions (continued)**

Hard suction hoses removed (WP 0019)  
 Propeller shaft removed from transfer case to  
 number three axle (TM 9-2320-325-14&P)  
 Portable water tank stowage compartment  
 removed (WP 0337)  
 Foam tank level probe removed (WP 0175)  
 Foam tank fill port extension and cover removed  
 (WP 0185)  
 Water tank level probe removed (WP 0190)  
 Water tank vent fill tower removed (WP 0192)  
 Stowage compartment (top front passenger side)  
 removed (WP 0359)  
 Stowage compartment (top front driver side)  
 removed (WP 0358)  
 Stowage compartment (top rear passenger side)  
 removed (WP 0360)  
 Hose bed assembly removed (WP 0329)  
 Light bezels removed (WP 0334)  
 Walkway grating removed (WP 0364)  
 Driver side body wire harness removed  
 (WP 0286)  
 Passenger side body wire harness removed  
 (WP 0298)  
 Power cable assembly removed (SINCGARS)  
 (WP 0260)  
 Rear access ladder removed (WP 0343)  
 Side manual bray valves removed (WP 0188)

**REMOVAL****NOTE**

Tag and mark hoses upon removal.

1. Remove hose (1) from fitting (2).



2. Remove two couplings (3) and (4) from vehicle (WP 0313).
3. Loosen two clamps (5) and (6) and slide hump hose (7) on pipe (8) from tank outlet pipe (9).

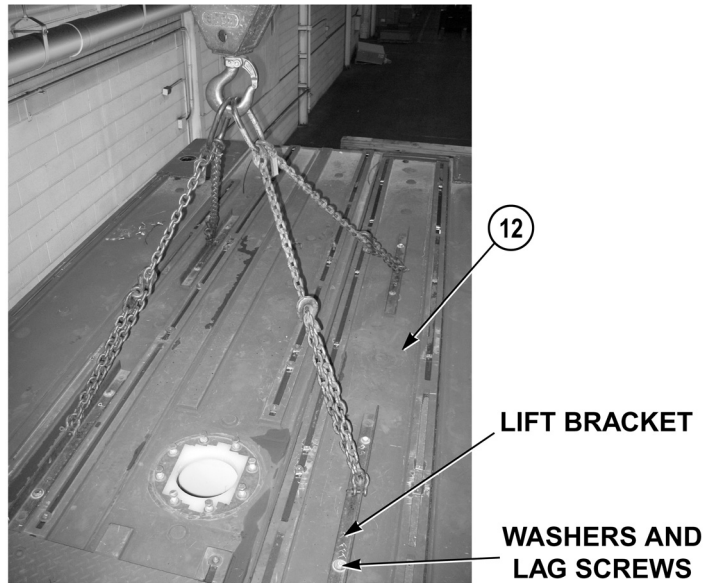
**NOTE**

Tank outlet pipe is part of tank and is not removed from tank.

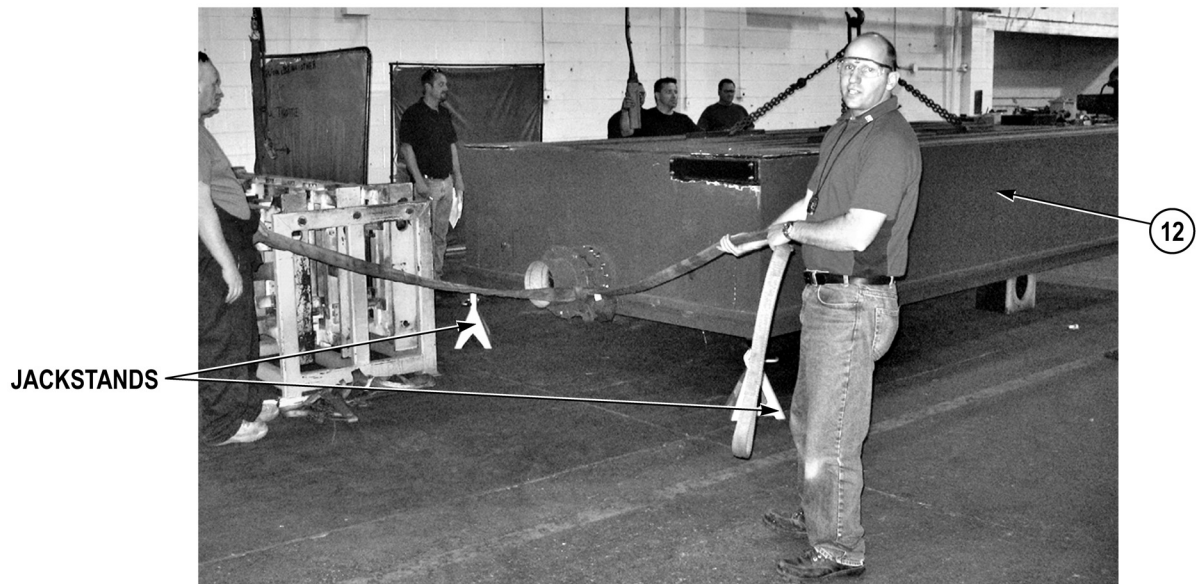
4. Remove two pipes (10) and (11) from water tank (12).



5. Remove 48 screws (13) and eight brackets (14) from cradle (15) and water tank (12).



6. Attach four lift brackets on water tank (12) with eight washers and lag screws.



### WARNING



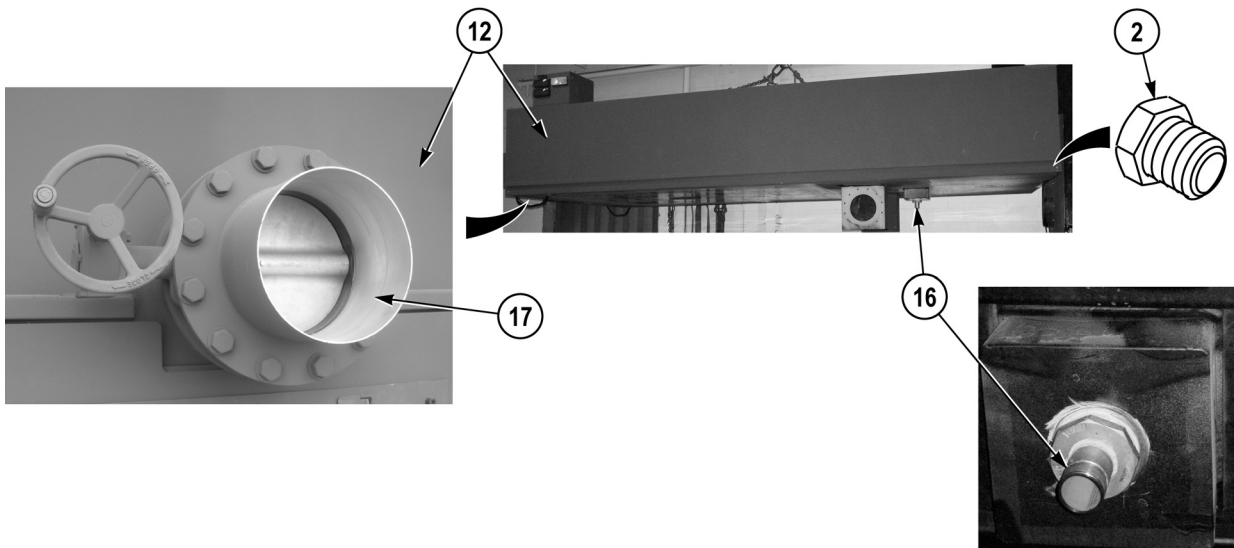
- Water tank weighs 2500 lb. (1135 kg). Do not attempt to move or lift water tank without the aid of three assistants and a suitable lifting device. Failure to comply may result in serious injury to personnel or damage to equipment.
- Do not stand between water tank cradle and water tank or under water tank when removing from vehicle. Water tank may swing toward vehicle or fall causing injury or death to personnel.
- All personnel must stand clear during lifting operations. A swinging or shifting load may cause death or injury to personnel.

### CAUTION

Water tank must be placed on four jack stands placed at four corners of water tank. Failure to comply may cause damage to equipment.

### NOTE

- Use tiedown straps as needed to guide water tank during removal.
  - Two tiedown straps are attached to rear manual bray dump valve.
7. With the aid of two assistants guiding water tank (12) with tie down straps, an assistant guiding from front of water tank (12), and using a suitable lifting device, remove water tank (12) from vehicle and set water tank (12) on four jackstands.



8. Remove fitting (2) from water tank (12).
9. Remove adapter (16) from water tank (12) (WP 0321).
10. Remove rear manual bray valve (17) from water tank (12) (WP 0188).

#### END OF TASK

#### INSTALLATION

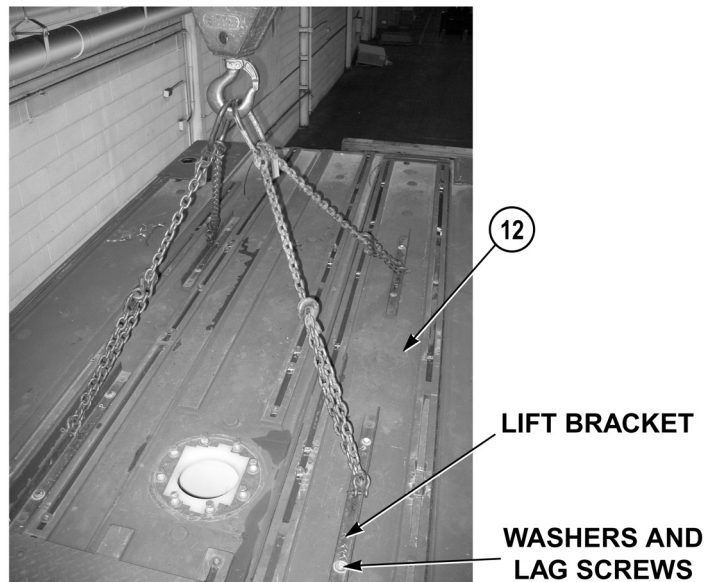
1. Install rear manual bray valve (17) on water tank (12) (WP 0188).
2. Install adapter (16) on water tank (12) (WP 0321).

#### WARNING



**Adhesives, solvents, and sealing compounds can burn easily, can give off harmful vapors, and are harmful to skin and clothing. To avoid injury or death, keep away from open fire and use in well-ventilated area. If adhesive, solvent, or sealing compound gets on skin or clothing, wash immediately with soap and water.**

3. Apply sealing compound to threads of fitting (2).
4. Install fitting (2) in water tank (12).

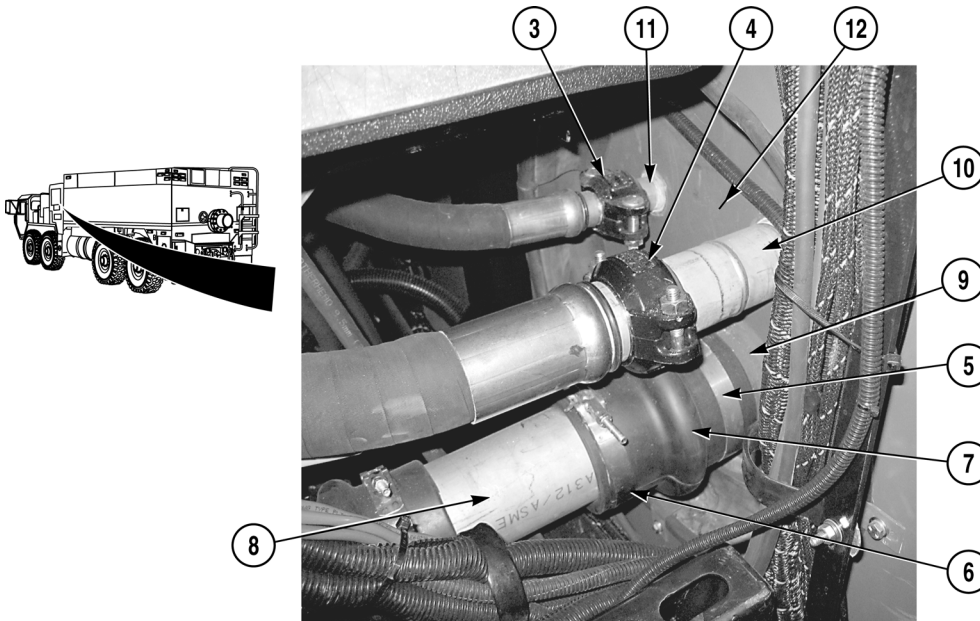
**WARNING**

**Water tank weighs 2500 lb. (1135 kg). Do not attempt to move or lift water tank without the aid of three assistants and a suitable lifting device. Failure to comply may result in serious injury to personnel or damage to equipment.**

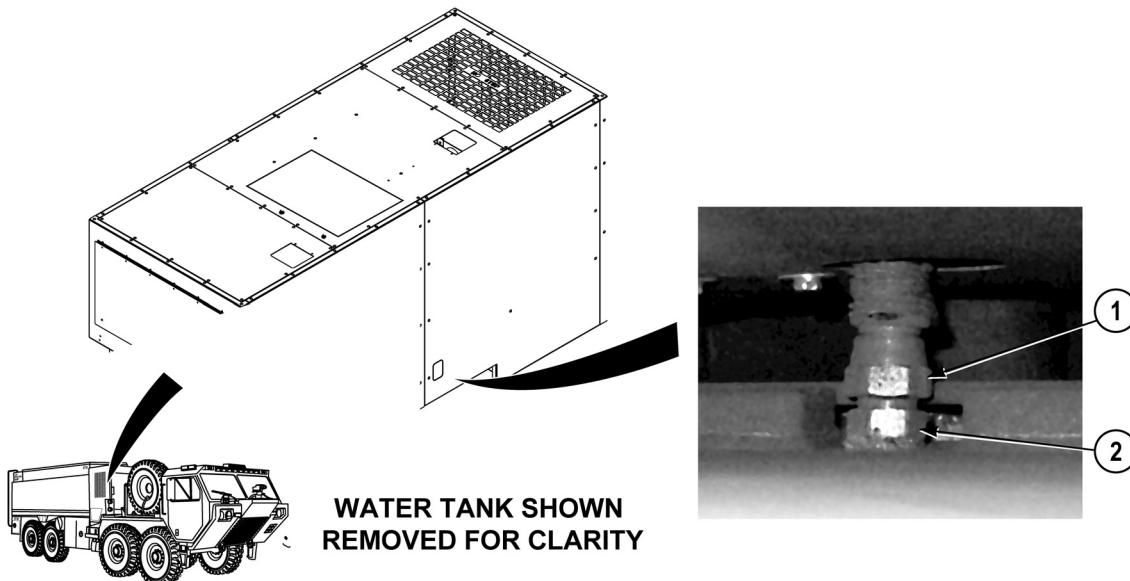
5. With the aid of three assistants and suitable lifting device, install water tank (12) on vehicle.
6. Remove eight lag screws, washers, and four lift brackets from water tank (12).



7. Install eight brackets (14) on cradle (15) and water tank (12) with 48 screws (13).



8. Install two pipes (11) and (10) on water tank (12) (WP 0318).
9. Slide hump hose (7) on tank outlet pipe (9) and tighten two clamps (6) and (5).
10. Install two couplings (4) and (3) on vehicle (WP 0313).



11. Install hose (1) on fitting (2).

**END OF TASK**



---

**FOLLOW-ON MAINTENANCE**

1. Install side manual bray valves (WP 0188)
2. Install rear access ladder (WP 0343)
3. Install power cable assembly (SINCGARS) (WP 0260)
4. Install passenger side body wire harness (WP 0298)
5. Install driver side body wire harness (WP 0286)
6. Install walkway grating (WP 0364)
7. Install light bezels (WP 0334)
8. Install hose bed assembly (WP 0329)
9. Install stowage compartment (top rear passenger side) (WP 0360)
10. Install stowage compartment (top front driver side) (WP 0358)
11. Install stowage compartment (top front passenger side) (WP 0359)
12. Install water tank vent fill tower (WP 0192)
13. Install water tank level probe (WP 0190)
14. Install foam tank fill port extension and cover (WP 0185)
15. Install foam tank level probe (WP 0175)
16. Install portable water tank stowage compartment (WP 0337)
17. Install propeller shaft from transfer case to number three axle (TM 9-2320-325-14&P)
18. Install hard suction hoses (WP 0019)
19. Install small compartment doors (hard suction hoses) (WP 0350)
20. Install direct tank fill valve (WP 0311)
21. Install water tank drain valve (WP 0172)
22. Install hose reel (WP 0247)

**END OF TASK****END OF WORK PACKAGE**



---

**FIELD LEVEL MAINTENANCE**  
**WATER TANK CRADLE REPLACEMENT**

---

**INITIAL SETUP:****Tools and Special Tools**

Tool Kit, General Mechanic's: Automotive  
(WP 0398, Item 17)

**Materials/Parts**

Adhesive, Spray (WP 0400, Item 5)  
Lockwasher (4)  
Locknut (2)  
Lockwasher (2)  
Locknut (1)  
Locknut (18)  
Locknut (1)  
Locknut (2)  
Locknut (1)  
Lockwasher (1)  
Lockwasher (14)

**Personnel Required**

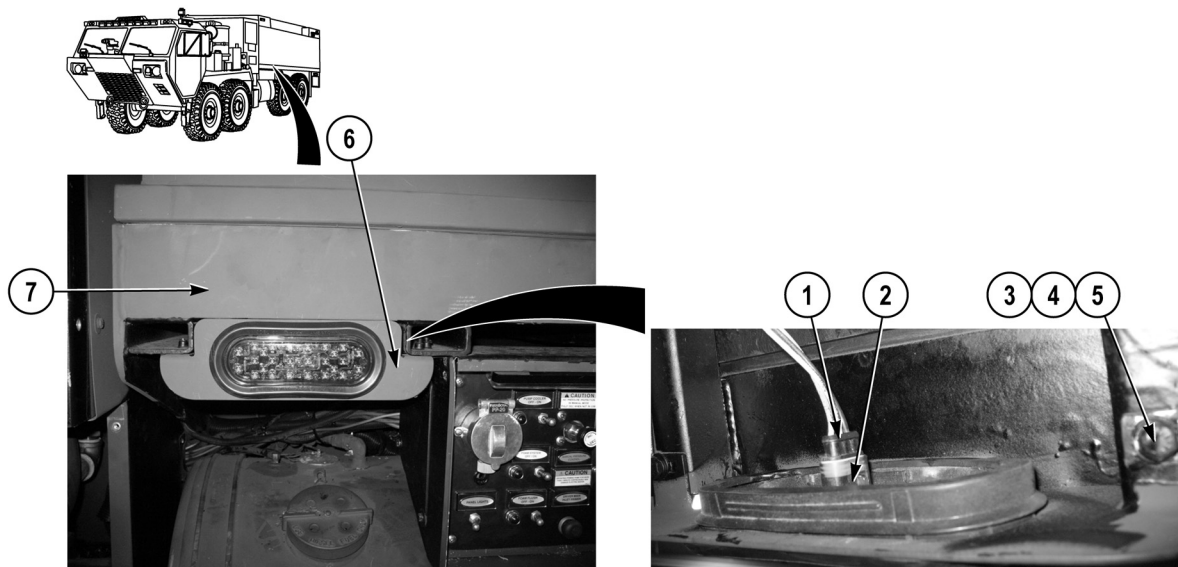
MOS 63B Wheeled Vehicle Mechanic (2)

**References**

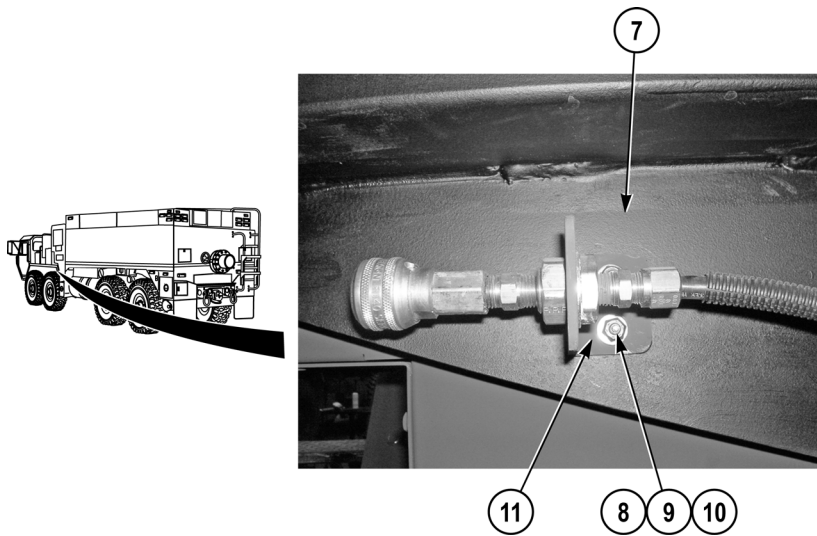
WP 0391, Fig. 25

**Equipment Conditions**

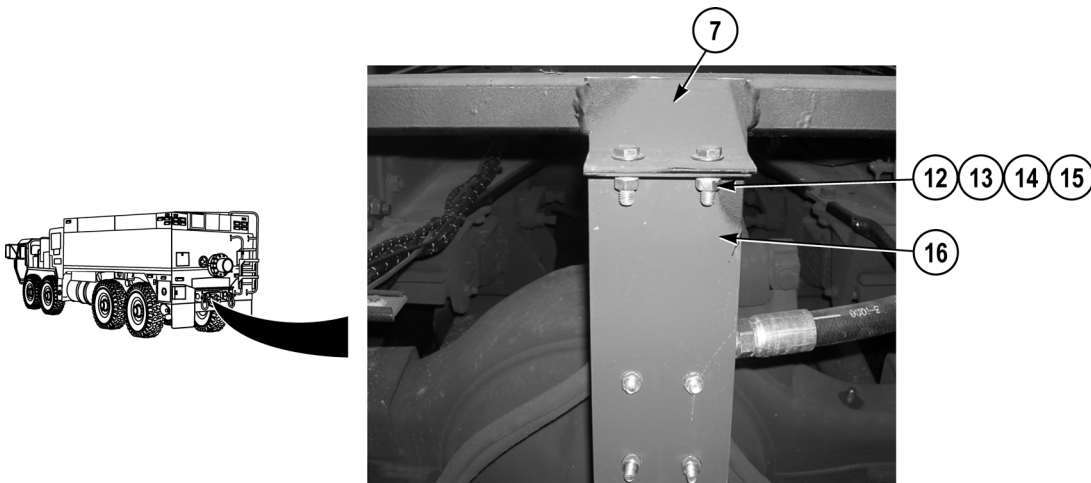
Water tank removed (WP 0193)  
Wheel chocks stowage compartment removed  
(WP 0365)  
Pump operator's panel removed (WP 0208)  
Stowage compartment (lower front passenger  
side) removed (WP 0354)  
Stowage compartment (lower rear passenger  
side) removed (WP 0357)  
Stowage compartment (lower rear driver side)  
removed (WP 0356)  
Portable ladder (folding) unstowed (WP 0013)

**REMOVAL**

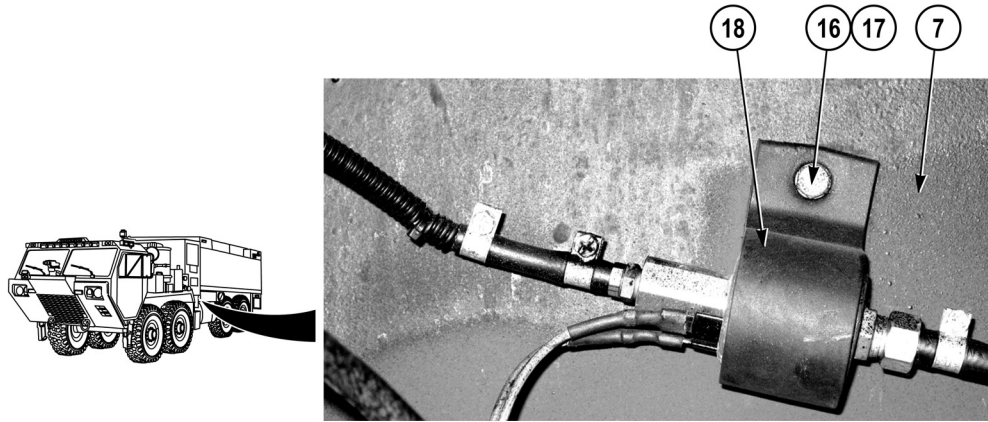
1. Disconnect side marker light wire harness (1) from side marker light (2).
2. Remove four screws (3), lockwashers (4), washers (5), and bracket (6) from water tank cradle (7). Discard lockwashers.



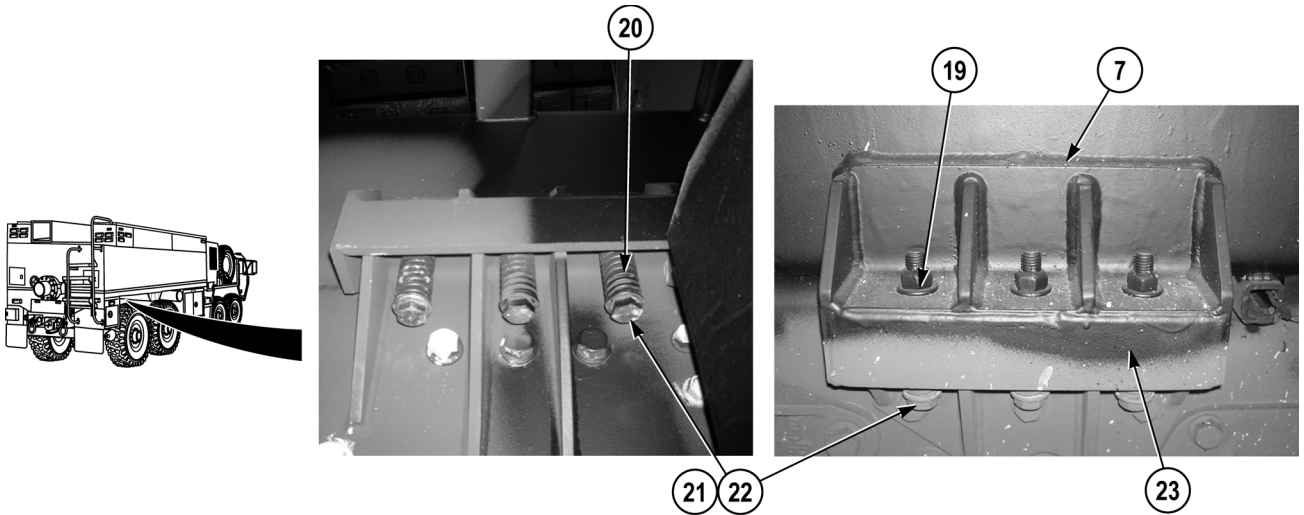
3. Remove two locknuts (8), washers (9), screws (10), and tire inflator connect bracket (11) from water tank cradle (7). Discard locknuts.



4. Remove two nuts (12), lockwashers (13), four washers (14), two screws (15), and rear under truck nozzle bracket (16) from water tank cradle (7). Discard lockwashers.



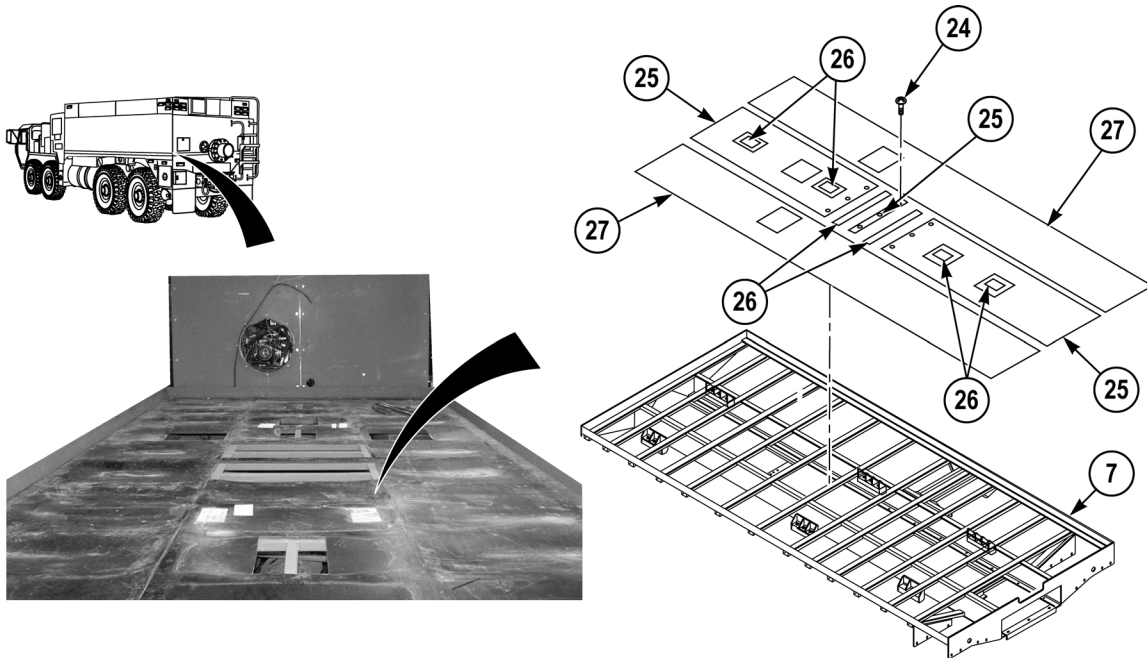
5. Remove locknut (16), screw (17), and pump house heater fuel pump bracket (18) from water tank cradle (7). Discard locknut.



**NOTE**

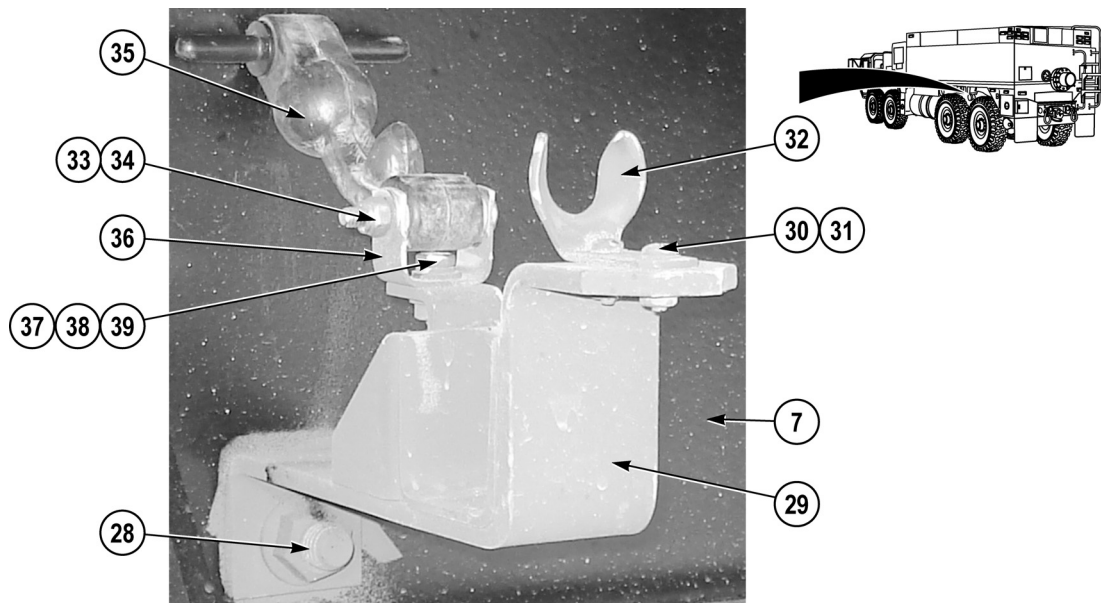
Note locators of washers prior to removal to ensure proper installation.

6. Remove 18 locknuts (19), springs (20), 36 washers (21), and 18 screws (22) from water tank cradle (7) and six frame rail mounting brackets (23). Discard locknuts.



### NOTE

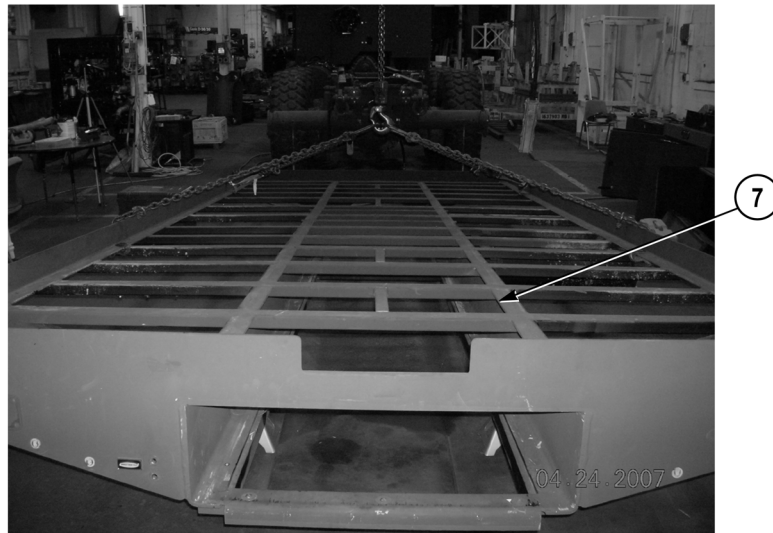
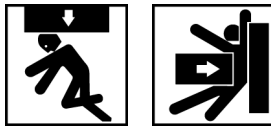
- Note position of rubber tank padding strips prior to removal to ensure proper installation.
  - Three rubber tank padding strips are held in place with screws.
  - Six rubber tank padding strips are held in place with adhesive.
7. Remove nine screws (24) and three rubber tank padding strips (25) from water tank cradle (7).
  8. Remove six rubber tank padding strips (26) and two rubber tank padding strips (27) from water tank cradle (7).



### NOTE

Both portable ladder brackets are removed the same way. Front ladder bracket shown.

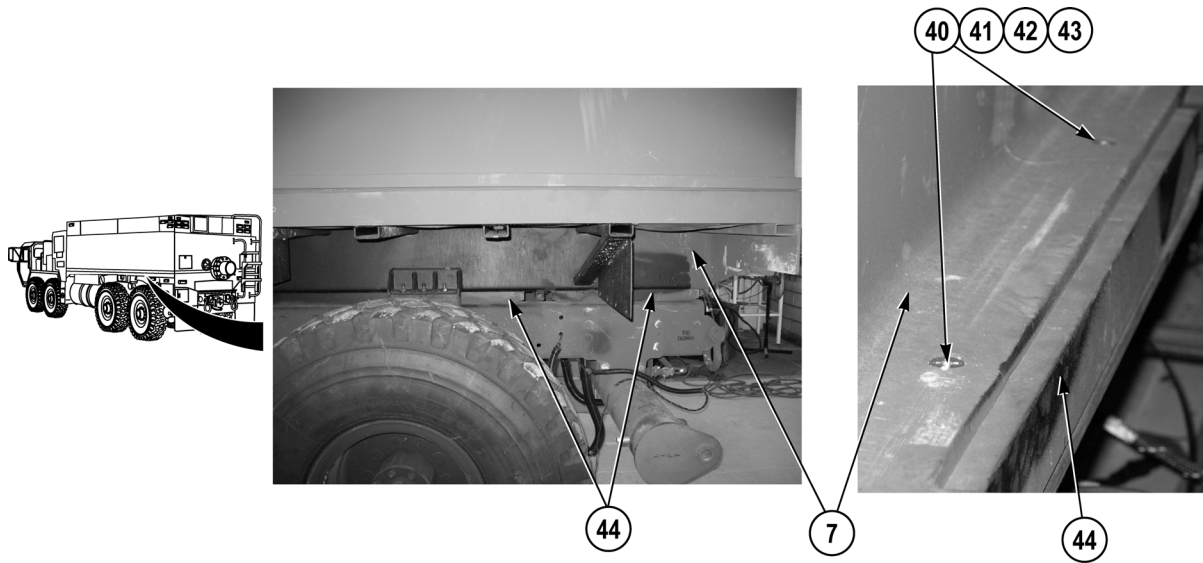
9. Remove locknut (28) and portable ladder bracket (29) from water tank cradle (7). Discard locknut.
10. Remove two locknuts (30), screws (31), and anchor (32) from portable ladder bracket (29). Discard locknuts.
11. Remove locknut (33), screw (34), and rubber draw latch (35) from bracket (36). Discard locknut.
12. Remove screw (37), lockwasher (38), washer (39), and bracket (36) from portable ladder bracket (29). Discard lockwasher.

**WARNING**

- Do not stand between vehicle and water tank cradle or under water tank cradle when removing from vehicle. Water tank cradle may swing toward vehicle or fall causing injury or death to personnel.
- Water tank cradle weighs approximately 2,000 lb. (908 kg). Do not attempt to lift or move water tank cradle without the aid of an assistant and a suitable lifting device. Failure to comply may result in injury or death to personnel.
- All personnel must stand clear during lifting operations. A swinging or shifting load may cause death or injury to personnel.

13. With the aid of an assistant and a suitable lifting device, remove water tank cradle (7) from vehicle.



**NOTE**

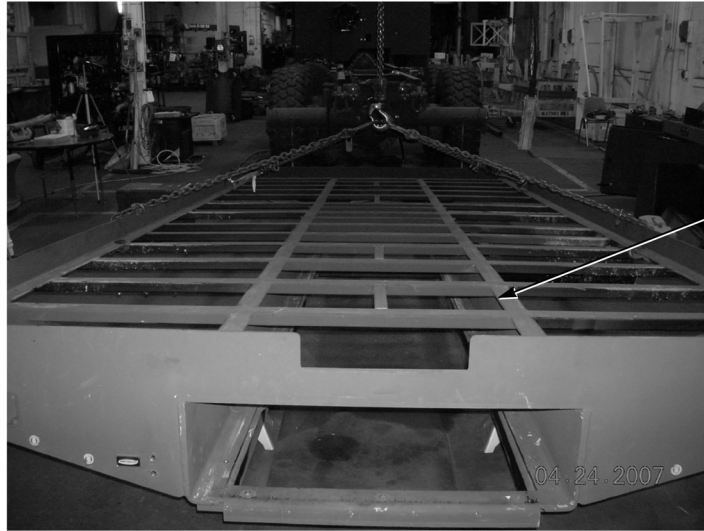
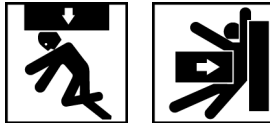
Note position of wooden spacers prior to removal to ensure proper installation.

14. Remove 14 nuts (40), lockwashers (41), washers (42) screws (43), and four wooden spacers (44) from water tank cradle (7). Discard lockwashers.

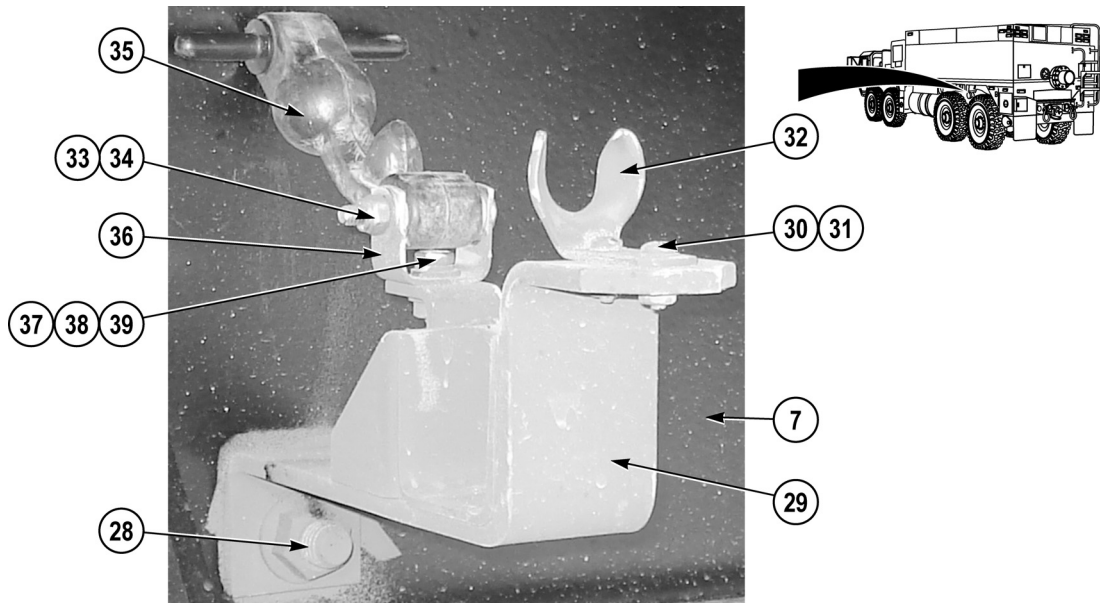
**END OF TASK****INSTALLATION****NOTE**

Install wooden spacers as noted prior to removal.

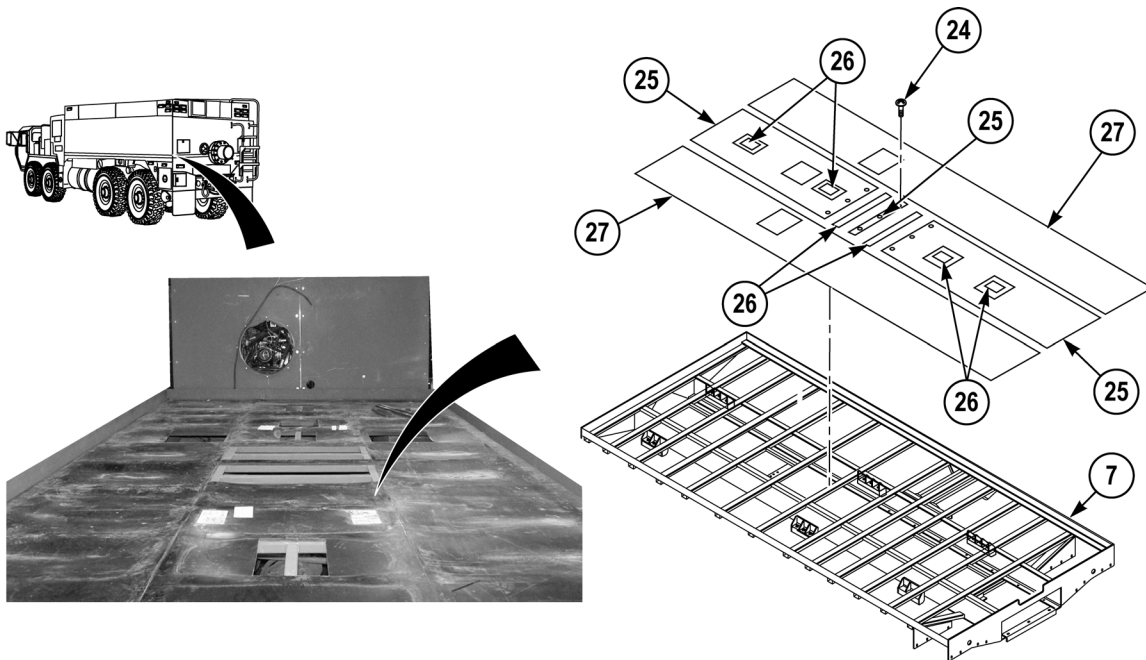
1. Install four wooden spacers (44) on water tank (7) with 14 screws (43), washers (42), lockwashers (41), and nuts (40).

**WARNING**

- Do not stand between vehicle and water tank cradle or under water tank cradle when removing from vehicle. Water tank cradle may swing toward vehicle or fall causing injury or death to personnel.
  - Water tank cradle weighs approximately 2,000 lb. (908 kg). Do not attempt to lift or move water tank cradle without the aid of an assistant and a suitable lifting device. Failure to comply may result in injury or death to personnel.
  - All personnel must stand clear during lifting operations. A swinging or shifting load may cause death or injury to personnel.
2. With the aid of an assistant and a suitable lifting device, position water tank cradle (7) on vehicle.



3. Install bracket (36) on portable ladder bracket (29) with washer (39), lockwasher (38), and screw (37).
4. Install rubber draw latch (35) on bracket (36) with screw (34) and locknut (33).
5. Install anchor (32) on portable ladder bracket (29) with two screws (31) and locknuts (30).
6. Install portable ladder bracket (29) on water tank cradle (7) with locknut (28).



### NOTE

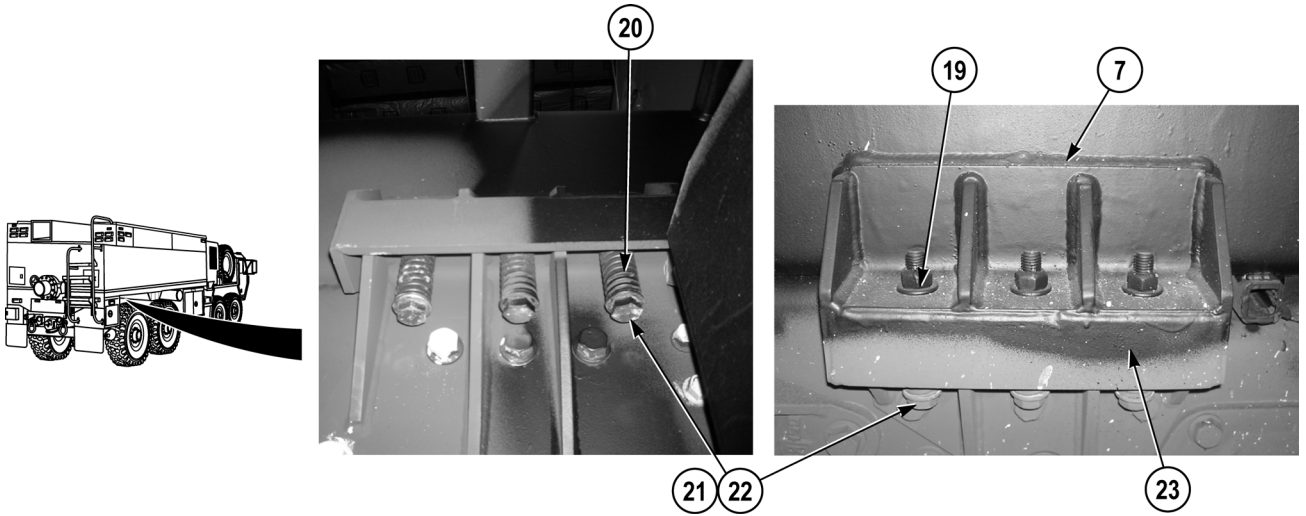
- Install rubber tank padding as noted prior to removal.
  - Three rubber tank padding strips are held in place with screws.
  - Six rubber tank padding strips are held in place with adhesive.
7. Install two rubber tank padding strips (27) on water tank cradle (7).

### WARNING



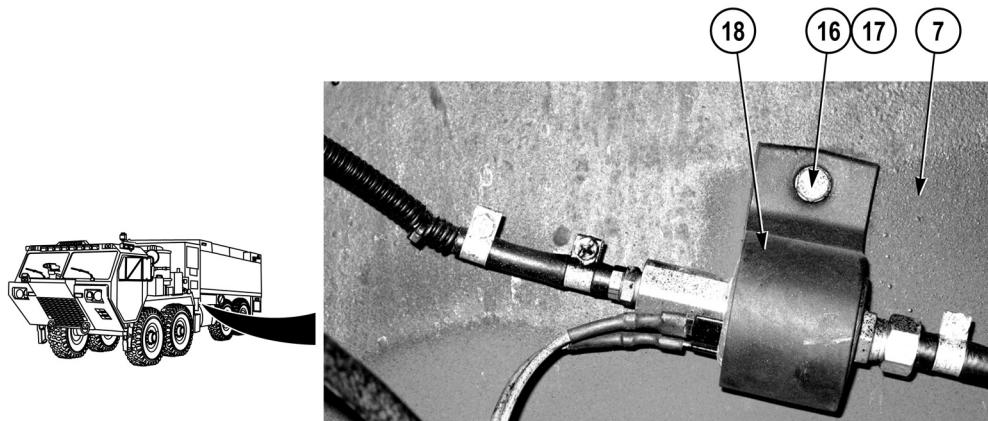
**Adhesives, solvents, and sealing compounds can burn easily, can give off harmful vapors, and are harmful to skin and clothing. To avoid injury or death, keep away from open fire and use in well-ventilated area. If adhesive, solvent, or sealing compound gets on skin or clothing, wash immediately with soap and water.**

8. Apply adhesive to six rubber tank padding strips (26).
9. Install six rubber tank padding strips (26) on water tank cradle (7).
10. Install three rubber tank padding strips (25) on water tank cradle (7) with nine screws (24).

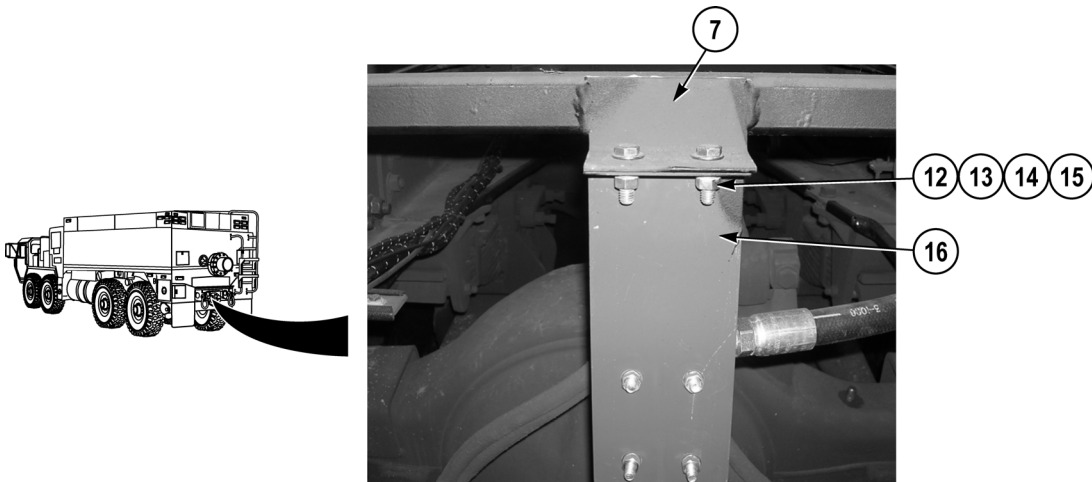


**NOTE**

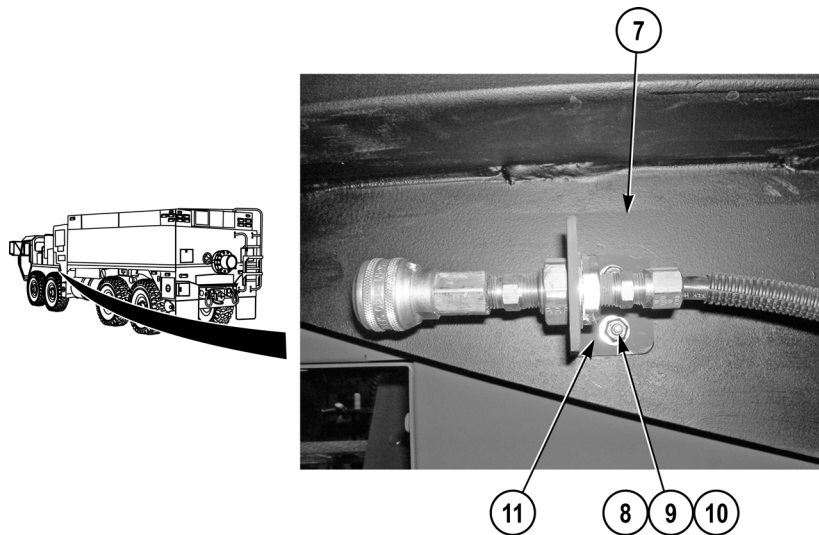
- Install washers as noted prior to removal.
  - Screw threads must have 0.75 in. (1.91 cm) or seven threads showing.
11. Install 18 screws (22), 36 washers (21), 18 springs (20), and locknuts (19) on six frame rail mounting brackets (23) and water tank cradle (7).



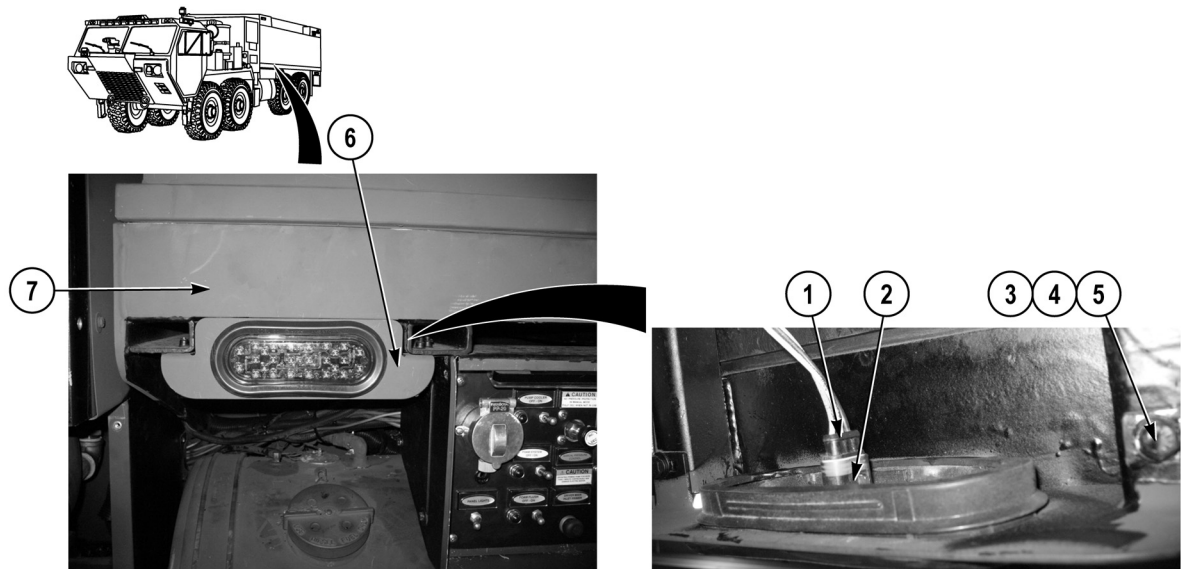
12. Install pump house heater fuel pump bracket (18) on water tank cradle (7) with screw (17), and locknut (16).



13. Install rear under truck nozzle bracket (16) on water tank cradle (7) with two screws (15), four washers (14), two lockwashers (13), and nuts (12).



14. Install tire inflator connect bracket (11) on water tank cradle (7) with two screws (10), washers (9), and locknuts (8).



15. Install bracket (6) on water tank cradle (7) with four washers (5), lockwashers (4), and screws (3).
16. Connect main wire harness connector (2) to side marker light (1).

#### END OF TASK

#### FOLLOW-ON MAINTENANCE

1. Stow portable (folding) ladder (WP 0013)
2. Install stowage compartment (lower rear driver side) (WP 0356)
3. Install stowage compartment (lower rear passenger side) (WP 0357)
4. Install stowage compartment (lower front passenger side) (WP 0354)
5. Install wheel chocks stowage compartments (WP 0365)
6. Install pump operator's panel (WP 0208)
7. Install water tank (WP 0193)

#### END OF TASK

#### END OF WORK PACKAGE





## FIELD LEVEL MAINTENANCE

## CHECK FOR OPEN COMPARTMENT DOOR WHEN LIGHT IS ON INDICATOR REPLACEMENT

## INITIAL SETUP:

**Tools and Special Tools**

Tool Kit, General Mechanic's: Automotive  
(WP 0398, Item 17)

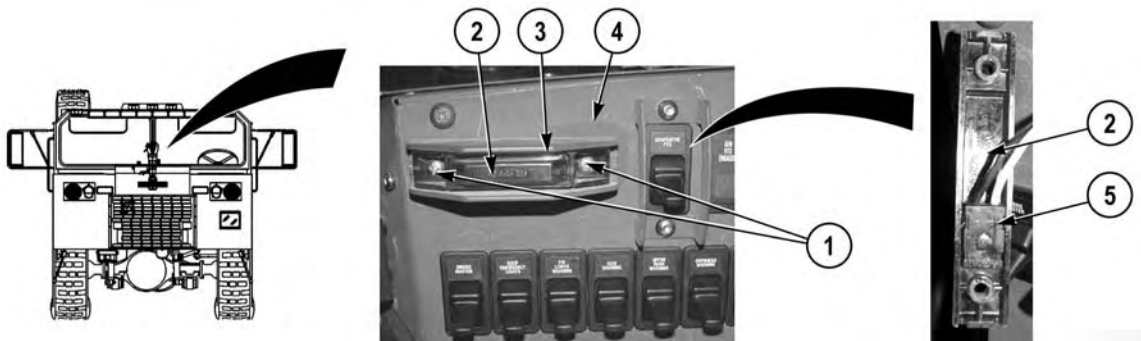
**Equipment Conditions**

Batteries disconnected (TM 9-2320-325-14&P)

**References**

WP 0391, Fig. 26

## REMOVAL



1. Remove two screws (1), indicator (2), and indicator guard (3) from cab instrument panel (4).
2. Disconnect indicator connector (5) from indicator (2).

## END OF TASK

## INSTALLATION

1. Pull indicator connector (5) through indicator guard (3).
2. Connect indicator connector (5) on indicator (2).
3. Install indicator guard (3) and indicator (2) on cab instrument panel (4) with two screws (1).

## END OF TASK

## FOLLOW-ON MAINTENANCE

Connect batteries (TM 9-2320-325-14&P)

## END OF TASK

## END OF WORK PACKAGE



## FIELD LEVEL MAINTENANCE

WARNING LIGHT AND CHECK FOR OPEN COMPARTMENT DOOR WHEN LIGHT IS ON FLASHER UNIT(S)  
REPLACEMENT

## INITIAL SETUP:

**Tools and Special Tools**

Tool Kit, General Mechanic's: Automotive  
(WP 0398, Item 17)

**Materials/Parts**

Tags, Identification (WP 0400, Item 23)  
Ties, Cable, Plastic (WP 0400, Item 26)  
Locknut (2)  
Locknut (2)

**Materials/Parts (continued)**

Locknut (2)  
Locknut (2)

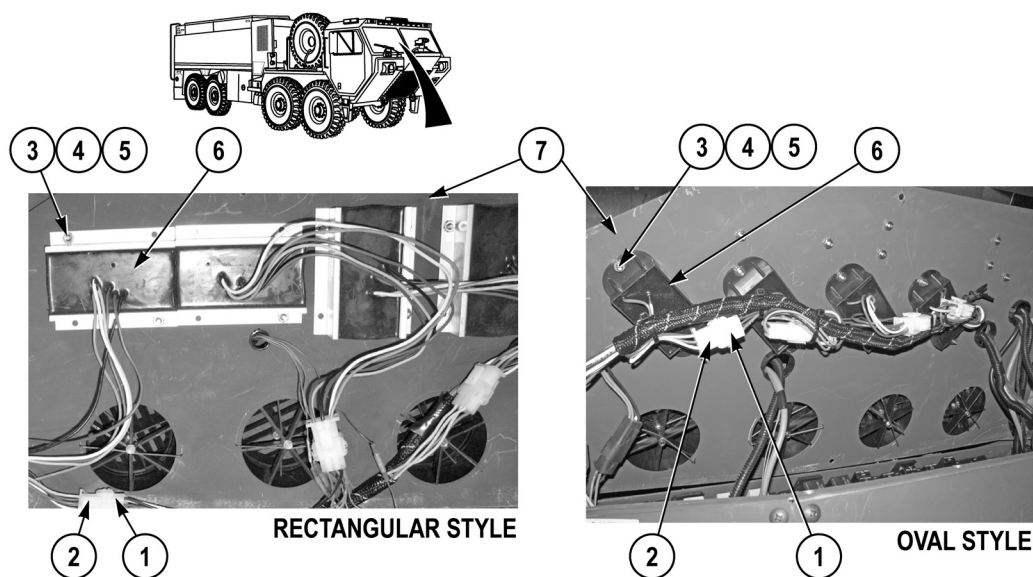
**References**

WP 0391, Fig. 26

**Equipment Conditions**

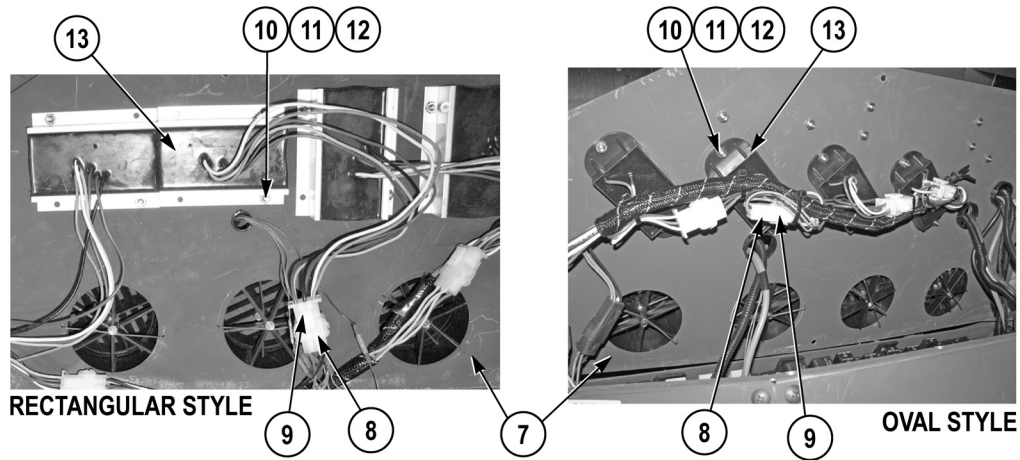
Cab instrument panel A removed (WP 0205)

## REMOVAL

**NOTE**

- Remove cable ties as required.
- Tag and mark wires prior to removal to ensure proper installation.
- Flasher units may be rectangular or oval. Both are replaced the same way.
- Perform Steps (1) and (2) if upper rear warning light flasher unit needs to be removed.

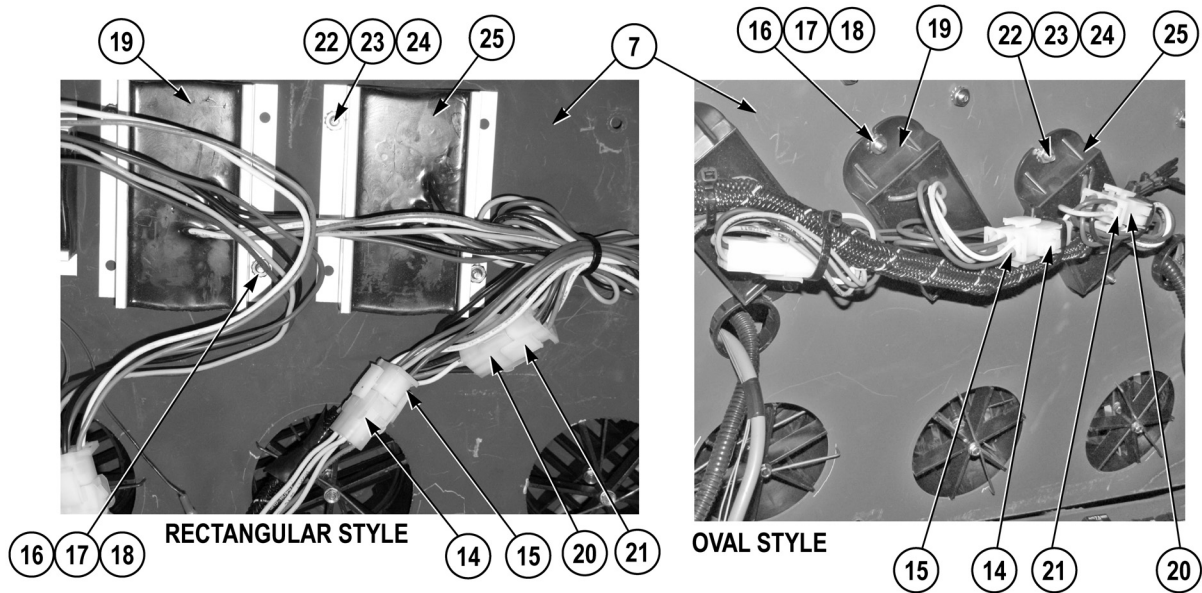
1. Disconnect cab instrument panel wire harness connector (1) from upper rear warning light flasher unit wire connector (2).
2. Remove two locknuts (3), nylon washers (4), screws (5), and upper rear warning light flasher unit (6) from cab instrument panel A (7). Discard locknuts.



### NOTE

Perform Steps (3) and (4) if check for open compartment doors when light is on flasher unit needs to be removed.

3. Disconnect cab instrument panel wire harness connector (8) from check for open compartment doors when light is on flasher unit wire connector (9).
4. Remove two locknuts (10), nylon washers (11), screws (12), and check for open compartment doors when light is on flasher unit (13) from cab instrument panel A (7). Discard locknuts.



### NOTE

Perform Steps (5) and (6) if side warning light flasher unit needs to be removed.

5. Disconnect cab instrument panel wire harness connector (14) from side warning light flasher unit wire connector (15).
6. Remove two locknuts (16), nylon washers (17), screws (18), and side warning light flasher unit (19) from cab instrument panel A (7). Discard locknuts.

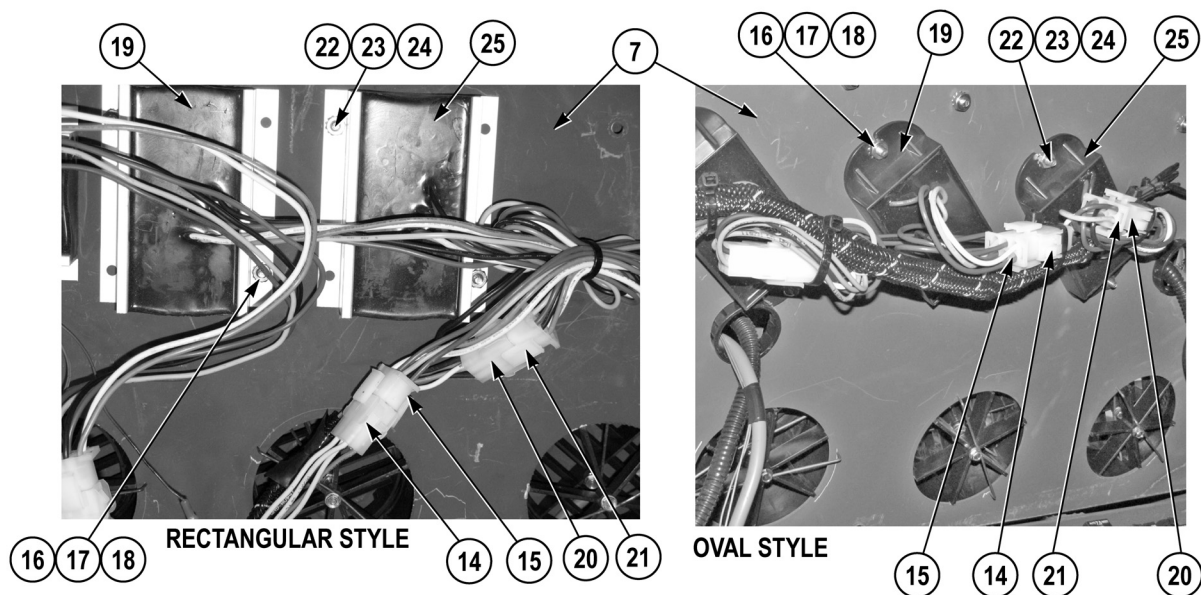
### NOTE

Perform Steps (7) and (8) if front and rear warning light flasher unit needs to be removed.

7. Disconnect cab instrument panel wire harness connector (20) from front and rear warning light flasher unit wire connector (21).
8. Remove two locknuts (22), nylon washers (23), screws (24), and front and rear warning light flasher unit (25) from cab instrument panel A (7). Discard locknuts.

**END OF TASK**

## INSTALLATION

**NOTE**

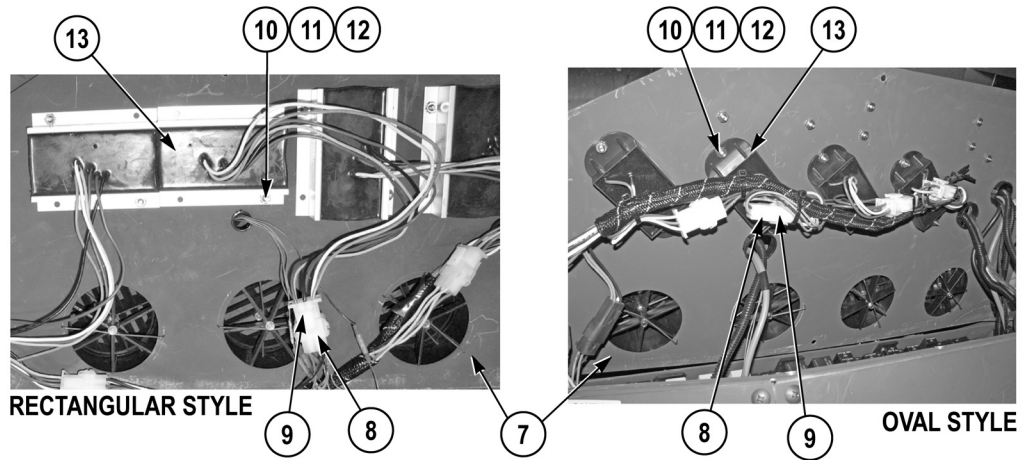
- Install cable ties as required.
- Perform Steps (1) and (2) if front and rear warning light flasher unit was removed.

1. Install front and rear warning light flasher unit (25) on cab instrument panel A (7) with two screws (24), nylon washers (23), and locknuts (22).
2. Connect front and rear warning light flasher unit wire connector (21) to cab instrument panel wire harness connector (20).

**NOTE**

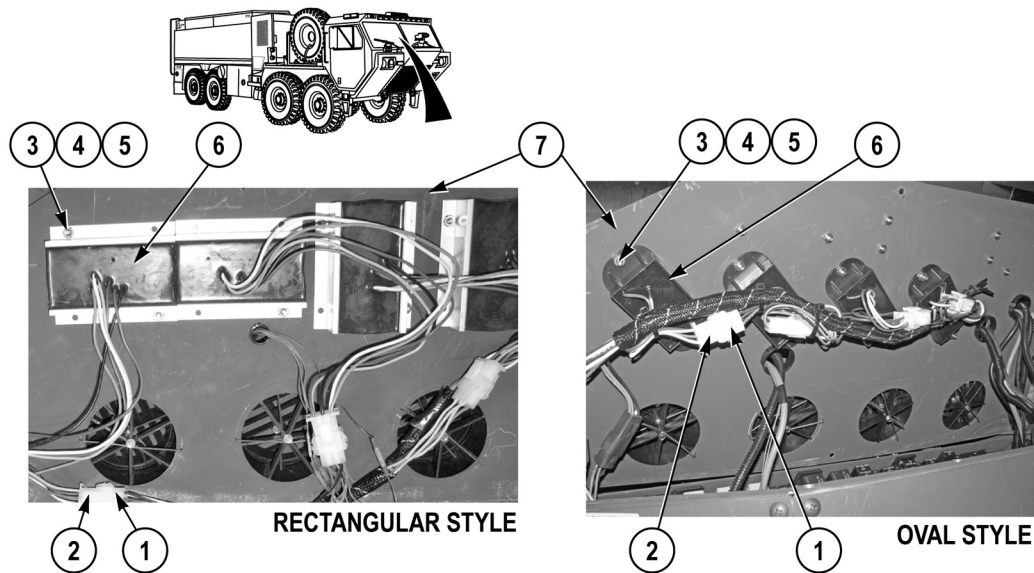
Perform Steps (3) and (4) if side warning light flasher unit was removed.

3. Install side warning light flasher unit (19) on cab instrument panel A (7) with two screws (18), nylon washers (17), and locknuts (16).
4. Connect side warning light flasher unit wire connector (15) to cab instrument panel wire harness connector (14).



### NOTE

- Perform Steps (5) and (6) if check for open compartment doors when light is on flasher unit was removed.
5. Install check for open compartment doors when light is on flasher unit (13) on cab instrument panel A (7) with two screws (12), nylon washers (11), and locknuts (10).
  6. Connect check for open compartment doors when light is on flasher unit wire connector (9) to cab instrument panel wire harness connector (8).



### NOTE

Perform Steps (7) and (8) if upper rear warning light flasher unit was removed.

7. Install upper rear warning light flasher unit (6) on cab instrument panel (7) with two screws (5), lockwashers (4), and locknuts (3).
8. Connect upper rear warning light flasher unit wire connector (2) to cab instrument panel wire harness connector (1).

**END OF TASK**

### FOLLOW ON MAINTENANCE

Install cab instrument panel A (WP 0205)

**END OF TASK**

**END OF WORK PACKAGE**



## FIELD LEVEL MAINTENANCE

## CAB PRESSURE GOVERNOR CONTROL REPLACEMENT

## INITIAL SETUP:

**Tools and Special Tools**

Tool Kit, General Mechanic's: Automotive  
(WP 0398, Item 17)

**References**

WP 0391, Fig. 26

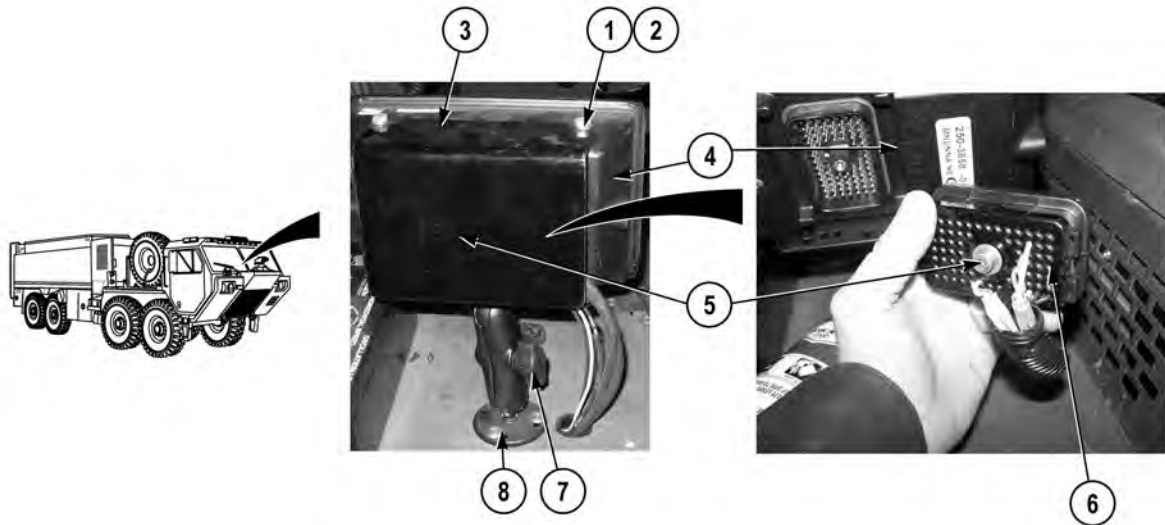
**Materials/Parts**

Lockwasher (2)  
Locknut (3)

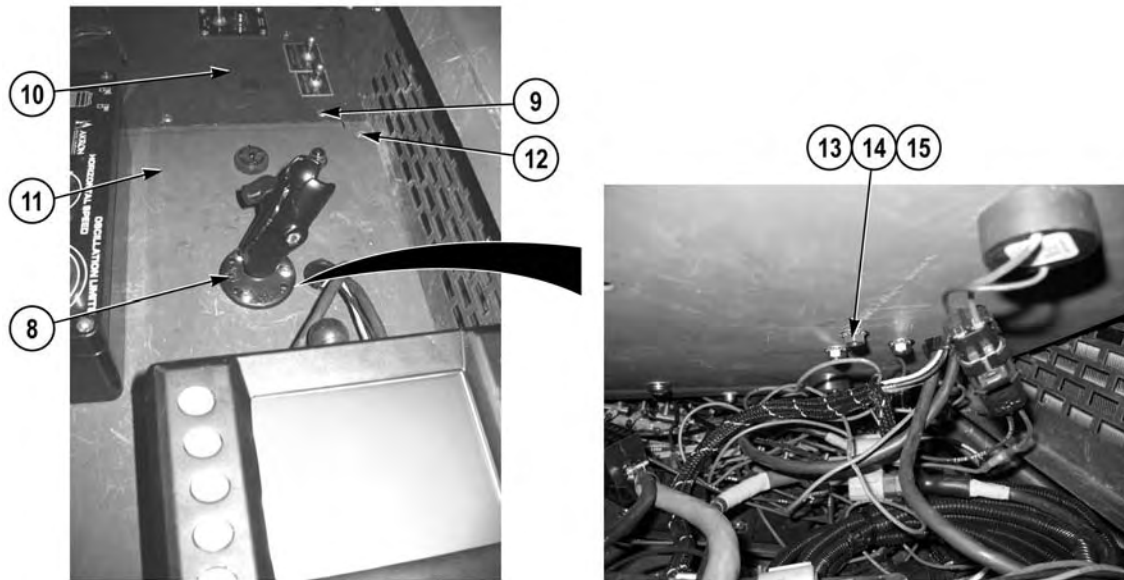
**Equipment Conditions**

Batteries disconnected (TM 9-2320-325-14&P)

## REMOVAL



1. Remove two screws (1), lockwashers (2), and cover (3) from pressure governor control (4). Discard lockwashers.
2. Loosen screw (5) and disconnect pressure governor control connector (6) from pressure governor control (4).
3. Loosen knob (7) and remove pressure governor control (4) from pressure governor control base (8).



### NOTE

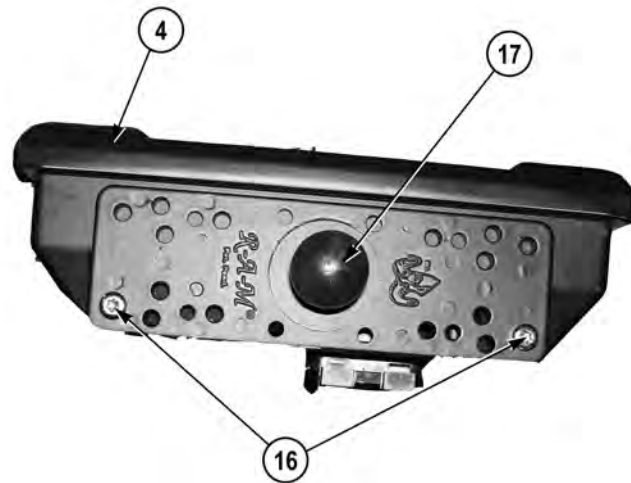
Perform Steps (4) through (7) if pressure governor control base needs to be removed.

4. Remove three screws (9) from panel (10) and center panel (11).
5. Remove six screws (12) from center panel (11) and vehicle.

### CAUTION

**When lifting center panel, wires and cables are still attached. Only lift center panel high enough to access attaching hardware. Failure to comply may result in damage to equipment.**

6. Lift center panel (11) and remove three locknuts (13), washers (14), screws (15), and pressure governor control base (8) from center panel (11). Discard locknuts.



7. Remove two screws (16) and swivel base (17) from pressure governor control (4).

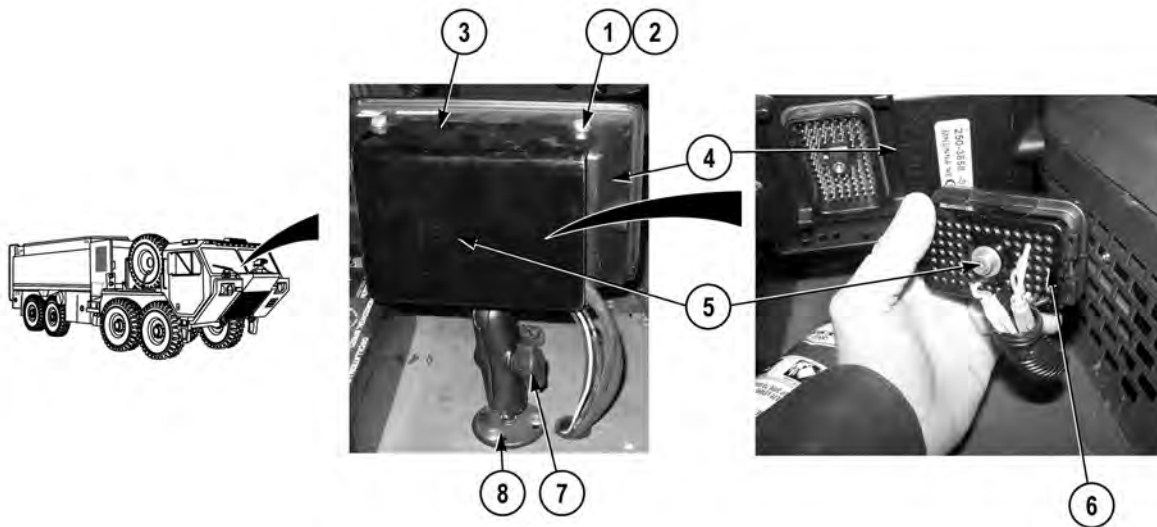
#### END OF TASK

#### INSTALLATION

#### NOTE

Perform Steps (1) through (4) if pressure governor control base was removed.

1. Install swivel base (17) on pressure governor control (4) with two screws (16).
2. Install pressure governor control base (8) on center panel (11) with three screws (15), washers (14), and locknuts (13).
3. Install center panel (11) on vehicle with six screws (12).
4. Install three screws (9) on panel (10) and center panel (11).



5. Position pressure governor control (4) on pressure governor control base (8) and tighten knob (7).
6. Connect pressure governor control connector (6) on pressure governor control (4) and tighten screw (5).
7. Install cover (3) on pressure governor control (4) with two lockwashers (2) and screws (1).

#### END OF TASK

#### FOLLOW-ON MAINTENANCE

Connect batteries (TM 9-2320-325-14&P)

#### END OF TASK

#### END OF WORK PACKAGE

---

**FIELD LEVEL MAINTENANCE**  
**CAB PANEL INDICATOR REPLACEMENT**

---

**INITIAL SETUP:****Tools and Special Tools**

Tool Kit, General Mechanic's: Automotive  
(WP 0398, Item 17)

**References**

WP 0391, Fig. 26

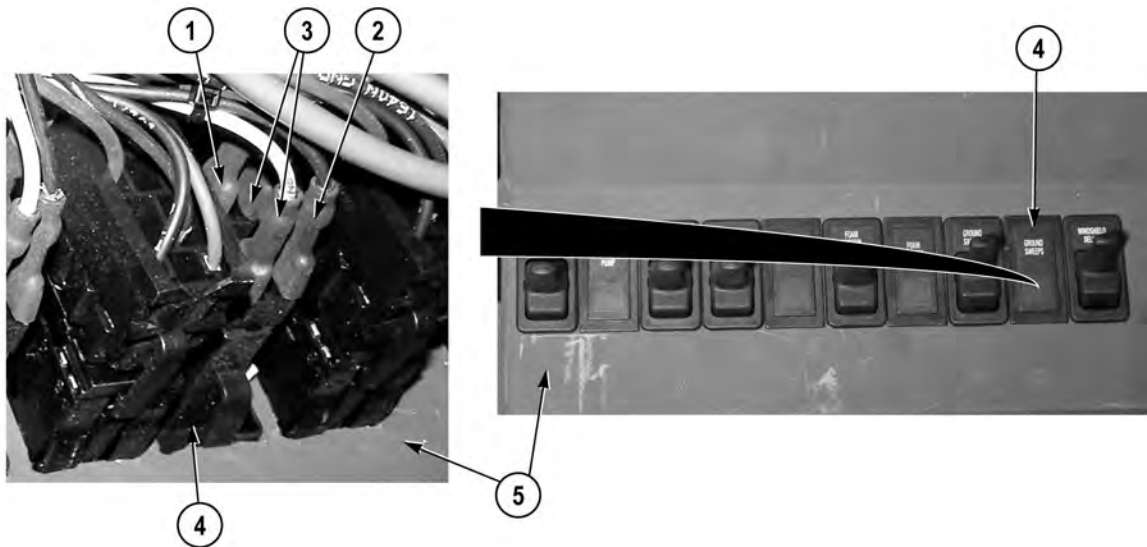
**Materials/Parts**

Tags, Identification (WP 0400, Item 23)

**Equipment Conditions**

Cab instrument panel B removed (WP 0205)

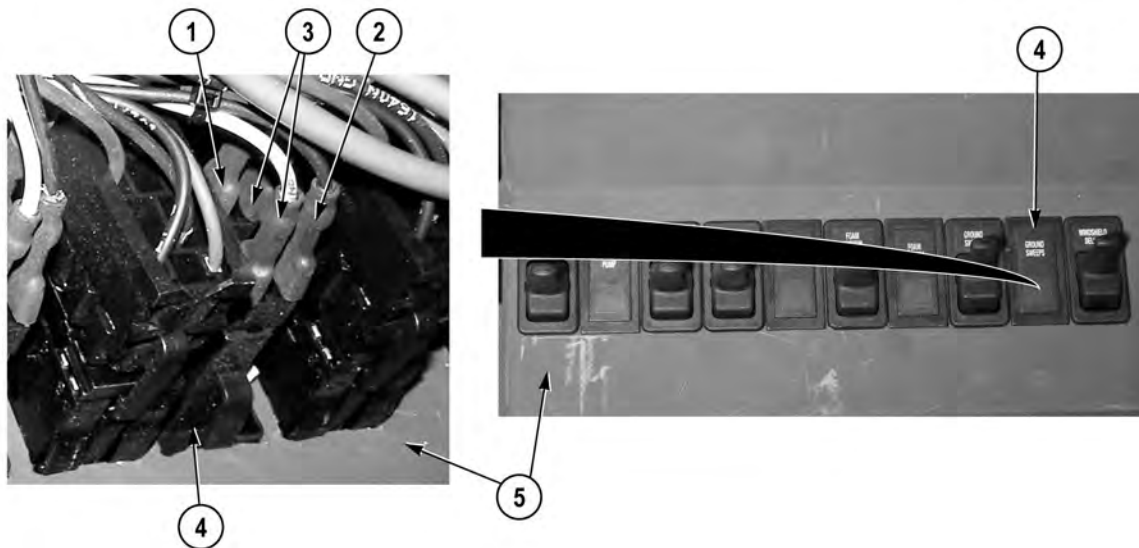
---

**REMOVAL****NOTE**

- All indicators are removed the same way. Under truck nozzles indicator shown.
- Tag and mark wires prior to removal to ensure proper installation.

1. Remove wire 2772 (1), wire 1023 (2), and wire 2768 (3) from indicator (4).
2. Remove indicator (4) from instrument panel (5).

**END OF TASK**

**INSTALLATION**

**ALL INDICATORS ARE INSTALLED THE SAME WAY. UNDER TRUCK NOZZLES INDICATOR SHOWN.**

1. Install indicator (4) on instrument panel (5).
2. Install wire 2768 (3), wire 1023 (2), and wire 2772 (1) on indicator (4).

**END OF TASK**

**FOLLOW-ON MAINTENANCE**

Install cab instrument panel B (WP 0205)

**END OF TASK**

**END OF WORK PACKAGE**

---

**FIELD LEVEL MAINTENANCE**  
**CAB ROCKER SWITCH REPLACEMENT**

---

**INITIAL SETUP:****Tools and Special Tools**

Tool Kit, General Mechanic's: Automotive  
(WP 0398, Item 17)

**References**

WP 0391, Fig. 24

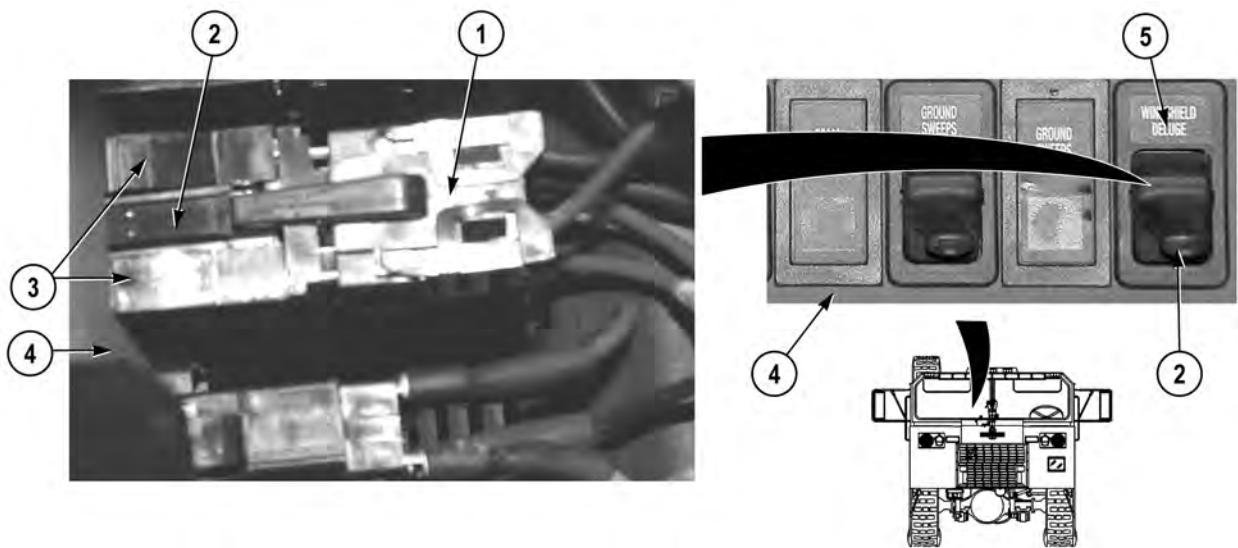
**Materials/Parts**

Adhesive, Spray (WP 0400, Item 5)

**Equipment Conditions**

Cab instrument panel B removed (WP 0205)

---

**REMOVAL****NOTE**

All rocker switches are removed the same way. Windshield deluge switch shown.

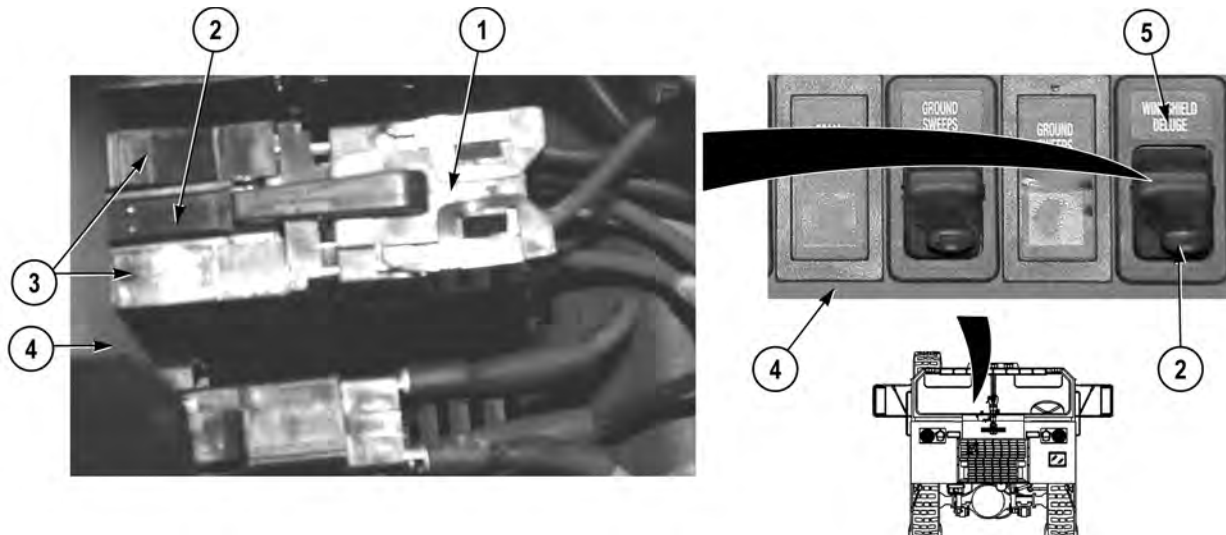
1. Disconnect windshield deluge switch connector (1) from switch (2).
2. Press four clips (3) and remove switch (2) from instrument panel (4).

**NOTE**

- Perform Step (3) if decal needs to be removed.
- Use care when removing decal to prevent damage.

3. Remove decal (5) from switch (2).

**END OF TASK**

**INSTALLATION****WARNING**

Adhesives, solvents, and sealing compounds can burn easily, can give off harmful vapors, and are harmful to skin and clothing. To avoid injury or death, keep away from open fire and use in well-ventilated area. If adhesive, solvent, or sealing compound gets on skin or clothing, wash immediately with soap and water.

**NOTE**

Perform Steps (1) and (2) if decal was removed.

1. Apply adhesive to decal (5).
2. Install decal (5) on switch (2).

**NOTE**

All rocker switches are installed the same way. Windshield deluge switch shown.

3. Install switch (2) on instrument panel (4) with four clips (3).
4. Connect windshield deluge switch connector (1) on switch (2).

**END OF TASK****FOLLOW-ON MAINTENANCE**

Install cab instrument panel B (WP 0205)

**END OF TASK****END OF WORK PACKAGE**



## FIELD LEVEL MAINTENANCE

## CAB WATER AND/OR FOAM LEVEL GAUGE(S) REPLACEMENT

## INITIAL SETUP:

**Tools and Special Tools**

Tool Kit, General Mechanic's: Automotive  
(WP 0398, Item 17)

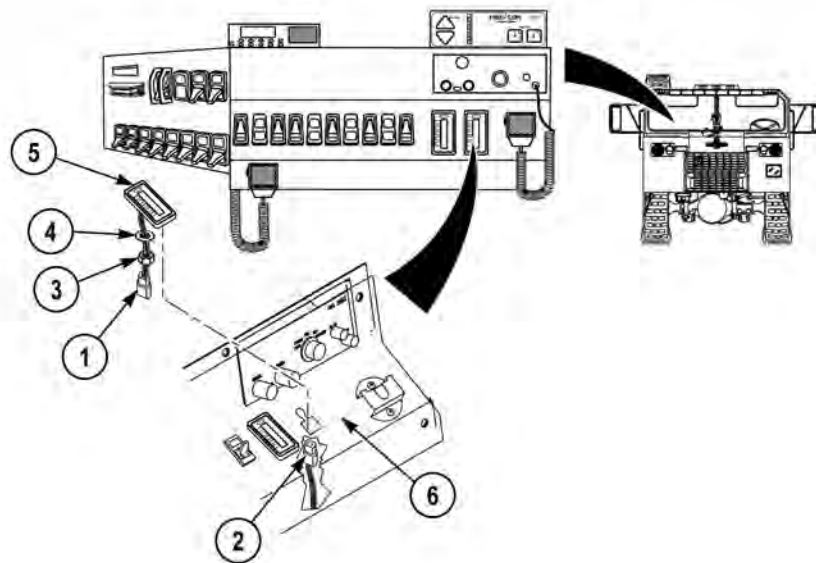
**Equipment Conditions**

Cab instrument panel B removed (WP 0205)

**References**

WP 0391, Fig. 26

## REMOVAL

**NOTE**

- Water and foam level gauges are removed the same way. Water level gauge shown.
- Note orientation of gauge prior to removal to ensure proper installation.

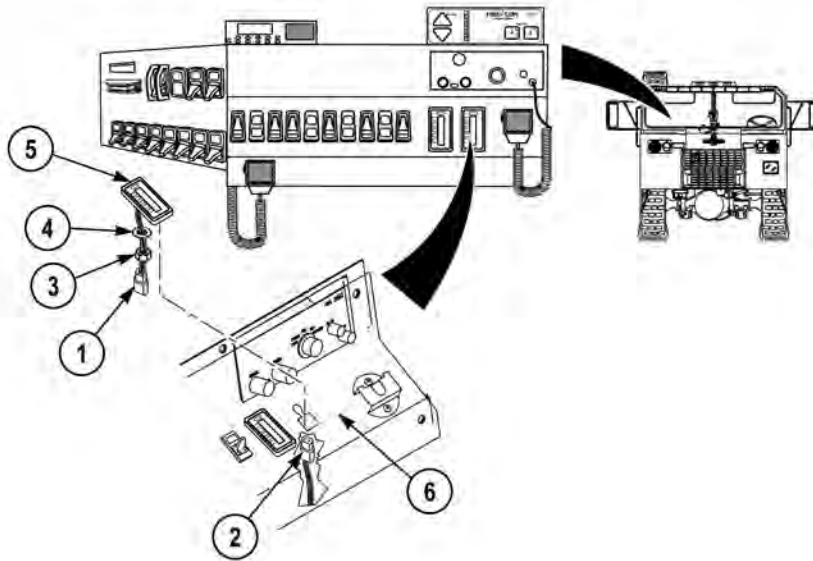
1. Disconnect water level gauge connector (1) from cab pump control wire harness connector (2).

**NOTE**

Nut and lockwasher remains attached to wires on water level gauge.

2. Remove nut (3) and lockwasher (4) from water level gauge (5).
3. Remove water level gauge (5) from instrument panel B (6).

**END OF TASK**

**INSTALLATION****NOTE**

- Water and foam level gauges are installed the same way. Water level gauge shown.
- Install gauge in same orientation as noted prior to removal.

1. Install water level gauge (5) on instrument panel B (6) with lockwasher (4) and nut (3).
2. Connect water level gauge connector (1) on cab pump control wire harness connector (2).

**END OF TASK****FOLLOW-ON MAINTENANCE**

Install cab instrument panel B (WP 0205)

**END OF TASK****END OF WORK PACKAGE**

## FIELD LEVEL MAINTENANCE

## CAB 1-2-3 SIGNAL INDICATOR LAMP HOLDER REPLACEMENT

## INITIAL SETUP:

**Tools and Special Tools**

Tool Kit, General Mechanic's: Automotive  
(WP 0398, Item 17)

**References**

WP 0391, Fig. 26

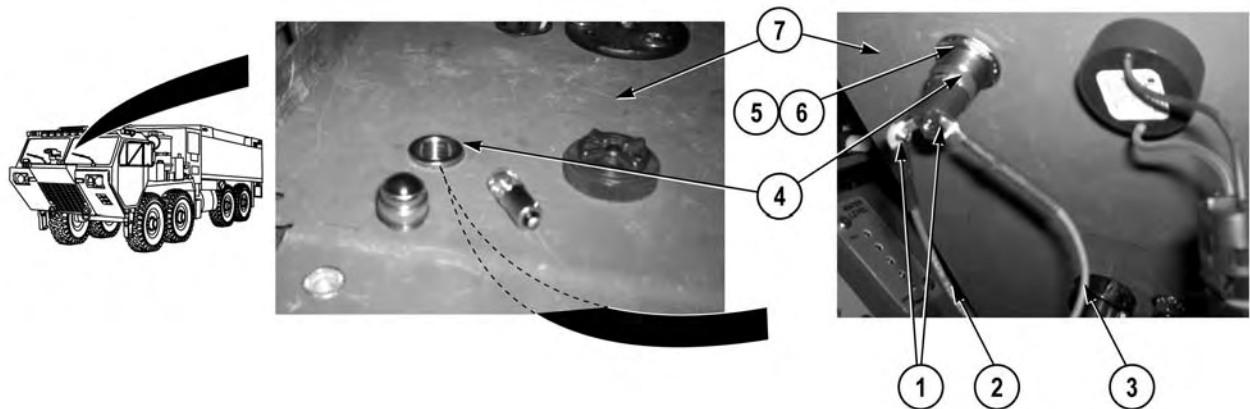
**Materials/Parts**

Compound, Sealing (WP 0400, Item 10)  
Tags, Identification (WP 0400, Item 23)  
Lockwasher (1)

**Equipment Conditions**

Cab 1-2-3 signal indicator lamp removed  
(WP 0202)  
Cab instrument panel E removed (WP 0205)

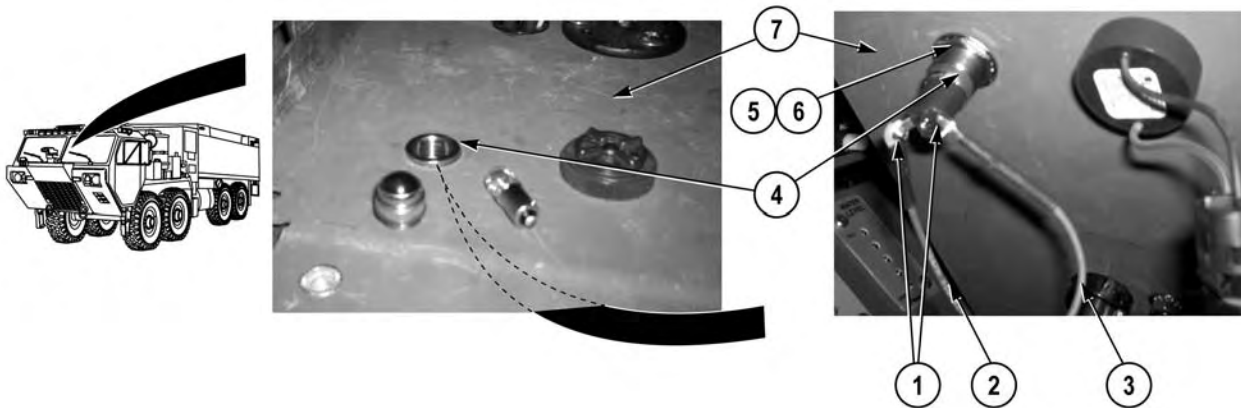
## REMOVAL

**NOTE**

Tag and mark wires prior to removal to ensure proper installation.

1. Remove two screws (1), wire 1647 (2), and wire 1614 (3) from lamp holder (4).
2. Remove nut (5) and lockwasher (6) and lamp holder (4) from panel (7). Discard lockwasher.

**END OF TASK**

**INSTALLATION**

1. Install lamp holder (4) on panel (7) with lockwasher (6) and nut (5).
2. Install wire 1614 (3) and wire 1647 (2) on lamp holder (4) with two screws (1).

**WARNING**

**Adhesives, solvents, and sealing compounds can burn easily, can give off harmful vapors, and are harmful to skin and clothing. To avoid injury or death, keep away from open fire and use in well-ventilated area. If adhesive, solvent, or sealing compound gets on skin or clothing, wash immediately with soap and water.**

3. Apply sealing compound on two screws (1), wire 1647 (2), and wire 1614 (3).

**END OF TASK****FOLLOW-ON MAINTENANCE**

1. Install cab instrument panel E (WP 0205)
2. Install cab 1-2-3 signal indicator lamp (WP 0202)

**END OF TASK****END OF WORK PACKAGE**

---

**FIELD LEVEL MAINTENANCE****CAB 1-2-3 SIGNAL INDICATOR LAMP REPLACEMENT**

---

**INITIAL SETUP:****Tools and Special Tools**

Tool Kit, General Mechanic's: Automotive  
(WP 0398, Item 17)

**Materials/Parts**

Preformed Packing (1)

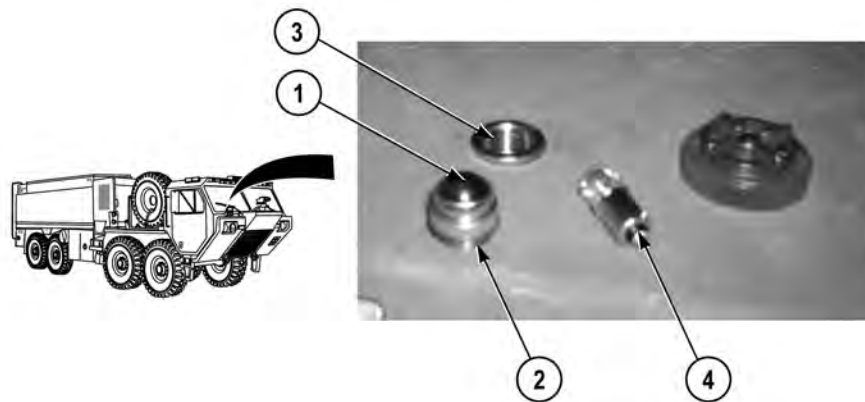
**References**

WP 0391, Fig. WP 26

**Equipment Conditions**

Engine OFF (TM 9-2320-422-10)  
Wheels chocked (TM 9-2320-422-10)

---

**REMOVAL**

1. Remove lamp cover (1) and preformed packing (2) from lamp holder (3). Discard preformed packing.
2. Remove lamp (4) from lamp holder (3).

**END OF TASK****INSTALLATION**

1. Install lamp (4) in lamp holder (3).
2. Install preformed packing (2) and lamp cover (1) on lamp holder (3).

**END OF TASK****FOLLOW-ON MAINTENANCE**

Remove wheel chocks (TM 9-2320-422-10)

**END OF TASK****END OF WORK PACKAGE**



## FIELD LEVEL MAINTENANCE

## WARNING BUZZER (CAB AND PUMP OPERATOR'S PANEL) REPLACEMENT

## INITIAL SETUP:

**Tools and Special Tools**

Tool Kit, General Mechanic's: Automotive  
(WP 0398, Item 17)

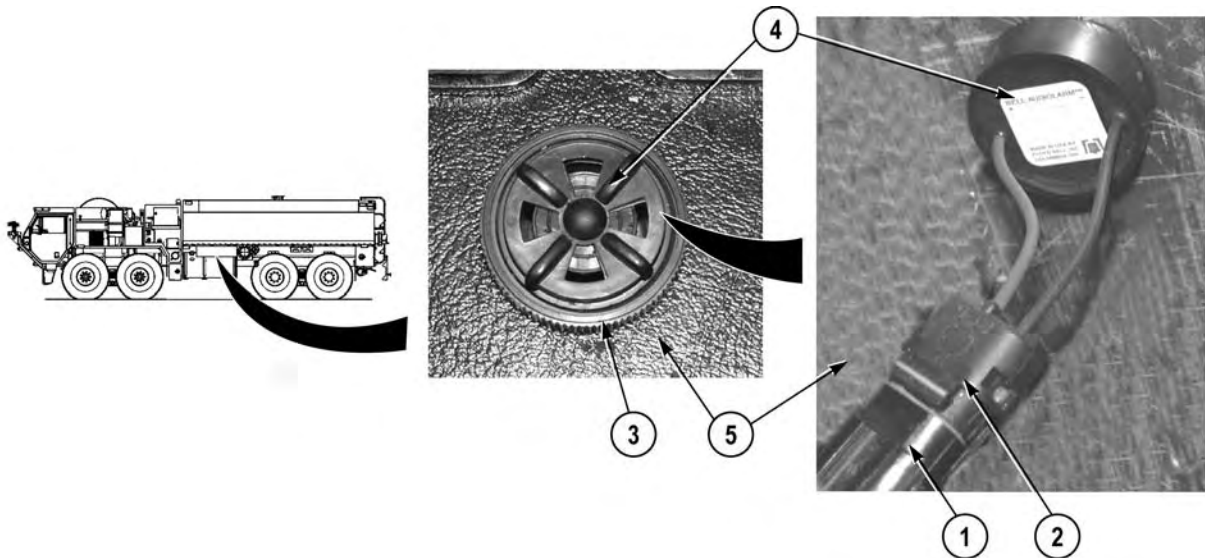
**References**

WP 0391, Fig. 26

**Equipment Conditions**

Pump operator's panel opened (Pump operator's panel warning buzzer) (WP 0207)  
Cab instrument Panel E removed (Cab instrument panel warning buzzer) (WP 0205)

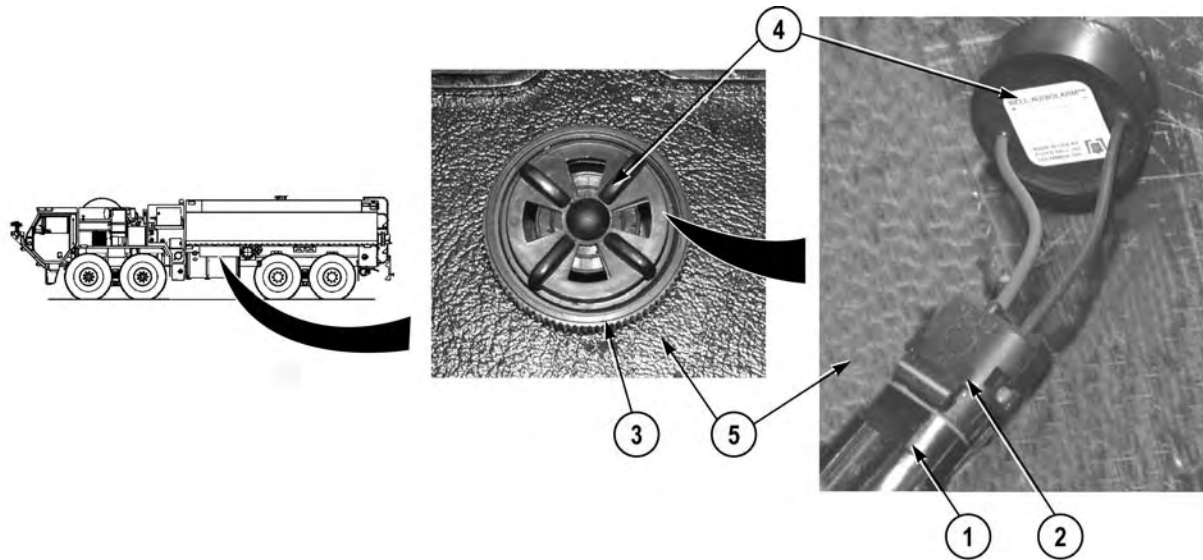
## REMOVAL

**NOTE**

Cab and pump operator's panel warning buzzer removed the same way. Pump operator's panel warning buzzer shown.

1. Disconnect connector (1) from buzzer audio alarm connector (2).
2. Remove retainer (3) and buzzer audio alarm (4) from pump operator's panel (5).

**END OF TASK**

**INSTALLATION****NOTE**

Cab and pump operator's panel warning buzzer installed the same way. Pump operator's panel shown.

1. Install buzzer audio alarm (4) on pump operator's panel (5) with retainer (3).
2. Connect connector (1) on buzzer audio alarm connector (2).

**END OF TASK****FOLLOW-ON MAINTENANCE**

1. Close pump operator's panel (pump operator's panel warning buzzer) (WP 0207)
2. Install cab instrument panel E (cab instrument panel warning buzzer) (WP 0205)

**END OF TASK****END OF WORK PACKAGE**



## FIELD LEVEL MAINTENANCE

## CAB INSTRUMENT PANEL ASSEMBLY REPLACEMENT

## INITIAL SETUP:

**Tools and Special Tools**

Tool Kit, General Mechanic's: Automotive  
(WP 0398, Item 17)

**Materials/Parts**

Tags, Identification (WP 0400, Item 23)  
Lockwasher (1)  
Lockwasher (1)  
Lockwasher (1)  
Locknut (1)  
Locknut (1)  
Locknut (1)

**References**

TM 9-2320-325-14&P  
WP 0391, Fig. 26

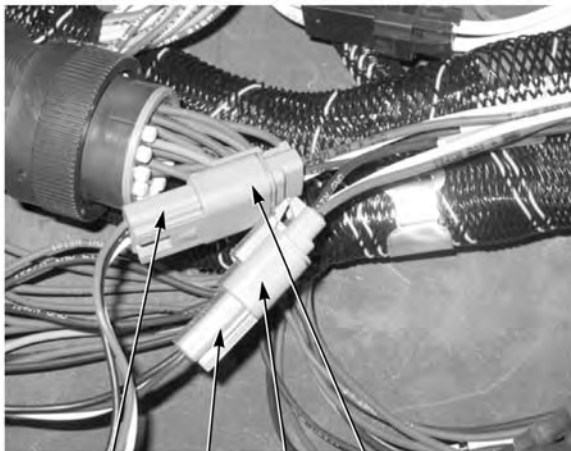
**Personnel Required**

MOS 63B Wheeled Vehicle Mechanic (2)

**Equipment Conditions**

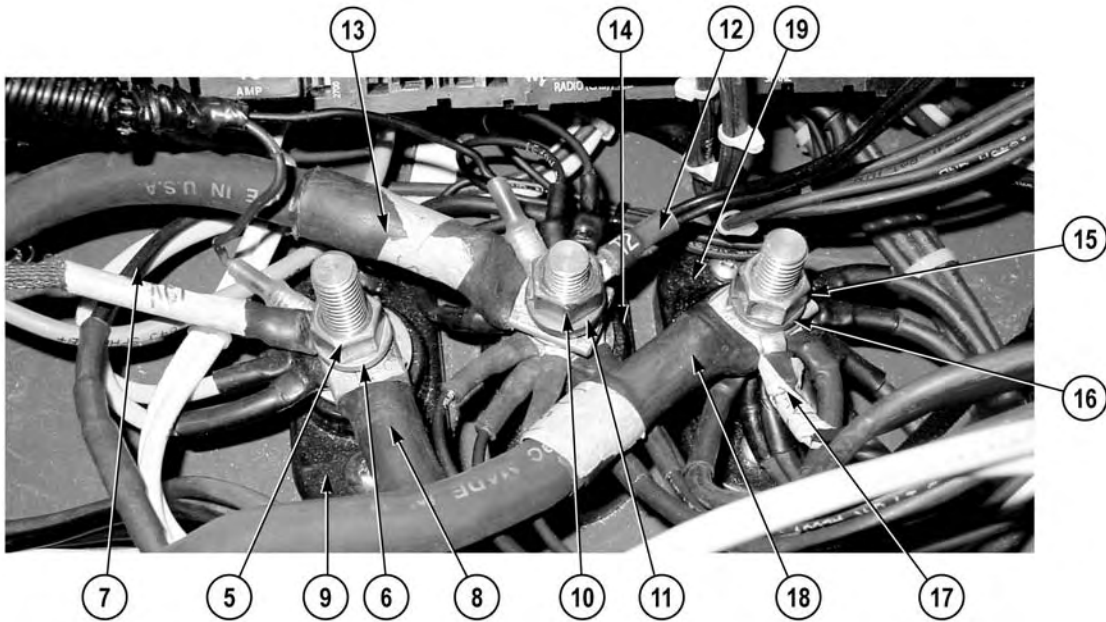
Siren removed (WP 0380)  
Cab instrument panels D and E removed  
(WP 0205)  
Skid plate grille removed (WP 0349)

## REMOVAL

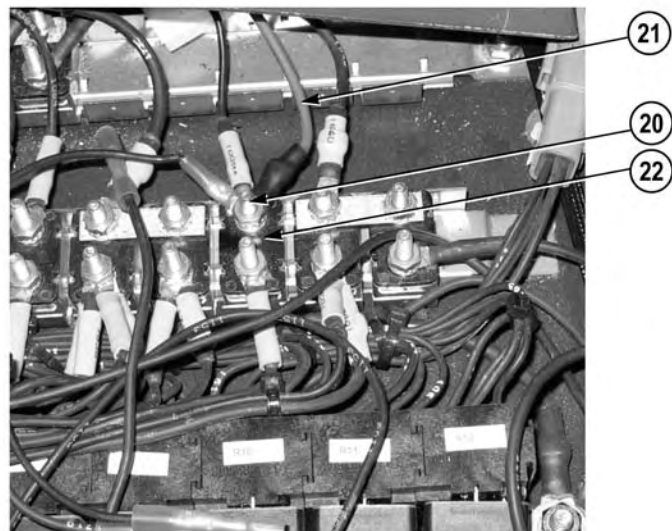
**NOTE**

- Tag and mark wires and connectors prior to removal to ensure proper installation.
- Note routing of wires prior to removal to ensure proper installation.
- Note position and remove cable ties, split loom, and cushion clips as required.

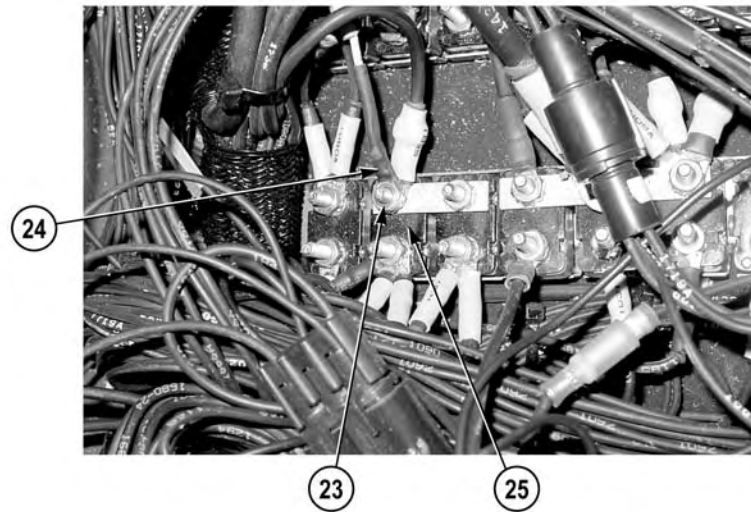
1. Disconnect cab pump control wire harness connector (1) from cab foam level gauge connector (2).
2. Disconnect cab pump control wire harness connector (3) from cab water level gauge connector (4).



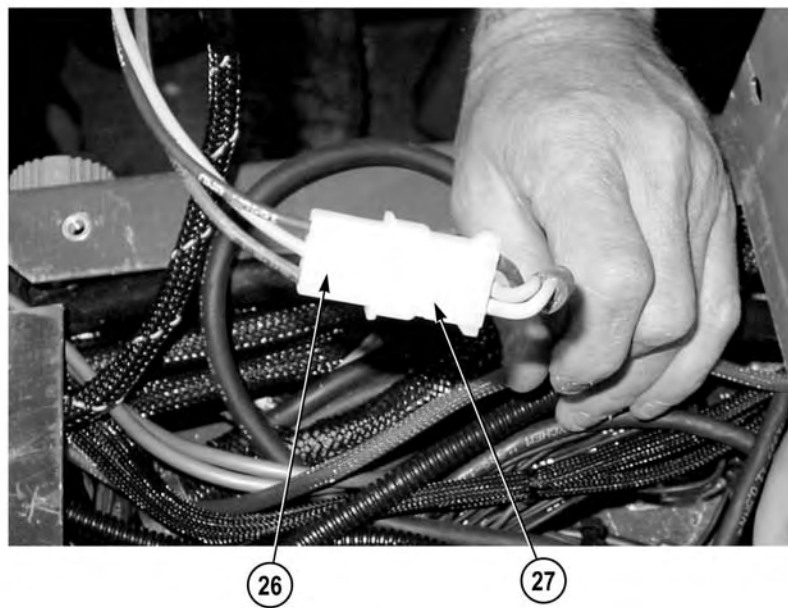
3. Remove nut (5), lockwasher (6), wire 1663 (7), and high amperage cable (8) from 12 VDC terminal block (9). Discard lockwasher.
4. Remove nut (10), lockwasher (11), power cable assembly (SINGGARS) (12), and ground cable (13) from ground terminal block (14). Discard lockwasher.
5. Remove nut (15), lockwasher (16), power cable assembly (SINGGARS) (17), and high amperage cable (18) from 24 VDC terminal block (19). Discard lockwasher.



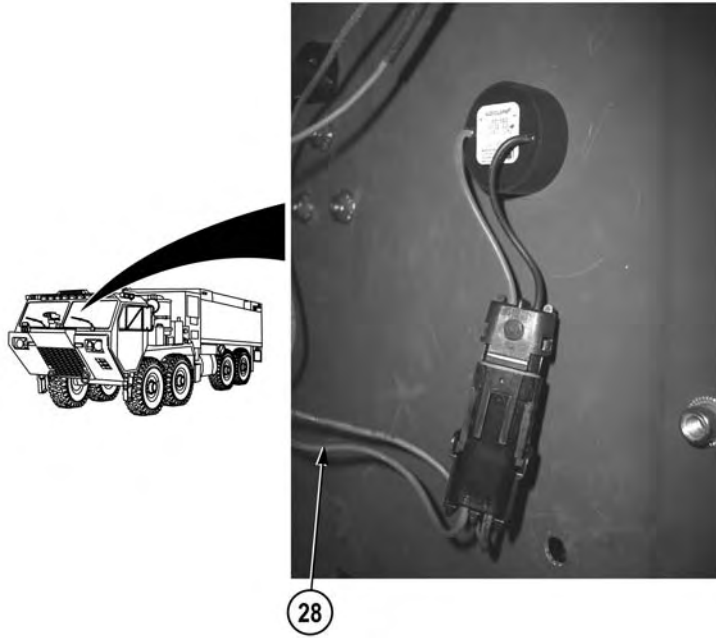
6. Remove locknut (20) and wire 1118 (21) from circuit breaker 10 (22). Discard locknut.



7. Remove locknut (23) and wire H835 (24) from circuit breaker 2 (25). Discard locknut.



8. Disconnect cab instrument panel wire harness connector (26) from bumper turret connector (27).



9. Cut wire 1647 (28) (TM 9-2320-325-14&P).



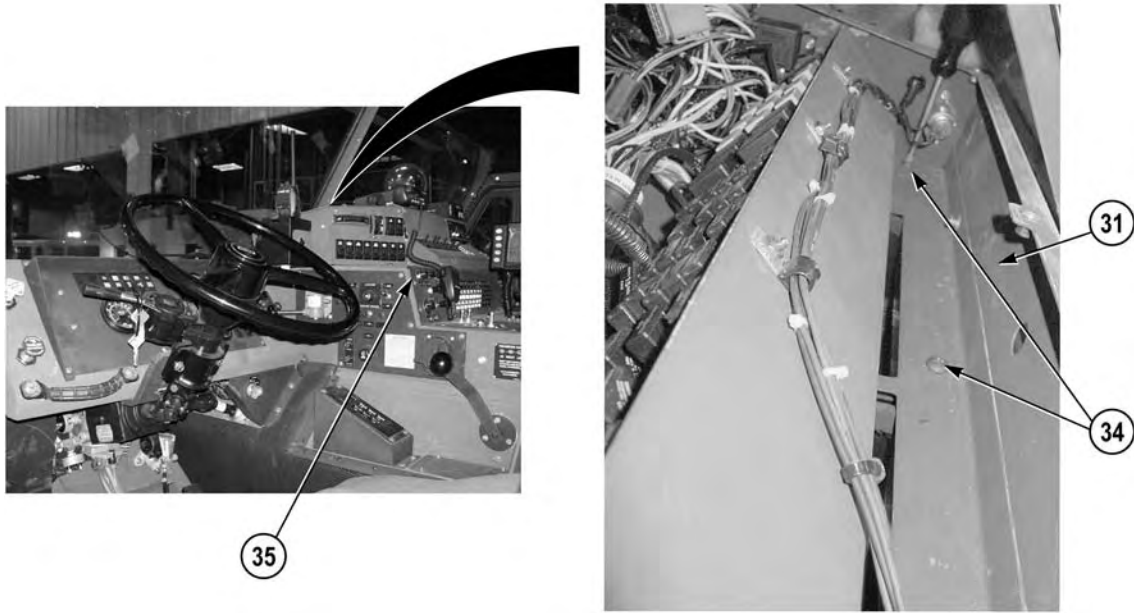
**⚠ CAUTION**

**When performing Steps (10) and (11), lift cab instrument panels B and C only enough to access screws. Wire harnesses are still attached to cab instrument panels B and C. Failure to comply may cause damage to equipment.**

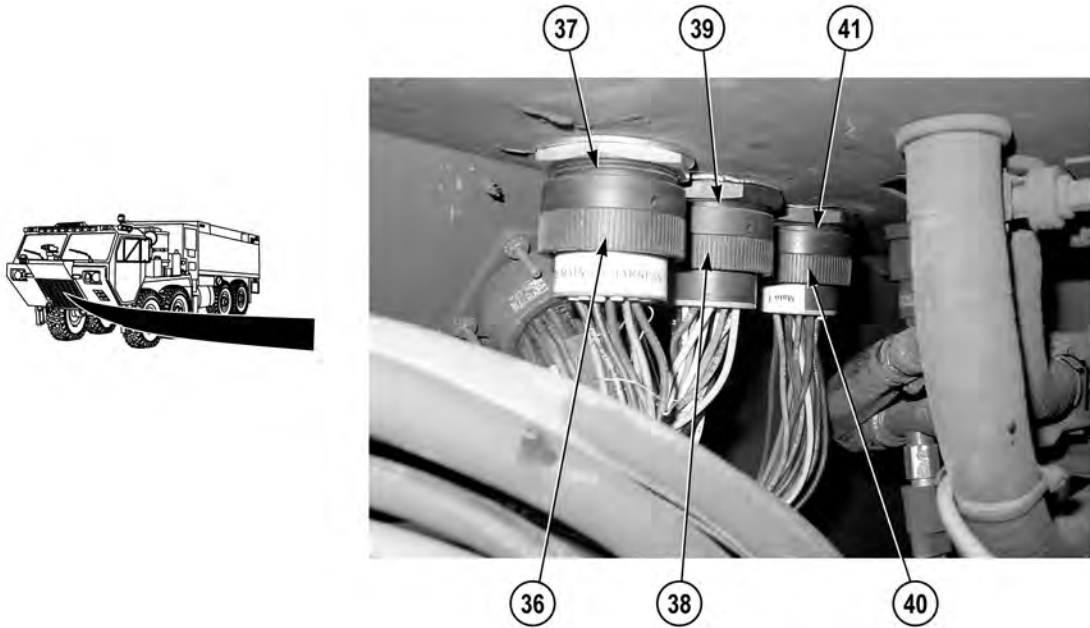
**NOTE**

Cab instrument panels B and C interlock. Lifting cab instrument panel B away from cab instrument panel assembly slightly, allows cab instrument panel C to move freely.

10. Remove five screws (29) and lift cab instrument panel B (30) away from cab instrument panel assembly (31).
11. Remove three screws (32) and pull cab instrument panel C (33) away from cab instrument panel assembly (31).



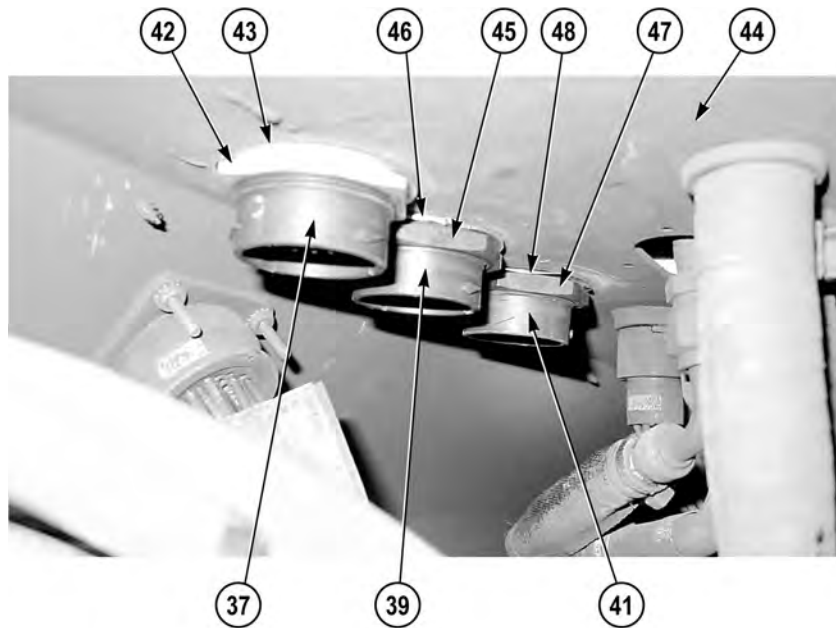
12. Remove six screws (34) from cab instrument panel assembly (31) and top heater compartment (35).



13. Disconnect main wire harness connector (36) from main 3 connector (37).

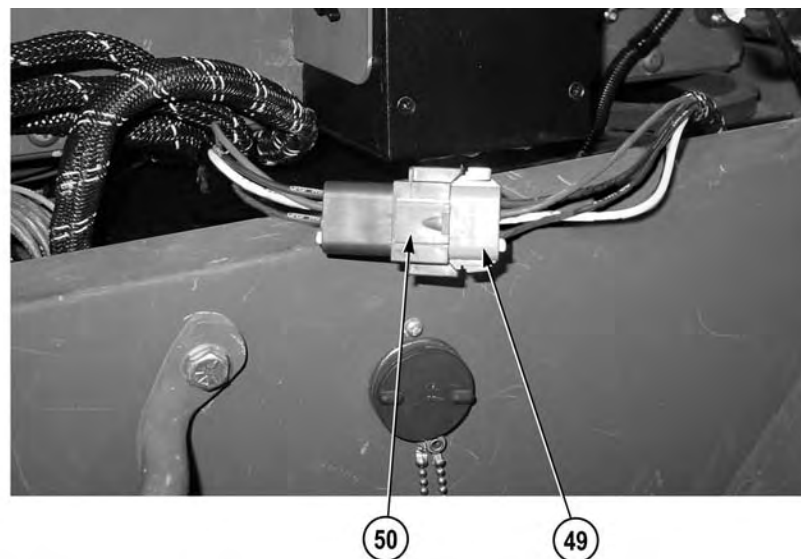
14. Disconnect main wire harness connector (38) from main 2 connector (39).

15. Disconnect main wire harness connector (40) from main 1 connector (41).

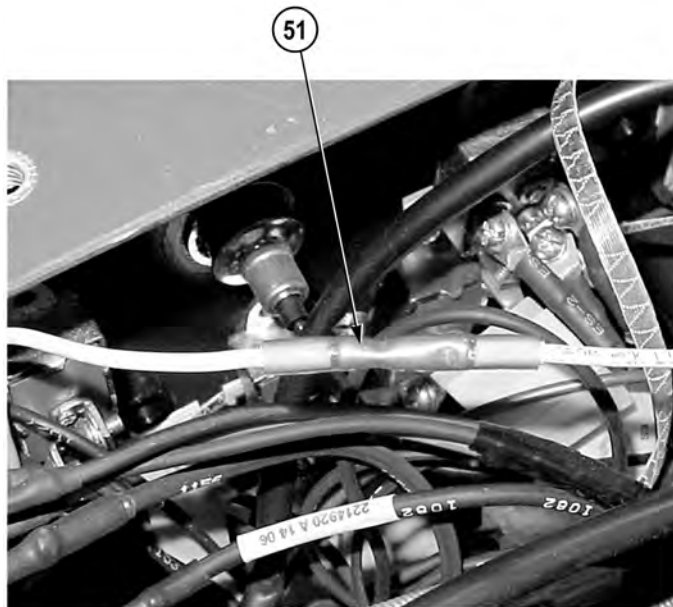
**NOTE**

Rotate cab instrument panel assembly on top heater compartment to access connectors.

16. With the aid of an assistant, remove nut (42), lockwasher (43), and main 3 connector (37) from cab (44).
17. With the aid of an assistant, remove nut (45), lockwasher (46), and main 2 connector (39) from cab (44).
18. With the aid of an assistant, remove nut (47), lockwasher (48), and main 1 connector (41) from cab (44).



19. Disconnect cab roof wire harness connector (49) from cab instrument panel wire harness connector (50).



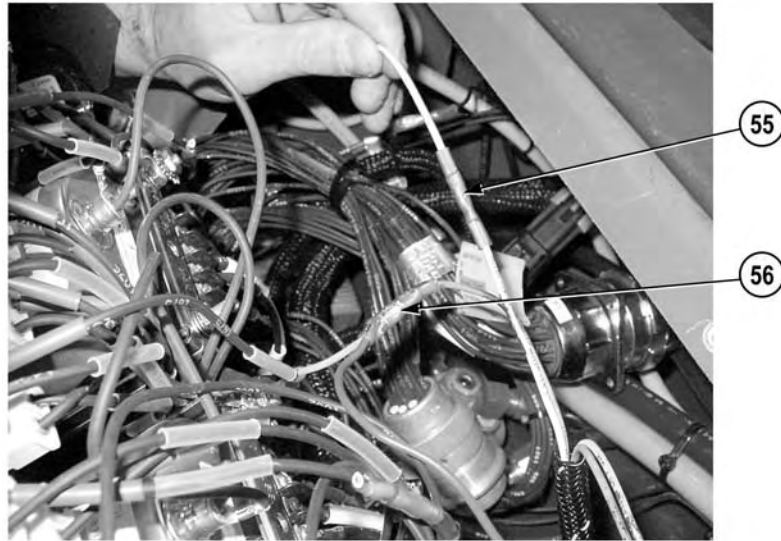
20. Cut wire H052 (51) (TM 9-2320-325-14&P).



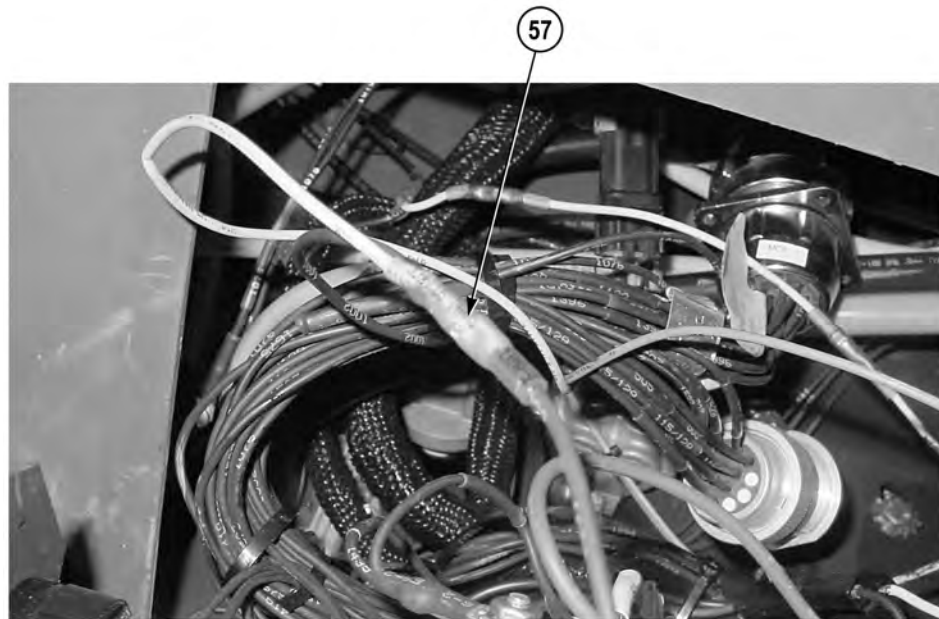
21. Remove six screws (52) and sunshield (53) from instrument panel (54).

22. Place instrument panel (54) in service position.

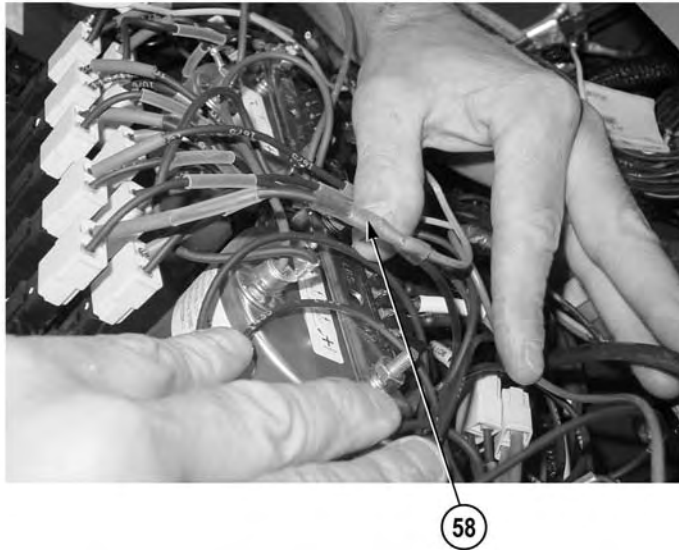




23. Cut wire H012 (55) (TM 9-2320-325-14&P).
24. Cut wire 1020 (56) (TM 9-2320-325-14&P).



25. Cut wire 1411 (57) (TM 9-2320-325-14&P).



26. Cut wire 1412 (58) (TM 9-2320-325-14&P).



### NOTE

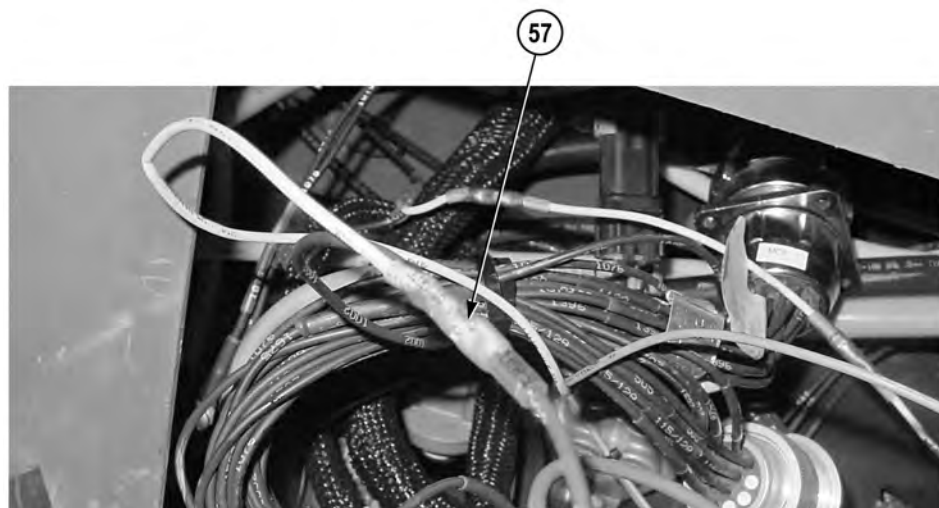
Installing screws on cab instrument panels B and C and cab instrument panel assembly secures cab instrument panels for removal from vehicle.

27. Install two screws (59) on cab instrument panel C (33) and cab instrument panel assembly (31).
28. Install five screws (29) on cab instrument panel B (30) and cab instrument panel assembly (31).
29. With the aid of an assistant, remove cab instrument panel assembly (31) from vehicle.

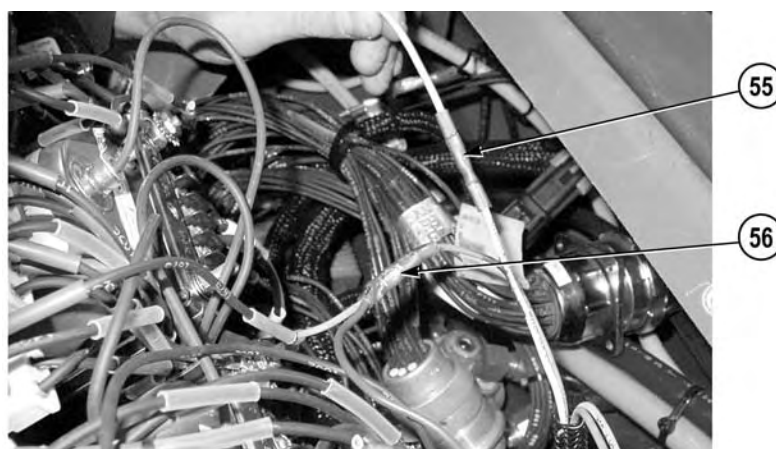
**END OF TASK**

**INSTALLATION****NOTE**

- Route wires as noted prior to removal.
  - Install cable ties, split loom, and cushion clips as required.
1. With the aid of an assistant, place cab instrument panel assembly (31) in vehicle.
  2. Remove five screws (29) from cab instrument panel B (30) and cab instrument panel assembly (31).
  3. Remove two screws (59) from cab instrument panel C (33) and cab instrument panel assembly (31).
  4. Repair wire 1412 (58) (TM 9-2320-325-14&P).



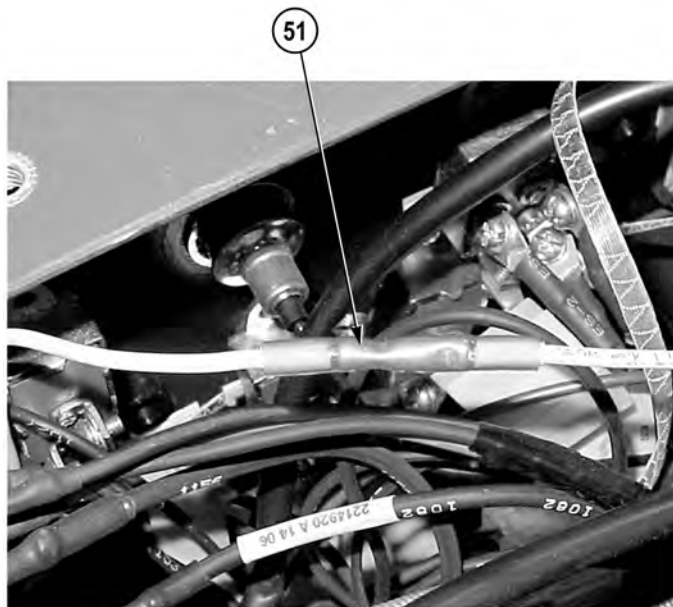
5. Repair wire 1411 (57) (TM 9-2320-325-14&P).



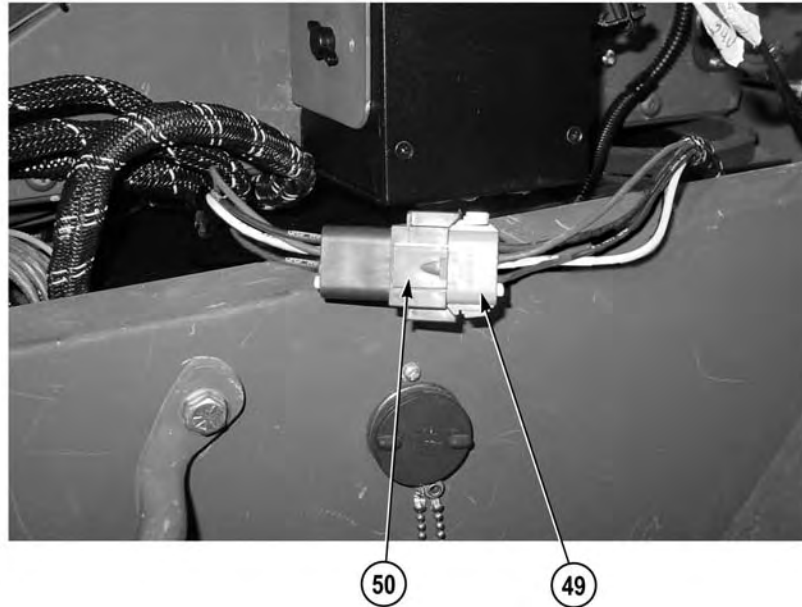
6. Repair wire 1020 (56) (TM 9-2320-325-14&P).
7. Repair wire H012 (55) (TM 9-2320-325-14&P).



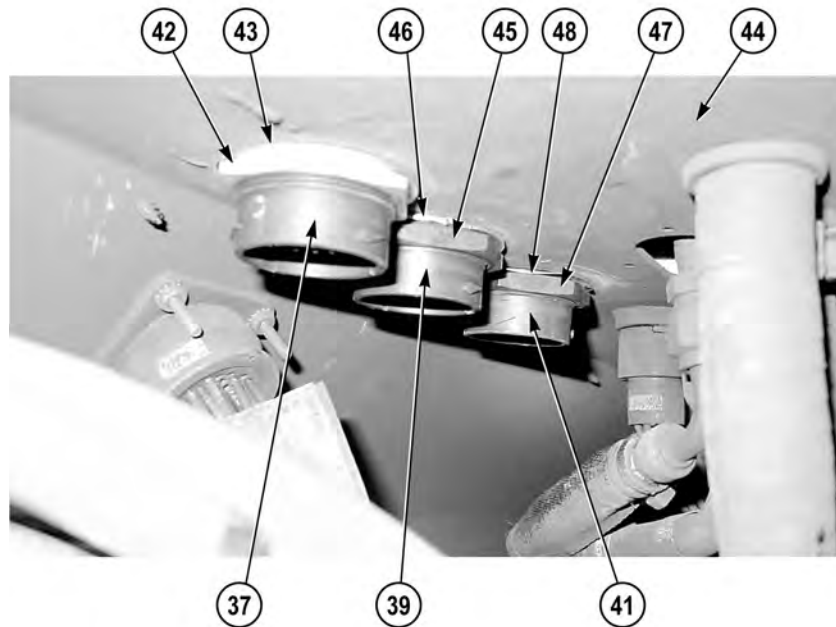
8. Install sunshield (53) on instrument panel (54) with six screws (52).



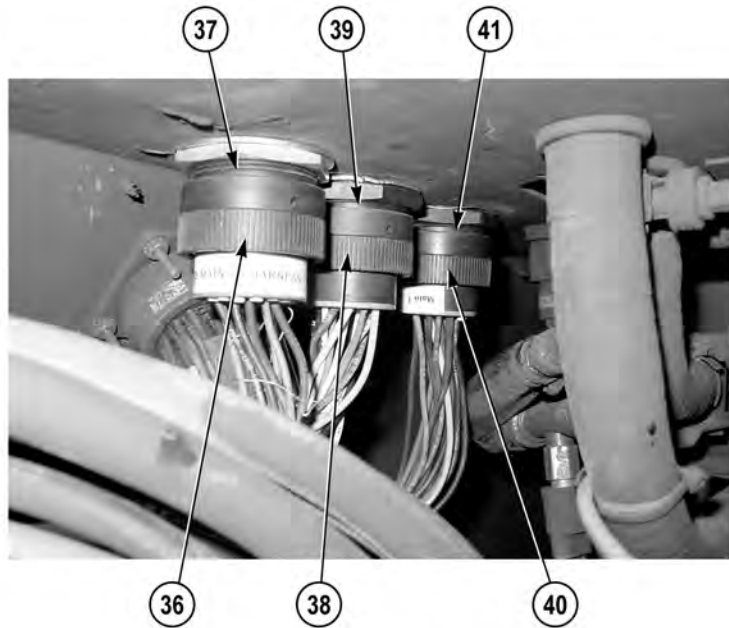
9. Repair wire H052 (51) (TM 9-2320-325-14&P).



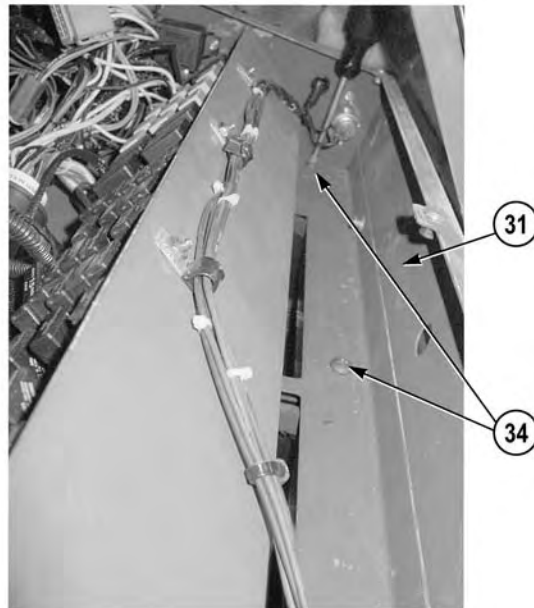
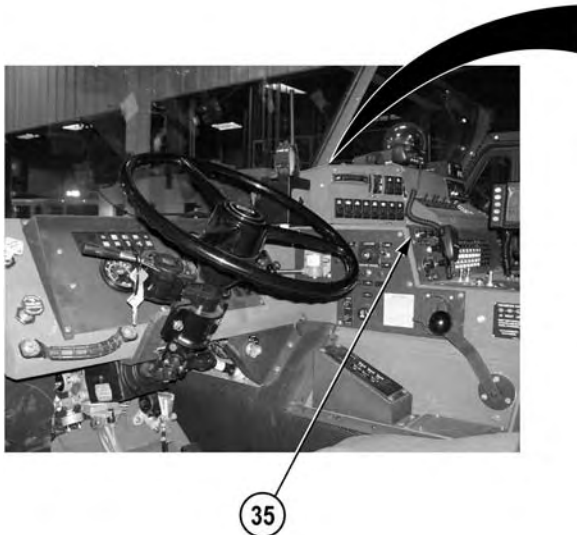
10. Connect cab roof wire harness connector (49) on cab instrument panel wire harness connector (50).



11. With the aid of an assistant, install main 1 connector (41) on cab (44) with lockwasher (48) and nut (47).
12. With the aid of an assistant, install main 2 connector (39) on cab (44) with lockwasher (46) and nut (45).
13. With the aid of an assistant, install main 3 connector (37) on cab (44) with lockwasher (43) and nut (42).



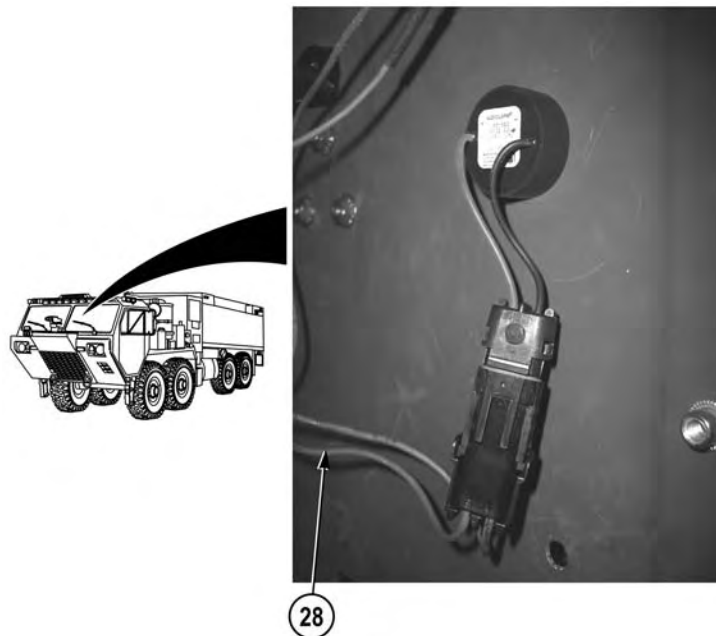
14. Connect main wire harness connector (40) on main 1 connector (41).
15. Connect main wire harness connector (38) on main 2 connector (39).
16. Connect main wire harness connector (36) on main 3 connector (37).



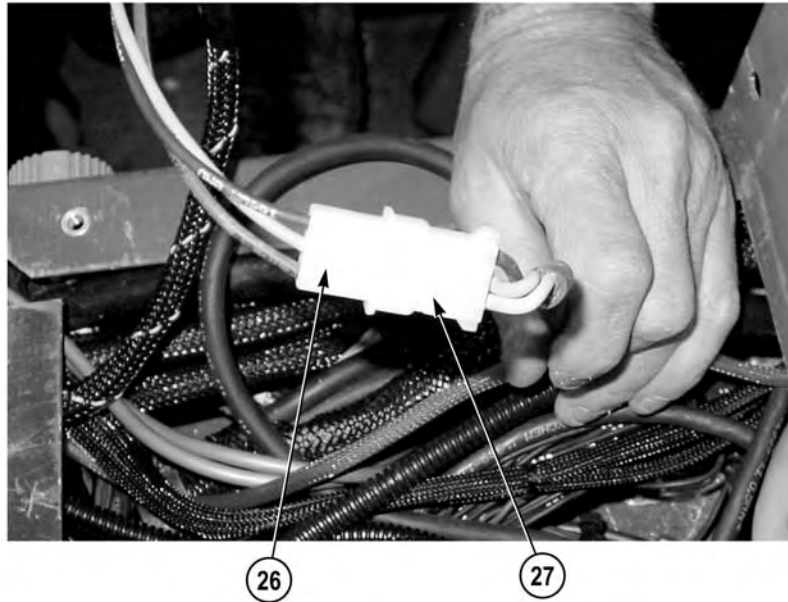
17. Install cab instrument panel assembly (31) on top heater compartment (35) with six screws (34).



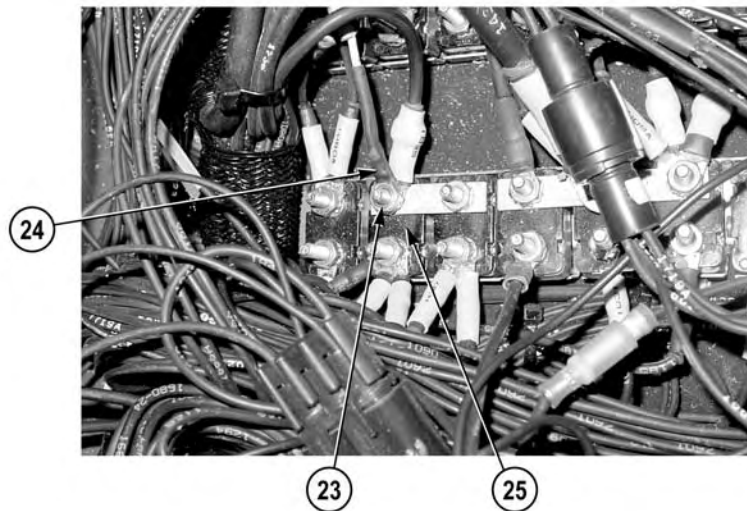
18. Install cab instrument panel C (30) on cab instrument panel assembly (31) with three screws (29).
19. Install cab instrument panel B (33) on cab instrument panel assembly (31) with five screws (32).



20. Repair wire 1647 (28) (TM 9-2320-325-14&P).

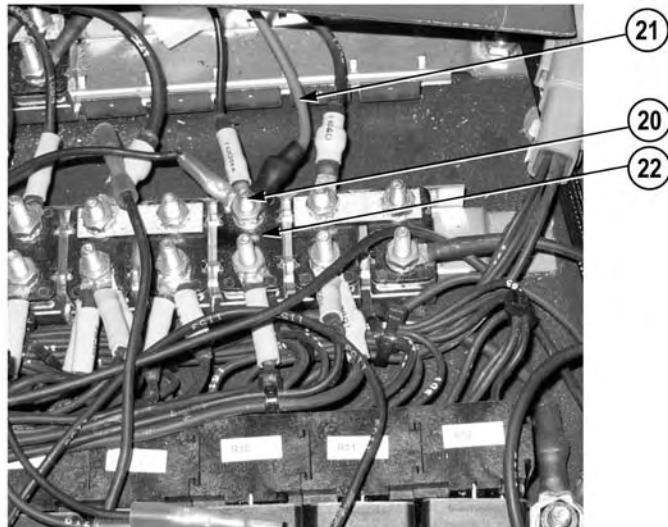


21. Connect cab instrument panel wire harness connector (26) on bumper turret connector (27).

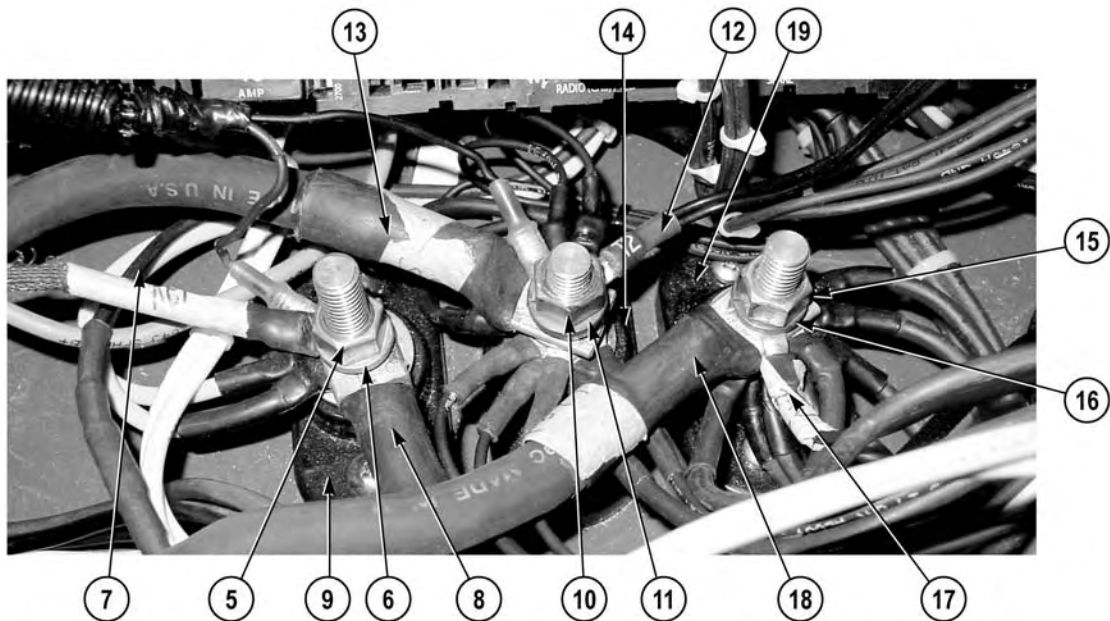


22. Install wire H835 (24) on circuit breaker 2 (25) with locknut (23).

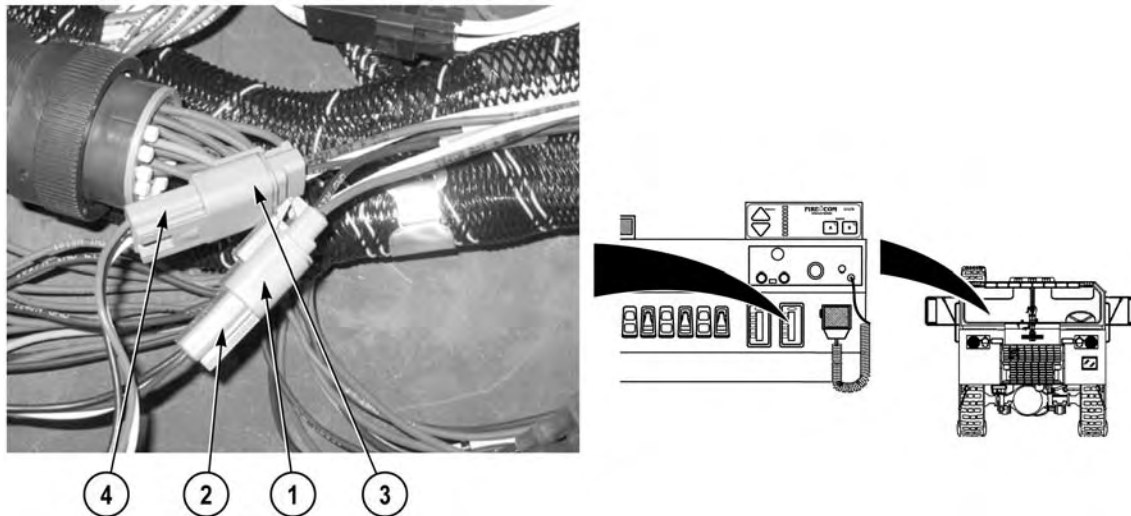




23. Install wire 1118 (21) on circuit breaker 10 (22) with locknut (20).



24. Install power cable assembly (SINCGARS) (17) and high amperage cable (18) on 24 VDC terminal block (19) with lockwasher (16) and nut (15).
25. Install power cable assembly (SINCGARS) (12) and ground cable (13) on ground terminal block (14) with lockwasher (11) and nut (10).
26. Install wire 1663 (7) and high amperage cable (8) on 12 VDC terminal block (9) with lockwasher (6) and nut (5).



27. Connect cab pump control wire harness connector (3) on cab water level gauge connector (4).
28. Connect cab foam tank level indicator wire harness connector (1) on cab foam level gauge connector (2).

#### END OF TASK

#### FOLLOW-ON MAINTENANCE

1. Install skid plate grille (WP 0349)
2. Install cab instrument panels D and E (WP 0205)
3. Install siren (WP 0380)

#### END OF TASK

#### END OF WORK PACKAGE

**FIELD LEVEL MAINTENANCE**  
**CAB INSTRUMENT PANEL REPLACEMENT**

**INITIAL SETUP:**

**Tools and Special Tools**

Tool Kit, General Mechanic's: Automotive  
(WP 0398, Item 17)

**Materials/Parts**

Tags, Identification (WP 0400, Item 23)  
Ties, Cable, Plastic (WP 0400, Item 26)  
Lockwasher (2)

**References**

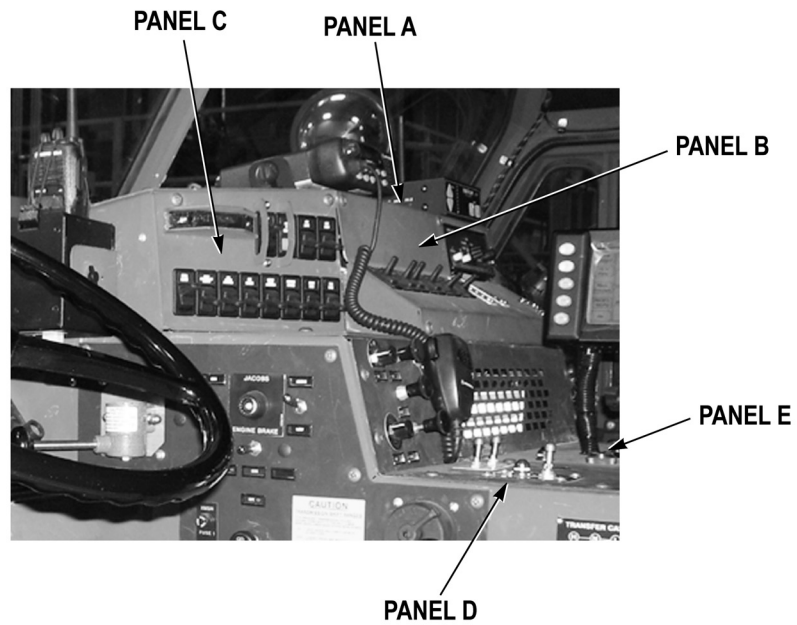
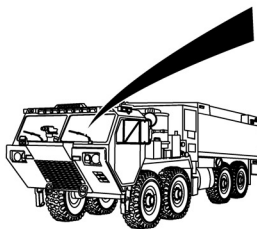
TM 9-2320-325-14&P  
WP 0195  
WP 0196  
WP 0197  
WP 0198  
WP 0199

**References (continued)**

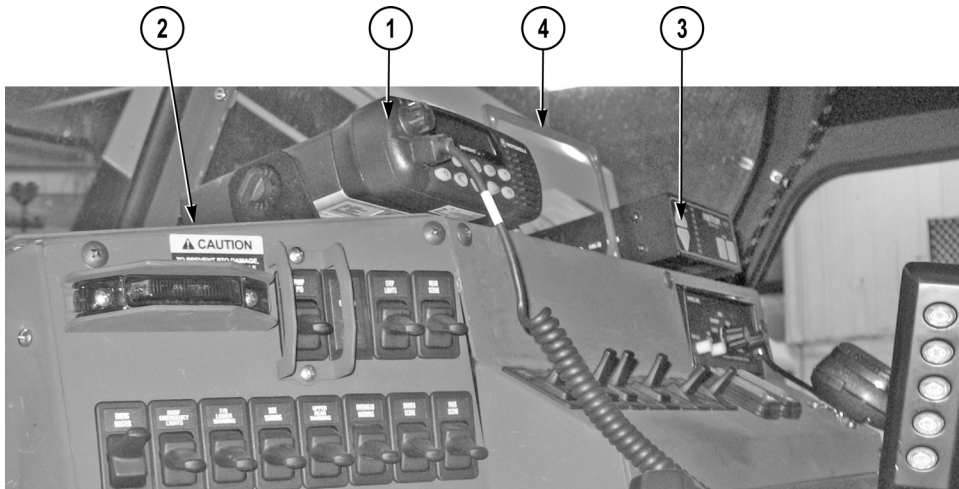
WP 0200  
WP 0201  
WP 0203  
WP 0217  
WP 0244  
WP 0256  
WP 0276  
WP 0305.2  
WP 0375  
WP 0380  
WP 0391, Fig. 26

**Equipment Conditions**

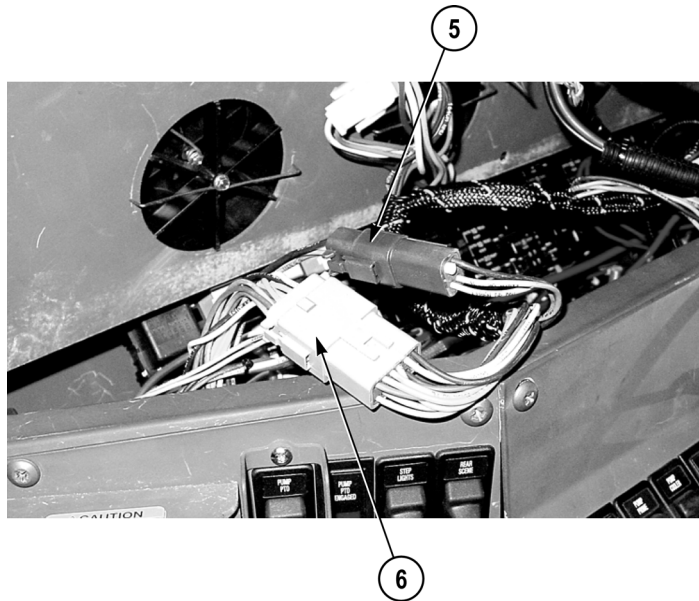
Batteries disconnected (TM 9-2320-325-14&P)



## PANEL A REMOVAL

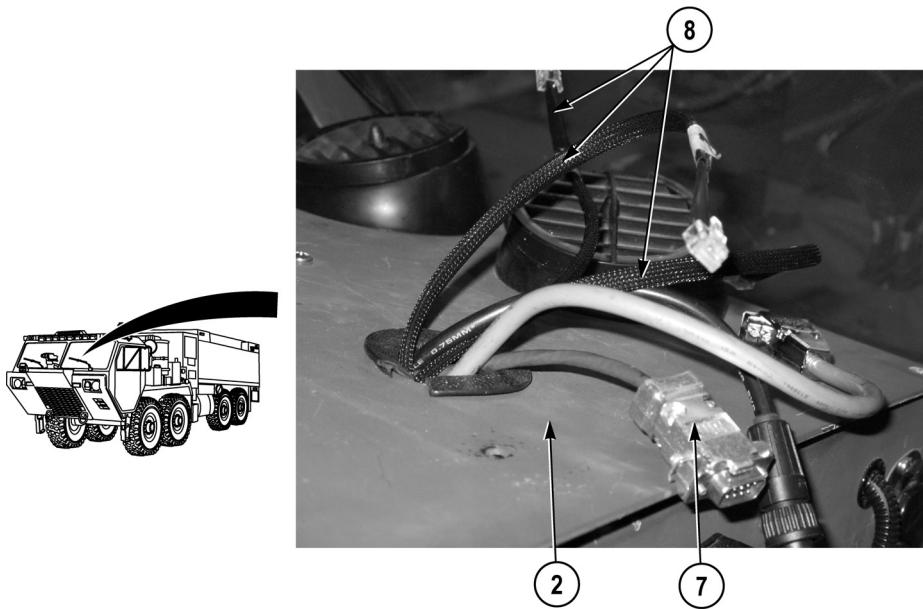


1. Remove two-way radio (1) from cab instrument panel A (2) (WP 0276).
2. Remove intercom (3) from cab instrument panel A (2) (WP 0256).
3. Remove VRCU bracket (4) from cab instrument panel A (2) (WP 0305.2).

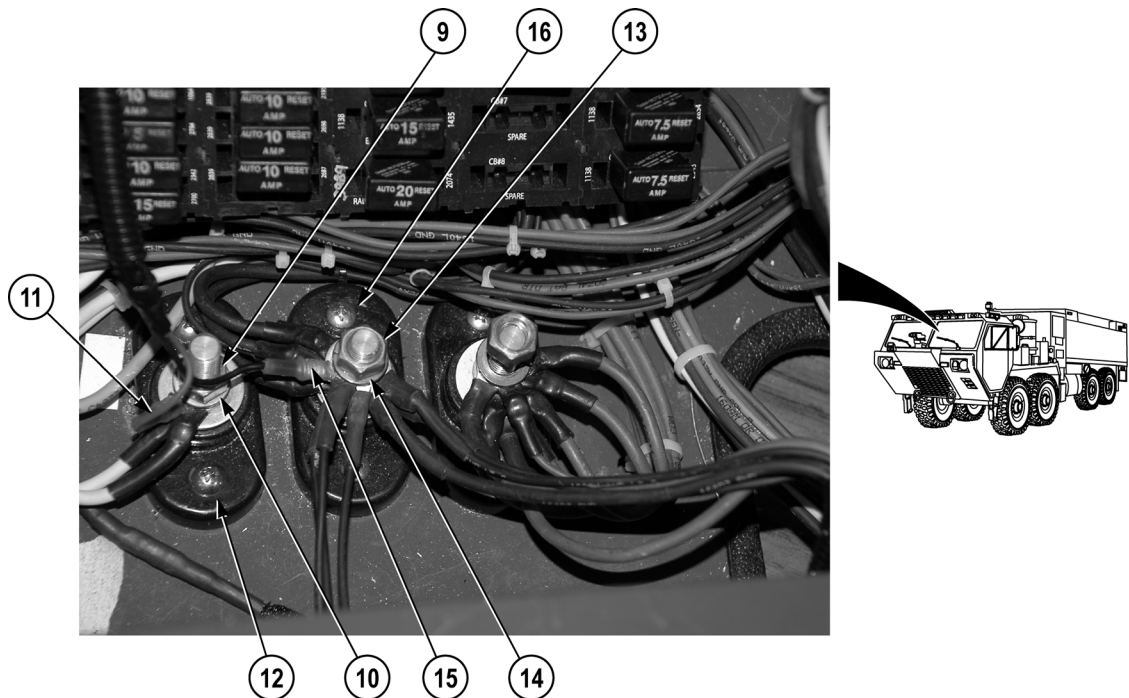


### NOTE

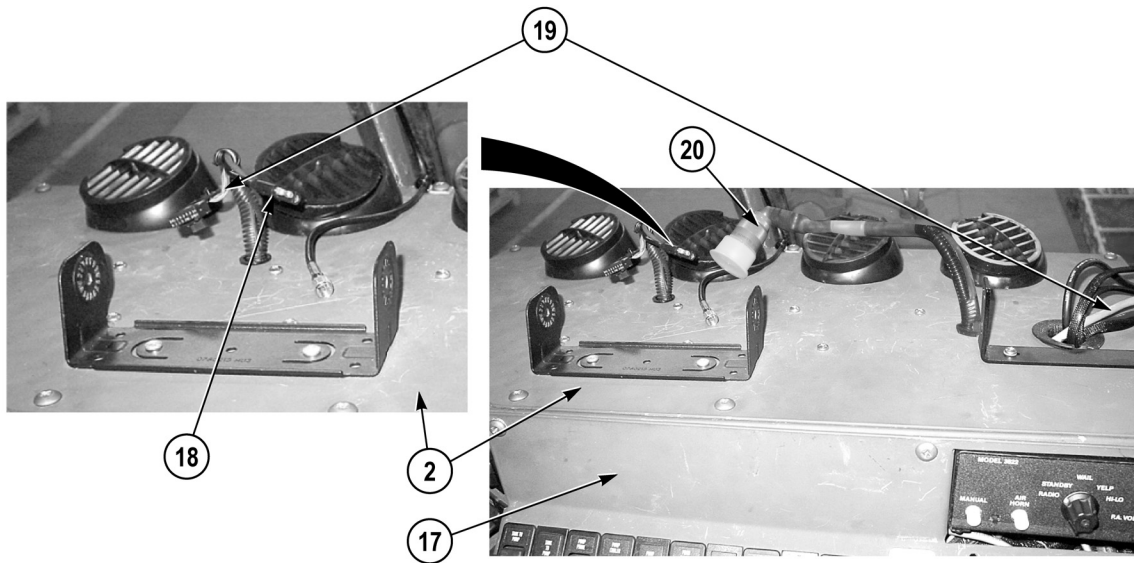
- Note routing of harnesses prior to removal to ensure proper installation.
  - Note location and remove cable ties, split loom, and cushion clips as required.
4. Disconnect cab instrument panel wire harness four pin connector (5).
  5. Disconnect cab instrument panel wire harness 12 pin connector (6).



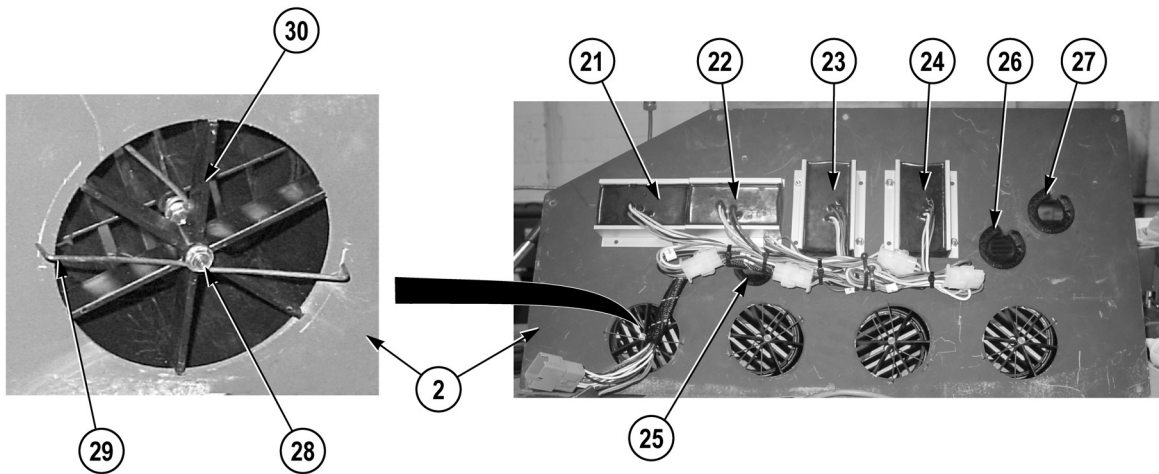
6. Remove SINGARS interface wire harness connector (7) from cab instrument panel A (2).
7. Remove three intercom wire harness wires (8) from cab instrument panel A (2).



8. Remove nut (9), lockwasher (10), and two-way radio power wire (11) from cab 12 VDC terminal block (12). Discard lockwasher.
9. Remove nut (13), lockwasher (14), and two-way radio ground wire (15) from cab ground terminal block (16). Discard lockwasher.



10. Remove cab instrument panel A (2) from cab instrument panel assembly (17).
11. Remove two-way radio power cable (18) from cab instrument panel A (2).
12. Remove two-way radio interface wire harness (19) from cab instrument panel A (2).
13. Remove VRCU cable (20) from cab instrument panel A (2).



14. Remove upper rear warning flasher unit (21) from cab instrument panel A (2) (WP 0196).
15. Remove check for open compartment door when light is on flasher unit (22) from cab instrument panel A (2) (WP 0196).
16. Remove side warning flasher unit (23) from cab instrument panel A (2) (WP 0196).
17. Remove front and rear lower warning flasher unit (24) from cab instrument panel A (2) (WP 0196).

18. Remove three grommets (25), (26), and (27) from cab instrument panel A (2).

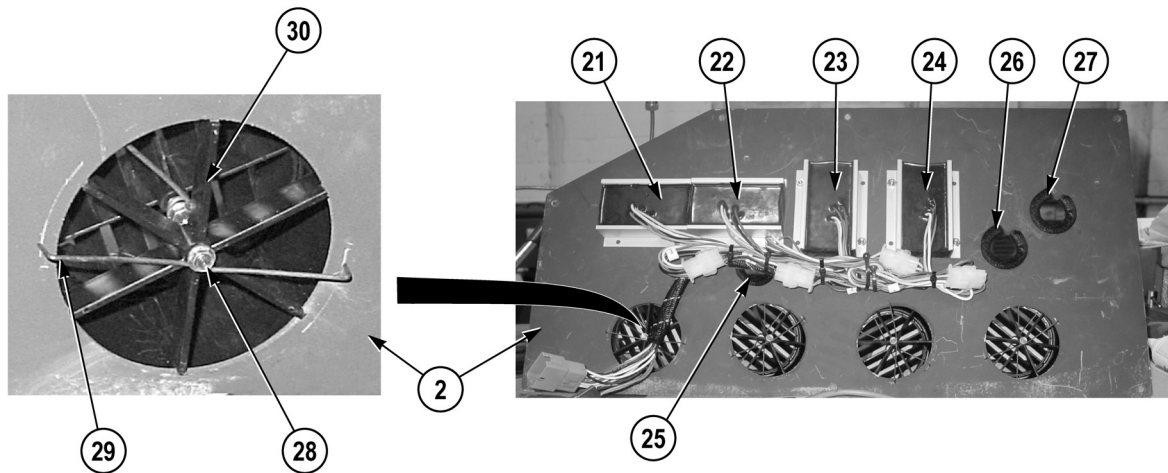
### NOTE

All four louvers are removed the same way. Driver side outer louver shown.

19. Remove screw (28), spring (29), and louver assembly (30) from cab instrument panel A (2).

### END OF TASK

### PANEL A INSTALLATION



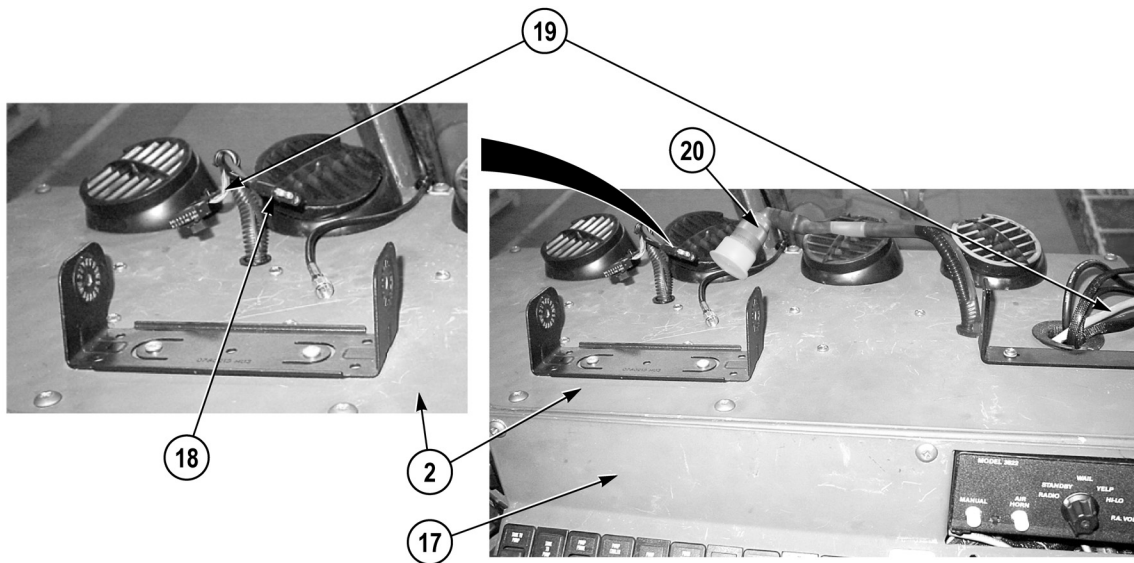
### NOTE

All four louvers are installed the same. Driver side outer louver shown.

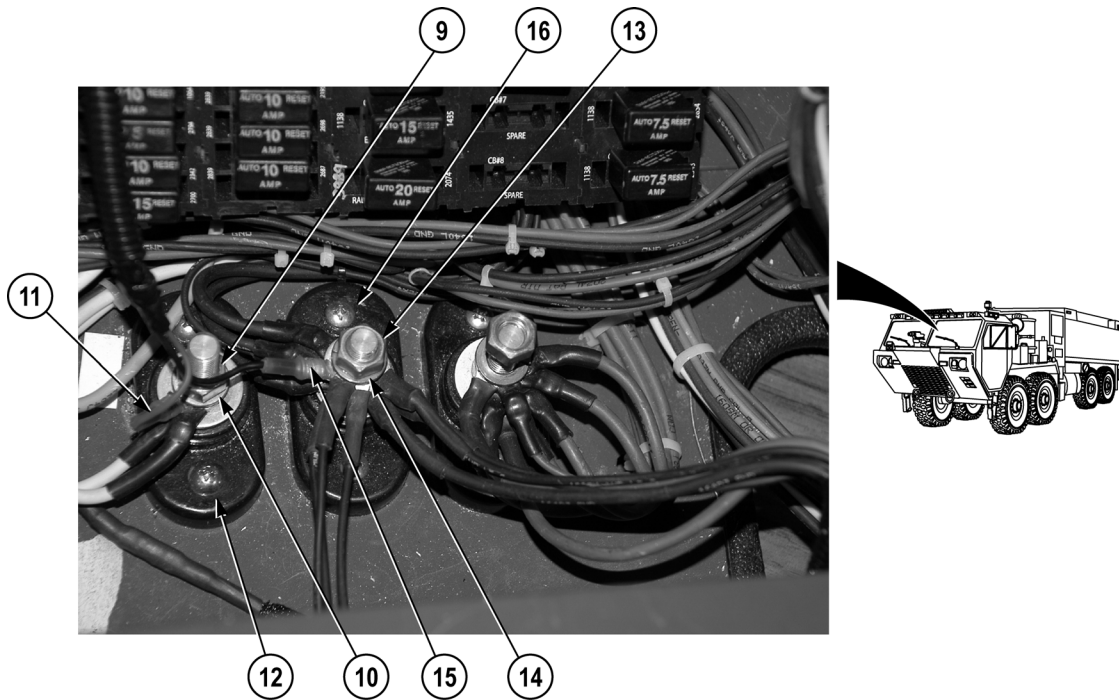
1. Install louver assembly (30) on cab instrument panel A (2) with spring (29) and screw (28).
2. Install three grommets (27), (26), and (25) on cab instrument panel A (2).

### NOTE

- Route harnesses as noted prior to removal.
  - Install cable ties, split loom, and cushion clips as required.
3. Install front and rear lower warning flasher unit (24) on cab instrument panel A (2) (WP 0196).
  4. Install side warning flasher unit (23) on cab instrument panel A (2) (WP 0196).
  5. Install check for open compartment door when light is on flasher unit (22) on cab instrument panel A (2) (WP 0196).
  6. Install upper rear warning flasher unit (21) on cab instrument panel A (2) (WP 0196).

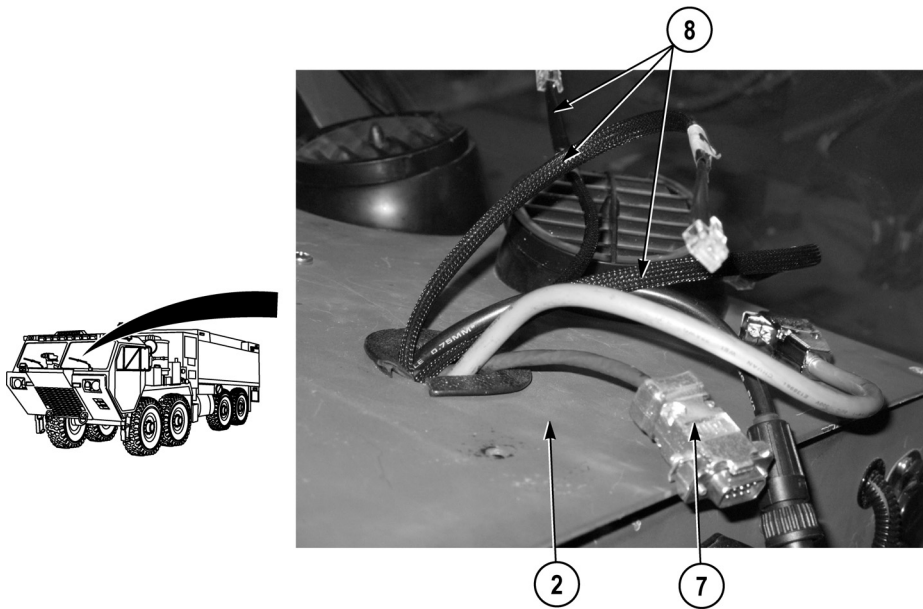


7. Install VRCU cable (20) on cab instrument panel A (2).
8. Install two-way radio interface wire harness (19) on cab instrument panel A (2).
9. Install two-way radio power cable (18) on cab instrument panel A (2).
10. Set cab instrument panel A (2) on cab instrument panel assembly (17).

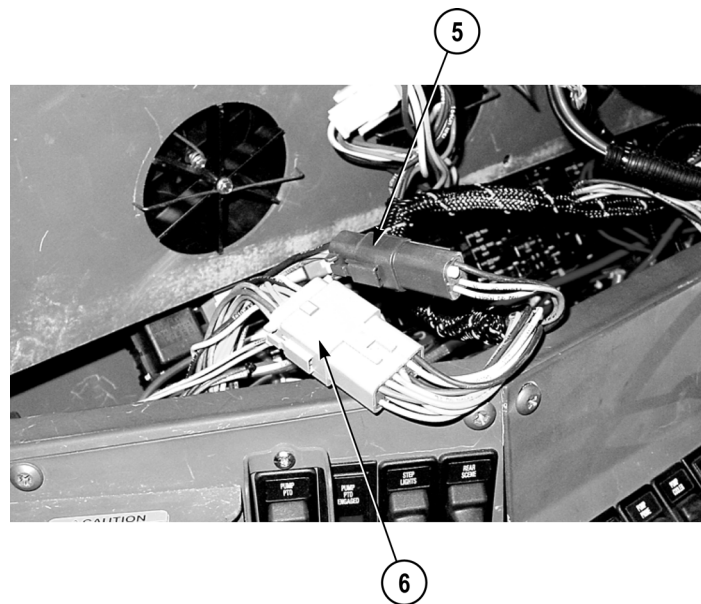


11. Install two-way radio power wire (11) on cab 12 VDC terminal block (12) with lockwasher (10) and nut (9).
12. Install two-way radio ground wire (15) on cab ground terminal block (16) with lockwasher (14) and nut (13).

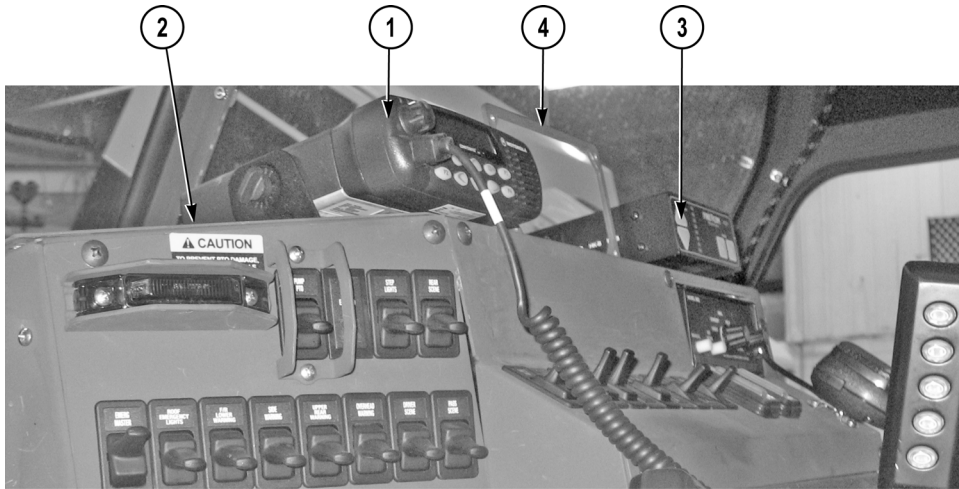




13. Install three intercom wire harness wires (8) on cab instrument panel A (2).
14. Install SINCGARS interface wire harness connector (7) on cab instrument panel A (2).



15. Connect cab instrument panel wire harness 12 pin connector (6).
16. Connect cab instrument panel wire harness four pin connector (5).



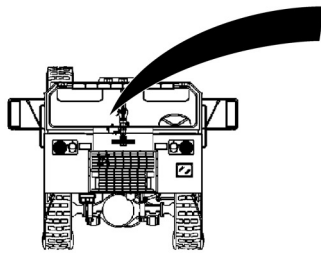
17. Install VRCU bracket (4) on cab instrument panel A (2) (WP 0305.2).
18. Install intercom (3) on cab instrument panel A (2) (WP 0256).
19. Install two-way radio (1) on cab instrument panel A (2) (WP 0276).

**END OF TASK**

CAB INSTRUMENT PANEL B REMOVAL



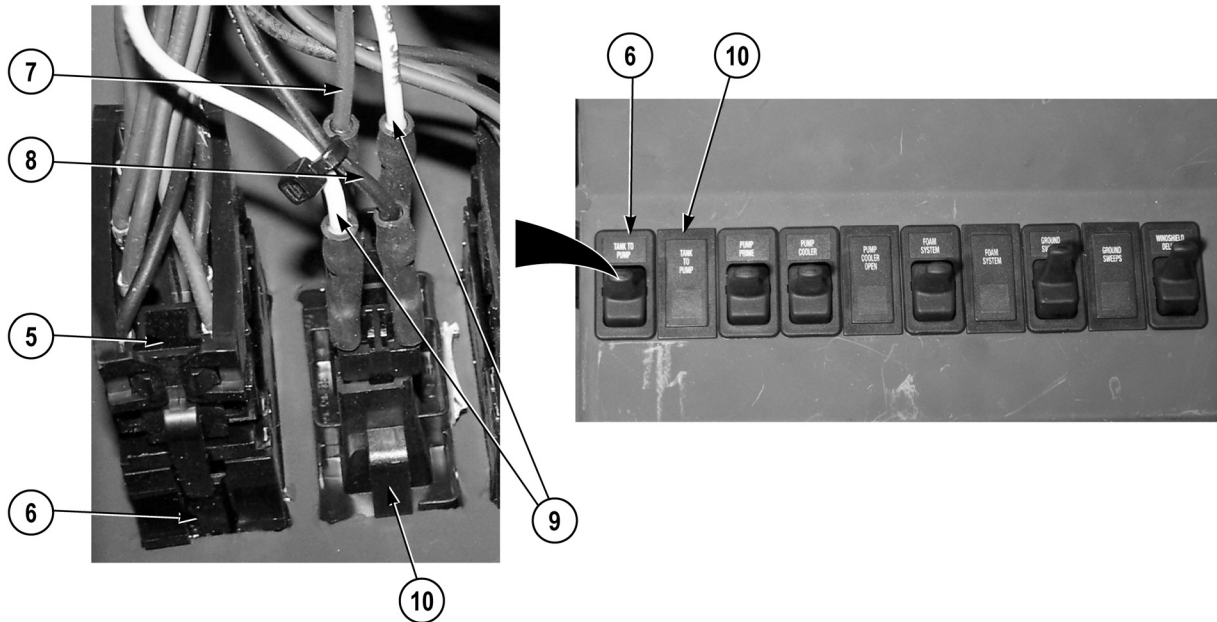
1. Remove siren control (1) from vehicle (WP 0380).



**⚠ CAUTION**

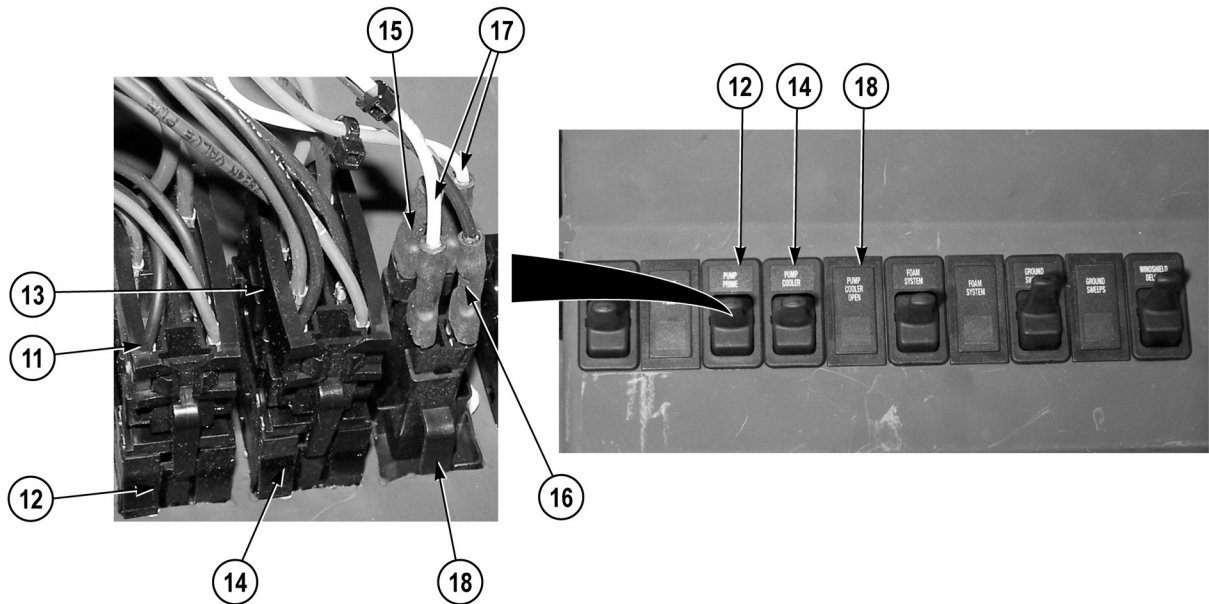
When performing Step (2), lift out and stow cab instrument panel B only enough to access wire harness connectors. Cab pump control and foam and water level gauge wire harnesses are still attached. Failure to comply may cause damage to equipment.

2. Remove five screws (2) and stow cab instrument panel B (3) away from cab instrument panel assembly (4).

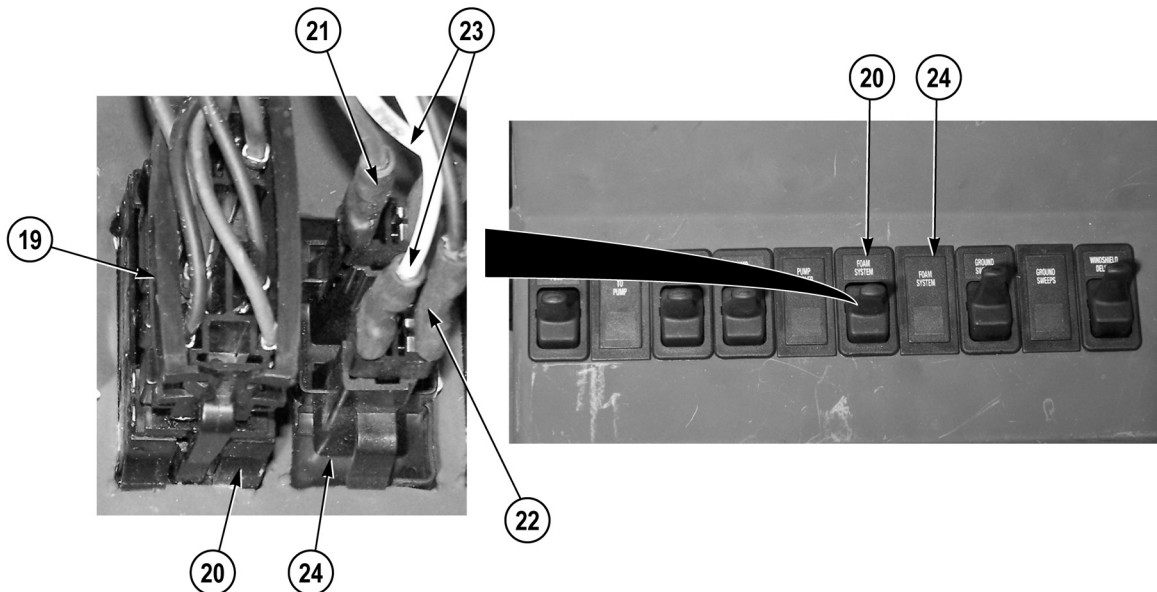


### NOTE

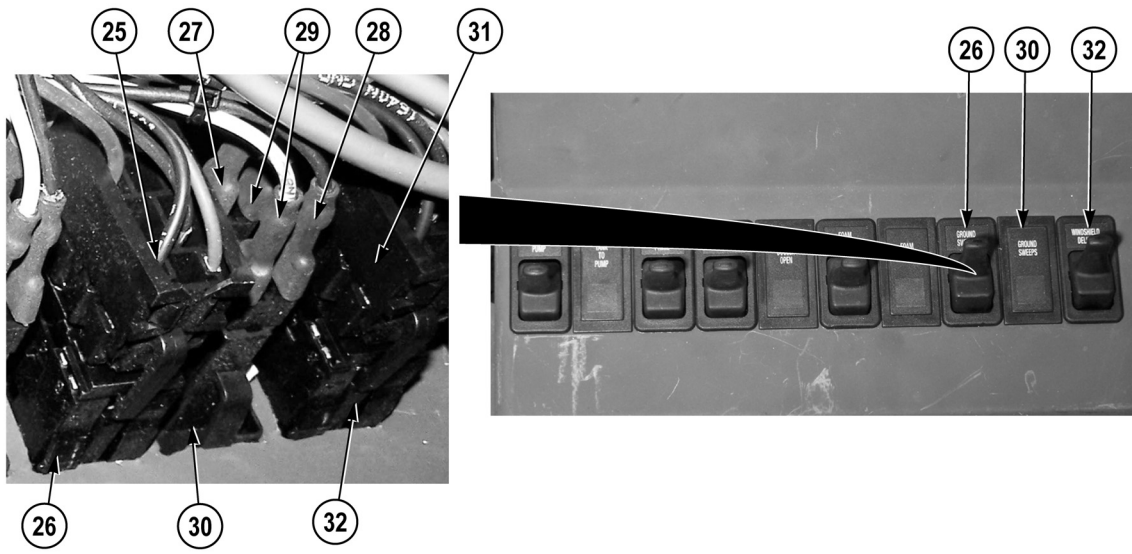
- Tag and mark wires prior to removal to ensure proper installation.
  - Note routing of harnesses prior to removal to ensure proper installation.
  - Note position and remove cable ties as required.
3. Disconnect cab pump control wire harness connector (5) from TANK TO PUMP switch (6).
  4. Disconnect wire 2855 (7), wire 1023 (8), and jumperwire 2768 (9) from TANK TO PUMP indicator light (10).



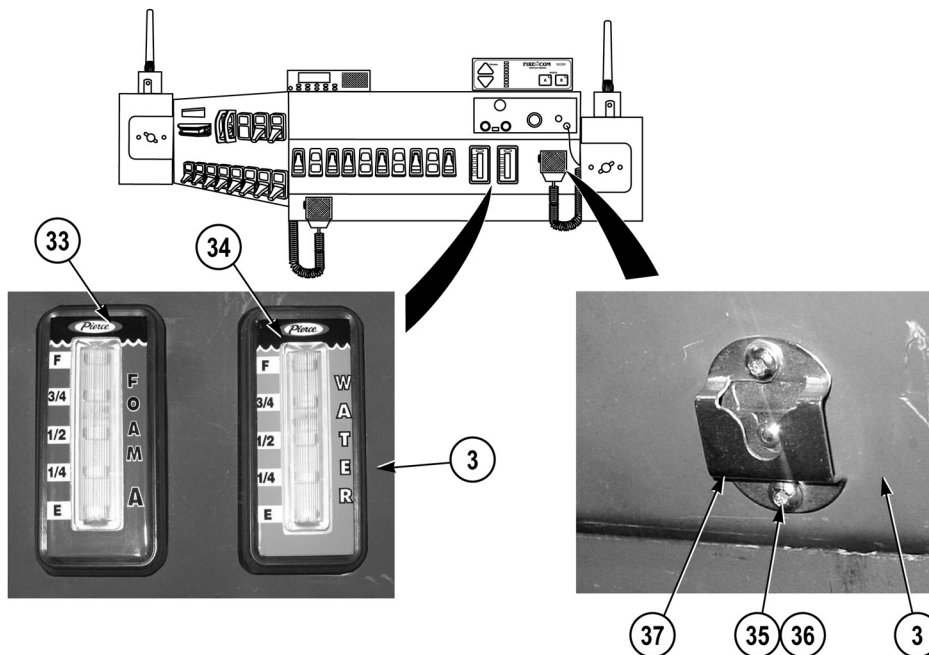
5. Disconnect cab pump control wire harness connector (11) from PUMP PRIMER switch (12).
6. Disconnect cab pump control wire harness connector (13) from PUMP COOLER switch (14).
7. Disconnect wire 4037 (15), wire 1023 (16), and jumperwire 2768 (17) from PUMP COOLER OPEN indicator light (18).



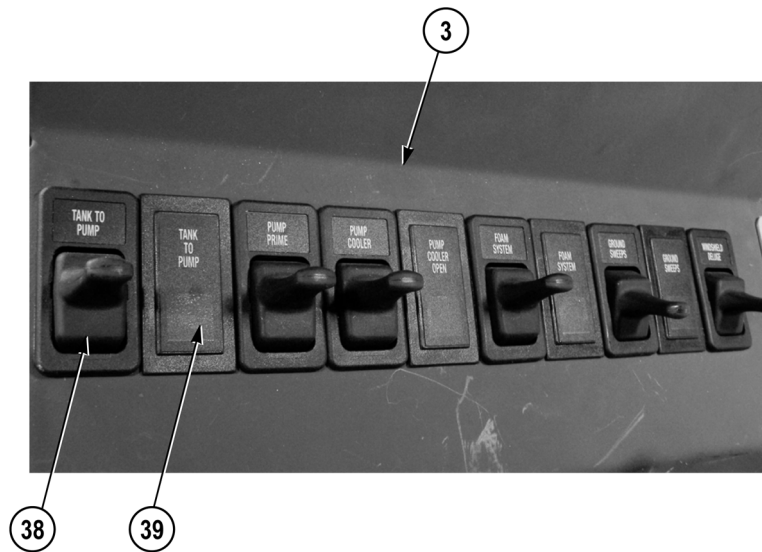
8. Disconnect cab pump control wire harness connector (19) from FOAM SYSTEM switch (20).
9. Disconnect wire 2830 (21), wire 1023 (22), and jumperwire 2768 (23) from FOAM SYSTEM indicator light (24).



10. Disconnect cab pump control wire harness connector (25) from UNDER TRUCK NOZZLES switch (26).
11. Disconnect wire 2772 (27), wire 1023 (28), and jumperwire 2768 (29) from UNDER TRUCK NOZZLES indicator light (30).
12. Disconnect cab pump control wire harness connector (31) from WINDSHIELD DELUGE switch (32).



13. Remove cab foam (33) and water (34) level gauges from cab instrument panel B (3) (WP 0200).
14. Remove cab instrument panel B (3) from vehicle.
15. Remove two nuts (35), screws (36), and bracket (37) from cab instrument panel B (3).

**NOTE**

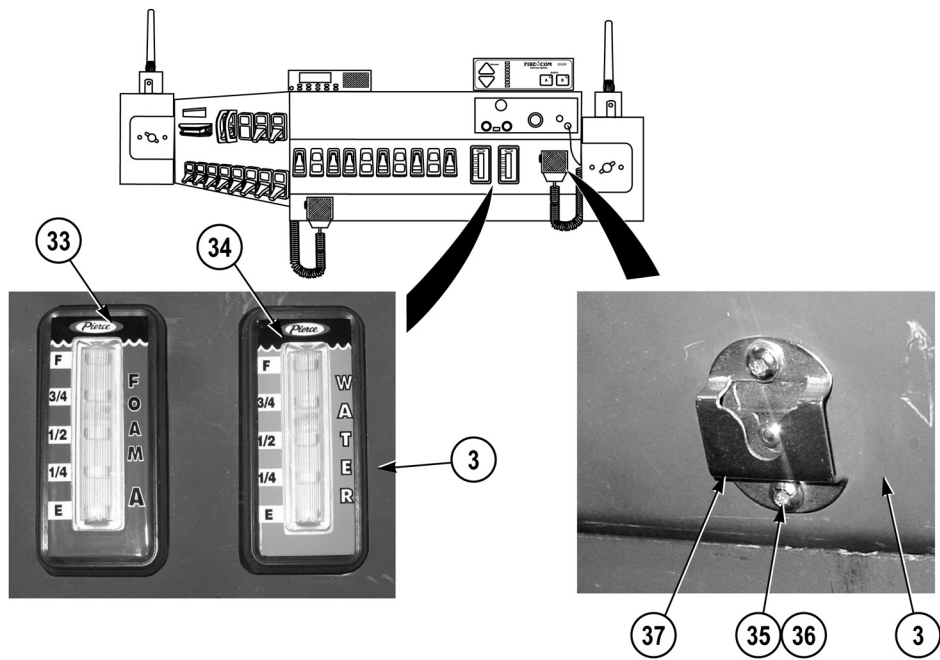
Mark switches and indicators prior to removal to ensure proper installation.

16. Remove six switches (38) from cab instrument panel B (3) (WP 0199).
17. Remove four indicator lights (39) from cab instrument panel B (3) (WP 0198).

**END OF TASK****CAB INSTRUMENT PANEL B INSTALLATION****NOTE**

Install switches and indicators as noted prior to removal.

1. Install four indicator lights (39) on cab instrument panel B (3) (WP 0198).
2. Install six switches (38) on cab instrument panel B (3) (WP 0199).

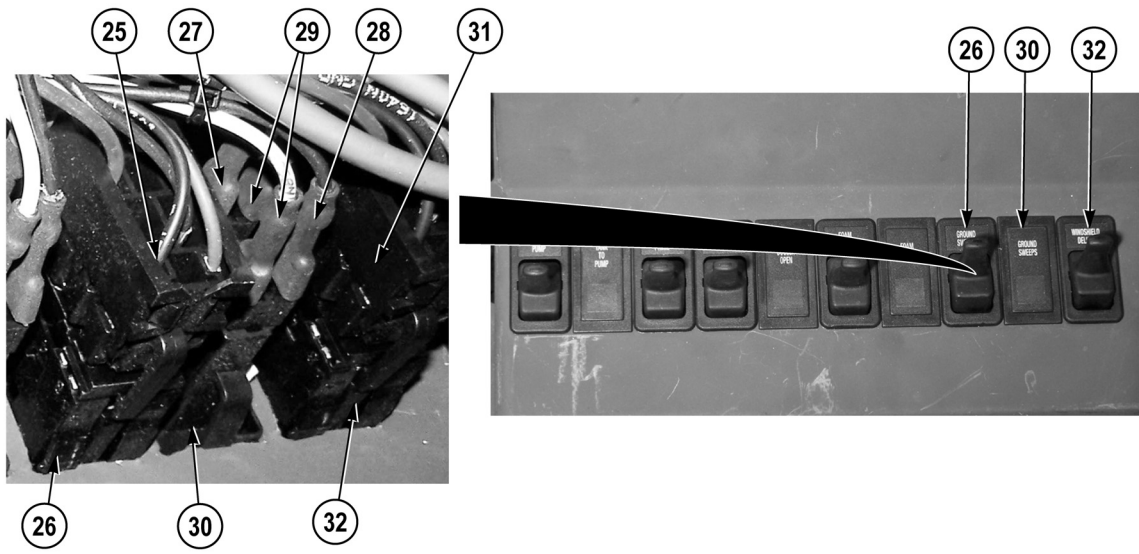


3. Install bracket (37) on cab instrument panel B (3) with two screws (36) and nuts (35).
4. Place cab instrument panel B (3) in stow position on vehicle.

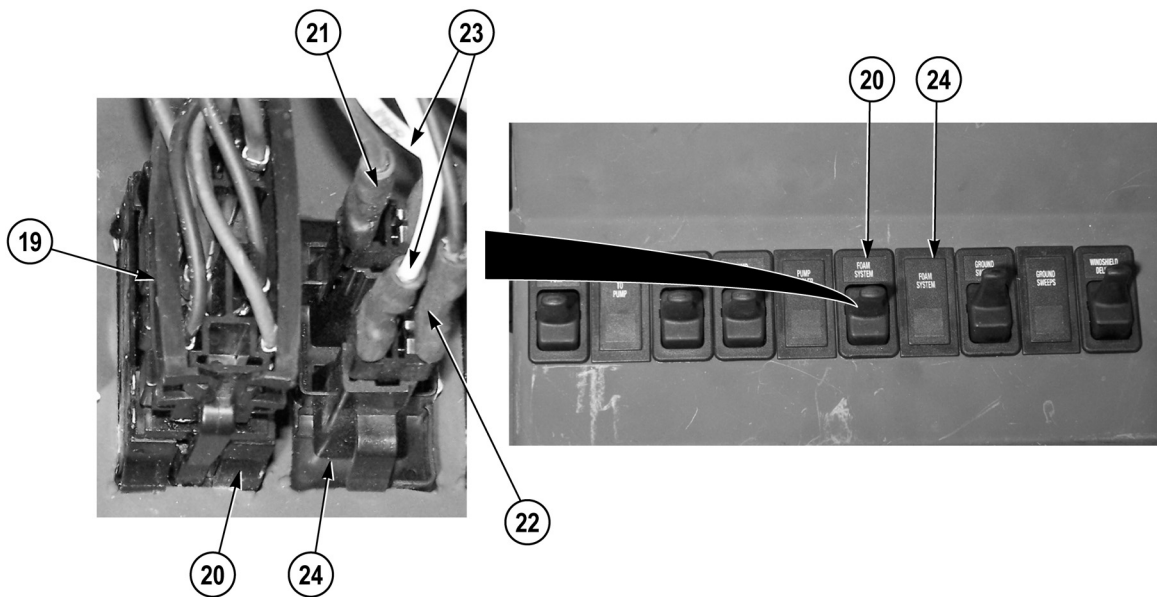
**NOTE**

- Route harnesses as noted prior to removal.
  - Install cable ties as required.
5. Install cab foam (33) and water (34) level gauges on cab instrument panel B (3) (WP 0200).

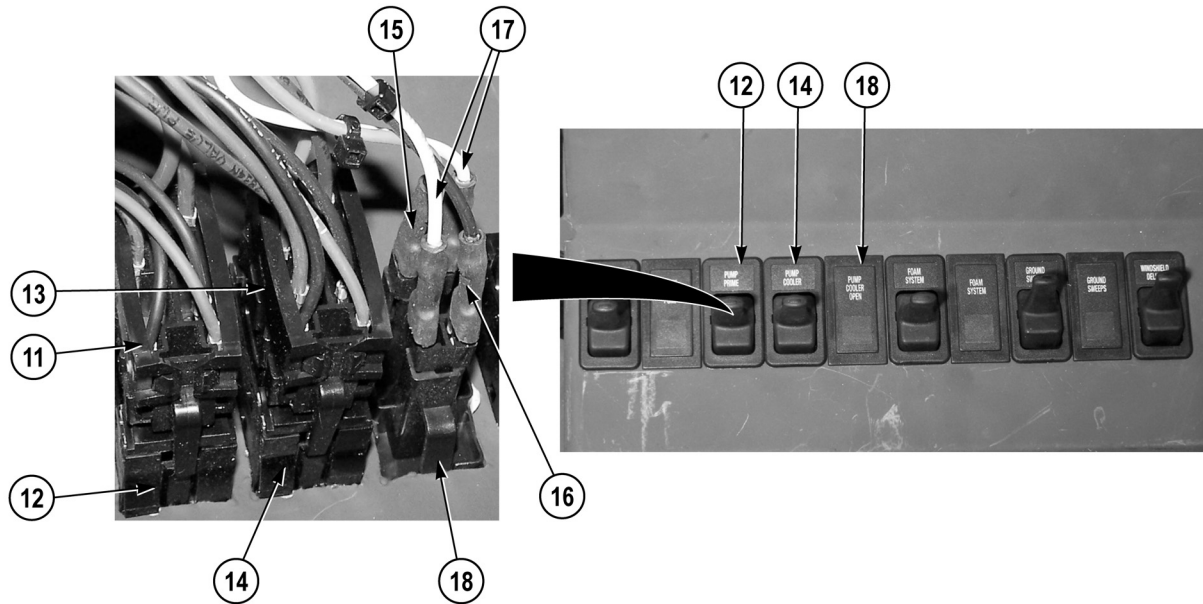




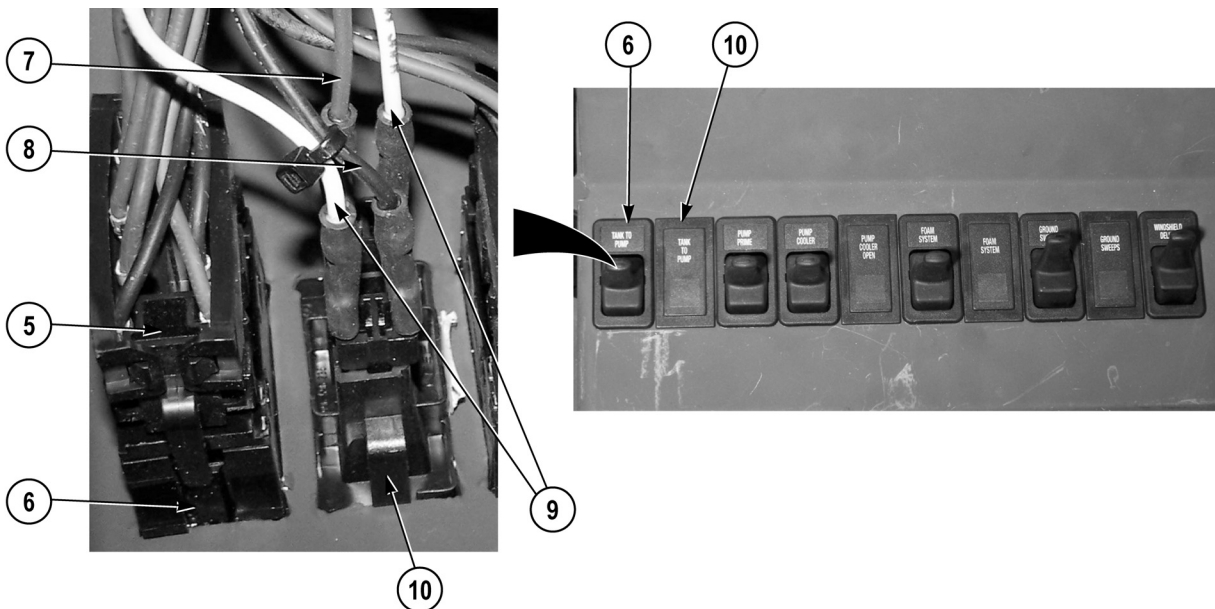
6. Connect cab pump control wire harness connector (31) on WINDSHIELD DELUGE switch (32).
7. Connect wire 2772 (27), wire 1023 (28), and jumperwire 2768 (29) on UNDER TRUCK NOZZLES indicator light (30).
8. Connect cab pump control wire harness connector (25) on UNDER TRUCK NOZZLES switch (26).



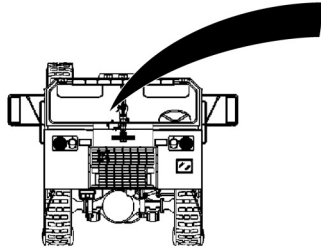
9. Connect wire 2830 (21), wire 1023 (22), and jumperwire 2768 (23) on FOAM SYSTEM indicator light (24).
10. Connect cab pump control wire harness connector (19) on FOAM SYSTEM switch (20).



11. Connect wire 4037 (15), wire 1023 (16), and jumperwire 2768 (17) on PUMP COOLER OPEN indicator light (18).
12. Connect cab pump control wire harness connector (13) on PUMP COOLER switch (14).
13. Connect cab pump control wire harness connector (11) on PUMP PRIMER switch (12).



14. Connect wire 2855 (7), wire 1023 (8), and jumperwire 2768 (9) on TANK TO PUMP indicator light (10).
15. Connect cab pump control wire harness connector (5) on TANK TO PUMP switch (6).



16. Install cab instrument panel B (3) on cab instrument panel assembly (4) with five screws (2).



17. Install siren control (1) on vehicle (WP 0380).

**END OF TASK**

## CAB INSTRUMENT PANEL C REMOVAL



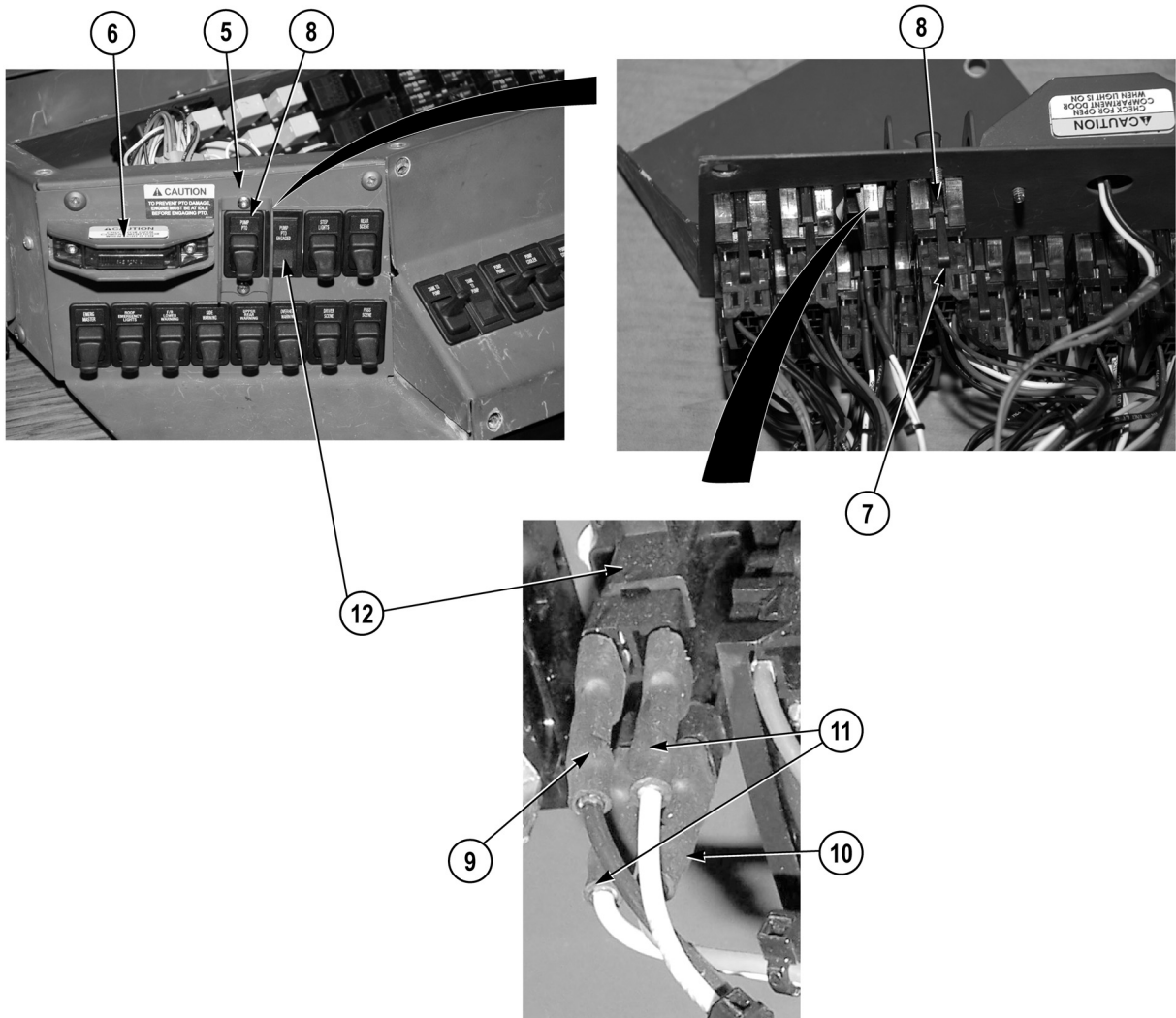
**⚠ CAUTION**

When performing Steps (1) and (2), lift out and stow cab instrument panel B and C only enough to access wire harness connectors. Cab pump control and foam and water level gauge wire harnesses are still attached to cab instrument panel B. Cab instrument panel wire harness connectors are still attached to cab instrument panel C. Failure to comply may cause damage to equipment.

**NOTE**

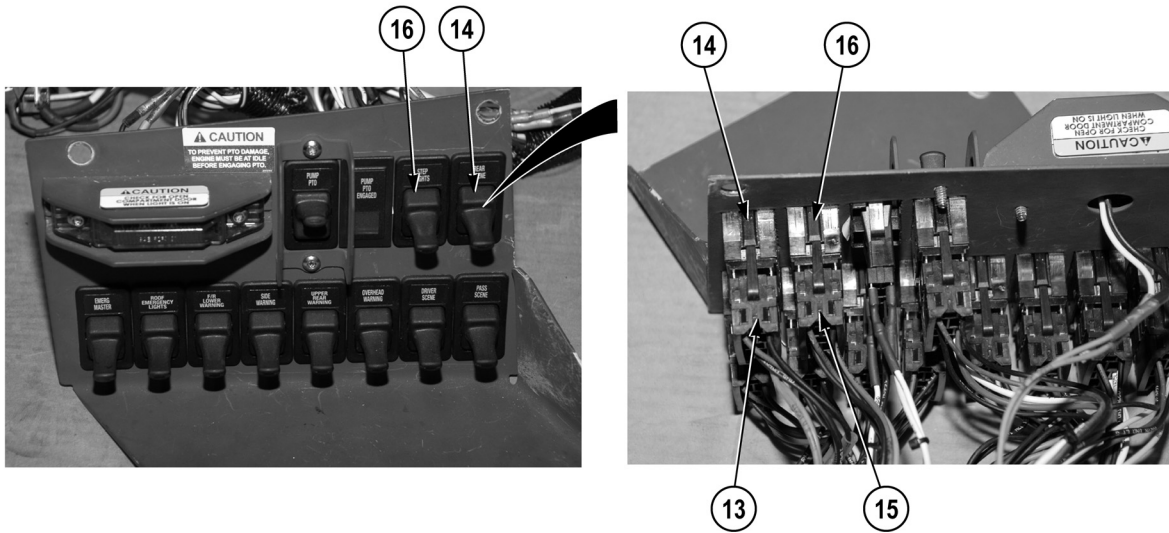
Cab instrument panels B and C interlock. Lifting cab instrument panel B away from cab instrument panel assembly slightly, allows cab instrument panel C to move freely.

1. Remove five screws (1) and stow cab instrument panel B (2) away from cab instrument panel assembly (3).
2. Remove three screws (4) and pull cab instrument panel C (5) away from cab instrument panel assembly (3).

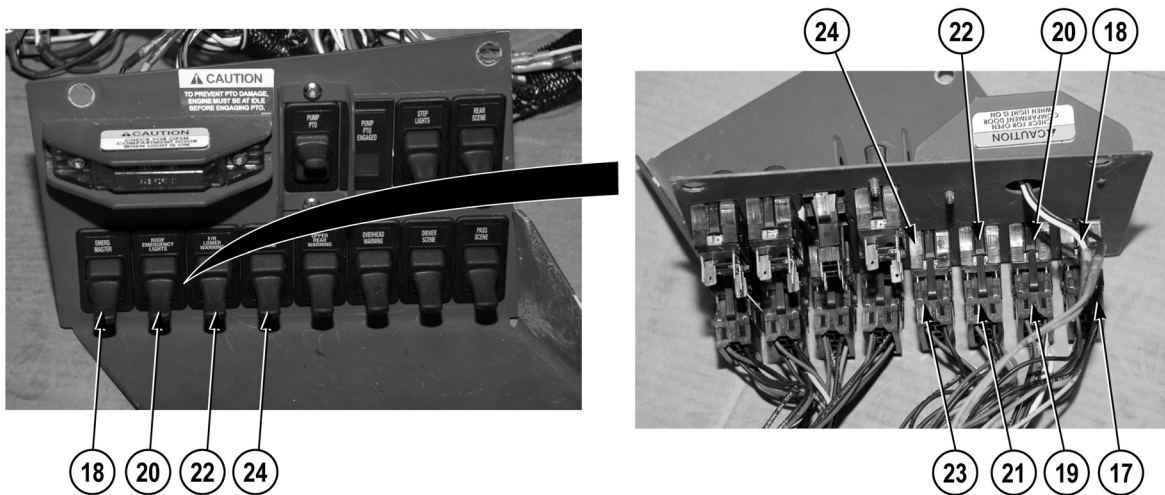


**NOTE**

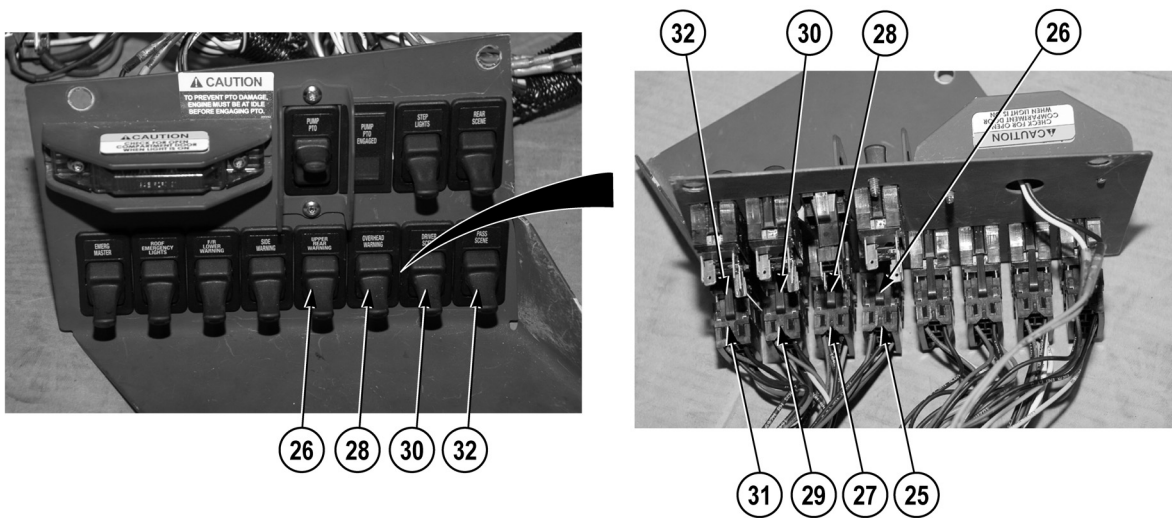
- Tag and mark wires prior to removal to ensure proper installation.
  - Note routing of cab power distribution wire harness to ensure correct installation.
  - Note position and remove cable ties and cushion clips as required.
3. Remove CHECK FOR OPEN COMPARTMENT DOORS WHEN LIGHT IS ON indicator (6) from cab instrument panel C (5) (WP 0195).
  4. Disconnect cab instrument panel wire harness connector (7) from PUMP PTO switch (8).
  5. Disconnect wire 1677 (9), wire 1640 (10) and jumperwire 2768 (11) from PUMP PTO ENGAGED indicator light (12).



6. Disconnect cab instrument panel wire harness connector (13) from STEP LIGHTS switch (14).
7. Disconnect cab instrument panel wire harness connector (15) from REAR SCENE switch (16).
8. Disconnect cab instrument panel wire harness connector (17) from EMERG MASTER switch (18).



9. Disconnect cab instrument panel wire harness connector (19) from ROOF EMERGENCY LIGHTS switch (20).
10. Disconnect cab instrument panel wire harness connector (21) from F/R LOWER WARNING switch (22).
11. Disconnect cab instrument panel wire harness connector (23) from SIDE WARNING switch (24).



12. Disconnect cab instrument panel wire harness connector (25) from UPPER REAR WARNING switch (26).
13. Disconnect cab instrument panel wire harness connector (27) from OVERHEAD WARNING switch (28).
14. Disconnect cab instrument panel wire harness connector (29) from DRIVER SCENE switch (30).
15. Disconnect cab instrument panel wire harness connector (31) from PASS SCENE switch (32).



### NOTE

Mark switches and indicator prior to removal to ensure proper installation.

16. Remove two screws (33) and switch guard (34) from cab instrument panel C (5).
17. Remove 11 switches (35) from cab instrument panel C (5) (WP 0199).
18. Remove indicator light (36) from cab instrument panel C (5) (WP 0198).
19. Remove cab instrument panel C (5) from cab instrument panel assembly (3) and remove from vehicle.
20. Remove two decals (37) and (38) from cab instrument panel C (5).

### END OF TASK

### CAB INSTRUMENT PANEL C INSTALLATION

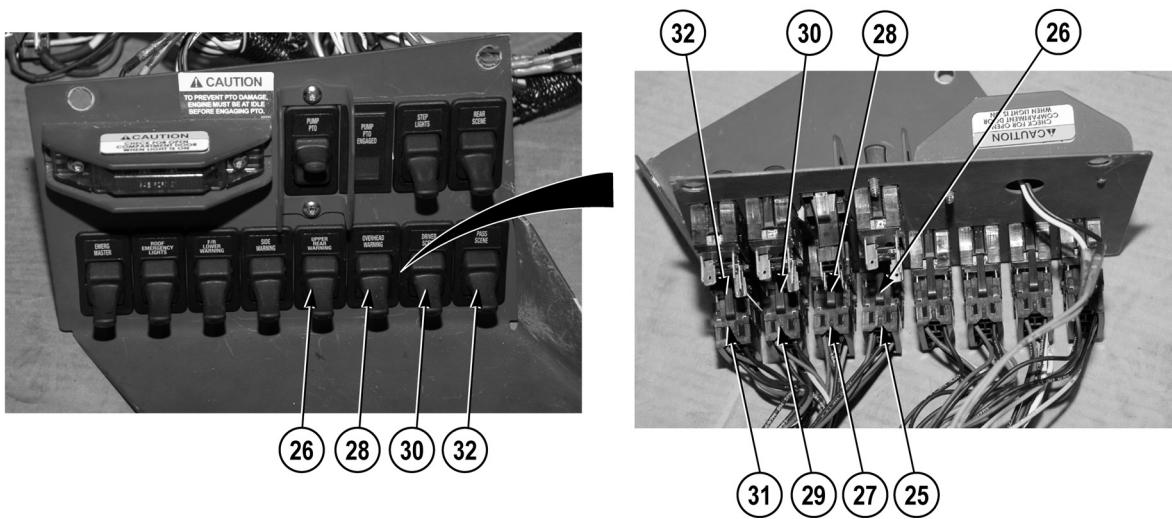
1. Install two decals (38) and (37) on cab instrument panel C (5).
2. Place cab instrument panel C (5) on cab instrument panel assembly (3).

### NOTE

Install switches and indicator as noted prior to removal.

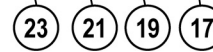
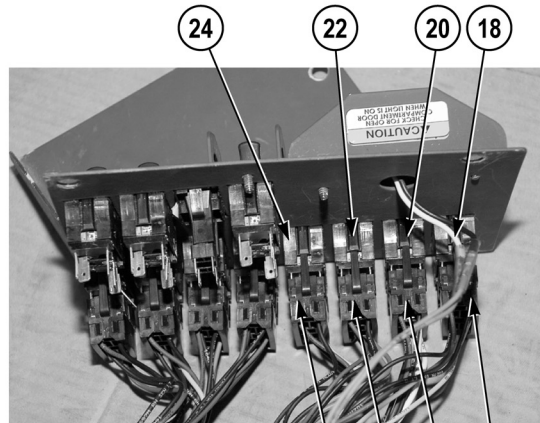
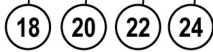
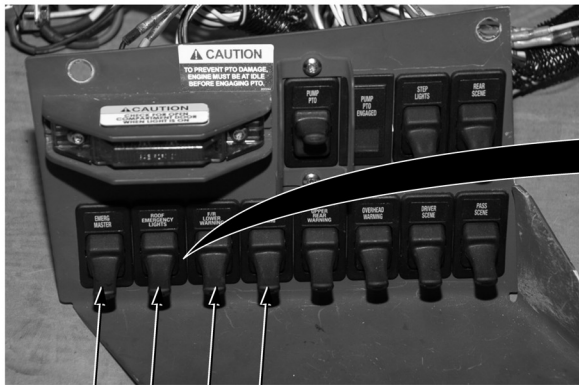
3. Install indicator light (36) on cab instrument panel C (5) (WP 0198).
4. Install 11 switches (35) on cab instrument panel C (5) (WP 0199).
5. Install switch guard (34) on cab instrument panel C (5) with two screws (33).



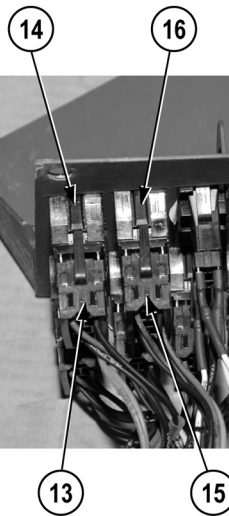
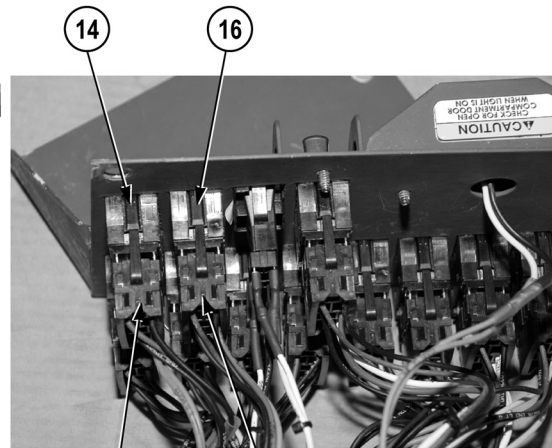
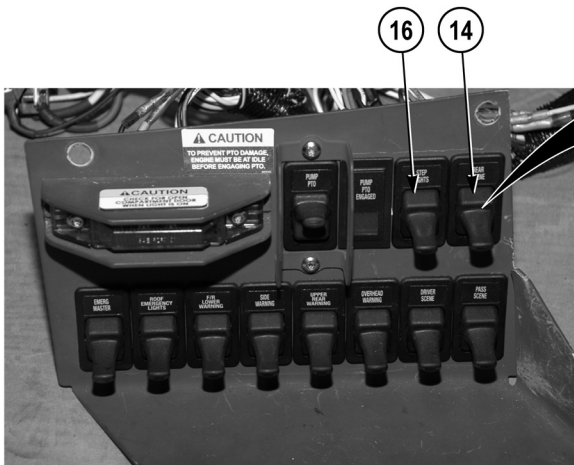


**NOTE**

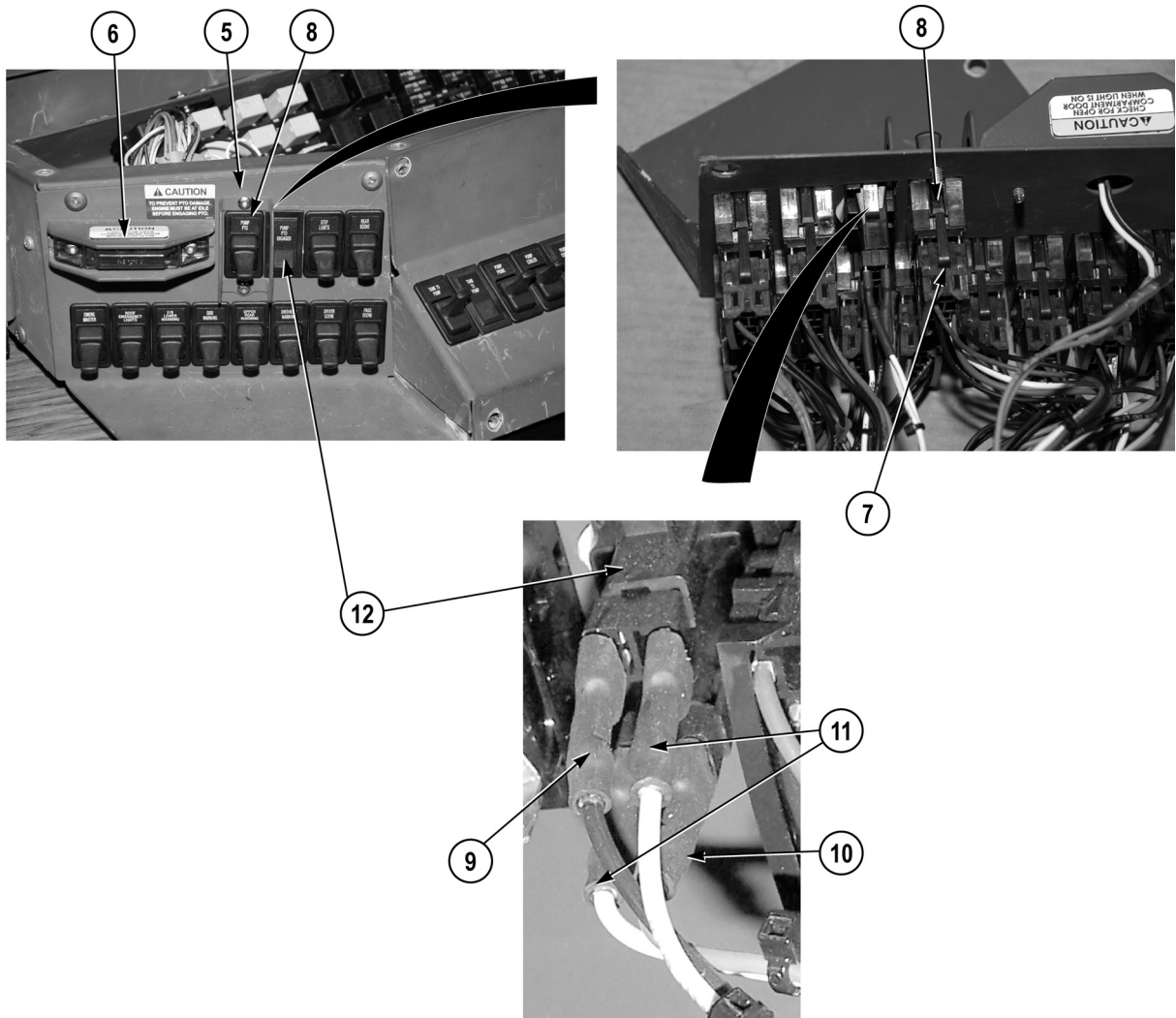
- Route cab power distribution wire harness as noted prior to removal.
  - Install cable ties and cushion clips as required.
6. Connect cab instrument panel wire harness connector (31) on PASS SCENE switch (32).
  7. Connect cab instrument panel wire harness connector (29) on DRIVER SCENE switch (30).
  8. Connect cab instrument panel wire harness connector (27) on OVERHEAD WARNING switch (28).
  9. Connect cab instrument panel wire harness connector (25) on UPPER REAR WARNING switch (26).



- 10. Connect cab instrument panel wire harness connector (23) on SIDE WARNING switch (24).
- 11. Connect cab instrument panel wire harness connector (21) on F/R LOWER WARNING switch (22).
- 12. Connect cab instrument panel wire harness connector (19) on ROOF EMERGENCY LIGHTS switch (20).
- 13. Connect cab instrument panel wire harness connector (17) on EMERG MASTER switch (18).



- 14. Connect cab instrument panel wire harness connector (15) on REAR SCENE switch (16).
- 15. Connect cab instrument panel wire harness connector (13) from STEP LIGHTS switch (14).

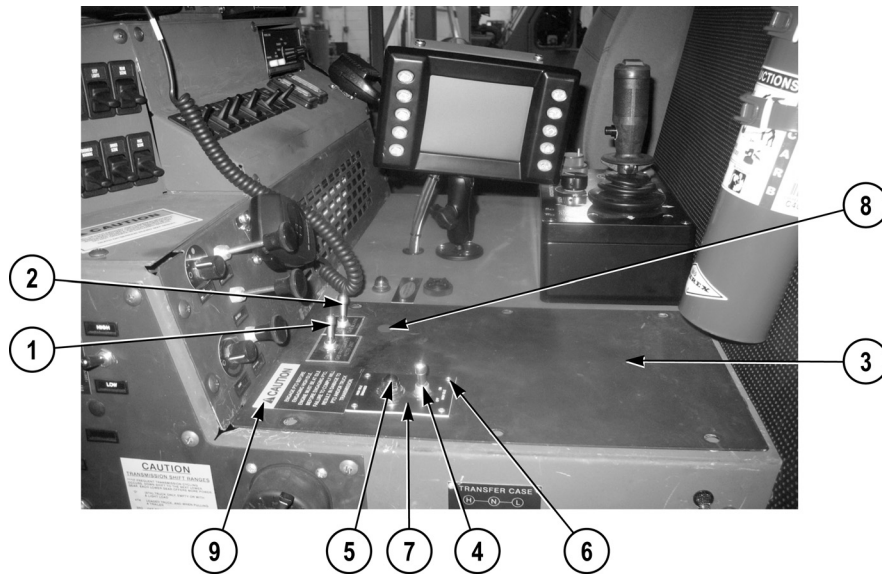


16. Connect wire 1677 (9), wire 1640 (10) and jumperwire 2768 (11) on PUMP PTO ENGAGED indicator light (12).
17. Connect cab instrument panel wire harness connector (7) on PUMP PTO switch (8).
18. Install CHECK FOR OPEN COMPARTMENT DOORS WHEN LIGHT IS ON indicator (6) on cab instrument panel C (5) (WP 0195).



19. Install cab instrument panel C (5) on cab instrument panel assembly (3) with three screws (4).
20. Install cab instrument panel B (2) on cab instrument panel assembly (3) with five screws (1).

**END OF TASK**

**CAB INSTRUMENT PANEL D REMOVAL****NOTE**

Cab instrument panel D fasteners are removed in Step (1).

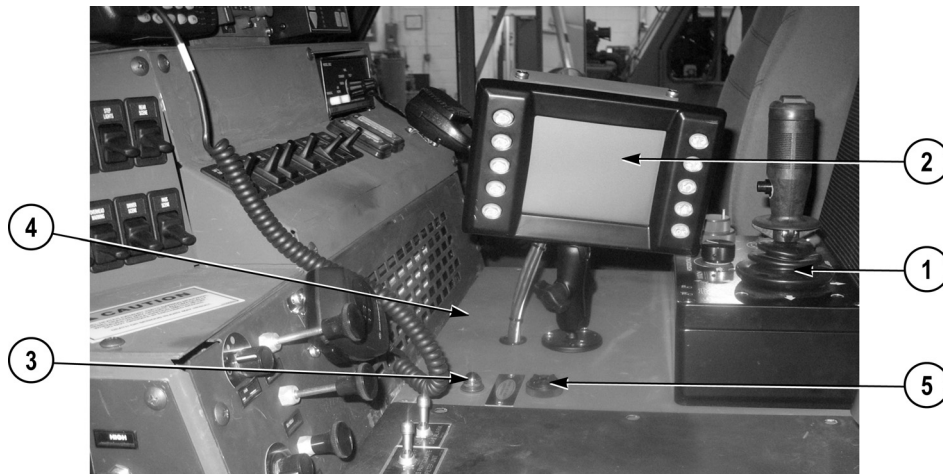
1. Remove GAS PARTICULATE FILTER UNIT switch (1) and GAS ALARM switch (2) from cab instrument panel D (3) (TM 9-2320-325-14&P).
2. Remove cab HIGH IDLE switch (4) and indicator (5) from cab instrument panel D (3) (WP 0217).
3. Remove four screws (6) and data plate (7) from cab instrument panel D (3).
4. Remove plug (8) from cab instrument panel D (3).
5. Remove data plate (9) from cab instrument panel D (3).
6. Remove cab instrument panel D (3) from vehicle.

**END OF TASK****CAB INSTRUMENT PANEL D INSTALLATION**

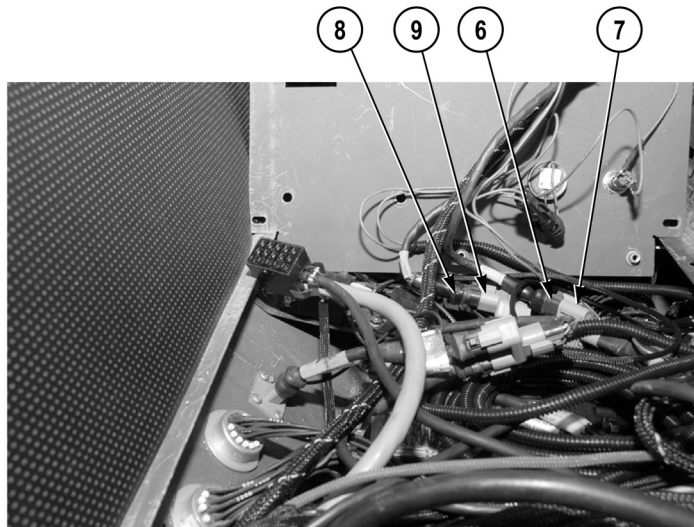
1. Place cab instrument panel D (3) in stow position on vehicle.
2. Install data plate (9) on cab instrument panel D (3).
3. Install plug (8) on cab instrument panel D (3).
4. Install data plate (7) on cab instrument panel D (3) with four screws (6).
5. Install cab HIGH IDLE switch (4) and indicator (5) on cab instrument panel D (3) (WP 0217).
6. Install GAS PARTICULATE FILTER UNIT switch (1) and GAS ALARM switch (2) on cab instrument panel D (3) (TM 9-2320-325-14&P).

**END OF TASK**

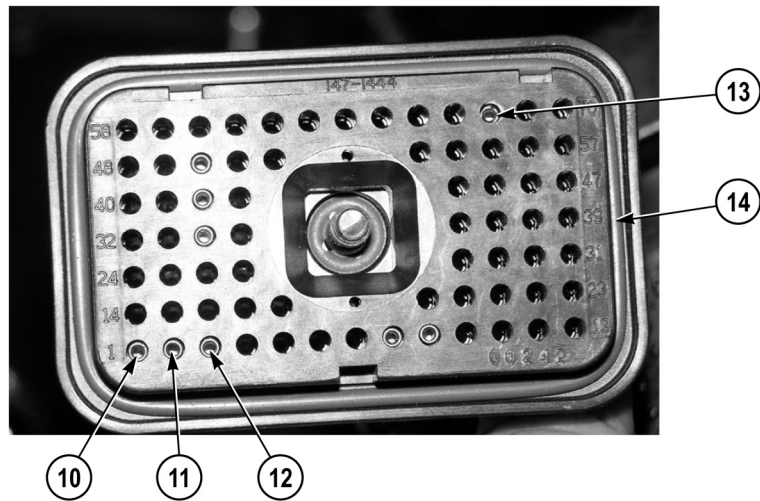
## CAB INSTRUMENT PANEL E REMOVAL



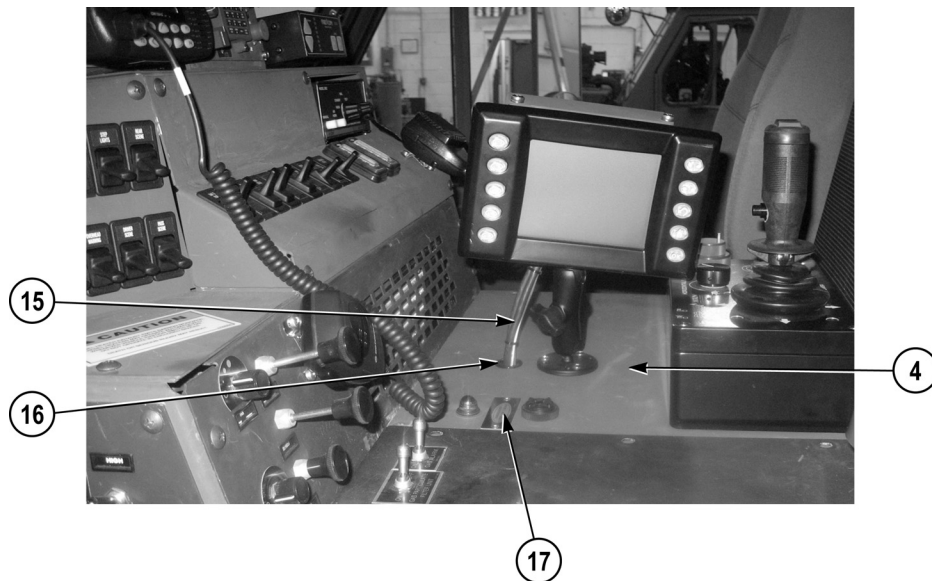
1. Remove bumper turret control (1) from vehicle (WP 0375).
2. Remove pressure governor control (2) from vehicle (WP 0197).
3. Remove cab 1-2-3 signal indicator (3) from cab instrument panel E (4) (WP 0201).
4. Remove cab 1-2-3 buzzer audio alarm (5) from cab instrument panel E (4) (WP 0203).

**NOTE**

- To locate correct datalink cable, follow yellow and green banded datalink cables from cab pressure governor control connector to first Y connector in series.
  - Tag and mark all wires prior to removal for proper installation.
  - Note routing of wires prior to removal for proper installation.
5. Disconnect main wire harness connector (6) from pressure governor control ECU datalink Y connector (7).
  6. Disconnect main wire harness connector (8) from chassis datalink Y connector (9).



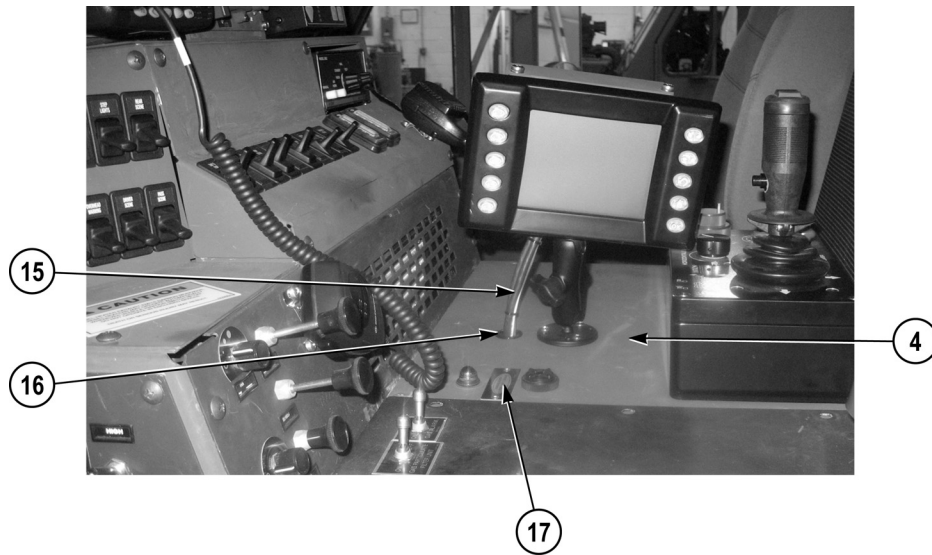
7. De-pin main wire harness, wire 1118 (10), wire 1640 (11), wire 2839 (12), and wire 3285 (13) from cab pressure governor control connector (14) (TM 9-2320-325-14&P).



8. Remove cab instrument panel E (4) from vehicle.
9. Remove pressure governor control connector and wires (15) from cab instrument panel E (4).
10. Remove grommet (16) from cab instrument panel E (4).
11. Remove data plate (17) from cab instrument panel E (4).

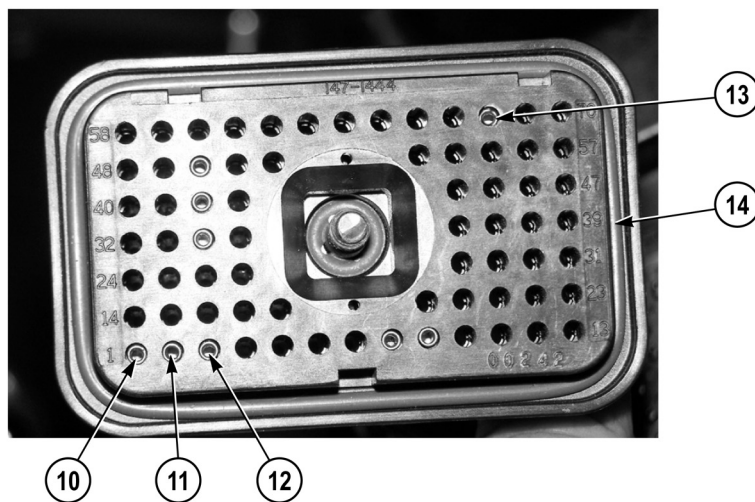
**END OF TASK**

## CAB INSTRUMENT PANEL E INSTALLATION



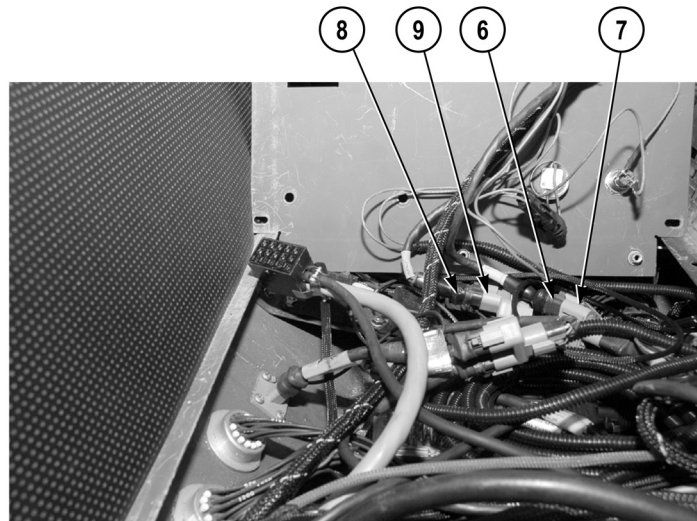
### ROUTE WIRES AS NOTED PRIOR TO REMOVAL.

1. Install data plate (17) on cab instrument panel E (4).
2. Install grommet (16) on cab instrument panel E (4).
3. Route pressure governor control connector and wires (15) on cab instrument panel E (4).
4. Place cab instrument panel E (4) in stow position on vehicle.

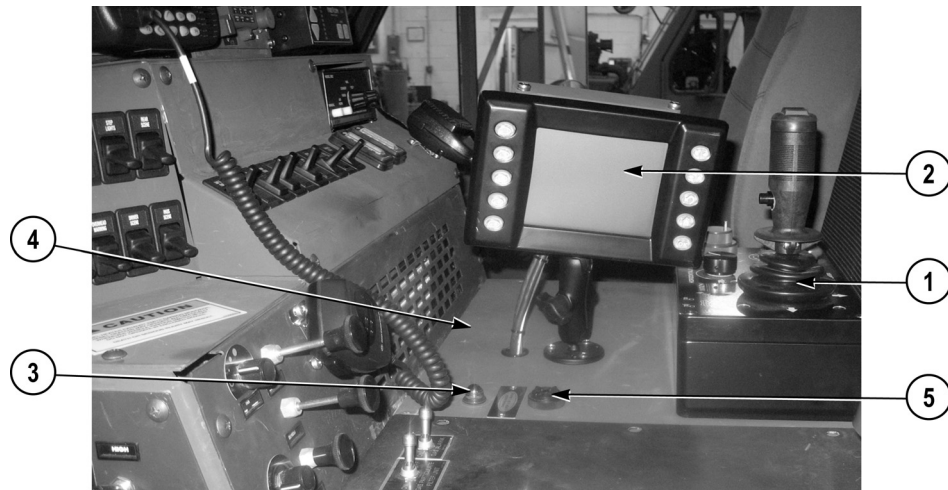


5. Pin wire 1118 (10), wire 1640 (11), wire 2839 (12), and wire 3285 (13) on main wire harness cab pressure governor control connector (14) (TM 9-2320-325-14&P).





6. Connect main wire harness connector (8) on chassis datalink Y connector (9).
7. Connect main wire harness connector (6) on pressure governor control ECU datalink Y connector (7).



8. Install cab 1-2-3 buzzer audio alarm (5) on cab instrument panel E (4) (WP 0203).
9. Install cab 1-2-3 signal indicator (3) on cab instrument panel E (4) (WP 0201).
10. Install pressure governor control (2) (WP 0197).
11. Install bumper turret control (1) (WP 0375).

### FOLLOW-ON MAINTENANCE

Connect batteries (TM 9-2320-325-14&P)

### END OF TASK

### END OF WORK PACKAGE



---

**FIELD LEVEL MAINTENANCE**  
**PUMP OPERATOR'S PANEL COVER REPLACEMENT**

---

**INITIAL SETUP:****Tools and Special Tools**

Tool Kit, General Mechanic's: Automotive  
(WP 0398, Item 17)

**References**

WP 0010  
WP 0326  
WP 0391, Fig. 82

**Materials/Parts**

Locknut (9)  
Locknut (2)  
Door Seal (1)  
Locknut (9)  
Locknut (4)

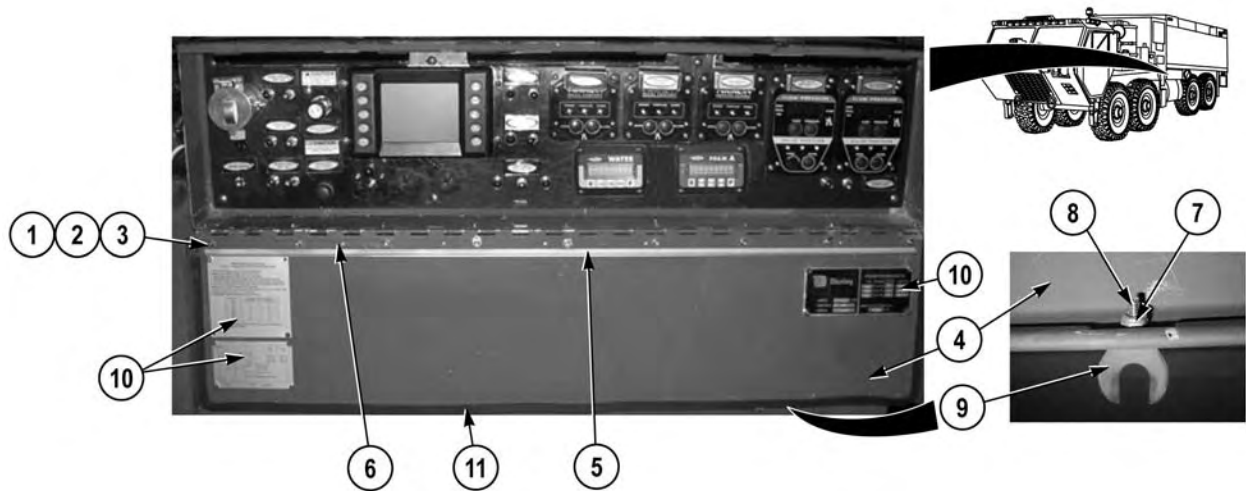
**Equipment Conditions**

Engine OFF (TM 9-2320-422-10)  
Wheels chocked (TM 9-2320-422-10)  
Pump operator's panel cover opened (WP 0010)  
Reflector removed (WP 0346)

**Personnel Required**

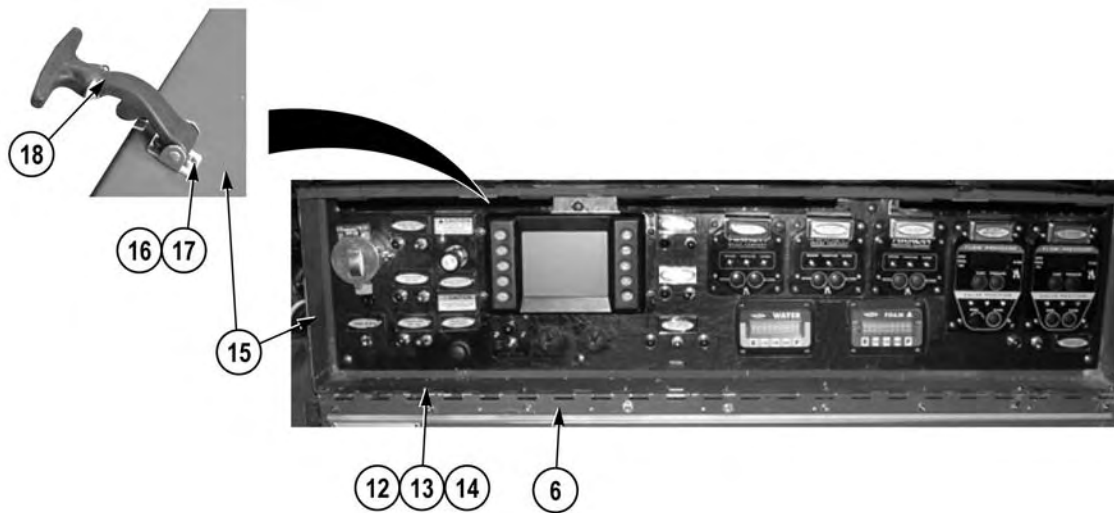
MOS 63B Wheeled Vehicle Mechanic (2)

---

**REMOVAL****NOTE**

An assistant may be required to help remove pump operator's panel cover when removing last screw.

1. Remove nine locknuts (1), washers (2), screws (3), pump operator's panel cover (4), and door stop (5) from hinge (6). Discard locknuts.
2. Remove two locknuts (7), screws (8), and hooks (9) from pump operator's panel cover (4). Discard locknuts.
3. Remove three data plates (10) from pump operator's panel cover (4) (WP 0326).
4. Remove door seal (11) from pump operator's panel cover (4). Discard door seal.

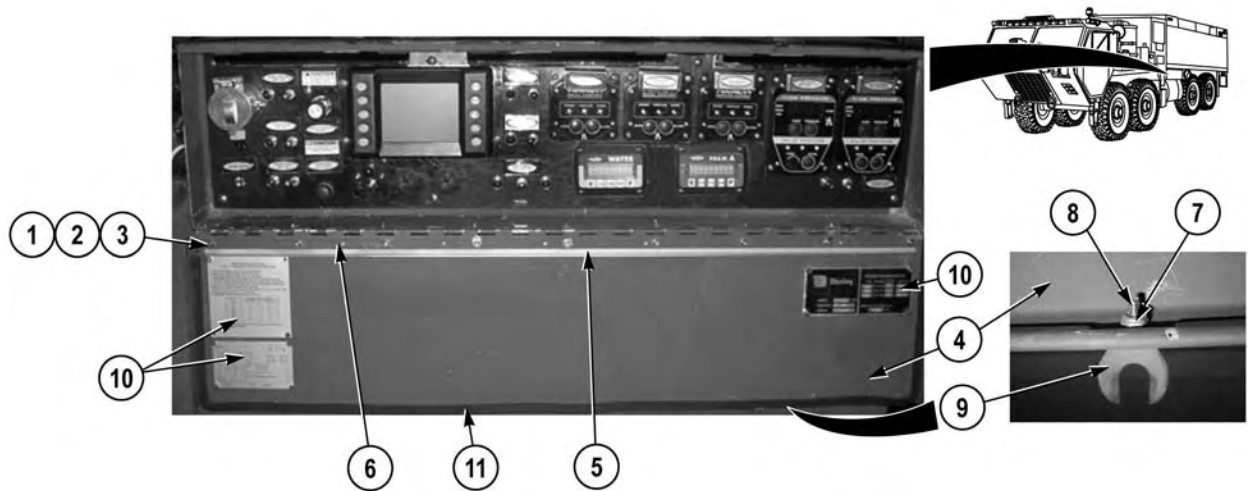


5. Remove nine locknuts (12), washers (13), screws (14), and hinge (6) from housing (15). Discard locknuts.
6. Remove four locknuts (16), screws (17), and two rubber latches (18) from housing (15). Discard locknuts.

#### END OF TASK

#### INSTALLATION

1. Install two rubber latches (18) on housing (15) with four screws (17) and locknuts (16).
2. Install hinge (6) on housing (15) with nine screws (14), washers (13), and locknuts (12).



3. Install door seal (11) on pump operator's panel (4).
4. Install three data plates (10) on pump operator's panel cover (4) (WP 0326).
5. Install two hooks (9) on pump operator's panel cover (4) with two screws (8) and locknuts (7).

### NOTE

An assistant may be required to help install pump operator's pump cover when installing first screw.

6. Install pump operator's panel cover (4) and door stop (5) on hinge (6) with nine screws (3), washers (2), and locknuts (1).

### END OF TASK

### FOLLOW-ON MAINTENANCE

1. Install reflector (WP 0346)
2. Close pump operator's panel cover (1) (WP 0010)
3. Remove wheel chocks (TM 9-2320-422-10)

### END OF TASK

### END OF WORK PACKAGE



---

**FIELD LEVEL MAINTENANCE**  
**PUMP OPERATOR'S PANEL OPEN/CLOSE**

---

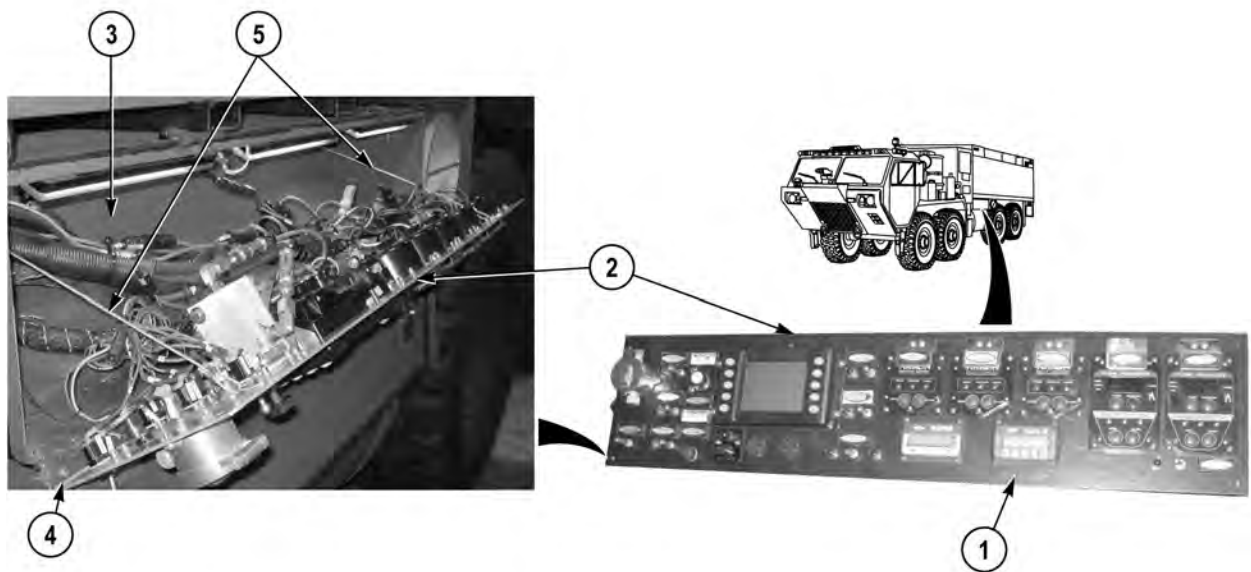
**INITIAL SETUP:****Tools and Special Tools**

Tool Kit, General Mechanic's: Automotive  
(WP 0398, Item 17)

**Equipment Conditions**

Batteries disconnected (TM 9-2320-325-14&P)  
Pump operator's panel cover opened (WP 0010)

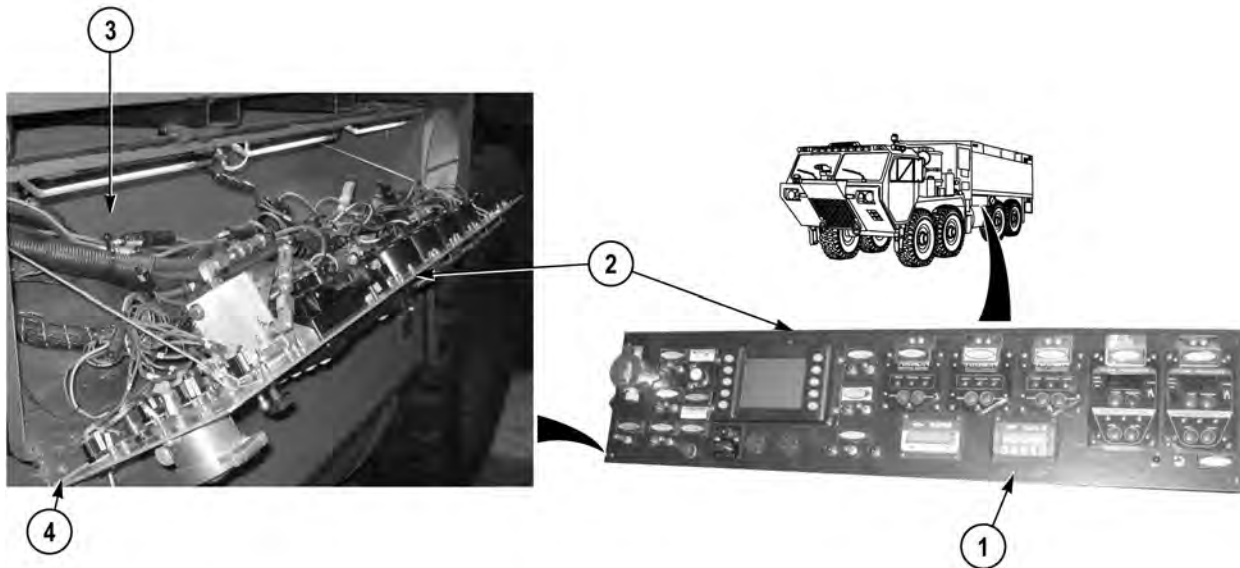
---

**OPEN****NOTE**

To open panel, lift and tilt the bottom out, then tilt the top end out.

1. Remove eight screws (1) from pump operator's panel (2) and housing (3).
2. Position pump operator's panel (2) on door stop (4) supported by two tethers (5).

**END OF TASK**

**CLOSE**

1. Remove pump operator's panel (2) from door stop (4) and position in housing (3).
2. Install pump operator's panel (2) on housing (3) with eight screws (1).

**END OF TASK****FOLLOW-ON MAINTENANCE**

1. Close pump operator's panel cover (WP 0010)
2. Connect batteries (TM 9-2320-325-14&P)

**END OF TASK****END OF WORK PACKAGE**



---

**FIELD LEVEL MAINTENANCE****PUMP OPERATOR'S PANEL REPLACEMENT**

---

**INITIAL SETUP:****Tools and Special Tools**

Tool Kit, General Mechanic's: Automotive  
(WP 0398, Item 17)

**Materials/Parts**

Locknut (2)  
Locknut (2)

**References**

WP 0391, Fig. 82

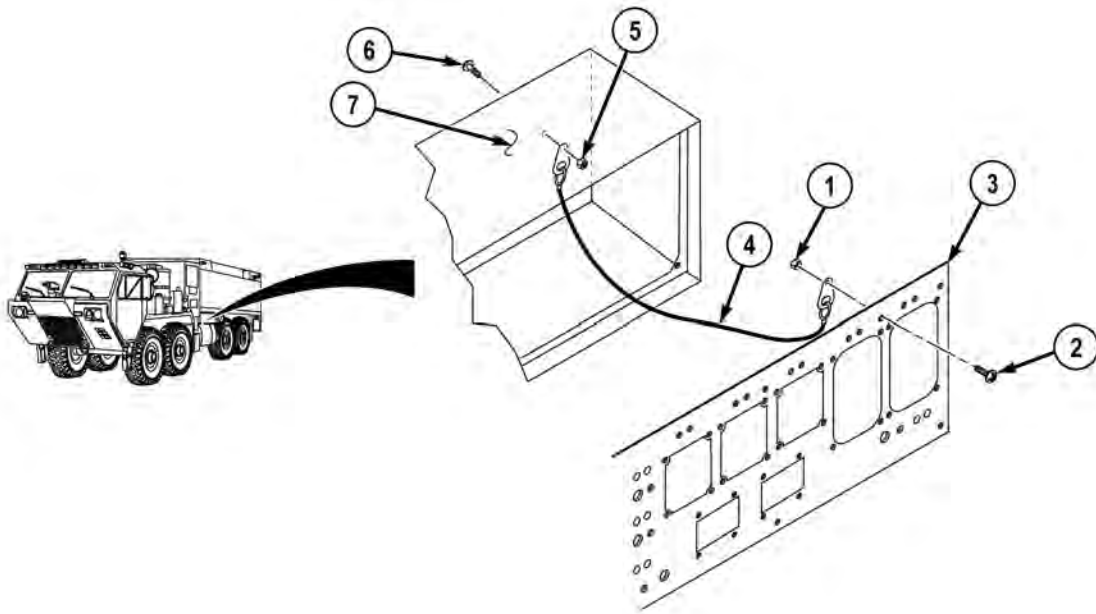
**Equipment Conditions**

Intercom cables and connectors removed (pump operator's panel headset jack connector only) (WP 0257)  
Hydraulic pressure control removed (WP 0143)  
Pump operator's panel pressure governor control removed (WP 0216)  
Pump operator's panel electric valve controls removed (WP 0209)

**Equipment Conditions (continued)**

Pump operator's panel electric valve control meters removed (WP 0210)  
Pump operator's panel water level gauge removed (WP 0212)  
Pump operator's panel foam level gauge removed (WP 0211)  
Pump operator's panel toggle switches (two-position) removed (WP 0220)  
Pump operator's panel toggle switches (three-position) removed (WP 0221)  
Pump operator's panel warning buzzers removed (WP 0203)  
Pump operator's panel driver main inlet primer button removed (WP 0219)  
Pump operator's panel overheat test button and indicator removed (WP 0218)  
Pump operator's panel indicators removed (WP 0213)  
Decal and data plates removed (WP 0326)

---

**REMOVAL**

1. Remove two locknuts (1), screws (2), and pump operator's panel (3) from two tethers (4) and vehicle. Discard locknuts.

**NOTE**

Perform Step (2) if tethers need to be removed.

2. Remove two locknuts (5), screws (6), and tethers (4) from housing (7). Discard locknuts.

**END OF TASK****INSTALLATION****NOTE**

Perform Step (1) if tethers were removed.

1. Install two tethers (4) on housing (7) with two screws (6) and locknuts (5).
2. Install two tethers (4) on pump operator's panel (3) with two screws (2) and locknuts (1).

**END OF TASK**

**FOLLOW-ON MAINTENANCE**

1. Install decals and data plates (WP 0326)
2. Install pump operator's panel indicators (WP 0213)
3. Install pump operator's panel overheat test button and indicator (WP 0218)
4. Install pump operator's panel driver main inlet primer button (WP 0219)
5. Install pump operator's panel warning buzzers (WP 0203)
6. Install pump operator's panel toggle switches (three-position) (WP 0221)
7. Install pump operator's panel toggle switches (two-position) (WP 0220)
8. Install pump operator's panel foam level gauge (WP 0211)
9. Install pump operator's panel water level gauge (WP 0212)
10. Install pump operator's panel electric valve control meters (WP 0210)
11. Install pump operator's panel electric valve controls (WP 0209)
12. Install pump operator's panel pressure governor control (WP 0216)
13. Install hydraulic pressure control valve (WP 0143)
14. Install intercom cables and connector (pump operator's panel headset jack connector only) (WP 0257)

**END OF TASK****END OF WORK PACKAGE**



## FIELD LEVEL MAINTENANCE

## PUMP OPERATOR'S PANEL ELECTRIC VALVE CONTROL REPLACEMENT

## INITIAL SETUP:

**Tools and Special Tools**

Tool Kit, General Mechanic's: Automotive  
(WP 0398, Item 17)

**Materials/Parts**

Tags, Identification (WP 0400, Item 23)  
Ties, Cable, Plastic (WP 0400, Item 26)

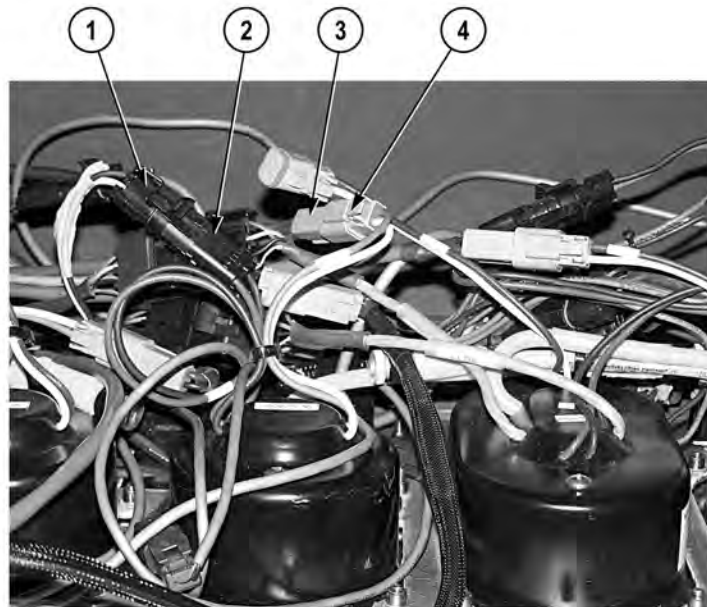
**References**

WP 0391, Fig. 34

**Equipment Conditions**

Pump operator's panel open (WP 0207)

## REMOVAL

**NOTE**

- All electrical valve controls are removed the same way. Driver side auxiliary inlet shown.
  - Tag and mark wires prior to removal to ensure proper installation.
  - Remove cable ties as required.
1. Disconnect pump operator's panel wire harness connector (1) from electric valve control connector (2).
  2. Disconnect valve control wire harness connector (3) from electric valve control connector (4).



3. Remove two screws (5) and data plate bracket (6) from pump operator's control panel (7).
4. Remove four screws (8) and electric valve control (9) from pump operator's control panel (7).

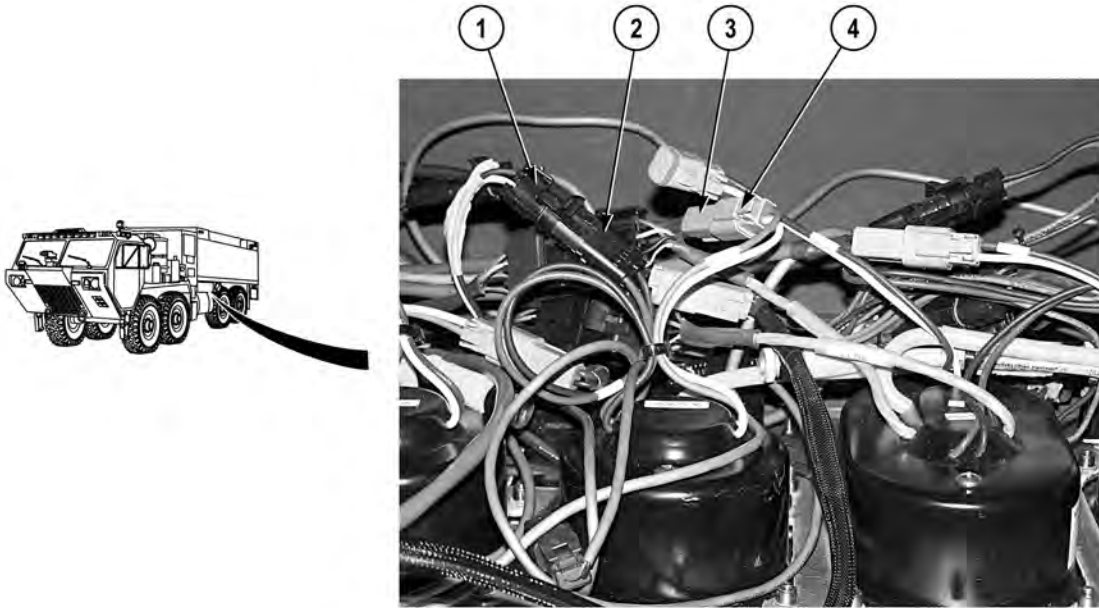
#### END OF TASK

#### INSTALLATION

#### NOTE

All electric valve controls are installed the same way. Driver side auxiliary inlet shown.

1. Install electric valve control (9) on pump operator's control panel (7) with four screws (8).
2. Install data plate bracket (6) on pump operator's control panel (7) with two screws (5).

**NOTE**

Install cable ties as required.

3. Connect electric valve control connector (4) to valve control wire harness connector (3).
4. Connect electric valve control connector (2) to pump operator's panel wire harness connector (1).

**FOLLOW-ON MAINTENANCE**

Close pump operator's panel (WP 0207)

**END OF TASK**

**END OF WORK PACKAGE**





## FIELD LEVEL MAINTENANCE

## PUMP OPERATOR'S PANEL ELECTRIC VALVE CONTROL METER REPLACEMENT AND CALIBRATION

## INITIAL SETUP:

**Tools and Special Tools**

Tool Kit, General Mechanic's: Automotive  
(WP 0398, Item 17)

**References**

TM 9-2320-325-14&P  
WP 0007  
WP 0391, Fig. 34

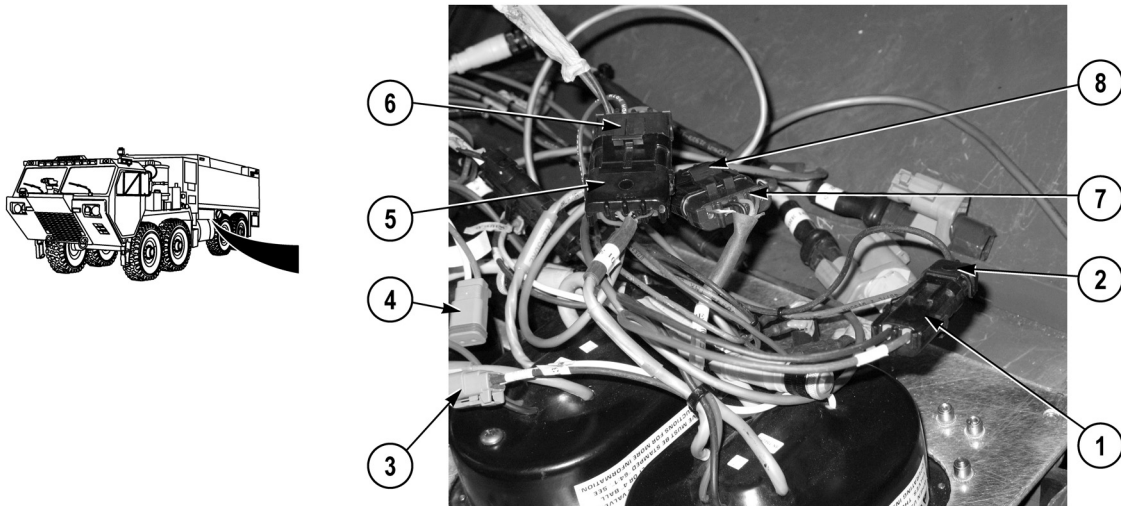
**Materials/Parts**

Tags, Identification (WP 0400, Item 23)  
Ties, Cable, Plastic (WP 0400, Item 26)

**Equipment Conditions**

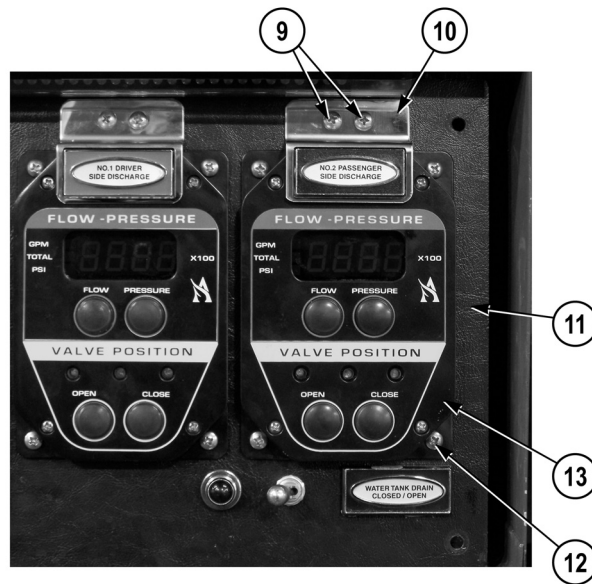
Pump operator's panel opened (WP 0207)

## REMOVAL

**NOTE**

- Tag and mark connectors prior to removal to ensure proper installation.
- Remove cable ties as required.
- Both electric valve control meters are removed the same way. Passenger side discharge electric valve control meter shown.

1. Disconnect electric valve control meter power connector (1) from pump operator's panel wire harness power connector (2).
2. Disconnect electric valve control meter valve motor connector (3) from valve control wire harness (4).
3. Disconnect electric valve control meter pressure transducer connector (5) from pressure transducer wire harness connector (6).
4. Disconnect electric valve control meter flow sensor connector (7) from flow sensor wire harness connector (8).



5. Remove two screws (9) and bracket (10) from pump operator's panel (11).
6. Remove four screws (12) and electric valve control meter (13) from pump operator's panel (11).
7. Remove electric valve control meter (13) from pump operator's panel (11).

#### END OF TASK

#### INSTALLATION

#### NOTE

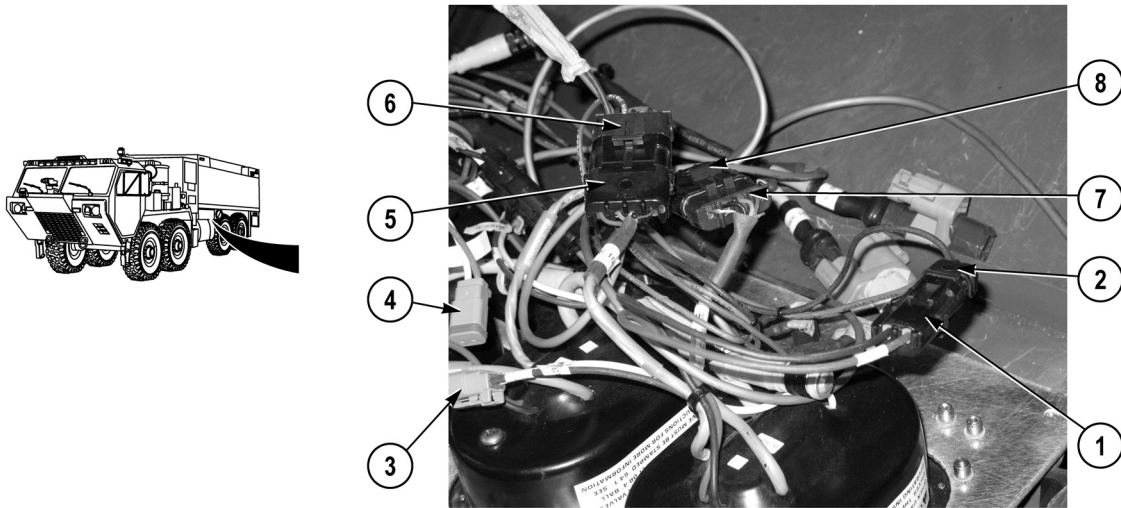
Both electric valve control meters are installed the same way. Passenger side discharge electric valve control meter shown.

1. Position electric valve control meter (13) on pump operator's panel (11).

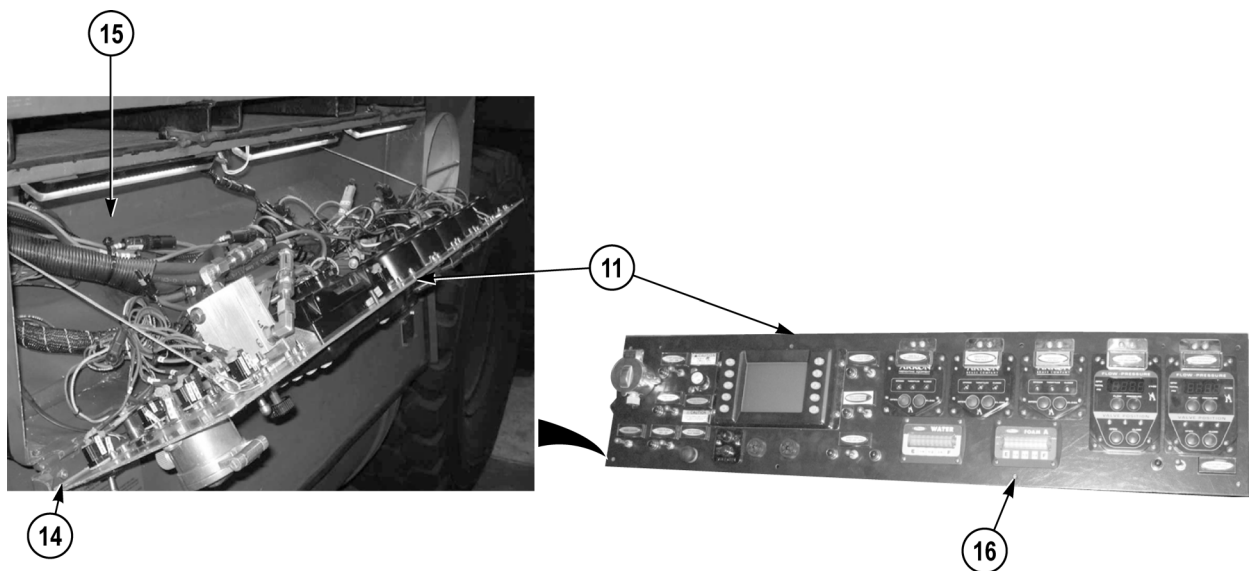
#### NOTE

Install cable ties as required.

2. Install electric valve control meter (13) on pump operator's panel (11) with four screws (12).
3. Install bracket (10) on pump operator's panel (11) with two screws (9).



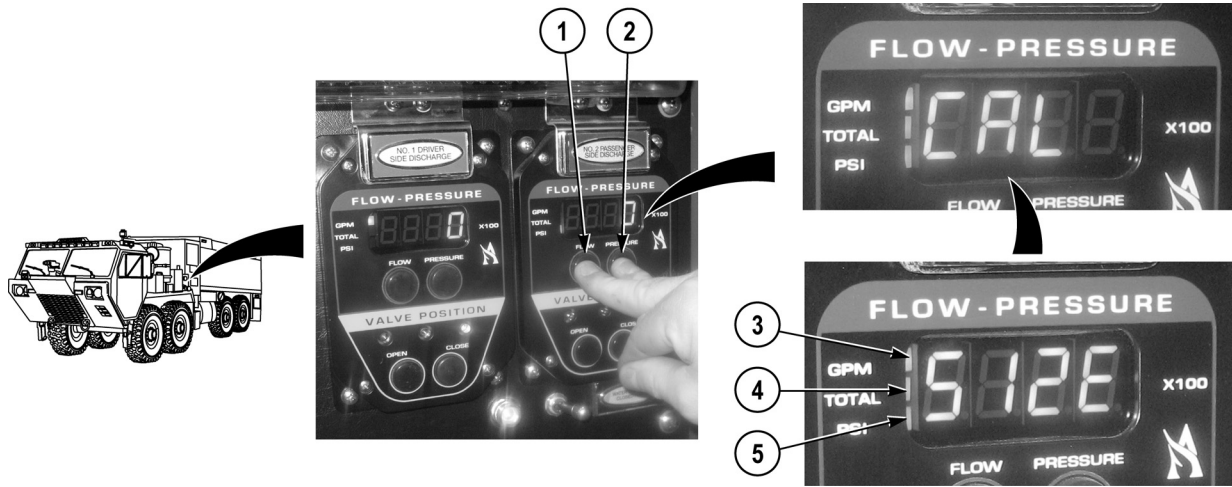
4. Connect flow sensor wire harness connector (8) to electric valve control meter flow sensor connector (7).
5. Connect pressure transducer wire harness connector (6) to electric valve control meter pressure transducer connector (5).
6. Connect valve control wire harness connector (4) to electric valve control meter valve motor connector (3).
7. Connect pump operator's panel wire harness power connector (2) to electric valve control meter power connector (1).



8. Remove pump operator's panel (11) from door stop (14) and position in housing (15).
9. Install pump operator's panel (11) on housing (15) with eight screws (16).

**END OF TASK**

## CALIBRATION



### **WARNING**



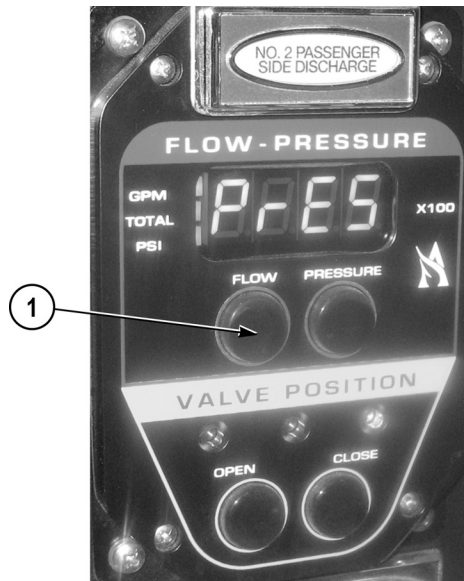
**Vehicle engine must be turned off and all water pressure relieved from system before performing the following procedures. Failure to comply may cause injury to personnel.**

1. Connect batteries (TM 9-2320-325-14&P).
2. Push battery disconnect switch to on position (WP 0007).

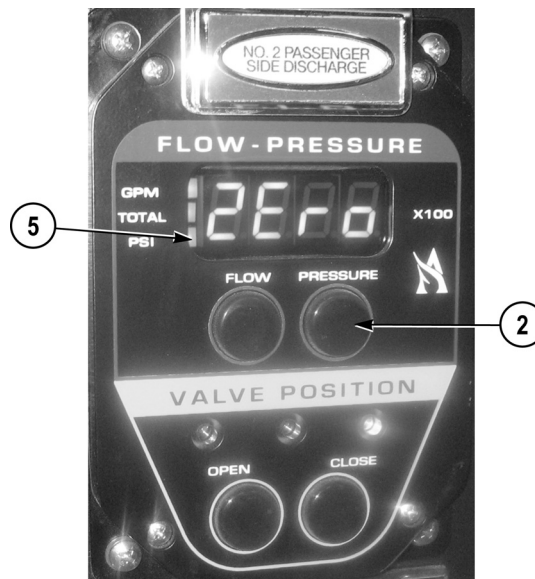
### **NOTE**

Both electric valve control meters are calibrated the same way. No. 2 passenger side discharge electric valve control meter shown.

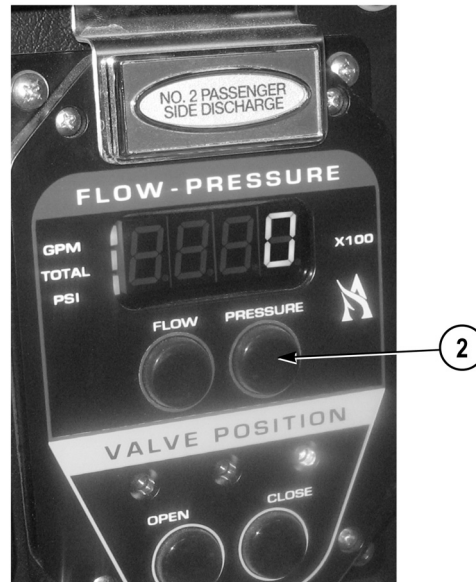
3. Push both FLOW button (1) and PRESSURE button (2) simultaneously until the display flashes CAL.
4. Release FLOW button (1) and PRESSURE button (2) and display will flash 512E (SIZE).
5. Three mode lights GPM (3), TOTAL (4), and PSI (5) will be illuminated when 512E (SIZE) flashes.



6. Push FLOW button (1) and display will flash PrE5 (PRES).



7. Push PRESSURE button (2) and display will show 2Ero (ZERO) and mode light PSI (5) will blink after pressing PRESSURE button (2).



### NOTE

- Electric valve controller is calibrated after display flashes 0.
  - After calibration, display may show number one.
8. Push PRESSURE button (2) again, and 2Ero (ZERO) will blink two to three times and display will show 0.
  9. Repeat Steps (3) through (8) if display does not show 0 or 1.
  10. Pull battery disconnect switch to off position (WP 0007).

### END OF TASK

### FOLLOW-ON MAINTENANCE

- Close pump operator's panel cover (WP 0010)

### END OF TASK

### END OF WORK PACKAGE

**FIELD LEVEL MAINTENANCE**

**PUMP OPERATOR'S PANEL FOAM LEVEL GAUGE REPLACEMENT AND CALIBRATION**

**INITIAL SETUP:**

**Tools and Special Tools**

Tool Kit, General Mechanic's: Automotive  
(WP 0398, Item 17)

**References (Continued)**

WP 0022  
WP 0391, Fig. 34

**Materials/Parts**

Deleted

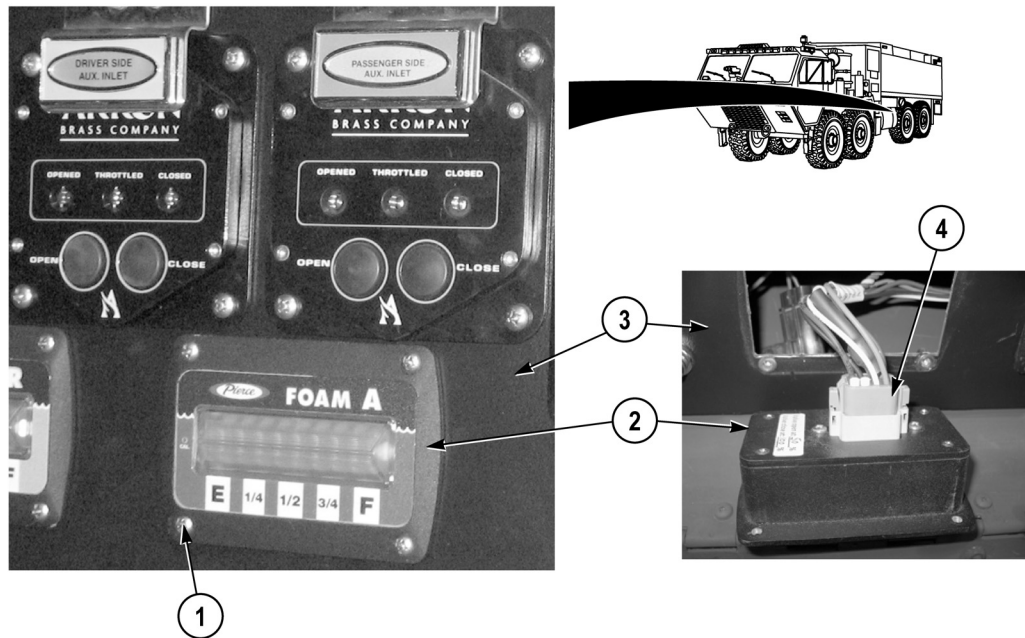
**Equipment Conditions**

Batteries disconnected (TM 9-2320-325-14&P)  
Pump operator's panel opened (WP 0010)

**References**

TM 9-2320-325-14&P  
WP 0007

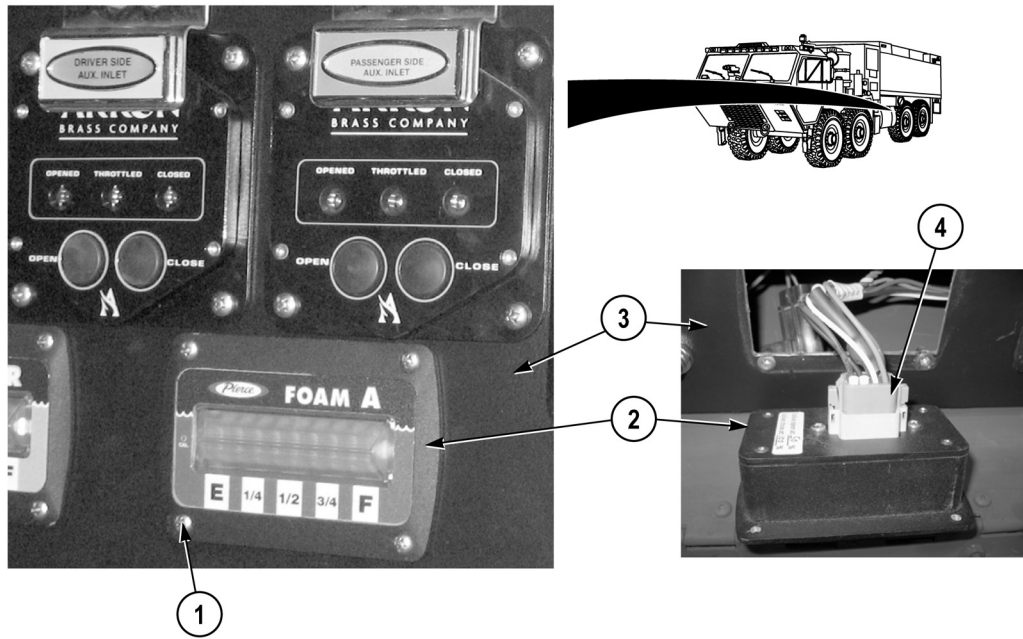
**REMOVAL**



1. Remove four screws (1) and foam level gauge (2) from pump operator's panel (3).
2. Disconnect cab pump control wire harness connector (4) from foam level gauge (2).

**END OF TASK**

## INSTALLATION



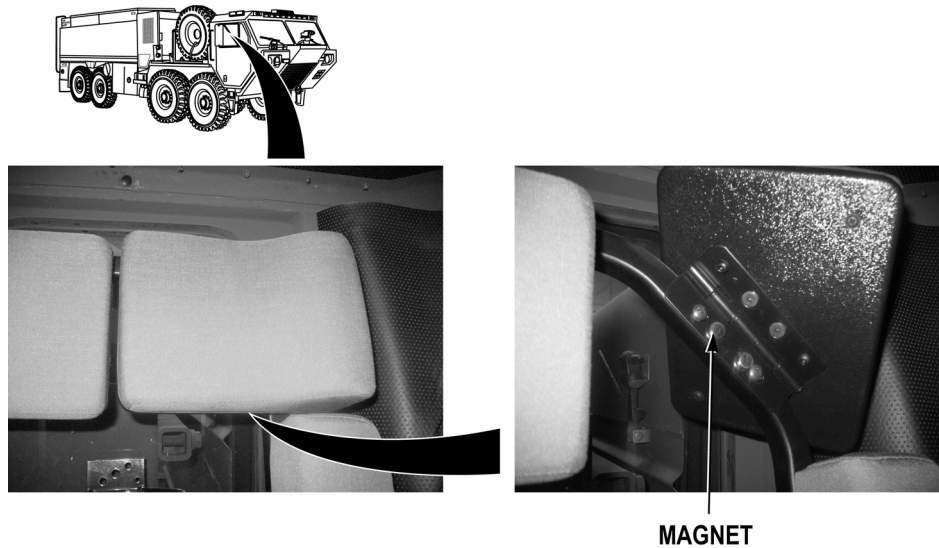
1. Connect cab pump control wire harness connector (4) on foam level gauge (2).
2. Install foam level gauge (2) on pump operator's panel (3) with four screws (1).

## END OF TASK

## CALIBRATION

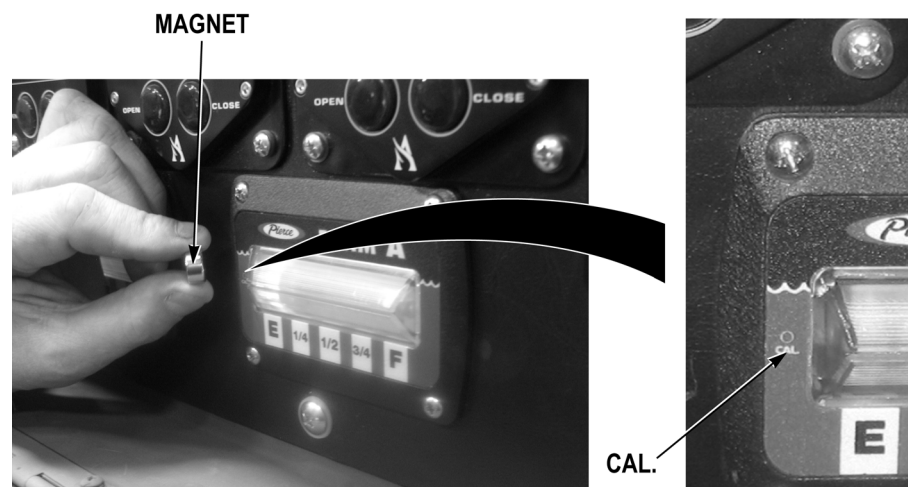
1. Connect batteries (TM 9-2320-325-14&P).
2. Push battery disconnect to on position (WP 0007).





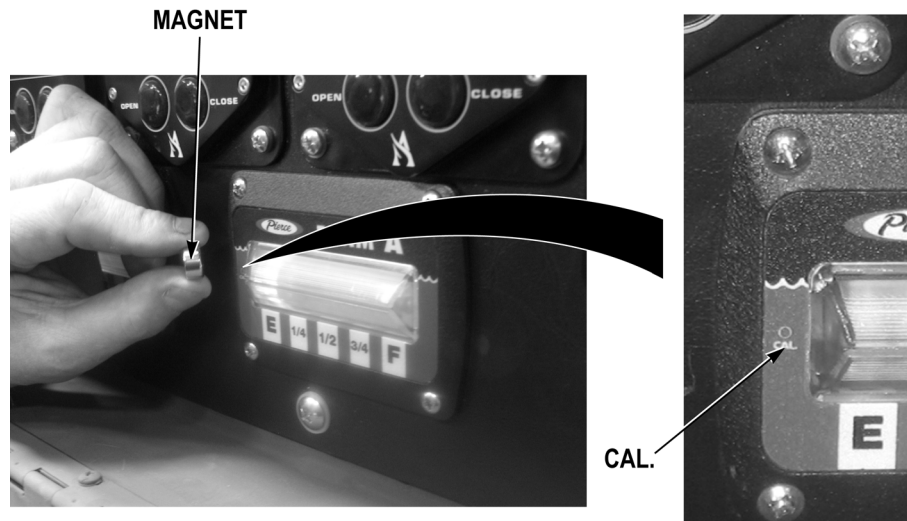
### NOTE

- Visually verify that foam tank is filled to within two inches from the top of the foam tank (WP 0022).
- The magnet used to calibrate foam level gauge is taken from behind passenger side SCBA seat headrest.



### NOTE

- The term “swipe” means to move the magnet up to and then away from CAL. located just left of the LED display on the foam level gauge. The magnet must be moved at least 1 in. (2.54 cm) away when “swiping” the sensor.
- The sensor that is activated behind CAL. is activated by the north pole of the magnet. The sensor will not respond to the south pole. Polarity of magnet can be determined by rolling magnet over a non magnetic surface and observing the side of the magnet that faces north.
- Once the calibration procedure starts, there is a six second time out. Do not wait more than six seconds to move from Step (4) to Step (5).



3. Swipe the magnet over CAL. five times to enter the calibration mode. Five right display LEDs will flash on and off.
4. After three seconds swipe the magnet five more times to set the calibration into memory. Five right display LEDs go on.
5. After six seconds the calibration process will terminate and all LEDs will go on to show that foam tank is full.

#### END OF TASK

#### FOLLOW-ON MAINTENANCE

1. Push battery disconnect to off position (WP 0007)
2. Close pump operator's panel cover (WP 0010)

#### END OF TASK

#### END OF WORK PACKAGE

## FIELD LEVEL MAINTENANCE

## PUMP OPERATOR'S PANEL WATER LEVEL GAUGE REPLACEMENT AND CALIBRATION

## INITIAL SETUP:

**Tools and Special Tools**

Tool Kit, General Mechanic's: Automotive  
(WP 0398, Item 17)

**Materials/Parts**

Deleted

**References**

TM 9-2320-325-14&P  
WP 0007

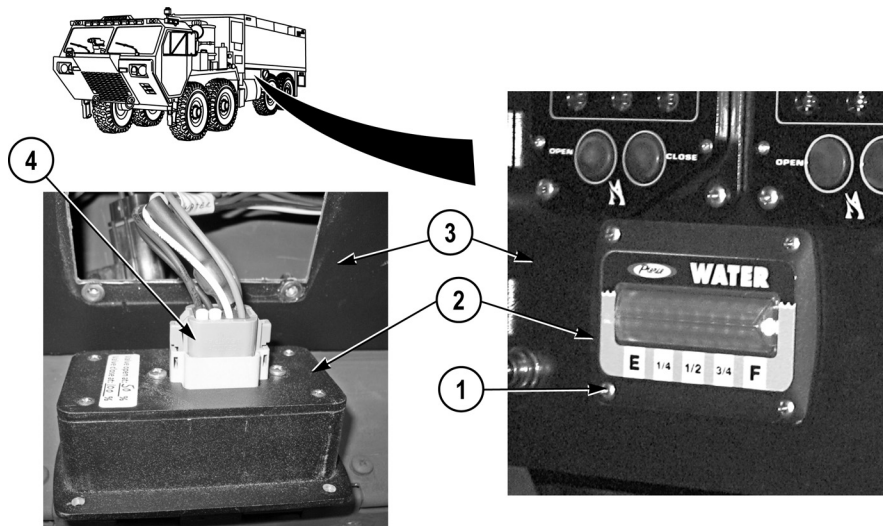
**References (Continued)**

WP 0015  
WP 0391, Fig. 34

**Equipment Conditions**

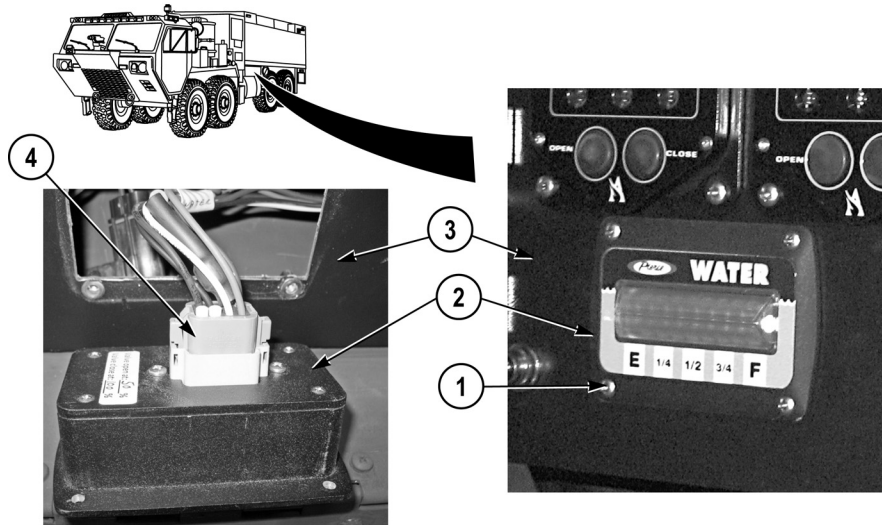
Batteries disconnected (TM 9-2320-325-14&P)  
Pump operator's panel opened (WP 0010)

## REMOVAL



1. Remove four screws (1) and water level gauge (2) from pump operator's panel (3).
2. Disconnect pump panel wire harness connector (4) from water level gauge (2).

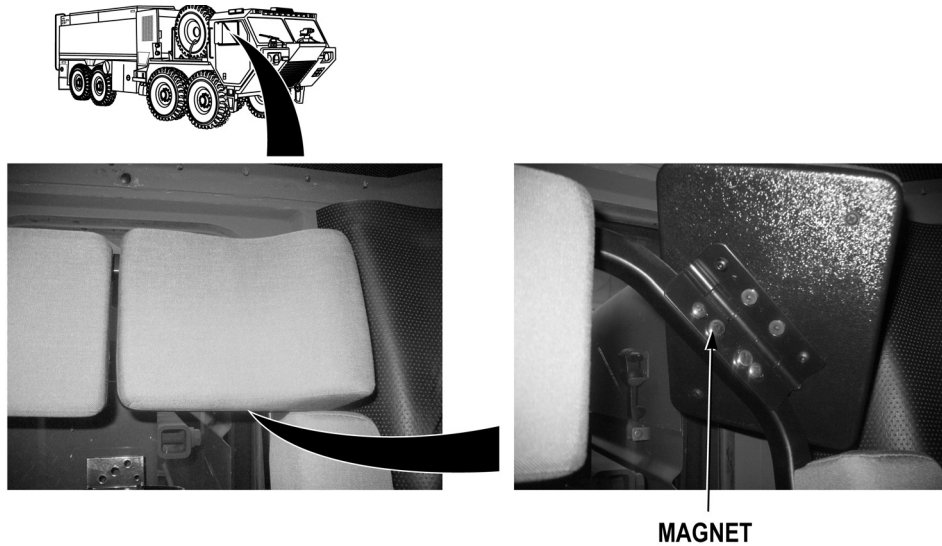
## END OF TASK

**INSTALLATION**

1. Connect pump panel wire harness connector (4) on water level gauge (2).
2. Install water level gauge (2) on pump operator's panel (3) with four screws (1).

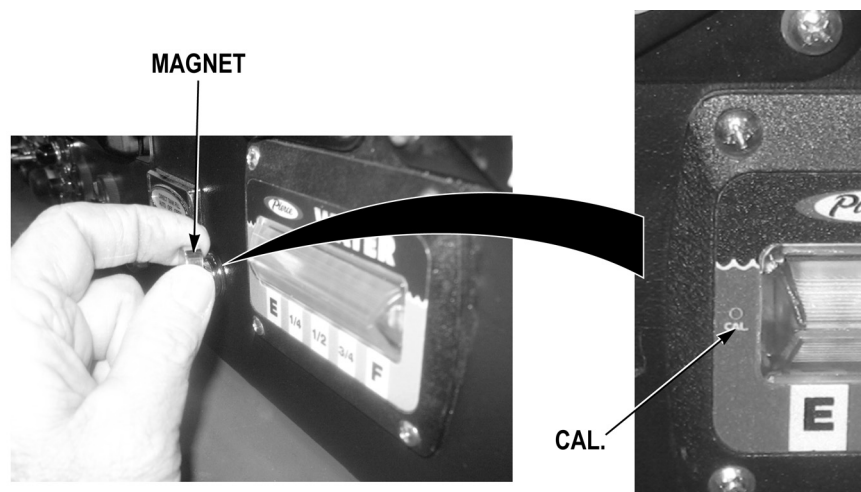
**END OF TASK****CALIBRATION**

1. Connect batteries (TM 9-2320-325-14&P).
2. Push battery disconnect to on position (WP 0007).



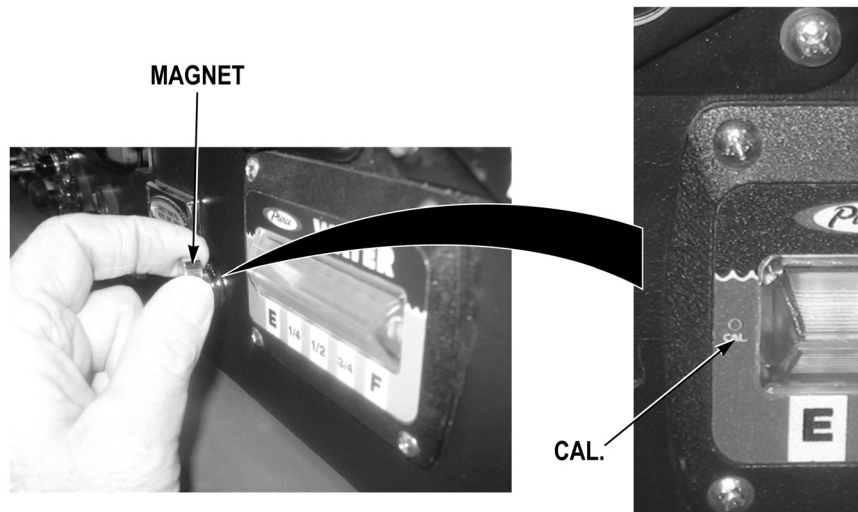
### NOTE

- Visually verify that water tank is filled to within two inches from the top of the water tank (WP 0015).
- The magnet used to calibrate water level gauge is taken from behind passenger side SCBA seat headrest.



### NOTE

- The term “swipe” means to move the magnet up to and then away from CAL. located just left of the LED display on the water level gauge. The magnet must be moved at least 1 in. (2.54 cm) away when “swiping” the sensor.
- The sensor that is activated behind CAL. is activated by the north pole of the magnet. The sensor will not respond to the south pole. Polarity of magnet can be determined by rolling magnet over a non magnetic surface and observing the side of the magnet that faces north.
- Once the calibration procedure starts, there is a six second time out. Do not wait more than six seconds to move from Step (4) to Step (5).



3. Swipe the magnet over CAL. five times to enter the calibration mode. Five right display LEDs will flash on and off.
4. After three seconds swipe the magnet five more times to set the calibration into memory. Five right display LEDs go on.
5. After six seconds the calibration process will terminate and all LEDs will go on to show that water tank is full.

#### **FOLLOW-ON MAINTENANCE**

1. Push battery disconnect to off position (WP 0007)
2. Close pump operator's panel cover (WP 0010)

#### **END OF TASK**

#### **END OF WORK PACKAGE**

## FIELD LEVEL MAINTENANCE

## PUMP OPERATOR'S PANEL INDICATOR REPLACEMENT

## INITIAL SETUP:

**Tools and Special Tools**

Tool Kit, General Mechanic's: Automotive  
(WP 0398, Item 17)

**References**

WP 0391, Fig. 34

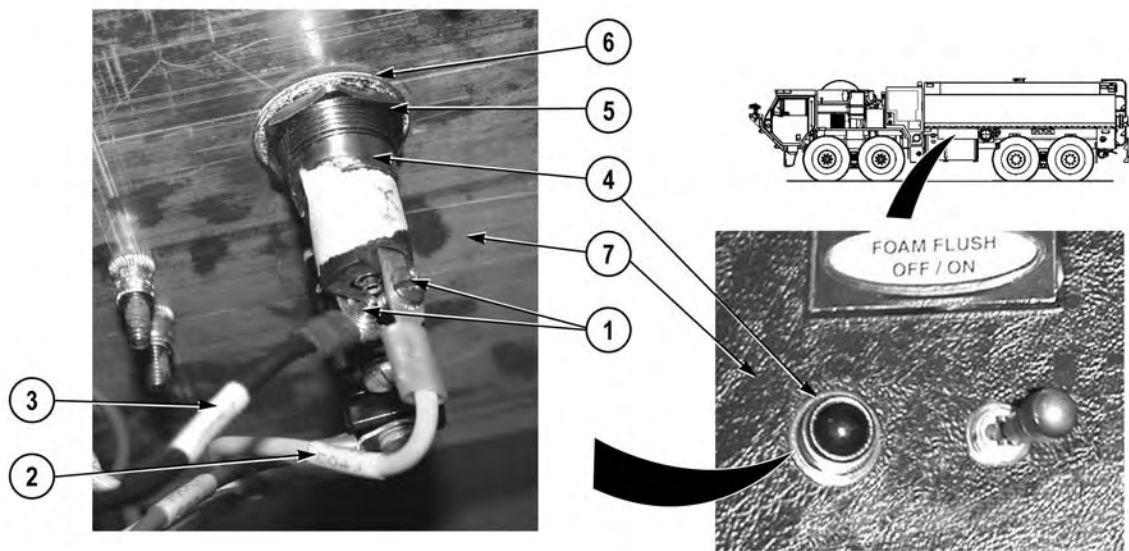
**Materials/Parts**

Tags, Identification (WP 0400, Item 23)  
Compound, Sealing (WP 0400, Item 10)  
Lockwasher (1)

**Equipment Conditions**

Pump operator's panel opened (WP 0207)

## REMOVAL

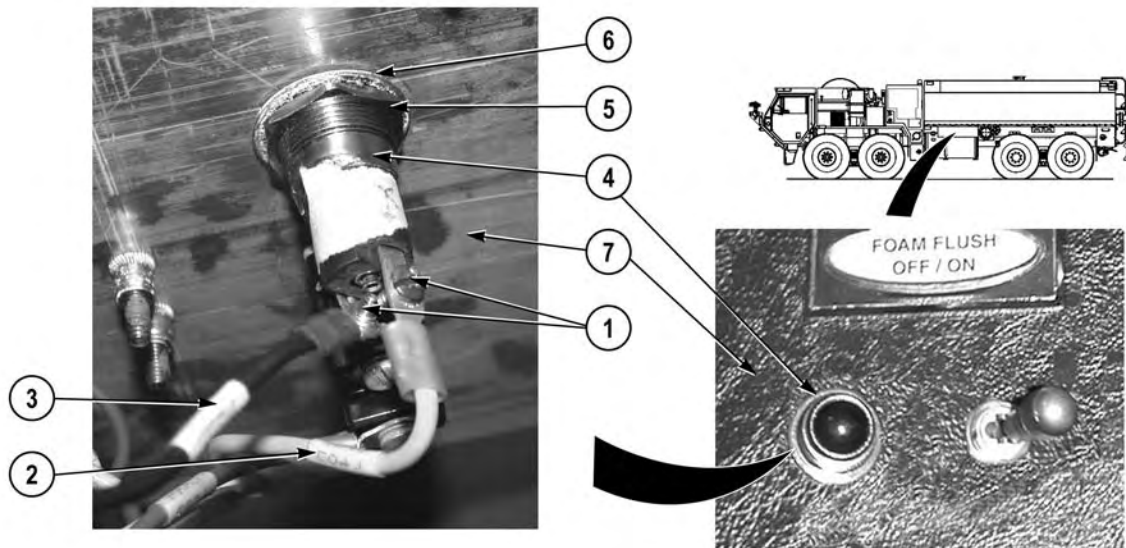
**NOTE**

- Tag and mark wires prior to removal to ensure proper installation.
- All indicators are removed the same way. Foam flush indicator shown.

1. Remove two screws (1), wire 3895 (2), and wire 2849 (3) from indicator (4).
2. Remove nut (5), lockwasher (6), and indicator (4) from pump operator's panel (7). Discard lockwasher.

**END OF TASK**

## INSTALLATION



### NOTE

All indicators are installed the same way. Foam flush indicator shown.

1. Install indicator (4) on pump operator's panel (7) with lockwasher (6) and nut (5).
2. Install wire 2849 (3) and wire 3895 (2) on indicator (4) with two screws (1).

### WARNING



**Adhesives, solvents, and sealing compounds can burn easily, can give off harmful vapors, and are harmful to skin and clothing. To avoid injury or death, keep away from open fire and use in well-ventilated area. If adhesive, solvent, or sealing compound gets on skin or clothing, wash immediately with soap and water.**

3. Apply sealing compound to ends of wire 2849 (3) and wire 3895 (2).

### END OF TASK

### FOLLOW-ON MAINTENANCE

Close pump operator's panel (WP 0207)

### END OF TASK

### END OF WORK PACKAGE



## FIELD LEVEL MAINTENANCE

## PUMP OPERATOR'S PANEL INDICATOR LAMP REPLACEMENT

## INITIAL SETUP:

**Tools and Special Tools**

Tool Kit, General Mechanic's: Automotive  
(WP 0398, Item 17)

**References**

WP 0391, Fig. 34

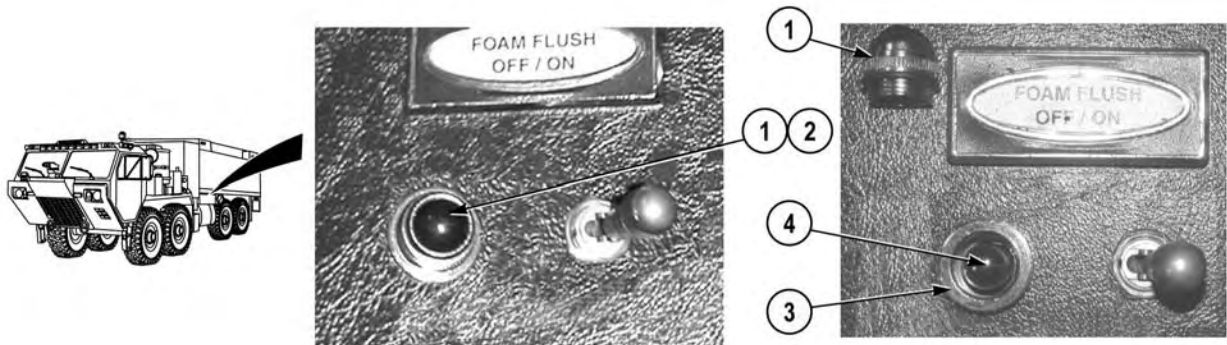
**Materials/Parts**

Preformed Packing (1)

**Equipment Conditions**

Pump operator's panel opened (WP 0207)

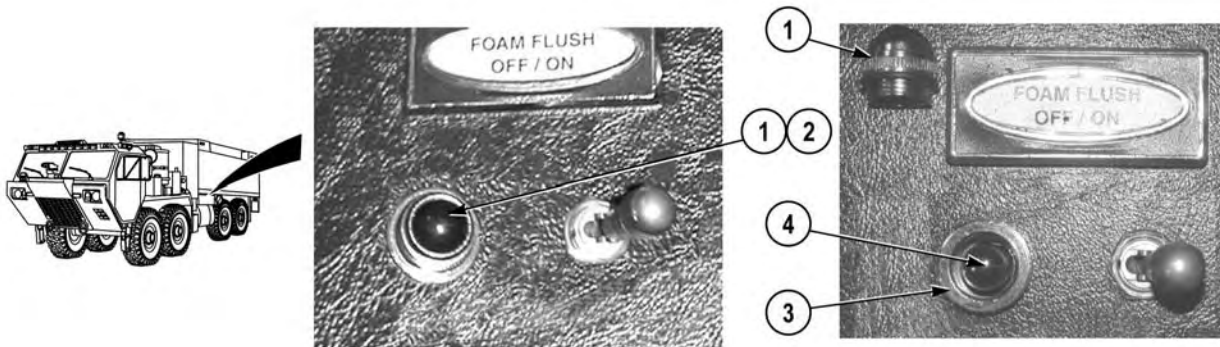
## REMOVAL

**NOTE**

All pump operator's panel indicator lamps are removed the same way. Foam/flush indicator lamp shown.

1. Remove lamp cover (1) and preformed packing (2) from indicator light (3). Discard preformed packing.
2. Remove indicator lamp (4) from indicator light (3).

**END OF TASK**

**INSTALLATION****NOTE**

All pump operator's panel indicator lamps are installed the same way. Foam/flush indicator lamp shown.

1. Install indicator lamp (4) in indicator light (3).
2. Install preformed packing (2) and lamp cover (1) on indicator light (3).

**END OF TASK****FOLLOW-ON MAINTENANCE**

Close pump operator's panel (WP 0207)

**END OF TASK****END OF WORK PACKAGE**

## FIELD LEVEL MAINTENANCE

## STRIPLIGHT REPLACEMENT

## INITIAL SETUP:

**Tools and Special Tools**

Tool Kit, General Mechanic's: Automotive  
(WP 0398, Item 17)

**References**

WP 0391, Fig. 62

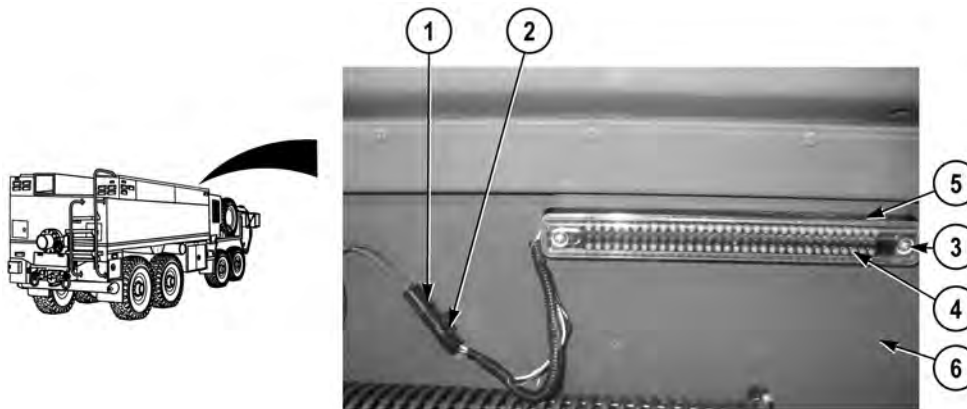
**Materials/Parts**

Tags, Identification (WP 0400, Item 23)  
Ties, Cable, Plastic (WP 0400, Item 26)  
Lockwasher (4)

**Equipment Conditions**

Batteries disconnected (TM 9-2320-325-14&P)  
Compartment door opened (WP 0008)

## REMOVAL

**NOTE**

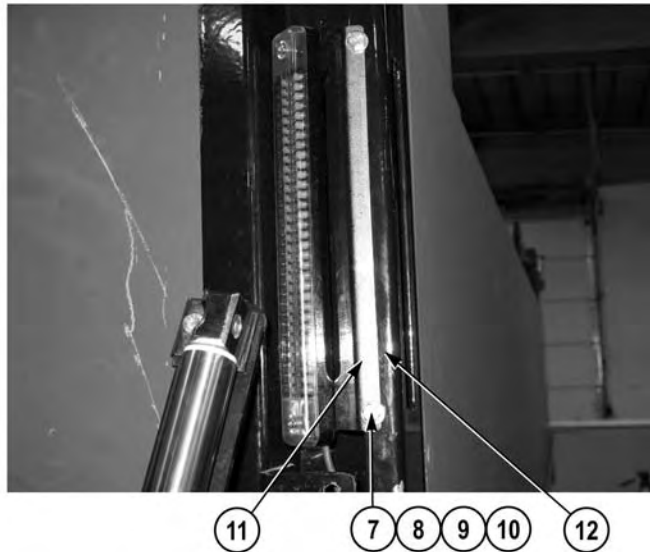
- Tag and mark wires prior to removal to ensure proper installation.
- Remove cable ties as required.
- All striplights except pump operator's panel are removed the same way. Top stowage compartment striplight shown.
- Pump operator's panel striplights have connectors.

1. Disconnect connector (1) from connector (2).

**NOTE**

Striplight and cover are removed as an assembly.

2. Remove two screws (3), cover (4), and striplight (5) from stowage compartment box (6).



### NOTE

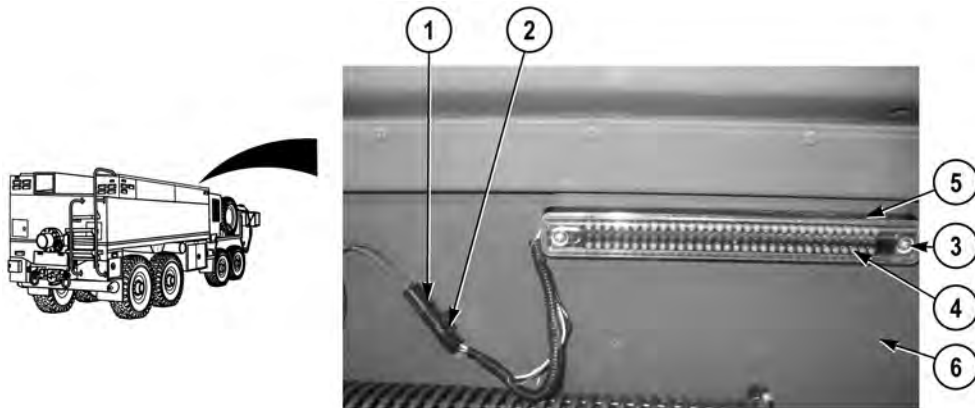
- Perform Step (3) if striplight bracket needs to be removed.
  - All striplight brackets are removed the same way. Top driver side pump house bracket shown.
  - Number of screws, washers, lockwashers, and nuts may vary.
3. Remove four nuts (7), lockwashers (8), eight washers (9), four screws (10), and striplight bracket (11) from pump house frame (12). Discard lockwashers.

### END OF TASK

### INSTALLATION

### NOTE

- Perform Step (1) if striplight bracket was removed.
  - All striplight brackets are installed the same way. Top driver side pump house bracket shown.
  - Number of screws, washers, lockwashers, and nuts may vary.
1. Install striplight bracket (11) on pump house frame (12) with four screws (10), eight washers (9), four lockwashers (8), and nuts (7).



### NOTE

- All striplights except pump operator's panel are installed the same way. Top stowage compartment striplight shown.
- Pump operator's panel has connectors.
- Install cable ties as required.
- Striplight and cover are installed as an assembly.

2. Install striplight (5) and cover (4) on stowage compartment box (6) with two screws (3).
3. Connect connector (1) to connector (2).

### END OF TASK

### FOLLOW-ON MAINTENANCE

1. Connect batteries (TM 9-2320-325-14&P)
2. Close compartment door (WP 0008)

### END OF TASK

### END OF WORK PACKAGE



## FIELD LEVEL MAINTENANCE

## PUMP OPERATOR'S PANEL PRESSURE GOVERNOR CONTROL REPLACEMENT

## INITIAL SETUP:

**Tools and Special Tools**

Tool Kit, General Mechanic's: Automotive  
(WP 0398, Item 17)

**References**

WP 0391, Fig. 34

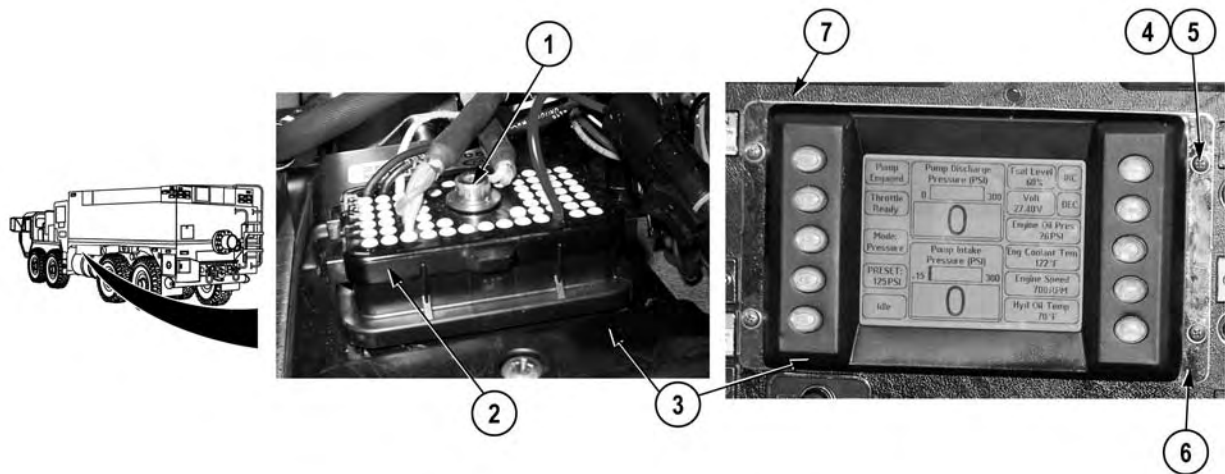
**Materials/Parts**

Lockwasher (2)

**Equipment Conditions**

Pump operator's panel opened (WP 0207)

## REMOVAL



1. Loosen screw (1) and disconnect pressure governor control connector (2) from pressure governor control (3).

**NOTE**

Note orientation of pressure governor control prior to removal to ensure proper installation.

2. Remove four screws (4), washers (5), pressure governor control (3), and mounting bezel (6) from pump operator's panel (7).

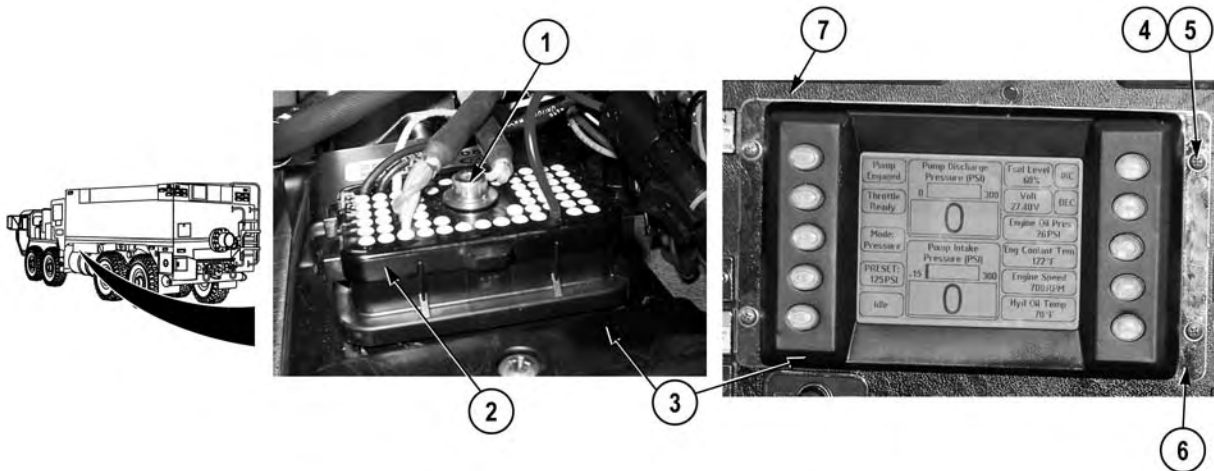


3. Remove two screws (8), lockwashers (9), and mounting bezel (6) from pressure governor control (3). Discard lockwashers.

**END OF TASK**

**INSTALLATION**

1. Install mounting bezel (6) on pressure governor control (3) with two lockwashers (9) and screws (8).



**NOTE**

Install pressure governor control in same orientation as noted prior to removal.

2. Install mounting bezel (6) and pressure governor control (3) on pump operator's panel (7) with four washers (5) and screws (4).
3. Install pressure governor control connector (2) on pressure governor control (3).
4. Tighten screw (1) on pressure governor control connector (2).

**END OF TASK**



**FOLLOW-ON MAINTENANCE**

Close pump operator's panel (WP 0207)

**END OF TASK**

**END OF WORK PACKAGE**



## FIELD LEVEL MAINTENANCE

## CAB HIGH IDLE SWITCH AND INDICATOR REPLACEMENT

## INITIAL SETUP:

**Tools and Special Tools**

Tool Kit, General Mechanic's: Automotive  
(WP 0398, Item 17)

**References**

WP 0391, Fig. 34

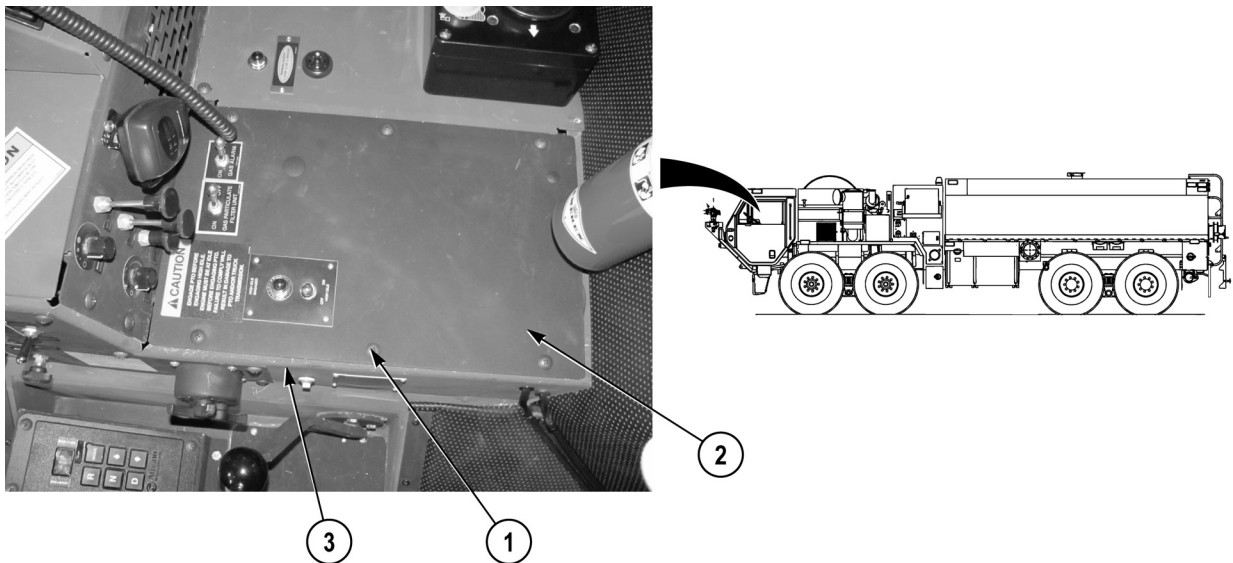
**Materials/Parts**

Compound, Sealing (WP 0400, Item 10)  
Tags, Identification (WP 0400, Item 23)

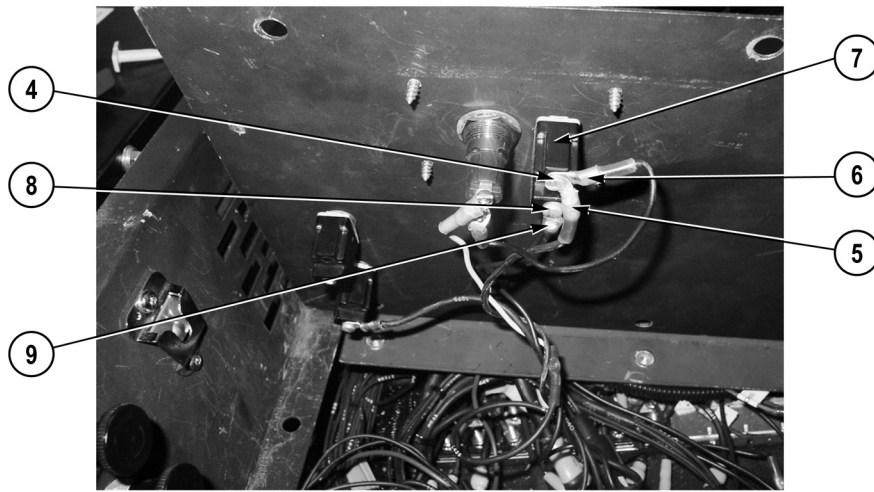
**Equipment Conditions**

Batteries disconnected (TM 9-2320-325-14&P)

## REMOVAL



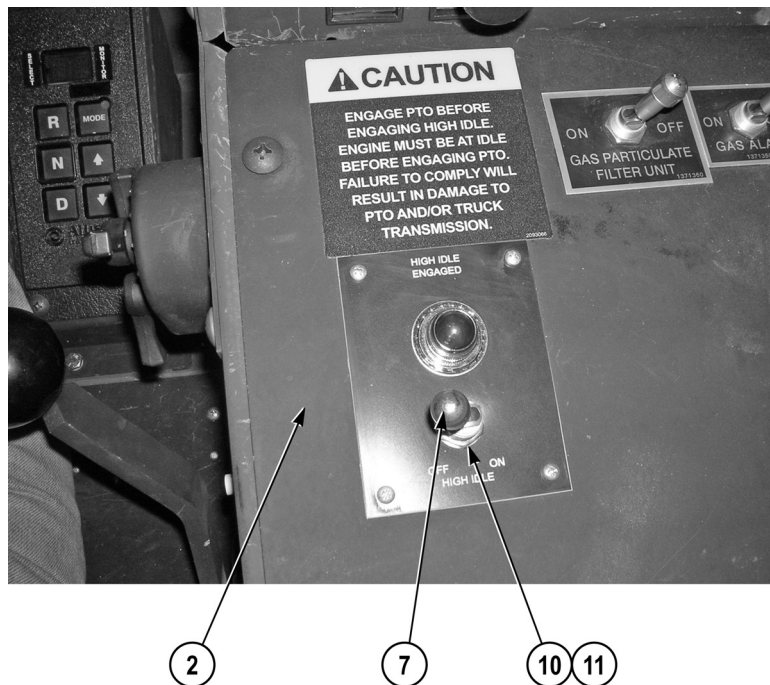
1. Remove six screws (1) and panel (2) from center console (3).



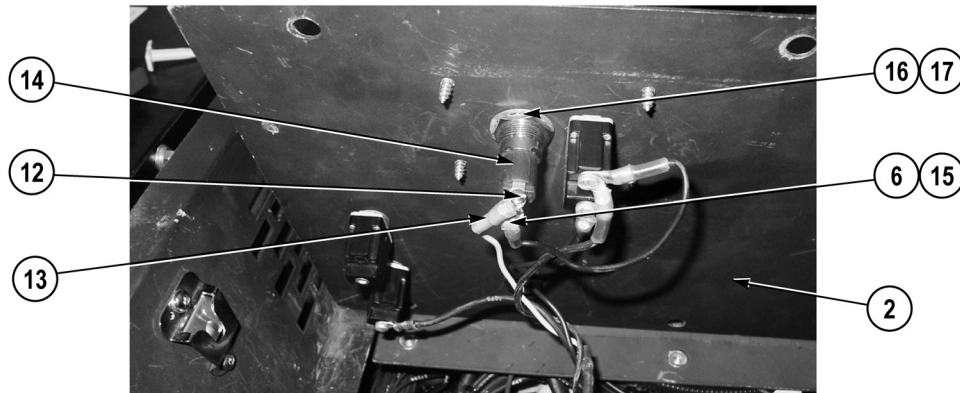
**NOTE**

- Tag and mark wires prior to removal to ensure proper installation.
- Perform Steps (2) through (4) for high idle engage switch replacement.

2. Remove screw (4), wire 1840 (5), and jumperwire (6) from high idle engage switch (7).
3. Remove screw (8) and power wire (9) from high idle engage switch (7).



4. Remove nut (10), washer (11), and high idle engage switch (7) from panel (2).



### NOTE

- Tag and mark wires prior to removal to ensure proper installation.
- Perform Steps (5) through (7) for high idle engage indicator replacement.

5. Remove screw (12) and wire 1435 (13) from indicator (14).
6. Remove screw (15) and jumperwire (6) from indicator (14).
7. Remove nut (16), washer (17), and indicator (14) from panel (2).

### END OF TASK

### INSTALLATION

### NOTE

Perform Steps (1) through (4) for high idle engage indicator installation.

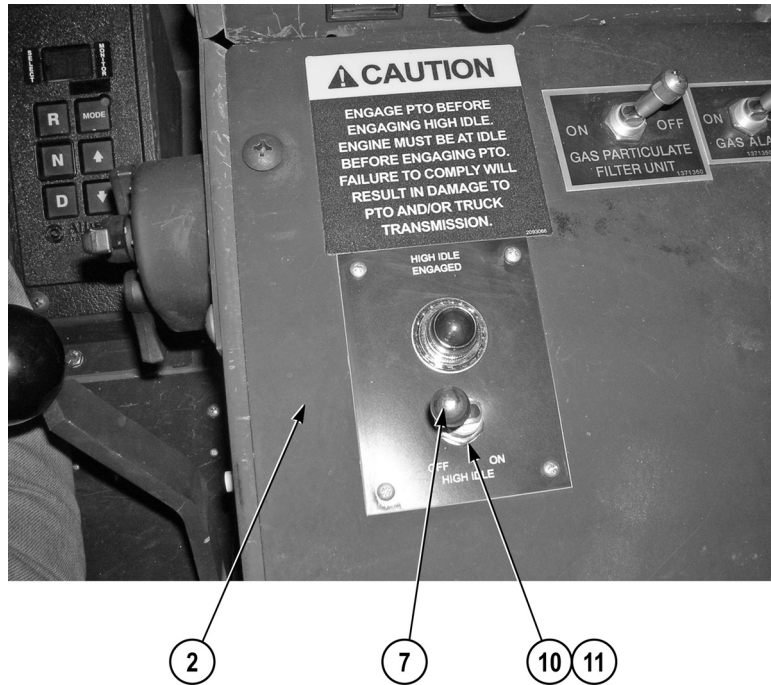
1. Install indicator (14) on panel (2) with washer (17) and nut (16).
2. Install jumperwire (6) on indicator (14) with screw (15).
3. Install wire 1435 (13) on indicator (14) with screw (12).

### WARNING

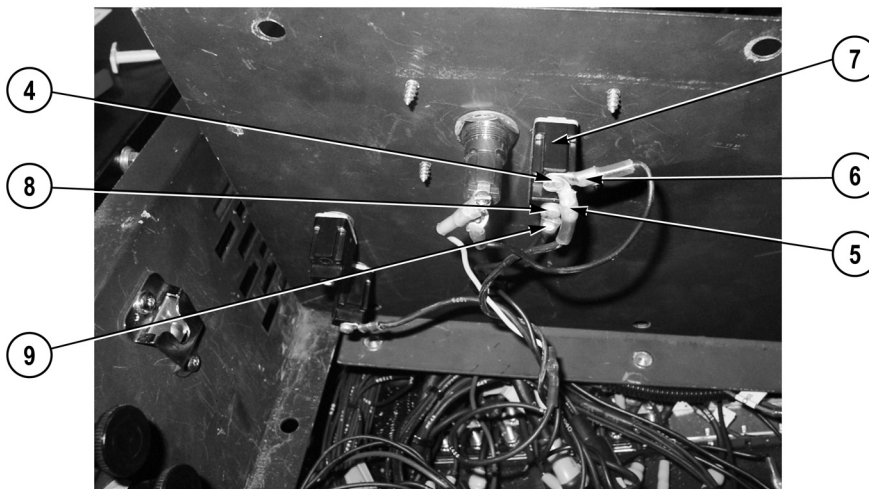


**Adhesives, solvents, and sealing compounds can burn easily, can give off harmful vapors, and are harmful to skin and clothing. To avoid injury or death, keep away from open fire and use in well-ventilated area. If adhesive, solvent, or sealing compound gets on skin or clothing, wash immediately with soap and water.**

4. Apply sealing compound to thread of two screws (15) and (12).



5. Install high idle engage switch (7) on panel (2) with washer (11) and nut (10).

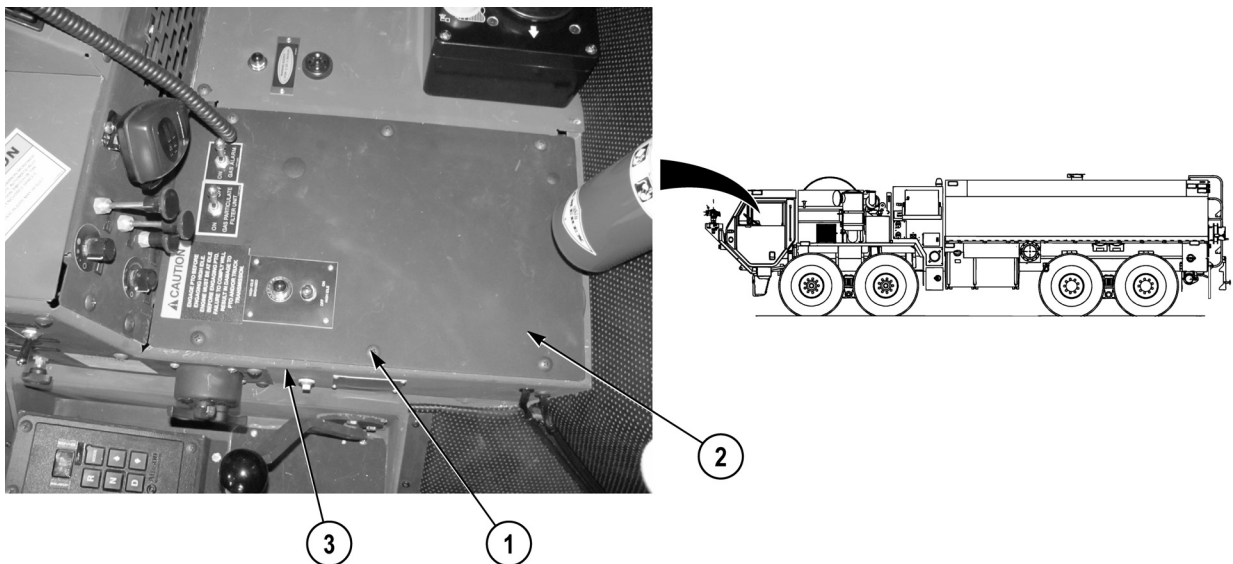


6. Install power wire (9) on high idle engage switch (7) with screw (8).
7. Install jumperwire (6) and wire 1840 (5) on high idle engage switch (7) with screw (4).

**WARNING**

Adhesives, solvents, and sealing compounds can burn easily, can give off harmful vapors, and are harmful to skin and clothing. To avoid injury or death, keep away from open fire and use in well-ventilated area. If adhesive, solvent, or sealing compound gets on skin or clothing, wash immediately with soap and water.

8. Apply sealing compound to threads of two screws (8) and (4).



9. Install panel (2) on center console (3) with six screws (1).

**END OF TASK**

**FOLLOW-ON MAINTENANCE**

Connect batteries (TM 9-2320-325-14&P)

**END OF TASK**

**END OF WORK PACKAGE**





## FIELD LEVEL MAINTENANCE

## PUMP OPERATOR'S PANEL OVERHEAT TEST BUTTON AND INDICATOR REPLACEMENT

## INITIAL SETUP:

**Tools and Special Tools**

Tool Kit, General Mechanic's: Automotive  
(WP 0398, Item 17)

**References**

TM 9-2320-325-14&P  
WP 0391, Fig. 34

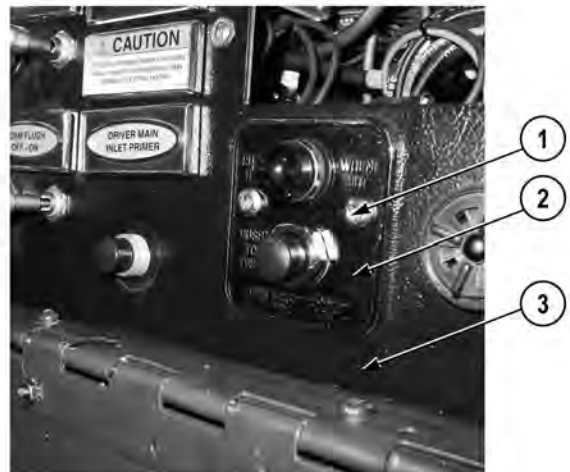
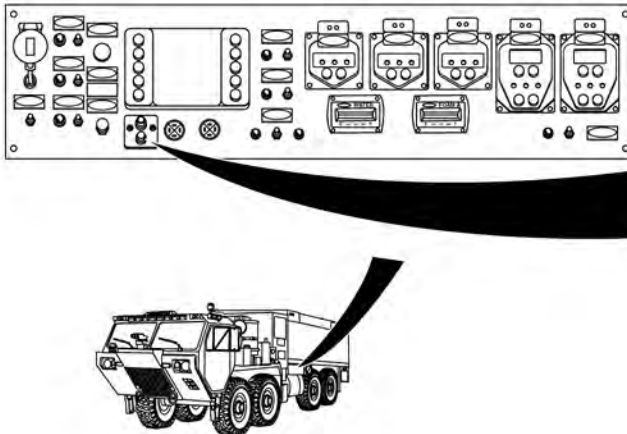
**Materials/Parts**

Compound, Sealing (WP 0400, Item 10)  
Tags, Identification (WP 0400, Item 23)  
Lockwasher (1)

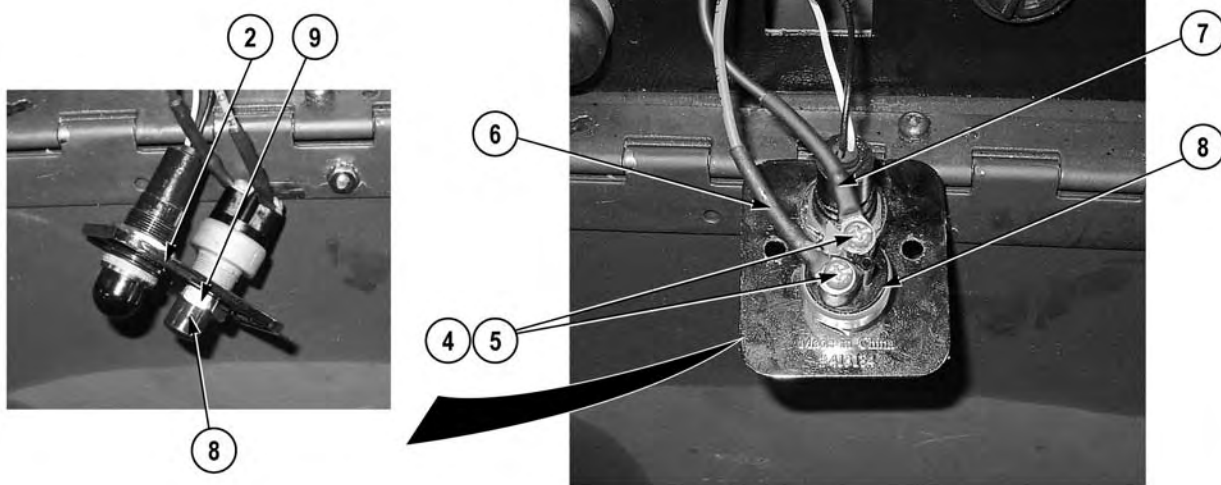
**Equipment Conditions**

Pump operator's panel cover opened (WP 0010)

## REMOVAL



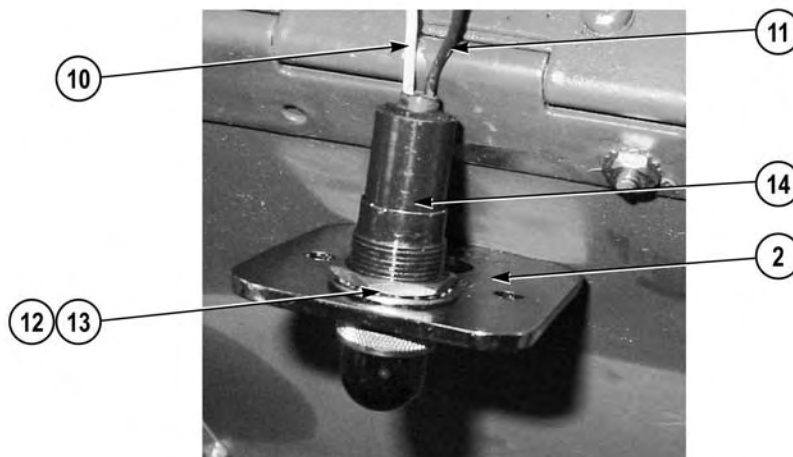
1. Remove two screws (1) and cover plate (2) from pump operator's panel (3).



**NOTE**

- Tag and mark wires prior to removal to ensure proper installation.
- Perform Steps (2) and (3) for overheated test button removal.

2. Remove two screws (4), washers (5), wire 1405, (6) and wire 4085 (7) from overheated test button (8).
3. Remove nut (9) and overheated test button (8) from cover plate (2).



**NOTE**

Perform Steps (4) and (5) for indicator removal.

4. Cut wire 1405 (10) and wire 3895 (11) (TM 9-2320-325-14&P).
5. Remove nut (12), lockwasher (13), and indicator (14) from cover plate (2). Discard lockwasher.

**END OF TASK**

---

**INSTALLATION****NOTE**

Perform Steps (1) and (2) for indicator installation.

1. Install indicator (14) on cover plate (2) with lockwasher (13) and nut (12).
2. Repair wire 3895 (11) and wire 1405 (10) (TM 9-2320-325-14&P).

**NOTE**

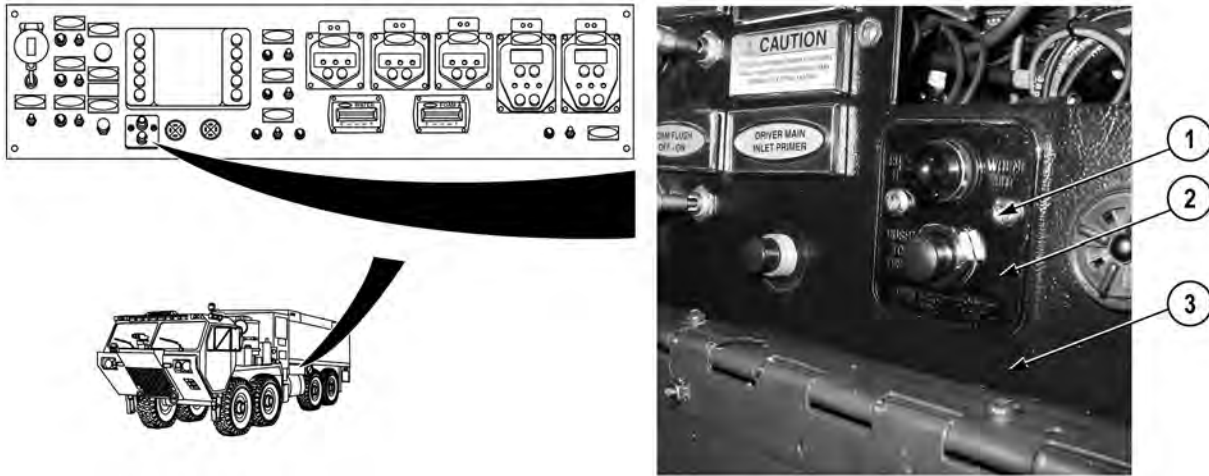
Perform Steps (3) through (5) for overheat test button installation.

3. Install overheat test button (8) on cover plate (2) with nut (9).
4. Install wire 4085 (7) and wire 1405 (6) on overheat test button (8) with two washers (5) and screws (4).

**WARNING**

**Adhesives, solvents, and sealing compounds can burn easily, can give off harmful vapors, and are harmful to skin and clothing. To avoid injury or death, keep away from open fire and use in well-ventilated area. If adhesive, solvent, or sealing compound gets on skin or clothing, wash immediately with soap and water.**

5. Apply sealing compound to ends of wire 4085 (7) and wire 1405 (6).



6. Install cover plate (2) on pump operator's panel (3) with two screws (1).

**END OF TASK**

**FOLLOW-ON MAINTENANCE**

Close pump operator's panel cover (WP 0010)

**END OF TASK**

**END OF WORK PACKAGE**

## FIELD LEVEL MAINTENANCE

## PUMP OPERATOR'S PANEL DRIVER MAIN INLET PRIMER BUTTON REPLACEMENT

## INITIAL SETUP:

**Tools and Special Tools**

Tool Kit, General Mechanic's: Automotive  
(WP 0398, Item 17)

**References**

WP 0391, Fig. 34

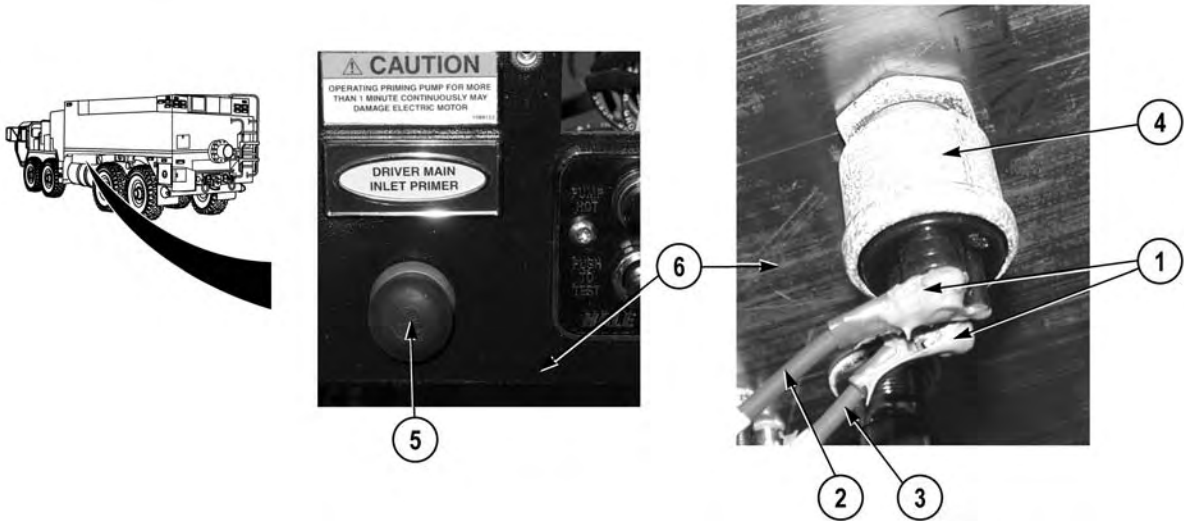
**Materials/Parts**

Compound, Sealing (WP 0400, Item 10)  
Tags, Identification (WP 0400, Item 23)  
Ties, Cable, Plastic (WP 0400, Item 26)

**Equipment Conditions**

Pump operator's panel opened (WP 0207)

## REMOVAL

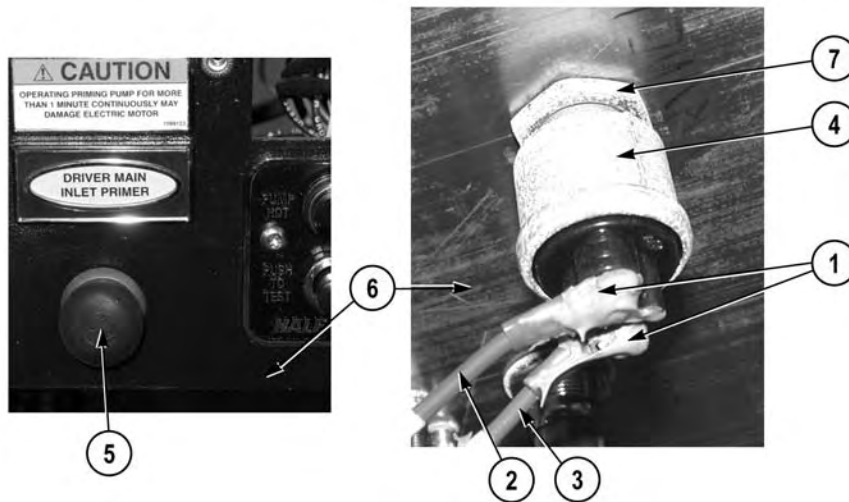
**NOTE**

- Tag and mark wires prior to removal to ensure proper installation.
- Remove cable tie as required.

1. Remove two screws (1), wire 2773 (2), and wire 1590 (3) from driver main inlet primer button (4).
2. Remove cover (5) and driver main inlet primer button (4) from pump operator's panel (6).

**END OF TASK**

## INSTALLATION



### NOTE

Adjusting nut comes with switch.

1. Adjust nut (7) on driver main inlet primer button (4).
2. Install driver main inlet primer button (4) on pump operator's panel (6) with cover (5).
3. Install wire 1590 (3) and wire 2773 (2) on driver main inlet primer button (4) with two screws (1).

### WARNING



**Adhesives, solvents, and sealing compounds can burn easily, can give off harmful vapors, and are harmful to skin and clothing. To avoid injury or death, keep away from open fire and use in well-ventilated area. If adhesive, solvent, or sealing compound gets on skin or clothing, wash immediately with soap and water.**

4. Apply sealing compound on two screws (1), wire 2773 (2), and wire 1590 (3).

**END OF TASK**

### FOLLOW-ON MAINTENANCE

Close pump operator's panel (WP 0207)

**END OF TASK**

**END OF WORK PACKAGE**

## FIELD LEVEL MAINTENANCE

## PUMP OPERATOR'S PANEL TOGGLE SWITCH (TWO-POSITION) REPLACEMENT

## INITIAL SETUP:

**Tools and Special Tools**

Tool Kit, General Mechanic's: Automotive  
(WP 0398, Item 17)

**References**

WP 0391, Fig. 34

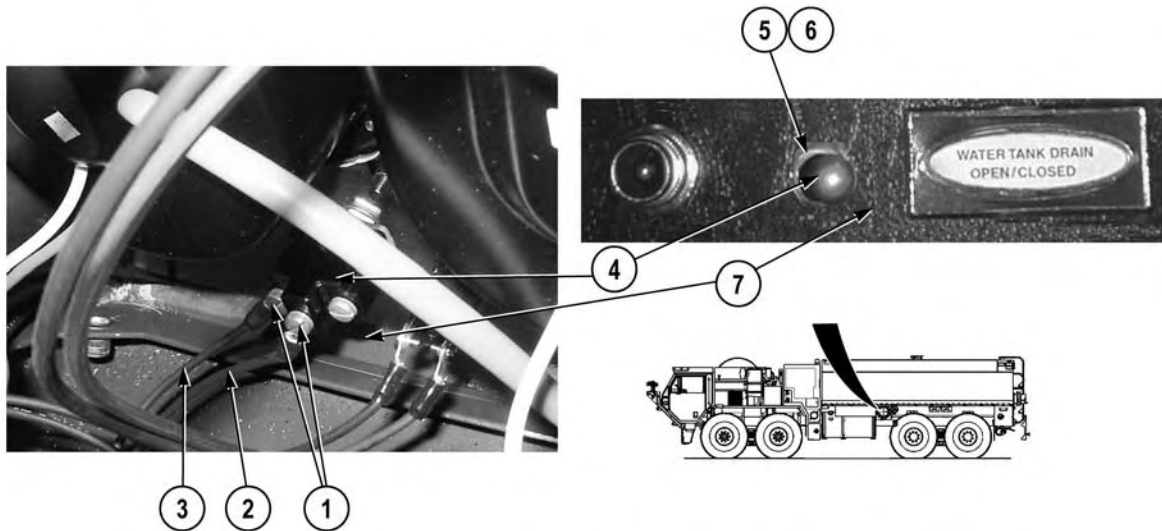
**Materials/Parts**

Tags, Identification (WP 0400, Item 23)  
Compound, Sealing (WP 0400, Item 10)

**Equipment Conditions**

Pump operator's panel opened (WP 0207)

## REMOVAL

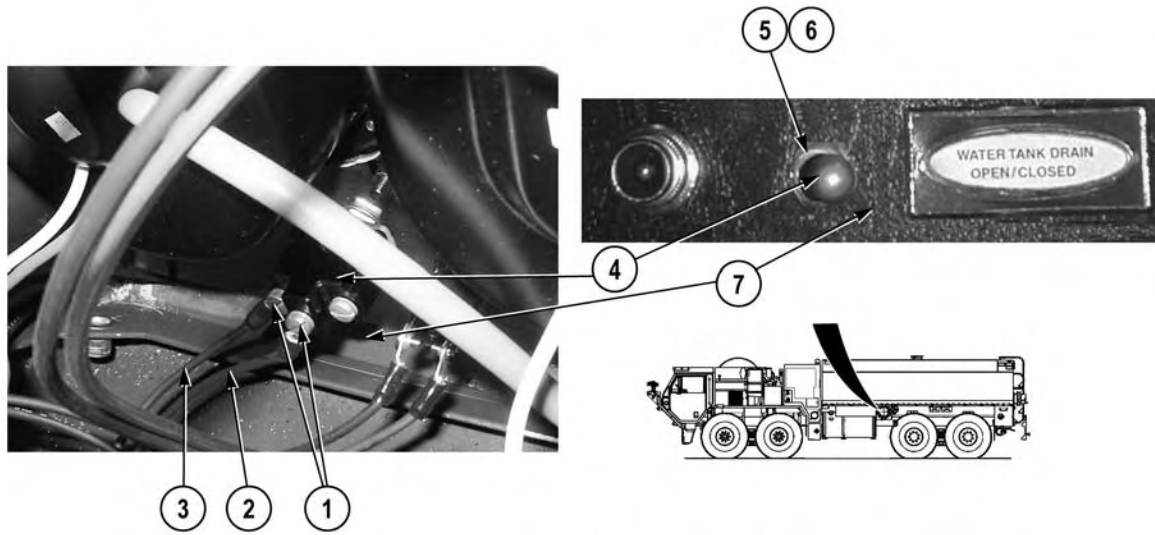
**NOTE**

- All two-position toggle switches are removed the same way. WATER TANK DRAIN two-position toggle switch shown.
- Note position of two-position toggle switch prior to removal to ensure proper installation.
- Tag and mark wires prior to removal to ensure proper installation.

1. Remove two screws (1), wire 2834 (2), and wire 4053 (3) from two-position toggle switch (4).
2. Remove nut (5), washer (6), and two-position toggle switch (4) from pump panel (7).

**END OF TASK**

## INSTALLATION



### NOTE

All two-position toggle switches are installed the same way.

1. Install two-position toggle switch (4) on pump panel (7) with washer (6) and nut (5).
2. Install wire 4053 (3) and wire 2834 (2) on toggle switch (4) with two screws (1).

### WARNING



**Adhesives, solvents, and sealing compounds can burn easily, can give off harmful vapors, and are harmful to skin and clothing. To avoid injury or death, keep away from open fire and use in well-ventilated area. If adhesive, solvent, or sealing compound gets on skin or clothing, wash immediately with soap and water.**

3. Apply sealing compound to ends of wire 4053 (3) and wire 2834 (2).

**END OF TASK**

### FOLLOW-ON MAINTENANCE

Close pump operator's panel (WP 0207)

**END OF TASK**

**END OF WORK PACKAGE**



## FIELD LEVEL MAINTENANCE

## PUMP OPERATOR'S PANEL TOGGLE SWITCH (THREE-POSITION) REPLACEMENT

## INITIAL SETUP:

**Tools and Special Tools**

Tool Kit, General Mechanic's: Automotive  
(WP 0398, Item 17)

**Materials/Parts**

Compound, Sealing (WP 0400, Item 10)  
Tags, Identification (WP 0400, Item 23)  
Ties, Cable, Plastic (WP 0400, Item 26)

**Materials/Parts (continued)**

Lockwasher (3)

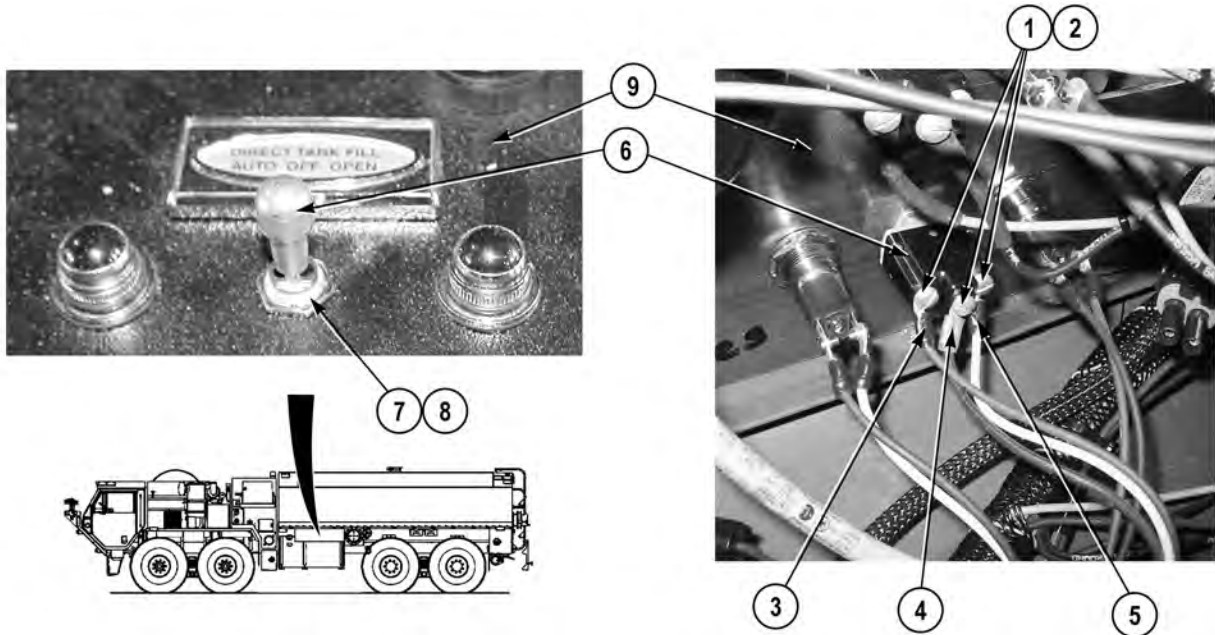
**References**

WP 0391, Fig. 34

**Equipment Conditions**

Pump operator's panel opened (WP 0207)

## REMOVAL

**NOTE**

- Tag and mark wires prior to removal to ensure proper installation.
- Remove cable ties as required.

1. Remove three screws (1), lockwashers (2), wire 2316 (3), wire 2314 (4), and wire 2315 (5) from three-position toggle switch (6). Discard lockwashers.

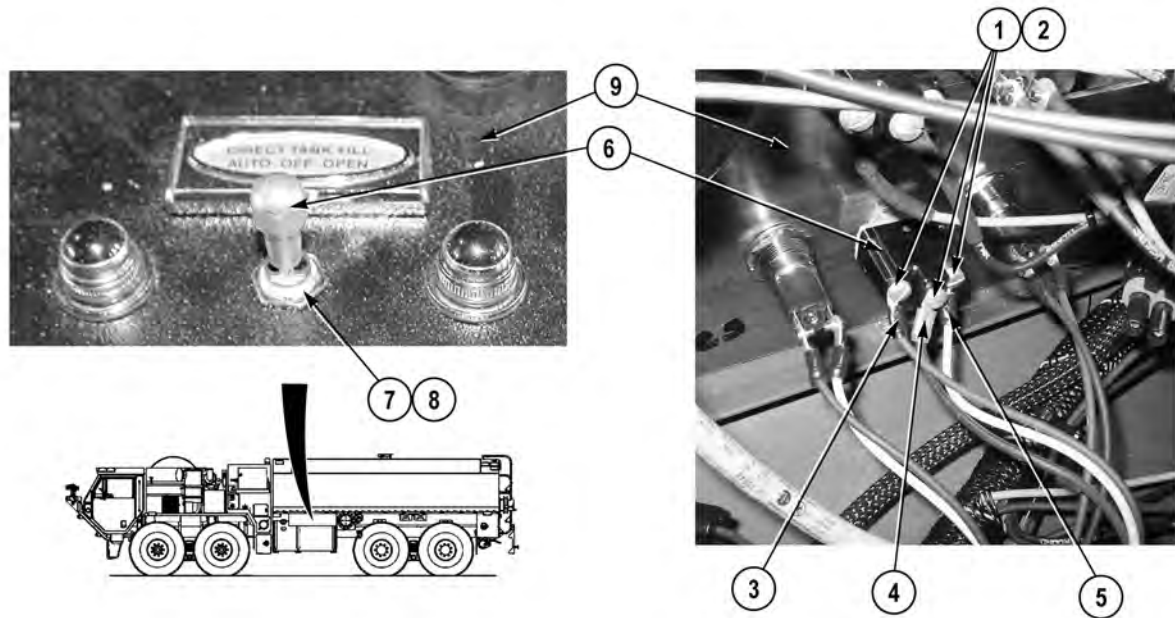
**NOTE**

Note position of three-position toggle switch prior to removal to ensure proper installation.

2. Remove nut (7), washer (8), and three-position toggle switch (6) from pump operator's panel (9).

**END OF TASK**

## INSTALLATION

**NOTE**

- Install three-position toggle switch as noted prior to removal.
  - Install cable ties as required.
1. Install three-position toggle switch (6) on pump operator's panel (9) with washer (8) and nut (7).
  2. Install wire 2315 (5), wire 2314 (4), and wire 2316 (3) on three-position toggle switch (6) with three lockwashers (2) and screws (1).

**WARNING**

**Adhesives, solvents, and sealing compounds can burn easily, can give off harmful vapors, and are harmful to skin and clothing. To avoid injury or death, keep away from open fire and use in well-ventilated area. If adhesive, solvent, or sealing compound gets on skin or clothing, wash immediately with soap and water.**

3. Apply sealing compound to three screws (1), lockwashers (2), wire 2316 (3), wire 2314 (4), and wire 2315 (5).

**END OF TASK****FOLLOW-ON MAINTENANCE**

Close pump operator's panel (WP 0207)

**END OF TASK****END OF WORK PACKAGE**

---

**FIELD LEVEL MAINTENANCE**  
**PUMP PRIMER MOTOR DIODE PACK REPLACEMENT**

---

**INITIAL SETUP:****Tools and Special Tools**

Tool Kit, General Mechanic's: Automotive  
(WP 0398, Item 17)

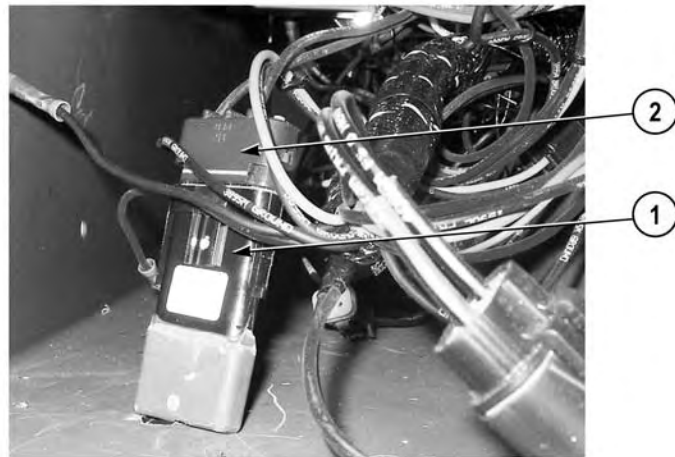
**Equipment Conditions**

Pump operator's panel opened (WP 0207)

**References**

WP 0391, Fig. 56

---

**REMOVAL**

Remove diode (1) from diode connector (2).

**END OF TASK****INSTALLATION**

Install diode (1) on diode connector (2).

**END OF TASK****FOLLOW-ON MAINTENANCE**

Close pump operator's panel (WP 0207)

**END OF TASK****END OF WORK PACKAGE**



## FIELD LEVEL MAINTENANCE

## CAB CLEARANCE LIGHTS AND BRACKET REPLACEMENT

## INITIAL SETUP:

**Tools and Special Tools**

Tool Kit, General Mechanic's: Automotive  
(WP 0398, Item 17)

**References**

WP 0391, Fig. 27, 28

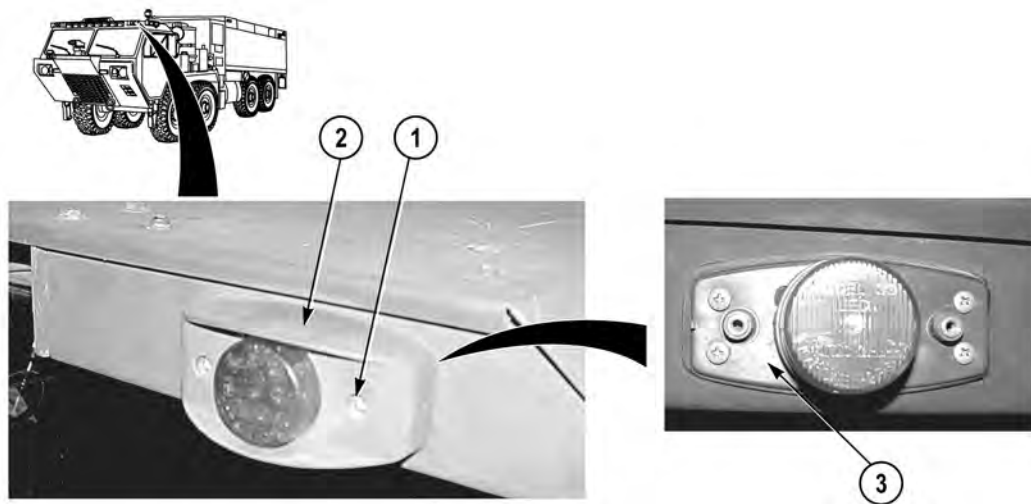
**Materials/Parts**

Locknut (4)

**Equipment Conditions**

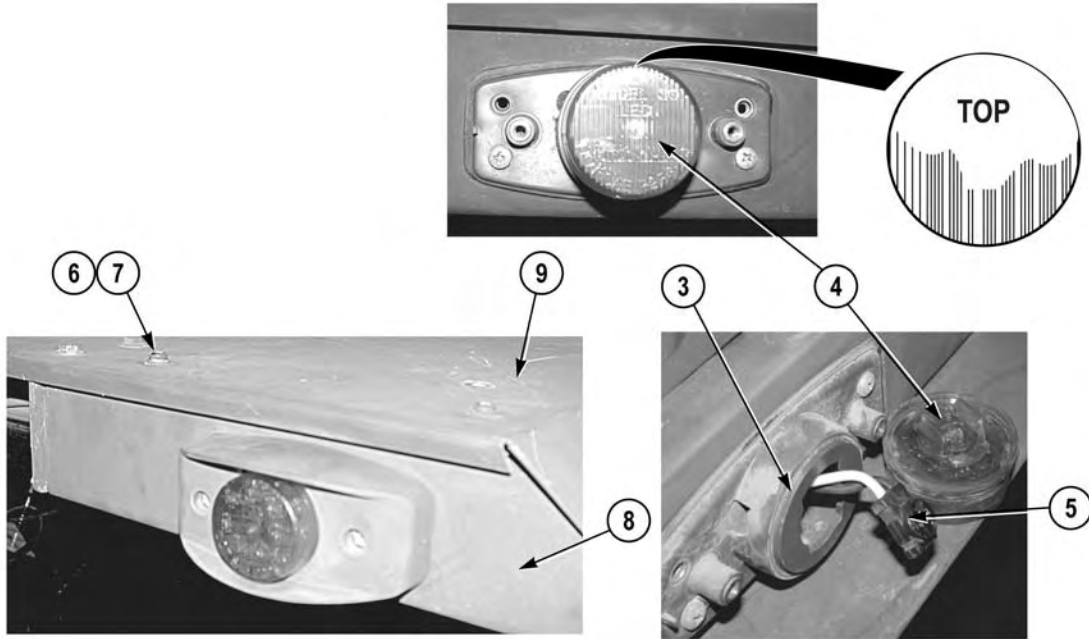
Batteries disconnected (TM 9-2320-325-14&P)

## REMOVAL

**NOTE**

Passenger side and driver side clearance lights are removed the same way. Driver side shown.

1. Remove two screws (1) and light cover (2) from mounting base (3).

**NOTE**

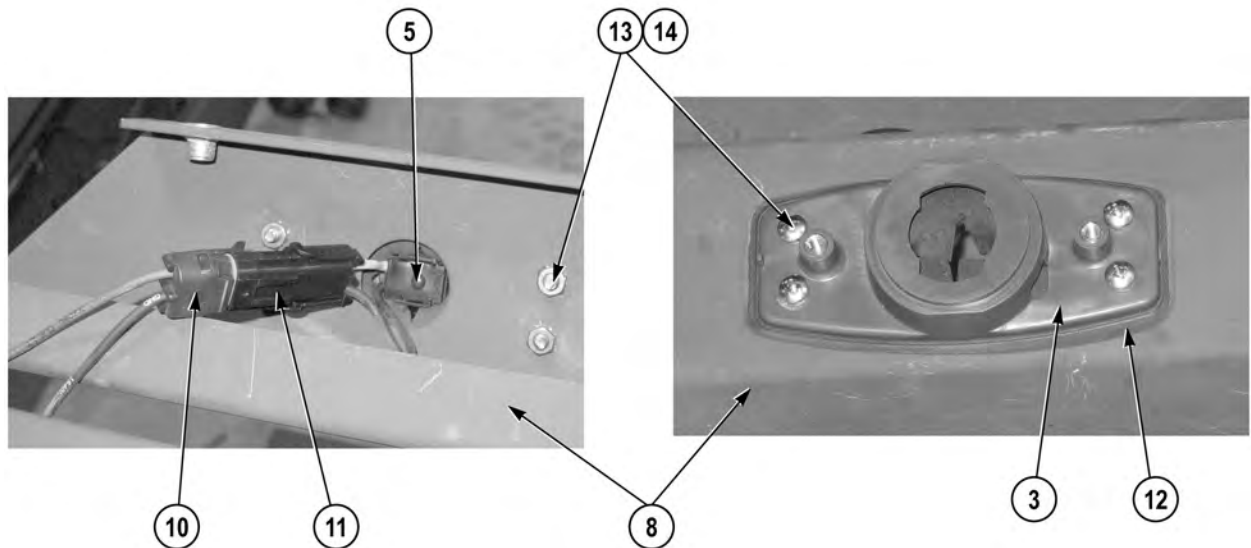
Lamp must be replaced as indicated on lamp cover with TOP facing up. Rotate lamp 90 degrees in order to remove lamp from mounting base.

2. Remove lamp (4) from mounting base (3).

**NOTE**

- Lamp will only function if correctly installed on rubber mounting of pigtail. Plastic tabs on lamp must align with openings on rubber mounting of pigtail. It is possible to force lamp on rubber mounting of pigtail in opposite position, which will not allow lamp to operate.
- Note position of lamp on rubber mounting of pigtail prior to removal to ensure proper installation.

3. Remove lamp (4) from rubber mounting of pigtail (5).
4. Remove two screws (6), washers (7), and bracket (8) from cab roof (9).



5. Disconnect lightbar wire harness connector (10) from cab clearance light connector (11) and remove pigtail (5) from gasket (12).
6. Remove four locknuts (13), screws (14), mounting base (3), and gasket (12) from bracket (8). Discard locknuts.

#### END OF TASK

#### INSTALLATION

#### NOTE

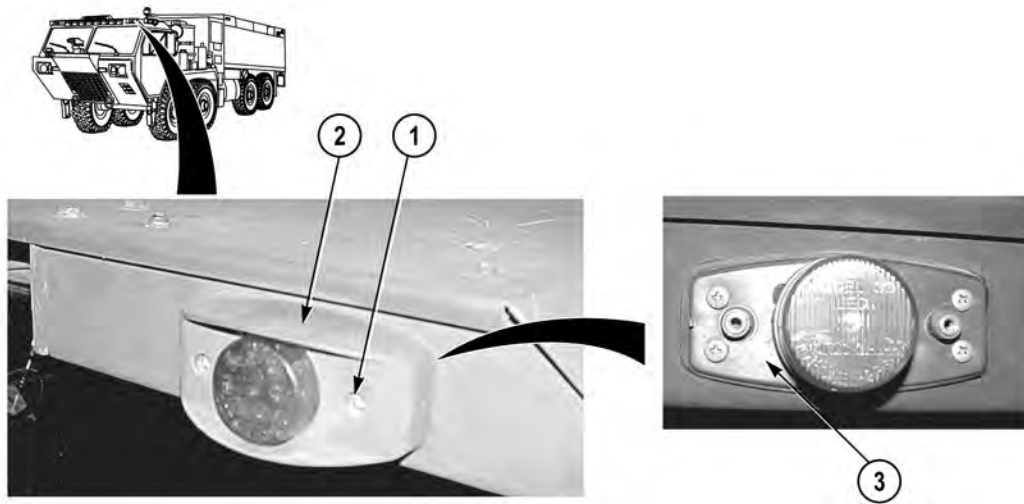
Passenger side and driver side clearance lights are installed the same way. Driver side shown.

1. Install gasket (12) and mounting base (3) on bracket (8) with four screws (14) and locknuts (13).
2. Position pigtail (5) in gasket (12) and connect cab clearance light connector (11) on lightbar wire harness (10).
3. Install bracket (8) on cab roof (9) with two washers (7), and screws (6).

#### NOTE

Install lamp on rubber mounting of pigtail as noted prior to removal.

4. Install lamp (4) on rubber mounting of pigtail (5).
5. Install lamp (4) on mounting base (3).

**NOTE**

Install lamp as noted prior to removal.

6. Install light cover (2) on mounting base (3) with two screws (1).

**END OF TASK**

**FOLLOW-ON MAINTENANCE**

Connect batteries (TM 9-2320-325-14&P)

**END OF TASK**

**END OF WORK PACKAGE**



---

**FIELD LEVEL MAINTENANCE**  
**CAB FRONT LIGHTBAR REPLACEMENT**

---

**INITIAL SETUP:****Tools and Special Tools**

Tool Kit, General Mechanic's: Automotive  
(WP 0398, Item 17)

**Materials/Parts**

Tags, Identification (WP 0400, Item 23)  
Ties, Cable, Plastic (WP 0400, Item 26)  
Lockwasher (1)  
Lockwasher (1)  
Lockwasher (1)  
Lockwasher (2)  
Lockwasher (1)  
Lockwasher (1)

**References**

WP 0391, Fig. 27

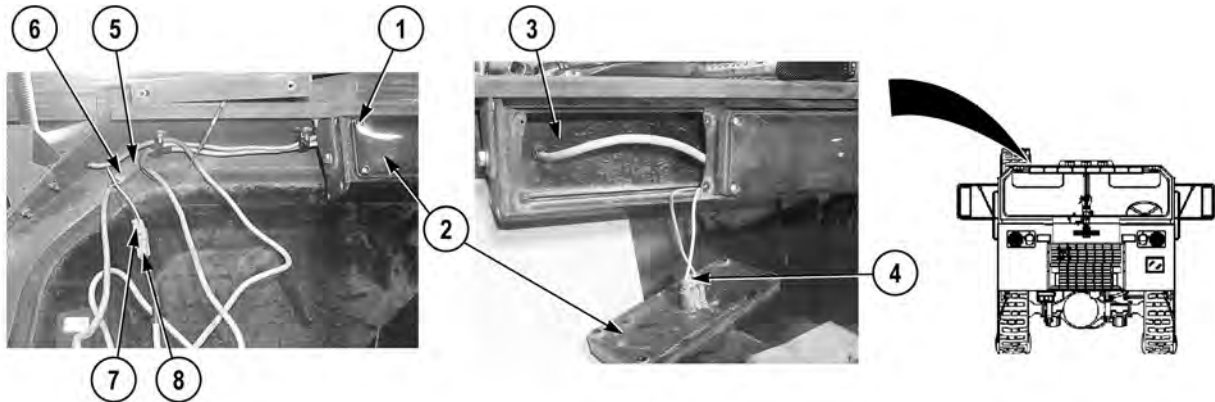
**Personnel Required**

MOS 63B Wheeled Vehicle Mechanic (2)

**Equipment Conditions**

Cab clearance lights and brackets removed  
(WP 0223)

---

**REMOVAL****NOTE**

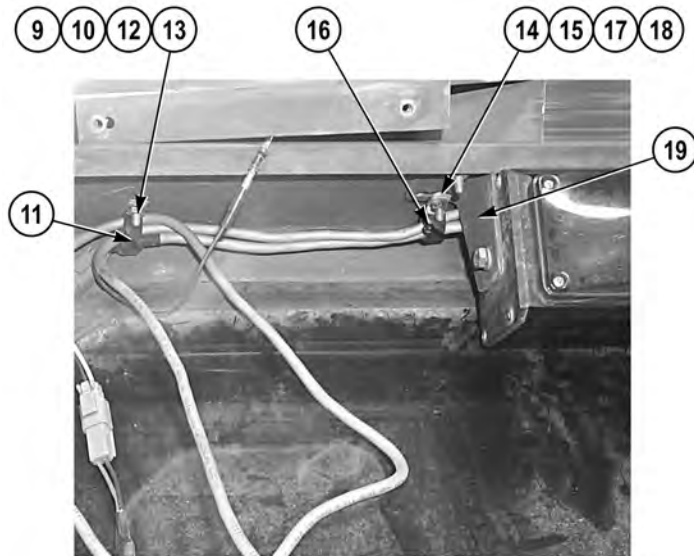
- Perform Steps (1) and (2) if removing cab front lightbar lights.
- All cab front lightbar lights are removed the same. Passenger side lights shown.

1. Remove four screws (1) and cab front lightbar light (2) from cab front lightbar (3).
2. Disconnect cab front lightbar wire harness connector (4) from cab front lightbar light (2).

**NOTE**

- Perform Steps (3) through (10) if removing cab front lightbar.
- Tag and mark wires prior to removal to ensure proper installation.
- Remove cable ties as required.

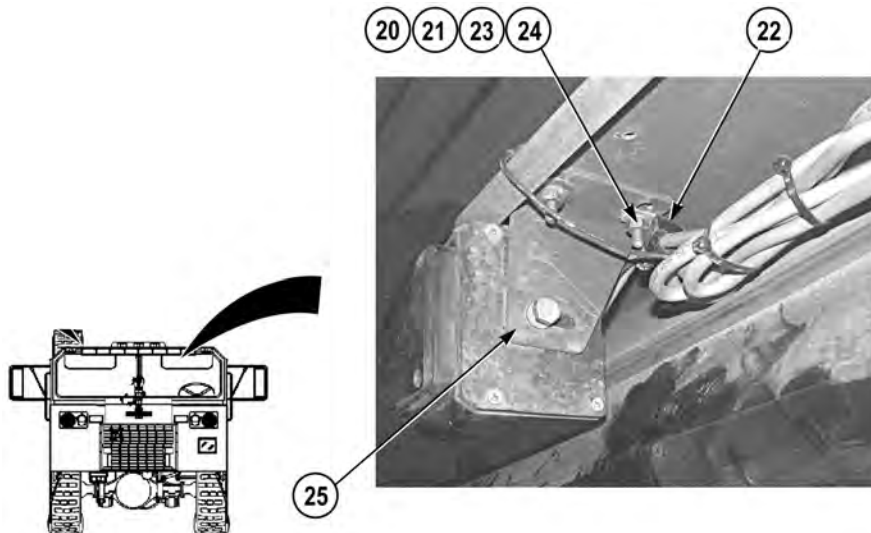
3. Disconnect cab front lightbar cable connector (5) from cab lightbar cable assembly branch connector (6).
4. Disconnect cab front lightbar cable connector (7) from cab roof wire harness connector (8).



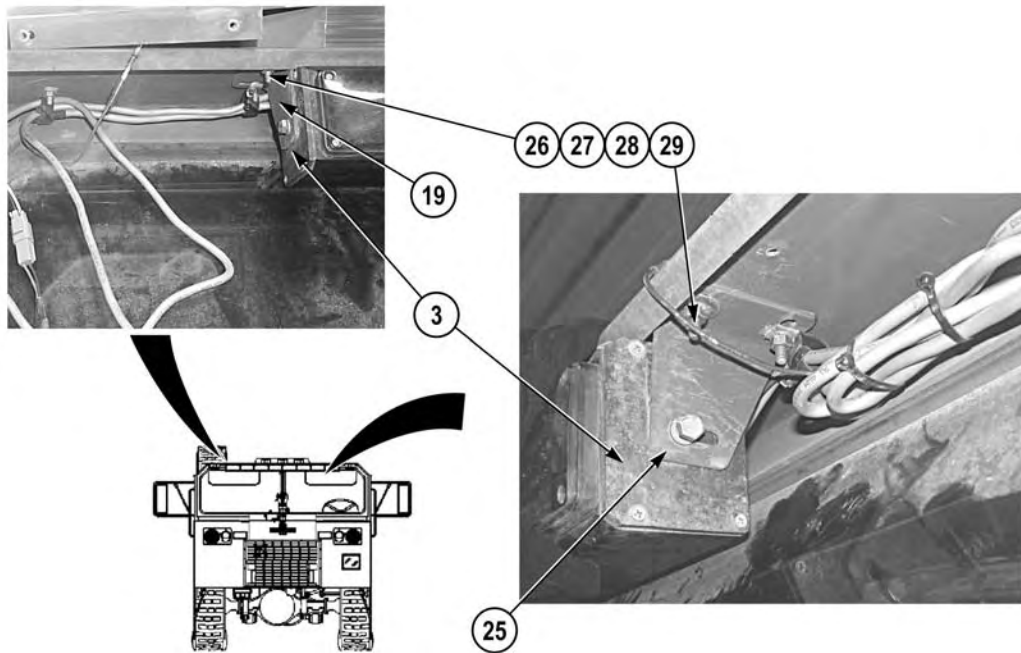
**NOTE**

Note position of washers prior to removal to ensure proper installation.

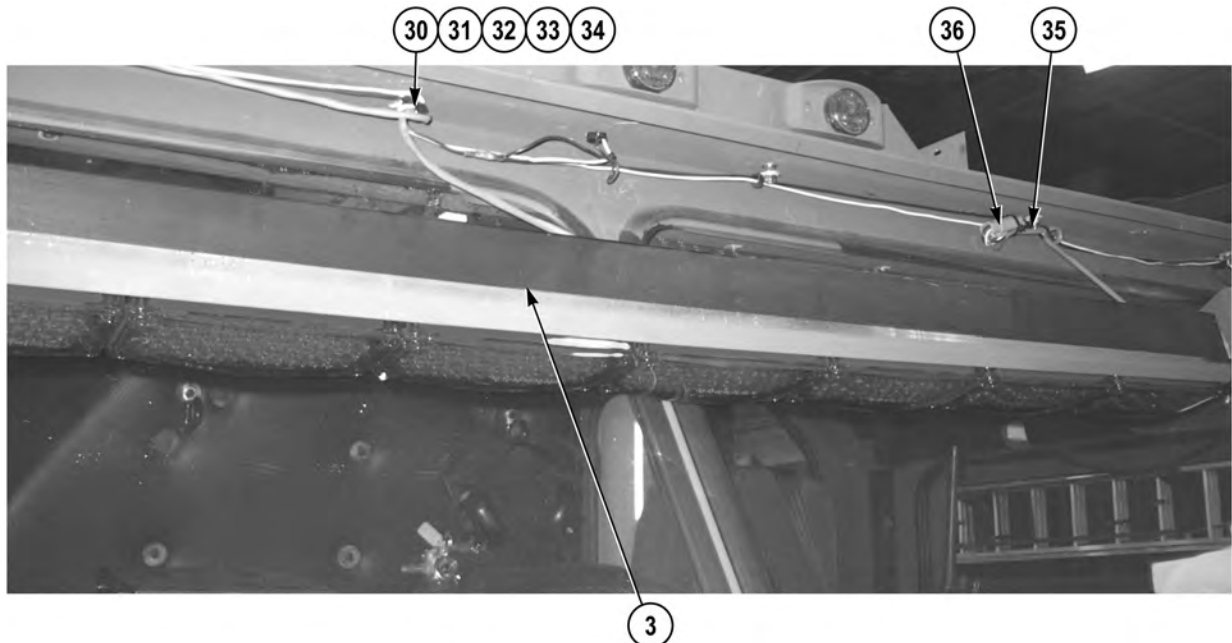
5. Remove nut (9), lockwasher (10), cushion clip (11), washer (12), and screw (13) from vehicle. Discard lockwasher.
6. Remove nut (14), lockwasher (15), cushion clip (16), washer (17), and screw (18) from cab front lightbar bracket (19) and vehicle. Discard lockwasher.



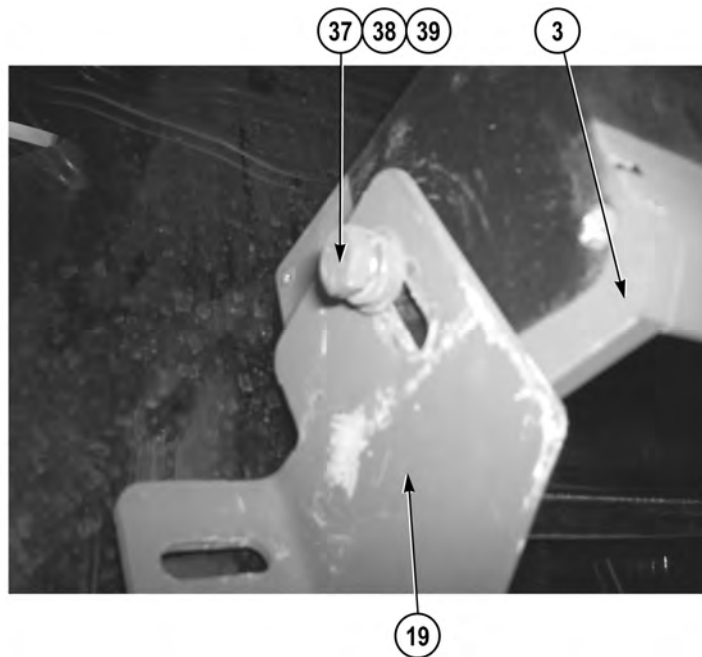
7. Remove nut (20), lockwasher (21), cushion clip (22), washer (23), and screw (24) from cab front lightbar bracket (25) and vehicle. Discard lockwasher.



8. With the aid of an assistant, support cab front lightbar (3) and remove two nuts (26), lockwashers (27), four washers (28), two screws (29), cab front lightbar bracket (19), and cab front lightbar bracket (25), from vehicle. Discard lockwashers.



9. With the aid of an assistant, lower cab front lightbar (3) from vehicle, and remove nut (30), lockwasher (31), cushion clip (32), and washer (33) from screw (34). Discard lockwasher.
10. Disconnect cab front lightbar cable connector (35) from cab lightbar cable assembly branch connector (36).



### NOTE

- Perform Step (11) if removing cab front lightbar brackets.
- Both cab front lightbar brackets are removed the same. Passenger side shown.

11. Remove screw (37), lockwasher (38), washer (39), and cab front lightbar bracket (19) from cab front lightbar (3). Discard lockwasher.

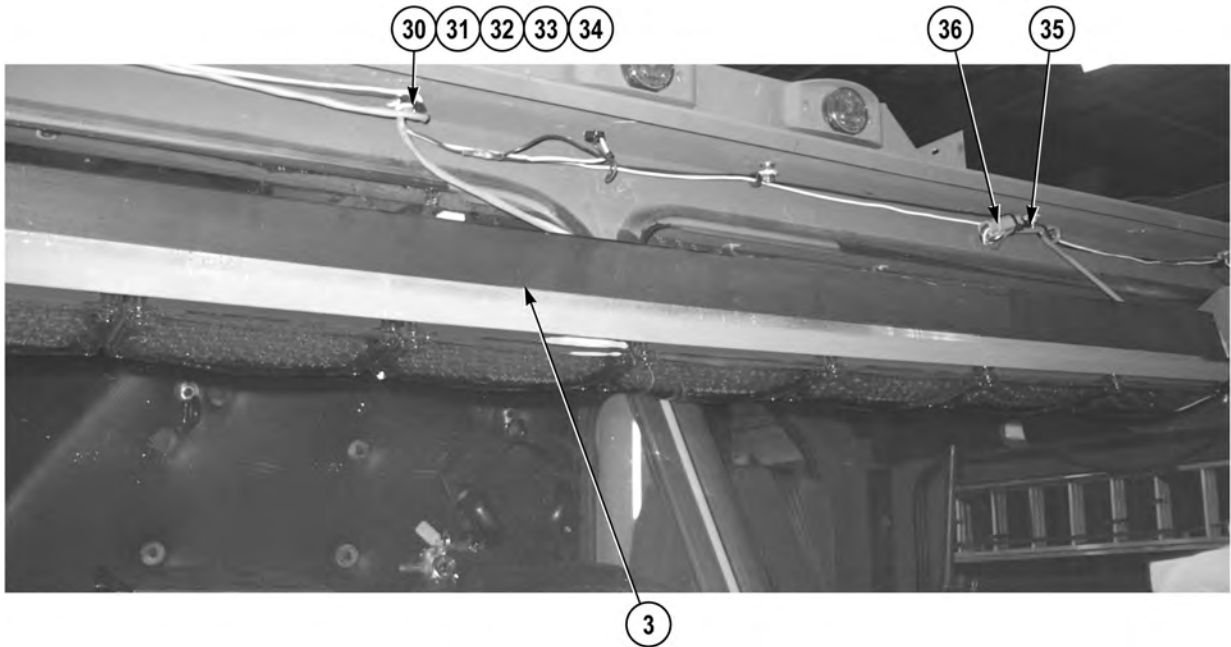
### END OF TASK

### INSTALLATION

### NOTE

- Perform Step (1) if installing cab front lightbar brackets.
- Both cab front lightbar brackets are installed the same. Passenger side shown.

1. Position cab front lightbar bracket (19) on cab front lightbar (3) with washer (39), lockwasher (38), and screw (37).

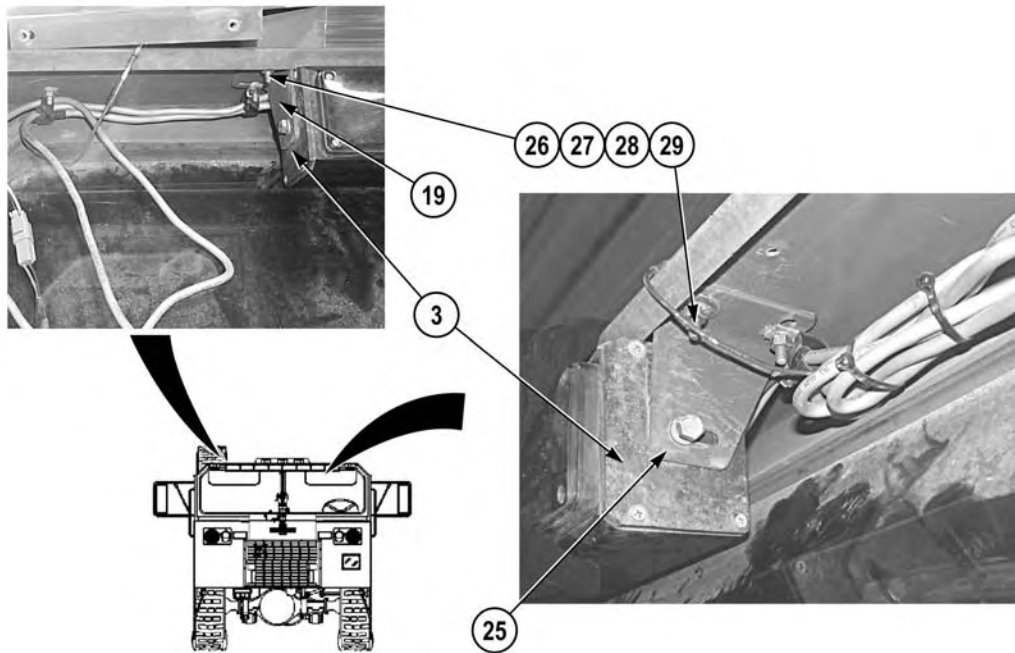
**NOTE**

- Perform Steps (2) through (9) if installing cab front lightbar.
  - Install cable ties as required.
2. With the aid of an assistant, support cab front lightbar (3) and connect cab lightbar cable assembly branch connector (36) on cab front lightbar cable connector (35).

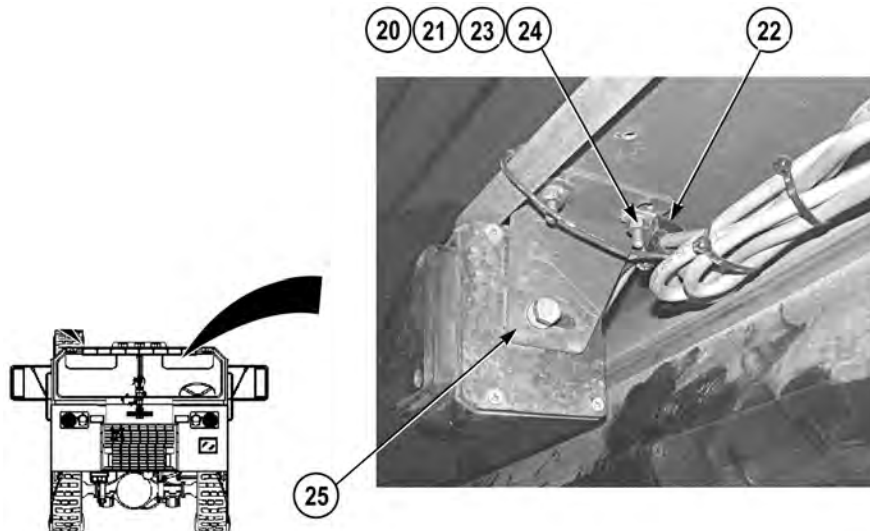
**NOTE**

Install washers as noted prior to removal.

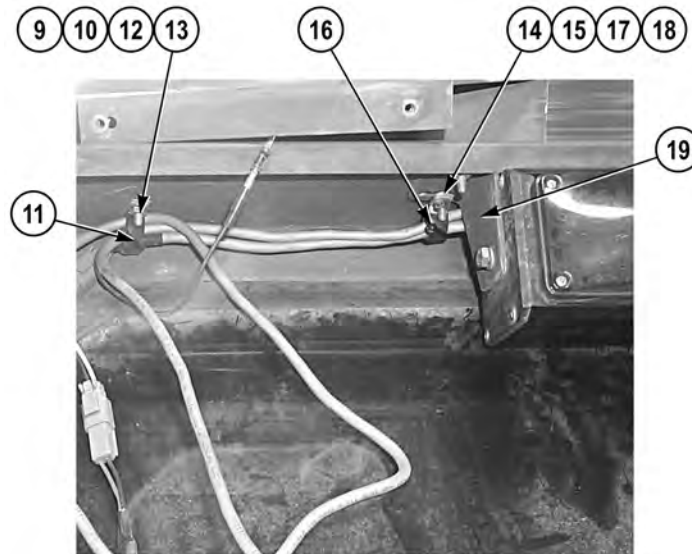
3. Install washer (33) and cushion clip (32) on vehicle with screw (34), lockwasher (31), and nut (30).



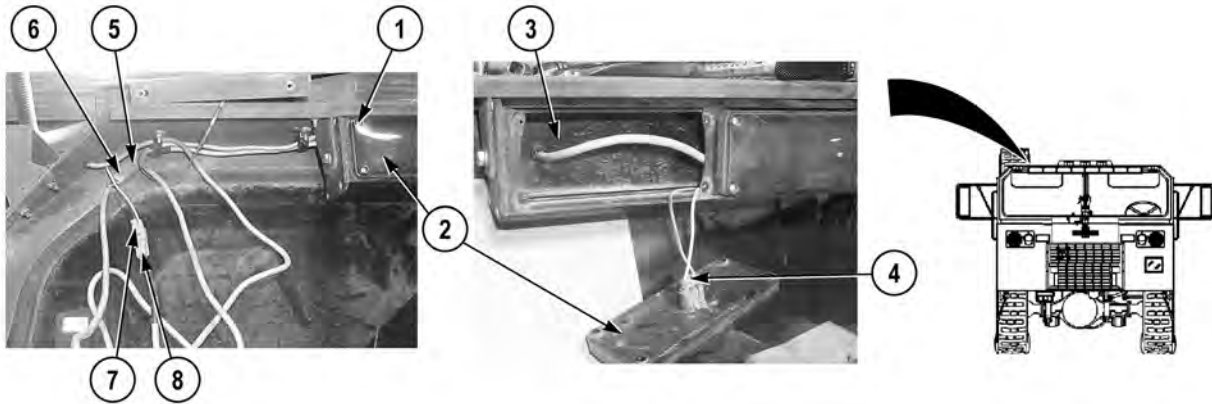
4. With the aid of an assistant, position cab front lightbar (3) and install cab front lightbar bracket (25) and cab front lightbar bracket (19) on vehicle with two screws (29), four washers (28), two lockwashers (27), and nuts (26).



5. Install screw (24) and washer (23), on vehicle and cab front lightbar bracket (25) with cushion clip (22), lockwasher (21) and nut (20).



6. Install screw (18) and washer (17) on vehicle and cab front lightbar bracket (19) with cushion clip (16), lockwasher (15), and nut (14).
7. Install screw (13) and washer (12) on vehicle with cushion clip (11), lockwasher (10), and nut (9).



8. Connect cab roof wire harness connector (8) on cab front lightbar cable connector (7).
9. Connect cab lightbar cable assembly branch connector (6) on cab front lightbar cable connector (5).

### NOTE

- Perform Steps (10) and (11) if installing cab front lightbar lights.
- All cab front lightbar lights are installed the same. Passenger side lights shown.

10. Connect cab front lightbar light (2) on cab front lightbar wire harness connector (4).
11. Install cab front lightbar light (2) on cab front lightbar (3) with four screws (1).

### END OF TASK

### FOLLOW-ON MAINTENANCE

Install cab clearance lights and brackets (WP 0223)

### END OF TASK

### END OF WORK PACKAGE



---

**FIELD LEVEL MAINTENANCE**  
**CAB SIDE LIGHTBAR REPLACEMENT**

---

**INITIAL SETUP:****Tools and Special Tools**

Tool Kit, General Mechanic's: Automotive  
(WP 0398, Item 17)

**Materials/Parts**

Tags, Identification (WP 0400, Item 23)  
Ties, Cable, Plastic (WP 0400, Item 26)  
Lockwasher (2)

**Materials/Parts (continued)**

Lockwasher (2)

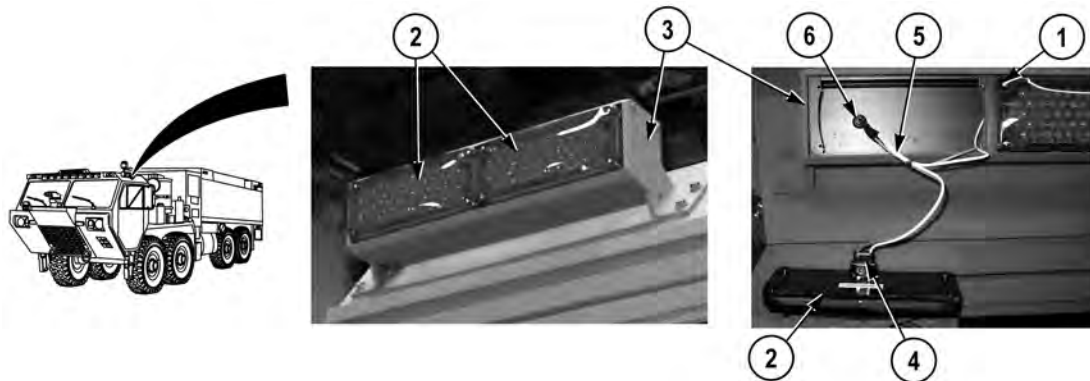
**References**

WP 0391, Fig. 27

**Equipment Conditions**

Batteries disconnected (TM 9-2320-325-14&P)

---

**REMOVAL****NOTE**

Both cab side lightbars are removed the same way. Driver side shown.

1. Remove eight screws (1) and two lights (2) from cab side lightbar (3).

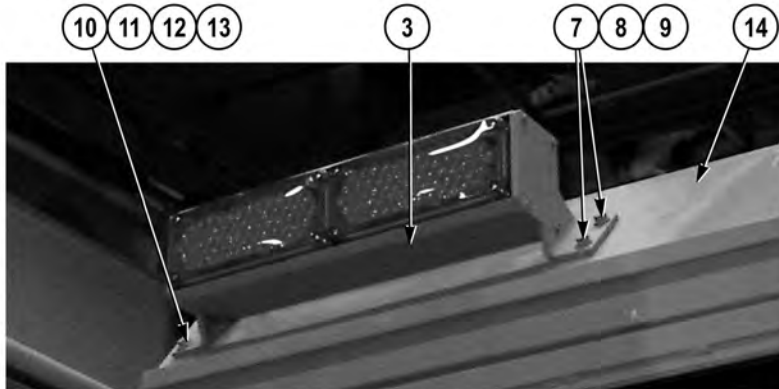
 **CAUTION**

**Support lights while removing wires from connectors to ensure lights do not drop.  
Failure to do so may cause damage to equipment.**

2. Disconnect two lights (2) from connectors (4).

**NOTE**

- Tag and mark wires prior to removal to ensure proper installation.
  - Remove cable ties as required.
  - The white and black wires are spliced together.
3. Cut four wires (5) (TM 9-2320-325-14&P)
  4. Remove four wires (5) and grommet (6) from cab side lightbar (3).



5. Remove two screws (7), lockwashers (8), and washers (9) from cab side lightbar (3). Discard lockwashers.
6. Remove two nuts (10), lockwashers (11), four washers (12), two screws (13), and cab side lightbar (3) from cab (14). Discard lockwashers.

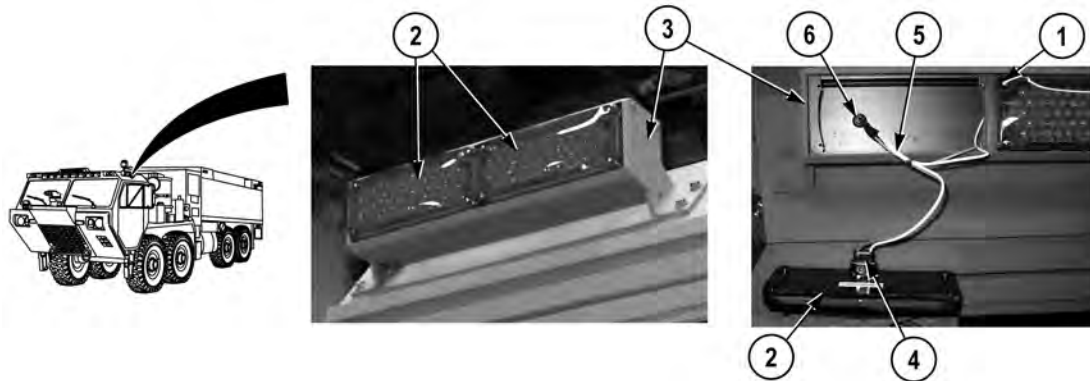
#### END OF TASK

#### INSTALLATION

#### NOTE

Both cab side lightbars are installed the same way. Driver side shown.

1. Install cab side lightbar (3) on cab (14) with two screws (13), four washers (12), two lockwashers (11), and nuts (10).
2. Install two washers (9), lockwashers (8), and screws (7) on cab side lightbar (3).



3. Install grommet (6) in cab side lightbar (3).
4. Insert four wires (5) in grommet (6).

### NOTE

Install cable ties as required.

5. Repair four wires (5) (TM 9-2320-325-14&P)
6. Connect two connectors (4) to lights (2).
7. Install two lights (2) on cab side lightbar (3) with eight screws (1).

**END OF TASK**

### FOLLOW-ON MAINTENANCE

Connect batteries (TM 9-2320-325-14&P)

**END OF TASK**

**END OF WORK PACKAGE**



---

**FIELD LEVEL MAINTENANCE****CAB LIGHTBAR REPAIR**

---

**INITIAL SETUP:****Tools and Special Tools**

Tool Kit, General Mechanic's: Automotive  
(WP 0398, Item 17)

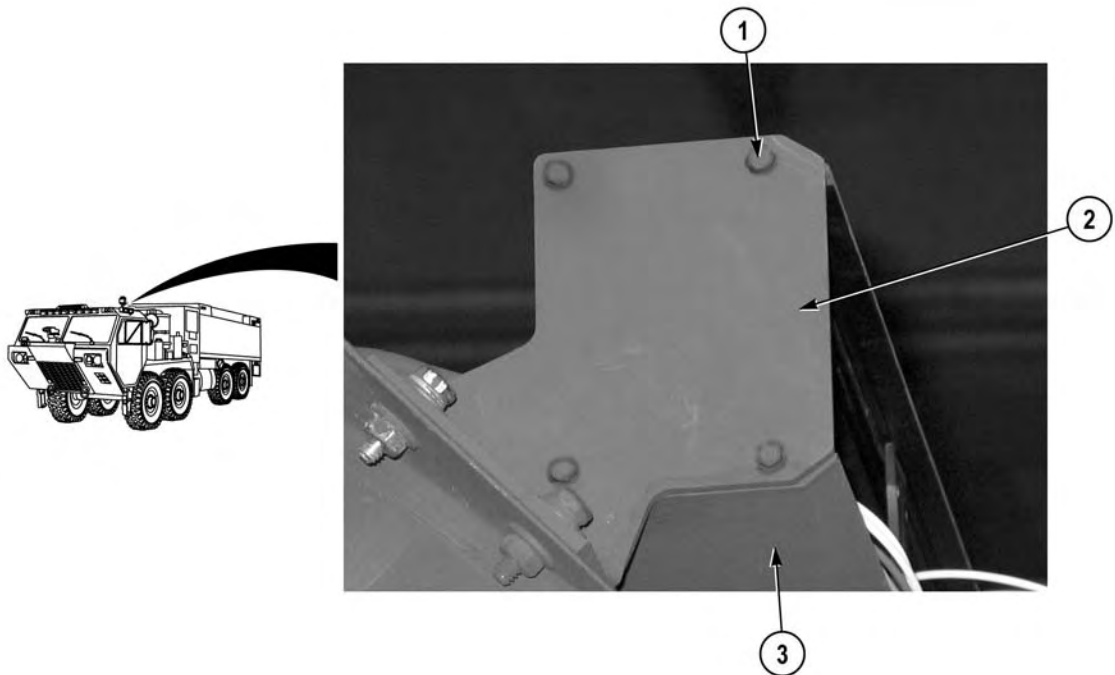
**Equipment Conditions**

Cab front lightbar removed (WP 0224)  
Cab side lightbar removed (WP 0225)

**References**

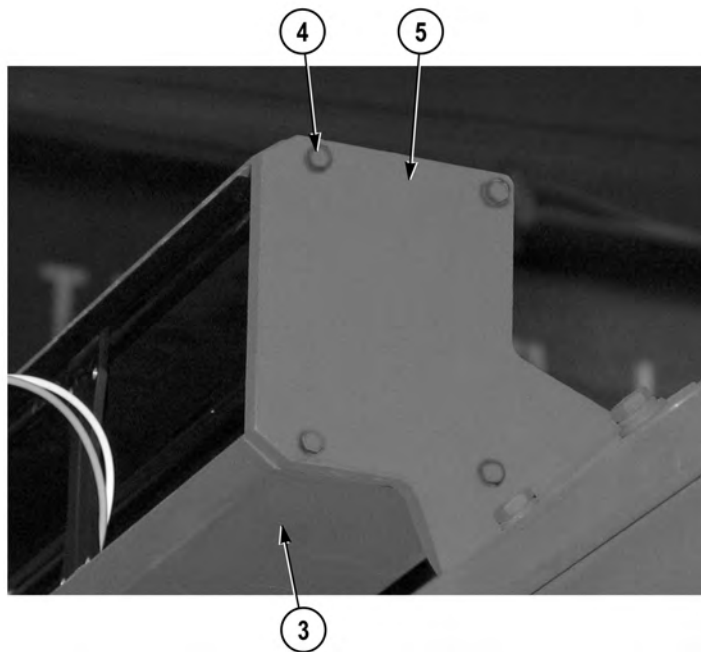
WP 0391, Fig. 27

---

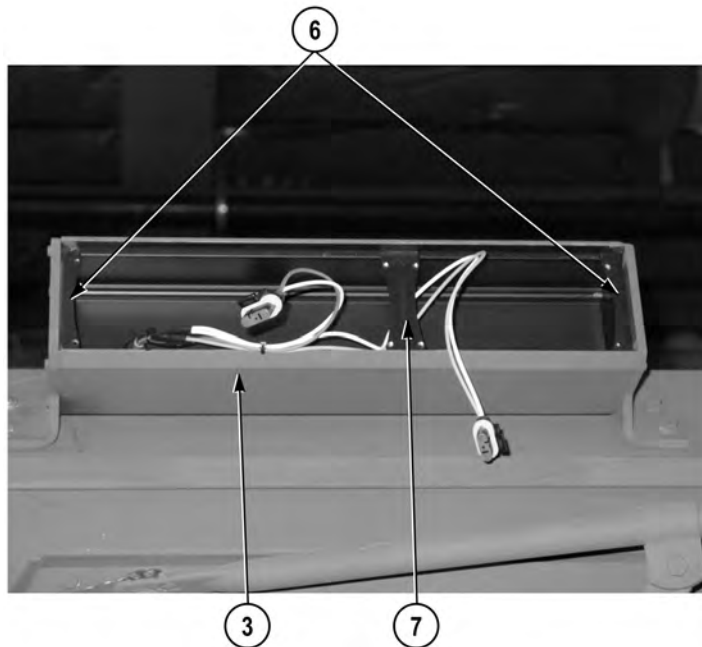
**CAB SIDE LIGHTBAR DISASSEMBLY****NOTE**

Both cab side lightbars are disassembled the same. Driver side shown.

1. Remove four screws (1) and bracket (2) from cab side lightbar (3).



2. Remove four screws (4) and bracket (5) from cab side lightbar (3).

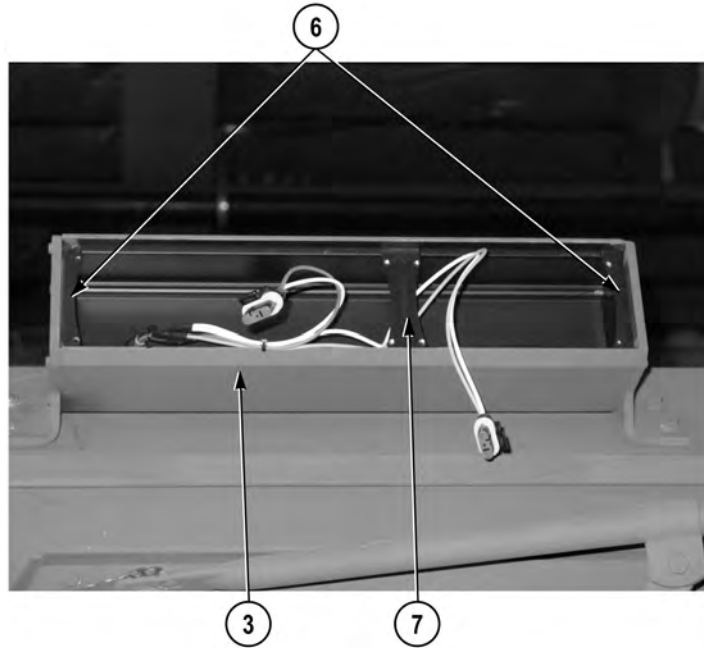


#### NOTE

Note position of brackets prior to removal to ensure proper installation.

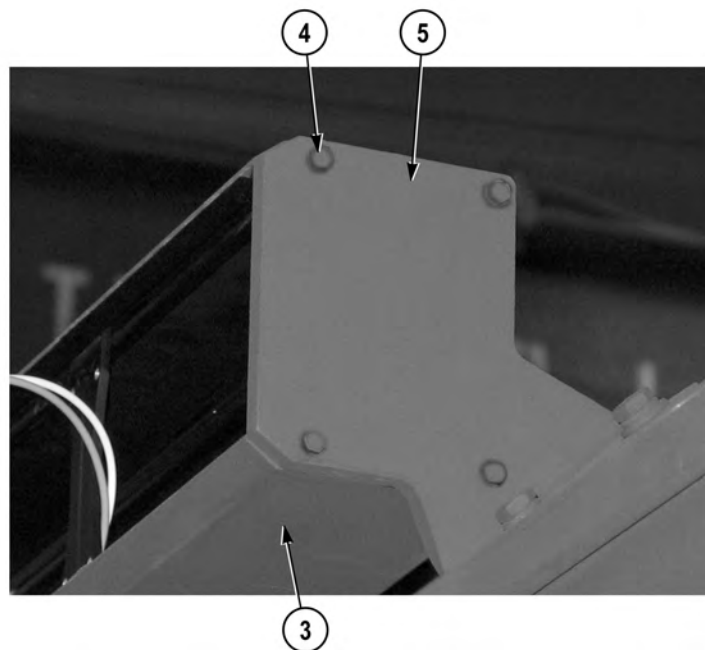
3. Remove two, brackets (6) and bracket (7) from side lightbar (3).

**END OF TASK**

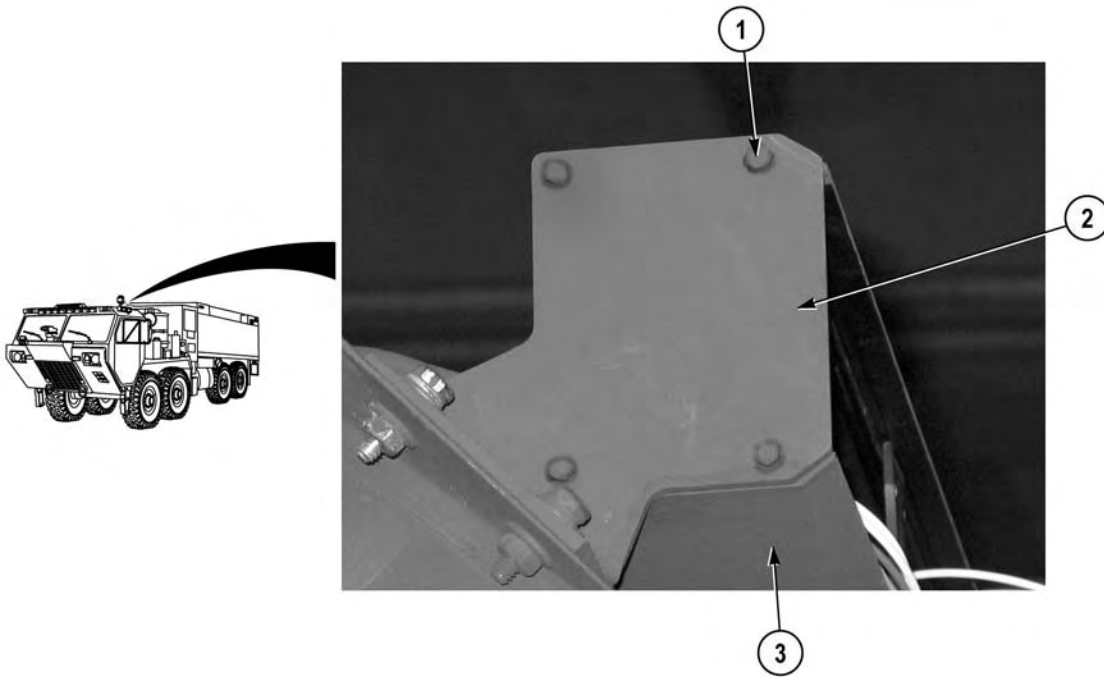
**CAB SIDE LIGHTBAR ASSEMBLY****NOTE**

- Both cab side lightbars are assembled the same way. Driver side shown.
- Install all brackets in same position as noted prior to removal.

1. Position bracket (7) and two brackets (6) on cab side lightbar (3).



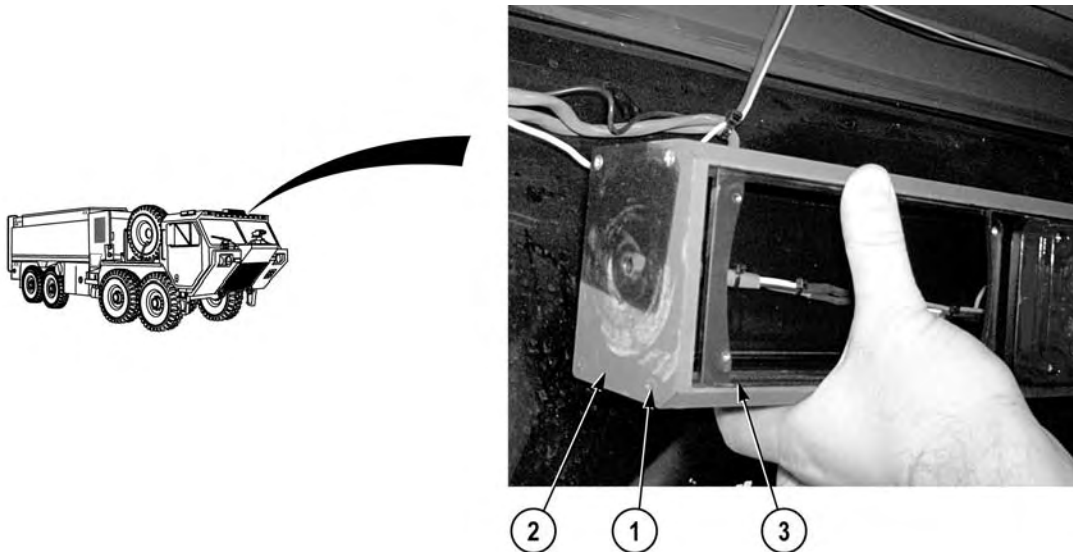
2. Install rear cab side lightbar bracket (5) on cab side lightbar (3) with four screws (4).



3. Install bracket (2) on cab side lightbar (3) with four screws (1).

**END OF TASK**

#### **CAB FRONT LIGHTBAR DISASSEMBLY**

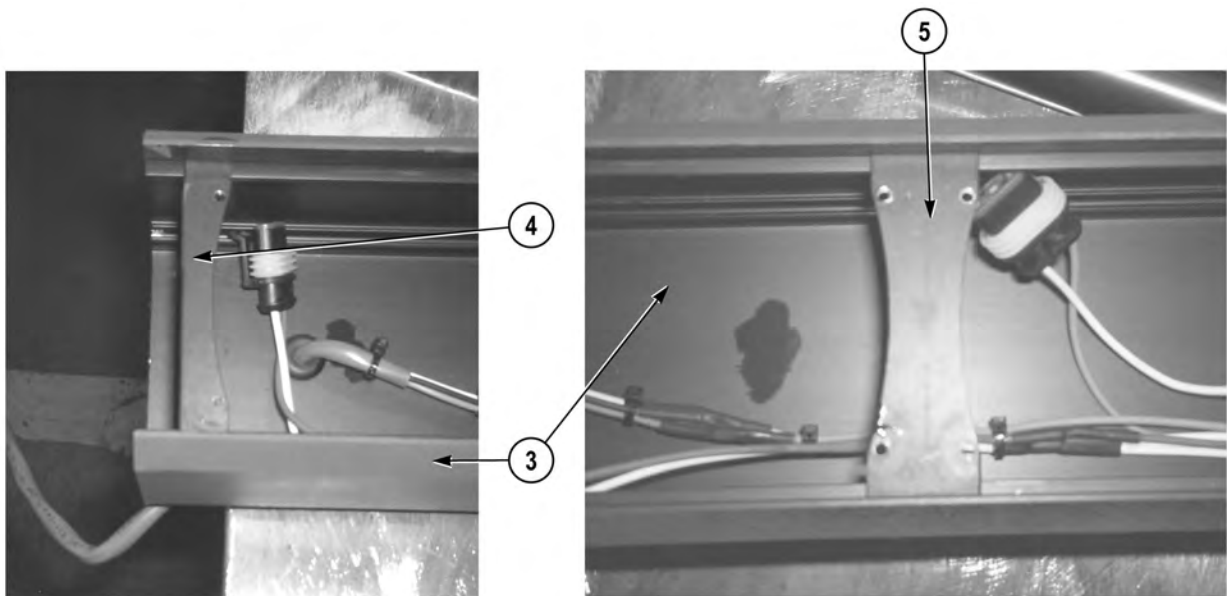


#### **NOTE**

Both cab front lightbar end caps are removed the same way. Passenger side shown.

1. Remove four screws (1) and cab front lightbar end cap (2) from cab front lightbar (3).



**NOTE**

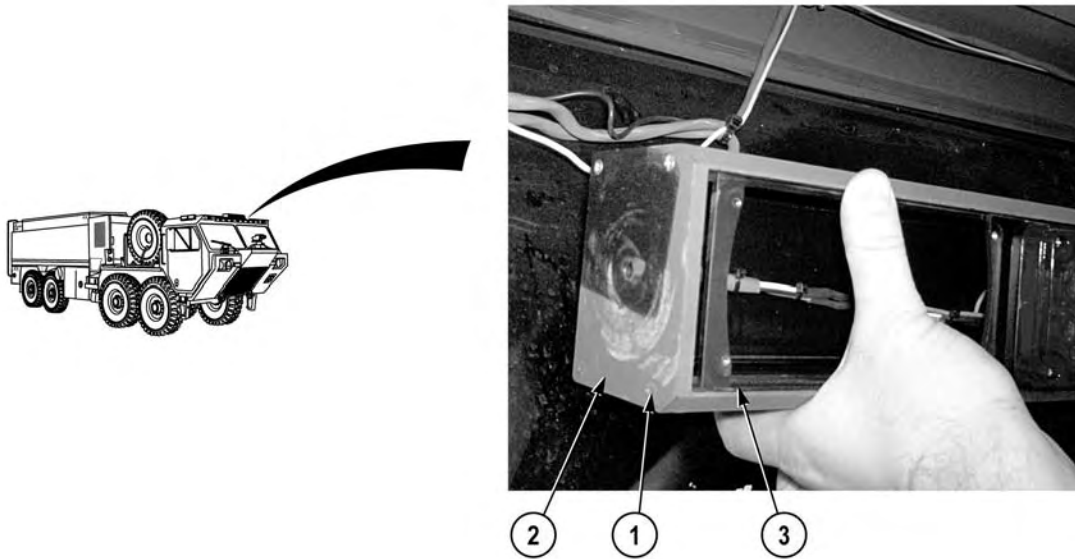
Note position of brackets prior to removal to ensure proper installation.

2. Remove two brackets (4) and seven brackets (5) from cab front lightbar (3).

**END OF TASK****CAB FRONT LIGHTBAR ASSEMBLY****NOTE**

Install brackets in same position as noted prior to removal.

1. Position seven brackets (5) and two brackets (4) on cab front lightbar (3).



### NOTE

Both cab front lightbar end caps are installed the same way. Passenger side shown.

2. Install cab front lightbar end cap (2) on cab front lightbar (3) with four screws (1).

**END OF TASK**

### FOLLOW ON MAINTENANCE

1. Install cab side lightbar (WP 0225)
2. Install cab front lightbar (WP 0224)

**END OF TASK**

**END OF WORK PACKAGE**

## FIELD LEVEL MAINTENANCE

## LOWER REAR MARKER LIGHTS AND BRACKET REPLACEMENT

## INITIAL SETUP:

**Tools and Special Tools**

Tool Kit, General Mechanic's: Automotive  
(WP 0398, Item 17)

**References**

WP 0391, Fig. 32

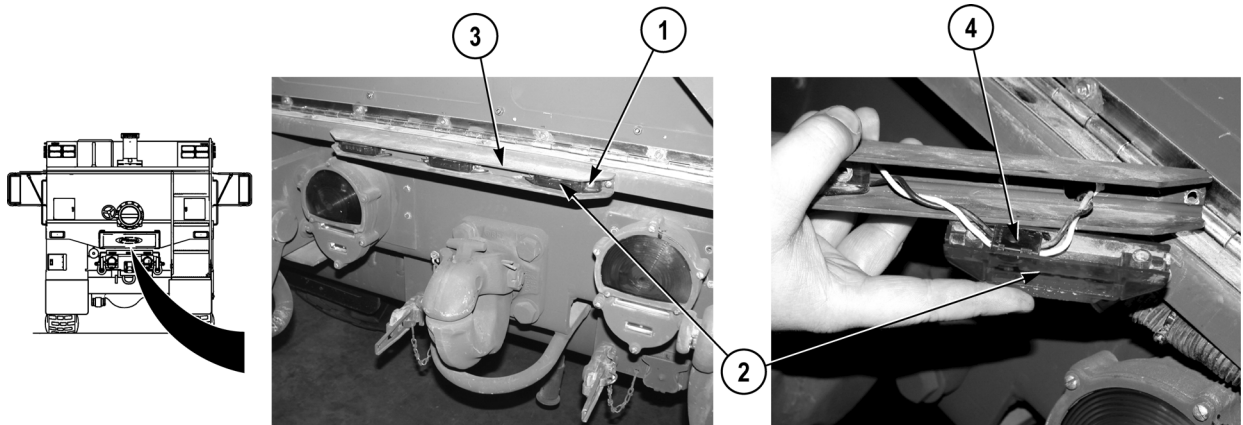
**Materials/Parts**

Tags, Identification (WP 0400, Item 23)  
Ties, Cable, Plastic (WP 0400, Item 26)  
Locknut (2)  
Lockwasher (2)

**Equipment Conditions**

Batteries disconnected (TM 9-2320-325-14&P)

## REMOVAL

**NOTE**

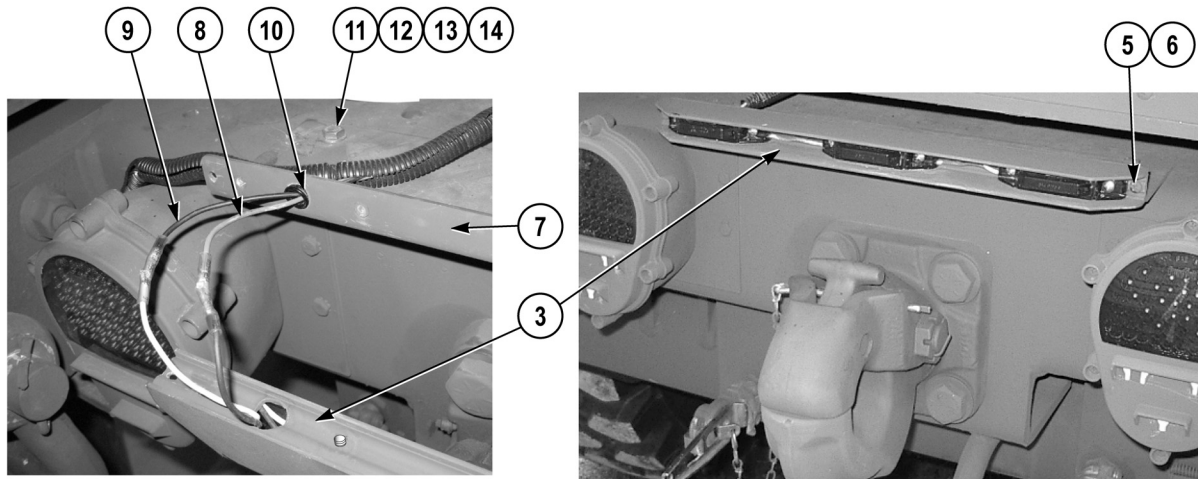
Marker lights are replaced the same way. Right side marker light shown.

1. Remove two screws (1) and marker light (2) from light bracket (3).

**NOTE**

Marker light will only function if properly installed on rubber mounting of pigtail. Plastic tabs on lamp must align with openings on rubber mounting of pigtail. It is possible to force lamp on rubber mounting of pigtail in opposite position, which will not allow lamp to operate. Note position of lamp on rubber mounting of pigtail prior to removal to ensure proper installation.

2. Remove marker light (2) from rubber mounting of pigtail (4).



3. Remove two locknuts (5), screws (6), and light bracket (3) from bracket (7). Discard locknuts.

#### NOTE

- Tag and mark wires prior to removal to ensure proper installation.
- Remove cable ties as required.

4. Cut wire 1606 (8) and wire 1640 (9) (TM 9-2320-325-14&P), and remove light bracket (3) from vehicle.
5. Remove grommet (10) from bracket (7).
6. Remove two nuts (11), four washers (12), two lockwashers (13), screws (14), and bracket (7) from vehicle. Discard lockwashers.

#### END OF TASK

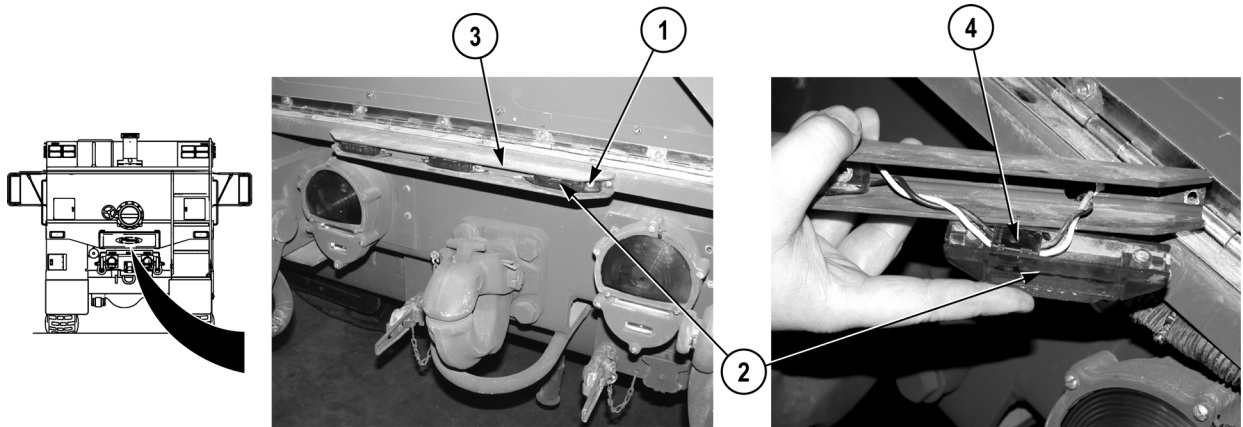
#### INSTALLATION

1. Install bracket (7) on vehicle with two screws (14), lockwashers (13), four washers (12), and nuts (11).
2. Install grommet (10) on bracket (7).

#### NOTE

Install cable ties as required.

3. Repair wire 1606 (8) and wire 1640 (9) (TM 9-2320-325-14&P)
4. Install light bracket (3) on bracket (7) with two screws (6) and locknuts (5).



### NOTE

Marker light will only function if properly installed on rubber mounting of pigtail. Plastic tabs on lamp must align with openings on rubber mounting of pigtail. It is possible to force lamp on rubber mounting of pigtail in opposite position, which will not allow lamp to operate. Install lamp on rubber mounting of pigtail as noted prior to removal.

5. Install rubber mounting of pigtail (4) on marker light (2).
6. Install marker light (2) on bracket (3) with two screws (1).

### END OF TASK

### FOLLOW-ON MAINTENANCE

Connect batteries (TM 9-2320-325-14&P)

### END OF TASK

### END OF WORK PACKAGE



## FIELD LEVEL MAINTENANCE

## REAR MARKER/CLEARANCE DIRECTIONAL LED REPLACEMENT

## INITIAL SETUP:

**Tools and Special Tools**

Tool Kit, General Mechanic's: Automotive  
(WP 0398, Item 17)

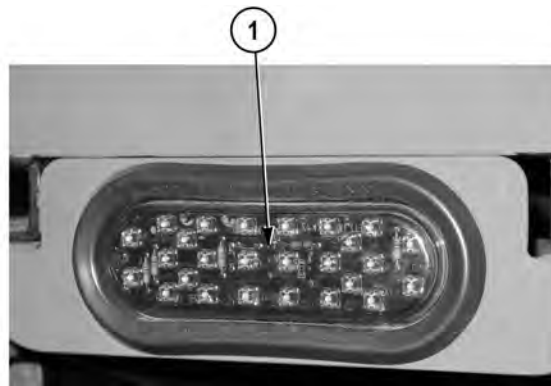
**Equipment Conditions**

Batteries disconnected (TM 9-2320-325-14&P)

**References**

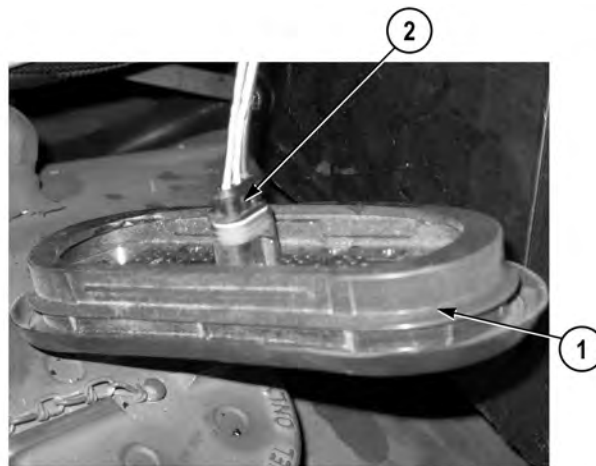
WP 0391, Fig. 30

## REMOVAL

**NOTE**

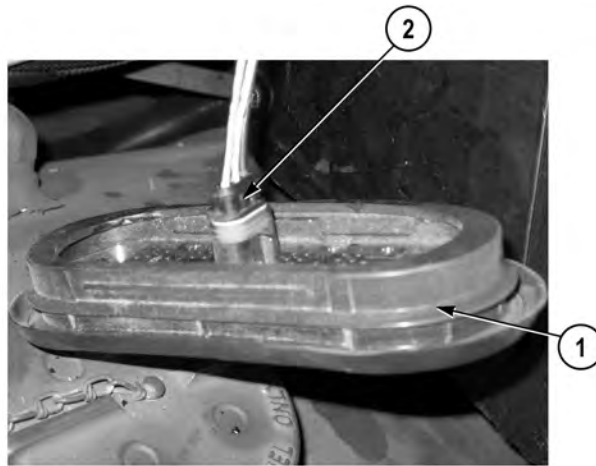
Both rear marker/clearance directional LEDs are removed the same way.

1. Remove rear marker/clearance directional LED (1) from vehicle.



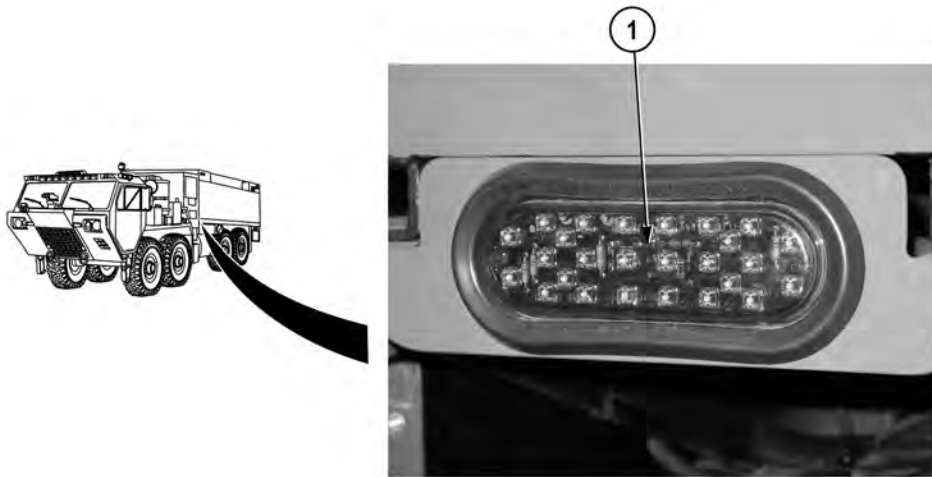
2. Disconnect connector (2) from back of rear marker/clearance directional LED (1).

**END OF TASK**

**INSTALLATION****NOTE**

Both rear marker/clearance directional LEDs are installed the same way.

1. Connect connector (2) to rear marker/clearance directional LED (1).



2. Install rear marker/clearance directional LED (1) on vehicle.

**END OF TASK**

**FOLLOW-ON MAINTENANCE**

Connect batteries (TM 9-2320-325-14&P)

**END OF TASK**

**END OF WORK PACKAGE**



---

**FIELD LEVEL MAINTENANCE**  
**REAR MARKER/CLEARANCE LED REPLACEMENT**

---

**INITIAL SETUP:****Tools and Special Tools**

Tool Kit, General Mechanic's: Automotive  
(WP 0398, Item 17)

**References**

WP 0391, Fig. 27

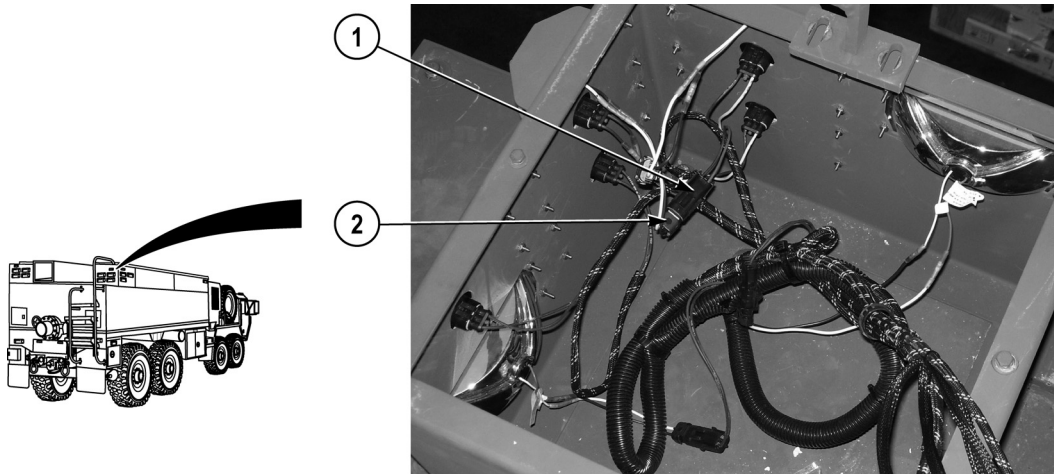
**Materials/Parts**

Locknut (2)

**Equipment Conditions**

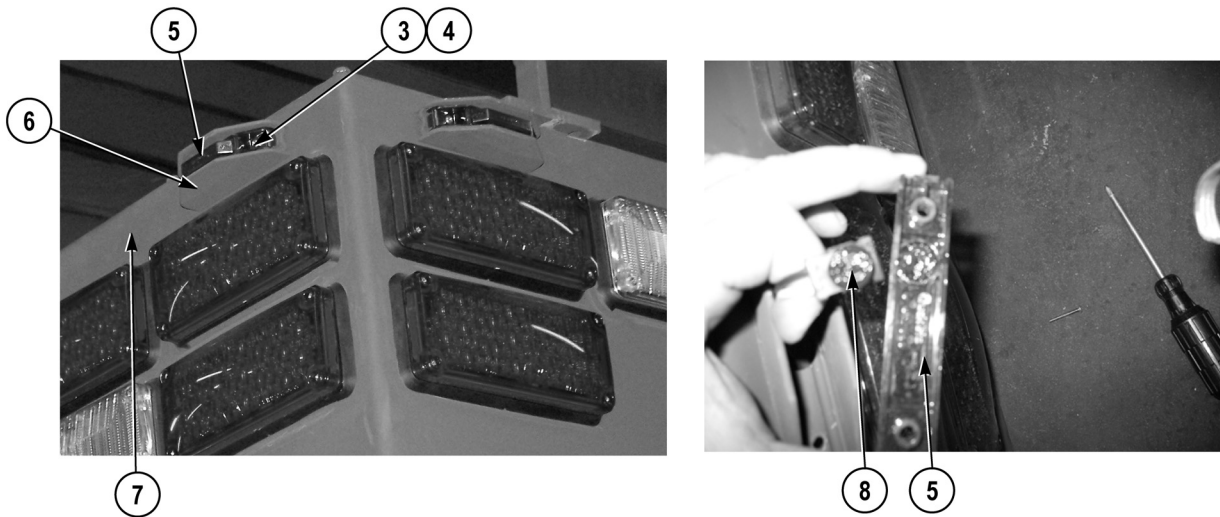
Light bezel covers removed (WP 0335)

---

**REMOVAL****NOTE**

All four marker/clearance LEDs are removed the same way. Rear passenger side shown.

1. Disconnect wire harness connector (1) from marker/clearance LED connector (2).



- Remove two locknuts (3), screws (4), marker/clearance LED (5), and marker/clearance LED cover (6) from light bezel (7). Discard locknuts.

#### NOTE

- Lamp will only function if correctly installed on rubber mounting of pigtail. It is possible to force lamp on rubber mounting of pigtail in opposite position, which will not allow lamp to operate.
- Note position of lamp on rubber mounting of pigtail prior to removal to ensure proper installation.

- Remove marker/clearance LED pigtail connector (8) from marker/clearance LED (5).
- Remove marker/clearance LED (5) from marker/clearance LED cover (6).

#### END OF TASK

#### INSTALLATION

#### NOTE

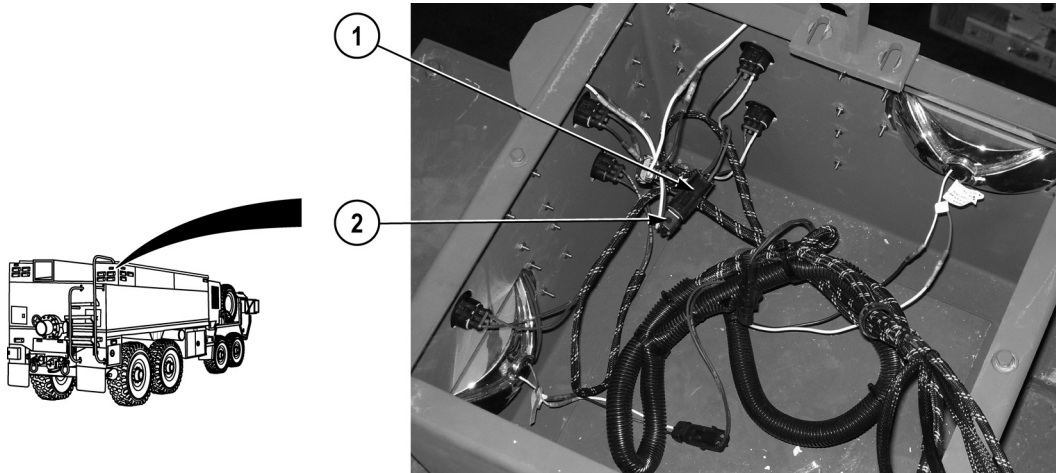
All four marker/clearance LEDs are installed the same way. Rear passenger side shown.

- Install marker/clearance LED cover (6) on marker/clearance LED (5).

#### NOTE

- Lamp will only function if correctly installed on rubber mounting of pigtail. It is possible to force lamp on rubber mounting of pigtail in opposite position, which will not allow lamp to operate.
- Install lamp pigtail as noted prior to removal.

- Install LED pigtail connector (8) on marker/clearance LED (5).
- Install marker/clearance LED cover (6) and marker/clearance LED (5) on light bezel (7) with two screws (4), and locknuts (3).



4. Connect marker/clearance LED connector (2) on wire harness connector (1).

**END OF TASK**

**FOLLOW-ON MAINTENANCE**

Install light bezel cover (WP 0334)

**END OF TASK**

**END OF WORK PACKAGE**



## FIELD LEVEL MAINTENANCE

## ROOF MOUNTED CLEARANCE LIGHT(S) REPLACEMENT

## INITIAL SETUP:

**Tools and Special Tools**

Tool Kit, General Mechanic's: Automotive  
(WP 0398, Item 17)

**References**

WP 0391, Fig. 27, 28

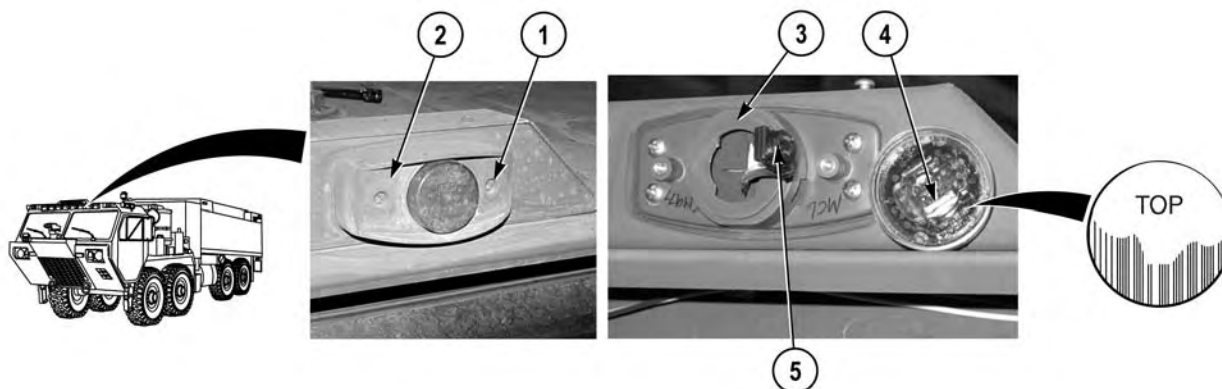
**Materials/Parts**

Tags, Identification (WP 0400, Item 23)  
Ties, Cable, Plastic (WP 0400, Item 26)  
Lockwasher (2)  
Lockwasher (2)  
Locknut (4)

**Equipment Conditions**

Batteries disconnected (TM 9-2320-325-14&P)

## REMOVAL

**NOTE**

All three clearance lights are removed the same way. Driver side shown.

1. Remove two screws (1) and cover (2) from mounting base (3).

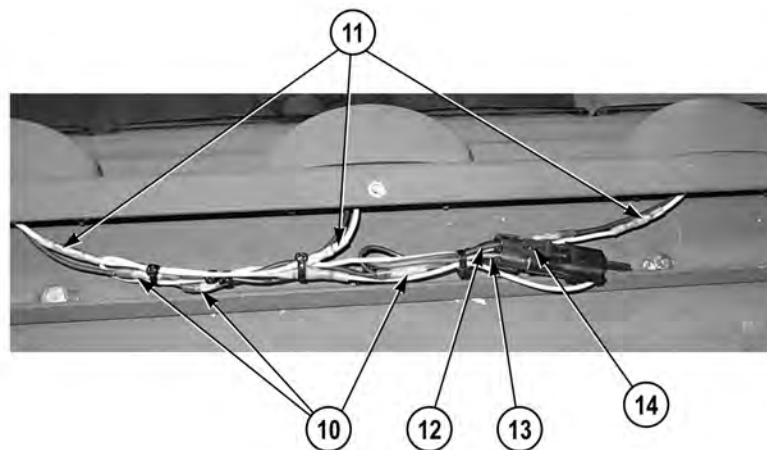
**NOTE**

Lamp must be rotated 90 degrees in order to remove lamp from mounting base.

2. Remove lamp (4) from mounting base (3).
  - Lamp will only function if correctly installed on rubber mounting of pigtail. Plastic tabs on lamp must align with openings on rubber mounting of pigtail. It is possible to force lamp on rubber mounting of pigtail in opposite position, which will not allow lamp to operate.
  - Note position of lamp on rubber mounting of pigtail prior to removal to ensure proper installation.
3. Remove lamp (4) from rubber mounting of pigtail (5).

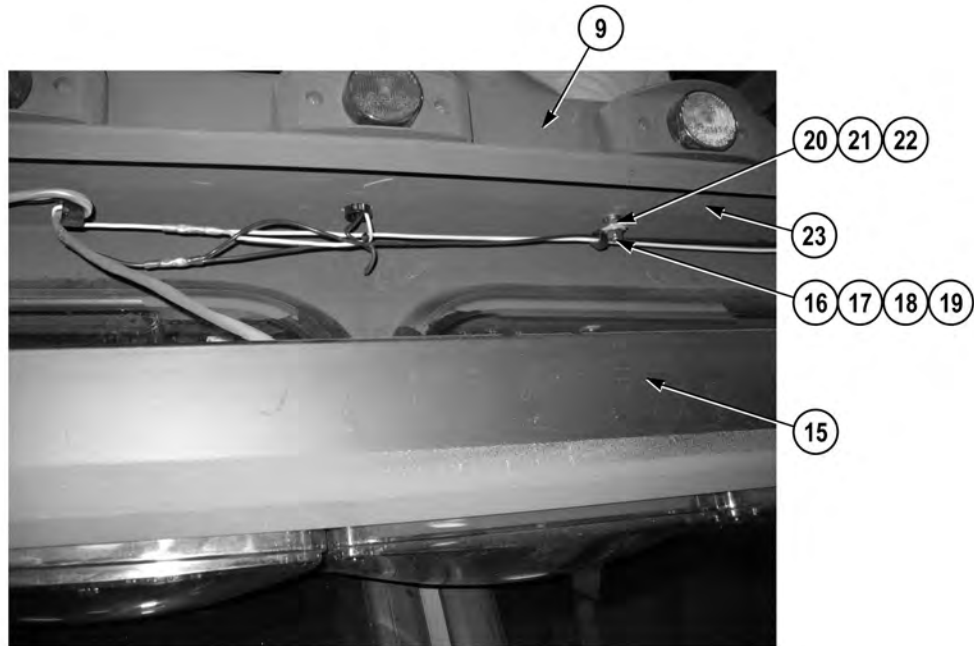


4. Remove five screws (6), washers (7), and cover (8) from mounting bracket (9).



#### NOTE

- Tag and mark wires prior to removal to ensure proper installation.
  - Remove cable ties as required.
  - Note routing of wires prior to removal to ensure proper installation.
5. Cut three wires (10), and wires (11) (TM 9-2320-325-14&P).
  6. De-pin wire 2906 (12) and wire 1640 (13) from connector (14) (TM 9-2320-325-14&P).

**NOTE**

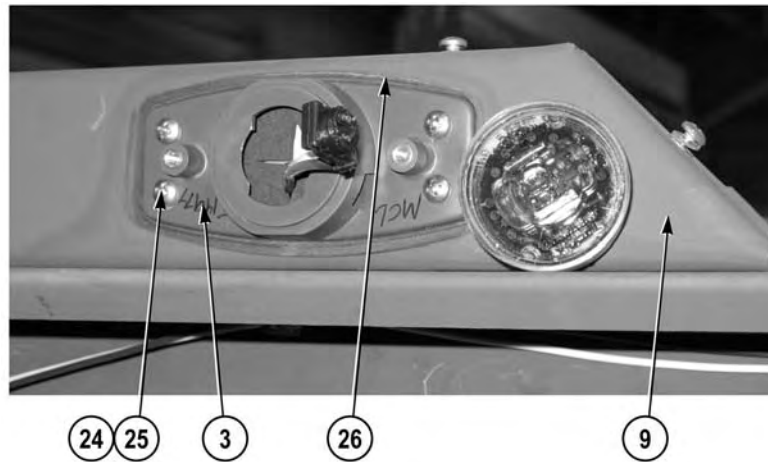
Cab front lightbar needs to be removed to access mounting bracket hardware.

7. Remove cab front lightbar (15) (WP 0224).

**NOTE**

Note position of cushion clip prior to removal to ensure proper installation.

8. Remove two nuts (16), lockwashers (17), and cushion clips (18) from screws (19). Discard lockwashers.
9. Remove two nuts (20), lockwashers (21), four washers (22), two screws (19), and mounting bracket (9) from cab roof (23). Discard lockwashers.



10. Remove four locknuts (24), screws (25), mounting base (3), and gasket (26) from mounting bracket (9). Discard locknuts.

#### END OF TASK

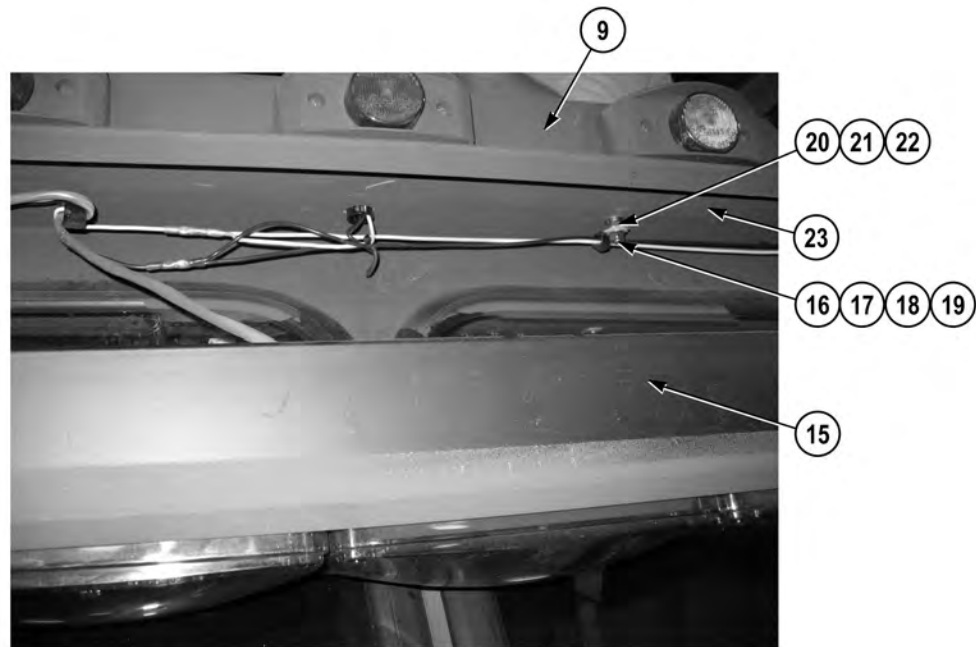
#### INSTALLATION

#### NOTE

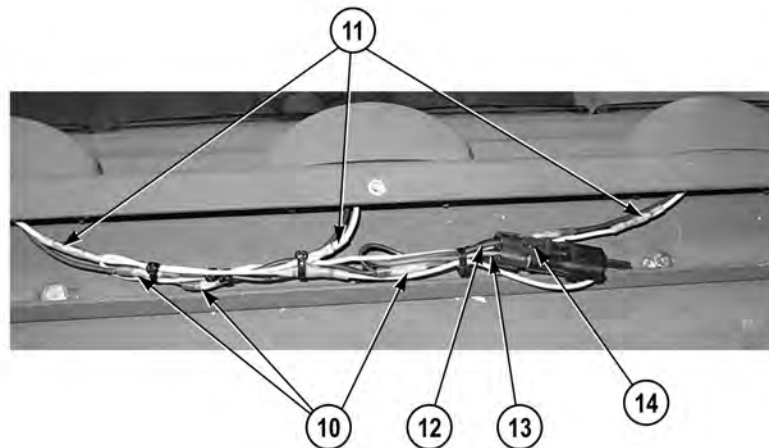
All three clearance lights are installed the same way. Driver side shown.

1. Install gasket (26) and mounting base (3) on mounting bracket (9) with four screws (25) and locknuts (24).





2. Install mounting bracket (9) on cab roof (23) with two screws (19), four washers (22), two lockwashers (21) and nuts (20).
3. Install two cushion clips (18) on screws (19) with two lockwashers (17) and nuts (16).
4. Install cab front lightbar (15) (WP 0224).



5. Install wire 1640 (13) and wire 2906 (12) on connector (14) (TM 9-2320-325-14&P).

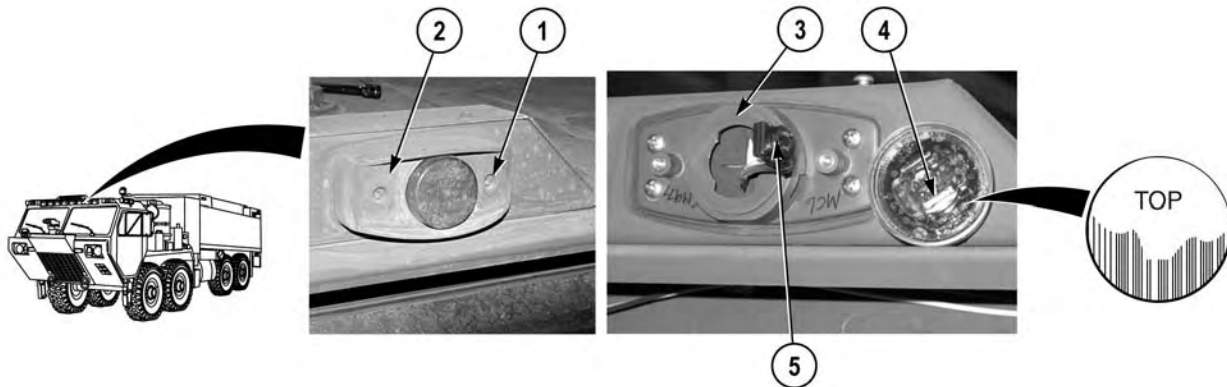
#### NOTE

Install cable ties as required.

6. Repair three wires (11) and wires (10) (TM 9-2320-325-14&P).



7. Install cover (8) on mounting bracket (9) with five washers (7) and screws (6).



**⚠ CAUTION**

**Install lamp on rubber mounting of pigtail as noted prior to removal. Failure to connect lamp on rubber mounting of pigtail correctly will not allow lamp to function.**

8. Install lamp (4) on rubber mounting of pigtail (5).

**NOTE**

Install lamp as noted prior to removal. Lamp must be installed with TOP facing up.

9. Install lamp (4) on mounting base (3).
10. Install cover (2) on mounting base (3) with two screws (1).

**END OF TASK**

**FOLLOW-ON MAINTENANCE**

Connect batteries (TM 9-2320-325-14&P)

**END OF TASK**

**END OF WORK PACKAGE**

**FIELD LEVEL MAINTENANCE**  
**WARNING LIGHT(S) REPLACEMENT**

**INITIAL SETUP:****Tools and Special Tools**

Tool Kit, General Mechanic's: Automotive  
(WP 0398, Item 17)

**References**

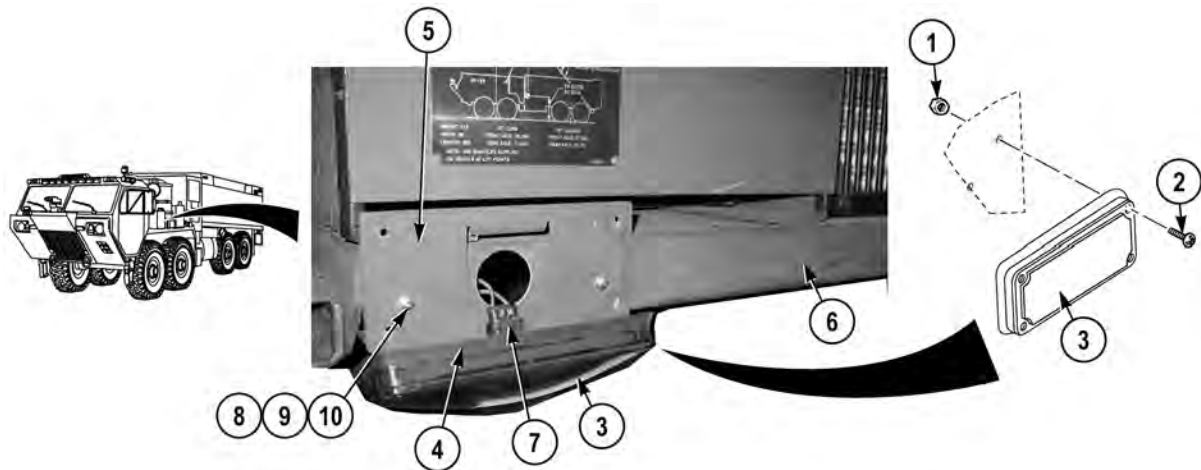
WP 0391, Fig. 27

**Materials/Parts**

Locknut (4)  
Locknut (2)

**Equipment Conditions**

Batteries disconnected (TM 9-2320-325-14&P)

**REMOVAL**

**⚠ CAUTION**

**Bottom of light and seal both have weep holes to allow water to drain. Note position of weep holes prior to removal to ensure proper installation. Failure to comply may cause damage to equipment.**

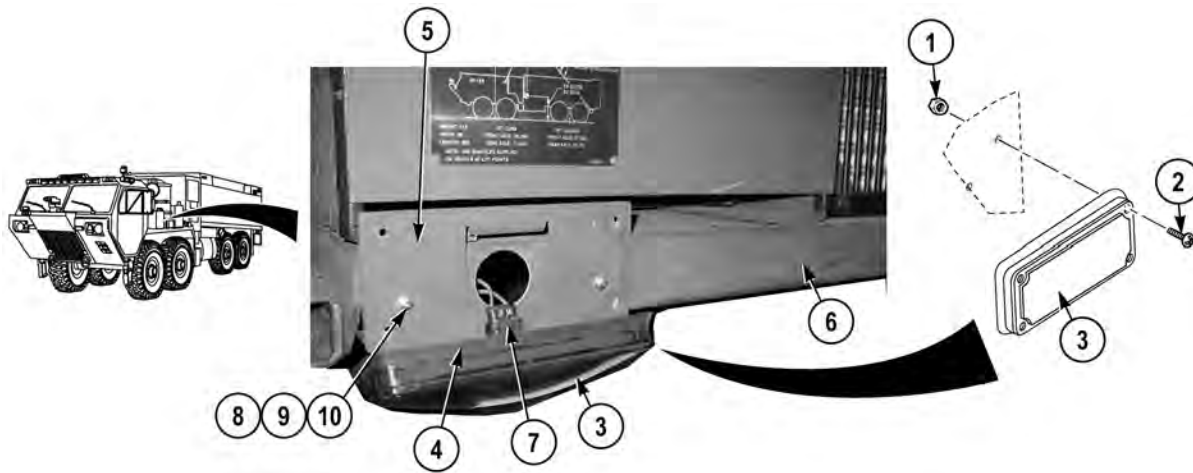
**NOTE**

All warning lights may not have brackets. Driver side shown.

1. Remove four locknuts (1), screws (2), light (3), and seal (4) from bracket (5) and fender (6). Discard locknuts.
2. Disconnect warning light main harness connector (7) from light (3).
3. Remove two locknuts (8), washers (9), screws (10), and bracket (5) from fender (6). Discard locknuts.

**END OF TASK**

## INSTALLATION

**NOTE**

All warning lights installed similarly. Driver side shown.

1. Install bracket (5) on fender (6) with two screws (10), washers (9), and locknuts (8).
2. Connect warning light main harness connector (7) on light (3).

**⚠ CAUTION**

**Bottom of light and seal both have weep holes to allow water to drain. Note position of weep holes prior to removal to ensure proper installation. Failure to comply may cause damage to equipment.**

3. Install seal (4) and light (3) on bracket (5) and fender (6) with four screws (2) and locknuts (1).

**END OF TASK**

**FOLLOW-ON MAINTENANCE**

Connect batteries (TM 9-2320-325-14&P)

**END OF TASK**

**END OF WORK PACKAGE**

---

**FIELD LEVEL MAINTENANCE**  
**OVERHEAD WARNING BEACON REPLACEMENT**

---

**INITIAL SETUP:****Tools and Special Tools**

Tool Kit, General Mechanic's: Automotive  
(WP 0398, Item 17)

**Materials/Parts**

Locknut (2)

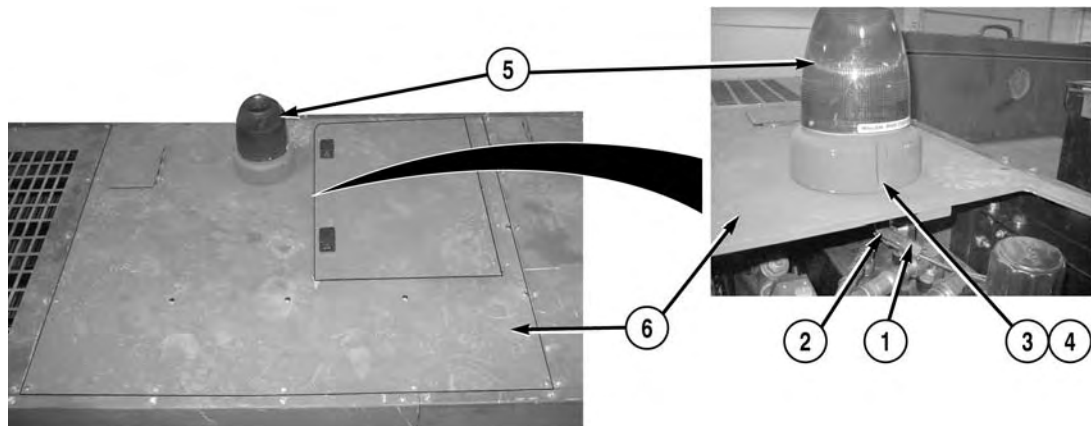
**References**

WP 0391, Fig. 31, 72

**Equipment Conditions**

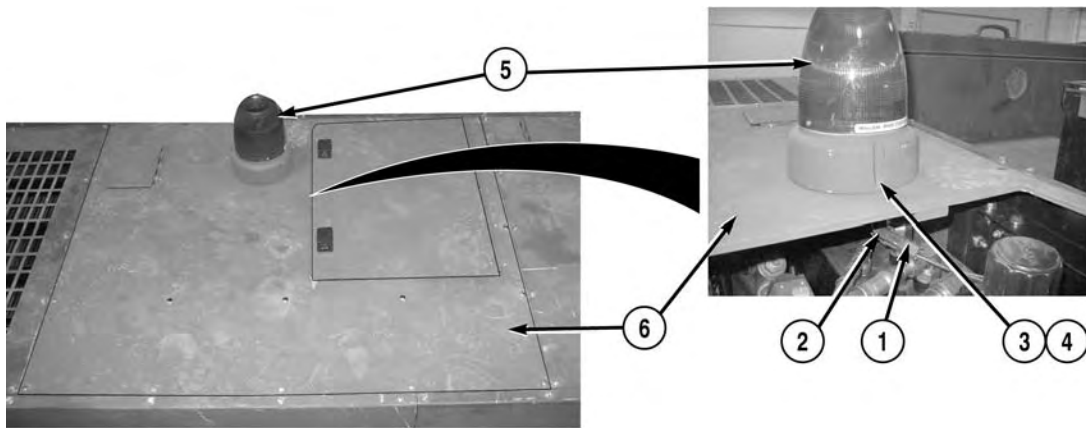
Batteries disconnected (TM 9-2320-325-14&P)  
Pump house panel K access door  
opened (WP 0008)

---

**REMOVAL**

1. Disconnect main wire harness connector (1) from beacon light connector (2).
2. Remove two locknuts (3), screws (4), and beacon light (5) from pump house panel K (6). Discard locknuts.

**END OF TASK**

**INSTALLATION**

1. Install beacon light (5) on pump house panel K (6) with two screws (4) and locknuts (3).
2. Connect main wire harness connector (1) on beacon light connector (2).

**END OF TASK****FOLLOW-ON MAINTENANCE**

1. Close pump house panel K access door (WP 0008)
2. Connect batteries (TM 9-2320-325-14&P)

**END OF TASK****END OF WORK PACKAGE**

---

**FIELD LEVEL MAINTENANCE**  
**SCENE LIGHT(S) REPLACEMENT**

---

**INITIAL SETUP:****Tools and Special Tools**

Tool Kit, General Mechanic's: Automotive  
(WP 0398, Item 17)

**References**

WP 0391, Fig. 21

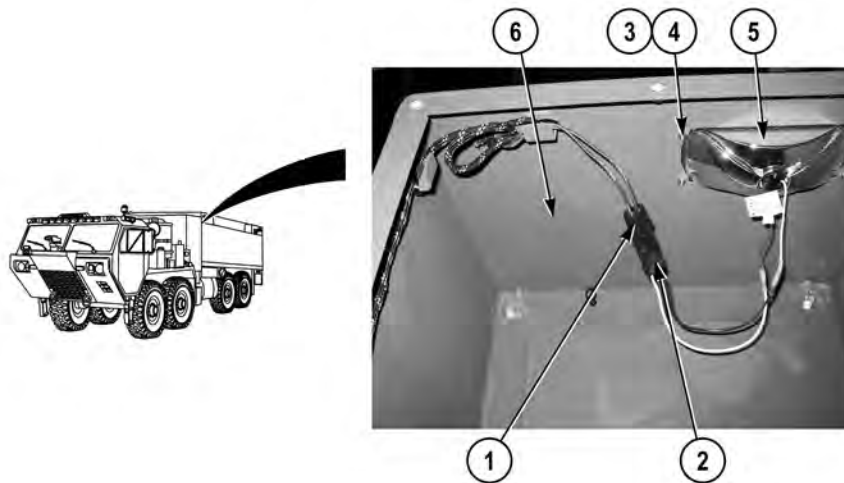
**Materials/Parts**

Tags, Identification (WP 0400, Item 23)  
Locknut (4)

**Equipment Conditions**

Batteries disconnected (TM 9-2320-325-14&P)  
Light bezel cover removed (WP 0335)

---

**REMOVAL****NOTE**

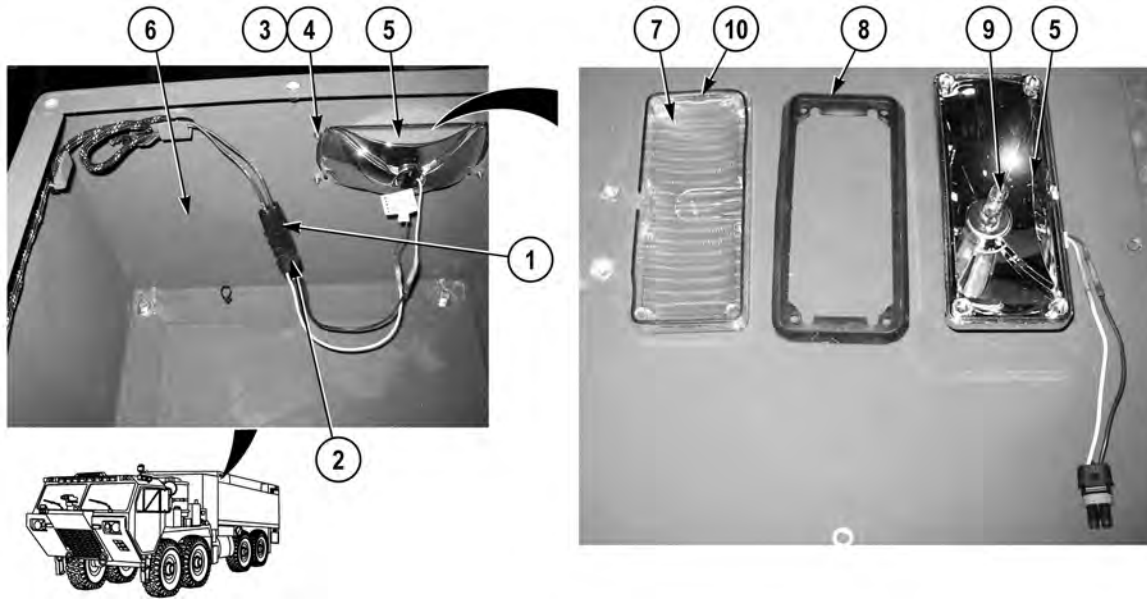
- All scene lights are removed the same way. Driver side front bezel box and scene light shown.
- Tag and mark wires prior to removal to ensure proper installation.

1. Disconnect upper driver side body wire harness connector (1) from scene light connector (2).

**NOTE**

Note top of scene light and gaskets prior to removal to ensure proper installation.

2. Remove four locknuts (3), screws (4), and scene light (5) from bezel box (6). Discard locknuts.



3. Remove lens (7), gasket (8), and light bulb (9) from scene light (5).
4. Remove gasket (10) from lens (7).

**END OF TASK**

**INSTALLATION**

**NOTE**

- All scene lights are installed the same way. Driver side front bezel box and scene light shown.
- Install scene light and gaskets as noted prior to removal.

1. Install gasket (10) on lens (7).
2. Install light bulb (9), gasket (8), and lens (7) on scene light (5).
3. Install scene light (5) on bezel box (6) with four screws (4) and locknuts (3).
4. Connect scene light connector (2) on upper driver side body wire harness connector (1).

**END OF TASK**

**FOLLOW-ON MAINTENANCE**

1. Install light bezel cover (WP 0335)
2. Connect batteries (TM 9-2320-325-14&P)

**END OF TASK**

**END OF WORK PACKAGE**



---

**FIELD LEVEL MAINTENANCE****STEP LIGHT(S) REPLACEMENT**

---

**INITIAL SETUP:****Tools and Special Tools**

Tool Kit, General Mechanic's: Automotive  
(WP 0398, Item 17)

**References**

WP 0391, Fig. 62

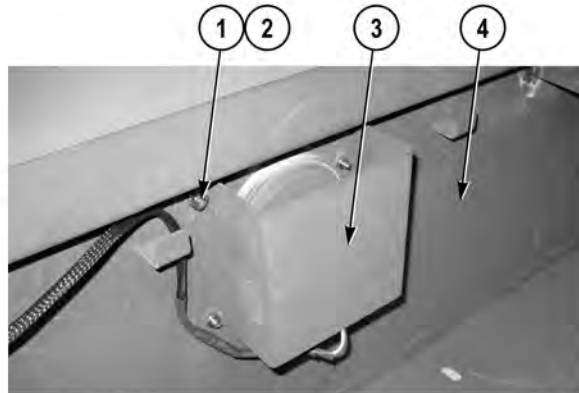
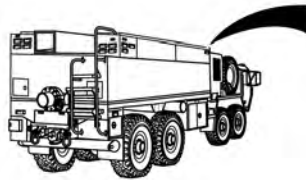
**Materials/Parts**

Locknut (4)  
Locknut (7)

**Equipment Conditions**

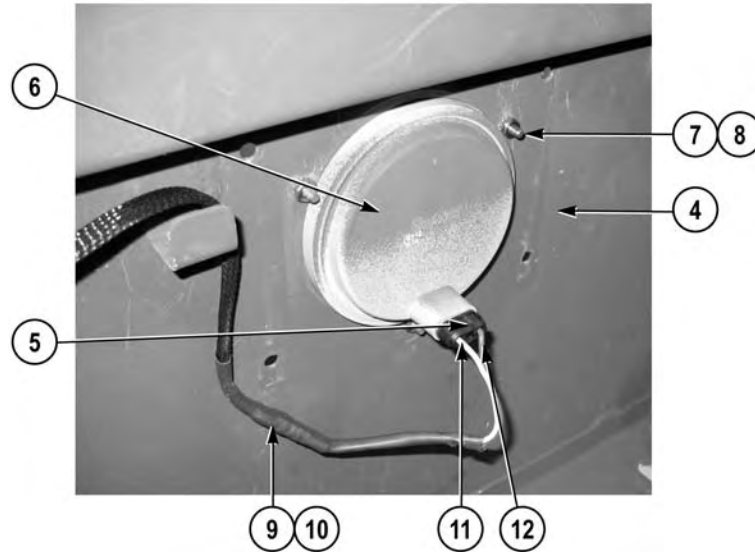
Batteries disconnected (TM 9-2320-325-14&P)  
Open stowage compartment doors (WP 0008)

---

**REMOVAL****NOTE**

All step lights are removed the same way. Top front passenger side stowage compartment box shown.

1. Remove four locknuts (1), screws (2), and guard (3) from stowage compartment box (4). Discard locknuts.



2. Disconnect step light connector (5) from step light (6).
3. Remove three locknuts (7), screws (8), and step light (6) from stowage compartment box (4). Discard locknuts.

#### **NOTE**

Perform Step (4) if step light connector was removed.

4. Cut wire 1615 (9) and wire 2740 (10) from step light connector wire (11) and wire (12) (TM 9-2320-325-14&P)

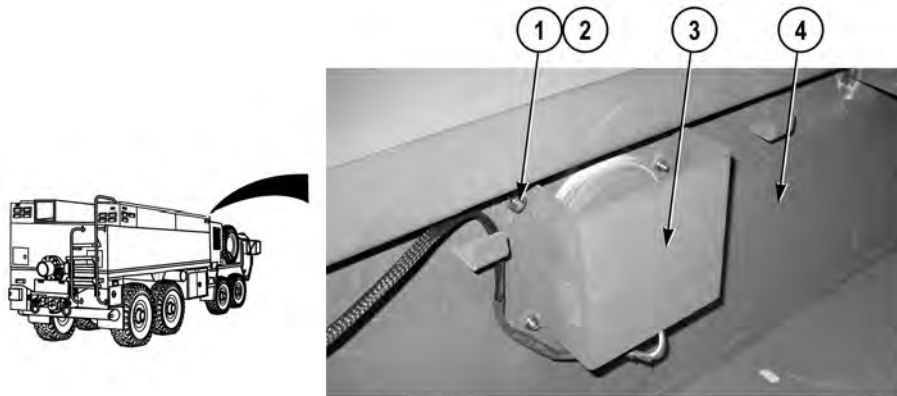
#### **END OF TASK**

#### **INSTALLATION**

#### **NOTE**

Perform Step (1) if step light connector was removed.

1. Connect step light connector wire (12) and wire (11) on wire 2740 (10) and wire 1615 (9) (TM 9-2320-325-14&P)
2. Install step light (6) on stowage compartment box (4) with three screws (8) and locknuts (7).
3. Connect step light connector (5) on step light (6).



4. Install guard (3) on stowage compartment box (4) with four screws (2) and locknuts (1).

**END OF TASK**

#### **FOLLOW-ON MAINTENANCE**

1. Close stowage compartment doors (WP 0008)
2. Connect batteries (TM 9-2320-325-14&P)

**END OF TASK**

**END OF WORK PACKAGE**



## FIELD LEVEL MAINTENANCE

## DOME LIGHT REPLACEMENT

## INITIAL SETUP:

**Tools and Special Tools**

Tool Kit, General Mechanic's: Automotive  
(WP 0398, Item 17)

**References**

WP 0391, Fig. 33

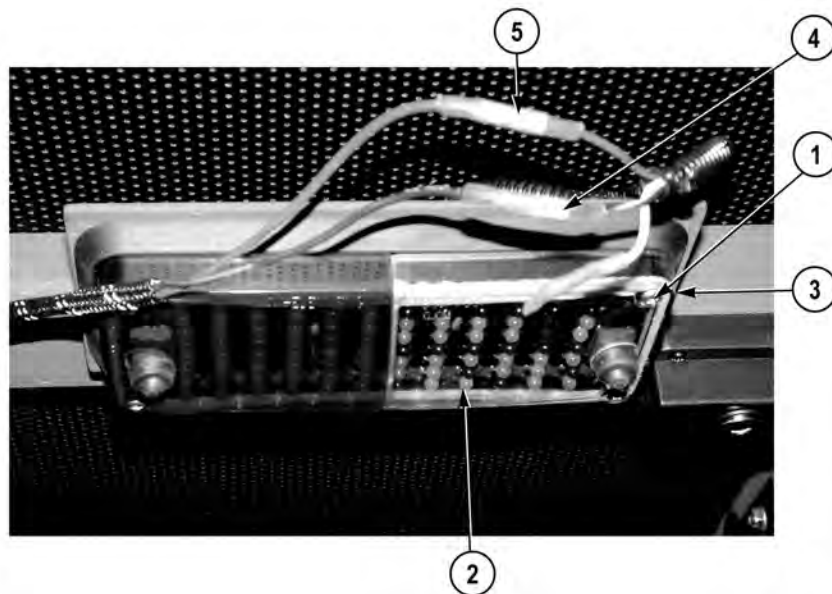
**Materials/Parts**

Tags, Identification (WP 0400, Item 23)

**Equipment Conditions**

Batteries disconnected (TM 9-2320-325-14&P)

## REMOVAL

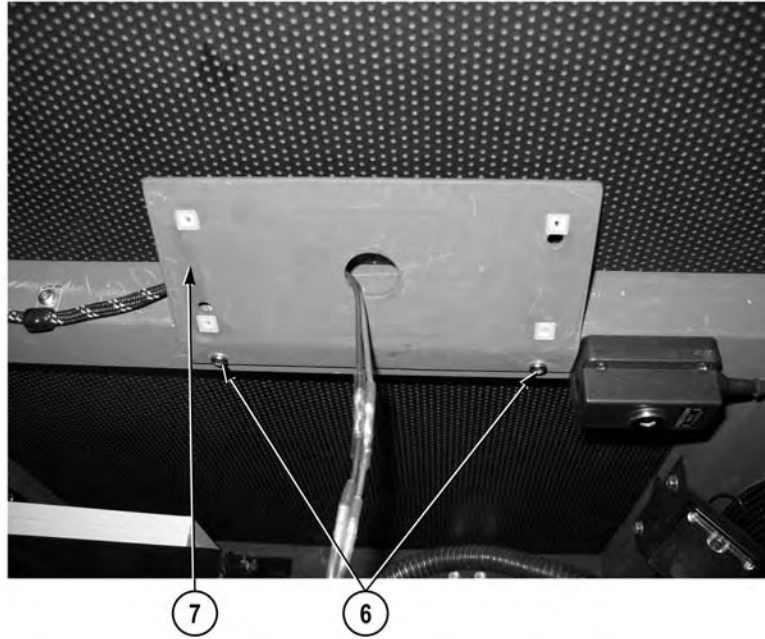


1. Remove four screws (1) and light (2) from bracket (3).

**NOTE**

Tag and mark wires prior to removal to ensure proper installation.

2. Cut wire 2640 (4) and wire 1047 (5) (TM 9-2320-325-14&P)

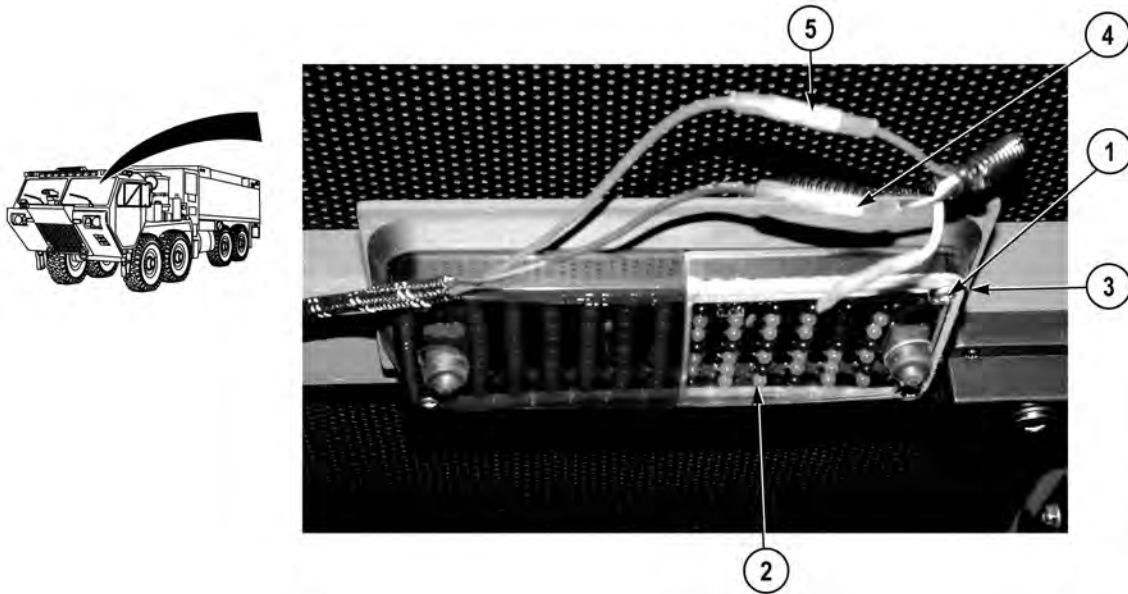


3. Remove two screws (6) and bracket (7) from vehicle.

#### **END OF TASK**

#### **INSTALLATION**

1. Install bracket (7) on vehicle with two screws (6).



2. Repair wire 1047 (5) and wire 2640 (4) (TM 9-2320-325-14&P)
3. Install light (2) and four screws (1) on bracket (3).

**END OF TASK**

**FOLLOW-ON MAINTENANCE**

Connect batteries (TM 9-2320-325-14&P)

**END OF TASK**

**END OF WORK PACKAGE**





---

**FIELD LEVEL MAINTENANCE**  
**BATTERY DISCONNECT SWITCH REPLACEMENT**

---

**INITIAL SETUP:****Tools and Special Tools**

Tool Kit, General Mechanic's: Automotive  
(WP 0398, Item 17)

**References**

WP 0391, Fig. 35

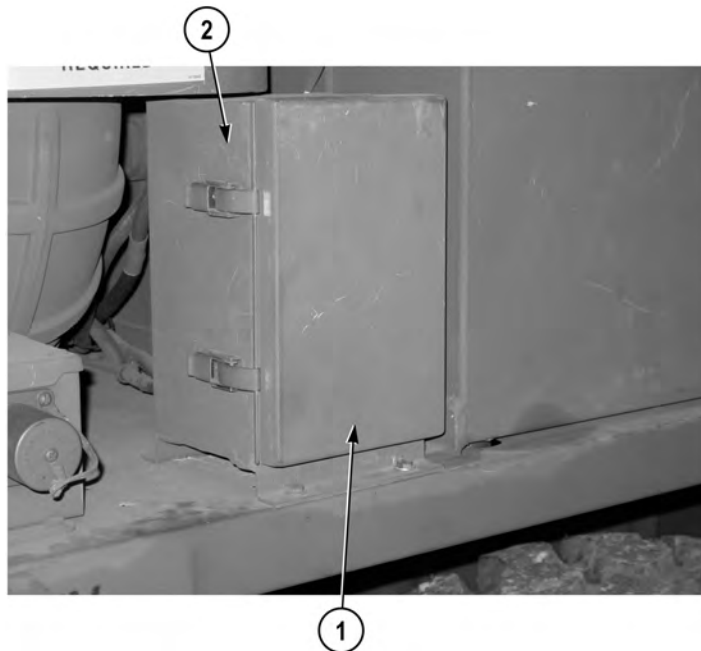
**Materials/Parts**

Compound, Sealing (WP 0400, Item 10)  
Tags, Identification (WP 0400, Item 23)  
Lockwasher (4)  
Lockwasher (4)  
Locknut (2)

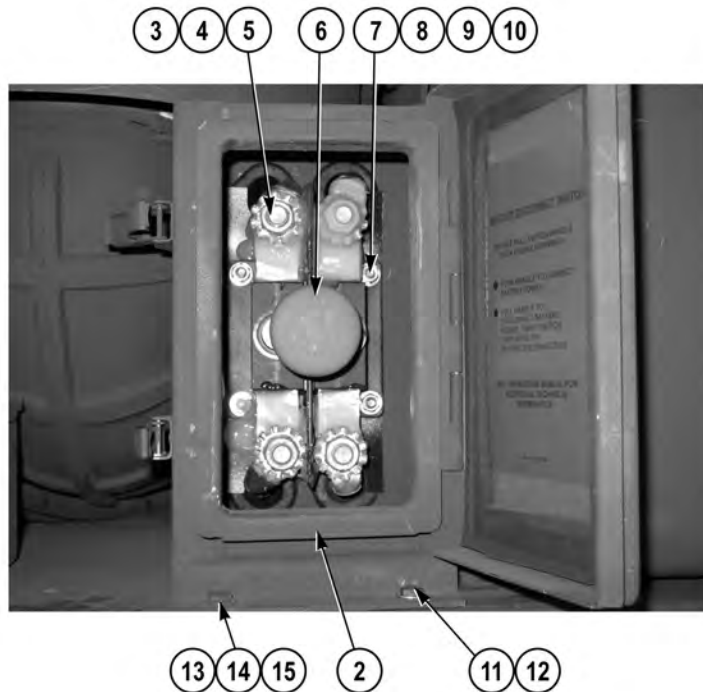
**Equipment Conditions**

Batteries disconnected (TM 9-2320-325-14&P)

---

**REMOVAL**

1. Open door (1) on battery disconnect switch box (2).



### NOTE

Tag and mark wires before removal to ensure proper installation.

2. Remove four nuts (3), lockwashers (4), and wires (5) from battery disconnect switch (6). Discard lockwashers.
3. Remove four nuts (7), lockwashers (8), washers (9), screws (10), and battery disconnect switch (6) from battery disconnect switch box (2). Discard lockwashers.

### NOTE

Perform Steps (4) through (7) if removing battery disconnect switch box.

4. Remove four wires (5) from battery disconnect switch box (2).
5. Remove two screws (11) and washers (12) from battery disconnect switch box (2) and vehicle.
6. Remove two screws (13), washers (14), and locknuts (15) from battery disconnect switch box (2) and vehicle. Discard locknuts.
7. Remove battery disconnect switch box (2) from vehicle.

**END OF TASK**

---

**INSTALLATION****NOTE**

Perform Steps (1) through (3) if battery disconnect switch box was removed.

1. Install battery disconnect switch box (2) on vehicle with two locknuts (15), four washers (14), and two screws (13).
2. Install two washers (12) and screws (11) on battery disconnect switch box (2) and vehicle.
3. Install four wires (5) in battery disconnect switch box (2).
4. Install battery disconnect switch (6) in battery disconnect switch box (2) with four screws (10), washers (9), lockwashers (8), and nuts (7).

**NOTE**

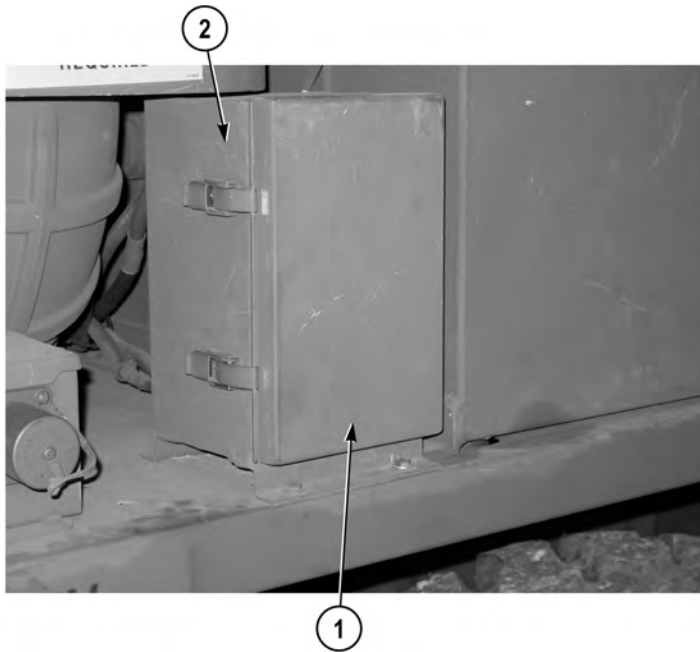
Install wires as noted prior to removal.

5. Install four wires (5) on battery disconnect switch (6) with four lockwashers (4) and nuts (3).

**WARNING**

**Adhesives, solvents, and sealing compounds can burn easily, can give off harmful vapors, and are harmful to skin and clothing. To avoid injury or death, keep away from open fire and use in well-ventilated area. If adhesive, solvent, or sealing compound gets on skin or clothing, wash immediately with soap and water.**

6. Apply sealing compound to four wires (5), lockwashers (4), and nuts (3).



7. Close door (1) on battery disconnect switch box (2).

**END OF TASK**

**FOLLOW-ON MAINTENANCE**

Connect batteries (TM 9-2320-325-14&P)

**END OF TASK**

**END OF WORK PACKAGE**

## FIELD LEVEL MAINTENANCE

## 24-VOLT 10 AMP PER BANK BATTERY CHARGER AND BRACKET REPLACEMENT

## INITIAL SETUP:

**Tools and Special Tools**

Tool Kit, General Mechanic's: Automotive  
(WP 0398, Item 17)

**Materials/Parts**

Tags, Identification (WP 0400, Item 23)  
Ties, Cable, Plastic (WP 0400, Item 26)  
Lockwasher (1)  
Lockwasher (1)  
Lockwasher (1)  
Lockwasher (3)  
Lockwasher (4)

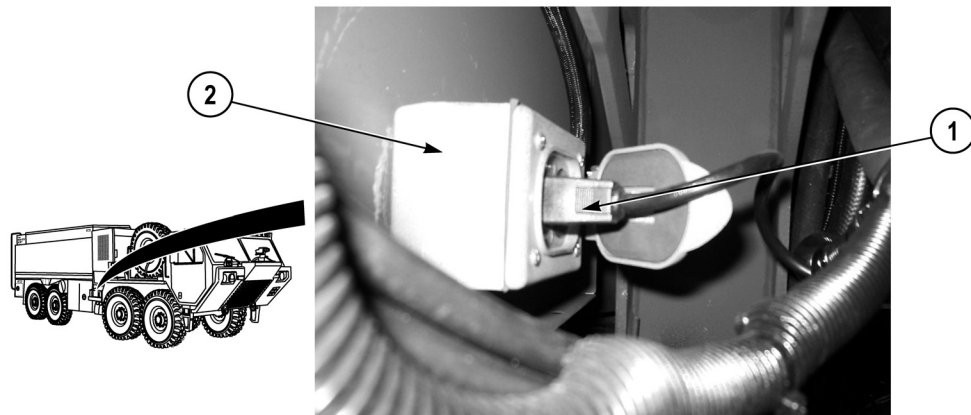
**References**

WP 0159  
WP 0162  
WP 0171  
WP 0215  
WP 0321  
WP 0326  
WP 0384  
WP 0391, Fig. 41

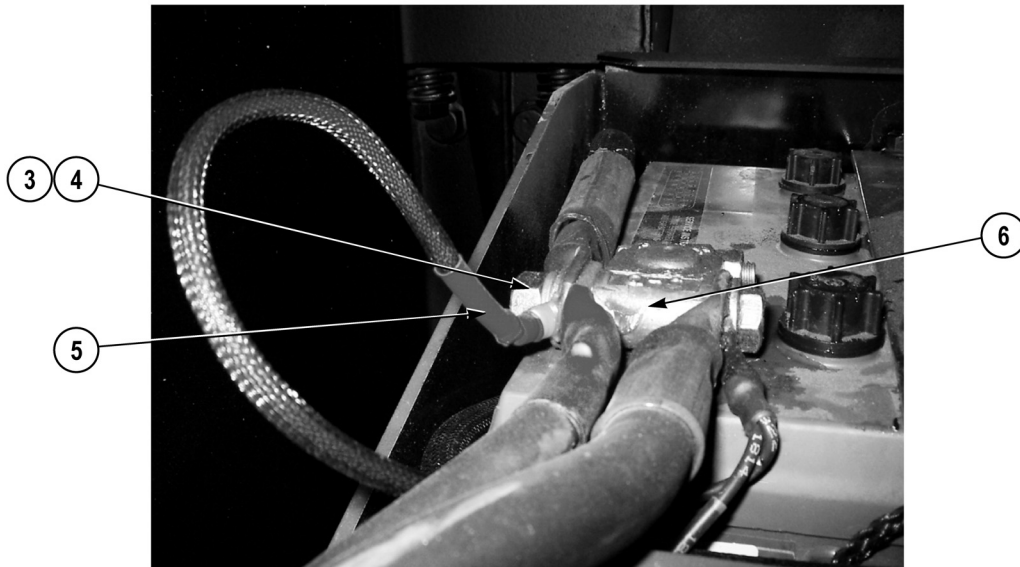
**Equipment Conditions**

Batteries disconnected (TM 9-2320-325-14&P  
Deleted)

## REMOVAL



1. Remove power cord plug (1) from receptacle (2).

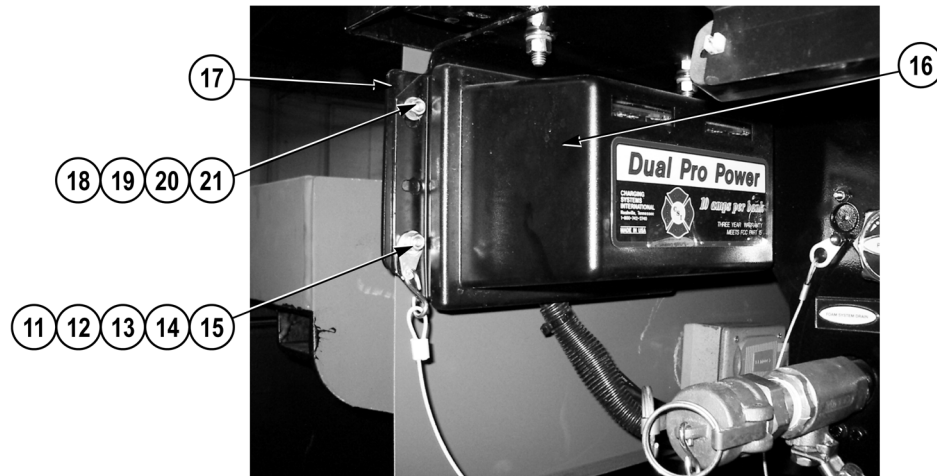


**NOTE**

- Tag and mark wires prior to removal to ensure proper installation.
  - Remove split loom and plastic ties as required.
2. Remove nut (3), lockwasher (4), and braided red wire (5) from cable terminal (6). Discard lockwasher.



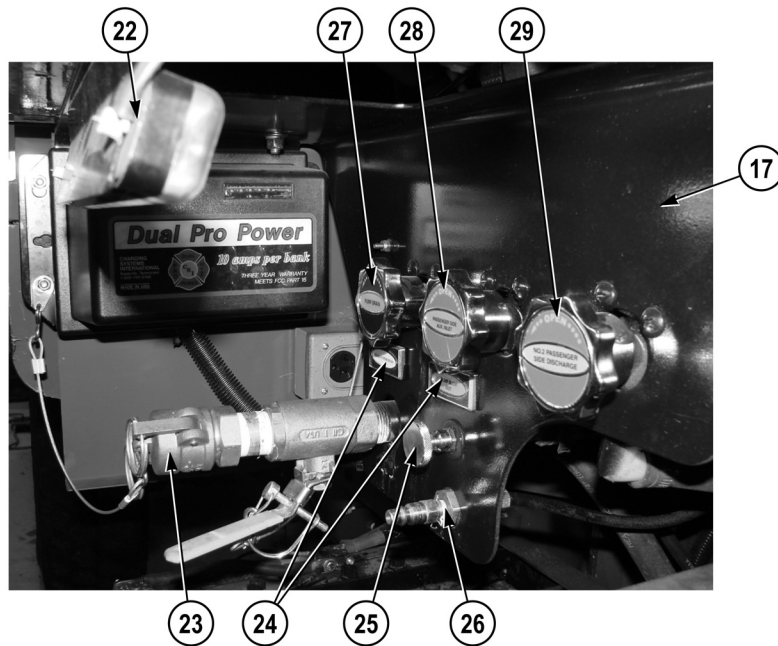
3. Remove nut (7), lockwasher (8), and braided black wire (9) from cable terminal (10). Discard lockwasher.



4. Remove nut (11), lockwasher (12), two washers (13), clip (14), and screw (15) from 24-volt 10 amp per bank battery charger (16) and bracket (17). Discard lockwasher.
5. Remove three nuts (18), lockwashers (19), six washers (20), three screws (21), and 24-volt 10 amp per bank battery charger (16) from bracket (17). Discard lockwashers.

#### NOTE

- The 10 amp per bank battery charger has been replaced with a 15 amp per bank battery charger effective February 2009. If the 10 amp per bank battery charger is not defective and is being reinstalled continue with this work package.
- If 10 amp per bank battery charge is defective and needs to be replaced, proceed to the installation of 15 amp per bank battery charger (WP 0237.1).



### NOTE

Perform Steps (6) through (14) if bracket needs to be removed.

6. Remove striplight and bracket (22) from bracket (17) (WP 0215).
7. Remove foam system drain valve (23) from bracket (17) (WP 0171).
8. Remove decals and data plates (24) from bracket (17) (WP 0326).
9. Remove water pump blow out valve (25) from bracket (17) (WP 0384).
10. Remove water pump blow out air line and fitting (26) from bracket (17) (WP 0384).
11. Remove pump drain valve (27) from bracket (17) (WP 0321).
12. Remove passenger side auxiliary inlet valve (28) from bracket (17) (WP 0159).
13. Remove No. 2 passenger side discharge valve (29) from bracket (17) (WP 0162).





14. Remove four nuts (30), lockwashers (31), eight washers (32), four screws (33), and bracket (17) from pump house frame (34) and vehicle. Discard lockwashers.

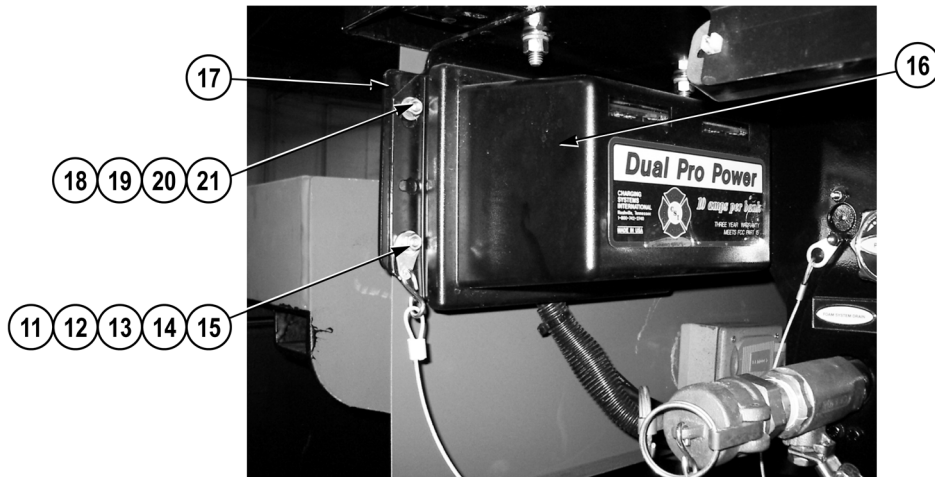
#### END OF TASK

#### INSTALLATION

#### NOTE

Perform Steps (1) through (9) if bracket was removed.

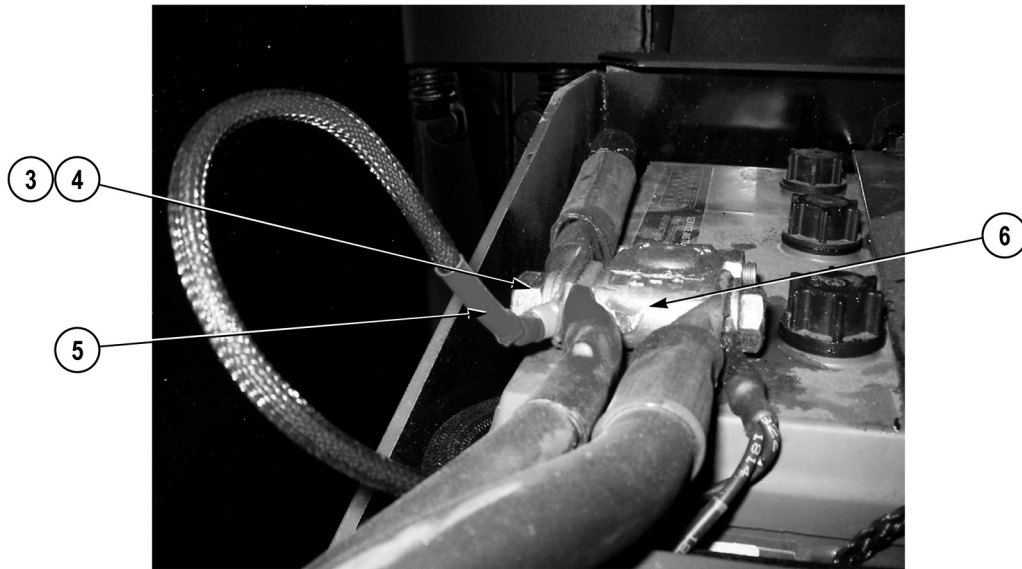
1. Install bracket (17) on pump house frame (34) with four screws (33), eight washers (32), four lockwashers (31), and four nuts (30).
2. Install No. 2 passenger side discharge valve (29) on bracket (17) (WP 0162).
3. Install passenger side auxiliary inlet valve (28) on bracket (17) (WP 0159).
4. Install pump drain valve (27) on bracket (17) (WP 0321).
5. Install water pump blow out air line and fitting (26) on bracket (17) (WP 0384).
6. Install water pump blow out valve (25) on bracket (17) (WP 0384).
7. Install decals and data plates (24) on bracket (17) (WP 0326).
8. Install foam system drain valve (23) on bracket (17) (WP 0171).
9. Install striplight and bracket (22) on bracket (17) (WP 0215).



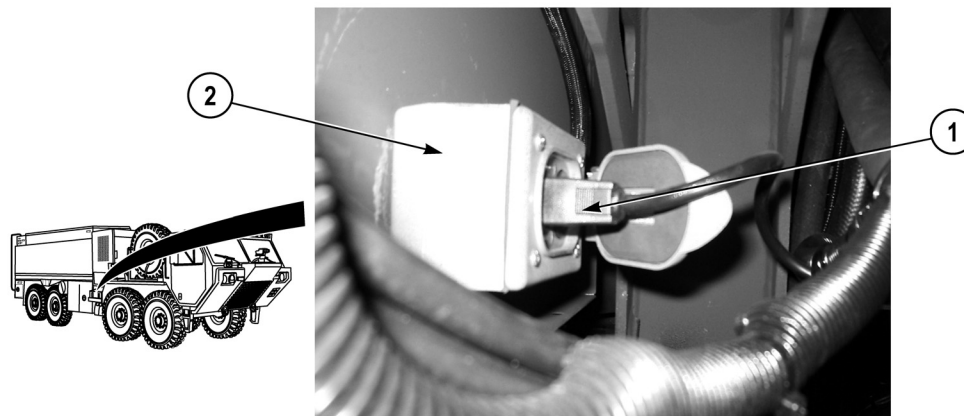
- 10. Install 24-volt 10 amp per bank battery charger (16) on bracket (17) with three screws (21), six washers (20), three lockwashers (19), and nuts (18).
- 11. Install clip (14) on battery (17) and 24-volt 10 amp per bank battery charger (16) with screw (15), two washers (13), lockwasher (12), and nut (11).



- 12. Install braided black wire (9), lockwasher (8), and nut (7) to cable terminal (10).



13. Install braided red wire (5), lockwasher (4), and nut (3) on cable terminal (6).



14. Install power cord plug (1) in receptacle (2).

**END OF TASK**

**FOLLOW-ON MAINTENANCE**

Connect batteries (TM 9-2320-325-14&P)

**END OF TASK**

**END OF WORK PACKAGE**



---

**FIELD LEVEL MAINTENANCE****24-VOLT 15 AMP PER BANK BATTERY CHARGER REMOVAL/INSTALLATION**

---

**INITIAL SETUP:****Tools and Special Tools**

- Standard Automotive Tool Set (SATS),  
(WP 0398, Item 15)
- Wrench, Torque, Click, Ratcheting,  
1/2" Drive, 75 ft-lb
- Tool Kit, General Mechanic's: Automotive  
(WP 0398, Item 17)

**References**

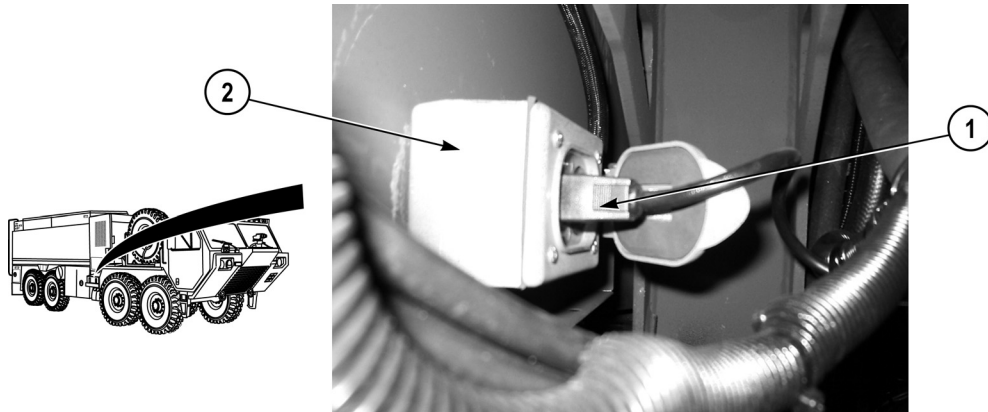
- TM 9-2320-325-14&P, Fig. 136  
WP 0391, Fig. 41

**Equipment Conditions**

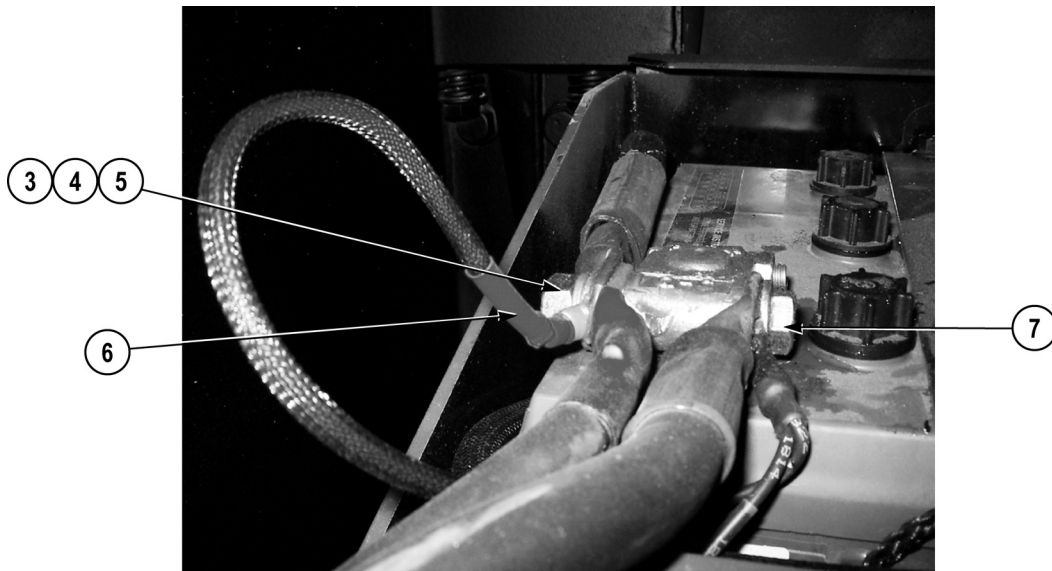
- Batteries disconnected (TM 9-2320-325-14&P)

**Materials/Parts**

- Tags, Identification (WP 0400, Item 23)  
Ties, Cable, Plastic (WP 0400, Item 26)  
Lockwasher (2)  
Lockwasher (8)
- 

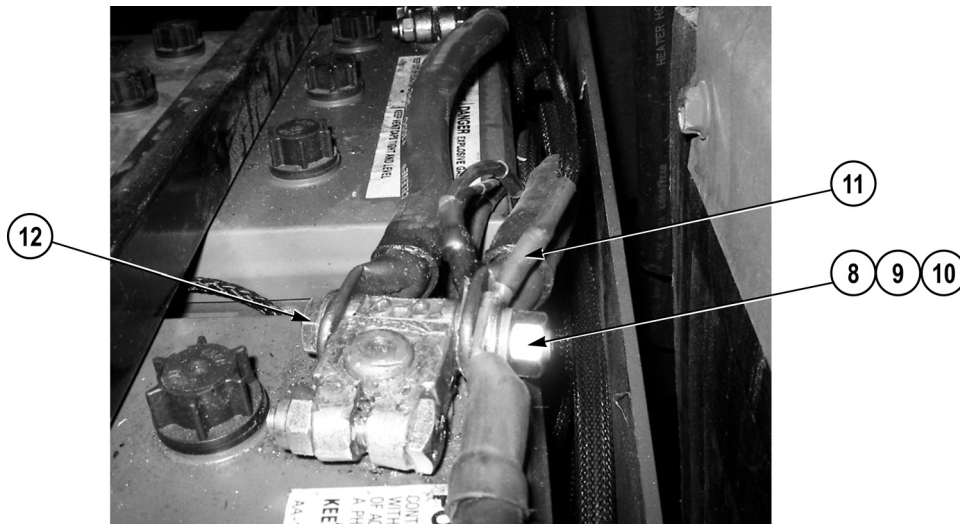
**REMOVAL**

1. Remove power cord plug (1) from receptacle (2).

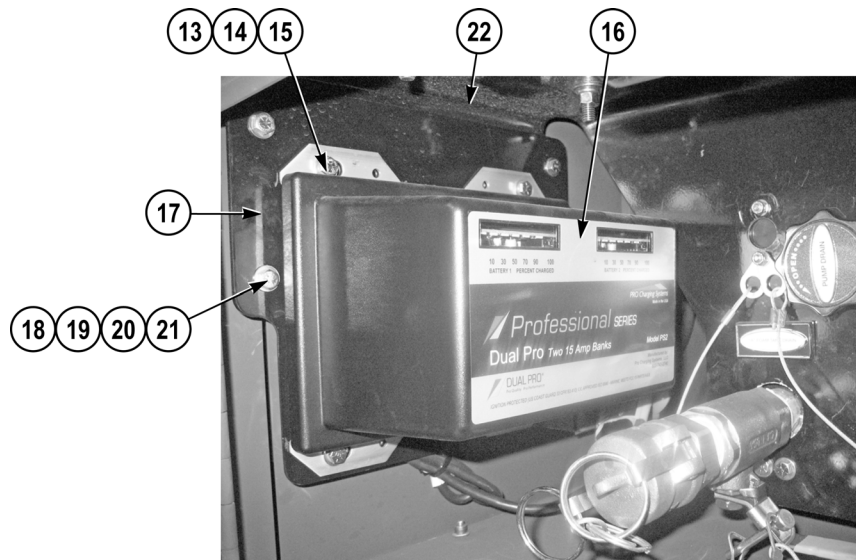


### NOTE

- Tag and mark wires prior to removal to ensure proper installation.
  - Remove split loom and cable ties as required.
2. Remove nut (3), lockwasher (4), washer (5), and braided red wire (6) from screw (7). Discard lockwasher.



3. Remove nut (8), lockwasher (9), washer (10), and braided black wire (11) from screw (12). Discard lockwasher.



4. Remove four screws (13), lockwashers (14), washers (15), and 24-volt 15 amp per bank battery charger (16) from bracket (17). Discard lockwashers.
5. Remove four nuts (18), lockwashers (19), eight washers (20), four screws (21), and bracket (17) from bracket (22). Discard lockwasher.

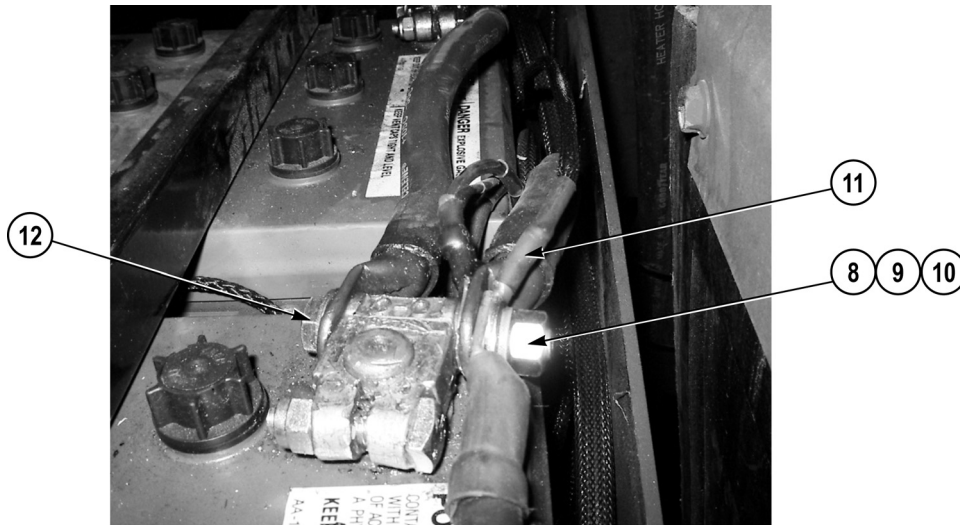
#### END OF TASK

#### INSTALLATION

#### NOTE

Bracket (17) must be installed on bracket (22) when installing 15 amp per bank battery charger.

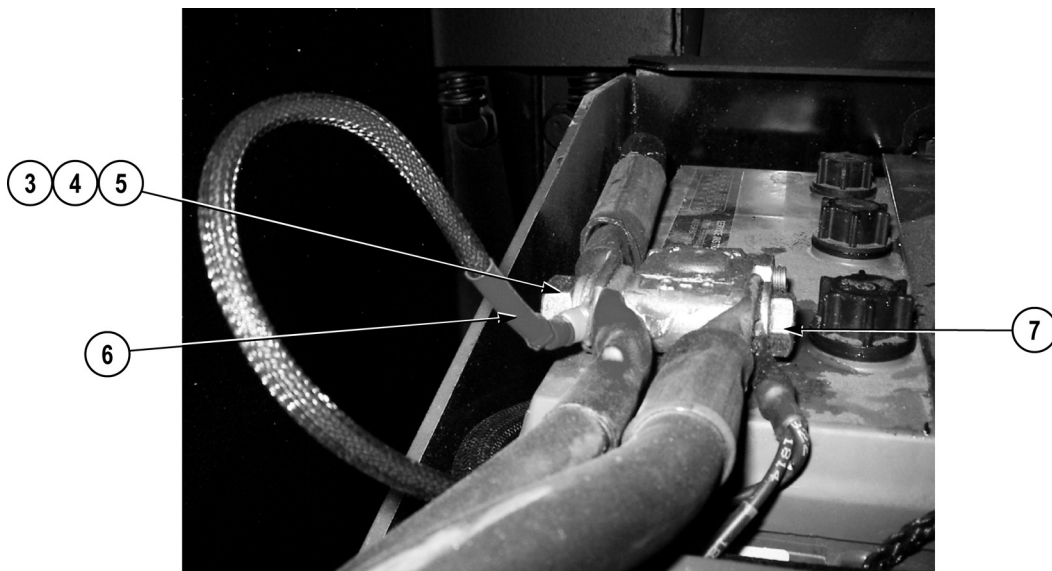
1. Install bracket (17) on bracket (22) with four screws (21), eight washers (20), four lockwashers (19), and nuts (18).
2. Install 24-volt 15 amp per bank battery charger (16) on bracket (17) with four washers (15), lockwashers (14), and screws (13).



### NOTE

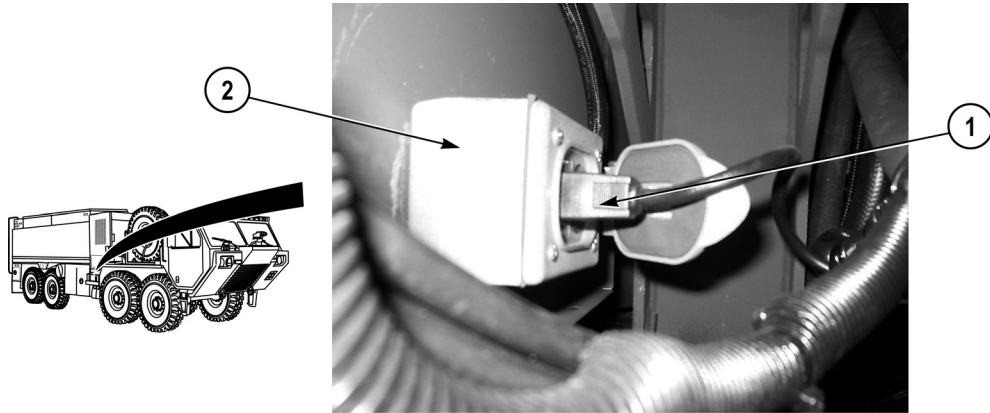
Install split loom and cable ties as required.

3. Install braided black wire (11) on screw (12) with washer (10), lockwasher (9), and nut (8). Tighten nut to 12 to 16 lb-ft (16 to 21 N•m).



4. Install braided red wire (6) on screw (7) with washer (5), lockwasher (4), and nut (3). Tighten nut to 12 to 16 lb-ft (16 to 21 N•m).





5. Install power cord plug (1) in receptacle (2).

**END OF TASK**

**FOLLOW-ON MAINTENANCE**

Connect batteries (TM 9-2320-325-14&P)

**END OF TASK**

**END OF WORK PACKAGE**



## FIELD LEVEL MAINTENANCE

## BATTERY BOX AND BRACKET REPLACEMENT

## INITIAL SETUP:

**Tools and Special Tools**

- Standard Automotive Tool Set (SATS),  
(WP 0398, Item 15)
- Wrench, Torque, Click, Ratcheting, 1/2" Drive  
250 ft-lb, Regular, 1-1/8"
- Tool Kit, General Mechanic's: Automotive  
(WP 0398, Item 17)

**Materials/Parts**

- Locknut (6)
- Locknut (3)
- Locknut (3)
- Locknut (3)
- Locknut (5)

**Personnel Required**

MOS 63B Wheeled Vehicle Mechanic (2)

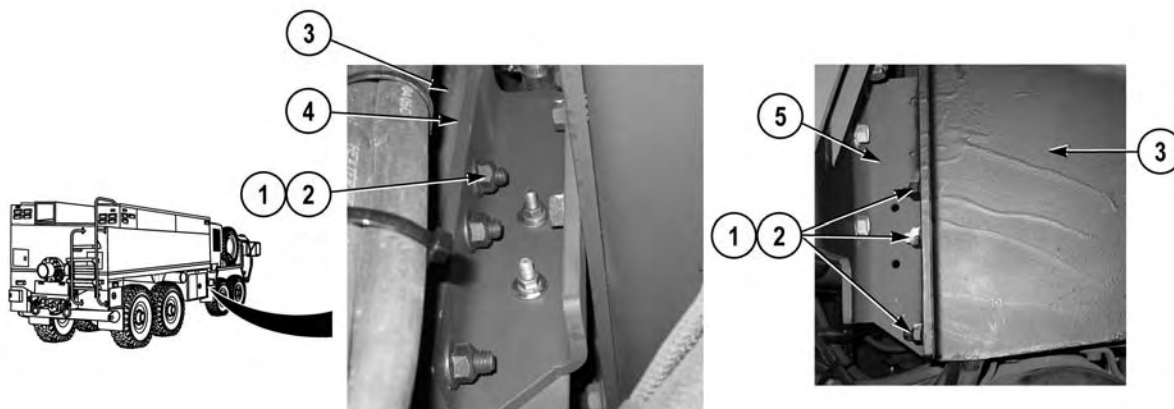
**References**

WP 0139  
WP 0391, Fig. 48

**Equipment Conditions**

Batteries removed (TM 9-2320-325-14&P)  
Air tanks 1 and 3  
removed (TM 9-2320-325-14&P)

## REMOVAL

**WARNING**

**Battery box weighs approximately 50 lb. (25 kg). Do not attempt to lift or move battery box without the aid of an assistant. Failure to comply may result in the injury to personnel and/or damage to equipment.**

1. With the aid of an assistant, remove six locknuts (1), screws (2), and battery box (3) from front battery box bracket (4) and rear battery box bracket (5). Discard locknuts.



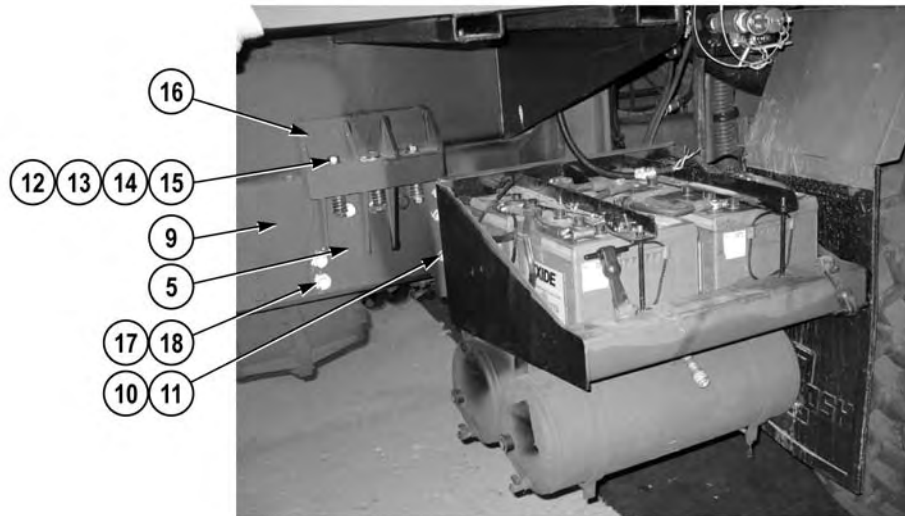
### NOTE

Perform Steps (2) through (6) if battery box brackets need to be removed.

2. Remove hydraulic drain mounting bracket (6) from front battery box bracket (4) (WP 0139).



3. Remove three locknuts (7), screws (8), and front battery box bracket (4) from frame rail (9). Discard locknuts.



4. Remove three locknuts (10) and screws (11) from rear battery box bracket (5) and frame rail (9). Discard locknuts.
5. Remove three locknuts (12), springs (13), six washers (14), and three screws (15) from water tank cradle bracket (16) and rear battery box bracket (5). Discard locknuts.
6. Remove five locknuts (17), screws (18), and rear battery box bracket (5) from frame rail (9). Discard locknuts.

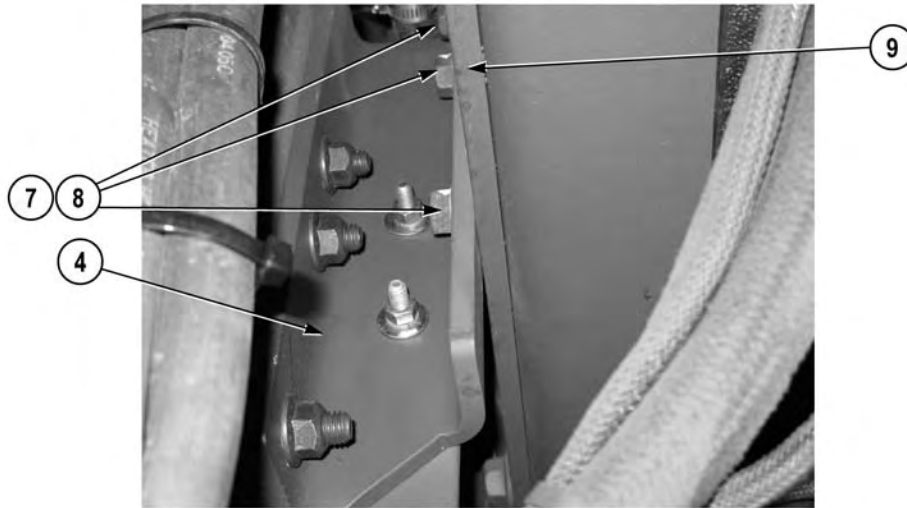
#### END OF TASK

#### INSTALLATION

#### NOTE

Perform Steps (1) through (5) if batter box brackets were removed.

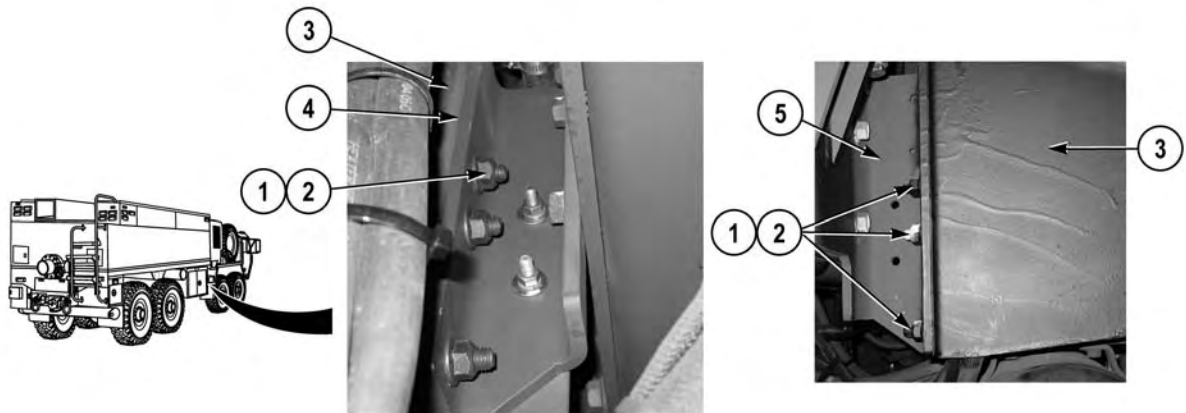
1. Install rear battery box bracket (5) on frame rail (9) with five screws (18) and locknuts (17). Tighten screws (18) to 220 lb-ft (298 N•m).
2. Install three screws (15), six washers (14), three springs (13) and locknuts (12) on rear battery box bracket (5) and water tank cradle bracket (16).
3. Install three screws (11), and locknuts (10) on frame rail (9) and rear battery box bracket (5). Tighten screws (11) to 96 lb-ft (130 N•m).



4. Install front battery box bracket (4) on frame rail (9) with three screws (8) and locknuts (7). Tighten screws (8) to 96 lb-ft (130 N•m).



5. Install hydraulic drain mounting bracket (6) on front battery box bracket (4) (WP 0139).



### **WARNING**



**Batter box weighs approximately 50 lb. (25 kg). Do not attempt to lift or move battery box without the aid of an assistant. Failure to comply may result in the injury to personnel and/or damage to equipment.**

6. Install battery box (3) on rear battery box bracket (5) and front battery box bracket (4) with six screws (2) and locknuts (1). Tighten screws (2) to 96 lb-ft (130 N•m).

**END OF TASK**

### **FOLLOW-ON MAINTENANCE**

1. Install air tanks 1 and 3 (TM 9-2320-325-14&P)
2. Install batteries (TM 9-2320-325-14&P)

**END OF TASK**

**END OF WORK PACKAGE**





---

**FIELD LEVEL MAINTENANCE**  
**120-VOLT RECEPTACLE REPLACEMENT**

---

**INITIAL SETUP:****Tools and Special Tools**

Tool Kit, General Mechanic's: Automotive  
(WP 0398, Item 17)

**References**

WP 0391, Fig. 41

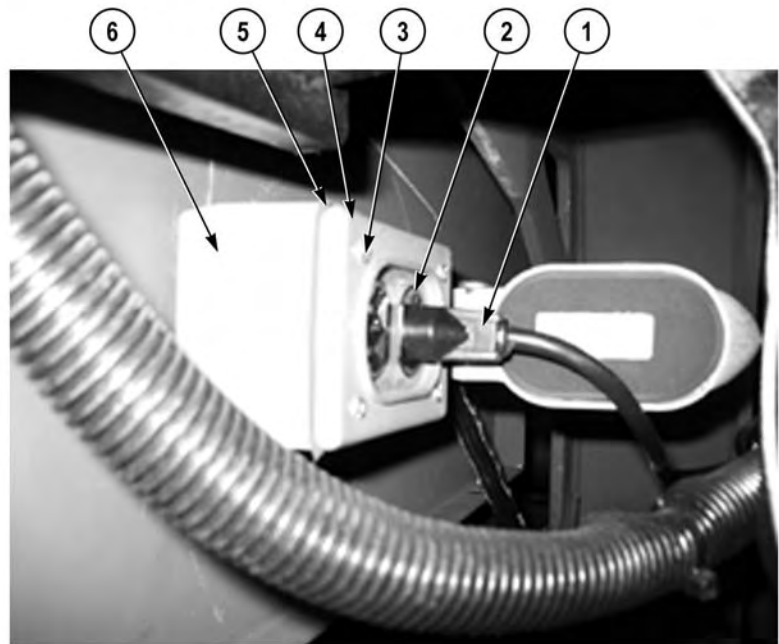
**Materials/Parts**

Tags, Identification (WP 0400, Item 23)  
Lockwasher (2)

**Equipment Conditions**

Pump house panels H and P removed (WP 0339)

---

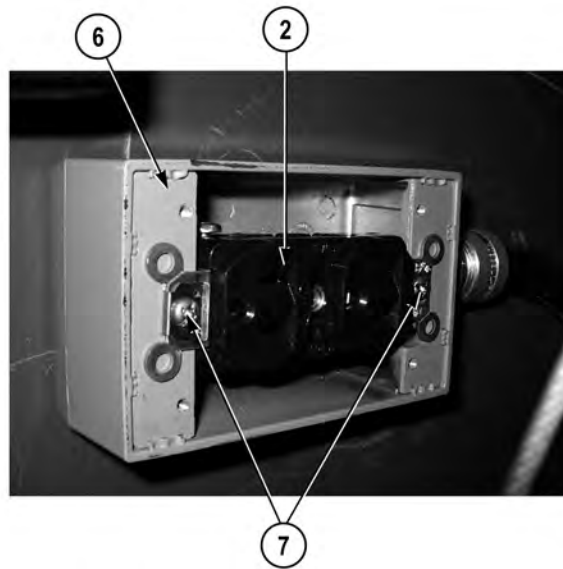
**REMOVAL**

1. Remove power cord (1) from 120-volt receptacle (2).

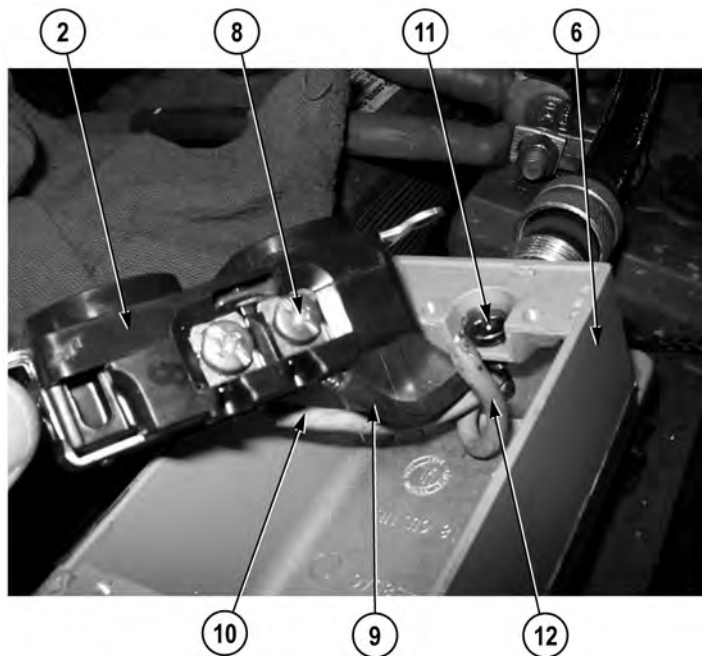
**NOTE**

Note orientation of 120-volt receptacle cover prior to removal to ensure proper installation.

2. Remove four screws (3), cover (4), and seal (5) from 120-volt receptacle box (6).



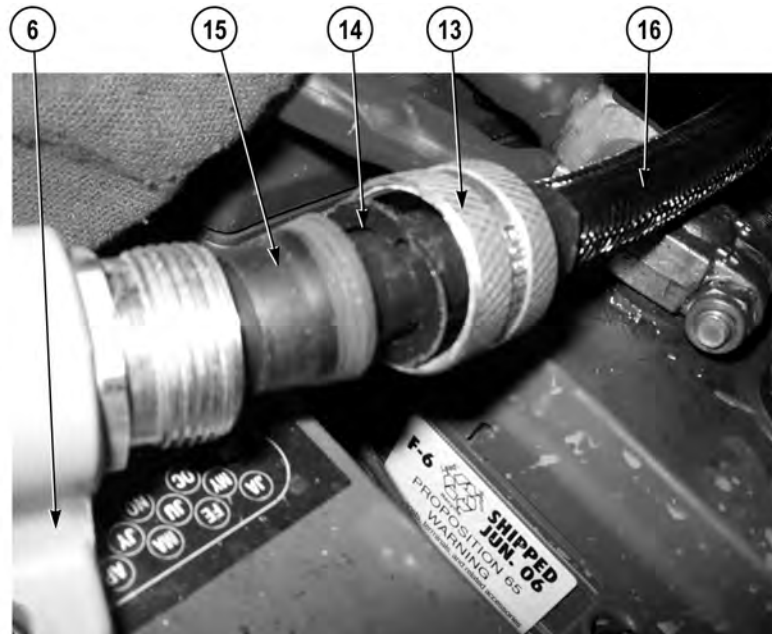
3. Remove two screws (7) and 120-volt receptacle (2) from 120-volt receptacle box (6).



#### NOTE

Tag and mark wires prior to removal to ensure proper installation.

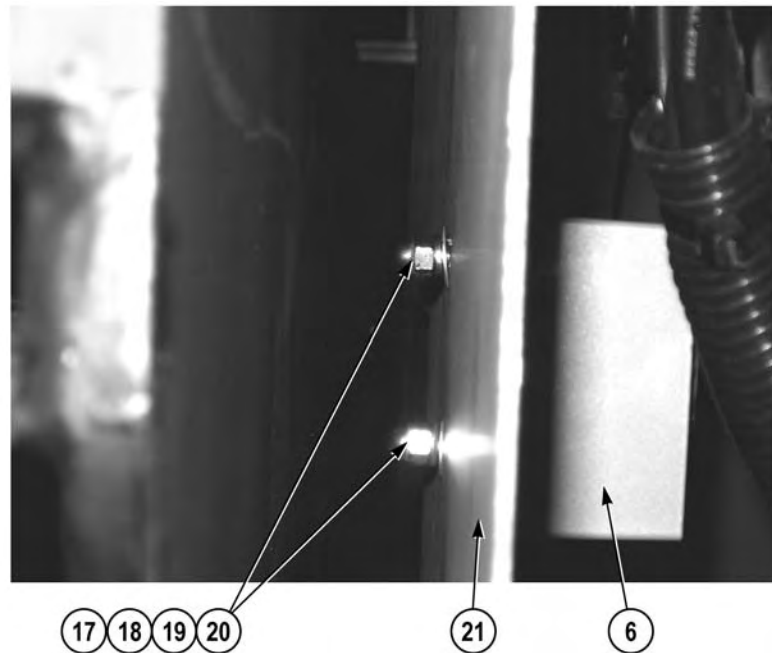
4. Loosen two screws (8) and remove black (hot) wire (9) and white (common) wire (10) from 120-volt receptacle (2).
5. Loosen screw (11) and remove green (ground) wire (12) from 120-volt receptacle box (6).



**NOTE**

Perform Steps (6) and (7) if 120-volt receptacle box needs to be removed.

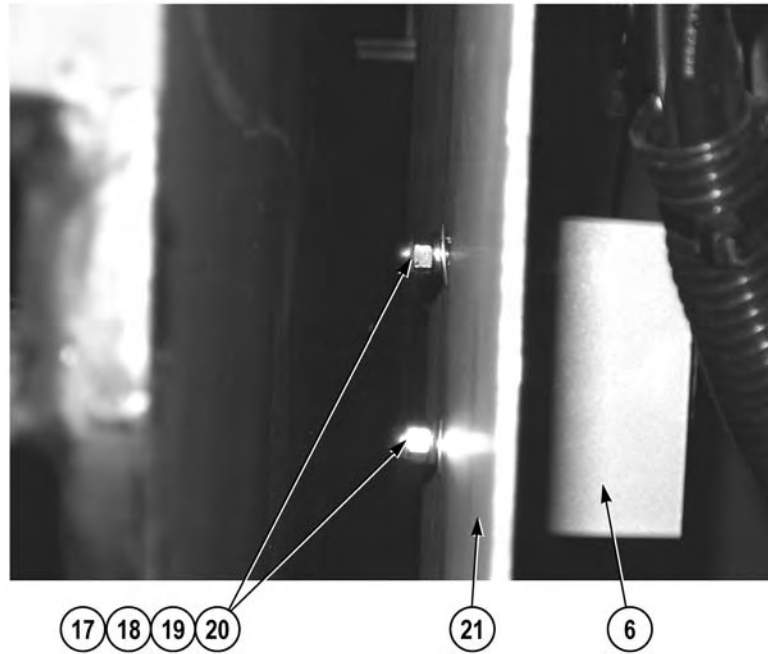
6. Remove strain relief (13), compression ring (14), rubber grommet (15), and shoreline inlet receptacle wire harness (16) from 120-volt receptacle box (6).



7. Remove two nuts (17), lockwashers (18), washers (19), screws (20), and 120-volt receptacle box (6) from pump house panel O (21). Discard lockwashers.

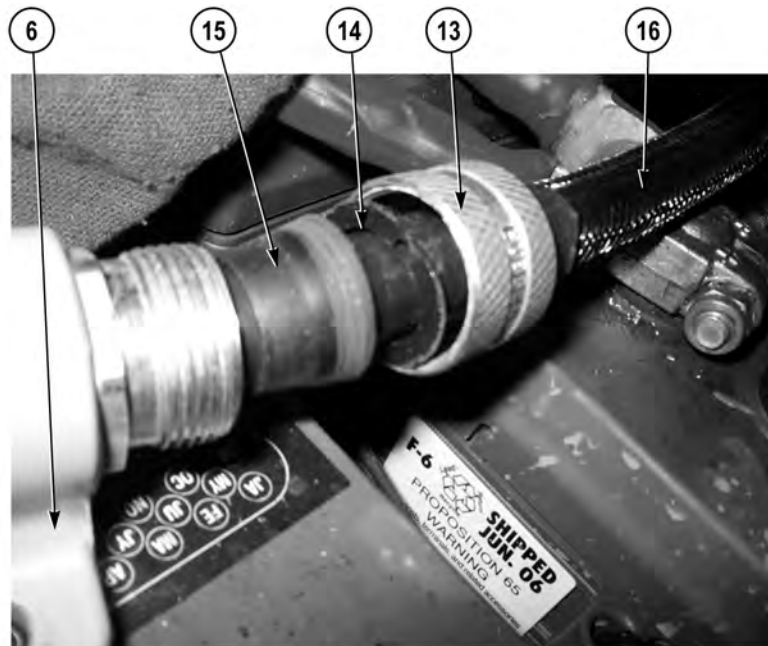
**END OF TASK**

## INSTALLATION

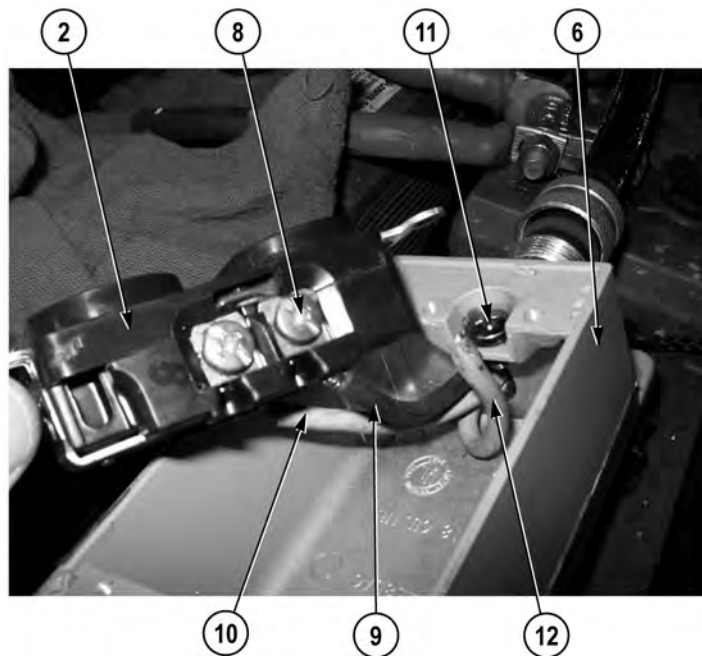
**NOTE**

Perform Steps (1) and (2) if 120-volt receptacle box was removed.

1. Install 120-volt receptacle box (6) on pump house panel O (21) with two screws (20), washers (19), lockwashers (18), and nuts (17).

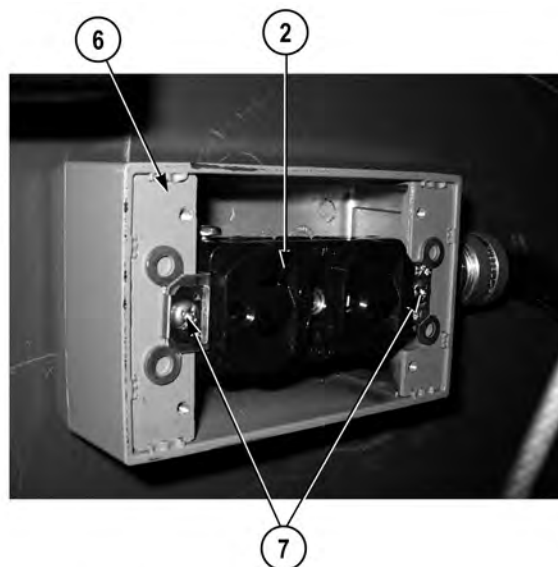


2. Install shoreline inlet receptacle wire harness (16) on 120-volt receptacle box (6) with rubber grommet (15), compression ring (14), and strain relief (13).

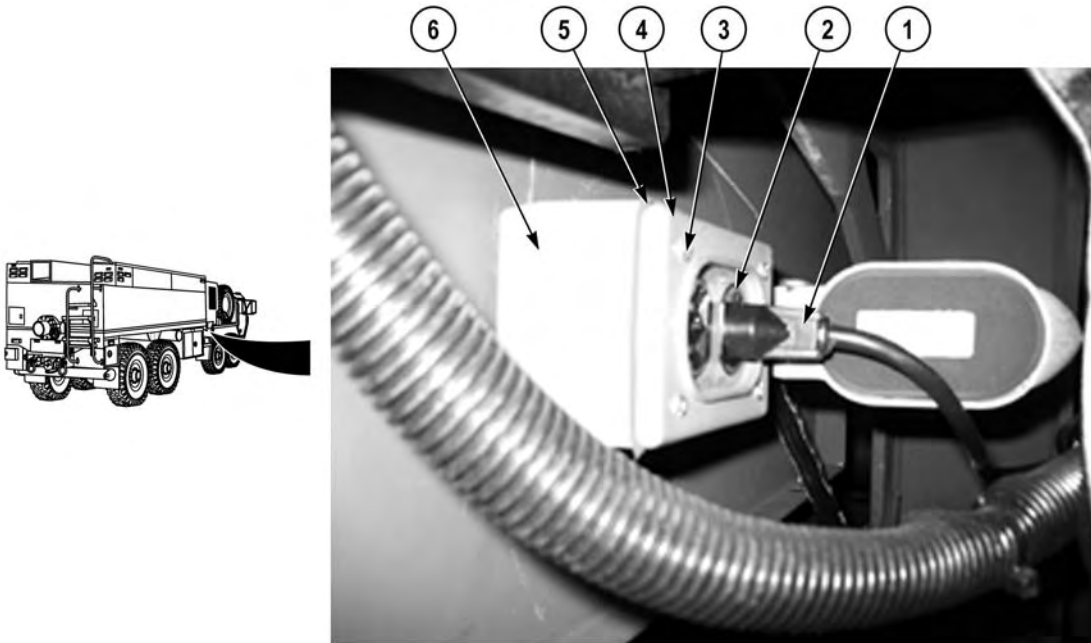


### NOTE

- Green wires ground, green screw
  - White wire common, silver screw
  - Black wire hot, gold screw
3. Position (ground) green wire (12) on 120-volt receptacle box (6) and tighten screw (11).
  4. Position (common) white wire (10) and (hot) black wire (9) in 120-volt receptacle (2) and tighten two screws (8).



5. Install 120-volt receptacle (2) on 120-volt receptacle box (6) with two screws (7).



### NOTE

Position cover on 120-volt receptacle box as noted prior to removal.

6. Install seal (5) and cover on 120-volt receptacle box (6) with four screws (3).
7. Install power cord (1) on 120-volt receptacle (2).

**END OF TASK**

### FOLLOW-ON MAINTENANCE

Install pump house panels H and P (WP 0339)

**END OF TASK**

**END OF WORK PACKAGE**

---

**FIELD LEVEL MAINTENANCE**  
**BLACKOUT RELAY(S) REPLACEMENT**

---

**INITIAL SETUP:****Tools and Special Tools**

Tool Kit, General Mechanic's: Automotive  
(WP 0398, Item 17)

**References**

WP 0391, Fig. 26

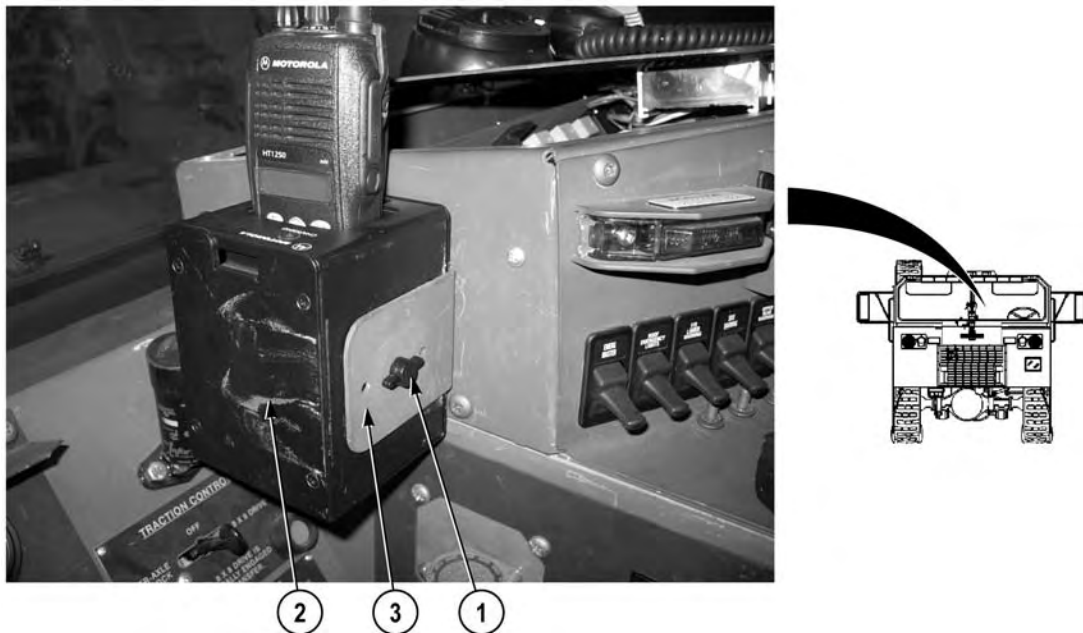
**Materials/Parts**

Tags, Identification (WP 0400, Item 23)  
Locknut (2)

**Equipment Conditions**

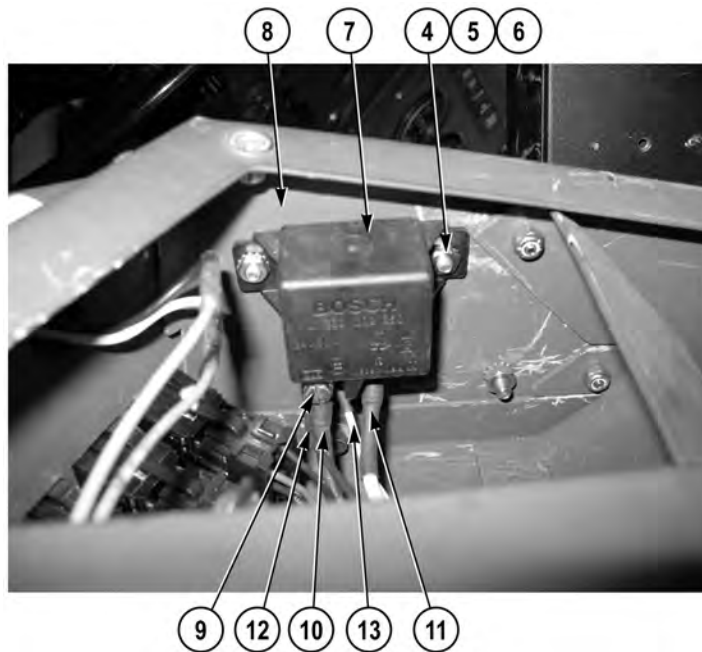
Cab instrument panel A removed (WP 0205)

---

**REMOVAL****NOTE**

Both blackout relays are removed the same way. Driver side blackout relay shown.

1. Remove two screws (1) and handheld radio charger (2) from bracket (3).



2. Remove two locknuts (4), washers (5), screws (6), and blackout relay (7) from cab power distribution box (8). Discard locknuts.

#### NOTE

Tag and mark wires prior to removal to ensure proper installation.

3. Remove two screws (9), wire 1138J (10), and wire 2839J (11) from blackout relay (7).
4. Disconnect wire 1640M (12) and wire H835M (13) from blackout relay (7).

#### END OF TASK

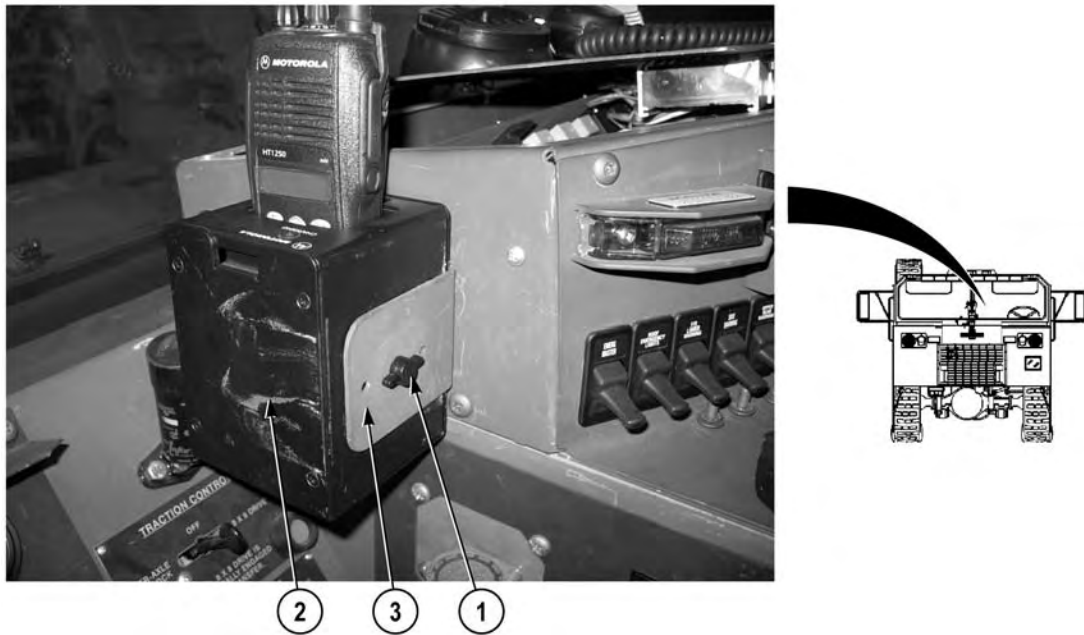
#### INSTALLATION

#### NOTE

Both blackout relays are installed the same way. Driver side shown.

1. Connect wire H835 M (13) and wire 1640M (12) on blackout relay (7).
2. Install wire 2839J (11) and wire 1138J (10) on blackout relay (7) with two screws (9).
3. Install blackout relay (7) on cab power distribution box (8) with two screws (6), washers (5), and locknuts (4).





4. Install handheld radio charger (2) on bracket (3) with two screws (1).

**END OF TASK**

**FOLLOW-ON MAINTENANCE**

Install cab instrument panel A (WP 0205)

**END OF TASK**

**END OF WORK PACKAGE**



---

**FIELD LEVEL MAINTENANCE**  
**TERMINAL BLOCK (PASS-THROUGH) REPLACEMENT**

---

**INITIAL SETUP:****Tools and Special Tools**

Tool Kit, General Mechanic's: Automotive  
(WP 0398, Item 17)

**References**

WP 0391, Fig. 42

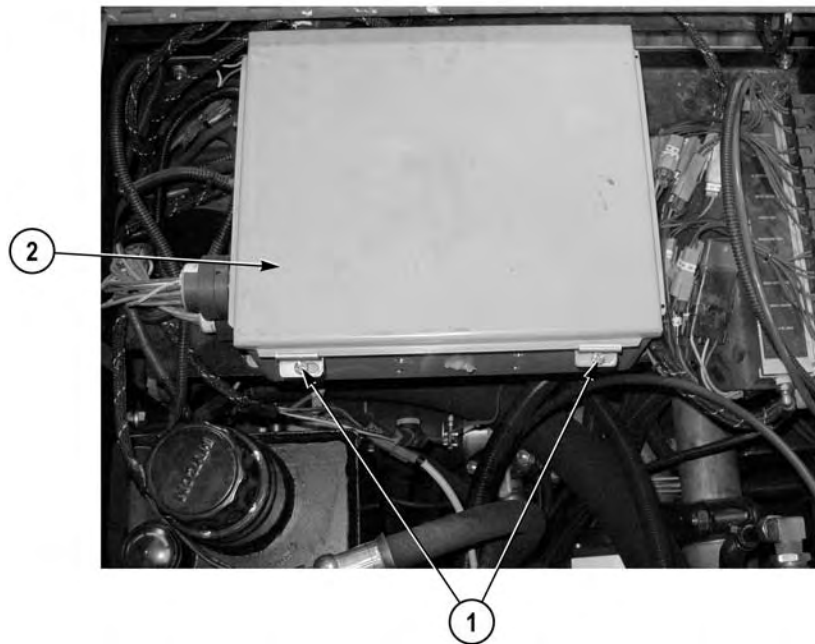
**Materials/Parts**

Compound, Sealing (WP 0400, Item 10)  
Tags, Identification (WP 0400, Item 23)  
Lockwasher (2)  
Lockwasher (2)  
Locknut (2)  
Locknut (2)

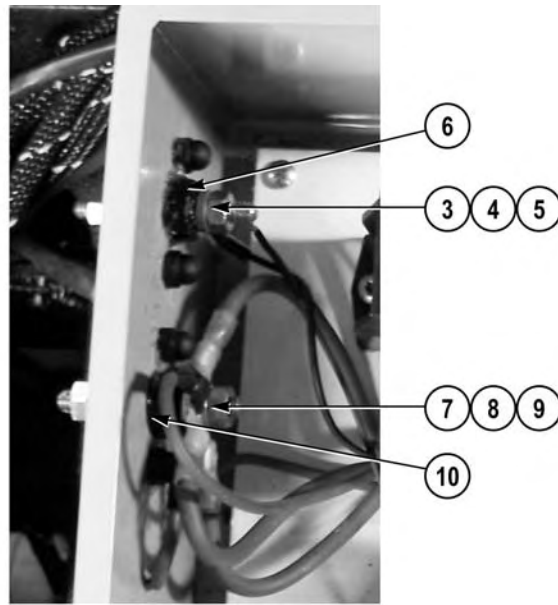
**Equipment Conditions**

Pump house panel K removed (WP 0339)

---

**REMOVAL**

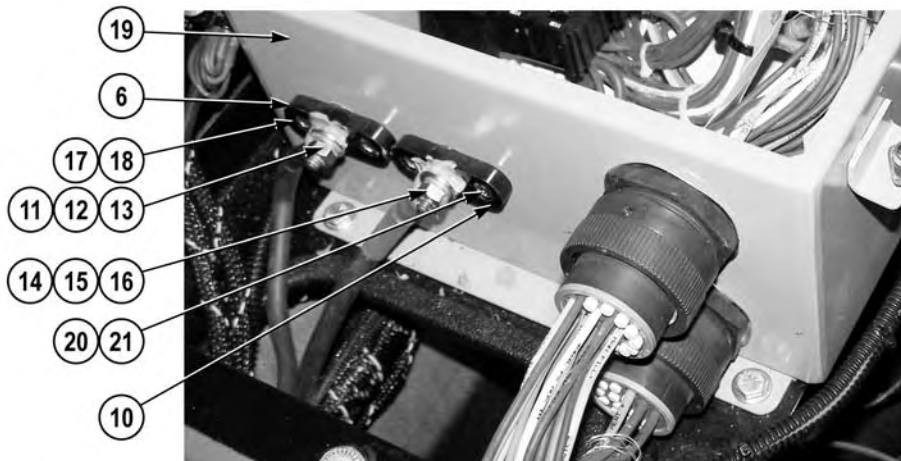
1. Loosen two screws (1) and open pump house control box cover (2).



### NOTE

Tag and mark wires prior to removal to ensure proper installation.

2. Remove nut (3), lockwasher (4), and wire 1640 (5) from negative block terminal (6). Discard lockwasher.
3. Remove nut (7), lockwasher (8), and five wires 1138 (9) from positive block terminal (10). Discard lockwasher.

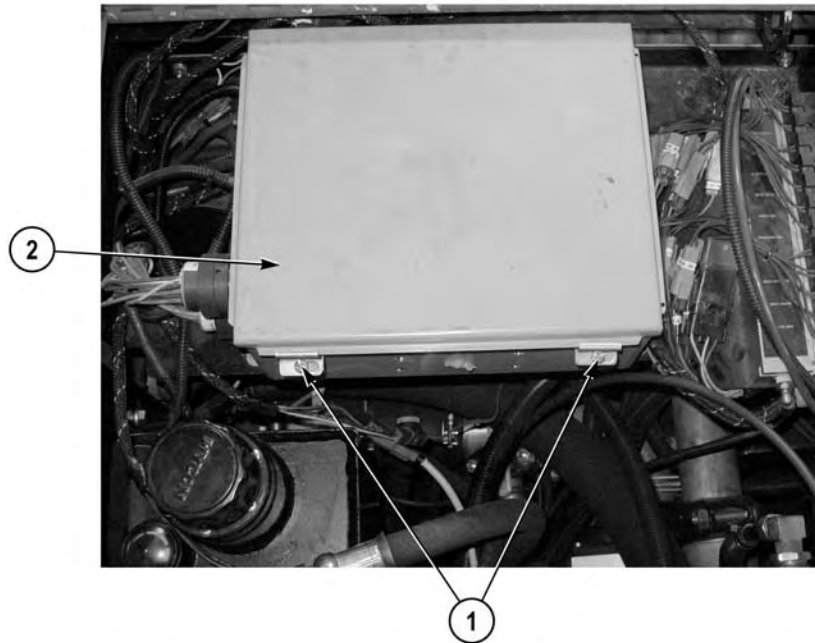


4. Remove nut (11), lockwasher (12), and wire (13) from negative block terminal (6). Discard lockwasher.
5. Remove nut (14), lockwasher (15), and wire (16) from positive block terminal (10). Discard lockwasher.
6. Remove two screws (17), locknuts (18), and negative block terminal (6) from pump house control box (19). Discard locknuts.
7. Remove two screws (20), locknuts (21), and positive block terminal (10) from pump house control box (19). Discard locknuts.

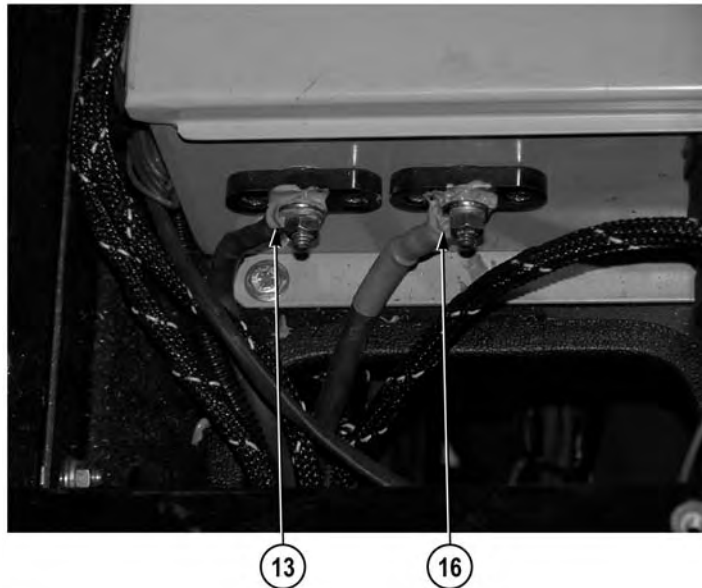
**END OF TASK**

**INSTALLATION**

1. Install positive block terminal (10) on pump house control box (19) with two locknuts (21) and screws (20).
2. Install negative block terminal (6) on pump house control box (19) with two locknuts (18) and screws (17).
3. Install wire (16) on positive block terminal (10) with lockwasher (15) and nut (14).
4. Install wire (13) on negative block terminal (6) with lockwasher (12) and nut (11).
5. Install five wires 1138 (9) on positive block terminal (10) with lockwasher (8) and nut (7).
6. Install wire 1640 (5) on negative block terminal (6) with lockwasher (4) and nut (3).



7. Close pump house control box cover (2) and tighten two screws (1).

**WARNING**

Adhesives, solvents, and sealing compounds can burn easily, can give off harmful vapors, and are harmful to skin and clothing. To avoid injury or death, keep away from open fire and use in well-ventilated area. If adhesive, solvent, or sealing compound gets on skin or clothing, wash immediately with soap and water.

8. Apply sealing compound to connectors on wire (16) and wire (13).

**END OF TASK**

**FOLLOW-ON MAINTENANCE**

Install pump house panel K (WP 0339)

**END OF TASK**

**END OF WORK PACKAGE**

## FIELD LEVEL MAINTENANCE

## CAB POWER DISTRIBUTION BLOCK CIRCUIT BREAKER REPLACEMENT

## INITIAL SETUP:

**Tools and Special Tools**

Tool Kit, General Mechanic's: Automotive  
(WP 0398, Item 17)

**Equipment Conditions**

Cab instrument panel A removed (WP 0205)

**References**

WP 0391, Fig. 42

## REMOVAL

**NOTE**

All circuit breakers are removed the same way.

Remove circuit breaker (1) from cab power distribution block (2).

**END OF TASK****INSTALLATION****NOTE**

All circuit breakers installed the same way.

Install circuit breaker (1) on cab power distribution block (2).

**END OF TASK****FOLLOW-ON MAINTENANCE**

Install cab instrument panel A (WP 0205)

**END OF TASK****END OF WORK PACKAGE**





---

**FIELD LEVEL MAINTENANCE**  
**CAB POWER DISTRIBUTION BLOCK DIODE REPLACEMENT**

---

**INITIAL SETUP:****Tools and Special Tools**

Tool Kit, General Mechanic's: Automotive  
(WP 0398, Item 17)

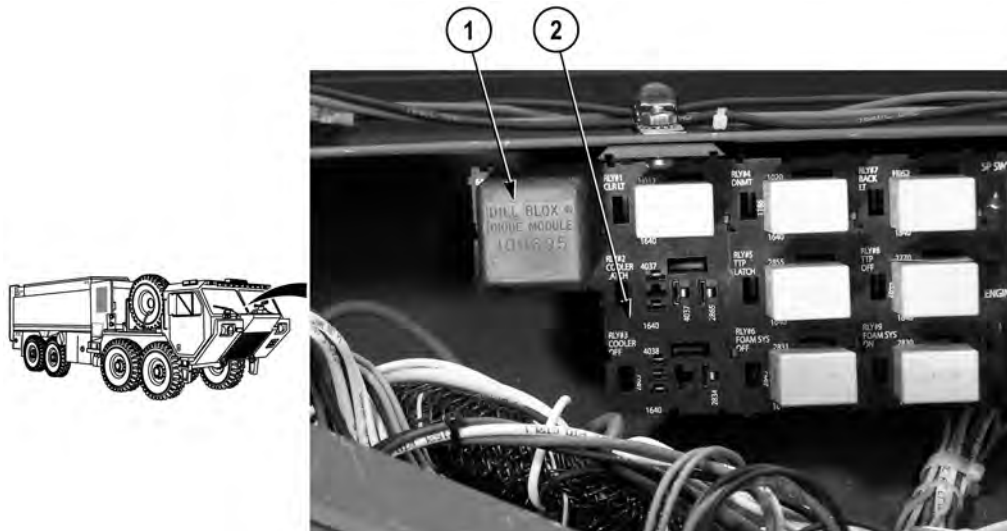
**Equipment Conditions**

Cab instrument panel A removed (WP 0205)

**References**

WP 0391, Fig. 42

---

**REMOVAL**

Remove block diode (1) from cab power distribution block (2).

**END OF TASK****INSTALLATION**

Install block diode (1) on cab power distribution block (2).

**END OF TASK****FOLLOW-ON MAINTENANCE**

Install cab instrument panel A (WP 0205)

**END OF TASK****END OF WORK PACKAGE**



---

**FIELD LEVEL MAINTENANCE**  
**CAB POWER DISTRIBUTION BLOCK RELAY(S) REPLACEMENT**

---

**INITIAL SETUP:****Tools and Special Tools**

Tool Kit, General Mechanic's: Automotive  
(WP 0398, Item 17)

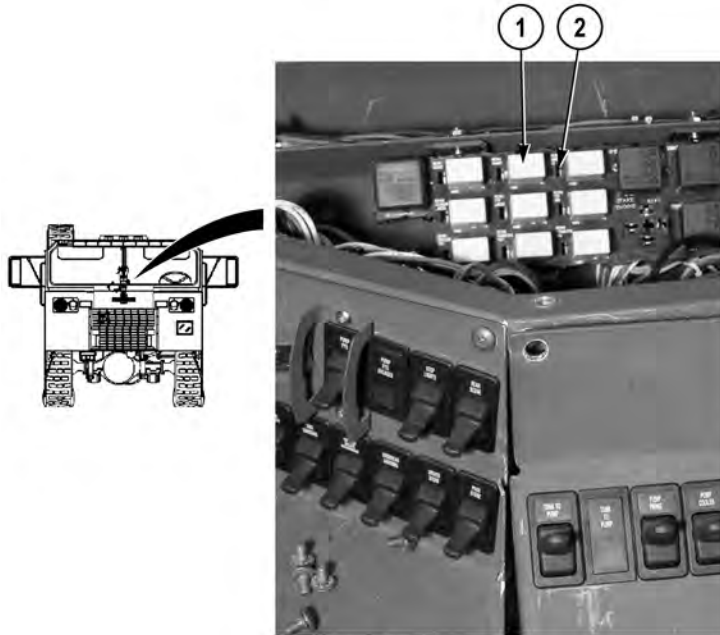
**Equipment Conditions**

Cab instrument control panel A removed  
(WP 0205)

**References**

WP 0391, Fig. 42

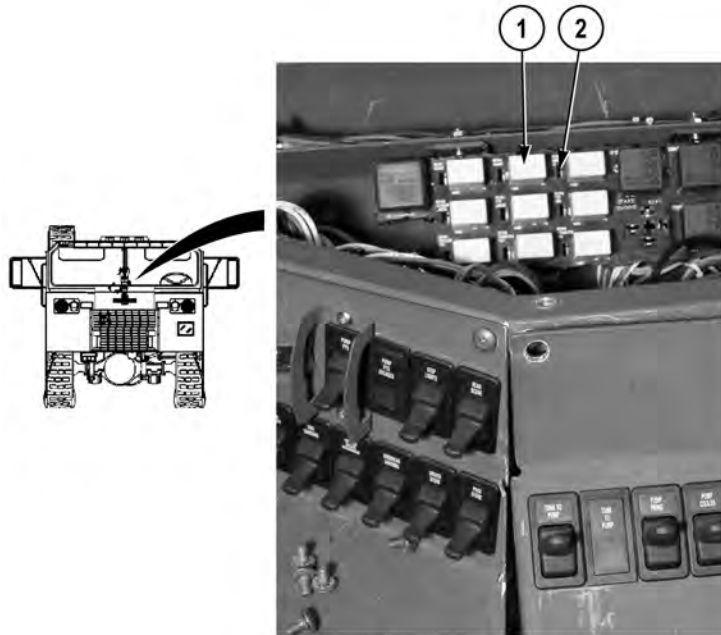
---

**REMOVAL****NOTE**

All cab power distribution block relays are removed the same way.

Remove block relay (1) from cab power distribution block (2).

**END OF TASK**

**INSTALLATION**

Install block relay (1) on cab power distribution block (2).

**END OF TASK**

**FOLLOW-ON MAINTENANCE**

Install cab instrument control panel (WP 0205)

**END OF TASK**

**END OF WORK PACKAGE**

---

**FIELD LEVEL MAINTENANCE**  
**DISCHARGE PRESSURE TRANSDUCER REPLACEMENT**

---

**INITIAL SETUP:****Tools and Special Tools**

Tool Kit, General Mechanic's: Automotive  
(WP 0398, Item 17)

**Materials/Parts**

Compound, Sealing, Pipe Thread  
(WP 0400, Item 11)

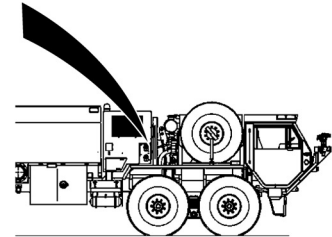
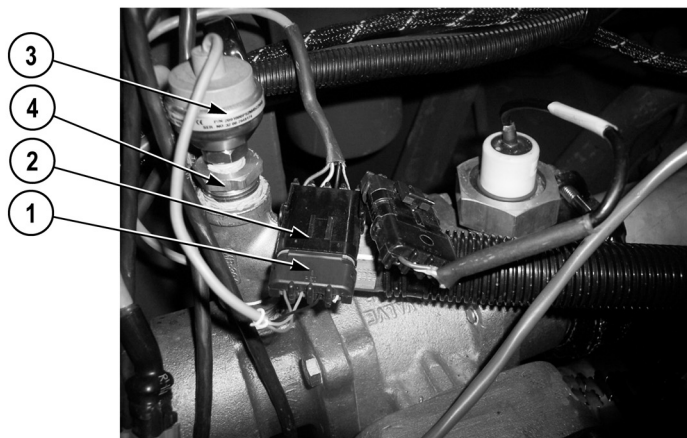
**References**

WP 0391, Fig. 65

**Equipment Conditions**

Pump house panel G removed (WP 0339)

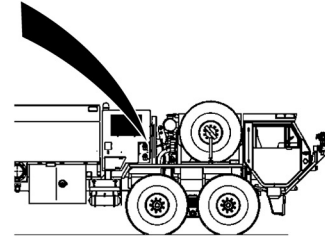
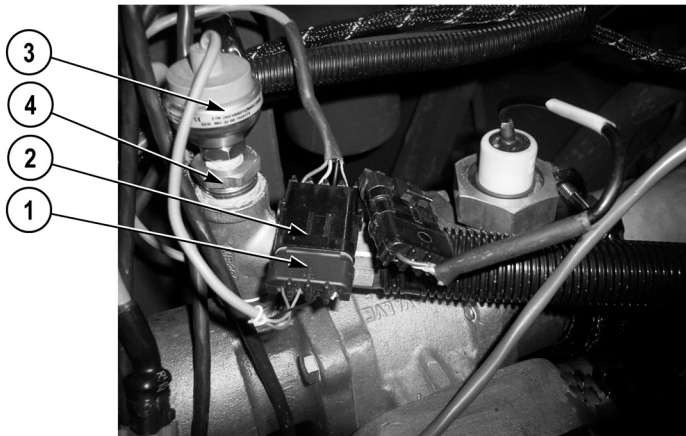
---

**REMOVAL****NOTE**

Both discharge pressure transducers are removed the same way. Passenger side shown.

1. Disconnect pressure transducer connector (1) from pressure transducer wire harness connector (2).
2. Remove pressure transducer (3) from fitting (4).

**END OF TASK**

**INSTALLATION****WARNING**

Adhesives, solvents, and sealing compounds can burn easily, can give off harmful vapors, and are harmful to skin and clothing. To avoid injury or death, keep away from open fire and use in well-ventilated area. If adhesive, solvent, or sealing compound gets on skin or clothing, wash immediately with soap and water.

**CAUTION**

Use sealing compound sparingly only on pipe threads. Do not apply compound to hose connections. Damage to equipment may result.

**NOTE**

Both discharge pressure transducers are installed the same way. Passenger side shown.

1. Apply sealing compound on threads of pressure transducer (3).
2. Install pressure transducer (3) on fitting (4).
3. Connect pressure transducer connector (1) on pressure transducer wire harness connector (2).

**END OF TASK****FOLLOW-ON MAINTENANCE**

1. Install pump house panel G (WP 0339)
2. Calibrate pump operator's panel electric valve controller (WP 0210)

**END OF TASK****END OF WORK PACKAGE**

---

**FIELD LEVEL MAINTENANCE****DOOR SWITCH REPLACEMENT**

---

**INITIAL SETUP:****Tools and Special Tools**

Tool Kit, General Mechanic's: Automotive  
(WP 0398, Item 17)

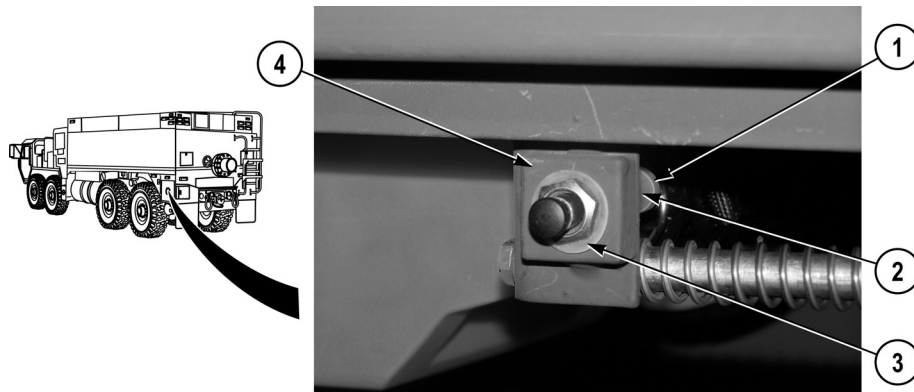
**Equipment Conditions**

Batteries disconnected (TM 9-2320-325-14&P)

**References**

WP 0391, Fig. 61

---

**REMOVAL****NOTE**

All door switches are removed the same way. Driver side rear compartment door shown.

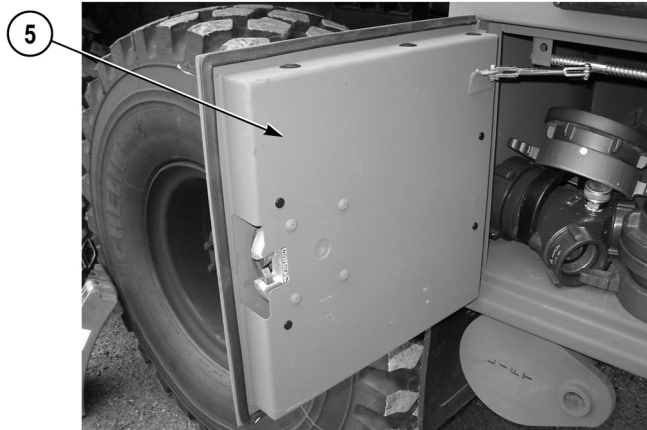
1. Disconnect passenger side body wire harness connector (1) from door switch (2).
2. Remove door switch (2) and washer (3) from door switch bracket (4).
3. Remove washer (3) from door switch (2).

**END OF TASK****INSTALLATION****NOTE**

All door switches are installed the same way. Driver side rear compartment door shown.

1. Install washer (3) on door switch (2).
2. Install door switch (2) on door switch bracket (4) with washer (3).
3. Connect passenger side body wire harness connector (1) on door switch (2).

**END OF TASK**

**ADJUSTMENT****NOTE**

Switch self adjusts on first door closure.

Close door (5).

**END OF TASK**

**FOLLOW-ON MAINTENANCE**

Connect batteries (TM 9-2320-325-14&P)

**END OF TASK**

**END OF WORK PACKAGE**



## FIELD LEVEL MAINTENANCE

## HOSE REEL REPLACEMENT

## INITIAL SETUP:

**Tools and Special Tools**

Tool Kit, General Mechanic's: Automotive  
(WP 0398, Item 17)

**Materials/Parts**

Compound, Sealing, Pipe Thread  
(WP 0400, Item 11)  
Compound, Sealing (WP 0400, Item 10)  
Tags, Identification (WP 0400, Item 23)  
Ties, Cable, Plastic (WP 0400, Item 26)  
Lockwasher (1)  
Lockwasher (4)  
Lockwasher (2)  
Lockwasher (2)  
Lockwasher (2)  
Lockwasher (2)

**Materials/Parts (continued)**

Lockwasher (2)  
Lockwasher (2)

**Personnel Required**

MOS 63B Wheeled Vehicle Mechanic (2)

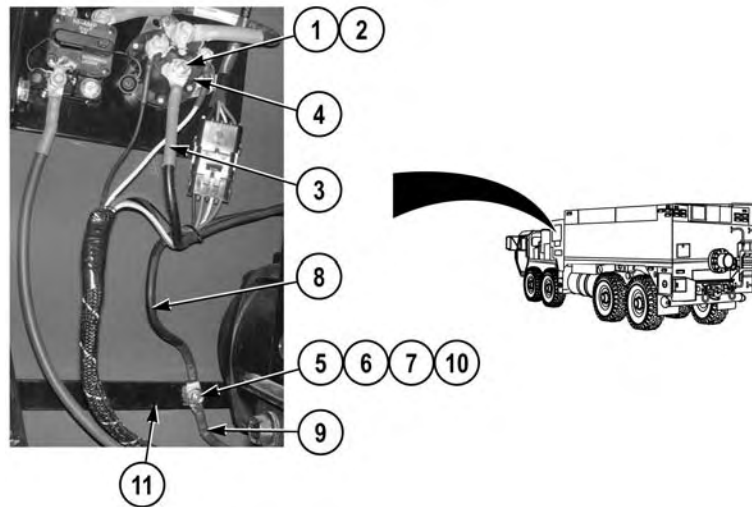
**References**

WP 0313  
WP 0391, Fig. WP 40

**Equipment Conditions**

Pump house panels A, E, and L removed  
(WP 0339)  
Hose reel hose removed (WP 0316)

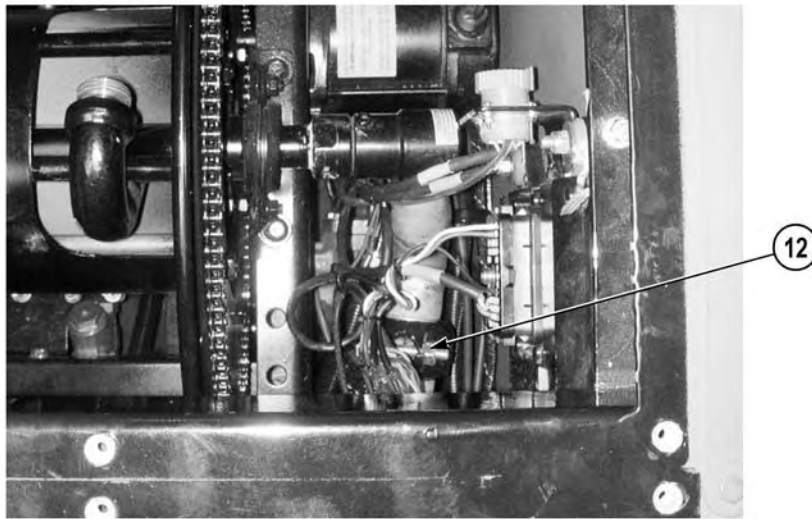
## REMOVAL

**NOTE**

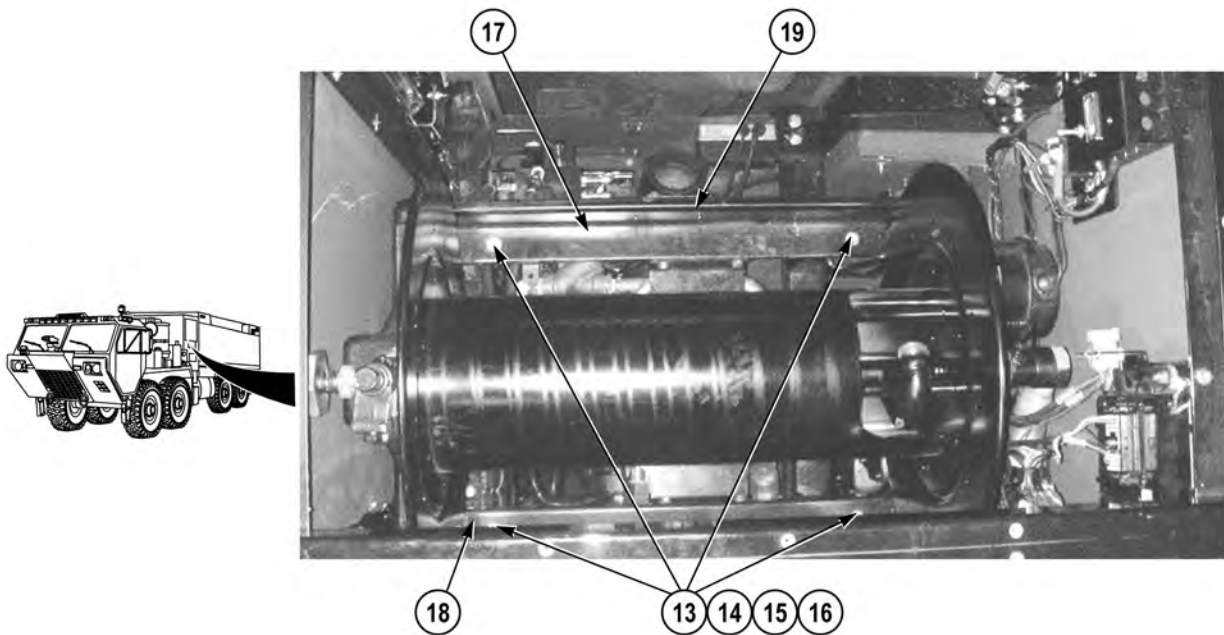
- Tag and mark wires prior to removal to ensure proper installation.
- Remove cable ties as required.

1. Remove nut (1), washer (2), and wire (3) from solenoid (4).
2. Remove nut (5), lockwasher (6), washer (7), two wires (8) and (9), and screw (10) from bracket (11). Discard lockwasher.

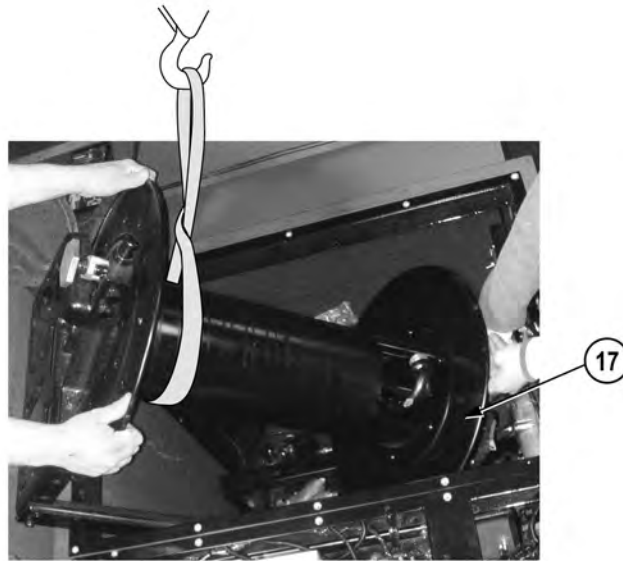
TOP VIEW



3. Remove coupling (12) from vehicle (WP 0313).



4. Remove four nuts (13), lockwashers (14), eight washers (15), and screws (16) from hose reel (17), bracket (18) and bracket (19). Discard lockwashers.

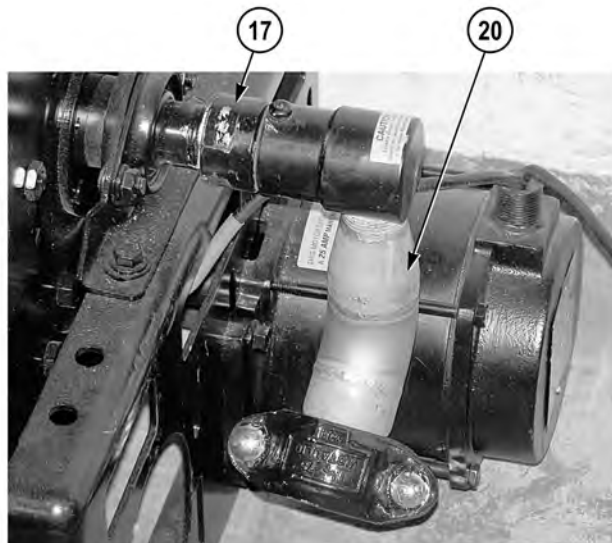
**WARNING**

Hose reel assembly weighs 125 lb. (57 kg). Do not attempt to lift or move hose reel without the aid of an assistant and a suitable lifting device. Failure to comply may result in serious injury to personnel or damage to equipment.

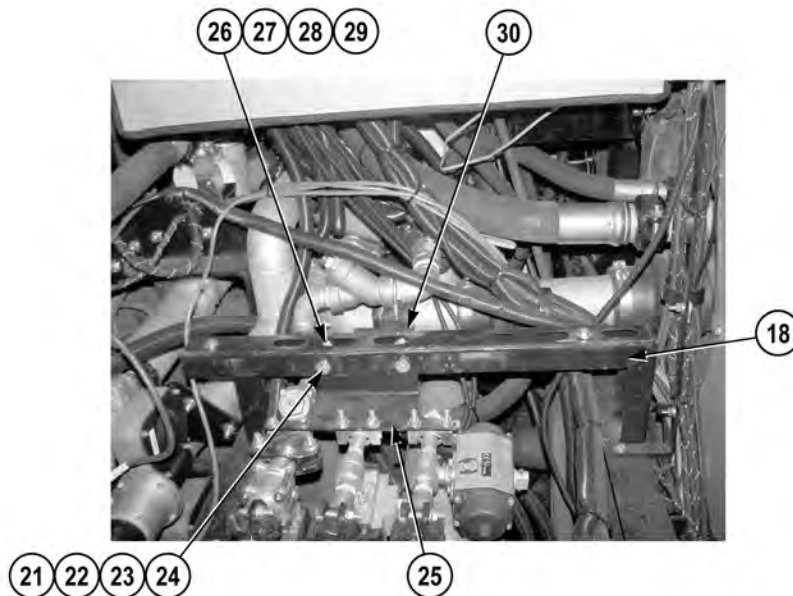
**NOTE**

Lifting device must be attached near rear end of hose reel. Hose reel is severely angled, and rear end if removed first. Failure to comply may result in damage to equipment.

5. With the aid of an assistant and a suitable lifting device, carefully remove hose reel (17) from vehicle.



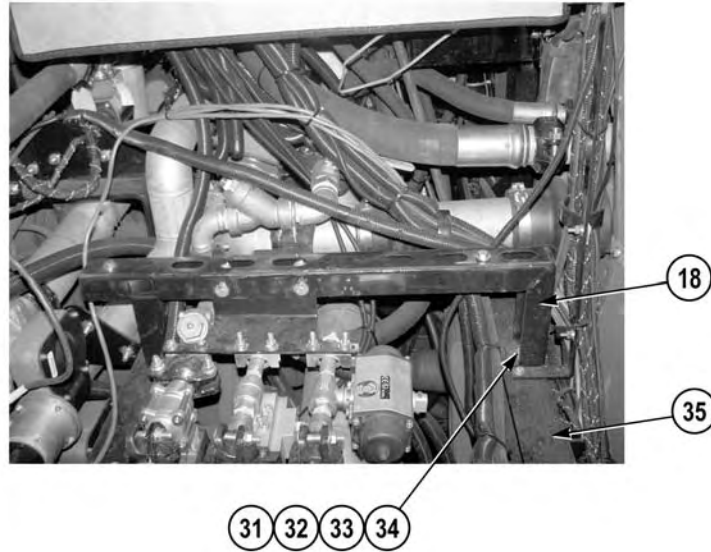
6. Remove pipe (20) from hose reel (17).



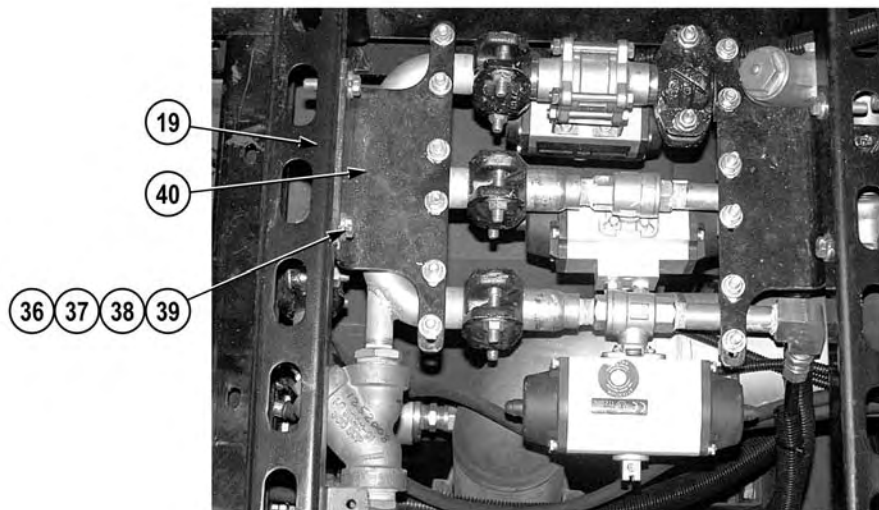
### NOTE

Perform Steps (7) through (11) if brackets need to be removed.

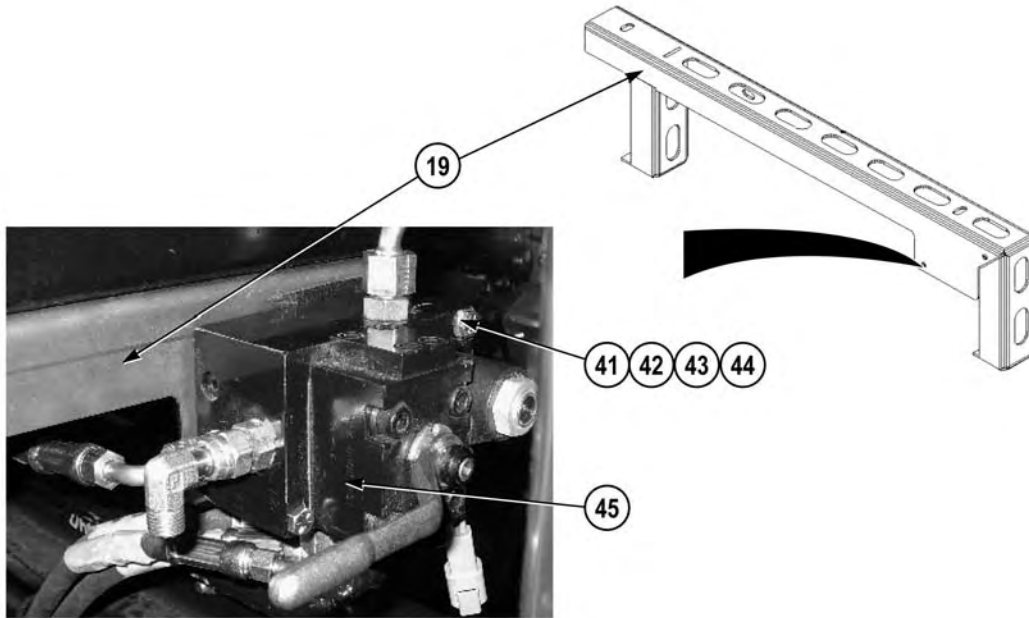
7. Remove two nuts (21), lockwashers (22), four washers (23), and two screws (24), from bracket (25) and bracket (18). Discard lockwashers.
8. Remove two nuts (26), lockwashers (27), four washers (28), and two screws (29), from bracket (30) and bracket (18). Discard lockwashers.



9. Remove two nuts (31), lockwashers (32), four washers (33), two screws (34), and bracket (18), from pump house frame (35). Discard lockwashers.



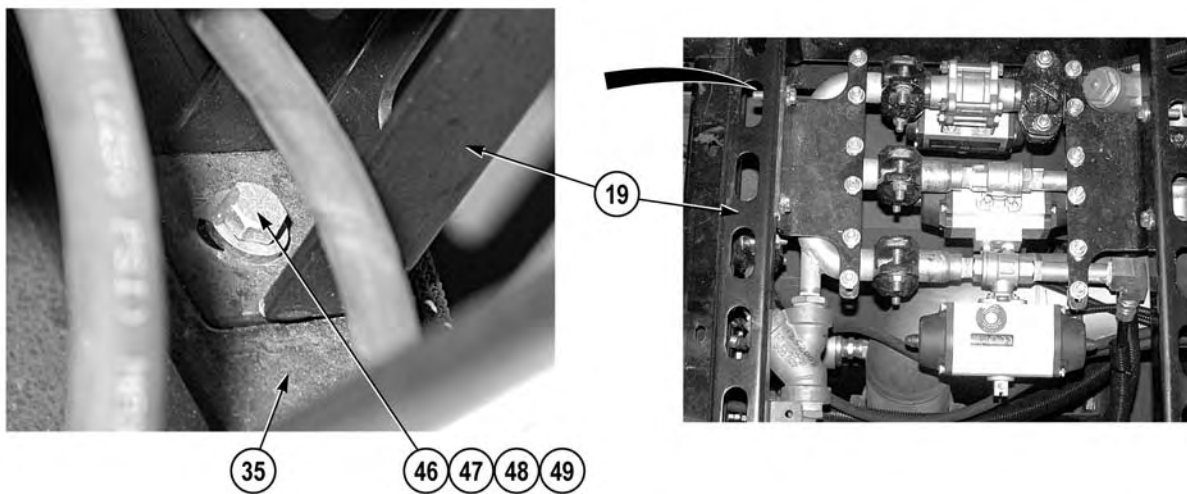
10. Remove two nuts (36), lockwashers (37), four washers (38), and two screws (39), from bracket (40) and bracket (19). Discard lockwashers.



**NOTE**

Hydraulic override manifold remains in place supported by hydraulic lines.

11. Remove two nuts (41), lockwashers (42), washers (43), screws (44), and hydraulic override manifold (45) from bracket (19). Discard lockwashers.



12. Remove two nuts (46), lockwashers (47), four washers (48), two screws (49), and bracket (19) from pump house frame (35). Discard lockwashers.

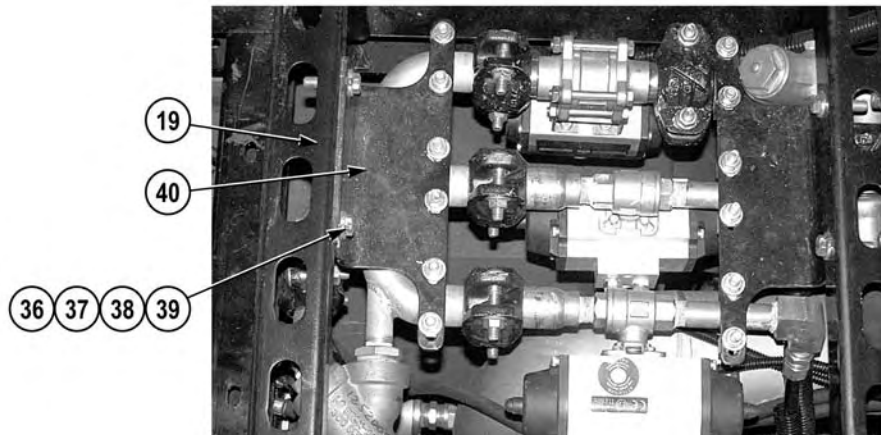
**END OF TASK**

## INSTALLATION

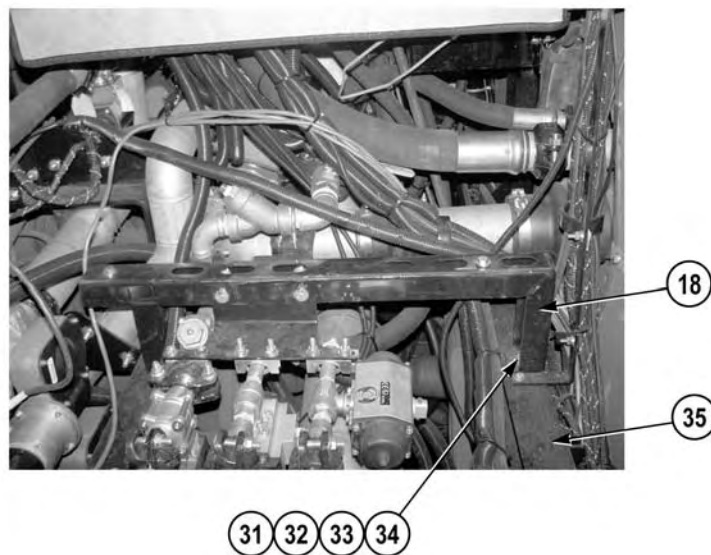
### NOTE

Perform Steps (1) through (6) if brackets were removed.

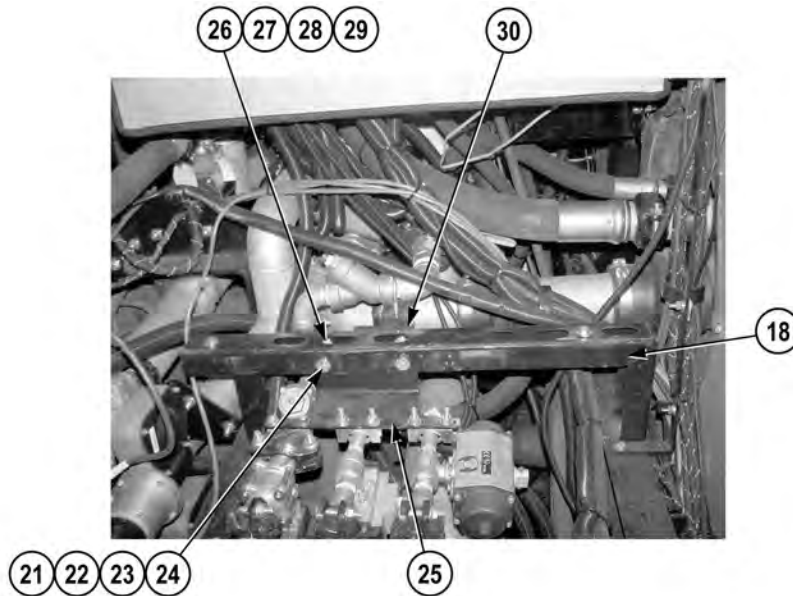
1. Install bracket (19) on pump house frame (35) with two screws (49), four washers (48), two lockwashers (47), and nuts (46).
2. Install hydraulic override manifold (45) on bracket (19) with two screws (44), washers (43), lockwashers (42), and nuts (41).



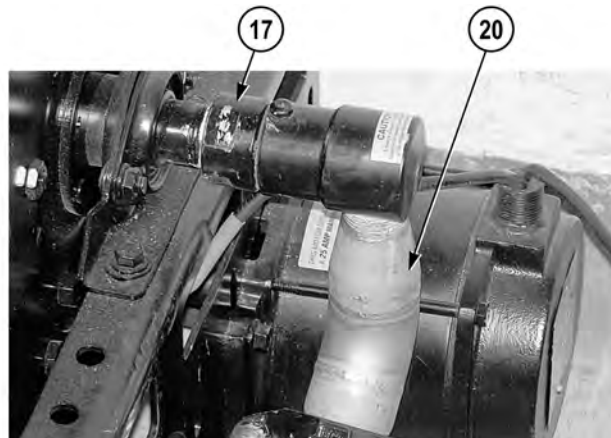
3. Install bracket (40) on bracket (19) with two screws (39), four washers (38), two lockwashers (37), and nuts (36).



4. Install bracket (18) on pump house frame (35) with two screws (34), four washers (33), two lockwashers (32), and nuts (31).



5. Install bracket (30) on bracket (18) with two screws (29), four washers (28), two locknuts (27), and nuts (26).
6. Install bracket (25) on bracket (18) with two screws (24), four washers (23), two locknuts (22), and nuts (21).



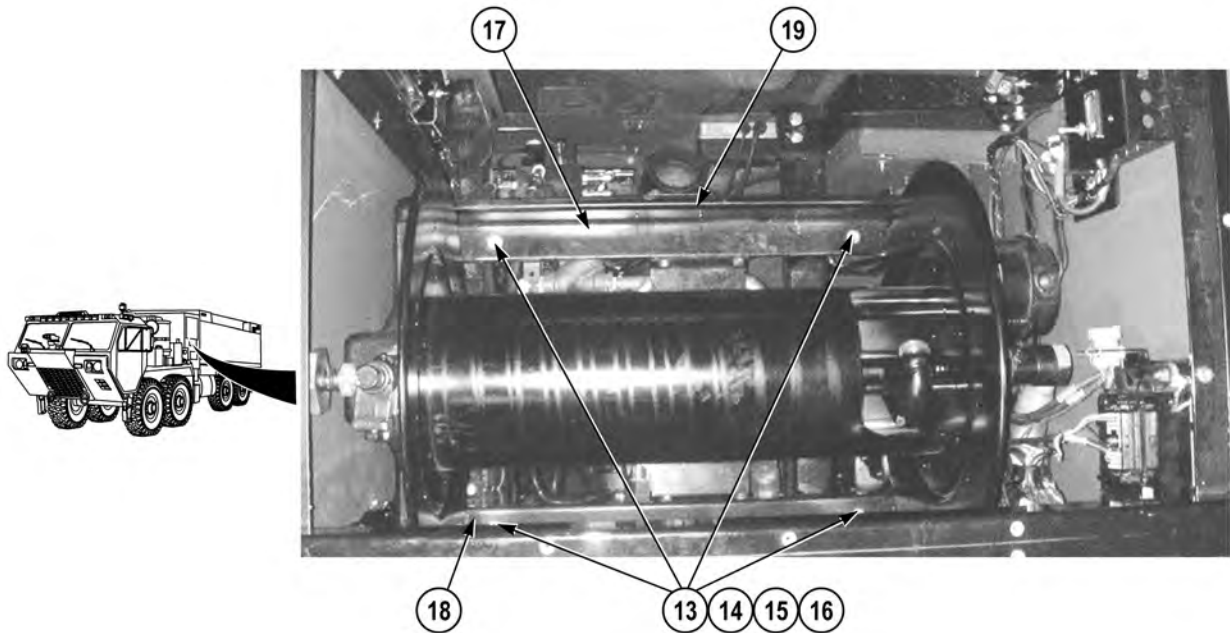
### **WARNING**



**Adhesives, solvents, and sealing compounds can burn easily, can give off harmful vapors, and are harmful to skin and clothing. To avoid injury or death, keep away from open fire and use in well-ventilated area. If adhesive, solvent, or sealing compound gets on skin or clothing, wash immediately with soap and water.**

7. Apply sealing compound to threads of pipe (20).
8. Install pipe (20) on hose reel (17).





### **WARNING**



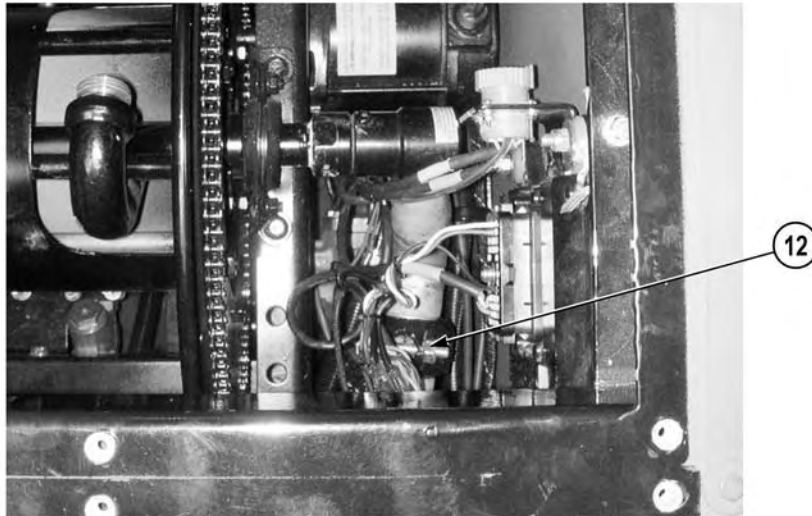
Hose reel assembly weighs 125 lb. (57 kg). Do not attempt to lift or move hose reel without the aid of an assistant and a suitable lifting device. Failure to comply may result in serious injury to personnel or damage to equipment.

### **NOTE**

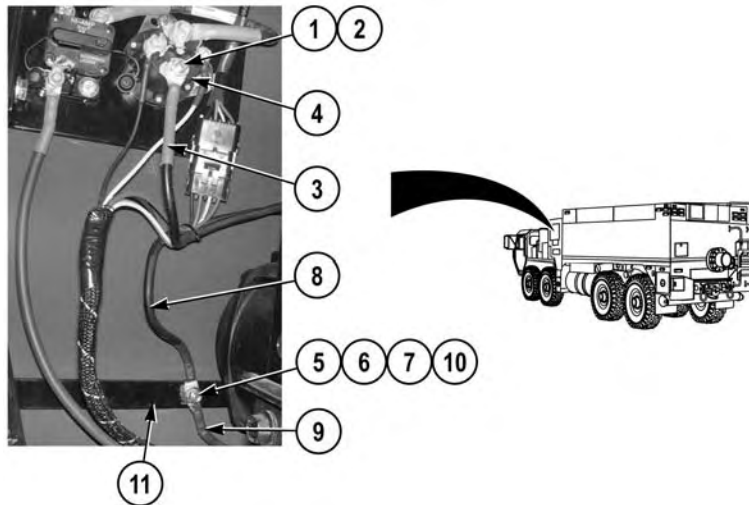
Lifting device must be attached near rear end of hose reel. Hose reel is severely angled, and front end is installed first. Failure to comply may result in damage to equipment.

9. With the aid of an assistant and a suitable lifting device, install hose reel assembly (17) on bracket (18) and bracket (19) with four screws (16), eight washers (15), four lockwashers (14), and nuts (13).

TOP VIEW



10. Install coupling (12) on vehicle (WP 0313).



11. Install two wires (9) and (8) on bracket (11) with screw (10), washer (7), lockwasher (6), and nut (5).

**⚠ CAUTION**

**Do not over tighten electrical connections on solenoid. Failure to comply may result in damage to equipment.**

**NOTE**

Install cable ties as required.

12. Install wire (3) on solenoid (4) with washer (2) and nut (1).
13. Apply sealing compound to solenoid electrical connectors.

**END OF TASK**

**FOLLOW-ON MAINTENANCE**

1. Install hose on hose reel (WP 0316)
2. Install pump house panels A, E, and L (WP 0339)

**END OF TASK**

**END OF WORK PACKAGE**



## FIELD LEVEL MAINTENANCE

## ELECTRICALLY-OPERATED BALL VALVE ELECTRIC MOTOR AND DRIVE ASSEMBLY REPLACEMENT

## INITIAL SETUP:

**Tools and Special Tools**

Tool Kit, General Mechanic's: Automotive  
(WP 0398, Item 17)

**References**

WP 0391, Fig. 65

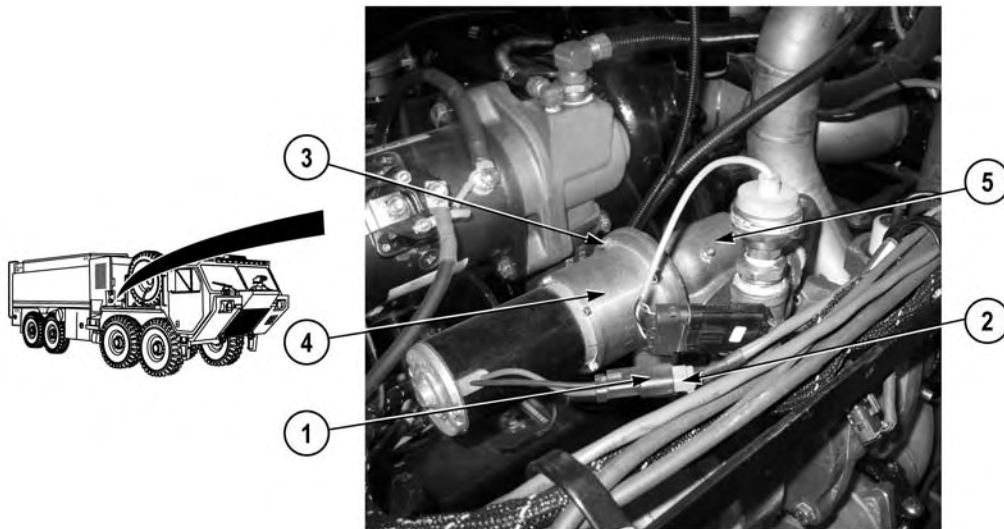
**Materials/Parts**

Adhesive, Thread, Locking (WP 0400, Item 6)  
Oil, Lubricating (WP 0400, Fig. Item 14)  
Preformed Packing (1)  
Preformed Packing (1)

**Equipment Conditions**

Pump house panel G removed (WP 0339)

## REMOVAL

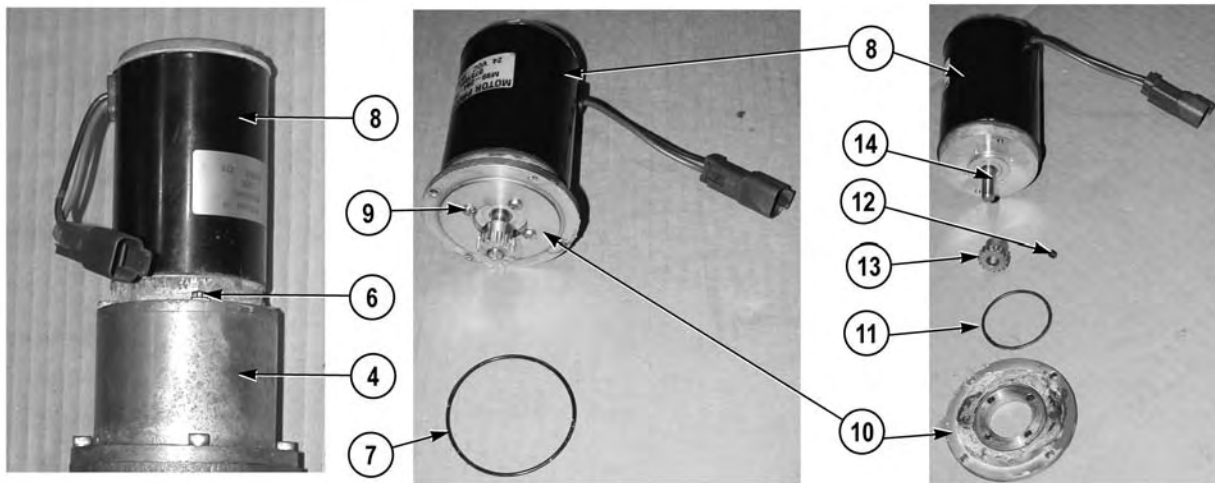
**NOTE**

All five electrically-operated ball valve electric motors and drive assemblies are removed the same way. Passenger side shown.

1. Disconnect electric motor connector (1) from valve motor control wire harness connector (2).

**NOTE**

- Electric motor and drive assembly are removed as an assembly.
  - Note position of electric motor and drive housing on valve prior to removal to ensure proper installation.
2. Remove four screws (3) and drive housing (4) from valve (5).



3. Remove four screws (6), preformed packing (7), and electric motor (8) from drive housing (4). Discard preformed packing.
4. Remove four screws (9), adapter (10), and preformed packing (11) from electric motor (8). Discard preformed packing.

### NOTE

Note position of gear on shaft prior to removal to ensure proper installation.

5. Remove setscrew (12) and gear (13) from shaft (14).

### END OF TASK

### INSTALLATION

#### WARNING

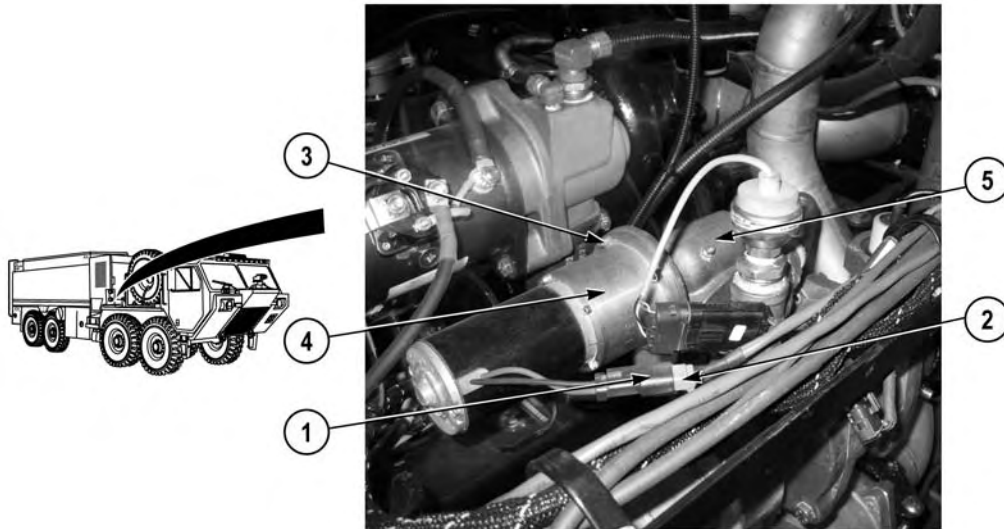


**Adhesives, solvents, and sealing compounds can burn easily, can give off harmful vapors, and are harmful to skin and clothing. To avoid injury or death, keep away from open fire and use in well-ventilated area. If adhesive, solvent, or sealing compound gets on skin or clothing, wash immediately with soap and water.**

### NOTE

- All five electrically-operated ball valve electric motors are installed the same way. Passenger side shown.
  - Install gear on shaft as noted prior to removal.
1. Apply adhesive to threads of eight screws (3) and (6) and setscrew (12).

2. Install gear (13) on shaft (14) with setscrew (12).
3. Lightly lubricate preformed packing (11) with clean oil, and install preformed packing (11) and adapter (10) on electric motor (8) with four screws (9).
4. Lightly lubricate preformed packing (7) with clean oil, and install electric motor (8) and preformed packing (7) on drive housing (4) with packing screws (6).



#### NOTE

- Electric motor and drive assembly are installed as an assembly.
  - Install electric motor and drive housing on valve as noted prior to removal.
5. Install drive housing (4) on valve (5) with four screws (3).
  6. Connect electric motor connector (1) on valve motor control wire harness connector (2).

**END OF TASK**

#### FOLLOW-ON MAINTENANCE

Install pump house panel G (WP 0339)

**END OF TASK**

**END OF WORK PACKAGE**





---

**FIELD LEVEL MAINTENANCE****ELECTRICALLY-OPERATED BALL VALVE SEATS AND PREFORMED PACKING REPLACEMENT**

---

**INITIAL SETUP:****Tools and Special Tools**

Tool Kit, General Mechanic's: Automotive  
(WP 0398, Item 17)

**References**

WP 0391, Fig. 65

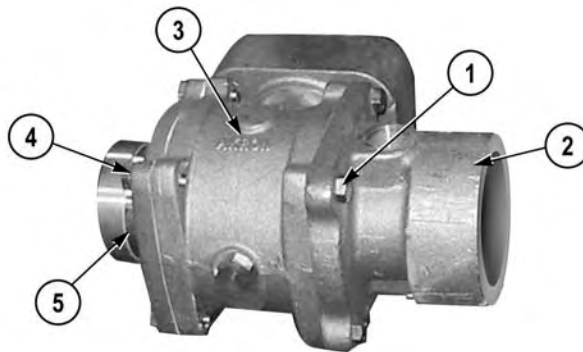
**Materials/Parts**

Lubricant, Silicone Compound  
(WP 0400, Item 22)  
Seal (2)  
Preformed Packing (1)

**Equipment Conditions**

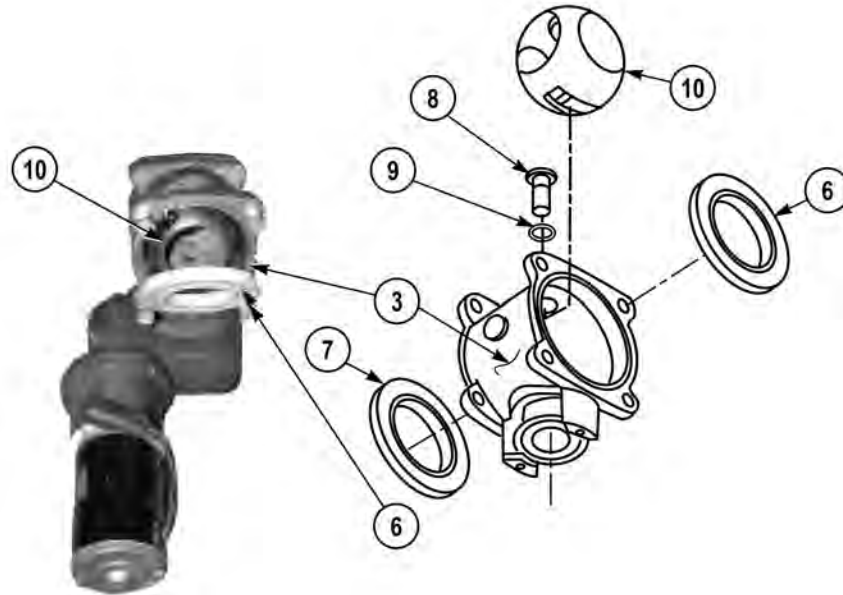
Inlet valve removed (driver side) (WP 0186)

---

**REMOVAL****NOTE**

- All electrically-operated ball valve seats and preformed packing are removed the same way. Driver side inlet valve shown.
- Perform task with electrically-operated ball valve on clean work surface.

1. Remove four screws (1) and adapter (2) from valve body (3).
2. Remove four screws (4) and adapter (5) from valve body (3).



3. Remove two seals (6) and (7) from valve body (3). Discard seals.

### NOTE

Valve must be placed in open position before replacing valve ball.

4. Remove trunnion (8), preformed packing (9), and valve ball (10) from valve body (3). Discard preformed packing.

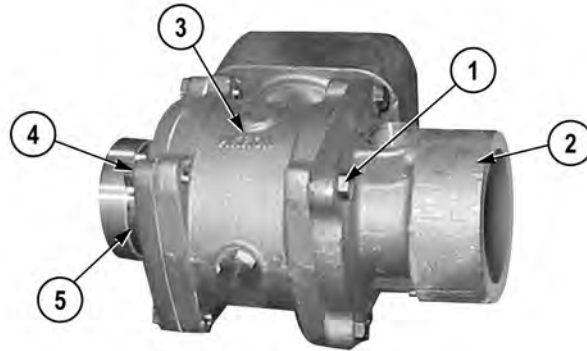
### END OF TASK

### INSTALLATION

### NOTE

All electrically-operated ball valve seats and preformed packing are installed the same way. Driver side inlet valve shown.

1. Coat preformed packing (9) with silicone, and install valve ball (10) on valve body (3) with preformed packing (9) and trunnion (8).
2. Install two seals (7) and (6) on valve body (3).



3. Install adapter (5) on valve body (3) with four screws (4).
4. Install adapter (2) on valve body (3) with four screws (1).

**END OF TASK**

**FOLLOW-ON MAINTENANCE**

Install inlet valve (driver side) (WP 0186)

**END OF TASK**

**END OF WORK PACKAGE**



---

**FIELD LEVEL MAINTENANCE**  
**FLOW SENSOR REPLACEMENT**

---

**INITIAL SETUP:****Tools and Special Tools**

- Standard Automotive Tool Set (SATS),  
(WP 0398, Item 15)
- Wrench, Adjustable, Automotive, 15 in.
- Tool Kit, General Mechanic's: Automotive  
(WP 0398, Item 17)

**References**

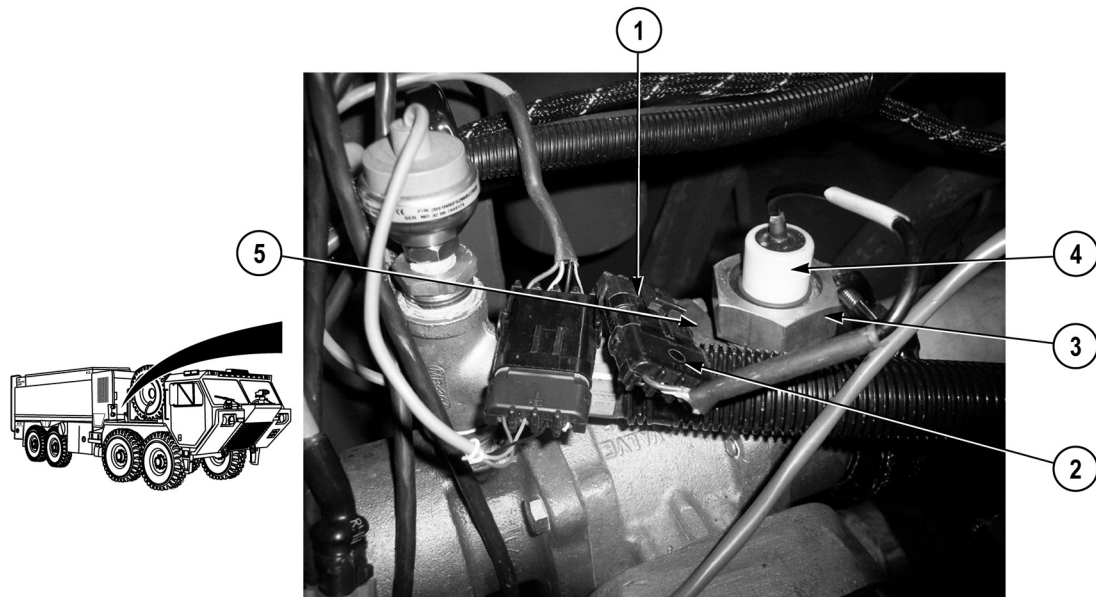
WP 0391, Fig. 65

**Equipment Conditions**

Pump house panel G removed (WP 0339)  
Water system drained (WP 0015)

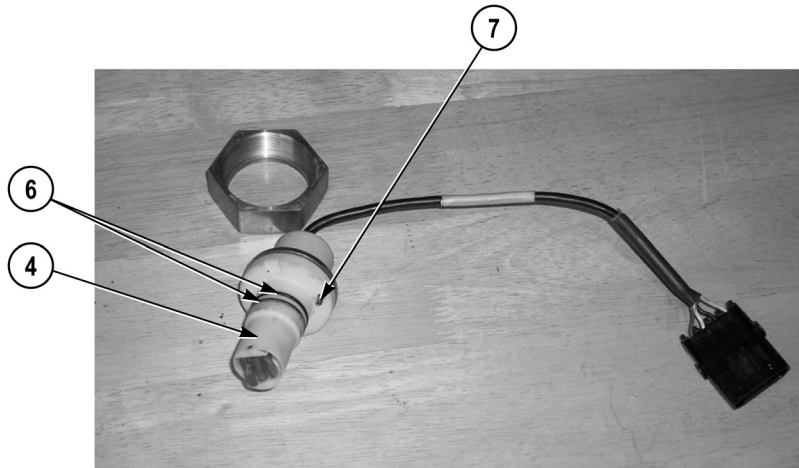
**Materials/Parts**

- Oil, Lubricating (WP 0400, Item 20)  
Preformed Packing (2)
- 

**REMOVAL****NOTE**

All flow sensors are removed the same way. Flow sensor on No.1 passenger side discharge valve shown.

1. Disconnect flow sensor connector (1) from flow sensor wire harness connector (2).
2. Loosen nut (3) and remove flow sensor (4) from adapter (5).



3. Remove two preformed packings (6) from flow sensor (4). Discard preformed packings.

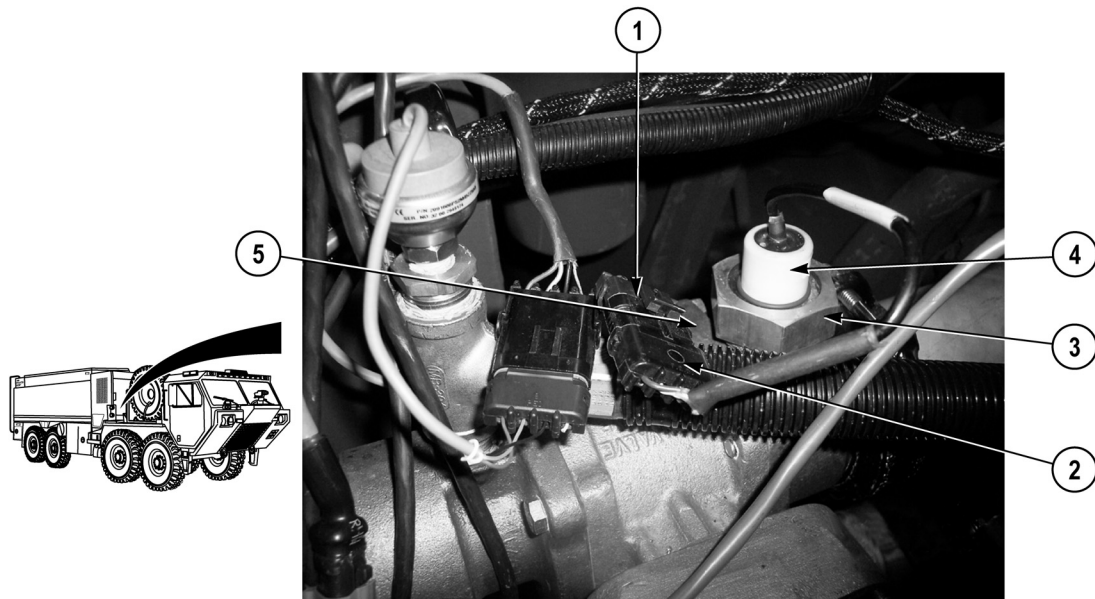
#### END OF TASK

#### INSTALLATION

#### NOTE

All flow sensors are installed the same way. Flow sensor on No. 1 passenger side discharge valve shown.

1. Lightly lubricate two preformed packings (6) with lubricating oil and install two preformed packings (6) on flow sensor (4).

**NOTE**

Alignment pin must align with hole on adapter before tightening nut.

2. Align alignment pin (7) on flow sensor (4) with hole in adapter (5).
3. Install flow sensor (4) on adaptor (5) and tighten nut (3).
4. Connect flow sensor wire harness connector (2) to flow sensor connector (1).

**END OF TASK****FOLLOW ON MAINTENANCE**

1. Install pump house access panel G (WP 0339)
2. Calibrate pump operator's panel electric valve controller (WP 0210)

**END OF TASK****END OF WORK PACKAGE**





---

**FIELD LEVEL MAINTENANCE**  
**HIGH AMPERAGE CABLE(S) REPLACEMENT**

---

**INITIAL SETUP:****Tools and Special Tools**

Tool Kit, General Mechanic's: Automotive  
(WP 0398, Item 17)

**References**

WP 0008  
WP 0339

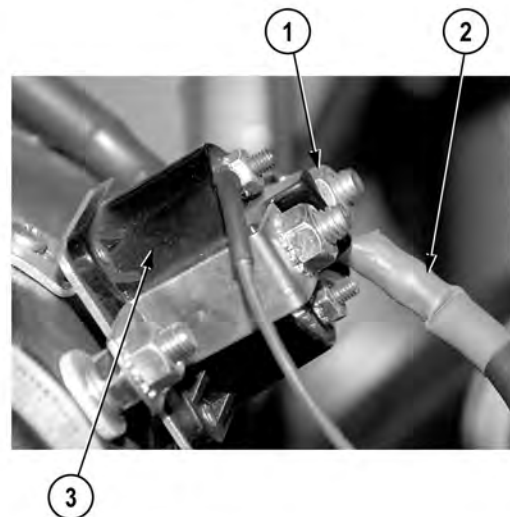
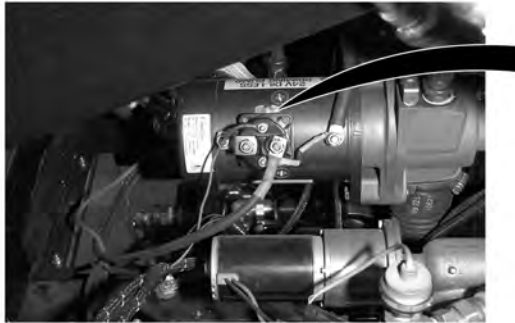
**Materials/Parts**

Ties, Cable, Plastic (WP 0400, Item 26)

**Equipment Conditions**

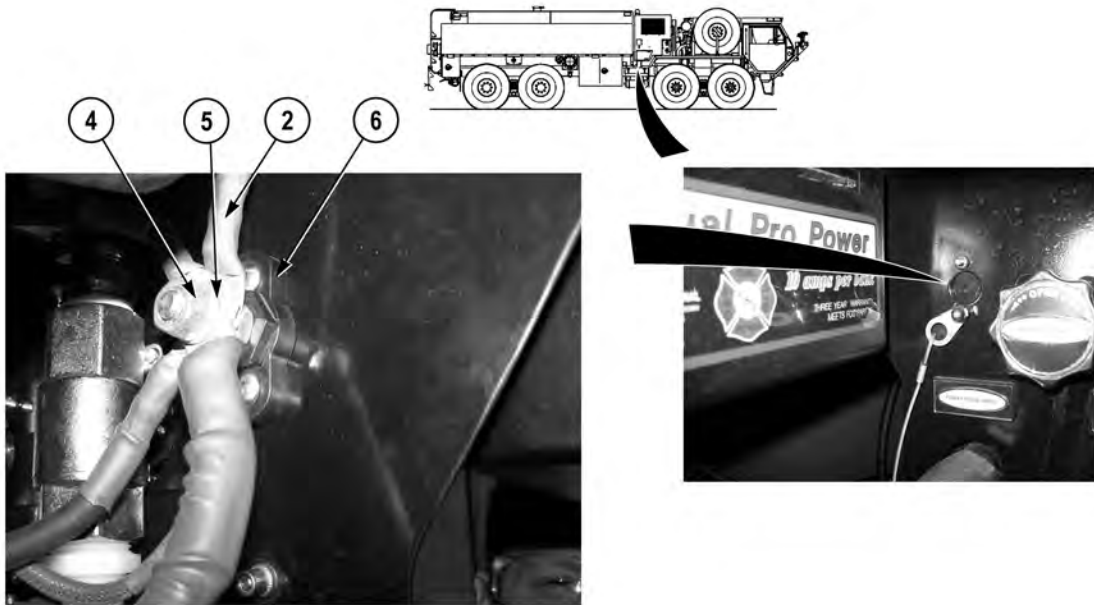
Batteries disconnected (TM 9-2320-325-14&P)

---

**REMOVAL****NOTE**

- Pump house panel and cab instrument panel removal may vary depending on location of high amperage cable.
- Tag and mark wires prior to removal to ensure proper installation.
- Note routing of high amperage cable prior to removal to ensure proper installation.
- Note position and remove cable ties, split loom, and cushion clips as required.
- All high amperage cables are removed the same way, primer pump high amperage cable shown.

1. Remove pump house panel G (WP 0339).
2. Remove locknut (1) and high amperage cable (2) from primer pump solenoid (3).
3. Open passenger side pump house control access door (WP 0008).



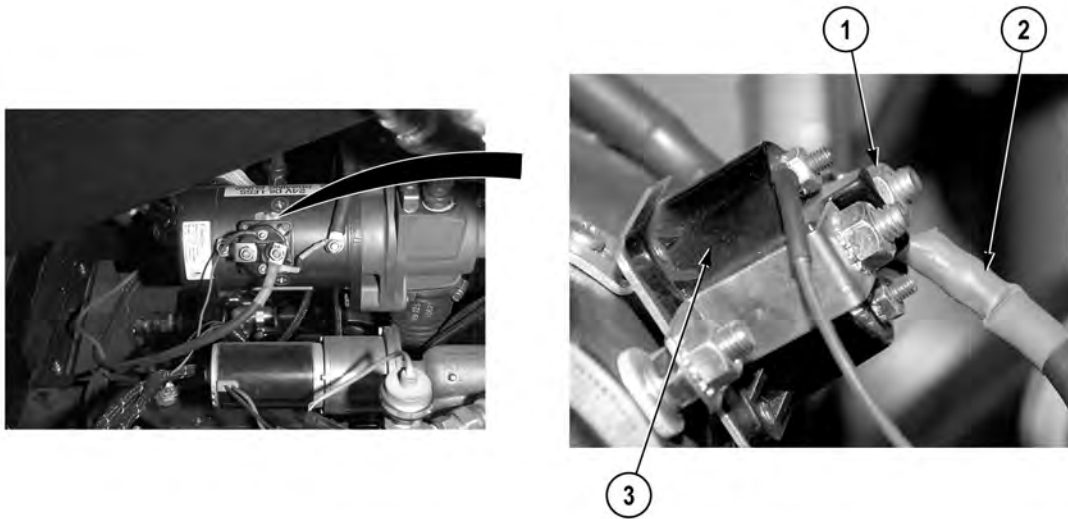
4. Remove nut (4), washer (5), and high amperage cable (2) from pump house B+ stud (6).
5. Remove high amperage cable (2) from vehicle.

#### END OF TASK

#### INSTALLATION

#### NOTE

- Route high amperage cable as noted prior to removal.
  - Install cable ties, split loom, and cushion clips as required.
1. Install high amperage cable (2) on vehicle.
  2. Install high amperage cable (2) on pump house B+ stud (6) with washer (5) and nut (4).
  3. Close passenger side pump house control access door (WP 0008).



4. Install high amperage cable (2) on primer pump solenoid (3) with locknut (1).
5. Install pump house panel G (WP 0339).

**END OF TASK**

**FOLLOW-ON MAINTENANCE**

Connect batteries (TM 9-2320-325-14&P)

**END OF TASK**

**END OF WORK PACKAGE**



---

**FIELD LEVEL MAINTENANCE**  
**HOSE REEL CIRCUIT BREAKER REPLACEMENT**

---

**INITIAL SETUP:****Tools and Special Tools**

Tool Kit, General Mechanic's: Automotive  
(WP 0398, Item 17)

**References**

WP 0254  
WP 0391, Fig. 40

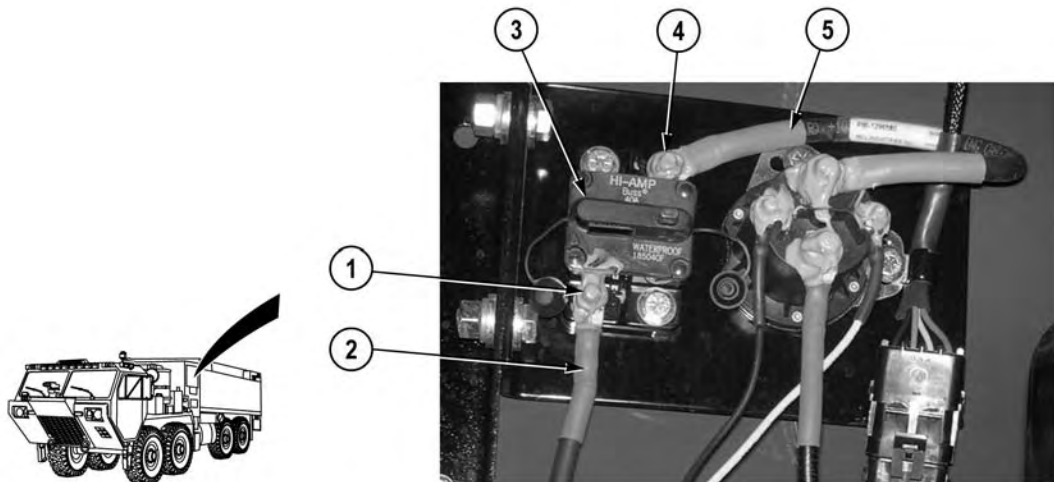
**Materials/Parts**

Compound, Sealing (WP 0400, Item 10)  
Tags, Identification (WP 0400, Item 23)  
Ties, Cable, Plastic (WP 0400, Item 26)  
Locknut (1)  
Locknut (1)  
Lockwasher (2)  
Lockwasher (2)

**Equipment Conditions**

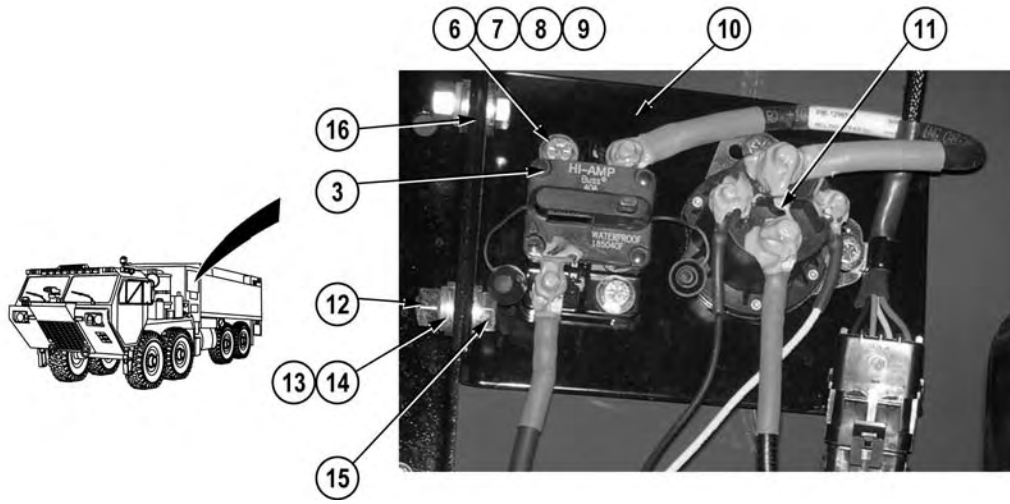
Pump house panels E removed (WP 0339)  
Pump house access door opened (WP 0009)

---

**REMOVAL****NOTE**

Tag and mark wires prior to removal to ensure proper installation.

1. Remove locknut (1) and wire (2) from circuit breaker (3). Discard locknut.
2. Remove locknut (4) and wire 1296580 (5) from circuit breaker (3). Discard locknut.



3. Remove two nuts (6), lockwashers (7), four washers (8), two screws (9), and circuit breaker (3) from bracket (10). Discard lockwashers.

### NOTE

Perform Steps (4) and (5) if bracket needs to be removed.

4. Remove hose reel solenoid (11) (WP 0254).
5. Remove two nuts (12), lockwashers (13), four washers (14), screws (15), and bracket (10) from pump house frame (16). Discard lockwashers.

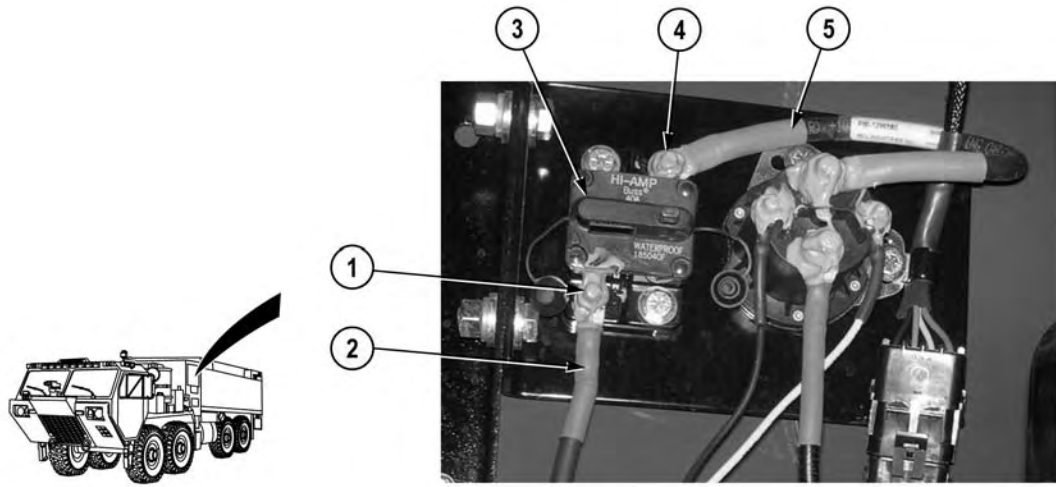
### END OF TASK

### INSTALLATION

### NOTE

Perform Steps (1) and (2) if bracket was removed.

1. Install bracket (10) on pump house frame (16) with two screws (15), four washers (14), two lockwashers (13), and nuts (12).
2. Install hose reel solenoid (11) (WP 0254).
3. Install circuit breaker (3) on bracket (10) with two screws (9), four washers (8), two lockwashers (7), and nuts (6).



4. Install wire 1296580 (5) on circuit breaker (3) with locknut (4).
5. Install wire (2) on circuit breaker (3) with locknut (1).

### **WARNING**



**Adhesives, solvents, and sealing compounds can burn easily, can give off harmful vapors, and are harmful to skin and clothing. To avoid injury or death, keep away from open fire and use in well-ventilated area. If adhesive, solvent, or sealing compound gets on skin or clothing, wash immediately with soap and water.**

6. Apply sealing compound to wire 1296580 (5) and wire (2).

**END OF TASK**

### **FOLLOW-ON MAINTENANCE**

1. Close pump house access door (WP 0009)
2. Install pump house panel E (WP 0339)

**END OF TASK**

**END OF WORK PACKAGE**





---

**FIELD LEVEL MAINTENANCE**  
**REEL REWIND SWITCH REPLACEMENT**

---

**INITIAL SETUP:****Tools and Special Tools**

Tool Kit, General Mechanic's: Automotive  
(WP 0398, Item 17)

**References**

WP 0391, Fig. 40

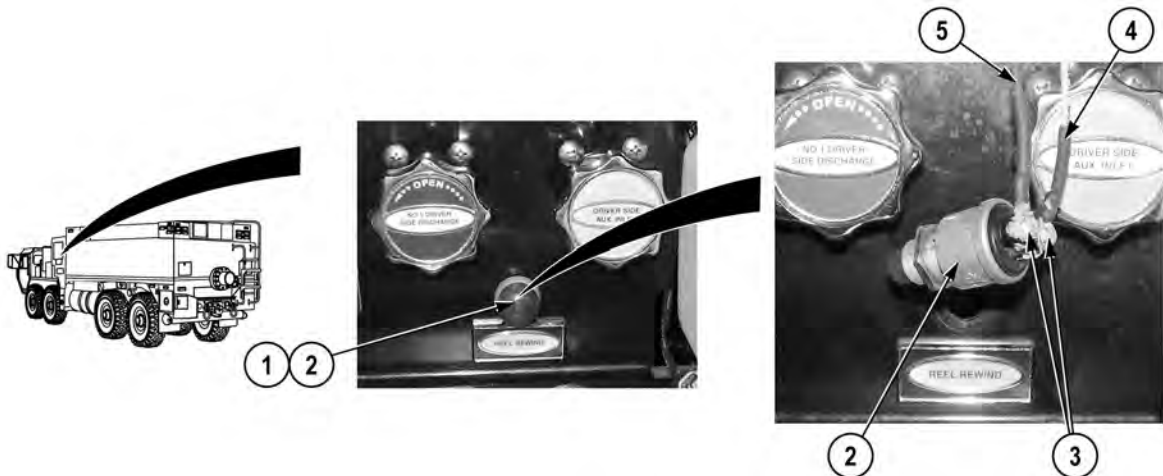
**Materials/Parts**

Tags, Identification (WP 0400, Item 23)  
Compound, Sealing (WP 0400, Item 10)

**Equipment Conditions**

Pump house panels A and B removed (WP 0339)

---

**REMOVAL**

1. Remove cover (1) from switch (2).
2. Remove switch (2) from vehicle.

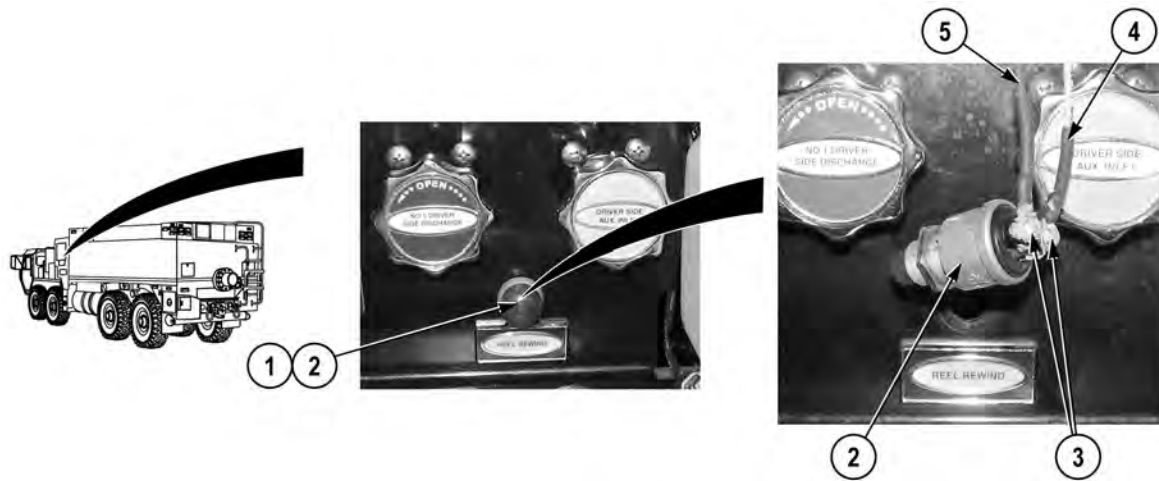
**NOTE**

Tag and mark wires prior to removal to ensure proper installation.

3. Remove two screws (3), wire 2341 (4) and wire 1664 (5) from switch (2).

**END OF TASK**

## INSTALLATION



### NOTE

Jam nut on switch may require adjustment after switch installation.

1. Install wire 1664 (5), wire 2341 (4), and screws (3) on switch (2).

### WARNING



**Adhesives, solvents, and sealing compounds can burn easily, can give off harmful vapors, and are harmful to skin and clothing. To avoid injury or death, keep away from open fire and use in well-ventilated area. If adhesive, solvent, or sealing compound gets on skin or clothing, wash immediately with soap and water.**

2. Apply sealant to two screws (3), wire 1664 (5), and wire 2341 (4).
3. Install switch (2) on vehicle.
4. Install cover (1) on switch (2).

### END OF TASK

### FOLLOW-ON MAINTENANCE

Install pump house panels A and B (WP 0339)

### END OF TASK

### END OF WORK PACKAGE

---

**FIELD LEVEL MAINTENANCE**  
**HOSE REEL SOLENOID REPLACEMENT**

---

**INITIAL SETUP:****Tools and Special Tools**

Tool Kit, General Mechanic's: Automotive  
(WP 0398, Item 17)

**References**

WP 0391, Fig. 40

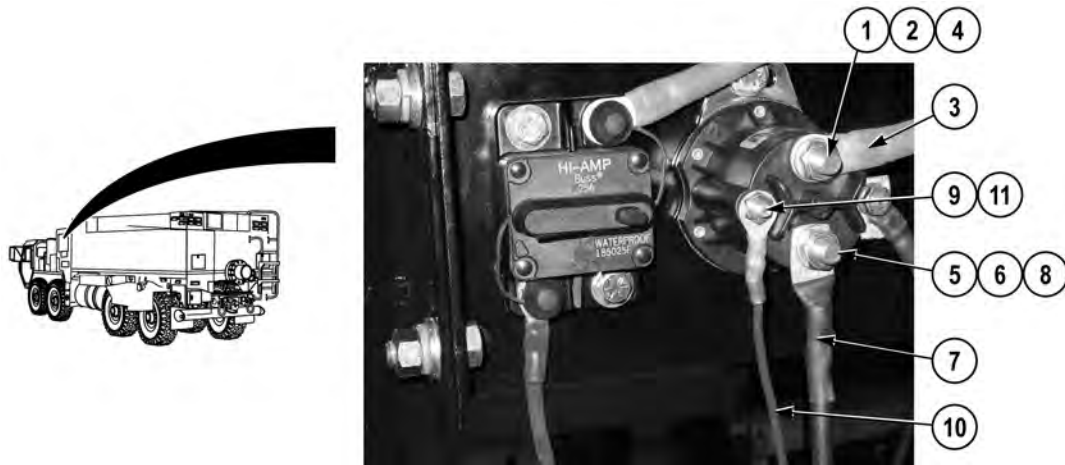
**Materials/Parts**

Tags, Identification (WP 0400, Item 23)  
Lockwasher (1)  
Lockwasher (1)  
Lockwasher (2)

**Equipment Conditions**

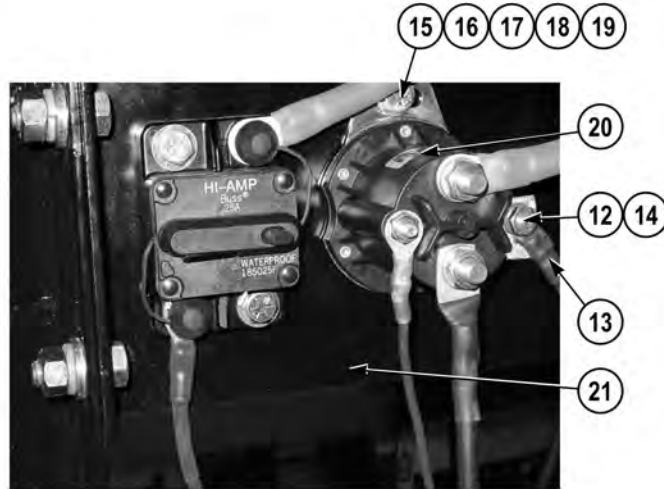
Batteries disconnected (TM 9-2320-325-14&P)  
Pump house access door opened (WP 0009)

---

**REMOVAL****NOTE**

Tag and mark wires prior to removal to ensure proper installation.

1. Remove nut (1), lockwasher (2), and wire 1296580 (3) from stud (4). Discard lockwasher.
2. Remove nut (5), lockwasher (6), and hose reel wire (7) from stud (8). Discard lockwasher.
3. Remove nut (9) and wire 1640L (10) from stud (11).



4. Remove nut (12) and wire 1664L (13) from stud (14).

#### NOTE

Note position of cushion clip prior to removal to ensure proper installation.

5. Remove two nuts (15), lockwashers (16), four washers (17), cushion clip (18), two screws (19), and solenoid (20) from bracket (21). Discard lockwashers.

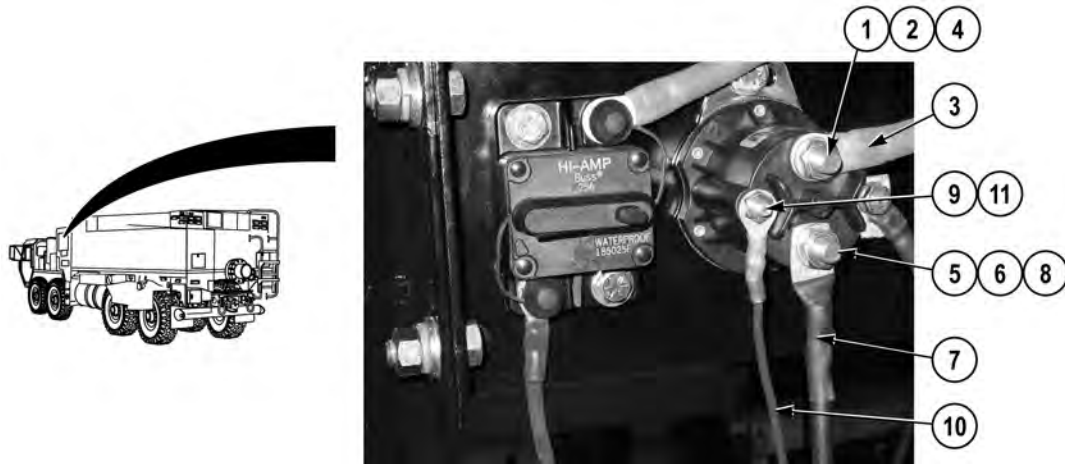
#### END OF TASK

#### INSTALLATION

#### NOTE

Install cushion clip as noted prior to removal.

1. Install solenoid (20) and cushion clip (18) on bracket (21) with two screws (19), four washers (17), two lockwashers (16), and nuts (15).
2. Install wire 1664L (13) on stud (14) with nut (12).



3. Install wire 1640L (10) on stud (11) with nut (9).
4. Install hose reel wire (7) on stud (8) with lockwasher (6) and nut (5).
5. Install wire 1296580 (3) on stud (4) with lockwasher (2) and nut (1).

#### END OF TASK

#### FOLLOW-ON MAINTENANCE

1. Close pump house access door (WP 0009)
2. Connect batteries (TM 9-2320-325-14&P)

#### END OF TASK

#### END OF WORK PACKAGE



---

**FIELD LEVEL MAINTENANCE****INLINE FUSE REPLACEMENT**

---

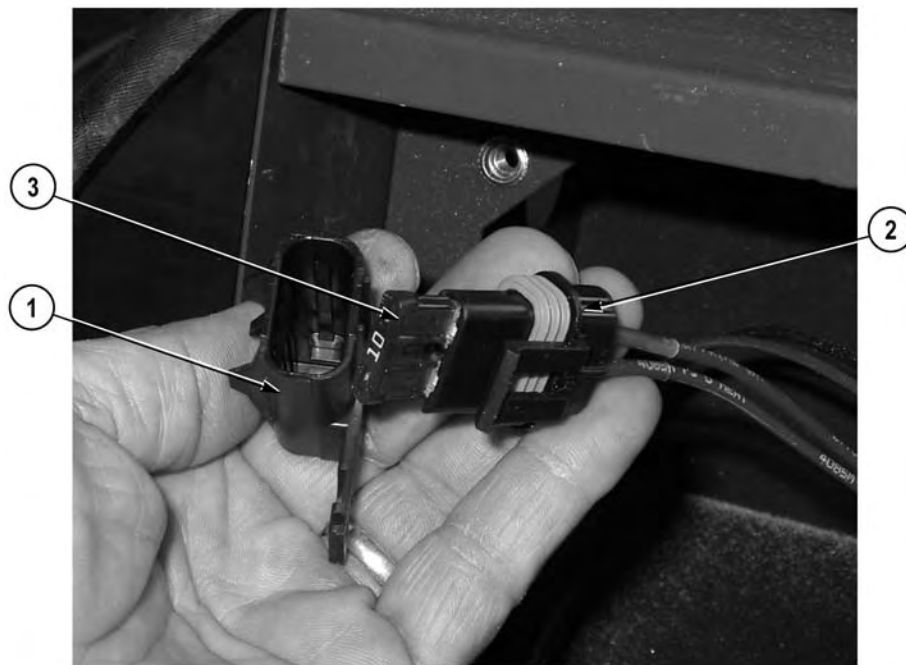
**INITIAL SETUP:****Tools and Special Tools**

Tool Kit, General Mechanic's: Automotive  
(WP 0398, Item 17)

**Equipment Conditions**

Batteries disconnected (TM 9-2320-325-14&P)

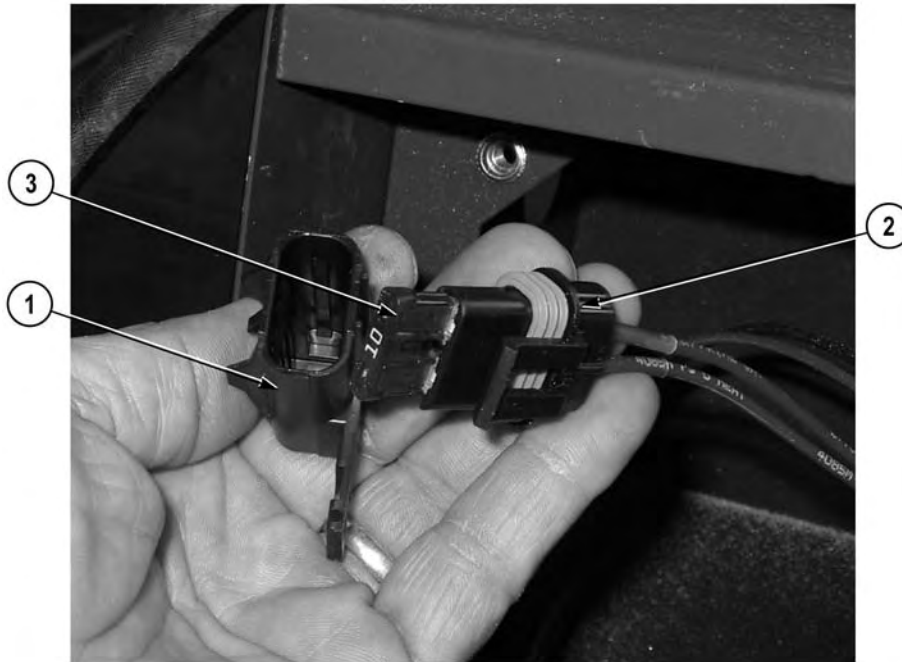
---

**REMOVAL****NOTE**

All inline fuses removed the same way.

1. Remove fuse cover (1) from fuse holder (2).
2. Remove fuse (3) from fuse holder (2).

**END OF TASK**

**INSTALLATION****NOTE**

All inline fuses installed the same way.

1. Install fuse (3) in fuse holder (2).
2. Install fuse cover (1) on fuse holder (2).

**END OF TASK****FOLLOW-ON MAINTENANCE**

Connect batteries (TM 9-2320-325-14&P)

**END OF TASK****END OF WORK PACKAGE**



---

**FIELD LEVEL MAINTENANCE****INTERCOM REPLACEMENT**

---

**INITIAL SETUP:****Tools and Special Tools**

Tool Kit, General Mechanic's: Automotive  
(WP 0398, Item 17)

**Materials**

Tags, Identification (WP 0398, Item 6)  
Locknut (2)  
Lockwasher (1)  
Lockwasher (1)

**References**

TM 9-2320-325-14&P  
WP 0276  
WP 0391, Fig. 43

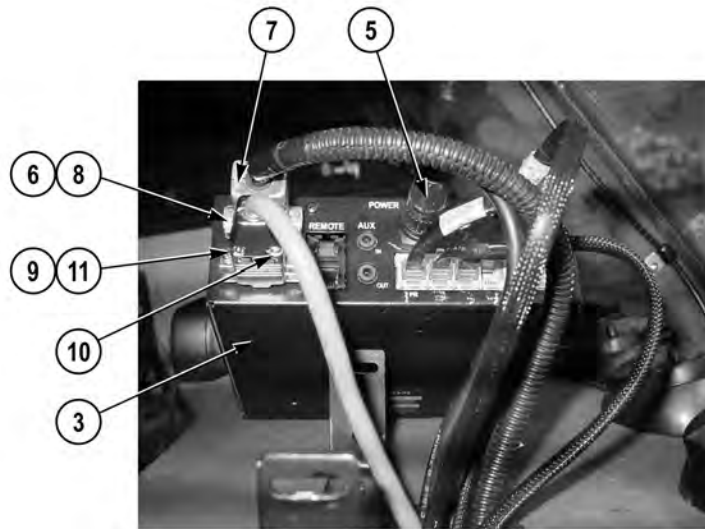
**Equipment Conditions**

Batteries disconnected (TM 9-2320-422-10)

---

**REMOVAL**

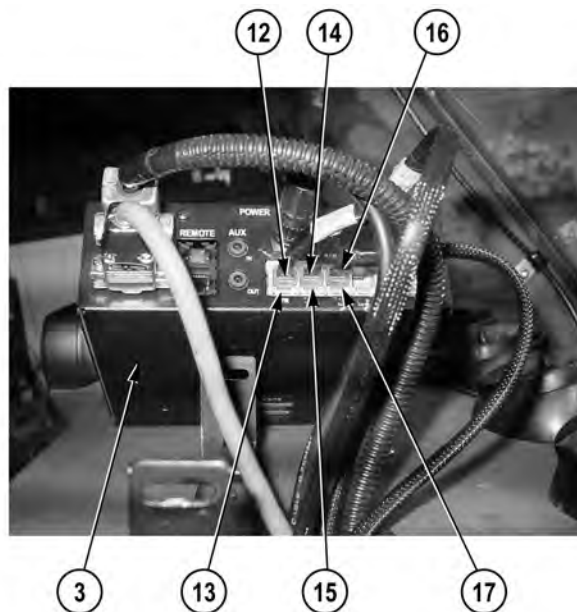
1. Remove four screws (1), washers (2), and intercom (3) from intercom bracket (4).



**NOTE**

Tag and mark wires prior to removal to ensure proper installation.

2. Remove intercom power supply wire harness (5) from intercom (3).
3. Loosen two screws (6) and remove SINCGARS interface wire harness connector (7) from intercom RADIO B terminal (8).
4. Loosen two screws (9) and remove two-way radio interface wire harness connector (10) from intercom RADIO A terminal (11).



**NOTE**

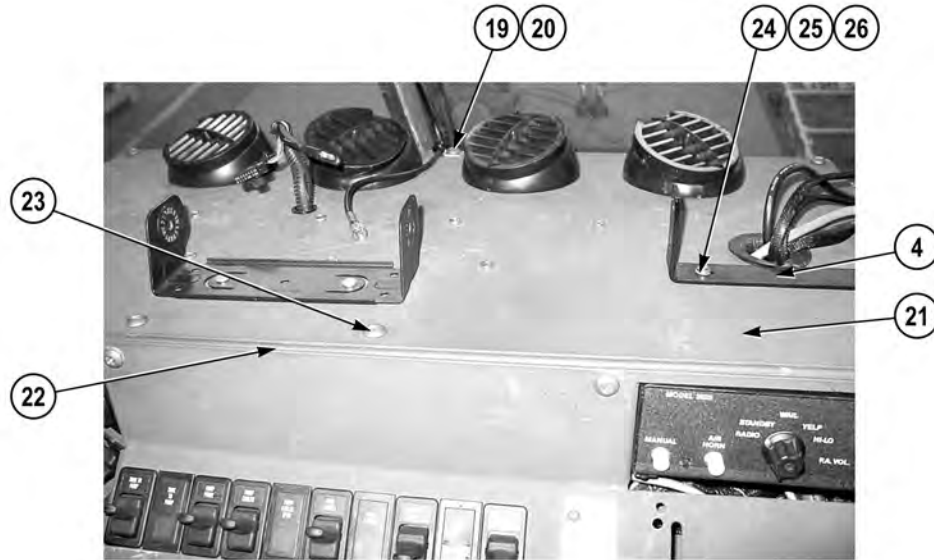
Intercom PR terminal jack has priority over other jacks during communication from intercom system.

5. Remove remote intercom cable (12) from intercom terminal PR jack (13).
6. Remove remote intercom cable (14) from intercom terminal jack (15).
7. Remove remote intercom cable (16) from intercom terminal jack (17).
8. Remove intercom (3) from vehicle.

**NOTE**

Perform Steps (9) through (15) if intercom bracket and/or power supply wire harness needs to be removed.

9. Remove two-way radio (18) from vehicle (WP 0276).

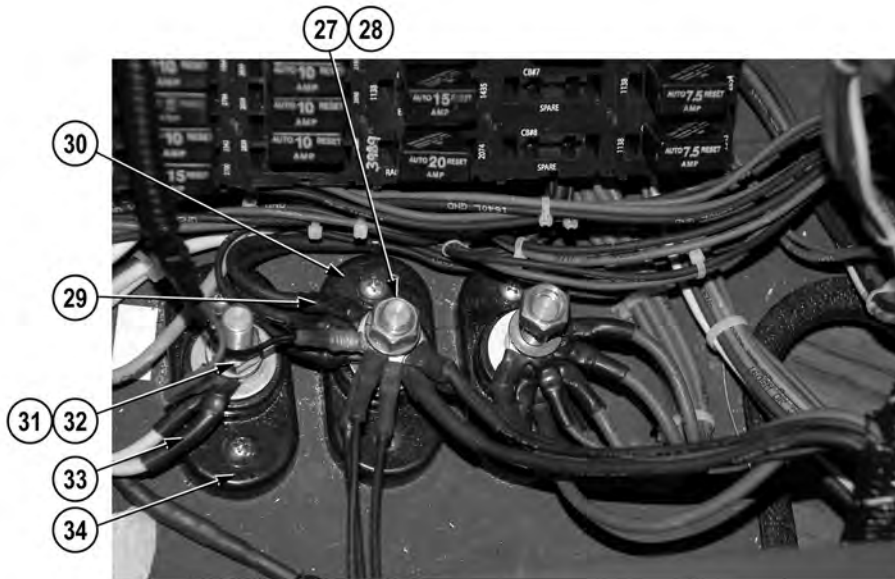


10. Remove screw (19) and cushion clip (20) from cab instrument panel A (21) and cab instrument panel assembly (22).

**⚠ CAUTION**

**When performing Step (11), lift cab instrument panel A only enough to access wires. Wires for flasher units and two-way radio are still attached. Failure to comply may cause damage to equipment.**

11. Remove six screws (23) and lift cab instrument panel A (21) slightly from cab instrument panel assembly (22).
12. Remove two locknuts (24), washers (25), screws (26), and intercom bracket (4) from cab instrument panel A (21). Discard locknuts.



**NOTE**

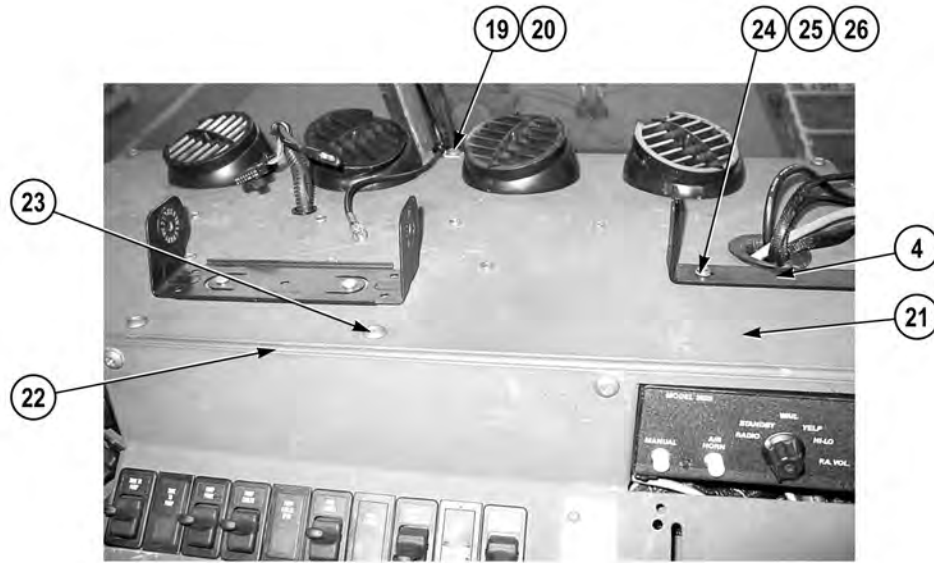
- Note routing of intercom power supply wire harness prior to removal to ensure proper installation.
  - Note position and remove split loom as required.
13. Remove nut (27), lockwasher (28), and intercom power supply wire harness black wire (29) from ground terminal block (30). Discard lockwasher.
  14. Remove nut (31), lockwasher (32), and intercom power supply wire harness red wire (33) from 12 VDC terminal block (34). Discard lockwasher.



15. Remove intercom power supply wire harness (5) from vehicle.

**END OF TASK****INSTALLATION****NOTE**

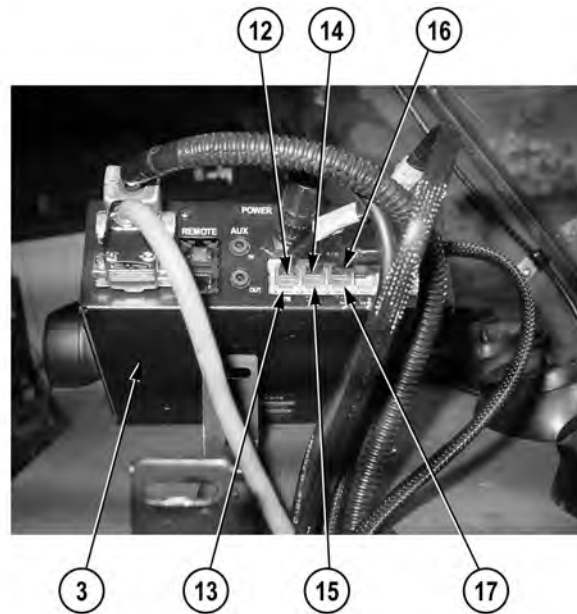
- Perform Steps (1) through (7) if intercom bracket and/or power supply wire harness were removed.
  - Route intercom power supply wire harness as noted prior to removal.
  - Install split loom as required.
1. Position intercom power supply wire harness (5) on vehicle.
  2. Install intercom power supply wire harness red wire (33) on 12 VDC terminal block (34) with lockwasher (32) and nut (31).
  3. Install intercom power supply wire harness black wire (29) on ground terminal block (30) with lockwasher (28) and nut (27).



4. Install intercom bracket (4) on cab instrument panel A (21) with two screws (26), washers (25), and locknuts (24).
5. Install cab instrument panel A (21) on cab instrument panel assembly (22) with six screws (23).
6. Install cushion clip (20) on cab instrument panel A (21) and cab instrument panel assembly (22) with screw (19).



7. Install two-way radio (18) on vehicle (WP 0276).

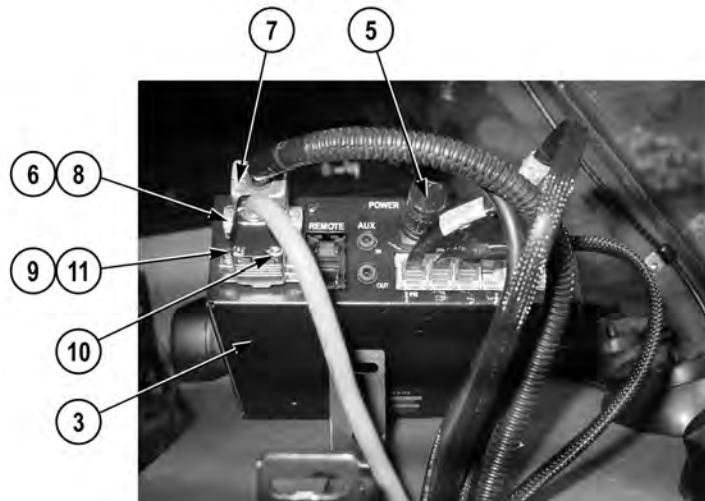


8. Position intercom (3) on vehicle.

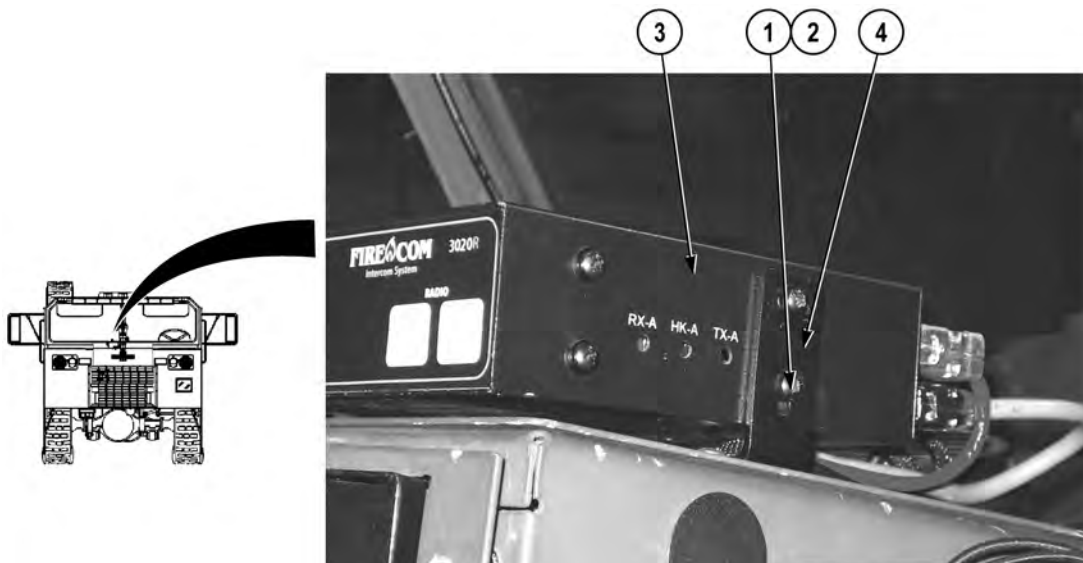
### NOTE

Install wires as noted prior to removal.

9. Install intercom cable (16) on intercom terminal jack (17).
10. Install intercom cable (14) on intercom terminal jack (15).
11. Install intercom cable (12) on intercom terminal PR jack (13).



12. Install two-way radio interface wire harness connector (10) on intercom RADIO A terminal (11) with two screws (9).
13. Install SINCGARS interface wire harness connector (7) on intercom RADIO B terminal (8) with two screws (6).
14. Install intercom power supply wire harness connector (5) on intercom (3).



15. Install intercom (3) on intercom bracket (4) with four washers (2) and screws (1).

**END OF TASK**

**FOLLOW ON MAINTENANCE**

Connect batteries (TM 9-2320-325-14&P)

**END OF TASK**

**END OF WORK PACKAGE**



---

**FIELD LEVEL MAINTENANCE**  
**INTERCOM CABLES AND CONNECTORS REPLACEMENT**

---

**INITIAL SETUP:****Tools and Special Tools**

Tool Kit, General Mechanic's: Automotive  
(WP 0398, Item 17)

**References**

WP 0207  
WP 0391, Fig. 59

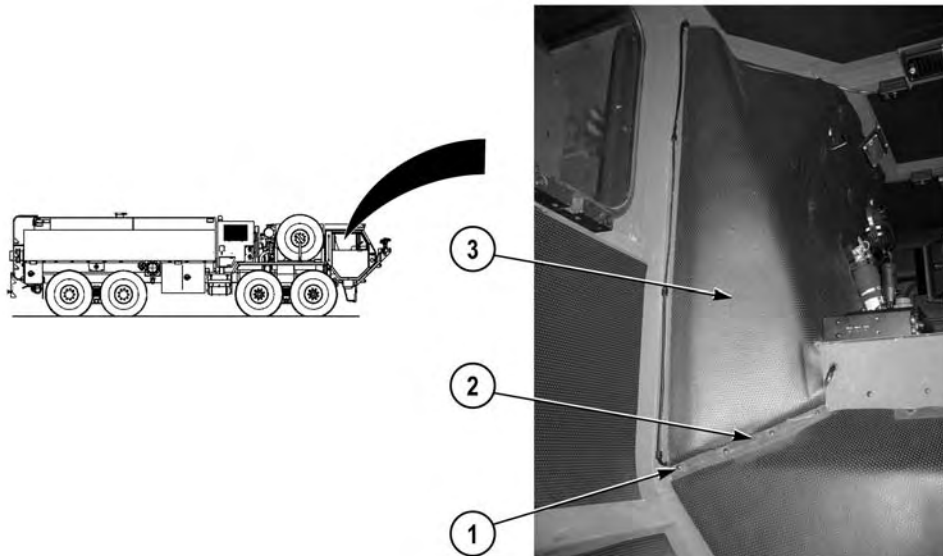
**Materials/Parts**

Tags, Identification (WP 0400, Item 23)  
Tape, Insulation, Electrical (WP 0400, Item 24)  
Ties, Cable, Plastic (WP 0400, Item 26)

**Equipment Conditions**

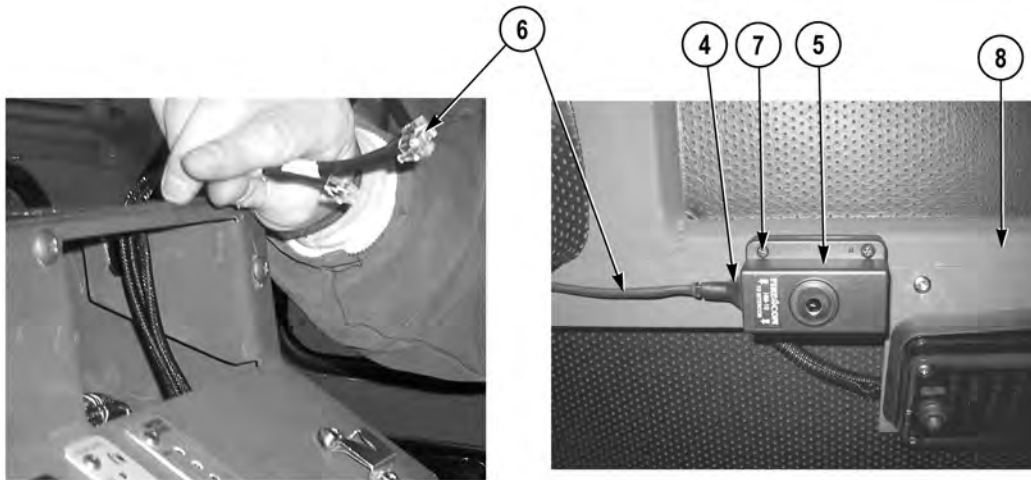
Cab instrument panels A, D, and E removed  
(WP 0205)

---

**REMOVAL****NOTE**

- Note location and routing of intercom cables prior to removal to ensure proper installation.
- Driver side and passenger side intercom cables are removed the same way. Passenger side shown.
- Perform Steps (1) through (4) if passenger side intercom cable and headset jack needs to be removed.

1. Remove four screws (1) and trim (2) from passenger side cab (3).

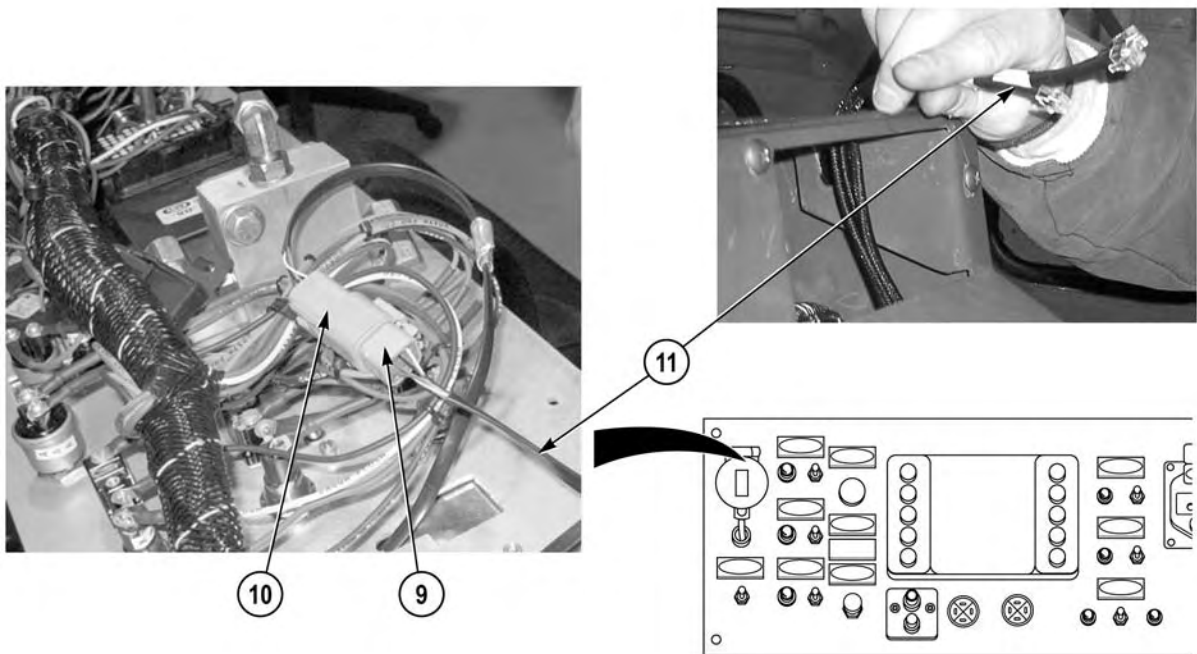


**CAUTION**

**Intercom cable RJ12 connector must be protected with electrical tape during removal. Failure to comply may result in damage to equipment.**

**NOTE**

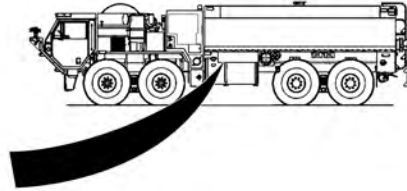
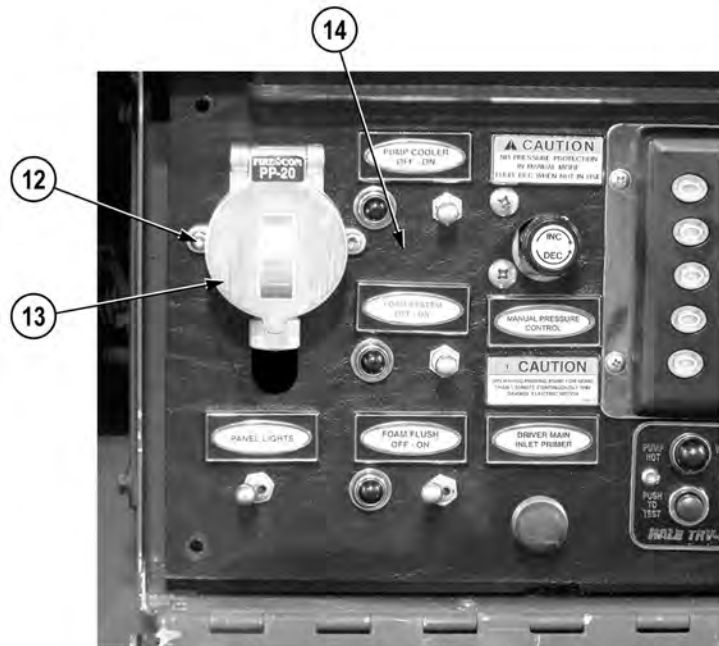
- Note position and remove cable ties, split loom, and cushion clips as required.
  - Tag and mark wires prior to removal to ensure proper installation.
2. Disconnect intercom cable connector (4) from headset jack (5).
  3. Carefully remove passenger side intercom cable (6) from vehicle.
  4. Remove four screws (7) and headset jack (5) from cab roof (8).



### NOTE

Perform Step (5) through (8) if pump operator's panel intercom cable and pump operator's panel headset jack needs to be removed.

5. Open pump operator's panel (WP 0207).
6. Disconnect intercom cable connector (9) from pump operator's panel headset jack connector (10).
7. Carefully remove pump operator's panel intercom cable (11) from vehicle.



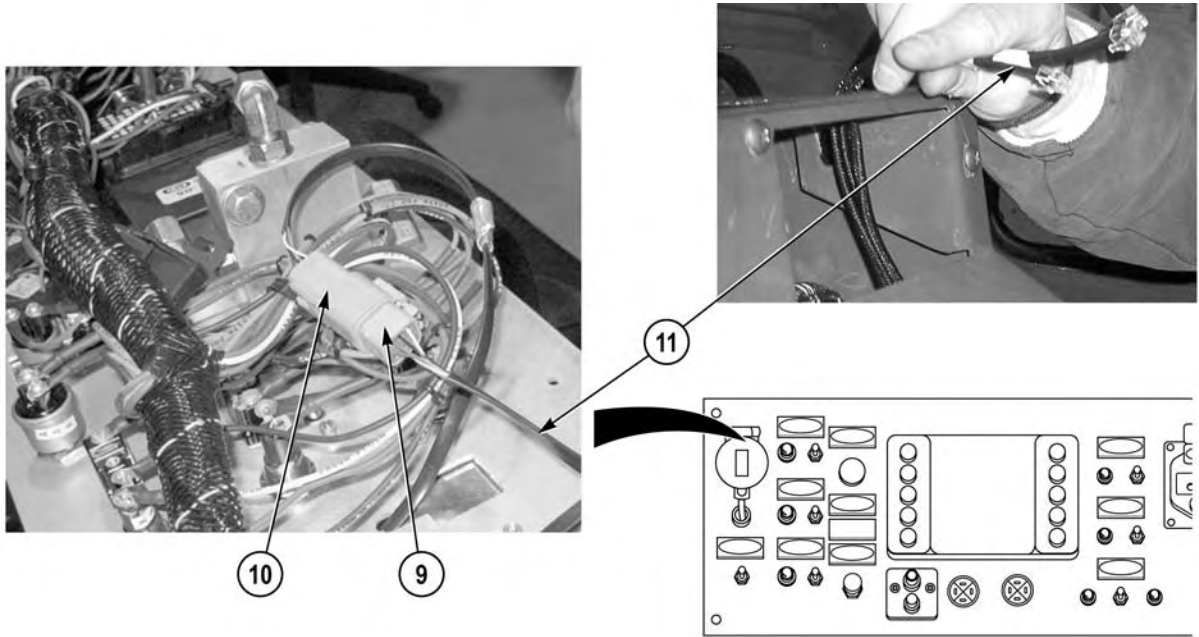
8. Remove two screws (12) and pump operator's panel headset jack connector (13) from pump operator's panel (14).

#### END OF TASK

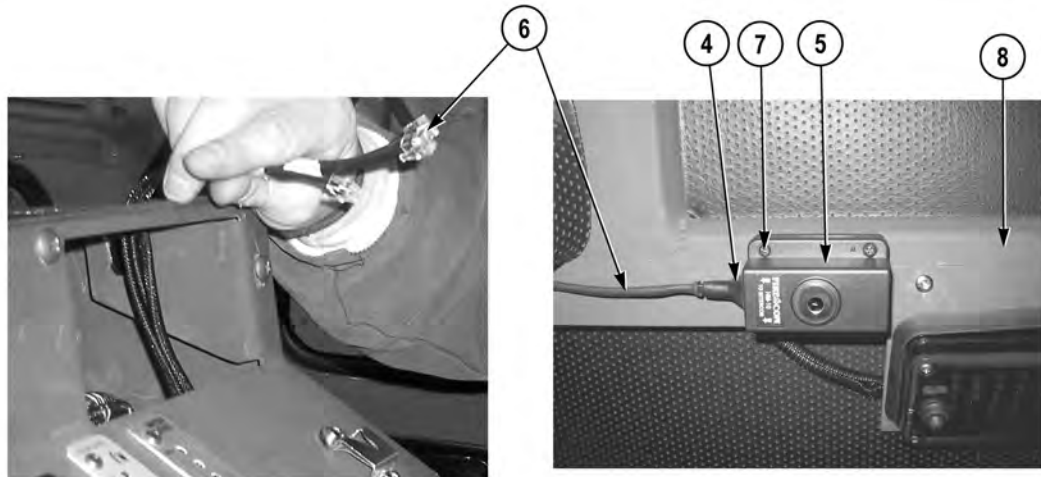
#### INSTALLATION

#### NOTE

- Route intercom cables as noted prior to removal.
  - Install cable ties, split loom, and cushion clips as noted prior to removal.
  - Perform Step (1) through (4) if pump operator's panel headset jack and pump operator's panel intercom cable needs to be installed.
1. Install pump operator's panel headset jack connector (13) on pump operator's panel (14) with two screws (12).



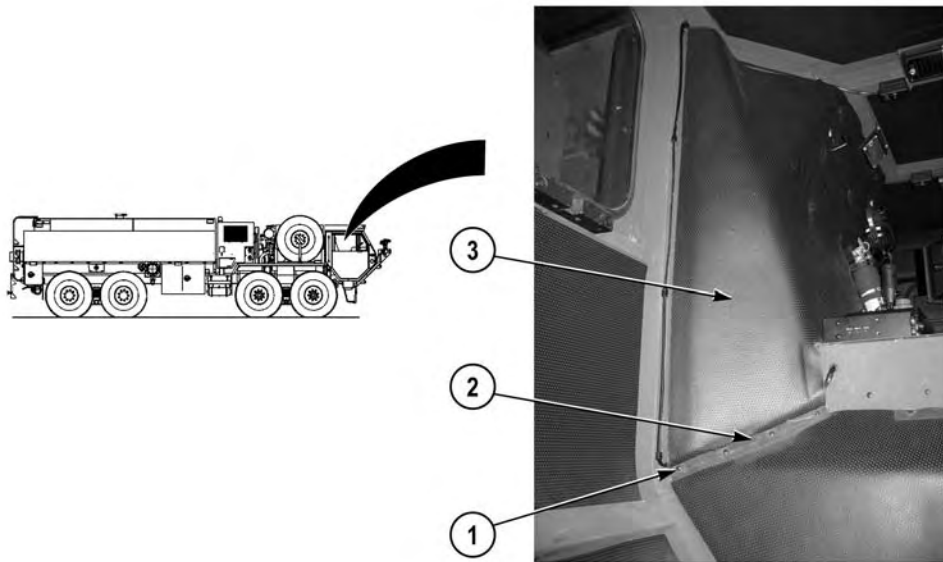
2. Carefully position pump operator's panel intercom cable (11) on vehicle.
3. Connect pump operator's panel headset jack connector (10) on intercom cable connector (9).
4. Close pump operator's panel (WP 0207).



**NOTE**

Perform Steps (5) through (8) if headset jack and passenger side intercom cable were removed.

5. Install headset jack (5) on cab roof (8) with four screws (7).
6. Carefully install intercom cable (6) on vehicle.
7. Connect intercom cable connector (4) on headset jack (5).



8. Install trim (2) on passenger side cab (3) with four screws (1).

**END OF TASK**

**FOLLOW-ON MAINTENANCE**

Install cab instrument panels E, D, and A (WP 0205)

**END OF TASK**

**END OF WORK PACKAGE**

---

**FIELD LEVEL MAINTENANCE**  
**INTERCOM HEADSET HANGERS REPLACEMENT**

---

**INITIAL SETUP:****Tools and Special Tools**

Tool Kit, General Mechanic's: Automotive  
(WP 0398, Item 17)

**References**

WP 0391, Fig. 43

**Materials/Parts**

Lockwasher (1)

**Equipment Conditions**

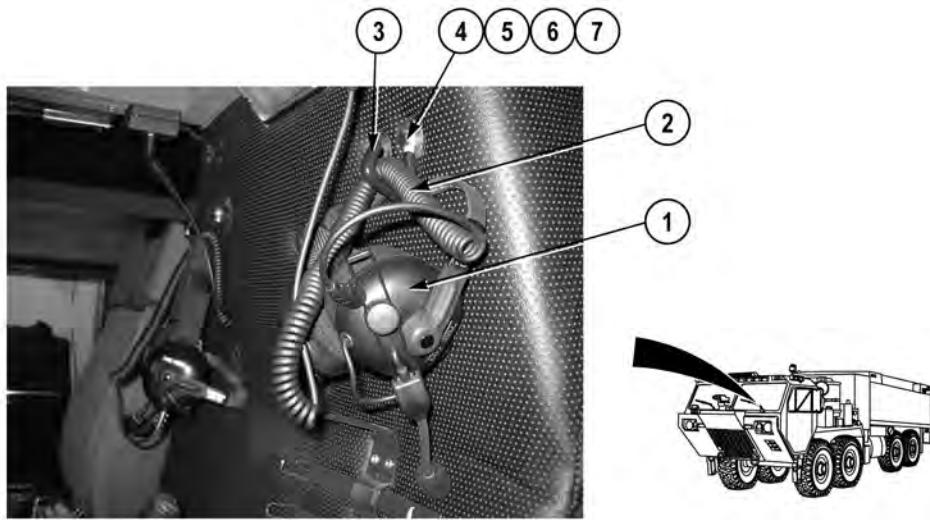
Engine OFF (TM 9-2320-422-10)

Wheels chocked (TM 9-2320-422-10)

**Personnel Required**

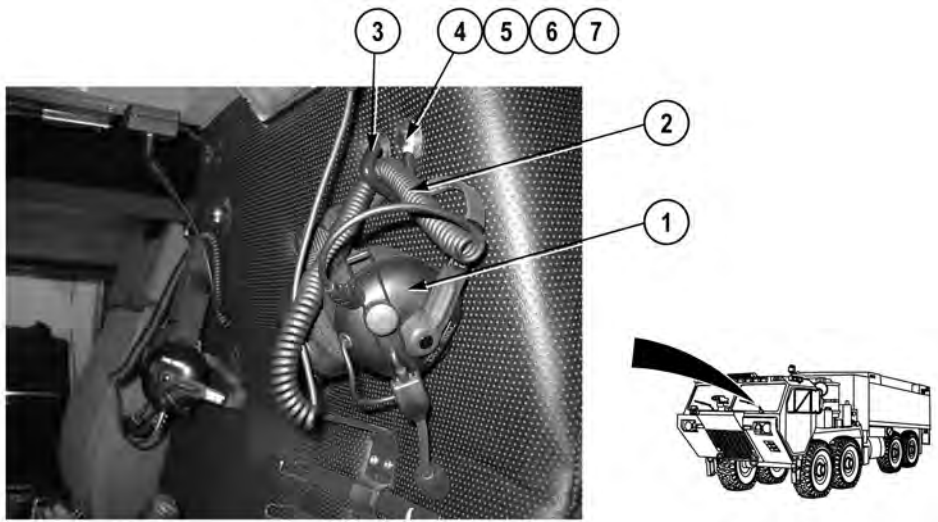
MOS 63B Wheeled Vehicle Mechanic (2)

---

**REMOVAL****NOTE**

Both headset hangers are removed the same way.

1. Remove headset (1) and cord (2) from hook (3).
2. With the aid of an assistant, remove nut (4), lockwasher (5), washer (6), screw (7), and hook (3) from vehicle. Discard lockwasher.

**INSTALLATION****NOTE**

Both headset intercoms are installed the same way.

1. With the aid of an assistant, install hook (3) on vehicle with screw (7), washer (6), lockwasher (5), and nut (4).
2. Position headset (1) and cord (2) on hook (3).

**END OF TASK****FOLLOW-ON MAINTENANCE**

Remove wheel chocks (TM 9-2320-422-10)

**END OF TASK****END OF WORK PACKAGE**



## FIELD LEVEL MAINTENANCE

## PORTABLE HANDHELD RADIO AND CHARGER REPLACEMENT

## INITIAL SETUP:

**Tools and Special Tools**

Tool Kit, General Mechanic's: Automotive  
(WP 0398, Item 17)

**References**

WP 0391, Fig. 44

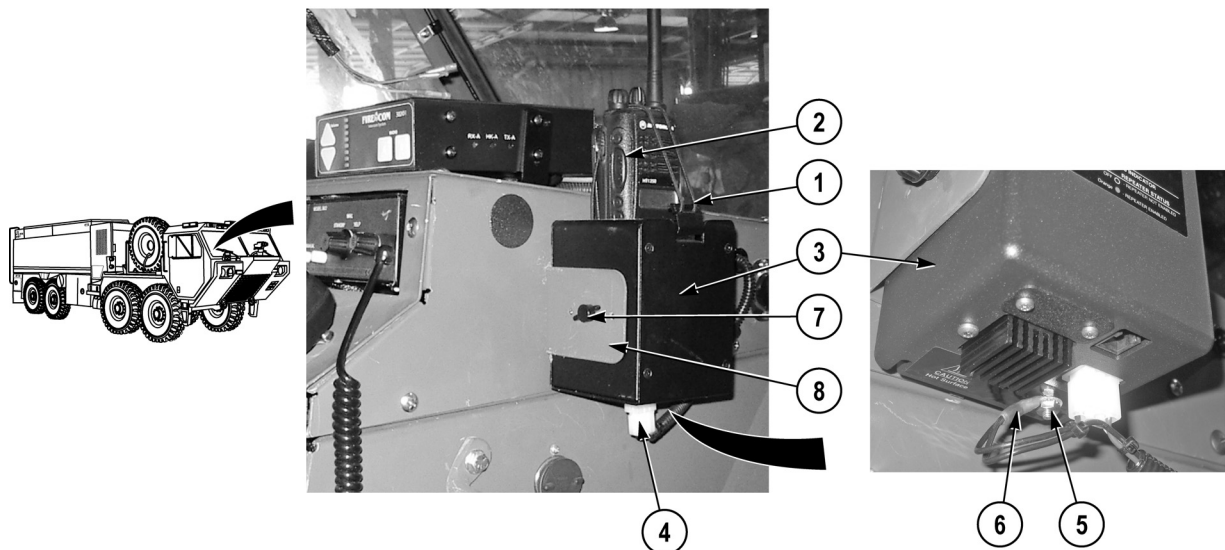
**Materials/Parts**

Locknut (2)

**Equipment Conditions**

Cab instrument panel A removed (WP 0205)

## REMOVAL

**NOTE**

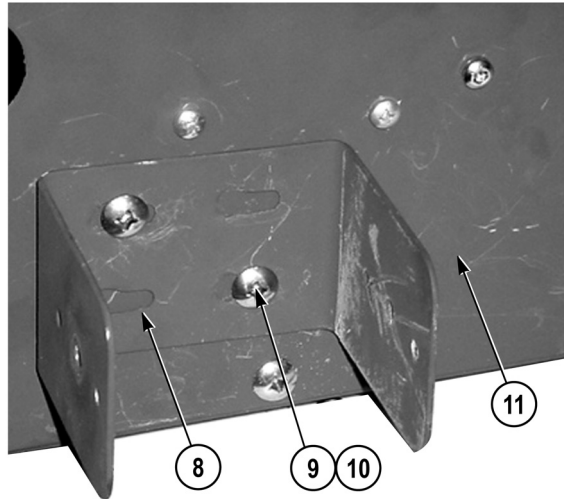
Both handheld radios and chargers are removed the same way.

1. Unlatch radio retainer (1) and remove radio (2) from charger (3).
2. Disconnect radio charger connector (4) from charger (3).

**NOTE**

Perform Step (3) if charger is equipped with ground wire.

3. Remove locknut (5) and ground wire (6) from charger (3). Discard locknut.
4. Remove two screws (7) and charger (3) from bracket (8).



5. Remove two locknuts (9), screws (10), and bracket (8) from panel (11). Discard locknuts.

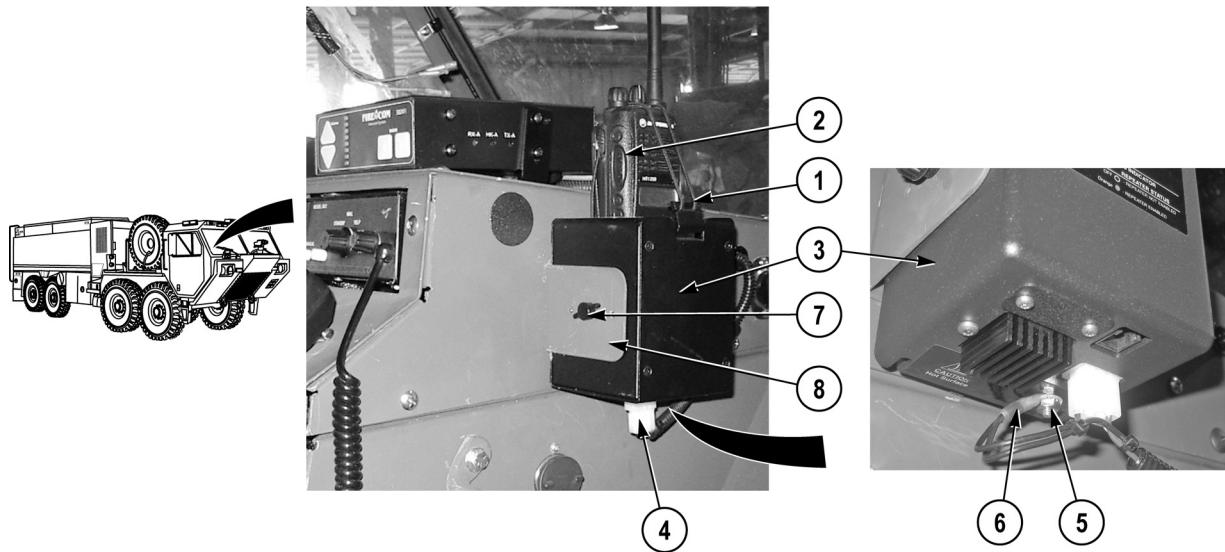
#### END OF TASK

#### INSTALLATION

#### NOTE

Both handheld radios and chargers are installed the same way.

1. Install bracket (8) on panel (11) with two screws (10) and locknuts (9).



2. Install charger (3) on bracket (8) with two screws (7).

### NOTE

Perform Step (3) if charger is equipped with ground wire.

3. Install ground wire (6) on charger (3) with locknut (5).
4. Connect radio charger connector (4) on charger (3).
5. Install radio (2) on charger (3) with radio retainer (1).

### END OF TASK

### FOLLOW-ON MAINTENANCE

Install cab instrument panel A (WP 0205)

### END OF TASK

### END OF WORK PACKAGE



## FIELD LEVEL MAINTENANCE

## POWER CABLE ASSEMBLY REPLACEMENT (SINGGARS)

## INITIAL SETUP:

**Tools and Special Tools**

Tool Kit, General Mechanic's: Automotive  
(WP 0398, Item 17)

**References**

WP 0008  
WP 0391, Fig. 26

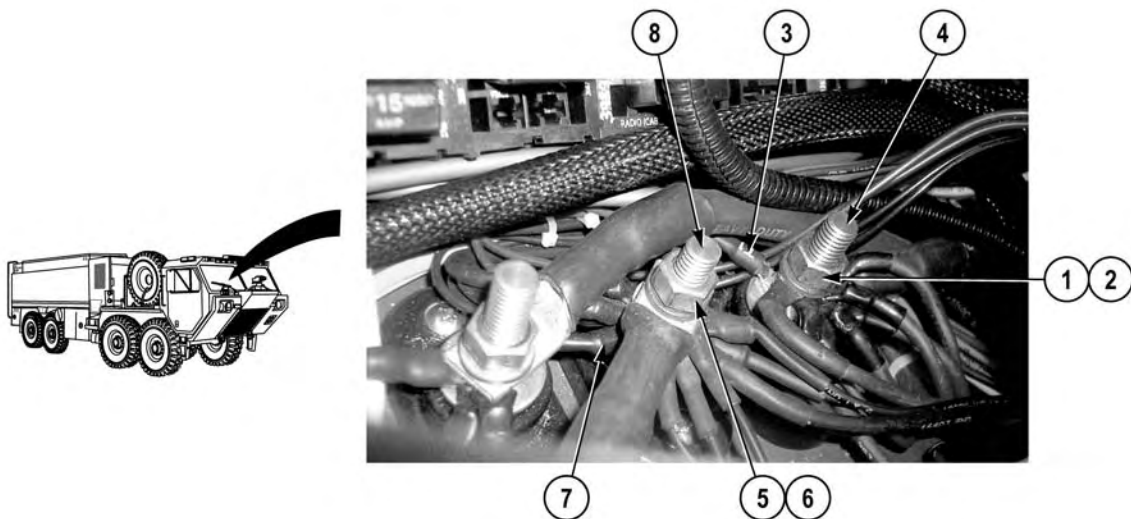
**Materials/Parts**

Tags, Identification (WP 0400, Item 23)  
Ties, Cable, Plastic (WP 0400, Item 26)  
Lockwasher (1)  
Lockwasher (1)

**Equipment Conditions**

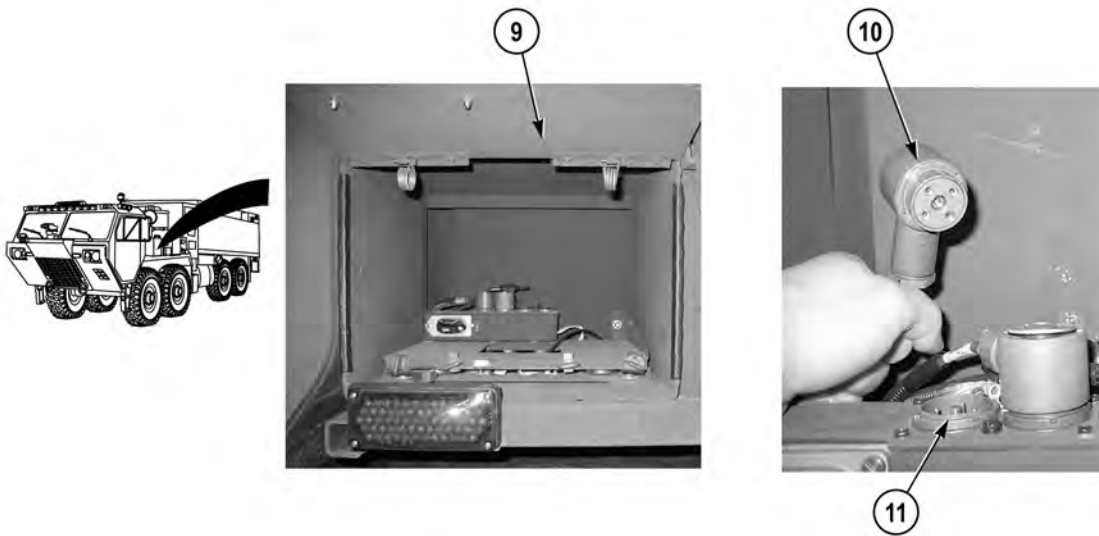
Cab instrument panel A removed (WP 0205)

## REMOVAL

**NOTE**

- Tag and mark wires prior to removal to ensure proper installation.
- Note routing of power cable assembly to ensure correct installation prior to removal to ensure proper installation.
- Remove cable ties and cushion clips as required.

1. Remove nut (1), lockwasher (2), and T1 connector (3) from power terminal (4). Discard lockwasher.
2. Remove nut (5), lockwasher (6), and T2 connector (7) from ground terminal (8). Discard lockwasher.



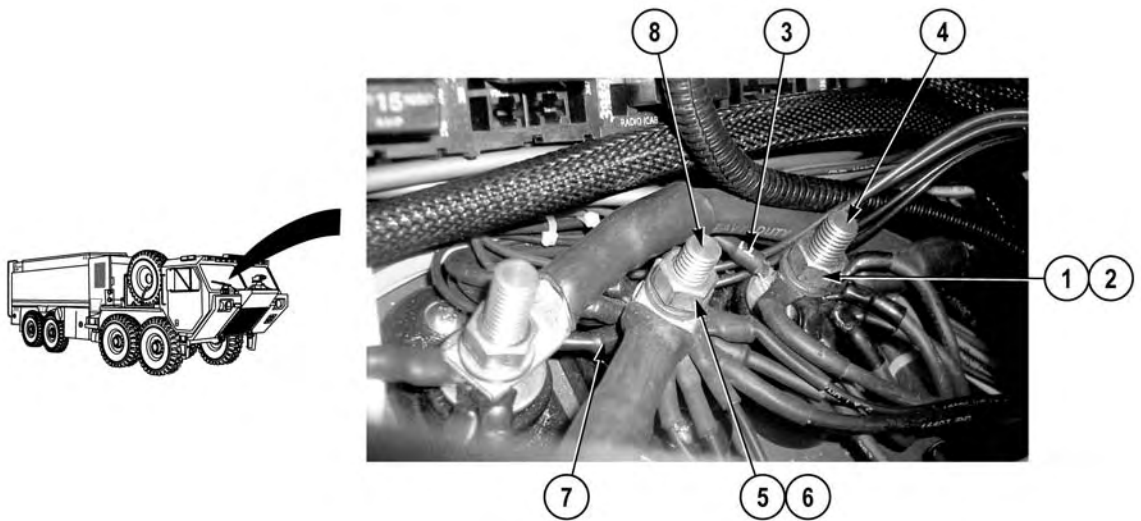
3. Open SINGARS door (9) (WP 0008).
4. Disconnect power cable (10) from SINGARS connector (11).
5. Remove power cable (10) from vehicle.

#### END OF TASK

#### INSTALLATION

#### NOTE

- Route power cable assembly as noted prior to removal.
  - Install cable ties and cushion clips as required.
1. Install power cable (10) on vehicle.
  2. Connect power cable (10) on SINGARS connector (11).
  3. Close SINGARS door (9) (WP 0008).



4. Connect T2 connector (7) on ground terminal (8) with lockwasher (6) and nut (5).
5. Connect T1 connector (3) on power terminal (4) with lockwasher (2) and nut (1).

**END OF TASK**

**FOLLOW-ON MAINTENANCE**

Install cab instrument panel A (WP 0205)

**END OF TASK**

**END OF WORK PACKAGE**





---

**FIELD LEVEL MAINTENANCE**  
**STREAMLIGHT AND CHARGER REPLACEMENT**

---

**INITIAL SETUP:****Tools and Special Tools**

Tool Kit, General Mechanic's: Automotive  
(WP 0398, Item 17)

**References**

WP 0391, Fig. 47

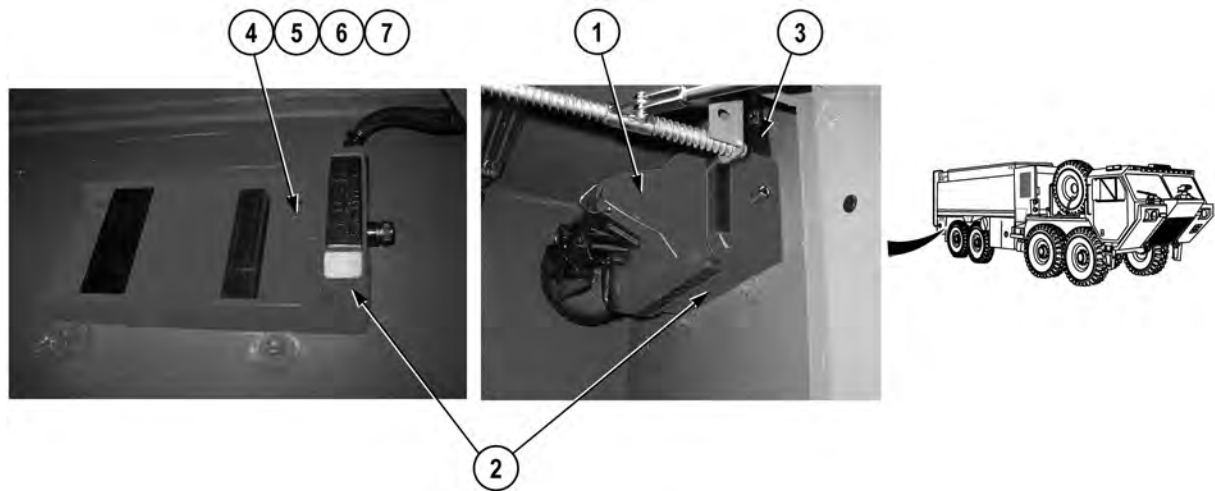
**Materials/Parts**

Lockwasher (4)

**Equipment Conditions**

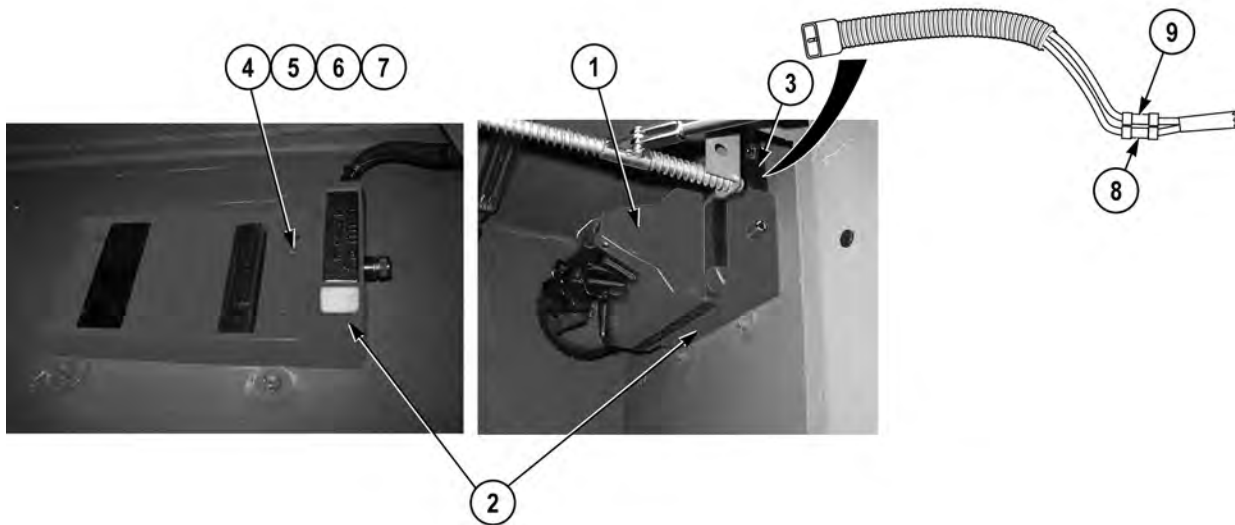
Batteries disconnected (TM 9-2320-325-14&P)  
Compartment door opened (WP 0008)

---

**REMOVAL****NOTE**

Both streamlights and chargers are removed the same way. Front charger shown.

1. Remove streamlight (1) from charger (2).
2. Disconnect streamlight connector (3) from charger (2).
3. Remove four nuts (4), lockwashers (5), washers (6), screws (7), and charger (2) from vehicle. Discard lockwashers.

**NOTE**

Perform Step (4) if pigtail needs to be removed.

4. Cut wire 2075 (8) and wire 2740 (9) (TM 9-2320-325-14&P).

**END OF TASK****INSTALLATION****NOTE**

- Both streamlights and chargers are installed the same way.
- Perform Step (1) if pigtail needs to be installed.

1. Repair wire 2740 (9) and wire 2075 (8) (TM 9-2320-325-14&P).
2. Install charger (2) on vehicle with four screws (7), washers (6), lockwashers (5), and nuts (4).
3. Connect streamlight connector (3) on charger (2).
4. Install streamlight (1) on charger (2).

**END OF TASK****FOLLOW-ON MAINTENANCE**

1. Connect batteries (TM 9-2320-325-14&P)
2. Close compartment door (WP 0008)

**END OF TASK****END OF WORK PACKAGE**

---

**FIELD LEVEL MAINTENANCE****PUMP HOUSE POWER DISTRIBUTION BLOCK CIRCUIT BREAKER REPLACEMENT**

---

**INITIAL SETUP:****Tools and Special Tools**

Tool Kit, General Mechanic's: Automotive  
(WP 0398, Item 17)

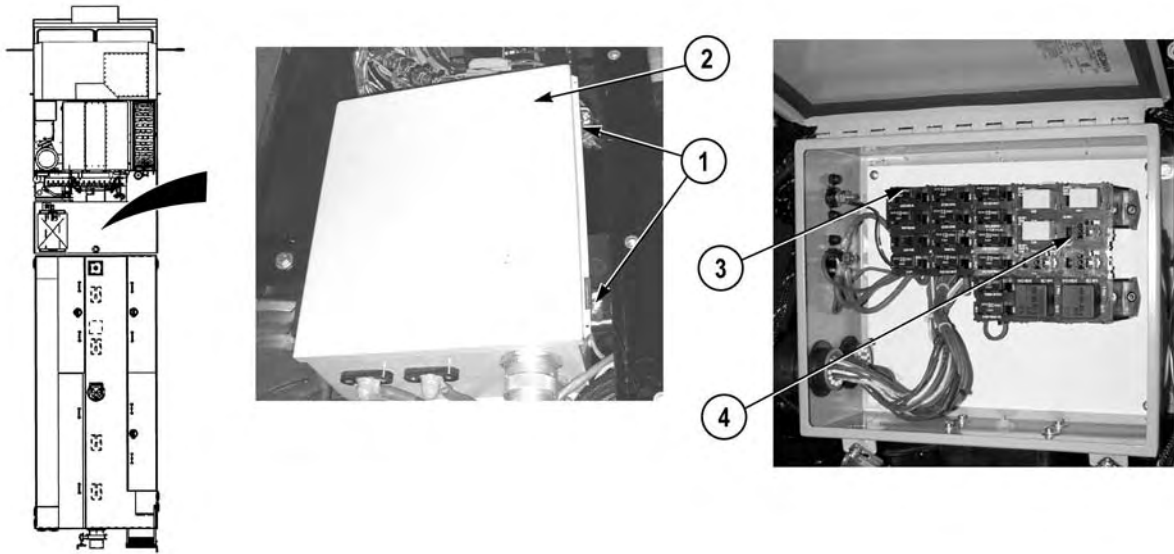
**Equipment Conditions**

Pump house panel K removed (WP 0339)

**References**

WP 0391, Fig. 42

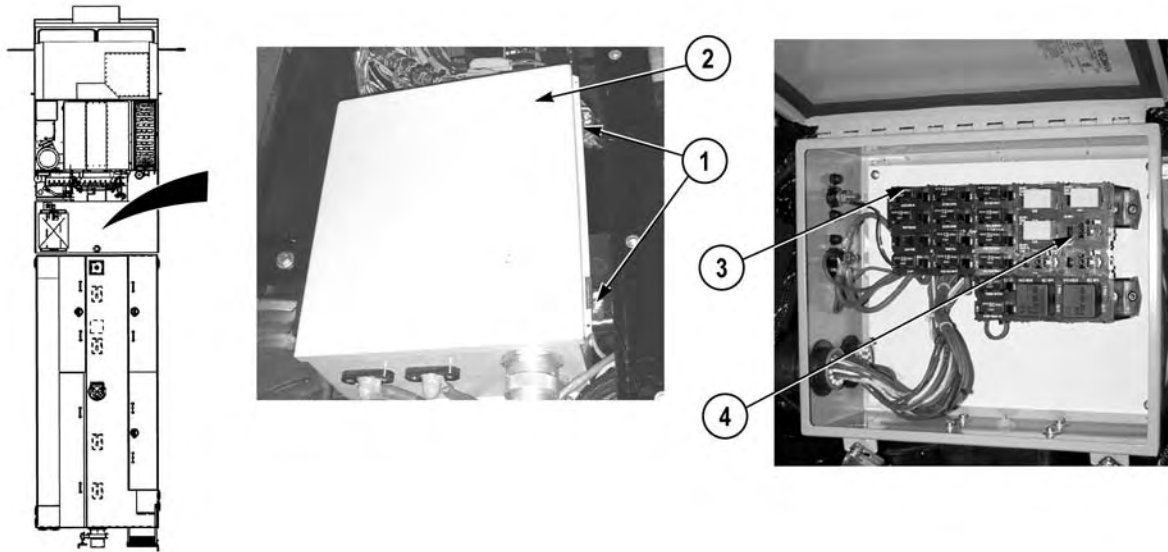
---

**REMOVAL****NOTE**

All pump house distribution box circuit breakers are replaced the same way.

1. Loosen two screws (1) and open power distribution box cover (2).
2. Remove circuit breaker (3) from subpanel (4).

**END OF TASK**

**INSTALLATION**

1. Install circuit breaker (3) on subpanel (4).
2. Close power distribution box cover (2) and tighten two screws (1).

**END OF TASK****FOLLOW-ON MAINTENANCE**

Install pump house panel K (WP 0339)

**END OF TASK****END OF WORK PACKAGE**

---

**FIELD LEVEL MAINTENANCE****PUMP HOUSE POWER DISTRIBUTION BLOCK RELAY REPLACEMENT**

---

**INITIAL SETUP:****Tools and Special Tools**

Tool Kit, General Mechanic's: Automotive  
(WP 0398, Item 17)

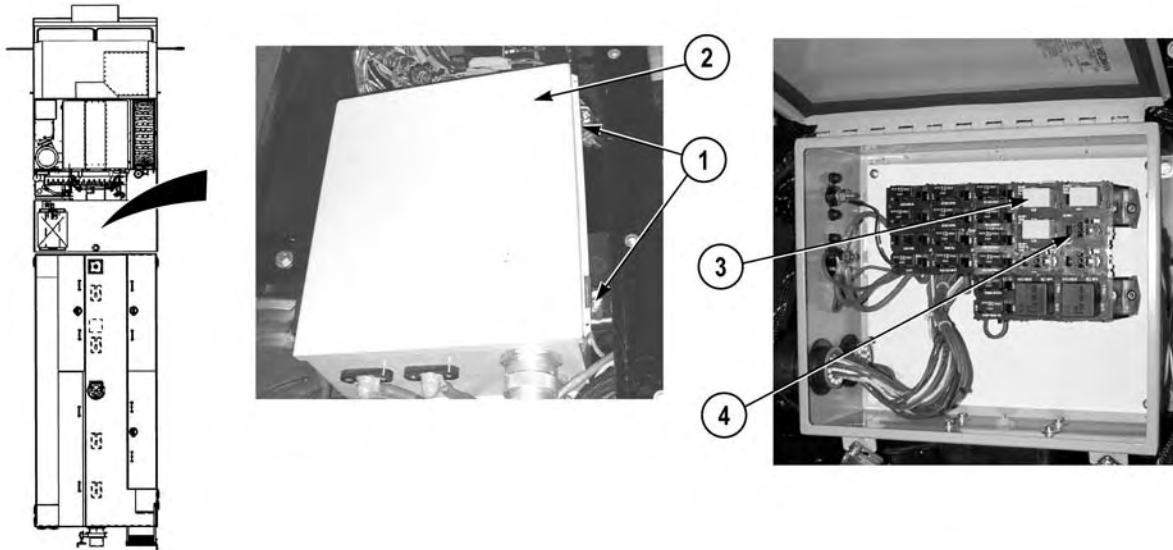
**Equipment Conditions**

Pump house panel K removed (WP 0339)

**References**

WP 0391, Fig. 42

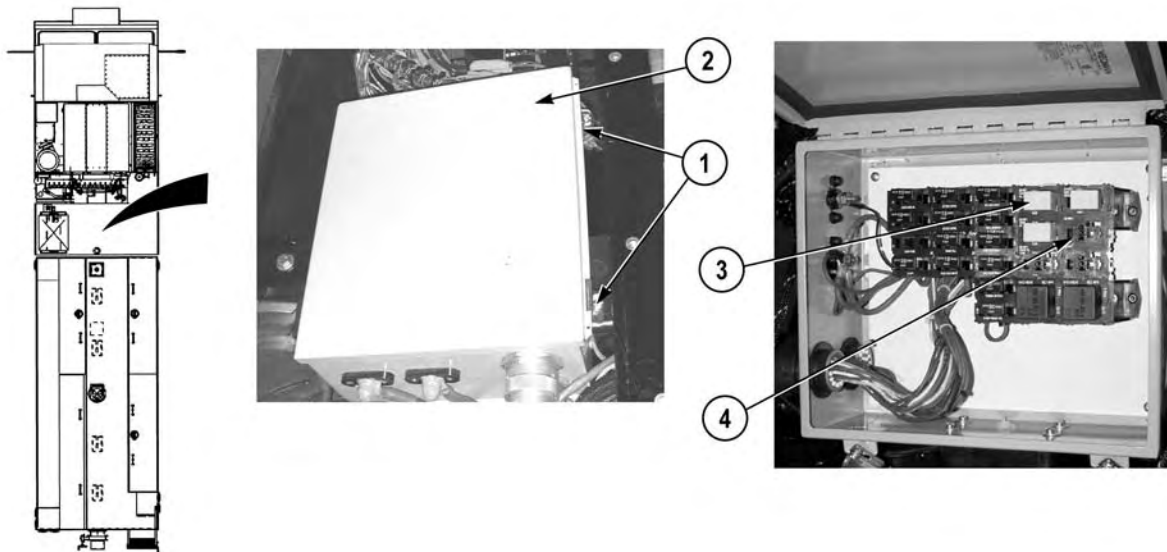
---

**REMOVAL****NOTE**

All pump house distribution box relays are removed the same way.

1. Loosen two screws (1) and open power distribution box cover (2).
2. Remove relay (3) from subpanel (4).

**END OF TASK**

**INSTALLATION**

**ALL PUMP HOUSE DISTRIBUTION BOX RELAYS ARE INSTALLED THE SAME WAY.**

1. Install relay (3) on subpanel (4).
2. Close power distribution box cover (2) and tighten two screws (1).

**END OF TASK**

**FOLLOW-ON MAINTENANCE**

Install pump house panel K (WP 0339)

**END OF TASK**

**END OF WORK PACKAGE**

## FIELD LEVEL MAINTENANCE

## PUMP HOUSE POWER DISTRIBUTION BOX REPLACEMENT

## INITIAL SETUP:

**Tools and Special Tools**

Tool Kit, General Mechanic's: Automotive  
(WP 0398, Item 17)

**Materials/Parts**

Tags, Identification (WP 0400, Item 23)  
Lockwasher (2)  
Lockwasher (4)  
Lockwasher (4)

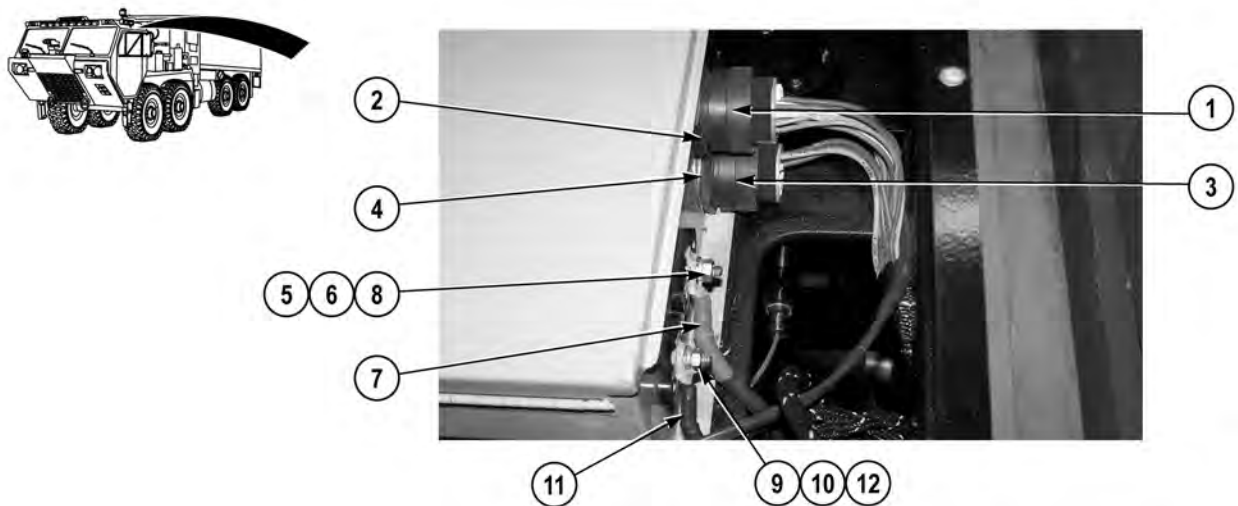
**References**

WP 0241  
WP 0270  
WP 0299  
WP 0391, Fig. 42

**Equipment Conditions**

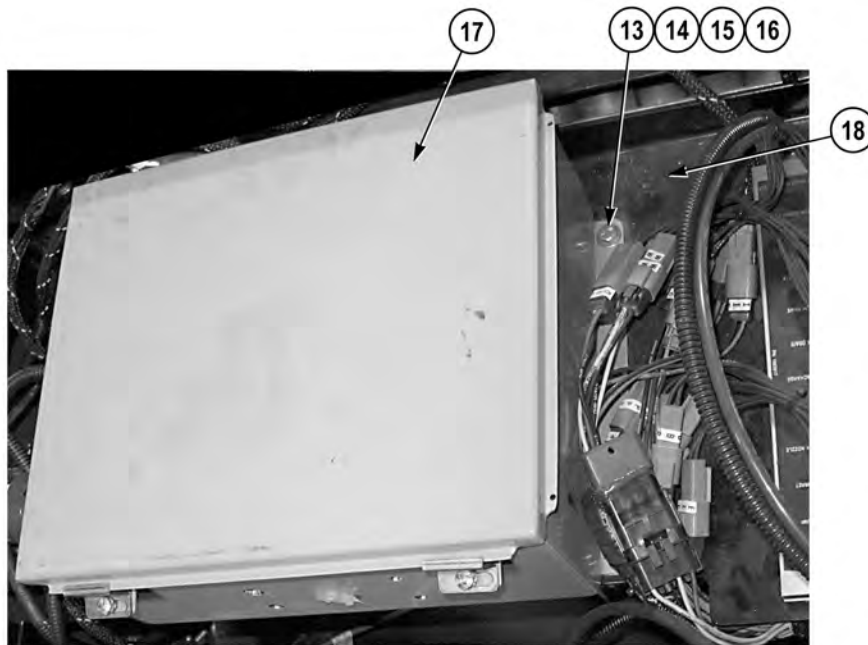
Pump house panel K removed (WP 0339)

## REMOVAL

**NOTE**

Tag and mark connectors and wires prior to removal to ensure proper installation.

1. Disconnect pump house wire harness connector (1) from pump house power distribution box connector DP2 (2).
2. Disconnect pump house wire harness connector (3) from pump house power distribution box connector DP1 (4).
3. Remove nut (5), lockwasher (6), and power wire (7) from stud (8). Discard lockwasher.
4. Remove nut (9), lockwasher (10), and ground wire (11) from stud (12). Discard lockwasher.



5. Remove four nuts (13), lockwashers (14), eight washers (15), four screws (16), and power distribution box (17) from bracket (18). Discard lockwashers.

#### **NOTE**

Perform Steps (6) and (7) if pass-through terminal blocks and pump house power distribution wire harness and block needs to be removed from power distribution box.

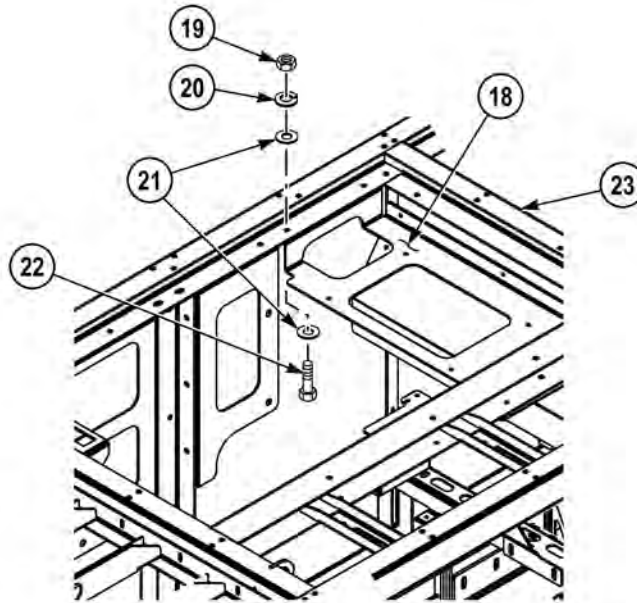
6. Remove pump house power distribution wire harness and block (WP 0299).
7. Remove two pass-through terminal blocks (WP 0241).

#### **NOTE**

Perform Steps (8) and (9) if bracket needs to be removed.

8. Remove shutoff control valve manifold (WP 0270).





9. Remove four nuts (19), lockwashers (20), eight washers (21), screws (22), and bracket (18) from pump house frame (23). Discard lockwashers.

#### END OF TASK

#### INSTALLATION

##### NOTE

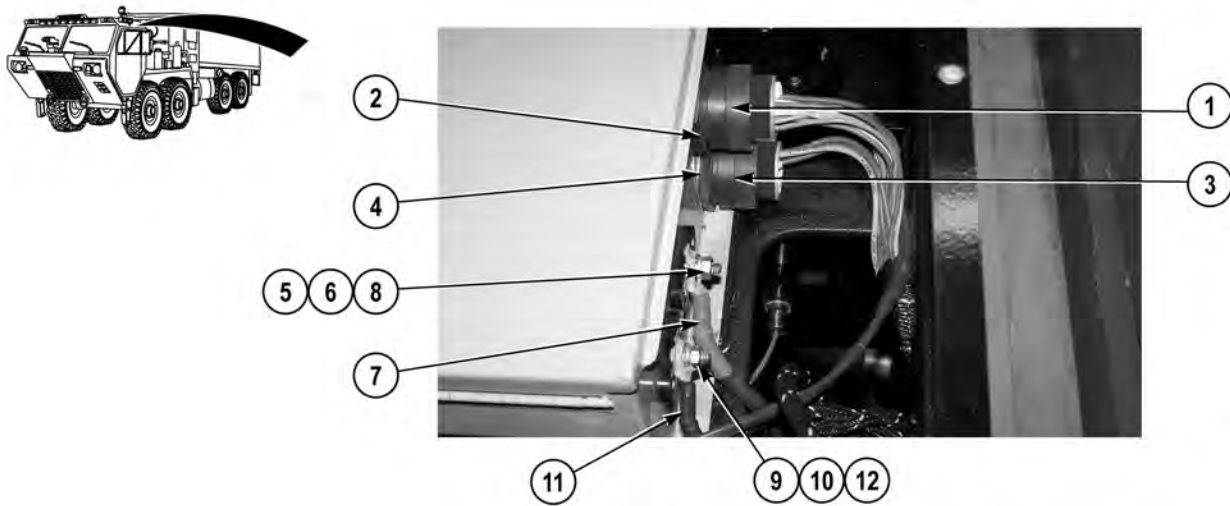
Perform Steps (1) and (2) if bracket was removed.

1. Install bracket (18) on pump house frame (23) with four screws (22), eight washers (21), four lockwashers (20), and nuts (19).
2. Install shutoff control valve manifold (WP 0270).

##### NOTE

Perform Steps (3) and (4) if pump house power distribution wire harness and block and pass-through terminal blocks need to be installed on power distribution box.

3. Install two pass-through terminal blocks (WP 0241).
4. Install pump house power distribution wire harness and block (WP 0299).
5. Install distribution box (17) on bracket (18) with four screws (16), eight washers (15), four lockwashers (14), and nuts (13).



6. Install ground wire (11) on stud (12) with lockwasher (10) and nut (9).
7. Install power wire (7) on stud (8) with lockwasher (6) and nut (5).
8. Connect pump house wire harness connector (3) on pump house power distribution box connector DP1 (4).
9. Connect pump house wire harness connector (1) on pump house power distribution box connector DP2 (2).

#### END OF TASK

#### FOLLOW-ON MAINTENANCE

Install pump house panel K (WP 0339)

#### END OF TASK

#### END OF WORK PACKAGE

## FIELD LEVEL MAINTENANCE

## PUMP INPUT AND DISCHARGE PRESSURE TRANSDUCERS REPLACEMENT

## INITIAL SETUP:

**Tools and Special Tools**

Tool Kit, General Mechanic's: Automotive  
(WP 0398, Item 17)

**References**

WP 0391, Fig. 38

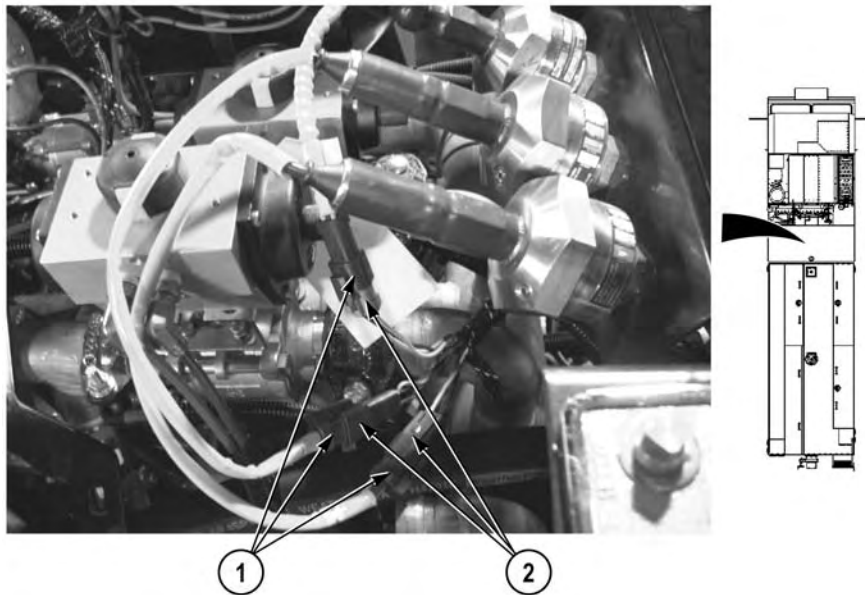
**Materials/Parts**

Compound, Sealing, Pipe Thread  
(WP 0400, Item 11)  
Tags, Identification (WP 0400, Item 23)  
Lockwasher (1)  
Lockwasher (1)  
Lockwasher (1)  
Lockwasher (3)

**Equipment Conditions**

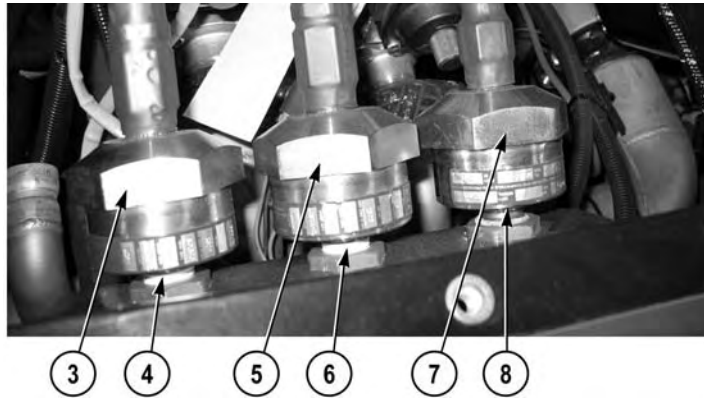
Pump house panel K removed (WP 0339)

## REMOVAL

**NOTE**

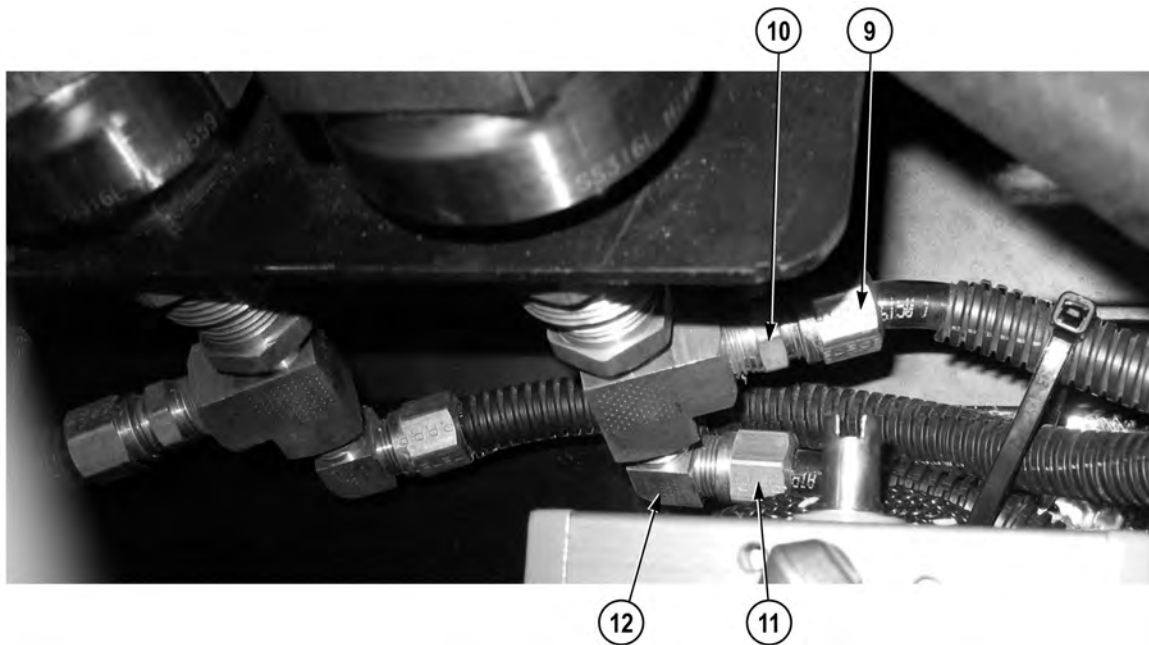
Tag and mark connectors prior to removal to ensure proper installation.

1. Disconnect three transducer connectors (1) from pump house wire harness connectors (2).

**NOTE**

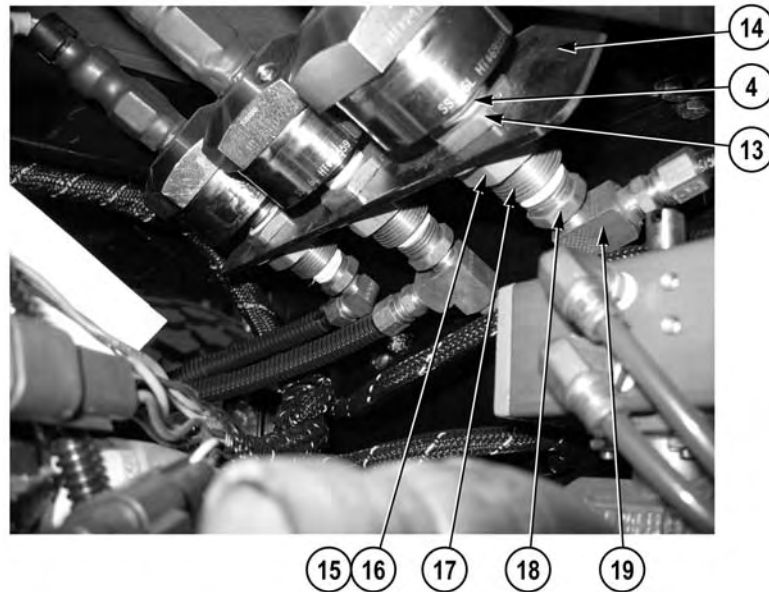
If only intake transducer needs to be replaced, discharge transducer or vacuum transducer must be removed.

2. Remove discharge transducer (3) from nipple (4).
3. Remove intake transducer (5) from nipple (6).
4. Remove vacuum transducer (7) from nipple (8).

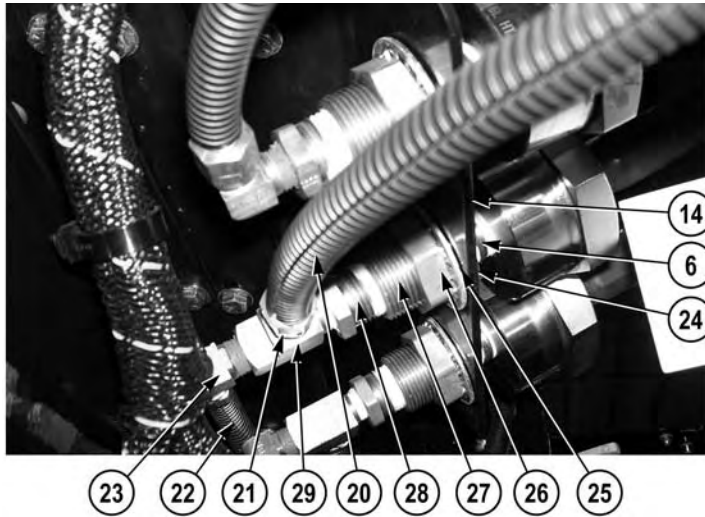
**NOTE**

- Note position of hoses, fittings, and elbows prior to removal to ensure proper installation.
- Tag and mark hoses prior to removal to ensure proper installation.

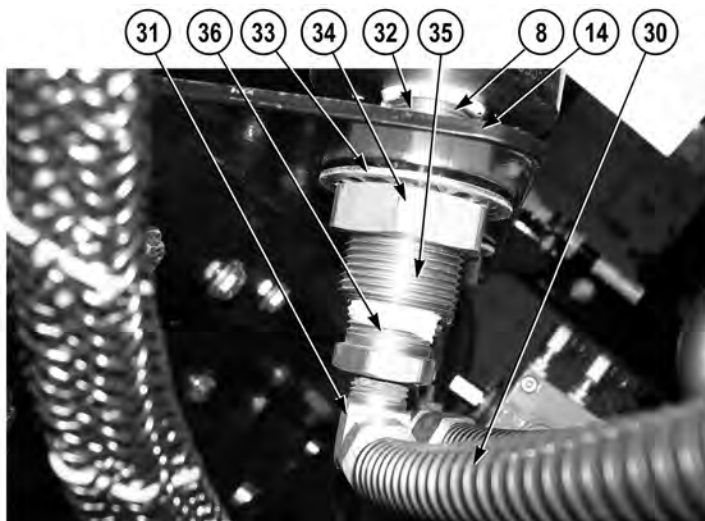
5. Remove hose (9) from fitting (10).
6. Remove hose (11) from elbow (12).



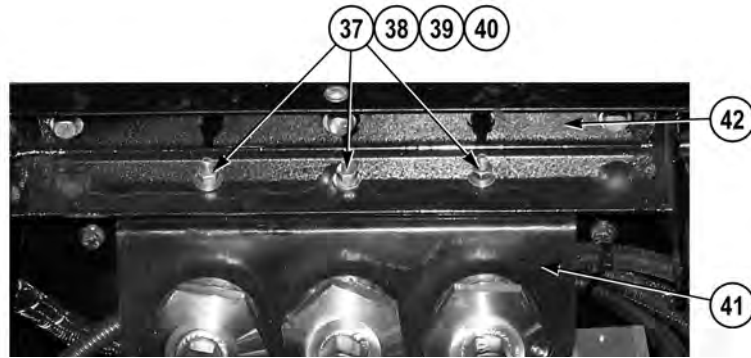
7. Remove nut (13) and nipple (4) from bracket (14).
8. Remove lockwasher (15), nipple (4), and nut (16) from fitting (17). Discard lockwasher.
9. Remove fitting (17) from fitting (18).
10. Remove elbow (12), fitting (10), and fitting (18) from tee (19).



11. Remove hose (20) from fitting (21).
12. Remove hose (22) from elbow (23).
13. Remove nut (24) and nipple (6) from bracket (14).
14. Remove lockwasher (25), nipple (6), and nut (26) from fitting (27). Discard lockwasher.
15. Remove fitting (27) from fitting (28).
16. Remove fitting (21), elbow (23), and fitting (28) from tee (29).



17. Remove hose (30) from elbow (31).
18. Remove nut (32) and nipple (8) from bracket (14).
19. Remove lockwasher (33), nipple (8), and nut (34) from fitting (35). Discard lockwasher.
20. Remove fitting (35) from fitting (36).
21. Remove fitting (36) from elbow (31).



22. Remove three nuts (37), lockwashers (38), six washers (39), three screws (40), and bracket (41) from pump house frame (42). Discard lockwashers.

### END OF TASK

### INSTALLATION

1. Install bracket (41) on pump house frame (42) with three screws (40), six washers (39), three lockwashers (38), and nuts (37).

### WARNING



**Adhesives, solvents, and sealing compounds can burn easily, can give off harmful vapors, and are harmful to skin and clothing. To avoid injury or death, keep away from open fire and use in well-ventilated area. If adhesive, solvent, or sealing compound gets on skin or clothing, wash immediately with soap and water.**

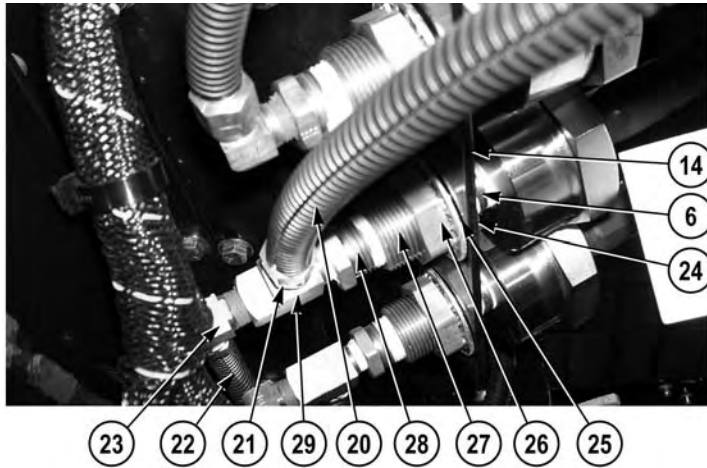
### CAUTION

**Use sealing compound sparingly only on pipe threads. Do not apply compound to hose connections. Damage to equipment may result.**

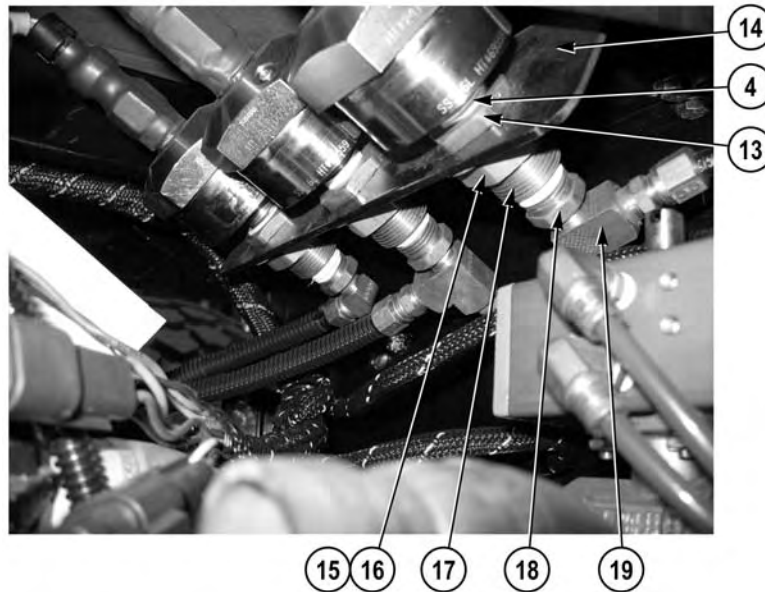
### NOTE

Install hoses, fittings, and elbows as noted prior to removal.

2. Apply sealing compound to threads of three nipples (4), (6), and (8), eight fittings (10), (17), (18), (21), (27), (28), (35), and (36), three elbows (12), (23), and (31), and two tees (19) and (29).
3. Install fitting (36) on elbow (31).
4. Install fitting (35) on fitting (36).
5. Install nut (34), nipple (8), and lockwasher (33) on fitting (35).
6. Install nipple (8) on bracket (14) with nut (32).
7. Install hose (30) on elbow (31).

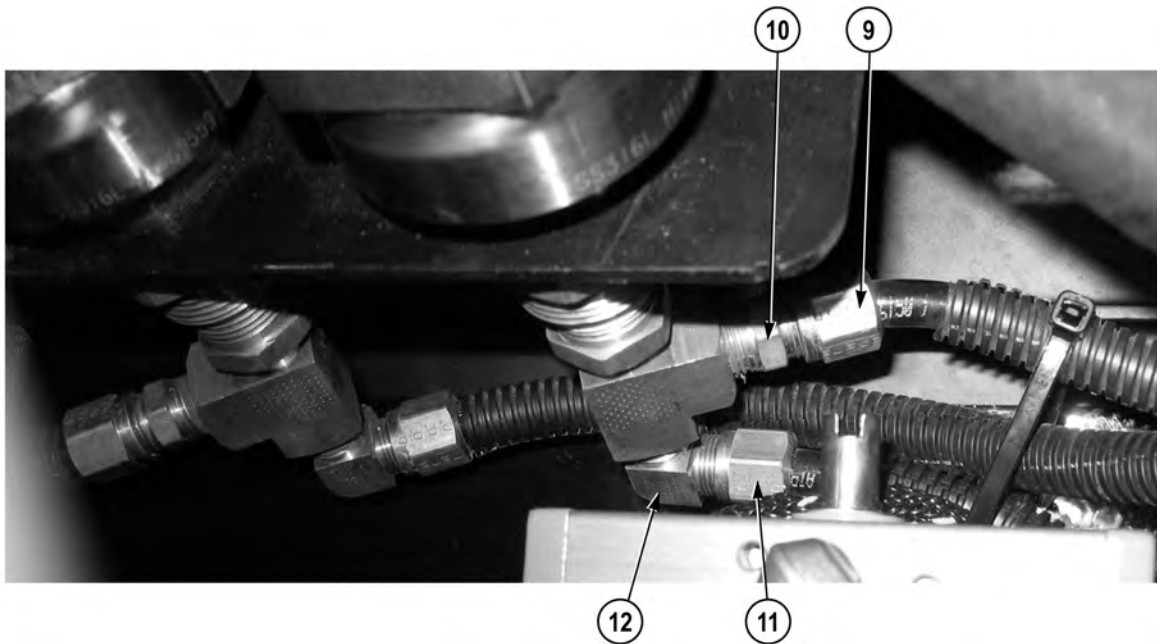


8. Install fitting (28), elbow (23), and fitting (21) on tee (29).
9. Install fitting (27) on fitting (28).
10. Install nut (26), nipple (6), and lockwasher (25) on fitting (27).
11. Install nipple (6) on bracket (14) with nut (24).
12. Install hose (22) on elbow (23).
13. Install hose (20) on fitting (21).

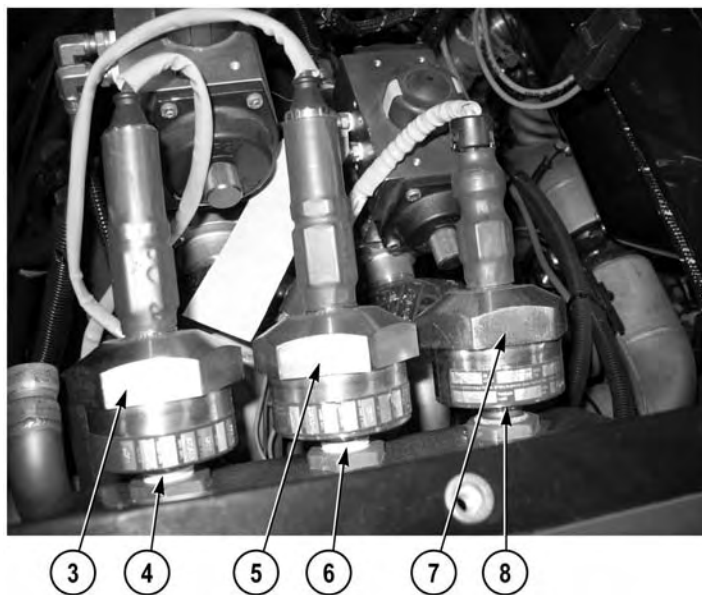


14. Install fitting (18), fitting (10), and elbow (12) on tee (19).
15. Install fitting (17) on fitting (18).
16. Install nut (16), nipple (4), and lockwasher (15) on fitting (17).
17. Install nipple (4) on bracket (14) with nut (13).

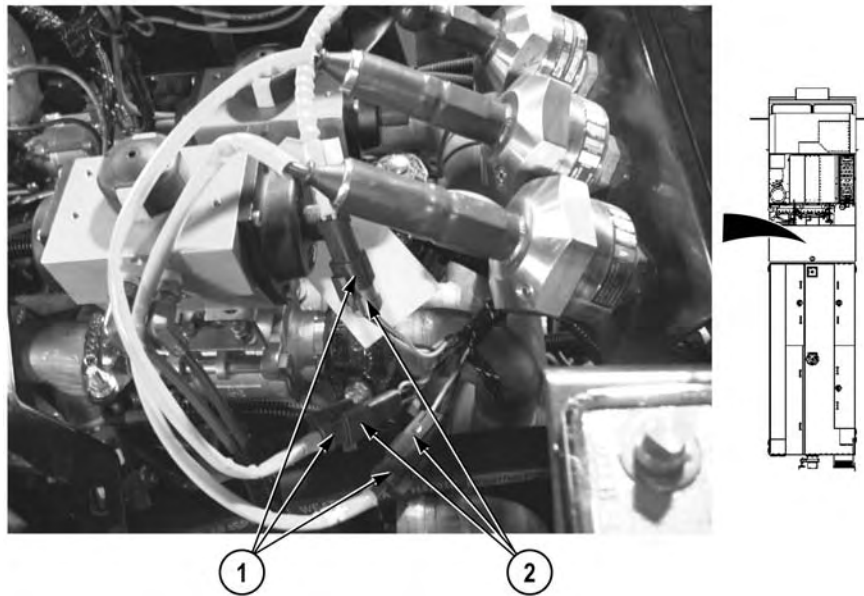




18. Install hose (11) on elbow (12).
19. Install hose (9) on fitting (10).



20. Install vacuum transducer (7) on nipple (8).
21. Install intake transducer (5) on nipple (6).
22. Install discharge transducer (3) on nipple (4).



23. Connect three transducers connectors (1) on pump house wire harness connectors (2).

**END OF TASK**

**FOLLOW-ON MAINTENANCE**

Install pump house panel K (WP 0339)

**END OF TASK**

**END OF WORK PACKAGE**

## FIELD LEVEL MAINTENANCE

## REAR STEP BUZZER BUTTON AND CABLE REPLACEMENT

## INITIAL SETUP:

**Tools and Special Tools**

Tool Kit, General Mechanic's: Automotive  
(WP 0398, Item 17)

**References**

WP 0008  
WP 0391, Fig. 60

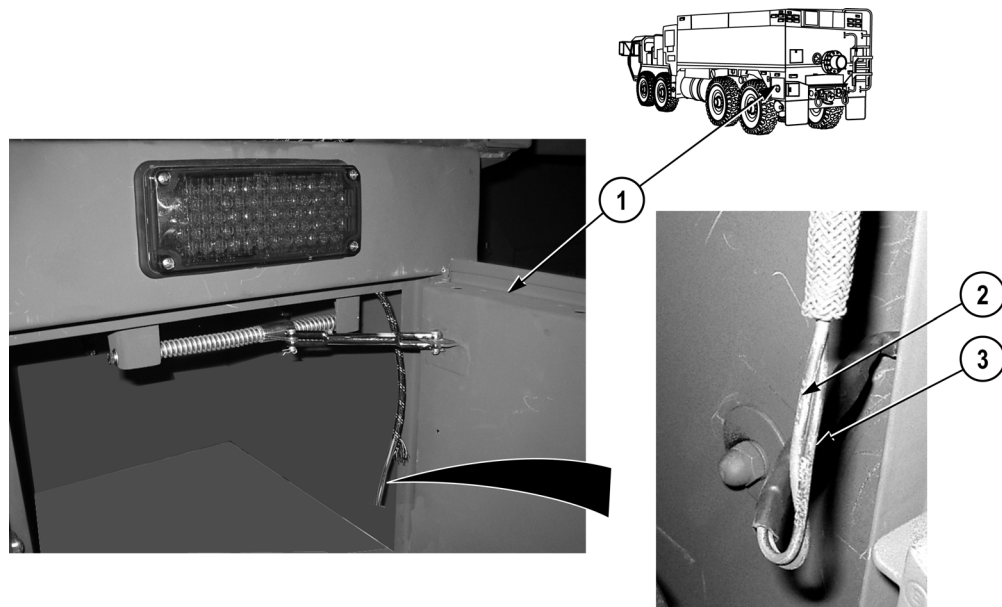
**Materials/Parts**

Tags, Identification (WP 0400, Item 23)

**Equipment Conditions**

Batteries disconnected (TM 9-2320-325-14&P)

## REMOVAL

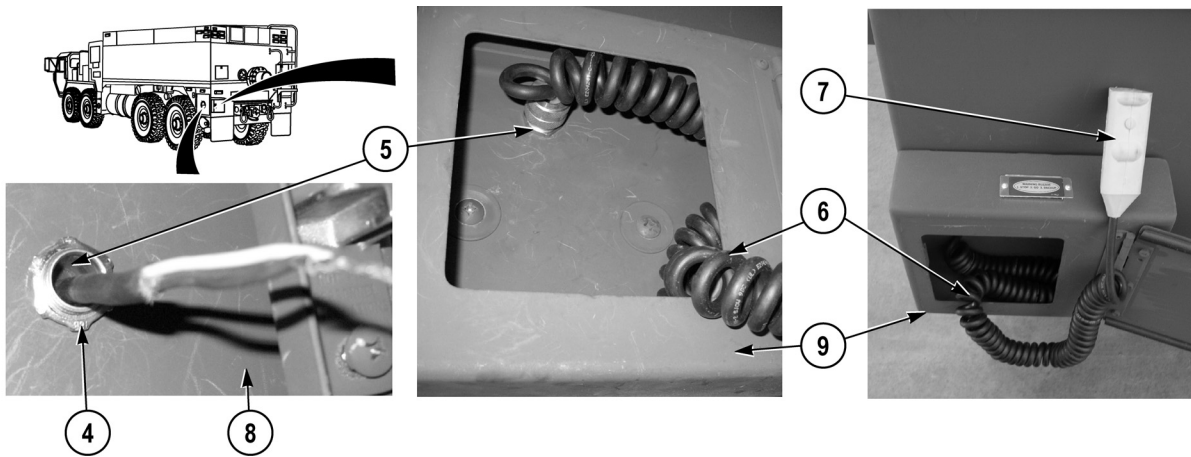


1. Open compartment door (1) (WP 0008).

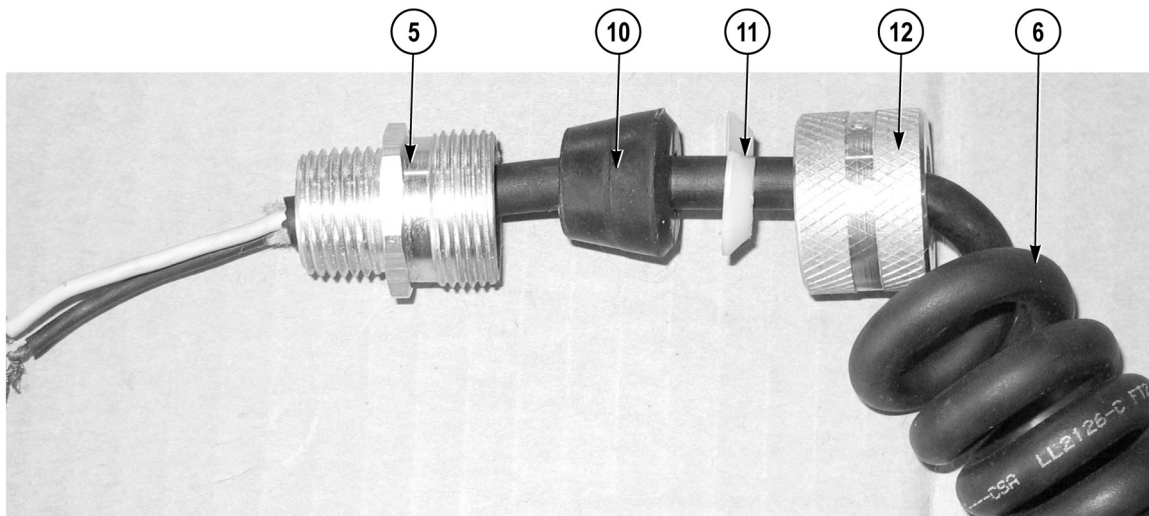
**NOTE**

Tag and mark wires prior to removal to ensure proper installation.

2. Cut wire 1614 (2) and wire 2640 (3) (TM 9-2320-325-14&P).



3. Remove nut (4), reducer (5), cable (6), and handle (7) from stowage compartment (8) and buzzer box (9).

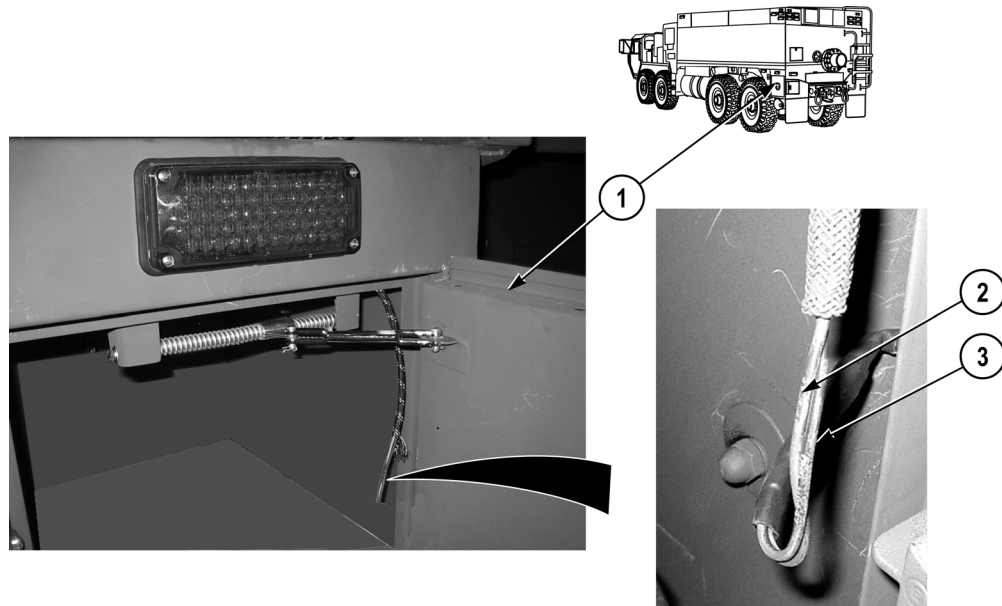


4. Remove reducer (5), grommet (10), backing washer (11), and collar (12) from cable (6).

**END OF TASK**

**INSTALLATION**

1. Install reducer (5) on cable (6) with grommet (10), collar (12), and backing washer (11).
2. Install reducer (5), handle (7), and cable (6) on buzzer box (9) and stowage compartment (8) with nut (4).



3. Repair wire 1614 (2) and wire 2640 (3) (TM 9-2320-325-14&P).
4. Close compartment door (1) (WP 0008).

**END OF TASK**

**FOLLOW-ON MAINTENANCE**

Connect batteries (TM 9-2320-325-14&P)

**END OF TASK**

**END OF WORK PACKAGE**



## FIELD LEVEL MAINTENANCE

## REAR STEP BUZZER BUTTON COMPARTMENT REPLACEMENT

## INITIAL SETUP:

**Tools and Special Tools**

Tool Kit, General Mechanic's: Automotive  
(WP 0398, Item 17)

**Materials/Parts**

Lockwasher (2)

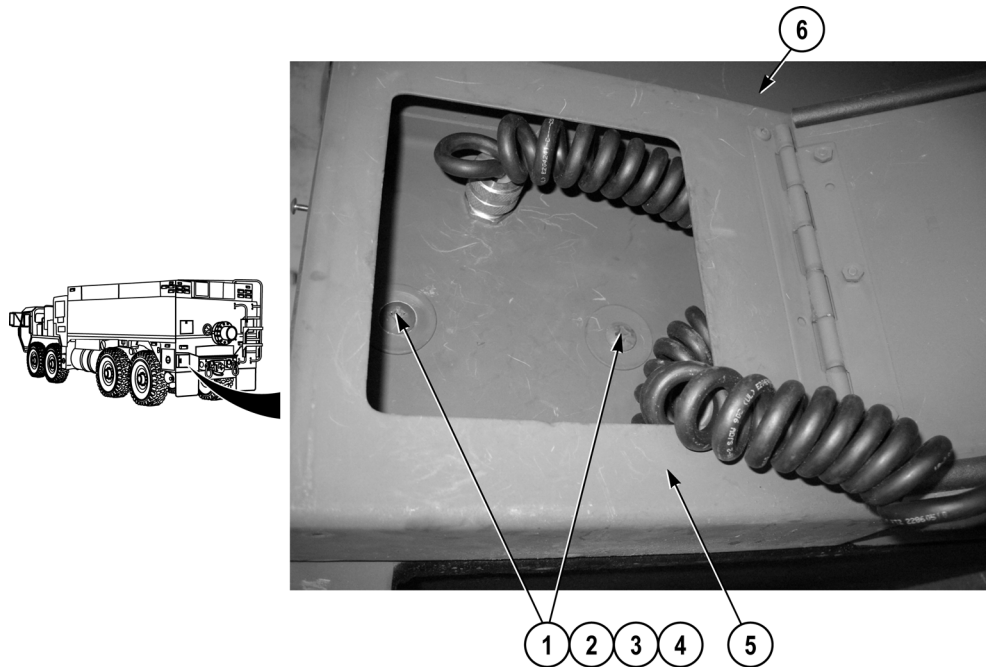
**References**

WP 0326  
WP 0350  
WP 0391, Fig. 60

**Equipment Conditions**

Rear step buzzer button and cable removed  
(WP 0266)

## REMOVAL

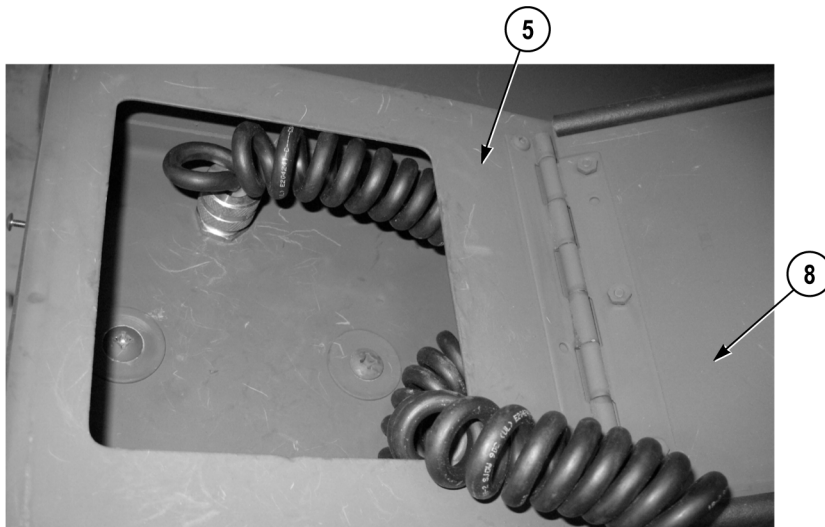


1. Remove two nuts (1), lockwashers (2), four washers (3), two screws (4), and buzzer button compartment (5) from stowage compartment (6). Discard lockwashers.

**NOTE**

Perform Step (2) if decal needs to be removed.

2. Remove decal (7) from buzzer button compartment (5) (WP 0326).

**NOTE**

Perform Step (3) if buzzer button compartment door needs to be removed.

3. Remove buzzer button compartment door (8) from buzzer button compartment (5) (WP 0350).

**END OF TASK**



**INSTALLATION****NOTE**

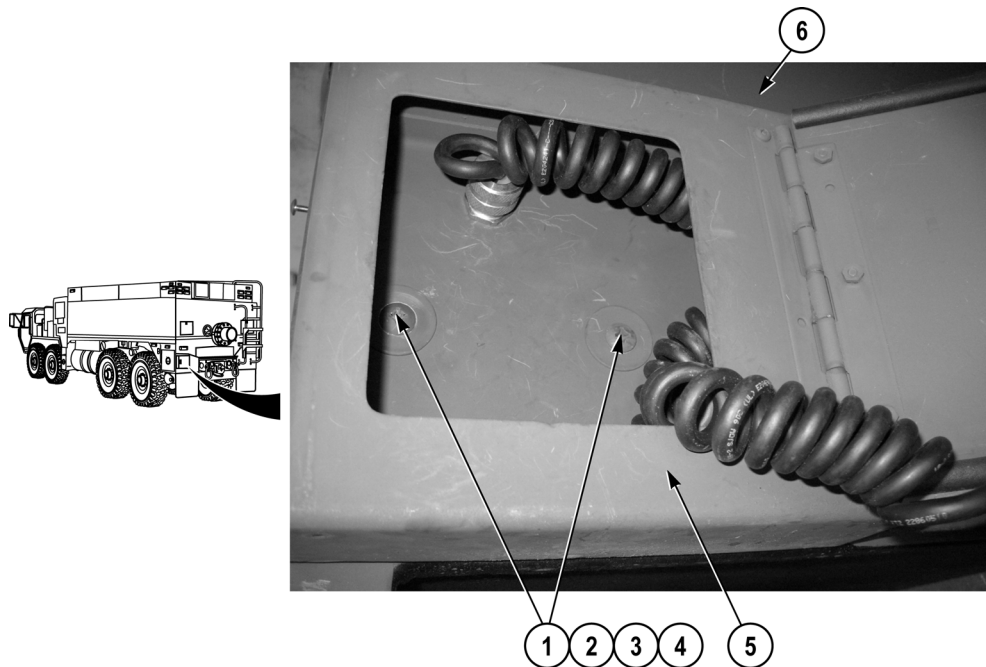
Perform Step (1) if compartment door was removed.

1. Install buzzer button compartment door (8) on buzzer button compartment (5) (WP 0350).

**NOTE**

Perform Step (2) if decal was removed.

2. Install decal (7) on buzzer button compartment (5) (WP 0326).



3. Install buzzer button compartment (5) on stowage compartment (6) with two screws (4), four washers (3), two lockwashers (2), and nuts (1).

**END OF TASK****FOLLOW-ON MAINTENANCE**

Install rear step buzzer button and cable (WP 0266)

**END OF TASK****END OF WORK PACKAGE**



---

**FIELD LEVEL MAINTENANCE**  
**SHORELINE INLET RECEPTACLE REPLACEMENT**

---

**INITIAL SETUP:****Tools and Special Tools**

Tool Kit, General Mechanic's: Automotive  
(WP 0398, Item 17)

**Materials/Parts**

Tags, Identification (WP 0400, Item 23)  
Ties, Cable, Plastic (WP 0400, Item 26)  
Lockwasher (2)  
Locknut (2)  
Lockwasher (3)

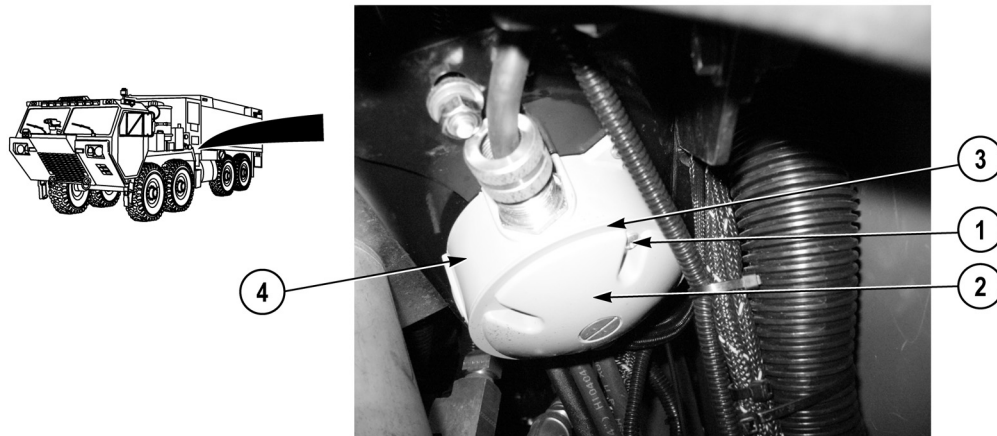
**References**

TM 9-2320-325-14&P  
WP 0326  
WP 0391, Fig. 65, 71

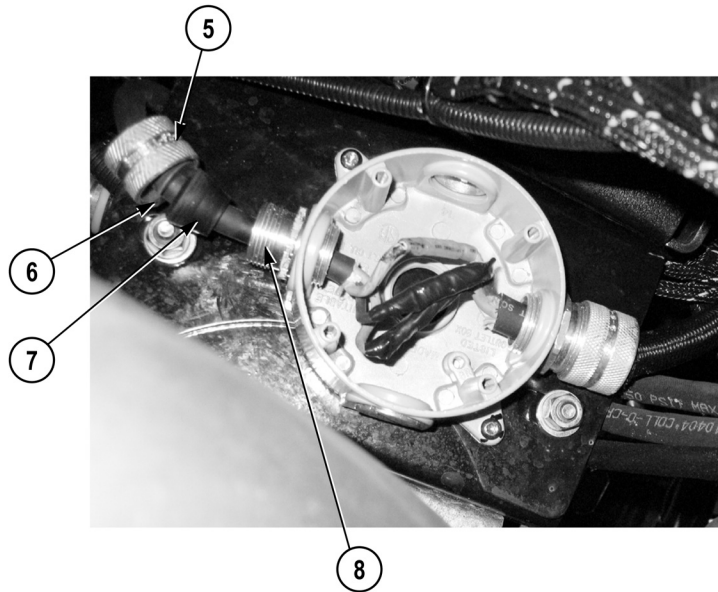
**Equipment Conditions**

Pump house panel B removed (WP 0339)

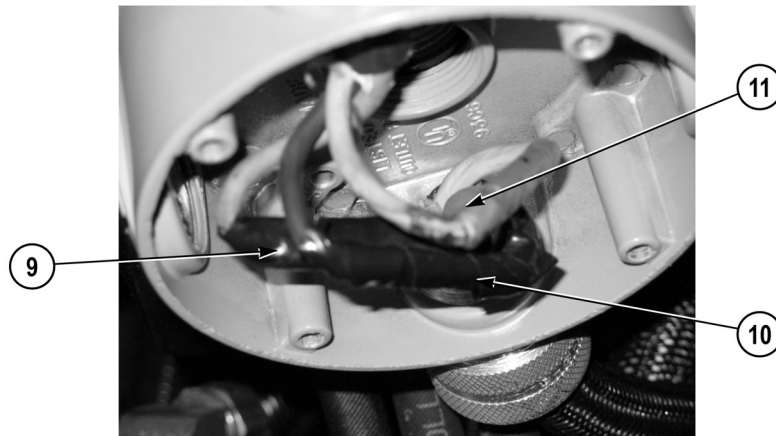
---

**REMOVAL**

1. Remove two screws (1), cover (2), and gasket (3) from waterproof splice box (4).



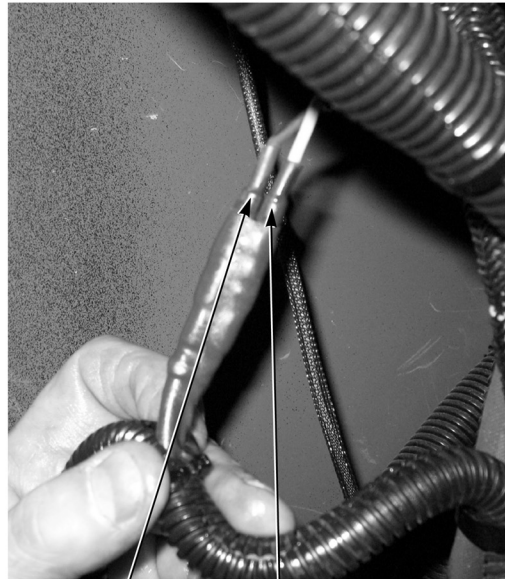
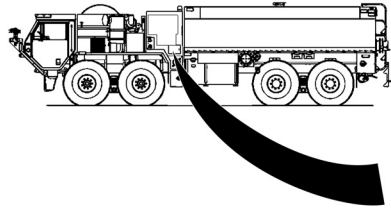
2. Remove strain relief (5), backing washer (6), and grommet (7) from fitting (8).



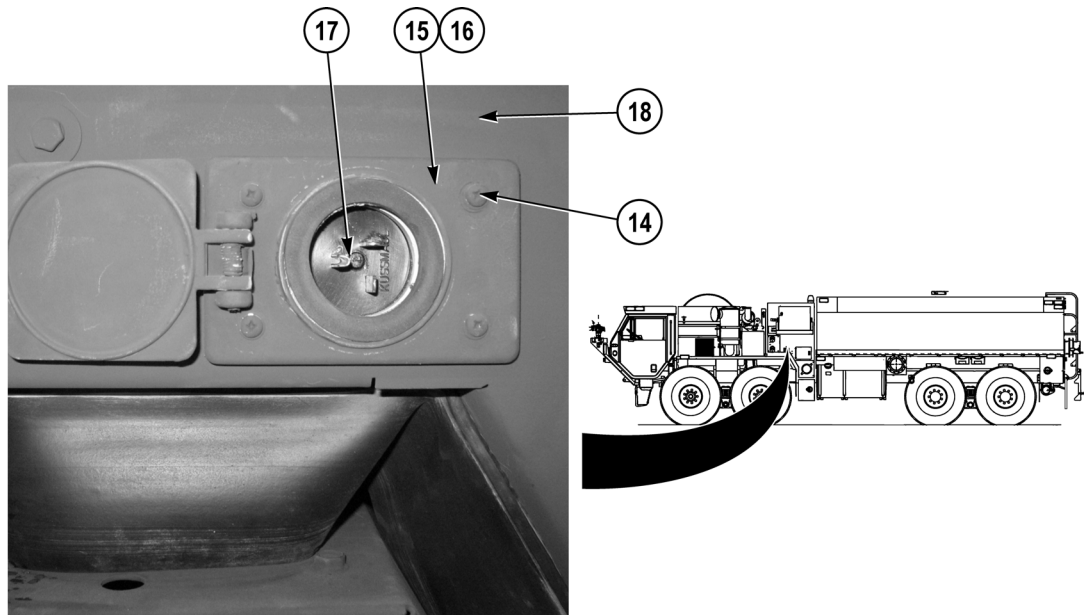
#### NOTE

- Tag and mark wires prior to removal to ensure proper installation.
- Remove cable ties as required.

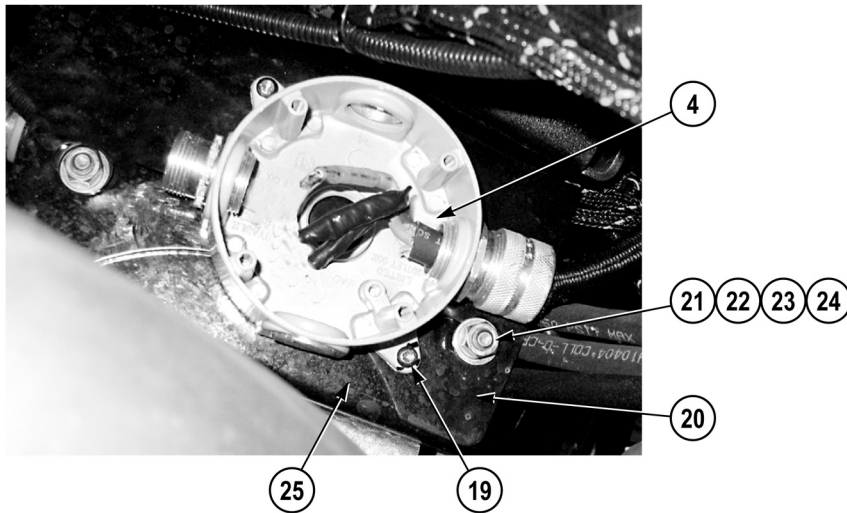
3. Cut green wire (9), black wire (10), and yellow wire (11) (TM 9-2320-325-14&P).



4. Cut yellow wire (12) and black wire (13) (TM 9-2320-325-14&P).



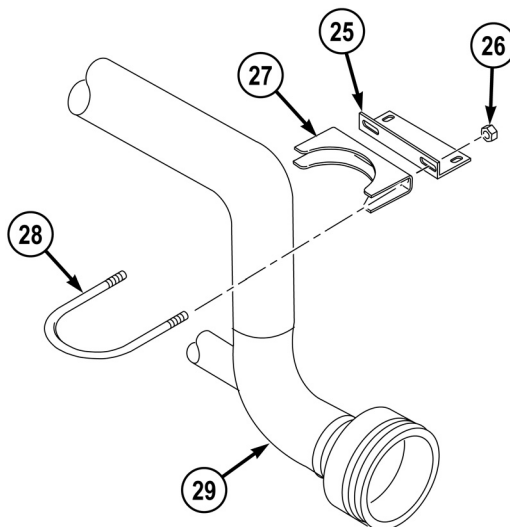
5. Remove four screws (14), cover plate (15), gasket (16), and shoreline inlet receptacle (17) from pump house panel A (18).



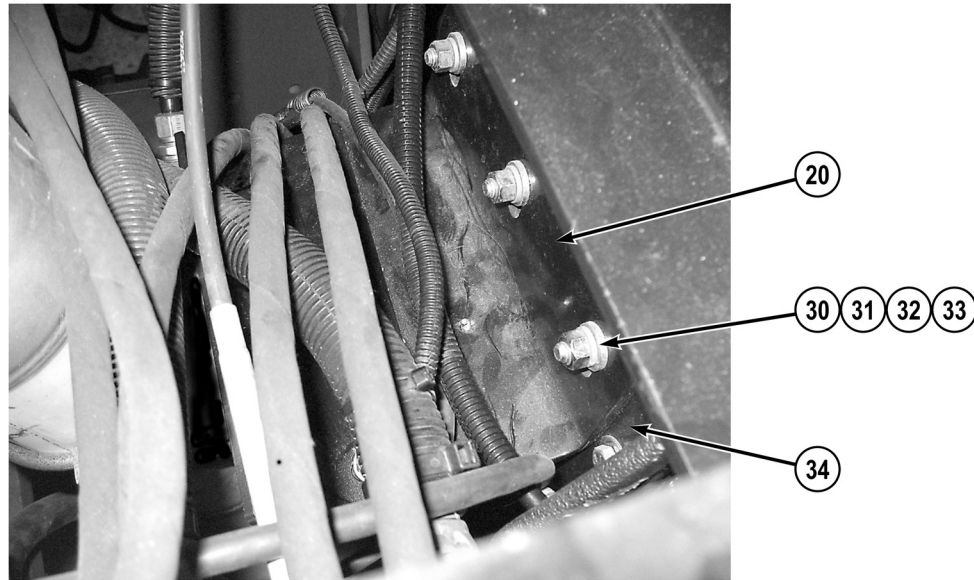
### NOTE

Perform Steps (6) through (9) if brackets need to be removed.

6. Remove two screws (19) and waterproof splice box (4) from bracket (20).
7. Remove two nuts (21), lockwashers (22), four washers (23), and two screws (24) from bracket (20) and bracket (25). Discard lockwashers.



8. Remove two locknuts (26), bracket (25), cradle (27), and U-bolt (28) from intake pipe (29). Discard locknuts.



9. Remove three nuts (30), lockwashers (31), six washers (32), three screws (33), and bracket (20) from bracket (34). Discard lockwashers.

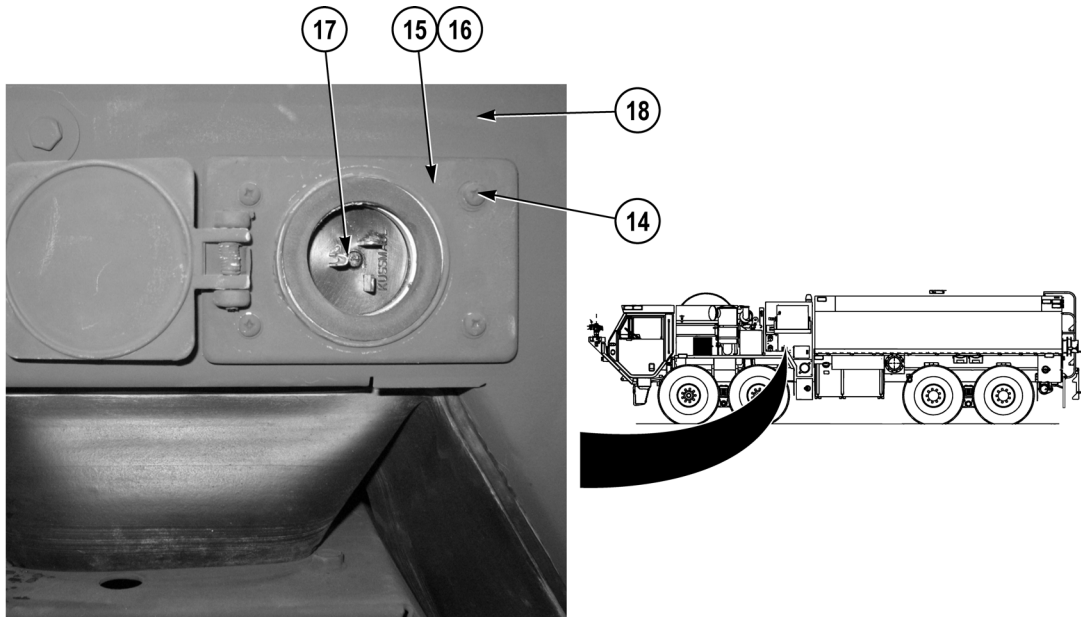
#### END OF TASK

#### INSTALLATION

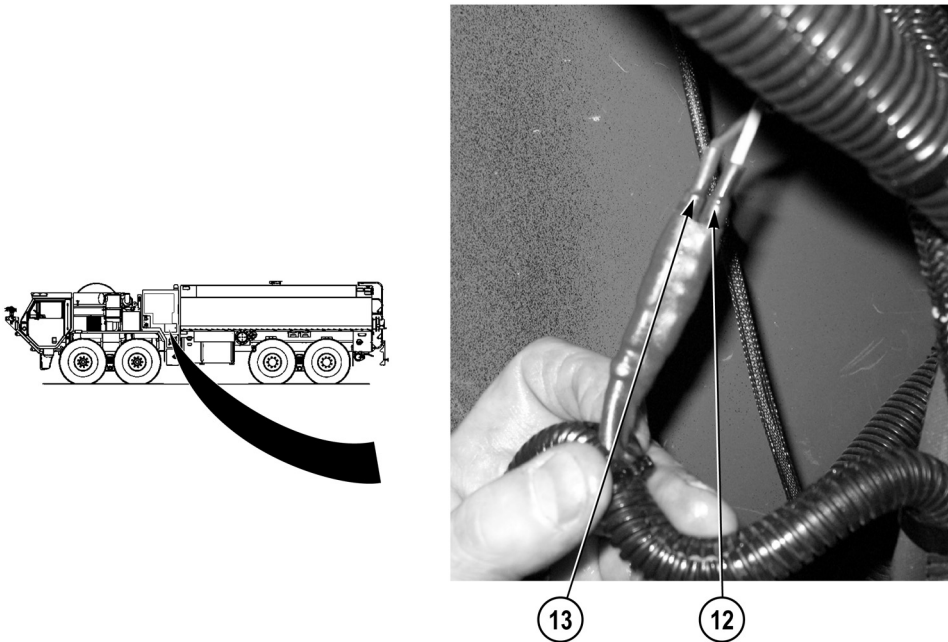
#### NOTE

Perform Steps (1) through (5) if brackets need to be installed.

1. Install bracket (20) on bracket (34) with three screws (33), six washers (32), three lockwashers (31), and nuts (30).
2. Install cradle (27) and bracket (25) on intake pipe (29) with U-bolt (28) and two locknuts (26). Do not tighten locknuts.
3. Install bracket (20) on bracket (25) with two screws (24), four washers (23), two lockwashers (22), and nuts (21).
4. Tighten two locknuts (26).
5. Install waterproof splice box (4) on bracket (20) with two screws (19).

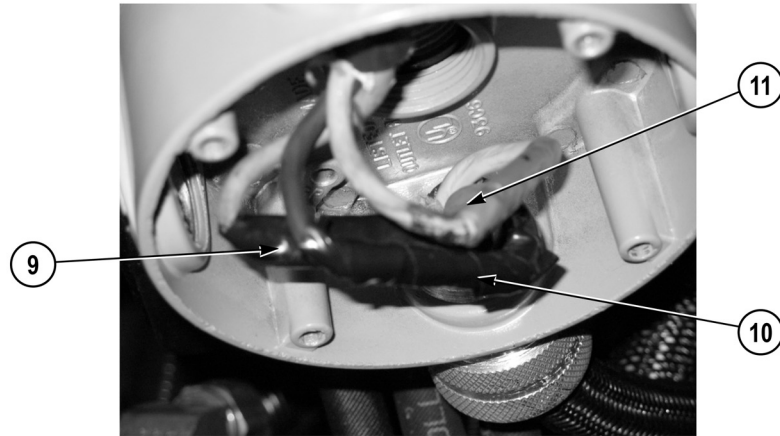


6. Install shoreline inlet receptacle (17), gasket (16), and cover plate (15) on pump house panel A (18) with four screws (14).



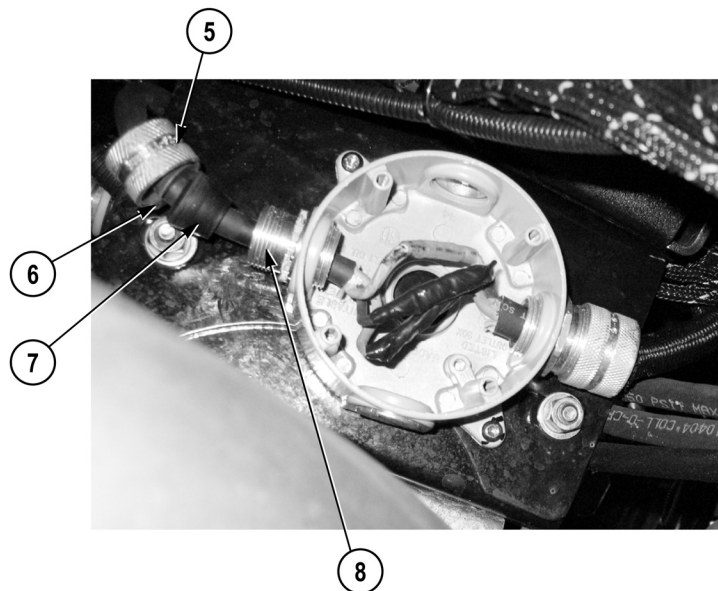
7. Repair black wire (13) and yellow wire (12) (TM 9-2320-325-14&P).



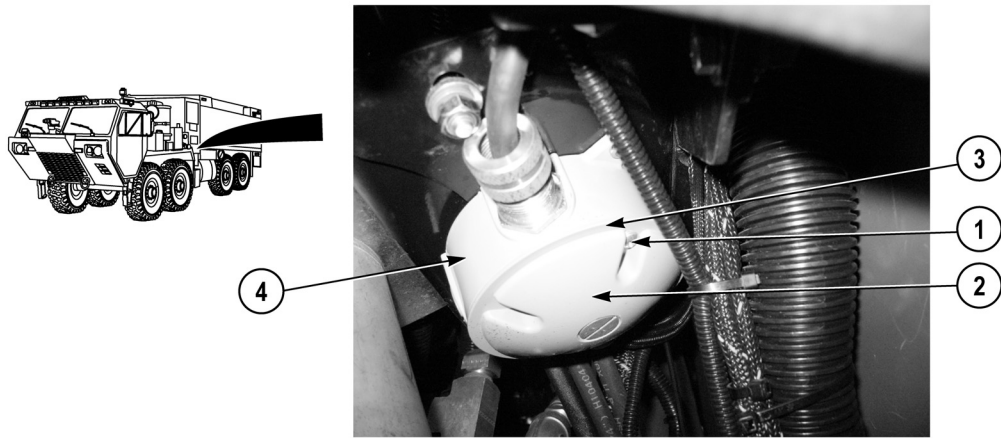
**NOTE**

Install cable ties as required.

8. Repair yellow wire (11), black wire (10), and green wire (9) (TM 9-2320-325-14&P).



9. Install grommet (7) and backing washer (6) on fitting (8) with strain relief (5).



10. Install gasket (3) and cover (2) on waterproof splice box (4) with two screws (1).

**END OF TASK**

**FOLLOW-ON MAINTENANCE**

Install pump house panel B (WP 0339)

**END OF TASK**

**END OF WORK PACKAGE**

---

**FIELD LEVEL MAINTENANCE**  
**SHUTOFF CONTROL VALVE DIODE REPLACEMENT**

---

**INITIAL SETUP:****Tools and Special Tools**

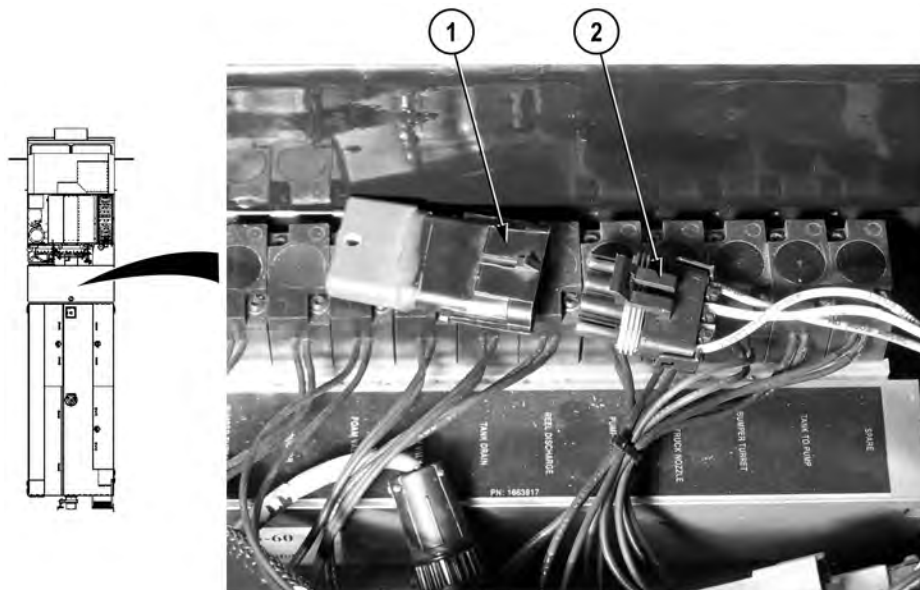
Tool Kit, General Mechanic's: Automotive  
(WP 0398, Item 17)

**References**

WP 0391, Fig. 56

**Equipment Conditions**

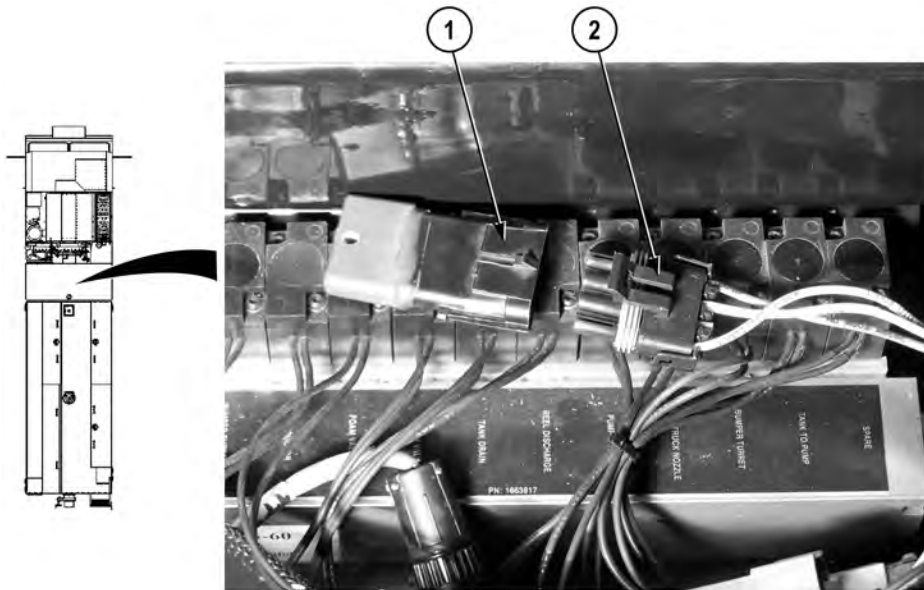
Engine OFF (TM 9-2320-422-10)  
Wheels chocked (TM 9-2320-422-10)  
Pump house panel access door  
opened (WP 0008)

**REMOVAL****NOTE**

- All shutoff control valve diode packs are removed the same way.
- Educator control valve diode shown.

Remove shutoff control valve diode (1) from diode connector (2).

**END OF TASK**

**INSTALLATION**

Install shutoff control valve diode (1) on diode connector (2).

**END OF TASK****FOLLOW-ON MAINTENANCE**

1. Close pump house panel access door (WP 0008)
2. Remove wheel chocks (TM 9-2320-422-10)

**END OF TASK****END OF WORK PACKAGE**

## FIELD LEVEL MAINTENANCE

## SHUTOFF CONTROL VALVE MANIFOLD REPLACEMENT

## INITIAL SETUP:

**Tools and Special Tools**

Tool Kit, General Mechanic's: Automotive  
(WP 0398, Item 17)

**References**

WP 0391, Fig. 3

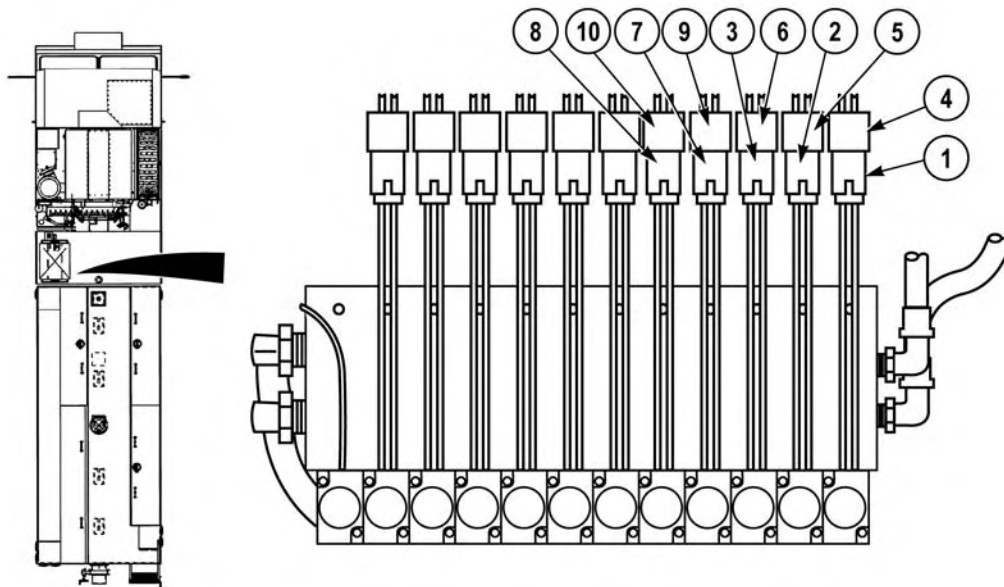
**Materials/Parts**

Tape, Teflon (WP 0400, Item 25)  
Tags, Identification (WP 0400, Item 23)  
Ties, Cable, Plastic (WP 0400, Item 26)  
Lockwasher (2)

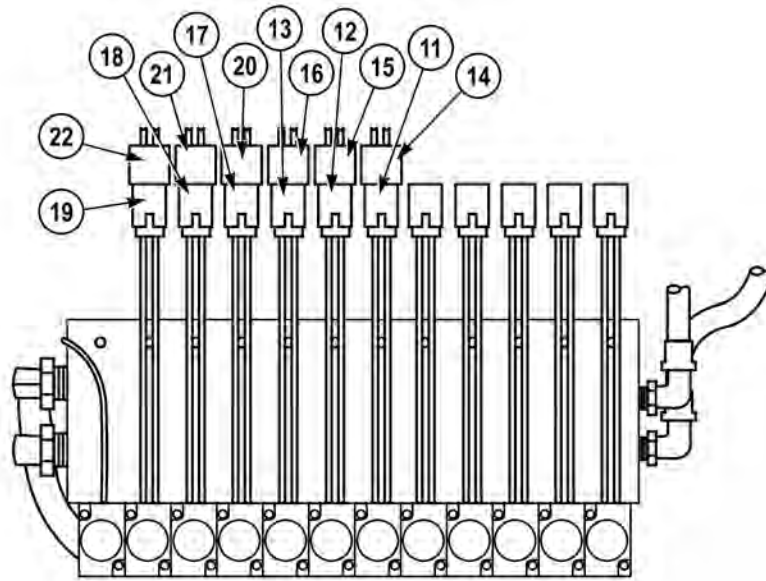
**Equipment Conditions**

Air system drained (TM 9-2320-422-10)  
Hose reel removed (WP 0247)

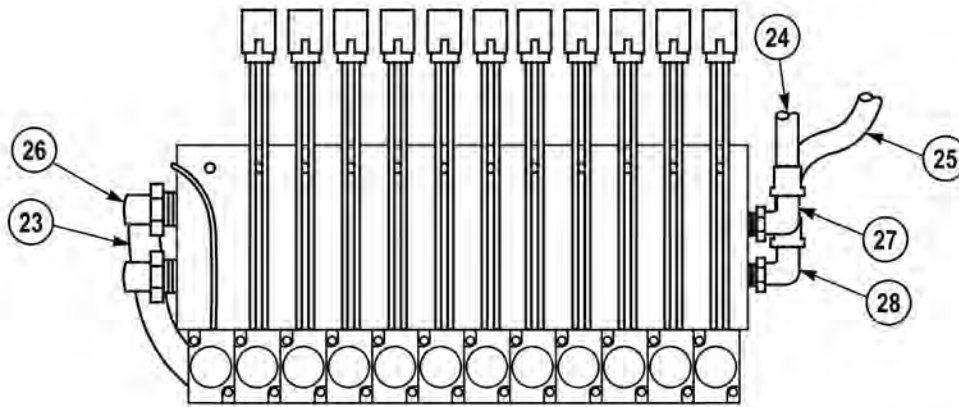
## REMOVAL

**NOTE**

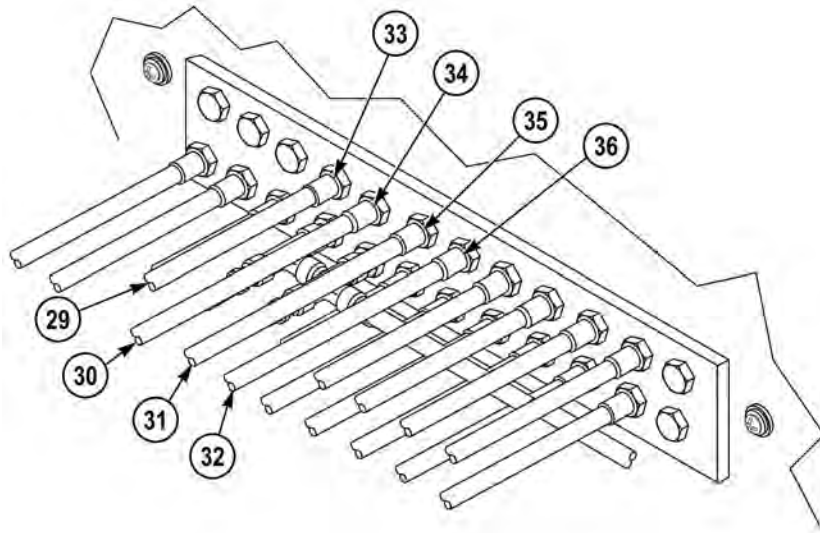
- Remove cable ties as required.
  - Tag and mark connectors and air lines prior to removal to ensure proper installation.
1. Remove under truck nozzle foam valve connector (1), bumper turret foam valve connector (2), and eductor valve connector (3) from three valve control wire harness connectors (4), (5), and (6).
  2. Remove foam valve connector (7) and flush valve connector (8) from two valve control wire harness connectors (9) and (10).



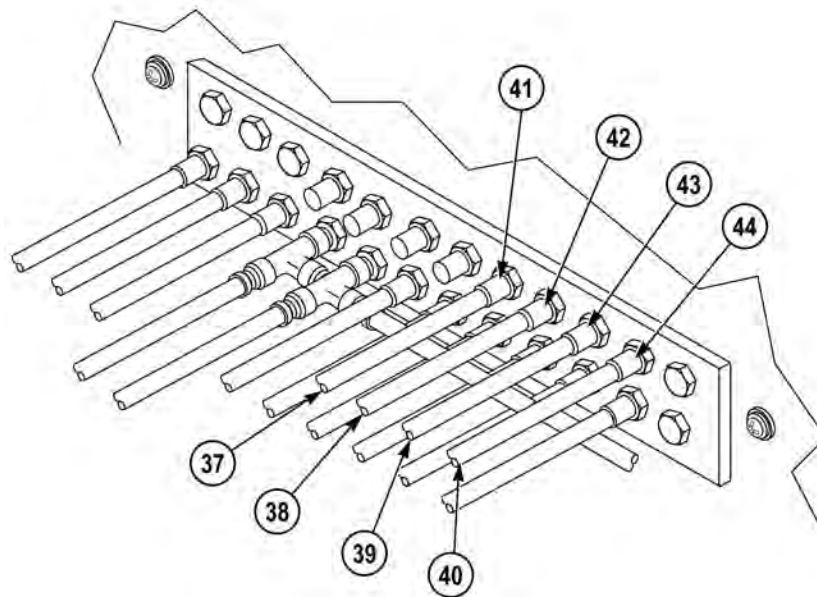
3. Remove tank drain valve connector (11), hose reel discharge valve connector (12), and pump cooler valve connector (13) from three valve control wire harness connectors (14), (15) and (16).
4. Remove under truck nozzles valve connector (17) bumper turret valve connector (18) and tank discharge valve connector (19) from three valve control wire harness connectors (20), (21), and (22).



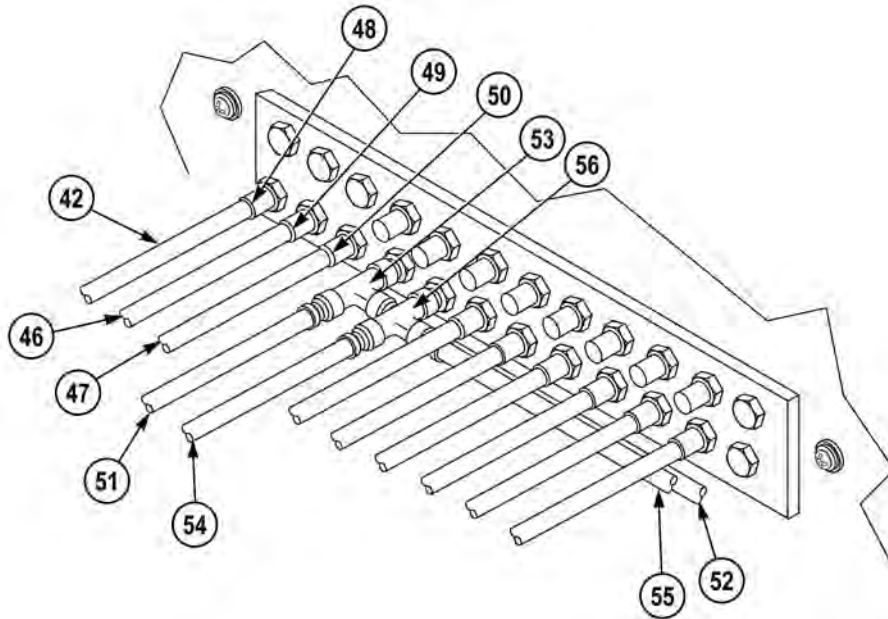
5. Remove three air lines (23), (24), and (25) from elbows (26), (27), and (28).



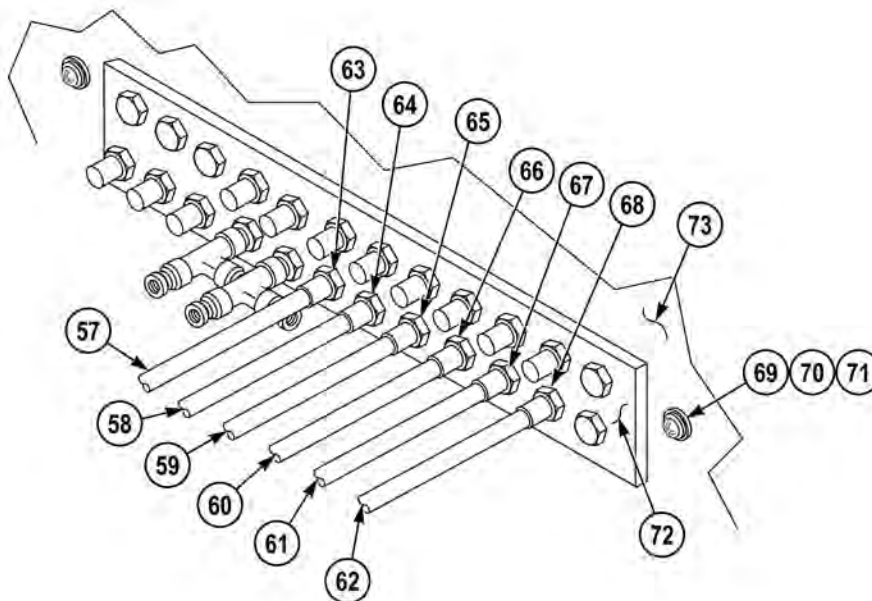
6. Remove four air lines (29), (30), (31), and (32) from fittings (33), (34), (35), and (36).



7. Remove four air lines (37), (38), (39), and (40) from fittings (41), (42), (43) and (44).

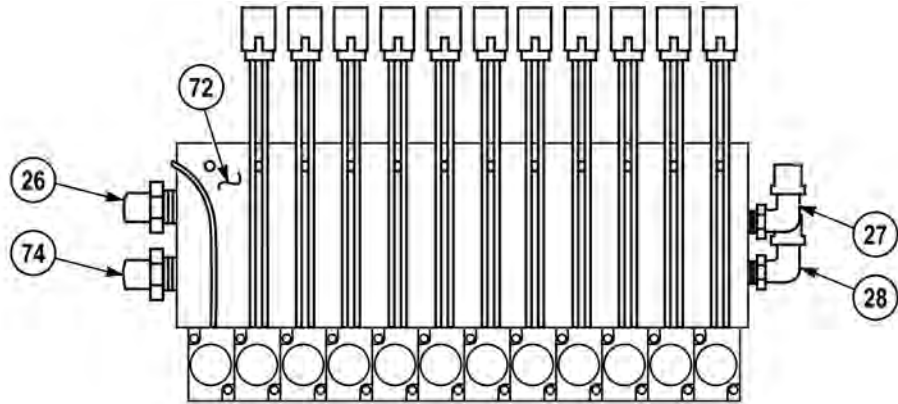


8. Remove three air lines (45), (46), and (47) from fittings (48), (49), and (50).
9. Remove two air lines (51) and (52) from tee (53).
10. Remove two air lines (54) and (55) from tee (56).



11. Remove six air lines (57), (58), (59), (60), (61), and (62) from fittings (63), (64), (65), (66), (67), and (68).
12. Remove two screws (69), lockwashers (70), washer (71), and control valve manifold (72) from bracket (73). Discard lockwashers.

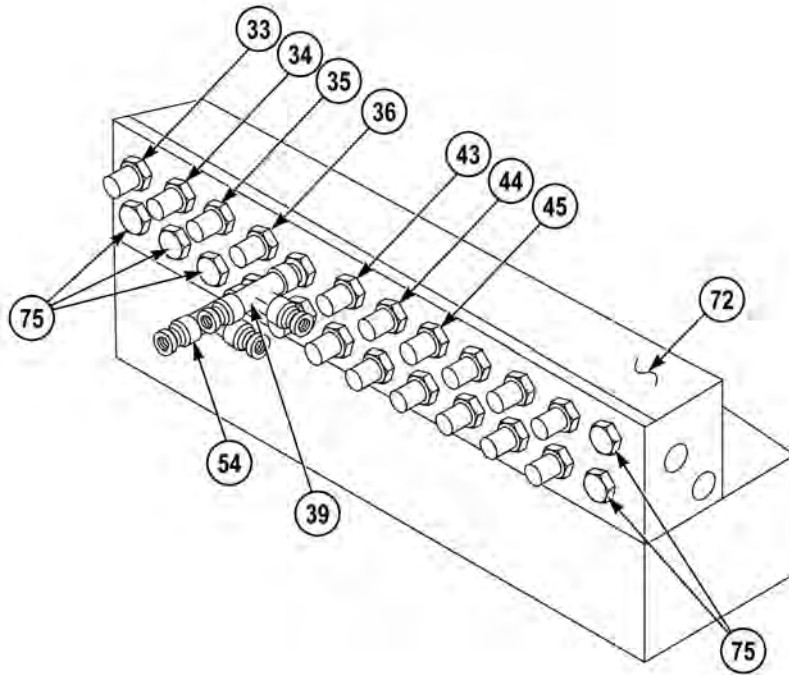




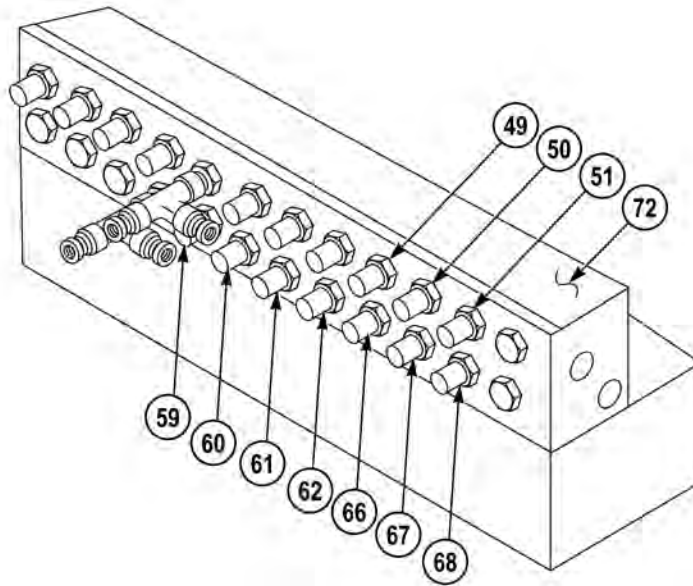
**NOTE**

Note position of elbows prior to removal to ensure proper installation.

13. Remove three elbows (26), (27), and (28) and muffler (74) from control valve manifold (72).



14. Remove five plugs (75) from control valve manifold (72).
15. Remove four fittings (33), (34), (35), and (36) and two tees (39) and (54) from control valve manifold (72).
16. Remove three fittings (43), (44), and (45) from control valve manifold (72).



17. Remove three fittings (49), (50), and (51) from control valve manifold (72).

18. Remove seven fittings (59), (60), (61), (62), (66), (67), and (68) from control valve manifold (72).

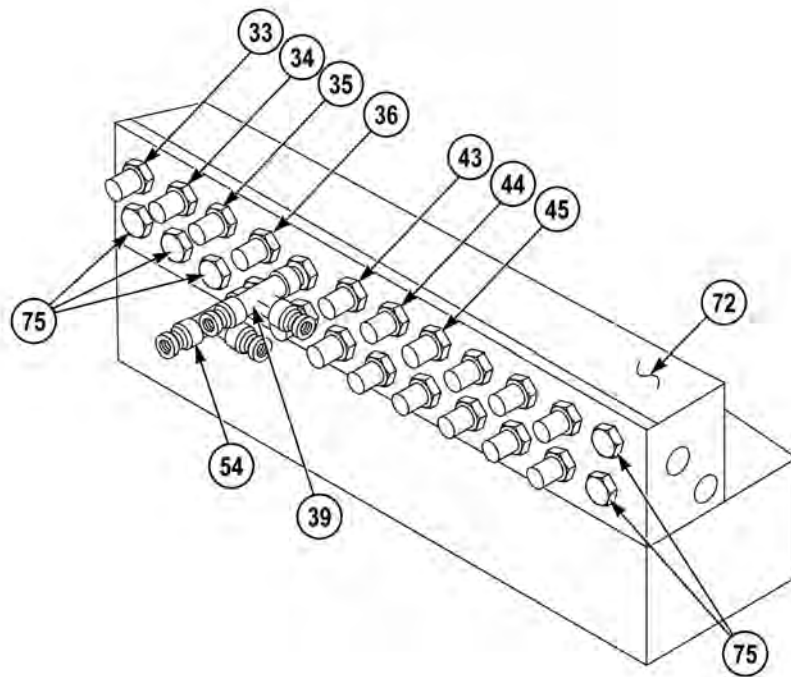
#### END OF TASK

#### INSTALLATION

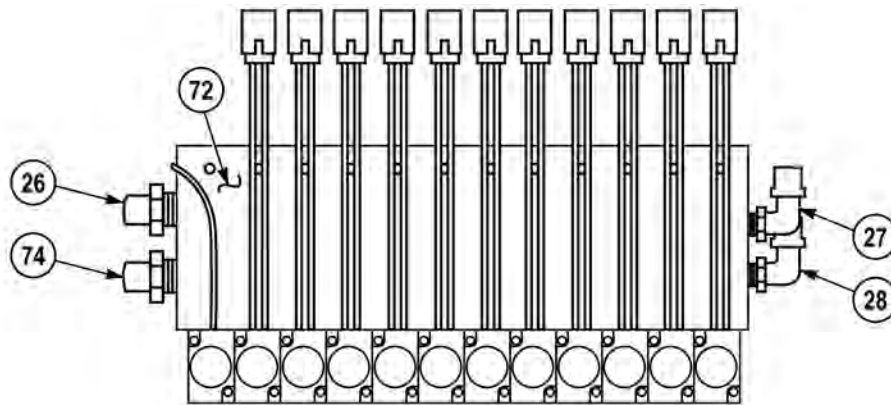
#### NOTE

Install cable ties as required.

1. Apply teflon tape to threads of ten fittings (49), (50), (51), (59), (60), (61), (62), (66), (67), and (68).
2. Install seven fittings (59), (60), (61), (62), (66), (67), and (68) on control valve manifold (72).
3. Install three fittings (49), (50), and (51) on control valve manifold (72).



4. Apply teflon tape to threads of seven fittings (33), (34), (35), (36), (43), (44), and (45) five plugs (75) and two tees (39) and (54).
5. Install three fittings (43), (44), and (45) on control valve manifold (72).
6. Install four fittings (33), (34), (35), and (36) and two tees (39) and (54) on control valve manifold (72).
7. Install five plugs (75) on control valve manifold (72).

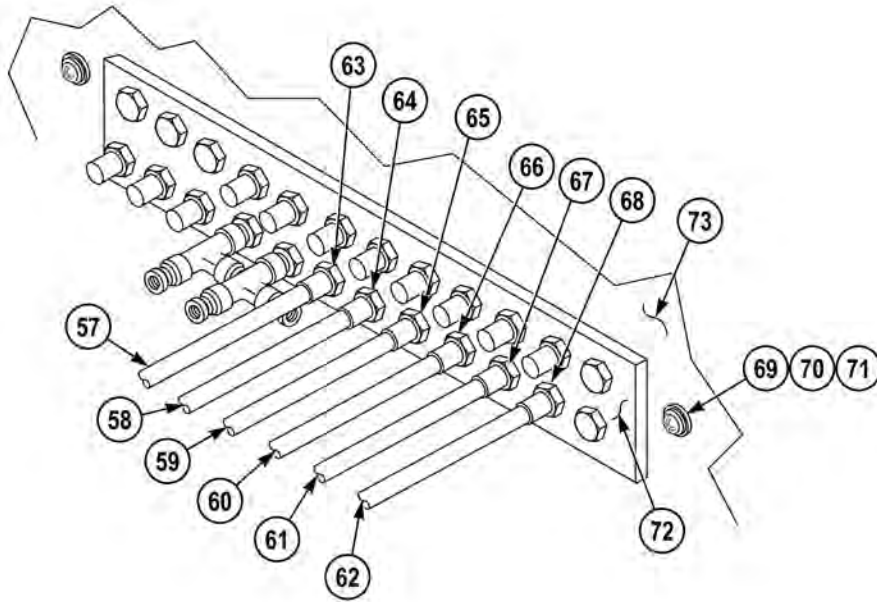


8. Apply teflon tape to threads of three elbows (26), (27), and (28) and muffler (74).

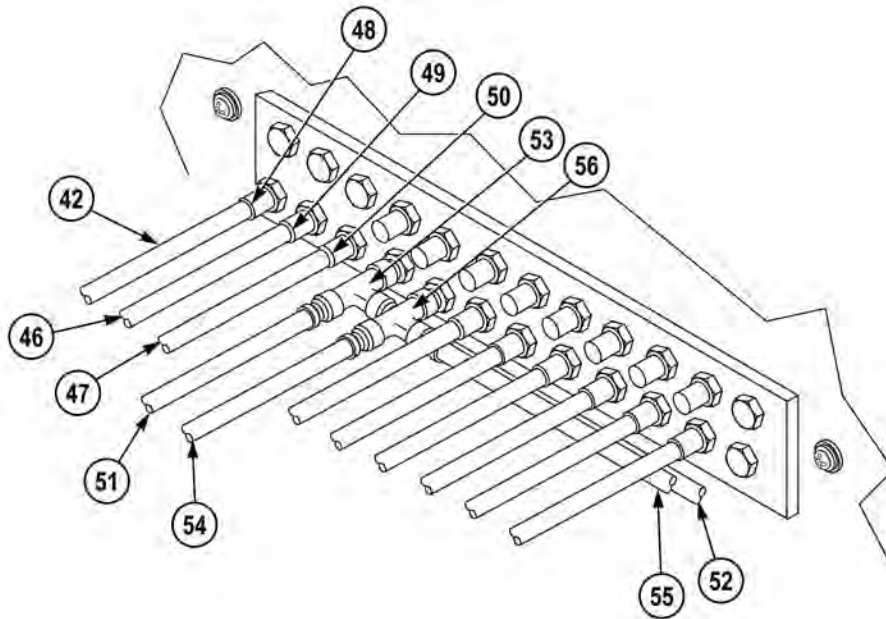
**NOTE**

Install elbows in same position as noted prior to removal.

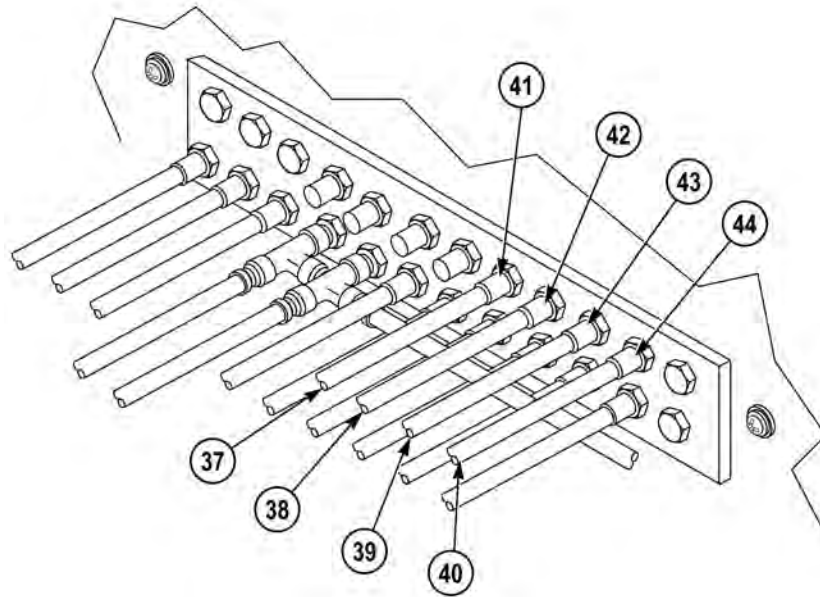
9. Install three elbows (26), (27), and (28) and muffler (74) on control valve manifold (72).



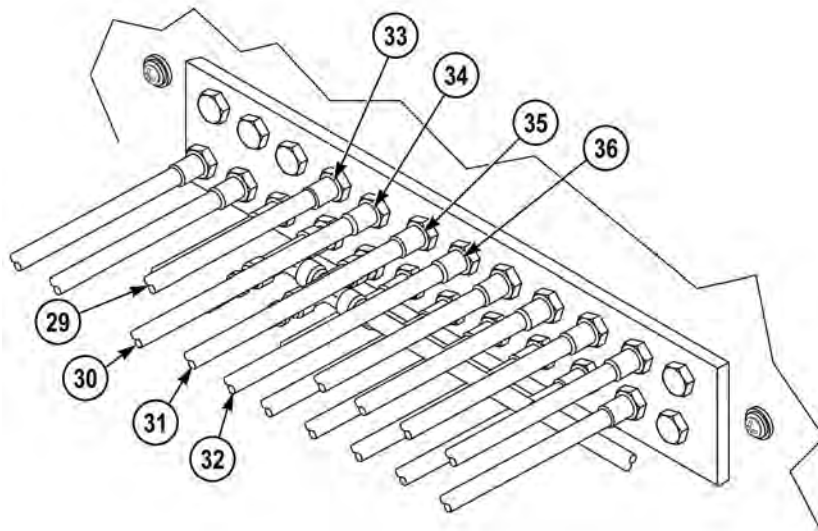
10. Install control valve manifold (72) on bracket (73) with two washers (71), lockwashers (70), and screws (69).
11. Install six air lines (57), (58), (59), (60), (61), and (62) on fittings (63), (64), (65), (66), (67), and (68).



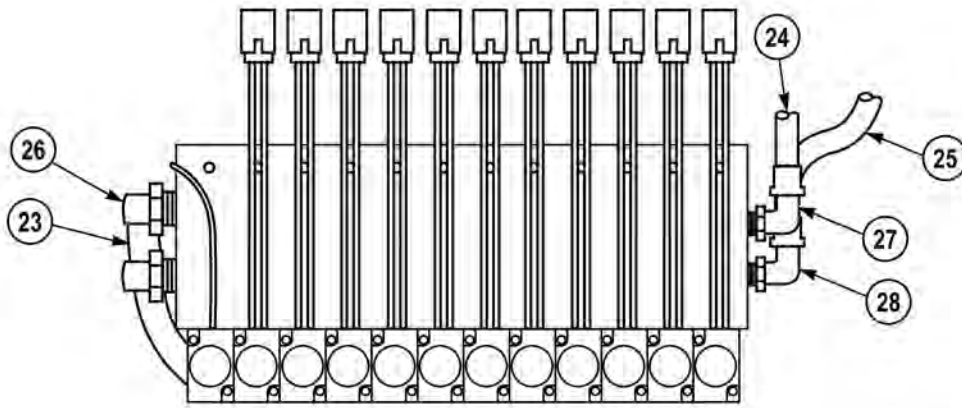
12. Install two air lines (54) and (55) on tee (56).
13. Install two air lines (51) and (52) on tee (53).
14. Install three air lines (45), (46), and (47) on fittings (48), (49), and (50).



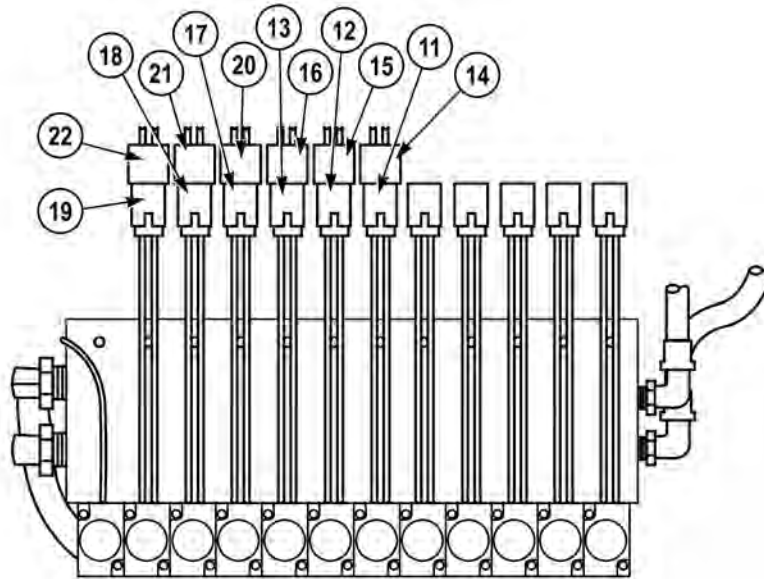
15. Install four air lines (37), (38), (39), and (40) on fittings (41), (42), (43), and (44).



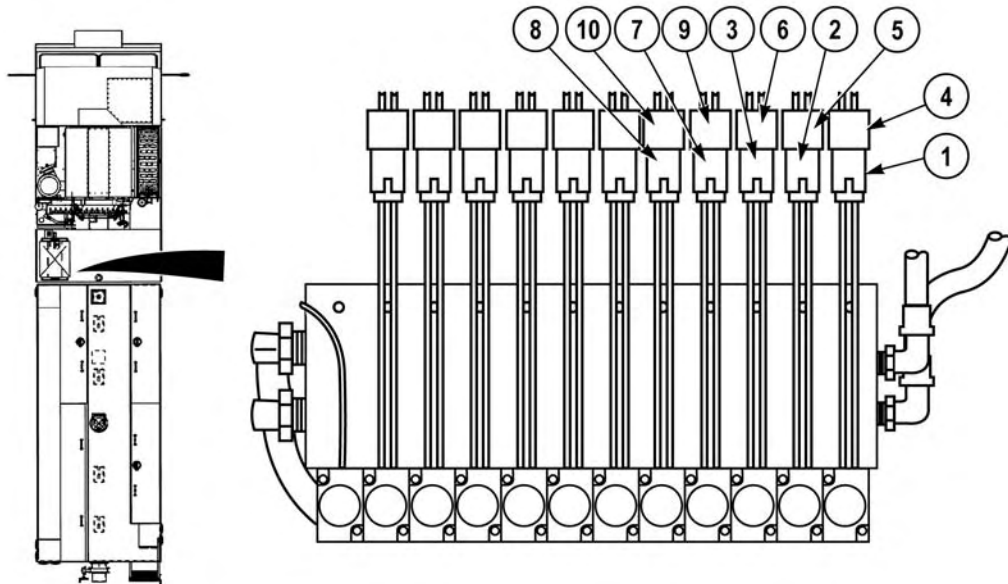
16. Install four air lines (29), (30), (31), and (32) on fittings (33), (34), (35), and (36).



17. Install three air lines (23), (24), and (25) on elbows (26), (27), and (28).



18. Connect under truck nozzle valve connector (17), bumper turret valve connector (18), and tank discharge valve connector (19) on three valve control wire harness connectors (20), (21), and (22).
19. Connect tank drain valve connector (11), hose reel discharge valve connector (12), and pump cooler valve connector (13) on three valve control wire harness connectors (14), (15), and (16).



20. Connect foam valve connector (7) and flush valve connector (8) on two valve control wire harness connectors (9) and (10).
21. Connect under truck nozzle foam valve connector (1), bumper turret foam valve connector (2), and eductor valve connector (3) on three valve control wire harness connectors (4), (5), and (6).

#### END OF TASK

#### FOLLOW-ON MAINTENANCE

Install hose reel (WP 0247)

#### END OF TASK

#### END OF WORK PACKAGE





---

**FIELD LEVEL MAINTENANCE**  
**SHUTOFF CONTROL VALVE REPLACEMENT**

---

**INITIAL SETUP:****Tools and Special Tools**

Tool Kit, General Mechanic's: Automotive  
(WP 0398, Item 17)

**References**

WP 0391, Fig. 3

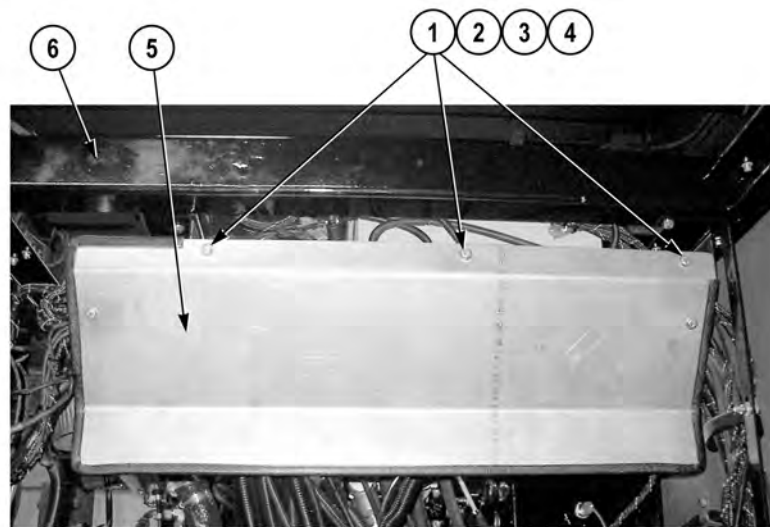
**Materials/Parts**

Ties, Cable, Plastic (WP 0400, Item 26)  
Lockwasher (3)  
Preformed Packing (3)  
Preformed Packing (1)

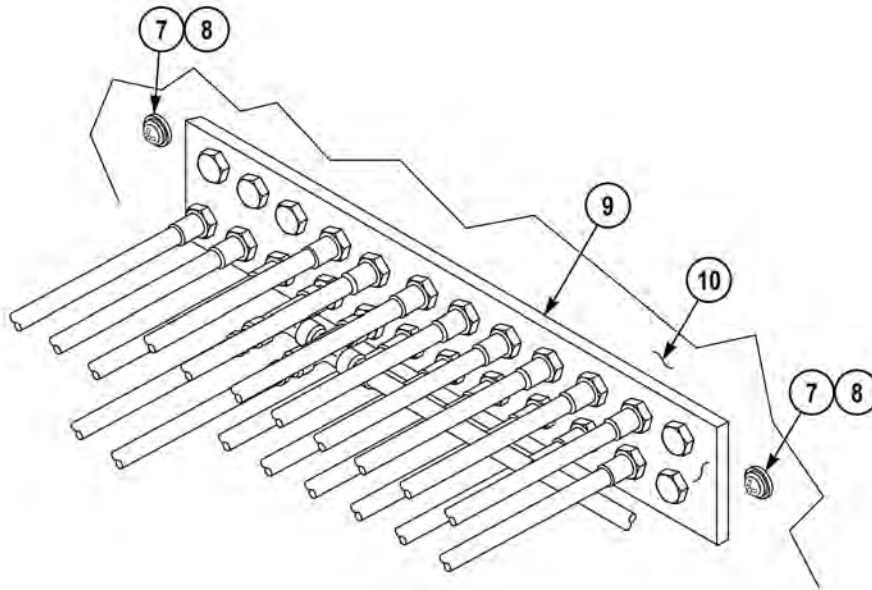
**Equipment Conditions**

Air system drained (TM 9-2320-422-10)  
Pump hose panels K and L removed (WP 0339)

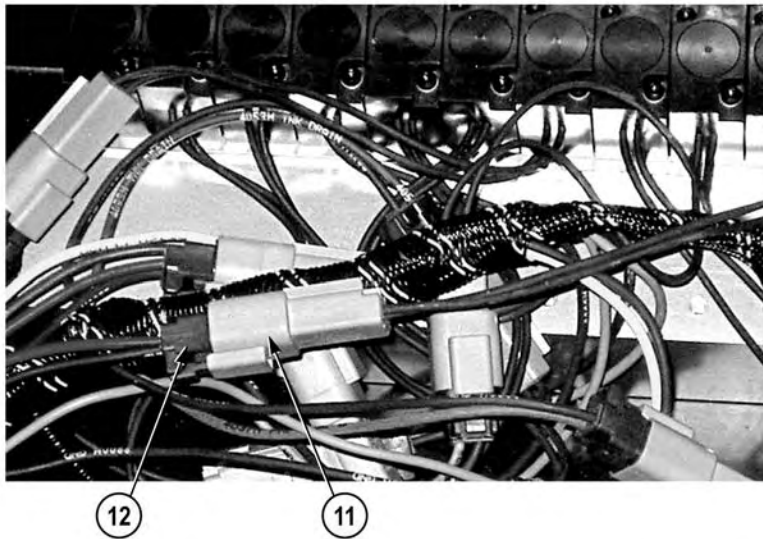
---

**REMOVAL****NOTE**

- It is not necessary to remove cushion clips and wires attach to booster reel deflector.
  - Booster reel deflector shield shown with hose reel removed.
1. Remove three nuts (1), lockwashers (2), six washers (3), three screws (4), and lower booster reel deflector (5) from pump house frame (6). Discard lockwashers.



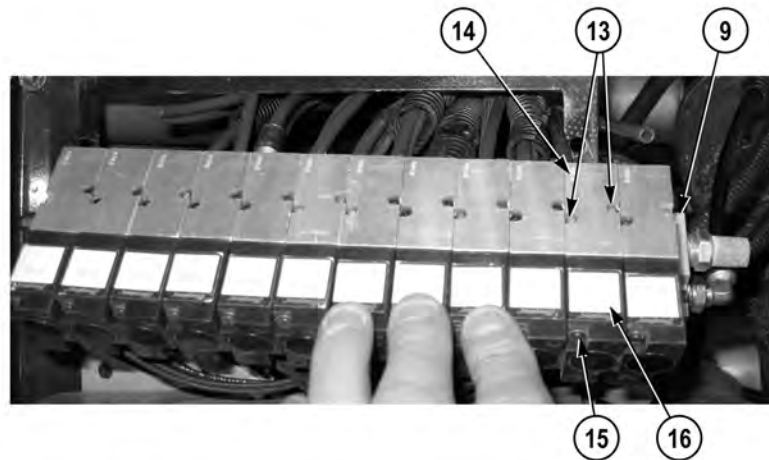
2. Remove two screws (7), washers (8), and shutoff control valve manifold (9) from bracket (10).



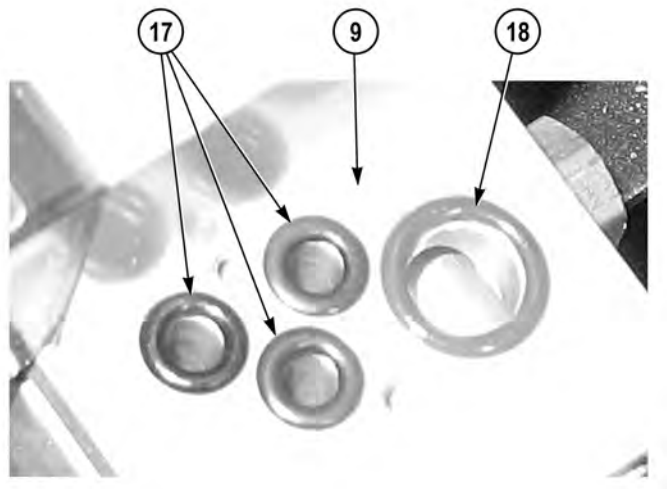
### NOTE

All shutoff control valves are removed the same way. Tank to pump control valve shown.

3. Disconnect tank-to-pump valve connector (11) from tank-to-pump valve control wire harness connector (12).



4. Remove two screws (13) and tank-to-pump valve (14) from shutoff control valve manifold (9).
5. Remove two screws (15) and solenoid (16) from tank-to-pump valve (14).

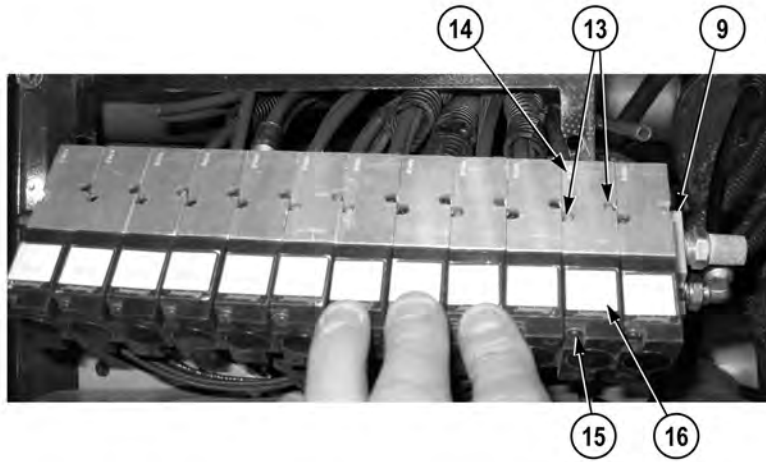


6. Remove three preformed packings (17) from shutoff control valve manifold (9). Discard preformed packing.
7. Remove preformed packing (18) from shutoff control valve manifold (9). Discard preformed packing.

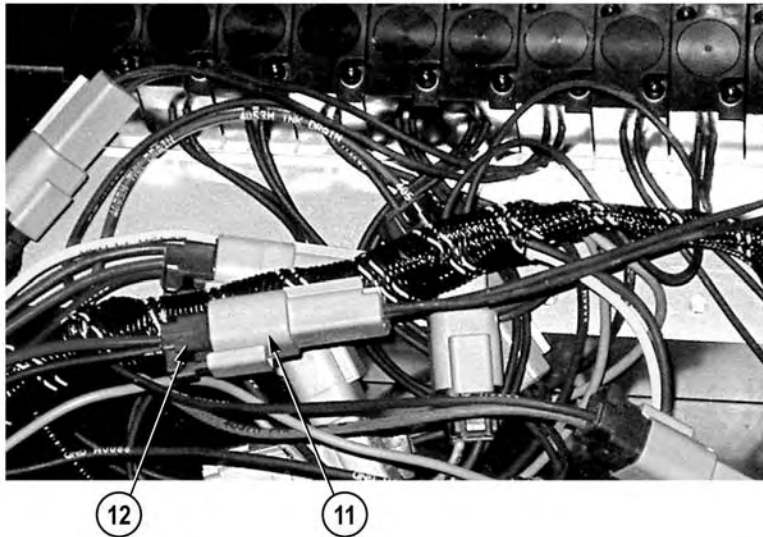
#### END OF TASK

#### INSTALLATION

1. Install preformed packing (18) on shutoff control valve manifold (9).
2. Install three preformed packing (17) on shutoff control valve manifold (9).



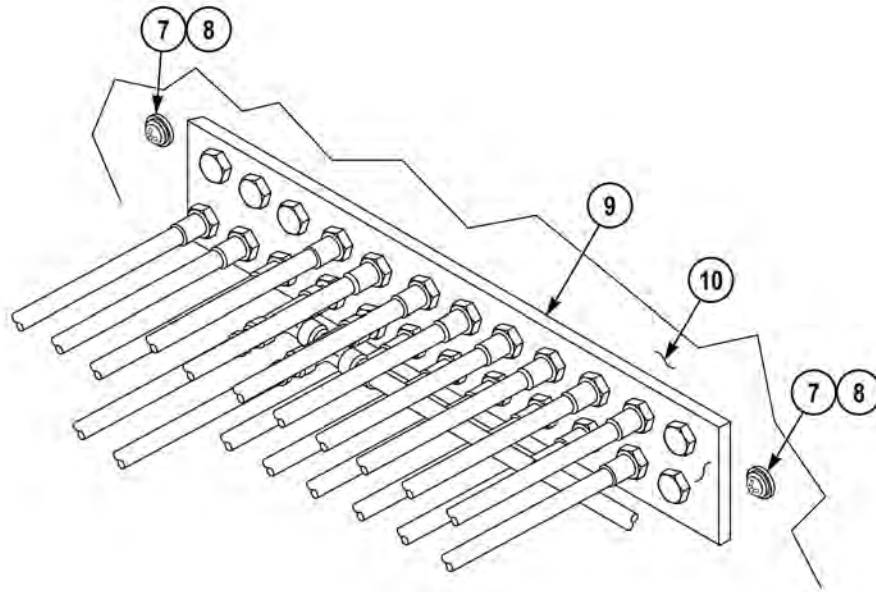
3. Install solenoid (16) on tank-to-pump valve (14) with two screws (15).
4. Install tank-to-pump valve (14) on shutoff control valve manifold (9) with two screws (13).



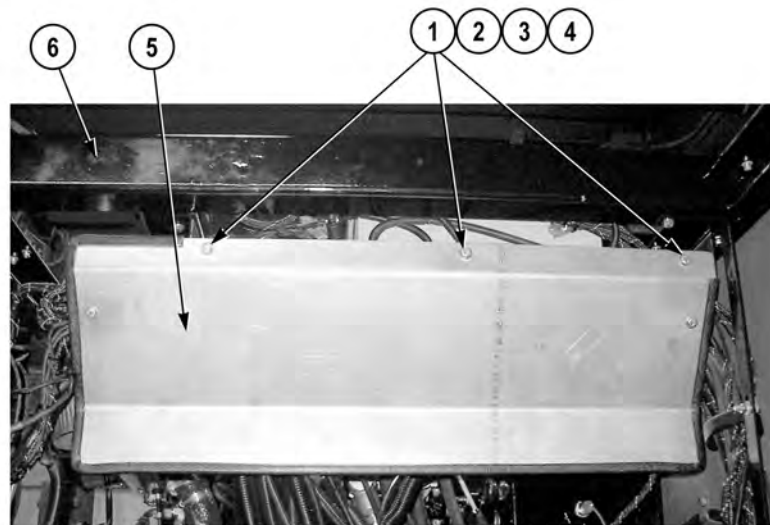
#### NOTE

Install cable ties as required.

5. Connect tank-to-pump valve control wire harness connector (12) to tank-to-pump valve connector (11).



6. Install shutoff control valve manifold (9) on bracket (10) with two washers (8) and screws (7).



7. Install booster reel deflector (5) on pump house frame (6) with three screws (4), six washers (3), three lockwashers (2), and nuts (1).

**END OF TASK**

**FOLLOW-ON MAINTENANCE**

Install pump house panels L and K (WP 0339)

**END OF TASK**

**END OF WORK PACKAGE**



## FIELD LEVEL MAINTENANCE

## COVER, DOOR, AND ELECTRONIC MOUNTING BASE REPLACEMENT (SINGGARS)

## INITIAL SETUP:

**Tools and Special Tools**

Tool Kit, General Mechanic's: Automotive  
(WP 0398, Item 17)

**References**

WP 0391, Fig. 37

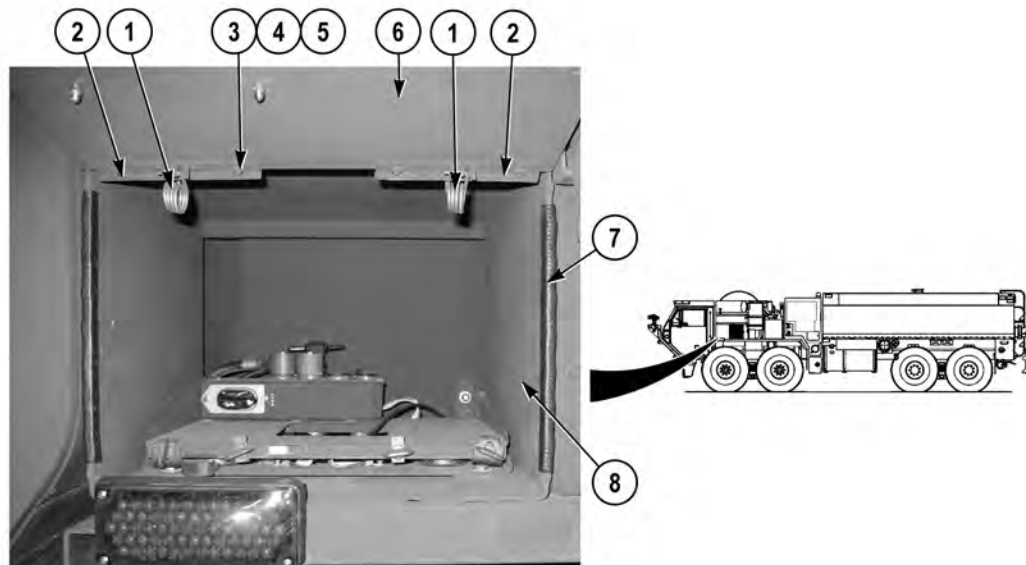
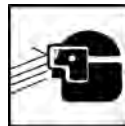
**Materials/Parts**

Locknut (4)  
Locknut (4)  
Lockwasher (8)

**Equipment Conditions**

Radio/transmitter, amplifiers, and communication  
cables removed (TM 11 5820-890-10-1)  
Power cable assembly (SINGGARS)  
removed (WP 0260)

## REMOVAL

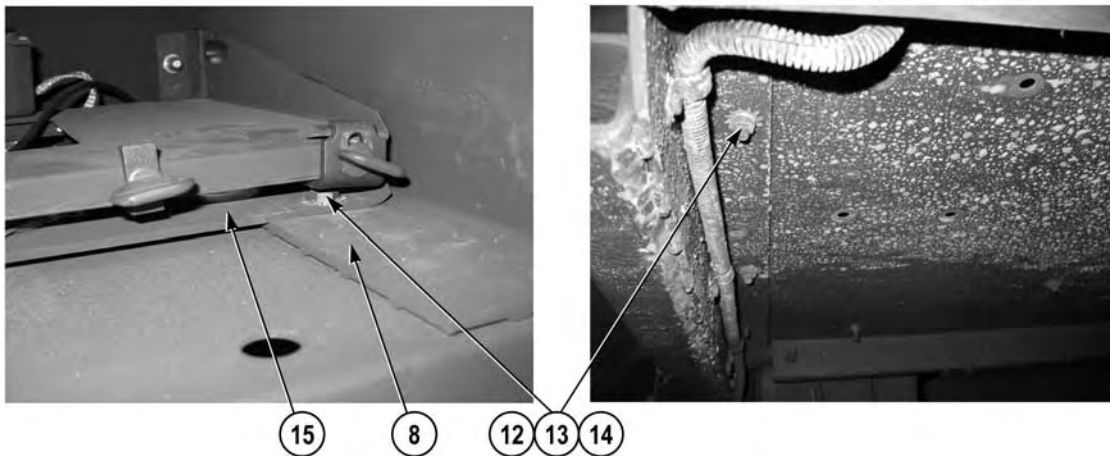
**WARNING**

**Springs are under pressure. Wear safety goggles and use caution when removing or installing springs, snaprings, retaining rings, and other parts under spring tension. These parts can act as projectiles, resulting in serious injury to personnel.**

1. Remove two springs (1) from hinges (2).
2. Remove four locknuts (3), eight washers (4), four screws (5), and door (6) from two hinges (2). Discard locknuts.
3. Remove two door seals (7) from cover (8).



4. Remove four locknuts (9), eight washers (10), four screws (11), and two hinges (2) from cover (8). Discard locknuts.



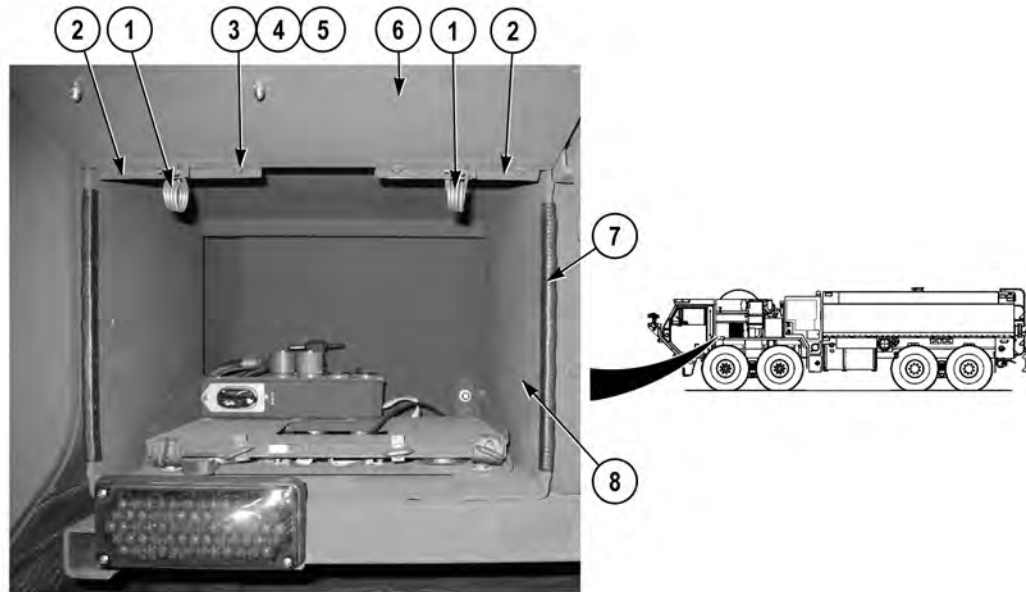
5. Remove four nuts (12), eight lockwashers (13), four screws (14), mounting base (15), and cover (8) from vehicle. Discard lockwashers.

**END OF TASK**

**INSTALLATION**

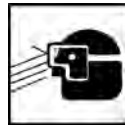
1. Install cover (8) and mounting base (15) on vehicle with four screws (14), eight lockwashers (13), and four nuts (12).
2. Install two hinges (2) on cover (8) with four screws (11), eight washers (10), and four locknuts (9).





3. Install two door seals (7) on cover (8).
4. Install door (6) on two hinges (2) with four screws (5), eight washers (4), and four locknuts (3).

### **WARNING**



**Springs are under pressure. Wear safety goggles and use caution when removing or installing springs, snaprings, retaining rings, and other parts under spring tension. These parts can act as projectiles, resulting in serious injury to personnel.**

5. Install two springs (1) on hinges (2).

**END OF TASK**

### **FOLLOW-ON MAINTENANCE**

1. Install power cable assembly (SINCGARS) (WP 0260)
2. Install radio/transmitter, amplifiers, and communication cables (TM 11-5820-890-10-1)

**END OF TASK**

**END OF WORK PACKAGE**



## FIELD LEVEL MAINTENANCE

## SPEAKER REPLACEMENT

## INITIAL SETUP:

**Tools and Special Tools**

Tool Kit, General Mechanic's: Automotive  
(WP 0398, Item 17)

**References**

WP 0391, Fig. 43

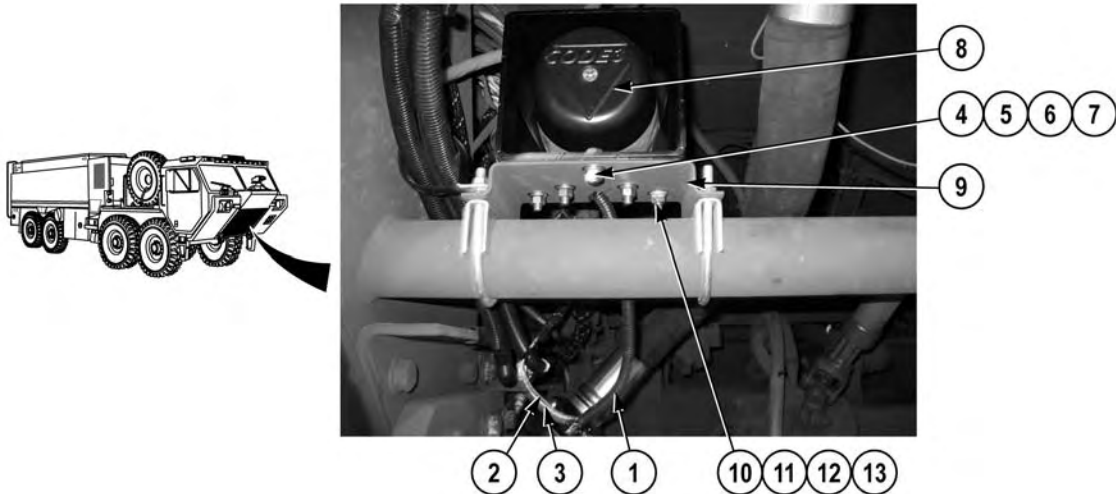
**Materials/Parts**

Tags, Identification (WP 0400, Item 23)  
Lockwasher (1)  
Lockwasher (4)  
Locknut (1)  
Locknut (4)

**Equipment Conditions**

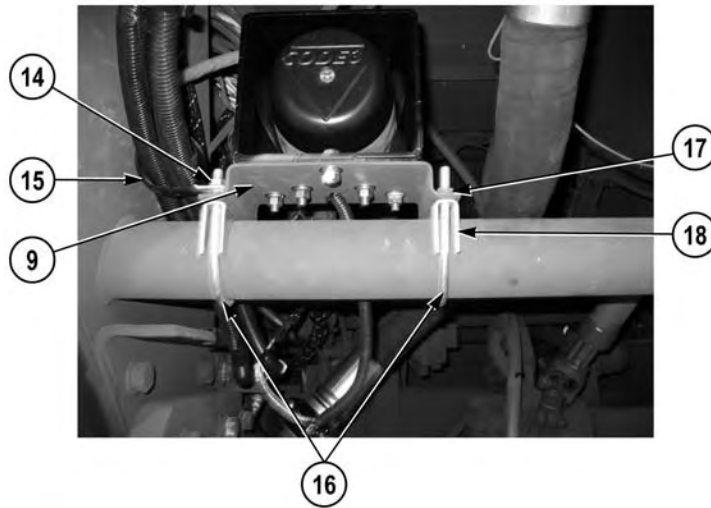
Batteries disconnected (TM 9-2320-325-14&P)  
Skid plate grille removed (WP 0349)

## REMOVAL

**NOTE**

Tag and mark wires prior to removal to ensure proper installation.

1. Open loom (1) and cut wire 1052 (2) and wire 1053 (3) (TM 9-2320-325-14&P)
2. Remove nut (4), lockwasher (5), washer (6), and screw (7) from speaker (8) and bracket (9). Discard lockwasher.
3. Remove four nuts (10), lockwashers (11), washers (12), screws (13), and speaker (8) from bracket (9). Discard lockwashers.

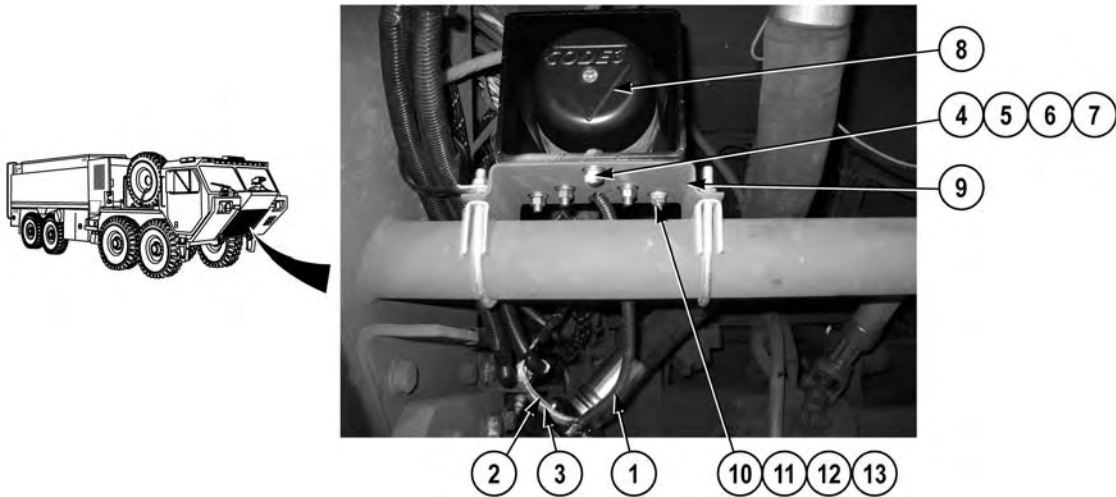


4. Remove locknut (14) and cushion clamp (15) from U-bolt (16). Discard locknut.
5. Remove four locknuts (17), two U-bolts (16), cradles (18), and bracket (9) from vehicle. Discard locknuts.

#### END OF TASK

#### INSTALLATION

1. Install bracket (9) on vehicle with two cradles (18), U-bolts (16), and four locknuts (17).
2. Install cushion clamp (15) on U-bolt (16) with locknut (14).



3. Install speaker (8) on bracket (9) with four screws (13), washers (12), lockwashers (11), and nuts (10).
4. Install screw (7), washer (6), lockwasher (5), and nut (4) on speaker (8) and bracket (9).
5. Repair wire 1052 (3) and wire 1053 (2) (TM 9-2320-325-14&P) and close loom (1).

#### END OF TASK

#### FOLLOW-ON MAINTENANCE

1. Install skid plate grille (WP 0349)
2. Connect batteries (TM 9-2320-325-14&P)

#### END OF TASK

#### END OF WORK PACKAGE



---

**FIELD LEVEL MAINTENANCE**  
**TERMINAL BLOCK REPLACEMENT**

---

**INITIAL SETUP:****Tools and Special Tools**

Tool Kit, General Mechanic's: Automotive  
(WP 0398, Item 17)

**References**

WP 0391, Fig. 26

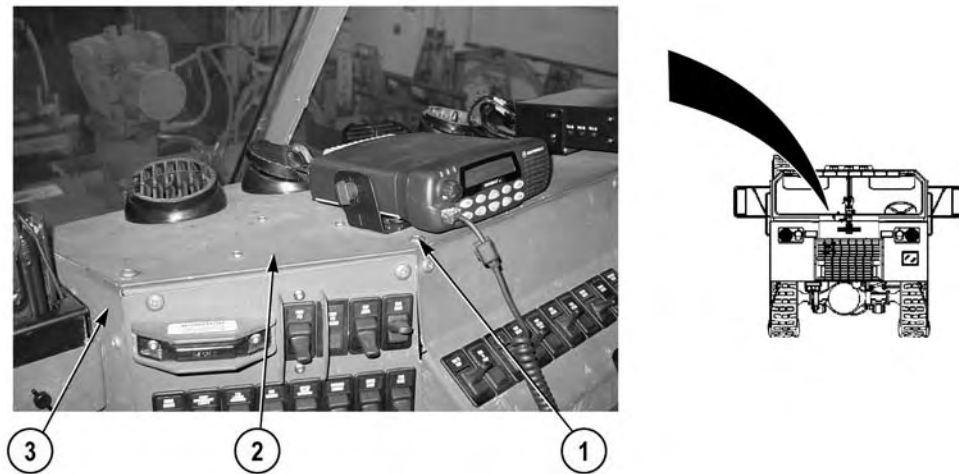
**Materials/Parts**

Tags, Identification (WP 0400, Item 23)  
Ties, Cable, Plastic (WP 0400, Item 26)  
Lockwasher (3)  
Locknut (6)  
Locknut (2)  
Lockwasher (1)  
Locknut (2)

**Equipment Conditions**

Batteries disconnected (TM 9-2320-325-14&P)

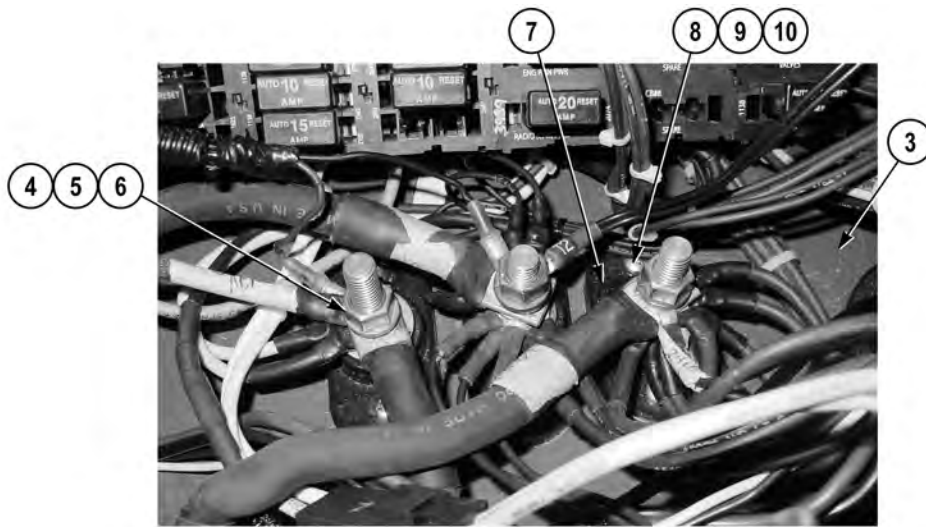
---

**TERMINAL BLOCKS IN CAB REMOVAL**

 **CAUTION**

**Wires are attached to cab instrument panel A. Lift panel only far enough to access terminal blocks. Failure to comply may cause damage to equipment.**

1. Remove six screws (1) and lift cab instrument panel A (2) from cab instrument panel assembly (3).



### NOTE

- Tag and mark wires prior to removal to ensure proper installation.
  - Remove cable ties as required.
2. Remove three nuts (4), lockwashers (5), and wires (6) from three terminal blocks (7). Discard lockwashers.
  3. Remove six locknuts (8), washers (9), screws (10), and three terminal blocks (7) from cab instrument panel assembly (3). Discard locknuts.

### END OF TASK

### TERMINAL BLOCKS IN CAB INSTALLATION

#### CAUTION

**Do not overtighten locknuts when installing terminal blocks. Failure to comply may cause damage to equipment.**

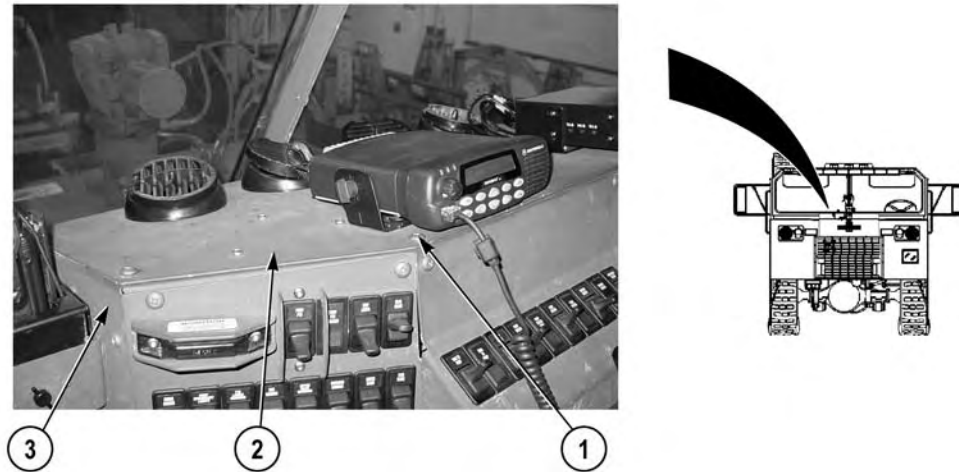
1. Install three terminal blocks (7) on cab instrument panel assembly (3) with six screws (10), washers (9), and locknuts (8).

### NOTE

Install cable ties as required.

2. Install wires (6) on three terminal blocks (7) with three lockwashers (5) and nuts (4).

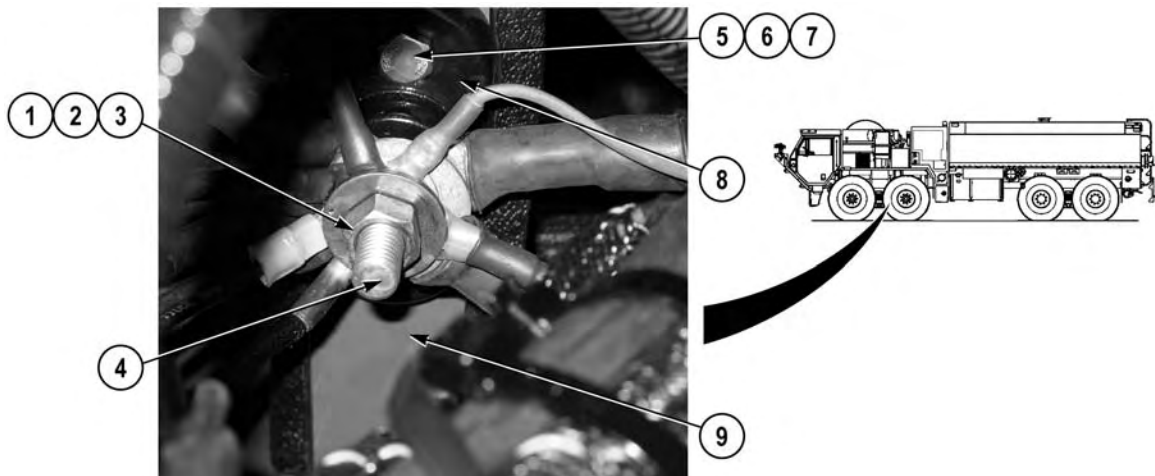




3. Install cab instrument panel A (2) on cab instrument panel assembly (3) with six screws (1).

**END OF TASK**

**TERMINAL BLOCK ON FRAME RAIL BY BATTERY DISCONNECT SWITCH REMOVAL**



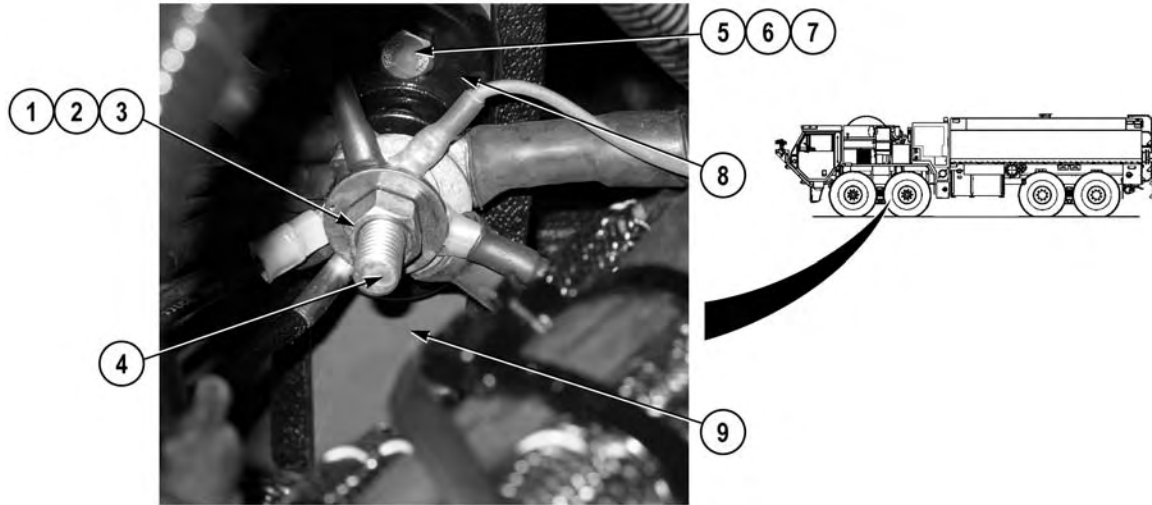
**NOTE**

- Tag and mark wires prior to removal to ensure proper installation.
- Remove cable ties as required.

1. Remove nut (1), washer (2), and wires (3) from screw (4).
2. Remove two locknuts (5), washers (6), screws (7), and terminal block (8) from wire harness bracket (9). Discard locknuts.

**END OF TASK**

---

**TERMINAL BLOCK ON FRAME RAIL BY BATTERY DISCONNECT SWITCH INSTALLATION**


**⚠ CAUTION**

Do not overtighten locknuts when installing terminal block. Failure to comply may cause damage to equipment.

**NOTE**

Install cable ties as required.

1. Install terminal block (8) on wire harness bracket (9) with two screws (7), washers (6), and locknuts (5).
2. Install wires (3) on screw (4) with washer (2) and nut (1).

**END OF TASK**

**TERMINAL BLOCK AT D1 STOWAGE COMPARTMENT REMOVAL****NOTE**

- Tag and mark wires prior to removal to ensure proper installation.
- Remove cable ties as required.

1. Remove nut (1), lockwasher (2), washer (3), and five wires (4) from screw (5). Discard lockwasher.
2. Remove two locknuts (6), washers (7), screws (8), and terminal block (9) from wire harness bracket (10). Discard locknuts

**END OF TASK****TERMINAL BLOCK AT D1 STOWAGE COMPARTMENT INSTALLATION**

**Do not overtighten locknuts when installing terminal block. Failure to comply may cause damage to equipment.**

**NOTE**

Install cable ties as required.

1. Install terminal block (9) on wire harness bracket (10) with two screws (8), washers (7), and locknuts (6).
2. Install five wires (4) on screw (5) with washer (3), lockwasher (2), and nut (1).

**END OF TASK****FOLLOW-ON MAINTENANCE**

Connect batteries (TM 9-2320-325-14&P)

**END OF TASK****END OF WORK PACKAGE**



---

**FIELD LEVEL MAINTENANCE**  
**THERMAL RELIEF VALVE SWITCH REPLACEMENT**

---

**INITIAL SETUP:****Tools and Special Tools**

Tool Kit, General Mechanic's: Automotive  
(WP 0398, Item 17)

**References**

WP 0391, Fig. 13

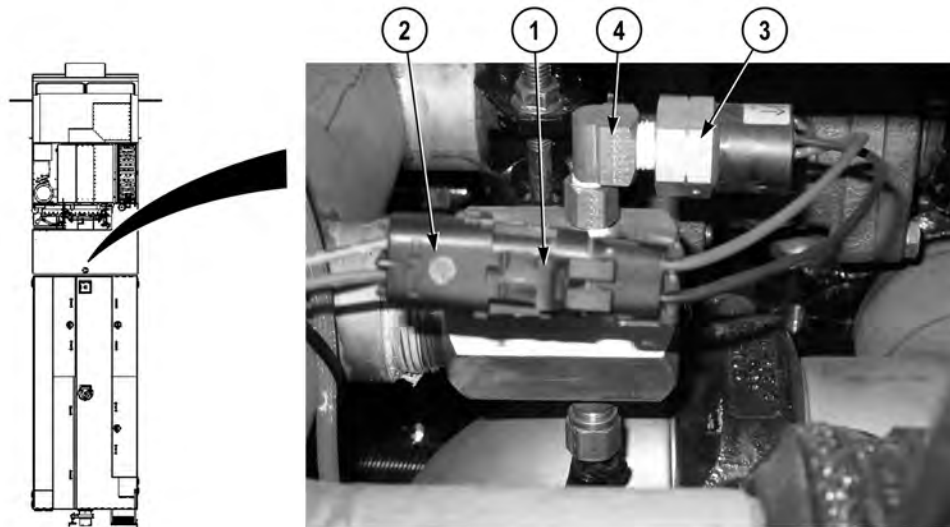
**Materials/Parts**

Tape, Teflon (WP 0400, Item 17)

**Equipment Conditions**

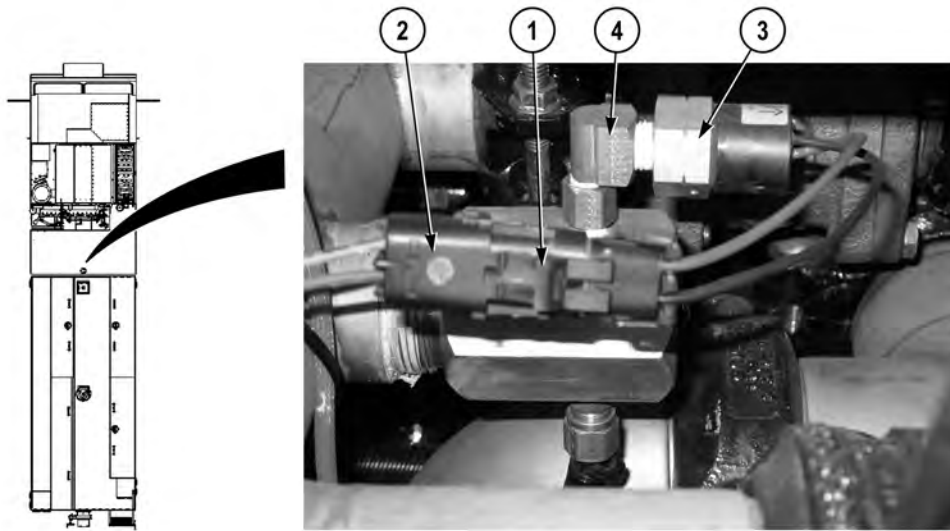
Pump house panel G removed (WP 0339)

---

**REMOVAL**

1. Disconnect thermal relief valve switch connector (1) from pump house wire harness connector (2).
2. Remove thermal relief valve switch (3) from elbow (4).

**END OF TASK**

**INSTALLATION**

1. Apply teflon tape to threads of elbow (4).
2. Install thermal relief valve switch (3) on elbow (4).
3. Connect thermal relief valve switch connector (1) on pump house wire harness connector (2).

**END OF TASK****FOLLOW-ON MAINTENANCE**

Install pump house panel G (WP 0339)

**END OF TASK****END OF WORK PACKAGE**

---

**FIELD LEVEL MAINTENANCE**  
**TWO-WAY RADIO REPLACEMENT**

---

**INITIAL SETUP:****Tools and Special Tools**

Tool Kit, General Mechanic's: Automotive  
(WP 0398, Item 17)

**References**

WP 0391, Fig. 44

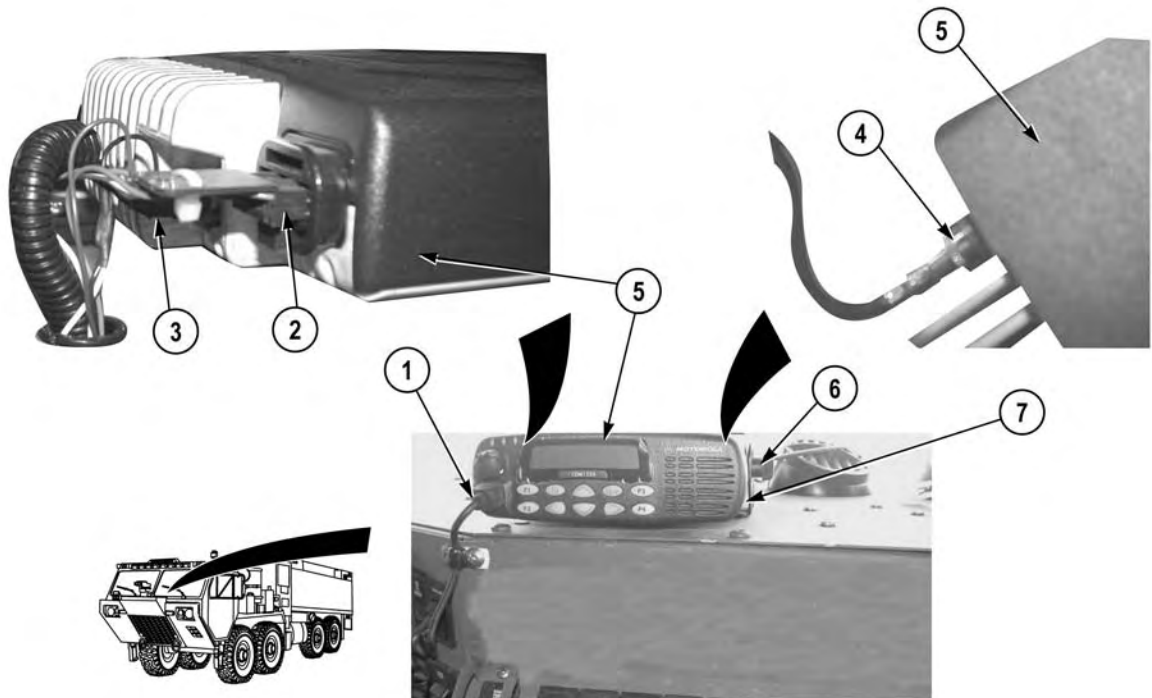
**Materials/Parts**

Tags, Identification (WP 0400, Item 23)  
Locknut (2)

**Equipment Conditions**

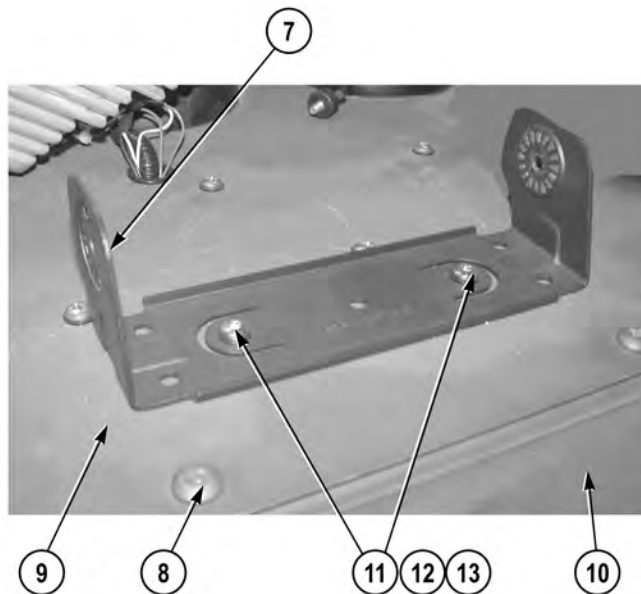
Batteries disconnected (TM 9-2320-325-14&P)

---

**REMOVAL****NOTE**

Tag and mark wire connectors prior to removal to ensure proper installation.

1. Disconnect four two-way radio connectors (1), (2), (3), and (4) from two-way radio (5).
2. Remove two screws (6) and two-way radio (5) from bracket (7).

**NOTE**

Perform Steps (3) and (4) if bracket needs to be removed.

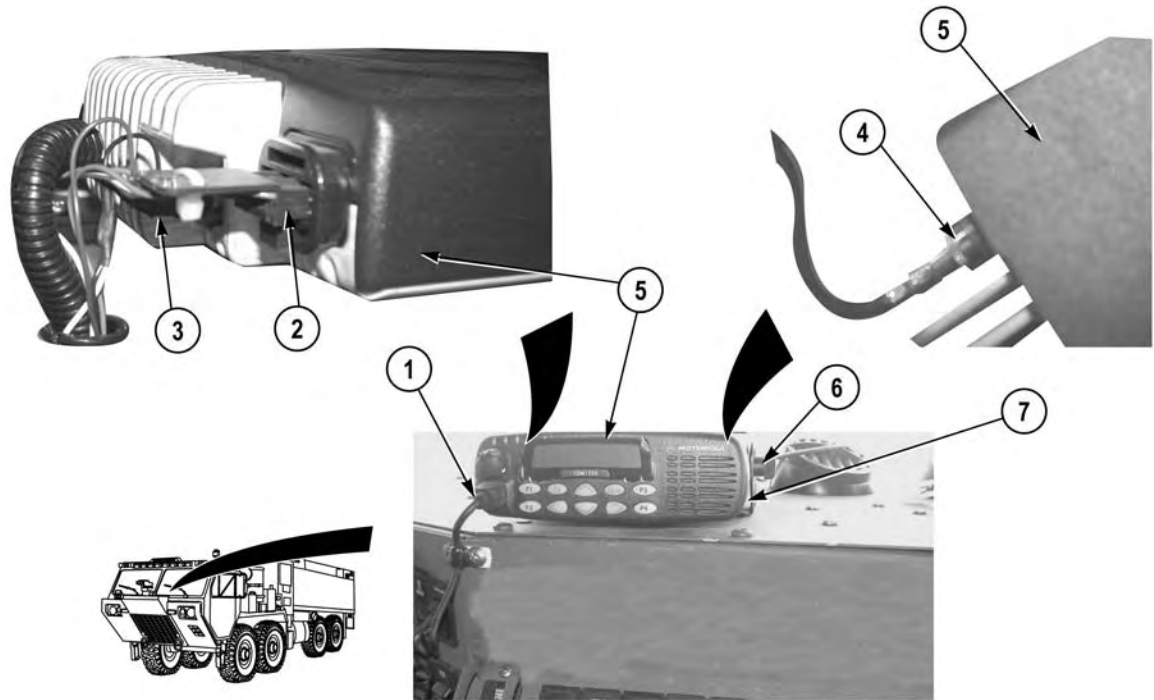
3. Remove seven screws (8) and cab instrument panel A (9) from control panel (10).
4. Remove two locknuts (11), washers (12), screws (13), and bracket (7) from control panel (9). Discard locknuts.

**END OF TASK****INSTALLATION****NOTE**

Perform Steps (1) and (2) if bracket was removed.

1. Install bracket (7) on control panel (9) with two screws (13), washers (12), and locknuts (11).
2. Install cab instrument panel A (9) on control panel (10) with seven screws (8).





3. Install two-way radio (5) on bracket (7) with two screws (6).
4. Connect four two-way radio connectors (1), (2), (3), and (4) on two-way radio (5).

**END OF TASK**

#### **FOLLOW-ON MAINTENANCE**

Connect batteries (TM 9-2320-325-14&P)

**END OF TASK**

**END OF WORK PACKAGE**



---

**FIELD LEVEL MAINTENANCE**  
**WINDSHIELD DELUGE MOTOR REPLACEMENT**

---

**INITIAL SETUP:****Tools and Special Tools**

Tool Kit, General Mechanic's: Automotive  
(WP 0398, Item 17)

**Materials/Parts**

Tags, Identification (WP 0400, Item 23)  
Ties, Cable, Plastic (WP 0400, Item 26)  
Preformed Packing (1)  
Lockwasher (2)  
Lockwasher (4)

**Personnel Required**

MOS 63B Wheeled Vehicle Mechanic (2)

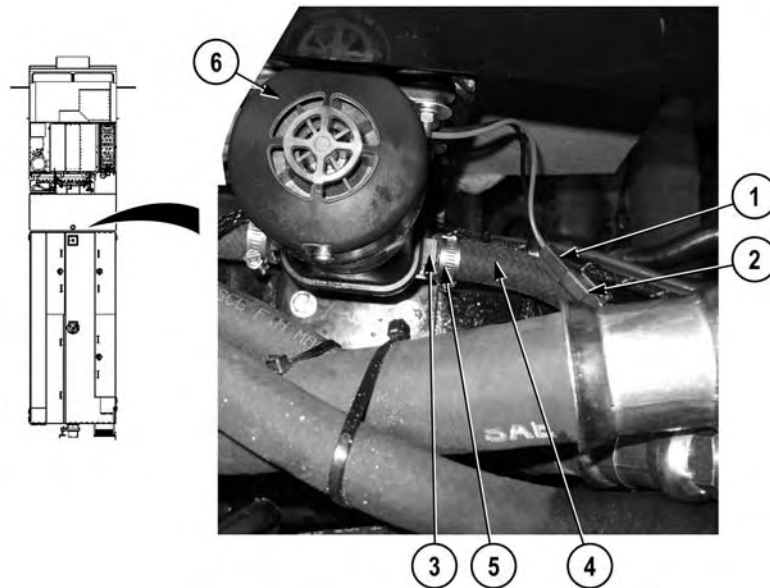
**References**

WP 0391, Fig. 94

**Equipment Conditions**

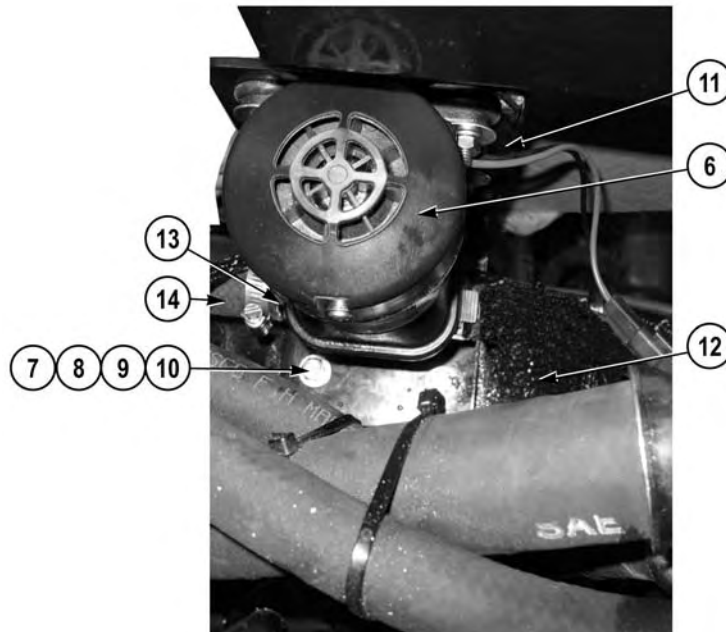
Hydraulic reservoir removed (WP 0148)

---

**REMOVAL****NOTE**

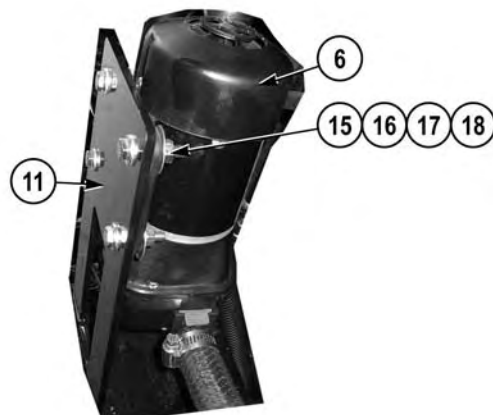
- Tag and mark hoses prior to removal to ensure proper installation.
- Remove cable ties as required.

1. Disconnect windshield deluge motor connector (1) from pump house wire harness connector (2).
2. Lift retainer clip (3), remove hose (4), and preformed packing (5) from windshield deluge motor (6). Discard preformed packing.

**NOTE**

Nuts, lockwashers, and washers holding windshield deluge motor support bracket to frame are removed from below with the aid of an assistant.

3. With the aid of an assistant, remove two nuts (7), lockwashers (8), four washers (9), and two screws (10) from windshield deluge motor support bracket (11) and frame rail (12). Discard lockwashers.
4. Lift retainer clip (13), and remove windshield deluge motor (6) from hose (14) and vehicle.

**NOTE**

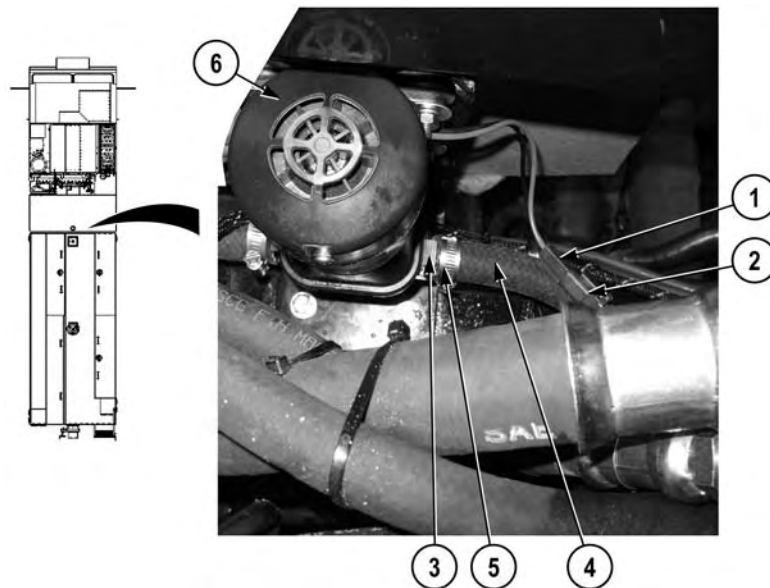
Note position of washers prior to removal to ensure proper installation.

5. Remove four nuts (15), lockwashers (16), eight washers (17), four screws (18), and windshield deluge motor (6) from windshield deluge support bracket (11). Discard lockwashers.

**END OF TASK**

**INSTALLATION****NOTE**

- Install washers as noted prior to removal.
  - Install cable ties as required.
1. Install windshield deluge motor (6) on windshield deluge motor support bracket (11) with four screws (18), eight washers (17), four lockwashers (16), and nuts (15).
  2. Install windshield deluge motor (6) on vehicle and hose (14) and secure with retainer clip (13).
  3. With the aid of an assistant, install windshield deluge motor support bracket (11) on frame rail (12) with two screws (10), four washers (9), two lockwashers (8), and nuts (7).



4. Lightly lubricate preformed packing (5) with clean oil, and install preformed packing in hose (4).
5. Install hose (4) on windshield deluge motor (6) and secure with retainer clip (3).
6. Connect windshield deluge motor connector (1) on pump house wire harness connector (2).

**END OF TASK****FOLLOW-ON MAINTENANCE**

Install hydraulic reservoir (WP 0148)

**END OF TASK****END OF WORK PACKAGE**



---

**FIELD LEVEL MAINTENANCE**  
**BUMPER TURRET WIRE HARNESS REPLACEMENT**

---

**INITIAL SETUP:****Tools and Special Tools**

Tool Kit, General Mechanic's: Automotive  
(WP 0398, Item 17)

**References**

WP 0391, Fig. 92

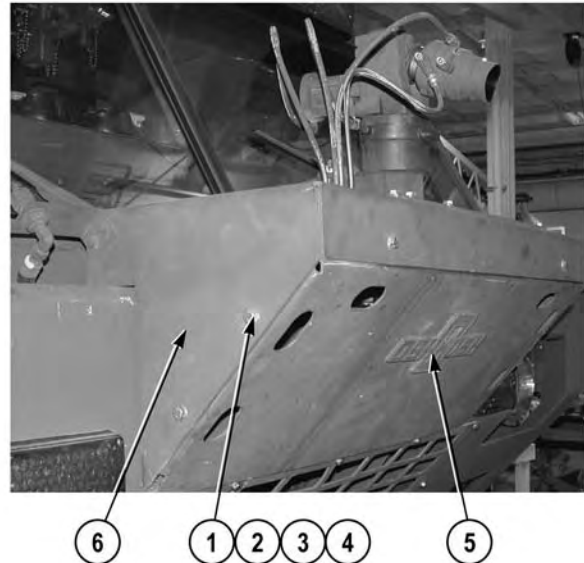
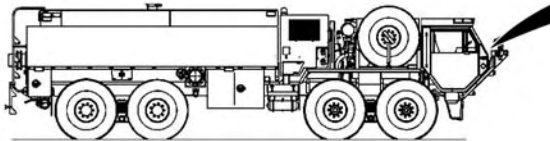
**Materials/Parts**

Ties, Cable, Plastic (WP 0400, Item 26)  
Lockwasher (6)

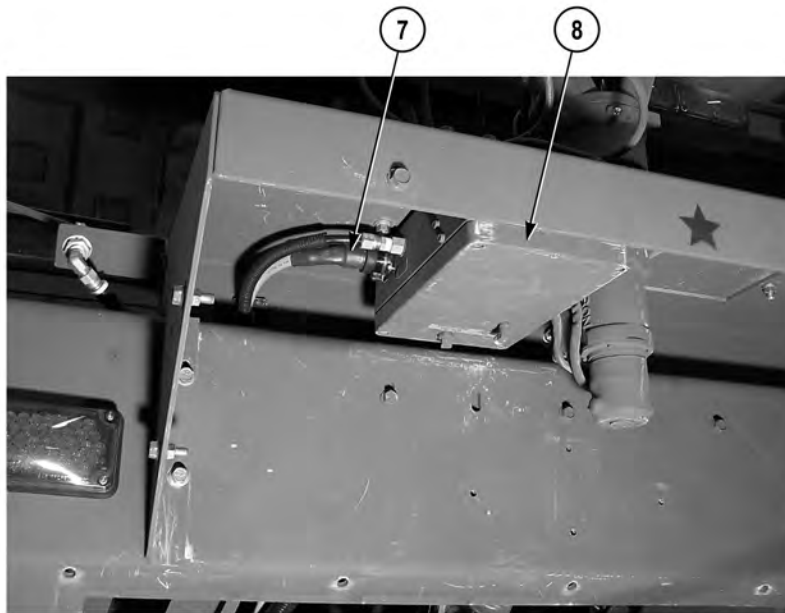
**Equipment Conditions**

Cab instrument panel E removed (WP 0205)  
Skid plate grille removed (WP 0349)

---

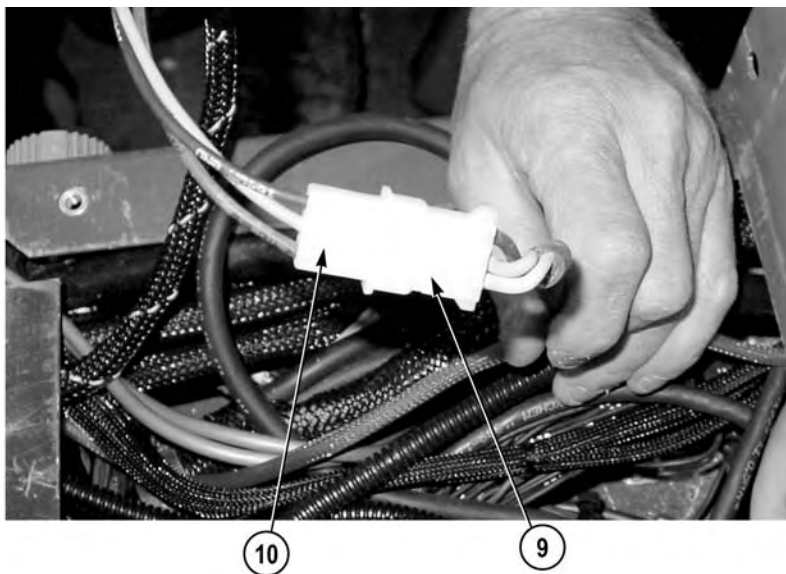
**REMOVAL**

1. Remove six nuts (1), lockwashers (2), 12 washers (3), six screws (4), and cover (5) from bumper turret mount (6). Discard lockwashers.



### NOTE

- Tag and mark wires prior to removal to ensure proper installation.
  - Note routing of bumper turret wire harness prior to removal to ensure proper installation.
  - Note position and remove cable ties, split loom, and cushion clips as required.
2. Disconnect bumper turret wire harness connector (7) from bumper turret junction box (8).



3. Disconnect bumper turret connector (9) from cab power distribution wire harness connector (10).



**NOTE**

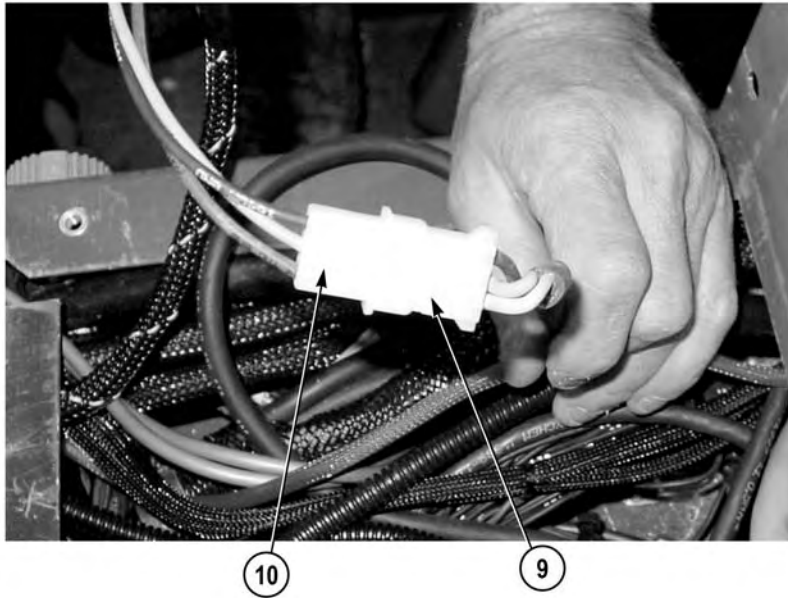
Bumper turret wire harness must be routed into cab for removal from vehicle.

4. Remove bumper turret wire harness (11) from vehicle.

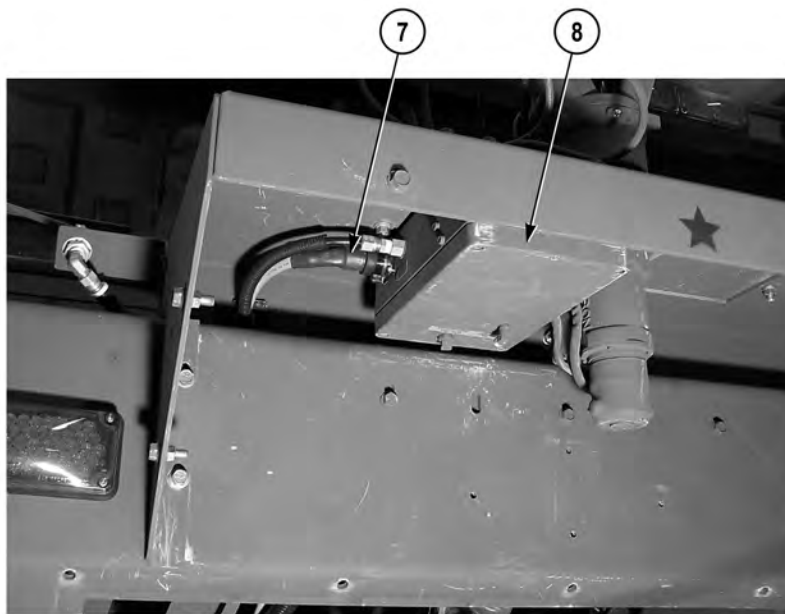
**END OF TASK****INSTALLATION****NOTE**

- Route bumper turret wire harness on vehicle as noted prior to removal.
- Install cable ties, split loom, and cushion clips as required.

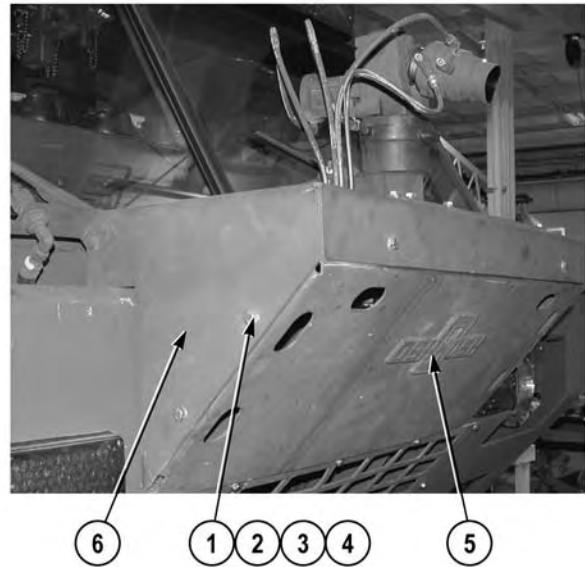
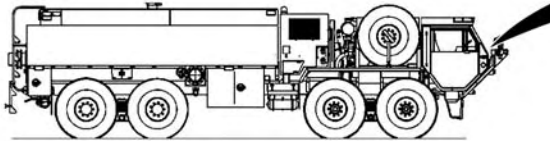
1. Install bumper turret wire harness (11) on vehicle.



2. Connect bumper turret control connector (9) on cab power distribution wire harness connector (10).



3. Connect bumper turret wire harness connector (7) on bumper turret junction box (8).



4. Install cover (5) on bumper turret mount (6) with six screws (4), 12 washers (3), six lockwashers (2), and nuts (1).

**END OF TASK**

**FOLLOW-ON MAINTENANCE**

1. Install skid plate grille (WP 0349)
2. Install cab instrument panel E (WP 0205)

**END OF TASK**

**END OF WORK PACKAGE**



---

**FIELD LEVEL MAINTENANCE**  
**CAB INSTRUMENT PANEL WIRE HARNESS REPLACEMENT**

---

**INITIAL SETUP:****Tools and Special Tools**

Tool Kit, General Mechanic's: Automotive  
(WP 0398, Item 17)

**References**

TM 9-2320-325-14&P  
WP 0391, Fig. 51

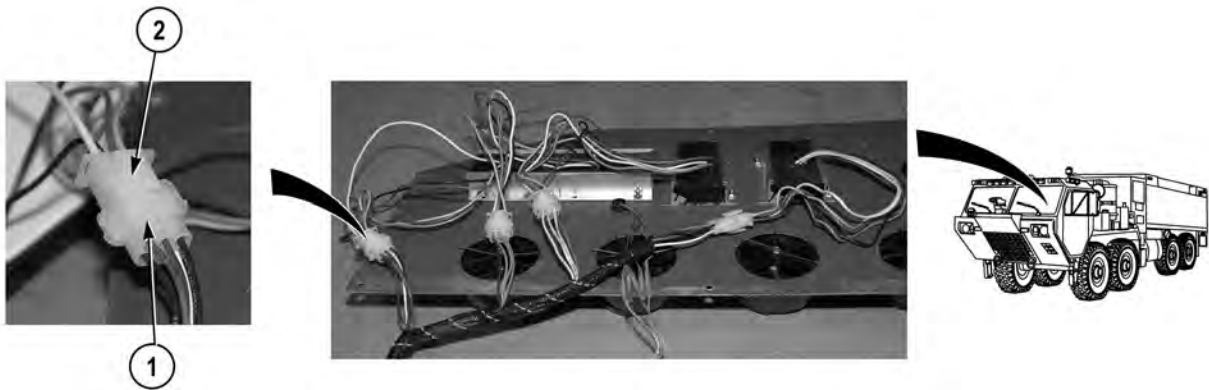
**Materials/Parts**

Tags, Identification (WP 0400, Item 23)  
Ties, Cable, Plastic (WP 0400, Item 26)  
Lockwasher (2)

**Equipment Conditions**

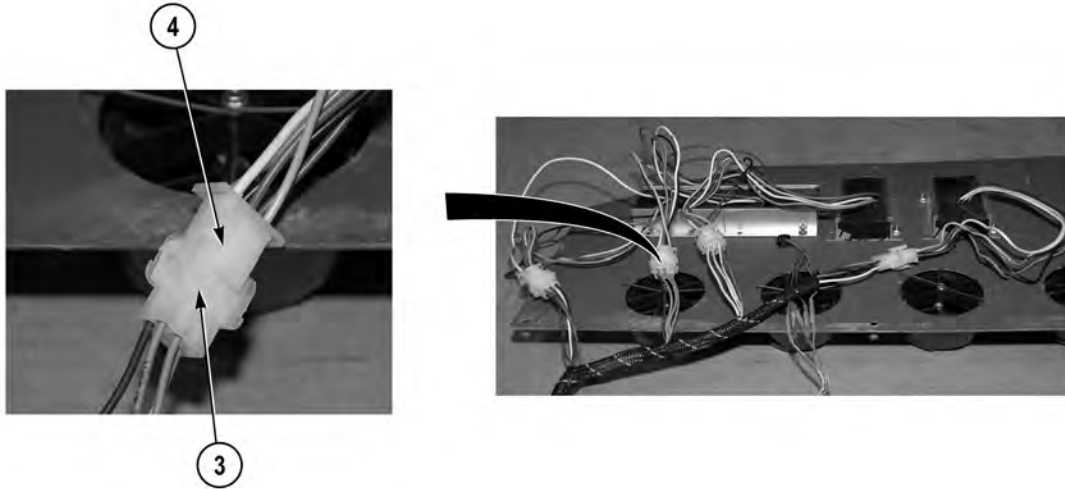
Cab instrument panel assembly  
removed (WP 0204)  
Blackout relays removed (WP 0240)

---

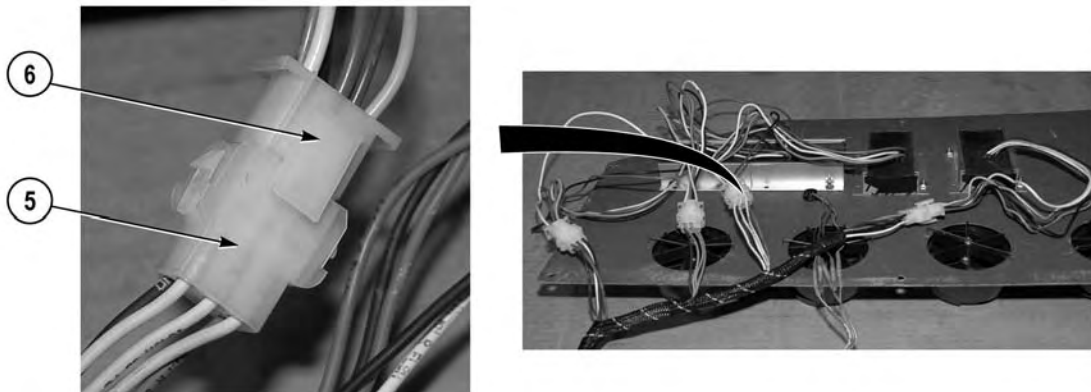
**REMOVAL****NOTE**

- Tag and mark wires prior to removal to ensure proper installation.
- Note routing of cab power distribution wire harness to ensure correct installation.
- Note position and remove cable ties and cushion clips as required.
- Refer to schematic for wire locations.

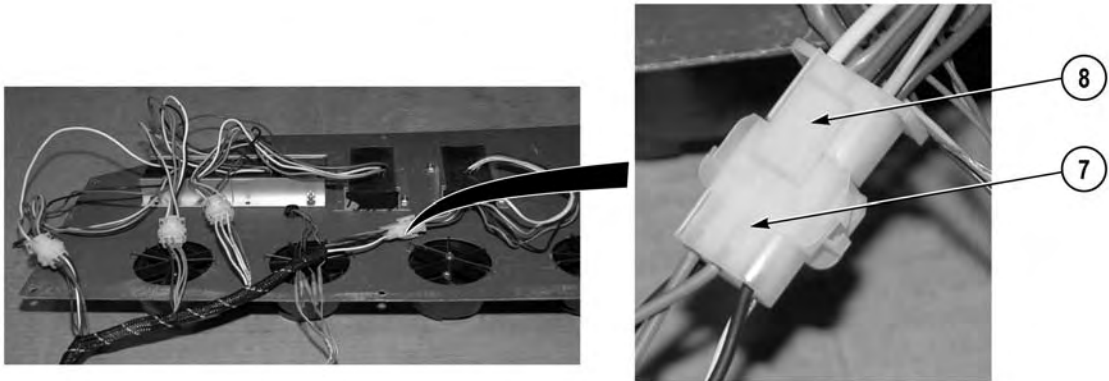
1. Disconnect cab instrument panel wire harness connector (1) from upper rear warning flasher unit (2).



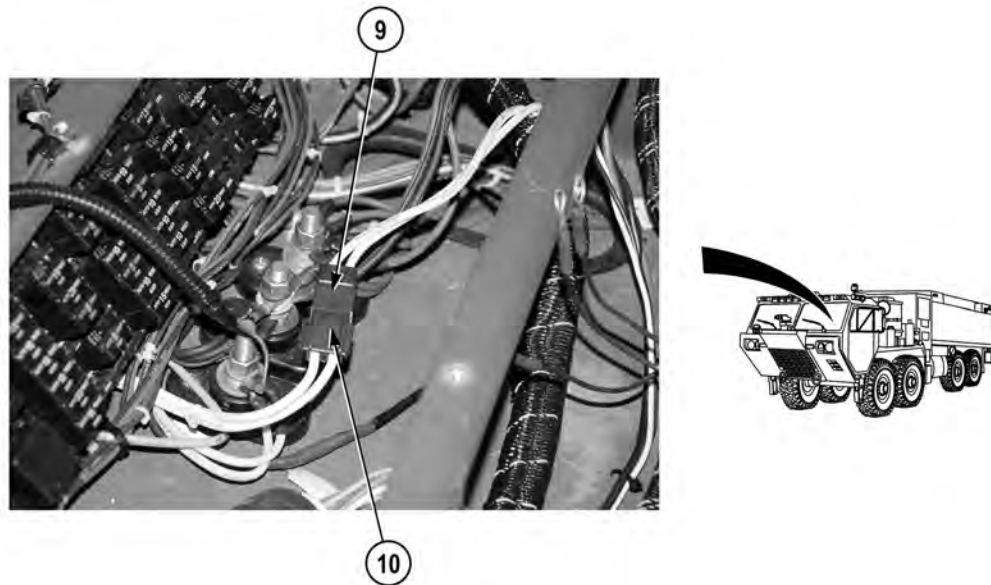
2. Disconnect cab instrument panel wire harness connector (3) from check for open compartment door when light is on flasher unit (4).



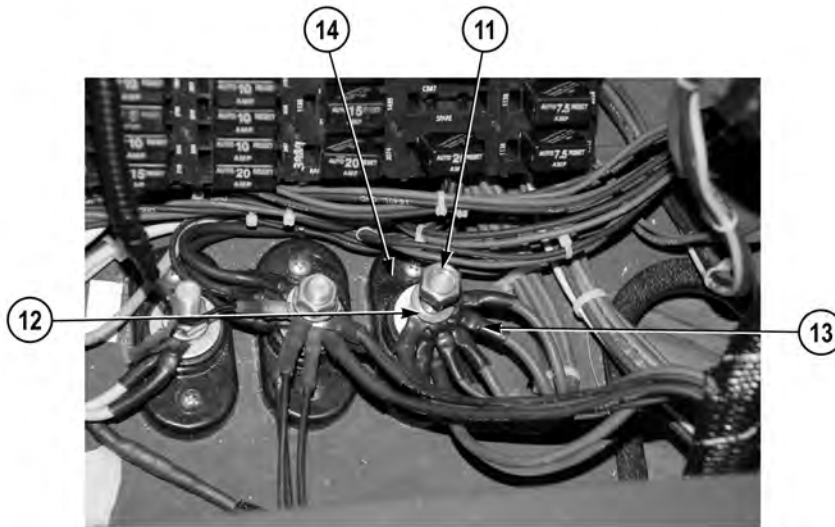
3. Disconnect cab instrument panel wire harness connector (5) from side warning flasher unit (6).



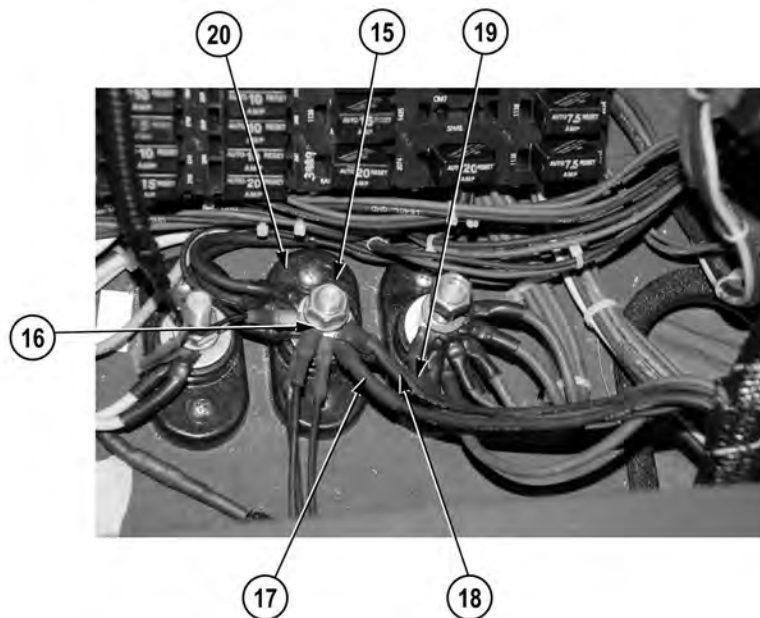
4. Disconnect cab instrument panel wire harness connector (7) from front and rear lower warning flasher unit (8).



5. Disconnect cab instrument panel wire harness connector MP1 (9) from cab power distribution wire harness connector MP1 (10).

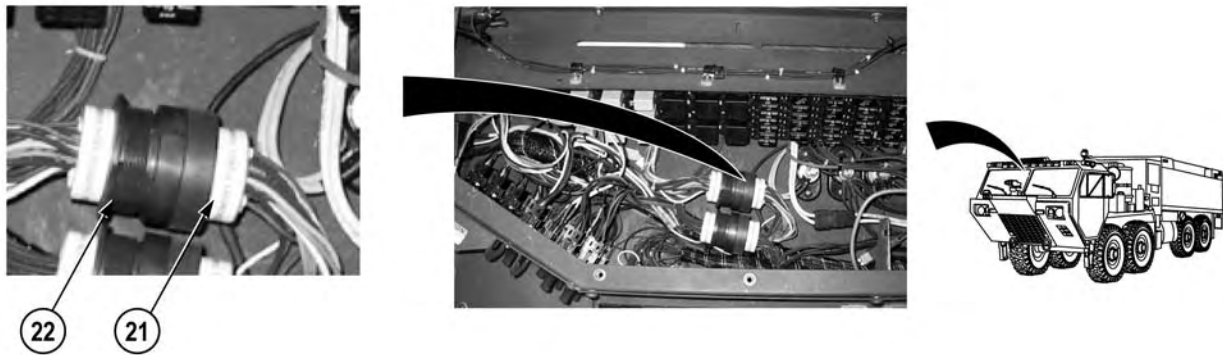


6. Remove nut (11), lockwasher (12), and two wires 1138 (13) from cab 24 VDC terminal block (14). Discard lockwasher.



7. Remove nut (15), lockwasher (16), wire 1640 (17), wire 1027 (18), and wire 2640 (19) from cab ground terminal block (20). Discard lockwasher.





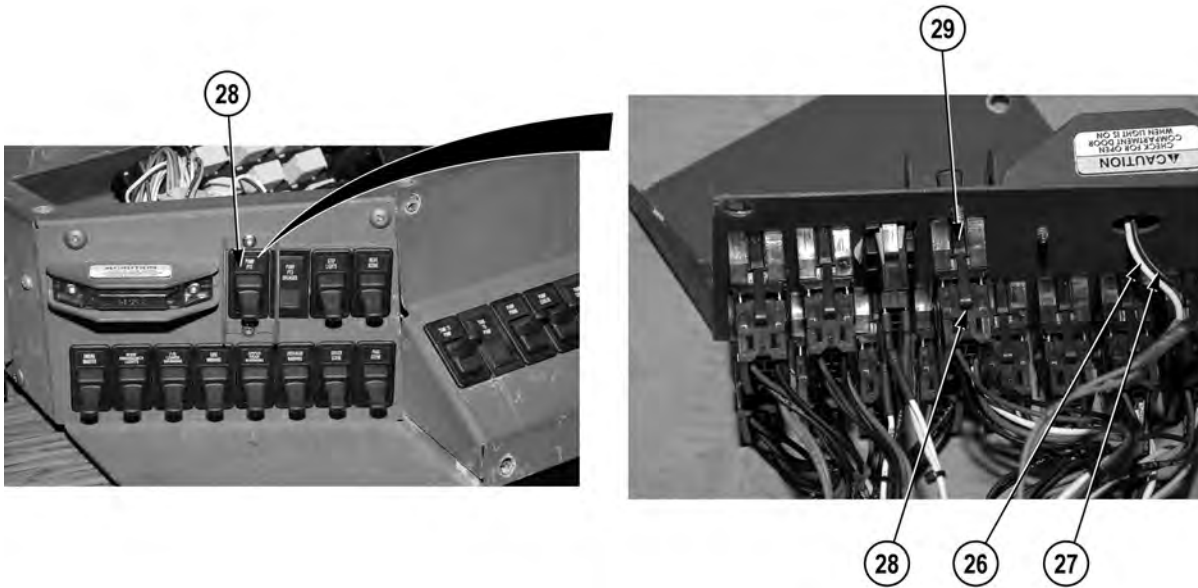
8. Disconnect cab instrument panel wire harness connector (21) from cab power distribution wire harness connector (22).



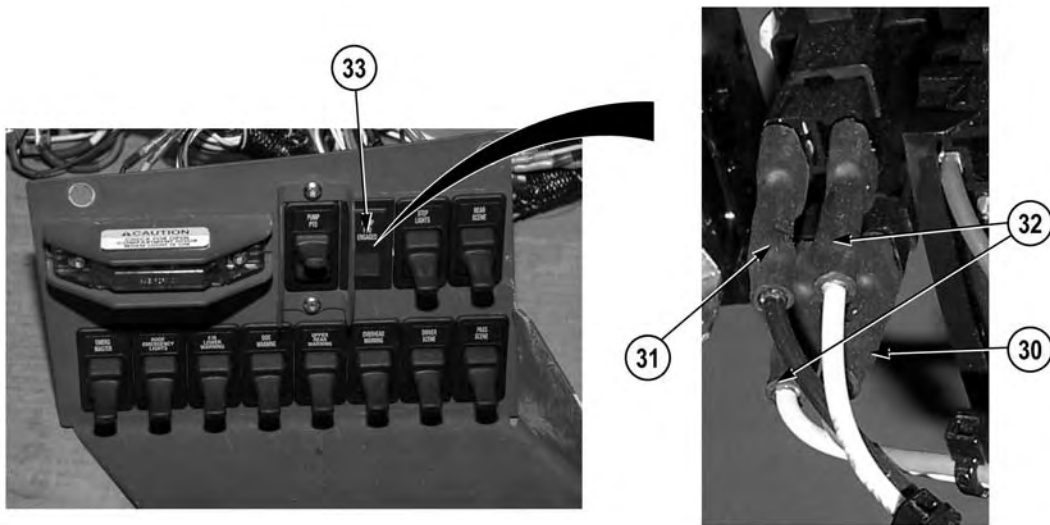
**NOTE**

Cab instrument panels B and C interlock. Lifting cab instrument panel B away from cab instrument panel assembly slightly, allows cab instrument panel C to move freely.

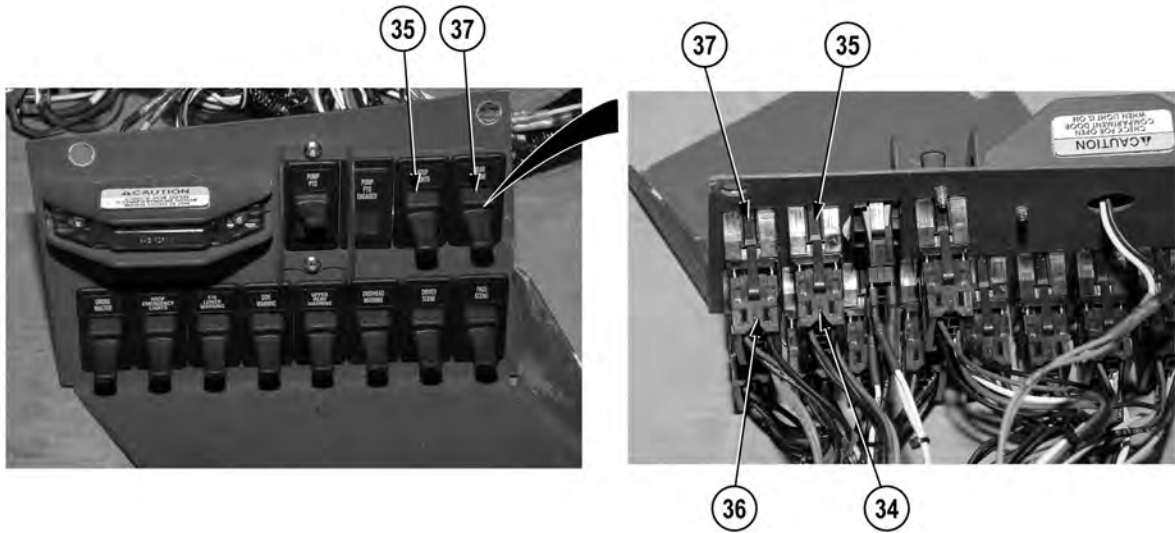
9. Remove two screws (23) and cab instrument panel C (24) from cab instrument panel assembly (25).



10. Cut wire 1187 (26) and wire 1592 (27) (TM 9-2320-325-14&P).
11. Disconnect cab instrument panel wire harness connector (28) from PUMP PTO switch (29).



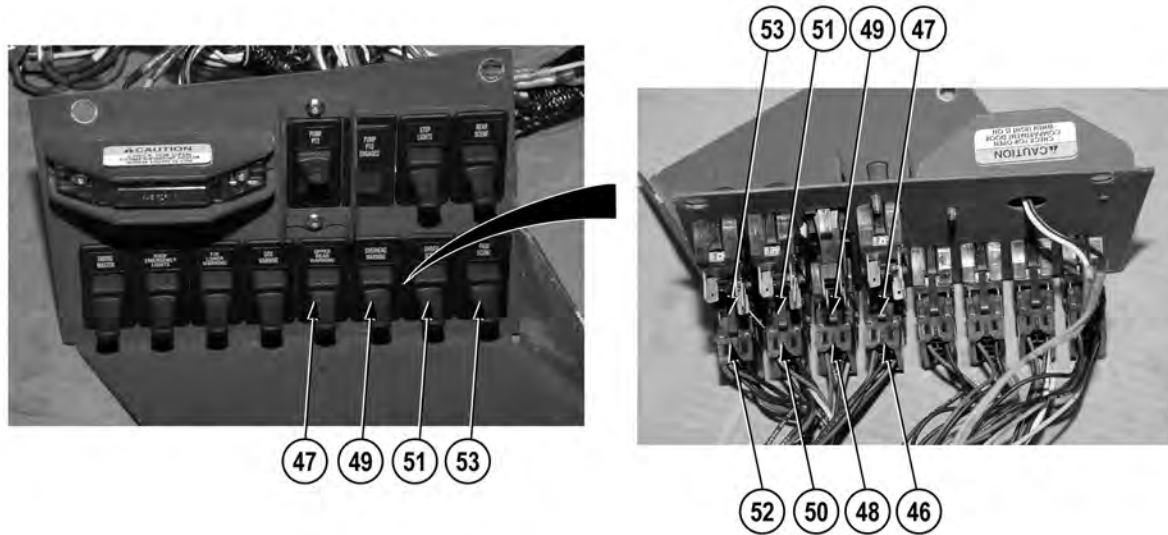
12. Disconnect wire 1677 (30), wire 1640 (31) and jumperwire 2768 (32) from PUMP PTO ENGAGED indicator light (33).



13. Disconnect cab instrument panel wire harness connector (34) from STEP LIGHTS switch (35).
14. Disconnect cab instrument panel wire harness connector (36) from REAR SCENE switch (37).



15. Disconnect cab instrument panel wire harness connector (38) from EMERG MASTER switch (39).
16. Disconnect cab instrument panel wire harness connector (40) from ROOF EMERGENCY LIGHTS switch (41).
17. Disconnect cab instrument panel wire harness connector (42) from F/R LOWER WARNING switch (43).
18. Disconnect cab instrument panel wire harness connector (44) from SIDE WARNING switch (45).



19. Disconnect cab instrument panel wire harness connector (46) from UPPER REAR WARNING switch (47).
20. Disconnect cab instrument panel wire harness connector (48) from OVERHEAD WARNING switch (49).
21. Disconnect cab instrument panel wire harness connector (50) from DRIVER SCENE switch (51).
22. Disconnect cab instrument panel wire harness connector (52) from PASS SCENE switch (53).

#### END OF TASK

#### INSTALLATION

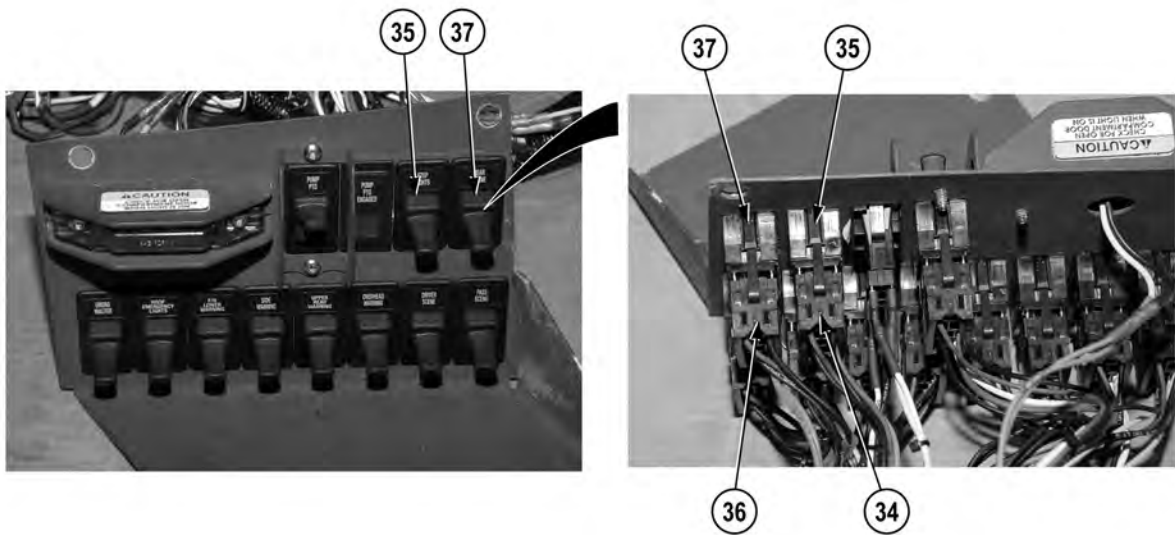
#### NOTE

Install cable ties and cushion clips as required.

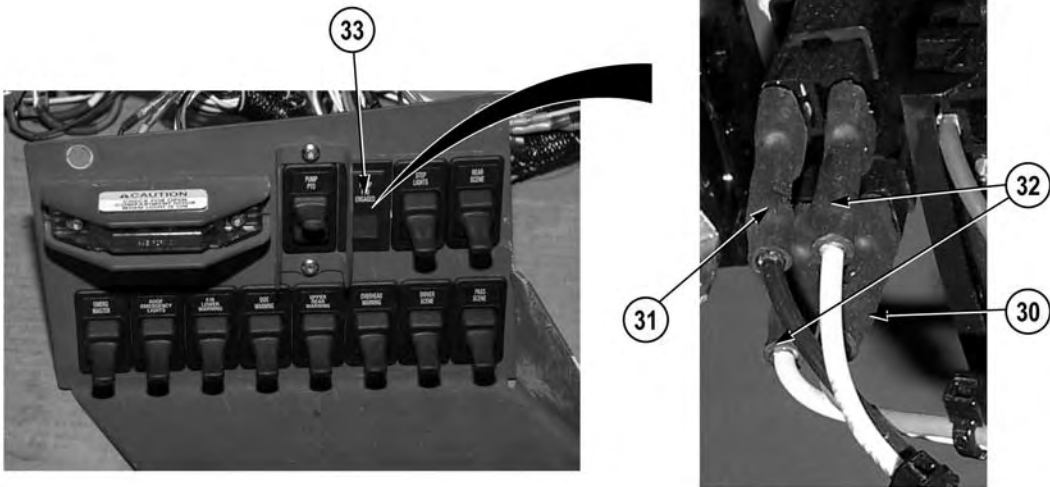
1. Connect cab instrument panel wire harness connector (52) on PASS SCENE switch (53).
2. Connect cab instrument panel wire harness connector (50) on DRIVER SCENE switch (51).
3. Connect cab instrument panel wire harness connector (48) on OVERHEAD WARNING switch (49).
4. Connect cab instrument panel wire harness connector (46) on UPPER REAR WARNING switch (47).



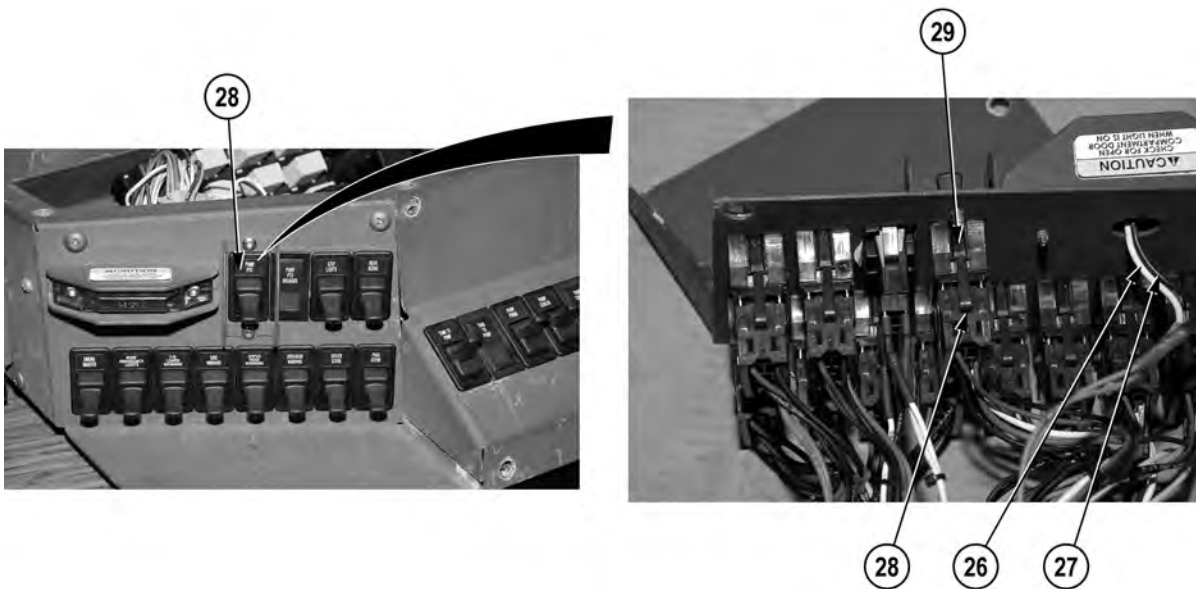
5. Connect cab instrument panel wire harness connector (44) on SIDE WARNING switch (45).
6. Connect cab instrument panel wire harness connector (42) on F/R LOWER WARNING switch (43).
7. Connect cab instrument panel wire harness connector (40) on ROOF EMERGENCY LIGHTS switch (41).
8. Connect cab instrument panel wire harness connector (38) on EMERG MASTER switch (39).



9. Connect cab instrument panel wire harness connector (36) on REAR SCENE switch (37).
10. Connect cab instrument panel wire harness connector (34) on STEP LIGHTS switch (35).



11. Connect wire 1677 (30), wire 1640 (31) and jumperwire 2768 (32) on PUMP PTO ENGAGED indicator light (33).



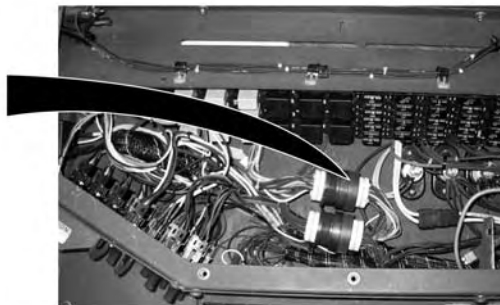
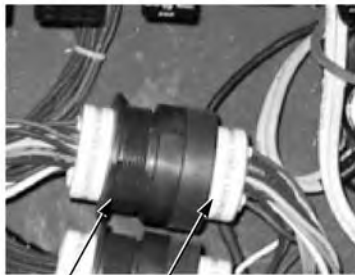
12. Connect cab instrument panel wire harness connector (28) on PUMP PTO switch (29).
13. Repair wire 1187 (26) and wire 1592 (27) (TM 9-2320-325-14&P).



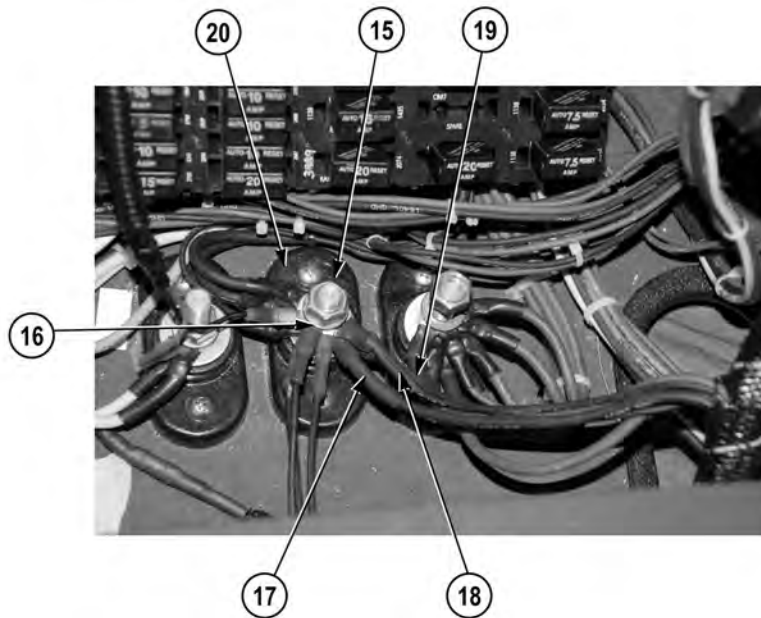
**NOTE**

Cab instrument panels B and C interlock.

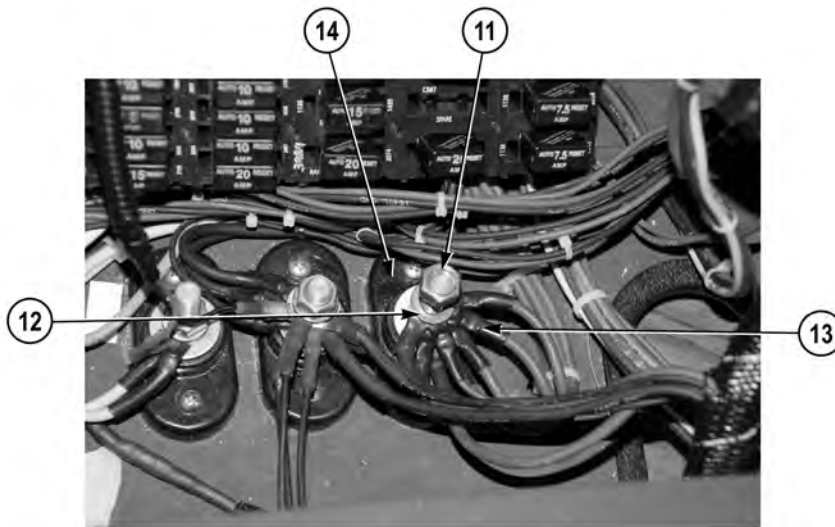
14. Install cab instrument panel C (24) on cab instrument panel assembly (25) with two screws (23).



15. Connect cab instrument panel wire harness connector (21) on cab power distribution wire harness connector (22).

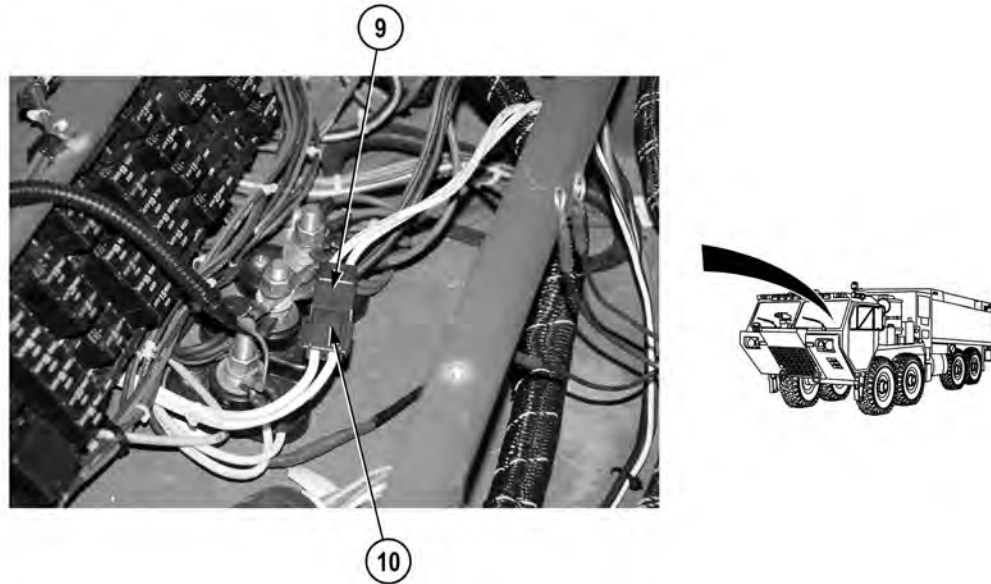


16. Install wire 1640 (17), wire 1027 (18), and wire 2640 (19) on cab ground terminal block (20) with lockwasher (16) and nut (15).

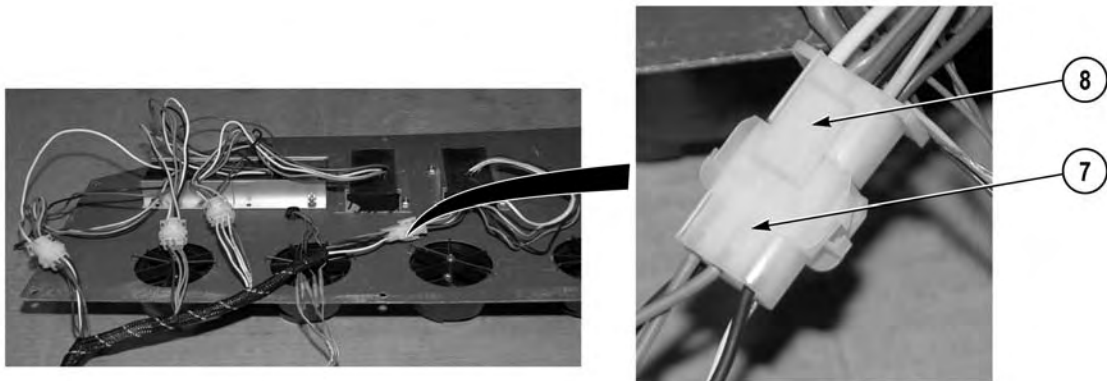


17. Install two wires 1138 (13) on cab 24 VDC terminal block (14) with lockwasher (12) and nut (11).

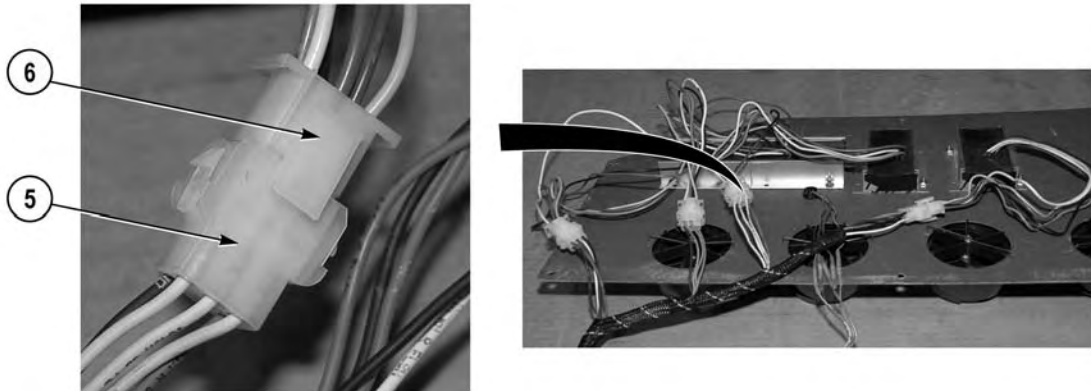




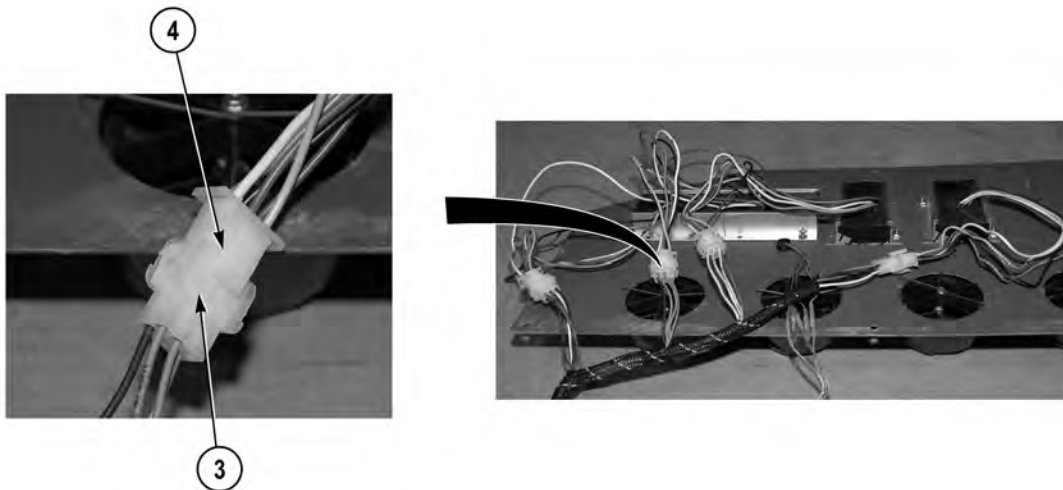
18. Connect cab instrument panel wire harness connector MP1 (9) on cab power distribution wire harness connector MP1 (10).



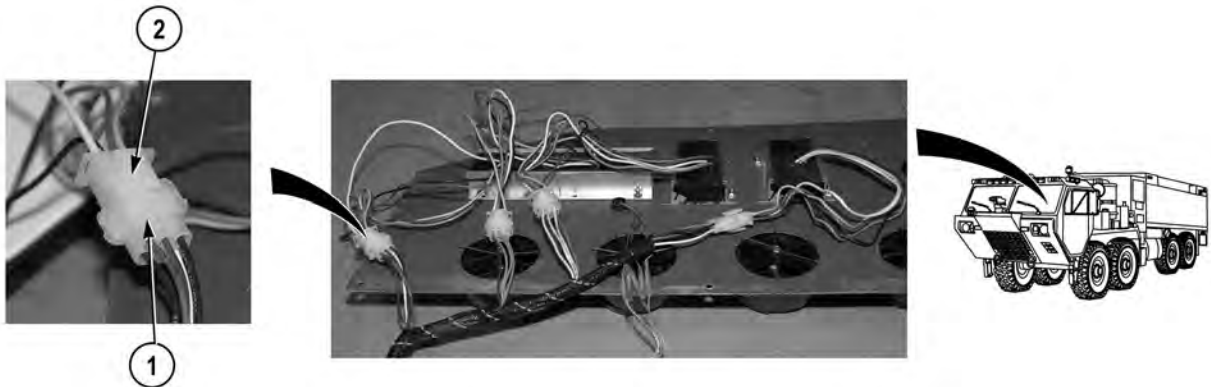
19. Connect cab instrument panel wire harness connector (7) on front and rear lower warning flasher unit (8).



20. Connect cab instrument panel wire harness connector (5) on side warning flasher unit (6).



21. Connect cab instrument panel wire harness connector (3) on check for open compartment door when light is on flasher unit (4).



22. Connect cab instrument panel wire harness connector (1) on upper rear warning flasher unit (2).

**END OF TASK**

**FOLLOW-ON MAINTENANCE**

1. Install blackout relays (WP 0240)
2. Install cab instrument panel assembly (WP 0204)

**END OF WORK PACKAGE**



## FIELD LEVEL MAINTENANCE

## CAB POWER DISTRIBUTION WIRE HARNESS AND BLOCK REPLACEMENT

## INITIAL SETUP:

**Tools and Special Tools**

Tool Kit, General Mechanic's: Automotive  
(WP 0398, Item 17)

**References**

TM 9-2320-325-14&P  
WP 0391, Fig. 50

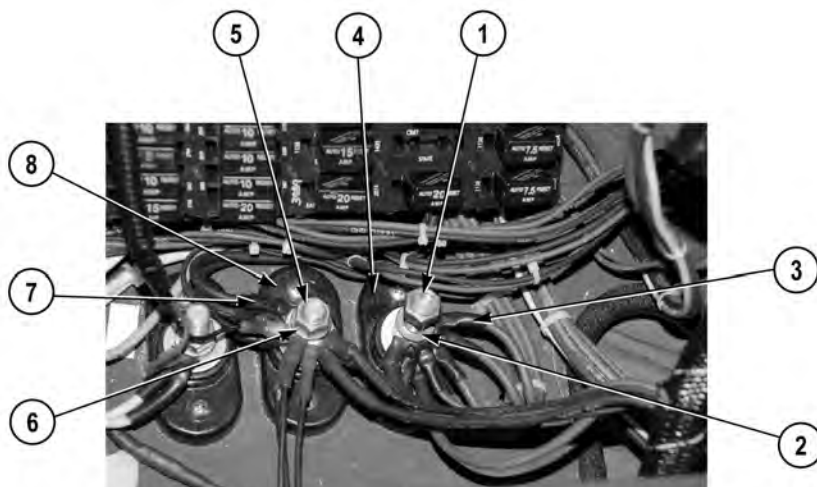
**Materials/Parts**

Tags, Identification (WP 0400, Item 23)  
Ties, Cable, Plastic (WP 0400, Item 26)  
Lockwasher (1)  
Lockwasher (1)  
Lockwasher (1)  
Locknut (3)

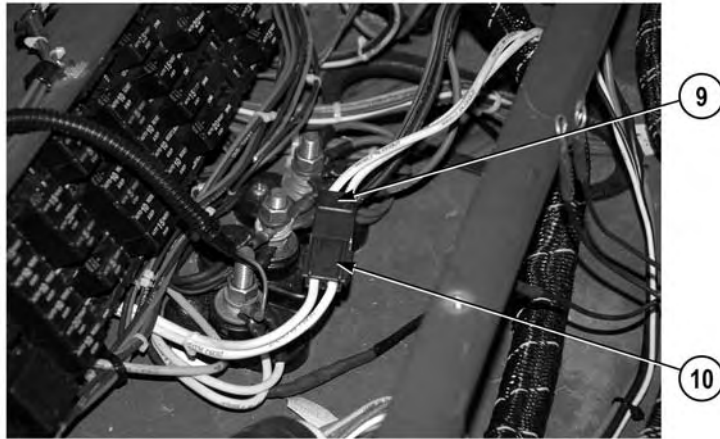
**Equipment Conditions**

Cab instrument panel assembly  
removed (WP 0204)  
Cab power distribution block circuit breakers  
removed (WP 0242)  
Cab power distribution block diode  
removed (WP 0243)  
Cab power distribution block relays  
removed (WP 0244)

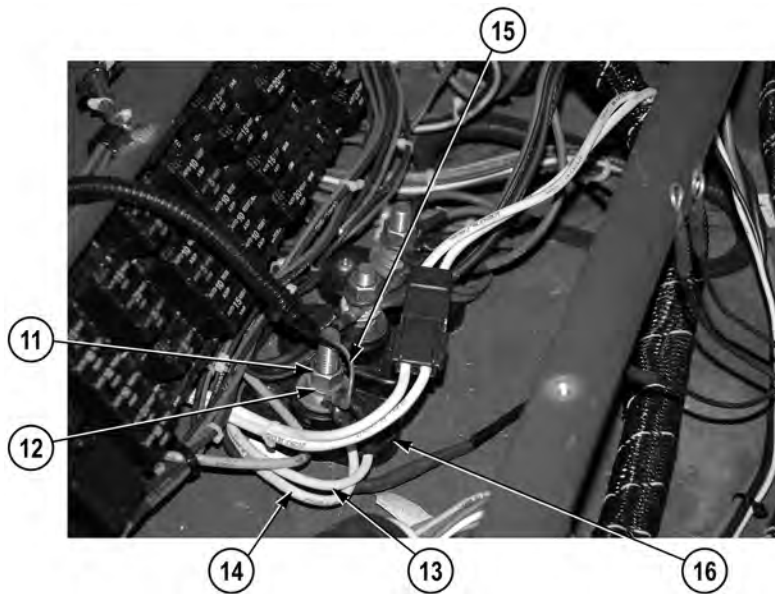
## REMOVAL

**NOTE**

- Tag and mark wires prior to removal to ensure proper installation.
  - Note routing of cab power distribution wire harness prior to removal to ensure proper installation.
  - Note position and remove cable ties, split loom, and cushion clips as required.
1. Remove nut (1), lockwasher (2), and seven wires 1138 (3) from cab 24 VDC terminal block (4). Discard lockwasher.
  2. Remove nut (5), lockwasher (6), and five wires 1640 (7) from cab ground terminal block (8). Discard lockwasher.



3. Disconnect cab instrument panel wire harness connector MP1 (9) from cab power distribution wire harness connector MP1 (10).



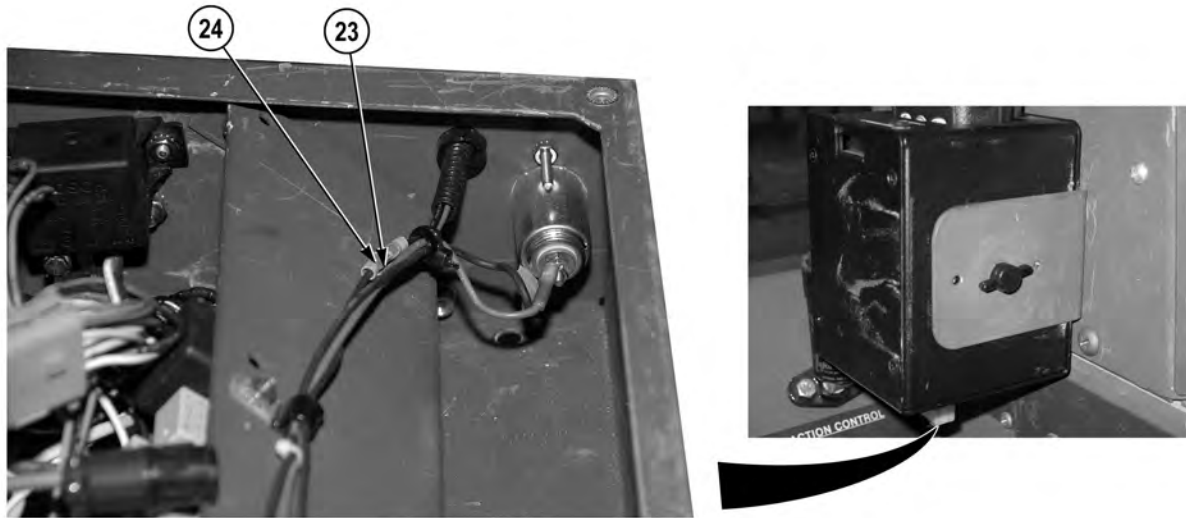
4. Remove nut (11), lockwasher (12), wire 3989 (13), wire 3990 (14), and wire 2138 (15), from cab 12 VDC terminal block (16). Discard lockwasher.



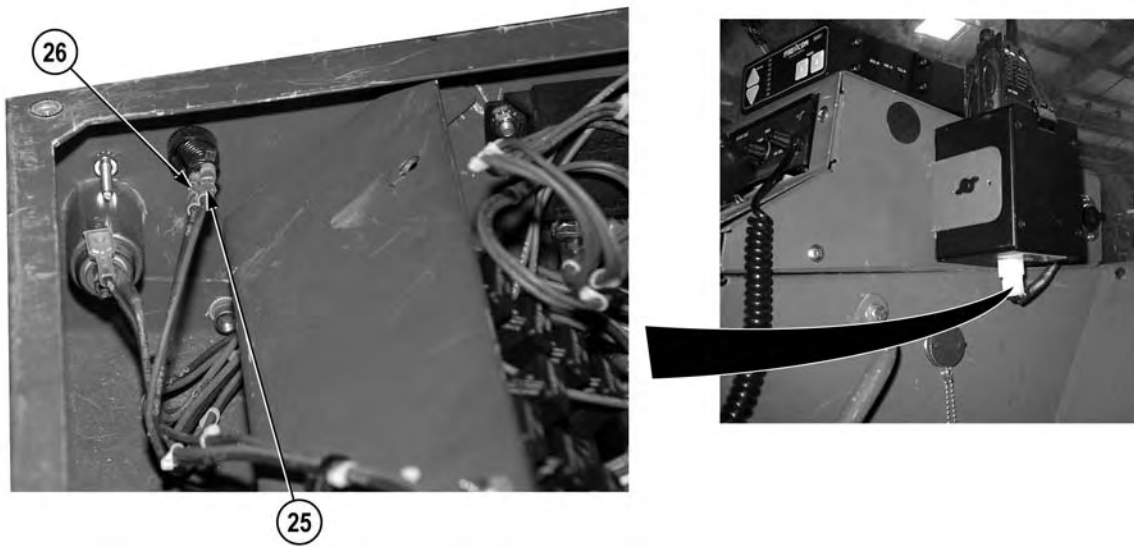
5. Disconnect wire 2074 (17) and wire 1640 (18) from driver side 12 VDC auxiliary outlet (19).



6. Disconnect wire 2074 (20) and wire 1640 (21) from passenger side 12 VDC auxiliary outlet (22).

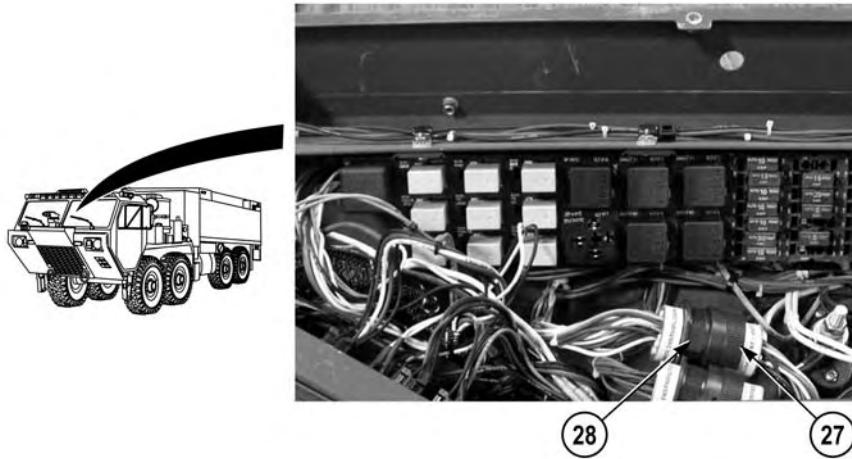


7. Cut wire 2074 (23) and wire 1640 (24) (TM 9-2320-325-14&P).



8. Cut wire 2074 (25) and wire 1640 (26) (TM 9-2320-325-14&P).

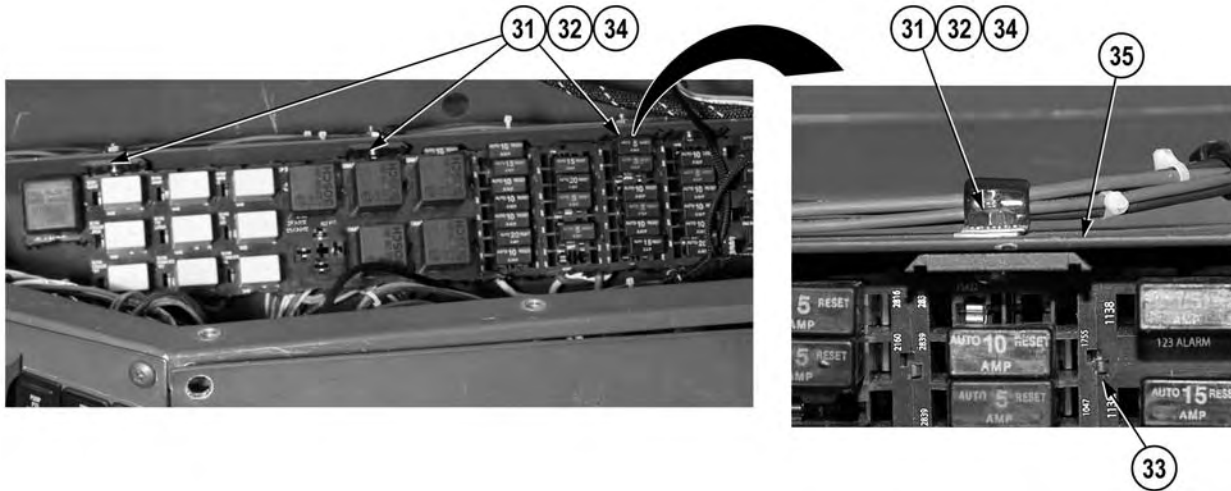




9. Disconnect cab instrument panel wire harness connector (27) from cab power distribution wire harness connector (28).



10. Disconnect cab pump control wire harness connector (29) from cab power distribution wire harness connector (30).



11. Remove three locknuts (31), cushion clips (32), cab power distribution wire harness block (33), and three screws (34) from cab instrument panel assembly (35). Discard locknuts.

#### END OF TASK

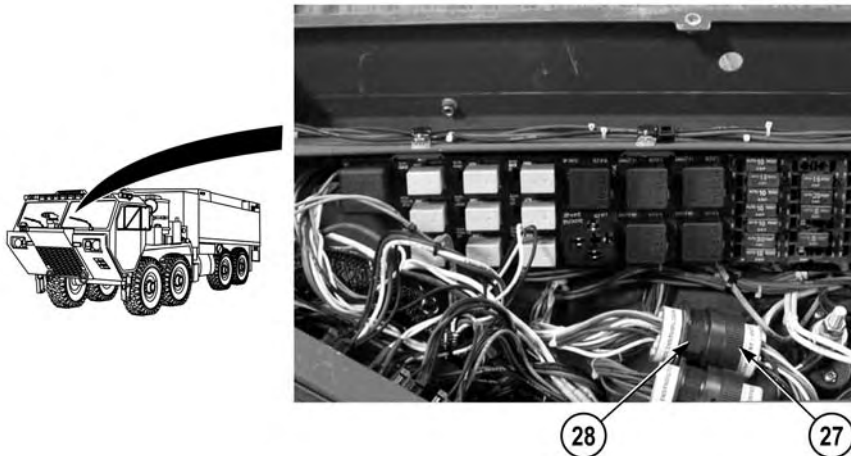
#### INSTALLATION

#### NOTE

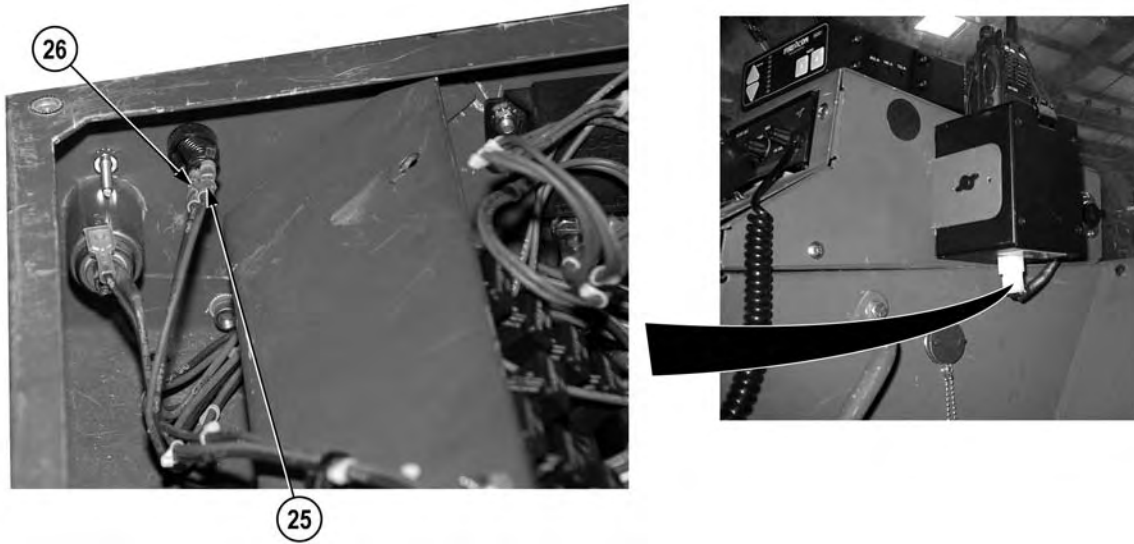
- Route cab power distribution wire harness as noted prior to removal.
  - Install cable ties, split loom, and cushion clips as required.
1. Install cab power distribution wire harness block (33), on cab instrument panel assembly (35) with three screws (34), cushion clips (32), and locknuts (31).



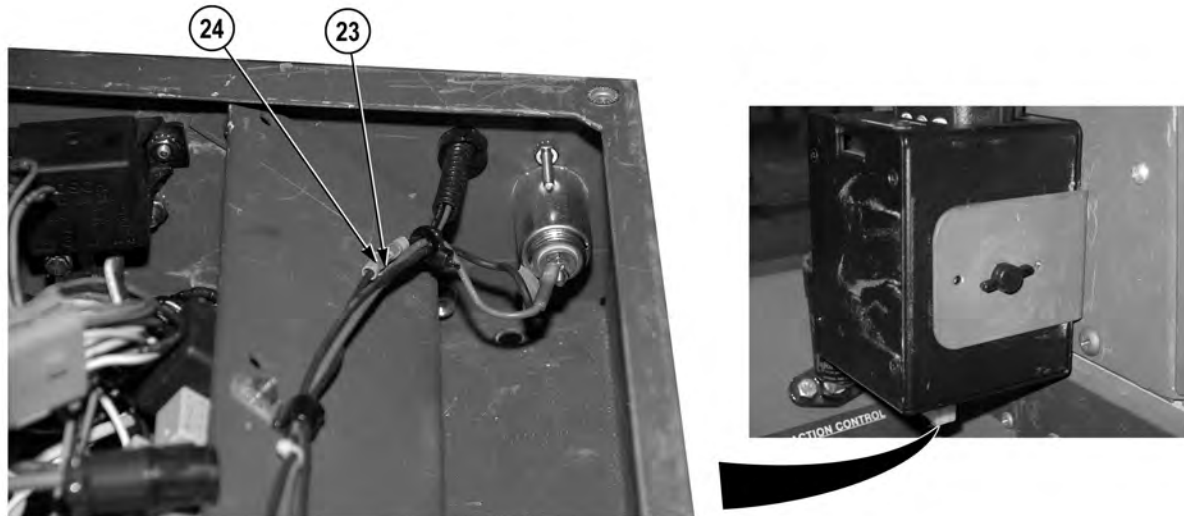
2. Connect cab pump control wire harness connector (29) on cab power distribution wire harness connector (30).



3. Connect cab instrument panel wire harness connector (27) on cab power distribution wire harness connector (28).



4. Repair wire 2074 (25) and wire 1640 (26) (TM 9-2320-325-14&P)



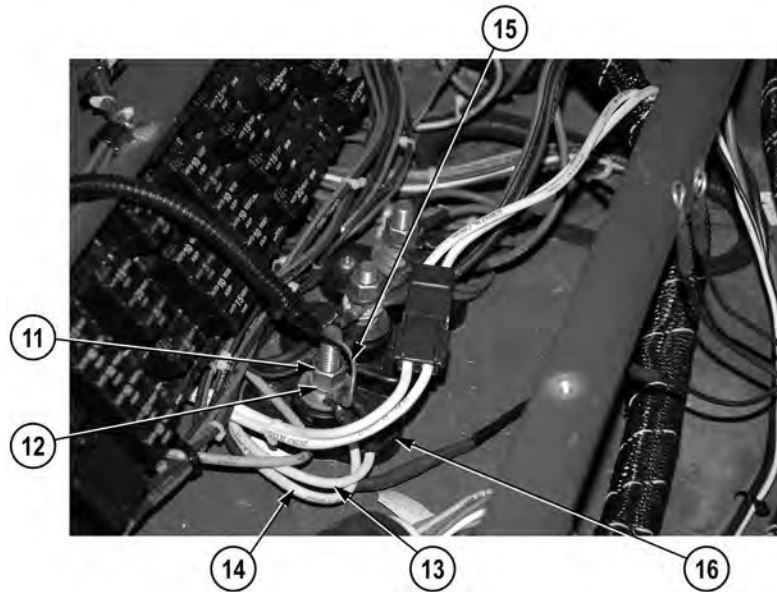
5. Repair wire 2074 (23) and wire 1640 (24) (TM 9-2320-325-14&P)



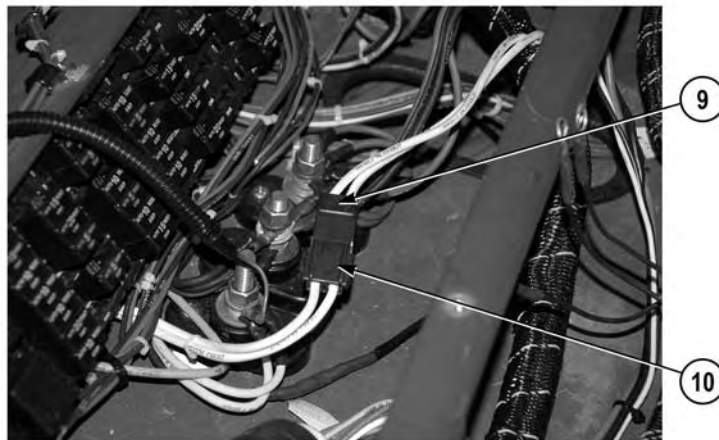
6. Connect wire 2074 (20) and wire 1640 (21) on passenger side 12 VDC auxiliary outlet (22).



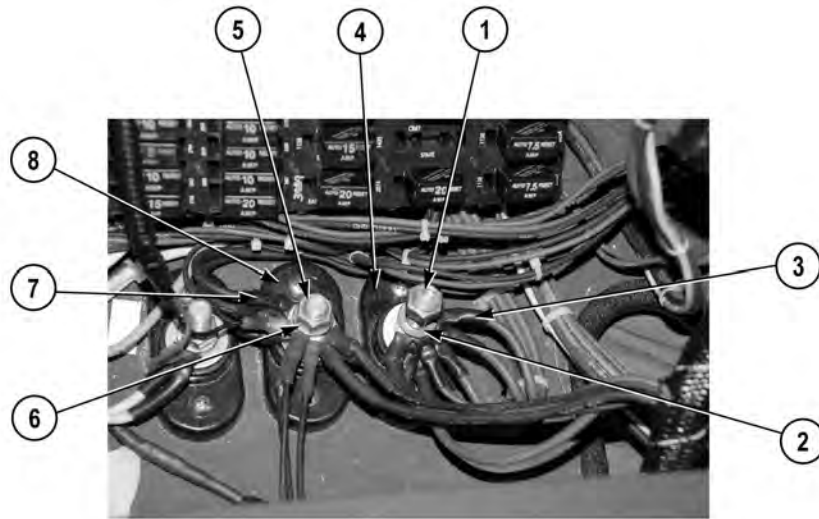
7. Connect wire 2074 (17) and wire 1640 (18) on driver side 12 VDC auxiliary outlet (19).



8. Install wire 3989 (13), wire 3990 (14), and wire 2138 (15) on cab 12 VDC terminal block (16) with lockwasher (12) and nut (11).



9. Connect cab instrument panel wire harness connector MP1 (9) on cab power distribution wire harness connector MP1 (10).



10. Install five wires 1640 (7) on cab ground terminal block (8) with lockwasher (6) and nut (5).
11. Install seven wires 1138 (3) on cab 24 VDC terminal block (4) with lockwasher (2) and nut (1).

#### **END OF TASK**

#### **FOLLOW-ON MAINTENANCE**

1. Install cab power distribution block relays (WP 0244)
2. Install cab power distribution block diode (WP 0243)
3. Install cab power distribution block circuit breakers (WP 0242)
4. Install cab instrument panel assembly (WP 0204)

#### **END OF TASK**

#### **END OF WORK PACKAGE**





## FIELD LEVEL MAINTENANCE

## CAB PUMP CONTROL WIRE HARNESS REPLACEMENT

## INITIAL SETUP:

**Tools and Special Tools**

Tool Kit, General Mechanic's: Automotive  
(WP 0398, Item 17)

**References**

WP 0391, Fig. 57

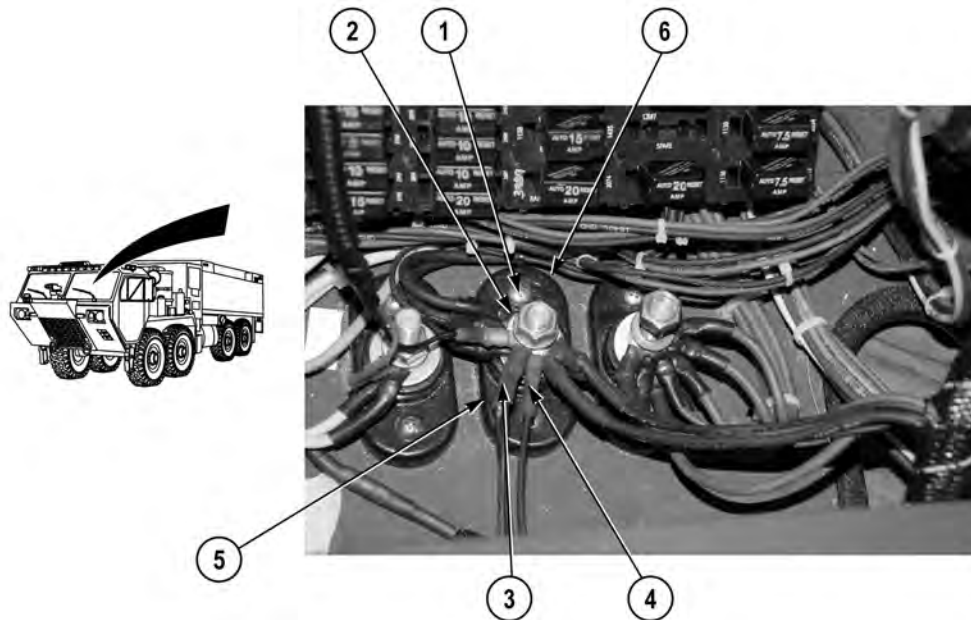
**Materials/Parts**

Tags, Identification (WP 0400, Item 23)  
Ties, Cable, Plastic (WP 0400, Item 26)  
Lockwasher (1)

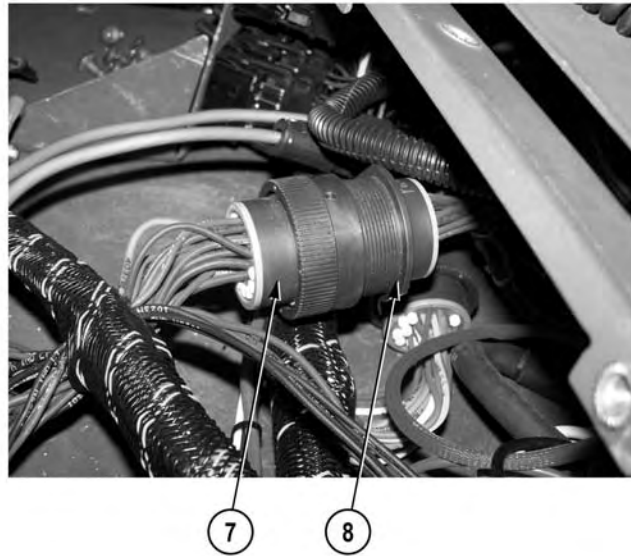
**Equipment Conditions**

Cab instrument panel assembly removed  
(WP 0204)

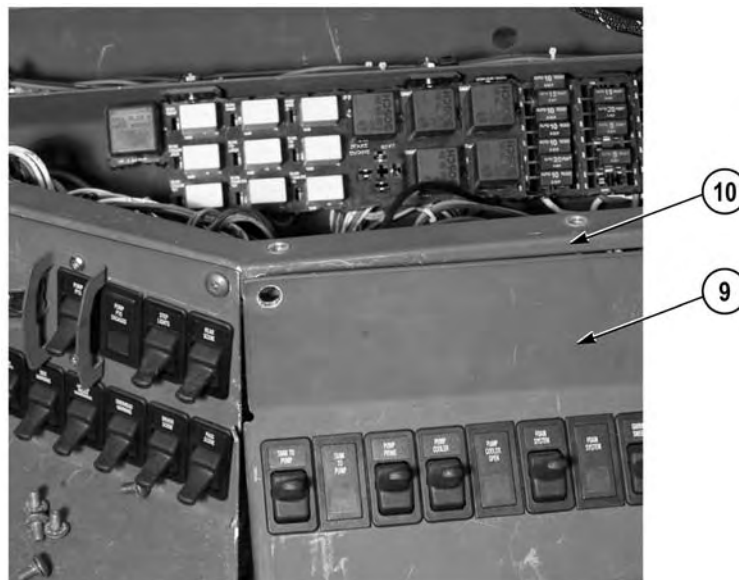
## REMOVAL

**NOTE**

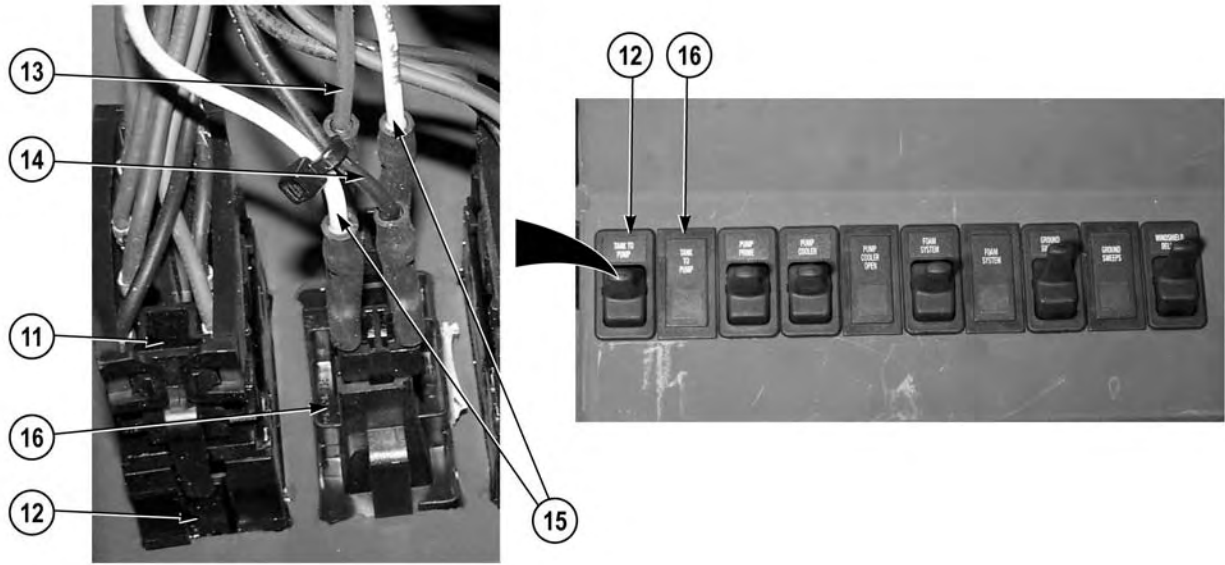
- Tag and mark wires prior to removal to ensure proper installation.
  - Note routing of cab pump control wire harness prior to removal to ensure proper installation.
  - Note position and remove cable ties, split loom, and cushion clips as required.
1. Remove nut (1), lockwasher (2), wire 1027 (3), wire 1640 (4), and wire 1023 (5) from cab ground terminal block (6). Discard lockwasher.



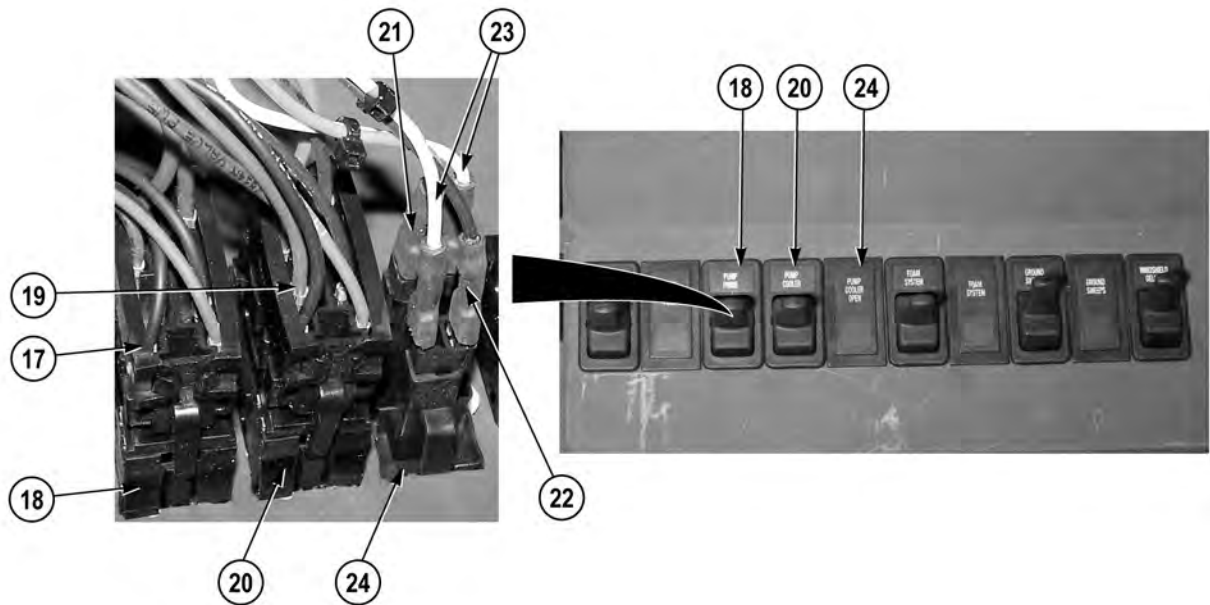
2. Disconnect cab pump control wire harness connector (7) from cab power distribution wire harness connector (8).



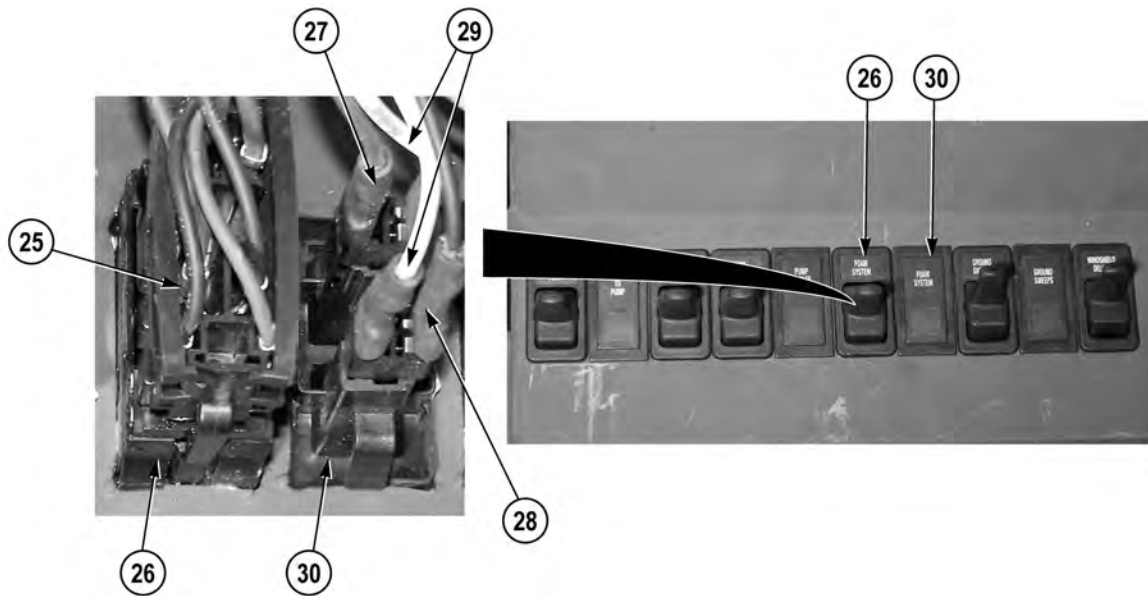
3. Remove cab instrument panel B (9) from cab instrument panel assembly (10).



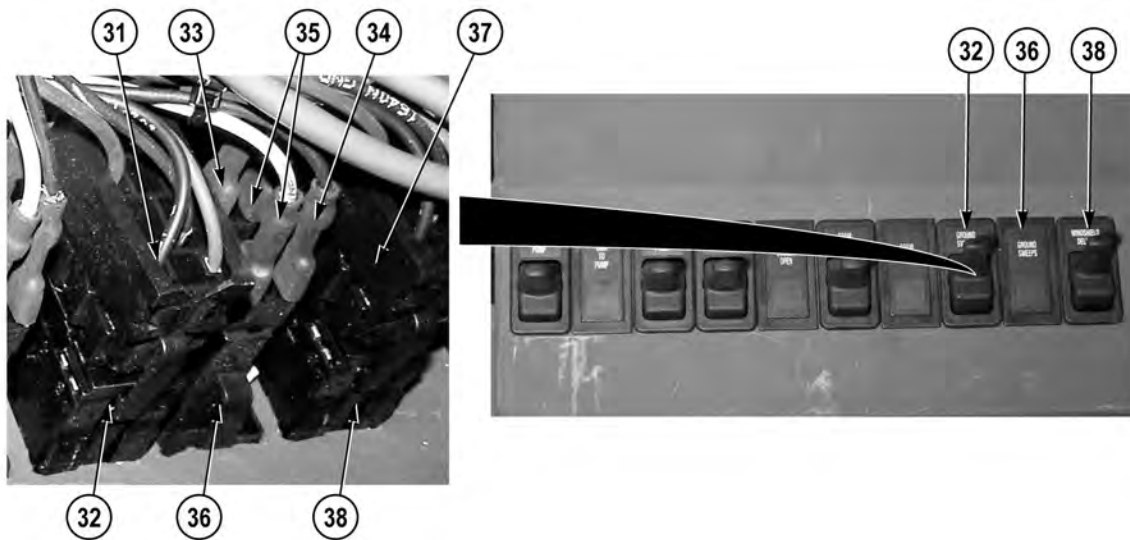
4. Disconnect cab pump control wire harness connector (11) from TANK TO PUMP switch (12).
5. Disconnect wire 2855 (13), wire 1023 (14), and jumperwire 2768 (15) from TANK TO PUMP indicator light (16).



6. Disconnect cab pump control wire harness connector (17) from PUMP PRIMER switch (18).
7. Disconnect cab pump control wire harness connector (19) from PUMP COOLER switch (20).
8. Disconnect wire 4037 (21), wire 1023 (22), and jumperwire 2768 (23) from PUMP COOLER OPEN indicator light (24).



9. Disconnect cab pump control wire harness connector (25) from FOAM SYSTEM switch (26).
10. Disconnect wire 2830 (27), wire 1023 (28), and jumperwire 2768 (29) from FOAM SYSTEM indicator light (30).



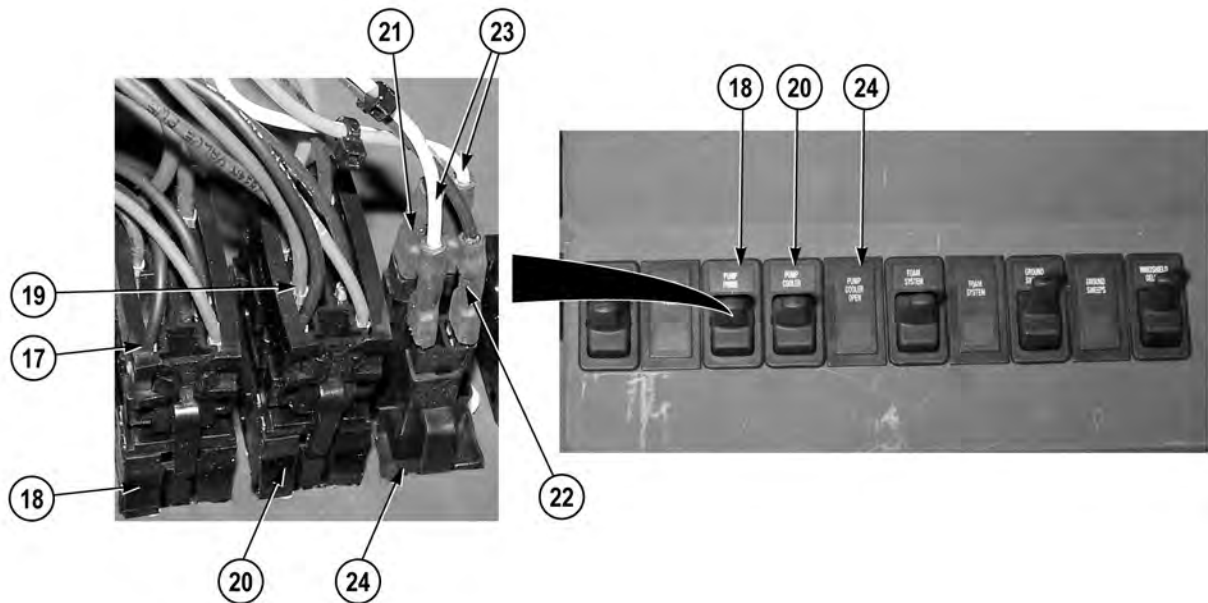
11. Disconnect cab pump control wire harness connector (31) from UNDER TRUCK NOZZLES switch (32).
12. Disconnect wire 2772 (33), wire 1023 (34), and jumperwire 2768 (35) from UNDER TRUCK NOZZLES indicator light (36).
13. Disconnect cab pump control wire harness connector (37) from WINDSHIELD DELUGE switch (38).

**END OF TASK**

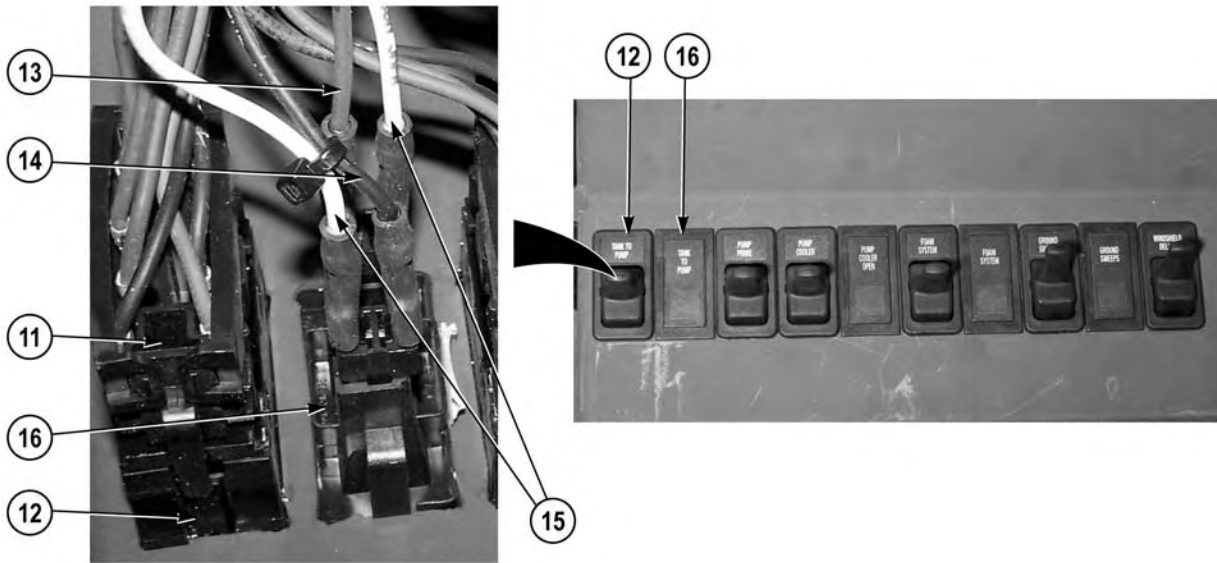
## INSTALLATION

### NOTE

- Route cab pump control wire harness as noted prior to removal.
  - Install cable ties, split loom, and cushion clips as required.
1. Connect cab pump control wire harness connector (37) on WINDSHIELD DELUGE switch (38).
  2. Connect wire 2772 (33), wire 1023 (34), and jumperwire 2768 (35) on UNDER TRUCK NOZZLES indicator light (36).
  3. Connect cab pump control wire harness connector (31) on UNDER TRUCK NOZZLES switch (32).
  4. Connect wire 2830 (27), wire 1023 (28), and jumperwire 2768 (29) on FOAM SYSTEM indicator light (30).
  5. Connect cab pump control wire harness connector (25) on FOAM SYSTEM switch (26).



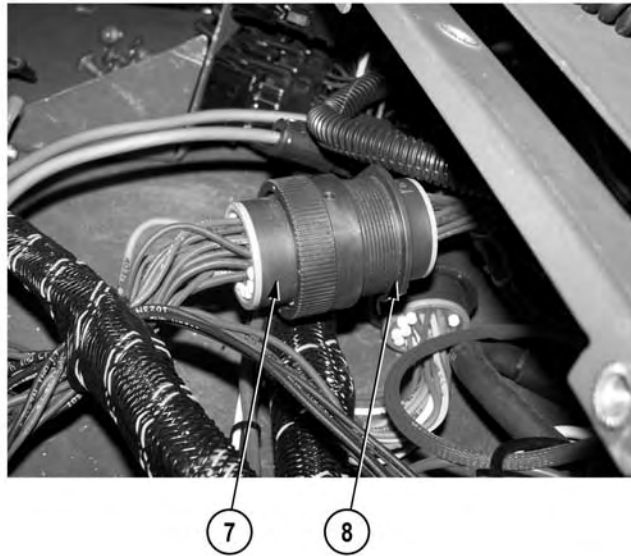
6. Connect wire 4037 (21), wire 1023 (22), and jumperwire 2768 (23) on PUMP COOLER OPEN indicator light (24).
7. Connect cab pump control wire harness connector (19) on PUMP COOLER switch (20).
8. Connect cab pump control wire harness connector (17) on PUMP PRIMER switch (18).



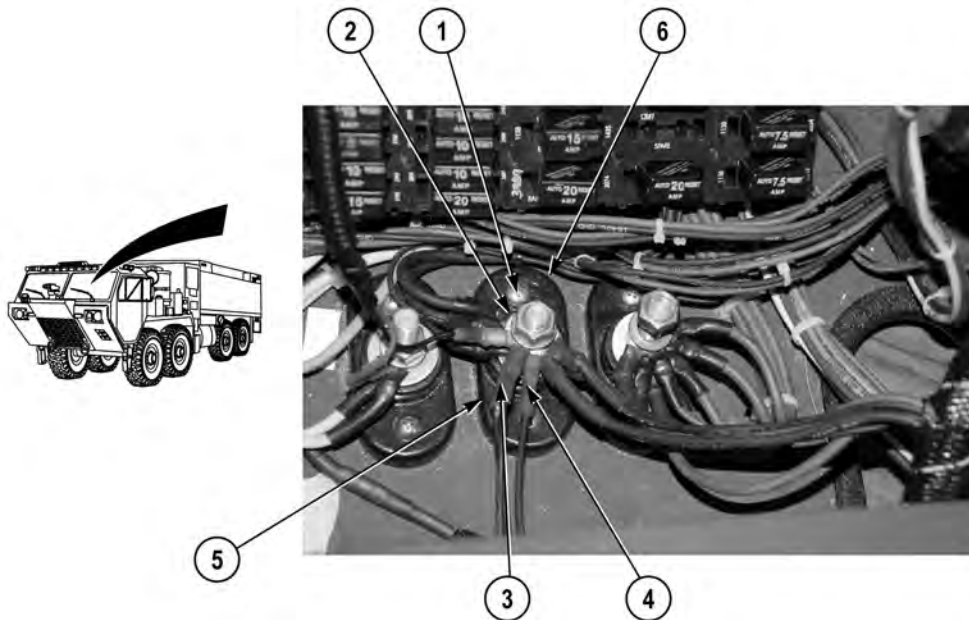
9. Connect wire 2855 (13), wire 1023 (14), and jumperwire 2768 (15) on TANK TO PUMP indicator light (16).
10. Connect cab pump control wire harness connector (11) on TANK TO PUMP switch (12).



11. Install cab instrument panel B (9) on cab instrument panel assembly (10).



12. Connect cab pump control wire harness connector (7) on cab power distribution wire harness connector (8).



 **CAUTION**

**Do not over tighten nut when installing cab ground terminal block. Failure to comply may result in damage to equipment.**

13. Install wire 1027 (3), wire 1640 (4), and wire 1023 (5) on cab ground terminal block (6) with lockwasher (2) and nut (1).

**END OF TASK**

**FOLLOW-ON MAINTENANCE**

Install cab instrument panel assembly (WP 0204)

**END OF TASK**

**END OF WORK PACKAGE**



---

**FIELD LEVEL MAINTENANCE**  
**CAB ROOF WIRE HARNESS REPLACEMENT**

---

**INITIAL SETUP:****Tools and Special Tools**

Tool Kit, General Mechanic's: Automotive  
(WP 0398, Item 17)

**References**

TM 9-2320-325-14&P  
WP 0391, Fig. 58

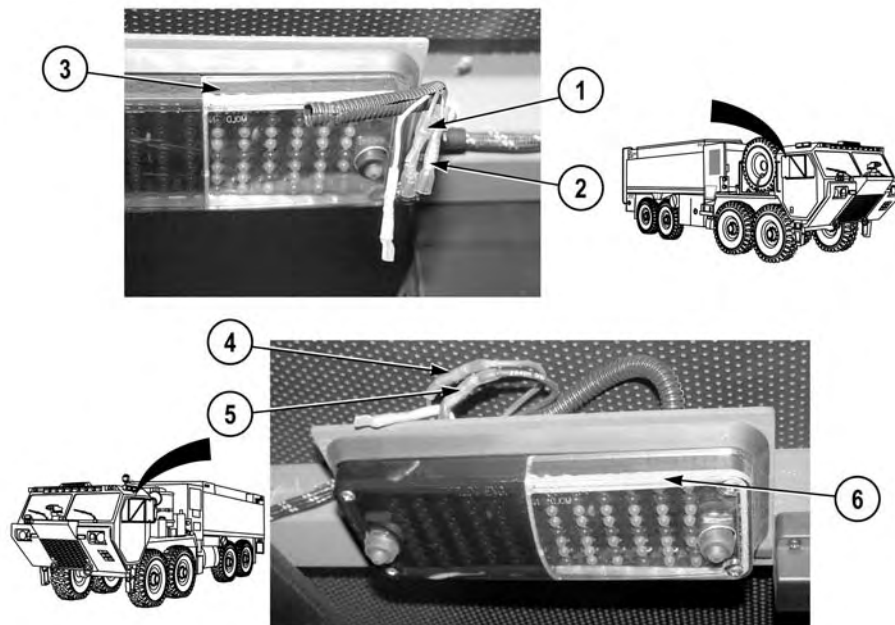
**Materials/Parts**

Adhesive, RTV (WP 0400, Item 2)  
Tags, Identification (WP 0400, Item 23)  
Ties, Cable, Plastic (WP 0400, Item 26)  
Locknut (2)

**Equipment Conditions**

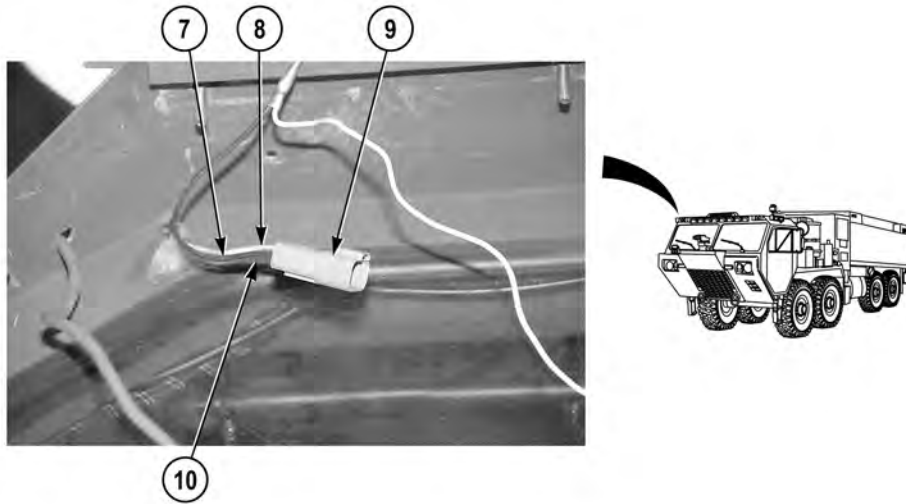
Cab instrument panel assembly removed  
(WP 0204)  
Passenger side cab clearance light and bracket  
removed (WP 0223)

---

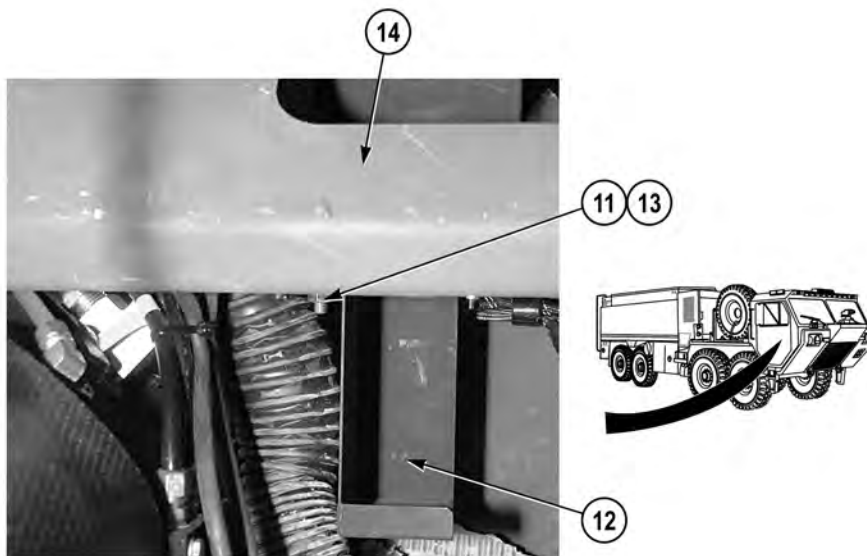
**REMOVAL****NOTE**

- Tag and mark wires prior to removal to ensure proper installation.
- Note routing of cab wire harness prior to removal to ensure proper installation.
- Note position and remove cable ties, split loom, and cushion clips as required.

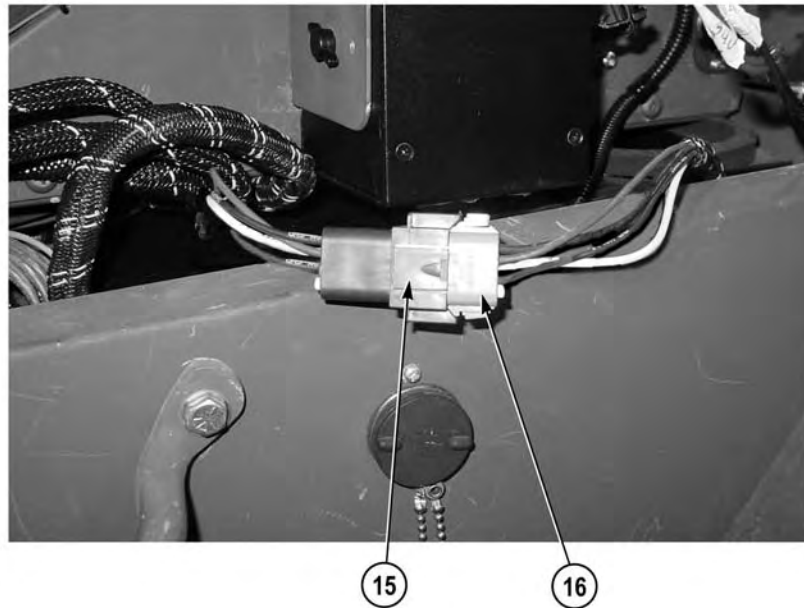
1. Cut wire 1047 (1) and wire 2640 (2) from passenger side dome light (3) (TM 9-2320-325-14&P)
2. Cut wire 1047 (4) and wire 2640 (5) from driver side dome light (6) (TM 9-2320-325-14&P)



3. Cut cab roof wire harness (7) wire 1626 (8) from cab roof lightbar cable assembly connector (9) (TM 9-2320-325-14&P)
4. Cut cab roof wire harness (7) wire 1640 (10) from cab roof lightbar cable assembly connector (9) (TM 9-2320-325-14&P)



5. Remove two locknuts (11), bracket (12), and two screws (13) from cab dash assembly (14). Discard locknuts.



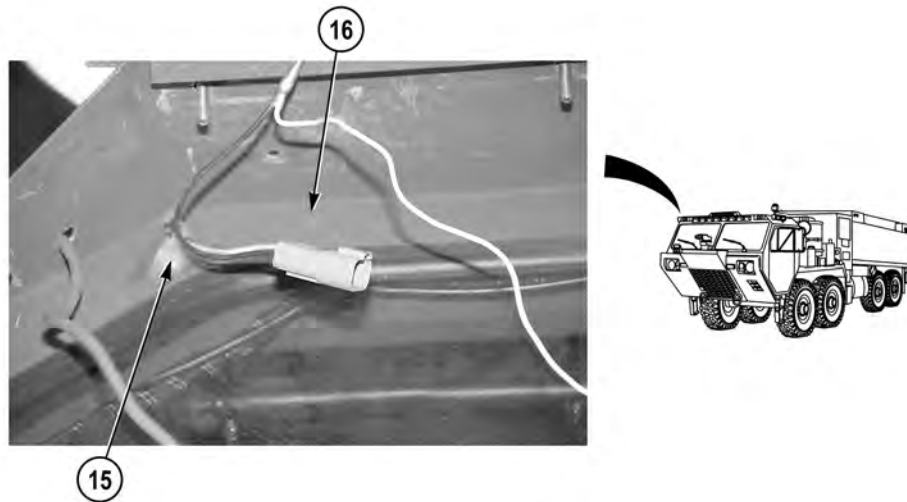
6. Disconnect cab instrument panel wire harness connector (15) from cab roof wire harness connector (16).
7. Remove cab roof wire harness (7) from vehicle.

#### END OF TASK

#### INSTALLATION

#### NOTE

- Install cable ties, split loom, and cushion clips as required.
  - Route cab roof wire harness as noted prior to removal.
1. Install cab roof wire harness (7) on vehicle.
  2. Connect cab instrument panel wire harness connector (15) on cab roof wire harness connector (16).
  3. Install bracket (12) on cab dash assembly (14) with two screws (13) and locknuts (11).
  4. Repair cab roof wire harness (7) wire 1640 (10) on cab roof lightbar cable assembly connector (9) (TM 9-2320-325-14&P)
  5. Repair cab roof wire harness (7) wire 1626 (8) on cab roof lightbar cable assembly connector (9) (TM 9-2320-325-14&P)

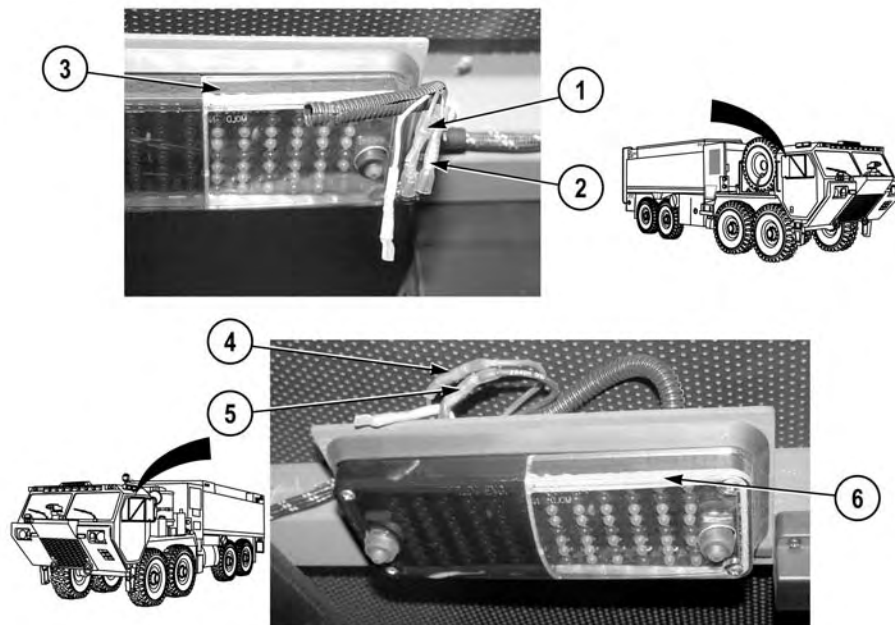
**WARNING**

Adhesives, solvents, and sealing compounds can burn easily, can give off harmful vapors, and are harmful to skin and clothing. To avoid injury or death, keep away from open fire and use in well-ventilated area. If adhesive, solvent, or sealing compound gets on skin or clothing, wash immediately with soap and water.

**NOTE**

Apply a liberal amount of RTV adhesive around cab roof wire harness until cab is sealed.

6. Seal hole (15) in cab roof (16) with RTV adhesive.



7. Repair wire 1047 (4) and wire 2640 (5) on driver side dome light (6) (TM 9-2320-325-14&P)
8. Repair wire 1047 (1) and wire 2640 (2) on passenger side dome light (3) (TM 9-2320-325-14&P)

#### END OF TASK

#### FOLLOW-ON MAINTENANCE

1. Install cab instrument panel assembly (WP 0204)
2. Install passenger side cab clearance light and bracket (WP 0223)

#### END OF TASK

#### END OF WORK PACKAGE



---

**FIELD LEVEL MAINTENANCE**  
**DIRECT TANK FILL VALVE WIRE HARNESS REPLACEMENT**

---

**INITIAL SETUP:****Tools and Special Tools**

Tool Kit, General Mechanic's: Automotive  
(WP 0398, Item 17)

**Materials/Parts**

Tags, Identification (WP 0400, Item 23)  
Ties, Cable, Plastic (WP 0400, Item 26)

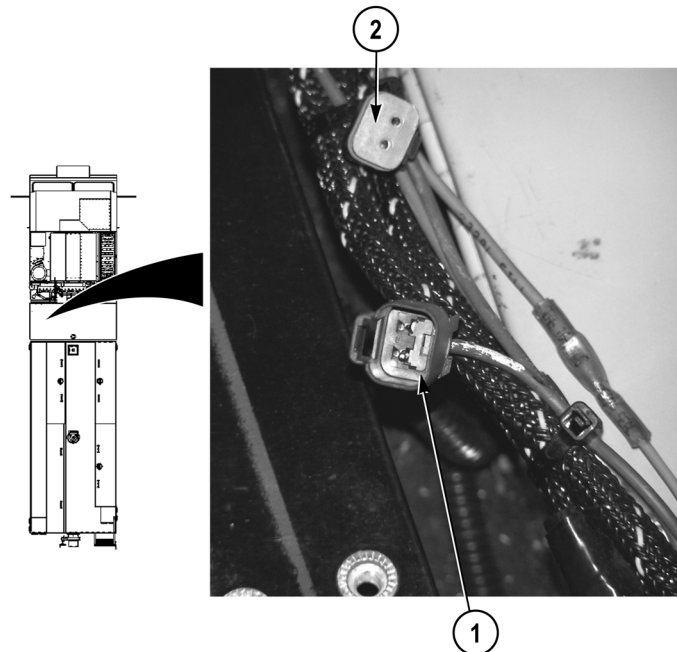
**References**

WP 0391, Fig. 54, 55

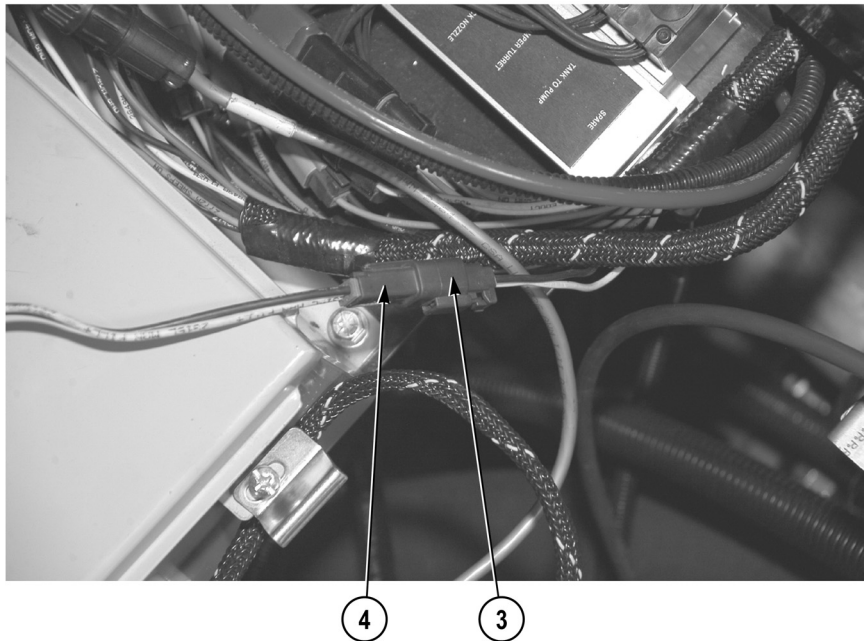
**Equipment Conditions**

Pump house panel K removed (WP 0339)

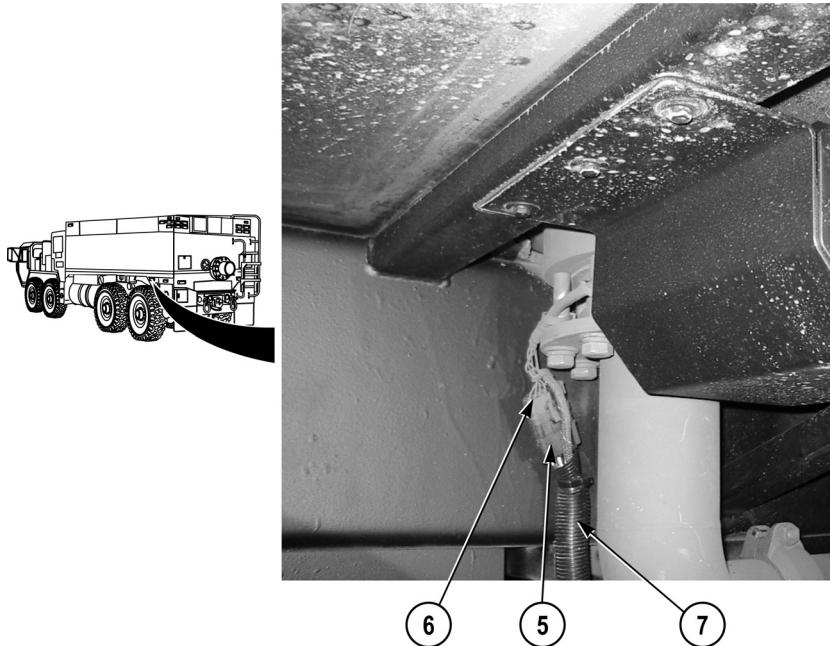
---

**REMOVAL****NOTE**

- Note routing of direct tank fill valve wire harness prior to removal to ensure proper installation.
  - Note position and remove split loom, cushion clips, and cable ties as required.
  - Tag and mark connectors prior to removal to ensure proper installation.
1. Disconnect direct tank fill valve wire harness connector (1) from main wire harness connector (2).



2. Disconnect direct tank fill valve control wire harness connector (3) from pump operator's panel wire harness connector (4) and remove from vehicle.



3. Disconnect direct tank fill valve wire harness connector (5) from direct tank fill valve connector (6).
4. Remove direct tank fill valve wire harness (7) from vehicle.

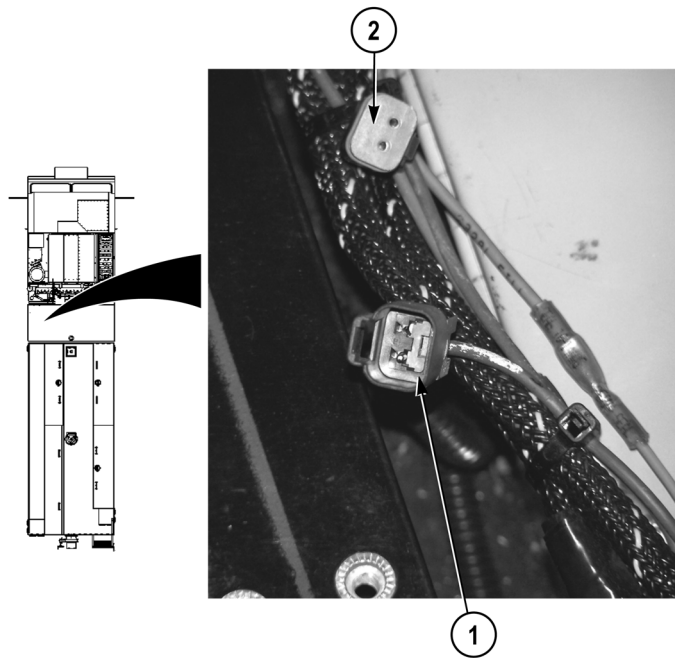
**END OF TASK**



**INSTALLATION****NOTE**

- Route direct tank fill valve control wire harness as noted.
- Install cable ties, cushion clips, and split loom as noted.

1. Install direct tank fill valve wire harness (7) on vehicle.
2. Connect direct tank fill valve connector (6) on direct tank fill valve wire harness connector (5).
3. Connect pump operator's panel wire harness connector (4) on direct tank fill valve control wire harness connector (3).



4. Connect main wire harness connector (2) on direct tank fill valve wire harness connector (1).

**END OF TASK****FOLLOW-ON MAINTENANCE**

Install pump house panel K (WP 0339)

**END OF TASK****END OF WORK PACKAGE**



## FIELD LEVEL MAINTENANCE

## DISCHARGE VALVE CONTROL WIRE HARNESS REPLACEMENT

## INITIAL SETUP:

**Tools and Special Tools**

Tool Kit, General Mechanic's: Automotive  
(WP 0398, Item 17)

**References**

WP 0391, Fig. 34

**Materials/Parts**

Tags, Identification (WP 0400, Item 23)  
Ties, Cable, Plastic (WP 0400, Item 26)

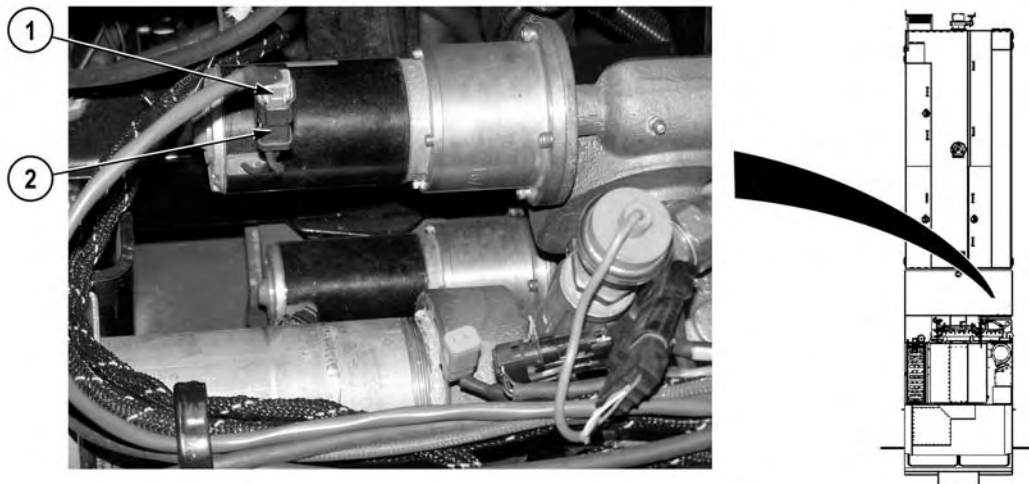
**Equipment Conditions**

Pump operator's panel opened (WP 0207)  
Pump house panel E or G removed (WP 0339)

**Personnel Required**

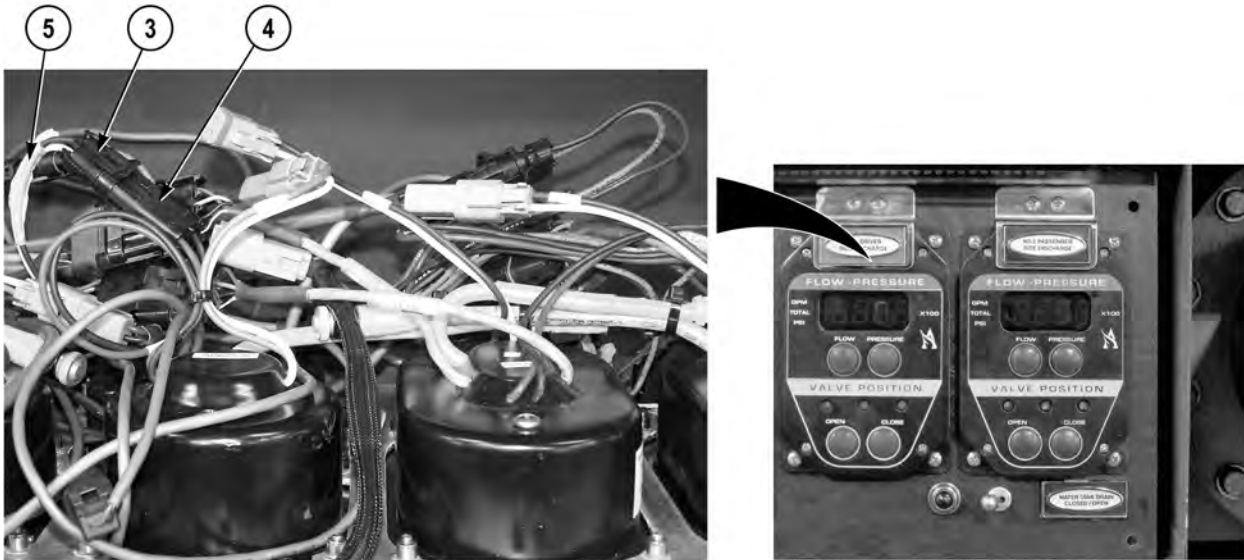
MOS 63B Wheeled Vehicle Mechanic (2)

## REMOVAL

**NOTE**

- Discharge valve control wire harnesses are routed from pump house to pump operator's panel assembly.
- Note position and remove split loom, cushion clips, and cable ties as required.
- Note routing of discharge valve control wire harness prior to removal to ensure proper installation.
- Tag and mark connectors prior to removal to ensure proper installation.
- Driver side and passenger side discharge valve control wire harnesses are removed the same way. Driver side shown.

1. Disconnect discharge valve control wire harness connector (1) from discharge valve control connector (2).



### NOTE

The aid of an assistant may be required to remove discharge valve control wire harness.

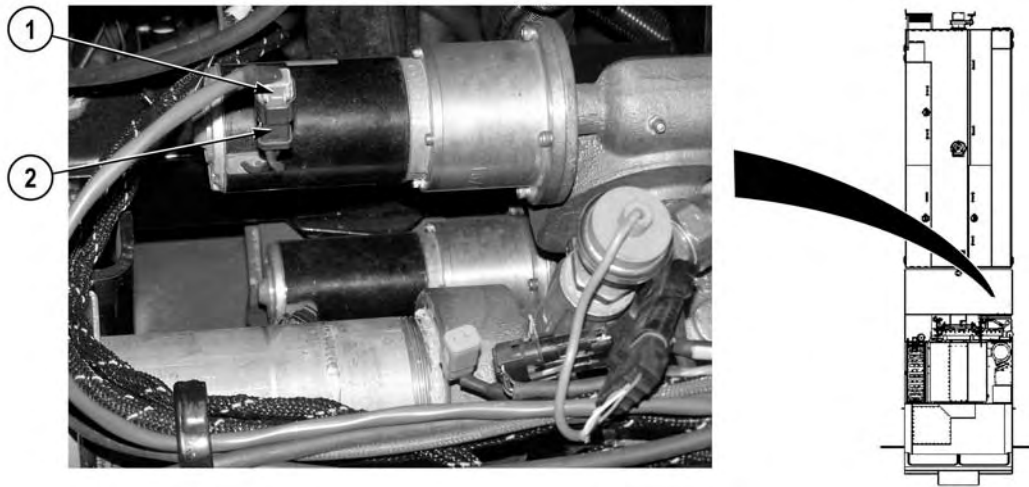
2. Disconnect discharge valve control wire harness connector (3) from discharge line connector (4) and remove discharge valve control wire harness (5) from vehicle.

### END OF TASK

### INSTALLATION

### NOTE

- Driver side and passenger side discharge valve control wire harnesses are installed the same way. Driver side shown.
  - Install split loom, cushion clips, and cable ties as noted prior to removal.
  - Route discharge valve control wire harness as noted prior to removal.
1. Connect discharge valve control wire harness connector (3) to discharge line connector (4) and route discharge valve control wire harness (5) on vehicle.



2. Connect discharge valve control connector (2) to discharge valve control wire harness connector (1).

**END OF TASK**

**FOLLOW-ON MAINTENANCE**

1. Install pump house panel E or G (WP 0339)
2. Close pump operator's panel (WP 0207)

**END OF TASK**

**END OF WORK PACKAGE**



## FIELD LEVEL MAINTENANCE

## DRIVER SIDE AUXILIARY INLET VALVE CONTROL WIRE HARNESS REPLACEMENT

## INITIAL SETUP:

**Tools and Special Tools**

Tool Kit, General Mechanic's: Automotive  
(WP 0398, Item 17)

**References**

WP 0391, Fig. 53

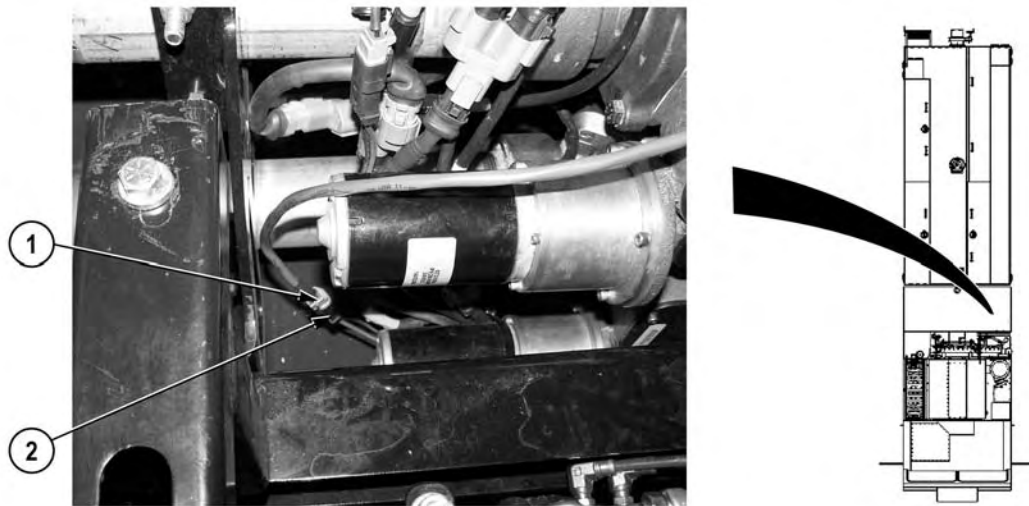
**Materials/Parts**

Tags, Identification (WP 0400, Item 23)  
Ties, Cable, Plastic (WP 0400, Item 26)

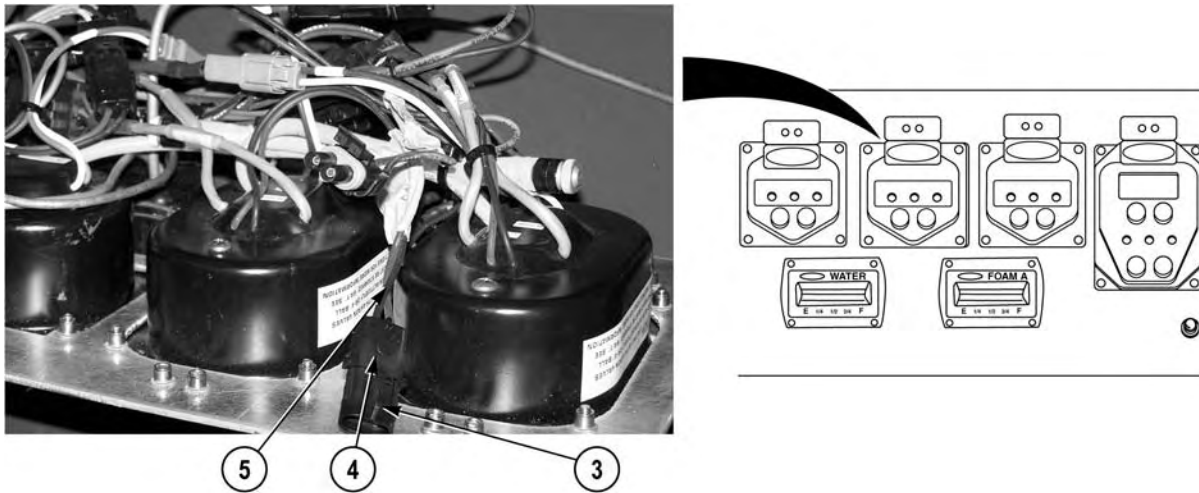
**Equipment Conditions**

Pump operator's panel opened (WP 0207)  
Pump house panel E removed (WP 0339)

## REMOVAL

**NOTE**

- Note routing of driver side auxiliary inlet valve control wire harness prior to removal to ensure proper installation.
  - Driver side auxiliary inlet valve control wire harness is routed through pump house panel N and pump operator's panel assembly.
  - Note position and remove harness split loom, cushion clips, and cable ties as required.
  - Tag and mark connectors prior to removal to ensure proper installation.
1. Disconnect driver side auxiliary inlet valve wire harness connector (1) from driver side auxiliary inlet valve control connector (2).



2. Disconnect driver side auxiliary inlet valve wire harness connector (3) from driver side auxiliary inlet valve line connector (4).
3. Remove driver side auxiliary inlet valve wire harness (5) from vehicle.

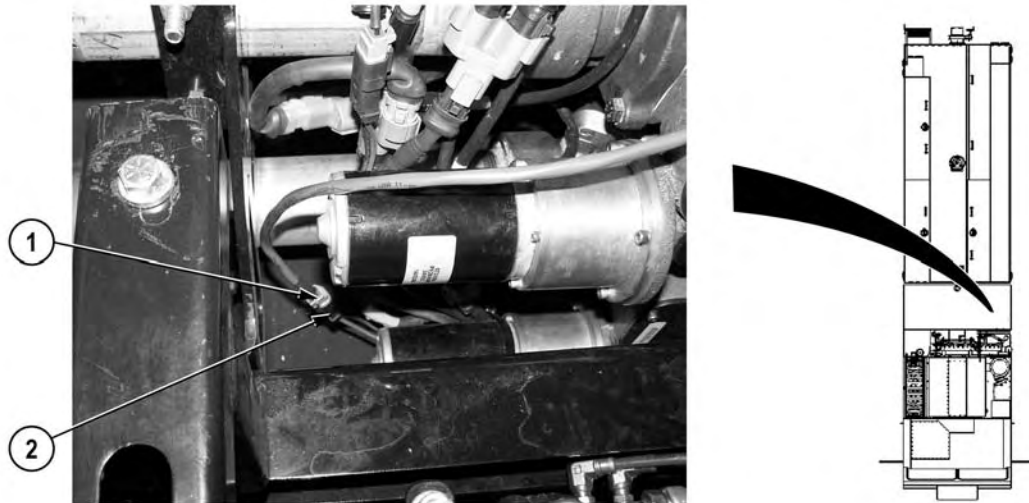
#### END OF TASK

#### INSTALLATION

#### NOTE

- Route driver side auxiliary inlet valve wire harness as noted prior to removal.
  - Install cable ties, split loom, and cushion clips as required.
1. Install driver side auxiliary inlet valve wire harness (5) on vehicle.
  2. Connect driver side auxiliary inlet valve wire harness connector (3) to driver side auxiliary inlet valve line connector (4).





3. Connect driver side auxiliary inlet valve control connector (2) to driver side auxiliary inlet valve wire harness connector (1).

**END OF TASK**

**FOLLOW-ON MAINTENANCE**

1. Install pump house panel E (WP 0339)
2. Close pump operator's panel (WP 0207)

**END OF TASK**

**END OF WORK PACKAGE**



## FIELD LEVEL MAINTENANCE

## DRIVER SIDE BODY WIRE HARNESS REPLACEMENT

## INITIAL SETUP:

**Tools and Special Tools**

Tool Kit, General Mechanic's: Automotive  
(WP 0398, Item 17)

**Materials/Parts**

Tags, Identification (WP 0400, Item 23)  
Ties, Cable, Plastic (WP 0400, Item 26)

**Personnel Required**

MOS 63B Wheeled Vehicle Mechanic (2)

**References**

WP 0391, Fig. 53

**Equipment Conditions**

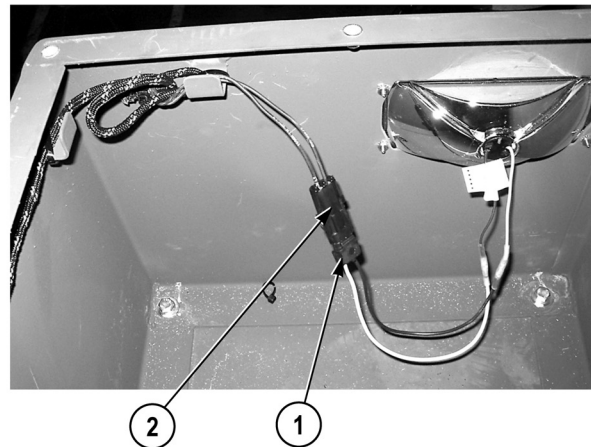
Driver side top stowage compartment door opened for upper driver side body wire harness (WP 0008)

Front and rear driver side light bezel covers removed for upper driver side body wire harness (WP 0335)

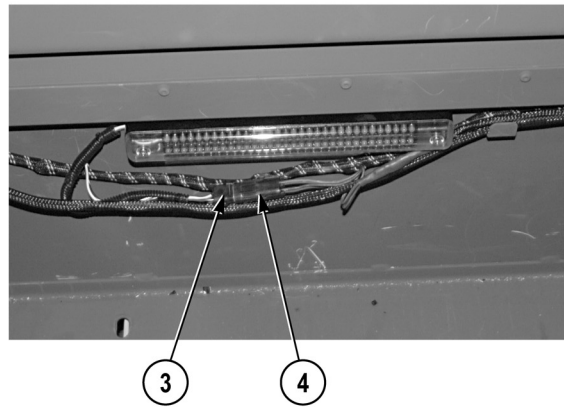
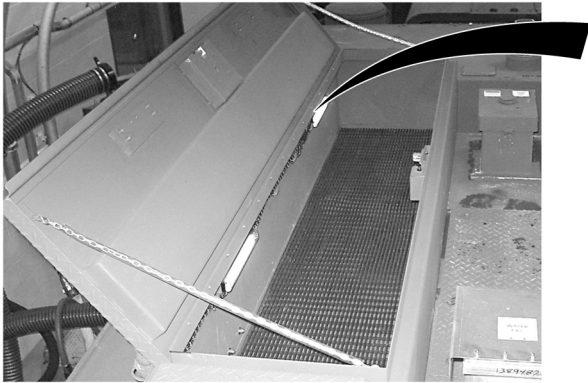
Driver side lower rear stowage compartment removed for lower driver side body wire harness (WP 0356)

Rear driver side light bezel cover removed for lower driver side body wire harness (WP 0335)

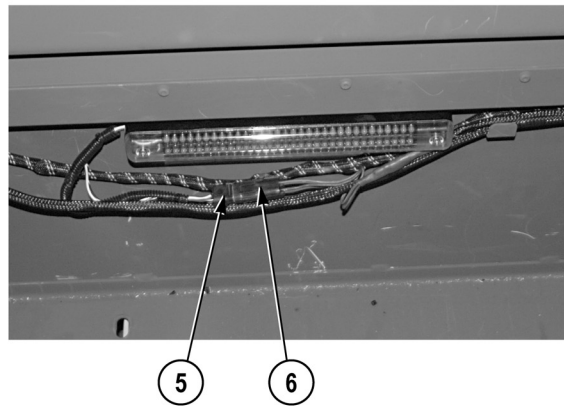
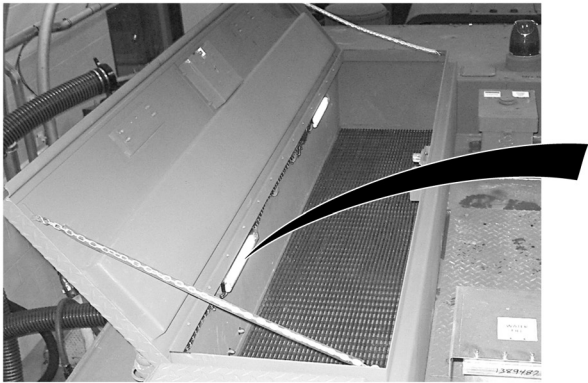
## REMOVAL

**NOTE**

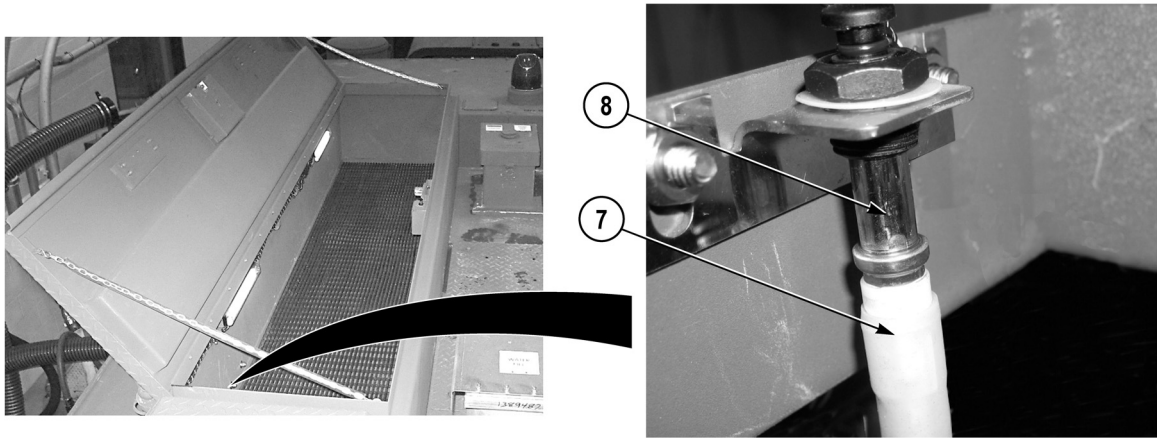
- Perform Steps (1) through (6) to remove upper driver side body wire harness from vehicle.
  - Tag and mark wires prior to removal to ensure proper installation.
  - Note routing of upper driver side body wire harness prior to removal to ensure proper installation.
  - Note position and remove cable ties, split loom, and cushion clips as required.
1. Disconnect scene light connector (1) from upper driver side body wire harness connector (2).



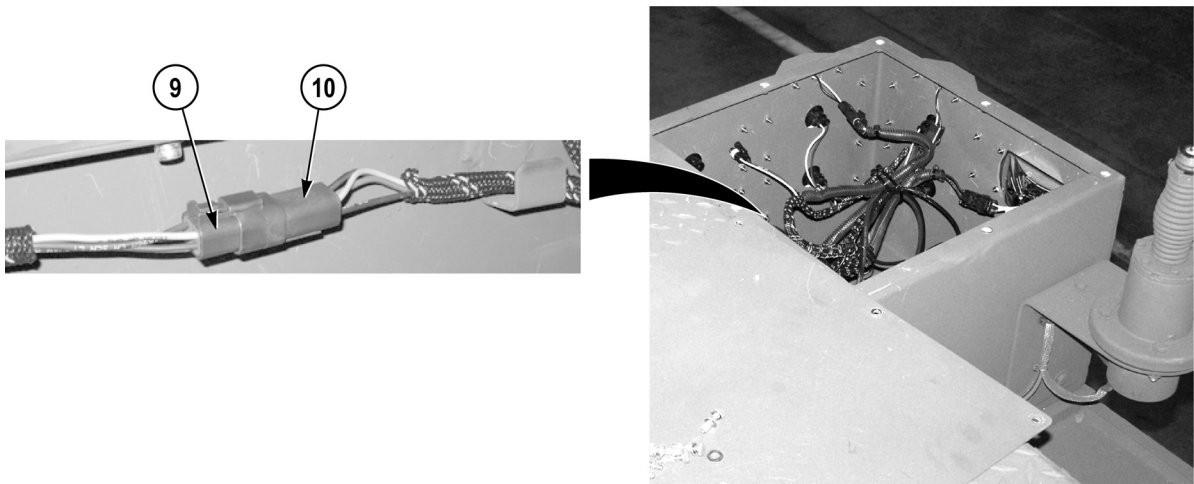
2. Disconnect striplight connector (3) from upper driver side body wire harness connector (4).



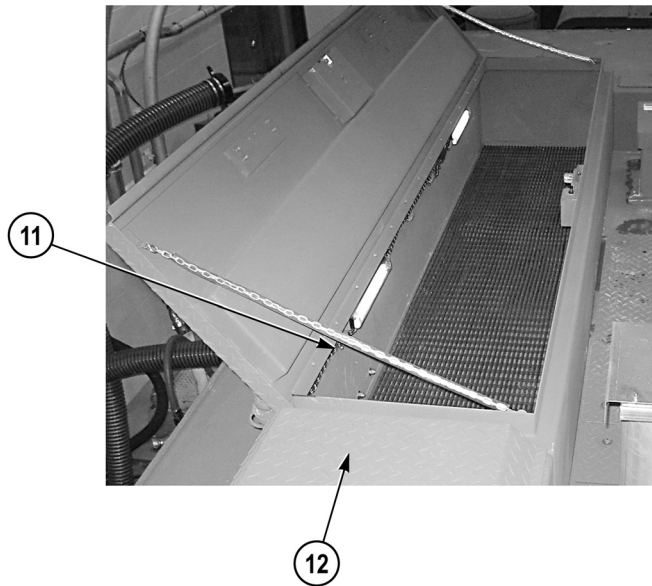
3. Disconnect striplight connector (5) from upper driver side body wire harness connector (6).



4. Disconnect upper driver side body wire harness connector (7) from front driver side top stowage compartment door switch (8).



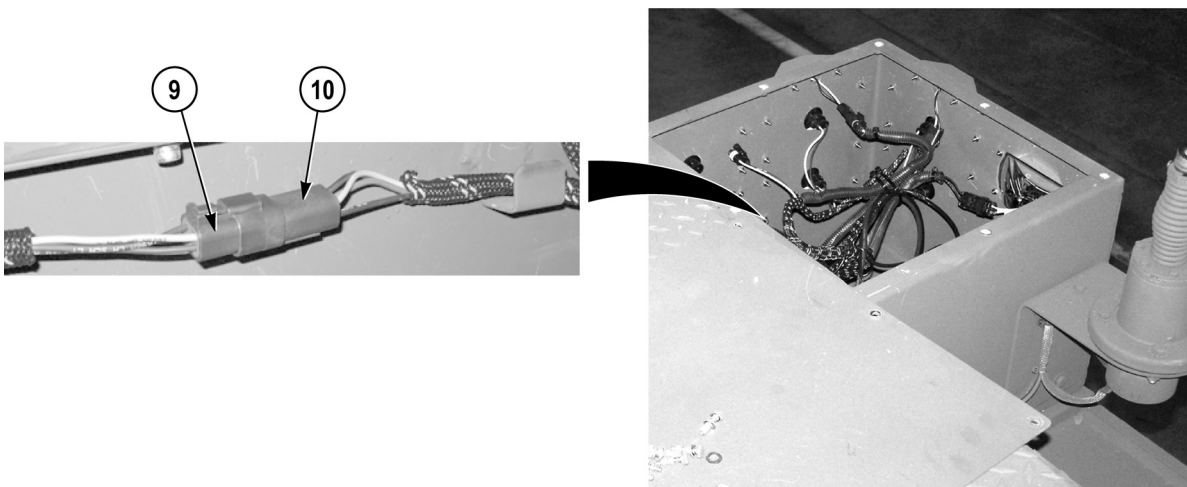
5. Disconnect upper driver side body wire harness connector (9) from lower driver side body wire harness connector (10).



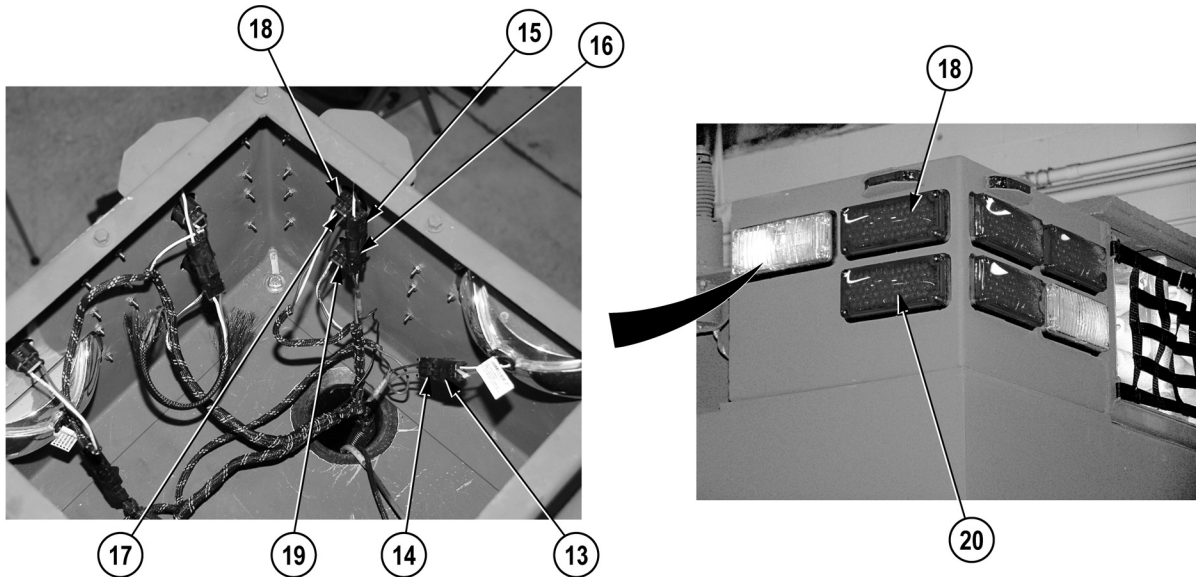
6. Route upper driver side body wire harness (11) through hose bed assembly (12) and remove upper driver side body wire harness (11) from vehicle.

#### NOTE

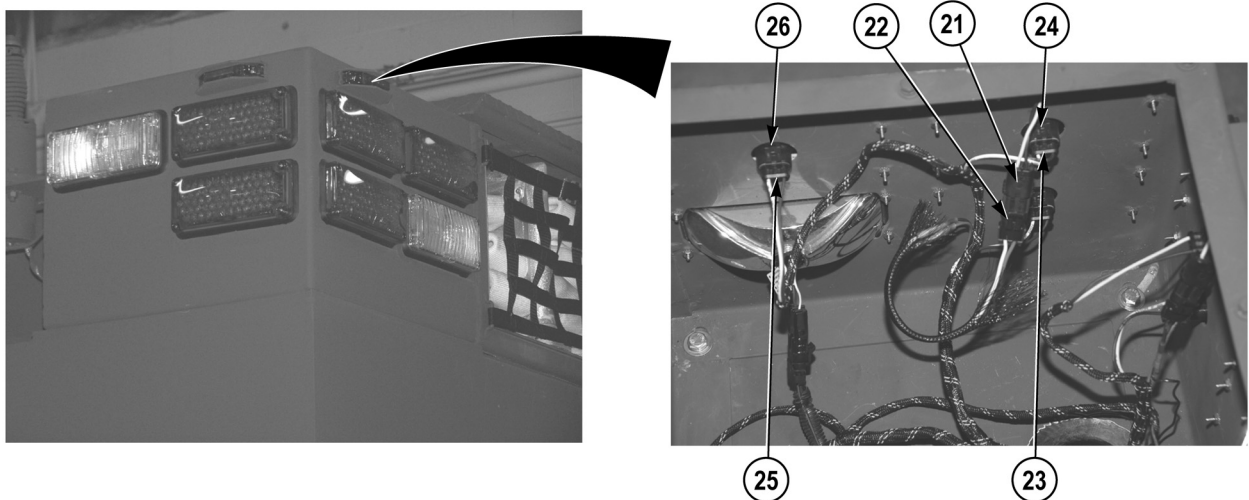
- Perform Step (7) through (19) to remove lower driver side body wire harness from vehicle.
- Perform Step (7) only if lower driver side body wire harness connector needs to be disconnected from upper driver side body wire harness connector.



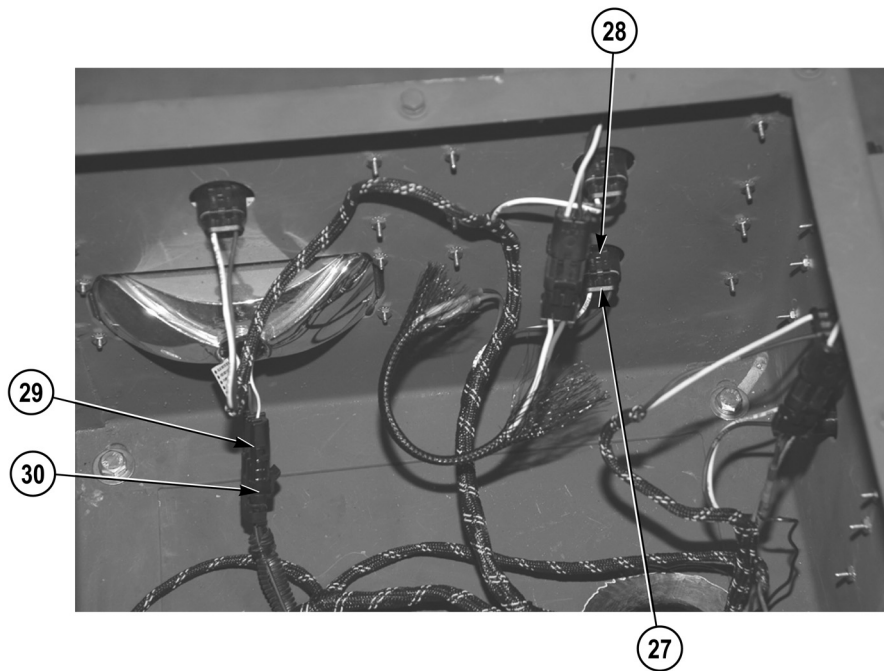
7. Disconnect upper driver side body wire harness connector (9) from lower driver side body wire harness connector (10).



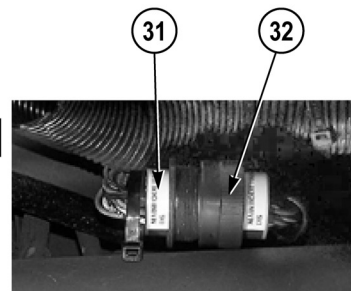
8. Disconnect scene light connector (13) from lower driver side body wire harness connector (14).
9. Disconnect clearance light connector (15) from lower driver side body wire harness connector (16).
10. Disconnect lower driver side body wire harness connector (17) from (top upper) side warning light (18).
11. Disconnect lower driver side body wire harness connector (19) from (bottom upper) side warning light (20).



12. Disconnect clearance light connector (21) from lower driver side body wire harness connector (22).
13. Disconnect lower driver side body wire harness connector (23) from (top outer) upper rear warning light (24).
14. Disconnect lower driver side body wire harness connector (25) from (top inner) upper rear warning light (26).



15. Disconnect lower driver side body wire harness connector (27) from (bottom outer) upper rear warning light (28).
16. Disconnect scene light connector (29) from lower driver side body wire harness connector (30).



17. Disconnect lower driver side body wire harness connector (31) from main wire harness connector (32).





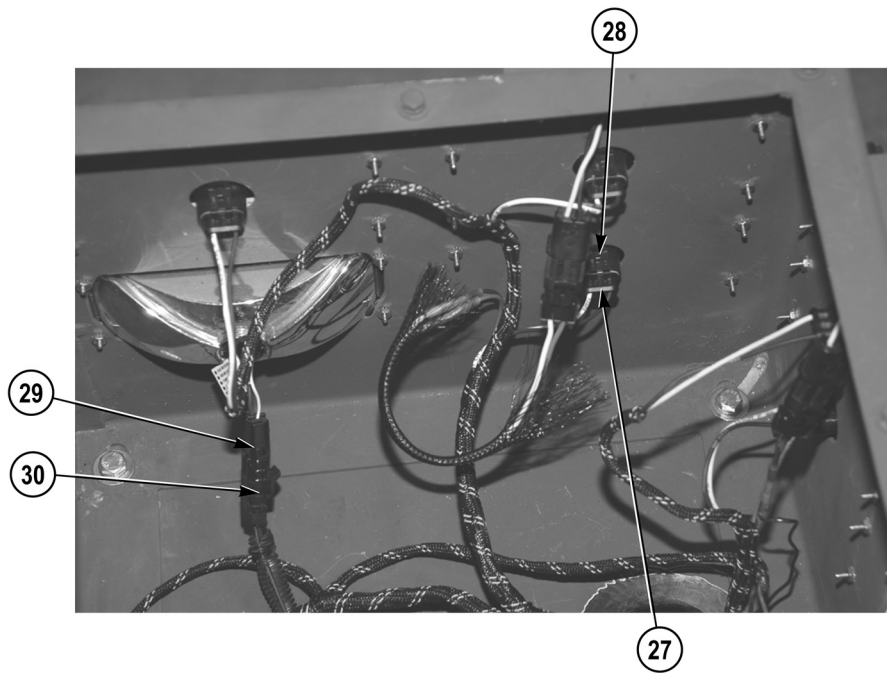
18. With the aid of an assistant, remove lower driver side body wire harness (33) from onboard water tank (34), routing harness into driver side rear light bezel box (35).
19. Remove lower driver side body wire harness (33) from vehicle.

#### END OF TASK

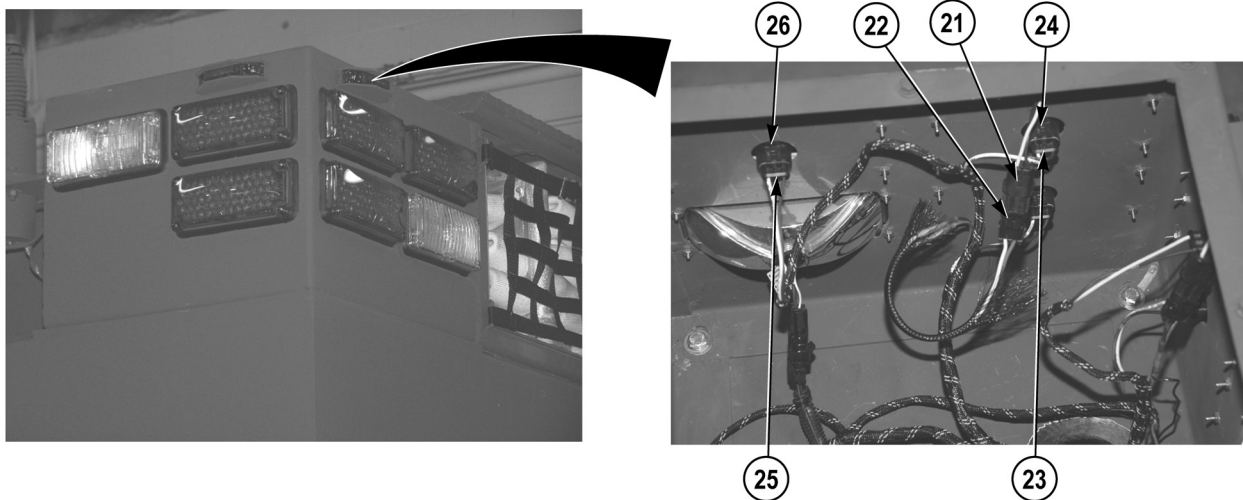
#### INSTALLATION

#### NOTE

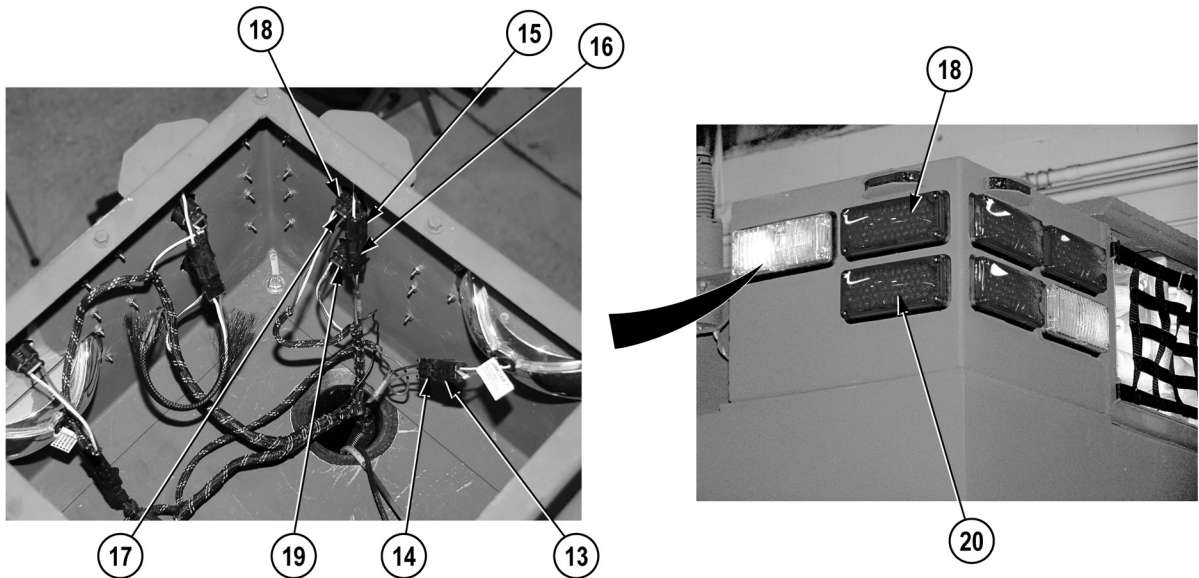
- Install cable ties and cushion clips as required.
  - Perform Steps (1) through (13) if lower driver side body wire harness was removed.
1. Position lower driver side body wire harness (33) on vehicle.
  2. With the aid of an assistant, route lower driver side body wire harness (33) through onboard water tank (34).
  3. Connect lower driver side body wire harness connector (31) on main wire harness connector (32).



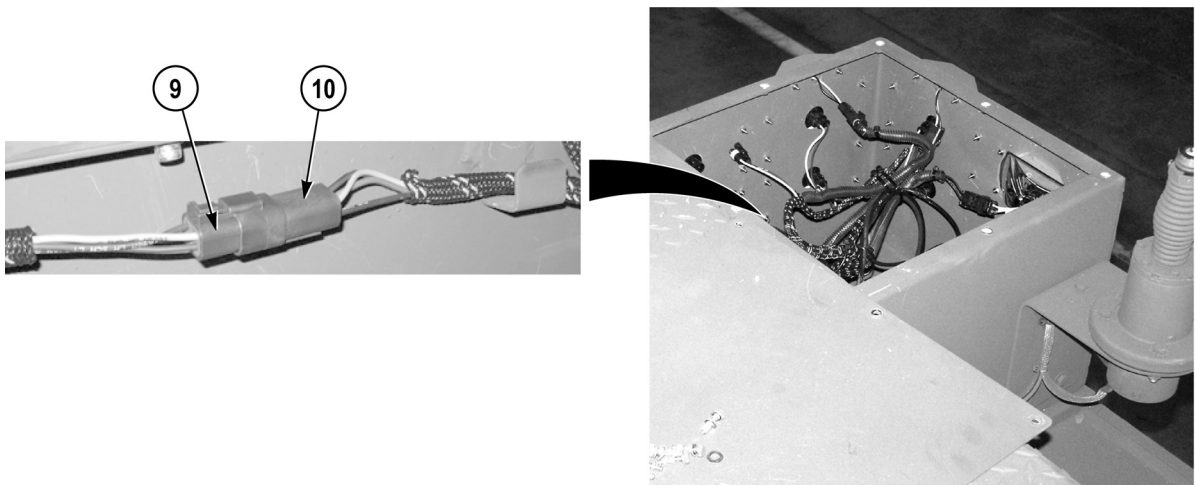
4. Connect lower driver side body wire harness connector (30) on scene light connector (29).
5. Connect lower driver side body wire harness connector (27) on (bottom outer) upper rear warning light (28).



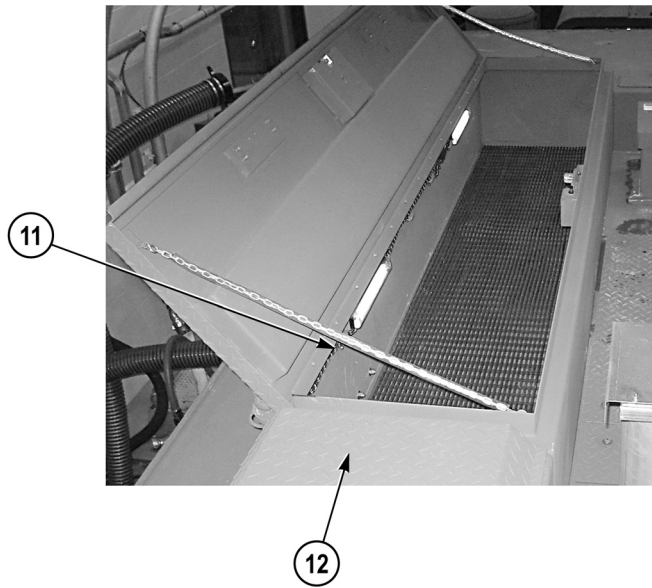
6. Connect lower driver side body wire harness connector (25) on (top inner) upper rear warning light (26).
7. Connect lower driver side body wire harness connector (23) on (top outer) upper rear warning light (24).
8. Connect lower driver side body wire harness connector (22) on clearance light connector (21).



9. Connect lower driver side body wire harness connector (19) on (bottom upper) side warning light (20).
10. Connect lower driver side body wire harness connector (17) on (top upper) side warning light (18).
11. Connect lower driver side body wire harness connector (16) on clearance light connector (15).
12. Connect lower driver side body wire harness connector (14) on scene light connector (13).

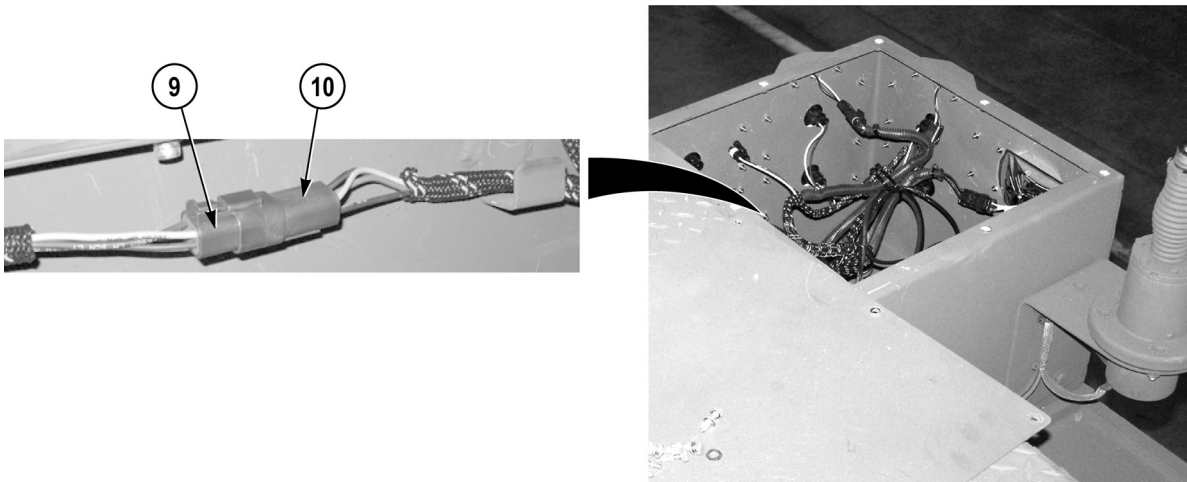


13. Connect lower driver side body wire harness connector (10) on upper driver side body wire harness connector (9).

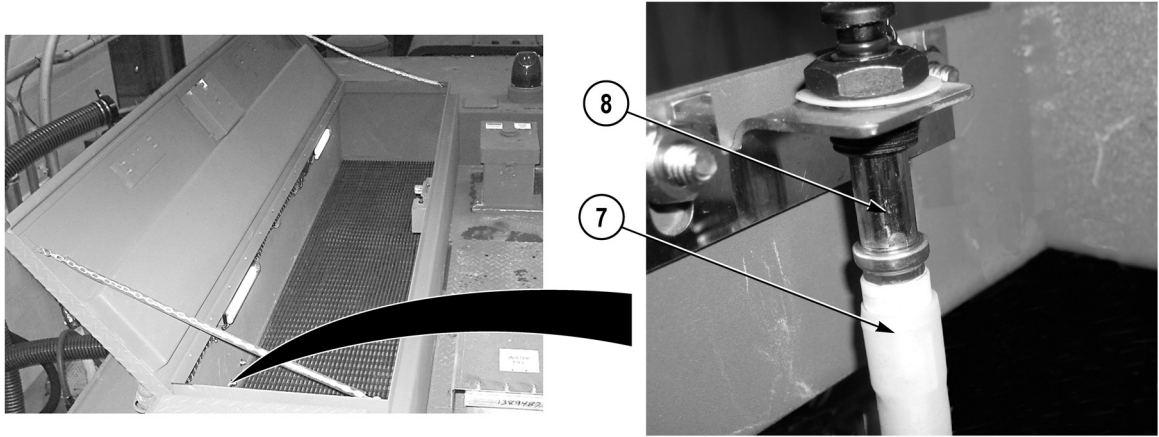
**NOTE**

Perform Steps (14) through (19) if upper driver side body wire harness was removed.

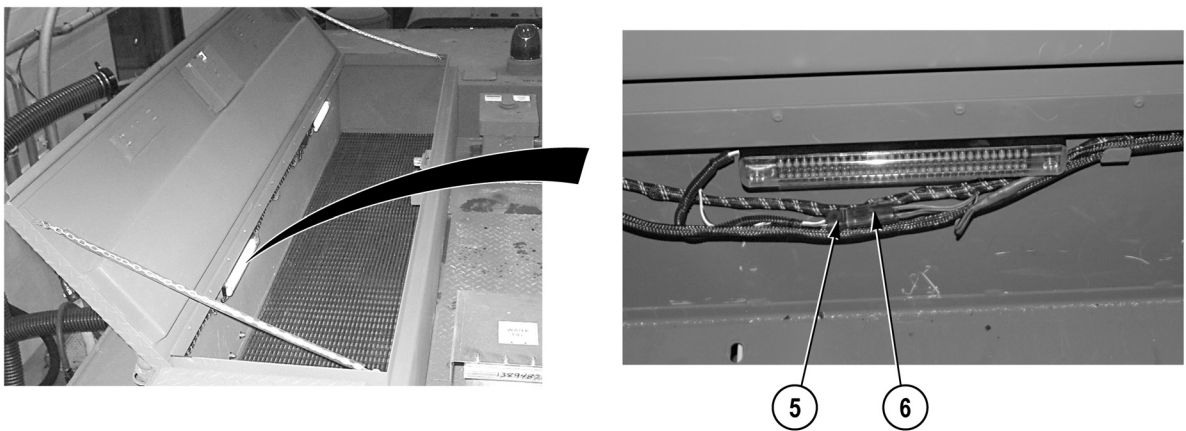
14. Route upper driver side body wire harness (11) through hose bed assembly (12).



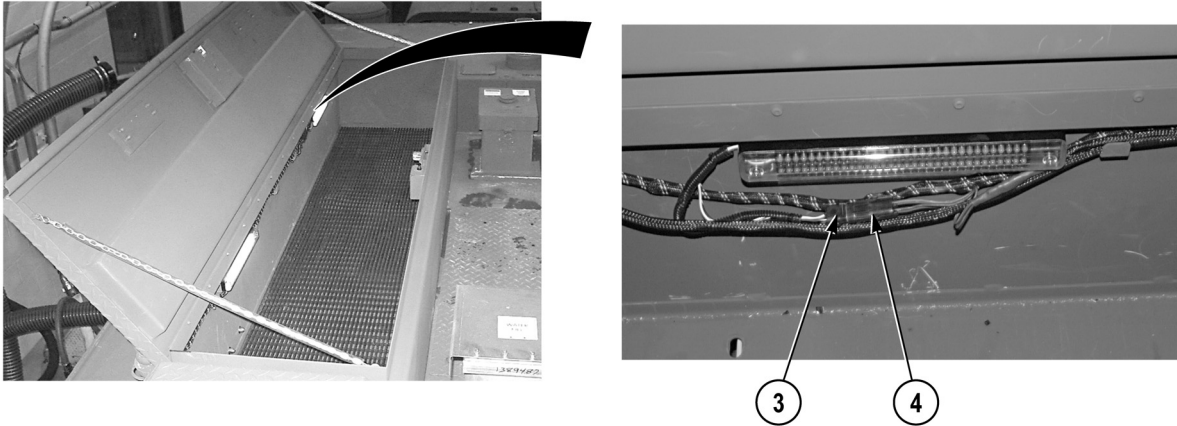
15. Connect lower driver side body wire harness connector (10) on upper driver side body wire harness connector (9).



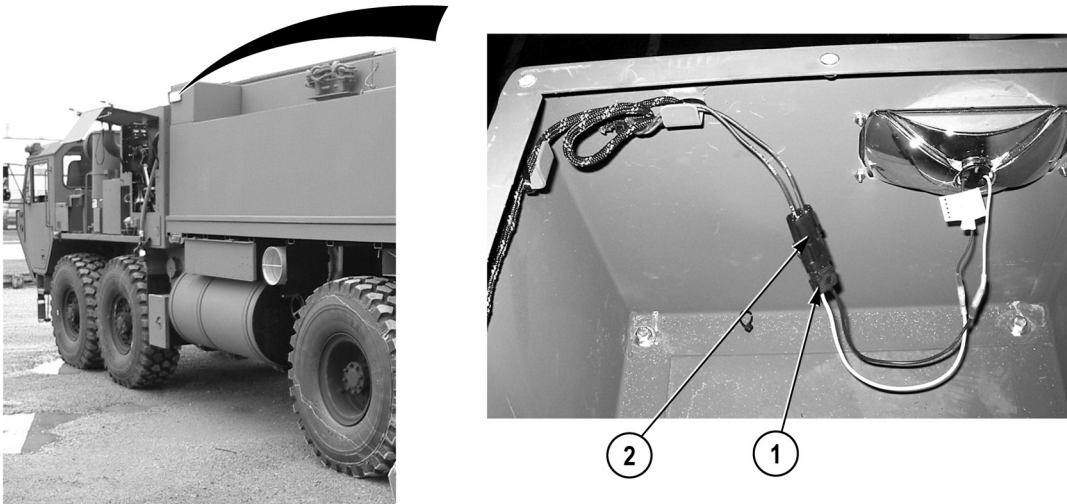
16. Connect upper driver side body wire harness connector (7) on front driver side top stowage compartment door switch (8).



17. Connect upper driver side body wire harness connector (6) on striplight connector (5).



18. Connect upper driver side body wire harness connector (4) on striplight connector (3).



19. Connect upper driver side body wire harness connector (2) on scene light connector (1).

#### END OF TASK

#### FOLLOW-ON MAINTENANCE

1. Install front and rear driver side light bezel covers (WP 0335)
2. Close driver side top stowage compartment door (WP 0008)
3. Install driver side lower rear stowage compartment (WP 0356)

#### END OF TASK

#### END OF WORK PACKAGE

---

**FIELD LEVEL MAINTENANCE**  
**LIGHTBAR FLASHER UNIT REPLACEMENT**

---

**INITIAL SETUP:****Tools and Special Tools**

Drill, Electric, Portable 1/4 in. (WP 0398, Item 5)  
Drill Set, Twist (WP 0398, Item 6)  
Tool Kit, Blind Rivet (WP 0398, Item 16)

**Materials/Parts**

Tags, Identification (WP 0400, Item 23)

**References**

WP 0226  
WP 0391, Fig. 58

**Equipment Conditions**

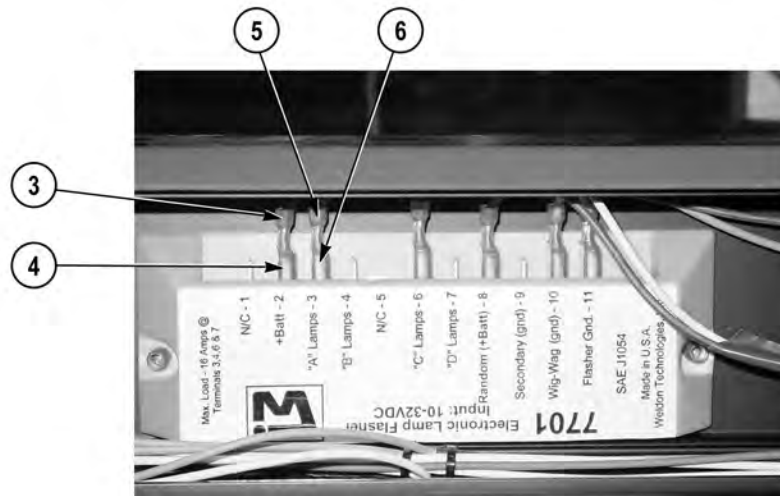
Cab front lightbar removed (WP 0224)

---

**REMOVAL****NOTE**

Lights removed in Step (1) are 3rd and 4th lights from driver side of vehicle.

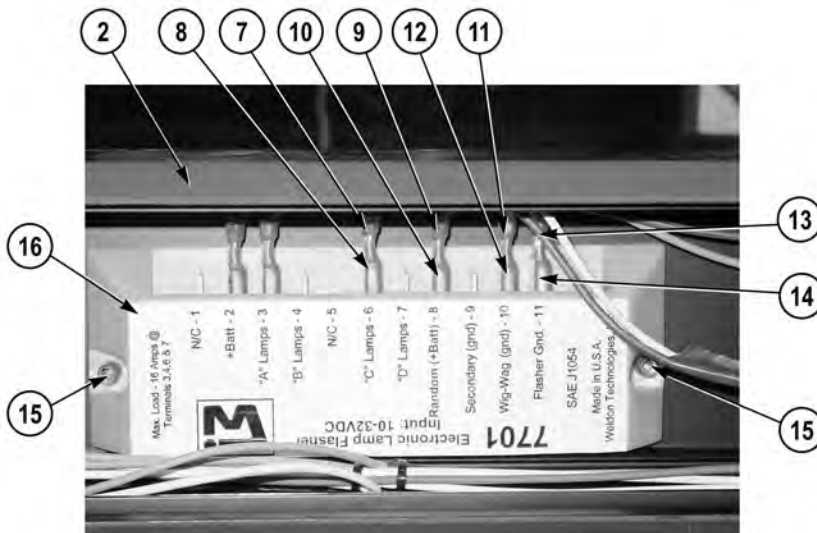
1. Remove two lights (1) from cab front lightbar (2) (WP 0226).



**NOTE**

Tag and mark wires prior to removal to ensure proper installation.

2. Remove red wire (3) from lightbar flasher unit, terminal 2 (4).
3. Remove green wire (5) from lightbar flasher unit, terminal 3 (6).



4. Remove blue wire (7) from lightbar flasher unit, terminal 6 (8).
5. Remove red wire (9) from lightbar flasher unit, terminal 8 (10).
6. Remove white wire (11) from lightbar flasher unit, terminal 10 (12).
7. Remove white wire (13) from lightbar flasher unit, terminal 11 (14).
8. Remove two rivets (15) and lightbar flasher unit (16) from cab front lightbar (2).

**END OF TASK**



**INSTALLATION**

1. Install lightbar flasher unit (16) on cab front lightbar (2) with two rivets (15).
2. Install white wire (13) on lightbar flasher unit, terminal 11 (14).
3. Install white wire (11) on lightbar flasher unit, terminal 10 (12).
4. Install red wire (9) on lightbar flasher unit, terminal 8 (10).
5. Install blue wire (7) on lightbar flasher unit, terminal 6 (8).
6. Install green wire (5) on lightbar flasher unit, terminal 3 (6).
7. Install red wire (3) on lightbar flasher unit, terminal 2 (4).



8. Install two lights (1) on front cab front lightbar (2) (WP 0226).

**END OF TASK****FOLLOW-ON MAINTENANCE**

Install cab front lightbar (WP 0224).

**END OF TASK****END OF WORK PACKAGE**



---

**FIELD LEVEL MAINTENANCE**  
**PRESSURE GOVERNOR ECU REPLACEMENT**

---

**INITIAL SETUP:****Tools and Special Tools**

Tool Kit, General Mechanic's: Automotive  
(WP 0398, Item 17)

**References**

Deleted

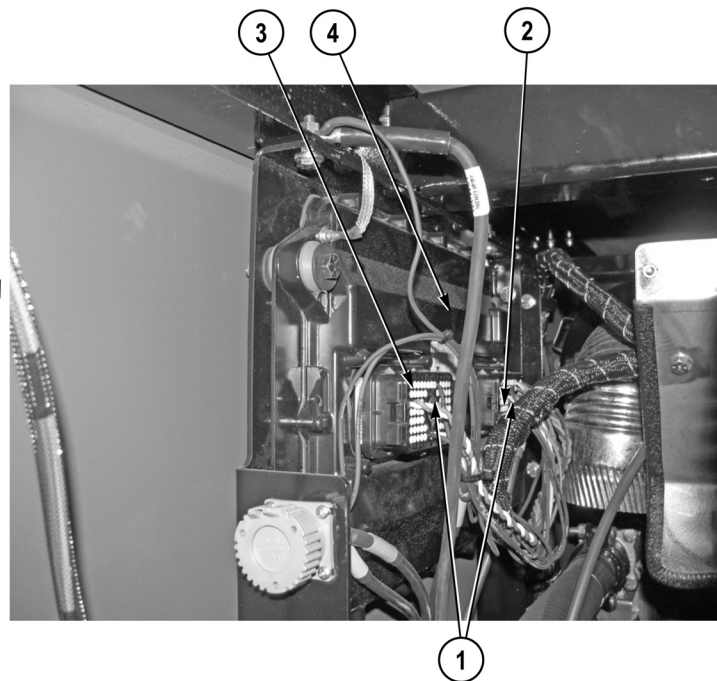
**Materials/Parts**

Compound, Sealing (WP 0400, Item 10)  
Lockwasher (1)  
Locknut (4)  
Locknut (4)  
Lockwasher (4)  
Lockwasher (4)

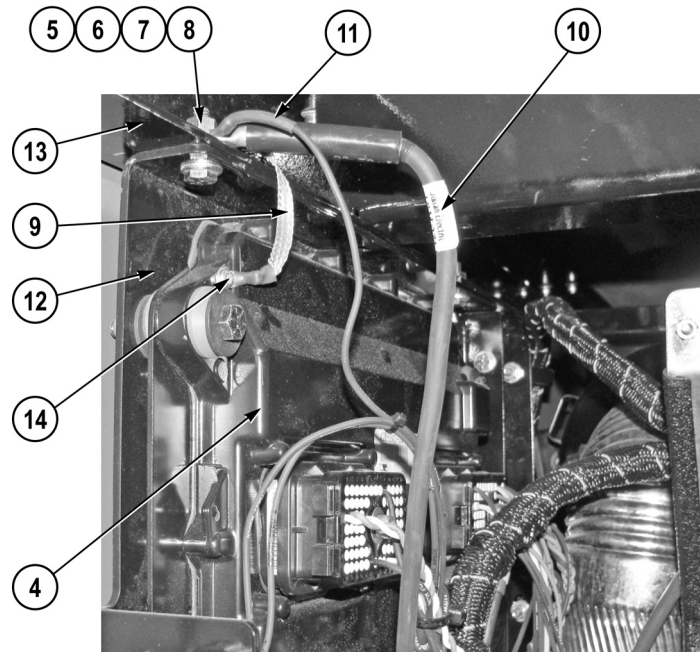
**Equipment Conditions**

Pump house panels E and L removed (WP 0339)

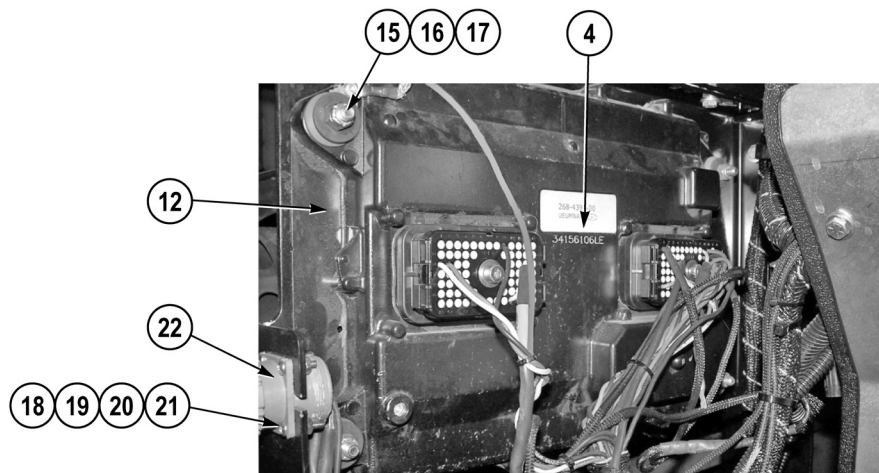
---

**REMOVAL**

1. Loosen two screws (1) and remove J1 connector (2) and J2 connector (3) from pressure governor ECU (4).



2. Remove nut (5), lockwasher (6), two washers (7), screw (8), ground strap (9), ground cable (10), and wire 1100 (11) from bracket (12) and pump house frame (13). Discard lockwasher.
3. Remove screw (14) and ground strap (9) from pressure governor ECU (4).

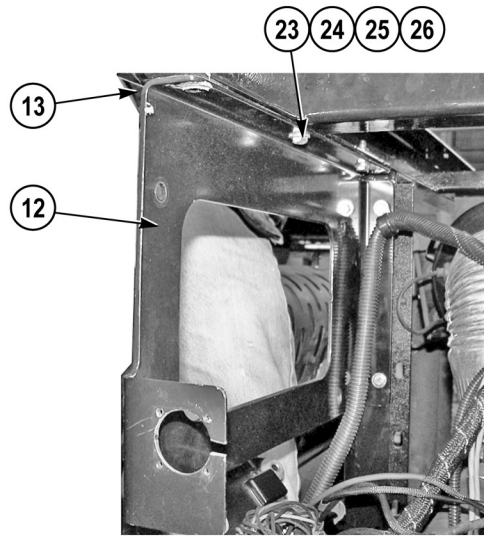


4. Remove four locknuts (15), eight washers (16), four screws (17), and pressure governor ECU (4) from bracket (12). Discard locknuts.

### NOTE

Perform Steps (5) and (6) if bracket needs to be removed.

5. Remove four locknuts (18), lockwashers (19), washers (20), screws (21), and pressure governor ECU service connector (22) from bracket (12). Discard locknuts and lockwashers.



6. Remove four nuts (23), lockwashers (24), eight washers (25), four screws (26), and bracket (12) from pump house frame (13). Discard lockwashers.

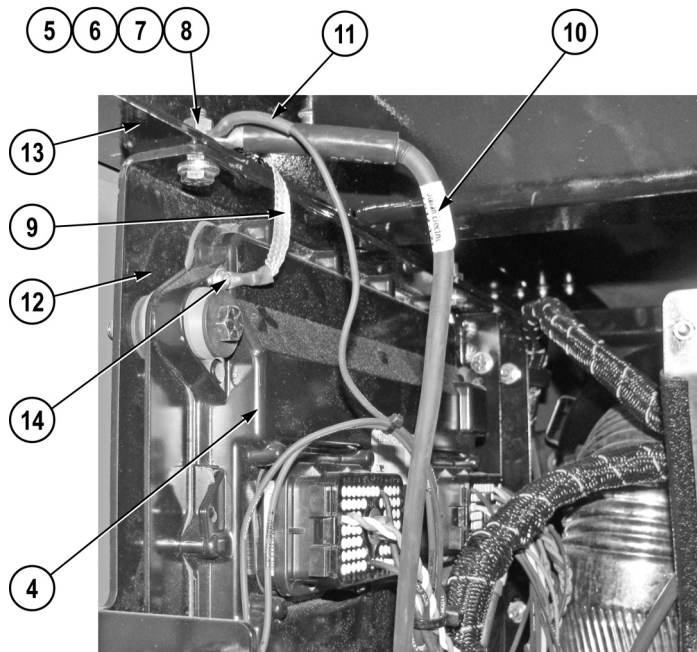
#### END OF TASK

#### INSTALLATION

#### NOTE

Perform Steps (1) and (2) if bracket was removed.

1. Install bracket (12) on pump house frame (13) with four screws (26), eight washers (25), four lockwashers (24), and nuts (23).
2. Install pressure governor ECU service connector (22) on bracket (12) with four screws (21), washers (20), lockwashers (19), and locknuts (18).
3. Install pressure governor ECU (4) on bracket (12) with four screws (17), eight washers (16), and four locknuts (15).



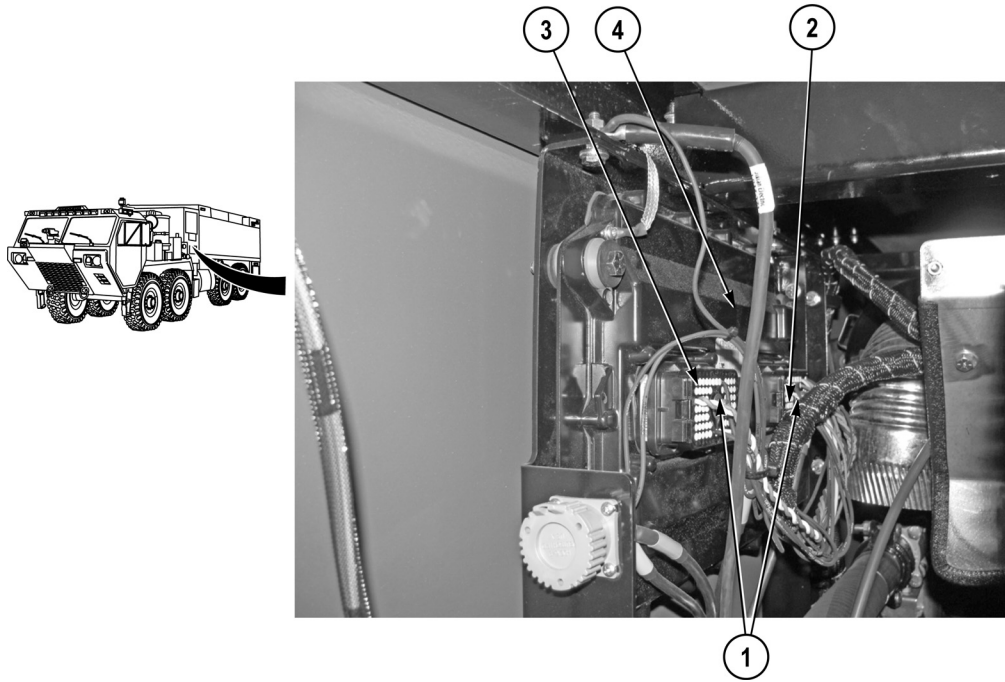
4. Install ground strap (9) on pressure governor ECU (4) with screw (14).
5. Install wire 1100 (11), ground cable (10), and ground strap (9) on pump house frame (13) and bracket (12) with screw (8), two washers (7), lockwasher (6), and nut (5).

### WARNING



**Adhesives, solvents, and sealing compounds can burn easily, can give off harmful vapors, and are harmful to skin and clothing. To avoid injury or death, keep away from open fire and use in well-ventilated area. If adhesive, solvent, or sealing compound gets on skin or clothing, wash immediately with soap and water.**

6. Apply sealing compound to head of screw (8), washer (7), wire 1100 (11), ground cable (10), and ground strap (9).



7. Install J2 connector (3) and J1 connector (2) on pressure governor ECU (4) and tighten two screws (1).

**END OF TASK**

**FOLLOW-ON MAINTENANCE**

Install pump house panels E and L (WP 0339)

**END OF TASK**

**END OF WORK PACKAGE**





---

**FIELD LEVEL MAINTENANCE**  
**INTERCOM WIRE HARNESS REPLACEMENT**

---

**INITIAL SETUP:****Tools and Special Tools**

Tool Kit, General Mechanic's: Automotive  
(WP 0398, Item 17)

**Materials/Parts**

Tags, Identification (WP 0400, Item 23)  
Ties, Cable, Plastic (WP 0400, Item 26)

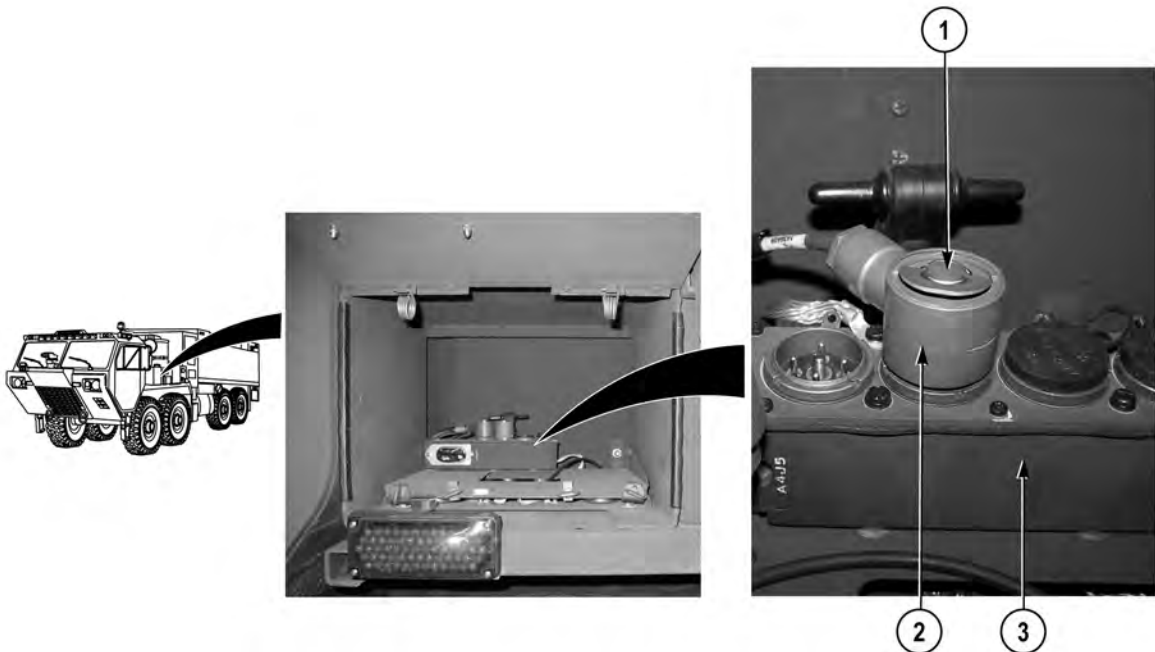
**References**

TM 9-2320-325-14&P  
TM 11-5820-890-10  
WP 0391, Fig. 37

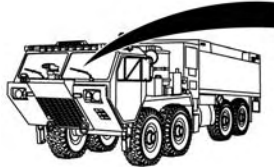
**Equipment Conditions**

Intercom removed (WP 0256)

---

**SINCGARS INTERFACE WIRE HARNESS REMOVAL****NOTE**

- Tag and mark wires prior to removal to ensure proper installation.
  - Note routing of intercom wire harness prior to removal to ensure proper installation.
  - Note position and remove cable ties, split loom, and cushion clips as required.
1. Remove SINCGARS receiver transmitter and power adapter from electronic mounting base (TM 11-5820-890-10).
  2. Loosen thumbscrew (1) and remove intercom wire harness connector (2) from electronic mounting base (3).



3. Remove intercom wire harness (4) from vehicle.

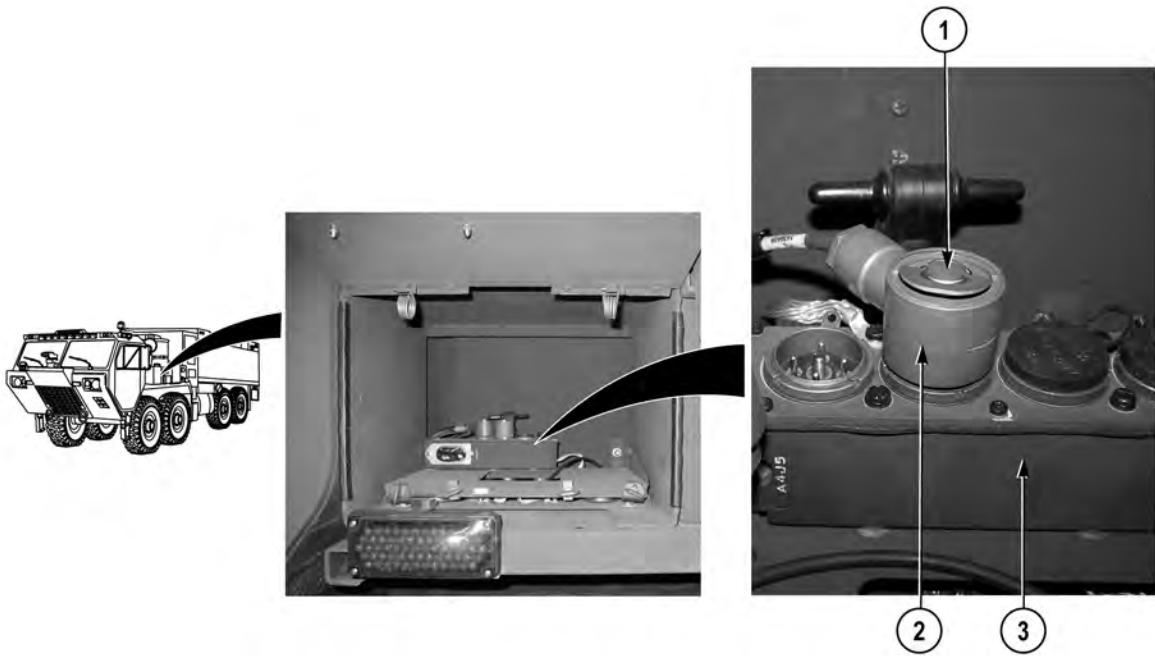
#### END OF TASK

#### SINGGARS INTERFACE WIRE HARNESS INSTALLATION

##### NOTE

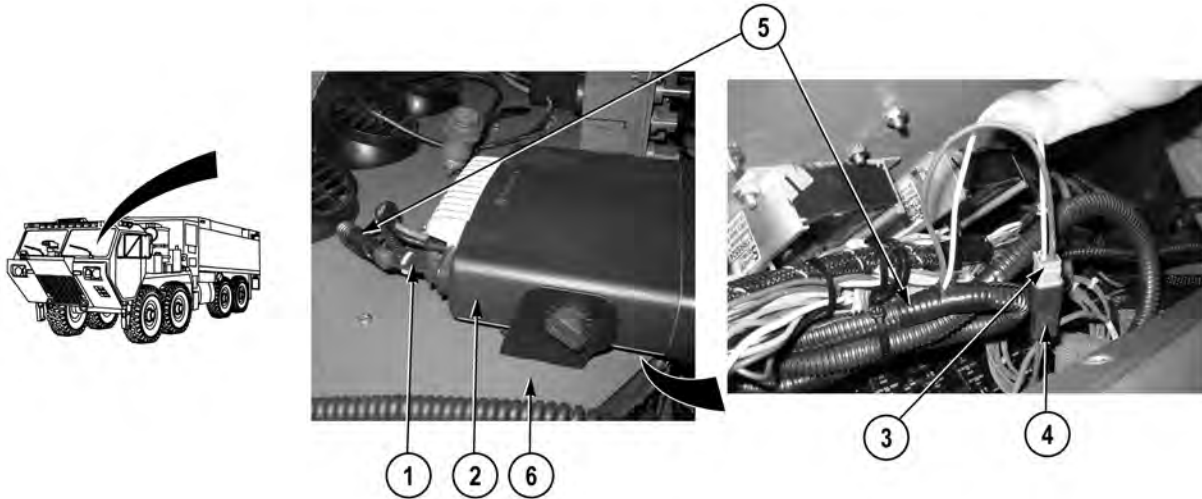
- Route intercom wire harness on vehicle as noted prior to removal.
- Install cable ties, split loom, and cushion clips as required.

1. Install intercom wire harness (4) on vehicle.



2. Install intercom wire harness connector (2) on electronic mounting base (3) with thumbscrew (1).
3. Install power adapter and SINCGARS receiver transmitter on electronic mounting base (TM 11-5820-890-10).

**END OF TASK**

**TWO-WAY RADIO INTERFACE WIRE HARNESS REMOVAL****NOTE**

- Tag and mark connectors prior to removal to ensure proper installation.
- Note routing of intercom wire harness prior to removal to ensure proper installation.
- Note position and remove cable ties as required.

1. Disconnect two-way radio interface wire harness connector (1) from two-way radio (2).
2. Disconnect two-way radio interface wire harness connector (3) from wire harness connector (4).
3. Remove two-way radio interface wire harness (5) from cab instrument panel A (6).
4. Remove two-way radio interface wire harness (5) from vehicle.

**END OF TASK**

**TWO-WAY RADIO INTERFACE WIRE HARNESS INSTALLATION****NOTE**

- Route intercom wire harness as noted prior to removal.
  - Install cable ties as required.
1. Position two-way radio interface wire harness (5) on cab instrument panel A (6).
  2. Install wire harness connector (4) on two-way radio interface wire harness connector (3).
  3. Connect two-way radio interface wire harness connector (1) on two-way radio (2).

**FOLLOW-ON MAINTENANCE**

Install intercom (WP 0256)

**END OF TASK**

**END OF WORK PACKAGE**



---

**FIELD LEVEL MAINTENANCE**  
**LIGHTBAR CABLE ASSEMBLY BRANCH REPLACEMENT**

---

**INITIAL SETUP:****Tools and Special Tools**

Tool Kit, General Mechanic's: Automotive  
(WP 0398, Item 17)

**References**

TM 9-2320-325-14&P  
WP 0391, Fig. 27

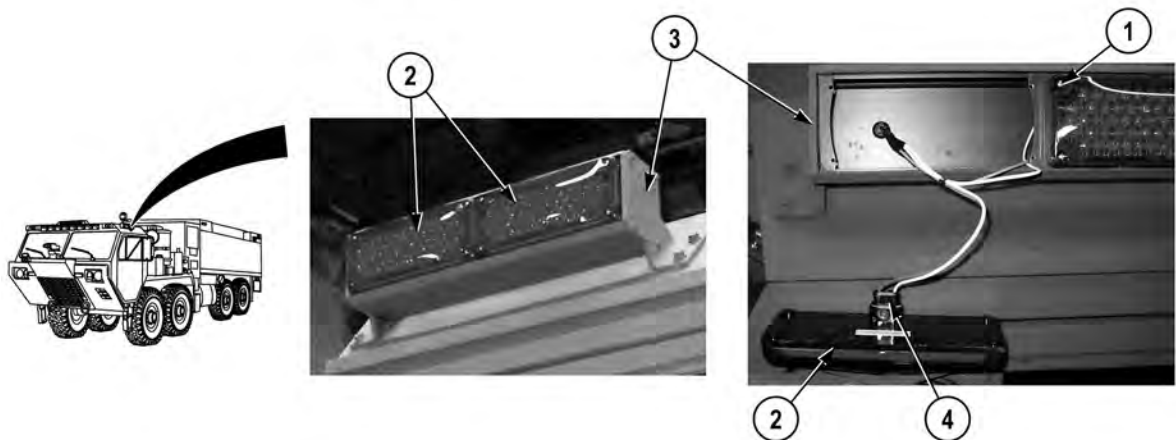
**Materials/Parts**

Tags, Identification (WP 0400, Item 23)  
Ties, Cable, Plastic (WP 0400, Item 26)  
Lockwasher (1)

**Equipment Conditions**

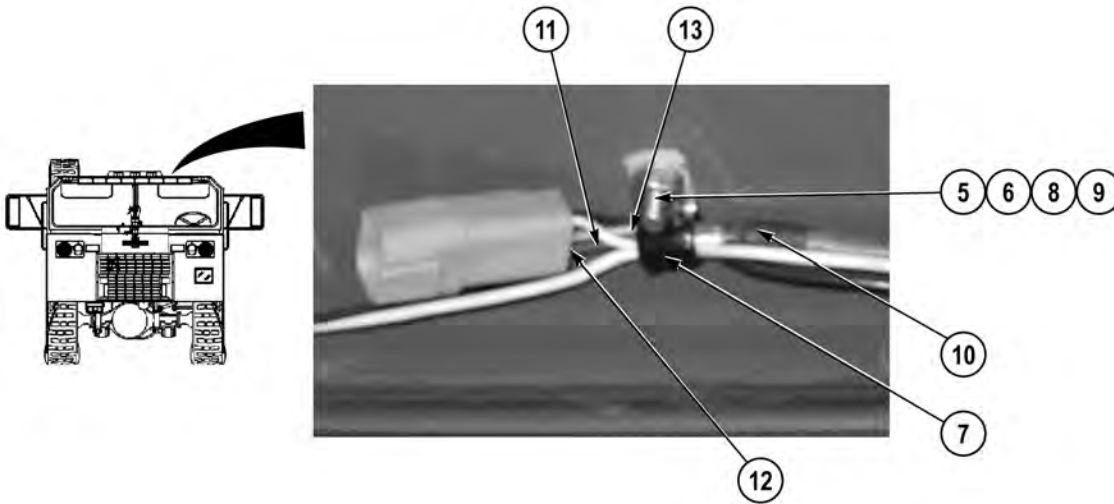
Cab front lightbar removed driver side only  
(WP 0224)

---

**REMOVAL****NOTE**

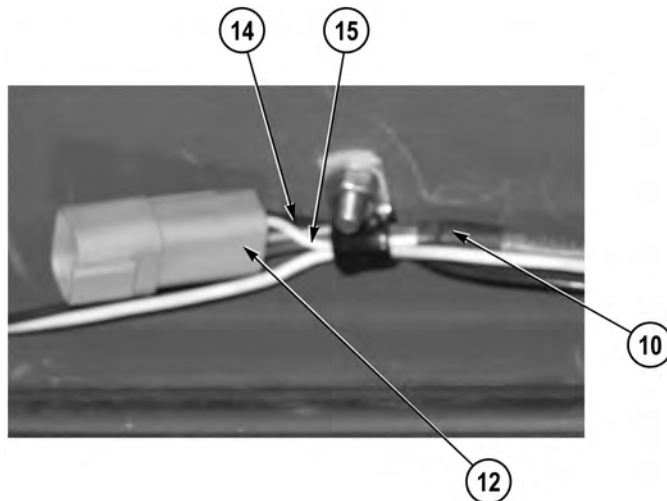
Both lightbar cable assembly branches are replaced the same way. Driver side shown.

1. Remove eight screws (1) and two lights (2) from cab side lightbar (3).
2. Disconnect two lightbar cable assembly connectors (4) from lights (2).



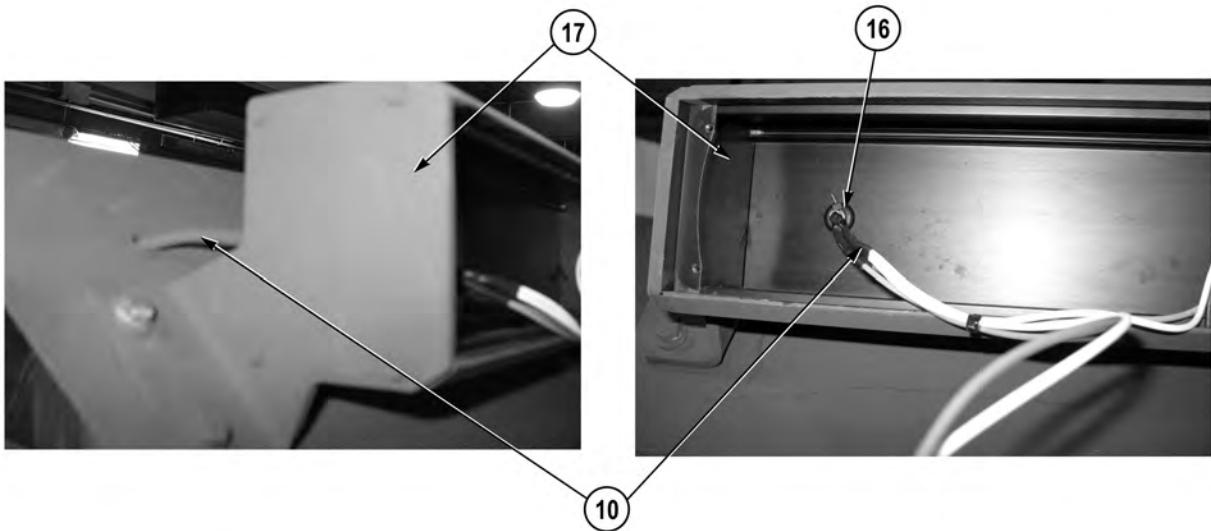
**NOTE**

- Tag and mark wires prior to removal to ensure proper installation.
  - Remove cable ties as required.
3. Remove nut (5), lockwasher (6), cushion clip (7), washer (8), and screw (9) from vehicle. Discard lockwasher.
  4. Cut lightbar cable assembly branch (10) red wire (11) from connector (12) (TM 9-2320-325-14&P).
  5. Cut lightbar cable assembly branch (10) green wire (13) from connector (12) (TM 9-2320-325-14&P).



6. Cut lightbar cable assembly branch (10) black wire (14) from connector (12) (TM 9-2320-325-14&P).
7. De-pin lightbar cable assembly branch (10) white wire (15) from connector (12) (TM 9-2320-325-14&P).





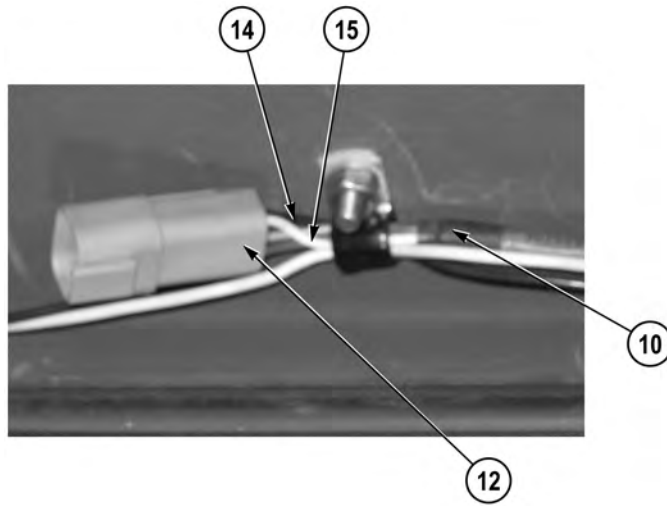
8. Remove lightbar cable assembly branch (10) and grommet (16) from cab side lightbar (17).

#### END OF TASK

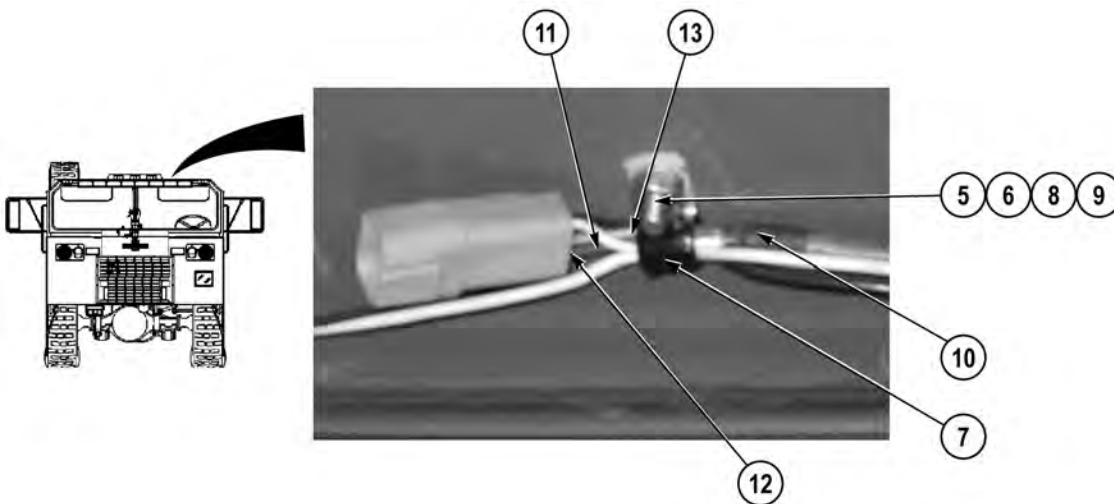
#### INSTALLATION

#### NOTE

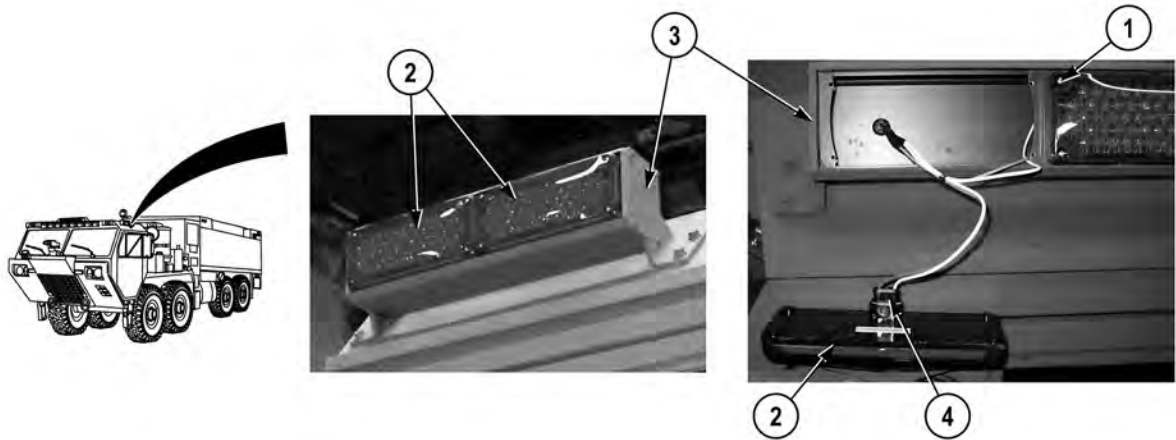
- Both lightbar cable assembly branches are installed the same way. Driver side shown.
  - Install cable ties as required.
1. Install grommet (16) and lightbar cable assembly branch (10) on cab side lightbar (17).



2. Repair lightbar cable assembly branch (10) white wire (15) on connector (12) (TM 9-2320-325-14&P).
3. Repair lightbar cable assembly branch (10) black wire (14) on connector (12).



4. Repair lightbar cable assembly branch (10) green wire (13) on connector (12) (TM 9-2320-325-14&P).
5. Repair lightbar cable assembly branch (10) red wire (11) on connector (12) (TM 9-2320-325-14&P).
6. Position screw (9) on vehicle with washer (8), cushion clip (7), lockwasher (6), and nut (5).



7. Connect two lights (2) on lightbar cable assembly connectors (4).
8. Install two lights (2) on cab side lightbar (3) with eight screws (1).

**END OF TASK**

**FOLLOW-ON MAINTENANCE**

Install cab front lightbar driver side only (WP 0224)

**END OF TASK**

**END OF WORK PACKAGE**



---

**FIELD LEVEL MAINTENANCE**  
**LIGHTBAR CABLE ASSEMBLY REPLACEMENT**

---

**INITIAL SETUP:****Tools and Special Tools**

Tool Kit, General Mechanic's: Automotive  
(WP 0398, Item 17)

**Materials/Parts**

Tags, Identification (WP 0400, Item 23)  
Ties, Cable, Plastic (WP 0400, Item 26)

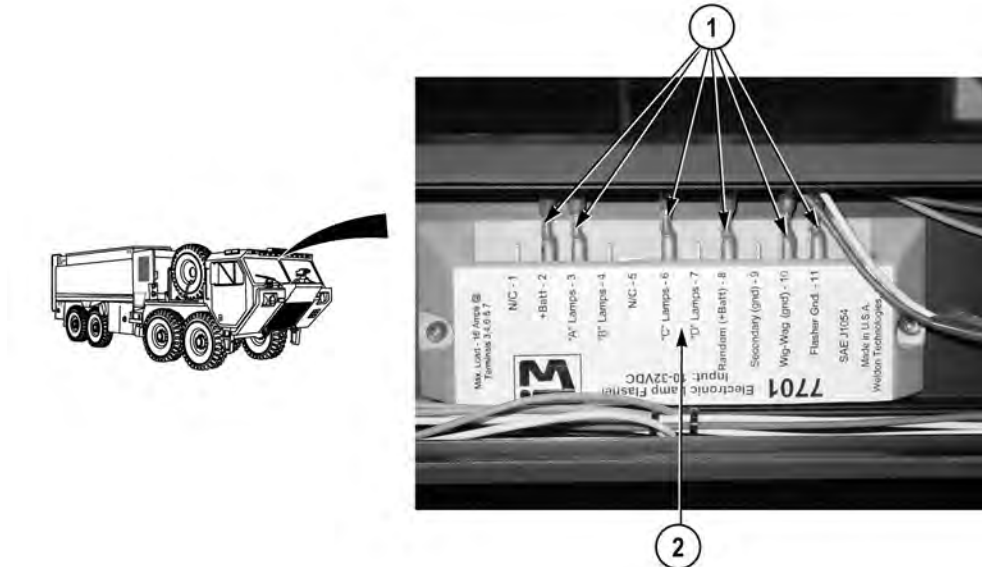
**References**

TM 9-2320-325-14&P  
WP 0287  
WP 0391, Fig. 27

**Equipment Conditions**

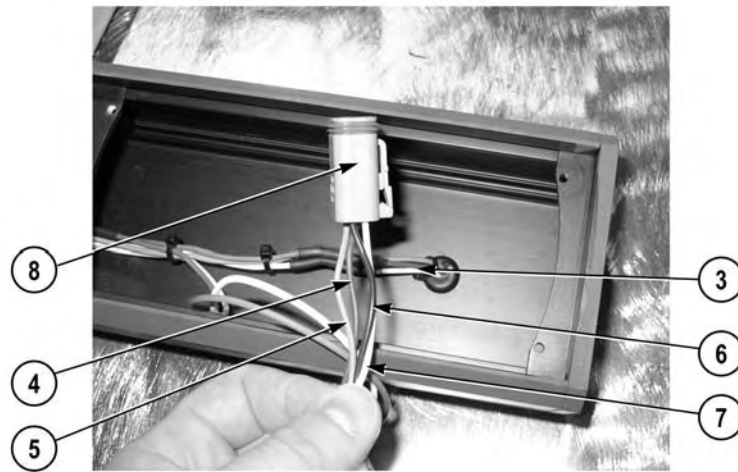
Cab front lightbar removed (WP 0224)

---

**REMOVAL****NOTE**

- Tag and mark wires prior to removal to ensure proper installation.
- Note routing of wires prior to removal to ensure proper installation.
- Remove cable ties as required.

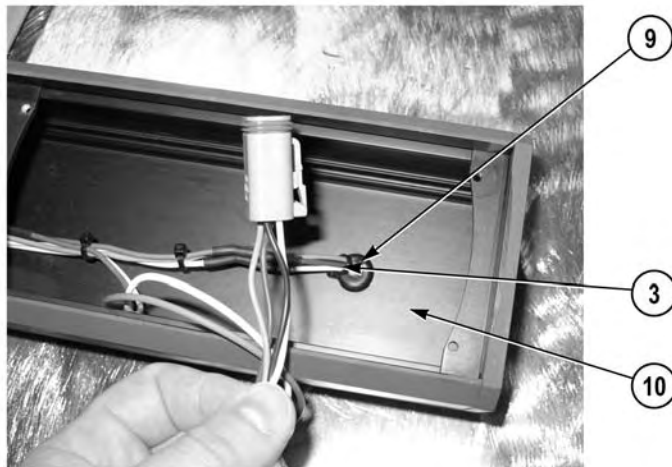
1. Remove six wires (1) from lightbar flasher unit (2) (WP 0287).



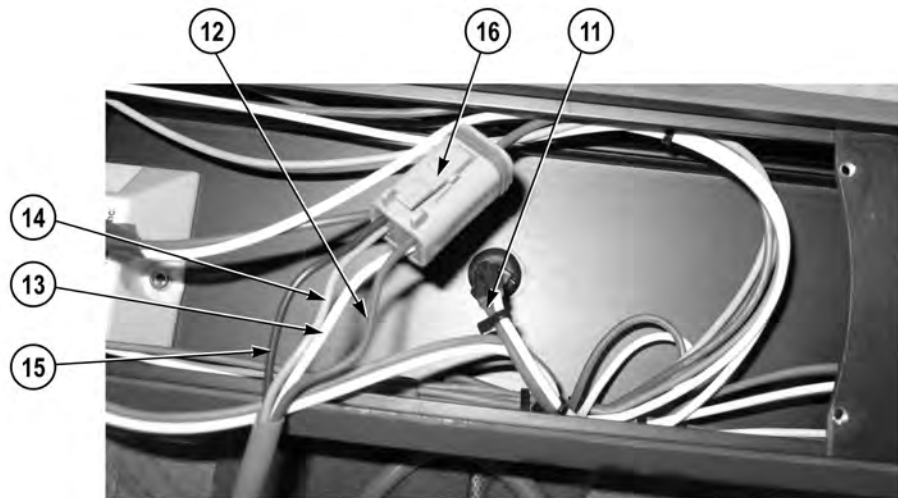
### NOTE

Perform Steps (2) through (3) to remove driver side lightbar end cable.

2. Cut driver side lightbar end cable (3) red wire (4), green wire (5), black wire (6), and white wire (7) from connector (8) (TM 9-2320-325-14&P).

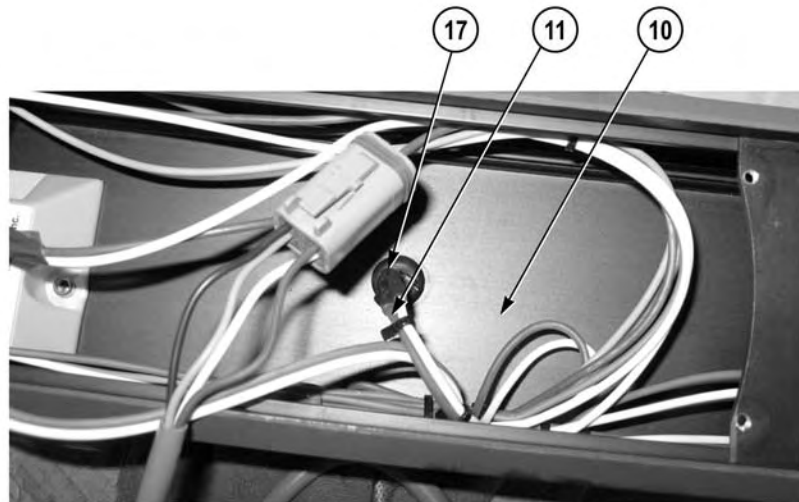


3. Remove driver side lightbar end cable (3) and grommet (9) from cab front lightbar (10).

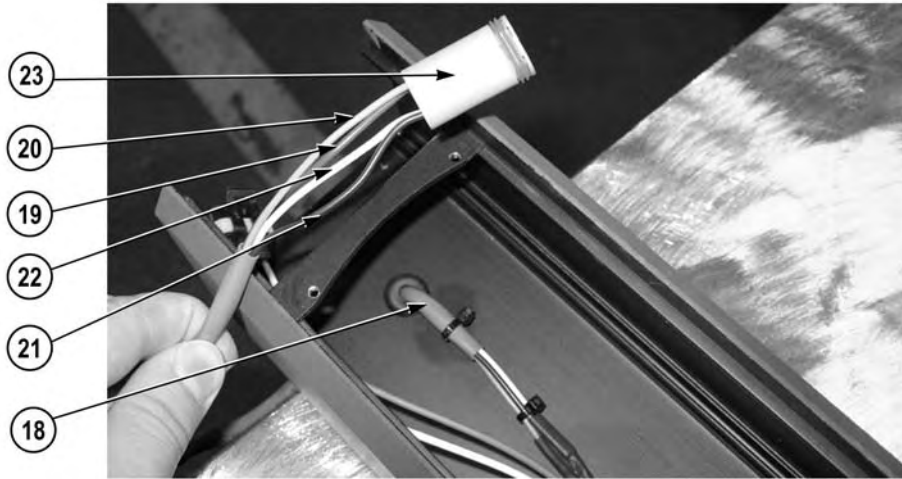
**NOTE**

Perform Steps (4) and (5) to remove center lightbar cable assembly.

4. Cut center cable (11) red wire (12), white wire (13), green wire (14), and black wire (15) from connector (16) (TM 9-2320-325-14&P).



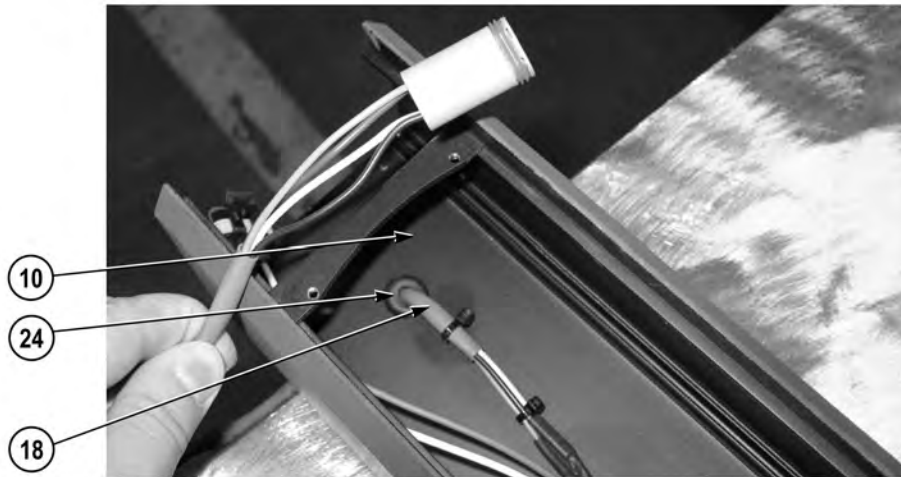
5. Remove lightbar center cable (11) and grommet (17) from cab front lightbar (10).



**NOTE**

Perform Steps (6) and (7) to remove passenger side lightbar cable.

6. Cut passenger side lightbar end cable (18), red wire (19), green wire (20), black wire (21), and white wire (22) from connector (23) (TM 9-2320-325-14&P).



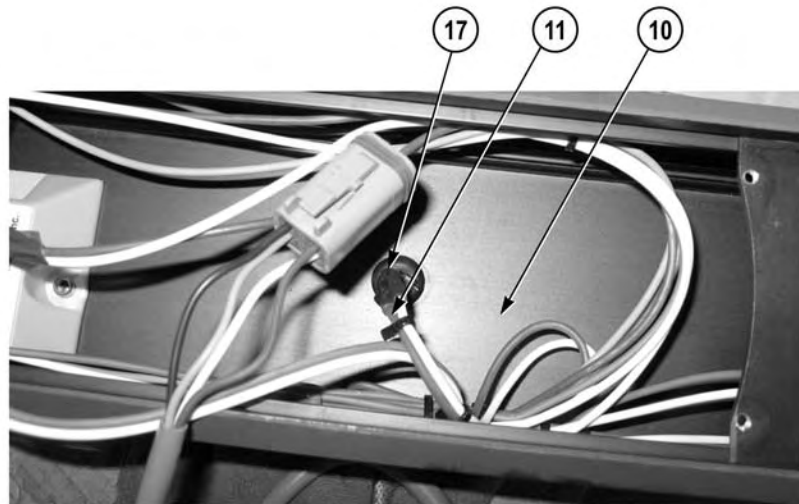
7. Remove passenger side lightbar end cable (18) and grommet (24) from cab front lightbar (10).

**END OF TASK**



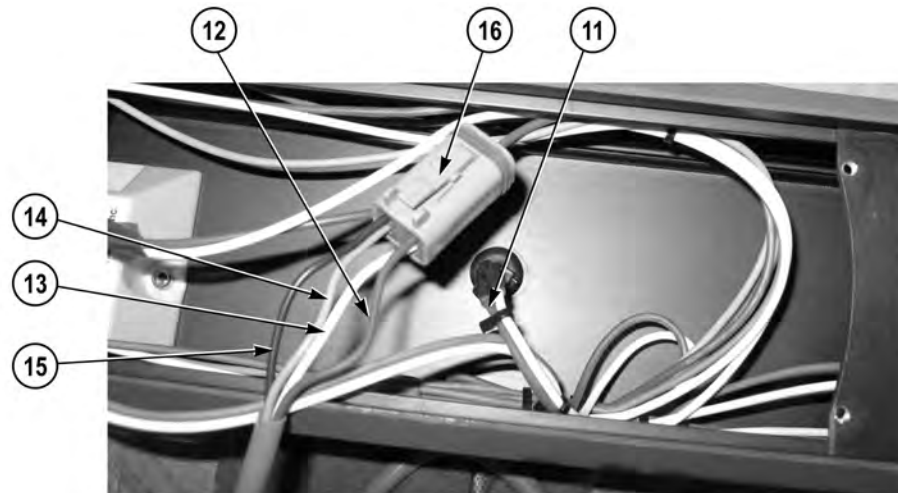
**INSTALLATION****NOTE**

- Perform Steps (1) and (2) to install passenger side lightbar end cable.
  - Install cable ties as required.
  - Route wires as noted prior to removal.
1. Install grommet (24) and passenger side lightbar end cable (18) on cab front lightbar (10).
  2. Repair passenger side lightbar end cable (18) white wire (22), black wire (21), green wire (20), and red wire (19) on connector (23) (TM 9-2320-325-14&P).

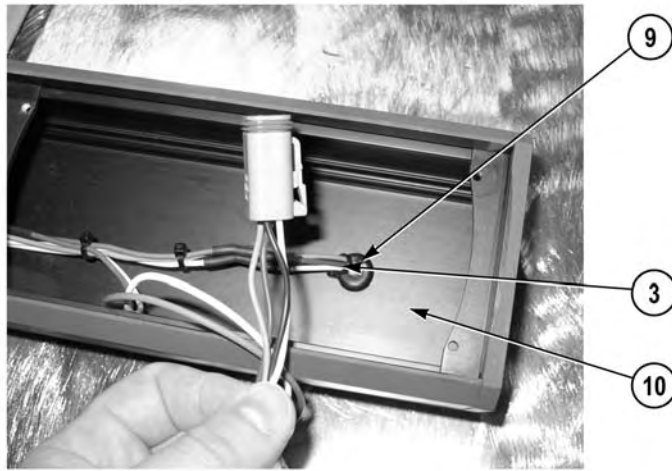
**NOTE**

Perform Steps (3) and (4) to install center lightbar cable.

3. Install grommet (17) and lightbar center cable (11) on cab front lightbar (10).



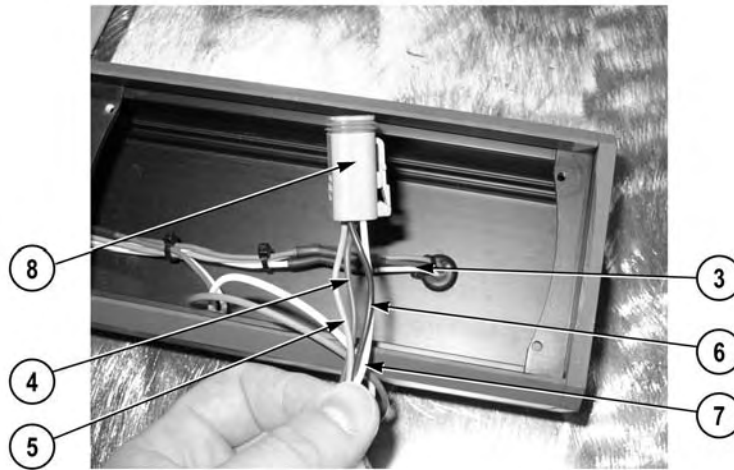
4. Repair center cable (11) black wire (15), green wire (14), white wire (13), and red wire (12) on connector (16) (TM 9-2320-325-14&P).



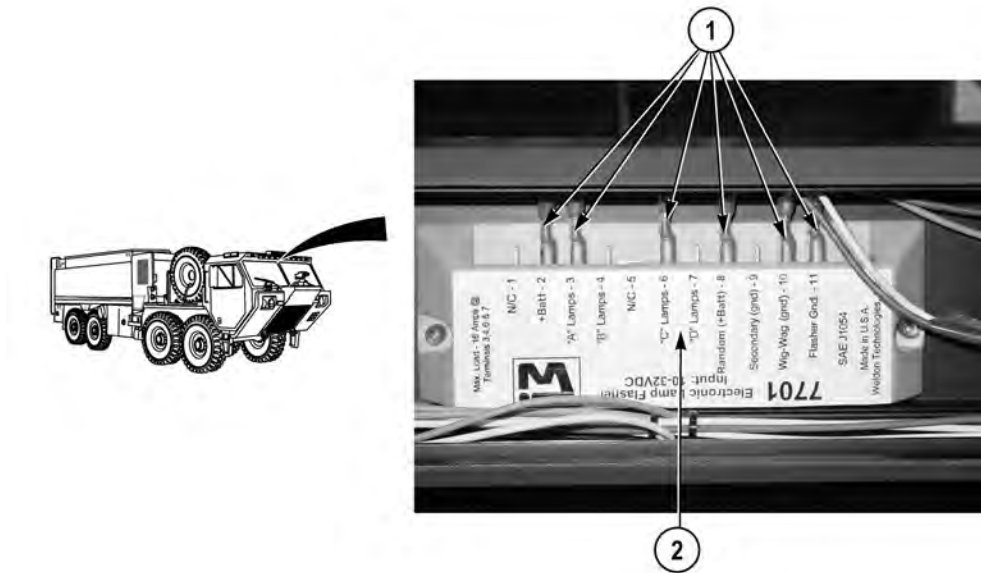
**NOTE**

Perform Steps (5) and (6) to install driver side lightbar end cable.

5. Install grommet (9) and driver side lightbar end cable (3) on cab front lightbar (10).



6. Repair driver side lightbar end cable (3) white wire (7), black wire (6), green wire (5), and red wire (4) on connector (8) (TM 9-2320-325-14&P).



7. Install six wires (1) on lightbar flasher unit (2) (WP 0287).

**END OF TASK**

**FOLLOW-ON MAINTENANCE**

Install cab front lightbar (WP 0224)

**END OF TASK**

**END OF WORK PACKAGE**



---

**FIELD LEVEL MAINTENANCE**  
**MAIN WIRE HARNESS REPLACEMENT**

---

**INITIAL SETUP:****Tools and Special Tools**

Tool Kit, General Mechanic's: Automotive  
(WP 0398, Item 17)

**Materials/Parts**

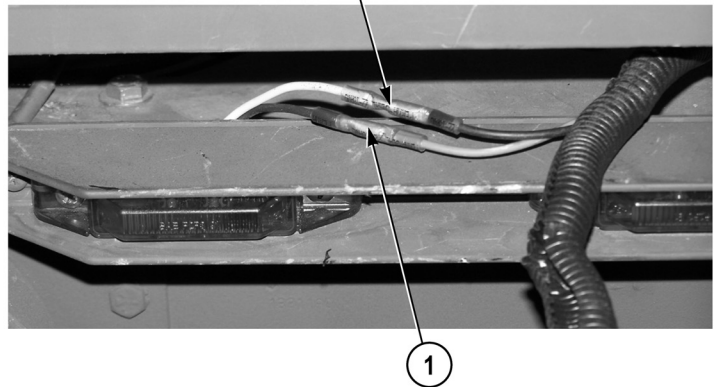
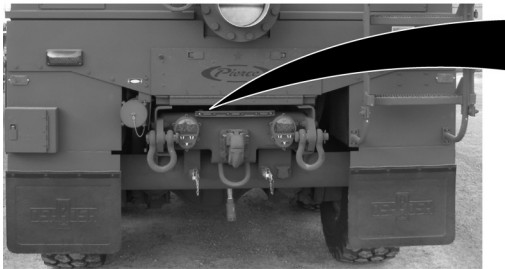
Tags, Identification (WP 0400, Item 23)  
Ties, Cable, Plastic (WP 0400, Item 26)  
Lockwasher (1)  
Lockwasher (1)  
Lockwasher (1)

**References**

TM 9-2320-325-14&P  
WP 0391, Fig. 49

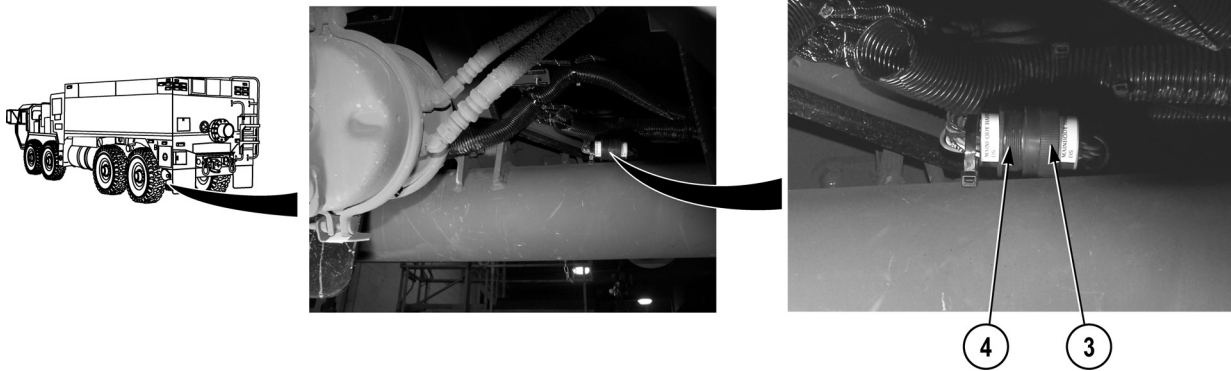
**Equipment Conditions**

Pump house panel K removed (WP 0339)  
Cab instrument panel A, D, and E  
removed (WP 0205)  
Skid plate grille removed (WP 0349)  
Passenger side center lower stowage  
compartment door opened (WP 0008)  
Driver side lower stowage compartment door  
opened (WP 0008)  
Passenger side rear lower stowage compartment  
door opened (WP 0008)  
Lower warning lights removed (WP 0231)

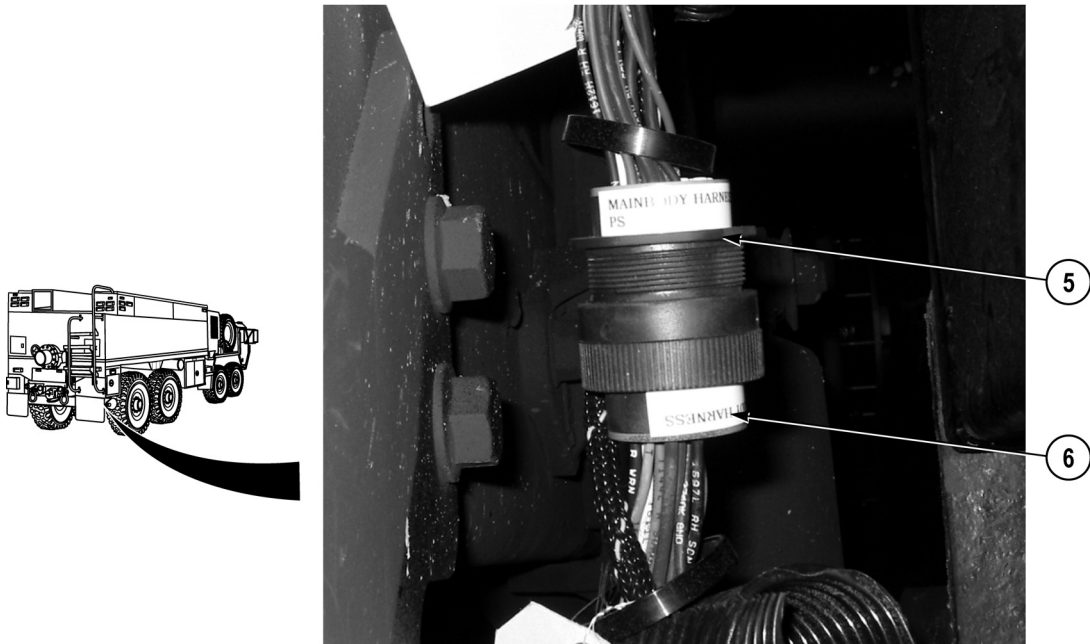
**REMOVAL****NOTE**

- Tag and mark wires prior to removal to ensure proper installation.
- Note routing of main wire harness prior to removal to ensure proper installation.
- Note position and remove cable ties, split loom, and cushion clips as required.

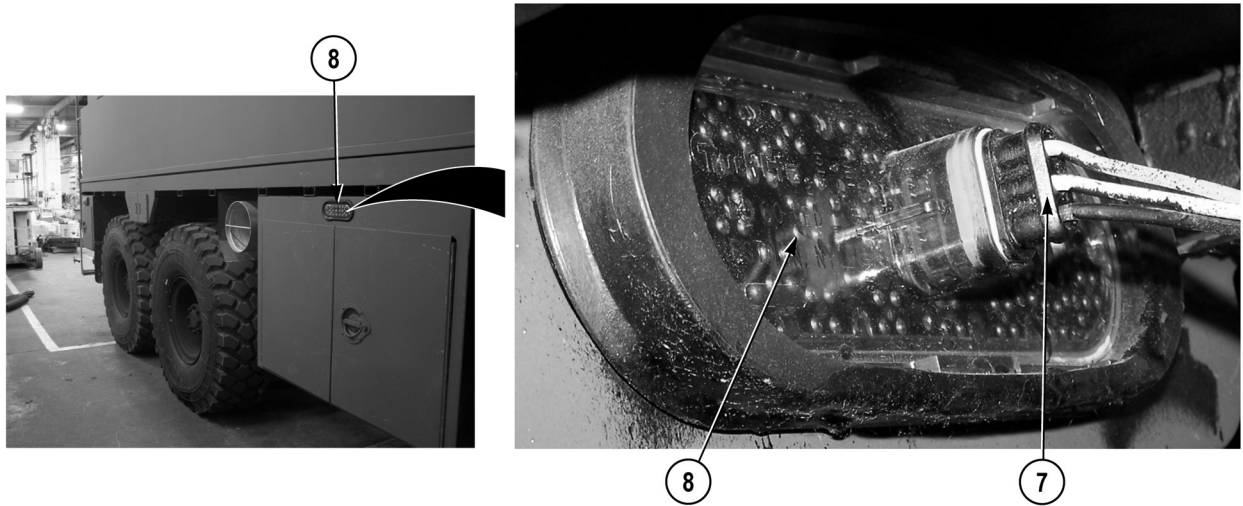
1. Cut wire 1606 (1) and wire 1640 (2) (TM 9-2320-325-14&P).



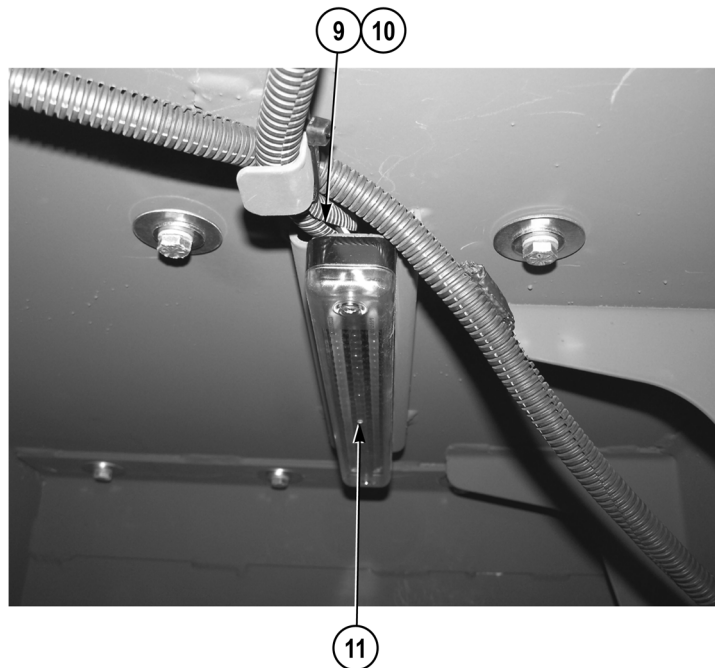
2. Disconnect driver side body wire harness connector (3) from main wire harness connector (4).



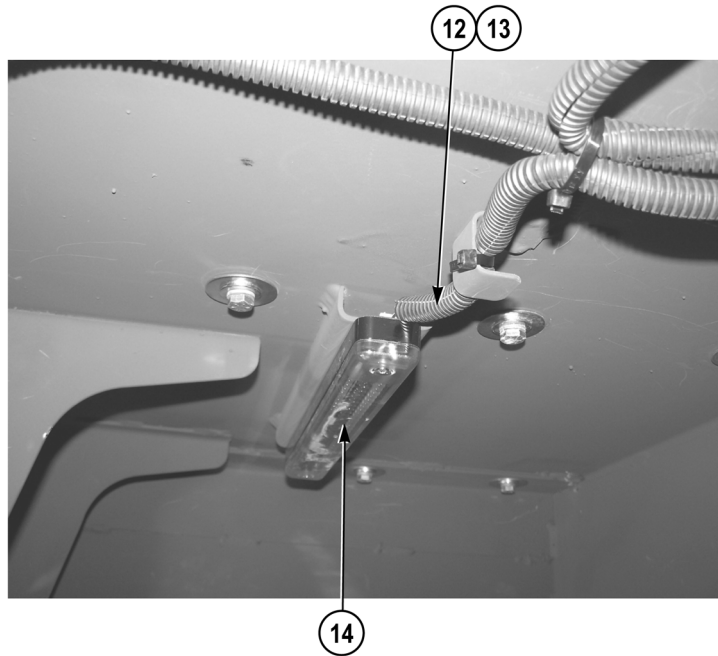
3. Disconnect passenger side body wire harness connector (5) from main wire harness connector (6).



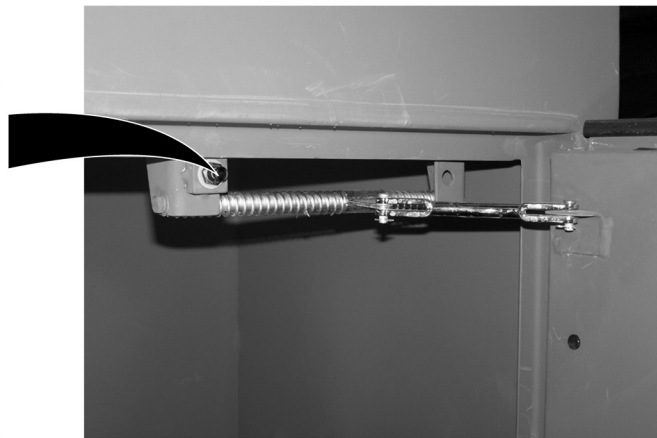
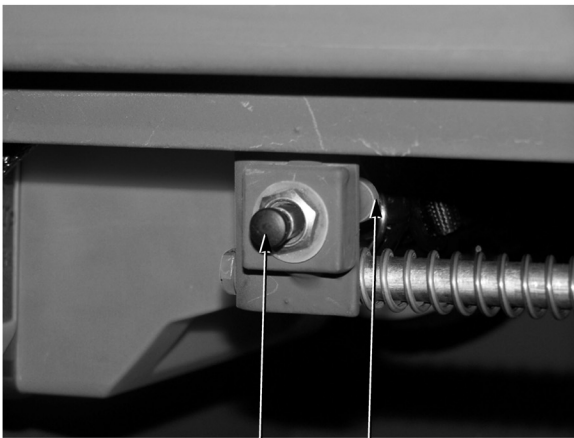
4. Disconnect main wire harness connector (7) from passenger side marker/clearance/side turn (amber) LED light assembly (8).



5. Cut wire 1189 (9) and wire 1479 (10) from passenger side center lower stowage compartment (forward) striplight (11) (TM 9-2320-325-14&P).

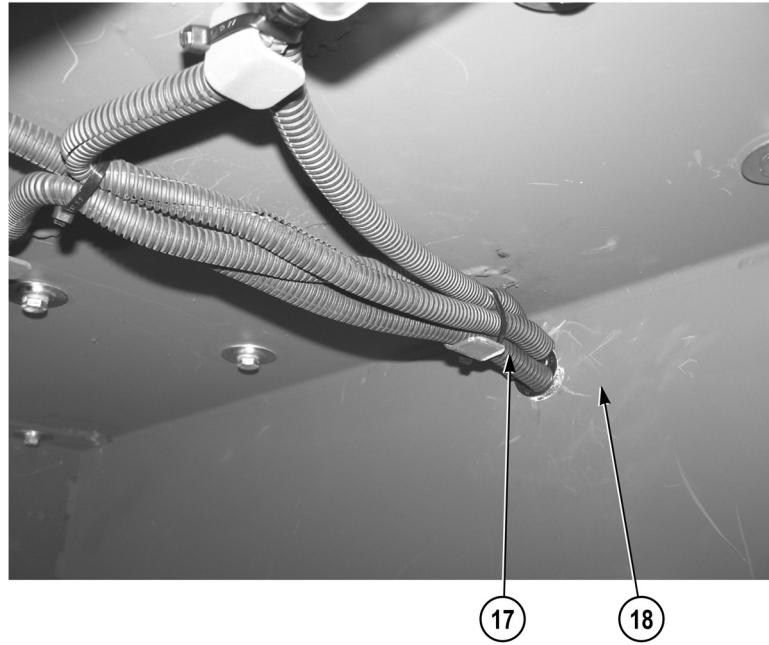


6. Cut wire 1189 (12) and wire 1479 (13) from passenger side center lower stowage compartment (rear) striplight (14) (TM 9-2320-325-14&P).

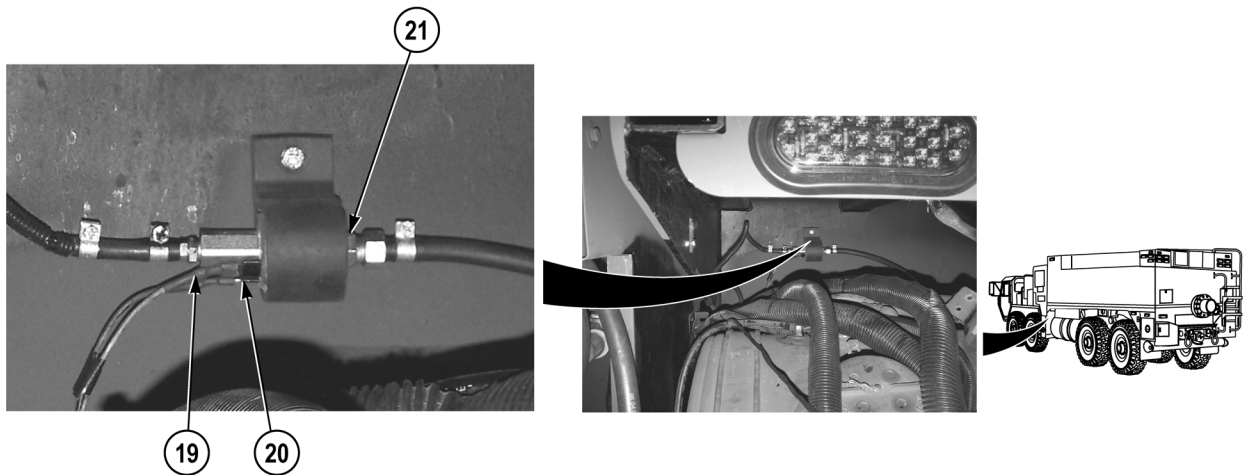


7. Disconnect main wire harness connector (15) from passenger side center lower stowage compartment door switch (16).

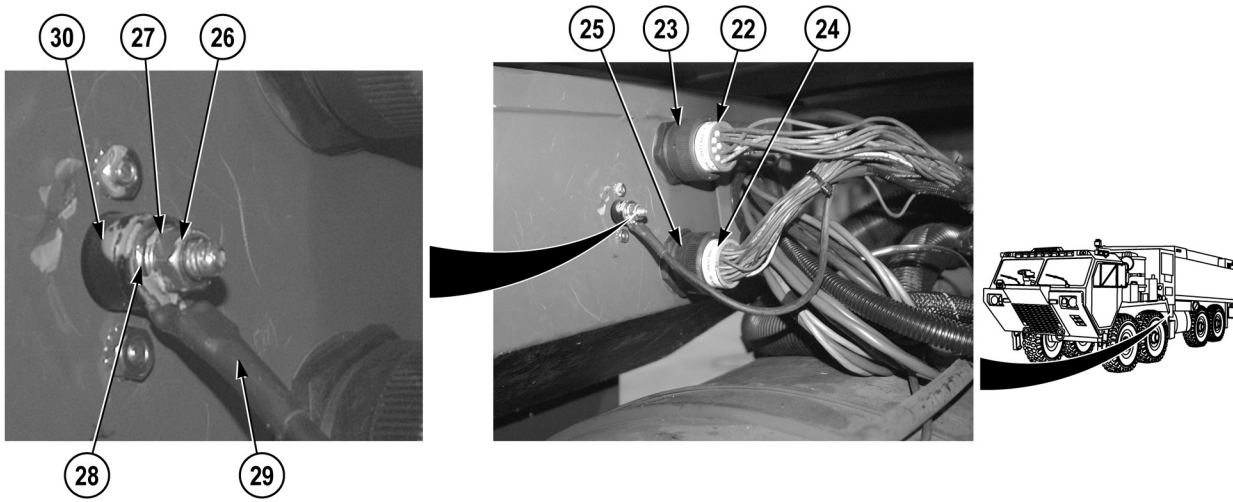




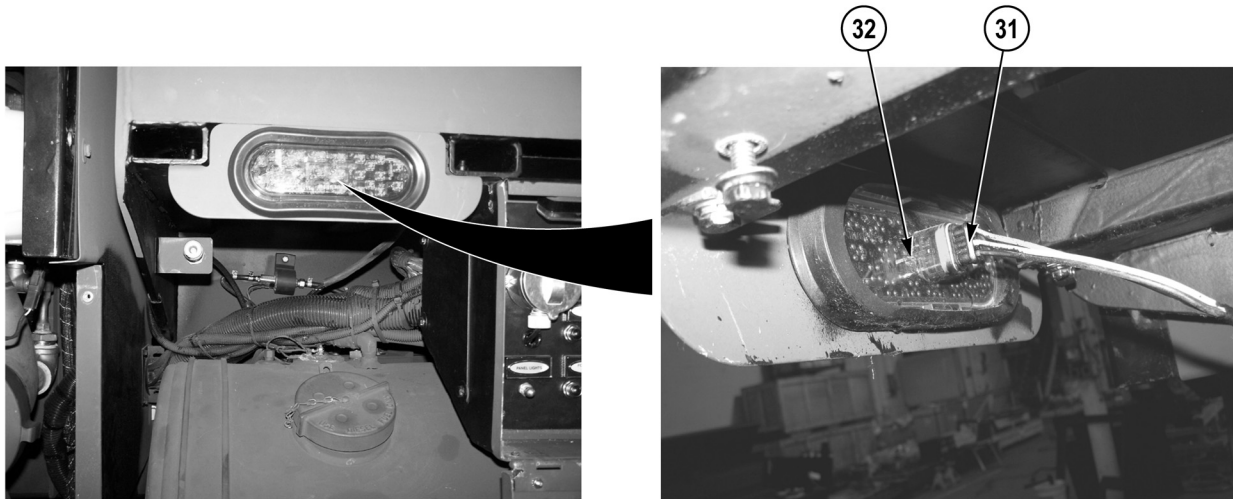
8. Remove main wire harness (17) from passenger side center lower storage compartment (18).



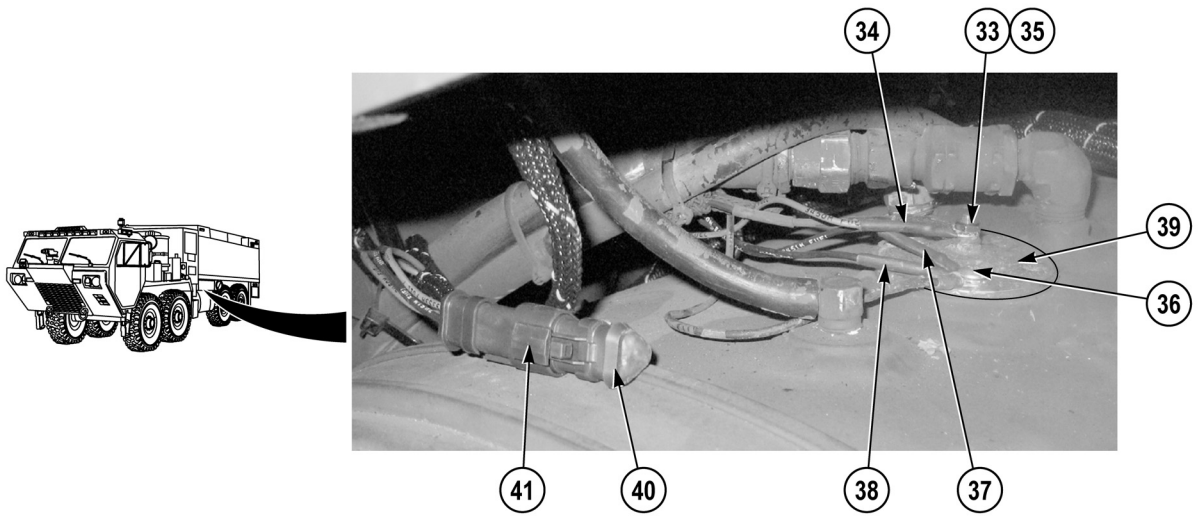
9. Disconnect wire 4089 (19) and wire 4090 (20) connector from pump house heater fuel pump (21).



10. Disconnect main wire harness connector (22) from pump operator's panel wire harness connector (23).
11. Disconnect main wire harness connector (24) from pump operator's panel wire harness connector (25).
12. Remove nut (26), lockwasher (27), washer (28), and wire 3230 (29) from pump operator's panel ground terminal block (30). Discard lockwasher.



13. Disconnect main wire harness connector (31) from driver side marker/clearance/side turn (amber) LED light assembly (32).

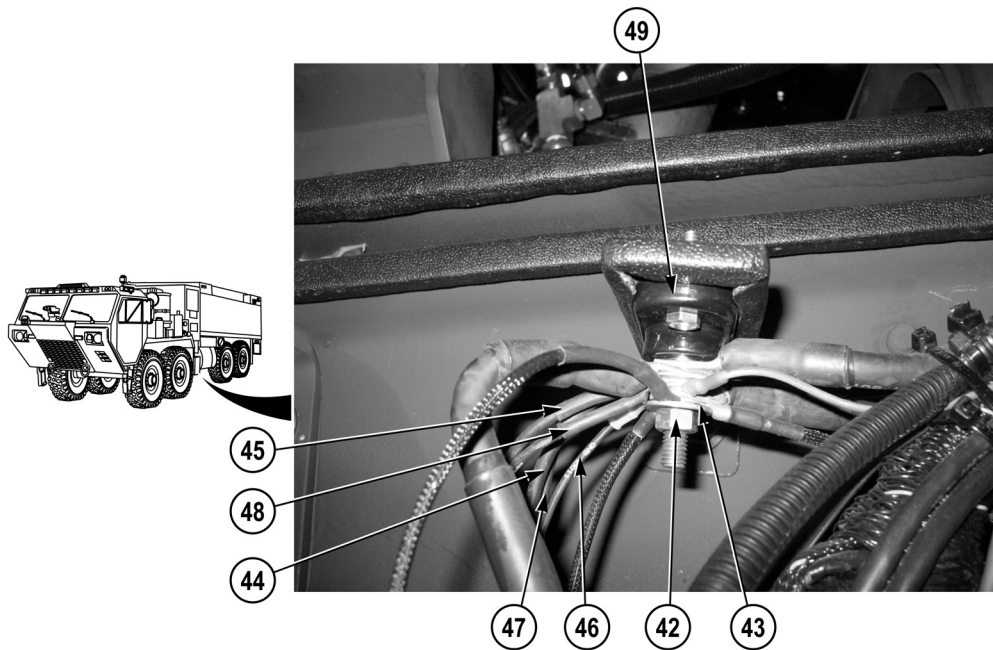


14. Remove locknut (33) and wire 3450 (34) from stud (35). Discard locknut.
15. Remove screw (36), wire 3400 (37), and wire 2451 (38) from fuel tank pickup (39).

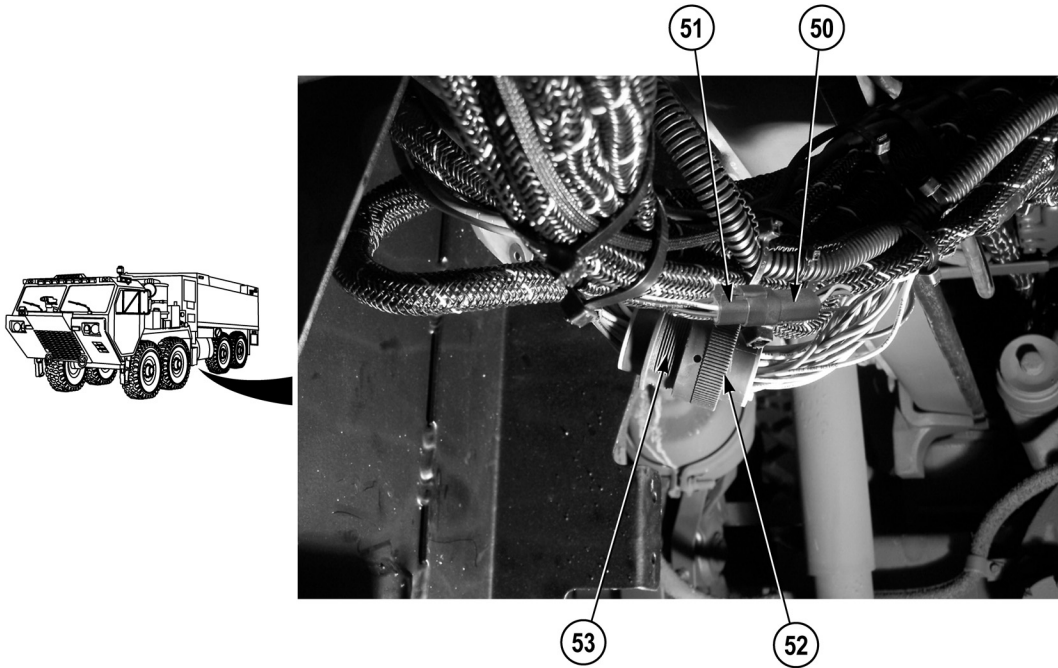
**NOTE**

Perform Step (16) if resistor pack needs to be removed from wire harness resistor pack connector.

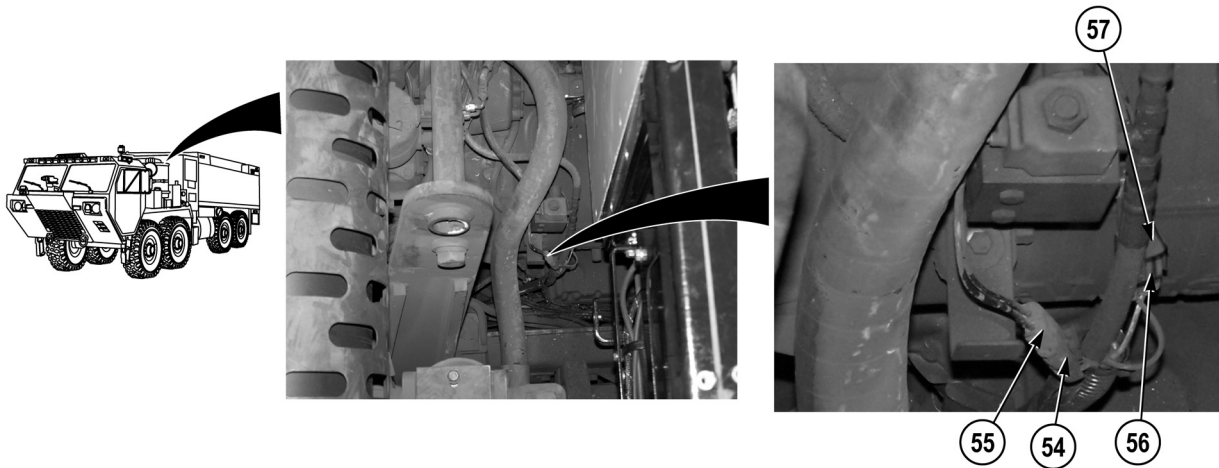
16. Remove resistor pack (40) from main wire harness resistor pack connector (41).



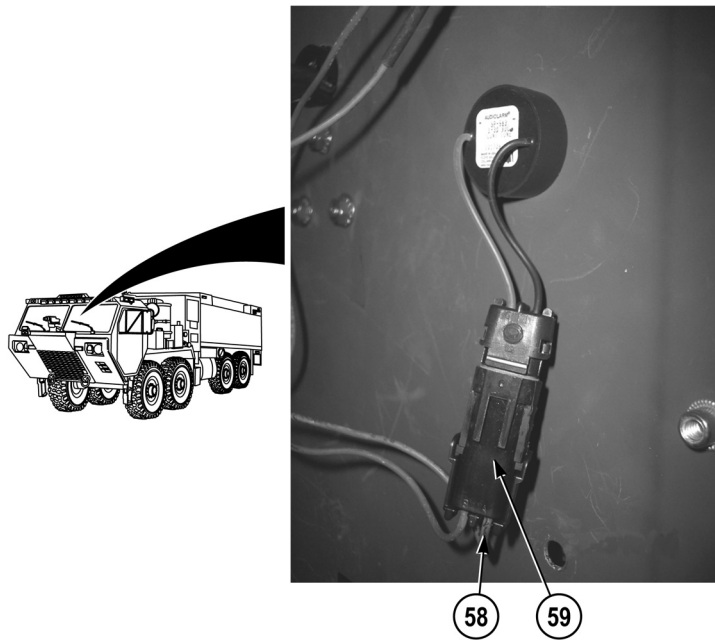
17. Remove nut (42), washer (43), wire 3230 (44), wire 1640 (45), wire 1100 (46), wire 2640 (47), and wire 2740 (48) from ground terminal block (49).



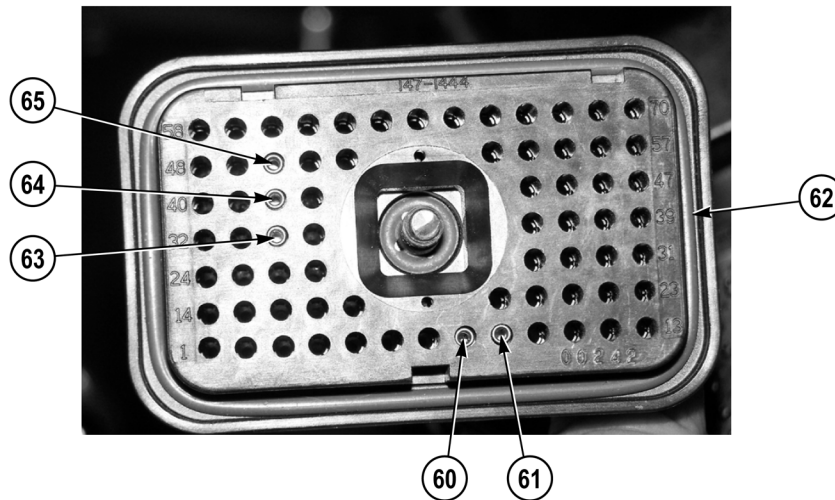
- 18. Disconnect main wire harness connector (50) from pump house wire harness connector (51).
- 19. Disconnect main wire harness connector (52) from pump house wire harness connector (53).



- 20. Disconnect main wire harness connector (54) from pump PTO solenoid connector (55).
- 21. Disconnect main wire harness connector (56) from pump PTO pressure switch connector (57).



22. De-pin wire 1647 (58) from rear step buzzer audio alarm connector (59) (TM 9-2320-325-14&P).

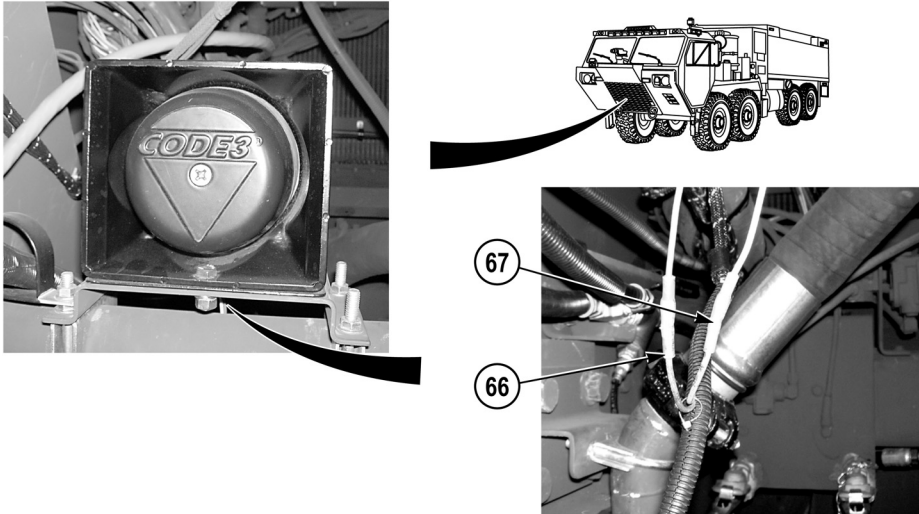


**NOTE**

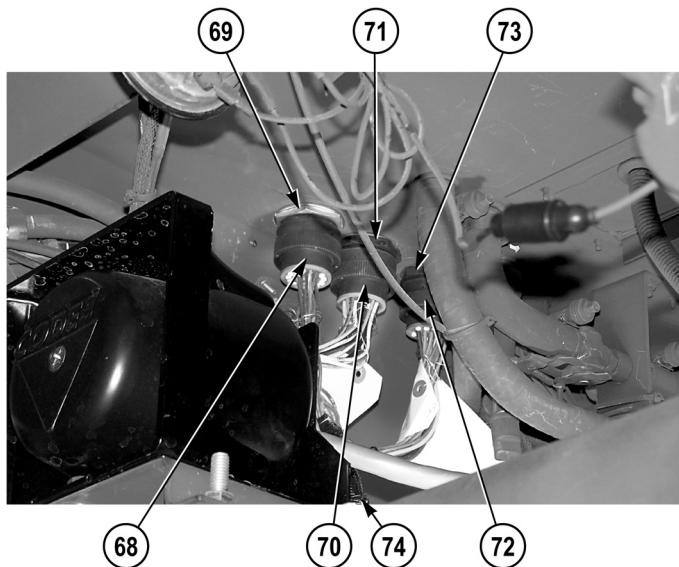
Perform Steps (23) and (24) if datalink connectors need to be removed from hydraforce display connector.

23. De-pin cat datalink pins (60) and (61) from main wire harness hydraforce display connector (62).

24. De-pin chassis datalink pins (63), (64), and (65) from main wire harness hydraforce display connector (62).

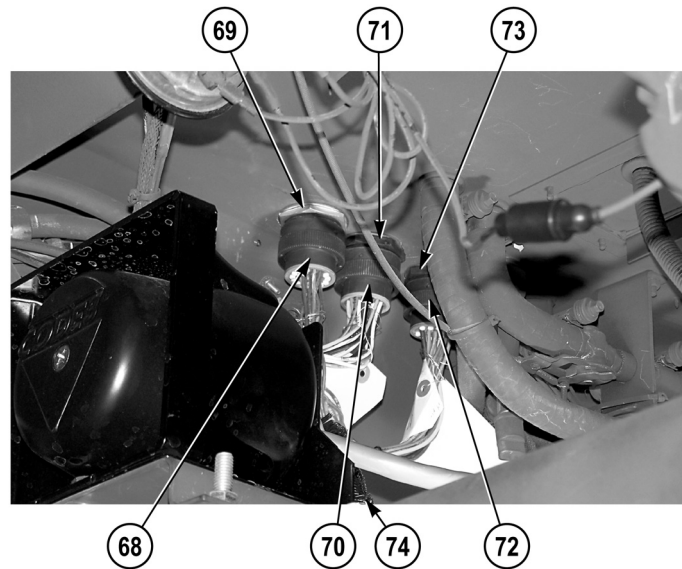


25. Cut wire 1611 (66) and wire 1640 (67) (TM 9-2320-325-14&P).

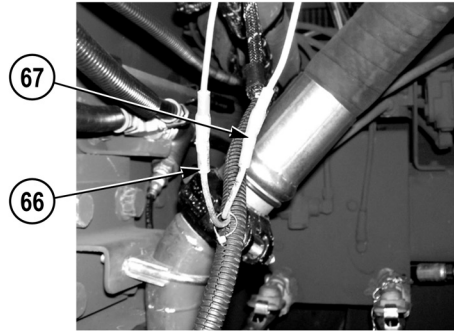
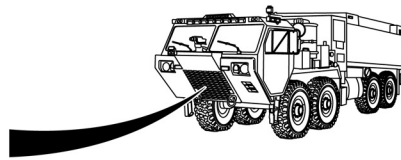


26. Disconnect main wire harness connector (68) from main 3 connector (69).
27. Disconnect main wire harness connector (70) from main 2 connector (71).
28. Disconnect main wire harness connector (72) from main 1 connector (73).
29. Remove main wire harness (74) from vehicle.

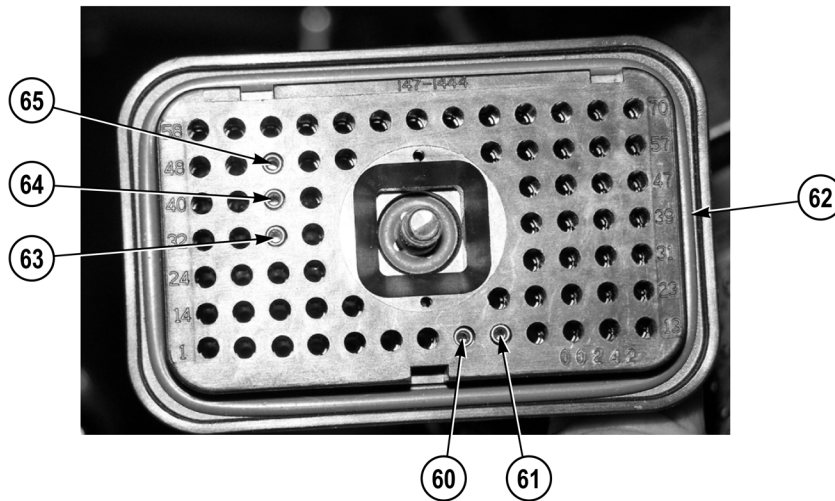
**END OF TASK**

**INSTALLATION****NOTE**

- Route main wire harness on vehicle as noted prior to removal.
  - Install cushion clips, split loom, and cable ties as required.
1. Position main wire harness (74) on vehicle.
  2. Connect main wire harness connector (72) on main 1 connector (73).
  3. Connect main wire harness connector (70) on main 2 connector (71).
  4. Connect main wire harness connector (68) on main 3 connector (69).



5. Repair wire 1611 (66) and wire 1640 (67) (TM 9-2320-325-14&P).

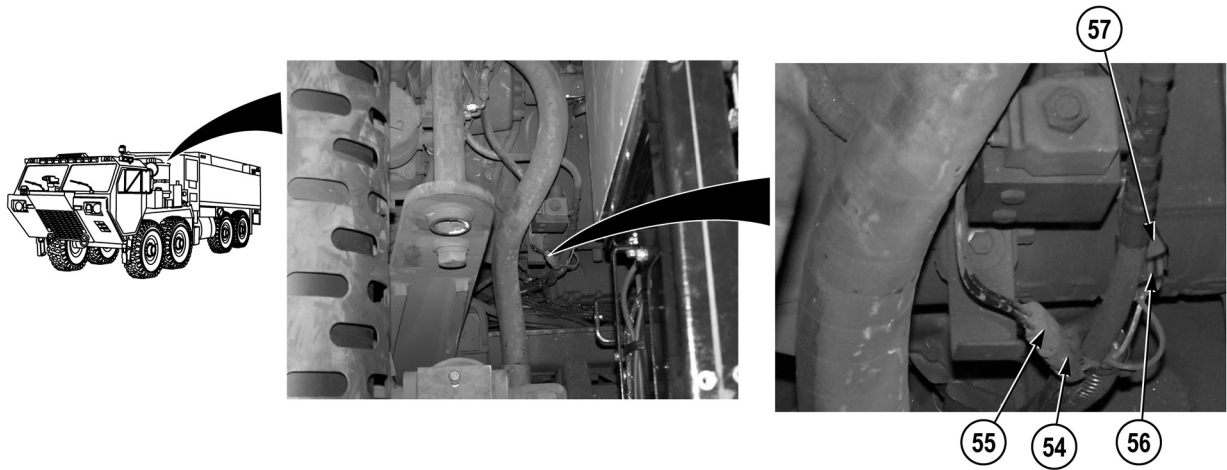


**NOTE**

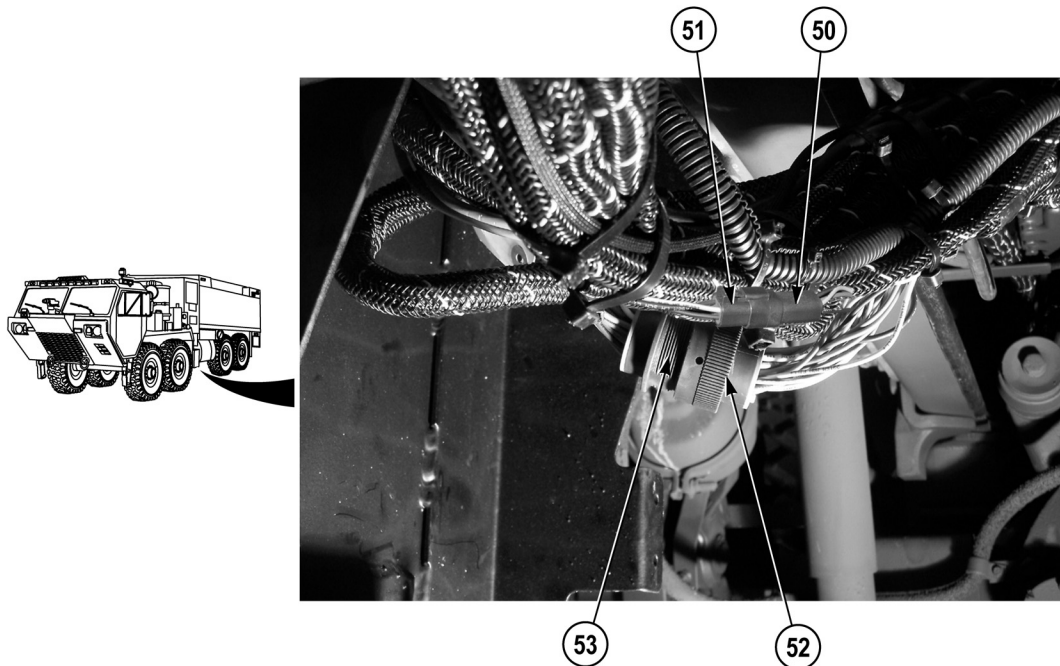
Perform Steps (6) and (7) if datalink connectors were removed from hydraforce display connector.

6. Install chassis datalink pins (63), (64), and (65) on main wire harness hydraforce display connector (62) (TM 9-2320-325-14&P).
7. Install cat datalink pins (60) and (61) on main wire harness hydraforce display connector (62) (TM 9-2320-325-14&P).

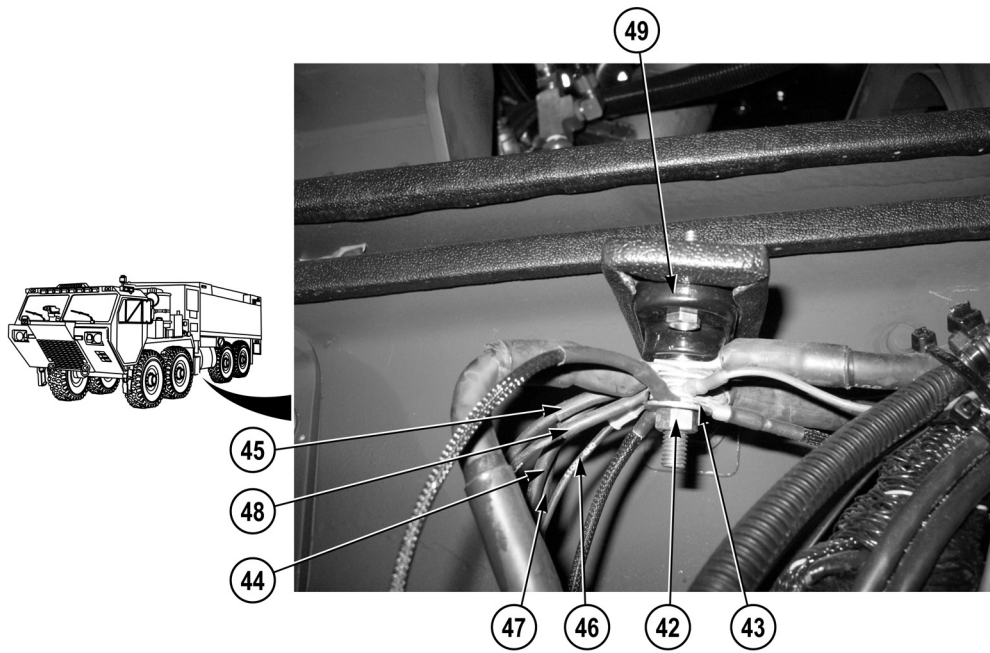




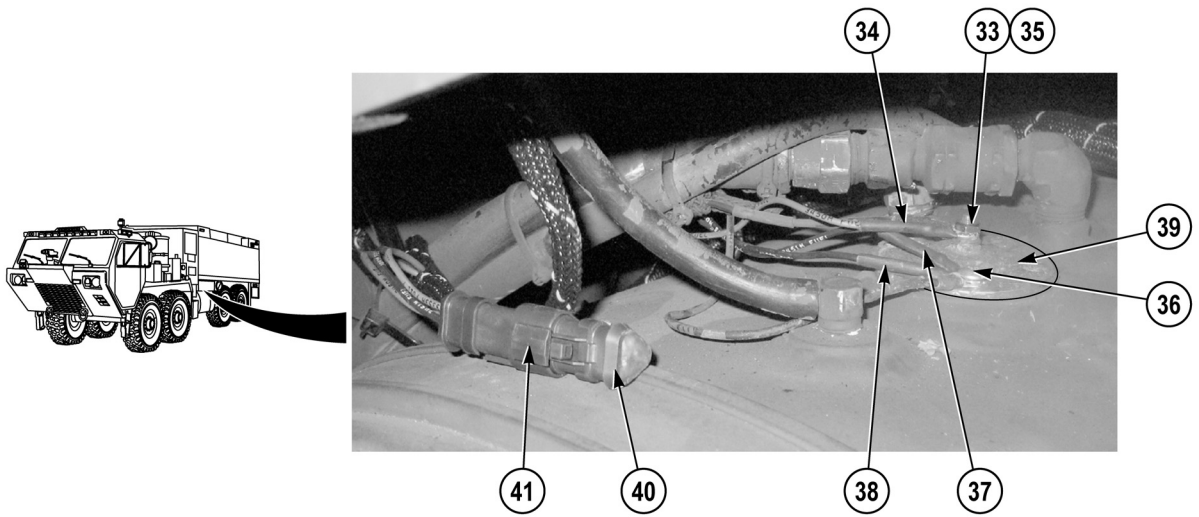
8. Connect main wire harness connector (56) on pump PTO pressure switch connector (57).
9. Connect main wire harness connector (54) on pump PTO solenoid connector (55).



10. Connect pump house wire harness connector (53) on main wire harness connector (52).
11. Connect pump house wire harness connector (51) on main wire harness connector (50).



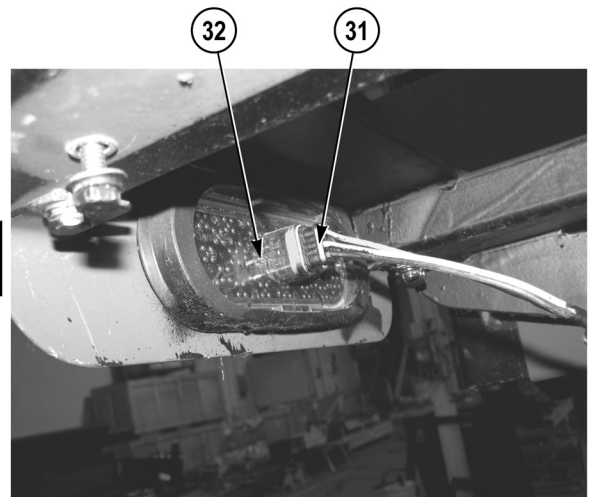
12. Install wire 2740 (48), wire 2640 (47), wire 1100 (46), wire 1640 (45), and wire 3230 (44) on ground terminal block (49) with washer (43) and nut (42).



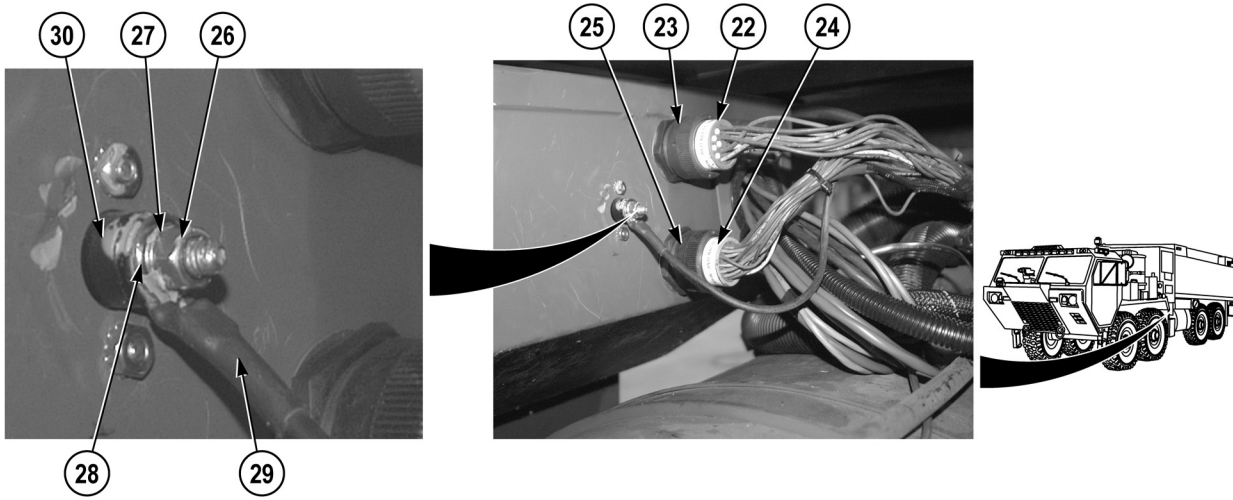
**NOTE**

Perform Step (13) if resistor pack was removed from main wire harness resistor pack connector.

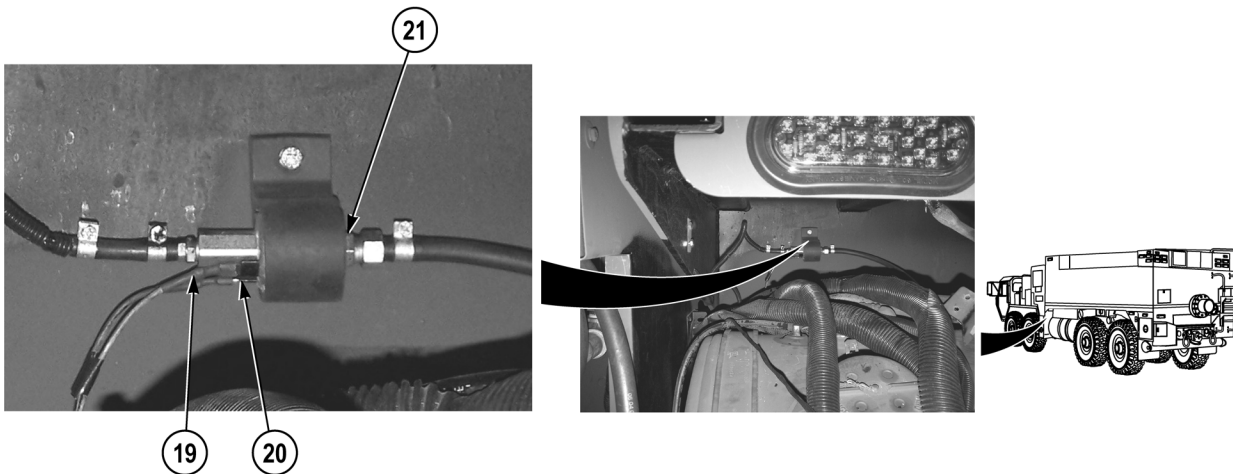
13. Install resistor pack (40) on main wire harness resistor pack connector (41).
14. Install wire 3451 (38) and wire 3400 (37) on fuel tank pickup (39) with screw (36).
15. Install wire 3450 (34) on stud (35) with locknut (33).



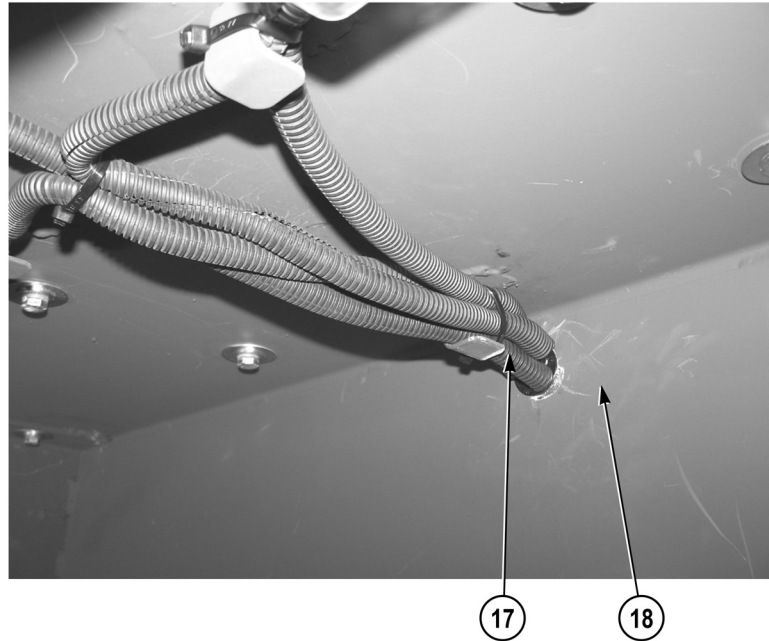
16. Connect main wire harness connector (31) on driver side marker/clearance/side turn (amber) LED light assembly (32).



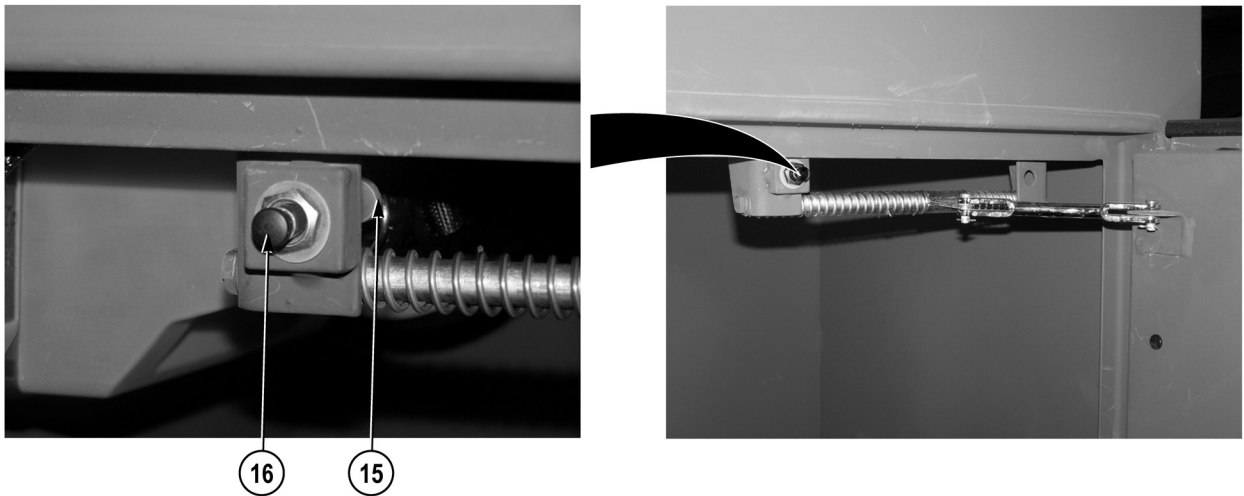
17. Install wire 3230 (29) on pump operator's panel ground terminal block (30) with washer (28), lockwasher (27), and nut (26).
18. Connect main wire harness connector (24) on pump operator's panel wire harness connector (25).
19. Connect main wire harness connector (22) on pump operator's panel wire harness connector (23).



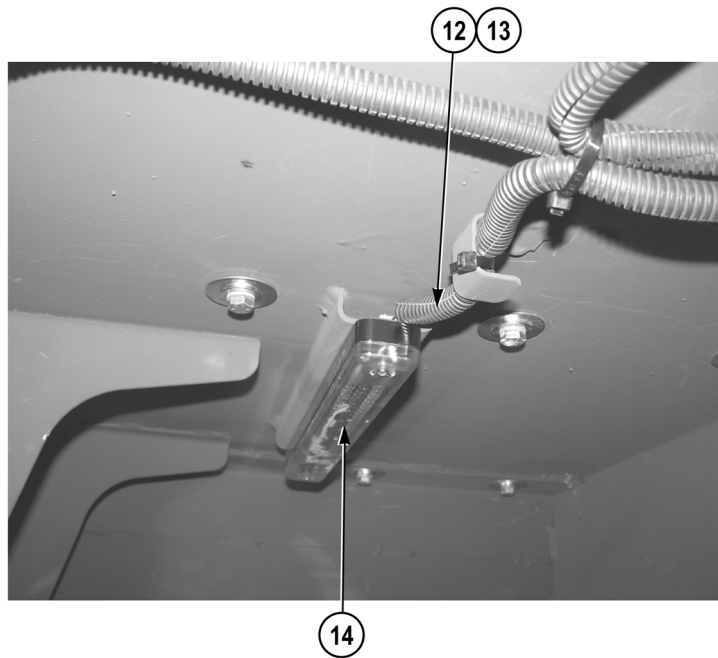
20. Connect wire 4089 (19) and wire 4090 (20) connectors on pump house heater fuel pump (21).



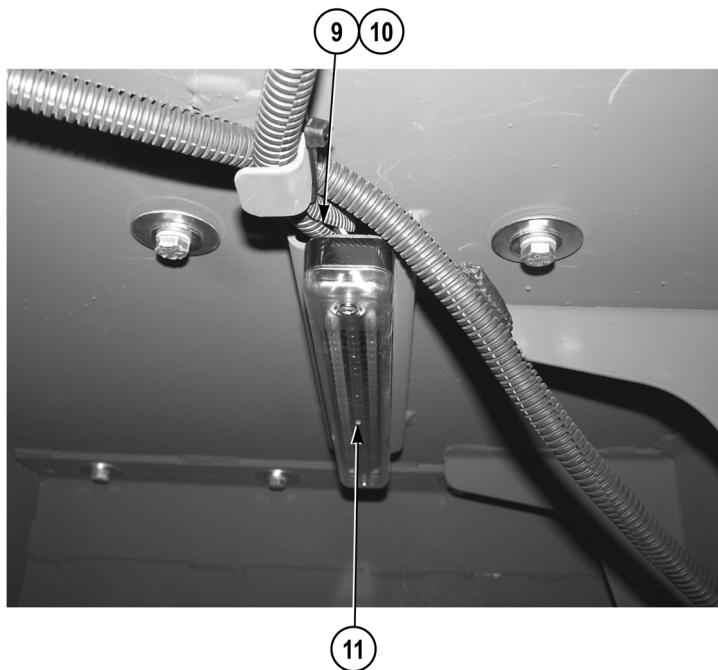
21. Route main wire harness (17) on passenger side center lower stowage compartment (18).



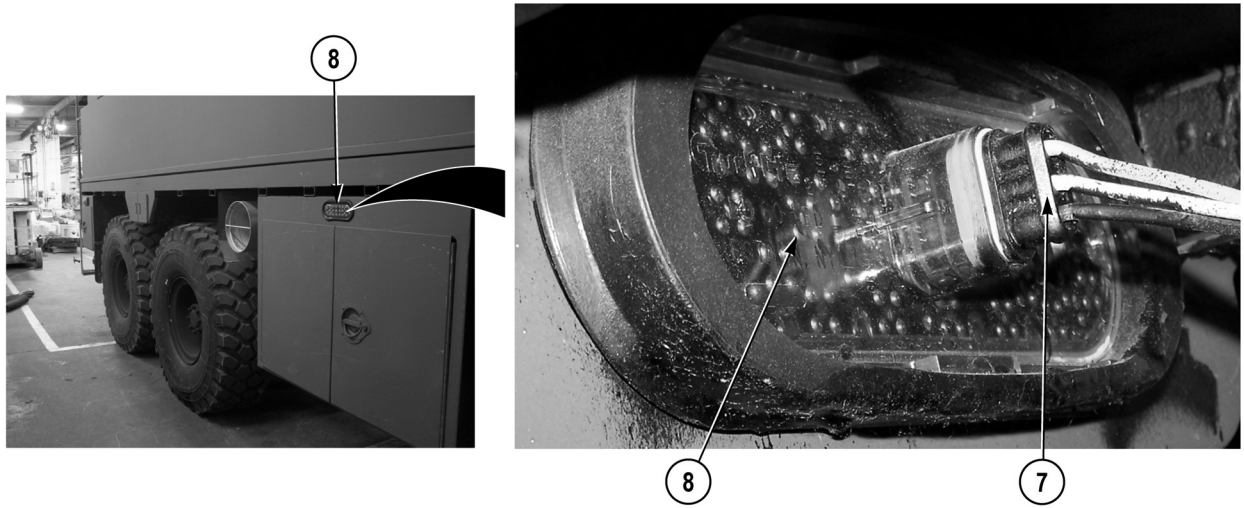
22. Connect main wire harness connector (15) on passenger side center lower stowage compartment door switch (16).



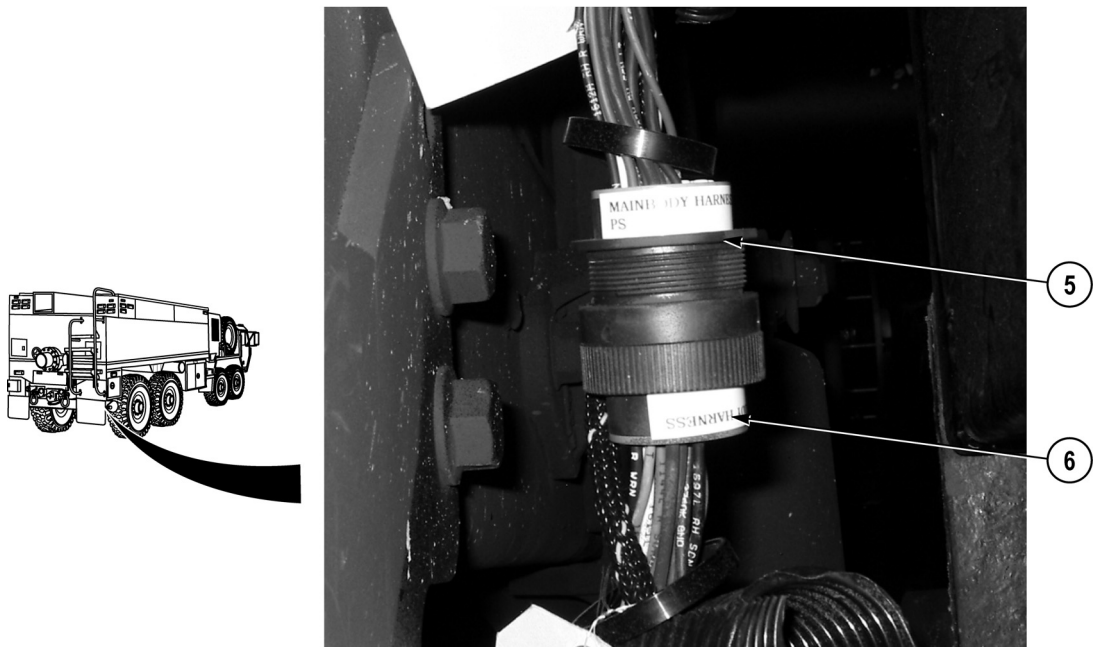
23. Repair wire 1189 (12) and wire 1479 (13) on passenger side center lower stowage compartment (rear) striplight (14).



24. Repair wire 1189 (9) and wire 1479 (10) on passenger side center lower stowage compartment (forward) striplight (11).



25. Connect main wire harness connector (7) on passenger side marker/clearance/side turn (amber) LED light assembly (8).



26. Connect passenger side body wire harness connector (5) on main wire harness connector (6).



27. Connect driver side body wire harness connector (3) on main wire harness connector (4).



28. Repair wire 1606 (1) and wire 1640 (2) (TM 9-2320-325-14&P).

#### END OF TASK

#### FOLLOW-ON MAINTENANCE

1. Install lower warning lights (WP 0231)
2. Close passenger side rear lower stowage compartment door (WP 0008)
3. Close driver side lower stowage compartment door (WP 0008)
4. Close passenger side center lower stowage compartment door (WP 0008)
5. Install skid plate grille (WP 0349)

#### END OF TASK

#### END OF WORK PACKAGE



## FIELD LEVEL MAINTENANCE

## NO. 1 DRIVER SIDE FLOW SENSOR WIRE HARNESS REPLACEMENT

## INITIAL SETUP:

**Tools and Special Tools**

Tool Kit, General Mechanic's: Automotive  
(WP 0398, Item 17)

**References**

WP 0391, Fig. 34

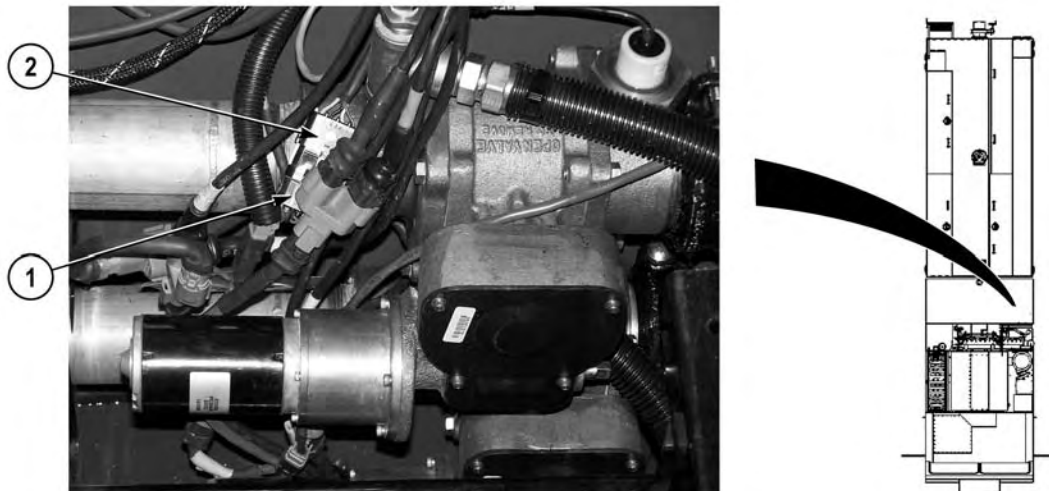
**Materials/Parts**

Tags, Identification (WP 0400, Item 23)  
Ties, Cable, Plastic (WP 0400, Item 26)

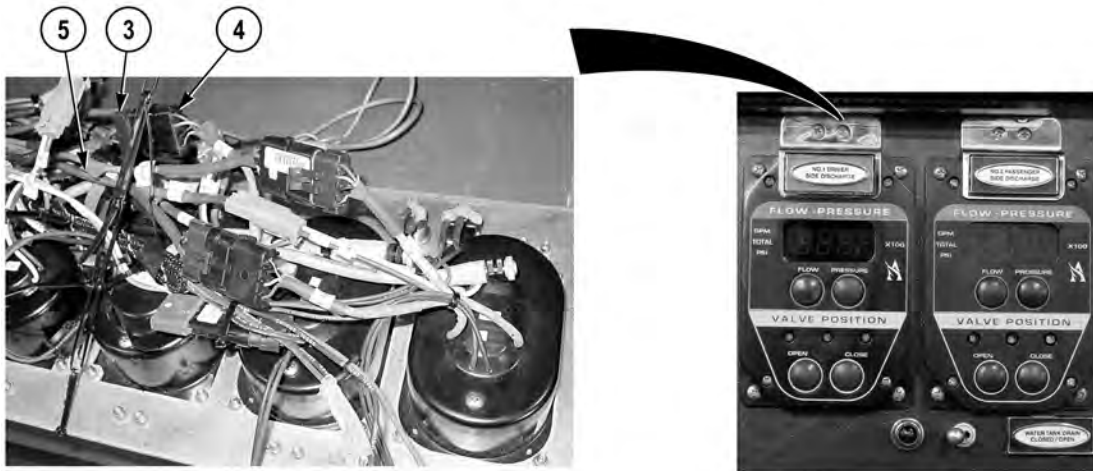
**Equipment Conditions**

Pump operator's panel opened (WP 0207)  
Pump house panel E removed (WP 0339)  
Pump house access door opened (WP 0008)

## REMOVAL

**NOTE**

- Note routing of No. 1 driver side flow sensor wire harness prior to removal to ensure proper installation.
  - No. 1 driver side flow sensor wire harness is routed from pump house to pump operator's panel assembly.
  - Note position and remove split loom, cushion clips, and cable ties as required.
  - Tag and mark connectors prior to removal to ensure proper installation.
1. Disconnect No. 1 driver side flow sensor wire harness connector (1) from No. 1 driver side flow sensor valve control connector (2).



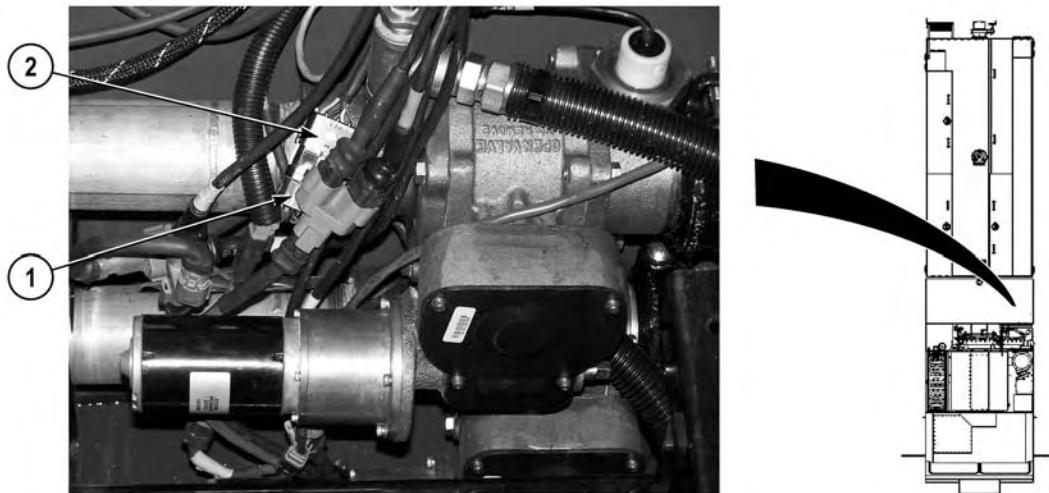
2. Disconnect No.1 driver side flow sensor wire harness connector (3) from No. 1 driver side flow sensor line connector (4).
3. Remove No. 1 driver side flow sensor wire harness (5) from vehicle.

#### END OF TASK

#### INSTALLATION

#### NOTE

- Route No. 1 driver side flow sensor wire harness as noted.
  - Install split loom, cushion clips, and cable ties as noted prior to removal.
1. Install No. 1 driver side flow sensor wire harness (5) on vehicle.
  2. Connect No. 1 driver side flow sensor wire harness connector (3) to No. 1 driver side flow sensor line connector (4).



3. Connect No. 1 driver side flow sensor valve control connector (2) to No. 1 driver side flow sensor wire harness connector (1).

**END OF TASK**

**FOLLOW-ON MAINTENANCE**

1. Install pump house panel E (WP 0339)
2. Close pump operator's panel (WP 0207)

**END OF TASK**

**END OF WORK PACKAGE**



## FIELD LEVEL MAINTENANCE

## NO. 1 DRIVER SIDE PRESSURE TRANSDUCER WIRE HARNESS REPLACEMENT

## INITIAL SETUP:

**Tools and Special Tools**

Tool Kit, General Mechanic's: Automotive  
(WP 0398, Item 17)

**References**

WP 0391, Fig. 34

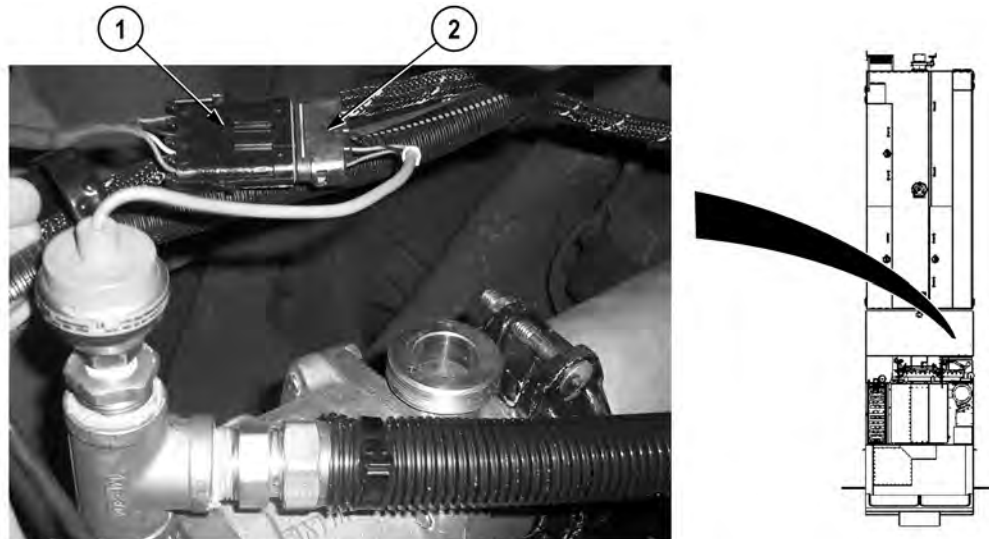
**Materials/Parts**

Tags, Identification (WP 0400, Item 23)  
Ties, Cable, Plastic (WP 0400, Item 26)

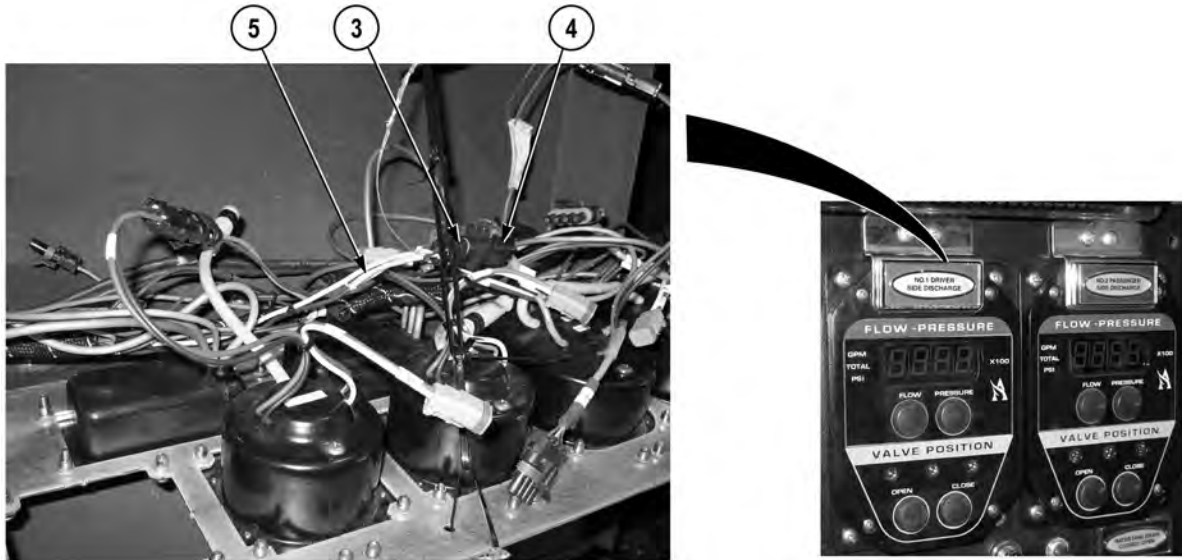
**Equipment Conditions**

Pump operator's panel opened (WP 0207)  
Pump house panel G removed (WP 0339)

## REMOVAL

**NOTE**

- Note routing of No. 1 driver side pressure transducer wire harness prior to removal to ensure proper installation.
  - No. 1 driver side pressure transducer wire harness is routed from pump house to pump operator's panel assembly.
  - Note position and remove split loom, cushion clips, and cable ties as required.
  - Tag and mark connectors prior to removal to ensure proper installation.
1. Disconnect No. 1 driver side pressure transducer wire harness connector (1) from No. 1 driver side pressure transducer valve control connector (2).



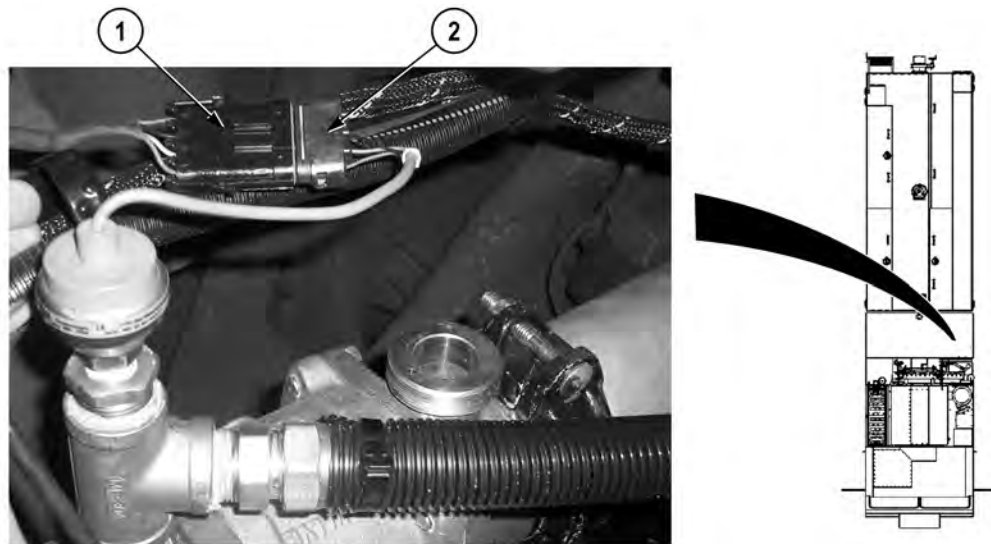
2. Disconnect No. 1 driver side pressure transducer wire harness connector (3) from No. 1 driver side pressure transducer line connector (4).
3. Remove No. 1 driver side pressure transducer wire harness (5) from vehicle.

#### END OF TASK

#### INSTALLATION

#### NOTE

- Route No. 1 driver side pressure transducer wire harness as noted.
  - Install cable ties, cushion clips, and split loom as noted.
1. Install No. 1 driver side pressure transducer wire harness (5) on vehicle.
  2. Connect No. 1 driver side pressure transducer wire harness connector (3) to No. 1 driver side pressure transducer line connector (4).



3. Connect No. 1 driver side pressure transducer valve control connector (2) to No. 1 driver side pressure transducer wire harness connector (1).

**END OF TASK**

**FOLLOW-ON MAINTENANCE**

1. Install pump house panel G (WP 0339)
2. Close pump operator's panel (WP 0207)

**END OF TASK**

**END OF WORK PACKAGE**





## FIELD LEVEL MAINTENANCE

## NO. 2 PASSENGER SIDE FLOW SENSOR WIRE HARNESS REPLACEMENT

## INITIAL SETUP:

**Tools and Special Tools**

Tool Kit, General Mechanic's: Automotive  
(WP 0398, Item 17)

**References**

WP 0391, Fig. 34

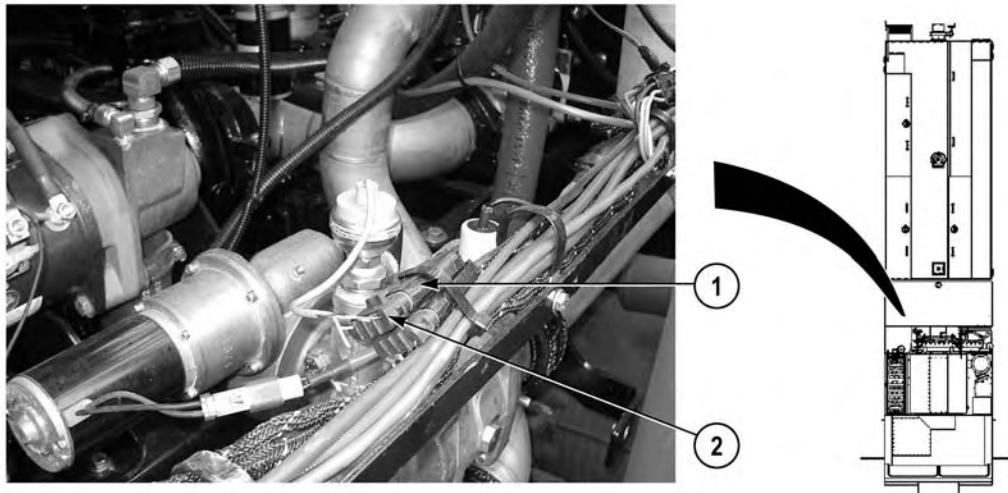
**Materials/Parts**

Tags, Identification (WP 0400, Item 23)  
Ties, Cable, Plastic (WP 0400, Item 26)

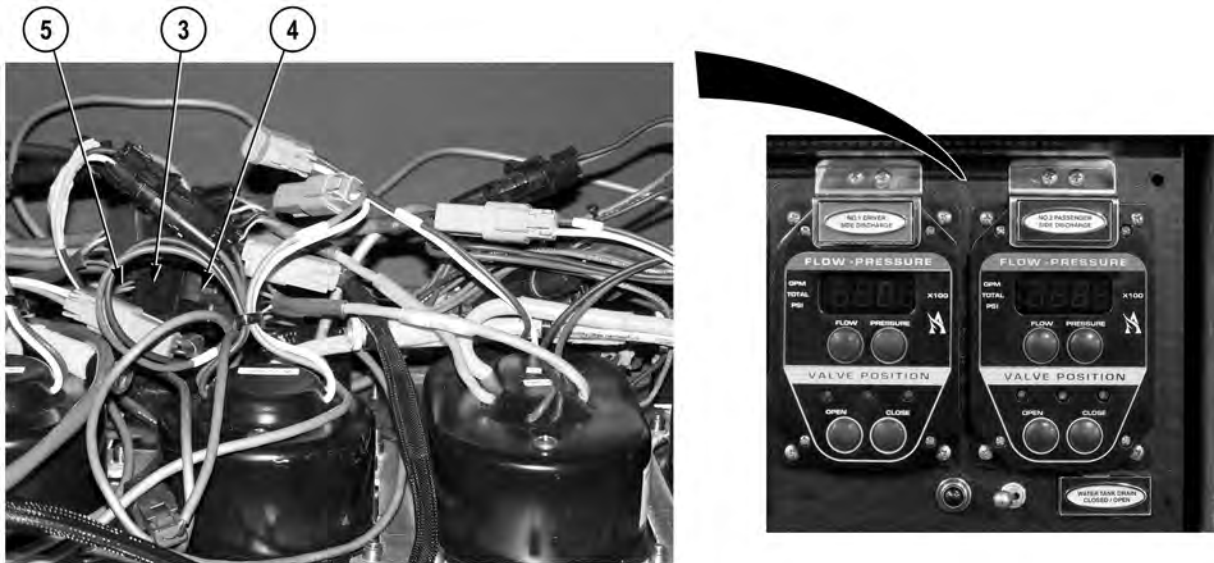
**Equipment Conditions**

Pump operator's panel opened (WP 0207)  
Pump house panel G removed (WP 0339)

## REMOVAL

**NOTE**

- Note routing of No. 2 passenger side flow sensor wire harness prior to removal to ensure proper installation.
  - No. 2 passenger side flow sensor wire harness is routed from pump house to pump operator's panel assembly.
  - Note position and remove split loom, cushion clips, and cable ties as required.
  - Tag and mark connectors prior to removal to ensure proper installation.
1. Disconnect No. 2 passenger side flow sensor wire harness connector (1) from No. 2 passenger side flow sensor control connector (2).



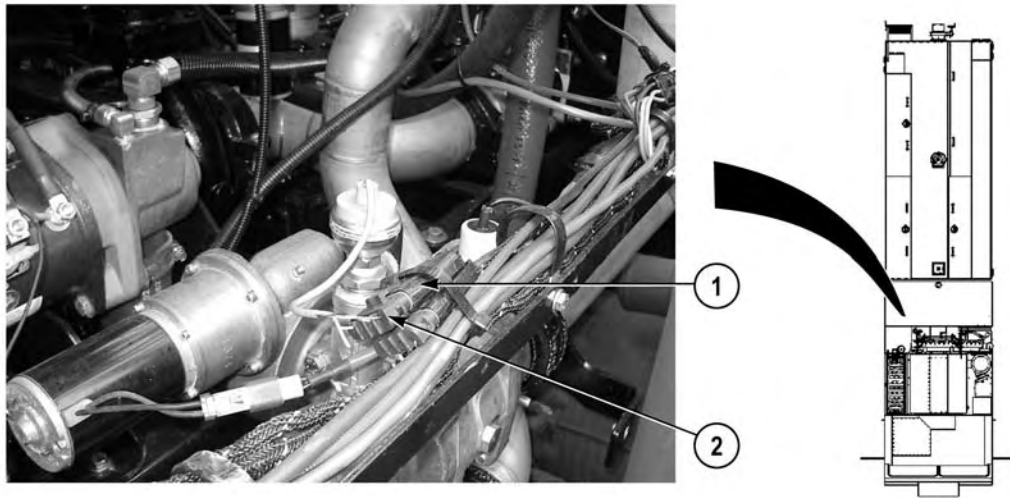
2. Disconnect No. 2 passenger side flow sensor wire harness connector (3) from No. 2 passenger side flow sensor line connector (4).
3. Remove No. 2 passenger side flow sensor wire harness (5) from vehicle.

#### END OF TASK

#### INSTALLATION

#### NOTE

- Route No. 2 passenger side flow sensor wire harness as noted.
  - Install cable ties, cushion clips, and split loom as noted.
1. Install No. 2 passenger side flow sensor wire harness (5) on vehicle.
  2. Connect No. 2 passenger side flow sensor wire harness connector (3) to No. 2 passenger side flow sensor line connector (4).



3. Connect No. 2 passenger side flow sensor control connector (2) to No. 2 passenger side flow sensor wire harness connector (1).

**END OF TASK**

**FOLLOW-ON MAINTENANCE**

1. Install pump house panel G (WP 0339)
2. Close pump operator's panel (WP 0207)

**END OF TASK**

**END OF WORK PACKAGE**



---

**FIELD LEVEL MAINTENANCE****PASSENGER SIDE AUXILIARY INLET VALVE CONTROL WIRE HARNESS REPLACEMENT**

---

**INITIAL SETUP:****Tools and Special Tools**

Tool Kit, General Mechanic's: Automotive  
(WP 0398, Item 17)

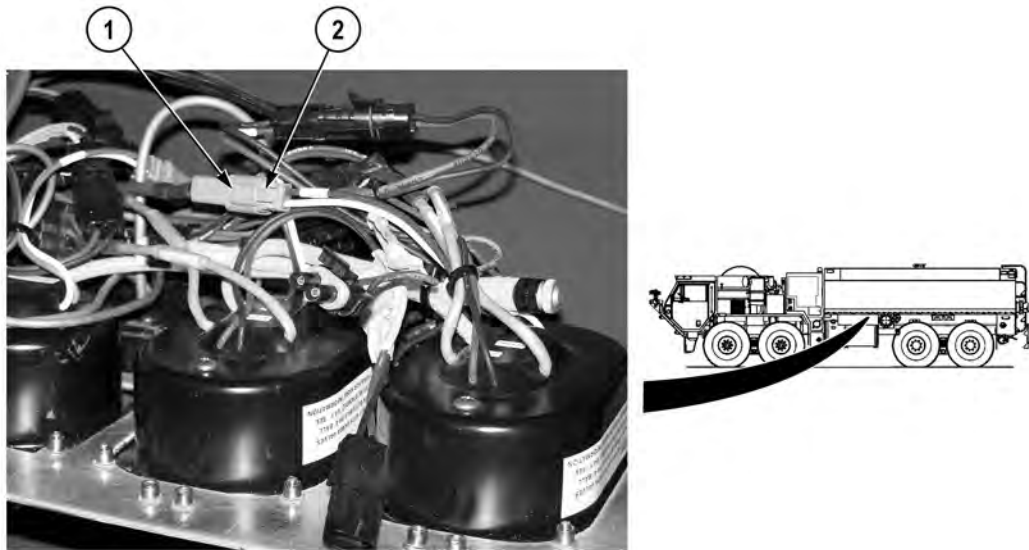
**Equipment Conditions**

Pump operator's panel opened (WP 0207)  
Pump house panel G removed (WP 0339)

**Materials/Parts**

Tags, Identification (WP 0400, Item 23)  
Ties, Cable, Plastic (WP 0400, Item 26)

---

**REMOVAL****NOTE**

- Note routing of passenger side auxiliary inlet valve control wire harness prior to removal to ensure proper installation.
  - Passenger side auxiliary inlet valve control wire harness is routed from pump house to pump operator's panel assembly.
  - Note position and remove split loom, cushion clips, and cable ties as required.
  - Tag and mark connectors prior to removal to ensure proper installation.
1. Disconnect passenger side auxiliary inlet valve control wire harness connector (1) from passenger side auxiliary inlet valve control gauge connector (2).



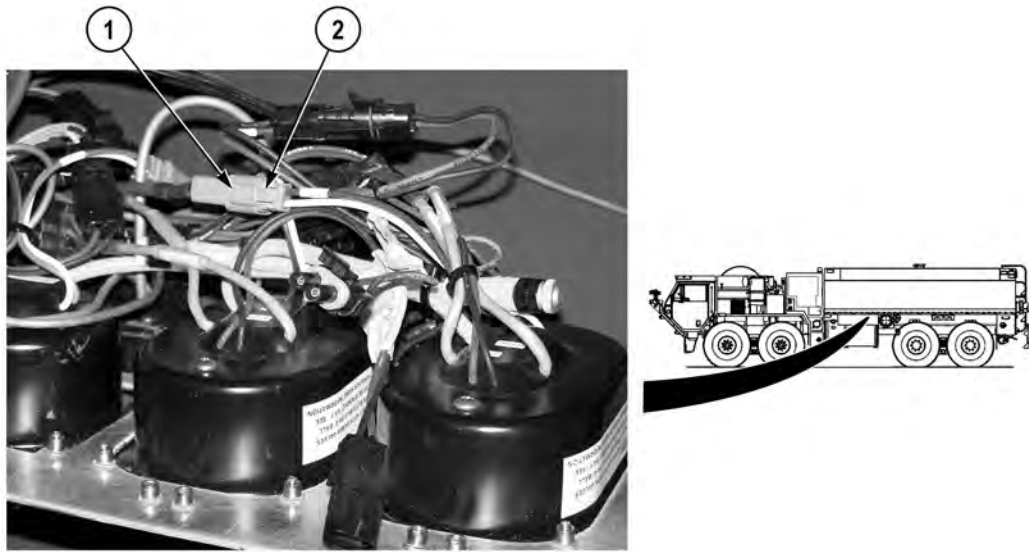
2. Disconnect passenger side auxiliary inlet valve control wire harness connector (3) from passenger side auxiliary inlet valve control connector (4).
3. Remove passenger side auxiliary inlet valve control wire harness (5) from vehicle.

#### END OF TASK

#### INSTALLATION

#### NOTE

- Route passenger side auxiliary inlet valve control wire harness as noted.
  - Install cable ties, cushion clips, and split loom as required.
1. Install passenger side auxiliary inlet valve control wire harness (5) on vehicle.
  2. Connect passenger side auxiliary inlet valve control connector (4) to passenger side auxiliary inlet valve control wire harness connector (3).



3. Connect passenger side auxiliary inlet valve control gauge connector (2) to passenger side auxiliary inlet valve control wire harness connector (1).

**END OF TASK**

**FOLLOW-ON MAINTENANCE**

1. Install pump house panel G (WP 0339)
2. Close pump operator's panel (WP 0207)

**END OF TASK**

**END OF WORK PACKAGE**





## FIELD LEVEL MAINTENANCE

## NO. 2 PASSENGER SIDE PRESSURE TRANSDUCER WIRE HARNESS REPLACEMENT

## INITIAL SETUP:

**Tools and Special Tools**

Tool Kit, General Mechanic's: Automotive  
(WP 0398, Item 17)

**References**

WP 0391, Fig. 34

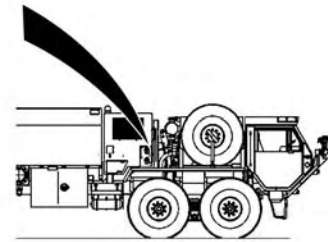
**Materials/Parts**

Tags, Identification (WP 0400, Item 23)  
Ties, Cable, Plastic (WP 0400, Item 26)

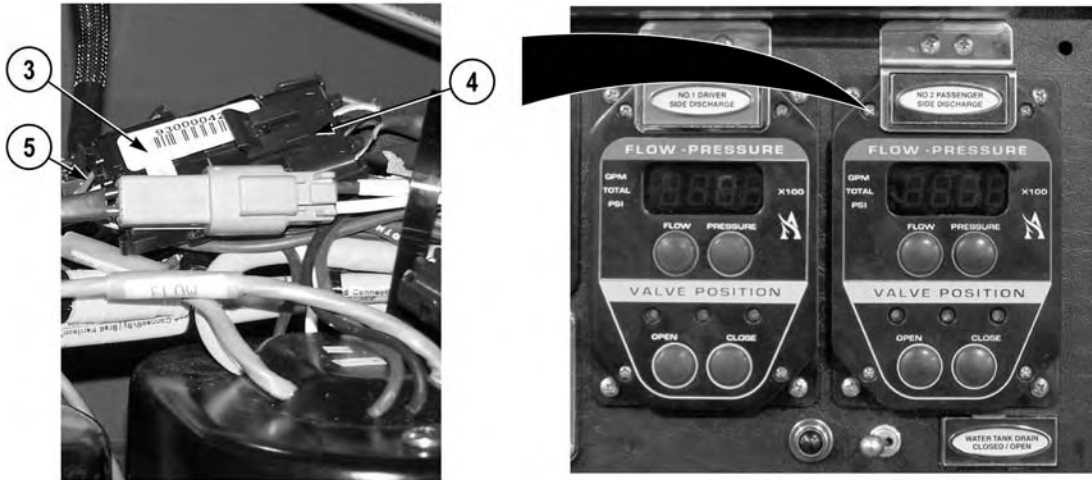
**Equipment Conditions**

Pump operator's panel opened (WP 0207)  
Pump house panel G removed (WP 0339)

## REMOVAL

**NOTE**

- Note routing of No. 2 passenger side pressure transducer wire harness prior to removal to ensure proper installation.
  - No. 2 passenger side pressure transducer wire harness is routed from pump house to pump operator's panel assembly.
  - Note position and remove split loom, cushion clips, and cable ties as required.
  - Tag and mark connectors prior to removal to ensure proper installation.
1. Disconnect No. 2 passenger side pressure transducer wire harness connector (1) from No. 2 passenger side pressure transducer connector (2).



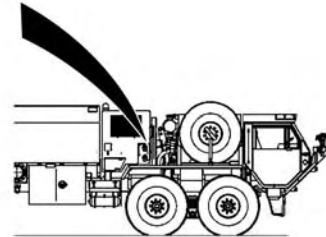
2. Disconnect No. 2 passenger side pressure transducer wire harness connector (3) from No. 2 passenger side pressure transducer line connector (4).
3. Remove No. 2 passenger side pressure transducer wire harness (5) from vehicle.

#### END OF TASK

#### INSTALLATION

#### NOTE

- Route No. 2 passenger side pressure transducer wire harness as noted.
  - Install cable ties, cushion clips, and split loom as noted.
1. Install No. 2 passenger side pressure transducer wire harness (5) on vehicle.
  2. Connect No. 2 passenger side pressure transducer wire harness connector (3) to No. 2 passenger side pressure transducer line connector (4).



3. Connect No. 2 passenger side pressure transducer connector (2) to No. 2 passenger side pressure transducer wire harness connector (1).

**END OF TASK**

**FOLLOW-ON MAINTENANCE**

1. Close pump house panel G (WP 0339)
2. Close pump operator's panel (WP 0207)

**END OF TASK**

**END OF WORK PACKAGE**



---

**FIELD LEVEL MAINTENANCE****PASSENGER SIDE BODY WIRE HARNESS REPLACEMENT**

---

**INITIAL SETUP:****Tools and Special Tools**

Tool Kit, General Mechanic's: Automotive  
(WP 0398, Item 17)

**Materials/Parts**

Tags, Identification (WP 0400, Item 23)  
Ties, Cable, Plastic (WP 0400, Item 26)  
Tube, Shrink (WP 0400, Item 27)

**Personnel Required**

MOS 63B Wheeled Vehicle Mechanic (2)

**References**

TM 9-2320-325-14&P  
WP 0391, Fig. 52

**Equipment Conditions**

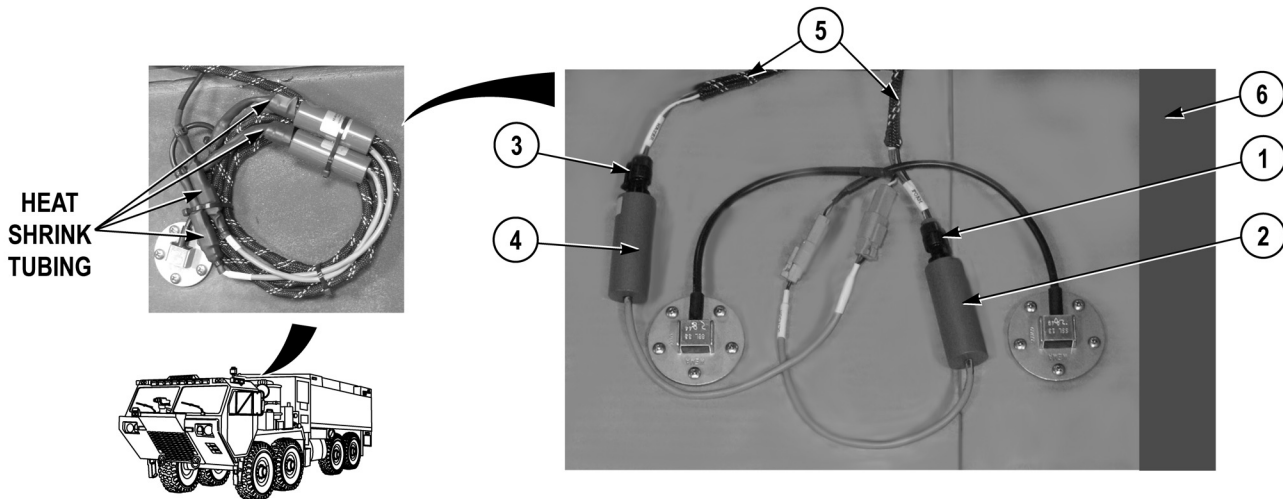
Stowage compartment (lower rear passenger side) removed for lower passenger side body wire harness (WP 0357)

Passenger side top stowage compartment doors opened for upper passenger side body wire harness (WP 0008)

Light bezel cover (passenger side) removed (WP 0335)

Foam/Water tank level probe cover removed for upper passenger side body wire harness (WP 0189)

## REMOVAL

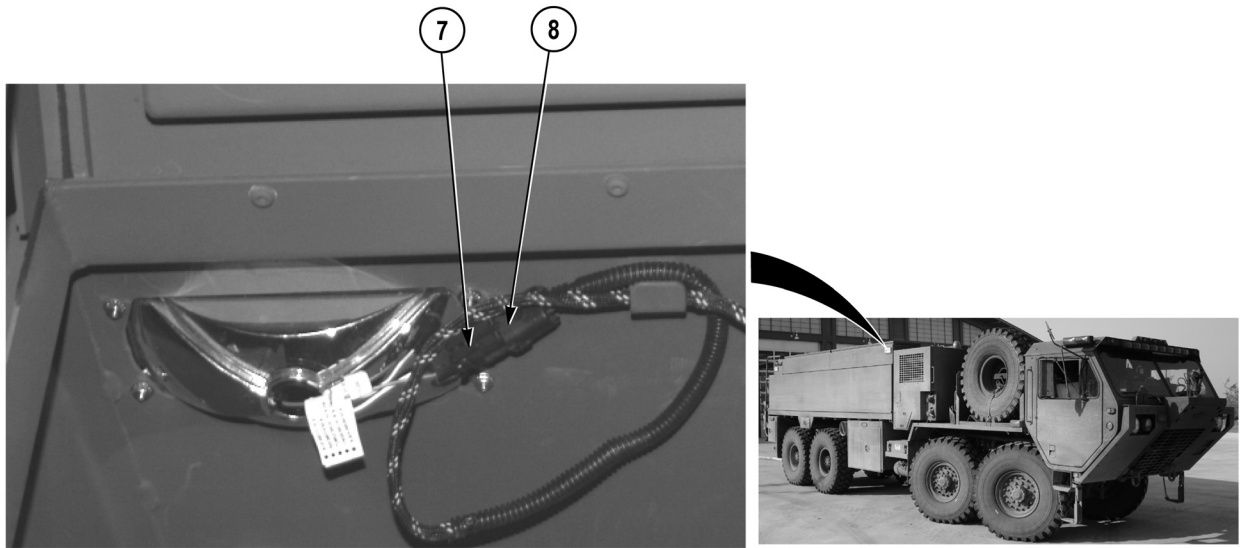


**⚠ CAUTION**

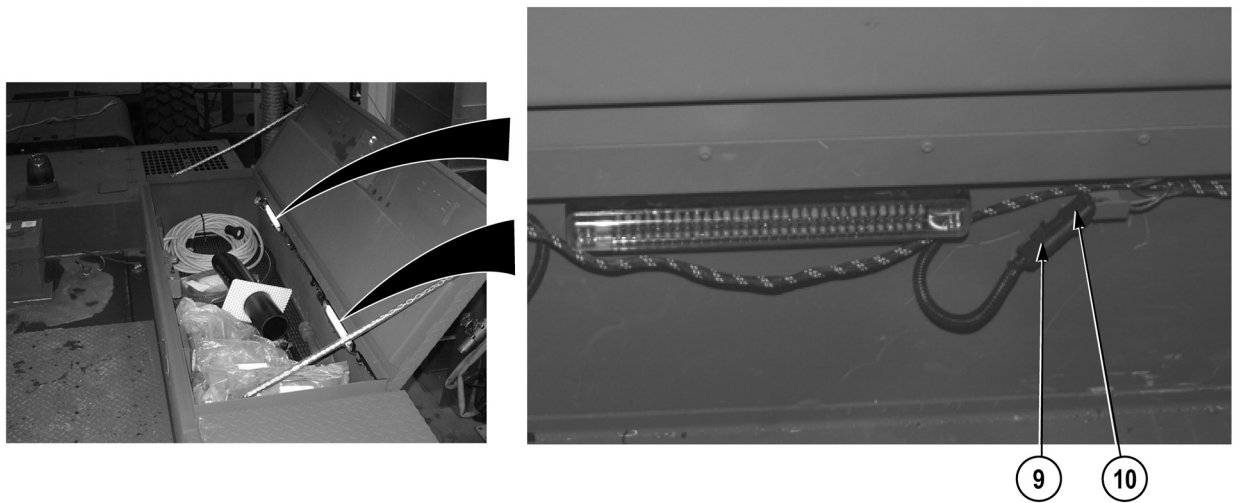
Both water level probe adapter and foam level probe adapter are connected to upper passenger side body wire harness and must be covered with heat shrink tubing. Failure to comply will allow moisture to enter connector ends and not allow foam and water level gauges to function properly.

**NOTE**

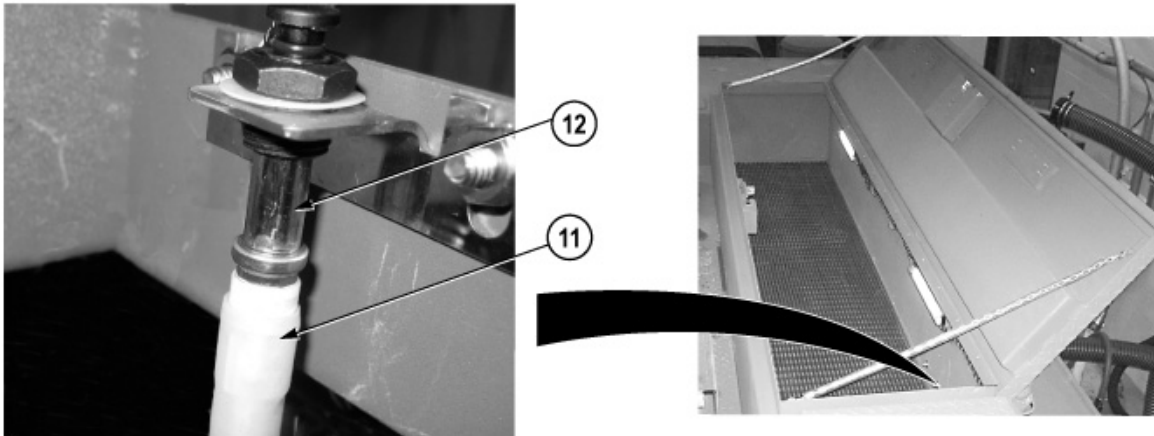
- Perform Steps (1) through (13) to remove upper passenger side body wire harness.
  - Tag and mark wires prior to removal to ensure proper installation.
  - Note routing of upper passenger side body wire harness prior to removal to ensure proper installation.
  - Note position and remove cable ties, split loom, and cushion clips as required.
1. Disconnect upper passenger side body wire harness connector (1) from water level probe adapter (2).
  2. Disconnect upper passenger side body wire harness connector (3) from foam level probe adapter (4) and route passenger side body wire harness (5) into top front passenger side stowage compartment (6).



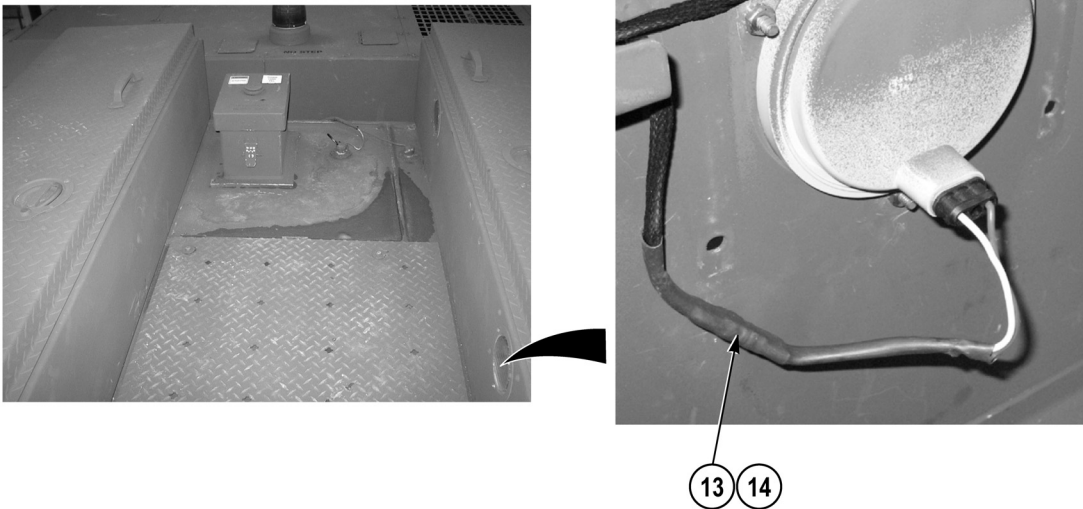
3. Disconnect scene light connector (7) from upper passenger side body wire harness connector (8).



4. Disconnect two striplight connectors (9) from upper passenger side body wire harness connectors (10).



5. Disconnect upper passenger side body wire harness connector (11) from front passenger side top stowage compartment door switch (12).

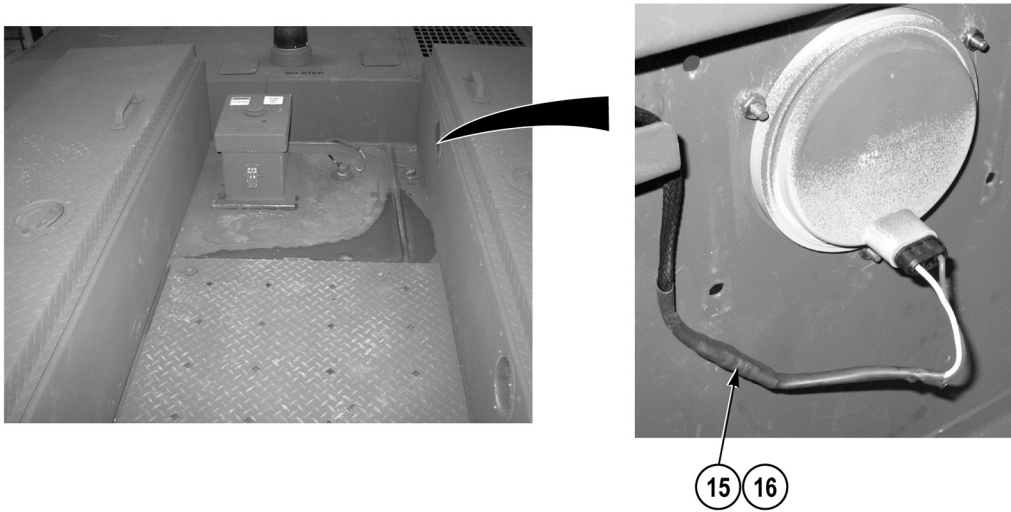


**NOTE**

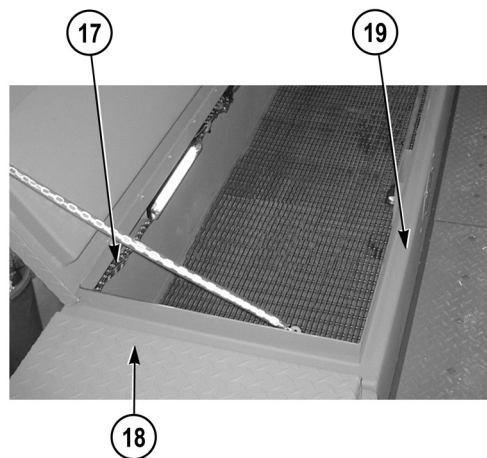
Wires must be cut if replacing existing upper passenger side body wire harness with a new harness.

6. Cut wire 1615 (13) and wire 2740 (14) (TM 9-2320-325-14&P).

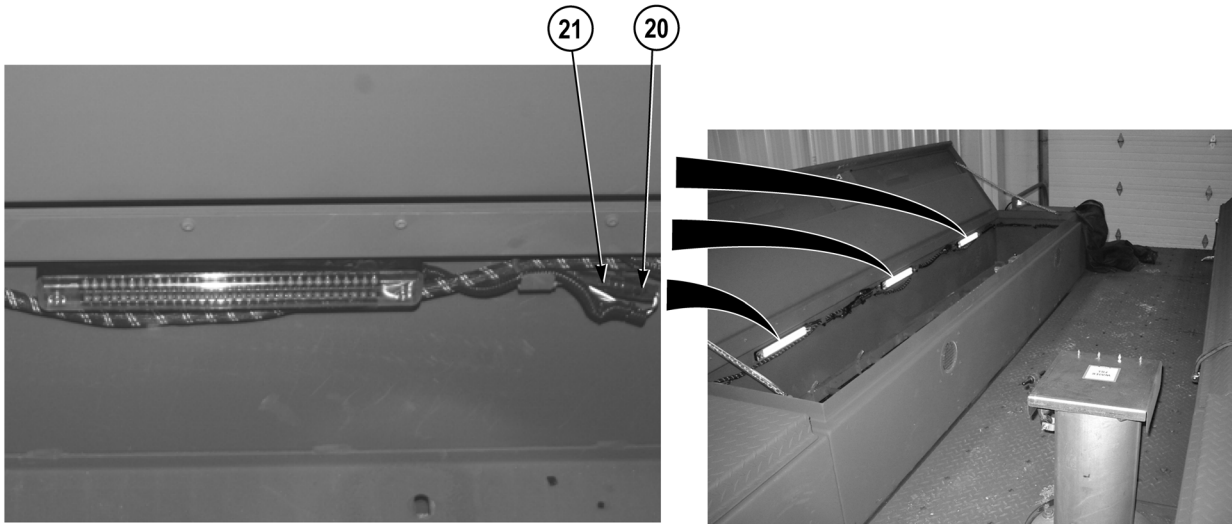




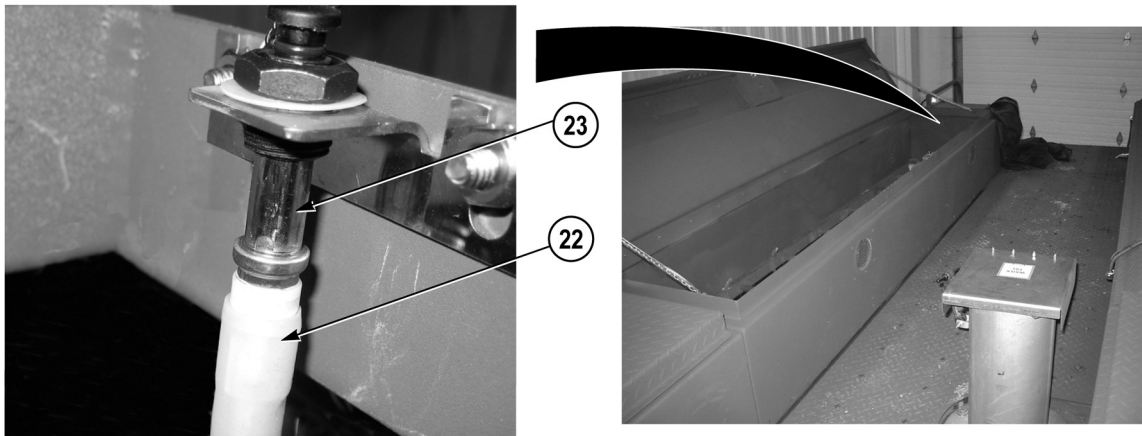
7. Cut wire 1615 (15) and wire 2740 (16) (TM 9-2320-325-14&P).



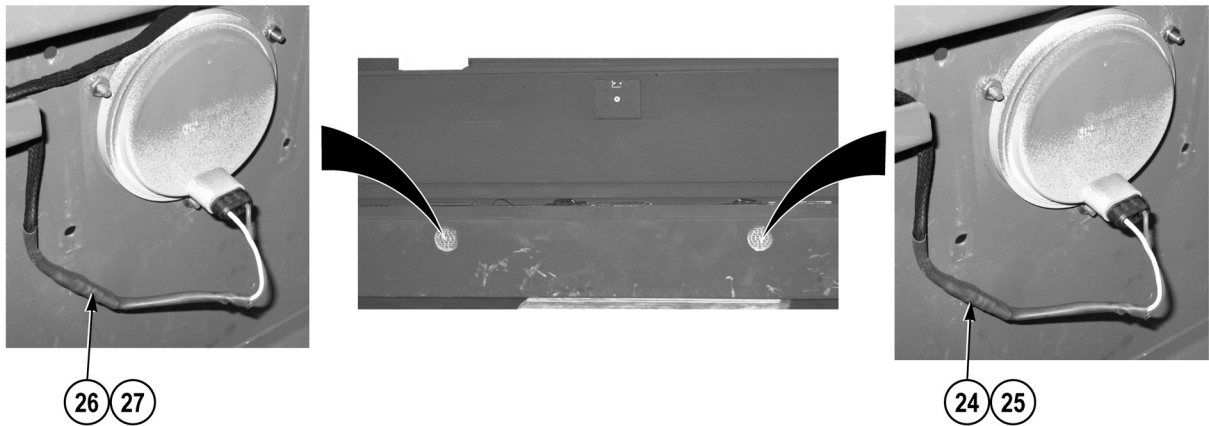
8. Remove upper passenger side body wire harness (17) from front passenger side top stowage compartment (18), routing harness into rear passenger side top stowage compartment (19).



9. Disconnect three striplight connectors (20) from upper passenger side body wire harness connectors (21).



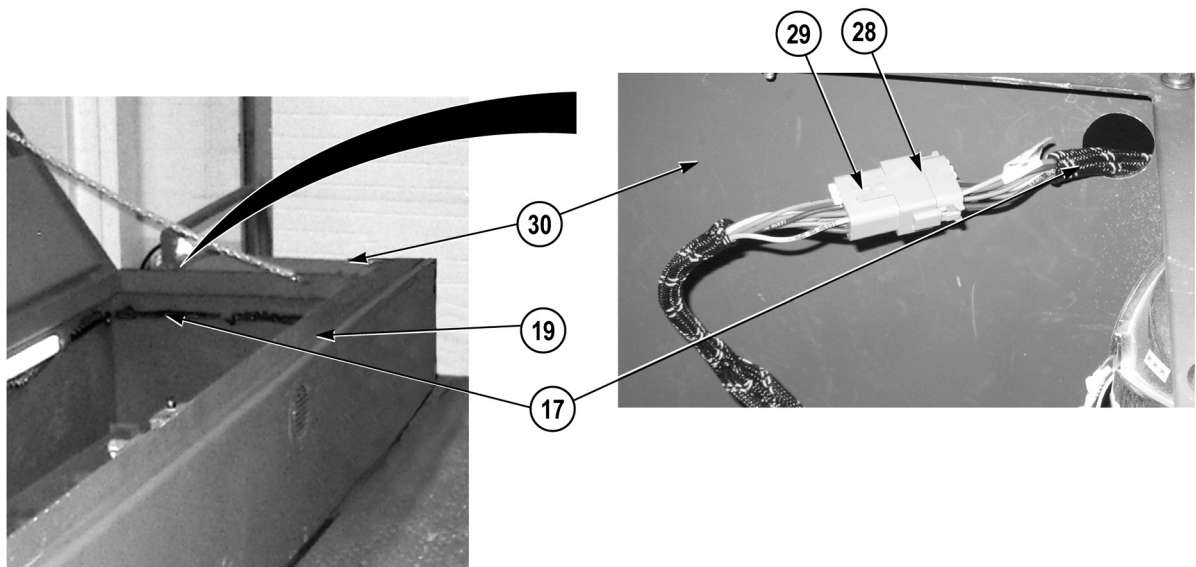
10. Disconnect upper passenger side body wire harness connector (22) from rear passenger side top stowage compartment door switch (23).



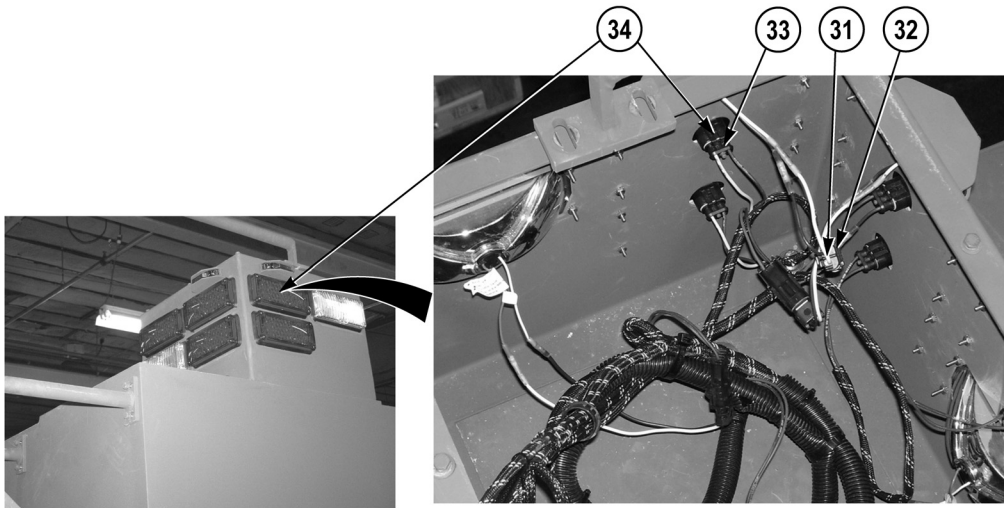
### NOTE

Wires must be cut if replacing existing upper passenger side body wire harness with a new wire harness.

11. Cut wire 1615 (24) and wire 2740 (25) (TM 9-2320-325-14&P).
12. Cut wire 1615 (26) and wire 2740 (27) (TM 9-2320-325-14&P).

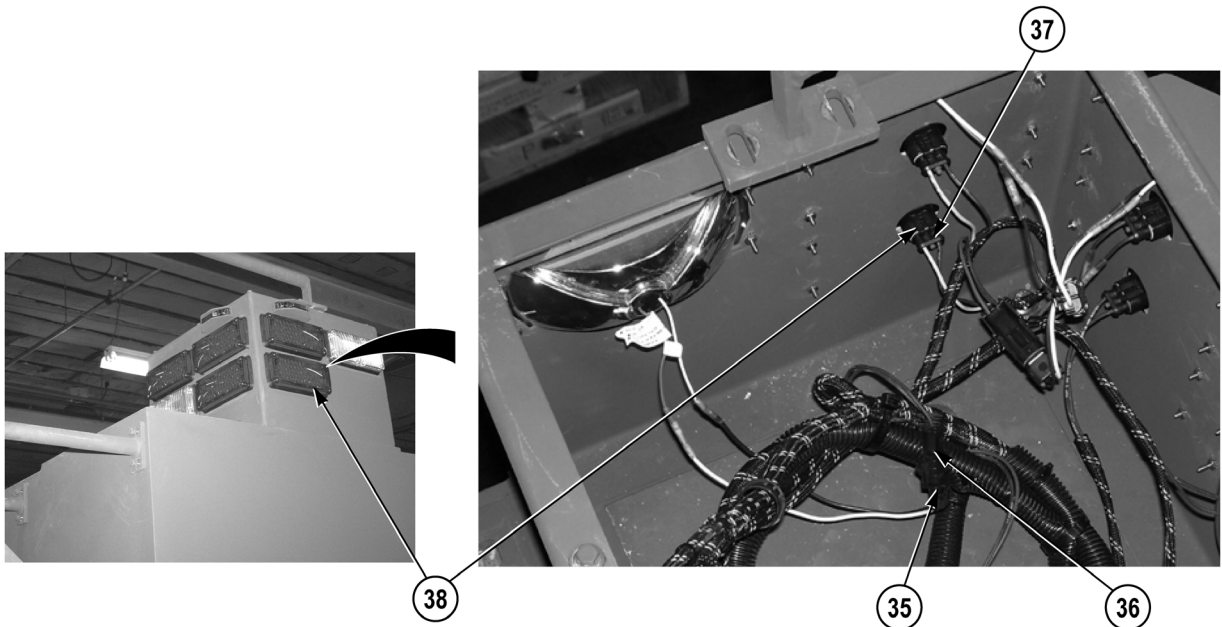


13. Disconnect upper passenger side body wire harness connector (28) from lower passenger side body wire harness connector (29) and route upper passenger side body wire harness (17) from passenger side light bezel box (30) into rear passenger side top stowage compartment (19).

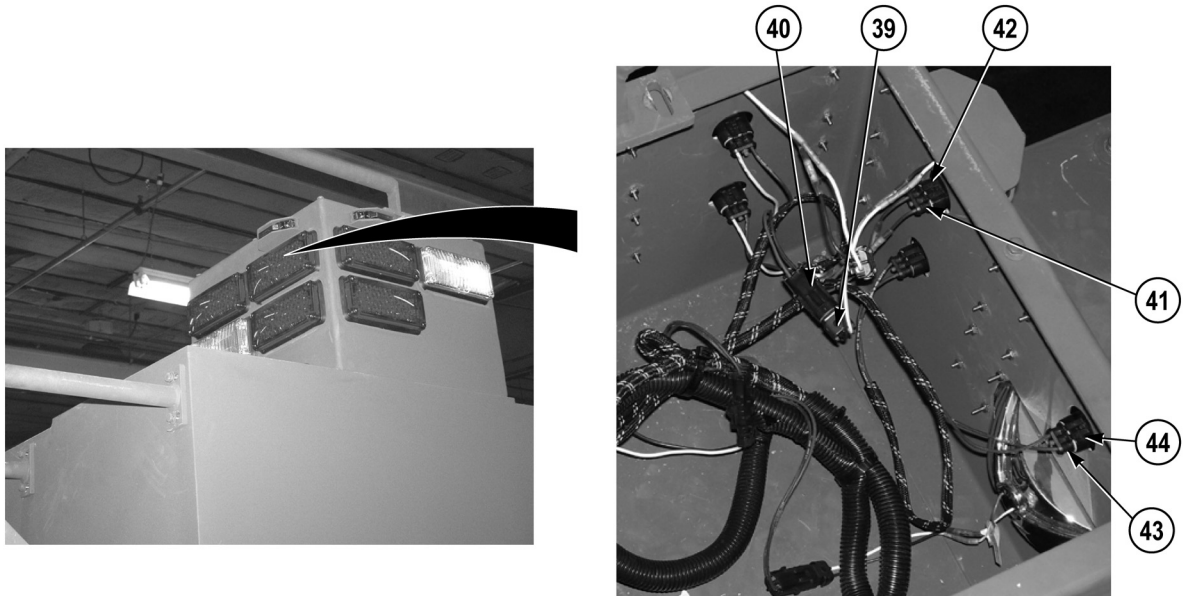


### NOTE

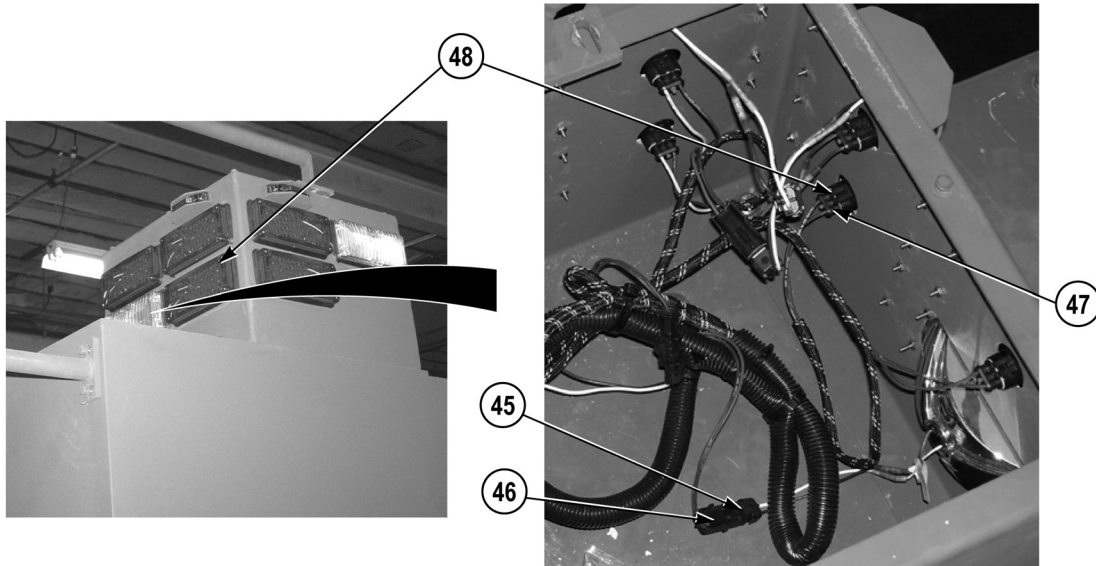
- Perform Steps (14) through (26) to remove lower passenger side body wire harness.
  - Perform Step (14) only if lower passenger side body wire harness needs to be disconnected from upper passenger side body wire harness.
14. Disconnect upper passenger side body wire harness connector (28) from lower passenger side body wire harness connector (29).
  15. Disconnect clearance light connector (31) from lower passenger side body wire harness connector (32).
  16. Disconnect lower passenger side body wire harness connector (33) from (top upper) side warning light (34).



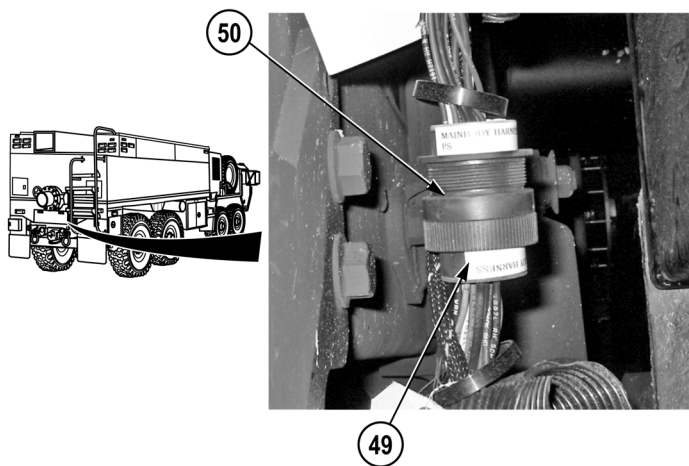
17. Disconnect scene light connector (35) from lower passenger side body wire harness connector (36).
18. Disconnect lower passenger side body wire harness connector (37) from (bottom upper) side warning light (38).



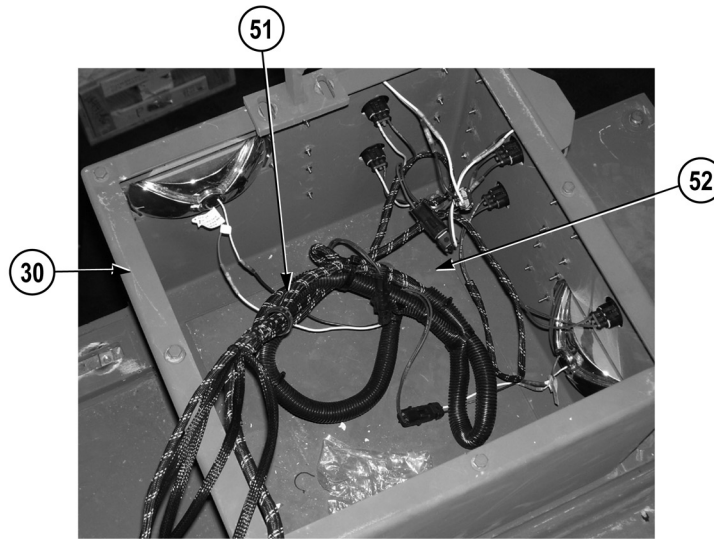
19. Disconnect clearance light connector (39) from lower passenger side body wire harness connector (40).
20. Disconnect lower passenger side body wire harness connector (41) from (top outer) upper rear warning light (42).
21. Disconnect lower passenger side body wire harness connector (43) from (top inner) upper rear warning light (44).



22. Disconnect scene light connector (45) from lower passenger side body wire harness connector (46).
23. Disconnect lower passenger side body wire harness connector (47) from (bottom upper) rear warning light (48).



24. Disconnect lower passenger side body wire harness connector (49) from main wire harness connector (50).



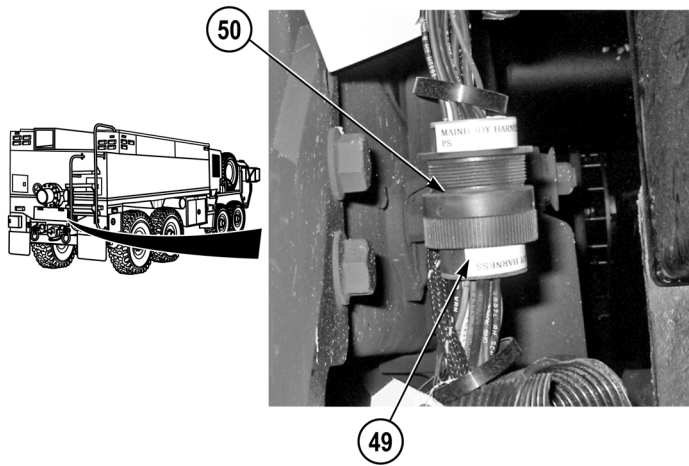
25. With aid of an assistant, remove lower passenger side body wire harness (51) from onboard water tank (52), routing harness through passenger side light bezel box (30).
26. Remove lower passenger side body wire harness (51) from vehicle.

#### END OF TASK

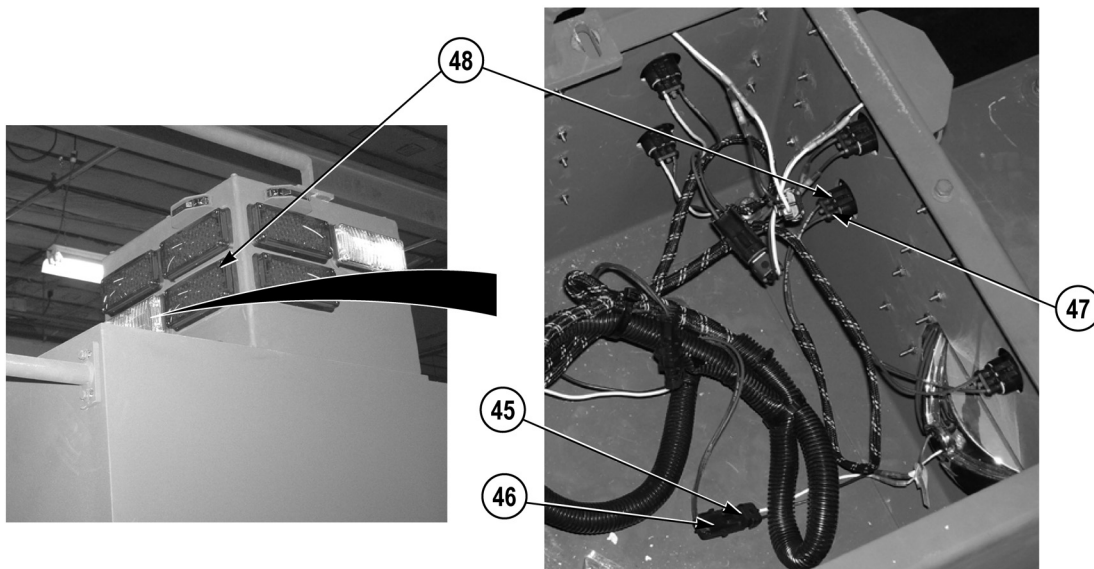
#### INSTALLATION

#### NOTE

- Perform Steps (1) through (13) if lower passenger side body wire harness was removed.
  - Route lower passenger side body wire harness as noted prior to removal.
  - Install cable ties, split loom, and cushion clips as required.
1. Position lower passenger side body wire harness (51) on vehicle.
  2. With the aid of an assistant, install lower passenger side body wire harness (51) on onboard water tank (52).

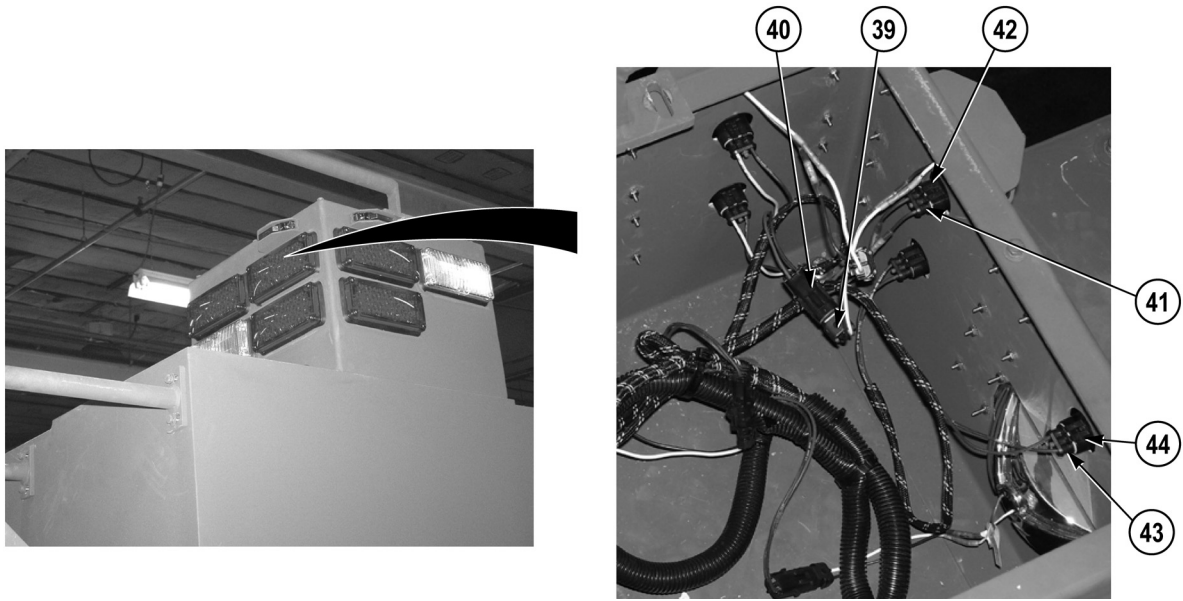


3. Connect main wire harness connector (50) on lower passenger side body wire harness connector (49).

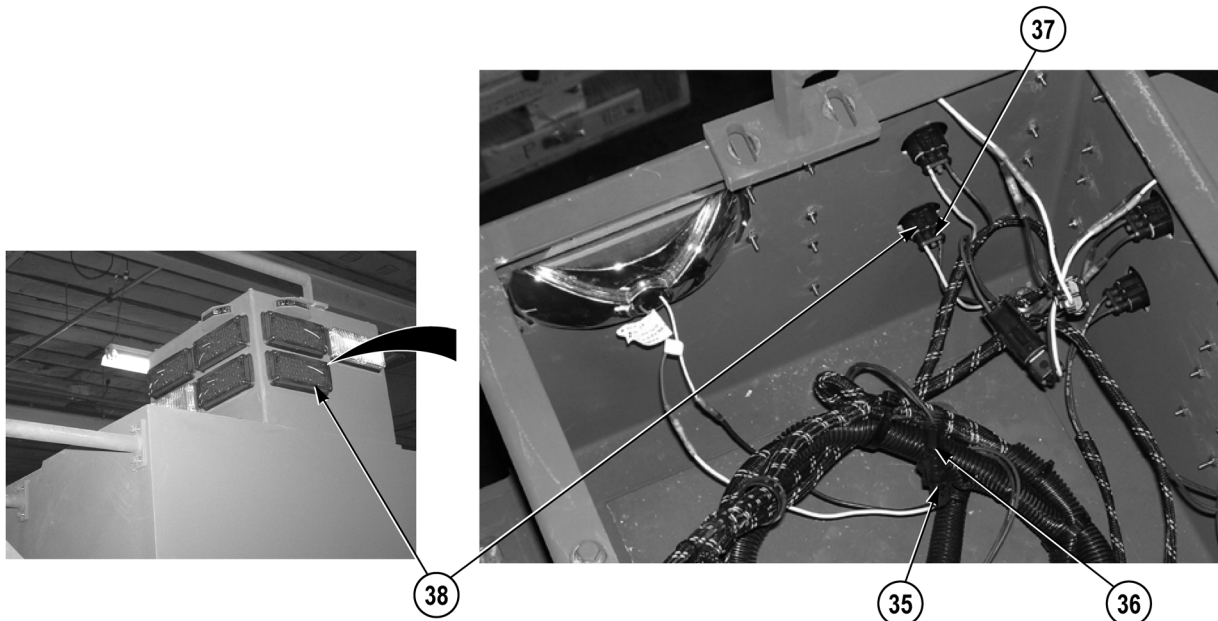


4. Connect lower passenger side body wire harness connector (47) on (bottom upper) rear warning light (48).
5. Connect lower passenger side body wire harness connector (46) on scene light connector (45).

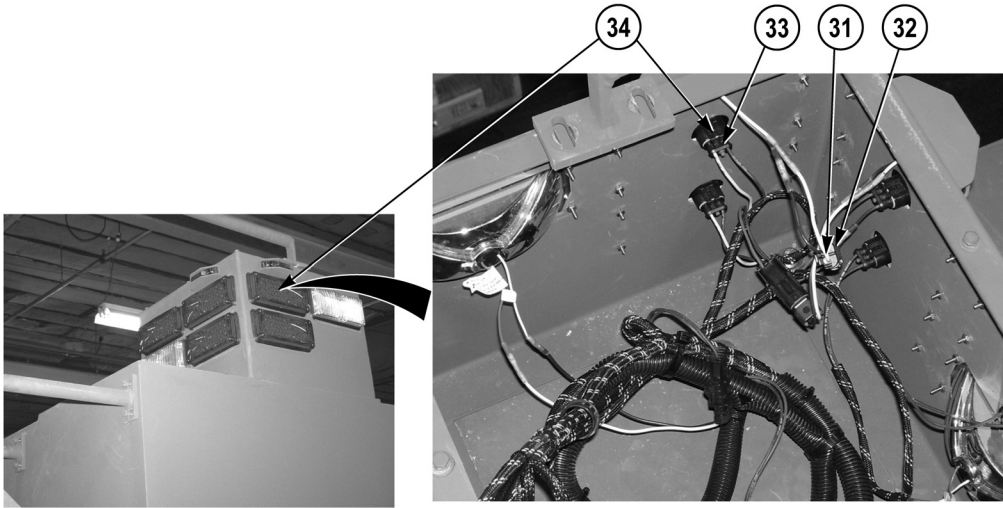




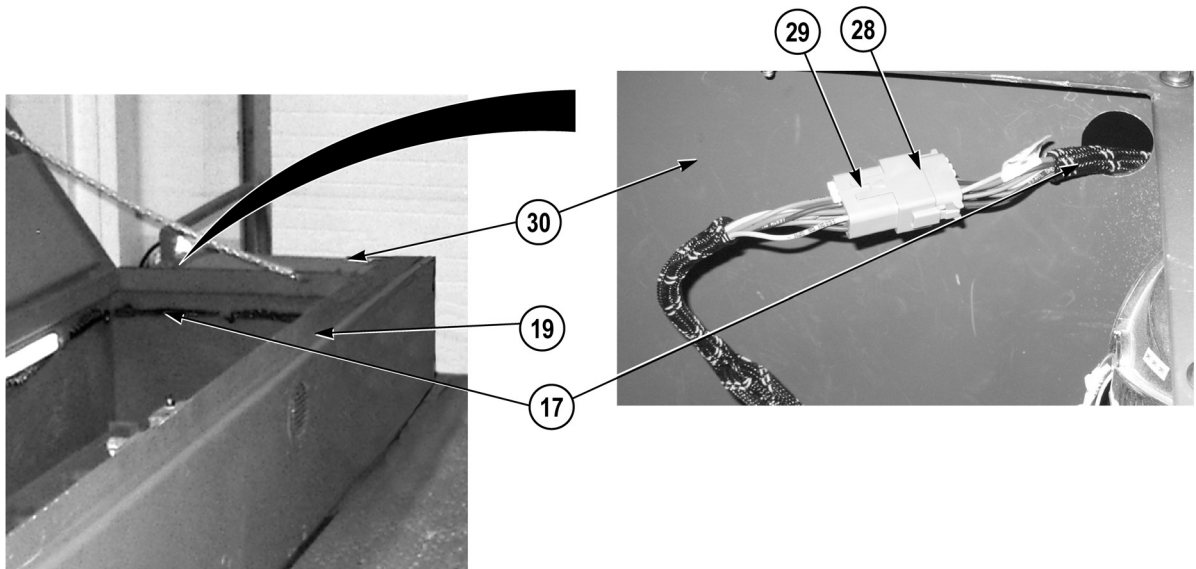
6. Connect lower passenger side body wire harness connector (43) on (top inner) upper rear warning light (44).
7. Connect lower passenger side body wire harness connector (41) on (top outer) upper rear warning light (42).
8. Connect lower passenger side body wire harness connector (40) on clearance light connector (39).



9. Connect lower passenger side body wire harness connector (37) on (bottom upper) side warning light (38).
10. Connect lower passenger side body wire harness connector (36) on scene light connector (35).



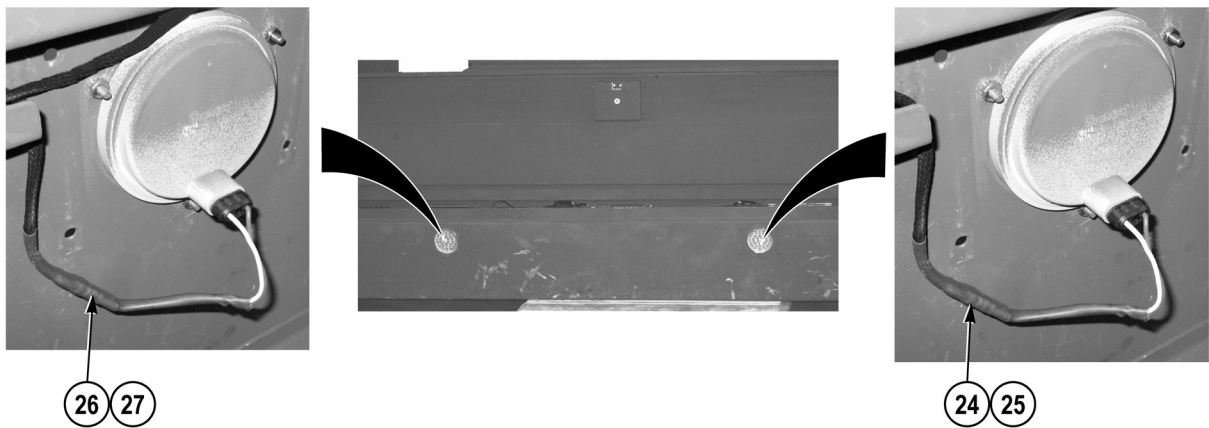
11. Connect lower passenger side body wire harness connector (33) on (top upper) side warning light (34).
12. Connect lower passenger side body wire harness connector (32) on clearance light connector (31).



**NOTE**

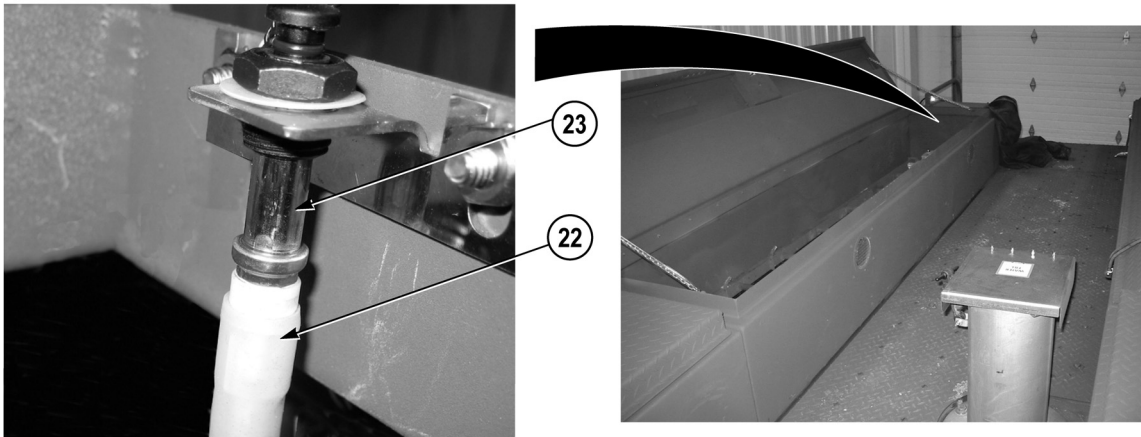
- Perform Steps (13) through (25) if upper passenger side body wire harness was removed.
- Install cable ties, split loom, and cushion clips as required.

13. Route upper passenger side body wire harness (17) from rear passenger side top stowage compartment (19) into passenger side light bezel box (30) and connect lower passenger side body wire harness connector (29) on upper passenger side body wire harness connector (28).

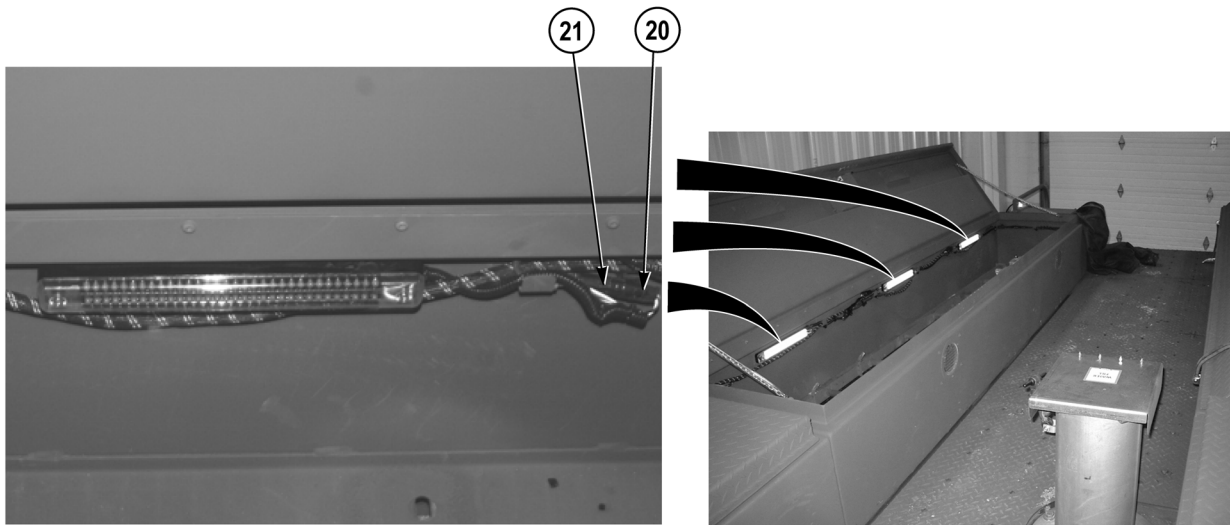


14. Repair wire 2740 (27) and wire 1615 (26) (TM 9-2320-325-14&P).

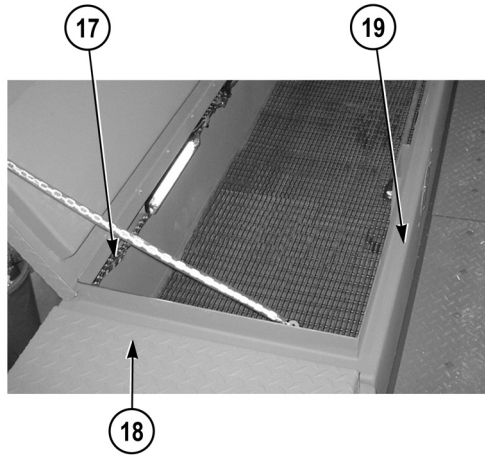
15. Repair wire 2740 (25) and wire 1615 (24) (TM 9-2320-325-14&P).



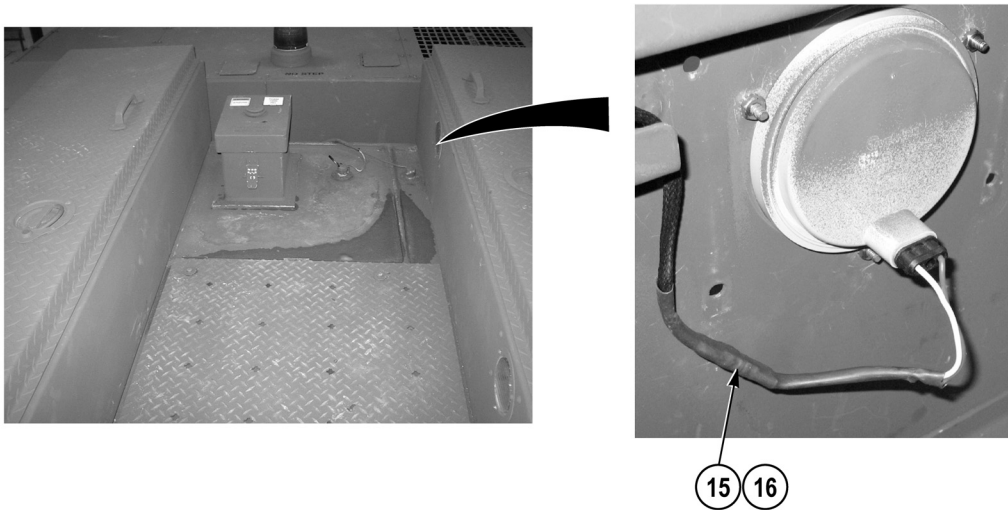
16. Connect upper passenger side body wire harness connector (22) on rear passenger side top stowage compartment door switch (23).



17. Connect upper passenger side body wire harness connector (21) on three striplight connectors (20).



18. Route upper passenger side body wire harness (17) from rear passenger side top stowage compartment (19) into front passenger side top stowage compartment (18).

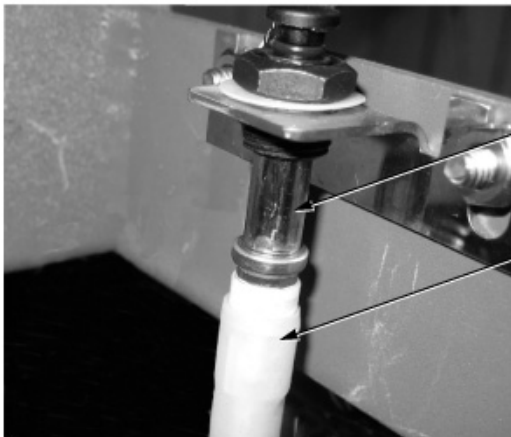


19. Repair wire 2740 (16) and wire 1615 (15) (TM 9-2320-325-14&P).



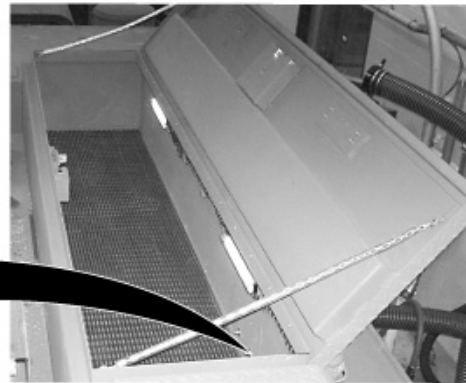
13 14

20. Repair wire 2740 (14) and wire 1615 (13) (TM 9-2320-325-14&P).

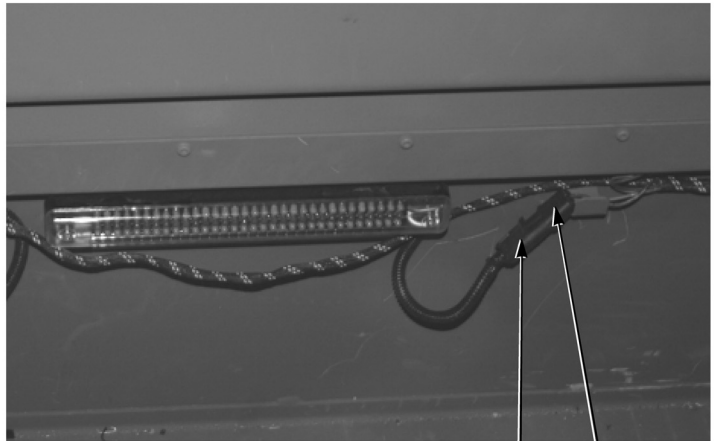


12

11

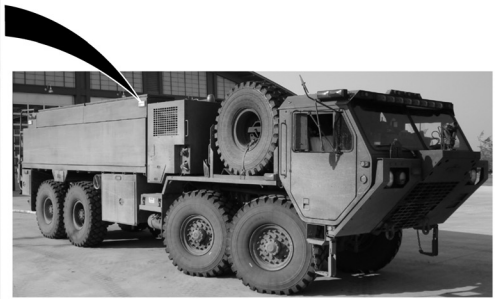
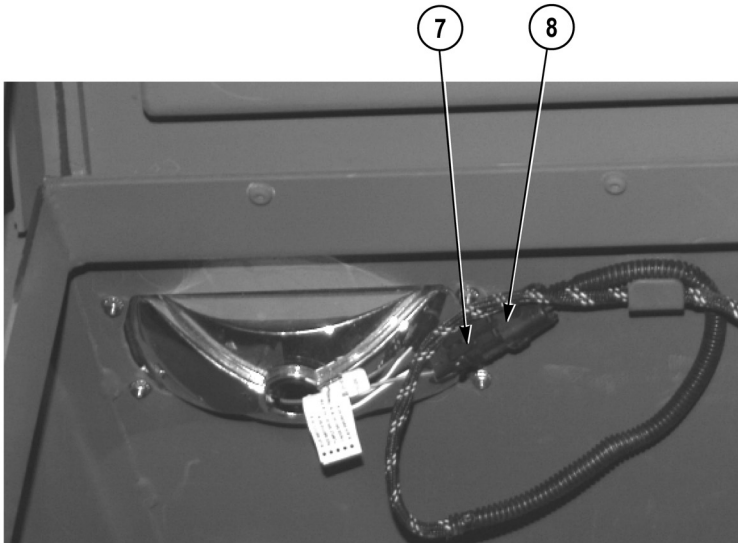


21. Connect upper passenger side body wire harness connector (11) on front passenger side top stowage compartment door switch (12).

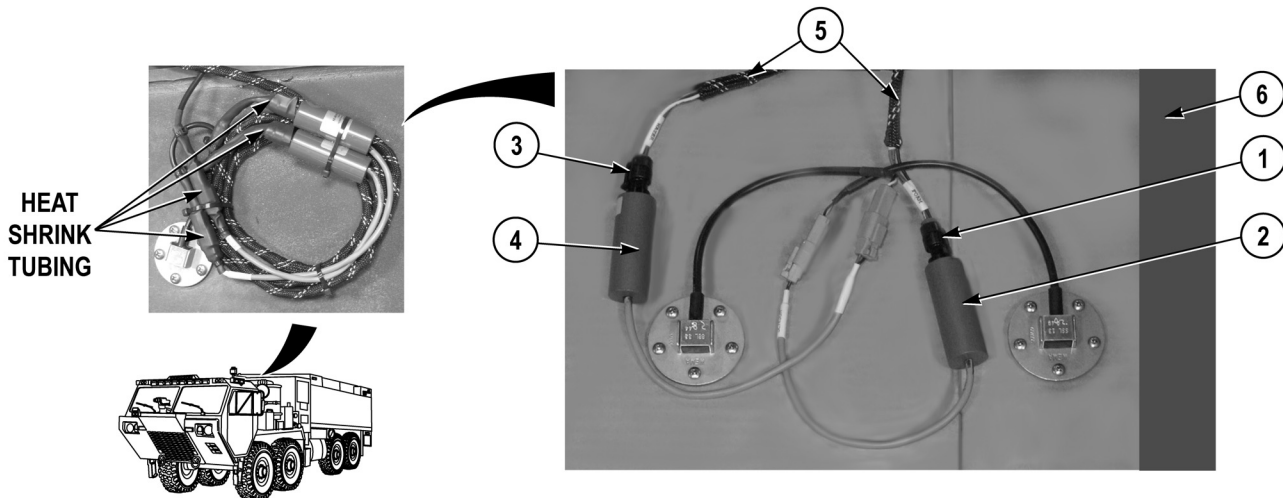


9 10

22. Connect two passenger side body wire harness connectors (10) on striplight connector (9).



23. Connect upper passenger side body wire harness connector (8) on scene light connector (7).



### NOTE

Both water level probe adapter and foam level probe adapter must be covered with heat shrink tubing before connecting to upper passenger side body wire harness (TM 9-2320-325-14&P).

24. Route upper passenger side body wire harness (5) from top front passenger side stowage compartment (6) and connect foam level probe adapter (4) on upper passenger side body wire harness connector (3).
25. Connect water level probe adapter (2) on upper passenger side body wire harness connector (1).

### END OF TASK

### FOLLOW-ON MAINTENANCE

1. Install foam/water tank level probe cover for upper passenger side body wire harness (WP 0189)
2. Install light bezel cover (passenger side) (WP 0335)
3. Install passenger side top stowage compartment doors for upper passenger side body wire harness (WP 0008)
4. Install stowage compartment (lower rear passenger side) for lower passenger side body wire harness (WP 0357)

### END OF TASK

### END OF WORK PACKAGE



---

**FIELD LEVEL MAINTENANCE****PUMP HOUSE POWER DISTRIBUTION WIRE HARNESS AND BLOCK REPLACEMENT**

---

**INITIAL SETUP:****Tools and Special Tools**

Tool Kit, General Mechanic's: Automotive  
(WP 0398, Item 17)

**References**

WP 0391, Fig. 42, 54

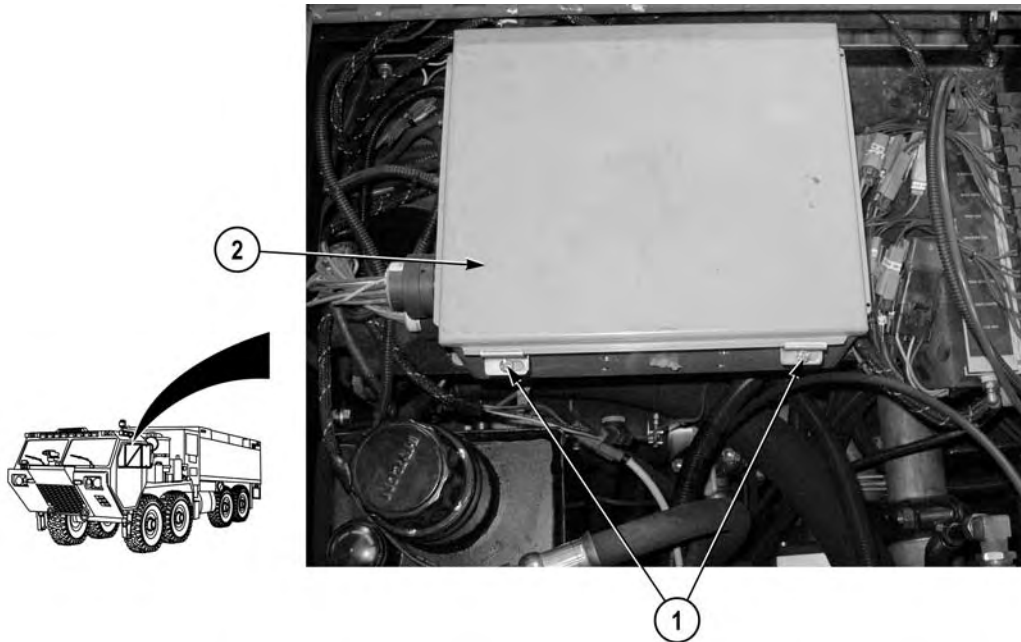
**Materials/Parts**

Tags, Identification (WP 0400, Item 23)  
Ties, Cable, Plastic (WP 0400, Item 26)  
Lockwasher (2)  
Lockwasher (2)

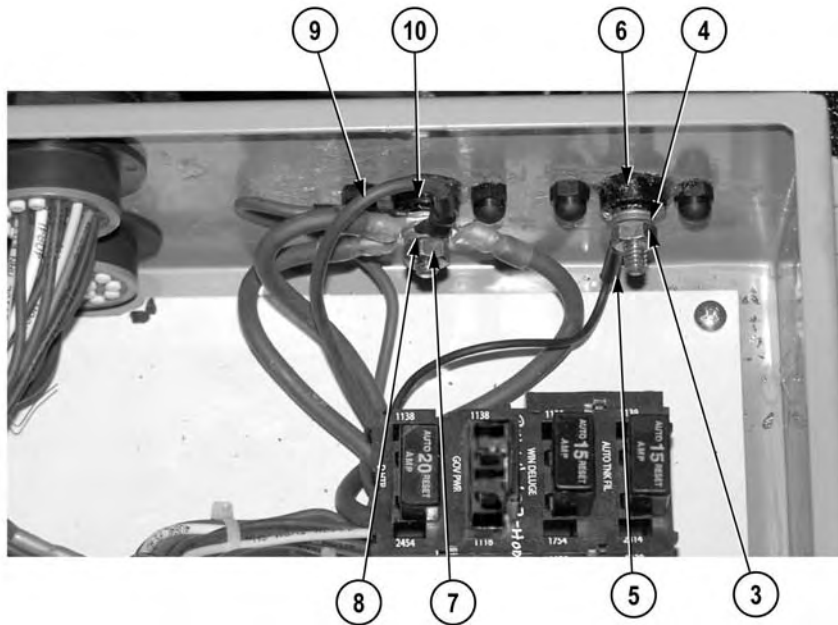
**Equipment Conditions**

Pump house panel K removed (WP 0339)

---

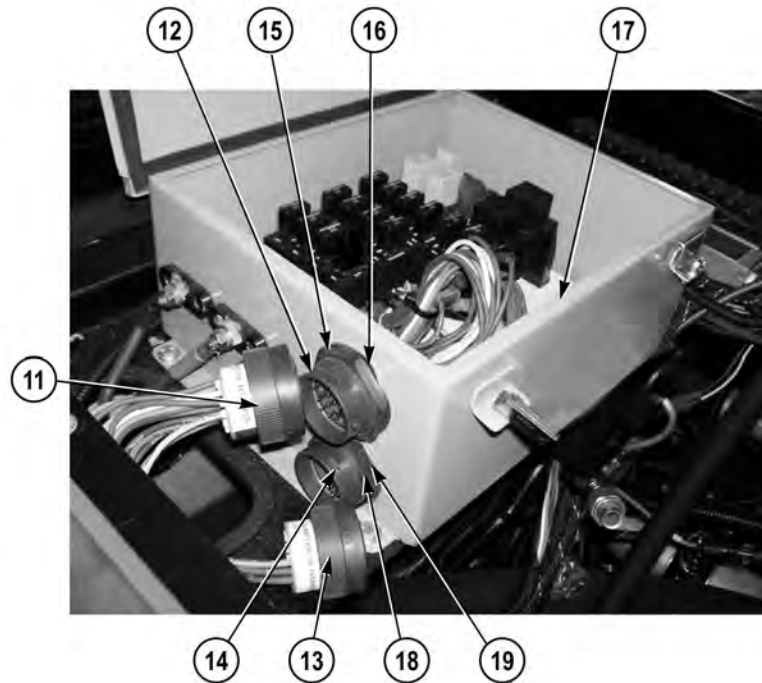
**REMOVAL**

1. Loosen two screws (1) and open cover (2).

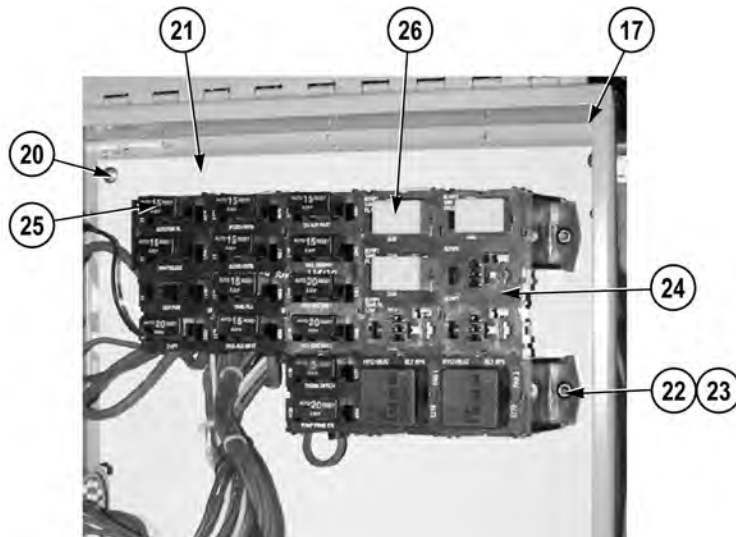


### NOTE

- Tag and mark wires prior to removal to ensure proper installation.
  - Remove cable ties as required.
2. Remove nut (3), lockwasher (4), and wire 1640 (5) from pass-through terminal block (6). Discard lockwasher.
  3. Remove nut (7), lockwasher (8), and five wires 1138 (9) from pass-through terminal block (10). Discard lockwasher.



4. Disconnect pump house wire harness connector (11) from pump house power distribution wire harness connector DP2 (12).
5. Disconnect pump house wire harness connector (13) from pump house power distribution wire harness connector DP1 (14).
6. Remove nut (15), lockwasher (16), and pump house power distribution wire harness connector DP2 (12) from power distribution box (17). Discard lockwasher.
7. Remove nut (18), lockwasher (19), and pump house power distribution wire harness connector DP1 (14) from power distribution box (17). Discard lockwasher.



8. Remove four screws (20) and plate (21) from pump house power distribution box (17).
9. Remove three screws (22), washers (23), and pump house power distribution wire harness block (24) from plate (21).

### NOTE

Note position of circuit breakers and relays prior to removal to ensure proper installation.

10. Remove 13 circuit breakers (25) and five relays (26), from pump house power distribution wire harness block (24).

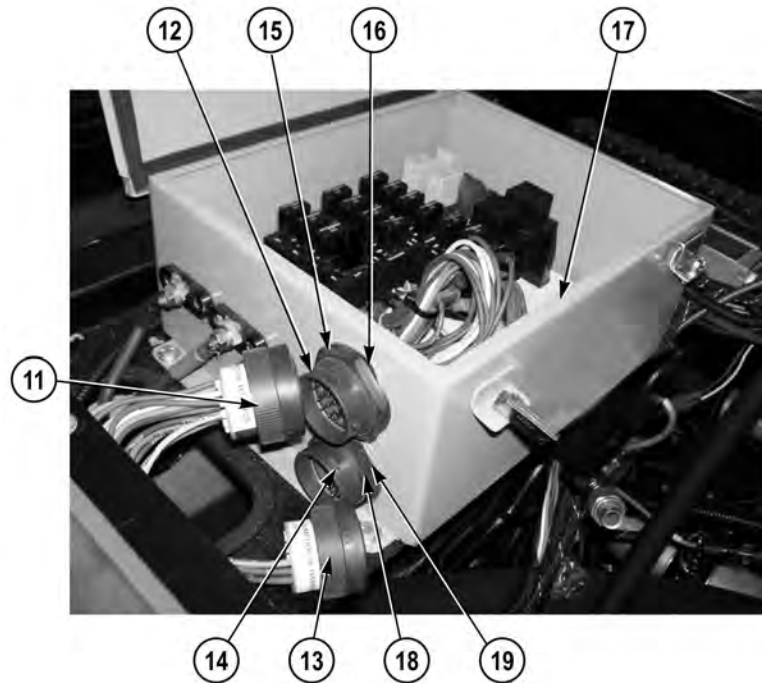
### END OF TASK

### INSTALLATION

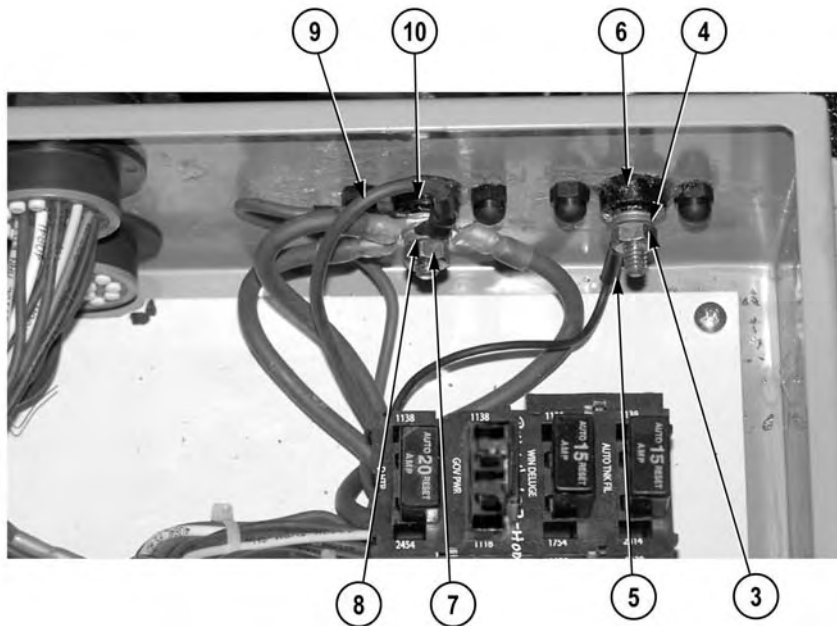
### NOTE

- Install circuit breakers and relays in same position as noted prior to removal.
- Install cable ties as required.

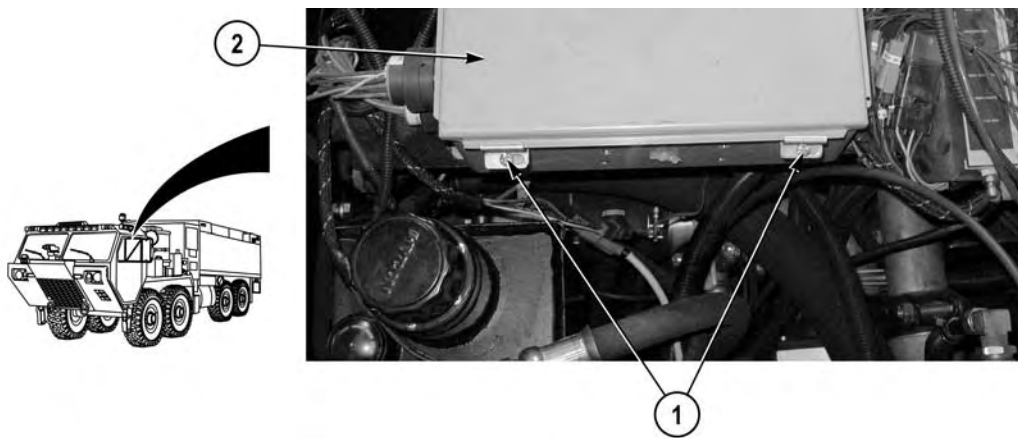
1. Install five relays (26) and 13 circuit breakers (25) on pump house power distribution wire harness block (24).
2. Install pump house power distribution wire harness block (24) on plate (21) with three washers (23) and screws (22).
3. Install plate (21) on pump house power distribution box (17) with four screws (20).



4. Install pump house power distribution wire harness connector DP1 (14) on power distribution box (17) with lockwasher (19) and nut (18).
5. Install pump house power distribution wire harness connector DP2 (12) on power distribution box (17) with lockwasher (16) and nut (15).
6. Connect pump house wire harness connector (13) on pump house power distribution wire harness connector DP1 (14).
7. Connect pump house wire harness connector (11) on pump house power distribution wire harness connector DP2 (12).



- 8. Install five wires 1138 (9) on pass-through terminal block (10) with lockwasher (8) and nut (7).
- 9. Install wire 1640 (5) on pass-through terminal block (6) with lockwasher (4) and nut (3).



- 10. Close cover (2) and tighten two screws (1).

**END OF TASK**

**FOLLOW-ON MAINTENANCE**

Install pump house panel K (WP 0339)

**END OF TASK**

**END OF WORK PACKAGE**

## FIELD LEVEL MAINTENANCE

## PRIMER PUMP CONTROL SOLENOID REPLACEMENT

## INITIAL SETUP:

**Tools and Special Tools**

Tool Kit, General Mechanic's: Automotive  
(WP 0398, Item 17)

**References**

WP 0391, Fig. 17

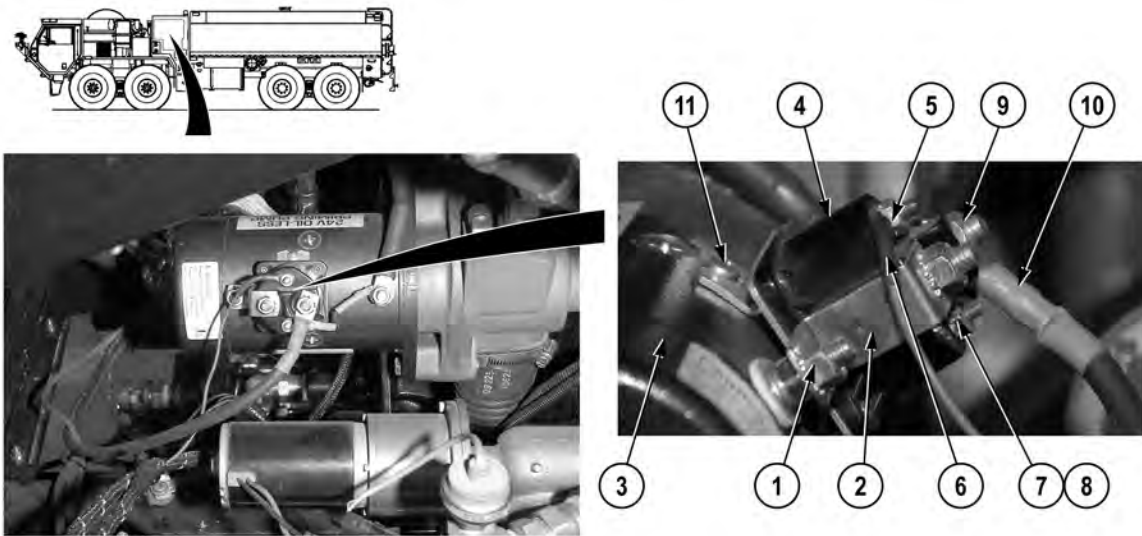
**Materials/Parts**

Tags, Identification (WP 0400, Item 23)  
Locknut (2)  
Locknut (1)  
Locknut (1)  
Locknut (1)

**Equipment Conditions**

Pump house panel G removed (WP 0339)

## REMOVAL



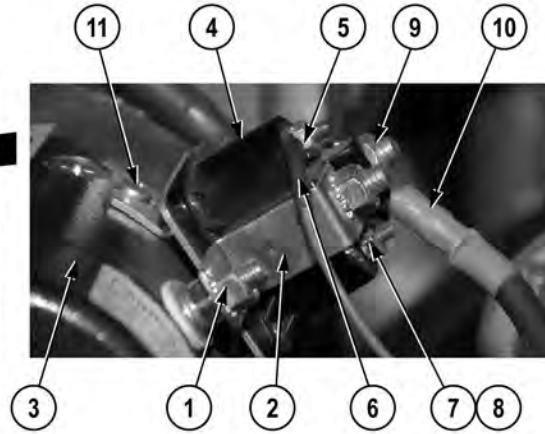
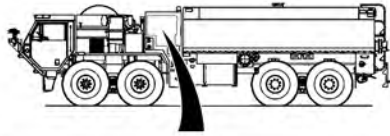
1. Remove two locknuts (1) and electrical strip (2) from primer pump motor (3) and primer pump control solenoid (4). Discard locknuts.

**NOTE**

Tag and mark wires prior to removal to ensure proper installation.

2. Remove locknut (5) and wire 2774 (6) from primer pump control solenoid (4). Discard locknut.
3. Remove locknut (7) and jumperwire (8) from primer pump control solenoid (4). Discard locknut.
4. Remove locknut (9) and wire (10) from primer pump control solenoid (4). Discard locknut.
5. Remove two screws (11) and primer pump control solenoid (4) from primer pump motor (3).

**END OF TASK**

**INSTALLATION**

1. Install primer pump control solenoid (4) on primer pump motor (3) with two screws (11).
2. Install wire (10) on primer pump control solenoid (4) with locknut (9).
3. Install jumperwire (8) on primer pump control solenoid (4) with locknut (7).
4. Install wire 2774 (6) on primer pump control solenoid (4) with locknut (5).
5. Install electrical strip (2) on primer pump motor (3) and primer pump control solenoid (4) with two locknuts (1).

**END OF TASK****FOLLOW-ON MAINTENANCE**

Install pump house panel G (WP 0339)

**END OF TASK****END OF WORK PACKAGE**



**FIELD LEVEL MAINTENANCE**  
**PUMP HOUSE B+ STUD REPLACEMENT**

**INITIAL SETUP:****Tools and Special Tools**

Tool Kit, General Mechanic's: Automotive  
(WP 0398, Item 17)

**References**

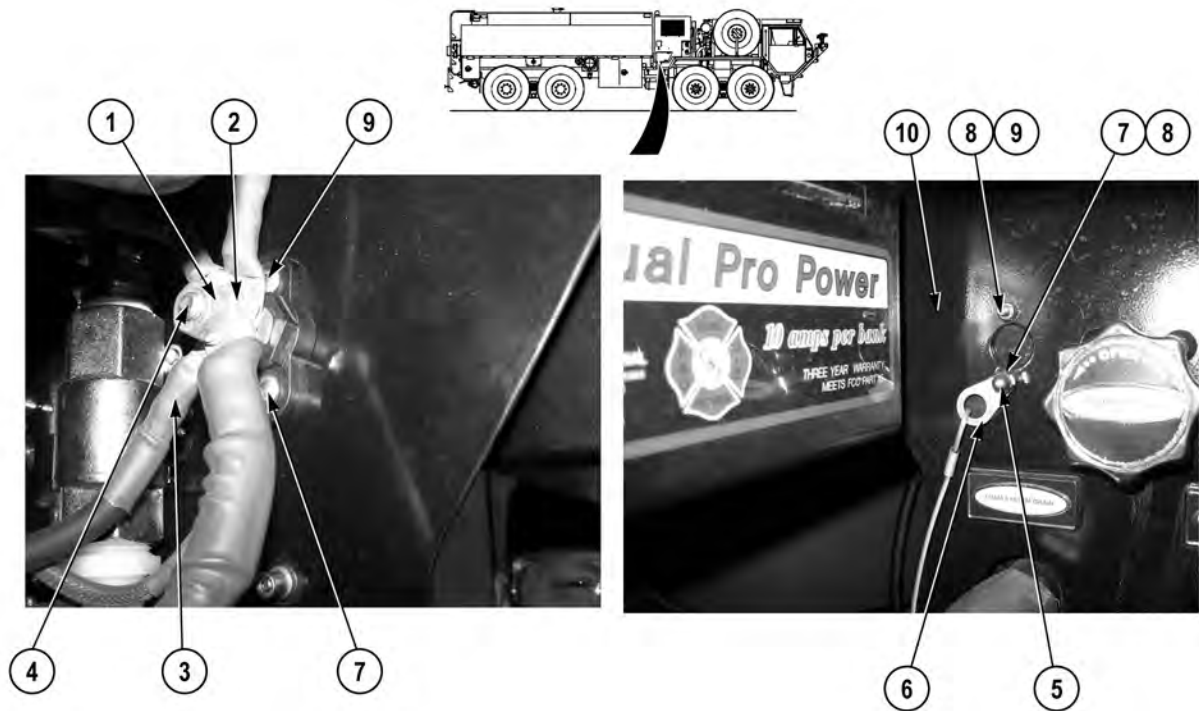
WP 0391, Fig. 14

**Materials/Parts**

Locknut (1)  
Locknut (2)

**Equipment Conditions**

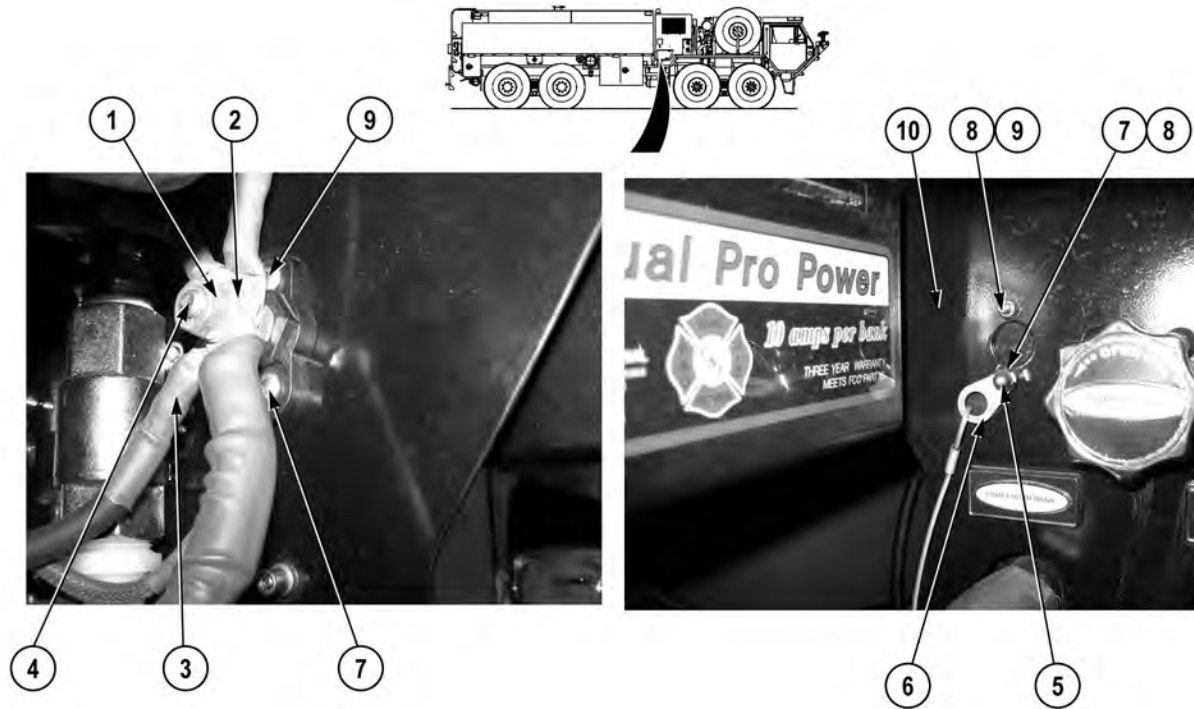
Batteries disconnected (TM 9-2320-325-14&P)  
Pump house compartment door P opened  
(WP 0008)

**REMOVAL**

1. Remove nut (1), washer (2), and five wires (3) from B+ stud (4).
2. Remove locknut (5) and anchor clip (6) from screw (7). Discard locknut.
3. Remove two locknuts (8), screws (7) and (9), and B+ stud (4) from bracket (10). Discard locknuts.

**END OF TASK**

## INSTALLATION



1. Install B+ stud (4) on bracket (10) with two screws (9) and (7) and locknuts (8).
2. Install anchor clip (6) on screw (7) with locknut (5).

**⚠ CAUTION**

**Do not overtighten nut on B+ stud when installing wires. Failure to comply may cause damage to equipment.**

3. Install five wires (3) on B+ stud (4) with washer (2) and nut (1).

## END OF TASK

## FOLLOW-ON MAINTENANCE

1. Close pump house compartment door P (WP 0008)
2. Connect batteries (TM 9-2320-325-14&P)

## END OF TASK

## END OF WORK PACKAGE

---

**FIELD LEVEL MAINTENANCE**  
**PUMP HOUSE WIRE HARNESS REPLACEMENT**

---

**INITIAL SETUP:****Tools and Special Tools**

Tool Kit, General Mechanic's: Automotive  
(WP 0398, Item 17)

**Materials/Parts**

Tags, Identification (WP 0400, Item 23)  
Ties, Cable, Plastic (WP 0400, Item 26)  
Lockwasher (1)  
Lockwasher (1)  
Locknut (1)  
Locknut (4)  
Lockwasher (4)

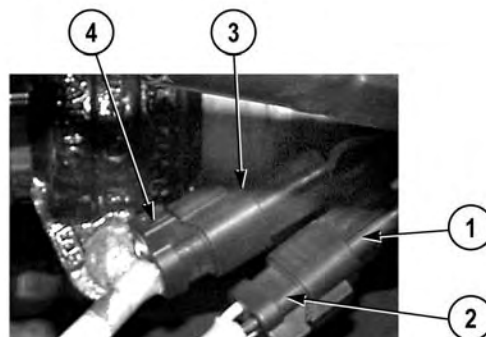
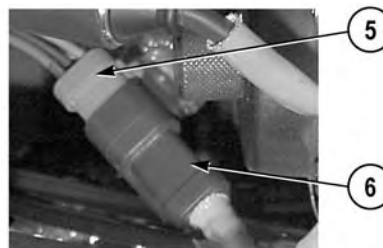
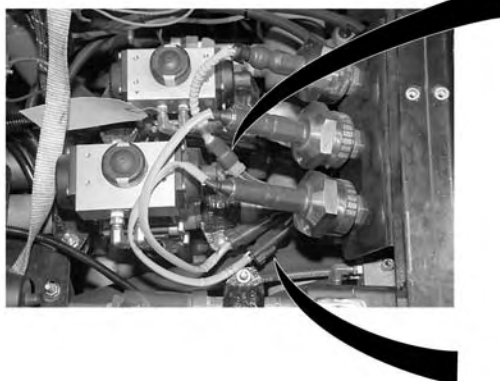
**References**

TM 9-2320-325-14&P  
WP 0391, Fig. 18, 55

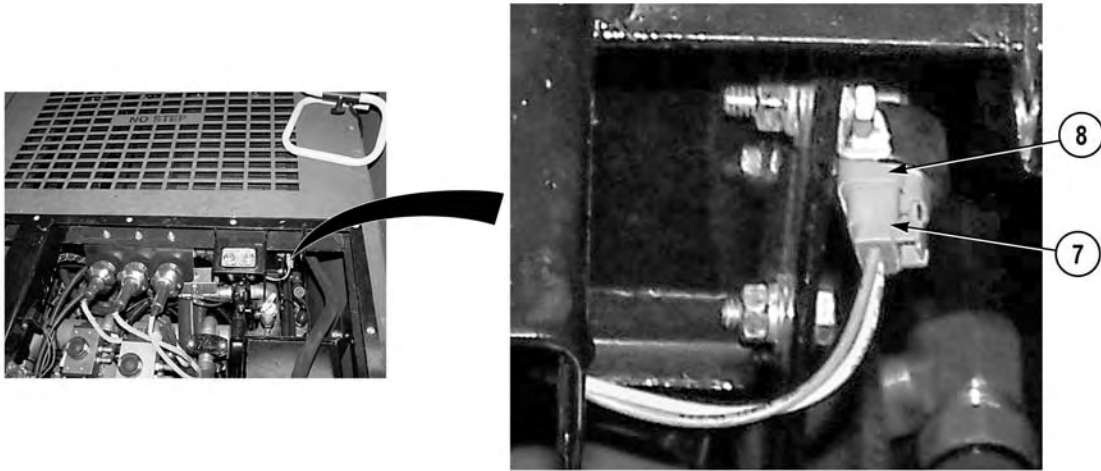
**Equipment Conditions**

Pump house panel A, E, G, H, and K  
removed (WP 0339)  
Reel rewind switch removed (WP 0253)  
Hose reel removed (WP 0247)

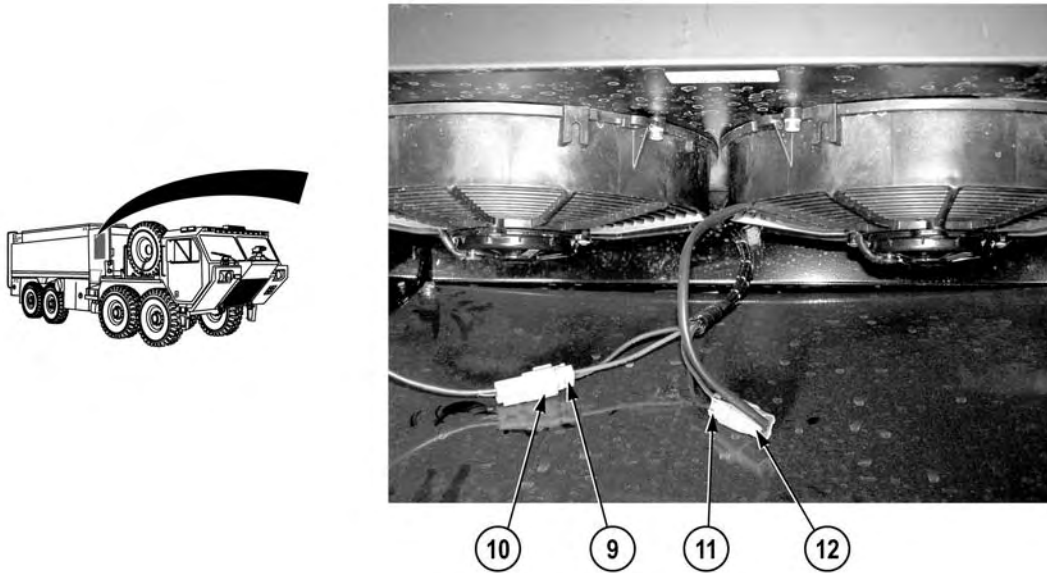
---

**REMOVAL****NOTE**

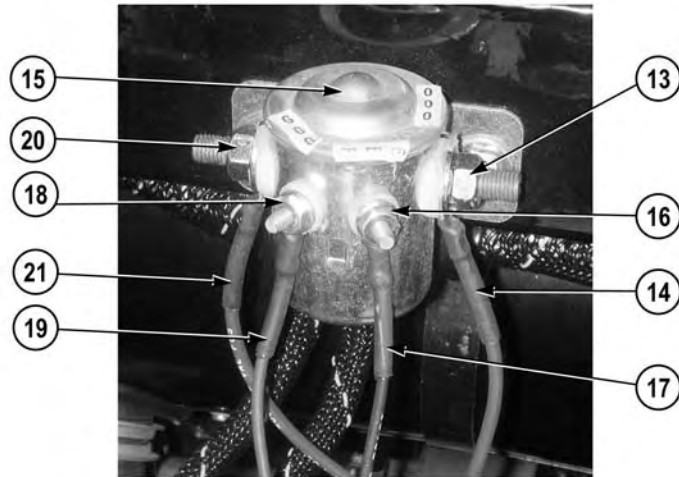
- Tag and mark wires prior to removal to ensure proper installation.
  - Note routing of pump house wire harness prior to removal to ensure proper installation.
  - Note position and remove cable ties, split loom, and cushion clips as required.
1. Disconnect pump house wire harness connector (1) from discharge pressure transducer connector (2).
  2. Disconnect pump house wire harness connector (3) from intake pressure transducer connector (4).
  3. Disconnect pump house wire harness (5) from intake vacuum transducer connector (6).



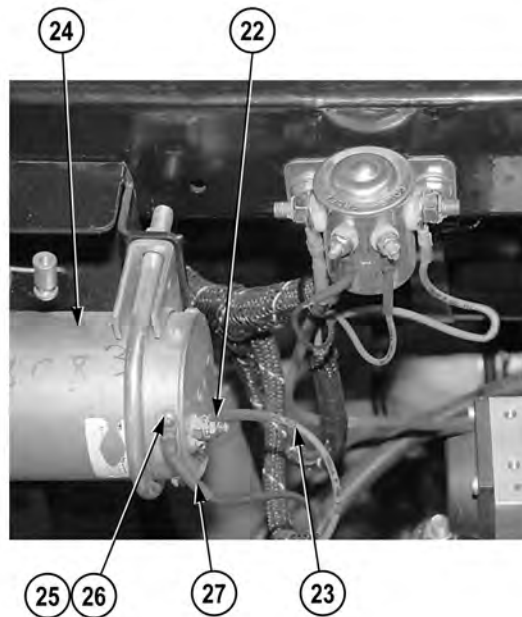
4. Disconnect pump house wire harness connector (7) from hydraulic heat exchanger thermal switch connector (8).



5. Disconnect pump house wire harness connector (9) from hydraulic heat exchanger fan 1 connector (10).
6. Disconnect pump house wire harness connector (11) from hydraulic heat exchanger fan 2 connector (12).



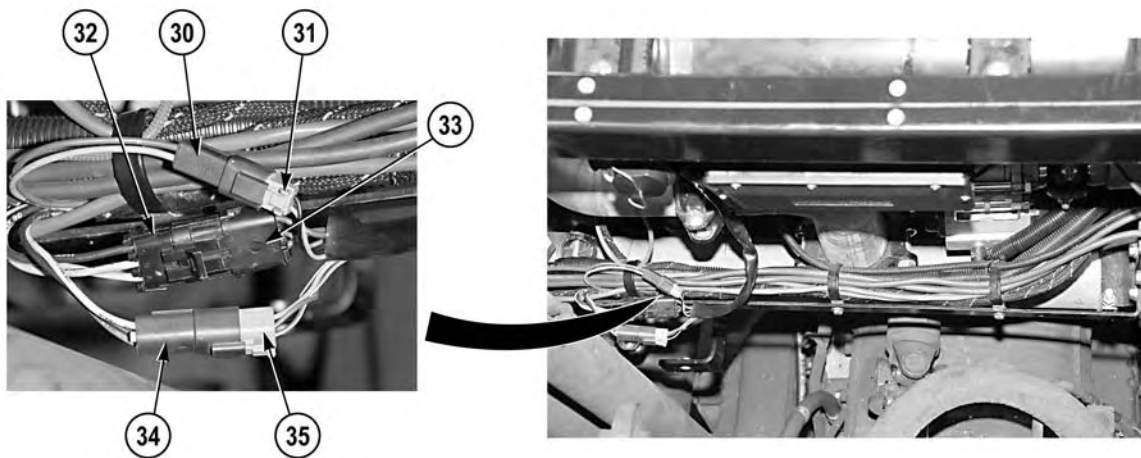
7. Remove nut (13) and wire 4064 (14) from primer valve control solenoid (15).
8. Remove nut (16) and wire 1640 (17) from primer valve control solenoid (15).
9. Remove nut (18) and wire 1590 (19) from primer valve control solenoid (15).
10. Remove nut (20) and wire 4065 (21) from primer valve control solenoid (15).



11. Remove locknut (22) and wire 4065 (23) from primer valve (24). Discard locknut.
12. Remove screw (25), lockwasher (26), and wire 4068 (27) from primer valve (24). Discard lockwasher.



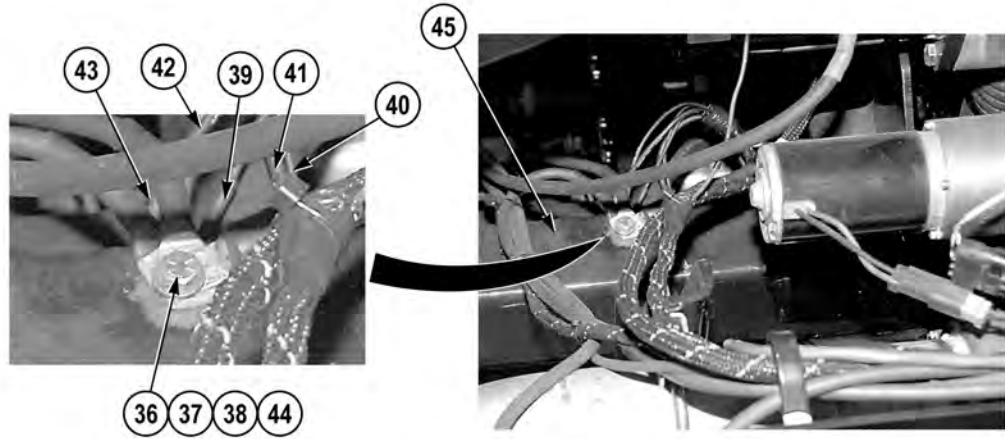
13. Disconnect pump house wire harness connector (28) from thermal relief sensor connector (29).



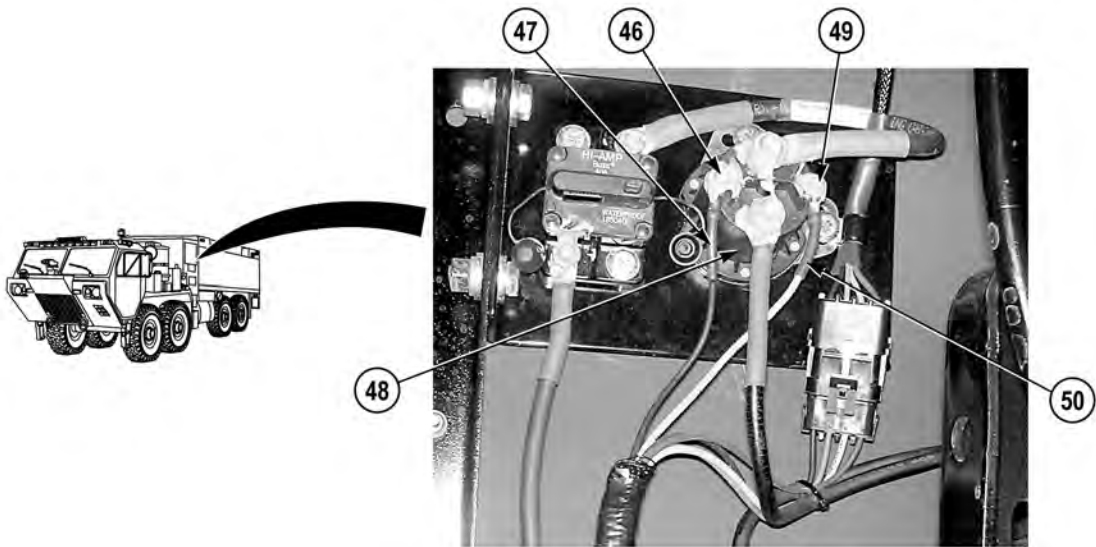
14. Disconnect pump house wire harness connector (30) from diesel heater connector (31).

15. Disconnect pump house wire harness connector (32) from diesel heater connector (33).

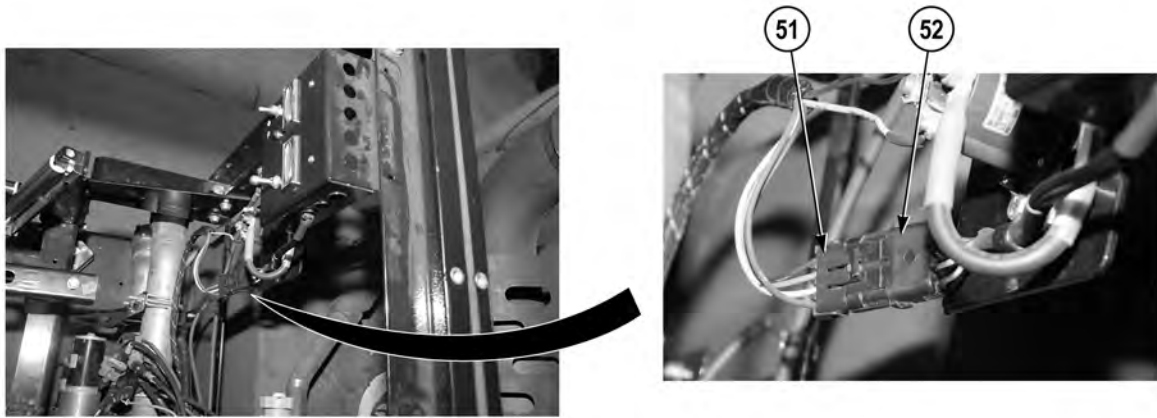
16. Disconnect pump house wire harness connector (34) from diesel heater connector (35).



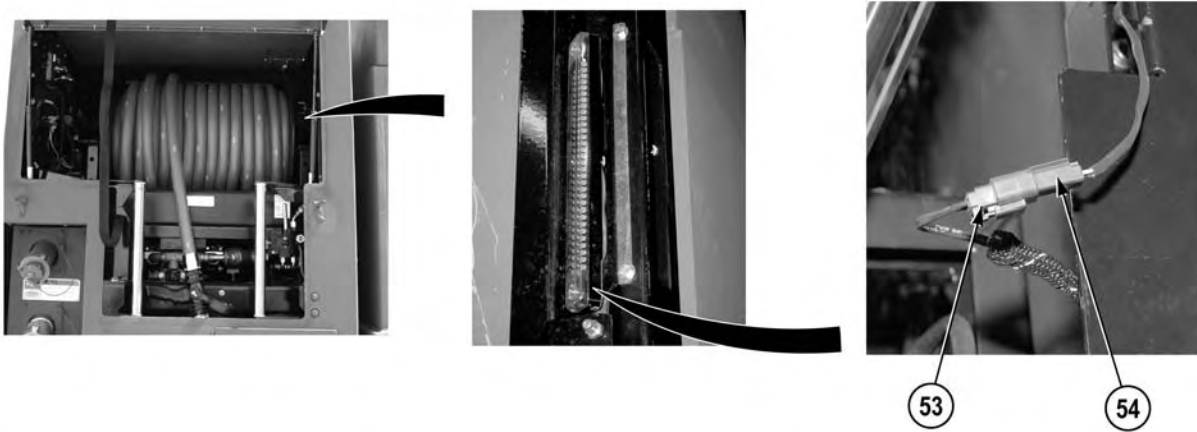
17. Remove nut (36), lockwasher (37), two washers (38), wire 4068 (39), wire 2640 (40), wire 2740 (41), wire 2200 (42), wire 1640 (43) and screw (44) from frame rail (45). Discard lockwasher.



18. Remove nut (46) and wire 1640 (47) from hose reel rewind solenoid (48).
19. Remove nut (49) and wire 1664 (50) from hose reel rewind solenoid (48).

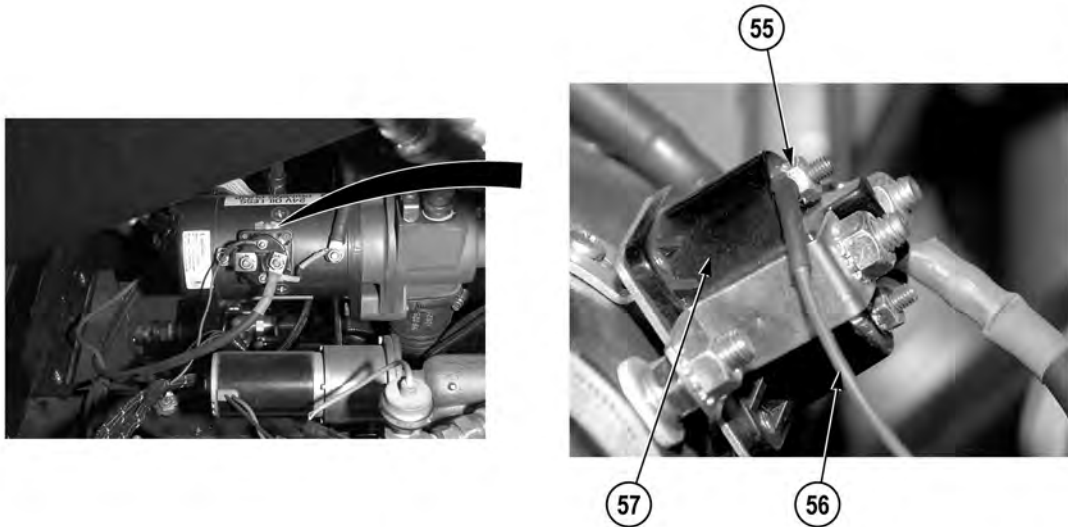


20. Disconnect pump house wire harness connector (51) from diesel heater control connector (52).

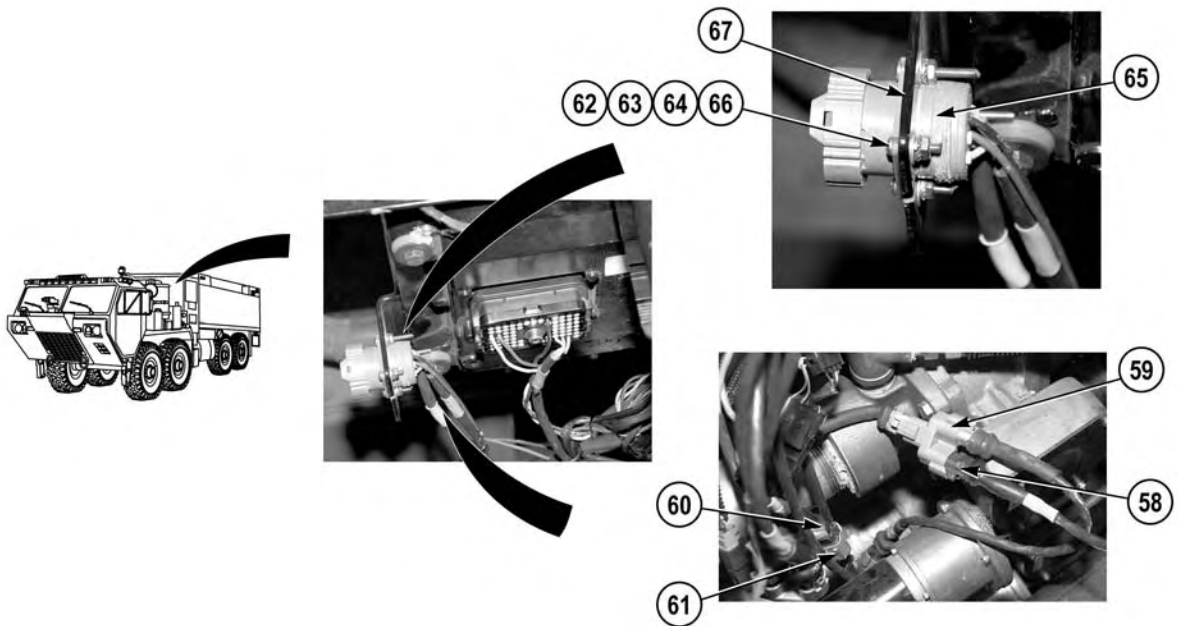


21. Disconnect pump house wire harness connector (53) from pump house hose reel striplight connector (54).





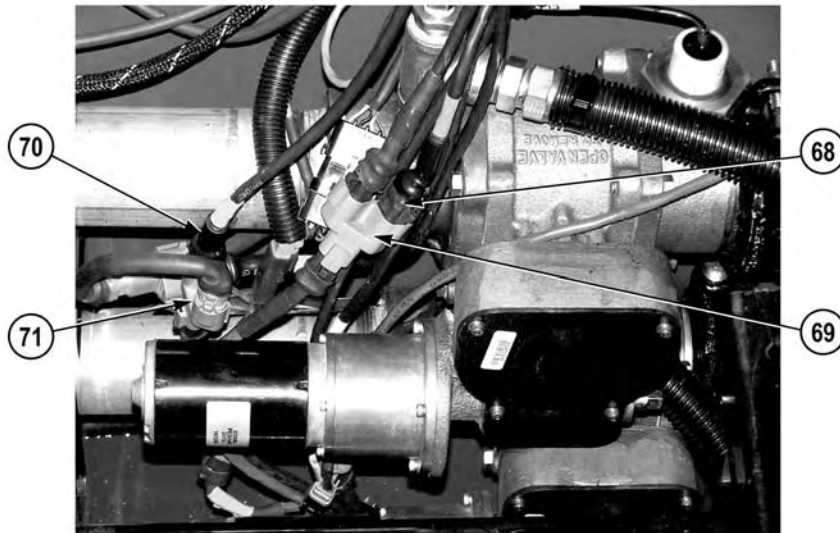
22. Remove locknut (55) and wire 2774 (56) from primer pump solenoid (57). Discard locknut.



**NOTE**

To locate correct datalink cable, follow yellow and green banded datalink cables from pressure governor ECU service connector to first Y connector in series.

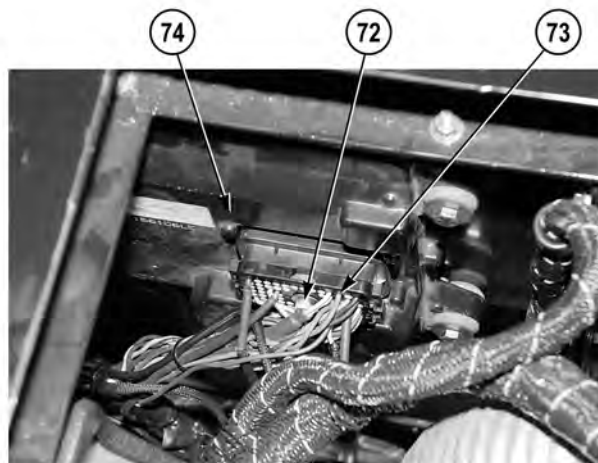
- 23. Disconnect pump house wire harness connector (58) from pressure governor control ECU datalink Y connector (59).
- 24. Disconnect pump house wire harness connector (60) from chassis datalink Y connector (61).
- 25. Remove four locknuts (62), lockwashers (63), washers (64), pressure governor ECU service connector (65), and four screws (66) from bracket (67). Discard locknuts and lockwashers.



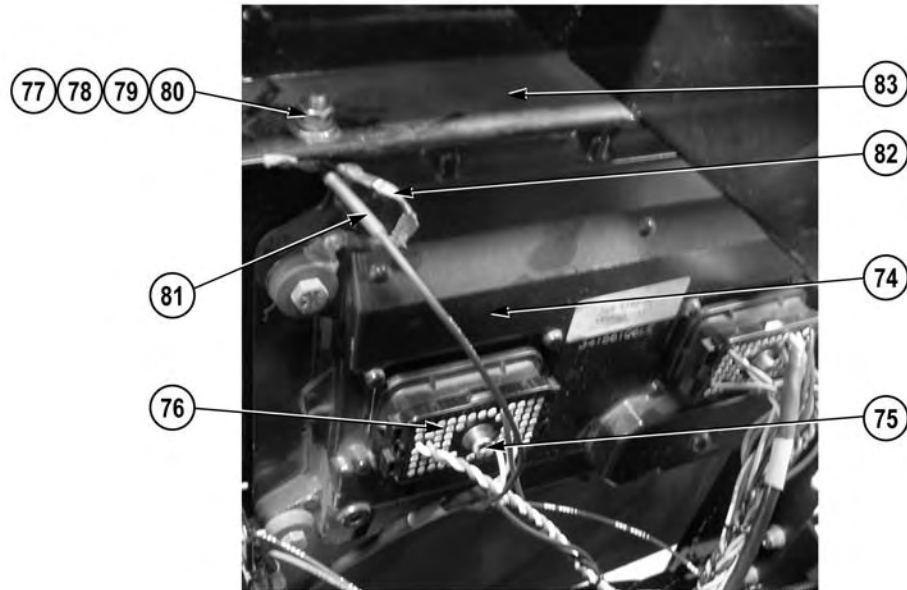
### NOTE

To locate correct datalink cable, follow yellow and green banded datalink cables from pressure governor ECU, J1 and J2 connectors, to first Y connector in series.

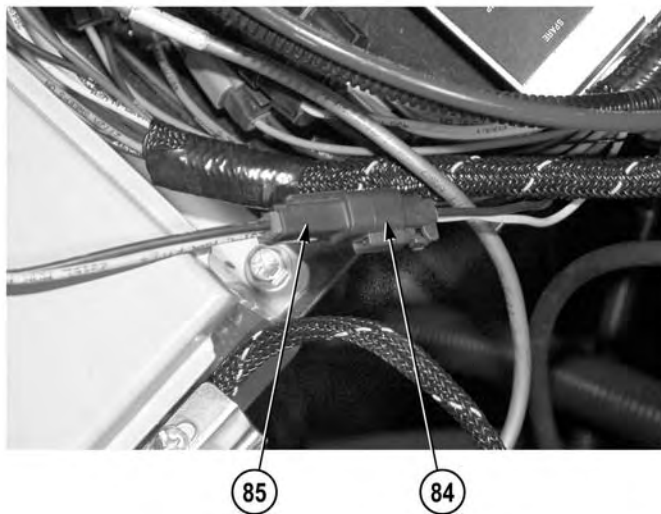
26. Disconnect pump house wire harness connector (68) from pressure governor control ECU datalink Y connector (69).
27. Disconnect pump house wire harness connector (70) from chassis datalink Y connector (71).



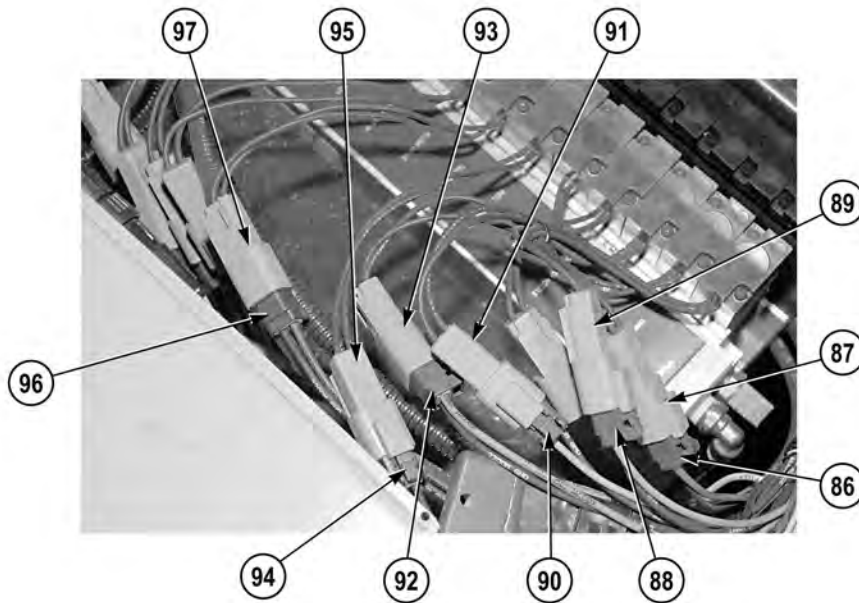
28. Loosen screw (72) and remove pump house wire harness J1 connector (73) from pressure governor ECU (74).



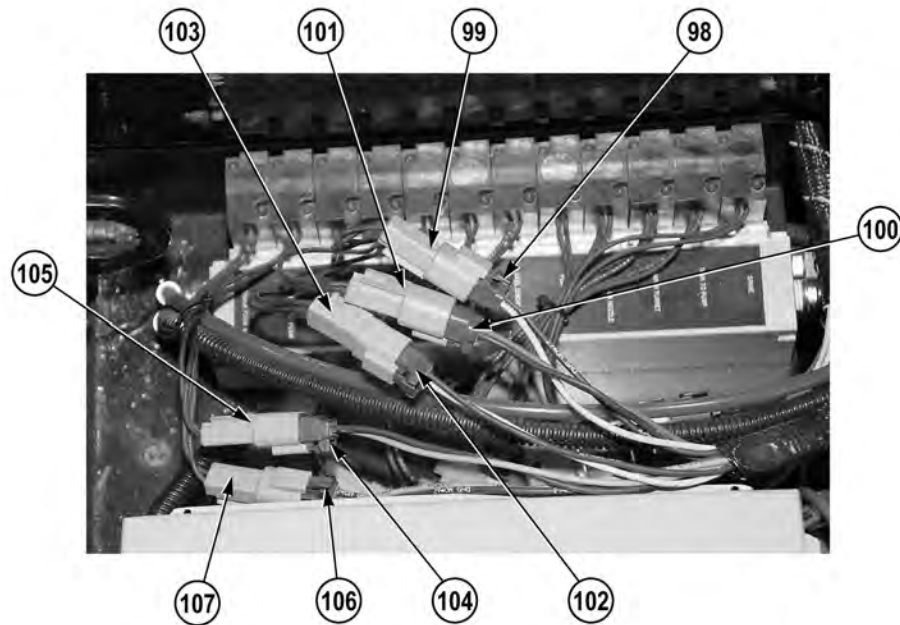
29. Loosen screw (75) and remove pump house wire harness J2 connector (76) from pressure governor ECU (74).
30. Remove nut (77), lockwasher (78), four washers (79), screw (80), wire 1100 (81), and ground wire (82) from frame (83).



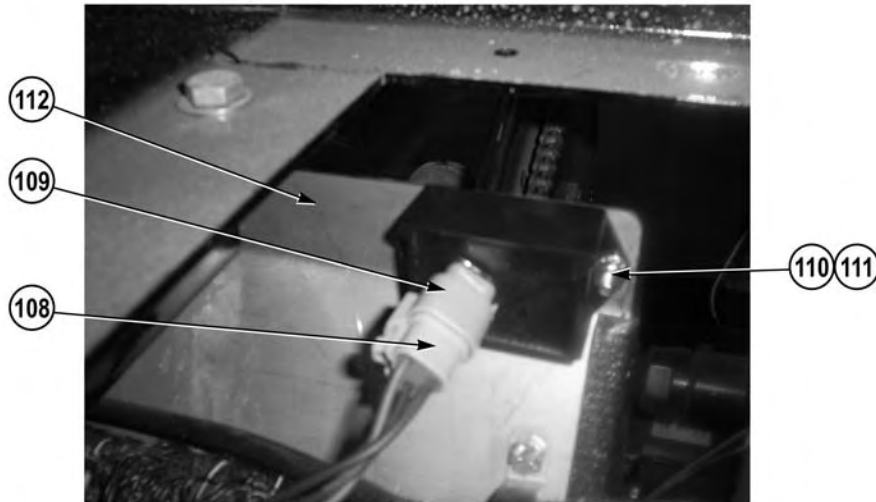
31. Disconnect pump house wire harness connector (84) from direct tank fill valve wire harness connector (85).



32. Disconnect pump house wire harness connector (86) from tank-to-pump valve control connector (87).
33. Disconnect pump house wire harness connector (88) from bumper turret valve control connector (89).
34. Disconnect pump house wire harness connector (90) from under truck nozzles valve control connector (91).
35. Disconnect pump house wire harness connector (92) from pump cooler valve control connector (93).
36. Disconnect pump house wire harness connector (94) from hose reel valve control connector (95).
37. Disconnect pump house wire harness connector (96) from water tank drain valve control connector (97).



38. Disconnect pump house wire harness connector (98) from foam flush valve control connector (99).
39. Disconnect pump house wire harness connector (100) from foam system valve control connector (101).
40. Disconnect pump house wire harness connector (102) from eductor valve control connector (103).
41. Disconnect pump house wire harness connector (104) from bumper turret foam valve control connector (105).
42. Disconnect pump house wire harness connector (106) from under truck nozzles foam valve control connector (107).

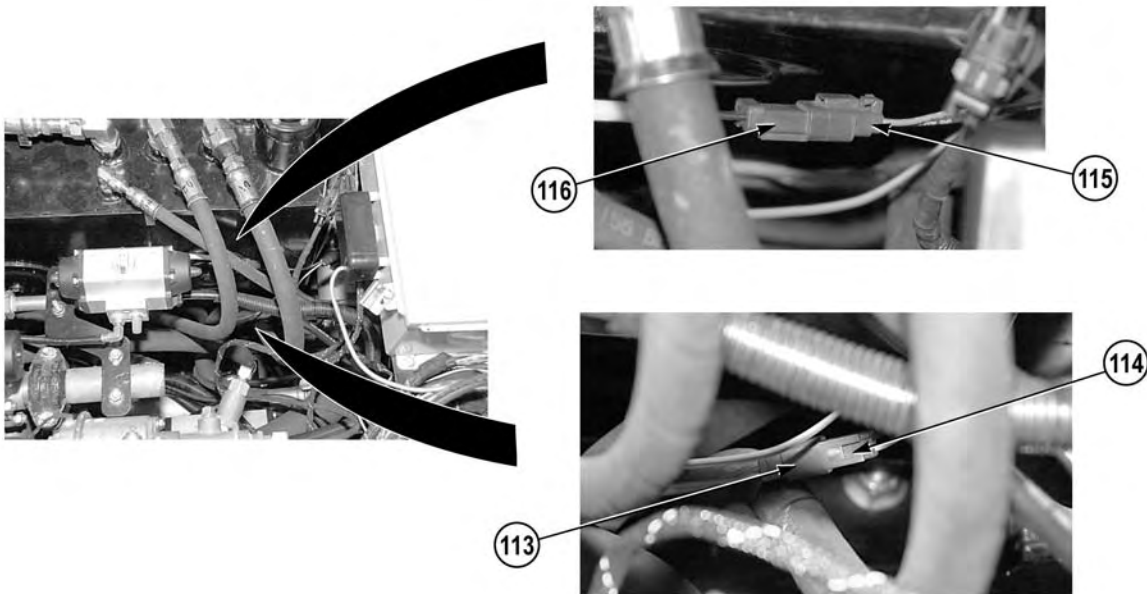


43. Disconnect pump house wire harness pressure governor transorb module connector (108) from transorb module (109).

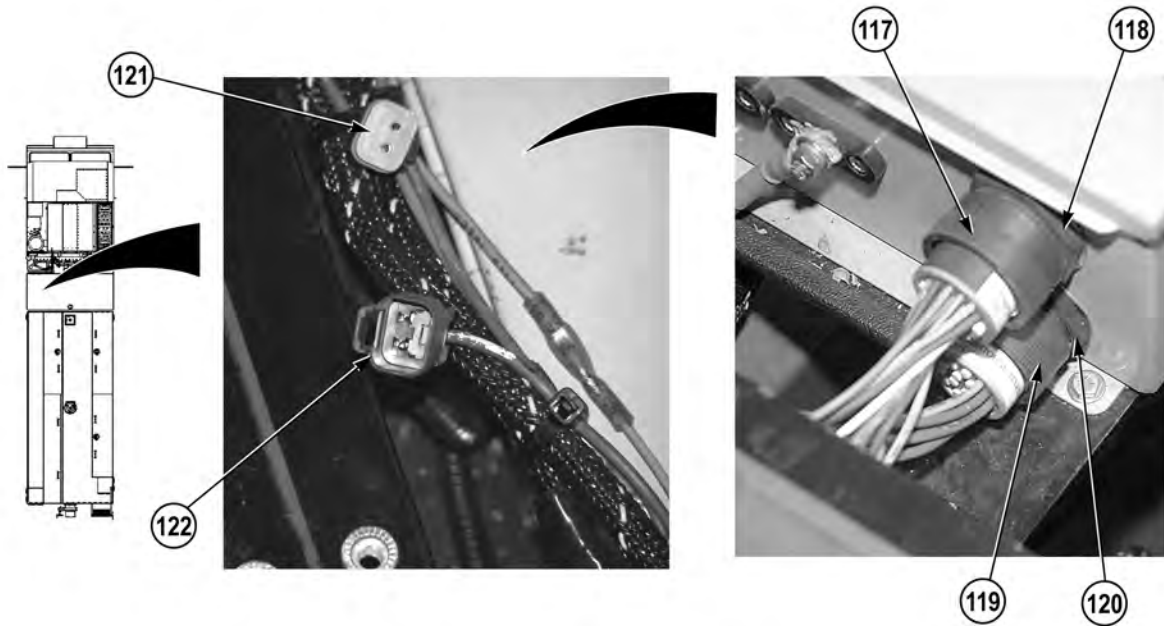
**NOTE**

Perform Step (43) if transorb module needs to be removed.

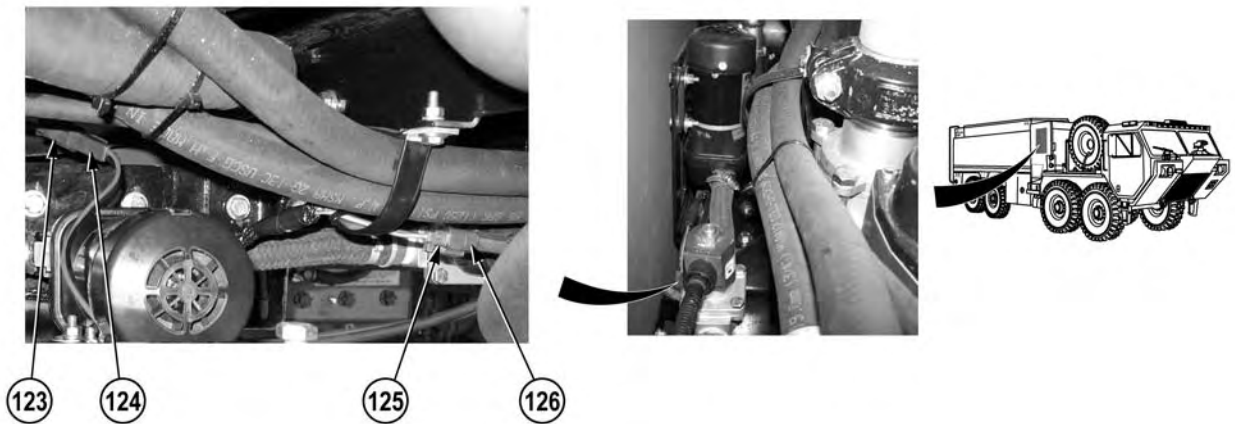
44. Remove two locknuts (110), screws (111), and transorb module (109) from shield (112). Discard locknuts.



45. Disconnect pump house wire harness connector (113) from hydraulic oil level sensor connector (114).
46. Disconnect pump house wire harness connector (115) from hydraulic oil temperature sensor connector (116).



47. Disconnect pump house wire harness connector (117) from pump house power distribution wire harness connector DP2 (118).
48. Disconnect pump house wire harness connector (119) from pump house power distribution wire harness connector DP1 (120).
49. Disconnect main wire harness connector (121) from direct tank fill valve wire harness connector (122).



50. Disconnect pump house wire harness connector (123) from windshield deluge pump connector (124).
51. Disconnect pump house wire harness connector (125) from windshield shutoff valve connector (126).



52. Disconnect pump house wire harness connector (127) from passenger side pump house striplight connector (128).

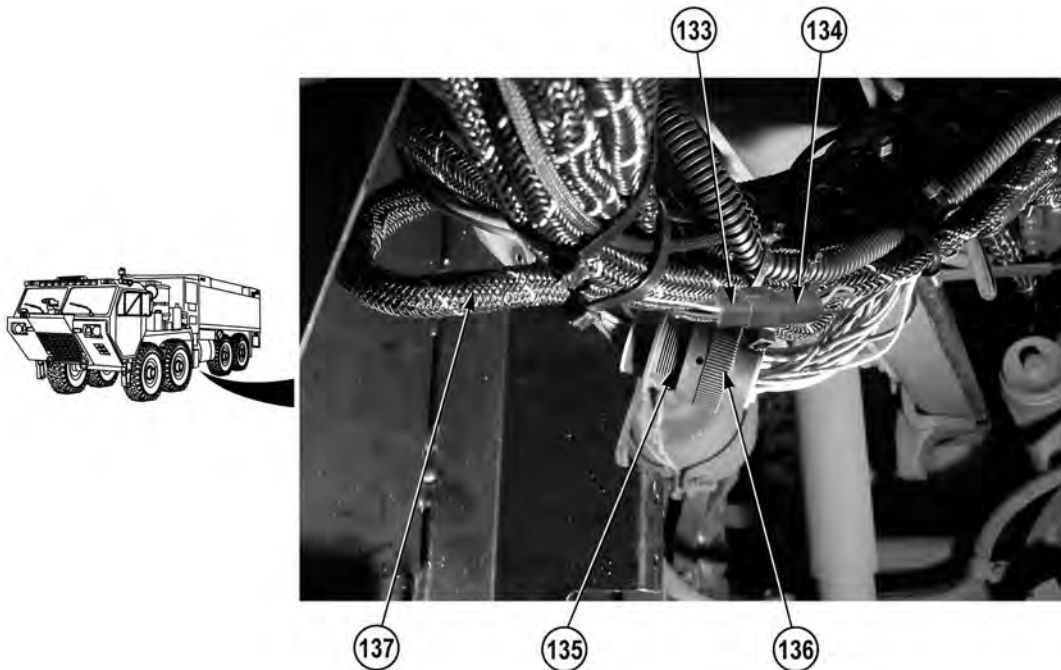


53. Disconnect pump house wire harness connector (129) from driver side pump house striplight connector (130).



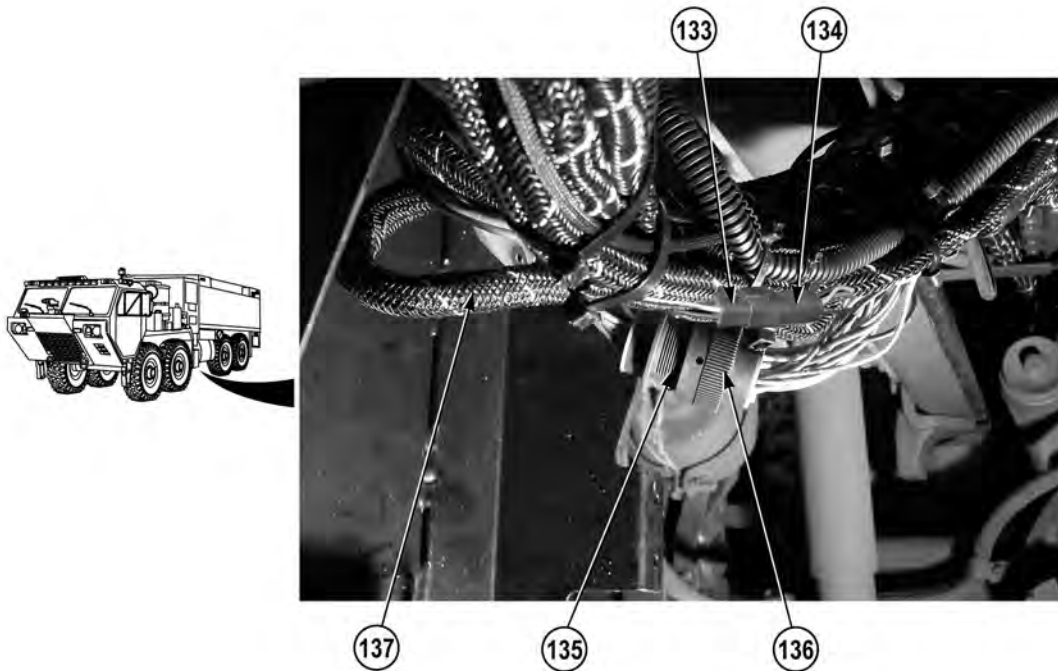


54. Disconnect pump house wire harness connector (131) from manual override manifold solenoid connector (132).



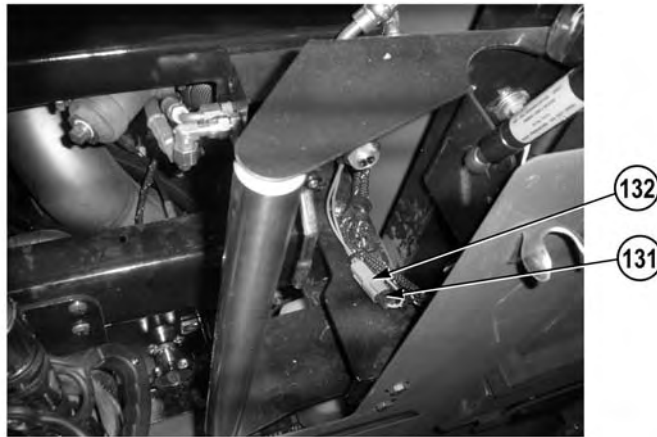
55. Disconnect pump house wire harness connector (133) from main wire harness connector (134).  
 56. Disconnect pump house wire harness connector (135) from main wire harness connector (136).  
 57. Remove main wire harness (137) from vehicle.

**END OF TASK**

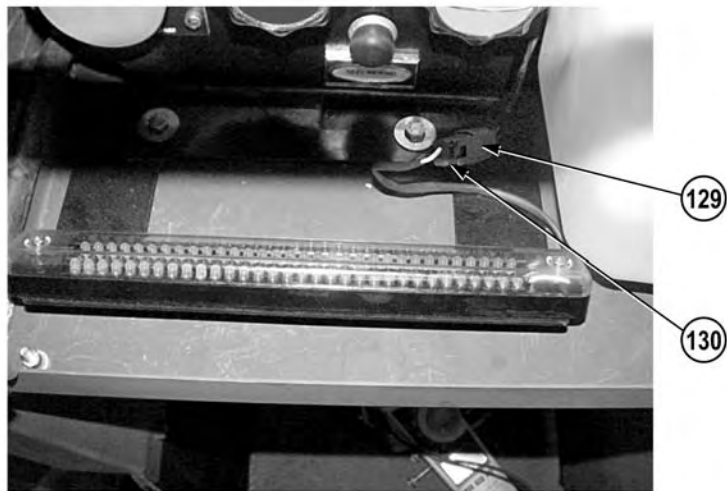
**INSTALLATION****NOTE**

- Route pump house wire harness as noted prior to removal.
- Install cable ties, split loom, and cushion clips as required.

1. Position pump house wire harness (137) on vehicle.
2. Connect main wire harness connector (136) on pump house wire harness connector (135).
3. Connect main wire harness connector (134) on pump house wire harness connector (133).



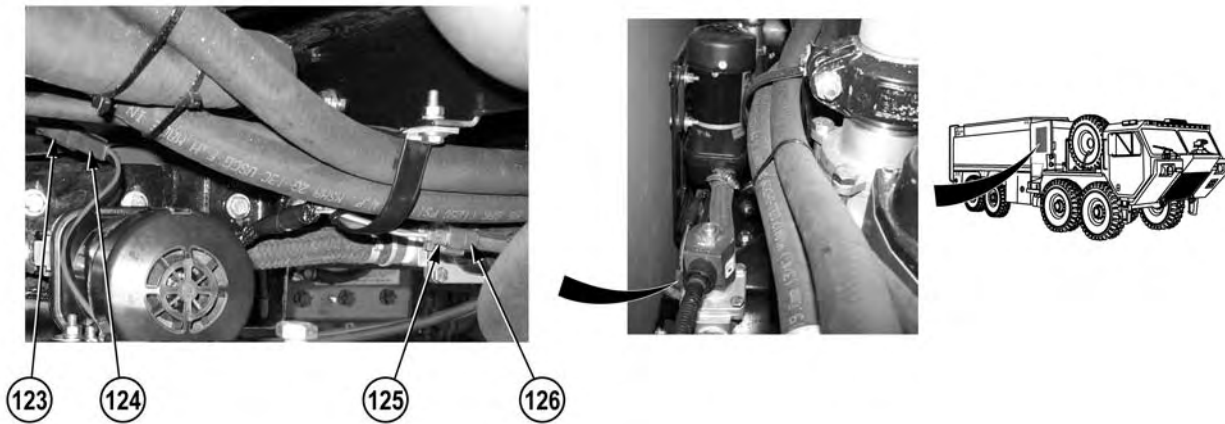
4. Connect manual override manifold solenoid connector (132) on pump house wire harness connector (131).



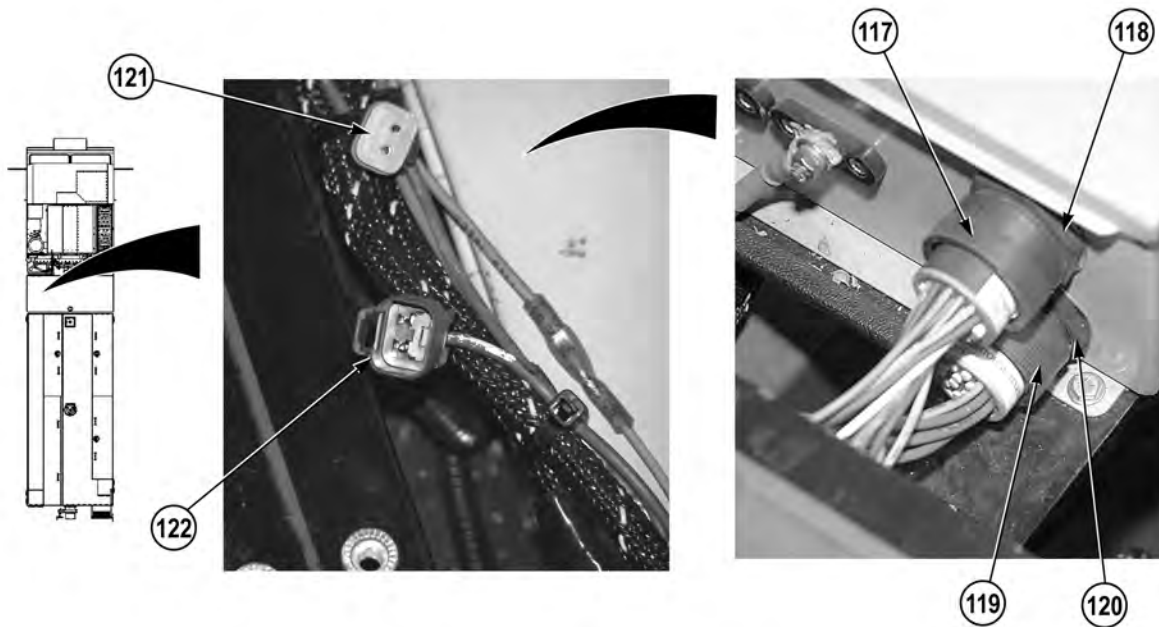
5. Connect driver side pump house striplight connector (130) on pump house wire harness connector (129).



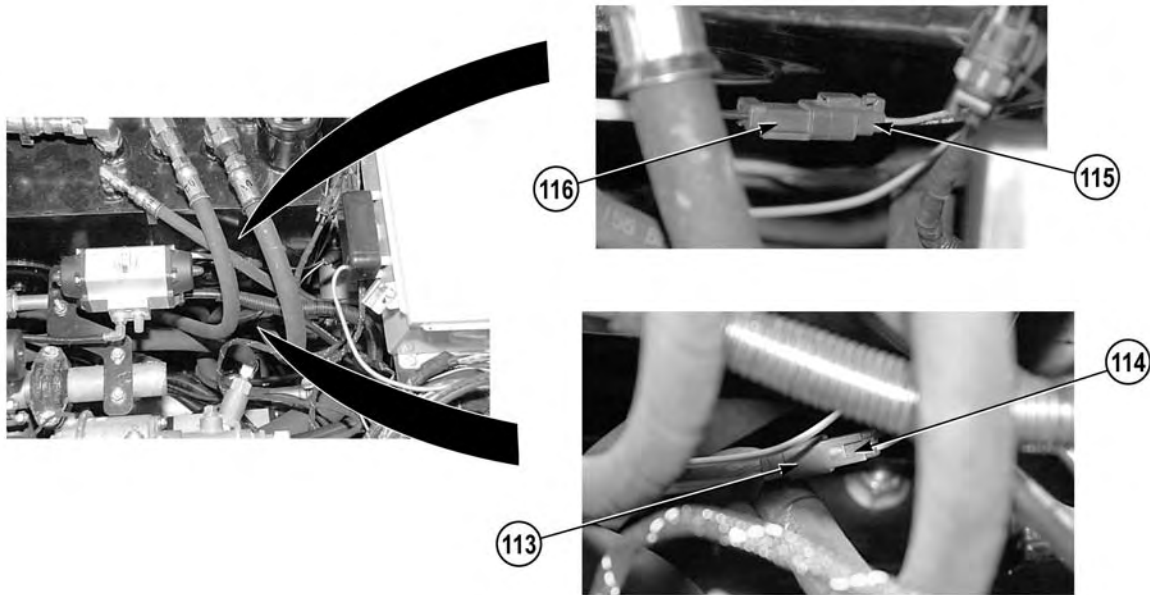
6. Connect passenger side pump house striplight connector (128) on pump house wire harness connector (127).



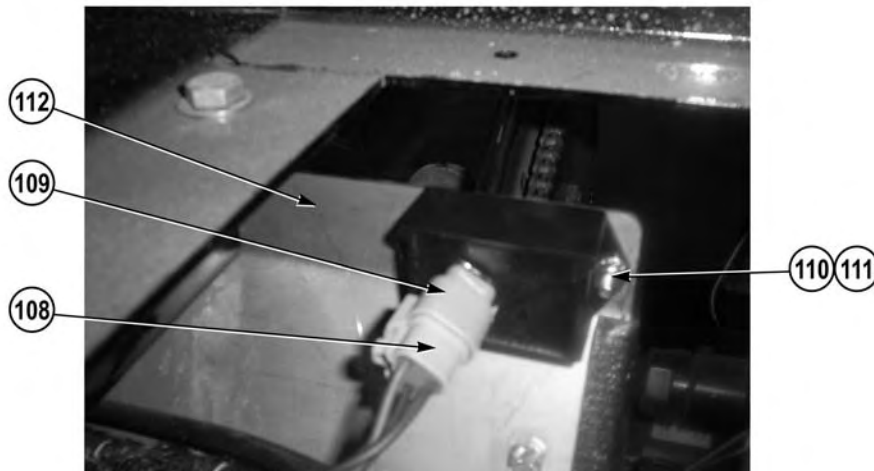
7. Connect windshield deluge shutoff valve connector (126) on pump house wire harness connector (125).
8. Connect windshield deluge pump connector (124) on pump house wire harness connector (123).



9. Connect direct tank fill valve wire harness connector (122) on main wire harness connector (121).
10. Connect pump house wire harness connector (119) on pump house power distribution wire harness connector DP1 (120).
11. Connect pump house wire harness connector (117) on pump house power distribution wire harness connector DP2 (118).



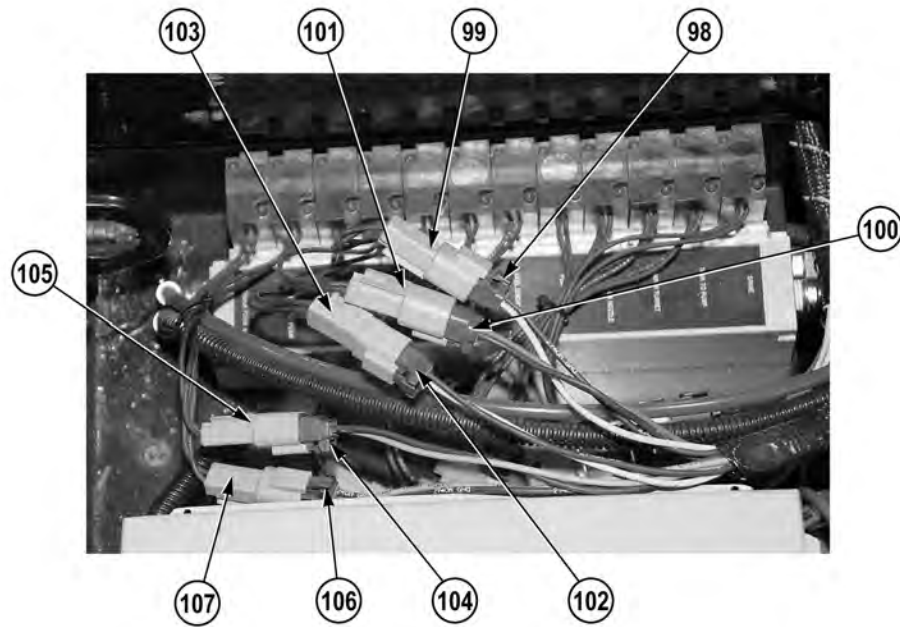
12. Connect hydraulic oil temperature sensor connector (115) on pump house wire harness connector (116).
13. Connect hydraulic oil level sensor connector (114) on pump house wire harness connector (113).



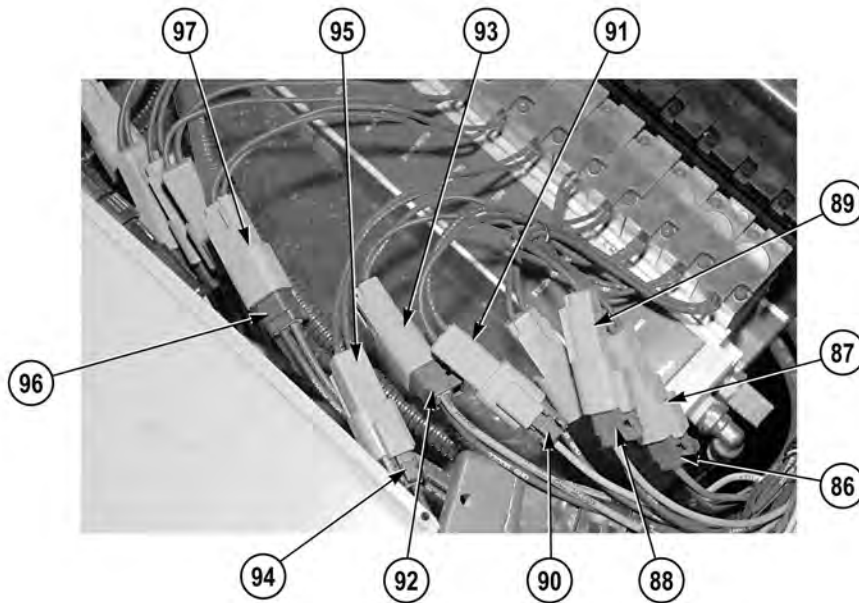
**NOTE**

Perform Step (14) if transorb module was removed.

14. Install transorb module (109) on shield (112) with two screws (111) and locknuts (110).
15. Connect pump house wire harness pressure governor transorb module connector (108) on transorb module (109).

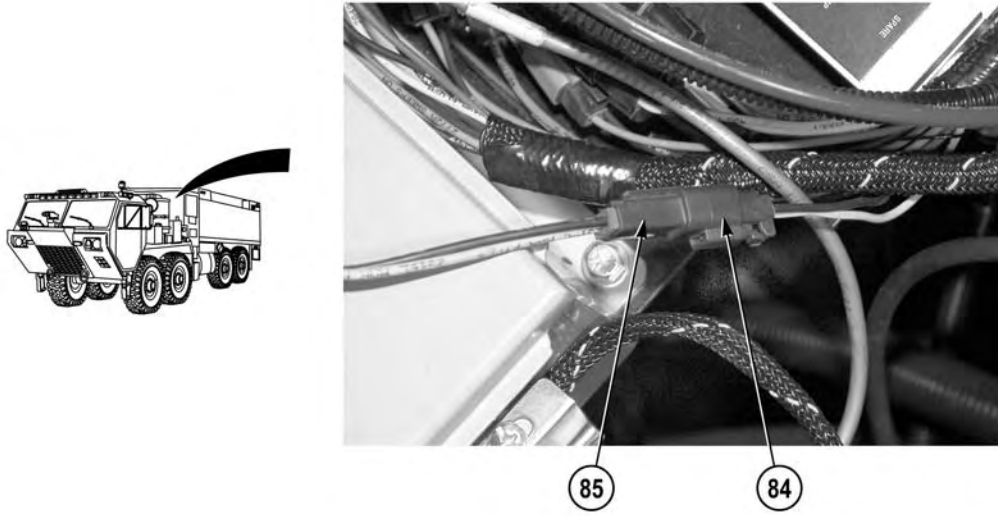


16. Connect under truck nozzles foam valve control connector (107) on pump house wire harness connector (106).
17. Connect bumper turret foam valve control connector (105) on pump house wire harness connector (104).
18. Connect eductor valve control connector (103) on pump house wire harness connector (102).
19. Connect foam system valve control connector (101) on pump house wire harness connector (100).
20. Connect foam flush valve control connector (99) on pump house wire harness connector (98).

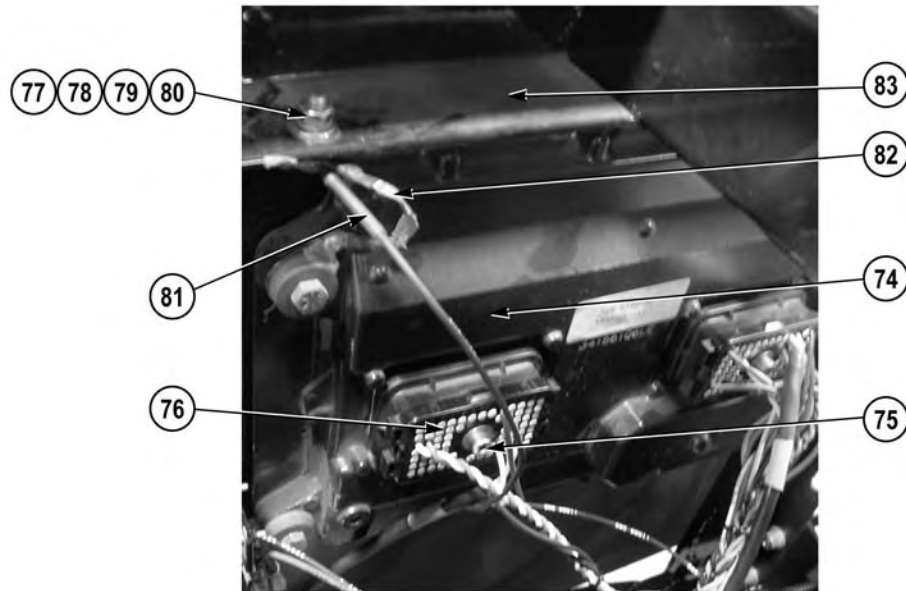


21. Connect water tank drain valve control connector (97) on pump house wire harness connector (96).
22. Connect hose reel valve control connector (95) on pump house wire harness connector (94).
23. Connect pump cooler valve control connector (93) on pump house wire harness connector (92).
24. Connect under truck nozzles valve control connector (91) on pump house wire harness connector (90).
25. Connect bumper turret valve control connector (89) on pump house wire harness connector (88).
26. Connect tank-to-pump valve control connector (87) on pump house wire harness connector (86).



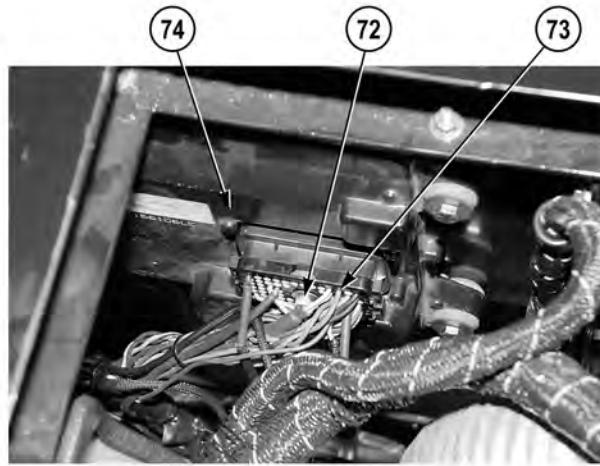


27. Connect direct tank fill valve wire harness connector (85) on pump house wire harness connector (84).

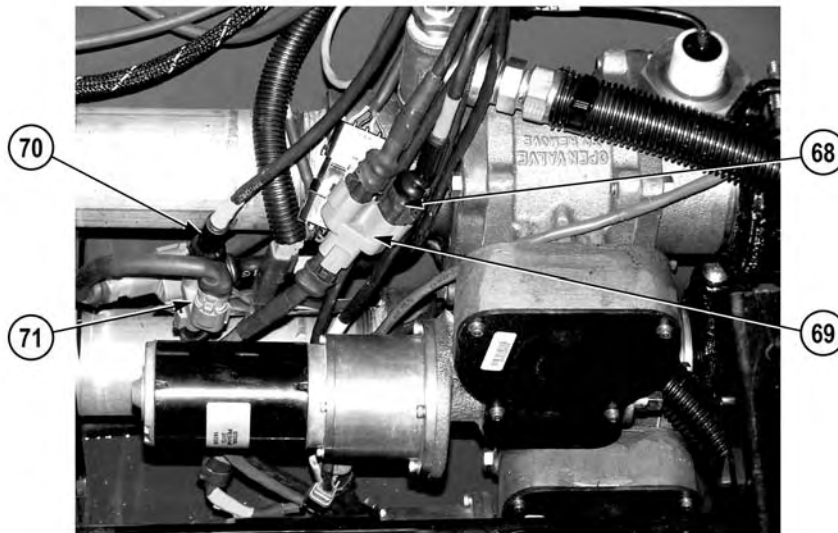


28. Install ground wire (82) and wire 1100 (81) on frame (83) with screw (80), four washers (79), lockwashers (78), and nut (77).

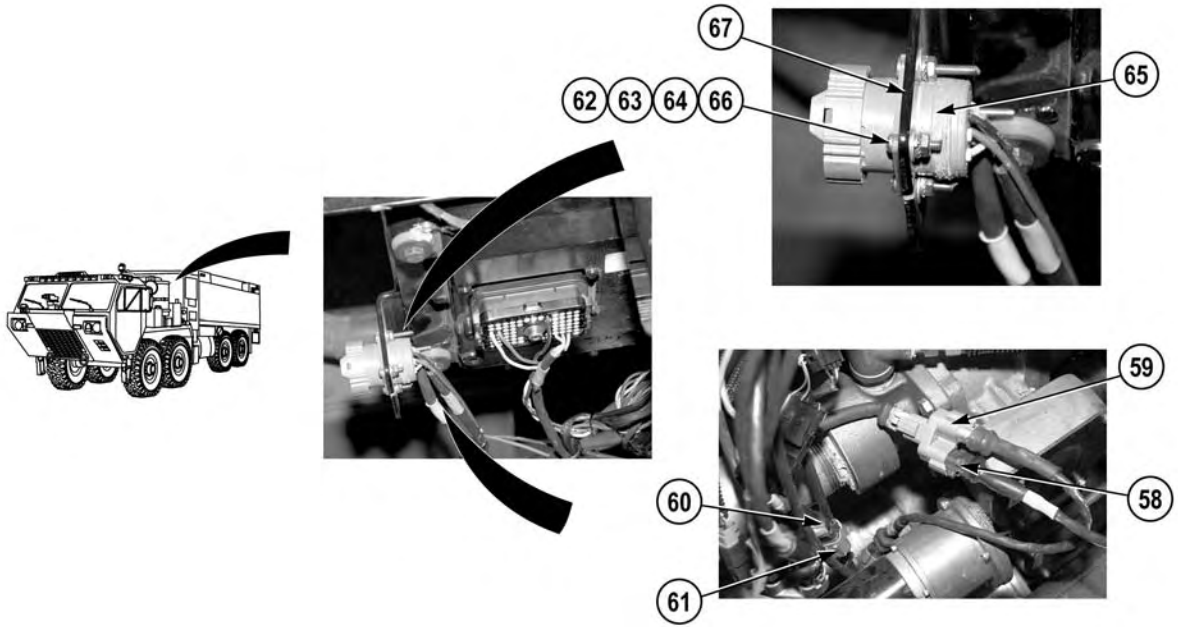
29. Install pump house wire harness J2 connector (76) on pressure governor ECU (74) with screw (75).



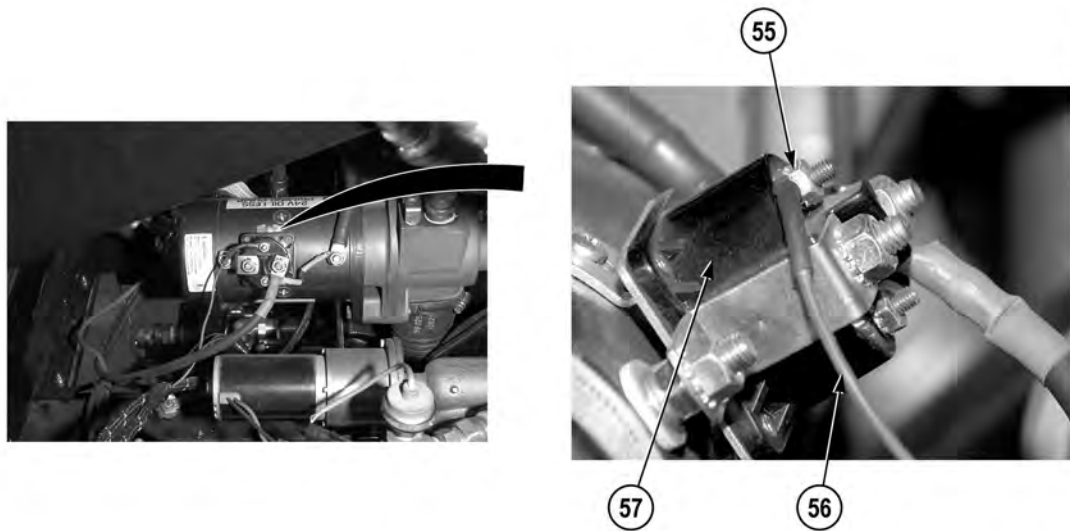
30. Install pump house wire harness J1 connector (73) on pressure governor ECU (74) with screw (72).



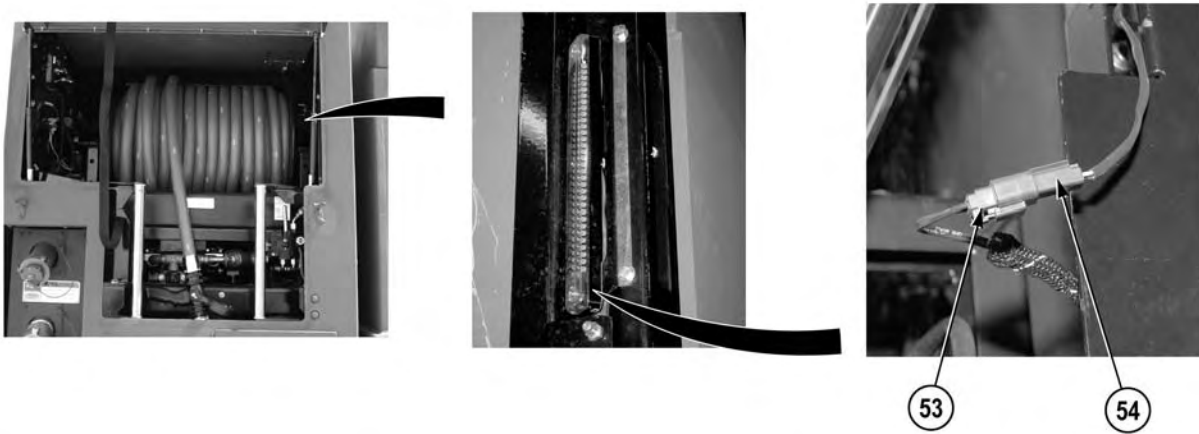
31. Connect pump house wire harness connector (70) on chassis datalink Y connector (71).
32. Connect pump house wire harness connector (68) on pressure governor control ECU datalink Y connector (69).



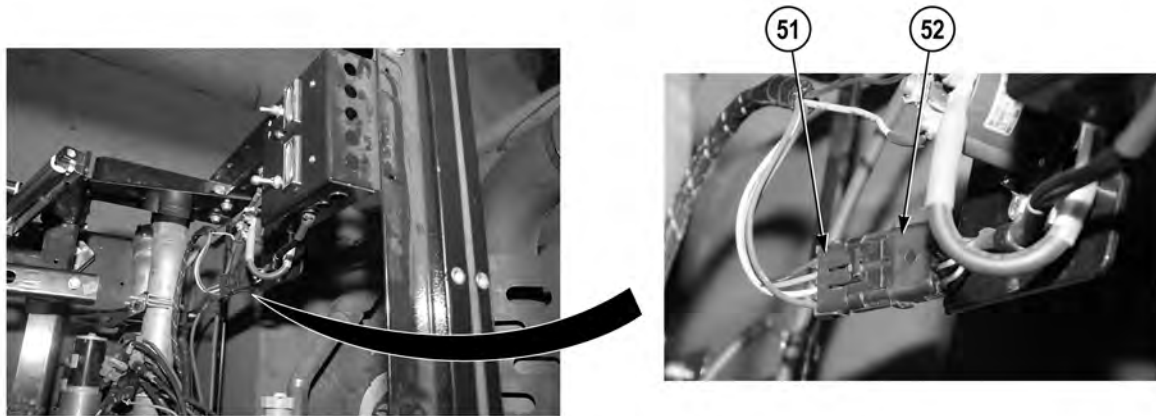
33. Install pressure governor ECU service connector (65) on bracket (67) with four screws (66), lockwashers (63), washers (64), and locknuts (62).
34. Connect pump hose wire harness connector (60) on chassis datalink Y connector (61).
35. Connect pump house wire harness connector (58) on pressure governor control ECU datalink Y connector (59).



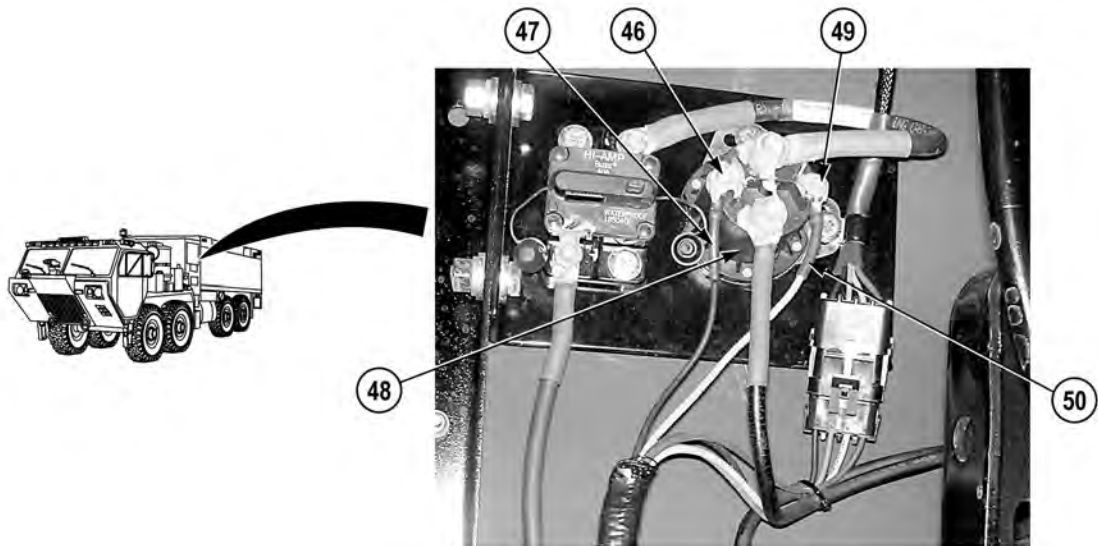
36. Install wire 2774 (56) on primer pump solenoid (57) with locknut (55).



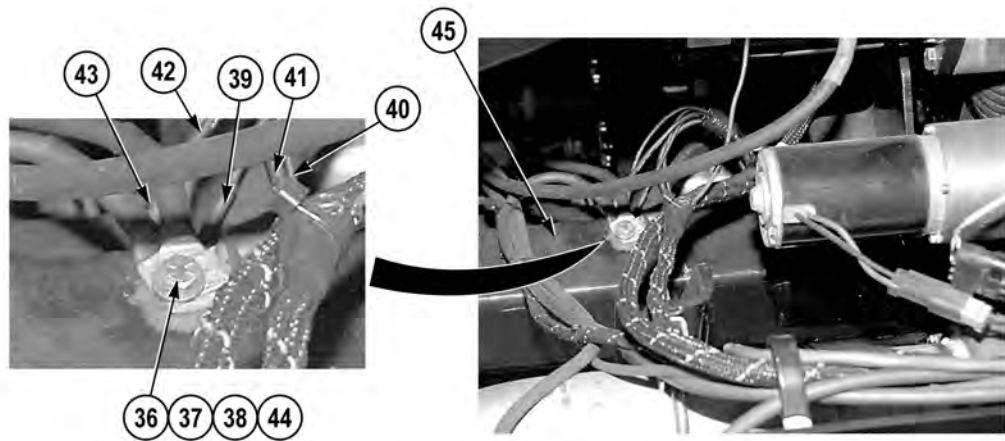
37. Connect pump house wire harness connector (53) on pump house hose reel striplight connector (54).



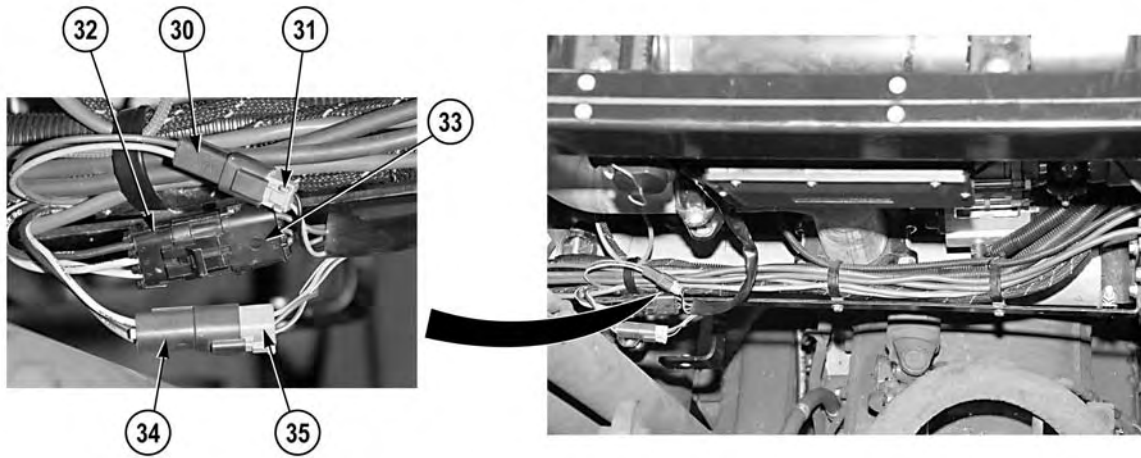
38. Connect pump hose wire harness connector (51) on diesel heater control connector (52).



- 39. Install wire 1664 (50) on hose reel rewind solenoid (48) with nut (49).
- 40. Install wire 1640 (47) on hose reel rewind solenoid (48) with nut (46).



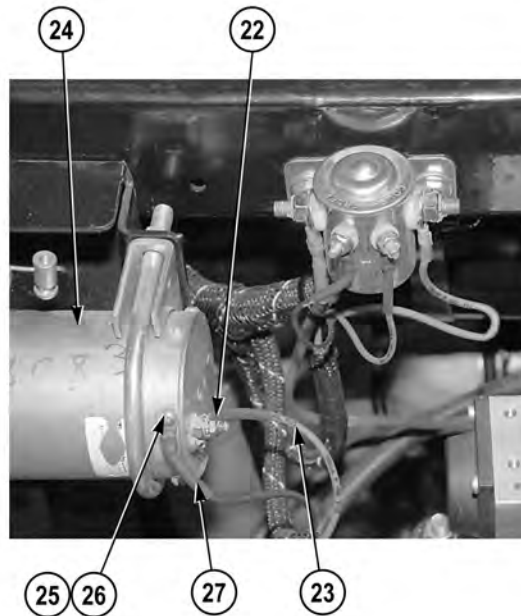
- 41. Install wire 4068 (39), wire 2640 (40), wire 2740 (41), wire 2200 (42), and wire 1640 (43) on frame rail (45) with screw (44), two washers (38), lockwasher (37), and nut (36).



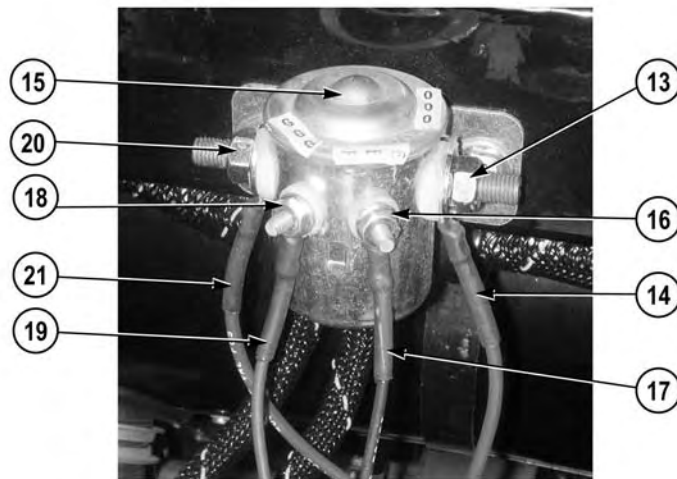
- 42. Connect pump house wire harness connector (34) on diesel heater connector (35).
- 43. Connect pump house wire harness connector (32) on diesel heater connector (33).
- 44. Connect pump house wire harness connector (30) on diesel heater connector (31).



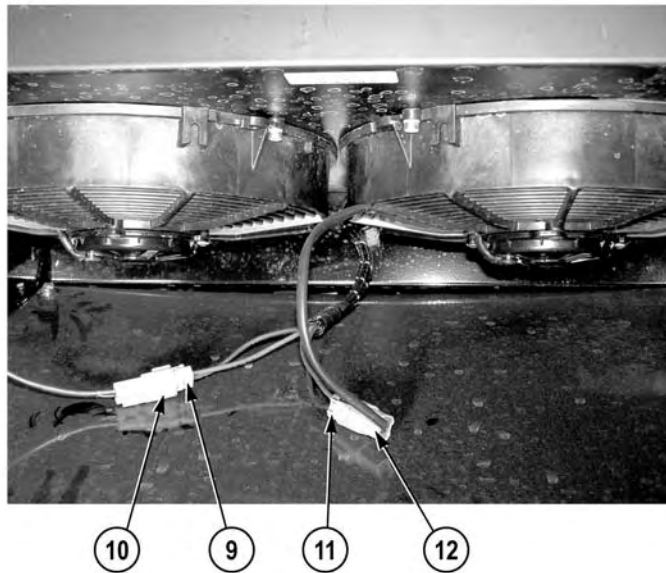
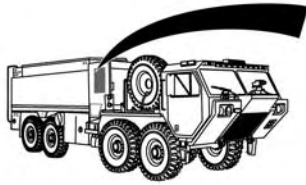
- 45. Connect pump house wire harness connector (28) on thermal relief sensor connector (29).



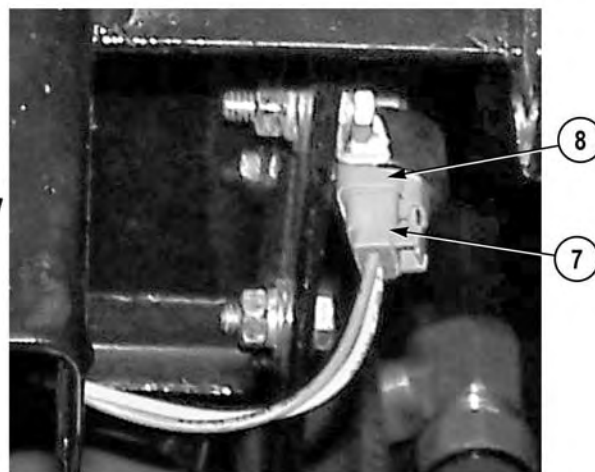
46. Install wire 4068 (27) on primer valve (24) with lockwasher (26) and screw (25).
47. Install wire 4065 (23) on primer valve (24) with locknut (22).



48. Install wire 4065 (21) on primer valve control solenoid (15) with nut (20).
49. Install wire 1590 (19) on primer valve control solenoid (15) with nut (18).
50. Install wire 1640 (17) on primer valve control solenoid (15) with nut (16).
51. Install wire 4064 (14) on primer valve control solenoid (15) and nut (13).

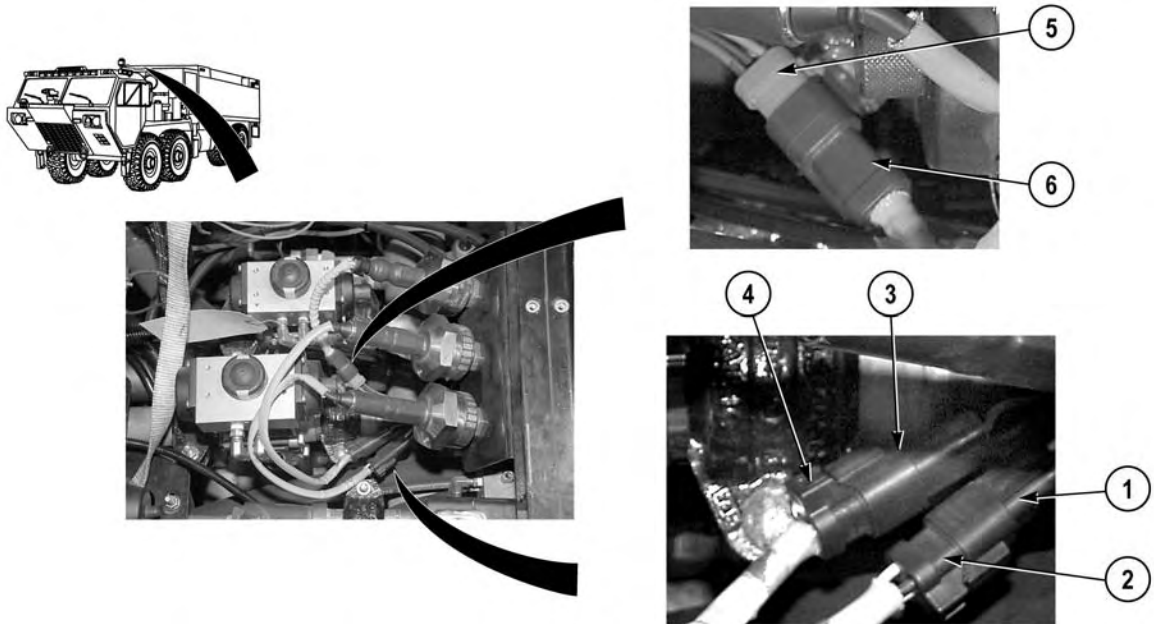


- 52. Connect pump house wire harness connector (11) on hydraulic heat exchanger fan 2 connector (12).
- 53. Connect pump house wire harness connector (9) on hydraulic heat exchanger fan 1 connector (10).



- 54. Connect pump house wire harness connector (7) on hydraulic heat exchanger thermal switch connector (8).





55. Connect pump house wire harness connector (5) on intake vacuum transducer connector (6).
56. Connect pump house wire harness connector (3) on intake pressure transducer connector (4).
57. Connect pump house wire harness connector (1) on discharge pressure transducer connector (2).

#### END OF TASK

#### FOLLOW-ON MAINTENANCE

1. Install hose reel (WP 0247)
2. Install reel rewind switch (WP 0253)
3. Install pump house panel A, E, G, H, and K (WP 0339)

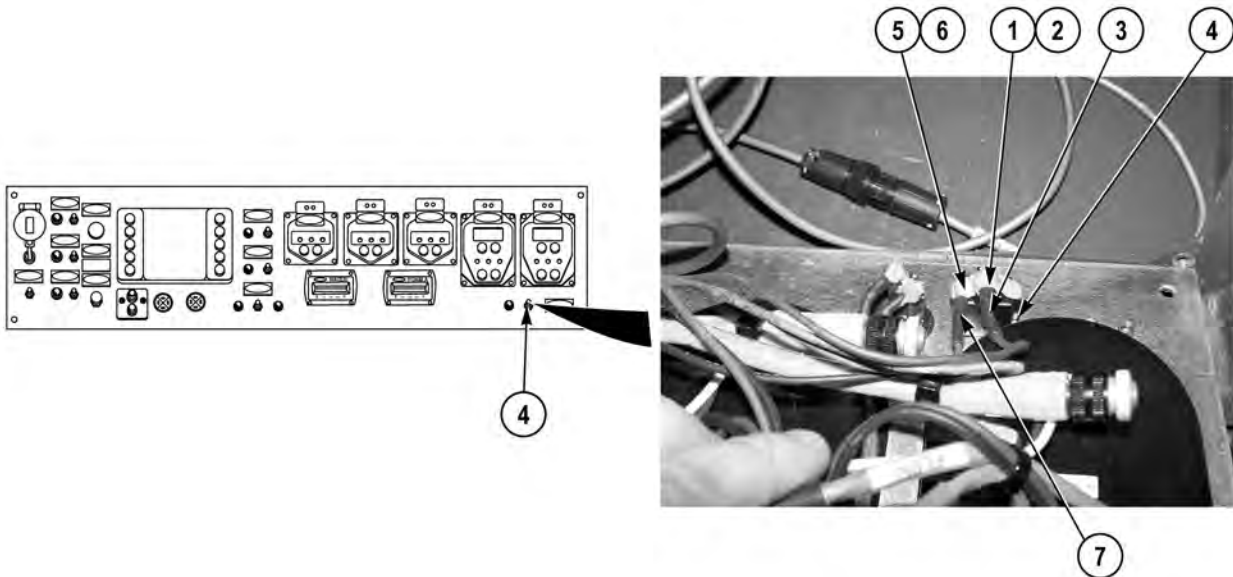
#### END OF TASK

#### END OF WORK PACKAGE





## REMOVAL

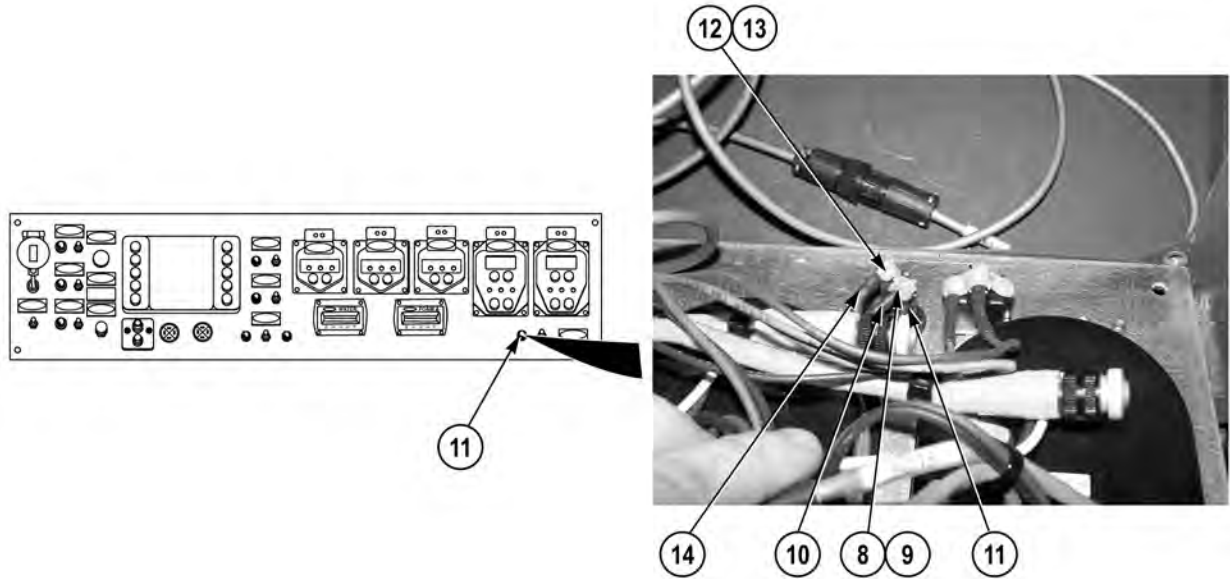


 **CAUTION**

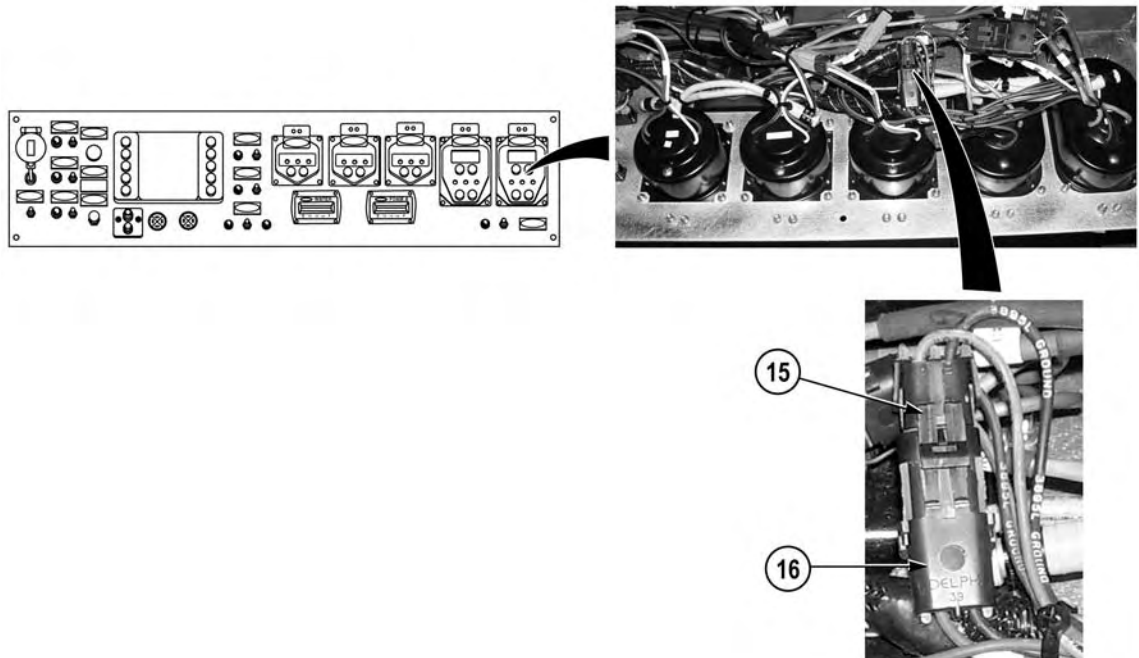
Care must be taken to ensure electronic parts do not come in contact with other parts of vehicle. Damage to equipment may result.

**NOTE**

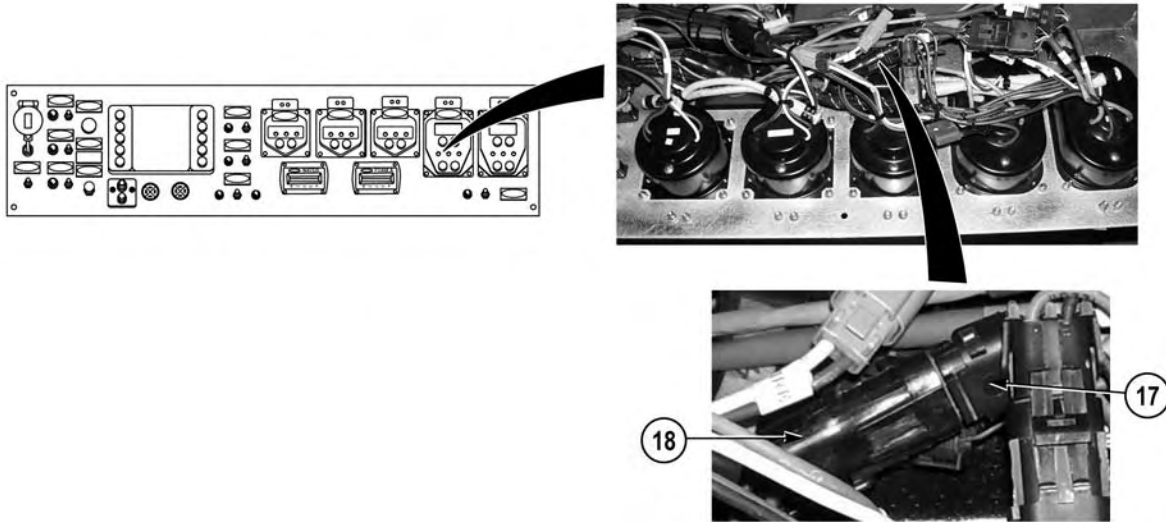
- Tag and mark wires prior to removal to ensure proper installation.
  - Note routing of pump operator's panel wire harness to ensure correct installation.
  - Note position and remove cable ties and cushion clips as required.
  - An assistant may be required.
1. Remove screw (1), lockwasher (2), and wire 2834 (3) from WATER TANK DRAIN switch (4). Discard lockwasher.
  2. Remove screw (5), lockwasher (6), and wire 4053 (7) from WATER TANK DRAIN switch (4). Discard lockwasher.



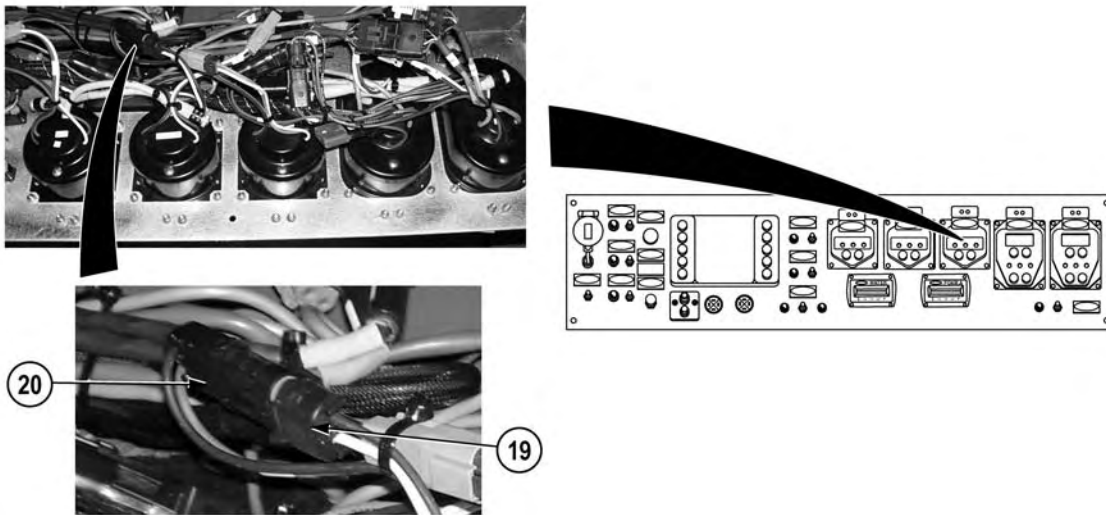
3. Remove screw (8), lockwasher (9), and wire 4053 (10) from WATER TANK DRAIN indicator (11). Discard lockwasher.
4. Remove screw (12), lockwasher (13), and wire 3895 (14) from WATER TANK DRAIN indicator (11). Discard lockwasher.



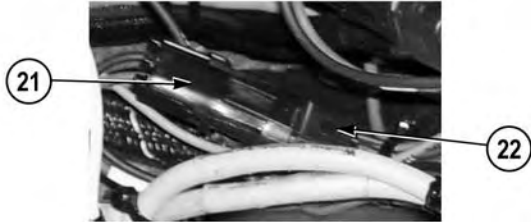
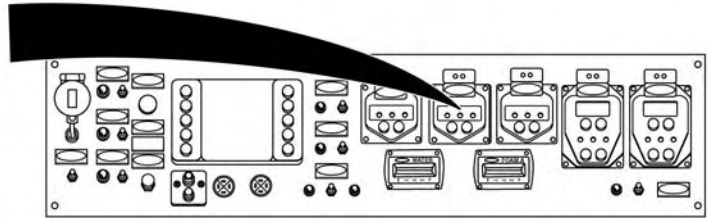
5. Disconnect pump operator's panel wire harness connector (15) from No. 2 passenger side discharge valve control connector (16).



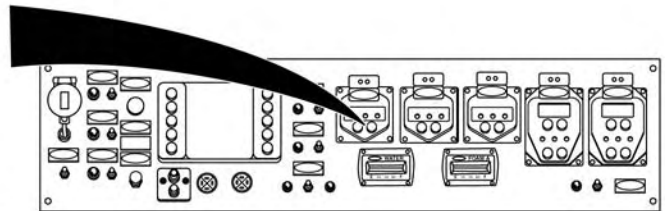
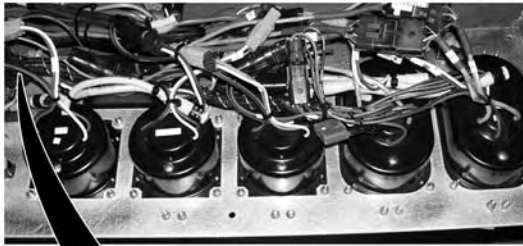
6. Disconnect pump operator's panel wire harness connector (17) from No. 1 driver side discharge valve control connector (18).



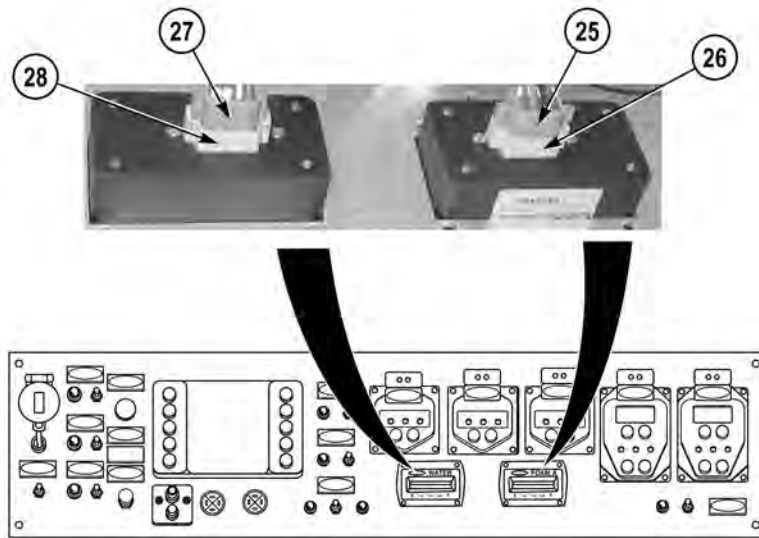
7. Disconnect pump operator's panel wire harness connector (19) from passenger side auxiliary inlet valve control connector (20).



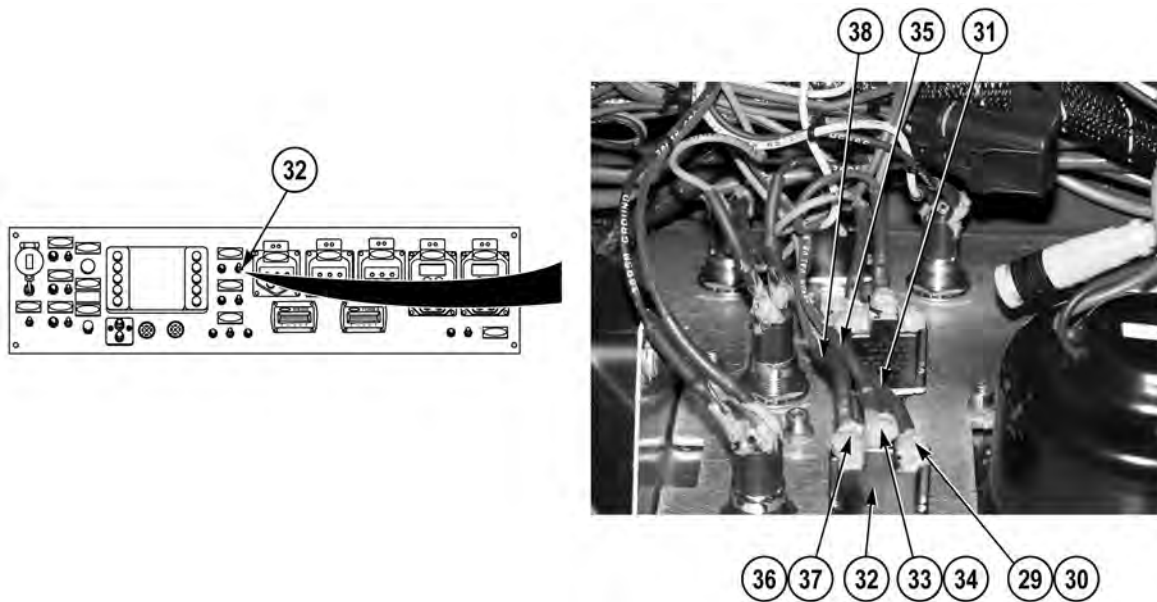
8. Disconnect pump operator's panel wire harness connector (21) from driver side auxiliary inlet valve control connector (22).



9. Disconnect pump operator's panel wire harness connector (23) from tank fill & re-circulating line valve control connector (24).

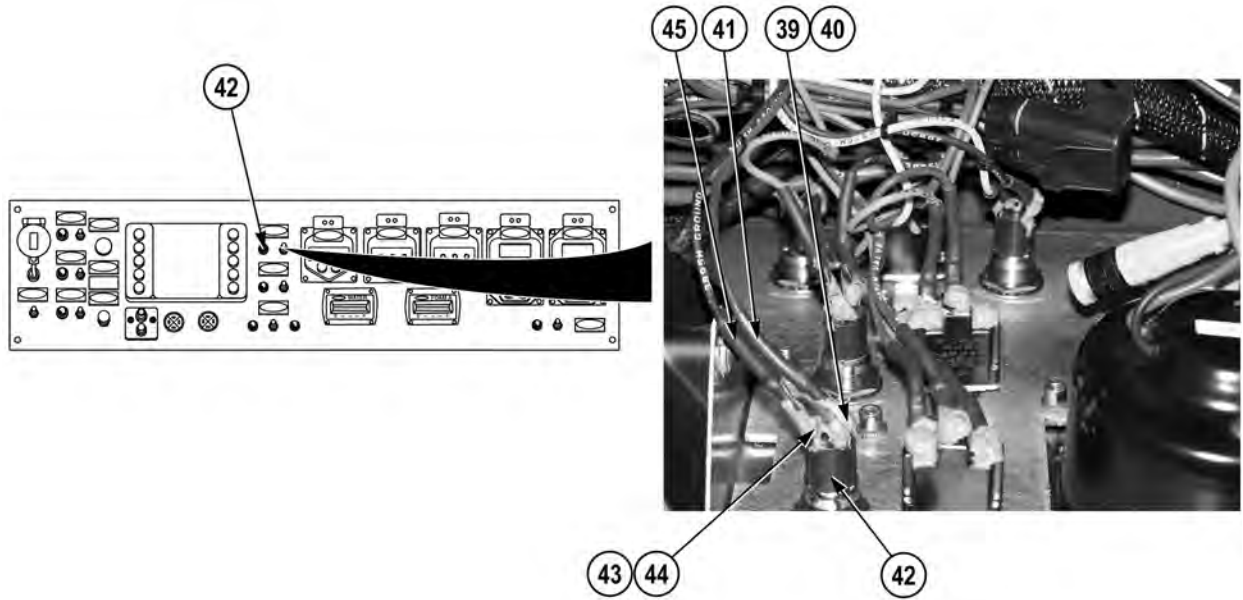


10. Disconnect pump operator's panel wire harness connector (25) from foam level gauge connector (26).
11. Disconnect pump operator's panel wire harness connector (27) from water level gauge connector (28).

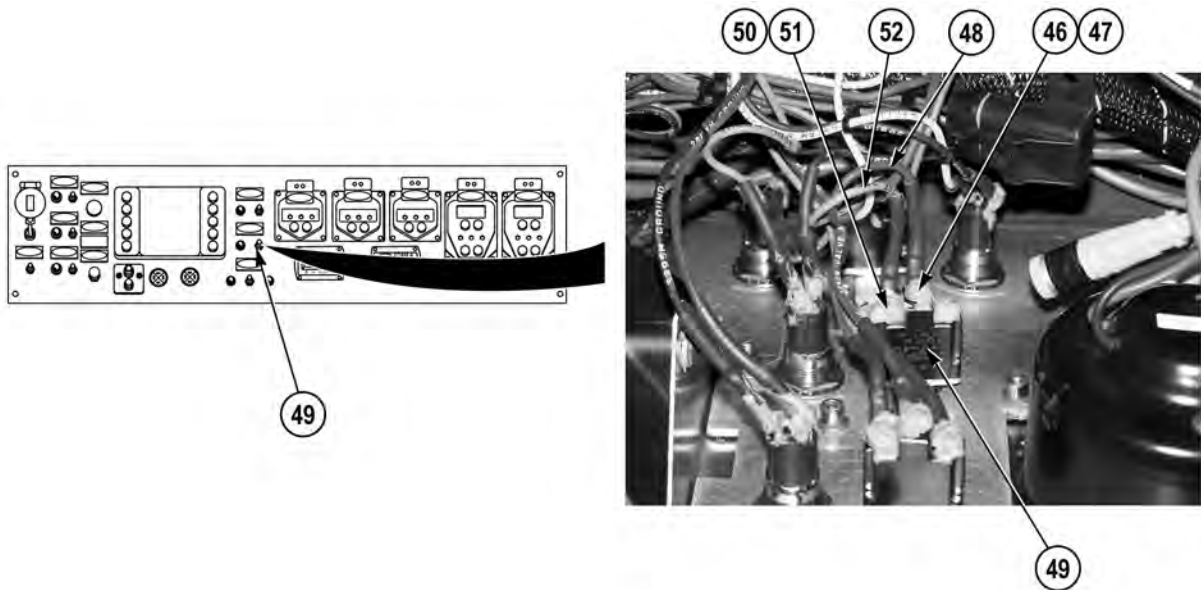


12. Remove screw (29), lockwasher (30), and wire 2770 (31) from TANK TO PUMP switch (32). Discard lockwasher.
13. Remove screw (33), lockwasher (34), and wire 2854 (35) from TANK TO PUMP switch (32). Discard lockwasher.
14. Remove screw (36), lockwasher (37), and wire 2855 (38) from TANK TO PUMP switch (32). Discard lockwasher.

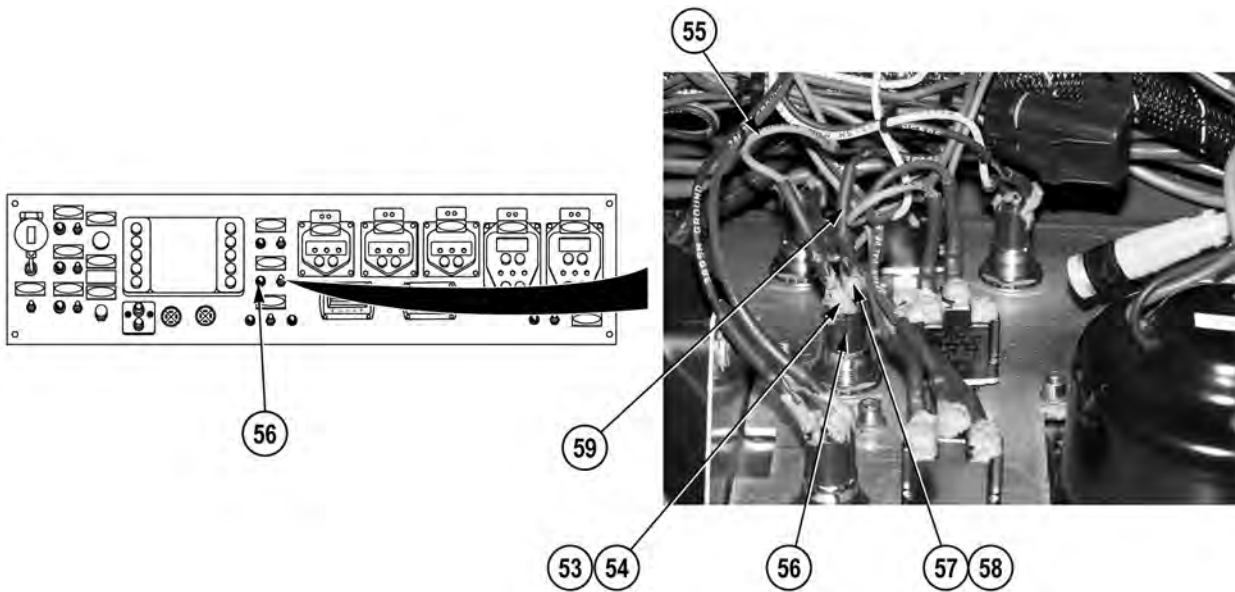




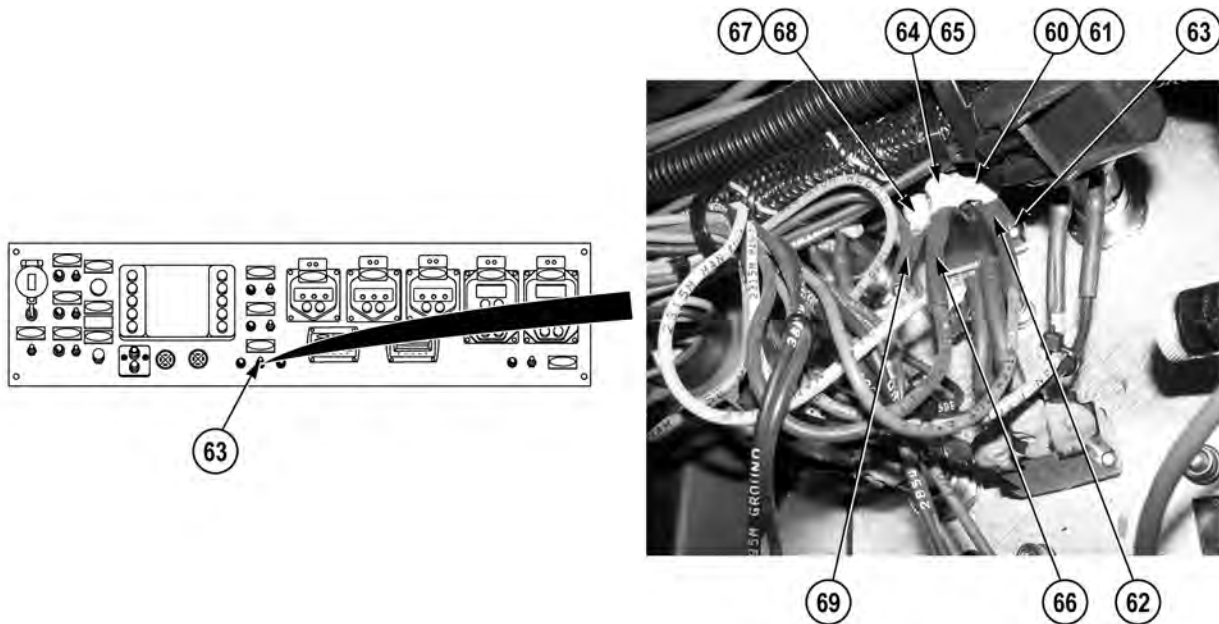
15. Remove screw (39), lockwasher (40), and wire 2855 (41) from TANK TO PUMP indicator (42). Discard lockwasher.
16. Remove screw (43), lockwasher (44), and wire 3895 (45) from TANK TO PUMP indicator (42). Discard lockwasher.



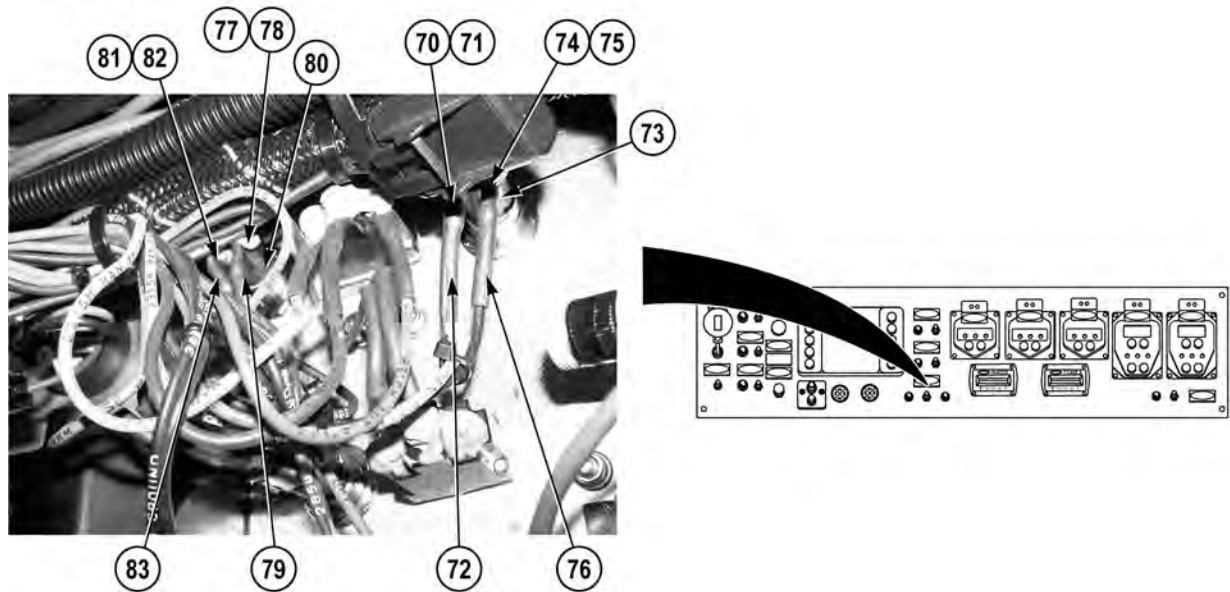
17. Remove screw (46), lockwasher (47), and wire 2834 (48) from REEL DISCHARGE switch (49). Discard lockwasher.
18. Remove screw (50), lockwasher (51), and wire 4098 (52) from REEL DISCHARGE switch (49). Discard lockwasher.



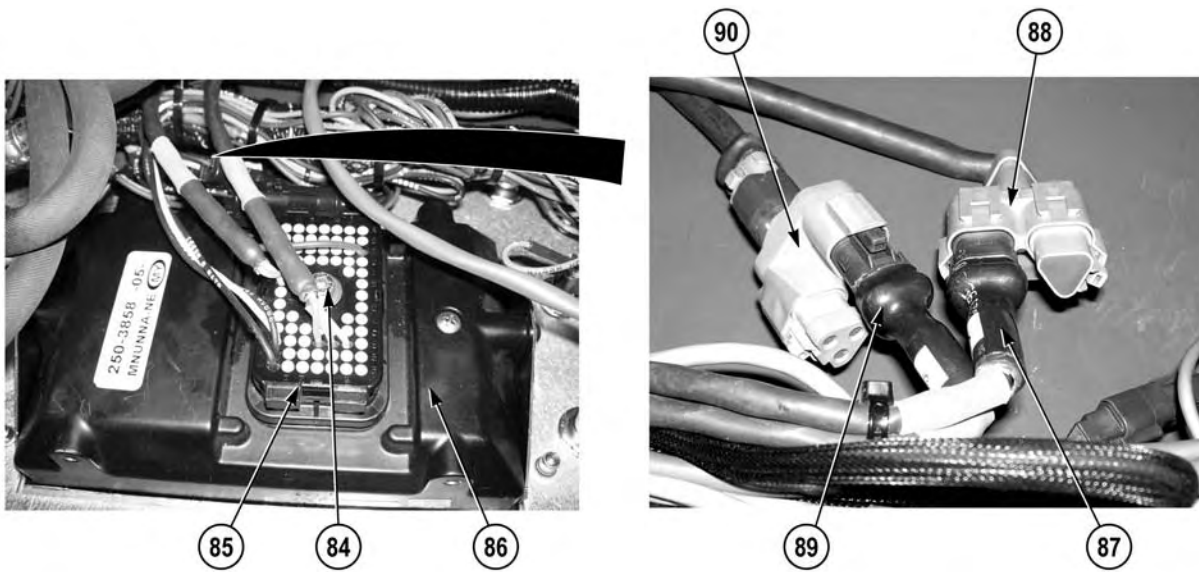
19. Remove screw (53), lockwasher (54), and wire 4098 (55) from REEL DISCHARGE indicator (56). Discard lockwasher.
20. Remove screw (57), lockwasher (58), and wire 3895 (59) from REEL DISCHARGE indicator (56). Discard lockwasher.



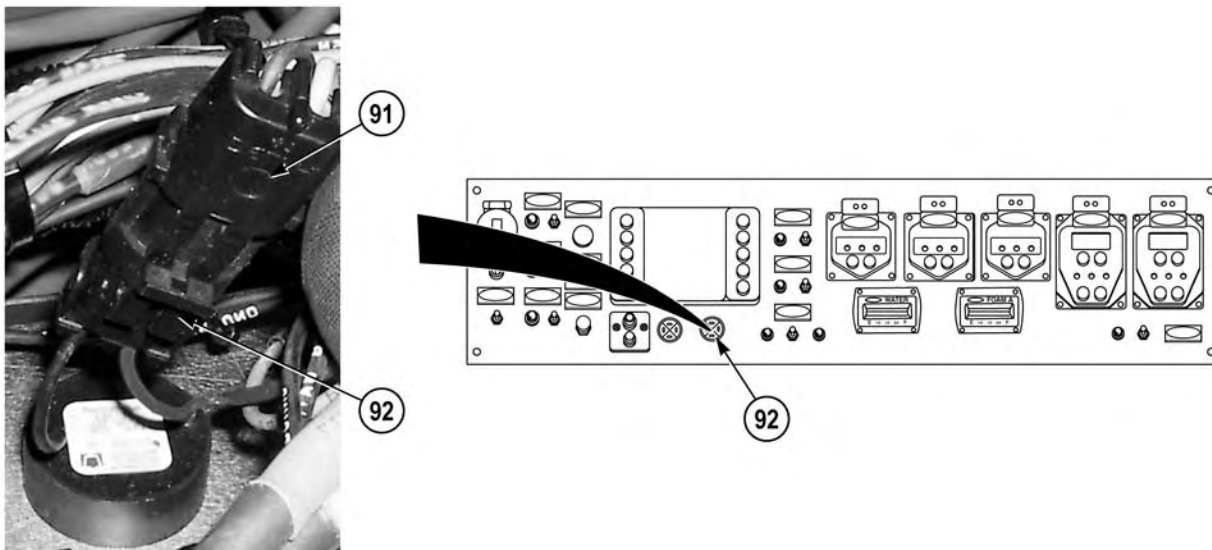
21. Remove screw (60), lockwasher (61), and wire 2316 (62) from DIRECT TANK FILL switch (63). Discard lockwasher.
22. Remove screw (64), lockwasher (65), and wire 2314 (66) from DIRECT TANK FILL switch (63). Discard lockwasher.
23. Remove screw (67), lockwasher (68), and wire 2315 (69) from DIRECT TANK FILL switch (63). Discard lockwasher.



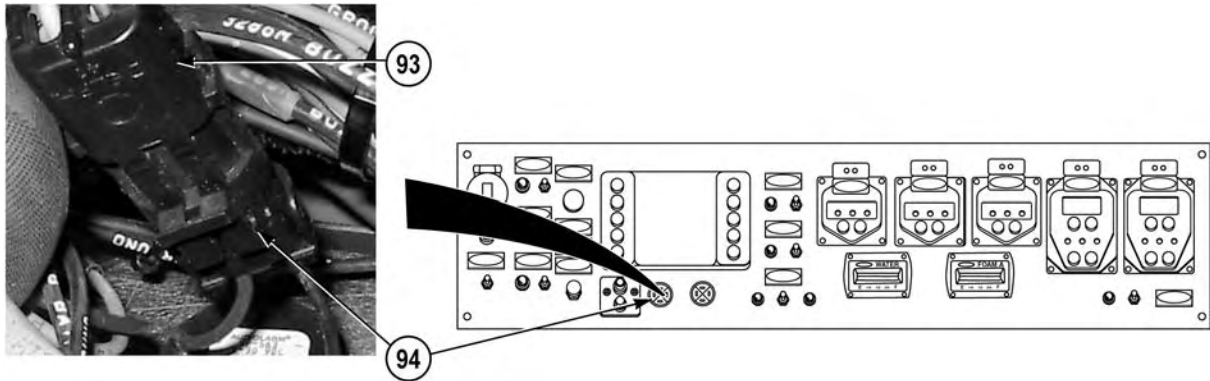
24. Remove screw (70), lockwasher (71), and wire 2315 (72) from DIRECT TANK FILL open indicator (73). Discard lockwasher.
25. Remove screw (74), lockwasher (75), and wire 3895 (76) from DIRECT TANK FILL open indicator (73). Discard lockwasher.
26. Remove screw (77), lockwasher (78), and wire 2316 (79) from DIRECT TANK FILL auto indicator (80). Discard lockwasher.
27. Remove screw (81), lockwasher (82), and wire 3895 (83) from DIRECT TANK FILL auto indicator (80). Discard lockwasher.



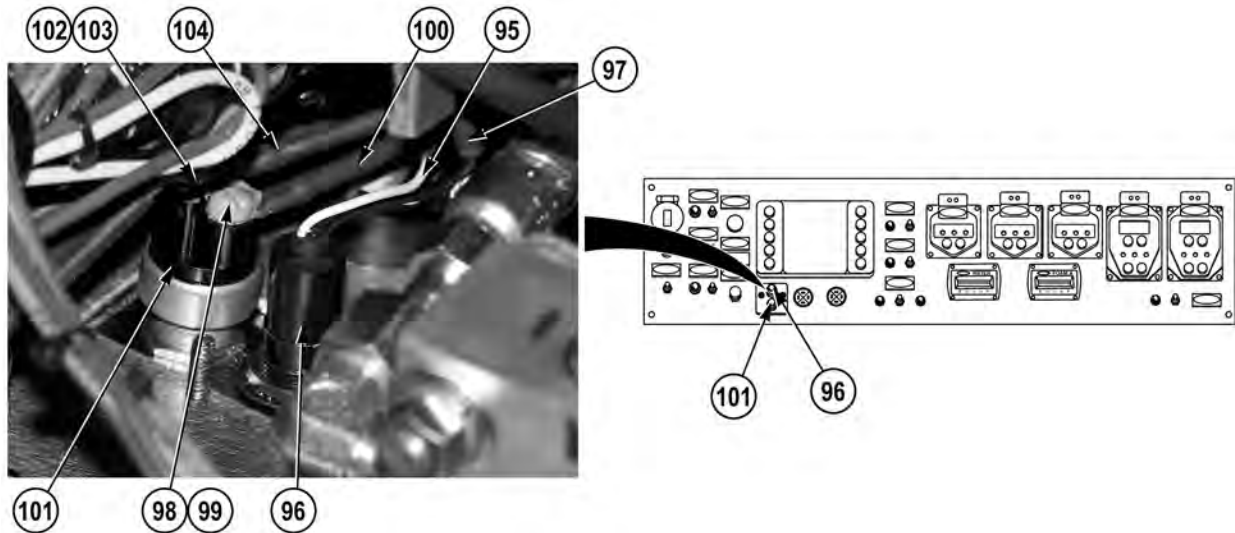
28. Loosen screw (84) and remove pump operator's panel wire harness connector (85) from pressure governor control (86).
29. Disconnect pump operator's panel wire harness connector (87) from pressure governor control ECU datalink Y connector (88).
30. Disconnect pump operator's panel wire harness connector (89) from chassis datalink Y connector (90).



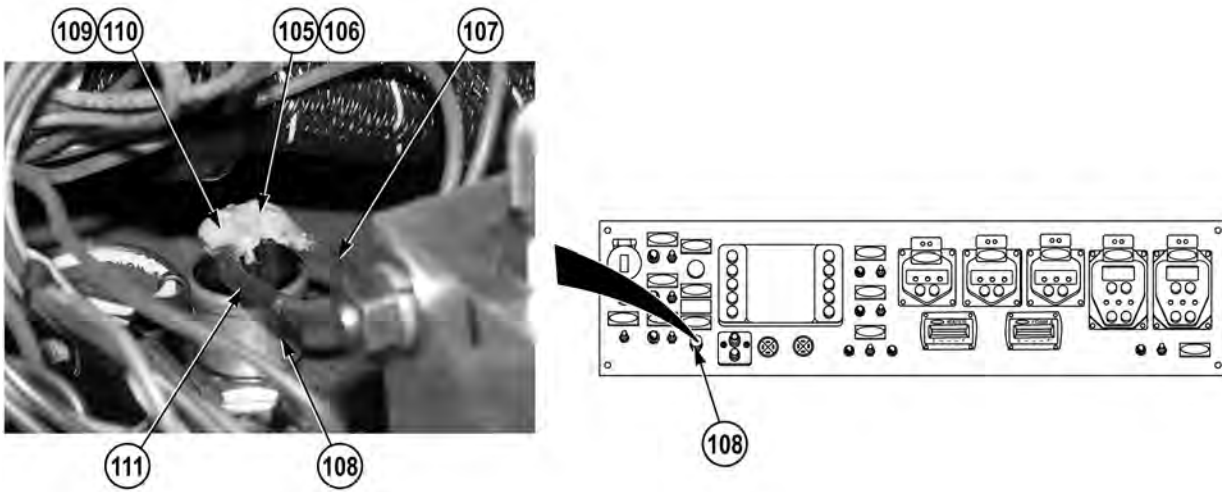
31. Disconnect pump operator's panel wire harness connector (91) from pressure governor control audio alarm (92).



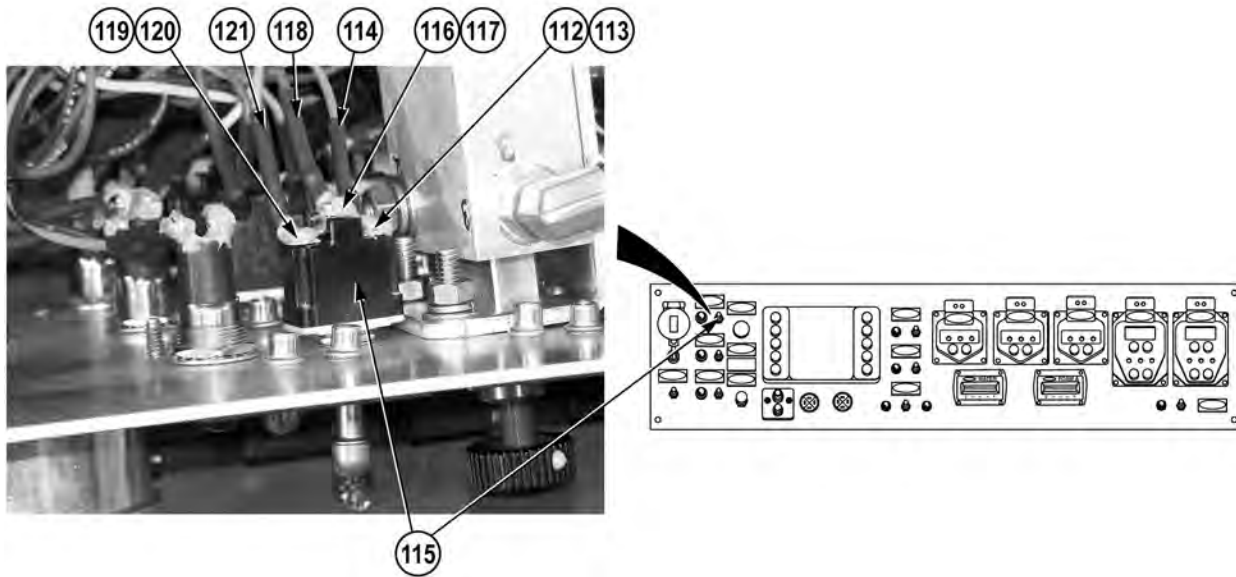
32. Disconnect pump operator's panel wire harness connector (93) from pump hot audio alarm (94).



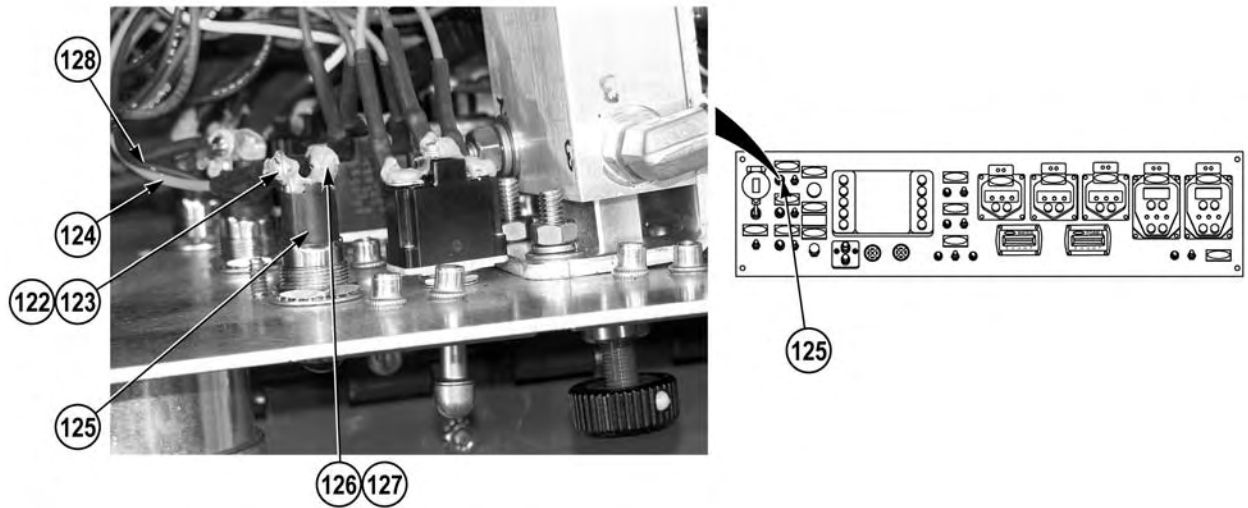
33. Cut wire 1405 (95) from PUMP HOT indicator (96) (TM 9-2320-325-14&P).
34. Cut wire 3895 (97) from PUMP HOT indicator (96) (TM 9-2320-325-14&P).
35. Remove screw (98), lockwasher (99), and wire 4085 (100) from PUMP HOT PUSH TO TEST button (101). Discard lockwasher.
36. Remove screw (102), lockwasher (103), and wire 1405 (104) from PUMP HOT PUSH TO TEST button (101). Discard lockwasher.



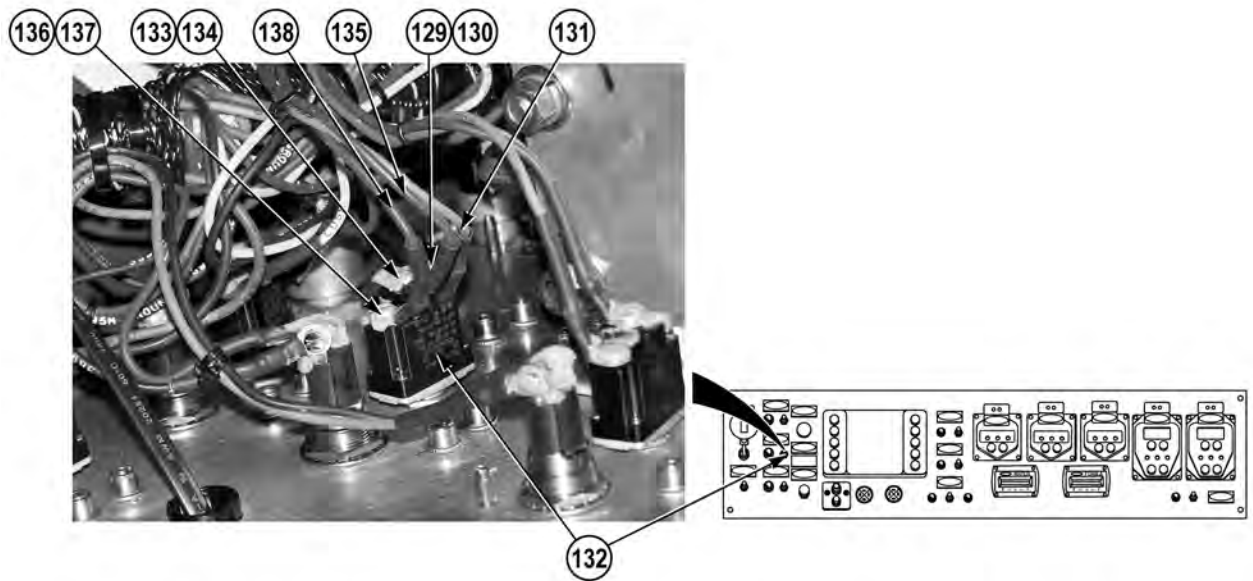
- 37. Remove screw (105), lockwasher (106), and wire 2773 (107) from DRIVER MAIN INLET PRIMER button (108). Discard lockwasher.
- 38. Remove screw (109), lockwasher (110), and wire 1590 (111) from DRIVER MAIN INLET PRIMER button (108). Discard lockwasher.



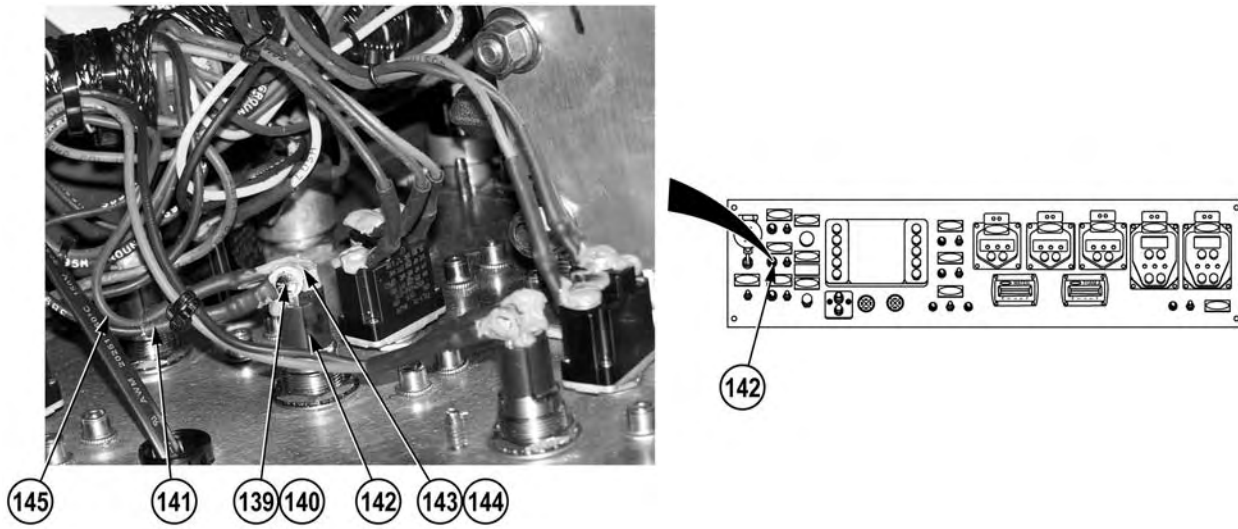
- 39. Remove screw (112), lockwasher (113), and wire 4038 (114) from PUMP COOLER switch (115). Discard lockwasher.
- 40. Remove screw (116), lockwasher (117), and wire 2834 (118) from PUMP COOLER switch (115). Discard lockwasher.
- 41. Remove screw (119), lockwasher (120), and wire 4037 (121) from PUMP COOLER switch (115). Discard lockwasher.



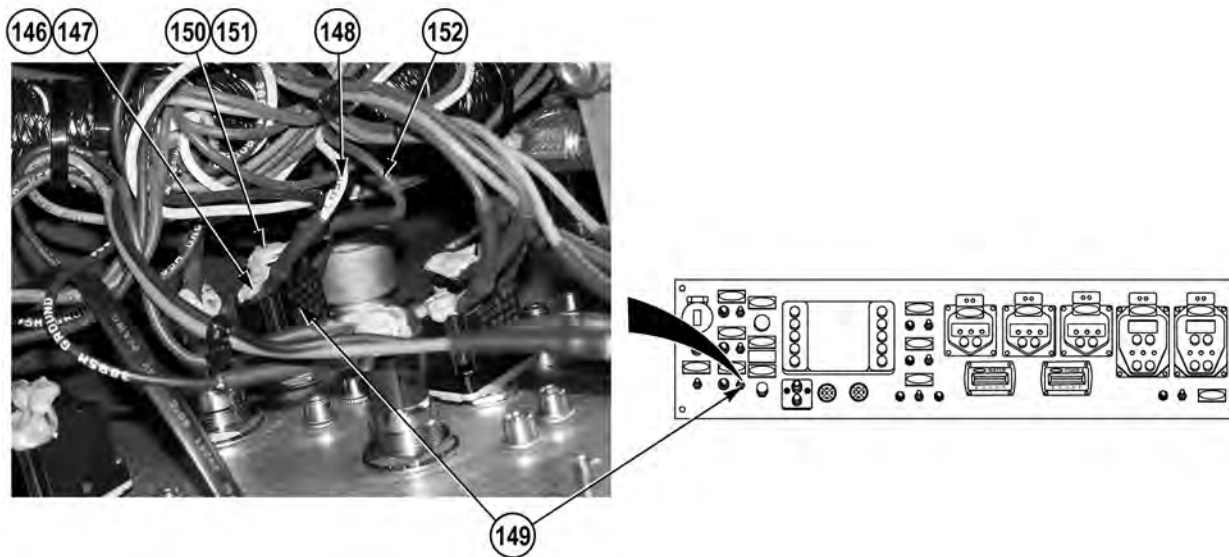
42. Remove screw (122), lockwasher (123), and wire 4037 (124) from PUMP COOLER indicator (125). Discard lockwasher.
43. Remove screw (126), lockwasher (127), and wire 3895 (128) from PUMP COOLER indicator (125). Discard lockwasher.



44. Remove screw (129), lockwasher (130), and wire 2831 (131) from FOAM SYSTEM switch (132). Discard lockwasher.
45. Remove screw (133), lockwasher (134), and wire 2830 (135) from FOAM SYSTEM switch (132). Discard lockwasher.
46. Remove screw (136), lockwasher (137), and wire 2816 (138) from FOAM SYSTEM switch (132). Discard lockwasher.

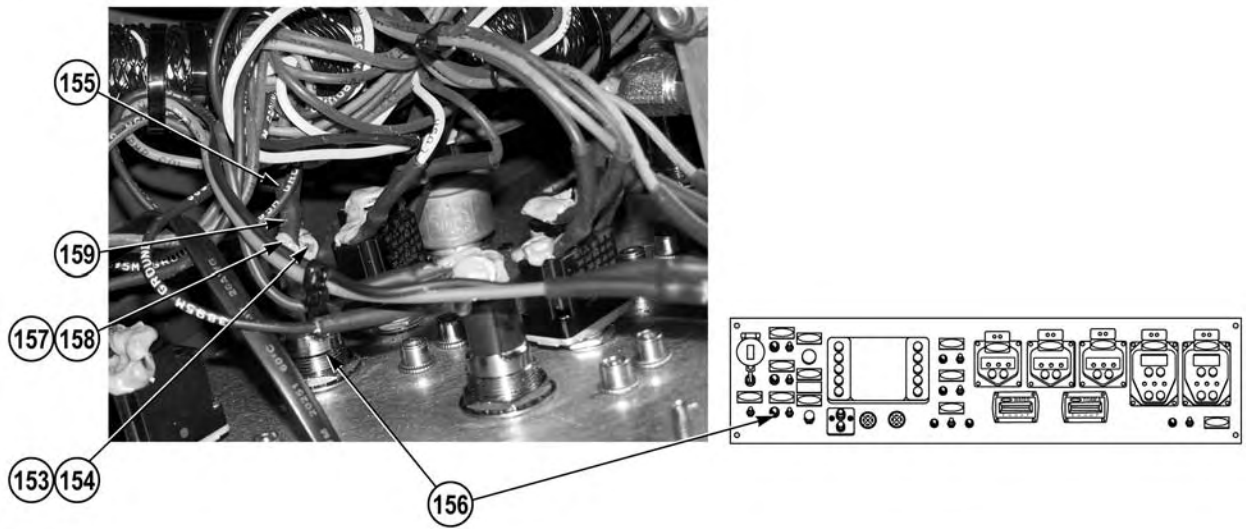


47. Remove screw (139), lockwasher (140), and wire 2830 (141) from FOAM SYSTEM indicator (142). Discard lockwasher.
48. Remove screw (143), lockwasher (144), and wire 3895 (145) from FOAM SYSTEM indicator (142). Discard lockwasher.

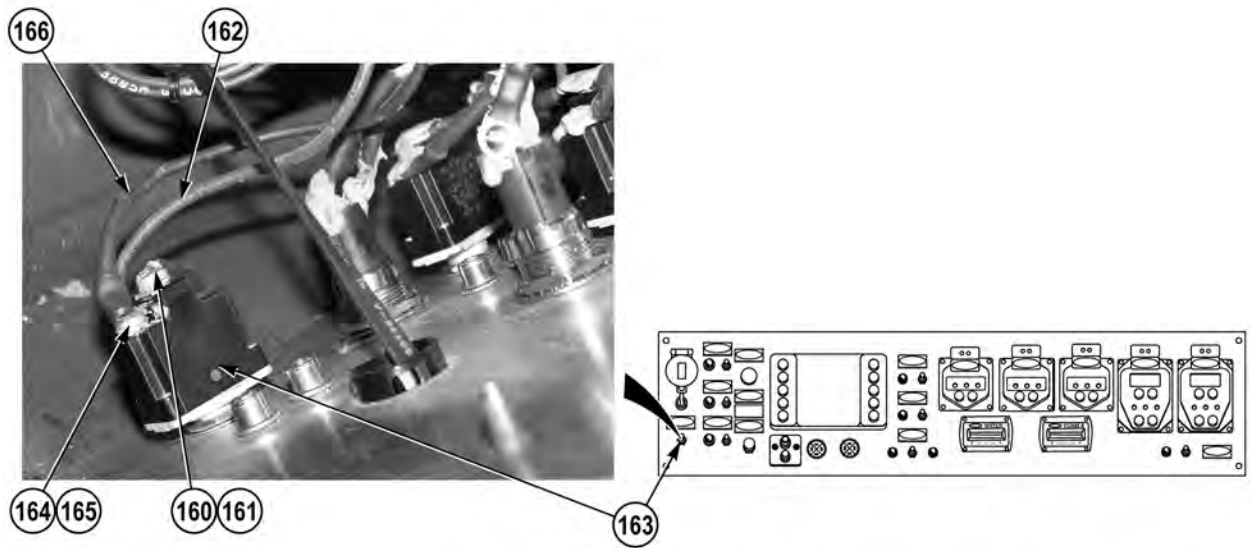


49. Remove screw (146), lockwasher (147), and wire 2849 (148) from FOAM FLUSH switch (149). Discard lockwasher.
50. Remove screw (150), lockwasher (151), and wire 2834 (152) from FOAM FLUSH switch (149). Discard lockwasher.

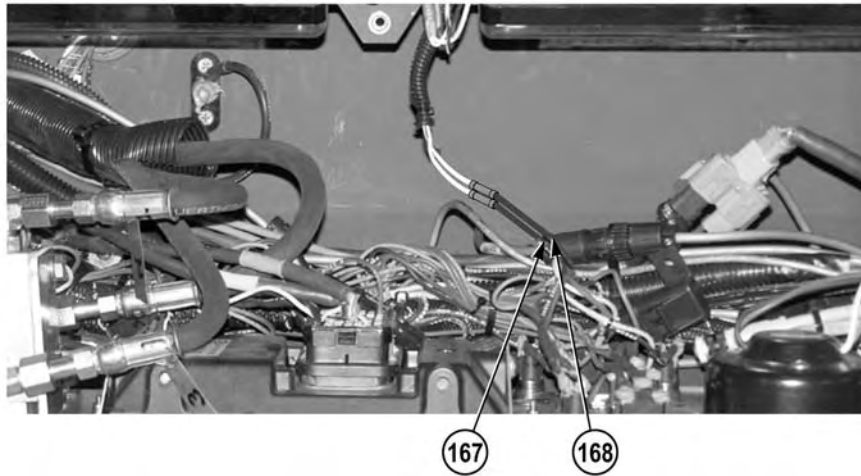




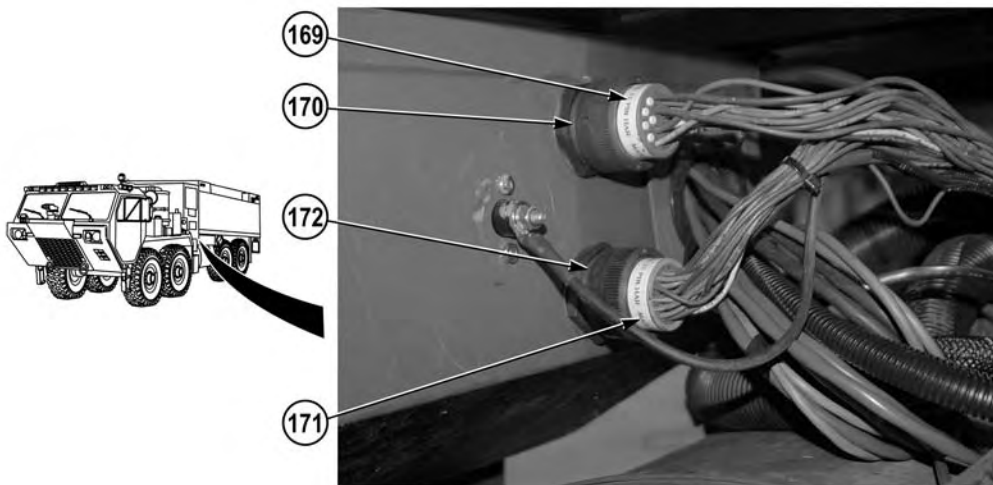
51. Remove screw (153), lockwasher (154), and wire 2849 (155) from FOAM FLUSH indicator (156). Discard lockwasher.
52. Remove screw (157), lockwasher (158), and wire 3895 (159) from FOAM FLUSH indicator (156). Discard lockwasher.



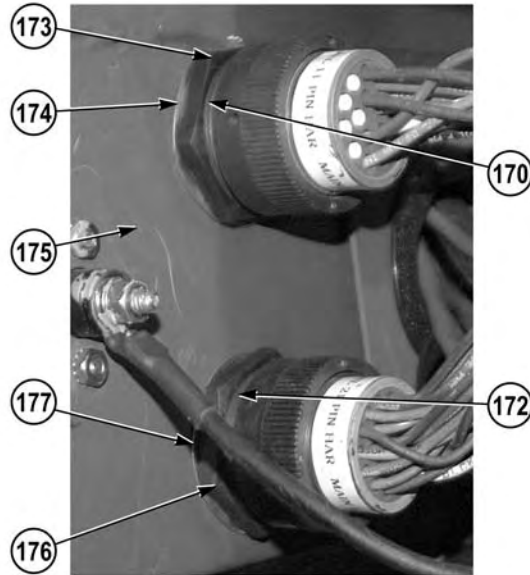
53. Remove screw (160), lockwasher (161), and wire 2346 (162) from PANEL LIGHTS switch (163). Discard lockwasher.
54. Remove screw (164), lockwasher (165), and wire 1661 (166) from PANEL LIGHTS switch (163). Discard lockwasher.



55. Cut wire 1661 (167) and wire 3895 (168).



56. Disconnect main wire harness connector (169) from pump operator's panel wire harness connector (170).
57. Disconnect main wire harness connector (171) from pump operator's panel wire harness connector (172).



58. Remove nut (173), lockwasher (174), and pump operator's panel wire harness connector (170) from pump operator's panel housing (175). Discard lockwasher.
59. Remove nut (176), lockwasher (177), and pump operator's panel wire harness connector (172) from pump operator's panel housing (175). Discard lockwasher.



60. Remove nut (178), lockwasher (179), and wire 3895 (180) from terminal block (181). Discard lockwasher.
61. Remove pump operator's panel wire harness (182) from vehicle.

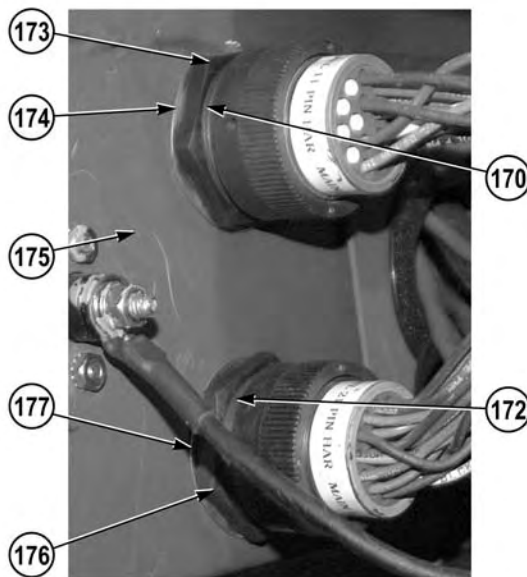
**END OF TASK**

## INSTALLATION

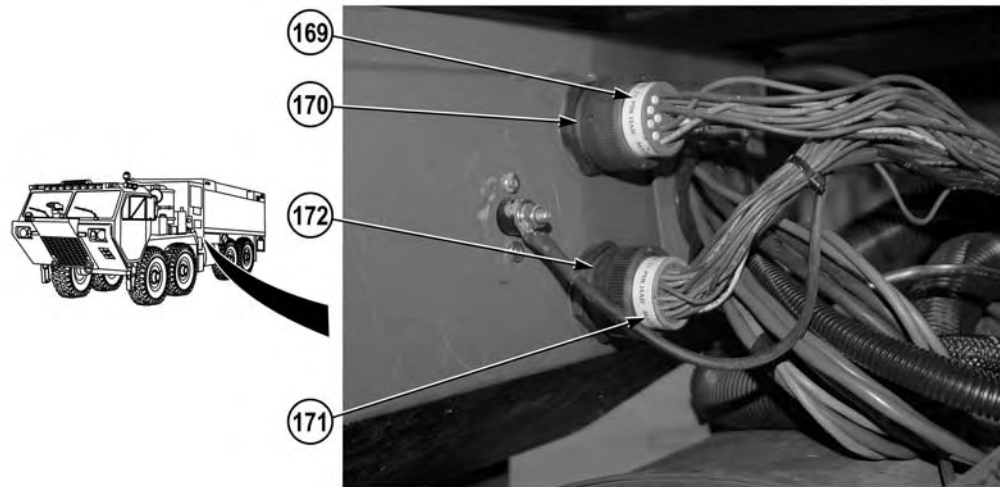
**NOTE**

- Route pump operator's panel wire harness as noted prior to removal.
- Install cable ties and cushion clips as required.

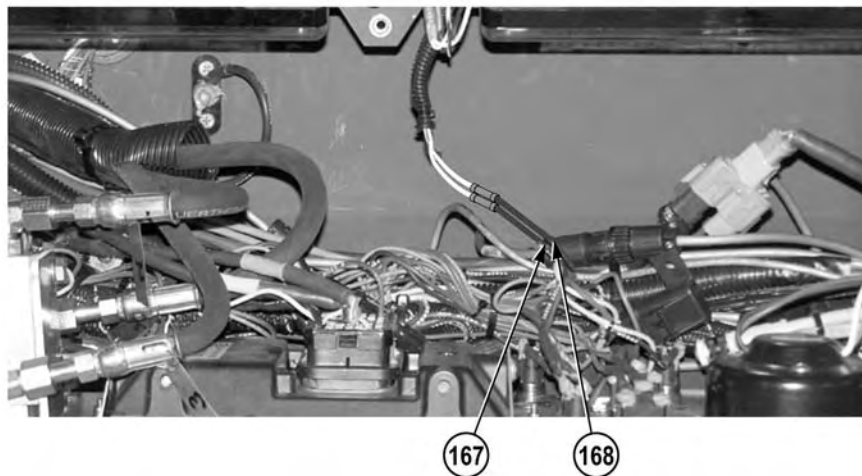
1. Position wire harness (182) in vehicle.
2. Install wire 3895 (180) on terminal block (181) with lockwasher (179) and nut (178).



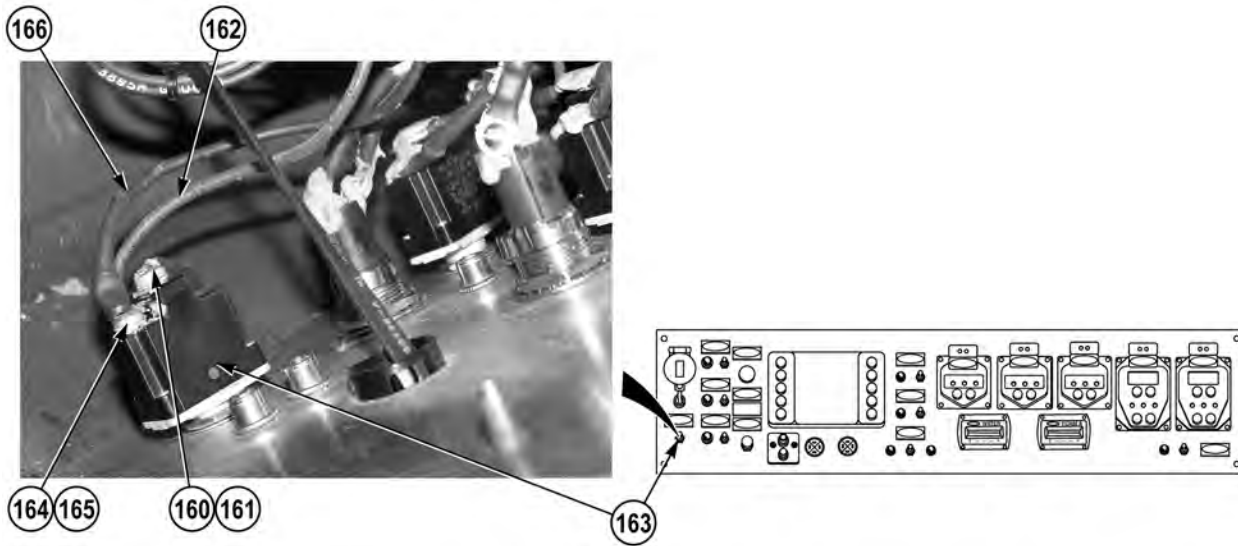
3. Install pump operator's panel wire harness connector (172) on pump operator's panel housing (175) with lockwasher (177) and nut (176).
4. Install pump operator's panel wire harness connector (170) on pump operator's panel housing (175) with lockwasher (174) and nut (173).



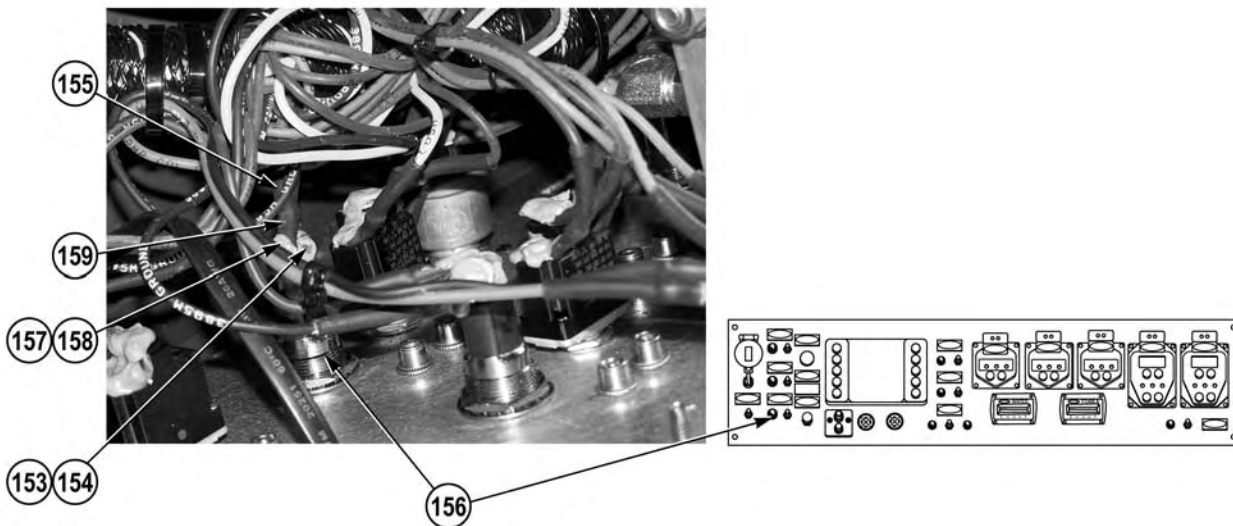
5. Connect main wire harness connector (171) on pump operator's panel wire harness connector (172).
6. Connect main wire harness connector (169) on pump operator's panel wire harness connector (170).



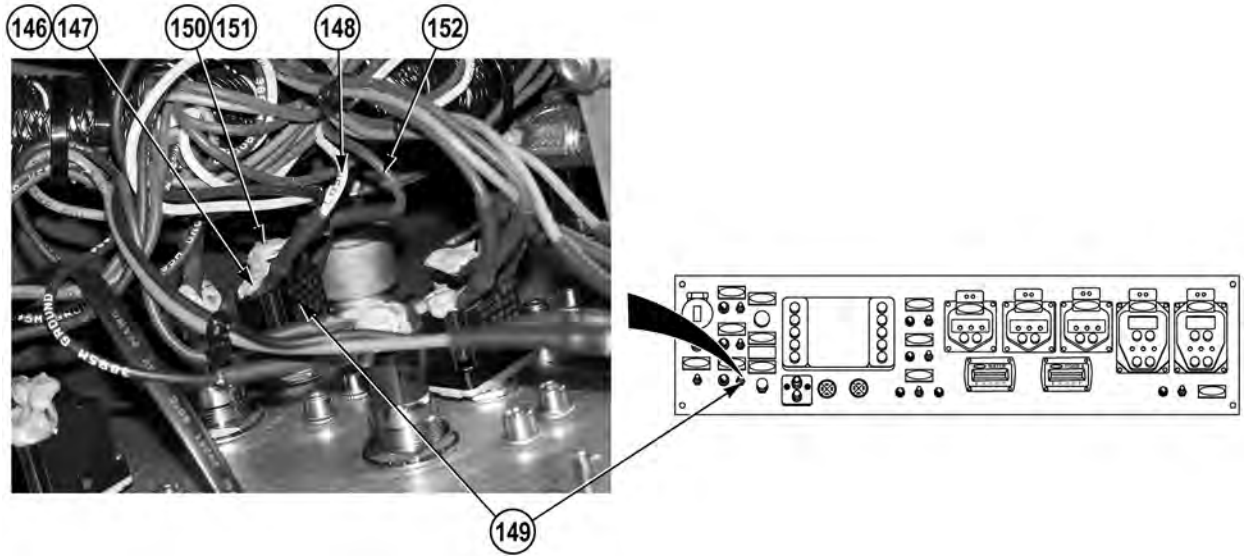
7. Repair wire 3895 (168) and wire 1661 (167) (TM 9-2320-325-14&P).



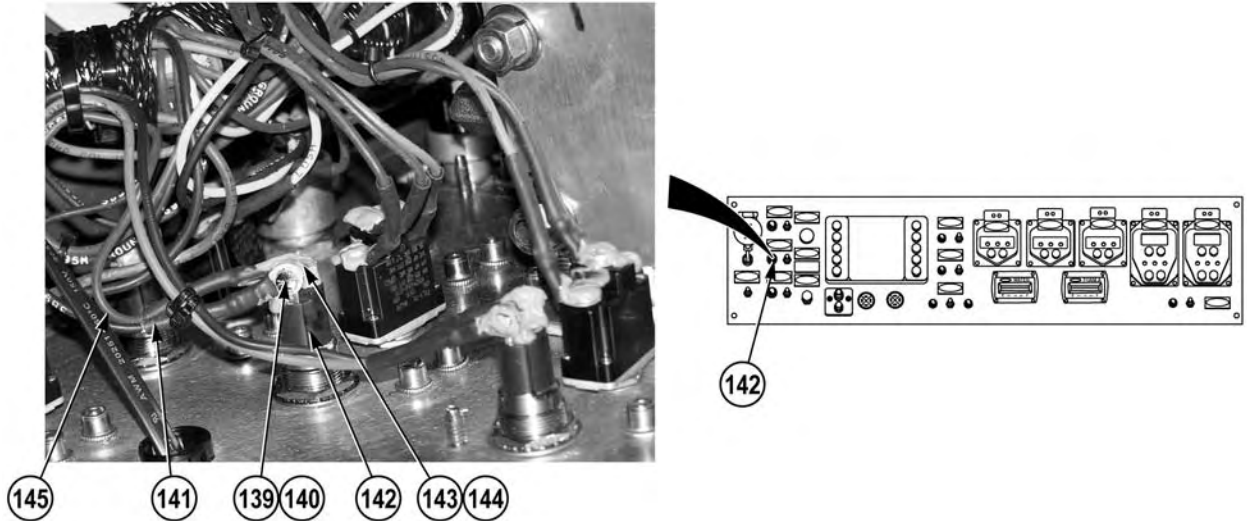
8. Install wire 1661 (166) on PANEL LIGHTS switch (163) with lockwasher (165) and screw (164).
9. Install wire 2346 (162) on PANEL LIGHTS switch (163) with lockwasher (161) and screw (160).



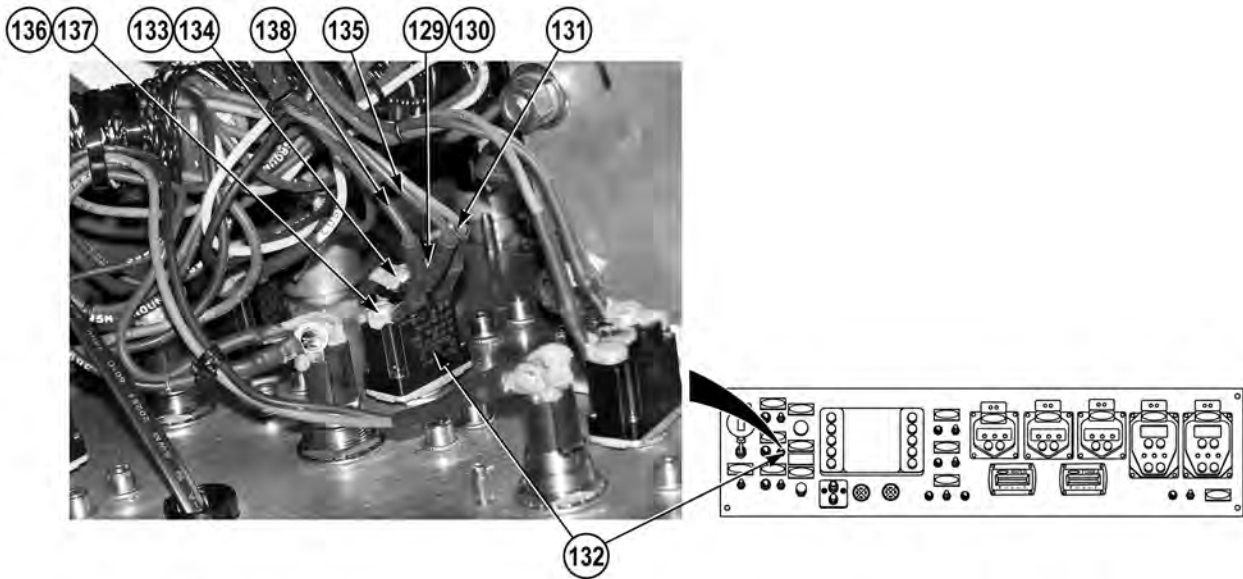
10. Install wire 3895 (159) on FOAM FLUSH indicator (156) with lockwasher (158) and screw (157).
11. Install wire 2849 (155) on FOAM FLUSH indicator (156) with lockwasher (154) and screw (153).



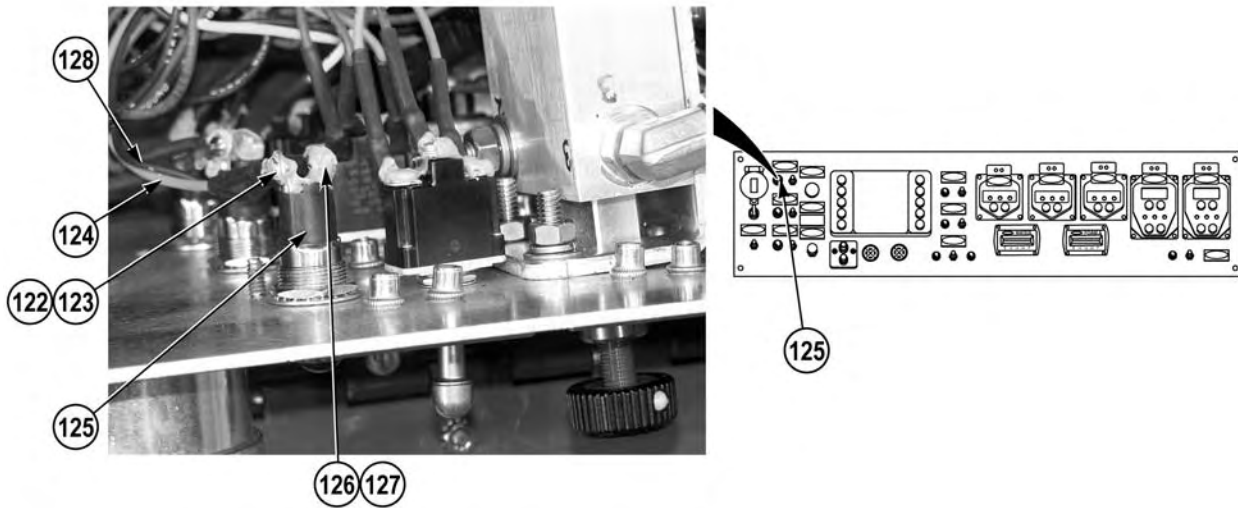
12. Install wire 2834 (152) on FOAM FLUSH switch (149) with lockwasher (151) and screw (150).
13. Install wire 2849 (148) on FOAM FLUSH switch (149) with lockwasher (147) and screw (146).



14. Install wire 3895 (145) on FOAM SYSTEM indicator (142) with lockwasher (144) and screw (143).
15. Install wire 2830 (141) on FOAM SYSTEM indicator (142) with lockwasher (140) and screw (139).

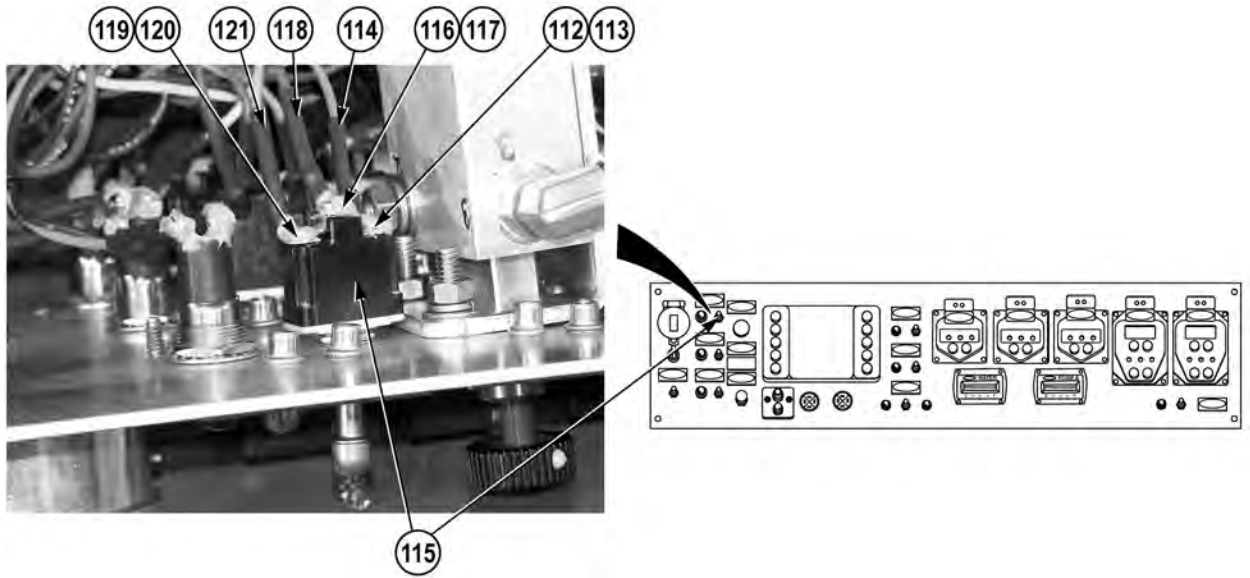


16. Install wire 2816 (138) on FOAM SYSTEM switch (132) with lockwasher (137) and screw (136).
17. Install wire 2830 (135) on FOAM SYSTEM switch (132) with lockwasher (134) and screw (133).
18. Install wire 2831 (131) on FOAM SYSTEM switch (132) with lockwasher (130) and screw (129).

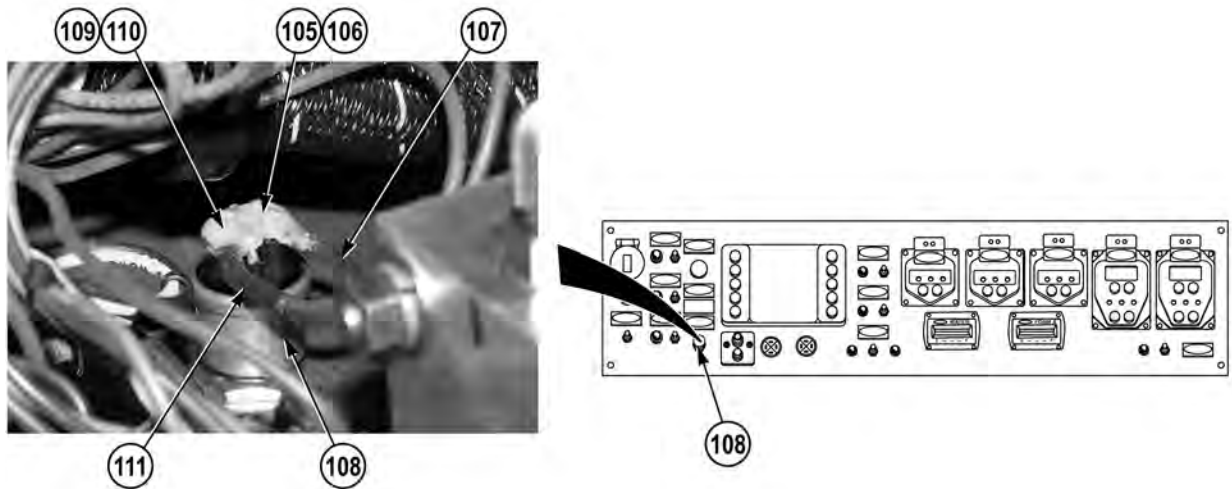


19. Install wire 3895 (128) on PUMP COOLER indicator (125) with lockwasher (127) and screw (126).
20. Install wire 4037 (124) on PUMP COOLER indicator (125) with lockwasher (123) and screw (122).

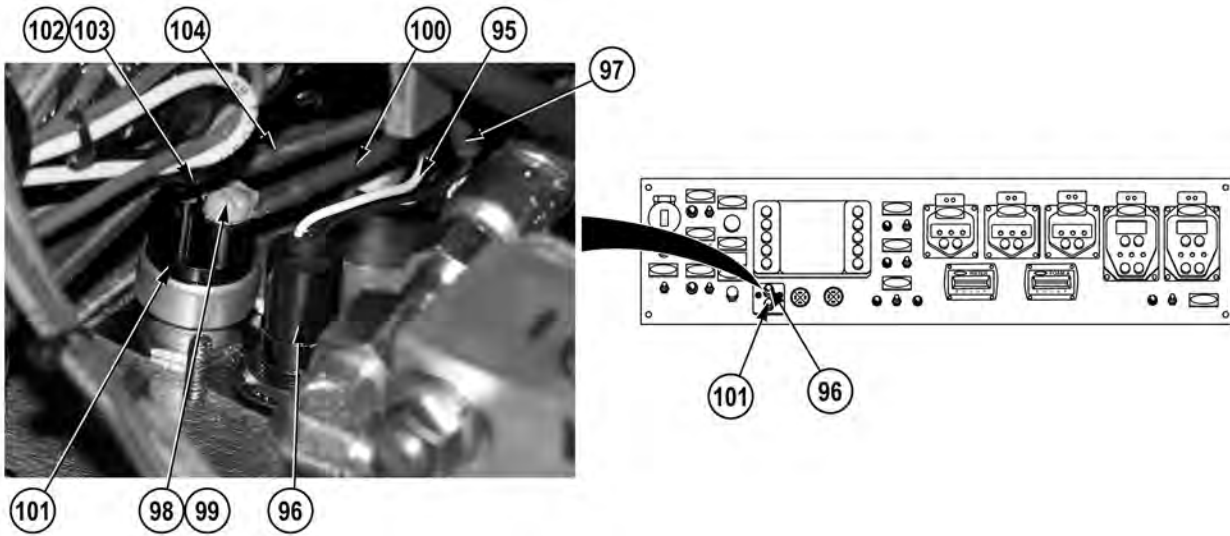




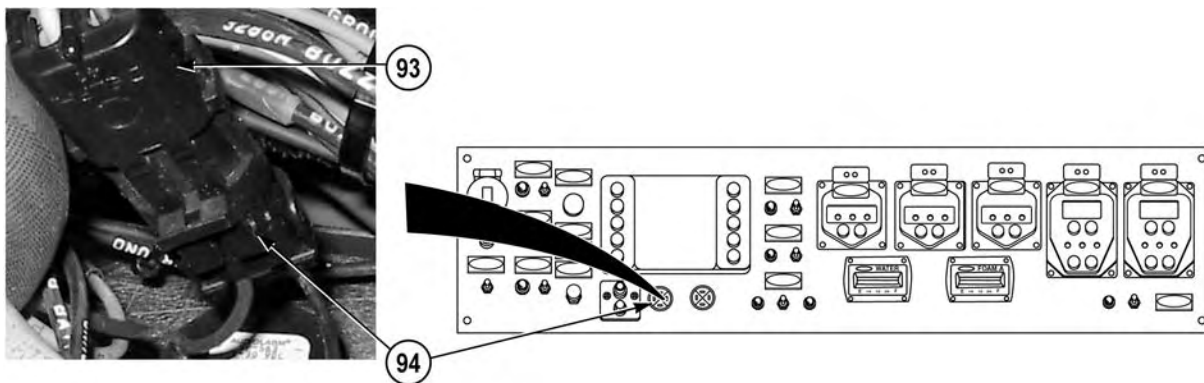
21. Install wire 4037 (121) on PUMP COOLER switch (115) with lockwasher (120) and screw (119).
22. Install wire 2834 (118) on PUMP COOLER switch (115) with lockwasher (117) and screw (116).
23. Install wire 4038 (114) on PUMP COOLER switch (115) with lockwasher (113) and screw (112).



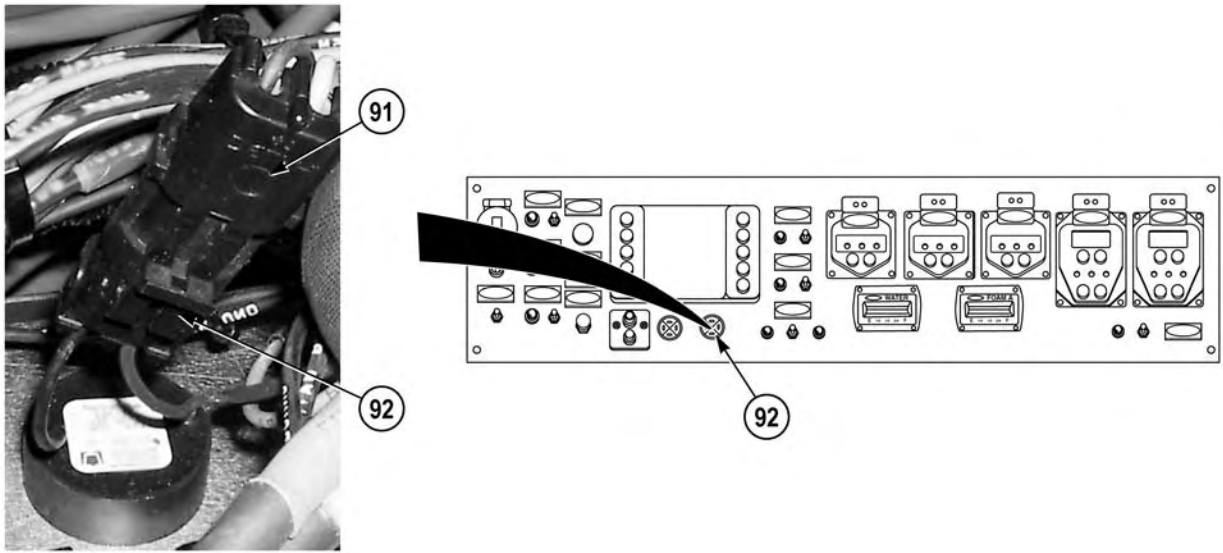
24. Install wire 1590 (111) on DRIVER MAIN INLET PRIMER button (108) with lockwasher (110) and screw (109).
25. Install wire 2773 (107) on DRIVER MAIN INLET PRIMER button (108) with lockwasher (106) and screw (105).



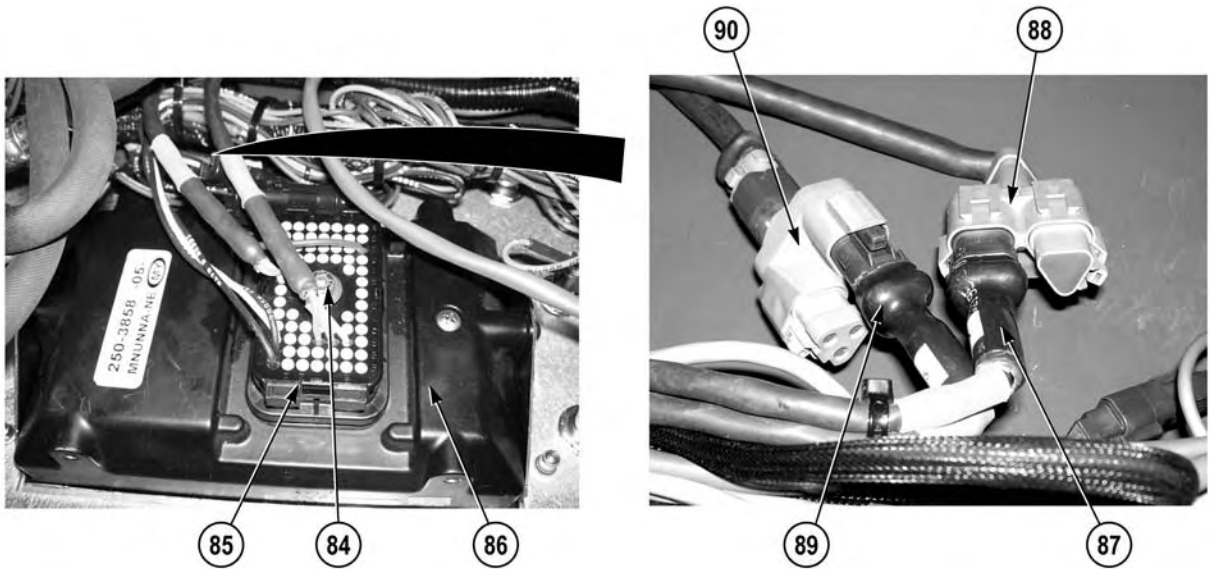
26. Install wire 1405 (104) on PUMP HOT PUSH TO TEST button (101) with lockwasher (103) and screw (102).
27. Install wire 4085 (100) on PUMP HOT PUSH TO TEST button (101) with lockwasher (99) and screw (98).
28. Repair wire 3895 (97) (TM 9-2320-325-14&P) to PUMP HOT indicator (96).
29. Repair wire 1405 (95) (TM 9-2320-325-14&P) to PUMP HOT indicator (96).



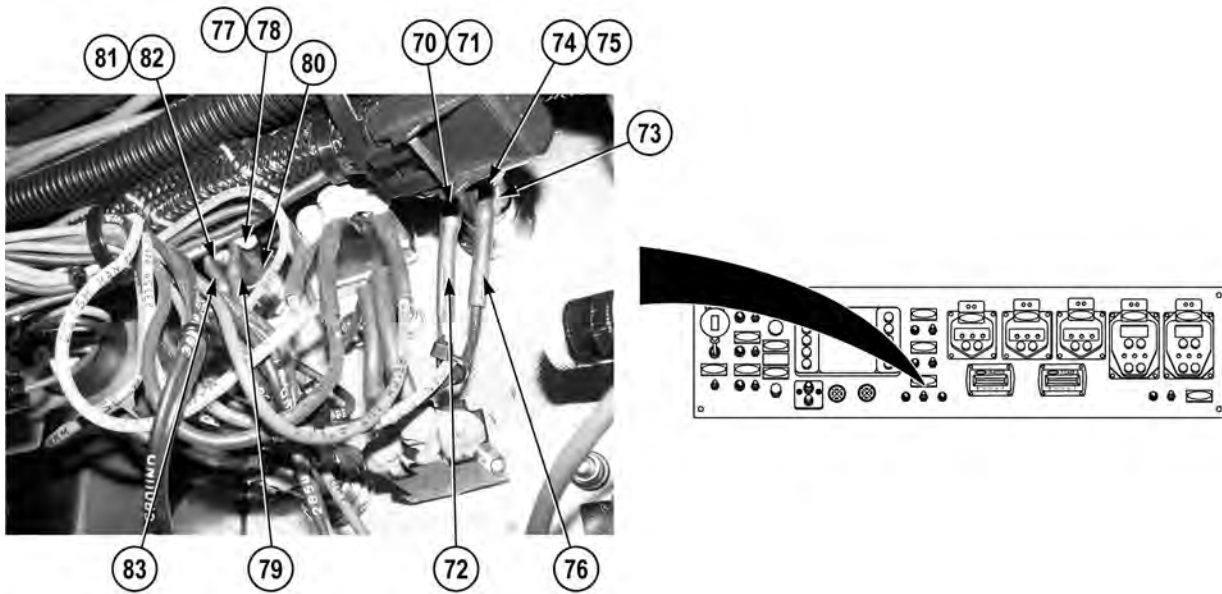
30. Connect pump operator's panel wire harness connector (93) on pump hot audio alarm (94).



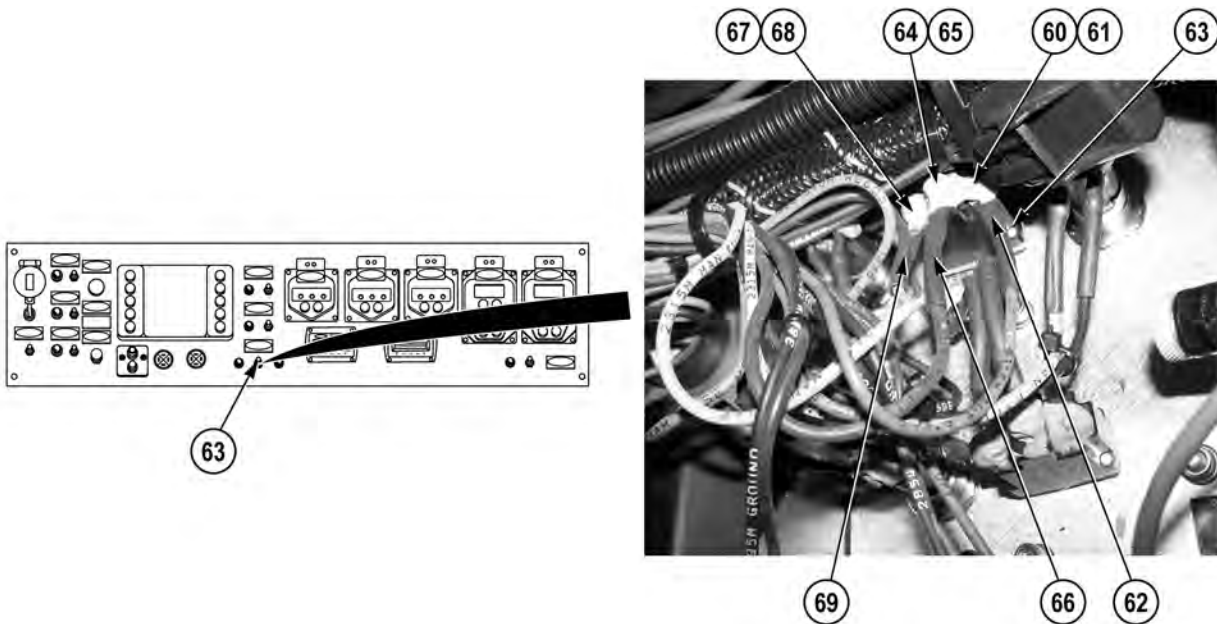
31. Connect pump operator's panel wire harness connector (91) on pressure governor control audio alarm (92).



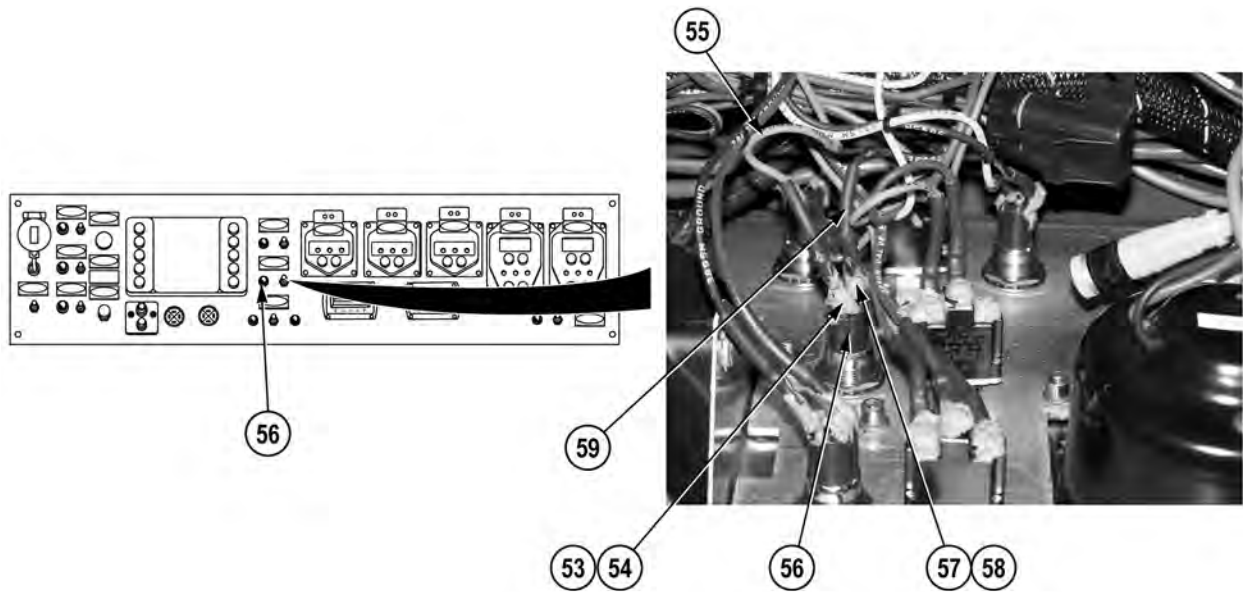
32. Connect pump operator's panel wire harness connector (89) on chassis datalink Y connector (90).
33. Connect pump operator's panel wire harness connector (87) on pressure governor control ECU datalink Y connector (88).
34. Install pump operator's panel wire harness connector (85) on pressure governor control (86) with screw (84).



- 35. Install wire 3895 (83) on DIRECT TANK FILL auto indicator (80) with lockwasher (82) and screw (81).
- 36. Install wire 2316 (79) on DIRECT TANK FILL auto indicator (80) with lockwasher (78) and screw (77).
- 37. Install wire 3895 (76) on DIRECT TANK FILL open indicator (73) with lockwasher (75) and screw (74).
- 38. Install wire 2315 (72) on DIRECT TANK FILL open indicator (73) with lockwasher (71) and screw (70).

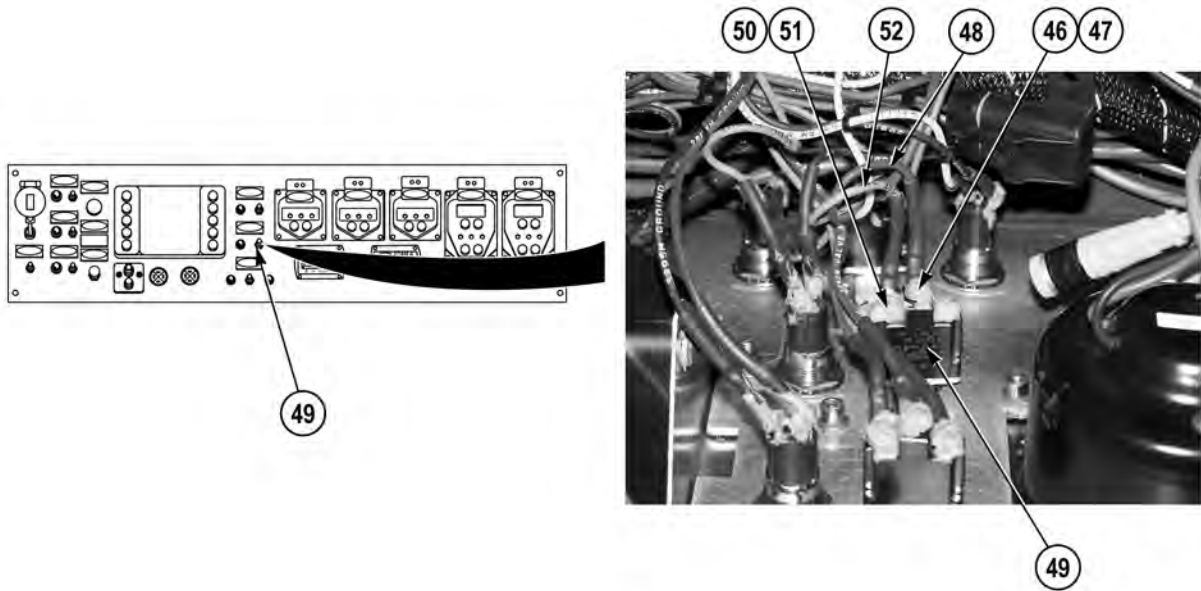


- 39. Install wire 2315 (69) on DIRECT TANK FILL switch (63) with lockwasher (68) and screw (67).
- 40. Install wire 2314 (66) on DIRECT TANK FILL switch (63) with lockwasher (65) and screw (64).
- 41. Install wire 2316 (62) on DIRECT TANK FILL switch (63) with lockwasher (61) and screw (60).



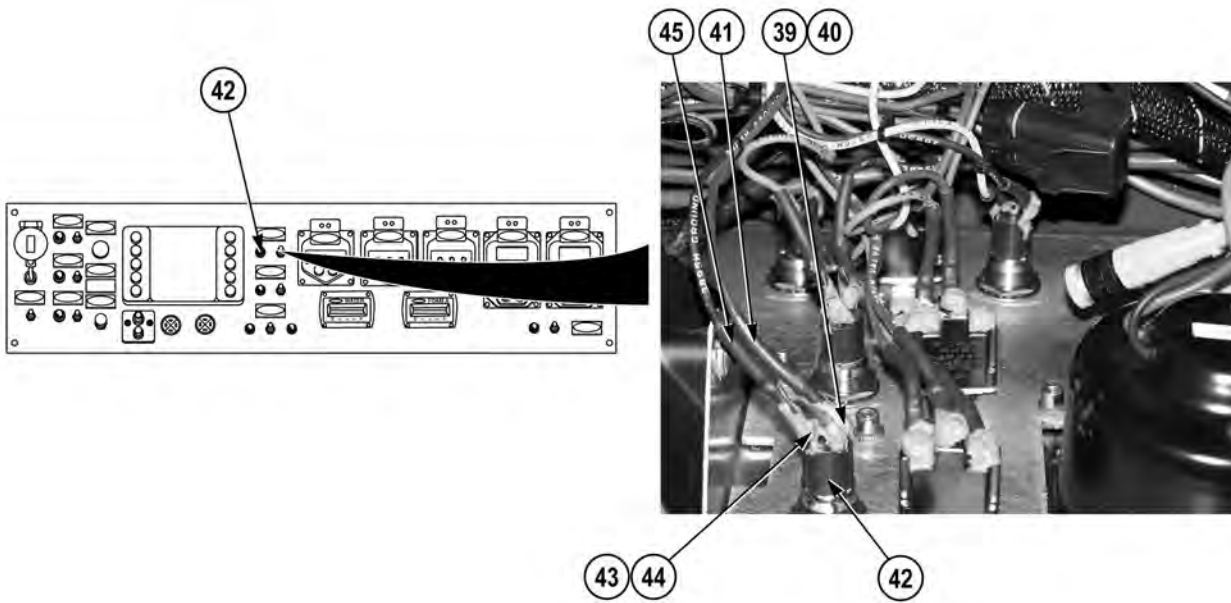
42. Install wire 3895 (59) on REEL DISCHARGE indicator (56) with lockwasher (58) and screw (57).

43. Install wire 4098 (55) on REEL DISCHARGE indicator (56) with lockwasher (54) and screw (53).

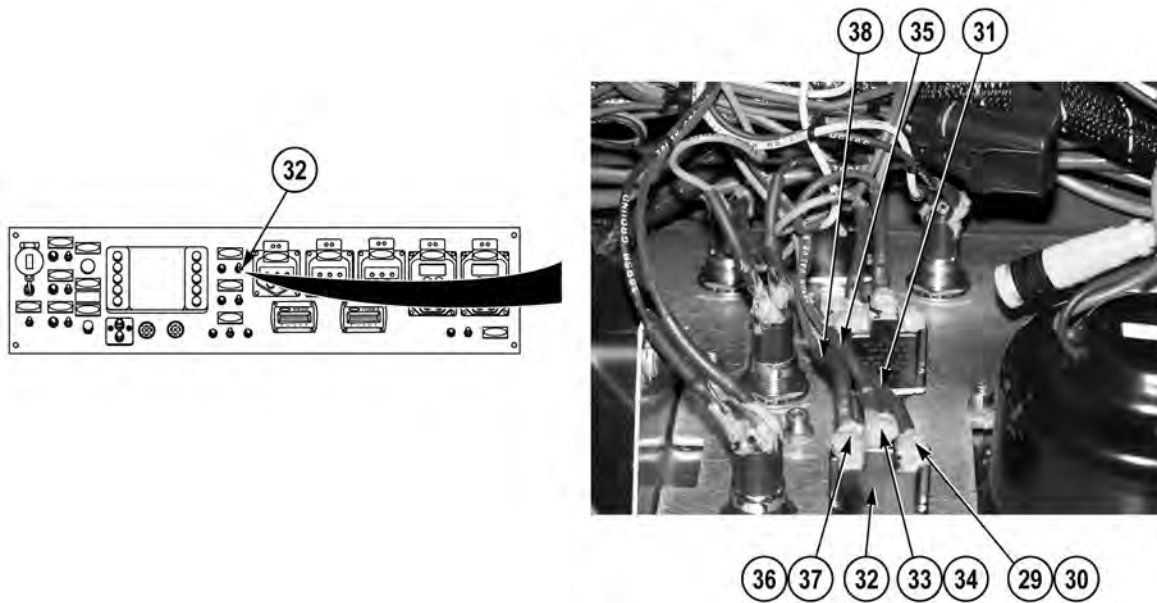


44. Install wire 4098 (52) on REEL DISCHARGE switch (49) with lockwasher (51) and screw (50).

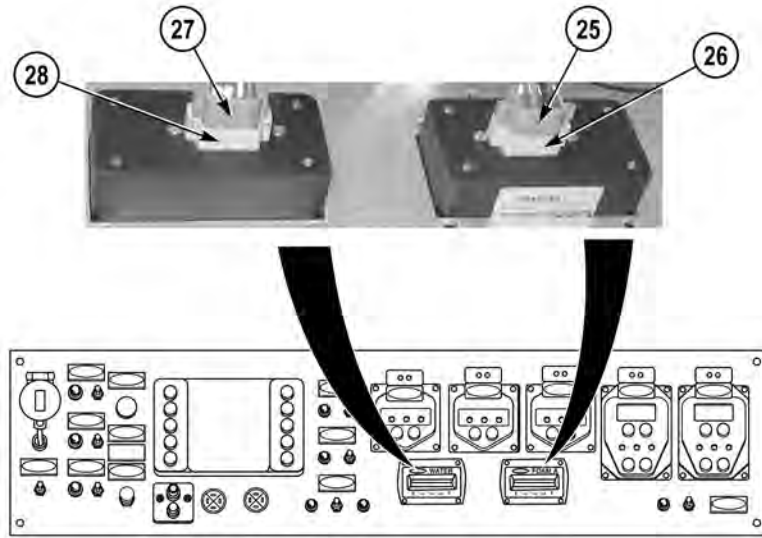
45. Install wire 2834 (48) on REEL DISCHARGE switch (49) with lockwasher (47) and screw (46).



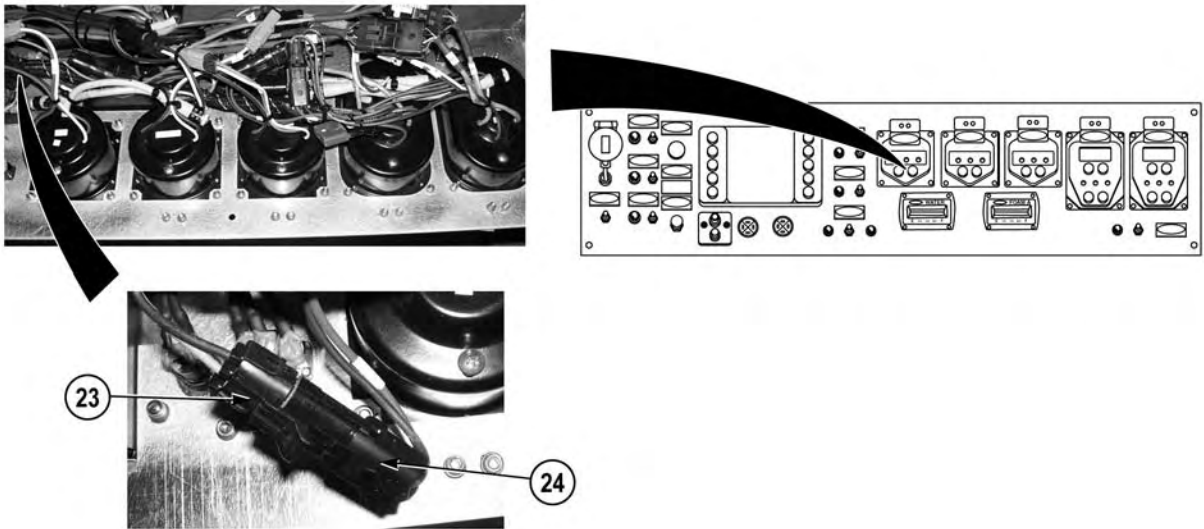
- 46. Install wire 3895 (45) on TANK TO PUMP indicator (42) with lockwasher (44) and screw (43).
- 47. Install wire 2855 (41) on TANK TO PUMP indicator (42) with lockwasher (40) and screw (39).



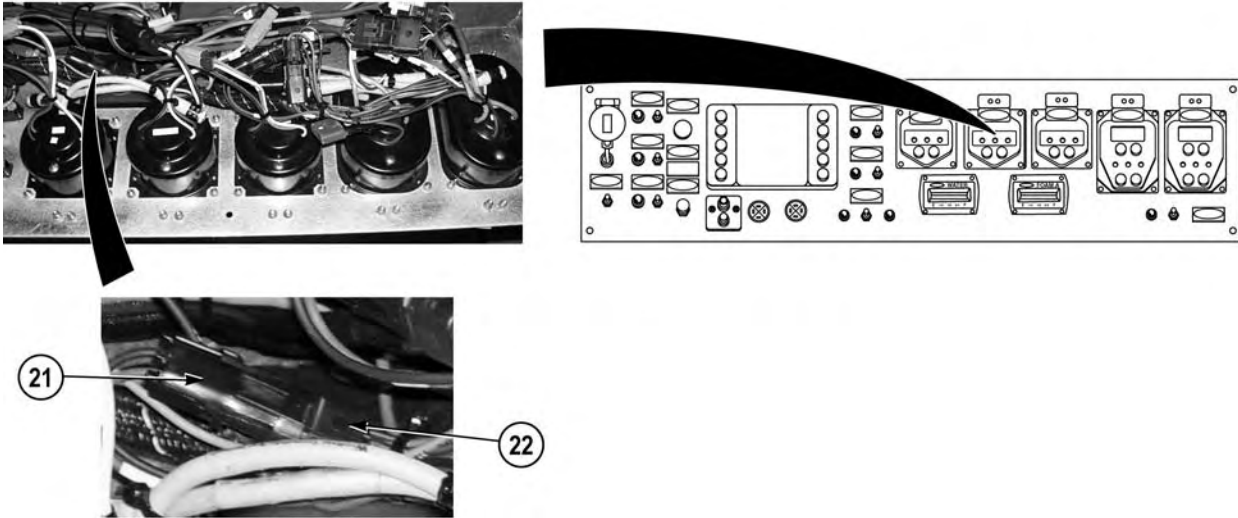
- 48. Install wire 2855 (38) on TANK TO PUMP switch (32) with lockwasher (37) and screw (36).
- 49. Install wire 2854 (35) on TANK TO PUMP switch (32) with lockwasher (34) and screw (33).
- 50. Install wire 2770 (31) on TANK TO PUMP switch (32) with lockwasher (30) and screw (29).



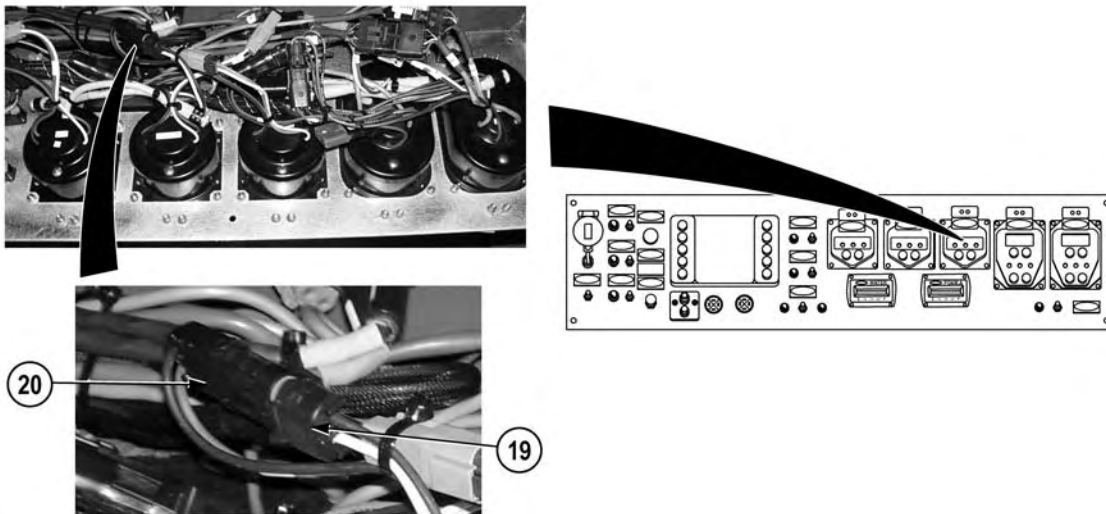
51. Connect pump operator's panel wire harness connector (27) on water level gauge connector (28).
52. Connect pump operator's panel wire harness connector (25) on foam level gauge connector (26).



53. Connect pump operator's panel wire harness connector (23) on tank fill & re-circulating line valve control connector (24).

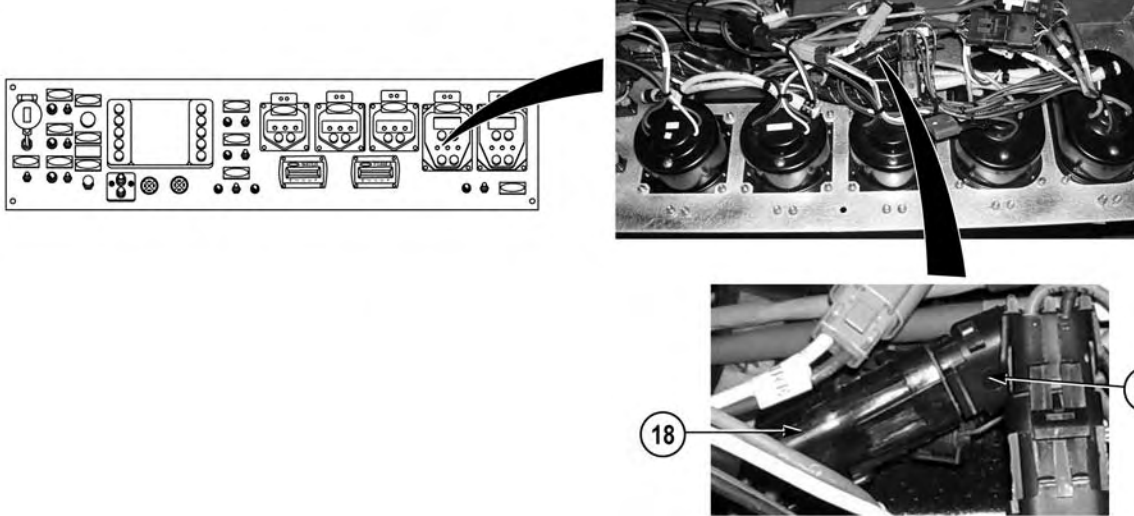


54. Connect pump operator's panel wire harness connector (21) on driver side auxiliary inlet valve control connector (22).

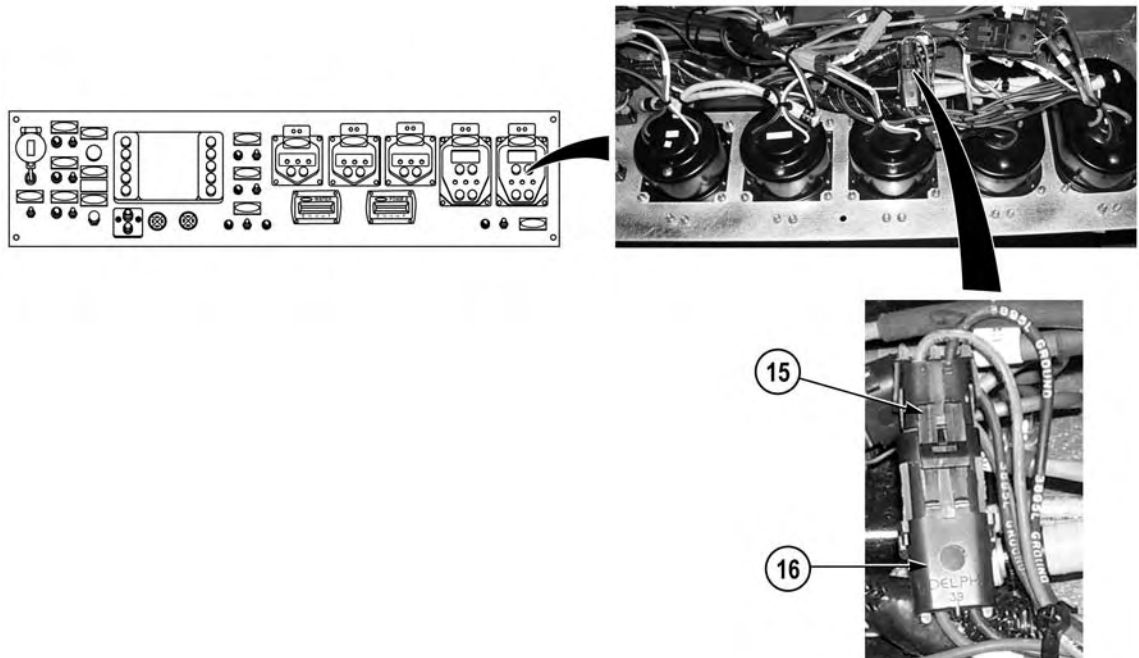


55. Connect pump operator's panel wire harness connector (19) on passenger side auxiliary inlet valve control connector (20).

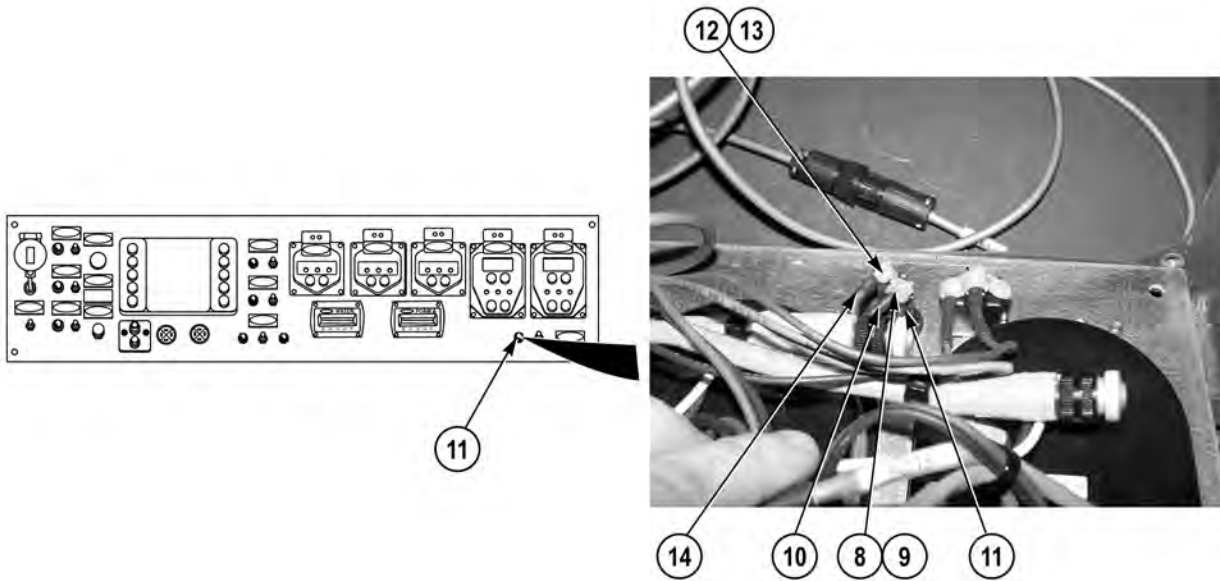




56. Connect pump operator's panel wire harness connector (17) on No. 1 driver side discharge valve control connector (18).

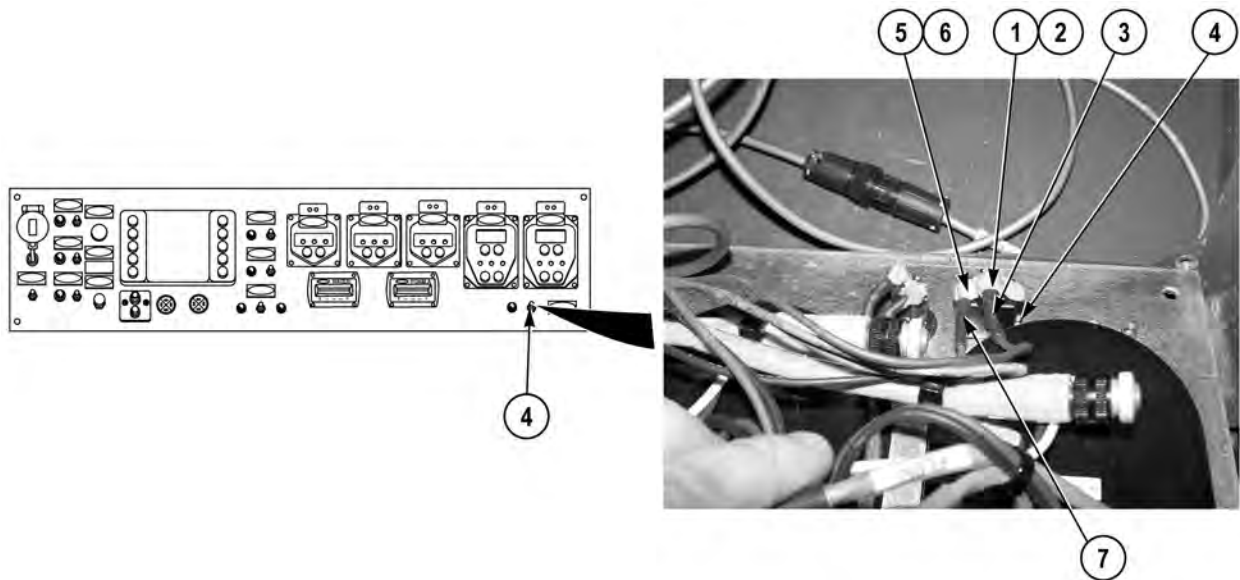


57. Connect pump operator's panel wire harness connector (15) on No. 2 passenger side discharge valve control connector (16).



58. Install wire 3895 (14) on WATER TANK DRAIN indicator (11) with lockwasher (13) and screw (12).

59. Install wire 4053 (10) on WATER TANK DRAIN indicator (11) with lockwasher (9) and screw (8).



60. Install wire 4053 (7) on WATER TANK DRAIN switch (4) with lockwasher (6) and screw (5).
61. Install wire 2834 (3) on WATER TANK DRAIN switch (4) with lockwasher (2) and screw (1).

### **WARNING**



**Adhesives, solvents, and sealing compounds can burn easily, can give off harmful vapors, and are harmful to skin and clothing. To avoid injury or death, keep away from open fire and use in well-ventilated area. If adhesive, solvent, or sealing compound gets on skin or clothing, wash immediately with soap and water.**

62. Apply sealing compound to all switches and indicators that have exposed terminals.

**END OF TASK**

### **FOLLOW-ON MAINTENANCE**

Close pump operator's panel (WP 0207)

**END OF TASK**

**END OF WORK PACKAGE**



## FIELD LEVEL MAINTENANCE

## WATER TANK FILL &amp; RE-CIRCULATING LINE VALVE CONTROL WIRE HARNESS REPLACEMENT

## INITIAL SETUP:

**Tools and Special Tools**

Tool Kit, General Mechanic's: Automotive  
(WP 0398, Item 17)

**References**

WP 0391, Fig. 49, 54, 55

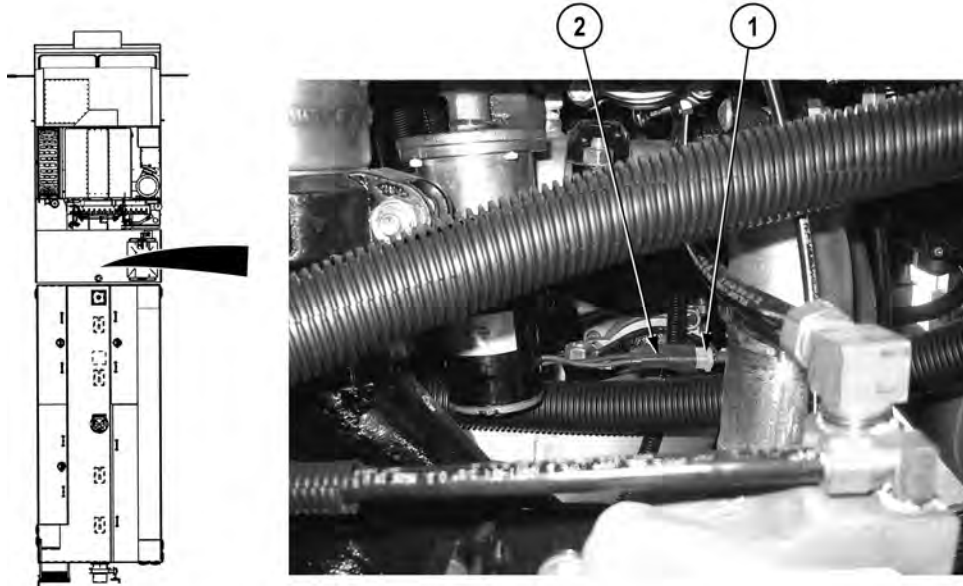
**Materials/Parts**

Tags, Identification, (WP 0400, Item 23)  
Ties, Cable, Plastic (WP 0400, Item 26)

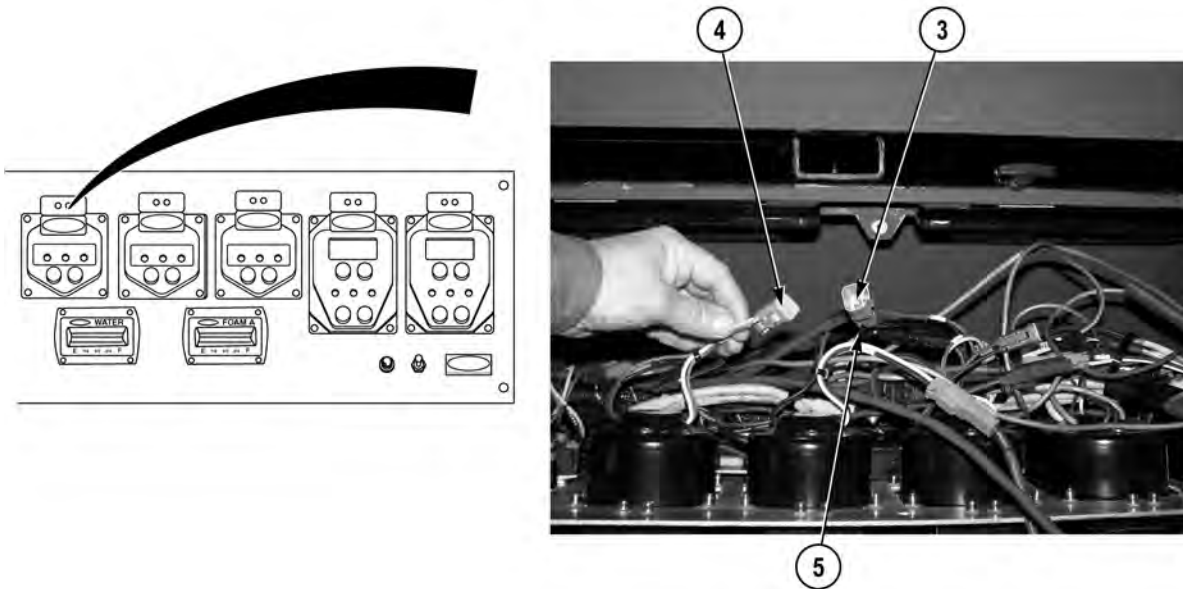
**Equipment Conditions**

Pump operator's panel opened (WP 0207)  
Pump house panels E and G removed (WP 0339)

## REMOVAL

**NOTE**

- Note routing of water tank fill & re-circulating line valve control wire harness prior to removal to ensure proper installation.
  - Water tank fill & re-circulating line valve control wire harness is routed through pump house panel N and pump operator's panel assembly.
  - Remove split loom, cushion clips, and cable ties as required.
  - Tag and mark connectors prior to removal to ensure proper installation.
1. Disconnect water tank fill & re-circulating line valve control wire harness connector (1) from water tank fill & re-circulating line valve control connector (2).



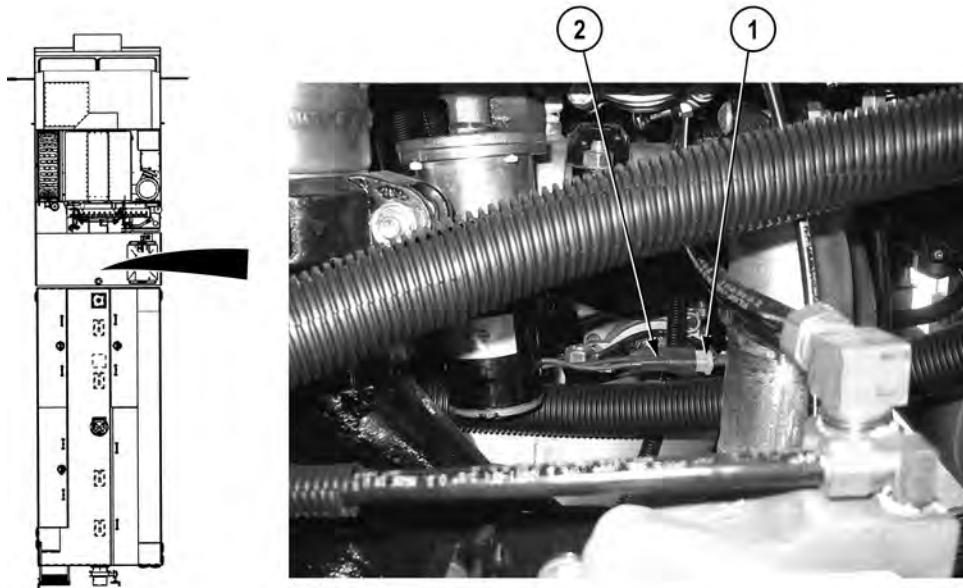
2. Disconnect water tank fill & re-circulating line valve control wire harness connector (3) from water tank fill & re-circulating line connector (4).
3. Remove water tank fill & re-circulating line valve control wire harness (5) from vehicle.

#### END OF TASK

#### INSTALLATION

#### NOTE

- Route water tank fill & re-circulating line valve control wire harness as noted.
  - Install cable ties, split loom, and cushion clips as required.
1. Install water tank fill & re-circulating line valve control wire harness (5) on vehicle.
  2. Connect water tank fill & re-circulating line valve control wire harness connector (3) to water tank fill & re-circulating line connector (4).



3. Connect water tank fill & re-circulating line valve control connector (2) to water tank fill & re-circulating line valve control wire harness connector (1).

**END OF TASK**

**FOLLOW-ON MAINTENANCE**

1. Install pump house panels E and G (WP 0339)
2. Close pump operator's panel (WP 0207)

**END OF TASK**

**END OF WORK PACKAGE**





---

**FIELD LEVEL MAINTENANCE**  
**WATERPROOF SPLICE BOX REPLACEMENT**

---

**INITIAL SETUP:****Tools and Special Tools**

Tool Kit, General Mechanic's: Automotive  
(WP 0398, Item 17)

**References**

TM 9-2320-325-14&P  
WP 0391, Fig. 41

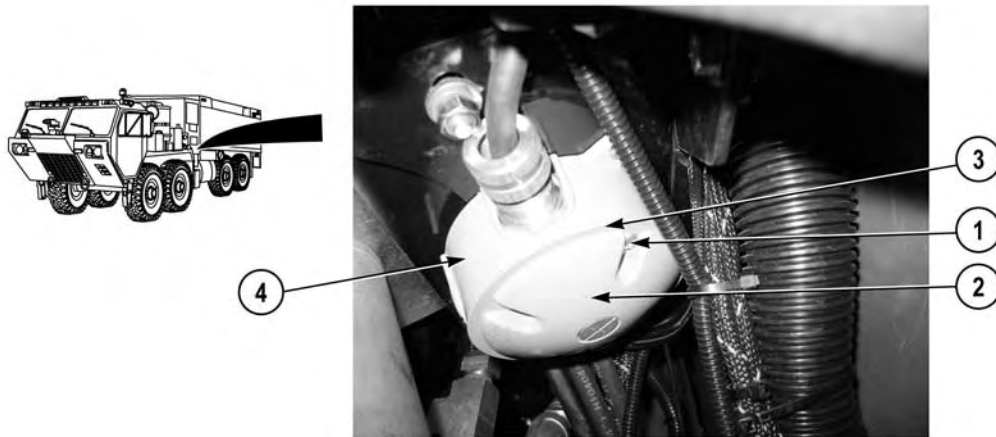
**Materials/Parts**

Tags, Identification (WP 0400, Item 23)  
Gasket (1)

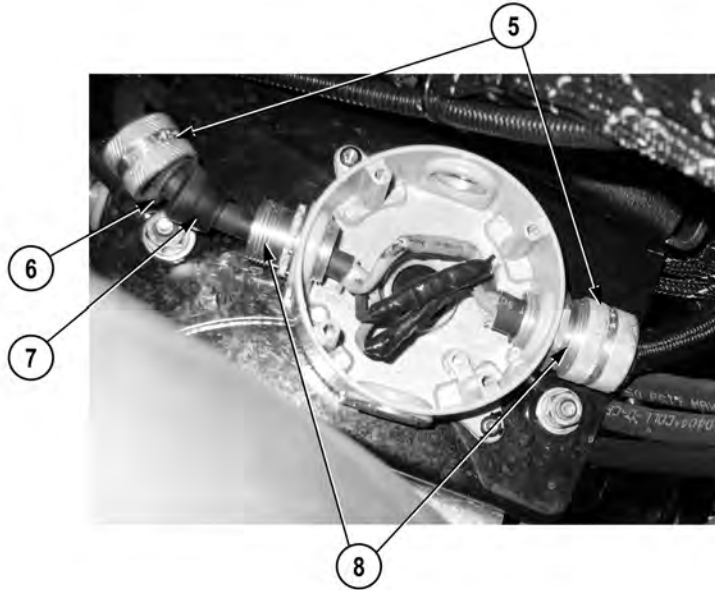
**Equipment Conditions**

Pump house panel B removed (WP 0339)  
Shoreline inlet unplugged (WP 0004)

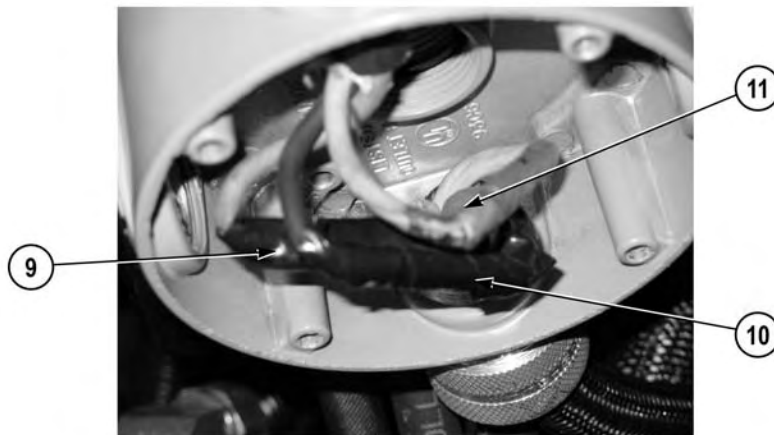
---

**REMOVAL**

1. Remove two screws (1), cover (2), and gasket (3) from waterproof splice box (4). Discard gasket.



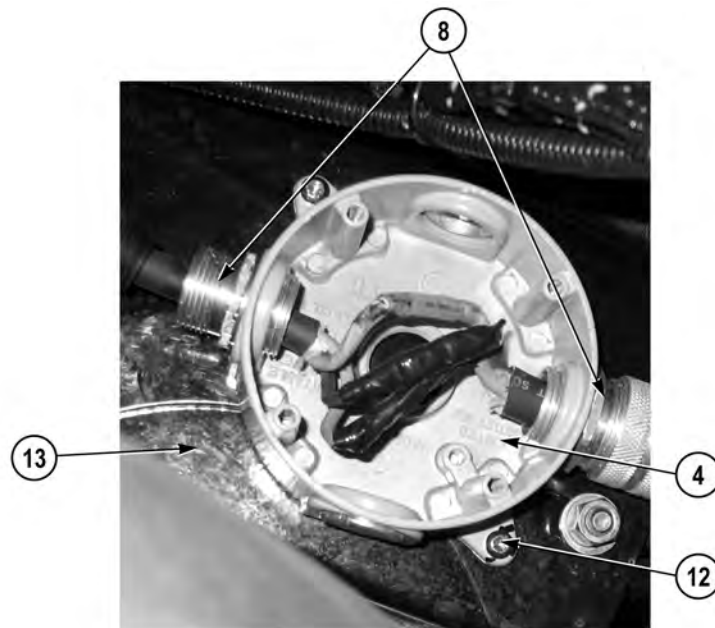
2. Remove two strain relief's (5), plastic backers (6), and rubber compression grommets (7) from fittings (8).



### NOTE

Tag and mark wires prior to removal to ensure proper installation.

3. Cut green wire (9), black wire (10), yellow wire (11) (TM 9-2320-325-14&P).

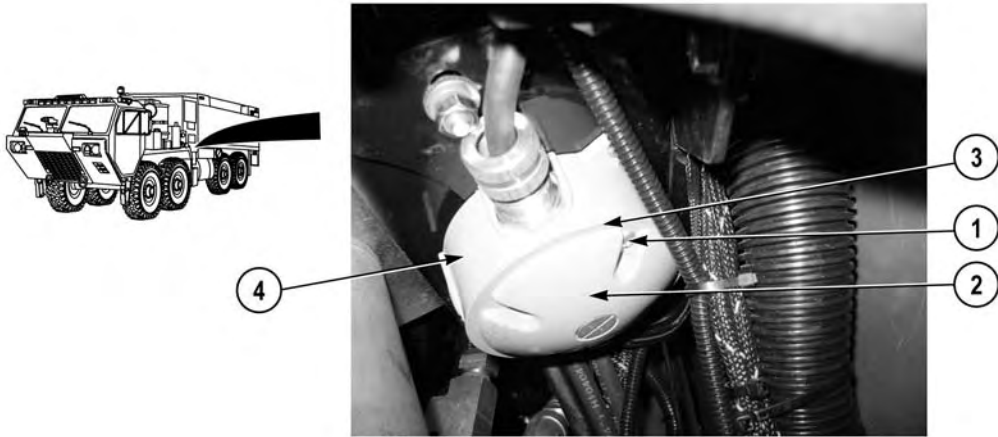


4. Remove two screws (12) and waterproof splice box (4) from bracket (13).
5. Remove two fittings (8) from waterproof splice box (4).

#### END OF TASK

#### INSTALLATION

1. Install two fittings (8) on waterproof splice box (4).
2. Install waterproof splice box (4) on bracket (13) with two screws (12).
3. Install two rubber compression grommets (7), plastic backers (6), and strain relief's (5) on fittings (8).
4. Repair yellow wire (11), black wire (10), and green wire (9) (TM 9-2320-325-14&P)



5. Install gasket (3) and cover (2) on waterproof splice box (4) with two screws (1).

**END OF TASK**

**FOLLOW ON MAINTENANCE**

Install pump house panel B (WP 0339)

**END OF TASK**

**END OF WORK PACKAGE**

## FIELD LEVEL MAINTENANCE

## HYDRAULIC OVERRIDE MANIFOLD SOLENOID AND PROPORTIONING VALVE REPLACEMENT

## INITIAL SETUP:

**Tools and Special Tools**

- Drain Pan (WP 0398, Item 4)
- Standard Automotive Tool Set (SATS), (WP 0398, Item 15)
  - Wrench, Torque, Dial, 3/8" Drive, 300 in-lb
- Tool Kit, General Mechanic's: Automotive (WP 0398, Item 17)

**References**

WP 0391, Fig. 39

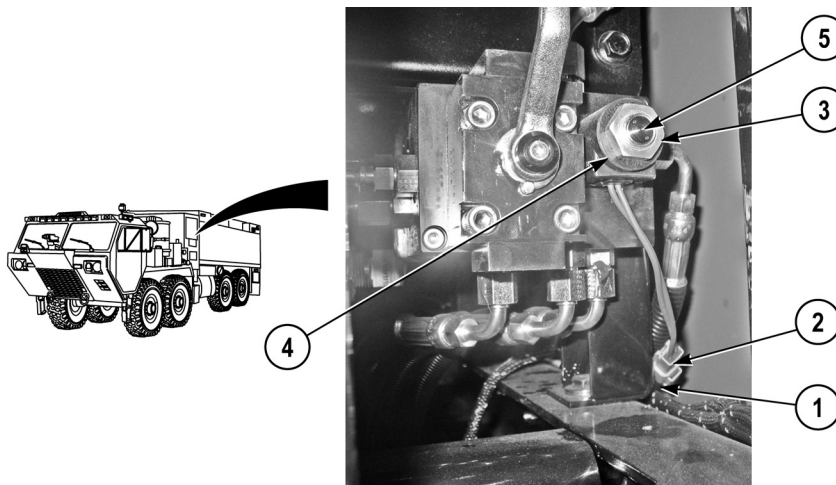
**Equipment Conditions**

- Pump house access door opened (WP 0009)
- Hydraulic reservoir drained (WP 0145)
- Batteries disconnected (TM 9-2320-325-14&P)

**Materials/Parts**

- Fluid, Hydraulic (WP 0400, Item 17)
- Proportioning Valve (Includes Preformed Packings and Solenoid) (1)

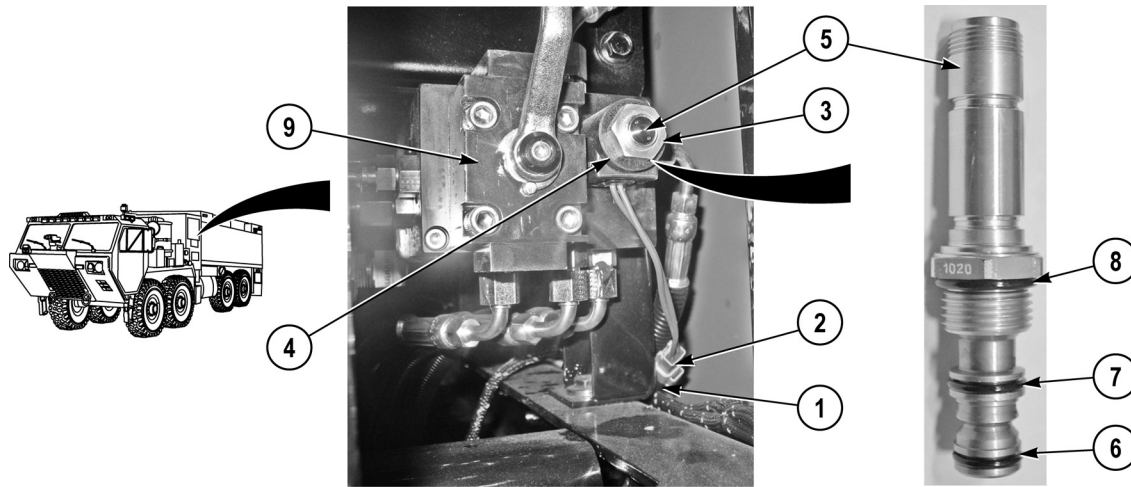
## REMOVAL



1. Disconnect pump house wire harness connector (1) from solenoid connector (2).

**NOTE**

- Nut holding solenoid on proportioning valve can only be installed with indexing ring facing proportioning valve. Note position of nut prior to removal to ensure proper installation.
  - Note orientation of solenoid prior to removal to ensure proper installation.
2. Remove nut (3) and solenoid (4) from proportioning valve (5). Discard solenoid.



### NOTE

Position suitable drain pan under proportioning valve to catch hydraulic fluid.

3. Remove proportioning valve (5) and three preformed packings (6), (7), and (8) from hydraulic override manifold (9). Discard proportioning valve and preformed packings.

### END OF TASK

### INSTALLATION

### CAUTION

**Do not overtighten proportioning valve on hydraulic override manifold. Failure to comply may cause damage to equipment.**

1. Lightly lubricate three preformed packings (6), (7), and (8) and install three preformed packings (6), (7), and (8) and proportioning valve (5) on hydraulic override manifold (9). Tighten proportioning valve to 29 lb-in (3.3 N•m).

### NOTE

- Install solenoid as noted prior to removal.
  - Install nut as noted prior to removal.
2. Install solenoid (4) on proportioning valve (5) with nut (3).
  3. Connect solenoid connector (2) on pump house wire harness connector (1).

### END OF TASK

**FOLLOW-ON MAINTENANCE**

1. Fill hydraulic reservoir (WP 0145)
2. Close pump house access door (WP 0009)
3. Connect batteries (TM 9-2320-325-14&P)

**END OF TASK****END OF WORK PACKAGE**





---

**FIELD LEVEL MAINTENANCE**  
**VRCU CABLE AND BRACKET REPLACEMENT**

---

**INITIAL SETUP:****Tools and Special Tools**

Tool Kit, General Mechanic's: Automotive  
(WP 0398, Item 17)

**Materials/Parts**

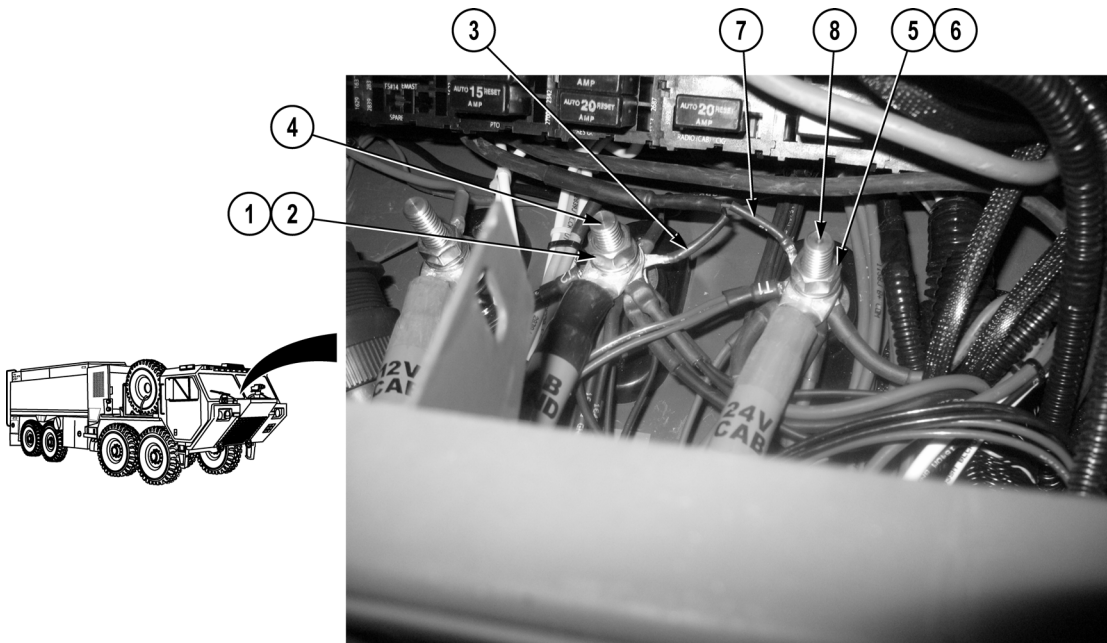
Tags, Identification (WP 0400, Item 23)  
Ties, Cable, Plastic (WP 0400, Item 26)  
Lockwasher (2)  
Locknut (4)

**References**

WP 0391, Fig. 26

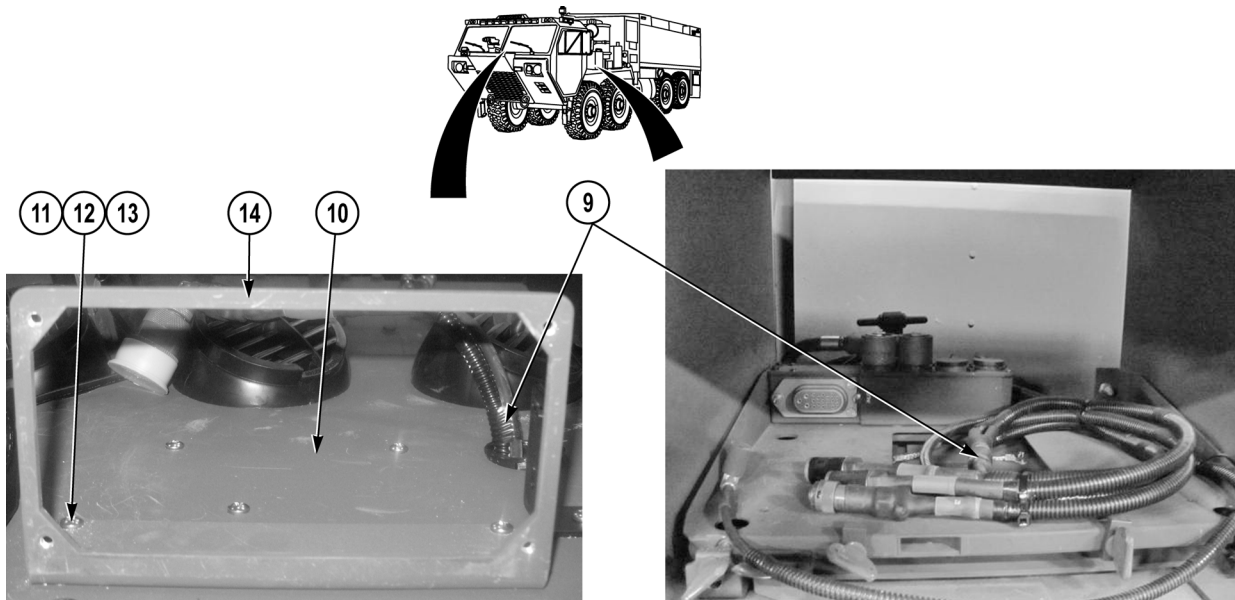
**Equipment Conditions**

Siren control removed (WP 0380)  
Cab instrument panel E removed (WP 0205)  
SINGARS cover door opened (WP 0011)

**REMOVAL****NOTE**

Tag and mark wires prior to removal to ensure proper installation.

1. Remove nut (1), lockwasher (2), and wire (3) from negative stud (4). Discard lockwasher.
2. Remove nut (5), lockwasher (6), and wire (7) from positive stud (8). Discard lockwasher.

**NOTE**

- Note routing of VRCU cable prior to removal to ensure proper installation.
- Remove cable ties and cushion clips as required.

3. Remove VRCU cable (9) from cab instrument panel A (10) and vehicle.

**NOTE**

Perform Step (4) if bracket needs to be removed.

4. Remove four locknuts (11), washers (12), screws (13), and bracket (14) from cab instrument panel A (10). Discard locknuts.

**END OF TASK****INSTALLATION****NOTE**

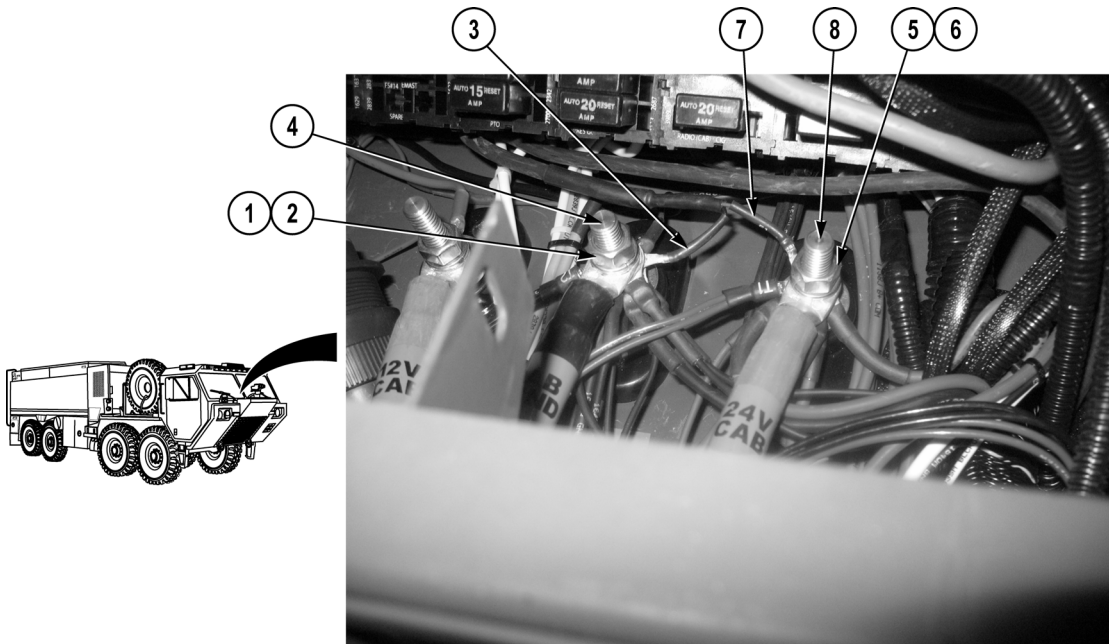
Perform Step (1) if bracket needs to be installed.

1. Install bracket (14) on cab instrument panel A (10) with four screws (13), washers (12), and locknuts (11).

**NOTE**

- Route VRCU cable as noted prior to removal.
- Install cable ties and cushion clips as required.

2. Position VRCU cable (9) on vehicle and cab instrument panel A (10).



3. Install wire (7) on positive stud (8) with lockwasher (6) and nut (5).
4. Install wire (3) on negative stud (4) with lockwasher (2) and nut (1).

#### END OF TASK

#### FOLLOW-ON MAINTENANCE

1. Close SINCGARS cover door (WP 0011)
2. Install cab instrument panel E (WP 0205)
3. Install siren control (WP 0380)

#### END OF TASK

#### END OF WORK PACKAGE



## FIELD LEVEL MAINTENANCE

## PUMP HOUSE HEATER TEST SWITCH REPLACEMENT

## INITIAL SETUP:

**Tools and Special Tools**

Tool Kit, General Mechanic's: Automotive  
(WP 0398, Item 17)

**Materials/Parts**

Tags, Identification (WP 0400, Item 23)  
Ties, Cable, Plastic (WP 0400, Item 26)

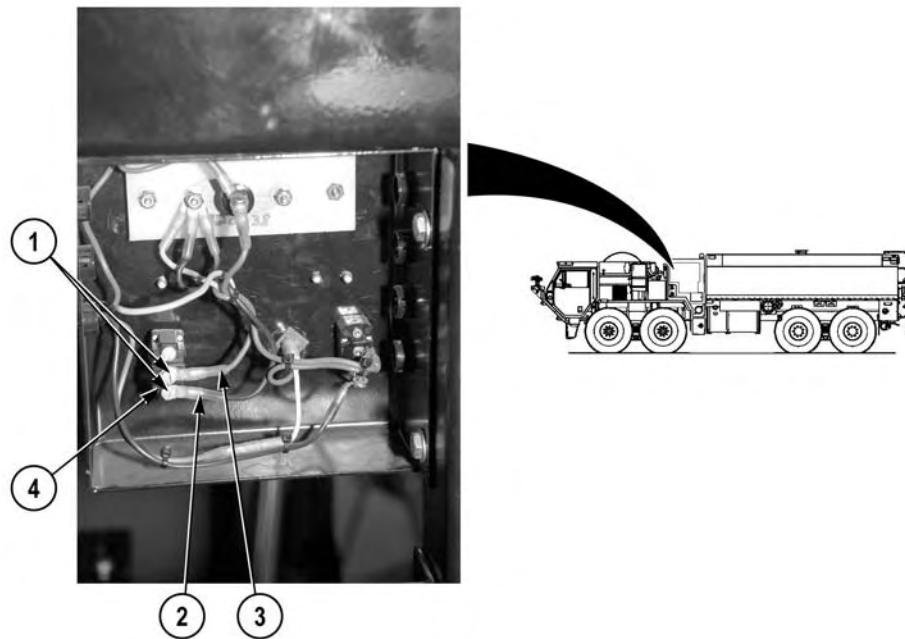
**References**

WP 0391, Fig. 63

**Equipment Conditions**

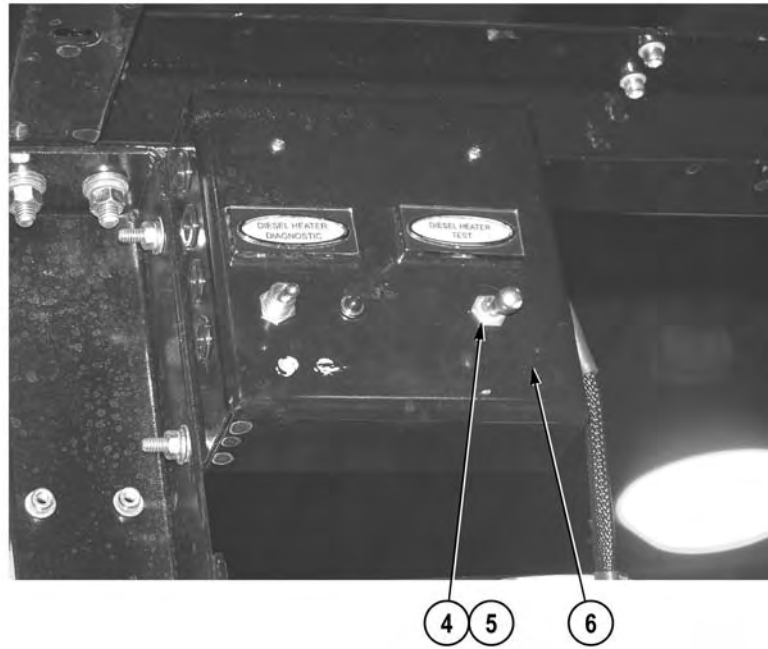
Pump house panel E removed (WP 0339)  
Pump house access door assembly opened  
(WP 0009)

## REMOVAL

**NOTE**

- Tag and mark wires prior to removal to ensure proper installation.
- Remove cable ties as required.

1. Remove two screws (1), black wire (2), and red wire (3) from pump house heater test switch (4).



2. Remove nut (5) and pump house heater test switch (4) from bracket (6).

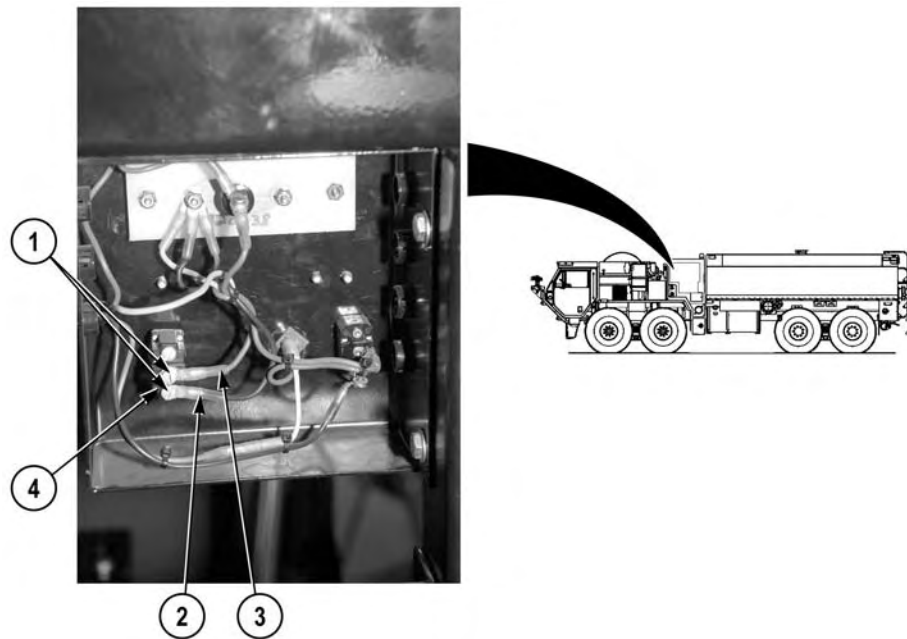
#### END OF TASK

#### INSTALLATION

#### NOTE

Install cable ties as necessary.

1. Install pump house heater test switch (4) on bracket (6) with nut (5).



2. Install red wire (3) and black wire (2) on pump house heater test switch (4) with two screws (1).

**END OF TASK**

**FOLLOW-ON MAINTENANCE**

1. Close pump house access door assembly (WP 0009)
2. Install pump house panel E (WP 0339)

**END OF TASK**

**END OF WORK PACKAGE**





## FIELD LEVEL MAINTENANCE

## PUMP HOUSE HEATER DIAGNOSTIC AND THERMAL SWITCH(ES) REPLACEMENT

## INITIAL SETUP:

**Tools and Special Tools**

Tool Kit, General Mechanic's: Automotive  
(WP 0398, Item 17)

**Materials/Parts**

Tags, Identification (WP 0400, Item 23)  
Ties, Cable, Plastic (WP 0400, Item 26)  
Locknut (1)  
Lockwasher (1)  
Locknut (1)  
Lockwasher (2)

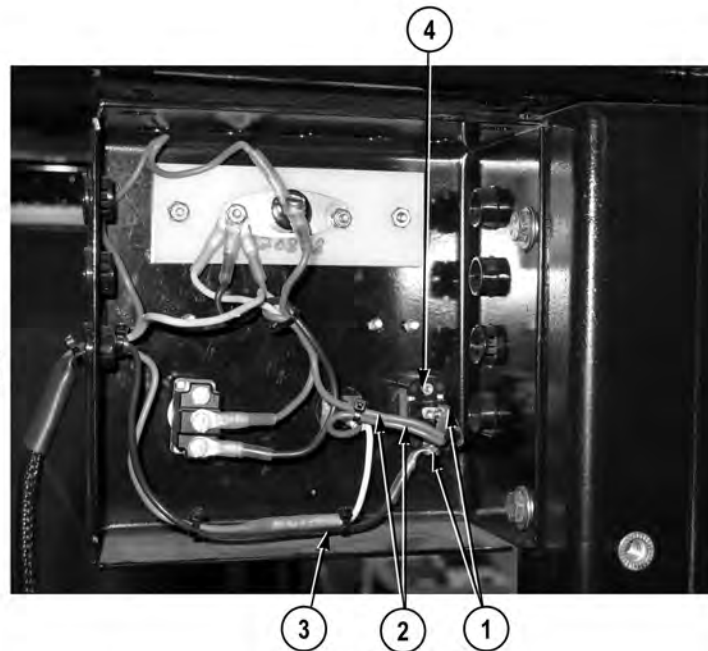
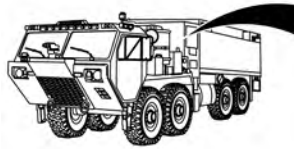
**References**

TM 9-2320-325-14&P  
WP 0306  
WP 0391, Fig. 63

**Equipment Conditions**

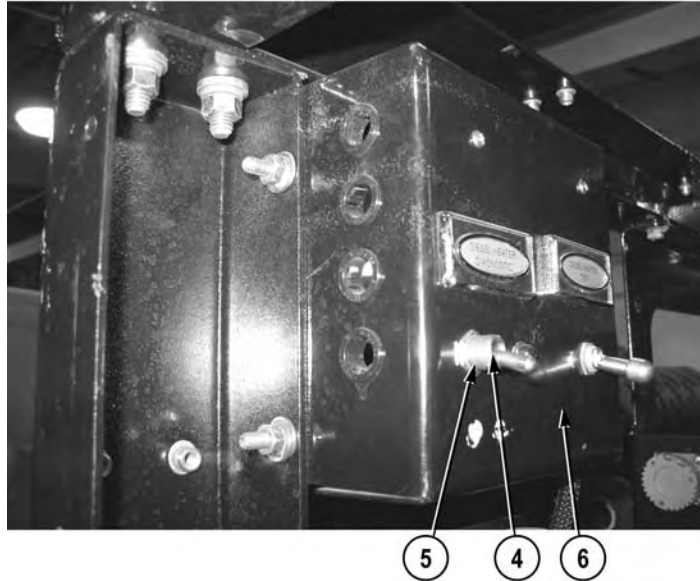
Pump house access door assembly opened  
(WP 0008)  
Pump house panel E removed (WP 0339)

## REMOVAL

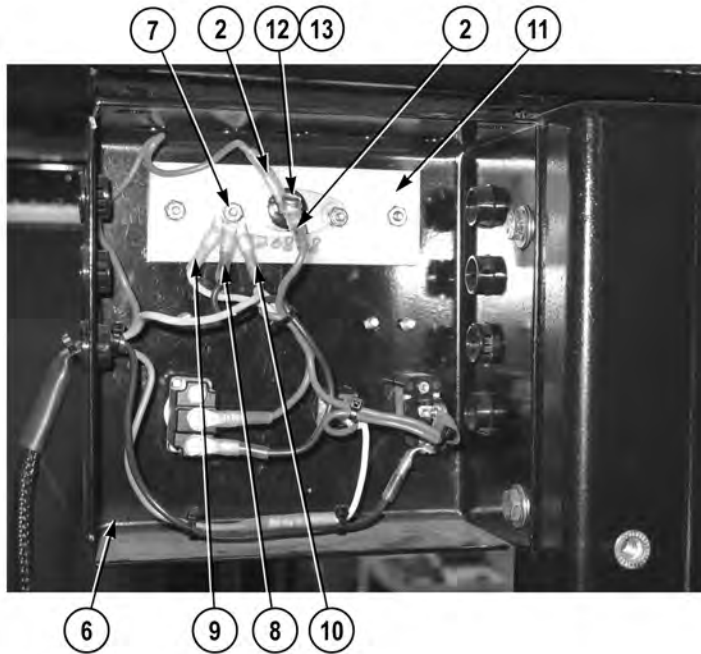
**NOTE**

- Tag and mark wires prior to removal to ensure proper installation.
- Remove cable ties as required.

1. Remove two screws (1), two wires 2852 (2) and wire 4088 (3) from heater diagnostic switch (4).



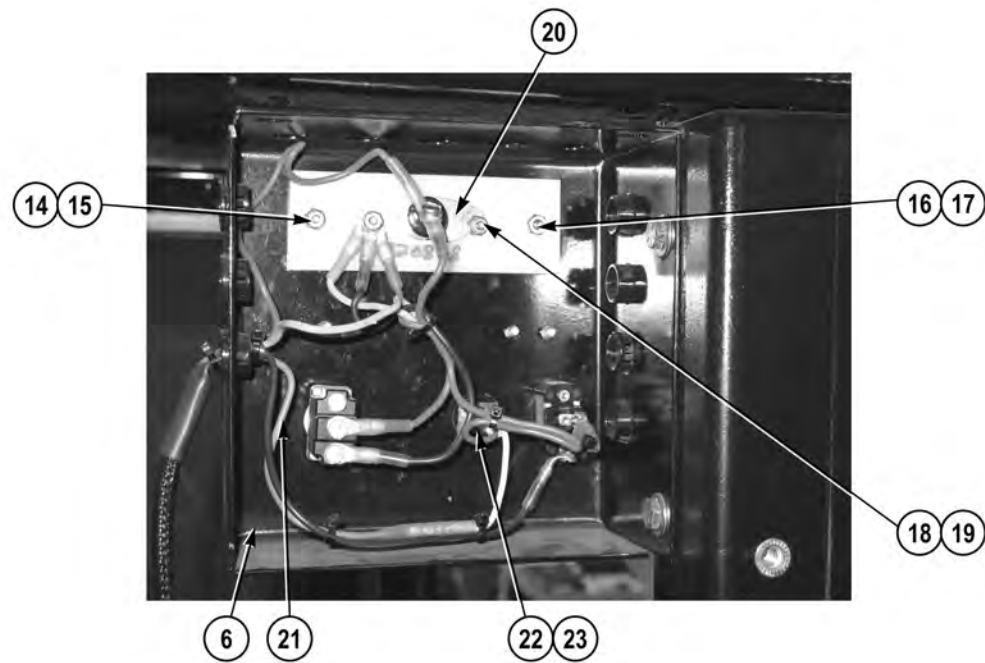
2. Remove nut (5) and heater diagnostic switch (4) from heater diagnostic switch box (6).



**NOTE**

Perform Steps (3) through (9) if thermostatic switch must be removed.

3. Remove locknut (7), wire 4088 (8), wire 4086 (9), and wire 2852 (10) from isolator (11). Discard locknut.
4. Remove screw (12), lockwasher (13), two wires 2852 (2) from isolator (11). Discard lockwasher.

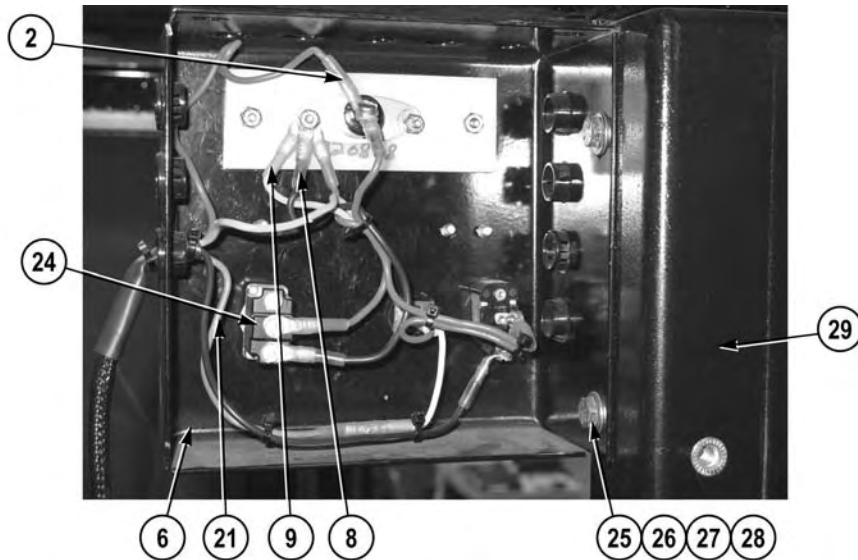


5. Remove and discard locknut (14) from screw (15).
6. Remove nut (16) from screw (17) and isolator (11) from heater diagnostic switch box (6).
7. Remove locknut (18) from screw (19) and thermostatic switch (20) from isolator (11). Discard locknut.

### NOTE

Perform Steps (8) through (12) if heater diagnostic switch box needs to be removed.

8. Cut wire 4087 (21) (TM 9-2320-325-14&P)
9. Remove clip (22) and LED indicator light (23) from heater diagnostic switch box (6).

**NOTE**

Note location of switch prior to removal to ensure proper installation.

10. Remove pump house heater test switch (24) from heater diagnostic switch box (6) (WP 0306).

**NOTE**

Note routing of wires prior to removal to ensure proper installation.

11. Remove wire 4088 (8), wire 4086 (9), wire 4087 (21), and wire 2852 (2) from heater diagnostic switch box (6).
12. Remove two nuts (25), lockwashers (26), four washers (27) two screws (28) and heater diagnostic switch box (6) from pump house frame (29). Discard lockwashers.

**END OF TASK****INSTALLATION****NOTE**

Perform Steps (1) through (5) if heater diagnostic switch box was removed.

1. Install heater diagnostic switch box (6) on pump house frame (29) with two screws (28), four washers (27), two lockwashers (26) and nuts (25).

**NOTE**

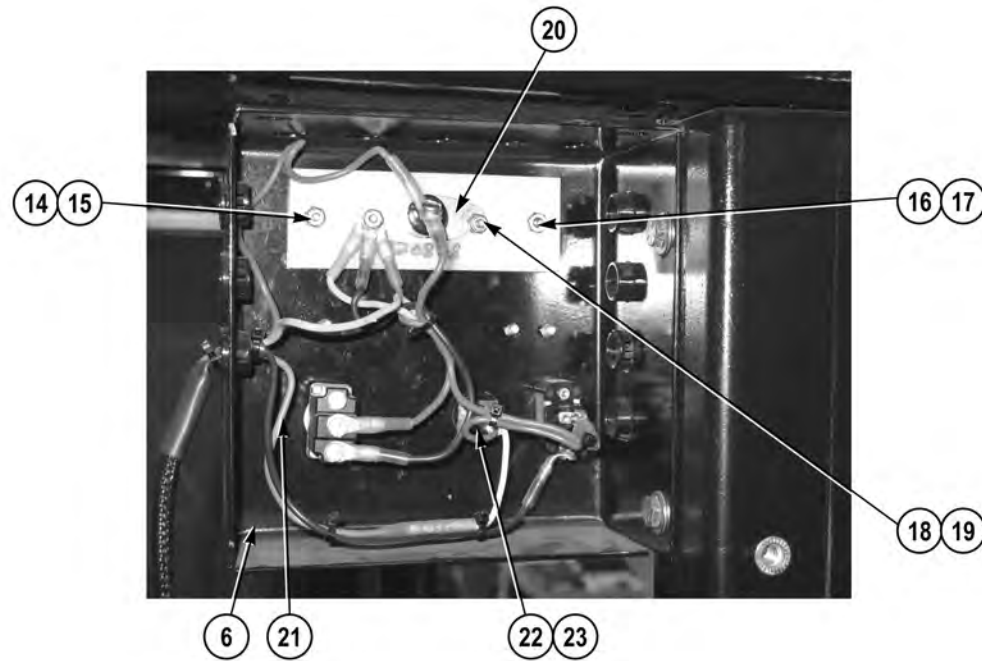
Route wires as noted prior to removal.

2. Route wire 2852 (2), wire 4087 (21), wire 4086 (9), and wire 4088 (3) in heater diagnostic switch box (6).

**NOTE**

Install switch in same position as noted.

3. Install pump house heater test switch (24) on heater diagnostic switch box (6) (WP 0306).

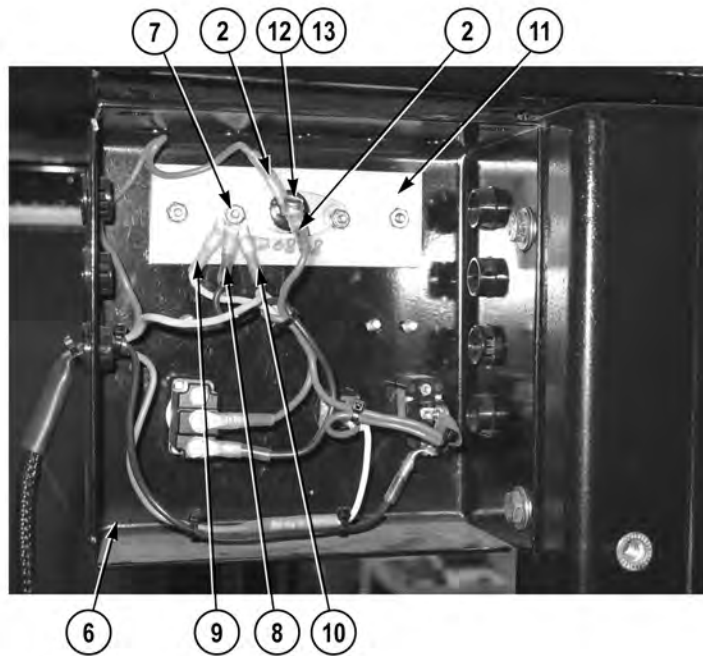


4. Install LED indicator light (23) and clip (22) on bracket (6).
5. Repair wire 4087 (21) (TM 9-2320-325-14&P)

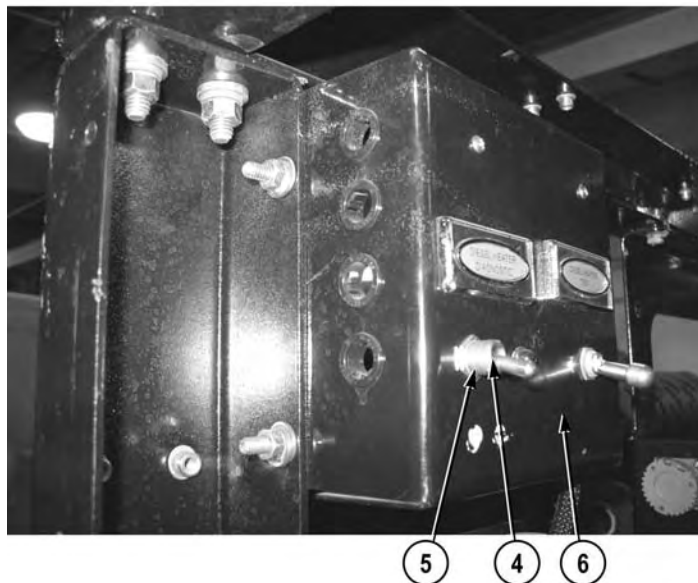
#### NOTE

Perform Steps (6) through (10) if thermostatic switch was removed.

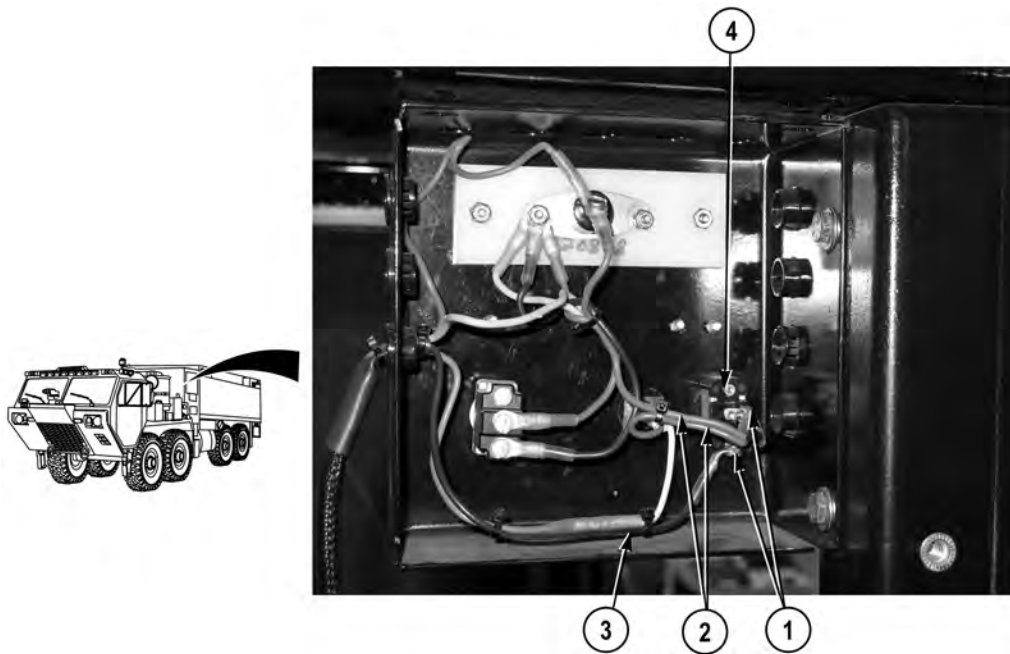
6. Install thermostatic switch (20) on isolator (11) with screw (19) and locknut (18).
7. Install isolator (11) on bracket (6) with screw (17) and nut (16).
8. Install locknut (14) on screw (15).



- 9. Install two wires 2852 (2), lockwasher (13) and screw (12) on isolator (11).
- 10. Install wire 2852 (10), wire 4086 (9), and wire 4088 (8) on isolator (11) with locknut (7).



- 11. Install heater diagnostic switch (4) on bracket (6) with nut (5).



12. Install wire 4088 (3) and two wires 2852 (2) on heater diagnostic switch (4) with two screws (1).

#### **FOLLOW-ON MAINTENANCE**

1. Install pump house panel E (WP 0339)
2. Close pump house access door assembly (WP 0008)
3. Connect batteries (TM 9-2320-325-14&P)

**END OF TASK**

**END OF WORK PACKAGE**





---

**FIELD LEVEL MAINTENANCE**  
**HEATER FUEL PUMP REPLACEMENT**

---

**INITIAL SETUP:****Tools and Special Tools**

Drain Pan (WP 0398, Item 4)  
Tool Kit, General Mechanic's: Automotive  
(WP 0398, Item 17)

**Materials/Parts**

Tags, Identification (WP 0400, Item 23)  
Locknut (1)

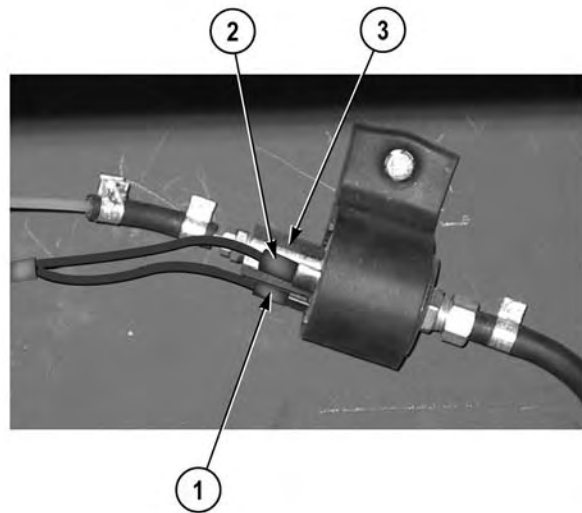
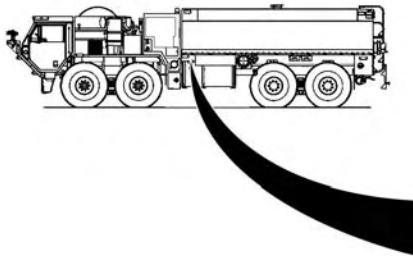
**References**

WP 0391, Fig. 63

**Equipment Conditions**

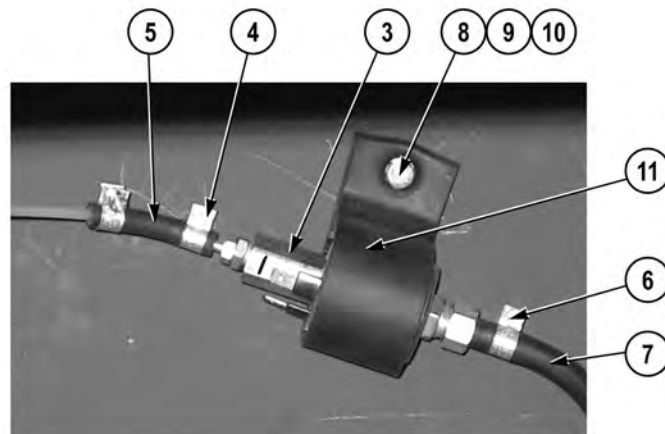
Batteries disconnected (TM 9-2320-325-14&P)

---

**REMOVAL****NOTE**

Tag and mark hoses and wires prior to removal to ensure proper installation.

1. Remove wire 4089 (1) and wire 4090 (2) from heater fuel pump (3).



### **WARNING**



**Fuel is very flammable and can explode easily. To avoid serious injury or death, keep fuel away from open fire and keep fire extinguisher within easy reach when working with fuel. Do not work on fuel system when engine is hot. Fuel can be ignited by hot engine. When working with fuel, post signs that read NO SMOKING WITHIN 50 FEET of vehicle.**

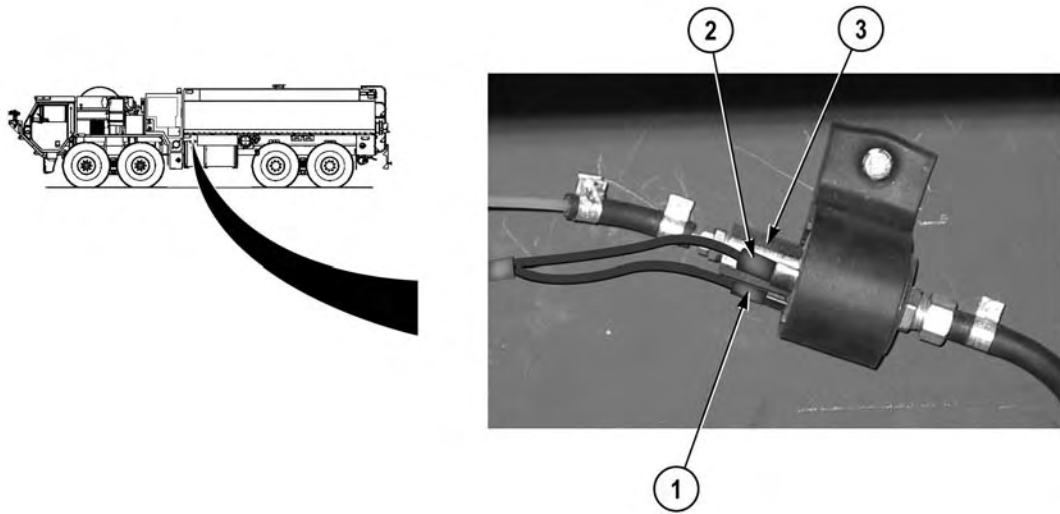
### **NOTE**

- Fuel may spill when clamps and hoses are removed.
  - Position suitable drain pan under hoses to catch excess fuel.
2. Remove clamp (4) and hose (5) from heater fuel pump (3).
  3. Remove clamp (6) and hose (7) from heater fuel pump (3).
  4. Remove locknut (8), washer (9), screw (10), clamp (11), and heater fuel pump (3) from vehicle. Discard locknut.
  5. Remove pump (3) from clamp (11).

### **END OF TASK**

### **INSTALLATION**

1. Position clamp (11) on heater fuel pump (3).
2. Install clamp (11) and heater fuel pump (3) on vehicle with screw (10) and washer (9) and locknut (8).
3. Install hose (7) on heater fuel pump (3) with clamp (6).
4. Install hose (5) on heater fuel pump (3) with clamp (4).



5. Install wire 4089 (1) and wire 4090 (2) on heater fuel pump (3).

**END OF TASK**

**FOLLOW-ON MAINTENANCE**

Connect batteries (TM 9-2320-325-14&P)

**END OF TASK**

**END OF WORK PACKAGE**



---

**FIELD LEVEL MAINTENANCE**  
**HEATER FUEL TANK PICKUP REPLACEMENT**

---

**INITIAL SETUP:****Tools and Special Tools**

Tool Kit, General Mechanic's: Automotive  
(WP 0398, Item 17)

**References**

TM 9-2320-325-14&P  
WP 0391, Fig. 63

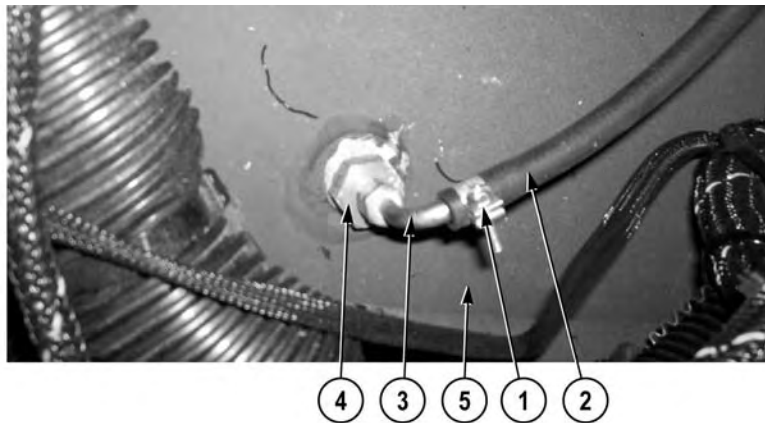
**Materials/Parts**

Compound, Sealing, Pipe Thread  
(WP 0400, Item 11)

**Equipment Conditions**

Engine OFF (TM 9-2320-422-10)  
Wheels chocked (TM 9-2320-422-10)

---

**REMOVAL****WARNING**

**Fuel is very flammable and can explode easily. To avoid serious injury or death, keep fuel away from open fire and keep fire extinguisher within easy reach when working with fuel. Do not work on fuel system when engine is hot. Fuel can be ignited by hot engine. When working with fuel, post signs that read NO SMOKING WITHIN 50 FEET OF VEHICLE.**

1. Remove clamp (1) and hose (2) from heater fuel tank pickup (3).
2. Remove fuel tank (TM 9-2320-325-14&P).
3. Remove bushing (4) and heater fuel tank pickup (3) from fuel tank (5).
4. Remove heater fuel tank pickup (3) from bushing (4).

**END OF TASK**

## INSTALLATION

**WARNING**

**Fuel is very flammable and can explode easily. To avoid serious injury or death, keep fuel away from open fire and keep fire extinguisher within easy reach when working with fuel. Do not work on fuel system when engine is hot. Fuel can be ignited by hot engine. When working with fuel, post signs that read NO SMOKING WITHIN 50 FEET OF VEHICLE.**

1. Install bushing (4) on heater fuel tank pickup (3).

**WARNING**

**Adhesives, solvents, and sealing compounds can burn easily, can give off harmful vapors, and are harmful to skin and clothing. To avoid injury or death, keep away from open fire and use in well-ventilated area. If adhesive, solvent, or sealing compound gets on skin or clothing, wash immediately with soap and water.**

2. Apply sealing compound to threads of bushing (4).
3. Install heater fuel tank pickup (3) on fuel tank (5) with bushing (4).
4. Install fuel tank (TM 9-2320-325-14&P).
5. Install hose (2) and clamp (1) on heater fuel tank pickup (3).

**END OF TASK**

**FOLLOW-ON MAINTENANCE**

Remove wheel chocks (TM 9-2320-422-10)

**END OF TASK**

**END OF WORK PACKAGE**





---

**FIELD LEVEL MAINTENANCE**  
**PUMP HOUSE HEATER REPLACEMENT**

---

**INITIAL SETUP:****Tools and Special Tools**

Tool Kit, General Mechanic's: Automotive  
(WP 0398, Item 17)

**Materials/Parts**

Tags, Identification (WP 0400, Item 23)  
Lockwasher (4)

**Personnel Required**

MOS 63B Wheeled Vehicle Mechanic (2)

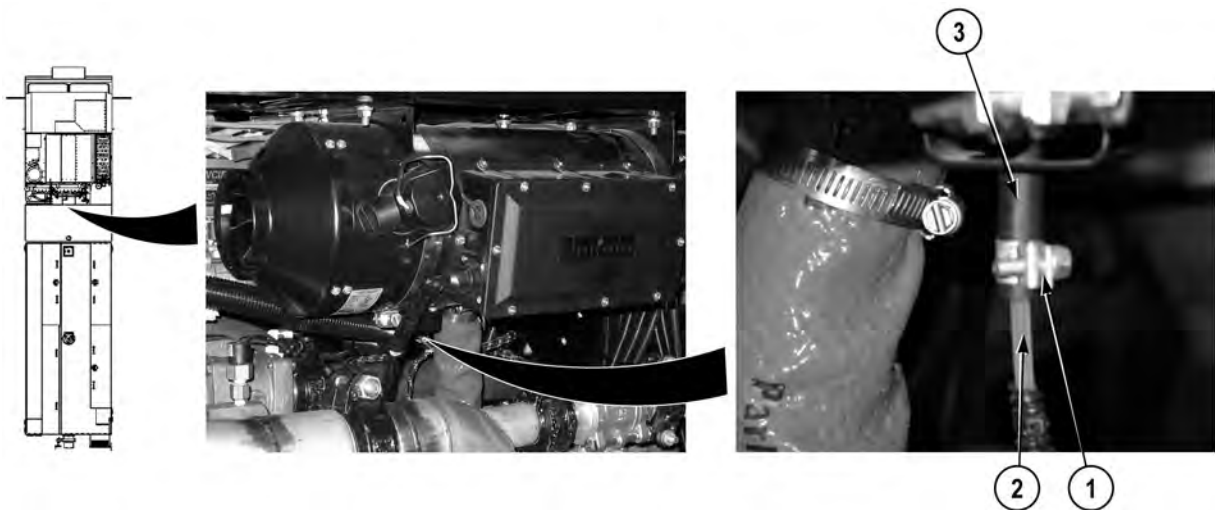
**References**

WP 0391, Fig. 63

**Equipment Conditions**

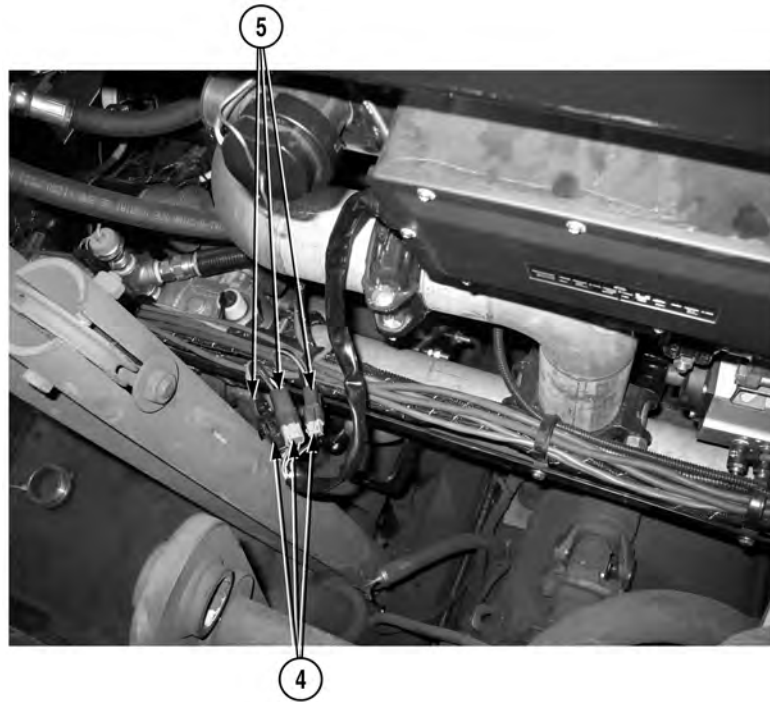
Pump house panels K, G, and E removed  
(WP 0339)

---

**REMOVAL****WARNING**

**Fuel is very flammable and can explode easily. To avoid serious injury or death, keep fuel away from open fire and keep fire extinguisher within easy reach when working with fuel. Do not work on fuel system when engine is hot. Fuel can be ignited by hot engine. When working with fuel, post signs that read NO SMOKING WITHIN 50 FEET OF VEHICLE.**

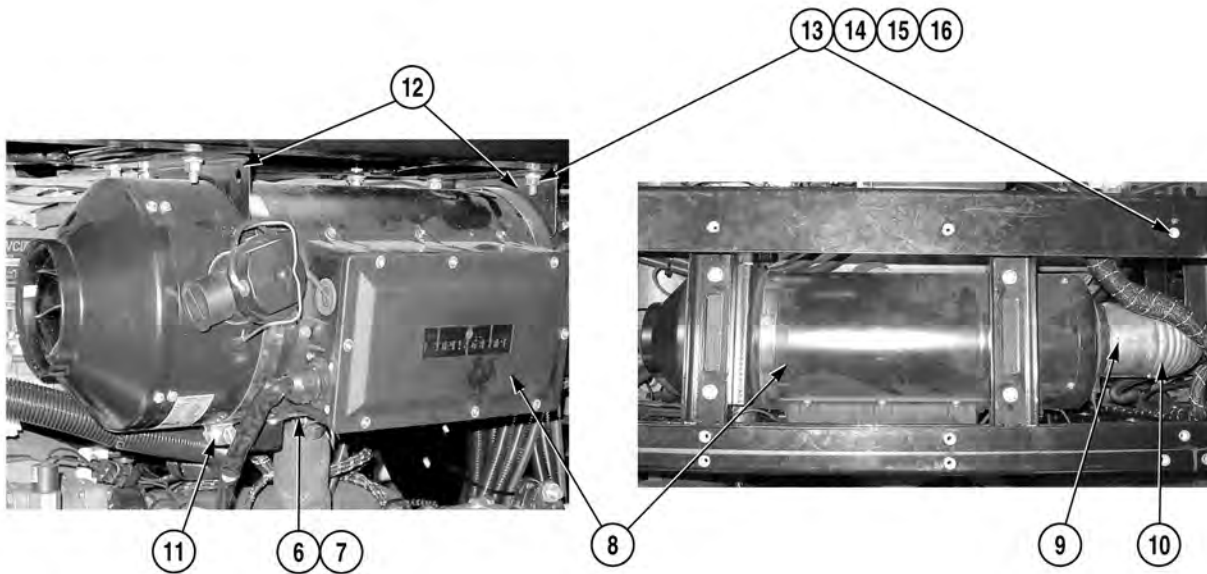
1. Loosen clamp (1) and remove fuel line (2) from tube (3).



**NOTE**

Tag and mark wires prior to removal to ensure proper installation.

2. Disconnect three heater wire harness connectors (4) from pump house wire harness connectors (5).



3. Loosen clamp (6) and exhaust tube (7) from pump house heater (8).

- 
4. Remove screw (9) and elbow (10) from pump house heater (8).
  5. With the aid of an assistant, remove two clamps (11) and pump house heater (8) from two brackets (12) and vehicle.

#### **NOTE**

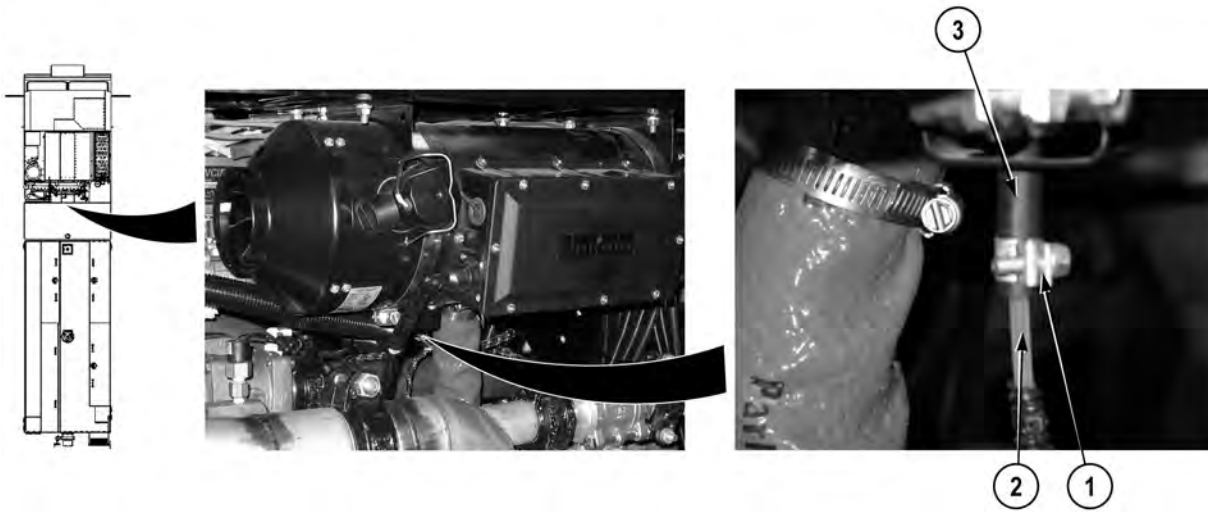
- Perform Step (6) if brackets need to be removed.
  - Note position of brackets prior to removal to ensure proper installation.
6. Remove four nuts (13), lockwashers (14), eight washers (15), four screws (16), and two brackets (10) from vehicle. Discard lockwashers.

#### **END OF TASK**

#### **INSTALLATION**

#### **NOTE**

- Perform Step (1) if brackets were removed.
  - Install brackets as noted prior to removal.
1. Install two brackets (10) on vehicle with four screws (16), eight washers (15), four lockwashers (14), and nuts (13).
  2. With the aid of an assistant, install pump house heater (8) on two brackets (12) with two clamps (11).
  3. Install elbow (10) on pump house heater (8) with screw (9).
  4. Install exhaust tube (7) on pump house heater (8) and tighten clamp (6).
  5. Connect three pump house wire harness connectors (5) to three pump house heater wire harness connectors (4).



6. Install fuel line (2) on tube (3) and tighten clamp (1).

**END OF TASK**

**FOLLOW-ON MAINTENANCE**

Install pump house on panels K, G, and E (WP 0339)

**END OF TASK**

**END OF WORK PACKAGE**

## FIELD LEVEL MAINTENANCE

## DIRECT TANK FILL VALVE REPLACEMENT

## INITIAL SETUP:

**Tools and Special Tools**

Standard Automotive Tool Set (SATS),  
(WP 0398, Item 15)

- Wrench, Torque, Click, Ratcheting,  
3/8" Drive, 75 ft-lb

Tool Kit, General Mechanic's: Automotive  
(WP 0398, Item 17)

**Materials/Parts**

Adhesive, Sealant, Silicone RTV  
(WP 0400, Item 3)

Ties, Cable, Plastic (WP 0400, Item 26)

Locknut (2)

Lockwasher (3)

Lockwasher (8)

Gasket (3)

**Personnel Required**

MOS 63B Wheeled Vehicle Mechanic (2)

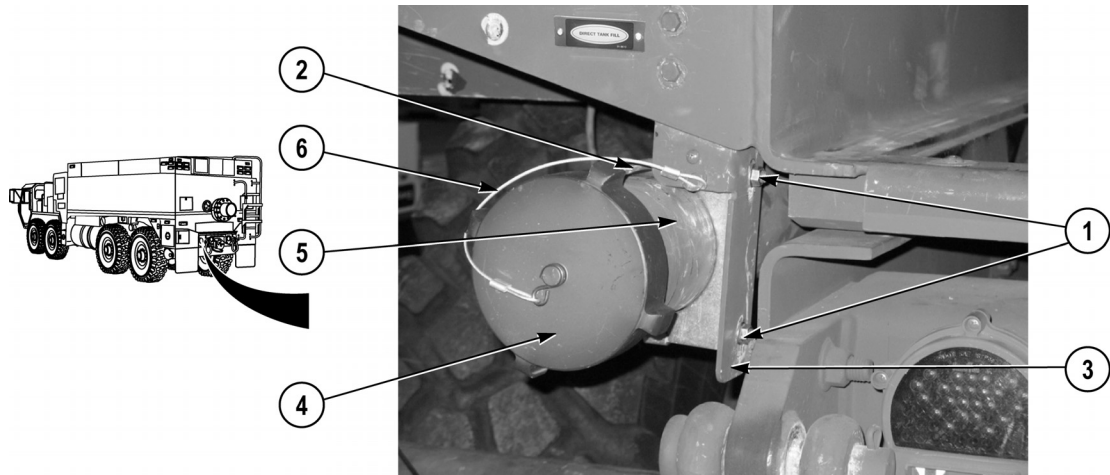
**References**

WP 0369  
WP 0391, Fig. WP 23

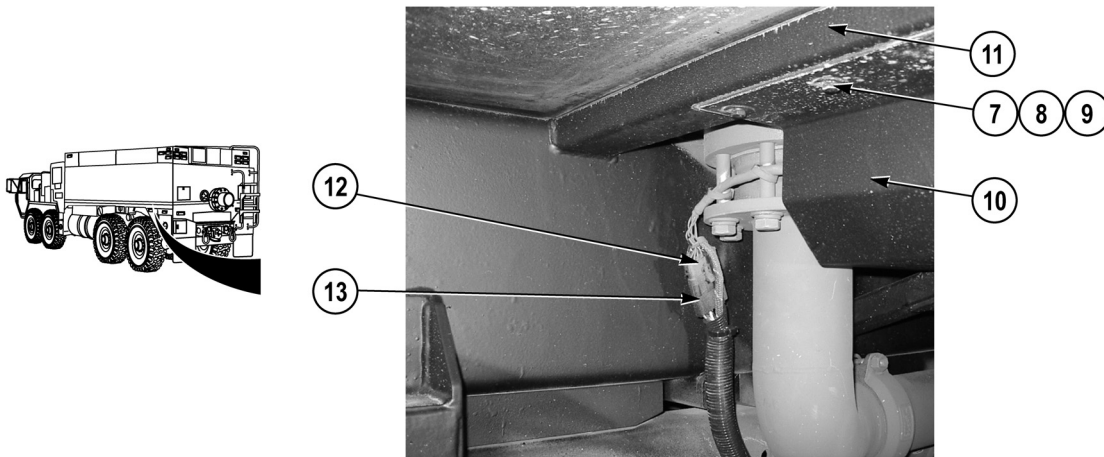
**Equipment Conditions**

Engine OFF (TM 9-2320-422-10)  
Wheels chocked (TM 9-2320-422-10)  
Water system drained (WP 0030)

## REMOVAL



1. Remove two locknuts (1) and clamp (2) from bracket (3). Discard locknuts.
2. Remove cap (4) from direct tank fill pipe (5).
3. Remove wire rope (6) from cap (4) and vehicle (WP 0369).

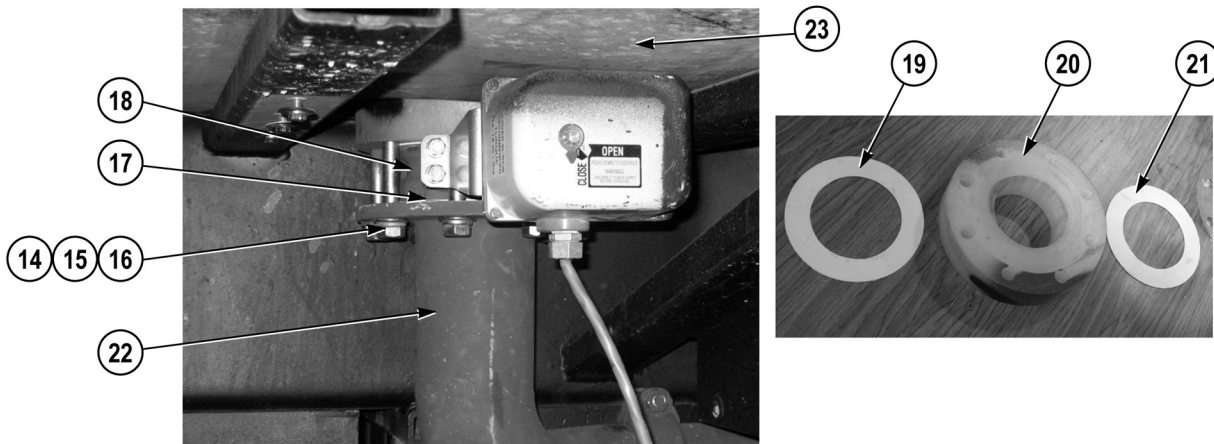


- Remove three screws (7), lockwashers (8), washers (9), and guard (10) from water tank cradle (11). Discard lockwashers.

**NOTE**

Remove cable ties as required.

- Disconnect direct tank fill valve connector (12) from direct tank fill valve wire harness connector (13).



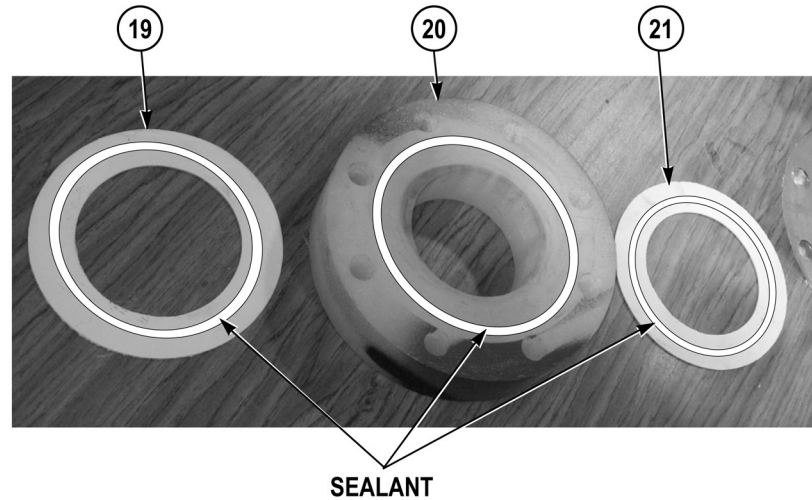
**NOTE**

- Note position of gaskets prior to removal to ensure proper installation.
- Note orientation of valve prior to removal to ensure proper installation.

- With the aid of an assistant, remove eight screws (14), lockwashers (15), washers (16), gasket (17), valve (18), gasket (19), spacer (20), and gasket (21) from flange (22) and water tank (23). Discard lockwashers and gaskets.

**END OF TASK**

## INSTALLATION



### **WARNING**



**Adhesives, solvents, and sealing compounds can burn easily, can give off harmful vapors, and are harmful to skin and clothing. To avoid injury or death, keep away from open fire and use in well-ventilated area. If adhesive, solvent, or sealing compound gets on skin or clothing, wash immediately with soap and water.**

### **NOTE**

Install gaskets as noted prior to removal.

1. Apply silicone sealant to both sides of spacer (20).
2. Position gasket (21) and gasket (19) on spacer (20).
3. Apply silicone sealant to gasket (19) and gasket (21).

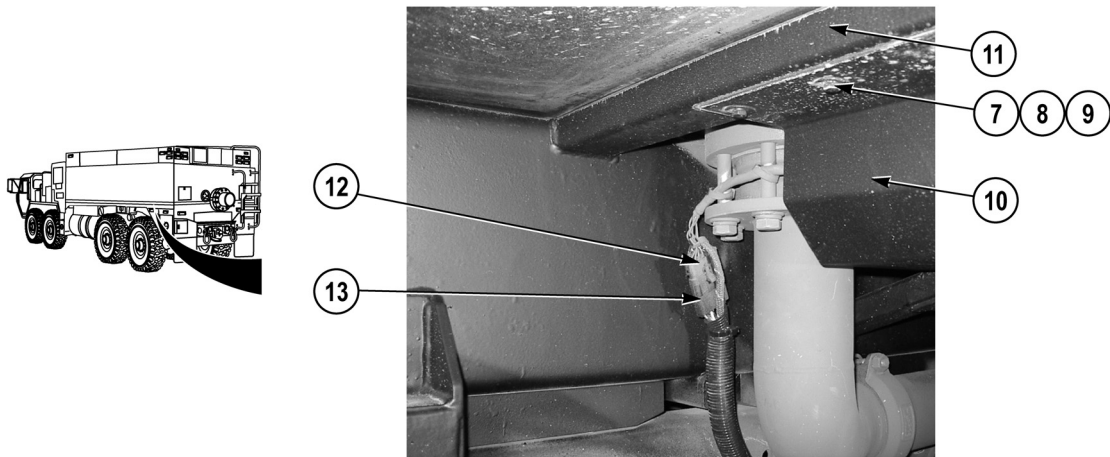
### **NOTE**

Install valve as noted prior to removal.

4. With the aid of an assistant, position gasket (21), spacer (20), gasket (19), valve (18), and gasket (17) on water tank (23) and flange (22).

### **NOTE**

- All torque values will need to be verified and retorqued if necessary after a minimum 24 hours.
  - Retorque screws to torque valve in Step (5).
5. Install eight washers (16), lockwashers (15), and screws (14) on water tank (17) and flange (16). Tighten screws (14) to 18 lb-ft (24.4 N•m).

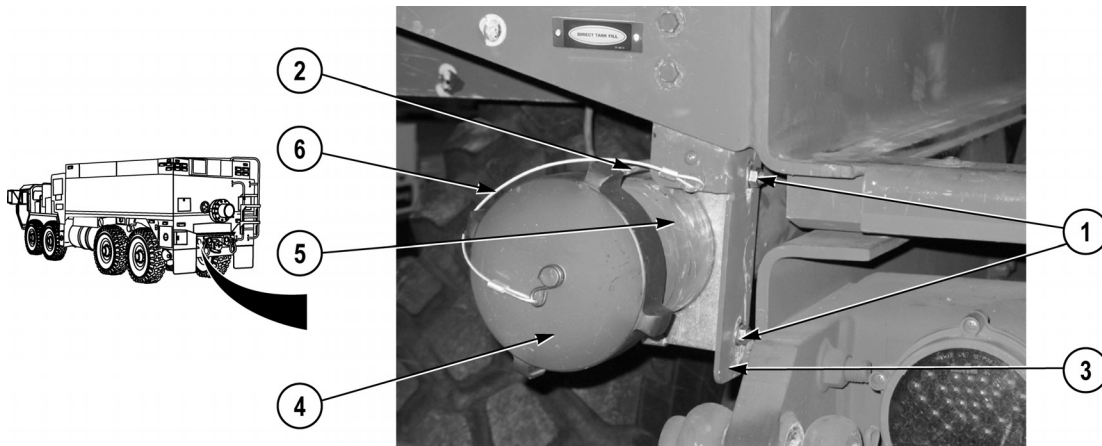


6. Connect direct tank fill valve wire harness connector (13) on direct tank fill valve connector (12).

**NOTE**

Install cable ties as required.

7. Install guard (10) on water tank cradle (11) with three washers (9), lockwashers (8), and screws (7).



8. Install wire rope (6) on cap (4) and vehicle (WP 0369).
9. Install cap (4) on direct tank fill pipe (5).
10. Install clamp (2) on bracket (3) with two locknuts (1).

**END OF TASK**

**FOLLOW-ON MAINTENANCE**

Remove wheel chocks (TM 9-2320-422-10)

**END OF TASK**

**END OF WORK PACKAGE**



---

**FIELD LEVEL MAINTENANCE**  
**BUMPER TURRET VALVE REPLACEMENT**

---

**INITIAL SETUP:****Tools and Special Tools**

Tool Kit, General Mechanic's: Automotive  
(WP 0398, Item 17)

**References**

WP 0313  
WP 0391, Fig. 64

**Materials/Parts**

Compound, Sealing, Pipe Thread  
(WP 0400, Item 11)  
Tags, Identification (WP 0400, Item 23)

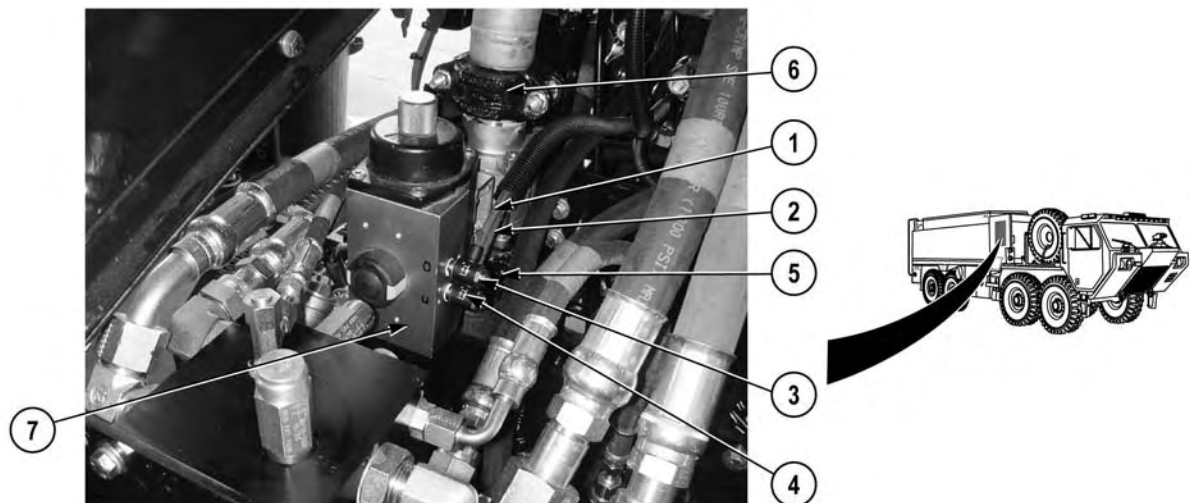
**Equipment Conditions**

Air system drained (TM 9-2320-422-10)  
Lower heat exchanger shroud  
removed (WP 0135)

**Personnel Required**

MOS 63B Wheeled Vehicle Mechanic (2)

---

**REMOVAL****NOTE**

Tag and mark air lines prior to removal to ensure proper installation.

1. Remove two air lines (1) and (2) from fittings (3) and (4).
2. With the aid of an assistant, remove two couplings (5) and (6) and bumper turret valve (7) from vehicle (WP 0313).

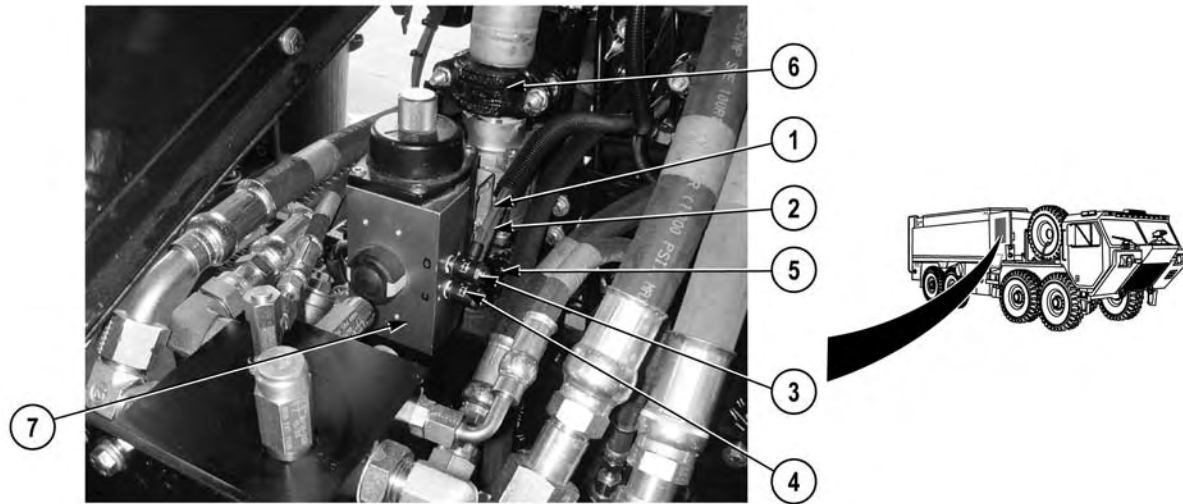
**NOTE**

Tag and mark fittings prior to removal to ensure proper installation.

3. Remove two fittings (3) and (4) from bumper turret valve (7).

**END OF TASK**

## INSTALLATION

**WARNING**

Adhesives, solvents, and sealing compounds can burn easily, can give off harmful vapors, and are harmful to skin and clothing. To avoid injury or death, keep away from open fire and use in well-ventilated area. If adhesive, solvent, or sealing compound gets on skin or clothing, wash immediately with soap and water.

**CAUTION**

Use sealing compound sparingly only on pipe threads. Do not apply compound to hose connections. Damage to equipment may result.

1. Apply sealing compound on threads of two fittings (3) and (4).
2. Install two fittings (4) and (3) on bumper turret valve (7).
3. With the aid of an assistant, install bumper turret valve (7) and two couplings (6) and (5) on vehicle (WP 0313).
4. Install two air lines (2) and (1) on fittings (4) and (3).

**END OF TASK****FOLLOW-ON MAINTENANCE**

Install lower heat exchanger shroud (WP 0137)

**END OF TASK****END OF WORK PACKAGE**

---

**FIELD LEVEL MAINTENANCE****COUPLING REPLACEMENT**

---

**INITIAL SETUP:****Tools and Special Tools**

Tool Kit, General Mechanic's: Automotive  
(WP 0398, Item 17)

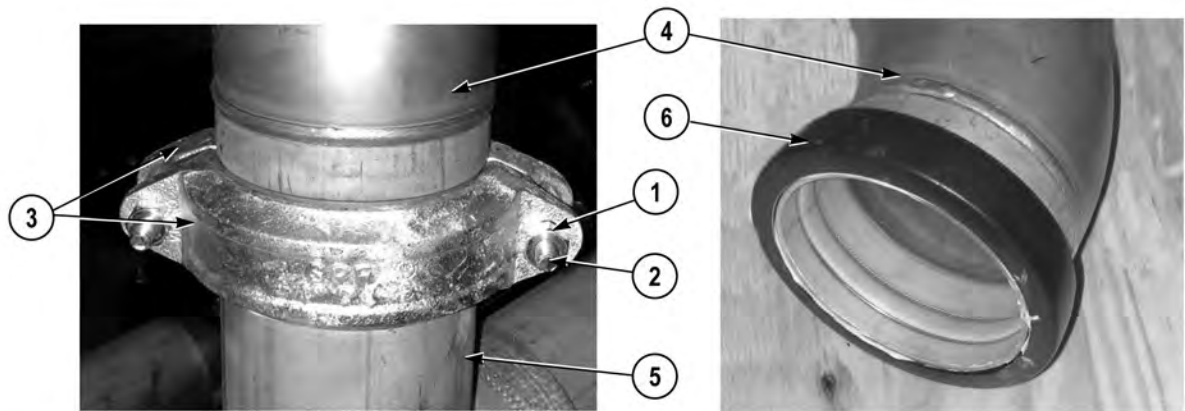
**Equipment Conditions**

Water tank drained (WP 0015)  
Foam tank drained (WP 0022)

**Materials/Parts**

Grease, Spline Lubricant (WP 0400, Item 16)

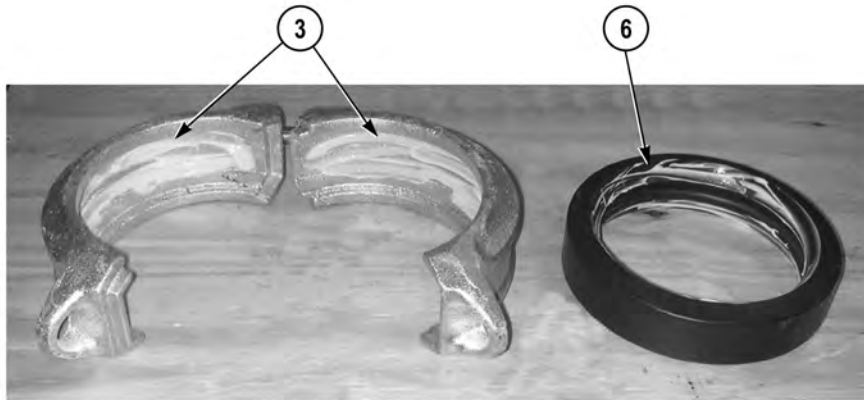
---

**REMOVAL****NOTE**

- Coupling consists of two coupling halves.
- Coupling replacement can be made to a valve, pipe, manifold, adapter, elbow, or weldment.

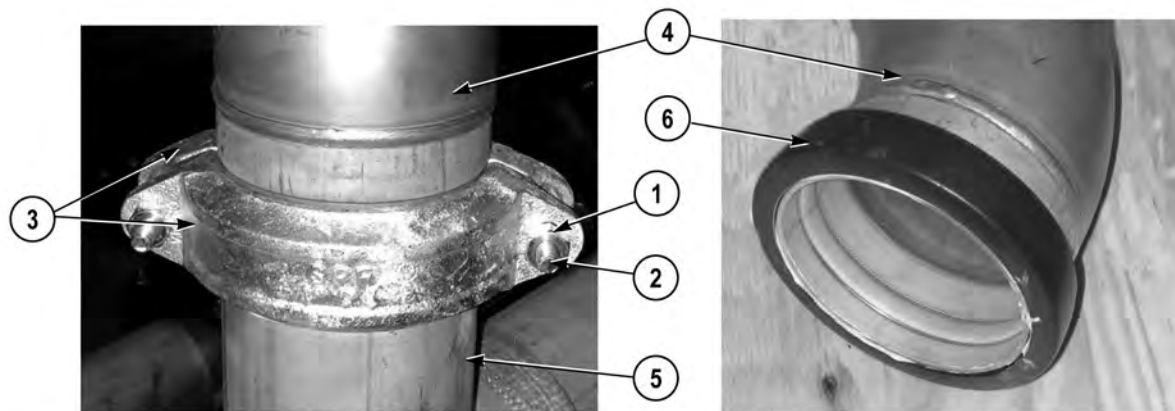
1. Remove two nuts (1), screws (2), and coupling halves (3) from elbow (4) and pipe (5).
2. Remove gasket (6) from pipe (5) and elbow (4).

**END OF TASK**

**INSTALLATION****NOTE**

- Sealing surface must be clean prior to installing gasket.
- Inspect gasket for damage. If damaged, replace gasket.

1. Apply light coat of grease to inside of gasket (6) and two coupling halves (3).



2. Install gasket (6) on elbow (4).

**NOTE**

Gasket is properly positioned when half of the gasket is on elbow and the other half of the gasket is on pipe.

3. Position pipe (5) against elbow (4), and install gasket (6) on pipe (5).

**NOTE**

Tighten screws equally on each side of clamp.

4. Install two coupling halves (3) on elbow (4) and pipe (5) with two screws (2) and nuts (1).

**END OF TASK**

**END OF WORK PACKAGE**

## FIELD LEVEL MAINTENANCE

## NO. 1 DRIVER SIDE DISCHARGE VALVE REPLACEMENT

## INITIAL SETUP:

**Tools and Special Tools**

Tool Kit, General Mechanic's: Automotive  
(WP 0398, Item 17)

**Materials/Parts**

Compound, Sealing, Pipe Thread  
(WP 0400, Item 7)  
Ties, Cable, Plastic (WP 0400, Item 26)  
Locknut (2)  
Lockwasher (2)  
Locknut (2)

**Personnel Required**

MOS 63B Wheeled vehicle mechanic (2)

**References**

WP 0248  
WP 0313  
WP 0318  
WP 0391, Fig. 65

**Equipment Conditions**

Discharge pressure transducer removed  
(WP 0245)  
Flow sensor removed (WP 0250)  
Pump house panels C and E removed (WP 0339)

## REMOVAL

**NOTE**

Remove cable ties as required.

1. Disconnect electric motor connector (1) from electric motor wire harness connector (2).



2. Remove hose (3) from fitting (4).
3. Remove coupling (5) from vehicle (WP 0313).

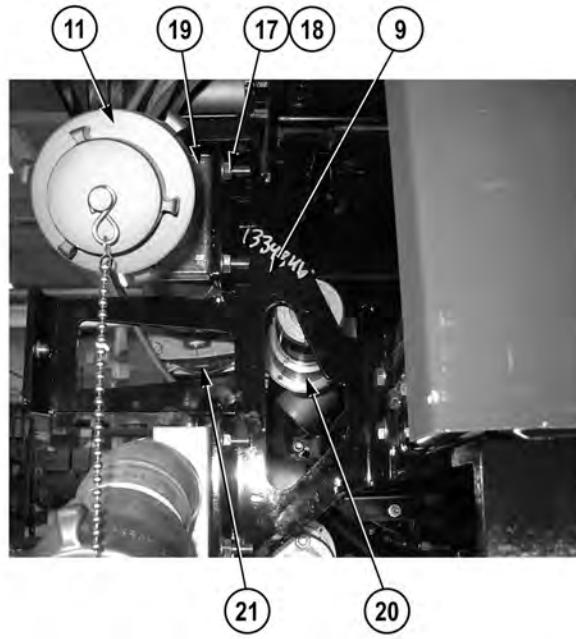


4. Remove two locknuts (6), U-bolt (7), and cradle (8) from bracket (9) and pipe (10). Discard locknuts.

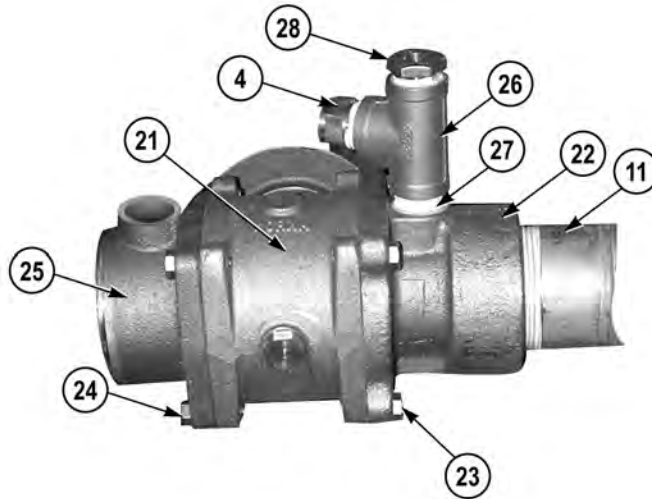
**NOTE**

Pipe, valve, and bracket are removed as an assembly.

5. With the aid of an assistant, support pipe (11) and remove two nuts (12), lockwashers (13), four washers (14), and two screws (15) from bracket (9) and channel bracket (16). Discard lockwashers.
6. With the aid of an assistant, remove pipe (11) and bracket (9) from vehicle.



7. Remove two locknuts (17), U-bolt (18), cradle (19), and bracket (9) from pipe (11). Discard locknuts.
8. Remove electric motor and drive assembly (20) from valve (21) (WP 0248).



9. Remove pipe (11) from adapter (22).
10. Remove four screws (23) and adapter (22) from valve (21).
11. Remove four screws (24) and adapter (25) from valve (21).

### NOTE

Note position of fittings prior to removal to ensure proper installation.

12. Remove tee (26) and nipple (27) from adapter (22).
13. Remove nipple (27) and two fittings (4) and (28) from tee (26).

### END OF TASK

### INSTALLATION

### WARNING



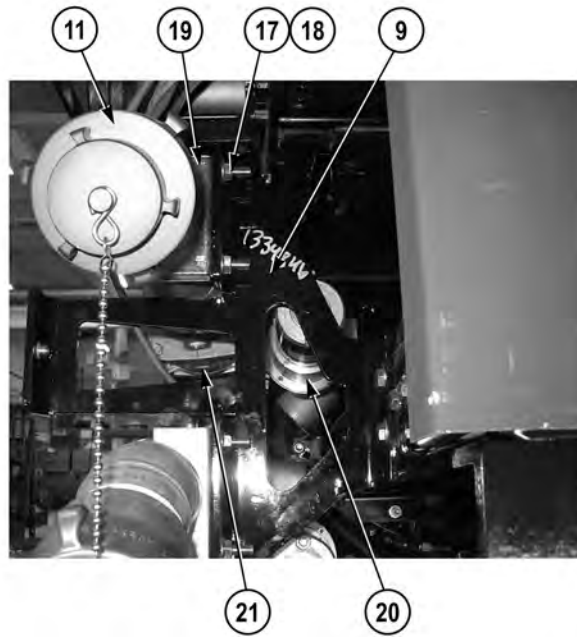
**Adhesives, solvents, and sealing compounds can burn easily, can give off harmful vapors, and are harmful to skin and clothing. To avoid injury or death, keep away from open fire and use in well-ventilated area. If adhesive, solvent, or sealing compound gets on skin or clothing, wash immediately with soap and water.**

### NOTE

- Install cable ties as required.
  - Install fittings as noted prior to removal.
1. Apply sealing compound to threads of nipple (27) and two fittings (28) and (4).



2. Install nipple (27) and two fittings (28) and (4) on tee (26) (WP 0318).
3. Install tee (26) and nipple (27) on adapter (22) (WP 0318).
4. Install adapter (25) on valve (21) with four screws (24).
5. Install adapter (22) on valve (21) with four screws (23).
6. Install pipe (11) on adapter (22) (WP 0318).



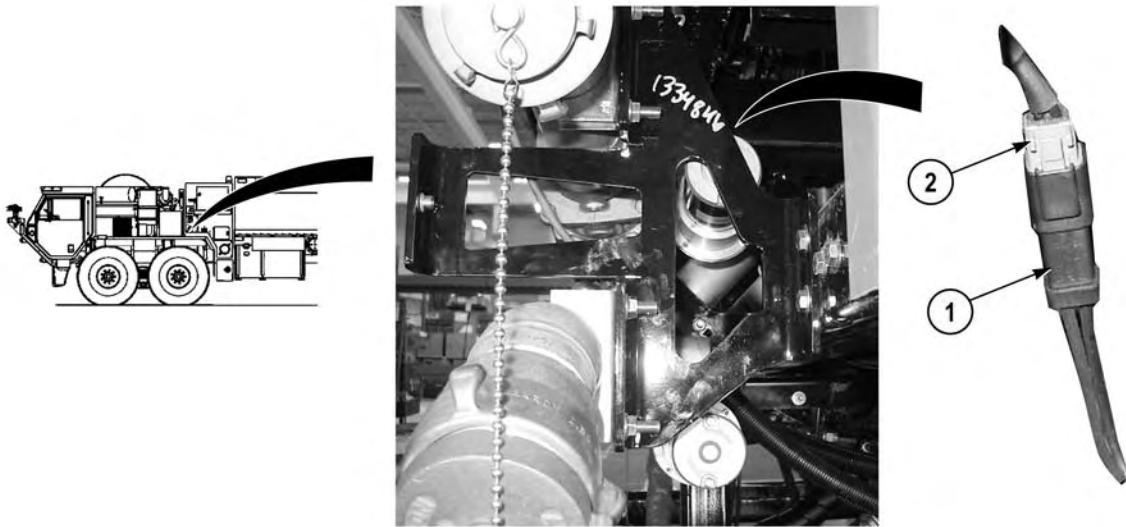
7. Install electric motor and drive assembly (20) on valve (21) (WP 0248).
8. Install pipe (11) on bracket (9) with cradle (19), U-bolt (18), and two locknuts (17). Do not tighten locknuts.
9. With the aid of an assistant, position pipe (11) and bracket (9) on vehicle.



10. With the aid of an assistant, install bracket (9) on channel bracket (16) with two screws (15), four washers (14), two lockwashers (13), and nuts (12).
11. Install bracket (9) on pipe (10) with U-bolt (7), cradle (8), and two locknuts (6).
12. Tighten two locknuts (17).



13. Install coupling (5) on vehicle (WP 0313).
14. Install hose (3) on fitting (4).



15. Connect electric motor connector (1) on electric motor wire harness connector (2).

**END OF TASK**

**FOLLOW-ON MAINTENANCE**

1. Install flow sensor (WP 0250)
2. Install discharge pressure transducer (WP 0245)
3. Install pump house panels C and E (WP 0339)

**END OF TASK**

**END OF WORK PACKAGE**



## FIELD LEVEL MAINTENANCE

## NO. 2 PASSENGER SIDE DISCHARGE VALVE REPLACEMENT

## INITIAL SETUP:

**Tools and Special Tools**

Tool Kit, General Mechanic's: Automotive  
(WP 0398, Item 17)

**Materials/Parts**

Compound, Sealing, Pipe Thread  
(WP 0400, Item 11)  
Ties, Cable, Plastic (WP 0400, Item 26)  
Locknut (2)

**Personnel Required**

MOS 63B Wheeled vehicle mechanic (2)

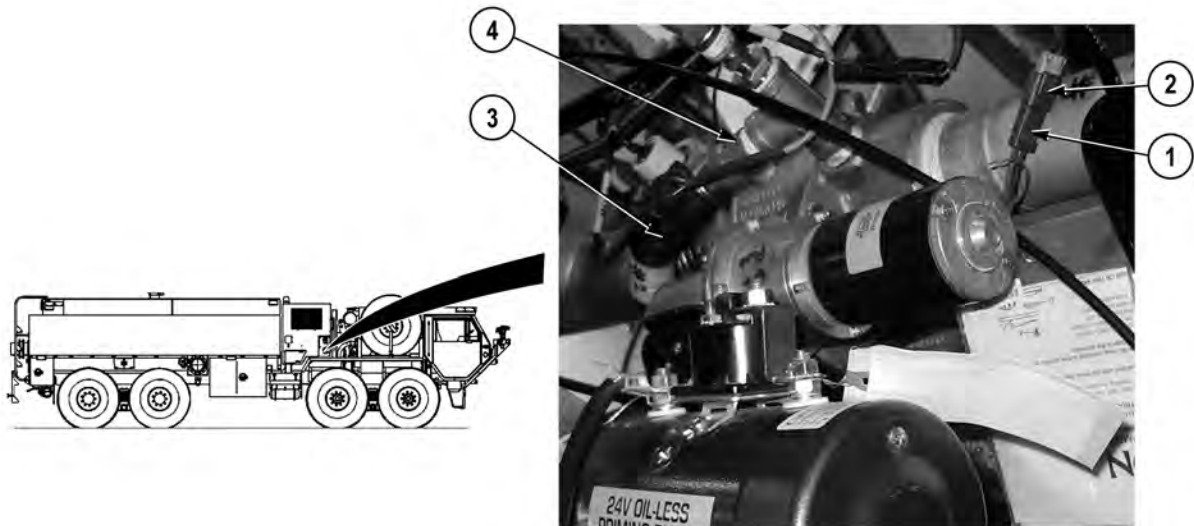
**References**

WP 0248  
WP 0313  
WP 0318  
WP 0391, Fig. 65

**Equipment Conditions**

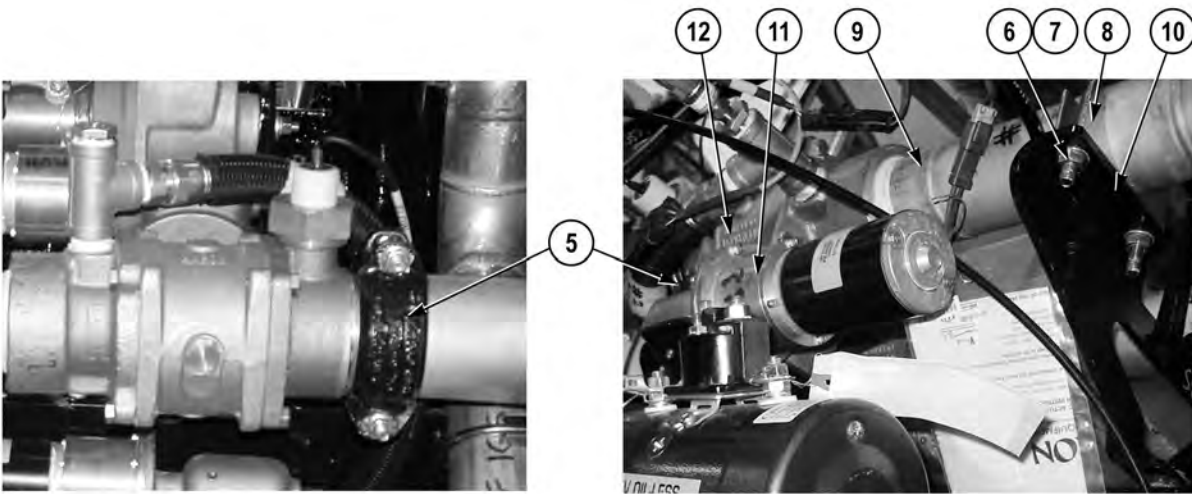
Discharge pressure transducer removed  
(WP 0245)  
Flow sensor removed (WP 0250)

## REMOVAL

**NOTE**

Remove cable ties as required.

1. Disconnect electric motor connector (1) from electric motor harness connector (2).
2. Remove hose (3) from fitting (4).



3. Remove coupling (5) from vehicle (WP 0313).

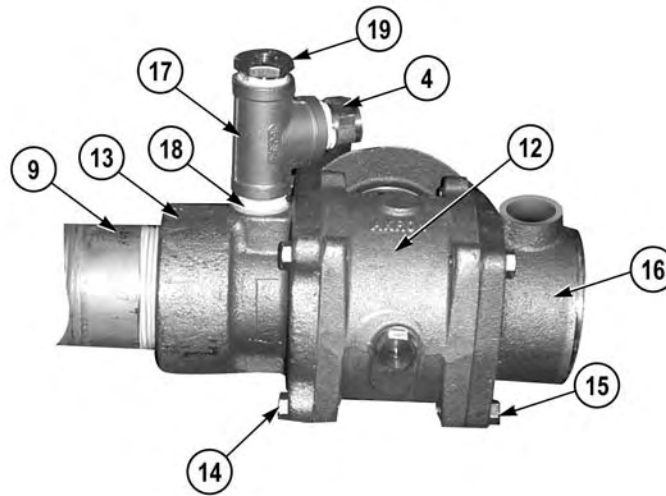
** CAUTION**

**Pipe and valve assembly is awkward. Do not remove pipe assembly without the aid of an assistant. Failure to comply may cause damage to equipment.**

**NOTE**

Pipe and valve are removed as an assembly.

4. With the aid of an assistant, remove two locknuts (6), U-bolt (7), cradle (8), and pipe (9) from bracket (10) and vehicle. Discard locknuts.
5. Remove electric motor and drive assembly (11) from valve (12) (WP 0248).



6. Remove pipe (9) from adapter (13).
7. Remove four screws (14) and adapter (13) from valve (12).
8. Remove four screws (15) and adapter (16) from valve (12).

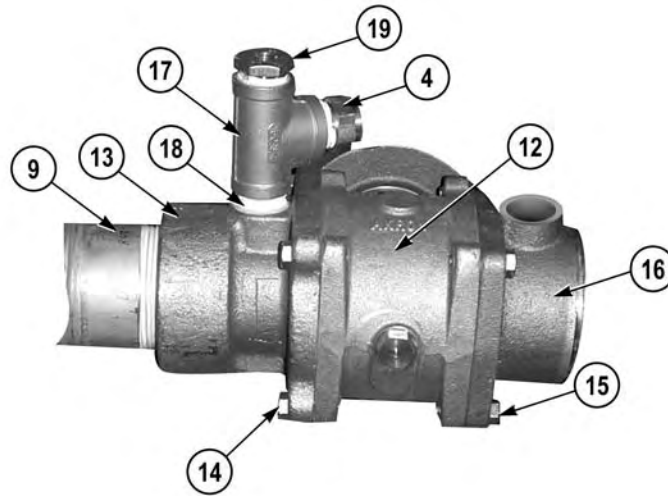
### NOTE

Note position of elbows and fittings prior to removal to ensure proper installation.

9. Remove tee (17) and nipple (18) from adapter (13).
10. Remove nipple (18) and two fittings (4) and (19) from tee (17).

**END OF TASK**

## INSTALLATION



### **WARNING**



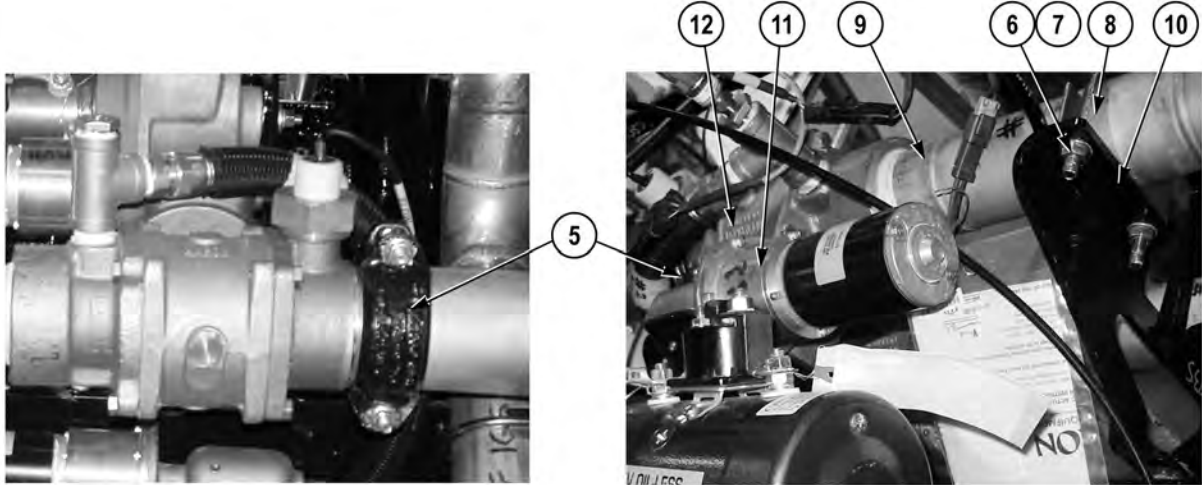
**Adhesives, solvents, and sealing compounds can burn easily, can give off harmful vapors, and are harmful to skin and clothing. To avoid injury or death, keep away from open fire and use in well-ventilated area. If adhesive, solvent, or sealing compound gets on skin or clothing, wash immediately with soap and water.**

1. Apply sealing compound to threads of nipple (18) and two fittings (4) and (19).

### **NOTE**

- Install cable ties as required.
  - Install elbows and fittings as noted prior to removal.
2. Install nipple (18) and two fittings (19) and (4) on tee (17).
  3. Install tee (17) and nipple (18) on adapter (13).
  4. Install adapter (16) on valve (12) with four screws (15).
  5. Install adapter (13) on valve (12) with four screws (14).
  6. Install pipe (9) on adapter (13) (WP 0318).



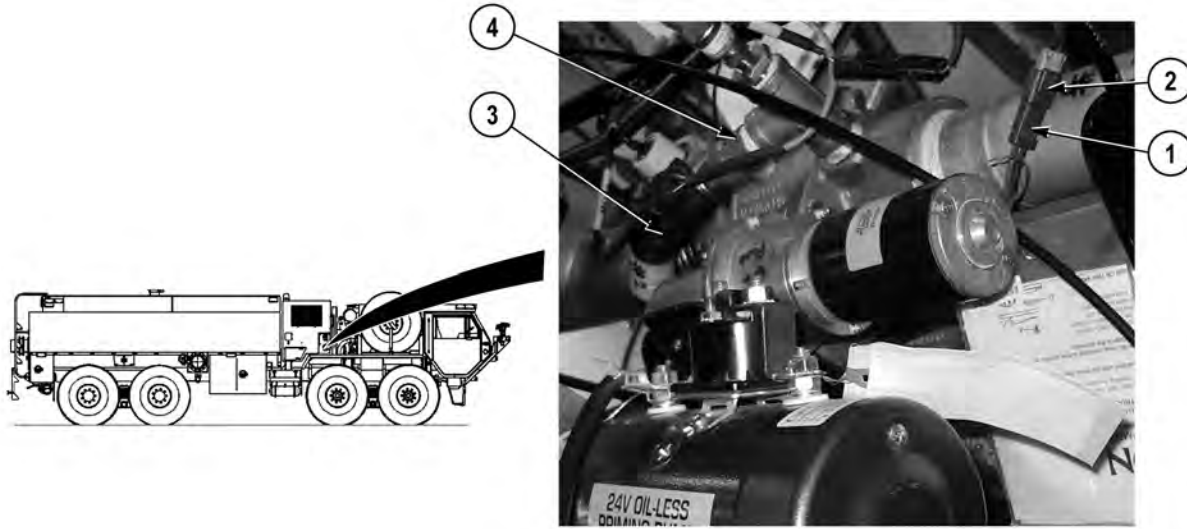


7. Install electric motor and drive assembly (11) (WP 0248) on valve (12).

** CAUTION**

**Pipe and valve assembly is awkward, do not install pipe and valve assembly without the aid of an assistant. Failure to comply may result in damage to equipment.**

8. With the aid of an assistant, install pipe (9) on bracket (10) with cradle (8), U-bolt (7), and two locknuts (6). Do not tighten locknuts.
9. Install coupling (5) on vehicle (WP 0313).
10. Tighten two locknuts (6).



11. Install hose (3) on fitting (4).
12. Connect electric motor connector (1) on electric motor harness connector (2).

**END OF TASK****FOLLOW-ON MAINTENANCE**

1. Install flow sensor (WP 0250)
2. Install discharge pressure transducer (WP 0245)

**END OF TASK****END OF WORK PACKAGE**

---

**FIELD LEVEL MAINTENANCE**  
**HOSE REEL HOSE REPLACEMENT**

---

**INITIAL SETUP:****Tools and Special Tools**

Tool Kit, General Mechanic's: Automotive  
(WP 0398, Item 17)

**References**

WP 0391, Fig. 40, 71

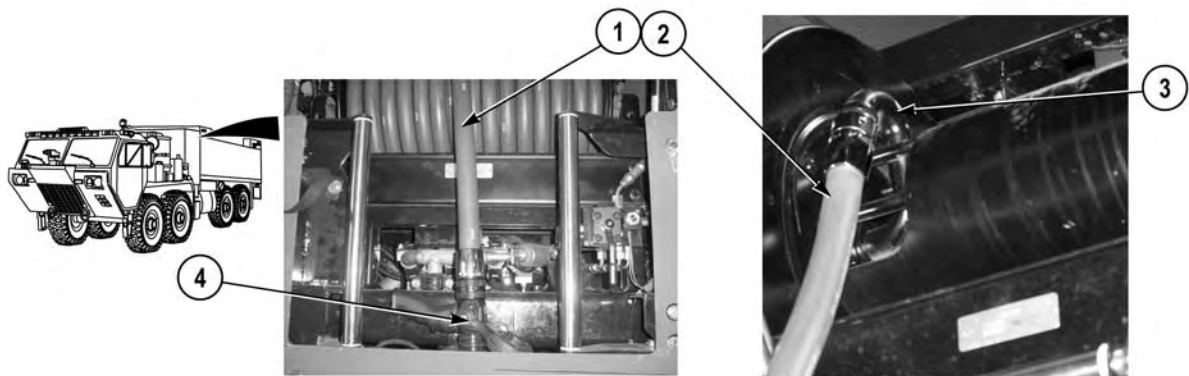
**Materials/Parts**

Preformed Packing (1)  
Lockwasher (4)  
Lockwasher (1)

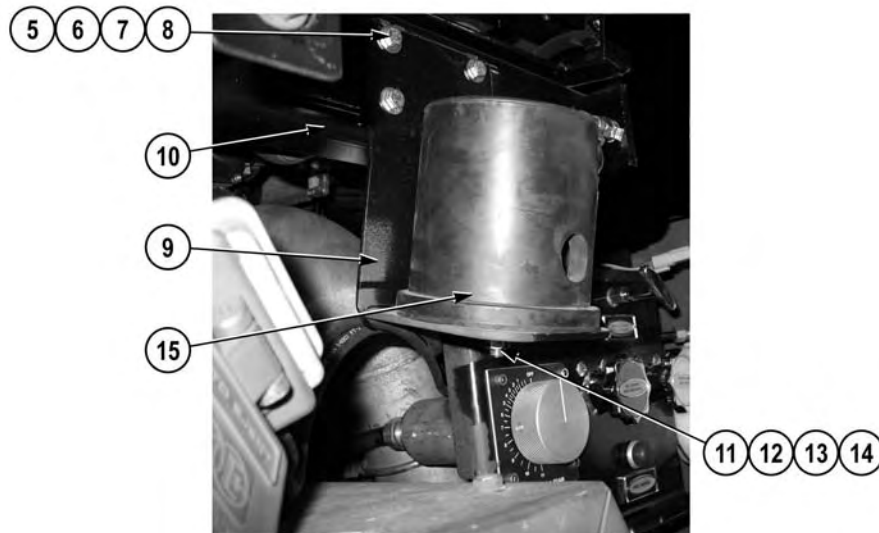
**Equipment Conditions**

Hose reel hose unwound (WP 0025)

---

**REMOVAL**

1. Remove hose (1) and preformed packing (2) from hose reel (3). Discard preformed packing.
2. Remove nozzle (4) from hose (1).



### NOTE

Perform Steps (3) and (4) if nozzle cup bracket needs to be removed.

3. Remove four nuts (5), lockwashers (6), eight washers (7), four screws (8), and nozzle cup bracket (9) from pump house frame (10) and vehicle. Discard lockwashers.
4. Remove nut (11), lockwasher (12), washer (13), screw (14), and nozzle cup (15) from nozzle cup bracket (9). Discard lockwasher.

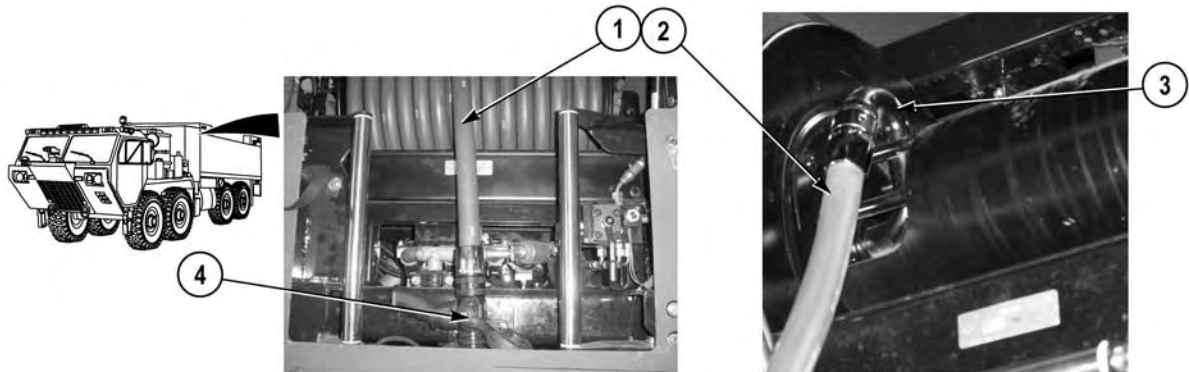
### END OF TASK

### INSTALLATION

### NOTE

Perform Steps (1) and (2) if nozzle cup bracket was removed.

1. Install nozzle cup (15) on nozzle cup bracket (9) with screw (14), washer (13), lockwasher (12), and nut (11).
2. Install nozzle cup bracket (9) on pump house frame (10) with four screws (8), eight washers (7), four lockwashers (6), and nuts (5).



3. Install nozzle (4) on hose (1).
4. Install hose (1) and preformed packing (2) on hose reel (3).

**END OF TASK**

**FOLLOW-ON MAINTENANCE**

Wind hose reel hose (WP 0025)

**END OF TASK**

**END OF WORK PACKAGE**



---

**FIELD LEVEL MAINTENANCE**  
**HOSE REEL DISCHARGE VALVE REPLACEMENT**

---

**INITIAL SETUP:****Tools and Special Tools**

Tool Kit, General Mechanic's: Automotive  
(WP 0398, Item 17)

**References**

WP 0313  
WP 0391, Fig. 40

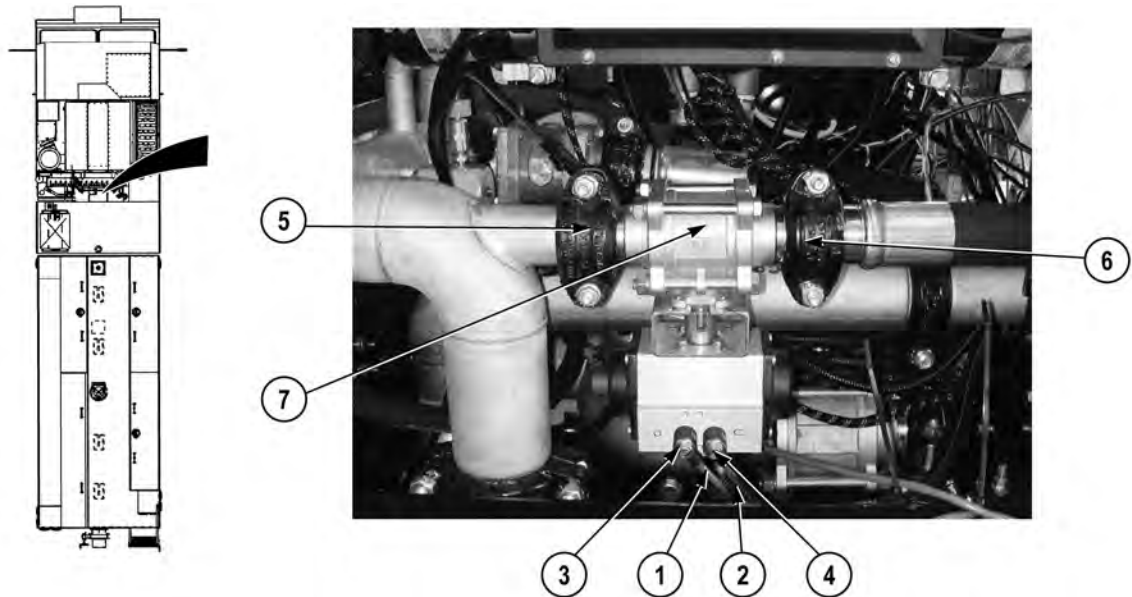
**Materials/Parts**

Compound, Sealing, Pipe Thread  
(WP 0400, Item 11)  
Tags, Identification (WP 0400, Item 23)

**Equipment Conditions**

Air system drained (TM 9-2320-422-10)  
Pump house panel G removed (WP 0339)

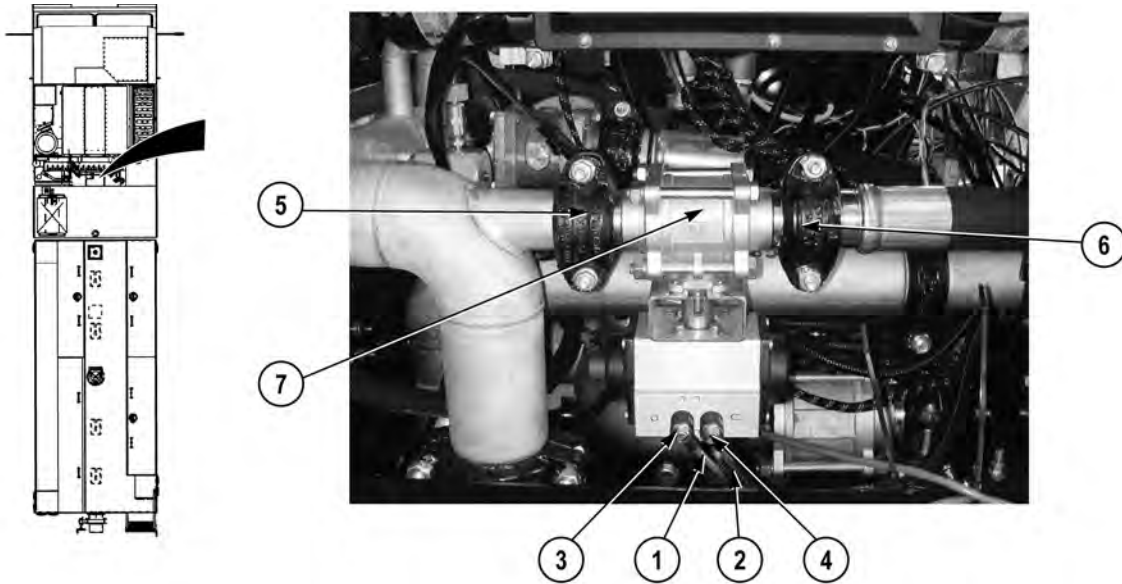
---

**REMOVAL****NOTE**

Tag and mark air lines prior to removal to ensure proper installation.

1. Remove two air lines (1) and (2) from fittings (3) and (4).
2. Remove two couplings (5) and (6) and valve (7) from vehicle (WP 0313).
3. Remove two fittings (3) and (4) from valve (7).

**END OF TASK**

**INSTALLATION****WARNING**

Adhesives, solvents, and sealing compounds can burn easily, can give off harmful vapors, and are harmful to skin and clothing. To avoid injury or death, keep away from open fire and use in well-ventilated area. If adhesive, solvent, or sealing compound gets on skin or clothing, wash immediately with soap and water.

**CAUTION**

Use sealing compound sparingly only on pipe threads. Do not apply compound to hose connections. Failure to comply may cause damage to equipment.

1. Apply sealing compound to threads of two fittings (3) and (4).
2. Install two fittings (4) and (3) on valve (7).
3. Install valve (7) and two couplings (6) and (5) on vehicle (WP 0313).
4. Install two air lines (2) and (1) on fittings (4) and (3).

**END OF TASK**

**FOLLOW-ON MAINTENANCE**

Install pump house panel G (WP 0339)

**END OF TASK**

**END OF WORK PACKAGE**



---

**FIELD LEVEL MAINTENANCE****PIPING ASSEMBLY (PIPE THREAD SEALING COMPOUND)**

---

**INITIAL SETUP:****Tools and Special Tools**

Tool Kit, General Mechanic's: Automotive  
(WP 0398, Item 17)

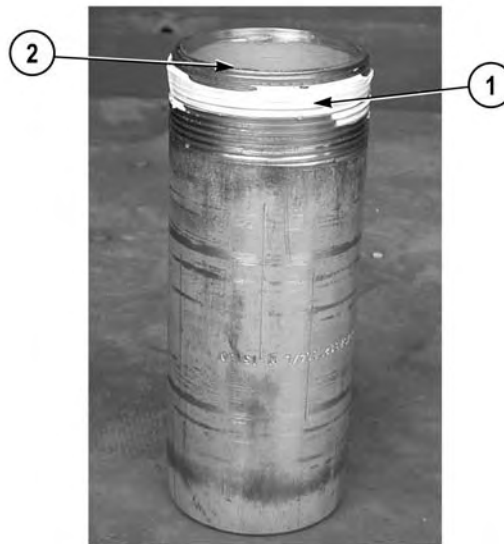
**Equipment Conditions**

Engine OFF (TM 9-2320-422-10)  
Wheels chocked (TM 9-2320-422-10)

**Materials/Parts**

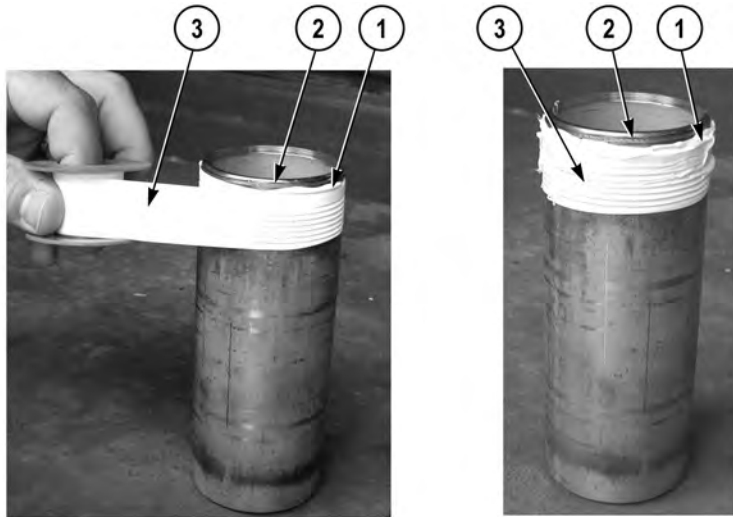
Compound, Sealing, Pipe Thread  
(WP 0400, Item 11)  
Tape, Teflon (WP 0400, Item 25)

---

**ASSEMBLY****WARNING**

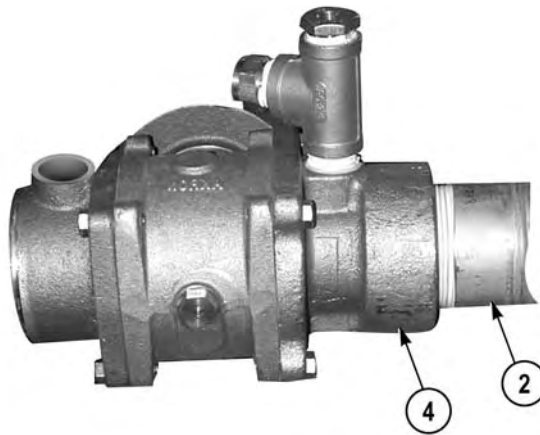
Adhesives, solvents, and sealing compounds can burn easily, can give off harmful vapors, and are harmful to skin and clothing. To avoid injury or death, keep away from open fire and use in well-ventilated area. If adhesive, solvent, or sealing compound gets on skin or clothing, wash immediately with soap and water.

1. Apply pipe sealant (1) to threads of pipe (2).



**NOTE**

- Pipes under 1.5 in. (38.1 mm) diameter, apply pipe sealant only.
  - Pipes 1.5 in. (38.1 mm) diameter or over, apply pipe sealant and teflon tape.
  - Leave first two or three threads exposed when applying pipe sealant and teflon tape.
2. Apply four to five wraps of teflon tape (3) over threads of pipe (2) where pipe sealant (1) was applied.
  3. Apply pipe sealant (1) over threads of pipe (2) again, where teflon tape (3) was applied.



4. Install pipe (2) in adapter (4). Screw pipe until completely tight and desired position is obtained.

**END OF TASK**

**FOLLOW-ON MAINTENANCE**

Remove wheel chocks (TM 9-2320-422-10)

**END OF TASK**

**END OF WORK PACKAGE**

## FIELD LEVEL MAINTENANCE

## PUMP COOLER (DUMP-TO-GROUND) VALVE REPLACEMENT

## INITIAL SETUP:

**Tools and Special Tools**

Tool Kit, General Mechanic's: Automotive  
(WP 0398, Item 17)

**References**

WP 0313  
WP 0391, Fig. 65

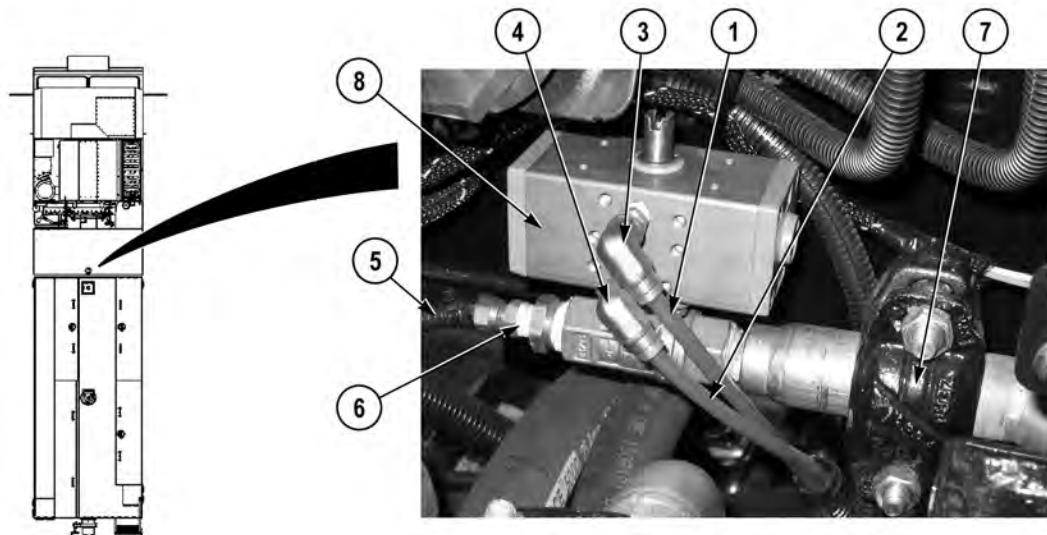
**Materials/Parts**

Compound, Sealing, Pipe Thread  
(WP 0400, Item 11)  
Tags, Identification (WP 0400, Item 23)  
Ties, Cable (WP 0400, Item 26)

**Equipment Conditions**

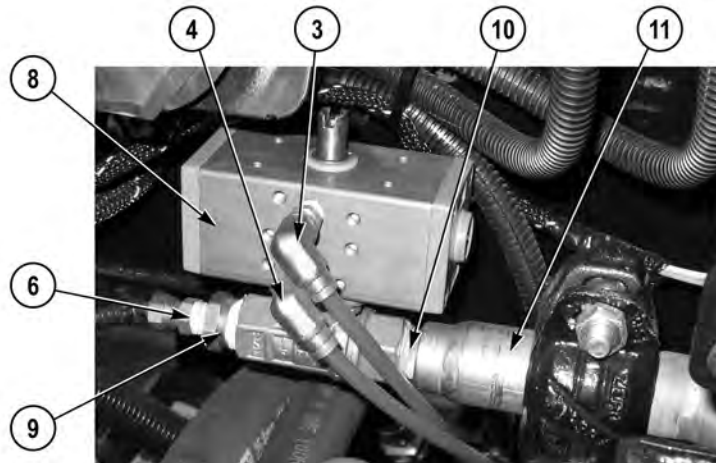
Air system drained (TM 9-2320-422-10)  
Pump house panel K removed (WP 0339)

## REMOVAL

**NOTE**

- Tag and mark air lines and drain line prior to removal to ensure proper installation.
- Remove cable ties as required.

1. Remove two air lines (1) and (2) from elbows (3) and (4).
2. Remove drain line (5) from fitting (6).
3. Remove coupling (7) and valve (8) from vehicle (WP 0313).



4. Remove two elbows (3) and (4) from valve (8).
5. Remove fitting (9) from valve (8).
6. Remove nipple (10) and pipe (11) from valve (8).
7. Remove nipple (10) from pipe (11).
8. Remove fitting (6) from fitting (9).

#### END OF TASK

#### INSTALLATION

#### WARNING

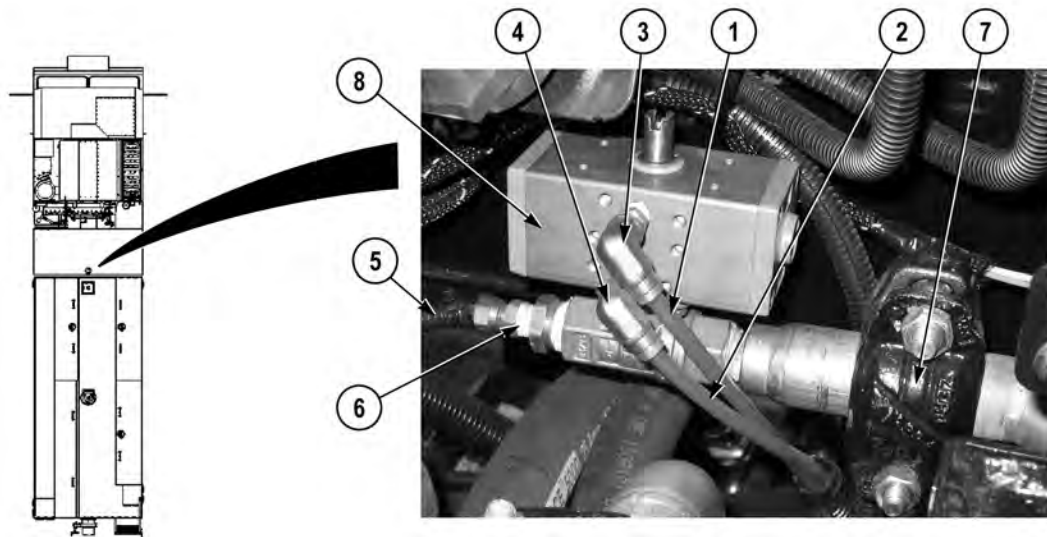


**Adhesives, solvents, and sealing compounds can burn easily, can give off harmful vapors, and are harmful to skin and clothing. To avoid injury or death, keep away from open fire and use in well-ventilated area. If adhesive, solvent, or sealing compound gets on skin or clothing, wash immediately with soap and water.**

#### NOTE

Install cable ties as required.

1. Apply sealing compound to threads of two fittings (6) and (9), elbows (3) and (4), and nipple (10).
2. Install fitting (6) on fitting (9).
3. Install fitting (9) on valve (8).
4. Install nipple (10) on fitting (11).
5. Install nipple (10) and pipe (11) on valve (8).
6. Install two elbows (4) and (3) on valve (8).



7. Install valve (8) and coupling (7) on vehicle (WP 0313).
8. Install drain line (5) on fitting (6).
9. Install two air lines (2) and (1) on elbows (4) and (3).

**END OF TASK**

**FOLLOW-ON MAINTENANCE**

Install pump house panel K (WP 0339)

**END OF TASK**

**END OF WORK PACKAGE**



---

**FIELD LEVEL MAINTENANCE**  
**PLUMBING, HOSES, AND PIPING REPLACEMENT**

---

**INITIAL SETUP:****Tools and Special Tools**

Tool Kit, General Mechanic's: Automotive  
(WP 0398, Item 17)

**References**

WP 0391, Fig. 21, 64, 65

**Equipment Conditions**

Water tank drained (WP 0015)  
Foam tank drained (WP 0022)  
Pump house panels removed (WP 0339)  
Coupling(s) removed (WP 0313)

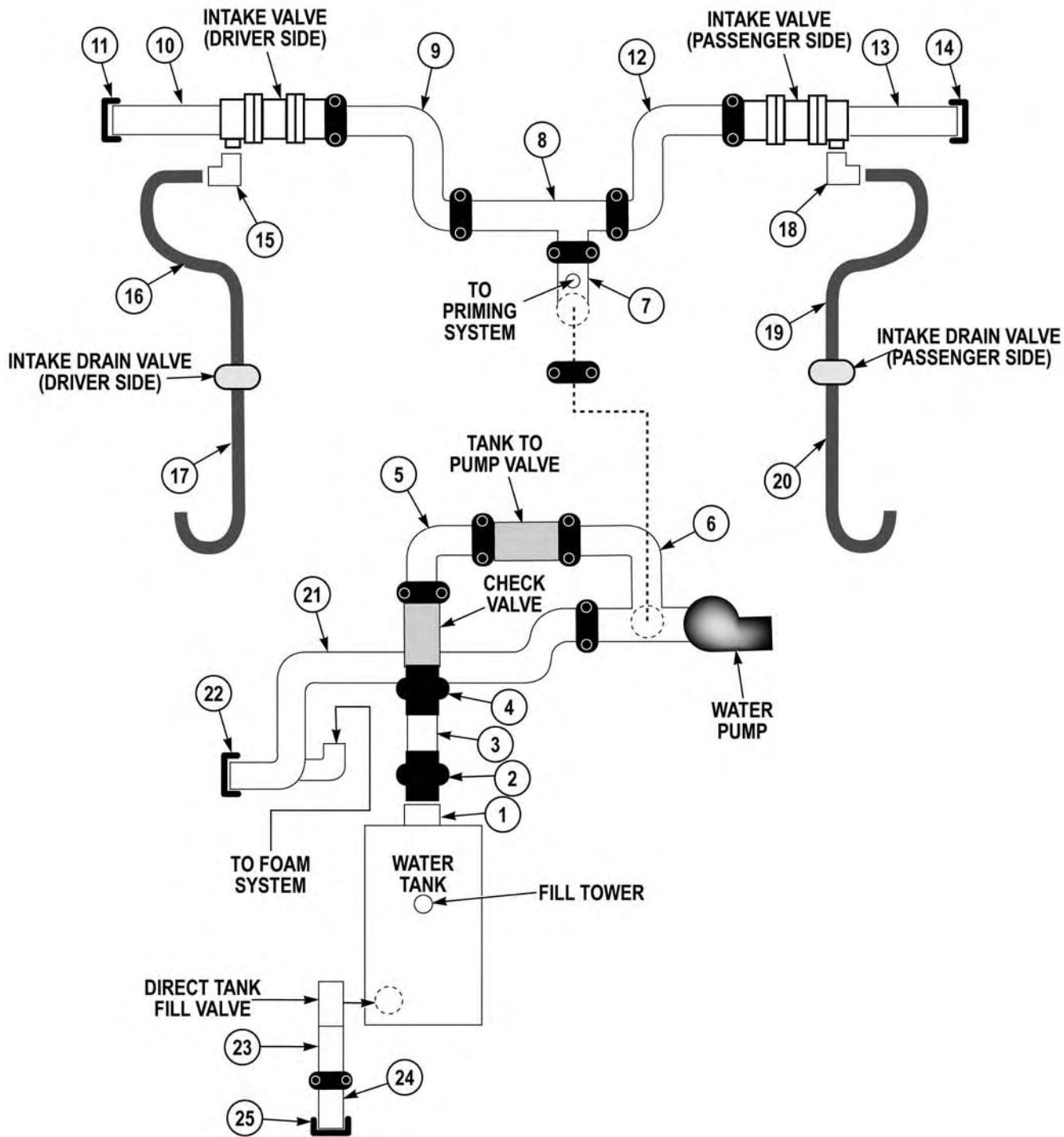


Figure 1. Water Intake System.



Item	Water Intake System - Description
1	Pipe (Part of Tank)
2	Flexible Coupling
3	Pipe Weldment
4	Flexible Coupling
5	Elbow Weldment
6	Manifold Weldment
7	Elbow Weldment
8	Manifold Weldment
9	Inlet Weldment (Driver Side)
10	Elbow Weldment (Driver Side)
11	Cap/Adapter
12	Inlet Weldment (Passenger Side)
13	Elbow Weldment (Passenger Side)
14	Cap/Adapter
15	Elbow
16	Intake Drain Valve Hose (Driver Side)
17	Intake Drain Valve Hose (Driver Side) To Ground
18	Elbow
19	Intake Drain Valve Hose (Passenger Side)
20	Intake Drain Valve Hose (Passenger Side) To Ground
21	Main Inlet Manifold
22	Cap
23	Pipe Weldment
24	Pipe Weldment
25	Cap

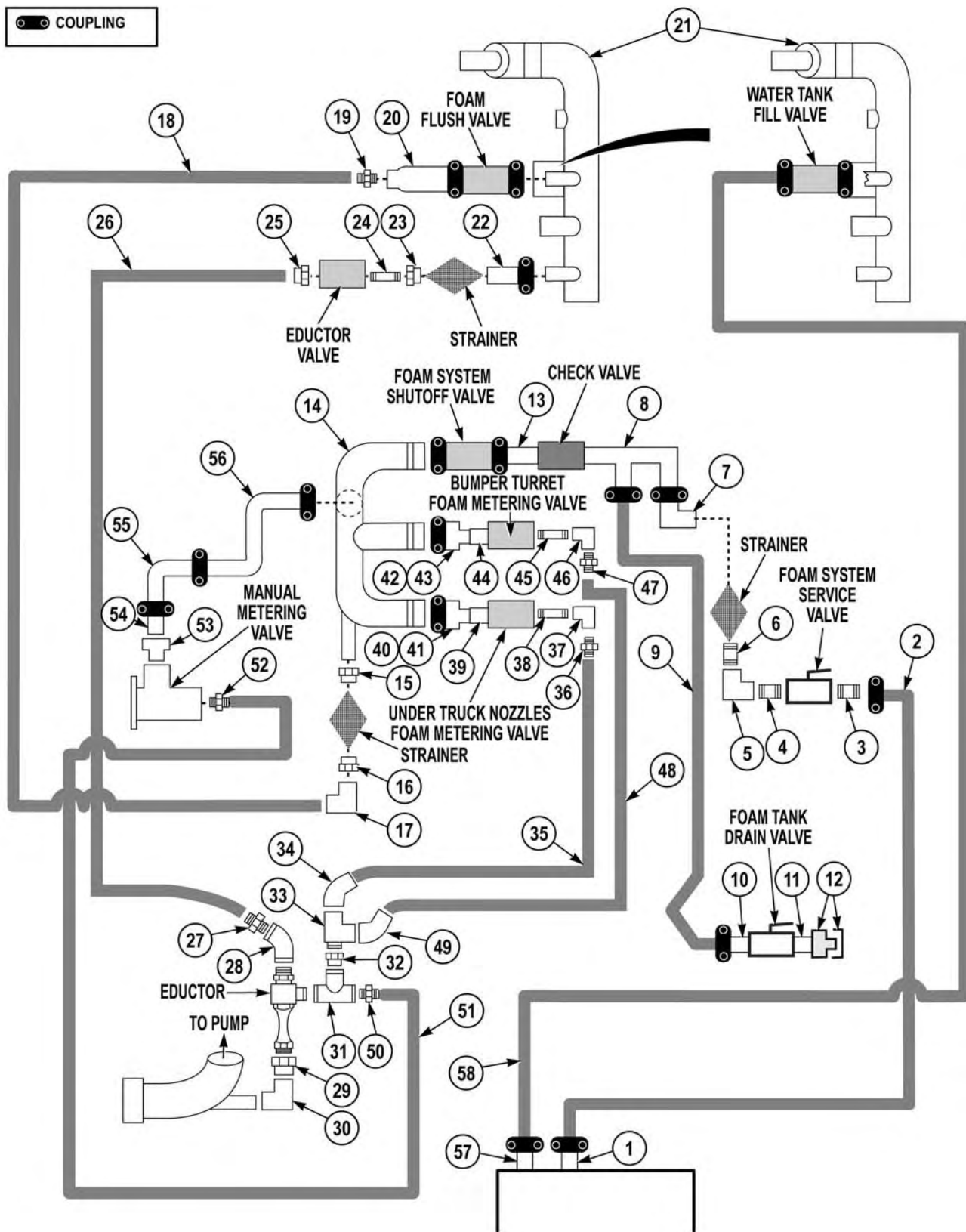


Figure 2. Foam and Water Tank Fill Systems.

Item	Foam and Water Tank Fill Systems - Description
1	Pipe
2	Hose
3	Pipe Nipple
4	Nipple
5	Elbow
6	Nipple
7	Elbow
8	Foam Supply/Drain Weldment
9	Hose
10	Foam Drain Valve Weldment
11	Nipple
12	Foam Drain, Cap, and Fitting
13	Weldment
14	Main Foam Manifold Weldment
15	Reducer
16	Reducer
17	Elbow
18	Line
19	Fitting
20	Reducer
21	Pump Discharge Manifold
22	Weldment
23	Reducer
24	Nipple
25	Reducer
26	Line
27	Fitting
28	Elbow
29	Reducer
30	Elbow
31	Tee
32	Fitting
33	Tee
34	Elbow

Item	Foam and Water Tank Fill Systems - Description (Continued)
35	Line
36	Fittings
37	Elbow
38	Nipple (Pipe)
39	Nipple
40	Adapter
41	Orifice Fitting
42	Adapter
43	Orifice Fitting
44	Nipple
45	Nipple (Pipe)
46	Elbow
47	Nipple
48	Line
49	Elbow
50	Fitting
51	Line
52	Fitting
53	Fitting
54	Weldment
55	Weldment
56	Weldment
57	Pipe
58	Hose

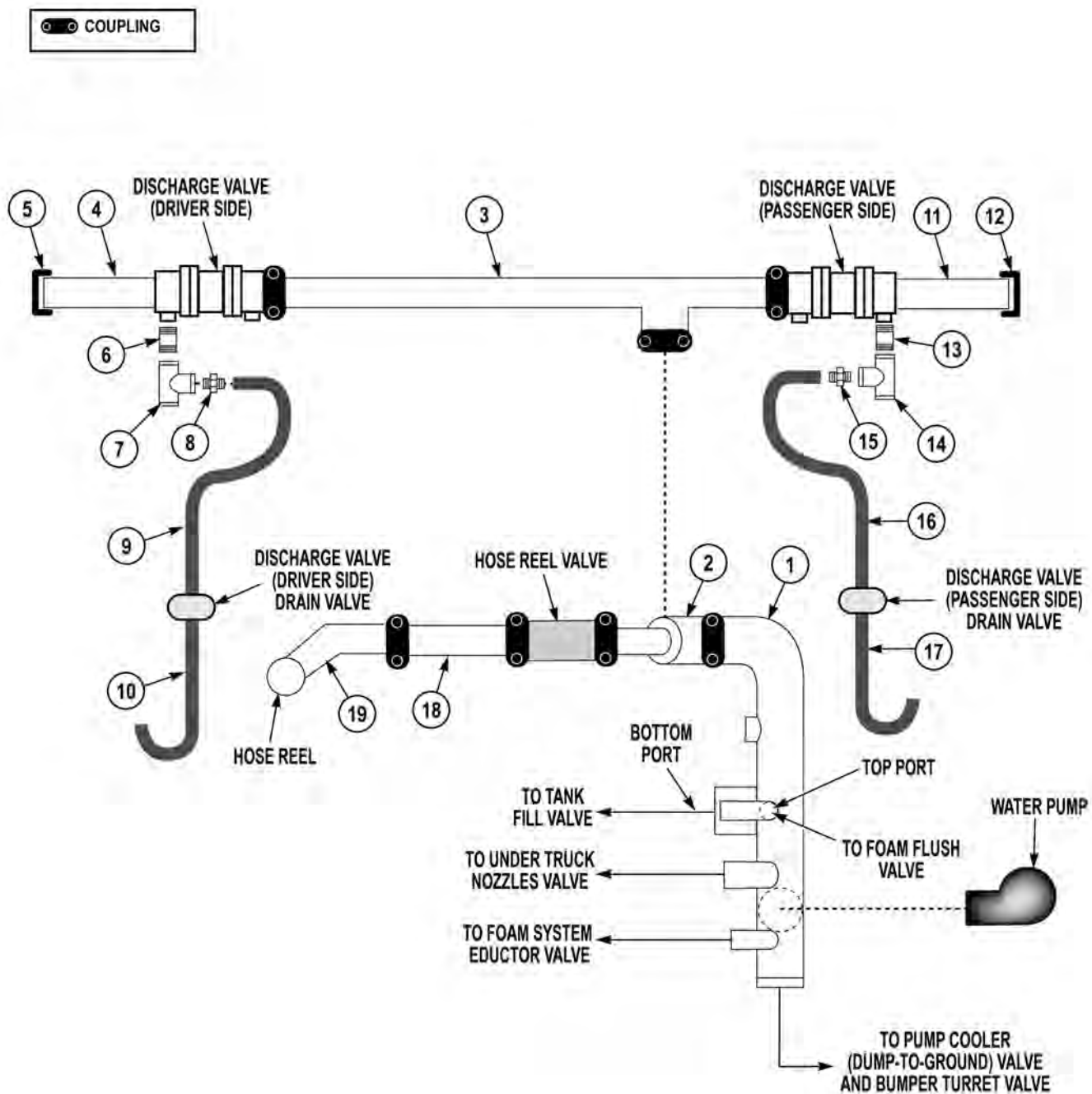


Figure 3. Side and Hose Reel Discharge System.

Item	Side and Hose Reel Discharge System - Description
1	Pump Discharge Manifold
2	Discharge Elbow
3	Driver Side/Passenger Side Discharge Manifold
4	Side Outlet Weldment
5	Cap/Adapter
6	Nipple
7	Tee
8	Fitting
9	Discharge Drain Valve Hose (Driver Side)
10	Discharge Drain Valve Hose (Driver Side) To Ground
11	Side Outlet Weldment
12	Cap/Adapter
13	Nipple
14	Tee
15	Fitting
16	Discharge Drain Valve Hose (Passenger Side)
17	Discharge Drain Valve Hose (Passenger Side) To Ground
18	Hose
19	Hose Reel Discharge Elbow

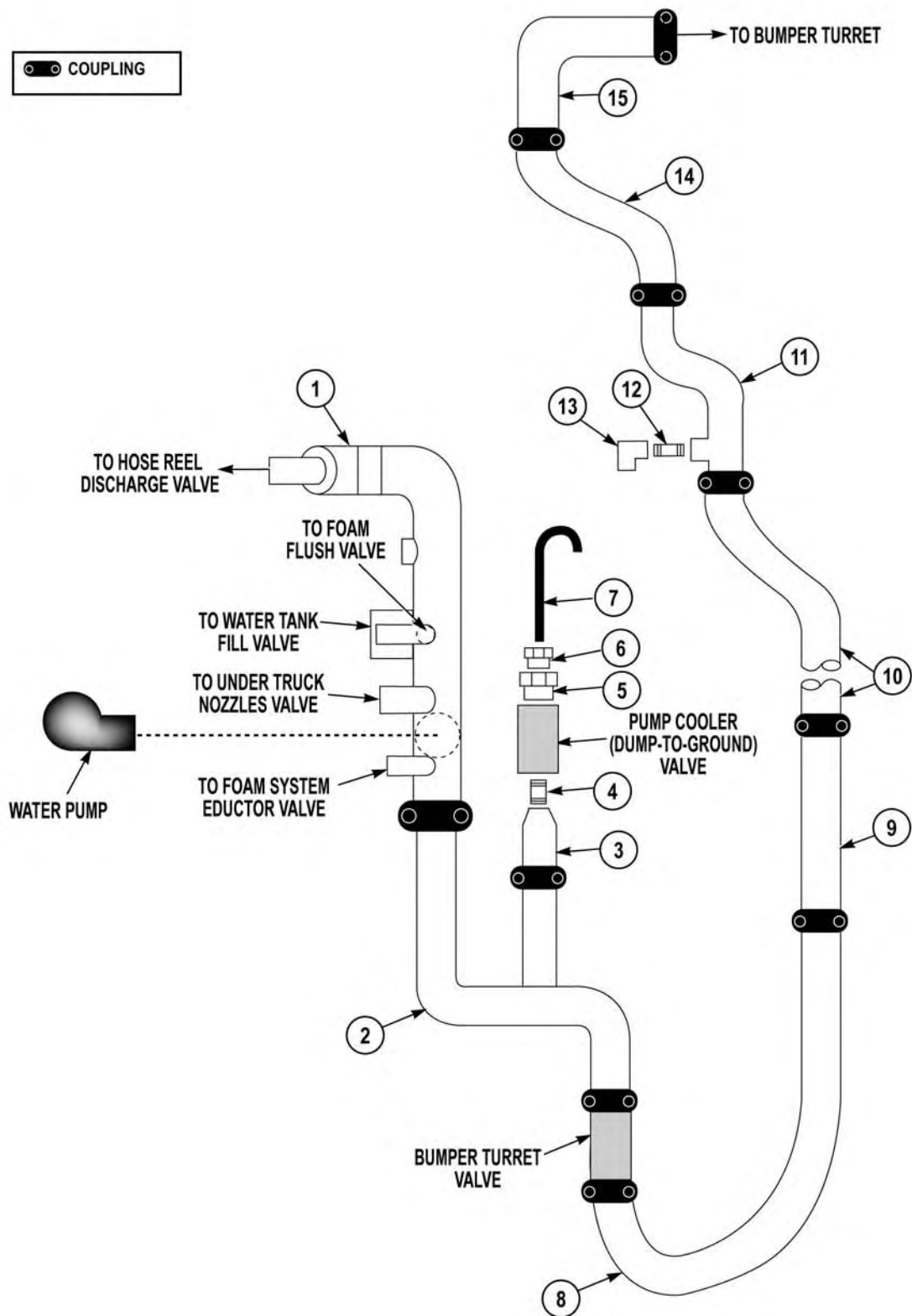


Figure 4. Pump Cooler (Dump-To-Ground) and Bumper Turret System.

1. Remove brackets and clamps as required.

Item	Pump Cooler (Dump-To-Ground) and Bumper Turret System - Description
1	Pump Discharge Manifold
2	Turret/Cooler Elbow
3	Reducer Weldment
4	Nipple
5	Reducer
6	Reducer
7	Pump Cooler (Dump-To-Ground) Valve Hose
8	Hose
9	Pipe
10	Pipe
11	Pipe
12	Fitting
13	Drain Valve
14	Hose
15	Pipe

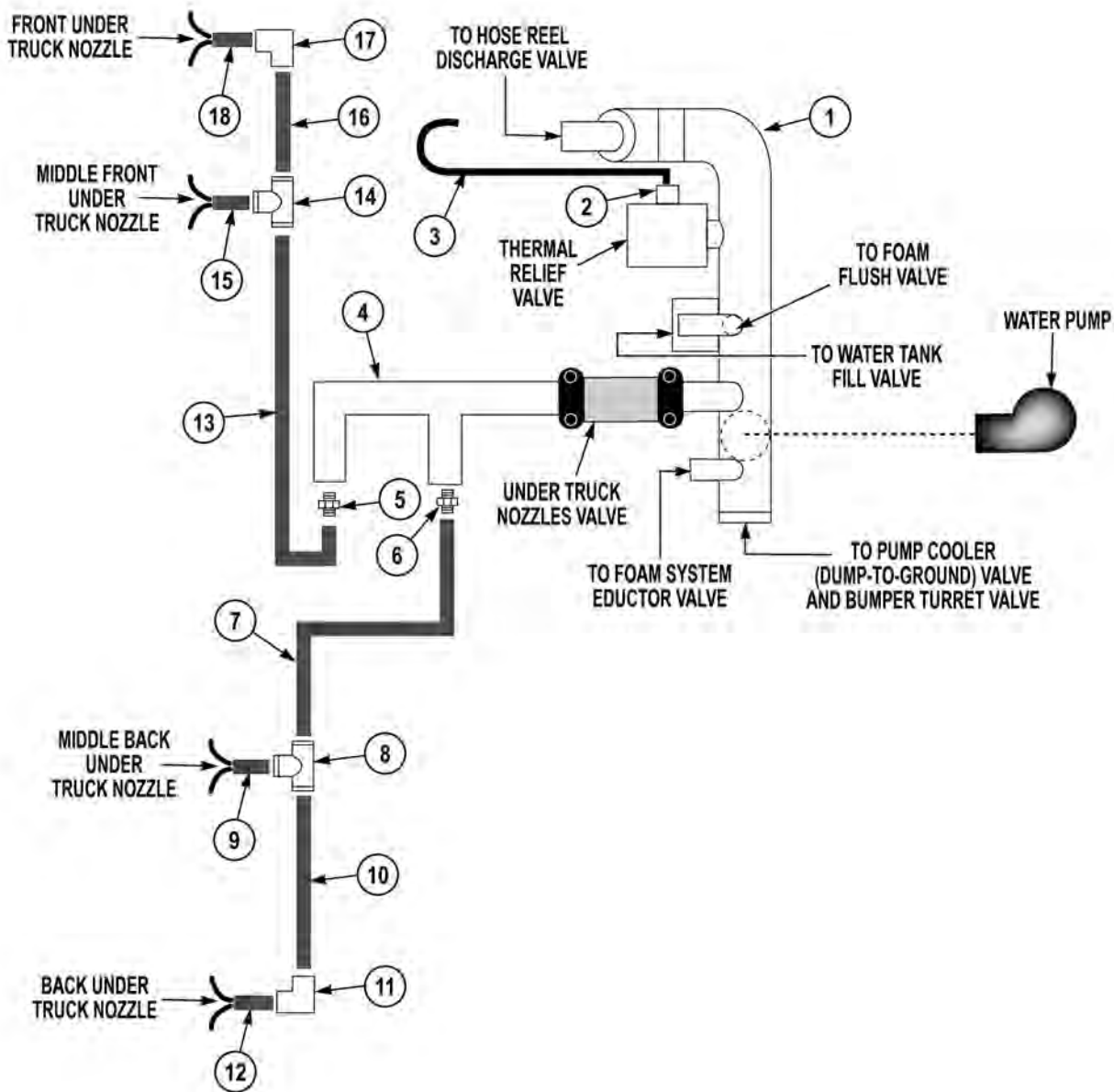
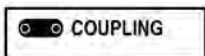


Figure 5. Under Truck Nozzles and Thermal Relief System.



---

Item	Under Truck Nozzles and Thermal Relief System - Description
1	Pump Discharge Manifold
2	Fitting
3	Hose
4	Under Truck Nozzles Weldment
5	Fitting
6	Fitting
7	Hose
8	Tee
9	Hose
10	Hose
11	Elbow
12	Hose
13	Hose
14	Tee
15	Hose
16	Hose
17	Elbow
18	Hose

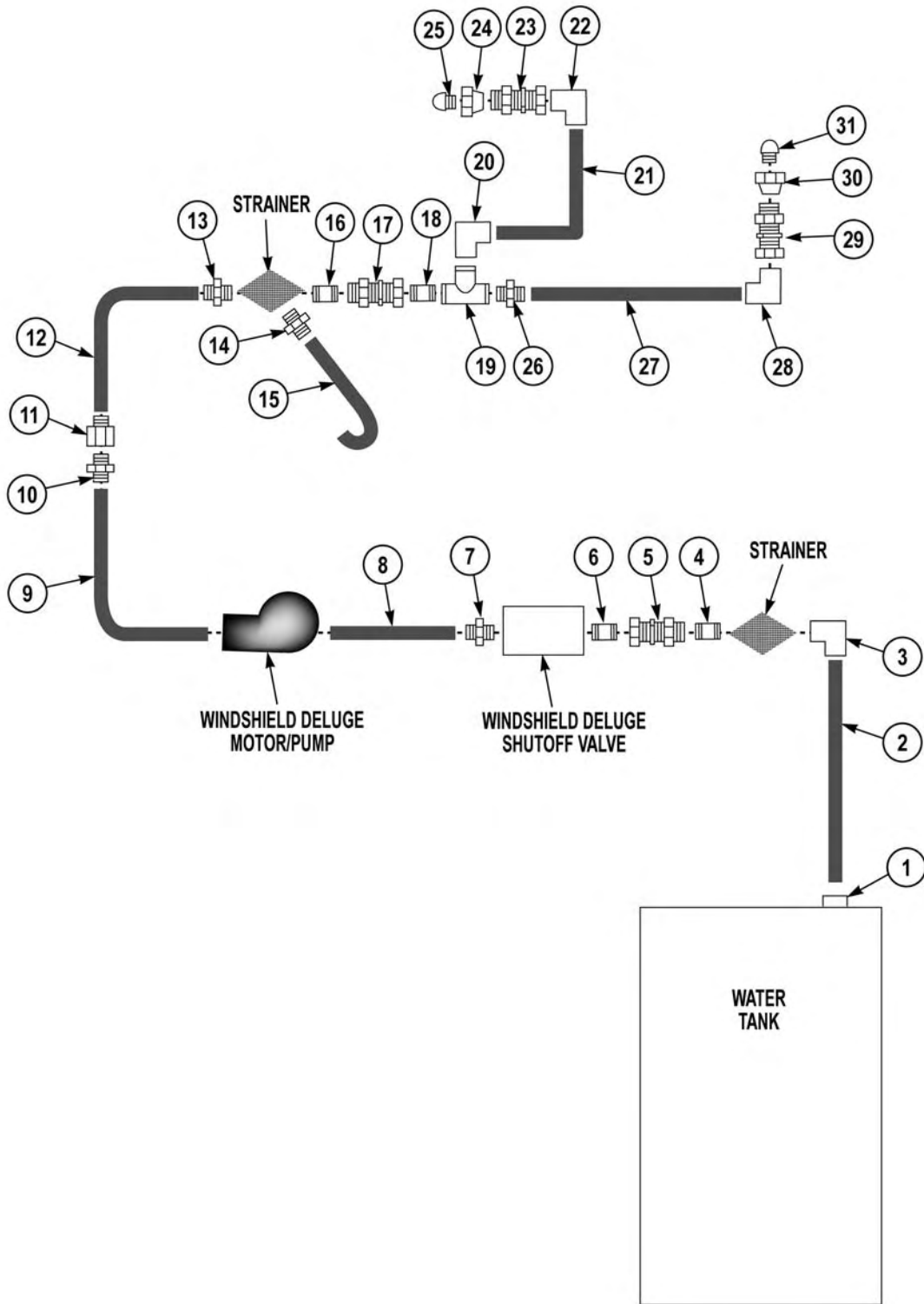


Figure 6. Windshield Deluge System.

---

Item	Windshield Deluge System - Description
1	Fitting
2	Hose
3	Elbow
4	Nipple
5	Bulkhead Fitting
6	Nipple
7	Fitting
8	Hose
9	Hose
10	Fitting
11	Fitting
12	Fitting
13	Fitting
14	Drain
15	Drain Hose
16	Nipple
17	Bulkhead Fitting
18	Nipple
19	Tee
20	Elbow
21	Hose
22	Elbow
23	Bulkhead Fitting
24	Nozzle
25	Adjustable Ball Fitting
26	Fitting
27	Hose
28	Elbow
29	Bulkhead Fitting
30	Nozzle
31	Adjustable Ball Fitting

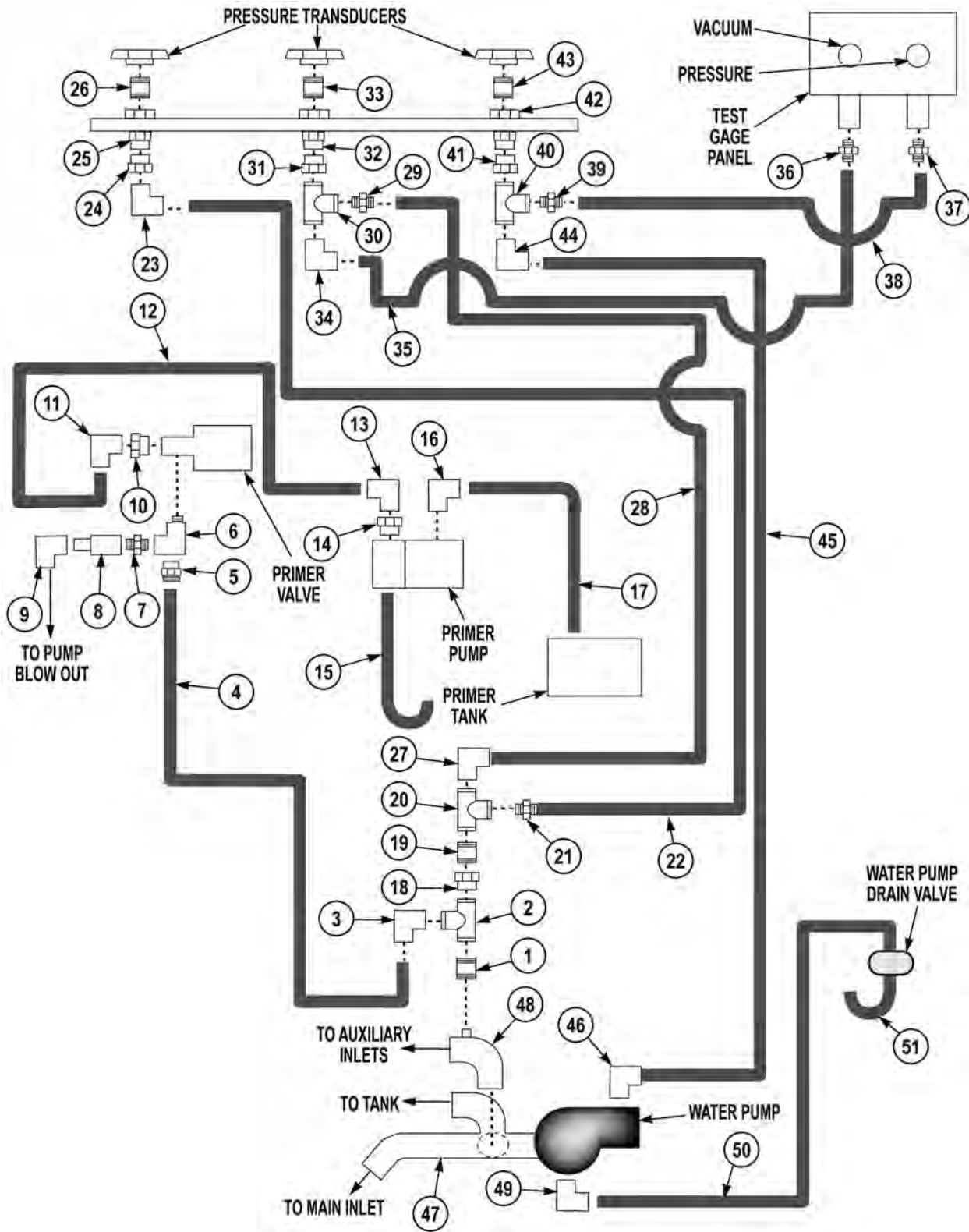


Figure 7. Priming and Pump Drain Systems.

Item	Priming and Pump Drain Systems - Description
1	Nipple
2	Tee
3	Elbow
4	Line
5	Fitting
6	Tee
7	Fitting
8	Check Valve
9	Elbow
10	Fitting
11	Elbow
12	Line
13	Elbow
14	Fitting
15	Drain Hose
16	Elbow
17	Line
18	Fitting
19	Nipple
20	Tee
21	Fitting
22	Line
23	Elbow
24	Fitting
25	Bulkhead Fitting
26	Nipple
27	Elbow
28	Line
29	Fitting
30	Tee
31	Fitting
32	Bulkhead Fitting
33	Nipple
34	Elbow

Item	Priming and Pump Drain Systems - Description
35	Line
36	Fitting
37	Fitting
38	Line
39	Fitting
40	Tee
41	Fitting
42	Bulkhead Fitting
43	Nipple
44	Elbow
45	Line
46	Elbow
47	Main Inlet Manifold
48	Elbow Weldment
49	Elbow
50	Line
51	Line

**END OF TASK**

**FOLLOW-ON MAINTENANCE**

1. Piping Assembly (Pipe Thread Sealing Compound) (WP 0318)
2. Install coupling(s) (WP 0313)
3. Install pump house panels (WP 0339)

**END OF TASK****END OF WORK PACKAGE**

---

**FIELD LEVEL MAINTENANCE**  
**PUMP DRAIN VALVE REPLACEMENT**

---

**INITIAL SETUP:****Tools and Special Tools**

Tool Kit, General Mechanic's: Automotive  
(WP 0398, Item 17)

**Materials/Parts**

Adhesive, Spray (WP 0400, Item 5)  
Tape, Teflon (WP 0400, Item 25)  
Tags, Identification (WP 0400, Item 23)  
Locknut (1)

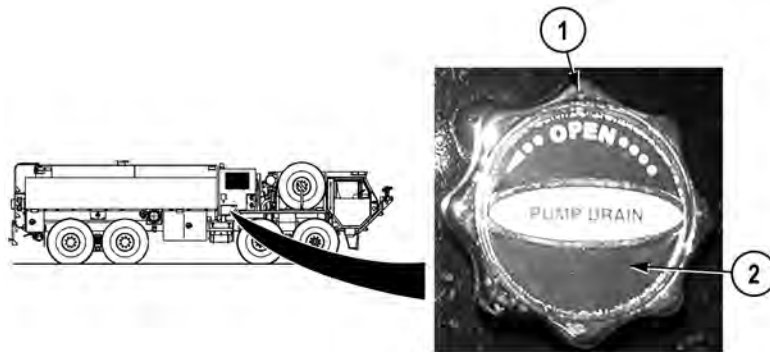
**References**

WP 0391, Fig. 14

**Equipment Conditions**

Pump house panel H access door  
opened (WP 0008)  
Pump house panel P removed (WP 0339)

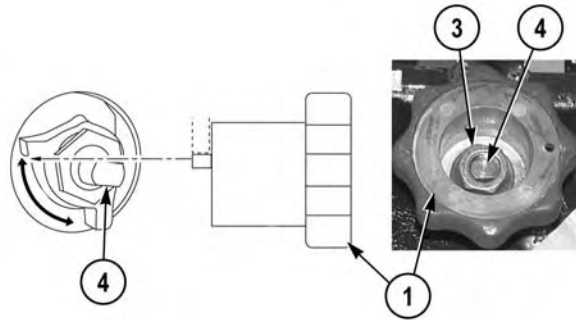
---

**REMOVAL**

1. Turn valve handle (1) clockwise to closed position.

**NOTE**

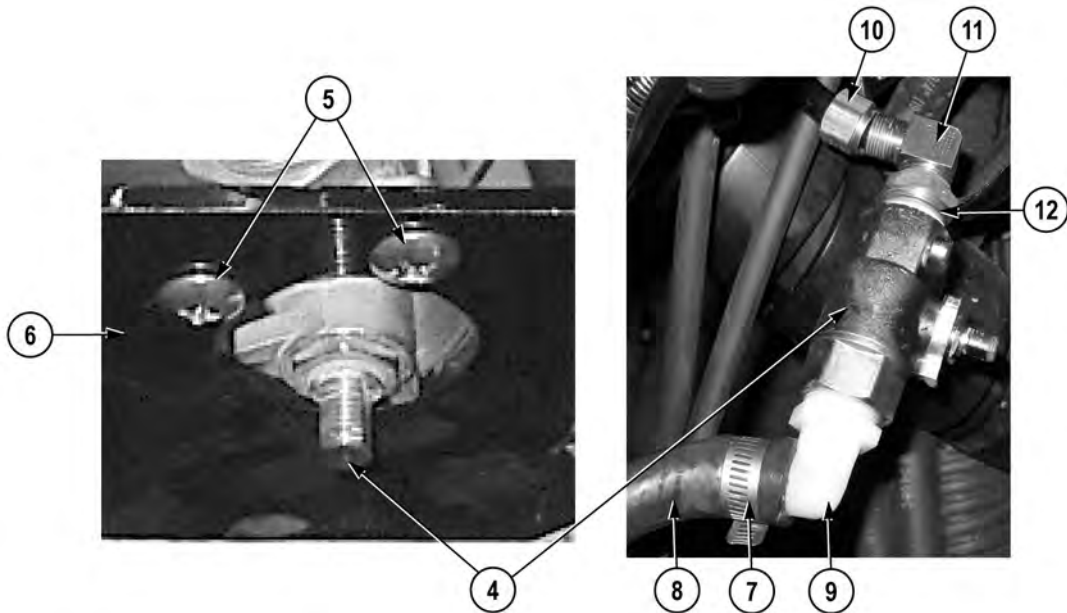
- Cover is attached to valve handle with adhesive.
  - Note position of cover prior to removal to ensure proper installation.
  - Use care when removing cover.
2. Pry cover (2) from valve handle (1).



**NOTE**

- Stop on valve handle is positioned between 90 degree indent on valve.
- Note position of valve handle on valve prior to removal to ensure proper installation.

3. Remove locknut (3) and valve handle (1) from valve (4). Discard locknut.



4. Remove two screws (5) and valve (4) from manual valve control mounting bracket (6).
5. Loosen clamp (7) and remove hose (8) from elbow (9).
6. Remove hose (10) from elbow (11).



**NOTE**

Note location of elbow and adapter prior to removal to ensure proper installation.

7. Remove elbow (11) from adapter (12).
8. Remove elbow (9) and adapter (12) from valve (4).

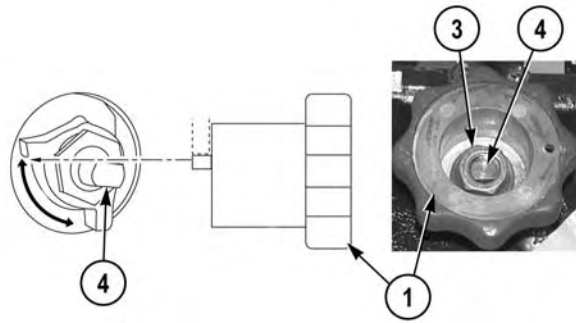
**END OF TASK****INSTALLATION**

1. Apply teflon tape to threads of elbow (9), elbow (11), and adapter (12).

**NOTE**

Install elbow and adapter as noted prior to removal.

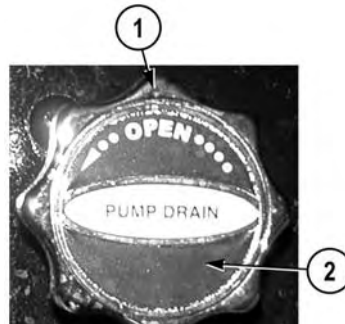
2. Install adapter (12) on valve (4).
3. Install elbow (11) on adapter (12).
4. Install elbow (9) on valve (4).
5. Install hose (10) on fitting (11).
6. Install hose (8) on fitting (9) and tighten clamp (7).
7. Install valve (4) on manual valve control mounting bracket (6) with two screws (5).



**NOTE**

Install handle in the position as noted prior to removal.

8. Install valve handle (1) on valve (4) with locknut (3).



**WARNING**



**Adhesives, solvents, and sealing compounds can burn easily, can give off harmful vapors, and are harmful to skin and clothing. To avoid injury or death, keep away from open fire and use in well-ventilated area. If adhesive, solvent, or sealing compound gets on skin or clothing, wash immediately with soap and water.**

9. Apply adhesive to back of cover (2).

**NOTE**

Install cover on handle as noted prior to removal.

10. Install cover (2) on handle (1).

**END OF TASK**

**FOLLOW-ON MAINTENANCE**

1. Close pump house panel H access door (WP 0008)
2. Install pump house panel P (WP 0339)

**END OF TASK**

**END OF WORK PACKAGE**



---

**FIELD LEVEL MAINTENANCE**  
**TANK-TO-PUMP VALVE REPLACEMENT**

---

**INITIAL SETUP:****Tools and Special Tools**

Tool Kit, General Mechanic's: Automotive  
(WP 0398, Item 17)

**References**

WP 0313  
WP 0391, Fig. 20

**Materials/Parts**

Compound, Sealing, Pipe Thread  
(WP 0400, Item 11)  
Tags, Identification (WP 0400, Item 23)

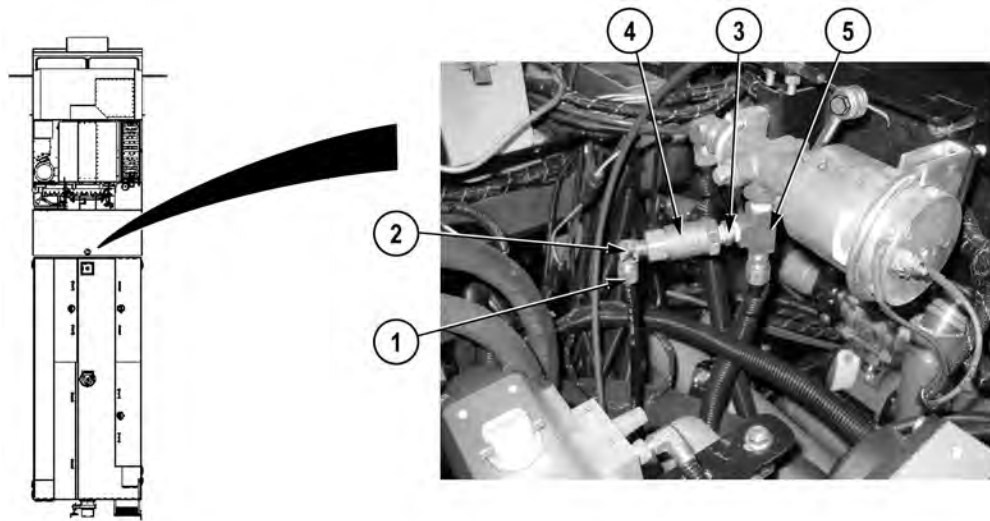
**Equipment Conditions**

Air system drained (TM 9-2320-422-10)  
Water tank drained (WP 0015)  
Pump house panels K and G removed (WP 0339)

**Personnel Required**

MOS 63B Wheeled Vehicle Mechanic (2)

---

**REMOVAL****NOTE**

- Check valve and fitting must be removed in order to provide clearance when removing tank-to-pump valve.
- Tag and mark air lines prior to removal to ensure proper installation.

1. Remove line (1) from elbow (2).
2. Remove fitting (3) and check valve (4) from tee (5).



### NOTE

Hose to water tank valve needs to be removed from water tank fill valve in order to remove tank-to-pump valve.

3. Remove coupling (6) and reposition hose (7) (WP 0313).
4. Remove two air lines (8) and (9) from elbows (10) and (11).



### NOTE

- Driver side coupling needs to be removed from below tank-to-pump valve.
  - Tank-to-pump valve is awkward and needs to be removed with the aid of an assistant.
5. With the aid of an assistant, remove two couplings (12) and (13) (WP 0313) and tank-to-pump valve (14) from vehicle.



6. Remove two elbows (10) and (11) from tank-to-pump valve (14).

#### END OF TASK

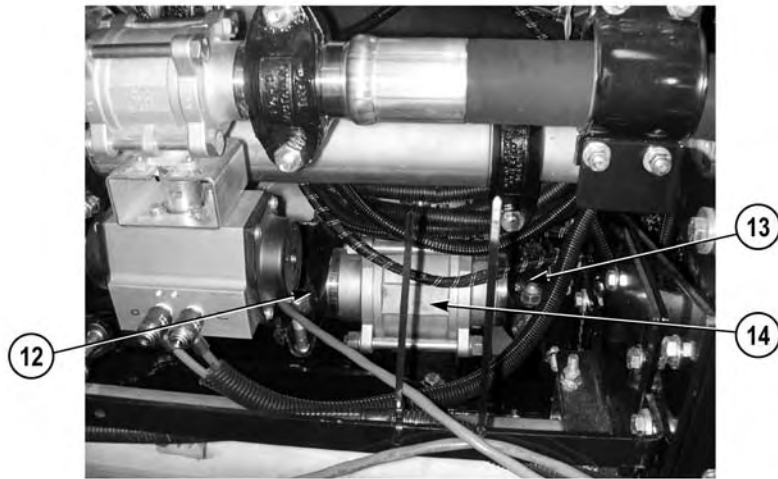
#### INSTALLATION

#### WARNING



**Adhesives, solvents, and sealing compounds can burn easily, can give off harmful vapors, and are harmful to skin and clothing. To avoid injury or death, keep away from open fire and use in well-ventilated area. If adhesive, solvent, or sealing compound gets on skin or clothing, wash immediately with soap and water.**

1. Apply sealing compound to threads of two elbows (10) and (11).
2. Install two elbows (11) and (10) on tank-to-pump valve (14).

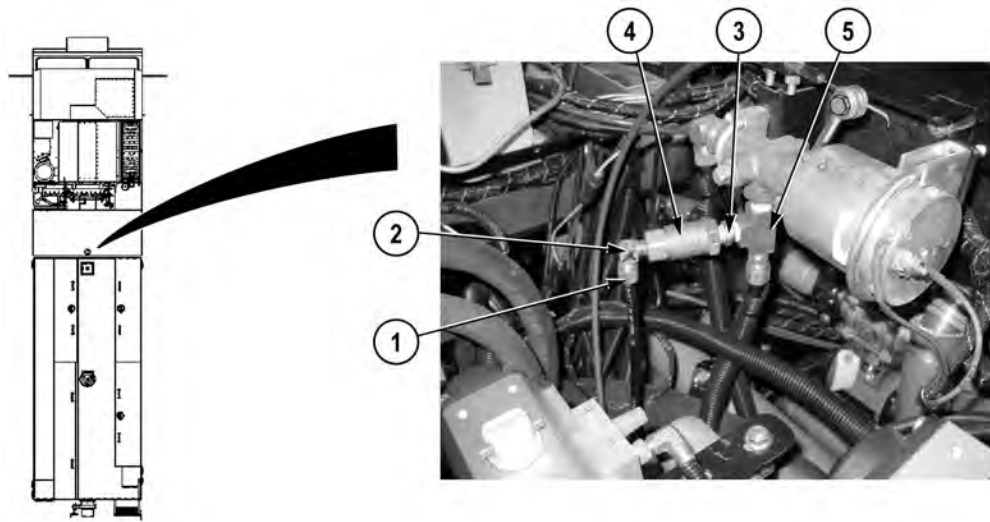


3. With the aid of an assistant, install two couplings (13) and (12) (WP 0313) and tank-to-pump valve (14) on vehicle.



4. Install two air lines (9) and (8) on elbows (11) and (10).
5. Position hose (7) and install coupling (6) (WP 0313).





**WARNING**



**Adhesives, solvents, and sealing compounds can burn easily, can give off harmful vapors, and are harmful to skin and clothing. To avoid injury or death, keep away from open fire and use in well-ventilated area. If adhesive, solvent, or sealing compound gets on skin or clothing, wash immediately with soap and water.**

6. Apply sealing compound to threads of fitting (3).
7. Install fitting (3) and check valve (4) on tee (5).
8. Install line (1) on elbow (2).

**END OF TASK**

**FOLLOW-ON MAINTENANCE**

Install pump house panels K and G (WP 0339)

**END OF TASK**

**END OF WORK PACKAGE**



---

**FIELD LEVEL MAINTENANCE**  
**UNDER TRUCK NOZZLES VALVE REPLACEMENT**

---

**INITIAL SETUP:****Tools and Special Tools**

Tool Kit, General Mechanic's: Automotive  
(WP 0398, Item 17)

**References**

WP 0313  
WP 0391, Fig. 93

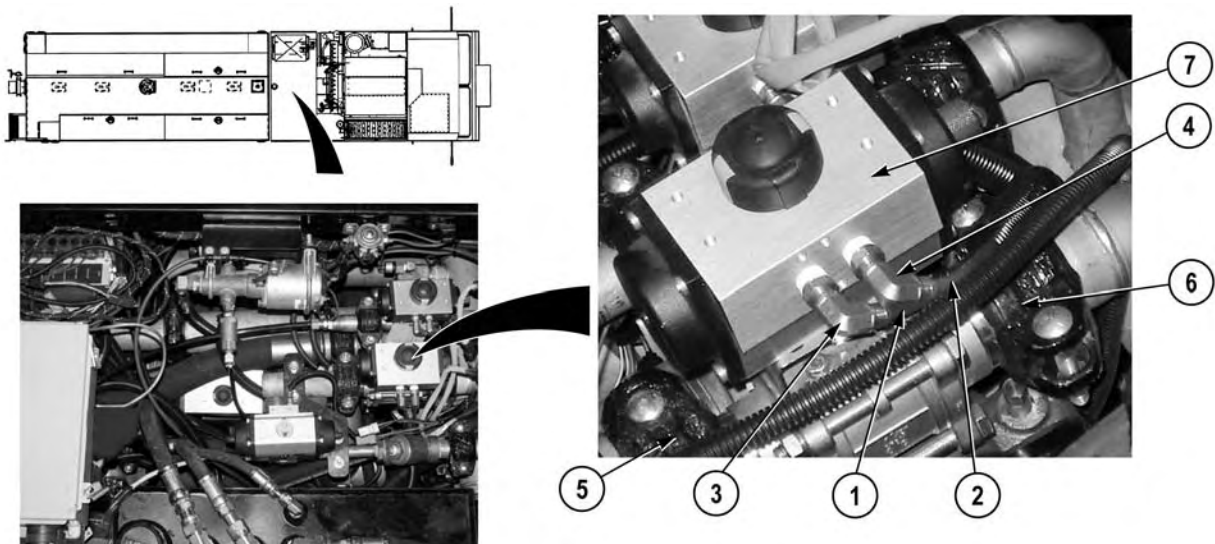
**Materials/Parts**

Compound, Sealing, Pipe Thread  
(WP 0400, Item 11)  
Tags, Identification (WP 0400, Item 23)

**Equipment Conditions**

Air system drained (TM 9-2320-422-10)  
Pump house panel K removed (WP 0339)

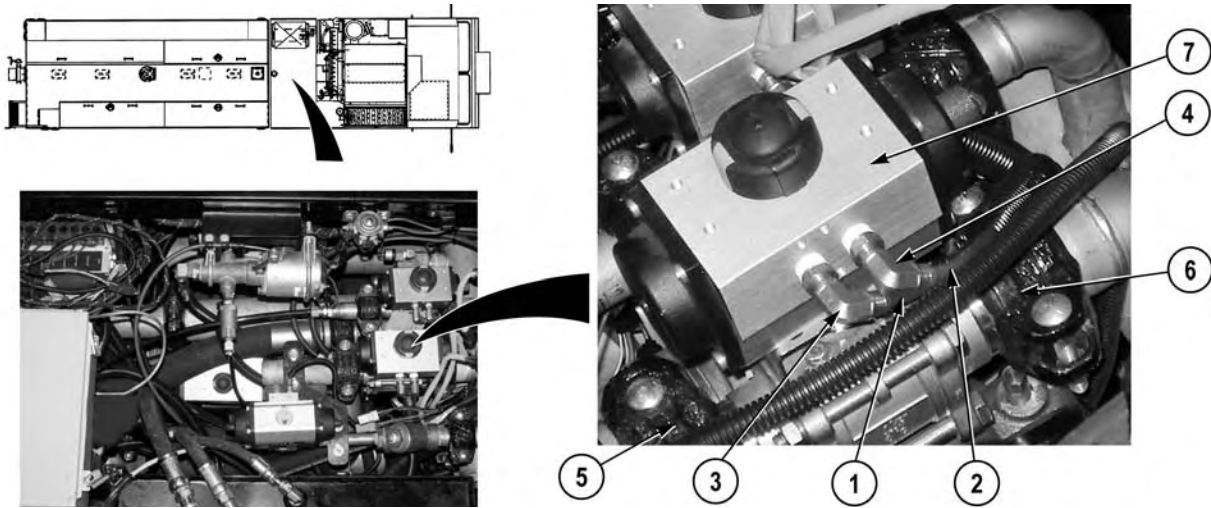
---

**REMOVAL****NOTE**

- Note position of elbows prior to removal to ensure proper installation.
- Tag and mark air lines prior to removal to ensure proper installation.

1. Remove two air lines (1) and (2) from elbows (3) and (4).
2. Remove two couplings (5) and (6) and valve (7) from vehicle (WP 0313).
3. Remove two elbows (3) and (4) from valve (7).

**END OF TASK**

**INSTALLATION****WARNING**

Adhesives, solvents, and sealing compounds can burn easily, can give off harmful vapors, and are harmful to skin and clothing. To avoid injury or death, keep away from open fire and use in well-ventilated area. If adhesive, solvent, or sealing compound gets on skin or clothing, wash immediately with soap and water.

**CAUTION**

Use sealing compound sparingly only on pipe threads. Do not apply compound to hose connections. Failure to comply may result in damage to equipment.

1. Apply sealing compound to threads of two elbows (3) and (4).

**NOTE**

Install elbows in same position as noted prior to removal.

2. Install two elbows (4) and (3) on valve (7).
3. Install valve (7) and two couplings (6) and (5) (WP 0313) on vehicle.
4. Install two air lines (2) and (1) on elbows (4) and (3).

**END OF TASK****FOLLOW-ON MAINTENANCE**

Install pump house panel K (WP 0339)

**END OF TASK****END OF WORK PACKAGE**

## FIELD LEVEL MAINTENANCE

## WINDSHIELD DELUGE AUTOMATIC DRAIN VALVE REPLACEMENT

## INITIAL SETUP:

**Tools and Special Tools**

Tool Kit, General Mechanic's: Automotive  
(WP 0398, Item 17)

**Materials/Parts**

Compound, Sealing, Pipe Thread  
(WP 0400, Item 11)  
Tags, Identification (WP 0400, Item 23)  
Gasket (1)  
Lockwasher (1)

**Materials/Parts (continued)**

Locknut (1)  
Lockwasher (1)

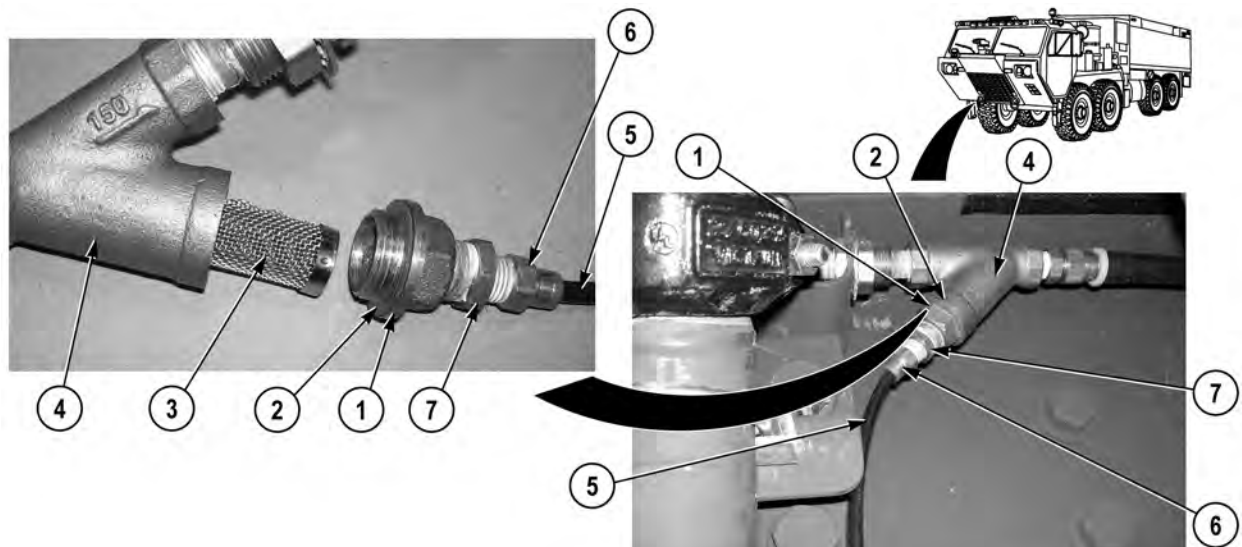
**References**

WP 0391, Fig. 94

**Equipment Conditions**

Skid plate grille removed (WP 0349)

## STRAINER REMOVAL



1. Remove fitting (1), gasket (2), and strainer (3) from strainer body (4). Discard gasket.

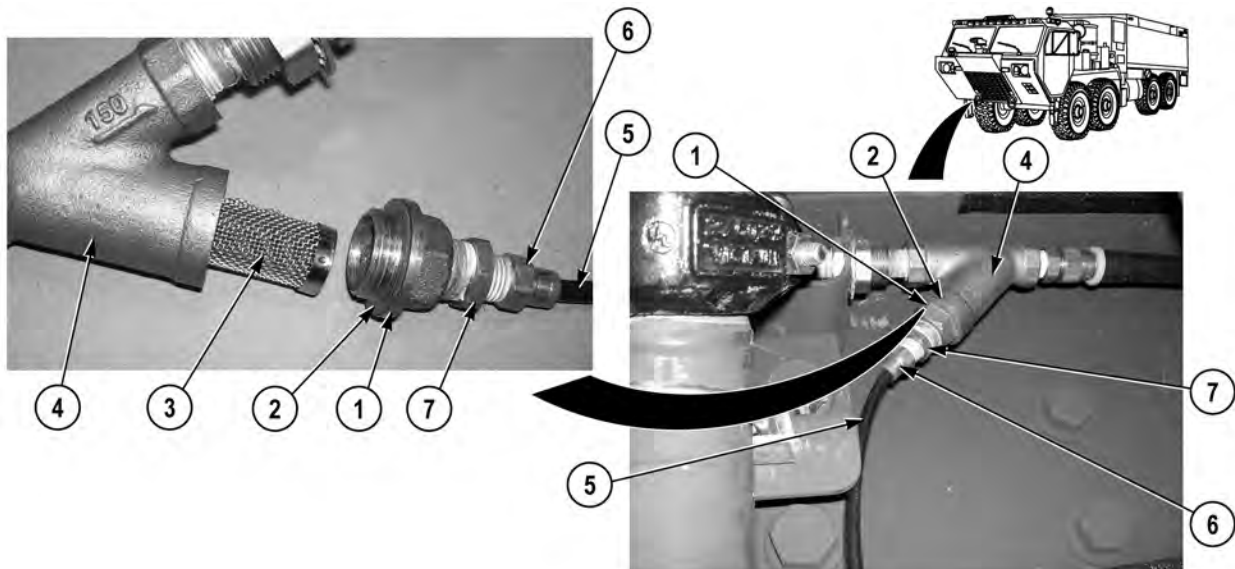
**NOTE**

- Note position of fitting and reducer prior to removal to ensure proper installation.
- Perform Steps (2) through (4) if fittings need to be removed.

2. Remove line (5) from fitting (6).
3. Remove fitting (6) from reducer (7).
4. Remove reducer (7) from fitting (1).

**END OF TASK**

## STRAINER INSTALLATION

**WARNING**

Adhesives, solvents, and sealing compounds can burn easily, can give off harmful vapors, and are harmful to skin and clothing. To avoid injury or death, keep away from open fire and use in well-ventilated area. If adhesive, solvent, or sealing compound gets on skin or clothing, wash immediately with soap and water.

**NOTE**

Perform Steps (1) through (4) if fittings were removed.

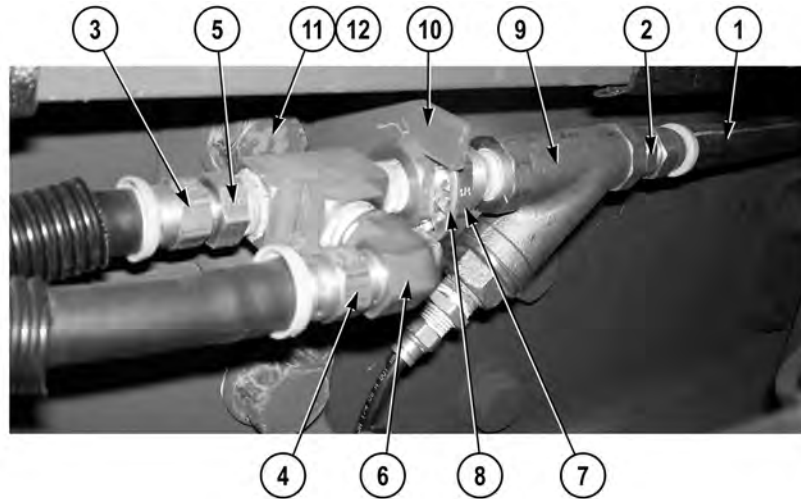
1. Apply sealing compound to threads of reducer (7).

**NOTE**

Install reducer and fitting as noted prior to removal.

2. Install reducer (7) on fitting (1).
3. Install fitting (6) on reducer (7).
4. Install line (5) on fitting (6).
5. Install strainer (3), gasket (2), and fitting (1) on strainer body (4).

**END OF TASK**

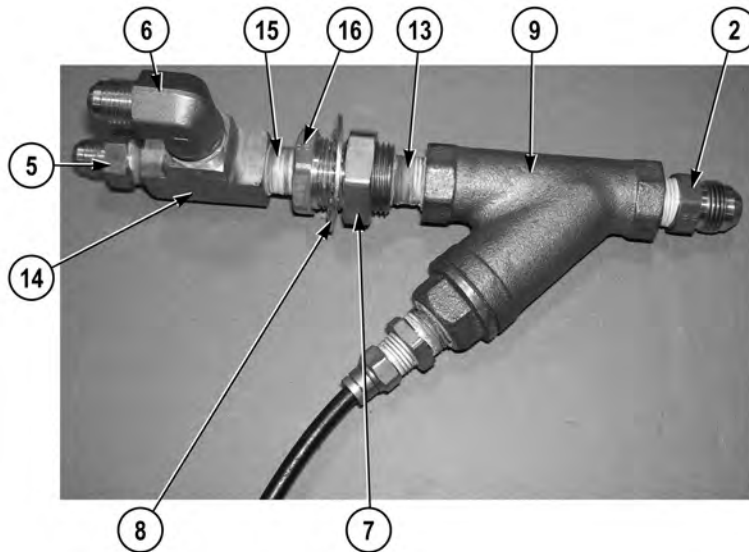
**STRAINER BODY AND TEE ASSEMBLY REMOVAL****NOTE**

- Tag and mark hoses prior to removal to ensure proper installation.
- Note position of elbows and fittings prior to removal to ensure proper installation.

1. Remove hose (1) from fitting (2).
2. Remove two hoses (3) and (4) from fitting (5) and elbow (6).
3. Loosen jam nut (7), lockwasher (8), and remove strainer body (9) from bracket (10). Discard lockwasher.

**NOTE**

- Perform Step (4) if bracket needs to be removed.
  - Note position of bracket prior to removal to ensure proper installation.
4. Remove locknut (11), screw (12), and bracket (10) from vehicle. Discard locknut.



5. Remove fitting (2) from strainer body (9).
6. Remove nipple (13) from strainer body (9).
7. Remove fitting (5) and elbow (6) from tee (14).
8. Remove tee (14) from nipple (15).
9. Remove two nipples (13) and (15) from bulkhead fitting (16).
10. Remove jam nut (7) and lockwasher (8) from bulkhead fitting (16). Discard lockwasher.

#### END OF TASK

#### STRAINER BODY AND TEE ASSEMBLY INSTALLATION

1. Install lockwasher (8) and jam nut (7) on bulk head fitting (16).

#### **WARNING**



**Adhesives, solvents, and sealing compounds can burn easily, can give off harmful vapors, and are harmful to skin and clothing. To avoid injury or death, keep away from open fire and use in well-ventilated area. If adhesive, solvent, or sealing compound gets on skin or clothing, wash immediately with soap and water.**

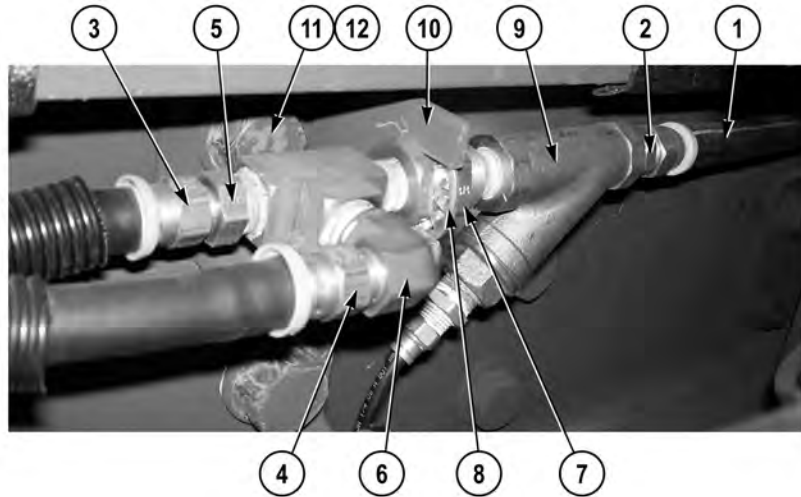
#### **NOTE**

Install elbows and fittings as noted prior to removal.

2. Apply sealing compound to threads of two fittings (2) and (5), two nipples (15) and (13), and elbow (6).



3. Install two nipples (15) and (13) on bulkhead fitting (16).
4. Install tee (14) on nipple (15).
5. Install elbow (6) and fitting (5) on tee (14).
6. Install nipple (13) on strainer body (9).
7. Install fitting (2) on strainer body (9).



### NOTE

Perform Step (8) if bracket was removed.

8. Install bracket (10) on vehicle with screw (12) and locknut (11).
9. Install strainer body (9) on bracket (10) with lockwasher (8) and jam nut (7).
10. Install two hoses (4) and (3) on elbow (6) and fitting (5).
11. Install hose (1) on fitting (2).

**END OF TASK**

### FOLLOW-ON MAINTENANCE

Install skid plate grille (WP 0349)

**END OF TASK**

**END OF WORK PACKAGE**



**ALPHABETICAL INDEX**

**Subject**

**WP Sequence No.-Page No.**

**Numerics**

120-Volt Receptacle	
Installation . . . . .	WP 0239-4
Removal . . . . .	WP 0239-1
12-Volt Handheld Radio Charger(s) Does Not Operate . . . . .	WP 0113-1
12-Volt Streamlight Charger(s) Does Not Operate . . . . .	WP 0114-1
24-Volt 10 AMP Per Bank Battery Charger and Bracket Replacement	
Installation . . . . .	WP 0237-5
Removal . . . . .	WP 0237-1
24-Volt 15 AMP Per Bank Battery Charger	
Installation . . . . .	WP 0237.1-3
Removal . . . . .	WP 0237.1-1
24-Volt Battery Charger Does Not Operate . . . . .	WP 0044-1
24-Volt Battery Charger Does Not Operate Properly . . . . .	WP 0115-1

**A**

Air Lines and Fittings	
Air Hose Fittings . . . . .	WP 0374-1
Air Hose Replacement . . . . .	WP 0374-3
Air Reservoir	
Installation . . . . .	WP 0370-4
Removal . . . . .	WP 0370-1

**B**

Basic Issue Items (BII) . . . . .	WP 0399-1
Batteries	
Connect . . . . .	WP 0007-1
Disconnect . . . . .	WP 0007-1
Battery Box and Bracket	
Installation . . . . .	WP 0238-3
Removal . . . . .	WP 0238-1
Battery Disconnect Switch	
Installation . . . . .	WP 0236-3
Removal . . . . .	WP 0236-1
Blackout Relay(s)	
Installation . . . . .	WP 0240-2
Removal . . . . .	WP 0240-1
Bumper Turret	
Assembly . . . . .	WP 0379-6
Bumper Turret Nozzle Speed Adjustment . . . . .	WP 0132-4
Bumper Turret Vertical Speed Adjustment . . . . .	WP 0132-1
Disassembly . . . . .	WP 0379-2
Installation . . . . .	WP 0378-2
Removal . . . . .	WP 0378-1
Repair . . . . .	WP 0379-1

## ALPHABETICAL INDEX (CONTINUED)

<u>Subject</u>	<u>WP Sequence No.-Page No.</u>
Bumper Turret Auto Drain Valve	
Installation .....	WP 0170-2
Removal .....	WP 0170-1
Bumper Turret Controls	
Installation .....	WP 0375-3
Removal .....	WP 0375-1
Bumper Turret Does Not Operate Properly When Selected .....	WP 0063-1
Bumper Turret Foam Metering Valve and Orifice	
Removal .....	WP 0173-1
Bumper Turret Junction Box	
Assembly .....	WP 0377-5
Disassembly .....	WP 0377-1
Installation .....	WP 0376-4
Removal .....	WP 0376-1
Repair .....	WP 0377-1
Bumper Turret Mount	
Installation .....	WP 0371-2
Removal .....	WP 0371-1
Bumper Turret Operation .....	WP 0027-1
Bumper Turret Valve	
Installation .....	WP 0312-2
Removal .....	WP 0312-1
Bumper Turret Wire Harness	
Installation .....	WP 0278-3
Removal .....	WP 0278-1

### C

Cab 1-2-3 Signal Indicator Lamp	
Installation .....	WP 0202-1
Removal .....	WP 0202-1
Cab 1-2-3 Signal Indicator Lamp Holder	
Installation .....	WP 0201-2
Removal .....	WP 0201-1
Cab Clearance Lights and Bracket	
Removal .....	WP 0223-1
Cab Dome Light(s) Does Not Operate .....	WP 0112-1
Cab Front Lightbar	
Installation .....	WP 0224-4
Removal .....	WP 0224-1
Cab High Idle Switch and Indicator	
Installation .....	WP 0217-3
Removal .....	WP 0217-1

## ALPHABETICAL INDEX (CONTINUED)

<u>Subject</u>	<u>WP Sequence No.-Page No.</u>
Cab Instrument Panel	
Cab Instrument Panel C Installation .....	WP 0205-23
Cab Instrument Panel D Installation .....	WP 0205-27
Cab Instrument Panel D Removal .....	WP 0205-27
Cab Instrument Panel E Installation .....	WP 0205-30
Cab Instrument Panel E Removal .....	WP 0205-28
Panel A Installation .....	WP 0205-6
Panel A Removal .....	WP 0205-2
Panel B Installation .....	WP 0205-14
Panel B Removal .....	WP 0205-10
Panel C Removal .....	WP 0205-19
Cab Instrument Panel Assembly	
Installation .....	WP 0204-11
Removal .....	WP 0204-1
Cab Instrument Panel Wire Harness	
Installation .....	WP 0279-8
Removal .....	WP 0279-1
Cab Lightbar	
Cab Front Lightbar Assembly .....	WP 0226-5
Cab Front Lightbar Disassembly .....	WP 0226-4
Cab Side Lightbar Assembly .....	WP 0226-3
Cab Side Lightbar Disassembly .....	WP 0226-1
Cab Panel Indicator	
Installation .....	WP 0198-2
Removal .....	WP 0198-1
Cab Power Distribution Block Circuit Breaker	
Installation .....	WP 0242-1
Removal .....	WP 0242-1
Cab Power Distribution Block Diode	
Installation .....	WP 0243-1
Removal .....	WP 0243-1
Cab Power Distribution Block Relay(s)	
Installation .....	WP 0244-2
Removal .....	WP 0244-1
Cab Power Distribution Wire Harness and Block	
Installation .....	WP 0280-6
Removal .....	WP 0280-1
Cab Pressure Governor Control	
Installation .....	WP 0197-3
Removal .....	WP 0197-1
Cab Pump Control Wire Harness	
Installation .....	WP 0281-5
Removal .....	WP 0281-1
Cab Rocker Switch	
Installation .....	WP 0199-2
Removal .....	WP 0199-1
Cab Roof Wire Harness	
Installation .....	WP 0282-3
Removal .....	WP 0282-1

## ALPHABETICAL INDEX (CONTINUED)

<u>Subject</u>	<u>WP Sequence No.-Page No.</u>
Cab Side Lightbar	
Installation .....	WP 0225-2
Removal .....	WP 0225-1
Cab Step	
Installation .....	WP 0325-4
Removal .....	WP 0325-1
Cab Switch Backlighting Does Not Operate .....	WP 0086-1
Cab Water and/or Foam Level Gauge(s)	
Installation .....	WP 0200-2
Removal .....	WP 0200-1
CHECK FOR OPEN COMPARTMENT DOORS WHEN LIGHT IS ON Indicator	
Installation .....	WP 0195-1
Removal .....	WP 0195-1
CHECK FOR OPEN COMPARTMENT DOORS WHEN LIGHT IS ON Indicator Does Not Operate Properly .....	WP 0089-1
CHECK FOR OPEN COMPARTMENT DOORS WHEN LIGHT IS ON Indicator Flashes .....	WP 0045-1
Clearance and/or Directional Light(s) Does Not Operate .....	WP 0116-1
Compartment Doors	
Draw Latch, Close .....	WP 0008-4
Draw Latch, Open .....	WP 0008-4
D-Ring Handle, Close .....	WP 0008-1
D-Ring Handle, Open .....	WP 0008-1
Hose Bed Cover, Close .....	WP 0008-5
Hose Bed Cover, Open .....	WP 0008-5
Lift-Turn Latch, Close .....	WP 0008-3
Lift-Turn Latch, Open .....	WP 0008-3
Component of End Item (COEI) and Basic Issue Items (BII) .....	WP 0399-1
Controls and Indicators	
Bumper Turret Controls .....	WP 0004-7
Cab Instrument Panel - Lower Left .....	WP 0004-2
Cab Instrument Panel - Lower Right .....	WP 0004-3
Cab Instrument Panel - Upper Left .....	WP 0004-1
Cab Instrument Panel - Upper Right/Electronic Siren Controls .....	WP 0004-5
Cab Instrument Panel - Upper Right/Radio .....	WP 0004-4
Cab/Pump Operator's Panel Pressure Governor Controls .....	WP 0004-15
Driver Side - Pump House .....	WP 0004-16
Driver Side - Rear Vehicle .....	WP 0004-20
Passenger Side - Pump House .....	WP 0004-18
Personnel Cab .....	WP 0004-6
Personnel Cab - Center Console .....	WP 0004-9
Pump House Top .....	WP 0004-21
Pump Operator's Panel - Center Left .....	WP 0004-11
Pump Operator's Panel - Electronic Metering Valves .....	WP 0004-14
Pump Operator's Panel - Electronic Valves .....	WP 0004-13
Pump Operator's Panel - Left .....	WP 0004-10
Pump Operator's Panel - Upper Center/Bottom Right .....	WP 0004-12
Vehicle Water Tank Body - Rear/Sides .....	WP 0004-22
Controls and Indicators Introduction .....	WP 0004-1

## ALPHABETICAL INDEX (CONTINUED)

<u>Subject</u>	<u>WP Sequence No.-Page No.</u>
Coupling	
Installation .....	WP 0313-2
Removal .....	WP 0313-1
Cover, Door, and Electronic Mounting Base (SINCGARS)	
Installation .....	WP 0272-2
Removal .....	WP 0272-1
 <b>D</b> 	
Decal And Data Plate	
Data Plate Installation .....	WP 0326-4
Data Plate Removal .....	WP 0326-3
Decal Plate Installation .....	WP 0326-2
Decal Plate Removal .....	WP 0326-1
Direct Tank Fill AUTO Indicator Does Not Illuminate (Pump Operator's Panel) .....	WP 0087-1
Direct Tank Fill OPEN Indicator Does Not Illuminate (Pump Operator's Panel) .....	WP 0088-1
Direct Tank Fill Valve	
Installation .....	WP 0311-3
Removal .....	WP 0311-1
Direct Tank Fill Valve Does Not Operate Properly (Auto or Manual Mode) .....	WP 0064-1
Direct Tank Fill Valve Wire Harness	
Installation .....	WP 0283-3
Removal .....	WP 0283-1
Discharge Control Valve(s) Display Pressure After PTO Shutdown .....	WP 0055.1-1
Discharge Pressure Transducer	
Installation .....	WP 0245-2
Removal .....	WP 0245-1
Discharge Valve Control Wire Harness	
Installation .....	WP 0284-2
Removal .....	WP 0284-1
Discharges Have Abnormal Water Stream .....	WP 0055-1
Dome Light	
Installation .....	WP 0235-2
Removal .....	WP 0235-1
Door Latch Striker	
Lower Stowage Compartment Door Latch Striker Adjustment .....	WP 0131-1
Upper Stowage Compartment Door Latch Striker Adjustment .....	WP 0131-2
Door Switch	
Adjustment .....	WP 0246-2
Installation .....	WP 0246-1
Removal .....	WP 0246-1
Drain Valves or Main Inlet Cap Leaking During Pumping Operations .....	WP 0052-1
Driver Side Auxiliary Inlet Drain Valve	
Installation .....	WP 0160-3
Removal .....	WP 0160-1
Driver Side Auxiliary Inlet Valve Control Wire Harness	
Installation .....	WP 0285-2
Removal .....	WP 0285-1

## ALPHABETICAL INDEX (CONTINUED)

<u>Subject</u>	<u>WP Sequence No.-Page No.</u>
Driver Side Auxiliary Inlet Valve Does Not Operate Properly .....	WP 0065-1
Driver Side Body Wire Harness	
Installation .....	WP 0286-7
Removal .....	WP 0286-1
Driver Side Scene Light(s) Does Not Operate .....	WP 0108-1
Driver Side Stowage Compartment Striplight(s) Does Not Operate .....	WP 0117-1

### E

Electrically-Operated Ball Valve Electric Motor and Drive Assembly	
Installation .....	WP 0248-2
Removal .....	WP 0248-1
Electrically-Operated Ball Valve Seats and Preformed Packing	
Installation .....	WP 0249-2
Removal .....	WP 0249-1
Equipment Description and Data	
Equipment Characteristics, Capabilities, and Features .....	WP 0002-1
Equipment Data .....	WP 0002-4
Location and Description of Major Components .....	WP 0002-2
Expendable Supplies and Materials List .....	WP 0400-1

### F

First Aid Kit Mounting Bracket	
Installation .....	WP 0327-2
Removal .....	WP 0327-1
Flow Sensor	
Installation .....	WP 0250-2
Removal .....	WP 0250-1
Foam Agent	
Draining/Flushing Foam Agent Tank .....	WP 0022-3
Filling Foam Agent Tank .....	WP 0022-1
FOAM FLUSH Indicator Does Not Illuminate (Pump Operator's Panel) .....	WP 0090-1
Foam Not Delivered From All Systems (Bumper Turret, Under Truck Nozzles, and Manual Metering Controls) or System Does Not Shut Off .....	WP 0057-1
Foam Not Delivered From Bumper Turret .....	WP 0058-1
Foam Not Delivered From Under Truck Nozzles .....	WP 0059-1
Foam Not Delivered When Manual Metering Control Is Operated .....	WP 0060-1
Foam System and Instrument Panel Standby Mode	
Foam System-Standby Mode .....	WP 0023-1
Instrument Panel - Standby Mode .....	WP 0023-2
Foam System Cannot Be Flushed .....	WP 0061-1
Foam System Does Not Operate .....	WP 0047-1
Foam System Eductor	
Installation .....	WP 0177-3
Removal .....	WP 0177-1



## ALPHABETICAL INDEX (CONTINUED)

<u>Subject</u>	<u>WP Sequence No.-Page No.</u>
Foam System Eductor Valve	
Installation .....	WP 0178-2
Removal .....	WP 0178-1
Foam System Flush Valve	
Installation .....	WP 0179-2
Removal .....	WP 0179-1
Foam System Flushing	
Foam Agent Piping Flush .....	WP 0029-1
Foam System General Information .....	WP 0021-1
FOAM SYSTEM Indicator Does Not Illuminate (Cab) .....	WP 0091-1
FOAM SYSTEM Indicator Does Not Illuminate (Pump Operator's Panel) .....	WP 0092-1
Foam System Inlet Check Valve	
Installation .....	WP 0180-3
Removal .....	WP 0180-1
Foam System Manual Metering Valve	
Installation .....	WP 0181-5
Removal .....	WP 0181-1
Foam System Operating Procedures	
Starting Foam System Operation (Cab Instrument Panel) .....	WP 0024-1
Starting Foam System Operation (Pump Operator's Panel) .....	WP 0024-3
Stopping Foam System Operation (Cab Instrument Panel) .....	WP 0024-2
Foam System Operating Procedures (Cab and Pump Operator's Panel)	
Foam System Deactivation/Clean-up .....	WP 0024-2
Stopping Foam System Operation (Pump Operator's Panel) .....	WP 0024-5
Foam System Service Valve	
Installation .....	WP 0182-2
Removal .....	WP 0182-1
Foam System Shutoff Valve	
Installation .....	WP 0176-2
Removal .....	WP 0176-1
Foam System Strainer(s)	
Foam System Eductor Strainer Installation .....	WP 0183-6
Foam System Eductor Strainer Removal .....	WP 0183-5
Foam System Flush Strainer Installation .....	WP 0183-4
Foam System Flush Strainer Removal .....	WP 0183-4
Foam System Supply Strainer Installation .....	WP 0183-2
Foam System Supply Strainer Removal .....	WP 0183-1
Foam Tank Drain Valve	
Installation .....	WP 0171-3
Removal .....	WP 0171-1
Foam Tank Fill Port Extension and Cover	
Installation .....	WP 0185-2
Removal .....	WP 0185-1
Foam Tank Level Indicator Gauge Does Not Operate Properly .....	WP 0062-1
Foam Tank Level Probe	
Installation .....	WP 0175-2
Removal .....	WP 0175-1

**ALPHABETICAL INDEX (CONTINUED)**

<u>Subject</u>	<u>WP Sequence No.-Page No.</u>
Foam Tank Pressure/Vacuum/Vent	
Installation .....	WP 0184-1
Removal .....	WP 0184-1
Foam/Water Level Gauge(s) Does Not Illuminate .....	WP 0118-1
Foam/Water Tank Level Cover	
Installation .....	WP 0189-2
Removal .....	WP 0189-1
Fuel Tank Bracket	
Installation .....	WP 0372-2
Removal .....	WP 0372-1

**G**

General Information	
Corrosion Prevention and Control .....	WP 0001-2
Demolition By Mechanical Means .....	WP 0001-2
Demolition By Misuse .....	WP 0001-2
Destruction of Army Materiel To Prevent Enemy Use .....	WP 0001-2
List of Abbreviations/Acronyms .....	WP 0001-4
List of Warning Icons/Descriptions .....	WP 0001-5
Maintenance Forms, Records, and Reports .....	WP 0001-2
Nomenclature Cross-Reference List .....	WP 0001-3
Quality of Material .....	WP 0001-7
Repair Parts .....	WP 0001-8
Reporting Equipment Improvement Recommendations (EIR) .....	WP 0001-2
Scope .....	WP 0001-1
Warranty Information .....	WP 0001-3
Grab Handle	
Installation .....	WP 0328-1
Removal .....	WP 0328-1

**H**

Handheld Radio Battery Charger(s) Does Not Charge Batteries .....	WP 0053-1
Heater Fuel Pump	
Installation .....	WP 0308-2
Removal .....	WP 0308-1
Heater Fuel Tank Pickup	
Installation .....	WP 0309-2
Removal .....	WP 0309-1
High Amperage Cable(s)	
Installation .....	WP 0251-2
Removal .....	WP 0251-1
Hose Bed Assembly	
Installation .....	WP 0329-6
Removal .....	WP 0329-1

## ALPHABETICAL INDEX (CONTINUED)

<u>Subject</u>	<u>WP Sequence No.-Page No.</u>
Hose Bed Divider	
Installation .....	WP 0330-2
Removal .....	WP 0330-1
Hose Reel	
Installation .....	WP 0247-7
Removal .....	WP 0247-1
Hose Reel Circuit Breaker	
Installation .....	WP 0252-2
Removal .....	WP 0252-1
Hose Reel Discharge Valve	
Installation .....	WP 0317-2
Removal .....	WP 0317-1
Hose Reel Discharge Valve Does Not Operate When Selected .....	WP 0067-1
Hose REEL DISCHARGE Valve Indicator Does Not Illuminate (Pump Operator's Panel) .....	WP 0093-1
Hose Reel Guides	
Installation .....	WP 0331-2
Removal .....	WP 0331-1
Hose Reel Hose	
Installation .....	WP 0316-2
Removal .....	WP 0316-1
Hose Reel Motor	
Installation .....	WP 0332-2
Removal .....	WP 0332-1
Hose Reel Operation .....	WP 0025-1
Stowing Hose on Hose Reel (Powered Rewind) .....	WP 0025-3
Hose Reel Rewind Control Does Not Operate .....	WP 0066-1
Hose Reel Solenoid	
Installation .....	WP 0254-2
Removal .....	WP 0254-1
Hose Restraint Netting	
Installation .....	WP 0333-2
Removal .....	WP 0333-1
Hydraulic Heat Exchanger	
Installation .....	WP 0134-5
Removal .....	WP 0134-1
Hydraulic Heat Exchanger Bottom Shroud Panel	
Installation .....	WP 0135-2
Removal .....	WP 0135-1
Hydraulic Heat Exchanger Fan(s)	
Installation .....	WP 0136-2
Removal .....	WP 0136-1
Hydraulic Heat Exchanger Fan(s) Do Not Operate .....	WP 0056-1
Hydraulic Heat Exchanger Fan(s) Switch	
Installation .....	WP 0133-2
Removal .....	WP 0133-1

## ALPHABETICAL INDEX (CONTINUED)

<u>Subject</u>	<u>WP Sequence No.-Page No.</u>
Hydraulic Heat Exchanger Shroud	
Shroud A Installation .....	WP 0137-2
Shroud A Removal .....	WP 0137-1
Shroud B Installation .....	WP 0137-4
Shroud B Removal .....	WP 0137-3
Shroud C Installation .....	WP 0137-6
Shroud C Removal .....	WP 0137-5
Shroud D Installation .....	WP 0137-7
Shroud D Removal .....	WP 0137-7
Hydraulic Hose	
Hydraulic Hoses .....	WP 0138-3
Typical Hydraulic Hose Installation .....	WP 0138-2
Typical Hydraulic Hose Removal .....	WP 0138-1
Hydraulic Oil Drain Mounting Bracket	
Installation .....	WP 0139-2
Removal .....	WP 0139-1
Hydraulic Oil Filter	
Installation .....	WP 0140-2
Removal .....	WP 0140-1
Hydraulic Oil Filter Base	
Installation .....	WP 0141-6
Removal .....	WP 0141-2
Hydraulic Override Manifold	
Installation .....	WP 0142-6
Removal .....	WP 0142-2
Hydraulic Override Manifold Solenoid and Proportioning Valve Replacement	
Installation .....	WP 0305.1-2
Removal .....	WP 0305.1-1
Hydraulic Pressure Control	
Installation .....	WP 0143-3
Removal .....	WP 0143-1
Hydraulic Reservoir	
Drain .....	WP 0145-1
Fill .....	WP 0145-2
Hydraulic Reservoir and Bracket	
Installation .....	WP 0148-7
Removal .....	WP 0148-2
Hydraulic Reservoir Breather	
Installation .....	WP 0144-2
Removal .....	WP 0144-1
Hydraulic Reservoir Fluid Level Gauge	
Installation .....	WP 0146-2
Removal .....	WP 0146-1
Hydraulic Reservoir Fluid Level Switch	
Installation .....	WP 0147-2
Removal .....	WP 0147-1
Hydraulic Reservoir Strainer	
Installation .....	WP 0149-2
Removal .....	WP 0149-1

## ALPHABETICAL INDEX (CONTINUED)

<u>Subject</u>	<u>WP Sequence No.-Page No.</u>
Hydraulic Reservoir Temperature Sensor	
Installation .....	WP 0150-2
Removal .....	WP 0150-1
Hydrostatic Charge Pump	
Installation .....	WP 0152-8
Removal .....	WP 0152-2
Hydrostatic Pump Motor	
Installation .....	WP 0151-5
Removal .....	WP 0151-2

### I

Illustrated List of Manufactured Items .....	WP 0386-1
Inlet Valve	
Installation .....	WP 0186-4
Removal .....	WP 0186-1
Inline Fuse	
Installation .....	WP 0255-2
Removal .....	WP 0255-1
Intercom	
Installation .....	WP 0256-5
Removal .....	WP 0256-1
Intercom and Headsets Do Not Operate Properly .....	WP 0120-1
Intercom Cables and Connectors	
Installation .....	WP 0257-4
Removal .....	WP 0257-1
Intercom Headset Hangers	
Installation .....	WP 0258-2
Removal .....	WP 0258-1
Intercom Wire Harness	
Singars Interface Wire Harness Installation .....	WP 0289-2
Singars Interface Wire Harness Removal .....	WP 0289-1
Two-Way Radio Interface Wire Harness Installation .....	WP 0289-5
Two-Way Radio Interface Wire Harness Removal .....	WP 0289-4

### L

Light Bezel Cover(s)	
Driver Side Light Bezel Cover Installation .....	WP 0335-1
Driver Side Light Bezel Cover Removal .....	WP 0335-1
Passenger Side Light Bezel Cover Installation .....	WP 0335-2
Passenger Side Light Bezel Cover Removal .....	WP 0335-2
Light Bezel(s)	
Installation .....	WP 0334-2
Removal .....	WP 0334-1
Lightbar Cable Assembly	
Installation .....	WP 0291-5
Removal .....	WP 0291-1

## ALPHABETICAL INDEX (CONTINUED)

<u>Subject</u>	<u>WP Sequence No.-Page No.</u>
Lightbar Cable Assembly Branch	
Installation .....	WP 0290-3
Removal .....	WP 0290-1
Lightbar Flasher Unit	
Installation .....	WP 0287-3
Removal .....	WP 0287-1
Lower Rear Marker Lights and Bracket	
Installation .....	WP 0227-2
Removal .....	WP 0227-1
Lubrication Instructions	
Preventive Maintenance Checks and Services (PMCS) Table .....	WP 0129-1

### M

Main Wire Harness	
Installation .....	WP 0292-11
Removal .....	WP 0292-1
Maintenance Allocation Chart (MAC) .....	WP 0398-1
Maintenance Allocation Chart (MAC) Introduction .....	WP 0397-1
Maintenance General Introduction	
General Cleaning Instructions .....	WP 0130-5
General Inspection Instructions .....	WP 0130-8
General Installation Instructions .....	WP 0130-8
General Maintenance Procedures .....	WP 0130-3
General Removal Instructions .....	WP 0130-4
Inspection and Service Upon Receipt .....	WP 0130-2
Repair Parts .....	WP 0130-1
Scope .....	WP 0130-1
Special Tools, TMDE, And Support Equipment .....	WP 0130-1
Standard Army Tools And Equipment .....	WP 0130-1
Manual Bray Dump Valve(s)	
Installation .....	WP 0188-5
Removal .....	WP 0188-1
Manual Hose Reel Rewind .....	WP 0036-1
Manual Primer Handle	
Installation .....	WP 0164-2
Removal .....	WP 0164-1
Manual Priming Pump Operation	
Cab .....	WP 0037-1
Pump Operator's Panel .....	WP 0037-3

### N

No. 1 Driver Side Discharge Drain Valve	
Installation .....	WP 0161-3
Removal .....	WP 0161-1

## ALPHABETICAL INDEX (CONTINUED)

<u>Subject</u>	<u>WP Sequence No.-Page No.</u>
No. 1 Driver Side Discharge Valve	
Installation .....	WP 0314-4
Removal .....	WP 0314-1
No. 1 Driver Side Discharge Valve Does Not Operate Properly .....	WP 0068-1
No. 1 Driver Side Flow Sensor Wire Harness	
Installation .....	WP 0293-2
Removal .....	WP 0293-1
No. 1 Driver Side Pressure Transducer Wire Harness	
Installation .....	WP 0294-2
Removal .....	WP 0294-1
No. 2 Passenger Side Discharge Drain Valve	
Installation .....	WP 0162-3
Removal .....	WP 0162-1
No. 2 Passenger Side Discharge Valve	
Installation .....	WP 0315-4
Removal .....	WP 0315-1
No. 2 Passenger Side Discharge Valve Does Not Operate Properly .....	WP 0069-1
No. 2 Passenger Side Flow Sensor Wire Harness	
Installation .....	WP 0295-2
Removal .....	WP 0295-1
No. 2 Passenger Side Pressure Transducer Wire Harness	
Installation .....	WP 0297-2
Removal .....	WP 0297-1

### O

On-Truck Load Plan .....	WP 0040-1
Operation in Cold Environment, -25 to 32°F (-32 to 0°C) .....	WP 0034-1
Operation in Extreme Hot Environment 105°F (40°C) or Above .....	WP 0035-1
Overhead Warning Beacon	
Installation .....	WP 0232-2
Removal .....	WP 0232-1

### P

Passenger Side Auxiliary Inlet Drain Valve	
Installation .....	WP 0159-3
Removal .....	WP 0159-1
Passenger Side Auxiliary Inlet Valve Control Wire Harness	
Installation .....	WP 0296-2
Removal .....	WP 0296-1
Passenger Side Auxiliary Inlet Valve Does Not Operate Properly .....	WP 0070-1
Passenger Side Body Wire Harness	
Installation .....	WP 0298-10
Removal .....	WP 0298-1
Passenger Side Scene Light(s) Does Not Operate .....	WP 0110-1
Passenger Side Stowage Compartment Striplight(s) Does Not Operate .....	WP 0121-1

## ALPHABETICAL INDEX (CONTINUED)

<u>Subject</u>	<u>WP Sequence No.-Page No.</u>
Personnel Cab Clearance Light and Bracket	
Installation . . . . .	WP 0223-3
Piping Assembly (Pipe Thread Sealing Compound)	
Assembly . . . . .	WP 0318-1
Plumbing, Hoses, and Piping Replacement . . . . .	WP 0320-1
Pneumatic Spring	
Installation . . . . .	WP 0336-2
Removal . . . . .	WP 0336-1
Portable Handheld Radio and Charger	
Installation . . . . .	WP 0259-2
Removal . . . . .	WP 0259-1
Portable Ladder (Folding)	
Stow Access Ladder . . . . .	WP 0013-2
Unstow Access Ladder . . . . .	WP 0013-1
Portable Water Tank	
Stow . . . . .	WP 0014-3
Unstow . . . . .	WP 0014-1
Portable Water Tank Stowage Compartment	
Installation . . . . .	WP 0337-2
Removal . . . . .	WP 0337-1
Post Operation Procedures . . . . .	WP 0030-1
Power Cable Assembly (SINCGARS)	
Installation . . . . .	WP 0260-2
Removal . . . . .	WP 0260-1
Power Steering Pump Removal/Modification/Installation and Adapter Replacement	
Adapter Installation . . . . .	WP 0376.1-9
Adapter Removal . . . . .	WP 0376.1-8
Installation of Power Steering Pump On Adapter . . . . .	WP 0376.1-6
Modification of New Steering Pump . . . . .	WP 0376.1-3
Power Steering Pump Removal From Adapter . . . . .	WP 0376.1-1
Power Take Off (PTO)	
Installation . . . . .	WP 0153-6
Removal . . . . .	WP 0153-1
Power Take Off (PTO) Drive Shaft	
Installation . . . . .	WP 0154-2
Removal . . . . .	WP 0154-1
Power Take Off (PTO) Solenoid and Pressure Switch	
Installation . . . . .	WP 0155-2
Removal . . . . .	WP 0155-1
Preparation for Operation-Operational Modes . . . . .	WP 0006-1
Preparation for Storage (Long Term	
6 Months or Longer) . . . . .	WP 0032-1
Prepare to Operate Vehicle . . . . .	WP 0005-1
Pressure Governor Control Displays WARNING! or CAUTION! . . . . .	WP 0048-1
Pressure Governor Controls Do Not Operate . . . . .	WP 0049-1
Pressure Governor Controls Do Not Operate Properly . . . . .	WP 0072-1
Pressure Governor Controls Slow to Respond To Request . . . . .	WP 0072.1-1



## ALPHABETICAL INDEX (CONTINUED)

<u>Subject</u>	<u>WP Sequence No.-Page No.</u>
Pressure Governor ECU	
Installation . . . . .	WP 0288-3
Removal . . . . .	WP 0288-1
Pressure Governor Operation	
Personnel Cab Display . . . . .	WP 0017-1
Pump Operator's Panel Display . . . . .	WP 0017-19
Preventive Maintenance Checks and Services (PMCS)	
Explanation of Table Entries . . . . .	WP 0128-3
Introduction . . . . .	WP 0128-1
Leakage Classification and Definition . . . . .	WP 0128-5
PMCS Warnings and Cautions . . . . .	WP 0128-3
Routing Diagram . . . . .	WP 0128-4
Primer Pump	
Installation . . . . .	WP 0165-3
Removal . . . . .	WP 0165-1
Primer Pump Control Solenoid	
Installation . . . . .	WP 0300-2
Removal . . . . .	WP 0300-1
Primer Tank and Bracket	
Installation . . . . .	WP 0166-2
Removal . . . . .	WP 0166-1
Primer Valve	
Installation . . . . .	WP 0169-3
Removal . . . . .	WP 0169-1
Primer Valve Cable	
Installation . . . . .	WP 0167-2
Removal . . . . .	WP 0167-1
Primer Valve Control Solenoid	
Installation . . . . .	WP 0168-2
Removal . . . . .	WP 0168-1
Priming Water Pump	
Priming Water Pump from Cab . . . . .	WP 0016-1
Priming Water Pump From Pump Operator's Panel . . . . .	WP 0016-2
Pump and Plumbing Blow Out Procedures . . . . .	WP 0033-1
Pump Cooler (Dump-To-Ground) Valve	
Installation . . . . .	WP 0319-2
Removal . . . . .	WP 0319-1
Pump Cooler (Dump-To-Ground) Valve Does Not Operate Properly . . . . .	WP 0071-1
PUMP COOLER Indicator Does Not Illuminate (Cab) . . . . .	WP 0094-1
PUMP COOLER Indicator Does Not Illuminate (Pump Operator's Panel) . . . . .	WP 0095-1
Pump Does Not Prime . . . . .	WP 0050-1
Pump Drain Valve	
Installation . . . . .	WP 0321-3
Removal . . . . .	WP 0321-1
PUMP HOT Audio Alarm or Indicator Does Not Operate Properly (Pump Operator's Panel) . . . . .	WP 0097-1
Pump House Access Door Assembly	
Close . . . . .	WP 0009-2
Open . . . . .	WP 0009-1

## ALPHABETICAL INDEX (CONTINUED)

<u>Subject</u>	<u>WP Sequence No.-Page No.</u>
Pump House Access Door(s)	
Pump House Panel H Access Door Removal .....	WP 0338-4
Pump House Assembly	
Installation .....	WP 0340-15
Removal .....	WP 0340-2
Pump House B+ Stud	
Installation .....	WP 0301-2
Removal .....	WP 0301-1
Pump House Frame	
Installation .....	WP 0341-2
Removal .....	WP 0341-1
Pump House Heater	
Installation .....	WP 0310-3
Removal .....	WP 0310-1
Pump House Heater Diagnostic and Thermal Switch(es)	
Installation .....	WP 0307-4
Removal .....	WP 0307-1
Pump House Heater Does Not Operate Properly .....	WP 0127-1
Pump House Heater Test Switch	
Installation .....	WP 0306-2
Removal .....	WP 0306-1
Pump House or Pump Operator's Panel Striplight(s) Does Not Operate .....	WP 0122-1

## ALPHABETICAL INDEX (CONTINUED)

<u>Subject</u>	<u>WP Sequence No.-Page No.</u>
Pump House Panel(s)	
Pump House Panel A Installation . . . . .	WP 0339-4
Pump House Panel A Removal . . . . .	WP 0339-2
Pump House Panel B Installation . . . . .	WP 0339-7
Pump House Panel B Removal . . . . .	WP 0339-6
Pump House Panel C Installation . . . . .	WP 0339-10
Pump House Panel C Removal . . . . .	WP 0339-9
Pump House Panel D Installation . . . . .	WP 0339-11
Pump House Panel D Removal . . . . .	WP 0339-11
Pump House Panel E Installation . . . . .	WP 0339-12
Pump House Panel E Removal . . . . .	WP 0339-12
Pump House Panel F Installation . . . . .	WP 0339-13
Pump House Panel F Removal . . . . .	WP 0339-13
Pump House Panel G Installation . . . . .	WP 0339-14
Pump House Panel G Removal . . . . .	WP 0339-14
Pump House Panel H Installation . . . . .	WP 0339-16
Pump House Panel H Removal . . . . .	WP 0339-15
Pump House Panel I Installation . . . . .	WP 0339-17
Pump House Panel I Removal . . . . .	WP 0339-16
Pump House Panel J Installation . . . . .	WP 0339-19
Pump House Panel J Removal . . . . .	WP 0339-19
Pump House Panel K Installation . . . . .	WP 0339-20
Pump House Panel K Removal . . . . .	WP 0339-20
Pump House Panel L Installation . . . . .	WP 0339-21
Pump House Panel L Removal . . . . .	WP 0339-21
Pump House Panel M Installation . . . . .	WP 0339-22
Pump House Panel M Removal . . . . .	WP 0339-22
Pump House Panel N Installation . . . . .	WP 0339-25
Pump House Panel N Removal . . . . .	WP 0339-23
Pump House Panel O Installation . . . . .	WP 0339-27
Pump House Panel O Removal . . . . .	WP 0339-27
Pump House Panel P Installation . . . . .	WP 0339-28
Pump House Panel P Removal . . . . .	WP 0339-28
Pump House Power Distribution Block Circuit Breaker	
Installation . . . . .	WP 0262-2
Removal . . . . .	WP 0262-1
Pump House Power Distribution Block Relay	
Installation . . . . .	WP 0263-2
Removal . . . . .	WP 0263-1
Pump House Power Distribution Box	
Installation . . . . .	WP 0264-3
Removal . . . . .	WP 0264-1
Pump House Power Distribution Wire Harness and Block	
Installation . . . . .	WP 0299-4
Removal . . . . .	WP 0299-1
Pump House Wire Harness	
Installation . . . . .	WP 0302-16
Removal . . . . .	WP 0302-1

## ALPHABETICAL INDEX (CONTINUED)

<u>Subject</u>	<u>WP Sequence No.-Page No.</u>
Pump Input and Discharge Pressure Transducers	
Installation .....	WP 0265-5
Removal .....	WP 0265-1
Pump Loses Prime or Pressure Governor Displays LOW SUPPLY or PRESET NOT MET, and Pump Returns to Idle Mode .....	WP 0051-1
Pump Operator's Panel	
Close .....	WP 0207-2
Installation .....	WP 0208-2
Open .....	WP 0207-1
Removal .....	WP 0208-2
Pump Operator's Panel Cover	
Close .....	WP 0010-1
Installation .....	WP 0206-2
Open .....	WP 0010-1
Removal .....	WP 0206-1
Pump Operator's Panel Driver Main Inlet Primer Button	
Installation .....	WP 0219-2
Removal .....	WP 0219-1
Pump Operator's Panel Electric Valve Control	
Installation .....	WP 0209-2
Removal .....	WP 0209-1
Pump Operator's Panel Electric Valve Control Meter	
Installation .....	WP 0210-2
Removal .....	WP 0210-1
Pump Operator's Panel Foam Level Gauge	
Installation .....	WP 0211-2
Removal .....	WP 0211-1
Pump Operator's Panel Housing	
Installation .....	WP 0342-9
Removal .....	WP 0342-2
Pump Operator's Panel Indicator	
Installation .....	WP 0213-2
Removal .....	WP 0213-1
Pump Operator's Panel Indicator Lamp	
Installation .....	WP 0214-2
Removal .....	WP 0214-1
Pump Operator's Panel Overheat Test Button and Indicator	
Installation .....	WP 0218-3
Removal .....	WP 0218-1
Pump Operator's Panel Pressure Governor Control	
Installation .....	WP 0216-2
Removal .....	WP 0216-1
Pump Operator's Panel Toggle Switch (Three-Position)	
Installation .....	WP 0221-2
Removal .....	WP 0221-1
Pump Operator's Panel Toggle Switch (Two-Position)	
Installation .....	WP 0220-2
Removal .....	WP 0220-1

## ALPHABETICAL INDEX (CONTINUED)

<u>Subject</u>	<u>WP Sequence No.-Page No.</u>
Pump Operator's Panel Water Level Gauge	
Installation .....	WP 0212-2
Removal .....	WP 0212-1
Pump Operator's Panel Wire Harness	
Installation .....	WP 0303-18
Removal .....	WP 0303-2
Pump Primer Motor Diode Pack	
Installation .....	WP 0222-1
Removal .....	WP 0222-1
Pump Priming System Does Not Operate Properly .....	WP 0073-1
PUMP PTO ENGAGED Indicator Does Not Illuminate (Cab) .....	WP 0096-1
Pumping from Draft (Main Inlet) .....	WP 0018-1
Pumping from Hydrant or In Relay (Positive Water Sources) .....	WP 0020-1
Pumping from Onboard Water Tank .....	WP 0019-1
Pumping Operations (Manual Override)	
Starting Manual Override Pumping Operations .....	WP 0038-1
Stopping Manual Override Pumping Operations .....	WP 0038-2

### R

Rear Access Ladder	
Disassembly .....	WP 0343-3
Assembly .....	WP 0343-4
Installation .....	WP 0343-6
Removal .....	WP 0343-1
Rear Hard Lift	
Installation .....	WP 0344-5
Removal .....	WP 0344-1
Rear Marker/Clearance Directional LED	
Installation .....	WP 0228-2
Removal .....	WP 0228-1
Rear Marker/Clearance LED	
Installation .....	WP 0229-2
Removal .....	WP 0229-1
Rear Scene Light(s) Does Not Operate .....	WP 0111-1
Rear Splash Guard	
Installation .....	WP 0345-2
Removal .....	WP 0345-1
Rear Step Buzzer Audio Alarm Does Not Operate .....	WP 0123-1
Rear Step Buzzer Button and Cable	
Installation .....	WP 0266-2
Removal .....	WP 0266-1
Rear Step Buzzer Button Compartment	
Installation .....	WP 0267-3
Removal .....	WP 0267-1
Reel Rewind Switch	
Installation .....	WP 0253-2
Removal .....	WP 0253-1

## ALPHABETICAL INDEX (CONTINUED)

<u>Subject</u>	<u>WP Sequence No.-Page No.</u>
References .....	WP 0396-1
Reflector	
Installation .....	WP 0346-2
Removal .....	WP 0346-1
Repair Parts and Special Tools List (RPSTL) Introduction .....	WP 0388-1
Repair Parts and Special Tools List (RPSTL) NSN Index .....	WP 0394-1
Repair Parts and Special Tools List (RPSTL) Part Number Index .....	WP 0395-1
Right Rear Access Ladder	
Stow .....	WP 0012-1
Unstow .....	WP 0012-2

### S

SCBA Seat	
Installation .....	WP 0347-3
Removal .....	WP 0347-1
SCBA Seat Belt	
Installation .....	WP 0348-3
Removal .....	WP 0348-1
Scene Light(s)	
Installation .....	WP 0233-2
Removal .....	WP 0233-1
Scene Lights, Step Lights, Cab Dome Lights, Clearance Lights, and Stowage Compartment Lights or Warning Lights Do Not Operate .....	WP 0054-1
Shoreline Inlet Receptacle	
Installation .....	WP 0268-5
Removal .....	WP 0268-1
Shoreline Inlet Receptacle Does Not Operate Properly .....	WP 0126-1
Shutoff Control Valve	
Installation .....	WP 0271-3
Removal .....	WP 0271-1
Shutoff Control Valve Diode	
Installation .....	WP 0269-2
Removal .....	WP 0269-1
Shutoff Control Valve Manifold	
Installation .....	WP 0270-6
Removal .....	WP 0270-1
SINCGARS Cover Door	
Close .....	WP 0011-1
Open .....	WP 0011-1
SINCGARS Do Not Operate Properly .....	WP 0124-1
SINCGARS Vehicle Remote Control Unit (VRCU) Does Not Operate Properly .....	WP 0124.1-1
Siren Control	
Installation .....	WP 0380-3
Removal .....	WP 0380-1
Siren Does Not Operate Properly .....	WP 0125-1

## ALPHABETICAL INDEX (CONTINUED)

<u>Subject</u>	<u>WP Sequence No.-Page No.</u>
Skid Plate Grille	
Installation .....	WP 0349-2
Removal .....	WP 0349-1
Small Compartment Door(s)	
Air Tank Access Door/Rear Step Buzzer Compartment Door Installation .....	WP 0350-3
Portable Water Tank Compartment Door Installation .....	WP 0350-5
Portable Water Tank Compartment Door Removal .....	WP 0350-4
Pump House Panel A Access Door Installation .....	WP 0350-7
Pump House Panel A Access Door Removal .....	WP 0350-6
Pump House Panel H Access Door Installation .....	WP 0350-10
Pump House Panel H Access Door Removal .....	WP 0350-9
SCBA Tank Access Door/Rear Step Buzzer Compartment Door Removal .....	WP 0350-1
Spanner and Hydrant Wrench Holder	
Installation .....	WP 0373-2
Removal .....	WP 0373-1
Speaker	
Installation .....	WP 0273-2
Removal .....	WP 0273-1
Spreader Bar Bracket	
Installation .....	WP 0351-4
Removal .....	WP 0351-1
Static Pump Idle Pressure Adjustment .....	WP 0131.1-1
Step (Hose Bed) Light(s) Does Not Operate .....	WP 0109-1
Step Light(s)	
Installation .....	WP 0234-2
Removal .....	WP 0234-1
Stowage and Data Plate Guide .....	WP 0039-1
Stowage Compartment (Bottom Front Passenger Side)	
Installation .....	WP 0354-2
Removal .....	WP 0354-1
Stowage Compartment (Lower Front Driver Side)	
Installation .....	WP 0355-2
Removal .....	WP 0355-1
Stowage Compartment (Lower Rear Driver Side)	
Installation .....	WP 0356-3
Removal .....	WP 0356-1
Stowage Compartment (Lower Rear Passenger Side)	
Installation .....	WP 0357-2
Removal .....	WP 0357-1
Stowage Compartment (Top Front Driver Side)	
Installation .....	WP 0358-3
Removal .....	WP 0358-1
Stowage Compartment (Top Front Passenger Side)	
Installation .....	WP 0359-3
Removal .....	WP 0359-1
Stowage Compartment (Top Rear Passenger Side)	
Installation .....	WP 0360-3
Removal .....	WP 0360-1

## ALPHABETICAL INDEX (CONTINUED)

<u>Subject</u>	<u>WP Sequence No.-Page No.</u>
Stowage Compartment Door(s) and Stay Arm	
Stay Arm Installation .....	WP 0352-6
Stay Arm Removal .....	WP 0352-5
Stowage Compartment Door Installation .....	WP 0352-3
Stowage Compartment Door Removal .....	WP 0352-1
Stowage Compartment Door(s) Latch	
Driver Side Front Lower Stowage Compartment Door Latch Installation .....	WP 0353-5
Driver Side Front Lower Stowage Compartment Door Latch Removal .....	WP 0353-5
Lower Stowage Compartment Door Latch Installation .....	WP 0353-9
Lower Stowage Compartment Door Latch Removal .....	WP 0353-6
Top Stowage Compartment Door Latch Installation .....	WP 0353-3
Top Stowage Compartment Door Latch Removal .....	WP 0353-1
Streamlight and Charger	
Installation .....	WP 0261-2
Removal .....	WP 0261-1
Streamlight Battery Charger(s) Does Not Charge Batteries .....	WP 0046-1
Striplight	
Installation .....	WP 0215-2
Removal .....	WP 0215-1
System Will Not Build or Hold Pressure During Blow Out Procedure .....	WP 0074-1

### T

Tank Fill & Re-Circulating Line Valve Does Not Operate Properly .....	WP 0075-1
TANK TO PUMP Indicator Does Not Illuminate (Cab) .....	WP 0099-1
TANK TO PUMP Indicator Does Not Illuminate (Pump Operator's Panel) .....	WP 0100-1
Tank-To-Pump Check Valve	
Installation .....	WP 0187-2
Removal .....	WP 0187-1
Tank-To-Pump Valve	
Installation .....	WP 0322-3
Removal .....	WP 0322-1
Tank-To-Pump Valve Does Not Operate Properly .....	WP 0076-1
Terminal Block	
Terminal Block At D1 Stowage Compartment Installation .....	WP 0274-5
Terminal Block At D1 Stowage Compartment Removal .....	WP 0274-5
Terminal Block On Frame Rail By Battery Disconnect Switch Installation .....	WP 0274-4
Terminal Block On Frame Rail By Battery Disconnect Switch Removal .....	WP 0274-3
Terminal Block (Pass Through)	
Installation .....	WP 0241-3
Removal .....	WP 0241-1
Terminal Blocks In Cab	
Installation .....	WP 0274-2
Removal .....	WP 0274-1
Test Gauge Panel	
Installation .....	WP 0381-2
Removal .....	WP 0381-1



## ALPHABETICAL INDEX (CONTINUED)

<u>Subject</u>	<u>WP Sequence No.-Page No.</u>
Theory of Operation	
Air System . . . . .	WP 0003-2
Electrical System . . . . .	WP 0003-2
Foam System . . . . .	WP 0003-1
Pressure Governor . . . . .	WP 0003-1
System Introduction . . . . .	WP 0003-1
Water Pumping System . . . . .	WP 0003-1
Windshield Deluge System . . . . .	WP 0003-2
Winterization Package . . . . .	WP 0003-2
Thermal Relief Valve	
Installation . . . . .	WP 0163-2
Removal . . . . .	WP 0163-1
Thermal Relief Valve Switch	
Installation . . . . .	WP 0275-2
Removal . . . . .	WP 0275-1
Threaded Screw Insert	
Installation . . . . .	WP 0362-2
Removal . . . . .	WP 0362-1
Tire Inflator Connectors	
Installation . . . . .	WP 0382-3
Removal . . . . .	WP 0382-1
Top Stowage Compartment Door(s)	
Installation . . . . .	WP 0361-4
Removal . . . . .	WP 0361-1
Torque Limits . . . . .	WP 0387-1
Transmission Dipstick and Tube	
Installation . . . . .	WP 0363-2
Removal . . . . .	WP 0363-1
Troubleshooting Fault Index	
Field Level . . . . .	WP 0043-1
Operator Level . . . . .	WP 0042-1
Troubleshooting Instructions Introduction . . . . .	WP 0041-1
Two-Way Radio	
Installation . . . . .	WP 0276-2
Removal . . . . .	WP 0276-1
Two-Way Radio Does Not Operate Properly . . . . .	WP 0119-1

### U

Under Truck Nozzles and Pump and Roll/Drive Operation	
Starting Under Truck Nozzles and Pump and Roll Operations . . . . .	WP 0028-1
Stopping Under Truck Nozzle and Pump and Roll Operations . . . . .	WP 0028-2

## ALPHABETICAL INDEX (CONTINUED)

<u>Subject</u>	<u>WP Sequence No.-Page No.</u>
Under Truck Nozzles Assembly	
Back Under Truck Nozzle Installation . . . . .	WP 0383-8
Back Under Truck Nozzle Removal . . . . .	WP 0383-7
Front Under Truck Nozzle Installation . . . . .	WP 0383-2
Front Under Truck Nozzle Removal . . . . .	WP 0383-1
Middle Back Under Truck Nozzle Installation . . . . .	WP 0383-6
Middle Back Under Truck Nozzle Removal . . . . .	WP 0383-5
Middle Front Under Truck Nozzle Installation . . . . .	WP 0383-4
Middle Front Under Truck Nozzle Removal . . . . .	WP 0383-3
Under Truck Nozzles Do Not Operate When Selected . . . . .	WP 0077-1
Under Truck Nozzles Foam Metering Valve and Orifice	
Installation . . . . .	WP 0174-2
Removal . . . . .	WP 0174-1
UNDER TRUCK NOZZLES Indicator Does Not Illuminate (CAB) . . . . .	WP 0101-1
Under Truck Nozzles Valve	
Installation . . . . .	WP 0323-2
Removal . . . . .	WP 0323-1

### V

VRCU Cable and Bracket Replacement	
Installation . . . . .	WP 0305.2-1
Removal . . . . .	WP 0305.2-1

### W

Walkway Grating	
Installation . . . . .	WP 0364-2
Removal . . . . .	WP 0364-1
Warning Buzzer (Cab and Pump Operator's Panel)	
Installation . . . . .	WP 0203-2
Removal . . . . .	WP 0203-1
Warning Light(s)	
Installation . . . . .	WP 0231-2
Removal . . . . .	WP 0231-1
Warning Light(s) and CHECK FOR OPEN COMPARTMENT DOORS WHEN LIGHT IS ON	
Flasher Unit(s)	
Installation . . . . .	WP 0196-4
Removal . . . . .	WP 0196-1
Warning Lights (All) Do Not Operate . . . . .	WP 0102-1
Warning Lights (Cab Roof Lightbar) Do Not Operate . . . . .	WP 0105-1
Warning Lights (Front and Rear Lower) Do Not Operate . . . . .	WP 0103-1
Warning Lights (Overhead Beacon) Do Not Operate . . . . .	WP 0104-1
Warning Lights (Side) Do Not Operate . . . . .	WP 0106-1
Warning Lights (Upper Rear) Do Not Operate . . . . .	WP 0107-1
Water Pump	
Installation . . . . .	WP 0158-10
Removal . . . . .	WP 0158-1

## ALPHABETICAL INDEX (CONTINUED)

<u>Subject</u>	<u>WP Sequence No.-Page No.</u>
Water Pump and Water Tank Flush	
Water Pump Flush .....	WP 0031-1
Water Tank Flush .....	WP 0031-4
Water Pump Blow Out Component(s)	
Installation .....	WP 0384-5
Removal .....	WP 0384-1
Water Pump Dipstick Assembly	
Installation .....	WP 0156-2
Removal .....	WP 0156-1
Water Pump Gear Case	
Installation .....	WP 0157-2
Removal .....	WP 0157-1
Water Pump Input Pressure Low or Pressure Governor Displays CAVITATION, LOW SUPPLY Pressure, and Pump Returns to Idle Mode .....	WP 0082-1
Water Pump Is Noisy .....	WP 0078-1
Water Pump Is Overheating .....	WP 0083-1
Water Pump Output Pressure Low or Pressure Governor Displays PRESET NOT MET, and Pump Returns to Idle Mode .....	WP 0084-1
Water PUMP PTO Does Not Engage When Selected .....	WP 0079-1
Water Tank	
Installation .....	WP 0193-6
Removal .....	WP 0193-2
Water Tank Cradle	
Installation .....	WP 0194-7
Removal .....	WP 0194-1
WATER TANK DRAIN Indicator Does Not Illuminate (Pump Operator's Panel) .....	WP 0098-1
Water Tank Drain Valve	
Installation .....	WP 0172-2
Removal .....	WP 0172-1
Water Tank Drain Valve Does Not Operate When Selected .....	WP 0080-1
Water Tank Fill & Re-Circulating Line Valve	
Installation .....	WP 0191-2
Removal .....	WP 0191-1
Water Tank Fill & Re-Circulating Line Valve Control Wire Harness	
Installation .....	WP 0304-2
Removal .....	WP 0304-1
Water Tank Level Indicator Gauge Does Not Operate Properly .....	WP 0081-1
Water Tank Level Probe	
Installation .....	WP 0190-2
Removal .....	WP 0190-1
Water Tank Vent Fill Tower	
Installation .....	WP 0192-3
Removal .....	WP 0192-1
Water Tank, Drain .....	WP 0015-17

## ALPHABETICAL INDEX (CONTINUED)

<u>Subject</u>	<u>WP Sequence No.-Page No.</u>
Water Tank, Fill	
Auxiliary Inlets .....	WP 0015-5
Direct Tank Fill .....	WP 0015-9
Filling From Draft .....	WP 0015-13
Main Inlet (Positive Water Source) .....	WP 0015-1
Overhead Fill .....	WP 0015-12
Waterproof Splice Box	
Installation .....	WP 0305-3
Removal .....	WP 0305-1
Wheel Chocks Stowage Compartment	
Installation .....	WP 0365-2
Removal .....	WP 0365-1
Windshield Deluge Automatic Drain Valve	
Strainer Body and Tee Assembly Installation .....	WP 0324-4
Strainer Body and Tee Assembly Removal .....	WP 0324-3
Strainer Installation .....	WP 0324-2
Strainer Removal .....	WP 0324-1
Windshield Deluge Motor	
Installation .....	WP 0277-3
Removal .....	WP 0277-1
Windshield Deluge Nozzle(s)	
Installation .....	WP 0367-2
Removal .....	WP 0367-1
Windshield Deluge Operation	
Starting .....	WP 0026-1
Stopping .....	WP 0026-1
Windshield Deluge Pump House Strainer Screen	
Installation .....	WP 0366-2
Removal .....	WP 0366-1
Windshield Deluge Shutoff Valve and Strainer Assembly	
Installation .....	WP 0385-3
Removal .....	WP 0385-1
Windshield Deluge System Does Not Operate Properly .....	WP 0085-1
Wire Harness Mounting Bracket	
Installation .....	WP 0368-2
Removal .....	WP 0368-1
Wire Rope	
Installation .....	WP 0369-3
Removal .....	WP 0369-1

<b>RECOMMENDED CHANGES TO PUBLICATIONS AND BLANK FORMS</b>						Use Part II ( <i>reverse</i> ) for Repair Parts and Special Tool Lists (RPSTL) and Supply Catalogs/Supply Manuals (SC/SM).	DATE
<small>For use of this form, see AR 25-30; the proponent agency is OAASA</small>							
<b>TO:</b> ( <i>Forward to proponent of publication or form</i> ) ( <i>Include ZIP Code</i> )						<b>FROM:</b> ( <i>Activity and location</i> ) ( <i>Include ZIP Code</i> )	
<b>PART I - ALL PUBLICATIONS (EXCEPT RPSTL AND SC/SM) AND BLANK FORMS</b>							
PUBLICATION/FORM NUMBER						DATE	TITLE
ITEM	PAGE	PARA- GRAPH	LINE	FIGURE NO.	TABLE	RECOMMENDED CHANGES AND REASON	
<small>* Reference to line numbers within the paragraph or subparagraph.</small>							
TYPED NAME, GRADE OR TITLE						TELEPHONE EXCHANGE/AUTOVON, PLUS EXTENSION	SIGNATURE

<b>TO:</b> <i>(Forward direct to addressee listed in publication)</i>	<b>FROM:</b> <i>(Activity and location) (Include ZIP Code)</i>	<b>DATE</b>
---	--	-------------

**PART II - REPAIR PARTS AND SPECIAL TOOL LISTS AND SUPPLY CATALOGS/SUPPLY MANUALS**

PUBLICATION NUMBER			DATE		TITLE			
PAGE NO.	COLM NO.	LINE NO.	NATIONAL STOCK NUMBER	REFERENCE NO.	FIGURE NO.	ITEM NO.	TOTAL NO. OF MAJOR ITEMS SUPPORTED	RECOMMENDED ACTION

**PART III - REMARKS** *(Any general remarks or recommendations, or suggestions for improvement of publications and blank forms. Additional blank sheets may be used if more space is needed.)*

TYPED NAME, GRADE OR TITLE	TELEPHONE EXCHANGE/AUTOVON, PLUS EXTENSION	SIGNATURE
----------------------------	--	-----------

<b>RECOMMENDED CHANGES TO PUBLICATIONS AND BLANK FORMS</b>						Use Part II ( <i>reverse</i> ) for Repair Parts and Special Tool Lists (RPSTL) and Supply Catalogs/Supply Manuals (SC/SM).	DATE
For use of this form, see AR 25-30; the proponent agency is OAASA							
TO: ( <i>Forward to proponent of publication or form</i> ) ( <i>Include ZIP Code</i> )				FROM: ( <i>Activity and location</i> ) ( <i>Include ZIP Code</i> )			
<b>PART I - ALL PUBLICATIONS (EXCEPT RPSTL AND SC/SM) AND BLANK FORMS</b>							
PUBLICATION/FORM NUMBER					DATE		TITLE
ITEM	PAGE	PARA- GRAPH	LINE	FIGURE NO.	TABLE	RECOMMENDED CHANGES AND REASON	
* Reference to line numbers within the paragraph or subparagraph.							
TYPED NAME, GRADE OR TITLE				TELEPHONE EXCHANGE/AUTOVON, PLUS EXTENSION		SIGNATURE	

<b>TO:</b> <i>(Forward direct to addressee listed in publication)</i>	<b>FROM:</b> <i>(Activity and location) (Include ZIP Code)</i>	<b>DATE</b>
---	--	-------------

**PART II - REPAIR PARTS AND SPECIAL TOOL LISTS AND SUPPLY CATALOGS/SUPPLY MANUALS**

PUBLICATION NUMBER			DATE		TITLE			
PAGE NO.	COLM NO.	LINE NO.	NATIONAL STOCK NUMBER	REFERENCE NO.	FIGURE NO.	ITEM NO.	TOTAL NO. OF MAJOR ITEMS SUPPORTED	RECOMMENDED ACTION

**PART III - REMARKS** *(Any general remarks or recommendations, or suggestions for improvement of publications and blank forms. Additional blank sheets may be used if more space is needed.)*

TYPED NAME, GRADE OR TITLE	TELEPHONE EXCHANGE/AUTOVON, PLUS EXTENSION	SIGNATURE
----------------------------	--	-----------



<b>RECOMMENDED CHANGES TO PUBLICATIONS AND BLANK FORMS</b>						Use Part II ( <i>reverse</i> ) for Repair Parts and Special Tool Lists (RPSTL) and Supply Catalogs/Supply Manuals (SC/SM).	DATE
For use of this form, see AR 25-30; the proponent agency is OAASA							
TO: ( <i>Forward to proponent of publication or form</i> ) ( <i>Include ZIP Code</i> )				FROM: ( <i>Activity and location</i> ) ( <i>Include ZIP Code</i> )			
<b>PART I - ALL PUBLICATIONS (EXCEPT RPSTL AND SC/SM) AND BLANK FORMS</b>							
PUBLICATION/FORM NUMBER					DATE		TITLE
ITEM	PAGE	PARA- GRAPH	LINE	FIGURE NO.	TABLE	RECOMMENDED CHANGES AND REASON	
* Reference to line numbers within the paragraph or subparagraph.							
TYPED NAME, GRADE OR TITLE				TELEPHONE EXCHANGE/AUTOVON, PLUS EXTENSION		SIGNATURE	

<b>TO:</b> <i>(Forward direct to addressee listed in publication)</i>	<b>FROM:</b> <i>(Activity and location) (Include ZIP Code)</i>	<b>DATE</b>
---	--	-------------

**PART II - REPAIR PARTS AND SPECIAL TOOL LISTS AND SUPPLY CATALOGS/SUPPLY MANUALS**

PUBLICATION NUMBER			DATE		TITLE			
PAGE NO.	COLM NO.	LINE NO.	NATIONAL STOCK NUMBER	REFERENCE NO.	FIGURE NO.	ITEM NO.	TOTAL NO. OF MAJOR ITEMS SUPPORTED	RECOMMENDED ACTION

**PART III - REMARKS** *(Any general remarks or recommendations, or suggestions for improvement of publications and blank forms. Additional blank sheets may be used if more space is needed.)*

TYPED NAME, GRADE OR TITLE	TELEPHONE EXCHANGE/AUTOVON, PLUS EXTENSION	SIGNATURE
----------------------------	--	-----------

By order of the Secretary of the Army:

GEORGE W. CASEY, JR.  
*General, United States Army*  
*Chief of Staff*

Official:

A handwritten signature in cursive script that reads "Joyce E. Morrow".

JOYCE E. MORROW  
*Administrative Assistant to the*  
*Secretary of the Army*  
0900902

Distribution: To be distributed in accordance with the initial distribution number (IDN) 381179, requirements for TM 9-2320-328-13&P-2.



## THE METRIC SYSTEM AND EQUIVALENTS

### LINEAR MEASURE

1 Centimeter=10 Millimeters=0.01 Meters=0.3937 Inches  
 1 Meter=100 Centimeters=1000 Millimeters=39.37 Inches  
 1 Kilometer=1000 Meters=0.621 Miles

### WEIGHTS

1 Gram=0.001 Kilograms=1000 Milligrams=0.035 Ounces  
 1 Kilogram=1000 Grams=2.2 Lb  
 1 Metric Ton=1000 Kilograms=1 Megagram=1.1 Short Tons

### LIQUID MEASURE

1 Milliliter=0.001 Liters=0.0338 Fluid Ounces  
 1 Liter=1000 Milliliters=33.82 Fluid Ounces

### SQUARE MEASURE

1 Sq Centimeter=100 Sq Millimeters=0.155 Sq Inches  
 1 Sq Meter=10,000 Sq Centimeters=10.76 Sq Feet  
 1 Sq Kilometer=1,000,000 Sq Meters=0.386 Sq Miles

### CUBIC MEASURE

1 Cu Centimeter=1000 Cu Millimeters=0.06 Cu Inches  
 1 Cu Meter=1,000,000 Cu Centimeters=35.31 Cu Feet

### TEMPERATURE

$5/9 (^{\circ}\text{F} - 32) = ^{\circ}\text{C}$   
 212° Fahrenheit is equivalent to 100° Celsius  
 90° Fahrenheit is equivalent to 32.2° Celsius  
 32° Fahrenheit is equivalent to 0° Celsius  
 $9/5 \text{ C}^{\circ} + 32 = \text{F}^{\circ}$

### APPROXIMATE CONVERSION FACTORS

<u>TO CHANGE</u>	<u>TO</u>	<u>MULTIPLY BY</u>
Inches.....	Centimeters.....	2.540
Feet .....	Meters .....	0.305
Yards .....	Meters .....	0.914
Miles.....	Kilometers.....	1.609
Square Inches.....	Square Centimeters.....	6.451
Square Feet.....	Square Meters.....	0.093
Square Yards.....	Square Meters.....	0.836
Square Miles.....	Square Kilometers.....	2.590
Acres.....	Square Hectometers.....	0.405
Cubic Feet.....	Cubic Meters.....	0.028
Cubic Yards.....	Cubic Meters.....	0.765
Fluid Ounces.....	Milliliters.....	29.573
Pints.....	Liters.....	0.473
Quarts.....	Liters.....	0.946
Gallons.....	Liters.....	3.785
Ounces.....	Grams.....	28.349
Pounds.....	Kilograms.....	0.454
Short Tons.....	Metric Tons.....	0.907
Pound-Feet.....	Newton-Meters.....	1.356
Pounds/Sq Inch.....	Kilopascals.....	6.895
Miles per Gallon.....	Kilometers per Liter.....	0.425
Miles per Hour.....	Kilometers per Hour.....	1.609

<u>TO CHANGE</u>	<u>TO</u>	<u>MULTIPLY BY</u>
Centimeters.....	Inches.....	0.394
Meters .....	Feet .....	3.280
Meters .....	Yards .....	1.094
Kilometers.....	Miles.....	0.621
Sq Centimeters.....	Square Inches.....	0.155
Square Meters.....	Square Feet.....	10.764
Square Meters.....	Square Yards.....	1.196
Square Kilometers.....	Square Miles.....	0.386
Sq Hectometers.....	Acres.....	2.471
Cubic Meters.....	Cubic Feet.....	35.315
Cubic Meters.....	Cubic Yards.....	1.308
Milliliters.....	Fluid Ounces.....	0.034
Liters.....	Pints.....	2.113
Liters.....	Quarts.....	1.057
Liters.....	Gallons.....	0.264
Grams.....	Ounces.....	0.035
Kilograms.....	Pounds.....	2.205
Metric Tons.....	Short Tons.....	1.102
Newton-Meters.....	Pound-Feet.....	0.738
Kilopascals.....	Pounds per Sq Inch.....	0.145
Km per Liter.....	Miles per Gallon.....	2.354
Km per Hour.....	Miles per Hour.....	0.621

