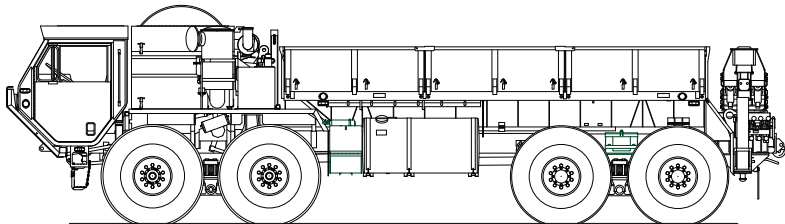


# **\*TM 9-2320-428-10**

---

## **TECHNICAL MANUAL OPERATOR'S MANUAL FOR**

### **TRUCK, CARGO, 8X8 M977 W/WINCH NSN 2320-01-097-0260 (EIC B2D) M977 W/O WINCH NSN 2320-01-099-6426 (EIC B2G)**



\*SUPERSEDURE NOTICE - TM 9-2320-428-10, TM 9-2320-429-10, TM 9-2320-430-10, TM 9-2320-432-10, TM 9-2320-433-10, TM 9-2320-434-10, TM 9-2320-435-10, dated 15 Jun 09; supersedes TM 9-2320-279-10-1, dated 21 Nov 86 including all changes.

DISTRIBUTION STATEMENT A - Approved for public release; distribution is unlimited.

---

**HEADQUARTERS, DEPARTMENT OF THE ARMY  
15 JUNE 2009**







## WARNING SUMMARY




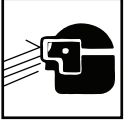

### GENERAL SAFETY CAUTION/WARNING SUMMARY

- This list summarizes critical warnings. They are repeated here to let you know how important they are.
- Study these warnings carefully.
- They can save your life and the lives of personnel you work with.
- If there is any doubt about handling tools, materials, equipment, and procedures, see TB 43-0216, Safety and Hazard Warnings for Operation and Maintenance of TACOM Equipment.

**Table 1. Warning Icons Used In This Manual.**






WARNING ICON	DESCRIPTION
	<p><u>AIR PRESSURE</u> - human hand blocking air gun shows the need to reduce air pressure before use, or debris may injure user and/or damage equipment.</p>
	<p><u>BIOLOGICAL</u> - abstract symbol bug shows that a material may contain bacteria or viruses that present a danger to life or health.</p>
	<p><u>CHEMICAL</u> - drops of liquid on hand show that the material will cause burns or irritation to human skin or tissue.</p>
	<p><u>CRYOGENIC</u> - hand in block of ice shows that the material is extremely cold and can injure human skin and tissue.</p>

**Table 1. Warning Icons Used In This Manual. - Continued**






WARNING ICON	DESCRIPTION
	<p><u>ELECTRICAL</u> - electrical wire to arm with electricity symbol running through human body shows that shock hazard is present.</p>
	<p><u>EXPLOSION</u> - rapidly expanding symbol shows that the material may explode if subjected to high temperatures, sources of ignition, or high pressure.</p>
	<p><u>EXTREMELY COLD SURFACE</u> - hand touching object with ice formed on both shows that surface is extremely cold and can damage human tissue.</p>
	<p><u>EYE PROTECTION</u> - person with goggles shows that the material will injure the eyes.</p>
	<p><u>FIRE</u> - flame shows that material may ignite and cause burns.</p>








**Table 1. Warning Icons Used In This Manual. - Continued**

WARNING ICON	DESCRIPTION
	<p><u>FIRE EXTINGUISHER</u> - fire extinguisher shows that material may ignite and a fire extinguisher should be within easy reach.</p>
	<p><u>HEAVY OBJECT</u> - human figure stooping over heavy object shows physical injury potential for improper lifting technique, and/or aid of assistant(s) and/or lifting device (as required).</p>
	<p><u>HEAVY PARTS</u> - hand with heavy object on top shows that heavy parts can crush and harm.</p>
	<p><u>HEAVY PARTS</u> - foot with heavy object on top shows that heavy parts can crush and harm.</p>
	<p><u>HEAVY PARTS</u> - moving heavy object pinning human figure against stationary object shows that heavy, moving parts/objects present a danger to life or limb.</p>






**Table 1. Warning Icons Used In This Manual.**

WARNING ICON	DESCRIPTION
	<p><u>HEAVY PARTS</u> - heavy object on human figure shows that heavy parts present a danger to life or limb.</p>
	<p><u>HOT AREA</u> - hand over object radiating heats shows that part is hot and can burn.</p>
	<p><u>MOVING PARTS</u> - hand with fingers caught between gears shows that the moving parts of the equipment present a danger to life or limb.</p>
	<p><u>PRESSURE/TENSION HAZARD</u> - human body being impacted by rotating projectile shows that equipment is under pressure or tension presenting a danger to life or limb if pressure or tension is not carefully released.</p>
	<p><u>PROJECTILE HAZARD</u> - human body with object passing through it shows that a projectile hazard exists.</p>



**Table 1. Warning Icons Used In This Manual.**

WARNING ICON	DESCRIPTION
	<p><u>RADIATION</u> - three circular wedges show that the material emits radioactive energy and can injure human tissue.</p>
	<p><u>ROLLOVER HAZARD</u> - vehicle indicating direction of human figure shows that vehicle may roll over if conditions are not avoided, presenting a danger to life or limb.</p>
	<p><u>RUN OVER HAZARD</u> - vehicle running over human body shows hazard.</p>
	<p><u>SHARP OBJECT</u> - pointed object in hand shows that a sharp object presents a danger to life or limb.</p>
	<p><u>SKIN IRRITATION</u> - hand radiating shows that material can cause skin irritation.</p>

**Table 1. Warning Icons Used In This Manual.**

WARNING ICON	DESCRIPTION
	<p><u>SLICK FLOOR</u> - wavy line on floor with legs prone shows that slick floor presents a danger of falling.</p>
	<p><u>STEAM HAZARD</u> - human engulfed in steam cloud shows steam hazard exists that could injure/burn human tissue.</p>
	<p><u>TIRE BLOWOUT</u> - tire with hole shows that an over or under inflated tire may rupture, presenting a danger to life or limb.</p>
	<p><u>VAPOR</u> - human figure in a cloud shows that material vapors present a danger to life or health.</p>
	<p><u>WARNING/CAUTION</u> - triangle with exclamation point within shows that a WARNING or CAUTION is present that indicates a potential hazard, which may cause injury or death to personnel (warning), or damage to equipment (caution).</p>

**Table 1. Warning Icons Used In This Manual.**

WARNING ICON	DESCRIPTION
	<p><u>WIRE CABLE/ROPE</u> - human hand with frayed wire cable/rope running across shows injury to unprotected (bare) hands may result.</p>
	<p><u>EAR PROTECTION</u> - headphones over ears show that noise level will harm ears.</p>

**FOR INFORMATION ON FIRST AID:**

Reference FM 4-25.11. (WP 0161)

**WARNING**



**MODIFICATION HAZARD**

- Unauthorized modifications to, alterations to, or installations on this equipment are prohibited and are in violation of AR 750-10.
- Failure to comply may result in injury or death to personnel or damage to equipment.

## WARNING



### HIGH-PRESSURE HYDRAULIC SYSTEM

- Hydraulic systems can cause serious injuries if high-pressure lines or equipment fails.
- Never work on hydraulic systems or equipment unless there is another person nearby who is familiar with the operation and hazards of the equipment and can give first aid.
- Never disconnect any hydraulic hose or part while the engine is running. Allow several minutes to elapse after shutting off engine, to allow pressure to relieve itself, before attempting to remove hoses. Failure to comply may result in injury to personnel.
- The HEMTT vehicles contain hydraulic systems operating at oil pressures up to 3,000 psi (20 685 kPa) and 3,200 psi (22 064 kPa). Never disconnect any hydraulic line or fitting without first dropping the pressure to zero. Failure to comply may result in serious injury or death to personnel.

## WARNING



### ELECTRICAL SYSTEM

- Remove all jewelry, such as rings, ID tags, bracelets, etc. If jewelry or tools contact electrical circuits, a direct short may result. Failure to comply may result in serious injury or death to personnel.
- Do not smoke, use open flame, make sparks or other ignition sources around batteries. A battery giving off gas could explode. Failure to comply may result in serious injury or death to personnel.
- Be careful when working on or with electrical equipment. Do not be misled by the term "low voltage". Voltages as low as 50 volts can cause death. For artificial respiration, refer to FM 4-25.11.
- When working inside the vehicle with power off, be sure to ground every capacitor likely to hold a dangerous voltage potential.

- Never work on electronic equipment unless there is another person nearby who is familiar with the operation and hazards of the equipment.

### WARNING



### SOLVENT CLEANING COMPOUND

- Solvent cleaning compound MIL-PRF-680 Type II and III may be irritating to the eyes and skin. Use protective gloves and goggles. Use in a well-ventilated area. Use respirator as needed. Accidental ingestion can cause irritation of digestive tract and respiratory tract, may cause lung and central nervous system damage. Can be fatal if swallowed. Inhalation of high/massive concentrations can cause coma or be fatal. First aid for ingestion: do not induce vomiting. Seek immediate medical attention. First aid of skin contact: remove contaminated clothing. Wash skin thoroughly with soap and water. If symptoms persist, seek medical attention. First aid for eye contact: flush with water for 15 minutes or until irritation subsides. If symptoms persist, seek medical attention. First aid for inhalation: move to fresh air. If not breathing, provide artificial respiration. If symptoms persist, seek medical attention. Keep away from open flames and other sources of ignition. Failure to follow this warning may result in injury or death to personnel.
- The flashpoint for Type II solvent cleaning compound is 141 to 198°F (61 to 92°C), and Type III is 200 to 241°F (93 to 116°C).
- Improper cleaning methods and use of unauthorized cleaning solvents may injure personnel and damage equipment.
- Fire extinguishers should be placed nearby when using solvent cleaning compound. Failure to follow this warning may result in injury or death.
- Cloths or rags saturated with solvent cleaning compound must be disposed of IAW authorized facilities' procedures. Failure to follow this warning may result in injury.
- Eye shields must be worn when cleaning with a wire brush. Flying rust and metal particles may cause injury.

**WARNING****POLYURETHANE COATING (CARC)**

- Eye and hearing protection must be worn at all times when using power tools for grinding, cutting, sawing, and drilling. Failure to do so may result in injury to personnel. Chemical Agent Resistant Coating (CARC) paint contains isocyanate which is highly irritating to skin and respiratory system. High concentrations of isocyanate can produce symptoms of itching and reddening of skin, a burning sensation in the throat and nose, and watering of the eyes. In extreme concentrations, isocyanate can cause cough, shortness of breath, pain during respiration, increased sputum production, and chest tightness. First aid for ingestion: do not induce vomiting. Seek immediate medical attention. First aid for skin contact: remove contaminated clothing. Wash skin thoroughly with soap and water. If symptoms persist, seek medical attention. First aid for eye contact: flush with water for 15 minutes or until irritation subsides. If symptoms persist, seek medical attention. First aid for inhalation: move to fresh air. If not breathing, provide artificial respiration. If symptoms persist, seek medical attention.
- The following precautions must be taken whenever using CARC paint:
- Protective equipment (gloves, goggles, ventilation mask) must be worn when using CARC paint.
- NEVER cut CARC-coated materials without high-efficiency, air-purifying respirators in use.
- DO NOT grind or sand painted equipment without high-efficiency, air-purifying respirators in use.
- BE AWARE of CARC paint exposure symptoms; symptoms can occur a few days after initial exposure. Seek medical help immediately if symptoms are detected.
- Use only in well-ventilated area. Check with local environmental office for methods and locations approved for painting in accordance with local and state environmental regulations.
- Always use air line respirators when using CARC paint unless air sampling shows exposure to be below standards. Use chemical cartridge respirator if air sampling is below standards.



## WARNING



### ADHESIVE

- Adhesive, solvents and sealing compounds can burn easily and are harmful causing immediate bonding on contact with eyes, skin, or clothing and gives off harmful vapors.
- If adhesive, solvent, or sealing compound gets on skin or clothing, wash immediately with soap and water.
- If adhesive gets in your eyes, try to keep them open; flush them with water for 15 minutes and get immediate medical attention.
- Wear protective goggles and use in a well-ventilated area.
- Keep away from open fire and use in well-ventilated area to avoid injury or death.

## WARNING

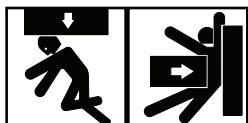


### FLAMMABLE LIQUID AND COMBUSTIBLE VAPOR

- Gasoline, fuel oil, lubricating oil, grease, paint, paint thinner, cleaning solvents, and other combustible liquids present a serious fire hazard.
- Combustible liquids must ALWAYS be stored in their approved containers and designated compartments or deck storage locations.
- Ensure exhaust and ventilation fans are operating while using cleaning solvents or paint products.
- Never store or charge batteries in a confined space without ventilation or near electrical equipment.
- Fuel is very flammable and can explode easily.
- To avoid serious injury or death, keep fuel away from open fire and keep fire extinguisher within easy reach when working with fuel.
- Do not work on fuel system when engine is hot. Fuel can be ignited by hot engine.

- When working with fuel, post signs that read NO SMOKING WITHIN 50 FEET OF VEHICLE.
- Starting fluid is toxic and flammable. Do not store in cab and do not breathe fumes. Do not puncture or burn containers. Dispose of container following manufacturer's recommendations on the container.

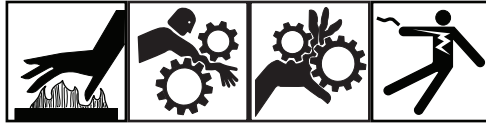
### WARNING



### **LIFTING OPERATIONS This section is applicable to all lifting operations regardless of lifting equipment (crane, LHS, etc.) used.**

- All personnel must stand clear during lifting operations. A swinging or shifting load may cause injury or death to personnel.
- Never crawl under equipment when performing maintenance unless equipment is securely blocked. Failure to comply may cause injury or death to personnel.
- Keep clear of equipment when it is being raised or lowered. Failure to comply may cause injury or death to personnel.
- Do not work on any item supported only by lift jacks or hoist. Always use blocks or proper stands to support the item prior to any work. Failure to comply may result in injury or death to personnel.
- Do not lift a load greater than the rated load capacity of the crane or materiel handling equipment. Failure to comply may result in injury or death to personnel or damage to equipment.
- Do not allow heavy components to swing while hanging by lifting device. Failure to comply may cause injury or death to personnel.
- Any part or component that weighs between 50 lbs (23 kg) and 75 lbs (34 kg) must be removed with the aid of an assistant. Any part or component that weighs over 75 lbs (34 kg) must be removed with the aid of an assistant and a lifting device. Failure to comply may cause injury or death to personnel.
- Ensure all chains, hooks, and slings are in good condition and are of correct capacity. Ensure hooks are positioned correctly. Failure to comply may result in injury or death to personnel.

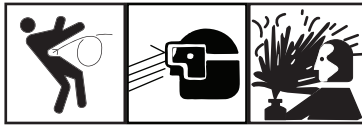
## WARNING



### MOVING MACHINERY

- Use extreme care when operating or working near moving machinery including running engine, rotating shafts, and other moving parts. Failure to comply may result in injury or death to personnel.
- Use extreme care when measuring voltage while engine is running. Avoid contact with rotating fan blade and hot engine parts. Failure to comply may result in injury or death to personnel.

## WARNING



### PARTS UNDER PRESSURE

- Wear safety goggles and use caution when removing or installing springs, snap rings, retaining rings, and other parts under spring tension. These parts can act as projectiles. Failure to comply may result in injury or death to personnel.
- The radiator is very hot and pressurized during vehicle operation. Let radiator cool before removing cap. Failure to do so can result in serious burns.
- During pressure tests, ensure air pressure is drained to 0 psi (0 kPa) before taking off any components. If pressure is not released, plates or line could blow off and harm personnel. Do not drain air from tank with any part of body in air spray path. Skin embolisms and/or debris in eyes can occur from released pressure.
- High air pressure may be released from valve stem when valve core is removed. Stay clear of valve stem after core is removed. Ensure all personnel wear suitable eye protection. Failure to comply may result in injury to personnel.
- Stand clear of trajectory area during deflation or personal injury or death may result.

- Lock-ring is under tension. If lock-ring breaks loose it could cause injury to personnel. Keep hands and fingers away from lock-ring when removing.
- Never adjust relief valve so that personnel must stand on strongback to operate latch.
- If there is any residual pressure in tank when relief valve is open, personnel may lose their balance and fall. Failure to comply may result in injury or death to personnel.
- Use extreme care when removing or installing spring retainers. Spring retainers are under tension and can act as projectiles when released suddenly. Ensure proper eye protection is worn to prevent injury to personnel.
- Use extreme care when removing or installing springs. Springs are under tension and can act as projectiles when released. Ensure proper eye protection is worn to prevent injury to personnel. Eye protection is required during all grinding operations. Failure to comply may result in serious injury to personnel.
- Failure to relieve tank pressure may result in sudden, unexpected loss of pressure. Failure to comply may result in personal injury or death.
- Do not remove the radiator cap when the engine is hot, as steam and hot coolant can escape. Failure to comply may result in personal injury or death.

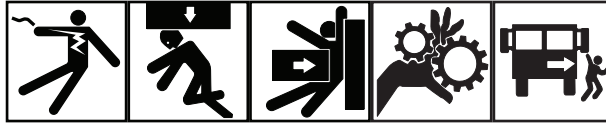
## WARNING



## HEAVY PARTS

Any part or component that weigh over 50 lbs (23 kg) must be removed with the aid of an assistant and a lifting device. Failure to comply may result in personal injury or death.

## WARNING



### CRANE SYSTEM

- Always refer to the range diagram BEFORE making any lift. It is extremely important that the crane is properly leveled to prevent oversteering.
- Do not operate crane unless outriggers are set up. Always chock front wheels when using outriggers. Failure to comply may result in injury or death to personnel.
- When using crane on any vehicle, park vehicle clear of all overhead powerlines. If operating crane under power lines, do not allow vehicle to contact high-voltage connections. Failure to comply will result in death to personnel.
- Do not stand under crane. Failure to comply may result in injury or death to personnel.
- Refuse to work with worn, frayed, or damaged wire rope. Always wear heavy gloves when handling winch cables; never let cable run through hands. Frayed cables can cut. Never operate winch with less than five wraps of cable on winch drum. Failure to comply may result in injury or death to personnel.
- When using crane on any vehicle, park vehicle clear of all overhead power lines. Do not operate crane near overhead power lines. Failure to comply may result in injury or death to personnel.
- Boom has a 370 degree rotation and is mechanically stopped at five degrees on either side of the left outrigger beam. Swing operations must be slowed no later than 15 degrees prior to contacting the stop.
- Keep boom clear of electrical powerlines and other obstacles. Do not operate crane near overhead powerlines. Failure to comply will result in death to personnel.
- Avoid quick, jerking, winch operation. Keep other personnel well away from vehicles involved in winching operations. A snapped cable or shifting load can cause serious injury or death.
- If possible, keep one hand away from equipment to reduce the hazard of current flowing through vital organs of the body.
- Keep fingers clear of top of lift-hook. Failure to comply could result in personnel injury.

## WARNING



### **CARBON MONOXIDE (EXHAUST GAS) CAN CAUSE DEATH**

- Carbon monoxide does not have color or smell and can cause death.
- Breathing air with carbon monoxide produces symptoms of headache, dizziness, loss of muscular control, a sleepy feeling and coma. Brain damage or death can result from heavy exposure.
- Carbon monoxide is in exhaust fumes of fuel-burning heaters and internal combustion engines.
- Carbon monoxide can become dangerously concentrated under conditions of no ventilation.
- Precautions must be followed to ensure crew safety when the personnel heater or engine of any vehicle is operated for any purpose. Failure to comply may result in injury or death to personnel.
- DO NOT operate vehicle engine in a closed place unless the place has proper ventilation. Failure to comply may result in injury or death to personnel.
- DO NOT drive any vehicle with inspection plates, cover plates, or engine compartment covers removed unless necessary for maintenance purposes. Failure to comply may result in injury or death to personnel.
- BE ALERT at all times during vehicle operation for exhaust odors and exposure symptoms. If either odor or exposure symptoms are present, IMMEDIATELY VENTILATE personnel compartments. If symptoms continue, remove affected crew to fresh air and keep warm. DO NOT PERMIT PHYSICAL EXERCISE. If necessary, give artificial respiration and get immediate medical attention. For artificial respiration, refer to FM 4-25.11 . Failure to comply may result in injury or death to personnel.
- BE AWARE that the gas particulate filter unit or the field protection mask for nuclear-biological-chemical protection WILL NOT offer safety from carbon monoxide poisoning.

**WARNING**



**EXTREME HEAT**

If required to remain inside the vehicle during extreme heat, occupants should follow the water intake, work/rest cycle, and other heat stress preventive medicine measures contained in FM 21-10, Field Hygiene and Sanitation.

**WARNING**



**CABLES**

- Always wear heavy gloves when handling winch cables; never let cable run through hands. Frayed cables can cut. Failure to comply may result in injury or death to personnel.
- Never operate winch with less than five wraps of cable on winch drum. Frayed cables can cut. Failure to comply may result in injury or death to personnel.

**WARNING**



**LEAD-ACID BATTERIES**

- Wear proper eye protection when working around batteries. Failure to comply may result in injury or death to personnel.
- Use extreme care not to short out battery terminals. Remove all jewelry such as rings, ID tags, bracelets, etc. prior to working on or

around vehicle. Jewelry and tools can catch on equipment, contact positive electrical circuits, and cause a direct short, severe burns, or electrical shock. Failure to comply may result in injury or death to personnel.

- Batteries produce explosive gases. Do not smoke or use open flame near batteries. Do not allow hot, sparking, or glowing objects near batteries. If batteries are giving off gases, presence of a heat, flame, or spark may cause fire and/or explosion. Failure to comply may result in injury or death to personnel.
- Battery electrolyte is harmful to skin, and eyes. Avoid battery electrolyte contact with skin, eyes, or clothing. If battery electrolyte spills, take immediate action to stop burning effects:

### WARNING



### NBC

- NBC-contaminated air filters must be handled and disposed of only by authorized and trained personnel.
- The unit commander or senior officer in charge of maintenance personnel must ensure that prescribed protective clothing (FM 3-11.4) is used, and prescribed safety measures and decontamination procedures (FM 3-11.5) are followed.
- The local unit SOP is responsible for final disposal of contaminated air filters. Failure to comply may cause severe injury or death to personnel.

### WARNING



### TIRE OPERATION

- Operating a vehicle with a tire in an overinflated or underinflated condition, or with a questionable defect, may lead to premature tire failure. Ensure tire has proper tire pressure. Failure to comply may result in injury or death to personnel.



- When inflating tires mounted on the vehicle, all personnel must remain out of trajectory of the side ring and lock-ring as shown by the areas indicated. Failure to follow proper procedures may result in serious injury or death to personnel.
- Cracked, broken, bent or otherwise damaged rim components shall not be reworked, welded, brazed, or otherwise heated or damage or personal injury or death may result.
- No heat shall be applied to a multi-piece wheel or wheel component or damage or injury or death may result.
- Failure to place wheel/tire assembly in safety cage prior to initial inflation could result in serious injury or death to personnel.
- When a wheel/tire is in a restraining device, do not rest or lean any part of body or equipment on or against the restraining device, or injury or death could result.
- While changing tires or while performing tire maintenance, stay out of the trajectory path. Failure to comply may result in injury or death to personnel.
- Always use an inflation hose with an in-line gauge and a clip-on chuck when inflating tires. The gauge and valve must be mounted a minimum of 10 feet (3.10 m) away from air chuck.
- High air pressure may be released from valve stem when valve core is removed. Stay clear of valve stem after core is removed. Ensure all personnel wear suitable eye protection. Failure to comply may result in injury to personnel.
- Tire is heavy. Brace tire to ensure tire will not fall over on you or on others.

## WARNING



## VEHICLE OPERATION

- Speed limits posted on curves reflect speeds that are considered safe for automobiles. Heavy trucks with a high center of gravity can roll over at these speed limits. Use caution and reduce your speed below the posted limit before entering a curve. Failure to comply may result in vehicle crash and injury to personnel.

- Use caution and reduce your speed below the posted limit before entering a curve. Failure to comply may result in vehicle crash and injury to personnel.
- Always use seatbelts when operating vehicle. Failure to use seatbelt can result in serious injury or death in case of accident.
- Operation at speeds over 15 mph (24 kph) on paved roads can be achieved when the operator determines that the vehicle being towed and the terrain allow safe operation.
- Under no condition can speeds over 35 mph (55 kph) on paved road and 15 mph (24 kph) off-road be allowed. Loss of control can cause serious injury or death. Excessive speed can cause damage to vehicle being towed.

### WARNING



### BRAKES

- Ensure all personnel are clear from front of truck before performing brake stall check. Be ready to apply service brake. Operator must remain in cab while performing this check. Failure to comply could result in personnel injury.
- Never use parking brake for normal braking or wheels will lock up causing severe skid. Skidding vehicle may result in serious personal injury or death.
- Engine must be shut OFF and parking brake set before performing PMCS walkaround. Failure to comply may result in injury or death to personnel.

### WARNING



### BURNS

The exhaust pipe and muffler can become very hot during vehicle operation. Be careful not to touch these parts with bare hands, or allow

body to come in contact with exhaust pipe or muffler. Exhaust system parts can become hot enough to cause serious burns.

## WARNING



## HEARING PROTECTION

- Excessive noise levels are present any time the heavy-duty winch or crane is operating.
- Wear single hearing protection (earplugs or equivalent) while working around equipment while it is running. Failure to do so could result in damage to your hearing.
- Seek medical aid should you suspect a hearing problem.

## WARNING



## COMPRESSED AIR

- Brake shoes may be coated with dust. Breathing this dust may be harmful to your health.
- Do not use compressed air to clean brake shoes. Wear a filter mask approved for use against brake dust. Failure to comply may result in injury or death to personnel.
- Compressed air used for cleaning purposes will not exceed 30 psi (207 kPa).
- Use only with effective chip guarding and personal protective equipment, goggles, shield, and gloves.



## LIST OF EFFECTIVE PAGES/WORK PACKAGES

NOTE:

TM 9-2320-428-10 dated 15 June 2009 supersedes TM 9-2320-279-10-1, 21 Nov 86, including all changes. Zero in the "Change No." column indicates an original page or work package.

Date of issue for the original manual is:

Original 15 June 2009

**TOTAL NUMBER OF PAGES FOR FRONT AND REAR  
MATTER IS 79 AND TOTAL NUMBER OF WORK PACKAGES  
IS 164, CONSISTING OF THE FOLLOWING:**

Page/WP No.	Change No.	Page/WP No.	Change No.
Front Cover	0	WP 0022 (6 pages)	0
Warning Summary	0	WP 0023 (2 pages)	0
i-xliv	0	WP 0024 (4 pages)	0
Chp 1 - General Information, Equipment Description and Theory of Operation	0	WP 0025 (2 pages)	0
		WP 0026 (4 pages)	0
WP 0001 (12 pages)	0	WP 0027 (4 pages)	0
WP 0002 (10 pages)	0	WP 0028 (4 pages)	0
WP 0003 (2 pages)	0	WP 0029 (2 pages)	0
WP 0004 (4 pages)	0	WP 0030 (4 pages)	0
WP 0005 (2 pages)	0	WP 0031 (2 pages)	0
WP 0006 (10 pages)	0	WP 0032 (4 pages)	0
WP 0007 (2 pages)	0	WP 0033 (2 pages)	0
WP 0008 (4 pages)	0	WP 0034 (4 pages)	0
WP 0009 (4 pages)	0	WP 0035 (4 pages)	0
WP 0010 (2 pages)	0	WP 0036 (4 pages)	0
WP 0011 (2 pages)	0	WP 0037 (4 pages)	0
WP 0012 (4 pages)	0	WP 0038 (4 pages)	0
WP 0013 (4 pages)	0	WP 0039 (2 pages)	0
WP 0014 (2 pages)	0	WP 0040 (8 pages)	0
WP 0015 (2 pages)	0	WP 0041 (24 pages)	0
WP 0016 (2 pages)	0	WP 0042 (26 pages)	0
Chp 2 - Operator Instructions	0	WP 0043 (14 pages)	0
WP 0017 (2 pages)	0	WP 0044 (8 pages)	0
WP 0018 (4 pages)	0	WP 0045 (2 pages)	0
WP 0019 (2 pages)	0	WP 0046 (2 pages)	0
WP 0020 (6 pages)	0	WP 0047 (2 pages)	0
WP 0021 (6 pages)	0	WP 0048 (4 pages)	0
		WP 0049 (2 pages)	0

Page/WP No.	Change No.	Page/WP No.	Change No.
WP 0050 (2 pages)	0	WP 0094 (2 pages)	0
WP 0051 (4 pages)	0	WP 0095 (6 pages)	0
WP 0052 (4 pages)	0	WP 0096 (4 pages)	0
WP 0053 (2 pages)	0	WP 0097 (2 pages)	0
WP 0054 (2 pages)	0	WP 0098 (2 pages)	0
WP 0055 (4 pages)	0	WP 0099 (6 pages)	0
WP 0056 (2 pages)	0	WP 0100 (4 pages)	0
WP 0057 (2 pages)	0	WP 0101 (16 pages)	0
WP 0058 (4 pages)	0	WP 0102 (8 pages)	0
WP 0059 (8 pages)	0	WP 0103 (4 pages)	0
WP 0060 (4 pages)	0	WP 0104 (2 pages)	0
WP 0061 (2 pages)	0	WP 0105 (2 pages)	0
WP 0062 (2 pages)	0	WP 0106 (8 pages)	0
WP 0063 (2 pages)	0	Chp 3 - Troubleshooting	
WP 0064 (2 pages)	0	Procedures	0
WP 0065 (4 pages)	0	WP 0107 (8 pages)	0
WP 0066 (2 pages)	0	WP 0108 (8 pages)	0
WP 0067 (4 pages)	0	WP 0109 (6 pages)	0
WP 0068 (4 pages)	0	WP 0110 (4 pages)	0
WP 0069 (4 pages)	0	WP 0111 (6 pages)	0
WP 0070 (2 pages)	0	WP 0112 (6 pages)	0
WP 0071 (2 pages)	0	WP 0113 (4 pages)	0
WP 0072 (2 pages)	0	WP 0114 (4 pages)	0
WP 0073 (2 pages)	0	WP 0115 (6 pages)	0
WP 0074 (6 pages)	0	WP 0116 (6 pages)	0
WP 0075 (4 pages)	0	WP 0117 (6 pages)	0
WP 0076 (4 pages)	0	WP 0118 (4 pages)	0
WP 0077 (2 pages)	0	WP 0119 (4 pages)	0
WP 0078 (2 pages)	0	WP 0120 (4 pages)	0
WP 0079 (4 pages)	0	WP 0121 (6 pages)	0
WP 0080 (2 pages)	0	WP 0122 (4 pages)	0
WP 0081 (4 pages)	0	WP 0123 (4 pages)	0
WP 0082 (2 pages)	0	WP 0124 (4 pages)	0
WP 0083 (8 pages)	0	WP 0125 (8 pages)	0
WP 0084 (4 pages)	0	WP 0126 (4 pages)	0
WP 0085 (2 pages)	0	WP 0127 (6 pages)	0
WP 0086 (38 pages)	0	WP 0128 (4 pages)	0
WP 0087 (2 pages)	0	WP 0129 (6 pages)	0
WP 0088 (4 pages)	0	WP 0130 (4 pages)	0
WP 0089 (2 pages)	0	WP 0131 (8 pages)	0
WP 0090 (18 pages)	0	WP 0132 (6 pages)	0
WP 0091 (4 pages)	0	WP 0133 (4 pages)	0
WP 0092 (4 pages)	0	WP 0134 (4 pages)	0
WP 0093 (6 pages)	0	WP 0135 (2 pages)	0

<b>Page/WP No.</b>	<b>Change No.</b>	<b>Page/WP No.</b>	<b>Change No.</b>
WP 0136 (4 pages)	0	WP 0152 (4 pages)	0
WP 0137 (6 pages)	0	WP 0153 (6 pages)	0
WP 0138 (2 pages)	0	WP 0154 (2 pages)	0
WP 0139 (2 pages)	0	WP 0155 (20 pages)	0
WP 0140 (6 pages)	0	WP 0156 (2 pages)	0
WP 0141 (4 pages)	0	WP 0157 (6 pages)	0
WP 0142 (4 pages)	0	WP 0158 (8 pages)	0
WP 0143 (2 pages)	0	WP 0159 (6 pages)	0
Chp 4 - Preventive Maintenance Checks and Services (PMCS)	0	WP 0160 (4 pages)	0
WP 0144 (4 pages)	0	Chp 6 - Supporting Information	0
WP 0145 (40 pages)	0	WP 0161 (8 pages)	0
WP 0146 (4 pages)	0	WP 0162 (12 pages)	0
WP 0147 (44 pages)	0	WP 0163 (6 pages)	0
WP 0148 (54 pages)	0	WP 0164 (10 pages)	0
WP 0149 (30 pages)	0		
WP 0150 (16 pages)	0		
Chp 5 - Maintenance Instructions	0		
WP 0151 (14 pages)	0		





**HEADQUARTERS  
DEPARTMENT OF THE ARMY  
WASHINGTON, D.C., 15 JUNE 2009**

**TECHNICAL MANUAL**

**OPERATOR'S MANUAL  
TRUCK, CARGO, 8X8  
M977, W/WINCH (NSN 2320-01-097-0260)  
M977, W/O WINCH (NSN 2320-01-099-6426)**

**REPORTING ERRORS AND RECOMMENDING IMPROVEMENTS**

You can help improve this publication. If you find any errors, or if you would like to recommend any improvements to the procedures in this publication, please let us know. The preferred method is to submit your DA Form 2028 (Recommended Changes to Publications and Blank Forms) through the Internet, on the Army Electronic Product Support (AEPS) website. The Internet address is <https://aeps.ria.army.mil>. The DA Form 2028 is located under the Public Applications section in the AEPS Public Home Page. Fill out the form and click on SUBMIT. Using this form on the AEPS will enable us to respond quicker to your comments and better manage the DA Form 2028 program. You may also mail, e-mail, or fax your comments or DA Form 2028 directly to the U.S. Army TACOM Life Cycle Management Command. The postal mail address is U.S. Army TACOM Life Cycle Management Command, ATTN: AMSTA-LC-LMPP / TECH PUBS, 1 Rock Island Arsenal, Rock Island, IL 61299-7630. The e-mail address is [tacomlcmc.daform2028@us.army.mil](mailto:tacomlcmc.daform2028@us.army.mil). The fax number is DSN 793-0726 or Commercial (309) 782-0726.

\***SUPERSEDURE NOTICE** - TM 9-2320-428-10, TM 9-2320-429-10, TM 9-2320-430-10, TM 9-2320-432-10, TM 9-2320-433-10, TM 9-2320-434-10, TM 9-2320-435-10, dated 15 Jun 09; supersedes TM 9-2320-279-10-1, dated 21 Nov 86 Including all changes.

DISTRIBUTION STATEMENT A - Approved for public release; distribution is unlimited.



# TABLE OF CONTENTS

	<u>WP Sequence No.</u>
	<u>Page No.</u>
Warning Summary	
How to Use this Manual	
<b>Chapter 1 - General Information, Equipment Description and Theory of Operation</b>	
INTRODUCTION.....	WP 0001
Table 1. Overview.....	0001-1
Figure 1. ....	0001-1
Table 2. Common Nomenclature.....	0001-3
Table 3. Common Abbreviations.....	0001-4
Table 4. Significant Hazard And Safety Recommendations.....	0001-10
WARRANTY PROGRAM.....	WP 0002
Table 1. Vehicle Information.....	0002-3
Table 2. Vehicle Information.....	0002-4
EQUIPMENT CHARACTERISTICS, CAPABILITIES, AND FEATURES.....	WP 0003
LOCATION AND DESCRIPTION OF MAJOR COMPONENTS.....	WP 0004
Table 1. HEMTT Series Vehicle Common Component Location.....	0004-1
Figure 1. ....	0004-1
Table 2. M977/M985 Cargo Vehicle Specific Component Location.....	0004-3
Figure 2. ....	0004-3
DIFFERENCES BETWEEN MODELS.....	WP 0005
Table 1. Differences Between HEMTT BASE Models.....	0005-1

## TABLE OF CONTENTS - Continued

	<u>WP Sequence No.</u>
	<u>Page No.</u>
Table 2. Notes.....	0005-2
EQUIPMENT DATA.....	WP 0006
Table 1. Vehicle Operation.....	0006-1
Table 2. M977 Cargo Vehicle Dimensions.....	0006-1
Table 3. M977 Cargo Vehicle Weight.....	0006-1
Table 4. M977 Cargo Vehicle Weight.....	0006-2
Table 5. M977 Cargo Vehicle Weight Distribution.....	0006-2
Table 6. M977 Cargo Vehicle Weight Distribution.....	0006-2
Table 7. Vehicle Performance.....	0006-2
Table 8. Fluid Capacities.....	0006-3
Table 9. Engine.....	0006-3
Table 10. Fuel System.....	0006-4
Table 11. Electrical System.....	0006-4
Table 12. Cooling System.....	0006-5
Table 13. Transmission.....	0006-5
Table 14. Transfer Case.....	0006-5
Table 15. Front Tandem Axles.....	0006-6
Table 16. Rear Tandem Axles.....	0006-6
Table 17. Brake System.....	0006-6
Table 18. Wheels.....	0006-6
Table 19. Tires.....	0006-6
Table 20. Steering System.....	0006-7

**TABLE OF CONTENTS - Continued**

	<u>Page No.</u>	<u>WP Sequence No.</u>
Table 21. Towing Eyes.....	0006-7	
Table 22. Pintle Hook.....	0006-7	
Table 23. Cab.....	0006-7	
Table 24. Self-Recovery Winch.....	0006-7	
Table 25. Material Handling Crane.....	0006-8	
Table 26. Auxiliary Equipment.....	0006-8	
Table 27. Load Classification.....	0006-9	
Table 28. Tire Pressures.....	0006-9	
Table 29. Operating Speeds.....	0006-10	
SELF-RECOVERY WINCH.....		WP 0007
Figure 1. ....	0007-1	
ELECTRICAL SYSTEM.....		WP 0008
Figure 1. ....	0008-2	
Figure 2. ....	0008-3	
AIR SYSTEM.....		WP 0009
Figure 1. ....	0009-2	
MAIN HYDRAULIC SYSTEM.....		WP 0010
Figure 1. ....	0010-1	
Figure 2. ....	0010-2	
STEERING SYSTEM.....		WP 0011
Figure 1. ....	0011-1	
POWER TRAIN.....		WP 0012

## TABLE OF CONTENTS - Continued

	<u>Page No.</u>	<u>WP Sequence No.</u>
Figure 1. ....	0012-1	
Figure 2. ....	0012-2	
Figure 3. ....	0012-3	
Figure 4. ....	0012-3	
Figure 5. ....	0012-4	
ENGINE SYSTEMS.....		WP 0013
Figure 1. ....	0013-1	
Figure 2. ....	0013-2	
Figure 3. ....	0013-3	
Figure 4. ....	0013-4	
CAB.....		WP 0014
Figure 1. ....	0014-1	
WHEELS AND TIRES.....		WP 0015
Figure 1. ....	0015-1	
CRANE.....		WP 0016
Figure 1. ....	0016-1	
<b>Chapter 2 - Operator Instructions</b>		
CAB-MOUNTED FOOT CONTROLS.....		WP 0017
Table 1. Cab-Mounted Foot Controls.....	0017-2	
Figure 1. ....	0017-2	
CAB-MOUNTED HAND CONTROLS.....		WP 0018
Table 1. Cab-Mounted Hand Controls.....	0018-2	

## TABLE OF CONTENTS - Continued

	<u>Page No.</u>	<u>WP Sequence No.</u>
Figure 1. ....	0018-2	
STEERING COLUMN MOUNTED CONTROLS.....		WP 0019
Table 1. Steering Column Mounted Controls.....	0019-1	
Figure 1. ....	0019-1	
TUNNEL PANEL CONTROLS AND INDICATORS.....		WP 0020
Table 1. Tunnel panel controls and indicators.....	0020-2	
Figure 1. ....	0020-2	
INSTRUMENT PANEL CONTROLS AND INDICATORS.....		WP 0021
Table 1. Instrument Panel Controls and Indicators.....	0021-1	
Figure 1. ....	0021-1	
Figure 2. ....	0021-3	
Figure 3. ....	0021-4	
HEATER COMPARTMENT CONTROLS AND INDICATORS.....		WP 0022
Table 1. Heater Compartment Controls and Indicators.....	0022-1	
Figure 1. ....	0022-1	
Figure 2. ....	0022-4	
Figure 3. ....	0022-5	
OPERATOR AND CREW FOUR-POINT SEATBELT/AIR-RIDE SEAT ADJUSTMENT CONTROLS.....		WP 0023
Table 1. Operator and Crew Four-Point Seatbelt/ Air-Ride Seat Adjustment Controls.....	0023-1	
Figure 1. ....	0023-1	

## TABLE OF CONTENTS - Continued

	<u>WP Sequence No.</u>
	<u>Page No.</u>
OPERATOR AND CREW THREE-POINT SEATBELT/SEAT ADJUSTMENT CONTROLS.....	WP 0024
Table 1. Operator And Crew Three-Point Seatbelt/ Seat Adjustment Controls.....	0024-2
Figure 1. ....	0024-2
HYDRAULIC SELECTOR VALVE CONTROL.....	WP 0025
Table 1. Hydraulic Selector Valve Control.....	0025-1
Figure 1. ....	0025-1
GROVE CRANE CONTROL LEVERS.....	WP 0026
Table 1. Grove Crane Control Levers.....	0026-2
Figure 1. ....	0026-2
GROVE CRANE BOXES AND REMOTE-CONTROL UNIT.....	WP 0027
Table 1. Grove Crane Boxes and Remote-Control Unit.....	0027-2
Figure 1. ....	0027-2
RIFLE STOWAGE MOUNT.....	WP 0028
Table 1. Rifle Stowage Mount.....	0028-2
Figure 1. ....	0028-2
ARCTIC ENGINE HEATER CONTROLS AND INDICATORS.....	WP 0029
Table 1. Arctic Engine Heater Controls And Indicators.....	0029-1
Figure 1. ....	0029-1
GAS PARTICULATE FILTER UNIT (GPFU) CONTROLS AND INDICATORS .....	WP 0030
Table 1. Gas Particulate Filter Unit (GPFU) Controls And Indicators.....	0030-2



**TABLE OF CONTENTS - Continued**

	<u>WP Sequence No.</u>	
	<u>Page No.</u>	
Figure 1. ....	0030-2	
MACHINE GUN MOUNT.....		WP 0031
Table 1. Machine Gun Mount.....	0031-2	
Figure 1. ....	0031-2	
M-8 CHEMICAL ALARM CONTROLS AND INDICATORS.....		WP 0032
Table 1. M-8 Chemical Alarm Controls And Indicators.....	0032-2	
Figure 1. ....	0032-2	
M-13 DECONTAMINATION KIT.....		WP 0033
Table 1. M-13 Decontamination Kit.....	0033-2	
Figure 1. ....	0033-2	
RADIO INSTALLATION HARDWARE.....		WP 0034
Table 1. Radio Installation Hardware.....	0034-2	
Figure 1. ....	0034-2	
OPERATE WINDSHIELD WIPERS/WASHER.....		WP 0035
Figure 1. ....	0035-1	
Figure 2. ....	0035-2	
OPERATE CAB TEMPERATURE CONTROLS.....		WP 0036
Figure 1. ....	0036-2	
Figure 2. ....	0036-3	
OPERATE FIRE EXTINGUISHER.....		WP 0037
Figure 1. ....	0037-2	
Figure 2. ....	0037-3	

## TABLE OF CONTENTS - Continued

	<u>WP Sequence No.</u>	
	<u>Page No.</u>	
Figure 3. ....	0037-4	
OPERATE ACCESS LADDER.....		WP 0038
Figure 1. ....	0038-1	
Figure 2. ....	0038-2	
Figure 3. ....	0038-3	
OPERATE DRAIN PLUG.....		WP 0039
Figure 1. ....	0039-1	
Figure 2. ....	0039-2	
CONNECT/DISCONNECT TRAILER.....		WP 0040
Figure 1. ....	0040-2	
Figure 2. ....	0040-3	
Figure 3. ....	0040-3	
Figure 4. ....	0040-4	
Figure 5. ....	0040-5	
Figure 6. ....	0040-6	
Figure 7. ....	0040-7	
CARGO BODY OPERATION.....		WP 0041
Figure 1. ....	0041-2	
Figure 2. ....	0041-4	
Figure 3. ....	0041-6	
Figure 4. ....	0041-7	
Figure 5. ....	0041-8	

## TABLE OF CONTENTS - Continued

	<u>WP Sequence No.</u> <u>Page No.</u>
Figure 6. ....	0041-9
Figure 7. ....	0041-10
Figure 8. ....	0041-11
Figure 9. ....	0041-12
Figure 10. ....	0041-12
Figure 11. ....	0041-13
Figure 12. ....	0041-13
Figure 13. ....	0041-14
Figure 14. ....	0041-14
Figure 15. ....	0041-15
Figure 16. ....	0041-16
Figure 17. ....	0041-17
Figure 18. ....	0041-18
Figure 19. ....	0041-19
Figure 20. ....	0041-19
Figure 21. ....	0041-20
Figure 22. ....	0041-20
Figure 23. ....	0041-21
Figure 24. ....	0041-21
Figure 25. ....	0041-22
Figure 26. ....	0041-22
Figure 27. ....	0041-23

## TABLE OF CONTENTS - Continued

	<u>WP Sequence No.</u>
	<u>Page No.</u>
Figure 28. ....	0041-23
Figure 29. ....	0041-24
GROVE CRANE OPERATION (MANUAL CONTROL).....	WP 0042
Figure 1. ....	0042-3
Figure 2. ....	0042-4
Figure 3. ....	0042-5
Figure 4. ....	0042-5
Figure 5. ....	0042-7
Figure 6. ....	0042-8
Figure 7. ....	0042-8
Figure 8. ....	0042-9
Figure 9. ....	0042-10
Figure 10. ....	0042-11
Figure 11. ....	0042-12
Figure 12. ....	0042-13
Figure 13. ....	0042-14
Figure 14. ....	0042-15
Figure 15. ....	0042-16
Figure 16. ....	0042-17
Figure 17. ....	0042-18
Figure 18. ....	0042-20
Figure 19. ....	0042-21

**TABLE OF CONTENTS - Continued**

	<u>Page No.</u>	<u>WP Sequence No.</u>
Figure 20. ....	0042-22	
Figure 21. ....	0042-23	
Figure 22. ....	0042-24	
Figure 23. ....	0042-24	
Figure 24. ....	0042-25	
GROVE CRANE OPERATION (REMOTE CONTROL).....		WP 0043
Figure 1. ....	0043-2	
Figure 2. ....	0043-3	
Figure 3. ....	0043-5	
Figure 4. ....	0043-7	
Figure 5. ....	0043-8	
Figure 6. ....	0043-10	
Figure 7. ....	0043-11	
Figure 8. ....	0043-12	
Figure 9. ....	0043-13	
Figure 10. ....	0043-14	
START ENGINE.....		WP 0044
Figure 1. ....	0044-2	
Figure 2. ....	0044-3	
Figure 3. ....	0044-5	
Figure 4. ....	0044-6	
Figure 5. ....	0044-7	

## TABLE OF CONTENTS - Continued

	<u>Page No.</u>	<u>WP Sequence No.</u>
Figure 6. ....	0044-8	
OPERATE PARKING BRAKES.....		WP 0045
Figure 1. ....	0045-1	
OPERATE SERVICE BRAKES.....		WP 0046
Figure 1. ....	0046-1	
OPERATE TRAILER BRAKES.....		WP 0047
Figure 1. ....	0047-1	
OPERATE TRANSMISSION AND TRANSFER CASE.....		WP 0048
Figure 1. ....	0048-1	
Figure 2. ....	0048-2	
OPERATE ENGINE BRAKE.....		WP 0049
Figure 1. ....	0049-2	
DRIVE VEHICLE FORWARD.....		WP 0050
Figure 1. ....	0050-2	
DRIVE VEHICLE IN REVERSE.....		WP 0051
Figure 1. ....	0051-2	
DRIVE VEHICLE IN CITY TRAFFIC AND ON HIGHWAY.....		WP 0052
Figure 1. ....	0052-2	
Figure 2. ....	0052-3	
DRIVE VEHICLE IN OFF-ROAD CONDITIONS.....		WP 0053
Figure 1. ....	0053-1	
DRIVE VEHICLE UP/DOWN STEEP GRADE.....		WP 0054

**TABLE OF CONTENTS - Continued**

	<u>Page No.</u>	<u>WP Sequence No.</u>
Figure 1. ....	0054-1	
Figure 2. ....	0054-2	
DRIVE VEHICLE IN SLIPPERY CONDITIONS.....		WP 0055
Figure 1. ....	0055-2	
PARK VEHICLE.....		WP 0056
Figure 1. ....	0056-1	
SHUT OFF ENGINE.....		WP 0057
Figure 1. ....	0057-1	
OPERATE ARCTIC ENGINE HEATER.....		WP 0058
Figure 1. ....	0058-3	
OPERATE GAS PARTICULATE FILTER UNIT (GPFU).....		WP 0059
Figure 1. ....	0059-2	
Figure 2. ....	0059-3	
Figure 3. ....	0059-3	
Figure 4. ....	0059-4	
Figure 5. ....	0059-5	
Figure 6. ....	0059-5	
Figure 7. ....	0059-6	
Figure 8. ....	0059-7	
Figure 9. ....	0059-7	
Figure 10. ....	0059-8	
Figure 11. ....	0059-8	

## TABLE OF CONTENTS - Continued

	<u>WP Sequence No.</u>
	<u>Page No.</u>
OPERATE RIFLE STOWAGE MOUNT.....	WP 0060
Figure 1. ....	0060-2
Figure 2. ....	0060-3
OPERATE MACHINE GUN MOUNT.....	WP 0061
OPERATE M-8 CHEMICAL ALARM.....	WP 0062
OPERATE M-13 DECONTAMINATION KIT.....	WP 0063
OPERATE RADIO.....	WP 0064
PORTABLE WORK LAMP OPERATION.....	WP 0065
Figure 1. ....	0065-1
Figure 2. ....	0065-2
Figure 3. ....	0065-3
OPERATE DOME LIGHT.....	WP 0066
Figure 1. ....	0066-1
OPERATE PANEL LIGHTS.....	WP 0067
Figure 1. ....	0067-2
OPERATE PARKING LIGHTS.....	WP 0068
Figure 1. ....	0068-2
OPERATE SERVICE DRIVE LIGHTS.....	WP 0069
Figure 1. ....	0069-1
Figure 2. ....	0069-2
Figure 3. ....	0069-3
OPERATE STOPLIGHTS.....	WP 0070



**TABLE OF CONTENTS - Continued**

	<u>WP Sequence No.</u>	
	<u>Page No.</u>	
Figure 1. ....	0070-2	
OPERATE CLEARANCE LIGHTS.....		WP 0071
Figure 1. ....	0071-1	
OPERATE BLACKOUT DRIVE LIGHT.....		WP 0072
Figure 1. ....	0072-1	
OPERATE BLACKOUT MARKERS.....		WP 0073
Figure 1. ....	0073-2	
PORTABLE BEACON LIGHT OPERATION.....		WP 0074
Figure 1. ....	0074-1	
Figure 2. ....	0074-2	
Figure 3. ....	0074-3	
Figure 4. ....	0074-4	
Figure 5. ....	0074-5	
OPERATE TURN SIGNALS.....		WP 0075
Figure 1. ....	0075-2	
OPERATE EMERGENCY FLASHERS.....		WP 0076
Figure 1. ....	0076-2	
INSTALL/REMOVE WHEEL CHOCKS.....		WP 0077
Figure 1. ....	0077-1	
Figure 2. ....	0077-2	
CHANGE VEHICLE WEIGHT INDICATOR.....		WP 0078
Figure 1. ....	0078-1	

## TABLE OF CONTENTS - Continued

	<u>WP Sequence No.</u>
	<u>Page No.</u>
ADJUST SEAT.....	WP 0079
Figure 1. ....	0079-1
Figure 2. ....	0079-2
Figure 3. ....	0079-3
OPERATE THREE-POINT SEATBELT.....	WP 0080
Figure 1. ....	0080-1
ADJUST AIR-RIDE SEAT.....	WP 0081
Figure 1. ....	0081-2
OPERATE FOUR-POINT SEATBELT.....	WP 0082
Figure 1. ....	0082-1
INSTALL/REMOVE TIRE CHAINS.....	WP 0083
Figure 1. ....	0083-2
Figure 2. ....	0083-2
Figure 3. ....	0083-3
Figure 4. ....	0083-4
Figure 5. ....	0083-5
Figure 6. ....	0083-5
Figure 7. ....	0083-6
Figure 8. ....	0083-6
FORD WATER OBSTACLE.....	WP 0084
Figure 1. ....	0084-2

**TABLE OF CONTENTS - Continued**

	<u>WP Sequence No.</u>
	<u>Page No.</u>
INTERIM NUCLEAR, BIOLOGICAL, AND CHEMICAL (NBC) DECONTAMINATION PROCEDURES.....	WP 0085
SELF-RECOVER VEHICLE USING SELF-RECOVERY WINCH.....	WP 0086
Figure 1. ....	0086-1
Figure 2. ....	0086-2
Figure 3. ....	0086-3
Figure 4. ....	0086-4
Figure 5. ....	0086-4
Figure 6. ....	0086-5
Figure 7. ....	0086-6
Figure 8. ....	0086-7
Figure 9. ....	0086-8
Figure 10. ....	0086-9
Table 1. Self-Recovery Winch Pull Capacity.....	0086-10
Figure 11. ....	0086-12
Figure 12. ....	0086-14
Figure 13. ....	0086-16
Figure 14. ....	0086-17
Figure 15. ....	0086-18
Figure 16. ....	0086-19
Figure 17. ....	0086-20
Figure 18. ....	0086-21

**TABLE OF CONTENTS - Continued**

	<u>WP Sequence No.</u>
	<u>Page No.</u>
Figure 19. ....	0086-22
Figure 20. ....	0086-22
Figure 21. ....	0086-23
Figure 22. ....	0086-24
Figure 23. ....	0086-25
Figure 24. ....	0086-25
Figure 25. ....	0086-26
Figure 26. ....	0086-28
Figure 27. ....	0086-29
Table 2. Self-Recovery Winch Pull Capacity.....	0086-30
Figure 28. ....	0086-31
Figure 29. ....	0086-32
Figure 30. ....	0086-35
Figure 31. ....	0086-35
Figure 32. ....	0086-36
Figure 33. ....	0086-38
Figure 34. ....	0086-38
<b>SNATCH BLOCK INSTALLATION/REMOVAL.....</b>	<b>WP 0087</b>
Figure 1. ....	0087-1
Figure 2. ....	0087-2
<b>CONNECT/DISCONNECT SELF-RECOVERY WINCH CABLE TO ANOTHER VEHICLE.....</b>	<b>WP 0088</b>

**TABLE OF CONTENTS - Continued**

	<u>Page No.</u>	<u>WP Sequence No.</u>
Figure 1. ....	0088-1	
Figure 2. ....	0088-2	
Figure 3. ....	0088-3	
Figure 4. ....	0088-4	
TOW DISABLED VEHICLE.....		WP 0089
Figure 1. ....	0089-2	
CONNECT/DISCONNECT TOW BAR.....		WP 0090
Figure 1. ....	0090-2	
Figure 2. ....	0090-3	
Figure 3. ....	0090-3	
Figure 4. ....	0090-5	
Figure 5. ....	0090-7	
Figure 6. ....	0090-8	
Figure 7. ....	0090-9	
Figure 8. ....	0090-10	
Figure 9. ....	0090-11	
Figure 10. ....	0090-12	
Figure 11. ....	0090-13	
Figure 12. ....	0090-14	
Figure 13. ....	0090-15	
Figure 14. ....	0090-16	
OPERATE VEHICLE IN EXTREME HEAT.....		WP 0091

## TABLE OF CONTENTS - Continued

	<u>Page No.</u>	<u>WP Sequence No.</u>
Figure 1. ....	0091-2	
OPERATION IN EXTREME DUST.....		WP 0092
Figure 1. ....	0092-1	
Figure 2. ....	0092-2	
Figure 3. ....	0092-3	
OPERATE VEHICLE IN SAND OR MUD.....		WP 0093
Figure 1. ....	0093-2	
Figure 2. ....	0093-4	
OPERATE VEHICLE IN DESERT ENVIRONMENT.....		WP 0094
OPERATE VEHICLE IN COLD ENVIRONMENT (32°F [0°C] to -25°F [-32°C]).....		WP 0095
Figure 1. ....	0095-2	
OPERATION IN EXTREME COLD ENVIRONMENT.....		WP 0096
Figure 1. ....	0096-3	
OPERATE VEHICLE IN FOREST OR ROCKY TERRAIN.....		WP 0097
OPERATE VEHICLE IN SALTWATER AREAS.....		WP 0098
SET UP/SECURE HIGHWAY EMERGENCY MARKER KIT.....		WP 0099
Figure 1. ....	0099-1	
Figure 2. ....	0099-2	
Figure 3. ....	0099-2	
Figure 4. ....	0099-2	
Figure 5. ....	0099-3	

**TABLE OF CONTENTS - Continued**

	<u>Page No.</u>	<u>WP Sequence No.</u>
Figure 6. ....	0099-3	
Figure 7. ....	0099-4	
Figure 8. ....	0099-4	
Figure 9. ....	0099-5	
Figure 10. ....	0099-5	
Figure 11. ....	0099-6	
MANUALLY RELEASE SPRING BRAKES.....		WP 0100
Figure 1. ....	0100-1	
Figure 2. ....	0100-2	
Figure 3. ....	0100-3	
Figure 4. ....	0100-3	
LIMP HOME/FLAT TIRE WITH NO SPARE.....		WP 0101
Figure 1. ....	0101-2	
Figure 2. ....	0101-2	
Figure 3. ....	0101-3	
Figure 4. ....	0101-3	
Figure 5. ....	0101-4	
Figure 6. ....	0101-5	
Figure 7. ....	0101-5	
Figure 8. ....	0101-6	
Figure 9. ....	0101-6	
Figure 10. ....	0101-7	

## TABLE OF CONTENTS - Continued

	<u>Page No.</u>	<u>WP Sequence No.</u>
Figure 11. ....	0101-8	
Figure 12. ....	0101-9	
Figure 13. ....	0101-10	
Figure 14. ....	0101-10	
Figure 15. ....	0101-11	
Figure 16. ....	0101-12	
Figure 17. ....	0101-13	
Figure 18. ....	0101-13	
Figure 19. ....	0101-14	
Figure 20. ....	0101-14	
Figure 21. ....	0101-15	
SLAVE START VEHICLE.....		WP 0102
Figure 1. ....	0102-2	
Figure 2. ....	0102-3	
Figure 3. ....	0102-3	
Figure 4. ....	0102-4	
Figure 5. ....	0102-5	
Figure 6. ....	0102-5	
Figure 7. ....	0102-7	
Figure 8. ....	0102-7	
Figure 9. ....	0102-8	



**TABLE OF CONTENTS - Continued**

	<u>WP Sequence No.</u>
	<u>Page No.</u>
PERFORM IMMEDIATE ACTION FOR LOSS OF AIR SUPPLY SYSTEM PRESSURE.....	WP 0103
Figure 1. ....	0103-1
PERFORM IMMEDIATE ACTION FOR LOSS OF HYDRAULIC SYSTEM.....	WP 0104
PERFORM EMERGENCY HYDRAULIC OPERATION WHEN GROVE CRANE ELECTRICAL POWER FAILS .....	WP 0105
Figure 1. ....	0105-2
STOWAGE AND SIGN GUIDE.....	WP 0106
Table 1. Inside Driver Side Door.....	0106-1
Table 2. Front Exterior.....	0106-3
Table 3. M977 Cargo Cabin.....	0106-4
Table 4. M977 Cargo Driver Side Exterior.....	0106-5
Table 5. M977 Cargo Passenger Side Exterior.....	0106-6
Table 6. M977 Cargo Rear Exterior.....	0106-7
Table 7. Miscellaneous Decals/Placards/Plates/ Stencils.....	0106-7
<b>Chapter 3 - Troubleshooting Procedures</b>	
BUZZER SOUNDS AND AIR INDICATOR IS LIT.....	WP 0107
Figure 1. ....	0107-1
Figure 2. ....	0107-2
Figure 3. ....	0107-3
Figure 4. ....	0107-5
Figure 5. ....	0107-6

## TABLE OF CONTENTS - Continued

	<u>WP Sequence No.</u>	
	<u>Page No.</u>	
Figure 6. ....	0107-7	
WINDSHIELD WASHER WILL NOT OPERATE.....		WP 0108
Figure 1. ....	0108-2	
Figure 2. ....	0108-4	
Figure 3. ....	0108-5	
Figure 4. ....	0108-6	
Figure 5. ....	0108-7	
Figure 6. ....	0108-8	
AIR SYSTEM LOSES PRESSURE DURING OPERATION.....		WP 0109
Figure 1. ....	0109-2	
Figure 2. ....	0109-3	
Figure 3. ....	0109-4	
Figure 4. ....	0109-5	
TRAILER BRAKE DOES NOT APPLY WHEN SERVICE BRAKE TREADLE OR PARKING BRAKE IS USED.....		WP 0110
Figure 1. ....	0110-2	
Figure 2. ....	0110-3	
AIR HORN WILL NOT OPERATE.....		WP 0111
Figure 1. ....	0111-2	
Figure 2. ....	0111-3	
Figure 3. ....	0111-4	
ARCTIC ENGINE HEATER FAILS TO OPERATE.....		WP 0112

## TABLE OF CONTENTS - Continued

	<u>Page No.</u>	<u>WP Sequence No.</u>
Figure 1. ....	0112-2	
Figure 2. ....	0112-3	
Figure 3. ....	0112-5	
ONE OR MORE LIGHTING CIRCUITS NOT OPERATING.....		WP 0113
Figure 1. ....	0113-1	
Figure 2. ....	0113-3	
FAILS TO CRANK WHEN ENGINE START SWITCH IS TURNED TO START POSITION.....		WP 0114
Figure 1. ....	0114-1	
Figure 2. ....	0114-2	
CRANKS BUT FAILS TO START.....		WP 0115
Figure 1. ....	0115-2	
Figure 2. ....	0115-3	
Figure 3. ....	0115-4	
Figure 4. ....	0115-5	
STARTS OR RUNS ROUGHLY AFTER PROPER WARM-UP, DOES NOT MAKE FULL POWER, OR MAKES EXCESSIVE EXHAUST SMOKE.....		WP 0116
Figure 1. ....	0116-2	
Figure 2. ....	0116-4	
Figure 3. ....	0116-5	
ENGINE OVERHEATS.....		WP 0117
Figure 1. ....	0117-2	

## TABLE OF CONTENTS - Continued

	<u>Page No.</u>	<u>WP Sequence No.</u>
Figure 2. ....	0117-4	
LOW OIL PRESSURE GAUGE INDICATION.....		WP 0118
Figure 1. ....	0118-2	
EXCESSIVE OIL CONSUMPTION.....		WP 0119
Figure 1. ....	0119-2	
HYDRAULIC SYSTEM OPERATES TOO SLOW, TOO FAST, WITH JERKY MOVEMENTS; OR ONE OR MORE HYDRAULICS CIRCUITS WILL NOT OPERATE.....		WP 0120
Figure 1. ....	0120-2	
Figure 2. ....	0120-3	
BOOM OPERATION ABNORMAL WHEN TELESCOPING IN OR OUT.....		WP 0121
Figure 1. ....	0121-2	
Figure 2. ....	0121-2	
Figure 3. ....	0121-3	
Figure 4. ....	0121-4	
Figure 5. ....	0121-5	
BOOM RAISES OR LOWERS SLOWLY.....		WP 0122
Figure 1. ....	0122-2	
Figure 2. ....	0122-4	
BOOM WILL NOT RAISE OR LOWER.....		WP 0123
Figure 1. ....	0123-2	
BOOM WILL NOT TELESCOPE IN OR OUT.....		WP 0124
Figure 1. ....	0124-2	

**TABLE OF CONTENTS - Continued**

	<u>WP Sequence No.</u>
	<u>Page No.</u>
CRANE CONTROLS STICKING IN ENGAGED POSITION.....	WP 0125
Figure 1. ....	0125-2
Figure 2. ....	0125-4
Figure 3. ....	0125-6
Figure 4. ....	0125-7
Figure 5. ....	0125-8
CRANE WILL NOT OPERATE, OR OPERATES ABNORMALLY.....	WP 0126
Figure 1. ....	0126-2
Figure 2. ....	0126-3
Figure 3. ....	0126-4
HOIST OPERATION SLOW OR ABNORMAL WHEN LIFTING OR LOWERING LOAD.....	WP 0127
Figure 1. ....	0127-2
Figure 2. ....	0127-3
Figure 3. ....	0127-4
Figure 4. ....	0127-5
Figure 5. ....	0127-6
HOIST WILL NOT LIFT LOAD.....	WP 0128
Figure 1. ....	0128-2
Figure 2. ....	0128-3
MAST RAISES OR LOWERS ABNORMALLY.....	WP 0129
Figure 1. ....	0129-2

## TABLE OF CONTENTS - Continued

	<u>WP Sequence No.</u>	
	<u>Page No.</u>	
Figure 2. ....	0129-4	
MAST RAISES OR LOWERS SLOWLY.....		WP 0130
Figure 1. ....	0130-2	
Figure 2. ....	0130-4	
OUTRIGGER OPERATION SLOW OR ABNORMAL.....		WP 0131
Figure 1. ....	0131-2	
Figure 2. ....	0131-3	
Figure 3. ....	0131-5	
Figure 4. ....	0131-6	
Figure 5. ....	0131-6	
SWING OPERATION ABNORMAL IN BOTH DIRECTIONS.....		WP 0132
Figure 1. ....	0132-2	
Figure 2. ....	0132-3	
Figure 3. ....	0132-4	
Figure 4. ....	0132-5	
Figure 5. ....	0132-6	
SWING OPERATION ABNORMAL IN ONLY ONE DIRECTION.....		WP 0133
Figure 1. ....	0133-2	
Figure 2. ....	0133-3	
Figure 3. ....	0133-4	
SELF-RECOVERY WINCH DOES NOT WORK.....		WP 0134
Figure 1. ....	0134-2	

## TABLE OF CONTENTS - Continued

	<u>Page No.</u>	<u>WP Sequence No.</u>
Figure 2. ....	0134-3	
UNUSUALLY NOISY WHEN OPERATING.....		WP 0135
Figure 1. ....	0135-1	
Figure 2. ....	0135-2	
VEHICLE IS HARD TO STEER, SHIMMIES, WANDERS, OR PULLS TO ONE SIDE.....		WP 0136
Figure 1. ....	0136-2	
Figure 2. ....	0136-3	
VEHICLE STEERING SLOW TO RESPOND OR INTERMITTENT.....		WP 0137
Figure 1. ....	0137-2	
Figure 2. ....	0137-4	
UNUSUALLY NOISY WHEN OPERATING.....		WP 0138
Figure 1. ....	0138-1	
SLOW OR DIFFICULT ENGAGEMENT.....		WP 0139
Figure 1. ....	0139-1	
TRANSFER CASE SHIFT LEVER WILL NOT SHIFT.....		WP 0140
Figure 1. ....	0140-2	
Figure 2. ....	0140-3	
Figure 3. ....	0140-4	
Figure 4. ....	0140-5	
TRANS TEMP GAUGE INDICATES OVERHEATING DURING NORMAL OPERATION.....		WP 0141
Figure 1. ....	0141-2	

## TABLE OF CONTENTS - Continued

	<u>Page No.</u>	<u>WP Sequence No.</u>
Figure 2. ....	0141-3	
WHEEL WOBBLES.....		WP 0142
Figure 1. ....	0142-2	
Figure 2. ....	0142-3	
TIRES WORN UNEVENLY OR EXCESSIVELY.....		WP 0143
Figure 1. ....	0143-2	
<b>Chapter 4 - Preventive Maintenance Checks and Services (PMCS)</b>		
INTRODUCTION - PREVENTIVE MAINTENANCE .....		WP 0144
Figure 1. ....	0144-3	
BEFORE - PREVENTIVE MAINTENANCE.....		WP 0145
Table 1. PMCS - BEFORE.....	0145-1	
Figure 1. ....	0145-5	
Figure 2. ....	0145-7	
Figure 3. ....	0145-9	
Figure 4. ....	0145-10	
Figure 5. ....	0145-11	
Figure 6. ....	0145-15	
Figure 7. ....	0145-18	
Figure 8. ....	0145-21	
Figure 9. ....	0145-23	
Figure 10. ....	0145-24	
Figure 11. ....	0145-26	



**TABLE OF CONTENTS - Continued**

	<u>Page No.</u>	<u>WP Sequence No.</u>
Figure 12. ....	0145-29	
Figure 13. ....	0145-32	
Figure 14. ....	0145-34	
Figure 15. ....	0145-36	
Figure 16. ....	0145-37	
Figure 17. ....	0145-38	
DURING - PREVENTIVE MAINTENANCE.....		WP 0146
Table 1. PMCS - DURING.....	0146-1	
Figure 1. ....	0146-2	
AFTER - PREVENTIVE MAINTENANCE .....		WP 0147
Table 1. PMCS - AFTER.....	0147-1	
Figure 1. ....	0147-5	
Figure 2. ....	0147-8	
Figure 3. ....	0147-10	
Figure 4. ....	0147-12	
Figure 5. ....	0147-13	
Figure 6. ....	0147-14	
Figure 7. ....	0147-15	
Figure 8. ....	0147-17	
Figure 9. ....	0147-18	
Figure 10. ....	0147-20	
Figure 11. ....	0147-21	

## TABLE OF CONTENTS - Continued

	<u>WP Sequence No.</u>
	<u>Page No.</u>
Figure 12. ....	0147-24
Figure 13. ....	0147-26
Figure 14. ....	0147-31
Figure 15. ....	0147-32
Figure 16. ....	0147-33
Figure 17. ....	0147-34
Figure 18. ....	0147-36
Figure 19. ....	0147-39
WEEKLY - PREVENTIVE MAINTENANCE.....	WP 0148
Table 1. PMCS - WEEKLY.....	0148-1
Figure 1. ....	0148-4
Figure 2. ....	0148-6
Figure 3. ....	0148-7
Figure 4. ....	0148-9
Figure 5. ....	0148-10
Figure 6. ....	0148-12
Figure 7. ....	0148-13
Figure 8. ....	0148-14
Figure 9. ....	0148-15
Figure 10. ....	0148-16
Figure 11. ....	0148-17
Figure 12. ....	0148-19

**TABLE OF CONTENTS - Continued**

	<u>Page No.</u>	<u>WP Sequence No.</u>
Figure 13. ....	0148-20	
Figure 14. ....	0148-21	
Figure 15. ....	0148-23	
Figure 16. ....	0148-24	
Figure 17. ....	0148-25	
Figure 18. ....	0148-26	
Figure 19. ....	0148-28	
Figure 20. ....	0148-30	
Figure 21. ....	0148-31	
Figure 22. ....	0148-34	
Figure 23. ....	0148-36	
Figure 24. ....	0148-41	
Figure 25. ....	0148-42	
Figure 26. ....	0148-43	
Figure 27. ....	0148-44	
Figure 28. ....	0148-46	
Figure 29. ....	0148-49	
SEMIANNUAL - PREVENTIVE MAINTENANCE.....		WP 0149
Table 1. PMCS- SEMIANNUAL.....	0149-1	
Figure 1. ....	0149-3	
Figure 2. ....	0149-6	
Figure 3. ....	0149-8	

## TABLE OF CONTENTS - Continued

	<u>Page No.</u>	<u>WP Sequence No.</u>
Figure 4. ....	0149-10	
Figure 5. ....	0149-11	
Figure 6. ....	0149-13	
Figure 7. ....	0149-14	
Figure 8. ....	0149-15	
Figure 9. ....	0149-16	
Figure 10. ....	0149-17	
Figure 11. ....	0149-18	
Figure 12. ....	0149-19	
Figure 13. ....	0149-20	
Figure 14. ....	0149-21	
Figure 15. ....	0149-22	
Figure 16. ....	0149-23	
Figure 17. ....	0149-25	
Figure 18. ....	0149-26	
Figure 19. ....	0149-27	
Figure 20. ....	0149-28	
MONTHLY - PREVENTIVE MAINTENANCE.....		WP 0150
Table 1. PMCS - MONTHLY.....	0150-1	
Figure 1. ....	0150-4	
Figure 2. ....	0150-5	
Figure 3. ....	0150-6	

## TABLE OF CONTENTS - Continued

	<u>Page No.</u>	<u>WP Sequence No.</u>
Figure 4. ....	0150-7	
Figure 5. ....	0150-8	
Figure 6. ....	0150-9	
Figure 7. ....	0150-11	
Figure 8. ....	0150-13	
Figure 9. ....	0150-14	
 <b>Chapter 5 - Maintenance Instructions</b>		
LUBRICATION INSTRUCTIONS.....		WP 0151
Table 1. Engine Lubrication.....	0151-2	
Table 2. Transmission and Transfer Case Lubrication.....	0151-3	
Table 3. Axle Lubrication.....	0151-4	
Table 4. Hydraulic Reservoir Servicing.....	0151-6	
Table 5. Radiator Servicing.....	0151-7	
Table 6. Self-Recovery Winch Lubrication.....	0151-9	
Table 7. Material Handling Crane Lubrication.....	0151-10	
Table 8. Oil Can Point Lubrication.....	0151-11	
Table 9. Miscellaneous Lubrication Points.....	0151-12	
Table 10. Vehicle Cleaning.....	0151-13	
CLOSE/OPEN HEATER VALVES.....		WP 0152
Figure 1. ....	0152-2	
Figure 2. ....	0152-3	
PRE/POST TOWING PROCEDURE (FRONT LIFT ONLY).....		WP 0153

## TABLE OF CONTENTS - Continued

	<u>Page No.</u>	<u>WP Sequence No.</u>
Figure 1. ....	0153-2	
Figure 2. ....	0153-3	
Figure 3. ....	0153-4	
Figure 4. ....	0153-5	
CLEAN VEHICLE.....		WP 0154
Figure 1. ....	0154-1	
Figure 2. ....	0154-2	
CHANGE WHEEL AND TIRE ASSEMBLY.....		WP 0155
Figure 1. ....	0155-2	
Figure 2. ....	0155-3	
Figure 3. ....	0155-4	
Figure 4. ....	0155-4	
Figure 5. ....	0155-5	
Figure 6. ....	0155-5	
Figure 7. ....	0155-6	
Figure 8. ....	0155-7	
Figure 9. ....	0155-8	
Figure 10. ....	0155-8	
Figure 11. ....	0155-9	
Figure 12. ....	0155-10	
Figure 13. ....	0155-11	
Figure 14. ....	0155-12	

**TABLE OF CONTENTS - Continued**

	<u>Page No.</u>	<u>WP Sequence No.</u>
Figure 15. ....	0155-13	
Figure 16. ....	0155-13	
Figure 17. ....	0155-14	
Figure 18. ....	0155-15	
Figure 19. ....	0155-16	
Figure 20. ....	0155-17	
Figure 21. ....	0155-18	
Figure 22. ....	0155-19	
CLEAN FUEL TANK STRAINER.....		WP 0156
Figure 1. ....	0156-1	
Figure 2. ....	0156-2	
SERVICE AIR CLEANER ELEMENT.....		WP 0157
Figure 1. ....	0157-1	
Figure 2. ....	0157-2	
Figure 3. ....	0157-3	
Figure 4. ....	0157-4	
Figure 5. ....	0157-5	
Figure 6. ....	0157-5	
Figure 7. ....	0157-6	
SERVICE TIRES.....		WP 0158
Figure 1. ....	0158-2	
Figure 2. ....	0158-3	

## TABLE OF CONTENTS - Continued

	<u>Page No.</u>	<u>WP Sequence No.</u>
Figure 3. ....	0158-4	
Figure 4. ....	0158-5	
Figure 5. ....	0158-7	
OPEN/CLOSE BATTERY BOX.....		WP 0159
Figure 1. ....	0159-3	
Figure 2. ....	0159-5	
OPEN/CLOSE ENGINE COVERS AND ENGINE SIDE PANEL REMOVAL/INSTALLATION.....		WP 0160
Figure 1. ....	0160-1	
Figure 2. ....	0160-2	
Figure 3. ....	0160-3	
Figure 4. ....	0160-3	
<b>Chapter 6 - Supporting Information</b>		
REFERENCES.....		WP 0161
COMPONENTS OF END ITEM AND BASIC ISSUE ITEMS LISTS.....		WP 0162
Table 1. List of Usable On Codes.....	0162-2	
Table 2. Components of End Item.....	0162-2	
Table 3. Basic Issue Items.....	0162-3	
ADDITIONAL AUTHORIZATION LIST (AAL).....		WP 0163
Table 1. List of Usable On Codes.....	0163-1	
Table 2. Additional Authorization List.....	0163-2	
EXPENDABLE AND DURABLE ITEMS LIST.....		WP 0164



## TABLE OF CONTENTS - Continued

	<u>WP Sequence No.</u>
	<u>Page No.</u>
Table 1. Expendable and Durable Items List.....	0164-1



## HOW TO USE THIS MANUAL

### USABLE ON CODE (UOC) INFORMATION

Usable On Code (UOC) - the user should be aware that the BASE model M977 Cargo HEMTT series vehicle (with self-recovery winch installed) UOC is "H01". Dependent on the format used for printing this manual, the user may or may not see instructions printed in this manual stating what information is applicable to which model HEMTT series vehicle by UOC.

### USABLE ON CODE (UOC) INFORMATION

Usable On Code (UOC) - the user should be aware that the BASE model M977 Cargo HEMTT series vehicle (without self-recovery winch installed) UOC is "H06". Dependent on the format used for printing this manual, the user may or may not see instructions printed in this manual stating what information is applicable to which model HEMTT series vehicle by UOC.

### WARNINGS, CAUTIONS, AND NOTES

Read all WARNINGS, CAUTIONS, AND NOTES before performing any procedure.

Warnings, cautions, notes, subject headings, and other essential information are printed in **BOLD** type, making them easier for the user to see.

### GENERAL INFORMATION

This manual is designed to help operate and maintain the Heavy Expanded Mobility Tactical Truck (HEMTT). Listed below are some features included in this manual to help locate and use the required information:

- Chapter 1 of this manual includes HEMTT series vehicle general information, theory of operation, differences between models, etc.
- Chapter 2 of this manual provides operating procedures and operator Preventive Maintenance Checks and Services (PMCS) for both the HEMTT series vehicle, and its accompanying operating systems.
- Chapter 3 of this manual provides operator troubleshooting procedures for both the HEMTT series vehicle, and its accompanying operating systems.

In addition to text, there are illustrations showing:

1. Components, controls, and indicators.
2. How to take a component off, and put it back on.
3. Cleaning and inspection criteria are also listed when necessary.



CHAPTER 1

GENERAL  
INFORMATION,  
EQUIPMENT  
DESCRIPTION AND  
THEORY OF  
OPERATION

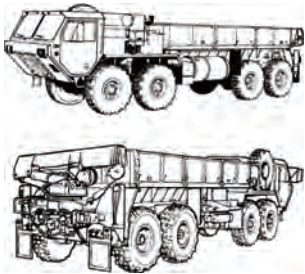


**OPERATOR MAINTENANCE  
INTRODUCTION**

**SCOPE**

This manual is used for operation and operator-performed maintenance of HEMTT series vehicles which consist of a number of different models all built on similar chassis, but specially equipped to perform different missions.

*Table 1. Overview.*

<b>M977 CARGO</b>	<b>DESCRIPTION</b>
 <p data-bbox="255 1002 362 1033"><i>Figure 1.</i></p>	<p data-bbox="497 664 1204 815">Cargo vehicle with 62,000 lbs (28 148 kg) GVWR and 100,000 lbs (45 400 kg) GCWR. Vehicle has an 18 ft. (5.5 m) cargo body and is equipped with a material handling crane which has a maximum load capacity of 2500 lbs (1 135 kg) at 19 ft. (5.8 m) boom radius.</p>

**MAINTENANCE FORMS AND RECORDS**

Department of the Army forms and procedures used for equipment maintenance will be those prescribed by DA PAM 750-8 The Army Maintenance Management System (TAMMS) Users Manual. (WP 0161)

**EQUIPMENT IMPROVEMENT REPORT AND MAINTENANCE DIGEST (EIR MD) AND QUALITY DEFICIENCY REPORTING (QDR).**

The quarterly TB 43-0001-62 (series) Equipment Improvement Report and Maintenance Digest (WP 0161) contains valuable field information on equipment covered in this manual. Information in the TB 43-0001-62 (series) Equipment Improvement Report and Maintenance Digest (WP 0161) is compiled from some of the Equipment Improvement Reports (EIR) that have been prepared on vehicles covered in this manual. Many of these articles result from comments, suggestions, and improvement recommendations that were submitted to the EIR program. TB 43-0001-62 (series) Equipment Improvement Report and

## **EQUIPMENT IMPROVEMENT REPORT AND MAINTENANCE DIGEST (EIR MD) AND QUALITY DEFICIENCY REPORTING (QDR). - Continued**

Maintenance Digest (WP 0161) contains information on equipment improvements, minor alterations, proposed Modification Work Orders (MWOs), warranties (if applicable), actions taken on some of the DA Form 2028's (WP 0161) (Recommended Changes to Publications), and advance information on proposed changes that may affect this manual. Refer to the TB 43-0001-62 (series) Equipment Improvement Report and Maintenance Digest (WP 0161) periodically for the most current and authoritative information on the equipment. The information will help to do a better job and will advise of the latest changes to this manual. Also refer to DA PAM 25-30, (WP 0161) Consolidated Index of Army Publications and Blank Forms at <http://www.army.mil/usapa/2530.html>, and reference section (WP 0161) of this manual. If you have a change recommendation to this manual, submit a DA Form 2028's (WP 0161) (Recommended Changes to Publications) via e-mail to: ROCK-TACOM-TECH-PUBS@conus.army.mil.

You can help improve this publication. If you find any mistakes or if you know of a way to improve the procedures, please let us know. Submit your DA Form 2028 (WP 0161) (Recommended Changes to Equipment Technical Publications) through the Internet, on the Army Electronic Product Support (AEPS) website. The Internet address is <https://aeps.ria.army.mil>. The DA Form 2028 (WP 0161) is located under the Public Applications section in the AEPS Public Home Page. Fill out the form and click on SUBMIT. Using this form on the AEPS will enable us to respond quicker to your comments and better manage the DA Form 2028 program. You may also mail, fax or e-mail your letter or DA Form 2028 (WP 0161) direct to: TACOM Life Cycle Management Command, ATTN: AMSTA-LC-LMPP / TECH PUBS, TACOM-RI, 1 Rock Island Arsenal, Rock Island, IL 61299-7630. The e-mail address is ROCK-TACOM-TECH-PUBS@conus.army.mil. The fax number is DSN 793-0726 or Commercial (309) 782-0726.

## **HAND RECEIPT (HR) INFORMATION**

The is a companion document to this manual which consists of preprinted hand receipts (DA Form 2062) (WP 0161) that list end item related equipment (COEI, BII, (WP 0162) and AAL (WP 0163)) which must be accounted for. As an aid to property accountability, additional Hand Receipt (-HR) Manuals may be requisitioned from the following source in accordance with procedures in DA PAM 25-30, (WP 0161) Consolidated Index of Army Publications and Blank Forms; Commander US Army Distribution Operation Facility, 1655 Woodson Road, St Louis, MO 63114-6181.

## **CORROSION PREVENTION AND CONTROL**

Corrosion prevention and control (CPC) of Army material is a continuing concern. It is important that any corrosion problems be reported so they can be corrected and improvements can be made to prevent problems in the future. While corrosion is typically associated with the rusting of metals, it can also include deterioration of other materials, such as rubber and plastic. Unusual cracking, softening, swelling, or breaking of these materials may be a corrosion problem.



## **CORROSION PREVENTION AND CONTROL - Continued**

If a corrosion problem is identified, it can be reported using SF 368 (WP 0161). The use of key words, such as "corrosion", "rust", "deterioration", and "cracking" will ensure that the information is identified as a CPC problem.

## **DESTRUCTION OF ARMY MATERIAL TO PREVENT ENEMY USE**

Procedures for the destruction of Army materiel to prevent enemy use are contained in TM 750-244-6 (WP 0161).

## **PREPARATION FOR STORAGE OR SHIPMENT**

See information on preparing the HEMTT series vehicle for storage or shipment.

## **WARRANTY INFORMATION**

The HEMTT series vehicles are warranted by Oshkosh Truck Corporation for 12 months or 12,000 miles (19 308 km), whichever comes first. The warranty starts on the date found in block 23 of DA Form 2408-9 (WP 0161) in the vehicle logbook. Report all defects in material or workmanship to the supervisor, who will take appropriate action through the field level maintenance shop.

## **NOMENCLATURE CROSS-REFERENCE LIST**

*Table 2. Common Nomenclature.*

<b>COMMON NAME</b>	<b>OFFICIAL NOMENCLATURE</b>
Brake Pedal	Service Brake Pedal
Cable/Hoist Cable	Wire Rope
Cold Start System	Ether Quick-Start System
Electrical Control Box	Junction Box
Engine Coolant	Antifreeze, Ethylene Glycol Mixture
Glad Hand	Quick Disconnect Coupling
High Idle Switch	Engine Speed Control Switch
Jake Brake, Jacobs® Brake	Engine Retarder, Engine Brake

**NOMENCLATURE CROSS-REFERENCE LIST - Continued***Table 2. Common Nomenclature. - Continued*

<b>COMMON NAME</b>	<b>OFFICIAL NOMENCLATURE</b>
Manual Controls	Directional Control Valves
O-Ring	Preformed Packing
Snap Ring	Retaining Ring

**LIST OF ABBREVIATIONS***Table 3. Common Abbreviations.*

<b>ABBREVIATION</b>	<b>OFFICIAL NOMENCLATURE</b>
AAL	Additional Authorization List
AMDF	Army Master Data File
amp	Ampere
BAP	Bridge Adapter Pallet
bar	Barometric Pressure
BII	Basic Issue Items
BL	Bottom Load
BOI	Basis of Issue
C	Celsius
CAGEC	Commercial And Government Entity/Code
CARC	Chemical Agent Resistant Coating
CBR	Chemical, Biological, Radiological
CBT	Common Bridge Transporter

## LIST OF ABBREVIATIONS - Continued

*Table 3. Common Abbreviations. - Continued*

<b>ABBREVIATION</b>	<b>OFFICIAL NOMENCLATURE</b>
CCA	Cold Cranking Amperes
CHU	Container Handling Unit
CID	Cubic Inch Displacement
CKT	Circuit
cm	Centimeter
COEI	Components of End Item
CPC	Corrosion Prevention Control
CROP	Container Roll-In/Out Platform
CTA	Common Table of Allowance
DA	Department of the Army
dia.	Diameter
DS	Direct Support
EIR	Equipment Improvement Recommendations
F	Fahrenheit
FHTV	Family of Heavy Tactical Vehicles
FLA	Front Lift Adapter
fl. oz.	Fluid Ounce
FR	Flatrack
FRS	Forward Repair System
ft.	Foot

## LIST OF ABBREVIATIONS - Continued

*Table 3. Common Abbreviations. - Continued*

<b>ABBREVIATION</b>	<b>OFFICIAL NOMENCLATURE</b>
GAA	Grease, Automotive, and Artillery
gal	Gallon
GCWR	Gross Combination Weight Rating
GMT	Guided Missile Transport
GPFU	Gas Particulate Filter Unit
gpm	Gallons Per Minute
GS	General Support
GVWR	Gross Vehicle Weight Rating
HDI	Hexamethylene Diisocyanate
HEMTT	Heavy Expanded Mobility Tactical Truck
hp	Horsepower
HVAC	Heating, Ventilation, and Air Conditioning
IBC	Improved Boat Cradle
I.D.	Inside Diameter
in.	Inch
ISO	International Standards Organization
JTA	Joint Table of Allowances
kg	Kilogram
km	Kilometer
Kmh or km/h	Kilometer per Hour

## LIST OF ABBREVIATIONS - Continued

*Table 3. Common Abbreviations. - Continued*

<b>ABBREVIATION</b>	<b>OFFICIAL NOMENCLATURE</b>
kPa	Kilopascals
kw	Kilowatt
L	Liter
lbs	Pound
lb-ft	Pound-Foot
lb-in	Pound-Inch
LCD	Liquid Crystal Display
LED	Light Emitting Diode
LH	Left-Hand
LHS	Load Handling System
M	Meter
MAC	Maintenance Allocation Chart
mi	Mile
ml	Milliliter
MLC	Military Load Class
mm	Millimeter
Mph	Miles Per Hour
MTOE	Modified Tables of Organization and Equipment
NBC	Nuclear, Biological, Chemical
NIIN	National Item Identification Number

## LIST OF ABBREVIATIONS - Continued

*Table 3. Common Abbreviations. - Continued*

<b>ABBREVIATION</b>	<b>OFFICIAL NOMENCLATURE</b>
Nm	Newton Meter
NOC	Not Usable-On Code
NSN	National Stock Number
O.D.	Outside Diameter
OEA	Oil, Engine, Arctic
OE/HDO	Oil, Engine/Hydraulic Oil
O/R	Outrigger
OTC	Oshkosh Truck Corporation
Oz	Ounce
PLS	Palletized Load System
PMCS	Preventive Maintenance Checks and Services
psi	Pounds per Square Inch
pt.	Pint
PTO	Power Take-Off
qt.	Quart
Qty. Recm.	Quantity Recommended
Qty. Rqr.	Quantity Required
RCU	Remote Control Unit
RFI	Radio-Frequency Interference
RH	Right-Hand

**LIST OF ABBREVIATIONS - Continued****Table 3. Common Abbreviations. - Continued**

<b>ABBREVIATION</b>	<b>OFFICIAL NOMENCLATURE</b>
rpm	Revolutions Per Minute
RPSTL	Repair Parts and Special Tools List
SAE	Society of Automotive Engineers
SMR	Source, Maintenance, and Recoverability
SRA	Specialized Repair Activity
SRW	Self-Recovery Winch
TAMMS	The Army Maintenance Management System
TDA	Tables of Distribution and Allowance
TM	Technical Manual
TMDE	Test, Measuring, and Diagnostic Equipment
TOE	Tables of Organization and Equipment
u/m	Unit of Measure
UOC	Usable-On Code
Vdc	Volts Direct Current
XHD	Extra Heavy-Duty

**SAFETY, CARE, AND HANDLING**

Significant hazards and safety recommendations are listed in the table below.

**SAFETY, CARE, AND HANDLING - Continued**

**Table 4. Significant Hazard And Safety Recommendations.**

<b>HAZARD</b>	<b>SAFETY RECOMMENDATION OR PRECAUTION</b>	<b>OPERATING CONDITION</b>
Low air pressure for brakes.	Do not drive vehicle while low air pressure warning buzzer is sounding or red light is on.	Abnormal
Vehicle instability with crane use.	Ensure that outriggers are down on firm ground, side slope does not exceed 5 degrees, and crane is not overloaded.	Abnormal
Connecting towing devices.	Do not go between vehicles until vehicles are stopped and brakes are set.	Normal
Refueling vehicle.	Shut off engine and no smoking when filling tank.	Normal

**NOTE**

Category of hazards as to whether or not they may be expected under normal or abnormal operating conditions.

**NOTE**

- Material handling cranes have overload shutdown and/or tilt warning (unstable) systems. Always apply PARKING BRAKE control (WP 0045) prior to crane operation.
- When cranes are overloaded, the overload system will automatically shut off power to telescope boom out, raise boom, or hoist load higher. The overload system will also prevent lowering the boom. An overload condition can be corrected by lowering load to ground or other supporting surface. All crane functions will be restored in approximately six seconds.

**NOTE**

- The crane operating instruction plates are located on the heater compartment cover in the cab and at each of the fixed operating station.



**SAFETY, CARE, AND HANDLING - Continued****Table 4. Significant Hazard And Safety Recommendations. - Continued**

<b>HAZARD</b>	<b>SAFETY RECOMMENDATION OR PRECAUTION</b>	<b>OPERATING CONDITION</b>
	<ul style="list-style-type: none"><li data-bbox="278 396 1025 456">• The outrigger leg plates are located on each of the outrigger cylinders.</li></ul>	

**METRIC SYSTEM**

The equipment described herein contains metric components and requires metric, common, and special tools. Therefore, metric units and English units will be used throughout this publication. An English-to-metric conversion table is included as the last page of this manual inside the back cover.

**END OF WORK PACKAGE**



---

## OPERATOR MAINTENANCE WARRANTY PROGRAM

---

### General

This work package provides implementation instructions for the warranty on the HEMTT. It contains instructions for obtaining services and/or supplies covered under warranty. This work package also describes methods of processing warranty claims. For additional warranty information on the HEMTT or any U.S. Army Tank-Automotive and Armaments Command (TACOM) equipment, contact your local Warranty Control Office/Officer (WARCO) or TACOM Logistics Assistance Representative (LAR). If your WARCO or TACOM LAR is not available, or if additional information is required, contact TACOM.

### Explanation of Terms

#### Abuse

The improper use, maintenance, repair or handling of warranted items that may cause the warranty of those items to become void (for example, not following service intervals, using the vehicle for other than what is intended).

#### Acceptance

The execution of the acceptance block and signing of DD Form 250 (WP 0161), by the authorized Government representative, unless end items are placed in storage in which case acceptance shall mean date of shipment from storage facility as reflected on DD Form 1149 (WP 0161) or DD Form 1348-1. (WP 0161)

#### Acceptance Date

The date an item of equipment is accepted into the Army's inventory by the execution of the acceptance block and signing of a DD Form 250 (WP 0161) or approved acceptance document, by an authorized representative of the Government.

#### Contractor

The supplier of equipment who enters into an agreement directly with the Government to furnish supplies.

#### Correction

The elimination of a defect.

---

## Explanation of Terms - Continued

### Defect

Any condition or characteristic in any supplies furnished by the contractor that does not otherwise function, or threatens not to function, as intended.

### Failure

A part, component, or end item that fails to perform its intended use.

### Manufacturer's Recall

**Safety Recall** An item is recalled to repair or replace a defective part or assembly which may affect safety.

**Service Recall** An item is recalled to repair or replace a defective part(s) or assembly which does not affect the safe use of this item.

### Owning Unit

The Army Unit authorized to operate, maintain, and use the equipment.

### Reimbursement

A written provision in this warranty in which the Using/Support Unit may make the necessary repairs, with or without prior approval from the contractor, and the Government will be reimbursed for the repair parts and labor costs.

### Repair

A maintenance action required to restore an item to serviceable condition without affecting the warranty.

### Supplies

The end item and all assemblies/parts furnished by the contractor.

### Supporting Repair Facility

The repair activity authorized to accomplish warrantable repairs at the appropriate level of maintenance identified in the Maintenance Allocation Chart.

### WARCO

Serves as the intermediary between the troops owning the equipment and the local dealer, contractor, or manufacturer. All warranty claim actions will be processed through the WARCO.

**Explanation of Terms - Continued**

**Warranty**

A written agreement between a contractor and the Government which outlines the rights and obligations of both parties for defective supplies.

**Warranty Claim**

Action started by the equipment user for authorized warranty repair reimbursement.

**Warranty Expiration Date**

The date the warranty is no longer valid. This date will be 13 months from the contractor shipment date. This warranty period covers the basic 12 months plus on additional month for shipping time.

**Warranty Period**

Time during which the warranty is in effect; normally measured as the maximum number of years, months, days, miles, or hours used.

**Warranty Start Date**

The day shipment is put into effect (Contractor Shipment Date).

**Coverage-Specific**

This work package applies to:

**Table 1. Vehicle Information**

Noun	Model	NSN	Cage
Truck, Cargo	M977 (without winch)	2320-01-099-6426	45152

**NOTE**

The item is manufactured by Oshkosh Truck Corporation (OTC), under contract #W56HZV-07-C-0248. Inquiries to OTC can be made by calling (920) 235-9151.

**Coverage-Specific - Continued****Table 2. Vehicle Information**

Noun	Model	NSN	Cage
Truck, Cargo	M977 (with winch)	2320-01-097-0260	45152
<p style="text-align: center;"><b>NOTE</b></p> <p style="text-align: center;">The item is manufactured by Oshkosh Truck Corporation (OTC), under contract #W56HZV-07-C-0248. Inquiries to OTC can be made by calling (920) 235-9151.</p>			

The contractor warrants the supplies are free from defects in design, material, and workmanship for a period of thirteen (13) months from warranty start date.

If a Safety recall defect occurs during the vehicle warranty period, the contractor agrees to extend the terms of the warranty to the time required to make necessary safety defect corrections. Also, if the contractor or his supplier(s) provide a greater warranty for the supplies furnished, the contractor will provide the greater warranty to the Government.

If a defect/failure is caused by or falls within any of the following categories, it is not considered warrantable and a claim should not be initiated:

1. Misuse or negligence
2. Accidents
3. Improper operation
4. Improper storage
5. Improper transport
6. Improper or insufficient maintenance
7. Improper alterations or repairs
8. Defect/failure discovered or occurring after warranty expiration date.
9. Fair wear and tear items (brake shoes, pads, armatures, brushes, etc.).

In addition to the 13 month warranty, the vehicles will be warranted for a total service life of 10 years including extended periods in a corrosion hazard military environment. During this 10 year service life, there will be no damage caused by corrosion requiring repair or replacement of parts. No actions beyond normal washing or replacement of accident-damaged paint shall be necessary to maintain the corrosive protection in place.

This 13 month warranty is extended up to nine (9) months from date of acceptance if the vehicle is put into government storage before use. In this case, the warranty starts when

**Coverage-Specific - Continued**

the vehicle is either taken out of storage or until nine (9) months from the warranty start date shown on the warranty data plate, whichever occurs first. Refer to preparation for storage.

**Contractor Responsibilities**

When the owning unit has directed the contractor to correct the supplies, the contractor will furnish all material required to correct the defective supplies. Repairs and parts shall be initiated/provided within ten (10) working days after receipt of written claim notification. Furthermore, the contractor will provide a copy of the work order to owning unit upon completion of repair.

When the contractor receives written notification requiring contractor repair, they will have the option:

1. Correct the supplies in the field.
2. Return the vehicle or parts to the contractor's designated facility for correction.

When the contractor corrects the supplies, all labor involved shall be borne by the contractor. Additionally, the contractor shall arrange and bear all transportation costs of the supplies to its facility and return to user.

The contractor, within five (5) working days of receiving such notice, shall notify the warranty claimant by telephone as to the method of correction, date(s) work is to be performed and by whom.

**Government Responsibilities**

The Major Subordinate Command for the HEMTT is the U.S. Army Tank-Automotive and Armaments Command (TACOM), Warren, MI 48397-5000. TACOM is responsible for managing and implementing the warranty.

**TACOM will:**

Insure the contractor performs in accordance to the terms of the contract.

**Equipment owning unit will:**

1. Identify defects/failures and verify the defects/failures are warrantable.
2. Submit warranty claims, using DA Form 2407 (WP 0161) or DA Form 2407-1 (WP 0161) to your local Warranty Coordinator.
3. Tag and retain (IAW DA PAM 750-8 and this work package) (WP 0161) parts, pieces of parts and/or assemblies removed at the owning unit level and as a result of a warrantable defect/failure and/or correction.

## Government Responsibilities - Continued

### Supporting repair facility will:

1. Identify defects/failures as warrantable (if owning unit has not already identified them). Verify defects/failures are warrantable.
2. Review, process, and submit valid warranty claims to the local WARCO if the DA Form 2407 (WP 0161) is complete and correctly filled out.
3. Reject invalid warranty claims or request additional information for incomplete and incorrect claims.
4. Coordinate with the owning unit and decide which option for repair is desired to correct the warrantable defect/failure.
5. Depending on which repair option was chosen (Government or contract repair) provide labor/parts required to accomplish the warrantable repairs.
6. Tag and retain (IAW DA PAM 750-8 and this work package) (WP 0161) all parts, pieces, or parts and/or assemblies removed as a result of warrantable defect/failure and/or correction.

### Local WARCO will:

1. Verify, review, process, and if valid and complete, submit claims (reimbursable and/or disputes) to the contractor.
2. Reject claims that are not valid, and send them back to the local Unit with a short explanation of why the claim is rejected.
3. Request additional information for incomplete claims.
4. Provide warranty claim acknowledgment closeout and/or parts/assemblies disposition instructions to the local Unit.
5. Insure the contractor performs in accordance to the terms of the contract.
6. Verify, administer and process warranty claims.
7. Act as a liaison between owning unit, the contractor, supporting repair facility and TACOM.
8. Notify the owning units of all warranty claim acknowledgments/close-outs, information and/or instructions received from TACOM or the contractor.
9. Act as a liaison between local dealers and the Army.
10. Enter all open and closed WCAs into the Army Electronics Product Support (AEPS), Electronic Deficiency Reporting System.
11. The information/data provided on the DA Form 2407 (WP 0161) are placed into the AEPS Deficiency Reporting System (DRS) at the installation WARCO office to facilitate MSC management and tracking of warranties.

## Alterations/Modifications

Alterations/modifications shall not be applied unless authorized by TACOM.

## Warranty Data Plate

All vehicles will have a warranty data plate. The contractor is required to mount his data plate within clear view of the operator.



## Warranty Data Plate - Continued

When the vehicle is received, the owning unit should locate the warranty data plate and check the warranty start date with date shown on the applicable DD Form 250 (WP 0161) or DD Form 1149. (WP 0161) If these dates differ, disregard the data plate. The date shown on the DD Form 250 (WP 0161) or DD Form 1149. (WP 0161) is the date to be used as a warranty start date.

## Claim Procedures

The procedures for reporting warranty claims are found in DA PAM 750-8 (WP 0161) and this work package. Responsibilities of the MACOM are found in AR 700-139. (WP 0161) All Warranty Claim Actions are processed on DA Form 2407 (WP 0161) and DA Form 2407-1. (WP 0161) It is very important to fill in the blocks on the forms as accurately as possible.

The contractor shall be notified in writing within 30 days, utilizing DA Form 2407 (WP 0161) by the local Warranty Control Office/Officer (WARCO) following the discovery of a defect in supplies which requires contractor repair and/or replacement parts. This shall constitute formal notification of a warranty claim, and initiate the time period for contractor responsibilities and action under the warranty. This notification shall include, but not be limited to furnishing of the equipment serial number, operating hours, part number or NSN of the defective part and circumstances surrounding the defect(s). At this time, the contractor will further be informed whether the owning unit has elected:

1. To correct the defect themselves.
2. To direct the contractor to correct the defect.

Upon completion of contractor repair, forward completed warranty claims (Information Only) electronically to AEPS (Army Electronic Product Support) <http://aeprs.ria.army.mil>.

The contractor shall reimburse the government for the cost of labor and/or replacement parts involved in the government correction of the defect. The government's Maintenance Allocation Chart (MAC) determines the times. Additionally, the cost of replacement parts obtained through the Government's supply channels will be determined by the amount identified in the contractor's current commercial dealer net price or Army Master Data File (AMDF) price, whichever is less. Furthermore, the owning unit may direct the contractor to provide the replacement parts that prove to be defective within the warranty period, without costs to the government, directly to their location or F.O.B., U.S. Port of Embarkation for OCONUS. The contractor shall furnish replacement parts within 10 working days after receipt of written claim notification. DO NOT submit warranty claims for reimbursement where repair labor costs and replacement parts costs combined do not exceed \$150.00 for any one failure.

Identification Of Failed Items. Failed warranty items shall be tagged/identified to prevent improper repair or use. Documents that describe the use of DA Form 2402 Maintenance Tag (WP 0161) and DA Form 2407 Maintenance Request (WP 0161) shall be referenced. Items requiring special handling, storage, or shipment during the processing of claims shall be identified.

## **Claim Procedures - Continued**

Disposition. The repair activity shall retain defective supplies for thirty (30) days following receipt of acknowledgment of warranty claim from WARCO or contractor. If receipt of acknowledgment is not received, inquiries should be made to your local WARCO. If receipt of acknowledgment is received but no instructions are forthcoming within thirty (30) days of receipt, supplies may be disposed.

Invalid Warranty Claims. When supplies are inspected by the contractor and found to be non-warrantable due to abuse or improper maintenance, or the supplies are found to be serviceable, the repair activity submitting the claim will be required to make reimbursement for contractor services. All failed items returned for warranty claim action will be monitored by the WARCO. Additionally, regarding contractor repair, the local WARCO must stipulate at the time of request for services that either no non-warranty work be done or be prepared to pay for such work.

## **Reimbursement for Army Repair**

In the event that the repair activity should receive any reimbursement from the contractor, the monies must be forwarded to the following address: Defense Accounting Office, DAOTACOM, ATTN: DFAS-IN/EM-BED, TACOM, Warren, Michigan 48397-5000.

## **Claim Denial/Disputes**

All denials or disputes will be handled by TACOM.

## **Reporting**

Reporting or recording action on a failed item shall be specified in DA PAM 750-8. (WP 0161) Contractor or repair activity unique forms shall not be used.

## **Storage/Shipment/Handling**

### **Storage**

See coverage-specific data above (last paragraph) and preparation for storage for further information.

### **Shipment**

See contractor responsibilities data above (second paragraph), claim procedures (third paragraph), and preparation of equipment for transportation/shipment for further information.

**Storage/Shipment/Handling - Continued****Handling**

See contractor responsibilities data above (second paragraph), claim procedures (third paragraph), and safety, care, and handling for further information.

**END OF WORK PACKAGE**



---

## OPERATOR MAINTENANCE EQUIPMENT CHARACTERISTICS, CAPABILITIES, AND FEATURES

---

### EQUIPMENT CHARACTERISTICS

The M977 cargo vehicle is used for ammunition resupply and other logistic missions.

### EQUIPMENT CAPABILITIES

#### NOTE

Trailer/semitrailer may affect maximum fording depth. Refer to applicable trailer/semitrailer operator manual for further information on fording depth restrictions.

1. All models are capable of operating in temperatures from -25 to 120°F (-32 to 49°C) and to -50 to 120°F (-46 to 49°C) with arctic kit installed.
2. All models can ford water up to 48 in. (1 219 mm) deep for 5 minutes without damage or without requiring maintenance before operation can continue.
3. Normal operating range of all models is 300 miles (483 km), based upon 154 gallons (583 L) of fuel and 100,000 lbs (45 400 kg) GCWR, traveling over mixed terrain. Varying loads, prolonged idle, use of power takeoff (PTO), off-road driving, and climatic conditions affect operating range.
4. All models are provided with sufficient tie down points located so vehicles can be restrained in all directions during air transport in C-130, C-5A, and C-17 type aircraft.
5. All models are also capable of being transported by highway, rail, and sea.

### EQUIPMENT FEATURES

1. Detroit Diesel eight-cylinder, V-Type, 2-cycle, fuel injected, turbocharged diesel engine.
2. Automatic transmission with one reverse speed and four forward speeds.
3. Operator controlled 4-wheel/8-wheel drive and high and low range transfer case for positive traction in areas of unimproved road surfaces.
4. Power steering system consists of basic manual steering system with hydraulic boost. Mechanical linkage also provides operator control in event of hydraulic oil pressure loss.
5. Fuel system includes one fuel tank, fuel lines, fuel/water separator, fuel pump, secondary filter, fuel pipes, and fuel injectors.
6. Two front and two rear towing eyes.
7. Manual-release-type rear pintle hook which will allow towing of a trailer.
8. Radio frequency interference suppression to permit voice radio communications during all phases of operation.

**END OF WORK PACKAGE**

**OPERATOR MAINTENANCE  
LOCATION AND DESCRIPTION OF MAJOR COMPONENTS**

**VEHICLE COMPONENT LOCATION**

*Table 1. HEMTT Series Vehicle Common Component Location.*

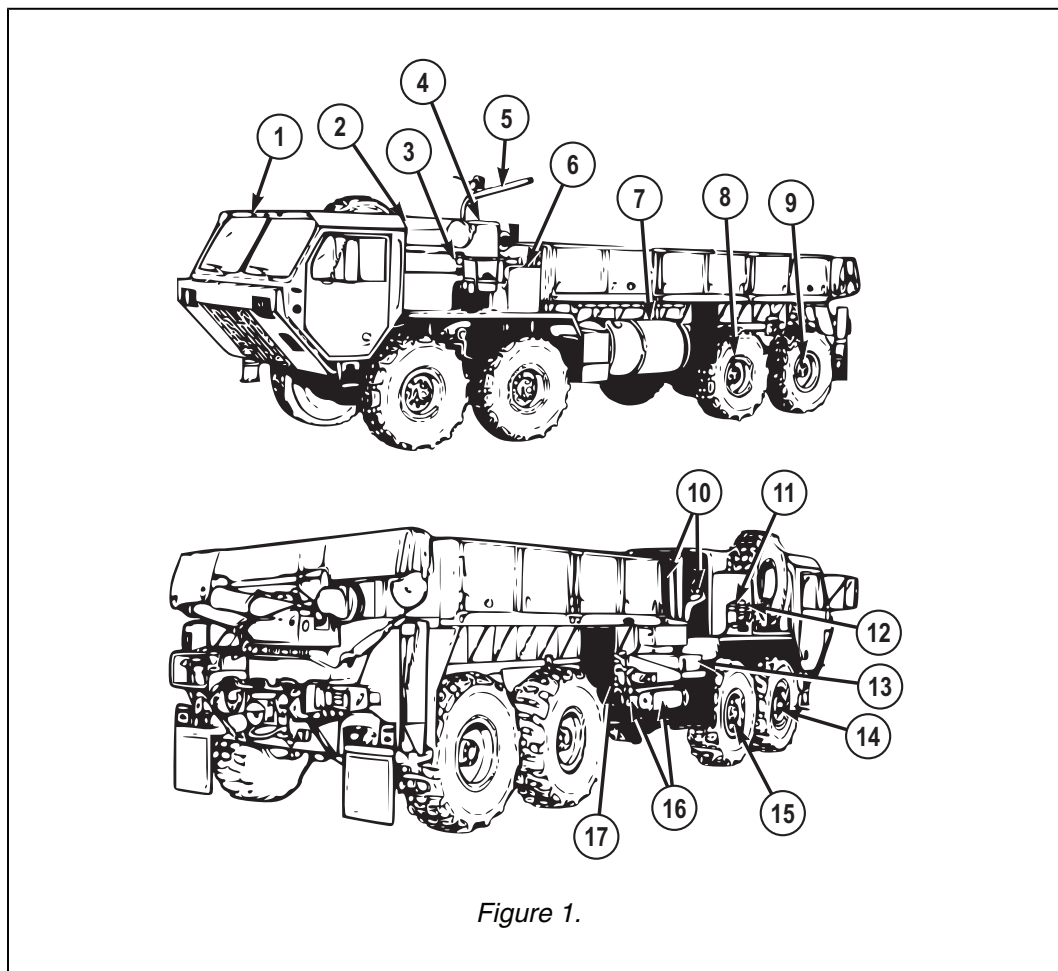


Figure 1.

1	<b>Personnel Cab.</b> Provides protection from weather for crew and vehicle controls, gauges, and indicators.
---	---

## VEHICLE COMPONENT LOCATION - Continued

*Table 1. HEMTT Series Vehicle Common Component Location. - Continued*

2	<b>Engine Compartment.</b> Engine supplies power to move vehicle and operate equipment and accessories.
3	<b>Ether Canister.</b> Contains ether for use as cold weather starting aid.
4	<b>Air Cleaner.</b> Filters out dust and debris from air entering air induction system.
5	<b>Tire Davit (shown assembled).</b> Used to raise and lower spare tire.
6	<b>Hydraulic Reservoir.</b> Stores, cools, and filters oil used in hydraulic and power steering systems.
7	<b>Fuel Tank.</b> Stores fuel used to operate engine. Receives excess fuel not used by engine fuel injection system.
8	<b>No. 3 Driving Axle.</b> Supports weight of vehicle, and transmits power to hubs to turn rear wheels.
9	<b>No. 4 Driving Axle.</b> Supports weight of vehicle, and transmits power to hubs to turn rear wheels.
10	<b>Tire Davit (shown in stowed position).</b> Used to raise and lower spare tire.
11	<b>Air Dryer.</b> Used to remove dirt and moisture from compressed air before air enters air reservoirs.
12	<b>Fuel/Water Separator.</b> Acts as primary fuel filter and removes any water from fuel before entering engine.
13	<b>Battery Box.</b> Houses and protects four storage batteries.
14	<b>No. 1 Driving Axle.</b> Controls direction of vehicle when in motion. When needed, transmits power to hubs to turn wheels.
15	<b>No. 2 Driving Axle.</b> Controls direction of vehicle when in motion. When needed, transmits power to hubs to turn wheels.
16	<b>Air Reservoirs.</b> Used to store air system air.
17	<b>Self-Recovery Winch (not used on all vehicles).</b> Used to help vehicle pull itself free of obstructions.



VEHICLE COMPONENT LOCATION - Continued

Table 2. M977/M985 Cargo Vehicle Specific Component Location.

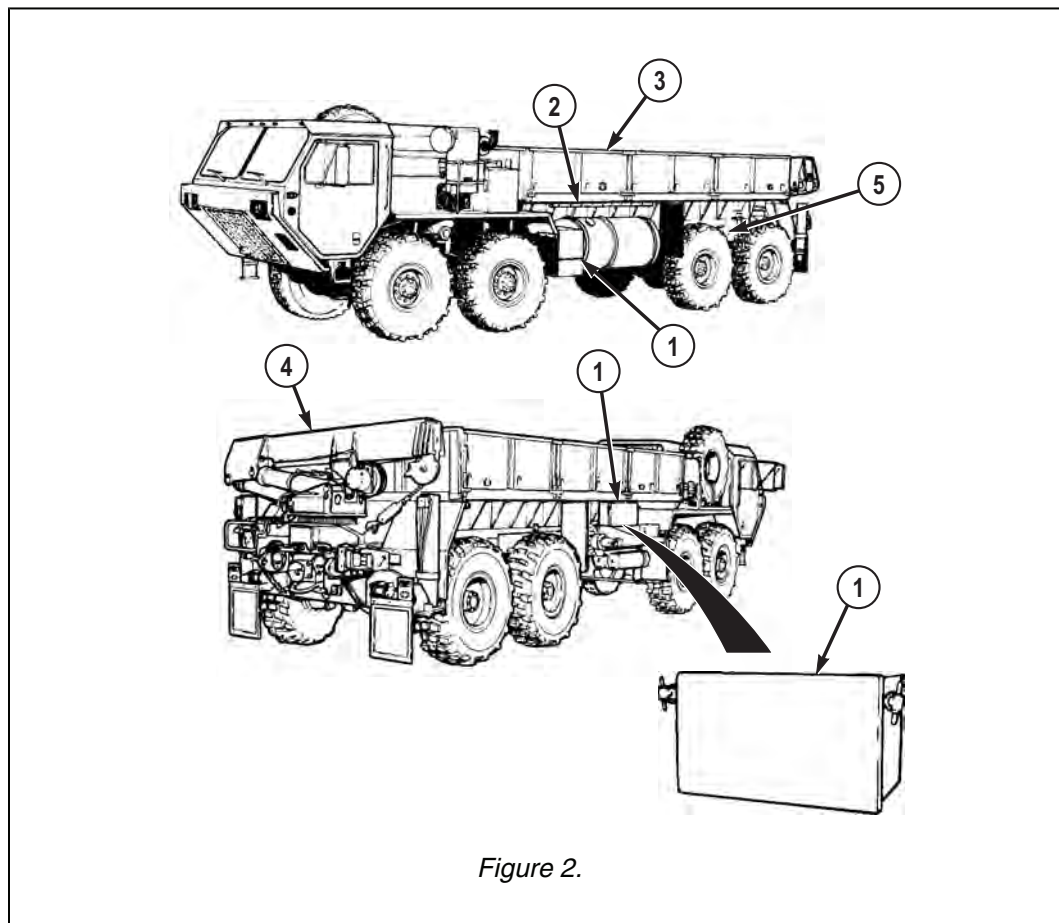


Figure 2.

1	<b>Stowage Boxes.</b> Used to stow COEI, BII, (WP 0162)AAL, (WP 0163) and other mission essential items.
2	<b>Access Ladder.</b> Used by crew to clean windows, check oil, or perform other tasks requiring access to parts of vehicle.
3	<b>Cargo Body.</b> Used to carry palletized ammunition. Tie downs are provided to allow ammunition pallets to be tied down.
4	<b>Material Handling Crane.</b> Used to load and unload cargo.

**VEHICLE COMPONENT LOCATION - Continued*****Table 2. M977/M985 Cargo Vehicle Specific Component Location. - Continued***

5	<b>Wheel Chock Stowage Box.</b> Used to stow two wooden wheel chocks.
---	---

**END OF WORK PACKAGE**

**OPERATOR MAINTENANCE  
DIFFERENCES BETWEEN MODELS**

*Table 1. Differences Between HEMTT BASE Models.*

Equipment	Model							
	M977 (Note 1)	M978 (Note 1)	M983 (Note 2)	M984 (Note 2)	M985 (Note 1)	M985 E1 (Note 2)	M1120 LHS (Note 1)	M1977 CBT (Note 1)
10 ft. (3.05 m) Equipment Body				•				
18 ft. (5.49 m) Cargo Body	•				•	•		
Cargo Cover Kit	•				•	•		
Heavy-Duty Winch				•				
Rear Beacon Lights (Note 4)				•				
Work Lights (Note 5)			•	•				•
MHC977 Grove Crane	•							
MHC985 Grove Crane					•			
MHC984				•				

**Table 1. Differences Between HEMTT BASE Models. - Continued**

Equipment	Model							
	M977 (Note 1)	M978 (Note 1)	M983 (Note 2)	M984 (Note 2)	M985 (Note 1)	M985 E1 (Note 2)	M1120 LHS (Note 1)	M1977 CBT (Note 1)
Grove Crane								
8108/-2 HIAB Crane (Note 6)						•		
Fifth Wheel			•					
3.5 inch (89 mm) Kingpin			•					
Semitrailer Spare Tire Carrier			•					
Load Handling System							•	•

**Table 2. Notes.**

**Note:**

1. Vehicle can be equipped in either of two configurations: with or without optional self-recovery winch.
2. Vehicle equipped with self-recovery winch.
3. Self-recovery winch not available for this model.
4. All HEMTT series vehicles are authorized to carry portable beacon light as an optional accessory.
5. All HEMTT series vehicles are authorized to carry portable work lamp as an optional accessory.
6. See data plate on base of crane loader body unit to determine model number.

**END OF WORK PACKAGE**

---

**OPERATOR MAINTENANCE  
EQUIPMENT DATA**

---

**EQUIPMENT DATA**

*Table 1. Vehicle Operation.*

<b>Operating Mode:</b> On- and off-road
<b>Operating Temperature w/o Arctic Kit:</b> -25 to 120°F (-32 to 49°C)
<b>Operating Temperature w/Arctic Kit:</b> -50 to 120°F (-46 to 49°C)

*Table 2. M977 Cargo Vehicle Dimensions.*

<b>Width (overall):</b> 96 in. (2 438 mm)
<b>Height (overall):</b> 112 in. (2 845 mm)
<b>Height (reduced for shipping):</b> 102 in. (2 591 mm)
<b>Length (overall):</b> 401 in. (10 185 mm)
<b>Wheelbase:</b> 210 in. (5 334 mm)
<b>Turn Circle (curb to curb):</b> 105 ft. (32 m)
<b>Ground Clearance:</b> 24 in. (610 mm)
<b>Center of Gravity:</b> See shipping data plate on outside of driver side rear of cab or inside of driver side door.

*Table 3. M977 Cargo Vehicle Weight.*

<b>Curb Weight:</b> 38,800 lbs (17 615 kg)
<b>Gross Vehicle Weight Rating (GVWR):</b> 59,500 lbs (27 013 kg)
<b>Gross Combination Weight Rating (GCWR):</b> 100,000 lbs (45 400 kg)

## EQUIPMENT DATA - Continued

**Table 4. M977 Cargo Vehicle Weight.**

<b>Curb Weight:</b> 37,900 lbs (17 207 kg)
<b>Gross Vehicle Weight Rating (GVWR):</b> 59,500 lbs (27 013 kg)
<b>Gross Combination Weight Rating (GCWR):</b> 100,000 lbs (45 400 kg)

**Table 5. M977 Cargo Vehicle Weight Distribution.**

<b>Front Tandem Axles-Curb:</b> 21,300 lbs (9 670 kg)
<b>Front Tandem Axles-Loaded:</b> 30,000 lbs (13 620 kg)
<b>Rear Tandem Axles-Curb:</b> 17,500 lbs (7 945 kg)
<b>Rear Tandem Axles-Loaded (maximum):</b> 32,000 lbs (14 528 kg)

**Table 6. M977 Cargo Vehicle Weight Distribution.**

<b>Front Tandem Axles-Curb:</b> 20,900 lbs (9 489 kg)
<b>Front Tandem Axles-Loaded:</b> 30,000 lbs (13 620 kg)
<b>Rear Tandem Axles-Curb:</b> 17,000 lbs (7 718 kg)
<b>Rear Tandem Axles-Loaded (maximum):</b> 32,000 lbs (14 528 kg)

**Table 7. Vehicle Performance.**

<b>Cruising Range at GCWR:</b> 300 mi. (483 km)
<b>Maximum Sustained Forward Speed (at 2100 rpm) - 3rd Gear:</b> 41 mph (66 km/h)
<b>Maximum Sustained Forward Speed (at 2100 rpm) - 2nd Gear:</b> 28 mph (45 km/h)
<b>Maximum Sustained Forward Speed (at 2100 rpm) - 1st Gear:</b> 15 mph (24 km/h)
<b>Speed on 3% Grade at GCWR:</b> 25 mph (40 km/h)
<b>Speed on 3% Grade at GVWR:</b> 40 mph (64 km/h)

**EQUIPMENT DATA - Continued**

***Table 7. Vehicle Performance. - Continued***

<b>Speed on 30% Grade at GCWR:</b> 3 mph (5 km/h)
<b>Speed on 30% Grade at GVWR:</b> 5 mph (8 km/h)
<b>Maximum Grade at GCWR:</b> 30 percent
<b>Maximum Grade at GVWR:</b> 60 percent
<b>Maximum Side Slope w/Adequate Traction Surface:</b> 30 percent
<b>Maximum Towed Speed (refer to FM 4-30.31 ):</b> 15 mph (24 km/h)
<b>Maximum Ford Depth:</b> 48 in. (1 219 mm)
<b>Approach Angle:</b> 41 degrees
<b>Departure Angle:</b> 45 degrees
<b>Limp Home Speed:</b> 10 mph (16 km/h) for up to 30 miles (48 km)

***Table 8. Fluid Capacities.***

Refer to lubrication instructions in operator's PMCS (WP 0151) for vehicle fluid capacities.
--

***Table 9. Engine.***

<b>Make:</b> Detroit Diesel Corporation
<b>Model:</b> 8V92TA
<b>Type:</b> 2-Stroke, V-Type Diesel
<b>Cylinders:</b> 8
<b>Bore:</b> 4.84 in. (123 mm)
<b>Stroke:</b> 5 in. (127 mm)
<b>Displacement:</b> 736 cid (12 L)

## EQUIPMENT DATA - Continued

**Table 9. Engine. - Continued**

<b>Torque:</b>
Model No. 8087-7899: 1250 lb-ft (1695 Nm) at 1300 rpm
Model No. 8083-7493: 1330 lb-ft (1803 Nm) at 1200 rpm
<b>Maximum Brake Horsepower (at 2100 rpm):</b>
Model No. 8087-7899: 445 BHP (332 kW)
Model No. 8083-7493: 450 BHP (336 kW)
<b>Maximum Governed Engine Speed - Loaded:</b> 2050 - 2150 rpm
<b>Maximum Governed Engine Speed - No Load:</b> 2225 - 2275 rpm
<b>Oil Filter Type:</b> Full flow, replaceable element
<b>Oil Filter Quantity:</b> 1

**Table 10. Fuel System.**

<b>Type:</b> Diesel Injection
<b>Tank Quantity:</b> 1
<b>Air Cleaner Type:</b> Dry element
<b>Element Quantity:</b> (1 primary, 1 secondary)

**Table 11. Electrical System.**

<b>Voltage:</b> 24
<b>Alternator (amps):</b> 65
<b>RFI Suppression Ability:</b> Yes
<b>Number of Batteries:</b> 4



## EQUIPMENT DATA - Continued

*Table 11. Electrical System. - Continued*

<b>Battery Voltage (each):</b> 12 volts
<b>Battery Connection:</b> Series - parallel
<b>Battery Capacity (at 20 hour rate):</b> 900 amp
<b>Battery Reserve Capacity (each, at 80°F/27°C):</b> 180 minutes
<b>Battery Cold Cranking Amps (each, at 80°F/27°C):</b> 575 CCA
<b>Battery Amp Hours (each, at 20 hour rate):</b> 100 amp

*Table 12. Cooling System.*

<b>Radiator Working Pressure:</b> 7 psi (48 kPa)
--

*Table 13. Transmission.*

<b>Make:</b> Allison
<b>Model:</b> HT740D
<b>Type:</b> Automatic
<b>Number of Forward Speeds:</b> 4
<b>Number of Reverse Speeds:</b> 1

*Table 14. Transfer Case.*

<b>Make:</b> Oshkosh
<b>Model:</b> 55000
<b>Type:</b> Air-operated front tandem disconnect
<b>Ratios:</b> 0.98:1 and 2.66:1

## EQUIPMENT DATA - Continued

*Table 15. Front Tandem Axles.*

<b>Front Tandem</b>
<b>Make:</b> Oshkosh/Dana Heavy Axle
<b>Differential Carrier Model Nos.:</b> No. 1 axle: RS480, No. 2 axle: DS480-P
<b>Maximum Steering Angle:</b> 32 degrees

*Table 16. Rear Tandem Axles.*

<b>Make:</b> Dana Heavy Axle
<b>Differential Carrier Model Nos.:</b> No. 3 axle: DS480-P, No. 4 axle: RS480

*Table 17. Brake System.*

<b>Actuation:</b> Air
<b>Number of Brake Chambers:</b> 8
<b>Pressure Range:</b> 60 - 120 psi (414 - 827 kPa)

*Table 18. Wheels.*

<b>Type:</b> Two-piece bolt together wheel
<b>Quantity:</b> 8
<b>Spare Quantity:</b> 1
<b>Rim Size:</b> 20 x 10
<b>Stud Quantity Per Wheel:</b> 10

*Table 19. Tires.*

<b>Type:</b> Radial without tube
<b>Quantity:</b> 8

**EQUIPMENT DATA - Continued****Table 19. Tires. - Continued**

<b>Spare Quantity:</b> 1
<b>Tread Type:</b> Radial traction, non-directional
<b>Size:</b> 16.00R x 20 in.
<b>Load Range:</b> M

**Table 20. Steering System.**

<b>Type:</b> Dual gear with integrated hydraulic power assist
---

**Table 21. Towing Eyes.**

<b>Quantity:</b> 4 (2 front, 2 rear)
<b>Maximum Load Capacity Each:</b> 60,000 lbs (27 240 kg)

**Table 22. Pintle Hook.**

<b>Type:</b> Manual Release
<b>Maximum Load Capacity - Pulling:</b> 30,000 lbs (13 620 kg) in off-road application
<b>Maximum Load Capacity - Vertical:</b> 1,700 lbs (771 kg)

**Table 23. Cab.**

<b>Windshield:</b> Tinted, two-piece, safety glass
<b>Personnel Capacity:</b> 2

**Table 24. Self-Recovery Winch.**

<b>Make:</b> DP Manufacturing
<b>Model:</b> 20K-HEMTT

## EQUIPMENT DATA - Continued

*Table 24. Self-Recovery Winch. - Continued*

<b>Wire Rope Diameter:</b> 9/16 in. (14.3 mm)
<b>Wire Rope Length:</b> 200 ft. (61 m)
<b>Line Pull - 1st Layer (Five Wraps Minimum):</b> 20,000 lbs (9 080 kg)
<b>Line Pull - 2nd Layer:</b> 18,173 lbs (8 251 kg)
<b>Line Pull - 3rd Layer:</b> 16,663 lbs (7 565 kg)
<b>Line Pull - 4th Layer:</b> 15,361 lbs (6 974 kg)
<b>Line Pull - 5th Layer:</b> 14,254 lbs (6 471 kg)

*Table 25. Material Handling Crane.*

<b>Make:</b> Grove
<b>Model:</b> MHC977
<b>Maximum Capacity at Boom Length of 19 ft. (5.8 m):</b> 2500 lbs (1 135 kg)

*Table 26. Auxiliary Equipment.*

Arctic Engine Heater Kit
Chemical Alarm
Decontamination Unit
Gas Particulate Filter Unit
Machine Gun Ring
Radio Installation Kit
Rifle Mounting Kit
<b>Note:</b> Vehicle may or may not be equipped with any of these items depending on mission, climate, or other factors.

**EQUIPMENT DATA - Continued**

*Table 27. Load Classification.*

<b>MODEL</b>	<b>UNLOADED (TONS)</b>	<b>FULL LOAD (TONS)</b>	<b>WITH TRAILER LOADED (TONS)</b>
M977	16	28	
M978	15	25	
M983	14		C-29 (w/Patriot)
M984A1	19		C-48 (towing loaded M985)
M985	17	28	C-38 (towing HEMAT M989)
M985 E1	17	28	
M1120 LHS	18	28	

**TIRE PRESSURES**

*Table 28. Tire Pressures.*

<b>TIRE</b>	<b>HIGHWAY</b>	<b>CROSS-COUNTRY (DRY)</b>	<b>CROSS-COUNTRY (WET)</b>	<b>SANDY TERRAIN</b>
<b>Front Tire Pressure</b>				
<b>STANDARD (XZL) TIRE</b>	60 psi (414 kPa)	35 psi (241 kPa)	20 psi (138 kPa)	30 psi (207 kPa)
<b>SAND TIRE</b>	60 psi (414 kPa)	NA	NA	25 psi (172 kPa)
<b>Rear Tire Pressure</b>				
<b>STANDARD (XZL) TIRE</b>	70 psi (483 kPa)	40 psi (276 kPa)	30 psi (207 kPa)	35 psi (241 kPa)
<b>SAND TIRE</b>	70 psi (483 kPa)	NA	NA	30 psi (207 kPa)

**OPERATING SPEEDS***Table 29. Operating Speeds.*

	<b>HIGHWAY</b>	<b>CROSS-COUNTRY (DRY)</b>	<b>CROSS-COUNTRY (WET)</b>	<b>SANDY TERRAIN</b>
<b>Maximum Speed</b>				
<b>STANDARD (XZL) TIRE</b>	55 mph (88 km/h)	40 mph (64 km/h)	20 mph (32 km/h)	20 mph (32 km/h)
<b>SAND TIRE</b>	55 mph (88 km/h)	NA	NA	20 mph (32 km/h)

**END OF WORK PACKAGE**

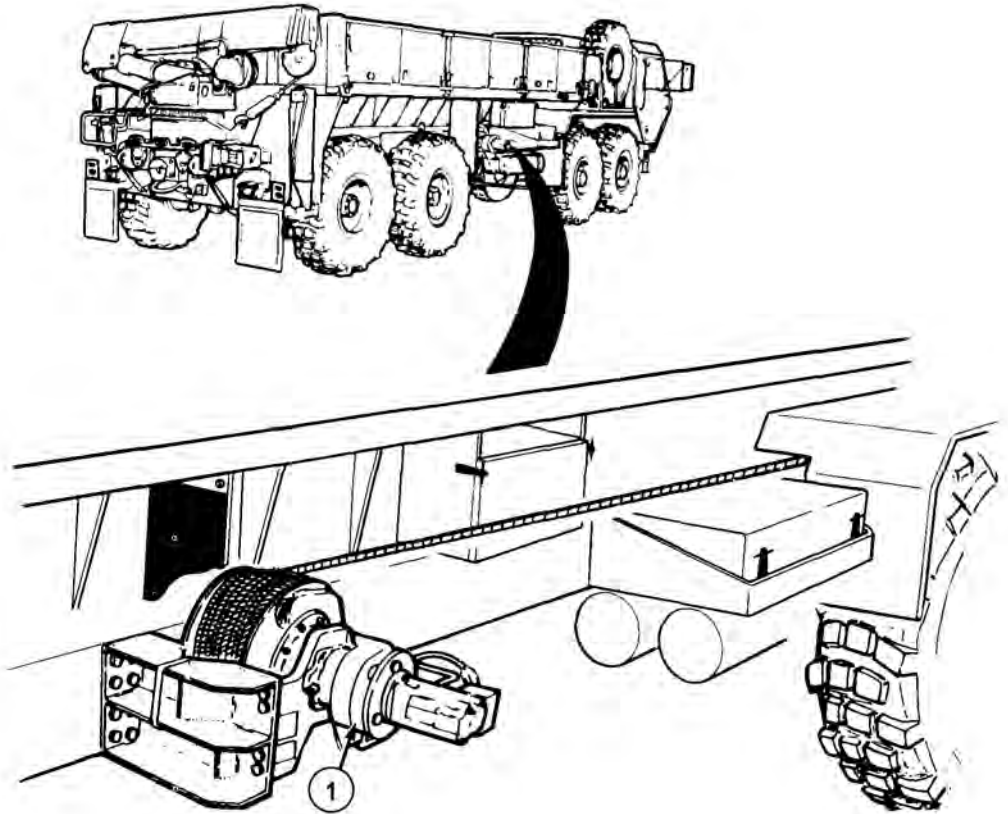
---

## OPERATOR MAINTENANCE SELF-RECOVERY WINCH

---

### SELF-RECOVERY WINCH

The self-recovery winch, when used, is mounted on the passenger side chassis frame rail between the second and third axles.



*Figure 1.*

The winch is powered by a reversible hydraulic motor which drives the winch drum through a planetary gearbox.

It is equipped with an automatic brake that is applied whenever the cab control lever is in the center position.

**SELF-RECOVERY WINCH - Continued****NOTE**

The M984A wrecker equipped with a self-recovery winch does not employ an operator controlled, two-position hydraulic selector valve to activate the reversible winch motor.

All vehicles (except the M984A wrecker) equipped with a self-recovery winch (1) have an operator controlled, two-position hydraulic selector valve (WP 0025) to activate the reversible winch motor.

**END OF WORK PACKAGE**



**OPERATOR MAINTENANCE  
ELECTRICAL SYSTEM**

---

**NOTE**

- Wiring harnesses are used to carry current to operate equipment and accessories.
- The electrical system is a 24 VDC system.

Four 12 VDC storage batteries (1) are connected in series-parallel with the negative terminal grounded.

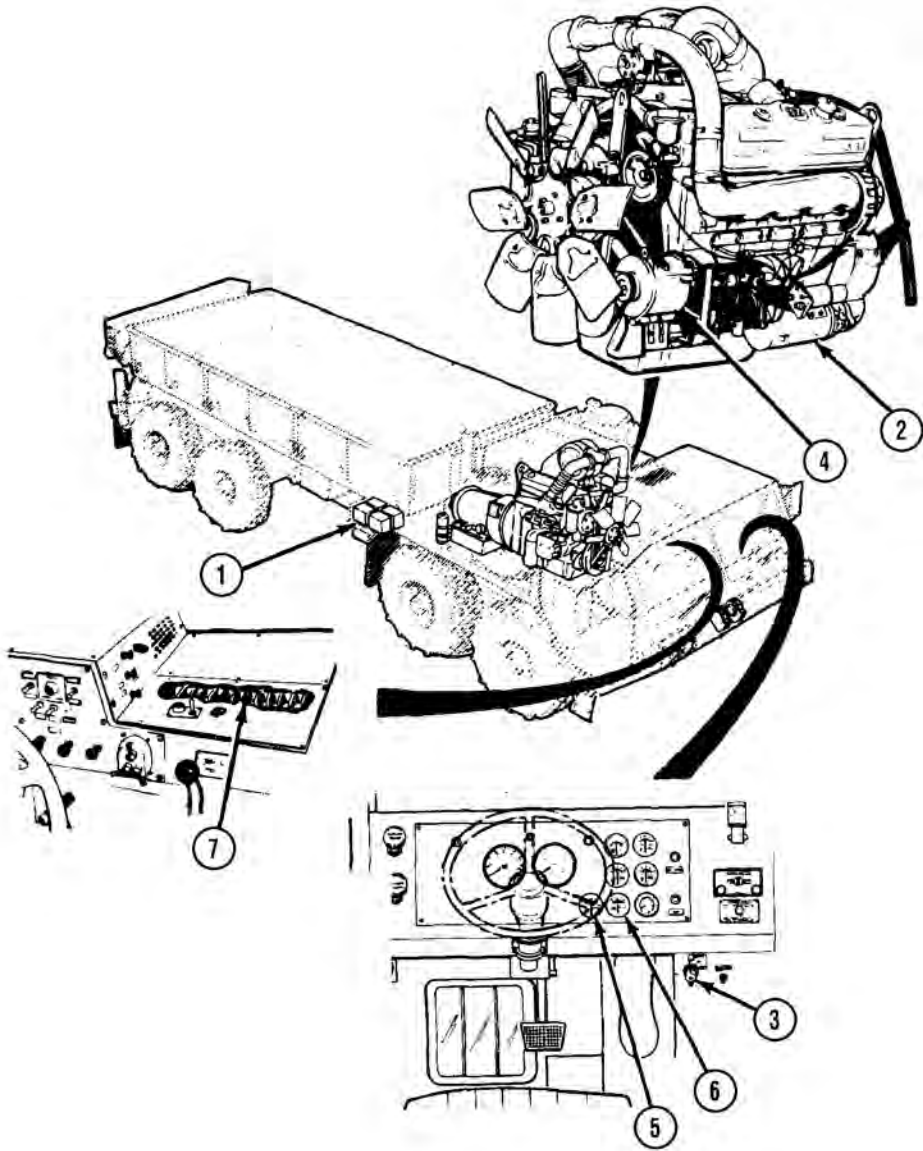


Figure 1.

The starting motor (2) operates directly from the 24 VDC source through the engine start switch (3).

A belt-driven 24 VDC alternator (4) having a capacity of 65 amps (M983 - 100 amps) or 130 amps maintains the charge on the batteries.

The AMPERES gauge (5) shows the alternator output.

The BATTERY gauge (6) shows the state of charge of the batteries and alternator voltage output.

The vehicle electrical circuits are protected against overloads by automatic reset circuit breakers (7) located below the heater compartment panel.

### MAJOR ELECTRICAL SYSTEM COMPONENT LOCATION

The voltage and the current for the electrical system are indicated by a battery gauge (1) and an ammeter (2) located on the dash panel inside the driver's compartment.

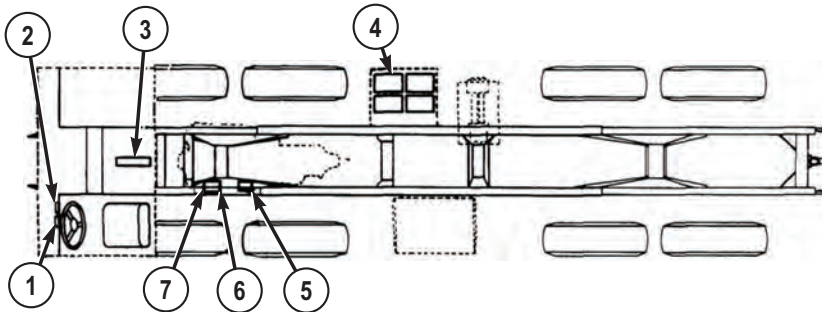


Figure 2.

Circuit breakers (3) located in the cab protect the main circuits.

Electrical power is provided by four 12-volt series-parallel connected batteries (4).

### NOTE

Power is distributed throughout the vehicle by wiring harnesses. The harnesses are interconnected by pin connectors. Connectors are provided at the rear of the vehicle to supply power for towed loads.

A heavy-duty starting motor (5) is mounted on the engine flywheel housing and provides the cranking power necessary for starting the engine.

The voltage regulator (6) is mounted on the belt driven alternator (7) and maintains a 24-volt level for battery charging.

### END OF WORK PACKAGE



**OPERATOR MAINTENANCE  
AIR SYSTEM**

---

**AIR SYSTEM**

The air system consists of an engine-driven air compressor (1) and four air reservoirs (2, 3, 4, and 5). Reservoir (4) is used on all vehicles except the M983 tractor, which has a reservoir (6) instead.

AIR SYSTEM - Continued

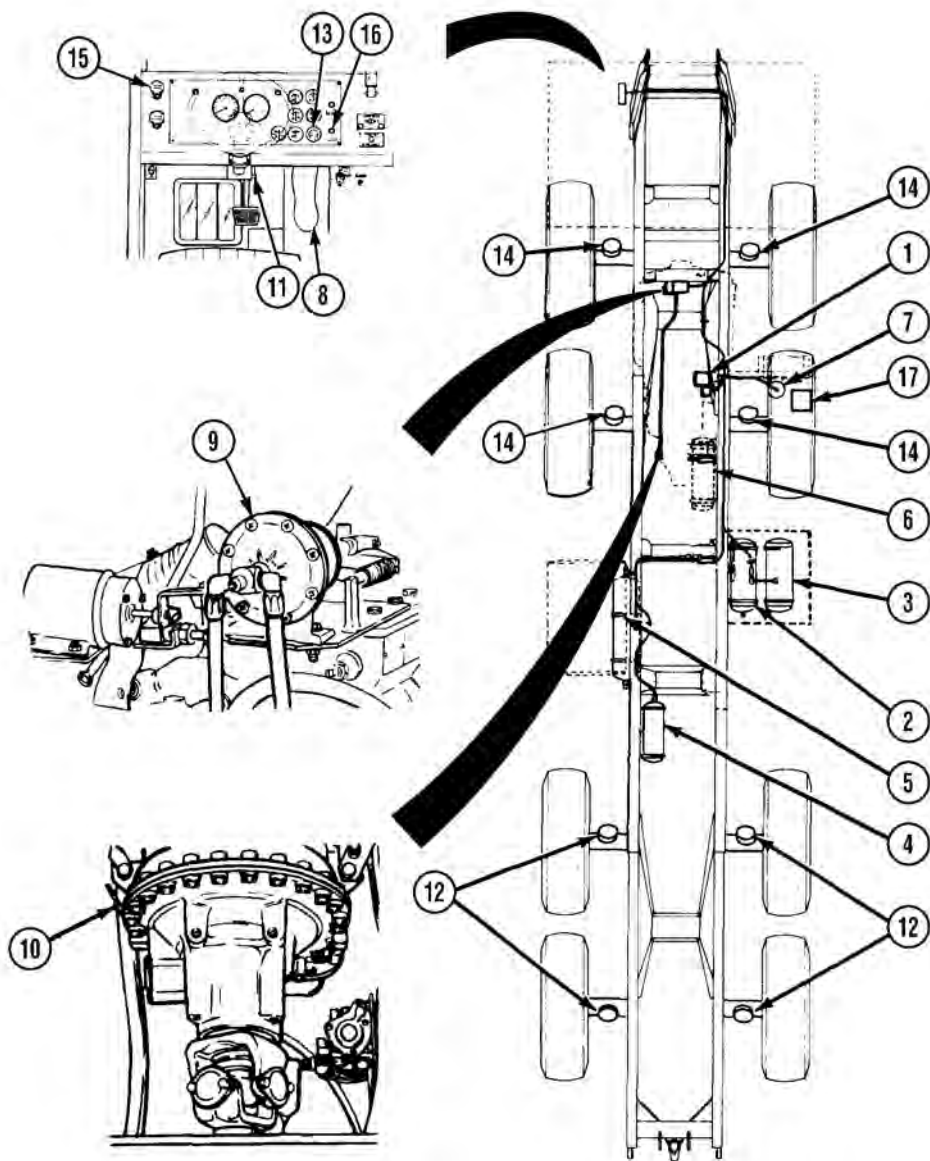


Figure 1.

**AIR SYSTEM - Continued****NOTE**

The air system includes the necessary valves and air lines to control the vehicle's air-operated parts.

Pressurized air from the air compressor (1) is passed through the air dryer (7) to the quick buildup reservoir (2).

The air dryer (7) removes dirt and moisture from the pressurized air. Air from reservoir (2) goes to the throttle treadle (8).

Depending on how far the throttle treadle is depressed, 0 to 60 psi (0 to 414 kPa) is supplied to the engine throttle air cylinder (9) and to the transmission modulator (10). This air pressure control the vehicle speed.

Once air pressure in reservoir (2) rises above 75 psi (517 kPa), a valve opens and allows reservoirs (3, 4, or 6, and 5) to be pressurized up to 120 psi (827 kPa).

Air from reservoir (4 or 6) goes to the brake treadle valve (11). This air controls the rear axle service parking brakes (12).

Air pressure in this system is shown by the red needle on the AIR PRESS gauge (13).

Air from reservoir (3) goes to the brake treadle valve.

This air controls the front axle service brakes (14).

Air pressure in this system is shown by the green needle on the AIR PRESS gauge.

The PARKING BRAKE valve (15) controls air from reservoirs (3 and 5) and applies or releases the rear axle service (parking) brakes.

Reservoirs (3, 4, or 6, and 5) are interconnected so that if one reservoir fails, air is supplied to release the rear axle service (parking) brakes from whichever reservoir is functioning. If air pressure falls below 60 to 75 psi (414 kPa to 517 kPa), a buzzer will sound and the AIR indicator (16) will illuminate.

Specific to the M984A1, the front brake actuator valve (17) is used to apply the front axle service brakes when using heavy-duty winch.

**END OF WORK PACKAGE**





## OPERATOR MAINTENANCE MAIN HYDRAULIC SYSTEM

### MAIN HYDRAULIC SYSTEM

The main hydraulic system consists of a power take-off (PTO) driven hydraulic pump (1) and a fluid reservoir (2) shared with the power steering hydraulic system.

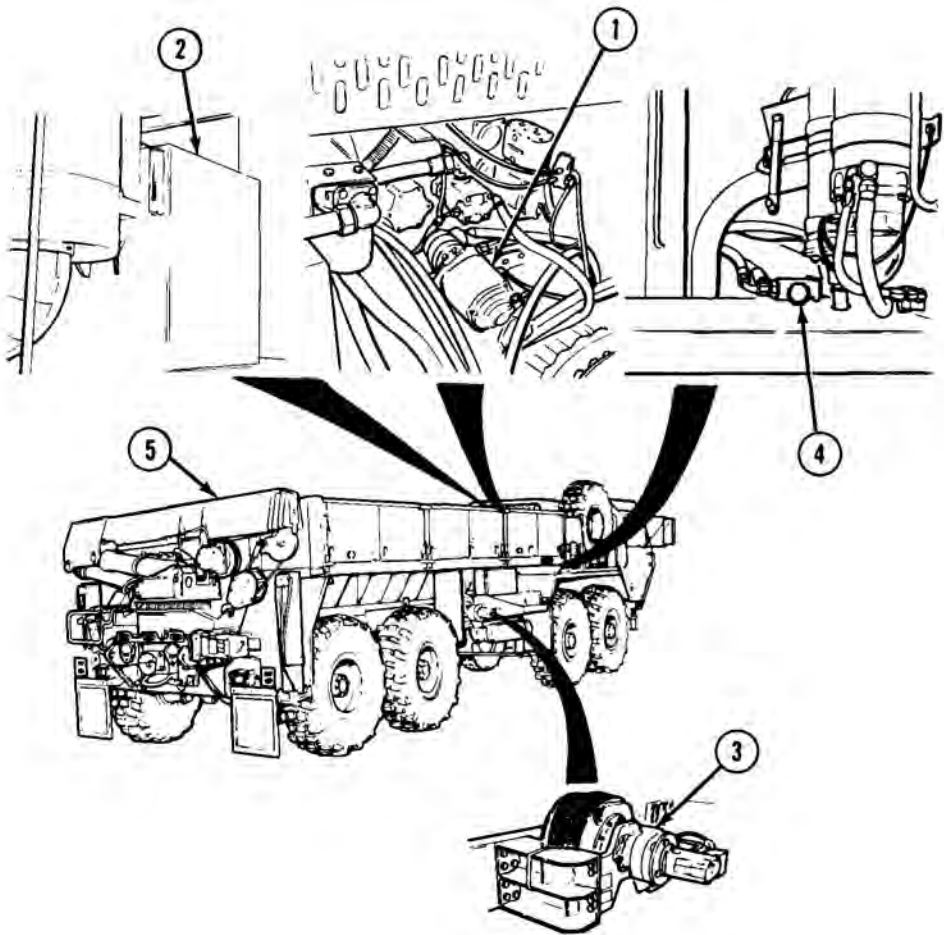


Figure 1.

Any vehicle may also be equipped with a self-recovery winch (3) and a selector valve (4).

## MAIN HYDRAULIC SYSTEM - Continued

The main hydraulic system includes the material handling crane (5) on the HEMTT series vehicle.

The fuel pump on the M978 tanker is part of the main hydraulic system.

## FLUID SYSTEM

Pump (1) mounted on the rear of engine provides the fluid power to operate the power steering (2) only.

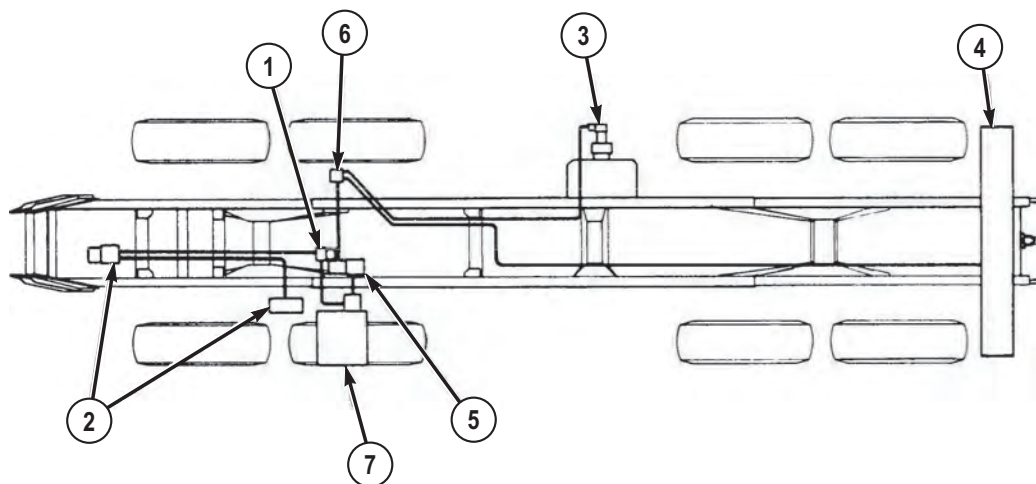


Figure 2.

Fluid power for the self-recovery winch (3), crane (4), and fuel tanker dispensing components (M978 only) is provided by a hydraulic pump (5) driven by the power take-off (PTO) mounted on the transmission.

A manually-operated selector valve (6) is used to activate either the self-recovery winch (3), crane (4), fuel tanker dispensing components (M978 only), or load handling system (LHS) on M1120 LHS and M1977 CBT.

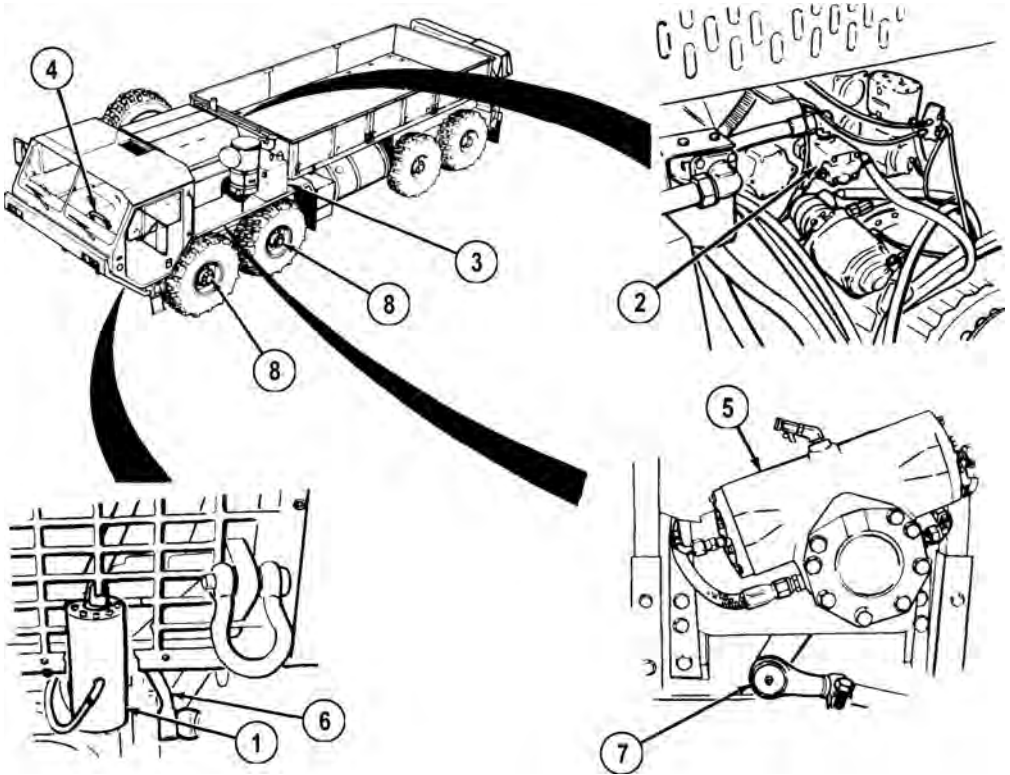
Both pumps (1) and (5) share the same reservoir (7).

## END OF WORK PACKAGE

## OPERATOR MAINTENANCE STEERING SYSTEM

### POWER STEERING HYDRAULIC SYSTEM

Power is supplied to the main steering gear (1) by an engine-driven pump (2).



*Figure 1.*

The fluid reservoir (3) is shared with the main hydraulic system.

The steering wheel (4), which is mechanically linked to the main steering gear (1), rotates a gear that positions a spool in the main steering gear.

This motion is hydraulically transmitted to a piston in the slave gear (5) causing it to follow the rotation of the main gear.

The main gear pitman arm (6) is mechanically connected to the slave gear pitman arm (7).

**POWER STEERING HYDRAULIC SYSTEM - Continued**

These pitman arms move the steering mechanism on the front axles (8) left or right causing the vehicle to steer left or right.

**END OF WORK PACKAGE**

---

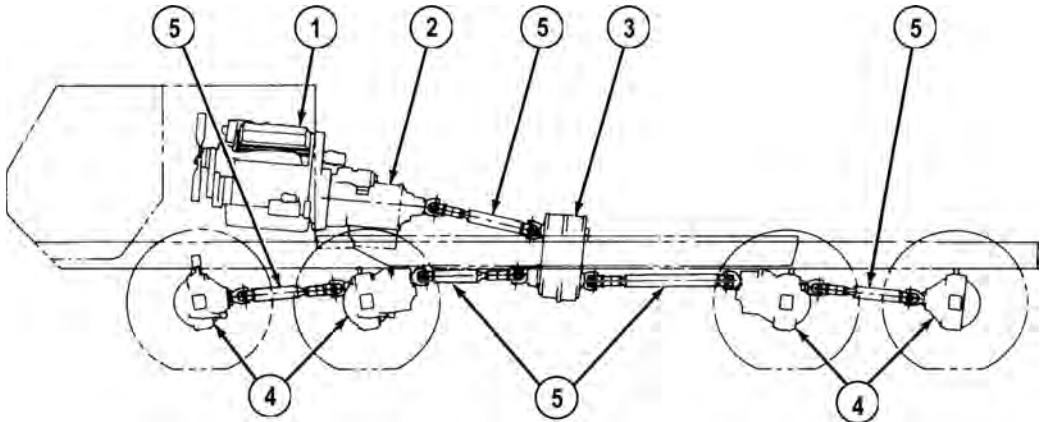
## OPERATOR MAINTENANCE POWER TRAIN

---

### POWER TRAIN

The drivetrain control system consists of the engine and transmission systems.

Power for the vehicle is provided by a diesel engine (1), which is coupled directly to an automatic transmission (2).

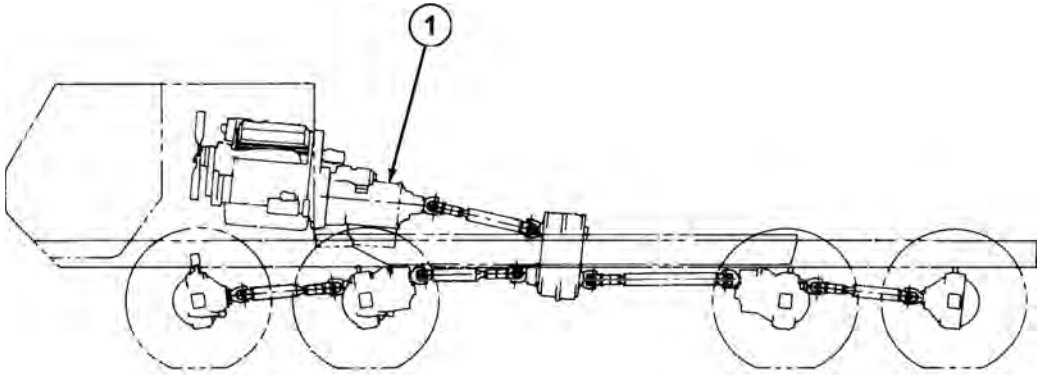


*Figure 1.*

Power from the transmission is transferred to the transfer case (3) and on to front and rear tandem axles (4) through a series of drive shafts and universal joints (5).

### AUTOMATIC TRANSMISSION

The automatic transmission (1) provides four speeds forward and one reverse.

**AUTOMATIC TRANSMISSION - Continued***Figure 2.*

Drive (D) is used for all normal driving conditions.

The vehicle will start moving in 1st gear, and as the accelerator is depressed, transmission will upshift to 2nd gear, 3rd gear, and 4th gear automatically.

As the vehicle slows down, the transmission will downshift to the correct gear automatically.

Placing the range selector lever in the 3 or 2 position will prevent the transmission from upshifting past the 3rd or 2nd gear, respectively.

This is useful if road or load conditions require low gear operation.

When conditions improve, the range selector lever can be returned to the normal (D) driving position.

Drive vehicle (Operations under usual conditions) (WP 0050) provides full operating instructions for the transmission.

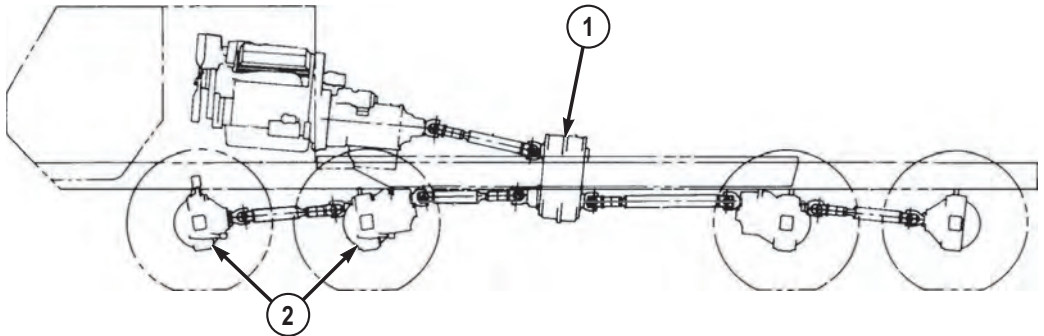
The transmission includes an electrically controlled power takeoff (PTO).

The PTO provides power to a hydraulic pump, which powers the vehicle's hydraulic system.

The hydraulic system operates the self-recovery winch, the material handling crane, the heavy-duty recovery winch, and the pumping equipment, depending on how the vehicle is equipped.

**TRANSFER CASE**

The transfer case (1) connects the drivetrain to the No.1 and No. 2 axles (2) when 8-wheel drive is needed.

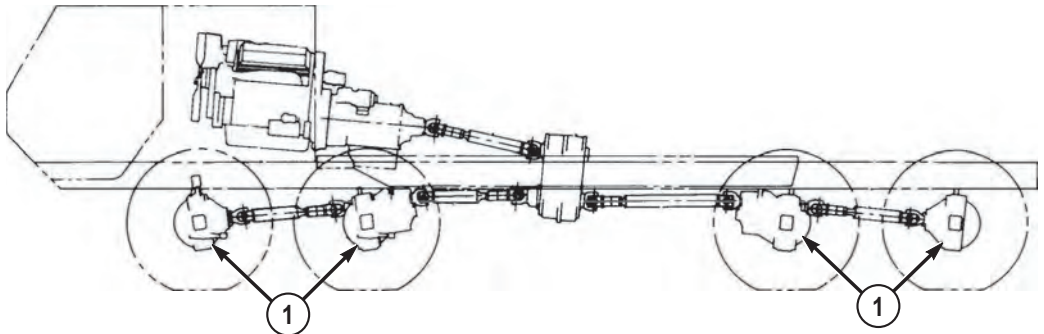
**TRANSFER CASE - Continued***Figure 3.*

The transfer case has two gear ratios (high and low) and neutral. The vehicle must be stopped before the transfer case can be shifted between ranges because the gears are not synchronized.

Engagement of the transfer case in low range will automatically engage the drivetrain to the front axles.

**TANDEM AXLES AND SUSPENSION**

Front and rear tandem axles (1) are single reduction, full floating axle shaft type.

*Figure 4.*

The front tandem provides steering

The rear tandem is non-steering.

Both front and rear tandems are equipped with wheel differentials and inter-axle differentials.

## TANDEM AXLES AND SUSPENSION - Continued

The inter-axle differentials have driver-controlled lockouts for positive drive to all axles in low range.

The rear tandem is equipped with permanently engaged controller traction differentials.

The front and rear suspensions are tandem axle type with leaf springs and equalizing beams.

## PROPELLER SHAFTS AND UNIVERSAL JOINTS

The propeller shafts and universal joints (1) transmit engine power to the axles.

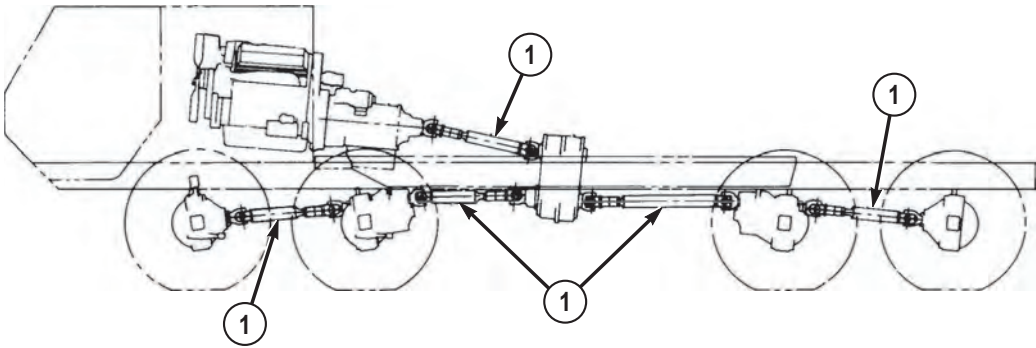


Figure 5.

**END OF WORK PACKAGE**



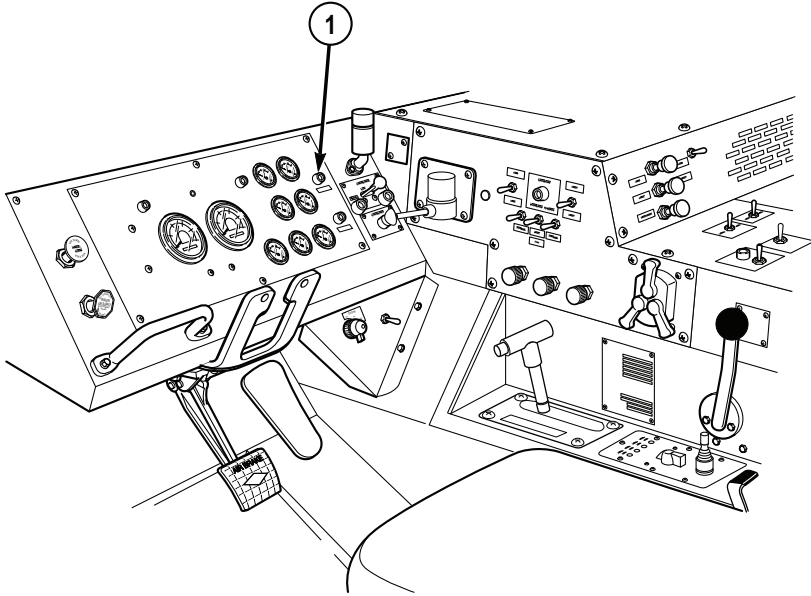
---

## OPERATOR MAINTENANCE ENGINE SYSTEMS

---

### ENGINE

The vehicle is equipped with a Detroit Diesel Corporation (DDC) Model 8V92TA engine.

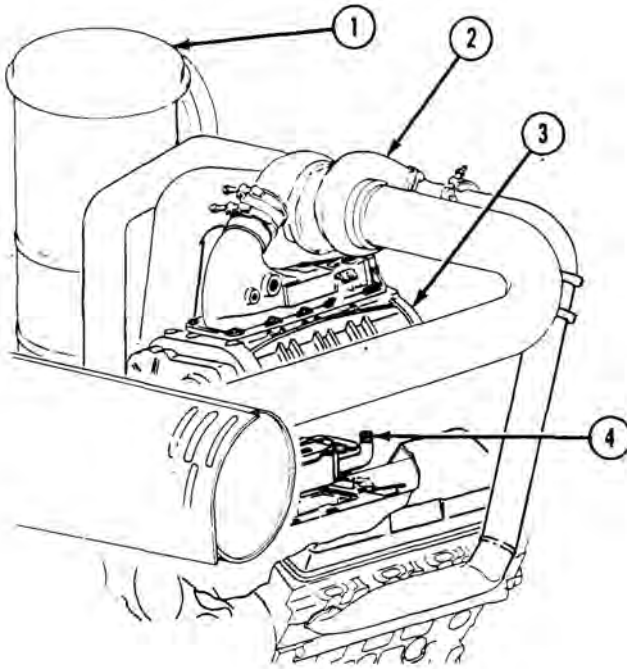


*Figure 1.*

An oil/water light (1) will light up when a critical fault occurs. Immediately shut vehicle off.

### AIR INTAKE SYSTEM

The air intake system consists of a dry type air cleaner (1), turbocharger (2), engine blower (3), and an aftercooler (4).

**AIR INTAKE SYSTEM - Continued**

*Figure 2.*

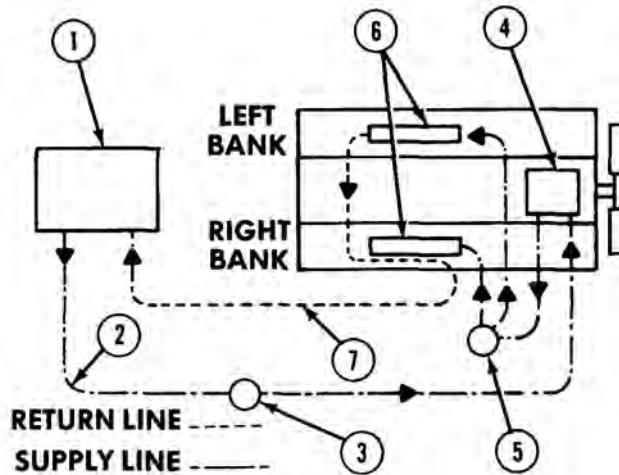
Engine exhaust gases flow through the turbocharger (2) driving a turbine wheel.

A compressor wheel on the opposite end of the turbine wheel shaft rotates and draws in fresh air through the air cleaner (1), compresses the air, and delivers it to the engine blower (3).

Air from the engine blower (3) flows through the aftercooler (4) which cools the air before it is delivered to the engine cylinders.

**FUEL SYSTEM**

Fuel drawn from the fuel tank (1) passes through the supply line (2) to a fuel/water separator (3), fuel pump (4), and secondary filter (5) to the engine fuel injectors (6).

**FUEL SYSTEM - Continued***Figure 3.*

Surplus fuel from injectors is returned to the fuel tank (1) through the return line (7).

**NOTE**

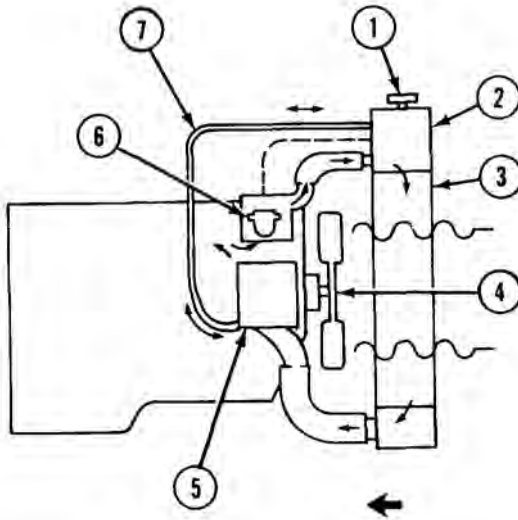
The fuel/water separator removes water and large solid particles from the fuel.

The finer particles are removed by the secondary filter (5) before they can enter the fuel injectors.

**COOLING SYSTEM****NOTE**

The pressure type cooling system protects the engine by removing heat generated during the combustion process.

Pressure within the cooling system is regulated by a pressure release in the radiator filler cap (1).

**COOLING SYSTEM - Continued***Figure 4.*

The hot coolant flows from the engine to top of radiator tank (2) and through radiator core (3) where a stream of air removes heat.

This stream of air is drawn through the core by an air-activated fan (4).

A water pump (5) draws the coolant from the bottom of the radiator and pushes it through the engine repeating the cooling process.

Thermostats (6), mounted in each coolant outlet elbow, remain closed until the coolant approaches a predetermined temperature at which time they open.

**NOTE**

When the coolant temperature drops below the thermostatic rating, the thermostats close.

An air vent line (7) between the radiator (2) and the water pump (5) inlet removes air trapped in the engine when the cooling system is being filled.

**END OF WORK PACKAGE**

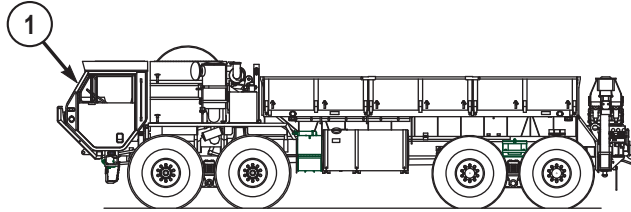
---

## OPERATOR MAINTENANCE CAB

---

### CAB

The cab (1) contains all of the driving controls and gauges, operating controls for some of the mounted equipment, and adjustable seats for a crew of two. For explanation of cab controls, refer to vehicle controls and indicators.



*Figure 1.*

**END OF WORK PACKAGE**



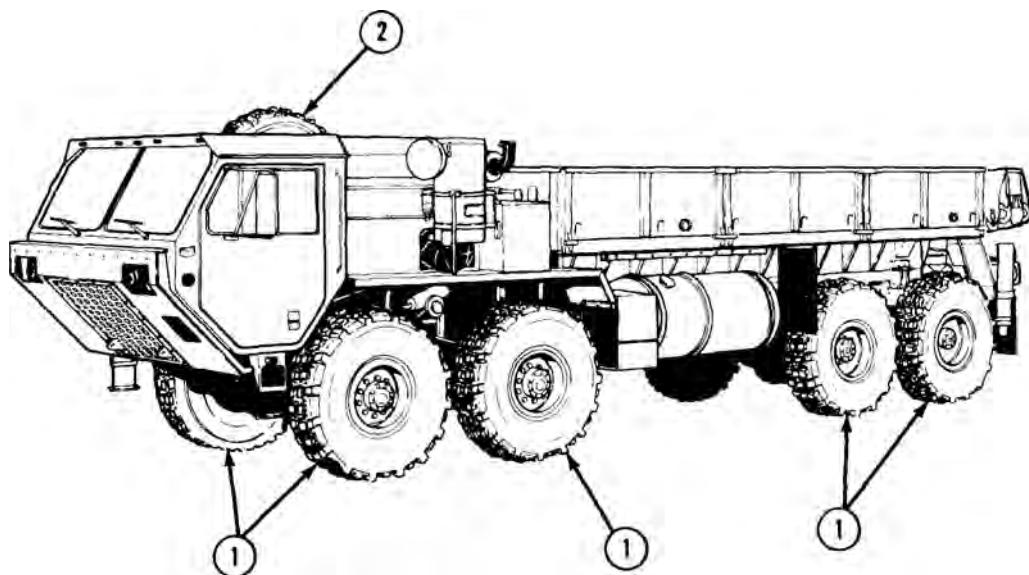
---

## OPERATOR MAINTENANCE WHEELS AND TIRES

---

### WHEELS AND TIRES

There are four front and four rear steel disc, 20.00 x 10.00 wheels (1) with 16.00 R20, tubeless, radial traction, non-directional tires.



*Figure 1.*

One spare tire (2) is mounted to the passenger side of vehicle.

### END OF WORK PACKAGE





---

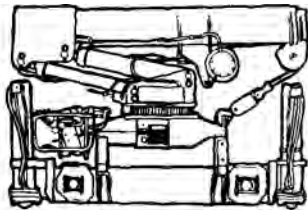
## OPERATOR MAINTENANCE CRANE

---

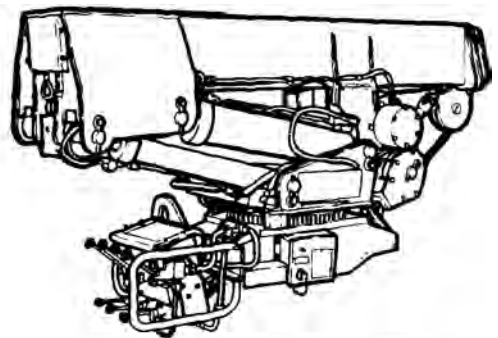
### CRANE OVERVIEW

The cranes are operated by two functional systems: the electrical system and the hydraulic system.

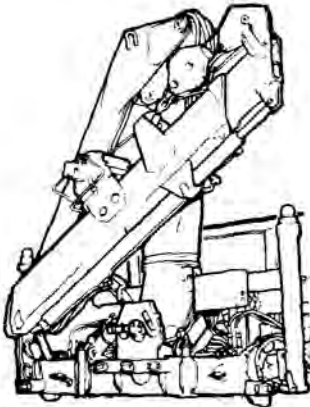
A number of cranes are used on the HEMTT series vehicles:



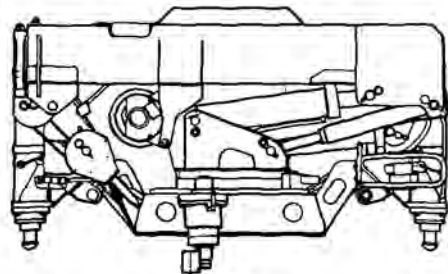
**M977 CARGO VEHICLE**



**M985 CARGO VEHICLE**



**M985 E1/GMT CARGO VEHICLE**



**M984  
WRECKER-RECOVERY VEHICLE**

*Figure 1.*

Refer to operator's manuals for specifications, dimensions, and operating procedures for the different crane models.

The cranes are completely hydraulic powered and their principles of operation are the same.

## **CRANE OVERVIEW - Continued**

Individual control panels, boom-hydraulic cylinder arrangements, and lifting capacities are different.

All cranes are powered from the vehicle's hydraulic system.

All are equipped with outriggers for stability during operation.

All cranes use a combination of hinged joints and telescoping members to give them their motions.

The hydraulic-powered hoisting winch has an automatic brake to prevent accidental lowering of the load.

## **CRANE OPERATING INSTRUCTION PLATE LOCATIONS**

### **NOTE**

Refer to stowage and decal/data plate guide for more information on plate locations.

The crane operating instruction plates are located on the heater compartment cover in the cab at each of the fixed operating stations.

The outrigger leg signs are located on each of the outrigger cylinders.

The load capacity signs are located at the main and auxiliary control panels, and on M984A they are located on the wrecker body rear stowage box doors.

## **CRANE ELECTRICAL SYSTEM**

Material handling cranes for models M977, M984A, and M985 all have overload shutdown and/or tilt warning (unstable) systems.

When M977, M985, and M984A cranes are overloaded, the overload system will automatically shut off power to telescope boom out, raise boom, or hoist load higher. The M977 and M984A overload system will also prevent lowering the boom. An overload condition can be corrected by lowering the boom. An overload condition can be corrected by lowering load to ground or other supporting surface. All functions will be restored in approximately six seconds.

The crane electrical system is supplied with power by the vehicle 24 VDC system.

The junction box on the crane connects and distributes the various control circuits of the crane.

Tilt warning, outrigger extended warning, and remote control systems are electronically controlled.

## **END OF WORK PACKAGE**

CHAPTER 2  
OPERATOR  
INSTRUCTIONS



## **OPERATOR MAINTENANCE CAB-MOUNTED FOOT CONTROLS**

---

### **CONTROLS AND INDICATORS INTRODUCTION**

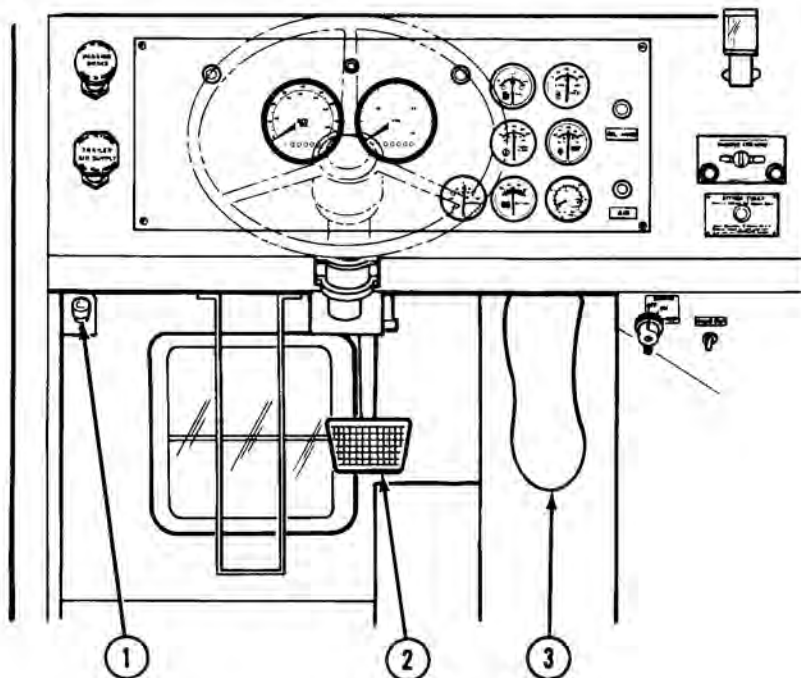
This section displays the location and describes the use of cab-mounted foot controls which are used in the operation of HEMTT series vehicles. Controls and indicators described in this section are the same for all vehicles, except where otherwise indicated.

### **LOCATION AND USE OF CONTROLS AND INDICATORS**

Know the location and proper use of every control and indicator before operating HEMTT series vehicles. Separate illustrations with keys are provided for learning about cab-mounted foot controls.

*Table 1. Cab-Mounted Foot Controls.*

Key	Control/ Indicator	Function
-----	-----------------------	----------



*Figure 1.*

1	Headlight Dimmer Switch	Press switch to raise or lower headlight beams. High beam indicator will illuminate (red) when high beams are on (WP 0021).
2	Service Brake Pedal	Applies service brakes. If vehicle is properly coupled to a trailer, trailer brakes will also operate when vehicle service brakes are applied.
3	Throttle Pedal	Controls vehicle speed.

**END OF WORK PACKAGE**

## **OPERATOR MAINTENANCE CAB-MOUNTED HAND CONTROLS**

---

### **CONTROLS AND INDICATORS INTRODUCTION**

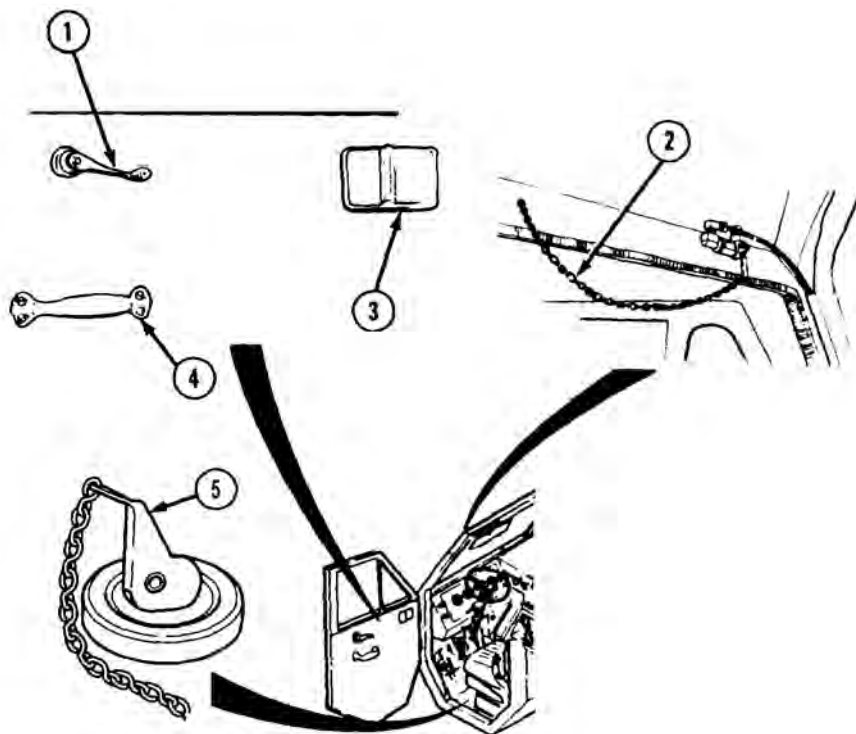
This section displays the location and describes the use of cab-mounted hand controls which are used in the operation of HEMTT series vehicles. Controls and indicators described in this section are the same for all vehicles, except where otherwise indicated.

### **LOCATION AND USE OF CONTROLS AND INDICATORS**

Know the location and proper use of every control and indicator before operating HEMTT series vehicles. Separate illustrations with keys are provided for learning about cab-mounted hand controls.

*Table 1. Cab-Mounted Hand Controls.*

Key	Control/ Indicator	Function
-----	-----------------------	----------



*Figure 1.*

1	Cab Door Window Glass Regulator (one on each door)	Rotate driver side regulator counterclockwise to lower left window glass, clockwise to raise left window glass. Rotate passenger side regulator clockwise to lower right window glass, counterclockwise to raise right window glass.
2	Air Horn Chain	Pull chain to sound air horn. Release chain to silence air horn.
3	Cab Door Inside Handle	Pull to open cab door from inside of cab.



---

*Table 1. Cab-Mounted Hand Controls. - Continued*

---

<b>Key</b>	<b>Control/ Indicator</b>	<b>Function</b>
	(one on each door)	
4	Cab Door Handle (one on each door)	Pull to close cab door from inside of cab.
5	Drain Plug (one under both operator seat and crew seat)	Pull up on lever to remove drain plug and drain liquid from floor of cab.

---

**END OF WORK PACKAGE**



**OPERATOR MAINTENANCE  
STEERING COLUMN MOUNTED CONTROLS**

**CONTROLS AND INDICATORS INTRODUCTION**

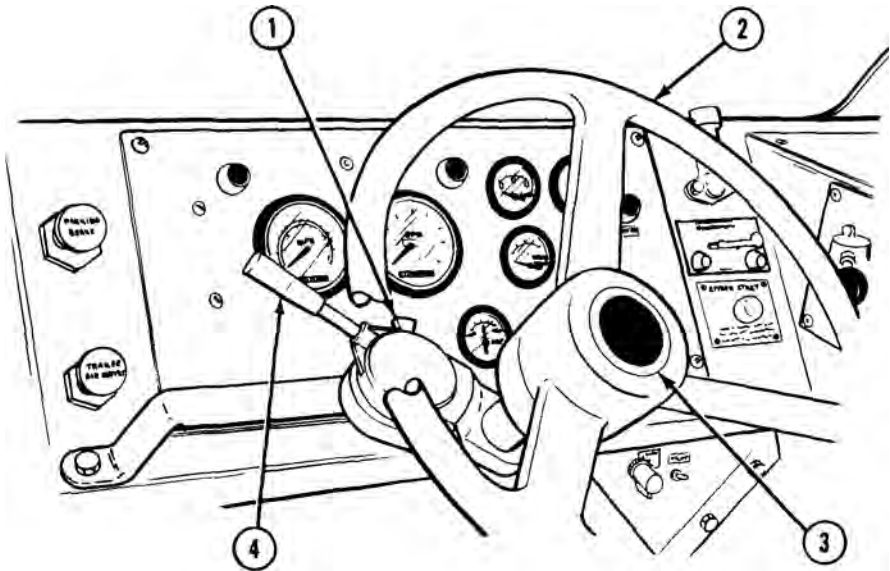
This section displays the location and describes the use of steering column mounted controls which are used in the operation of HEMTT series vehicles. Controls and indicators described in this section are the same for all vehicles, except where otherwise indicated.

**LOCATION AND USE OF CONTROLS AND INDICATORS**

Know the location and proper use of every control and indicator before operating HEMTT series vehicles. Separate illustrations with keys are provided for learning about steering column mounted controls.

*Table 1. Steering Column Mounted Controls.*

Key	Control/ Indicator	Function
-----	-----------------------	----------



*Figure 1.*

1	Emergency Flasher Control	To turn on emergency flashers, light control must be in STOP LIGHT or SER DRIVE (WP 0022). Simultaneously press emergency flasher control (1) down and push turn signal lever
---	---------------------------	---

---

**Table 1. Steering Column Mounted Controls. - Continued**

---

<b>Key</b>	<b>Control/ Indicator</b>	<b>Function</b>
		(4) up past the right turn position as far as it will go. To turn emergency flashers off, push turn signal lever (4) down to center position.
2	Steering Wheel	Controls direction of vehicle.
3	Horn Button	Sounds electric horn when pressed. Release to silence horn.
4	Turn Signal Lever	Push up to signal right turn. Pull down to signal left turn. When turn is complete, return lever to center position.

---

**END OF WORK PACKAGE**

## **OPERATOR MAINTENANCE TUNNEL PANEL CONTROLS AND INDICATORS**

---

### **CONTROLS AND INDICATORS INTRODUCTION**

This section displays the location and describes the use of tunnel panel controls and indicators which are used in the operation of HEMTT series vehicles. Controls and indicators described in this section are the same for all vehicles, except where otherwise indicated.

### **LOCATION AND USE OF CONTROLS AND INDICATORS**

Know the location and proper use of every control and indicator before operating HEMTT series vehicles. Separate illustrations with keys are provided for learning about tunnel panel controls and indicators.

Table 1. Tunnel panel controls and indicators.

Key	Control/ Indicator	Function
-----	-----------------------	----------

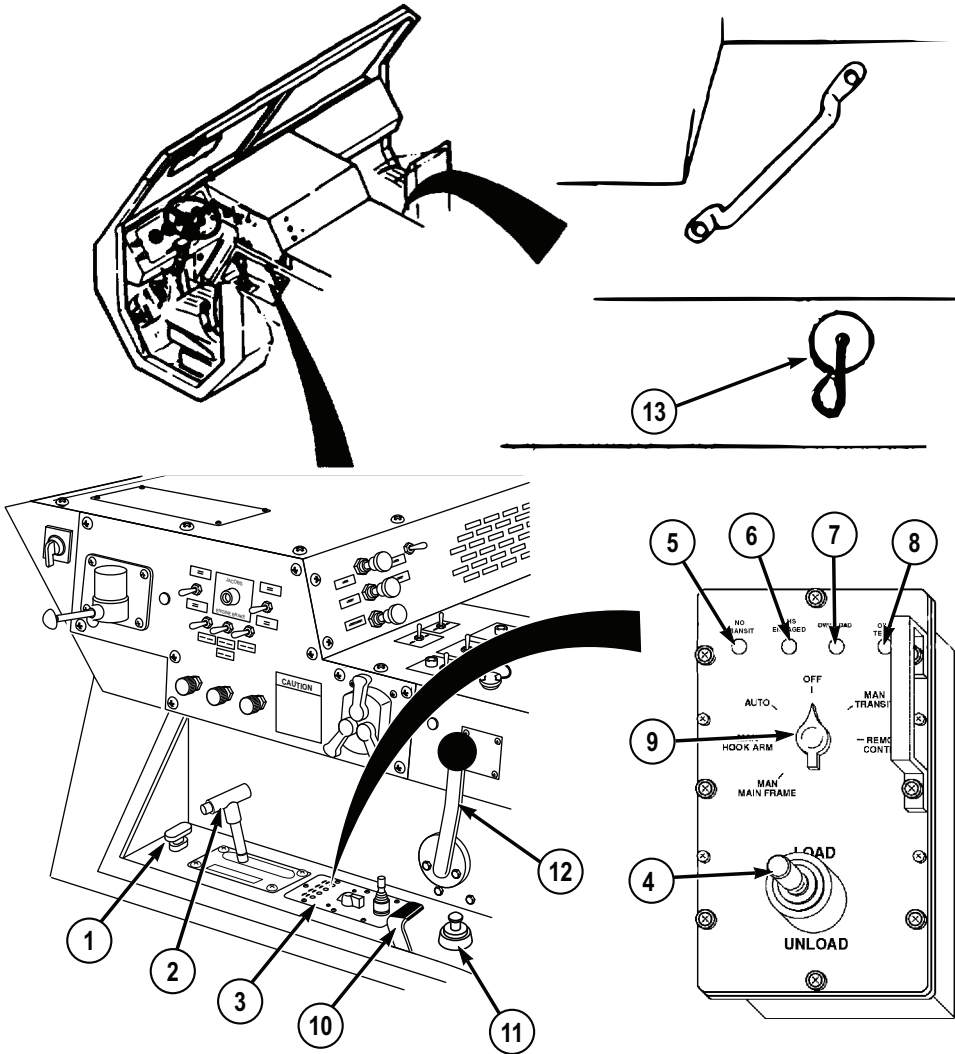


Figure 1.

**Table 1. Tunnel panel controls and indicators. - Continued**

<b>Key</b>	<b>Control/ Indicator</b>	<b>Function</b>
1	Shut Down Handle	Used to shutdown engine in emergencies. Not included in later base models.
2	Transmission Range Selector	<p>R (reverse) - Used to back up vehicle.</p> <p>N (neutral) - Used when starting vehicle, parking vehicle, or if vehicle controls are left unattended while engine is running.</p> <p>D (drive) - Used for all normal driving conditions. When vehicle is in motion, transmission will upshift/downshift automatically.</p> <p>3 - Low gear range. 2 - Lower gear range. 1 - Lowest gear range.</p>
3	CBT Control Panel (M1977 only)	Used to control CBT load handling system (LHS) operations.
4	Joystick (M1977 only)	Used to operate the LHS from the cab. The function being controlled is determined by the LHS MODE SELECT switch.
5	NO TRANSIT Indicator (M1977 only)	Illuminates when the hook arm assembly is not in the completely stowed position. The CBT is not to be driven except in the immediate loading and unloading area as long as NO TRANSIT indicator is illuminated.
6	LHS ENGAGED	Illuminates when hydraulic pressure is supplied to the LHS.

**Table 1. Tunnel panel controls and indicators. - Continued**

Key	Control/ Indicator	Function
	Indicator (M1977 only)	
7	OVERLOAD Indicator (M1977 only)	Illuminates whenever main hydraulic relief valve is opened during loading or unloading. Indicates LHS has reached an overload condition or that hydraulic system is lifting very near maximum capacity. If the LHS is overloaded, the light illuminates and the LHS is automatically locked out.
8	OIL TEMP Indicator (M1977 only)	Illuminates when LHS oil temperature exceeds limits.
9	LHS MODE Select Switch (M1977 only)	<p>OFF - The LHS is not operational. This setting is used for transport.</p> <p>AUTO - Provides automatic operation of the LHS during NATO flatrack retrieval.</p> <p>MAN HOOK ARM - Places the LHS in manual mode for moving the hook arm when the AUTO mode electric circuit is malfunctioning.</p> <p>MAN MAIN FRAME - Places the LHS in manual mode for moving the main frame when the AUTO mode electric circuit is malfunctioning.</p> <p>REMOTE CONTROL - Energizes the LHS remote-control unit.</p>



**Table 1. Tunnel panel controls and indicators. - Continued**

<b>Key</b>	<b>Control/ Indicator</b>	<b>Function</b>
		TRANSPORT - Provides for safe travel when the AUTO mode electric circuit has failed and the MAN HOOK ARM and/or MAN MAIN FRAME modes have been used.
10	Self-Recovery Winch (SRW) Lever	Used to pay out (push lever forward) and take up (pull lever aft) winch cable. Lever will return to neutral (center) position when released. Lever not included in vehicles without SRW.
11	LHS Joystick (M1120 only)	Controls loading (LOAD) and unloading (UNLOAD) operations of vehicle LHS.
12	TRANSFER CASE Shift Lever	Used to select high (HI) or low (LO) range. Center position is neutral (NEUT).
13	STE/ICE Receptacle	Receptacle for connecting simplified test equipment/internal combustion engine (STE/ICE).

**END OF WORK PACKAGE**



**OPERATOR MAINTENANCE  
INSTRUMENT PANEL CONTROLS AND INDICATORS**

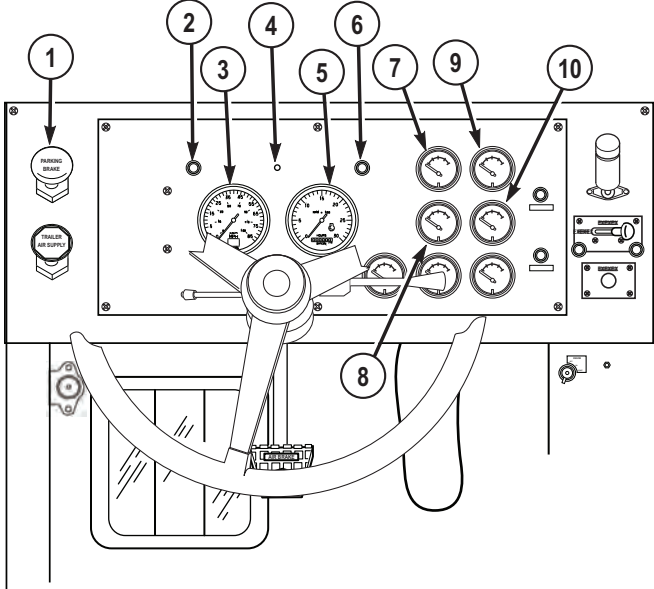
**CONTROLS AND INDICATORS INTRODUCTION**

This section displays the location and describes the use of instrument panel controls and indicators which are used in the operation of HEMTT series vehicles. Controls and indicators described in this section are the same for all vehicles, except where otherwise indicated.

**LOCATION AND USE OF CONTROLS AND INDICATORS**

Know the location and proper use of every control and indicator before operating HEMTT series vehicles. Separate illustrations with keys are provided for learning about instrument panel controls and indicators.

*Table 1. Instrument Panel Controls and Indicators.*

Key	Control/ Indicator	Function
		

*Figure 1.*

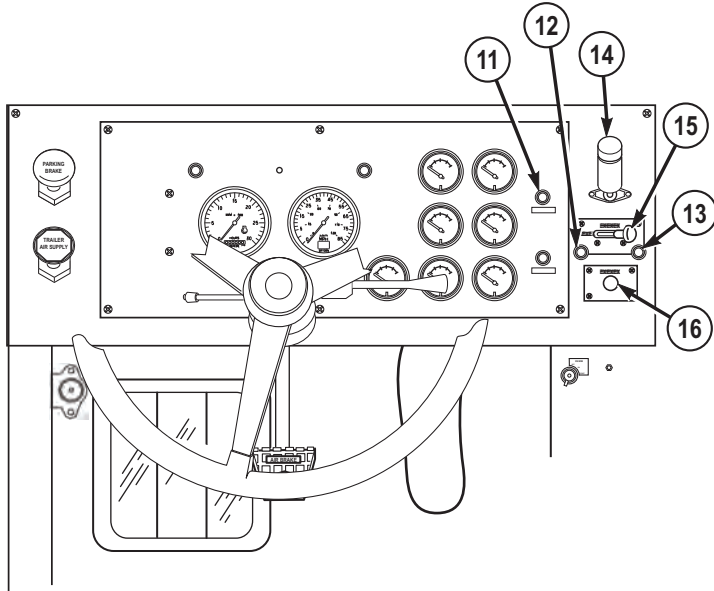
**Table 1. Instrument Panel Controls and Indicators. - Continued**

<b>Key</b>	<b>Control/ Indicator</b>	<b>Function</b>
1	PARKING BRAKE Control	Applies and releases vehicle parking brakes.
2	Left Turn Indicator	Flashes (green) when left turn signal is on.
3	Speedometer/ Odometer	Shows vehicle traveling speed (in MPH and Km/h) and total miles traveled.
4	High Beam Indicator	Illuminates (red) when vehicle headlights are on high beam.
5	Tachometer/ Hourmeter	Displays engine operating speed (RPM x 100) and total operating time (HOURS).
6	Right Turn Indicator	Flashes (green) when right turn signal is on.
7	FUEL Gauge	Displays amount of fuel in fuel tank.
8	TRANS TEMP Gauge	Displays transmission fluid temperature in degrees Fahrenheit (°F) and Celsius (°C).
9	OIL PRESS Gauge	Displays engine oil pressure (psi and kPa).

**Table 1. Instrument Panel Controls and Indicators. - Continued**

Key	Control/ Indicator	Function
-----	-----------------------	----------

10	WATER TEMP Gauge	Displays engine coolant temperature in degrees Fahrenheit (°F) and Celsius (°C).
----	------------------	--

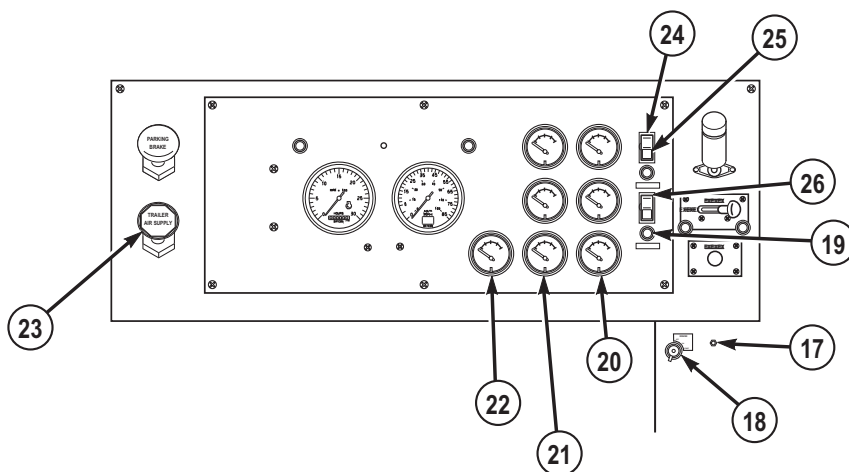


*Figure 2.*

11	OIL-WATER Indicator	Illuminates (red) when engine oil pressure is too low or when engine coolant temperature too high. Buzzer sounds at the same time.
12	INTER-AXLE DIFF. LOCK Indicator	Indicator illuminates (orange) when TRACTION CONTROL is in INTER-AXLE DIFF. LOCK position.
13	8x8 DRIVE Indicator	Illuminates (orange) when TRACTION CONTROL is in 8x8 DRIVE position or when TRANSFER CASE is in LO.

**Table 1. Instrument Panel Controls and Indicators. - Continued**

Key	Control/ Indicator	Function
14	Air Filter Restriction Indicator	Displays condition of air cleaner filter. Indicator window will show red when filter becomes clogged. VACUUM INCHES H <sup>2</sup> O window displays degree of restriction. Push button on top of gauge to reset.
15	TRACTION CONTROL Lever	Lever in left position (INTER-AXLE DIFF. LOCK) locks inter-axle differentials in front and rear tandems. Lever in right position (8x8 DRIVE) engages transfer case drive to front axles.
16	ETHER START Control	Injects ether into engine intake manifold for cold weather starting.



*Figure 3.*

17	ENGINE STOP Switch (Momentary)	Push down and hold to stop engine. Release when engine stops. Switch returns to run position when released.
----	--------------------------------	---

**Table 1. Instrument Panel Controls and Indicators. - Continued**

<b>Key</b>	<b>Control/ Indicator</b>	<b>Function</b>
18	ENGINE Switch (Three-Position)	Straight up is OFF position. ON position operates electrical system. Hold switch in START position to operate engine cranking circuit. When switch is released after engine starts, switch will return to ON position.
19	AIR Indicator	Illuminates (red) and remains lit until airbrake air pressure in each section of dual system is between 60 psi (414 kPa) to 75 psi (517 kPa). Buzzer will sound anytime indicator is lit.
20	AIR PRESS Gauge	Displays air pressure (in psi and kPa) in both sections of airbrake system. Green needle shows front section air pressure. Red needle shows rear section air pressure.
21	BATTERY Gauge	Displays state of charge of batteries and alternator voltage output.
22	AMPERES Gauge	Displays alternator output in Amperes.
23	TRAILER AIR SUPPLY Control	Supplies air to (push in) and shuts off (pull out) air to trailer brake system. When TRAILER AIR SUPPLY control is applied (pushed in), vehicle PARKING BRAKE control activates/deactivates the trailer parking brakes in concert with the vehicle.
24	LHS NO TRANSIT Indicator (M1120 only)	Illuminates (red) when LHS system is not properly stowed in transport position.

**Table 1. Instrument Panel Controls and Indicators. - Continued**

Key	Control/ Indicator	Function
25	LHS OVER LOAD Indicator (M1120 only)	Illuminates (yellow) whenever main hydraulic relief valve is opened during loading or unloading. When light illuminates, driver will be warned that LHS has reached an overload condition or that hydraulic system is lifting very near maximum capacity. OVER LOAD indicator will come on any time main relief valve is cracked open, therefore, load or unload operation may not come to a complete stop, but light will come on momentarily. This situation would indicate that system is lifting near maximum capacity. If the LHS is overloaded, the light illuminates and the system is automatically blocked out. Off-load/on-load flatrack, and attempt second operation. If, during this second attempt, the LHS shuts down, stop operation and redistribute weight or reduce payload before attempting load or unload. When attempting to load/unload Forward Repair System (FRS), manual procedures must be followed or LHS overload system will shut down the LHS system.
26	LHS Indicator (M1120 only)	Illuminates (green) when Hydraulic Selector Switch is in AUTO, MAN H.A., or MAN M.F. positions.

**END OF WORK PACKAGE**



**OPERATOR MAINTENANCE  
HEATER COMPARTMENT CONTROLS AND INDICATORS**

**CONTROLS AND INDICATORS INTRODUCTION**

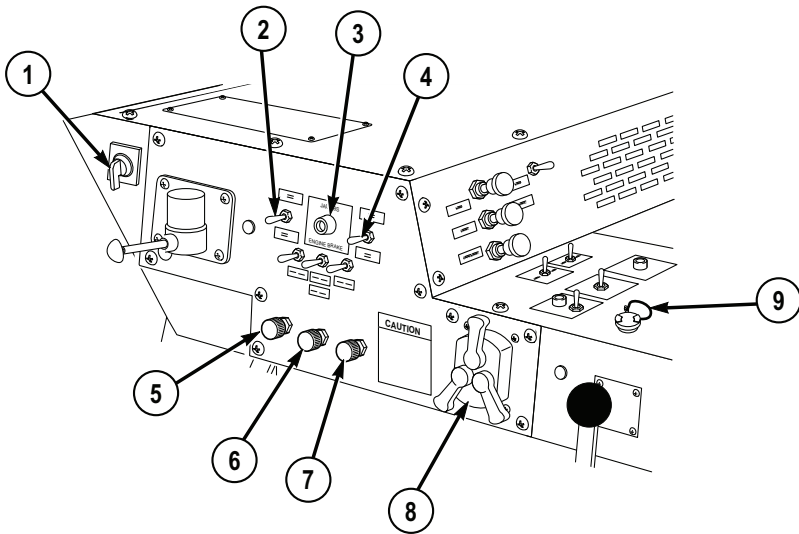
This section displays the location and describes the use of heater compartment controls and indicators which are used in the operation of HEMTT series vehicles. Controls and indicators described in this section are the same for all vehicles, except where otherwise indicated.

**LOCATION AND USE OF CONTROLS AND INDICATORS**

Know the location and proper use of every control and indicator before operating HEMTT series vehicles. Separate illustrations with keys are provided for learning about heater compartment controls and indicators.

*Table 1. Heater Compartment Controls and Indicators.*

Key	Control/ Indicator	Function
1	Hydraulic Selector	OFF position: The LHS is not operational. This mode is used for transport.



*Figure 1.*

**Table 1. Heater Compartment Controls and Indicators. - Continued**

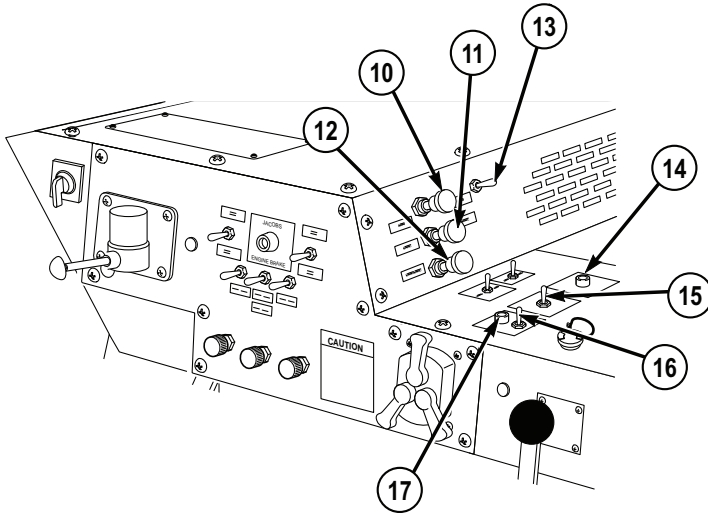
Key	Control/ Indicator	Function
	Switch (M1120 only)	<p>AUTO position: For normal loading/unloading operations.</p> <p>MAN H.A. (Manual Hook Arm): Places the LHS in manual mode for moving the hook arm when the AUTO mode electronic circuits fail. Also used during loading/unloading operations to/from trailer or docks.</p> <p>MAN M.F. (Manual Main Frame) position: Places the LHS in manual mode for moving the main frame when the AUTO mode electronic circuits fail. Also used during loading/unloading operations to/from trailer or docks.</p> <p>MAN TRANS (Manual Transit) position: This position must be selected if vehicle is to travel after the LHS AUTO mode electronic circuit has failed and the MAN H.A. and/or MAN M.F. modes have been used.</p> <p>CRANE/SRW position: Not used on this vehicle.</p>
2	JACOBS ® ENGINE BRAKE ON/OFF Switch	Supplies or shuts off electrical power to JACOBS ® ENGINE BRAKE.
3	JACOBS ® ENGINE BRAKE Indicator	Illuminates (green) when JACOBS ® ENGINE BRAKE ON-OFF switch is in ON position.

**Table 1. Heater Compartment Controls and Indicators. - Continued**

<b>Key</b>	<b>Control/ Indicator</b>	<b>Function</b>
4	JACOBS ® ENGINE BRAKE HIGH/ LOW Switch	Selects number of engine cylinders used for engine braking action. HIGH position provides maximum braking. LOW position provides less engine braking.
5	Wiper Control (Driver Side)	Controls operation of driver side windshield wiper.
6	Wiper Control (Passenger Side)	Controls operation of passenger side windshield wiper.
7	WASHER Control	Controls spray of cleaning fluid on windshield.
8	Light Control	Controls all electrical power to all parts of lighting system.

**Table 1. Heater Compartment Controls and Indicators. - Continued**

Key	Control/ Indicator	Function
9	Utility Outlet	Supplies electrical power to operate portable beacon light (WP 0074) and portable work lamp. (WP 0065)

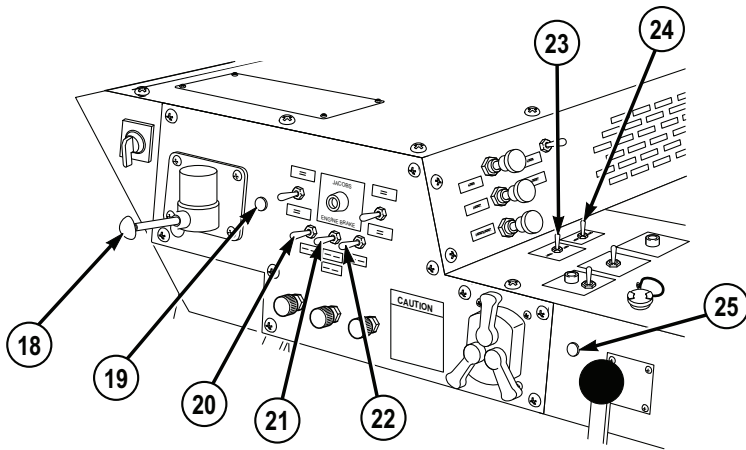


*Figure 2.*

10	AIR Control	Controls amount of outside air entering cab through fresh air vent.
11	HEAT Control	Controls amount of hot air entering cab.
12	DEFROST Control	Controls amount of hot air blown on windshield.
13	FAN Control	Controls speed of heater fan.
14	CRANE OUTRIGGER EXTENDED	Illuminates (red) when HIAB crane outriggers are extended.

**Table 1. Heater Compartment Controls and Indicators. - Continued**

Key	Control/ Indicator	Function
	Indicator (M985E1 only)	
15	High Idle Switch (M1977 only)	When set to ON position, increases engine speed (RPM) from low to high for operating CBT/LHS equipment.
16	PTO ENGAGE Control	Turns electrical power to power take-off (PTO) ON/OFF.
17	PTO ENGAGE Indicator	Illuminates (red) when PTO ENGAGE control is set to ON position.



*Figure 3.*

18	Trailer Handbrake Control	Used to test the trailer brakes. Pull control lever back to apply, push forward to release trailer brakes.
----	---------------------------	--

**Table 1. Heater Compartment Controls and Indicators. - Continued**

<b>Key</b>	<b>Control/ Indicator</b>	<b>Function</b>
19	LHS System Circuit Breaker (M1120 only)	Protects LHS System from electrical overload.
20	CL LPS Switch	Light control (8) must be in STOP LIGHT or SER DRIVE position for CL LPS switch to work. Up position turns clearance lights on. Down position turns clearance lights off.
21	DOME Light Switch	Light control (8) must be in STOP LIGHT or SER DRIVE position for CL LPS switch to work. Up position turns cab dome light on. Down position turns cab dome light off.
22	WORK LIGHT Switch (M983, M984A1, and M1977 only)	Light control (8) must be in STOP LIGHT or SER DRIVE position for CL LPS switch to work. Up position turns on work lights. Down position turns work lights off.
23	GAS ALARM Switch	Turns M-8 chemical alarm ON/OFF.
24	GPFU Switch	Turns gas particulate filter unit (GPFU) ON/OFF.
25	Auxiliary Equipment Circuit Breaker	Protects auxiliary equipment from electrical overload.

**END OF WORK PACKAGE**

**OPERATOR MAINTENANCE  
OPERATOR AND CREW FOUR-POINT SEATBELT/AIR-RIDE SEAT ADJUSTMENT  
CONTROLS**

**CONTROLS AND INDICATORS INTRODUCTION**

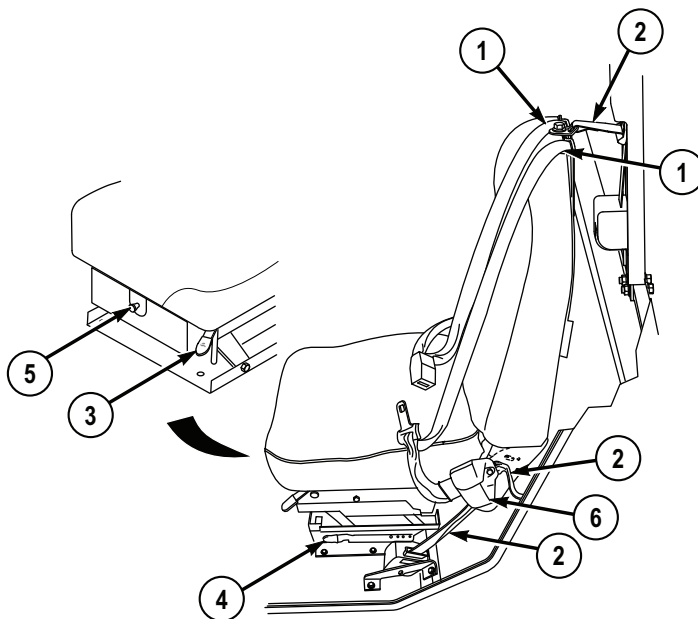
This section displays the location and describes the use of operator and crew four-point seatbelt/air-ride seat adjustment controls which are used in the operation of HEMTT series vehicles. Controls and indicators described in this section are the same for all vehicles, except where otherwise indicated.

**LOCATION AND USE OF CONTROLS AND INDICATORS**

Know the location and proper use of every control and indicator before operating HEMTT series vehicles. Separate illustrations with keys are provided for learning about operator and crew four-point seatbelt/air-ride seat adjustment controls.

***Table 1. Operator and Crew Four-Point Seatbelt/Air-Ride Seat Adjustment Controls.***

Key	Control/ Indicator	Function
-----	-----------------------	----------



*Figure 1.*

**Table 1. Operator and Crew Four-Point Seatbelt/Air-Ride Seat Adjustment Controls. - Continued**

---

<b>Key</b>	<b>Control/ Indicator</b>	<b>Function</b>
1	Seatbelt	Secures personnel to seat.
2	Seat Connector Straps	Secures seat to cab frame.
3	Height Adjustment Control	Used to adjust seat height.
4	Forward/ Backward Adjustment Control	Used to move seat forward or backward on slides.
5	Ride Adjustment Control	Used to adjust seat tension and ride firmness.
6	Retractor	Locks seatbelt in event of accident, stows belt when not in use.

---

**END OF WORK PACKAGE**



**OPERATOR MAINTENANCE**  
**OPERATOR AND CREW THREE-POINT SEATBELT/SEAT ADJUSTMENT CONTROLS**

---

**CONTROLS AND INDICATORS INTRODUCTION**

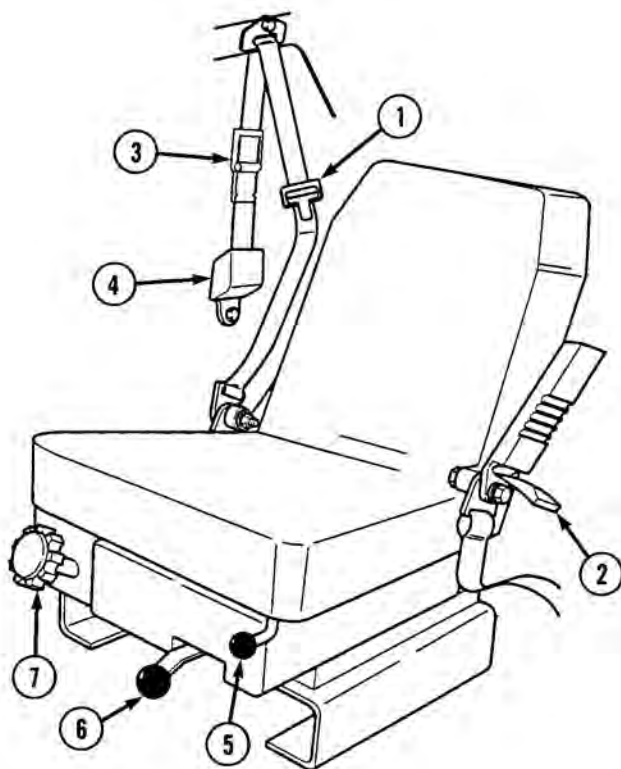
This section displays the location and describes the use of operator and crew three-point seatbelt/seat adjustment controls which are used in the operation of HEMTT series vehicles. Controls and indicators described in this section are the same for all vehicles, except where otherwise indicated.

**LOCATION AND USE OF CONTROLS AND INDICATORS**

Know the location and proper use of every control and indicator before operating HEMTT series vehicles. Separate illustrations with keys are provided for learning about operator and crew three-point seatbelt/seat adjustment controls.

**Table 1. Operator And Crew Three-Point Seatbelt/Seat Adjustment Controls.**

Key	Control/ Indicator	Function
-----	--------------------	----------



*Figure 1.*

1	Seatbelt	Secures personnel to seat.
2	Seat Connector Strap	Secures seat to cab frame.
3	Comfort Latch Buckle	Adjusts shoulder belt pressure.

**Table 1. Operator And Crew Three-Point Seatbelt/Seat Adjustment Controls. -  
Continued**

<b>Key</b>	<b>Control/ Indicator</b>	<b>Function</b>
4	Retractor	Locks seatbelt in event of accident, stows belt when not in use.
5	Height Adjustment Control	Used to adjust seat height.
6	Forward/ Backward Adjustment Control	Used to move seat forward or backward on slides.
7	Ride Adjustment Control	Used to adjust seat tension and ride firmness.

**END OF WORK PACKAGE**



**OPERATOR MAINTENANCE  
HYDRAULIC SELECTOR VALVE CONTROL**

**CONTROLS AND INDICATORS INTRODUCTION**

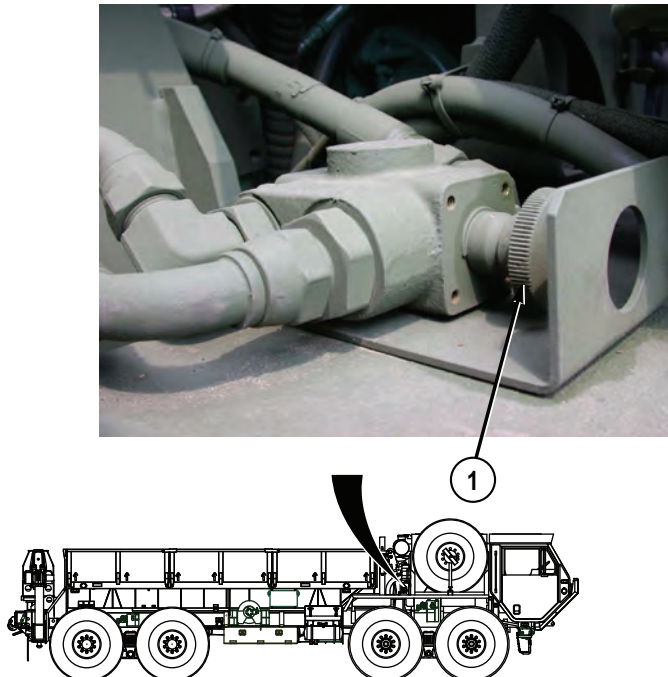
This section displays the location and describes the use of Hydraulic Selector Valve Control which are used in the operation of HEMTT series vehicles. Controls and indicators described in this section are the same for all vehicles, except where otherwise indicated.

**LOCATION AND USE OF CONTROLS AND INDICATORS**

Know the location and proper use of every control and indicator before operating HEMTT series vehicles. Separate illustrations with keys are provided for learning about Hydraulic Selector Valve Control.

*Table 1. Hydraulic Selector Valve Control.*

Key	Control/ Indicator	Function
-----	-----------------------	----------



*Figure 1.*

---

*Table 1. Hydraulic Selector Valve Control. - Continued*

---

Key	Control/ Indicator	Function
1	Hydraulic Selector Valve Control	Diverts main hydraulic power to/from Self-Recovery Winch:  Self-Recovery Winch operation - PULL OUT.  All other operations - PUSH IN (shown).

---

**END OF WORK PACKAGE**

## **OPERATOR MAINTENANCE GROVE CRANE CONTROL LEVERS**

---

### **CONTROLS AND INDICATORS INTRODUCTION**

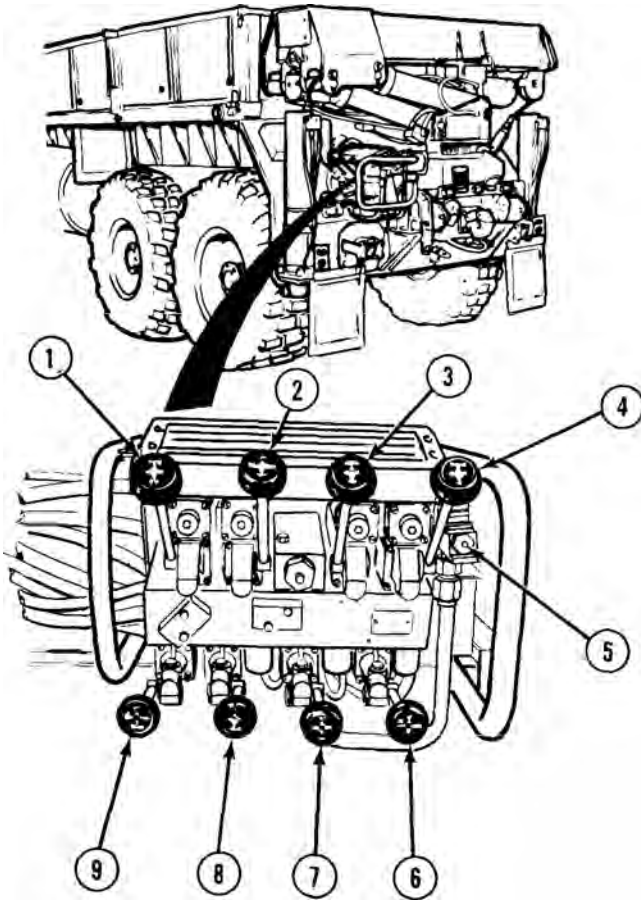
This section displays the location and describes the use of grove crane control levers which are used in the operation of HEMTT series vehicles. Controls and indicators described in this section are the same for all vehicles, except where otherwise indicated.

### **LOCATION AND USE OF CONTROLS AND INDICATORS**

Know the location and proper use of every control and indicator before operating HEMTT series vehicles. Separate illustrations with keys are provided for learning about grove crane control levers.

*Table 1. Grove Crane Control Levers.*

Key	Control/ Indicator	Function
-----	-----------------------	----------



*Figure 1.*

1	SWING Control Lever	Rotates crane boom clockwise (CW) and counterclockwise (CCW).
2	TELESCOPE Control Lever	Extends and retracts first and second stages of boom.



*Table 1. Grove Crane Control Levers. - Continued*

---

<b>Key</b>	<b>Control/ Indicator</b>	<b>Function</b>
3	BOOM Control Lever	Raises and lowers boom.
4	HOIST Control Lever	Reels in and pays out hoist cable.
5	Shut-Down Solenoid Valve Button	Provides emergency hydraulic power when electrical power fails.
6	RH O/R JACK Control Lever	Lowers and raises right outrigger jack.
7	O/R EXT Control Lever	Extends and retracts outrigger beams.
8	MAST Control Lever	Raises mast to operating position and lowers mast to stowage position.
9	LH O/R JACK Control Lever	Lowers and raises left outrigger jack.

---

**END OF WORK PACKAGE**



## **OPERATOR MAINTENANCE GROVE CRANE BOXES AND REMOTE-CONTROL UNIT**

---

### **CONTROLS AND INDICATORS INTRODUCTION**

This section displays the location and describes the use of grove crane boxes and remote-control unit which is used in the operation of HEMTT series vehicles. Controls and indicators described in this section are the same for all vehicles, except where otherwise indicated.

### **LOCATION AND USE OF CONTROLS AND INDICATORS**

Know the location and proper use of every control and indicator before operating HEMTT series vehicles. Separate illustrations with keys are provided for learning about grove crane boxes and remote-control unit.

*Table 1. Grove Crane Boxes and Remote-Control Unit.*

Key	Control/Indicator	Function
1	POWER Switch	Turns crane electrical power ON/OFF.
2	REMOTE CONTROL CONNECTOR	Receptacle for connecting remote-control unit cable.
3	SWING Control Lever	Moves crane clockwise (CW) and counterclockwise (CCW).

*Figure 1.*

- |   |                                |  |
|---|--------------------------------|--|
| 1 | POWER<br>Switch                | Turns crane electrical power ON/OFF.                   |
| 2 | REMOTE<br>CONTROL<br>CONNECTOR | Receptacle for connecting remote-control unit cable.   |
| 3 | SWING<br>Control Lever         | Moves crane clockwise (CW) and counterclockwise (CCW). |

**Table 1. Grove Crane Boxes and Remote-Control Unit. - Continued**

<b>Key</b>	<b>Control/ Indicator</b>	<b>Function</b>
4	TELESCOPE Control Lever	Extends (OUT) and retracts (IN) first and second stages of boom.
5	BOOM Control Lever	Raises (UP) and lowers (DOWN) boom.
6	HOIST Control Lever	Reels in (UP) and pays out (DOWN) hoist cable.
7	REMOTE- CONTROL UNIT ON/OFF Switch	Turns remote-control unit ON/OFF.
8	ENGINE HIGH IDLE Power Switch	Turns ENGINE HIGH IDLE LATCH switch electrical power ON/OFF.
9	ENGINE HIGH IDLE LATCH Switch	Increases engine speed to high idle.

**END OF WORK PACKAGE**



## **OPERATOR MAINTENANCE RIFLE STOWAGE MOUNT**

---

### **CONTROLS AND INDICATORS INTRODUCTION**

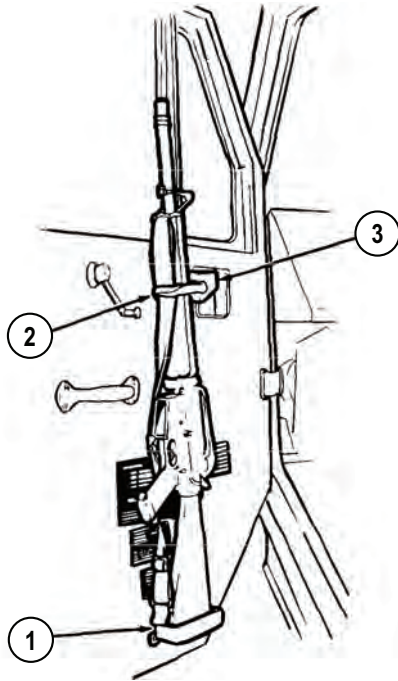
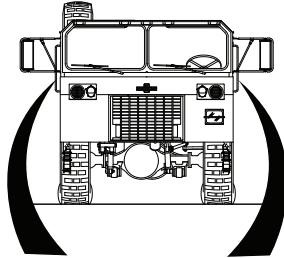
This section displays the location and describes the use of Rifle Stowage Mounts which are used in the operation of HEMTT series vehicles. Controls and indicators described in this section are the same for all vehicles, except where otherwise indicated.

### **LOCATION AND USE OF CONTROLS AND INDICATORS**

Know the location and proper use of every control and indicator before operating HEMTT series vehicles. Separate illustrations with keys are provided for learning about Rifle Stowage Mount.

*Table 1. Rifle Stowage Mount.*

Key	Control/ Indicator	Function
-----	-----------------------	----------



*Figure 1.*

1	Lower Rifle Mount	Holds butt of rifle.
---	-------------------	----------------------



---

*Table 1. Rifle Stowage Mount. - Continued*

---

<b>Key</b>	<b>Control/ Indicator</b>	<b>Function</b>
2	Rifle Mount Handle	Secures heat guard of rifle against top rifle mount.
3	Top Rifle Mount	Holds heat guard of rifle.

---

**END OF WORK PACKAGE**



**OPERATOR MAINTENANCE  
ARCTIC ENGINE HEATER CONTROLS AND INDICATORS**

**CONTROLS AND INDICATORS INTRODUCTION**

This section displays the location and describes the use of Arctic Engine Heater controls and indicators (optional accessory) which are used in the operation of HEMTT series vehicles. Controls and indicators described in this section are the same for all vehicles, except where otherwise indicated.

**LOCATION AND USE OF CONTROLS AND INDICATORS**

Know the location and proper use of every control and indicator before operating HEMTT series vehicles. Separate illustrations with keys are provided for learning about Arctic Engine Heater controls and indicators (optional accessory).

*Table 1. Arctic Engine Heater Controls And Indicators.*

Key	Control/ Indicator	Function

*Figure 1.*

**Table 1. Arctic Engine Heater Controls And Indicators. - Continued**

---

<b>Key</b>	<b>Control/ Indicator</b>	<b>Function</b>
1	ON/OFF Switch	Two position switch starts operation of arctic engine heater.
2	Arctic Engine Heater Light Indicator	Light illuminates when arctic engine heater switch is placed in ON position. If light does not illuminate or if light flashes intermittently, arctic engine heater is malfunctioning.

---

**END OF WORK PACKAGE**

**OPERATOR MAINTENANCE  
GAS PARTICULATE FILTER UNIT (GPFU) CONTROLS AND INDICATORS**

---

**CONTROLS AND INDICATORS INTRODUCTION**

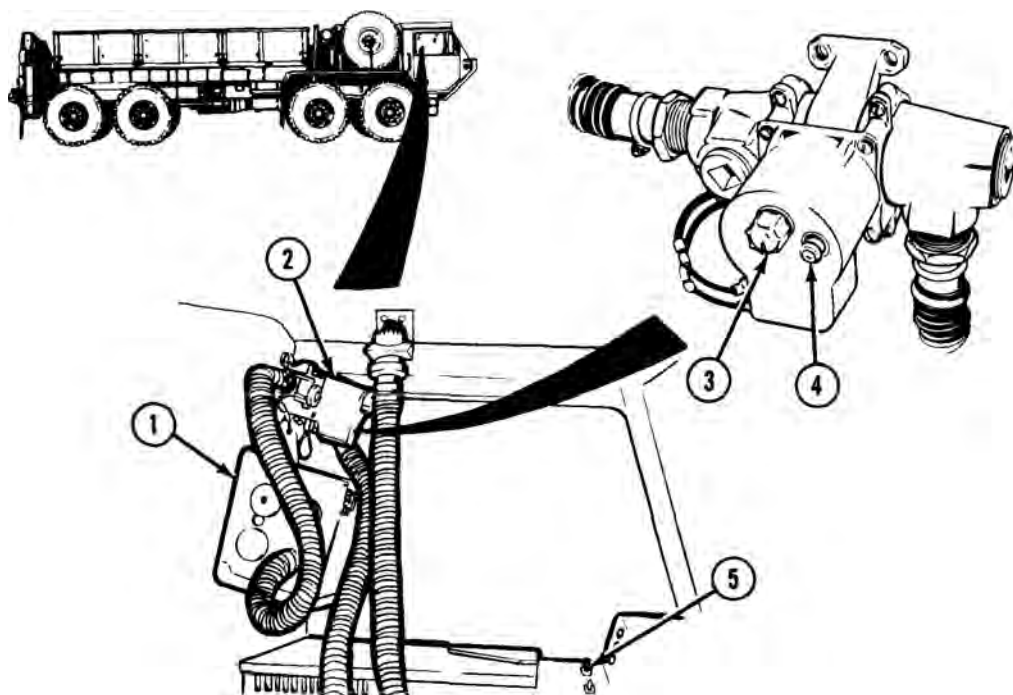
This section displays the location and describes the use of Gas Particulate Filter Unit (GPFU) controls and indicators which is used in the operation of HEMTT series vehicles. Controls and indicators described in this section are the same for all vehicles, except where otherwise indicated.

**LOCATION AND USE OF CONTROLS AND INDICATORS**

Know the location and proper use of every control and indicator before operating HEMTT series vehicles. Separate illustrations with keys are provided for learning about Gas Particulate Filter Unit (GPFU) controls and indicators.

**Table 1. Gas Particulate Filter Unit (GPFU) Controls And Indicators.**

Key	Control/ Indicator	Function
-----	-----------------------	----------



*Figure 1.*

1	Gas Particulate Filter	Filters nuclear, biological, and chemical (NBC) contaminants from air.
2	M-3 Heater	Warms air entering protective mask.
3	M-3 Heater Control Knob	Turn clockwise (CW) for warmer air turn counterclockwise (CCW) for cooler air. Turn to OFF to shut off heater.
4	M-3 Heater Indicator Light	Illuminates when heater is operating.

---

*Table 1. Gas Particulate Filter Unit (GPFU) Controls And Indicators. - Continued*

---

<b>Key</b>	<b>Control/ Indicator</b>	<b>Function</b>
5	GAS PARTICULAT E FILTER UNIT Switch	Turns GPFU ON/OFF.

---

**END OF WORK PACKAGE**





## **OPERATOR MAINTENANCE MACHINE GUN MOUNT**

---

### **CONTROLS AND INDICATORS INTRODUCTION**

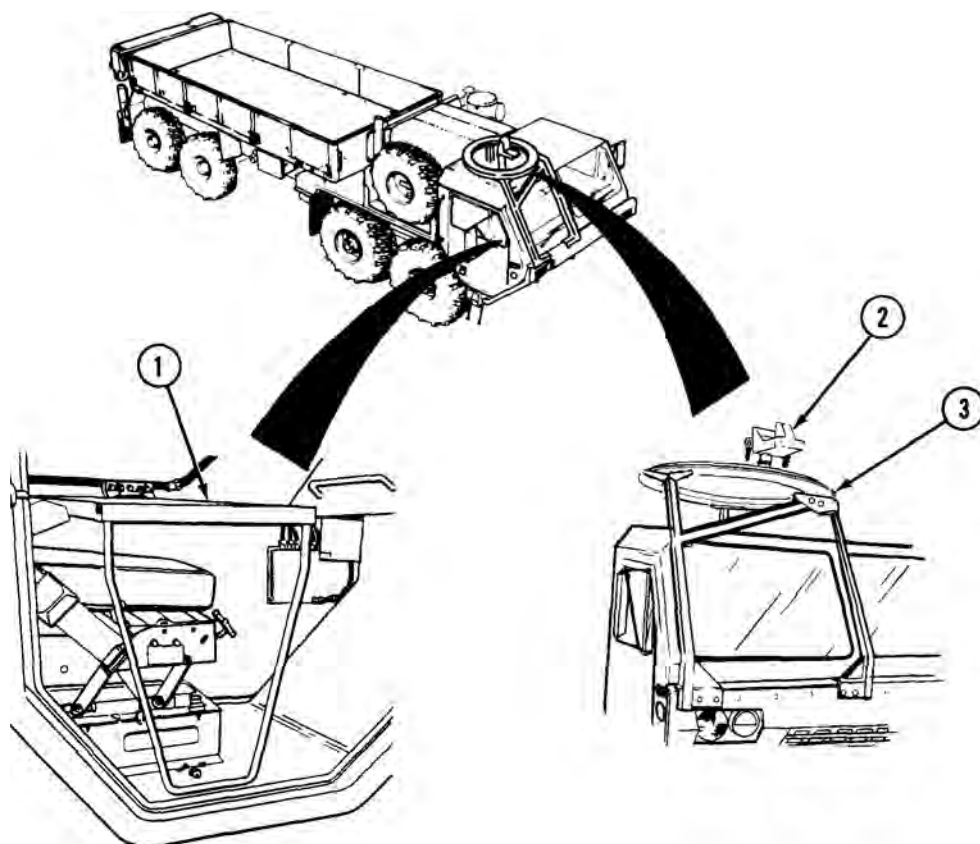
This section displays the location and describes the use of Machine Gun Mount (Optional Accessory) which is used in the operation of HEMTT series vehicles. Controls and indicators described in this section are the same for all vehicles, except where otherwise indicated.

### **LOCATION AND USE OF CONTROLS AND INDICATORS**

Know the location and proper use of every control and indicator before operating HEMTT series vehicles. Separate illustrations with keys are provided for learning about Machine Gun Mount (Optional Accessory).

*Table 1. Machine Gun Mount.*

Key	Control/ Indicator	Function
-----	-----------------------	----------



*Figure 1.*

1	Machine Gun Mount	Secures machine gun to machine gun ring.
2	Machine Gun Ring	Allows machine gun to turn 360 degrees.

**END OF WORK PACKAGE**

**OPERATOR MAINTENANCE  
M-8 CHEMICAL ALARM CONTROLS AND INDICATORS**

---

**CONTROLS AND INDICATORS INTRODUCTION**

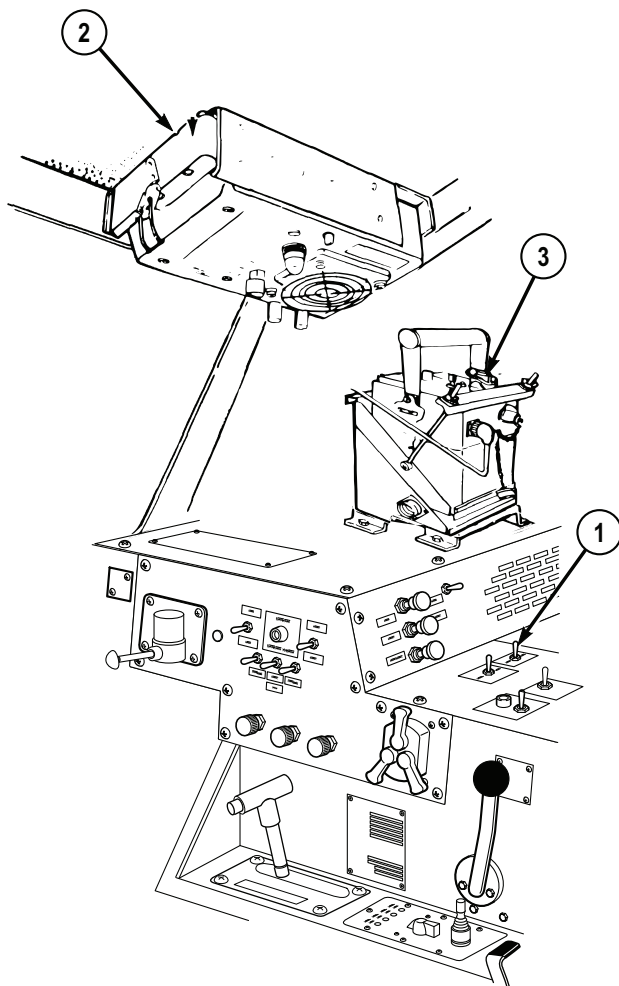
This section displays the location and describes the use of M-8 Chemical Alarm controls and indicators which are used in the operation of HEMTT series vehicles. Controls and indicators described in this section are the same for all vehicles, except where otherwise indicated.

**LOCATION AND USE OF CONTROLS AND INDICATORS**

Know the location and proper use of every control and indicator before operating HEMTT series vehicles. Separate illustrations with keys are provided for learning about M-8 Chemical Alarm controls and indicators.

*Table 1. M-8 Chemical Alarm Controls And Indicators.*

Key	Control/ Indicator	Function
-----	-----------------------	----------



*Figure 1.*

1	M-8 Chemical Alarm Switch	Operates alarm.
---	---------------------------	-----------------

---

**Table 1. M-8 Chemical Alarm Controls And Indicators. - Continued**

---

<b>Key</b>	<b>Control/ Indicator</b>	<b>Function</b>
2	M-8 Chemical Alarm	Sounds alarm when chemicals are detected.
3	Chemical Detector	Detects presence of chemical in the air.

---

**END OF WORK PACKAGE**



## **OPERATOR MAINTENANCE M-13 DECONTAMINATION KIT**

---

### **CONTROLS AND INDICATORS INTRODUCTION**

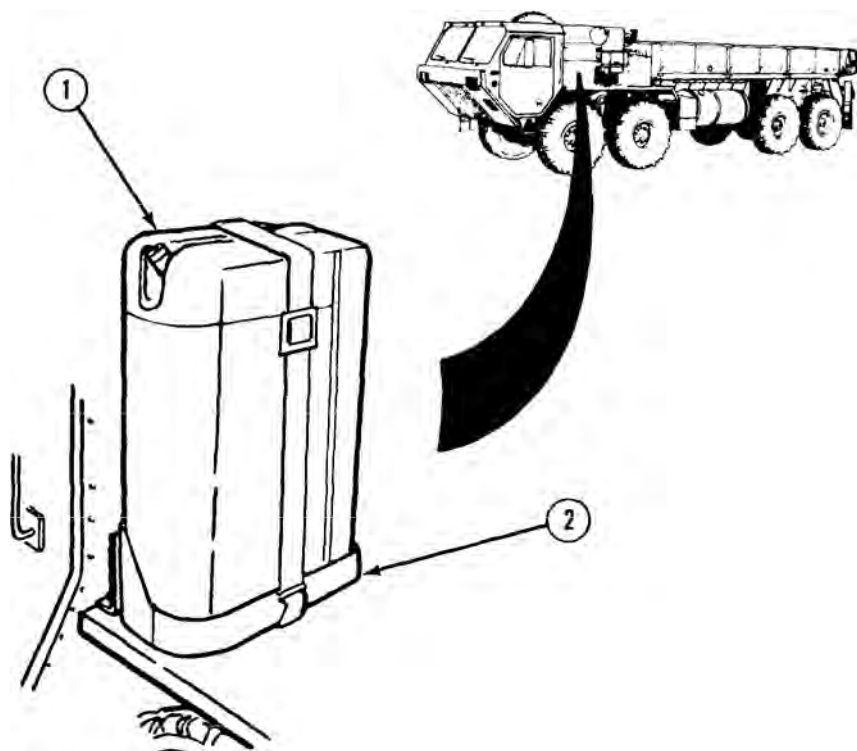
This section displays the location and describes the use of M-13 Decontamination Kit which is used in the operation of HEMTT series vehicles. Controls and indicators described in this section are the same for all vehicles, except where otherwise indicated.

### **LOCATION AND USE OF CONTROLS AND INDICATORS**

Know the location and proper use of every control and indicator before operating HEMTT series vehicles. Separate illustrations with keys are provided for learning about M-13 Decontamination Kit.

*Table 1. M-13 Decontamination Kit.*

Key	Control/ Indicator	Function
-----	-----------------------	----------



*Figure 1.*

1	M-13 Decontamination Unit	Holds and dispenses decontaminant.
2	Decontamination Unit Mount	Holds decontamination unit.

**END OF WORK PACKAGE**



## **OPERATOR MAINTENANCE RADIO INSTALLATION HARDWARE**

---

### **CONTROLS AND INDICATORS INTRODUCTION**

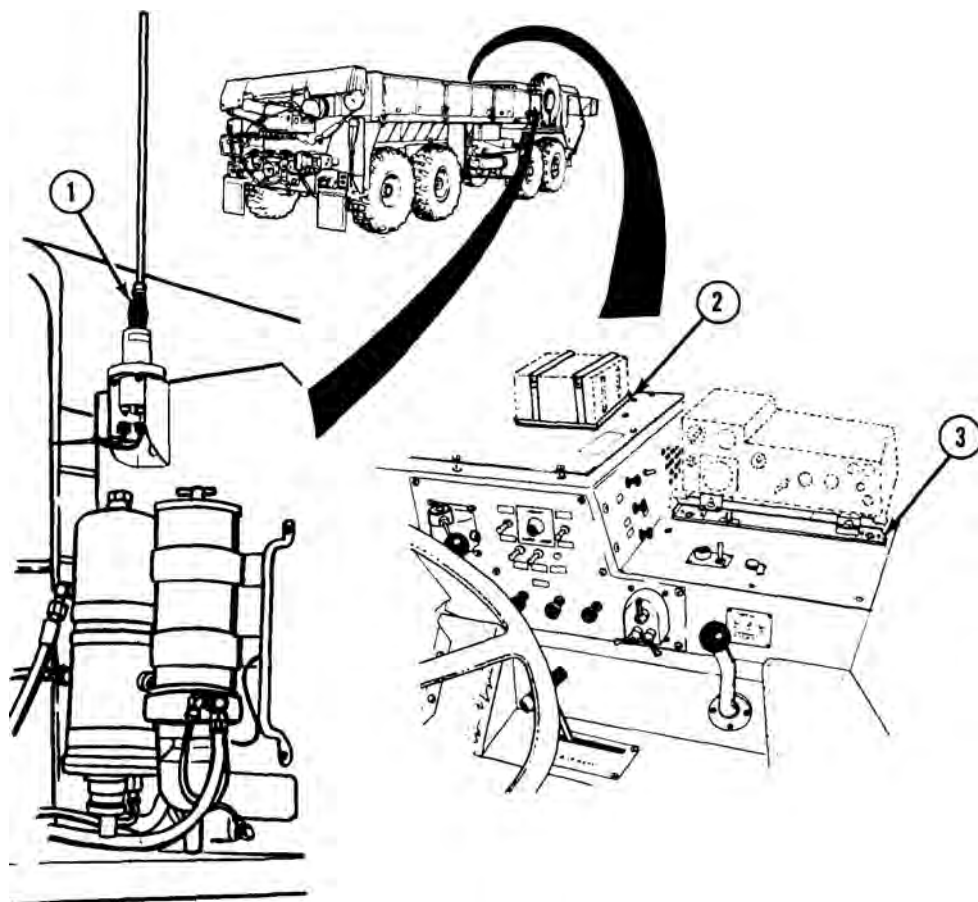
This section displays the location and describes the use of radio installation hardware which is used in the operation of HEMTT series vehicles. Controls and indicators described in this section are the same for all vehicles, except where otherwise indicated.

### **LOCATION AND USE OF CONTROLS AND INDICATORS**

Know the location and proper use of every control and indicator before operating HEMTT series vehicles. Separate illustrations with keys are provided for learning about radio installation hardware.

*Table 1. Radio Installation Hardware.*

Key	Control/ Indicator	Function
-----	-----------------------	----------



*Figure 1.*

1	Antenna Matching Unit	Holds antenna.
2	Security Unit Mount	Holds security unit.

---

*Table 1. Radio Installation Hardware. - Continued*

---

<b>Key</b>	<b>Control/ Indicator</b>	<b>Function</b>
3	Receiver/ Transmitter Mount	Holds receiver/transmitter.

---

**END OF WORK PACKAGE**



---

## OPERATOR MAINTENANCE OPERATE WINDSHIELD WIPERS/WASHER

---

### INITIAL SETUP:

Not Applicable

---

### OPERATE WINDSHIELD WIPERS

#### NOTE

- Some earlier vehicles are equipped with pull and turn control controls.
- ENGINE switch must be positioned to ON for windshield wipers to operate.

1. Turn WIPER control (1) clockwise to start and control speed of driver side windshield wiper.

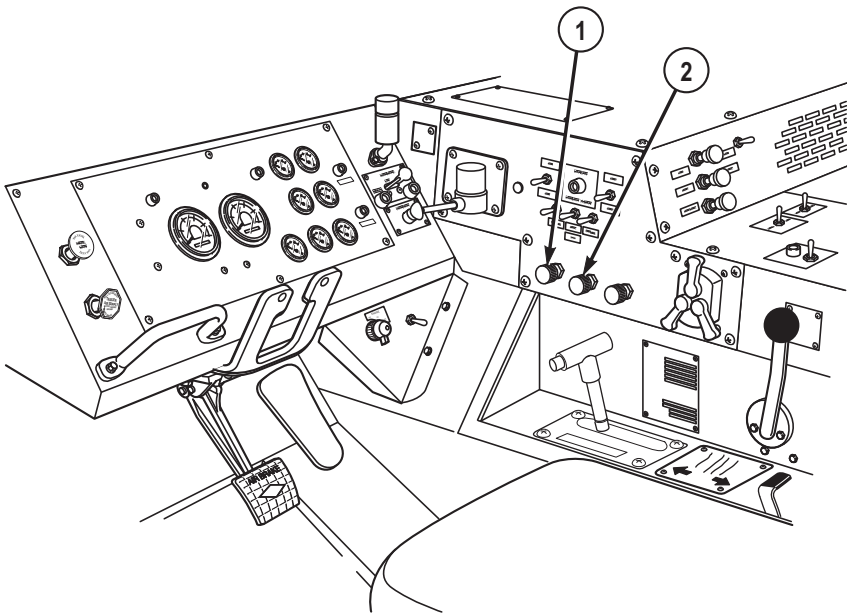


Figure 1.

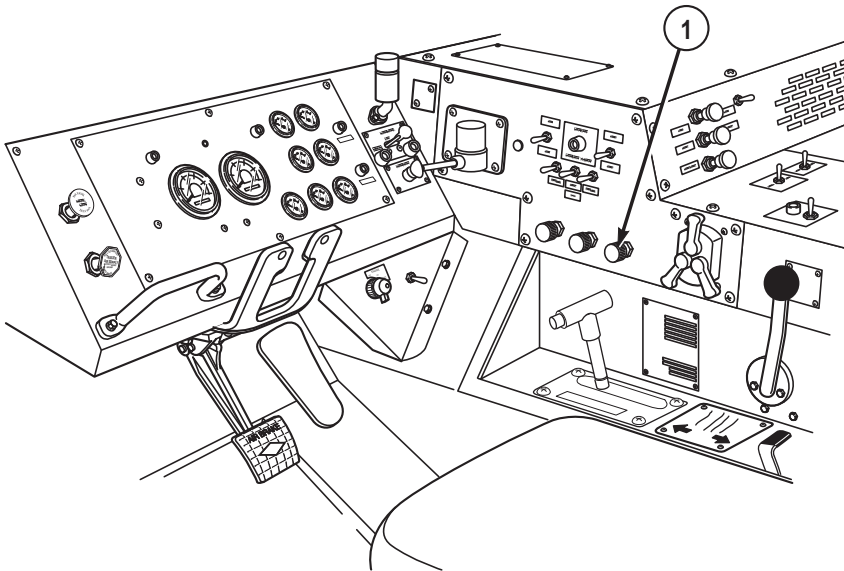
**OPERATE WINDSHIELD WIPERS - Continued**

2. Turn WIPER control (2) clockwise to start and control speed of passenger side windshield wiper.
3. Turn WIPER control (1) counterclockwise to stop driver side windshield wiper.
4. Turn WIPER control (2) counterclockwise to stop passenger side windshield wiper.
5. If wiper stops in middle of windshield:
  - a. Turn appropriate WIPER control (1 or 2) clockwise until wiper is at bottom of windshield.
  - b. Turn appropriate WIPER control (1 or 2) counterclockwise to stop wiper.

**OPERATE WINDSHIELD WASHER****NOTE**

- Some earlier vehicles are equipped with pull and turn control controls.
- ENGINE switch must be positioned to ON for windshield washer to operate.

1. Push in and hold WASH control (1) to spray cleaning fluid on windshield.

*Figure 2.*

**OPERATE WINDSHIELD WASHER - Continued**

2. Release WASH control (1) to stop washer spray.

**END OF TASK**

**END OF WORK PACKAGE**





---

**OPERATOR MAINTENANCE  
OPERATE CAB TEMPERATURE CONTROLS**

---

**INITIAL SETUP:**

Not Applicable

---

**OPERATE PERSONNEL HEATER**

**NOTE**

- If heater does not blow hot air, ensure heater valves are open.
  - Air temperature is controlled by position of HEAT control.
  - Pull HEAT control out to increase temperature.
  - Push HEAT control in to decrease temperature.
1. Pull out HEAT control (1) to desired position.
  2. Set FAN switch (2) to LO or HI airflow.

## OPERATE PERSONNEL HEATER - Continued

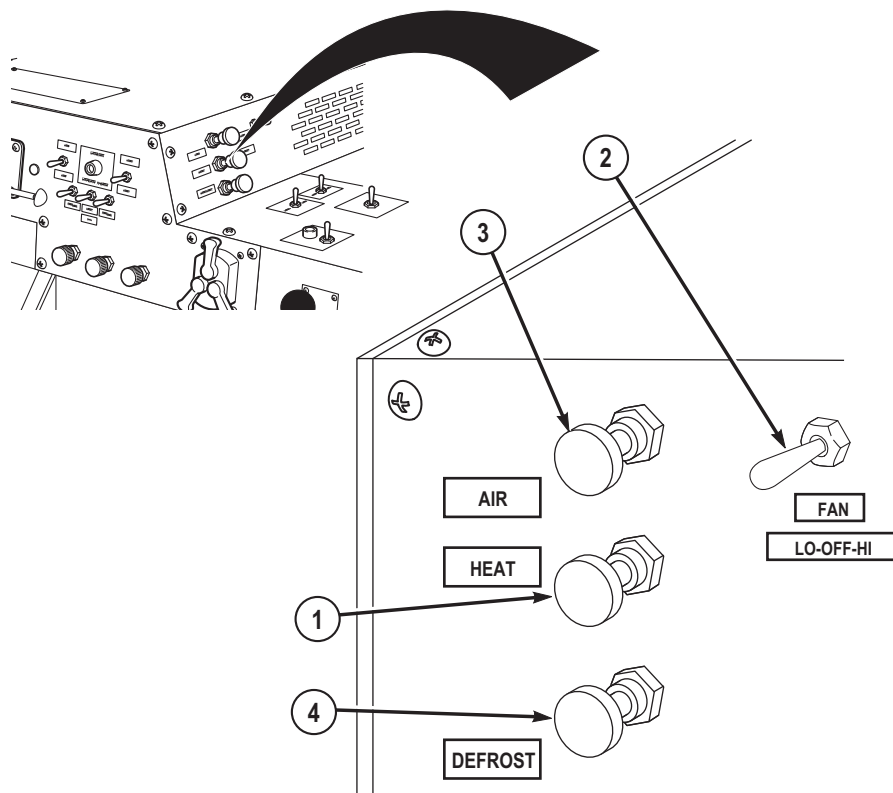


Figure 1.

**NOTE**

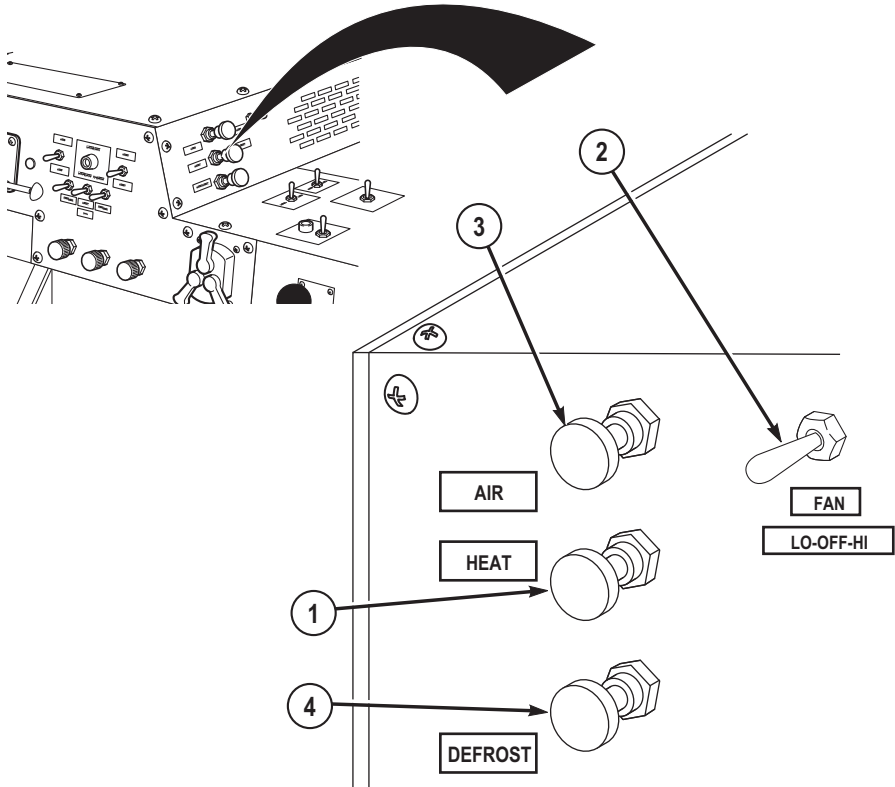
On later model vehicles, the AIR control has a "TURN TO LOCK" function which holds the vent open at the desired level when the control is rotated clockwise. Rotate control CCW until it stops to unlock the vent.

3. Adjust AIR control (3) as desired to control outside airflow for cab ventilation. Unlock, and push AIR control (3) all the way in to shut outside air ventilation off.
4. When personnel heater is no longer required:
  - a. Push in HEAT control (1) to turn heater off.
  - b. Set FAN switch (2) to OFF.

**OPERATE WINDSHIELD DEFROST****NOTE**

If windshield defrost does not blow hot air, ensure heater valves are open.

1. Pull out DEFROST control (4) to turn on.



*Figure 2.*

2. Pull out HEAT control (1) to desired position.
3. Set FAN switch (2) to desired position.
4. When defrost is no longer required:
  - a. Push in DEFROST control (4) to turn off.
  - b. Push in HEAT control (1) to turn heater off.

**OPERATE WINDSHIELD DEFROST - Continued**

- c. Set FAN switch (2) to OFF.

**END OF TASK**

**END OF WORK PACKAGE**

**OPERATOR MAINTENANCE  
OPERATE FIRE EXTINGUISHER**

---

**INITIAL SETUP:**

Not Applicable

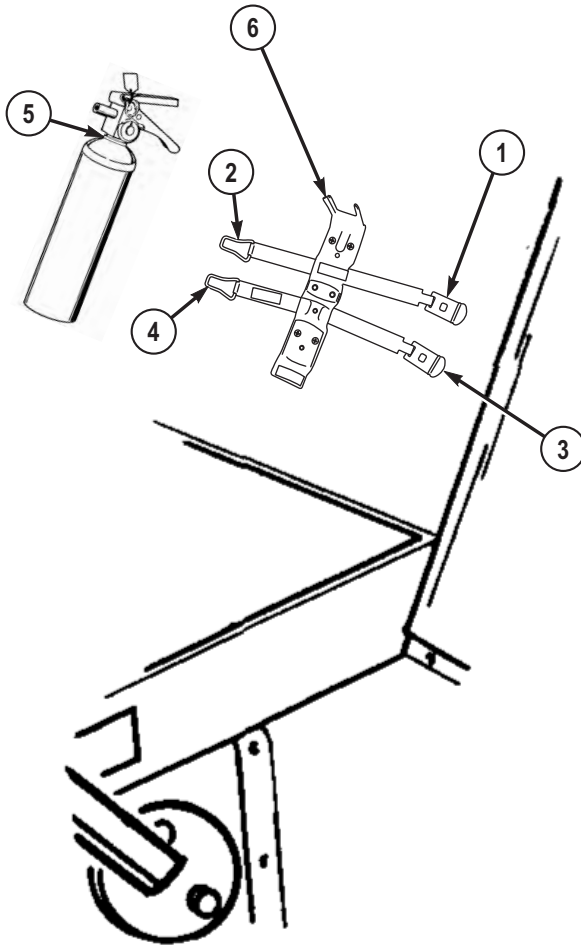
---

**REMOVE FIRE EXTINGUISHER FROM CAB**

**NOTE**

Fire extinguisher is located on rear bulkhead on inside of cab, just inboard of driver's seat.

1. Pull up top clamp (1) and disengage from top hook (2).

**REMOVE FIRE EXTINGUISHER FROM CAB - Continued***Figure 1.*

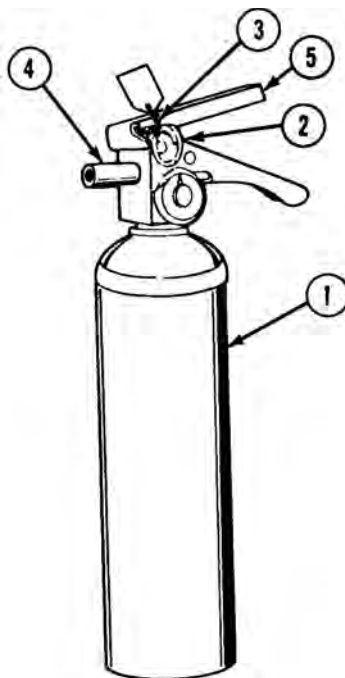
2. Pull up bottom clamp (3) and disengage from bottom hook (4).
3. Remove fire extinguisher (5) from bracket (6).

**EXTINGUISH FIRE****NOTE**

- Fire extinguisher is a dry chemical type. Refer to MSDS for specific extinguisher warnings and cautions for use.
- Remember the word "PASS" to operate fire extinguisher:

**EXTINGUISH FIRE - Continued**

1. Hold fire extinguisher (1) upright and pull safety pin (2) to break plastic tie (3).

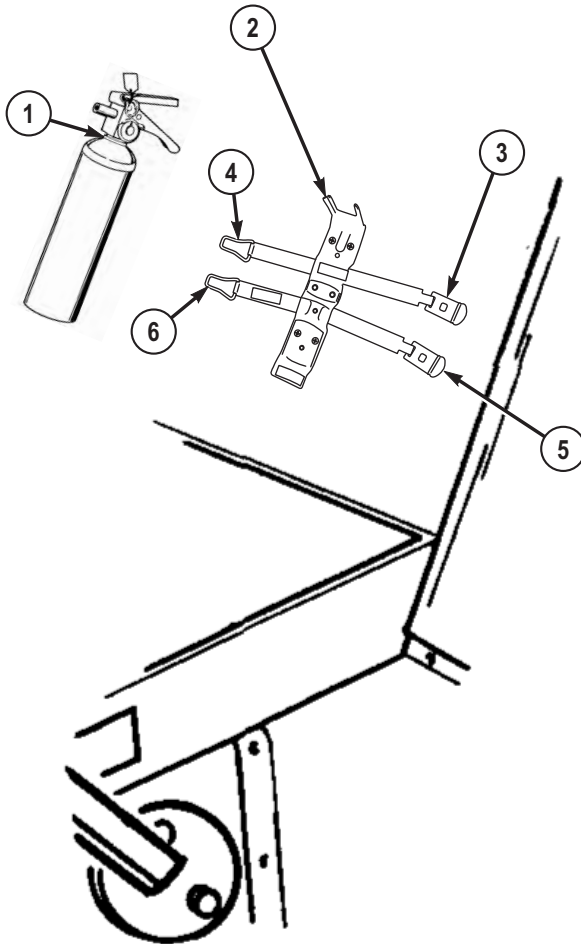


*Figure 2.*

2. Point nozzle (4) at base of fire.
3. Press down on stop lever (5) and spray discharge in a side-to-side motion at base of fire.
4. Let go of stop lever (5) when fire is out.
5. Notify field level maintenance to replace fire extinguisher.

**INSTALL FIRE EXTINGUISHER IN CAB**

1. Put neck of fire extinguisher (1) on bracket (2).

**INSTALL FIRE EXTINGUISHER IN CAB - Continued***Figure 3.*

2. Hook top clamp (3) on top hook (4) and push top clamp (3) down, tightening strap.
3. Hook bottom clamp (5) on bottom hook (6) and push bottom clamp (5) down, tightening strap.

**END OF TASK****END OF WORK PACKAGE**



---

**OPERATOR MAINTENANCE  
OPERATE ACCESS LADDER**

---

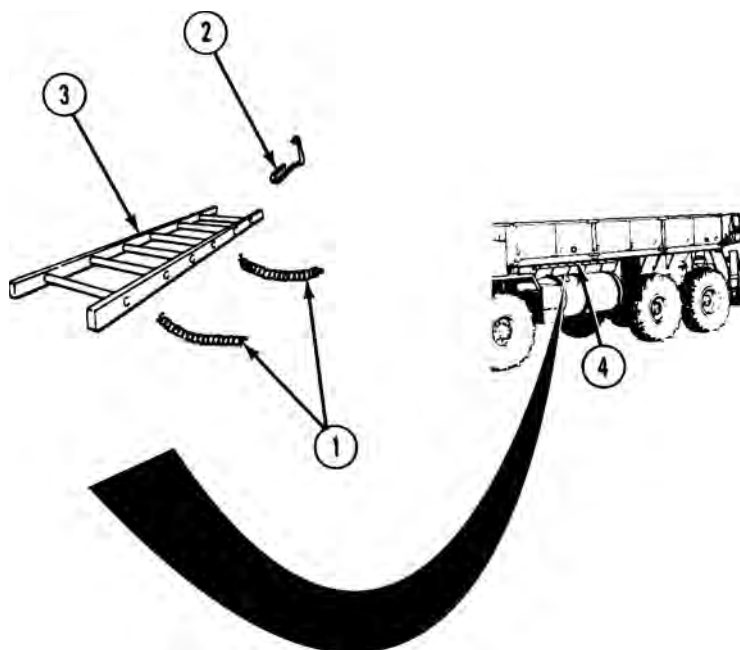
**INITIAL SETUP:**

Not Applicable

---

**INSTALL ACCESS LADDER**

1. Unhook two springs (1) from stowage rods (2).



*Figure 1.*

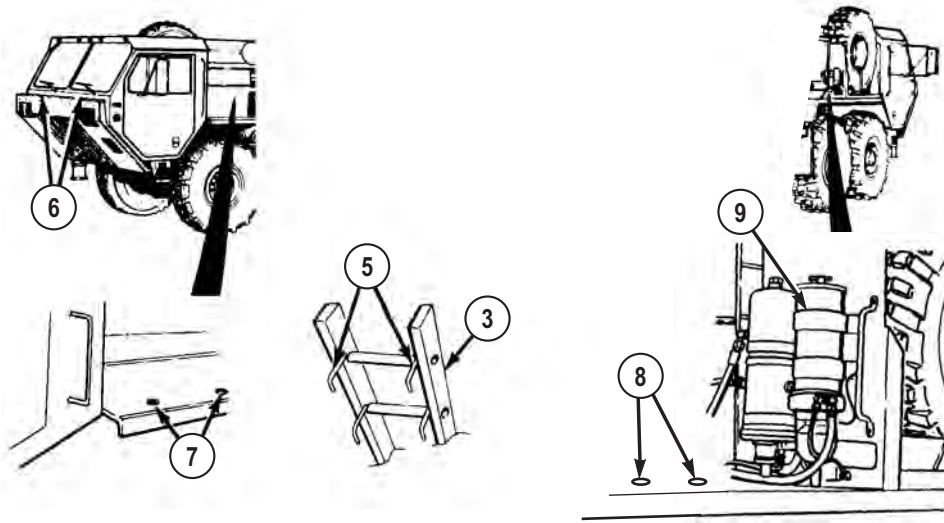
2. Remove access ladder (3) from under cargo body (4).

**CAUTION**

Do not hit fuel/water separator when installing access ladder on passenger side front fender. If access ladder hooks hit fuel/water separator, glass may break.

**INSTALL ACCESS LADDER - Continued**

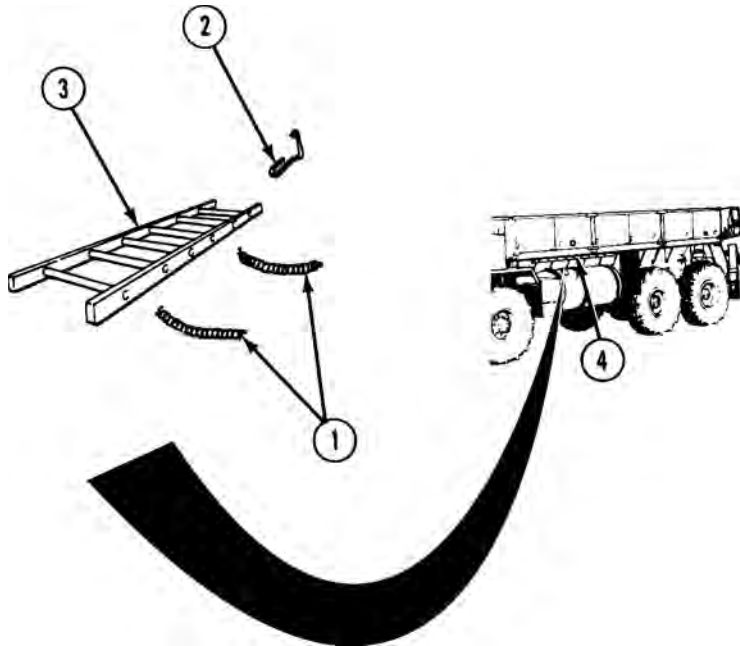
3. Install access ladder (3) hooks (5) in front skid plate holes (6), driver side front fender holes (7), or passenger side front fender holes (8), as required. Keep access ladder (3) clear of fuel/water separator (9).



*Figure 2.*

**STOW ACCESS LADDER**

1. Hook springs (1) on stowage rods (2).

**STOW ACCESS LADDER - Continued***Figure 3.*

2. Secure access ladder (3) under cargo body (4) with two springs (1) and stowage rods (2).

**END OF TASK****END OF WORK PACKAGE**



---

**OPERATOR MAINTENANCE  
OPERATE DRAIN PLUG**

---

**INITIAL SETUP:**

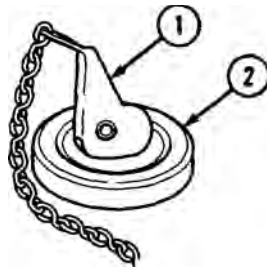
Not Applicable

---

**REMOVE DRAIN PLUG****NOTE**

There are two drain plugs. One located on each side of cab floor, just below operator/crew seats.

1. Pull up on lever (1).

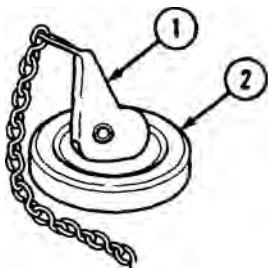


*Figure 1.*

2. Remove drain plug (2) to drain any liquid from floor of cab.

**INSTALL DRAIN PLUG**

1. Push drain plug (2) in opening on cab floor.

**INSTALL DRAIN PLUG - Continued**

*Figure 2.*

2. Press down on lever (1) to secure drain plug (2).

**END OF TASK**

**END OF WORK PACKAGE**

---

## OPERATOR MAINTENANCE CONNECT/DISCONNECT TRAILER

---

### INITIAL SETUP:

#### Personnel Required

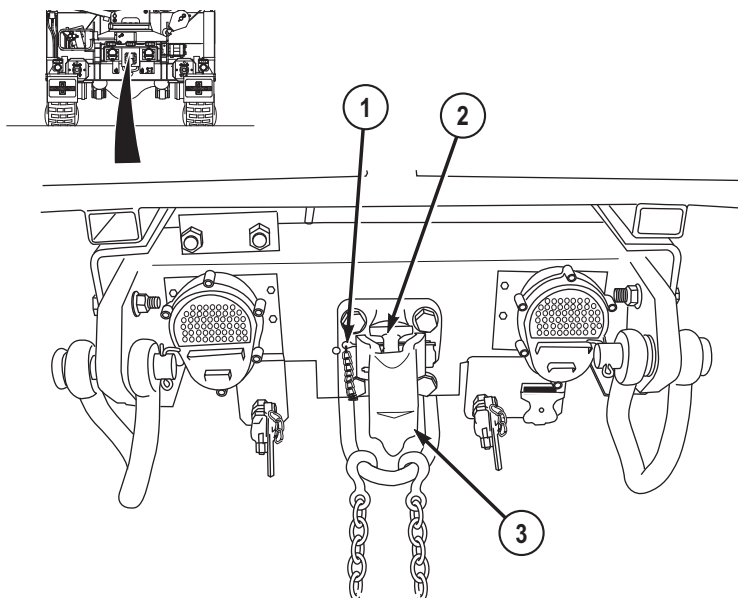
Operator and Assistant(s) - - - (3)

---

### CONNECT TRAILER (VEHICLES EQUIPPED WITH PINTLE HOOK)

#### NOTE

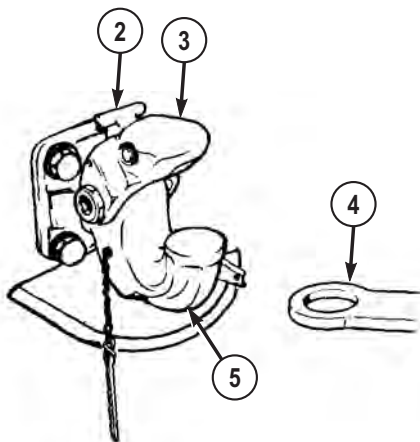
- This procedure is a three soldier task.
  - HEMTT series vehicles pull M105, M332, M989, and M1076 trailers. For more information on trailer hookup and towing procedures, refer to the following manuals:
    - M105 Trailer - TM 9-2330-213-14&P. (WP 0161)
    - M332 Trailer - TM 9-2330-231-14&P. (WP 0161)
    - M989 Trailer - TM 9-2330-385-14. (WP 0161)
    - M1076 Trailer - TM 9-2330-385-14. (WP 0161)
1. Park vehicle. (WP 0056)
  2. Shut off engine. (WP 0057)
  3. Remove cotter pin (1).

**CONNECT TRAILER (VEHICLES EQUIPPED WITH PINTLE HOOK) - Continued**

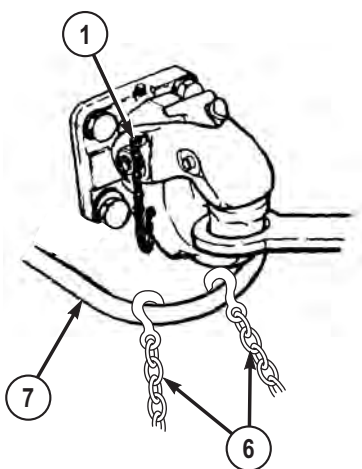
*Figure 1.*

4. Pull latch (2) away from vehicle and hold.
5. Lift top part of pintle hook (3) and let go of latch (2); hook will be locked open.
6. Put trailer connecting eye (4) on bottom part of pintle hook (5).



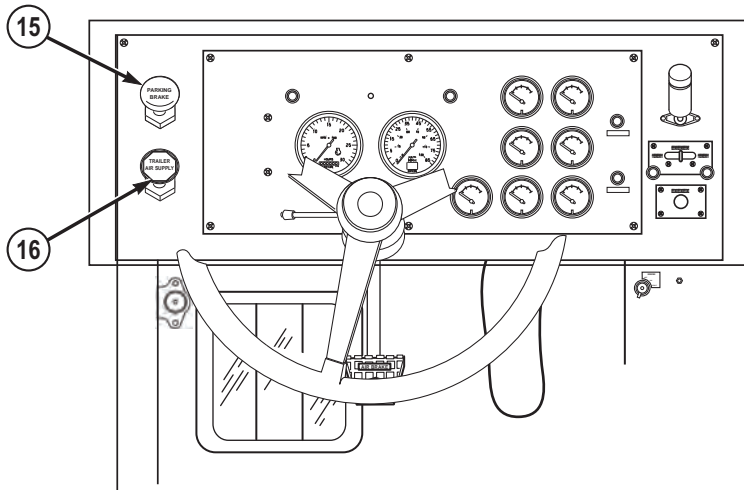
**CONNECT TRAILER (VEHICLES EQUIPPED WITH PINTLE HOOK) - Continued***Figure 2.*

7. Pull latch (2) away from vehicle to free top part of pintle hook (3).
8. Install cotter pin (1).

*Figure 3.*

9. Connect two safety chains (6) to safety chain hoop (7).
10. Lift cover (8) and connect inter-vehicular wiring harness (9) to connector on vehicle (10), and trailer.



**CONNECT TRAILER (VEHICLES EQUIPPED WITH PINTLE HOOK) - Continued**

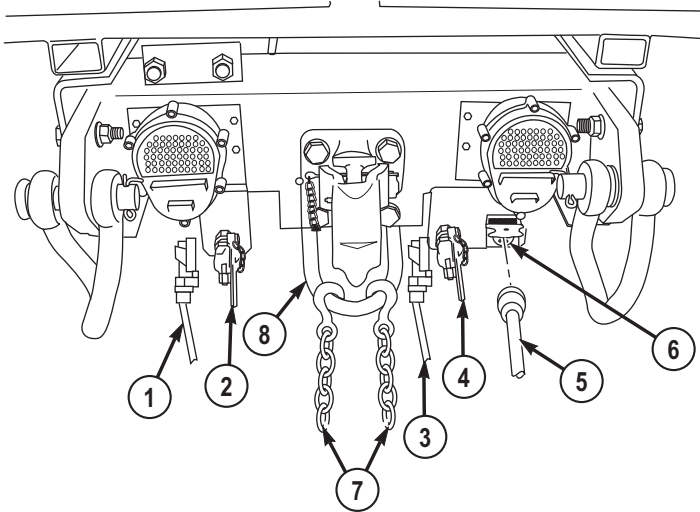
*Figure 5.*

16. Push in TRAILER AIR SUPPLY control (16) to charge trailer air system.
17. Pull out PARKING BRAKE control (15) once trailer air supply system is charged.

**DISCONNECT TRAILER (VEHICLES EQUIPPED WITH PINTLE HOOK)****NOTE**

This procedure is a three soldier task.

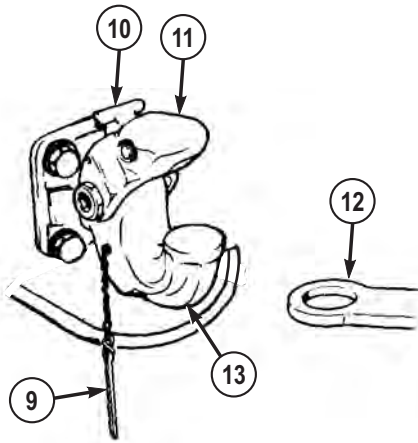
1. Park vehicle. (WP 0056)
2. Shut off engine. (WP 0057)
3. Remove emergency (red) air line (1) from emergency (red) gladhand (2) on driver side of vehicle and emergency (red) gladhand on driver side of trailer.

**DISCONNECT TRAILER (VEHICLES EQUIPPED WITH PINTLE HOOK) - Continued**

**TRAILER DRAWBAR  
SHOWN REMOVED FOR CLARITY**

*Figure 6.*

4. Remove service (blue) air line (3) from service (blue) gladhand (4) on passenger side of vehicle and service (blue) gladhand on passenger side of trailer.
5. Remove inter-vehicular wiring harness (5) from connector (6) on vehicle.
6. Remove inter-vehicular wiring harness (5) from trailer and return to vehicle stowage.
7. Remove two safety chains (7) from safety chain hoop (8).
8. Remove cotter pin (9).

**DISCONNECT TRAILER (VEHICLES EQUIPPED WITH PINTLE HOOK) - Continued***Figure 7.*

9. Pull latch (10) away from vehicle and hold.
10. Lift top part of pintle hook (11) and let go of latch (10); hook will be locked open.
11. Lift trailer connecting eye (12) off bottom of pintle hook (13).
12. Pull latch (10) away from top part of pintle hook (11).
13. Install cotter pin (9).

**END OF TASK****END OF WORK PACKAGE**



---

**OPERATOR MAINTENANCE  
CARGO BODY OPERATION**

---

**INITIAL SETUP:****Personnel Required**Operator and Assistant - - - (2)

---

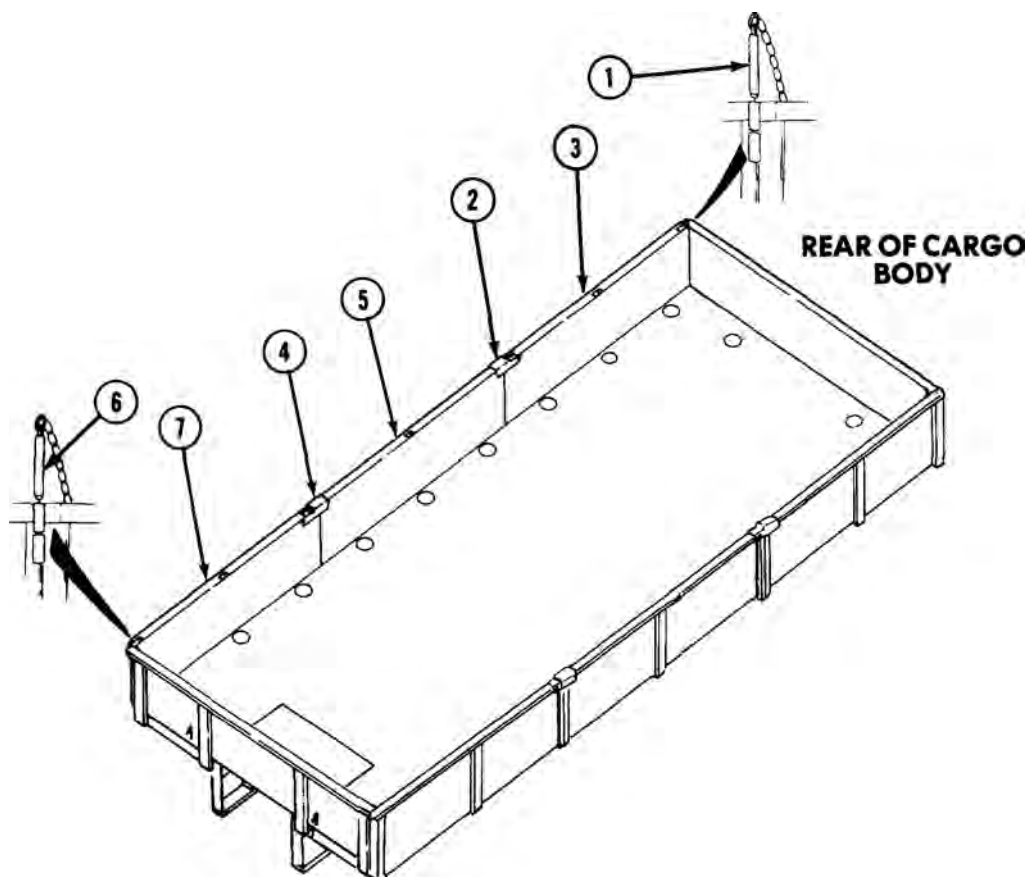
**LOWER CARGO BODY SIDE PANELS ONE AT A TIME****WARNING**

Side panels can slide off hinge pins when vehicle is parked on grade.  
Falling side panels can cause injury or death to personnel.

**NOTE**

This procedure is a two soldier task.

1. Remove lockpin (1) and pull latch (2) up while assistant holds side panel (3).

**LOWER CARGO BODY SIDE PANELS ONE AT A TIME - Continued**

*Figure 1.*

2. Lower side panel (3).
3. Pull latch (4) up while assistant holds side panel (5).
4. Lower side panel (5).
5. Remove lockpin (6) while assistant holds side panel (7).
6. Lower side panel (7).



**LOWER CARGO BODY SIDE PANELS ALL AT ONE TIME****WARNING**

Side panels can slide off hinge pins when vehicle is parked on grade.  
Falling side panels can cause injury or death to personnel.

**NOTE**

This procedure is a two soldier task.

1. Hold side panel (1) up while assistant removes lockpins (2) and climbs out of cargo body to help lower side panels.

## LOWER CARGO BODY SIDE PANELS ALL AT ONE TIME - Continued

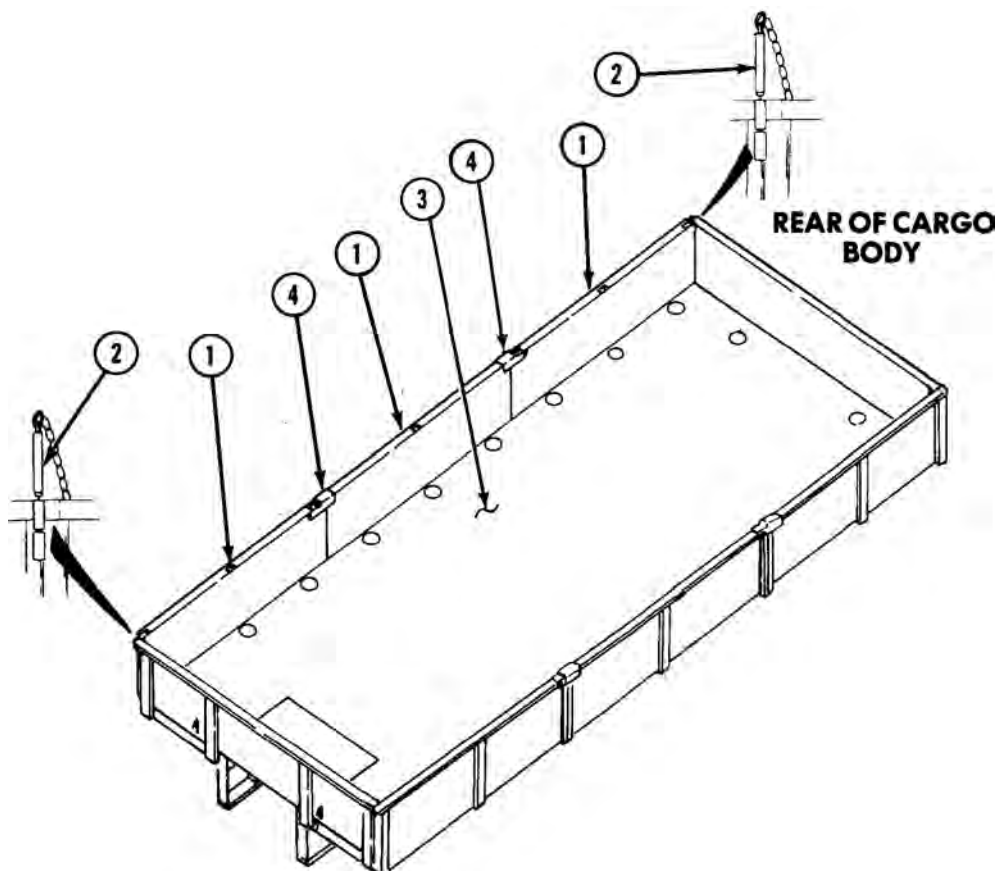


Figure 2.

2. With aid of an assistant, lower side panels (1) until side panels are even with cargo body floor (3).
3. Change hand position so each soldier holds a latch (4).
4. With aid of an assistant, lower side panels (1).

**RAISE AND SECURE CARGO BODY SIDE PANELS ONE AT A TIME****WARNING**

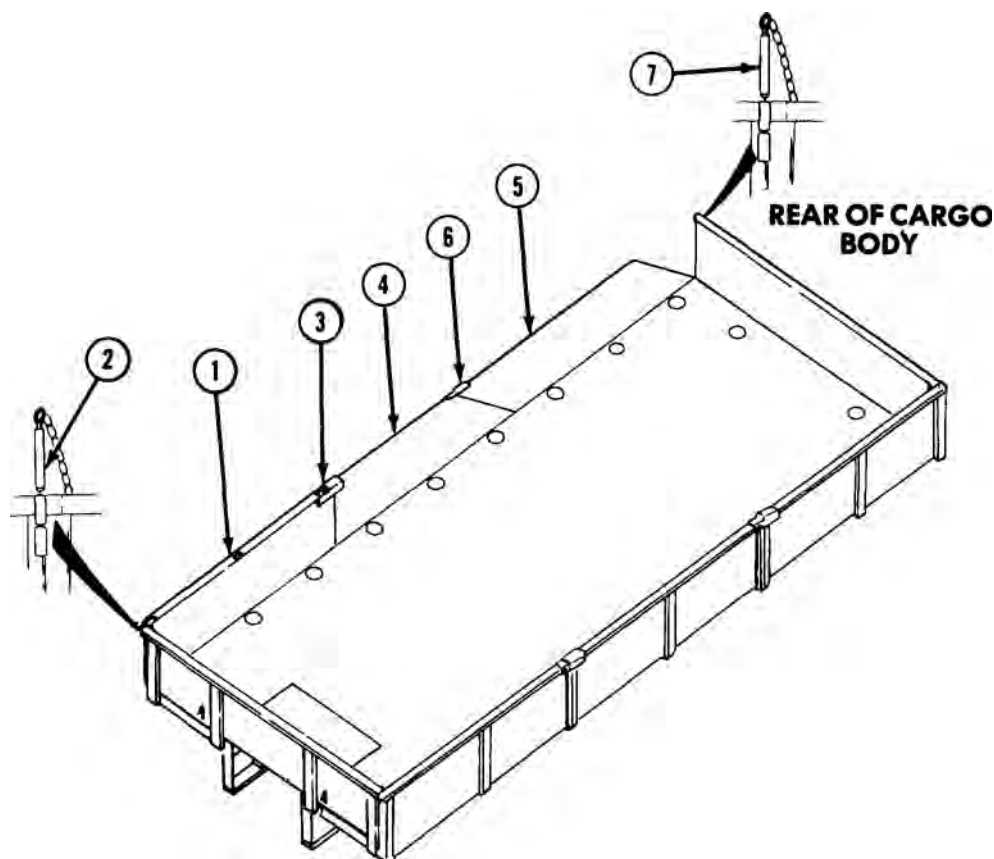
Side panels can slide off hinge pins when vehicle is parked on grade. Falling side panels can cause injury or death to personnel.

**NOTE**

This procedure is a two soldier task.

1. Raise and hold side panel (1) while assistant installs lockpins (2) and pulls latch (3) up.

## RAISE AND SECURE CARGO BODY SIDE PANELS ONE AT A TIME - Continued

*Figure 3.*

2. Raise and hold side panel (4) while assistant pushes latch (3) down.
3. Raise and hold side panel (5) while assistant pulls latch (6) up and installs lockpin (7).
4. Push latch (6) down.

**RAISE AND SECURE CARGO BODY SIDE PANELS ALL AT A TIME****WARNING**

Side panels can slide off hinge pins when vehicle is parked on grade. Falling side panels can cause injury or death to personnel.

**NOTE**

This procedure is a two soldier task.

1. With aid of an assistant, place latches (1) over edge of adjoining panel (2).

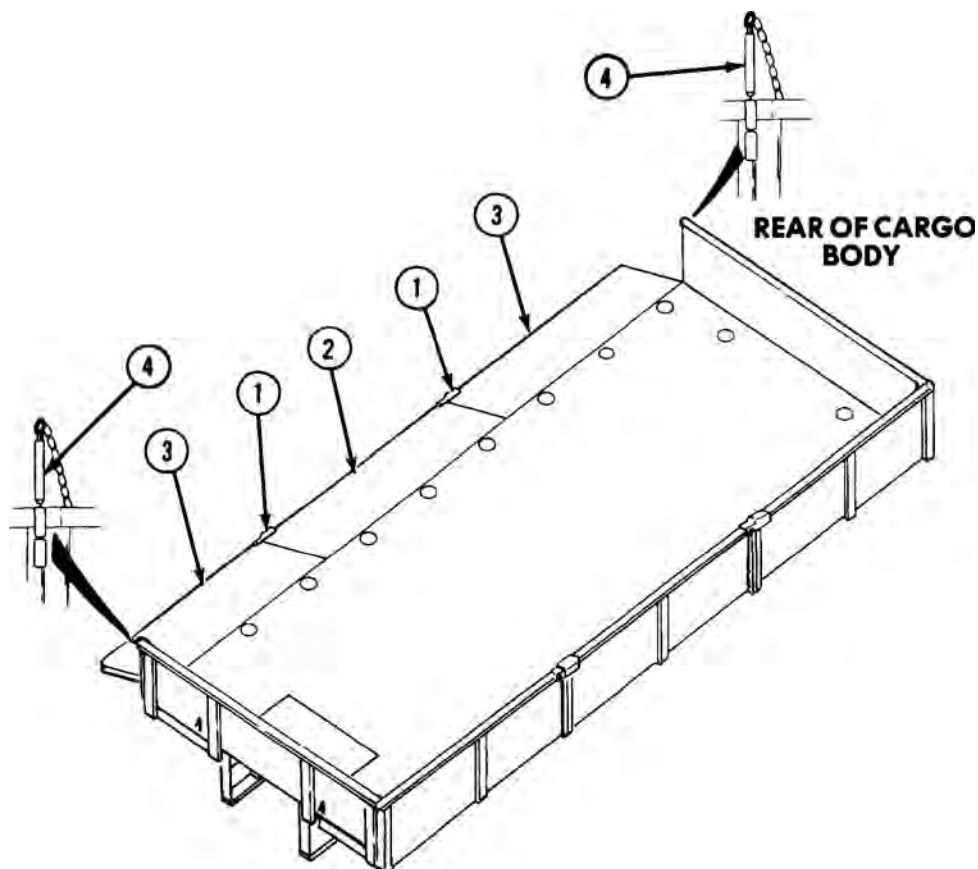


Figure 4.

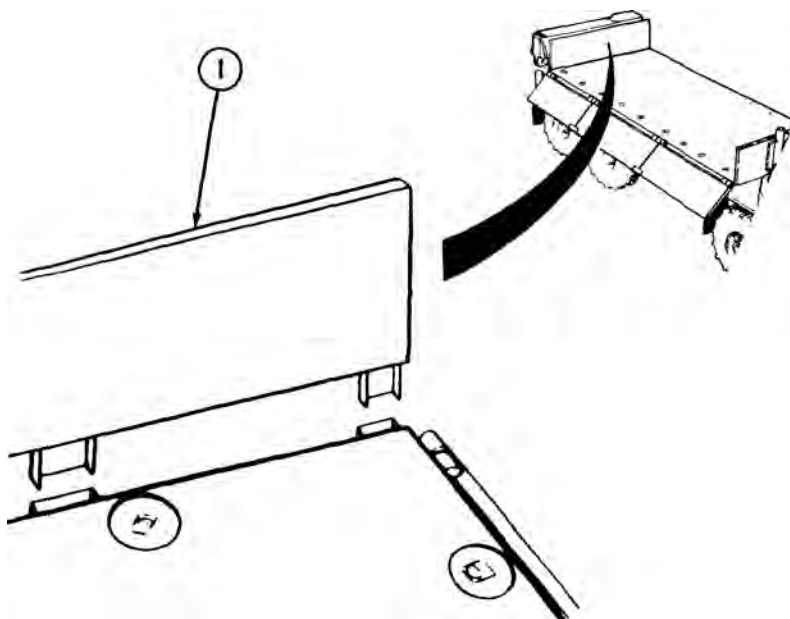
**RAISE AND SECURE CARGO BODY SIDE PANELS ALL AT A TIME - Continued**

2. With aid of an assistant, while holding latches (1) in place, raise three side panels (2 and 3).
3. Hold side panels (2 and 3) up, while assistant climbs into cargo body and installs lockpins (4).

**REMOVE CARGO BODY FRONT AND REAR PANELS****NOTE**

- This procedure is a two soldier task.
- All front and rear panels are removed the same way.

1. Lower cargo body side panels all at the same time.

*Figure 5.*

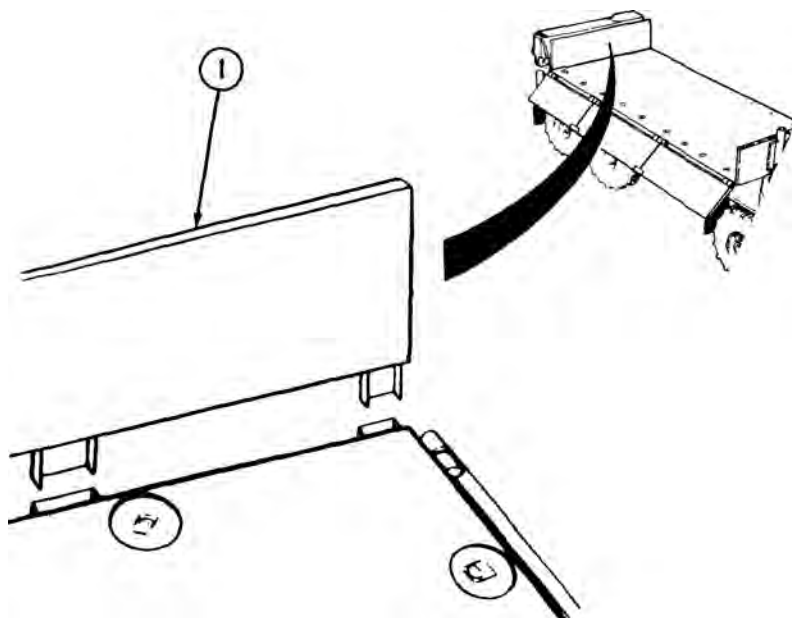
2. Remove rear panel (1) from cargo body.

**INSTALL CARGO BODY FRONT AND REAR PANELS****NOTE**

- This procedure is a two soldier task.

**INSTALL CARGO BODY FRONT AND REAR PANELS - Continued**

- All front and rear panels are removed the same way.
1. Install rear panel (1) on cargo body.

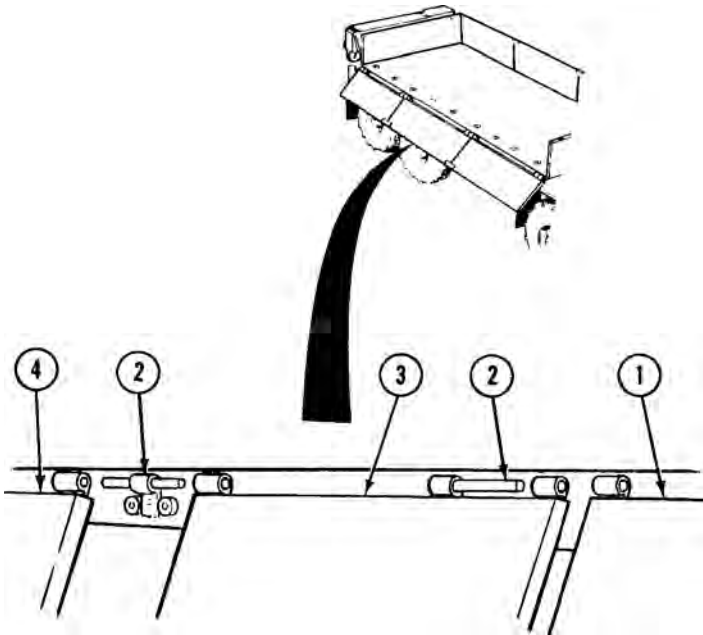


*Figure 6.*

2. Raise and secure cargo side panels all at one time.

**REMOVE CARGO BODY SIDE PANELS****NOTE**

- This procedure is a two soldier task.
  - All driver side and passenger side panels are removed the same way.
1. Lower cargo body side panels one at a time.

**REMOVE CARGO BODY SIDE PANELS - Continued***Figure 7.*

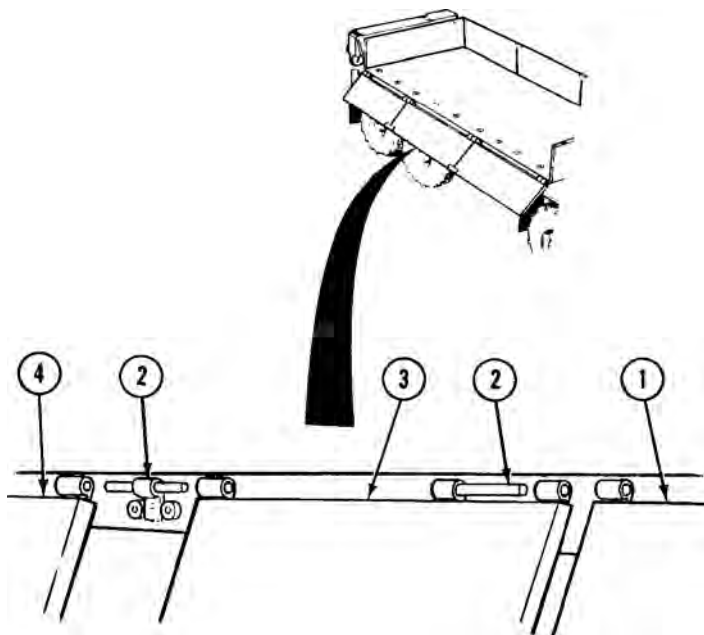
2. Raise front side panel (1) and slide panel forward off two pins (2).
3. Raise center side panel (3) and slide panel forward off two pins (2).
4. Raise rear side panel (4) and slide panel rearward off two pins (2).

**INSTALL CARGO BODY SIDE PANELS****NOTE**

- This procedure is a two soldier task.
- All driver side and passenger side panels are installed the same way.

1. Install rear side panel (4) on two pins (2) and slide forward.



**INSTALL CARGO BODY SIDE PANELS - Continued***Figure 8.*

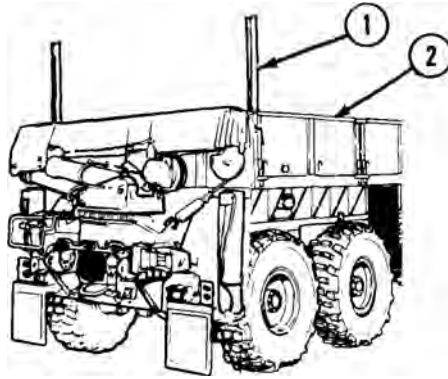
2. Install center side panel (3) on two pins (2) and slide rearward.
3. With aid of an assistant, install front side panel (1) on two pins (2) and slide rearward.
4. Raise and secure cargo body side panels one at a time.

**INSTALL CARGO COVER KIT****NOTE**

This procedure is a two soldier task.

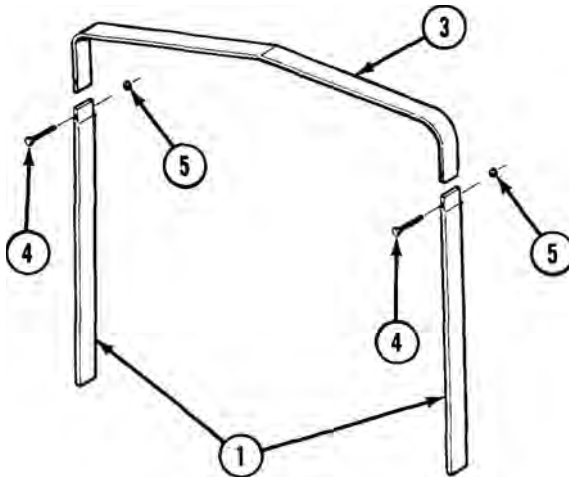
1. Park vehicle. (WP 0056)
2. Shut off engine. (WP 0057)
3. Install stakes (1) in top edge of side panels (2).

**INSTALL CARGO COVER KIT - Continued**



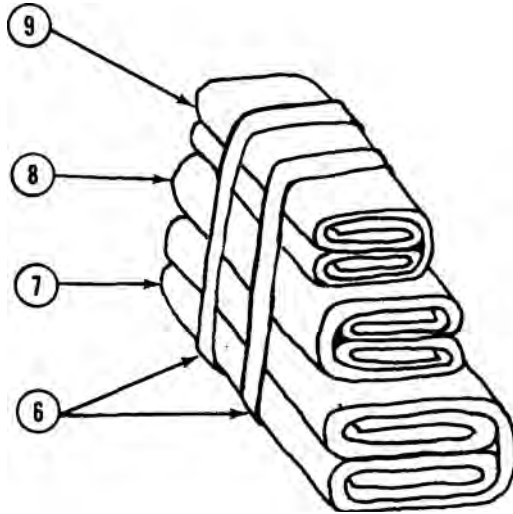
*Figure 9.*

4. Install bow (3) on stakes (1).

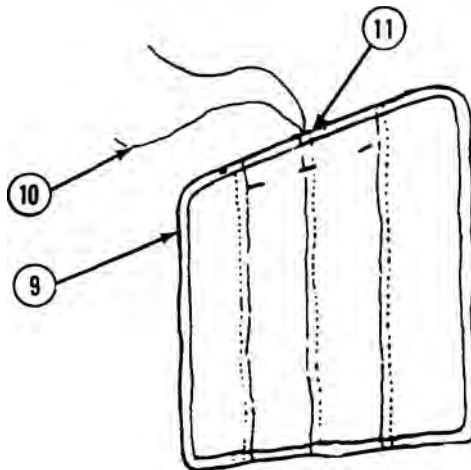


*Figure 10.*

5. Install two screws (4) and nuts (5).
6. Repeat Steps (3) through (5) for remaining bows and stakes.
7. Remove straps (6) from cargo cover (7), frontgate curtain (8), and tailgate curtain (9).

**INSTALL CARGO COVER KIT - Continued***Figure 11.*

8. Pull one lashing rope (10) through center eyelet (11) on tailgate curtain (9) until both ends of rope are even.

*Figure 12.*

9. With aid of an assistant, place tailgate curtain (9) on rear rib (12) so stitching is on inside.

## INSTALL CARGO COVER KIT - Continued

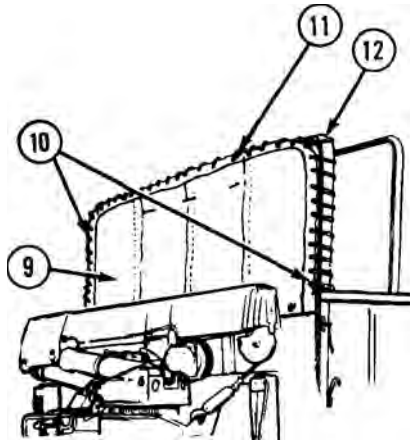


Figure 13.

10. Hold tailgate curtain (9) in place while assistant laces lashing rope (10) around rear rib (12) and through all eyelets (11).

**NOTE**

Both bottom-corner eyelets are secured in the same way. Passenger side shown.

11. Run end of lashing rope (10) through bottom-corner eyelet (13).

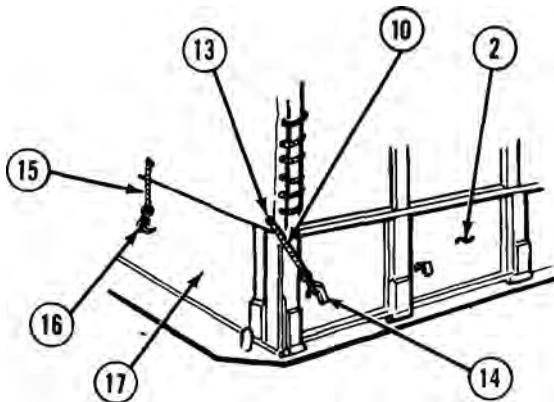
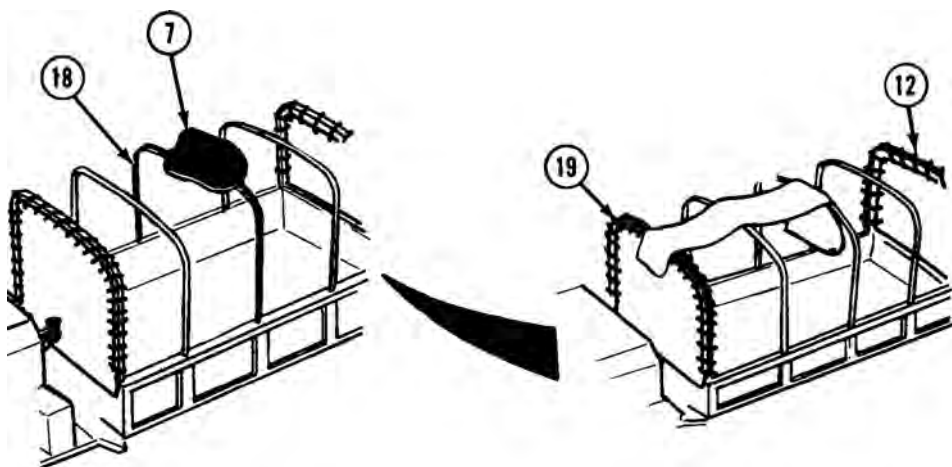


Figure 14.

12. Tie end of lashing rope (10) to tie down hook (14) on side panel (2).

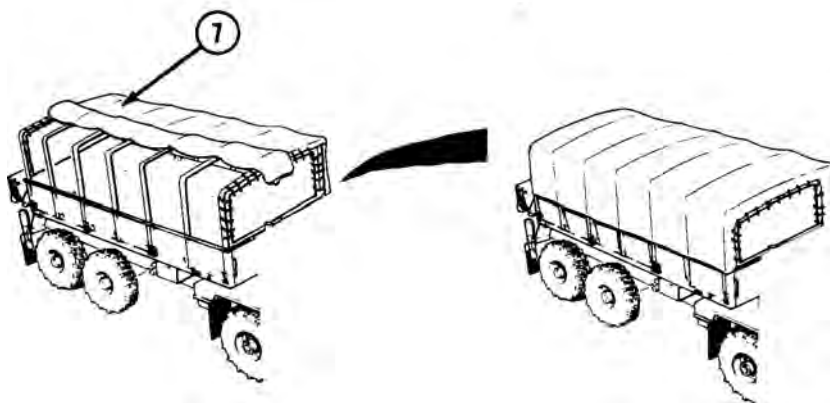
**INSTALL CARGO COVER KIT - Continued**

13. Tie bottom tie down ropes (15) to tie down hooks (16) on end panel (17).
14. Repeat Steps (11) through (13) for other side.
15. Install frontgate curtain same as tailgate.
16. With aid of an assistant, place cargo cover (7) on rib (18).



*Figure 15.*

17. Hold cargo cover (7) steady while assistant unfolds cargo cover to front rib (19) and rear rib (12).
18. Hold cargo cover (7) in place while assistant unfolds cargo cover over sides.

**INSTALL CARGO COVER KIT - Continued**

*Figure 16.*

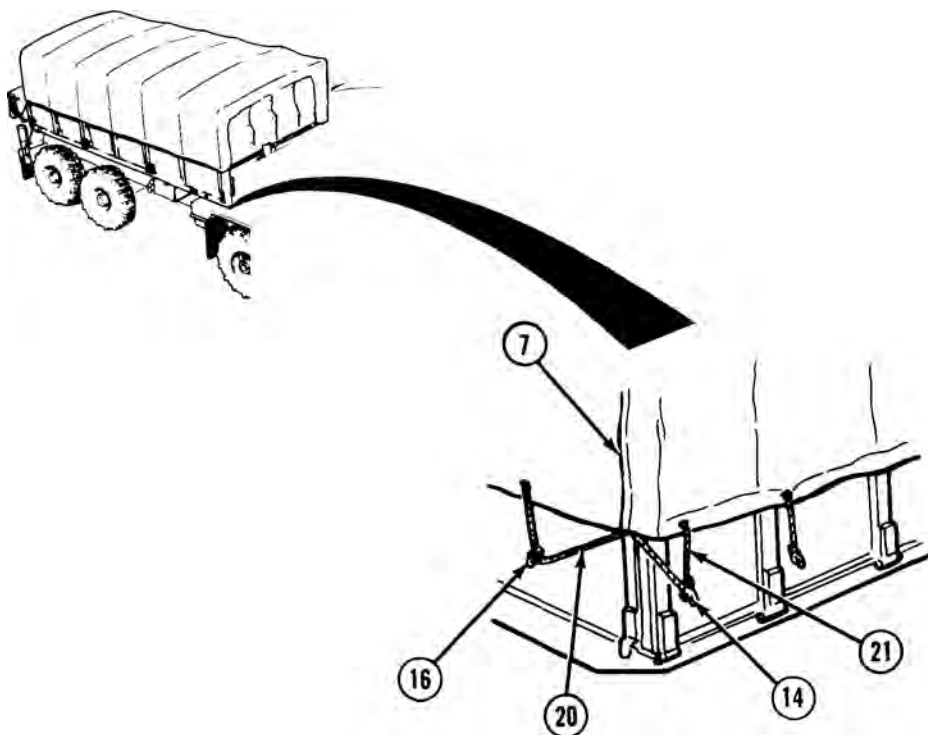
**CAUTION**

Do not tie lashing ropes too tight or cargo cover may tear.

**NOTE**

All corners are secured in the same way. Forward passenger side corner shown.

19. Tie front corner tie down rope (20) to tie down hook (16).

**INSTALL CARGO COVER KIT - Continued***Figure 17.*

20. Pull all slack out of cargo cover (7).
21. Repeat Steps (19) and (20) on remaining three corners.
22. Tie remaining lashing ropes (21) to remaining tie down hooks (14).

**REMOVE CARGO COVER KIT****NOTE**

This procedure is a two soldier task.

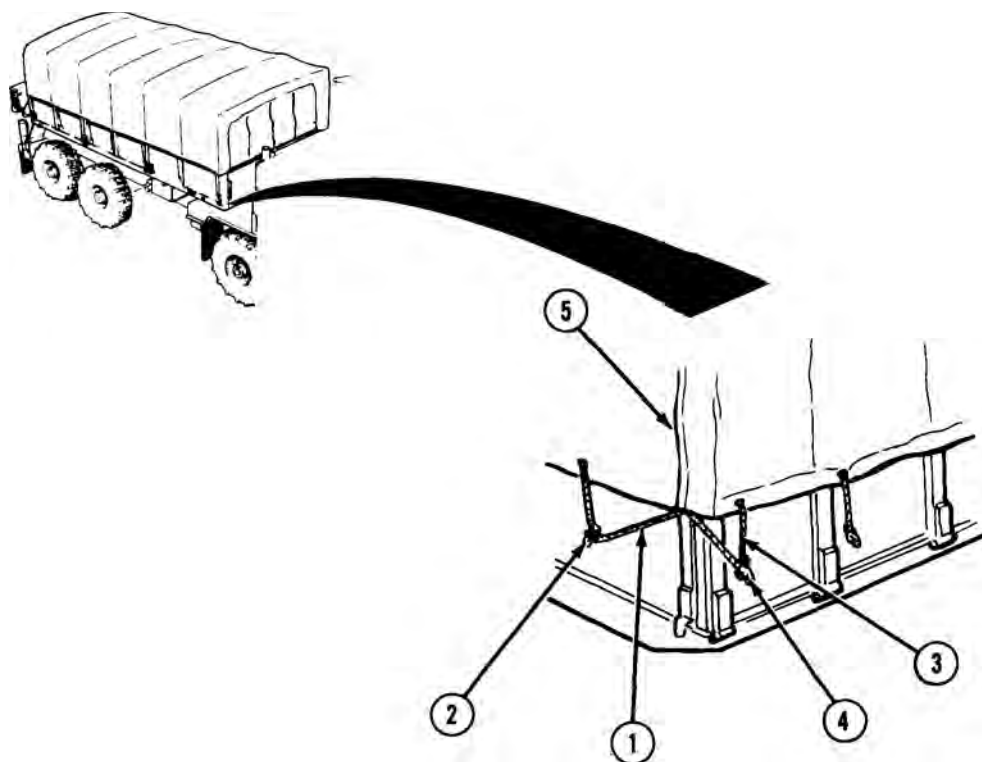
1. Park vehicle. (WP 0056)
2. Shut off engine. (WP 0057)

**NOTE**

All corners are untied in the same way. Forward passenger side corner shown.

**REMOVE CARGO COVER KIT - Continued**

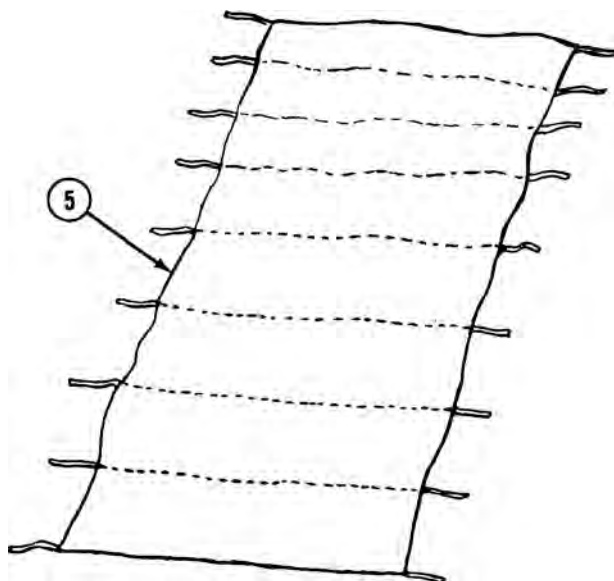
3. Untie both front corner tie down ropes (1) from tie down hooks (2).



*Figure 18.*

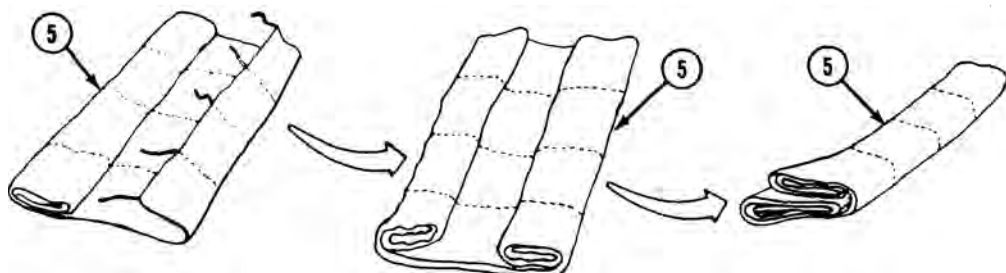
4. Repeat Step (3) for remaining three corners.
5. Untie lashing ropes (3) from all tie down hooks (4) on each side of vehicle.
6. With aid of an assistant, remove cargo cover (5) from vehicle.
7. With aid of an assistant, spread cargo cover (5) on smooth, dry surface so stitching is facing down.



**REMOVE CARGO COVER KIT - Continued***Figure 19.***CAUTION**

Do not fold cargo cover if it is wet. Cargo cover will mildew if stowed when wet.

8. With aid of an assistant, fold one side of cargo cover (5) towards center in two folds. Make each fold about 2 ft. (61 cm) wide.

*Figure 20.*

9. With aid of an assistant, fold other side of cargo cover (5) towards center in two folds.
10. Fold both sides of cargo cover (5) together.

**REMOVE CARGO COVER KIT - Continued**

11. Fold one end of cargo cover (5) towards center in two folds. Make each fold about 3 ft. (91 cm) wide.

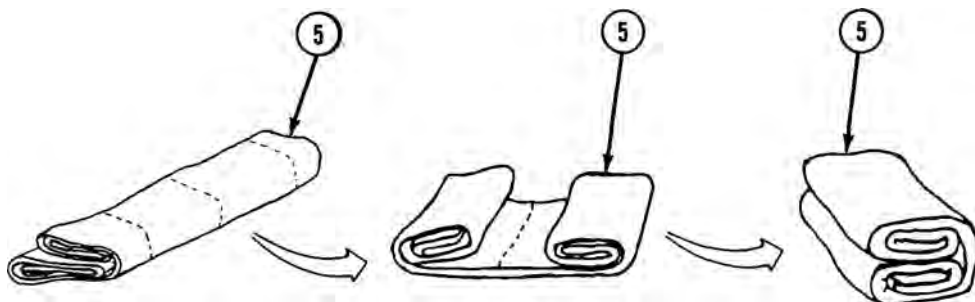


Figure 21.

12. Fold other end of cargo cover (5) towards center in two folds.  
 13. Fold both sides of cargo cover (5) together.  
 14. Untie bottom tie down ropes (6) from tie down hooks (2) on both sides of vehicle.

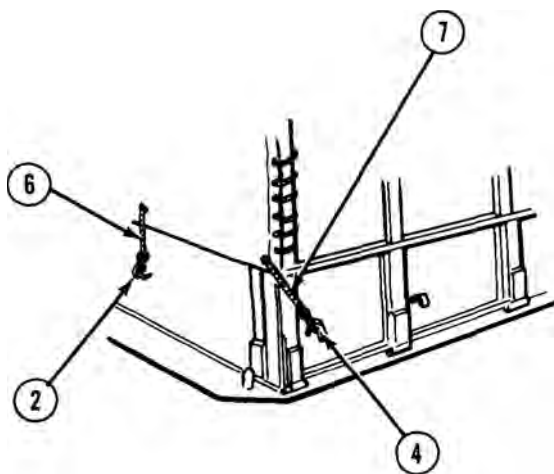
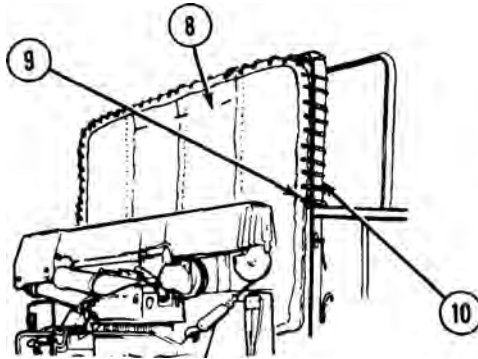
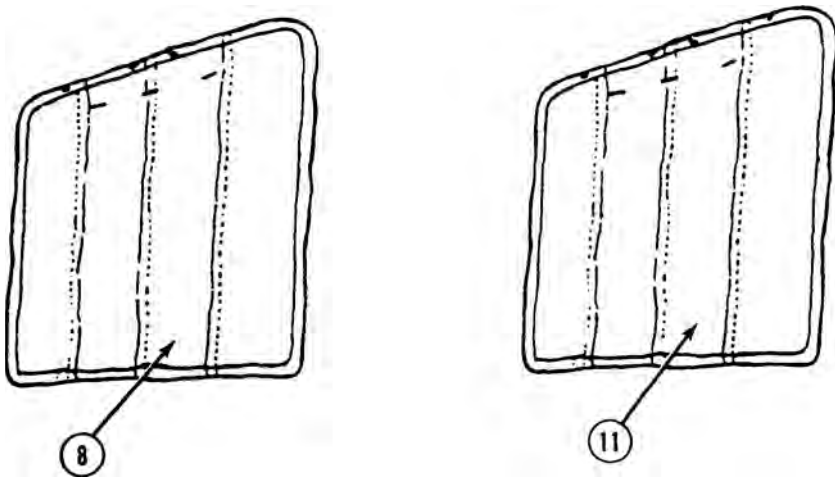


Figure 22.

15. Untie lashing ropes (7) from tie down hooks (4) on both sides of vehicle.  
 16. Hold tailgate curtain (8) while assistant unties lashing rope (9) from rear rib (10).

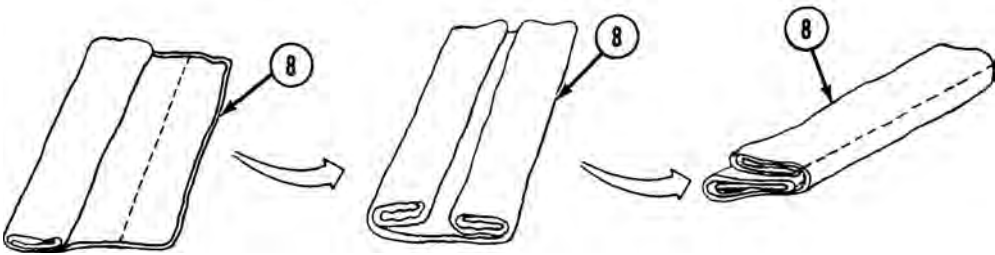
**REMOVE CARGO COVER KIT - Continued***Figure 23.*

17. With aid of an assistant, remove tailgate curtain (8).
18. Repeat Steps (14) through (17) to remove frontgate curtain.
19. With aid of an assistant, lay tail gate curtain (8) and frontgate curtain (11) on smooth, dry surface so stitching is facing down.

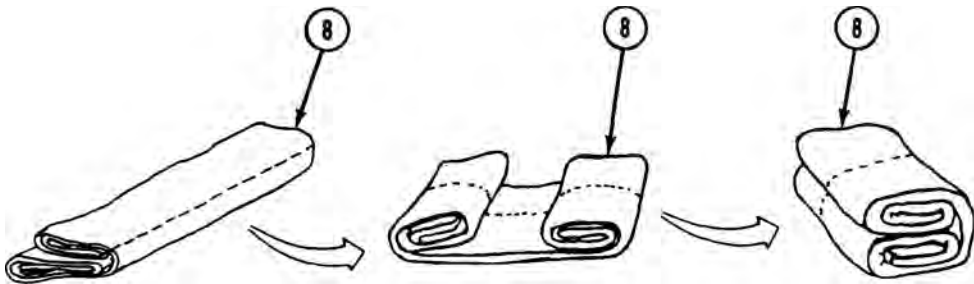
*Figure 24.***CAUTION**

Do not fold tailgate or frontgate curtains when wet. Curtains will mildew if stowed when wet.

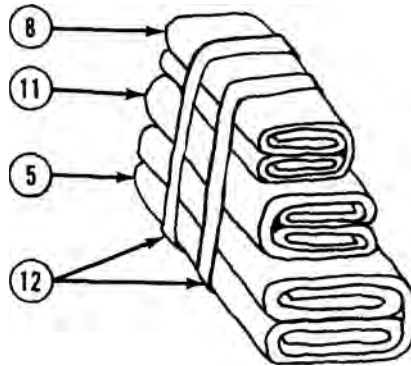
20. With aid of an assistant, fold one side of tailgate curtain (8) toward center in two folds.

**REMOVE CARGO COVER KIT - Continued***Figure 25.*

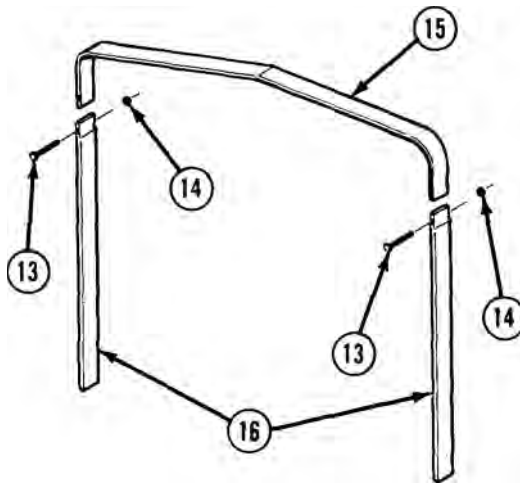
21. With aid of an assistant, fold other side of tailgate curtain (8) toward center in two folds.
22. Fold both sides of tailgate curtain (8) together.
23. Fold one end of tailgate curtain (8) toward center in two folds.

*Figure 26.*

24. Fold other end of tailgate curtain (8) toward center in two folds.
25. Fold both sides of tailgate curtain (8) together.
26. Repeat Steps (20) through (25) for frontgate curtain.
27. Bind curtains (8 and 11) and cargo cover (5) with straps (12).

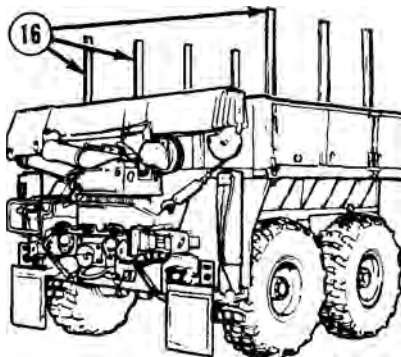
**REMOVE CARGO COVER KIT - Continued***Figure 27.*

28. Remove two screws (13) and nuts (14).

*Figure 28.*

29. Remove bow (15) from stakes (16).  
30. Repeat Steps (28) and (29) for remaining bows and stakes.  
31. With aid of an assistant, remove stakes (16).

**REMOVE CARGO COVER KIT - Continued**



*Figure 29.*

**END OF TASK**

**END OF WORK PACKAGE**

---

**OPERATOR MAINTENANCE  
GROVE CRANE OPERATION (MANUAL CONTROL)**

---

**INITIAL SETUP:**

Not Applicable

---

**PREPARE CRANE FOR USE**

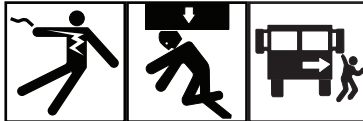
**WARNING**



Stand clear of outrigger beams while operating levers. Failure to comply may result in injury or death to personnel.

1. Chock wheels. (WP 0077)

**WARNING**



- Stand clear of outrigger beams while operating levers. Failure to comply may result in injury or death to personnel.
- Do not operate crane unless outriggers are firmly in place or vehicle could turn over. Failure to comply may result in injury or death to personnel.
- Keep boom clear of all electrical lines and other obstacles while operating crane. Failure to comply may result in injury or death to personnel.

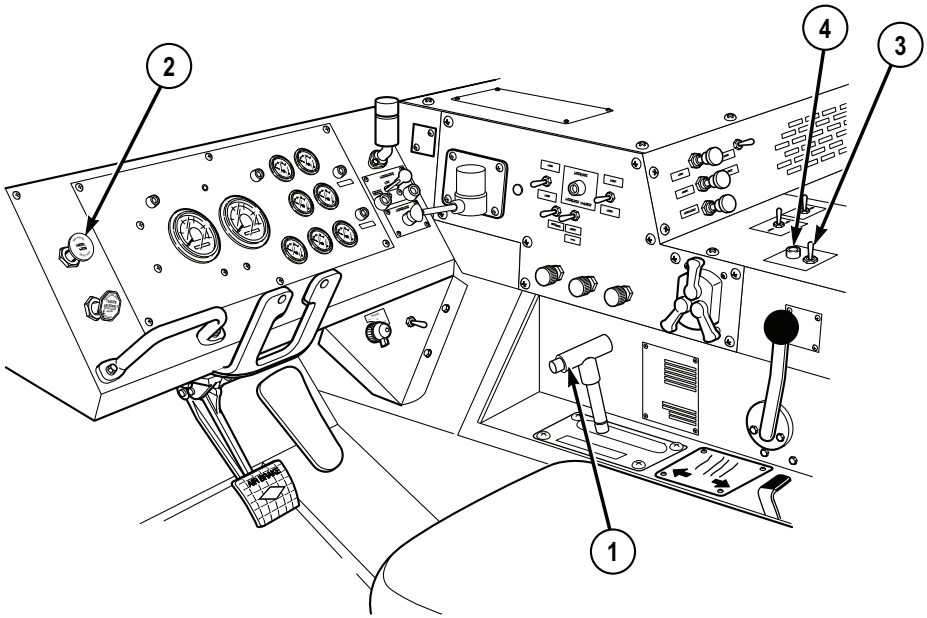
**PREPARE CRANE FOR USE - Continued****WARNING**

If operator cannot see load during operation, operate crane from REMOTE CONTROL UNIT. Failure to comply may result in injury or death to personnel.

**NOTE**

- Failure of hydraulic system will stop crane operation and lock crane in place. If hydraulic system fails during crane operation, refer to perform immediate action for loss of hydraulic system. (WP 0104)
  - If electrical system fails during crane operation, refer to perform emergency hydraulic operation when grove crane electrical power fails. (WP 0105)
  - Grove crane can operate on up to 5-degree side slope.
2. Start engine. (WP 0044)
  3. Position vehicle on level ground so all loading and unloading can be done from one position.
  4. Set transmission range selector (1) to N (neutral).
  5. Pull out PARKING BRAKE control (2).



**PREPARE CRANE FOR USE - Continued***Figure 1.*

6. Set PTO ENGAGE switch (3) to OFF position. Indicator light (4) will go out.

**CAUTION**

PTO ENGAGE switch must be in OFF position before moving hydraulic selector valve control to prevent equipment damage.

7. Push hydraulic selector valve control (5) in for crane operation.

## PREPARE CRANE FOR USE - Continued

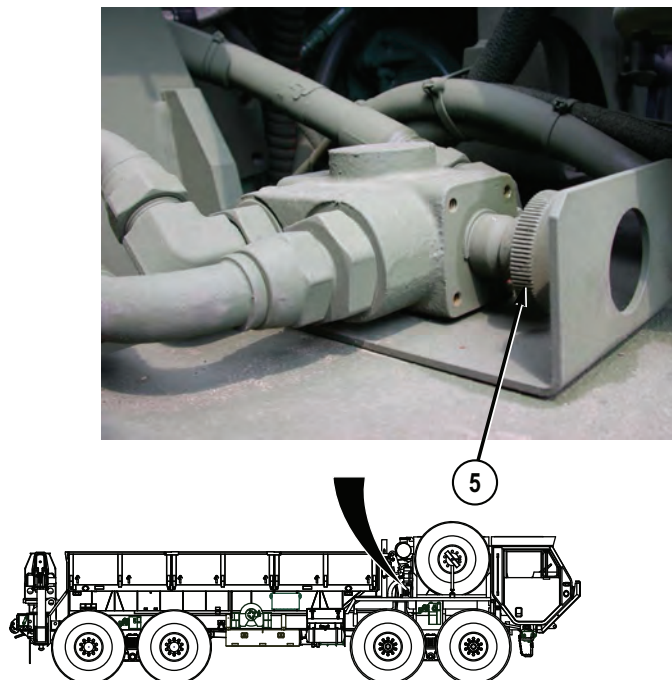


Figure 2.

8. Set PTO ENGAGE switch (3) to ON position. Indicator light (4) will illuminate.

PREPARE CRANE FOR USE - Continued

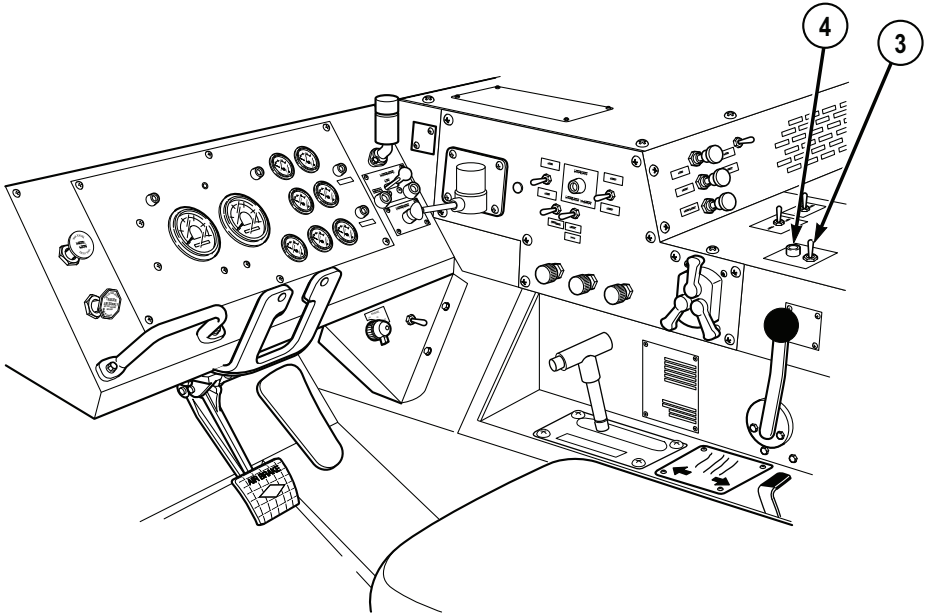


Figure 3.

9. Set electric control box ON/OFF POWER switch (6) to ON position.

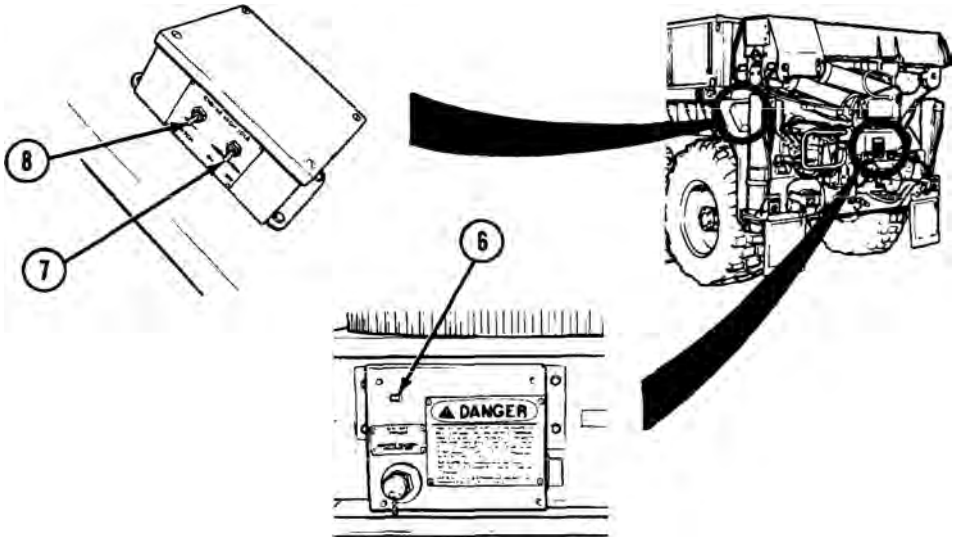


Figure 4.

**PREPARE CRANE FOR USE - Continued**

10. Set ENGINE HIGH IDLE ON/OFF switch (7) to ON position.
11. Push up and release LATCH switch (8) to raise engine speed to approximately 1500 rpm.

**SETUP OUTRIGGERS****WARNING**

Stand clear of outrigger beams while operating levers. Failure to comply may result in injury or death to personnel.

**NOTE**

- Always operate control levers with light, even pressure.
  - Outrigger beams will come out slower with light pressure on lever. Pushing lever to full travel will cause faster movement.
  - Although either right or left side outrigger may extend first, both outriggers will extend when O/R EXT control lever is positioned to OUT.
1. Move outrigger extension (O/R EXT) control lever (1) to OUT position until right and left outrigger beams (2) are fully extended.

## SETUP OUTRIGGERS - Continued

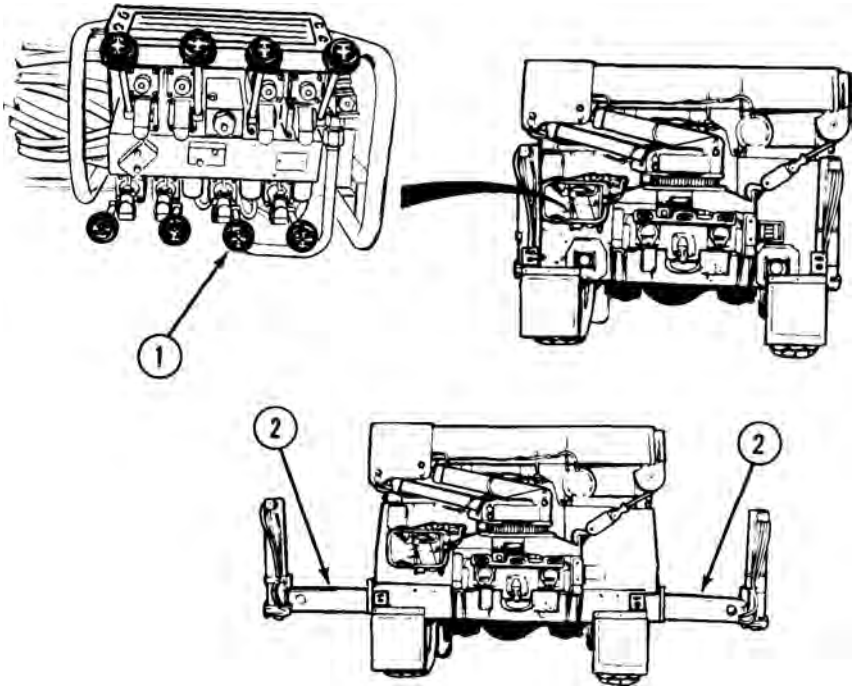


Figure 5.

### WARNING



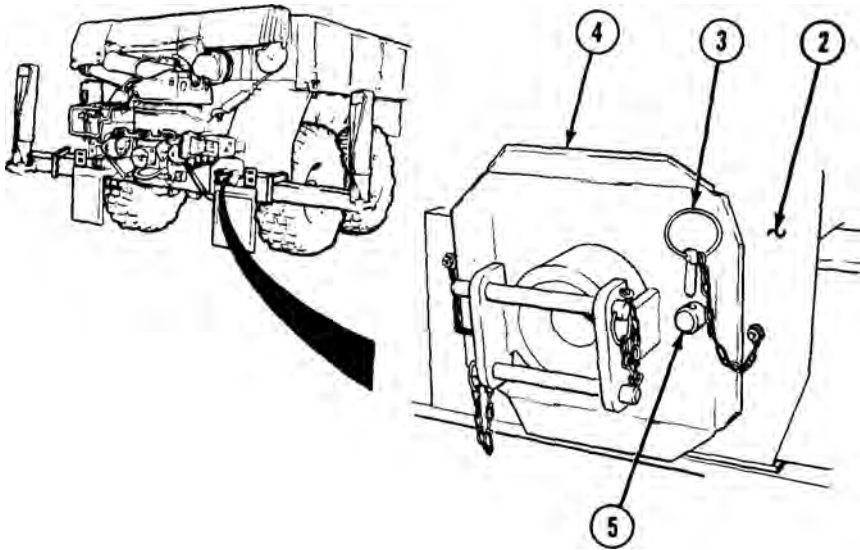
Stand clear of outrigger beams while operating levers. Failure to comply may result in injury or death to personnel.

### NOTE

Outrigger pad on passenger side is shown. Driver side is the same.

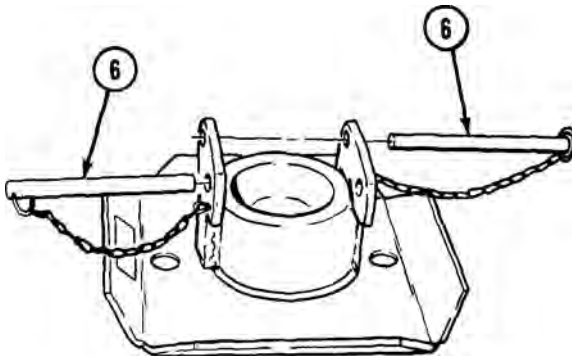
2. Remove two safety pins (3) and remove outrigger pad (4) from studs (5) on outrigger beam (2).

**SETUP OUTRIGGERS - Continued**



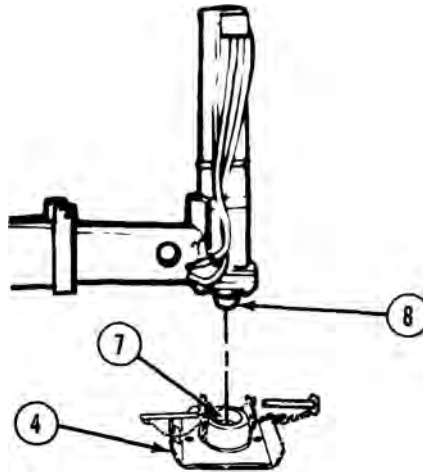
*Figure 6.*

3. Remove two retaining pins (6).

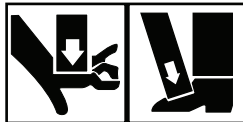


*Figure 7.*

4. Clean all foreign material from socket (7) in outrigger pad (4) and from rod end of outrigger jack cylinder (8).

**SETUP OUTRIGGERS - Continued***Figure 8.*

5. Position outrigger pad (4) directly below outrigger jack cylinder (8).
6. Repeat Steps (2) through (5) to set up driver side outrigger pad.

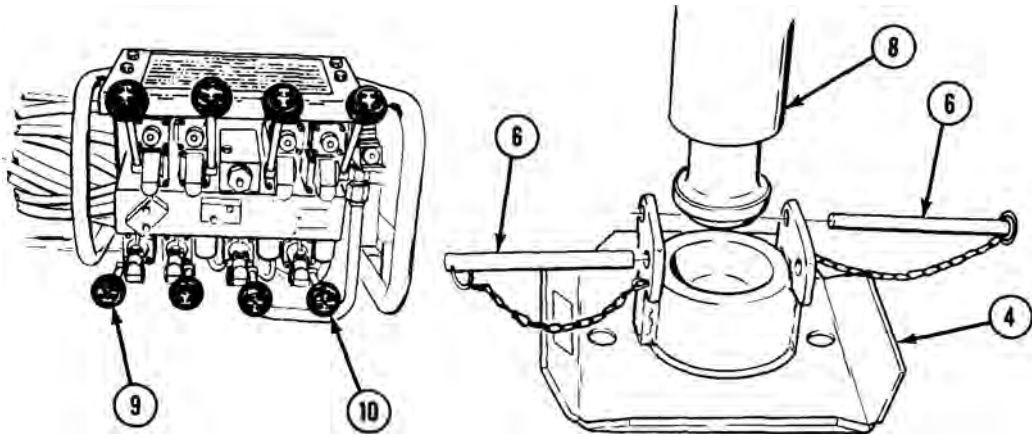
**WARNING**

Keep hands and feet clear of outrigger jack cylinders. Failure to comply may result in injury or death to personnel.

**NOTE**

Adjust outrigger pad position as required so rod end will lower into pad socket.

7. Move left-hand outrigger jack (LH O/R JACK) control lever (9) to DOWN position and lower outrigger jack cylinder (8) until rod end is seated in outrigger pad (4).

**SETUP OUTRIGGERS - Continued***Figure 9.*

8. Install two retaining pins (6).
9. Move right-hand outrigger jack (RH O/R JACK) control lever (10) to DOWN position and lower outrigger cylinder (8) until rod end is seated in outrigger pad (4).
10. Install two retaining pins (6).

**JACK OUTRIGGERS****WARNING**

- Do not raise vehicle tires off ground with outrigger jack cylinders. Vehicle could roll over. Always chock front wheels when using outriggers. Failure to comply may result in injury or death to personnel.
- Crane must be level from side to side. Use of crane in unlevel position can cause vehicle to turn. Failure to comply may result in injury or death to personnel.

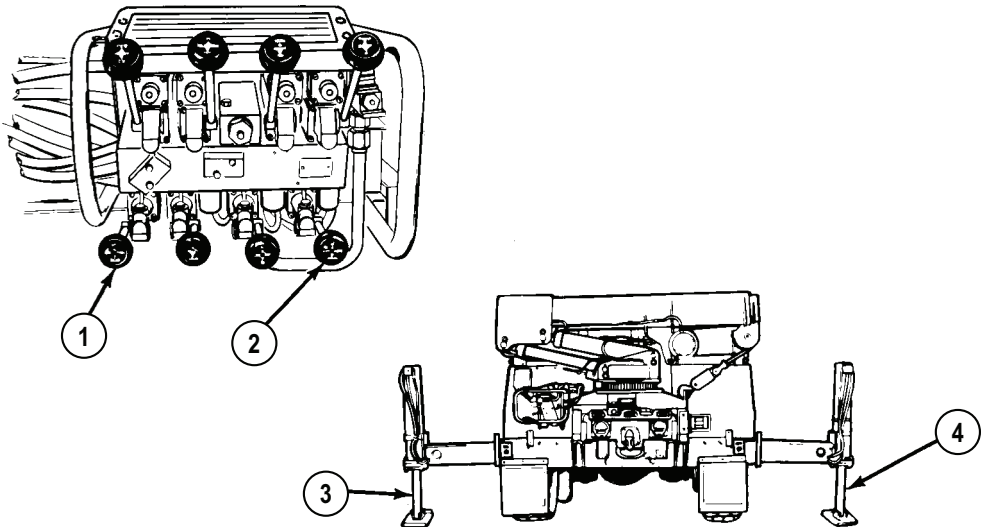
**NOTE**

- Operate left and right outrigger jack (LH O/R JACK and RH O/R JACK) control levers at same time.



**JACK OUTRIGGERS - Continued**

- Crane movement from one lever may be slower than the other when operating two levers together.
1. Simultaneously move left-hand (1) outrigger jack (LH O/R JACK) and right-hand (2) outrigger jack (RH O/R JACK) control levers to DOWN position.

*Figure 10.***NOTE**

Vehicle weight should be off No. 4 axle just enough so tires still have firm contact with ground but no longer bulge from weight of vehicle.

2. Lower driver side (3) and passenger side (4) outrigger jack cylinders until vehicle weight is off rear tires.

**RAISE BOOM TO OPERATING POSITION****WARNING**

Do not operate crane unless outriggers are firmly in place or vehicle could turn over. Failure to comply may result in injury or death to personnel.

**RAISE BOOM TO OPERATING POSITION - Continued****CAUTION**

Do not let cable unwind and become slack or cable may get tangled on drum.

1. Move HOIST control lever (1) to DOWN position and lower hoist cable (2) approximately 1 ft. (30 cm).

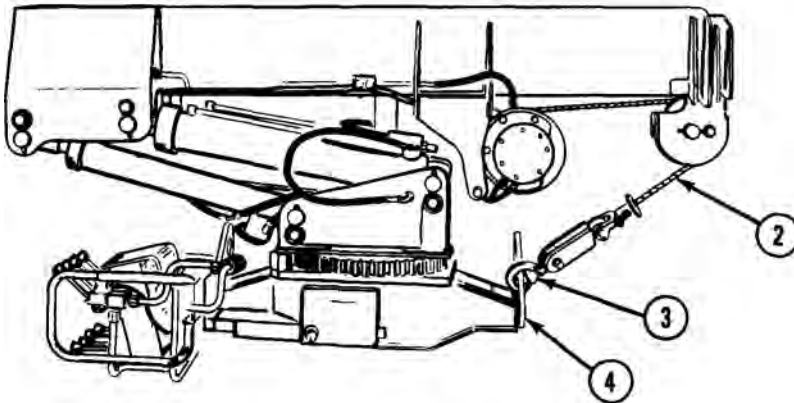
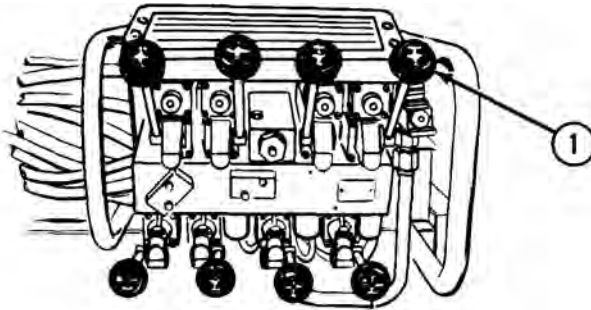


Figure 11.

**CAUTION**

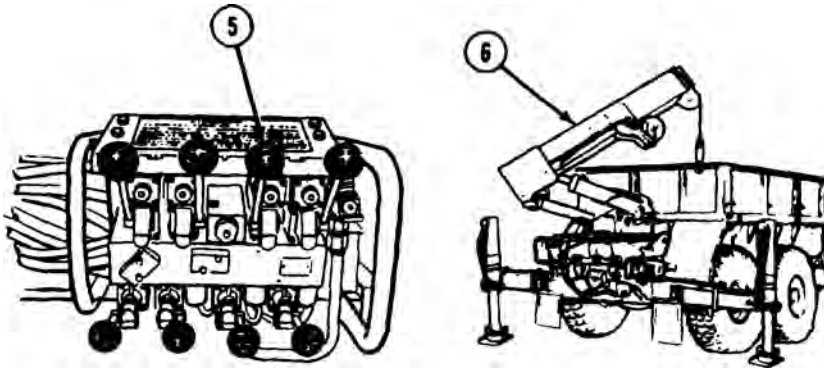
- Release hook lock before disconnecting load hook from stowage ring bracket to avoid hook lock damage.
- Do not let load hook fall and hit bracket.

2. Disconnect load hook (3) from stowage ring bracket (4).

**RAISE BOOM TO OPERATING POSITION - Continued****WARNING**

When using crane on any vehicle, park vehicle clear of all overhead electrical lines. Keep boom clear of all electrical lines and other obstacles while operating crane. Failure to comply may result in injury or death to personnel.

3. Move BOOM control lever (5) to UP position until boom (6) is approximately 45 degrees above horizontal.

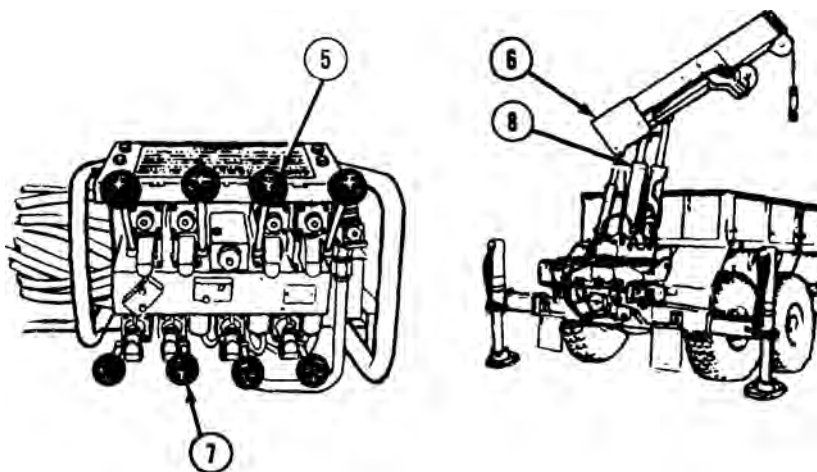


*Figure 12.*

**CAUTION**

To avoid damage to outrigger leg or load hook, do not hit outrigger leg with load hook.

4. Move MAST control lever (7) to UP position until the mast (8) is fully erect and the cylinders are fully extended.

**RAISE BOOM TO OPERATING POSITION - Continued***Figure 13.*

5. Move BOOM control lever (5) to UP position simultaneously as required to maintain the boom (6) at approximately 45 degrees above horizontal until the mast (8) is fully erect.
6. Hold MAST control lever (7) to UP position for two to three seconds after mast (8) is fully erect to ensure cylinders are fully filled with oil.
7. Operate crane with manual controls or remote-control unit. (WP 0043)

**ROTATE AND TELESCOPE BOOM****WARNING**

- When using crane on any vehicle, park vehicle clear of all overhead electrical lines. Keep boom clear of all electrical lines and other obstacles while operating crane. Failure to comply may result in injury or death to personnel.
- Ensure area is clear of personnel prior to moving SWING control lever. Boom should be swung slowly enough so crane operator has complete control. If operator cannot see load during operation, operate crane from REMOTE CONTROL UNIT. Failure to comply may result in injury or death to personnel.

**ROTATE AND TELESCOPE BOOM - Continued**

- Operator must keep control of load at all times. If necessary, attach cargo tie downs to load for control. Failure to comply may result in injury or death to personnel.
- If electrical power fails during crane operation, move switch on REMOTE CONTROL UNIT to SHUTDOWN position. Failure to comply may result in injury or death to personnel.

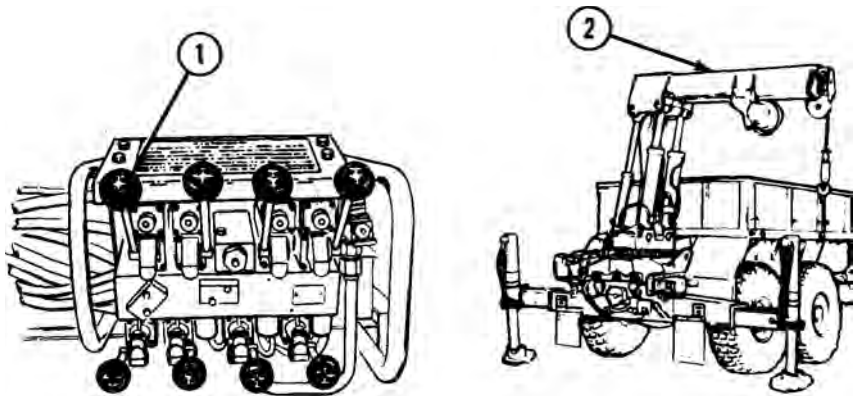
**CAUTION**

Boom must be above vehicle sides for clearance. Hitting side of vehicle with boom may cause damage to boom or vehicle.

**NOTE**

Operate control levers with light, even pressure. Moving lever slightly will cause slow movement of crane. Moving lever to full travel will cause faster movement of crane.

1. Move SWING control lever (1) to CW position to move boom (2) clockwise.



*Figure 14.*

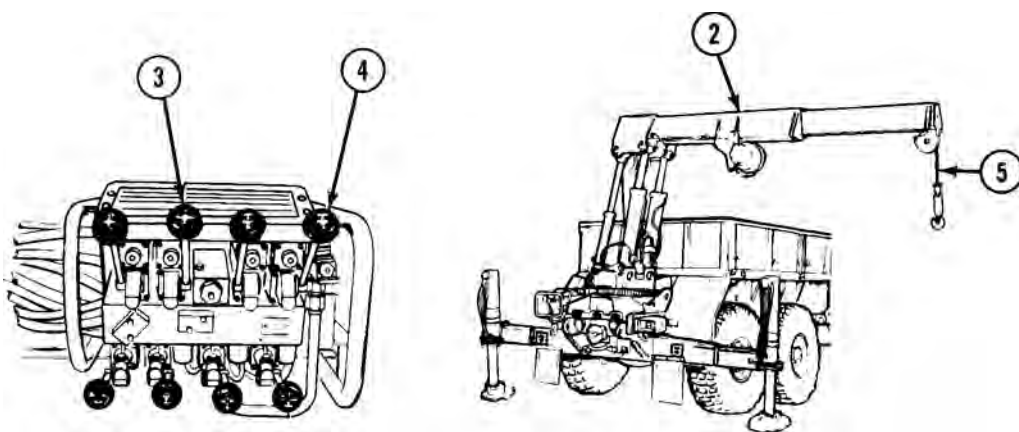
2. Move SWING control lever (1) to CCW position to move boom (2) counterclockwise.

**CAUTION**

Keep hook block at least 2 ft. (0.61 m) from end of boom. If hook block hits end of boom it may damage cable or hook block and crane will lose power. Wait six seconds for power to return and check crane for damage.

**ROTATE AND TELESCOPE BOOM - Continued****NOTE**

- When crane is overloaded, M977 and M985 overload system will automatically shut off power to telescope boom out, raise boom, or hoist load any higher. The M977 overload system will also prevent lowering boom. Overload condition can be corrected by lowering load to ground or other supporting surface by using HOIST control lever only.
  - When telescoping the boom, the TELESCOPE and HOIST control levers should be operated at the same time.
  - Crane movement from one lever may be slower than the other when operating two levers together.
3. Move TELESCOPE control lever (3) to OUT position to extend boom (2) and move HOIST control lever (4) to DOWN position to pay out cable (5).

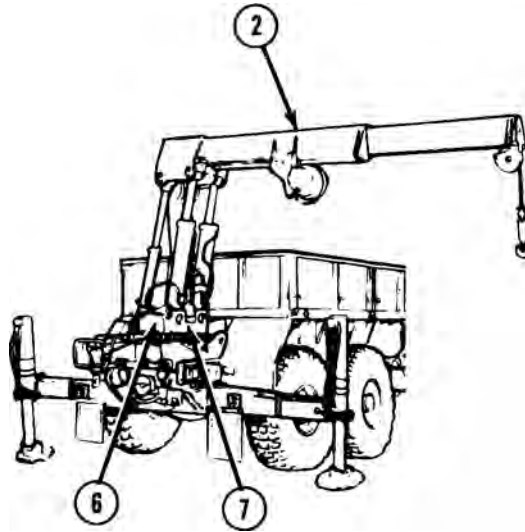
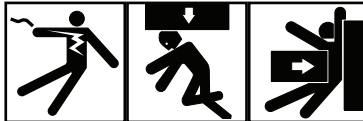
*Figure 15.***CAUTION**

Do not go over maximum load rating as shown on RANGE DIAGRAM. Going over load ratings will cause damage to equipment.

**NOTE**

When operating M977 crane, raise boom to approximately 60 degree angle to pick up maximum load.

4. Refer RANGE DIAGRAM (6) on turntable panel (7) to raise boom (2) to correct angle before connecting the load.

**ROTATE AND TELESCOPE BOOM - Continued***Figure 16.***RAISE AND LOWER LOAD****WARNING**

- When using crane on any vehicle, park vehicle clear of all overhead electrical lines. Keep boom clear of all electrical lines and other obstacles while operating crane. Failure to comply may result in injury or death to personnel.
- Ensure area is clear of personnel prior to moving SWING control lever. Boom should be swung slowly enough so crane operator has complete control. If operator cannot see load during operation, operate crane from REMOTE CONTROL UNIT. Failure to comply may result in injury or death to personnel.
- Operator must keep control of load at all times. If necessary, attach cargo tie downs to load for control. Failure to comply may result in injury or death to personnel.

**RAISE AND LOWER LOAD - Continued**

- If electrical power fails during crane operation, move switch on REMOTE CONTROL UNIT to SHUTDOWN position. Failure to comply may result in injury or death to personnel.

**CAUTION**

- Do not let cable become slack or cable may get tangled on drum.
- Do not drag load sideways on ground or damage to crane may result.

1. Operate SWING control lever (1) and center end of boom (2) directly over load.

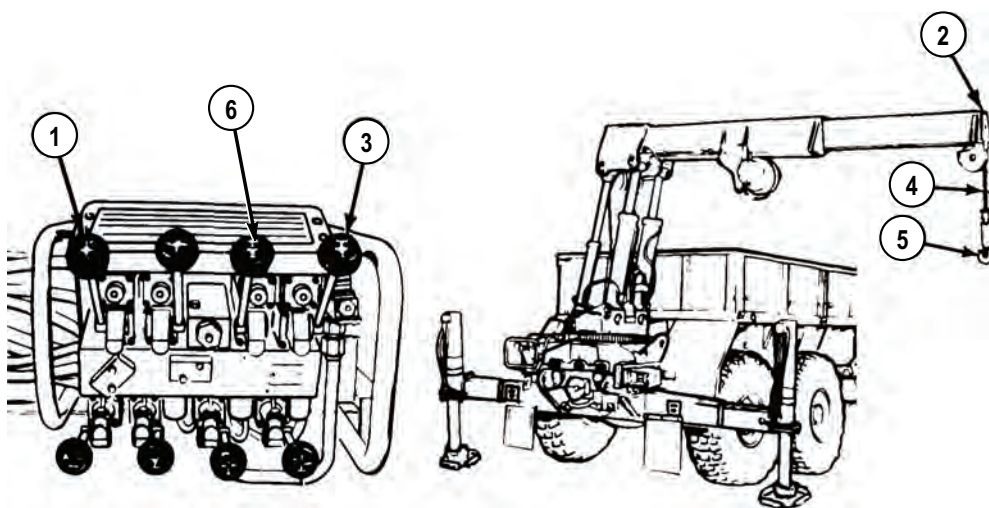


Figure 17.

**CAUTION**

Release hook lock before connecting load hook to avoid damage to hook lock.

2. Operate HOIST control lever (3) to raise or lower cable (4) and connect load hook (5) to load.



**RAISE AND LOWER LOAD - Continued****WARNING**

- Always wear protective gloves when handling winch cable. Never let cable run through hands. Frayed cables can cut severely. Failure to comply may result in injury or death to personnel.
- Never operate winch with less than five wraps of cable on winch drum. Failure to comply may result in injury or death to personnel.

**CAUTION**

- Do not jerk HOIST control lever or load will bounce causing possible damage to crane or load.
- Do not operate crane with boom below horizontal when there is a load on hook.
- For M977, maximum load limit with boom length under 9 ft. (2.75 m) is 4500 lbs (2 043 kg). Maximum load limit with boom extended over 9 ft. (2.75 m) is 2500 lbs (1 135 kg).
- For M985, maximum load limit is 5400 lbs (2 452 kg) for entire boom reach.

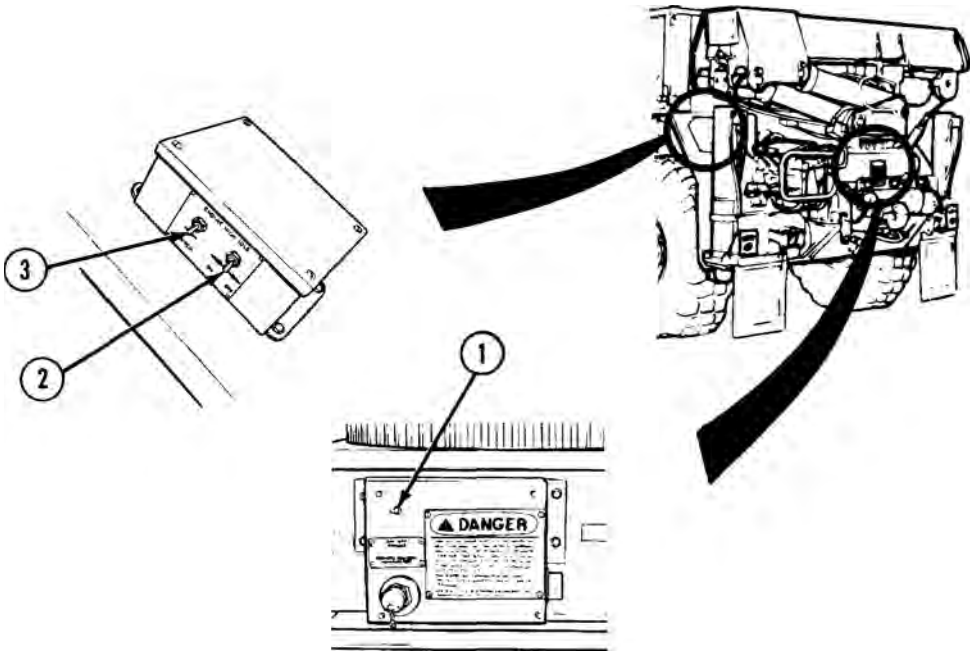
**NOTE**

- When M977 and M985 crane is overloaded, the overload systems will automatically shut off power to telescope boom out, raise boom, or hoist load any higher.
  - The M977 overload system will also prevent lowering load to ground or other supporting surface. All crane functions will be restored in approximately six seconds.
3. Move HOIST control lever (3) in UP position to lift load. Move BOOM control lever (6) in UP position to raise load higher.
  4. Move HOIST control lever (3) in DOWN position to lower load. Move BOOM control lever (6) in DOWN position to lower load further.
  5. Shutdown crane.

**SHUTDOWN CRANE****NOTE**

Steps (1) through (3) are needed only if REMOTE CONTROL UNIT was used during operation.

1. Set ON/OFF POWER switch (1) to ON position.



*Figure 18.*

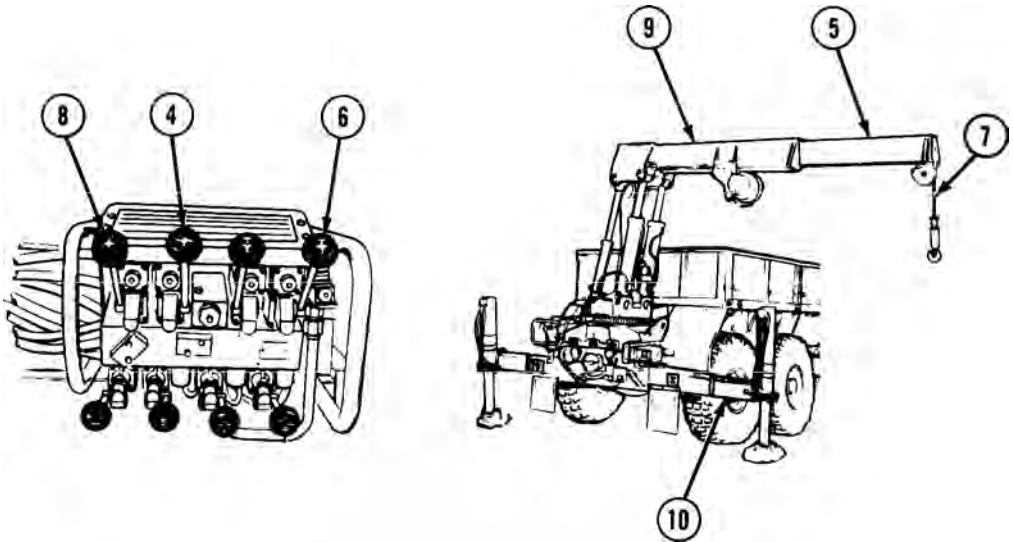
2. Set ENGINE HIGH IDLE ON/OFF switch (2) to ON position.
3. Push and release LATCH switch (3) to raise engine speed to approximately 1500 rpm.

**CAUTION**

- Keep hook block at least 2 ft. (0.61 m) from end of boom. If hook block hits end of boom it may damage cable or hook block and crane will lose power. Wait six seconds for power to return and check crane for damage.
- Do not let cable unwind and become slack or cable may get tangled on drum.

**SHUTDOWN CRANE - Continued****NOTE**

- Operate control lever with light, even pressure.
  - TELESCOPE and HOIST control levers should be operated at same time to keep hook block at least 2 ft. (0.61) from end of boom.
  - Crane movement from one lever may be slower than the other when operating levers together.
4. Move TELESCOPE control lever (4) to IN position to pull boom extensions (5) in and move HOIST control lever (6) to UP position to reel in cable (7) until all boom extensions (5) are fully retracted.

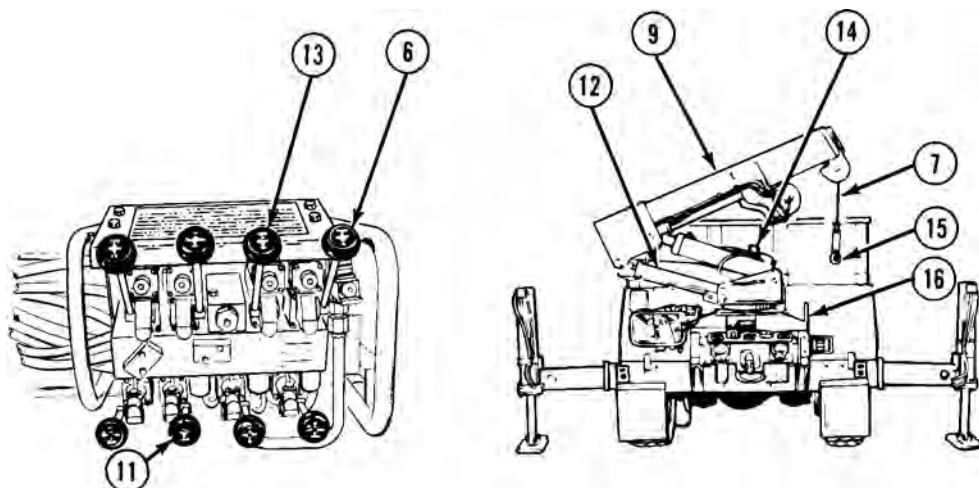
*Figure 19.*

5. Operate SWING control lever (8) to position boom (9) parallel with outrigger beam (10) on passenger side of vehicle.

**CAUTION**

Boom must rest on rest pad when transporting vehicle. If not, damage to equipment may result.

6. Move MAST control lever (11) to DOWN position to lower mast (12) until mast is completely folded down.

**SHUTDOWN CRANE - Continued***Figure 20.*

7. Move BOOM control lever (13) in concert with MAST control lever (11) as required to maintain boom (9) at approximately 45 degrees above horizontal until mast (12) is completely folded down.
8. Move BOOM control lever (13) to DOWN position until boom (9) comes to rest on mast rest pad (14).

**CAUTION**

Release hook lock before connecting load hook to stowage ring bracket to avoid damage to hook lock.

**NOTE**

Stowage ring is smallest hole in bracket.

9. Connect load hook (15) to stowage ring bracket (16). Move HOIST control lever (6) in UP position to remove slack from hoist cable (7).

**STOW OUTRIGGERS**

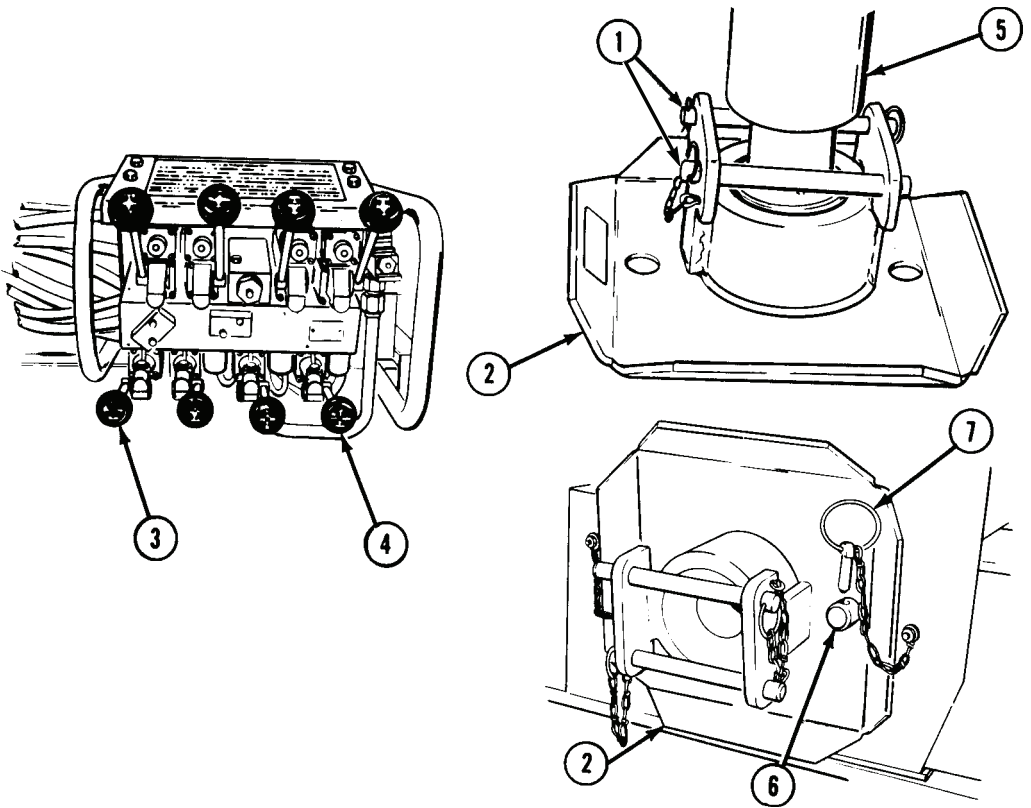
1. Remove two retaining pins (1) from each outrigger pad (2).

**NOTE**

Operate left and right outrigger jack (LH O/R JACK and RH O/R JACK) control levers at the same time until both outrigger jack cylinders are out of pads.

**STOW OUTRIGGERS - Continued**

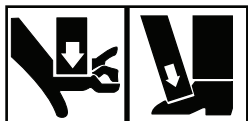
2. Move left outrigger jack (LH O/R JACK) and right outrigger jack (RH O/R JACK) control levers (3 and 4) to UP position to retract outrigger jack cylinders (5) completely.



*Figure 21.*

3. Install two retaining pins (1) into each outrigger pad (2).
4. Stow each outrigger pad (2) on appropriate stud (6).
5. Install safety pins (7) through each stud (6).

## STOW OUTRIGGERS - Continued

**WARNING**

Keep hands and feet clear of outrigger jack cylinders. Failure to comply may result in injury or death to personnel.

6. Move outrigger extension (O/R EXT) control lever (8) to IN position to retract outrigger beams (9) completely.

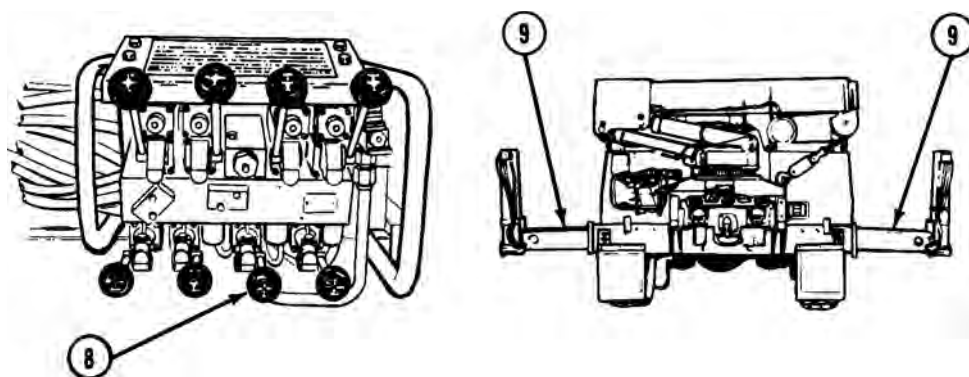


Figure 22.

7. Set ENGINE HIGH IDLE ON/OFF switch (10) to OFF position.

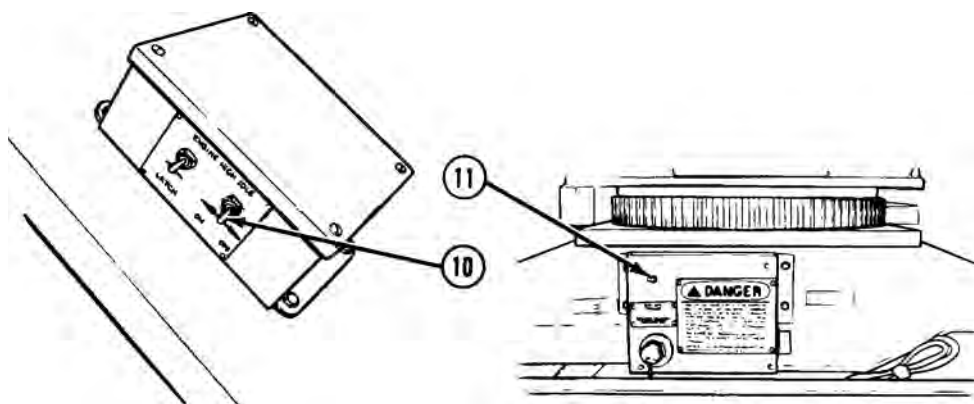


Figure 23.

**STOW OUTRIGGERS - Continued**

8. Set ON/OFF POWER switch (11) to OFF position.
9. Set PTO ENGAGE switch (12) to OFF position. Indicator light (13) will go out.

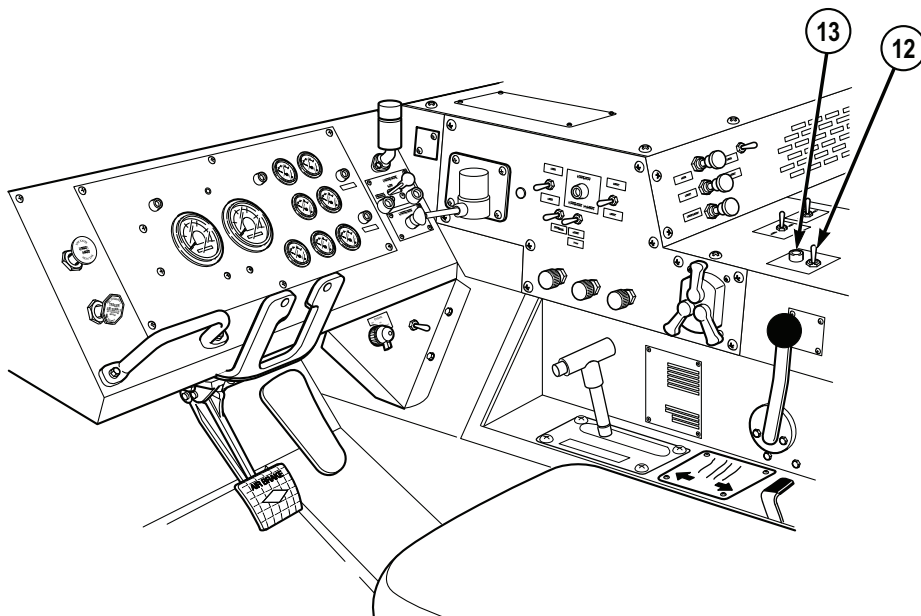


Figure 24.

10. Shut off engine. (WP 0057)

**END OF TASK**

**END OF WORK PACKAGE**





---

**OPERATOR MAINTENANCE  
GROVE CRANE OPERATION (REMOTE CONTROL)**

---

**INITIAL SETUP:**

Not Applicable

---

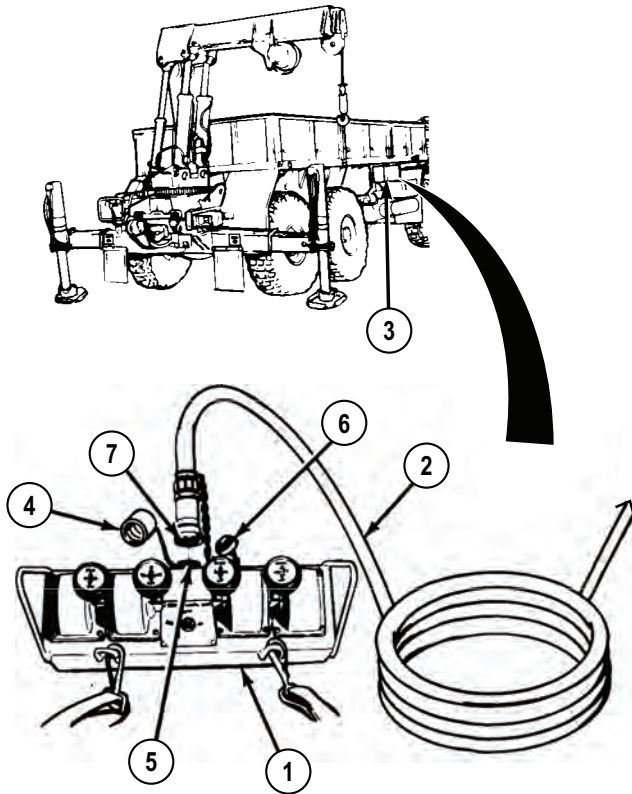
**SET UP REMOTE CONTROL UNIT**

**WARNING**



If operator cannot see load during operation, operate crane from REMOTE CONTROL UNIT. Failure to comply may result in injury or death to personnel.

1. Prepare crane for use.
2. Set up outriggers.
3. Jack outriggers.
4. Raise boom to operating position.
5. Remove REMOTE CONTROL UNIT (1) and cable (2) from stowage box (3).

**SET UP REMOTE CONTROL UNIT - Continued***Figure 1.*

6. Remove cover (4) and clean any dirt or water from REMOTE CONTROL UNIT receptacle (5).
7. Remove cover (6) and clean any dirt or water from cable plug (7).
8. Connect cable plug (7) to REMOTE CONTROL UNIT receptacle (5).

**CONNECT REMOTE CONTROL UNIT TO REAR OUTLET**

1. Set ON/OFF power switch (1) on electrical control box (2) to OFF position.

## CONNECT REMOTE CONTROL UNIT TO REAR OUTLET - Continued

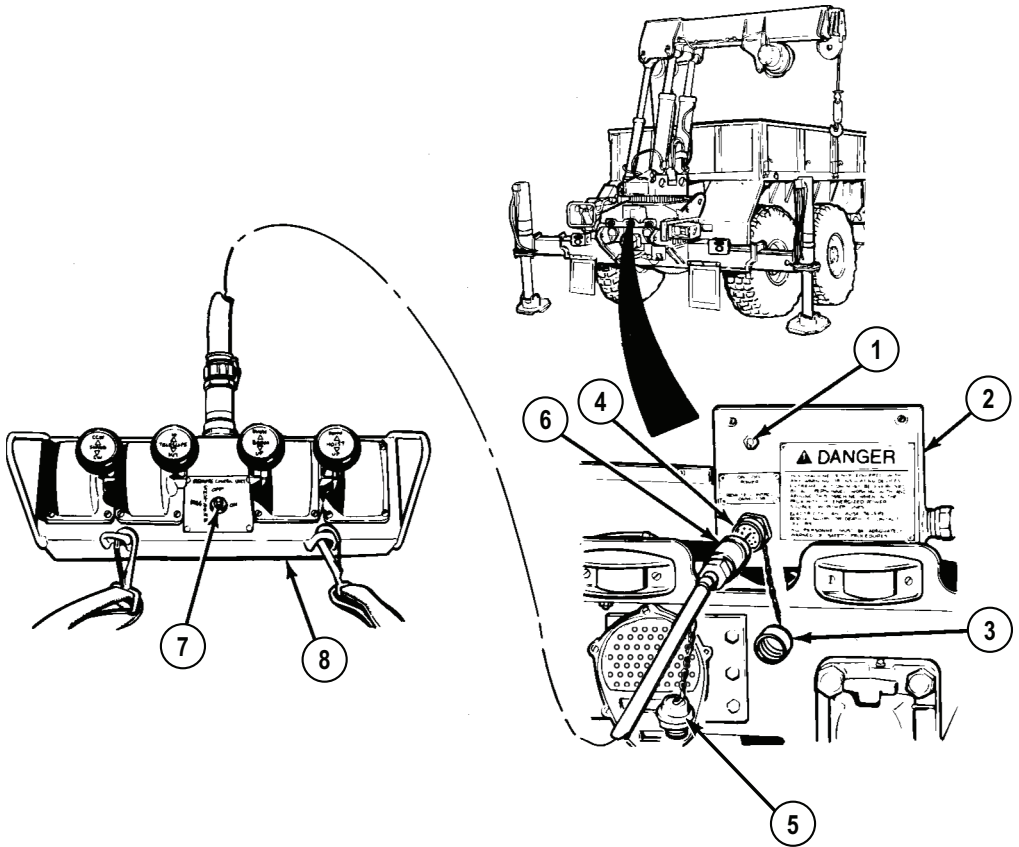


Figure 2.

2. Remove cover (3) and clean any dirt or water from REMOTE CONTROL CONNECTOR outlet (4).
3. Remove cover (5) and clean any dirt or water from cable plug (6).

**WARNING**

Ensure ON/OFF/MHC-SHUTDOWN power switch is in OFF position prior to connecting REMOTE CONTROL UNIT. Failure to comply may result in injury or death to personnel.

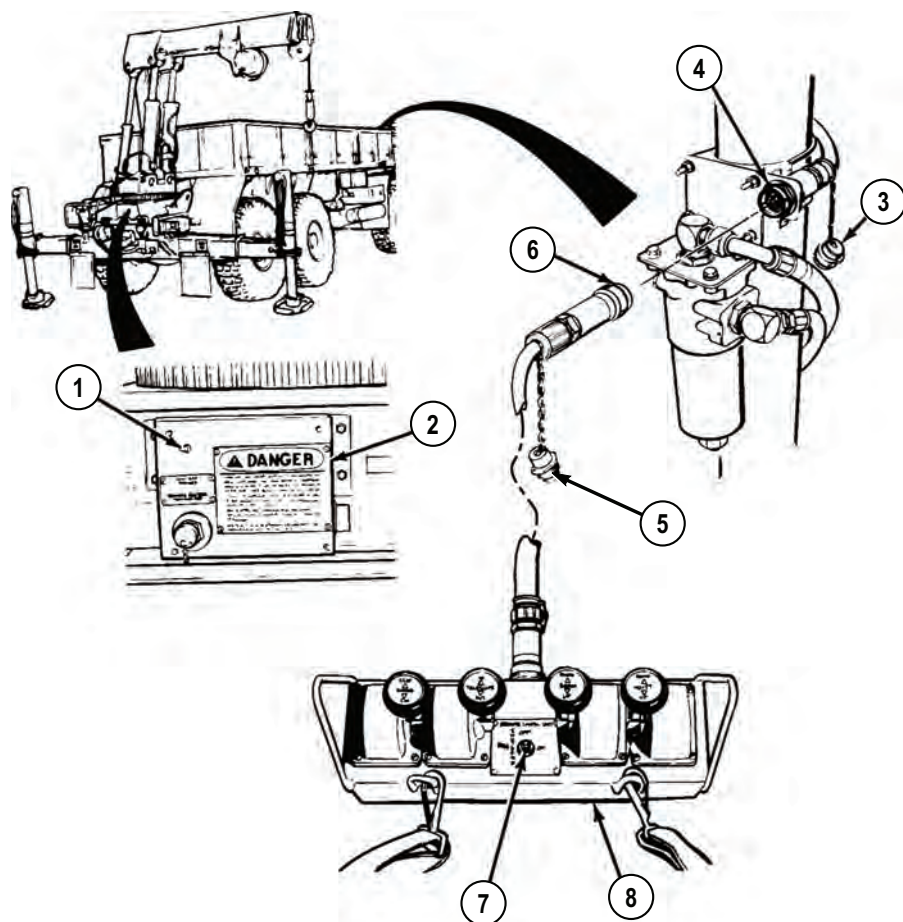
**CONNECT REMOTE CONTROL UNIT TO REAR OUTLET - Continued**

4. Set ON/OFF MHC-SHUTDOWN power switch (7) on REMOTE CONTROL UNIT (8) to OFF position.
5. Connect cable plug (6) to REMOTE CONTROL CONNECTOR outlet (4).
6. Set ON/OFF POWER switch (1) on electrical control box (2) to ON position.
7. Set ON/OFF MHC-SHUTDOWN power switch (7) on REMOTE CONTROL UNIT (8) to ON position.
8. Operate crane.

**CONNECT REMOTE CONTROL UNIT TO FORWARD OUTLET**

1. Set ON/OFF power switch (1) on electrical control box (2) to OFF position.

## CONNECT REMOTE CONTROL UNIT TO FORWARD OUTLET - Continued

*Figure 3.*

2. Remove cover (3) and clean any dirt or water from REMOTE CONTROL CONNECTOR outlet (4).
3. Remove cover (5) and clean any dirt or water from cable plug (6).

**CONNECT REMOTE CONTROL UNIT TO FORWARD OUTLET - Continued****WARNING**

Ensure ON/OFF/MHC-SHUTDOWN power switch is in OFF position prior to connecting REMOTE CONTROL UNIT. Failure to comply may result in injury or death to personnel.

4. Set ON/OFF MHC-SHUTDOWN power switch (7) on REMOTE CONTROL UNIT (8) to OFF position.
5. Connect cable plug (6) to REMOTE CONTROL CONNECTOR outlet (4).
6. Set ON/OFF POWER switch (1) on electric control box (2) to ON position.
7. Set ON/OFF MHC-SHUTDOWN power switch (7) on REMOTE CONTROL UNIT (8) to ON position.
8. Operate crane.

**ROTATE AND TELESCOPE BOOM****WARNING**

- When using crane on any vehicle, park vehicle clear of all overhead electrical lines. Keep boom clear of all electrical lines and other obstacles while operating crane. Failure to comply may result in injury or death to personnel.
- Ensure area is clear of personnel prior to moving SWING control lever. Boom should be swung slowly enough so crane operator has complete control. If operator cannot see load during operation, operate crane from REMOTE CONTROL UNIT. Failure to comply may result in injury or death to personnel.
- Operator must keep control of load at all times. If necessary, attach cargo tie downs to load for control. Failure to comply may result in injury or death to personnel.
- If electrical power fails during crane operation, move switch on REMOTE CONTROL UNIT to SHUTDOWN position. Failure to comply may result in injury or death to personnel.

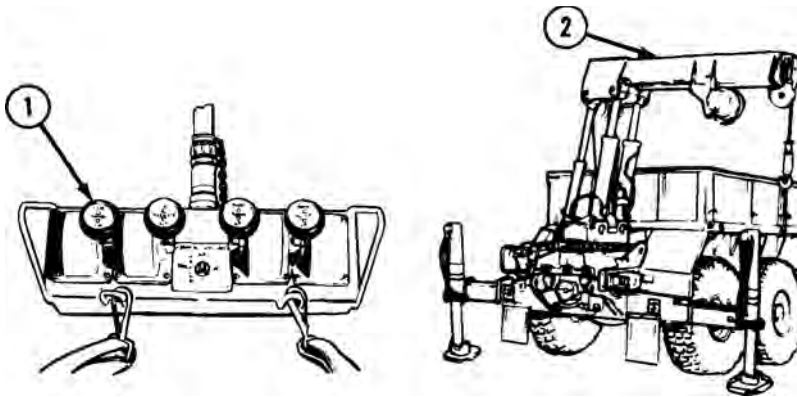
**ROTATE AND TELESCOPE BOOM - Continued****CAUTION**

Boom must be above vehicle sides for clearance. Hitting side of vehicle with boom may cause damage to equipment.

**NOTE**

Operate control levers with light, even pressure. Moving lever slightly will cause slow movement of crane. Moving lever to full travel will cause faster movement of crane.

1. Move SWING control lever (1) to CW position to move boom (2) clockwise.



*Figure 4.*

2. Move SWING control lever (1) to CCW position to move boom (2) counterclockwise.

**CAUTION**

Keep hook block at least 2 ft. (0.61 m) from end of boom. If hook block hits end of boom it may damage cable or hook block and crane will lose power. Wait six seconds for power to return and check crane for damage.

**NOTE**

- When crane is overloaded, vehicle overload system will automatically shut off power to telescope boom out, raise boom, or hoist load any higher. Vehicle overload system will also prevent lowering boom. Overload condition can be corrected by lowering load to ground or other supporting surface by using HOIST control lever only.

**ROTATE AND TELESCOPE BOOM - Continued**

- When telescoping (extending) the boom, the TELESCOPE and HOIST control levers should be operated at the same time to keep hook block at least 2 ft. (0.61 m) from end of boom.
  - Crane movement from one lever may be slower than other when operating two levers together.
3. Move TELESCOPE control lever (3) to OUT position to extend boom (2) and move HOIST control lever (4) to DOWN position to pay out cable (5).

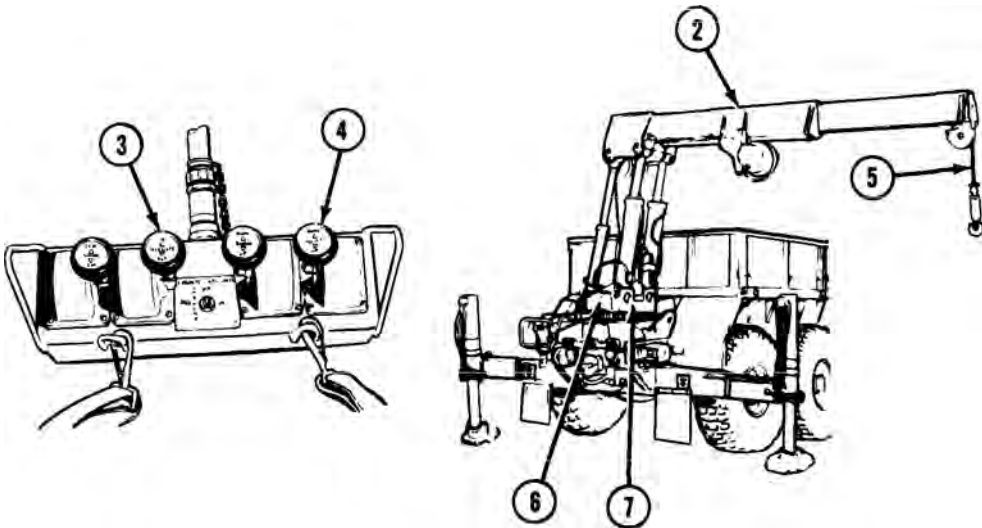
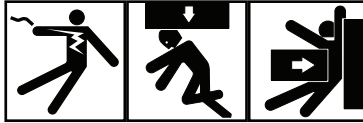


Figure 5.

**CAUTION**

- Do not go over maximum load rating as shown on RANGE DIAGRAM. Going over load rating could cause damage to equipment.
  - When operating Grove crane, raise boom to approximately 60° angle to pick up maximum load or equipment could be damaged.
4. Refer to RANGE DIAGRAM (6) on turntable panel (7) to raise boom (2) to correct angle before connecting load.



**RAISE AND LOWER LOAD****WARNING**

- When using crane on any vehicle, park vehicle clear of all overhead electrical lines. Keep boom clear of all electrical lines and other obstacles while operating crane. Failure to comply may result in injury or death to personnel.
- Ensure area is clear of personnel prior to moving SWING control lever. Boom should be swung slowly enough so crane operator has complete control. If operator cannot see load during operation, operate crane from REMOTE CONTROL UNIT. Failure to comply may result in injury or death to personnel.
- Operator must keep control of load at all times. If necessary, attach cargo tie downs to load for control. Failure to comply may result in injury or death to personnel.
- If electrical power fails during crane operation, move switch on REMOTE CONTROL UNIT to SHUTDOWN position. Failure to comply may result in injury or death to personnel.

**CAUTION**

- Do not let cable become slack. Cable may get tangled in drum and damage equipment.
  - Do not drag load sideways on ground. Dragging load could cause damage to equipment.
1. Operate SWING control lever (1) to center end of boom (2) directly over load.

## RAISE AND LOWER LOAD - Continued

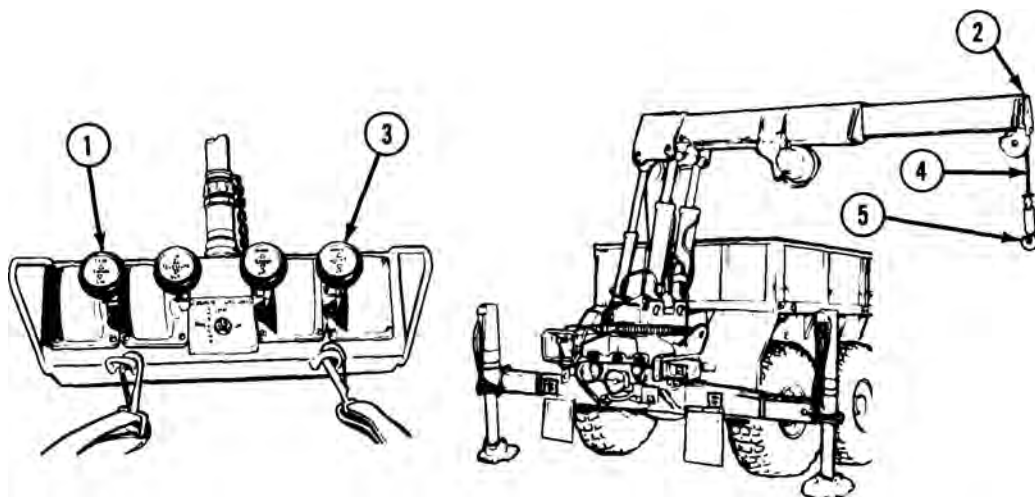


Figure 6.

**CAUTION**

Release hook lock before connecting load to avoid damage to equipment.

2. Operate HOIST control lever (3) to raise or lower cable (4) and connect load hook (5) to load.

**WARNING**

- Always wear protective gloves when handling winch cable. Never let cable run through hands. Frayed cables can cut severely. Failure to comply may result in injury or death to personnel.
- Never operate winch with less than five wraps of cable on winch drum. Failure to comply may result in injury or death to personnel.

**CAUTION**

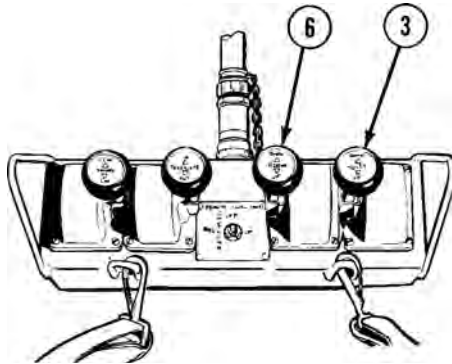
- Do not jerk HOIST control lever or load will bounce and damage to equipment may occur.
- Do not operate crane with boom below horizontal when there is a load on hook or damage to equipment may occur.

**RAISE AND LOWER LOAD - Continued**

- Do not go over maximum load limit. Going over maximum load limit will cause electrical shutdown for six seconds or until load is lowered.

**NOTE**

- For M977, maximum load limit with boom length under 9 ft. (2.75 m) is 4500 lbs (2 043 kg). Maximum load limit with boom extended over 9 ft. (2.75 m) is 2500 lbs (1 135 kg) (refer to RANGE DIAGRAM for more information).
  - For M985 maximum load limit is 5400 lbs (2 452 kg) for entire boom reach (refer to RANGE DIAGRAM for more information).
3. Move HOIST control lever (3) to UP position to lift load. Move BOOM control lever (6) to UP position to raise load higher.

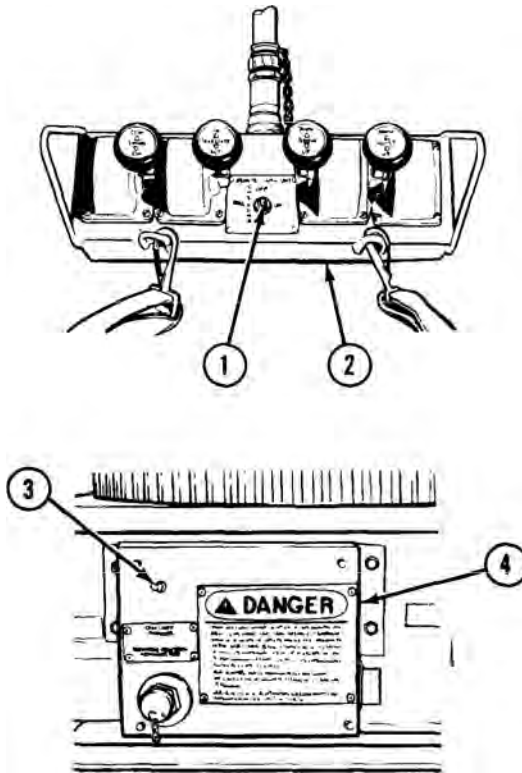


*Figure 7.*

4. Move HOIST control lever (3) to DOWN position to lower load. Move BOOM control lever (6) to DOWN position to lower load further.

**SHUT OFF SWITCHES**

1. Set ON/OFF/MHC-SHUTDOWN power switch (1) on REMOTE CONTROL UNIT (2) to OFF position.

**SHUT OFF SWITCHES - Continued***Figure 8.*

2. Set ON-OFF POWER switch (3) on electric control box (4) in OFF position.
3. Disconnect REMOTE CONTROL UNIT (2) from either rear or forward remote-control outlet (as applicable).

**DISCONNECT REMOTE CONTROL UNIT FROM REAR OUTLET**

1. Disconnect cable plug (1) and install cover (3) on REMOTE CONTROL CONNECTOR outlet (2).

## DISCONNECT REMOTE CONTROL UNIT FROM REAR OUTLET - Continued

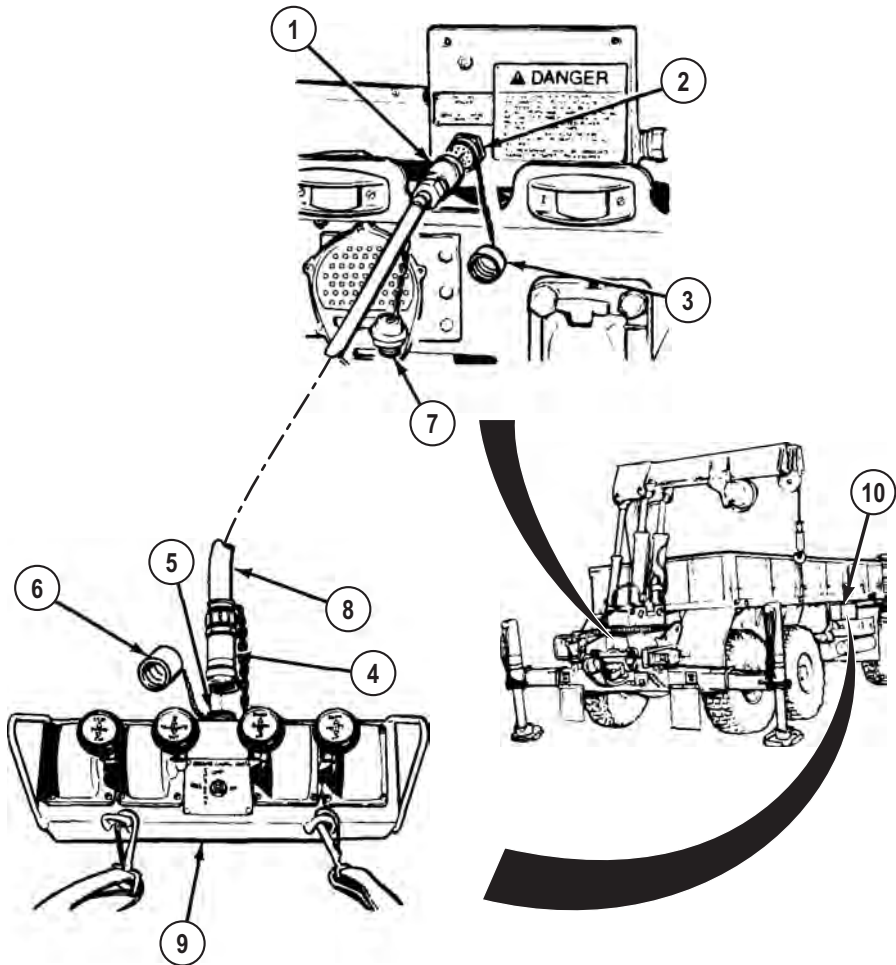
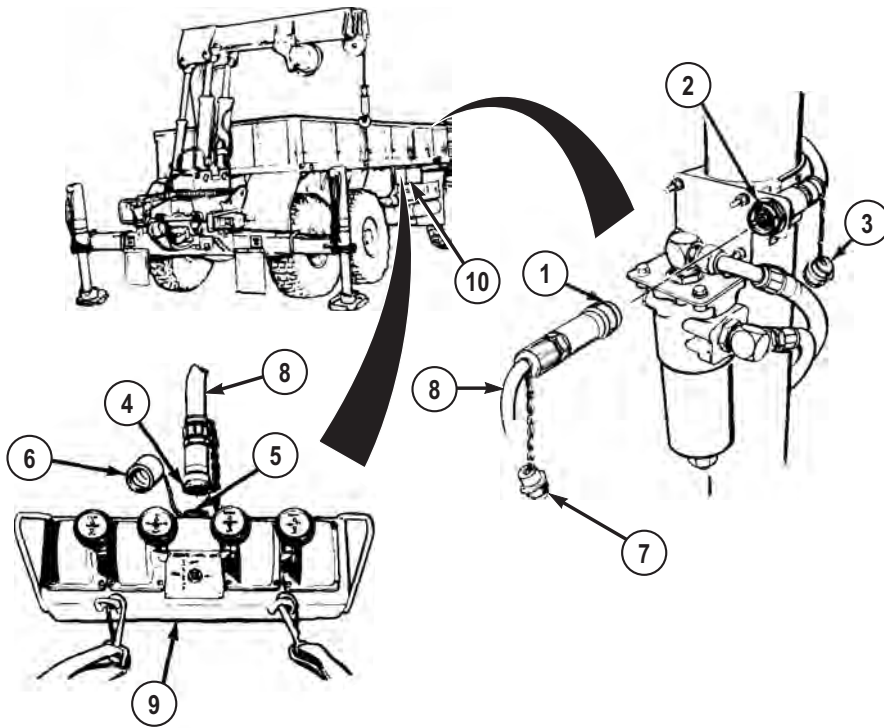


Figure 9.

2. Disconnect cable plug (4) from REMOTE CONTROL UNIT receptacle (5). Install cover (6).
3. Install covers (7) on both ends of cable (8) and coil cable (8) for stowage.
4. Return REMOTE CONTROL UNIT (9) and cable (8) to stowage box (10).
5. Shut down crane.

**DISCONNECT REMOTE CONTROL UNIT FROM FORWARD OUTLET**

1. Disconnect cable plug (1) and install cover (3) on REMOTE CONTROL CONNECTOR outlet (2).



*Figure 10.*

2. Disconnect cable plug (4) and install cover (6) on REMOTE CONTROL UNIT receptacle (5).
3. Install covers (7) on both ends of cable (8) and coil cable (8) for storage.
4. Return REMOTE CONTROL UNIT (9) and cable (8) to stowage box (10).
5. Shut down crane.

**END OF TASK**

**END OF WORK PACKAGE**

---

## OPERATOR MAINTENANCE START ENGINE

---

### INITIAL SETUP:

Not Applicable

---

### START COLD ENGINE

#### WARNING



Do not start, crank engine, or move vehicle when anyone is near, working on, or working under vehicle. Failure to comply may result in injury or death to personnel.

#### WARNING



Keep away from moving engine parts, alternator belts, and pulleys while engine is running. Failure to comply may result in injury or death to personnel.

1. Pull out PARKING BRAKE control (1).

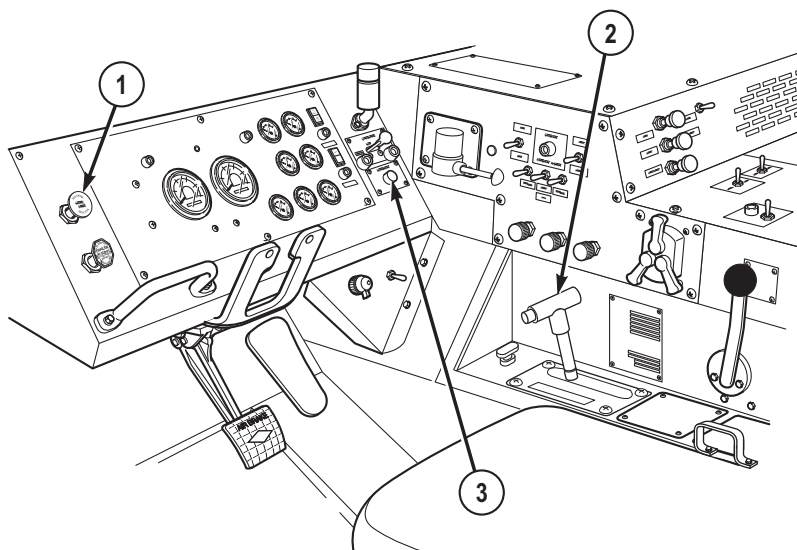
**START COLD ENGINE - Continued**

Figure 1.

2. Set transmission range selector (2) to N (neutral).

**CAUTION**

- Do not press ETHER START button more than three times in a single starting attempt. Failure to comply may result in damage to equipment.
  - Do not turn ENGINE switch to START position while engine is still running. Failure to comply may result in damage to equipment.
  - If engine fails to start, wait 15 seconds before next start attempt to allow starter motor to cool. Failure to comply may result in damage to equipment.
3. If outside temperature is above 45°F (7°C), go to Step (5). If outside temperature is below 45°F (7°C), go to Step (4).

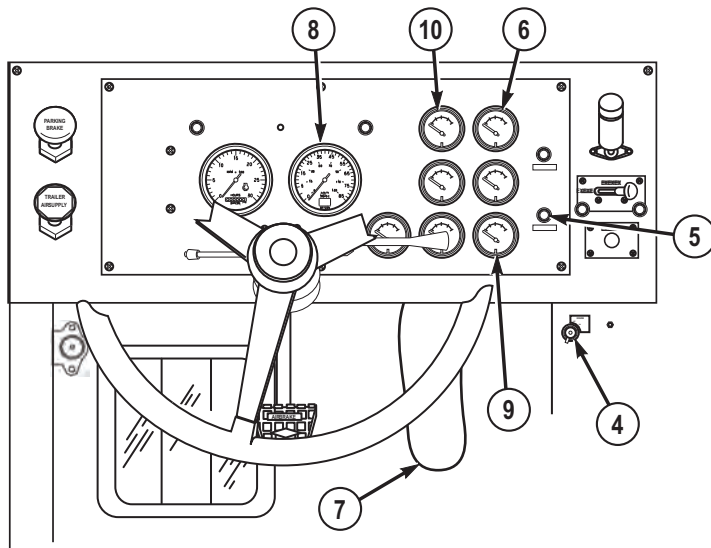
**NOTE**

- Do Step (4):
  - One time for temperatures between 45°F and 10°F (7°C and -12°C).
  - Two times for temperatures between 10°F and -10°F (-12°C and -23°C).



**START COLD ENGINE - Continued**

- Three times for temperatures between -10°F and -25°F (-23°C and -32°C).
  - Repeat Steps (4) and (5) up to four times. If engine fails to start after four starting attempts, notify field level maintenance.
  - Under extreme cold temperatures, it may be necessary to press the ETHER START button two or three times in a single starting attempt. Wait approximately three seconds between each press.
4. Press and hold ETHER START button (3) for three seconds, release, and wait three seconds.
  5. Turn ENGINE switch (4) to START for no more than 15 seconds, or until engine starts.

*Figure 2.***NOTE**

- ENGINE switch will spring back to ON position when released.
  - AIR indicator may illuminate and buzzer may sound upon engine start.
6. Release ENGINE switch (4). Air indicator (5) may light and buzzer may sound.

**START COLD ENGINE - Continued****CAUTION**

- Do not turn ENGINE switch to START position while engine is still running. Failure to comply may result in damage to equipment.
  - If OIL PRESS gauge does not show engine oil pressure within 10 to 15 seconds after starting engine, immediately shut off engine (WP 0057) and notify field level maintenance. Failure to comply may result in damage to equipment.
  - If engine fails to start, repeat Step (3) up to seven times. If engine doesn't start after eight starting attempts, notify field level maintenance.
7. Check that OIL PRESS gauge (6) reads 5 to 10 psi (34 to 69 kPa) at idle.
  8. Press throttle pedal (7) until tachometer (8) reads 800-1000 rpm.
  9. Run engine at 800-1000 rpm for about 5 minutes.

**CAUTION**

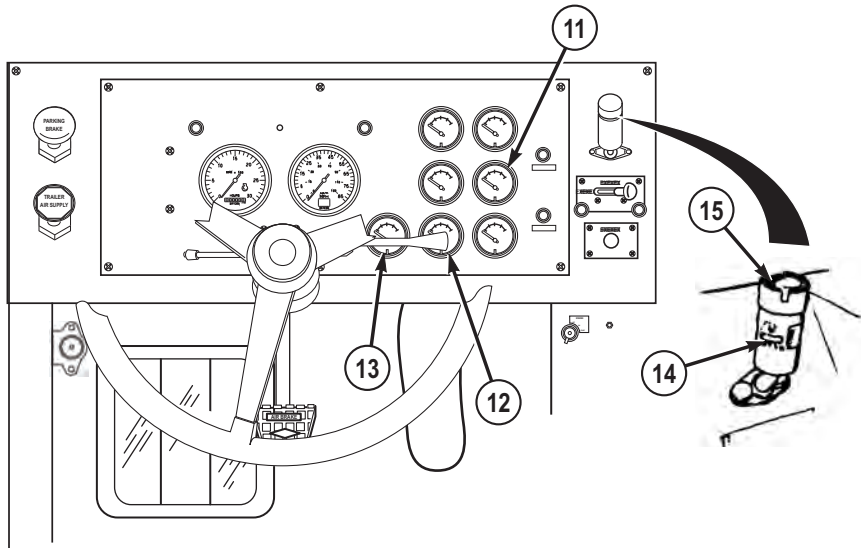
If red and green needles on AIR PRESS gauge do not read 60 to 120 psi (414 to 827 kPa) after warm-up, shut off engine (WP 0057) and notify field level maintenance. Failure to comply may result in damage to equipment.

10. Check that AIR PRESS gauge (9) reads 60 to 120 psi (414 to 827 kPa). AIR indicator (5) will light and buzzer will sound until both needles reach 60 to 75 psi (414 to 517 kPa).
11. Check that FUEL gauge (10) shows enough fuel to complete mission.

**NOTE**

WATER TEMP gauge may not show reading at engine idle.

12. Check that WATER TEMP gauge (11) does not read over 230°F (110°C).

**START COLD ENGINE - Continued***Figure 3.*

13. Check that BATTERY gauge (12) reads between 24 and 30 volts.
14. Check that AMPERES gauge (13) shows positive reading.
15. Check that air filter restriction indicator (14) shows yellow.
16. If air filter restriction indicator (14) shows red, press button (15).
17. If air filter restriction indicator (14) still shows red and/or VACUUM INCHES H<sub>2</sub>O window shows 18, shut off engine (WP 0057) and clean air filter elements. (WP 0157)

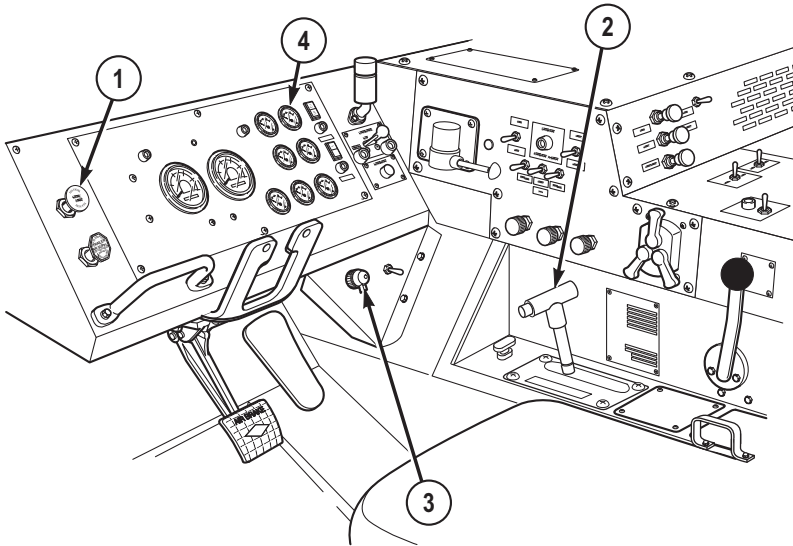
**START WARM ENGINE****WARNING**

Do not start, crank engine, or move vehicle when anyone is near, working on, or working under vehicle. Failure to comply may result in injury or death to personnel.

**START WARM ENGINE - Continued****WARNING**

Keep away from moving engine parts, alternator belts, and pulleys while engine is running. Failure to comply may result in injury or death to personnel.

1. Pull out PARKING BRAKE control (1).



*Figure 4.*

2. Set transmission range selector (2) to N (neutral).
3. Turn ENGINE switch (3) to START for no longer than 10 seconds, or until engine starts.

**NOTE**

ENGINE switch will spring back to ON position when released.

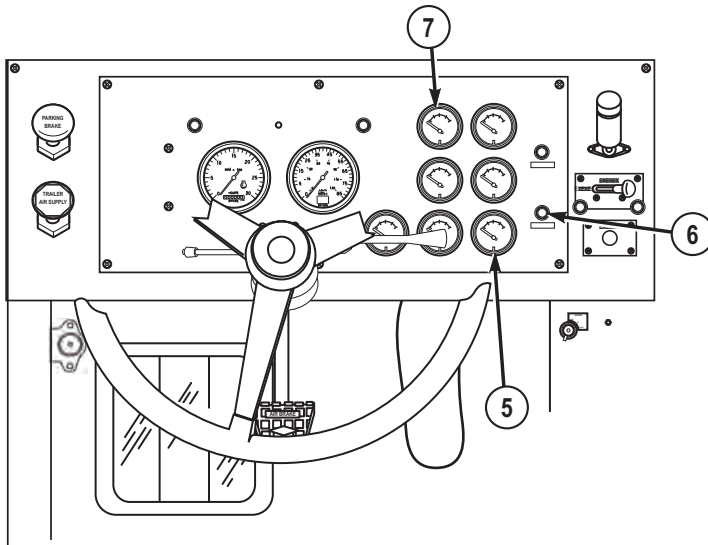
4. Release ENGINE switch (3).

**START WARM ENGINE - Continued****CAUTION**

If OIL PRESS gauge does not show engine oil pressure within 10 to 15 seconds after starting engine, shut off engine (WP 0057) immediately and notify field level maintenance. Failure to comply may result in damage to equipment.

**NOTE**

- Minimum engine oil pressure for safe operation (vehicle moving) is 30 psi (207 kPa).
  - At idle, engine oil pressure can drop as low as 5 psi (34 kPa), this is a normal condition.
5. Check that engine OIL PRESS gauge (4) indicates normal operating range of 40 to 70 psi (276 to 483 kPa) at 1800 to 2100 rpm.
  6. AIR PRESS gauge (5) reads 60 to 120 psi (414 to 827 kPa). AIR indicator (6) will light and buzzer will sound until both needles reach 60 to 75 psi (414 to 517 kPa).



*Figure 5.*

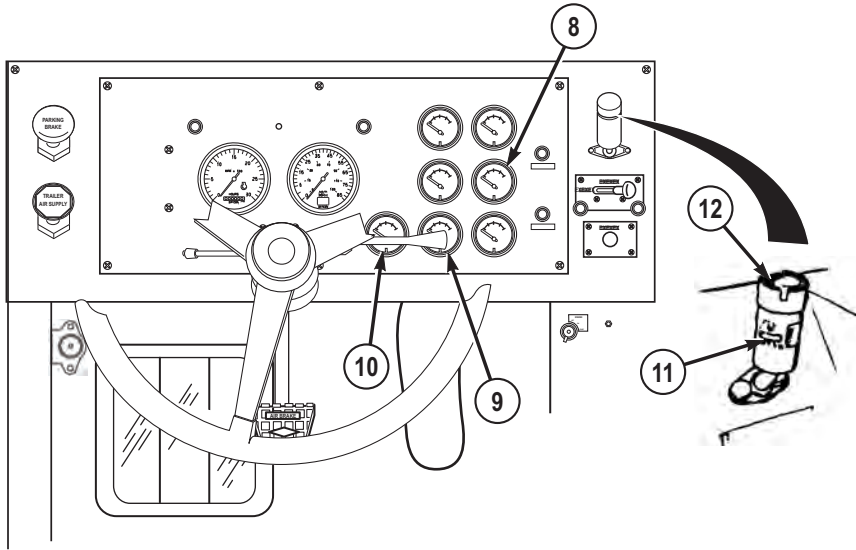
7. Check that FUEL gauge (7) shows enough fuel to complete mission.

**NOTE**

WATER TEMP gauge may not show reading at engine idle.

**START WARM ENGINE - Continued**

8. Check that WATER TEMP gauge (8) does not read over 230°F (110°C).



*Figure 6.*

9. Check that BATTERY gauge (9) reads between 24 and 30 volts.
10. Check that AMPERES gauge (10) shows positive reading.
11. Check that air filter restriction indicator (11) shows yellow.
12. If air filter restriction indicator (11) shows red, press button (12).
13. If air filter restriction indicator (11) still shows red and/or VACUUM INCHES H<sub>2</sub>O window shows 18, shut off engine (WP 0057) and clean air filter elements. (WP 0157)

**END OF TASK**

**END OF WORK PACKAGE**

---

## OPERATOR MAINTENANCE OPERATE PARKING BRAKES

---

### INITIAL SETUP:

Not Applicable

---

### OPERATE PARKING BRAKES

#### NOTE

- Vehicle may be equipped with manual parking brake valve (round/black knob) or automatic parking brake valve (square/yellow knob).
- Manual parking brake valve shown.

1. Pull out PARKING BRAKE control (1) to apply.

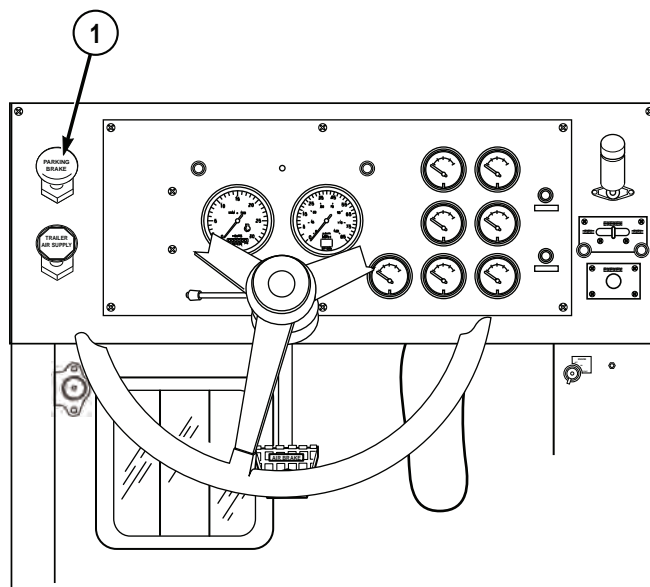


Figure 1.

**OPERATE PARKING BRAKES - Continued**

2. Push in PARKING BRAKE control (1) to release.

**END OF TASK**

**END OF WORK PACKAGE**



---

## OPERATOR MAINTENANCE OPERATE SERVICE BRAKES

---

### INITIAL SETUP:

Not Applicable

---

### OPERATE SERVICE BRAKES

#### WARNING



Do not press service brake treadle hard three or four times in a row. Air supply will be used up and service brakes will not work until air is built up again. Failure to comply may result in injury or death to personnel.

1. Ensure both needles (red and green) of AIR PRESS gauge (1) read at least 100 psi (690 kPa) before operating vehicle.

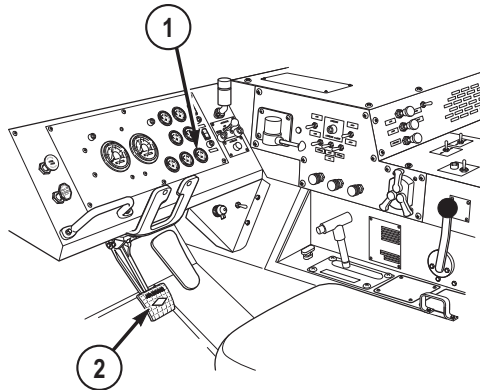


Figure 1.

**OPERATE SERVICE BRAKES - Continued**

2. Push down and hold service brake pedal (2) as needed to slow or stop vehicle.

**END OF TASK**

**END OF WORK PACKAGE**

---

## OPERATOR MAINTENANCE OPERATE TRAILER BRAKES

---

### INITIAL SETUP:

Not Applicable

---

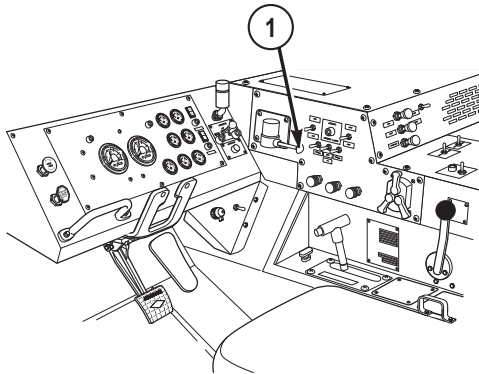
### OPERATE TRAILER BRAKES

#### WARNING



Trailer handbrake control is used only when testing trailer brakes. Do not use trailer handbrake control while driving or the trailer may skid and jackknife, causing an accident. Failure to comply may result in injury or death to personnel.

1. Slowly pull back trailer handbrake control (1) to test application of trailer brakes.



*Figure 1.*

**OPERATE TRAILER BRAKES - Continued**

2. Push trailer handbrake control (1) forward to test release of trailer brakes.

**END OF TASK**

**END OF WORK PACKAGE**

---

## OPERATOR MAINTENANCE OPERATE TRANSMISSION AND TRANSFER CASE

---

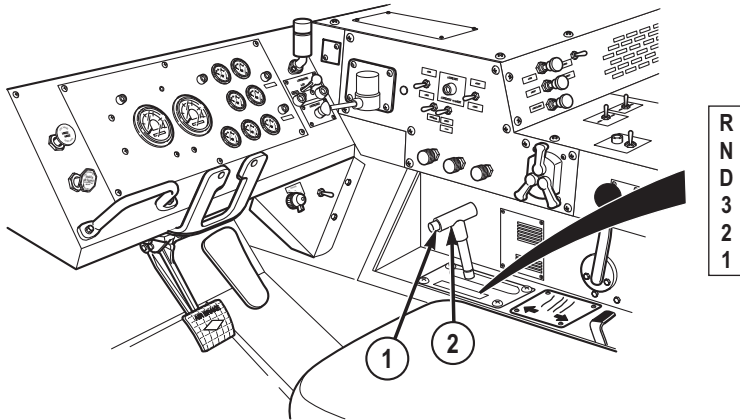
### INITIAL SETUP:

Not Applicable

---

### OPERATE TRANSMISSION

1. Push in button (1) and move transmission range selector (2) to desired position:
  - a. Select R (reverse) to:



*Figure 1.*

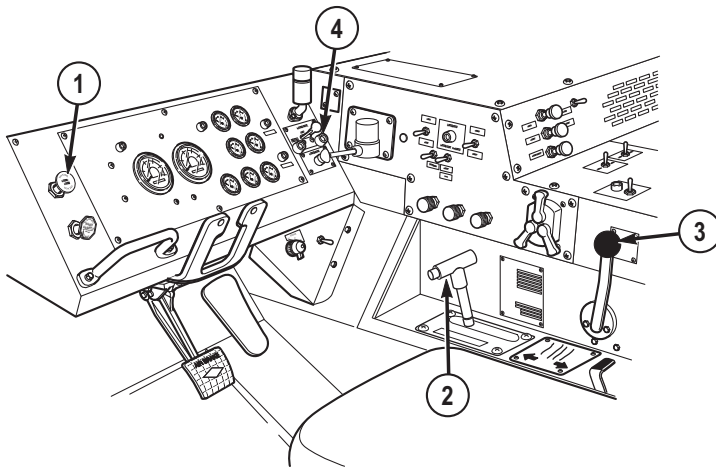
- (1) Drive vehicle in reverse. (WP 0051)
  - b. Select N (neutral) to:
    - (1) Start engine. (WP 0044)
    - (2) Park vehicle. (WP 0056)
    - (3) Perform stationary power takeoff.
    - (4) Shift transfer case.
  - c. Select D (drive) to:
    - (1) Drive in normal conditions.

**OPERATE TRANSMISSION - Continued**

- (2) Drive vehicle forward (WP 0050) from a stop.
- d. Select 3 (third gear range) to:
  - (1) Drive vehicle in off-road conditions. (WP 0053)
  - (2) Drive vehicle in city traffic and on highway. (WP 0052)
  - (3) Haul a heavy load.
- e. Select 2 (second gear range) to:
  - (1) Drive down moderate grades.
  - (2) Control vehicle speed.
- f. Select 1 (first gear range) to:
  - (1) Drive vehicle in slippery conditions. (WP 0055)
  - (2) Drive vehicle up/down steep grade. (WP 0054)
  - (3) Give maximum vehicle speed control.

**OPERATE TRANSFER CASE**

1. Start engine. (WP 0044)



*Figure 2.*

2. Push in PARKING BRAKE control (1). (WP 0045)
3. Set transmission range selector (2) to N (neutral).

**OPERATE TRANSFER CASE - Continued****CAUTION**

- Do not force TRANSFER CASE shift lever. Lever may work hard if there is drive line windup. Using excessive force on shift lever may cause damage to shift linkage or change linkage adjustment.
  - Do not move TRANSFER CASE shift lever when vehicle is moving, or when transmission is in gear. Severe damage to drive line may result.
4. Select transfer case position.

**NOTE**

If TRANSFER CASE shift lever is hard to move, set transmission range selector to D, then back to N. If transfer case will not shift, refer to troubleshooting procedures. (WP 0140)

5. Set TRANSFER CASE shift lever (3) to H (HI) for highway driving.

**NOTE**

Selecting L (LO) position automatically selects 8X8 drive in the vehicle traction control system.

6. Set TRANSFER CASE shift lever (3) to L (LO) for off-road driving, 8X8 indicator light (4) will illuminate.

**END OF TASK****END OF WORK PACKAGE**





---

**OPERATOR MAINTENANCE**  
**OPERATE ENGINE BRAKE**

---

**INITIAL SETUP:**

Not Applicable

---

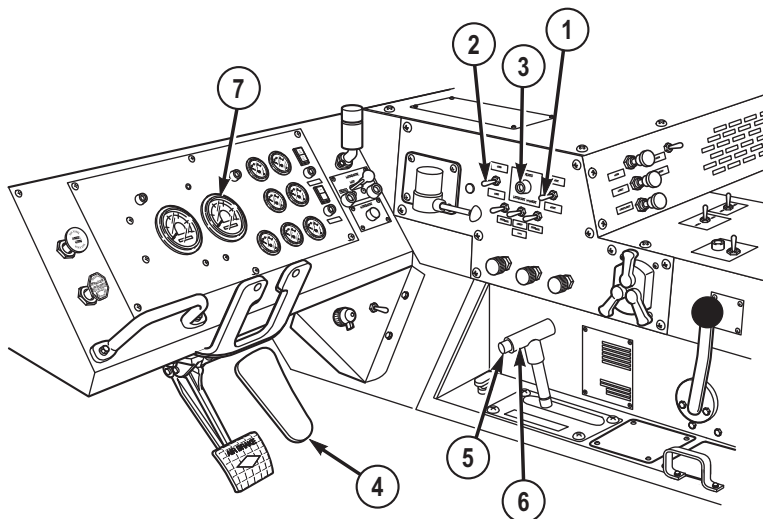
**OPERATE ENGINE BRAKE****WARNING**

Do not use engine brake when vehicle is on slippery surface. If engine brake is used incorrectly, vehicle may skid out of control. Failure to comply may result in injury or death to personnel.

**NOTE**

Service brakes must be used in addition to engine brake for optimum braking capability.

1. Set JACOBS® ENGINE BRAKE HIGH/LOW switch (1) to LOW.

**OPERATE ENGINE BRAKE - Continued**

*Figure 1.*

2. Set JACOBS® ENGINE BRAKE ON/OFF switch (2) to ON. JACOBS® ENGINE BRAKE indicator light (3) will come on.
3. Lift foot off throttle pedal (4). Engine brake will automatically slow vehicle.
4. If too much braking occurs, push in button (5) and set transmission range selector (6) to a higher range.
5. If more braking is required, set JACOBS® ENGINE BRAKE HIGH/LOW switch (1) to HIGH.

**NOTE**

Engine brake operates best when engine speed is between 1650 and 2100 rpm.

6. Check that tachometer (7) reads between 1650 and 2100 rpm whenever engine brake is used.

**END OF TASK**

**END OF WORK PACKAGE**

---

## OPERATOR MAINTENANCE DRIVE VEHICLE FORWARD

---

### INITIAL SETUP:

Not Applicable

---

### PREPARE VEHICLE

#### NOTE

If vehicle has less than 500 miles (805 km), check controls and indicators often during operation and listen for unusual noises or vibrations. Notify field level maintenance of any problems.

1. Remove and stow wheel chocks. (WP 0077)
2. Ensure cargo body end panels are in place.
3. Ensure cargo body side panels are secure. (WP 0041)
4. Ensure grove crane, outriggers, and outrigger pads are secured in stowed position. (WP 0042)
5. Ensure all cargo in cargo body is secured.
6. Adjust seat and mirrors as needed. (WP 0079)
7. Adjust air-ride seat and mirrors as needed. (WP 0081)
8. Adjust three-point seatbelt as needed. (WP 0080)
9. Adjust four-point seatbelt as needed. (WP 0082)
10. Start engine. (WP 0044)
11. Turn on lights as required.

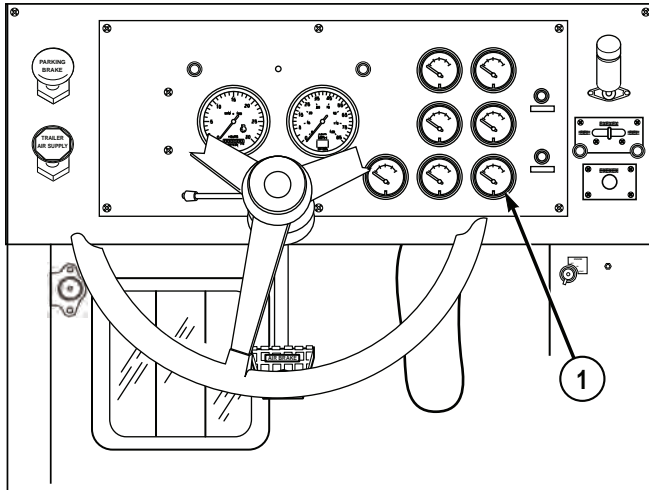
#### WARNING



Do not press service brake treadle hard three or four times in a row. Air supply will be used up and service brakes will not work until air is built up again. Failure to comply may result in injury or death to personnel.

**PREPARE VEHICLE - Continued**

12. Ensure both needles (red and green) AIR PRESS gauge (1) read at least 100 psi (690 kPa) before driving vehicle.



*Figure 1.*

**DRIVE VEHICLE FORWARD**

1. Drive vehicle in city traffic and on highway. (WP 0052)
2. Drive vehicle in off-road conditions. (WP 0053)
3. Drive vehicle in slippery conditions. (WP 0055)
4. Drive vehicle up/down steep grade. (WP 0054)

**END OF TASK****END OF WORK PACKAGE**

---

## OPERATOR MAINTENANCE DRIVE VEHICLE IN REVERSE

---

### INITIAL SETUP:

#### Personnel Required

Operator and Assistant - - - (2)

---

### PREPARE VEHICLE

1. Remove and stow wheel chocks.
2. Adjust seat and mirrors as needed.
3. Adjust air-ride seat and mirrors as needed. (WP 0081)
4. Adjust three-point seatbelt as needed. (WP 0080)
5. Adjust four-point seatbelt as needed. (WP 0082)
6. Start engine. (WP 0044)
7. Turn on lights as required.

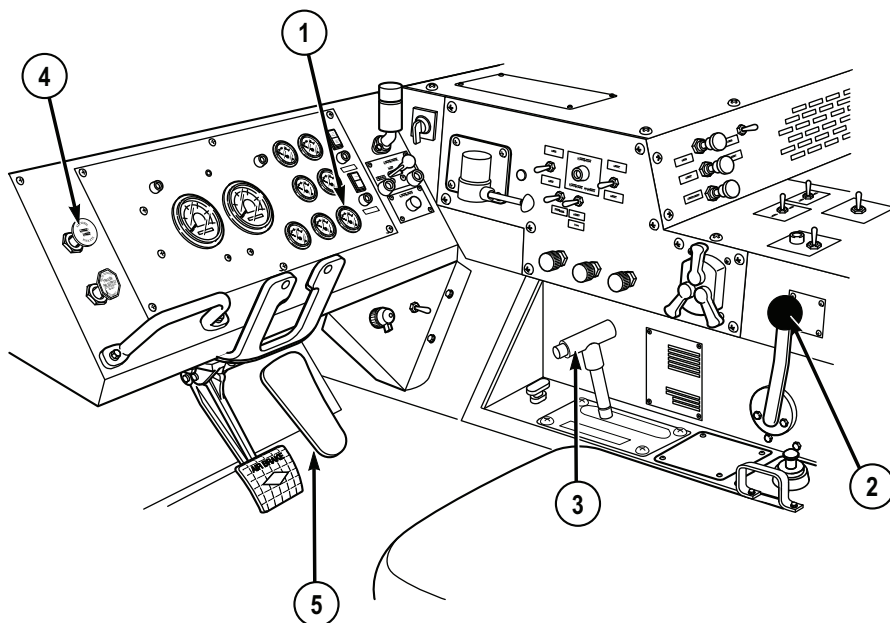
### DRIVE VEHICLE IN REVERSE

#### WARNING



Do not press service brake treadle hard three or four times in a row. Air supply will be used up and service brakes will not work until air is built up again. Failure to comply may result in injury or death to personnel.

1. Make sure both needles (red and green) on AIR PRESS gauge (1) read at least 100 psi (690 kPa) before driving vehicle.

**DRIVE VEHICLE IN REVERSE - Continued***Figure 1.***WARNING**

Driver has limited vision to rear. Ground guide is required when driving vehicle in reverse. Failure to comply may result in injury or death to personnel.

**CAUTION**

Do not move TRANSFER CASE shift lever when vehicle is moving or when transmission is in gear. Severe damage to drive line may result.

2. Set TRANSFER CASE shift lever (2) to HI.

**NOTE**

Reverse alarm will not sound if blackout lighting is selected.

3. Set transmission range selector (3) to R (reverse).

**DRIVE VEHICLE IN REVERSE - Continued**

4. Push in PARKING BRAKE control (4).
5. Slowly apply throttle pedal (5).
6. Follow direction from ground guide (as required).

**CAUTION**

Do not hold steering wheel at full left or full right position for longer than 10 seconds. Oil overheating and pump damage may result.

7. Accelerate, brake, and steer as required.

**END OF TASK****END OF WORK PACKAGE**





---

**OPERATOR MAINTENANCE  
DRIVE VEHICLE IN CITY TRAFFIC AND ON HIGHWAY**

---

**INITIAL SETUP:**

Not Applicable

---

**OPERATE VEHICLE**

**WARNING**

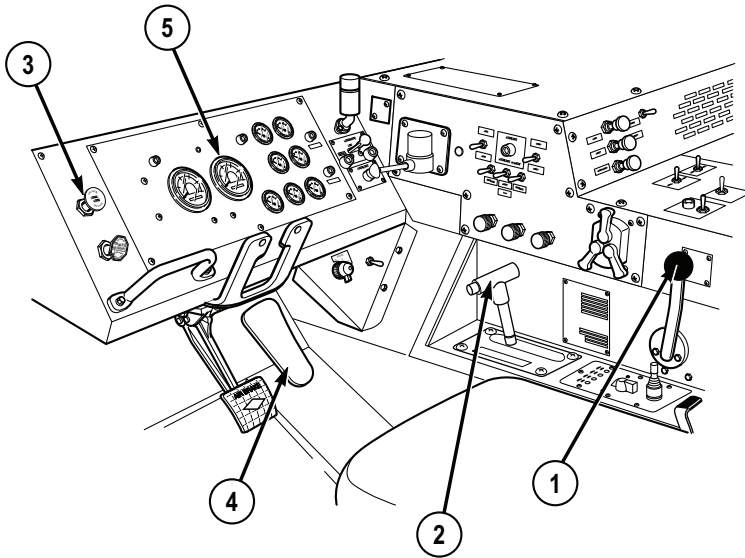


Speed limits posted on curves reflect speeds that are considered safe for automobiles. Heavy vehicles with a high center of gravity can roll over at these speed limits. Use care and reduce your speed below the posted limit prior to entering a curve. Failure to comply may result in injury or death to personnel.

**CAUTION**

Do not move TRANSFER CASE shift lever when vehicle is moving or when transmission is in gear. Severe damage to drive line will result.

1. Set TRANSFER CASE shift lever (1) to HI.

**OPERATE VEHICLE - Continued***Figure 1.*

2. Set transmission range selector (2) to D (drive).
3. Push in PARKING BRAKE control (3).

**CAUTION**

Maximum no-load governed engine speed is approximately 2250 rpm. Do not let engine speed go above this figure. Under full load, governed speed is approximately 2100 rpm. If engine speed goes above governed speeds, serious engine damage can result.

4. Slowly depress throttle pedal (4) until vehicle reaches desired speed. Tachometer (5) should read 1650 to 2100 rpm.

**CAUTION**

Do not hold steering wheel at full left or full right position for longer than 10 seconds. Power steering oil can overheat and pump can be damaged.

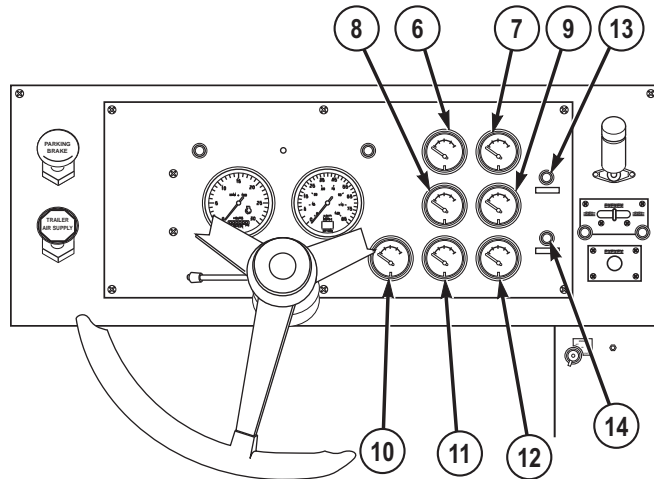
5. Accelerate, brake, and steer as required.

**NOTE**

Check system gauges often during vehicle operation. If gauges read other than normal, stop engine and troubleshoot problem.

**OPERATE VEHICLE - Continued**

6. Check that FUEL gauge (6) shows enough fuel to complete mission.



*Figure 2.*

7. Check that OIL PRESS gauge (7) reads 40 to 70 psi (276 to 483 kPa).
8. Check that TRANS TEMP (transmission temperature) gauge (8) reads 160 to 220° F (71 to 104° C).
9. Check that WATER TEMP gauge (9) reads 180 to 200° F (82 to 93° C).
10. Check that AMPERES gauge (10) reads about zero.
11. Check that BATTERY gauge (11) reads 24 to 28 volts.
12. Check that AIR PRESS gauge (12) red and green needles read 100 to 120 psi (690 to 827 kPa).
13. If OIL-WATER indicator (13) illuminates and buzzer sounds, park vehicle (WP 0056) and notify field level maintenance.
14. If WATER TEMP gauge (9) reads over 230°F (110° C), idle engine until water temperature cools. If water does not cool, shut off engine (WP 0057) and notify field level maintenance.
15. If OIL PRESS gauge (8) reads over 70 psi (483 kPa) or lower than 28 psi (193 kPa), park vehicle (WP 0056), shut off engine (WP 0057), and notify field level maintenance.

**OPERATE VEHICLE - Continued**

16. If AIR indicator (14) illuminates (red), perform immediate action for loss of air supply system pressure emergency procedures. (WP 0103)

**END OF TASK**

**END OF WORK PACKAGE**

---

## OPERATOR MAINTENANCE DRIVE VEHICLE IN OFF-ROAD CONDITIONS

---

### INITIAL SETUP:

Not Applicable

---

### DRIVE VEHICLE IN OFF-ROAD CONDITIONS

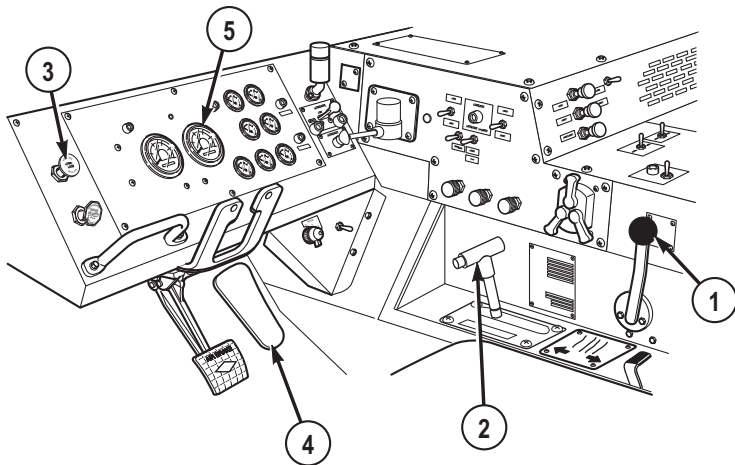
#### CAUTION

Do not move TRANSFER CASE shift lever when vehicle is moving or when transmission is in gear. Severe damage to drive line may result.

#### NOTE

8x8 DRIVE indicator (WP 0021) will illuminate when TRANSFER CASE shift lever is positioned to L (LO).

1. Set TRANSFER CASE shift lever (1) to L (LO).



*Figure 1.*

2. Set transmission range selector (2) to 2 (2nd gear range) or 1 (1st gear range), depending on ground condition. (WP 0048)
3. Push in PARKING BRAKE control (3).

**DRIVE VEHICLE IN OFF-ROAD CONDITIONS - Continued****CAUTION**

Never let engine exceed maximum no-load governed engine speed (approximately 2250 rpm) or maximum governed engine speed under load (approximately 2100 rpm). If engine is allowed to go over governed engine speeds, serious engine damage may result.

4. Slowly depress throttle pedal (4) until vehicle reaches desired speed. Tachometer (5) should read 1650 to 2100 rpm.

**CAUTION**

Do not hold steering wheel at full left or full right position for longer than 10 seconds. Power steering oil can overheat and pump may be damaged.

5. Accelerate, brake, and steer as required.

**END OF TASK****END OF WORK PACKAGE**

---

## OPERATOR MAINTENANCE DRIVE VEHICLE UP/DOWN STEEP GRADE

---

### INITIAL SETUP:

Not Applicable

---

### DRIVE VEHICLE UP STEEP GRADE

Press and hold throttle pedal (1) all the way down as vehicle moves up grade. Transmission will automatically downshift gears as needed.

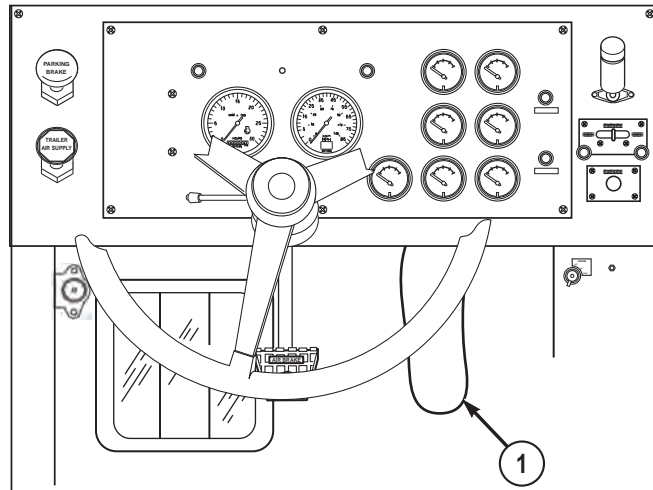


Figure 1.

### DRIVE VEHICLE DOWN STEEP GRADE

#### CAUTION

- Do not allow speed to go above 2100 RPM when driving downhill, or damage to engine can result.
- Engine brake operates best when engine speed is between 1650 and 2100 RPM. Transmission torque converter lockup valve may disengage below 1650 RPM resulting in loss of engine power.

**DRIVE VEHICLE DOWN STEEP GRADE - Continued**

1. Set transmission range selector (1) to lower range as needed to keep engine speed on tachometer (2) between 1650 and 2100 RPM.

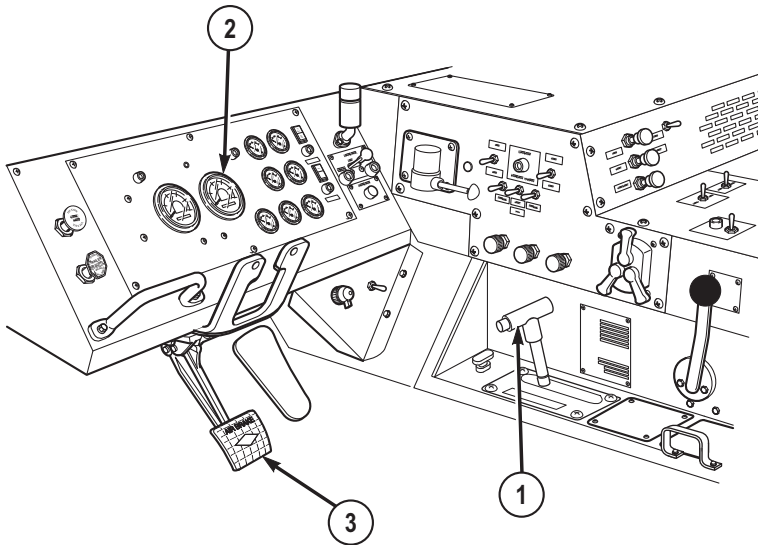


Figure 2.

**WARNING**

Do not press service brake treadle hard three or four times in a row. Air supply will be used up and service brakes will not work until air is built up again. Failure to comply may result in injury or death to personnel.

2. Use service brake pedal (3) as needed to control vehicle speed.
3. Operate engine brake (WP 0049) as required.

**END OF TASK**

**END OF WORK PACKAGE**



**OPERATOR MAINTENANCE  
DRIVE VEHICLE IN SLIPPERY CONDITIONS**

---

**INITIAL SETUP:**

Not Applicable

---

**OPERATE VEHICLE****CAUTION**

Do not shift TRACTION CONTROL lever while vehicle is moving.  
Damage to drive line may result.

**NOTE**

After TRACTION CONTROL lever is shifted, let vehicle creep forward several feet to allow shift collars to fully engage.

1. If TRANSFER CASE shift lever (1) is set to LO, 8X8 DRIVE is automatically engaged and indicator light (2) will illuminate. Set TRACTION CONTROL lever (3) to INTER-AXLE DIFF. LOCK. Indicator light (4) will illuminate.

## OPERATE VEHICLE - Continued

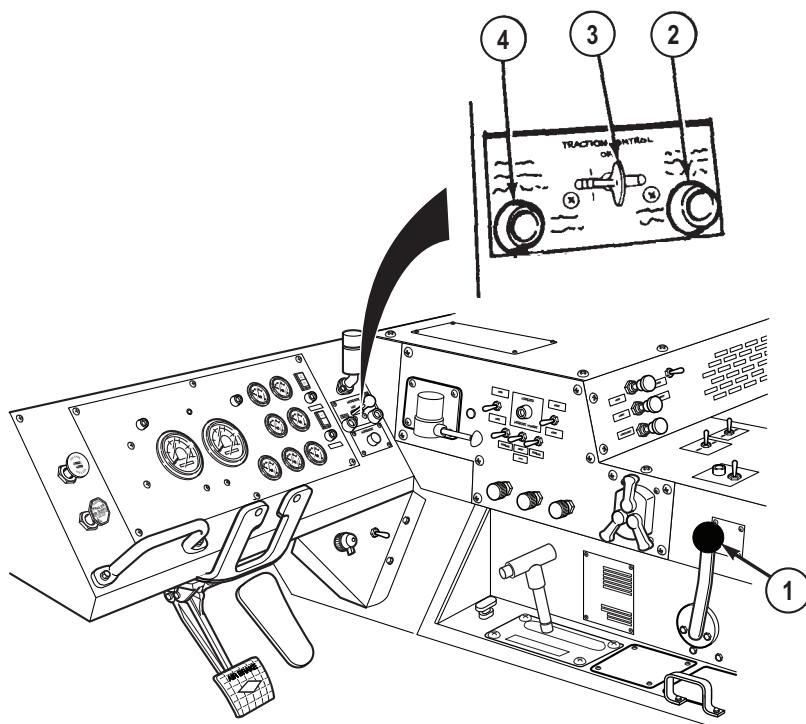


Figure 1.

2. If TRANSFER CASE shift lever (1) is set to HI, set TRACTION CONTROL lever (3) to 8X8 DRIVE. Indicator light (2) will illuminate.

**CAUTION**

Do not shift TRACTION CONTROL lever while vehicle is moving.  
Damage to drive line may result.

**NOTE**

After TRACTION CONTROL lever is set to OFF position, let vehicle creep forward several feet to allow shift collars to fully disengage.

**OPERATE VEHICLE - Continued**

3. When vehicle gets good traction again, stop vehicle and set TRACTION CONTROL lever (3) to OFF. Indicator light (2 or 4 as applicable) will go out.

**END OF TASK****END OF WORK PACKAGE**



---

## OPERATOR MAINTENANCE PARK VEHICLE

---

### INITIAL SETUP:

Not Applicable

---

### OPERATE VEHICLE

1. Lift foot off throttle pedal (1). Let automatic downshifting of transmission slow vehicle.

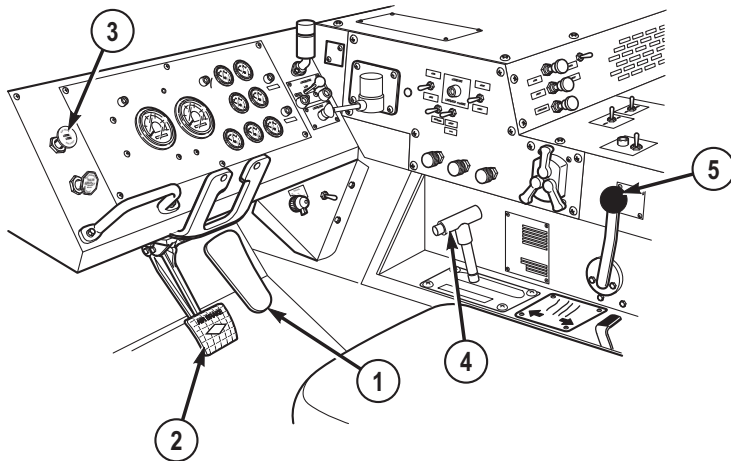


Figure 1.

### WARNING



Do not press service brake treadle hard three or four times in a row. Air supply will be used up and service brakes will not work until air is built up again. Failure to comply may result in injury or death to personnel.

2. Push down on service brake pedal (2) until vehicle comes to complete stop.
3. Pull out PARKING BRAKE control (3).

**OPERATE VEHICLE - Continued**

4. Set transmission range selector (4) to N (neutral).
5. Leave TRANSFER CASE shift lever (5) set to HI or LO.
6. Align front tires in straight-ahead position.
7. Install wheel chocks (WP 0077) as required.

**END OF TASK****END OF WORK PACKAGE**

---

## OPERATOR MAINTENANCE SHUT OFF ENGINE

---

### INITIAL SETUP:

Not Applicable

---

### SHUT OFF ENGINE

1. Park vehicle. (WP 0056)

### CAUTION

Before shutting down engine, run at reduced speed (800 to 1000 rpm) at no-load for three to five minutes to allow turbocharger to slow down and cool off. Turbocharger may be damaged if not allowed to cool off.

2. Push down and hold throttle pedal (1) until tachometer (2) reads 800 to 1000 rpm for three to five minutes.

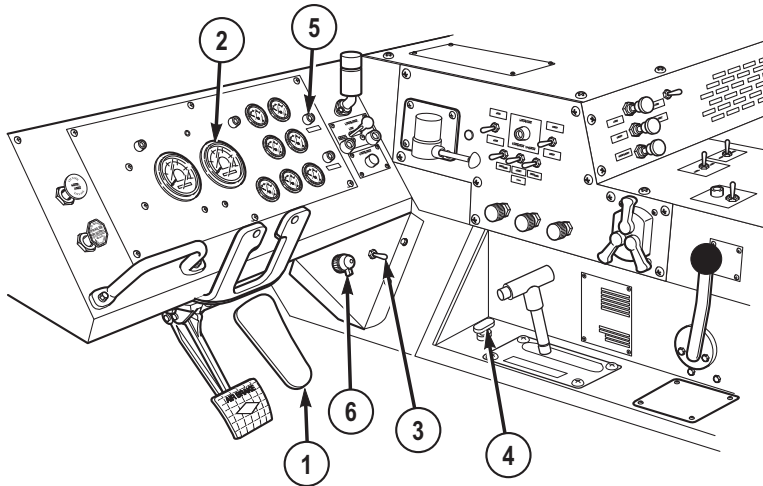


Figure 1.

3. Lift foot off throttle pedal (1).

**SHUT OFF ENGINE - Continued****NOTE**

Vehicle may have either ENGINE STOP switch or engine shut down handle, it will never have both.

4. Hold ENGINE STOP switch (3) all the way down, or pull engine shut down handle (4) all the way up until engine shuts down. Buzzer will sound, and OIL-WATER indicator (5) will light.
5. Release ENGINE STOP switch (3) or push engine shut down handle (4) back in.
6. Turn ENGINE switch (6) to OFF. Buzzer and OIL-WATER indicator (5) will go out.

**CAUTION**

Failure to place light switches in OFF position when vehicle is not in use may cause damage to equipment.

7. Turn off lights as required.

**END OF TASK****END OF WORK PACKAGE**



---

## OPERATOR MAINTENANCE OPERATE ARCTIC ENGINE HEATER

---

### INITIAL SETUP:

Not Applicable

---

### WARNING



#### **CARBON MONOXIDE (EXHAUST GAS) CAN CAUSE DEATH.**

- Carbon monoxide is a colorless, odorless, **DEADLY POISONOUS** gas that, when breathed, deprives body or oxygen and causes **SUFFOCATION**. Breathing air with carbon monoxide produces symptoms of headache, dizziness, loss of muscular control, a sleepy feeling, and coma. Permanent **BRAIN DAMAGE** or death can result from heavy exposure. Carbon monoxide occurs in the exhaust fumes of fuel-burning heaters and internal combustion engines. Carbon monoxide can become dangerously concentrated under conditions of no ventilation. Precautions **MUST** be followed to ensure personnel are safe whenever personnel heaters or engine is operated for any purpose. Failure to comply may result in injury or death to personnel.
- **DO NOT** operate engine in a closed place without proper ventilation. Failure to comply may result in injury or death to personnel.
- Do not drive vehicle with inspection plates, cover plates, or engine compartment covers removed unless necessary for maintenance purposes. Failure to comply may result in injury or death to personnel.
- **BE ALERT** at all times during vehicle operation for exhaust odors and exposure symptoms. If either is present, **IMMEDIATELY VENTILATE** personnel compartments. If symptoms persist, remove affected personnel to fresh air and keep warm. **DO NOT PERMIT PHYSICAL EXERCISE**. If necessary, give artificial respiration and get immediate medical attention. For artificial respiration, refer to FM 4-25.11 . Failure to comply may result in injury or death to personnel.

- BE AWARE that the gas particulate filter unit or field protection mask for nuclear-biological-chemical protection WILL NOT offer safety from carbon monoxide poisoning.
- THE BEST DEFENSE AGAINST CARBON MONOXIDE POISONING IS GOOD VENTILATION.

### WARNING



Attempting to operate heater with frozen or slushy coolant could cause coolant hose to burst or separate from heater. Make sure proper mixture of water and anti-freeze (refer to lubrication table) is maintained at all times. Failure to comply may result in damage to engine and/or injury to personnel.

### WARNING



- The arctic engine heater must be off when filling any fuel tanks on vehicle. Failure to comply may result in injury or death to personnel.
- Do not operate arctic engine heater in garages or enclosed areas without proper ventilation. Failure to comply may result in injury or death to personnel.

### CAUTION

- Do not attempt to operate arctic engine heater if arctic engine heater fails to start during normal startup, or shutdown occurs during normal operation. System shutdown may indicate an arctic engine heater system fault. Failure to comply may cause system lockout.
- Do not operate arctic engine heater if arctic engine heater light flashes intermittently during normal operations. Arctic engine heater indicator light flashing indicates an arctic engine heater system fault. Failure to comply may cause system lockout.

### NOTE

- The arctic engine heater will attempt to start two times per start cycle. After the second failed start attempt, the arctic engine heater will not

operate until the arctic engine heater on/off switch is turned OFF and back ON.

- If arctic engine heater flame out occurs during operation, arctic engine heater will attempt one restart. If unsuccessful, arctic engine heater will shutdown.
  - During operation, arctic engine heater continually monitors input voltage. If the arctic engine heater input voltage decreases below (20 V) or increases above (30 V), arctic engine heater will automatically shutdown.
1. Set arctic engine heater switch (1) to ON position. Observe arctic engine heater indicator light (2) for steady illumination.

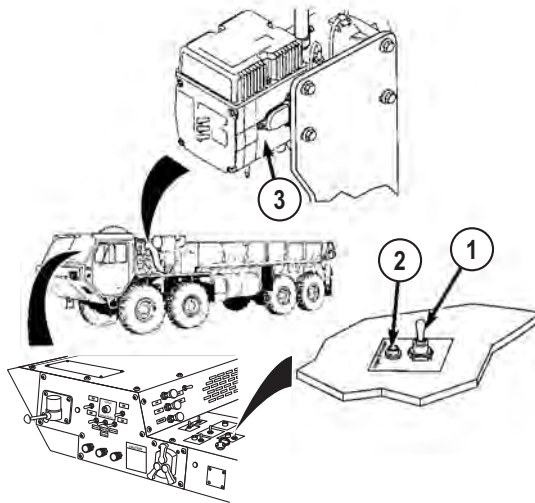


Figure 1.

2. Observe arctic engine heater (3) for proper operation.
3. Operate arctic engine heater (3) for 35 minutes to warm engine.
4. After 35 minutes, start engine. (WP 0044)
5. After engine is started, set arctic engine heater switch (1) in OFF position. Indicator light (2) will go out.

**END OF TASK**

**END OF WORK PACKAGE**



---

## OPERATOR MAINTENANCE OPERATE GAS PARTICULATE FILTER UNIT (GPFU)

---

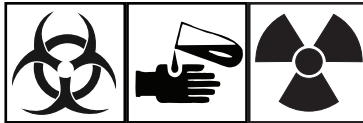
### INITIAL SETUP:

Not Applicable

---

### OPERATE GPFU

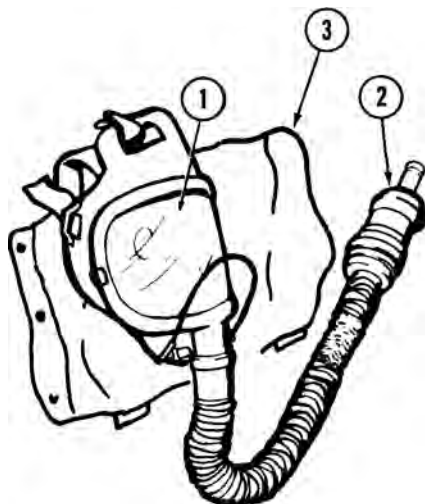
#### WARNING



- BE AWARE that the gas particulate filter unit or the field protective mask for nuclear-biological-chemical protection WILL NOT offer safety from carbon monoxide poisoning.
- If NBC exposure is suspected, all air filter media should be handled by personnel wearing protective equipment. Consult your unit NBC Officer or NBC NCO for appropriate handling or disposal procedures.
- If required to remain inside the vehicle during extreme heat, occupants should follow the water intake, work/rest cycle, and other heat stress preventive medicine measures contained in FM 21-10, Field Hygiene and Sanitation. Failure to comply may result in injury or death to personnel.

#### NOTE

- Do Steps (1) through (8) only when under Nuclear, Biological, or Chemical (NBC) attack and/or when ordered to do so.
  - For detailed information concerning protective mask, refer to TM 3-4240-280-10.
  - Both crew stations have M-3 heater, hose, and air duct sockets.
1. Remove two protective masks (1) and canisters (2) from pouches (3).

**OPERATE GPFU - Continued**

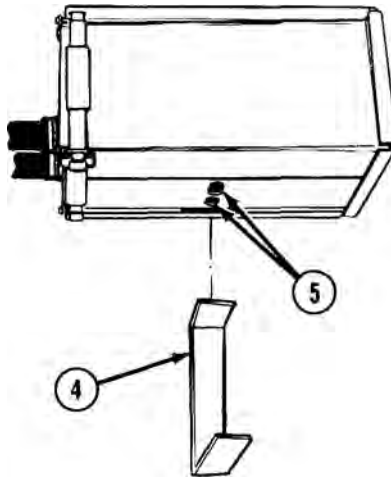
*Figure 1.*

2. Put on protective masks (1).
3. Clear and seal protective masks (1).

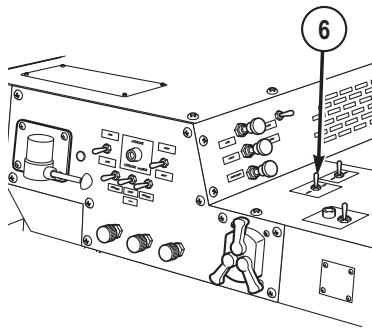
**NOTE**

Spring clip must be repositioned on filter assembly air intake so intake holes are open for gas particulate filter system to work. Clip is repositioned through bottom of bracket.

4. Pull down on spring clip (4) to uncover intake holes (5).

**OPERATE GPFU - Continued***Figure 2.*

5. Set GAS PARTICULATE FILTER switch (6) to ON.

*Figure 3.*

**OPERATE GPFU - Continued****NOTE**

One mount is located to left of drivers seat at roof brace. Second mount is located on middle cab roof brace to left of passenger seat.

6. Disconnect two air duct hose breakaway sockets (7) from mounts (8).

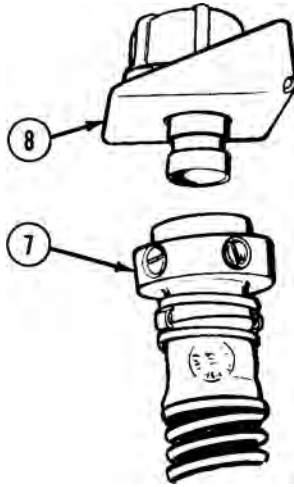


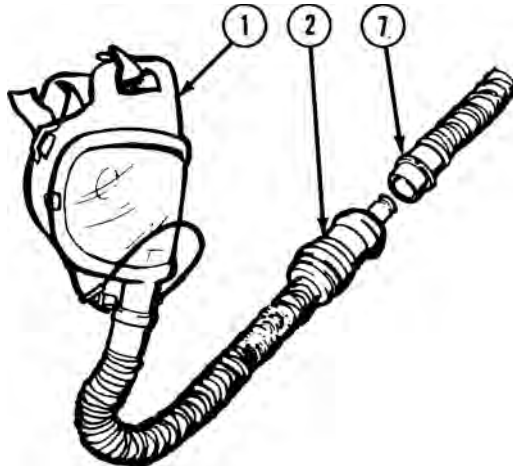
Figure 4.

**WARNING**

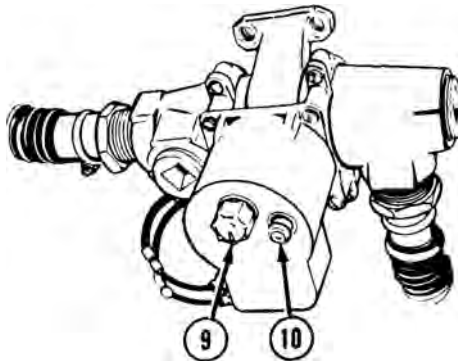
Under arctic conditions, danger of frostbite exists. Mask can be put on, but air duct hose socket shall not be connected to mask canister until M-3 heater has been on for 15 minutes. Failure to comply may result in injury or death to personnel.

7. Connect two air duct hose breakaway sockets (7) to canisters (2) of protective masks (1) and breathe through masks.



**OPERATE GPFU - Continued***Figure 5.***NOTE**

- There are two M-3 heaters. Both are the same.
  - Heater indicator light will go off and on during normal heater operation.
8. If air is too cold to breathe comfortably, turn knob (9) clockwise until heater indicator (10) lights. To adjust temperature:

*Figure 6.*

- a. Turn knob (9) clockwise for warmer air.
- b. Turn knob (9) counterclockwise for cooler air.

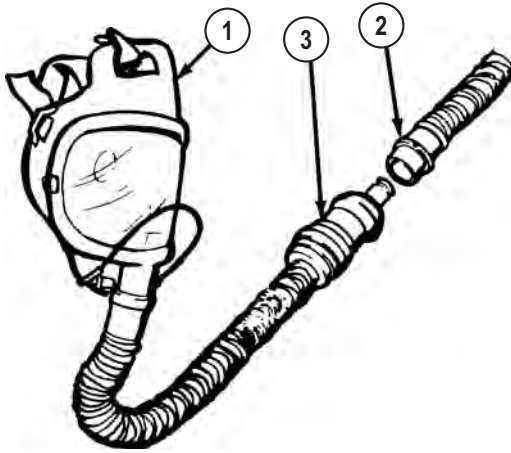
**OPERATE GPFU - Continued**

9. When heater is no longer needed, turn control knob (9) counterclockwise to OFF position.

**NOTE**

Do Steps (1) through (5) only when Nuclear, Biological, or Chemical (NBC) attack is over and/or when ordered to do so.

1. When protective masks (1) are no longer needed, disconnect air duct hose breakaway sockets (2) from canisters (3).



*Figure 7.*

2. Connect two air duct hose breakaway sockets (2) to mounts (4).

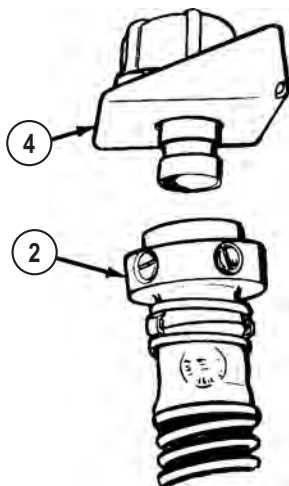


Figure 8.

3. Set GAS PARTICULATE FILTER switch (5) to OFF.

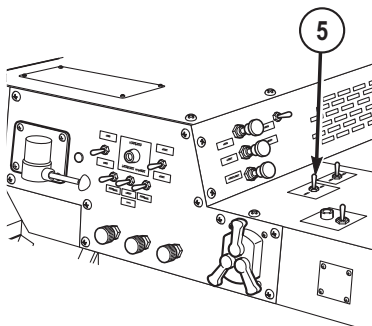


Figure 9.

4. Push up on spring clip (6) to cover intake holes (7).

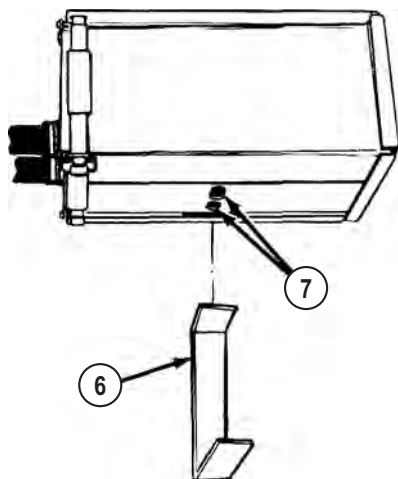


Figure 10.

5. Remove and stow two protective masks (1).

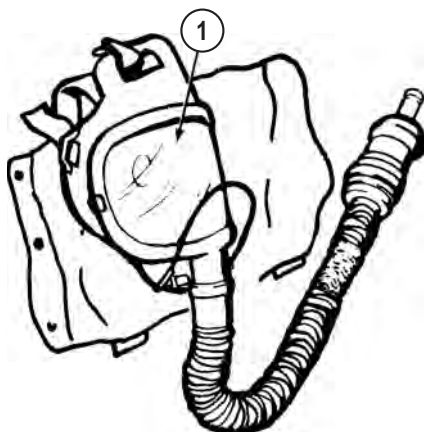


Figure 11.

**END OF TASK**

**END OF WORK PACKAGE**

**OPERATOR MAINTENANCE  
OPERATE RIFLE STOWAGE MOUNT**

---

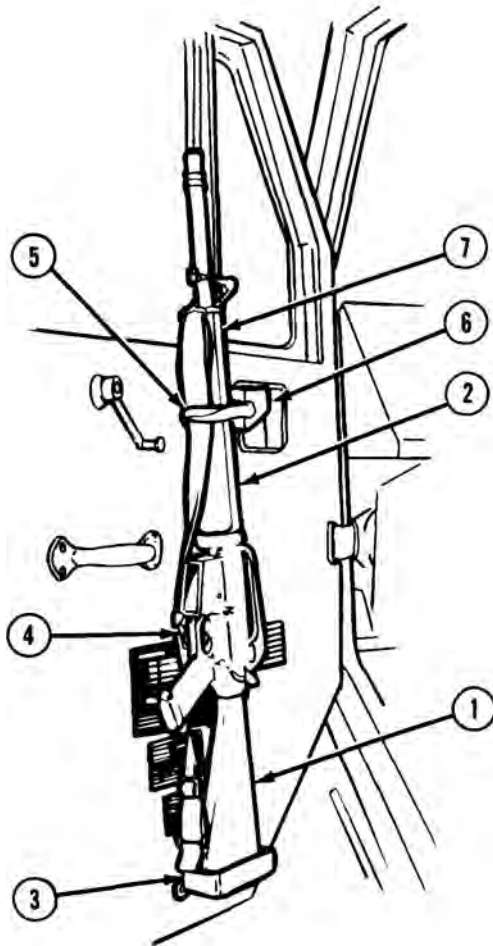
**INITIAL SETUP:**

Not Applicable

---

**STOW RIFLE IN STOWAGE MOUNT**

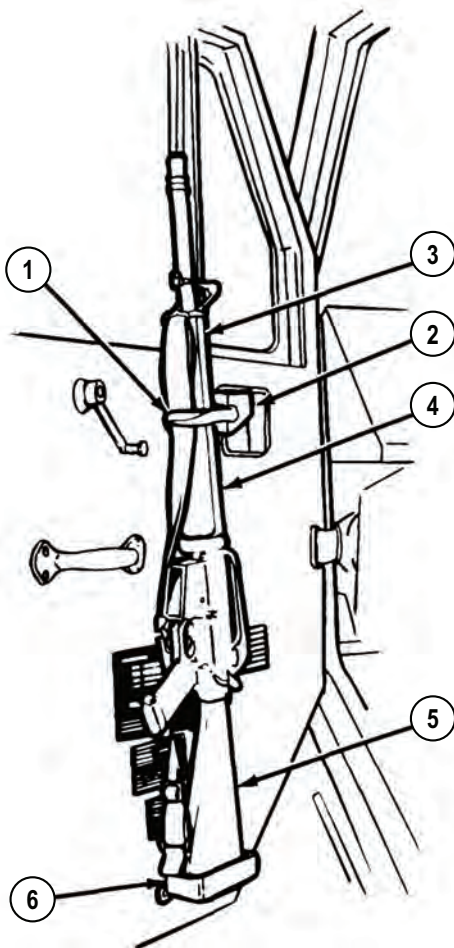
1. Position butt (1) of M-16 rifle (2) in lower mount (3) with trigger guard (4) toward rear of vehicle.

**STOW RIFLE IN STOWAGE MOUNT - Continued***Figure 1.*

2. Pull handle (5) of top mount (6) toward middle of cab.
3. Place heat guard (7) of M-16 rifle (2) in top mount (6).
4. Push handle (5) across heat guard (7).
5. Check that M-16 rifle (2) is held tightly.

**REMOVE RIFLE FROM STOWAGE MOUNT**

1. Pull handle (1) of top mount (2) down and toward middle of cab.

**REMOVE RIFLE FROM STOWAGE MOUNT - Continued***Figure 2.*

2. Remove heat guard (3) of M-16 rifle (4) from top mount (2).
3. Remove butt (5) of M-16 rifle (4) from lower mount (6).

**END OF TASK****END OF WORK PACKAGE**





**OPERATOR MAINTENANCE  
OPERATE MACHINE GUN MOUNT**

---

**INITIAL SETUP:**

Not Applicable

---

**REFERENCE**

For operation of the machine gun mount, refer to TM 9-1005-245-13&P. (WP 0161)

**END OF TASK**

**END OF WORK PACKAGE**



**OPERATOR MAINTENANCE  
OPERATE M-8 CHEMICAL ALARM**

---

**INITIAL SETUP:**

Not Applicable

---

**REFERENCE**

For operation of the M-8 Chemical Alarm, refer to TM 3-6665-225-12. (WP 0161)

**END OF TASK**

**END OF WORK PACKAGE**



**OPERATOR MAINTENANCE  
OPERATE M-13 DECONTAMINATION KIT**

---

**INITIAL SETUP:**

Not Applicable

---

**REFERENCE**

For operation of the M-13 Decontamination Kit, refer to TM 3-4230-214-12&P. (WP 0161)

**END OF TASK**

**END OF WORK PACKAGE**



**OPERATOR MAINTENANCE  
OPERATE RADIO**

---

**INITIAL SETUP:**

Not Applicable

---

**REFERENCE**

For operation of the radio, refer to TM 11-5820-498-12. (WP 0161)

**END OF TASK**

**END OF WORK PACKAGE**





---

## OPERATOR MAINTENANCE PORTABLE WORK LAMP OPERATION

---

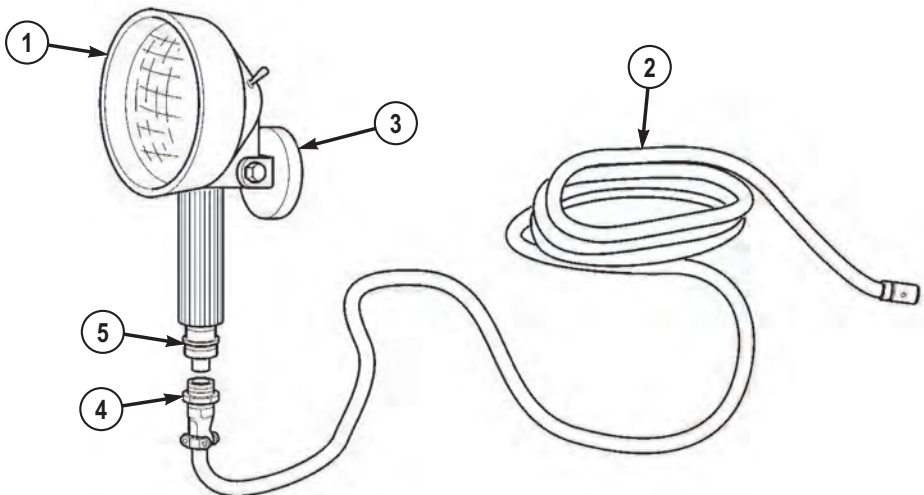
### INITIAL SETUP:

Not Applicable

---

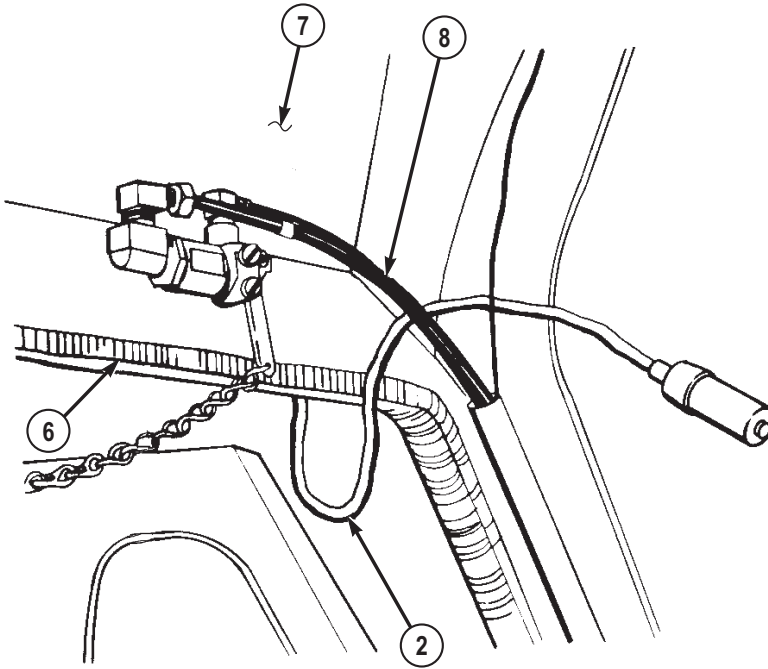
### INSTALL/OPERATE/REMOVE PORTABLE WORK LAMP

1. Remove work lamp (1) and work lamp harness (2) from stowage.



*Figure 1.*

2. Mount lamp (1) on vehicle using magnet (3).
3. Install work lamp harness plug (4) on work lamp terminal (5).
4. Route work lamp harness (2) through driver side door opening (6), between inside of cab roof (7) and air horn valve hoses (8).

**INSTALL/OPERATE/REMOVE PORTABLE WORK LAMP - Continued***Figure 2.*

5. Route work lamp harness (2) across driver side defroster (9) and across center console (10) to utility outlet (11).

## INSTALL/OPERATE/REMOVE PORTABLE WORK LAMP - Continued

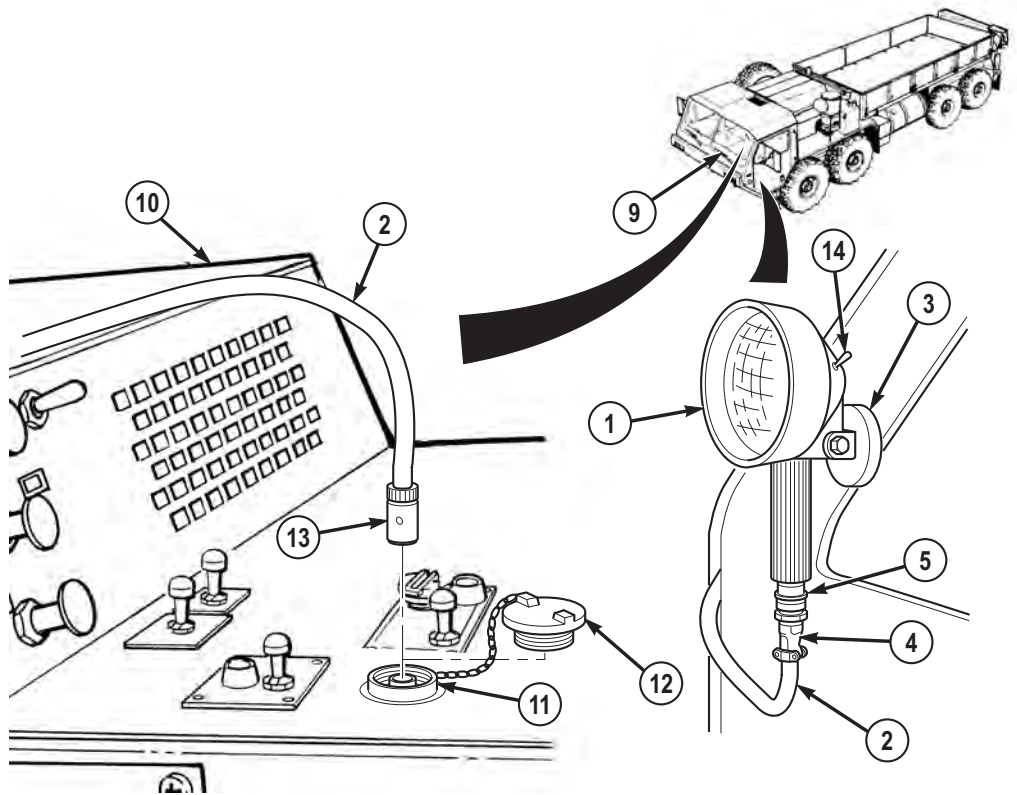


Figure 3.

6. Remove utility outlet cover (12). Insert work lamp harness plug (13) into utility outlet (11).
7. Turn on work lamp (1) using toggle switch (14).

**NOTE**

Perform Steps (8) through (13) when use of the portable work lamp is no longer required.

8. Turn off work lamp (1) using toggle switch (14).
9. Remove work lamp harness plug (13) from utility outlet (11). Install utility outlet cover (12).
10. Remove work lamp harness (2) from interior of cab.
11. Remove work lamp harness plug (4) from work lamp terminal (5).

**INSTALL/OPERATE/REMOVE PORTABLE WORK LAMP - Continued**

12. Disengage magnet (3) from vehicle.
13. Return work lamp (1) and work lamp harness (2) to stowage.

**END OF TASK**

**END OF WORK PACKAGE**

---

**OPERATOR MAINTENANCE  
OPERATE DOME LIGHT**

---

**INITIAL SETUP:**Not Applicable

---

**TURN DOME LIGHT ON/OFF****CAUTION**

Failure to place light switches in off position when vehicle is not in use may cause battery and/or vehicle damage.

**NOTE**

- Dome light is located on very rear of cabin overhead centered between operator and crew seats.
- Dome light switch is a 2-position switch; down is off, up is on.
- Dome light is disabled whenever blackout lights are selected on the light control.

1. Lift up and hold UNLOCK lever (1).

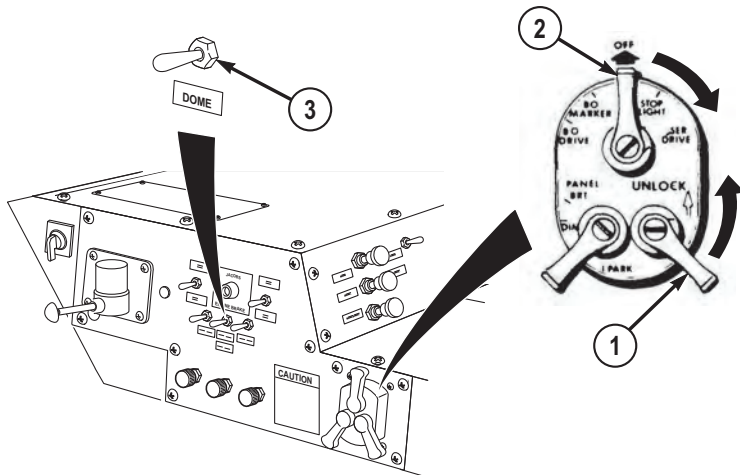


Figure 1.

**TURN DOME LIGHT ON/OFF - Continued**

2. Set lighting control lever (2) to STOP LIGHT or SER DRIVE position.
3. Release UNLOCK lever (1).
4. Set DOME switch (3) to ON position.

**NOTE**

Complete Steps (5) and (6) when dome light is no longer required.

5. Set DOME switch (3) to OFF position.
6. Set lighting control lever (2) to OFF position.

**END OF TASK****END OF WORK PACKAGE**

**OPERATOR MAINTENANCE  
OPERATE PANEL LIGHTS**

---

**INITIAL SETUP:**

Not Applicable

---

**TURN PANEL LIGHTS ON/OFF****CAUTION**

Failure to place light switches in the off position when vehicle is not in use may cause battery and/or vehicle damage.

1. Lift up and hold UNLOCK lever (1).

## TURN PANEL LIGHTS ON/OFF - Continued

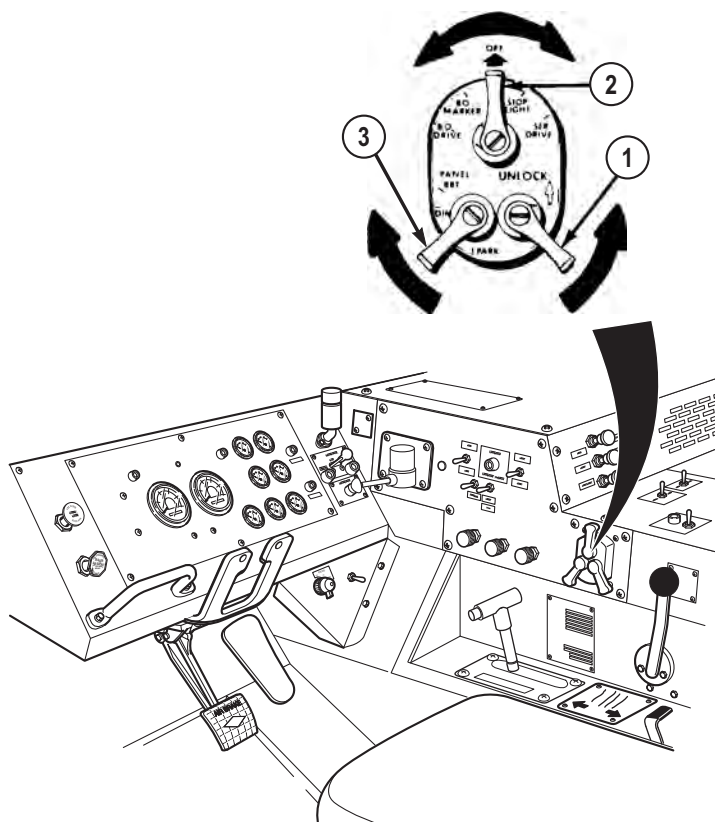


Figure 1.

**NOTE**

Panel lights will not function if lighting control lever is in OFF position.

2. Set lighting control lever (2) to desired position.
3. Release UNLOCK lever (1).
4. Set PANEL lever (3) to DIM or BRT (bright) as needed.

**NOTE**

Complete Steps (5) and (6) when panel lights are no longer required.

5. Set PANEL lever (3) to OFF position.



**TURN PANEL LIGHTS ON/OFF - Continued**

6. Set lighting control lever (2) to OFF position.

**END OF TASK**

**END OF WORK PACKAGE**



**OPERATOR MAINTENANCE  
OPERATE PARKING LIGHTS**

---

**INITIAL SETUP:**

Not Applicable

---

**TURN PARKING LIGHTS ON/OFF****CAUTION**

Failure to place light switches in the off position when vehicle is not in use may cause battery and/or vehicle damage.

1. Lift up and hold UNLOCK lever (1).

## TURN PARKING LIGHTS ON/OFF - Continued

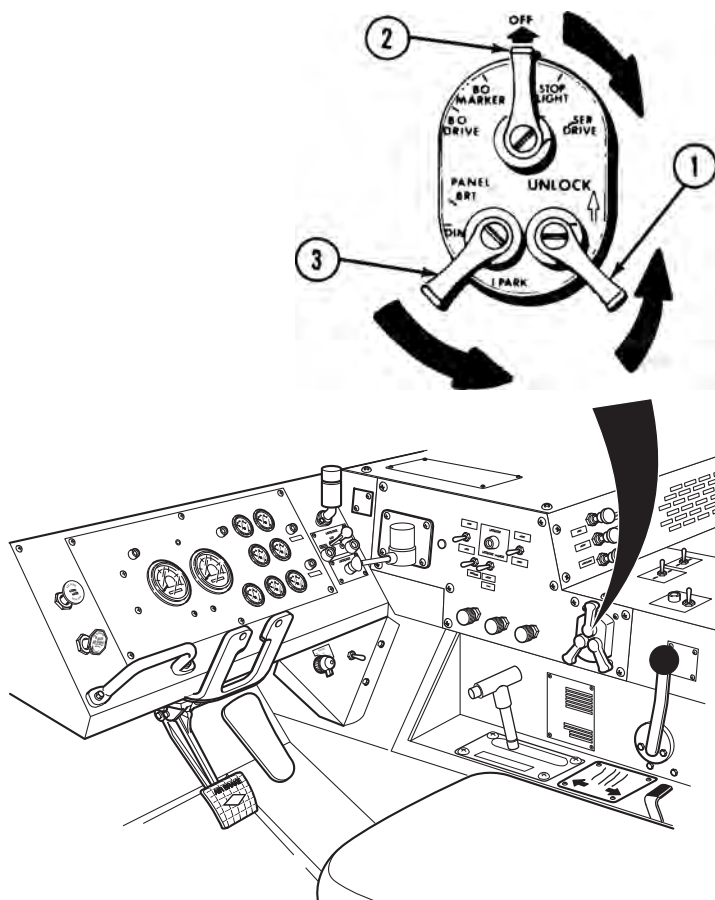


Figure 1.

2. Set lighting control lever (2) to SER DRIVE position.
3. Set PANEL lever (3) to PARK position.
4. Release UNLOCK lever (1).

**NOTE**

Complete Steps (5) and (6) when parking lights are no longer required.

5. Set PANEL lever (3) to OFF position.

**TURN PARKING LIGHTS ON/OFF - Continued**

6. Set lighting control lever (2) to OFF position.

**END OF TASK**

**END OF WORK PACKAGE**



## OPERATOR MAINTENANCE OPERATE SERVICE DRIVE LIGHTS

### INITIAL SETUP:

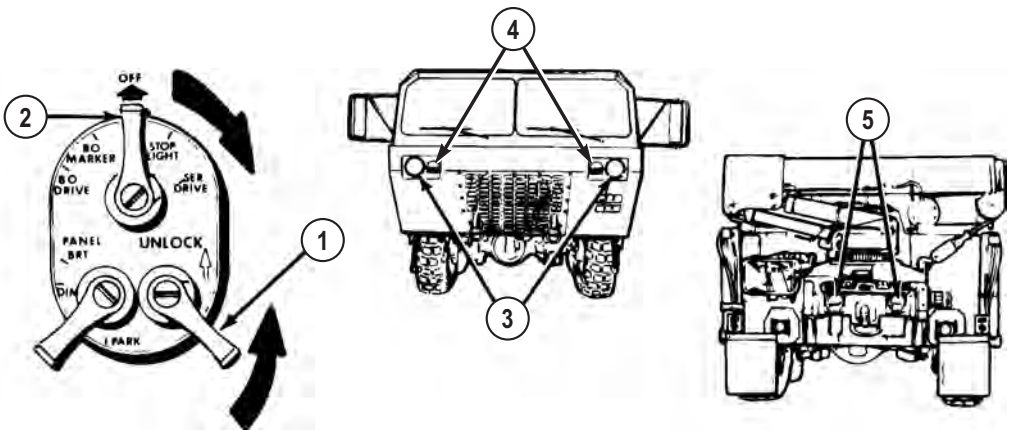
Not Applicable

### TURN SERVICE DRIVE LIGHTS ON/OFF

#### CAUTION

Failure to place light switches in the off position when vehicle is not in use may cause battery and/or vehicle damage.

1. Lift up and hold UNLOCK lever (1).



*Figure 1.*

2. Set lighting control lever (2) to SER DRIVE position.

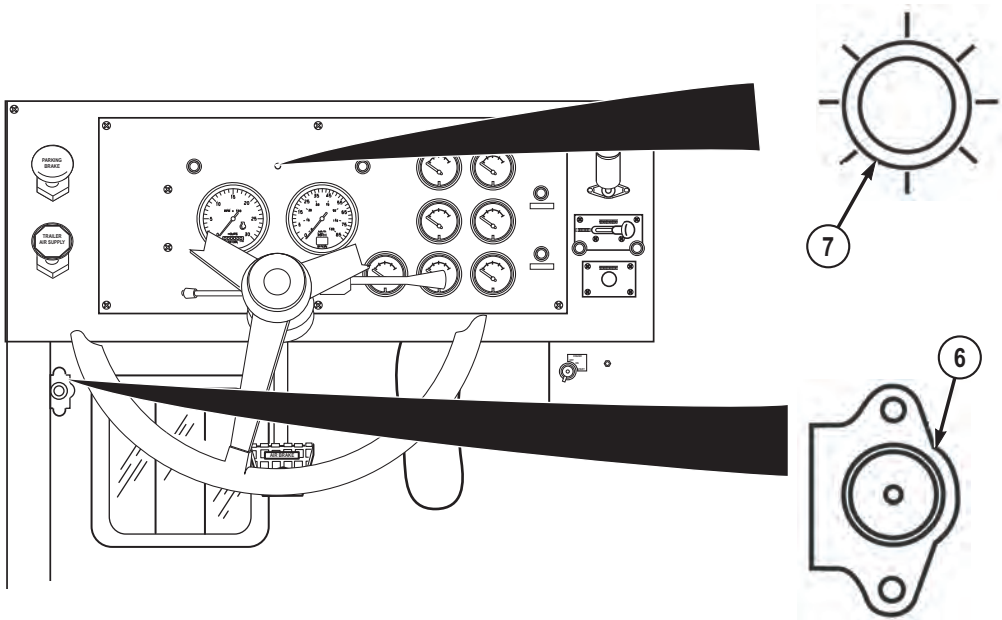
#### NOTE

Service stop lights (incorporated in taillights) will illuminate when service brake pedal is applied.

3. Release UNLOCK lever (1). Service headlights (3), composite lights (4), and taillights (5) will illuminate.

**TURN SERVICE DRIVE LIGHTS ON/OFF - Continued**

4. Press dimmer switch (6) with foot to cycle between high and low headlight beams. High beam indicator (7) will illuminate (red) when high beams are selected.



*Figure 2.*

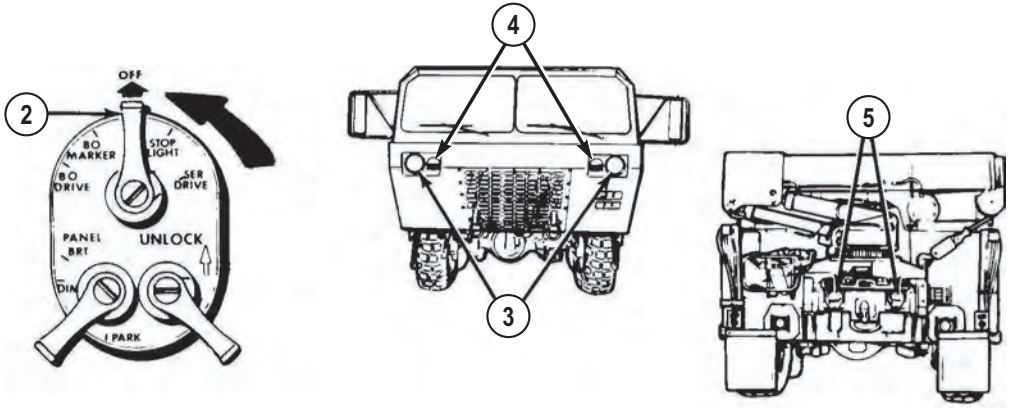
**NOTE**

Complete Step (5) when service drive lights are no longer required.

5. Set lighting control lever (2) to OFF position. Service headlights (3), composite lights (4), and taillights (5) will go out.



**TURN SERVICE DRIVE LIGHTS ON/OFF - Continued**



*Figure 3.*

**END OF TASK**

**END OF WORK PACKAGE**



**OPERATOR MAINTENANCE  
OPERATE STOPLIGHTS**

---

**INITIAL SETUP:**

Not Applicable

---

**TURN STOPLIGHTS ON/OFF****CAUTION**

Failure to place light switches in the OFF position when vehicle is not in use may cause battery and/or vehicle damage.

**NOTE**

Ensure service stoplights are turned on prior to driving vehicle.

1. Lift up and hold UNLOCK lever (1).

## TURN STOPLIGHTS ON/OFF - Continued

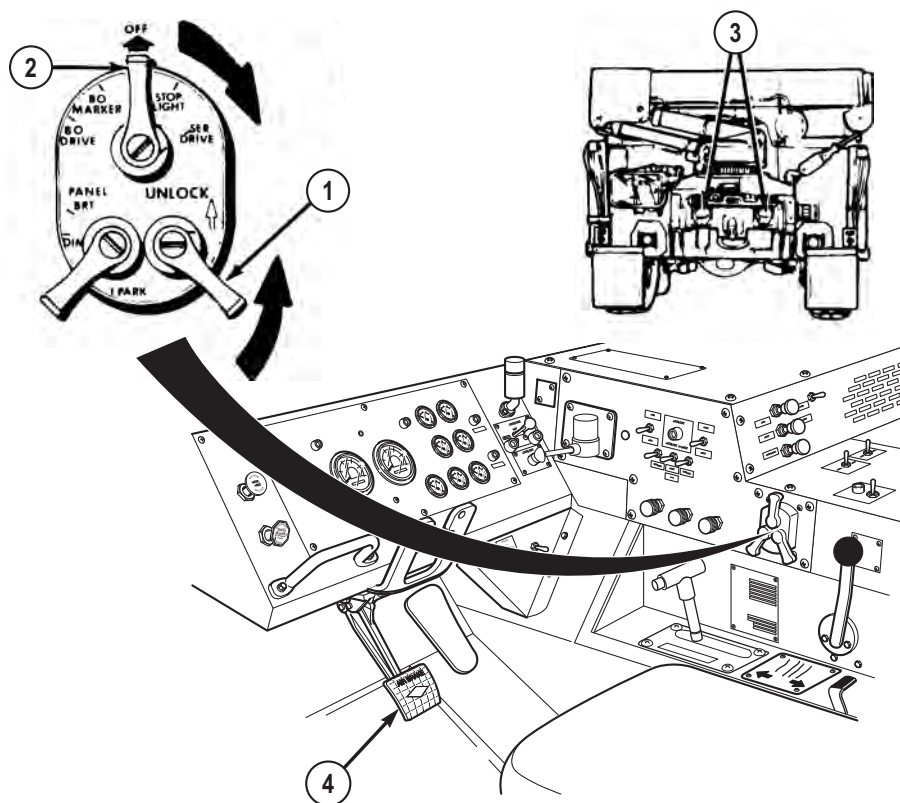


Figure 1.

2. Set lighting control lever (2) to STOP LIGHT position.
3. Release UNLOCK lever (1). Stoplights (3) will illuminate when service brake pedal (4) is applied.

**NOTE**

Complete Step (4) when stoplights are no longer required.

4. Set lighting control lever (2) to OFF position. Stoplights will no longer function.

**END OF TASK****END OF WORK PACKAGE**

---

## OPERATOR MAINTENANCE OPERATE CLEARANCE LIGHTS

---

### INITIAL SETUP:

Not Applicable

---

### TURN CLEARANCE LIGHTS ON/OFF

#### CAUTION

Failure to place light switches in the OFF position when vehicle is not in use may cause battery and/or vehicle damage.

1. Lift up and hold UNLOCK lever (1).

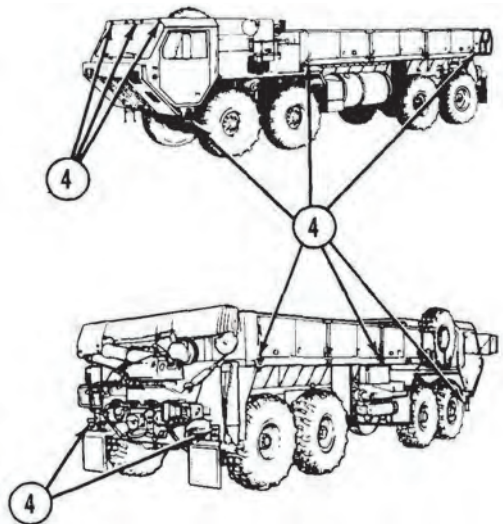
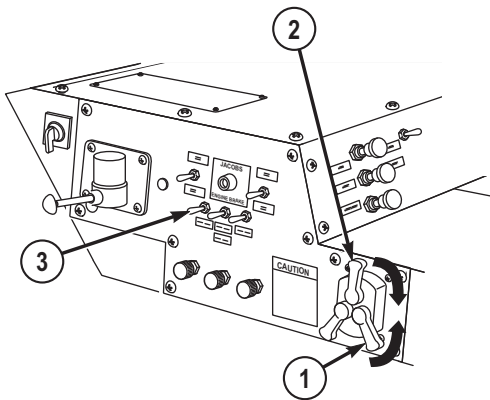


Figure 1.

2. Set lighting control lever (2) to either STOP LIGHT or SER DRIVE position.
3. Release UNLOCK lever (1).
4. Set CL LPS switch (3) to on position. Clearance lights (4) will illuminate.

**TURN CLEARANCE LIGHTS ON/OFF - Continued****NOTE**

Complete Steps (5) and (6) when clearance lights are no longer required.

5. Set CL LPS switch (3) to off position. Clearance lights (4) will go out.
6. Set lighting control lever (2) to OFF position.

**END OF TASK****END OF WORK PACKAGE**

## OPERATOR MAINTENANCE OPERATE BLACKOUT DRIVE LIGHT

### INITIAL SETUP:

Not Applicable

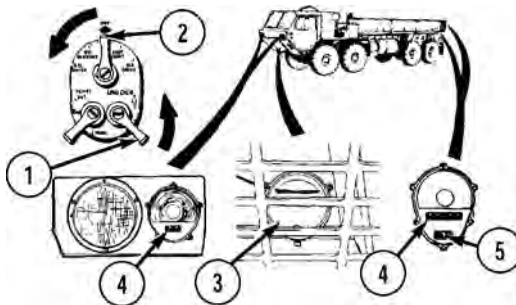
### TURN BLACKOUT DRIVE LIGHT ON/OFF

#### CAUTION

Failure to place light switches in the OFF position when vehicle is not in use may cause battery and/or vehicle damage.

#### NOTE

- Use blackout drive light for night driving under blackout conditions.
  - Cabin dome light/switch, vehicle mounted work lights/switch (M983, M984A1, M1977), rear beacon lights/switch (M984A only), electric horn (on steering column), and reverse alarm are disabled when lighting control lever is positioned to either blackout lighting position.
1. Lift up and hold UNLOCK lever (1).



*Figure 1.*

2. Set lighting control lever (2) to B.O. DRIVE position.
3. Release UNLOCK lever (1); blackout drive light (3) and blackout markers (4) will illuminate.
4. Blackout stoplights (5) will illuminate when service brake pedal is applied.

**TURN BLACKOUT DRIVE LIGHT ON/OFF - Continued****NOTE**

Complete Step (5) when blackout lights are no longer required.

5. Set lighting control lever (2) to OFF position; blackout drive light (3) and blackout markers (4) will go out.

**END OF TASK****END OF WORK PACKAGE**



---

**OPERATOR MAINTENANCE  
OPERATE BLACKOUT MARKERS**

---

**INITIAL SETUP:**

Not Applicable

---

**TURN BLACKOUT MARKERS ON/OFF**

**CAUTION**

Failure to place light switches in the OFF position when vehicle is not in use may cause battery and/or vehicle damage.

**NOTE**

Cabin dome light/switch, vehicle mounted work lights/switch (M983, M984A1, M1977), rear beacon lights/switch (M984A only), electric horn (on steering column), and reverse alarm are disabled when lighting control lever is positioned to either blackout lighting position.

1. Lift up and hold UNLOCK lever (1).

## TURN BLACKOUT MARKERS ON/OFF - Continued

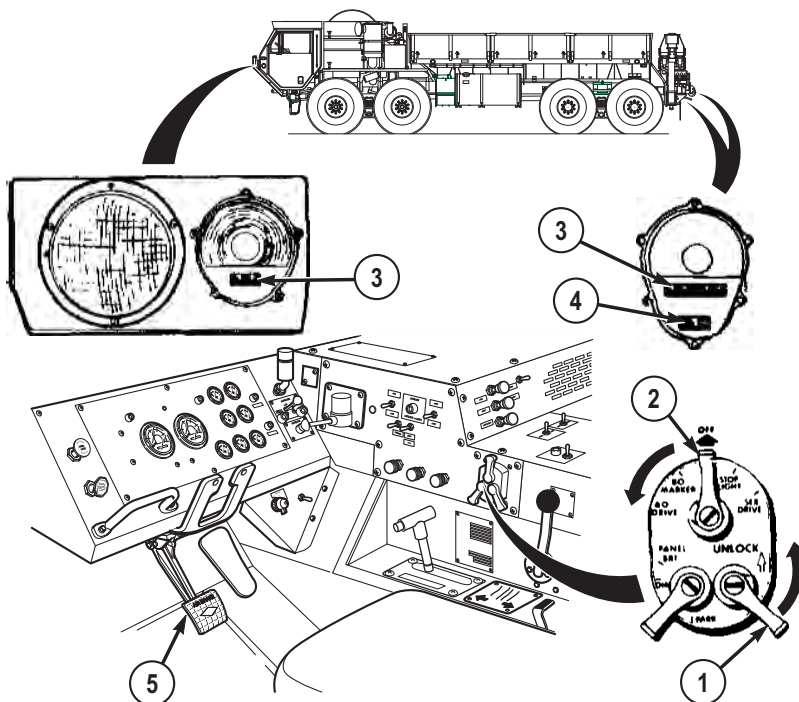


Figure 1.

2. Set lighting control lever (2) to B.O. MARKER position. Blackout markers (3) will illuminate.
3. Blackout stoplight markers (4), which are located on vehicle taillights, will illuminate when service brake pedal (5) is applied.

**NOTE**

Complete Step (4) when blackout markers are no longer required.

4. Set lighting control lever (1) to OFF. Blackout markers (3) will go out.

**END OF TASK**

**END OF WORK PACKAGE**

---

## OPERATOR MAINTENANCE PORTABLE BEACON LIGHT OPERATION

---

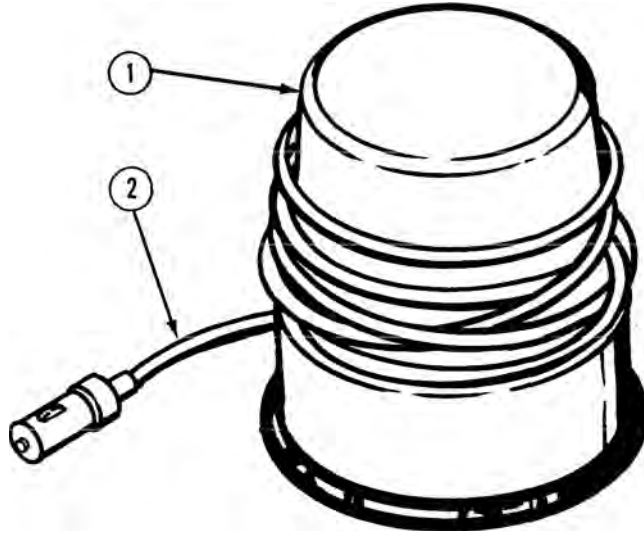
### INITIAL SETUP:

Not Applicable

---

### INSTALL/REMOVE PORTABLE BEACON LIGHT

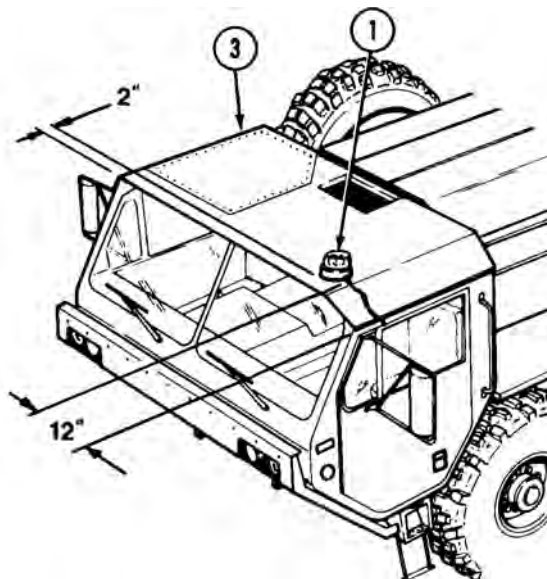
1. Remove beacon light (1) from stowage and unwind cord (2).



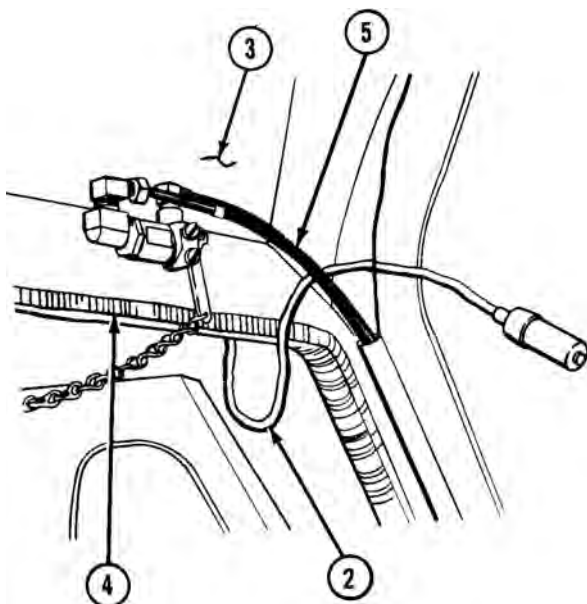
*Figure 1.*

2. Place beacon light (1) on driver side front corner of cab roof (3) approximately 12 in. (30 cm) from driver side cab, and approximately 2 in. (5 cm) from front edge of cab roof.

## INSTALL/REMOVE PORTABLE BEACON LIGHT - Continued

*Figure 2.*

3. Route beacon cord (2) through driver side door opening (4) and between inside of cab roof (3) and air horn valve hoses (5).

**INSTALL/REMOVE PORTABLE BEACON LIGHT - Continued***Figure 3.*

4. Route beacon cord (2) down left side of driver's windshield (6), across driver side defroster (7), and across center console (8) to utility outlet (9).

## INSTALL/REMOVE PORTABLE BEACON LIGHT - Continued

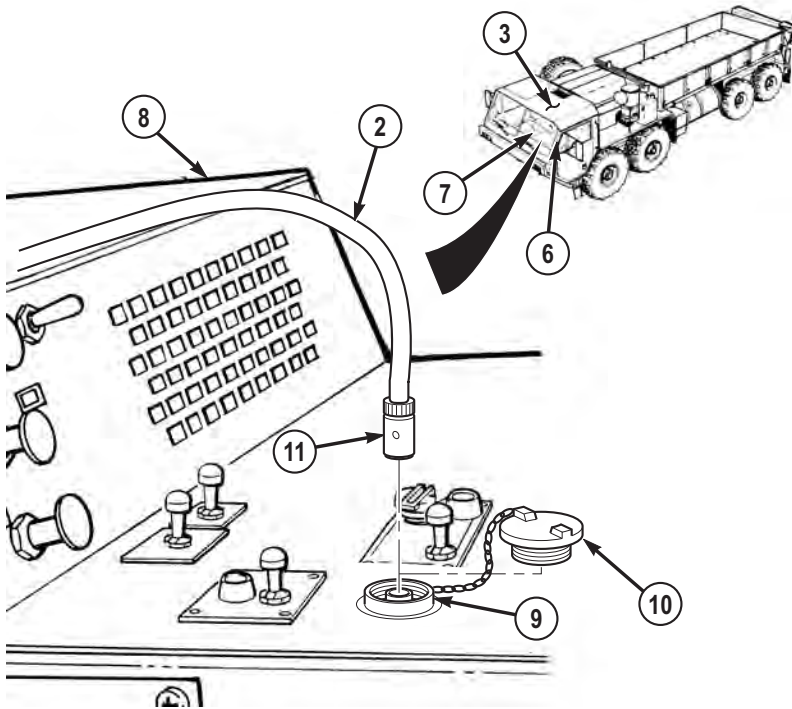


Figure 4.

5. Remove utility outlet cover (10).

**NOTE**

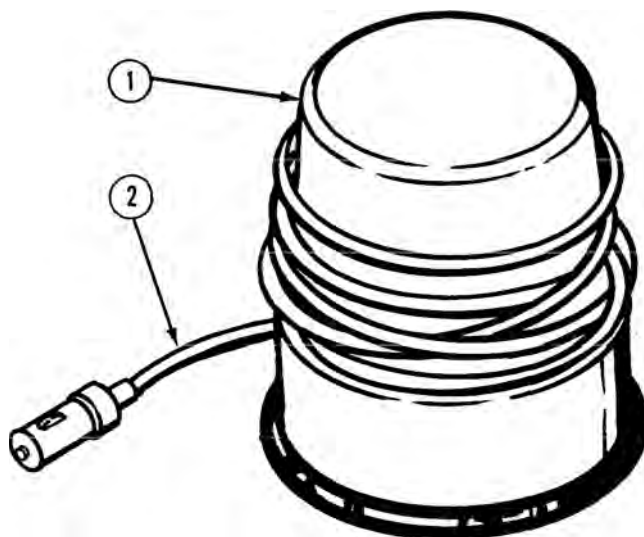
ENGINE switch must be positioned to ON for portable beacon light to operate.

6. Insert beacon cord plug (11) into utility outlet (9).

**INSTALL/REMOVE PORTABLE BEACON LIGHT - Continued****NOTE**

Perform Steps (7) through (11) when use of portable beacon light is no longer required.

7. Remove beacon cord plug (11) from utility outlet (9).
8. Install utility outlet cover (10).
9. Remove beacon cord (2) from interior of cab.
10. Remove beacon light from cab roof (3).
11. Rewind cord (2) and return beacon light (1) to appropriate stowage.



*Figure 5.*

**END OF TASK**

**END OF WORK PACKAGE**





**OPERATOR MAINTENANCE  
OPERATE TURN SIGNALS**

---

**INITIAL SETUP:**

Not Applicable

---

**SET TURN SIGNAL ON/OFF**

1. Lift up and hold UNLOCK lever (1).

SET TURN SIGNAL ON/OFF - Continued

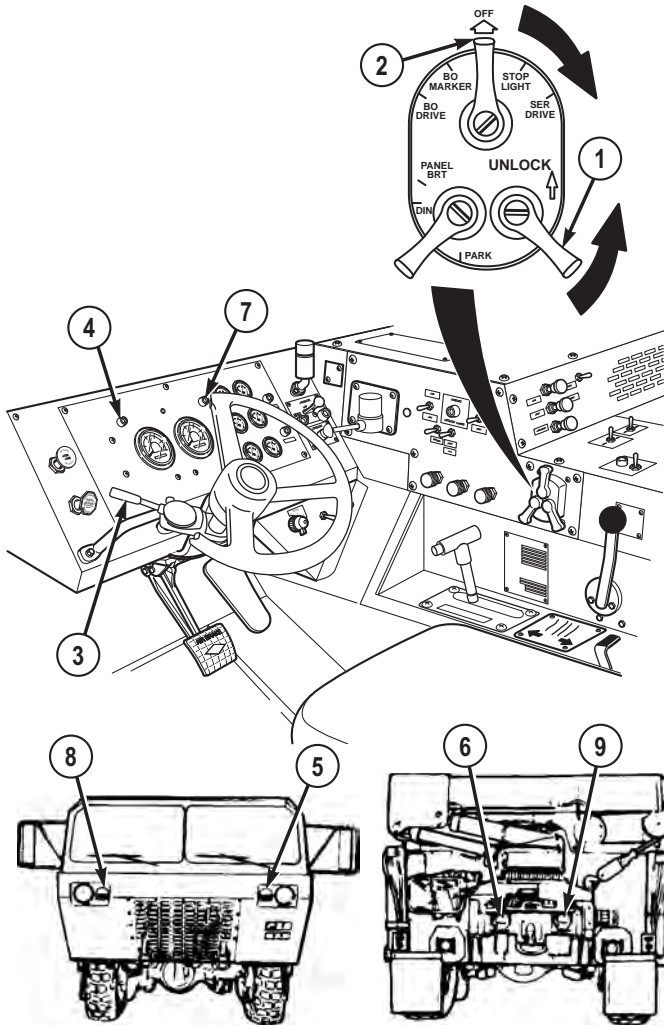


Figure 1.

2. Set lighting control lever (2) to SER DRIVE position.

**NOTE**

If left turn is desired, complete Step (3). If right turn is desired, skip to Step (4).

**SET TURN SIGNAL ON/OFF - Continued**

3. Set turn signal lever (3) down to left turn position. Left turn indicator (4), and driver side front (5) and rear (6) composite lights will flash (approximately once per second) simultaneously.

**NOTE**

If right turn is desired, complete Step (4).

4. Set turn signal lever (3) up to right turn position. Right turn indicator (7), and passenger side front (8) and rear (9) composite lights will flash (approximately once per second) simultaneously.

**NOTE**

Turn signal level may return to off (center) position automatically once turn is complete, if this is not the case and/or turn signal is no longer desired, complete Step (5).

5. Set turn signal lever (3) to center (off) position. Appropriate turn indicator and composite lights will go out.

**END OF TASK****END OF WORK PACKAGE**



**OPERATOR MAINTENANCE  
OPERATE EMERGENCY FLASHERS**

---

**INITIAL SETUP:**

Not Applicable

---

**TURN EMERGENCY FLASHERS ON/OFF****NOTE**

Highway Emergency Marker Kit (WP 0099) should be used to mark location and caution oncoming traffic whenever vehicle is disabled or must park in areas where there is other traffic.

1. Lift up and hold UNLOCK lever (1).

## TURN EMERGENCY FLASHERS ON/OFF - Continued

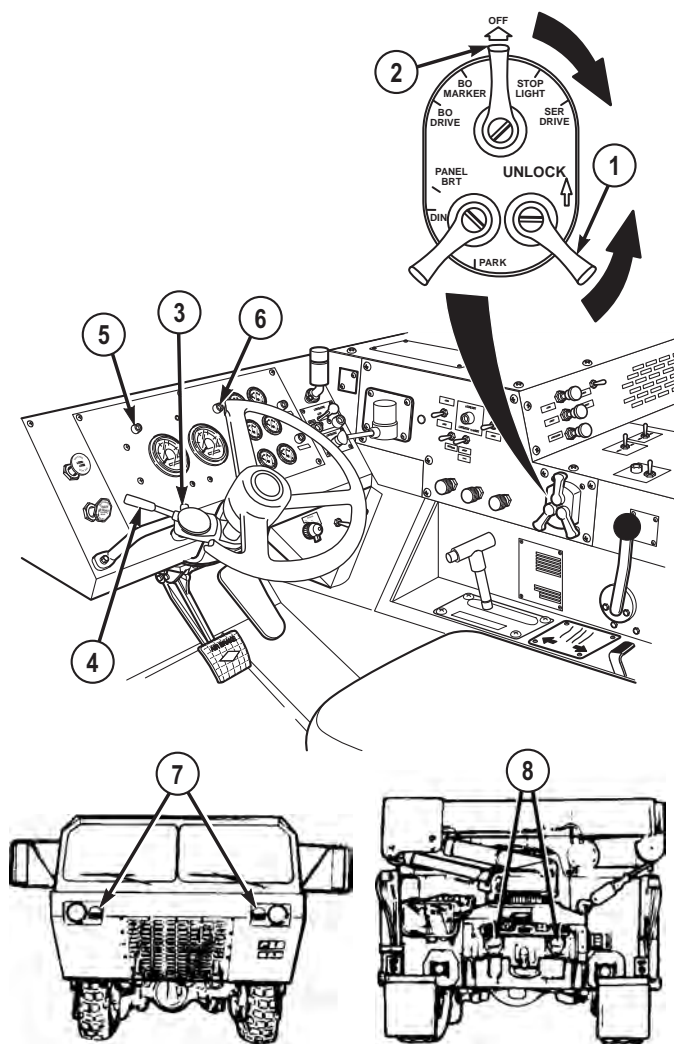


Figure 1.

2. Set lighting control lever (2) to SER DRIVE position.
3. Set turn signal lever (3) to right turn position.
4. Push down emergency flasher control (4) and push turn signal lever (3) up as far as it will go. Both left (5) and right (6) turn indicators, and front (7) and rear (8) composite lights will flash simultaneously at approximately once per second.

**TURN EMERGENCY FLASHERS ON/OFF - Continued****NOTE**

Perform Step (5) when emergency flashers are no longer desired.

5. Pull turn signal lever (3) down to center position.

**END OF TASK****END OF WORK PACKAGE**





---

## OPERATOR MAINTENANCE INSTALL/REMOVE WHEEL CHOCKS

---

### INITIAL SETUP:

Not Applicable

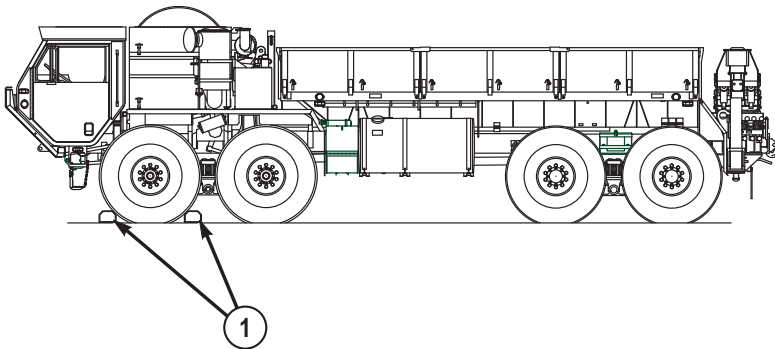
---

### INSTALL WHEEL CHOCKS

#### NOTE

- Vehicle is equipped with four wheel chocks.
- Always chock tires if vehicle is shut down on uneven terrain.
- Always chock tires if vehicle parking brake is inoperative.
- Ensure local policy for chocking vehicle tires is followed.

1. Remove two wheel chocks (1) from stowage.



*Figure 1.*

2. Place one wheel chock (1) snugly against both front and rear of tire (No. 1 axle driver side tire shown).

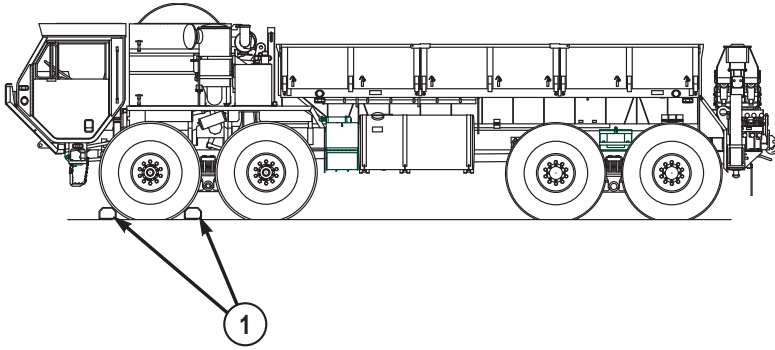
### REMOVE WHEEL CHOCKS

#### NOTE

- Vehicle is equipped with four wheel chocks.
- Ensure local policy for removing wheel chocks is followed.

**REMOVE WHEEL CHOCKS - Continued**

1. Remove wheel chocks (1) from both front and rear of tire (No. 1 axle driver side tire shown).



*Figure 2.*

2. Return wheel chocks (1) to stowage.
3. Repeat Steps (1) and (2) if more than one wheel is chocked.

**END OF TASK**

**END OF WORK PACKAGE**

---

## OPERATOR MAINTENANCE CHANGE VEHICLE WEIGHT INDICATOR

---

### INITIAL SETUP:

Not Applicable

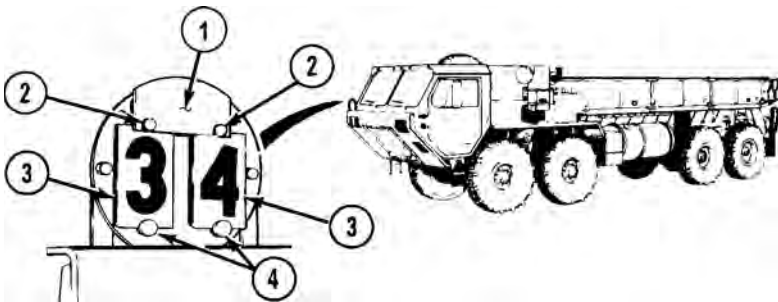
---

### CHANGE VEHICLE WEIGHT INDICATOR

#### NOTE

Refer to load classification table for appropriate vehicle weight.

1. Press in bottom of lockplate (1).



*Figure 1.*

2. Push lockplate (1) up and off one lockpin (2).
3. Remove number plates (3).
4. Place new number on top of number plates (3).
5. Install number plates (3) on lockpin (4).
6. Push down number plates (3). Slide lockplate (1) on lockpin (2).
7. Repeat Steps (1) through (7) to change other number.

**END OF TASK**

**END OF WORK PACKAGE**



---

## OPERATOR MAINTENANCE ADJUST SEAT

---

### INITIAL SETUP:

Not Applicable

---

### INSTALL FOOTREST

1. Remove safety pin (1) and yoke pin (2).

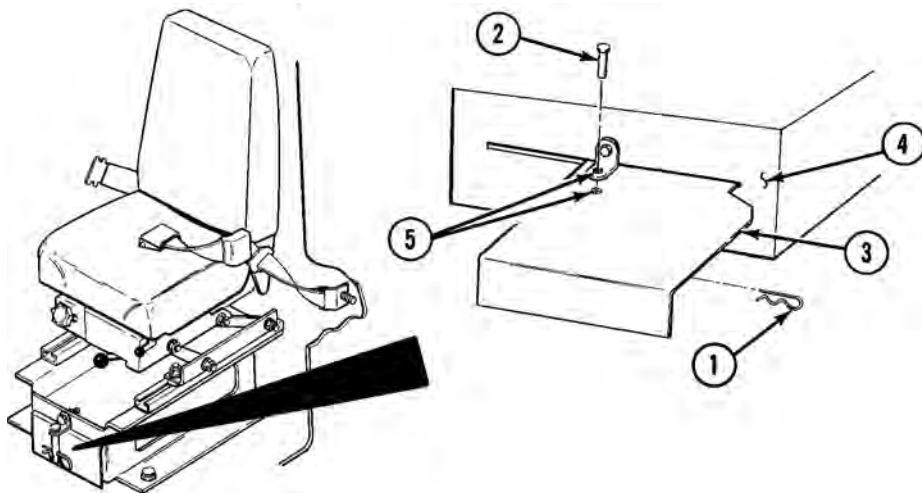
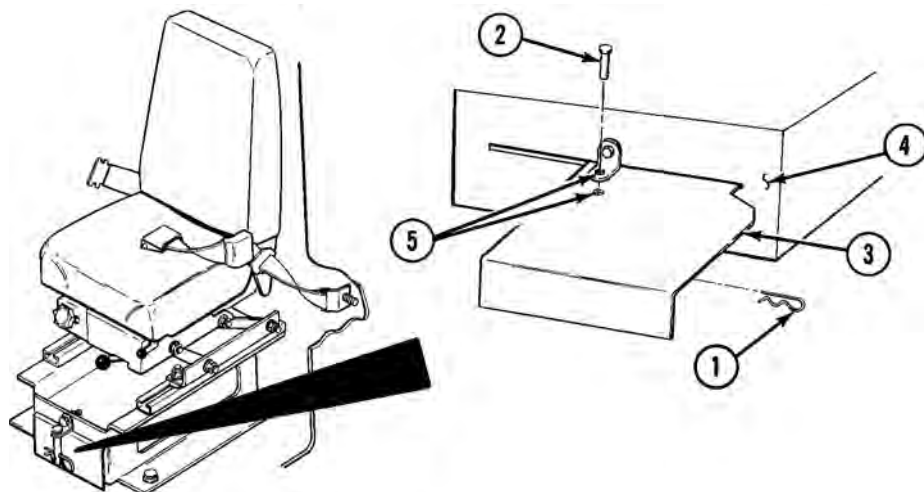


Figure 1.

2. Pull out footrest (3).
3. Slide footrest (3) toward seat brace (4) so holes (5) are aligned.
4. Install yoke pin (2) and safety pin (1).

### STOW FOOTREST

1. Remove safety pin (1) and yoke pin (2).

**STOW FOOTREST - Continued***Figure 2.*

2. Slide footrest (3) under seat brace (4).
3. Install yoke pin (2) and safety pin (1).

**ADJUST SEAT****WARNING**

Use care when adjusting knob. Seat collapses when knob screw is adjusted. Do not place hand between seat mount and low neck. Failure to comply may result in injury or death to personnel.

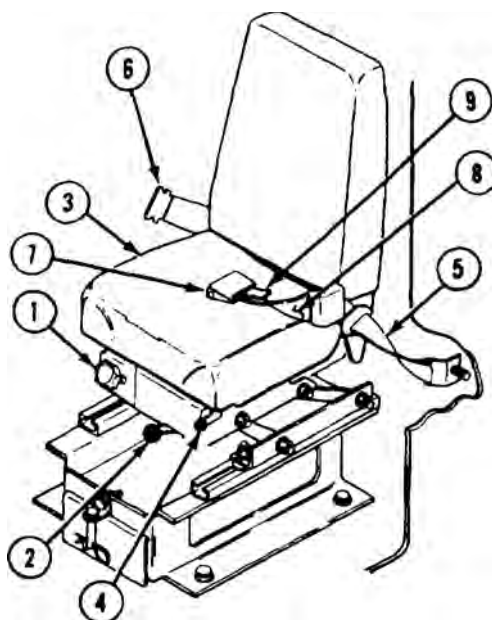
**NOTE**

- Sit in seat and perform Steps (1) through (8) as necessary.
  - Driver and crew (passenger side) side seats are adjusted the same way.
1. Turn knob (1) to control cushion firmness.

**ADJUST SEAT - Continued****NOTE**

Retaining straps may need to be loosened before moving seat forward.

2. Push lever (2) to left and slide seat (3) forward or backward.
3. Let go of lever (2) to lock seat (3) in place.



*Figure 3.*

4. Pull up lever (4) and lift self off seat (3) to raise seat (3).
5. Pull up lever (4) and push down on seat (3) to lower seat (3).
6. Let go of lever (4) to lock seat (3) in place.
7. Tighten seat retaining straps (5).
8. Adjust all vehicle mirrors as necessary once driver's seat is properly adjusted.

**END OF TASK**

**END OF WORK PACKAGE**





---

**OPERATOR MAINTENANCE  
OPERATE THREE-POINT SEATBELT**

---

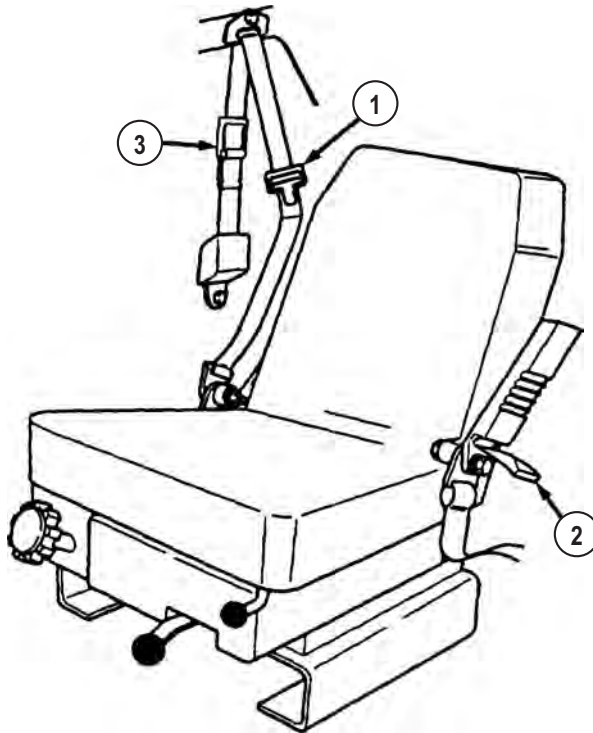
**INITIAL SETUP:**

Not Applicable

---

**OPERATE THREE-POINT SEATBELT**

1. Put seatbelt flat metal end (1) into interconnect (2) until click is heard.



*Figure 1.*

2. Pull out on comfort latch (3) locking handle and move comfort latch up and down strap until snug (but not tight) fit at shoulder is achieved.

**OPERATE THREE-POINT SEATBELT - Continued**

3. To release seatbelt, push in button on interconnect (2).

**END OF TASK**

**END OF WORK PACKAGE**

---

**OPERATOR MAINTENANCE  
ADJUST AIR-RIDE SEAT**

---

**INITIAL SETUP:**

Not Applicable

---

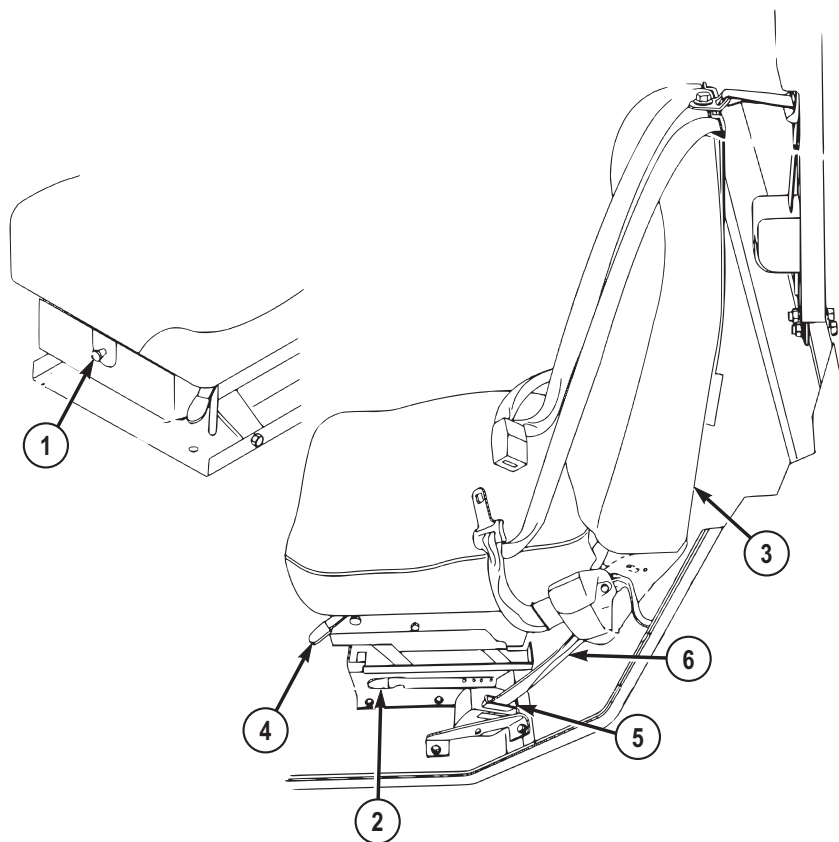
**ADJUST AIR-RIDE SEAT****WARNING**

When adjusting seat ride firmness, keep fingers out from under seat. Failure to comply may result in injury or death to personnel.

**NOTE**

- Sit in seat and perform Steps (1) through (6) as necessary.
  - Driver and crew (passenger side) side seats are adjusted the same way.
1. Pull out (increase) or push in (decrease) knob (1) to adjust seat ride firmness.

## ADJUST AIR-RIDE SEAT - Continued

*Figure 1.*

2. Move lever (2) away from seat (3) and slide seat (3) forward or backwards.
3. Move lever (2) towards seat (3) to lock seat (3) in place.
4. Pull up lever (4) and lift self off seat (3) to raise, or pull up lever (4) and push down on seat (3) to lower.
5. Release lever (4) to lock seat (3) in place.
6. Adjust all vehicle mirrors as necessary once driver's seat is properly adjusted.

**NOTE**

If vehicle is bounced too hard, seat tether may lock seat in down position.  
Park vehicle (WP 0056) and perform Steps (7) through (10) to free seat.

7. Push in knob (1) to decrease seat ride firmness.

**ADJUST AIR-RIDE SEAT - Continued**

8. Move lever (2) away from seat (3), and slide seat (3) backwards to relieve tension on retractor (5).
9. Feed some seat tether (6) into retractor (5) until it releases.
10. Perform Steps (1) through (5) as required to reset seat (3) to desired position.

**END OF TASK****END OF WORK PACKAGE**



---

## OPERATOR MAINTENANCE OPERATE FOUR-POINT SEATBELT

---

### INITIAL SETUP:

Not Applicable

---

### OPERATE FOUR-POINT SEATBELT

1. Insert seatbelt flat metal end (1) into buckle (2) until click is heard.

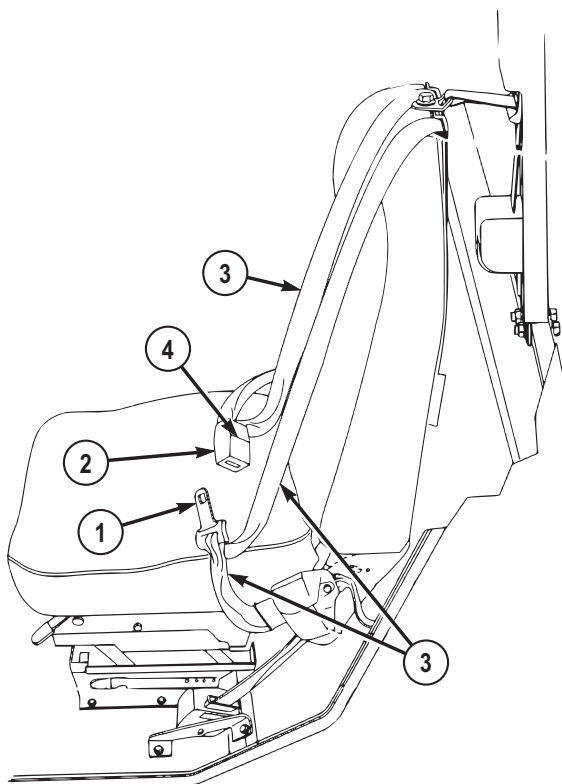


Figure 1.

**OPERATE FOUR-POINT SEATBELT - Continued**

2. To release seatbelt (3), push in button (4) on buckle (2).

**END OF TASK**

**END OF WORK PACKAGE**



---

## OPERATOR MAINTENANCE INSTALL/REMOVE TIRE CHAINS

---

### INITIAL SETUP:

#### Personnel Required

Operator and Assistant - - - (2)

---

### INSTALL TIRE CHAINS

#### CAUTION

When tire chains are used, they must be used on all four rear wheels. Chains must not be used when driving on hard surfaces where there is no wheel slippage. Improper use of tire chains may result in equipment damage.

#### NOTE

- This procedure is a two soldier task.
  - Tire chains on No. 3 and No. 4 axle tires are all installed the same. Passenger side No. 4 axle shown.
  - Maximum speed limit for vehicles driving with chains in city or on highway is 10 mph (16 km/h).
  - Maximum speed limit for vehicles driving with chains off-road is 15 mph (24 km/h).
1. With aid of an assistant, place tire chain (1) on ground with cross chain connecting links (2) facing down.

## INSTALL TIRE CHAINS - Continued

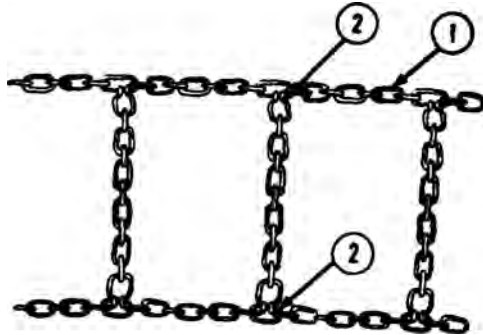


Figure 1.

**NOTE**

Assistant shall ensure vehicle is stopped when only tire in contact with tire chains is tire being equipped.

2. Move vehicle onto tire chain (1) while assistant guides vehicle so tire (3) is about one-third of way on tire chain.

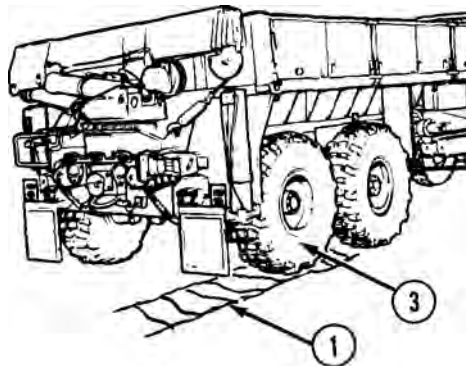
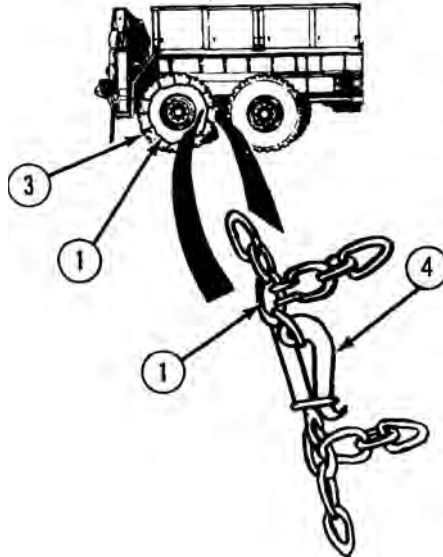


Figure 2.

**NOTE**

Ensure only tire in contact with tire chains is tire being equipped.

3. Park vehicle. (WP 0056)
4. With aid of an assistant, wrap tire chain (1) around tire (3).

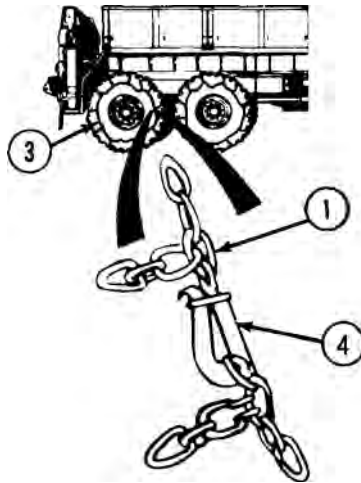
**INSTALL TIRE CHAINS - Continued***Figure 3.*

5. With aid of an assistant, connect and secure inside and outside clamps (4) so tire chain (1) is as tight as possible.
6. With aid of an assistant, repeat Steps (1) through (5) on remaining tires of No. 3 and No. 4 axles.
7. Drive vehicle forward (WP 0050) about 15 ft. (4.6 m) and then drive vehicle in reverse (WP 0051) about 15 ft. (4.6 m) as guided by assistant.
8. Park vehicle. (WP 0056)

**NOTE**

Tire chains on No. 3 and No. 4 axle tires are all tightened up the same.  
 Passenger side No. 4 axle shown.

9. With aid of an assistant, disconnect inside clamp (4) of tire chain (1) on tire (3).

**INSTALL TIRE CHAINS - Continued***Figure 4.*

10. With aid of an assistant, take up slack in tire chain (1).
11. With aid of an assistant, connect inside clamp (4).
12. With aid of an assistant, disconnect outside clamp (4) of tire chain (1) on tire (3).
13. With aid of an assistant, take up slack in tire chain (1).
14. With aid of an assistant, connect outside clamp (4).
15. With aid of an assistant, take up slack in tire chains on other three rear tires by repeating Steps (10) through (15).

**REMOVE TIRE CHAINS****NOTE**

- This procedure is a two soldier task.
- Tire chains on No. 4 axle tires are both removed the same. Passenger side shown.

1. Move vehicle into position so tire chain (1) and clamps (2) on tire (3) are at 4 o'clock position while assistant guides vehicle.

## REMOVE TIRE CHAINS - Continued

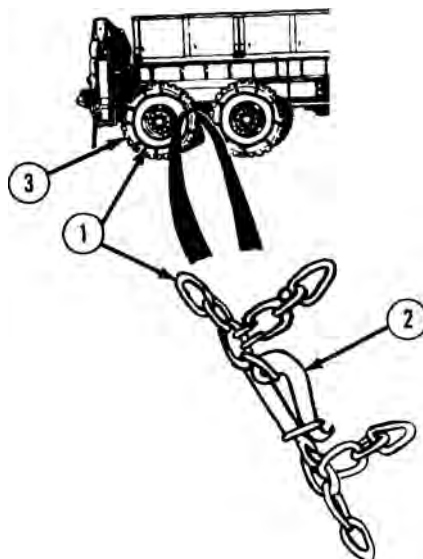


Figure 5.

2. Park vehicle. (WP 0056)
3. With aid of an assistant, disconnect inside and outside clamps (2) of tire chain (1).

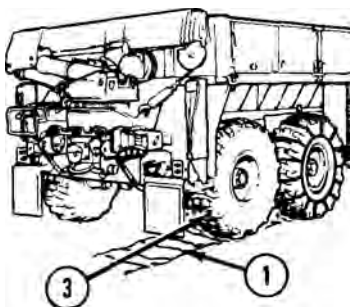


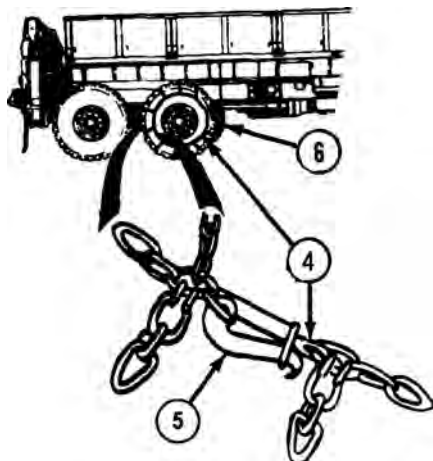
Figure 6.

4. With aid of an assistant, unwrap tire chain (1) from tire (3) and spread tire chain out on ground behind vehicle.
5. Drive vehicle forward (WP 0050) off tire chain (1) while assistant guides vehicle.
6. With aid of an assistant, repeat Steps (2) through (5) for opposite side tire.

**REMOVE TIRE CHAINS - Continued****NOTE**

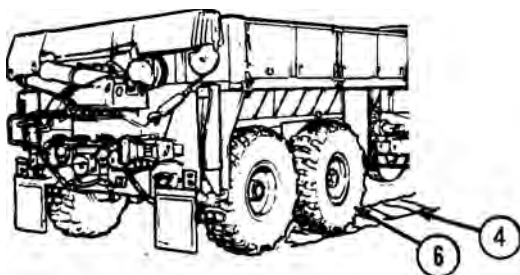
Tire chains on No. 3 axle tires are both removed the same. Passenger side shown.

7. Move vehicle into position so tire chain (4) and clamps (5) on tire (6) are at 8 o'clock position while assistant guides vehicle.



*Figure 7.*

8. Park vehicle. (WP 0056)
9. With aid of an assistant, disconnect inside and outside clamps (5) of tire chain (4).
10. With aid of an assistant, unwrap tire chain (4) from tire (6) and spread tire chain out on ground in front of tire.



*Figure 8.*

11. Drive vehicle forward (WP 0050) off tire chain (4) while assistant guides vehicle.

**REMOVE TIRE CHAINS - Continued**

12. With aid of an assistant, repeat Steps (7) through (11) for opposite side tire.

**END OF TASK**

**END OF WORK PACKAGE**





---

**OPERATOR MAINTENANCE  
FORD WATER OBSTACLE**

---

**INITIAL SETUP:**

Not Applicable

---

**WARNING**

Do not ford water unless depth is known. Water deeper than 4 ft. (1.2 m) may enter vehicle. Failure to comply may result in injury or death to personnel.

**NOTE**

After vehicle fords water obstacle, service all lubrication points below fording depth and check submerged gearboxes for presence of water upon return from mission (refer to lubrication instructions (WP 0151) for more information).

**CAUTION**

Towing a trailer may affect maximum fording depth (refer to applicable trailer operators manual). Do not ford water obstacle deeper than maximum depth allowed by either vehicle or trailer (whichever depth is less). Failure to comply may result in damage to equipment.

1. Ensure depth of fording site is not more than 4 ft. (1.2 m).
2. Ensure bottom at fording site is firm enough that 4 ft. (1.2 m) maximum fording depth will not be exceeded and vehicle will not become mired.
3. Stop vehicle at edge of water.
4. If brakes have been used heavily and are hot, allow drums and shoes to cool before entering water if possible.
5. Ensure engine is operating correctly before entering water.
6. Set TRANSFER CASE shift lever (1) to LO, 8X8 DRIVE indicator (2) will illuminate.

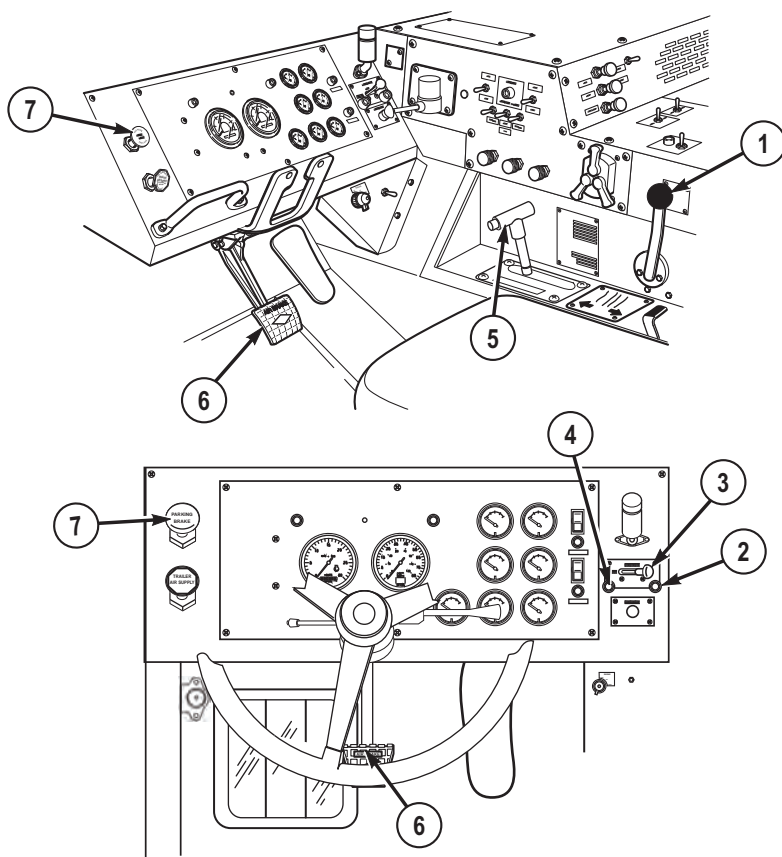


Figure 1.

7. Set TRACTION CONTROL lever (3) to INTER-AXLE DIFF. LOCK for added traction, INTER-AXLE LOCK indicator light (4) will come on.
8. Set transmission range selector (5) to 1 (1st gear range).
9. Drive vehicle slowly into water.
10. If engine stops, immediately attempt to restart engine. If engine will not start, tow or winch vehicle from water with another vehicle as soon as possible.
11. Drive vehicle at 3 to 4 mph (5 to 6 km/h) or less, through water.
12. Unless absolutely necessary, do not stop while in water.
13. If vehicle accidentally enters water deeper than 4 ft. (1.2 m), do the following:
  - a. Apply service brake pedal (6) and hold to stop vehicle.
  - b. Set transmission range selector (5) to R (reverse).

- c. Release service brake pedal (6).
  - d. Slowly back vehicle out of deep water.
14. After leaving water, lightly press service brake pedal (6) and hold while driving slowly to dry out brake linings.
  15. When clear of fording area, stop vehicle.
  16. Apply and release PARKING BRAKE control (WP 0045) (7) several times to remove water from brake components.
  17. Remove water and clean deposits from all vehicle parts as soon as possible.
  18. Deliver vehicle to field level maintenance as soon as possible.

**END OF TASK**

**END OF WORK PACKAGE**



---

**OPERATOR MAINTENANCE  
INTERIM NUCLEAR, BIOLOGICAL, AND CHEMICAL (NBC) DECONTAMINATION  
PROCEDURES**

---

**INITIAL SETUP:**

Not Applicable

---

**INTRODUCTION AND PROCEDURES**

**NOTE**

To reduce the effects of contamination in an NBC-contaminated environment, the HEMTT series vehicle should be operated with all windows, doors, and stowage boxes closed.

1. The HEMTT series vehicle is capable of being operated by personnel wearing nuclear, biological, or chemical (NBC) protective clothing without special tools or supporting equipment. Refer to FM 3-11.5 (WP 0161) for information on decontamination procedures. Specific procedures for the HEMTT series vehicle are as follows:
  - a. Rubber sleeves and other rubber items, rope, and gaskets will absorb and retain chemical agents. Replacement of these items is the recommended method of decontamination.
  - b. Lubricants or fluids may be present on the external surfaces of the HEMTT series vehicle or its components due to leaks or normal operation. These fluids will absorb NBC agents. The preferred method of decontamination is removal of these fluids using conventional decontamination methods in accordance with FM 3-11.5. (WP 0161)
  - c. Continued decontamination of the external HEMTT series vehicle surfaces with supertropical bleach (STB)/decontamination solution number 2 (DS2) will degrade clear plastic (e.g., hydraulic fluid reservoir sight glass) to the point where looking through it will become impossible. This problem will become more evident for soldiers wearing protective masks. Therefore, the use of STB or DS2 decontamination in the area of clear plastic should be minimized. Clear plastic should be decontaminated with warm, soapy water.
  - d. External surfaces of the HEMTT series vehicle and related equipment such as the remote control units that are marked with painted or stamped lettering will not withstand repeated decontamination with STB or DS2 without degradation of this lettering. Therefore, the recommended method of decontamination for these areas is washing with warm, soapy water.

**INTRODUCTION AND PROCEDURES - Continued****NOTE**

Replacement of hardware, as well as conventional methods of decontamination, are the preferred methods of decontamination for the areas listed below.

2. Areas that will entrap contaminants, making efficient decontamination extremely difficult include the following:
  - a. Exposed heads of screws.
  - b. Areas adjacent to and behind exposed hydraulic lines.
  - c. Hinged areas or access doors on the stowage boxes.
  - d. Retaining chains for lynchpins and lockpins.
  - e. Areas around the tie downs, lifting rings, crevices around access doors, external valves and drains, and exposed hydraulic connectors.
  - f. Areas behind knobs, levers, externally-mounted equipment, specification and advisory data plates, and roller and locking mechanisms.
  - g. Winch cable and winch hook assembly.
3. Conventional methods of decontamination should be used on all areas listed in Steps (1) and (2), while stressing the importance of thoroughness, and the probability of some degree of continuing contact, including vapor hazard.
4. For additional NBC information, refer to FM 3-11.3 (WP 0161) and FM 3-11.4. (WP 0161)

**END OF TASK****END OF WORK PACKAGE**

---

## OPERATOR MAINTENANCE SELF-RECOVER VEHICLE USING SELF-RECOVERY WINCH

---

### INITIAL SETUP:

#### Personnel Required

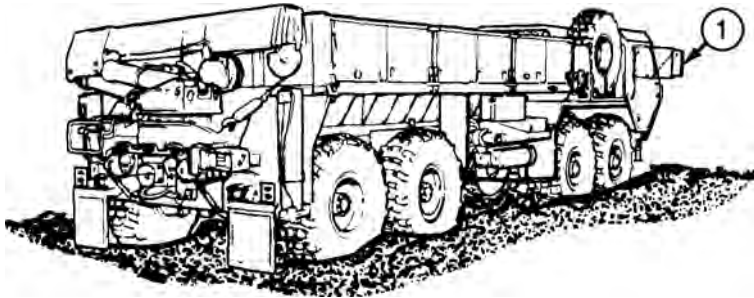
Operator and Assistant - - - (2)

---

### WINCH MIRED VEHICLE FORWARD

#### NOTE

- For additional information on vehicle self-recovery, refer to FM 4-30.31. (WP 0161)
  - Vehicle self-recovery is a two soldier task. Soldiers must communicate by hand signals.
1. Shut off engine. (WP 0057)
  2. Adjust mirror (1) so assistant can be clearly seen during procedure.



*Figure 1.*

#### CAUTION

PTO ENGAGE switch must be in OFF position before moving hydraulic selector valve control to prevent equipment damage.

3. Set PTO ENGAGE switch (2) to OFF position. Indicator light (3) will go out.

## WINCH MIRED VEHICLE FORWARD - Continued

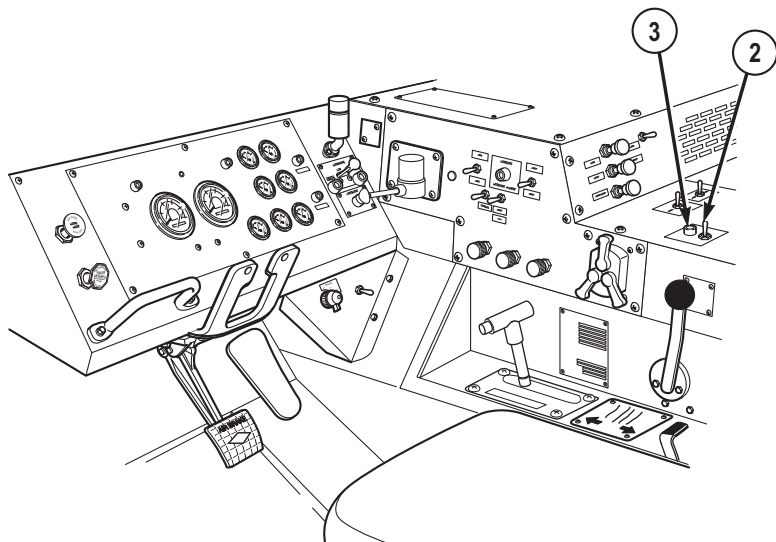
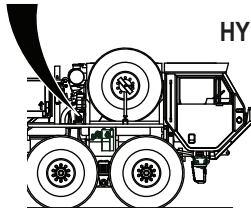
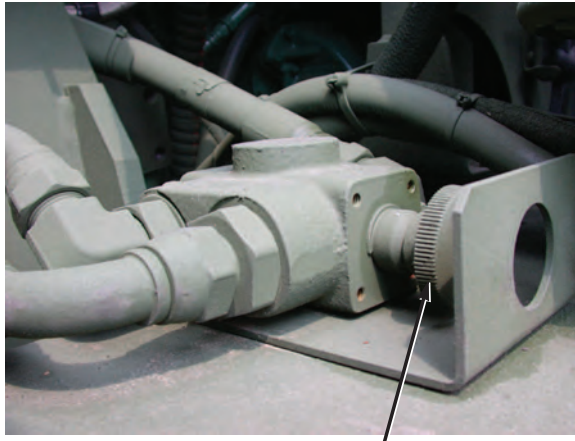


Figure 2.

4. Pull out hydraulic selector valve control.



**WINCH MIRED VEHICLE FORWARD - Continued**

**HYDRAULIC SELECTOR  
VALVE CONTROL**

*Figure 3.*

5. Start engine. (WP 0044)
6. Set PTO ENGAGE switch (2) to ON position. Indicator light (3) will illuminate.

## WINCH MIRED VEHICLE FORWARD - Continued

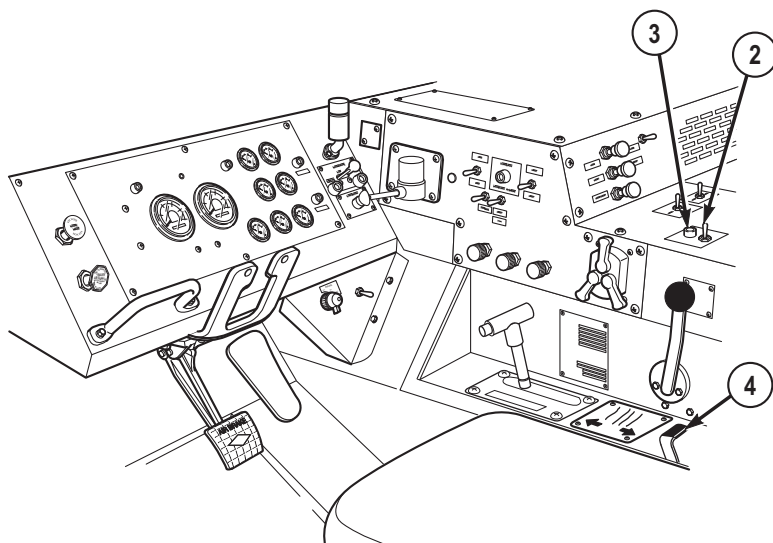


Figure 4.

7. Move winch shift lever (4) to OUT position to pay out small amount of cable.
8. Release winch shift lever (4) to center position.
9. Set PTO ENGAGE switch (2) to OFF position. Indicator light (3) will go out.
10. Remove cotter pin (5) from pin (6).

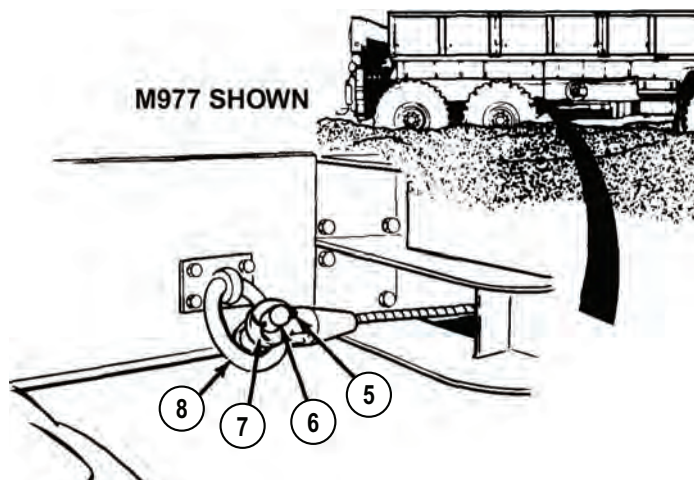


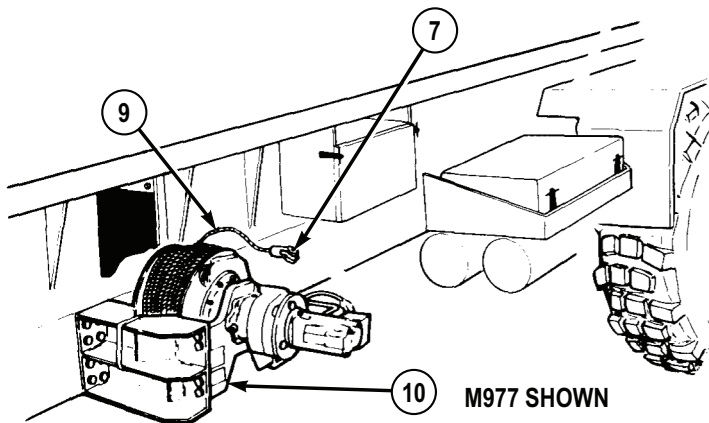
Figure 5.

**WINCH MIRED VEHICLE FORWARD - Continued**

11. Remove pin (6) from clevis (7) and disconnect clevis (7) from tie down ring (8).

**WARNING**

- Always wear protective gloves when handling winch cable. Never let cable run through hands. Frayed cables can cut severely. Failure to comply may result in injury or death to personnel.
  - Never operate winch with less than five wraps of cable on winch drum. Failure to comply may result in injury or death to personnel.
12. Route winch cable (9) around, and over top of winch (10) toward front of vehicle (as shown).



*Figure 6.*

13. Set PTO ENGAGE switch (2) to ON position. Indicator light (3) will illuminate.

## WINCH MIRED VEHICLE FORWARD - Continued

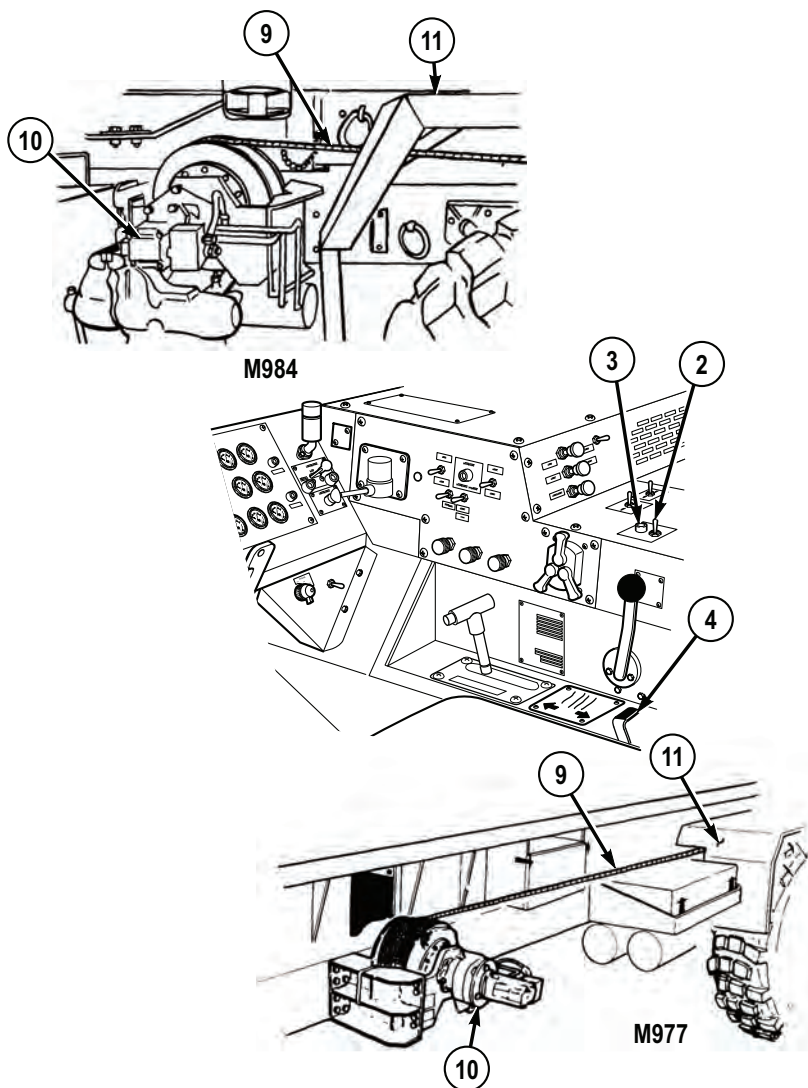


Figure 7.

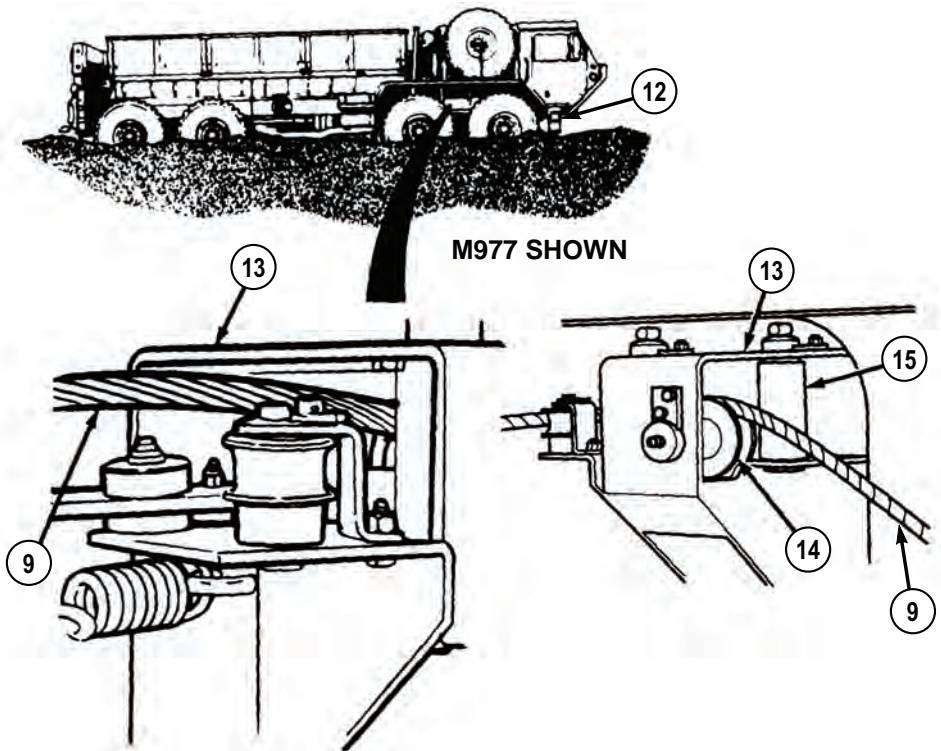
14. Move winch shift lever (4) to OUT and pay out winch cable (9), while assistant routes cable (9) through notch in fender (11).

**NOTE**

- Do not place cable between tensioning device pulleys at this time.

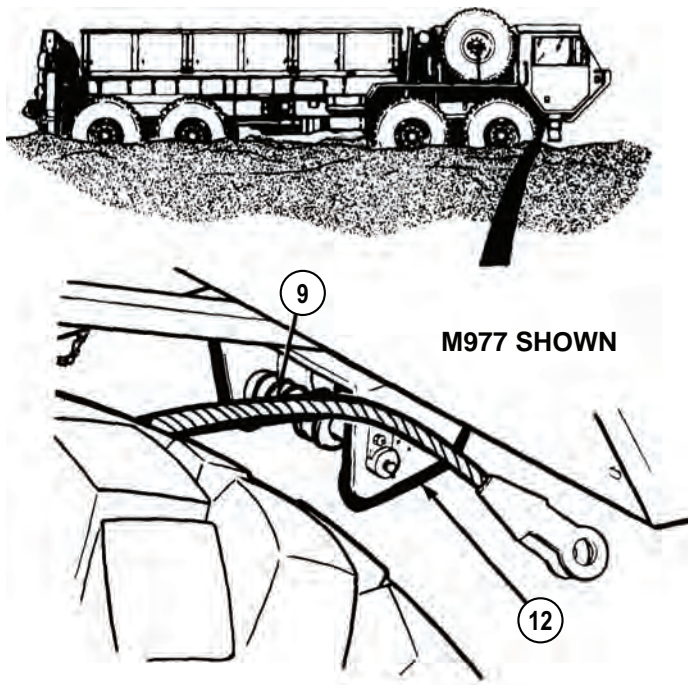
**WINCH MIRED VEHICLE FORWARD - Continued**

- When pulling cable through tensioning device, push sheave towards frame rail to allow clevis to pass through.
15. Pay out cable (9) while assistant pulls cable (9) until it is 6 in. to 1 ft. (15 cm to 30 cm) past the front roller guide (12).

*Figure 8.*

16. Stop paying out cable (9).
17. Assistant routes cable (9) through cable guide (13), over sheave (14), between roller (15), and side of cable guide (13).
18. Pay out winch cable (9) as assistant routes cable over first axle and 1 ft. (30 cm) past front roller guide assembly (12).

## WINCH MIRED VEHICLE FORWARD - Continued



*Figure 9.*

19. Release winch shift lever (4) to center position.



## WINCH MIRED VEHICLE FORWARD - Continued

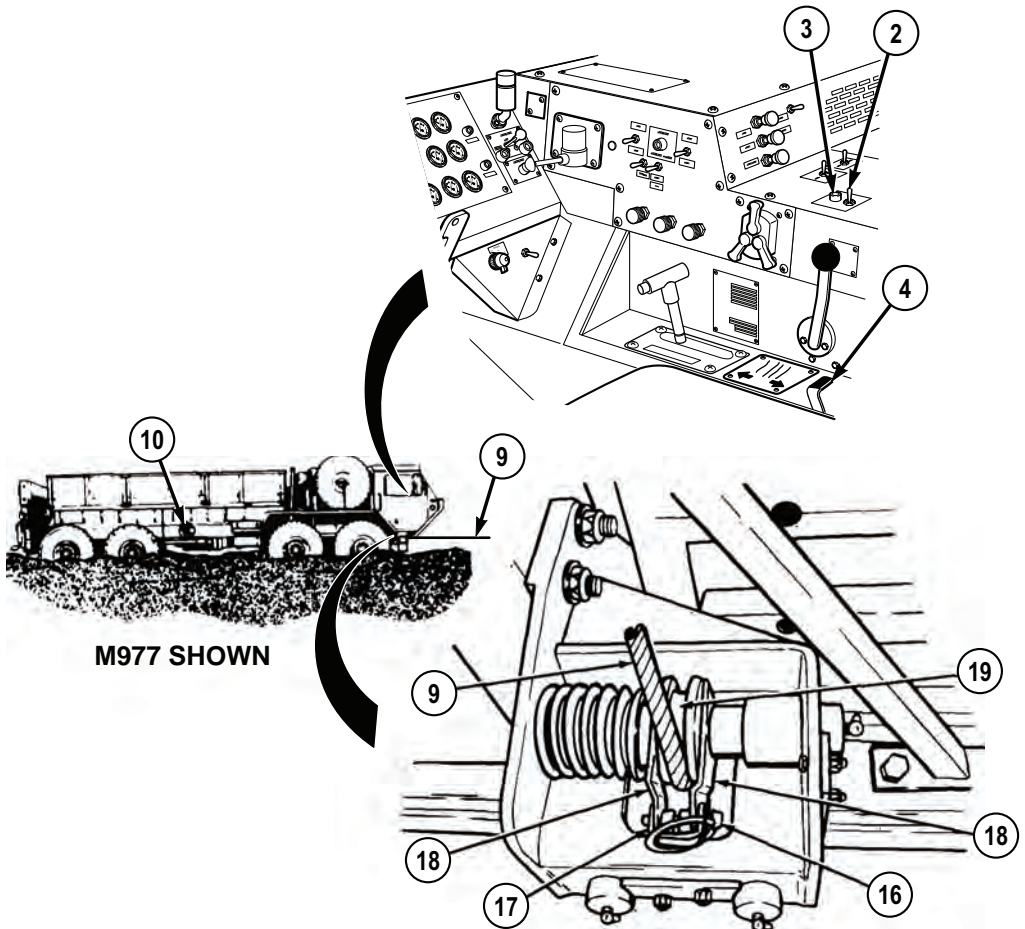


Figure 10.

20. Set PTO ENGAGE switch (2) to OFF position. Indicator light (3) will go out.
21. Remove quick release pin (16) and guide bracket (17). Move cable guide brackets (18) apart so cable (9) can be placed against bottom of sheave (19).
22. Move cable guide brackets (18) together and install guide bracket (17) and quick release pin (16).
23. Set PTO ENGAGE switch (2) to ON position. Indicator light (3) will illuminate.
24. Move winch shift lever (4) to OUT and pay out winch cable (9) while assistant pulls cable to tree, another heavy vehicle (WP 0088), or another heavy object refer to FM 4-30.31. (WP 0161)

**WINCH MIRED VEHICLE FORWARD - Continued**

25. When winch cable (9) is let out to heavy object, release winch shift lever (4) to center position.
26. Set PTO ENGAGE switch (2) to OFF position. Indicator light (3) will go out.
27. If snatch block must be used for self-recovery operation, attach self-recovery winch cable (9) to snatch block (WP 0087) and connect end of self-recovery winch cable to mired vehicle left front towing eye. (WP 0088) Attach snatch block to tree, another vehicle, or heavy object refer to FM 4-30.31. (WP 0161)

**CAUTION**

There must always be at least five wraps of cable on winch. If load is applied with less than five wraps of cable on winch, cable may come loose on drum.

28. Check that there are at least five wraps of winch cable (9) left on winch (10). If there are not at least five wraps of winch cable left on self-recovery winch, stop using self-recovery winch and continue with Step (54) of this procedure.

**CAUTION**

Do not go over winch pull capacity or winch may be damaged.

29. Ensure weight of mired vehicle and amount of winch cable (9) left on self-recovery winch (10) does not go over pull capacity (refer to FM 4-30.31 (WP 0161) and Self-Recovery Winch Pull Capacity table below). If pull will go over capacity, stop using self-recovery winch and continue with Step (54) of this procedure.

**Table 1. Self-Recovery Winch Pull Capacity.**

<b>Cable Layer</b>	<b>Maximum Line Pull</b>
1st layer (five wraps)	20,000 lbs (9 080 kg)
2nd layer	18,173 lbs (8 251 kg)
3rd layer	16,663 lbs (7 565 kg)
4th layer	15,361 lbs (6 974 kg)
5th layer	14,254 lbs (6 471 kg)

**NOTE**

If winch cable will be connected to another vehicle acting as a stationary anchor, refer to FM 4-30.31 (WP 0161) or Connect/Disconnect Self-



**WINCH MIRED VEHICLE FORWARD - Continued**

Recovery Winch Cable to Another Vehicle (WP 0088) for connecting procedures.

30. If it is determined using self-recovery winch (10) will not go over winch pull capacity, connect winch cable (9) to heavy object.
31. Ensure winch shift lever (4) is at center position.
32. Ensure PTO ENGAGE switch (2) is set to OFF position. Indicator light (3) will go out.

**WARNING**

- Always wear protective gloves when handling winch cable. Never let cable run through hands. Frayed cables can cut severely. Failure to comply may result in injury or death to personnel.
  - Never operate winch with less than five wraps of cable on winch drum. Failure to comply may result in injury or death to personnel.
33. Pull back and hold tension pulley lever (20).

## WINCH MIRED VEHICLE FORWARD - Continued

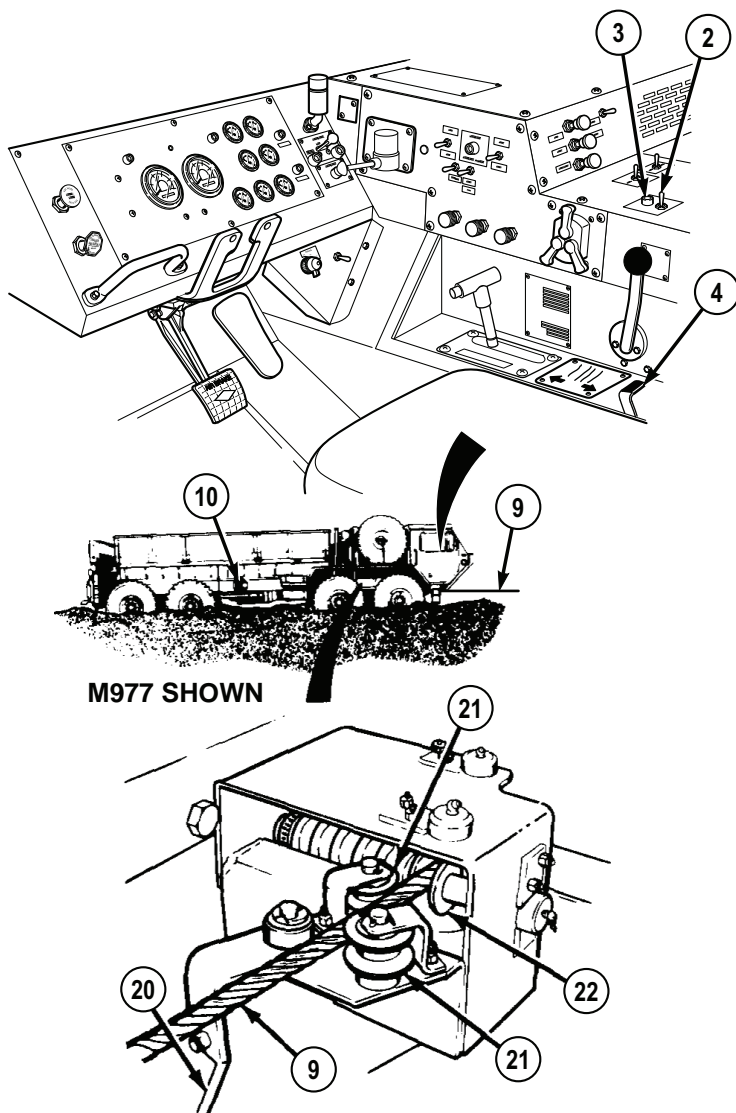


Figure 11.

34. Put winch cable (9) between tensioning device pulleys (21).
35. Release tension pulley lever (20).
36. Check that winch cable (9) rests inside grooves of both tensioning device pulleys (21) and sheave (22).

**WINCH MIRED VEHICLE FORWARD - Continued**

37. Check that winch cable (9) is not caught on vehicle or any other objects.

**WARNING**

Keep all personnel clear of area near winch cable when tension is on cable. Failure to comply may result in injury or death to personnel.

38. Ensure all personnel are clear of self-recovery winch (10) and winch cable (9).  
39. Set PTO ENGAGE switch (2) to ON position. Indicator light (3) will illuminate.  
40. Move winch shift lever (4) to IN until slack is out of cable.  
41. Release winch shift lever (4) to center position.

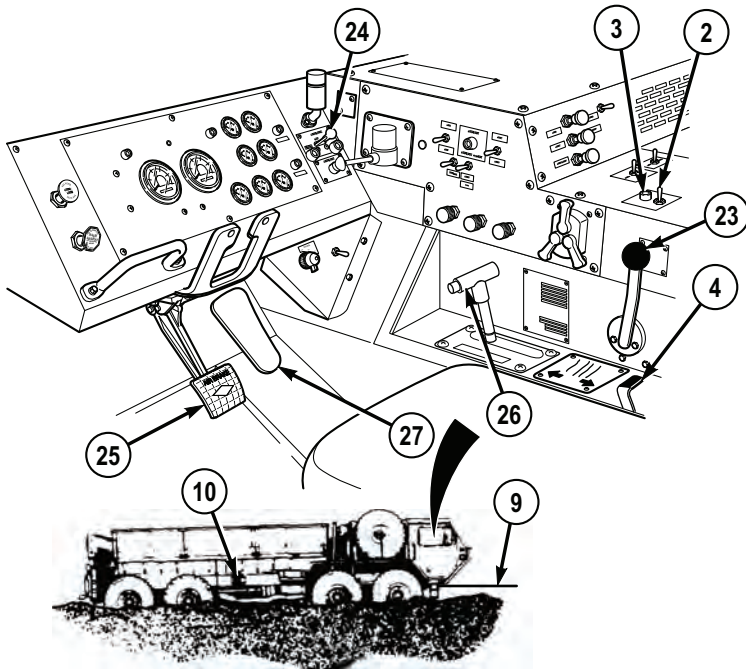
**WARNING**

Keep all personnel clear of area near winch cable when tension is on cable. Failure to comply may result in injury or death to personnel.

**CAUTION**

- Self-recovery winch is not designed to winch mired vehicle by itself. Mired vehicle drive system power must always be used with winch to self-recover vehicle, or damage to equipment can result.
  - If winch does not move mired vehicle, stop using winch, overheat damage may result.
42. Ensure TRANSFER CASE shift lever (23) is set to LO.

## WINCH MIRED VEHICLE FORWARD - Continued



M977 SHOWN

Figure 12.

43. Ensure TRACTION CONTROL lever (24) is set to INTER-AXLE DIFF. LOCK.
44. Apply service brake pedal (25).
45. Set transmission range selector (26) to 1 (1st gear range).
46. Release service brake pedal (25).
47. Move winch shift lever (4) to IN and apply slight pressure to throttle pedal (27).

**NOTE**

Keep winch cable tight at all times so cable does not get tangled with vehicle.

48. Adjust position of throttle pedal (27) to change engine speed as needed to keep winch cable (9) tight and vehicle moving.
49. When mired vehicle is on solid ground, release winch shift lever (4) to center position.
50. Park vehicle. (WP 0056)

**WINCH MIRED VEHICLE FORWARD - Continued**

51. Set winch shift lever (4) to OUT and pay out winch cable (9) until all tension is off cable.
52. When all tension is off winch cable (9), release winch shift lever (4) to center position.
53. Set PTO ENGAGE switch (2) to OFF position. Indicator light (3) will go out.

**NOTE**

If winch cable is connected to another vehicle, refer to Connect/ Disconnect Self-Recovery Winch Cable to Another Vehicle (WP 0088) for disconnecting procedures.

54. Disconnect winch cable (9) from heavy object.
55. If snatch block was used, disconnect end of winch cable (10) from vehicle and remove snatch block from winch cable and from tree, other vehicle, or heavy object refer to FM 4-30.31. (WP 0161)

**CAUTION**

Do not reel clevis end of winch cable through roller guides. Clevis may catch on roller guide and cause cable or roller guide to break.

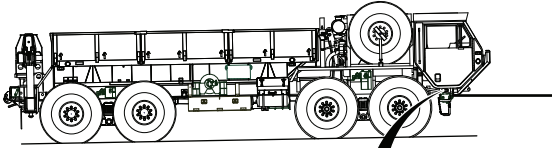
56. Set PTO ENGAGE switch (2) to ON position. Indicator light (3) will illuminate.
57. Move winch shift lever (4) to IN.

**WARNING**

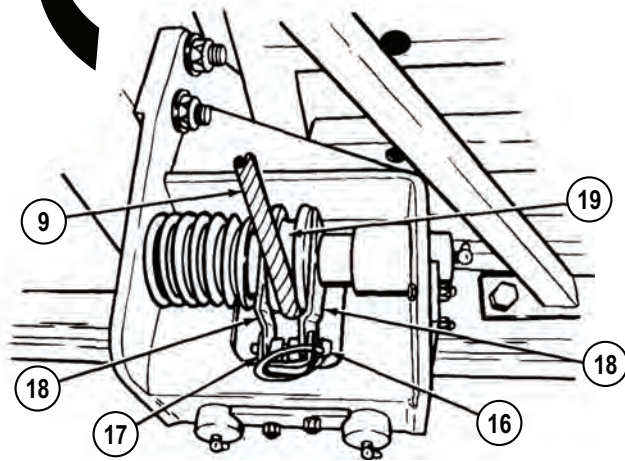
- Always wear protective gloves when handling winch cable. Never let cable run through hands. Frayed cables can cut severely. Failure to comply may result in injury or death to personnel.
  - Never operate winch with less than five wraps of cable on winch drum. Failure to comply may result in injury or death to personnel.
58. Reel in winch cable (9) while assistant uses tire iron extension handle to guide cable (9) onto self-recovery winch (10) so cable wraps are level across face of self-recovery winch (10).
  59. When end of cable (9) is near front of vehicle, release winch shift lever (4) to center position.
  60. Set PTO ENGAGE switch (2) to OFF position. Indicator light (3) will go out.

**WINCH MIRED VEHICLE FORWARD - Continued**

61. Remove quick release pin (16) and guide bracket (17). Move cable guide brackets (18) apart so winch cable (9) can be removed from sheave (19).

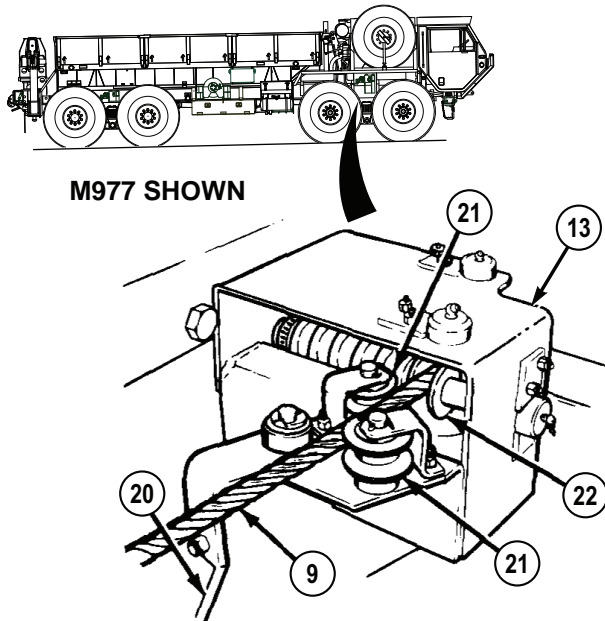


**M977 SHOWN**



*Figure 13.*

62. Move cable guide bracket (18) together. Install guide bracket (17) and quick release pin (16).
63. Pull back and hold tension pulley lever (20).

**WINCH MIRED VEHICLE FORWARD - Continued**

*Figure 14.*

64. Lift winch cable (9) out of tensioning device pulleys (21).
65. Release tension pulley lever (20).
66. Pull winch cable (9) back and out of cable guide (13).
67. Set PTO ENGAGE switch (2) to ON position. Indicator light (3) will illuminate.

## WINCH MIRED VEHICLE FORWARD - Continued

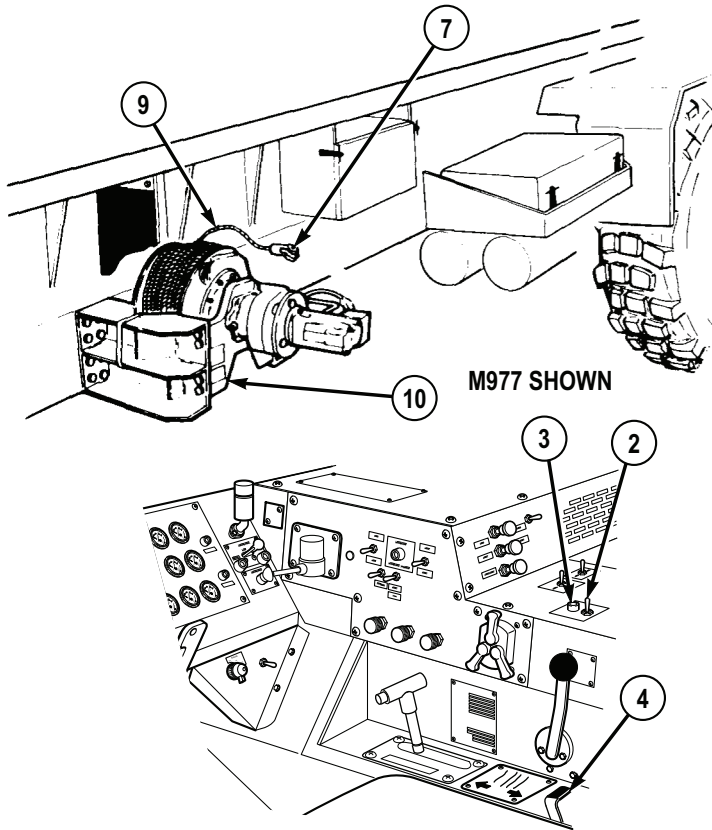
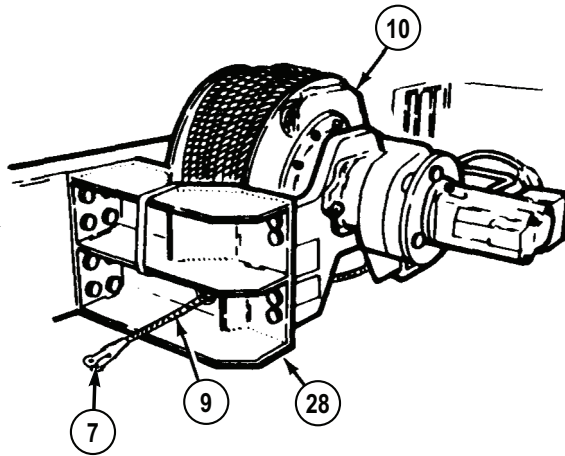


Figure 15.

68. While assistant guides winch cable (9), move winch shift lever (4) to IN.
69. When clevis (7) is approximately 2 ft. (61 cm) from winch (10), release winch shift lever (4) to center position.
70. Set PTO ENGAGE switch (2) to OFF position. Indicator light (3) will go out.
71. Assistant routes end of winch cable (9) down along front face of winch (10).



**WINCH MIRED VEHICLE FORWARD - Continued**

*Figure 16.*

72. Assistant routes end of winch cable (9) under winch (10) and out through hole in bottom of rear winch frame (28).
73. Assistant connects clevis (7) at end of winch cable (9) to tie down ring (8) with pin (6) and cotter pin (5).

## WINCH MIRED VEHICLE FORWARD - Continued

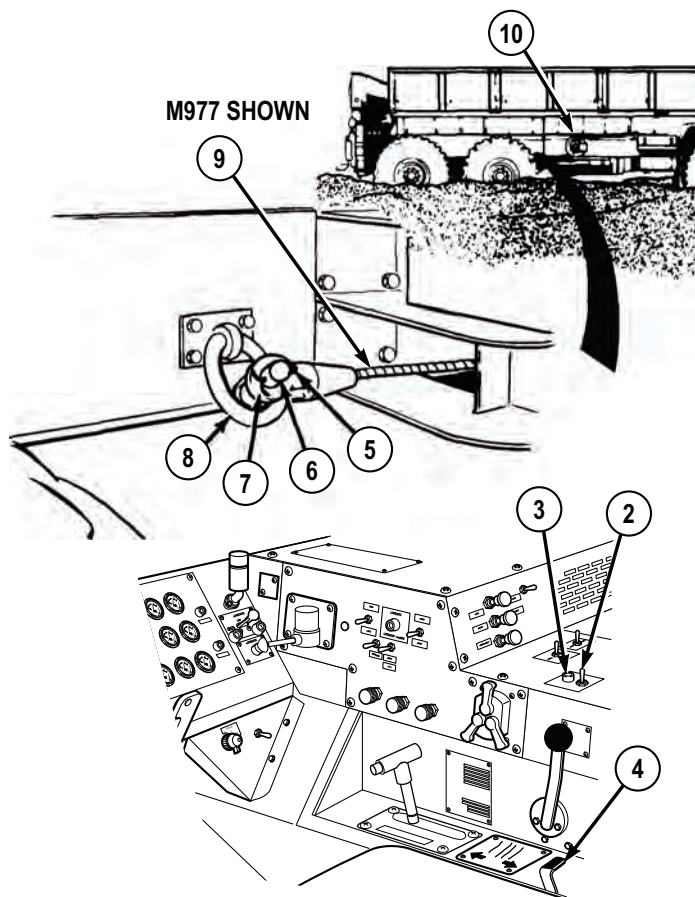


Figure 17.

74. Set PTO ENGAGE switch (2) to ON position. Indicator light (3) will illuminate.

**WARNING**

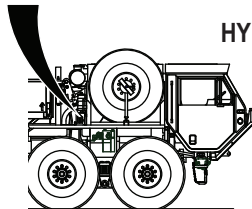
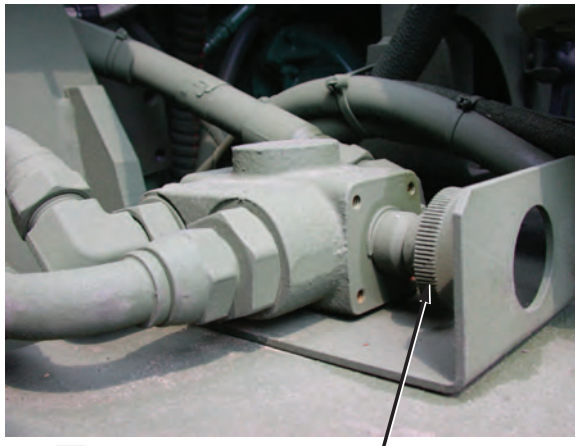
Keep all personnel clear of area near winch cable when tension is on cable. Failure to comply may result in injury or death to personnel.

75. Order all personnel to stand clear of area near winch (10).

**WINCH MIRED VEHICLE FORWARD - Continued****CAUTION**

Do not reel in winch cable too tightly. If too much tension is applied, cable or tie down ring can break, or winch may be damaged.

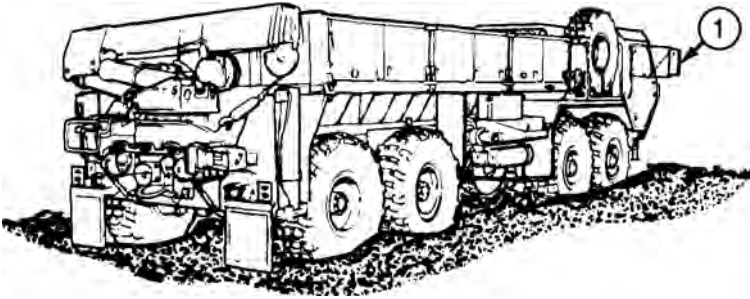
76. Once assistant and all other personnel are clear of area, move winch shift lever (4) to IN and take all slack out of winch cable (9).
77. When winch cable (9) is tight, release winch shift lever (4) to center position.
78. Set PTO ENGAGE switch (2) to OFF position. Indicator light (3) will go out.
79. Shut off engine. (WP 0057)
80. Push in hydraulic selector valve control.



HYDRAULIC SELECTOR  
VALVE CONTROL

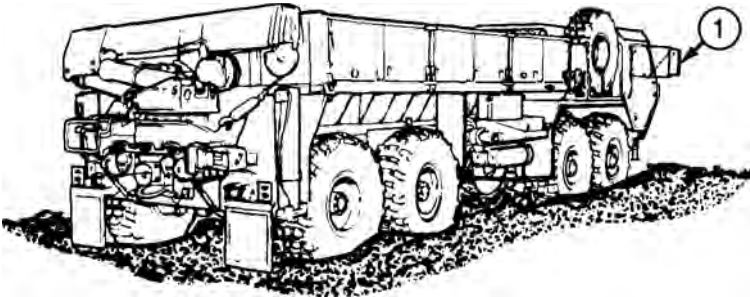
*Figure 18.*

81. Adjust mirror (1) for driving.

**WINCH MIRED VEHICLE FORWARD - Continued***Figure 19.***WINCH MIRED VEHICLE TO THE REAR****NOTE**

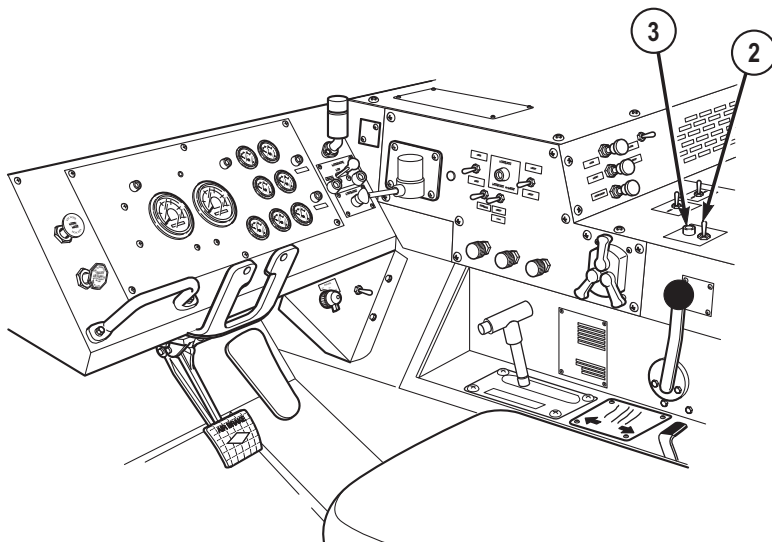
- For additional information on vehicle self-recovery refer to FM 4-30.31. (WP 0161)
- Vehicle self-recovery is a two soldier task. Soldiers must communicate by hand signals.

1. Shut off engine. (WP 0057)
2. Adjust mirror (1) so assistant can be clearly seen during procedure.

*Figure 20.***CAUTION**

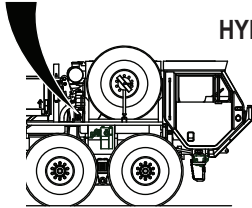
PTO ENGAGE switch must be in OFF position before moving hydraulic selector valve to prevent equipment damage.

3. Set PTO ENGAGE switch (2) to OFF position. Indicator light (3) will go out.

**WINCH MIRED VEHICLE TO THE REAR - Continued**

*Figure 21.*

4. Pull out hydraulic selector valve control.

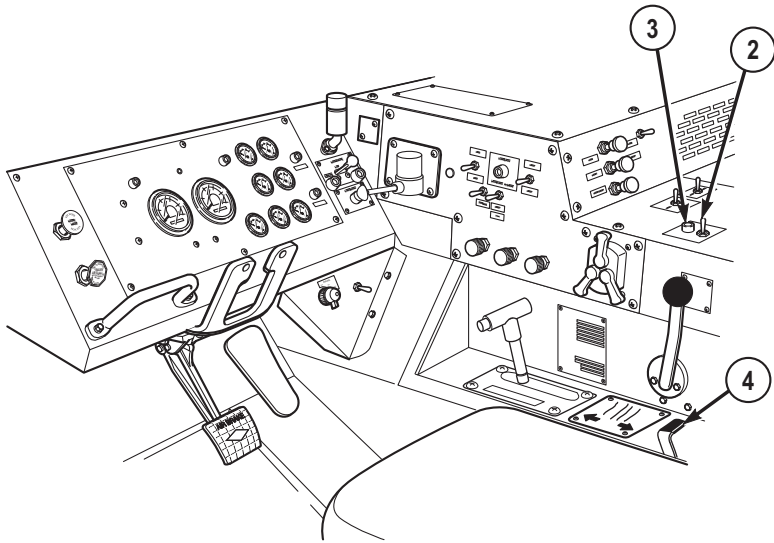
**WINCH MIRED VEHICLE TO THE REAR - Continued**

**HYDRAULIC SELECTOR  
VALVE CONTROL**

*Figure 22.*

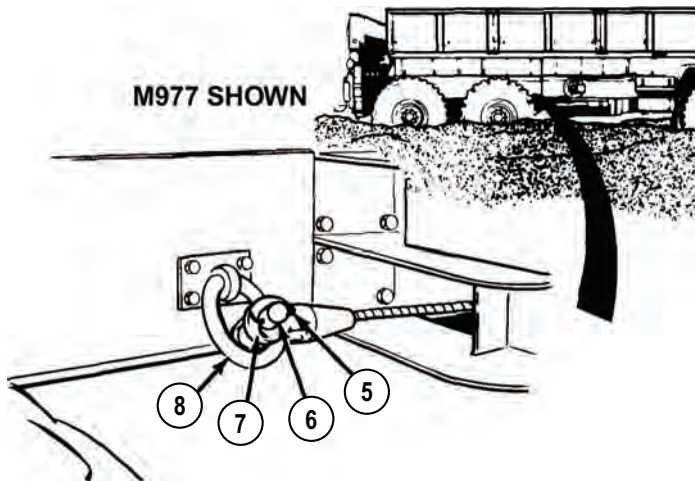
5. Set PTO ENGAGE switch (2) to ON position. Indicator light (3) will illuminate.

**WINCH MIRED VEHICLE TO THE REAR - Continued**



*Figure 23.*

6. Move winch shift lever (4) to OUT position to pay out small amount of cable.
7. Release winch shift lever (4) to center position.
8. Set PTO ENGAGE switch (2) to OFF position. Indicator light (3) will go out.
9. Remove cotter pin (5) from pin (6).



*Figure 24.*

**WINCH MIRED VEHICLE TO THE REAR - Continued**

10. Remove pin (6) from clevis (7) and disconnect clevis from tie down ring (8).
11. Set PTO ENGAGE switch (2) to ON position. Indicator light (3) will illuminate.

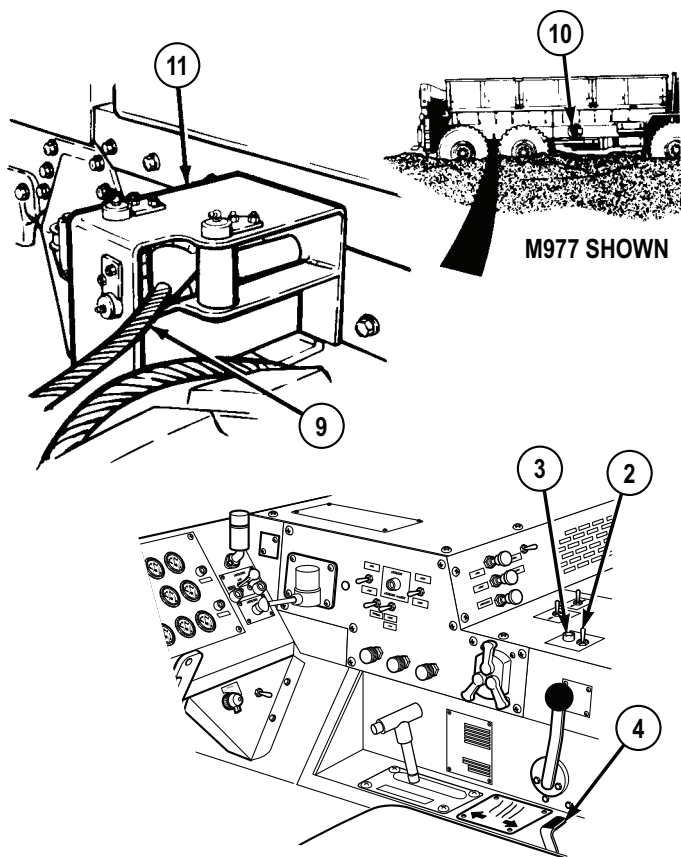


Figure 25.



**WINCH MIRED VEHICLE TO THE REAR - Continued****WARNING**

- Always wear protective gloves when handling winch cable. Never let cable run through hands. Frayed cables can cut severely. Failure to comply may result in injury or death to personnel.
  - Never operate winch with less than five wraps of cable on winch drum. Failure to comply may result in injury or death to personnel.
12. Move winch shift lever (4) to OUT while assistant pulls winch cable (9) from self-recovery winch (10) toward rear of vehicle.

**NOTE**

- Do not place cable between tensioning device pulleys at this time.
  - When pulling cable through tensioning device, push sheave towards frame rail to allow clevis to pass through.
13. Continue to pay out winch cable (9) while assistant routes cable through cable guide (11).
14. Continue to pay out winch cable (9) while assistant routes cable through hole (12) in fender and through roller guide (13).

## WINCH MIRED VEHICLE TO THE REAR - Continued

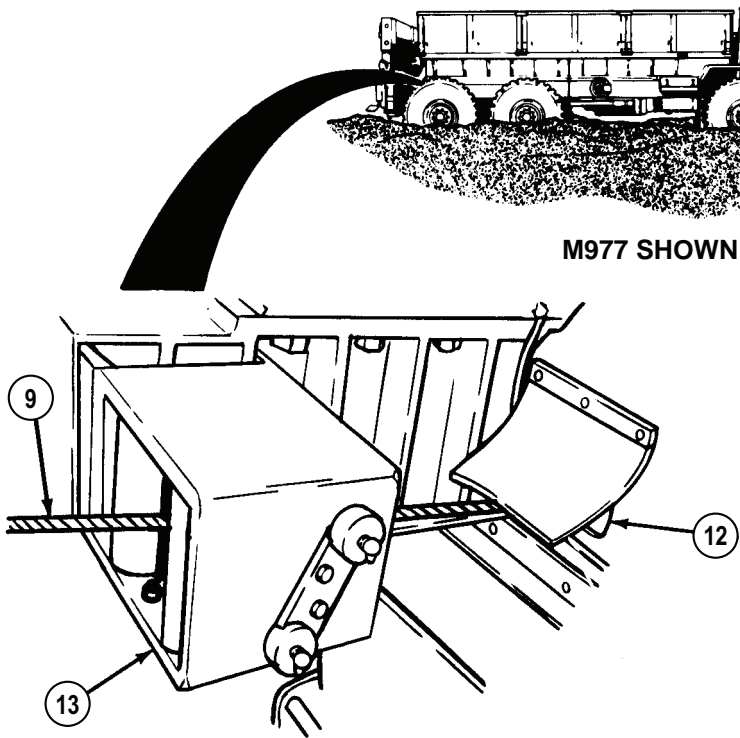
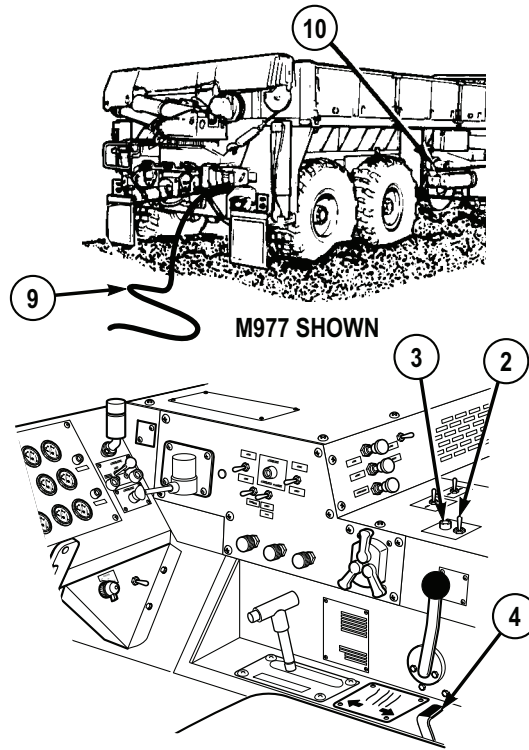


Figure 26.

15. Pay out winch cable (9) while assistant pulls cable to tree, another vehicle, or heavy object refer to FM 4-30.31. (WP 0161)
16. When winch cable (9) is let out to tree, another vehicle, heavy object, release winch shift lever (4) to center position.
17. Set PTO ENGAGE switch (2) to OFF position. Indicator light (3) will go out.

**WINCH MIRED VEHICLE TO THE REAR - Continued***Figure 27.*

18. If snatch block must be used for self-recovery operation, attach self-recovery winch cable (9) to snatch block (WP 0087) and connect end of self-recovery winch cable to mired vehicle left rear towing eye. (WP 0088) Attach snatch block to a tree, another vehicle, or heavy object refer to FM 4-30.31. (WP 0161)

**CAUTION**

There must be at least five wraps of cable on winch. If load is applied with less than five wraps of cable on winch, cable may come loose on drum.

19. Check that there are at least five wraps of winch cable (9) left on winch (10). If there are not at least five wraps of winch cable left on winch (10), stop using self-recovery winch (10) and continue with Step (46) of this procedure.

**CAUTION**

Do not go over winch pull capacity or winch could be damaged.

**WINCH MIRED VEHICLE TO THE REAR - Continued**

20. Ensure weight of mired vehicle and amount of winch cable (9) left on winch (10) does not go over pull capacity refer to FM 4-30.31 (WP 0161) and Self-Recovery Winch Pull Capacity table below). If pull will go over capacity, stop using self-recovery winch and continue with Step (46) of this procedure.

**Table 2. Self-Recovery Winch Pull Capacity.**

<b>Cable Layer</b>	<b>Maximum Line Pull</b>
1st layer (five wraps)	20,000 lbs (9 080 kg)
2nd layer	18,173 lbs (8 251 kg)
3rd layer	16,663 lbs (7 565 kg)
4th layer	15,361 lbs (6 974 kg)
5th layer	14,254 lbs (6 471 kg)

**NOTE**

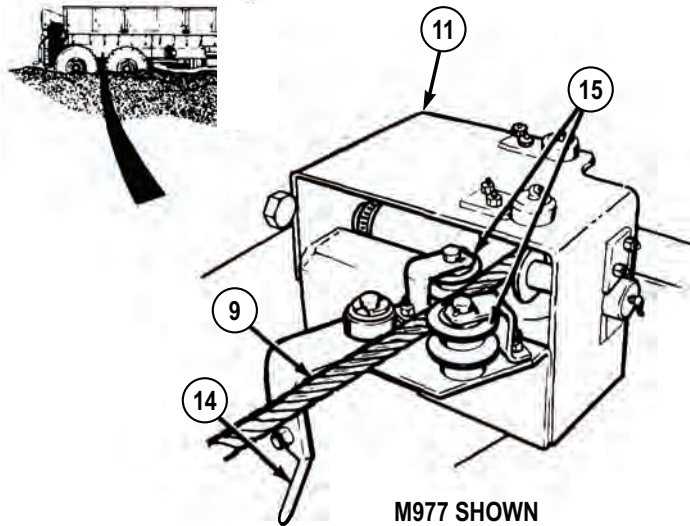
If winch cable will be connected to another vehicle acting as a stationary anchor, refer to FM 4-30.31 (WP 0161) or Connect/Disconnect Self-Recovery Winch Cable to Another Vehicle (WP 0088) for connecting procedures.

21. If it is determined using self-recovery winch (10) will not go over winch pull capacity, connect winch cable (9) to heavy object.
22. Ensure winch shift lever (4) is at center position.
23. Set PTO ENGAGE switch (2) to OFF position. Indicator light (3) will go out.

**WARNING**

Do not operate winch while personnel are working on or around tensioning device. Failure to comply may result in injury or death to personnel.

24. Pull back and hold tension pulley lever (14).

**WINCH MIRED VEHICLE TO THE REAR - Continued***Figure 28.*

25. Route winch cable (9) between pulleys (15).
26. Release tension pulley lever (14).
27. Ensure winch cable (9) rests inside grooves of both pulleys (15).
28. Ensure winch cable (9) is not caught on vehicle or any other objects.

**WARNING**

Keep all personnel clear of area near winch cable when tension is on cable. Failure to comply may result in injury or death to personnel.

29. Ensure all personnel are clear of winch (10) and winch cable (9).

## WINCH MIRED VEHICLE TO THE REAR - Continued

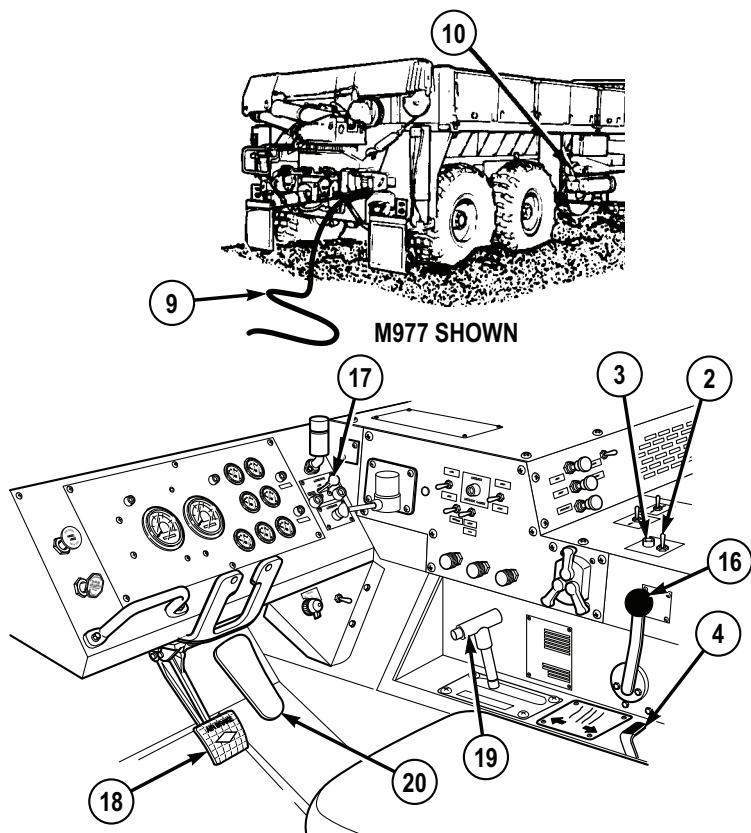


Figure 29.

30. Set PTO ENGAGE switch (2) to ON position. Indicator light (3) will illuminate.
31. Move winch shift lever (4) to IN until slack is out of winch cable (9).
32. Release winch shift lever (4) to center position.

**WARNING**

Keep all personnel clear of area near winch cable when tension is on cable. Failure to comply may result in injury or death to personnel.

**WINCH MIRED VEHICLE TO THE REAR - Continued****CAUTION**

- Self-recovery winch is not designed to winch mired vehicle by itself. Mired vehicle drive system power must always be used with winch to self-recover vehicle, or damage to equipment can result.
  - If winch does not move mired vehicle, stop using winch, overheating damage may result.
33. Ensure that TRANSFER CASE shift lever (16) is set to LO.
  34. Ensure TRACTION CONTROL lever (17) is set to INTER-AXLE DIFF. LOCK.
  35. Apply service brake pedal (18).
  36. Set transmission range selector (19) to R (reverse).
  37. Release service brake pedal (18).
  38. Slightly press throttle pedal (20) and move winch shift lever (4) to IN.

**NOTE**

Keep winch cable tight at all times so cable does not get tangled with vehicle.

39. Adjust position of throttle pedal (20) to change engine speed as needed to keep winch cable (9) tight and mired vehicle moving.
40. When mired vehicle is on solid ground, release winch shift lever (4) to center position.
41. Park vehicle. (WP 0056)
42. Set winch shift lever (4) to OUT and pay out winch cable (9) until all tension is released.
43. When all tension is off winch cable (9), release winch shift lever (4) to center position.
44. Set PTO ENGAGE switch (2) to OFF position. Indicator light (3) will go out.

**NOTE**

If winch cable is connected to another vehicle, refer to Connect/Disconnect Self-Recovery Winch Cable to Another Vehicle (WP 0088) for disconnecting procedures.

45. Disconnect winch cable (9) from heavy object.
46. If snatch block was used, disconnect end of winch cable (9) from vehicle. (WP 0088) Remove snatch block from winch cable (WP 0087) and tree, another vehicle, or heavy object refer to FM 4-30.31. (WP 0161)

**WINCH MIRED VEHICLE TO THE REAR - Continued****CAUTION**

Do not reel clevis end of winch cable through roller guides. Clevis may catch on roller guide and cause cable or roller guide to break.

47. Set PTO ENGAGE switch (2) to ON position. Indicator light (3) will illuminate.
48. Set winch shift lever (4) to IN.
49. When end of cable is near rear of vehicle, release winch shift lever (4) to center position.
50. Set PTO ENGAGE switch (2) to OFF position. Indicator light (3) will go out.

**WARNING**

- Always wear protective gloves when handling winch cable. Never let cable run through hands. Frayed cables can cut severely. Failure to comply may result in injury or death to personnel.
  - Never operate winch with less than five wraps of cable on winch drum. Failure to comply may result in injury or death to personnel.
51. Pull clevis (7) end of winch cable (9) forward through roller guide (13) and hole (12) in fender.



WINCH MIRED VEHICLE TO THE REAR - Continued

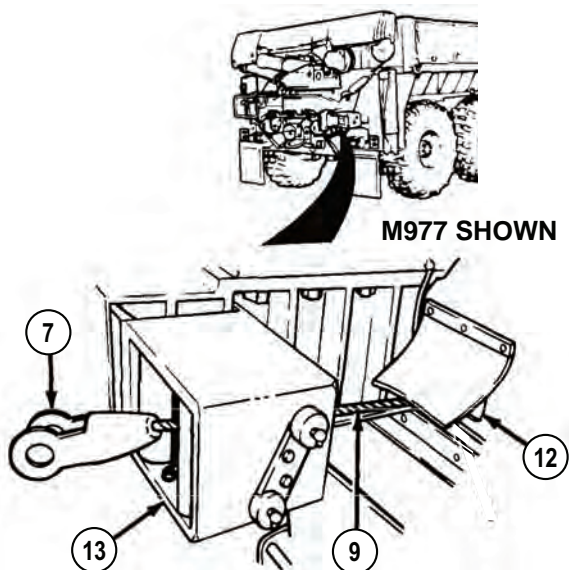


Figure 30.

52. Pull back and hold tension pulley lever (14).

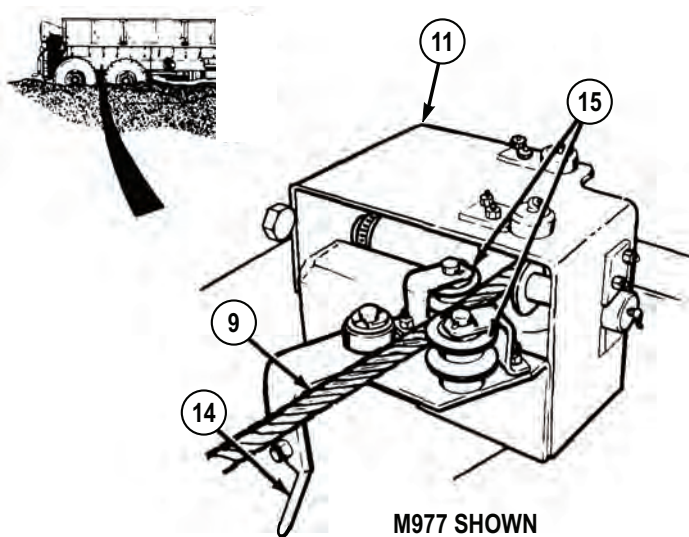
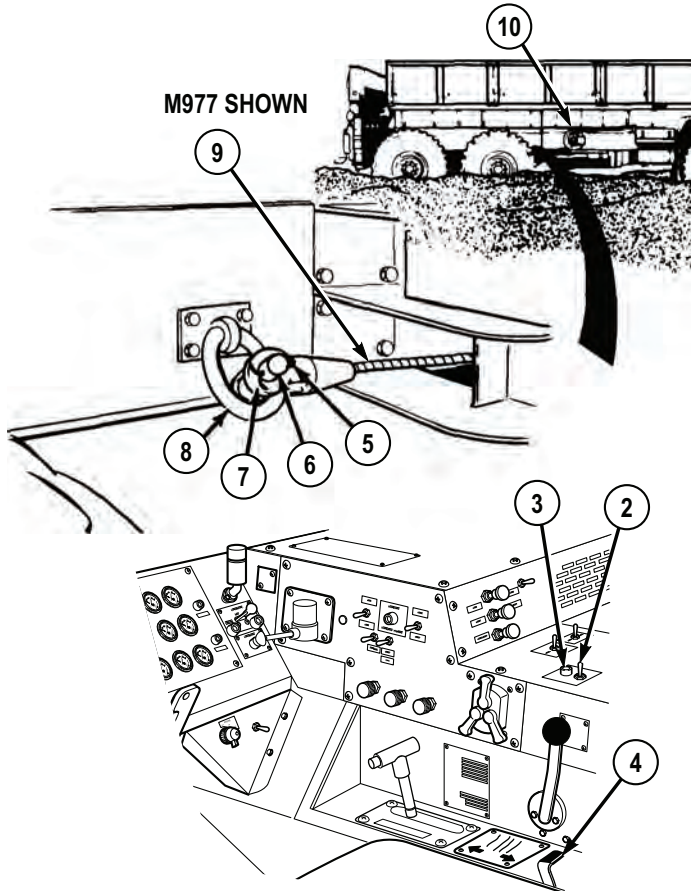


Figure 31.

**WINCH MIRED VEHICLE TO THE REAR - Continued**

53. Lift winch cable (9) out of pulleys (15).
54. Release tension pulley lever (14).
55. Pull winch cable (9) forward and out of cable guide (11).
56. Set PTO ENGAGE switch (2) to ON position. Indicator light (3) will illuminate.



*Figure 32.*

57. Move winch shift lever (4) to IN position to reel in cable while assistant guides winch cable (9) to tie down ring (8).
58. When clevis (7) is approximately 2 ft. (61 cm) from winch (10), release winch shift lever (4) to center position.

**WINCH MIRED VEHICLE TO THE REAR - Continued**

59. Assistant connects clevis (7) to tie down ring (8) with pin (6) and cotter pin (5).

**WARNING**

Keep all personnel clear of area near winch cable when tension is on cable. Failure to comply may result in injury or death to personnel.

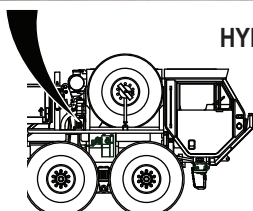
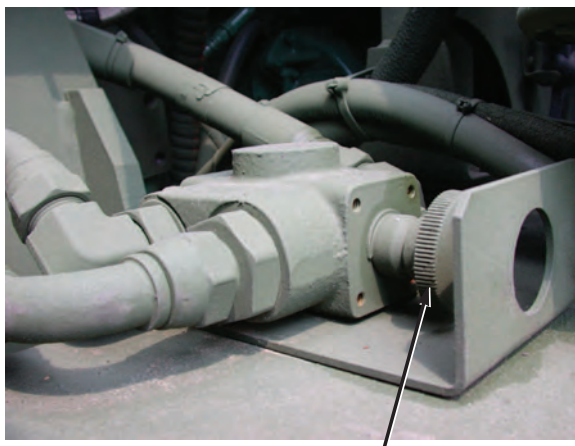
60. Order all personnel to stand clear of area near winch (10).

**CAUTION**

Do not reel in winch cable too tightly. If too much tension is applied, cable or tie down ring can break, or winch may be damaged.

61. Once assistant and all other personnel are clear of area, move winch shift lever (4) to IN and take all slack out of winch cable (9).
62. When cable is tight, release winch shift lever (4) to center position.
63. Set PTO ENGAGE switch (2) to OFF position. Indicator light (3) will go out.
64. Shut off engine. (WP 0057)
65. Push in hydraulic selector valve control.

WINCH MIRED VEHICLE TO THE REAR - Continued



HYDRAULIC SELECTOR  
VALVE CONTROL

Figure 33.

66. Adjust mirror (1) for driving.

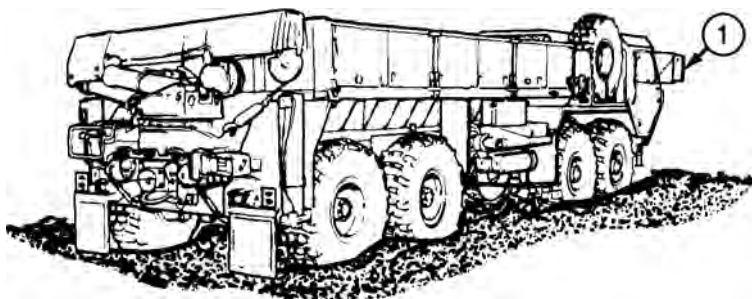


Figure 34.

END OF TASK

END OF WORK PACKAGE

---

## OPERATOR MAINTENANCE SNATCH BLOCK INSTALLATION/REMOVAL

---

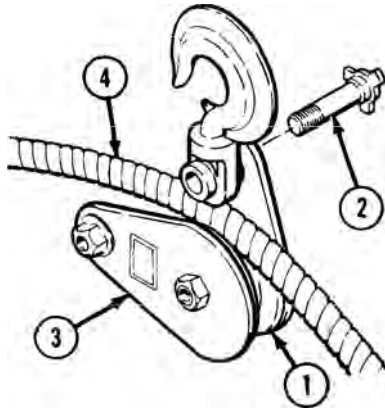
### INITIAL SETUP:

Not Applicable

---

### ATTACH SNATCH BLOCK TO SELF-RECOVERY WINCH CABLE

1. Remove snatch block (1) from stowage.

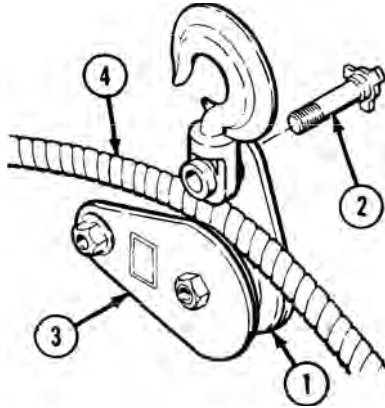


*Figure 1.*

2. Remove screw (2).
3. Move plate (3) to side to open snatch block (1).
4. Place winch cable (4) in snatch block (1).
5. Close plate (3) and align holes.
6. Install screw (2).
7. Ensure screw (2) is tight and winch cable (4) can be moved freely through snatch block (1).
8. Continue with self-recovery operation (WP 0086).

**REMOVE SNATCH BLOCK FROM SELF-RECOVERY WINCH CABLE**

1. Check that there is enough slack in winch cable (1).



*Figure 2.*

2. Remove screw (2).
3. Move plate (3) to side to open snatch block (4).
4. Take winch cable (1) out of snatch block (4).
5. Close plate (3) and align holes.
6. Install screw (2).
7. Stow snatch block (4) in stowage box.
8. Continue with self-recovery operation (WP 0086).

**END OF TASK**

**END OF WORK PACKAGE**

---

**OPERATOR MAINTENANCE**  
**CONNECT/DISCONNECT SELF-RECOVERY WINCH CABLE TO ANOTHER VEHICLE**

---

**INITIAL SETUP:**

Not Applicable

---

**CONNECT CABLE TO VEHICLE**

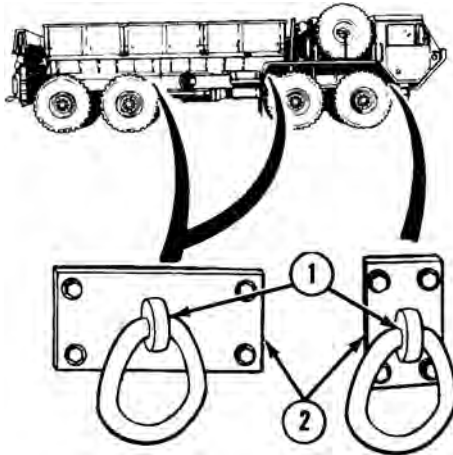
**CAUTION**

When attaching self-recovery winch cable to another vehicle, that vehicle must be used only as an anchor point or damage to equipment can result.

**NOTE**

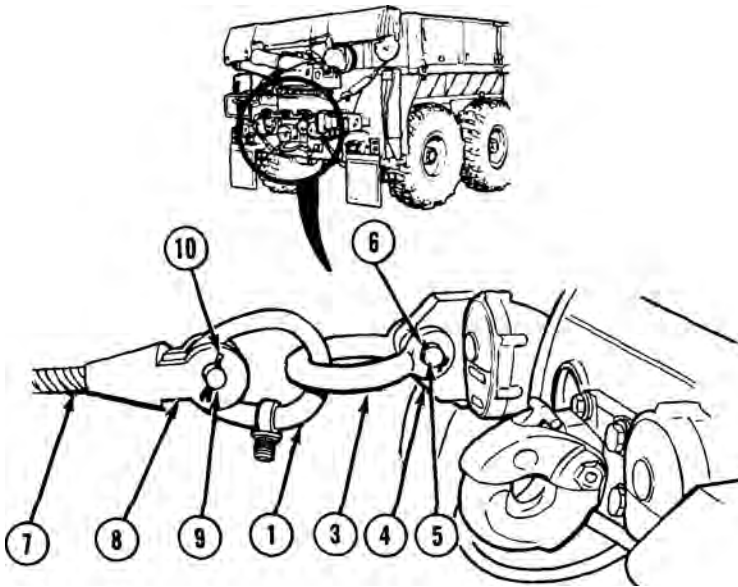
There are three tie down rings on each side of vehicle.

1. Unscrew one tie down ring (1) from mounting plate (2).



*Figure 1.*

2. Remove lifting shackle (3) from stowage.

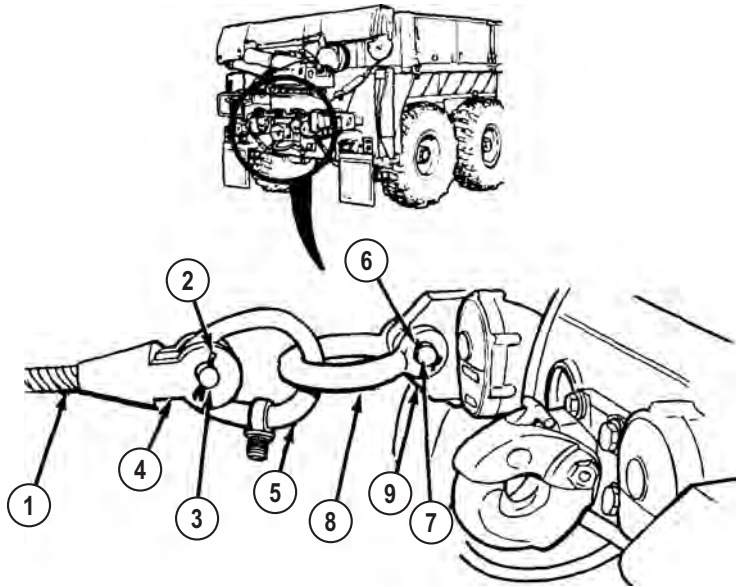
**CONNECT CABLE TO VEHICLE - Continued***Figure 2.*

3. Insert lifting shackle (3) through tie down ring (1).
4. Connect lifting shackle (3) to left front of left rear tow eye (4) with pin (5).
5. Install cotter pin (6).
6. Connect self-recovery winch cable (7) with clevis (8) to tie down ring (1) with pin (9).
7. Install cotter pin (10).
8. Continue with self-recovery winch operation. (WP 0086)

**DISCONNECT CABLE FROM VEHICLE**

1. Ensure there is enough slack in winch cable (1).



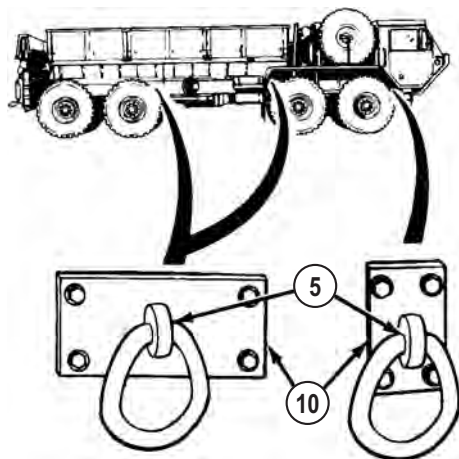
**DISCONNECT CABLE FROM VEHICLE - Continued***Figure 3.*

2. Remove cotter pin (2).
3. Remove pin (3) and disconnect clevis (4) from tie down ring (5).
4. Remove cotter pin (6).
5. Remove pin (7) and disconnect lifting shackle (8) from tow eye (9).
6. Remove tie down ring (5) from lifting shackle (8).
7. Stow lifting shackle (8).

**NOTE**

There are three tie down rings on each side of vehicle.

8. Install tie down ring (5) into mounting plate (10).

**DISCONNECT CABLE FROM VEHICLE - Continued**

*Figure 4.*

9. Continue with self-recovery winch operation. (WP 0086)

**END OF TASK**

**END OF WORK PACKAGE**

---

**OPERATOR MAINTENANCE  
TOW DISABLED VEHICLE**

---

**INITIAL SETUP:**

Not Applicable

---

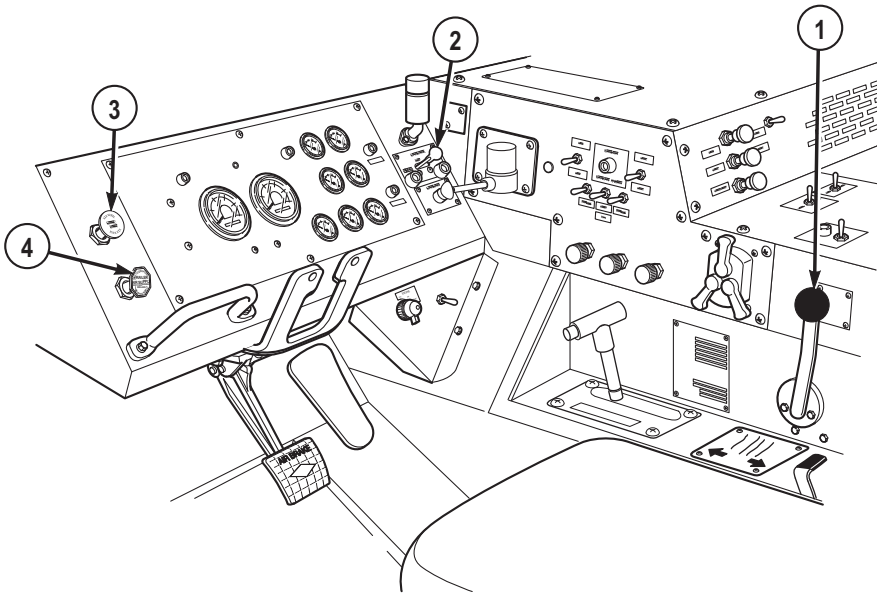
**TOW DISABLED VEHICLE****CAUTION**

- When towing another vehicle, do not go over GCWR given in equipment data (WP 0006). Failure to comply may result in damage to equipment.
- Propeller shaft must be removed by field level maintenance before towing disabled vehicle or equipment may be damaged.

**NOTE**

Disabled vehicles must be prepared and moved in accordance with FM 21-305 . If instructed to do so, manually release spring brakes (WP 0100) as part of preparing disabled vehicle for towing.

1. Install and operate portable beacon lights. (WP 0074)
2. Set TRANSFER CASE shift lever (1) to NEUT (neutral) position.
3. Set TRACTION CONTROL lever (2) to OFF.

**TOW DISABLED VEHICLE - Continued**

*Figure 1.*

4. Push in PARKING BRAKE control on disabled vehicle (refer to operator's manual).
5. Push in TRAILER AIR SUPPLY control (4) on recovery vehicle.
6. Transport disabled vehicle.

**END OF TASK**

**END OF WORK PACKAGE**

---

## OPERATOR MAINTENANCE CONNECT/DISCONNECT TOW BAR

---

### INITIAL SETUP:

#### Personnel Required

Operator and Assistant(s) - - - (3)

---

### CONNECT TOW BAR

#### WARNING



Do not use 10-ton tow bar with self-guided coupler (normally found on some M1120 LHS and M1977 CBT models). Self-guided coupler is not compatible with 10-ton tow bar. Failure to comply may result in injury or death to personnel

#### WARNING



Tow bar is heavy. Do not attempt to lift or move tow bar without the aid of two assistants and a lifting device. Failure to comply may result in injury or death to personnel.

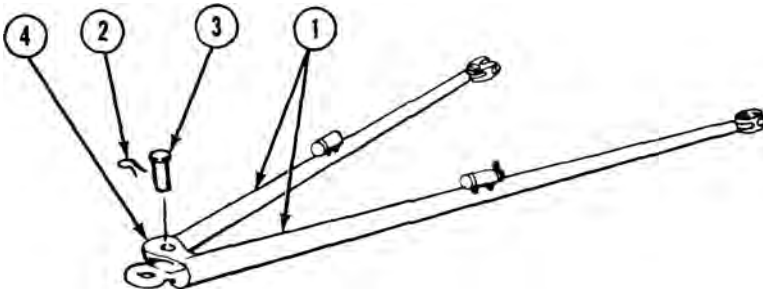
#### NOTE

- This procedure is a three soldier task.
  - The 10-ton tow bar should always be used in conjunction with two 16 ft. (5 m) safety chains.
  - Allow ample distance between towing vehicle and disabled vehicle to connect 10-ton tow bar.
1. Align rear of towing vehicle near front of disabled vehicle.

**CONNECT TOW BAR - Continued****WARNING**

Tow bar is heavy. Do not attempt to lift or move tow bar without the aid of two assistants and a lifting device. Failure to comply may result in injury or death to personnel.

2. With aid of two assistants and a lifting device, remove tow bar (1) from stowage.



*Figure 1.*

3. Remove cotter hairpin (2) and pin (3) from tow bar (1).
4. Separate tow bar (1) at pivot point (4).

**NOTE**

Towing eyes on all models of HEMTT series vehicles are same in appearance, operation, and location. HEMTT M977 shown.

5. Position legs of tow bar (1) in front of disabled vehicle with spare pins (5) facing up.

CONNECT TOW BAR - Continued

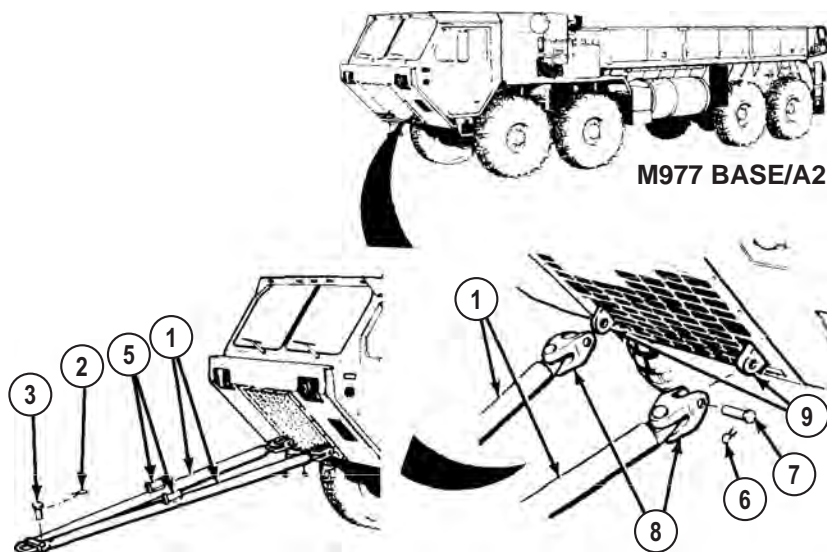


Figure 2.

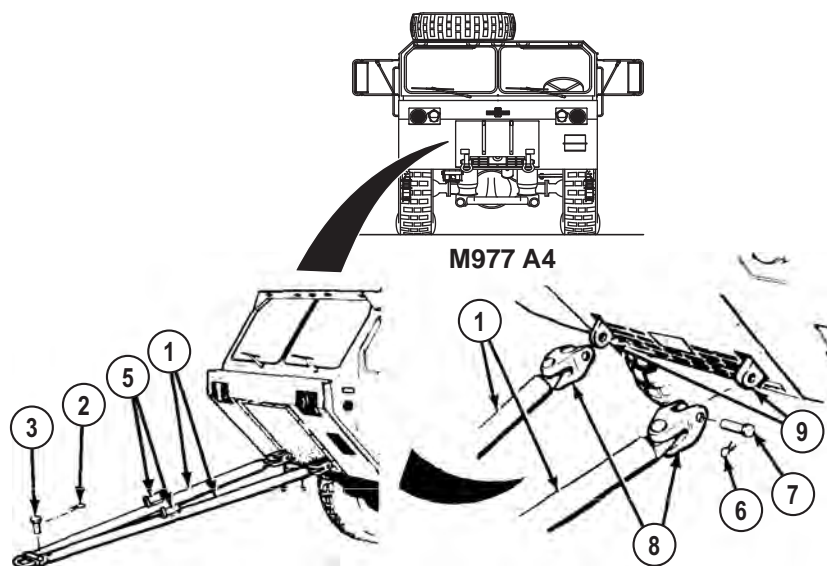


Figure 3.

6. Remove two cotter hairpins (6) and pins (7) from tow bar shackles (8).

**CONNECT TOW BAR - Continued****WARNING**

Tow bar is heavy. Do not attempt to lift or move tow bar without the aid of two assistants and a lifting device. Failure to comply may result in injury or death to personnel.

7. While two assistants hold one leg of tow bar (1) and align shackle (8) with towing eye (9), install pin (7) and cotter hairpin (6).
8. Repeat Step (7) for other leg of tow bar (1).
9. Align legs of tow bar (1) at pivot point (4) and install pin (3) and cotter hairpin (2).

**WARNING**

Do not use 10-ton tow bar with self-guided coupler (normally found on some M1120 LHS and M1977 CBT models). Self-guided coupler is not compatible with 10-ton tow bar. Failure to comply may result in injury or death to personnel

**NOTE**

Pintle hook on all models of HEMTT series vehicles are same in appearance, operation, and location. HEMTT M977 shown.

10. Position the towing vehicle so pintle hook is aligned with tow bar lunette eye.
11. Remove cotter pin (10) from pintle hook (11).



## CONNECT TOW BAR - Continued

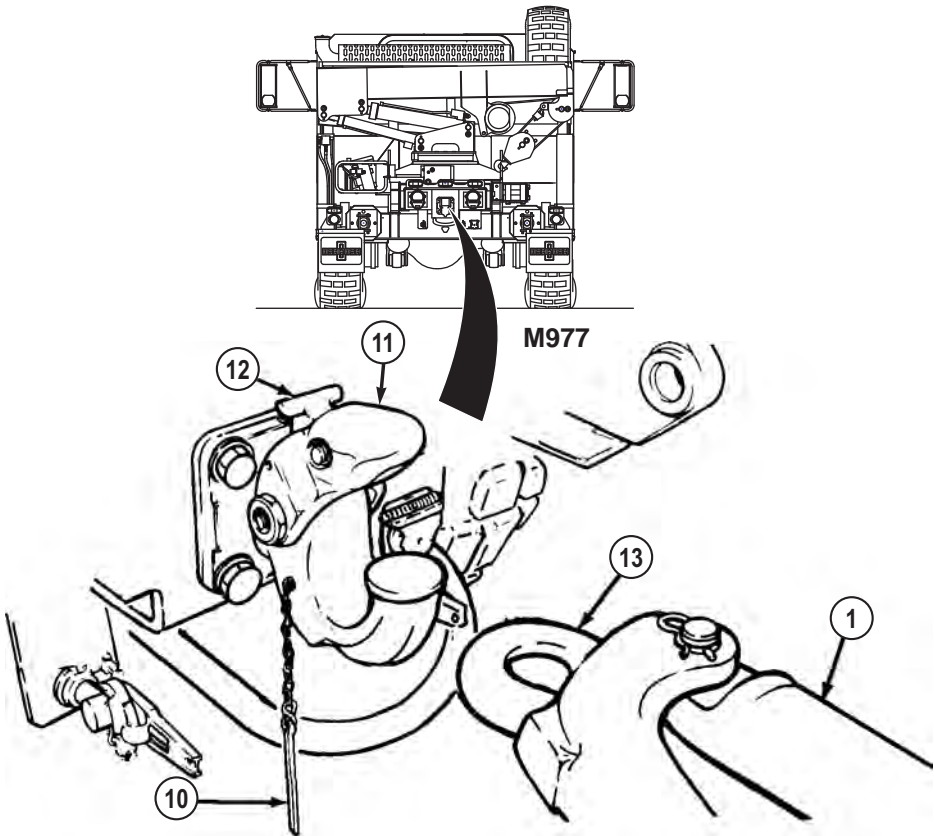


Figure 4.

12. Pull latch (12) away from vehicle and hold.
13. Lift top of pintle hook (11) and let go of latch (12). Pintle hook (11) will be locked open.

**WARNING**

Tow bar is heavy. Do not attempt to lift or move tow bar without the aid of two assistants and a lifting device. Failure to comply may result in injury or death to personnel.

**CONNECT TOW BAR - Continued****WARNING**

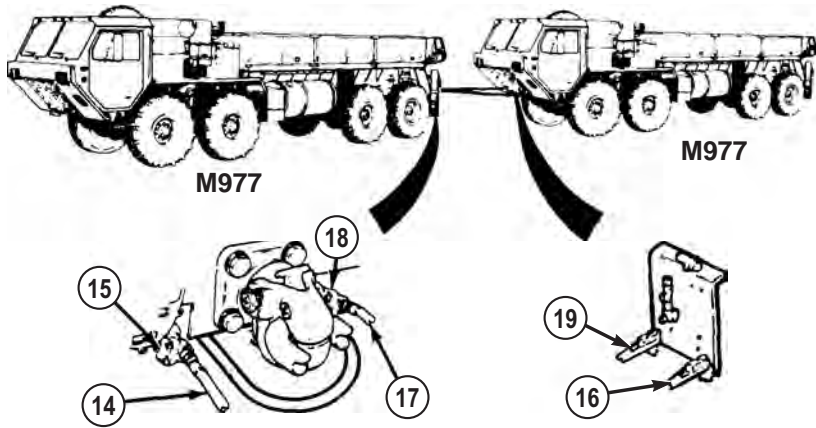
Do not put hands near pintle hook while aligning lunette eye with pintle hook. Failure to comply may result in injury or death to personnel.

14. While two assistants lift tow bar (1), slowly back up towing vehicle until tow bar lunette eye (13) connects to pintle hook (11).
15. Pull latch (12) and close top half of pintle hook (11).
16. Install cotter pin (10) in pintle hook (11).

**NOTE**

If air system of disabled vehicle is damaged, manually release spring brakes (WP 0100).

17. Remove two inter-vehicular air lines (14) from stowage.

**CONNECT TOW BAR - Continued***Figure 5.***NOTE**

Gladhands on all models of HEMTT series vehicles are same in appearance, operation, and location. HEMTT M977 shown.

18. Connect first intervehicular air line (14) to driver side rear gladhand (15) of towing vehicle and driver side front gladhand (16) of disabled vehicle.
19. Connect second intervehicular air line (17) to passenger side rear gladhand (18) of towing vehicle and passenger side front gladhand (19) of disabled vehicle.
20. Remove two 16 ft. (5 m) safety chains (20) from stowage.

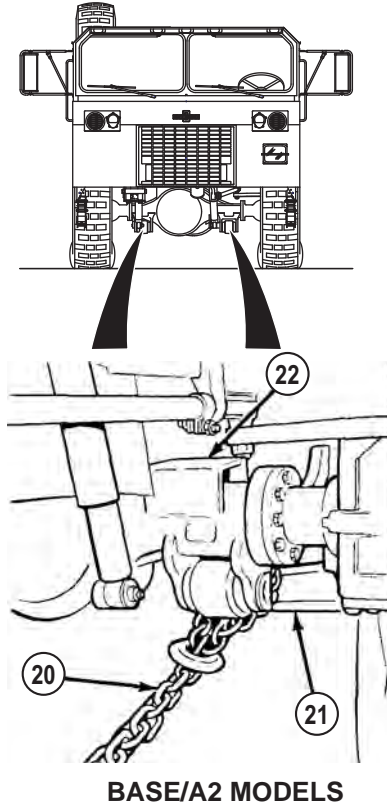
**NOTE**

- Both driver side and passenger side walking beams are same. Driver side shown.
- If disabled vehicle is either a BASE or A2 model HEMTT series vehicle (refer to data plate on inside of drivers door), complete Step

**CONNECT TOW BAR - Continued**

(21). If disabled vehicle is an A4 model HEMTT series vehicle (refer to data plate on inside of drivers door), skip to Step (22).

21. Route one 16 ft. (5 m) safety chain (20) over walking beam (21) behind No. 1 axle (22) on disabled vehicle, and hook 16 ft. (5 m) safety chain (20) back into itself under walking beam (21) as shown.



*Figure 6.*

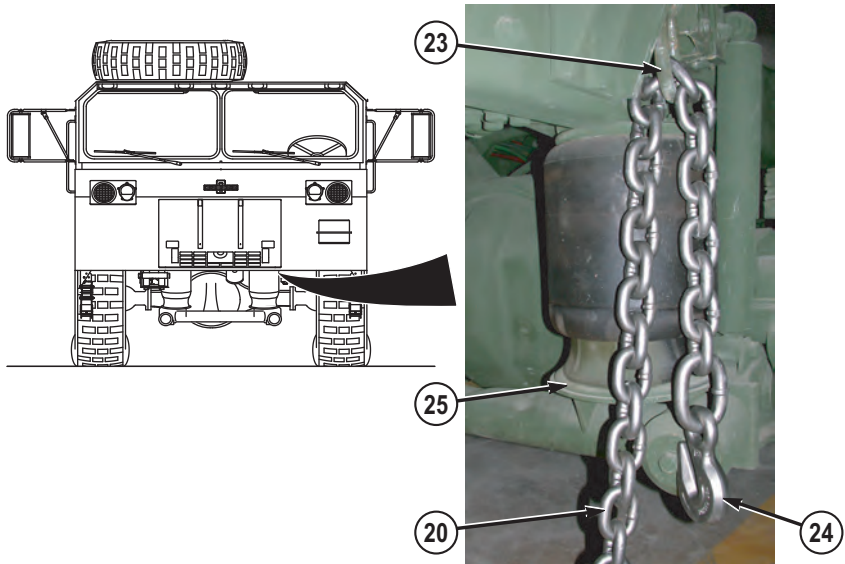
**CAUTION**

Special care should be taken when connecting 16 ft. (5 m) safety chain to tie down ring. The procedure listed below routes the 16 ft. (5 m) safety chain in such a way as to minimize excessive contact with vehicle air suspension air springs during towing. Failure to comply may result in damage to equipment.

**CONNECT TOW BAR - Continued****NOTE**

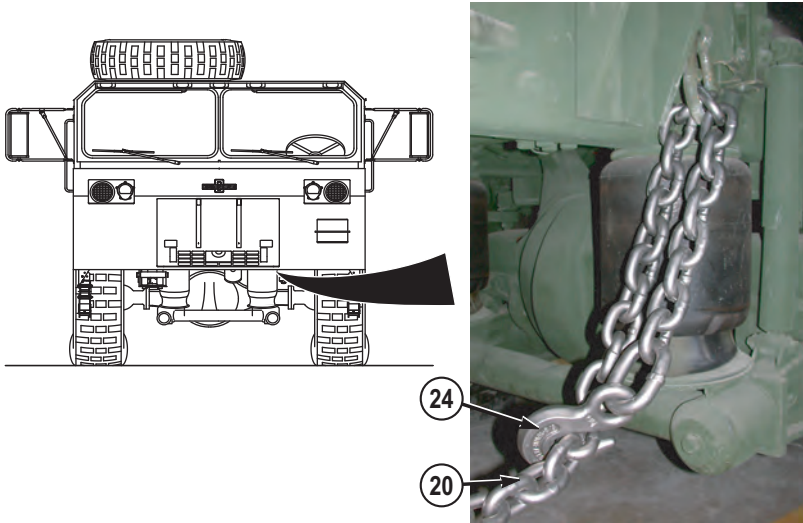
Both driver side and passenger side tie down rings are same. Driver side shown.

22. Connect 16 ft. (5 m) safety chain (20) to disabled vehicle tie down ring (23):
  - a. Route end (without safety shackle) of 16 ft. (5 m) safety chain (20) through tie down ring (23) from inboard to outboard until grab hook (24) hangs just below bottom of air spring (25).



*Figure 7.*

- b. Hook 16 ft. (5 m) safety chain (20) back to itself. Grab hook (24) should open towards ground (shown) when tension is applied to 16 ft. (5 m) safety chain (20).

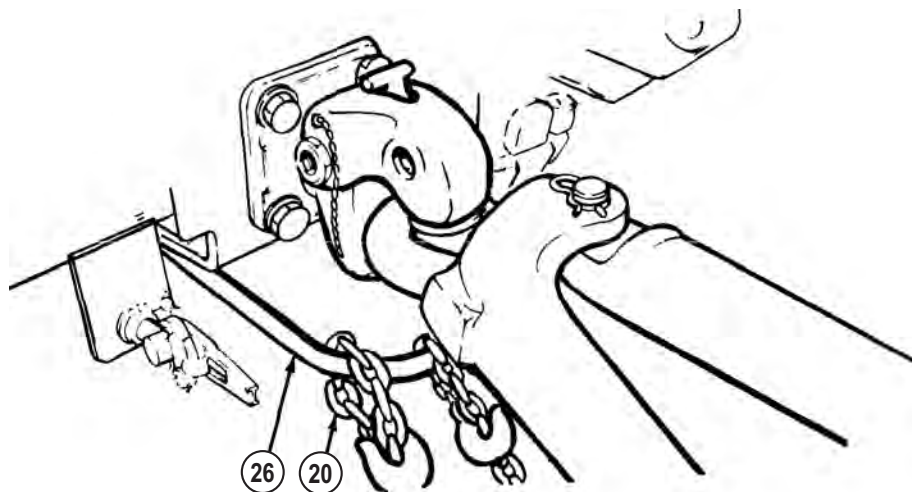
**CONNECT TOW BAR - Continued**

*Figure 8.*

23. Repeat Steps (21) or (22) for other side of disabled vehicle.

**NOTE**

- 16 ft. (5 m) safety chain may be attached to either safety chain loop or towing shackles.
  - 16 ft. (5 m) safety chain should be attached so they are just above, but not in contact with the ground.
24. Route free ends of two 16 ft. (5 m) safety chain (20) through safety chain loop (26) on towing vehicle and attach each 16 ft. (5 m) safety chain (20) back into itself as shown.

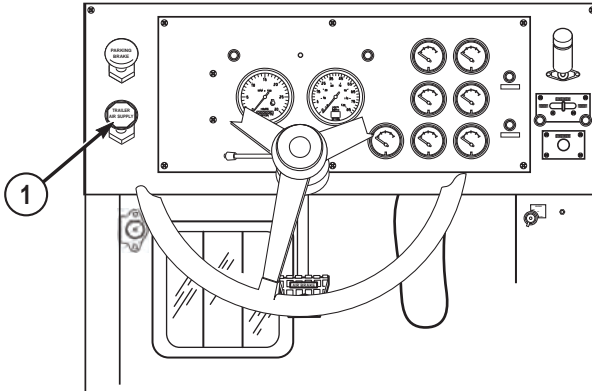
**CONNECT TOW BAR - Continued***Figure 9.*

25. Tow disabled vehicle. (WP 0089)

**DISCONNECT TOW BAR****NOTE**

- This procedure is a three soldier task.
- Vehicle should be parked and disconnected on level ground.

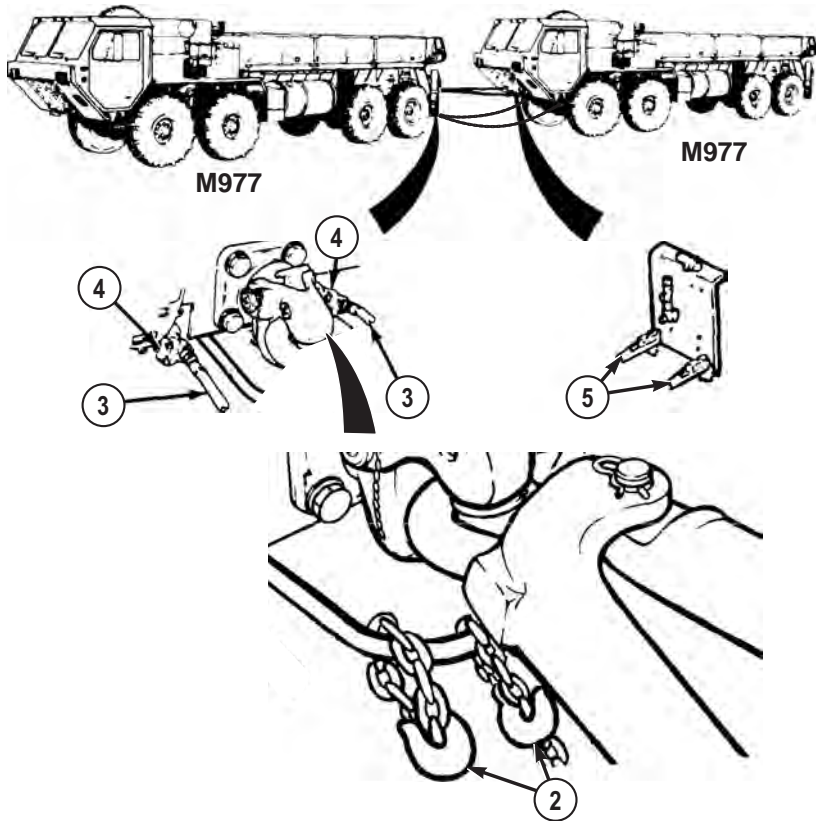
1. Park towing vehicle. (WP 0056)
2. Pull out TRAILER AIR SUPPLY control (1) on towing vehicle.

**DISCONNECT TOW BAR - Continued***Figure 10.***NOTE**

If disabled vehicle parking brake is inoperable and/or spring brakes on disabled vehicle were manually released, install wheel chocks (refer to operator's manual).

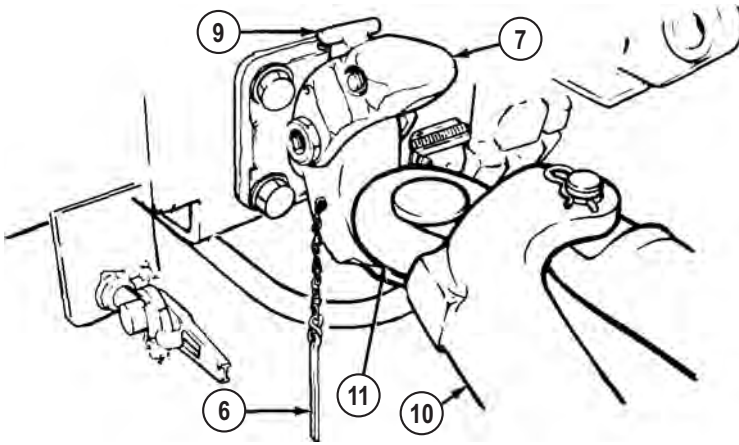
3. Engage parking brake on disabled vehicle (refer to operator's manual).
4. Disconnect two 16 ft. (5 m) safety chains (2) from towing vehicle and disabled vehicle. Return 16 ft. (5 m) safety chains (2) to stowage.



**DISCONNECT TOW BAR - Continued***Figure 11.***NOTE**

If spring brakes on disabled vehicle were manually released before towing, skip to Step (6).

5. Disconnect two intervehicular air lines (3) from towing vehicle rear gladhands (4) and from disabled vehicle front gladhands (5). Return intervehicular air lines (5) to stowage.
6. Remove cotter pin (6) from towing vehicle pintle hook (7).

**DISCONNECT TOW BAR - Continued***Figure 12.*

7. Pull latch (9) away from vehicle and hold.
8. Lift top of pintle hook (7) and let go of latch (9). Pintle hook (7) will be locked open.
9. As two assistants lift tow bar (10) until lunette eye (11) is clear of pintle hook (10), drive towing vehicle forward approximately 15 ft. (4.6 m).
10. As assistants lower tow bar (10) to the ground, park towing vehicle.
11. Pull latch (9) to close towing vehicle pintle hook (7) and install cotter pin (6) in pintle hook (7).
12. Remove cotter hairpin (12) and pin (13) and separate tow bar (10) at pivot point (14).

DISCONNECT TOW BAR - Continued

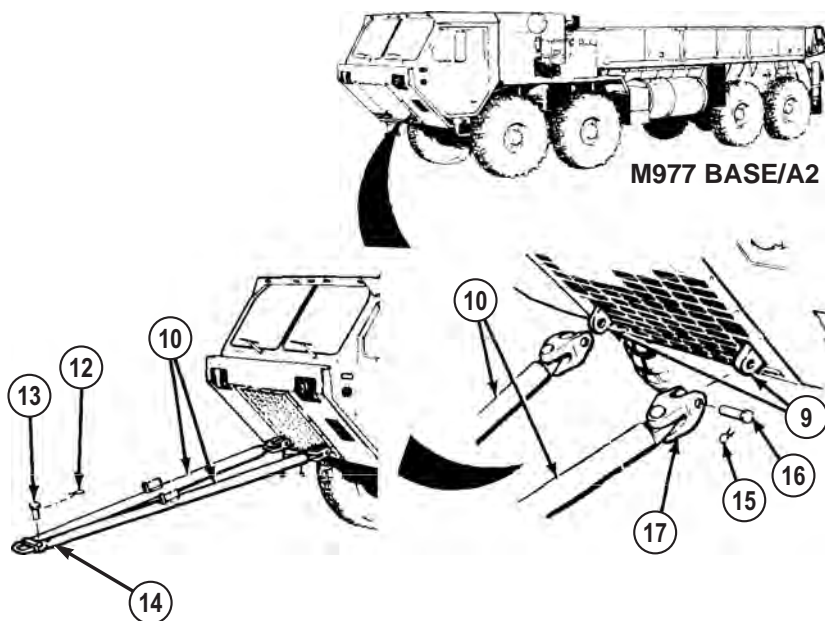


Figure 13.

## DISCONNECT TOW BAR - Continued

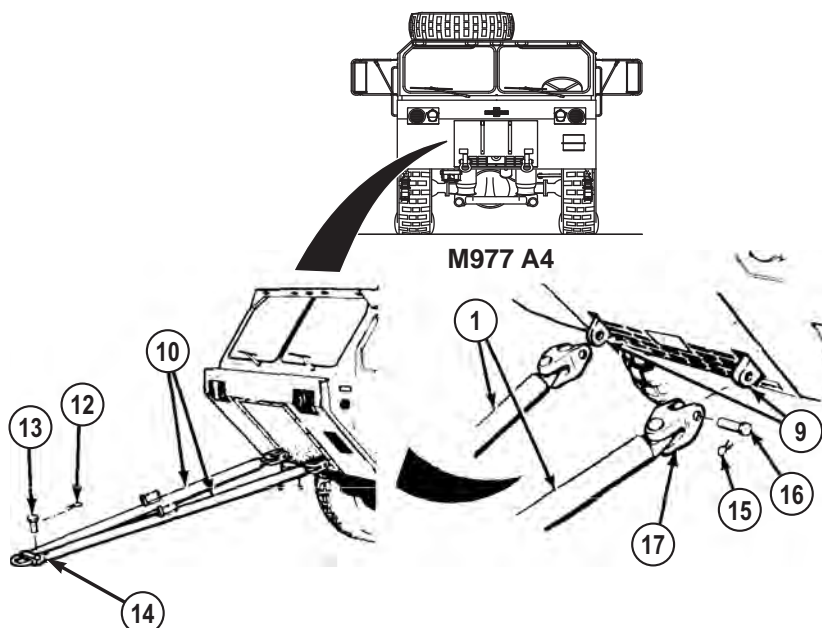


Figure 14.

13. With aid of an assistant, hold one leg of tow bar (10) while another assistant removes cotter hairpin (15) and pin (16) from shackle (17).
14. Repeat Step (13) for other leg of tow bar (10).
15. With aid of two assistants, lower tow bar (10) to the ground.
16. Install two pins (16) and cotter hairpins (15) in shackles (17).
17. Align legs of tow bar (10) at pivot point (14) and install pin (13) and cotter hairpin (12).

**WARNING**

Tow bar is heavy. Do not attempt to lift or move tow bar without the aid of two assistants and a lifting device. Failure to comply may result in injury or death to personnel.

**DISCONNECT TOW BAR - Continued**

18. With aid of two assistants and lifting device, return tow bar (10) to stowage.

**END OF TASK**

**END OF WORK PACKAGE**



---

## OPERATOR MAINTENANCE OPERATE VEHICLE IN EXTREME HEAT

---

### INITIAL SETUP:

Not Applicable

---

### EXTREME HEAT OPERATION

#### CAUTION

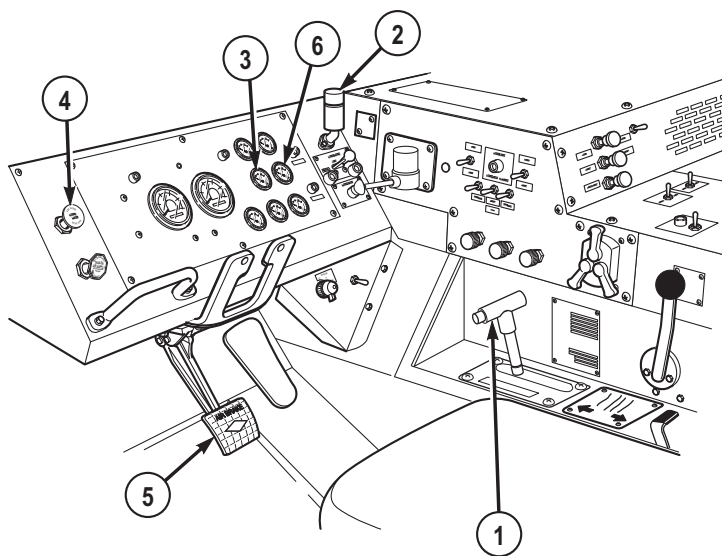
- When operating vehicle in very hot temperatures of above 100°F (38°C), extra care must be taken to prevent overheating engine (temperatures over 230°F (110°C) and transmission (temperatures over 250°F, 121°C). Watch water and transmission temperature gauges closely. Failure to comply may result in damage to equipment.
- Check oil levels often and keep operating strain as low as possible. Vehicle cooling and lubrication systems support each other. Failure of one system will rapidly cause failure of other systems.

#### NOTE

- Close heater valves to improve the efficiency of cabin air conditioning kit.
  - Closing the heater valves disables cabin heat.
1. Keep operating temperatures as low as possible:
    - a. Set transmission range selector (1) to N (neutral) while engine is running and not required to move.
    - b. Use low gear ranges only when necessary.
    - c. Stop vehicle for cooling off periods, and idle engine as often as possible. Let engine idle for approximately 3 minutes before shutting down. Idling will cool engine faster than quick shutdown and may prevent damage from remaining engine heat.
    - d. Check oil levels often. Oil seals are more likely to leak in extreme hot weather.
    - e. Check air filter restriction indicator (2) frequently. If indicator shows red:
      - (1) Park vehicle. (WP 0056)

**EXTREME HEAT OPERATION - Continued**

- (2) Shut off engine. (WP 0057)
- (3) Notify field level maintenance.



*Figure 1.*

2. If TRANS TEMP gauge (3) reads 250°F (121°C) or above, perform the following steps:
  - a. Slow vehicle.
  - b. Set transmission range selector (1) to next lower gear range.
  - c. Continue operation.
  - d. When TRANS TEMP gauge (3) reads normal range:
    - (1) Set transmission range selector (1) to normal gear range.
    - (2) Continue operation.
  - e. If TRANS TEMP gauge (3) does not return to normal range:
    - (1) Stop vehicle.
    - (2) Set transmission range selector (1) to N (neutral).
    - (3) Pull out PARKING BRAKE control (4).
    - (4) Allow transmission to cool.
  - f. When TRANS TEMP gauge (3) reads normal range:



**EXTREME HEAT OPERATION - Continued**

- (1) Apply service brake pedal (5).
  - (2) Push in PARKING BRAKE control (4).
  - (3) Set transmission range selector (1) to normal gear range.
  - (4) Continue operation.
3. If WATER TEMP gauge (6) indicates coolant temperature is near overheating, perform the following steps:
  - a. Slow vehicle.
  - b. Set transmission range selector (1) to next lower gear range.
  - c. Continue operation.
  - d. When WATER TEMP gauge (6) reads normal range:
    - (1) Set transmission range selector (1) to normal gear range.
    - (2) Continue operation.
  - e. If WATER TEMP gauge (6) does not return to normal range:
    - (1) Stop vehicle.
    - (2) Set transmission range selector (1) to N (neutral).
    - (3) Pull out PARKING BRAKE control (4).
    - (4) Allow engine to cool.
  - f. When WATER TEMP gauge (6) reads normal range:
    - (1) Apply service brake pedal (5).
    - (2) Push in PARKING BRAKE control (4).
    - (3) Set transmission range selector (1) to normal gear range.
    - (4) Continue operation.
4. Check cooling system often and notify field level maintenance if any of the following are found:
  - a. Low coolant level in radiator.
  - b. Leaking hose connections which have been tightened but still leak.
  - c. Cracked or leaking hoses.
  - d. Radiator or charge air cooler fins/grill plugged with mud, debris, etc.

**NOTE**

- Batteries do not hold charge well in extreme heat.

**EXTREME HEAT OPERATION - Continued**

- Battery will be tagged (white circle printed on top) for use in extreme heat conditions as specific gravity must be changed to adjust for heat (refer to TM 9-6140-200-14).
5. Keep batteries full, but do not overfill. Check battery electrolyte daily.
  6. In hot, damp climates check body and chassis often and notify field level maintenance if any of the following are found:
    - a. Signs of pitting or paint blistering on metal surfaces.
    - b. Signs of mildew, mold, or fungus on fabrics and rubber.
  7. Adjust lubrication intervals as specified in applicable lubrication instructions (refer to PMCS).
  8. Park vehicle (WP 0056) in sheltered area, out of wind if possible. If no shelter is available, park so vehicle does not face into wind.

**END OF TASK****END OF WORK PACKAGE**

---

## OPERATOR MAINTENANCE OPERATION IN EXTREME DUST

---

### INITIAL SETUP:

Not Applicable

---

### OPERATE VEHICLE IN EXTREME DUST

#### CAUTION

Clouds of dust can scratch glass surfaces. Keep glass surfaces covered as much as possible in these conditions to prevent scratching.

1. Leave glass surfaces covered if not needed for operations. Take extra care when cleaning glass to prevent scratching surfaces.
2. Keep close watch on air filter restriction indicator (1) located on top right side of driver's instrument panel.

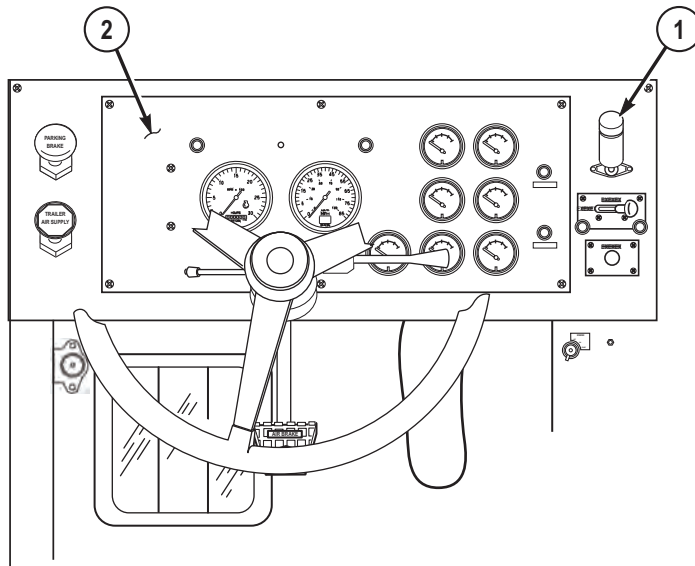
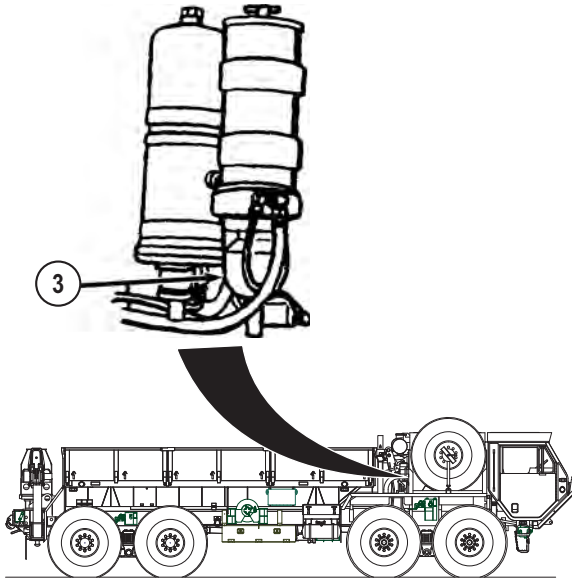


Figure 1.

3. Continuously scan gauges and indicators on driver's instrument panel (2) to be sure dust does not affect equipment.

**OPERATE VEHICLE IN EXTREME DUST - Continued**

4. Allow as much distance as possible between vehicles and operate at low speeds.
5. At stops, check and drain fuel/water separator (3).



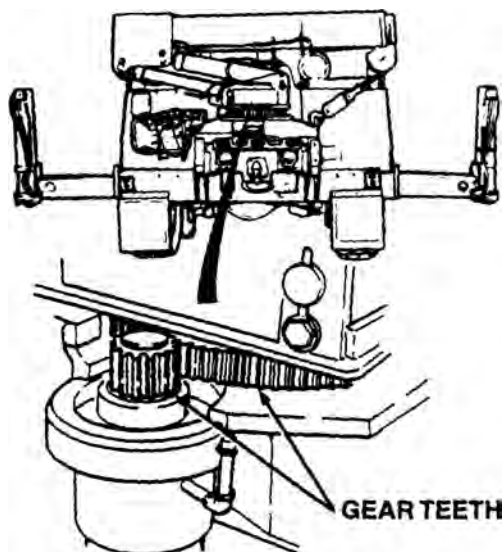
*Figure 2.*

6. When possible, park vehicle so it does not face into wind.

**OPERATE GROVE CRANE IN EXTREME DUST****NOTE**

Lubricate outrigger bottom plate, boom wear pads, and exposed rotation gears often when cranes are operating in dusty environment (refer to PMCS - Semiannual procedures (WP 0149) for more information).

1. When operating the grove crane in a blowing dust environment, perform the following:
  - a. Check gear teeth of rotation gear bearing and pinion for an accumulation of dust within the lubricant.

**OPERATE GROVE CRANE IN EXTREME DUST - Continued**

*Figure 3.*

- b. If level of dust prevents rotation of crane, notify field level maintenance and have lubricant removed.
- c. If necessary, notify field level maintenance to apply a light coating of wax to gear teeth for rust prevention.
- d. Refer to appropriate PMCS for proper lubrication of gear teeth when returning to normal operating conditions.

**END OF TASK**

**END OF WORK PACKAGE**



---

**OPERATOR MAINTENANCE  
OPERATE VEHICLE IN SAND OR MUD**

---

**INITIAL SETUP:**

Not Applicable

---

**OPERATE VEHICLE IN SAND OR MUD**

**CAUTION**

Blowing sand may scratch glass surfaces. Glass surfaces should remain covered as much as possible in these conditions to prevent scratching.

**NOTE**

Operating in mud can worsen vehicle braking and speed up brake wear. If braking worsens while operating in mud, dry brakes by driving vehicle approximately 500 ft. (153 m) with service brakes frequently applied. This must be done with brakedrums totally out of mud, so that drying action can take place. If adequate braking is not restored by drying brakes, notify field level maintenance.

1. Leave glass surfaces covered if not needed for operations. Extra care should be taken when cleaning glass surfaces to prevent scratching surfaces.

**NOTE**

Principles of driving in sand can also be applied to driving in mud. Best time to drive on sand is at night or early morning when sand is damp. Damp sand gives better traction.

- a. Check air filter restriction indicator (1) often.
2. Adjust tires to correct tire pressure for type tire and environment. (WP 0006)

**NOTE**

Positioning TRANSFER CASE shift lever to LO automatically activates 8X8 drive.

3. Set TRANSFER CASE shift lever (2) to LO. 8X8 DRIVE indicator (3) will illuminate.

OPERATE VEHICLE IN SAND OR MUD - Continued

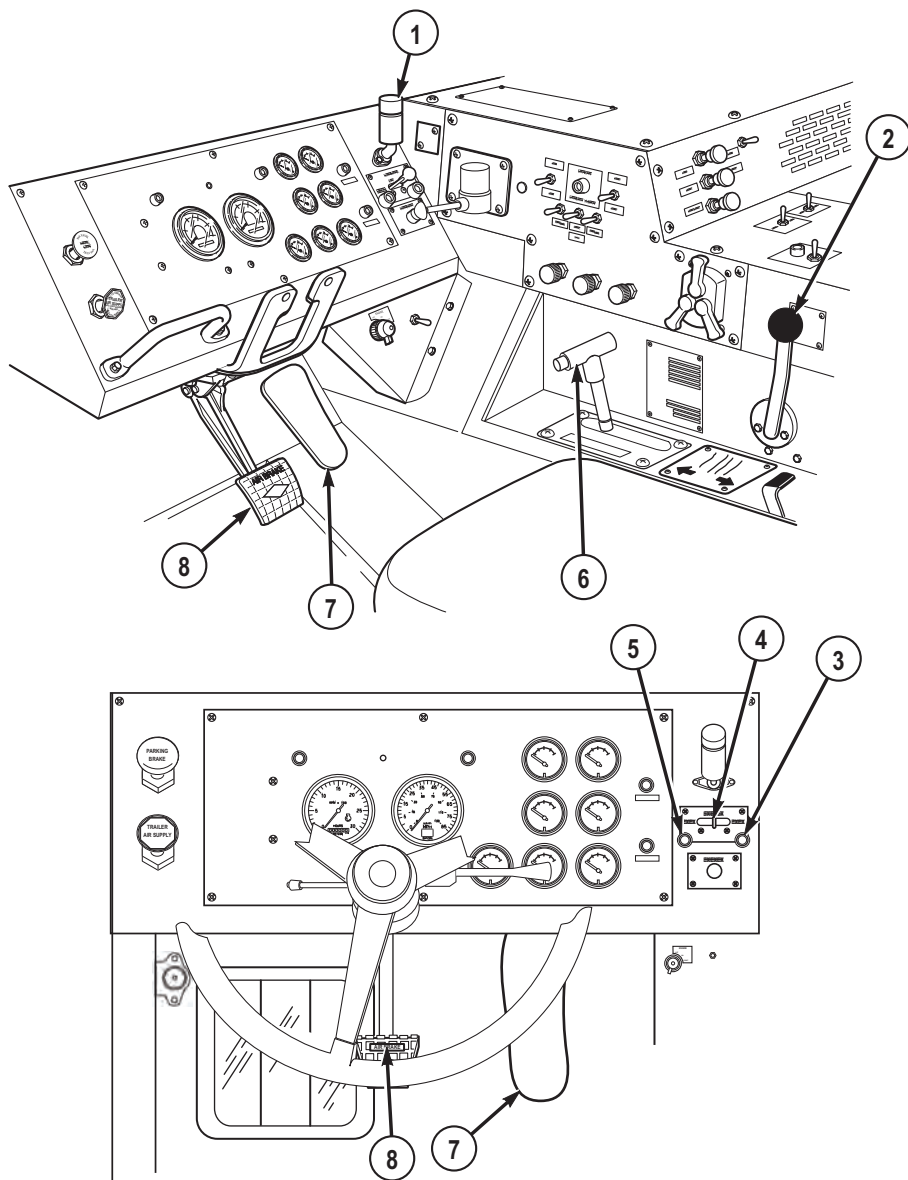


Figure 1.



**OPERATE VEHICLE IN SAND OR MUD - Continued****CAUTION**

Wheel hop condition should be avoided to prevent possible damage to drivetrain. If wheel hop begins to occur, ease up on throttle to allow tires to grip surface. If wheel hop continues, release throttle and apply brakes. Apply throttle slowly as traction permits.

4. Start slowly. Do not spin wheels when starting to move vehicle.
5. Set TRACTION CONTROL lever (4) to INTER-AXLE DIFF LOCK for added traction. Indicator light (5) will illuminate.
6. Set transmission range selector (6) to 2 (2nd) or 1 (1st), as needed for added traction.
7. Do not straddle sand mounds or drive on sides of two sand mounds. Loose sand will not support vehicle on steep slopes.
8. Keep throttle pedal (7) steady after vehicle reaches desired speed.
9. Turn vehicle slowly when on loose sand or mud.
10. Steer vehicle straight up and down hills if possible.
11. To move vehicle forward and turn after vehicle is stopped in loose sand or mud, do the following:
  - a. Set transmission range selector (6) to R (reverse).
  - b. Press throttle pedal (7) and move vehicle straight back about 20 ft. (6.1 m).
  - c. Release throttle pedal (7) and press service brake pedal (8).
  - d. Set transmission range selector (6) to 1 (1st).
  - e. Release service brake pedal (8) and press throttle pedal (7) to move vehicle forward.
  - f. Turn vehicle gradually.
  - g. Set transmission range selector (6) to D (drive) when vehicle picks up speed and is moving forward smoothly.
12. If vehicle starts to skid, do the following:
  - a. Release throttle pedal (7).
  - b. Steer in direction of skid until vehicle stops skidding.
  - c. Press throttle pedal (7) slowly and steer vehicle on straight course.

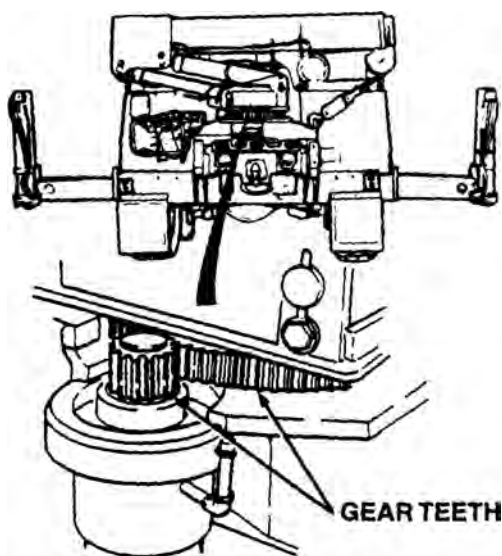
**OPERATE GROVE CRANE IN SAND OR MUD****CAUTION**

Take necessary precautions to ensure a firm footing for the crane outriggers by using a field-expedient blocking underneath the outrigger pads. Refer to FM 4-30.31 for additional information on vehicle recovery operations.

**NOTE**

Lubricate outrigger bottom plate, boom wear pads, and exposed rotation gears often when cranes are operating in dusty environment (refer to PMCS - Semiannual procedures (WP 0149) for more information).

1. When operating a grove crane in a blowing sand environment, perform the following:
2. Check gear teeth of rotation gear bearing and pinion for an accumulation of sand within the lubricant.



*Figure 2.*

3. If level of sand prevents rotation of crane, notify field level maintenance and have lubricant removed.
4. If necessary, notify field level maintenance to apply a light coating of wax to gear teeth for rust prevention.
5. Refer to PMCS for proper lubrication of gear teeth when returning to normal operating conditions.

**PARK VEHICLE**

1. Park vehicle as follows:
  - a. Vehicle should not face into wind.
  - b. Clean mud off vehicle as soon as possible.

**CAUTION**

- Do not hit axle breathers when cleaning mud from axles.
  - Do not direct high pressure water stream at glass surfaces, seals, air intake, axle breathers, exhaust outlet, or any other component of vehicle that could be easily damaged by high pressure water stream.
2. Clean mud from wheels, brakes, axles, universal joints, steering mechanism, and radiator as soon as possible.
  3. Make sure axle breather vent caps move freely on breather body.

**END OF TASK****END OF WORK PACKAGE**



---

**OPERATOR MAINTENANCE  
OPERATE VEHICLE IN DESERT ENVIRONMENT**

---

**INITIAL SETUP:**

Not Applicable

---

**DESERT ENVIRONMENT OPERATION****NOTE**

FM 90-3 contains detailed instructions for living and working in desert.

1. Principles for operating in extreme heat (WP 0091) and extreme dust (WP 0092), sand, or mud (WP 0093) apply to desert environment.

**NOTE**

- Close heater valves to improve the efficiency of cabin air conditioning kit.
  - Closing the heater valves disables cabin heat.
2. Temperatures may change as much as 70°F (21°C) degrees between day and night. These changes may damage equipment if vehicle is not properly prepared.
    - a. Due to expansion and contraction of all fluids and air, care should be taken when filling fuel tank and fluid reservoirs to prevent overflow when temperatures change.
    - b. Precision instruments may be affected by temperature changes and may need adjustment more often.

**END OF TASK****END OF WORK PACKAGE**



---

**OPERATOR MAINTENANCE**  
**OPERATE VEHICLE IN COLD ENVIRONMENT (32°F [0°C] TO -25°F [-32°C])**

---

**INITIAL SETUP:**

Not Applicable

---

**OPERATE VEHICLE IN COLD ENVIRONMENT**

**WARNING**



Do not touch extremely cold metal (below -26°F, -32°C to -65°F, -54°C). Bare skin may freeze to cold metal. Failure to comply may result in injury or death to personnel.

**CAUTION**

- Before operating vehicle in extreme cold environment, ensure engine arctic kit is installed and vehicle has been prepared as described in FM 9-207 . Refer to FM 31-70 , FM 31-71 , and FM 21-305 for additional information on operations in extreme cold environment.
- Watch instrument panel closely. If any unusual readings occur, stop vehicle and shut off engine. Check engine immediately.
- Park in shelter when possible. If shelter is not available, park so vehicle does not face into wind. Place planks or brush under wheels so vehicle will not freeze in place.
- Fuel filter should be drained before topping off fuel tank. Keep fuel tank as full as possible during cold operations. Water forms in empty fuel tank as it cools. Water in fuel system could freeze and block system.
- All snow and ice should be removed from vehicle as soon as possible. Snow and ice may slow or stop movement of critical parts if allowed to pile up.
- Special care must be used during operations in extreme cold environment. In extreme cold, engine coolant and fluid in windshield

**OPERATE VEHICLE IN COLD ENVIRONMENT - Continued**

washer can freeze. Batteries can freeze and crack. Oil and grease may get thick and stiff. Rubber and metal parts may crack or become brittle and break easily.

- Proper component lubrication is a must for extreme cold operation.

1. Install tire chains, as needed. (WP 0083)

**NOTE**

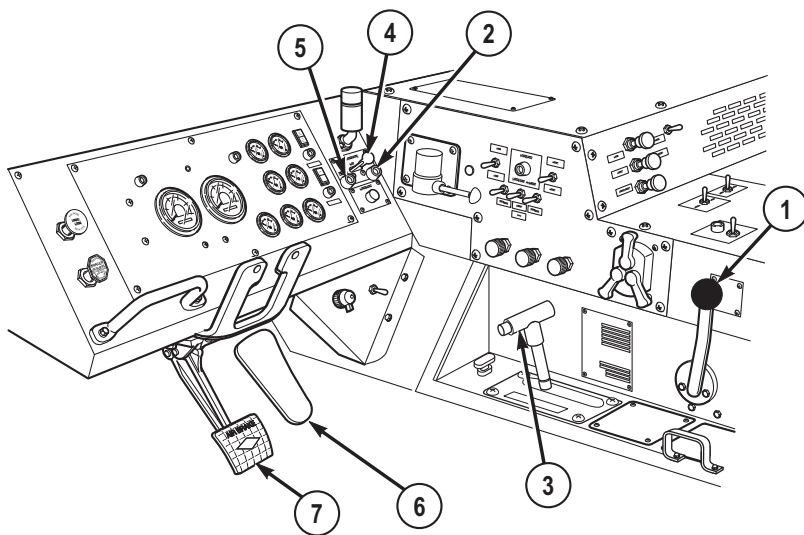
Use ether start system when starting a cold engine.

2. Start engine (WP 0044) and allow engine warm up thoroughly.
3. Let engine warm up thoroughly.

**NOTE**

Positioning TRANSFER CASE shift lever to LO automatically activates 8X8 drive.

4. Set TRANSFER CASE shift lever (1) to LO. 8X8 DRIVE indicator (2) will illuminate.



*Figure 1.*

5. Set transmission range selector (3) to 1 (1st gear range) and drive at lowest possible speed to warm driveline components and tires.
6. Drive on mud, snow, ice, and slippery surfaces as follows:



**OPERATE VEHICLE IN COLD ENVIRONMENT - Continued****NOTE**

- TRACTION CONTROL lever should be set to 8X8 DRIVE when transfer case shift lever is set to HI range while driving on slippery surfaces.
  - Positioning TRANSFER CASE shift lever to LO automatically activates 8X8 drive.
- a. Set TRANSFER CASE shift lever (1) to LO for added traction. 8X8 DRIVE indicator (2) will illuminate.

**NOTE**

TRACTION CONTROL lever should be set to INTER-AXLE DIFF. LOCK when transfer case shift lever is set to LO range while driving on slippery surfaces.

- b. Set TRACTION CONTROL lever (4) in INTER-AXLE DIFF. LOCK (when LO range is used - recommended) or 8X8 DRIVE (if HI range is required), as needed, when driving on slippery surfaces. INTER-AXLE LOCK indicator (5) and/or 8X8 DRIVE indicator (2) will illuminate as applicable.
- c. Press throttle pedal (6) slowly when changing speed.
- d. Keep throttle pedal (6) steady after vehicle reaches desired speed.
- e. Turn vehicle slowly when on slippery surfaces.
- f. Steer vehicle away from ruts and large snowbanks.
- g. Steer vehicle straight up and down hills if possible.
- h. Use gear range 2 (2nd) or 3 (3rd) to go down medium grades.
- i. Use gear range 1 (1st) to go down steep or very slippery grades.
- j. Drive at slower speeds and stay twice normal distance from vehicle ahead.
- k. Signal turns sooner than normal to give vehicles behind ample time to safely slow down.

**WARNING**

Do not use engine brake when vehicle is on slippery surface. If engine brake is used incorrectly, vehicle may skid out of control. Failure to comply may result in injury or death to personnel.

**OPERATE VEHICLE IN COLD ENVIRONMENT - Continued****NOTE**

Pressing service brake pedal lightly will help keep vehicle from skidding.

- l. Apply brakes sooner, and press service brake pedal (7) lightly to give early warning that vehicle will slow or stop.
- m. Downshift, if necessary, when slowing or stopping vehicle on slick surfaces.
- n. Keep windshield, windows, mirrors, headlights, stoplights, and body lights clean and free of snow and ice. Use defroster and windshield wipers to keep windshield free of snow and ice.
- o. Drive slowly and test brakes after driving through slush or water. If brakes slip, do the following:
  - (1) Continue to drive slowly.
  - (2) Apply moderate pressure on service brake pedal (7) to cause slight brake drag.
  - (3) When brakes are dry and no longer slip, release service brake pedal (7).
  - (4) Resume normal driving speed for conditions.
- p. If absolutely necessary for better traction, lower vehicle tire pressure to emergency air pressure limit:
  - (1) Ensure each tire has a valve cap.
  - (2) Drive at low speed when tire pressures are reduced.
- q. If rear of vehicle skids, do the following:
  - (1) Ease up on throttle pedal (6).
  - (2) Steer in same direction that vehicle is skidding.
  - (3) When vehicle is under control, lightly apply service brake pedal (7).
  - (4) Steer vehicle on a straight course and slowly apply throttle pedal (6).
- r. If vehicle starts to slide while climbing a grade, do the following:
  - (1) Ease up on throttle pedal (6).
  - (2) Steer in same direction that vehicle is skidding.
  - (3) Slowly apply throttle pedal (6) and steer vehicle on a straight course.
- s. If vehicle becomes stuck, do the following:
  - (1) Shovel a clear path ahead of each tire.
  - (2) Put boards, brush, or similar material in cleared paths to get better traction.

**OPERATE VEHICLE IN COLD ENVIRONMENT - Continued**

- (3) If vehicle remains stuck, use another vehicle to winch or tow stuck vehicle clear.
  - (4) If another vehicle is not available, self-recover vehicle using self-recovery winch. (WP 0086)
7. Park vehicle (WP 0056) as follows:

**NOTE**

If no shelter is available, park vehicle so it does not face into the wind. Vehicle facing opposite of the direction of the wind is optimal.

- a. Park vehicle in sheltered area, out of wind if possible.

**NOTE**

If no high, dry ground is available, spread out planks, brush, etc., to create a raised area so that vehicle tires will not freeze in snow, water, ice, or mud.

- b. Park vehicle on high, dry ground if possible.
- c. Park vehicle on level ground so vehicle body does not twist.
- d. Leave transfer case shift lever (1) in LO.

**NOTE**

Do not hit axle breathers when cleaning mud, snow, and ice from axles.

8. Clean snow, ice, and mud off vehicle as soon as possible.
9. Clean mud, snow, and ice from wheels, brakes, axles, universal joints, mirrors, steering mechanism, and radiator as soon as possible.
10. Ensure axle breather vent caps move freely on breather body.

**END OF TASK****END OF WORK PACKAGE**



---

## OPERATOR MAINTENANCE OPERATION IN EXTREME COLD ENVIRONMENT

---

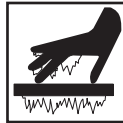
### INITIAL SETUP:

Not Applicable

---

### OPERATE VEHICLE IN EXTREME COLD ENVIRONMENT (-26°F[-32°C] to -65°F[-54°C])

#### WARNING



Do not touch extremely cold metal (below -26°F, -32°C to -65°F, -54°C). Bare skin may freeze to cold metal. Failure to comply may result in injury or death to personnel.

#### CAUTION

- Before operating vehicle in extreme cold environment, ensure engine arctic kit is installed and vehicle has been prepared as described in FM 9-207.
- Refer to FM 31-70 , FM 31-71 , and FM 21-305 for additional information on operations in extreme cold environment.
- Watch instrument panel closely. If any unusual readings occur, stop vehicle and shut off engine. Check immediately.
- Park in shelter when possible. If shelter is not available, park so vehicle does not face into wind. Place planks or brush under wheels so vehicle will not freeze in place.
- Fuel filter should be drained before topping off fuel tank. Keep fuel tank as full as possible during cold operations. Water forms in empty fuel tank as it cools. Water in fuel system could freeze and block system.
- All snow and ice should be removed from vehicle as soon as possible. Snow and ice may slow or stop movement of critical parts if allowed to pile up.

**OPERATE VEHICLE IN EXTREME COLD ENVIRONMENT (-26°F[-32°C] to -65°F[-54°C]) - Continued**

- Special care must be used during operations in extreme cold environment. In extreme cold, engine coolant and fluid in windshield washer can freeze. Batteries can freeze and crack. Oil and grease may get thick and stiff. Rubber and metal parts may crack or become brittle and break easily.
  - Proper component lubrication is a must for extreme cold operation.
1. Principles and procedures for operating in cold environment (WP 0095) also apply to extreme cold environment.
  2. Ensure arctic engine heater kit has been installed.
  3. Operate arctic engine heater (WP 0058) as needed.

**WARNING**

Do not touch extremely cold metal (below -26°F, -32°C to -65°F, -54°C). Bare skin may freeze to cold metal. Failure to comply may result in injury or death to personnel.

**NOTE**

If additional air is put in tires for standby periods, lower tire pressure to normal amounts before driving vehicle.

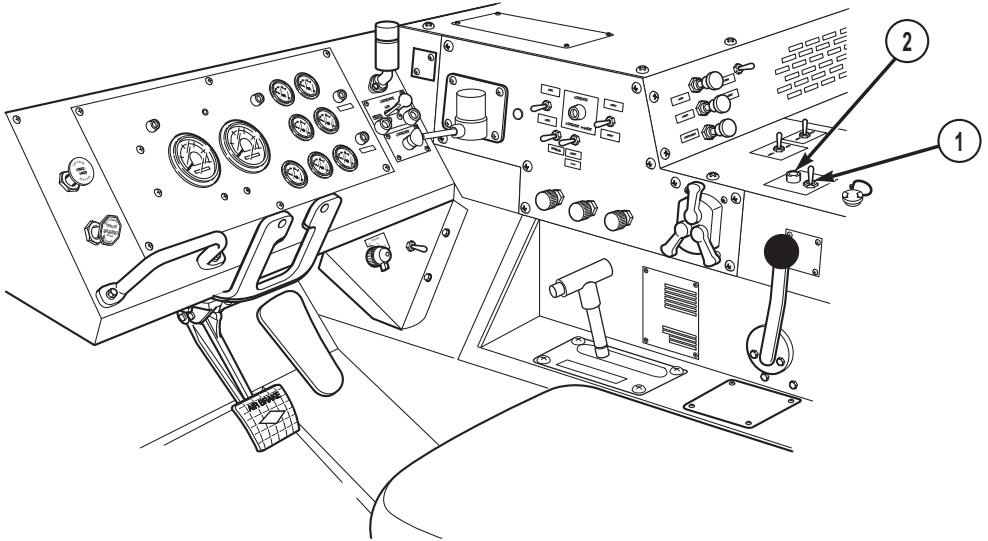
4. In areas where temperatures reach -50°F (-46°C) or colder, fill tires with air approximately 10 psi above normal for long standby periods and overnight.

**OPERATE GROVE CRANE IN EXTREME COLD ENVIRONMENT (-26°F[-32°C] to -65°F [-54°C])****WARNING**

Do not touch extremely cold metal (below -26°F, -32°C to -65°F, -54°C). Bare skin may freeze to cold metal. Failure to comply may result in injury or death to personnel.

**OPERATE GROVE CRANE IN EXTREME COLD ENVIRONMENT (-26°F[-32°C] to -65°F [-54°C]) - Continued**

1. Before operating crane, perform warm-up as follows:
  - a. Start engine. (WP 0044)
  - b. Properly warm up vehicle.
  - c. Set PTO ENGAGE switch (1) to ON position. Indicator light (2) will illuminate.



*Figure 1.*

- d. While engine is at low idle, fully exercise all functions of crane for at least 5 minutes.
    - e. With engine at high idle, fully exercise all functions of crane for at least 10 minutes.
2. Continue with operation of crane.

**END OF TASK**

**END OF WORK PACKAGE**





---

**OPERATOR MAINTENANCE  
OPERATE VEHICLE IN FOREST OR ROCKY TERRAIN**

---

**INITIAL SETUP:**

Not Applicable

---

**OPERATE VEHICLE IN FOREST OR ROCKY TERRAIN**

**WARNING**



Ensure tire pressure is correct for vehicle operation. Failure to comply may result in injury or death to personnel.

**NOTE**

When driving over very rocky terrain is part of the mission route, be sure spare wheel and tire are on vehicle, in good repair, and at correct pressure for normal operations. There is greater chance of tire punctures when operating in rocky terrain.

1. Fold vehicle side mirrors in far enough so area to rear of vehicle can still be seen, but mirrors will not be damaged by rocks, trees, and other obstructions.

**CAUTION**

Before driving over ground obstructions such as stumps and large rocks, ensure vehicle has adequate clearance. Stumps and rocks may damage components underneath vehicle.

2. Avoid driving over obstructions if possible.

**CAUTION**

Ensure vehicle can clear overhanging tree limbs and other obstructions. Low overhead obstructions may damage cargo, cargo cover, and other parts on top of vehicle.

3. Avoid low overhanging obstructions if possible.

**OPERATE VEHICLE IN FOREST OR ROCKY TERRAIN - Continued**

4. Check traction and braking. Rocks and fallen leaves can be very slick, especially when wet.

**END OF TASK**

**END OF WORK PACKAGE**

**OPERATOR MAINTENANCE  
OPERATE VEHICLE IN SALTWATER AREAS**

---

**INITIAL SETUP:**

Not Applicable

---

**OPERATION**

1. Inspect vehicle and major components (crane, tanker module, LHS, etc.) frequently for the buildup of salt deposits, rust, and corrosion.

**NOTE**

Do not direct high-pressure water hose nozzles, or steam cleaner nozzles into hydraulic system seals and/or electrical junction boxes.

2. If salt deposits are located, clean the affected areas using authorized local procedures.
3. Frequently wash the vehicle and major components to prevent the buildup of salt deposits.
4. If corrosion is present, notify your supervisor as these conditions need to be corrected immediately.

**END OF TASK****END OF WORK PACKAGE**



---

**OPERATOR MAINTENANCE  
SET UP/SECURE HIGHWAY EMERGENCY MARKER KIT**

---

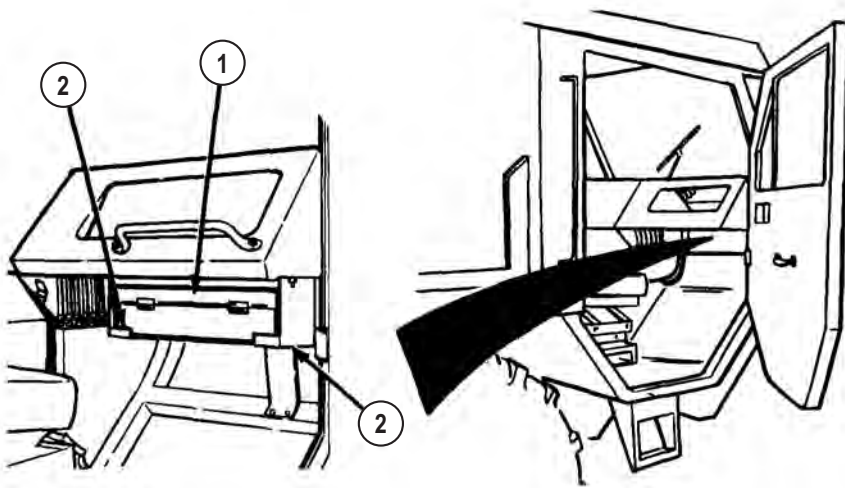
**INITIAL SETUP:**

Not Applicable

---

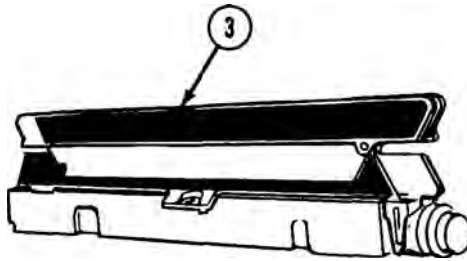
**PREPARE VEHICLE/MARKERS FOR USE**

1. Turn vehicle emergency flashers on. (WP 0076)
2. Remove emergency marker kit (1) from stowage brackets (2).



*Figure 1.*

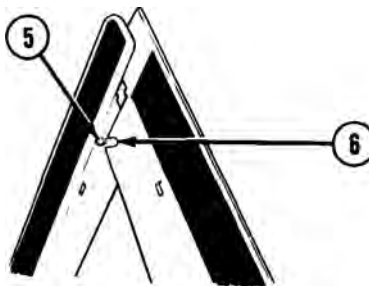
3. Remove markers (3) from case.

**PREPARE VEHICLE/MARKERS FOR USE - Continued***Figure 2.*

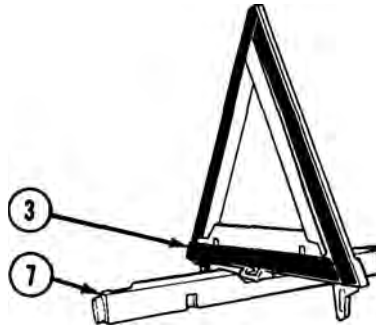
4. Raise arms (4).

*Figure 3.*

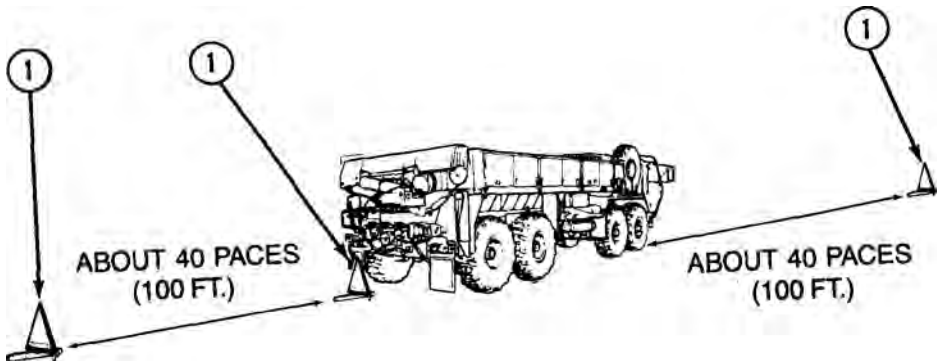
5. Snap pin (5) into slot (6).

*Figure 4.*

6. Rotate marker (3) about 1/4 turn on base (7) until it stops.

**PREPARE VEHICLE/MARKERS FOR USE - Continued***Figure 5.***PLACE MARKERS ON UNDIVIDED HIGHWAY**

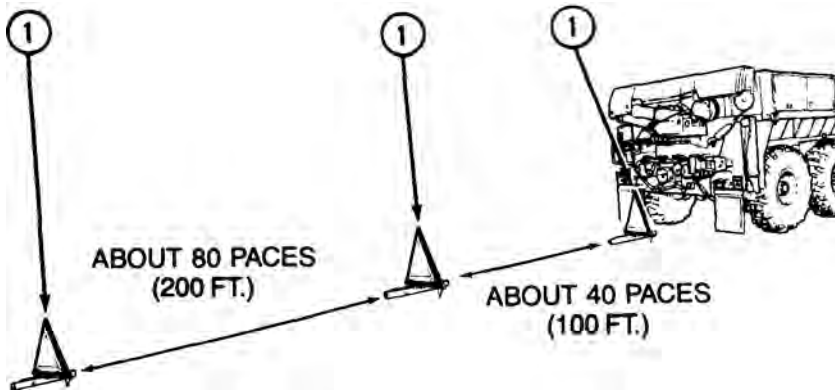
1. Place one marker (1) about 40 paces (100 ft. [30 m]) in front of vehicle, so marker faces traffic approaching from front.

*Figure 6.*

2. Place another marker (1) directly behind vehicle, so marker faces traffic approaching from rear.
3. Place third marker (1) approximately about 40 paces (100 ft. [30 m]) behind vehicle, so marker faces traffic approaching from rear.

**PLACE MARKERS ON DIVIDED HIGHWAY**

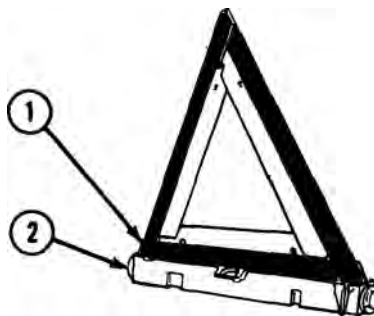
1. Place one marker (1) directly behind vehicle, so marker faces traffic approaching from rear.

**PLACE MARKERS ON DIVIDED HIGHWAY - Continued***Figure 7.*

2. Place second marker (1) about 40 paces (100 ft. [30 m]) behind vehicle, so marker faces traffic approaching from rear.
3. Place third marker (1) about 80 paces (200 ft. [60 m]) behind second marker, so marker faces traffic approaching from rear.

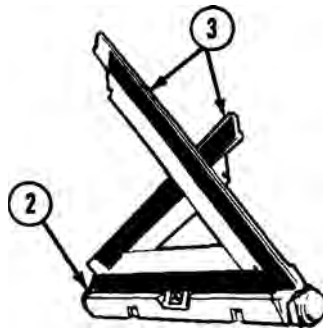
**SECURE MARKERS**

1. Rotate marker (1) over base (2).

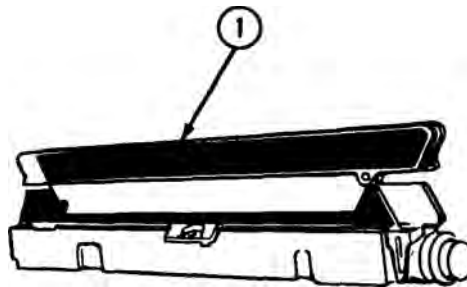
*Figure 8.*

2. Separate arms (3).

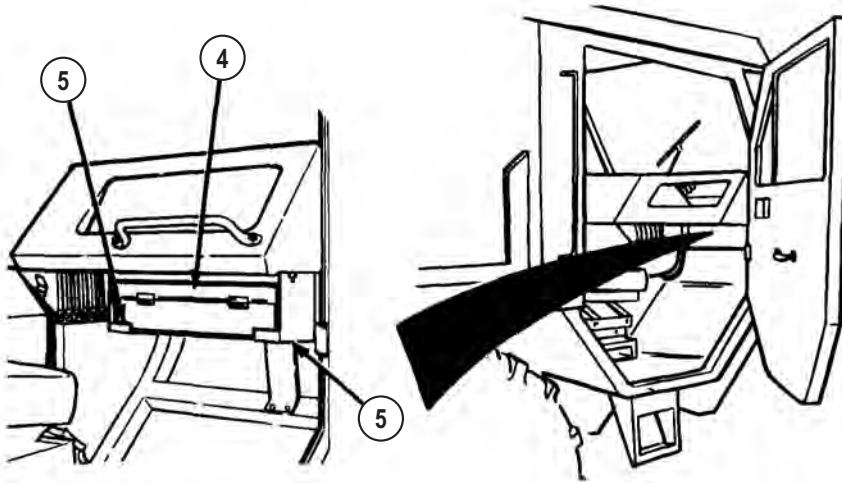


**SECURE MARKERS - Continued***Figure 9.*

3. Fold arms (3) down onto base (2).

*Figure 10.*

4. Put markers (1) in case.
5. Put emergency marker kit (4) in stowage brackets (5).

**SECURE MARKERS - Continued**

*Figure 11.*

6. Turn vehicle emergency flashers off. (WP 0076)

**END OF TASK**

**END OF WORK PACKAGE**

---

**OPERATOR MAINTENANCE  
MANUALLY RELEASE SPRING BRAKES**

---

**INITIAL SETUP:**

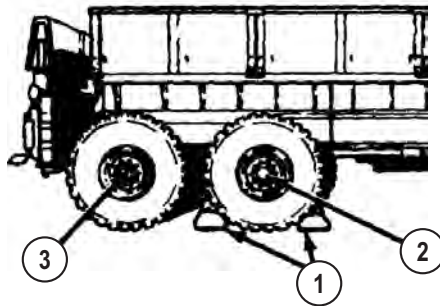
Not Applicable

---

**CHOCK REAR WHEELS****NOTE**

This procedure should only be used when vehicle air system is totally inoperative and vehicle cannot be towed with rear end raised by wrecker.

1. Remove wheel chocks (1) from stowage.



*Figure 1.*

2. Place wheel chocks (1) in front and back of one wheel on No. 3 (2) or No. 4 (3) axle.

**RELEASE BRAKES****WARNING**

Ensure brake chamber is caged while releasing brakes. Spring is under 2,500 lbs (1 135 kg) tension. Failure to comply may result in injury or death to personnel.

**NOTE**

Driver side brake chamber on No. 4 axle is shown. Steps are same for No. 4 axle passenger side and No. 3 axle.

1. Remove dust cap (1) from brake chamber (2).

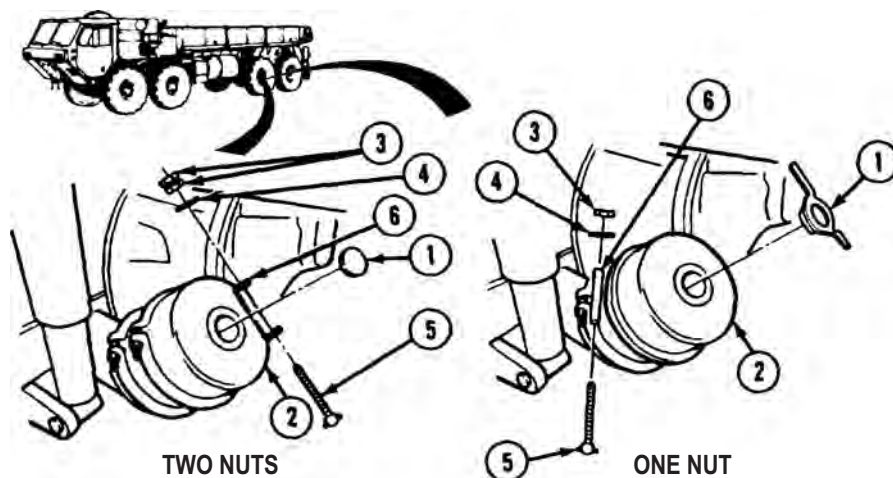
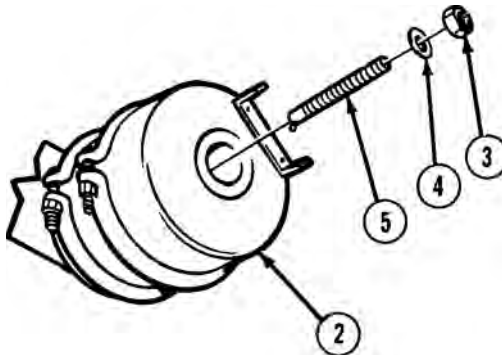


Figure 2.

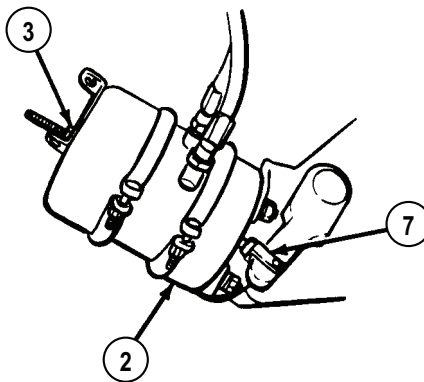
**NOTE**

There are two types of brake chambers: older vehicles have two nuts, newer vehicles have one nut.

2. Remove either one or two nuts (3) (as applicable), washer (4), and release-bolt (5) from bracket (6).
3. Insert release-bolt (5) into brake chamber (2).

**RELEASE BRAKES - Continued***Figure 3.*

4. Turn release-bolt (5) 1/4 turn to engage inside brake chamber (2).
5. Install washer (4) and nut (3) on release-bolt (5).
6. Tighten nut (3) until clevis (7) is pulled to rear of brake chamber (2).

*Figure 4.*

7. Repeat Steps (1) through (6) to release three remaining spring brakes on No. 3 and No. 4 axles.

**END OF TASK****END OF WORK PACKAGE**

This page intentionally left blank

---

**OPERATOR MAINTENANCE  
LIMP HOME/FLAT TIRE WITH NO SPARE**

---

**INITIAL SETUP:**

Not Applicable

---

**INSTALL LIMP HOME SETUP ON PASSENGER SIDE FRONT OR ANY REAR WHEEL**

**CAUTION**

- Do not use this procedure on fully loaded M983 vehicle with trailer in tow. Limp home setup will not support extra weight and equipment could be damaged.
- Vehicle must not be driven faster than 10 mph (16 km/h) or farther than 30 miles (48 km) in limp home condition.

**NOTE**

- Use limp home procedure for emergency only in case of wheel bearing failure, wheel damage, or when unable to change wheel and tire.
  - For limp home setup on driver side front No. 1 and 2 axles, refer to Limp Home Setup/Driver Side Front section.
  - Limp home setup for No. 4 axle is shown. Other limp home setups are done in same manner.
1. Remove two wheel chocks (1), jack base plate (2), jack (3), 7 ft. (2.1 m) chain (4), and shackle (5) from stowage.

## INSTALL LIMP HOME SETUP ON PASSENGER SIDE FRONT OR ANY REAR WHEEL - Continued

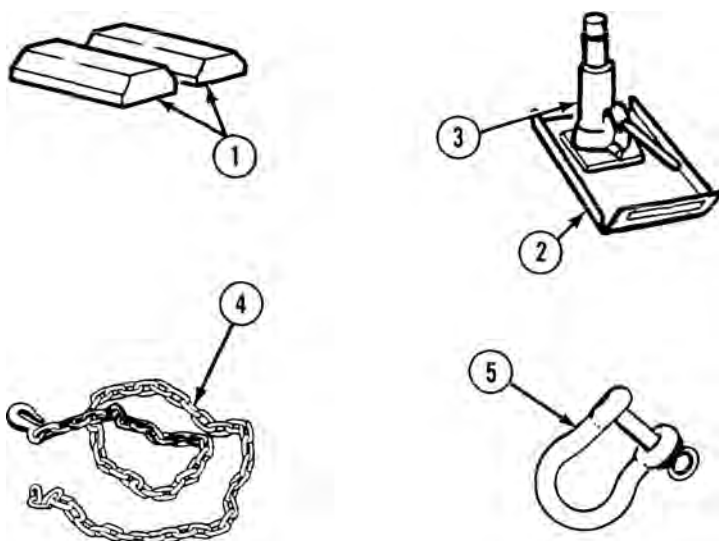


Figure 1.

2. Install two wheel chocks (WP 0077) (1) in front of and behind tire (6) across from tire (7) being raised.

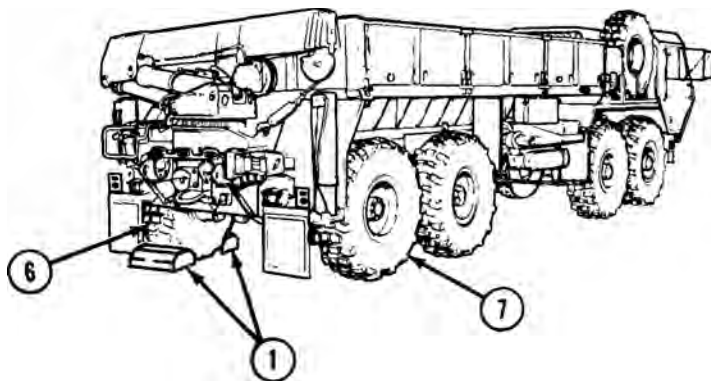
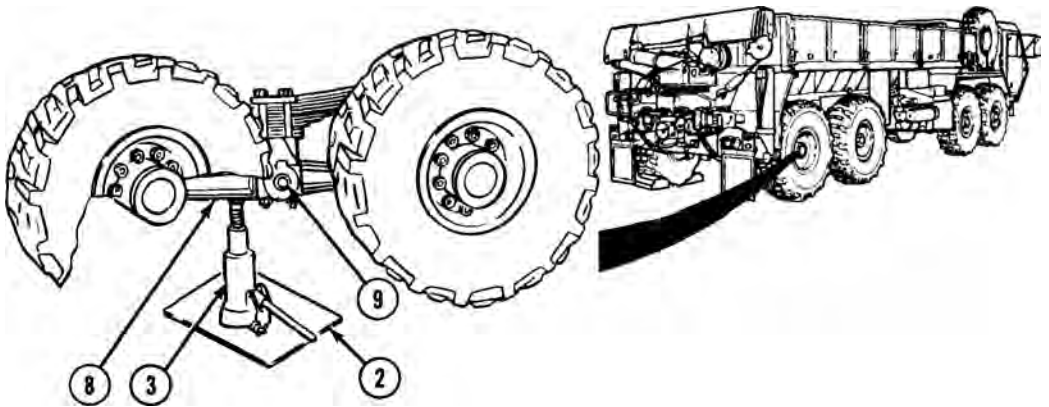


Figure 2.

3. Position jack base plate (2) and jack (3) under equalizer beam (8) 4 to 5 in. (102 to 127 mm) from center pivot point (9) towards axle to be raised (No. 4 axle shown).

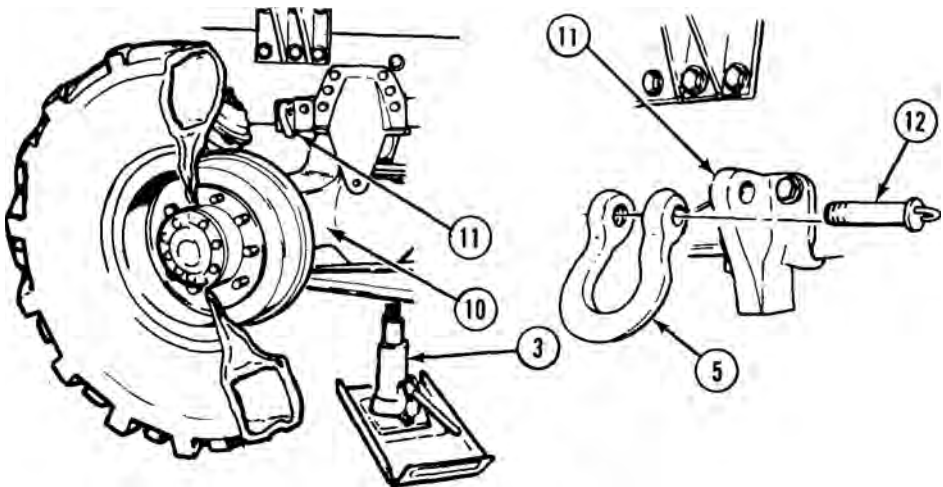


**INSTALL LIMP HOME SETUP ON PASSENGER SIDE FRONT OR ANY REAR WHEEL - Continued**



*Figure 3.*

4. Raise jack (3) until it touches equalizer beam (8).
5. Raise jack (3) until axle (10) is as close as it will go to axle stop (11).



*Figure 4.*

6. Install shackle (5) on axle stop (11) with pin (12).

**INSTALL LIMP HOME SETUP ON PASSENGER SIDE FRONT OR ANY REAR WHEEL - Continued****CAUTION**

Do not wrap 7 ft. (2.1 m) chain around any air line or brake chamber bracket. Air line could be crushed and damaged to bracket could result.

7. Route 7 ft. (2.1 m) chain (4) through shackle (5).



*Figure 5.*

8. Loop end of 7 ft. (2.1 m) chain (4) around axle (10).
9. Bring 7 ft. (2.1 m) chain (4) up to chain hook (13) and fasten as tight as possible.

**WARNING**

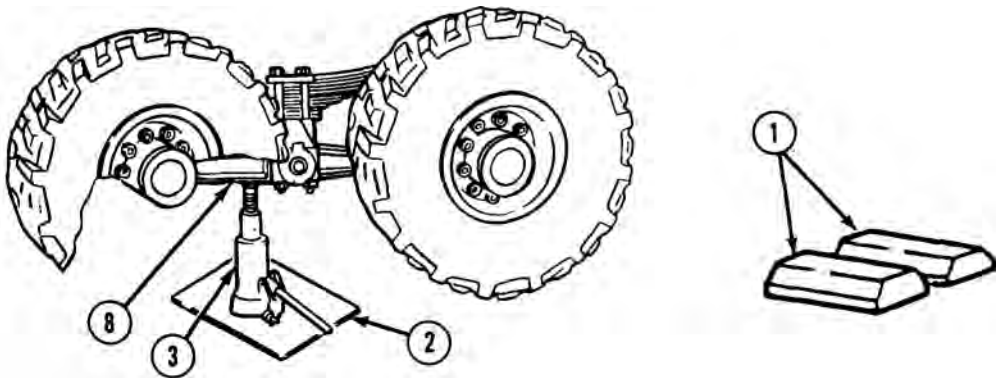
Keep hands away from chain when lowering jack. Hands and fingers could be crushed. Failure to comply may result in injury or death to personnel.

**NOTE**

Axle will drop slightly when jack is lowered.

10. Lower jack (3) and remove jack from under equalizer beam (8).

**INSTALL LIMP HOME SETUP ON PASSENGER SIDE FRONT OR ANY REAR WHEEL - Continued**

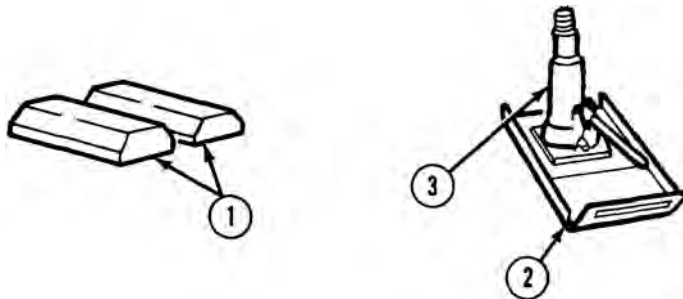


*Figure 6.*

11. Return jack (3), and jack base plate (2) to stowage.
12. Remove and stow two wheel chocks (1).

**REMOVE LIMP HOME SETUP FROM PASSENGER SIDE FRONT OR ANY REAR WHEEL**

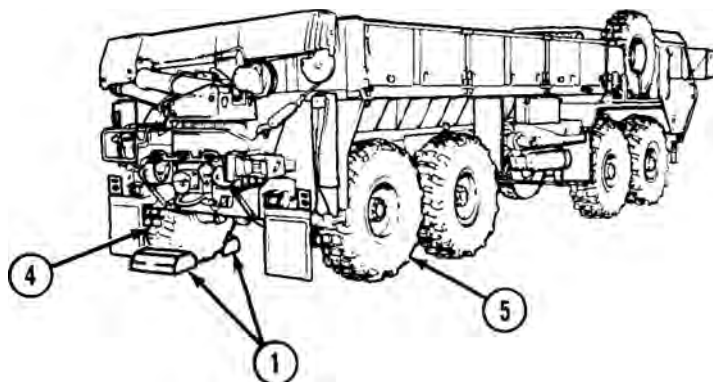
1. Remove two wheel chocks (1), jack base plate (2), and jack (3) from stowage.



*Figure 7.*

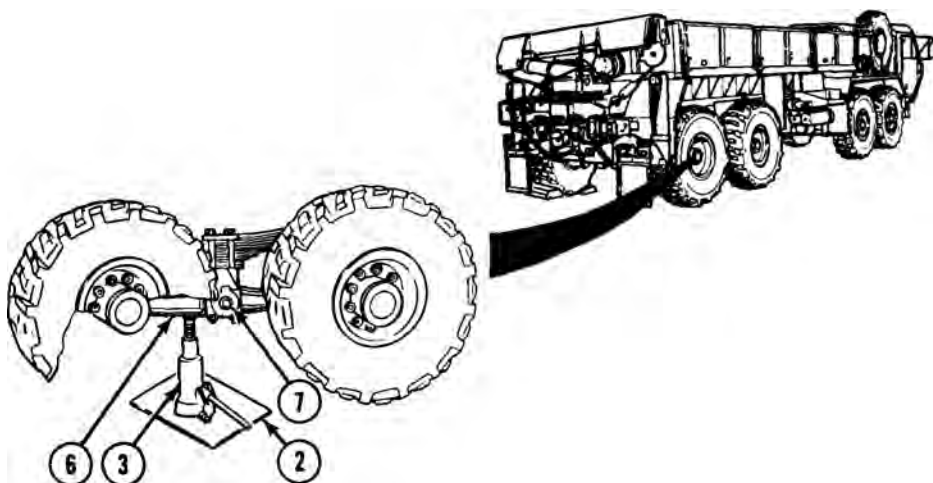
2. Install two wheel chocks (WP 0077) (1) in front of and behind tire (4) across from tire (5) being raised.

**REMOVE LIMP HOME SETUP FROM PASSENGER SIDE FRONT OR ANY REAR WHEEL - Continued**



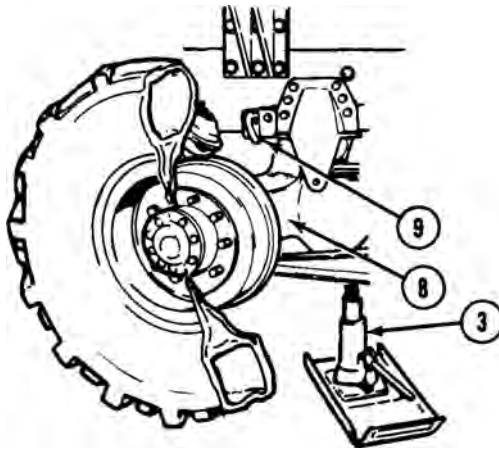
*Figure 8.*

3. Position jack base plate (2) and jack (3) under equalizer beam (6) 4 to 5 in. (102 to 127 mm) from center pivot point (7).



*Figure 9.*

4. Raise jack (3) until it touches equalizer beam (6).

**REMOVE LIMP HOME SETUP FROM PASSENGER SIDE FRONT OR ANY REAR WHEEL - Continued**

*Figure 10.*

5. Raise jack (3) until axle (8) is as close as it will go to axle stop (9).
6. Unhook 7 ft. (2.1 m) chain (10) and remove from shackle (11) and axle (8).

## REMOVE LIMP HOME SETUP FROM PASSENGER SIDE FRONT OR ANY REAR WHEEL - Continued

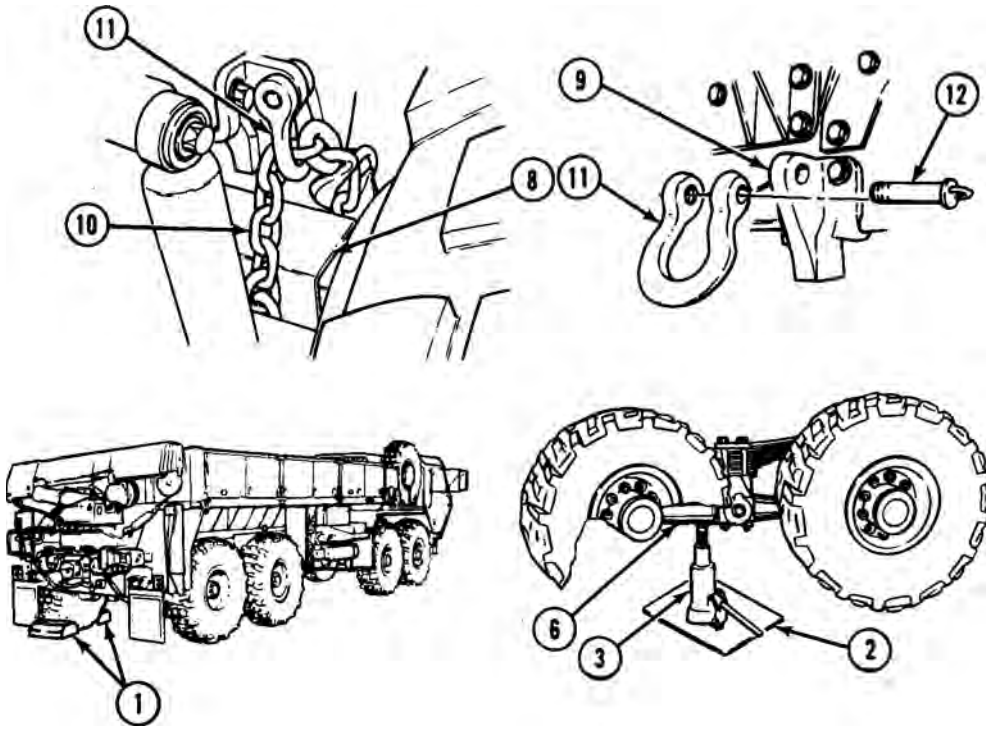


Figure 11.

7. Remove pin (12) from shackle (11) and axle stop (9).
8. Remove shackle (11) from axle stop (9) and reinstall pin (12) in shackle (11).
9. Lower jack (3) and remove jack (3) from equalizer beam (6).
10. Return jack base plate (2), jack (3), 7 ft. (2.1 m) chain (10), and shackle (11) to stowage.
11. Remove and stow two wheel chocks (1).

## INSTALL LIMP HOME SETUP/DRIVER SIDE FRONT

### CAUTION

- Do not use this procedure on fully loaded M983 vehicle with trailer in tow. Limp home setup will not support extra weight and equipment could be damaged.

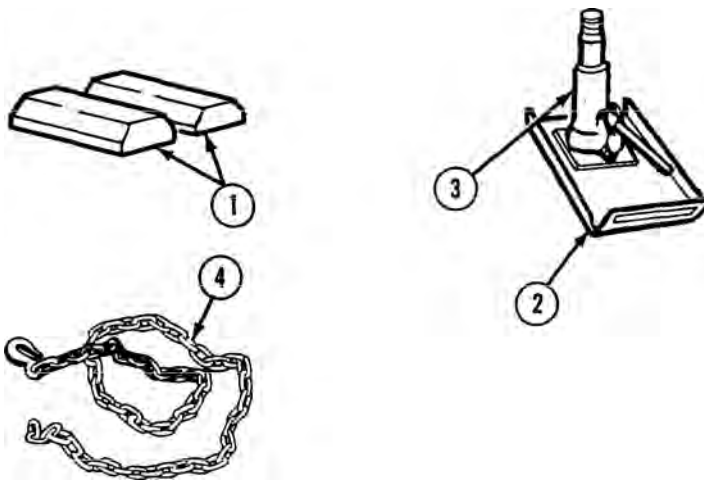


**INSTALL LIMP HOME SETUP/DRIVER SIDE FRONT - Continued**

- Vehicle must not be driven faster than 10 mph (16 km/h) or farther than 30 miles (48 km) in limp home condition.

**NOTE**

- Use limp home procedure for emergency only in case of wheel bearing failure, wheel damage, or when unable to change wheel and tire.
  - Limp home setup No. 1 axle is shown. Setup for No. 2 axle is done in same manner.
  - For limp home setup on other axles, refer to passenger side front or any rear wheel section above.
1. Remove two wheel chocks (1), jack base plate (2), jack (3), and 7 ft. (2.1 m) chain (4) from stowage.

*Figure 12.*

2. Install two wheel chocks (WP 0077) (1) in front of and behind tire (5) across from tire (6) being raised.

## INSTALL LIMP HOME SETUP/DRIVER SIDE FRONT - Continued

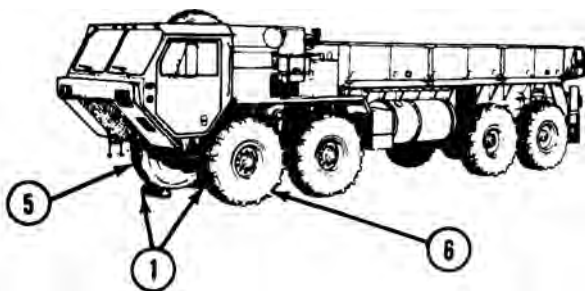


Figure 13.

3. Place jack base plate (2) and jack (3) under end of equalizer beam (7).

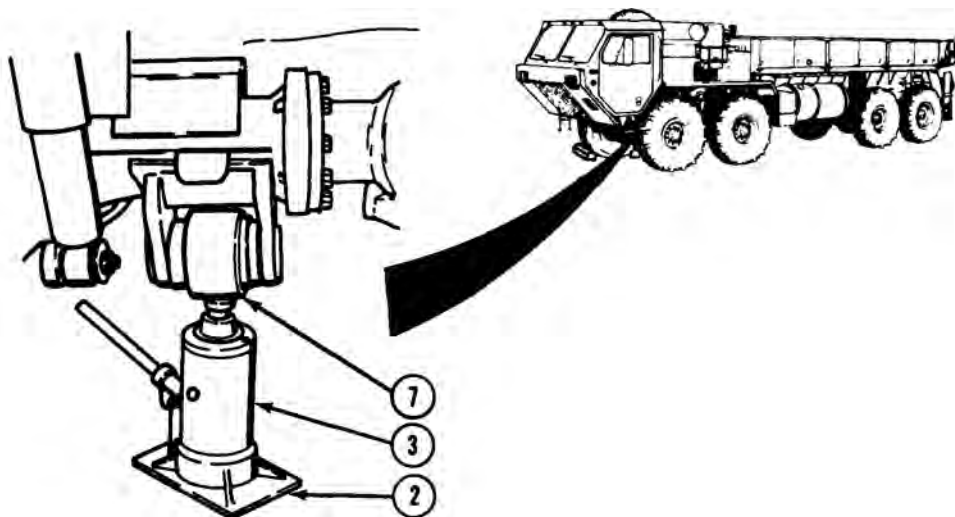
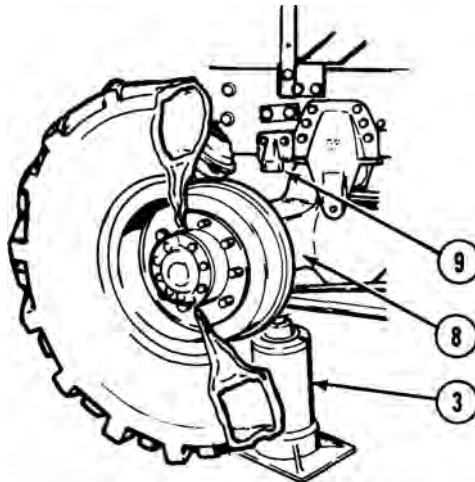


Figure 14.

4. Raise jack (3) until it touches end of equalizer beam (7).
5. Raise jack (3) until axle (8) is as close as it will go to axle stop (9).



**INSTALL LIMP HOME SETUP/DRIVER SIDE FRONT - Continued***Figure 15.***CAUTION**

Do not wrap 7 ft. (2.1 m) chain around lateral torque rod or shift cables as they could be crushed. Failure to comply may result in damage to equipment.

6. Loop end of 7 ft. (2.1 m) chain (4) around frame (10) and axle (8).

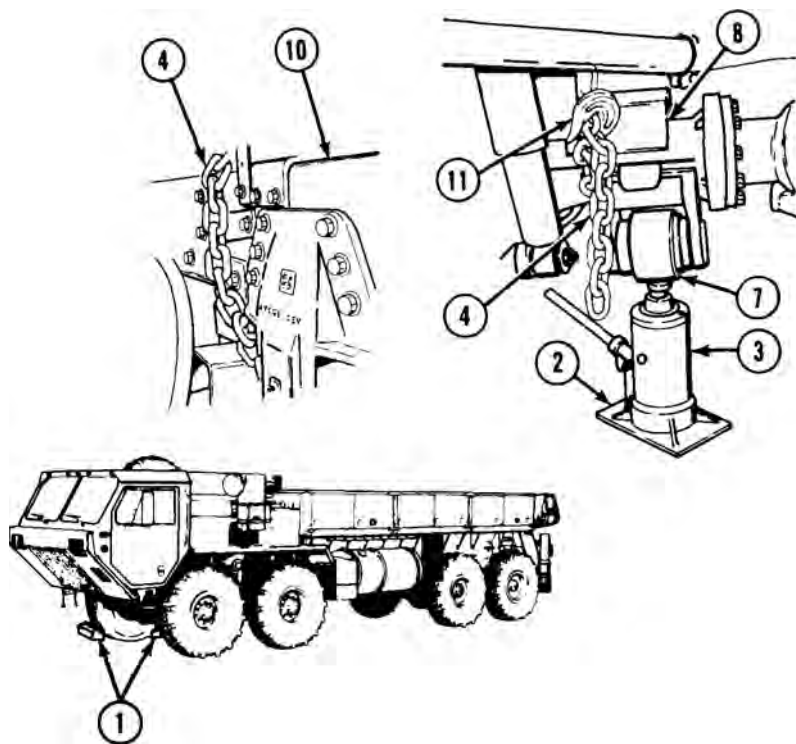
**INSTALL LIMP HOME SETUP/DRIVER SIDE FRONT - Continued**

Figure 16.

**WARNING**

Keep hands away from chain when lowering jack. Hands and fingers could be crushed. Failure to comply may result in injury or death to personnel.

7. Bring end of 7 ft. (2.1 m) chain (4) up to chain hook (11) and fasten back into itself as tight as possible.

**NOTE**

Axle will drop slightly when jack is lowered.

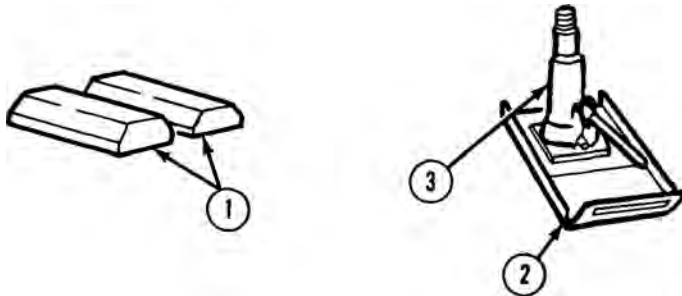
8. Lower jack (3) and remove jack (3) from end of equalizer beam (7).

**INSTALL LIMP HOME SETUP/DRIVER SIDE FRONT - Continued**

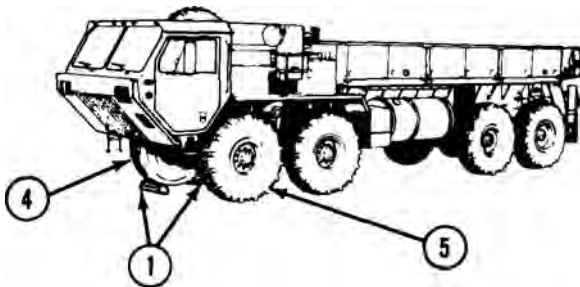
9. Return jack base plate (2), and jack (3) to stowage.
10. Remove and stow two wheel chocks (1).

**REMOVE LIMP HOME SETUP/DRIVER SIDE FRONT**

1. Remove two wheel chocks (1), jack base plate (2), and jack (3) from stowage.

*Figure 17.*

2. Install two wheel chocks (1) in front of and behind tire (4) across from tire (5) being raised.

*Figure 18.*

3. Place jack base plate (2) and jack (3) under end of equalizer beam (6).

## REMOVE LIMP HOME SETUP/DRIVER SIDE FRONT - Continued

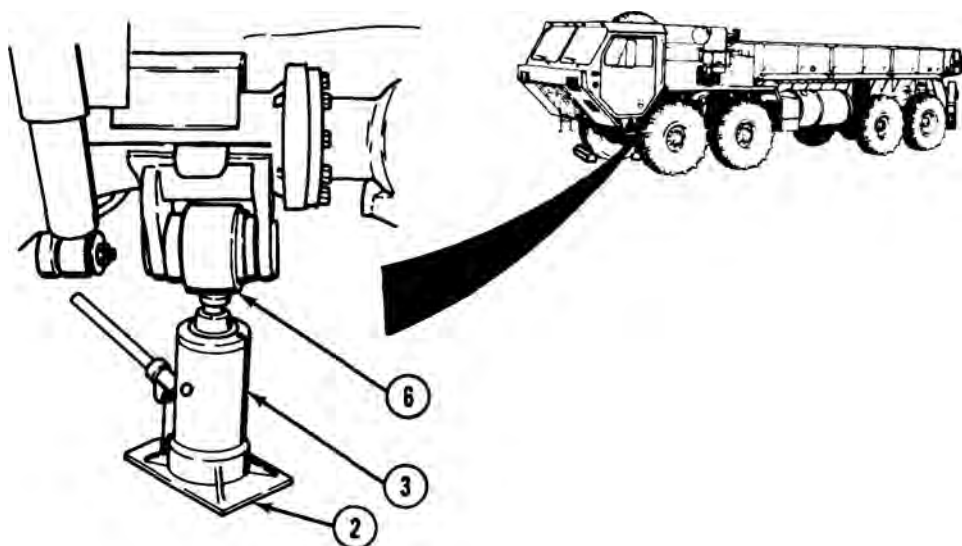


Figure 19.

4. Raise jack (3) until it touches end of equalizer beam (6).
5. Raise jack (3) until axle (7) is as close as it will go to axle stop (8).

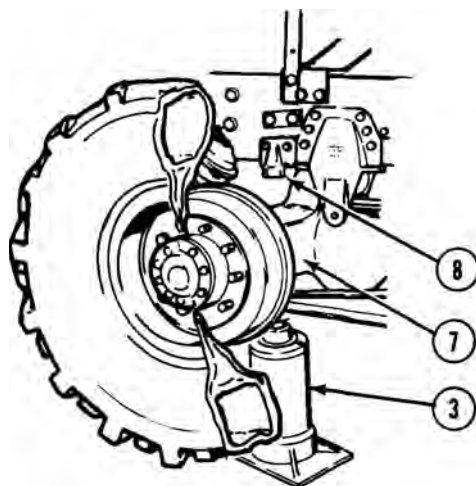
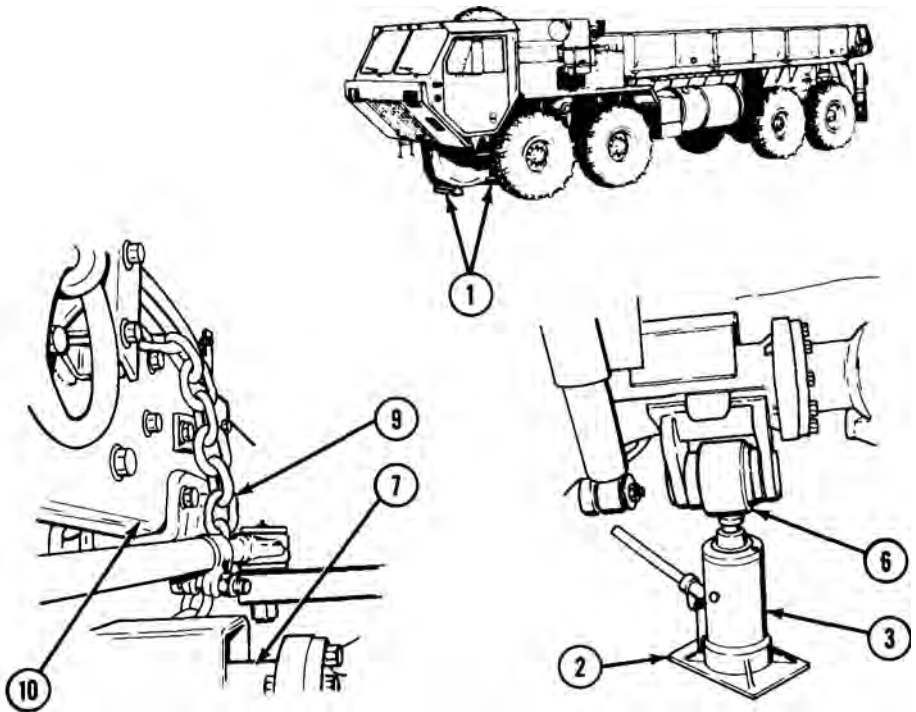


Figure 20.

6. Unhook 7 ft. (2.1 m) chain (9) and remove from around frame (10) and axle (7).

**REMOVE LIMP HOME SETUP/DRIVER SIDE FRONT - Continued***Figure 21.*

7. Lower jack (3) and remove jack from equalizer beam (6).
8. Return jack base plate (2), jack (3), and 7 ft. (2.1 m) chain (9) to stowage.
9. Remove and stow two wheel chocks (1).

**END OF TASK****END OF WORK PACKAGE**

This page intentionally left blank

---

**OPERATOR MAINTENANCE  
SLAVE START VEHICLE**

---

**INITIAL SETUP:****Personnel Required**Operator and Assistant - - - (2)

---

**PREPARE ASSIST VEHICLE****NOTE**

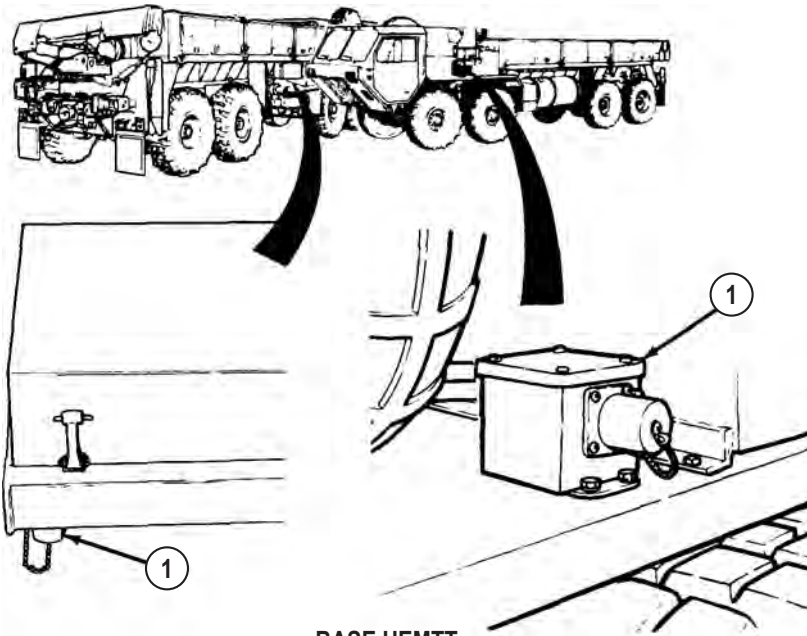
This procedure is a two soldier task.

1. Start engine of assist vehicle. (WP 0044)

**NOTE**

- Model of truck can be determined by information plate on inside of driver side cabin door.
  - Base Model HEMTT - Slave receptacle may be located either on battery box or driver side front fender.
  - A2 Model HEMTT - Slave receptacle is located on driver side front fender.
  - A4 Model HEMTT - Slave receptacle is located on driver side front fender.
2. Move assist vehicle into position beside disabled vehicle so slave receptacles (1) on both vehicles are side by side.

PREPARE ASSIST VEHICLE - Continued

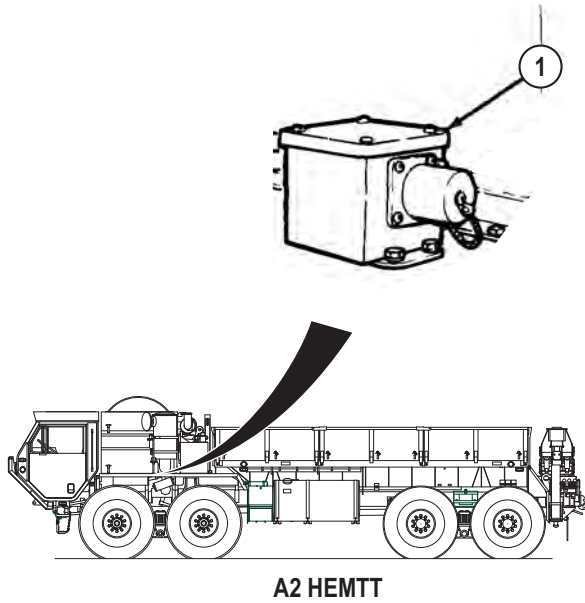


BASE HEMTT

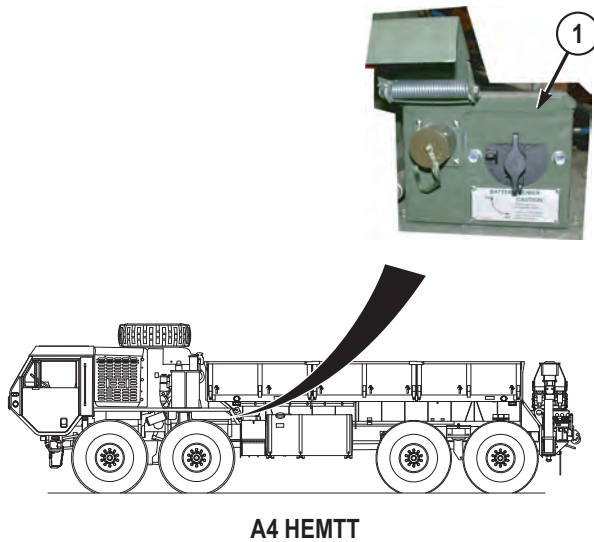
Figure 1.



**PREPARE ASSIST VEHICLE - Continued**



*Figure 2.*



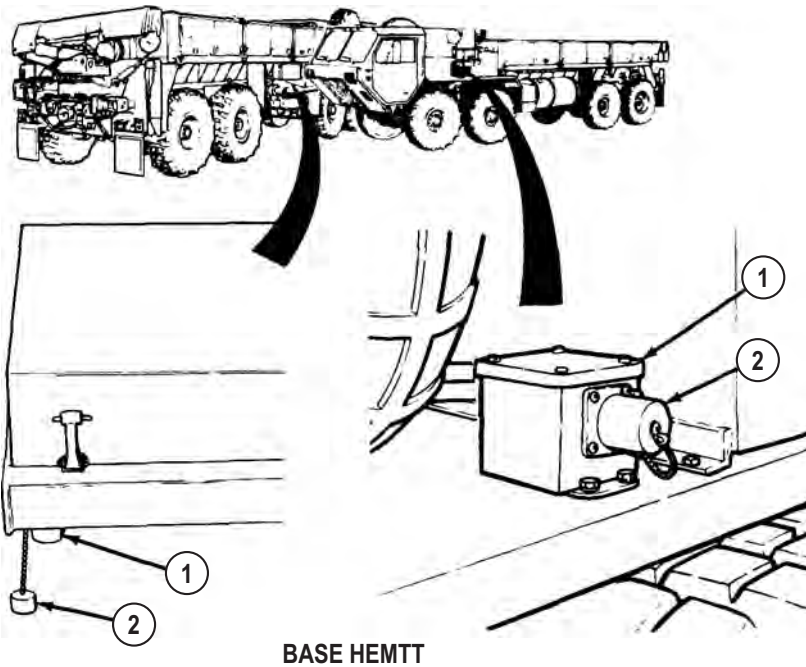
*Figure 3.*

3. Shut off engine of assist vehicle. (WP 0057)

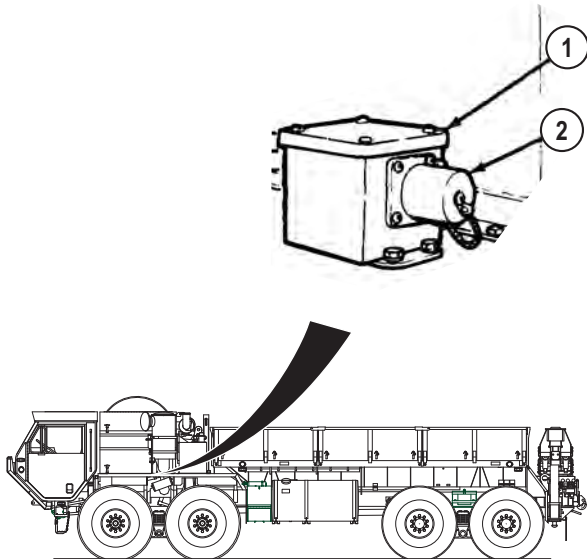
**SLAVE START DISABLED VEHICLE****NOTE**

- Model of truck can be determined by information plate on inside of driver side cabin door.
- Base Model HEMTT - Slave receptacle may be located either on battery box or driver side front fender.
- A2 Model HEMTT - Slave receptacle is located on driver side front fender.
- A4 Model HEMTT - Slave receptacle is located on driver side front fender.

1. Remove caps (2) from slave receptacles (1) on both vehicles.

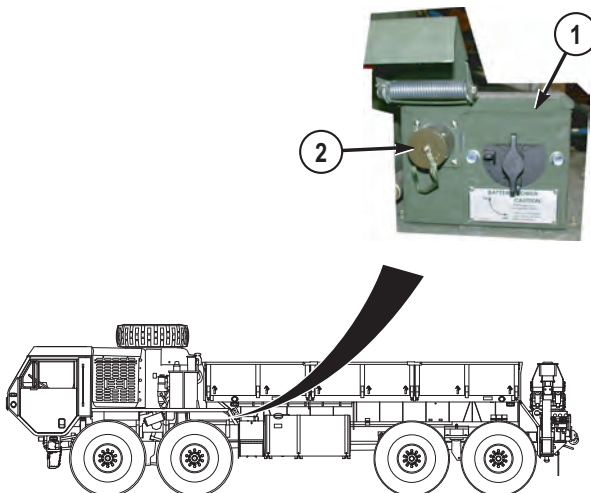
**BASE HEMTT***Figure 4.*

**SLAVE START DISABLED VEHICLE - Continued**



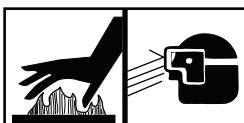
**A2 HEMTT**

*Figure 5.*



**A4 HEMTT**

*Figure 6.*

**SLAVE START DISABLED VEHICLE - Continued****WARNING**

Hot transmission/oil can cause severe burns. Wear gloves and proper eye protection while performing troubleshooting or maintenance. Failure to comply may result in injury or death to personnel.

**NOTE**

Make sure connectors and receptacles are free from dirt, sand, and debris before use.

2. Remove NATO slave cable from stowage and plug into slave receptacles of both vehicles.
3. Start engine of assist vehicle. (WP 0044)
4. Using the throttle pedal, increase assist vehicle engine speed to more than 1000 rpm, while assistant starts engine of disabled vehicle. (WP 0044)
5. As soon as disabled vehicle engine is running smoothly, remove NATO slave cable from slave receptacles (1) on both vehicles and return to stowage.
6. Install caps (2) on slave receptacles (1) of both vehicles.
7. Move assist vehicle. (WP 0050)
8. Shut off engine of assist vehicle. (WP 0057)

**NOTE**

- Model of truck can be determined by information plate on inside of driver side cabin door.
  - A4 Model HEMTT does not have an AMPERES gauge. Battery voltage readout is located in top right corner of Liquid Crystal Display (LCD) on instrument panel.
  - Gauges are located in different places dependent on model HEMTT. Select correct view below for model HEMTT being serviced.
9. Check BATTERY gauge (3) of disabled vehicle. If BATTERY gauge (3) shows less than 24 volts, notify field level maintenance. If BATTERY gauge (3) shows 24 volts or more, continue with Step (11).

SLAVE START DISABLED VEHICLE - Continued

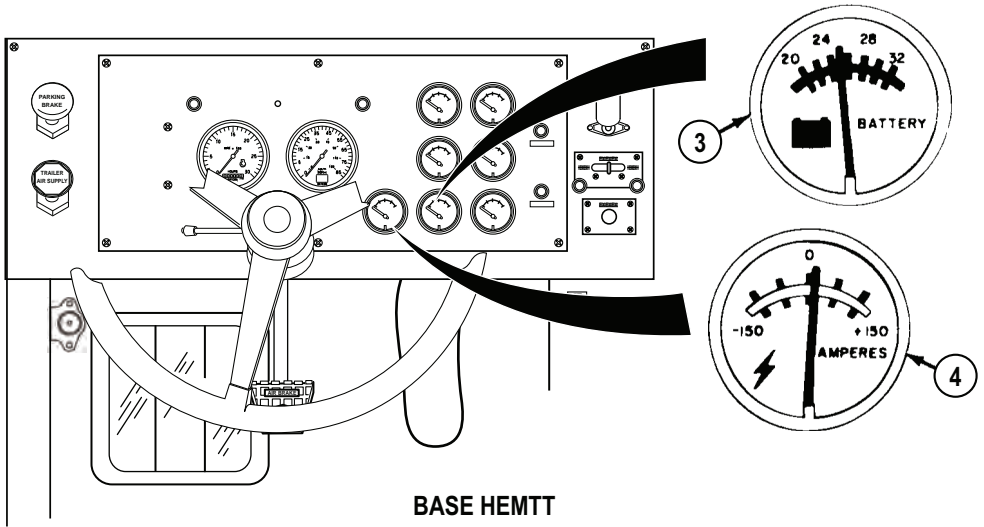


Figure 7.

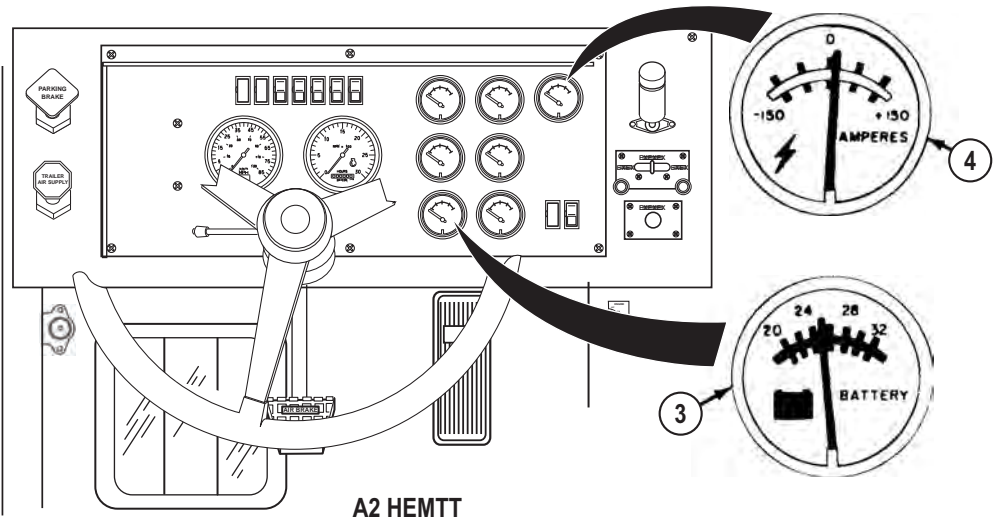
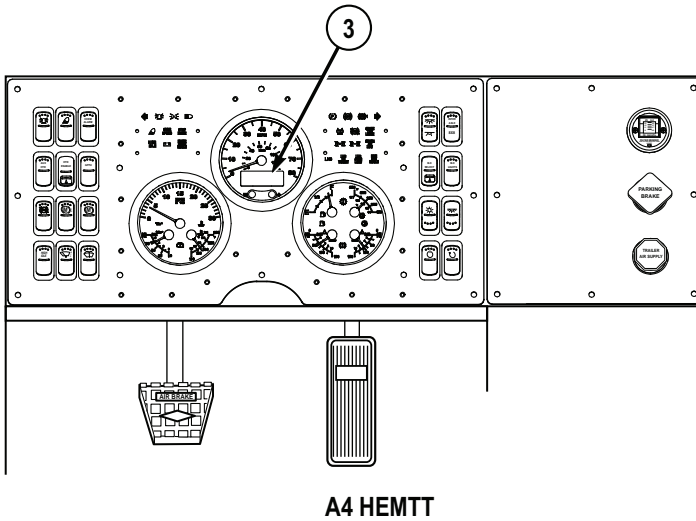


Figure 8.

**SLAVE START DISABLED VEHICLE - Continued****A4 HEMTT***Figure 9.*

10. Check AMPERES gauge (4) of disabled vehicle (as applicable). If AMPERES gauge shows discharge condition, notify field level maintenance. If AMPERES gauge (4) shows charging, continue operation of vehicle.

**END OF TASK****END OF WORK PACKAGE**

---

**OPERATOR MAINTENANCE**  
**PERFORM IMMEDIATE ACTION FOR LOSS OF AIR SUPPLY SYSTEM PRESSURE**

---

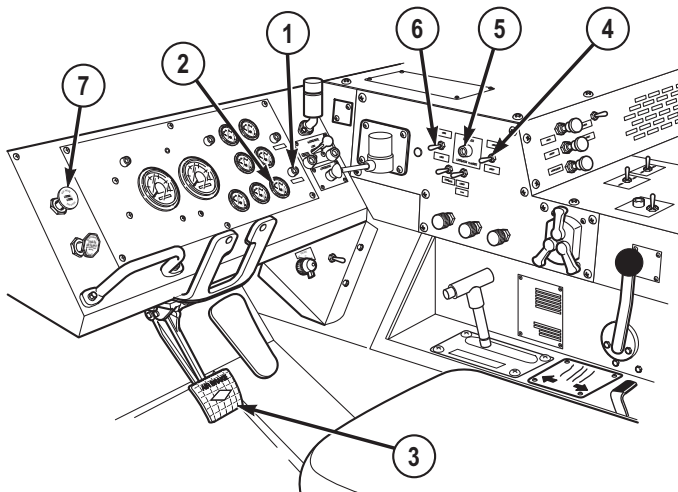
**INITIAL SETUP:**

Not Applicable

---

**PERFORM PROCEDURE**

1. If AIR indicator (1) illuminates and warning buzzer sounds while driving vehicle, check AIR PRESS gauge (2).



*Figure 1.*

**NOTE**

If both red needle and green needle on AIR PRESS gauge read zero, skip to Step (4).

2. If red pointer on AIR PRESS gauge (2) is at zero and green needle shows normal air pressure of 100 to 120 psi (690 to 827 kPa), complete the following:
  - a. Continue operation of vehicle. Brakes on all eight wheels and trailer will work even if air pressure from No. 2 air tank has been lost.
  - b. Notify field level maintenance as soon as possible.

**PERFORM PROCEDURE - Continued****WARNING**

When green pointer of AIR PRESS gauge is at zero, braking capability is greatly reduced. Extra care must be used to avoid collision. Failure to comply may result in injury or death to personnel.

**NOTE**

If both red needle and green needle on AIR PRESS gauge read zero, skip to Step (4).

3. If green needle on AIR PRESS gauge (2) is at zero and red needle shows normal air pressure of 100 to 120 psi (690 to 827 kPa), complete the following:
  - a. Continue operation of vehicle. Brakes on third and fourth axles and trailer will work even if air pressure from No. 3 air tank has been lost.
  - b. Leave additional distance between vehicles.
  - c. Apply service brake pedal (3) earlier than usual when slowing vehicle.
  - d. Downshift as necessary, when slowing vehicle.

**WARNING**

Do not use engine brake when vehicle is on slippery surface. If engine brake is used incorrectly, vehicle may skid out of control. Failure to comply may result in injury or death to personnel.

- e. If necessary to slow vehicle, set Jacobs engine brake HIGH/LOW switch (6) to LOW and set ON/OFF switch (7) to ON.
  - f. Notify field level maintenance as soon as possible.
4. If both red needle and green needle on AIR PRESS gauge (2) read zero, complete the following:
  - a. Downshift as needed to control vehicle speed until place is found to stop.



**PERFORM PROCEDURE - Continued****WARNING**

Use of service brake pedal will not slow or stop vehicle when both pointers of AIR PRESS gauge read zero. Use the following procedure to safely stop vehicle after loss of air pressure. Failure to comply may result in injury or death to personnel.

**NOTE**

When spring brakes are applied, vehicle will stop quickly. Vehicle cannot be driven again until malfunction is repaired and there is enough air supply for operation of service brakes.

- b. Look for place to stop vehicle without blocking other traffic.
- c. When suitable area is found to stop vehicle, pull out PARKING BRAKE control (8) to apply spring brakes on four rear wheels.
- d. Notify field level maintenance.

**END OF TASK****END OF WORK PACKAGE**

This page intentionally left blank

---

**OPERATOR MAINTENANCE  
PERFORM IMMEDIATE ACTION FOR LOSS OF HYDRAULIC SYSTEM**

---

**INITIAL SETUP:**

Not Applicable

---

**NOTE**

Steering wheel will be harder to turn after failure of hydraulic system.

1. If failure occurs while driving, continue steering as before.

**NOTE**

Failure of hydraulic system will stop operation of any crane, winch, or hydraulic motor on vehicle. All cranes and winches are equipped with automatic locking mechanisms to hold cranes and winches in position they were in before hydraulics failed.

2. Do not try to continue operation of any crane or winch.
3. Do not try to repair hydraulic system. Notify your supervisor.
4. Notify field level maintenance.

**END OF TASK**

**END OF WORK PACKAGE**

This page intentionally left blank

---

**OPERATOR MAINTENANCE  
PERFORM EMERGENCY HYDRAULIC OPERATION WHEN GROVE CRANE  
ELECTRICAL POWER FAILS**

---

**INITIAL SETUP:**

Not Applicable

---

**NOTE**

- If crane electrical power systems fails during crane operation, crane will be locked in position it was in at time of failure.
  - Do not try to operate any electrical equipment on vehicle or crane.
  - Do not try to repair electrical system.
  - This procedure will provide emergency hydraulic power to lower crane and load when electrical power has failed.
  - Screwdriver can be put in slot in front of solenoid valve button to hold button in while operating controls.
1. Push up and hold solenoid valve button (1).
  2. Shut down crane.

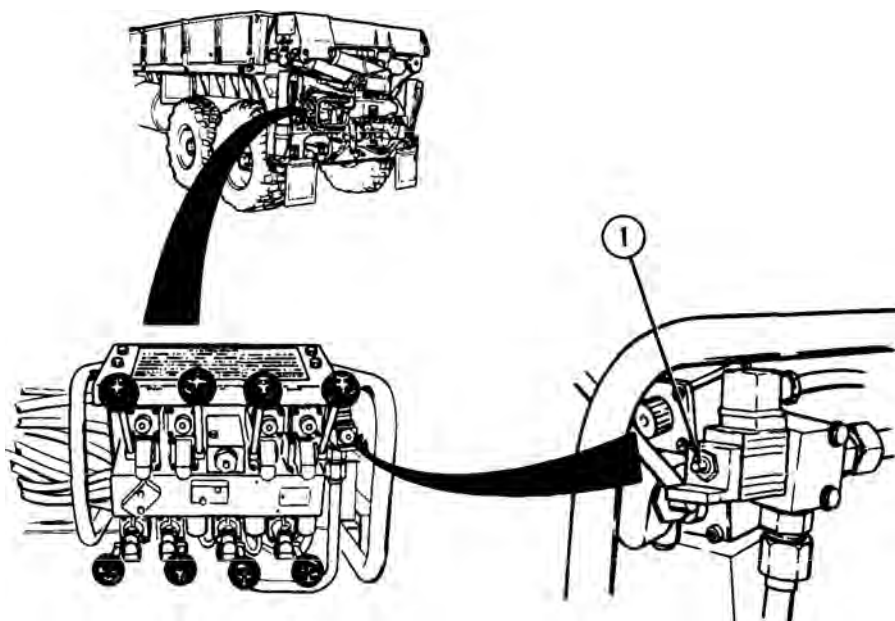


Figure 1.

3. Notify field level maintenance.

**END OF TASK**

**END OF WORK PACKAGE**

**OPERATOR MAINTENANCE  
STOWAGE AND SIGN GUIDE**

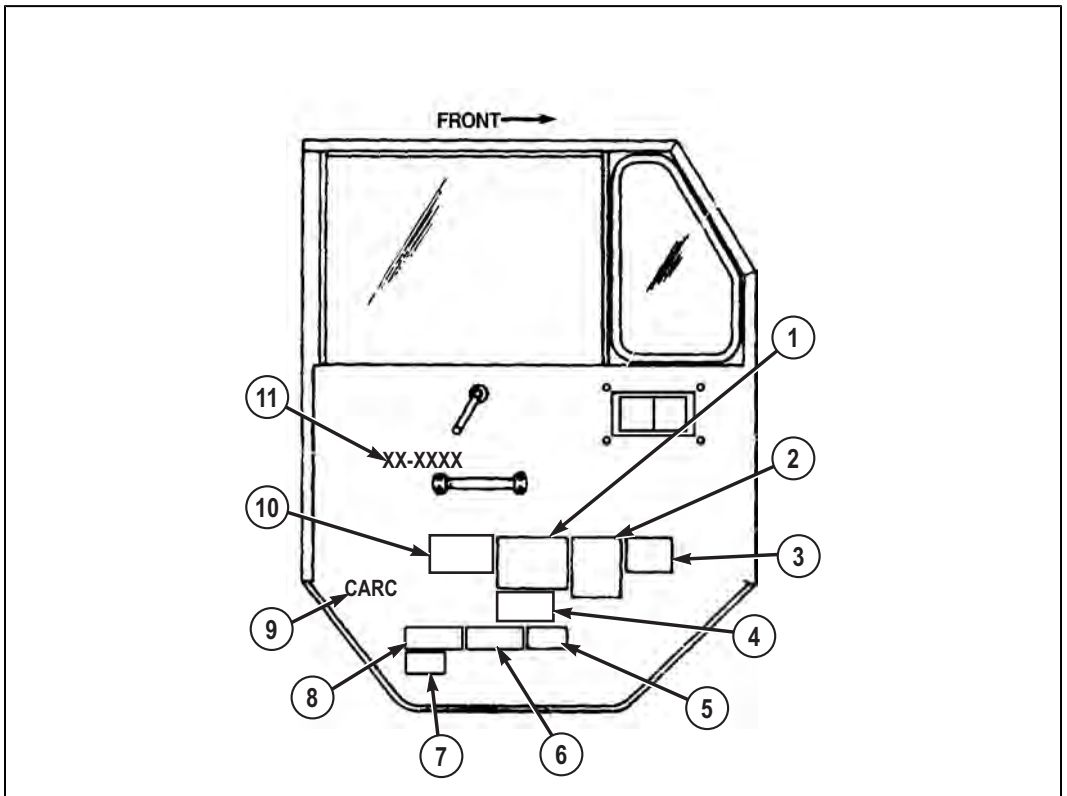
**Scope**

This work package shows locations for data plates, decals, and stencils that are required to be in place on the HEMTT series vehicles.

**General**

The following figures show the location of metal signs, decals, and stencils used on the vehicle. Most of these signs and stencils contain cautions or information needed to operate the vehicle safely. For stowage locations of Components Of End Item (COEI) and Basic Issue Items (BII), refer to Components of End Item and Basic Issue Items tables. (WP 0162)

**Table 1. Inside Driver Side Door.**



## General - Continued

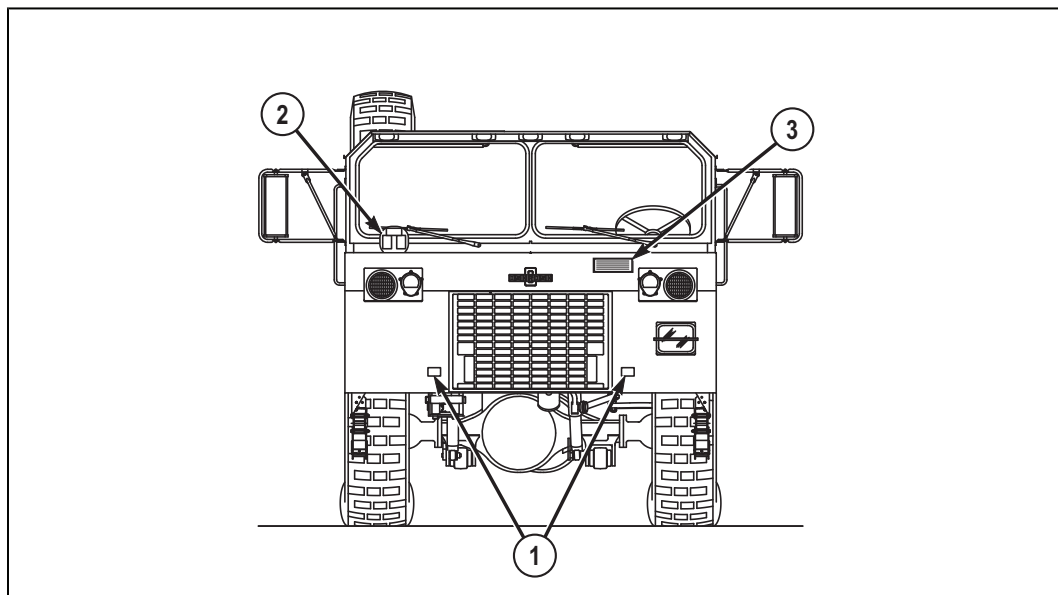
*Table 1. Inside Driver Side Door. - Continued*

INDEX	DECAL/PLATE/STENCIL
1	Manufacturer's Certification Information
2	Parts Data
3	Name Plate
4	Overhaul Data (not included on all vehicles)
5	Tire Inflation Data
6	Warranty Information
7	Rustproofing Data/Rustproofing CAUTION
8	Noise Exemption Decal (not included on all vehicles)
9	"CARC" Stencil (not included on all vehicles)
10	Shipping Data
11	Registration Number (inside both driver and passenger side doors) (not included on all vehicles)



General - Continued

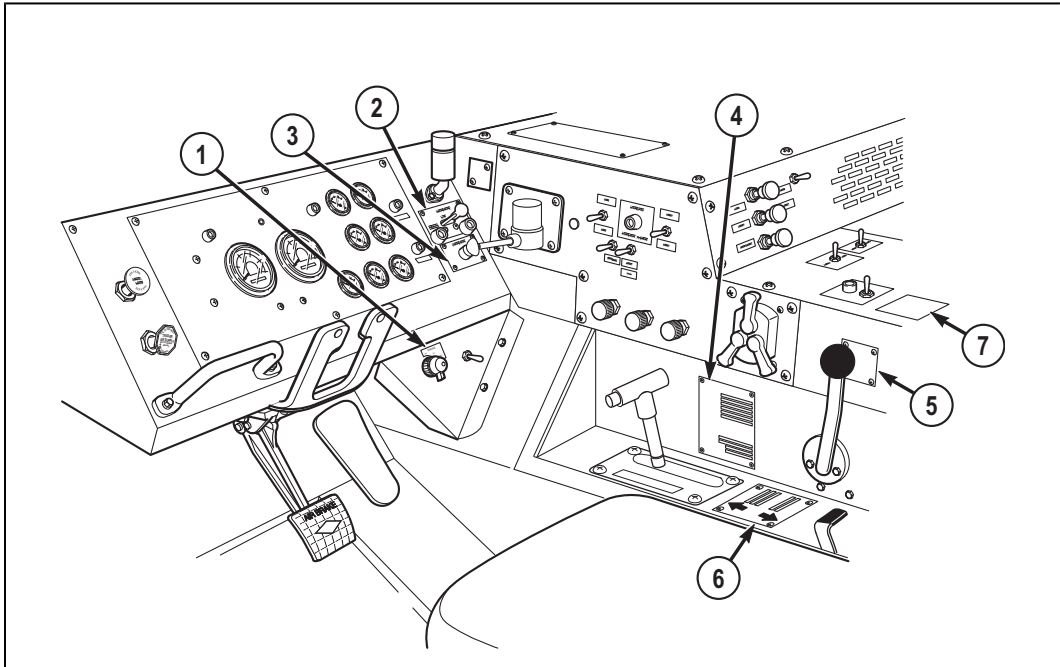
**Table 2. Front Exterior.**



INDEX	PLACARD/STENCIL
1	"TIE DOWN" Stencil
2	Sign Kit/Weight Indicator
3	"U.S. ARMY" Stencil

General - Continued

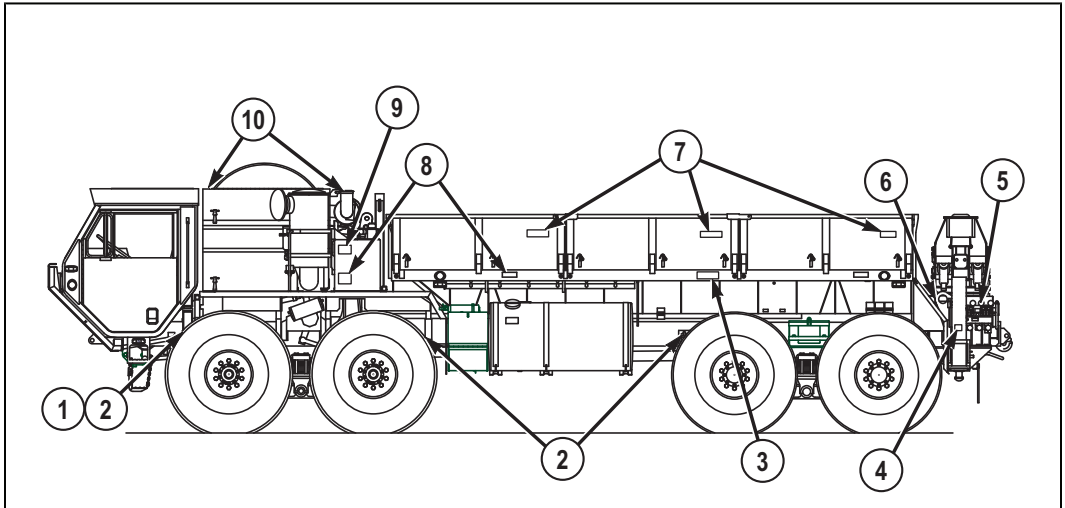
**Table 3. M977 Cargo Cabin.**



INDEX	DECAL/PLATE
1	Engine ON/OFF Decal
2	Traction Control Data Plate
3	Ether Start Data Plate
4	Vehicle Data Plate
5	Transfer Case Data Plate
6	Self-Recovery Winch Data Plate (vehicles equipped with self-recovery winch only)
7	Crane Data Plate

General - Continued

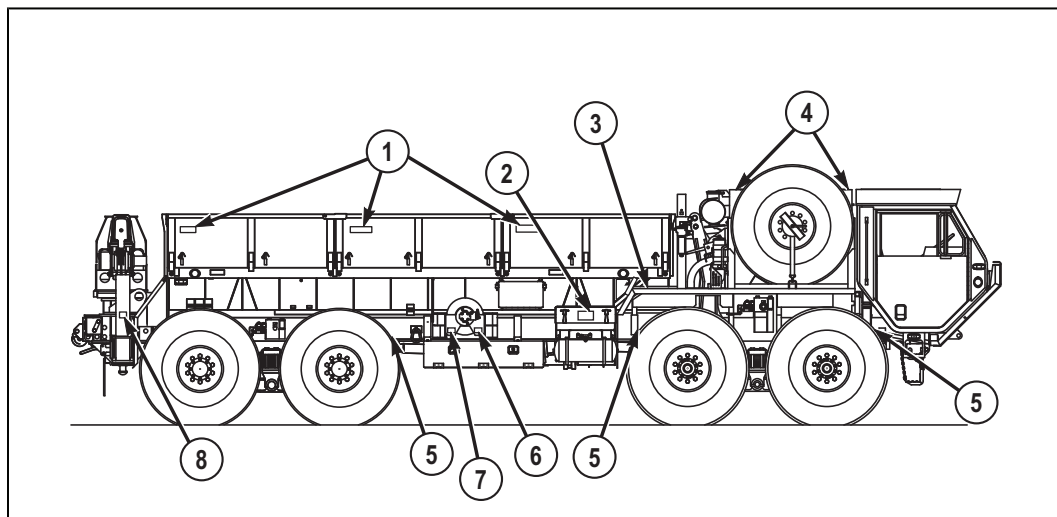
Table 4. M977 Cargo Driver Side Exterior.



INDEX	DECAL/PLACARD/PLATE/STENCIL
1	Vehicle Identification Number (VIN) Placard
2	"TIE DOWN" Stencil
3	"DANGER" Plate
4	Outrigger Instruction Placard
5	"DANGER" Plate (crane operation) and Crane Erection Procedure Steps Placard
6	Engine Speed Data Plate
7	"CAUTION DO NOT ALLOW PANEL TO SLIDE OFF PINS WHEN LOWERING" Stencil
8	CAUTION Decal (hearing protection required)
9	"FULL COLD" Stencil
10	"NO STEP" Stencil (multiple on exhaust and engine access panels)

General - Continued

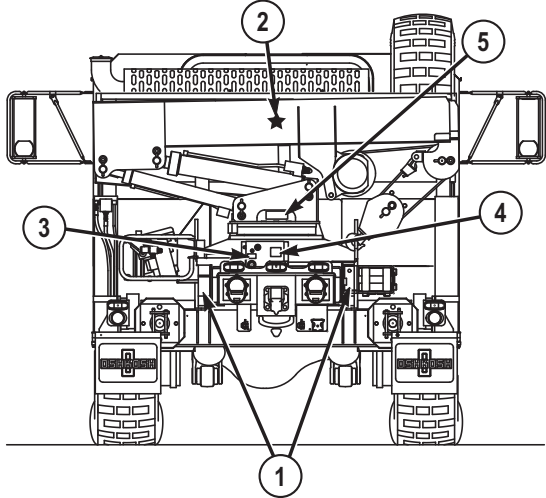
**Table 5. M977 Cargo Passenger Side Exterior.**



INDEX	DECAL/PLACARD/PLATE/STENCIL
1	"CAUTION DO NOT ALLOW PANEL TO SLIDE OFF PINS WHEN LOWERING" Stencil
2	CAUTION Decal (hearing protection required)
3	CAUTION (hydraulic selector valve) Decal (vehicles equipped with self-recovery winch only)
4	"NO STEP" Stencil (multiple on exhaust and engine access panels)
5	"TIE DOWN" Stencil
6	WARNING (self-recovery winch) Plate (vehicles equipped with self-recovery winch only)
7	Self-Recovery Winch Data Plate (vehicles equipped with self-recovery winch only)
8	Outrigger Instruction Placard

General - Continued

**Table 6. M977 Cargo Rear Exterior.**



INDEX	PLATE/STENCIL
1	"SLING POINT" and "TIE DOWN" Stencils (one each per side)
2	US Army Star Stencil
3	On/Off Power Remote-Control Connector Data Plate
4	"DANGER" Plate (electrical warning)
5	Crane Range Diagram Plate

**Table 7. Miscellaneous Decals/Placards/Plates/Stencils.**

LOCATION	M977/ M985	M978	M983	M984A 1	M985 E1	M1120 LHS	M1977 CBT
Axle Housing	4	4	4	4	4	4	4
Carrier	4	4	4	4	4	4	4

**General - Continued****Table 7. Miscellaneous Decals/Placards/Plates/Stencils. - Continued**

Transfer Case	1	1	1	1	1	1	1
Engine	1	1	1	1	1	1	1
Transmission	1	1	1	1	1	1	1
Heavy-Duty Winch	0	0	0	1	0	0	0
Total	11	11	11	12	11	11	11

**END OF WORK PACKAGE**

CHAPTER 3  
TROUBLESHOOTING  
PROCEDURES





---

**OPERATOR MAINTENANCE  
BUZZER SOUNDS AND AIR INDICATOR IS LIT**

---

**INITIAL SETUP:****Equipment Condition**

Engine OFF. (WP 0057)

**Equipment Condition - Continued**

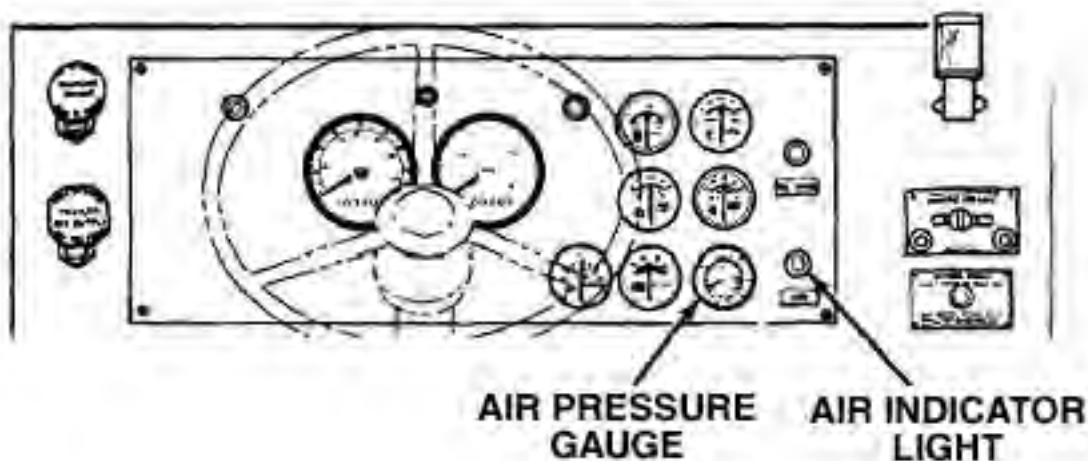
Parking brakes applied. (WP 0056)

Wheels chocked. (WP 0077)

---

**TROUBLESHOOTING PROCEDURE****BUZZER SOUNDS AND AIR INDICATOR IS LIT****TEST 1 - Is air pressure greater than 75 psi (517 kPa)?**

1. Start engine, (WP 0044) and allow air pressure to build.
2. Check air pressure.

*Figure 1.*

3. Turn engine OFF. (WP 0057)

**CONDITION/INDICATION**

Is air pressure greater than 75 psi (517 kPa)?

**DECISION**

No - Test 2 - Are any petcock valves open?

Yes - Notify Supervisor.

**TEST 2 - Are any petcock valves open?**

1. Check if any air reservoir petcock valves are open. If valve(s) open, close petcock(s).



*Figure 2.*

**CONDITION/INDICATION**

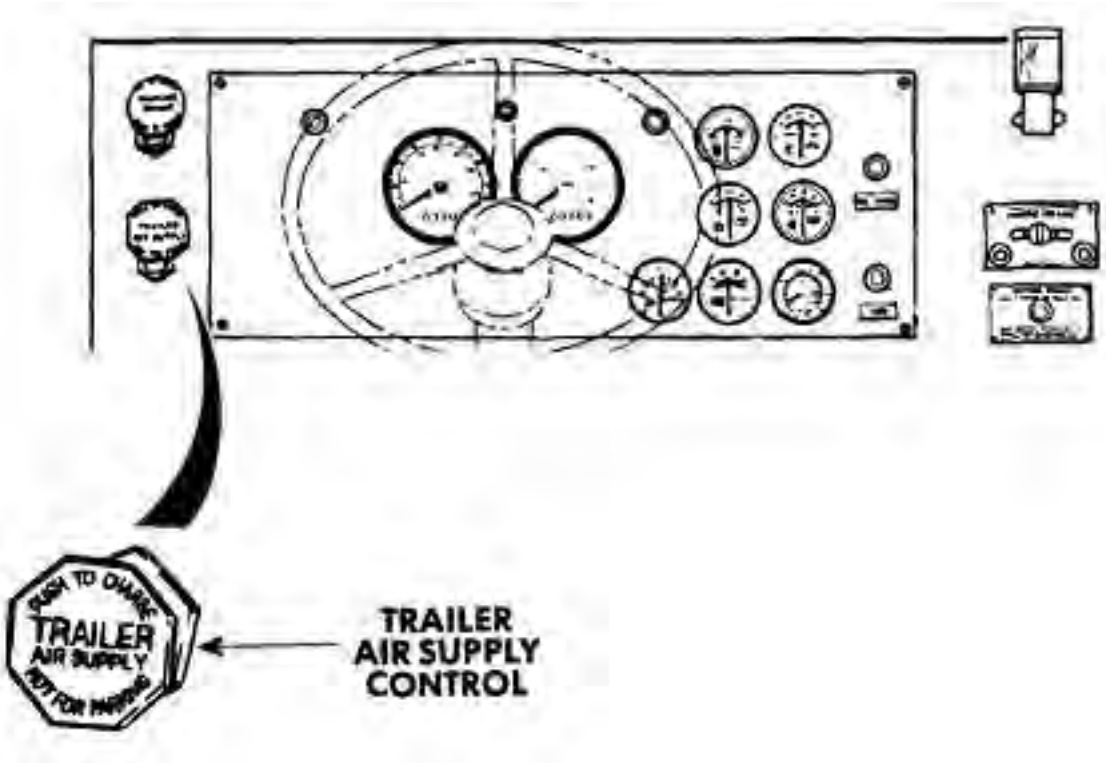
Are any petcock valves open?

**DECISION**

Petcock(s) open - Test 6 - Does buzzer stop, and air indicator light extinguish?  
 Petcock's closed - Test 3 - Is trailer air supply control in correct position?

**TEST 3 - Is trailer air supply control in correct position?**

1. Check that trailer air supply control is pulled out (OFF position) if no trailer is coupled, and pushed in (ON position) if trailer is coupled.
2. If trailer air control is found in an incorrect position, set to correct position.



*Figure 3.*

**CONDITION/INDICATION**

Is trailer air supply control in correct position?

**DECISION**

No - Test 6 - Does buzzer stop, and air indicator light extinguish?  
 Yes - Test 4 - Does air reservoir, hoses, lines, fittings, and/or connectors leak?

**TEST 4 - Does air reservoir, hoses, lines, fittings, and/or connectors leak?**

1. Check air reservoir, hoses, lines, fittings, and/or connectors for leaks. Tighten any leaks found.

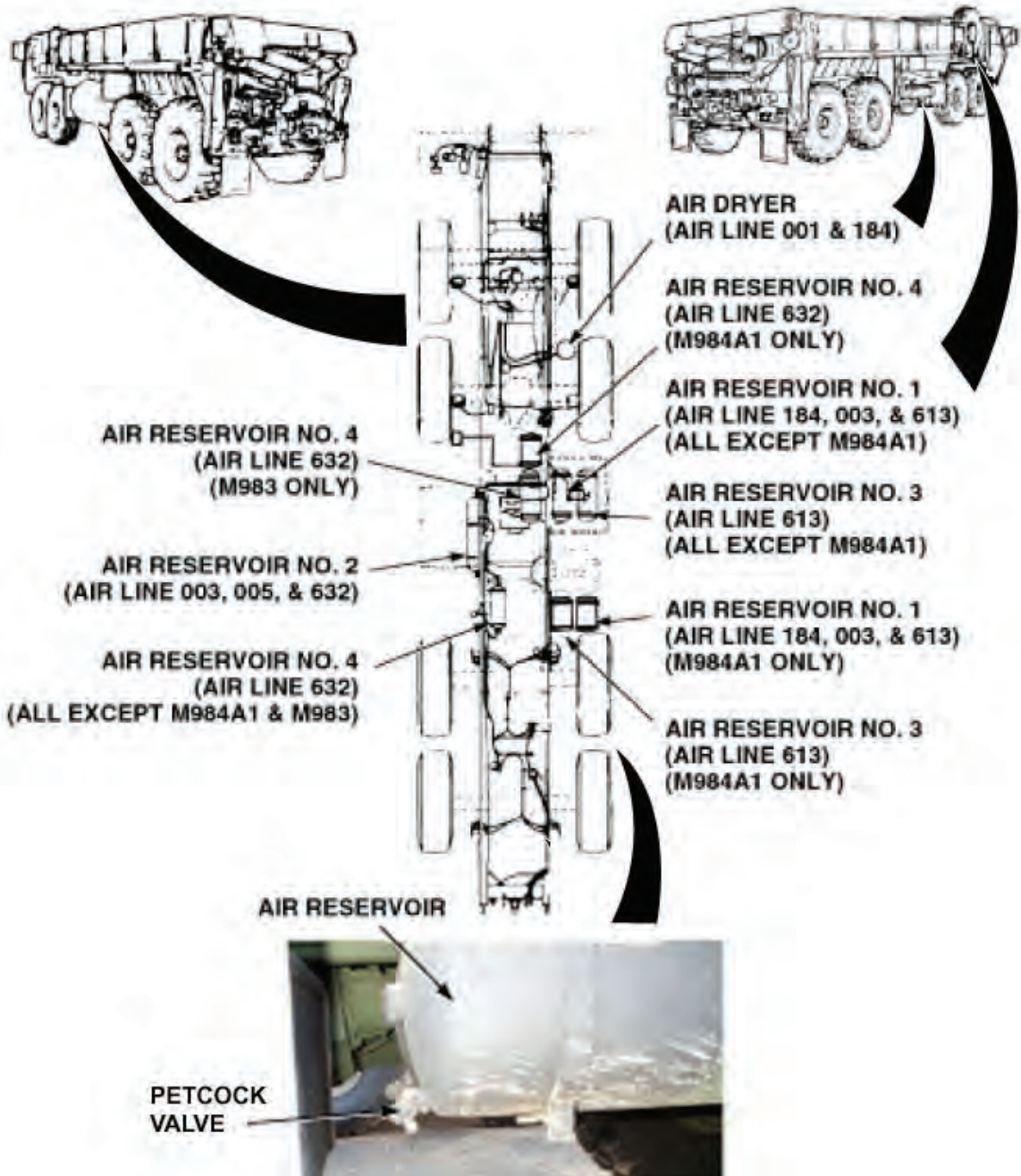


Figure 4.

**CONDITION/INDICATION**

Does air reservoir, hoses, lines, fittings, and/or connectors leak?

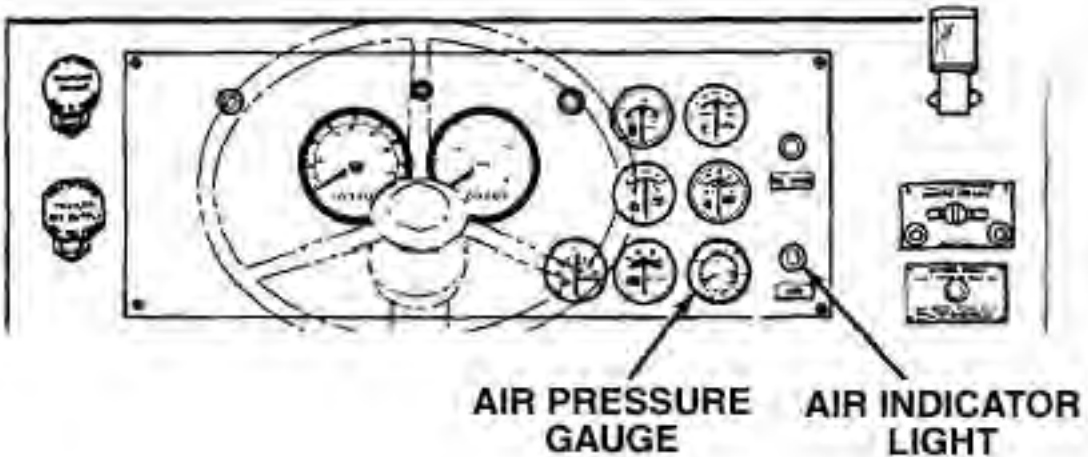
**DECISION**

Air reservoir, hoses, lines and/or connectors leak. - Notify Supervisor. Test 6 - Does buzzer stop, and air indicator light extinguish? Notify Supervisor.

Air reservoir, hoses, lines, fittings, and/or connectors OK - Test 5 - Does buzzer sound, and air indicator light illuminate when trailer is disconnected?

**TEST 5 - Does buzzer sound, and air indicator light illuminate when trailer is disconnected?**

1. If trailer is coupled, disconnect trailer (WP 0040) from vehicle.



*Figure 5.*

2. Start engine, (WP 0044) and allow air pressure to build.
3. Check if buzzer continues to sound, and if air indicator light is illuminated.
4. Turn engine off. (WP 0057)

**CONDITION/INDICATION**

Does buzzer sound, and air indicator light illuminate when trailer is disconnected?

**DECISION**

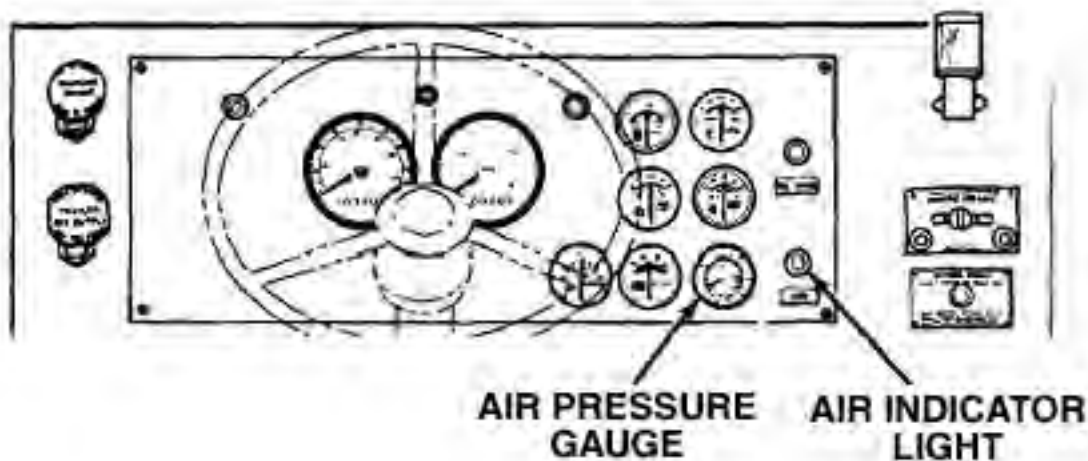
No - Notify Supervisor.

Yes - Problem corrected.

**TEST 6 - Does buzzer stop, and air indicator light extinguish?**

1. Start engine, (WP 0044) and allow air pressure to build.

2. Check that buzzer does not sound, and air indicator light is off.



*Figure 6.*

3. Turn engine off. (WP 0057)

**CONDITION/INDICATION**

Does buzzer stop, and air indicator light extinguish?

**DECISION**

No - Notify Supervisor.  
Yes - Problem corrected.

**END OF WORK PACKAGE**





**OPERATOR MAINTENANCE  
WINDSHIELD WASHER WILL NOT OPERATE**

---

**INITIAL SETUP:****Equipment Condition**

Engine OFF. (WP 0057)

**Equipment Condition - Continued**

Parking brakes applied. (WP 0056)

Wheels chocked. (WP 0077)

---

**TROUBLESHOOTING PROCEDURE  
WINDSHIELD WASHER WILL NOT OPERATE**

**TEST 1 - Is washer fluid reservoir free from damage or cracks?**

1. Check washer fluid reservoir for cracks and/or damage.



WINDSHIELD  
WASHER  
RESERVOIR

*Figure 1.*

**CONDITION/INDICATION**

Is washer fluid reservoir free from damage or cracks?

**DECISION**

No - Notify Supervisor.

Yes - Test 2 - Is washer fluid present in washer fluid reservoir?

**TEST 2 - Is washer fluid present in washer fluid reservoir?****CAUTION**

Do not fill windshield washer reservoir with water when temperatures are likely to be 32°F (0°C) or less. If water freezes, reservoir can crack or break.

1. Check washer fluid level in reservoir. if low, fill windshield washer reservoir.



WINDSHIELD  
WASHER  
RESERVOIR

*Figure 2.*

**CONDITION/INDICATION**

Is washer fluid present in washer fluid reservoir?

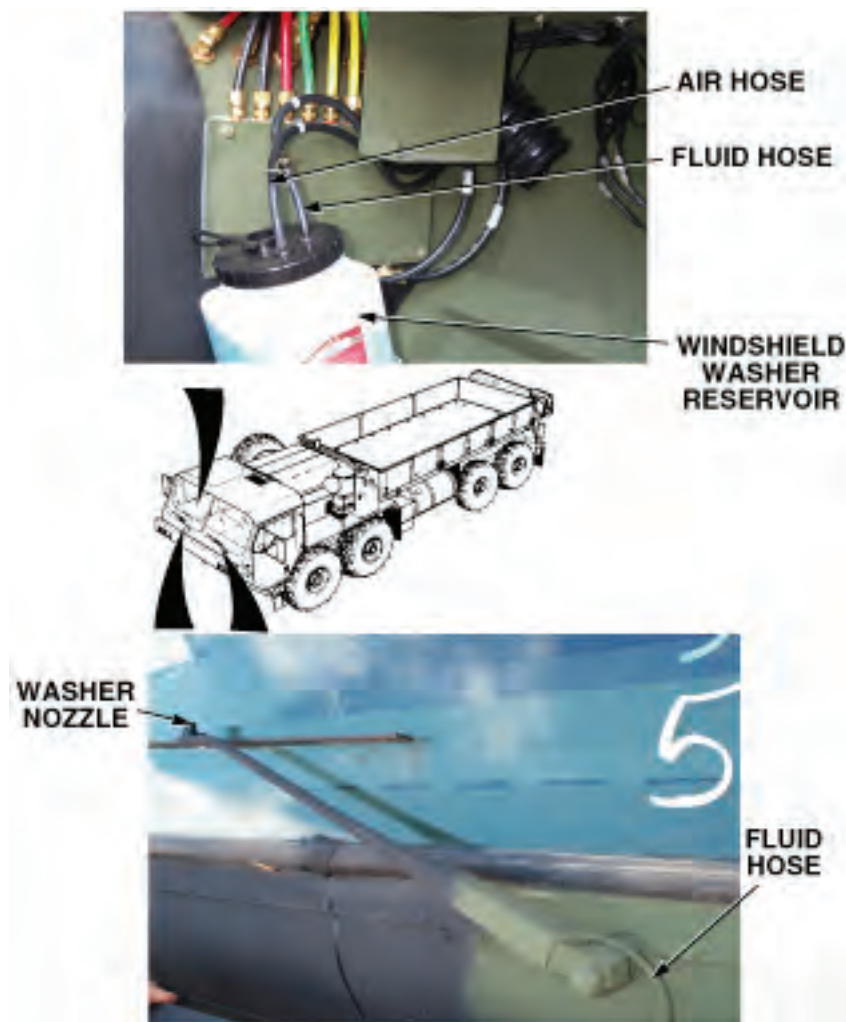
**DECISION**

No - Test 6 - Does the windshield washer operate?

Yes - Test 3 - Are all hoses securely attached to reservoir?

**TEST 3 - Are all hoses securely attached to reservoir?**

1. Check that all hoses are securely attached to reservoir. If loose hoses are found, attach to reservoir.



*Figure 3.*

**CONDITION/INDICATION**

Are all hoses securely attached to reservoir?

**DECISION**

No - Test 6 - Does the windshield washer operate?

Yes - Test 4 - Are hoses free of cracks or damage?

**TEST 4 - Are hoses free of cracks or damage?**

1. Check if hoses are cracked or damaged.



Figure 4.

**CONDITION/INDICATION**

Are hoses free of cracks or damage?

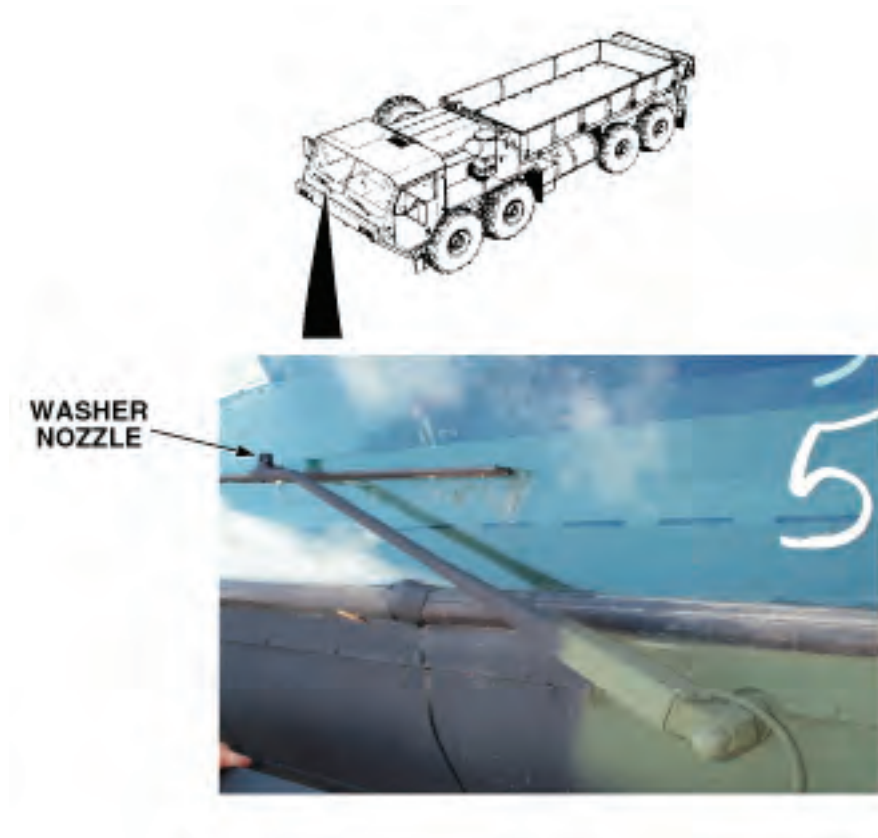
**DECISION**

No - Notify Supervisor.

Yes - Test 5 - Are washer spray openings free of debris?

**TEST 5 - Are washer spray openings free of debris?**

1. Check washer spray openings on wipers for clogs.



*Figure 5.*

2. If openings are clogged, clear washer spray opening using pin, wire, or similar item.

**CONDITION/INDICATION**

Are washer spray openings free of debris?

**DECISION**

No - Test 6 - Does the windshield washer operate?

Yes - Notify Supervisor.

**TEST 6 - Does the windshield washer operate?**

1. Start engine, (WP 0044) and allow air pressure to build.
2. Check windshield washer for proper operation.

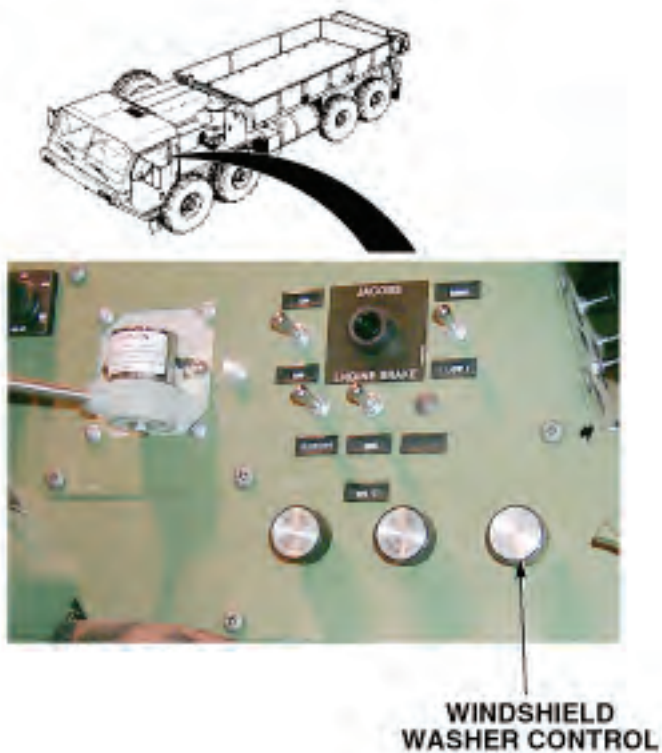


Figure 6.

**CONDITION/INDICATION**

Does the windshield washer operate?

**DECISION**

No - Notify Supervisor.

Yes - Problem corrected.

**END OF WORK PACKAGE**



---

**OPERATOR MAINTENANCE  
AIR SYSTEM LOSES PRESSURE DURING OPERATION**

---

**INITIAL SETUP:****Equipment Condition**

Engine OFF. (WP 0057)

**Equipment Condition - Continued**

Parking brakes applied. (WP 0056)

Wheels chocked. (WP 0077)

---

**TROUBLESHOOTING PROCEDURE  
AIR SYSTEM LOSES PRESSURE DURING OPERATION**

**TEST 1 - Are any petcock valves open?****WARNING**

Vehicles air system is pressurized, be sure to wear proper eye protection and keep face away from drain valves while draining air reservoirs. Open air drain valves slowly to prevent sudden blast of air. Failure to comply may result in injury to personnel.

1. Check to make sure all four air reservoir petcock valves are closed.



Figure 1.

### CONDITION/INDICATION

Are any petcock valves open?

### DECISION

Petcock(s) open - Test 5 - Does air system lose pressure during operation?  
Petcocks closed - Test 2 - Is trailer air supply control in correct position?

### TEST 2 - Is trailer air supply control in correct position?

1. Check if trailer air supply control is pulled out (OFF position) if no trailer is coupled, and pushed in (ON position) if trailer is coupled.

2. If trailer air control is found in an incorrect position, set to correct position.

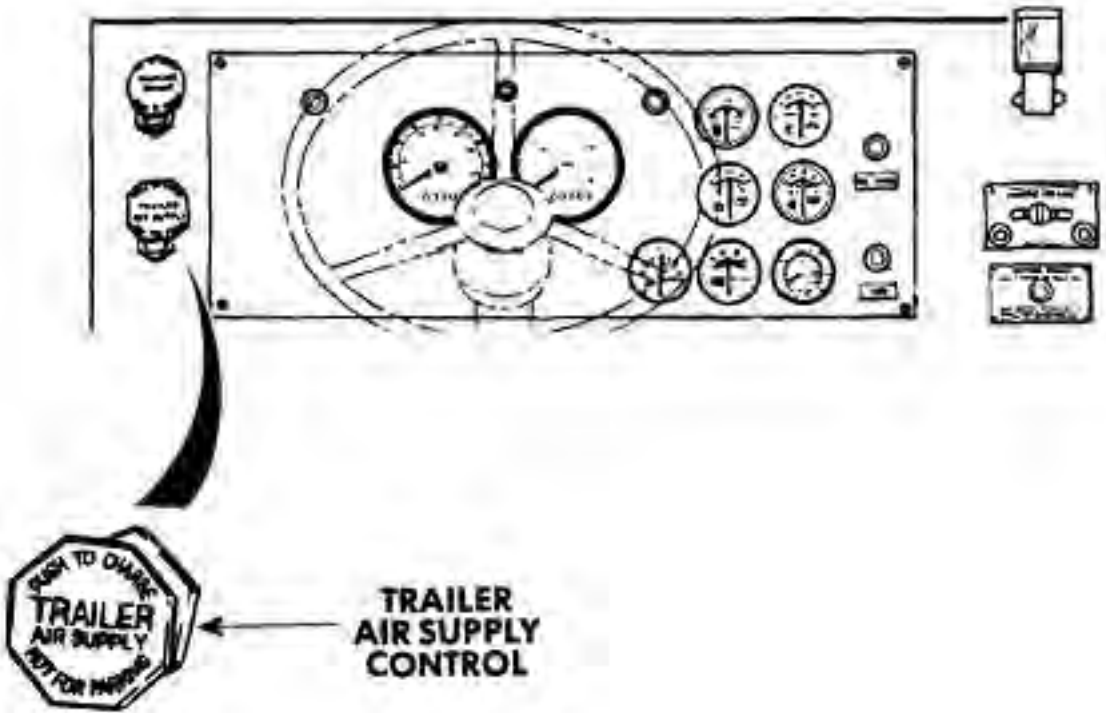


Figure 2.

#### CONDITION/INDICATION

Is trailer air supply control in correct position?

#### DECISION

No - Test 5 - Does air system lose pressure during operation?

Yes - Test 3 - Does air pressure reach 120 psi (827 kPa) with engine accelerated?

#### TEST 3 - Does air pressure reach 120 psi (827 kPa) with engine accelerated?

1. Start engine. (WP 0044)
2. Accelerate engine and check if air pressure reaches 120 psi (827 kPa).

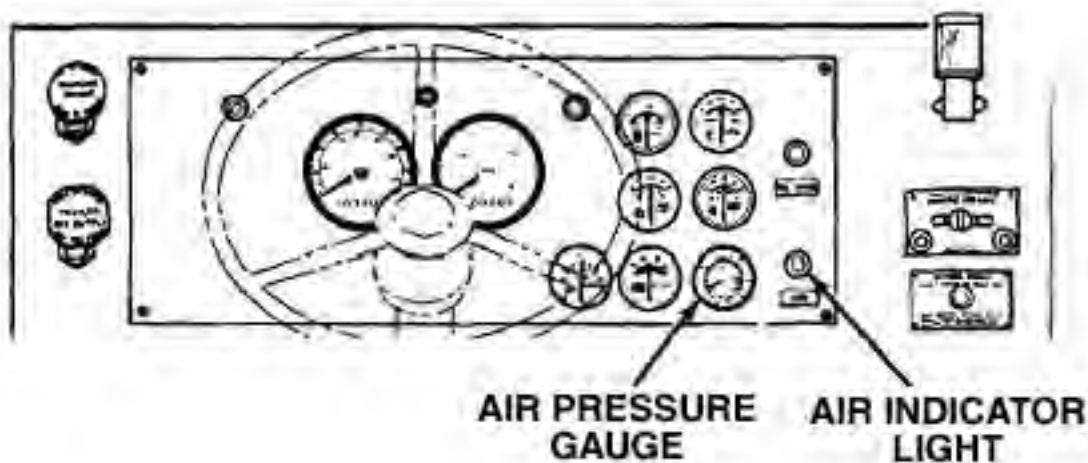


Figure 3.

#### CONDITION/INDICATION

Does air pressure reach 120 psi (827 kPa) with engine accelerated?

#### DECISION

No - Notify Supervisor.

Yes - Test 4 - Are air leaks present?

#### TEST 4 - Are air leaks present?

1. Turn engine off. (WP 0057)
2. Press service brake treadle completely down, and have crew member check for air leaks.

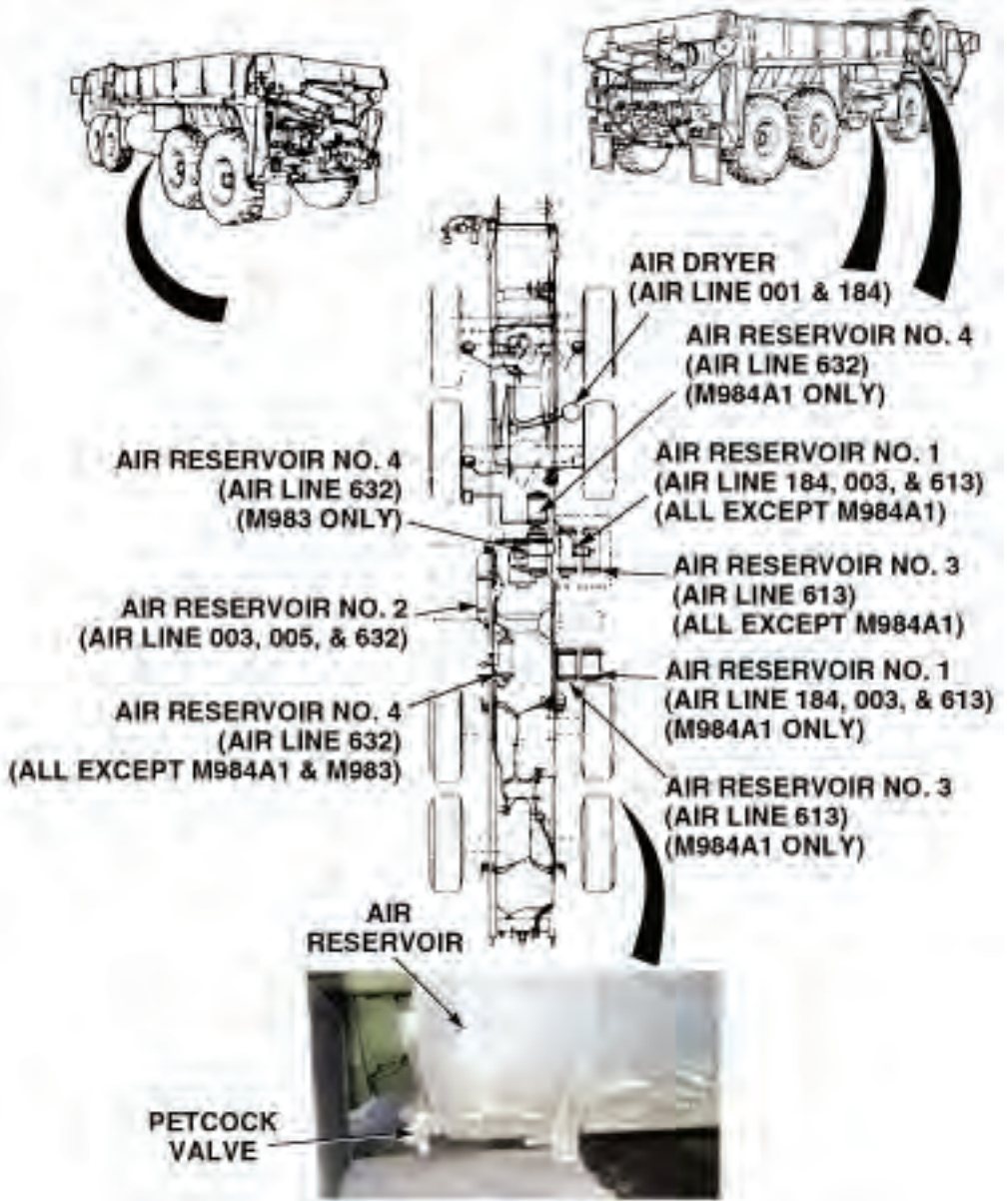


Figure 4.

3. If leaky fitting(s) found, tighten fittings.

**CONDITION/INDICATION**

Are air leaks present?

**DECISION**

Air leaks found - Notify Supervisor.

No air leaks found - Test 5 - Does air system lose pressure during operation?

**TEST 5 - Does air system lose pressure during operation?**

1. Start engine. (WP 0044)
2. Test drive vehicle.
3. Observe and note air pressure.

**CONDITION/INDICATION**

Does air system lose pressure during operation?

**DECISION**

No - Notify Supervisor.

Yes - Problem corrected.

**END OF WORK PACKAGE**

**OPERATOR MAINTENANCE  
TRAILER BRAKE DOES NOT APPLY WHEN SERVICE BRAKE TREADLE OR  
PARKING BRAKE IS USED**

---

**INITIAL SETUP:****Equipment Condition**

Engine OFF. (WP 0057)

**Equipment Condition - Continued**

Parking brakes applied. (WP 0056)

Wheels chocked. (WP 0077)

---

**TROUBLESHOOTING PROCEDURE**

**TRAILER BRAKE DOES NOT APPLY WHEN SERVICE BRAKE TREADLE OR  
PARKING BRAKE IS USED**

**TEST 1 - Are intervehicular air hoses securely and correctly connected?**

1. Check that intervehicular air hoses are secure and correctly connected. If not, reconnect correctly.

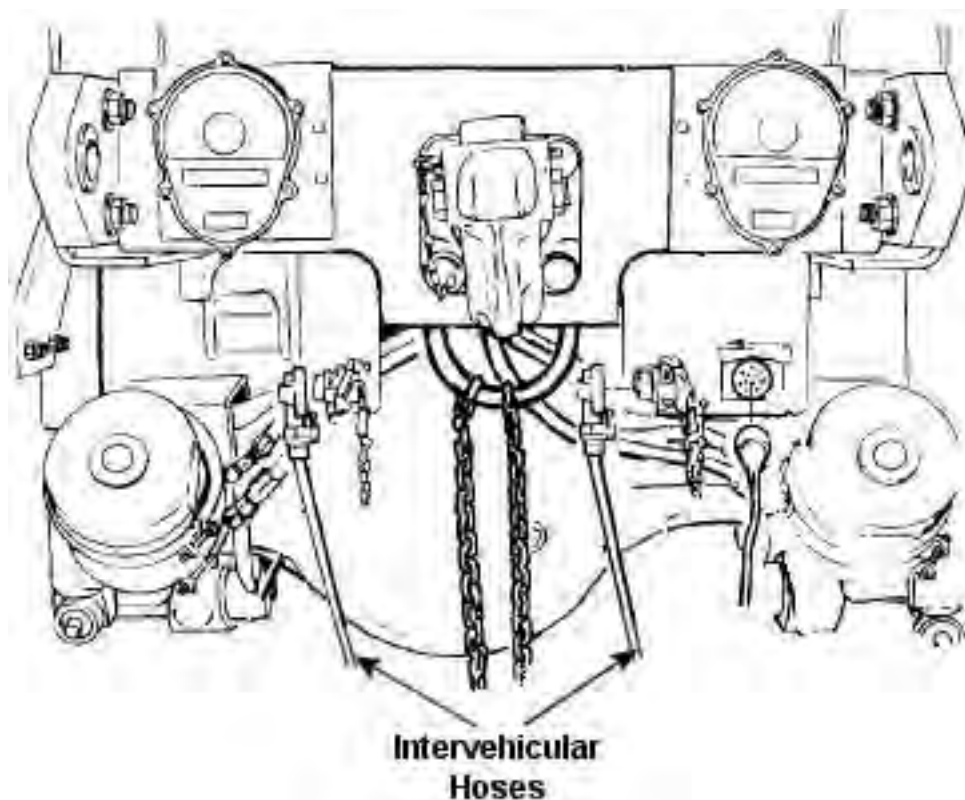


Figure 1.

#### CONDITION/INDICATION

Are intervehicular air hoses securely and correctly connected?

#### DECISION

No - Test 3 - Do trailer brakes apply when service brake treadle or parking brake is used?

Yes - Test 2 - Is trailer air supply control pushed in (ON position)?

#### TEST 2 - Is trailer air supply control pushed in (ON position)?

1. Check if trailer air supply control is pushed in (ON position).



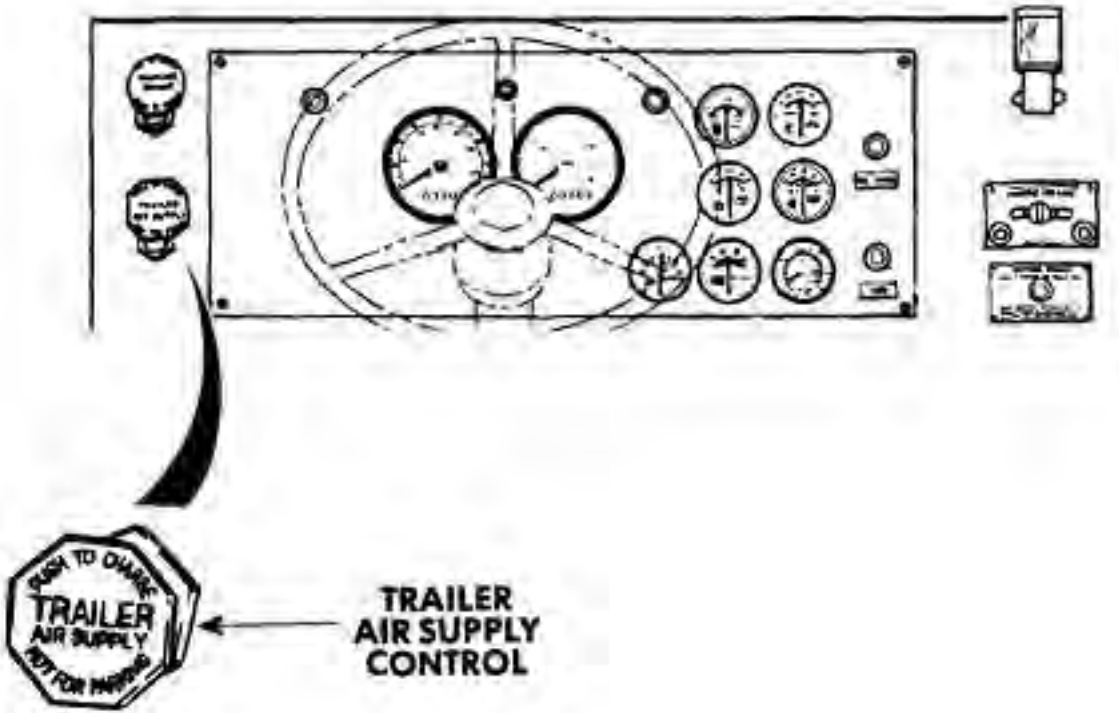


Figure 2.

2. If trailer air supply control is found pulled out (OFF position), push in.

**CONDITION/INDICATION**

Is trailer air supply control pushed in (ON position)?

**DECISION**

No - Test 3 - Do trailer brakes apply when service brake treadle or parking brake is used?

Yes - Notify Supervisor.

**TEST 3 - Do trailer brakes apply when service brake treadle or parking brake is used?**

1. Start engine. (WP 0044)
2. Test drive vehicle.
3. Note trailer brake operations.

**CONDITION/INDICATION**

Do trailer brakes apply when service brake treadle or parking brake is used?

**DECISION**

No - Notify Supervisor.

Yes - Problem corrected.

**END OF WORK PACKAGE**

---

**OPERATOR MAINTENANCE  
AIR HORN WILL NOT OPERATE**

---

**INITIAL SETUP:****Equipment Condition**

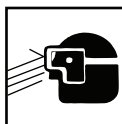
Engine OFF. (WP 0057)

**Equipment Condition - Continued**

Parking brakes applied. (WP 0056)

Wheels chocked. (WP 0077)

---

**TROUBLESHOOTING PROCEDURE  
AIR HORN WILL NOT OPERATE****TEST 1 - Are air hoses tight?****WARNING**

Caution the hose connections could be under pressure be sure to wear eye protection to avoid personal injury.

1. Check air hose connections for tightness. Tighten any loose hose connections found.

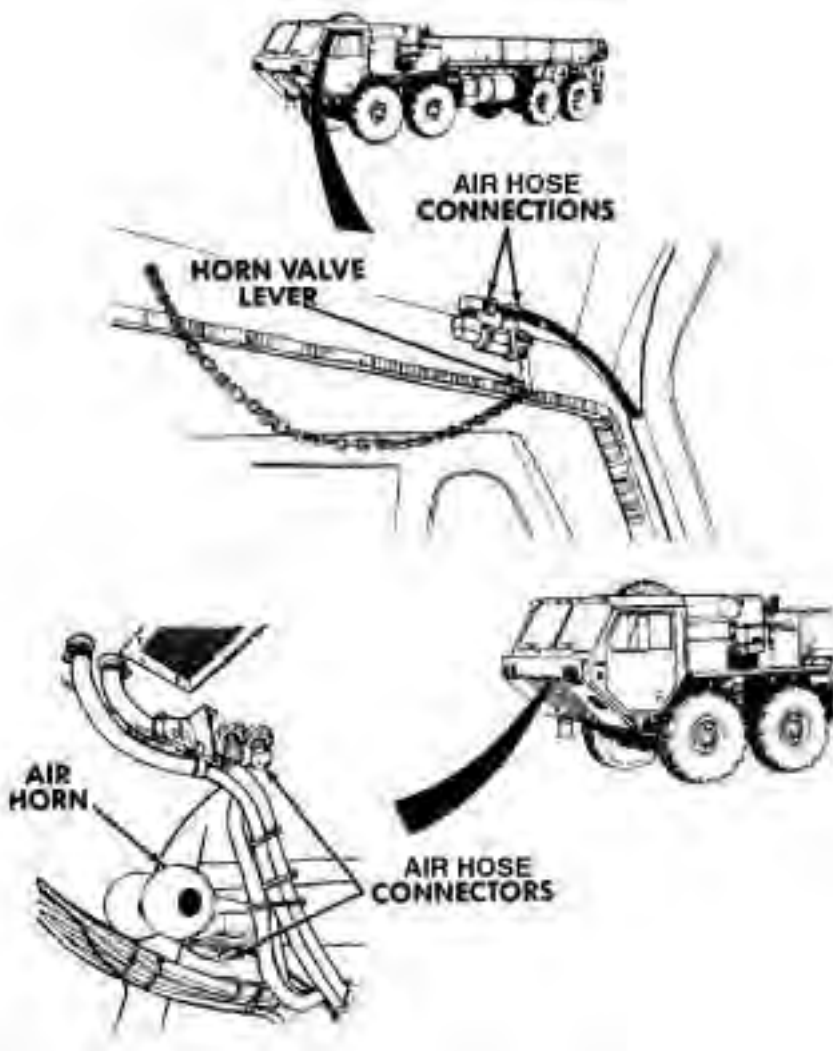


Figure 1.

**CONDITION/INDICATION**

Are air hoses tight?

**DECISION**

Connections loose - Test 3 - Does air horn operate?

Connections OK - Test 2 - Does horn valve lever move freely?

**TEST 2 - Does horn valve lever move freely?**

1. Check horn valve lever for freedom of movement.

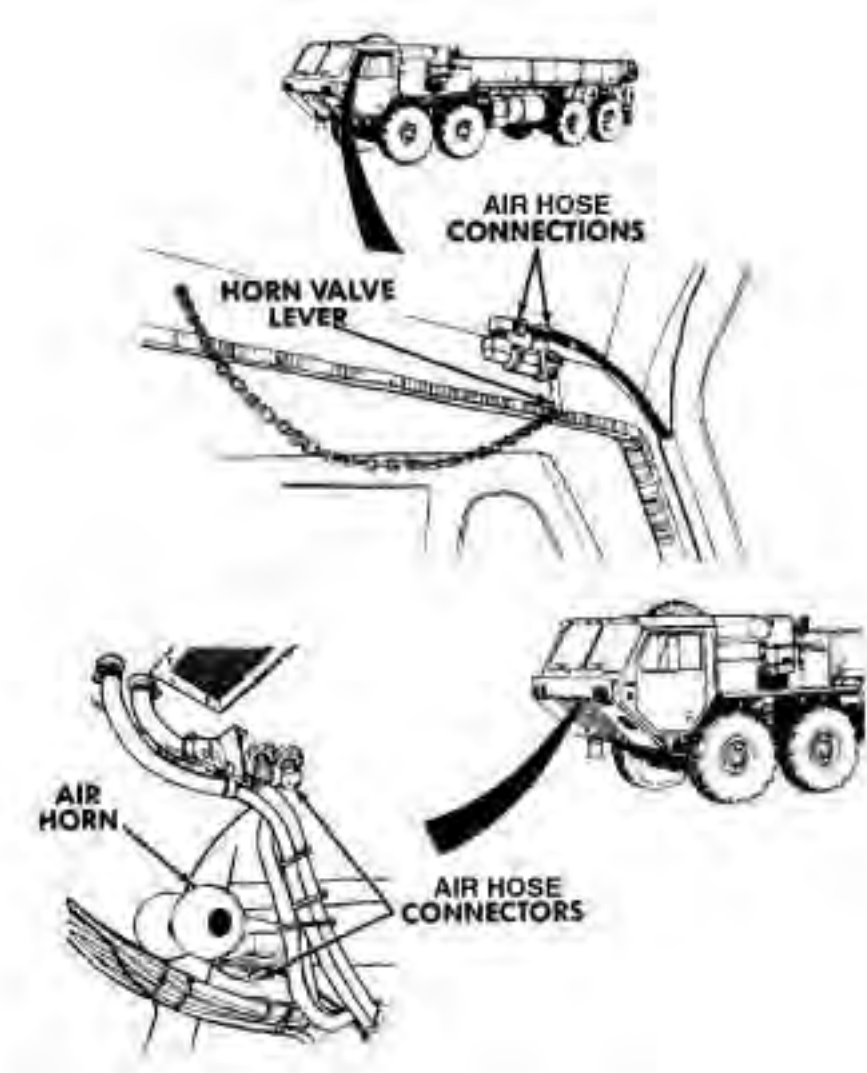


Figure 2.

**CONDITION/INDICATION**

Does horn valve lever move freely?

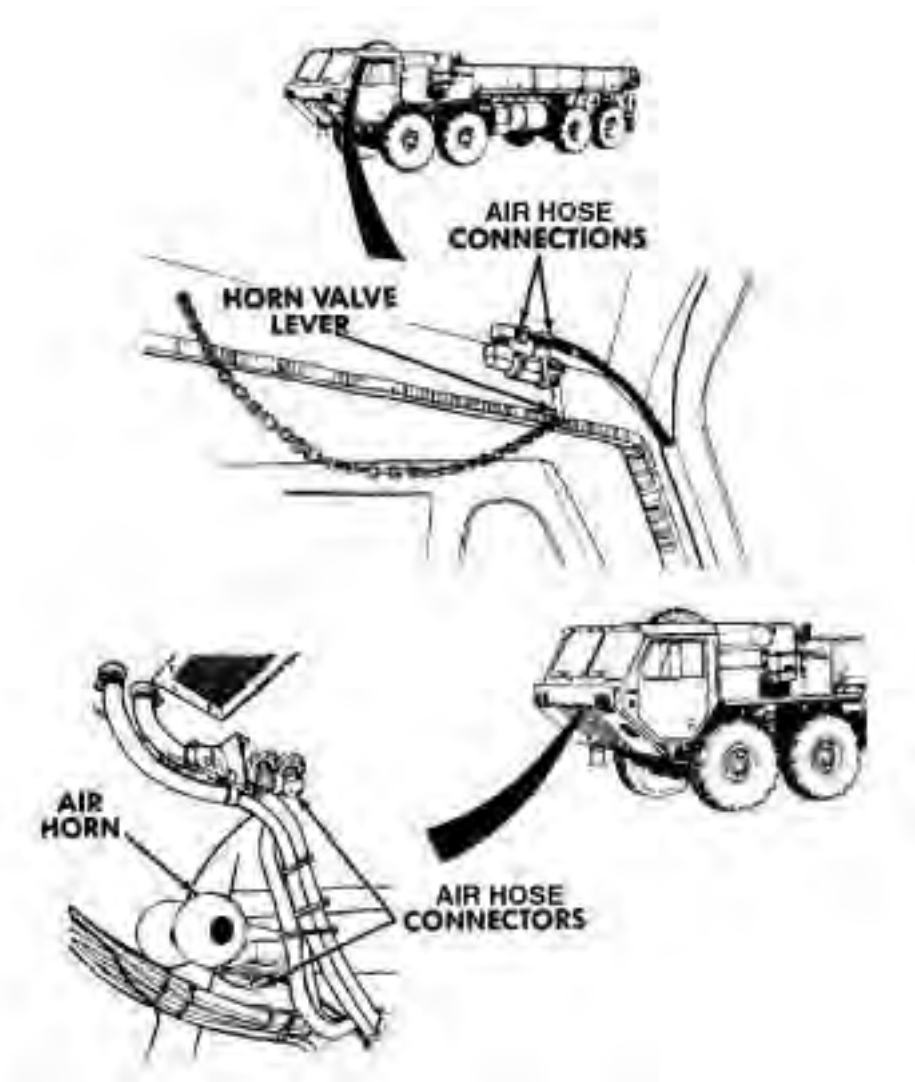
**DECISION**

No - Notify Supervisor.

Yes - Test 3 - Does air horn operate?

**TEST 3 - Does air horn operate?**

1. Start engine, (WP 0044) and allow air pressure to build.
2. Check air horn for proper operation.



*Figure 3.*

3. Turn engine off. (WP 0057)

**CONDITION/INDICATION**

Does air horn operate?

**DECISION**

No - Notify Supervisor.

Yes - Problem corrected.

**END OF WORK PACKAGE**





---

**OPERATOR MAINTENANCE  
ARCTIC ENGINE HEATER FAILS TO OPERATE**

---

**INITIAL SETUP:****Equipment Condition**

Engine OFF. (WP 0057)

**Equipment Condition - Continued**

Parking brakes applied. (WP 0056)

Wheels chocked. (WP 0077)

---

**TROUBLESHOOTING PROCEDURE  
ARCTIC ENGINE HEATER FAILS TO OPERATE**

**TEST 1 - Is fuel present in fuel tank?**

1. Turn engine start switch ON. (WP 0021)
2. Check fuel gauge for presence of fuel.



*Figure 1.*

3. Turn engine start switch OFF.
4. Add fuel to fuel tank if no fuel present.

#### **CONDITION/INDICATION**

Is fuel present in fuel tank?

#### **DECISION**

No - Test 3 - Does arctic heater operate?

Yes - Test 2 - Are arctic heater intake port and exhaust tube free from blockage?

#### **TEST 2 - Are arctic heater intake port and exhaust tube free from blockage?**

1. Inspect arctic heater inlet port and exhaust tube for foreign objects and obstructions. Remove any items found.

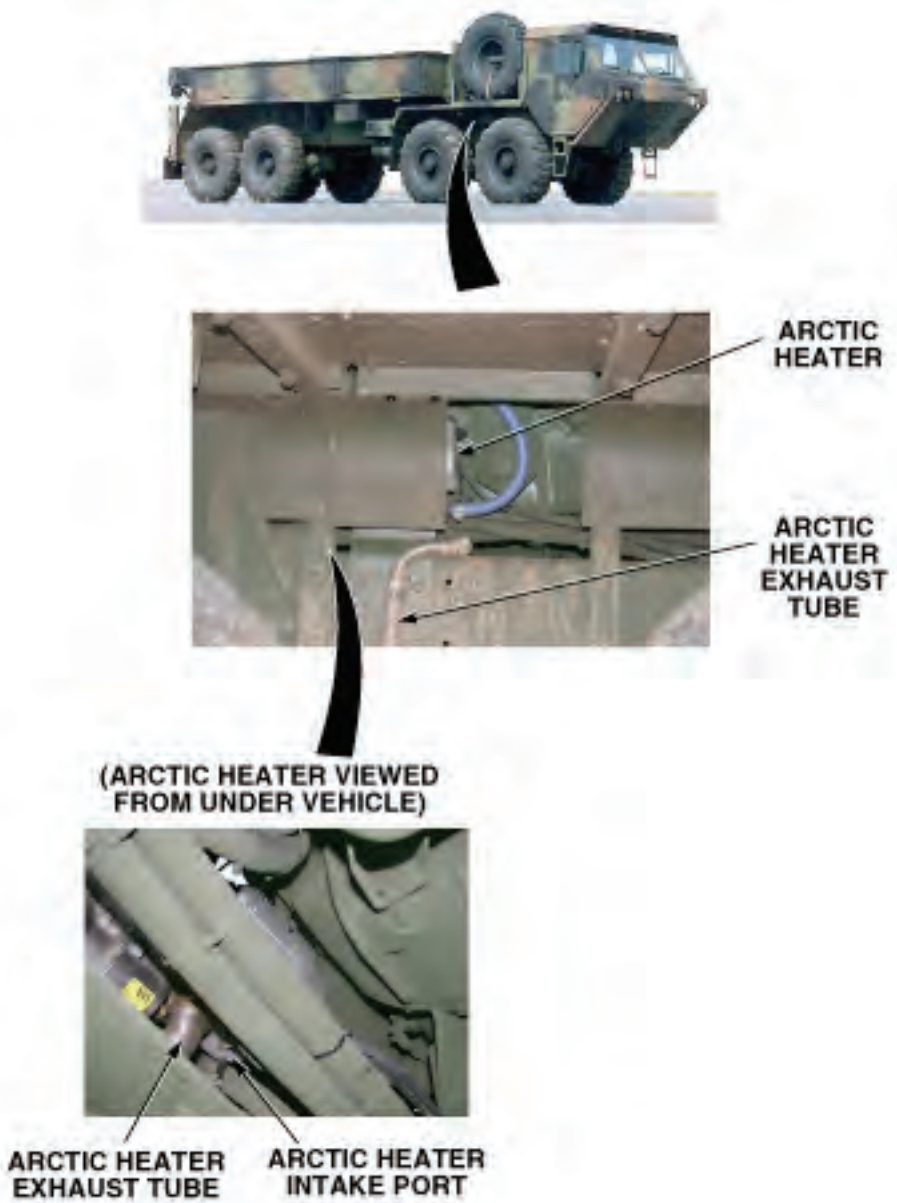


Figure 2.

**CONDITION/INDICATION**

Are arctic heater intake port and exhaust tube free from blockage?

**DECISION**

-  
Continue - Test 3 - Does arctic heater operate?

**TEST 3 - Does arctic heater operate?****CAUTION**

Do not attempt to operate arctic heater if arctic heater fails to start, or shutdown occurs during normal operation. System shutdown may indicate an arctic heater system fault. Failure to comply may cause system lockout.

**CAUTION**

Do not operate arctic heater if arctic heater indicator light flashes during normal operation. Arctic heater indicator light flashing indicates an arctic heater system fault. Failure to comply may cause system lockout.

**NOTE**

If arctic heater does not operate, arctic heater may be in lockout mode due to, either too many overheat occurrences (code 15), or too many start attempts (code 50). Arctic heater lockout mode (code 50) is activated if arctic heater fails to start after 20 successive start attempts (10 start cycles in succession).

**NOTE**

The arctic heater will attempt to start two times per start cycle. After the second failed start attempt, the arctic heater will not operate until the arctic heater on/off switch is turned off, then back on.

**NOTE**

Audible clicking from the arctic heater fuel metering pump may indicate that the arctic heater fuel system isn't primed. If audible clicking is heard from the arctic heater fuel metering pump, repeat steps (1) through (4) four times, or until arctic heater starts. Do not attempt to start arctic heater more than five times. The arctic heater should prime itself within nine start attempts.

1. Turn arctic heater ON. (WP 0058)
2. Observe arctic heater indicator light for steady illumination.
3. Observe arctic heater for proper operation.



*Figure 3.*

4. Turn arctic heater on/off switch OFF.

**CONDITION/INDICATION**

Does arctic heater operate?

**DECISION**

No - Notify Supervisor.

Yes - Problem corrected.

**END OF WORK PACKAGE**



---

**OPERATOR MAINTENANCE  
ONE OR MORE LIGHTING CIRCUITS NOT OPERATING**

---

**INITIAL SETUP:**

**Equipment Condition**

Engine OFF. (WP 0057)

**Equipment Condition - Continued**

Parking brakes applied. (WP 0056)

Wheels chocked. (WP 0077)

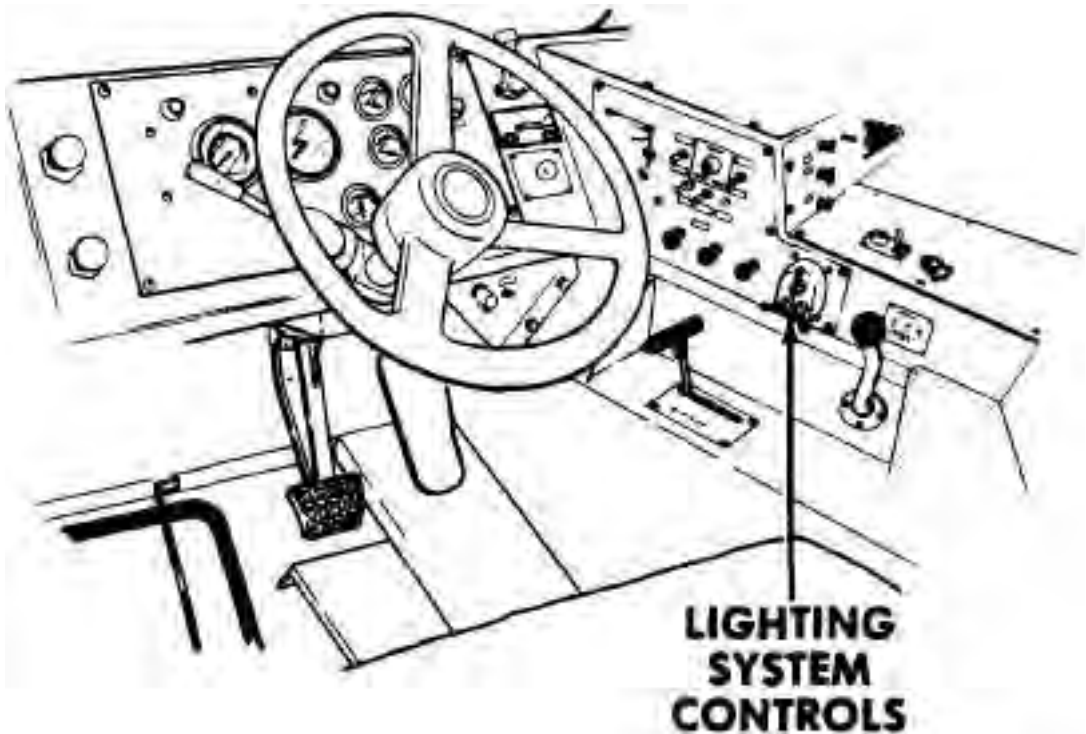
---

**TROUBLESHOOTING PROCEDURE**

**ONE OR MORE LIGHTING CIRCUITS NOT OPERATING**

**TEST 1 - Is the lighting system control in the ON or OPERATING position?**

1. Check if lighting system control is ON or in OPERATING position.



*Figure 1.*

**CONDITION/INDICATION**

Is the lighting system control in the ON or OPERATING position?

**DECISION**

No - Test 3 - Do all lighting circuits operate properly?

Yes - Test 2 - Is intervehicular connection secure and/or connected correctly?

**TEST 2 - Is intervehicular connection secure and/or connected correctly?**

1. If trailer is attached, and trailer lighting system is not working, check intervehicular connection. (WP 0040)
2. If trailer lights are the problem, make sure cable is securely connected.



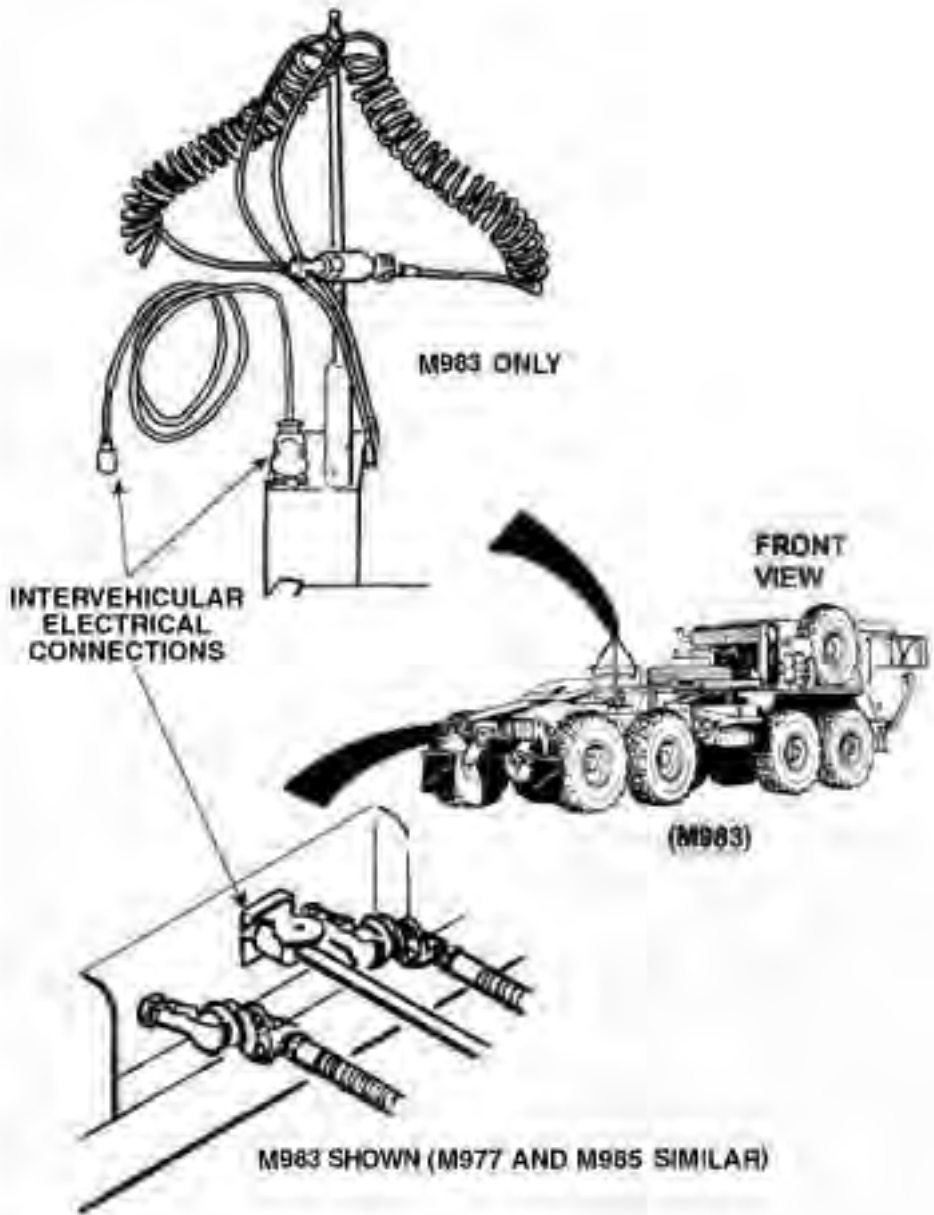


Figure 2.

**CONDITION/INDICATION**

Is intervehicular connection secure and/or connected correctly?

**DECISION**

Intervehicular cable loose. - Test 3 - Do all lighting circuits operate properly? Notify Supervisor.

Intervehicular connection OK. - Notify Supervisor.

**TEST 3 - Do all lighting circuits operate properly?**

1. Check for proper operation of dome lights. (WP 0066)
2. Check for proper operation of panel lights. (WP 0067)
3. Check for proper operation of service drive lights. (WP 0069)
4. Check for proper operation of parking lights. (WP 0068)
5. Check for proper operation of clearance lights. (WP 0071)
6. Check for proper operation of stoplight. (WP 0070)
7. Check for proper operation of blackout drive lights. (WP 0072)
8. Check for proper operation of blackout marker lights. (WP 0073)
9. Check for proper operation of turn signal lights. (WP 0075)

**CONDITION/INDICATION**

Do all lighting circuits operate properly?

**DECISION**

No - Notify Supervisor.

Yes - Problem corrected.

**END OF WORK PACKAGE**

---

**OPERATOR MAINTENANCE**  
**FAILS TO CRANK WHEN ENGINE START SWITCH IS TURNED TO START POSITION**

---

**INITIAL SETUP:**

**Equipment Condition**

Engine OFF. (WP 0057)

**Equipment Condition - Continued**

Parking brakes applied. (WP 0056)

Wheels chocked. (WP 0077)

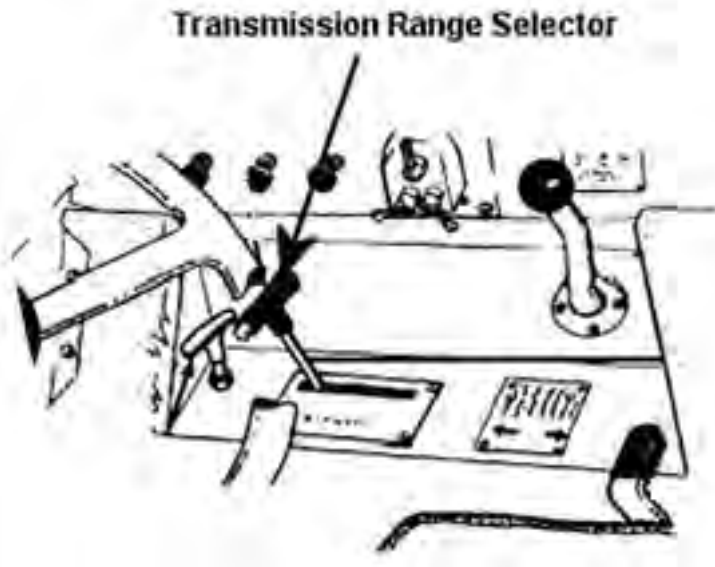
---

**TROUBLESHOOTING PROCEDURE**

**FAILS TO CRANK WHEN ENGINE START SWITCH IS TURNED TO START POSITION**

**TEST 1 - Is transmission range selector in neutral (N)?**

1. Verify range selector is in neutral (N) position. If not in neutral (N), shift it to neutral (N).



*Figure 1.*

**CONDITION/INDICATION**

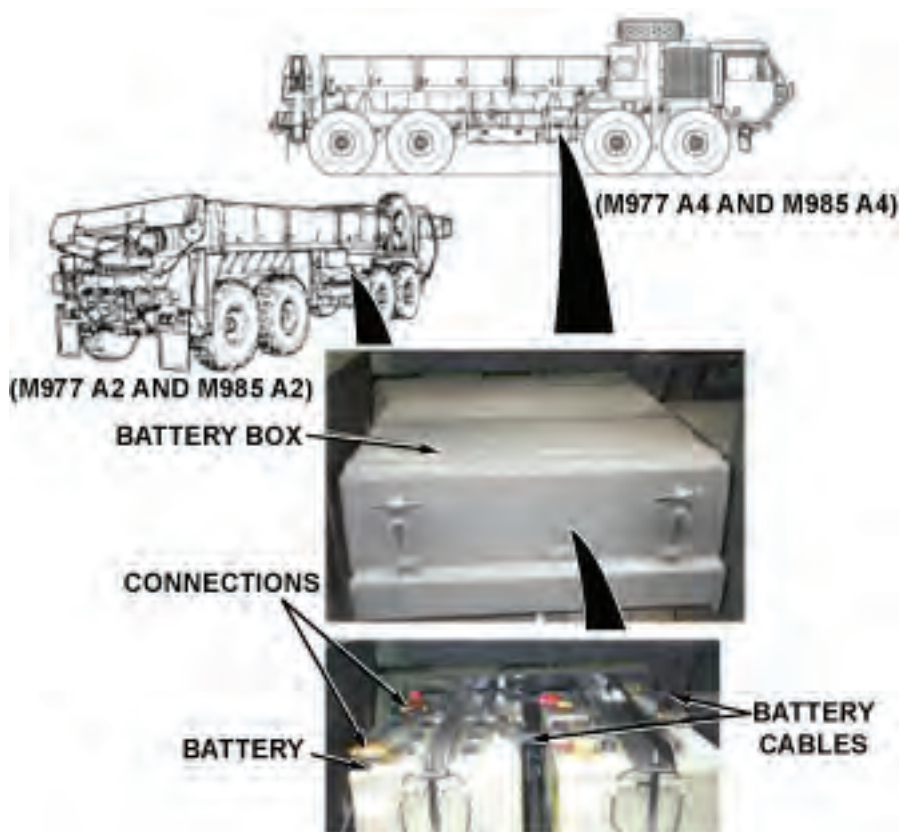
Is transmission range selector in neutral (N)?

**DECISION**

- No - Test 3 - Does engine crank when engine start switch is turned to start position?
- Yes - Test 2 - Are battery cable connections clean, tight, and free from damage?

**TEST 2 - Are battery cable connections clean, tight, and free from damage?**

1. Remove battery box cover. (WP 0159)
2. Check battery cable connections for dirt, corrosion and/or looseness.



*Figure 2.*

3. Check battery cables for damage.

**CONDITION/INDICATION**

Are battery cable connections clean, tight, and free from damage?

**DECISION**

- No - Notify Supervisor.
- Yes - Test 3 - Does engine crank when engine start switch is turned to start position?

**TEST 3 - Does engine crank when engine start switch is turned to start position?**

1. Install battery box cover. (WP 0159)
2. Attempt to start engine. (WP 0044)

**CONDITION/INDICATION**

Does engine crank when engine start switch is turned to start position?

**DECISION**

No - Notify Supervisor.  
Yes - Problem corrected.

**END OF WORK PACKAGE**



**OPERATOR MAINTENANCE  
CRANKS BUT FAILS TO START**

---

**INITIAL SETUP:****Equipment Condition**

Engine OFF. (WP 0057)

**Equipment Condition - Continued**

Parking brakes applied. (WP 0056)

Wheels chocked. (WP 0077)

---

**TROUBLESHOOTING PROCEDURE  
CRANKS BUT FAILS TO START**

**TEST 1 - Does fuel gauge indicate the presence of fuel?**

1. Turn engine start switch ON. (WP 0021)
2. Check fuel gauge for indication of fuel presence.



*Figure 1.*

3. Turn engine start switch OFF. (WP 0021)
4. If fuel gauge indicated no fuel present, add fuel to fuel tank.

#### **CONDITION/INDICATION**

Does fuel gauge indicate the presence of fuel?

#### **DECISION**

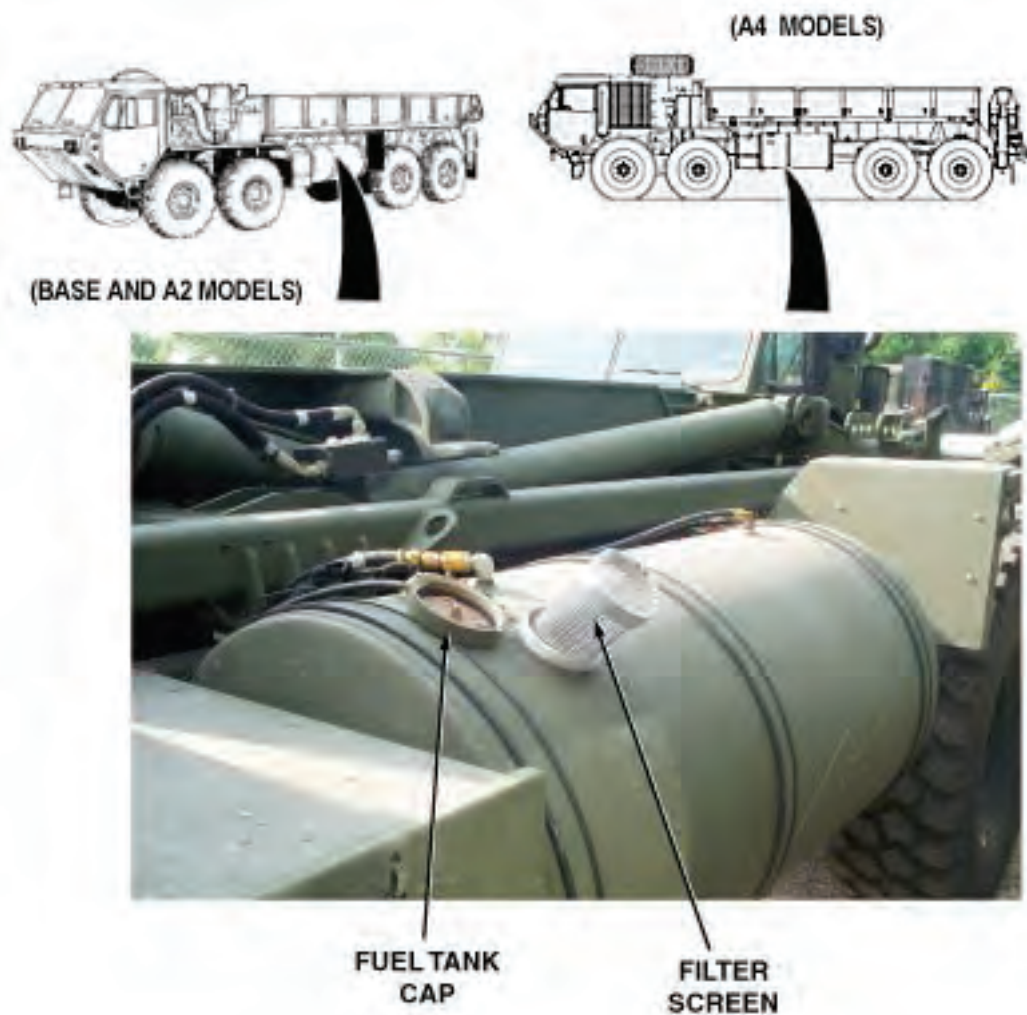
No - Test 5 - Does engine start?

Yes - Test 2 - Is there fuel present in fuel tank?

#### **TEST 2 - Is there fuel present in fuel tank?**

1. Remove fuel tank cap and filter screen from fuel tank.





*Figure 2.*

2. Check fuel tank for presence of fuel.
3. Add fuel to fuel tank if no fuel was present.
4. Replace filter screen and fuel tank cap on fuel tank.

#### **CONDITION/INDICATION**

Is there fuel present in fuel tank?

#### **DECISION**

No - Test 5 - Does engine start?  
 Yes - Test 3 - Is air filter restricted?

**TEST 3 - Is air filter restricted?**

1. Attempt to start engine and note indication on air filter restriction indicator.



*Figure 3.*

**CONDITION/INDICATION**

Is air filter restricted?

**DECISION**

Restricted - Test 4 - Does air filter restriction indicator showed yellow and/or VACUUM INCHES H<sub>2</sub>O window shows less than 18 after servicing air filter?

Not Restricted - Test 5 - Does engine start?

**TEST 4 - Does air filter restriction indicator showed yellow and/or VACUUM INCHES H2O window shows less than 18 after servicing air filter?**

1. Service air filter. (WP 0157)
2. Attempt to start engine and note indication on air filter restriction indicator.



*Figure 4.*

**CONDITION/INDICATION**

Does air filter restriction indicator showed yellow and/or VACUUM INCHES H2O window shows less than 18 after servicing air filter?

**DECISION**

Restricted - Notify Supervisor.

Not Restricted - Test 5 - Does engine start?

**TEST 5 - Does engine start?**

1. Attempt to start engine. (WP 0044)

**CONDITION/INDICATION**

Does engine start?

**DECISION**

- No. - Notify Supervisor.
- Yes. - Problem corrected.

**END OF WORK PACKAGE**

---

**OPERATOR MAINTENANCE**  
**STARTS OR RUNS ROUGHLY AFTER PROPER WARM-UP, DOES NOT MAKE FULL**  
**POWER, OR MAKES EXCESSIVE EXHAUST SMOKE**

---

**INITIAL SETUP:**

**Equipment Condition**

Engine OFF. (WP 0057)

**Equipment Condition - Continued**

Parking brakes applied. (WP 0056)

Wheels chocked. (WP 0077)

---

**TROUBLESHOOTING PROCEDURE**

**STARTS OR RUNS ROUGHLY AFTER PROPER WARM-UP, DOES NOT MAKE FULL**  
**POWER, OR MAKES EXCESSIVE EXHAUST SMOKE**

**TEST 1 - Is PTO engaged?**

1. Start engine and allow engine to reach normal operating temperature. (WP 0044)
2. Check PTO ENGAGE switch and PTO ENGAGE indicator to make sure that PTO is disengaged. Light should be off.

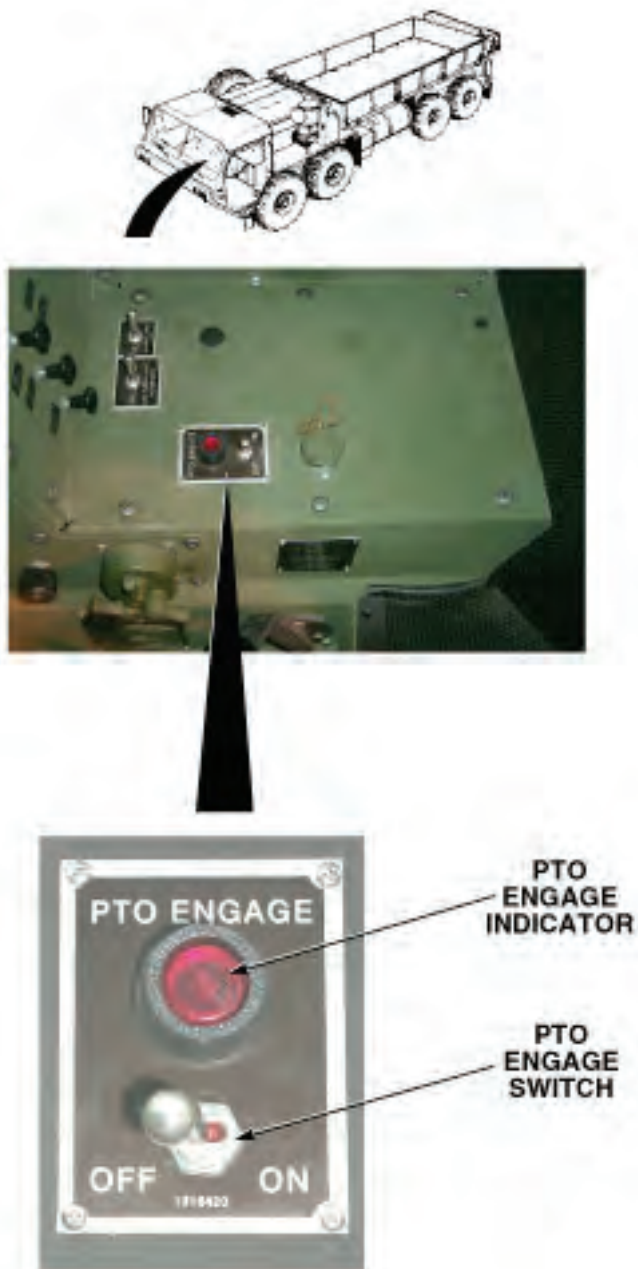


Figure 1.

**CONDITION/INDICATION**

Is PTO engaged?

**DECISION**

PTO engaged. - Test 4 - Does engine start or run roughly after proper warm-up, and/or does not make full power or makes excessive exhaust smoke?

PTO disengaged. - Test 2 - Does air filter restriction indicator show red and/or VACUUM INCHES H2O window show 18 or more after being reset?

**TEST 2 - Does air filter restriction indicator show red and/or VACUUM INCHES H2O window show 18 or more after being reset?**

1. Reset air filter restriction indicator.
2. Start engine. (WP 0044)
3. Check if air filter restriction indicator is red and/or VACUUM INCHES H2O window shows 18 or more.



*Figure 2.*

**CONDITION/INDICATION**

Does air filter restriction indicator show red and/or VACUUM INCHES H<sub>2</sub>O window show 18 or more after being reset?

**DECISION**

Restricted. - Test 3 - Does air filter restriction indicator show red and/or VACUUM INCHES H<sub>2</sub>O window show 18 or more after being cleaned?

Not restricted. - Test 4 - Does engine start or run roughly after proper warm-up, and/or does not make full power or makes excessive exhaust smoke?



**TEST 3 - Does air filter restriction indicator show red and/or VACUUM INCHES H2O window show 18 or more after being cleaned?**

1. Turn engine OFF. (WP 0057)
2. Clean air filter. (WP 0157)
3. Start engine. (WP 0044)
4. Check if air filter restriction indicator is red and/or VACUUM INCHES H2O window shows 18 or more.



Figure 3.

**CONDITION/INDICATION**

Does air filter restriction indicator show red and/or VACUUM INCHES H2O window show 18 or more after being cleaned?

**DECISION**

Restricted. - Notify Supervisor.

Not restricted. - Test 4 - Does engine start or run roughly after proper warm-up, and/or does not make full power or makes excessive exhaust smoke?

**TEST 4 - Does engine start or run roughly after proper warm-up, and/or does not make full power or makes excessive exhaust smoke?**

1. Test drive vehicle.

**CONDITION/INDICATION**

Does engine start or run roughly after proper warm-up, and/or does not make full power or makes excessive exhaust smoke?

**DECISION**

Runs rough. - Notify Supervisor.

Runs normal. - Problem corrected.

**END OF WORK PACKAGE**

---

## OPERATOR MAINTENANCE ENGINE OVERHEATS

---

### INITIAL SETUP:

#### Equipment Condition

Engine OFF. (WP 0057)

#### Equipment Condition - Continued

Parking brakes applied. (WP 0056)

Wheels chocked. (WP 0077)

---

### TROUBLESHOOTING PROCEDURE ENGINE OVERHEATS

#### TEST 1 - Are right-side radiator hoses and housing free from leaks?

#### WARNING



Radiator coolant hoses are very hot and pressurized during vehicle operation. Allow radiator to cool prior to checking hoses. Failure to comply may result in injury or death to personnel.

1. Open driver and passenger side engine covers. (WP 0160)
2. Check upper and lower radiator hoses and housing for leaks.
3. Check that all clamps are tight and secure.

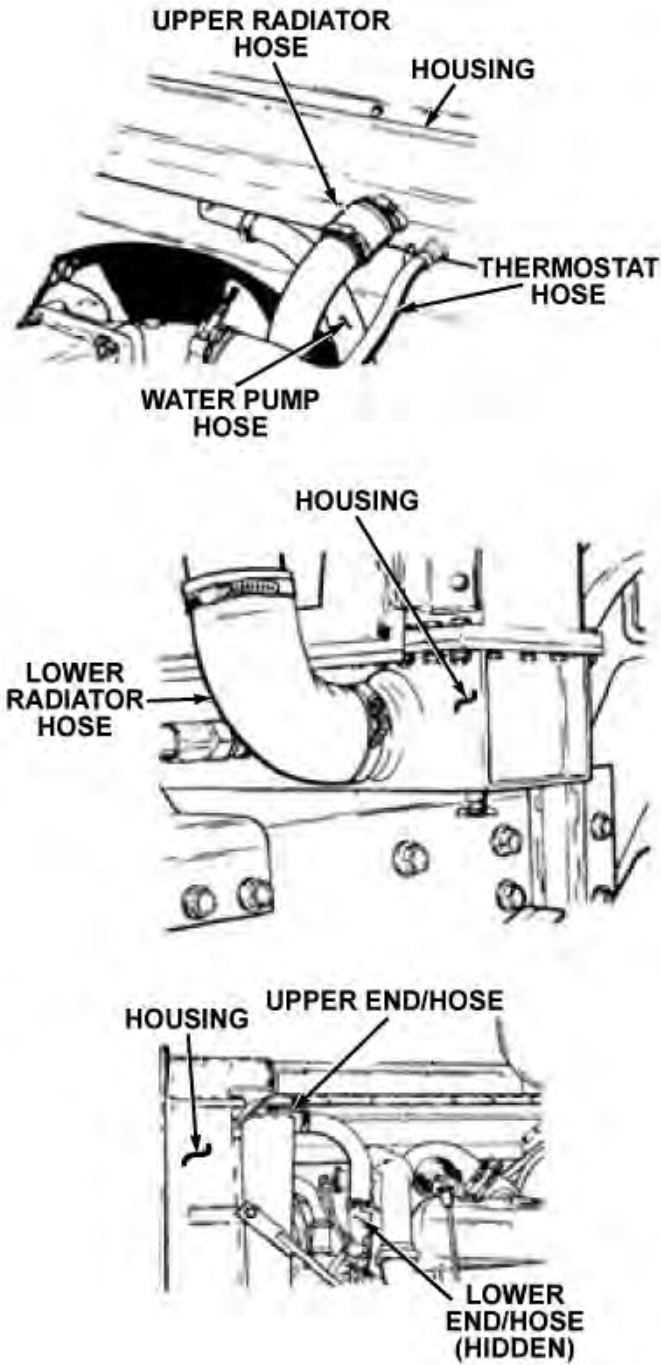


Figure 1.

**CONDITION/INDICATION**

Are right-side radiator hoses and housing free from leaks?

**DECISION**

Radiator hoses and/or housing damaged. - Notify Supervisor. Test 2 - Does engine overheat? Notify Supervisor.

Radiator hoses and/or housing free from damage and/or leaks. - Notify Supervisor.

**TEST 2 - Does engine overheat?**

1. Close driver and passenger side engine covers. (WP 0160)
2. Start engine. (WP 0044)

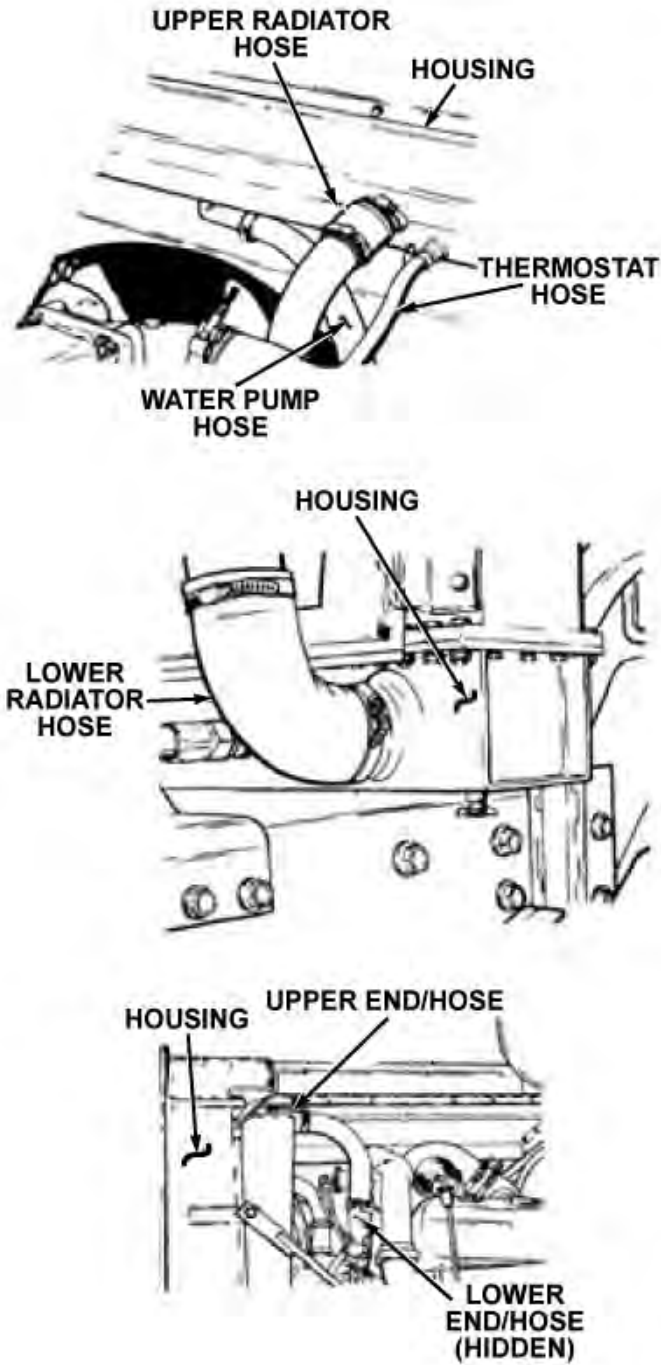


Figure 2.

3. Test drive vehicle.

**CONDITION/INDICATION**

Does engine overheat?

**DECISION**

Engine overheats - Notify Supervisor.

Engine OK - Problem corrected.

**END OF WORK PACKAGE**





**OPERATOR MAINTENANCE  
LOW OIL PRESSURE GAUGE INDICATION**

---

**INITIAL SETUP:****Equipment Condition**

Engine OFF. (WP 0057)

**Equipment Condition - Continued**

Parking brakes applied. (WP 0056)

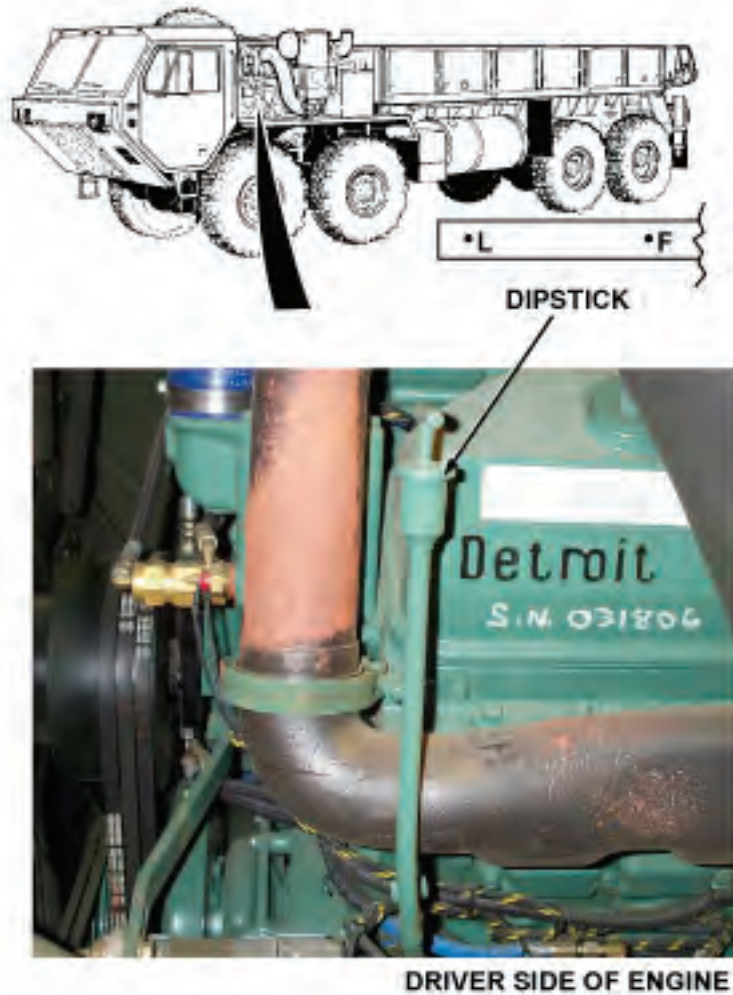
Wheels chocked. (WP 0077)

---

**TROUBLESHOOTING PROCEDURE  
LOW OIL PRESSURE GAUGE INDICATION**

**TEST 1 - Is engine oil level low?**

1. Check engine oil level. (WP 0147)



*Figure 1.*

2. If oil level is low, fill oil to proper level. (WP 0147)

**CONDITION/INDICATION**

Is engine oil level low?

**DECISION**

-  
Continue - Test 2 - Is engine oil pressure still low?

**TEST 2 - Is engine oil pressure still low?**

1. Start engine and allow engine to reach operating temperature. (WP 0044)
2. Check OIL PRESS gauge. Gauge should read as follows:
  - At idle, oil pressure can go as low as 5 psi (34 kPa).
  - Normal operation range is 40 psi to 60 psi (276 to 414 kPa) between engine speeds 1800 to 2100 rpm. Minimum for safe operation is 30 psi (207 kPa).

**CONDITION/INDICATION**

Is engine oil pressure still low?

**DECISION**

Oil pressure low. - Notify Supervisor.  
Oil pressure OK. - Problem corrected.

**END OF WORK PACKAGE**



---

## OPERATOR MAINTENANCE EXCESSIVE OIL CONSUMPTION

---

### INITIAL SETUP:

#### Equipment Condition

Engine OFF. (WP 0057)

#### Equipment Condition - Continued

Parking brakes applied. (WP 0056)

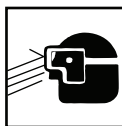
Wheels chocked. (WP 0077)

---

### TROUBLESHOOTING PROCEDURE EXCESSIVE OIL CONSUMPTION

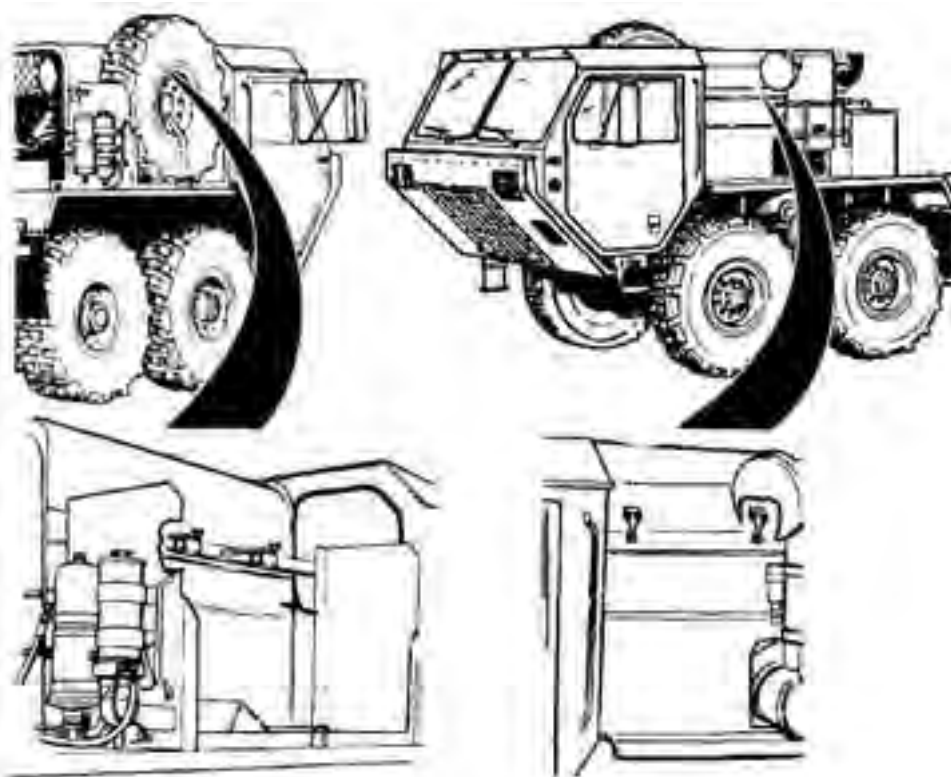
#### TEST 1 - Are engine oil lines loose?

#### WARNING



Caution the oil lines could be under pressure be sure to wear the proper eye protection to avoid personal injury.

1. Open driver and passenger side engine covers. (WP 0160)



*Figure 1.*

2. Check for loose engine oil lines or damaged components.

#### **CONDITION/INDICATION**

Are engine oil lines loose?

#### **DECISION**

Lines Loose - Notify Supervisor.

Lines OK - Test 2 - Are any engine oil leaks present?

#### **TEST 2 - Are any engine oil leaks present?**

1. Tighten any loose fittings/components if found.
2. Visually check for engine oil leaks.

#### **CONDITION/INDICATION**

Are any engine oil leaks present?

**DECISION**

Leaks found. - Notify Supervisor.

No leaks found. - Notify Supervisor.

**END OF WORK PACKAGE**





**OPERATOR MAINTENANCE**  
**HYDRAULIC SYSTEM OPERATES TOO SLOW, TOO FAST, WITH JERKY**  
**MOVEMENTS; OR ONE OR MORE HYDRAULICS CIRCUITS WILL NOT OPERATE**

---

**INITIAL SETUP:****Equipment Condition**

Engine OFF. (WP 0057)

**Equipment Condition - Continued**

Parking brakes applied. (WP 0056)

Wheels chocked. (WP 0077)

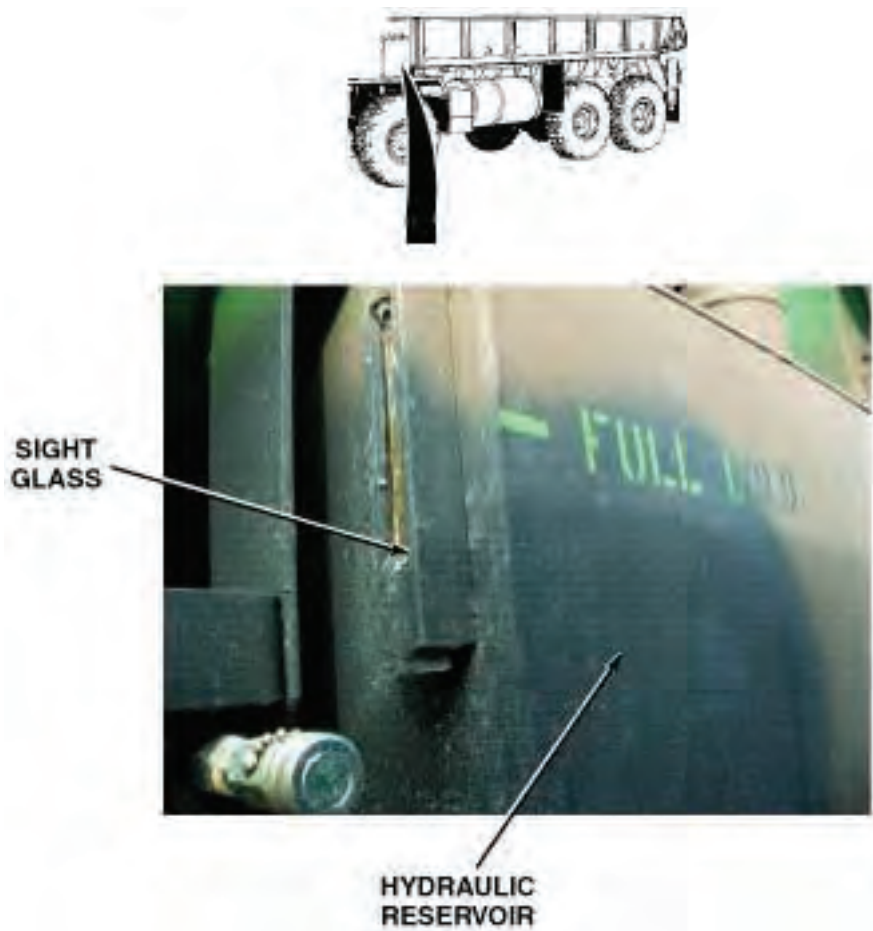
---

**TROUBLESHOOTING PROCEDURE**

**HYDRAULIC SYSTEM OPERATES TOO SLOW, TOO FAST, WITH JERKY**  
**MOVEMENTS; OR ONE OR MORE HYDRAULICS CIRCUITS WILL NOT OPERATE**

**TEST 1 - Is hydraulic fluid level within normal operating range?**

1. Check hydraulic fluid level. If low, add hydraulic fluid. (WP 0147)



*Figure 1.*

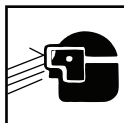
**CONDITION/INDICATION**

Is hydraulic fluid level within normal operating range?

**DECISION**

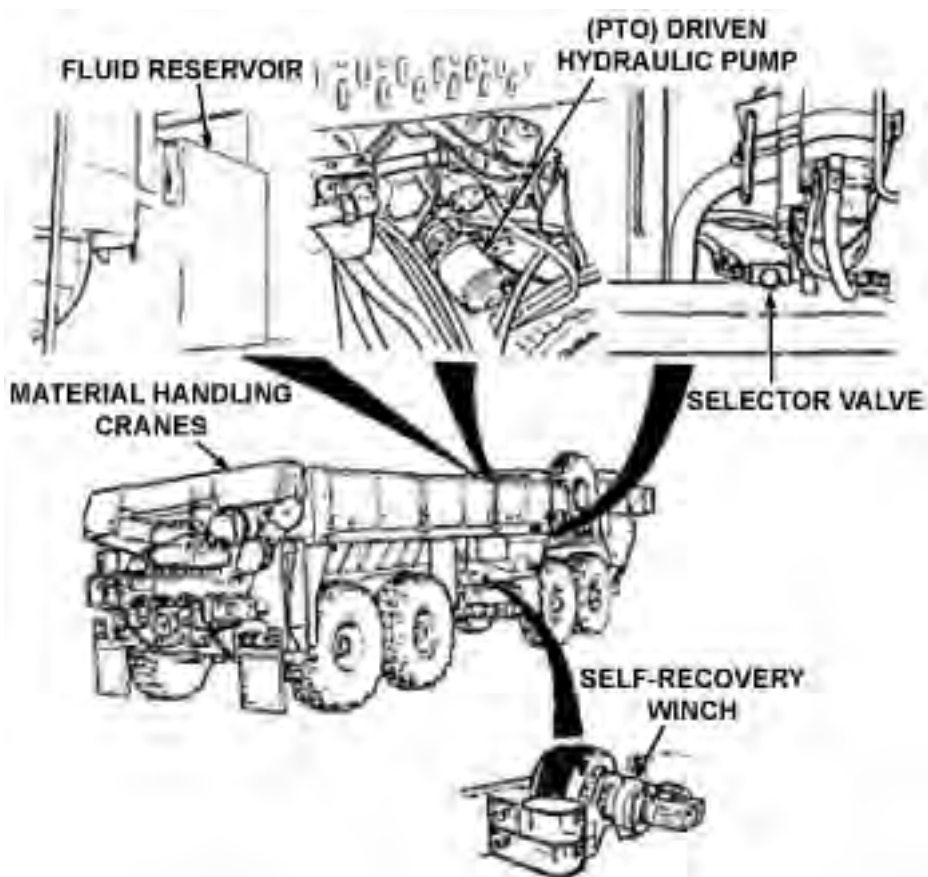
No - Test 3 - Do all hydraulic systems operate properly?

Yes - Test 2 - Are hydraulic hoses and connections free from leaks and/or damage?

**TEST 2 - Are hydraulic hoses and connections free from leaks and/or damage?****WARNING**

Caution the hydraulic system maybe under pressure be sure to wear the proper eye protection to avoid personal injury.

1. Check hydraulic hoses and connections for leaks and/or damage.



*Figure 2.*

2. Attempt to tighten loose hose(s) and/or connection(s).

**CONDITION/INDICATION**

Are hydraulic hoses and connections free from leaks and/or damage?

**DECISION**

Hydraulic hose or connection damaged. - Notify Supervisor. Test 3 - Do all hydraulic systems operate properly? Notify Supervisor.

Hydraulic hoses and connections OK. - Notify Supervisor.

**TEST 3 - Do all hydraulic systems operate properly?**

1. Start engine. (WP 0044)
2. Operate hydraulic systems to check for proper operation.

**CONDITION/INDICATION**

Do all hydraulic systems operate properly?

**DECISION**

No - Notify Supervisor.

Yes - Problem corrected.

**END OF WORK PACKAGE**

---

**OPERATOR MAINTENANCE  
BOOM OPERATION ABNORMAL WHEN TELESCOPING IN OR OUT**

---

**INITIAL SETUP:****Equipment Condition**

Vehicle setup for crane operations.  
(WP 0042)

---

**TROUBLESHOOTING PROCEDURE  
BOOM OPERATION ABNORMAL WHEN TELESCOPING IN OR OUT**

**TEST 1 - Is HIGH IDLE ON/OFF switch set to ON position?**

**NOTE**

**Common problems that crane operators may see are:**

1. Slow or abnormal operation.
2. Crane will not pick up load.

**Common causes of problems are:**

1. Cold hydraulic oil (slow operation).
2. Low engine speed (slow or abnormal operation).
3. Operating two craning functions at the same time (slow operation).
4. Load too heavy (will not pick up load).
5. Air in cylinder or hoist motor (abnormal operation).

**Report all problems to field level maintenance.**

1. Ensure HIGH IDLE ON/OFF switch is set to ON position. If switch found in OFF position, turn switch to ON. (WP 0042)

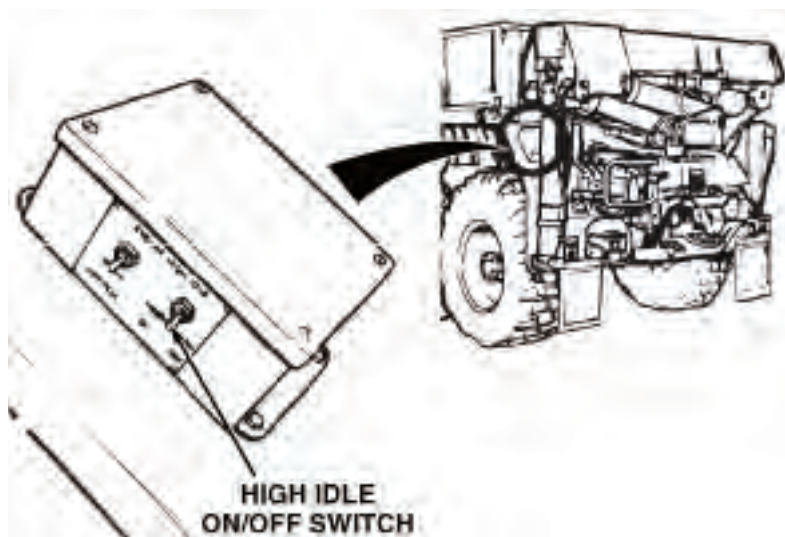


Figure 1.

#### CONDITION/INDICATION

Is HIGH IDLE ON/OFF switch set to ON position?

#### DECISION

No - Test 5 - Does boom operate normally when telescoping in or out?

Yes - Test 2 - Are boom sections properly lubricated?

#### TEST 2 - Are boom sections properly lubricated?

1. Inspect boom sections for proper lubrication.

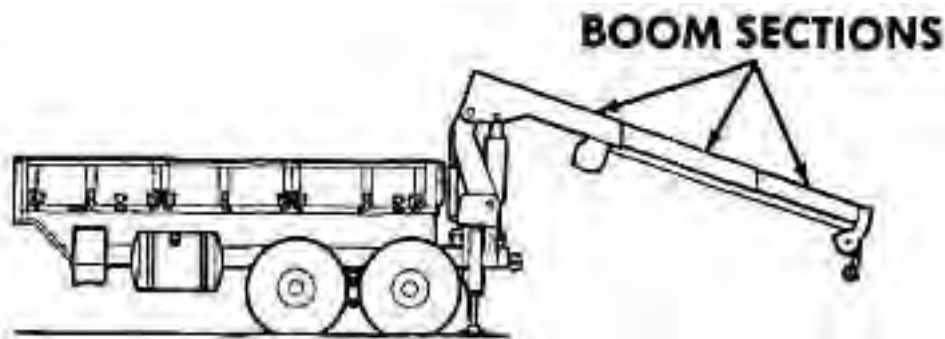


Figure 2.

**CONDITION/INDICATION**

Are boom sections properly lubricated?

**DECISION**

No - Lubricate boom sections. (WP 0149)

Yes - Test 3 - Are cylinders free from trapped air after telescoping boom in and out several times?

**TEST 3 - Are cylinders free from trapped air after telescoping boom in and out several times?**

1. Lower boom below horizontal position. (WP 0042)



*Figure 3.*

2. Fully TELESCOPE boom IN and OUT several times to remove air from cylinders. (WP 0042)

**CONDITION/INDICATION**

Are cylinders free from trapped air after telescoping boom in and out several times?

**DECISION**

No - Test 4 - Is boom operation normal after allowing boom to sit overnight?

Yes - Problem corrected.

**TEST 4 - Is boom operation normal after allowing boom to sit overnight?**

1. Swing boom to rear of vehicle. Fully telescope boom out. (WP 0042)
2. Lower boom as far as possible. (WP 0042)



*Figure 4.*

3. Shut down operation, (WP 0042) and allow boom to remain in lowered position overnight.
4. When starting operations, telescope boom in (WP 0042)(not out). Telescoping boom out could force air back into cylinders.
5. Telescope boom out and in. (WP 0042)

#### **CONDITION/INDICATION**

Is boom operation normal after allowing boom to sit overnight?

#### **DECISION**

No - Notify supervisor.

Yes - Problem corrected.

#### **TEST 5 - Does boom operate normally when telescoping in or out?**

1. Verify proper operation of boom telescoping. (WP 0042)





*Figure 5.*

**CONDITION/INDICATION**

Does boom operate normally when telescoping in or out?

**DECISION**

No - Notify supervisor.

Yes - Problem corrected.

**END OF WORK PACKAGE**



---

## OPERATOR MAINTENANCE BOOM RAISES OR LOWERS SLOWLY

---

### INITIAL SETUP:

#### Equipment Condition

Vehicle setup for crane operations.  
(WP 0042)

---

### TROUBLESHOOTING PROCEDURE BOOM RAISES OR LOWERS SLOWLY

**TEST 1 - Does boom raise or lower normally after running engine for 20 minutes with PTO engaged?**

#### NOTE

**Common problems that crane operators may see are:**

1. Slow or abnormal operation.
2. Crane will not pick up load.

**Common causes of problems are:**

1. Cold hydraulic oil (slow operation).
2. Low engine speed (slow or abnormal operation).
3. Operating two craning functions at the same time (slow operation).
4. Load too heavy (will not pick up load).
5. Air in cylinder or hoist motor (abnormal operation).

**Report all problems to field level maintenance.**

If outside temperature is 0°F (-17°C), hydraulic fluid may not flow easily.

1. Start engine. (WP 0044)
2. Set PTO ENGAGE switch to ON. (WP 0042)

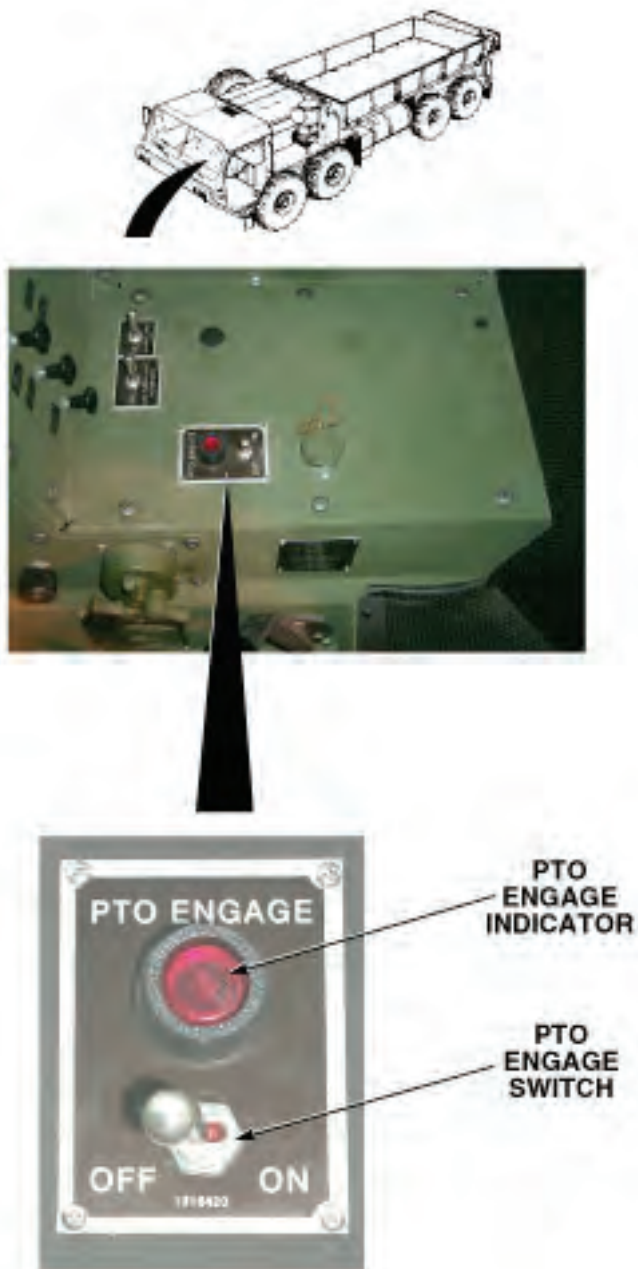


Figure 1.

3. Operate engine (WP 0044) for 20 minutes with PTO enabled to bring hydraulic fluid up to operating temperature.
4. Attempt to raise or lower boom. (WP 0042)

**CONDITION/INDICATION**

Does boom raise or lower normally after running engine for 20 minutes with PTO engaged?

**DECISION**

No - Test 2 - Does boom raise or lower normally after cycling mast?

Yes - Problem corrected.

**TEST 2 - Does boom raise or lower normally after cycling mast?**

1. Lower crane to stowed position. (WP 0042)
2. Operate MAST control DOWN. (WP 0042) Hold MAST control DOWN for approximately 30 seconds, then return control to NEUTRAL position. Repeat procedure several times until hydraulic fluid is warmed.



*Figure 2.*

3. Raise crane to operating position. (WP 0042)
4. Raise and lower boom. (WP 0042)

#### **CONDITION/INDICATION**

Does boom raise or lower normally after cycling mast?

#### **DECISION**

No - Notify Supervisor.  
Yes - Problem corrected.

#### **END OF WORK PACKAGE**

---

**OPERATOR MAINTENANCE  
BOOM WILL NOT RAISE OR LOWER**

---

**INITIAL SETUP:**

**Equipment Condition**

Vehicle setup for crane operations.  
(WP 0042)

---

**TROUBLESHOOTING PROCEDURE  
BOOM WILL NOT RAISE OR LOWER**

**TEST 1 - Does boom operate after checking for overloading?**

**NOTE**

**Common problems that crane operators may see are:**

1. Slow or abnormal operation.
2. Crane will not pick up load.

**Common causes of problems are:**

1. Cold hydraulic oil (slow operation).
2. Low engine speed (slow or abnormal operation).
3. Operating two craning functions at the same time (slow operation).
4. Load too heavy (will not pick up load).
5. Air in cylinder or hoist motor (abnormal operation).

**Report all problems to field level maintenance.**

1. Check that load is not over load limit. If load is found to be over limit, reduce weight to below load limit.

**RANGE DIAGRAM M977**  
**ALL DIMENSIONS ARE IN FEET UNLESS OTHERWISE SPECIFIED**

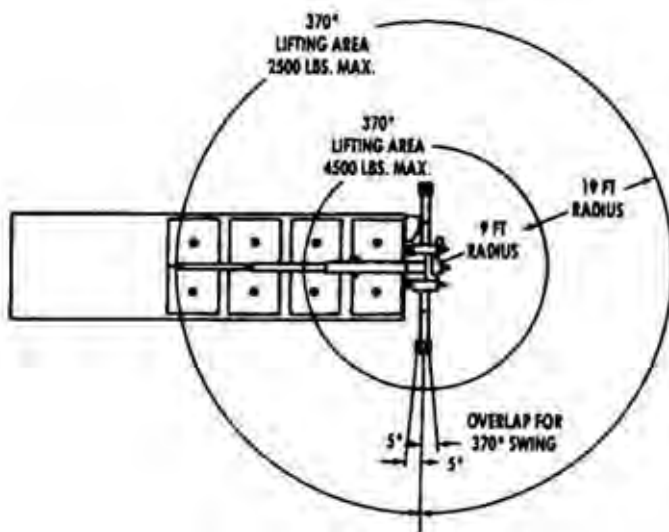
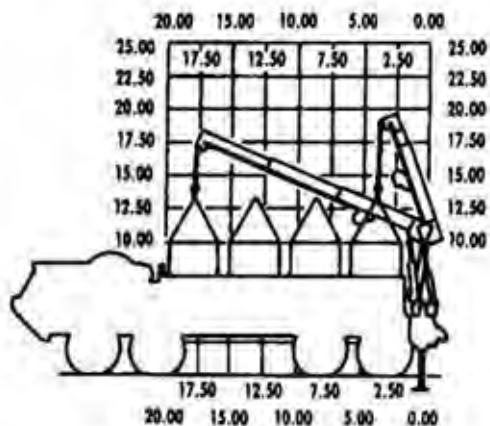


Figure 1.

2. Raise and lower boom. (WP 0042)

**CONDITION/INDICATION**

Does boom operate after checking for overloading?



**DECISION**

- No - Notify supervisor.
- Yes - Problem corrected.

**END OF WORK PACKAGE**



---

**OPERATOR MAINTENANCE  
BOOM WILL NOT TELESCOPE IN OR OUT**

---

**INITIAL SETUP:**

**Equipment Condition**

Vehicle setup for crane operations.  
(WP 0042)

---

**TROUBLESHOOTING PROCEDURE  
BOOM WILL NOT TELESCOPE IN OR OUT**

**TEST 1 - Does boom telescope in or out after checking for overloaded condition?**

**NOTE**

**Common problems that crane operators may see are:**

1. Slow or abnormal operation.
2. Crane will not pick up load.

**Common causes of problems are:**

1. Cold hydraulic oil (slow operation).
2. Low engine speed (slow or abnormal operation).
3. Operating two craning functions at the same time (slow operation).
4. Load too heavy (will not pick up load).
5. Air in cylinder or hoist motor (abnormal operation).

**Report all problems to field level maintenance.**

1. Check that load is not over load limit. If load is found to be over limit, reduce weight to below load limit.

**RANGE DIAGRAM M977**  
**ALL DIMENSIONS ARE IN FEET UNLESS OTHERWISE SPECIFIED**

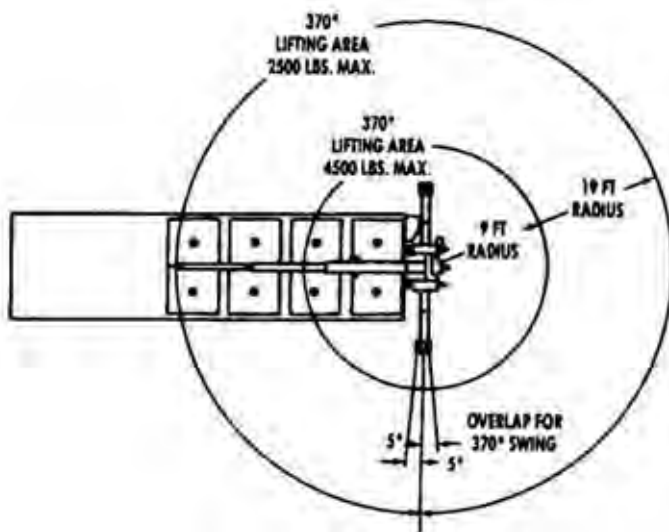
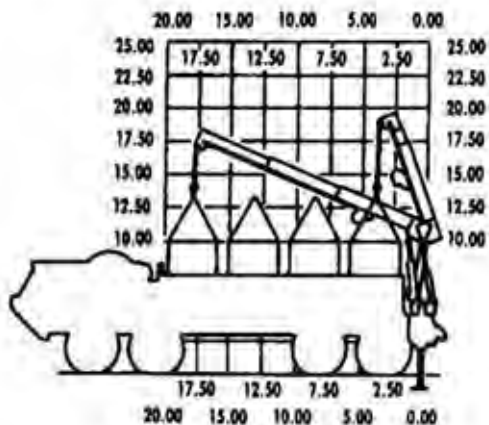


Figure 1.

- Operate crane by telescoping boom IN and OUT. (WP 0042)

**CONDITION/INDICATION**

Does boom telescope in or out after checking for overloaded condition?

**DECISION**

- No - Notify supervisor.
- Yes - Problem corrected.

**END OF WORK PACKAGE**



---

## OPERATOR MAINTENANCE CRANE CONTROLS STICKING IN ENGAGED POSITION

---

### INITIAL SETUP:

#### Equipment Condition

Vehicle setup for crane operations.  
(WP 0042)

---

### TROUBLESHOOTING PROCEDURE CRANE CONTROLS STICKING IN ENGAGED POSITION

#### TEST 1 - Is hydraulic fluid at normal operating temperature?

#### WARNING



Reservoir may be very hot. Use care when placing hand near reservoir. Reservoir can become hot enough to cause serious burns. Be careful not to touch the reservoir with bare hands or allow body to contact reservoir. Use gloves and insulated pads as necessary. Failure to comply may result in injury or death to personnel.

#### NOTE

#### Common problems that crane operators may see are:

1. Slow or abnormal operation.
2. Crane will not pick up load.

#### Common causes of problems are:

1. Cold hydraulic oil (slow operation).
2. Low engine speed (slow or abnormal operation).
3. Operating two craning functions at the same time (slow operation).
4. Load too heavy (will not pick up load).
5. Air in cylinder or hoist motor (abnormal operation).

**Report all problems to field level maintenance.**

**NOTE**

If outside temperature is 0°F (-17°C) or lower, hydraulic fluid may not flow easily.

1. Check hydraulic fluid temperature at reservoir.



HYDRAULIC  
RESERVOIR

*Figure 1.*

**CONDITION/INDICATION**

Is hydraulic fluid at normal operating temperature?

**DECISION**

Hydraulic fluid is below normal operating temperature. - Test 2 - Does hydraulic fluid reach normal operating temperature after running engine for 20 minutes with PTO engaged? Test 4 - Is hydraulic fluid overheated?

Hydraulic fluid is at normal operating temperature. - Test 5 - Do crane controls operate normally after hydraulic fluid is at normal operating temperature?

**TEST 2 - Does hydraulic fluid reach normal operating temperature after running engine for 20 minutes with PTO engaged?**

**WARNING**

Reservoir may be very hot. Use care when placing hand near reservoir. Reservoir can become hot enough to cause serious burns. Be careful not to touch the reservoir with bare hands or allow body to contact reservoir.



Use gloves and insulated pads as necessary. Failure to comply may result in injury or death to personnel.

1. Set PTO ENGAGE switch to ON. (WP 0042)

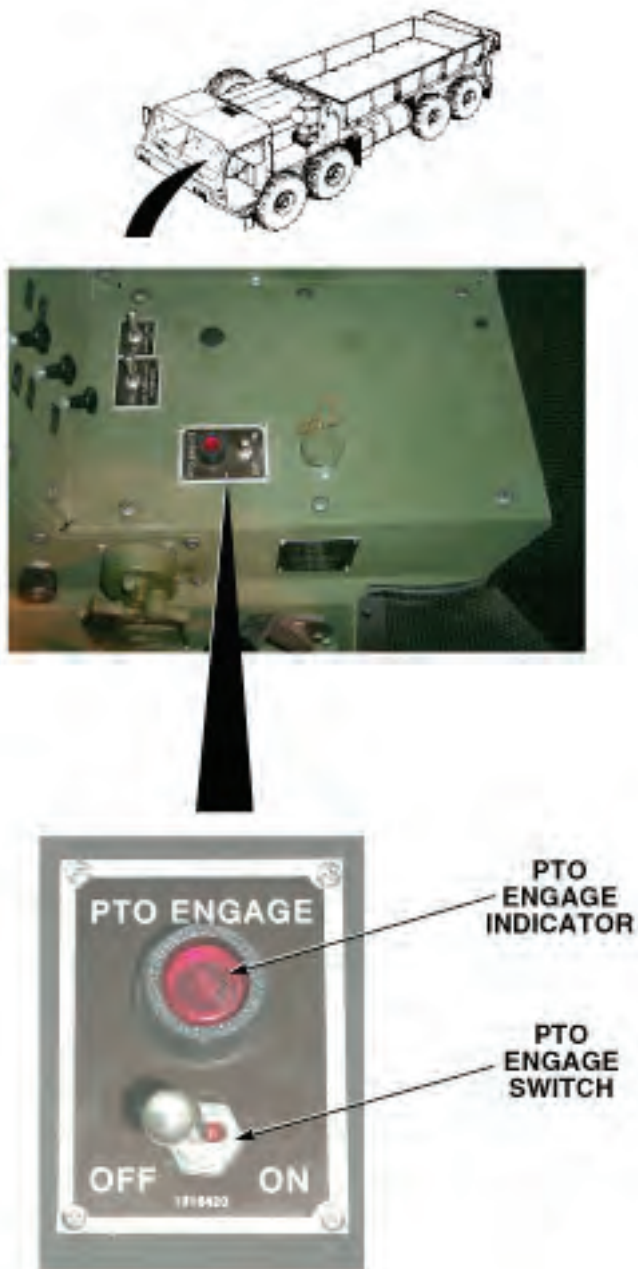


Figure 2.

2. Operate engine (WP 0044) for 20 minutes with PTO enabled to bring hydraulic fluid up to operating temperature.
3. Check hydraulic fluid temperature at reservoir. Reservoir should be warm.

**CONDITION/INDICATION**

Does hydraulic fluid reach normal operating temperature after running engine for 20 minutes with PTO engaged?

**DECISION**

Hydraulic fluid is below normal operating temperature. - Test 3 - Does hydraulic fluid reach normal operating temperature after cycling mast control down? Test 4 - Is hydraulic fluid overheated?

Hydraulic fluid is at normal operating temperature. - Test 5 - Do crane controls operate normally after hydraulic fluid is at normal operating temperature?

**TEST 3 - Does hydraulic fluid reach normal operating temperature after cycling mast control down?****WARNING**

Reservoir may be very hot. Use care when placing hand near reservoir. Reservoir can become hot enough to cause serious burns. Be careful not to touch the reservoir with bare hands or allow body to contact reservoir. Use gloves and insulated pads as necessary. Failure to comply may result in injury or death to personnel.

1. Lower crane to stowed position. (WP 0042)
2. Operate MAST control DOWN. (WP 0042) Hold MAST control DOWN for approximately 30 seconds, then return control to NEUTRAL position. Repeat procedure several times until hydraulic fluid is warmed.



*Figure 3.*

3. Check hydraulic fluid temperature at reservoir. Reservoir should be warm.

#### **CONDITION/INDICATION**

Does hydraulic fluid reach normal operating temperature after cycling mast control down?

#### **DECISION**

Hydraulic fluid is below normal operating temperature. - Notify Supervisor. Test 4 - Is hydraulic fluid overheated?

Hydraulic fluid is at normal operating temperature. - Test 5 - Do crane controls operate normally after hydraulic fluid is at normal operating temperature?

**TEST 4 - Is hydraulic fluid overheated?****WARNING**

Reservoir may be very hot. Use care when placing hand near reservoir. Reservoir can become hot enough to cause serious burns. Be careful not to touch the reservoir with bare hands or allow body to contact reservoir. Use gloves and insulated pads as necessary. Failure to comply may result in injury or death to personnel.

1. Set PTO ENGAGE switch to OFF.
2. Shut off engine. (WP 0057)
3. Allow hydraulic oil to cool. (WP 0057)



**HYDRAULIC  
RESERVOIR**

*Figure 4.*

**CONDITION/INDICATION**

Is hydraulic fluid overheated?

**DECISION**

-

Continue - Test 5 - Do crane controls operate normally after hydraulic fluid is at normal operating temperature?

**TEST 5 - Do crane controls operate normally after hydraulic fluid is at normal operating temperature?**

1. If off, start engine. (WP 0044)

2. Prepare vehicle for crane operation. (WP 0042)

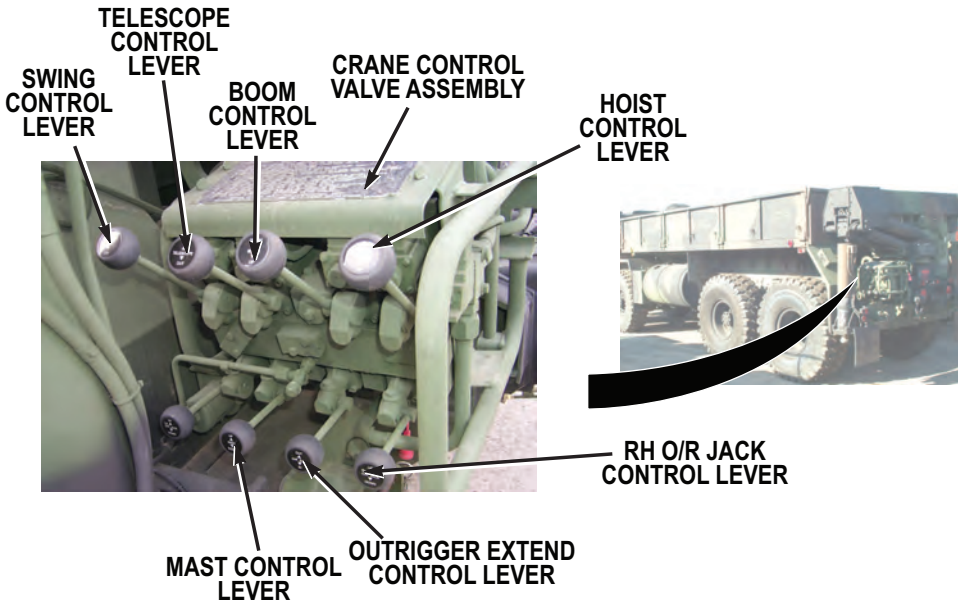


Figure 5.

3. Operate crane controls. (WP 0042)

**CONDITION/INDICATION**

Do crane controls operate normally after hydraulic fluid is at normal operating temperature?

**DECISION**

No - Notify supervisor.  
 Yes - Problem corrected.

**END OF WORK PACKAGE**

---

**OPERATOR MAINTENANCE  
CRANE WILL NOT OPERATE, OR OPERATES ABNORMALLY**

---

**INITIAL SETUP:****Equipment Condition**

Engine OFF. (WP 0057)

**Equipment Condition - Continued**

Parking brakes applied. (WP 0056)

Wheels chocked. (WP 0077)

---

**TROUBLESHOOTING PROCEDURE****CRANE WILL NOT OPERATE, OR OPERATES ABNORMALLY****TEST 1 - Is electrical connector on solenoid tight?****NOTE****Common problems that crane operators may see are:**

1. Slow or abnormal operation.
2. Crane will not pick up load.

**Common causes of problems are:**

1. Cold hydraulic oil (slow operation).
2. Low engine speed (slow or abnormal operation).
3. Operating two craning functions at the same time (slow operation).
4. Load too heavy (will not pick up load).
5. Air in cylinder or hoist motor (abnormal operation).

**Report all problems to field level maintenance.**

1. Check that electrical connector on solenoid valve is tight. If connector is loose, tighten.

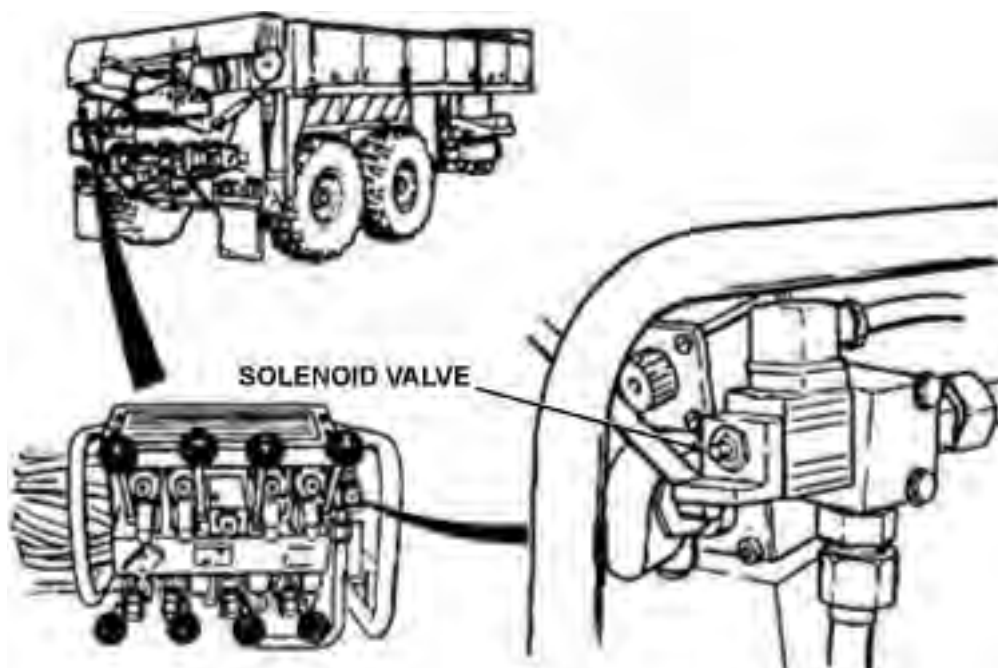


Figure 1.

### CONDITION/INDICATION

Is electrical connector on solenoid tight?

### DECISION

No - Test 3 - Does crane operate normally?

Yes - Test 2 - Does solenoid valve operate when power switch is set to ON?

### TEST 2 - Does solenoid valve operate when power switch is set to ON?

1. Check solenoid for proper operation when power is turned to ON position. (WP 0042) If solenoid is faulty, place a screwdriver in slot on front of solenoid to hold solenoid closed (WP 0105) until mission can be completed.



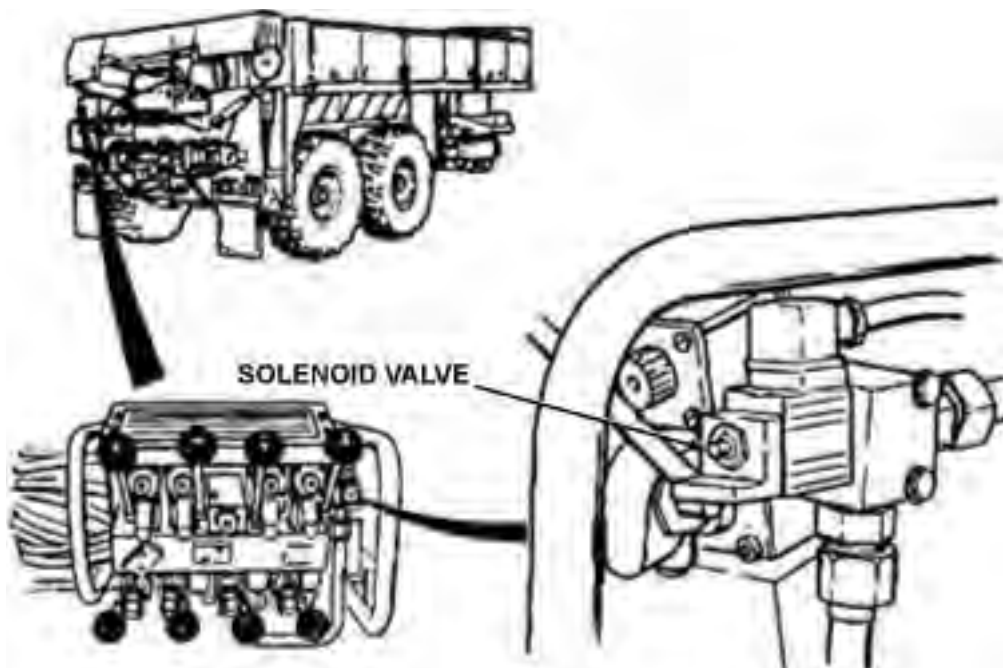


Figure 2.

**CONDITION/INDICATION**

Does solenoid valve operate when power switch is set to ON?

**DECISION**

No - Perform crane emergency hydraulic procedure. (WP 0105)

Yes - Notify Supervisor.

**TEST 3 - Does crane operate normally?**

1. Prepare vehicle for crane operation. (WP 0042)

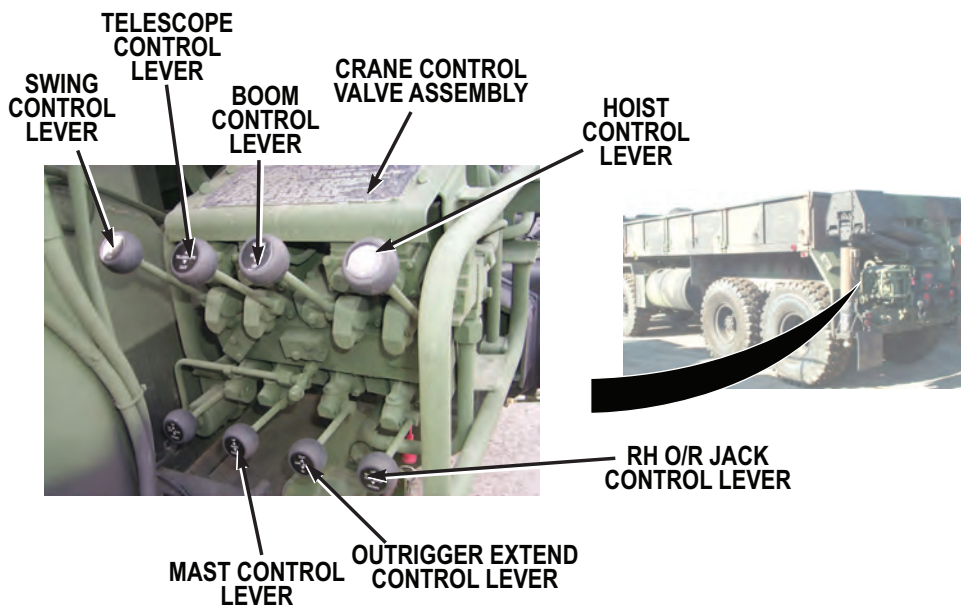


Figure 3.

2. Operate crane. (WP 0042)

**CONDITION/INDICATION**

Does crane operate normally?

**DECISION**

No - Notify supervisor.

Yes - Problem corrected.

**END OF WORK PACKAGE**

---

**OPERATOR MAINTENANCE**  
**HOIST OPERATION SLOW OR ABNORMAL WHEN LIFTING OR LOWERING LOAD**

---

**INITIAL SETUP:****Equipment Condition**

Vehicle setup for crane operations.  
(WP 0042)

---

**TROUBLESHOOTING PROCEDURE**  
**HOIST OPERATION SLOW OR ABNORMAL WHEN LIFTING OR LOWERING LOAD**

**TEST 1 - Does hoist operate normally after removing air from motor?****CAUTION**

Be sure to keep tension on cable. If tension is not maintained, cable may get tangled on drum.

**NOTE****Common problems that crane operators may see are:**

1. Slow or abnormal operation.
2. Crane will not pick up load.

**Common causes of problems are:**

1. Cold hydraulic oil (slow operation).
2. Low engine speed (slow or abnormal operation).
3. Operating two craning functions at the same time (slow operation).
4. Load too heavy (will not pick up load).
5. Air in cylinder or hoist motor (abnormal operation).

**Report all problems to field level maintenance.**

1. Set load down (WP 0042) and disconnect load hook.
2. Reel cable in and out several times to remove air from hoist motor.



Figure 1.

**CONDITION/INDICATION**

Does hoist operate normally after removing air from motor?

**DECISION**

- No - Test 2 - Is hydraulic fluid at normal operating temperature?
- Yes - Test 5 - Does hoist operate normally?

**TEST 2 - Is hydraulic fluid at normal operating temperature?****WARNING**

Reservoir may be very hot. Use care when placing hand near reservoir. Reservoir can become hot enough to cause serious burns. Be careful not to touch the reservoir with bare hands or allow body to contact reservoir. Use gloves and insulated pads as necessary. Failure to comply may result in injury or death to personnel.

**NOTE**

If outside temperature is 0°F (-17°C) or lower, hydraulic fluid may not flow easily.

1. Check hydraulic fluid temperature at reservoir.



**HYDRAULIC  
RESERVOIR**

*Figure 2.*

**CONDITION/INDICATION**

- Is hydraulic fluid at normal operating temperature?

**DECISION**

No - Test 3 - Is hydraulic fluid at normal operating temperature after running engine for 20 minutes with PTO engaged?

Yes - Test 5 - Does hoist operate normally?

**TEST 3 - Is hydraulic fluid at normal operating temperature after running engine for 20 minutes with PTO engaged?****WARNING**

Reservoir may be very hot. Use care when placing hand near reservoir. Reservoir can become hot enough to cause serious burns. Be careful not to touch the reservoir with bare hands or allow body to contact reservoir. Use gloves and insulated pads as necessary. Failure to comply may result in injury or death to personnel.

1. Lower crane to stowed position. (WP 0042)
2. Operate engine (WP 0044) for 20 minutes with PTO engaged to bring hydraulic fluid up to operating temperature.
3. Check hydraulic fluid temperature at reservoir. Reservoir should be warm.



HYDRAULIC  
RESERVOIR

*Figure 3.*

**CONDITION/INDICATION**

Is hydraulic fluid at normal operating temperature after running engine for 20 minutes with PTO engaged?

**DECISION**

No - Test 4 - Is hydraulic fluid at normal operating temperature after cycling mast control down?

Yes - Test 5 - Does hoist operate normally?

**TEST 4 - Is hydraulic fluid at normal operating temperature after cycling mast control down?**

1. Ensure crane is lowered to stowed position. (WP 0042)
2. Operate MAST control DOWN. (WP 0042) Hold MAST control DOWN for approximately 30 seconds, then return control to NEUTRAL position. Repeat procedure several times until hydraulic fluid is warmed.



*Figure 4.*

3. Check hydraulic fluid temperature at reservoir. Reservoir should be warm.

**CONDITION/INDICATION**

Is hydraulic fluid at normal operating temperature after cycling mast control down?

**DECISION**

No - Notify Supervisor.

Yes - Test 5 - Does hoist operate normally?

**TEST 5 - Does hoist operate normally?**

1. If stowed, raise crane to operating position. (WP 0042)
2. Operate hoist. (WP 0042)



*Figure 5.*

**CONDITION/INDICATION**

Does hoist operate normally?

**DECISION**

No - Notify supervisor.

Yes - Problem corrected.

**END OF WORK PACKAGE**



---

**OPERATOR MAINTENANCE  
HOIST WILL NOT LIFT LOAD**

---

**INITIAL SETUP:****Equipment Condition**

Vehicle setup for crane operations.  
(WP 0042)

---

**TROUBLESHOOTING PROCEDURE  
HOIST WILL NOT LIFT LOAD****TEST 1 - Is load within allowable limits?****NOTE****Common problems that crane operators may see are:**

1. Slow or abnormal operation.
2. Crane will not pick up load.

**Common causes of problems are:**

1. Cold hydraulic oil (slow operation).
2. Low engine speed (slow or abnormal operation).
3. Operating two craning functions at the same time (slow operation).
4. Load too heavy (will not pick up load).
5. Air in cylinder or hoist motor (abnormal operation).

**Report all problems to field level maintenance.**

1. Check that load is not over load limit. If load is found to be over-limit, reduce weight to below load limit.

**RANGE DIAGRAM M977**  
**ALL DIMENSIONS ARE IN FEET UNLESS OTHERWISE SPECIFIED**

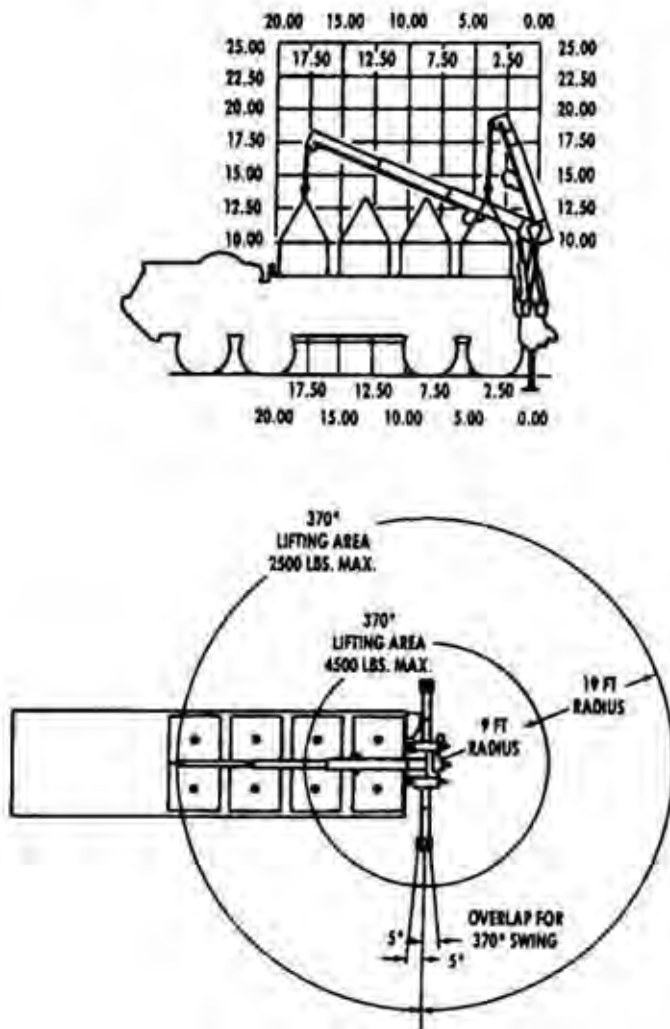


Figure 1.

**CONDITION/INDICATION**

Is load within allowable limits?

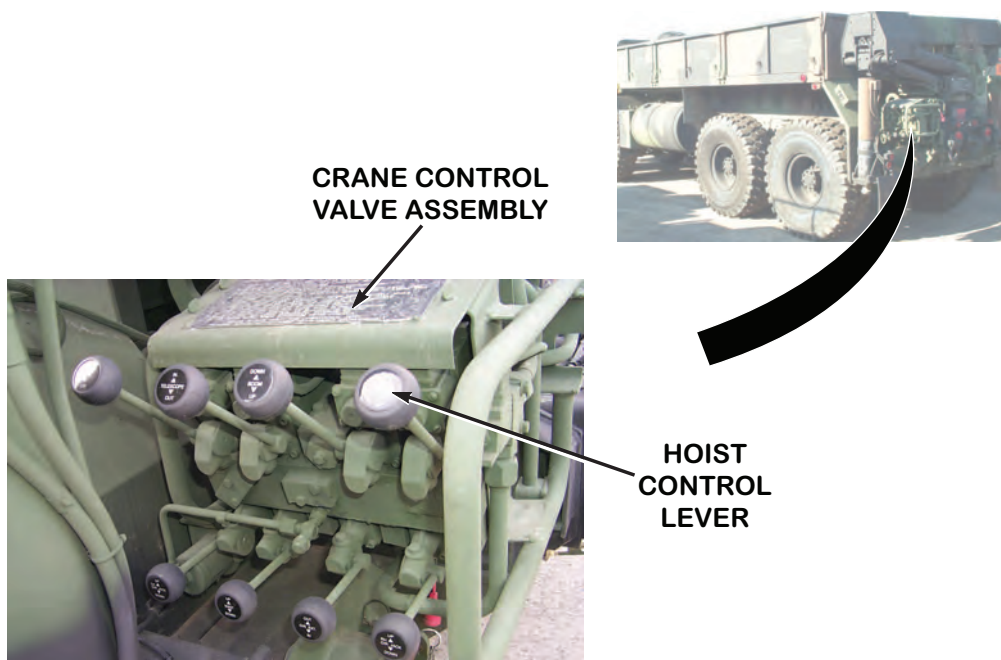
**DECISION**

No - Test 2 - Does hoist lift load?

Yes - Notify Supervisor.

**TEST 2 - Does hoist lift load?**

1. Operate hoist up and down. (WP 0042)



*Figure 2.*

**CONDITION/INDICATION**

Does hoist lift load?

**DECISION**

No - Notify supervisor.  
Yes - Problem corrected.

**END OF WORK PACKAGE**



---

**OPERATOR MAINTENANCE  
MAST RAISES OR LOWERS ABNORMALLY**

---

**INITIAL SETUP:**

**Equipment Condition**

Vehicle setup for crane operations.  
(WP 0042)

---

**TROUBLESHOOTING PROCEDURE  
MAST RAISES OR LOWERS ABNORMALLY**

**TEST 1 - Does mast raise and lower normally after cycling mast up and down to remove trapped air?**

**NOTE**

**Common problems that crane operators may see are:**

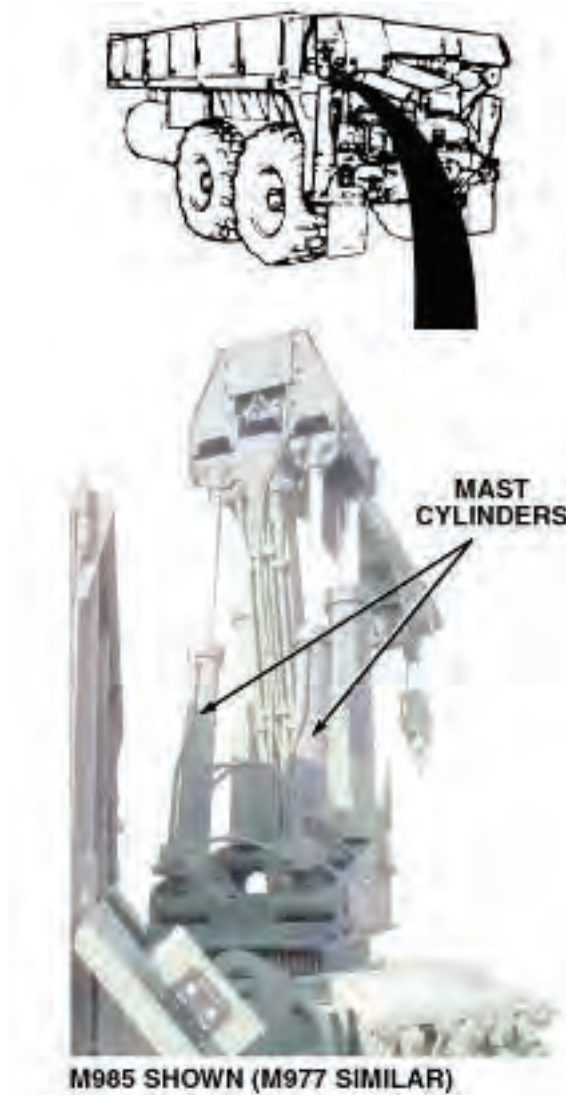
1. Slow or abnormal operation.
2. Crane will not pick up load.

**Common causes of problems are:**

1. Cold hydraulic oil (slow operation).
2. Low engine speed (slow or abnormal operation).
3. Operating two craning functions at the same time (slow operation).
4. Load too heavy (will not pick up load).
5. Air in cylinder or hoist motor (abnormal operation).

**Report all problems to field level maintenance.**

1. Fully raise and lower mast (WP 0042) several times to remove air from cylinders.



*Figure 1.*

**CONDITION/INDICATION**

Does mast raise and lower normally after cycling mast up and down to remove trapped air?

**DECISION**

- Notify supervisor. Test 2 - Does mast operate normally after leaving mast in fully raised position overnight?

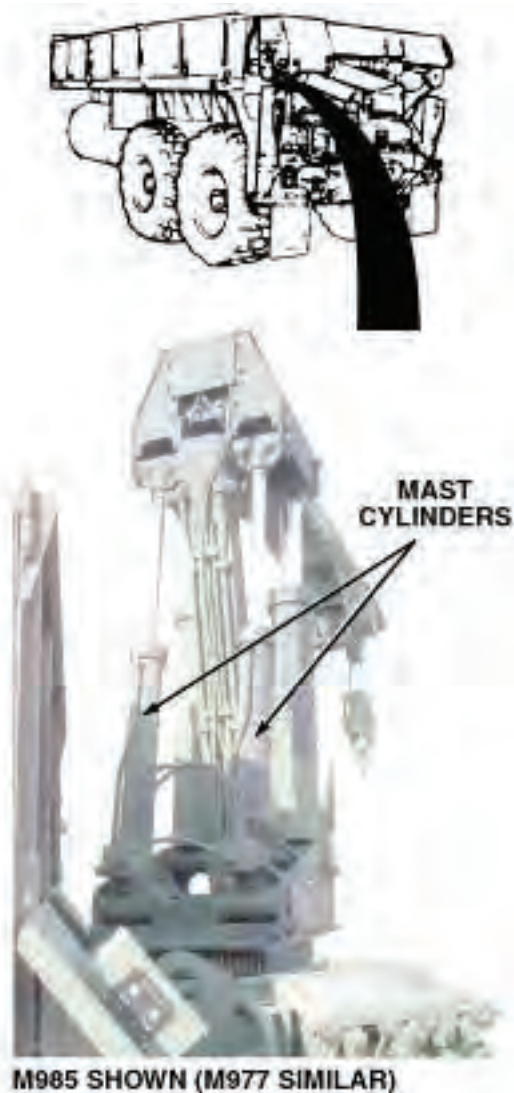
Yes - Problem corrected.

- Notify supervisor. Test 2 - Does mast operate normally after leaving mast in fully raised position overnight?

No - Problem corrected.

**TEST 2 - Does mast operate normally after leaving mast in fully raised position overnight?**

1. Raise boom to vertical position. (WP 0042)



*Figure 2.*

2. Fully raise mast. (WP 0042)
3. Shut down operation (WP 0042) and leave mast in raised position overnight.
4. Start engine. (WP 0044)
5. Prepare vehicle for crane operations. (WP 0042)

### **NOTE**

When starting operations, operate mast control down (not up) first. Operating controls UP could force air back into cylinders.



6. Lower and raise mast. (WP 0042)

**CONDITION/INDICATION**

Does mast operate normally after leaving mast in fully raised position overnight?

**DECISION**

No - Notify supervisor.

Yes - Problem corrected.

**END OF WORK PACKAGE**



---

## OPERATOR MAINTENANCE MAST RAISES OR LOWERS SLOWLY

---

### INITIAL SETUP:

#### Equipment Condition

Vehicle setup for crane operations.  
(WP 0042)

---

### TROUBLESHOOTING PROCEDURE MAST RAISES OR LOWERS SLOWLY

**TEST 1 - Does mast raise and lower normally after running engine for 20 minutes with PTO engaged?**

### NOTE

**Common problems that crane operators may see are:**

1. Slow or abnormal operation.
2. Crane will not pick up load.

**Common causes of problems are:**

1. Cold hydraulic oil (slow operation).
2. Low engine speed (slow or abnormal operation).
3. Operating two craning functions at the same time (slow operation).
4. Load too heavy (will not pick up load).
5. Air in cylinder or hoist motor (abnormal operation).

**Report all problems to field level maintenance.**

If outside temperature is 0°F (-17°C), hydraulic fluid may not flow easily.

1. If loaded, set load down (WP 0042) and disconnect load hook.
2. Operate engine (WP 0044) for 20 minutes with PTO ENGAGE switch set to ON to bring hydraulic fluid up to operating temperature.

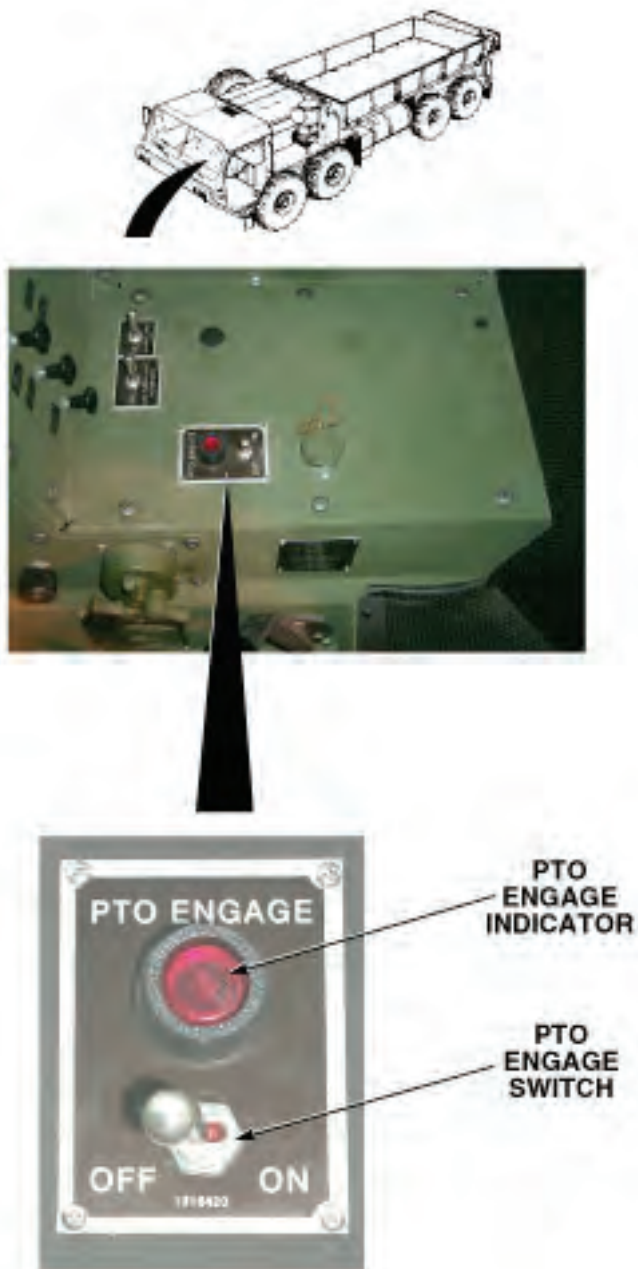


Figure 1.

3. Raise and lower mast. (WP 0042)

**CONDITION/INDICATION**

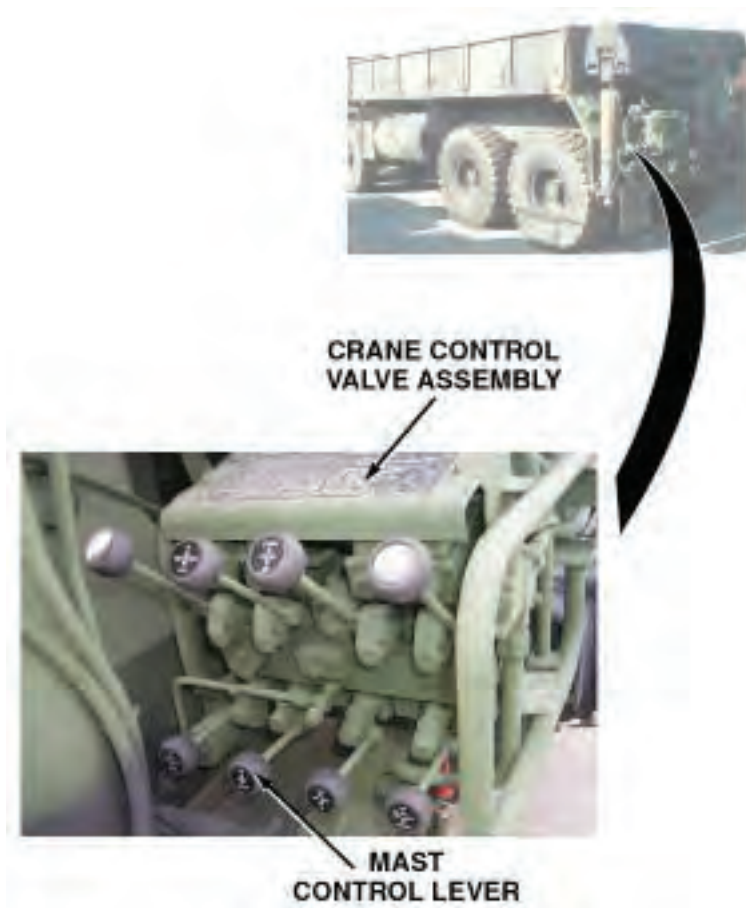
Does mast raise and lower normally after running engine for 20 minutes with PTO engaged?

**DECISION**

No - Test 2 - Does mast raise and lower normally after cycling mast?  
Yes - Problem corrected.

**TEST 2 - Does mast raise and lower normally after cycling mast?**

1. Lower crane to stowed position. (WP 0042)
2. Operate MAST control DOWN. (WP 0042) Hold MAST control DOWN for approximately 30 seconds, then return control to NEUTRAL position. Repeat procedure several times until hydraulic fluid is warmed.



*Figure 2.*

3. Raise and lower mast. (WP 0042)

**CONDITION/INDICATION**

Does mast raise and lower normally after cycling mast?

**DECISION**

No - Notify supervisor.

Yes - Problem corrected.

**END OF WORK PACKAGE**

---

## OPERATOR MAINTENANCE OUTRIGGER OPERATION SLOW OR ABNORMAL

---

### INITIAL SETUP:

#### Equipment Condition

Vehicle setup for crane operations.  
(WP 0042)

---

### TROUBLESHOOTING PROCEDURE OUTRIGGER OPERATION SLOW OR ABNORMAL

#### TEST 1 - Is hydraulic fluid at normal operating temperature?

#### WARNING



Reservoir may be very hot. Use care when placing hand near reservoir. Reservoir can become hot enough to cause serious burns. Be careful not to touch the reservoir with bare hands or allow body to contact reservoir. Use gloves and insulated pads as necessary. Failure to comply may result in injury or death to personnel.

#### NOTE

##### Common problems that crane operators may see are:

1. Slow or abnormal operation.
2. Crane will not pick up load.

##### Common causes of problems are:

1. Cold hydraulic oil (slow operation).
2. Low engine speed (slow or abnormal operation).
3. Operating two craning functions at the same time (slow operation).
4. Load too heavy (will not pick up load).
5. Air in cylinder or hoist motor (abnormal operation).

##### Report all problems to field level maintenance.

If outside temperature is 0°F (-17°C) or lower, hydraulic fluid may not flow easily.

1. Check hydraulic fluid temperature at reservoir.



HYDRAULIC  
RESERVOIR

*Figure 1.*

#### **CONDITION/INDICATION**

Is hydraulic fluid at normal operating temperature?

#### **DECISION**

No - Test 2 - Is hydraulic fluid at normal operating temperature after running engine for 20 minutes with PTO engaged?

Yes - Test 4 - Do outriggers operate normally?

**TEST 2 - Is hydraulic fluid at normal operating temperature after running engine for 20 minutes with PTO engaged?**

#### **WARNING**



Reservoir may be very hot. Use care when placing hand near reservoir. Reservoir can become hot enough to cause serious burns. Be careful not to touch the reservoir with bare hands or allow body to contact reservoir. Use gloves and insulated pads as necessary. Failure to comply may result in injury or death to personnel.

1. Start engine. (WP 0044)
2. Set PTO ENGAGE switch to ON. (WP 0042)



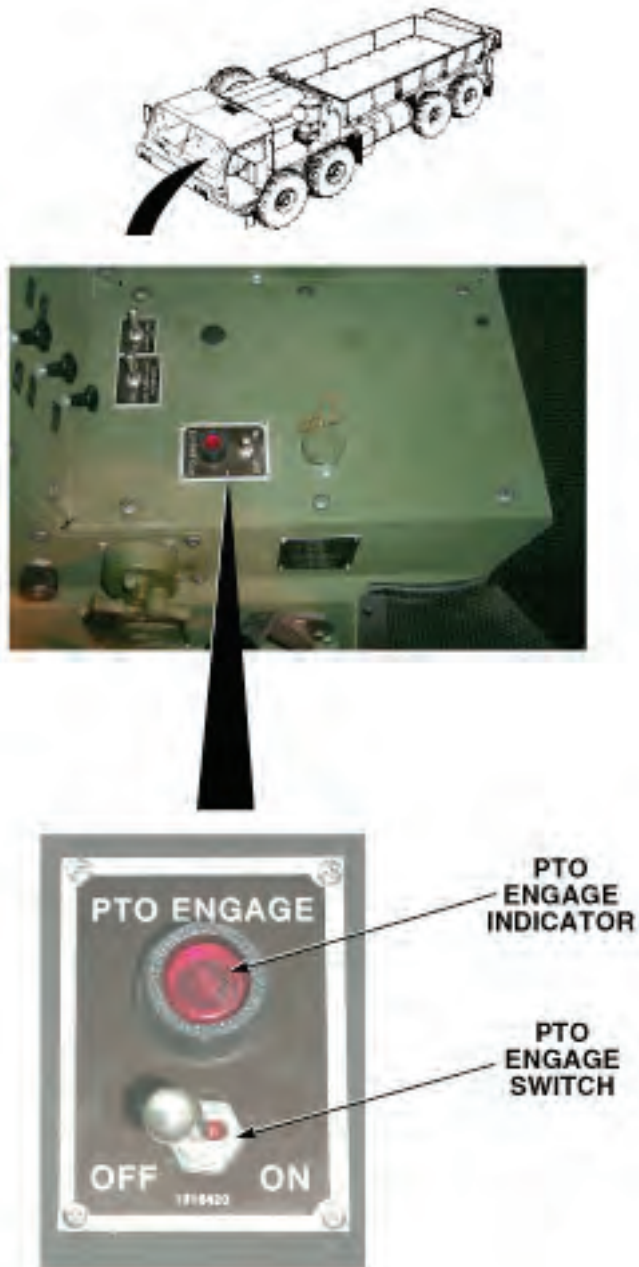


Figure 2.

3. Operate engine (WP 0044) for 20 minutes with PTO enabled to bring hydraulic fluid up to operating temperature.
4. Check hydraulic fluid temperature at reservoir. Reservoir should be warm.

**CONDITION/INDICATION**

Is hydraulic fluid at normal operating temperature after running engine for 20 minutes with PTO engaged?

**DECISION**

No - Test 3 - Is hydraulic fluid at normal operating temperature normal operating temperature after cycling mast control down?

Yes - Test 4 - Do outriggers operate normally?

**TEST 3 - Is hydraulic fluid at normal operating temperature normal operating temperature after cycling mast control down?**

1. Ensure crane is lowered to stowed position. (WP 0042)
2. Operate MAST control DOWN. (WP 0042) Hold MAST control DOWN for approximately 30 seconds, then return control to NEUTRAL position. Repeat procedure several times until hydraulic fluid is warmed.



*Figure 3.*

3. Check hydraulic fluid temperature at reservoir. Reservoir should be warm.

#### **CONDITION/INDICATION**

Is hydraulic fluid at normal operating temperature normal operating temperature after cycling mast control down?

#### **DECISION**

No - Notify Supervisor.

Yes - Test 4 - Do outriggers operate normally?

#### **TEST 4 - Do outriggers operate normally?**

1. Ensure crane is lowered to stowed position. (WP 0042)
2. Operate outrigger. (WP 0042)

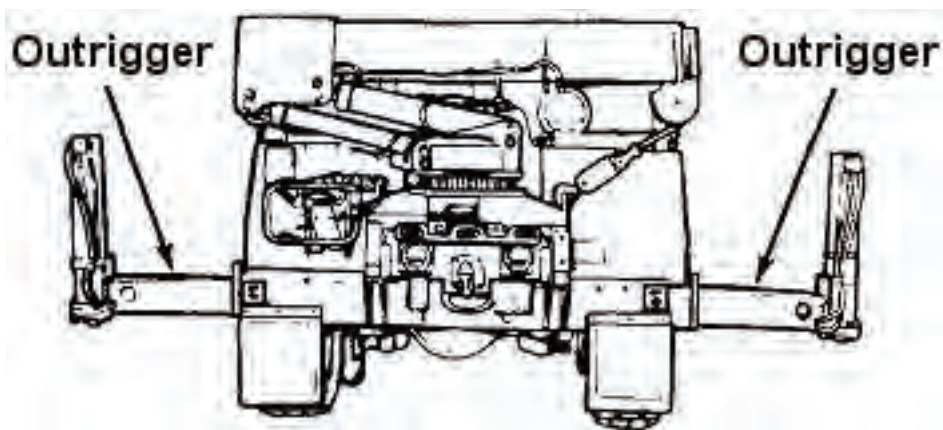


Figure 4.

#### CONDITION/INDICATION

Do outriggers operate normally?

#### DECISION

No - Test 5 - Do outriggers operate normally after purging cylinders of air?

Yes - Problem corrected.

#### TEST 5 - Do outriggers operate normally after purging cylinders of air?

1. Fully let out and draw back outriggers (WP 0042) several times to remove air from cylinders.

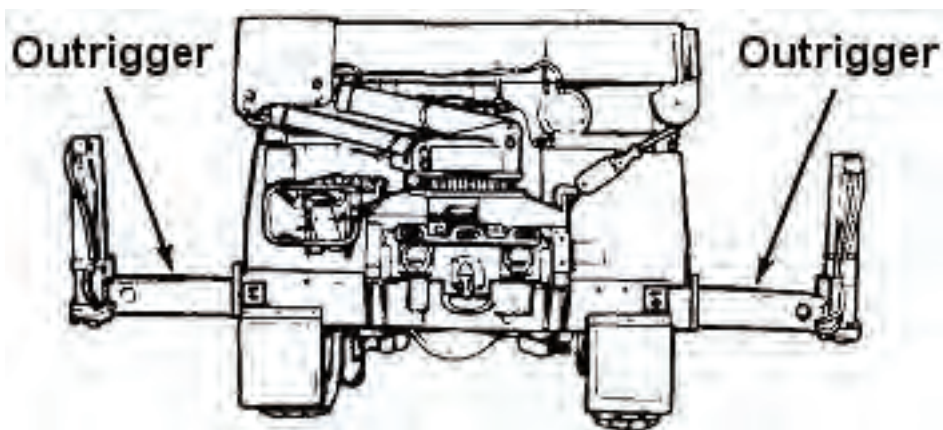


Figure 5.

2. Operate outriggers (WP 0042)

**CONDITION/INDICATION**

Do outriggers operate normally after purging cylinders of air?

**DECISION**

No - Notify Supervisor.

Yes - Problem corrected.

**END OF WORK PACKAGE**



---

**OPERATOR MAINTENANCE  
SWING OPERATION ABNORMAL IN BOTH DIRECTIONS**

---

**INITIAL SETUP:**

**Equipment Condition**

Vehicle setup for crane operations.  
(WP 0042)

---

**TROUBLESHOOTING PROCEDURE  
SWING OPERATION ABNORMAL IN BOTH DIRECTIONS**

**TEST 1 - Are control levers returned to neutral properly?**

**NOTE**

**Common problems that crane operators may see are:**

1. Slow or abnormal operation.
2. Crane will not pick up load.

**Common causes of problems are:**

1. Cold hydraulic oil (slow operation).
2. Low engine speed (slow or abnormal operation).
3. Operating two craning functions at the same time (slow operation).
4. Load too heavy (will not pick up load).
5. Air in cylinder or hoist motor (abnormal operation).

**Report all problems to field level maintenance.**

1. Verify that abnormal operation is not due to sharp movement of controls to NEUTRAL position.



*Figure 1.*

2. Feather control lever to NEUTRAL (WP 0042) to maintain smooth stopping action.

#### **CONDITION/INDICATION**

Are control levers returned to neutral properly?

#### **DECISION**

No - Test 2 - Is vehicle level?

Yes - Problem corrected.

#### **TEST 2 - Is vehicle level?**

1. Check if vehicle is level.





*Figure 2.*

**CONDITION/INDICATION**

Is vehicle level?

**DECISION**

- Level vehicle. Level vehicle. (WP 0042)

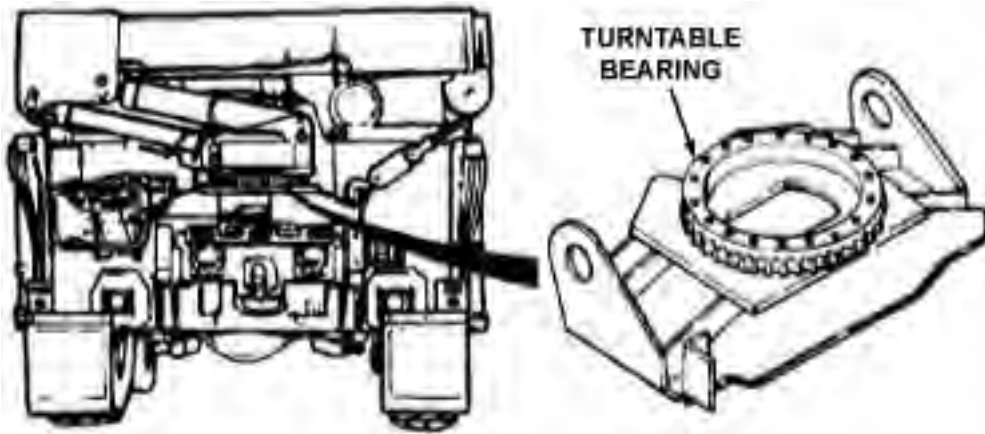
Yes - Test 3 - Is turntable bearing properly lubricated?

- Level vehicle. Level vehicle. (WP 0042)

No - Test 3 - Is turntable bearing properly lubricated?

**TEST 3 - Is turntable bearing properly lubricated?**

1. Check turntable bearing for proper lubrication.



*Figure 3.*

2. If improperly lubricated, rotate turntable 360 degrees (WP 0042) in both directions several times, and lubricate turntable bearing. (WP 0149)

#### **CONDITION/INDICATION**

Is turntable bearing properly lubricated?

#### **DECISION**

- Test 5 - Does swing operate normally?
- Yes - Test 4 - Is load within allowable limit?
- Test 5 - Does swing operate normally?
- No - Test 4 - Is load within allowable limit?

#### **TEST 4 - Is load within allowable limit?**

1. Verify that load is below weight limit.

**RANGE DIAGRAM M977**  
**ALL DIMENSIONS ARE IN FEET UNLESS OTHERWISE SPECIFIED**

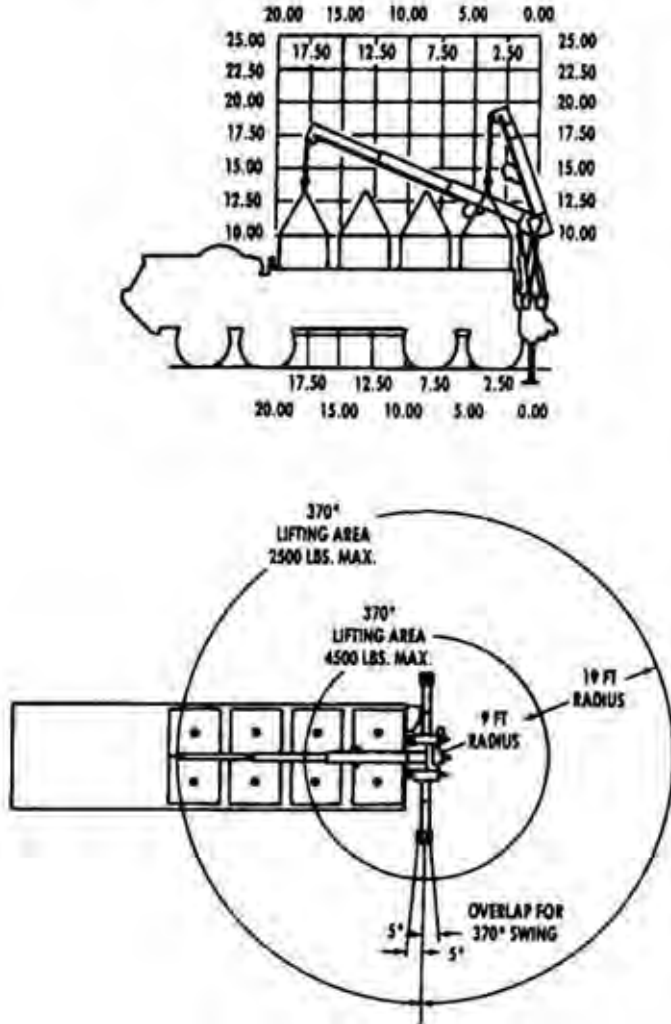


Figure 4.

2. If above weight limit, remove weight to decrease it to below the limit.

**CONDITION/INDICATION**

Is load within allowable limit?

**DECISION**

- No - Test 5 - Does swing operate normally?
- Yes - Notify Supervisor.

**TEST 5 - Does swing operate normally?**

1. Operate crane (WP 0042) to verify proper operation of swing.



*Figure 5.*

**CONDITION/INDICATION**

Does swing operate normally?

**DECISION**

- No - Notify Supervisor.
- Yes - Problem corrected.

**END OF WORK PACKAGE**

---

**OPERATOR MAINTENANCE  
SWING OPERATION ABNORMAL IN ONLY ONE DIRECTION**

---

**INITIAL SETUP:**

**Equipment Condition**

Vehicle setup for crane operations.  
(WP 0042)

---

**TROUBLESHOOTING PROCEDURE  
SWING OPERATION ABNORMAL IN ONLY ONE DIRECTION**

**TEST 1 - Is vehicle level?**

**NOTE**

**Common problems that crane operators may see are:**

1. Slow or abnormal operation.
2. Crane will not pick up load.

**Common causes of problems are:**

1. Cold hydraulic oil (slow operation).
2. Low engine speed (slow or abnormal operation).
3. Operating two craning functions at the same time (slow operation).
4. Load too heavy (will not pick up load).
5. Air in cylinder or hoist motor (abnormal operation).

**Report all problems to field level maintenance.**

1. Check if vehicle is level.



*Figure 1.*

**CONDITION/INDICATION**

Is vehicle level?

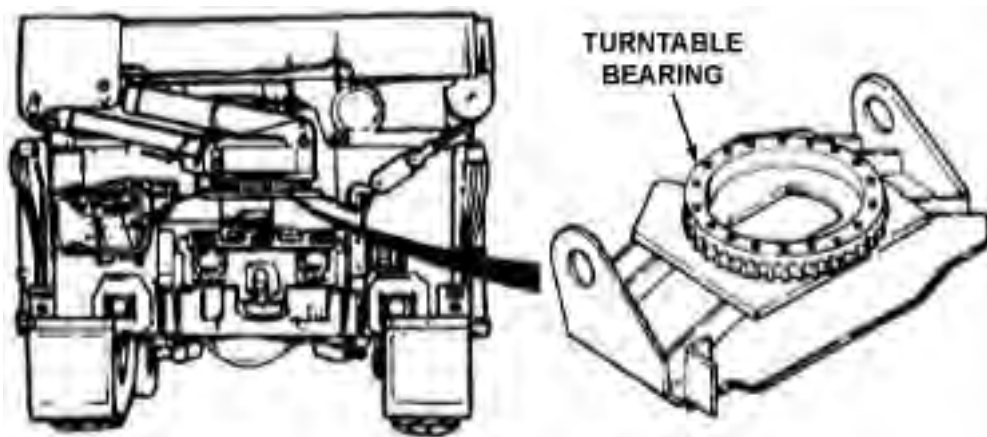
**DECISION**

Vehicle not level. - Level vehicle. (WP 0042)

Vehicle level. - Test 2 - Is turntable bearing properly lubricated?

**TEST 2 - Is turntable bearing properly lubricated?**

1. Check turntable bearing for proper lubrication.



*Figure 2.*

2. If improperly lubricated, rotate turntable 360 degrees (WP 0042) in both directions several times, and lubricate turntable bearing. (WP 0149)

#### **CONDITION/INDICATION**

Is turntable bearing properly lubricated?

#### **DECISION**

- Test 3 - Does swing operate normally?
- Yes - Test 3 - Does swing operate normally?
- Test 3 - Does swing operate normally?
- No - Test 3 - Does swing operate normally?

#### **TEST 3 - Does swing operate normally?**

1. Operate crane (WP 0042) to verify proper operation of swing.



*Figure 3.*

**CONDITION/INDICATION**

Does swing operate normally?

**DECISION**

No - Notify supervisor.

Yes - Problem corrected.

**END OF WORK PACKAGE**



---

**OPERATOR MAINTENANCE  
SELF-RECOVERY WINCH DOES NOT WORK**

---

**INITIAL SETUP:**

**Equipment Condition**

Engine OFF. (WP 0057)

**Equipment Condition - Continued**

Parking brakes applied. (WP 0056)

Wheels chocked. (WP 0077)

---

**TROUBLESHOOTING PROCEDURE**

**SELF-RECOVERY WINCH DOES NOT WORK**

**TEST 1 - Is hydraulic fluid level within normal operating range?**

1. Check hydraulic fluid level. If low, add hydraulic fluid. (WP 0147)

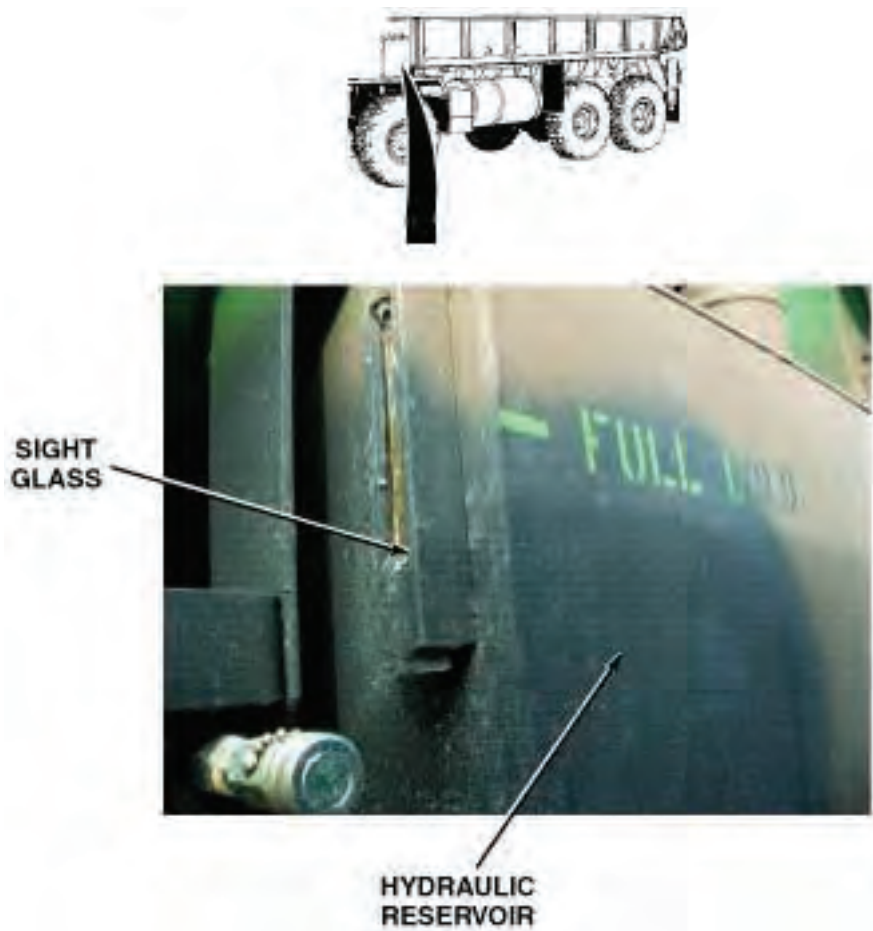


Figure 1.

#### CONDITION/INDICATION

Is hydraulic fluid level within normal operating range?

#### DECISION

No - Test 3 - Does self-recovery winch operate properly?

Yes - Test 2 - Is self-recovery winch shift linkage free from debris and damage?

#### TEST 2 - Is self-recovery winch shift linkage free from debris and damage?

1. Check self-recovery winch shift linkage for debris and damage. If debris found, clean shift linkage. (WP 0154)



Figure 2.

### CONDITION/INDICATION

Is self-recovery winch shift linkage free from debris and damage?

### DECISION

Linkage damaged. - Notify Supervisor. Test 3 - Does self-recovery winch operate properly? Notify Supervisor.

Linkage OK. - Notify Supervisor.

### TEST 3 - Does self-recovery winch operate properly?

1. Start engine. (WP 0044)
2. Check operation of self-recovery winch. (WP 0086)

### CONDITION/INDICATION

Does self-recovery winch operate properly?

### DECISION

No - Notify supervisor.

Yes - Problem corrected.

### END OF WORK PACKAGE



---

## OPERATOR MAINTENANCE UNUSUALLY NOISY WHEN OPERATING

---

### INITIAL SETUP:

#### Equipment Condition

Engine OFF. (WP 0057)

#### Equipment Condition - Continued

Parking brakes applied. (WP 0056)

Wheels chocked. (WP 0077)

---

### TROUBLESHOOTING PROCEDURE UNUSUALLY NOISY WHEN OPERATING

#### TEST 1 - Is self-recovery winch cable free of twists, tangles, or binding?

1. Check if self-recovery winch cable is twisted, tangled, or causing drum to bind. If cable is tangled, pay out or take up cable as necessary to straighten.

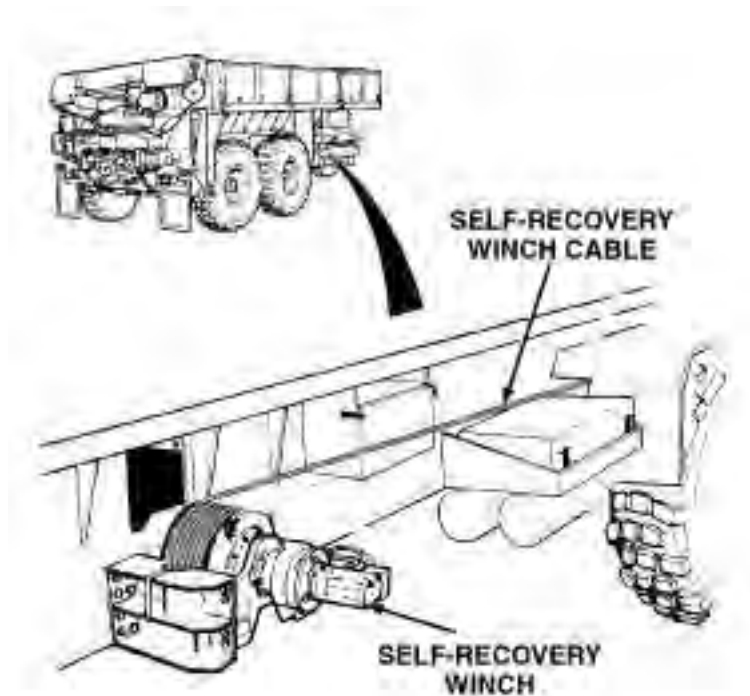


Figure 1.

**CONDITION/INDICATION**

Is self-recovery winch cable free of twists, tangles, or binding?

**DECISION**

No - Notify supervisor.

Yes - Test 2 - Is self-recovery winch free of unusual noise when operating?

**TEST 2 - Is self-recovery winch free of unusual noise when operating?**

1. Start engine. (WP 0044)



*Figure 2.*

2. Operate self-recovery winch, and listen for unusual noise. (WP 0086)

**CONDITION/INDICATION**

Is self-recovery winch free of unusual noise when operating?

**DECISION**

No - Notify supervisor.

Yes - Problem corrected.

**END OF WORK PACKAGE**

---

**OPERATOR MAINTENANCE**  
**VEHICLE IS HARD TO STEER, SHIMMIES, WANDERS, OR PULLS TO ONE SIDE**

---

**INITIAL SETUP:****Equipment Condition**

Engine OFF. (WP 0057)

**Equipment Condition - Continued**

Parking brakes applied. (WP 0056)

Wheels chocked. (WP 0077)

---

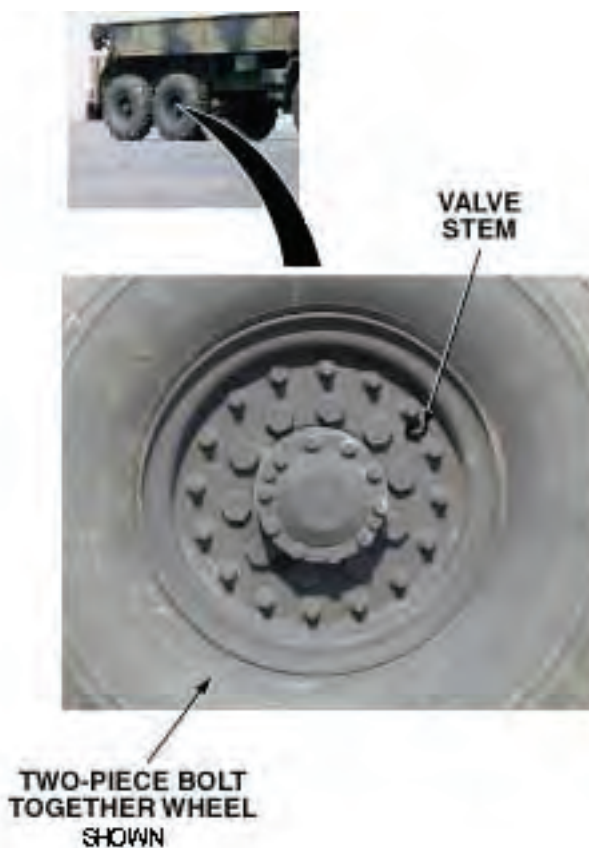
**TROUBLESHOOTING PROCEDURE****VEHICLE IS HARD TO STEER, SHIMMIES, WANDERS, OR PULLS TO ONE SIDE****TEST 1 - Are tires inflated to proper pressure for road condition?****WARNING**

Tire air pressure must be checked properly. Failure to comply may result in injury or death to personnel.

**NOTE**

- Inflate tires only when they are cool. Inflate to proper pressure for road condition.
- Tire tread is non-directional. Vehicle operation is not affected by direction of traction bars.

1. Check tires for proper inflation. (WP 0145)



*Figure 1.*

2. If tires are improperly inflated, inflate or deflate tires to proper pressure.

#### **CONDITION/INDICATION**

Are tires inflated to proper pressure for road condition?

#### **DECISION**

Improperly inflated - Test 3 - Is vehicle hard to steer; or does it shimmy, wander, or pull to one side?

Inflation OK - Test 2 - Are wheels free of loose, missing, or broken lugnuts?

#### **TEST 2 - Are wheels free of loose, missing, or broken lugnuts?**

1. Check for loose, missing, or broken lugnuts.





*Figure 2.*

**CONDITION/INDICATION**

Are wheels free of loose, missing, or broken lugnuts?

**DECISION**

No - Tighten and/or replace loose, missing, or damaged lugnut(s). (WP 0155)

Yes - Notify Supervisor.

**TEST 3 - Is vehicle hard to steer; or does it shimmy, wander, or pull to one side?**

1. Start engine. (WP 0044)
2. Test drive vehicle.

**CONDITION/INDICATION**

Is vehicle hard to steer; or does it shimmy, wander, or pull to one side?

**DECISION**

No - Notify Supervisor.

Yes - Problem corrected.

**END OF WORK PACKAGE**

**OPERATOR MAINTENANCE  
VEHICLE STEERING SLOW TO RESPOND OR INTERMITTENT**

---

**INITIAL SETUP:****Equipment Condition**

Engine OFF. (WP 0057)

**Equipment Condition - Continued**

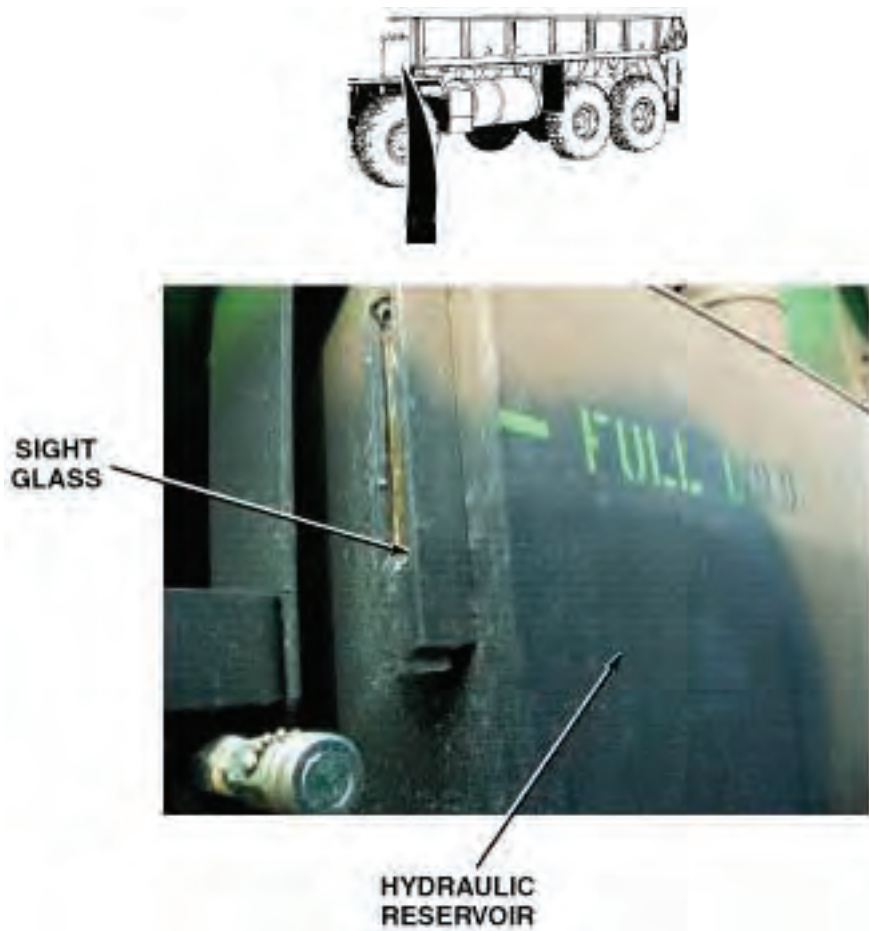
Parking brakes applied. (WP 0056)

Wheels chocked. (WP 0077)

---

**TROUBLESHOOTING PROCEDURE****VEHICLE STEERING SLOW TO RESPOND OR INTERMITTENT****TEST 1 - Is hydraulic fluid low?**

1. Check for low hydraulic fluid. (WP 0147)
2. If fluid level is low, add hydraulic fluid. (WP 0147)



*Figure 1.*

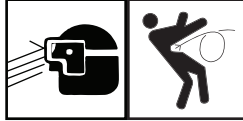
**CONDITION/INDICATION**

Is hydraulic fluid low?

**DECISION**

Fluid level low - Test 3 - Is steering slow to respond or intermittent?

Fluid level OK - Test 2 - Are there any leaking or damaged hydraulic fittings or lines?

**TEST 2 - Are there any leaking or damaged hydraulic fittings or lines?****WARNING**

Vehicles air system is pressurized, be sure to wear proper eye protection and keep face away from drain valves while draining air reservoirs. Open air drain valves slowly to prevent sudden blast of air. Failure to comply may result in injury to personnel.

1. Check for leaking or damaged hydraulic lines and/or fittings.

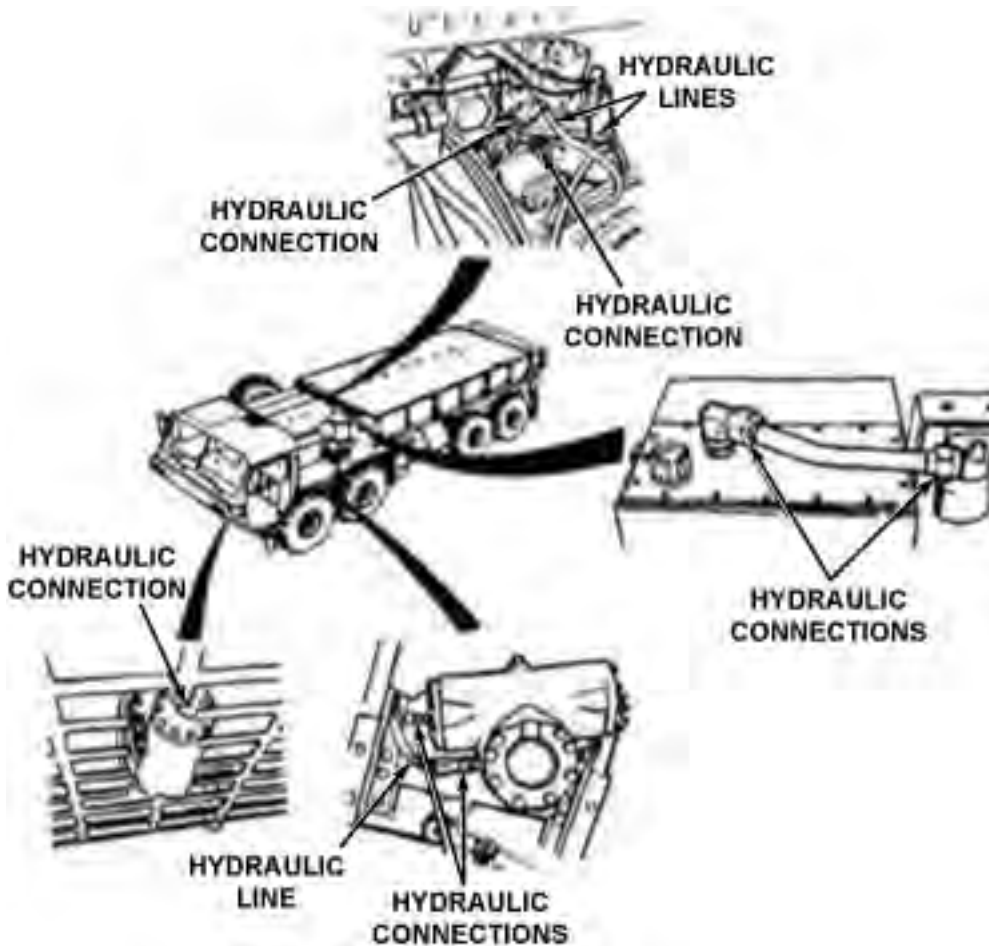


Figure 2.

2. If loose hydraulic fluid fittings are found, tighten fittings.

**CONDITION/INDICATION**

Are there any leaking or damaged hydraulic fittings or lines?

**DECISION**

Hydraulic lines damaged or leaking. - Ensure fittings are tightened and notify supervisor of faulty hydraulic lines. Tighten loose fittings. (Test 3 - Is steering slow to respond or intermittent?) Notify Supervisor.

No leaks, damaged lines or loose fittings found. - Notify Supervisor.

**TEST 3 - Is steering slow to respond or intermittent?**

1. Start engine. (WP 0044)

2. Test drive vehicle.

**CONDITION/INDICATION**

Is steering slow to respond or intermittent?

**DECISION**

Steering faulty - Notify Supervisor.

Steering OK - Problem corrected.

**END OF WORK PACKAGE**





---

## OPERATOR MAINTENANCE UNUSUALLY NOISY WHEN OPERATING

---

### INITIAL SETUP:

#### Equipment Condition

Engine OFF. (WP 0057)

#### Equipment Condition - Continued

Parking brakes applied. (WP 0056)

Wheels chocked. (WP 0077)

---

### TROUBLESHOOTING PROCEDURE UNUSUALLY NOISY WHEN OPERATING

#### TEST 1 - Is transmission/transfer case free from unusual noise while operating?

1. Start engine. (WP 0044)
2. Test drive vehicle.



*Figure 1.*

#### CONDITION/INDICATION

Is transmission/transfer case free from unusual noise while operating?

**DECISION**

No - Notify supervisor.

Yes - Problem corrected.

**END OF WORK PACKAGE**

---

**OPERATOR MAINTENANCE  
SLOW OR DIFFICULT ENGAGEMENT**

---

**INITIAL SETUP:****Equipment Condition**

Engine OFF. (WP 0057)

**Equipment Condition - Continued**

Parking brakes applied. (WP 0056)

Wheels chocked. (WP 0077)

---

**TROUBLESHOOTING PROCEDURE  
SLOW OR DIFFICULT ENGAGEMENT****TEST 1 - Does transmission and/or transfer case engage normally?**

1. Start engine. (WP 0044)
2. Test drive vehicle.



*Figure 1.*

**CONDITION/INDICATION**

Does transmission and/or transfer case engage normally?

**DECISION**

No - Notify Supervisor.

Yes - Problem corrected.

**END OF WORK PACKAGE**

---

**OPERATOR MAINTENANCE  
TRANSFER CASE SHIFT LEVER WILL NOT SHIFT**

---

**INITIAL SETUP:**

**Equipment Condition**

Engine OFF. (WP 0057)

**Equipment Condition - Continued**

Parking brakes applied. (WP 0056)

Wheels chocked. (WP 0077)

---

**TROUBLESHOOTING PROCEDURE**

**TRANSFER CASE SHIFT LEVER WILL NOT SHIFT**

**TEST 1 - Does transfer case shift lever shift when transmission is shifted from Neutral (N) to Drive (D)?**

1. Start engine (WP 0044)
2. Move transmission range selector from Neutral (N) to Drive (D). Apply throttle to roll vehicle slightly, and shift transmission from (D) to (N). As vehicle stops, shift TRANSFER CASE shift lever.

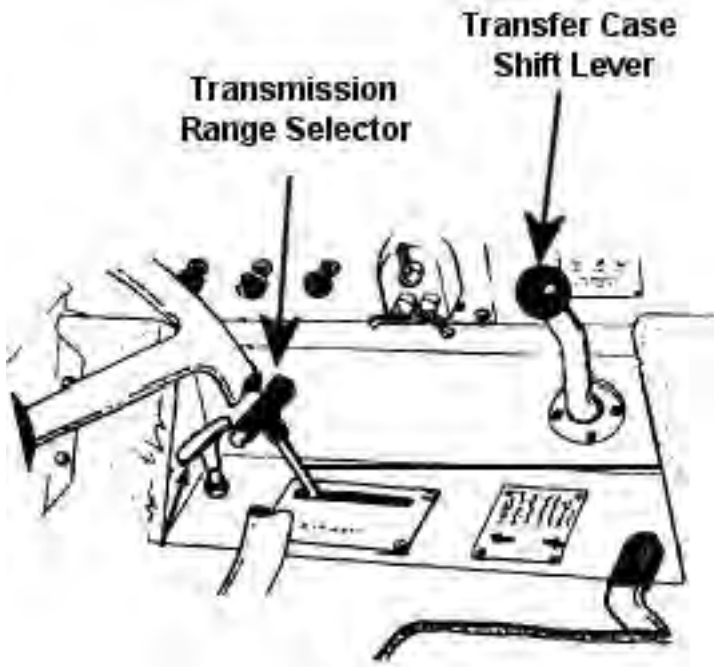


Figure 1.

### CONDITION/INDICATION

Does transfer case shift lever shift when transmission is shifted from Neutral (N) to Drive (D)?

### DECISION

No - Test 2 - Does transfer case shift lever shift when transmission is shifted from Neutral (N) to Reverse (R)?

Yes - Problem corrected.

### TEST 2 - Does transfer case shift lever shift when transmission is shifted from Neutral (N) to Reverse (R)?

1. Move transmission range selector from Neutral (N) to Reverse (R). Apply throttle to roll vehicle slightly and shift transmission from R to N. As vehicle stops, shift TRANSFER CASE shift lever.

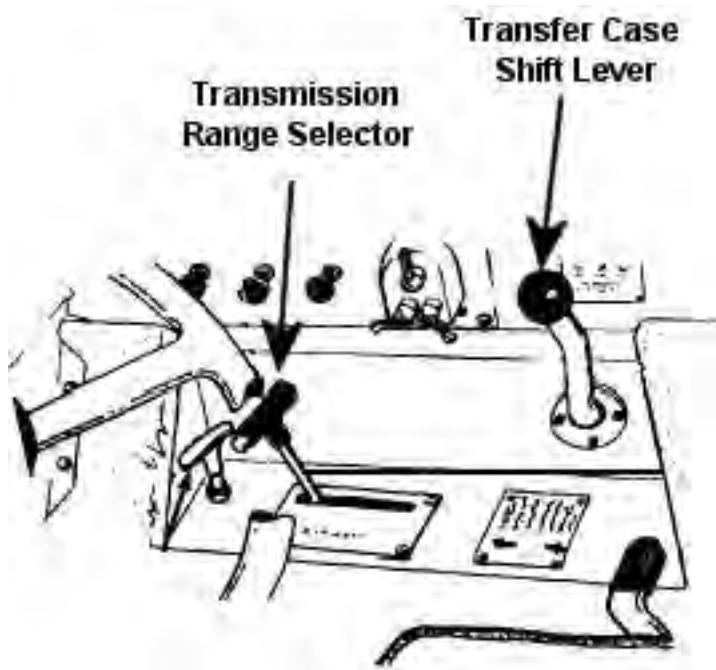


Figure 2.

**CONDITION/INDICATION**

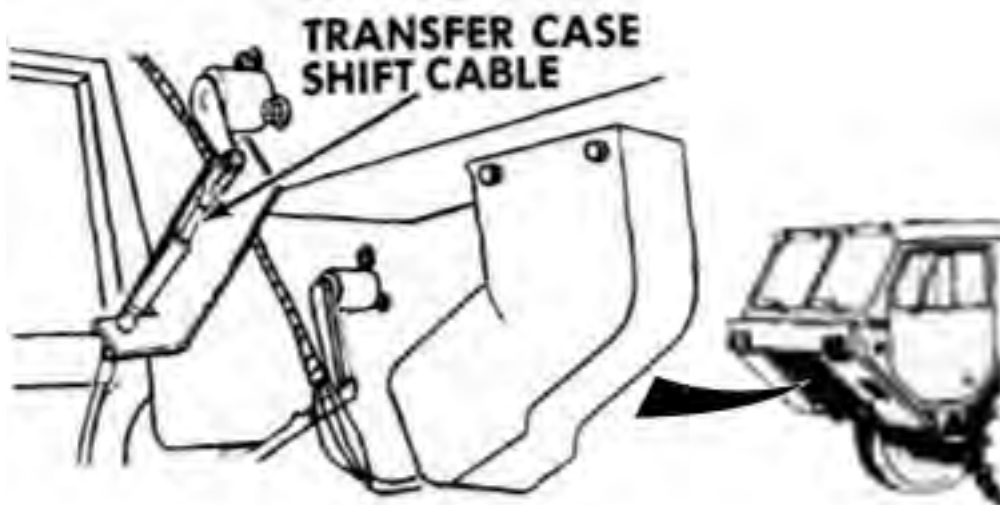
Does transfer case shift lever shift when transmission is shifted from Neutral (N) to Reverse (R)?

**DECISION**

No - Test 3 - Is shift cable free of mud and debris?  
Yes - Problem corrected.

**TEST 3 - Is shift cable free of mud and debris?**

1. Turn engine OFF. (WP 0057)
2. Check shift cable for mud and/or debris.



*Figure 3.*

3. If needed, clean shift cable. (WP 0154)

#### **CONDITION/INDICATION**

Is shift cable free of mud and debris?

#### **DECISION**

Dirty - Test 4 - Does transfer case shift lever shift normally?  
Clean - Notify Supervisor.

#### **TEST 4 - Does transfer case shift lever shift normally?**

1. Start engine. (WP 0044)
  - a. Test drive vehicle.
2. Attempt to shift transfer case. (WP 0048)



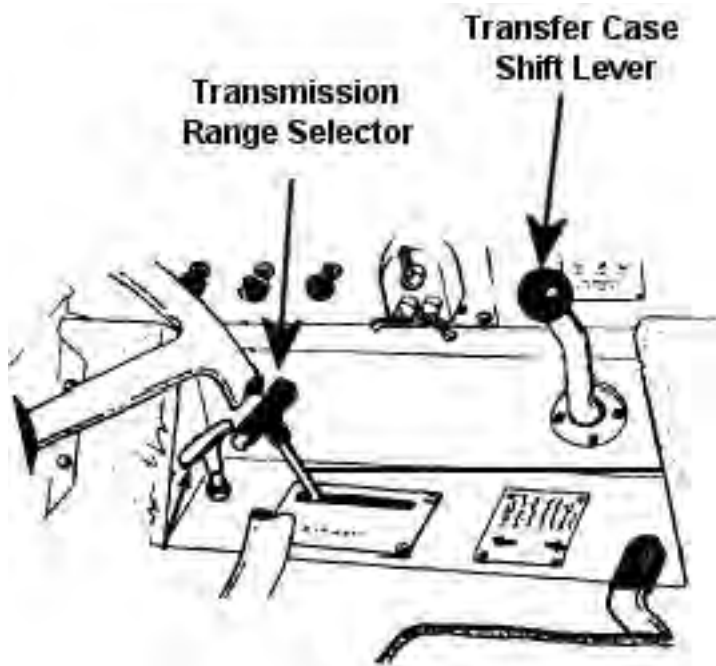


Figure 4.

3. Turn engine OFF. (WP 0057)

**CONDITION/INDICATION**

Does transfer case shift lever shift normally?

**DECISION**

No - Notify Supervisor.  
Yes - Problem corrected.

**END OF WORK PACKAGE**



---

**OPERATOR MAINTENANCE**  
**TRANS TEMP GAUGE INDICATES OVERHEATING DURING NORMAL OPERATION**

---

**INITIAL SETUP:**

**Equipment Condition**

Engine OFF. (WP 0057)

**Equipment Condition - Continued**

Parking brakes applied. (WP 0056)

Wheels chocked. (WP 0077)

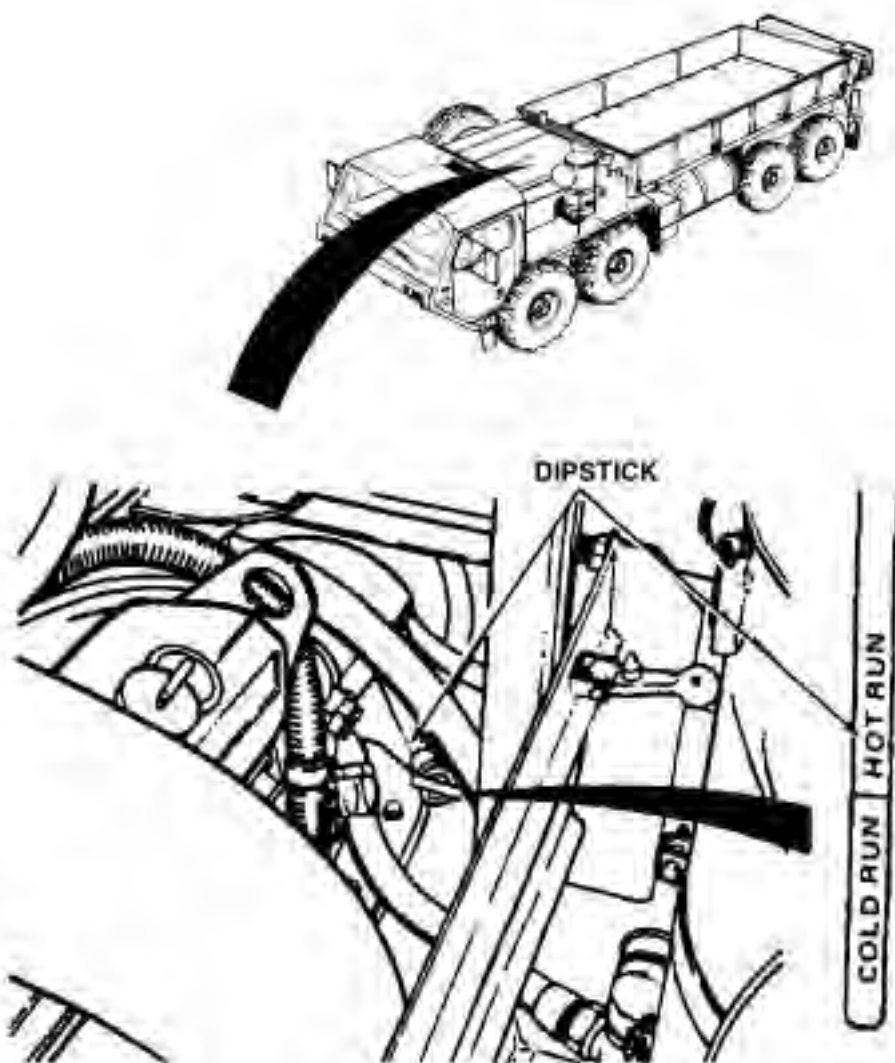
---

**TROUBLESHOOTING PROCEDURE**

**TRANS TEMP GAUGE INDICATES OVERHEATING DURING NORMAL OPERATION**

**TEST 1 - Is transmission fluid at proper operating level?**

1. Check transmission fluid level. (WP 0147)



*Figure 1.*

2. If transmission fluid is low, add transmission fluid. (WP 0147)

**CONDITION/INDICATION**

Is transmission fluid at proper operating level?

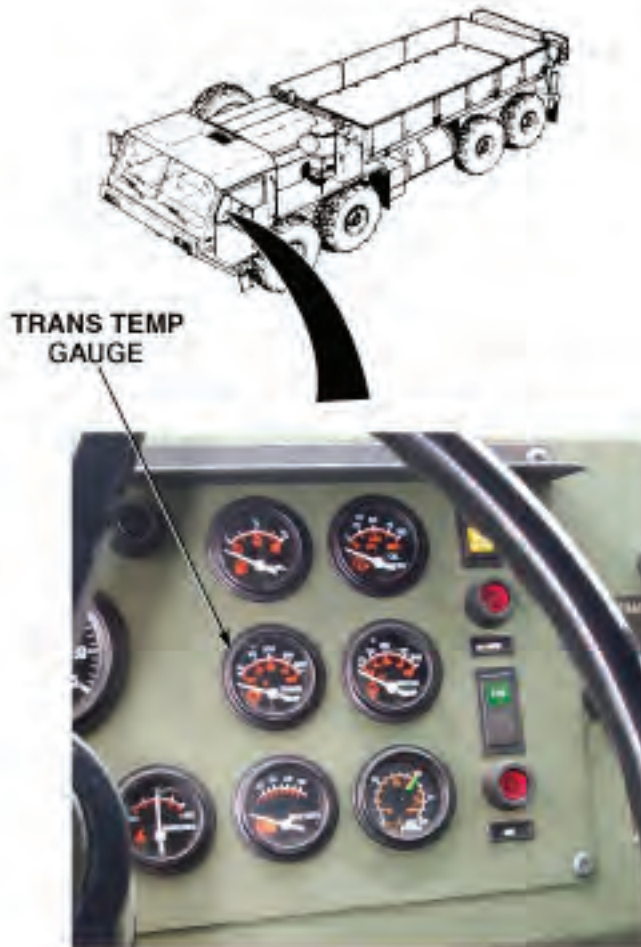
**DECISION**

Transmission fluid was high. - Notify Supervisor. Test 2 - Does TRANS TEMP gauge indicate overheating during normal operation?

Transmission fluid was at proper level. - Notify Supervisor.

**TEST 2 - Does TRANS TEMP gauge indicate overheating during normal operation?**

1. Start engine. (WP 0044)
2. Test drive vehicle.



*Figure 2.*

**CONDITION/INDICATION**

Does TRANS TEMP gauge indicate overheating during normal operation?

**DECISION**

Overheating - Notify Supervisor.

Correct temperature - Problem corrected.

**END OF WORK PACKAGE**

**OPERATOR MAINTENANCE  
WHEEL WOBBLES**

---

**INITIAL SETUP:****Equipment Condition**

Engine OFF. (WP 0057)

**Equipment Condition - Continued**

Parking brakes applied. (WP 0056)

Wheels chocked. (WP 0077)

---

**TROUBLESHOOTING PROCEDURE  
WHEEL WOBBLES****TEST 1 - Are any lugnuts loose, missing or broken?**

1. Check wheels for loose, missing or broken lugnuts.



*Figure 1.*

**CONDITION/INDICATION**

Are any lugnuts loose, missing or broken?

**DECISION**

No - Tighten or replace lugnut(s). (WP 0155)

Yes - Test 2 - Are any of the wheels bent?

**TEST 2 - Are any of the wheels bent?**

1. Check to see if any of the wheels are bent.





*Figure 2.*

**CONDITION/INDICATION**

Are any of the wheels bent?

**DECISION**

Wheel bent - Replace damaged wheel(s). (WP 0155)

Wheels OK - Notify Supervisor.

**TEST 3 - Do any of the wheels wobble?**

1. Start engine. (WP 0044)
2. Test drive vehicle.

**CONDITION/INDICATION**

Do any of the wheels wobble?

**DECISION**

Wheel wobbles - Notify Supervisor.

Wheel OK - Notify Supervisor.

**END OF WORK PACKAGE**

---

**OPERATOR MAINTENANCE  
TIRES WORN UNEVENLY OR EXCESSIVELY**

---

**INITIAL SETUP:****Equipment Condition**

Engine OFF. (WP 0057)

**Equipment Condition - Continued**

Parking brakes applied. (WP 0056)

Wheels chocked. (WP 0077)

---

**TROUBLESHOOTING PROCEDURE  
TIRES WORN UNEVENLY OR EXCESSIVELY**

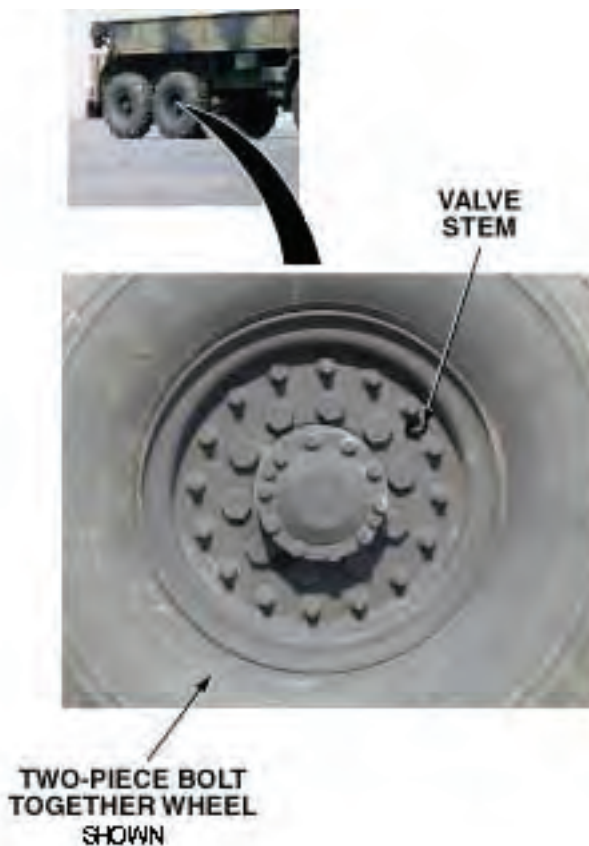
**TEST 1 - Are tires inflated to proper pressure for road condition?****WARNING**

Tire air pressure must be checked properly. Failure to comply may result in injury or death to personnel.

**NOTE**

- Inflate tires only when they are cool. Inflate to proper pressure for road condition.
- Tire tread is non-directional. Vehicle operation is not affected by direction of traction bars.

1. Check tires for proper inflation. (WP 0148)



*Figure 1.*

2. If tires are improperly inflated, inflate or deflate to proper pressure.

**CONDITION/INDICATION**

Are tires inflated to proper pressure for road condition?

**DECISION**

Improperly inflated - Notify Supervisor.

Inflation OK - Notify Supervisor.

**END OF WORK PACKAGE**

CHAPTER 4

PREVENTIVE  
MAINTENANCE  
CHECKS AND  
SERVICES (PMCS)



---

## OPERATOR MAINTENANCE INTRODUCTION - PREVENTIVE MAINTENANCE

---

### PMCS INTRODUCTION

This section contains PMCS requirements for HEMTT series vehicles. The PMCS tables contain checks and services necessary to ensure that the vehicle is ready for operation. Using PMCS tables, perform maintenance at specified intervals.

### MAINTENANCE FORMS AND RECORDS

Every mission begins and ends with paperwork. There is not much of it, but it must be kept up. The filled out forms and records have several uses. They are a permanent record of services, repairs, and modifications made on the vehicle; they are reports to unit maintenance and to your Commander; and they serve as a checklist to find out what is wrong with the vehicle after its last use, and whether those faults have been fixed. For the information needed on forms and records, refer to DA PAM 750-8. (WP 0161)

### PREVENTIVE MAINTENANCE CHECKS AND SERVICES

- Do the before (B) PREVENTIVE MAINTENANCE just before operating vehicle. Pay attention to the CAUTIONS and WARNINGS.
- Do the during (D) PREVENTIVE MAINTENANCE while vehicle and/or its component systems are in operation. Pay attention to the CAUTIONS and WARNINGS.
- Do the after (A) PREVENTIVE MAINTENANCE right after operating vehicle. Pay attention to the CAUTIONS and WARNINGS.
- Do the (W) PREVENTIVE MAINTENANCE weekly. Pay attention to the CAUTIONS and WARNINGS.
- Do the (M) PREVENTIVE MAINTENANCE once a month. Pay attention to the CAUTIONS and WARNINGS.
- Do the (S) PREVENTIVE MAINTENANCE once every six months. Pay attention to the CAUTIONS and WARNINGS.
- If something does not work, troubleshoot and notify the supervisor.
- Always do PREVENTIVE MAINTENANCE in the same order until it gets to be habit. Once practiced, problems can be spotted in a hurry.
- If something looks wrong and cannot be fixed right then, write it on DA Form 2404 (WP 0161) or DA Form 5988-E. (WP 0161) If something seems seriously wrong, report it to field level maintenance RIGHT NOW.
- When doing PREVENTIVE MAINTENANCE, take along the tools needed and a rag or two to make all the checks.

## GENERAL MAINTENANCE PROCEDURE

- **Cleanliness:** Dirt, grease, oil, and debris only get in the way and may cover up a serious problem. Use solvent cleaning compound (WP 0164, Table 1, Item 6, 7, 8, 9, 10, 11) on all metal surfaces and soapy water on rubber.
- **Bolts, Nuts, and Screws:** Check bolts, nuts, and screws for obvious looseness, missing, bent, or broken condition and tighten or replace as necessary. They cannot all be checked with a tool, of course, but look for chipped paint, bare metal, or rust around bolt heads.
- **Welds:** Look for loose or chipped paint, rust, or gaps where parts are welded together. If a bad weld is found, have it repaired.
- **Electric Wires and Connectors:** Look for cracked or broken insulation, bare wires, and loose or broken connectors. Tighten loose connectors and make sure wires are in good shape.
- **Hydraulic Lines and Fittings:** Look for wear, damage, and leaks, and make sure clamps and fittings are tight. Wet spots show leaks, of course, but a stain around a fitting or connector can indicate a leak. If a connector or fitting is loose, tighten it. If something is broken or worn out, repair or replace per applicable procedure.
- **Damage is defined as:** Any conditions that affect safety or would render the vehicle unserviceable for mission requirements.

## FLUID LEAKAGE

It is necessary to know how fluid leakage affects the status of fuel, oil, coolant, and the hydraulic systems. The following are definitions of types/classes of leakage necessary to know in order to determine the status of the vehicle.

### NOTE

Equipment operation is allowable with minor leakage (Class I or II). Consideration must be given to the fluid capacity in the item/system being checked/inspected. When in doubt, notify the supervisor. When operating with Class I or II leaks, continue to check fluid levels as required in the PMCS. Class III leaks should be repaired per applicable procedure.

**Class I :** Seepage of fluid (as indicated by wetness or discoloration) not great enough to form drops.

**Class II:** Leakage of fluid great enough to form drops but not enough to cause drops to drip from item being checked/inspected.

**Class III:** Leakage of fluid great enough to form drops that fall from the item being checked/inspected.

## PREVENTIVE MAINTENANCE CHECKS AND SERVICES (PMCS)

Prior to performing your PMCS, check with your PLL clerk to verify that the latest publications are being used.



**PREVENTIVE MAINTENANCE CHECKS AND SERVICES (PMCS) - Continued**

Listed below are the sections of the PMCS.

PMCS - BEFORE (WP 0145)

PMCS - DURING (WP 0146)

PMCS - AFTER (WP 0147)

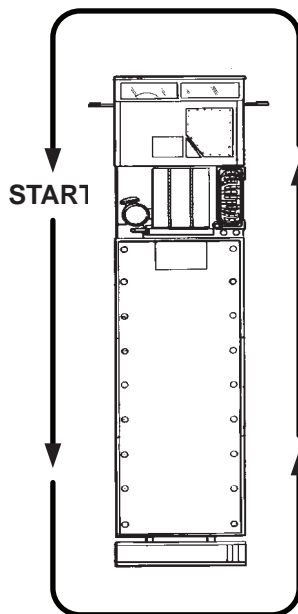
PMCS - WEEKLY (WP 0148)

PMCS - MONTHLY (WP 0150)

PMCS - SEMIANNUAL (WP 0149)

Vehicles designated or dispatched to transport Class A or B ammunition, explosives, poisons, or radioactive yellow III materials over public highways require more stringent inspections.

Daily Walk Around PMCS Diagram. This routing diagram will be of help to complete the B, D, or A PMCS. It shows the vehicle PMCS routing track, which matches the sequence of PMCS to be performed.



*Figure 1.*

**END OF WORK PACKAGE**



**OPERATOR MAINTENANCE  
BEFORE - PREVENTIVE MAINTENANCE**

**INITIAL SETUP:**

**Tools and Special Tools**

Gloves, Leather (WP 0163, Table 2)

*Table 1. PMCS - BEFORE*

Item No.	Interval	Item to be Checked or Serviced	Procedure	Equipment Not Ready/ Available If:
			<p style="text-align: center;"><b>WARNING</b></p> <div data-bbox="640 875 884 997" style="text-align: center;"> </div> <p>Do not start engine or move vehicle when personnel are under vehicle or working on brake lines. Failure to comply may result in injury or death to personnel.</p> <p style="text-align: center;"><b>WARNING</b></p> <div data-bbox="700 1252 824 1374" style="text-align: center;"> </div> <p>Ensure engine is OFF and eye protection is worn when checking for leaks. Failure to comply may result in injury or death to personnel.</p>	


**Table 1. PMCS - BEFORE - Continued**

Item No.	Interval	Item to be Checked or Serviced	Procedure	Equipment Not Ready/ Available If:
			<p style="text-align: center;"><b>NOTE</b></p> <p>Perform Operator's Before, After, and Weekly PMCS checks if:</p> <ul style="list-style-type: none"> <li>• You are the assigned driver but have not operated the vehicle since the last weekly inspection.</li> <li>• You are operating the vehicle for the first time.</li> </ul> <p style="text-align: center;"><b>NOTE</b></p> <ul style="list-style-type: none"> <li>• Clean all lubrication points with cleaning compound, solvent and allow to dry prior to servicing.</li> <li>• When using a grease gun, apply lubricant to the fitting until clean lubricant squeezes out of the part being lubricated.</li> <li>• Always refer to lubrication instructions (WP 0151) to ensure equipment has correct lubricants appropriate to operating environment (expected continuous temperatures). If not, remove/drain and reapply/refill equipment with appropriate lubricants for operating environment as</li> </ul>	

*Table 1. PMCS - BEFORE - Continued*

Item No.	Interval	Item to be Checked or Serviced	Procedure	Equipment Not Ready/ Available If:
1	Before	Driver Side Exterior	<p>prescribed in lubrication instructions. (WP 0151)</p> <p style="text-align: center;"><b>NOTE</b></p> <ul style="list-style-type: none"> <li>• Diesel engine slobber is an inherent condition of diesel engines. When diesel engines are allowed to idle for prolonged periods of time, this characteristic may be interpreted as a Class III leak. Check engine oil level. If there is any doubt, contact your supervisor or field level maintenance.</li> <li>• If leakage is detected, further investigation is needed to determine the location and cause of the leak. If there is any doubt, contact your supervisor or field level maintenance.</li> </ul> <p>1. Check underneath entire length of driver side of vehicle for fluid and air leaks.</p>	Any fuel leak, Class III leak (other than fuel), or air lines/fittings leaking or damaged.

**Table 1. PMCS - BEFORE - Continued**

Item No.	Interval	Item to be Checked or Serviced	Procedure	Equipment Not Ready/ Available If:
			<p>2. Visually check driver side of vehicle for obvious damage that would impair operation.</p> <p style="text-align: center;"><b>WARNING</b></p>  <ul style="list-style-type: none"> <li>• During normal vehicle operation, cooling system can become very hot. Allow cooling system to cool prior to servicing. Failure to comply may result in injury to personnel.</li> <li>• Use extreme care when removing radiator cap. Sudden release of pressure can cause a steam flash. Slowly loosen radiator cap to the first stop to relieve pressure before removing radiator cap completely. Failure to comply may result in injury to personnel.</li> <li>• Use a clean, thick waste cloth or like material to remove radiator cap.</li> </ul>	<p>Any damage that would impair operation.</p>

**Table 1. PMCS - BEFORE - Continued**

Item No.	Interval	Item to be Checked or Serviced	Procedure	Equipment Not Ready/ Available If:
2	Before	Radiator	<p>Avoid using gloves. If hot water soaks through gloves, personnel could be burned. Failure to comply may result in injury to personnel.</p> <p>Remove radiator cap and check radiator coolant level. Coolant level should be up to bottom of filler neck. If fluid level is low, fill to appropriate level.</p>	Coolant is low.

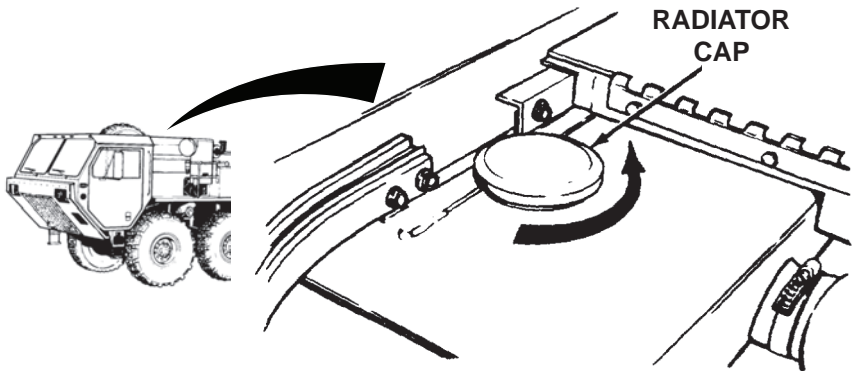


Figure 1.

**WARNING**



Do not operate a vehicle with a tire in an over-inflated or un-

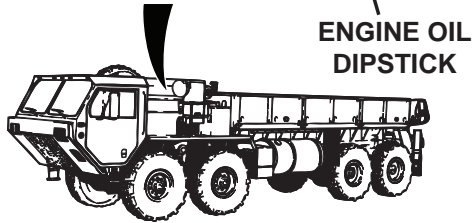
**Table 1. PMCS - BEFORE - Continued**

Item No.	Interval	Item to be Checked or Serviced	Procedure	Equipment Not Ready/ Available If:
			<p>der-inflated condition, or with a questionable defect. Failure to comply may result in injury or death to personnel and damage to equipment.</p> <p style="text-align: center;"><b>NOTE</b></p> <ul style="list-style-type: none"> <li>• A tire is bad or in need of repair if the bead, sidewall, and tread areas show signs of damage.</li> <li>• Remember that this process requires you to make judgment calls and the goal is to safely maintain equipment in top quality conditions.</li> </ul>	
3	Before	Driver Side Tires	Check for correct air pressure on each driver side tire and service tire (WP 0158) as required.	Tire missing, deflated, or un-serviceable.
4	Before	Engine	1. Check engine oil level on dipstick.	



*Table 1. PMCS - BEFORE - Continued*

Item No.	Interval	Item to be Checked or Serviced	Procedure	Equipment Not Ready/ Available If:



*Figure 2.*

**NOTE**

Engine oil level should be between L (low) and F (full) mark on dipstick.

- a. Add engine oil as required. (WP 0151)

*Table 1. PMCS - BEFORE - Continued*

Item No.	Interval	Item to be Checked or Serviced	Procedure	Equipment Not Ready/ Available If:
5	Before	Rear of Vehicle	<p>b. Drain excess engine oil as required, or notify field level maintenance.</p> <p>Visually check rear of vehicle for obvious damage that would impair operation.</p>	Any damage that would impair operation.
6	Before	Cargo Body	<p>1. Check that side panels, and front/rear end panels are not bent, broken, and have no broken welds.</p>	Any side panel or end panel is missing, bent, broken, or has a broken weld.

Table 1. PMCS - BEFORE - Continued

Item No.	Interval	Item to be Checked or Serviced	Procedure	Equipment Not Ready/ Available If:
----------	----------	--------------------------------	-----------	------------------------------------

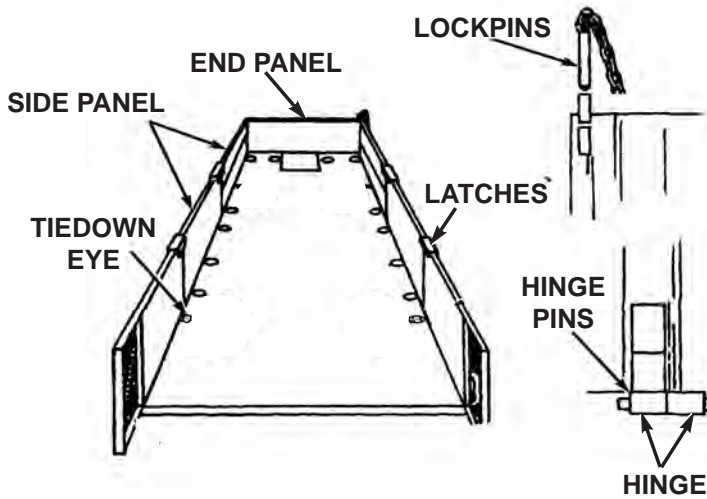
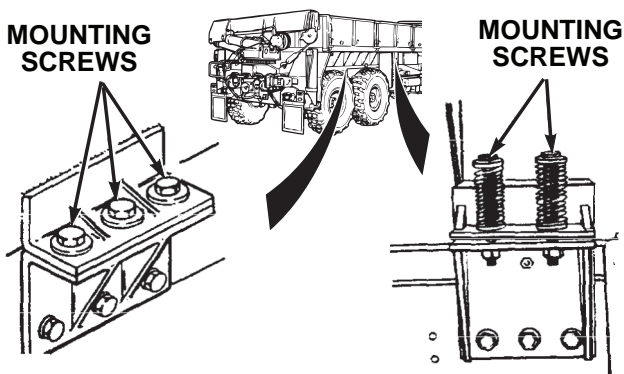


Figure 3.

		<ol style="list-style-type: none"> <li>2. Check for broken latches and missing lockpins.</li> <li>3. Check for broken, bent, or damaged hinge pins and tie down eyes.</li> <li>4. Check for broken or binding hinges.</li> </ol>	<p>A latch is broken or a lockpin is missing.</p> <p>Any hinge pin or tie down eye is missing, broken, or bent.</p> <p>Hinges are missing, broken, or</p>
--	--	--	---

*Table 1. PMCS - BEFORE - Continued*

Item No.	Interval	Item to be Checked or Serviced	Procedure	Equipment Not Ready/ Available If:
			<p style="text-align: center;"><b>NOTE</b></p> <p>Operation of vehicle with bent, broken, or missing cargo body screws may violate AR 385-55.</p> <p>5. Check that cargo body mounting screws are not broken, cracked, or missing.</p>	<p>have broken welds.</p> <p>One or more screws are broken, cracked, or missing.</p>



*Figure 4.*

7	Before	Self-Recovery Winch (SRW)	1. Inspect self-recovery winch for obvious damage.	Self-recovery winch unserviceable.
---	--------	---------------------------	--	------------------------------------

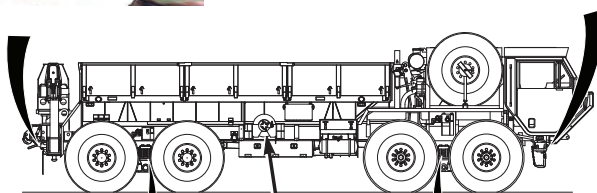
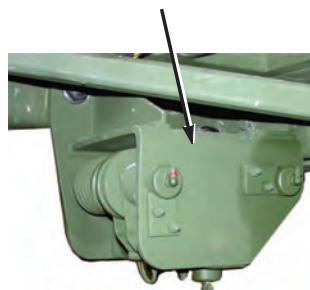
Table 1. PMCS - BEFORE - Continued

Item No.	Interval	Item to be Checked or Serviced	Procedure	Equipment Not Ready/ Available If:
----------	----------	--------------------------------	-----------	------------------------------------

REAR CABLE GUIDE



FRONT CABLE GUIDE



REAR TENSIONER



SELF-RECOVERY WINCH

FRONT TENSIONER



Figure 5.

2. Inspect front cable guide for any loose or missing parts and any obvious damage.

Front cable guide has loose or missing parts, or is

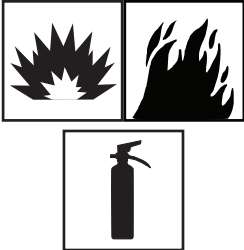
*Table 1. PMCS - BEFORE - Continued*

Item No.	Interval	Item to be Checked or Serviced	Procedure	Equipment Not Ready/ Available If:
8	Before	Wheel Chocks	<p>3. Inspect front tensioner for loose or missing parts and any obvious damage.</p> <p>4. Inspect rear tensioner for loose or missing parts and any obvious damage.</p> <p>5. Inspect rear cable guide for loose or missing parts and any obvious damage</p> <p>Ensure vehicle is equipped with four wheel chocks.</p> <p style="text-align: center;"><b>NOTE</b></p> <ul style="list-style-type: none"> <li>• Diesel engine slobber is an inherent condition of</li> </ul>	<p>unserviceable.</p> <p>Front tensioner has loose or missing parts, or is unserviceable.</p> <p>Rear tensioner has loose or missing parts, or is unserviceable.</p> <p>Rear cable guide has loose or missing parts, or is unserviceable.</p> <p>Vehicle is equipped with less than four wheel chocks.</p>

**Table 1. PMCS - BEFORE - Continued**

Item No.	Interval	Item to be Checked or Serviced	Procedure	Equipment Not Ready/ Available If:
9	Before	Passenger Side Exterior	<p>diesel engines. When diesel engines are allowed to idle for prolonged periods of time, this characteristic may be interpreted as a Class III leak. Check engine oil level. If there is any doubt, contact your supervisor or field level maintenance.</p> <ul style="list-style-type: none"> <li>• If leakage is detected, further investigation is needed to determine the location and cause of the leak. If there is any doubt, contact your supervisor or field level maintenance.</li> </ul> <ol style="list-style-type: none"> <li>1. Check underneath entire length of driver side of vehicle for fluid and air leaks.</li> <li>2. Visually check driver side of vehicle for obvious damage that would impair operation.</li> </ol>	<p>Any fuel leak, Class III leak (other than fuel), or air lines/fittings leaking or damaged.</p> <p>Any damage that would impair operation.</p>

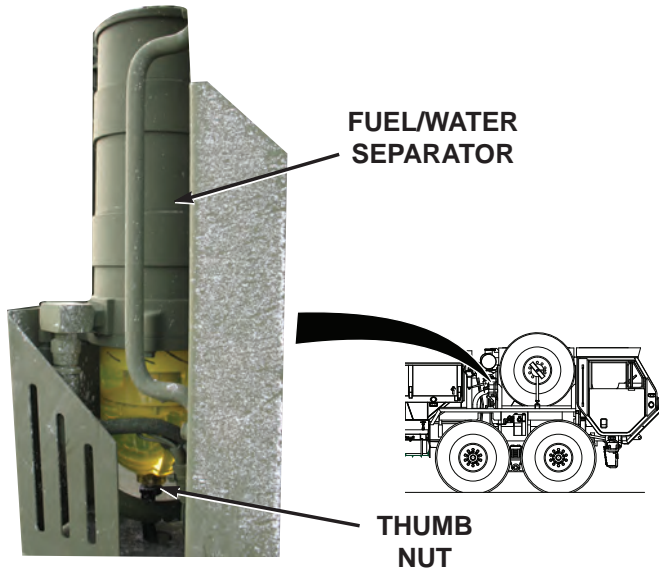
**Table 1. PMCS - BEFORE - Continued**

Item No.	Interval	Item to be Checked or Serviced	Procedure	Equipment Not Ready/ Available If:
10	Before	Fuel/ Water	<p style="text-align: center;"><b>WARNING</b></p> <div style="text-align: center;">  </div> <p>Fuel is very flammable and can explode easily. Keep fuel away from open fire and keep fire extinguisher within easy reach when working with fuel. Do not work on fuel system when engine is hot. Fuel can be ignited when engine is hot. When working with fuel, post signs that read NO SMOKING WITHIN 50 FEET OF VEHICLE. Failure to comply may result in injury or death to personnel.</p> <p style="text-align: center;"><b>NOTE</b></p> <ul style="list-style-type: none"> <li>• Drain fuel into suitable container.</li> <li>• Operation of vehicle with malfunctioning fuel/water separator may violate AR 385-55. (WP 0161)</li> </ul> <p>1. Check for level of water in bowl of fuel/water separator. If there is</p>	



**Table 1. PMCS - BEFORE - Continued**


Item No.	Interval	Item to be Checked or Serviced	Procedure	Equipment Not Ready/ Available If:
		Separator	water, turn thumb nut on bottom of bowl to open contaminant drain valve. Keep drain open until only pure fuel is flowing out of drain tube. Close drain valve by turning thumb nut.	



*Figure 6.*

	2. Check fuel/water separator for leaks and damage.	Any fuel leaking.
--	---	-------------------

*Table 1. PMCS - BEFORE - Continued*

Item No.	Interval	Item to be Checked or Serviced	Procedure	Equipment Not Ready/ Available If:
11	Before	Passenger Side Tires	<p style="text-align: center;"><b>WARNING</b></p>  <p>Do not operate a vehicle with a tire in an over-inflated or under-inflated condition, or with a questionable defect. Failure to comply may result in injury or death to personnel and damage to equipment.</p> <p style="text-align: center;"><b>NOTE</b></p> <ul style="list-style-type: none"> <li>• Remember that a tire in storage (spare) can be flat but not look like it. The HEMTT tire sidewalls can support the wheel. Don't be fooled.</li> <li>• A tire is bad or in need of repair if the bead, sidewall, and tread areas show signs of damage.</li> <li>• Remember that this process requires you to make judgment calls and the goal is to safely maintain equipment in top quality conditions.</li> </ul> <p>1. Check for correct air pressure on each passenger side tire</p>	Tire missing, deflating



*Table 1. PMCS - BEFORE - Continued*

Item No.	Interval	Item to be Checked or Serviced	Procedure	Equipment Not Ready/ Available If:
				or excessively worn.

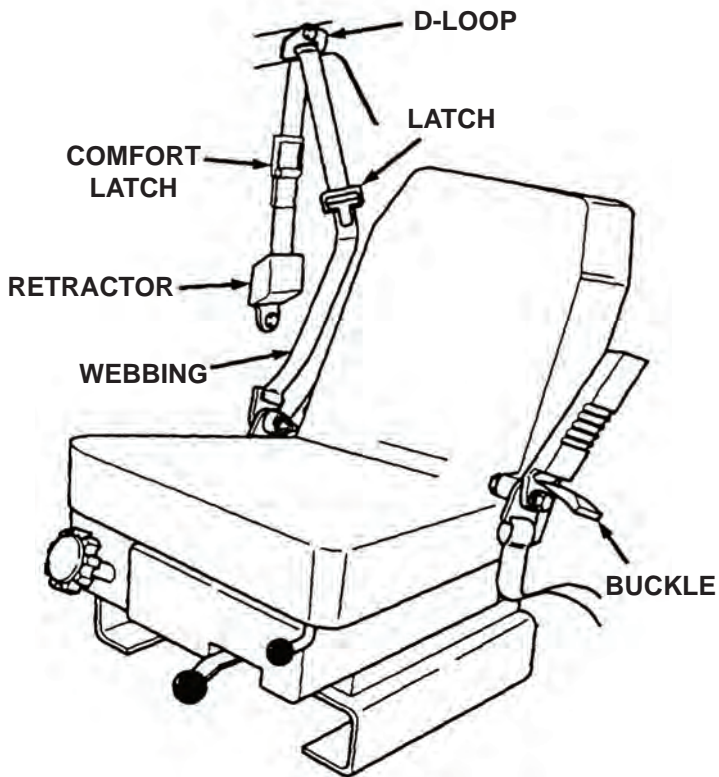


Figure 7.

		<p>b. Check D-loop for free rotation, deformation, cracks, or damage.</p>	<p>D-loop does not rotate freely or is deformed,</p>
--	--	---	--

**Table 1. PMCS - BEFORE - Continued**

Item No.	Interval	Item to be Checked or Serviced	Procedure	Equipment Not Ready/ Available If:
			<ul style="list-style-type: none"> <li>c. Check comfort latch for proper operation, cracks, or damage.</li> <li>d. Check latch and buckle for wear, deformation, damage, or broken casing.</li> <li>e. Check latch and buckle for proper operation.</li> </ul>	<p>cracked, or broken.</p> <p>Comfort latch is broken, or does not lock in place easily, and does not release by tugging down on webbing.</p> <p>Molded plastic around buckle/latch is deformed, cracked, or broken.</p> <p>Buckle/latch do not engage with a solid sounding "click" and/or do not release freely when button on buckle is pushed.</p>

*Table 1. PMCS - BEFORE - Continued*

Item No.	Interval	Item to be Checked or Serviced	Procedure	Equipment Not Ready/ Available If:
			<ul style="list-style-type: none"> <li>f. Check that retractor is not locked up, and pays out/reels in webbing properly.</li> <li>g. Check all seat belt mounting hardware for looseness and other damage.</li> </ul> <p>2. Check four-point seat belt system as follows:</p> <ul style="list-style-type: none"> <li>a. Check seat belt strap webbing wear, tears, fraying, etc.</li> </ul>	<p>Retractor does not operate properly or retractor cover is cracked/ broken.</p> <p>Seat belt hardware is loose, missing, rusted, corroded, or damaged.</p> <p>Webbing is cut, frayed or excessively worn.</p>

Table 1. PMCS - BEFORE - Continued

Item No.	Interval	Item to be Checked or Serviced	Procedure	Equipment Not Ready/ Available If:
----------	----------	--------------------------------	-----------	------------------------------------

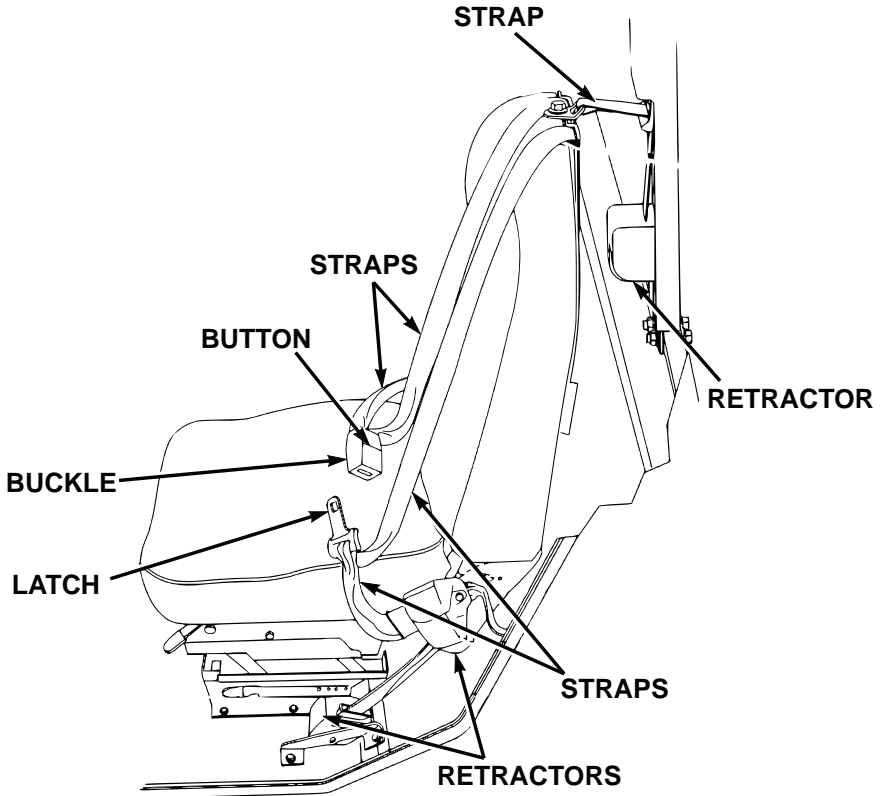


Figure 8.

		<p>b. Check latch and buckle for proper operation, wear, deformation, damage, and broken casing.</p>	<p>Buckle/latch does not engage with a solid-sounding "click" and/or does not</p>
--	--	--	---

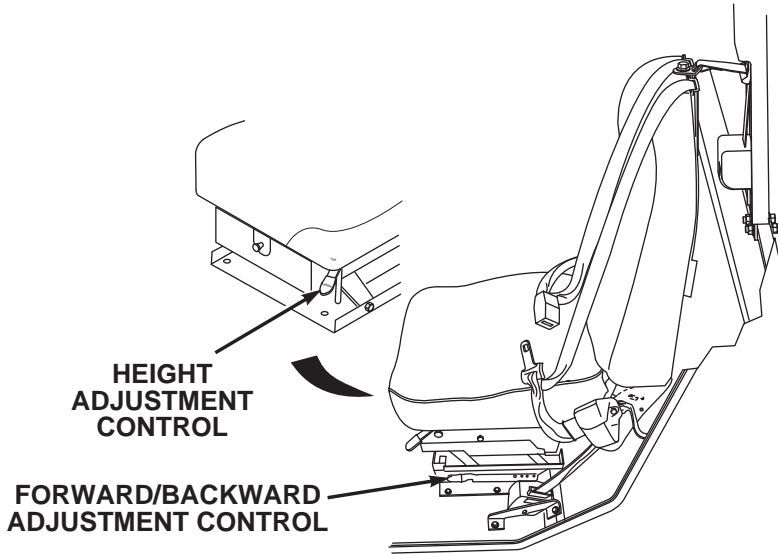
*Table 1. PMCS - BEFORE - Continued*

Item No.	Interval	Item to be Checked or Serviced	Procedure	Equipment Not Ready/ Available If:
13	Before	Seats	<p>c. Check all seat belt retractors are not locked up and pay out/reel in webbing straps properly.</p> <p>d. Check all seat belt mounting hardware for looseness and other damage.</p> <p>Check operation of seat adjusting mechanisms. (WP 0023)</p>	<p>release freely when button is pushed. Molded plastic around buckle/latch is deformed, cracked, or broken.</p> <p>Retractor(s) do not operate properly, or retractor cover(s) are cracked/ broken.</p> <p>Hardware is loose, missing, rusted, corroded, or damaged.</p> <p>Seat adjustment mechanism broken or missing.</p>



**Table 1. PMCS - BEFORE - Continued**

Item No.	Interval	Item to be Checked or Serviced	Procedure	Equipment Not Ready/ Available If:
----------	----------	--------------------------------	-----------	------------------------------------



*Figure 9.*

14	Before	Fire Extinguisher (cab)	1. Check for missing or damaged fire extinguisher.	Fire extinguisher missing or damaged.
----	--------	-------------------------	--	---------------------------------------

Table 1. PMCS - BEFORE - Continued

Item No.	Interval	Item to be Checked or Serviced	Procedure	Equipment Not Ready/ Available If:
----------	----------	--------------------------------	-----------	------------------------------------

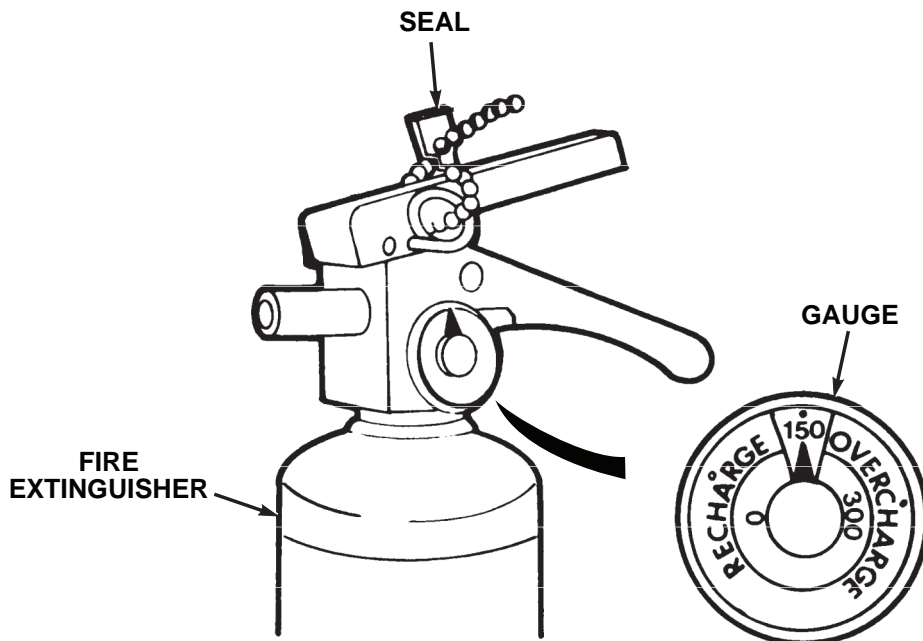


Figure 10.

		<ol style="list-style-type: none"> <li>2. Check gauge for proper pressure of about 150 psi (1034 kPa).</li> <li>3. Ensure fire extinguisher mounting is secure.</li> </ol>	<p>Pressure gauge needle in RECHARGE area.</p>
--	--	--	--

**Table 1. PMCS - BEFORE - Continued**

Item No.	Interval	Item to be Checked or Serviced	Procedure	Equipment Not Ready/ Available If:
			<p>4. Check for damaged or missing seal.</p> <p style="text-align: center;"><b>NOTE</b></p> <ul style="list-style-type: none"> <li>• Complete all start engine (WP 0044) procedures, and comply with all notes, cautions, and warnings within that procedure before completing the PMCS checks below.</li> <li>• Once all start engine (WP 0044) procedures are completed, engine should be kept running for the remaining PMCS checks.</li> </ul>	Seal broken or missing.
15	Before	Engine	<p>Start engine. (WP 0044)</p> <p style="text-align: center;"><b>NOTE</b></p> <p>Check the instruments listed below for damage, operation, and condition.</p>	Engine fails to start.
16	Before	Instruments	<p>1. Engine OIL PRESS gauge.</p>	Engine OIL PRESS gauge is in-operative.

*Table 1. PMCS - BEFORE - Continued*

Item No.	Interval	Item to be Checked or Serviced	Procedure	Equipment Not Ready/ Available If:
----------	----------	--------------------------------	-----------	------------------------------------

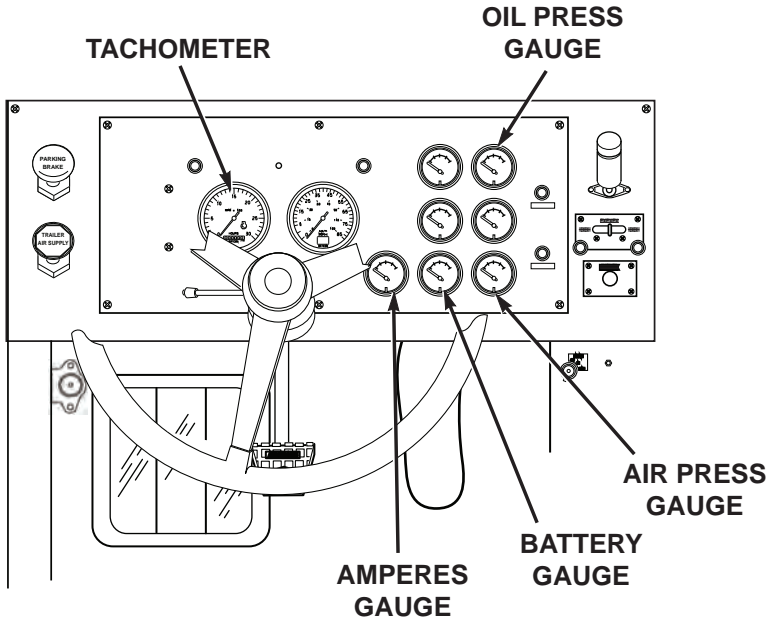


Figure 11.

		<p>2. Tachometer.</p>	<p>Tachometer is inoperative or indicates less than 700 rpm or more than 725 rpm at idle after engine has been properly warmed up (start en-</p>
--	--	-----------------------	--

*Table 1. PMCS - BEFORE - Continued*

Item No.	Interval	Item to be Checked or Serviced	Procedure	Equipment Not Ready/ Available If:
			<p data-bbox="543 607 807 638">3. BATTERY gauge.</p> <p data-bbox="543 944 807 975">4. AMPERES gauge.</p> <p data-bbox="716 1235 807 1266" style="text-align: center;"><b>NOTE</b></p> <p data-bbox="587 1284 937 1521">Air pressure buzzer will sound anytime low air indicator is illuminated. Ensure low air indicator and buzzer activate when air pressure falls below 60 to 75 psi (414 to 517 kPa) in either front or rear air system.</p> <p data-bbox="543 1557 807 1588">5. AIR PRESS gauge.</p>	<p data-bbox="1030 456 1173 575">gine (WP 0044) procedure completed).</p> <p data-bbox="1030 607 1173 911">BATTERY gauge is in-operative, or indicates less than 24 VDC or more than 30 VDC with engine running.</p> <p data-bbox="1030 944 1173 1184">AMPERES gauge is in-operative, or shows a negative reading with engine running.</p> <p data-bbox="1030 1557 1173 1616">AIR PRESS gauge is in-</p>

*Table 1. PMCS - BEFORE - Continued*

Item No.	Interval	Item to be Checked or Serviced	Procedure	Equipment Not Ready/ Available If:
			<p>6. Air filter restriction indicator.</p>	<p>operative or indicates either system is below 60 psi (414 kPa) after engine has been properly warmed up (start engine (WP 0044) procedure completed). Low air pressure indicator and/or buzzer remain on, or do not operate.</p> <p>Air filter restriction indicator inoperative, cracked, or unserviceable.</p>

*Table 1. PMCS - BEFORE - Continued*

Item No.	Interval	Item to be Checked or Serviced	Procedure	Equipment Not Ready/ Available If:
----------	----------	--------------------------------	-----------	------------------------------------

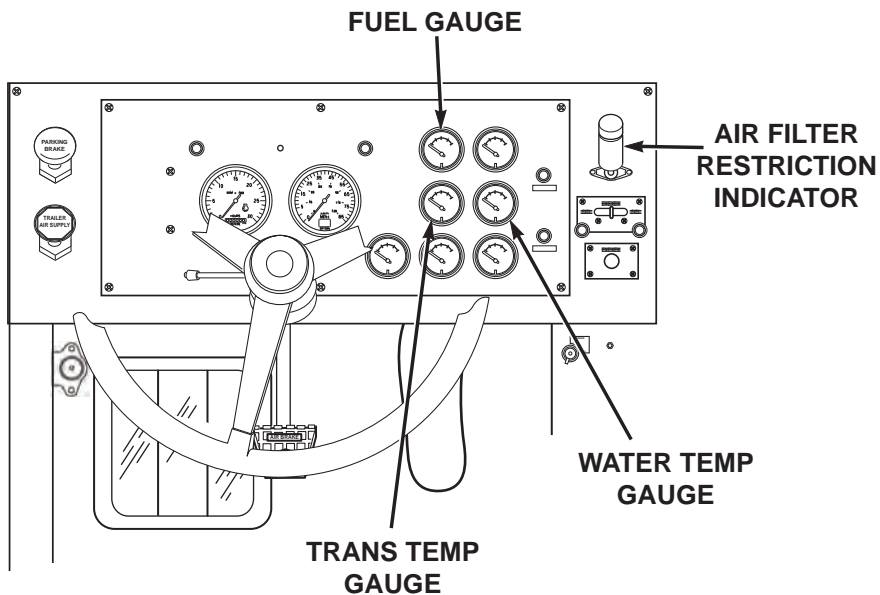


Figure 12.

**NOTE**

Several minutes are required for engine to warm up so an accurate reading can be taken.

- 7. WATER TEMP gauge.

WATER TEMP gauge is inoperative, or indicates less than

*Table 1. PMCS - BEFORE - Continued*

Item No.	Interval	Item to be Checked or Serviced	Procedure	Equipment Not Ready/ Available If:
			<p style="text-align: center;"><b>NOTE</b></p> <p>Transmission may not reach 160°F (71°C) oil temperature at idle for several minutes.</p> <p>8. TRANS TEMP gauge.</p> <p>9. FUEL gauge.</p>	<p>140°F (60°C) or more than 230°F (110°C) after engine has been properly warmed up (start engine (WP 0044) procedure completed).</p> <p>TRANS TEMP gauge indicates more than 250°F (121°C).</p> <p>FUEL gauge is inoperative, or indicates less than the required amount of fuel needed</p>



*Table 1. PMCS - BEFORE - Continued*

Item No.	Interval	Item to be Checked or Serviced	Procedure	Equipment Not Ready/ Available If:
17	Before	TRANSFER CASE Shift Lever and TRACTION CONTROL lever	<p style="text-align: center;"><b>CAUTION</b></p> <p>Vehicle must be parked when making this check. Failure to comply may result in damage to equipment. Transfer case will be damaged if shifted while vehicle is moving.</p> <p style="text-align: center;"><b>NOTE</b></p> <ul style="list-style-type: none"> <li>• Engine must be running to perform this check.</li> <li>• Transmission must be in N (neutral) to perform this check.</li> </ul> <p>1. TRANSFER CASE Shift Lever - Check operation: (WP 0048)</p>	to complete the mission.

Table 1. PMCS - BEFORE - Continued

Item No.	Interval	Item to be Checked or Serviced	Procedure	Equipment Not Ready/ Available If:
----------	----------	--------------------------------	-----------	------------------------------------

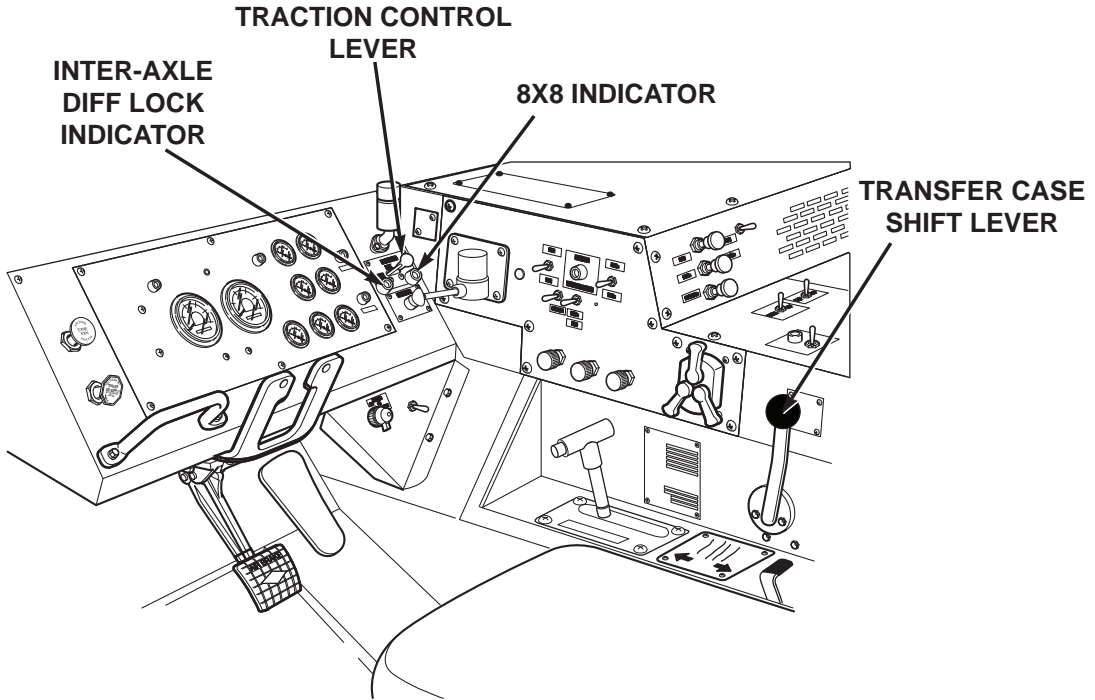


Figure 13.

- a. Set transfer case shift lever to each range position.
- b. Transfer case shift lever should move freely through all range positions.

TRANSFER CASE shift lever inoperable or binds between

**Table 1. PMCS - BEFORE - Continued**

Item No.	Interval	Item to be Checked or Serviced	Procedure	Equipment Not Ready/ Available If:
18	Before	Engine Retarder/ Brake	<p>2. TRACTION CONTROL Lever - Check operation: (WP 0021)</p> <p>a. TRACTION CONTROL lever should slide smoothly, and interact with transfer case shift lever to show correct indications on dash panel.</p> <p style="text-align: center;"><b>NOTE</b></p> <p>Engine must be running to perform this check.</p> <p>1. Check engine retarder/brake for proper operation (WP 0049) (vehicle stationary) using the following procedures:</p> <p>a. Pull out PARKING BRAKE control.</p>	<p>range de-tents.</p> <p>TRACTION CONTROL lever or indicators inoperable.</p>

*Table 1. PMCS - BEFORE - Continued*

Item No.	Interval	Item to be Checked or Serviced	Procedure	Equipment Not Ready/ Available If:
----------	----------	--------------------------------	-----------	------------------------------------

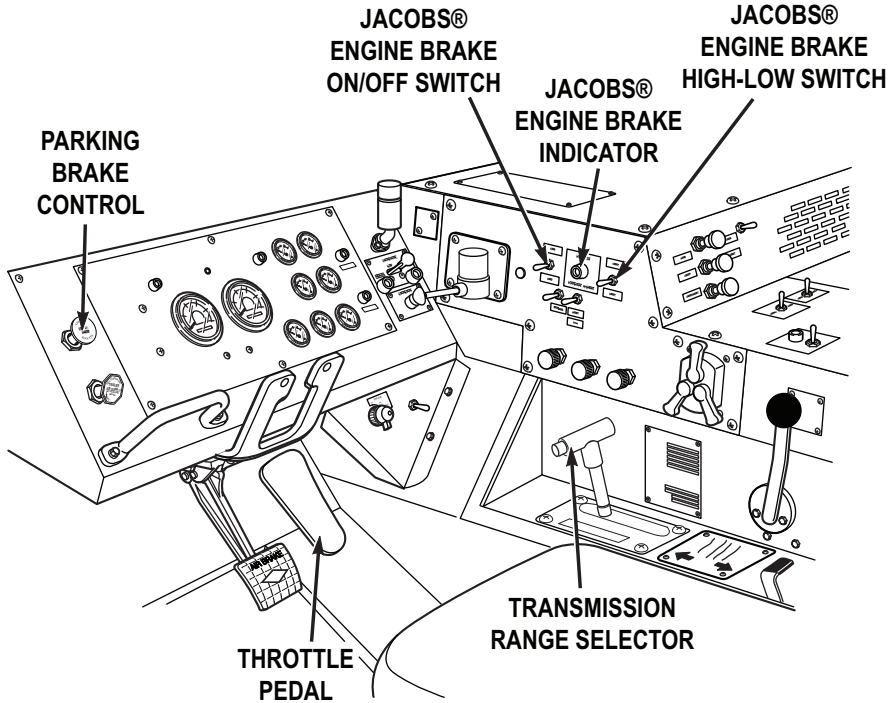


Figure 14.

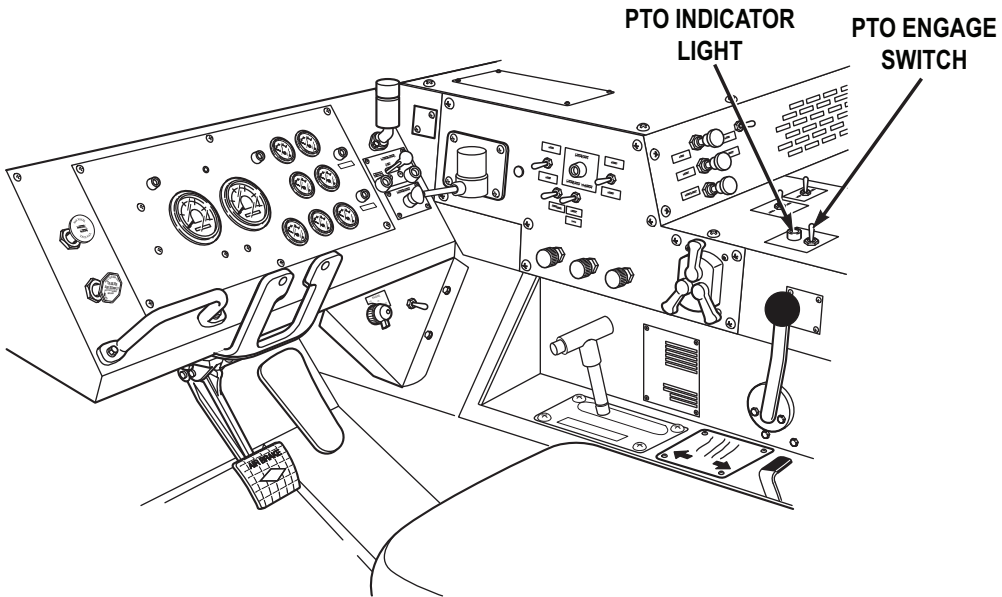
		<p>b. Set transmission range selector to N (neutral) position.</p> <p>c. Apply throttle pedal and increase engine speed to 1900-2100 rpm for several seconds to allow</p>	
--	--	---	--

**Table 1. PMCS - BEFORE - Continued**

Item No.	Interval	Item to be Checked or Serviced	Procedure	Equipment Not Ready/ Available If:
19	Before	Steering	<p>transmission to upshift to at least 2 (2nd gear range).</p> <p>d. Set JACOBS ® ENGINE BRAKE ON/OFF switch to ON position, JACOBS ® ENGINE BRAKE indicator light will come on.</p> <p>e. Release throttle pedal and listen for engine "popping" or "chattering" sounds that indicate engine retarder/ brake is engaged and operating.</p> <p style="text-align: center;"><b>NOTE</b></p> <p>Engine must be running to perform this check.</p> <p>1. Check vehicle steering for proper operation:</p> <p>a. Turn steering wheel from full left to full right, back to full left.</p> <p style="text-align: center;"><b>NOTE</b></p> <p>Engine must be running to perform this check.</p>	Steering inoperable or binds.
20	Before	PTO Switch	Set PTO ENGAGE switch to ON position. Indicator light will illuminate.	PTO ENGAGE switch and/or indicator

**Table 1. PMCS - BEFORE - Continued**

Item No.	Interval	Item to be Checked or Serviced	Procedure	Equipment Not Ready/ Available If:
				does not operate.



*Figure 15.*

**NOTE**

Operation of vehicle with malfunctioning windshield wiper may violate AR 385-55. (WP 0161)

21

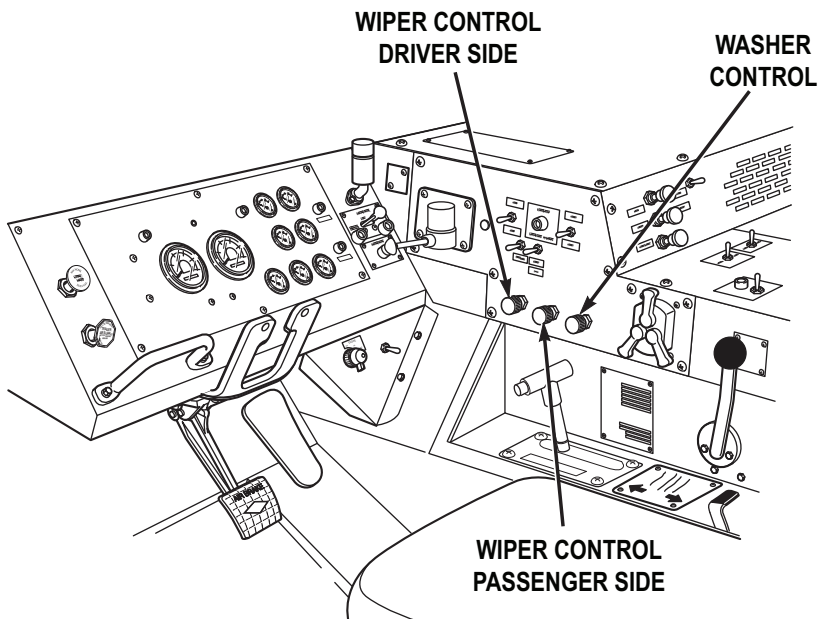
Before

WIPER/  
Washer  
Controls

1. Check WIPER controls (driver and passenger side) for proper operation. (WP 0035)

*Table 1. PMCS - BEFORE - Continued*

Item No.	Interval	Item to be Checked or Serviced	Procedure	Equipment Not Ready/ Available If:
----------	----------	--------------------------------	-----------	------------------------------------



*Figure 16.*

2. Check windshield washer control for proper operation. (WP 0035)

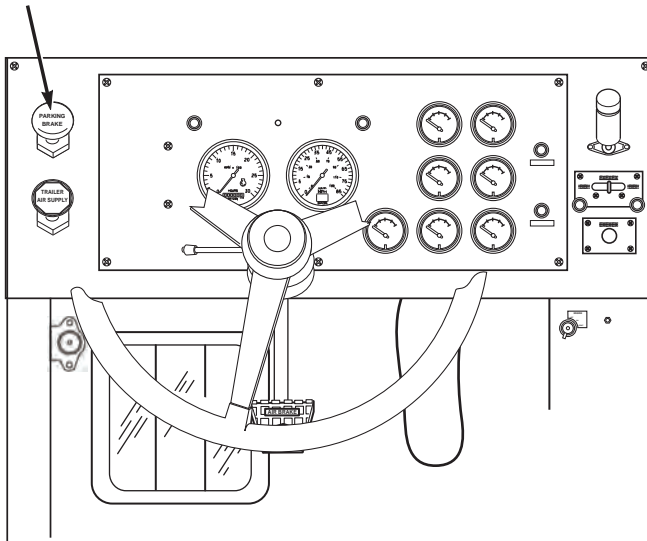
**NOTE**

- Engine must be running to perform this check.
- Operation of vehicle with malfunctioning windshield wiper may violate AR 385-55. (WP 0161)

**Table 1. PMCS - BEFORE - Continued**

Item No.	Interval	Item to be Checked or Serviced	Procedure	Equipment Not Ready/ Available If:
22	Before	Parking Brake Control	1. Check PARKING BRAKE control for proper operation: (WP 0045)	

**PARKING BRAKE CONTROL**



*Figure 17.*

- a. With vehicle at idle and service brake pedal engaged, (WP 0046) set transmission range selector to D (drive). (WP 0048)
- b. Apply (pull out) PARKING BRAKE control. (WP 0045)



**Table 1. PMCS - BEFORE - Continued**

Item No.	Interval	Item to be Checked or Serviced	Procedure	Equipment Not Ready/ Available If:
23	Before	Engine	<p>c. Release service brake pedal. (WP 0046)</p> <p>d. Set transmission range selector to N (neutral). (WP 0048)</p> <p style="text-align: center;"><b>NOTE</b></p> <p>Operator may continue on with mission if vehicle requires no servicing.</p> <p>Shut OFF engine (WP 0057) (as required).</p>	<p>Vehicle moves with PARKING BRAKE control applied (pulled out).</p>

**END OF WORK PACKAGE**




**OPERATOR MAINTENANCE  
DURING - PREVENTIVE MAINTENANCE**

**INITIAL SETUP:**

**Tools and Special Tools**

Gloves, Leather (WP 0163, Table 2)

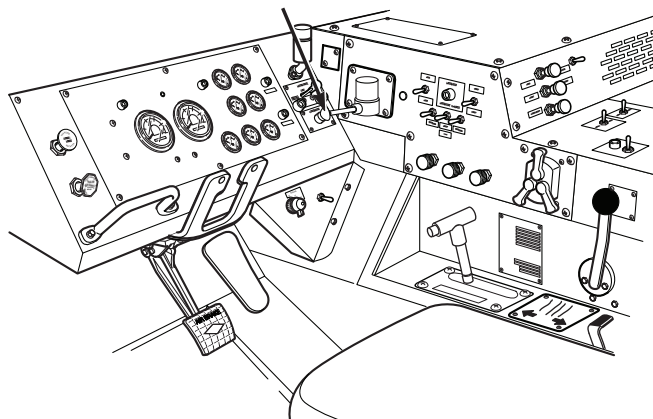
*Table 1. PMCS - DURING*

Item No.	Interval	Item to be Checked or Serviced	Procedure	Equipment Not Ready/ Available If:
1	During	Engine	<p style="text-align: center;"><b>WARNING</b></p> <div style="text-align: center;">  </div> <p>Ensure engine is OFF and eye protection is worn when checking for leaks. Failure to comply may result in injury or death to personnel.</p> <p>Check and/or listen for excessive smoke, unusual noise, rough running, and misfiring.</p> <p style="text-align: center;"><b>NOTE</b></p> <p>Check trailer handbrake control lever only if a trailer is hooked up to vehicle.</p>	<p>Engine has excessive smoke, unusual noise, runs rough, or misfires.</p>

**Table 1. PMCS - DURING - Continued**

Item No.	Interval	Item to be Checked or Serviced	Procedure	Equipment Not Ready/ Available If:
2	During	Trailer Handbrake Control Lever	Check trailer handbrake control lever for proper operation. (WP 0047)	Control lever does not apply trailer brakes.

**TRAILER HANDBRAKE CONTROL LEVER**



*Figure 1.*

Listen for actuation. If none, refer to applicable trailer operator's manual.

**NOTE**

During operation, all gauges should maintain the proper readings listed in the PMCS BEFORE checks. (WP 0145)

**Table 1. PMCS - DURING - Continued**

<b>Item No.</b>	<b>Interval</b>	<b>Item to be Checked or Serviced</b>	<b>Procedure</b>	<b>Equipment Not Ready/ Available If:</b>
3	During	Instruments	Monitor all gauges, indicators, and warning lights for proper reading and operation while operating vehicle.	Gauges, indicators, and warning lights do not read/operate properly.
4	During	Transmission	Check transmission for proper operation. (WP 0048)	Transmission slips or will not shift.
5	During	Steering	Be alert for any unusual noise, binding, or difficulty in steering during operation.	Steering binds or is unresponsive.
6	During	Service Brakes	Be alert for chatter, noise, and side pull.	Service brakes do not operate properly.

**END OF WORK PACKAGE**



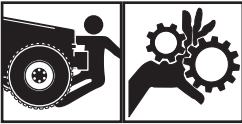

**OPERATOR MAINTENANCE  
AFTER - PREVENTIVE MAINTENANCE**

**INITIAL SETUP:**

**Tools and Special Tools**

Gloves, Leather (WP 0163, Table 2)

**Table 1. PMCS - AFTER**


Item No.	Interval	Item to be Checked or Serviced	Procedure	Equipment Not Ready/ Available If:
			<p style="text-align: center;"><b>WARNING</b></p>  <p>Do not start engine or move vehicle when personnel are under vehicle or working on brake lines. Failure to comply may result in injury or death to personnel.</p> <p style="text-align: center;"><b>WARNING</b></p>  <p>Ensure engine is OFF and eye protection is worn when checking for leaks. Failure to comply may result in injury or death to personnel.</p>	

**Table 1. PMCS - AFTER - Continued**

Item No.	Interval	Item to be Checked or Serviced	Procedure	Equipment Not Ready/ Available If:
			<p style="text-align: center;"><b>NOTE</b></p> <p>Perform Operator's Before, After, and Weekly PMCS checks if:</p> <ul style="list-style-type: none"> <li>• You are the assigned driver but have not operated the vehicle since the last weekly inspection.</li> <li>• You are operating the vehicle for the first time.</li> </ul> <p style="text-align: center;"><b>NOTE</b></p> <ul style="list-style-type: none"> <li>• Clean all lubrication points with cleaning compound, solvent and allow to dry prior to servicing.</li> <li>• When using a grease gun, apply lubricant to the fitting until clean lubricant squeezes out of the part being lubricated.</li> <li>• Always refer to lubrication instructions (WP 0151) to ensure equipment has correct lubricants appropriate to operating environment (expected continuous temperatures). If not, remove/drain and reapply/refill equipment with appropriate lubricants for operating environment as</li> </ul>	



**Table 1. PMCS - AFTER - Continued**

Item No.	Interval	Item to be Checked or Serviced	Procedure	Equipment Not Ready/ Available If:
1	After	Underneath Vehicle	<p>prescribed in lubrication instructions. (WP 0151)</p> <ol style="list-style-type: none"> <li>1. Check entire underside of vehicle for fluid and air leaks.</li> <li>2. Check entire underside of vehicle for signs of fluid leakage (fuel, oil, and coolant).</li> </ol> <p style="text-align: center;"><b>WARNING</b></p> <div style="text-align: center;">  </div> <p>Prolonged contact with lubricating oil may cause skin rash. Immediately wash skin and clothing that come in contact with lubricating oil thoroughly and remove saturated clothing. Keep area well-ventilated to keep fumes at a minimum. Failure to comply may result in injury or death to personnel.</p> <p style="text-align: center;"><b>CAUTION</b></p> <p>Do not fill hydraulic reservoir past FULL COLD mark. Fail-</p>	<p>Any fuel, Class III leak, or air lines/fittings leaking or damaged.</p> <p>Any fuel leak. Class III leak of any other fluid.</p>

**Table 1. PMCS - AFTER - Continued**

Item No.	Interval	Item to be Checked or Serviced	Procedure	Equipment Not Ready/ Available If:
2	After	Hydraulic Fluid Reservoir	<p>ure to comply may result in damage to equipment.</p> <p style="text-align: center;"><b>NOTE</b></p> <ul style="list-style-type: none"> <li>• Hydraulic oil expands when heated, which may give the operator false (high) fluid level readings if the vehicle has been recently operated.</li> <li>• If possible, wait until hydraulic reservoir is completely cooled down (minimum of 2 hours) prior to adding hydraulic oil, otherwise fill reservoir to FULL COLD mark.</li> </ul> <p>1. Check that hydraulic fluid level in sight glass on hydraulic fluid reservoir is at FULL COLD mark (may be above FULL COLD mark if vehicle has been recently operated). If low, add hydraulic oil to FULL COLD mark:</p>	

*Table 1. PMCS - AFTER - Continued*

Item No.	Interval	Item to be Checked or Serviced	Procedure	Equipment Not Ready/ Available If:




*Figure 1.*

- |  |  |   |
|--|--|---|
|  |  | <ol style="list-style-type: none"> <li>a. Remove cap from hydraulic reservoir.</li> <li>b. Fill hydraulic reservoir with lubricating oil (WP 0151, Table 4) until sight glass reads at FULL COLD mark.</li> <li>c. Install cap on hydraulic reservoir.</li> </ol> |
|--|--|---|

**Table 1. PMCS - AFTER - Continued**

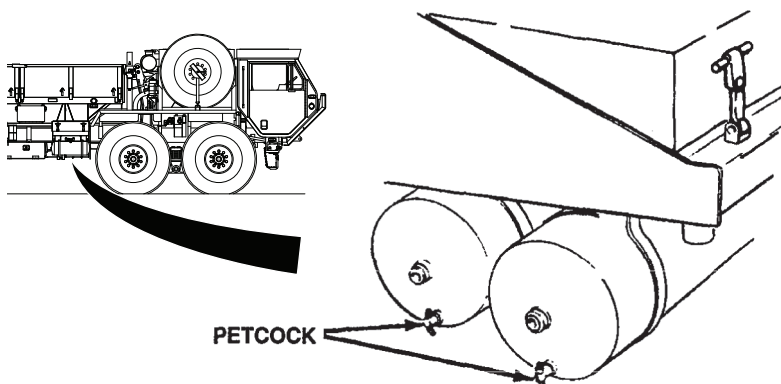
Item No.	Interval	Item to be Checked or Serviced	Procedure	Equipment Not Ready/ Available If:
3	After	Driver Side Wheels	<ol style="list-style-type: none"> <li>2. Check appearance of hydraulic fluid in sight glass. Make sure it is clear and not milky or foamy.</li> <li>1. Check wheels for broken, cracked, and bent surfaces.</li> <li>2. Check lugnuts and wheel studs for obvious looseness and damage. If loose, tighten and report to maintenance as soon as practical.</li> </ol>	<p>Fluid appears milky or foamy.</p> <p>Wheel is broken, cracked, or bent.</p> <p>Two or more lugnuts or studs on the same wheel are missing, broken, or bent.</p>
4	After	Driver Side Shock Absorbers	Check driver side shock absorbers for leaks and damage.	Damaged or Class III leak present.
5	After	Crane Control Knobs	Check all crane control knobs to make sure information on knobs is legible.	Information on crane control knobs is not legible.
6	After	Rear Exterior	Check rear of vehicle for obvious damage that would impair operation.	Any damage that would impair operation.

**Table 1. PMCS - AFTER - Continued**

Item No.	Interval	Item to be Checked or Serviced	Procedure	Equipment Not Ready/ Available If:
7	After	Towing Gladhands	Check for presence and condition of towing gladhands and rubber grommets.	
8	After	Passenger side Wheels	<ol style="list-style-type: none"> <li>1. Check wheels for broken, cracked, and bent surfaces.</li> <li>2. Check lugnuts and wheel studs for obvious looseness and damage. If loose, tighten and report to maintenance as soon as practical.</li> </ol>	<p>Wheel is broken, cracked, or bent.</p> <p>Two or more lugnuts or studs on the same wheel are missing, broken, or bent.</p>
9	After	Passenger Side Shock Absorbers	<p>Check passenger side shock absorbers for leaks and damage.</p> <p style="text-align: center;"><b>WARNING</b></p> <div style="text-align: center;">  </div> <p>Vehicles air system is pressurized, be sure to wear proper eye protection and keep face away from drain valves while draining air reservoirs. Open air drain valves slowly to prevent sudden blast of air.</p>	<p>Damaged or Class III leak present.</p>

*Table 1. PMCS - AFTER - Continued*

Item No.	Interval	Item to be Checked or Serviced	Procedure	Equipment Not Ready/ Available If:
10	After	Air Reservoirs	<p>Failure to comply may result in injury to personnel.</p> <p style="text-align: center;"><b>NOTE</b></p> <ul style="list-style-type: none"> <li>• Only drain air reservoirs that are located under the passenger side battery box.</li> <li>• The M983 has three air reservoirs under the battery box, all other models have two.</li> </ul> <p>1. Drain only air reservoirs under battery box as follows:</p>	



*Figure 2.*

- a. Turn petcock on bottom of reservoir to open position.

**Table 1. PMCS - AFTER - Continued**

Item No.	Interval	Item to be Checked or Serviced	Procedure	Equipment Not Ready/ Available If:
11	After	Transmission	<p>b. Let condensation drain off.</p> <p>c. Turn petcock on bottom of reservoir to closed position.</p> <p style="text-align: center;"><b>CAUTION</b></p> <p>Clean around end of fill tube prior to removing dipstick. This will aid in preventing dirt or foreign matter from entering the transmission and causing damage.</p> <p style="text-align: center;"><b>NOTE</b></p> <p>Vehicle is parked (WP 0056) on a flat, level surface.</p> <p>Engine is at idle.</p> <p>Transmission is at normal operating temperature, 160-200°F (71-93°C).</p> <p>1. With engine running, check transmission fluid level on dipstick:</p>	

Table 1. PMCS - AFTER - Continued

Item No.	Interval	Item to be Checked or Serviced	Procedure	Equipment Not Ready/ Available If:
----------	----------	--------------------------------	-----------	------------------------------------

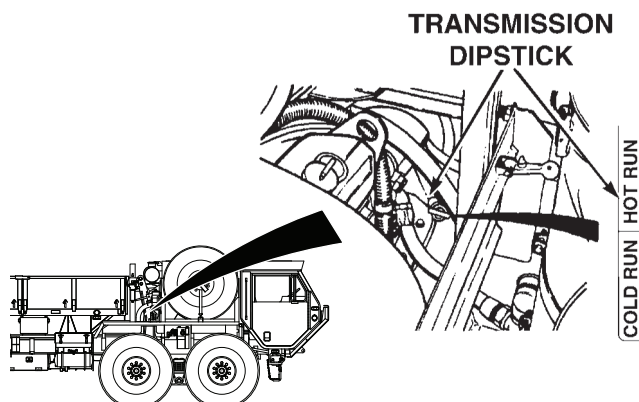


Figure 3.

**NOTE**

Fluid level should be between HOT FULL and HOT ADD marks.

2. Add OE/HDO (WP 0151, Table 2) as required or notify field level maintenance if overfull.

1. Check spare tire for cuts, gouges, cracks, or scratches. Remove any sharp objects.

12	After	Spare Tire/ Wheel	<p><b>NOTE</b></p> <p>Fluid level should be between HOT FULL and HOT ADD marks.</p> <p>2. Add OE/HDO (WP 0151, Table 2) as required or notify field level maintenance if overfull.</p> <p>1. Check spare tire for cuts, gouges, cracks, or scratches. Remove any sharp objects.</p>	Tire has cuts, gouges, or cracks that could result in tire failure. Tire is missing or
----	-------	----------------------	---	--

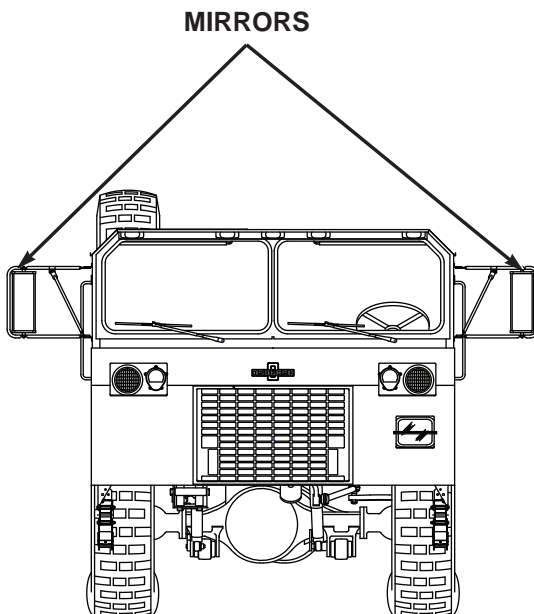


**Table 1. PMCS - AFTER - Continued**

Item No.	Interval	Item to be Checked or Serviced	Procedure	Equipment Not Ready/ Available If:
13	After	Exterior of Cab	<ol style="list-style-type: none"> <li>2. Check wheel for broken, cracked, and bent surfaces.</li> <li>3. Check lugnuts and wheel studs for obvious looseness and damage.</li> <li>1. Visually inspect cab and components for damage.</li> </ol> <p style="text-align: center;"><b>NOTE</b></p> <p>Operation of vehicle with broken/missing mirrors may violate AR 385-55. (WP 0161)</p>	<p>unserviceable.</p> <p>Wheel is broken, cracked, or bent.</p> <p>Two or more lugnuts or studs are missing, broken, or bent.</p> <p>Any component is damaged that would impair vehicle mission.</p>
14	After	Mirrors	Check condition of mirrors.	

*Table 1. PMCS - AFTER - Continued*

Item No.	Interval	Item to be Checked or Serviced	Procedure	Equipment Not Ready/ Available If:
----------	----------	--------------------------------	-----------	------------------------------------



*Figure 4.*

**NOTE**

Operation of vehicle with damaged or missing windshield may violate AR 385-55. (WP 0161)

15

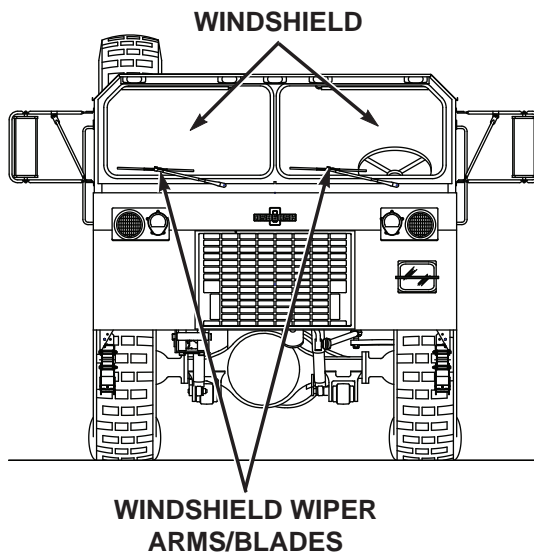
After

Windshield and Wiper Arms/Blades

1. Check windshield glass for presence and condition.

**Table 1. PMCS - AFTER - Continued**

Item No.	Interval	Item to be Checked or Serviced	Procedure	Equipment Not Ready/ Available If:
----------	----------	--------------------------------	-----------	------------------------------------

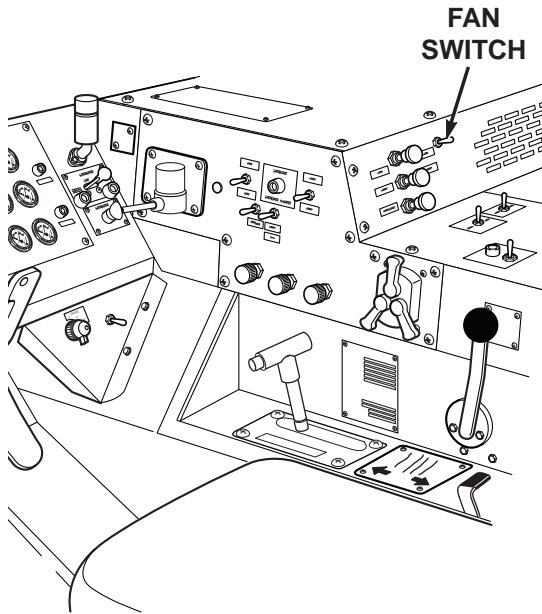


*Figure 5.*

<p>16</p> <p>After</p>	<p>Fan Switch</p>	<p style="text-align: center;"><b>NOTE</b></p> <p>Operation of vehicle with damaged wiper arms/blades may violate AR 385-55. (WP 0161)</p> <p>2. Check condition of wiper arms and blades.</p>
		<p>Check fan control switch for proper operation (WP 0036) in LO and HI positions.</p>

**Table 1. PMCS - AFTER - Continued**

Item No.	Interval	Item to be Checked or Serviced	Procedure	Equipment Not Ready/ Available If:
----------	----------	--------------------------------	-----------	------------------------------------



*Figure 6.*

**NOTE**

Operation of vehicle with malfunctioning windshield wiper may violate AR 385-55. (WP 0161)

17

After

WIPER/  
Washer  
Controls

1. Check WIPER controls (driver and passenger side) for proper operation. (WP 0035)

Table 1. PMCS - AFTER - Continued

Item No.	Interval	Item to be Checked or Serviced	Procedure	Equipment Not Ready/ Available If:
----------	----------	--------------------------------	-----------	------------------------------------

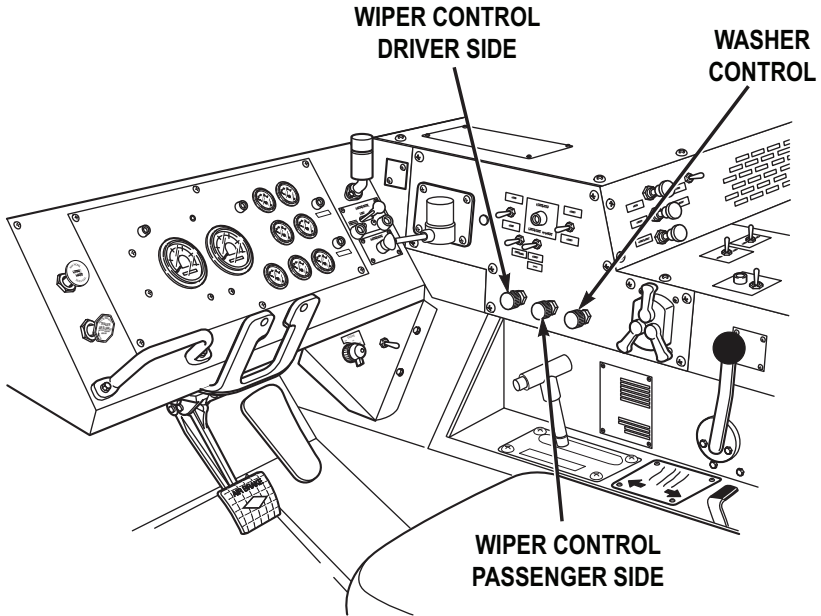


Figure 7.

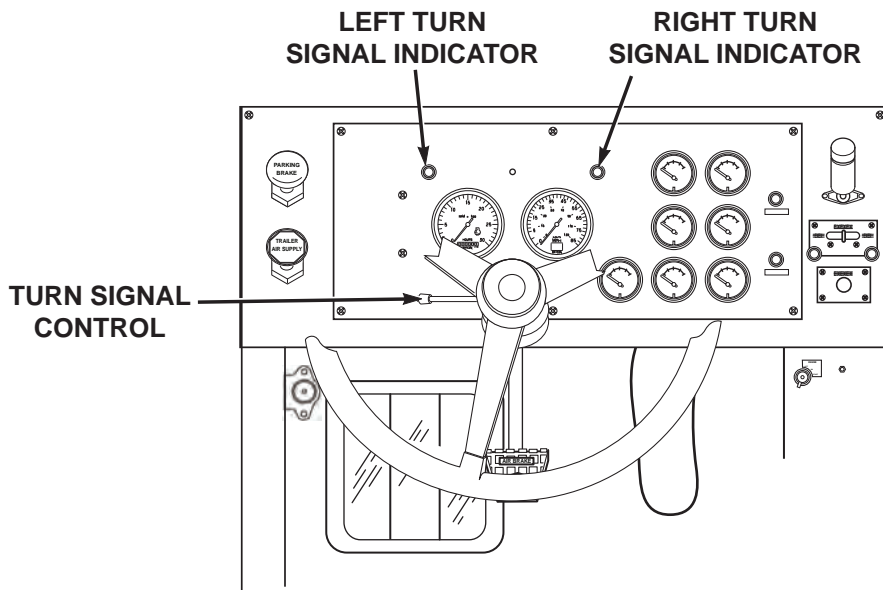
18	After	Horns	<p>2. Check windshield washer control for proper operation.</p> <p style="text-align: center;"><b>NOTE</b></p> <p>Operation of vehicle with malfunctioning horn may violate AR AR 385-55. (WP 0161)</p> <p>Check both horns (air and electric) for proper operation.</p>	
----	-------	-------	--	--

**Table 1. PMCS - AFTER - Continued**

Item No.	Interval	Item to be Checked or Serviced	Procedure	Equipment Not Ready/ Available If:
19	After	Turn Signal Control And Indicators	<p style="text-align: center;"><b>NOTE</b></p> <ul style="list-style-type: none"> <li>• Light checks will require assistance.</li> <li>• Operation of vehicle with malfunctioning turn signal control may violate AR 385-55. (WP 0161)</li> </ul> <p>1. Check turn signal control for proper operation. (WP 0019)</p>	

**Table 1. PMCS - AFTER - Continued**

Item No.	Interval	Item to be Checked or Serviced	Procedure	Equipment Not Ready/ Available If:
----------	----------	--------------------------------	-----------	------------------------------------



*Figure 8.*

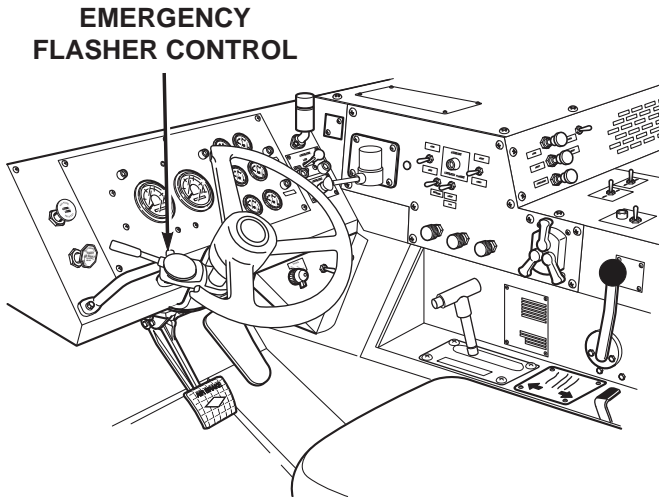
2. Check turn signal indicators for proper operation. (WP 0021)

**NOTE**

- Light checks will require assistance.
- Operation of vehicle with malfunctioning emergency flasher control may violate AR 385-55. (WP 0161)

**Table 1. PMCS - AFTER - Continued**

Item No.	Interval	Item to be Checked or Serviced	Procedure	Equipment Not Ready/ Available If:
20	After	Emergency Flasher Control	Check emergency flasher control for proper operation. (WP 0019)	



*Figure 9.*

**NOTE**

- Light checks will require assistance.
- Operation of vehicle with malfunctioning service lights may violate AR 385-55. (WP 0161)

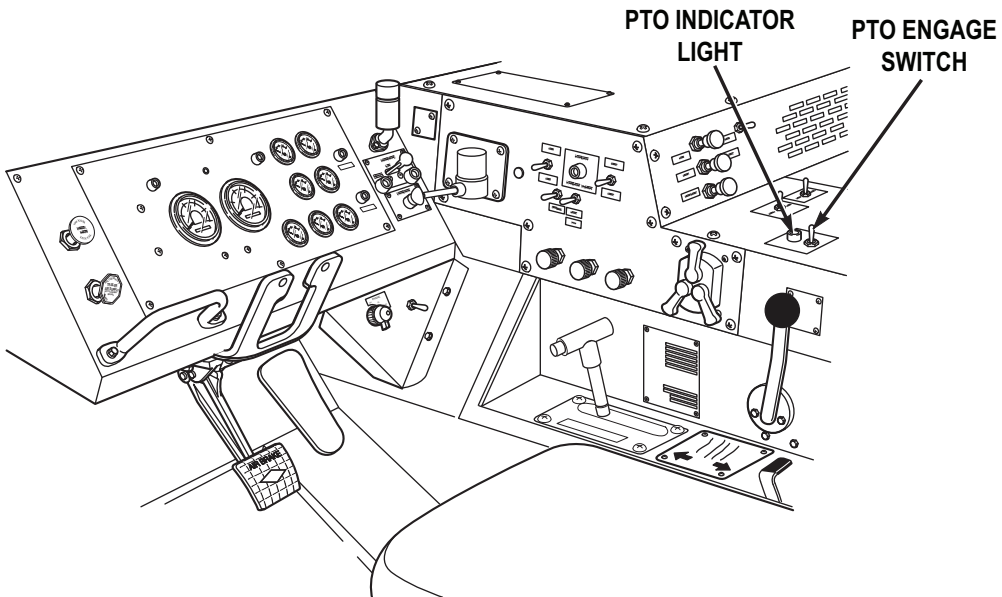


**Table 1. PMCS - AFTER - Continued**

Item No.	Interval	Item to be Checked or Serviced	Procedure	Equipment Not Ready/ Available If:
21	After	Lights	<p>Check headlights, clearance lights, turn signals, and brake lights for proper operation.</p> <p style="text-align: center;"><b>NOTE</b></p> <p>Operation of vehicle with malfunctioning beacon light may violate AR 385-55. (WP 0161)</p>	
22	After	Portable Beacon Light (If equipped )	<p>Remove beacon light from glove box and check for proper operation. (WP 0074)</p> <p style="text-align: center;"><b>NOTE</b></p> <p>Complete this PMCS procedure only if material handling crane was used during mission.</p>	
23	After	Material Handling Crane (if used)	<p>1. Inspect crane for loose nuts and bolts, hydraulic leaks, damage to hydraulic hoses and lines, and obvious damage.</p> <p style="text-align: center;"><b>NOTE</b></p> <p>For more information on material handling crane operating instructions, refer to grove crane operation (manual control) procedures. (WP 0042)</p>	<p>Class III leak or damage to hoses, lines, or fittings.</p>

**Table 1. PMCS - AFTER - Continued**

Item No.	Interval	Item to be Checked or Serviced	Procedure	Equipment Not Ready/ Available If:
			2. Check that crane hydraulic system is operable as follows: <ul style="list-style-type: none"> <li>a. Start engine. (WP 0044)</li> <li>b. Set PTO ENGAGE switch to ON position. PTO indicator light will illuminate.</li> </ul>	



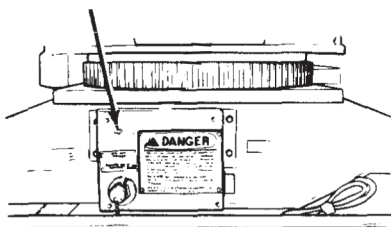
*Figure 10.*

			c. Set ON/OFF POWER switch to ON position.	
--	--	--	--	--

*Table 1. PMCS - AFTER - Continued*

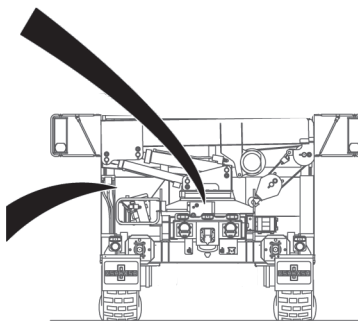
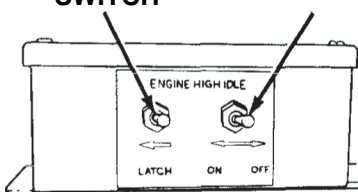
Item No.	Interval	Item to be Checked or Serviced	Procedure	Equipment Not Ready/ Available If:

**ON/OFF POWER SWITCH**



**LATCH SWITCH**

**ENGINE HIGH IDLE SWITCH**



*Figure 11.*


- d. Set HIGH IDLE CONTROL switch to CONTINUOUS.

**WARNING**



Excessive noise levels are present any time the heavy-duty winch, crane, or retrieval system is operating. Wear

**Table 1. PMCS - AFTER - Continued**

Item No.	Interval	Item to be Checked or Serviced	Procedure	Equipment Not Ready/ Available If:
			<p>single hearing protection (earplugs or equivalent) while working around equipment when it is running. Failure to comply may result in injury or death to personnel. Seek medical aid should you suspect a hearing problem.</p> <p>e. Push and release LATCH switch. Engine speed should increase to approximately 1500 rpm.</p> <p>3. Check crane manual control levers as follows:</p> <p style="text-align: center;"><b>WARNING</b></p> <div style="text-align: center;">  </div> <ul style="list-style-type: none"> <li>• Stand clear of outrigger beams while operating levers. Failure to comply may result in injury or death to personnel.</li> <li>• Do not operate crane unless outriggers are firmly in place or vehicle could turn over. Failure to</li> </ul>	

**Table 1. PMCS - AFTER - Continued**

Item No.	Interval	Item to be Checked or Serviced	Procedure	Equipment Not Ready/ Available If:
			<p>comply may result in injury or death to personnel.</p> <ul style="list-style-type: none"> <li>• Keep boom clear of all electrical lines and other obstacles while operating crane. Failure to comply may result in injury or death to personnel.</li> </ul> <p style="text-align: center;"><b>NOTE</b></p> <ul style="list-style-type: none"> <li>• Operate control levers with light, even pressure. Moving lever slightly will cause slow movement of crane. Moving lever to full travel will cause faster movement of crane.</li> <li>• Outrigger beams will come out slower with light pressure on lever. Pushing lever to full travel will cause fast movement.</li> </ul> <p>a. Move O/R EXT lever to IN position briefly.</p>	

Table 1. PMCS - AFTER - Continued

Item No.	Interval	Item to be Checked or Serviced	Procedure	Equipment Not Ready/ Available If:
----------	----------	--------------------------------	-----------	------------------------------------

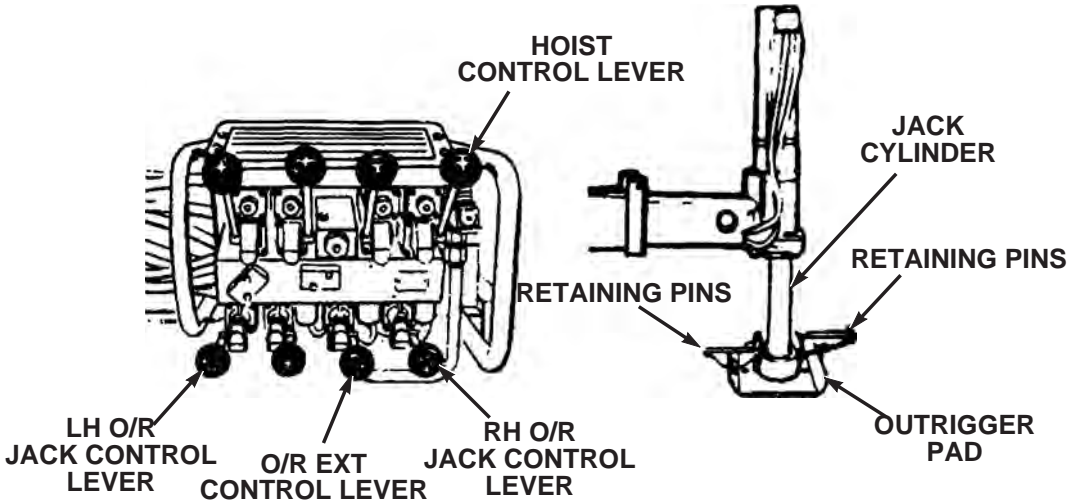
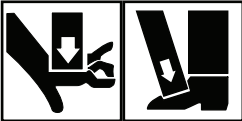


Figure 12.

		<p>b. Place both outrigger lockpins in unlock position.</p> <p>c. Check each control separately for malfunction, proper response, obvious damage, missing parts, binding, and extreme looseness.</p> <p>d. Move O/R EXT lever to OUT position until both outriggers is completely extended.</p> <p>e. Set up outrigger pads. Check that two retaining pins are</p>	<p>Controls malfunction, bind, or do not respond.</p> <p>Outrigger beam does not come out.</p> <p>Retaining pin missing</p>
--	--	--	---

**Table 1. PMCS - AFTER - Continued**

Item No.	Interval	Item to be Checked or Serviced	Procedure	Equipment Not Ready/ Available If:
			<p>attached to each outrigger pad.</p> <p style="text-align: center;"><b>WARNING</b></p>  <p>Keep hands and feet clear of outrigger jack cylinders. Failure to comply may result in injury or death to personnel.</p> <p style="text-align: center;"><b>NOTE</b></p> <p>Adjust outrigger pad position as required so rod end will lower into pad socket.</p> <p>f. Move LH O/R JACK control lever to DOWN position and lower outrigger jack until rod end is firmly seated in outrigger pad. Install retaining pins.</p> <p>g. Move RH O/R JACK control lever to DOWN position and lower outrigger jack until rod end is firmly seated in outrigger pad. Install retaining pins.</p>	<p>from either end.</p> <p>Outrigger jack cylinder will not come out or will not lower completely into pad.</p> <p>Outrigger jack cylinder will not come out or will not lower completely into pad.</p>

**Table 1. PMCS - AFTER - Continued**

Item No.	Interval	Item to be Checked or Serviced	Procedure	Equipment Not Ready/ Available If:
			<ul style="list-style-type: none"> <li>h. Check that outrigger jack cylinder on each side of vehicle is out and down.</li> <li>i. Seat outriggers.</li> <li>j. Raise boom to operating position:</li> </ul>	<p>Crane hydraulic system does not operate.</p>

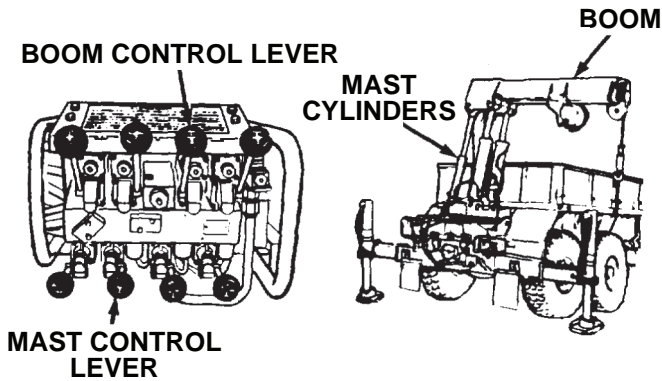


Figure 13.


		<p style="text-align: center;"><b>WARNING</b></p> <div style="text-align: center;">  </div> <p>Do not operate crane unless outriggers are firmly in place or vehicle could turn over.</p>
--	--	--



**Table 1. PMCS - AFTER - Continued**

Item No.	Interval	Item to be Checked or Serviced	Procedure	Equipment Not Ready/ Available If:
			<p>Failure to comply may result in injury or death to personnel.</p> <p style="text-align: center;"><b>CAUTION</b></p> <p>Do not let cable unwind and become slack, or cable may get tangled on drum.</p> <ol style="list-style-type: none"> <li>(1) Move HOIST control lever to DOWN position until hook block rests on fender.</li> <li>(2) Pull and turn lockpin handle so handle end rests on bracket to unstow hook block.</li> </ol> <p style="text-align: center;"><b>CAUTION</b></p> <p>Do not allow load hook to contact taillight during inspection. Failure to comply may result in damage to equipment.</p> <p style="text-align: center;"><b>NOTE</b></p> <p>Operation of vehicle with malfunctioning load hook may violate AR 385-55. (WP 0161)</p> <ol style="list-style-type: none"> <li>(3) Check hook block and load hook for cracks, and proper operation.</li> </ol>	<p>Hook block or load hook is cracked.</p>


**Table 1. PMCS - AFTER - Continued**

Item No.	Interval	Item to be Checked or Serviced	Procedure	Equipment Not Ready/ Available If:
			<p style="text-align: center;"><b>NOTE</b></p> <p>Operation of vehicle with malfunctioning load hook spring safety latch may violate AR 385-55. (WP 0161)</p> <p>(4) Check load hook spring safety latch for damage and proper operation.</p> <p>(5) Check hook block stowage guide wear plate for excessive wear.</p> <p style="text-align: center;"><b>WARNING</b></p> <div style="text-align: center;">  </div> <p>When using crane on any vehicle, park vehicle clear of all overhead electrical lines. Keep boom clear of all electrical lines and other obstacles while operating crane. Failure to comply may result in injury or death to personnel.</p>	<p>Load hook spring safety latch doesn't open and/or close properly.</p>

**Table 1. PMCS - AFTER - Continued**

Item No.	Interval	Item to be Checked or Serviced	Procedure	Equipment Not Ready/ Available If:
			<p style="text-align: center;"><b>CAUTION</b></p> <p>Do not hit outrigger leg with hook block. Failure to comply may result in damage to equipment.</p> <p>(6) Move BOOM control lever to UP position until hook is five to six feet (1.5 to 1.8 m) above driver side rear fender and boom is approximately 45° above horizontal.</p> <p>(7) Move MAST control lever to UP position until the mast is fully erect and the cylinders are fully extended. Use BOOM control lever UP simultaneously as required to maintain the boom at approximately 45° above horizontal until the mast is fully erect. Hold the MAST control lever to UP position for two to three seconds after mast is fully erect to ensure cylinders are fully filled with oil.</p> <p>k. Rotate and telescope boom:</p>	<p>Boom does not raise.</p> <p>Mast cylinder does not raise completely before stopping.</p>

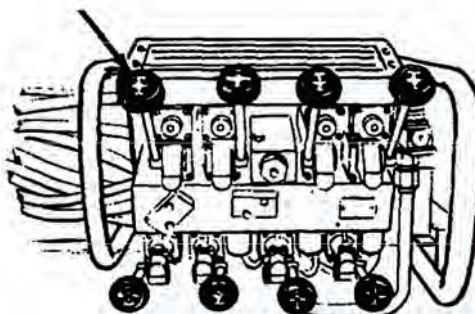
*Table 1. PMCS - AFTER - Continued*

Item No.	Interval	Item to be Checked or Serviced	Procedure	Equipment Not Ready/ Available If:
			<p style="text-align: center;"><b>WARNING</b></p>  <ul style="list-style-type: none"> <li>• When using crane on any vehicle, park vehicle clear of all overhead electrical lines. Keep boom clear of all electrical lines and other obstacles while operating crane. Failure to comply may result in injury or death to personnel.</li> <li>• Ensure area is clear of personnel prior to moving SWING lever. Boom should be swung slowly enough so crane operator has complete control. Failure to comply may result in injury or death to personnel.</li> </ul> <p style="text-align: center;"><b>CAUTION</b></p> <p>Boom must be above vehicle sides for clearance.</p> <p>(1) Move swing control lever to CW position to move boom clockwise.</p>	<p>Boom does not turn clockwise.</p>

*Table 1. PMCS - AFTER - Continued*

Item No.	Interval	Item to be Checked or Serviced	Procedure	Equipment Not Ready/ Available If:
----------	----------	--------------------------------	-----------	------------------------------------

**SWING CONTROL LEVER**



*Figure 14.*

- (2) Move swing control lever to CCW position to move boom counterclockwise.

Boom does not turn counterclockwise.

**CAUTION**

Keep hook block at least 1 ft. (30 cm) from end of boom. If hook block hits end of boom it may damage cable or hook block and crane will lose power. Wait six seconds for power to return and check crane for damage.

**NOTE**

- TELESCOPE and HOIST levers should be

**Table 1. PMCS - AFTER - Continued**

Item No.	Interval	Item to be Checked or Serviced	Procedure	Equipment Not Ready/ Available If:
			<p>operated at the same time.</p> <ul style="list-style-type: none"> <li>Crane movement from one lever may be slower than the other when operating two levers together.</li> </ul> <p>(3) Move TELESCOPE control lever to OUT position to extend boom while moving hoist control lever to DOWN position to pay out cable.</p>	<p>Extensions do not come out.</p>

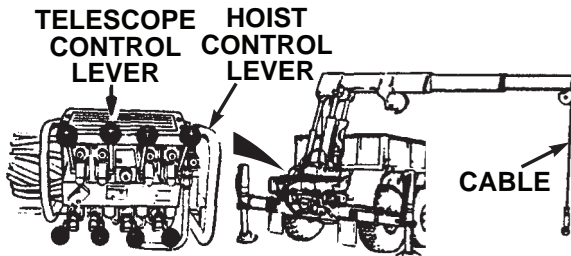


Figure 15.

		<p>(4) Check first, second, and third stages of boom for broken welds or obvious damage.</p>	<p>There are broken welds or obvious damage to boom.</p>
--	--	--	--

*Table 1. PMCS - AFTER - Continued*

Item No.	Interval	Item to be Checked or Serviced	Procedure	Equipment Not Ready/ Available If:
----------	----------	--------------------------------	-----------	------------------------------------

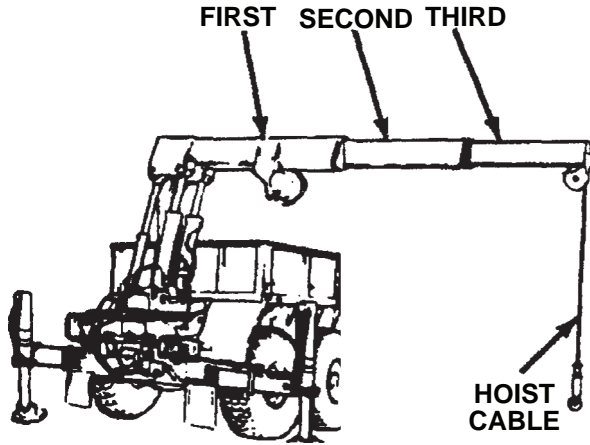


Figure 16.

**WARNING**



Always wear protective gloves when checking hoist cable. Never let cable run through hands. Frayed cables can cut severely. Failure to comply may result in injury or death to personnel.

- (5) Check cable on hoist for kinks, frays, or breaks.

Evidence of kinks, frays, or breaks.

*Table 1. PMCS - AFTER - Continued*

Item No.	Interval	Item to be Checked or Serviced	Procedure	Equipment Not Ready/ Available If:
			<p>(6) Check all hoses, fittings, valves, and cylinders for signs of leaks.</p> <p>(7) Check for cracked or broken welds.</p> <p>(8) Inspect turntable bearing bolts for obvious looseness.</p>	<p>Class III leak present.</p> <p>Cracked or broken welds are present.</p> <p>One or more turntable bearing bolts are loose.</p>

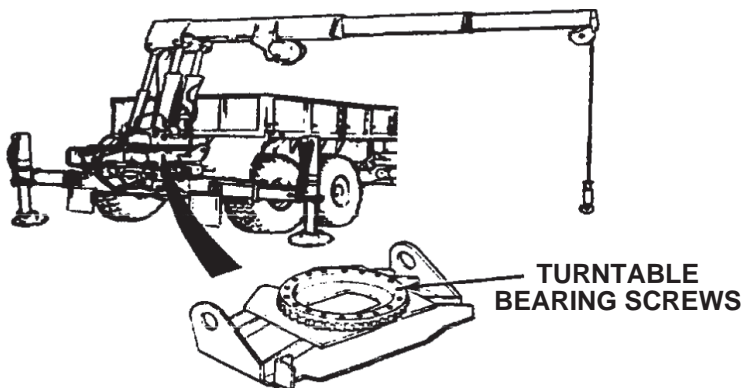


Figure 17.

**CAUTION**

Do not let cable become slack or cable may get tangled on drum.

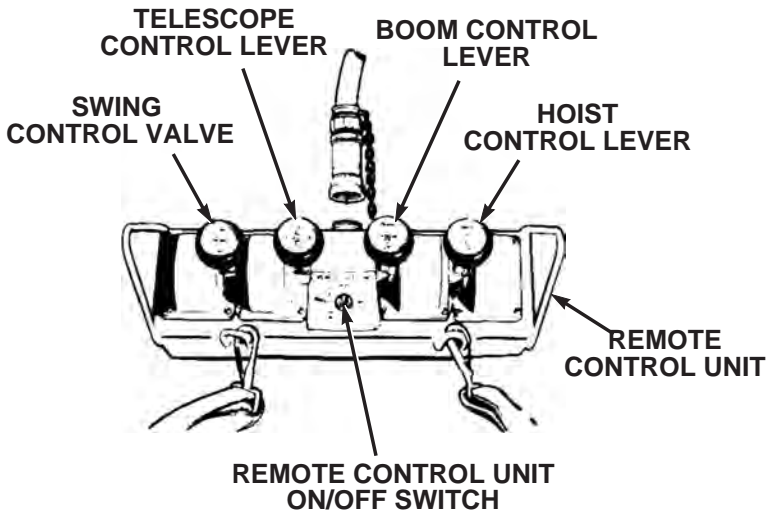


**Table 1. PMCS - AFTER - Continued**

Item No.	Interval	Item to be Checked or Serviced	Procedure	Equipment Not Ready/ Available If:
			<p>(9) Move HOIST control lever in UP position to reel in cable.</p> <p>(10) Move HOIST control lever in DOWN position to pay out cable.</p> <p style="text-align: center;"><b>NOTE</b></p> <p>For more information on material handling crane remote control operating instructions, refer to grove crane operation (remote control) procedures. (WP 0043)</p> <p>4. Check crane remote control levers as follows:</p>	<p>Cable does not reel in.</p> <p>Cable does not pay out.</p>

*Table 1. PMCS - AFTER - Continued*

Item No.	Interval	Item to be Checked or Serviced	Procedure	Equipment Not Ready/ Available If:



*Figure 18.*


- a. Set up REMOTE CONTROL UNIT passenger side. (WP 0043)

**WARNING**




- When using crane on any vehicle, park vehicle clear of all overhead electrical lines. Keep boom clear of all electrical lines and

**Table 1. PMCS - AFTER - Continued**

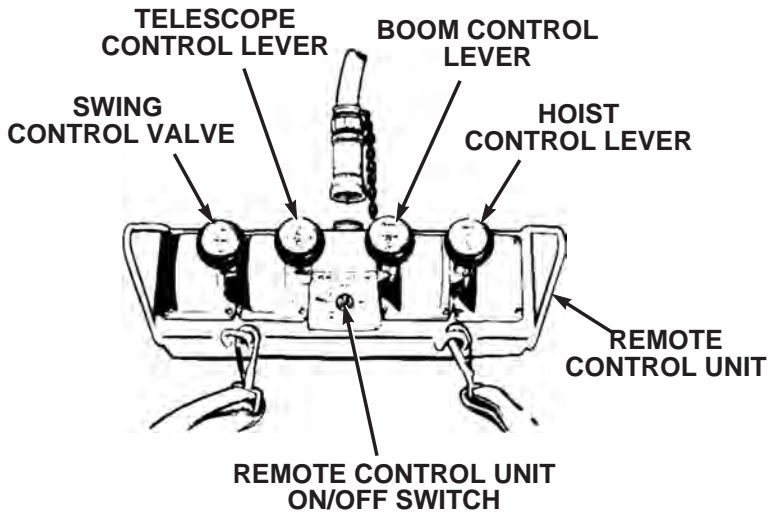
Item No.	Interval	Item to be Checked or Serviced	Procedure	Equipment Not Ready/ Available If:
			<p>other obstacles while operating crane. Failure to comply may result in injury or death to personnel.</p> <ul style="list-style-type: none"> <li>• Ensure area is clear of personnel prior to moving SWING lever. Boom should be swung slowly enough so crane operator has complete control. Failure to comply may result in injury or death to personnel.</li> </ul> <p><b>WARNING</b></p>  <p>If electrical power fails during crane operation, move switch on remote control unit to SHUTDOWN position. Failure to comply may result in injury or death to personnel.</p> <p><b>CAUTION</b></p> <p>Crane must be above vehicle sides for clearance.</p> <p><b>NOTE</b></p> <p>Operate control levers with light, even pressure. Moving lever slightly will cause slow</p>	

**Table 1. PMCS - AFTER - Continued**

Item No.	Interval	Item to be Checked or Serviced	Procedure	Equipment Not Ready/ Available If:
			<p>movement of crane. Moving lever to full travel will cause faster movement of crane.</p> <p>b. Check control levers for malfunction, proper response, obvious damage, missing parts, binding, and extreme looseness.</p> <p>c. Rotate and telescope boom:</p> <p style="text-align: center;"><b>WARNING</b></p> <div style="text-align: center;">  </div> <p>Ensure area is clear of personnel prior to moving SWING lever. Boom should be swung slowly enough so crane operator has complete control. Failure to comply may result in injury or death to personnel.</p> <p>(1) Move SWING control lever to CW position to turn boom clockwise.</p>	<p>Controls malfunction, bind, or do not respond.</p> <p>Boom does not turn clockwise.</p>

*Table 1. PMCS - AFTER - Continued*

Item No.	Interval	Item to be Checked or Serviced	Procedure	Equipment Not Ready/ Available If:



*Figure 19.*

- (2) Move SWING control lever to CCW position to turn boom counterclockwise.

Boom does not turn counterclockwise.

**WARNING**



When using crane on any vehicle, park vehicle clear of all overhead electrical lines. Keep boom clear of all elec-

**Table 1. PMCS - AFTER - Continued**

Item No.	Interval	Item to be Checked or Serviced	Procedure	Equipment Not Ready/ Available If:
			<p>trical lines and other obstacles while operating crane. Failure to comply may result in injury or death to personnel.</p> <p style="text-align: center;"><b>CAUTION</b></p> <p>Do not let cable become slack or cable may get tangled on drum.</p> <p>(3) Move HOIST control lever to UP position to take up cable. Move BOOM control lever to UP position to raise boom.</p> <p>(4) Move HOIST control lever to DOWN position to pay out cable. Move BOOM control lever to DOWN position to lower boom to horizontal position.</p> <p style="text-align: center;"><b>CAUTION</b></p> <ul style="list-style-type: none"> <li>Keep hook block at least 1 ft. (30 cm) from end of boom. If hook block hits end of boom it may damage cable or hook block and crane will lose power. Wait six seconds for power and check crane for damage.</li> </ul>	<p>Cable does not reel in or boom does not raise.</p> <p>Cable does not pay out or boom does not lower.</p>

**Table 1. PMCS - AFTER - Continued**

Item No.	Interval	Item to be Checked or Serviced	Procedure	Equipment Not Ready/ Available If:
			<ul style="list-style-type: none"> <li>• Do not let cable become slack or cable may get tangled on drum.</li> </ul> <p style="text-align: center;"><b>NOTE</b></p> <ul style="list-style-type: none"> <li>• TELESCOPE and HOIST levers should be operated at the same time.</li> <li>• Crane movement from one lever may be slower than the other when operating two levers together.</li> </ul> <p>(5) Move TELESCOPE control lever to OUT position while moving HOIST control lever to DOWN position to pay out cable.</p> <p>(6) Move HOIST control lever in UP position to reel in cable.</p> <p>(7) Check that crane and ENGINE HIGH IDLE do not operate when REMOTE CONTROL UNIT is in MHC-SHUTDOWN position. Notify organizational maintenance if crane and ENGINE HIGH IDLE</p>	<p>Extensions will not come out, or cable will not pay out.</p> <p>Cable will not reel in.</p> <p>Crane will operate and engine speed will increase to 1500 rpm.</p>

**Table 1. PMCS - AFTER - Continued**

Item No.	Interval	Item to be Checked or Serviced	Procedure	Equipment Not Ready/ Available If:
			<p>operates when in MHC-SHUTDOWN position.</p> <p>(8) Shut off remote control switches.</p> <p>(9) Disconnect remote control, passenger side.</p> <p>(10) Check operation of driver side remote control station.</p> <p>(11) Connect remote control to driver side remote control station.</p> <p>(12) Check operation of crane remote control levers.</p> <p>(13) Shut off remote control switches.</p> <p>(14) Disconnect and stow REMOTE CONTROL UNIT.</p> <p>5. Shut down material handling crane.</p> <p>6. Check all hoses, fittings, valves, and cylinders for signs of leaks and damage.</p>	<p>Any Class III leak present.</p>



*Table 1. PMCS - AFTER - Continued*

Item No.	Interval	Item to be Checked or Serviced	Procedure	Equipment Not Ready/ Available If:
			7. Check for cracked or broken welds.	Cracked or broken welds.

**END OF WORK PACKAGE**



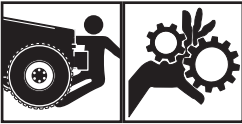

**OPERATOR MAINTENANCE  
WEEKLY - PREVENTIVE MAINTENANCE**

**INITIAL SETUP:**

**Tools and Special Tools**

Gloves, Leather (WP 0163, Table 2)

*Table 1. PMCS - WEEKLY*

Item No.	Interval	Item to be Checked or Serviced	Procedure	Equipment Not Ready/ Available If:
			<p style="text-align: center;"><b>WARNING</b></p>  <p>Do not start engine or move vehicle when personnel are under vehicle or working on brake lines. Failure to comply may result in injury or death to personnel.</p> <p style="text-align: center;"><b>WARNING</b></p>  <p>Ensure engine is OFF and eye protection is worn when checking for leaks. Failure to comply may result in injury or death to personnel.</p>	

**Table 1. PMCS - WEEKLY - Continued**

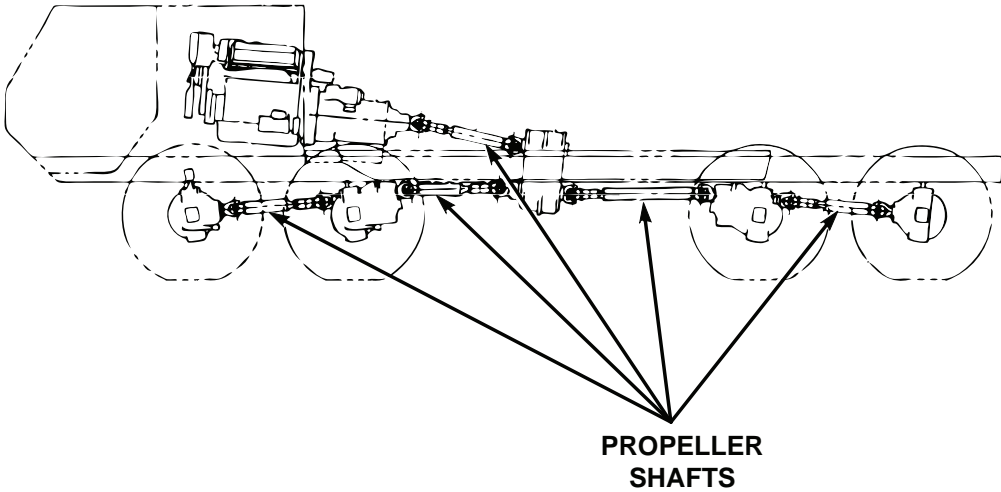
Item No.	Interval	Item to be Checked or Serviced	Procedure	Equipment Not Ready/ Available If:
			<p style="text-align: center;"><b>NOTE</b></p> <p>Perform Operator's Before, After, and Weekly PMCS checks if:</p> <ul style="list-style-type: none"> <li>• You are the assigned driver but have not operated the vehicle since the last weekly inspection.</li> <li>• You are operating the vehicle for the first time.</li> </ul> <p style="text-align: center;"><b>NOTE</b></p> <ul style="list-style-type: none"> <li>• Lubrication intervals are for normal operating conditions. Intervals may be shortened as required for severe operating conditions.</li> <li>• Clean all lubrication points with cleaning compound, solvent and allow to dry prior to servicing.</li> <li>• When using a grease gun, apply lubricant to the fitting until clean lubricant squeezes out of the part being lubricated.</li> <li>• Always refer to lubrication instructions (WP 0151) to ensure equipment has correct lubricants appropriate to operating environment (expected continuous</li> </ul>	

**Table 1. PMCS - WEEKLY - Continued**

Item No.	Interval	Item to be Checked or Serviced	Procedure	Equipment Not Ready/ Available If:
			<p>temperatures). If not, remove/drain and reapply/refill equipment with appropriate lubricants for operating environment as prescribed in lubrication instructions. (WP 0151)</p> <p style="text-align: center;"><b>WARNING</b></p> <div data-bbox="703 778 824 902" style="text-align: center;"> </div> <p>Do not operate a vehicle with a tire in an over-inflated or under-inflated condition, or with a questionable defect. Failure to comply may result in injury or death to personnel and damage to equipment.</p>	
1	Weekly	Driver Side Tires	Check tires for correct air pressure.	
2	Weekly	Propeller Shafts and U-Joints	1. Check propeller shafts and U-joints for excessive movement, obvious damage, and loose, missing or broken nuts and screws.	Propeller shaft or U-Joint has excessive movement, obvious damage, or one or more nuts or screws are loose, miss-

**Table 1. PMCS - WEEKLY - Continued**

Item No.	Interval	Item to be Checked or Serviced	Procedure	Equipment Not Ready/ Available If:
				ing, or damaged.



*Figure 1.*

**NOTE**

- When vehicle is operating under severe conditions, lubricate propeller shafts and universal joints every 50 hours of vehicle operation.
  - Complete Step 2 only if vehicle is operating under severe conditions.
2. Lubricate all propeller shafts, transmission to transfer case

**Table 1. PMCS - WEEKLY - Continued**

<b>Item No.</b>	<b>Interval</b>	<b>Item to be Checked or Serviced</b>	<b>Procedure</b>	<b>Equipment Not Ready/ Available If:</b>
3	Weekly	Axle Breathers	<p>propeller shaft, and U-joints with GAA (WP 0151) as required (refer to operator's semiannual PMCS table (item no. 2) for procedures. (WP 0149)</p> <p>Check four axle breathers for damage and free movement of vent caps on breather body.</p>	<p>Any axle breather caps are damaged or vent caps do not move freely on breather body.</p>

Table 1. PMCS - WEEKLY - Continued

Item No.	Interval	Item to be Checked or Serviced	Procedure	Equipment Not Ready/ Available If:
----------	----------	--------------------------------	-----------	------------------------------------

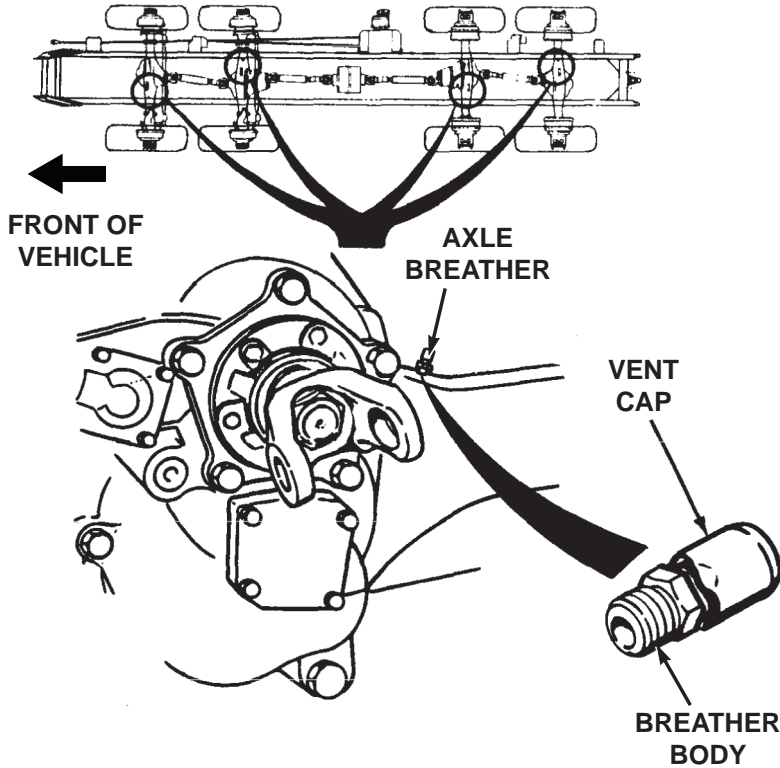


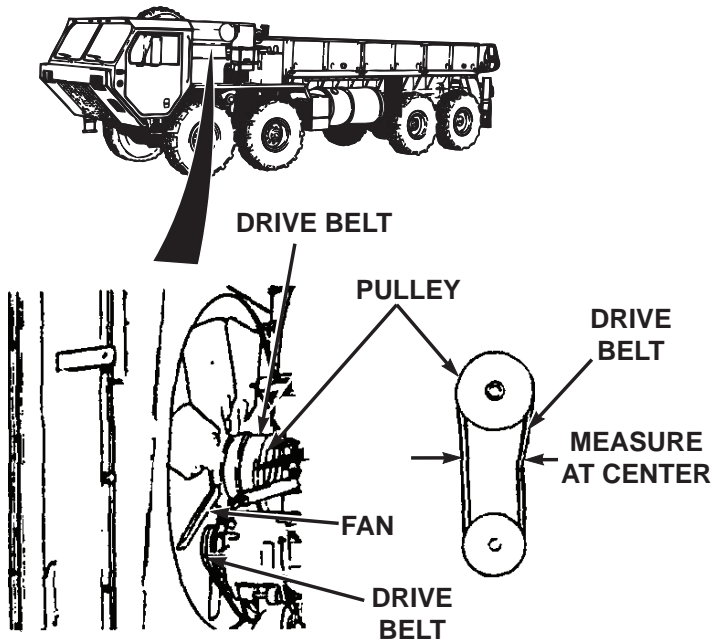
Figure 2.

4	Weekly	Drive Belts, Fan, and Pulleys	<ol style="list-style-type: none"> <li>1. Check drive belts for cracking, fraying, and breaks. Check for tightness. Play should be about 1/2 in. (13 mm).</li> </ol>	Any drive belt is broken, cracked to the belt fiber, has more than one crack
---	--------	-------------------------------	--	--



*Table 1. PMCS - WEEKLY - Continued*

Item No.	Interval	Item to be Checked or Serviced	Procedure	Equipment Not Ready/ Available If:
				(1/8 in. in depth or 50% of belt thickness), has frays more than 2 in. long or excessive play.



*Figure 3.*

**Table 1. PMCS - WEEKLY - Continued**

Item No.	Interval	Item to be Checked or Serviced	Procedure	Equipment Not Ready/ Available If:
5	Weekly	Exhaust System	<p>2. Check condition of fan for broken or cracked blades.</p> <p>3. Check for bent or damaged pulley.</p> <p style="text-align: center;"><b>NOTE</b></p> <p>Operation of vehicle with any exhaust leaks may violate AR 385-55. (WP 0161)</p> <p>Check exhaust pipe, muffler, heatshield, tailpipe, raincap, clamps, and mounting for obvious damage, looseness, exhaust leak, and carbon buildup.</p>	<p>Fan damaged or un-serviceable.</p> <p>Pulley damaged or un-serviceable.</p> <p>Exhaust pipe between turbocharger and exhaust manifold leaks. Any exhaust pipe missing or damaged.</p>

Table 1. PMCS - WEEKLY - Continued

Item No.	Interval	Item to be Checked or Serviced	Procedure	Equipment Not Ready/ Available If:
----------	----------	--------------------------------	-----------	------------------------------------

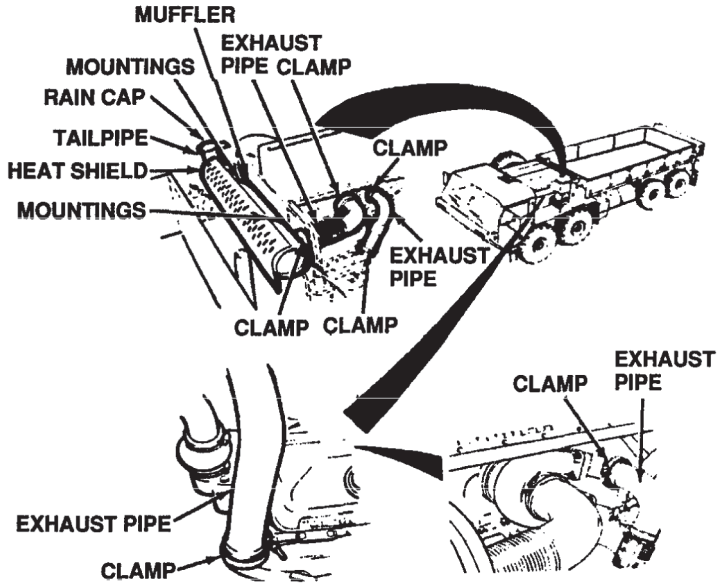


Figure 4.

6	Weekly	Air Intake System/ Ether Starting Aid	1. Squeeze air cleaner dust cap to remove excess dirt from canister.	
---	--------	--	--	--

Table 1. PMCS - WEEKLY - Continued

Item No.	Interval	Item to be Checked or Serviced	Procedure	Equipment Not Ready/ Available If:

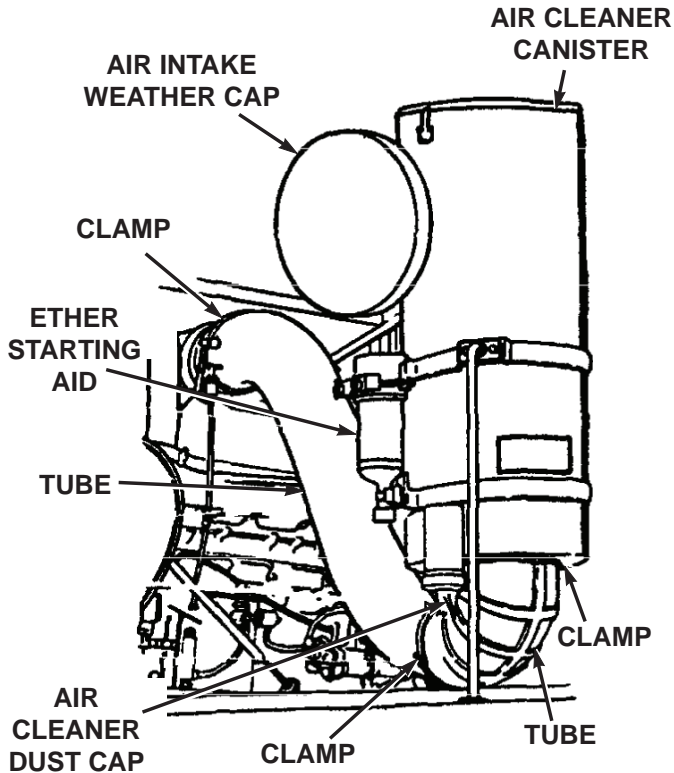


Figure 5.

2. Check that air intake weather cap is secure on air cleaner canister.

**NOTE**

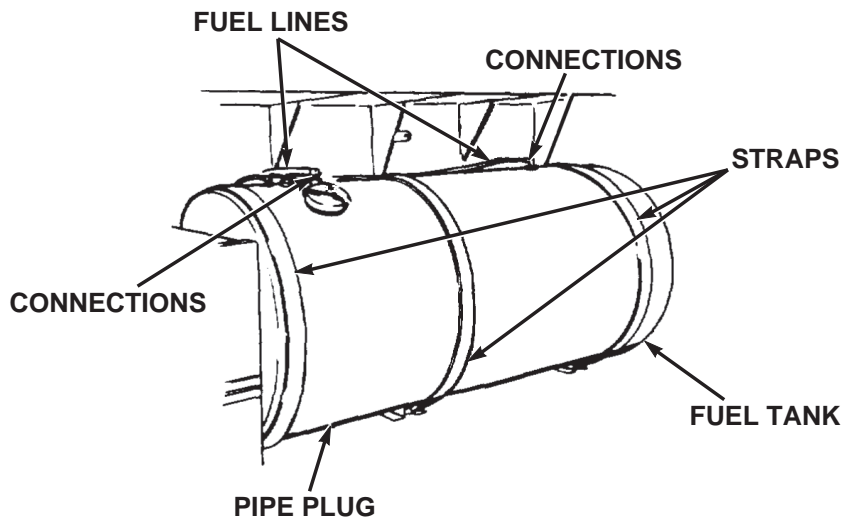
Ether starting aid cartridges will be removed and solenoid

**Table 1. PMCS - WEEKLY - Continued**

Item No.	Interval	Item to be Checked or Serviced	Procedure	Equipment Not Ready/ Available If:
7	Weekly	Fuel Tank	<p>valve will be capped in tropical environment.</p> <p>3. Check ether starting aid for damage and missing hardware.</p> <p>4. Check air intake system for loose or damaged clamps and damage to tube.</p> <p>Check fuel tank, fuel hoses, fuel tank connections, and fuel tank socket head pipe plug for leaks and/or damage.</p>	<p>Air intake system has missing or inoperable clamps, or damage to tube.</p> <p>Any fuel leak.</p>

*Table 1. PMCS - WEEKLY - Continued*

Item No.	Interval	Item to be Checked or Serviced	Procedure	Equipment Not Ready/ Available If:

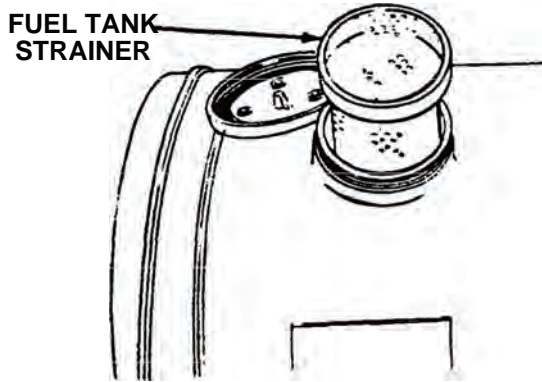


*Figure 6.*

8	Weekly	Fuel Tank Strainer	Check fuel tank strainer for clogs or damage. If strainer is clogged, clean strainer.	
---	--------	--------------------	---	--

**Table 1. PMCS - WEEKLY - Continued**

Item No.	Interval	Item to be Checked or Serviced	Procedure	Equipment Not Ready/ Available If:
----------	----------	--------------------------------	-----------	------------------------------------

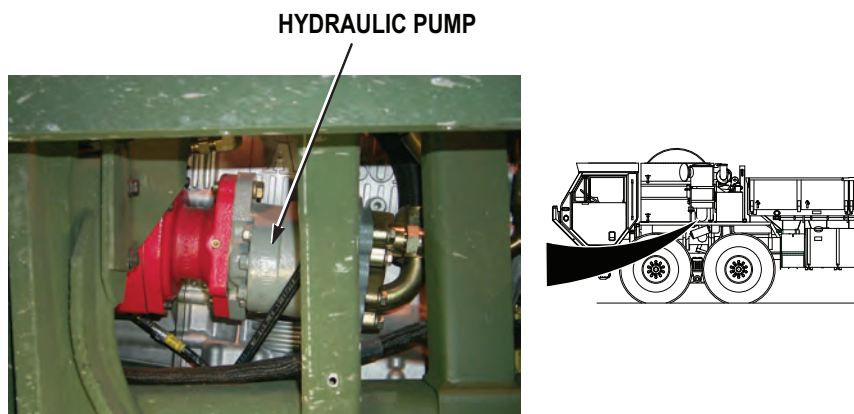


*Figure 7.*

9	Weekly	Hydraulic Pump	Check hydraulic pumps for loose screws, leaks, and damage. Check for loose hose fittings.	Class III leak present or any mounting screw is loose or missing.
---	--------	----------------	---	---

*Table 1. PMCS - WEEKLY - Continued*

Item No.	Interval	Item to be Checked or Serviced	Procedure	Equipment Not Ready/ Available If:
----------	----------	--------------------------------	-----------	------------------------------------



*Figure 8.*

10	Weekly	Hydraulic Hoses	<p>Check all hydraulic hose routing for obvious damage to hydraulic hoses, chaffing, and leaks.</p> <p style="text-align: center;"><b>NOTE</b></p> <p>Operation of vehicle with bent, broken, or missing cargo body screws may violate AR 385-55.</p>	<p>Class III leak present. Chaffing or obvious damage to hydraulic hose present.</p>
----	--------	-----------------	---	--



**Table 1. PMCS - WEEKLY - Continued**

Item No.	Interval	Item to be Checked or Serviced	Procedure	Equipment Not Ready/ Available If:
11	Weekly	Cargo Bed Mounting Screws	Check that cargo bed mounting screws (both driver and passenger side) are not loose, broken, or missing.	One or more cargo bed mounting screws are broken or missing.

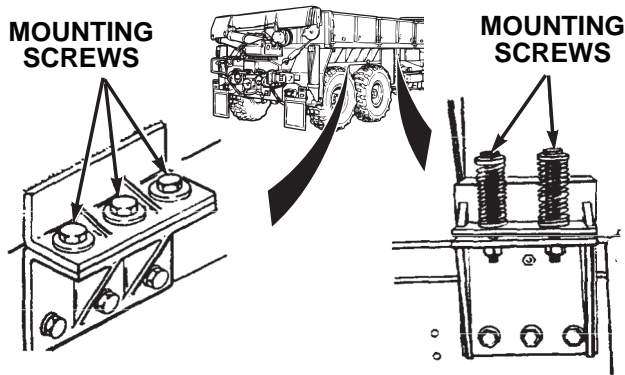
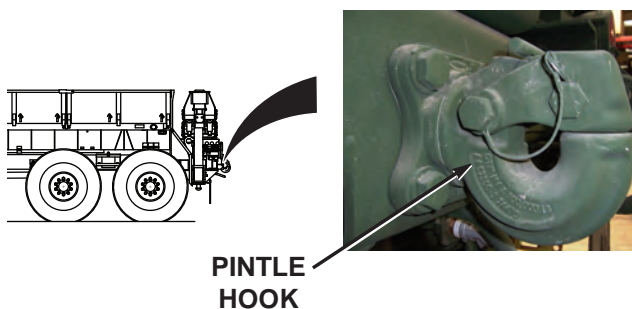


Figure 9.

12	Weekly	Storage Boxes	<ol style="list-style-type: none"> <li>1. Check all storage boxes/ compartments for missing hardware and other obvious damage.</li> <li>2. Check inside all storage boxes/ compartments for torn or damaged seals, water in bottom of storage box/compartment, or other obvious damage.</li> </ol>	
13	Weekly	Rear Spring/ Parking	Check rear spring/parking brake chambers to ensure dust covers are in place and secure.	

**Table 1. PMCS - WEEKLY - Continued**

Item No.	Interval	Item to be Checked or Serviced	Procedure	Equipment Not Ready/ Available If:
14	Weekly	Brake Chambers		
		Towing Shackles	Check towing shackles for serviceability.	
15	Weekly	Pintle Hook	1. Check pintle hook for looseness and damaged locking mechanism of locking pin.	Pintle hook loose or locking mechanism damaged/ unserviceable.

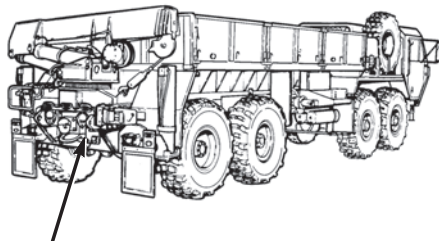


*Figure 10.*

16	Weekly	Rear Lifting Shackles	2. Clean pintle hook and coat with GAA. (WP 0151, Table 9) Check rear lifting shackles for serviceability.	
17	Weekly	Inter-vehicle	Check inter-vehicle connector seal and cable for damage.	

*Table 1. PMCS - WEEKLY - Continued*

Item No.	Interval	Item to be Checked or Serviced	Procedure	Equipment Not Ready/ Available If:
		Connector		



**INTER-VEHICLE  
ELECTRICAL  
CONNECTOR**

*Figure 11.*

**WARNING**



Do not operate a vehicle with a tire in an over-inflated or under-inflated condition, or with a questionable defect. Failure to comply may result in injury or death to personnel and damage to equipment.

**NOTE**

Inspection of passenger side tires includes spare tire.

**Table 1. PMCS - WEEKLY - Continued**

Item No.	Interval	Item to be Checked or Serviced	Procedure	Equipment Not Ready/ Available If:
18	Weekly	Passenger Side Tires	Check tires for correct air pressure.  <p style="text-align: center;"><b>NOTE</b></p> Operation of vehicle with damaged/malfunctioning air compressor may violate AR 385-55. (WP 0161)	
19	Weekly	Air Compressor	Check air compressor for loose screws, damaged mounting flange and air hoses, and loose fittings/connections.	Screws missing, mounting flange broken, air hoses damaged or fittings/connections loose.

*Table 1. PMCS - WEEKLY - Continued*

Item No.	Interval	Item to be Checked or Serviced	Procedure	Equipment Not Ready/ Available If:
----------	----------	--------------------------------	-----------	------------------------------------

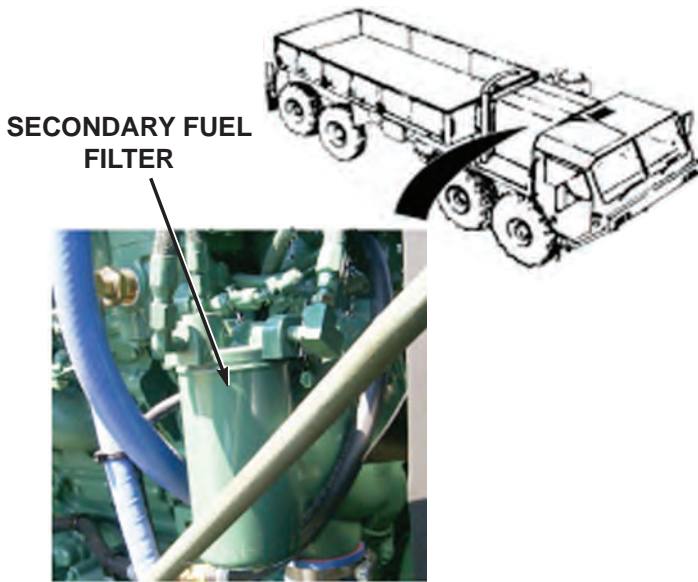


*Figure 12.*

20	Weekly	Secondary Fuel Filter	Check secondary fuel filter for leaks or damage.	Any fuel leak.
----	--------	-----------------------	--	----------------

*Table 1. PMCS - WEEKLY - Continued*

Item No.	Interval	Item to be Checked or Serviced	Procedure	Equipment Not Ready/ Available If:
----------	----------	--------------------------------	-----------	------------------------------------



*Figure 13.*

21	Weekly	Turbocharger Oil Line	Check turbocharger oil line and fittings from rear of engine for signs of leaks and damage.	Any Class III leak present.
----	--------	-----------------------	---	-----------------------------

*Table 1. PMCS - WEEKLY - Continued*

Item No.	Interval	Item to be Checked or Serviced	Procedure	Equipment Not Ready/ Available If:

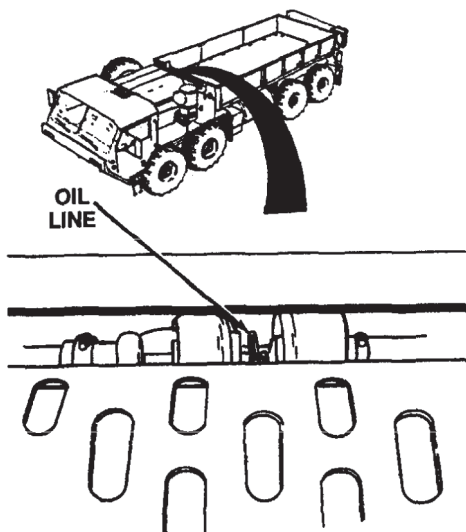


Figure 14.

**WARNING**



Wear proper eye and skin protection when working around batteries. Do not smoke, have open flames, or

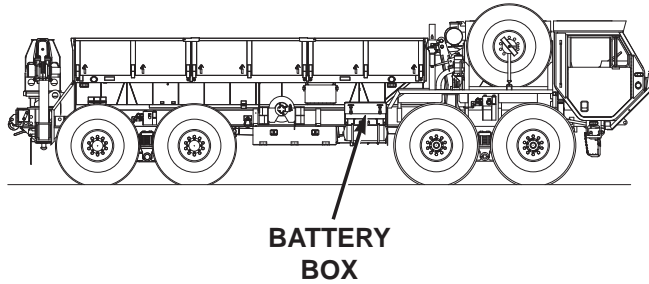
**Table 1. PMCS - WEEKLY - Continued**

Item No.	Interval	Item to be Checked or Serviced	Procedure	Equipment Not Ready/ Available If:
22	Weekly	Batteries	<p>make sparks around batteries, especially if caps are off. Batteries can explode. Failure to comply may result in injury or death to personnel.</p> <p style="text-align: center;"><b>WARNING</b></p> <div data-bbox="543 687 788 808" style="text-align: center;"> </div> <p>Remove all jewelry such as rings, ID tags, bracelets, etc. prior to working on or around vehicle. Jewelry and tools can catch on equipment, contact positive electrical circuits, and cause a direct short, severe burns, or electrical shock. Failure to comply may result in injury or death to personnel.</p> <p>1. Check battery box for damage.</p>	Cracks or holes in battery box.



**Table 1. PMCS - WEEKLY - Continued**

Item No.	Interval	Item to be Checked or Serviced	Procedure	Equipment Not Ready/ Available If:
----------	----------	--------------------------------	-----------	------------------------------------



*Figure 15.*

23	Weekly	Spare Tire Davit And Carrier	<ol style="list-style-type: none"> <li>2. Check battery cables for presence, frays, splits, and looseness.</li> <li>3. Check for loose, missing, or damaged batteries and corroded or burnt battery terminals.</li> </ol> <p>Check spare tire davit and carrier for damage, missing parts.</p>	<p>Battery cables missing, frayed, split, or loose.</p> <p>One or more batteries missing, cracked, or unserviceable. Any battery terminal corroded or burnt. Any hold down not secure.</p>
----	--------	------------------------------	--	--

Table 1. PMCS - WEEKLY - Continued

Item No.	Interval	Item to be Checked or Serviced	Procedure	Equipment Not Ready/ Available If:
----------	----------	--------------------------------	-----------	------------------------------------

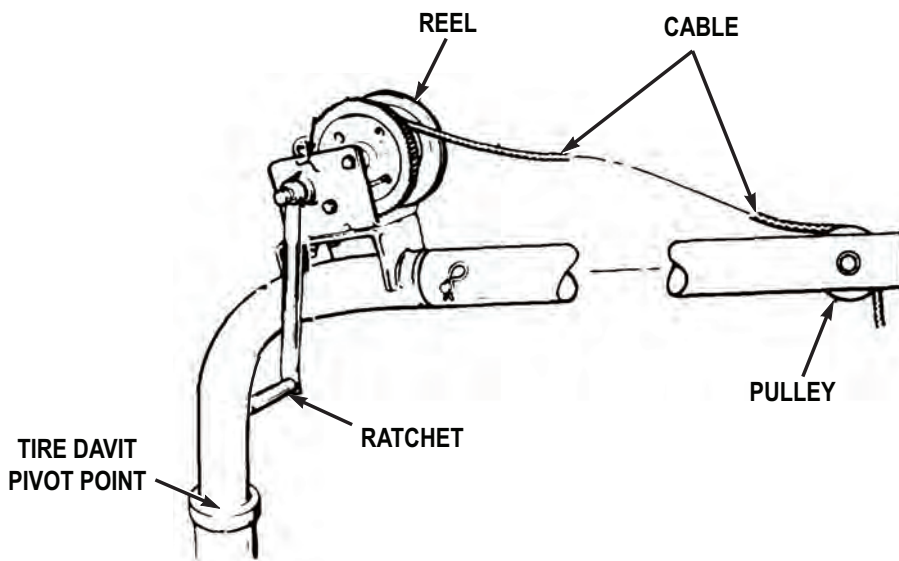
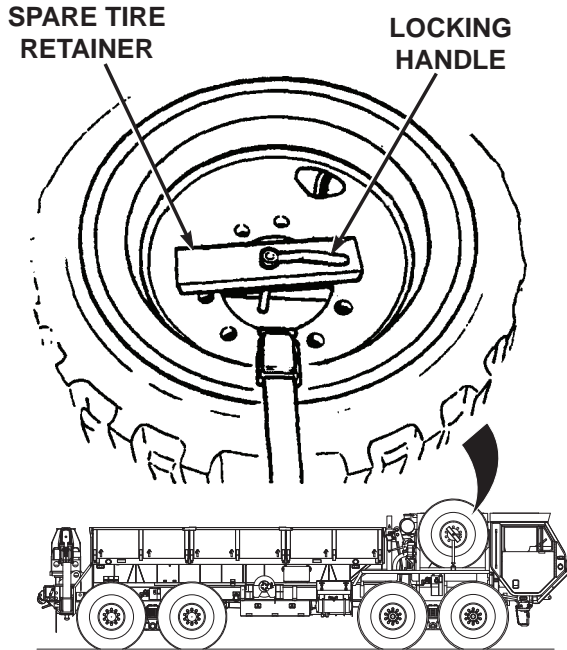


Figure 16.

24	Weekly	Spare Tire Retainer	Check spare tire retainer correctly seated and locking handle tight.	
----	--------	---------------------	--	--

*Table 1. PMCS - WEEKLY - Continued*

Item No.	Interval	Item to be Checked or Serviced	Procedure	Equipment Not Ready/ Available If:



*Figure 17.*

25	Weekly	Air Dryer	Check air dryer for loose screws and connections.	
----	--------	-----------	---	--

*Table 1. PMCS - WEEKLY - Continued*

Item No.	Interval	Item to be Checked or Serviced	Procedure	Equipment Not Ready/ Available If:
----------	----------	--------------------------------	-----------	------------------------------------

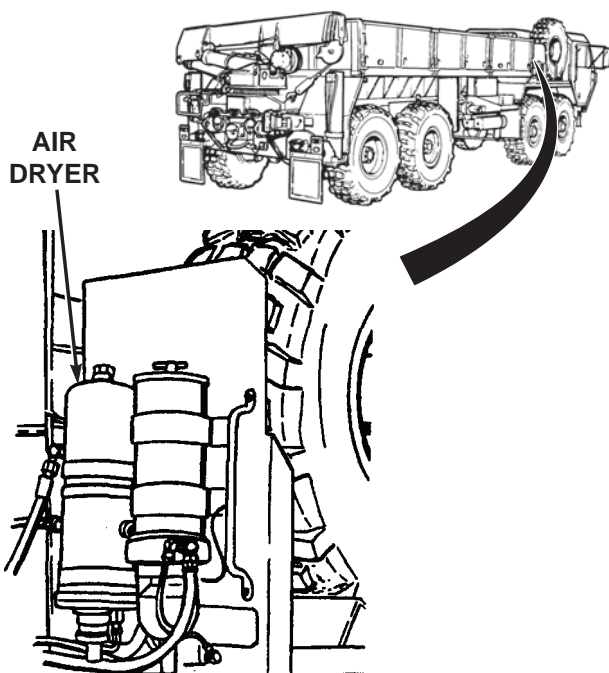


Figure 18.

**NOTE**

Pressurize air system prior to performing this check.

26

Weekly

Air Lines and Hoses

Check routing, for obvious damage to air lines and hoses. Check for leaks.

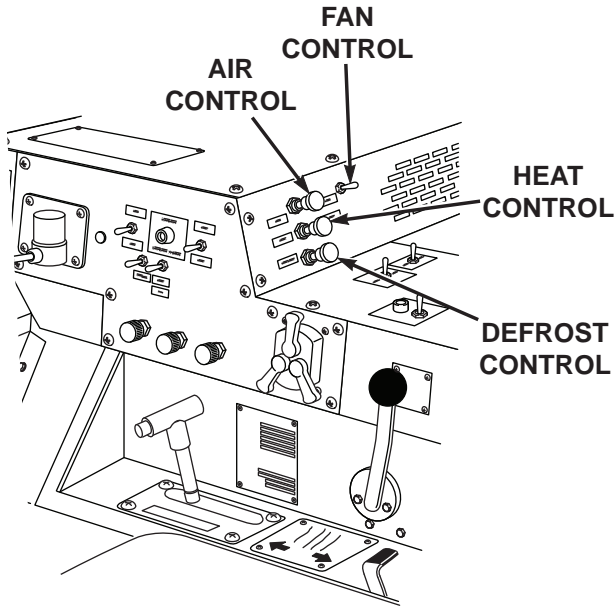
Any leaks or damage to air lines, hoses, or fit-

**Table 1. PMCS - WEEKLY - Continued**

Item No.	Interval	Item to be Checked or Serviced	Procedure	Equipment Not Ready/ Available If:
27	Weekly	Doors, Handles, and Windows	<p style="text-align: center;"><b>NOTE</b></p> <p>Operation of vehicle with damaged doors or windows may violate AR 385-55. (WP 0161)</p> <p>Check condition and operation of door, handles, and windows. (WP 0018)</p>	things are found.
28	Weekly	Cab Temperature Controls	<p style="text-align: center;"><b>NOTE</b></p> <p>Start Engine. (WP 0044) Engine must be running for remaining PMCS checks.</p> <p>1. Check cab temperature controls for proper for proper operation: (WP 0036)</p>	

**Table 1. PMCS - WEEKLY - Continued**

Item No.	Interval	Item to be Checked or Serviced	Procedure	Equipment Not Ready/ Available If:
----------	----------	--------------------------------	-----------	------------------------------------



*Figure 19.*

29	Weekly	Material Handling Crane	<ol style="list-style-type: none"> <li>a. Check AIR control.</li> <li>b. Check HEAT control.</li> <li>c. Check DEFROST control.</li> <li>d. Check FAN control.</li> </ol> <ol style="list-style-type: none"> <li>1. Inspect crane for loose nuts and bolts, hydraulic leaks, damage to</li> </ol>	Class III leak present or damage
----	--------	-------------------------	---	----------------------------------

**Table 1. PMCS - WEEKLY - Continued**

Item No.	Interval	Item to be Checked or Serviced	Procedure	Equipment Not Ready/ Available If:
			<p>hydraulic hoses and lines, and obvious damage.</p> <p style="text-align: center;"><b>NOTE</b></p> <p>For more information on material handling crane operating instructions, refer to grove crane operation (manual control) procedures. (WP 0042)</p> <p>2. Check that crane hydraulic system is operable as follows:</p> <ul style="list-style-type: none"> <li>a. Start engine. (WP 0044)</li> <li>b. Set PTO ENGAGE switch to ON position. PTO indicator light will illuminate.</li> </ul>	<p>to hoses, lines, or fittings.</p>

**Table 1. PMCS - WEEKLY - Continued**

Item No.	Interval	Item to be Checked or Serviced	Procedure	Equipment Not Ready/ Available If:

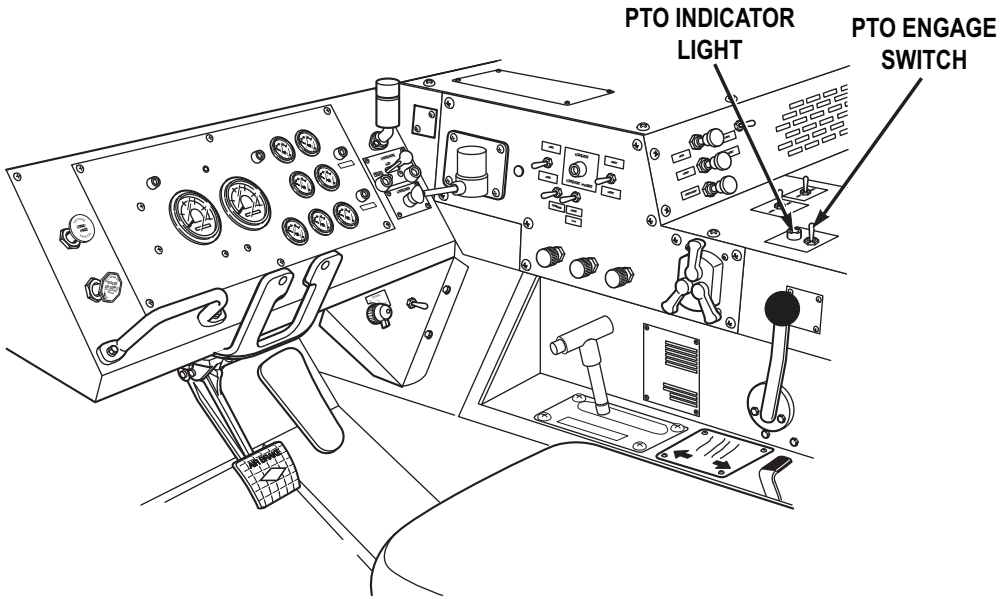


Figure 20.

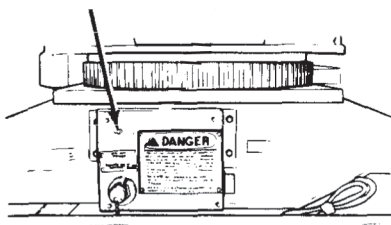
			c. Set ON/OFF POWER switch to ON position.	
--	--	--	--	--



**Table 1. PMCS - WEEKLY - Continued**

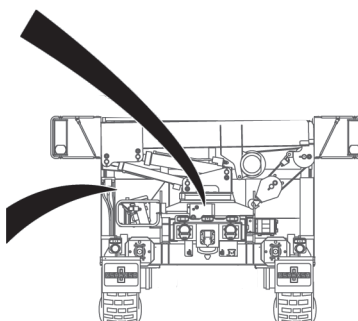
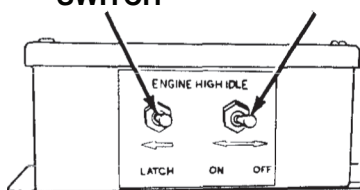
Item No.	Interval	Item to be Checked or Serviced	Procedure	Equipment Not Ready/ Available If:
----------	----------	--------------------------------	-----------	------------------------------------

**ON/OFF POWER SWITCH**



**LATCH SWITCH**

**ENGINE HIGH IDLE SWITCH**



*Figure 21.*


- d. Set HIGH IDLE CONTROL switch to CONTINUOUS.

**WARNING**



Excessive noise levels are present any time the heavy-duty winch, crane, or retrieval system is operating. Wear

**Table 1. PMCS - WEEKLY - Continued**

Item No.	Interval	Item to be Checked or Serviced	Procedure	Equipment Not Ready/ Available If:
			<p>single hearing protection (earplugs or equivalent) while working around equipment when it is running. Failure to comply may result in injury or death to personnel. Seek medical aid should you suspect a hearing problem.</p> <p>e. Push and release LATCH switch. Engine speed should increase to approximately 1500 rpm.</p> <p>3. Check crane manual control levers as follows:</p> <p style="text-align: center;"><b>WARNING</b></p> <div style="text-align: center;">  </div> <ul style="list-style-type: none"> <li>• Stand clear of outrigger beams while operating levers. Failure to comply may result in injury or death to personnel.</li> <li>• Do not operate crane unless outriggers are firmly in place or vehicle could turn over. Failure to</li> </ul>	

**Table 1. PMCS - WEEKLY - Continued**

Item No.	Interval	Item to be Checked or Serviced	Procedure	Equipment Not Ready/ Available If:
			<p>comply may result in injury or death to personnel.</p> <ul style="list-style-type: none"> <li>• Keep boom clear of all electrical lines and other obstacles while operating crane. Failure to comply may result in injury or death to personnel.</li> </ul> <p style="text-align: center;"><b>NOTE</b></p> <ul style="list-style-type: none"> <li>• Operate control levers with light, even pressure. Moving lever slightly will cause slow movement of crane. Moving lever to full travel will cause faster movement of crane.</li> <li>• Outrigger beams will come out slower with light pressure on lever. Pushing lever to full travel will cause fast movement.</li> </ul> <p>a. Move O/R EXT lever to IN position briefly.</p>	

Table 1. PMCS - WEEKLY - Continued

Item No.	Interval	Item to be Checked or Serviced	Procedure	Equipment Not Ready/ Available If:
----------	----------	--------------------------------	-----------	------------------------------------

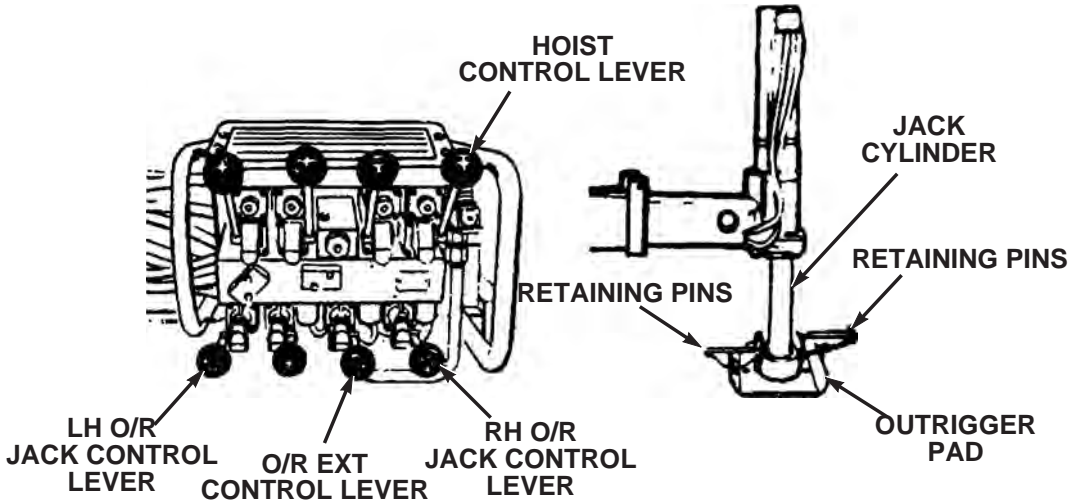
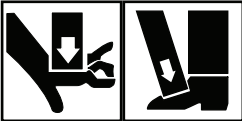


Figure 22.

		<p>b. Place both outrigger lockpins in unlock position.</p> <p>c. Check each control separately for malfunction, proper response, obvious damage, missing parts, binding, and extreme looseness.</p> <p>d. Move O/R EXT lever to OUT position until both outriggers is completely extended.</p> <p>e. Set up outrigger pads. Check that two retaining pins are</p>	<p>Controls malfunction, bind, or do not respond.</p> <p>Outrigger beam does not come out.</p> <p>Retaining pin missing</p>
--	--	--	---

**Table 1. PMCS - WEEKLY - Continued**

Item No.	Interval	Item to be Checked or Serviced	Procedure	Equipment Not Ready/ Available If:
			<p>attached to each outrigger pad.</p> <p style="text-align: center;"><b>WARNING</b></p>  <p>Keep hands and feet clear of outrigger jack cylinders. Failure to comply may result in injury or death to personnel.</p> <p style="text-align: center;"><b>NOTE</b></p> <p>Adjust outrigger pad position as required so rod end will lower into pad socket.</p> <p>f. Move LH O/R JACK control lever to DOWN position and lower outrigger jack until rod end is firmly seated in outrigger pad. Install retaining pins.</p> <p>g. Move RH O/R JACK control lever to DOWN position and lower outrigger jack until rod end is firmly seated in outrigger pad. Install retaining pins.</p>	<p>from either end.</p> <p>Outrigger jack cylinder will not come out or will not lower completely into pad.</p> <p>Outrigger jack cylinder will not come out or will not lower completely into pad.</p>

**Table 1. PMCS - WEEKLY - Continued**

Item No.	Interval	Item to be Checked or Serviced	Procedure	Equipment Not Ready/ Available If:
			<ul style="list-style-type: none"> <li>h. Check that outrigger jack cylinder on each side of vehicle is out and down.</li> <li>i. Seat outriggers.</li> <li>j. Raise boom to operating position:</li> </ul>	<p>Crane hydraulic system does not operate.</p>

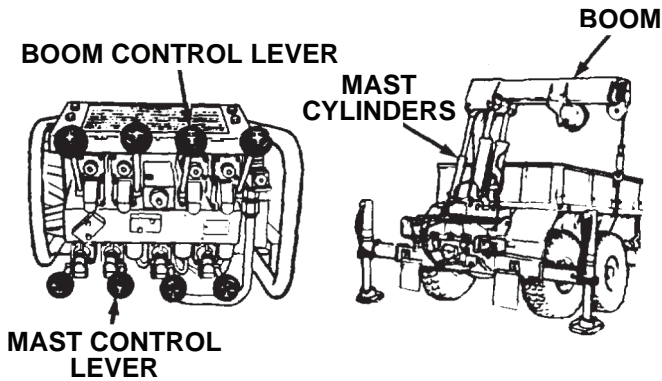



Figure 23.

		<p style="text-align: center;"><b>WARNING</b></p> <div style="text-align: center;">  </div> <p>Do not operate crane unless outriggers are firmly in place or vehicle could turn over.</p>
--	--	--

**Table 1. PMCS - WEEKLY - Continued**

Item No.	Interval	Item to be Checked or Serviced	Procedure	Equipment Not Ready/ Available If:
			<p>Failure to comply may result in injury or death to personnel.</p> <p style="text-align: center;"><b>CAUTION</b></p> <p>Do not let cable unwind and become slack, or cable may get tangled on drum.</p> <ol style="list-style-type: none"> <li>(1) Move HOIST control lever to DOWN position until hook block rests on fender.</li> <li>(2) Pull and turn lockpin handle so handle end rests on bracket to unstow hook block.</li> </ol> <p style="text-align: center;"><b>CAUTION</b></p> <p>Do not allow load hook to contact taillight during inspection. Failure to comply may result in damage to equipment.</p> <p style="text-align: center;"><b>NOTE</b></p> <p>Operation of vehicle with malfunctioning load hook may violate AR 385-55. (WP 0161)</p> <ol style="list-style-type: none"> <li>(3) Check hook block and load hook for cracks, and proper operation.</li> </ol>	<p>Hook block or load hook is cracked.</p>

**Table 1. PMCS - WEEKLY - Continued**


Item No.	Interval	Item to be Checked or Serviced	Procedure	Equipment Not Ready/ Available If:
			<p style="text-align: center;"><b>NOTE</b></p> <p>Operation of vehicle with malfunctioning load hook spring safety latch may violate AR 385-55. (WP 0161)</p> <p>(4) Check load hook spring safety latch for damage and proper operation.</p> <p>(5) Check hook block stowage guide wear plate for excessive wear.</p> <p style="text-align: center;"><b>WARNING</b></p> <div style="text-align: center;">  </div> <p>When using crane on any vehicle, park vehicle clear of all overhead electrical lines. Keep boom clear of all electrical lines and other obstacles while operating crane. Failure to comply may result in injury or death to personnel.</p>	<p>Load hook spring safety latch doesn't open and/or close properly.</p>



**Table 1. PMCS - WEEKLY - Continued**

Item No.	Interval	Item to be Checked or Serviced	Procedure	Equipment Not Ready/ Available If:
			<p style="text-align: center;"><b>CAUTION</b></p> <p>Do not hit outrigger leg with hook block. Failure to comply may result in damage to equipment.</p> <p>(6) Move BOOM control lever to UP position until hook is five to six feet (1.5 to 1.8 m) above driver side rear fender and boom is approximately 45° above horizontal.</p> <p>(7) Move MAST control lever to UP position until the mast is fully erect and the cylinders are fully extended. Use BOOM control lever UP simultaneously as required to maintain the boom at approximately 45° above horizontal until the mast is fully erect. Hold the MAST control lever to UP position for two to three seconds after mast is fully erect to ensure cylinders are fully filled with oil.</p> <p>k. Rotate and telescope boom:</p>	<p>Boom does not raise.</p> <p>Mast cylinder does not raise completely before stopping.</p>

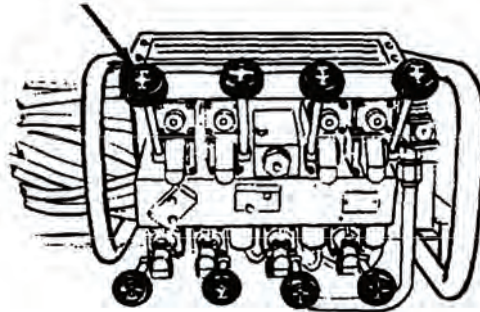
*Table 1. PMCS - WEEKLY - Continued*

Item No.	Interval	Item to be Checked or Serviced	Procedure	Equipment Not Ready/ Available If:
			<p style="text-align: center;"><b>WARNING</b></p>  <ul style="list-style-type: none"> <li>• When using crane on any vehicle, park vehicle clear of all overhead electrical lines. Keep boom clear of all electrical lines and other obstacles while operating crane. Failure to comply may result in injury or death to personnel.</li> <li>• Ensure area is clear of personnel prior to moving SWING lever. Boom should be swung slowly enough so crane operator has complete control. Failure to comply may result in injury or death to personnel.</li> </ul> <p style="text-align: center;"><b>CAUTION</b></p> <p>Boom must be above vehicle sides for clearance.</p> <p>(1) Move swing control lever to CW position to move boom clockwise.</p>	<p>Boom does not turn clockwise.</p>

**Table 1. PMCS - WEEKLY - Continued**

Item No.	Interval	Item to be Checked or Serviced	Procedure	Equipment Not Ready/ Available If:

**SWING CONTROL LEVER**



*Figure 24.*

- (2) Move swing control lever to CCW position to move boom counterclockwise.

Boom does not turn counterclockwise.

**CAUTION**

Keep hook block at least one ft. (30 cm) from end of boom. If hook block hits end of boom it may damage cable or hook block and crane will lose power. Wait six seconds for power to return and check crane for damage.

**NOTE**

- TELESCOPE and HOIST levers should be

**Table 1. PMCS - WEEKLY - Continued**

Item No.	Interval	Item to be Checked or Serviced	Procedure	Equipment Not Ready/ Available If:
			<p>operated at the same time.</p> <ul style="list-style-type: none"> <li>Crane movement from one lever may be slower than the other when operating two levers together.</li> </ul> <p>(3) Move TELESCOPE control lever to OUT position to extend boom while moving hoist control lever to DOWN position to pay out cable.</p>	<p>Extensions do not come out.</p>

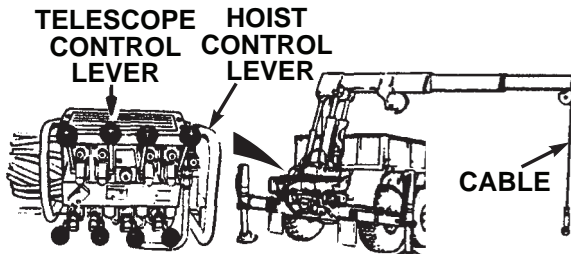


Figure 25.

		<p>(4) Check first, second, and third stages of boom for broken welds or obvious damage.</p>	<p>There are broken welds or obvious damage to boom.</p>
--	--	--	--

Table 1. PMCS - WEEKLY - Continued

Item No.	Interval	Item to be Checked or Serviced	Procedure	Equipment Not Ready/ Available If:
----------	----------	--------------------------------	-----------	------------------------------------

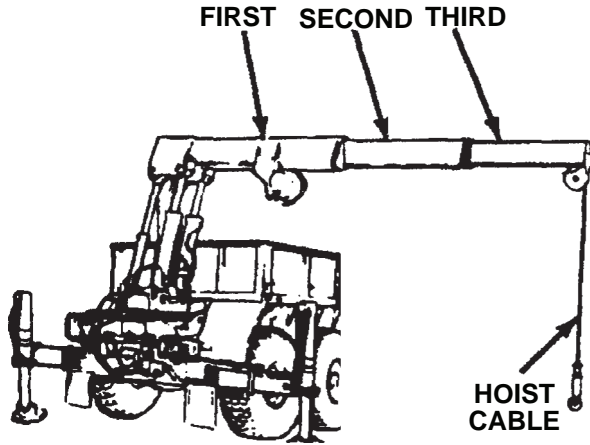


Figure 26.

**WARNING**



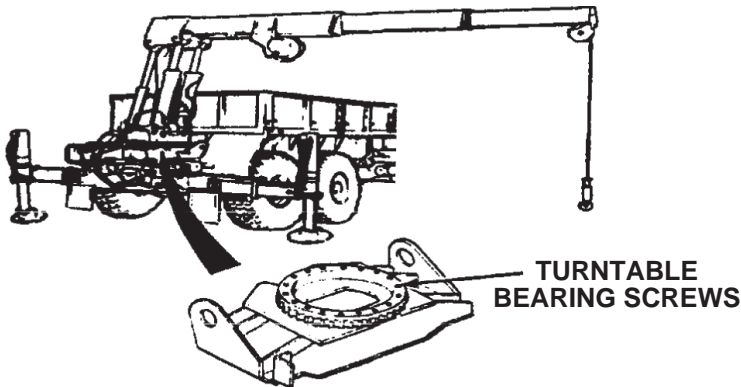
Always wear protective gloves when checking hoist cable. Never let cable run through hands. Frayed cables can cut severely. Failure to comply may result in injury or death to personnel.

- (5) Check cable on hoist for kinks, frays, or breaks.

Evidence of kinks, frays, or breaks.

**Table 1. PMCS - WEEKLY - Continued**

Item No.	Interval	Item to be Checked or Serviced	Procedure	Equipment Not Ready/ Available If:
			<p>(6) Check all hoses, fittings, valves, and cylinders for signs of leaks.</p> <p>(7) Check for cracked or broken welds.</p> <p>(8) Inspect turntable bearing bolts for obvious looseness.</p>	<p>Class III leak present.</p> <p>Cracked or broken welds are present.</p> <p>One or more turntable bearing bolts are loose.</p>



*Figure 27.*

**CAUTION**

Do not let cable become slack or cable may get tangled on drum.

**Table 1. PMCS - WEEKLY - Continued**

Item No.	Interval	Item to be Checked or Serviced	Procedure	Equipment Not Ready/ Available If:
			<p>(9) Move HOIST control lever in UP position to reel in cable.</p> <p>(10) Move HOIST control lever in DOWN position to pay out cable.</p> <p style="text-align: center;"><b>NOTE</b></p> <p>For more information on material handling crane remote-control operating instructions, refer to grove crane operation (remote-control) procedures. (WP 0043)</p> <p>4. Check crane remote-control levers as follows:</p>	<p>Cable does not reel in.</p> <p>Cable does not pay out.</p>

Table 1. PMCS - WEEKLY - Continued

Item No.	Interval	Item to be Checked or Serviced	Procedure	Equipment Not Ready/ Available If:

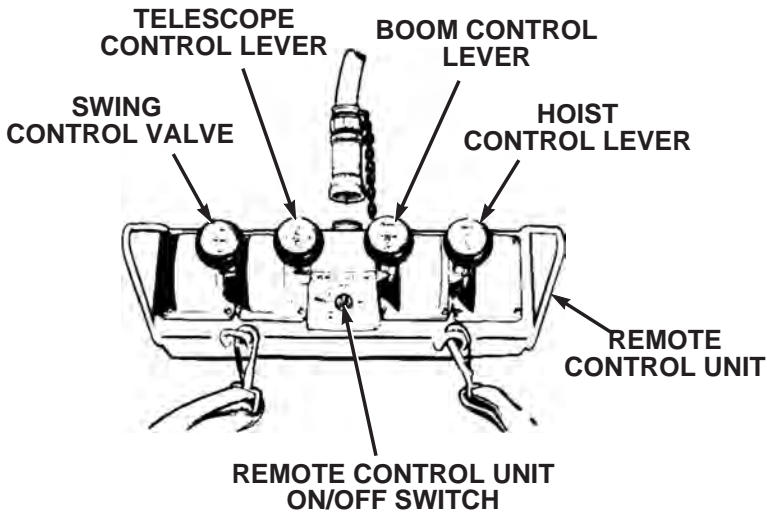


Figure 28.

- a. Set up REMOTE CONTROL UNIT passenger side. (WP 0043)


**WARNING**




- When using crane on any vehicle, park vehicle clear of all overhead electrical lines. Keep boom clear of all electrical lines and



**Table 1. PMCS - WEEKLY - Continued**

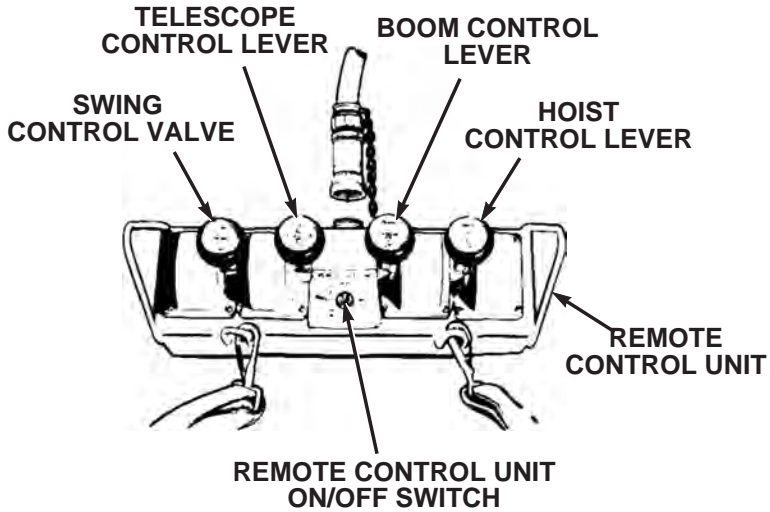
Item No.	Interval	Item to be Checked or Serviced	Procedure	Equipment Not Ready/ Available If:
			<p>other obstacles while operating crane. Failure to comply may result in injury or death to personnel.</p> <ul style="list-style-type: none"> <li>• Ensure area is clear of personnel prior to moving SWING lever. Boom should be swung slowly enough so crane operator has complete control. Failure to comply may result in injury or death to personnel.</li> </ul> <p><b>WARNING</b></p>  <p>If electrical power fails during crane operation, move switch on remote control unit to SHUTDOWN position. Failure to comply may result in injury or death to personnel.</p> <p><b>CAUTION</b></p> <p>Crane must be above vehicle sides for clearance.</p> <p><b>NOTE</b></p> <p>Operate control levers with light, even pressure. Moving lever slightly will cause slow</p>	

**Table 1. PMCS - WEEKLY - Continued**

Item No.	Interval	Item to be Checked or Serviced	Procedure	Equipment Not Ready/ Available If:
			<p>movement of crane. Moving lever to full travel will cause faster movement of crane.</p> <p>b. Check control levers for malfunction, proper response, obvious damage, missing parts, binding, and extreme looseness.</p> <p>c. Rotate and telescope boom:</p> <p style="text-align: center;"><b>WARNING</b></p> <div style="text-align: center;">  </div> <p>Ensure area is clear of personnel prior to moving SWING lever. Boom should be swung slowly enough so crane operator has complete control. Failure to comply may result in injury or death to personnel.</p> <p>(1) Move SWING control lever to CW position to turn boom clockwise.</p>	<p>Controls malfunction, bind, or do not respond.</p> <p>Boom does not turn clockwise.</p>

**Table 1. PMCS - WEEKLY - Continued**

Item No.	Interval	Item to be Checked or Serviced	Procedure	Equipment Not Ready/ Available If:



*Figure 29.*

- (2) Move SWING control lever to CCW position to turn boom counterclockwise.

Boom does not turn counterclockwise.

**WARNING**



When using crane on any vehicle, park vehicle clear of all overhead electrical lines. Keep boom clear of all elec-

**Table 1. PMCS - WEEKLY - Continued**

Item No.	Interval	Item to be Checked or Serviced	Procedure	Equipment Not Ready/ Available If:
			<p>trical lines and other obstacles while operating crane. Failure to comply may result in injury or death to personnel.</p> <p style="text-align: center;"><b>CAUTION</b></p> <p>Do not let cable become slack or cable may get tangled on drum.</p> <p>(3) Move HOIST control lever to UP position to take up cable. Move BOOM control lever to UP position to raise boom.</p> <p>(4) Move HOIST control lever to DOWN position to pay out cable. Move BOOM control lever to DOWN position to lower boom to horizontal position.</p> <p style="text-align: center;"><b>CAUTION</b></p> <ul style="list-style-type: none"> <li>Keep hook block at least one ft. (30 cm) from end of boom. If hook block hits end of boom it may damage cable or hook block and crane will lose power. Wait six seconds for power and check crane for damage.</li> </ul>	<p>Cable does not reel in or boom does not raise.</p> <p>Cable does not pay out or boom does not lower.</p>

**Table 1. PMCS - WEEKLY - Continued**

Item No.	Interval	Item to be Checked or Serviced	Procedure	Equipment Not Ready/ Available If:
			<ul style="list-style-type: none"> <li>• Do not let cable become slack or cable may get tangled on drum.</li> </ul> <p style="text-align: center;"><b>NOTE</b></p> <ul style="list-style-type: none"> <li>• TELESCOPE and HOIST levers should be operated at the same time.</li> <li>• Crane movement from one lever may be slower than the other when operating two levers together.</li> </ul> <p>(5) Move TELESCOPE control lever to OUT position while moving HOIST control lever to DOWN position to pay out cable.</p> <p>(6) Move HOIST control lever in UP position to reel in cable.</p> <p>(7) Check that crane and ENGINE HIGH IDLE do not operate when REMOTE CONTROL UNIT is in MHC-SHUTDOWN position. Notify organizational maintenance if crane and ENGINE HIGH IDLE</p>	<p>Extensions will not come out, or cable will not pay out.</p> <p>Cable will not reel in.</p> <p>Crane will operate and engine speed will increase to 1500 rpm.</p>

**Table 1. PMCS - WEEKLY - Continued**

Item No.	Interval	Item to be Checked or Serviced	Procedure	Equipment Not Ready/ Available If:
			<p>operates when in MHC-SHUTDOWN position.</p> <p>(8) Shut off remote-control switches.</p> <p>(9) Disconnect remote-control, passenger side.</p> <p>(10) Check operation of driver side remote-control station.</p> <p>(11) Connect remote-control to driver side remote-control station.</p> <p>(12) Check operation of crane remote-control levers.</p> <p>(13) Shut off remote-control switches.</p> <p>(14) Disconnect and stow REMOTE CONTROL UNIT.</p> <p>5. Shut down material handling crane.</p> <p>6. Check all hoses, fittings, valves, and cylinders for signs of leaks and damage.</p>	<p>Any Class III leak present.</p>

**Table 1. PMCS - WEEKLY - Continued**

Item No.	Interval	Item to be Checked or Serviced	Procedure	Equipment Not Ready/ Available If:
			7. Check for cracked or broken welds.	Cracked or broken welds.

**END OF WORK PACKAGE**





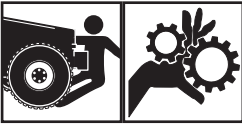

**OPERATOR MAINTENANCE  
SEMIANNUAL - PREVENTIVE MAINTENANCE**

**INITIAL SETUP:**

**Tools and Special Tools**

Gloves, Leather (WP 0163, Table 2)

*Table 1. PMCS- SEMIANNUAL*

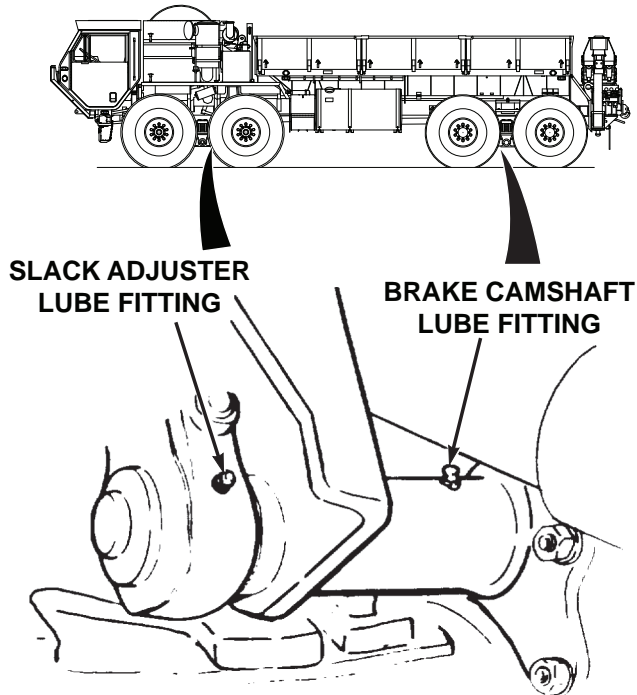
Item No.	Interval	Item to be Checked or Serviced	Procedure	Equipment Not Ready/ Available If:
			<p align="center"><b>WARNING</b></p>  <p>Do not start engine or move vehicle when personnel are under vehicle or working on brake lines. Failure to comply may result in injury or death to personnel.</p> <p align="center"><b>WARNING</b></p>  <p>Ensure engine is OFF and eye protection is worn when checking for leaks. Failure to comply may result in injury or death to personnel.</p>	

**Table 1. PMCS- SEMIANNUAL - Continued**

Item No.	Interval	Item to be Checked or Serviced	Procedure	Equipment Not Ready/ Available If:
1	Semian nual	Brake System	<p style="text-align: center;"><b>NOTE</b></p> <ul style="list-style-type: none"> <li>• Lubrication intervals are for normal operating conditions. Intervals may be shortened as required for severe operating conditions.</li> <li>• Clean all lubrication points with cleaning compound, solvent and allow to dry prior to servicing.</li> <li>• When using a grease gun, apply lubricant to the fitting until clean lubricant squeezes out of the part being lubricated.</li> <li>• Always refer to lubrication instructions (WP 0151) to ensure equipment has correct lubricants appropriate to operating environment (expected continuous temperatures). If not, remove/drain and reapply/refill equipment with appropriate lubricants for operating environment as prescribed in lubrication instructions. (WP 0151)</li> </ul> <p>Lubricate axles No. 1, No. 2, No. 3, and No. 4 brake camshafts and slack</p>	Fitting will not purge old lubricant

*Table 1. PMCS- SEMIANNUAL - Continued*

Item No.	Interval	Item to be Checked or Serviced	Procedure	Equipment Not Ready/ Available If:
			adjusters (four fittings per axle) with GAA. (WP 0151, Table 9)	out of component.



*Figure 1.*

**NOTE**

- When vehicle is operating under severe conditions, lubricate propeller shafts and universal joints every 50 hours of vehicle operation.

**Table 1. PMCS- SEMIANNUAL - Continued**

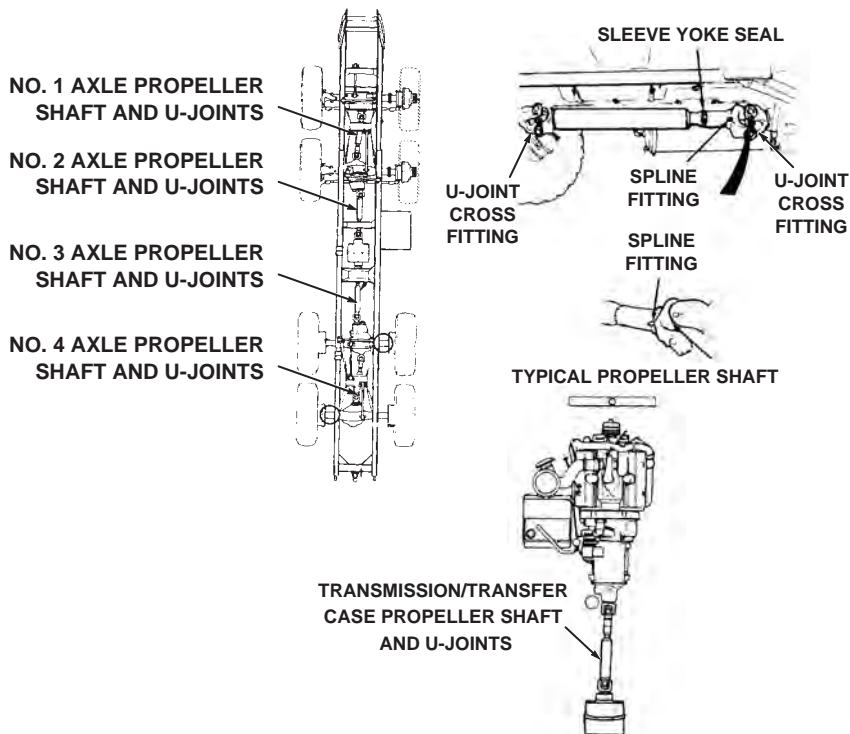
Item No.	Interval	Item to be Checked or Serviced	Procedure	Equipment Not Ready/ Available If:
			<ul style="list-style-type: none"> <li>• Use the proper lubricant to purge all four bearing seals of each universal joint. This flushes abrasive contaminants from each bearing and assures all four bearings are filled properly. Pop the seals, these seals are made to be popped.</li> <li>• If any seals fail to purge, move propeller shaft from side-to-side while applying gun pressure. This allows greater clearance on thrust end of bearing that is not purging. If seals still do not purge, rock vehicle by releasing the parking brake, start engine, put transmission in D (drive) or R (reverse), and allow vehicle to roll. This removes the windup in the drive line and allows for a greater clearance on the thrust end of the universal joint.</li> <li>• Because of the design of the universal joint seal, there will occasionally be one or more bearing seals of a joint that may not purge. If this occurs, notify field level maintenance.</li> </ul>	

**Table 1. PMCS- SEMIANNUAL - Continued**

Item No.	Interval	Item to be Checked or Serviced	Procedure	Equipment Not Ready/ Available If:
2	Semianual	Propeller Shafts and U-Joints	<ul style="list-style-type: none"> <li>• Universal joint may have one or two grease fittings. If there are two grease fittings, either fitting can be greased. It is not necessary to grease both fittings.</li> </ul> <ol style="list-style-type: none"> <li>1. Lubricate all axle propeller shafts, transmission to transfer case propeller shaft, and U-joints with GAA: (WP 0151, Table 9)</li> </ol>	Fitting will not purge old lubricant out of component.

*Table 1. PMCS- SEMIANNUAL - Continued*

Item No.	Interval	Item to be Checked or Serviced	Procedure	Equipment Not Ready/ Available If:
----------	----------	--------------------------------	-----------	------------------------------------



*Figure 2.*

		<p>a. Complete the following when lubricating the spline end of the propeller shafts:</p> <p>(1) Apply GAA (WP 0151, Table 9) to spline fitting</p>	<p>Fitting will not purge old lubricant out of component.</p>
--	--	---	---

**Table 1. PMCS- SEMIANNUAL - Continued**

Item No.	Interval	Item to be Checked or Serviced	Procedure	Equipment Not Ready/ Available If:
3	Semianual	Steering System	<p>until lubricant appears at pressure relief hole.</p> <p>(2) Cover pressure relief hole with finger and continue adding grease until it appears at sleeve yoke seal.</p> <p>1. Lubricate intergear link with GAA. (WP 0151, Table 9)</p>	Fitting will not purge old lubricant out of component.

*Table 1. PMCS- SEMIANNUAL - Continued*

Item No.	Interval	Item to be Checked or Serviced	Procedure	Equipment Not Ready/ Available If:
----------	----------	--------------------------------	-----------	------------------------------------

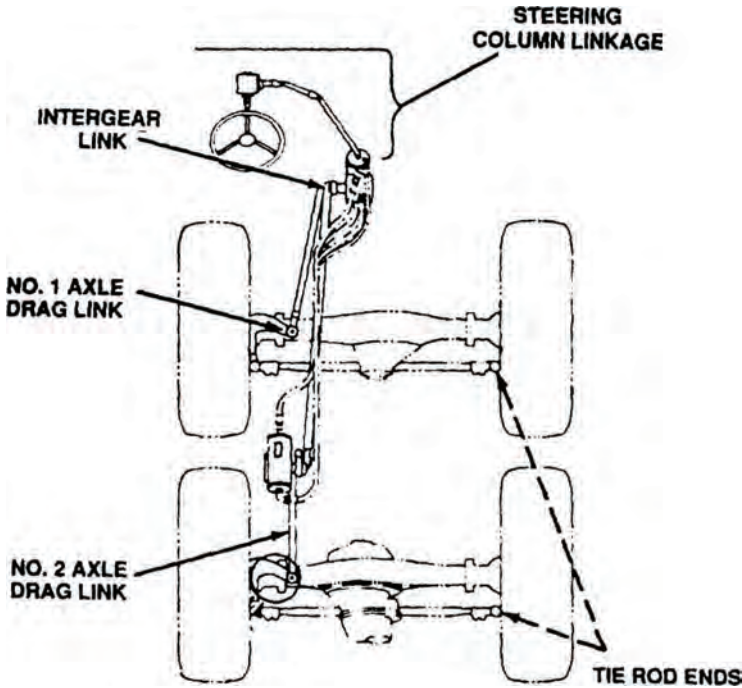


Figure 3.

		<ol style="list-style-type: none"> <li>2. Lubricate No. 1 axle drag link with GAA. (WP 0151, Table 9)</li> <li>3. Lubricate No. 2 axle drag link with GAA. (WP 0151, Table 9)</li> </ol>	<p>Fitting will not purge old lubricant out of component.</p> <p>Fitting will not purge old lubricant</p>
--	--	--	---



**Table 1. PMCS- SEMIANNUAL - Continued**

Item No.	Interval	Item to be Checked or Serviced	Procedure	Equipment Not Ready/ Available If:
			<p>4. Lubricate tie rod ends with GAA. (WP 0151, Table 9)</p> <p>5. Lubricate steering linkage U-joints and shafts with GAA. (WP 0151)</p> <p style="text-align: center;"><b>NOTE</b></p> <ul style="list-style-type: none"> <li>• The top trunnion bearing should be given 10 to 12 strokes with a grease gun through existing fitting.</li> <li>• The plug below the bottom should temporarily be removed and a grease fitting installed. The lower trunnion bearing should be lubricated with 10 to 12 strokes from a grease gun. The grease fitting should then be removed and the plug reinstalled.</li> </ul> <p>6. Lubricate No. 1 and No. 2 axle trunnion bearings with GAA. (WP 0151, Table 9)</p>	<p>out of component.</p> <p>Fitting will not purge old lubricant out of component.</p> <p>Fitting will not purge old lubricant out of component.</p>

*Table 1. PMCS- SEMIANNUAL - Continued*

Item No.	Interval	Item to be Checked or Serviced	Procedure	Equipment Not Ready/ Available If:
----------	----------	--------------------------------	-----------	------------------------------------

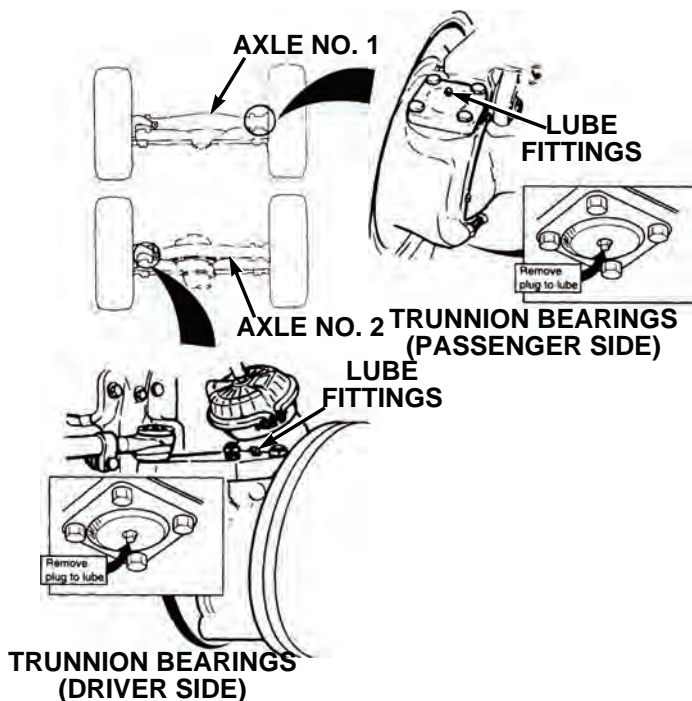
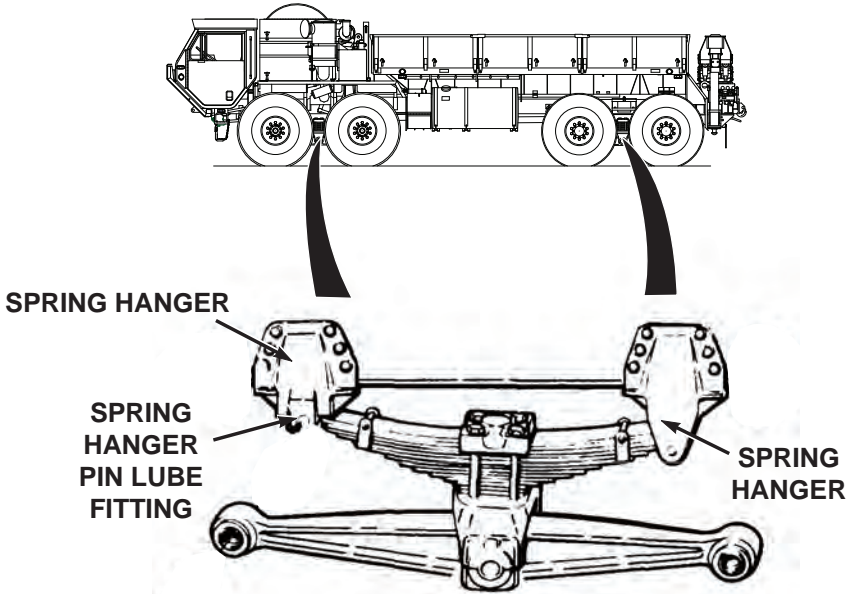


Figure 4.

4	Semian nual	Spring Hanger	1. Lubricate spring hanger pivot points (one fitting per spring) with GAA. (WP 0151, Table 9)	Fitting will not purge old lubricant out of component.
---	-------------	---------------	---	--

*Table 1. PMCS- SEMIANNUAL - Continued*

Item No.	Interval	Item to be Checked or Serviced	Procedure	Equipment Not Ready/ Available If:
----------	----------	--------------------------------	-----------	------------------------------------



*Figure 5.*

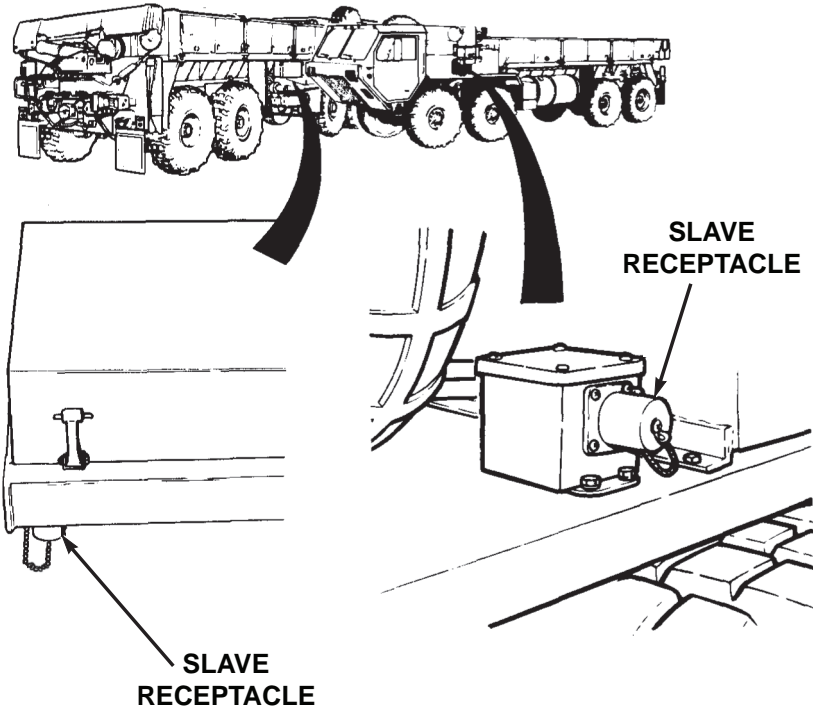
		<ol style="list-style-type: none"> <li>2. If spring hanger pin does not accept grease, perform the following:             <ol style="list-style-type: none"> <li>a. Relieve load on spring hanger pin by jacking up vehicle at frame rails, as close to spring hanger pin as possible.</li> <li>b. Lubricate spring hanger pin pivot.</li> </ol> </li> </ol>	
--	--	--	--

*Table 1. PMCS- SEMIANNUAL - Continued*

Item No.	Interval	Item to be Checked or Serviced	Procedure	Equipment Not Ready/ Available If:
5	Semian nual	Battery Electrical System	<p data-bbox="495 469 858 620">c. If springer hanger pin still fails to take grease, notify field level maintenance to remove spring hanger pin and replace as necessary.</p> <p data-bbox="621 669 713 698"><b>NOTE</b></p> <p data-bbox="491 717 841 866">Vehicle may be equipped with either a slave receptacle incorporated in bottom rear of battery box, or separate unit on driver side front fender.</p> <p data-bbox="446 902 880 960">Coat slave receptacle with corrosion preventive compound.</p>	

*Table 1. PMCS- SEMIANNUAL - Continued*

Item No.	Interval	Item to be Checked or Serviced	Procedure	Equipment Not Ready/ Available If:
----------	----------	--------------------------------	-----------	------------------------------------

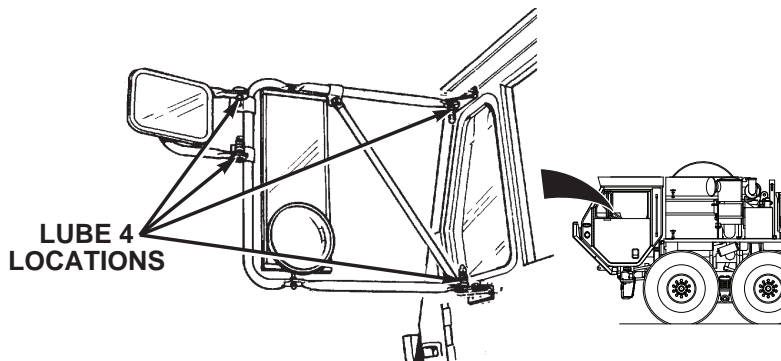


*Figure 6.*

6	Semianual	Mirror Assemblies	Lubricate mirror assembly swivel joints with GAA. (WP 0151, Table 9)	
---	-----------	-------------------	--	--

*Table 1. PMCS- SEMIANNUAL - Continued*

Item No.	Interval	Item to be Checked or Serviced	Procedure	Equipment Not Ready/ Available If:
----------	----------	--------------------------------	-----------	------------------------------------



*Figure 7.*

**NOTE**

Pintle hook plate lubrication fitting can be on any side.

7	Semian nual	Pintle Hook	<ol style="list-style-type: none"> <li>1. Lubricate pintle hook (3 fittings) with GAA. (WP 0151, Table 9)</li> </ol>	Fitting will not purge old lubricant out of component.
---	-------------	-------------	--	--

*Table 1. PMCS- SEMIANNUAL - Continued*

Item No.	Interval	Item to be Checked or Serviced	Procedure	Equipment Not Ready/ Available If:
----------	----------	--------------------------------	-----------	------------------------------------



Figure 8.

8	Semian nual	Crane (Grove)	<p style="text-align: center;"><b>NOTE</b></p> <p>Lubricate outrigger bottom plate, boom wear pads, and exposed rotation gears often when cranes are operating in sandy/dusty environment.</p> <p>1. Lubricate pivots at both ends of lift cylinders (eight fittings) with GAA. (WP 0151, Table 7)</p>	Fitting will not purge old lubricant out of component.
---	-------------	---------------	--	--

*Table 1. PMCS- SEMIANNUAL - Continued*

Item No.	Interval	Item to be Checked or Serviced	Procedure	Equipment Not Ready/ Available If:
----------	----------	--------------------------------	-----------	------------------------------------

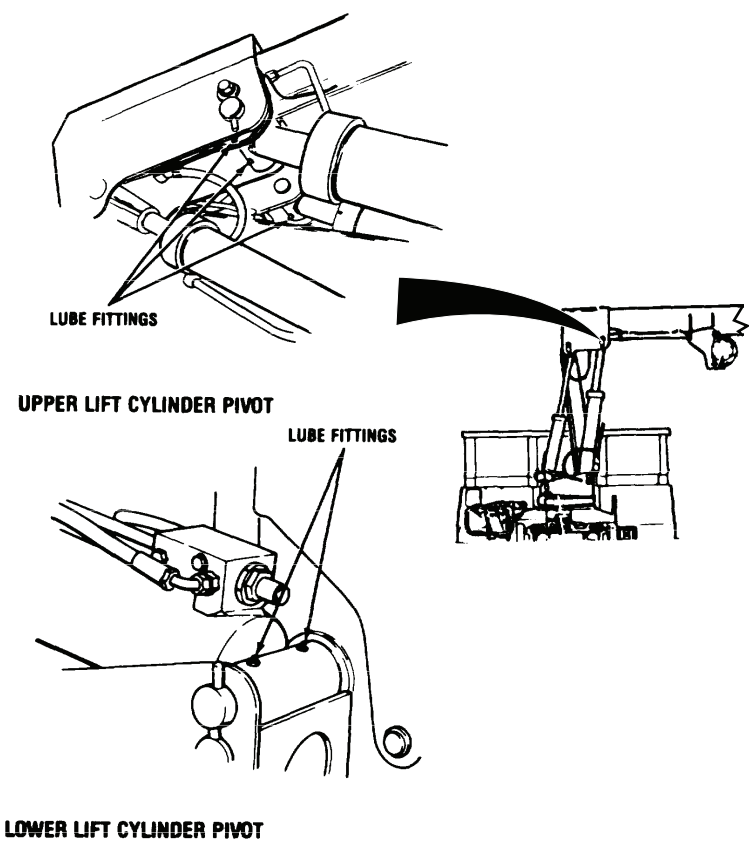


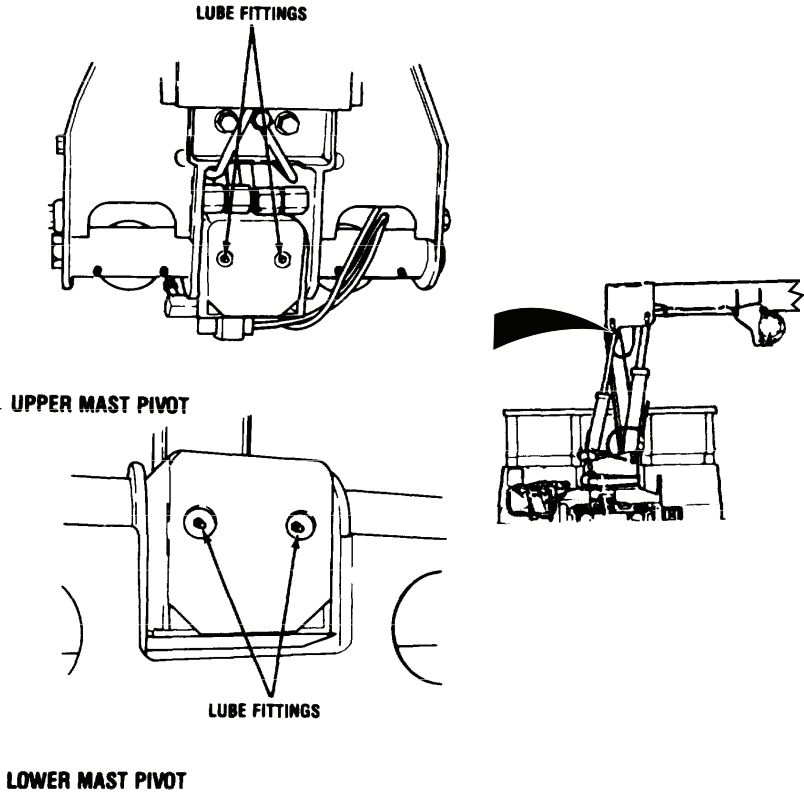
Figure 9.

		<p>2. Lubricate mast pivots (four fittings) with GAA. (WP 0151, Table 7)</p>	<p>Fitting will not purge old lubricant out of component.</p>
--	--	--	---



*Table 1. PMCS- SEMIANNUAL - Continued*

Item No.	Interval	Item to be Checked or Serviced	Procedure	Equipment Not Ready/ Available If:
----------	----------	--------------------------------	-----------	------------------------------------



*Figure 10.*

		<p>3. Lubricate pivots at both ends of erection cylinders (eight fittings) with GAA. (WP 0151, Table 7)</p>	<p>Fitting will not purge old lubricant out of component.</p>
--	--	---	---

*Table 1. PMCS- SEMIANNUAL - Continued*

Item No.	Interval	Item to be Checked or Serviced	Procedure	Equipment Not Ready/ Available If:

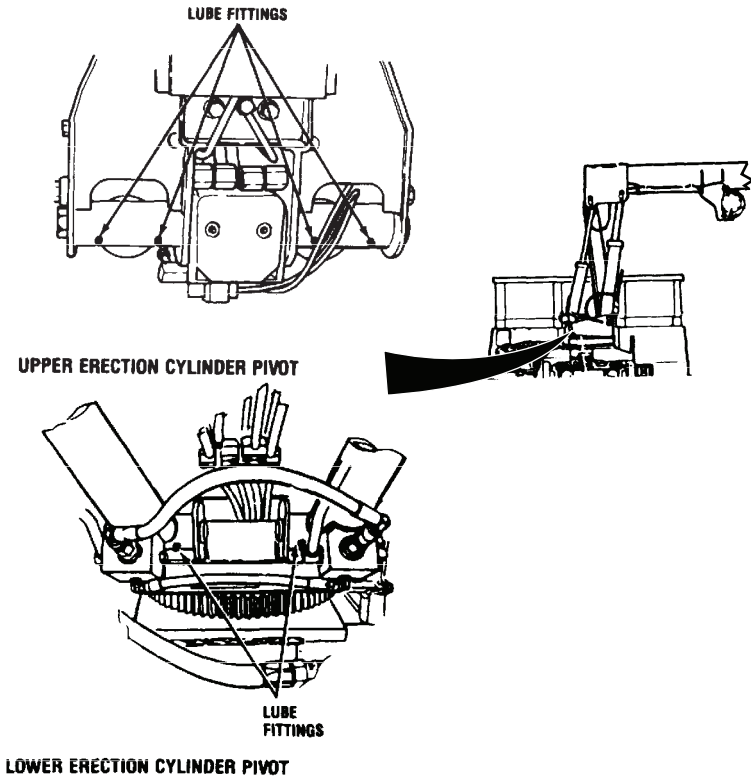


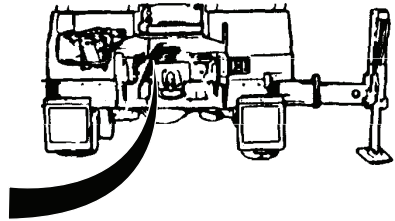
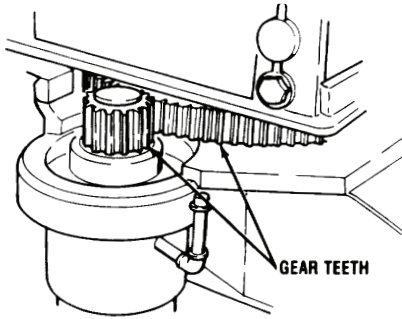
Figure 11.

**NOTE**

Always re-lubricate rotation gear and pinion teeth after high pressure wash.

*Table 1. PMCS- SEMIANNUAL - Continued*

Item No.	Interval	Item to be Checked or Serviced	Procedure	Equipment Not Ready/ Available If:
			4. Check and lubricate rotation gear and pinion teeth with light coat of GAA. (WP 0151, Table 7)	Gear teeth broken/ missing.



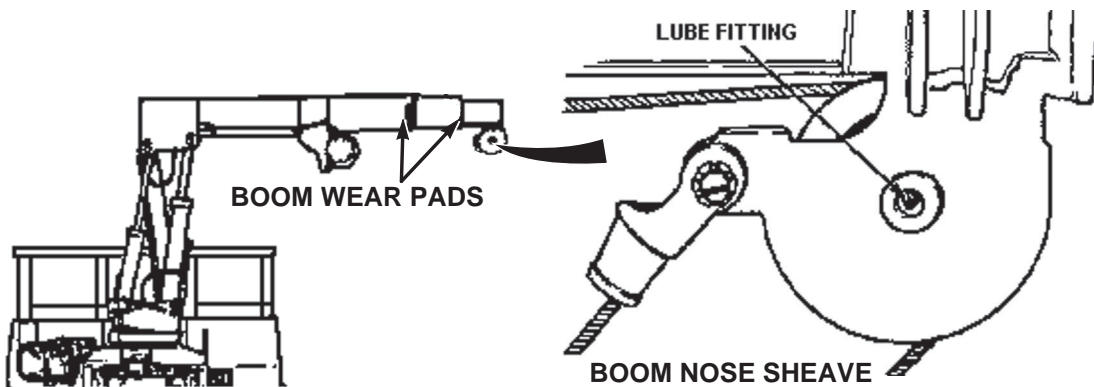
**ROTATION GEAR BEARING AND PINION TEETH**

*Figure 12.*

		5. Clean and lubricate boom wear pads with GAA. (WP 0151, Table 7)
--	--	--

*Table 1. PMCS- SEMIANNUAL - Continued*

Item No.	Interval	Item to be Checked or Serviced	Procedure	Equipment Not Ready/ Available If:
----------	----------	--------------------------------	-----------	------------------------------------

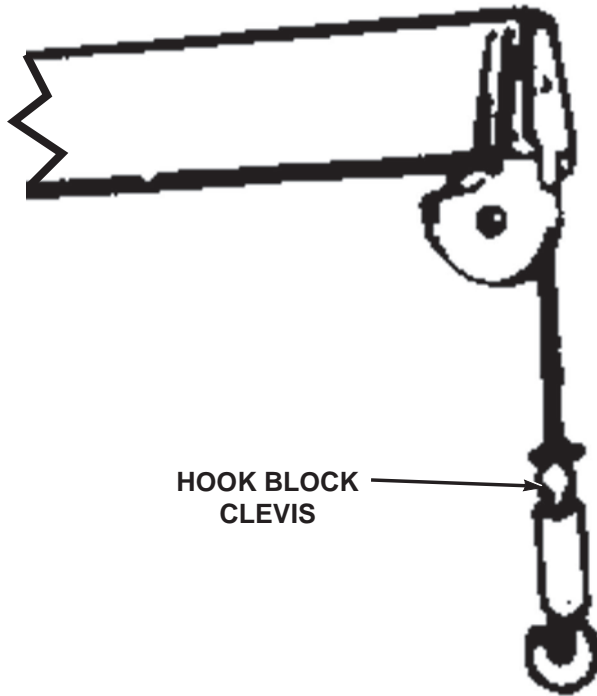


*Figure 13.*

		<ol style="list-style-type: none"> <li>6. Lubricate boom nose sheave bushing (one fitting) with GAA. (WP 0151, Table 7)</li> <li>7. Lubricate hook block clevis pivot point with OE/HDO. (WP 0151, Table 8)</li> </ol>	<p>Fitting will not purge old lubricant out of component.</p>
--	--	--	---

*Table 1. PMCS- SEMIANNUAL - Continued*

Item No.	Interval	Item to be Checked or Serviced	Procedure	Equipment Not Ready/ Available If:



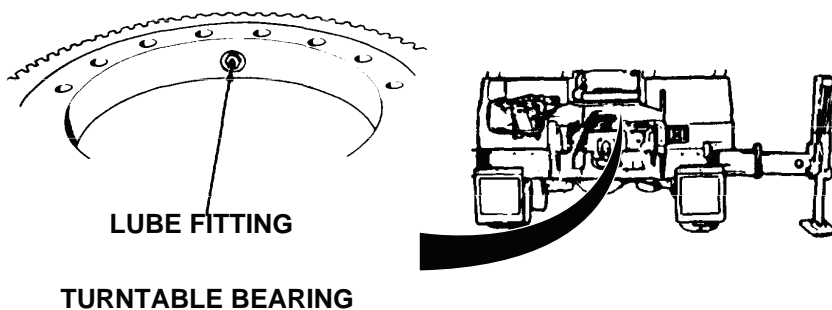
*Figure 14.*

**NOTE**

Raise crane mast until lube fitting comes into view. Turn and lubricate turntable every 90° until you have turned the turntable 360°, then rotate

*Table 1. PMCS- SEMIANNUAL - Continued*

Item No.	Interval	Item to be Checked or Serviced	Procedure	Equipment Not Ready/ Available If:
			crane a full 360° to spread lubricant.  8. Lubricate turntable bearing (one fitting) with GAA. (WP 0151, Table 7)	Fitting will not purge old lubricant out of component.



*Figure 15.*

		9. Clean and lubricate sliding surfaces of outtrigger bottom plates with GAA. (WP 0151, Table 7)
--	--	--

*Table 1. PMCS- SEMIANNUAL - Continued*

Item No.	Interval	Item to be Checked or Serviced	Procedure	Equipment Not Ready/ Available If:

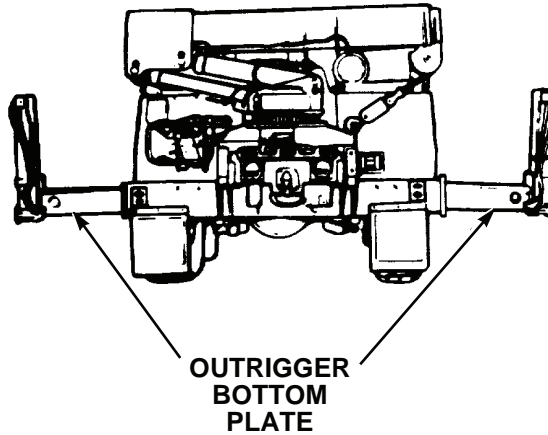


Figure 16.

**WARNING**



Always wear protective gloves when checking hoist cable. Never let cable run through hands. Frayed cables can cut severely. Failure to comply may result in injury or death to personnel.

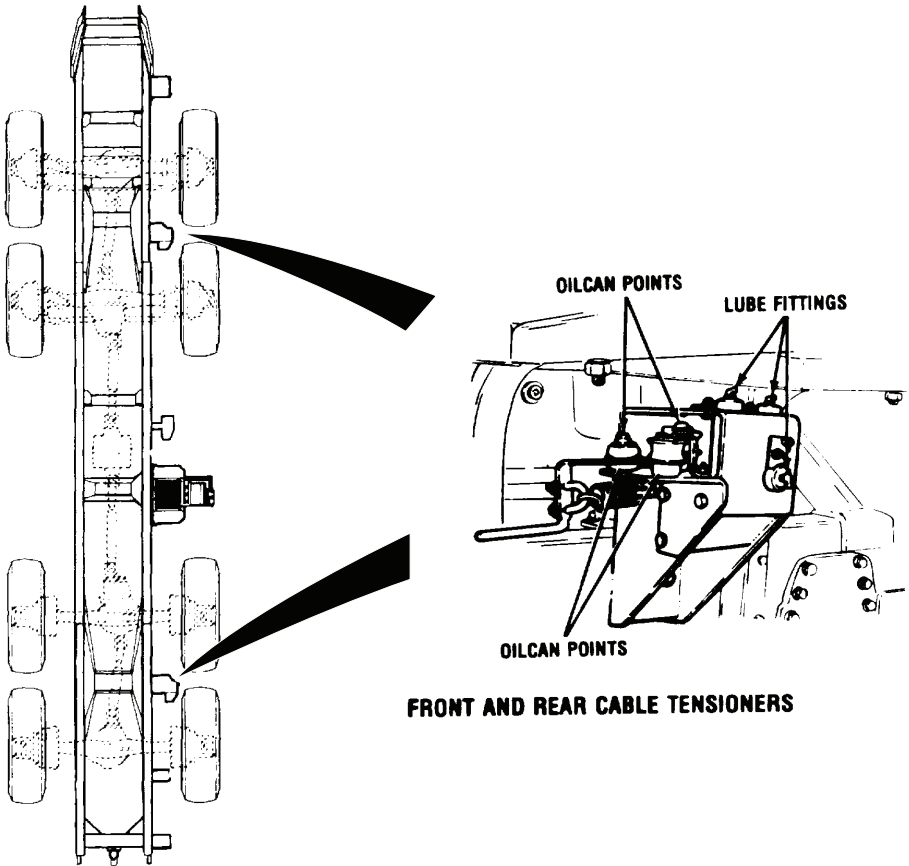
**Table 1. PMCS- SEMIANNUAL - Continued**

Item No.	Interval	Item to be Checked or Serviced	Procedure	Equipment Not Ready/ Available If:
9	Semianual	Crane Hoist Cable	<ol style="list-style-type: none"> <li>1. Unreel crane hoist cable and check hoist cable for kinks, broken strands, and wear.</li> <li>2. Clean and lubricate hoist cable with OE/HDO. (WP 0151, Table 7)</li> </ol>	<p>Kinks, broken strands, or wear present.</p> <p>Kinks, broken strands, or wear present.</p>
10	Semianual	Self-Recovery Winch	<ol style="list-style-type: none"> <li>1. Unreel, (WP 0086) clean, and lubricate cable with OE/HDO. (WP 0151, Table 6)</li> <li>2. Lubricate front and rear cable tensioner rollers (three fittings per tensioner) with GAA. (WP 0151, Table 9)</li> </ol>	<p>Fitting will not purge old lubricant out of component.</p>



**Table 1. PMCS- SEMIANNUAL - Continued**

Item No.	Interval	Item to be Checked or Serviced	Procedure	Equipment Not Ready/ Available If:
----------	----------	--------------------------------	-----------	------------------------------------

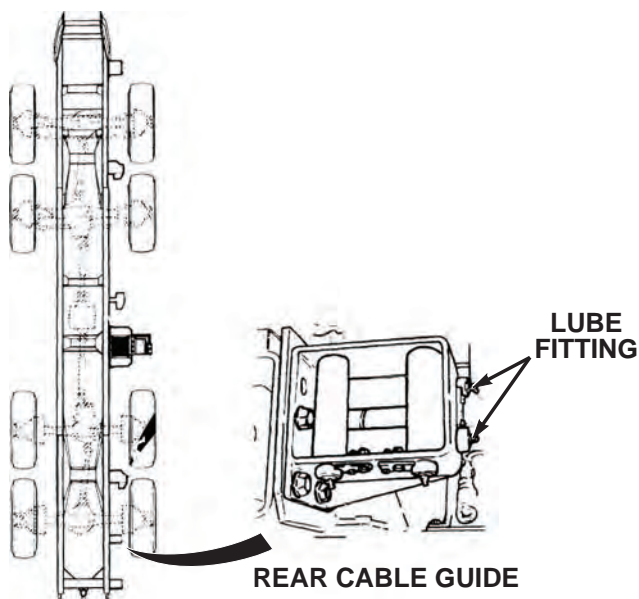


*Figure 17.*

- |  |  |   |  |
|--|--|---|--|
|  |  | <ol style="list-style-type: none"> <li>Lubricate pivot points and pressure rollers with OE/HDO. (WP 0151, Table 8)</li> </ol> |  |
|--|--|---|--|

**Table 1. PMCS- SEMIANNUAL - Continued**

Item No.	Interval	Item to be Checked or Serviced	Procedure	Equipment Not Ready/ Available If:
			4. Lubricate rear cable guide roller (four fittings) with GAA. (WP 0151, Table 9)	Fitting will not purge old lubricant out of component.

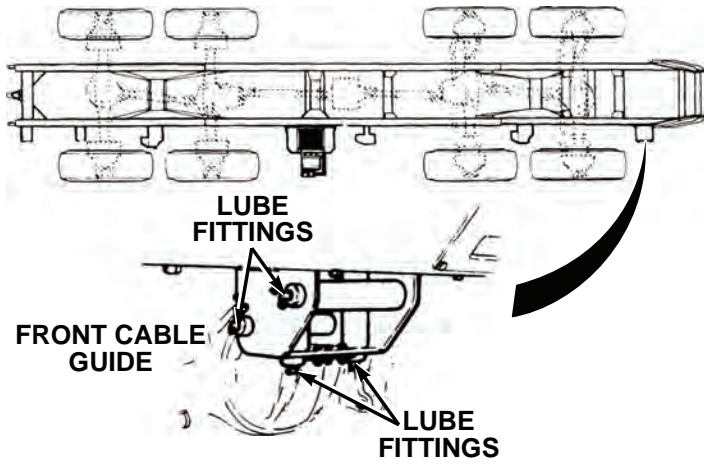


*Figure 18.*

		5. Lubricate front cable guide (four fittings) with GAA. (WP 0151, Table 9)	Fitting will not purge old lubricant
--	--	---	--------------------------------------

*Table 1. PMCS- SEMIANNUAL - Continued*

Item No.	Interval	Item to be Checked or Serviced	Procedure	Equipment Not Ready/ Available If:
				out of component.

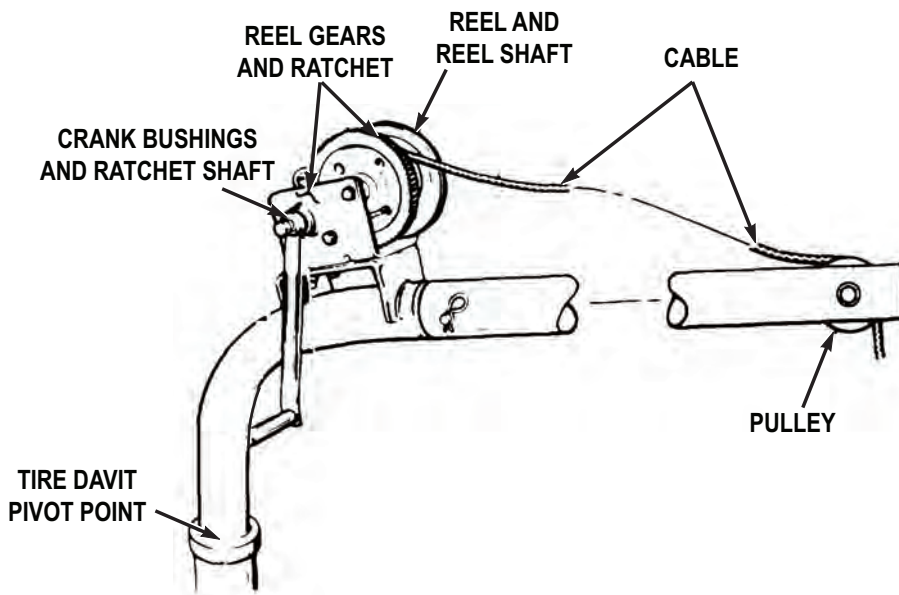


*Figure 19.*

11	Semian nual	Spare Tire Davit	1. Lubricate tire davit pivot point with light coating of GAA. (WP 0151, Table 9)	
----	-------------	------------------	---	--

*Table 1. PMCS- SEMIANNUAL - Continued*

Item No.	Interval	Item to be Checked or Serviced	Procedure	Equipment Not Ready/ Available If:
----------	----------	--------------------------------	-----------	------------------------------------



*Figure 20.*

		<ol style="list-style-type: none"> <li>2. Lubricate reel gears and ratchet with light coating of GAA. (WP 0151, Table 9)</li> <li>3. Lubricate crank bushings and ratchet shaft with OE/HDO. (WP 0151, Table 8)</li> <li>4. Lubricate reel and reel shaft with OE/HDO. (WP 0151, Table 8)</li> <li>5. Lubricate cable with OE/HDO. (WP 0151, Table 8)</li> </ol>
--	--	--

*Table 1. PMCS- SEMIANNUAL - Continued*

Item No.	Interval	Item to be Checked or Serviced	Procedure	Equipment Not Ready/ Available If:
			6. Lubricate pulley with OE/HDO. (WP 0151, Table 8)	

**END OF WORK PACKAGE**



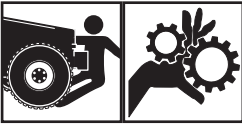

**OPERATOR MAINTENANCE  
MONTHLY - PREVENTIVE MAINTENANCE**

**INITIAL SETUP:**

**Tools and Special Tools**

Gloves, Leather (WP 0163, Table 2)

*Table 1. PMCS - MONTHLY*

Item No.	Interval	Item to be Checked or Serviced	Procedure	Equipment Not Ready/ Available If:
			<p style="text-align: center;"><b>WARNING</b></p>  <p>Do not start engine or move vehicle when personnel are under vehicle or working on brake lines. Failure to comply may result in injury or death to personnel.</p> <p style="text-align: center;"><b>WARNING</b></p>  <p>Ensure engine is OFF and eye protection is worn when checking for leaks. Failure to comply may result in injury or death to personnel.</p>	

**Table 1. PMCS - MONTHLY - Continued**

Item No.	Interval	Item to be Checked or Serviced	Procedure	Equipment Not Ready/ Available If:
1	Monthly	Damage And	<p style="text-align: center;"><b>NOTE</b></p> <ul style="list-style-type: none"> <li>• Lubrication intervals are for normal operating conditions. Intervals may be shortened as required for severe operating conditions.</li> <li>• Clean all lubrication points with cleaning compound, solvent and allow to dry prior to servicing.</li> <li>• When using a grease gun, apply lubricant to the fitting until clean lubricant squeezes out of the part being lubricated.</li> <li>• Always refer to lubrication instructions (WP 0151) to ensure equipment has correct lubricants appropriate to operating environment (expected continuous temperatures). If not, remove/drain and reapply/refill equipment with appropriate lubricants for operating environment as prescribed in lubrication instructions. (WP 0151)</li> </ul> <p>Check entire vehicle for obvious damage and/or corrosion.</p>	Any broken, cracked, bent frame

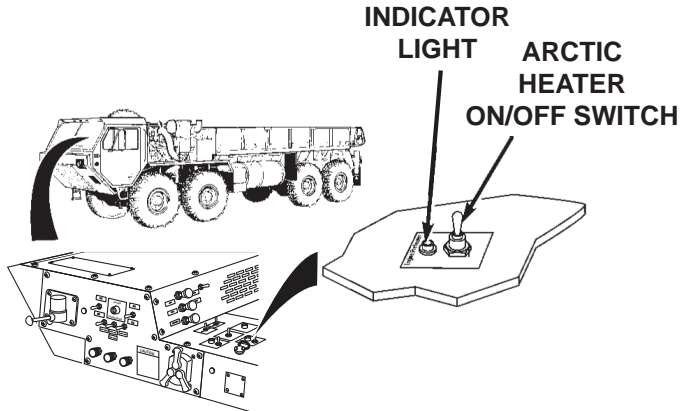


**Table 1. PMCS - MONTHLY - Continued**

Item No.	Interval	Item to be Checked or Serviced	Procedure	Equipment Not Ready/ Available If:
2	Monthly	Corrosion Check  Lubricate Oilcan Points	<ol style="list-style-type: none"> <li>1. Lubricate cabin door latching mechanisms and hinges with OE/HDO. (WP 0151)</li> <li>2. Lubricate all side panel and engine cover hinges, locks, and latches with OE/HDO. (WP 0151)</li> </ol> <p style="text-align: center;"><b>NOTE</b></p> <p>Steady illumination of the arctic engine heater indicator light indicates proper operation.</p>	rails, cross-members, or screws are found.
3	Monthly	Arctic Engine Heater	<ol style="list-style-type: none"> <li>1. Position arctic engine heater ON/OFF switch to ON position, indicator light will illuminate.</li> </ol>	

*Table 1. PMCS - MONTHLY - Continued*

Item No.	Interval	Item to be Checked or Serviced	Procedure	Equipment Not Ready/ Available If:



*Figure 1.*

		<p>2. Visually check all fuel lines for leaks, cuts, loose clamps, and other obvious damage.</p>	<p>Any Class III leak.</p>
--	--	--	----------------------------

Table 1. PMCS - MONTHLY - Continued

Item No.	Interval	Item to be Checked or Serviced	Procedure	Equipment Not Ready/ Available If:
----------	----------	--------------------------------	-----------	------------------------------------

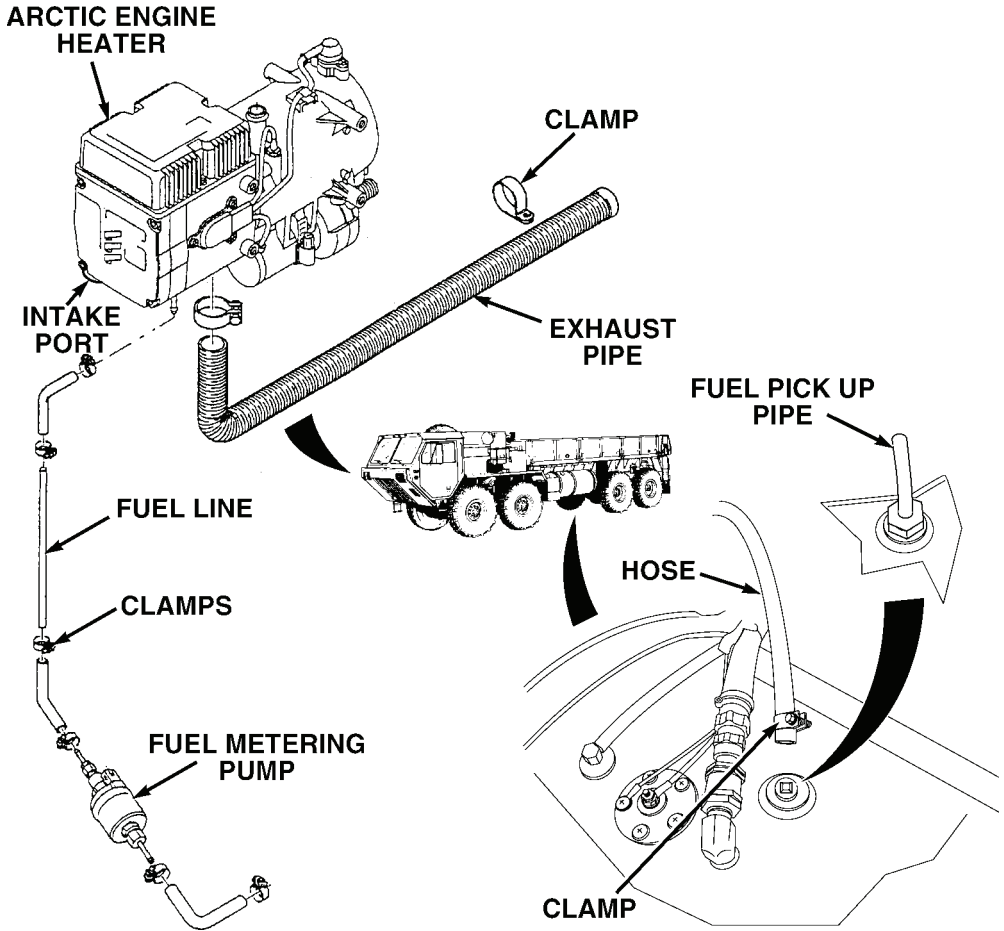
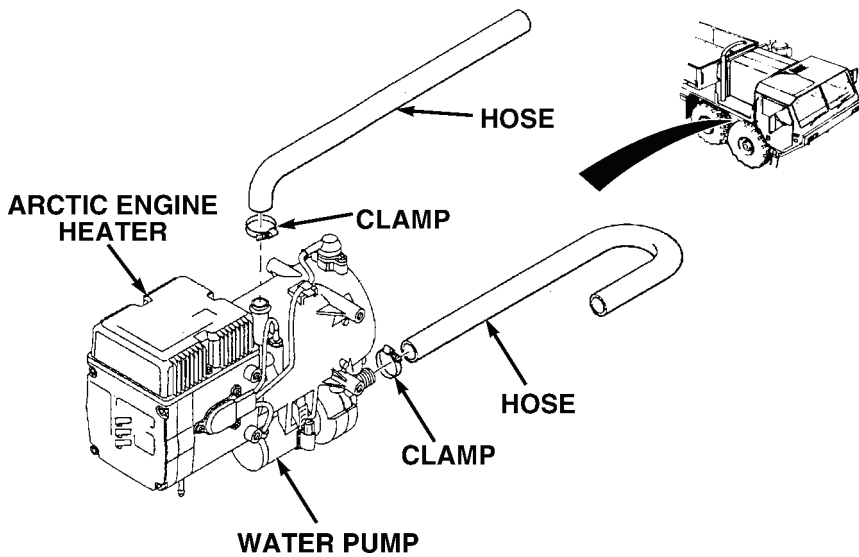


Figure 2.

3. Visually check intake port and exhaust pipe for blockage.

*Table 1. PMCS - MONTHLY - Continued*

Item No.	Interval	Item to be Checked or Serviced	Procedure	Equipment Not Ready/ Available If:
			4. Check water pump for unusual noise.	

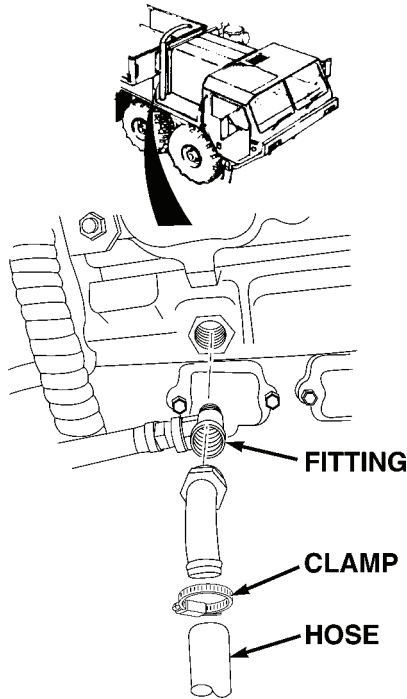


*Figure 3.*

			5. Check coolant hoses at arctic engine heater for leaks, cuts, loose hose clamps, and other obvious damage.	Any Class III leak.
			6. Check coolant hoses and fittings at passenger side of engine for leaks, cuts, loose hose clamps, and other obvious damage.	Any Class III leak.

*Table 1. PMCS - MONTHLY - Continued*

Item No.	Interval	Item to be Checked or Serviced	Procedure	Equipment Not Ready/ Available If:
----------	----------	--------------------------------	-----------	------------------------------------

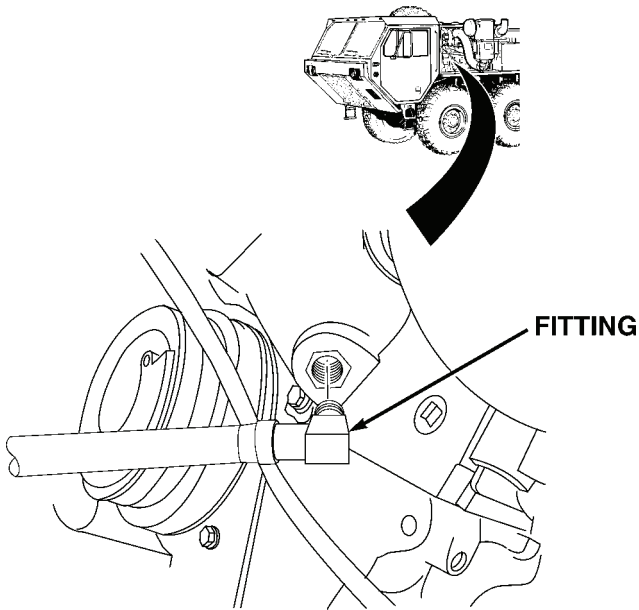


*Figure 4.*

		<p>7. Check coolant hoses and fittings at passenger side of engine for leaks, cuts, loose hose clamps, and other obvious damage.</p>	<p>Any Class III leak.</p>
--	--	--	----------------------------

**Table 1. PMCS - MONTHLY - Continued**

Item No.	Interval	Item to be Checked or Serviced	Procedure	Equipment Not Ready/ Available If:
----------	----------	--------------------------------	-----------	------------------------------------



*Figure 5.*

4	Monthly	Crane Control Levers	<ol style="list-style-type: none"> <li>8. Run arctic engine heater for a minimum of 15 minutes at least once a month.</li> <li>1. Lubricate crane control lever pivots with OE/HDO. (WP 0151, Table 8)</li> </ol>	
---	---------	----------------------	---	--

*Table 1. PMCS - MONTHLY - Continued*

Item No.	Interval	Item to be Checked or Serviced	Procedure	Equipment Not Ready/ Available If:
----------	----------	--------------------------------	-----------	------------------------------------

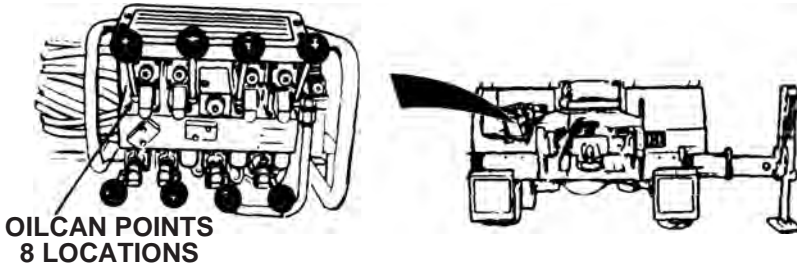


Figure 6.

**WARNING**



- Always wear protective gloves when handling winch cable. Never let cable run through hands. Frayed cables can cut severely. Failure to comply may result in injury or death to personnel.
- Never operate winch with less than five wraps of cable on winch drum. Failure to comply may result in injury or death to personnel.

**Table 1. PMCS - MONTHLY - Continued**

Item No.	Interval	Item to be Checked or Serviced	Procedure	Equipment Not Ready/ Available If:
5	Monthly	Self-Recovery Winch (SRW)	<ol style="list-style-type: none"> <li data-bbox="446 469 836 529">1. Check winch cable for kinks, frays, and breaks.</li> <li data-bbox="446 624 820 742">2. Check self-recovery winch (SRW) lever (WP 0020) for proper operation in both directions.</li> </ol>	Self-recovery winch (SRW) lever does not function.



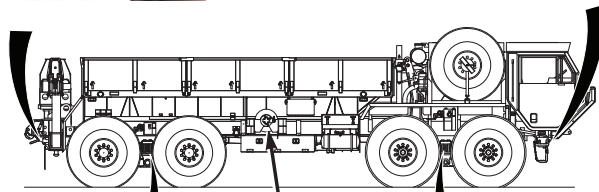
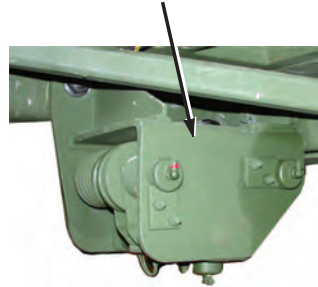
*Table 1. PMCS - MONTHLY - Continued*

Item No.	Interval	Item to be Checked or Serviced	Procedure	Equipment Not Ready/ Available If:
----------	----------	--------------------------------	-----------	------------------------------------

**REAR CABLE GUIDE**



**FRONT CABLE GUIDE**

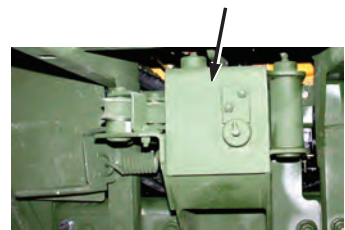


**REAR TENSIONER**



**SELF-RECOVERY WINCH**

**FRONT TENSIONER**



*Figure 7.*

3. Inspect front cable guide for any loose or missing parts and any obvious damage.

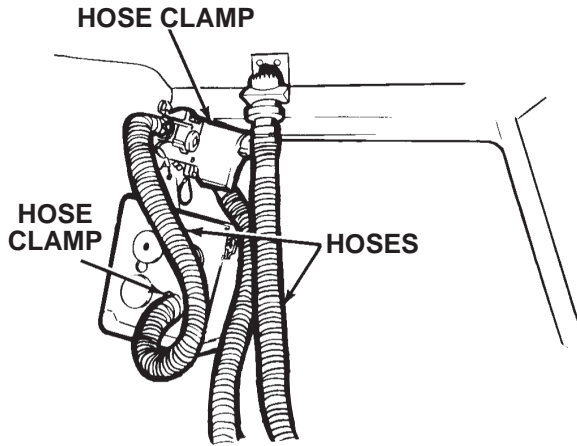
Front cable guide has loose/missing parts or

**Table 1. PMCS - MONTHLY - Continued**

Item No.	Interval	Item to be Checked or Serviced	Procedure	Equipment Not Ready/ Available If:
6	Monthly	Gas Particulate Filter Unit (GPFU)	<p>4. Inspect front tensioner for loose or missing parts and any obvious damage.</p> <p>5. Inspect rear tensioner for loose or missing parts and any other obvious damage.</p> <p>6. Inspect rear cable guide for loose or missing parts and any obvious damage.</p> <p style="text-align: center;"><b>NOTE</b></p> <p>Gas particulate filter unit must be in operation (WP 0059) to perform the following checks.</p> <p>1. Check heater for unusual loud noise or improper operation.</p>	<p>is unserviceable.</p> <p>Front tensioner has loose/missing parts or is unserviceable.</p> <p>Rear tensioner has loose/missing parts or is unserviceable.</p> <p>Rear cable guide has loose/missing parts or is unserviceable.</p> <p>Heater does not operate/operates abnormally and GPFU is required for mission.</p>

*Table 1. PMCS - MONTHLY - Continued*

Item No.	Interval	Item to be Checked or Serviced	Procedure	Equipment Not Ready/ Available If:
----------	----------	--------------------------------	-----------	------------------------------------

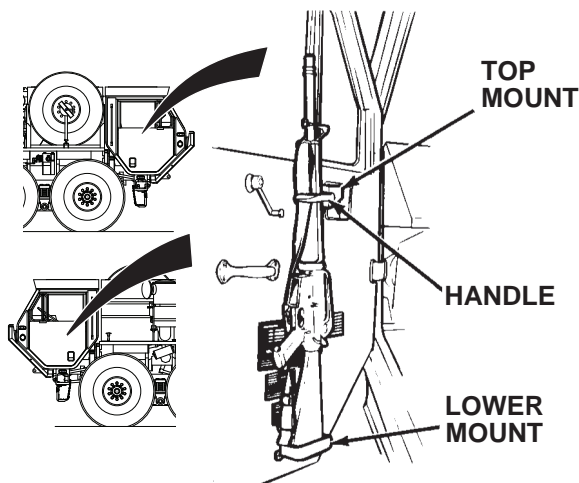


*Figure 8.*

		<ol style="list-style-type: none"> <li>2. Disconnect two air duct breakaway sockets from mount and feel for airflow.</li> <li>3. Turn heater control knob clockwise to make sure indicator light illuminates.</li> <li>4. Check hoses for cuts, tears, and other obvious damage.</li> </ol>	<p>No airflow or not enough air-flow and GPFU is required for mission.</p> <p>Heater is in-operative and GPFU is required for mission.</p> <p>Hoses cut, torn, or damaged and GPFU</p>
--	--	---	--

*Table 1. PMCS - MONTHLY - Continued*

Item No.	Interval	Item to be Checked or Serviced	Procedure	Equipment Not Ready/ Available If:
7	Monthly	Rifle Stowage Mount	<ol style="list-style-type: none"> <li>1. Check that mounting screws on top mount and lower mount are not broken or missing.</li> <li>5. Make sure hose clamps are secure.</li> </ol>	<p>is required for mission.</p> <p>Clamps loose and GPFU is required for mission.</p>



*Figure 9.*

		<ol style="list-style-type: none"> <li>2. Check handle for excessive looseness or binding.</li> </ol>	
--	--	---	--

**Table 1. PMCS - MONTHLY - Continued**

<b>Item No.</b>	<b>Interval</b>	<b>Item to be Checked or Serviced</b>	<b>Procedure</b>	<b>Equipment Not Ready/ Available If:</b>
8	Monthly	Machine Gun Operator's Platform Support	Check machine gun operator's platform support for loose, broken, or missing mounting screws.	
9	Monthly	Machine Gun Operator's Platform	Check machine gun operator's platform for cracks, loose or broken leg, missing or broken tie down strap.	
10	Monthly	Ring Mount	Check machine gun mounts for loose, broken, or missing mounting screws.	
11	Monthly	M-13 Decontamination Unit	Refer to TM 3-4230-214-12&P (WP 0161) for M-13 Decontamination Unit PMCS.	
12	Monthly	M-8 Chemical Alarm	Refer to TM 3-6665-225-12 (WP 0161) for M-8 Chemical Alarm PMCS.	
13	Monthly	Radio	Refer to TM 11-5820-498-12 (WP 0161) for radio PMCS.	

**END OF WORK PACKAGE**



CHAPTER 5

MAINTENANCE  
INSTRUCTIONS





---

## OPERATOR MAINTENANCE LUBRICATION INSTRUCTIONS

---

### INITIAL SETUP:

Not Applicable

---

### WARNING



Adhesives, solvents, and sealing compounds can burn easily, can give off harmful vapors, and are harmful to skin and clothing. Keep away from open fire and use in well-ventilated area. If adhesive, solvent, or sealing compound gets on skin or clothing, wash immediately with soap and water. Failure to comply may result in injury or death to personnel.

### NOTE

- The lowest level of maintenance authorized to lubricate a specific point is indicated by where that lubrication point falls within the PMCS tables. Operator/crew are only authorized to lubricate those points within the operator PMCS tables. Field level maintenance personnel are authorized to lubricate all points regardless of which tables (operator or field level) those lubrication points are listed.
- Refer to PMCS tables for specific lubrication points and localized views.
- Lubrication intervals are for normal operating conditions. Intervals may be shortened as required for severe operating conditions.
- Clean all lubrication points with cleaning compound, solvent and allow to dry prior to servicing.
- When using a grease gun, apply lubricant to the fitting until clean lubricant squeezes out of the part being lubricated.
- After a thorough high pressure washing, lubricate all grease fittings and oil can points outside and underneath vehicle.

- If vehicle fords water obstacle, service all lubrication points below fording depth and check submerged gearboxes for presence of water.
- Ensure equipment has correct lubricants appropriate to operating environment (expected continuous temperatures). If not, remove/drain and reapply/refill equipment with appropriate lubricants for operating environment as prescribed in these lubrication instructions.

**Table 1. Engine Lubrication.**

Item	Capacities	Expected Temperatures Above +15°F (-9°C)	Expected Temperatures +40 to -15°F (+4 to -26°C)	Expected Temperatures +40 to -50°F (+4 to -46°C)	Desert Conditions	Interval
Engine Oil (with filter change)	30 qt. (28.38 L)	OE/ HDO-15W/40 MIL-PRF-2104	OE/ HDO-15W/40 MIL-PRF-2104 or OEA MIL-PRF-46167 (Notes 1, 2, and 3)	OE/ HDO-15W/40 MIL-PRF-2104 or OEA MIL-PRF-46167 (Notes 1, 2, and 3)	OE/ HDO-40 MIL-PRF-2104	A-Annual (1 year)
Engine Oil (without filter change)	28 qt. (26.49 L)	OE/ HDO-15W/40 MIL-PRF-2104	OE/ HDO-15W/40 MIL-PRF-2104 or OEA MIL-PRF-46167 (Notes 1, 2, and 3)	OE/ HDO-15W/40 MIL-PRF-2104 or OEA MIL-PRF-46167 (Notes 1, 2, and 3)	OE/ HDO-40 MIL-PRF-2104	A-Annual (1 year)

**Table 1. Engine Lubrication. - Continued**

Item	Capacities	Expected Temperatures Above +15°F (-9°C)	Expected Temperatures +40 to -15°F (+4 to -26°C)	Expected Temperatures +40 to -50°F (+4 to -46°C)	Desert Conditions	Interval
<p><b>NOTE</b></p> <ol style="list-style-type: none"> <li>1. After changing to OEA, drain one pint (0.5 L) of oil from the oil sampling valve.</li> <li>2. OEA must be used when temperatures are consistently below 0°F (-18°C).</li> <li>3. OE/HDO-15W/40 must be used when temperatures are consistently above 0°F (-18°C).</li> </ol>						

**Table 2. Transmission and Transfer Case Lubrication.**

Item	Capacities	Expected Temperatures Above +15°F (-9°C)	Expected Temperatures +40 to -15°F (+4 to -26°C)	Expected Temperatures +40 to -50°F (+4 to -46°C)	Interval
Transmission Oil	31 qt. (29.33 L)	OE/HDO-15W/40 MIL-PRF-2104	OE/HDO-15W/40 MIL-PRF-2104 (Note 2)	OE/HDO-15W/40 MIL-PRF-2104 (Note 2)	A-Annual (1 year)
Transfer Case	5 qt. (4.73 L)	OE/HDO-40 MIL-PRF-2104	OE/HDO-40 MIL-PRF-2104 or OEA MIL-PRF-46167 (Notes 1 and 2)	OE/HDO-40 MIL-PRF-2104 or OEA MIL-PRF-46167 (Notes 1 and 2)	A-Annual (1 year)

**Table 2. Transmission and Transfer Case Lubrication. - Continued**

Item	Capacities	Expected Temperatures Above +15°F (-9°C)	Expected Temperatures +40 to -15°F (+4 to -26°C)	Expected Temperatures +40 to -50°F (+4 to -46°C)	Interval
All Other Transmission and Transfer Case Lubrication Points	As Required	GAA MIL-PRF-10924	GAA MIL-PRF-10924 (Note 2)	GAA MIL-PRF-10924 (Note 2)	As Required (Note 3)

**NOTE**

1. OE/HDO-40 must be used when temperatures are consistently above 0°F (-18°C).
2. Refer to FM 9-207 (WP 0161) for arctic operation.
3. Refer to PMCS tables for specific lubrication intervals.

**Table 3. Axle Lubrication.**

Item	Capacities	Expected Temperatures Above +15°F (-9°C)	Expected Temperatures +40 to -15°F (+4 to -26°C)	Expected Temperatures +40 to -50°F (+4 to -46°C)	Interval
Axle 1	17.5 qt. (16.56 L)	GO-85W/140 MIL-PRF-2105	GO-85W/140 MIL-PRF-2105 or GO-80W/90 MIL-PRF-2105 (Notes 1 and 3)	GO-80W/90 MIL-PRF-2105 or GO-75 MIL-PRF-2105 (Notes 2 and 3)	B-Biennial (2 Years) (Note 4)

**Table 3. Axle Lubrication. - Continued**

Item	Capacities	Expected Temperatures Above +15°F (-9°C)	Expected Temperatures +40 to -15°F (+4 to -26°C)	Expected Temperatures +40 to -50°F (+4 to -46°C)	Interval
Axle 2 (and Power Divider)	21.5 qt. (20.34 L)	GO-85W/ 140 MIL- PRF-2105	GO-85W/ 140 MIL- PRF-2105 or GO-80W/90 MIL- PRF-2105 (Notes 1 and 3)	GO-80W/90 MIL- PRF-2105 or GO-75 MIL- PRF-2105 (Notes 2 and 3)	B-Biennial (2 Years) (Note 4)
Axle 3 (and Power Divider)	21 qt. (19.87 L)	GO-85W/ 140 MIL- PRF-2105	GO-85W/ 140 MIL- PRF-2105 or GO-80W/90 MIL- PRF-2105 (Notes 1 and 3)	GO-80W/90 MIL- PRF-2105 or GO-75 MIL- PRF-2105 (Notes 2 and 3)	B-Biennial (2 Years) (Note 4)
Axle 4	16.5 qt. (15.61 L)	GO-85W/ 140 MIL- PRF-2105	GO-85W/ 140 MIL- PRF-2105 or GO-80W/90 MIL- PRF-2105 (Notes 1 and 3)	GO-80W/90 MIL- PRF-2105 or GO-75 MIL- PRF-2105 (Notes 2 and 3)	B-Biennial (2 Years) (Note 4)
Oil Lubed Wheel Bearings	N/A	GO-85W/ 140 MIL- PRF-2105	GO-85W/ 140 MIL- PRF-2105	GO-80W/90 MIL- PRF-2105 or	B-Biennial (2 Years)

**Table 3. Axle Lubrication. - Continued**

Item	Capacities	Expected Temperatures Above +15°F (-9°C)	Expected Temperatures +40 to -15°F (+4 to -26°C)	Expected Temperatures +40 to -50°F (+4 to -46°C)	Interval
			or GO-80W/90 MIL- PRF-2105 (Notes 1 and 3)	GO-75 MIL- PRF-2105 (Notes 2 and 3)	
All Other Axle Lubrication Points	As Required	GAA MIL- PRF-10924	GAA MIL- PRF-10924 (Note 3)	GAA MIL- PRF-10924 (Note 3)	As Required (Note 5)

**NOTE**

1. GO-85W/140 must be used when temperatures are consistently above 30°F (-1°C).
2. GO-85W/90 must be used when temperatures are consistently above -15°F (-26°C).
3. Refer to FM 9-207 (WP 0161) for arctic operation.
4. An initial lubrication change on new or rebuilt axles should occur between 500 mi. (805 km) and 1,000 miles (1 609 km). Refer to Field Level Annual PMCS for more information.
5. Refer to PMCS tables for specific lubrication intervals.

**Table 4. Hydraulic Reservoir Servicing.**

Item	Capacities	Expected Temperatures Above +15°F (-9°C)	Expected Temperatures +40 to -15°F (+4 to -26°C)	Expected Temperatures +40 to -50°F (+4 to -46°C)	Interval
Hydraulic Reservoir	120 qt. (113.52 L)	OE/HDO-10 MIL- PRF-2104	OE/HDO-10 MIL- PRF-2104	OEA MIL- PRF-46167	A-Annual (1 year)

**Table 4. Hydraulic Reservoir Servicing. - Continued**

Item	Capacities	Expected Temperatures Above +15°F (-9°C)	Expected Temperatures +40 to -15°F (+4 to -26°C)	Expected Temperatures +40 to -50°F (+4 to -46°C)	Interval
		or OE/HDO-30 MIL- PRF-2104 (Note 1)	(Note 2)	(Notes 2 and 3)	
<p><b>NOTE</b></p> <ol style="list-style-type: none"> <li>1. OE/HDO-30 must be used only when temperatures are consistently above 60°F (16°C).</li> <li>2. Refer to FM 9-207 (WP 0161) for arctic operation.</li> <li>3. OEA must be used when temperatures are consistently below 0°F (-18°C).</li> </ol>					

**Table 5. Radiator Servicing.**

Item	Capacities	Expected Temperatures Above +15°F (-9°C)	Expected Temperatures +40 to -15°F (+4 to -26°C)	Expected Temperatures +40 to -50°F (+4 to -46°C)	Interval
Antifreeze (CID A-A-52624) (Note 1)	80 qt. (75.68 L)	80 qt. (75.68 L) 50% Ethylene Glycol Type IC (Recycled) (Notes 1 and 2)	80 qt. (75.68 L) 50% Ethylene Glycol Type IC (Recycled) (Notes 1 and 2)	80 qt. (75.68 L) 60% Ethylene Glycol Arctic Type IB (Recycled) (Notes 1, 2, and 3)	A-Annual (1 year) (Note 4)

**Table 5. Radiator Servicing. - Continued**

Item	Capacities	Expected Temperatures Above +15°F (-9°C)	Expected Temperatures +40 to -15°F (+4 to -26°C)	Expected Temperatures +40 to -50°F (+4 to -46°C)	Interval
Antifreeze (CID A-A-52624) (Note 1)	80 qt. (75.68 L)	40 qt. (37.84 L) 100% Ethylene Glycol Type IA (Recycled) plus 40 qt. (37.84 L) water (Notes 1 and 5)	40 qt. (37.84 L) 100% Ethylene Glycol Type IA (Recycled) plus 40 qt. (37.84 L) water (Notes 1 and 5)	48 qt. (45.41 L) 100% Ethylene Glycol Type IA (Recycled) plus 32 qt. (30.27 L) water (Notes 1, 3, and 6)	A-Annual (1 year) (Note 4)
Antifreeze (CID A-A-52624) (Note 1)	80 qt. (75.68 L)	40 qt. (37.84 L) 100% Propylene Glycol Type IIA (virgin) plus 40 qt. (37.84 L) water (Notes 1 and 7)	40 qt. (37.84 L) 100% Propylene Glycol Type IIA (virgin) plus 40 qt. (37.84 L) water (Notes 1 and 7)	48 qt. (45.41 L) 100% Propylene Glycol Type IIA (virgin) plus 32 qt. (30.27 L) water (Notes 1, 3, and 8)	A-Annual (1 year) (Note 4)
Corrosion Inhibitor (Note 1)	2.4 qt. (2.27 L)	(Note 1)	(Note 1)	(Notes 1 and 3)	As Required

**NOTE**

1. Refer to TB 750-651 (WP 0161) for more information on antifreeze and additives used in the HEMTT series vehicle engine cooling system, and TM 750-254 (WP 0161) for detailed instructions for draining, cleaning, and flushing cooling systems of tactical vehicles.



**Table 5. Radiator Servicing. - Continued**

Item	Capacities	Expected Temperatures Above +15°F (-9°C)	Expected Temperatures +40 to -15°F (+4 to -26°C)	Expected Temperatures +40 to -50°F (+4 to -46°C)	Interval
<ol style="list-style-type: none"> <li>2. Type 1C (normal) and Type 1B (arctic) antifreeze is premixed, and DOES NOT REQUIRE the addition of water. Never add water or inhibitor to Type 1B antifreeze.</li> <li>3. Refer to FM 9-207 (WP 0161) for arctic operation.</li> <li>4. Engine coolant contaminant level is checked annually. Engine coolant does not need to be changed until it fails check.</li> <li>5. A mixture of 50% Ethylene Glycol (EG) antifreeze to 50% water will provide freeze protection down to -34°F (-37°C).</li> <li>6. A mixture of 50% Propylene Glycol (PG) antifreeze to 50% water will provide freeze protection down to -27°F (-33°C).</li> <li>7. A mixture of 60% Ethylene Glycol (EG) antifreeze to 40% water will provide freeze protection down to -62°F (-52°C).</li> <li>8. A mixture of 60% Propylene Glycol (PG) antifreeze to 40% water will provide freeze protection down to -56°F (-49°C).</li> </ol>					

**Table 6. Self-Recovery Winch Lubrication.**

Item	Capacities	Expected Temperatures Above +15°F (-9°C)	Expected Temperatures +40 to -15°F (+4 to -26°C)	Expected Temperatures +40 to -50°F (+4 to -46°C)	Interval
Self-Recovery Winch Gearbox (Note 1)	2 qt. (1.89 L)	GO-85W/140 MIL-PRF-2105	GO-75 MIL-PRF-2105 or GO-80W/90 MIL-PRF-2105 (Note 2)	GO-75 MIL-PRF-2105 (Note 2)	A-Annual (1 year)
Winch Cable	As Required	OE/HDO-30 MIL-PRF-2104	OE/HDO-10 MIL-PRF-2104	OEA MIL-PRF-46167	S-Semiannual (WP 0149)

**Table 6. Self-Recovery Winch Lubrication. - Continued**

Item	Capacities	Expected Temperatures Above +15°F (-9°C)	Expected Temperatures +40 to -15°F (+4 to -26°C)	Expected Temperatures +40 to -50°F (+4 to -46°C)	Interval
			(Note 1)	(Note 1)	(6 Months)
All Other Self-Recovery Winch Lubrication Points	As Required	GAA MIL-PRF-10924	GAA MIL-PRF-10924 (Note 2)	GAA MIL-PRF-10924 (Note 2)	As Required (Note 3)
<p><b>NOTE</b></p> <ol style="list-style-type: none"> <li>1. Pre-lubricated from manufacturer.</li> <li>2. Refer to FM 9-207 (WP 0161) for arctic operation.</li> <li>3. Refer to PMCS tables for specific lubrication intervals.</li> </ol>					

**Table 7. Material Handling Crane Lubrication.**

Item	Capacities	Expected Temperatures Above +15°F (-9°C)	Expected Temperatures +40 to -15°F (+4 to -26°C)	Expected Temperatures +40 to -50°F (+4 to -46°C)	Interval
Crane Swing Drive Gearbox	1 pt. (0.47 L)	GO-80W/90 MIL-PRF-2105	GO-80W/90 MIL-PRF-2105 (Note 1)	GO-75 MIL-PRF-2104 (Note 1)	A-Annual (1 year) (Note 2)
Crane Hoist	1 pt. (0.47 L)	GO-80W/90 MIL-PRF-2105	GO-80W/90 MIL-PRF-2105 (Note 1)	GO-75 MIL-PRF-2104 (Note 1)	A-Annual (1 year)

**Table 7. Material Handling Crane Lubrication. - Continued**

Item	Capacities	Expected Temperatures Above +15°F (-9°C)	Expected Temperatures +40 to -15°F (+4 to -26°C)	Expected Temperatures +40 to -50°F (+4 to -46°C)	Interval
Hoist Cable	As Required	OE/HDO-30 MIL-PRF-2104	OE/HDO-10 MIL-PRF-2104 (Note 1)	OEA MIL-PRF-46167 (Note 1)	S-Semiannual (WP 0149) (6 Months)
All Other Crane Lubrication Points	As Required	GAA MIL-PRF-10924	GAA MIL-PRF-10924 (Note 1)	GAA MIL-PRF-10924 (Note 1)	As Required (Note 3)

**NOTE**

1. Refer to FM 9-207 (WP 0161) for arctic operation.
2. Check level and add fluid as necessary. Currently there is no requirement to drain/fill crane swing drive gearbox.
3. Refer to PMCS tables for specific lubrication intervals.

**Table 8. Oil Can Point Lubrication.**

Capacities	Expected Temperatures Above +15°F (-9°C)	Expected Temperatures +40 to -15°F (+4 to -26°C)	Expected Temperatures +40 to -50°F (+4 to -46°C)	Intervals
As Required	OE/HDO-30 MIL-PRF-2104	OE/HDO-10 MIL-PRF-2104 (Note 1)	OEA MIL-PRF-46167 (Note 1)	As Required (Note 2)

**NOTE**

1. Refer to FM 9-207 (WP 0161) for arctic operation.
2. Refer to PMCS tables for specific oilcan lubrication intervals.

**Table 9. Miscellaneous Lubrication Points.**

Item	Capacities	Expected Temperatures Above +15°F (-9°C)	Expected Temperatures +40 to -15°F (+4 to -26°C)	Expected Temperatures +40 to -50°F (+4 to -46°C)	Interval
Cargo Body	As Required	GAA MIL-PRF-10924	GAA MIL-PRF-10924 (Note 1)	GAA MIL-PRF-10924 (Note 1)	S-Semiannual (WP 0149) (6 Months)
Engine Throttle Lever	As Required	GAA MIL-PRF-10924	GAA MIL-PRF-10924 (Note 1)	GAA MIL-PRF-10924 (Note 1)	A-Annual (1 year)
Pintle Hook	As Required	GAA MIL-PRF-10924	GAA MIL-PRF-10924 (Note 1)	GAA MIL-PRF-10924 (Note 1)	W-Weekly (WP 0148) S-Semiannual (WP 0149) (6 Months) (service fittings)
Propeller Driver Shafts and U-Joints	As Required	GAA MIL-PRF-10924	GAA MIL-PRF-10924 (Note 1)	GAA MIL-PRF-10924 (Note 1)	S-Semiannual (WP 0149) (6 Months) (Note 2)
Spare Tire Davit	As Required	GAA MIL-PRF-10924	GAA MIL-PRF-10924 (Note 1)	GAA MIL-PRF-10924 (Note 1)	S-Semiannual (WP 0149) (6 Months)
Spring Hanger Pins	As Required	GAA MIL-PRF-10924	GAA MIL-PRF-10924 (Note 1)	GAA MIL-PRF-10924 (Note 1)	S-Semiannual (WP 0149) (6 Months)

**Table 9. Miscellaneous Lubrication Points. - Continued**

Item	Capacities	Expected Temperatures Above +15°F (-9°C)	Expected Temperatures +40 to -15°F (+4 to -26°C)	Expected Temperatures +40 to -50°F (+4 to -46°C)	Interval
Steering System	As Required	GAA MIL-PRF-10924	GAA MIL-PRF-10924 (Note 1)	GAA MIL-PRF-10924 (Note 1)	S-Semiannual (WP 0149) (6 Months)

**Table 10. Vehicle Cleaning.**

Item	Capacities	Expected Temperature	Intervals
Cleaning Compound, Solvent (Note 1)	As Required	SD All Temperatures (Note 2)	As Required
<p style="text-align: center;"><b>NOTE</b></p> <ol style="list-style-type: none"> <li>1. After a thorough high pressure washing, lubricate all grease fittings and oil can points outside and underneath vehicle.</li> <li>2. Refer to FM 9-207 (WP 0161) for arctic operation.</li> </ol>			

**END OF WORK PACKAGE**



---

## OPERATOR MAINTENANCE CLOSE/OPEN HEATER VALVES

---

### INITIAL SETUP:

#### Equipment Condition

Engine OFF. (WP 0057)

#### Equipment Condition - Continued

Wheels chocked. (WP 0077)

Open passenger side engine cover.  
(WP 0160)

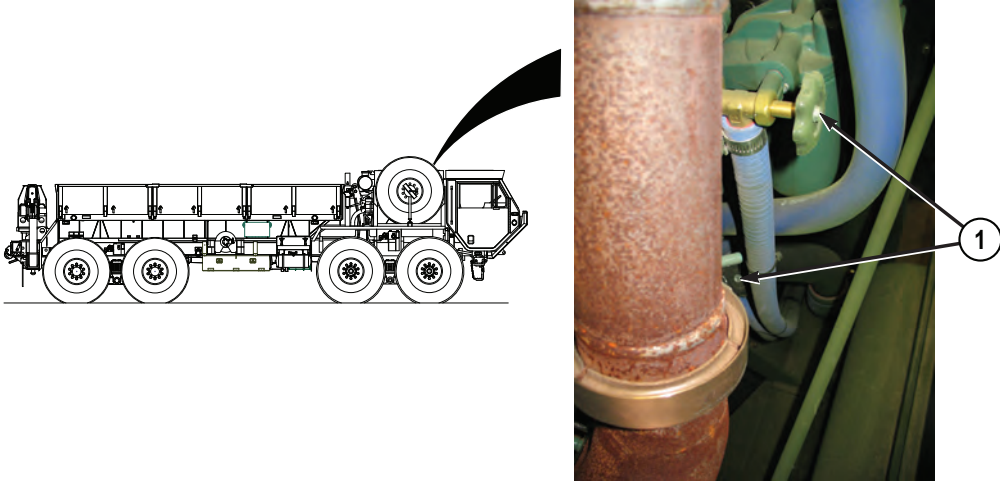
---

### CLOSE HEATER VALVES

#### NOTE

- Closing two heater valves will improve efficiency of air conditioning kit.
- Closing two heater valves will disable cabin heat.
- Two heater valve knobs are located on front passenger side of engine, the bottom valve is located approximately 18 in. (46 cm) below the top valve.

1. Turn two heater valve knobs (1) counterclockwise to close.

**CLOSE HEATER VALVES - Continued**

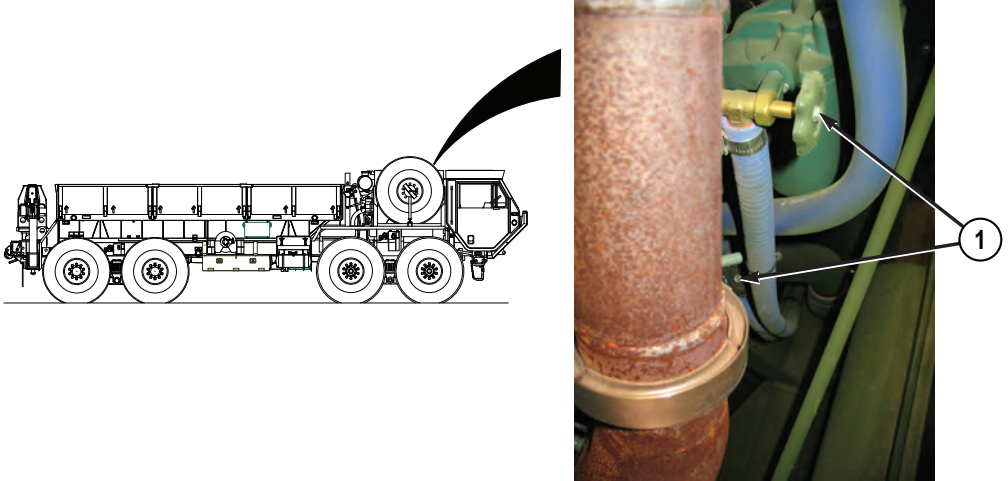
*Figure 1.*

**END OF TASK****OPEN HEATER VALVES****NOTE**

- Opening two heater valves will diminish efficiency of air conditioning kit.
- Opening two heater valves will enable cabin heat.
- Two heater valve knobs are located on front passenger side of engine, the bottom valve is located approximately 18 in. (46 cm) below the top valve.

1. Turn two heater valve knobs (1) clockwise to close.



**OPEN HEATER VALVES - Continued**

*Figure 2.*

**END OF TASK****FOLLOW-ON MAINTENANCE**

1. Close passenger side engine cover. (WP 0160)
2. Remove wheel chocks.

**END OF WORK PACKAGE**



---

**OPERATOR MAINTENANCE  
PRE/POST TOWING PROCEDURE (FRONT LIFT ONLY)**

---

**INITIAL SETUP:****Tools and Special Tools**

Chain, 8 ft. (supplied by wrecker)  
Chain, 7 ft. (supplied by wrecker)  
(WP 0162, Table 3, Item 6)

**Equipment Condition**

Engine OFF. (WP 0057)

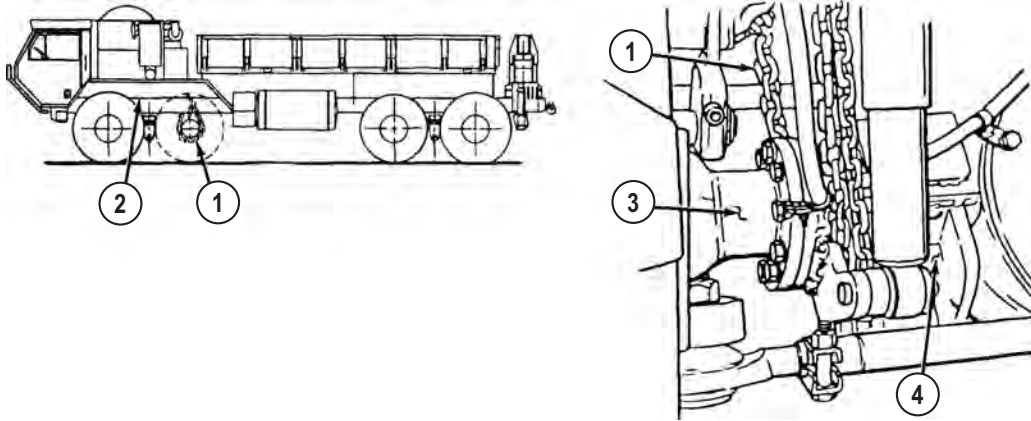
---

**PREPARE VEHICLE FOR TOWING****CAUTION**

When installing axle restraint chains, route chains so hoses or lines are not between frame and chain or axle and chain. Failure to comply may result in damage to equipment.

**NOTE**

- This procedure is applicable to preparation for towing a HEMTT series vehicle from the front ONLY (refer to tow HEMTT-front lift for further information).
  - If disabled vehicle is either a BASE or A2 model HEMTT series vehicle (refer to data plate on inside of driver side door), complete Step (1).
  - If disabled vehicle is an A4 model HEMTT series vehicle (refer to data plate on inside of driver side door), skip to Step (2).
1. Perform the following on disabled vehicle:
    - a. Remove propeller shaft between transfer case and No. 3 axle.
    - b. Install axle restraint chains (1):

**PREPARE VEHICLE FOR TOWING - Continued***Figure 1.***NOTE**

- Axle restraint chains are installed the same way, driver side shown.
- No. 2 axle should be restrained with chains on both sides of vehicle.

- (1) Route axle restraint chain (1) over frame rail (2) and around axle (3) beside walking beam (4).
- (2) Hook axle restraint chain (1) back into itself.
- (3) Repeat Steps (1) and (2) for opposite side of No. 2 axle (3).

**CAUTION**

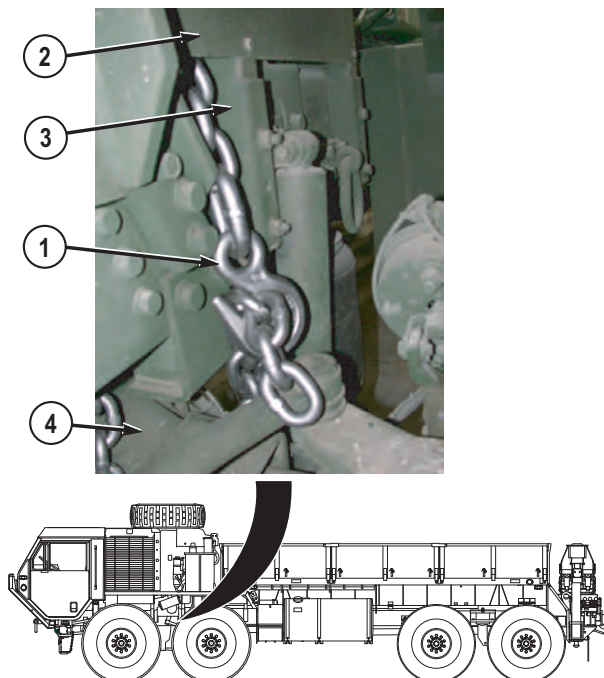
When installing axle restraint chains, route chain around frame rail and axle only. Do not wrap chain around lateral torque rod, shock absorber, shift cables, etc. as they could be crushed. Route chains so hoses or lines are not between frame and chain or axle and chain. Failure to comply may result in damage to equipment.

**NOTE**

- This procedure is applicable to preparation for towing a HEMTT series vehicle from the front ONLY (refer to tow HEMTT-front lift for further information).
- If disabled vehicle is an A4 model HEMTT series vehicle (refer to data plate on inside of driver side door), complete Step (2).

**PREPARE VEHICLE FOR TOWING - Continued**

2. Perform the following on disabled vehicle:
  - a. Remove propeller shaft between transfer case and No. 3 axle.
  - b. Install axle restraint chains (1):



*Figure 2.*

**NOTE**

- Axle restraint chains are installed the same way, driver side shown.
- No. 2 axle should be restrained with chains on both sides of vehicle.

- (1) Route axle restraint chain (1) under engine shroud (2), over frame rail (3), and around axle (4).
- (2) Hook axle restraint chain (1) back into itself as shown.
- (3) Repeat Steps (1) and (2) for opposite side of No. 2 axle (3).

**END OF TASK**

## POST TOWING PROCEDURE

### NOTE

- This post towing procedure is applicable to a HEMTT series vehicle that has been towed from the front ONLY (refer to tow HEMTT-front lift for further information).
- If disabled vehicle is either a BASE or A2 model HEMTT series vehicle (refer to data plate on inside of driver side door), complete Step (1).
- If disabled vehicle is an A4 model HEMTT series vehicle (refer to data plate on inside of driver side door), skip to Step (2).

1. Perform the following to disabled vehicle:
  - a. Remove two axle restraint chains (1) from around frame rails (2) and No. 2 axle (3).

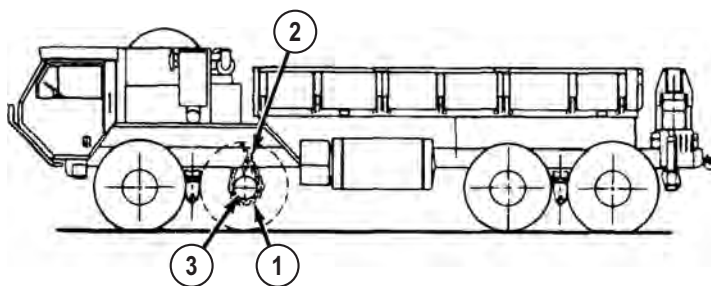


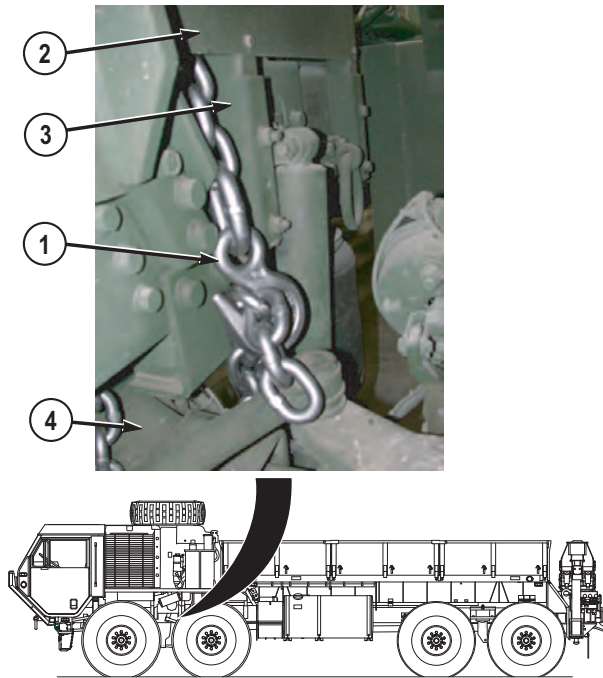
Figure 3.

- b. Return two axle restraint chains (1) to wrecker stowage.
- c. Install propeller shaft between transfer case and No. 3 axle.

### NOTE

- This post towing procedure is applicable to a HEMTT series vehicle that has been towed from the front ONLY (refer to tow HEMTT-front lift for further information).
- If disabled vehicle is an A4 model HEMTT series vehicle (refer to data plate on inside of driver side door), complete Step (2).

2. Perform the following to disabled vehicle:
  - a. Remove two axle restraint chains (1) from under engine shroud (2), around frame rail (3), and No. 2 axle (4).

**POST TOWING PROCEDURE - Continued**

*Figure 4.*

- b. Return two axle restraint chains (1) to wrecker stowage.
- c. Install propeller shaft between transfer case and No. 3 axle.

**END OF TASK**

**END OF WORK PACKAGE**





---

## OPERATOR MAINTENANCE CLEAN VEHICLE

---

### INITIAL SETUP:

#### Materials/Parts

Rag, Wiping (WP 0164, Table 1,  
Item 50)

#### Equipment Condition

Engine OFF. (WP 0057)  
Wheels chocked. (WP 0077)

---

### CLEAN EXTERIOR

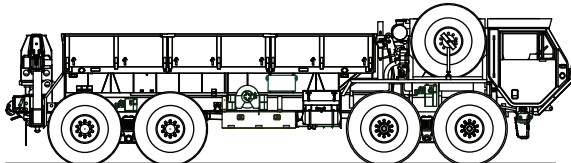
#### CAUTION

Do not wipe dirt off vehicle when vehicle is dry. Dirt, stones, or debris may scratch and damage vehicle.

#### NOTE

After a thorough high pressure washing, lubricate all grease fittings and oil can points outside and underneath vehicle (refer to lubrication instructions (WP 0151) for more information).

1. Wash vehicle often with cool or warm water. Do not use strong detergent or abrasives.



*Figure 1.*

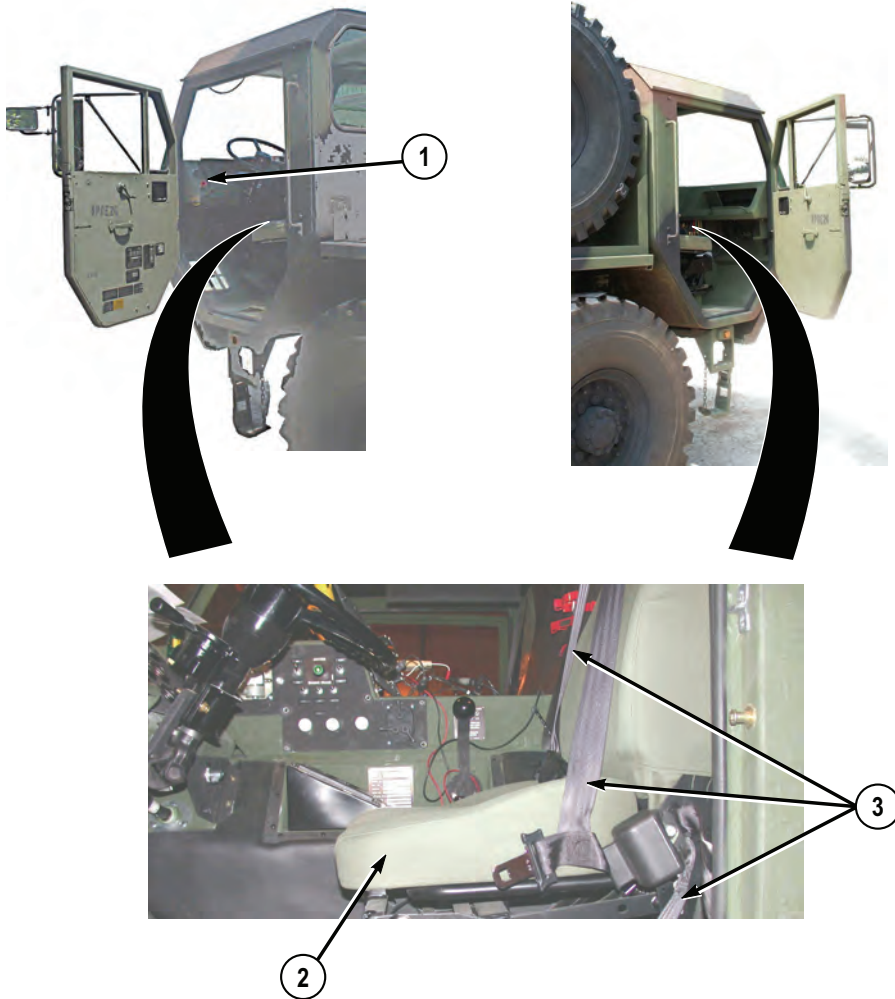
2. While cleaning vehicle, look closely for rust, corrosion, bare metal, or other damage. Report any damage to Field Level Maintenance.

### END OF TASK

#### CLEAN INTERIOR

1. Remove loose dirt and dust from cab interior components (1).
2. Clean seat cushions (2) and seatbelts (3) with warm soapy water. Do not use abrasives or solvents.

**CLEAN INTERIOR - Continued**



*Figure 2.*

- 3. Wipe seat cushions (2) and seatbelts (3) dry.

**END OF TASK**

**END OF WORK PACKAGE**

---

## OPERATOR MAINTENANCE CHANGE WHEEL AND TIRE ASSEMBLY

---

**INITIAL SETUP:****Tools and Special Tools**

Chocks, Wheel (2) (WP 0162, Table 3, Item 8)  
 Extension, Handle (WP 0162, Table 3, Item 12)  
 Handle, Wrench (WP 0162, Table 3, Item 13)  
 Jack, 12-ton, With Handle (WP 0162, Table 3, Item 16)  
 Jack, Base Plate (WP 0162, Table 3, Item 19)

**Tools and Special Tools - Continued**

Warning Device Set, Triangular (WP 0162, Table 3, Item 21)  
 Wrench, Wheel Lugnut (WP 0162, Table 3, Item 32)  
 Wrench, Adjustable (WP 0162, Table 3, Item 30)

**Personnel Required**

Operator and Assistant - - - (2)

---

**PREPARE VEHICLE**

1. Shut off engine. (WP 0057)

**WARNING**

Park vehicle in safe area, out of traffic, where there is no danger to personnel changing tire assembly. Park vehicle on hard level ground. Failure to comply may result in injury or death to personnel.

2. Turn on emergency flashers. (WP 0076)
3. Set up emergency marker kit, as necessary. (WP 0099)

**END OF TASK****SET UP TIRE DAVIT WINCH**

1. Remove hoist arm (1) from mounting bracket (2).

## SET UP TIRE DAVIT WINCH - Continued

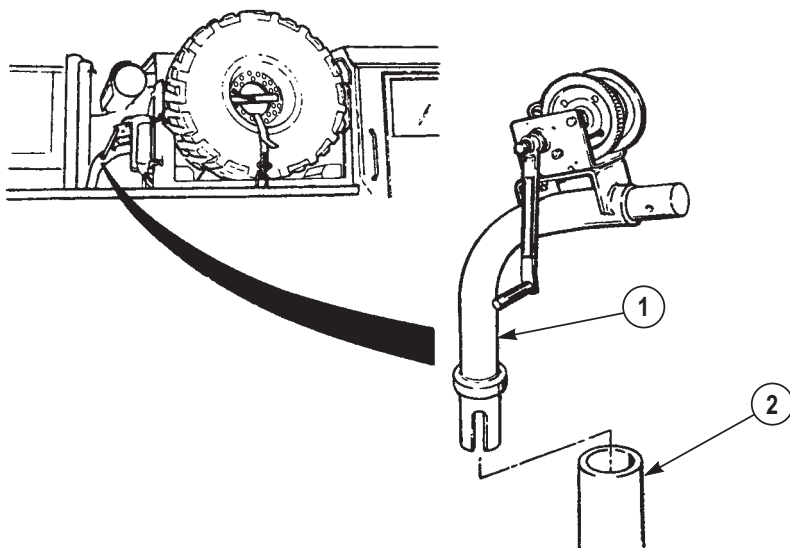
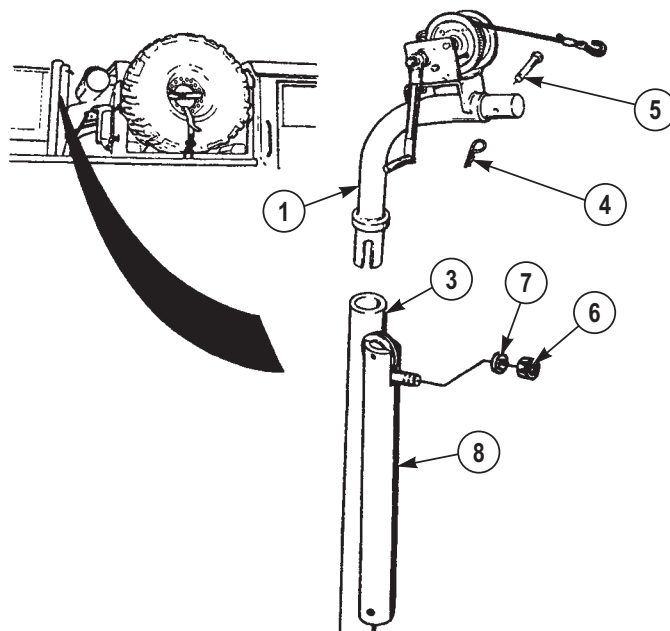


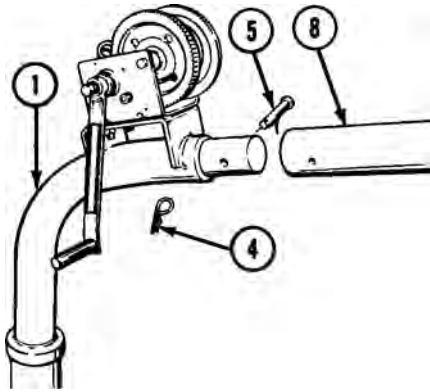
Figure 1.

2. Install hoist arm (1) in mount (3).

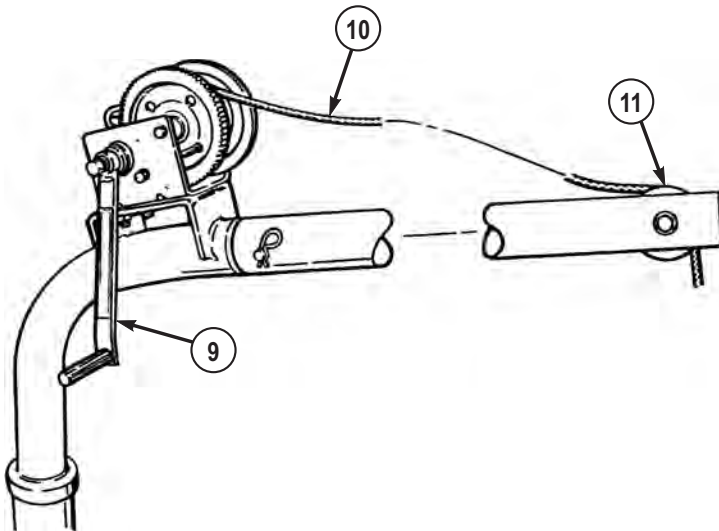
## SET UP TIRE DAVIT WINCH - Continued

*Figure 2.*

3. Remove and keep safety pin (4) and pin (5) from hoist arm (1).
4. Remove nut (6), washer, and extension (8) from mount (3).
5. Install extension (8) in hoist arm (1).

**SET UP TIRE DAVIT WINCH - Continued***Figure 3.*

6. Line up holes in extension (8) and hoist arm (1).
7. Install pin (5) and safety pin (4).
8. Turn hand crank (9) CCW and route cable (10) over end of pulley (11).

*Figure 4.***END OF TASK**

**REMOVE SPARE WHEEL AND TIRE ASSEMBLY**

1. Remove two wheel chocks (1) from under spare wheel and tire assembly (2).

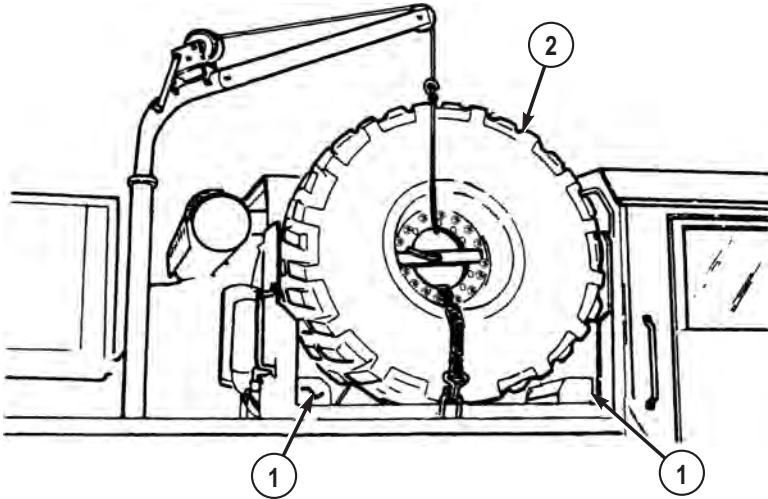


Figure 5.

2. Install two wheel chocks (WP 0077) (1) on wheel and tire assembly (3) that is across from flat wheel and tire assembly (4).

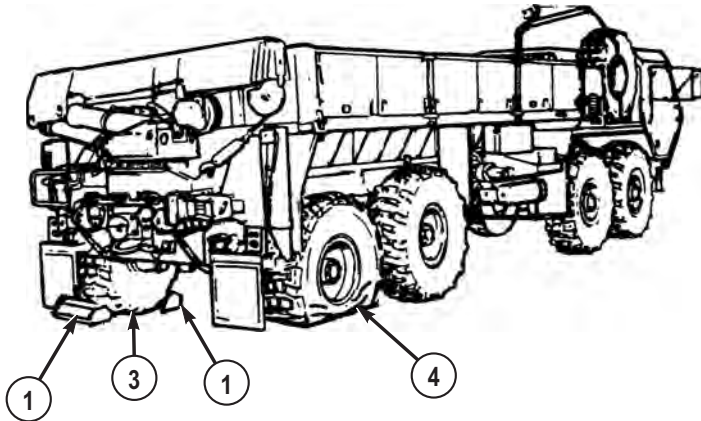
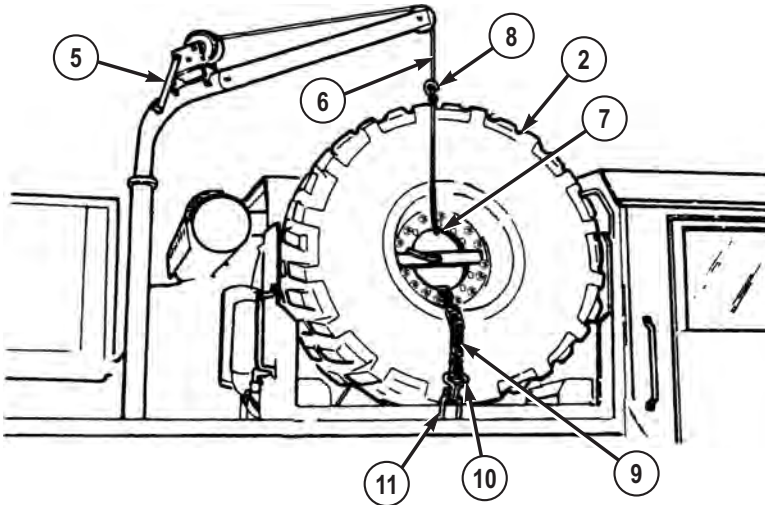


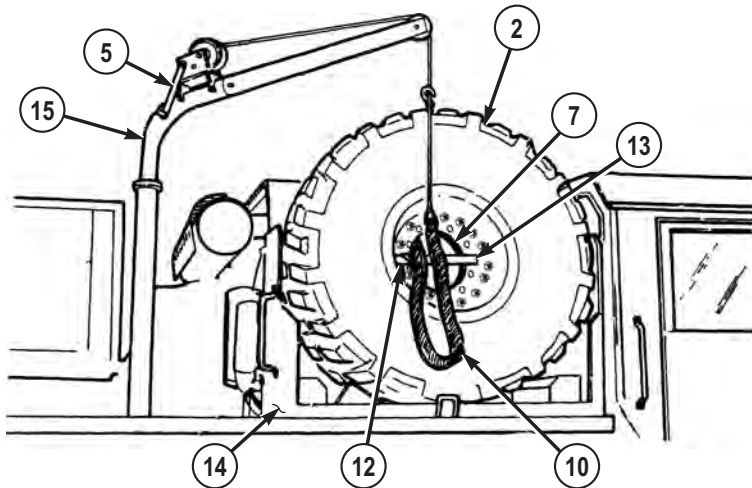
Figure 6.

3. Turn hand crank (5) counterclockwise to let out enough cable (6) to push through hole in wheel (7) and wrap around spare wheel and tire assembly (2).

**REMOVE SPARE WHEEL AND TIRE ASSEMBLY - Continued***Figure 7.*

4. Wrap cable (6) through hole in wheel (7) and around spare wheel and tire assembly (2), and secure with hook (8).
5. Turn hand crank (5) clockwise to put light tension on cable (6).
6. Release clamp (9), and disconnect tie down strap (10) from bracket (11) on both sides of spare wheel and tire assembly (2).
7. Hook tie down strap (10) on hole in wheel (7) on both sides of spare wheel and tire assembly (2).



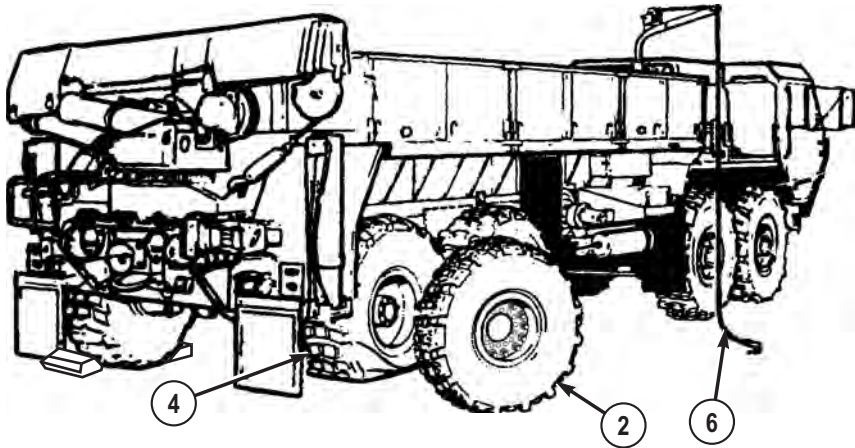
**REMOVE SPARE WHEEL AND TIRE ASSEMBLY - Continued***Figure 8.*

8. Turn lever (12) counterclockwise.
9. Remove lever (12) and holddown plate (13). Set aside lever (12) and holddown plate (13) for later use.

**NOTE**

Stand on passenger side front fender to operate tire davit winch while other assistant stands on ground near second axle to guide wheel and tire assembly down.

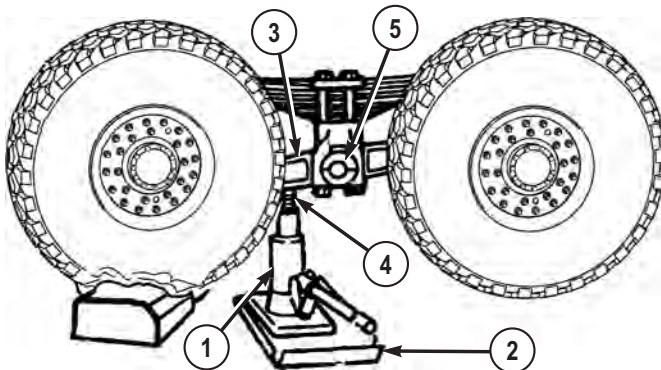
10. Turn hand crank (5) clockwise to lift spare wheel and tire assembly (2) just above carrier (14).
11. Swing hoist arm (15) so spare wheel and tire assembly (2) is clear of vehicle, while assistant pulls on tie down strap (10) to guide spare wheel and tire assembly out of carrier (14).
12. Turn hand crank (5) counterclockwise to lower spare wheel and tire assembly (2) to ground, while assistant holds spare wheel and tire assembly (2) steady with tie down strap (10).
13. Remove tie down strap (10).
14. Push spare wheel and tire assembly (2) against vehicle.

**REMOVE SPARE WHEEL AND TIRE ASSEMBLY - Continued***Figure 9.*

15. Remove cable (6) from spare wheel and tire assembly (2), and roll spare wheel and tire assembly (2) next to axle of flat wheel and tire assembly (4).
16. Check spare wheel and tire assembly (2) air pressure and service as required. (WP 0158)

**END OF TASK****REMOVE WHEEL AND TIRE ASSEMBLY**

1. Remove jack (1) and jack base plate (2) from stowage.

*Figure 10.*

**REMOVE WHEEL AND TIRE ASSEMBLY - Continued****NOTE**

It may be necessary to place wheel chock under flat wheel and tire assembly to get jack and jack base plate under equalizing beam.

2. Position jack (1) and jack base plate (2) under equalizing beam (3).
3. Unscrew jack ram (4) until it touches equalizing beam (3) approximately 4 to 5 in. (102 to 127 mm) from beam center pivot point (5).

**NOTE**

Studs and lugnuts on driver side of vehicle have left-hand threads. Rotate lugnuts clockwise to loosen, counterclockwise to tighten. Studs and lugnuts on passenger side of vehicle have right-hand threads. Rotate lugnuts counterclockwise to loosen, clockwise to tighten.

4. Loosen 10 lugnuts (6) until they turn easily.

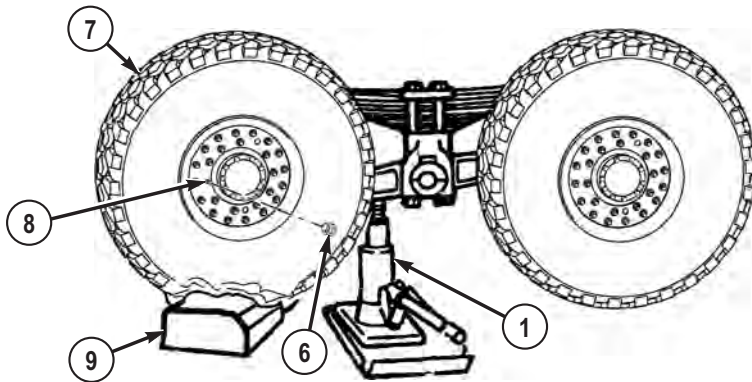


Figure 11.

**NOTE**

If chock was used to help position jack, wheel and tire assembly does not have to be clear of chock.

5. Raise jack (1) until flat wheel and tire assembly (7) can be removed.
6. Remove 10 lugnuts (6) from studs (8) and set lugnuts (6) aside.

**NOTE**

If wheel chock was not used to position jack, skip to Step (8).

7. Remove wheel chock (9) and return it to vehicle stowage.

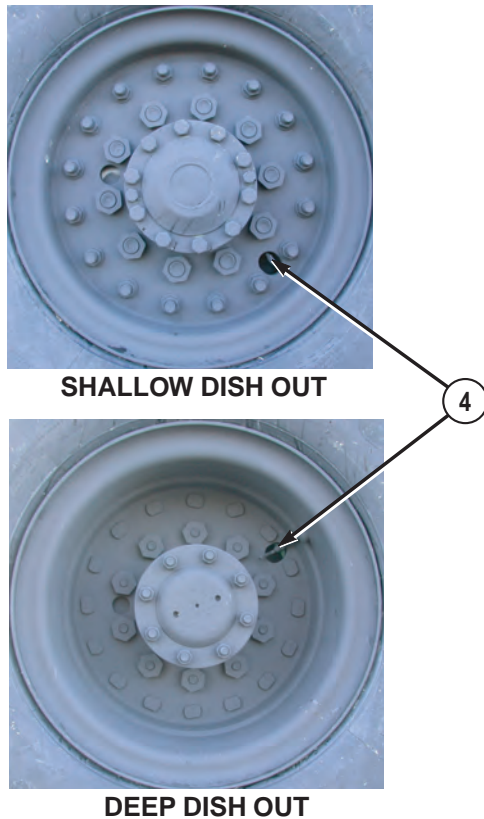


**INSTALL WHEEL AND TIRE ASSEMBLY - Continued**

2. Make sure deep side of spare wheel and tire assembly wheel dish (3) is in same position as flat/shredded wheel and tire assembly wheel dish when flat/shredded wheel and tire assembly was removed.

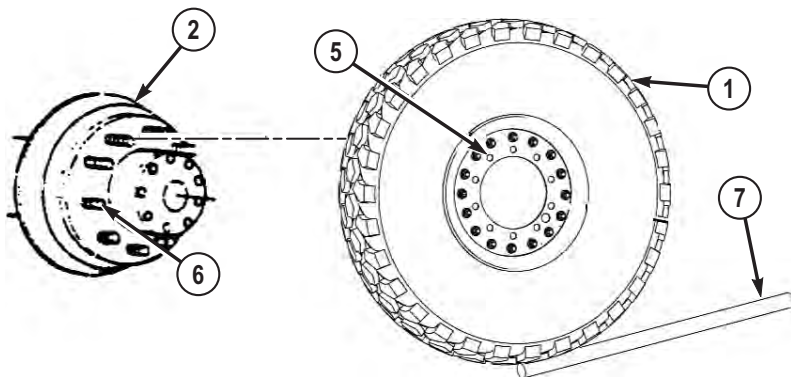
**NOTE**

- Tire valve stem extension must be removed to reposition wheel and tire assembly valve stem extension.
  - It may be necessary to reposition valve stem to accomplish installation of valve stem extension.
3. Make sure wheel and tire assembly valve stem (4) is pointing out, away from vehicle.



*Figure 13.*

4. Line up holes in rim (5) of wheel and tire assembly (1) with studs (6) on axle (2).

**INSTALL WHEEL AND TIRE ASSEMBLY - Continued***Figure 14.***WARNING**

Wheel/tire assembly weighs 540 lbs (245 kg). Do not attempt to lift or move wheel/tire assembly without the aid of an assistant and a lifting device. Failure to comply may result in injury or death to personnel.

5. Lean top of wheel and tire assembly (1) against studs (6) and axle (2).

**NOTE**

Install a lugnut on top stud, and hand-tighten to hold wheel and tire assembly in place.

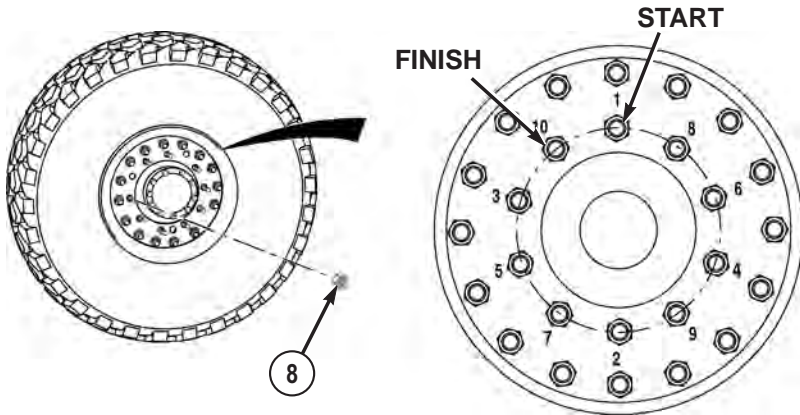
6. Using handle extension (7), slide spare wheel and tire assembly onto studs (6) while assistant raises vehicle with jack. Bottom of wheel and tire assembly (1) should swing toward axle (2).
7. Assistant lowers vehicle until wheel and tire assembly (1) just touches ground.
8. Repeat Steps (5) through (7) until wheel and tire assembly (1) is seated on axle (2) and studs (6).

**NOTE**

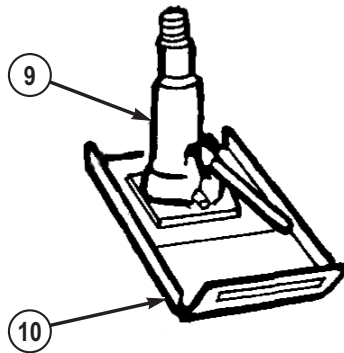
- Studs and lugnuts on driver side of vehicle have left-hand threads. Rotate lugnuts counterclockwise to tighten.

**INSTALL WHEEL AND TIRE ASSEMBLY - Continued**

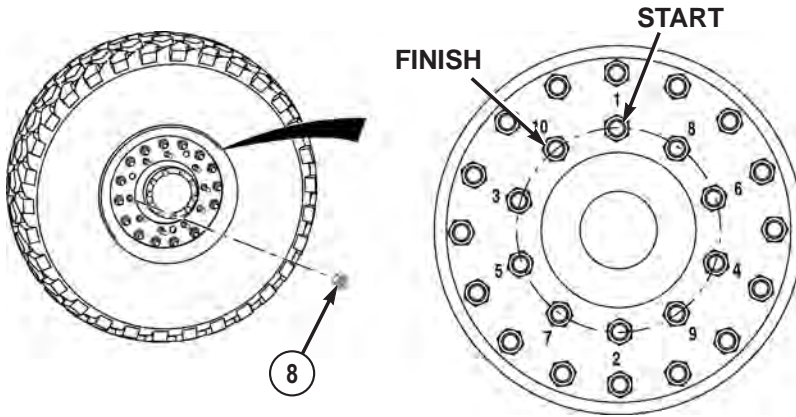
- Studs and lugnuts on passenger side of vehicle have right-hand threads. Rotate lugnuts clockwise to tighten.
9. Install and tighten 10 lugnuts (8) in order shown using wheel lugnut wrench.

*Figure 15.*

10. Assistant lowers jack (9) until vehicle weight is fully supported by suspension system.
11. Remove jack (9) and jack base plate (10) from under vehicle.

*Figure 16.*

12. Tighten 10 lugnuts (8) in order shown until they no longer tighten.

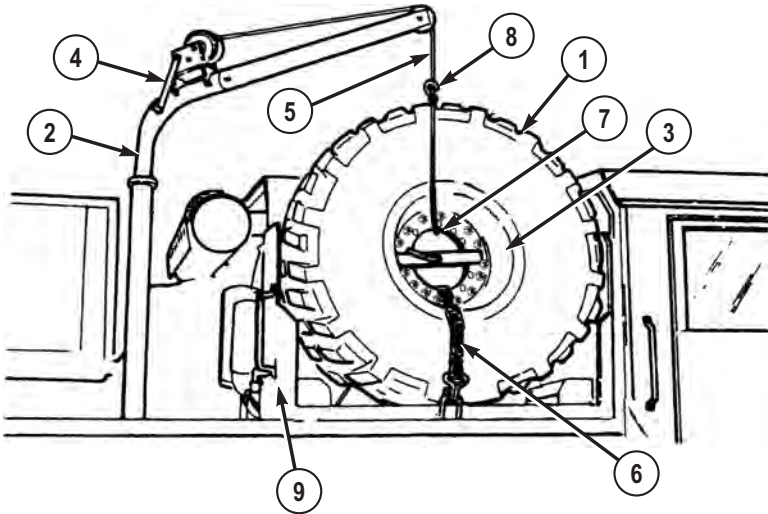
**INSTALL WHEEL AND TIRE ASSEMBLY - Continued***Figure 17.*

13. Return all tools and equipment to proper storage boxes.
14. Return vehicle to field level maintenance and have lugnuts (8) tightened to torque requirements as soon as possible.

**END OF TASK****STOW FLAT WHEEL AND TIRE ASSEMBLY**

1. Roll flat wheel and tire assembly (1) under hoist arm (2) so deep side of wheel dish (3) is facing out and away from vehicle.



**STOW FLAT WHEEL AND TIRE ASSEMBLY - Continued***Figure 18.***NOTE**

Assistant stands on passenger side front fender to operate tire davit winch while other assistant stands on ground near second axle to guide wheel and tire assembly into carrier.

2. Turn hand crank (4) counterclockwise to let out cable (5).
3. Pull tie down strap (6) through hole in wheel (7), and hook ends to hole on both sides of wheel.
4. Hook ends of tie down strap (6) to both sides of hole in wheel (7).
5. Pull cable (5) through hole in wheel (7) and secure hook (8) back into cable as shown.

**WARNING**

Inner wheel weighs 105 lbs (48 kg). Do not attempt to lift or move inner wheel without the aid of an assistant and a lifting device. Failure to comply may result in injury or death to personnel.

**STOW FLAT WHEEL AND TIRE ASSEMBLY - Continued**

6. Turn hand crank (4) clockwise to raise flat wheel and tire assembly (1) just above carrier (9) while assistant holds tie down strap (6) to steady wheel and tire assembly (1).
7. Swing hoist arm (2) so flat wheel and tire assembly (1) is over carrier (9) while assistant guides wheel and tire assembly with tie down strap (6).
8. Turn hand crank (4) counterclockwise to lower flat wheel and tire assembly (1) into carrier (9).
9. Remove tie down strap (6).
10. Hold flat wheel and tire assembly (1) steady, while assistant installs holddown plate (10).

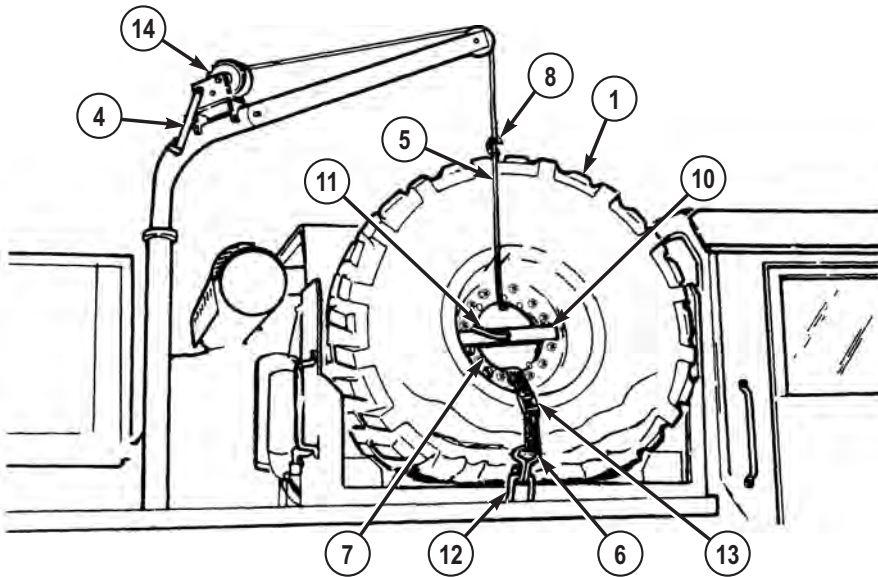


Figure 19.

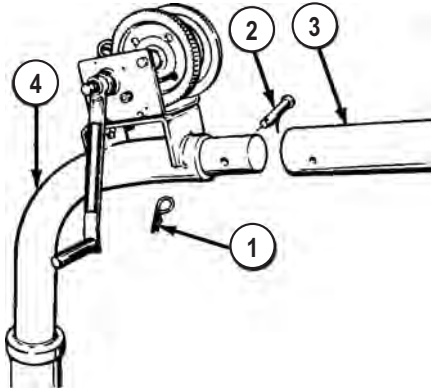
11. Install lever (11) and turn clockwise to tighten.
12. Slide tie down strap (6) through hole in wheel (7).
13. Connect tie down strap (6) to outside holddown bracket (12), while assistant connects tie down strap to inside holddown bracket.
14. Pull latch (13) down and lock to secure flat wheel and tire assembly (1).
15. Turn hand crank (4) counterclockwise to loosen cable (5).
16. Remove hook (8) and cable (5) from wheel and tire assembly (1).

**STOW FLAT WHEEL AND TIRE ASSEMBLY - Continued**

17. Turn hand crank (4) clockwise and wind cable (5) fully onto reel (14).

**END OF TASK****STOW TIRE DAVIT WINCH**

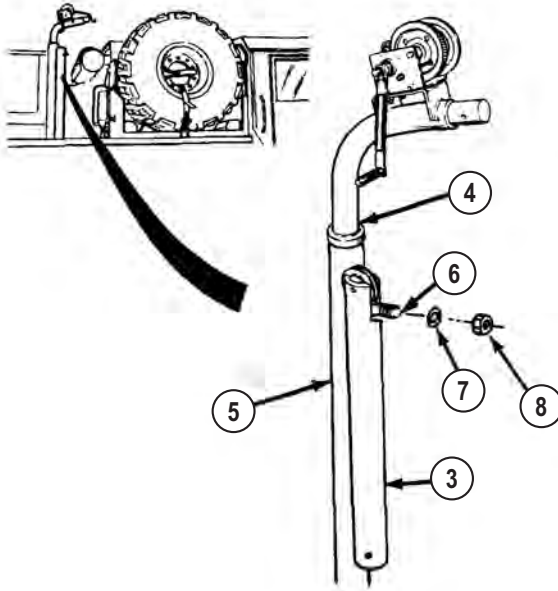
1. Remove safety pin (1) and pin (2) from extension (3).



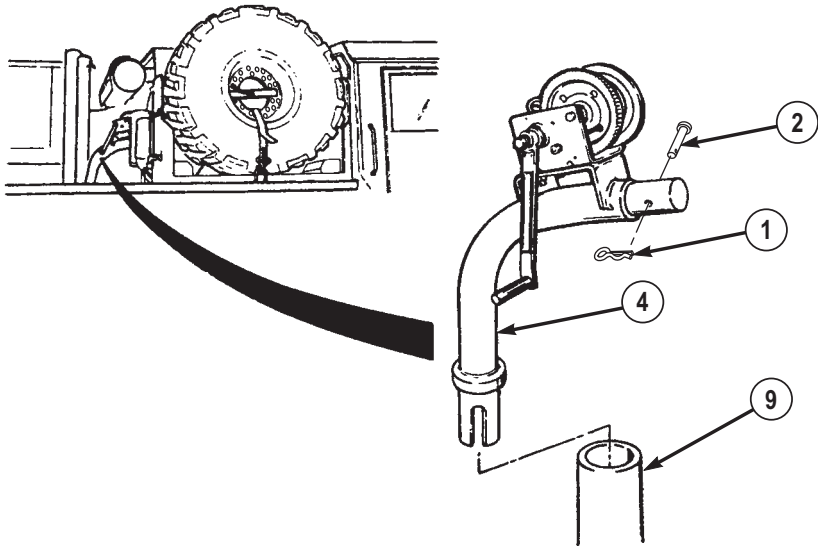
*Figure 20.*

2. Pull extension (3) from hoist arm (4).
3. Install extension (3) on mount (5).

## STOW TIRE DAVIT WINCH - Continued

*Figure 21.*

4. Slide top of extension (3) over stud (6).
5. Secure extension (3) with washer (7) and nut (8).
6. Pull hoist arm (4) from mount (5).
7. Put hoist arm (4) into mounting bracket (9).

**STOW TIRE DAVIT WINCH - Continued**

*Figure 22.*

8. Install pin (10) through hoist arm (4).
9. Secure pin (10) with safety pin (11).
10. Pick up and stow emergency marker kit (as necessary).

**END OF TASK**

**END OF WORK PACKAGE**



---

## OPERATOR MAINTENANCE CLEAN FUEL TANK STRAINER

---

### INITIAL SETUP:

#### Materials/Parts

Rag, Wiping (WP 0164, Table 1,  
Item 50)

#### Equipment Condition

Engine OFF. (WP 0057)  
Wheels chocked. (WP 0077)

---

### REMOVE/CLEAN FUEL TANK STRAINER

#### WARNING



Fuel is very flammable and can explode easily. Keep fuel away from open fire and keep fire extinguisher within easy reach when working with fuel. Do not work on fuel system when engine is hot. Fuel can be ignited when engine is hot. When working with fuel, post signs that read NO SMOKING WITHIN 50 FEET OF VEHICLE. Failure to comply may result in injury or death to personnel.

1. Wipe off dirt from fuel filler cap (1).

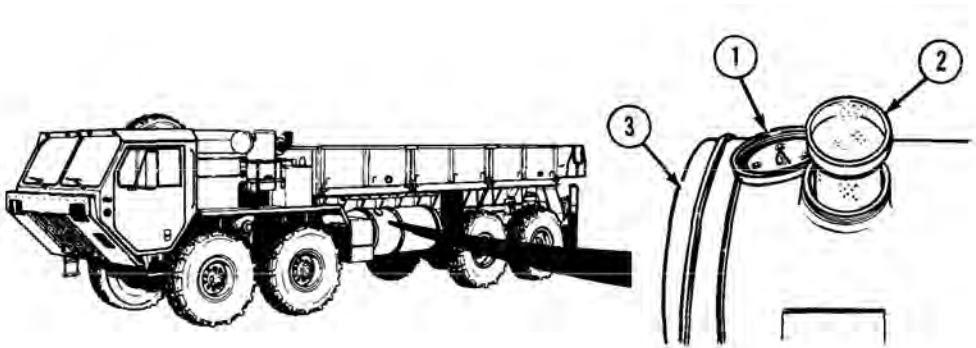


Figure 1.

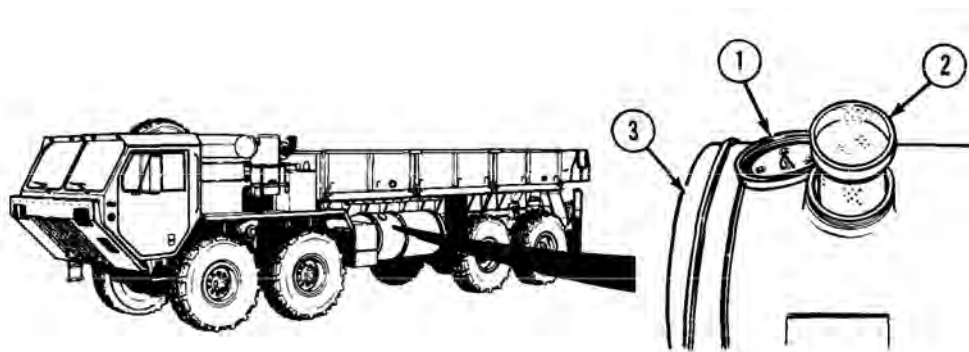
2. Remove fuel filler cap (1).
3. Pull strainer (2) out of fuel tank (3).

**REMOVE/CLEAN FUEL TANK STRAINER - Continued**

4. Clean strainer (2) with clean dry rag.

**END OF TASK****INSTALL FUEL TANK STRAINER**

1. Put strainer (2) in fuel tank (3).



*Figure 2.*

2. Install and tighten fuel filler cap (1).

**END OF TASK****FOLLOW-ON MAINTENANCE**

1. Remove wheel chocks.

**END OF WORK PACKAGE**



---

## OPERATOR MAINTENANCE SERVICE AIR CLEANER ELEMENT

---

### INITIAL SETUP:

#### Tools and Special Tools

Ladder (WP 0162, Table 2, Item 2)

#### Equipment Condition

Engine OFF. (WP 0057)

Wheels chocked. (WP 0077)

#### Materials/Parts

Rag, Wiping (WP 0164, Table 1, Item 50)

---

### REMOVE AIR CLEANER ELEMENT

1. Lift up three levers (1).

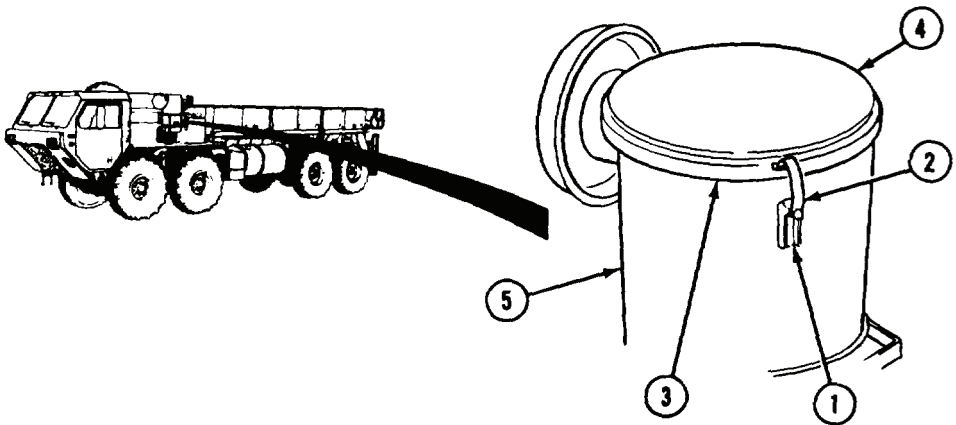
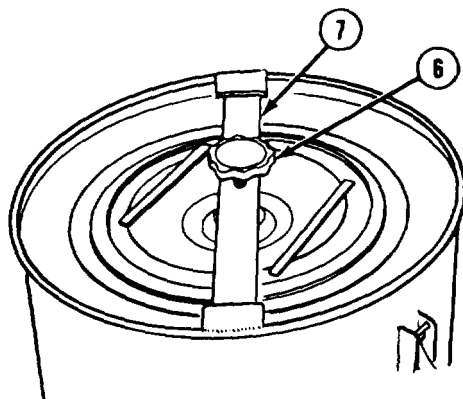


Figure 1.

2. Unhook three latches (2) from cover groove (3).
3. Remove cover (4) from canister (5).
4. Unscrew knob (6) until retaining bar (7) is loose.

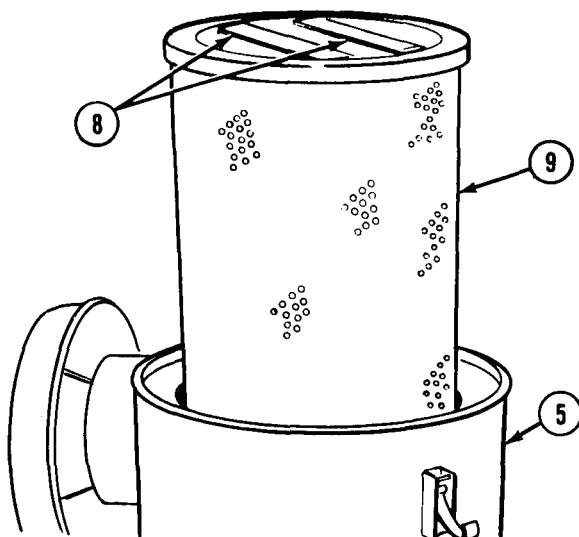
**REMOVE AIR CLEANER ELEMENT - Continued***Figure 2.*

5. Remove knob (6) and retaining bar (7).

**CAUTION**

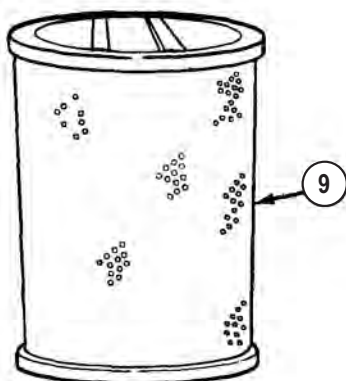
Do not remove secondary filter element. Dirt and debris can fall into canister and cause damage to engine.

6. Take hold of handles (8) and remove primary element (9) from canister (5).

**REMOVE AIR CLEANER ELEMENT - Continued***Figure 3.***END OF TASK****CLEAN AIR CLEANER ELEMENT****NOTE**

Notify field level maintenance if primary filter element is damaged or cannot be cleaned by tapping.

1. Tap side of primary element (9) lightly against hand.

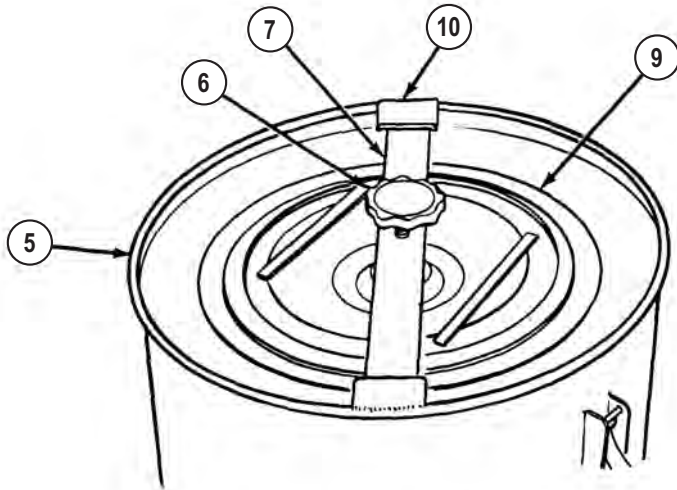
**CLEAN AIR CLEANER ELEMENT - Continued**

*Figure 4.*

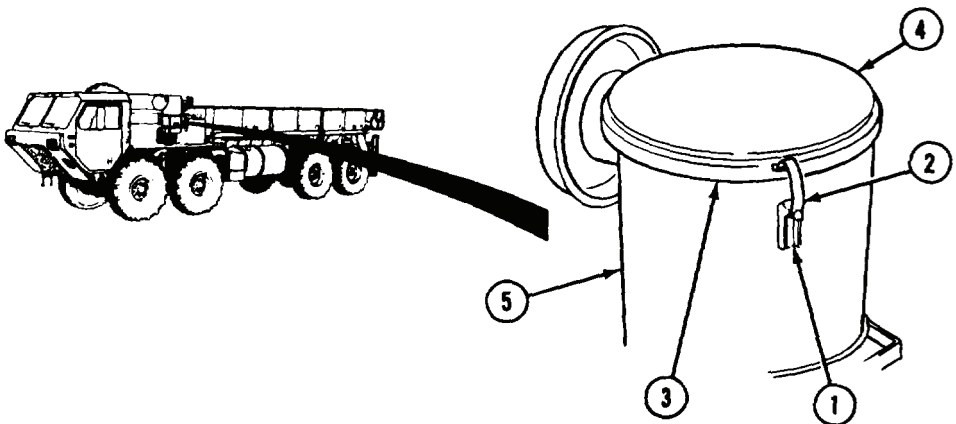
2. Dump out dirt and dust from primary element (9).
3. Wipe primary element (9) with clean rag.

**END OF TASK****INSTALL AIR CLEANER ELEMENT**

1. Install primary element (9) in air cleaner canister (5).

**INSTALL AIR CLEANER ELEMENT - Continued***Figure 5.*

2. Position knob (6) and retaining bar (7) over primary element (9). Make sure ends of retaining bar are in tabs (10).
3. Tighten knob (6) to secure primary element (9).
4. Put cover (4) on top of air cleaner canister (5).

*Figure 6.*

**INSTALL AIR CLEANER ELEMENT - Continued**

5. Put three latches (2) in cover groove (3).
6. Push three levers (1) down to secure cover (4).
7. Start engine. (WP 0044)
8. Push button (11) to reset air cleaner restriction indicator (12). If indicator window (13) shows VACUUM INCHES H<sub>2</sub>O below 20, continue with vehicle operation but notify Field Level Maintenance as soon as possible. If indicator window shows VACUUM INCHES H<sub>2</sub>O above 20, notify Field Level Maintenance.

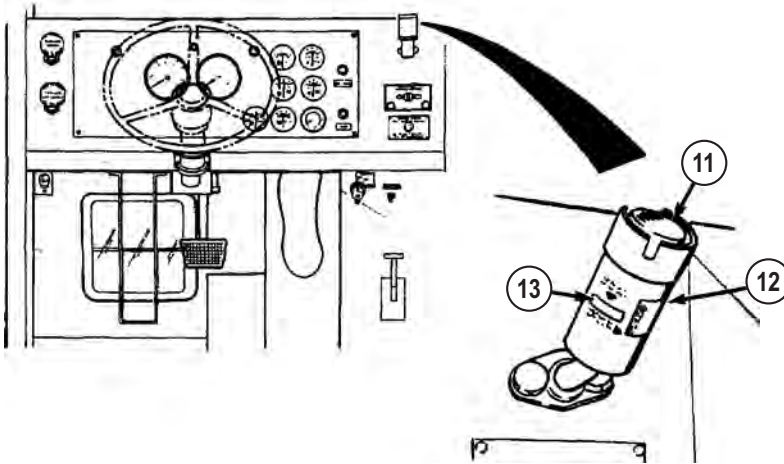


Figure 7.

9. Shut OFF engine. (WP 0057)

**END OF TASK****FOLLOW-ON MAINTENANCE**

1. Remove wheel chocks.

**END OF WORK PACKAGE**

---

## OPERATOR MAINTENANCE SERVICE TIRES

---

### INITIAL SETUP:

#### Tools and Special Tools

Gauge, Tire Pressure (WP 0162,  
Table 3, Item 11)

#### Tools and Special Tools - Continued

Gauge, Tire Pressure (WP 0162,  
Table 3, Item 15)  
Hose: Air, Pneumatic (WP 0162,  
Table 3, Item 14)

#### Equipment Condition

Engine OFF. (WP 0057)  
Wheels chocked. (WP 0077)

---

### CHECK TIRE PRESSURE

#### WARNING



Failure to comply with these procedures may result in faulty positioning of the tire and/or rim parts and cause the assembly to burst with explosive force. Never mount or use damaged tires or rims. Failure to comply may result in injury or death to personnel.

#### NOTE

There are two types of air pressure gauges. One is a separate handheld gauge. The other is a combined pressure gauge/inflation hose.

Both may be used to check air pressure in tire.

ALWAYS use combined pressure gauge/inflation hose to inflate tire.

1. Check tire air pressure with tire pressure gauge.
2. Ensure tires have correct air pressure for road conditions and driving speed .

### END OF TASK

**INFLATE TIRE**

1. Remove air hose (1) from stowage and connect air hose (1) to quick disconnect coupling (2) by pushing back sleeve (3).

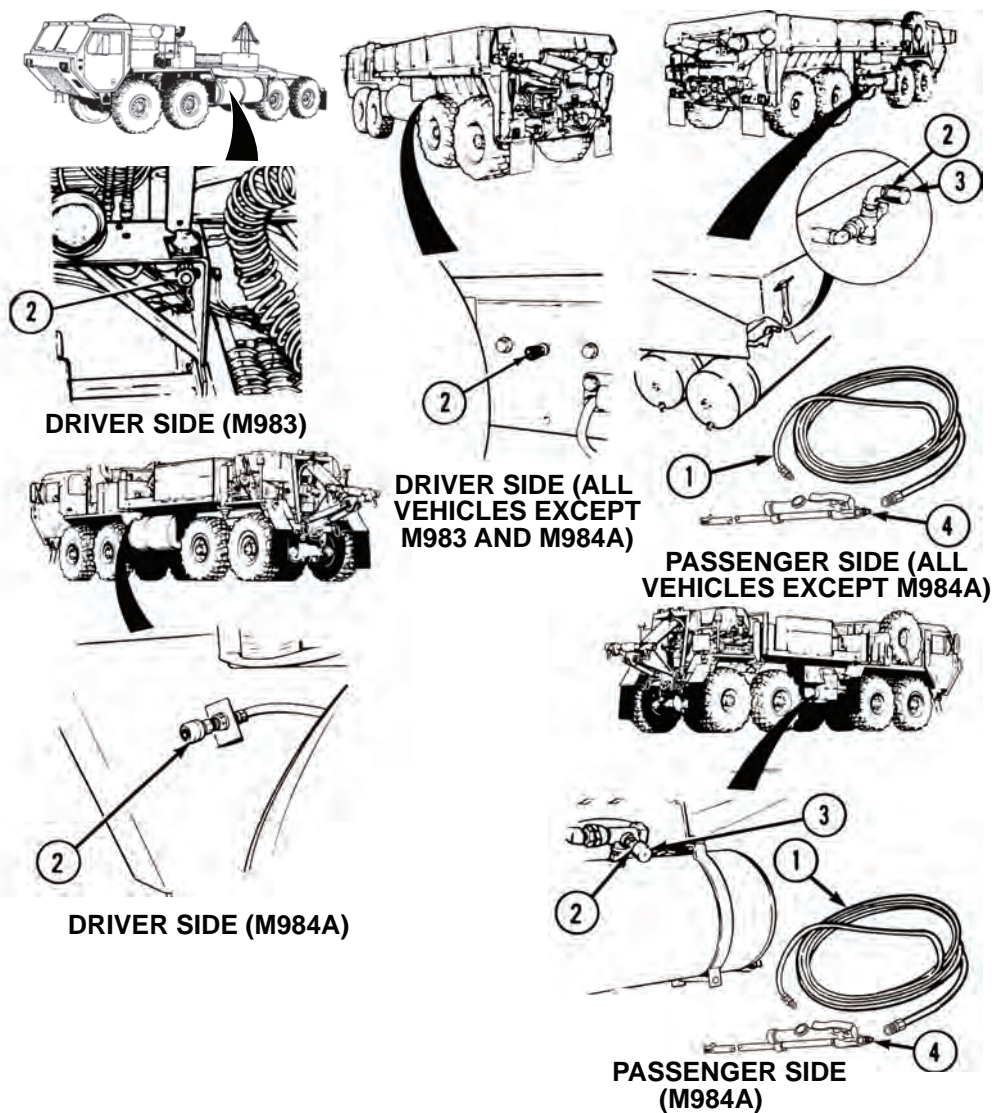


Figure 1.

2. Connect combined pressure gauge/inflation hose (4) to air hose (1).
3. Start engine. (WP 0044)



**INFLATE TIRE - Continued**

4. Remove valve stem cap (5) from valve stem (6).

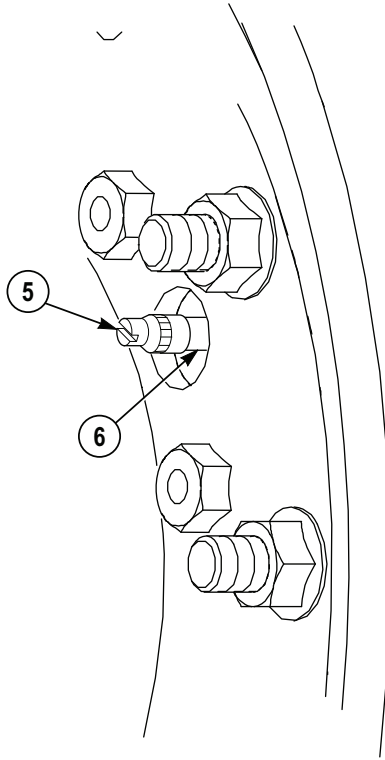


Figure 2.

**WARNING**

Prior to inflating or deflating tire, stand clear of trajectory area. Failure to comply may result in injury or death to personnel.

**NOTE**

- Trajectory area as shown applies to all wheel/tire assemblies.
- Air chuck must clamp securely with no leaks or air pressure gauge readings will be inaccurate.

**INFLATE TIRE - Continued**

- There are two types of air pressure gauges. One is a separate handheld gauge used on vehicle serial number 51130 and below. The other is a combined pressure gauge/inflation hose.
  - Both may be used to check air pressure in tire.
  - ALWAYS use combined pressure gauge/inflation hose to inflate tire.
5. Push latch handle (7) inward, while pushing air chuck (8) onto valve stem (6). Release latch handle (7) and immediately step out of the trajectory area and read tire air pressure gauge.

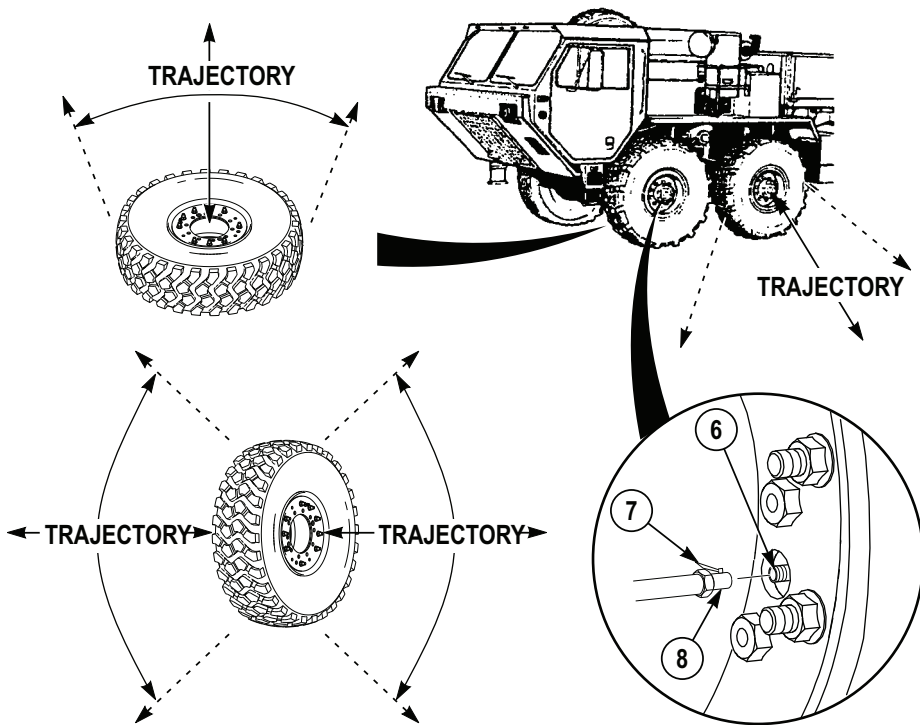


Figure 3.

**INFLATE TIRE - Continued**

**WARNING**



Prior to inflating or deflating tire, stand clear of trajectory area. Failure to comply may result in injury or death to personnel.

**NOTE**

Trajectory area as shown applies to all wheel/tire assemblies.

6. Inflate or deflate until proper pressure is attained. Press latch handle (7) and pull air chuck (8) from valve stem (6). Install valve stem cap (5).

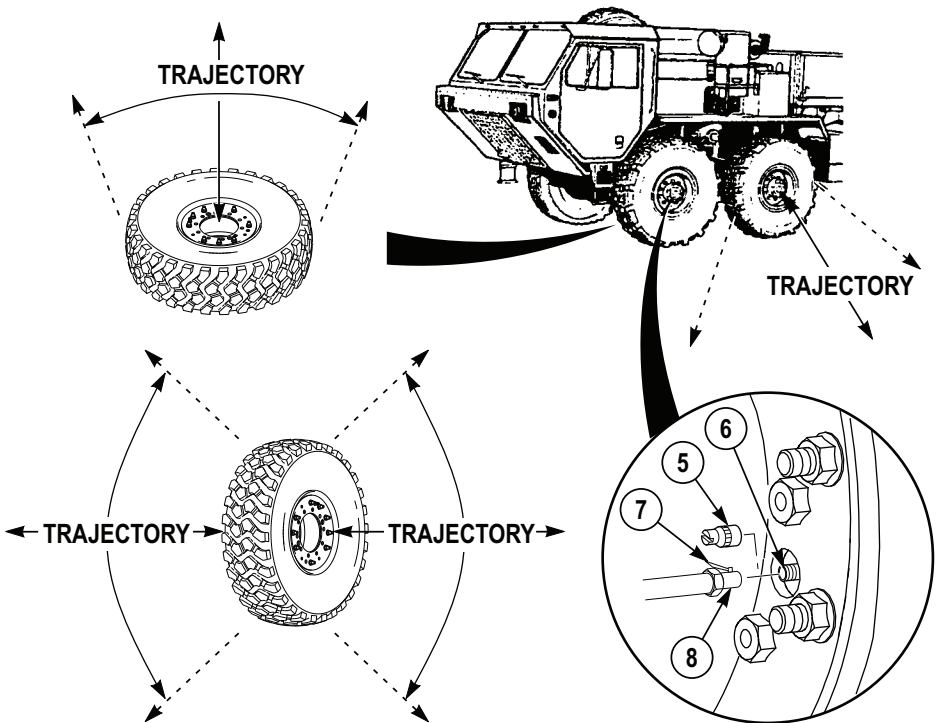


Figure 4.

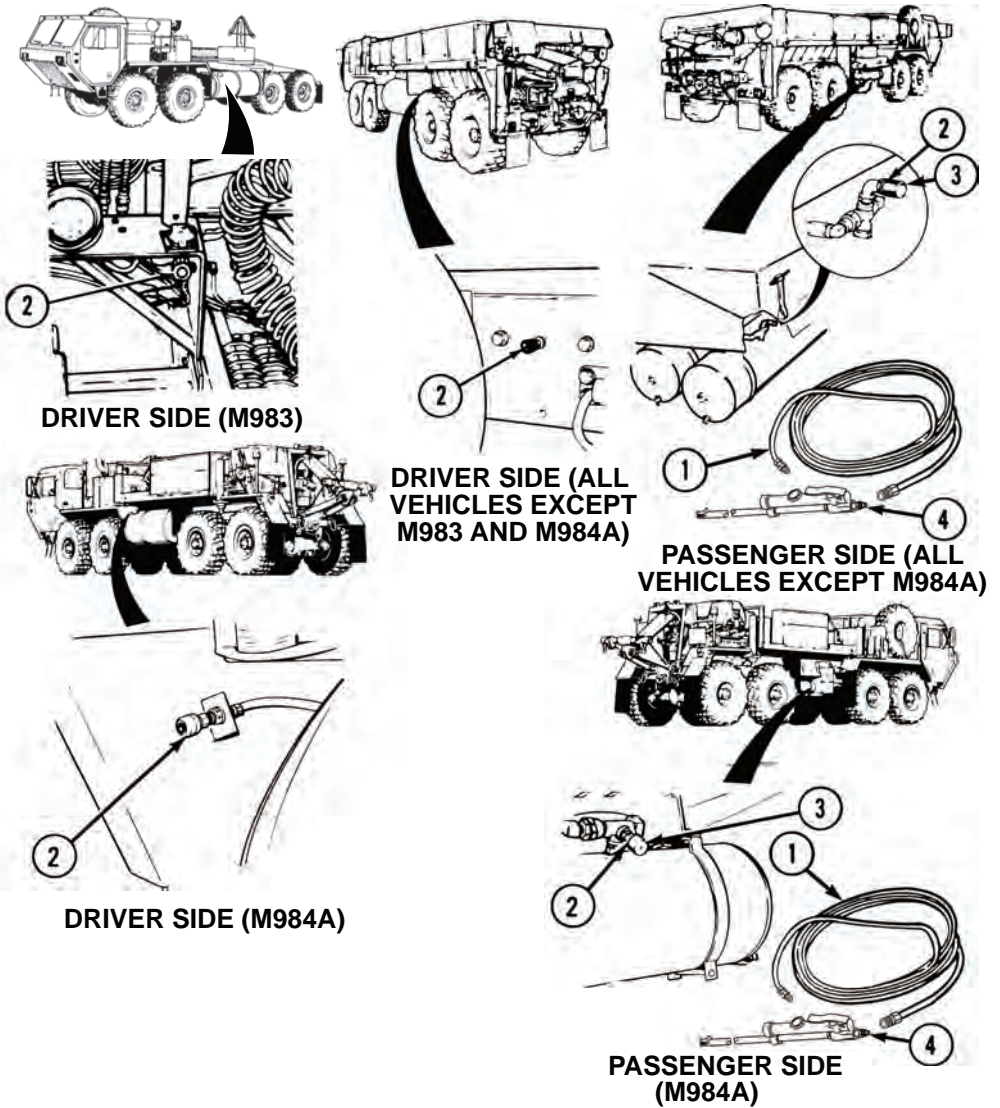
7. Shut OFF engine. (WP 0057)

**INFLATE TIRE - Continued****WARNING**

Hold end of air line when disconnecting from quick-disconnect coupling.  
Air line is under pressure and can be ejected at a high rate of speed.  
Failure to comply may result in injury or death to personnel.

8. Remove combined pressure gauge/inflation hose (4) from air hose (1).

**INFLATE TIRE - Continued**



*Figure 5.*

9. Hold end of air hose (1) and push sleeve (3) back and remove air hose (1) from quick-disconnect coupling (2).
10. Stow air hose (1) and combined pressure gauge/inflation hose (4).

**END OF TASK**

**FOLLOW-ON MAINTENANCE**

1. Remove wheel chocks. (WP 0077)

**END OF WORK PACKAGE**

---

## OPERATOR MAINTENANCE OPEN/CLOSE BATTERY BOX

---

### INITIAL SETUP:

#### Equipment Condition

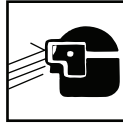
Engine OFF. (WP 0057)

Wheels chocked. (WP 0077)

---

### OPEN BATTERY BOX

#### WARNING



Wear proper eye protection when working around batteries. Failure to comply may result in injury or death to personnel.

#### WARNING



Batteries produce explosive gases. Do not smoke or use open flame near batteries. Do not allow hot, sparking, or glowing objects near batteries. If batteries are giving off gases, presence of a heat, flame, or spark may cause fire and/or explosion. Failure to comply may result in injury or death to personnel.

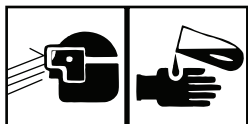
#### WARNING



Use extreme care not to short out battery terminals. Remove all jewelry such as rings, ID tags, bracelets, etc. prior to working on or around vehicle. Jewelry and tools can catch on equipment, contact positive

**OPEN BATTERY BOX - Continued**

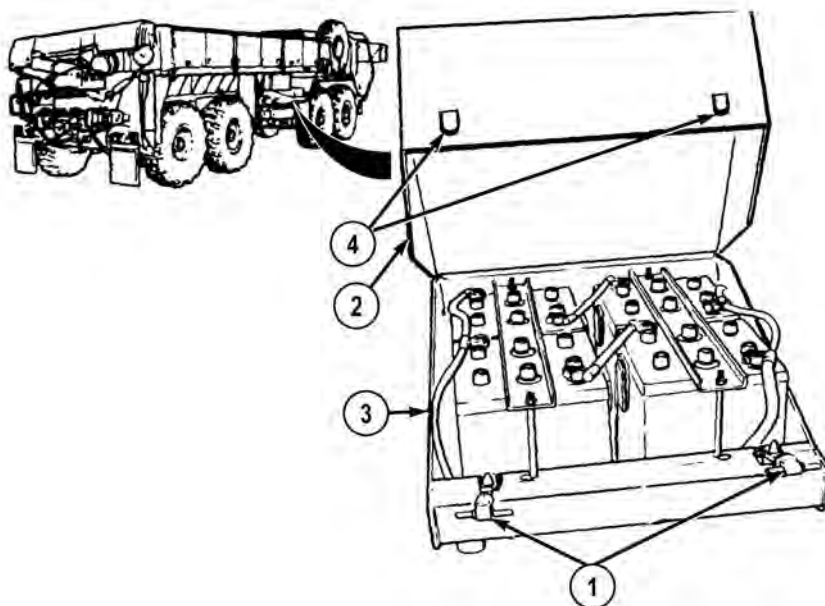
electrical circuits, and cause a direct short, severe burns, or electrical shock. Failure to comply may result in injury or death to personnel.

**WARNING**

**LEAD-ACID BATTERIES - Avoid battery electrolyte contact with skin, eyes, or clothing. If battery electrolyte spills, take immediate action to stop burning effects:**

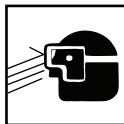
- External - If battery electrolyte contacts skin, immediately flush effected area with cold running water to remove all acid. Failure to comply may result in injury or death to personnel.
  - Eyes - If battery electrolyte contacts eyes, immediately flush eyes with cold water for 15 minutes and seek immediate medical attention. **IMPORTANT** - If only one eye is affected, ensure the affected eye is always (during both flushing and transport) kept lower (the lower the better) than unaffected eye. This will help keep affected eye from draining into (and contaminating) the unaffected eye. Failure to comply may result in injury or death to personnel.
  - Internal - If battery electrolyte is ingested (swallowed), drink large amounts of water or milk. Follow with milk of magnesia, a beaten egg, or vegetable oil and seek immediate medical attention. Failure to comply may result in injury or death to personnel.
  - Clothing or vehicle - Immediately flush area with cold water and neutralize battery electrolyte with baking soda or household ammonia solution. Failure to comply may result in injury or death to personnel.
1. Disconnect two rubber hooks (1).



**OPEN BATTERY BOX - Continued**

*Figure 1.*

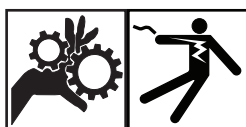
2. Slide cover (2) up and out.
3. Hold cover (2) in place or remove cover.

**END OF TASK****CLOSE BATTERY BOX****WARNING**

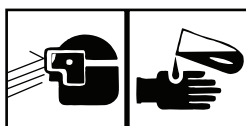
Wear proper eye protection when working around batteries. Failure to comply may result in injury or death to personnel.

**CLOSE BATTERY BOX - Continued****WARNING**

Batteries produce explosive gases. Do not smoke or use open flame near batteries. Do not allow hot, sparking, or glowing objects near batteries. If batteries are giving off gases, presence of a heat, flame, or spark may cause fire and/or explosion. Failure to comply may result in injury or death to personnel.

**WARNING**

Use extreme care not to short out battery terminals. Remove all jewelry such as rings, ID tags, bracelets, etc. prior to working on or around vehicle. Jewelry and tools can catch on equipment, contact positive electrical circuits, and cause a direct short, severe burns, or electrical shock. Failure to comply may result in injury or death to personnel.

**WARNING**

**LEAD-ACID BATTERIES - Avoid battery electrolyte contact with skin, eyes, or clothing. If battery electrolyte spills, take immediate action to stop burning effects:**

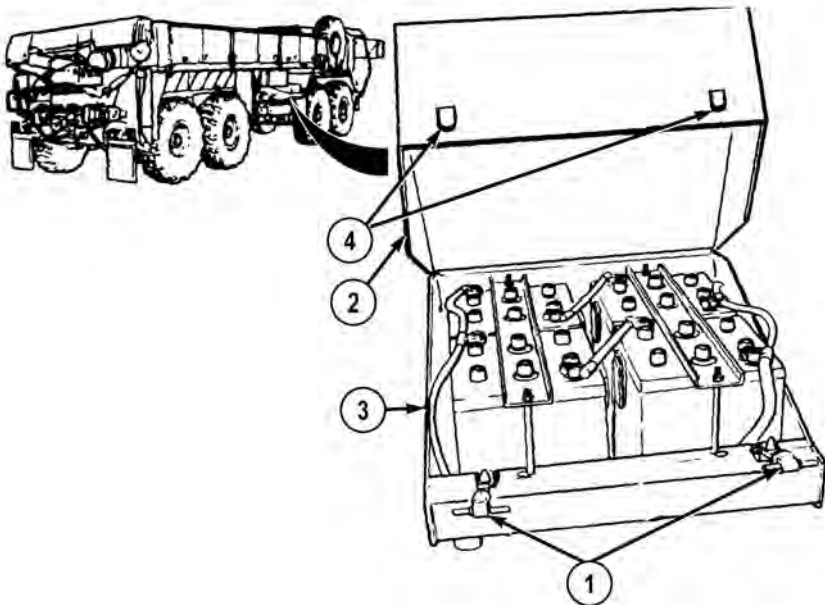
- External - If battery electrolyte contacts skin, immediately flush effected area with cold running water to remove all acid. Failure to comply may result in injury or death to personnel.
- Eyes - If battery electrolyte contacts eyes, immediately flush eyes with cold water for 15 minutes and seek immediate medical attention. **IMPORTANT** - If only one eye is affected, ensure the affected eye is always (during both flushing and transport) kept lower (the lower the better) than unaffected eye. This will help keep affected eye from

**CLOSE BATTERY BOX - Continued**

draining into (and contaminating) the unaffected eye. Failure to comply may result in injury or death to personnel.

- Internal - If battery electrolyte is ingested (swallowed), drink large amounts of water or milk. Follow with milk of magnesia, a beaten egg, or vegetable oil and seek immediate medical attention. Failure to comply may result in injury or death to personnel.
- Clothing or vehicle - Immediately flush area with cold water and neutralize battery electrolyte with baking soda or household ammonia solution. Failure to comply may result in injury or death to personnel.

1. Slide cover (2) on battery box (3).



*Figure 2.*

2. Align rubber hooks (1) and brackets (4).
3. Connect rubber hooks (1).

**END OF TASK**

**FOLLOW-ON MAINTENANCE**

1. Remove wheel chocks. (WP 0077)

**END OF WORK PACKAGE**

---

**OPERATOR MAINTENANCE**  
**OPEN/CLOSE ENGINE COVERS AND ENGINE SIDE PANEL REMOVAL/  
INSTALLATION**

---

**INITIAL SETUP:****Equipment Condition**

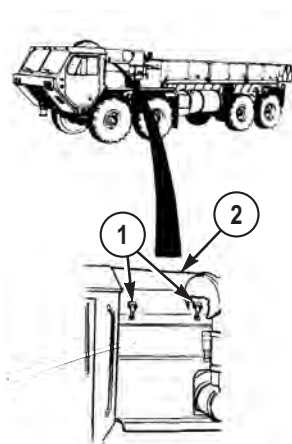
Engine OFF. (WP 0057)

**Equipment Condition - Continued**Wheels chocked. (WP 0077)  
Spare tire removed (if removing  
passenger side engine panel).  
(WP 0155)

---

**OPEN ENGINE COVERS**

1. Pull top rubber hooks (1) up and out.



*Figure 1.*

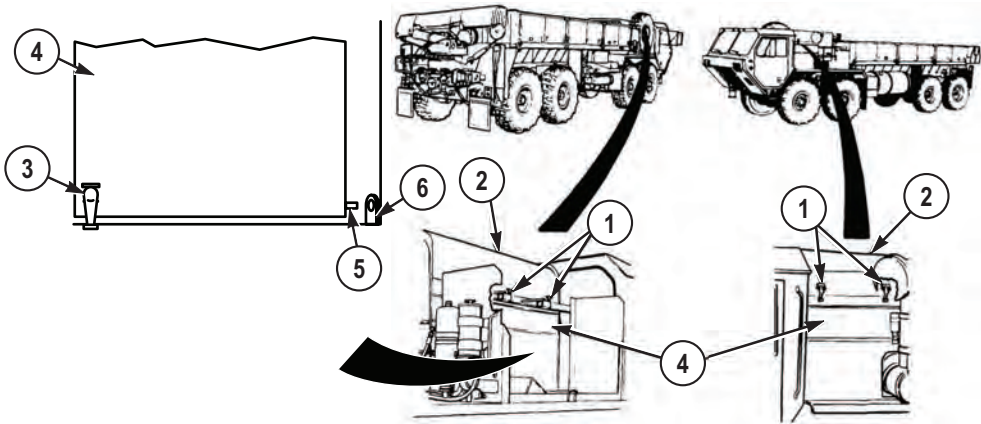
2. Lift hood (2) slowly until hood (2) lies on top of engine compartment.

**END OF TASK**

**ENGINE SIDE PANELS REMOVAL****NOTE**

- Driver side and passenger side engine side panels are removed the same way, except where noted.
- Passenger side engine side panel removal shown.

1. Pull bottom rubber hook (3) up and out.



*Figure 2.*

2. Slide engine side panel (4) toward rear of vehicle so stud (5) clears mount (6).
3. Lift and remove engine side panel (4) from vehicle.

**END OF TASK****ENGINE SIDE PANELS INSTALLATION**

1. Lift and install engine side panel (4) on vehicle.

**ENGINE SIDE PANELS INSTALLATION - Continued**

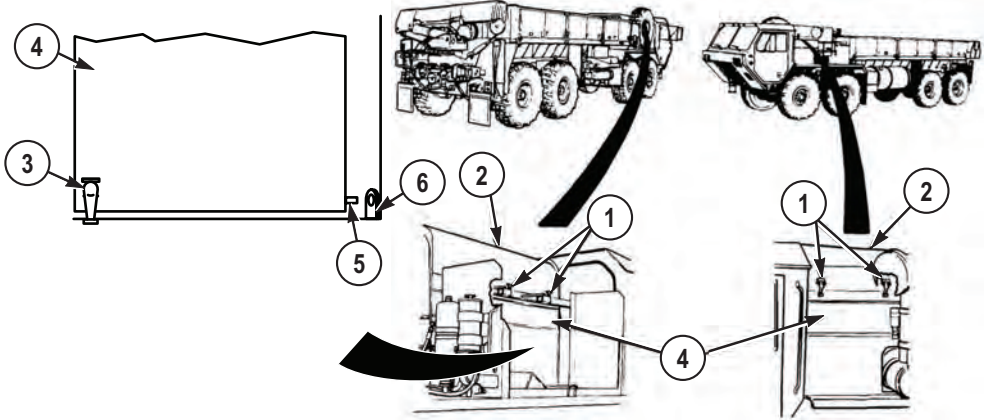


Figure 3.

2. Slide engine side panel (4) toward front of vehicle so stud (5) inserts into mount (6).
3. Pull bottom rubber hook (3) up and connect to engine side panel (4).

**END OF TASK**

**CLOSE ENGINE COVERS**

1. Pull hood (2) forward.

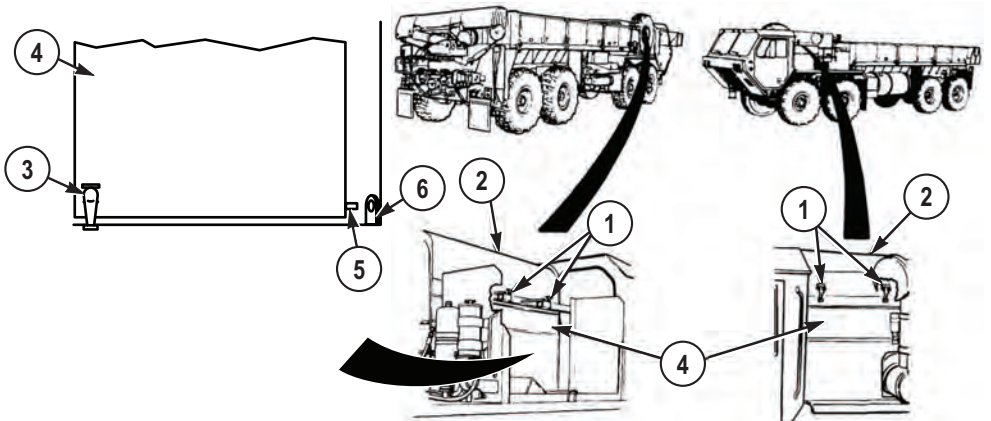


Figure 4.

**CLOSE ENGINE COVERS - Continued**

2. Push in engine side panel (4) and lower hood (2).
3. Pull top rubber hooks (1) up and connect to hood (2).

**END OF TASK****FOLLOW-ON MAINTENANCE**

1. Stow spare tire (if removed). (WP 0155)
2. Remove wheel chocks. (WP 0077)

**END OF WORK PACKAGE**



CHAPTER 6

SUPPORTING  
INFORMATION



---

## FIELD MAINTENANCE REFERENCES

---

### SCOPE

This work package lists all pamphlets, forms, field manuals, technical manuals, and other publications referenced in this manual. Also, those publications that should be consulted for additional information about vehicle operations are listed.

### DEPARTMENT OF ARMY PAMPHLETS

The following indexes should be consulted frequently for latest changes or revisions and for new publications relating to material covered in this technical manual.

DA PAM 25-30	Consolidated Index of Army Publications and Blank Forms
DA PAM 25-33	User's Guide for Army Publications and Forms
DA PAM 710-2-1	Using Unit Supply System (Manual Procedures)
DA PAM 750-8	The Army Maintenance Management System (TAMMS) Users Manual

### FORMS

DA FORM 2028	Recommended Changes to Publications and Blank Forms
DA FORM 2062	Hand Receipt
DA FORM 2401	Organization Control Record for Equipment
DA FORM 2402	Maintenance Tag
DA FORM 2404	Equipment Inspection and Maintenance Worksheet
DA FORM 2407	Maintenance Request
DA FORM 2407-1	Maintenance Request Continuation Sheet
DA FORM 2408	Equipment Log Assembly (Records)
DA FORM 2408-9	Equipment Control Record
DA FORM 5988-E	Equipment Inspection Maintenance Worksheet (EGA)
DD FORM 250	Material Inspection and Receiving Report
DD FORM 314	Preventive Maintenance Schedule and Record
DD FORM 1149	Requisition and Invoice/Shipping Document
DD FORM 1348-1	DOD Single Line Item Release/Receipt Document

**FORMS - Continued**

DD FORM 1397	Processing and Deprocessing Record for Shipment, Storage, and Issue of Vehicles and Spare Engines
DD FORM 2282	Reinspection Decal Convention for Safe Containers
OPTIONAL FORM 346	U.S. Government Motor Vehicle Operator Identification Card
STANDARD FORM 91	Motor Vehicle Accident Report
STANDARD FORM 364	Report of Discrepancy (ROD)
STANDARD FORM 368	Product Quality Deficiency Report
STANDARD FORM 4895	Equipment Preservation Data Sheet (EPDS)

**FIELD MANUALS**

FM 3-6	Field Behavior of NBC Agents (Including Smoke and Incendiaries)
FM 3-11.3	Multiservice Tactics, Techniques, and Procedures For Chemical, Biological, Radiological, and Nuclear Decontamination Avoidance {MCWP 3-37.2A, NTTP 3-11.25, AFTTP(I) 3-2.56}
FM 3-11.4	Multiservice Tactics, Techniques, and Procedures For Nuclear, Biological, and Chemical (NBC) Protection {MCWP 3-37.2; NTTP 3-11.27; AFTTP (I) 3-2.46} (This Item is included on EM 0205)
FM 3-11.5	Multiservice Tactics, Techniques, and Procedures For Chemical, Biological, Radiological, and Nuclear Decontamination {MCWP 3-37.3; NTTP 3-11.26; AFTTP(I) 3-2.60}
FM 4-25.11	First Aid
FM 4-30.31	Recovery and Battle Damage Assessment and Repair
FM 5-100-15	Corps Engineer Operations
FM 5-125	Rigging Techniques, Procedures, and Applications
FM 9-207	Operation and Maintenance of Ordnance Materiel in Cold Weather
FM 10-16	General Fabric Repair
FM 10-67-1	Concepts and Equipment of Petroleum Operations
FM 20-3	Camouflage, Concealment, and Decoys
FM 21-10	Field Hygiene and Sanitation
FM 21-305	Manual for the Wheeled Vehicle Driver
FM 31-70	Basic Cold Weather Manual

**FIELD MANUALS - Continued**

FM 31-71	Northern Operations
FM 55-21	Railway Operating and Safety Rules
FM 55-30	Army Motor Transport Units and Operations
FM 90-3	Desert Operations
FM 90-13	River Crossing Operations

**TECHNICAL BULLETINS**

TB ORD 1030	Manufacture of Data Plates
TB 5-5420-234-15	Warranty Program for Common Bridge Transporter (CBT)
TB 9-2300-281-35	Standards for Oversea Shipment or Domestic Issue of Special Purpose Vehicles, Combat, Tactical, Construction, and Selected Industrial and Troop Support US Army Tank-Automotive Materiel Readiness Command Managed Items
TB 9-2300-422-20	Security of Tactical Wheeled Vehicles
TB 43-0001-62-SERIES	Equipment Improvement Report and Maintenance Digest for Tank, Automotive, and Armament Equipment
TB 43-0142	Safety Inspection and Testing of Lifting Devices
TB 43-0209	Color, Marking and Camouflage Painting of Military Vehicles, Construction Equipment, and Materials Handling Equipment
TB 43-0212	Purging, Cleaning, and Coating Interior Ferrous and Terne Sheet Vehicle Fuel Tanks
TB 43-0216	Safety and Hazard Warnings for Operation and Maintenance of TACOM Equipment
TB 750-651	Use of Antifreeze Solutions, Antifreeze Extender, Cleaning Compounds and Test Kit in Engine Cooling Systems
TB 9-289	Reconditioning of Type I and Type II Reusable Metal Containers

**TECHNICAL MANUALS**

TM 3-4230-214-12&P	Operator's and Unit Maintenance Manual Including Repair Parts and Special Tools List for Decontamination Apparatus
TM 3-4240-280-10	Operator's Manual for Mask, Chemical-Biological: Aircraft, ABC-M24 and Accessories and Mask, Chemical-Biological, Tank, M25A1 and Accessories (Reprinted W/Basic Incl C1-2) (This item is included on EM 0045)
TM 3-6665-225-12	Operator's and Organizational Maintenance Manual: for Alarm Chemical
TM 5-1940-277-10	Operator's Manual for Boat, Bridge Erection, Twin Jet, Aluminum Hull, Models USCSBMK 1 (NSN 1940-01-105-5728) and USCSBMK 2 (1940-01-218-9165)

**TECHNICAL MANUALS - Continued**

TM 5-2090-202-12&P	Operator's and Unit Maintenance Manual (Including Repair Parts and Special Tools List) for Cradle, Bridge Erection Boat, Twin Jet, Aluminum Hull (NSN 2090-01-106-9789)
TM 5-5420-208-12&P	Operator and Unit Maintenance Manual Including Repair Parts and Special Tools List for Cargo Pallet, Ribbon Bridge Transporter (NSN 5420-01-006-7436)
TM 5-5420-209-12	Operator's and Unit Maintenance Manual for Improved Float Bridge (Ribbon Bridge)
TM 5-5420-277-14&P	Operator's, Unit, Direct Support, and General Support Maintenance Manual (Including Repair Parts and Special Tools List) for Cradle, Boat, Improved, M14, (NSN 3990-01-442-1914)
TM 9-214	Inspection, Care and Maintenance of Antifriction Bearings
TM 9-243	Use and Care of Hand Tools and Measuring Tools
TM 9-1005-245-13&P	Operator's, Unit, and Direct Support Maintenance Manual with Repair Parts and Special Tools List (RPSTL) for Machine Gun Mounts and Combinations for Tactical/Armored Vehicles
TM 9-1440-600-10	Operator's Manual, Launching Station, M901 Guided Missile, Semitrailer Mount
TM 9-2320-279-10HR	Hand Receipt Covering Contents Of Components Of End Item (COEI), Basic Issue Items (BII), And Additional Authorization List (AAL) for M977 Series, 8x8 Heavy Expanded Mobility Tactical Trucks
TM 9-2330-357-14&P	Operator's, Organizational, Direct Support, and General Support Maintenance Manual (Including Repair Parts and Special Tools Lists) For Semitrailer, Flatbed, Radar Set and Launching Station M860A1 (NSN 2330-01-117-3280) (This Item Is Included On EM 0049)
TM 9-2330-385-14	Operator's, Unit, Direct Support and General Support Maintenance Manual for Palletized Load System Trailer (PLST) Model M1076 (NSN 2330-01-303-5197)
TM 9-2330-385-24P	Unit, Direct Support and General Support Maintenance Repair Parts and Special Tools List for Trailer, Palletized Load System (PLST) Model M1076 (NSN 2330-01-303-5197)
TM 9-2320-279-20	Maintenance Instructions for Organizational Maintenance, M977 Series, 8x8 Heavy Expanded Mobility Tactical Trucks
TM 9-2320-279-34	Maintenance Instructions, Direct Support and General Support for M977 Series, 8x8 Heavy Expanded Mobility Tactical Trucks
TM 9-2610-200-14	Operator's, Unit, Direct Support, and General Support Maintenance Manual for Care, Maintenance, Repair, and Inspection of Pneumatic Tires and Inner Tubes
TM 9-3990-206-14&P	Operator's Unit, Direct Support and General Support Maintenance Manual (Including Repair Parts and Special Tools List) for Palletized Load System (PLS) Flatrack Model M1077/ M1077A1

**TECHNICAL MANUALS - Continued**

TM 9-3990-260-14&P	Operator's, Unit, Direct Support and General Support Maintenance Manual (Including Repair Parts and Special Tools List) For Container Roll-In/Out Platform (CROP) Model M3 (NSN 3990-01-442-2751); Container Roll-In/Out Platform (CROP) Model M3A1 (3990-01-450-5671) (This Item is Included on EM 0038 and EM 0052)
TM 9-2330-366-14&P	Operator's, Organizational, Direct Support, and General Support Maintenance Including Repair Parts and Special Tools Lists For Semitrailer, Lowbed, 12-Ton, XM974 (NSN 2330-01-116-0288)
TM 9-4910-571-12&P	Operator's and Organizational Maintenance Manual (Including Repair Parts and Special Tools List) for Simplified Test Equipment for Internal Combustion Engines (STE/ICE-R)
TM 9-4910-783-13&P	Operator's, Unit, and Direct Support Maintenance Manual (Including Repair Parts and Special Tools List) for Standard Automotive Test Set (SATS)
TM 9-4940-468-13	Operator's, Unit, and Direct Support Maintenance Manual for Tool Outfit, Hydraulic Systems Test and Repair Unit (HSTRU)
TM 9-4940-568-10	Operator's Maintenance Manual for Forward Repair System (FRS)
TM 9-6115-465-24P	Unit, Direct Support and General Support Maintenance Repair Parts and Special Tools List (Including Depot Maintenance Repair Parts and Special Tools List) for Generator Set, Diesel Engine-Driven, Tactical
TM 9-6140-200-14	Operator's, Unit, Direct Support and General Support Maintenance Manual for Lead-Acid Storage Batteries
TM 9-8000	Principles of Automotive Vehicles
TM 11-5820-498-12	Operator's and Organizational Maintenance Manual: Radio Sets
TM 11-5820-498-35	Direct Support, General Support, and Depot Maintenance Manual for Radio Sets
TM 38-250	Preparing Hazardous Materials for Military Air Shipments
TM 43-0139	Painting Instructions for Army Materiel
TM 55-2200-001-12	Transportability Guidance for Application of Blocking, Bracing and Tie Down Materials for Rail Transport
TM 55-2320-279-14	Transportability Guidance Heavy Expanded Mobility Tactical Truck (HEMTT)
TM 750-244-3	Procedures for Destruction of Equipment to Prevent Enemy Use (Mobility Equipment Command)
TM 750-244-6	Procedures for Destruction of Tank Automotive Equipment to Prevent Enemy Use (U.S. Army Tank-Automotive Command)
TM 750-254	Cooling Systems: Tactical Vehicles

**TECHNICAL MANUALS - Continued**

TM 5-2330-378-14&P	Operator's, Unit, Direct Support, and General Support Maintenance Manual (Including Repair Parts and Special Tools List) for Semitrailer, Lowbed: 40-Ton Construction Equipment Transporter, M870 (CCE) (CMI/Load King Model 403LF), and M870A1
TM 5-2330-325-14&P	Operator's, Unit, and Direct Support Maintenance Manual with Repair Parts and Special Tools List (RPSTL) for Trailer, Medium Heavy Equipment Transporter (MHET), 40-Ton, M870A3
TM 9-2330-213-14&P	Operator's, Unit, Direct Support, and General Support Maintenance Manual (Including Repair Parts and Special Tools Lists) For Trailer, Chassis: 1-1/2-Ton, 2-Wheel M103A1 (NSN 2330-00-835-8629) M103A3 (NSN 2330-00-141-8052) Trailer, Cargo: 1-1/2-Ton, 2-Wheel M105A1 (NSN 2330-00-835-8631) M105A2 (NSN 2330-00-141-8050) M105A2C (NSN 2330-00-542-5689) Trailer, Tank, Water: 1-1/2-Ton, 2-Wheel, 400-Gallon M107A1 (NSN 2330-00-835-8633) M107A2 (NSN 2330-00-141-8049) M107A2C (NSN 2330-00-542-5688) Trailer, Van, Shop: Folding Sides, 1-1/2-Ton, 2-Wheel M448 (NSN 2330-00-631-5692)
TM 9-2330-231-14&P	Technical Manual Operator's, Organizational, Direct Support, And General Support Maintenance (Including Repair Parts and Special Tools List) Trailer, Ammunition: 1 1/2-Ton, 2-Wheel, M332 (NSN 2330-00-200-1785)
TM 9-2330-368-14&P	Operators, Organizational, Including Repair Parts and Special Tools List For Trailer, Ammunition, Heavy Expanded Mobility, 11-Ton, M989 (NSN 2330-01-109-4258)

**MISCELLANEOUS PUBLICATIONS**

AR 70-1	Army Acquisition Policy
AR 200-1	Environmental Protection and Enhancement
AR 385-55	Prevention of Motor Vehicle Accidents
AR 700-138	Army Logistics Readiness and Sustainability
AR 700-139	Army Warranty Program
AR 702-7	Product Quality Deficiency Report Program
AR 750-1	Army Materiel Maintenance Policy
AR 750-10	Army Modification Program
CTA 8-100	Army Medical Department Expendable/Durable Items
CTA 50-970	Expendable/Durable Items (Except Medical, Class V, Repair Parts, and Heraldic Items)



**MISCELLANEOUS PUBLICATIONS - Continued**

GPM 94-02	Maintenance Advisory for Purging all Fuel Tankers using a Biodegradable Purging Solution
SB 725-92-1	US Army Missile Command Nonexpendable Reusable Shipping and Storage Containers
TC 9-237	Welding Theory and Application
TC 9-510	Metal Body Repair and Related Operations
TO 00-25-234	General Shop Practice Requirements for Repair, Maintenance, and Test of Electronic Equipment

**END OF WORK PACKAGE**



---

## OPERATOR MAINTENANCE COMPONENTS OF END ITEM AND BASIC ISSUE ITEMS LISTS

---

### INTRODUCTION

#### Scope

This work package lists COEI and BII for the HEMTT series vehicles to help you inventory items required for safe and efficient operation.

#### General

The Components of End Item and Basic Issue Items Lists are divided into the following lists:

**Components of End Item (COEI)** This listing is for informational purposes only and is not authority for requisition replacements. These items are part of the HEMTT series vehicle. As part of the end item, these items must be with the end item whenever it is issued or transferred between property accounts. Items of COEI are removed and separately packaged for transportation or shipment only when necessary. Illustrations are furnished to help you find and identify the items.

**Basic Issue Items (BII)** These are the minimum essential items required to place the HEMTT series vehicle in operation, to operate it, and to perform emergency repairs. Although shipped separately packaged, BII must be with the vehicle during operation and when it is transferred between property accounts. Listing these items is your authority to request/requisition them for replacement based on your authorization of the end item by the TOE/MTOE. Illustrations are furnished to help you find and identify the items.

#### Explanation of Entries in the COEI List and BII List

The following provides an explanation of columns found in the tabular listings:

**Item Number.** Gives you the reference number of the item listed.

**National Stock Number (NSN) and Illustration.** Identifies the stock number of the item to be used for requisitioning purposes and provides an illustration of the item.

**Description, Part Number/(CAGEC).** Identifies the Federal item name (in all capital letters) followed by a minimum description when needed. The stowage location of COEI and BII is also included in this entry. The last line below the description is the part number and the Commercial and Government Entity Code (CAGEC) (in parentheses).

**Usable On Code.** When applicable, gives you a code if the item you need is not the same for different models of equipment. These codes are identified below:

## INTRODUCTION - Continued

**Table 1. List of Usable On Codes**



Code	Used On
H01	M977 Cargo with winch
H06	M977 Cargo w/o winch

**Column (5) - U/I Unit of Issue (U/I)** U/I. Unit of Issue (U/I) indicates the physical measurement or count of the item as issued per the National Stock Number shown in column (2).



**Column (6) - Qty.** Indicates the quantity required.

## COMPONENTS OF END ITEM

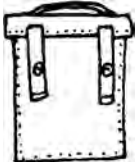
**Table 2. Components of End Item**

(1)	(2)	(3)	(4)	(5)	(6)
Illus No.	National Stock Number (NSN)	Description, Part Number/(CAGEC)	Usable On Code	U/I	Qty Rqr
1	6150-01-184-1901 	CABLE AND CONDUIT ASSEMBLY, ELECTRICAL: Crane (Located in passenger side stowage box) 2-198-6-00061(12361)	H01, H06	EA	1
2	2540-01-166-1384 	LADDER, VEHICLE BOARDING (Located over fuel tank on driver side of vehicle) 1766590W(45152)	H06, H01	EA	1





**Table 2. Components of End Item - Continued**

(1)	(2)	(3)	(4)	(5)	(6)
Illus No.	National Stock Number (NSN)	Description, Part Number/(CAGEC)	Usable On Code	U/I	Qty Rqr
3	2520-01-188-5129 	RECEIVER-TRANSMITTER, HYDRAULIC CONTROL: Crane RCU (Located in passenger side stowage box, under cargo body to rear of battery box) 2-198-6-00053(12361)	H01, H06	EA	1
4	2590-01-184-1902 	SHOE, JACK-SUPPORT: Outrigger Pad (Located on outrigger beam on rear of vehicle) 2-198-1-00028(12361)	H01, H06	EA	2




**Table 3. Basic Issue Items**

(1)	(2)	(3)	(4)	(5)	(6)
Illus No.	National Stock Number (NSN)	Description, Part Number/(CAGEC)	Usable On Code	U/I	Qty Rqr
1	8105-01-353-2497 	BAG, TEXTILE: Pamphlet (Located in cabin in glove box forward of passenger/ crew seat) 1362710(45152)	H01, H06	EA	1


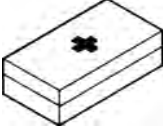

**Table 3. Basic Issue Items - Continued**

(1)  Illus No.	(2)  National Stock Number (NSN)	(3)  Description, Part Number/(CAGEC)	(4)  Usable On Code	(5)  U/I	(6)  Qty Rqr
2	7510-00-889-3494  	BINDER, LOOSE-LEAF (Located on passenger side of cab in glove box) 11677003(19207)	H01, H06	EA	1
3	3940-01-163-2319  	BLOCK, TACKLE: 20 Ton (Located in driver side tool box) 168400(75535)	H01	EA	1
4	6150-01-180-6035  	CABLE ASSEMBLY, POWER, ELECTRICAL: Worklamp (Located in driver side tool box) 1419770U(45152)	H01, H06	EA	1
5	6150-01-320-0719  	CABLE ASSEMBLY, SPECIAL PURPOSE, ELECTRICAL: Worklamp (Located in driver side tool box) 1771530W(45152)	H01, H06	EA	1

**Table 3. Basic Issue Items - Continued**




(1)  Illus No.	(2)  National Stock Number (NSN)	(3)  Description, Part Number/(CAGEC)	(4)  Usable On Code	(5)  U/I	(6)  Qty Rqr
6	4010-01-200-1506  	CHAIN ASSEMBLY, SINGLE LEG: 7 ft. Limp Home (Located in driver side tool box) 1452490(45152)	H01, H06	EA	1
7	4010-01-249-0548  	CHAIN ASSEMBLY, SINGLE LEG: 14 ft. Utility (Located in driver side tool box) 00044-9973(96508)	H01, H06	EA	1
8	2540-01-165-6136  	CHOCK, WHEEL- TRACK (Located in wheel chock stowage box [carries a maximum of two wheel chocks], vehicle mounted stowage boxes, and/or under spare tire) CS-2540-0067(16236)	H01, H06	EA	4

**Table 3. Basic Issue Items - Continued**




(1)  Illus No.	(2)  National Stock Number (NSN)	(3)  Description, Part Number/(CAGEC)	(4)  Usable On Code	(5)  U/I	(6)  Qty Rqr
9	4210-01-133-9053  	EXTINGUISHER, FIRE: 2.7 lbs, 10 BC (Located in cabin to right of driver's seat) 429101(03670)	H01, H06	EA	1
10	6545-00-922-1200  	FIRST AID KIT, GENERAL PURPOSE (Located in cabin in glove box forward of passenger/crew seat) SCC-6545-ILVOL2(64616)	H01, H06	EA	1
11	4910-01-003-9599  	GAUGE, TIRE PRESSURE, SELF-CONTAINED (Located in cabin in glove box forward of passenger/crew seat) 61-J2-1506(94894)	H01, H06	EA	2



**Table 3. Basic Issue Items - Continued**

(1)  Illus No.	(2)  National Stock Number (NSN)	(3)  Description, Part Number/(CAGEC)	(4)  Usable On Code	(5)  U/I	(6)  Qty Rqr
12	5340-01-209-7841  	HANDLE, EXTENSION (for lug wrench) (Located in driver side tool box) 1347720(45152)	H01, H06	EA	1
13	5120-01-233-9508  	HANDLE, SOCKET WRENCH: Wheel Lugnut (Located in driver side toolbox) ORR301(66784)	H01, H06	EA	1
14	4720-01-558-6415  	HOSE ASSEMBLY, NONMETALLIC: Air 50 ft. 2155210U(45152)	H01, H06	EA	2

**Table 3. Basic Issue Items - Continued**

(1)  Illus No.	(2)  National Stock Number (NSN)	(3)  Description, Part Number/(CAGEC)	(4)  Usable On Code	(5)  U/I	(6)  Qty Rqr
15	4910-01-386-4300  	INFLATOR-GAUGE, PNEUMATIC TIRE (Located in cabin in glove box forward of passenger/crew seat) I-405M(63900)	H01, H06	EA	2
16	5120-01-146-8096  	JACK, HYDRAULIC, HAND: 12 Ton with Handle (Located in driver side tool box) EBJ-12GC(26952)	H01, H06	EA	1
17	5340-00-158-3807  	PADLOCK: With Chain (for stowage boxes) AA59487-2SC(58536)	H01, H06	EA	4

**Table 3. Basic Issue Items - Continued**













(1)  Illus No.	(2)  National Stock Number (NSN)	(3)  Description, Part Number/(CAGEC)	(4)  Usable On Code	(5)  U/I	(6)  Qty Rqr
18	5340-00-158-3805  	PADLOCK: Without Chain (for steering column) (Located in steering column lock bracket under dash) AA59487-2S(58536)	H06, H01	EA	1
19	2540-01-165-5987  	PLATE, BASE, JACK (Located in driver side toolbox) 2540V0730(16236)	H01, H06	EA	1
20	5120-01-480-0640  	PLIERS, SLIP JOINT: 10 in. Adjustable (Located in driver side toolbox - part of tool roll) 1350150(45152)	H01, H06	EA	1
21	9905-01-480-0644  	REFLECTOR SET, HIGHWAY WARNING, TRIANGULAR (Located in cabin mounted under glove box forward of passenger/crew seat) 6432GBX(45152)	H01, H06	SE	1




Table 3. Basic Issue Items - Continued

(1) Illus No.	(2) National Stock Number (NSN)	(3) Description, Part Number/(CAGEC)	(4) Usable On Code	(5) U/I	(6) Qty Rqr
22	5140-01-167-1541 	ROLL, TOOLS AND ACCESSORIES (Located in driver side storage box) 1350190(45152)	H01, H06	EA	1
23	5120-01-398-8053 	SCREWDRIVER, CROSS TIP: Phillips No. 3 (Located in driver side toolbox - part of tool roll) SDFP56(96508)	H01, H06	EA	1
24	5120-00-293-3309 	SCREWDRIVER, FLAT TIP: No. 6 (Located in driver side toolbox - part of tool roll) 66-110(03914)	H01, H06	EA	1
25	4030-00-377-1397 	SHACKLE: Anchor, Limp Home (Located in driver side toolbox) RR-C-271 TY4AGRBCL2SZ 1.000(81348)	H01, H06	EA	1

**Table 3. Basic Issue Items - Continued**

(1)  Illus No.	(2)  National Stock Number (NSN)	(3)  Description, Part Number/(CAGEC)	(4)  Usable On Code	(5)  U/I	(6)  Qty Rqr
26	4030-01-316-1552  	SHACKLE: Towing: (Located on front and rear towing eyes) RR-C-271D TYIVAGRACL1 3/8 IN(81348)	H01, H06	EA	4
27	3940-01-209-6008  	SLING AND WIRE ROPE ASSEMBLY SET (Located in driver side equipment body, top forward stowage box) AC 2000 00331(28620)	H01, H06	EA	1
28	6220-01-326-2286  	SPOTLIGHT: Worklamp 1401182(78422)	H01, H06	EA	1
29	1670-00-725-1437  	TIE DOWN, CARGO 10045035(18876)	H01, H06	EA	24

**Table 3. Basic Issue Items - Continued**

(1)  Illus No.	(2)  National Stock Number (NSN)	(3)  Description, Part Number/(CAGEC)	(4)  Usable On Code	(5)  U/I	(6)  Qty Rqr
30	5120-01-436-2924  	WRENCH, ADJUSTABLE: 8 in. (Located in driver side toolbox - part of tool roll) AC18(96508)	H01, H06	EA	1
31	5120-00-264-3796  	WRENCH, ADJUSTABLE: 12 in. (Located in driver side toolbox - part of tool roll) 120405A(45152)	H01, H06	EA	1
32	5120-01-070-8386  	WRENCH, SOCKET: Wheel Nut (Located in driver side tool box) 1048-TR(45152)	H01, H06	EA	1

**END OF WORK PACKAGE**

---

## OPERATOR MAINTENANCE ADDITIONAL AUTHORIZATION LIST (AAL)

---

### Introduction

### Scope

This work package lists additional authorization items that are needed to operate and maintain the HEMTT Series Vehicles.

### General

This list identifies items that do not have to accompany the HEMTT Series Vehicles and that do not have to be turned in with it. These items are all authorized to you by CTA, MTOE, TDA, or JTA.

### Explanation of Columns in the AAL

Column (1) - National Stock Number (NSN). Identifies the stock number of the item to be used for requisitioning purposes.

Column (2) - Description, Part Number/(CAGEC). Identifies the Federal item name (in all capital letters) followed by a minimum description when needed. The last line below the description is the part number and the Commercial and Government Entity Code (CAGEC) (in parentheses).

Column (3) - Usable On Code. When applicable, gives you a code if the item you need is not the same for different models of equipment.

**Table 1. List of Usable On Codes**

Code	Used On
H01	M977 Cargo with winch
H06	M977 Cargo w/o winch

Column (4) - U/I. Unit of Issue (U/I) indicates the physical measurement or count of the item as issued per the National Stock Number.

Column (5) - Qty Recm. Indicates the quantity recommended.

**Table 2. Additional Authorization List**

(1) National Stock Number (NSN)	(2) Description, Part Number/ (CAGEC)	(3) Usable On Code	(4) U/I	(5) Qty Recom
5110-00-293-2 336	AXE, SINGLE BIT 6150925(19207)	H01, H06	EA	1
4910-00-347-9 703	BAR ASSEMBLY, HOISTING 8690061(52793)	H01, H06	EA	1
3940-01-247-3 682	BEAM, HOISTING: DOUBLE AC200000364(28620)	H06	EA	1
3940-01-247-3 681	BEAM, HOISTING: SINGLE AC200000354(28620)	H06	EA	1
2510-00-741-7 585	BOARD GROUND JACK 7417585(19207)	H01, H06	EA	2
2540-00-409-8 891	BRACKET ASSEMBLY, TOOL: PIONEER MS53053-1(96906)	H01, H06	EA	1
6150-01-022-6 004	CABLE ASSEMBLY, POWER, ELECTRICAL: NATO 11682336-1(19207)	H01, H06	EA	1
2540-01-152-7 813	CHAIN, TIRE, EMERGENCY 2624-10-8(46156)	H01, H06	PR	2
2540-01-198-7 409	COVER, FITTED, VEHICULAR BODY: CARGO BODY COVER 2178120U(45152)	H01, H06	EA	1
4230-01-220-3 221	DECONTAMINATION KIT, INDIVIDUAL EQUIPMENT 5705588(19207)	H01, H06	EA	1



**Table 2. Additional Authorization List - Continued**

(1) National Stock Number (NSN)	(2) Description, Part Number/ (CAGEC)	(3) Usable On Code	(4) U/I	(5) Qty Recom
5130-01-400-0 129	EXTENSION, SOCKET WRENCH: IMPACT 3/4 in. DRIVE, 13 in. LONG 07569(1CV05)	H01, H06	EA	1
4240-01-220-6 373	GAS PARTICULATE KIT 3SK663(45152)	H01, H06	KT	1
8415-00-634-4 658	GLOVES, LEATHER 37G2940(90142)	H01, H06	PR	2
5120-00-288-6 574	HANDLE, MATTOCK-PICK 10501973(56161)	H01, H06	EA	1
2990-01-509-1 954	HEATER, COOLANT, ENGINE: ARCTIC 3460259(45152)	H01, H06	EA	1
3940-01-247-3 681	HOISTING BEAM, SINGLE AC200000354(28620)	H06	EA	1
4720-01-341-4 912	HOSE ASSEMBLY 1759750U(45152)	H01, H06	EA	1
4720-01-254-0 189	HOSE ASSEMBLY, NONMETALLIC: INTER- VEHICULAR MS39325-9-140-8(96906)	H01, H06	EA	2
5895-01-506-4 503	INSTALLATION KIT, ELECTRONIC EQUIPMENT: C4ISR 3418900(45152)	H01, H06	EA	1

**Table 2. Additional Authorization List - Continued**

(1) National Stock Number (NSN)	(2) Description, Part Number/ (CAGEC)	(3) Usable On Code	(4) U/I	(5) Qty Recom
1005-01-519-2 126	INSTALLATION KIT: MOUNTING, MACHINE GUN 1301740UW/OR45152	H01, H06	KT	1
6665-01-220-3 220	KIT, CHEMICAL ALARM 5705589(19207)	H01, H06	KT	1
6220-01-250-5 190	LIGHT, WARNING: BEACON 3145661(45152)	H01, H06	EA	1
5120-00-243-2 395	MATTOCK: PICK 11677022(19207)	H01, H06	EA	1
5120-00-892-5 709	MIRROR, INSPECTION UH1487(11676)	H01, H06	EA	1
1005-01-266-1 233	MOUNT, RIFLE: INSTALLATION 5705590(19207)	H01, H06	EA	1
5120-00-197-9 473	PUNCH, BLACKSMITH'S: 17 in. 647008(60903)		EA	1
4030-01-316-1 552	SHACKLE: TOWING (used with tow bar, 10 ton) 1307540(45152)	H01, H06	EA	2
5120-00-293-3 336	SHOVEL: HAND 11655784(19207)	H06, H01	EA	1
3940-01-209-6 008	SLING AND WIRE ROPE ASSEMBLY SET AC 2000 00331(28620)	H01	EA	1
3940-00-040-2 297	SLING, MULTIPLE LEG 8330151(19207)	H01	EA	1

**Table 2. Additional Authorization List - Continued**

(1) National Stock Number (NSN)	(2) Description, Part Number/ (CAGEC)	(3) Usable On Code	(4) U/I	(5) Qty Recom
3940-01-083-9 313	SLING, MULTIPLE LEG SW71M(91796)	H06	EA	1
3940-01-241-7 400	SLING, MULTIPLE LEG AC200000332(28620)	H06	EA	1
3940-01-270-3 389	SLING, MULTIPLE LEG: 16 FT. SAFETY CHAINtwo (2) 16 ft. safety chains should be used in conjunction with Tow Bar: 10 Ton NSN: 2540-00-378-2012, P/N: 8383802, C/C: 19207. 1482010(45152)	H01, H06	EA	2
5130-01-400-0 164	SOCKET, SOCKET WRENCH (3/4 in. drive, 1 3/4 in. hex, impact) J07528L(1CV05)	H01, H06	EA	1
3990-01-204-3 009	TIE DOWN, CARGO, VEHICLE MIL-PRF-71224-1(OHK26)	H01, H06	EA	8
2540-00-378-2 012	TOW BAR, MOTOR VEHICLE: 10 tonShould be used in conjunction with two (2) safety chains: 16 ft. NSN: 3940-01-270-3389, P/N: 1482010, C/C: 45152. 8383802(19207)	H01, H06	EA	1
5130-01-428-3 751	WRENCH, IMPACT, PNEUMATIC 1789100U(45152)	H01, H06	EA	1

**END OF WORK PACKAGE**



---

## OPERATOR MAINTENANCE EXPENDABLE AND DURABLE ITEMS LIST

---

### Introduction

### Scope

This work package lists expendable supplies and materials that are needed to operate and maintain the HEMTT Series Vehicles. This list is for information only and is not authority to requisition the listed items. These items are authorized to you by CTA 50-970, Expendable/Durable Items (Except Medical, Class V Repair Parts, and Heraldic Items), CTA 50-909, Field and Garrison Furnishings and Equipment or CTA 8-100, Army Medical Department Expendable/Durable Items.

### Explanation of Entries in the Expendable/Durable Items List

**Item No.** This number is assigned to the entry in the list and is referenced in the narrative instructions to identify the item (e.g., Use brake fluid (Expendable/Durable Items List)).

**Level.** This column identifies the lowest level of maintenance that requires the listed item.

- C -- Operator/Crew
- O -- Unit/AMC
- F -- Direct Support/ASB
- H -- General Support
- D -- Depot

**National Stock Number (NSN).** This is the NSN assigned to the item which you can use to requisition it.

**Item Name, Description, Part Number/(CAGEC).** This column provides the other information you need to identify the item. The last line below the description is the part number and the Commercial and Government Entity Code (CAGEC) (in parentheses).

**(U/I).** Unit of Issue (U/I) code shows the physical measurement or count of an item, such as gallon, dozen, gross, etc.

**Table 1. Expendable and Durable Items List**

(1)	(2)	(3)	(4)	(5)
Item No.	Level	National Stock Number (NSN)	Item Name, Description, Part Number/ (CAGEC)	U/I

**Table 1. Expendable and Durable Items List - Continued**

(1) Item No.	(2) Level	(3) National Stock Number (NSN)	(4) Item Name, Description, Part Number/ (CAGEC)	(5) U/I
			<b>Antifreeze, Arctic Type</b>	
1	C	6850-01-464-9096	Antifreeze, Arctic Type 55-gal drum A-A-52624 (58536)	DR
			<b>Antifreeze, Permanent, Glycol, Inhibited</b>	
2	C	6850-01-464-9125	Antifreeze, Permanent, Glycol, Inhibited 1-gal container AA52624 (58536)	GL
3	C	6850-00-464-9137	Antifreeze, Permanent, Glycol, Inhibited 5-gal container MILA46153 (81349)	CO
4	C	6850-01-464-9152	Antifreeze, Permanent, Glycol, Inhibited 55-gal drum A-A-52624 TY I RECYCLED (58536)	DR
			<b>Cleaner, Lubricant</b>	
5	C	9150-01-079-6124	Cleaner, Lubricant A, 4 oz bottle w/ extender tube MIL-PRF-63460 (81349)	BT
			<b>Cleaning Compound, Solvent</b>	
6	C	6850-01-474-2319	Cleaning Compound, Solvent 1 gallon can MIL-PRF-680 Type II (81349)	GL
7	C	6850-01-474-2317	Cleaning Compound, Solvent 5 gallon can MIL-PRF-680 Type II (81349)	CO

**Table 1. Expendable and Durable Items List - Continued**

(1) Item No.	(2) Level	(3) National Stock Number (NSN)	(4) Item Name, Description, Part Number/ (CAGEC)	(5) U/I
8	C	6850-01-474-2316	Cleaning Compound, Solvent 55 gallon drum MIL-PRF-680 Type II (81349)	DR
9	C	6850-01-474-2318	Cleaning Compound, Solvent 1 gallon can MIL-PRF-680 Type III (81349)	GL
10	C	6850-01-474-2320	Cleaning Compound, Solvent 5 gallon can MIL-PRF-680 Type III (81349)	BX
11	C	6850-01-474-2321	Cleaning Compound, Solvent 55 gallon drum MIL-PRF-680 Type III (81349)	DR
			<b>Compound, Cleaning Windshield</b>	
12	C	6850-00-926-2275	Compound, Cleaning Windshield 1-pt can 0854-000 (0FTT5)	BX
			<b>Fuel, DF-1, Winter</b>	
13	C	9140-01-413-7511	Fuel, DF-1, Winter Bulk VV-F-800 (81348)	GL
14	C	9140-00-286-5286	Fuel, DF-1, Winter Bulk ASTM D 975 (81346)	GL
15	C	9140-00-286-5287	Fuel, DF-1, Winter 5-gal can ASTM D 975 (81346)	CN
16	C	9140-00-286-5288	Fuel, DF-1, Winter 55-gal drum, 16 gauge ASTM D 975 (81346)	DR
17	C	9140-00-286-5289	Fuel, DF-1, Winter 55-gal drum, 18 gauge ASTM D 975 (81346)	DR

**Table 1. Expendable and Durable Items List - Continued**

(1) Item No.	(2) Level	(3) National Stock Number (NSN)	(4) Item Name, Description, Part Number/ (CAGEC)	(5) U/I
			<b>Fuel</b>	
18	C	9130-01-031-5816	Fuel, JP8 Bulk MILT83133 GR JP8 (81349)	GL
19	C	9140-01-412-1311	Fuel, DF-2, Regular Bulk VV-F-800 (81348)	GL
20	C	9140-00-286-5294	Fuel, DF-2, Regular Bulk ASTM D 975 (81346)	GL
21	C	9140-00-286-5295	Fuel, DF-2, Regular 5-gal can ASTM D 975 (81346)	CN
22	C	9140-00-286-5296	Fuel, DF-2, Regular 55-gal drum, 16 gauge ASTM D 975 (81346)	DR
23	C	9140-00-286-5297	Fuel, DF-2, Regular 55-gal drum, 18 gauge ASTM D 975 (81346)	DR
			<b>Grease, Automotive and Artillery GAA</b>	
24	C	9150-01-197-7688	Grease, Automotive and Artillery GAA 2-1/2 oz tube M-10924-A (81349)	TU
25	C	9150-01-197-7693	Grease, Automotive and Artillery GAA 14-oz cartridge M-10924-B (81349)	CA
26	C	9150-01-197-7690	Grease, Automotive and Artillery GAA 1-lb can M-10924-C (81349)	CN



**Table 1. Expendable and Durable Items List - Continued**

(1) Item No.	(2) Level	(3) National Stock Number (NSN)	(4) Item Name, Description, Part Number/ (CAGEC)	(5) U/I
27	C	9150-01-197-7 689	Grease, Automotive and Artillery GAA 5-lb can M-10924-D (81349)	CN
28	C	9150-01-197-7 692	Grease, Automotive and Artillery GAA 35-lb can M-10924-E (81349)	CN
			<b>Oil, Lubricating Gear, GO 75 (MIL-L-2105)</b>	
29	C	9150-01-035-5 390	Oil, Lubricating Gear, GO 75 (MIL-L-2105) 1-qt can M2105-1-75W (81349)	QT
30	C	9150-01-035-5 391	Oil, Lubricating Gear, GO 75 5-gal can MIL-PRF-2105 (81349)	CN
			<b>Oil, Lubricating Gear, GO 80W/90 (MIL-L-2105C)</b>	
31	C	9150-01-035-5 393	Oil, Lubricating Gear, GO 80W/90 (MIL-L-2105C) 5-gal can J2360 (81343)	CN
			<b>Oil, Lubricating OEA Ice, Subzero</b>	
32	C	9150-00-403-2 372	Oil, Lubricating OEA Ice, Subzero 1-qt can EMERY3908D (33358)	QT
33	C	9150-00-402-2 372	Oil, Lubricating OEA Ice, Subzero 5-gal can MIL-PRF-46167 (81349)	CN

**Table 1. Expendable and Durable Items List - Continued**

(1) Item No.	(2) Level	(3) National Stock Number (NSN)	(4) Item Name, Description, Part Number/ (CAGEC)	(5) U/I
34	C	9150-00-491-7197	Oil, Lubricating OEA Ice, Subzero 55-gal drum, 16 gauge MIL-PRF-46167 (81349)	DR
			<b>Oil, Lubricating OE/HDO 10</b>	
35	C	9150-01-518-9471	Oil, Lubricating OE/HDO 10 1-qt can M2104-1-10W (81349)	QT
36	C	9150-00-186-6668	Oil, Lubricating OE/HDO 10 5-gal can M2104-3-10W (81349)	CN
37	C	9150-00-191-2772	Oil, Lubricating OE/HDO 10 55-gal drum, 18 gauge M2104-4-10W (98308)	DR
			<b>Oil, Lubricating OE/HDO 30, (SAE 30)</b>	
38	C	9150-01-496-1962	Oil, Lubricating OE/HDO 30, (SAE 30) Bulk M2104-2-30W (81349)	GL
39	C	9150-00-186-6681	Oil, Lubricating OE/HDO 30, (SAE 30) 1-qt can M2104-3-30W (81349)	QT
40	C	9150-00-188-9858	Oil, Lubricating OE/HDO 30, (SAE 30) 5-gal can MIL-PRF-2104 (81349)	CN
41	C	9150-01-433-7978	Oil, Lubricating OE/HDO 30, (SAE 30) 55-gal can M2104-4-30W (81349)	DR
42	C	9150-01-433-7978	Oil, Lubricating OE/HDO 30, (SAE 30) 55-gal drum, 18 gauge M2104-4-30W (81349)	DR

**Table 1. Expendable and Durable Items List - Continued**

(1) Item No.	(2) Level	(3) National Stock Number (NSN)	(4) Item Name, Description, Part Number/ (CAGEC)	(5) U/I
			<b>Oil, Lubricating OE/HDO 50</b>	
43	C	9150-00-188-9865	Oil, Lubricating OE/HDO 50 5-gal drum BRAYC0423H (98308)	CN
			<b>Oil, Lubricating Gear, GO 85W/140</b>	
44	C	9150-01-035-5396	Oil, Lubricating Gear, GO 85W/140 55-gallon drum J2360 (81343)	DR
45	C	9150-01-035-5395	Oil, Lubricating Gear, GO 85W/140 5-gallon can J2360 (81343)	CN
			<b>Oil, Lubricating, Internal Combustion Engine, Tactical Service OE/HDO 15W/40 (MIL-L-2104)</b>	
46	C	9150-01-421-1432	Oil, Lubricating, Internal Combustion Engine, Tactical Service OE/HDO 15W/40 (MIL-L-2104) 55-gal drum, 18 gauge M2104-5-15W40 (81349)	DR
47	C	9150-01-518-9477	Oil, Lubricating, Internal Combustion Engine, Tactical Service OE/HDO 15W/40 (MIL-L-2104) 1-quart can M2104-1-15W40 (81349)	QT
48	C	9150-01-421-1427	Oil, Lubricating, Internal Combustion Engine, Tactical Service OE/HDO 15W/40 (MIL-L-2104) 24-quart box MIL-PRF-2104 (81349)	QT

**Table 1. Expendable and Durable Items List - Continued**

(1) Item No.	(2) Level	(3) National Stock Number (NSN)	(4) Item Name, Description, Part Number/ (CAGEC)	(5) U/I
			<b>Oil, Lubricating, OE/HDO 40</b>	
49	C	9150-00-188-9862	Oil, Lubricating, OE/HDO 40 55-gal drum MIL-PRF-2104 (81349)	DR
			<b>Rag, Wiping</b>	
50	C	7920-00-205-1711	Rag, Wiping 50-pound bale 7920-00-205-1711 (80244)	BE
			<b>Rope</b>	
51	C	4020-00-968-1357	Rope, Fibrous MIL-R-17343 (81349)	RL
			<b>Oil, Lubricating, Preventative</b>	
52	C	9150-01-293-7696	Oil, Lubricating, Preventative 5-gal drum MIL-L-21260C (81349)	CN
53	C	9150-01-438-6079	Oil, Lubricating, Preventative 55-gallon drum J2363 (81349)	DR
			<b>Preventative, Rust MIL-C-16173 Texaco Type "L"</b>	
54	C	8030-00-062-5866	Preventative, Rust MIL-C-16173 Texaco Type "L" 1-gallon can MIL-C-16173 (81349)	GL
55	C	8030-00-231-2345	Preventative, Rust MIL-C-16173 Texaco Type "L" 1-gallon can MIL-C-16173 (81349)	GL

**Table 1. Expendable and Durable Items List - Continued**

(1) Item No.	(2) Level	(3) National Stock Number (NSN)	(4) Item Name, Description, Part Number/ (CAGEC)	(5) U/I
56	C	8030-00-244-1293	Preventative, Rust MIL-C-16173 Texaco Type "L" 5-gallon can MIL-PRF-16173 (81349)	CN
57	C	8030-00-244-129	Preventative, Rust MIL-C-16173 Texaco Type "L" 55-gallon drum; 18 gauge MIL-PRF-16173 (81349)	DR
58	C	8030-00-837-6557	Preventative, Rust MIL-C-16173 Texaco Type "L" 1-pint can 230-1313P1 (49956)	PT
59	C	8030-00-231-2344	Preventative, Rust MIL-C-16173 Texaco Type "L" 5-gallon can MIL-R-10036 (81349)	CN

**END OF WORK PACKAGE**



<b>RECOMMENDED CHANGES TO PUBLICATIONS AND BLANK FORMS</b> For use of this form, see AR 310-1; the proponent agency is the US Army Adjutant General Center.						Use Part II (reverse) for Repair Parts and Special Tool Lists (RPSTL) and Supply Catalogs/Supply Manuals (SC/SM).	DATE
TO: (Forward to proponent of publication or form) (Include ZIP Code)						FROM: (Activity and location) (Include ZIP Code)	
<b>PART I - ALL PUBLICATIONS (EXCEPT RPSTL AND SC/SM) AND BLANK FORMS</b>							
PUBLICATION/FORM NUMBER						DATE	TITLE
ITEM NO.	PAGE NO.	PARA-GRAPH	LINE NO.*	FIGURE NO.	TABLE NO.	RECOMMENDED CHANGES AND REASON (Exact wording of recommended change must be given)	
* Reference to line numbers within the paragraph or subparagraph.							
TYPED NAME, GRADE OR TITLE				TELEPHONE EXCHANGE/AUTOVON, PLUS EXTENSION		SIGNATURE	

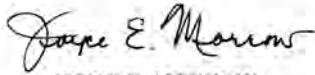
<b>TO:</b> <i>(Forward to proponent of publication or form) (Include ZIP Code)</i>				<b>FROM:</b> <i>(Activity and location) (Include ZIP Code)</i>			<b>DATE</b>	
<b>PART II - REPAIR PARTS AND SPECIAL TOOL LISTS AND SUPPLY CATALOGS/SUPPLY MANUALS</b>								
PUBLICATION/FORM NUMBER				DATE		TITLE		
PAGE NO.	COLM NO.	LINE NO.	FEDERAL STOCK NUMBER	REFERENCE NO.	FIGURE NO.	ITEM NO.	TOTAL NO. OF MAJOR ITEMS SUPPROTED	RECOMMENDED ACTION
<b>PART III - REMARKS</b> <i>(Any general remarks or recommendations, or suggestions for improvement of publications and blank forms. Additional blank sheets may be used if more space is needed.)</i>								
TYPED NAME, GRADE OR TITLE				TELEPHONE EXCHANGE/AUTOVON, PLUS EXTENSION			SIGNATURE	



By Order of the Secretary of the Army:

GEORGE W. CASEY, JR.  
*General, United States Army*  
*Chief of Staff*

Official:



JOYCE E. MORROW  
*Administrative Assistant to the*  
*Secretary of the Army*  
0817001

DISTRIBUTION: To be distributed in accordance with the initial distribution requirements for IDN: 380265, requirements for TM 9-2320-428-10.



THE METRIC SYSTEM AND EQUIVALENTS

LINEAR MEASURE

1 Centimeter = 10 Millimeters = 0.01 Meters = 0.3937 Inches  
 1 Meter = 100 Centimeters = 1000 Millimeters = 39.37 Inches  
 1 Kilometer = 1000 Meters = 0.621 Miles

SQUARE MEASURE

1 Sq Centimeter = 100 Sq Millimeters = 0.155 Sq Inches  
 1 Sq Meter = 10,000 Sq Centimeters = 10.76 Sq Feet  
 1 Sq Kilometer = 1,000,000 Sq Meters = 0.386 Sq Miles

WEIGHTS

1 Gram = 0.001 Kilograms = 1000 Milligrams = 0.035 Ounces  
 1 Kilogram = 1000 Grams = 2.2 Lb  
 1 Metric Ton = 1000 Kilograms = 1 Megagram = 1.1 Short Tons

CUBIC MEASURE

1 Cu Centimeter = 1000 Cu Millimeters = 0.06 Cu Inches  
 1 Cu Meter = 1,000,000 Cu Centimeters = 35.31 Cu Feet

LIQUID MEASURE

1 Milliliter = 0.001 Liters = 0.0338 Fluid Ounces  
 1 Liter = 1000 Milliliters = 33.82 Fluid Ounces

TEMPERATURE

5/9 (°F - 32) = °C  
 212° Fahrenheit is equivalent to 100° Celsius  
 90° Fahrenheit is equivalent to 32.2° Celsius  
 32° Fahrenheit is equivalent to 0° Celsius  
 9/5 C° + 32 = F°

APPROXIMATE CONVERSION FACTORS

<u>TO CHANGE</u>	<u>TO</u>	<u>MULTIPLY BY</u>
Inches . . . . .	Centimeters . . . . .	2.540
Feet . . . . .	Meters . . . . .	0.305
Yards . . . . .	Meters . . . . .	0.914
Miles . . . . .	Kilometers . . . . .	1.609
Square Inches . . . . .	Square Centimeters . . . . .	6.451
Square Feet . . . . .	Square Meters . . . . .	0.093
Square Yards . . . . .	Square Meters . . . . .	0.836
Square Miles . . . . .	Square Kilometers . . . . .	2.590
Acres . . . . .	Square Hectometers . . . . .	0.405
Cubic Feet . . . . .	Cubic Meters . . . . .	0.028
Cubic Yards . . . . .	Cubic Meters . . . . .	0.765
Fluid Ounces . . . . .	Milliliters . . . . .	29.573
Pints . . . . .	Liters . . . . .	0.473
Quarts . . . . .	Liters . . . . .	0.946
Gallons . . . . .	Liters . . . . .	3.785
Ounces . . . . .	Grams . . . . .	28.349
Pounds . . . . .	Kilograms . . . . .	0.454
Short Tons . . . . .	Metric Tons . . . . .	0.907
Pound-Feet . . . . .	Newton-Meters . . . . .	1.356
Pounds/Sq Inch . . . . .	Kilopascals . . . . .	6.895
Miles per Gallon . . . . .	Kilometers per Liter . . . . .	0.425
Miles per Hour . . . . .	Kilometers per Hour . . . . .	1.609

<u>TO CHANGE</u>	<u>TO</u>	<u>MULTIPLY BY</u>
Centimeters . . . . .	Inches . . . . .	0.394
Meters . . . . .	Feet . . . . .	3.280
Meters . . . . .	Yards . . . . .	1.094
Kilometers . . . . .	Miles . . . . .	0.621
Sq Centimeters . . . . .	Square Inches . . . . .	0.155
Square Meters . . . . .	Square Feet . . . . .	10.764
Square Meters . . . . .	Square Yards . . . . .	1.196
Square Kilometers . . . . .	Square Miles . . . . .	0.386
Sq Hectometers . . . . .	Acres . . . . .	2.471
Cubic Meters . . . . .	Cubic Feet . . . . .	35.315
Cubic Meters . . . . .	Cubic Yards . . . . .	1.308
Milliliters . . . . .	Fluid Ounces . . . . .	0.034
Liters . . . . .	Pints . . . . .	2.113
Liters . . . . .	Quarts . . . . .	1.057
Liters . . . . .	Gallons . . . . .	0.264
Grams . . . . .	Ounces . . . . .	0.035
Kilograms . . . . .	Pounds . . . . .	2.205
Metric Tons . . . . .	Short Tons . . . . .	1.102
Newton-Meters . . . . .	Pound-Feet . . . . .	0.738
Kilopascals . . . . .	Pounds per Sq Inch . . . . .	0.145
Km per Liter . . . . .	Miles per Gallon . . . . .	2.354
Km per Hour . . . . .	Miles per Hour . . . . .	0.621

