

NORMAL

MWO effective date is 1 OCTOBER 1991 and completion date is 30 SEPTEMBER 1995

MWO 9-2320-280-35-1

MODIFICATION WORK ORDER

MODIFICATION OF 1-1/4 TON VEHICLES

M998 SERIES

NOMENCLATURE	NSN
Truck, Utility, 1-1/4 Ton, 4x4:	
Cargo/Troop Carrier	2320-01-107-7155
Cargo/Troop Carrier, W/Winch	2320-01-107-7156
TOW Carrier, Armored	2320-01-107-7153
TOW Carrier, Armored, Winch	2320-01-107-7154
TOW Carrier, W/Supplemental Armor	2320-01-146-7191
TOW Carrier, W/Supplemental Armor, W/Winch	2320-01-146-7188
Armament Carrier, Armored	2320-01-128-9551
Armament Carrier, Armored, W/Winch	2320-01-128-9552
Armament Carrier, W/Supplemental Armor	2320-01-146-7190
Armament Carrier, W/Supplemental Armor, W/Wnch	2320-01-146-7189
Truck, Ambulance, 4x4:	
2-Litter, Soft Top	2310-01-146-7194

Headquarters, Department of the Army, Washington, D.C.

30 March 1990

REPORTING OF ERRORS AND RECOMMENDING IMPROVEMENTS

You can help improve this MWO. If you find any mistakes or if you know of a way to improve these procedures, please let us know. Write a letter or complete and mail a DA Form 2028, Recommended Changes to Publications and Blank Forms, to: U.S. Army Tank-Automotive Command, ATTN: AMSTA-MB, Warren, MI 48397-5000. A reply will be provided to you.

APPROVED FOR PUBLIC RELEASE; DISTRIBUTION IS UNLIMITED.

1. PURPOSE.

This modification provides a dual service parking brake that is more efficient and reliable than the single caliper parking brake.

2. PRIORITY.

This modification is classified as NORMAL.

3. END ITEM TO BE MODIFIED.

a. Truck, 1-1/4 Ton, 4x4, M998 Series, serial numbers 1 through 44824, inclusively.

NOMENCLATURE	NSN	PART NO.	CAGE	MODEL NO.
Truck, Utility, 1-1/4 Ton, 4x4:				
Cargo/Troop Carrier	2320-01-107-7155	8750055	19207	M998
Cargo/Troop Carrier, W/W	2320-01-107-7156	8750057	19207	M1038
TOW Carrier, Armored	2320-01-107-7153	8750058	19207	M966
TOW Carrier, Armored, W/W	2320-01-107-7154	8750050	19207	M1036
TOW Carrier, W/Supp Armor	2320-01-146-7191	8750082	19207	M1045
TOW Carrier, W/Supp Armor, W/W	2320-01-146-7188	8750083	19207	M1046
Armament Carrier, Armored	2320-01-128-9551	8750124	19207	M1025
Armament Carrier, Armored, W/W	2320-01-128-9552	8750123	19207	M1026
Armament Carrier, W/Supp Armor	2320-01-146-7190	8750122	19207	M1043
Armament Carrier, W/Supp Armor, W/W	2320-01-146-7189	8750121	19207	M1044
Truck, Ambulance, 4x4:				
2-Litter, Soft Top	2310-01-146-7194	8750116	19207	M1035

b. Vehicle National Stock Number (NSN) will not change as a result of this MWO.

4. MODULE TO BE MODIFIED.

Not applicable.

5. PARTS TO BE MODIFIED.

Not applicable.

6. APPLICATION.

a. Time Compliance Schedule: The effective date of this MWO is 1 October 1991 and its completion date is 30 September 1995.

b. The lowest level of maintenance authorized to apply the MWO is Direct Support.

c. Work force and man-hour requirements for application of the MWO to a single unit, end item or system:

REQUIREMENTS	
WORK FORCE/SKILLS	MAN-HOURS
2 Wheeled Vehicle Mechanics (MOS 63W) or equivalent	8
Total man-hours required for a single application of this MWO is 8 hours.	

7. TECHNICAL PUBLICATIONS AFFECTED/CHANGED AS A RESULT OF THE MWO.

Technical Publication	Date
TM 9-2320-280-10	1 April 1985
TM 9-2320-280-20	1 April 1985
TM 9-2320-280-34	1 April 1985
TM 9-2320-280-20P	12 June 1986
TM 9-2320-280-34P	12 June 1986

8. MWO KITS, PARTS, AND THEIR DISPOSITION.

a. The following kit is required to accomplish this modification. The security classification of the kit is unclassified. Shipping data is: Weight 57.00 lbs; the kit measures 53.25 x 9.25 x 6.75 in.; its volume is 1.924 cu ft.

NSN	NOMENCLATURE	CAGE	PART NO.
2530-01-312-1924	Parking Brake Retrofit Kit	19207	5705614

b. Parking Brake Retrofit Kit component parts are listed below. The listing is used to inventory the kit for completeness.

NSN	NOMENCLATURE	CAGE	PART NO.	QTY.
5330-01-200-0466	Gasket	19207	12338339	2
5340-01-212-3553	Clamp assembly	19207	12338343-1	1
5340-01-226-1718	Clamp assembly	19207	12338343-2	1
5310-01-189-8476	Washer	19207	12339204	2
5306-01-273-6333	Parking brake rod	19207	12341895	1
	Washer	19207	12341897	1
	R.H. cable assembly	19207	12341898-1	1
	L.H. cable assembly	19207	12341898-3	1
	Equalizer bar	19207	12341902	1
	Parking brake cable mounting bracket	19207	12341906	1
	Brake cable bracket	19207	12341986	2
	Pin, locating	19207	12342339	4
	Pad, brake	19207	12342340	4
	Caliper housing, R.H.	19207	12342341	1
	Caliper housing, L.H.	19207	12342342	1
5365-00-664-5389	Clip, ring	96906	MS16633-105O	4
5340-00-088-1254	Clamp	96906	MS21333-104	3
5340-00-809-1494	Clamp	96906	MS21333-105	2
5310-00-809-4058	Washer	96906	MS27183-10	1
5310-00-582-5965	Washer	96906	MS35338-44	2
5310-00-814-0673	Nut	96906	MS51943-33	1
5310-00-241-6658	Nut	96906	MS51943-34	1
5310-00-905-4600	Nut	96906	MS51968-6	1
5305-00-068-0502	Screw	96906	MS90725-6	1
5305-00-068-7837	Screw	96906	MS90728-5	2
	Washer	24617	123153	4
	Pin, cotter	24617	121222	3
5315:00-013-8084	Pin, clevis	24617	138084	1
	Washer	24617	2436163	1
	Nut	24617	271172	1
	Screw	24617	456644	4
5310-01-278-1692	Nut	24617	9422297	10
	Screw	24617	9431948	2

b. Parking Brake Retrofit Kit (Cont'd)

NSN	NOMENCLATURE	CAGE	PART NO.	QTY. REQ'D TO ACCOMPUSH ONE MWO
9905-00-858-5682	Plate, instruction, MWO	19207	10930014	1
5305-00-253-5614	Drivescrew	96906	MS21318-20	1

c. Bulk and expendable material.

NSN	NOMENCLATURE	CAGE	PART NO.	QTY. REQ'D TO ACCOMPUSH ONE MWO
8030-00-148-9833	Sealant	80244	MIL-S-46163	1
6850-00-177-5094	Silicone compound	81349	MIL-S-8660	1

d. Parts disposition. All parts not used during installation will be returned to stock for disposition in accordance with AR 725-50.

9. SPECIAL TOOLS; TOOL KITS; JIGS; TEST, MEASUREMENT AND DIAGNOSTIC EQUIPMENT (TMDE); AND FIXTURES REQUIRED.

a. Hand tools necessary to apply MWO are contained in this tool kit.

NOMENCLATURE	NSN	CAGE	SUPPLY CATALOGUE
Tool Kit, General Mechanic's	5180-00-177-7033	50980	SC 5180-90-CL-N26

b. Metal drilling equipment necessary to apply MWO is contained in this shop set.

NOMENCLATURE	NSN	CAGE	SUPPLY CATALOGUE
Shop Equipment, Automotive Maintenance and Repair, Common No. 1	4910-00-754-0654	19204	SC 4910-95-CL-A74

10. MODIFICATION PROCEDURES.

a. VEHICLE PREPARATION.

- (1) Chock front wheels. (Refer to TM 9-2320-280-20.)
- (2) Raise rear of vehicle. (Refer to TM 9-2320-280-20.)
- (3) Remove pioneer tool stowage rack. (Refer to TM 9-2320-280-10.)
- (4) Disconnect propeller shaft from differential. (Refer to TM 9-2320-280-20.)
- (5) Remove muffler, tailpipe, and tailpipe hanger. (Refer to TM 9-2320-280-20.)
- (6) Remove parking brake rod. (Refer to TM 9-2320-280-20.)

10. MODIFICATION PROCEDURES (Contd).

- (7) Remove parking brake cable. (Refer to TM 9-2320-280-20.)
- (8) Remove parking brake heat shield. (Refer to TM 9-2320-280 -20.)
- (9) Remove parking brake caliper. (Refer to TM 9-2320-280-20.)
- (10) Remove service brake calipers. (Refer to TM 9-2320-280-20.)
- (11) Slide locating pins and yokes from caliper assemblies. (Refer to TM 9-2320-280-20).
- (12) Remove screw from clamp on C-beam and pull harness out of the way as shown in figure 1.
- (13) Remove and discard locating pins from yokes. (Refer to TM 9-2320-280-20.)

NOTE

Ž Apply sealing compound to threads of locating pins.

Ž Lightly coat locating pins with silicone compound.

- (14) Install four 12342339 locating pins on yokes as shown in figure 3. Tighten 60 lb-ft (81 N·m).
- (15) Slide yokes onto 12342341 and 12342342 caliper assemblies as shown in figure 3.
- (16) Remove four rivets and parking brake cable support bracket from C-beam as shown in figure 1. Discard rivets and bracket.
- (17) Locate, mark, and drill two 0.578-inch diameter holes in C-beam as shown in figure 1. Remove paint around holes on both sides of C-beam.
- (18) Install harness on C-beam and secure with screw and clamp as shown in figure 1.
- (19) Using 12341986 brake cable bracket as a template, locate, mark, and drill four 0.296-inch diameter holes in support brackets as shown in figure 2.

b. INSTALLATION, REAR DUAL PARKING BRAKE PADS AND CALIPERS.

WARNING

Make sure brake pads are installed with lining facing rotor.

- (1) Position four 12342340 brake pads to rotors in adapters as shown in figure 3.
- (2) Remove brake line adapter fittings from existing calipers and install on calipers with two 12339204 washers as shown in figure 3.

NOTE

Apply sealing compound to threads of caliper mounting screws.

- (3) Secure two yokes, already mounted on caliper assemblies, on adapters with four screws and washers as shown in figure 3. Tighten 40 lb-ft (54 N·m).
- (4) Connect brake lines to calipers as shown in figure 3.

c. INSTALLATION, RIGHT PARKING BRAKE CABLE.

(1) Secure brake cable bracket to support bracket with two 456644 screws as shown in figure 4. Tighten 6 lb-ft (8 N·m).

(2) Install MS21333-105 clamp on 12341898-1 cable assembly and secure clamp to brake cable bracket with MS35338-44 washer and MS90728-5 screw as shown in figure 4.

(3) Route cable assembly over fuel tank and insert brake cable sleeve of cable assembly through C-beam and secure with MS16633-1050 ring clip as shown in figure 4.

(4) Install two MS21333-104 clamps to cable assembly and secure clamps to cargo floor support with two 9431948 screws as shown in figure 5.

d. INSTALLATION, LEFT PARKING BRAKE CABLE/MOUNTING BRACKET.

(1) Secure brake cable bracket to support bracket with two 456644 screws as shown in figure 4. Tighten 6 lb-ft (8 N·m).

(2) Install MS21333-105 clamp on 12341898-3 cable assembly and secure clamp to brake cable bracket with MS35338-44 washer and MS90728-5 screw as shown in figure 4.

(3) Route cable assembly over frame rail and insert brake cable sleeve of cable assembly through C-beam and secure with MS16633-1050 ring clip as shown in figure 4.

(4) Install 12341906 parking brake cable mounting bracket and tailpipe hanger to rear body mount and secure with two existing screws, four existing washers and two 9422297 nuts as shown in figure 6.

(5) Install MS21333-104 clamp to cable assembly and secure to parking brake cable mounting bracket with MS90725-6 screw, MS27183-10 washer, and 271172 nut as shown in figure 6.

e. INSTALLATION, PARKING BRAKE ROD.

(1) Position 12341902 equalizer bar on parking brake cable ends as shown in figure 7.

(2) Remove clevis, spring, nut, two washers, screw, and spacer from existing parking brake rod as shown in figure 8.

(3) Install spring and spacer to body support and secure with two washers, screw, and MS51943-33 nut as shown in figure 7.

(4) Install MS51968-6 nut and clevis on 12341895 brake rod as shown in figure 7.

(5) Slide brake rod rearward through spring as shown in figure 8.

(6) Connect brake rod to equalizer bar and secure with 12341897 conical washer and MS51943-34 nut as shown in figure 7. Install nut exposing 3-5 threads on end of brake rod.

(7) Spread boot and install clevis to bellcrank and secure with 138084 clevis pin, 2436163 washer, and 121222 cotter pin as shown in figure 7.

(8) Insert brake cable sleeves through slot of calipers and secure with two MS16633-1050 ring clips as shown in figure 4.

(9) Install clevis to rear caliper levers and secure with two clevis pins, washers, and two 121222 cotter pins as shown in figure 3.

(10) Install muffler. (Refer to TM 9-2320-280-20.)

- (11) Install tailpipe. (Refer to TM 9-2320-280-20.)
- (12) Connect propeller shaft to differential. (Refer to TM 9-2320-280-20.)
- (13) Install pioneer tool stowage rack. (Refer to TM 9-2320-280-10.)
- (14) Bleed brake system. (Refer to TM 9-2320-280-20.)
- (15) Lower rear of vehicle and remove front wheel chocks. (Refer to TM 9-2320-280-20.)
- (16) Adjust parking brake lever. (Refer to TM 9-2320-280-20.)
- (17) Road test vehicle. (Refer to TM 9-2320-280-20.)

11. CALIBRATION REQUIREMENTS.

Not applicable to this MWO.

12. WEIGHT AND BALANCE DATA.

Weight and balance are not significantly affected by this MWO.

13. QUALITY ASSURANCE REQUIREMENTS.

a. General. The following information is furnished to ensure the proper application of this MWO and provide clarification in regard to the adequacy of installer's inspection methods and procedures applicable to Quality Assurance (QA). Inspection shall be IAW TM 750-245-4, TM 9-2320-280-10, TM 9-2320-280-20, and MWO 9-2320-280-34.

b. Installer responsibilities. The installer is responsible for following instructions in MWO 9-2320-280-35-1, TM 9-2320-280-10, TM 9-2320-280-20, and TM 9-2320-280-34. The installer is responsible for rejecting any vehicle that has damaged, inoperative, or missing brake system components cited in Preventive Maintenance Checks and Services (PMCS), found in TM 9-2320-280-10 and TM 9-2320-280-20. The installer will report Parking Brake Retrofit Kits received that are damaged or missing component parts so the kit supplier can be properly notified. The installer is responsible for functional testing of brake systems after the Parking Brake Retrofit Kit is installed. Any discrepancies noted will be corrected before the vehicle leaves the installer's work area. Requirements contained in this MWO shall be included in the installer's inspection plan or quality assurance program. These requirements shall not be construed as eliminating the installer's responsibility from complete compliance with provisions of the contract and submitting to the Government products that meet all requirements of the contract.

c. Government verification. All QA operations and installation checks and inspections performed by the installer are subject to Government verification at unannounced and varying intervals. Verification will consist of observations and inspections to confirm that practices, methods, and procedures of the installer's written inspection plan are being properly applied; and that Government product inspection to confirm the quality of product offered for Government acceptance does not deviate from prescribed acceptance standards specified in TM 9-2320-280-10, TM 9-2320-280-20, and TM 750-245-4. Deviations will be brought to the attention of the installer for correction.

d. In-process inspection. During normal assembly operations, paragraph 10, Modification Procedures, will be used to check the installer's work. After installation is complete, the vehicle will be checked IAW the PMCS checklist for correct functioning of the Parking Brake Retrofit Kit components and to ensure there are no defects in the parking brake system. Any defects noted will be corrected by the installer before the vehicle is placed in service. All vehicles modified during a production shift will be checked to ensure product quality.

e. Workmanship inspection. Inspect all components installed or replaced during the installation of the MWO for smoothness of operation and security of mounting. Correct any faults found.

MWO 9-2320-280-35-1

14. RECORDING AND REPORTING OF THE MODIFICATION.

- a. Records and report forms. (Refer to DA PAM 738-750.)
- b. Marking Equipment.

(1) After Parking Brake Retrofit Kit is installed, mark MWO number "9-2320-280-35-1" in the MWO Applied Block and date applied in Date Block on MWO Instruction Plate NSN 9905-00-858-5682.

(2) Install MWO instruction plate by drilling a hole (# 37 drill) in side body reinforcement panel and secure with drivescrew NSN 5305-00-253-5614 as shown in figure 9.

(3) After drivescrew is installed, flatten or remove protruding excess drivescrew material from inside of side body reinforcement panel.

15. MATERIAL CHANGE PROGRAM NUMBER.

This MWO is authorized by Material Change Program number 1-88-06-4168.

16. MODIFICATION IDENTIFICATION.

- a. When installed correctly, the parking brake modification will appear as shown in figure 10.
- b. After the parking brake modification is installed, the parking brake should be tested for secure mounting and smooth operation. Any faults detected or discrepancies noted will be corrected before the vehicle is returned to normal service.

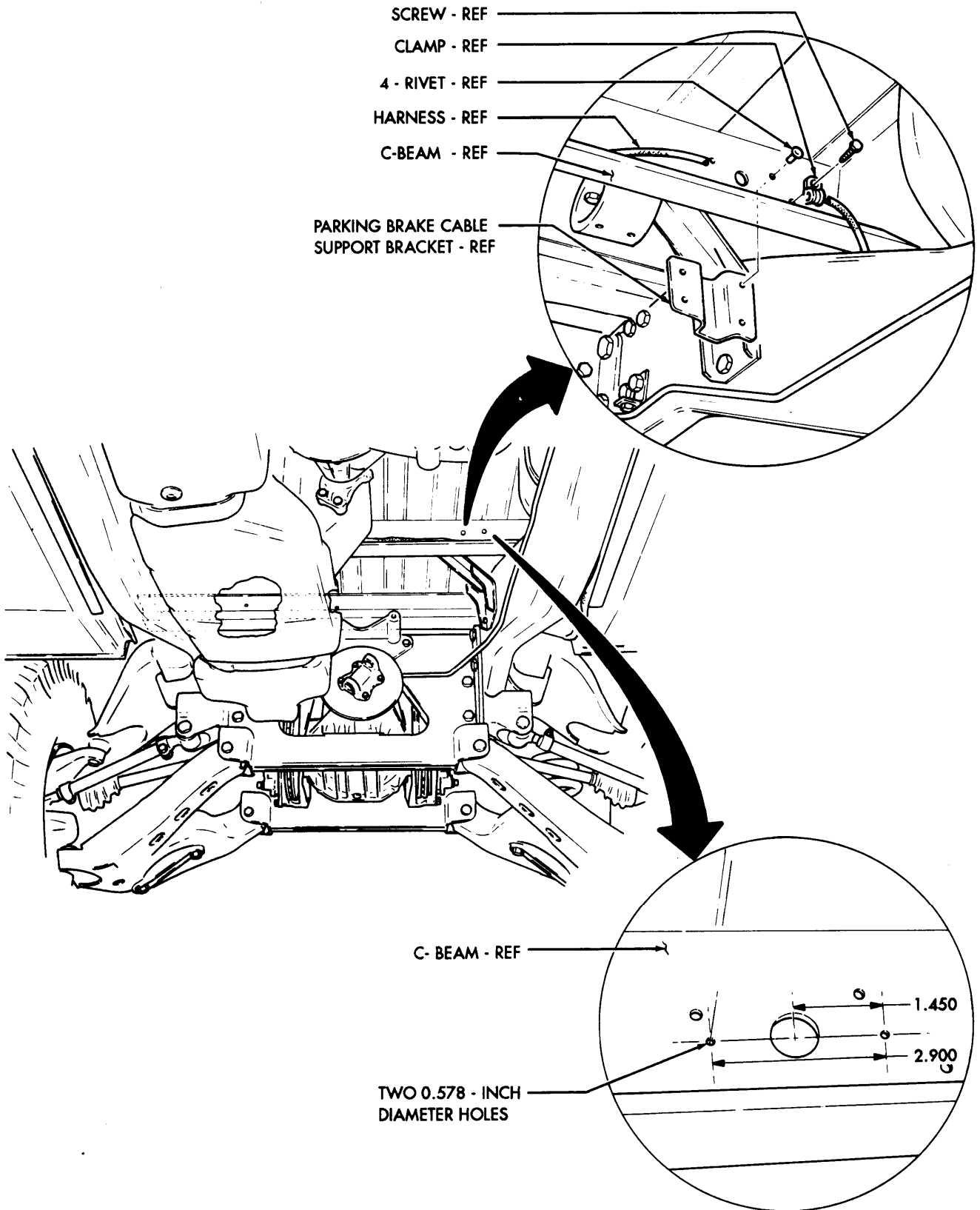
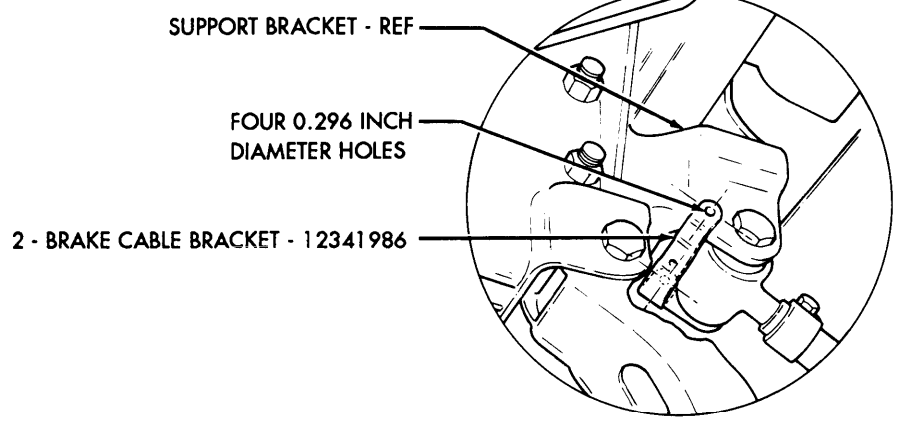
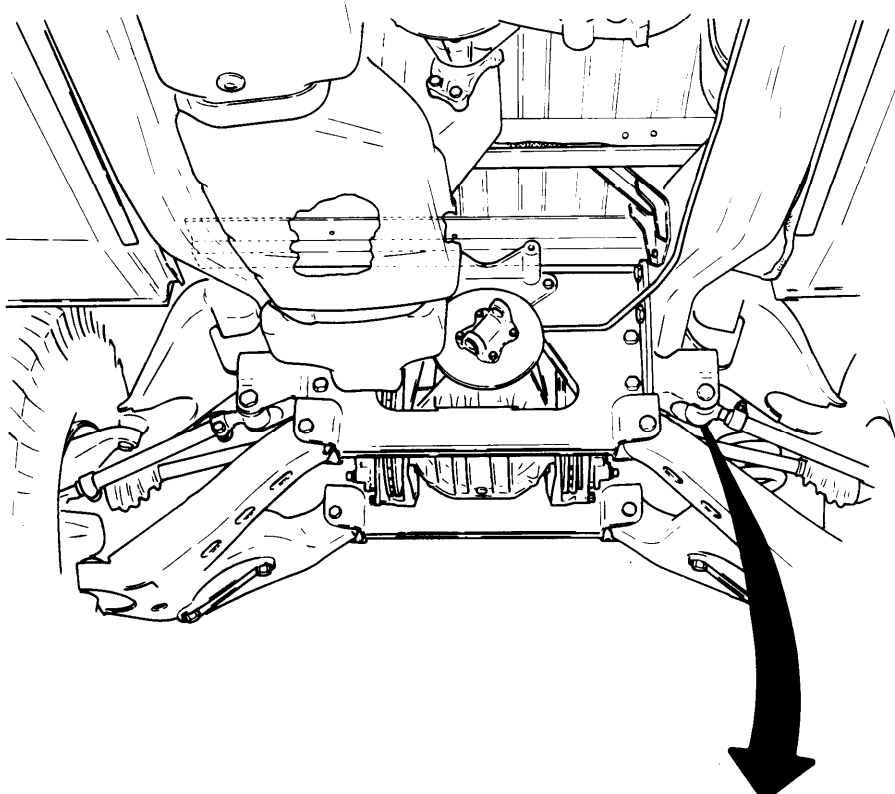
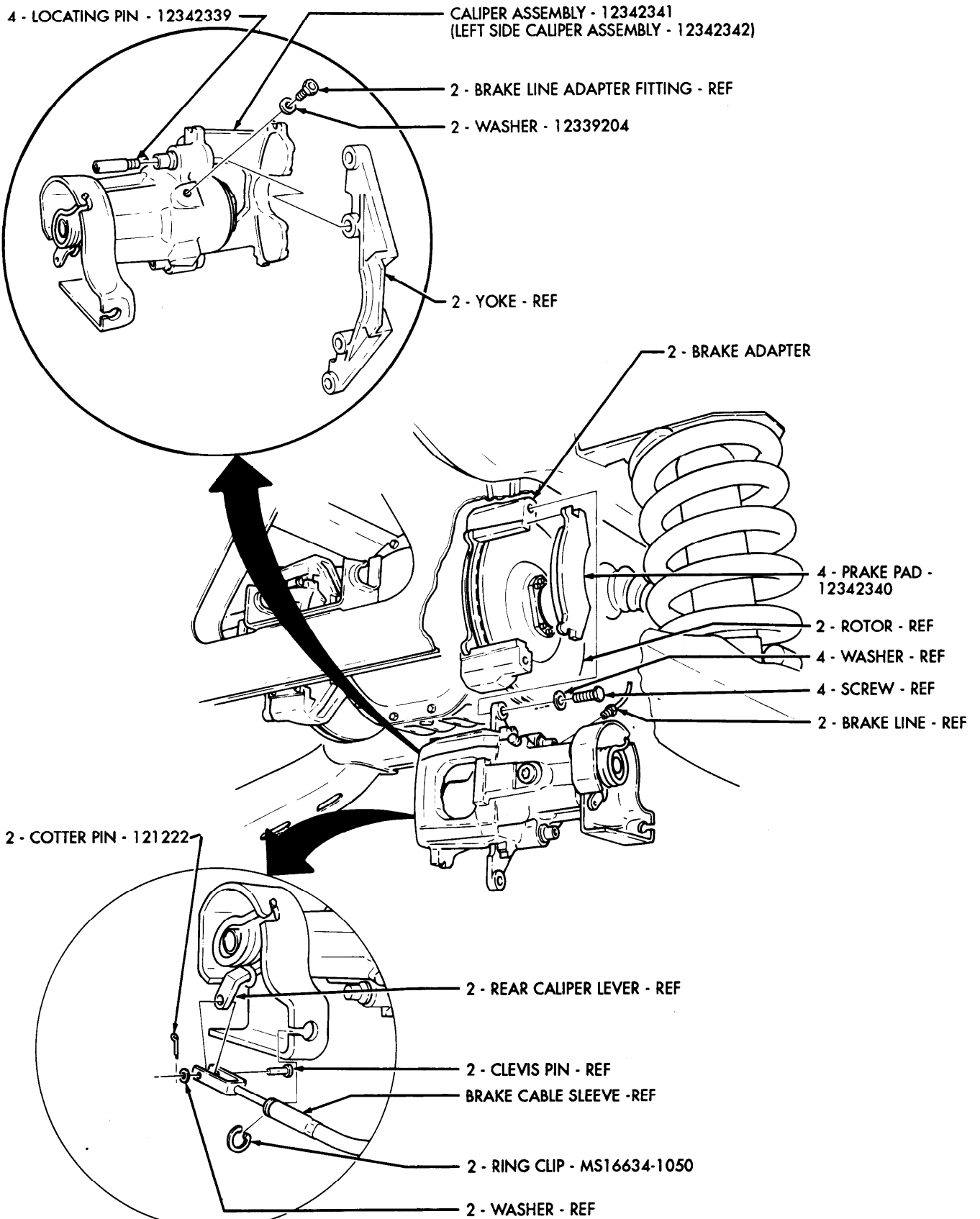

Figure 1



LEFT SIDE SHOWN, RIGHT SIDE OPPOSITE

Figure 2



RIGHT SIDE SHOWN, LEFT SIDE OPPOSITE *Figure 3*

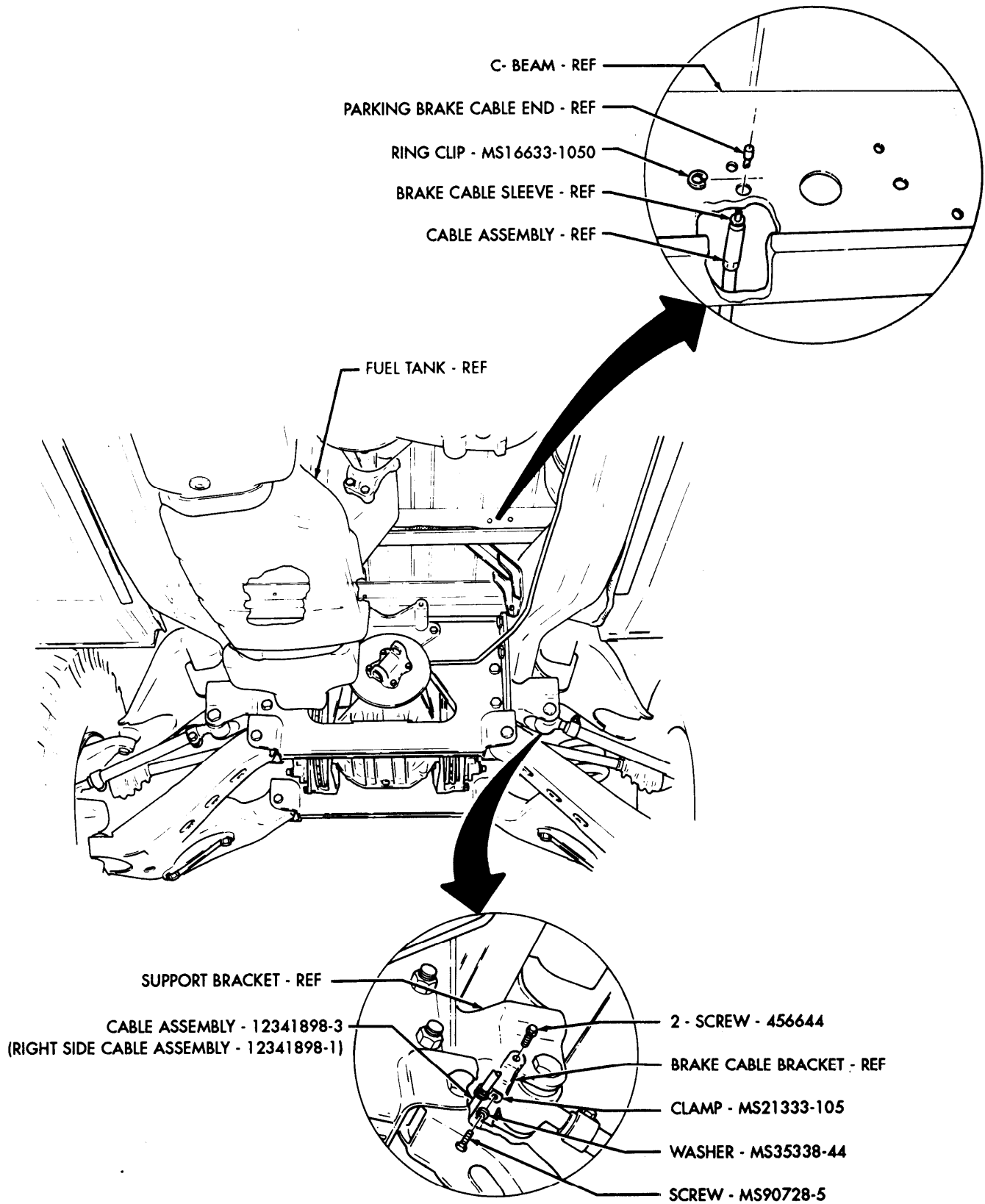

LEFT SIDE SHOWN, RIGHT SIDE OPPOSITE

Figure 4

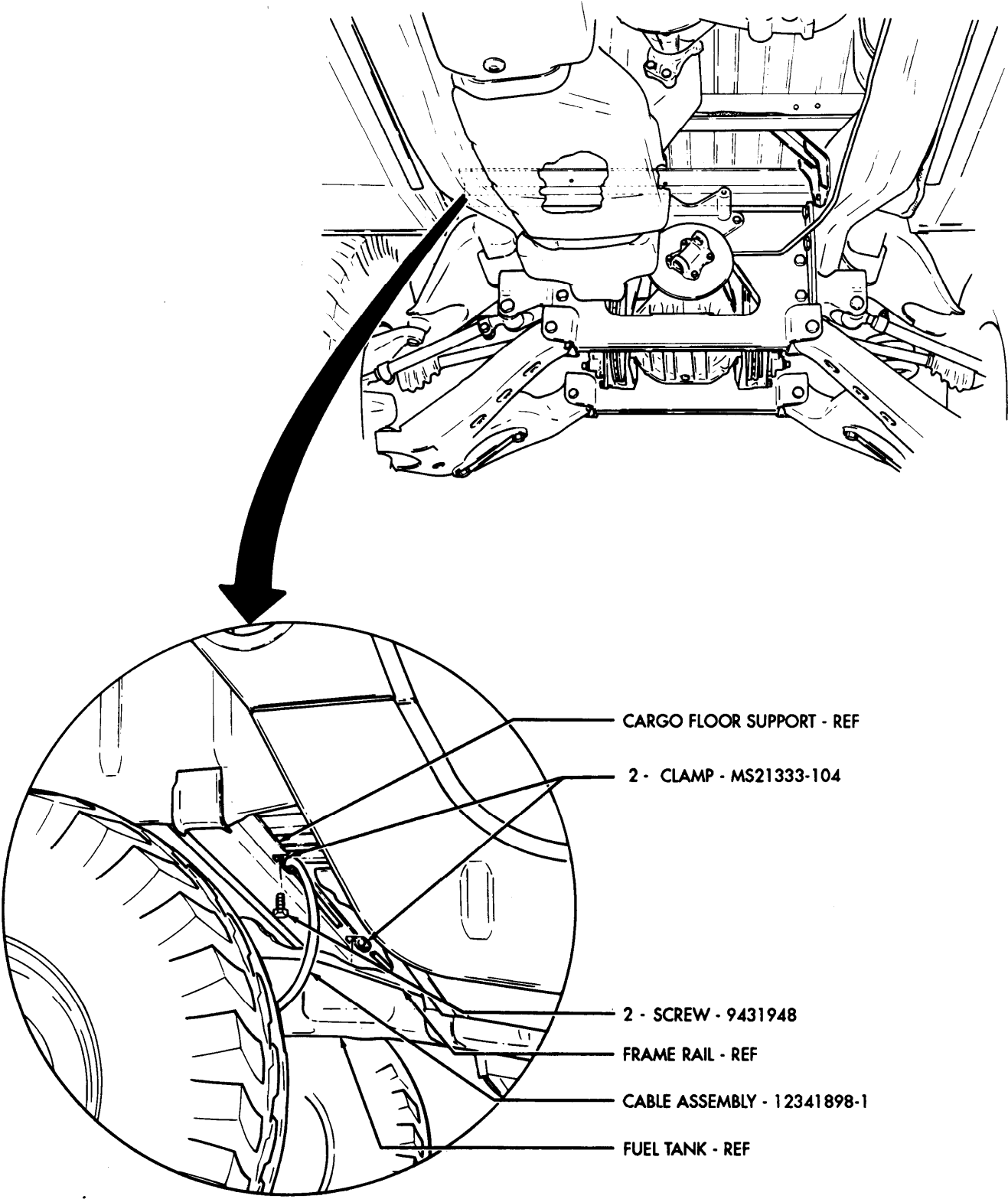

Figure 5

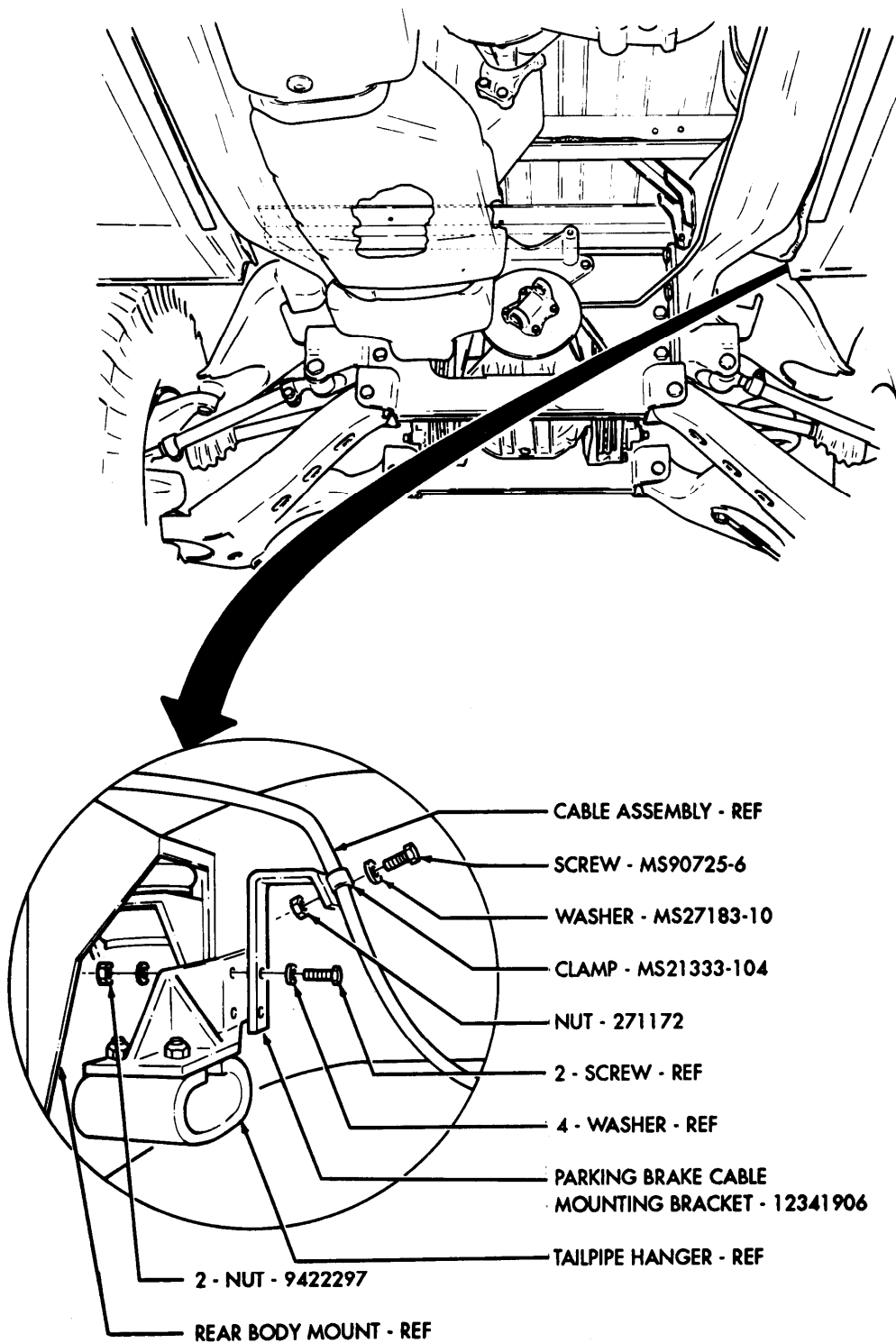

Figure 6

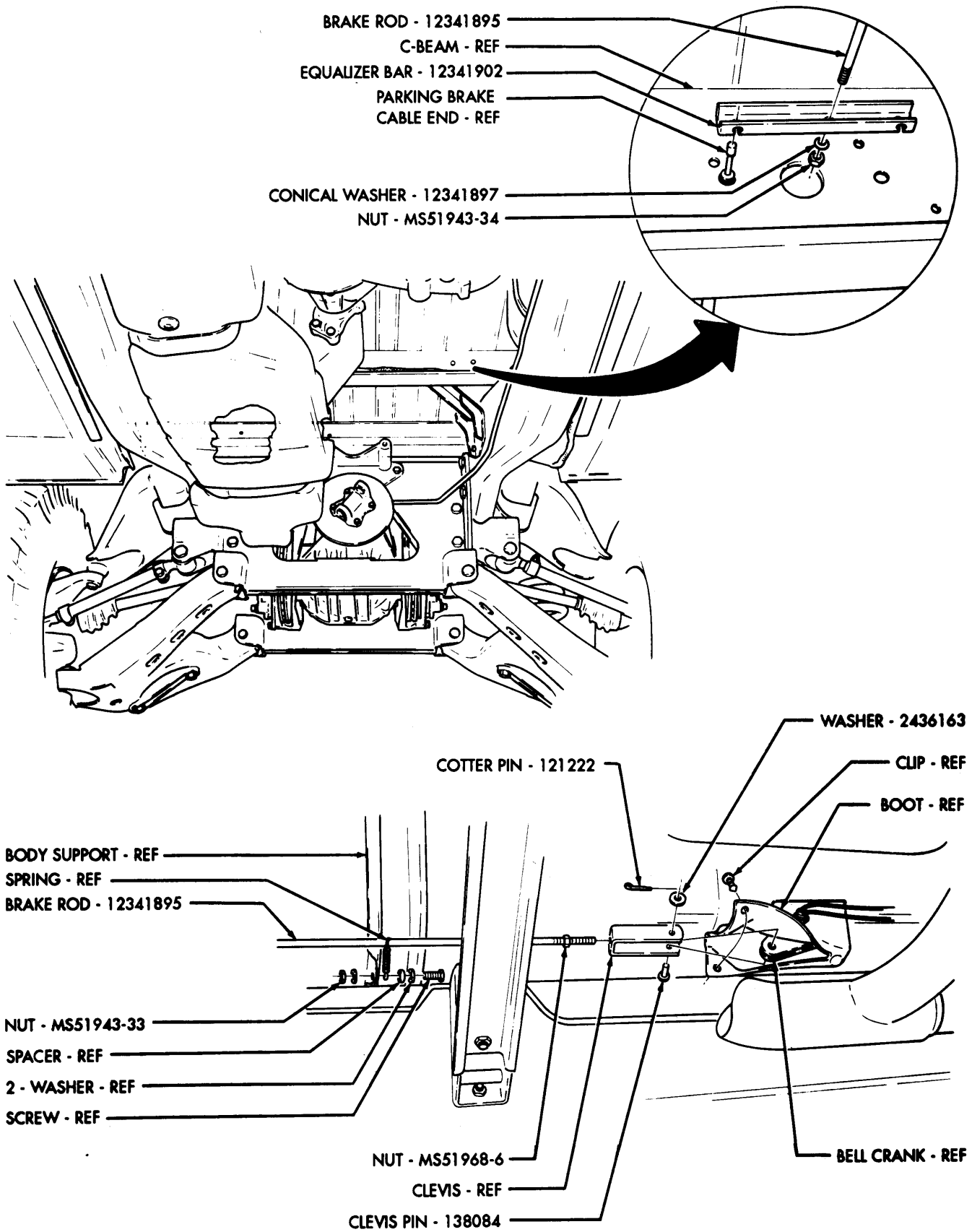

Figure 7

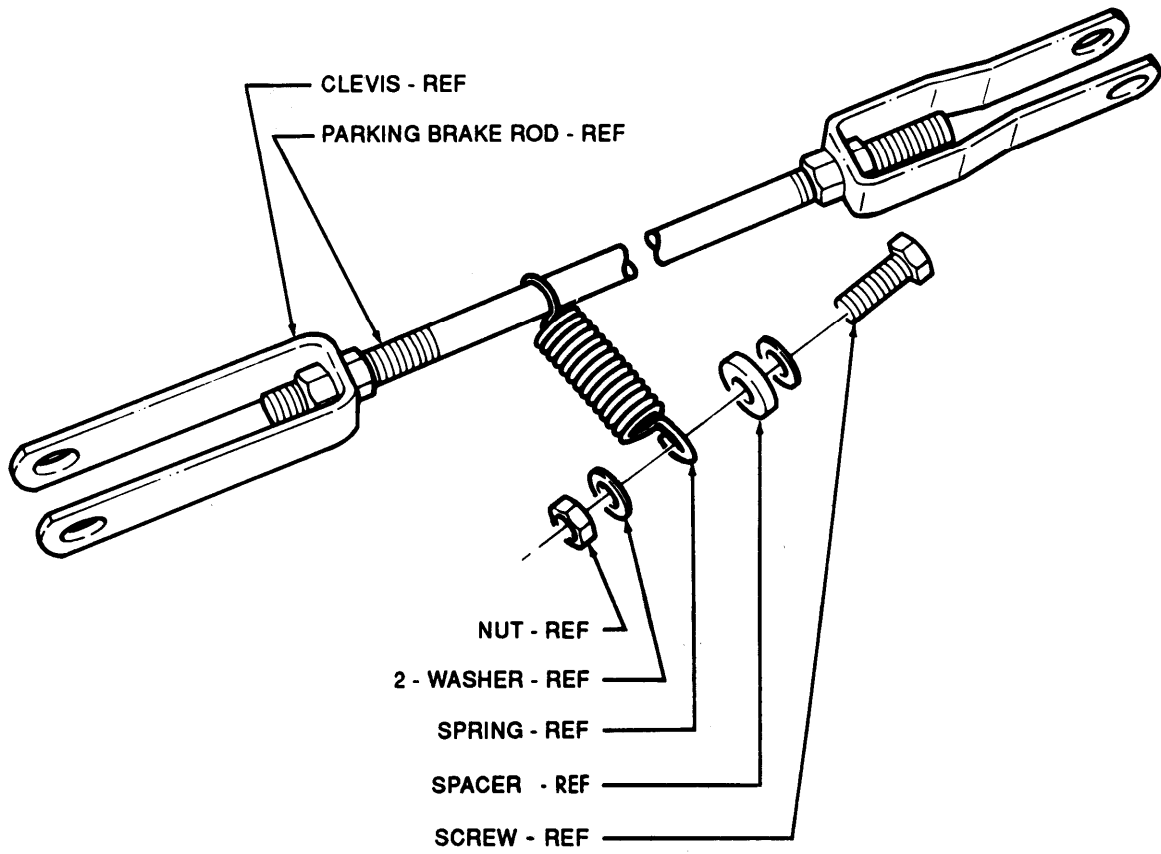

Figure 8

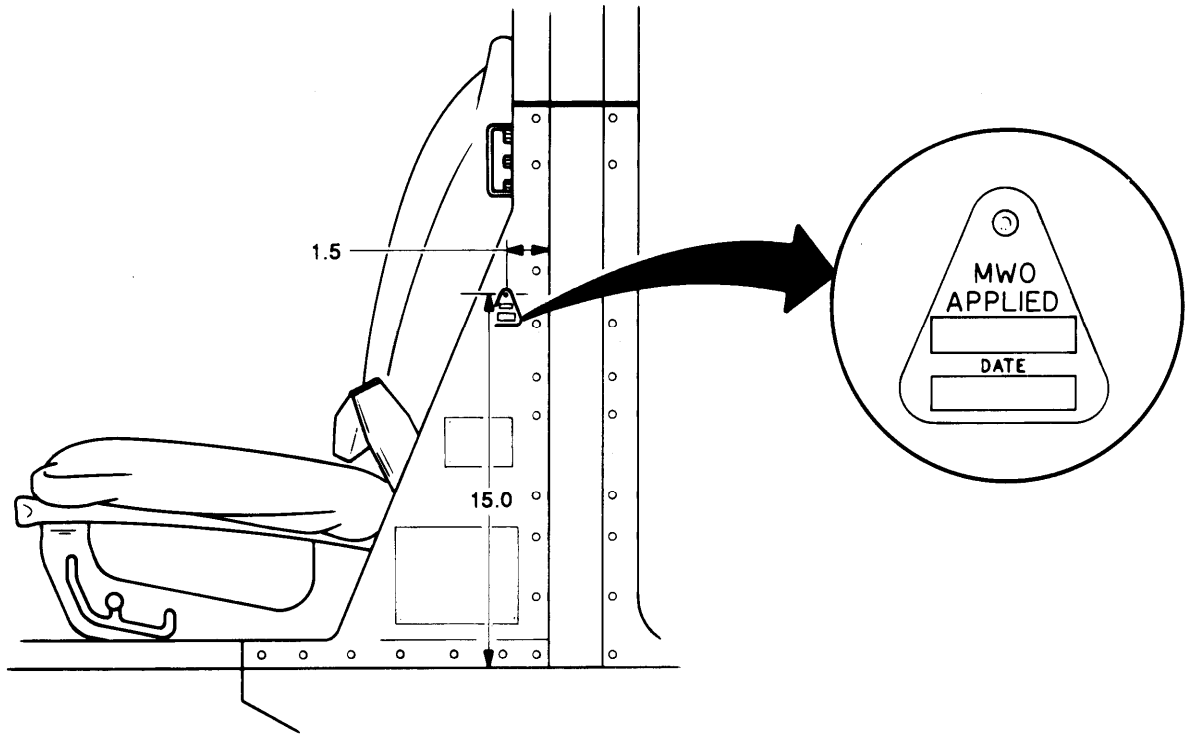

Figure 9

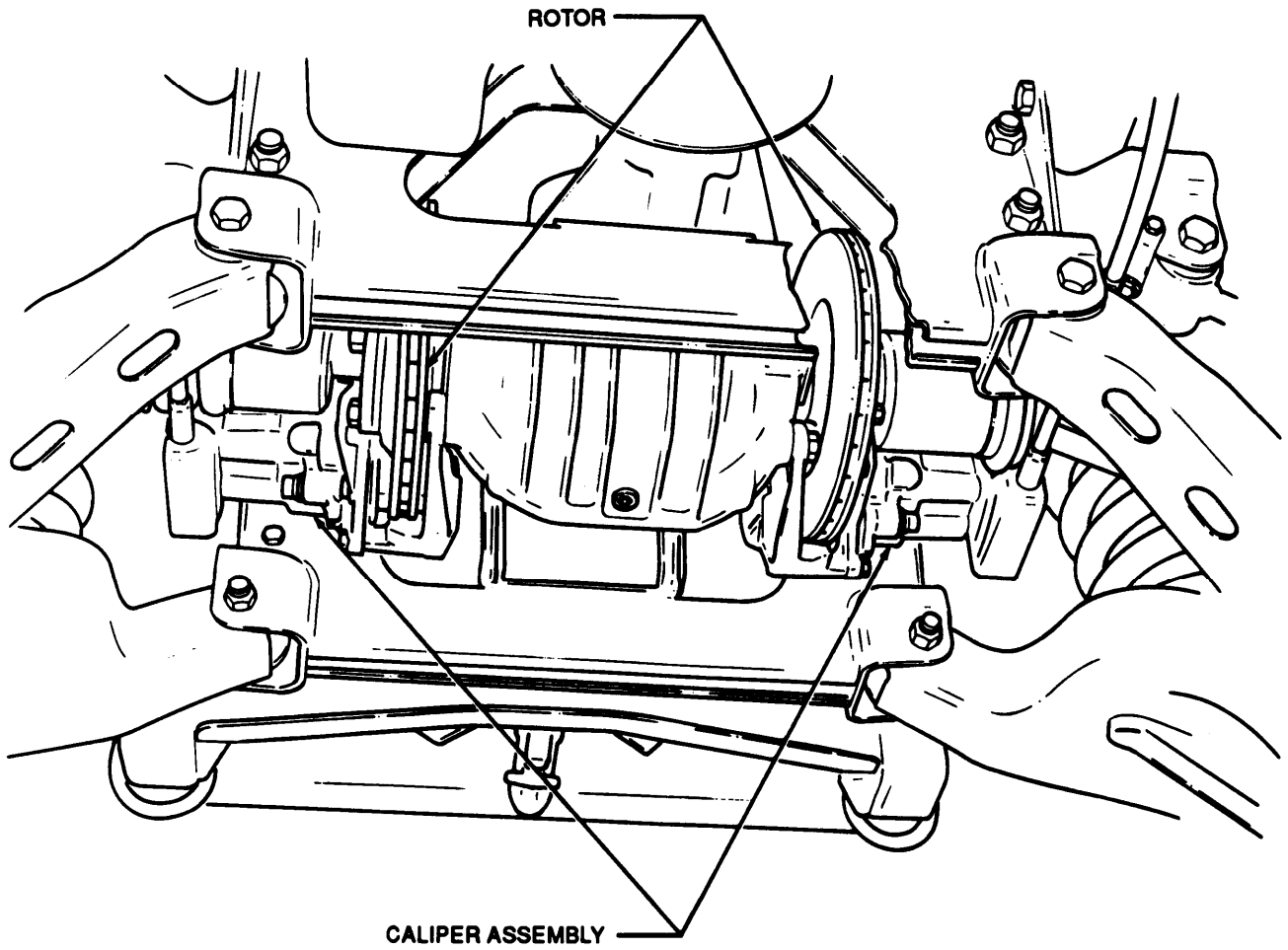

Figure 10

By Order of the Secretary of the Army:

CARL E. VUONO
General, United States Army
Chief of Staff

Official:

PATRICIA P. HICKERSON
Brigadier General, United States Army
The Adjutant General

Distribution:

To be distributed in accordance with DA Form 12-38E (Block 0970) Direct General Support and Depot maintenance requirements for MW09-2320-280-35-1.

*U.S. GOVERNMENT PRINTING OFFICE: 1991 543-016/40062

