

**TECHNICAL BULLETIN
INSTALLATION INSTRUCTIONS**

FOR SYSTEMS

**SINGLE CHANNEL GROUND AND
AIRBORNE RADIO SYSTEM (SINGARS)**

AN/VRC-88F, AN/VRC-89F, AN/VRC-90F, AN/VRC-91F, AN/VRC-92F

FORCE XXI BATTLE COMMAND, BRIGADE-AND-BELOW (FBCB2)

AN/UYK-128 (V)4

PRECISION LIGHTWEIGHT GPS RECEIVER (PLGR)

AN/PSN-11

ENHANCED POSITION LOCATION REPORTING SYSTEM (EPLRS)

AN/VSQ-2 (V)

VEHICULAR INTERCOMMUNICATION SET (VIS)

AN/VIC-3 (V)20

FOR VEHICLE

TRUCK, UTILITY: UP-ARMORED CARRIER, 4X4,

M1114 (2320-01-413-3739) (EIC: B6C).

Approved for public release; distribution is unlimited.

HEADQUARTERS, DEPARTMENT OF THE ARMY

OCTOBER 2005

CHANGE
NO. 1

HEADQUARTERS
DEPARTMENT OF THE ARMY,
Washington, D.C., 1 OCTOBER 2006

**TECHNICAL BULLETIN
INSTALLATION INSTRUCTIONS**

FOR SYSTEMS

**SINGLE CHANNEL GROUND AND
AIRBORNE RADIO SYSTEM (SINCGARS)
AN/VRC-88F, AN/VRC-89F, AN/VRC-90F, AN/VRC-91F,
AN/VRC-92F**

**FORCE XXI BATTLE COMMAND, BRIGADE-AND-BELOW (FBCB2)
AN/UYK-128 (V)4**

**PRECISION LIGHTWEIGHT GPS RECEIVER (PLGR)
AN/PSN-11**

**ENHANCED POSITION LOCATION REPORTING SYSTEM (EPLRS)
AN/VSQ-2 (V)**

**VEHICULAR INTERCOMMUNICATION SET (VIS)
AN/VIC-3 (V)20**

FOR VEHICLE

**TRUCK, UTILITY: UP-ARMORED CARRIER, 4X4,
M1114 (2320-01-413-3739) (EIC: B6C).**

TB 9-2320-387-35-1, 17 October 2005, is changed as follows:

1. Remove old pages and insert new pages as indicated below.
2. New or changed material is indicated by a vertical bar in the margin of the page.

Remove pages

A /(B blank)
i through iii/(iv blank)
4-1 through 4-6
5-15 through 5-26
5-47 through 5-50
5-53 through 5-56
DA Form 2028

Insert page

A /(B blank)
i through iii/(iv blank)
4-1 through 4-6
5-15 through 5-26
5-47 through 5-50
5-53 through 5-56
DA Form 2028

3. File this change sheet in front of the publication for reference purposes.

By Order of the Secretary of the Army:

PETER J. SCHOOMAKER
General, United States Army
Chief of Staff

Official:

A handwritten signature in black ink that reads "Joyce E. Morrow". The signature is written in a cursive style with a large, stylized initial "J".

JOYCE E. MORROW
Administrative Assistant to the
Secretary of the Army
0620105

Distribution:

To be distributed in accordance with the Initial Distribution Number (IDN) 344826 requirements for TB 9-2320-387-35-1.

LIST OF EFFECTIVE PAGES

NOTE

A vertical line in the outer margins of the page indicates the portion of text affected by the change.

Dates of issue for original and change pages are:

Original0 17 October 2005

Change11 October 2006

TOTAL NUMBER OF PAGES IN THIS PUBLICATION IS 87 PAGES.

Page No.	*Change No.
A/(B blank)1
i1
ii0
iii/(iv blank)1
1-1 – 4-10
4-2-4-61
5-1-5-140
5-15-5-241
5-24.1-5-24.2 Added1
5-251
5-26-5-470
5-481
5-48.1-5-48.4 Added1
5-491
5-50-5-520
5-53-5-561

*Zero in this column indicates original page.

TECHNICAL BULLETIN
NO. 9-2320-387-35-1

HEADQUARTERS,
DEPARTMENT OF THE ARMY
WASHINGTON, D.C., 17 OCTOBER 2005

TECHNICAL BULLETIN INSTALLATION INSTRUCTIONS

FOR SYSTEMS

SINGLE CHANNEL GROUND AND AIRBORNE RADIO SYSTEM (SINGARS)

AN/VRC-88F, AN/VRC-89F, AN/VRC-90F,
AN/VRC-91F, AN/VRC-92F

FORCE XXI BATTLE COMMAND, BRIGADE-AND-BELOW (FBCB2)

AN/UYK-128 (V)4

PRECISION LIGHTWEIGHT GPS RECEIVER (PLGR)

AN/PSN-11

ENHANCED POSITION LOCATION REPORTING SYSTEM (EPLRS)

AN/VSQ-2 (V)

VEHICULAR INTERCOMMUNICATION SET (VIS)

AN/VIC-3 (V)20

FOR VEHICLE

TRUCK, UTILITY: UP-ARMORED CARRIER, 4X4,

M1114 (2320-01-413-3739) (EIC: B6C).

REPORTING ERRORS AND RECOMMENDING IMPROVEMENTS

You can help improve this publication. If you find any mistakes or if you know of a way to improve the procedures, please let us know. Submit your DA Form 2028 (Recommended Changes to Equipment Technical Publications), through the Internet, on the Army Electronic Product Support (AEPS) website. The Internet address is <https://aeprs.ria.army.mil>. The DA Form 2028 is located under the Public Applications section in the AEPS Public Home Page. Fill out the form and click on SUBMIT. Using this form on the AEPS will enable us to respond quicker to your comments and better manage the DA Form 2028 program. You may also mail, fax or E-mail your letter or DA Form 2028 direct to: AMSTA-LC-LPIT / TECH PUBS, TACOM-RI, 1 Rock Island Arsenal, Rock Island, IL 61299-7630. The email address is TACOM-TECH-PUBS@ria.army.mil. The fax number is DSN 793-0726 or Commercial (309) 782-0726.

Approved for public release; distribution is unlimited.

TABLE OF CONTENTS

	Page
LIST OF TABLES	iv
CHAPTER 1. INTRODUCTION	1-1
Section I. Scope	1-1
Section II. Notes	1-1
Section III. General Information	1-1
Section IV. Maintenance Forms, Records, and Reports	1-1
Section V. Consolidated Index of Army Publications	1-1
CHAPTER 2. PURPOSE OF INSTALLATION	2-1
CHAPTER 3. COMPLETION TIME FOR INSTALLATION	3-1
CHAPTER 4. PREPARATION FOR INSTALLATION	4-1
Section I. Preparation of Vehicle	4-1
Section II. Items to be Removed	4-1
Section III. List of Items to be Retained	4-1
Section IV. Preparation of C4ISR Equipment	4-1
Section V. Precautions During Handling	4-1
Section VI. Unpack and Inspect Equipment	4-1
Section VII. Inventory C4ISR Equipment	4-1
Section VIII. Examine Each Item for Damage	4-1
Section IX. C4ISR Equipment, Distribution, and Consumables	4-2
Section X. Distribution and Issue Instructions	4-2
Section XI. Parts List	4-2
CHAPTER 5. INSTALLATION PROCEDURES	5-1
Section I. Scope	5-1
Section II. Installation of Terminal Boards	5-1
Section III. Cab Enclosure Panel, Terminal Board, and Cover Modification	5-1
Section IV. B-Beam Preparation	5-5
Section V. Assembly of Cab Enclosure Panel	5-6
Section VI. Final Assembly, Terminal Board Wiring, and Terminal Link	5-8
Section VII. Integrated Rack Installation	5-13
Section VIII. SINGARS Mounting Tray, Amp Guard, and FBCB2 Components Installation	5-19
Section IX. EPLRS Mounting Installation	5-26
Section X. EPLRS Antenna Installation	5-28
Section XI. EPLRS User Readout (URO) Installation	5-29
Section XII. SINGARS Antenna Installation	5-30

TABLE OF CONTENTS (Contd)

		Page
Section XIII.	Cables Installation	5-33
Section XIV.	VIC-3 Mounting Installation: Rear FFCS/L and Cables	5-48.1
Section XV.	PLGR Bracket Installation	5-50
Section XVI.	PLGR Power Cable Installation	5-53
Section XVII.	PLGR Antenna and Cable Installation	5-54

LIST OF TABLES

Table	Title	Page
4-1.	Kits Parts List for Installation of C4ISR Equipment	4-3
4-2.	Non-Kit Parts List for Installation of C4ISR Equipment	4-4

CHAPTER 1

INTRODUCTION

Section I. SCOPE

- 1-1.** This technical bulletin provides installation instructions for Command, Control, Communications, Computers, Intelligence, Surveillance, and Reconnaissance (C4ISR) equipment. The C4ISR equipment shall be installed in the following vehicles:
- Truck, Utility: Up-Armored Carrier, 4x4, M1114
- 1-2.** The information contained in this technical bulletin is the official authorization to perform the installation of the C4ISR equipment at the direct support maintenance level through contract maintenance teams.

Section II. NOTES

- 2-1.** This technical bulletin is not an authorization for requisition or turn-in of vehicles.
- 2-2.** This technical bulletin does not establish quantity or types of vehicles assigned to using units.

Section III. GENERAL INFORMATION

- 3-1.** Included in the C4ISR equipment are:
- a. Single Channel Ground and Airborne Radio System (SINCGARS), Radio Set AN/VRC-88F/89F/90F/91F/92F Series
 - b. Force XXI Battle Command, Brigade-and-Below (FBCB2), AN/UYK-128 (V)4
 - c. Precision Lightweight GPS Receiver (PLGR), AN/PSN-11
 - d. Enhanced Position Location Reporting System (EPLRS), AN/VSQ-2 (V)
 - e. Vehicular Intercommunication Set (VIS), AN/VIC-3 (V)20
 - f. Additional terminal boards
- 3-2.** The C4ISR equipment becomes operable when all the components are installed in the vehicle and correct power is supplied.

Section IV. MAINTENANCE FORMS, RECORDS, AND REPORTS

Use the following to report any discrepancies:

- a. Reports of Maintenance and Unsatisfactory Equipment. See chapter 4, sections VI through VIII for information.
- b. Report of Packaging and Handling Deficiencies. See chapter 4, sections VI through VIII for information.
- c. Discrepancy in Transportation Deficiency Report (TDR) (SF361). See chapter 4, sections VI through VIII for information.

Section V. CONSOLIDATED INDEX OF ARMY PUBLICATIONS

Refer to the latest issue of DA PAM 25-30 to determine whether there are new changes or additional publications pertaining to the C4ISR equipment.

CHAPTER 2

PURPOSE OF INSTALLATION

The purpose of installing the C4ISR equipment is to provide the primary means of integrating command and control capability.

CHAPTER 3

COMPLETION TIME FOR INSTALLATION

A total of 20 man hours are required for two personnel to install the C4ISR equipment. Typical vehicle downtime is 12 hours.

CHAPTER 4 PREPARATION FOR INSTALLATION

Section I. PREPARATION OF VEHICLE

To prepare the vehicle for installation, ensure that the site includes adequate lighting and a power source when drilling is required. Inspect the vehicle for damage that could affect installation. Have any such damage repaired before installing the C4ISR equipment.

Section II. ITEMS TO BE REMOVED

- 2-1. Remove batteries. (Refer to TM 9-2320-387-24.)
- 2-2. Remove right-hand rear fixed door if desired. (Refer to TM 9-2320-387-24.)
- 2-3. Remove right-hand rear cab enclosure panel. (Refer to TM 9-2320-387-24.)
- 2-4. Remove standard rack.
- 2-5. Remove right rear ammo storage tray.

Section III. LIST OF ITEMS TO BE RETAINED

- 3-1. Batteries
- 3-2. Right-hand rear cab enclosure (if applicable).
- 3-3. Right-hand rear fixed door (if applicable).

Section IV. PREPARATION OF C4ISR EQUIPMENT

To prepare C4ISR equipment, unpack, inspect, and check inventory.

Section V. PRECAUTIONS DURING HANDLING

Observe the following precautions to prevent equipment damage.

- a. Keep dust covers in place on connectors.
- b. Do not disassemble or modify parts in the C4ISR equipment unless authorized to do so.
- c. Keep mounting hardware covered and protected until needed.

Section VI. UNPACK AND INSPECT EQUIPMENT

- 6-1. Unpack and inspect packaging for evidence of damage.
- 6-2. Any shipping damage should be reported on SF364 Report of Discrepancy (ROD) as prescribed in AR 735-11-2/DLAR 4140.55/NAVMATINST 4355.73A/AFR 400-64/MCO 4430.F.

Section VII. INVENTORY C4ISR EQUIPMENT

If any item is missing, fill out and forward Transportation Deficiency Report (TDR) (SF361) as described in AR 55-38/NAVSUPINST 4610.33C/AFR 75-18/MCO P4610.19D/DLAR 450015.

Section VIII. EXAMINE EACH ITEM FOR DAMAGE

If any item is damaged, fill out and forward SF364 Report of Discrepancy (ROD) as prescribed in AR 735-11-2/DLAR 4140.55/NAVMATINST 4355.73A/AFR 400-64/MCO 4430.F. All damages should be reported as prescribed by DA PAM 738-750, as contained in the Maintenance Management Update.

Section IX. C4ISR EQUIPMENT, DISTRIBUTION, AND CONSUMABLES

- 9-1.** Use table 4-1 to identify and inventory C4ISR equipment installation parts supplied in kits.
- 9-2.** Use table 4-2 to identify and inventory C4ISR equipment installation parts not supplied in kits.

Section X. DISTRIBUTION AND ISSUE INSTRUCTIONS

- 10-1.** U.S. Forces: Do not requisition C4ISR equipment. They will be shipped automatically.
- 10-2.** U.S. Army Depots: Requisition C4ISR equipment through supply channels.
- 10-3.** Multiservice: Instructions shall be included for multiservice modifications.
- 10-4.** MAP/MAS countries: Instructions shall be provided for MAP/MAS countries.

Section XI. PARTS LIST

KITS REQUIRED FOR THIS INSTALLATION:

NOTE

- Not all material in kits is required for this installation. Material not used during installation will be returned to stock for disposition in accordance with AR 725-50.
- If maintenance is to be performed on a vehicle with an existing kit, do not order entire kit for necessary reinstallation.

SINGARS:

(A): MK-2801

PLGR:

(B): 57K4399

EPLRS:

(C): No kits available

FBCB2:

(D): No kits available

VIS:

(E): No kits available

MATERIAL REQUIRED FROM KITS:*Table 4-1. Kit Parts List for Installation of C4ISR Equipment.*

ITEM NO.	NOMENCLATURE	PART NUMBER	NSN	KIT	QTY.
1.	Bracket, Antenna	A3014546-1	5340-01-391-2742	(A)	1
2.	Bracket, Mounting	12480575	N/A	(B)	1
3.	Cable Assembly, Radio Frequency	A3014031-17	5995-01-225-1660	(A)	1
4.	Cable Assembly, Radio Frequency	A3014031-8	5995-01-219-7035	(A)	1
5.	Clamp, Loop	MS21333-67	5340-00-079-7837	(B)	2
6.	Clamp, Loop	MS21333-75	5340-00-050-2740	(A)	3
7.	Clamp, Loop	MS21333-77	5340-00-922-6300	(A)	2
8.	Clamp	MS21333-78	5340-00-958-8457	(B)	1
9.	Clamp, Loop	MS21333-96	5340-00-088-1255	(B)	1
10.	Gasket	A3013655-1	5330-01-205-2864	(A)	2
11.	Grommet	MS35489-31	5325-00-174-9336	(B)	1
12.	Grommet	12460299	5325-01-492-0008	(B)	1
13.	Mounting Base, Electrical Equipment	A3013367-1	5975-01-188-8873	(A)	1
14.	Nut, Lock	MS17829-3C	5310-00-689-3877	(B)	4
15.	Screw	MS35206-266	5305-00-984-6213	(B)	4
16.	Screw	MS35207-261	5305-00-990-6444	(B)	1
17.	Screw, Cap	MS35307-365	5305-00-847-1159	(A)	8
18.	Screw, Self-Tapping	9440025	5305-01-197-2320	(B)	2
19.	Terminal Lug	7728777	5940-00-983-4067	(B)	1
20.	Terminal Lug	7728780	5940-01-035-4212	(B)	1
21.	Washer, Lock	MS35338-43	5310-00-045-3296	(B)	1
22.	Washer, Lock	MS35338-44	5310-00-582-5965	(A)	20
23.	Washer, Lock	MS45904-72	5310-00-889-2527	(A)	29
24.	Washer, Lock	MS45904-76	5310-00-061-1258	(A)	8
25.	Washer, Lock	MS35338-43	5310-00-045-3296	(A)	2

MATERIAL REQUIRED BUT NOT INCLUDED IN KITS:*Table 4-2. Non-Kit Parts List for Installation of C4ISR Equipment.*

ITEM NO.	NOMENCLATURE	PART NUMBER	NSN	QTY.
1.	Antenna AS-3900/VRC	A3017889-2	5985-01-308-8988	1
2.	Antenna, AS-3499/VSQ-1	A3005031	5820-01-183-9462	1
3.	Antenna, Element (lower)	A3018230-1	5985-01-201-1498	1
4.	Antenna, Element (upper)	A3017901-2	5985-01-306-4622	1
5.	Antenna, PLGR	AT575-030	5985-01-375-4660	1
6.	Assembly, Display Lock	872843-1	N/A	1
7.	Bolt	MS35751-18	5306-00-108-9988	4
8.	Box, Stowage	889519-1	2540-01-499-0607	1
9.	Bracket, Mounting	889567-14	N/A	1
10.	Bracket, Mounting	A3046202	5340-01-237-8102	1
11.	Bracket, Support	12460300	5340-01-456-6554	1
12.	Bracket, PLGR	986-0645-001	5975-01-375-1302	1
13.	Bracket, User Readout (URO)	A3006206	5340-01-386-7841	1
14.	Cable Assembly, Antenna, EPLRS	SM-C-911480	5995-01-167-1269	1
15.	Cable Assembly, Antenna, PLGR	426-0141-050	6150-01-375-8662	1
16.	Cable Assembly, Ground	12480567-1	N/A	1
17.	Cable Assembly, Power	12480567-2	N/A	1
18.	Cable Assembly, Power, EPLRS	A3004939	5995-01-198-0538	1
19.	Cable Assembly, Power, PLGR	9728558-10	6150-01-375-8661	1
20.	Cable Assembly, INC-EPUU	A3279383-3	5995-01-453-9171	1
21.	Clamp, Loop	MS21333-69	5340-00-764-7051	1
22.	Clamp, Loop	MS21333-104	5340-00-088-1254	1
23.	Cable, W1	866003-3	5995-01-478-4908	1
24.	Cable, W2	881327-1	5995-01-478-4876	1
25.	Cable, W3N	881336-1	5995-01-478-4913	1
26.	Cable, W3P	881335-1	5995-01-478-4891	1
27.	Cover, Fuse	1209-9272	N/A	4
28.	CPU (Central Processing Unit)	881292-1	7021-01-474-3793	1
29.	Decal	12339060	7690-01-265-1135	1
30.	Decal	861868-2	N/A	1
31.	Device, Serial Interface Adapter	881331-1	4920-01-478-3722	1
32.	Display	881293-1	7025-01-475-0229	1
33.	Footrest Weldment	889567-21	N/A	1
34.	Grommet, Nonmetallic	MS21266-1N	5325-00-960-2410	A/R
35.	Grommet, Nonmetallic	12338098	5325-01-308-5424	1
36.	Grommet, Nonmetallic	2400	5325-01-289-7859	1
37.	Grommet, Nonmetallic	MS35498-149	N/A	1
38.	Guard, Amp	872842-1	5935-01-487-2172	1
39.	Insert	12446871-2	5310-01-411-3422	2
40.	Insert	ALS4-616-150	5325-01-483-7480	3

MATERIAL REQUIRED BUT NOT INCLUDED IN KITS (Contd):*Table 4-2. Non-Kit Parts List for Installation of C4ISR Equipment (Contd).*

ITEM NO.	NOMENCLATURE	PART NUMBER	NSN	QTY.
41.	Insert	12446871-11	5325-01-505-3122	1
42.	Insert	12446871-1	5310-01-413-3276	4
43.	Interface Unit, FFCS	A3206624	5895-01-469-6120	2
44.	Isolation Kit, CPU	872826-2	5340-01-481-5741	1
45.	Isolation Kit, Display	872870-1	5340-01-481-5757	1
46.	Lanyard	8925T5-7X19	4010-01-497-2675	1
47.	Left Rail Weldment	889567-12	N/A	1
48.	Master Control Station	A3206623	5895-01-469-3352	1
49.	Mount, Ramball	RAM-D-111U	5975-01-485-3615	1
50.	Mount, Resilient	MT-6146/VSQ-1	5340-01-167-8297	1
51.	Nut	MS35649-2252	5310-00-997-1888	4
52.	Nut	13218E0320-293	5310-00-913-8881	4
53.	Nut	9418931	5310-01-187-7610	4
54.	Nut	9418892	5310-01-157-9819	7
55.	Nut	9417954	5310-00-931-8167	7
56.	Nut	MS35649-63	5310-00-804-3859	5
57.	Nut	271169	5310-00-124-9265	5
58.	Nut, Lock	271175	5310-01-333-5245	6
59.	Nut, Lock	MS51943-31		4
60.	Panel, Enclosure	12447141	2510-01-413-5993	1
61.	Right Rail Weldment	889567-22	N/A	1
62.	Rivet, Blind	12339355-1	5320-01-271-6357	2
63.	Rod	889567-16	N/A	1
64.	Screw, Cap	B1821BH025C075N	5305-00-068-0508	2
65.	Screw, Cap	B1821BH031F100N	5305-00-051-4076	2
66.	Screw, Cap	B1821BH031F125N	5305-00-051-4078	6
67.	Screw, Cap	B1821AH025C150N		3
68.	Screw, Cap	B1821AH025C100N	5305-01-389-7984	6
69.	Screw, Cap	B1821AH025C063N	5305-01-457-8854	1
70.	Screw, Cap	B1821BH025C088N	5305-00-071-2505	6
71.	Screw, Cap	B1821BH031C075N		4
72.	Screw, Cap	B1821BH031C100N	5306-00-226-4827	4
73.	Screw, Cap	B1821BH031C150N		2
74.	Screw, Cap	B1821AH025C075N	5305-01-389-8000	3
75.	Screw, Machine	MS35206-230	5305-00-889-3000	5
76.	Screw, Machine	MS35190-287	5305-00-954-4295	2
77.	Screw, Machine	MS35190-291	5305-00-958-5247	2
78.	Screw, Machine	MS35207-263	5305-00-989-7434	2
79.	Screw, Self-Tapping	9421073	5305-01-162-8512	5
80.	Screw, Self-Tapping	9426635	N/A	4

MATERIAL REQUIRED BUT NOT INCLUDED IN KITS (Contd):

Table 4-2. Non-Kit Parts List for Installation of C4ISR Equipment (Contd).

ITEM NO.	NOMENCLATURE	PART NUMBER	NSN	QTY.
81.	Screw, Self-Tapping	12342499-2	5305-01-264-5809	11
82.	Spacer	92510A318	N/A	4
83.	Spacer	10705AL315C	5365-01-487-3145	4
84.	Spacer	5579297	5365-01-194-0761	3
85.	Strap, Tiedown	MS3367-1-0	5975-00-984-6582	2
86.	Support Rack	889509-22	N/A	1
87.	Terminal Board	12480570	N/A	1
88.	Terminal Board	MS27212-3-8	5940-00-950-7782	1
89.	Terminal Board Cover	12480569-1	N/A	1
90.	Terminal Board Cover	12480569-2	N/A	1
91.	Terminal Board Cover	MS18029-3S-2	5940-01-280-9304	2
92.	Terminal Link	MS25266-6N-2	6150-01-167-9267	1
93.	Terminal Lug	MS20659-108	5940-00-115-2674	1
94.	Terminal Lug	MS20659-141	5940-00-113-9825	4
95.	Tubing, Shrink	MS23053/4-302-0	5970-01-161-6796	A/R
96.	Washer	12338095	5310-01-208-7576	3
97.	Washer	MS51412-23	5310-01-333-0060	2
98.	Washer	MS27183-10	5310-00-809-4058	10
99.	Washer	2436161	5310-01-102-3270	9
100.	Washer	MS27183-47	5310-01-312-4959	2
101.	Washer	2436162	5310-01-119-1024	8
102.	Washer	2436164	5310-01-278-9555	6
103.	Washer, Lock	MS35338-45	5310-00-407-9566	6
104.	Washer, Lock	MS35338-48	5310-00-584-5272	3
105.	Washer, Lock	MS35338-41	5310-00-045-4007	5
106.	Wingnut	MS51553-420	5310-01-384-2546	4
107.	Wire Assembly, Fuse (12V)	12480568-2	N/A	1
108.	Wire Assembly, Fuse (24V)	12480568-1	N/A	3
109.	Wire, Braided	AA59569F30T0375	6145-00-191-8402	A/R
110.	Wire, Lock	MS20995C32	9505-00-293-4208	A/R

CHAPTER 5 INSTALLATION PROCEDURES

Section I. SCOPE

This chapter provides instructions for installation of the following C4ISR equipment:

- Single Channel Ground and Airborne Radio System (SINCGARS)
- Precision Lightweight Global Positioning System Receiver (PLGR)
- Enhanced Position Location Reporting System (EPLRS)
- Vehicular Intercommunications Set (VIS)
- Force XXI Battle Command, Brigade-and-Below (FBCB2)
- Additional terminal boards in the vehicle

Perform the steps in this chapter when installing SINCGARS, PLGR, EPLRS, VIS, FBCB2, and additional terminal boards. When installing C4ISR equipment, be sure to read and follow instructions and illustrations carefully.

Section II. INSTALLATION OF TERMINAL BOARDS

Use the following procedure to install additional terminal boards to provide adequate power connections. Vehicles must have dual-voltage alternators installed in order to have both 12V and 24V terminal boards installed.

Section III. CAB ENCLOSURE PANEL, TERMINAL BOARD, AND COVER MODIFICATION

NOTE

- Late model M1114 vehicles come with cab enclosure panel and 24V terminal board. For early model M1114 vehicles, perform sections three through six. For late model M1114 vehicles begin, at section seven.
- For vehicles without cab enclosure panel, begin with step 3-1.
- For vehicles with cab enclosure panel, begin with step 3-3.
- All dimensions are in inches.

- 3-1.** Place enclosure panel (3) in position. Locate, mark, and drill five 0.159-in. diameter holes marked A and B in B-beam (1) and battery box (2).
- 3-2.** Enlarge two lower mounting holes marked A to 0.390-in. diameter, and install two inserts (4) in battery box (2).

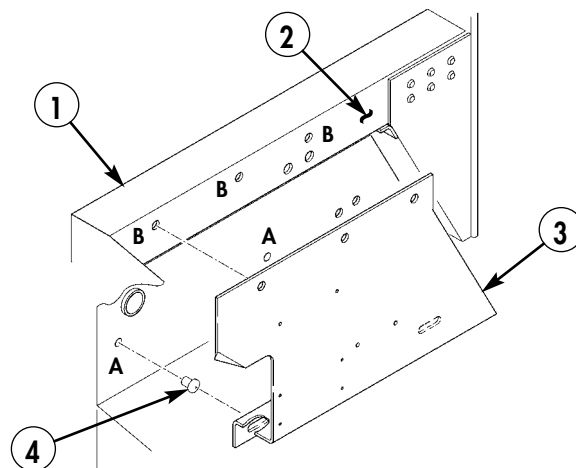

- 3. ENCLOSURE PANEL – 12447141 – QTY. 1**
- 4. INSERT – 12446871-2 – QTY. 2**

Figure 5-1.

NOTE

Do not install cab enclosure panel.

- 3-3. Locate, mark, and drill three 0.156-in. diameter holes marked A in cab enclosure panel (1).
- 3-4. Locate, mark, and drill two 0.196-in. diameter holes marked B in cab enclosure panel (1).
- 3-5. Locate, mark, and drill two 0.281-in. diameter holes marked C in cab enclosure panel (1).

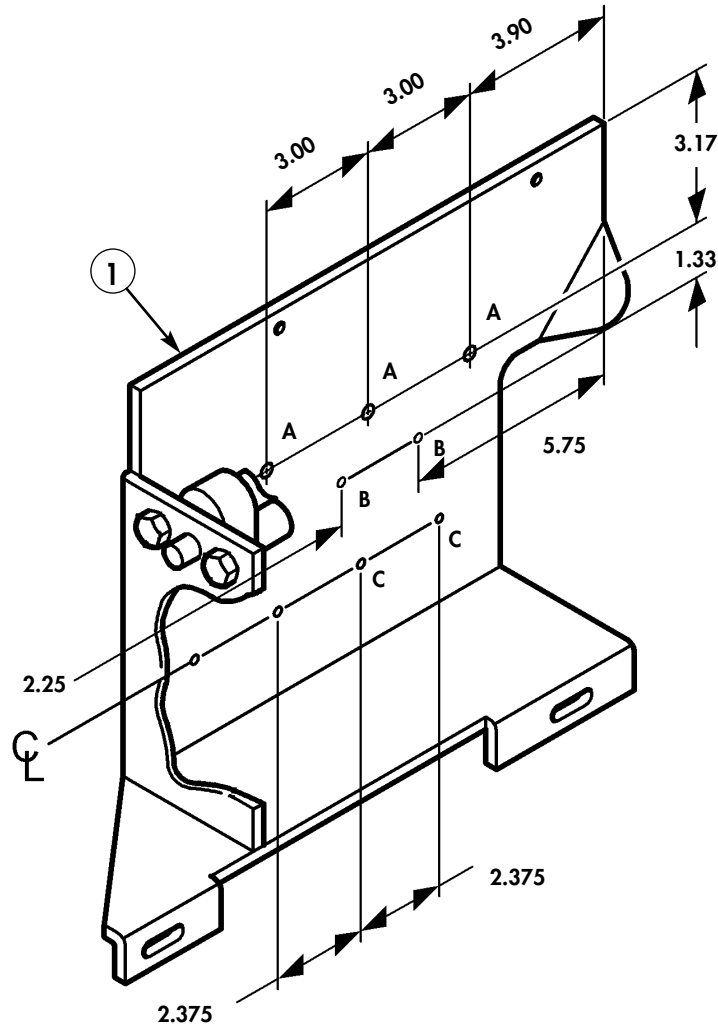

Figure 5-2.

NOTE

Perform steps 3-6 through 3-8 only if supplemental heater is installed.

- 3-6. Locate, mark, and cut corner of cab enclosure panel (1).
- 3-7. Locate, mark, and drill 0.154-in. diameter hole (5) in cab enclosure panel (1).

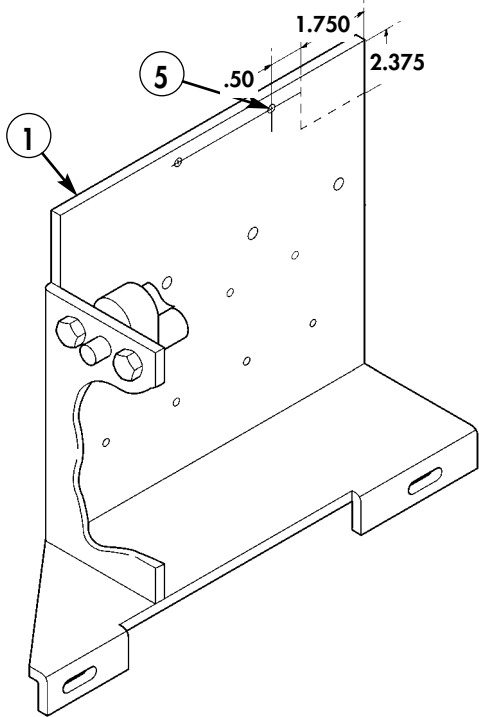
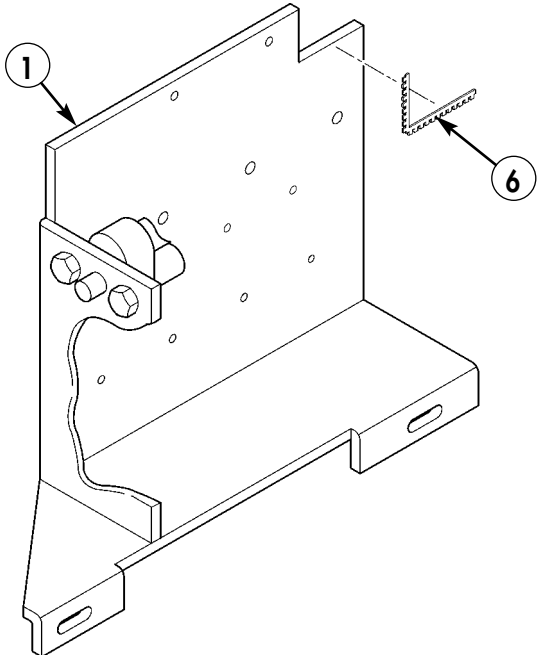

Figure 5-3.

- 3-8. Install grommet material (6) on cab enclosure panel (1) with RTV compound.



6. GROMMET MATERIAL – MS21266-1N – QTY. A/R

Figure 5-4.

CAUTION

Do not cut raised sections of terminal board. Terminal board is not usable if cut on raised section.

- 3-9. Measure and cut terminal board (6) in two places (7). Remove burrs and sharp edges.
- 3-10. Install five nut sleeves (10) in terminal board covers (8), (9), and (11), and secure with five snaprings (12).

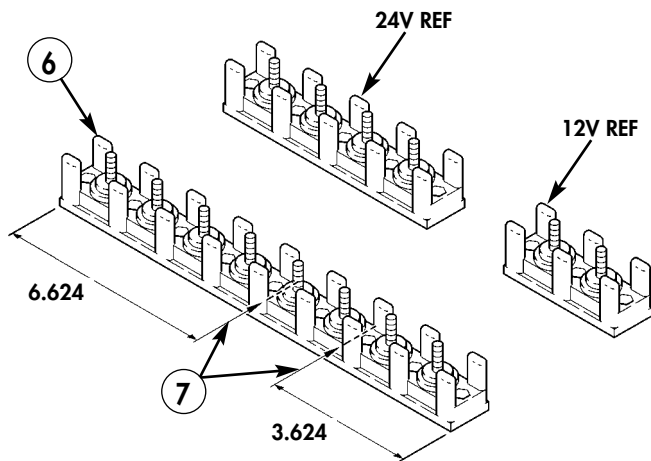

Figure 5-5.

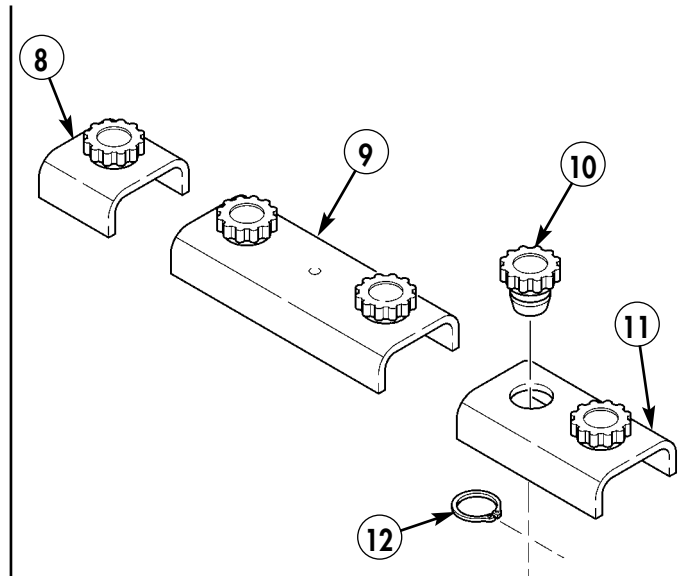
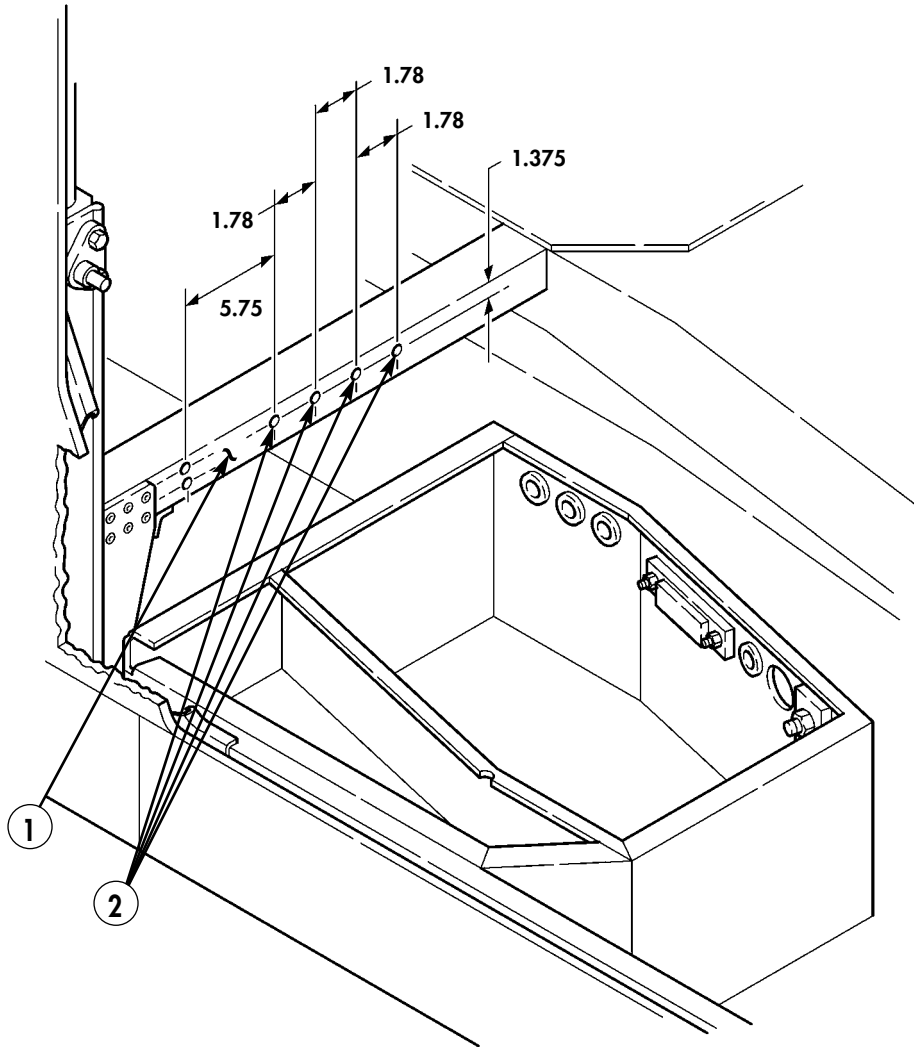

Figure 5-6.

- 6. TERMINAL BOARD – MS27212-3-8 – QTY. 1
- 8. TERMINAL BOARD COVER – 12480569-1 – QTY. 1
- 9. TERMINAL BOARD COVER – 12480569-2 – QTY. 1
- 11. TERMINAL BOARD COVER – MS18029-3S-2 – QTY. 1

Section IV. B-BEAM PREPARATION

Locate, mark, and drill four 0.159-in. diameter holes (2) in B-beam (1).



- 1. FUSE COVER – 1209-9272 – QTY. 3 OR 4
- 2. SELF-TAPPING SCREW – 12342499-2 – QTY. 3 OR 4

Figure 5-7.

Section V. ASSEMBLY OF CAB ENCLOSURE PANEL

NOTE

- For 12V terminal board installation on models with rifle mount bracket shown in figure 5-8, perform steps 5-1 through 5-3.
- If not installing 12V terminal board, begin with step 5-4.

- 5-1. Remove lower rifle mount bracket (1) from B-beam. (Refer to TM 9-2320-387-24.)
- 5-2. Locate, mark, and drill two 0.159-in. diameter holes marked A in lower rifle mount bracket (1), and install 12V terminal board (4) with two screws (2), lockwashers (3), and nuts (5).
- 5-3. Install lower rifle mount bracket (1) on B-beam. (Refer to TM 9-2320-387-24.)

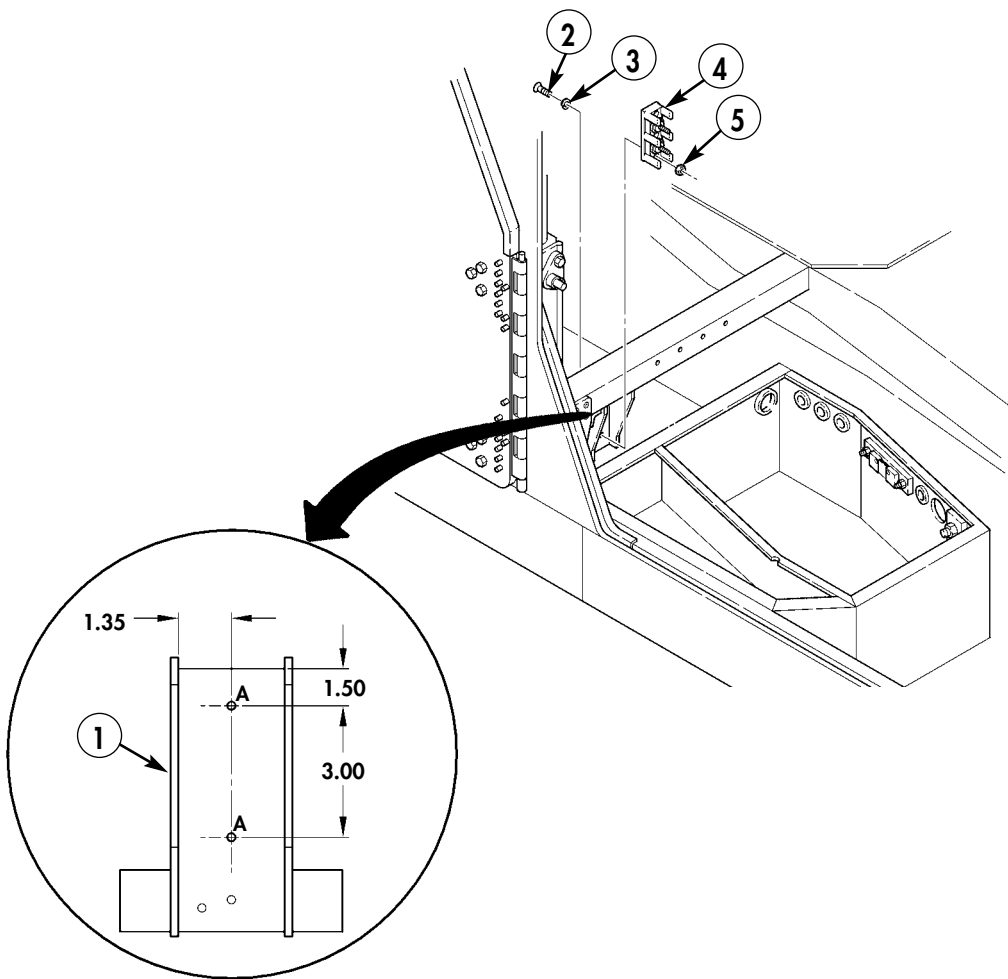

2. SCREW – MS35206-230 – QTY. 2
3. LOCKWASHER – MS35338-41 – QTY. 2
5. NUT – MS35649-63 – QTY. 2

Figure 5-8.

- 5-4. Install 24V terminal board (9) on enclosure panel (6) with three screws (2), lockwashers (3), and nuts (5).
- 5-5. Enlarge two holes marked A in terminal board (7) to 0.196 in., and secure terminal board (7) to panel (6) with two rivets (8).
- 5-6. Install three existing relays (11) in holes (12) on panel (6) with four existing screws (14), washers (13), and locknuts (10).

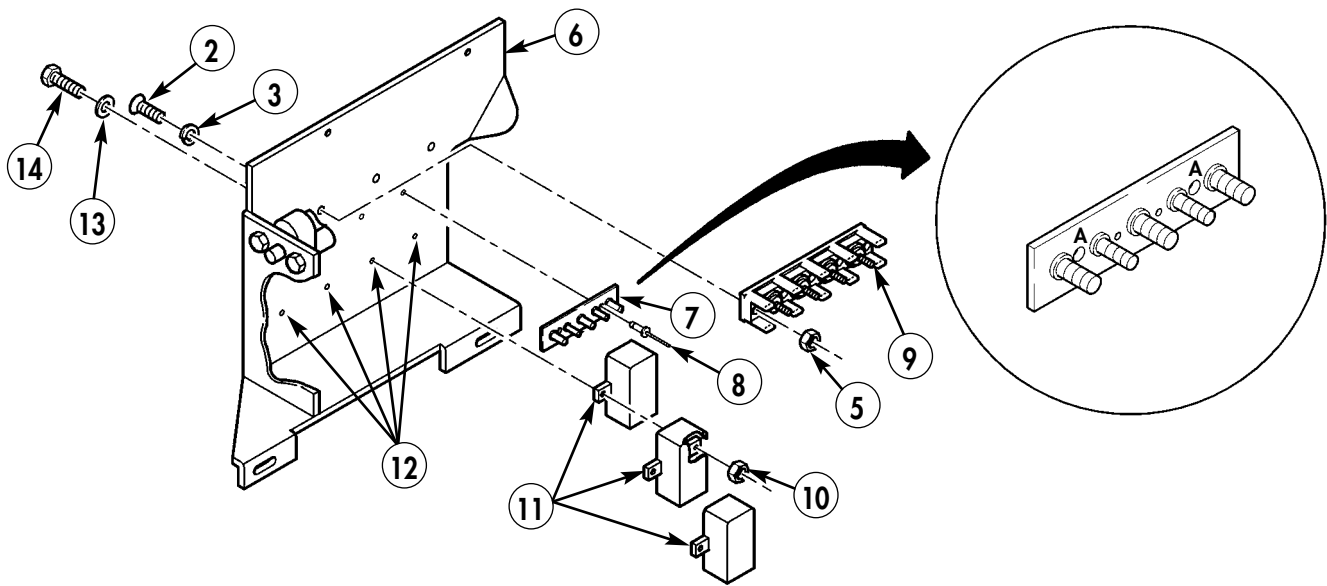

- 2. SCREW – MS35206-230 – QTY. 3
- 3. LOCKWASHER – MS35338-41 – QTY. 3
- 5. NUT – MS35649-63 – QTY. 3
- 7. TERMINAL BOARD – 12480570 – QTY. 1
- 8. BLIND RIVET – 12339355-1 – QTY. 2
- 10. LOCKNUT – MS51943-31 – QTY. 4

Figure 5-9.

Section VI. FINAL ASSEMBLY, TERMINAL BOARD WIRING, AND TERMINAL LINK

NOTE

- Refer to figure 5-10 for wiring overview.
- Perform steps 6-1 and 6-2 if hole and grommet do not exist in battery box.
- If installing 24V terminal board only, begin with step 6-6.

- 6-1.** Locate, mark, and drill 2.00-in. diameter hole (3) in upper right corner of rear wall of battery box.
- 6-2.** Install grommet (4) in hole (3).
- 6-3.** Secure terminal link (8) and fuse wire (7) to 12V terminal board (1) with two locknuts (6), and install cover (5).
- 6-4.** Route wire (2) through battery box hole (3).

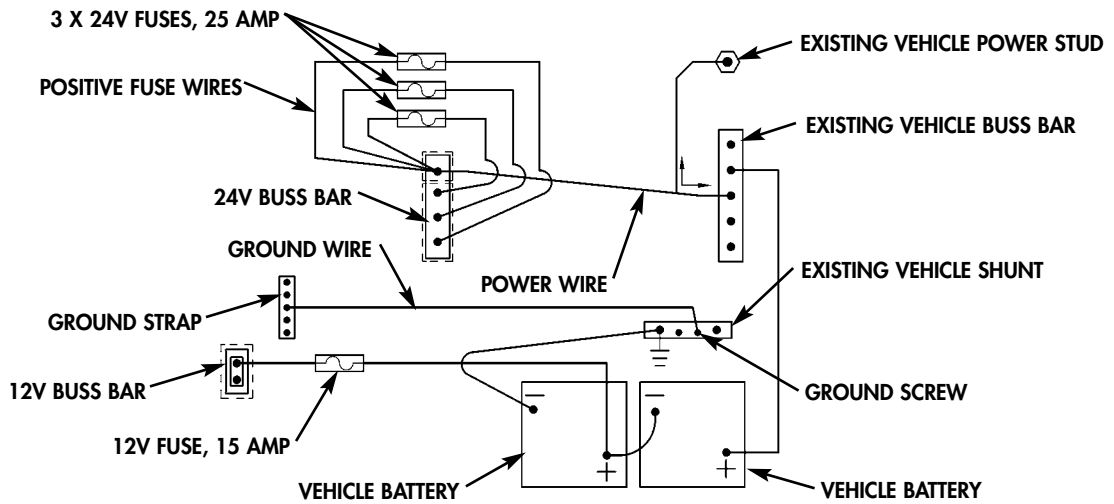

Figure 5-10.

- 4.** GROMMET - 2400 - QTY. 1
- 5.** TERMINAL BOARD COVER - MS18029-3S-2 - QTY. 1
- 6.** LOCKNUT - 271175 - QTY. 2
- 7.** FUSE WIRE ASSEMBLY (12V) - 12480568-2 - QTY. 1
- 8.** TERMINAL LINK - MS25226-6N-2 - QTY. 1

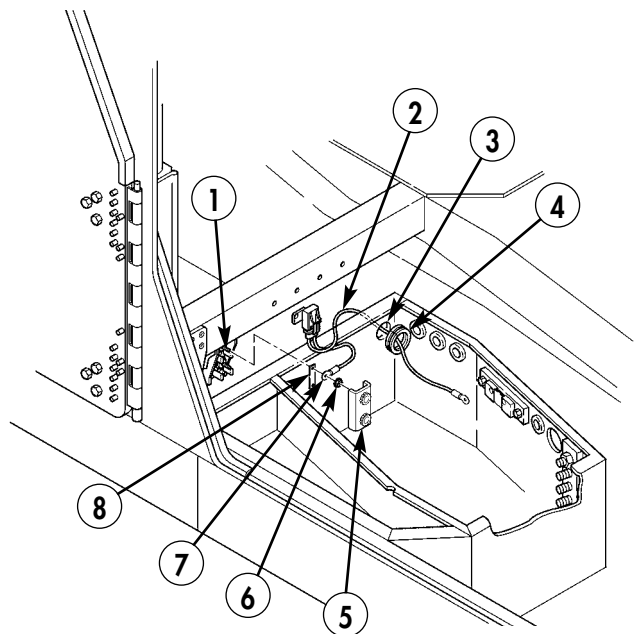

Figure 5-11.

- 6-5.** Connect wire (2) to existing positive 12V battery terminal end (10) with existing screw (9) and nut (11).

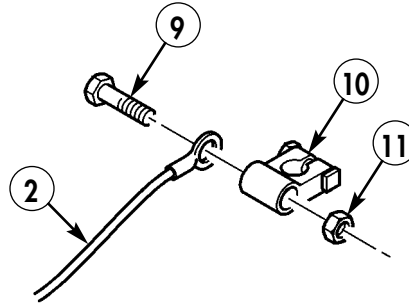
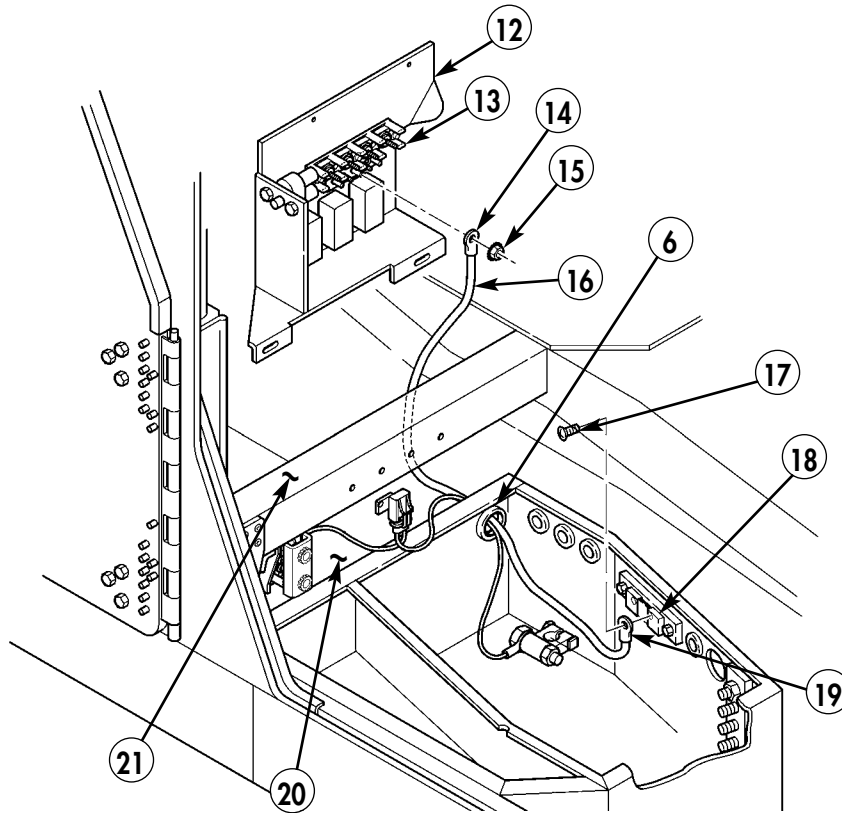

Figure 5-12.

- 6-6.** Position cab enclosure panel (12) in rear floor pan (20) and rear of B-beam (21). Do not secure cab enclosure panel (12) at this time.
- 6-7.** Route ground cable (16) through battery box hole (6).
- 6-8.** Secure terminal lug (14) on center terminal of terminal board (13) with nut (15), and secure terminal lug (19) on shunt (18) with existing screw (17).
- 6-9.** Install four additional plain-assembled nuts (15) on terminal board (13).



- 15. PLAIN-ASSEMBLED NUT – 271169 – QTY. 5**
16. GROUND CABLE ASSEMBLY – 12480567-1 – QTY. 1

Figure 5-13.

- 6-10. Route 24V power cable (27) through hole (6) and install 24V power cable terminal lug (23) on inboard stud (22) of terminal board (28). Do not secure 24V power cable terminal lug (23) at this time.
- 6-11. Secure three fuse wires (25) and 24V power cable terminal lug (23) to inboard terminal board stud (22) with locknut (26).
- 6-12. Secure three remaining fuse wires (24) to corresponding studs on 24V terminal board (28) with three locknuts (26).

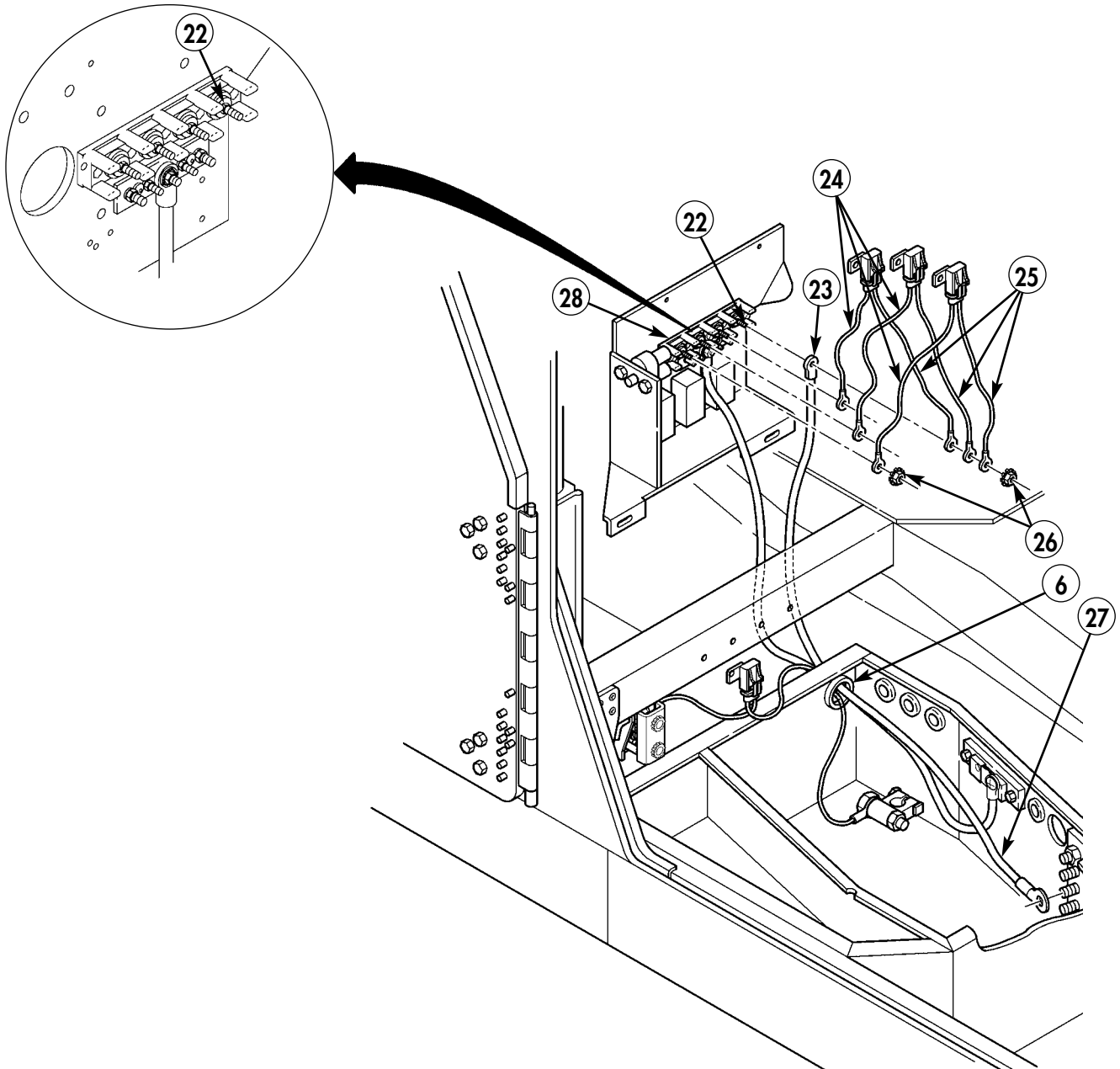

- 24. FUSE WIRE ASSEMBLY (24V) – 12480568-1 – QTY. 3
- 26. LOCKNUT – 271175 – QTY. 4
- 27. POWER CABLE ASSEMBLY – 12480567-2 – QTY. 1

Figure 5-14.

NOTE

For vehicles with new enclosure panel, begin with step 6-14.

- 6-13.** Install cab enclosure panel (12). (Refer to TM 9-2320-387-24.)
- 6-14.** Secure cab enclosure panel (12) to B-beam (21) with three self-tapping screws (29).
- 6-15.** Secure cab enclosure panel (12) to battery box (33) with two capscrews (30), lockwashers (31), and washers (32).

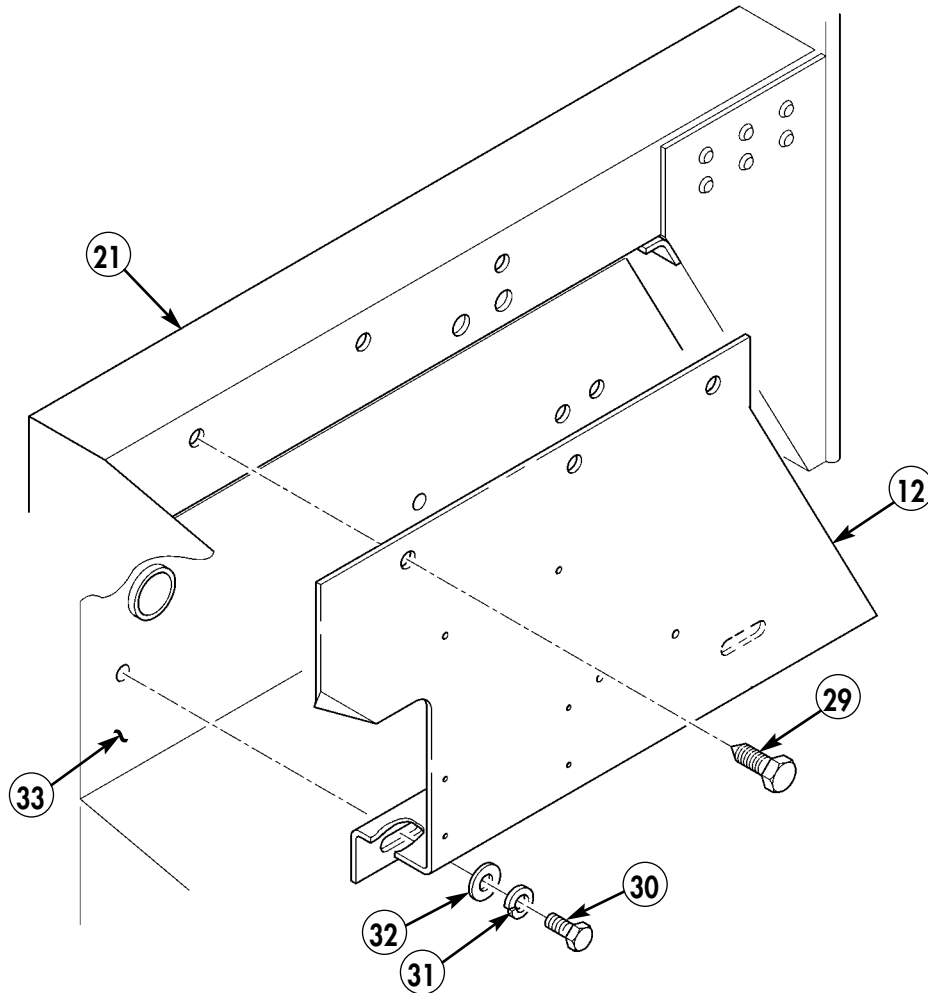

- 29. SELF-TAPPING SCREW – 12342499-2 – QTY. 3**
- 30. CAPSCREW – B1821BH025C075N – QTY. 2**
- 31. LOCKWASHER – MS35338-48 – QTY. 2**
- 32. WASHER – MS51412-23 – QTY. 2**

Figure 5-15.

- 6-16. Secure three 24V fusewire assemblies (24) and one 12V fusewire assembly (7) to B-beam (21) with four self-tapping screws (29).

NOTE

For models equipped with power stud, perform step 6-17.
Otherwise, proceed to step 6-18.

- 6-17. Secure 24V terminal board power wire terminal lug (27) to power stud (37) with lockwasher (31) and existing nut (36).
- 6-18. Secure 24V terminal board power wire terminal lug (27) to terminal board (35) with lockwasher (31) and existing nut (36).
- 6-19. Install decal (34) on B-beam (21).
- 6-20. If previously removed, install right-hand rear fixed door. (Refer to TM 9-2320-387-24.)
- 6-21. Install batteries. (Refer to TM 9-2320-387-24.)

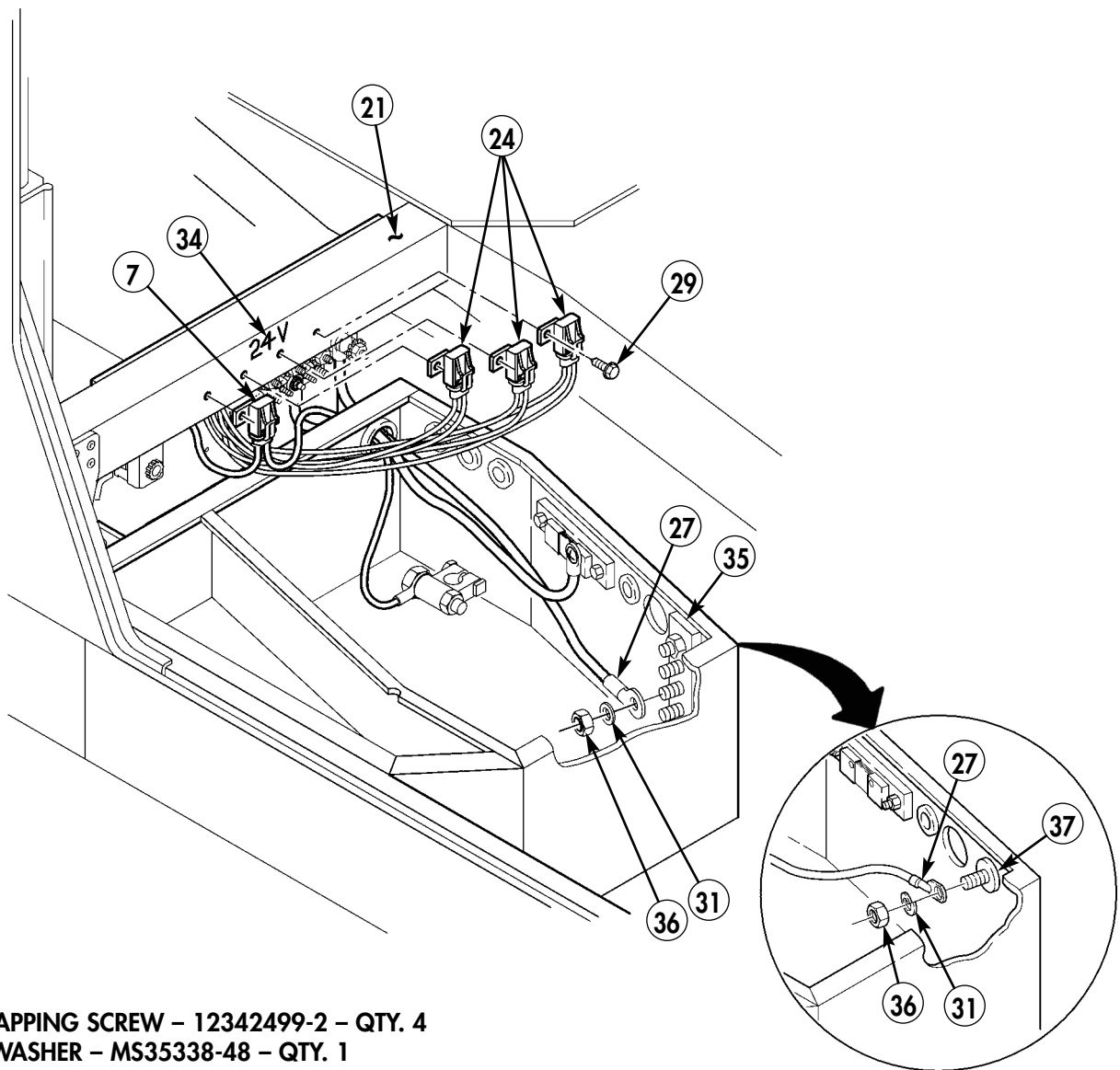

Figure 5-16.

Section VII. INTEGRATED RACK INSTALLATION

NOTE

Perform steps 7-1 and 7-2 if blast shield is installed. Perform steps 7-3 and 7-4 if blast shield is not installed.

- 7-1. Using rack support (1) as template, locate, mark, and drill three 0.375-in. diameter holes (3) in blast shield (4) and through tunnel (5).
- 7-2. Install three inserts (2) in holes (3) in blast shield (4).

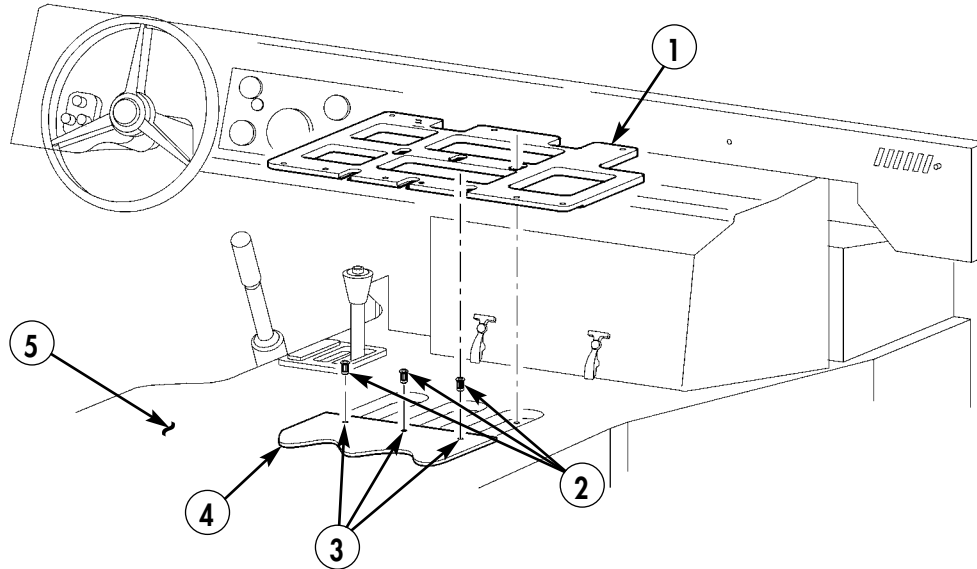

- 1. RACK SUPPORT – 889509-22 – QTY. 1
- 2. INSERT – ALS4-616-150 – QTY. 3

Figure 5-17.

- 7-3. Using rack support (1) as template, locate, mark, and drill three 0.375-in. diameter holes (3) in tunnel (5).
- 7-4. Install three inserts (2) in holes (3) in tunnel (5).

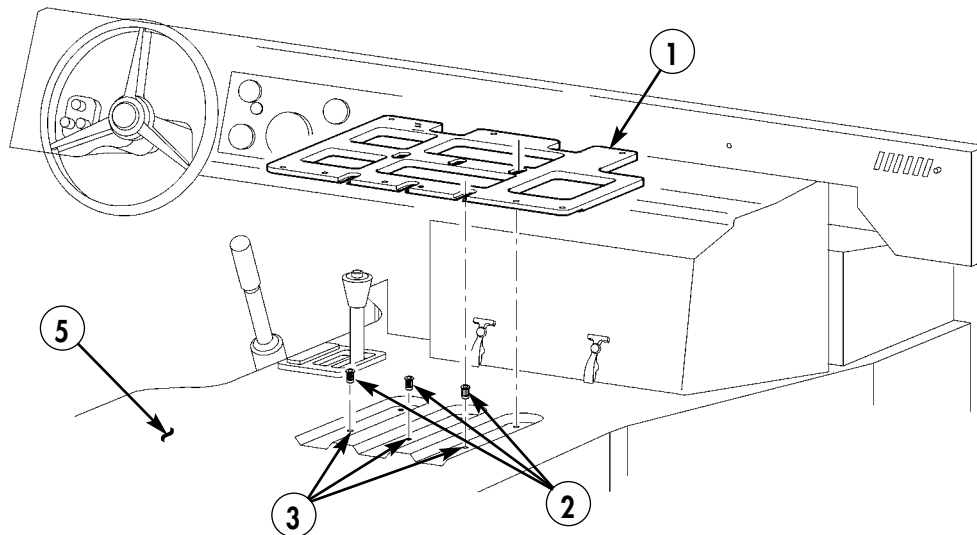
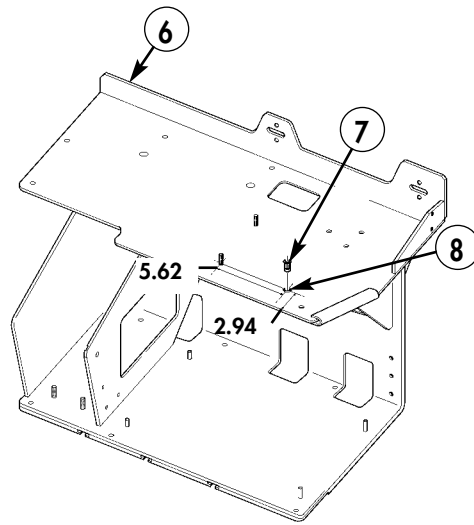

Figure 5-18.

- 7-5. Locate, mark, and drill 0.531-in. diameter hole (8) in integrated rack (6).
- 7-6. Install insert (7) in hole (8) in integrated rack (6).



8. INSERT – 12446871-11 – QTY. 1

Figure 5-19.

- 7-7. Install keyboard stowage box (9) on integrated rack (6) using four existing captive screws (10).

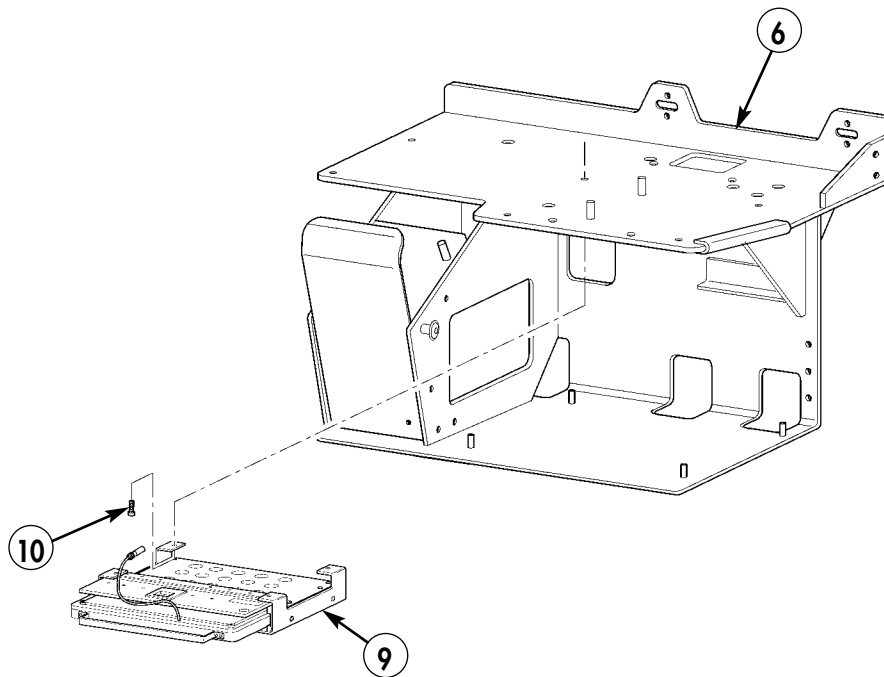

9. KEYBOARD STOWAGE BOX – 889519-1 – QTY. 1

Figure 5-20.

- 7-8. Install W3 cable (16) to Serial Interface Adapter Device (SIAD) (17).
- 7-9. Install W3N cable (14) to SIAD (17).
- 7-10. Install W3P cable (15) to SIAD (17).
- 7-11. Install SIAD (17) on integrated rack (6) using two screws (13), lockwashers (12), and washers (11).

- 11. WASHER – MS27183-47 – QTY. 2
- 12. LOCKWASHER – MS35338-43 – QTY. 2
- 13. SCREW – MS35207-263 – QTY. 2
- 14. W3N CABLE – 881336-1 – QTY. 1
- 15. W3P CABLE – 881335-1 – QTY. 1
- 16. W3 CABLE P/O – 881331-1 – QTY. 1
- 17. SIAD – 881331-1 – QTY. 1

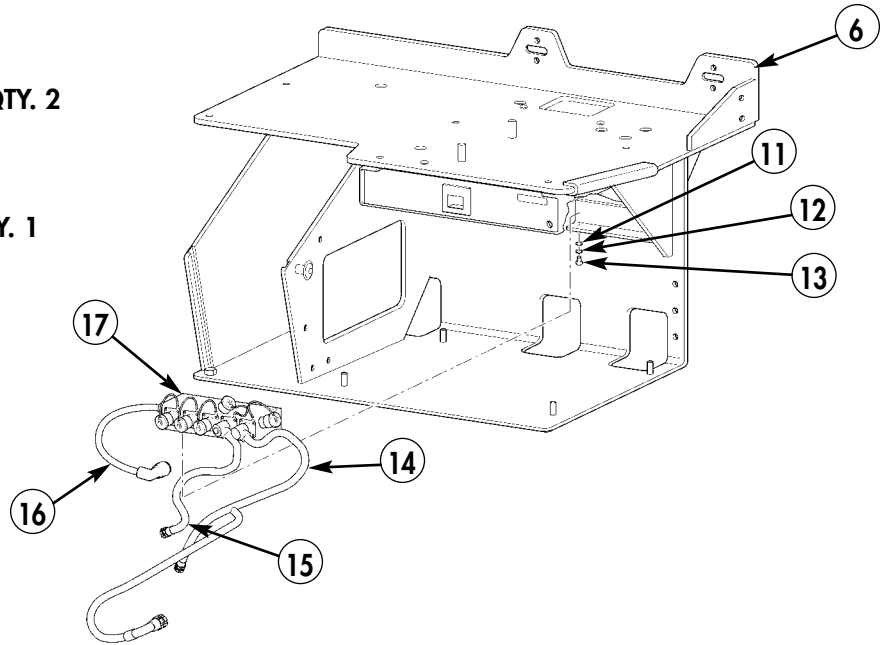

Figure 5-21.

- 7-12. Fabricate ground strap (23) from 8.00-in. length of braided wire and two terminal lugs.

NOTE

- Perform step 7-13 if blast shield is installed.
- Perform step 7-14 if blast shield is not installed.

- 7-13. Install rack support (1) on blast shield (4) and tunnel (5) with three capscrows (21), lockwashers (19), washers (20), and ground strap (23), and three existing capscrows (18), lockwashers (19), washers (20), and spacers (22). Do not tighten capscrows (21) and (18) at this time.

- 18. CAPSCREW – B1821BH025C150N – QTY. 3
- 19. LOCKWASHER – MS35338-44 – QTY. 6
- 20. WASHER – 2436161 – QTY. 6
- 21. CAPSCREW – B1821BH025C100N – QTY. 3
- 22. SPACER – 5579297 – QTY. 3
- 23. GROUND STRAP
 - BRAIDED WIRE – AA59569F30T0375 – QTY. A/R
 - TERMINAL LUG – MS20659-141 – QTY. 2

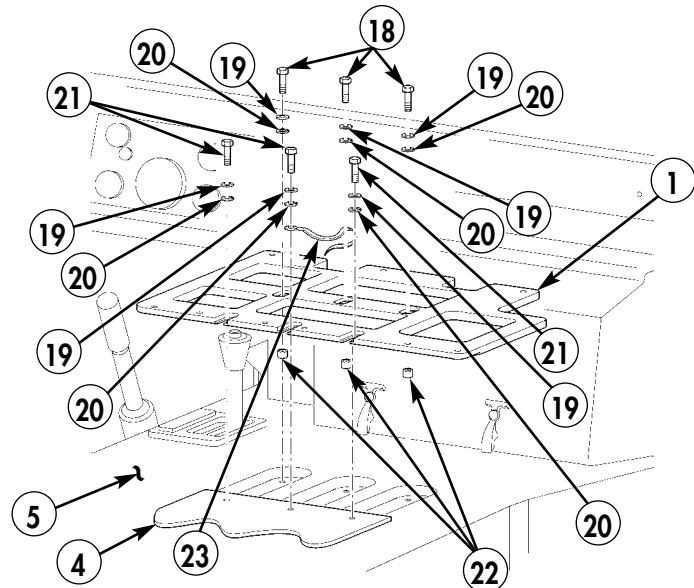

Figure 5-22.

NOTE

Blast shield may not be present in steps 7-14 through 7-22.

- 7-14. Install rack support (1) on tunnel (5) with three capscrews (21), lockwashers (19), washers (20), and ground strap (23), and three existing capscrews (18), lockwashers (19), washers (20), and spacers (22). Do not tighten capscrews (21) and (18) at this time.

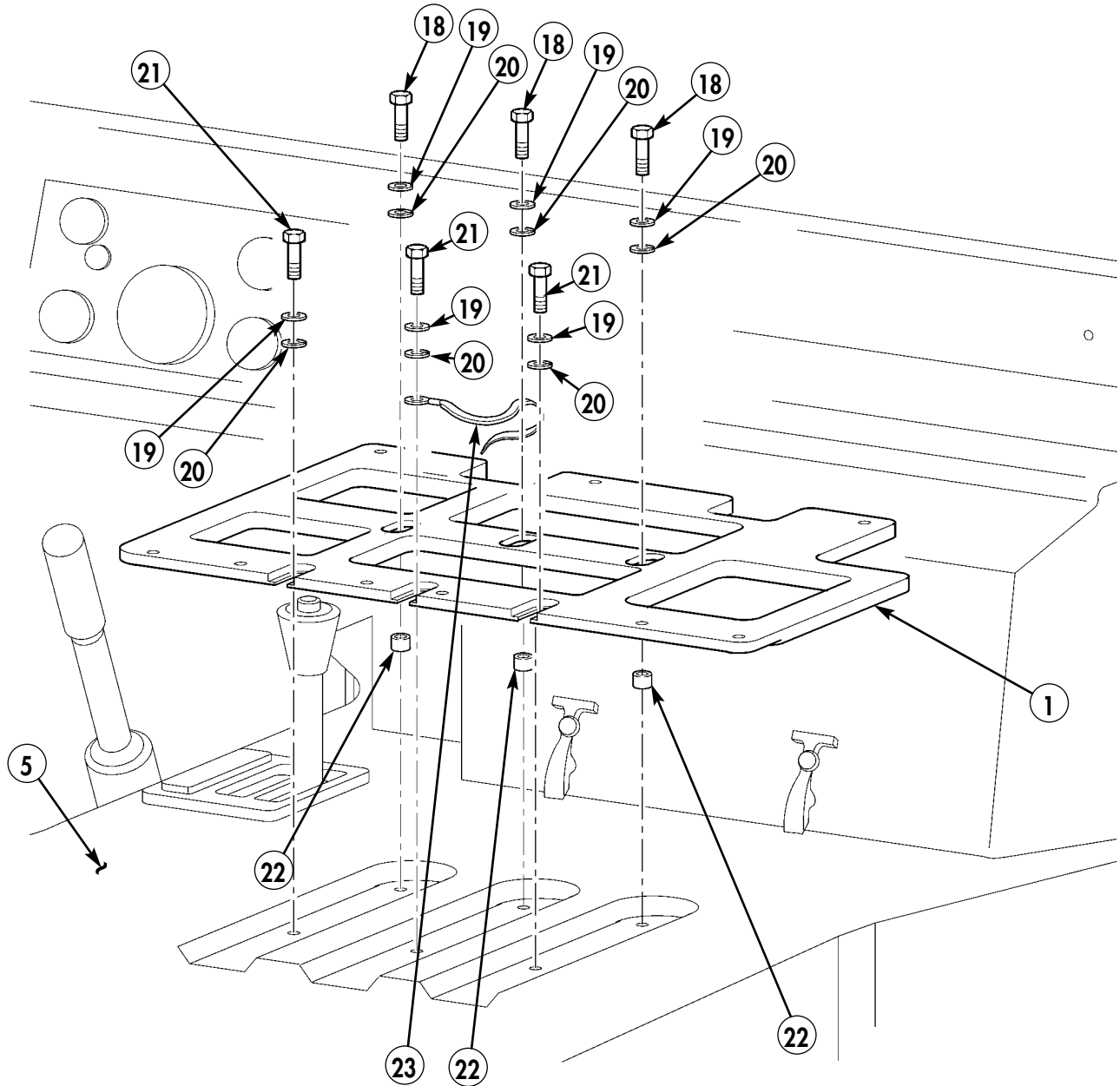

Figure 5-23.

- 7-15. Position integrated rack (6) on rack support (1).
- 7-16. Align integrated rack (6) top mounting holes (24) with holes (25) in dash panel (26).
- 7-17. Remove integrated rack (6) from rack support (1).
- 7-18. Tighten three capscrews (18) and three capscrews (21) securing rack support (1) to tunnel (5).

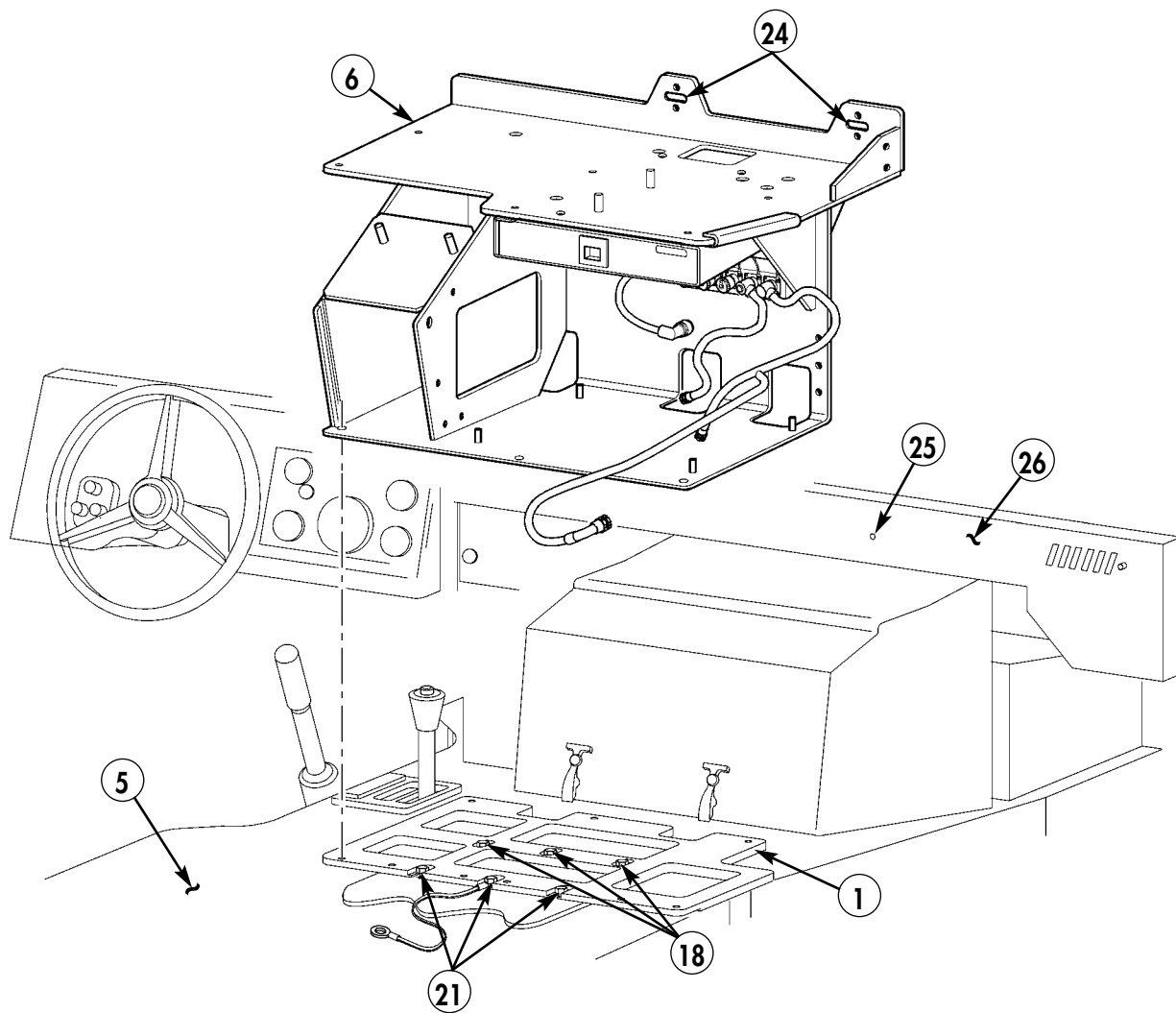
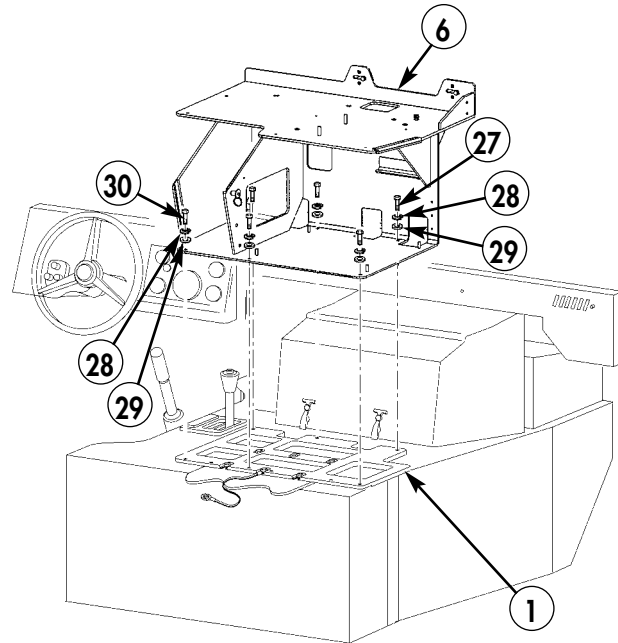

Figure 5-24.

- 7-19. Position integrated rack (6) on rack support (1).
- 7-20. Install integrated rack (6) on rack support (1) using five capscrews (27), lockwashers (28), and washers (29), and one capscrew (30), lockwasher (28), and washer (29).



- 27. CAPSCREW – B1821BH025C088N – QTY. 5
- 28. LOCKWASHER – MS35338-44 – QTY. 6
- 29. WASHER – MS27183-10 – QTY. 6
- 30. CAPSCREW – B1821BH025C063N – QTY. 1

Figure 5-25.

- 7-21. Fabricate ground strap (35) from 8-in. length of braided wire and two terminal lugs.

NOTE

Remove paint from vicinity of integrated rack mounting hole before performing step 7-22. Apply antiseize compound as required.

- 7-22. Attach integrated rack (6) to dash panel (34) using two capscrews (31), lockwashers (32), washers (33), and ground strap (35).

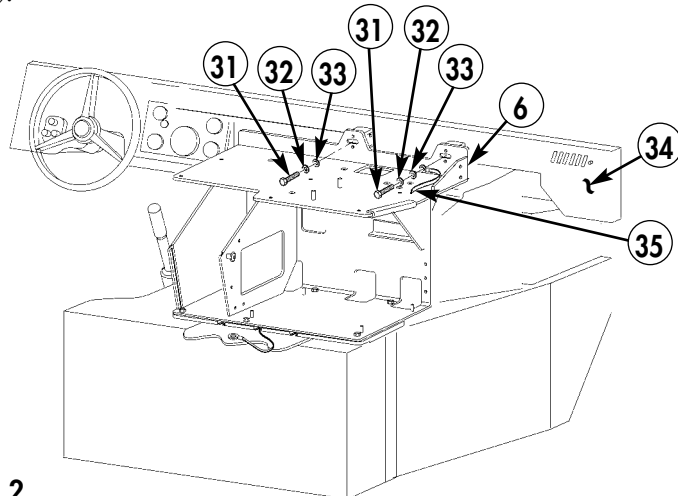

- 31. CAPSCREW – B1821BH025C100N – QTY. 2
- 32. LOCKWASHER – MS35338-44 – QTY. 2
- 33. WASHER – 2436161 – QTY. 2
- 35. GROUND STRAP
 - BRAIDED WIRE – AA59569F30T0375 – QTY. A/R
 - TERMINAL LUG – MS20659-141 – QTY. 2

Figure 5-26.

Section VIII. SINGARS MOUNTING TRAY, AMP GUARD, AND FBCB2 COMPONENTS INSTALLATION

- 8-1. Install ramball mount (6) on integrated rack (8) with two screws (5), lockwasher (11), lanyard (10), and washer (9).
- 8-2. Install display isolation kit (2) on display unit mount (1) with four bolts (13), spacers (14), one lanyard (10), and four wingnuts (15).
- 8-3. Install display unit (3) on display isolation kit (2) with four screws (4).
- 8-4. Install display unit mount (1) on ramball mount (6).
- 8-5. Install ground strap (7) on display ground stud (18) with existing lockwasher (17) and wingnut (16).

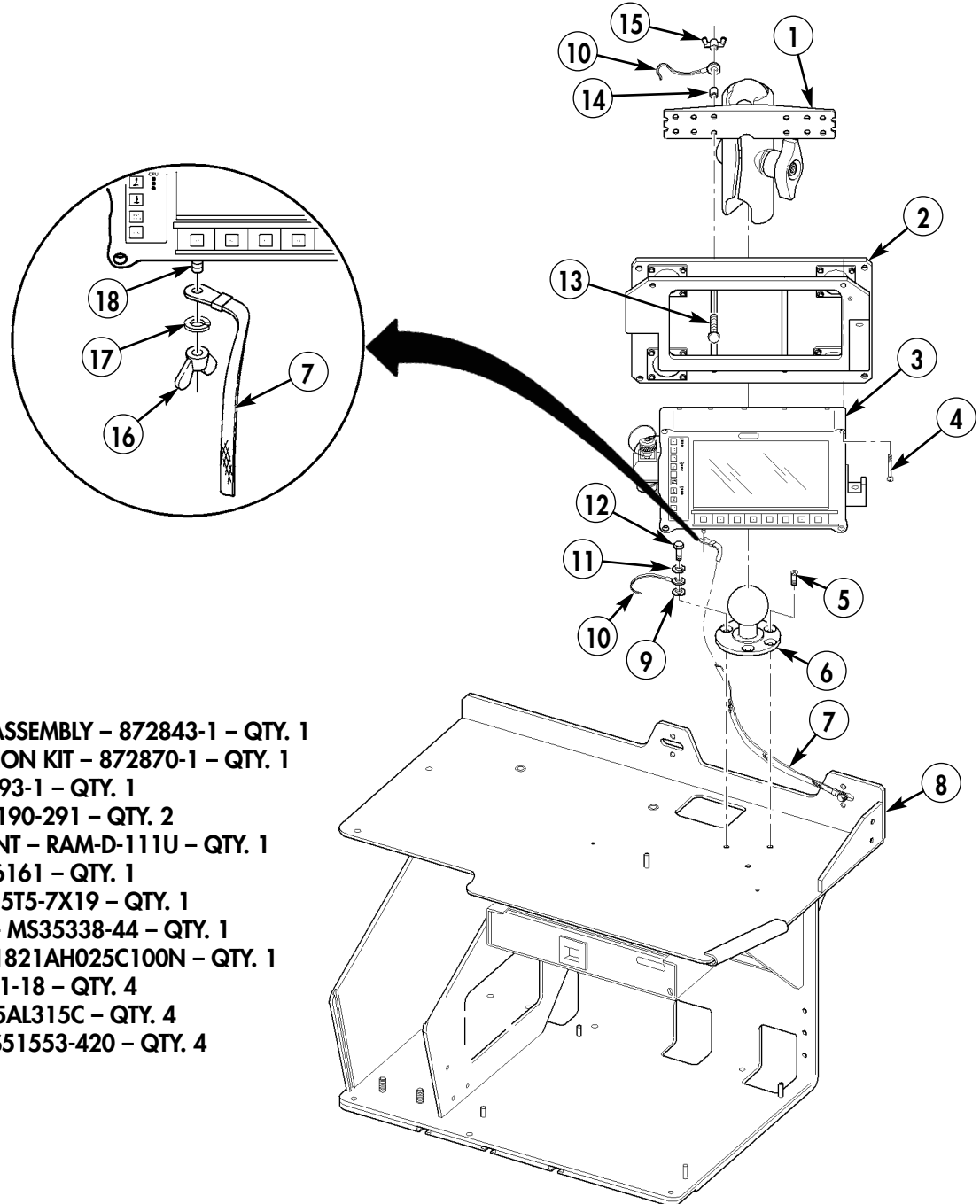

- 1. DISPLAY LOCK ASSEMBLY - 872843-1 - QTY. 1
- 2. DISPLAY ISOLATION KIT - 872870-1 - QTY. 1
- 3. DISPLAY - 881293-1 - QTY. 1
- 5. SCREW - MS35190-291 - QTY. 2
- 6. RAMBALL MOUNT - RAM-D-111U - QTY. 1
- 9. WASHER - 2436161 - QTY. 1
- 10. LANYARD - 8925T5-7X19 - QTY. 1
- 11. LOCKWASHER - MS35338-44 - QTY. 1
- 12. CAPSCREW - B1821AH025C100N - QTY. 4
- 13. BOLT - MS35751-18 - QTY. 4
- 14. SPACER - 10705AL315C - QTY. 4
- 15. WINGNUT - MS51553-420 - QTY. 4

Figure 5-27.

- 8-6. Place mounting bracket (25) on two existing studs (19).
- 8-7. Attach rod (22) to left rail weldment (24) and right rail weldment (21) with two screws (20).
- 8-8. Place rail assembly on two right-hand studs (19) on integrated rack (7) and attach left rail weldment (24) to integrated rack (7) with three capscrews (23).

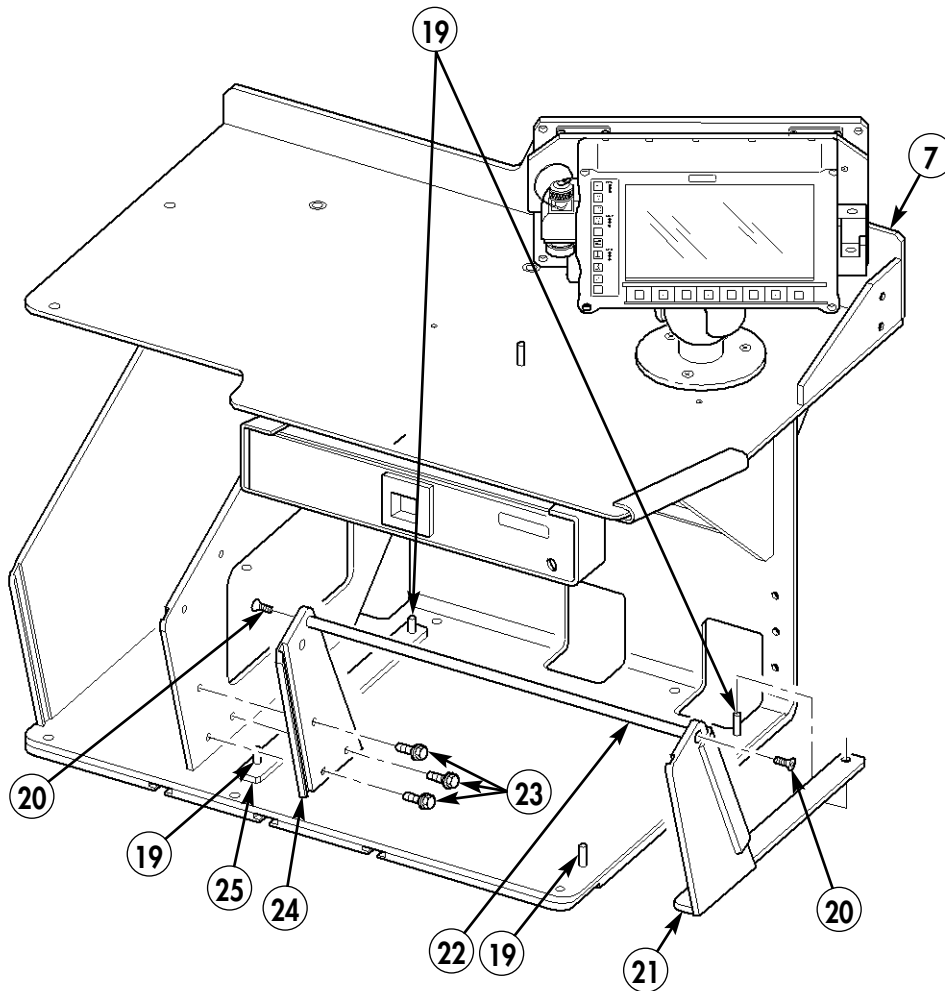

- 19. SCREW – MS35190-287 – QTY. 2
- 21. RIGHT RAIL WELDMENT – 889567-22 – QTY. 1
- 22. ROD – 889567-16 – QTY. 1
- 23. CAPSCREW – B1821AH025C075N – QTY. 3
- 24. LEFT RAIL WELDMENT – 889567-12 – QTY. 1
- 25. MOUNTING BRACKET – 889567-14 – QTY. 1

Figure 5-28.

- 8-9. Install CPU isolation kit (33) on integrated rack (7) with four existing studs (19), washers (35), lockwashers (36), and nuts (37).
- 8-10. Install CPU (26) on CPU isolation kit (33) with two existing fastener guards (34).
- 8-11. Install existing ground strap (28) on stud (27) on CPU (26) with existing wingnut (29), lockwasher (30), and washer (31).
- 8-12. Connect W3 cable (42) from Serial Interface Adapter Device (SIAD) (44) to J3 connector (39) on FBCB2 processor (26).
- 8-13. Connect W1 cable (41) to J1 connector (40) on FBCB2 processor (26). Route W1 cable (41) to integrated rack (7).

NOTE

Route W2 cable to integrated rack. Connect W2 cable to FBCB2 display unit in step 8-25.

- 8-14. Connect W2 cable (43) to J4 connector (38) on FBCB2 processor (26). Route W2 cable towards FBCB2 display unit (32) on integrated rack (7).

NOTE

Route W3N cable to integrated rack. Connect W3N cable to SINGARS mount in step 8-29.

- 8-15. Route W3N cable (45) from SIAD (44) to integrated rack (7).

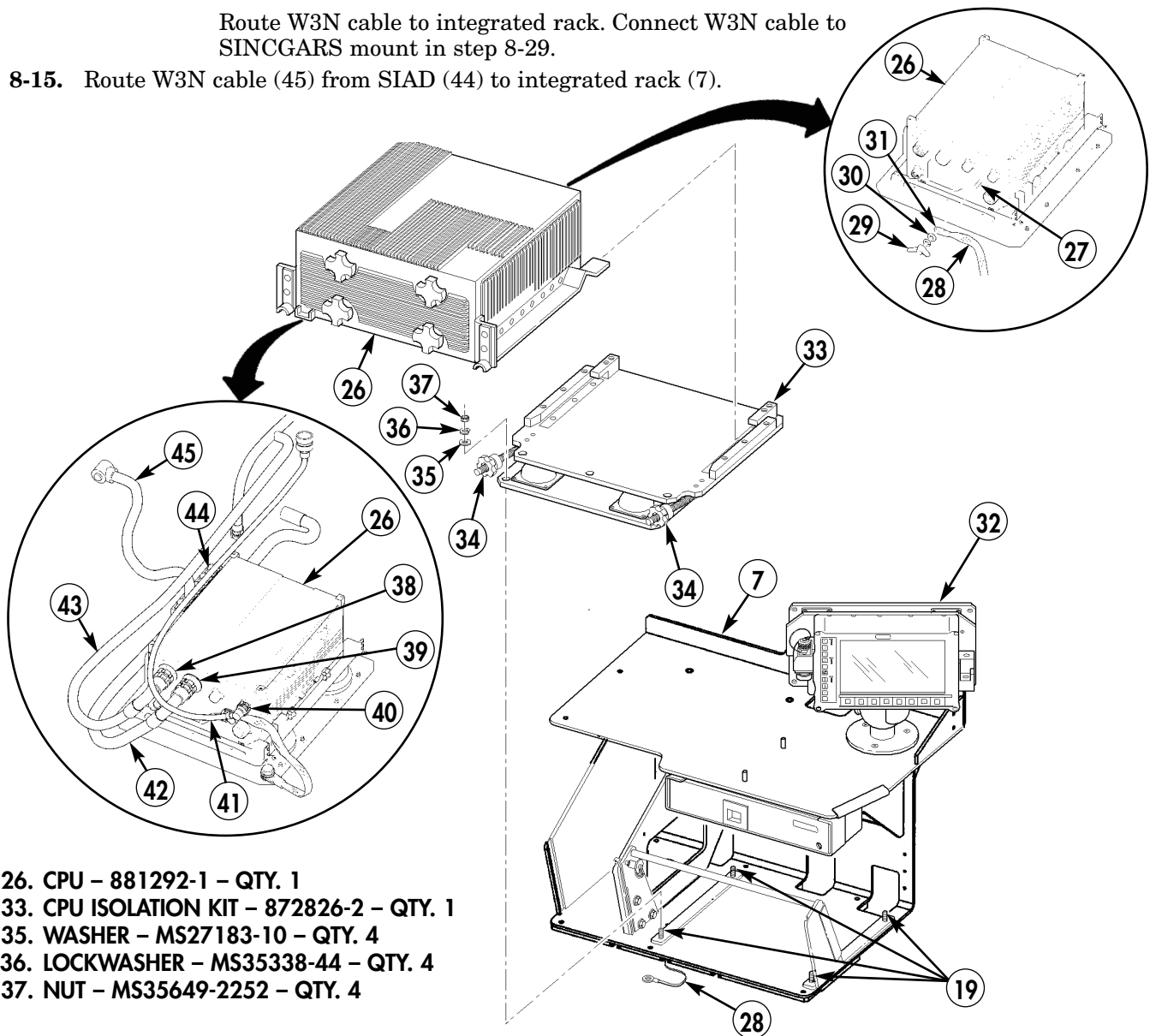

- 26. CPU – 881292-1 – QTY. 1
- 33. CPU ISOLATION KIT – 872826-2 – QTY. 1
- 35. WASHER – MS27183-10 – QTY. 4
- 36. LOCKWASHER – MS35338-44 – QTY. 4
- 37. NUT – MS35649-2252 – QTY. 4

Figure 5-29.

NOTE

Cables removed for clarity.

- 8-16. Remove paint from four mounting holes (51) on integrated rack (7). Apply antisieze compound as required.
- 8-17. Remove paint from four mounting holes (50) on MT-6352/VRC mounting base (49). Apply antisieze compound as required.

NOTE

Two lockwashers and nuts are used on driver's side screws only.

- 8-18. Mount MT-6352/VRC mounting base (49) and amp guard (53) on integrated rack (7) with two screws (46), four lockwashers (47), two nuts (52). Secure mount MT-6352/VRC mounting base (49) on integrated rack (7) with two capscrews (48) and two lockwashers (47).
- 8-19. Place warning decal (54) on amp guard (53).

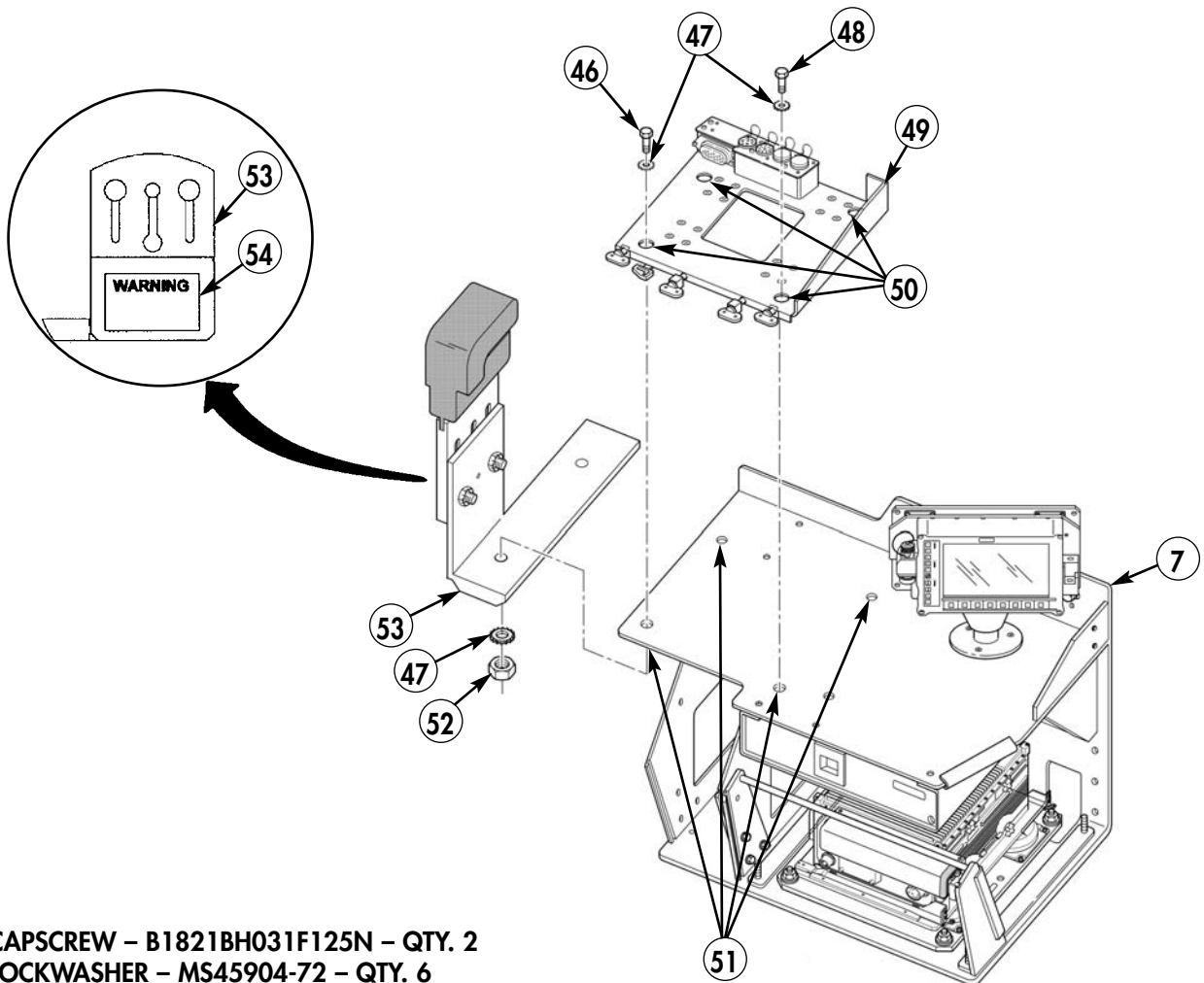

- 46. CAPSCREW – B1821BH031F125N – QTY. 2
- 47. LOCKWASHER – MS45904-72 – QTY. 6
- 48. CAPSCREW – B1821BH031F100N – QTY. 2
- 49. MOUNTING BASE, MT-6352/VRC – A3013367-1 – QTY. 1
- 52. NUT – 9418892 – QTY. 2
- 53. AMP GUARD – 872842-1 – QTY. 1
- 54. DECAL – 861868-2 – QTY. 1

Figure 5-30.

NOTE

Cables removed for clarity.

- 8-20.** Insert weldment (58) into grooves of integrated rack (7).
- 8-21.** Install Full Function Control Station (FFCS) (59) on weldment (58) using two existing studs (57), two washers (56), two washers (55), lockwashers (54), and nuts (52).

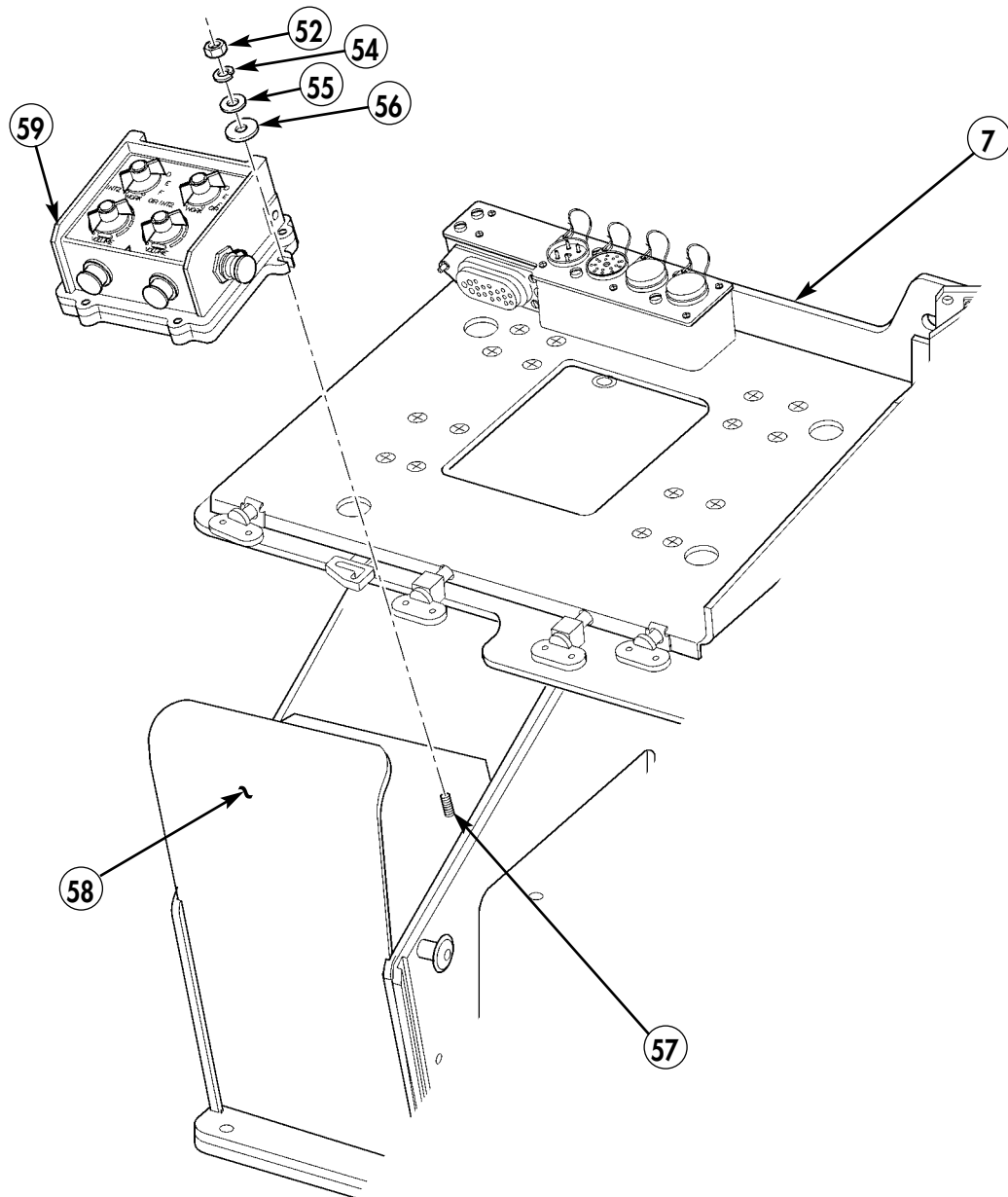

52. NUT - 9418892 - QTY. 2
 54. LOCKWASHER - MS35338-45 - QTY. 2
 55. WASHER - 2436162 - QTY. 2
 56. WASHER - 2436164 - QTY. 2
 59. FFCS - A3206624 - QTY. 1

Figure 5-31.

NOTE

Cables removed for clarity.

- 8-22. Insert footrest weldment (62) into grooves of right rail weldment (21) and left rail weldment (24).
- 8-23. Insert quick-release pin (61) through hole (60) in footrest weldment (62), left rail weldment (24), and integrated rack (7).

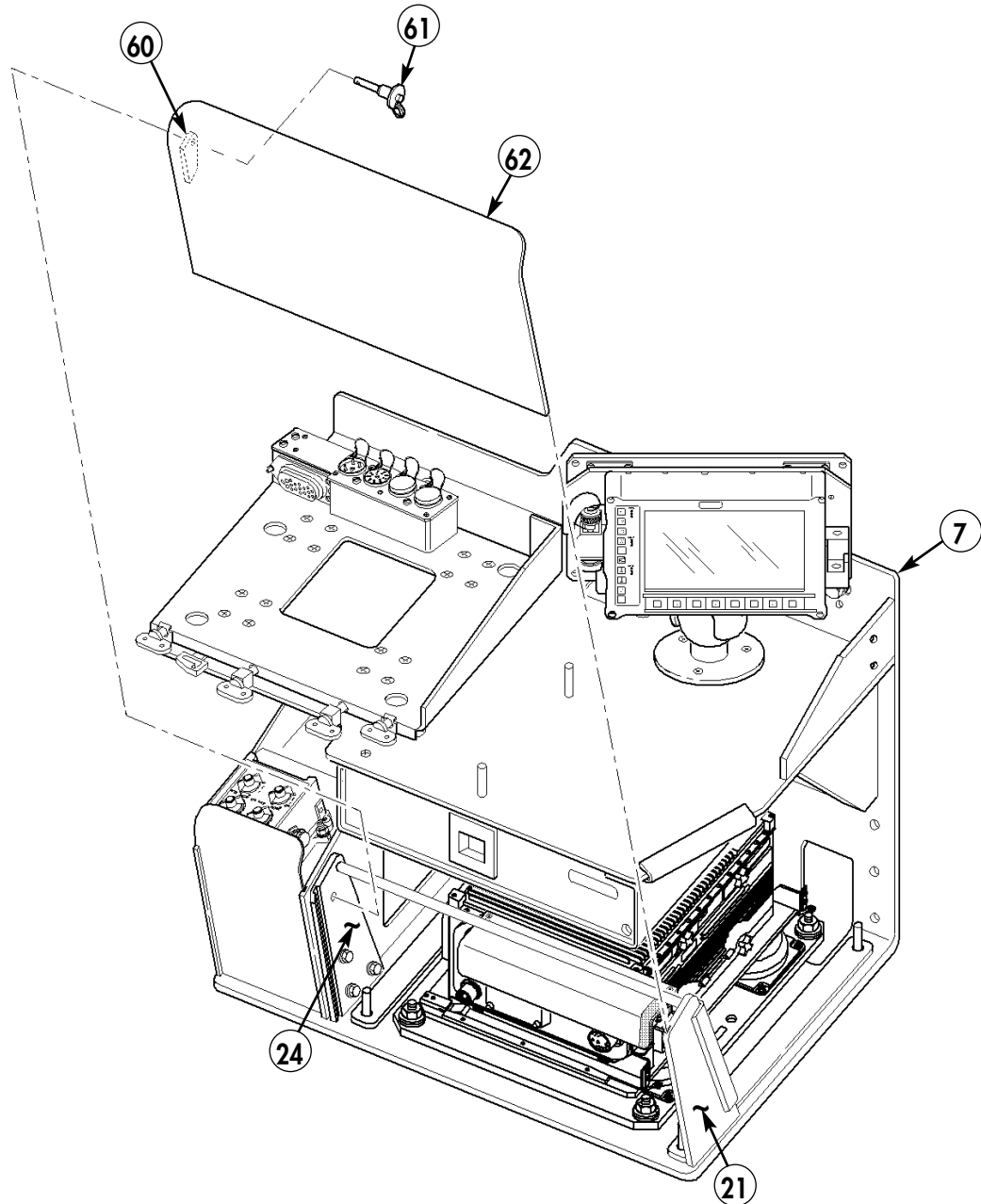

62. FOOTREST WELDMENT - 889567-21 - QTY. 1

Figure 5-32.

NOTE

Cables removed for clarity.

- 8-24.** Install master control station (65) on integrated rack (7) using existing stud (64), washer (56), washer (55), lockwasher (54), and nut (63), and capscrew (46), lockwasher (54), washer (55), and washer (56).

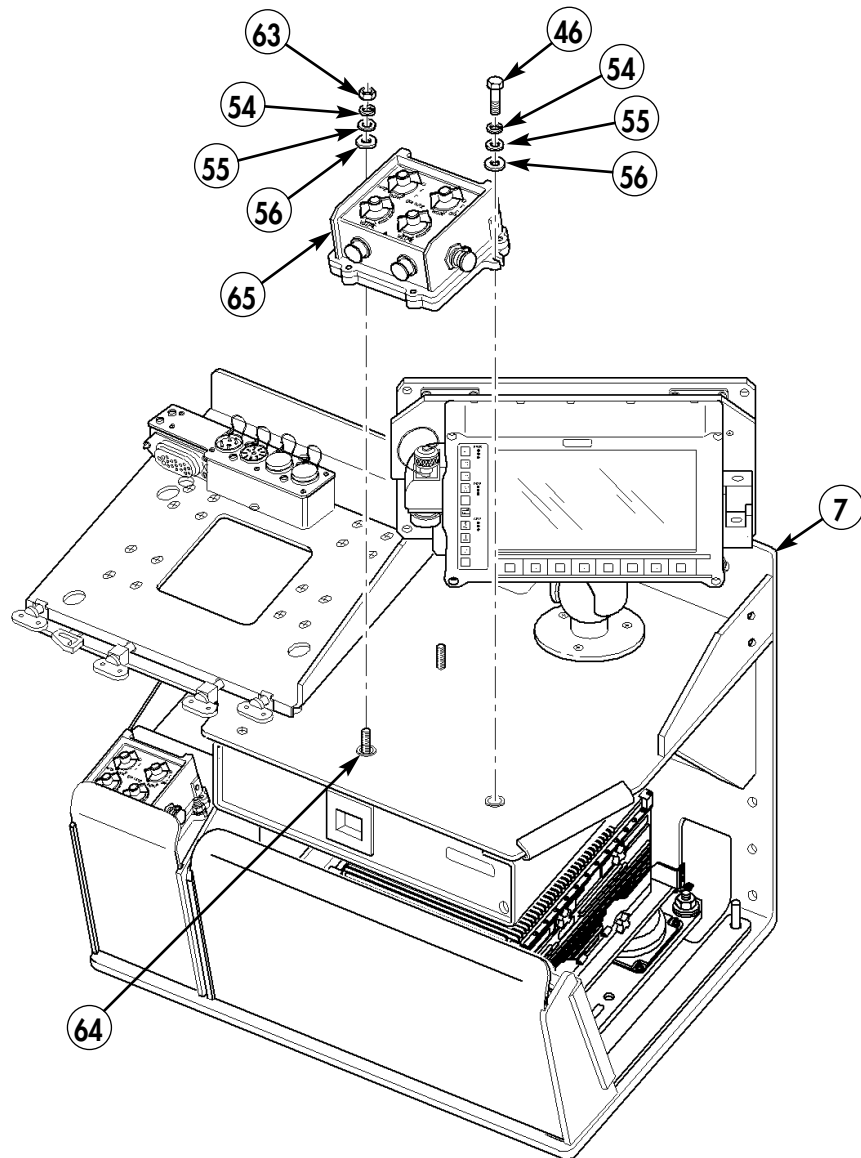

46. CAPSCREW – B1821BH031F125N – QTY. 1
 54. LOCKWASHER – MS35338-45 – QTY. 2
 55. WASHER – 2436162 – QTY. 2
 56. WASHER – 2436164 – QTY. 2
 63. NUT – 9417954 – QTY. 1
 65. MASTER CONTROL STATION – A3206623 – QTY. 1

Figure 5-33.

- 8-25. Connect W2 cable (43) to J1 connector (67) on FBCB2 display unit (32).
- 8-26. Connect W1 cable (41) to A4J2 connector (69).
- 8-27. Connect keyboard cable (68) to J2 connector (66) on FBCB2 display unit (32).

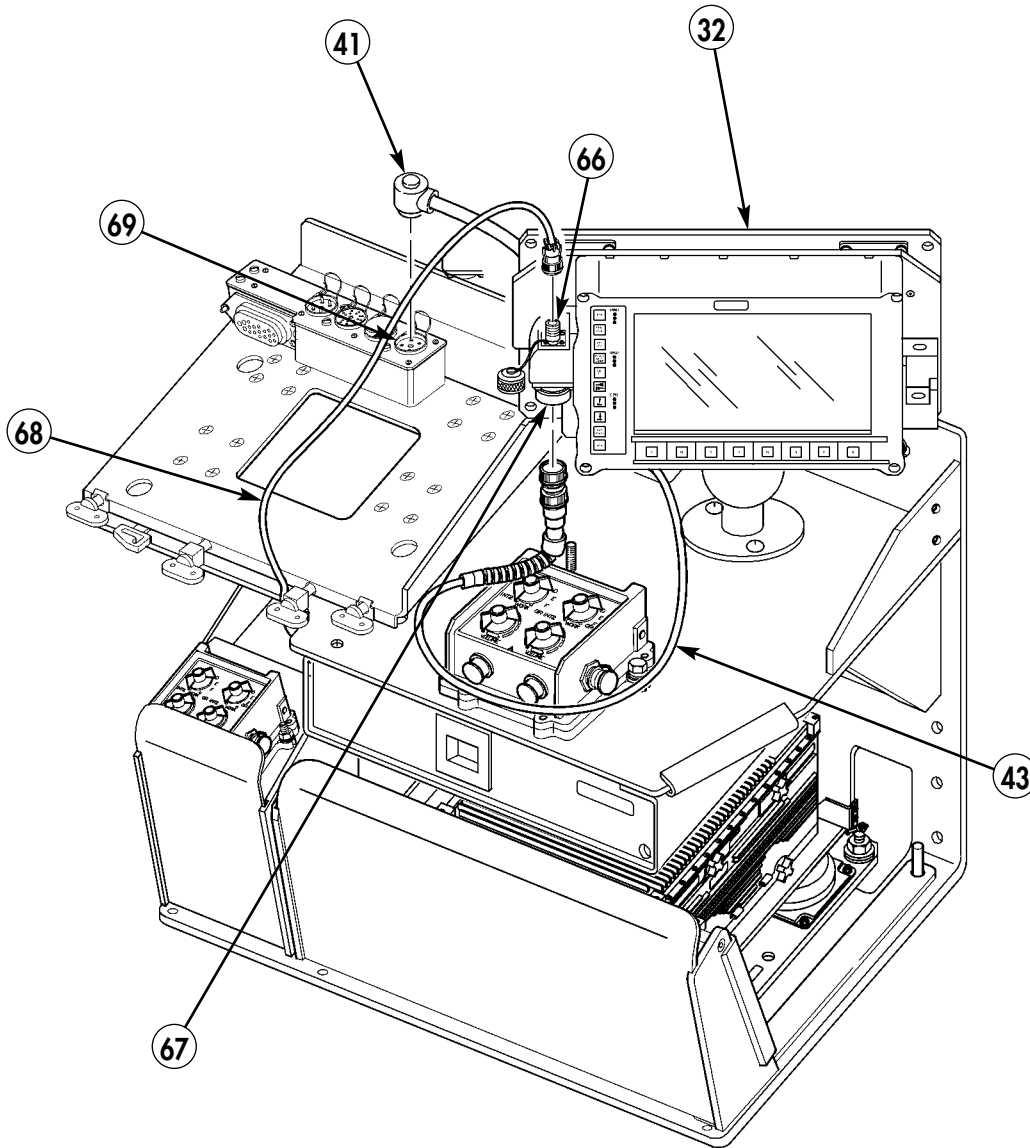

Figure 5-33.1.

8-28. Install Vehicular Amplifier Adapter (VAA) (70) into SINCGARS mount (40).

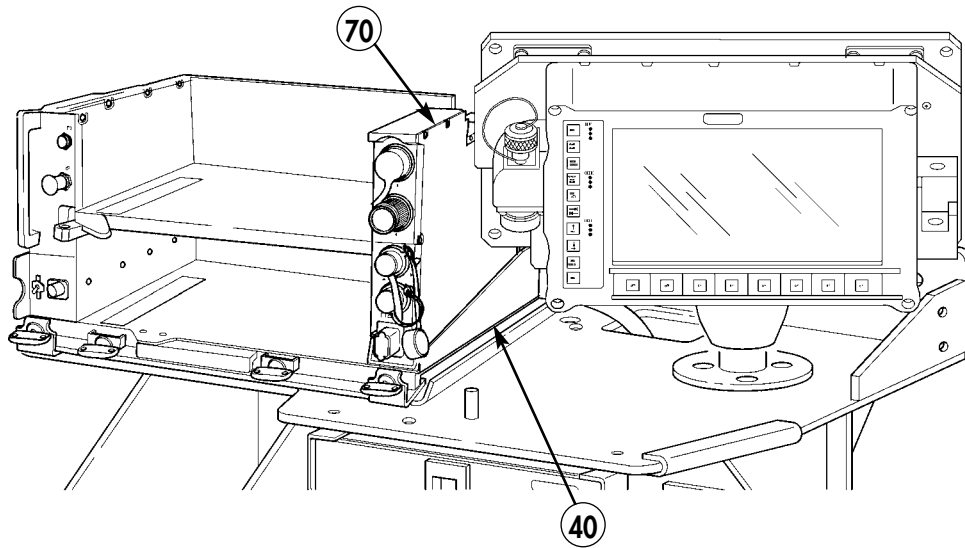

Figure 5-33.2.

8-29. Connect W3N cable (45) to J3 (71) connector on VAA (70).

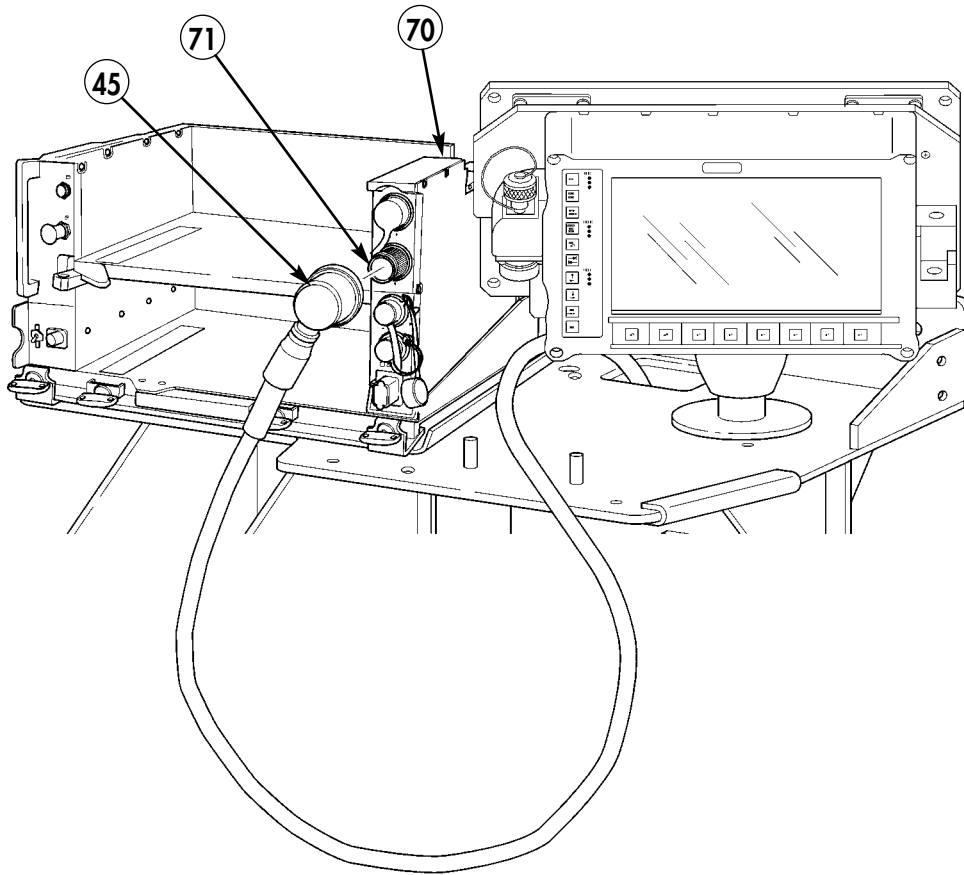
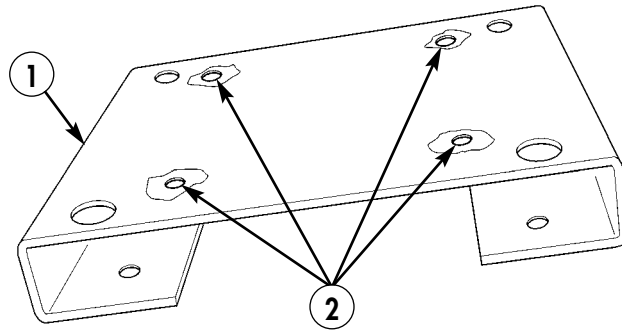

Figure 5-33.3.

Section IX. EPLRS MOUNTING INSTALLATION

- 9-1. Remove paint from vicinity of four mounting holes (2) on C-bracket mount (1). Apply antisieze compound as required.



1. C-BRACKET MOUNT - A3046202 - QTY. 1

Figure 5-34.

- 9-2. Remove paint from vicinity of four mounting holes (3) on bottom of MT-6146/VSQ-1 mount (4).

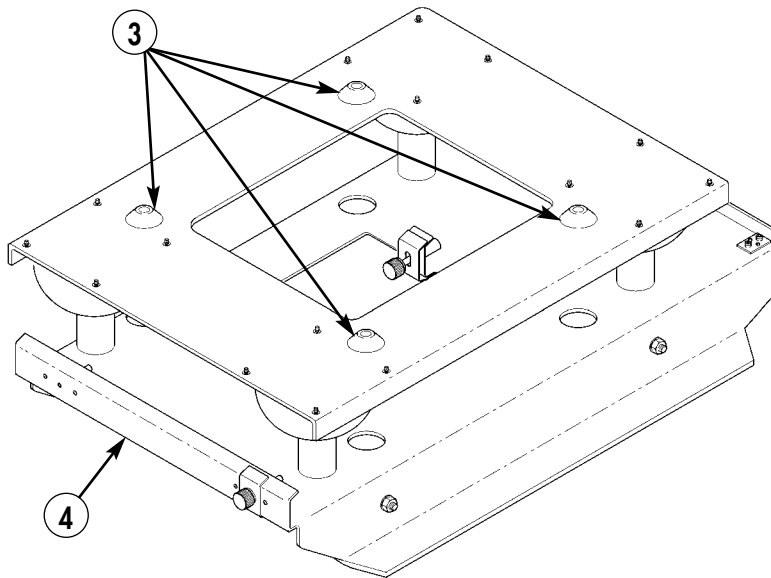

4. RESILIENT MOUNT - MT-6146/VSQ-1 - QTY. 1

Figure 5-35.

Section XI. EPLRS USER READOUT (URO) INSTALLATION

11-1. Remove two existing screws (2) and connector bracket (3) from URO bracket (1).

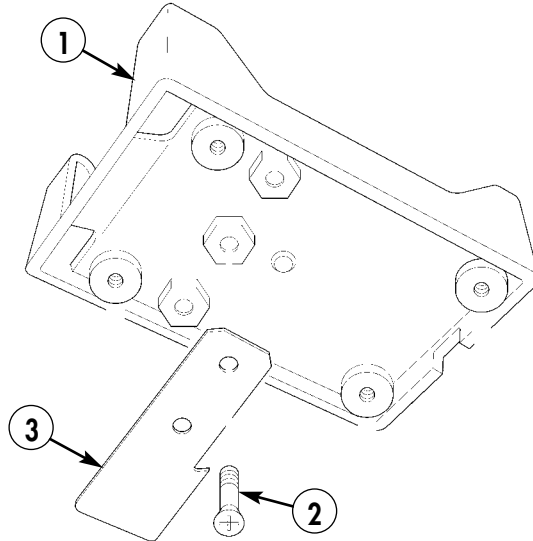
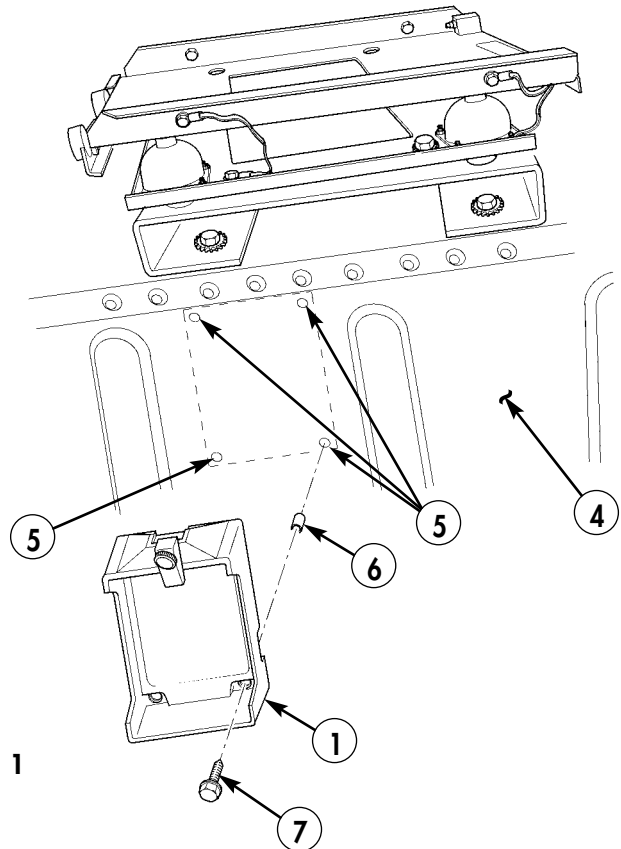

Figure 5-38.

11-2. Using URO bracket (1) as template, mark and drill four 0.147-in. holes (5) in right rear wheelhouse (4).

11-3. Install URO bracket (1) on right rear wheelhouse (4) with four self-tapping screws (7) and spacers (6).



- 1. USER READOUT BRACKET (URO) – A3006206 – QTY. 1
- 6. SPACER – 92510A318 – QTY. 4
- 7. SELF-TAPPING SCREW – 9426635 – QTY. 4

Figure 5-39.

Section XII. SINGARS ANTENNA INSTALLATION

- 12-1. Using antenna bracket (3) as template, locate, mark, and drill 1.375-in. diameter hole (2) in rear wall (4).
- 12-2. Locate, mark, and drill three 0.343-in. diameter holes (1) in rear wall (4).
- 12-3. Remove paint from vicinity of three holes (1) and three holes in rear of antenna bracket (3).
- 12-4. Apply antiseize compound to three holes (1) and rear of antenna bracket (3).

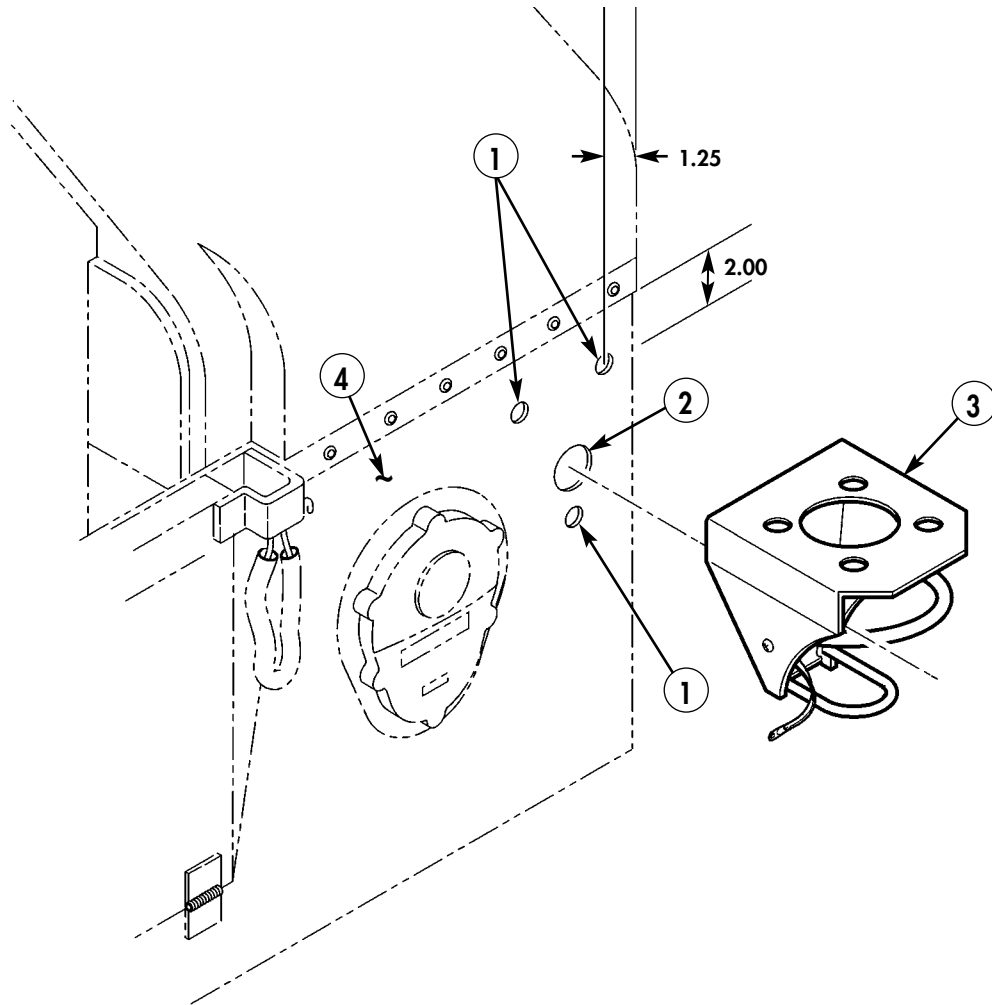
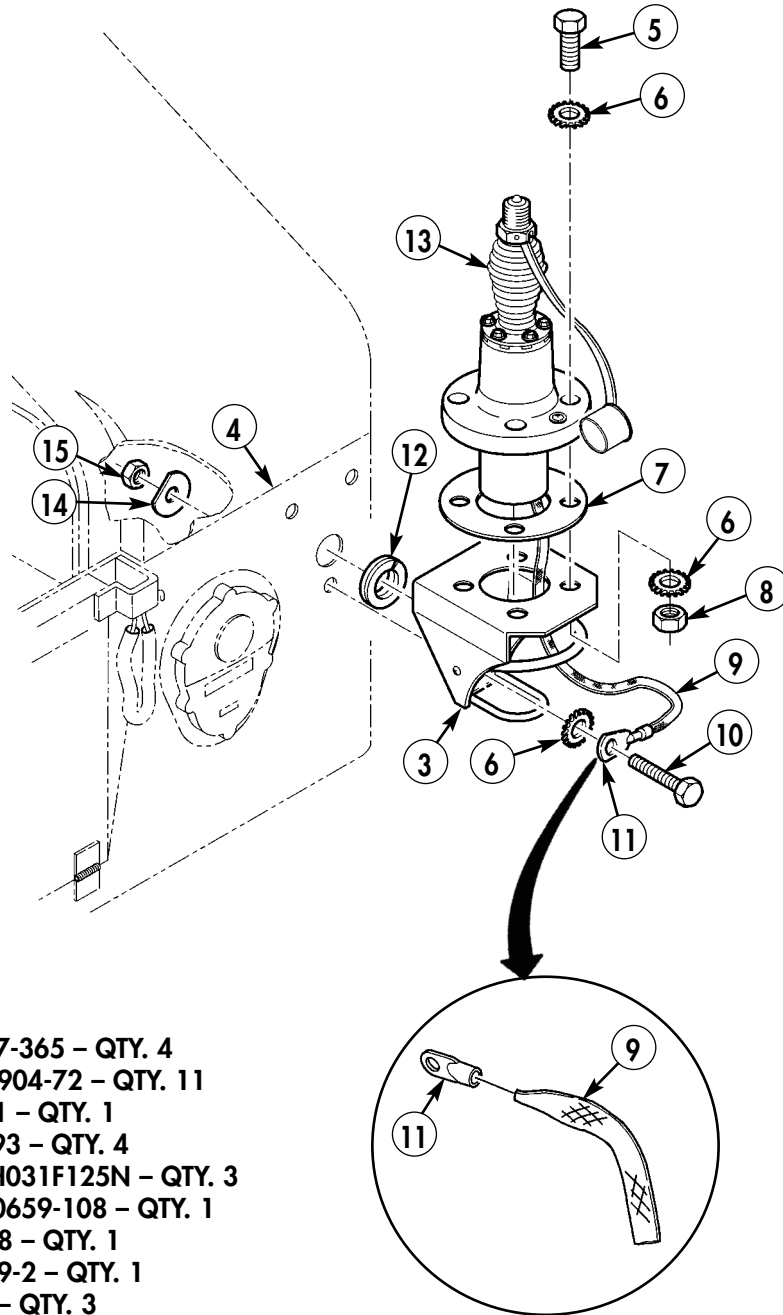

Figure 5-40.

3. ANTENNA MOUNTING BRACKET – A3014546-1 – QTY. 1

- 12-5. Install grommet (12) in hole of rear wall (4).
- 12-6. Position antenna (13) and gasket (7) on antenna bracket (3), and route existing ground strap (9) through antenna bracket (3).
- 12-7. Install antenna (13) on antenna bracket (3) with four capscrews (5), eight lockwashers (6), and four nuts (8).
- 12-8. Install antenna bracket (3) on rear wall (4) with two capscrews (10), lockwashers (6), washers (14), and nuts (15).
- 12-9. Remove old terminal lug and install new terminal lug (11) on ground strap (9). Install ground strap (9) and antenna bracket (3) on rear wall (4) with capscrew (10), lockwasher (6), washer (14), and nut (15).



- 5. CAPSCREW – MS35307-365 – QTY. 4
- 6. LOCKWASHER – MS45904-72 – QTY. 11
- 7. GASKET – A3013655-1 – QTY. 1
- 8. NUT – 13218E0320-293 – QTY. 4
- 10. CAPSCREW – B1821BH031F125N – QTY. 3
- 11. TERMINAL LUG – MS20659-108 – QTY. 1
- 12. GROMMET – 12338098 – QTY. 1
- 13. ANTENNA – A3017899-2 – QTY. 1
- 14. WASHER – 12338095 – QTY. 3
- 15. NUT – 9418892 – QTY. 3

Figure 5-41.

- 12-10. Attach upper antenna element (16) to lower antenna element (18).
- 12-11. Attach antenna assembly to antenna base (13).
- 12-12. Attach fiber rope assembly (17) to upper antenna element (16).
- 12-13. Secure lower antenna element (18) to antenna base (13) with lock wire (19).
- 12-14. Repeat steps 12-1 through 12-13 for other side of vehicle, if applicable.

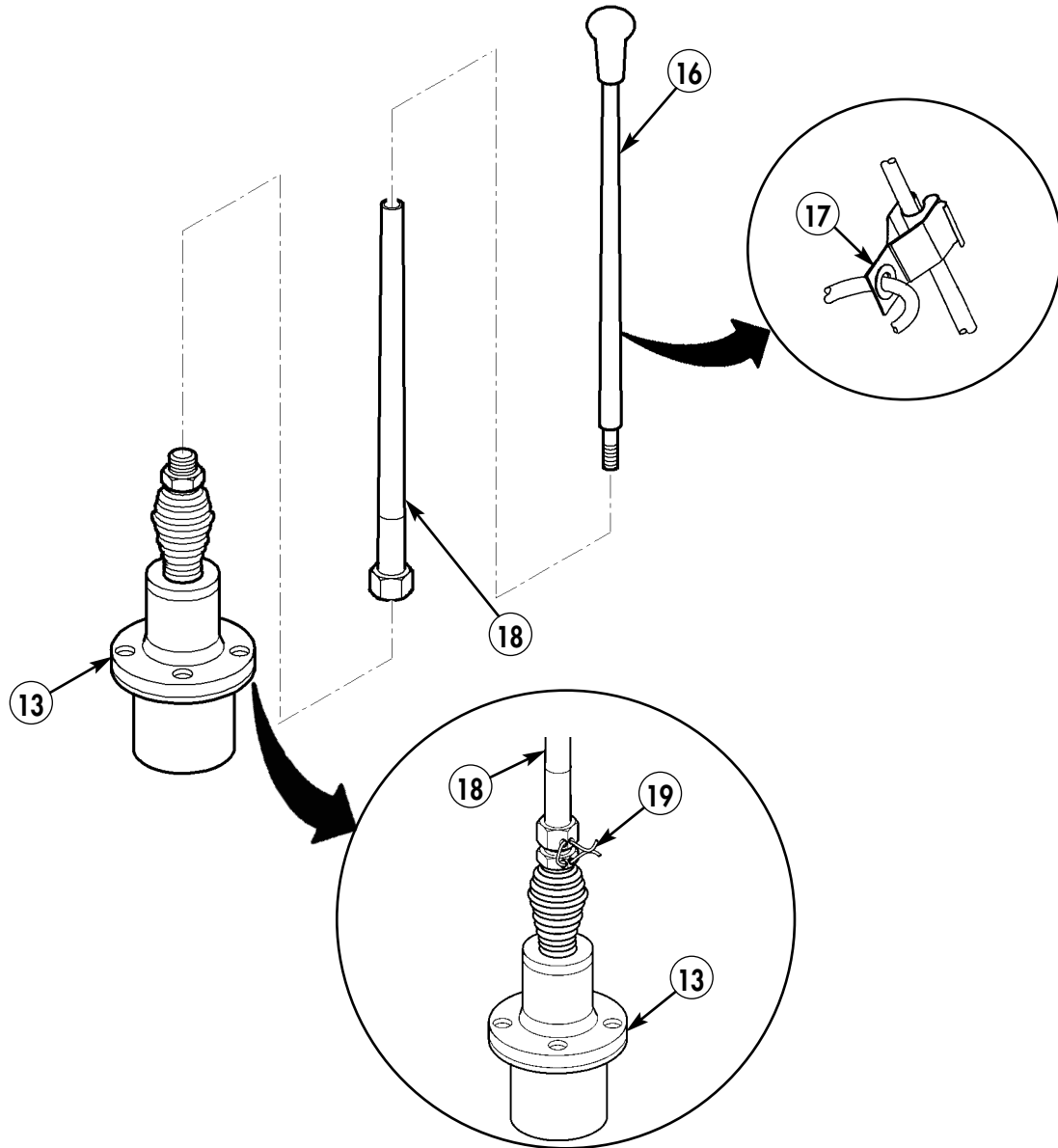

- 16. UPPER ANTENNA ELEMENT – A3017901-2 – QTY. 1
- 18. LOWER ANTENNA ELEMENT – A3018230-1 – QTY. 1
- 19. LOCK WIRE – MS20995C32 – QTY. A/R

Figure 5-42.

- 12-5. Install grommet (12) in hole of rear wall (4).
- 12-6. Position antenna (13) and gasket (7) on antenna bracket (3), and route existing ground strap (9) through antenna bracket (3).
- 12-7. Install antenna (13) on antenna bracket (3) with four capscrews (5), eight lockwashers (6), and four nuts (8).
- 12-8. Install antenna bracket (3) on rear wall (4) with two capscrews (10), lockwashers (6), washers (14), and nuts (15).
- 12-9. Remove old terminal lug and install new terminal lug (11) on ground strap (9). Install ground strap (9) and antenna bracket (3) on rear wall (4) with capscrew (10), lockwasher (6), washer (14), and nut (15).

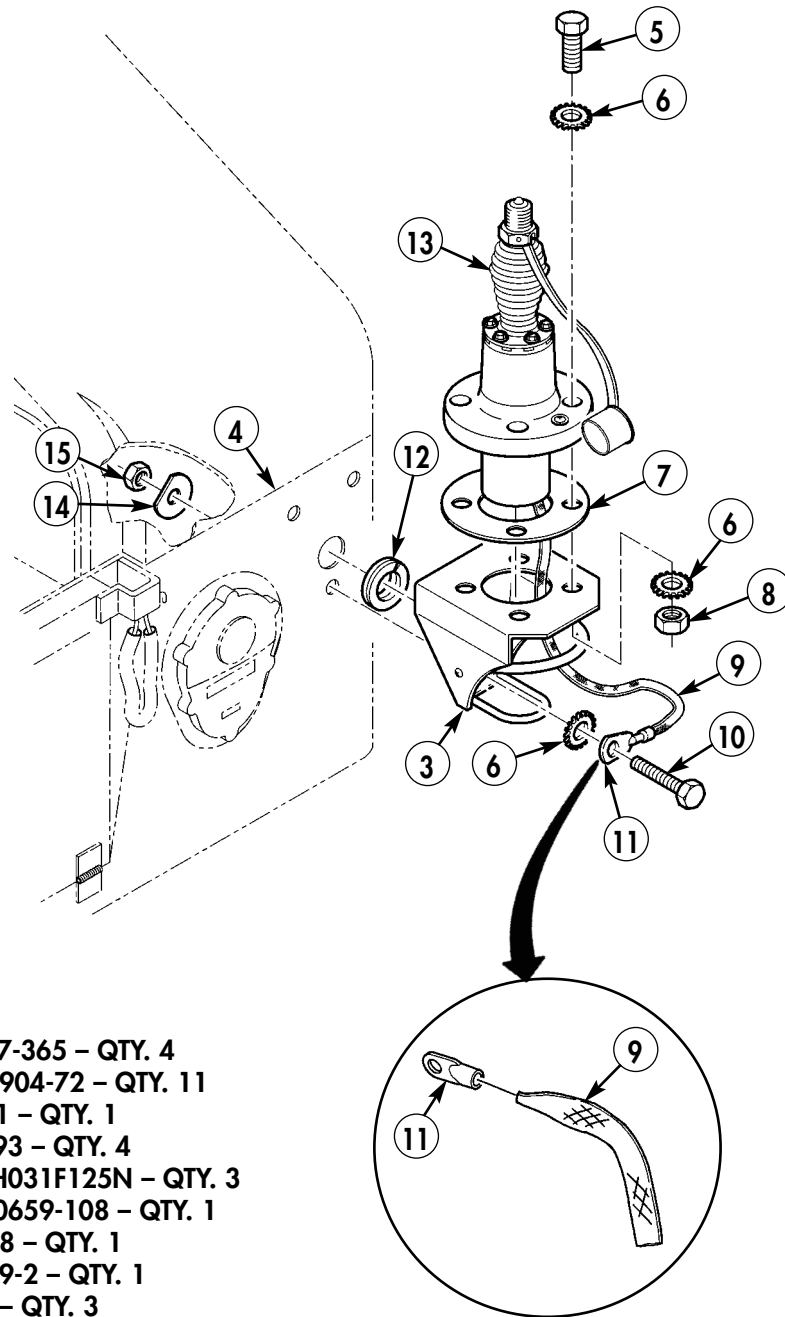

- 5. CAPSCREW – MS35307-365 – QTY. 4
- 6. LOCKWASHER – MS45904-72 – QTY. 11
- 7. GASKET – A3013655-1 – QTY. 1
- 8. NUT – 13218E0320-293 – QTY. 4
- 10. CAPSCREW – B1821BH031F125N – QTY. 3
- 11. TERMINAL LUG – MS20659-108 – QTY. 1
- 12. GROMMET – 12338098 – QTY. 1
- 13. ANTENNA – A3017899-2 – QTY. 1
- 14. WASHER – 12338095 – QTY. 3
- 15. NUT – 9418892 – QTY. 3

Figure 5-41.

- 12-10. Attach upper antenna element (16) to lower antenna element (18).
- 12-11. Attach antenna assembly to antenna base (13).
- 12-12. Attach fiber rope assembly (17) to upper antenna element (16).
- 12-13. Secure lower antenna element (18) to antenna base (13) with lock wire (19).
- 12-14. Repeat steps 12-1 through 12-13 for other side of vehicle, if applicable.

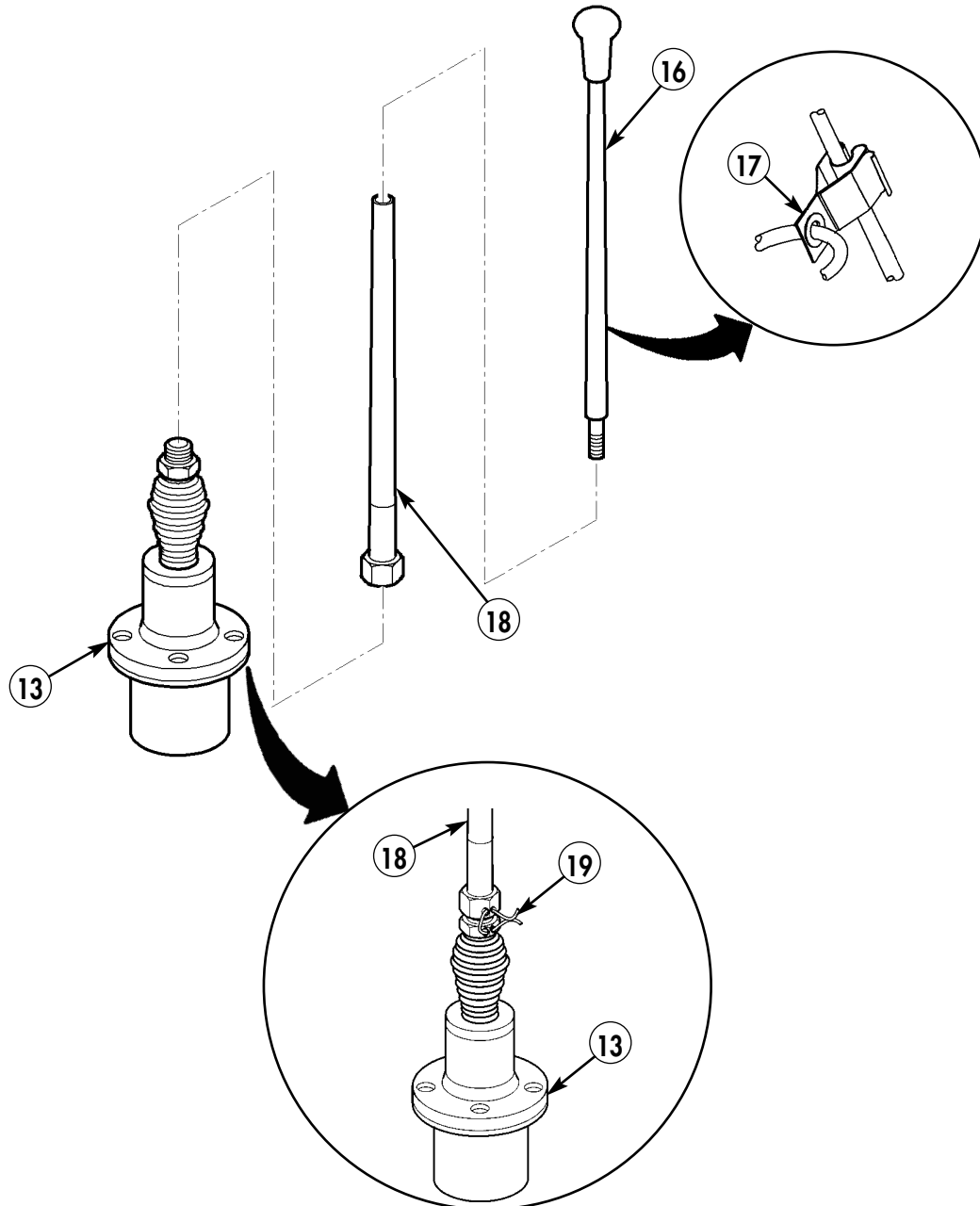

- 16. UPPER ANTENNA ELEMENT – A3017901-2 – QTY. 1
- 18. LOWER ANTENNA ELEMENT – A3018230-1 – QTY. 1
- 19. LOCK WIRE – MS20995C32 – QTY. A/R

Figure 5-42.

Section XIII. CABLES INSTALLATION

- 13-1. Drill one 0.147-in. hole (6) in right rear wheelhouse (7) between mount assembly (1) and antenna (4).
- 13-2. Connect antenna cable (2) to antenna (4) and route cable behind mount assembly (1), leaving enough cable length to connect to opposite side of EPLRS unit. Coil excess cable (8), and store under mount assembly (1).
- 13-3. Secure antenna cable (2) to wheelhouse (7) with clamp (5), and self-tapping screw (3).

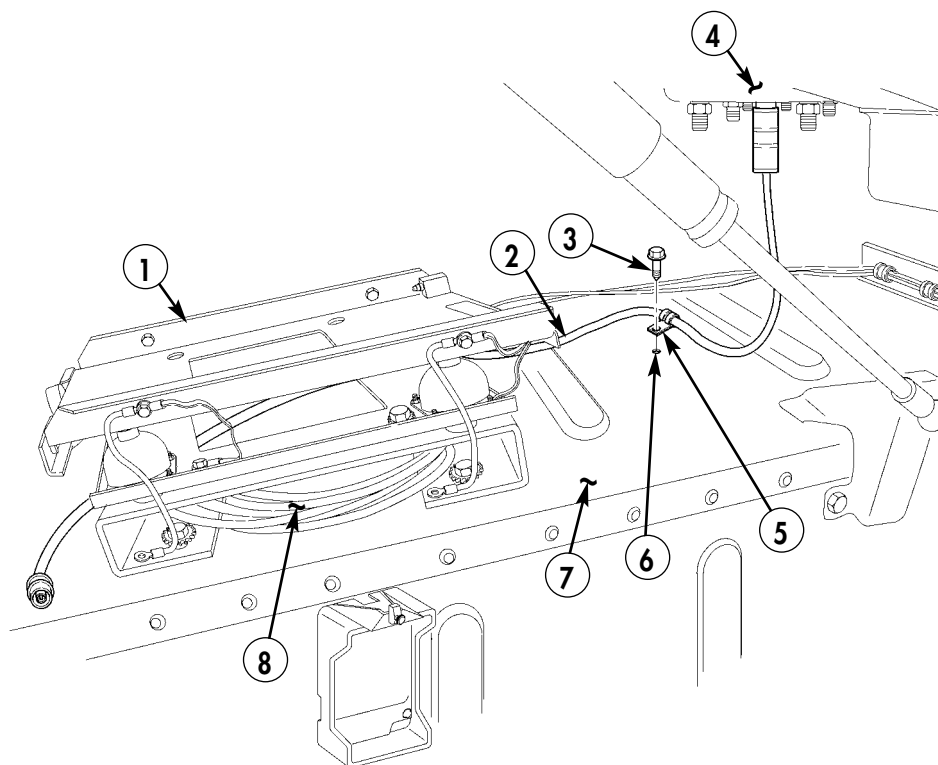

2. EPLRS ANTENNA CABLE – SM-C-911480 – QTY. 1
3. SELF-TAPPING SCREW – 9421073 – QTY. 1
5. CLAMP – MS21333-69 – QTY. 1

Figure 5-43.

- 13-4. Remove twelve screws (9), four screws (11), and cargo floor cover (10) from cargo floor (12). Retain all screws (9) and (11).

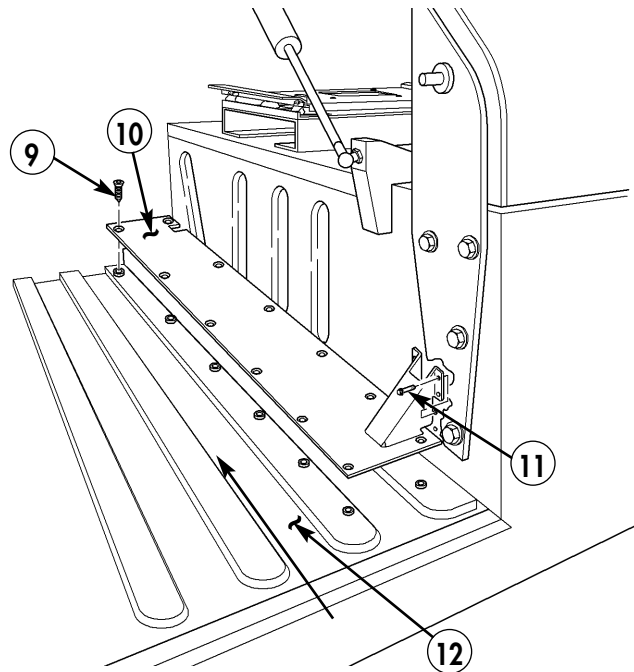
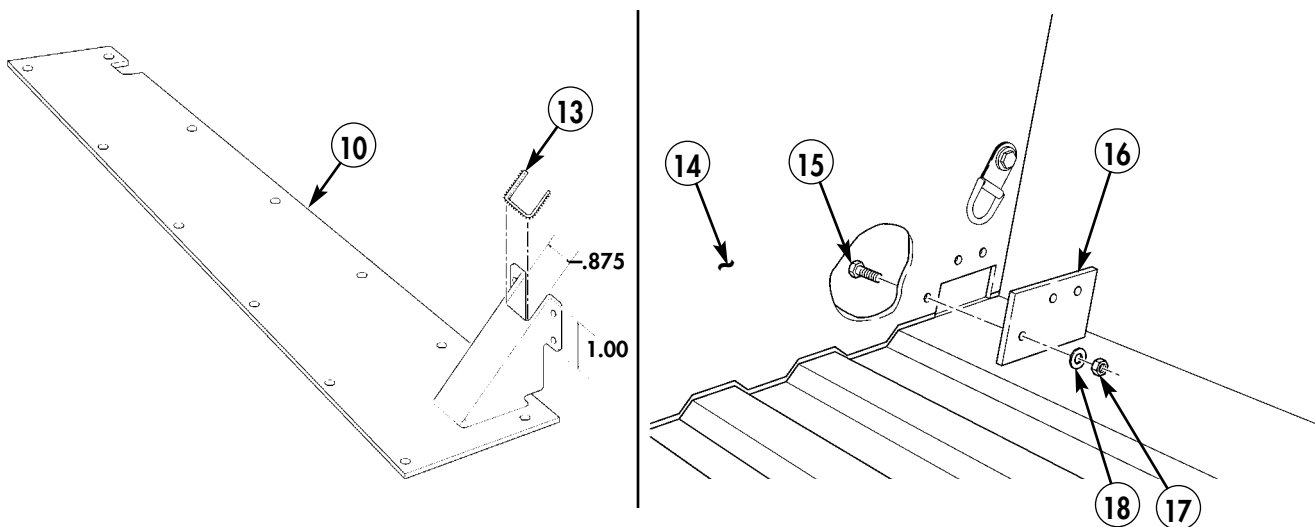

Figure 5-44.

- 13-5. Cut notch in cargo floor cover (10) as shown.
13-6. Cut and install grommet material (13) to fit. Secure with RTV compound.
13-7. Remove three screws (15), washers (18), nuts (17), and rear partition access cover (16) from rear partition (14).



13. GROMMET MATERIAL – MS21266-1N – QTY. A/R

Figure 5-45.

- 13-8. Locate, mark, and drill a 0.750-in. hole (15) in right rear wheelwell (14).
- 13-9. Insert grommet (16) into hole (15) in right rear wheelwell (14).

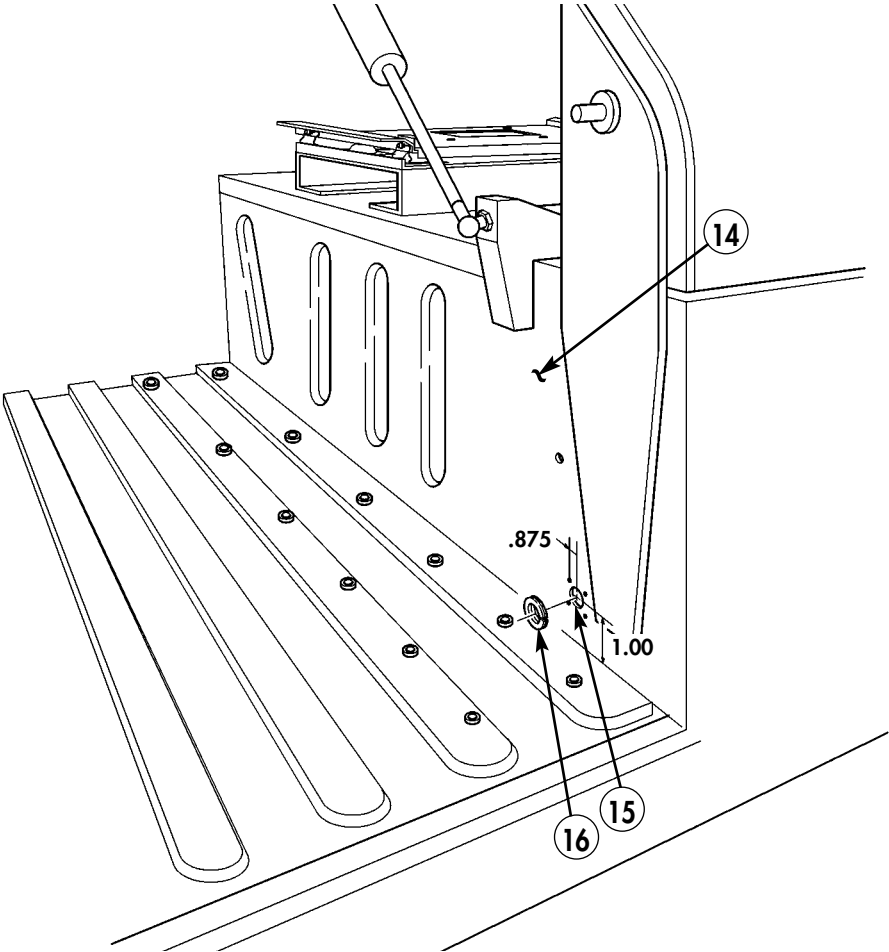

16. GROMMET – MS35498-149 – QTY. 1

Figure 5-46.

- 13-10.** Remove three screws (17) and cargo floor cover (18) from cargo floor (12) behind right rear seat (19).

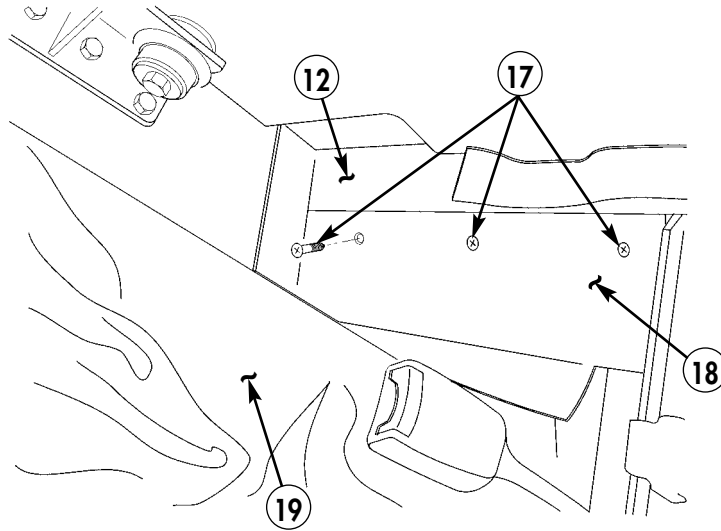
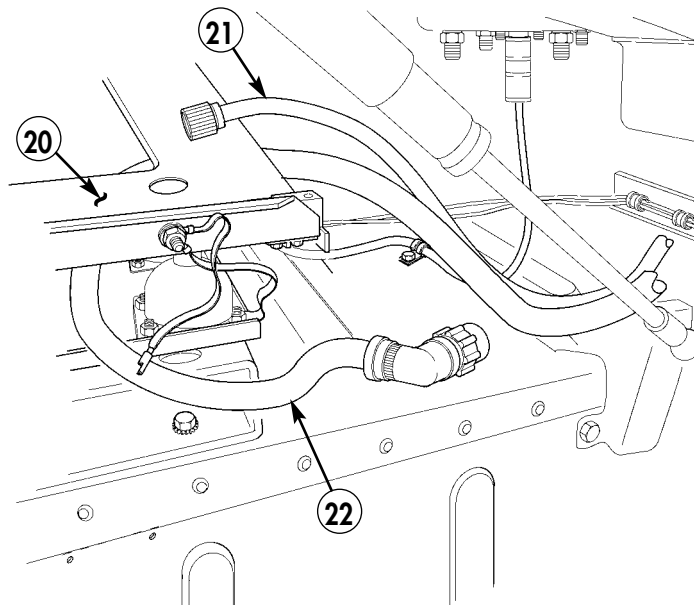

Figure 5-47.

- 13-11.** Lay EPLRS power cable (22) and INC-EPUU cable (21) connectors in vicinity of EPLRS mount (20). Ensure enough slack in cables to connect to equipment when installed.



- 21.** INC-EPUU CABLE – A3279383-3 – QTY. 1
22. EPLRS POWER CABLE – A3004939 – QTY. 1

Figure 5-48.

- 13-12. Drill one 0.147-in. diameter hole (26) in right rear wheelwell (7) near right gas spring (23).
- 13-13. Secure power cable (22) and INC-EPUU cable (21) to right rear wheelwell (7) with loop clamp (24) and self-tapping screw (25).

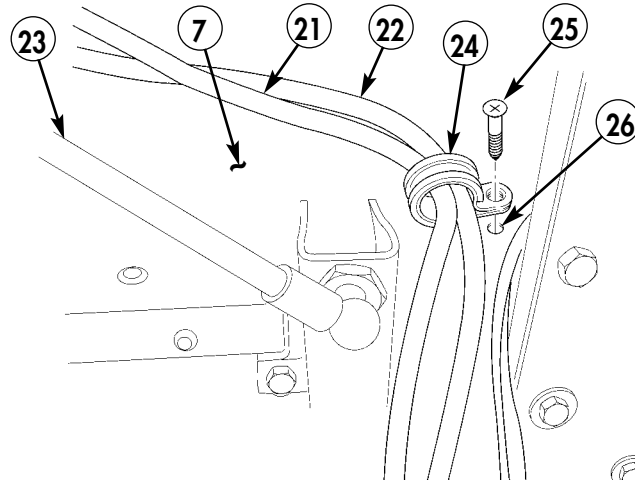

- 24. LOOP CLAMP – MS21333-77 – QTY. 1
- 25. SELF-TAPPING SCREW – 9421073 – QTY. 1

Figure 5-49.

- 13-14. Drill one 0.147-in. diameter hole (27) in right rear wheelwell (7).

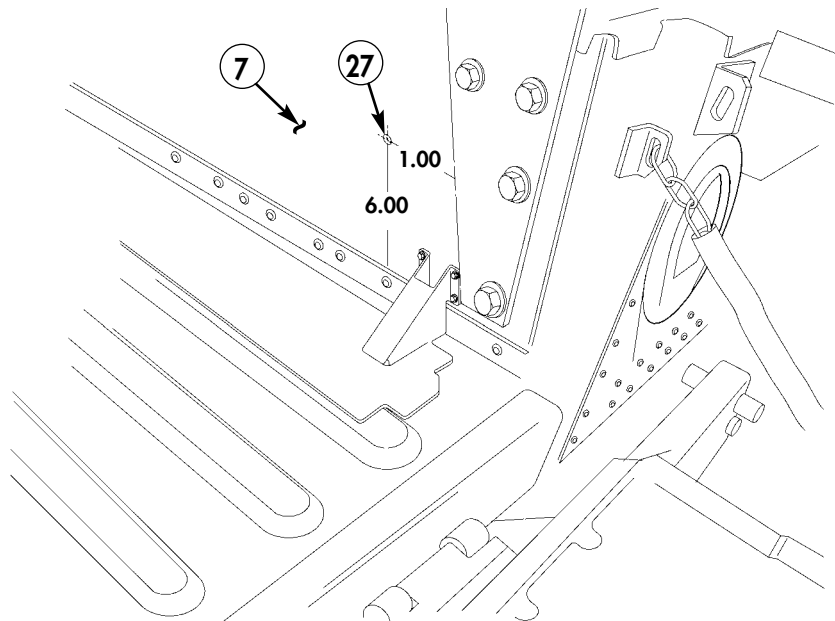
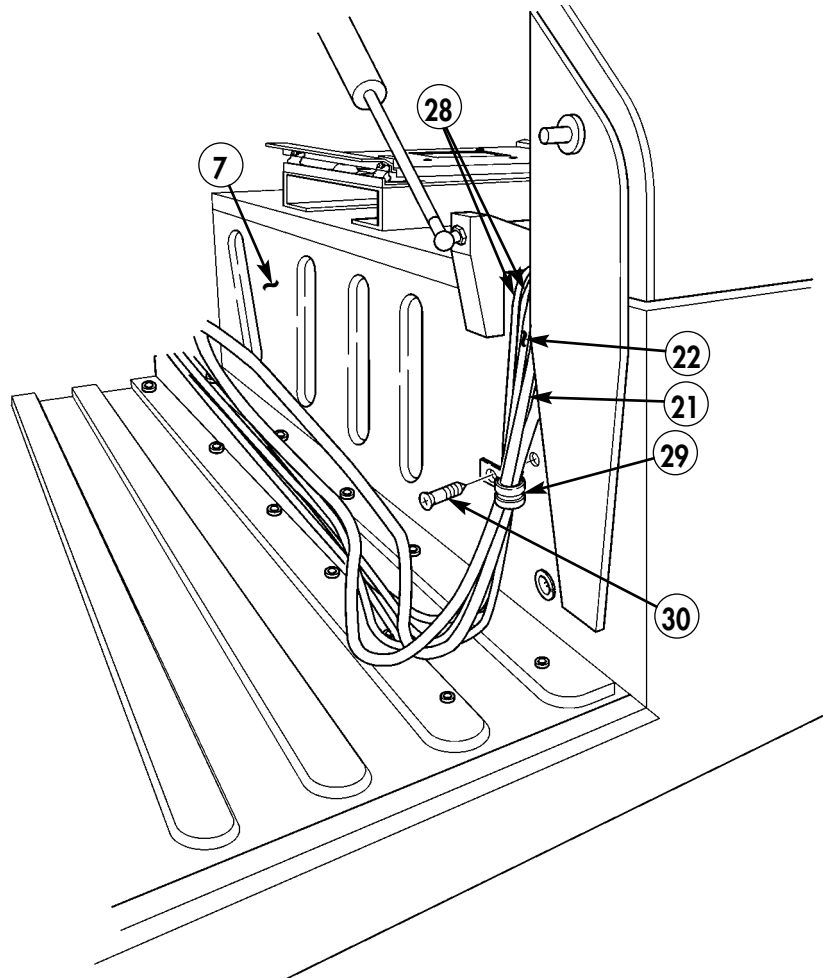

Figure 5-50.

NOTE

If Light Vehicle Obscuration Smoke System (LVOSS) is installed, use MS21333-77 clamp. If LVOSS is not installed, use MS21333-75 clamp.

- 13-15.** Route power cable (22), INC-EPUU cable (21), and LVOSS cables (28) along rear of right rear wheelwell (7) with one loop clamp (29) and self-tapping screw (30).



- 29. LOOP CLAMP – MS21333-77 – QTY. 1**
30. SELF-TAPPING SCREW – 9421073 – QTY. 1

Figure 5-51.

- 13-16. Connect SINCGARS antenna cable (32) to SINCGARS antenna (31).
- 13-17. Route SINCGARS antenna cable (32) through hole (33) in rear wall (34).

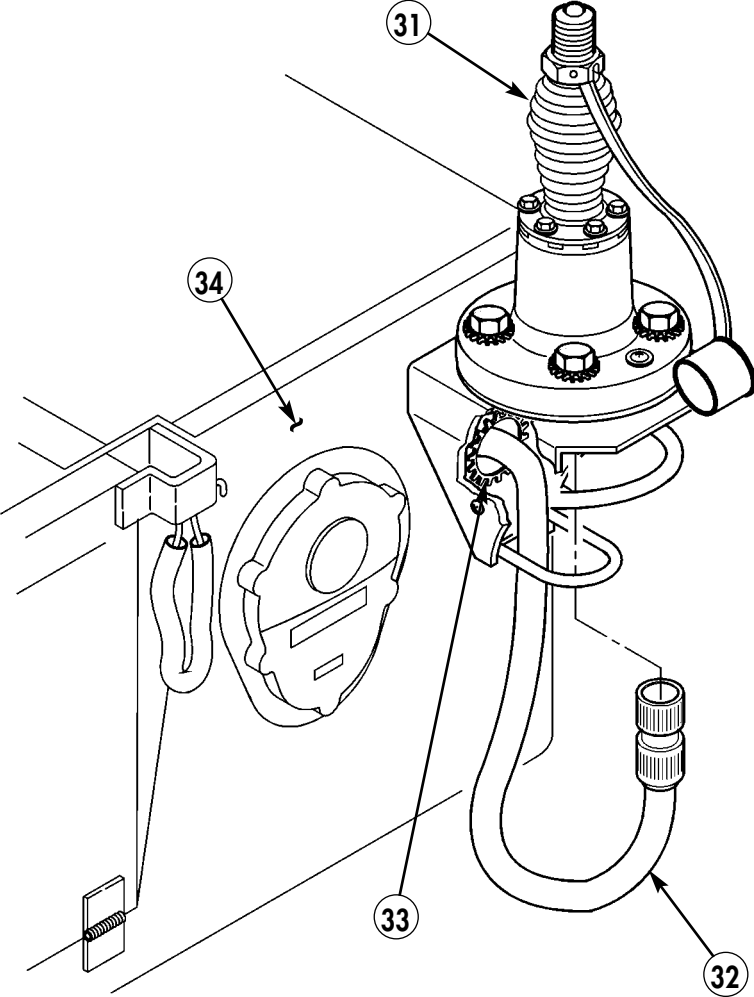

32. SINCGARS ANTENNA CABLE - A3014031-8 - QTY. 1

Figure 5-52.

- 13-18. Route SINCGARS antenna cable (32) along outer wall of right rear wheelwell (7) with existing loop clamp (35), screw (36), washer (37), lockwasher (38), and nut (39).
- 13-19. Route SINCGARS antenna cable (32) along taillight wiring harness with two existing loop clamps (42), self-tapping screws (40), and lockwashers (41).

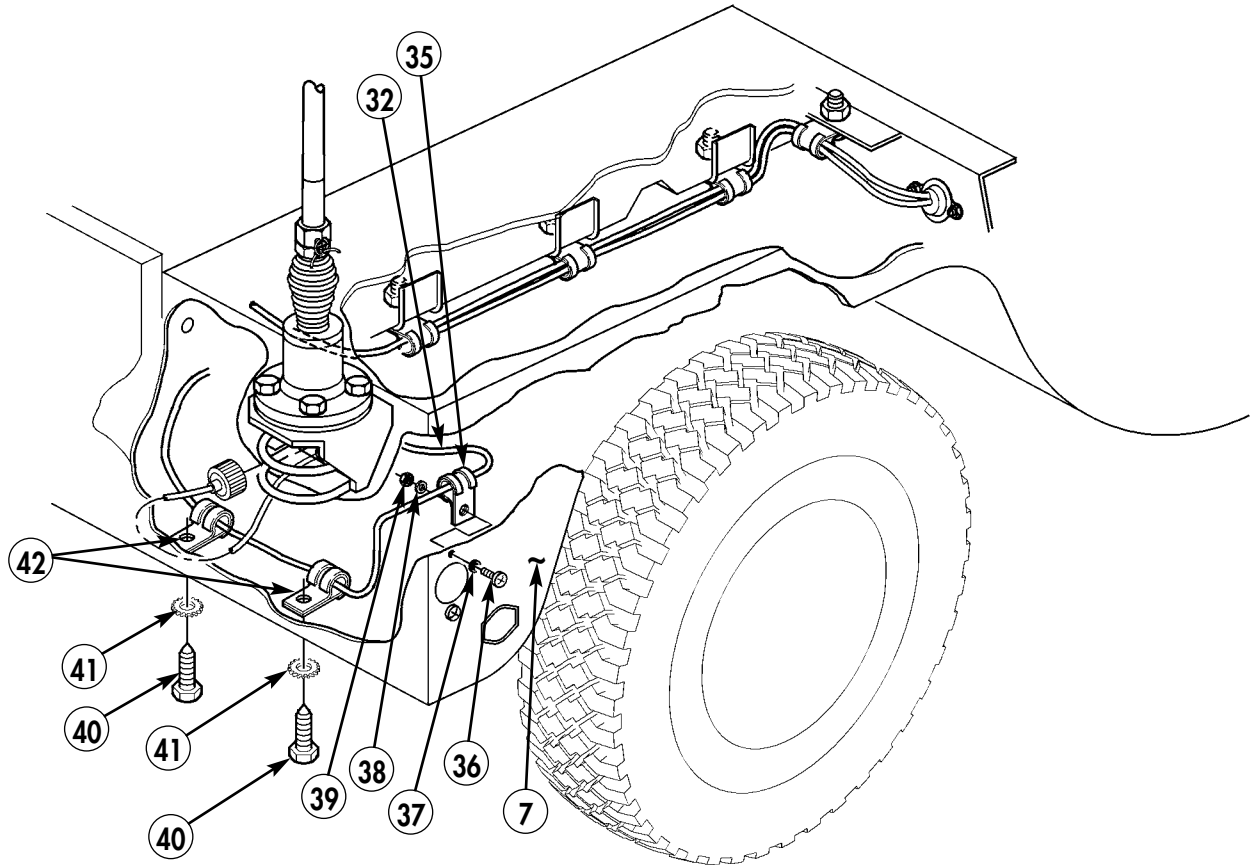
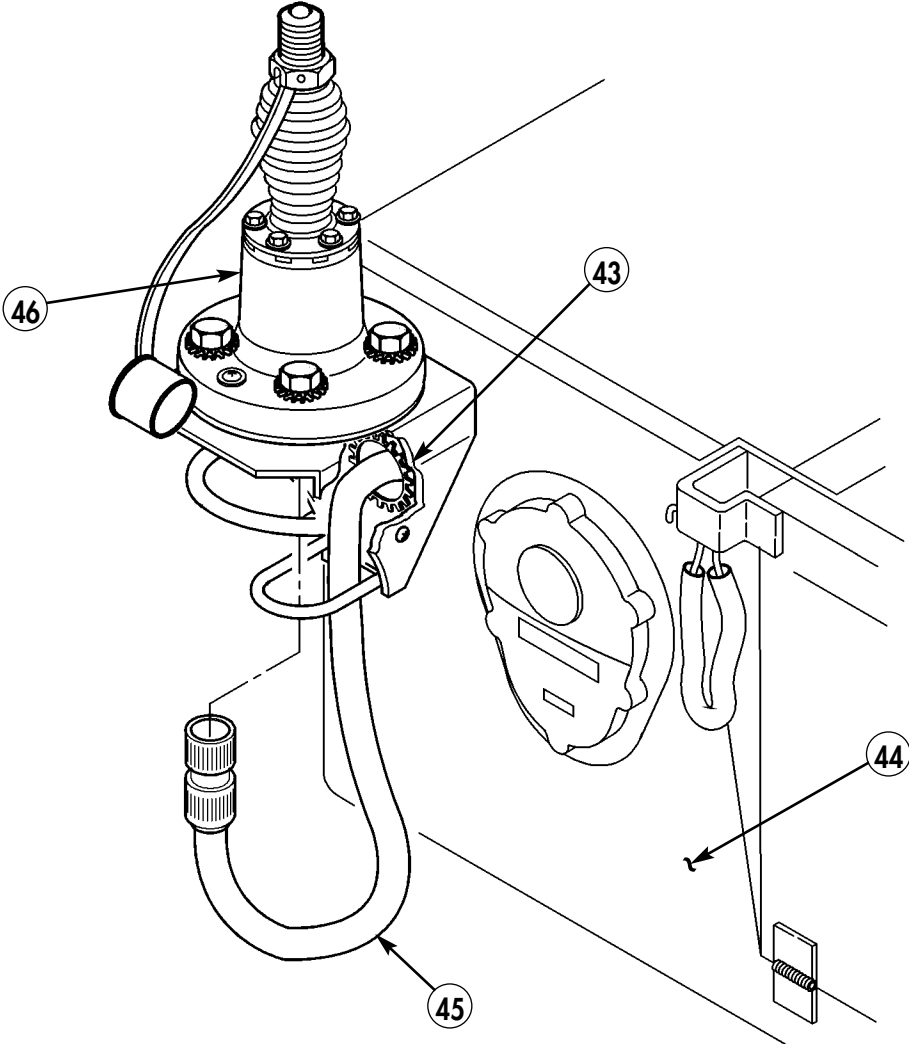

Figure 5-53.

- 13-20. Attach SINCGARS antenna cable (45) to antenna base (46).
- 13-21. Route SINCGARS antenna cable (45) through hole (43) in rear wall (44).



45. SINCGARS ANTENNA CABLE - A3014031-17 - QTY. 1

Figure 5-54.

- 13-22. Route SINCGARS antenna cable (45) along left rear wheelwell wall (53) with existing loop clamp (55), screw (54), lockwasher (47), and nut (48).
- 13-23. Route SINCGARS antenna cable (45) along existing taillight wiring harness on left side frame rail with two existing loop clamps (49), self-tapping screws (51), and lockwashers (50).

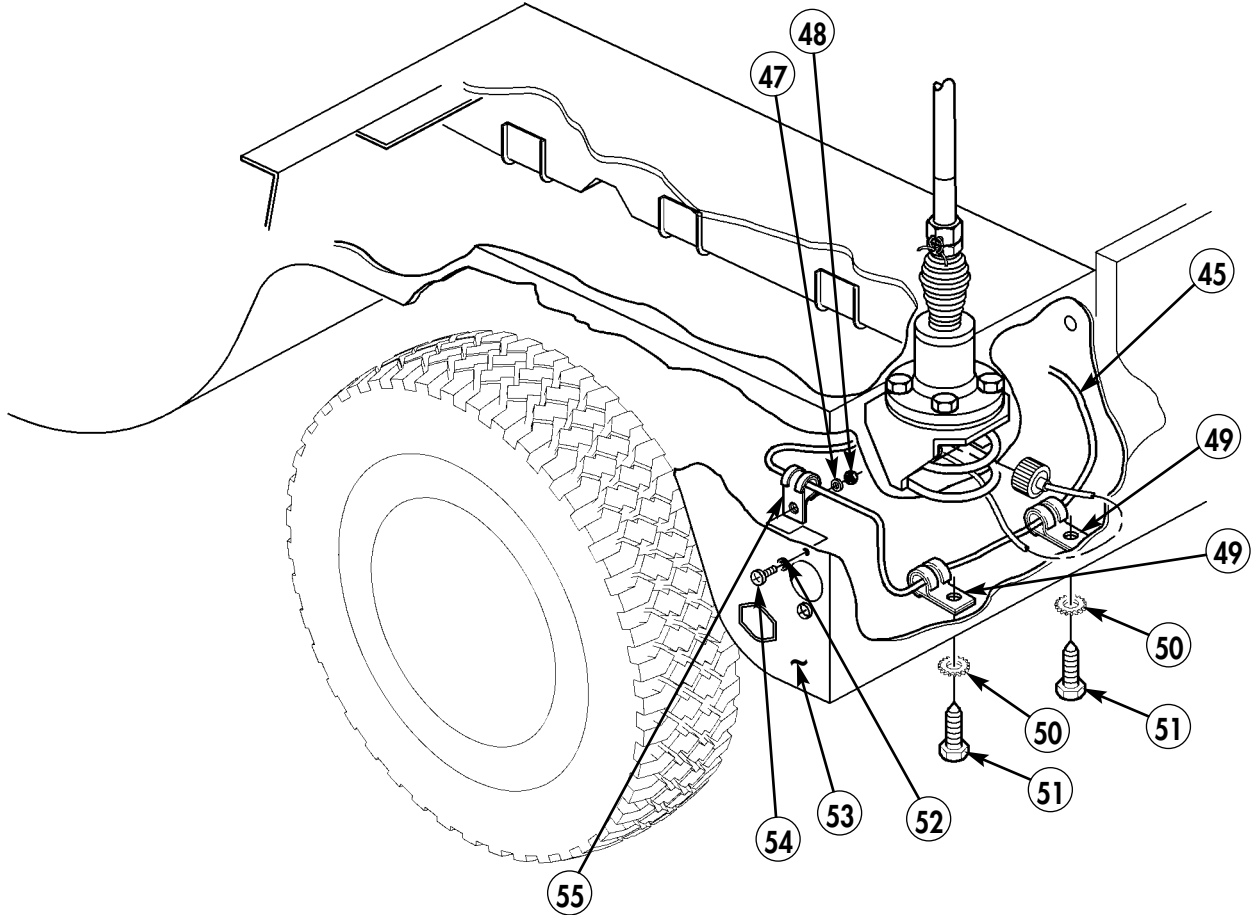

Figure 5-55.

- 13-24.** Route SINCGARS antenna cable (45) along existing taillight wiring harness (56) on rear cargo bed support and secure with five existing loop clamps (57) and self-tapping screws (58).

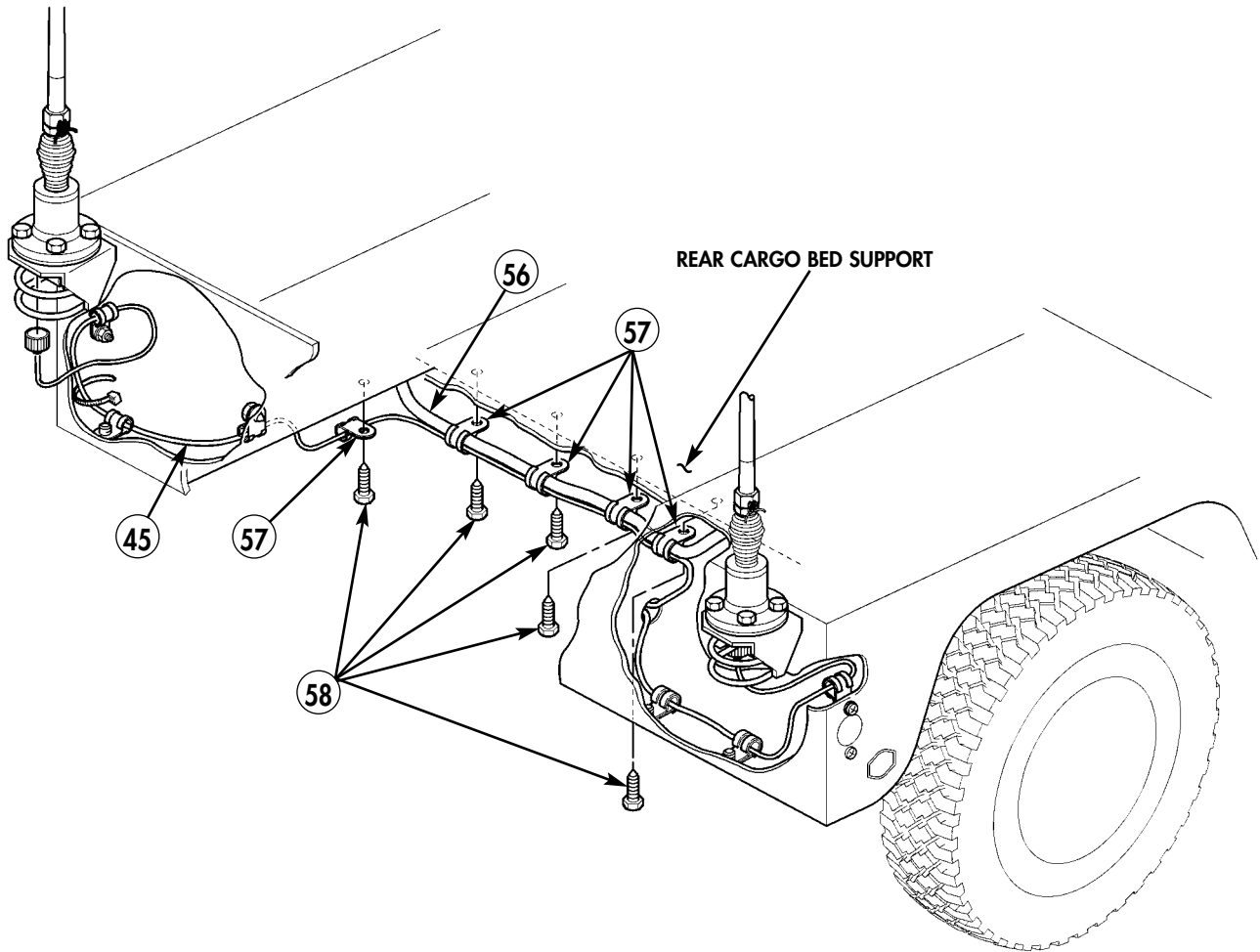

Figure 5-56.

13-25. Route SINCGARS antenna cables (32) and (45) through hole and grommet (59) in right rear wheelwell (60).

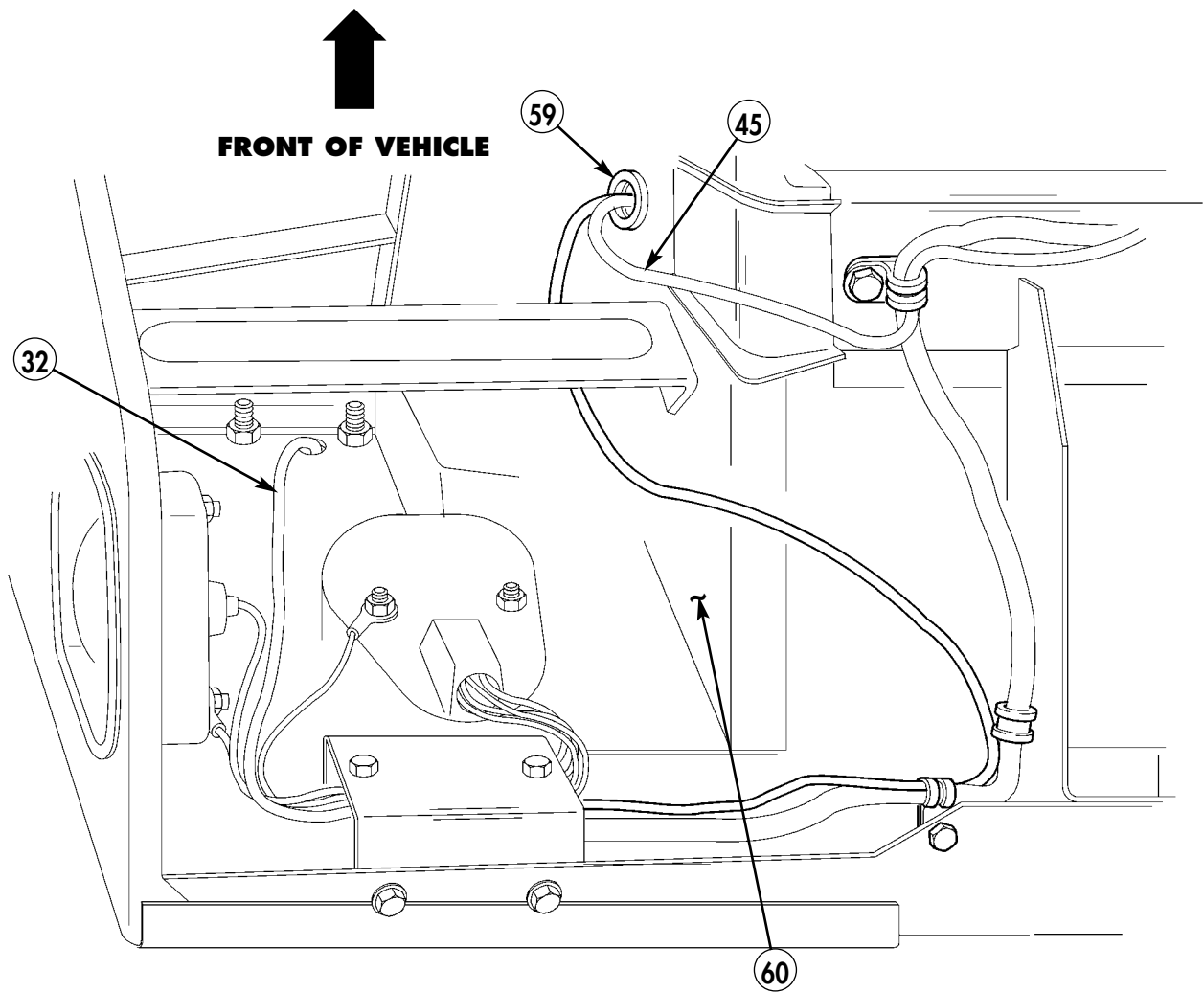

Figure 5-57.

13-26. Route power cable (22), INC-EPUU cable (21), LVOSS cables (28), and SINCGARS antenna cables (32) and (45) along channel of cargo floor (12) towards front of vehicle.

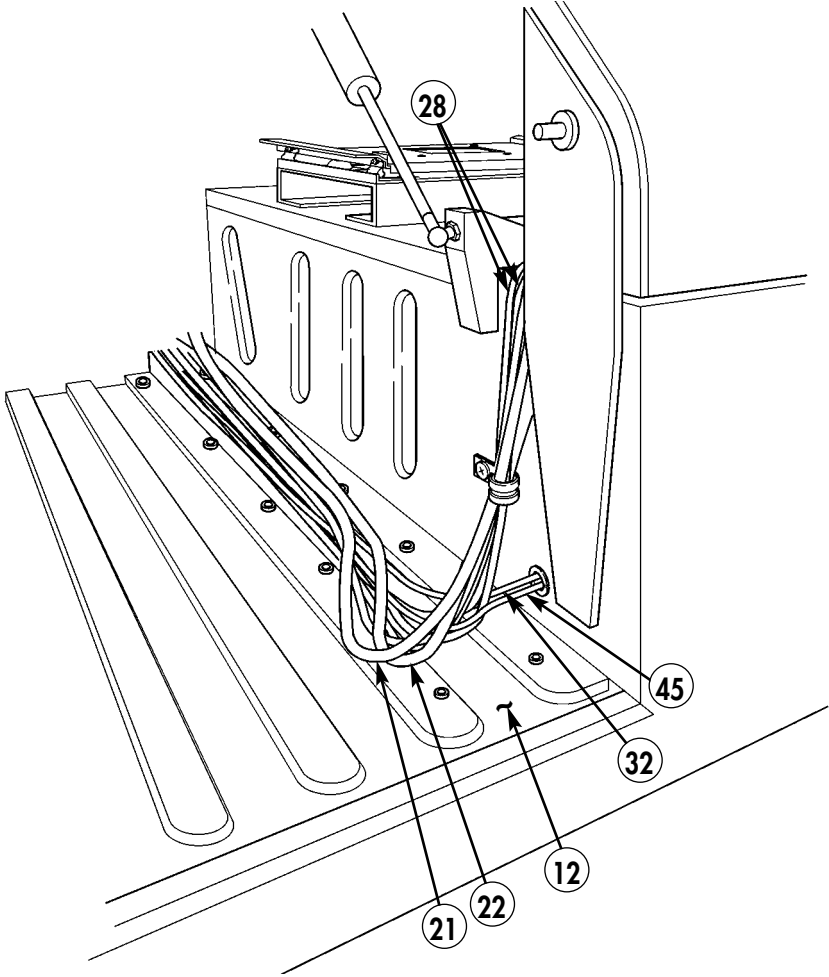

Figure 5-58.

13-27. Bundle all cables (62) and install in side channel (61) of cargo floor cover (10).

NOTE

Ensure all cables fit neatly within cargo floor channel before installing cargo floor cover.

13-28. Install cargo floor cover (10) on cargo floor (12) with twelve existing screws (9) and four screws (11) retained in step 13-4.

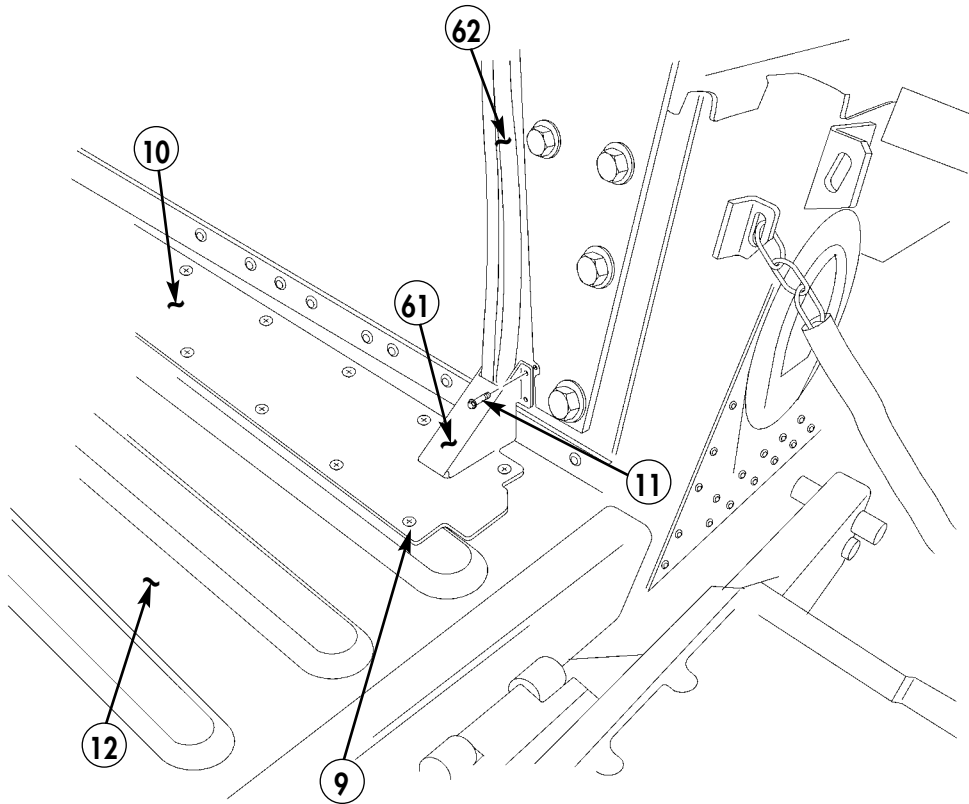

Figure 5-59.

13-29. Route all cables (62) forward from step 13-26 through cargo access hole (64) and in between tunnel (65) and right rear seat (63).

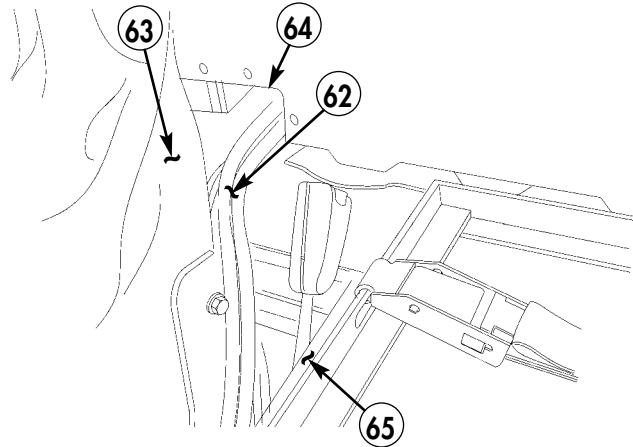

Figure 5-60.

NOTE

- Perform steps 13-30 and 13-31 if supplemental heater is not installed. Perform 13-32 and 13-33 if supplemental heater is installed.
- Use MS21333-75 clamp if LVOSS is not installed. Use MS21333-77 if LVOSS is installed.

13-30. Locate, mark, and drill three 0.147-in. diameter holes (66) in side of tunnel (67), evenly spaced apart.

13-31. Secure all cables (62) to side of tunnel (67) with three clamps (68) and self-tapping screws (69).

NOTE

Use MS21333-75 clamp if LVOSS is not installed. Use MS21333-77 if LVOSS is installed.

13-32. Locate, mark, and drill two 0.147-in. diameter holes (66) in side of tunnel (67), evenly spaced apart.

13-33. Secure all cables (62) to side of tunnel (67) with two loop clamps (68) and self-tapping screws (69), and clamp (68), existing bracket (71), and screw (70).

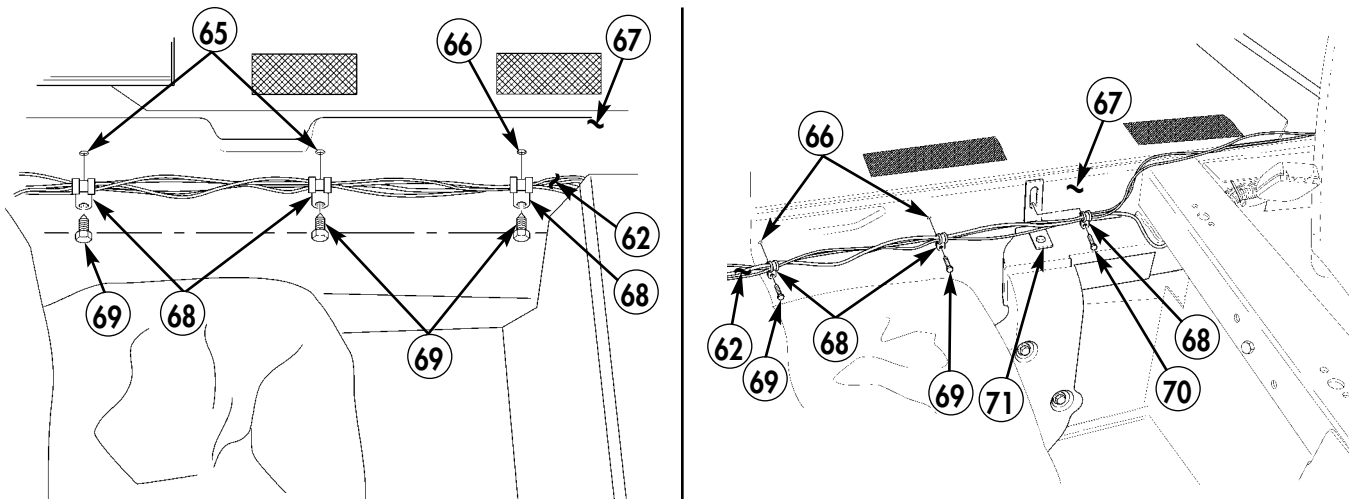

- 68. LOOP CLAMP – MS21333-75 – QTY. 3**
- 69. SELF-TAPPING SCREW – 9421073 – QTY. 2**

Figure 5-61.

NOTE

Remove terminal board cover before connecting leads, and reinstall cover after leads are connected.

- 13-34. Attach heat shrink tubing (74) and two terminal lugs (72) and (79) to power cable negative lead (78) and power cable positive lead (75). (Refer to TM 9-2320-387-24 for terminal connector repair.)
- 13-35. Connect power cable positive lead (75) to 24-volt terminal board (81), located on cab enclosure panel (82), with existing nut (83).
- 13-36. Connect power cable negative lead (78) to ground strap (80), located on cab enclosure panel (82), with existing nut (87). Secure leads (75) and (78) together with tiedown strap (76).

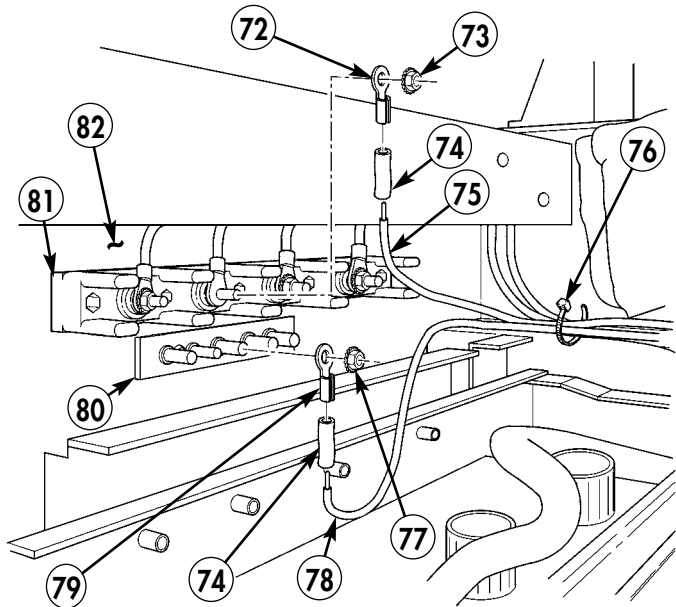

- 72. TERMINAL LUG – 7728780 – QTY. 1
- 74. SHRINK TUBING – MS23053/4-302-0 – QTY. A/R
- 76. TIEDOWN STRAP – MS3367-1-0 – QTY. A/R
- 79. TERMINAL LUG – 7728777 – QTY. 1

Figure 5-62.

- 13-37. Route remaining cables to integrated rack (83) using one loop clamp (85), existing capscrew (88), lockwasher (87), and washer (86).
- 13-38. Route cables along bar (89) to top of integrated rack (83) with two tiedown straps (84).

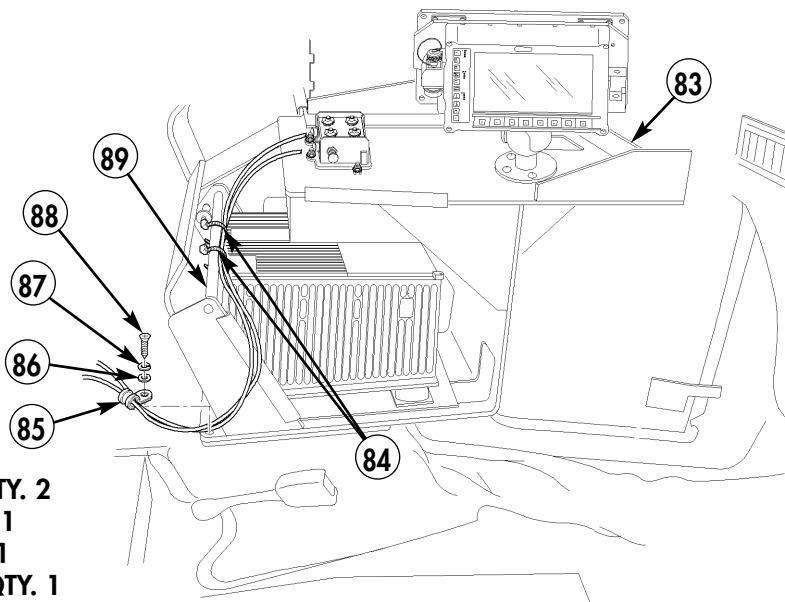

- 84. TIEDOWN STRAP – MS53367-1-0 – QTY. 2
- 85. LOOP CLAMP – MS21333-104 – QTY. 1
- 87. LOCKWASHER – MS35338-44 – QTY. 1
- 88. CAPSCREW – B1821BH025C088N – QTY. 1

Figure 5-63.

Section XIV. VIC-3 MOUNTING INSTALLATION: REAR FFCS/L AND CABLES

- 14-1. Install rear FFCS/L module (4) on existing bracket (7) with two capscrews (5), two washers (2), two washers (6), two lockwashers (3), two washers (2) and two nuts (1).

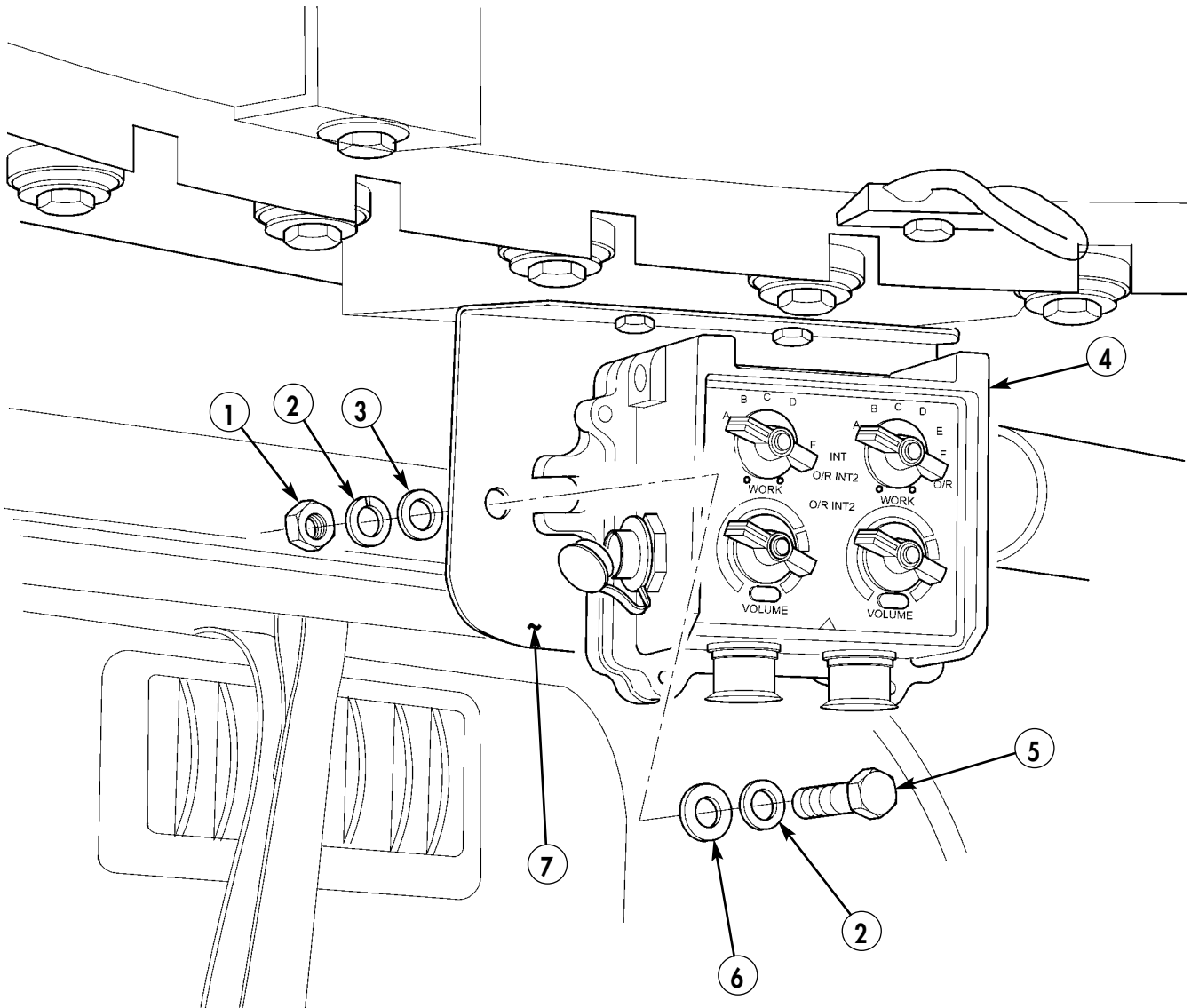

1. NUT - 9417954 - QTY. 2
2. WASHER - 2436162 - QTY. 4
3. LOCKWASHER - MS35338-45 - QTY. 2
4. REAR FFCS/L MODULE - A3206624 - QTY. 1
5. CAPSCREW - B1821BH031C150N - QTY. 2
6. WASHER - 2436164 - QTY. 2

Figure 5-64.

NOTE

Cables removed for clarity.

- 14-2. Install cable assembly (10) to front FFCS/L (11).
- 14-3. Install cable assembly (10) to MCS/L (14).
- 14-4. Install cable assembly (12) to front FFCS/L (11).
- 14-5. Install cable assembly (12) to MCS/L (14).
- 14-6. Install power cable assembly (13) to MCS/L (14).
- 14-7. Install R/T cable assembly (15) to MCS/L (14). Connect R/T cable assembly (15) to A4J4 connector (9) on SINCGARS mount (17).
- 14-8. Install R/T cable assembly (16) to MCS/L (14). Connect R/T cable assembly (16) to A4J3 connector (8) on SINCGARS mount (17).

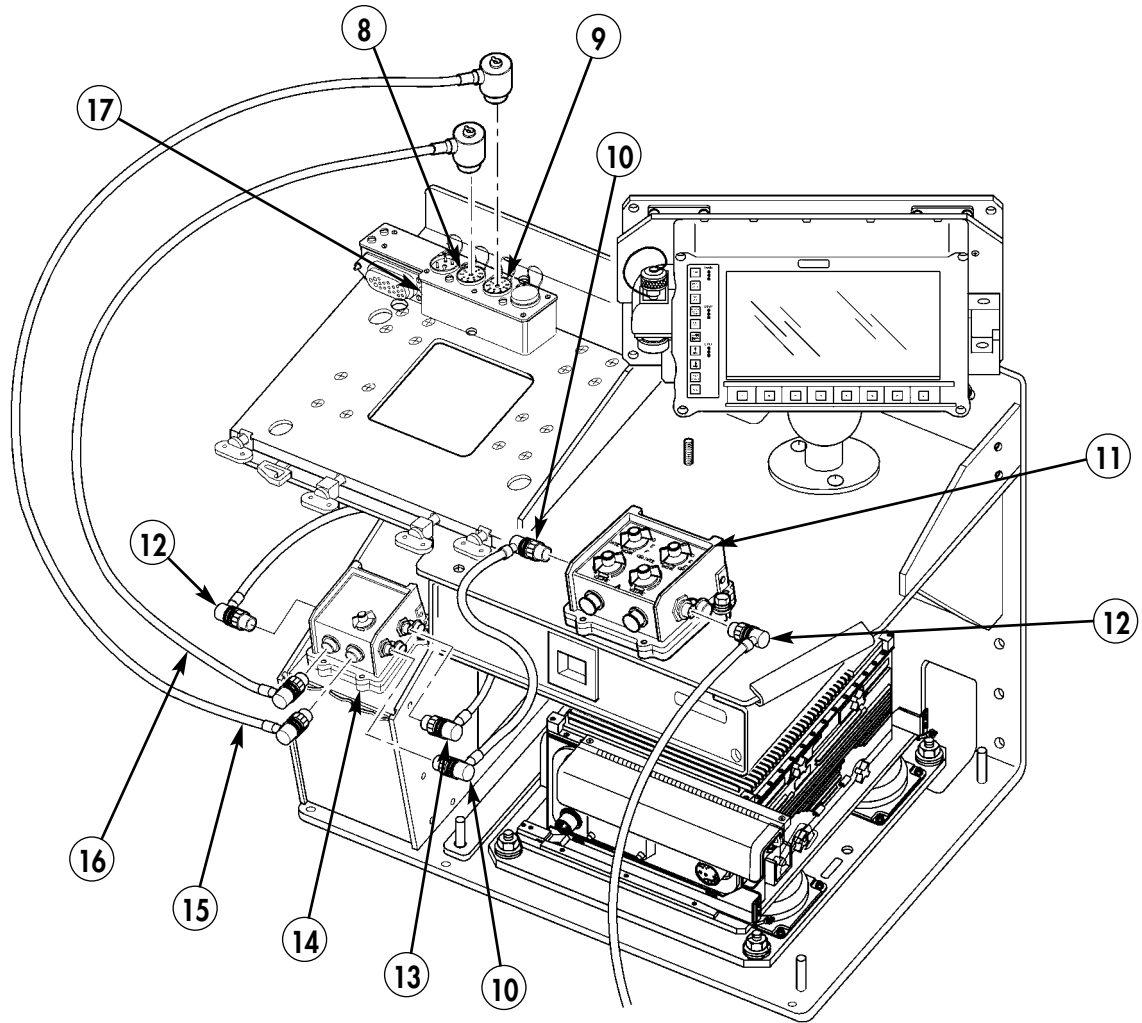

- 10. CABLE ASSEMBLY – A3206018-2 – QTY. 2
- 12. CABLE ASSEMBLY – A3206018-15 – QTY. 2
- 13. POWER CABLE ASSEMBLY – A3206017-3 – QTY. 1
- 15. CABLE ASSEMBLY, R/T – A3206019-3 – QTY. 1
- 16. CABLE ASSEMBLY, R/T – A3206127-3 – QTY. 1

Figure 5-64.1.

- 14-9. Route two cable assemblies (12) along underside of radio rack (22). Secure cable assemblies (12) to radio rack (22) with two loop clamps (19), self-tapping screws (20), and tiedown straps (21).
- 14-10. Route cable assemblies (12) under left side tunnel insulation (18).
- 14-11. Route cable assemblies (12) along tunnel (23). Secure cable assemblies (12) to tunnel (23) with three loop clamps (19) and self-tapping screws (20).
- 14-12. Route cable assemblies (12) behind left rear seat (25) and up rear wall (24) to rear FFCS/L (4). Secure cable assemblies (12) to rear wall with loop clamp (19) and self-tapping screw (20).
- 14-13. Connect cable assemblies (12) to rear FFCS/L (4).

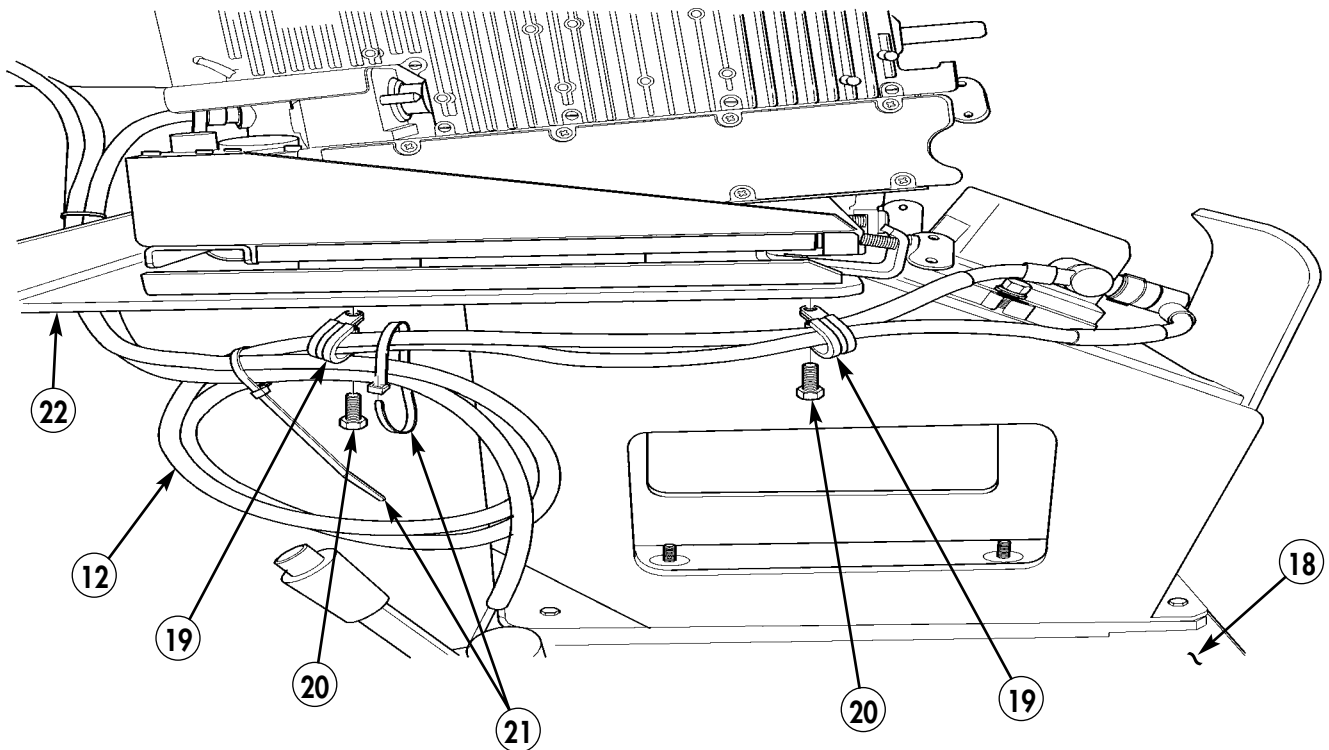

- 19. LOOP CLAMP – MS21333-69 – QTY. 1
- 20. SELF-TAPPING SCREW – 9421073 – QTY. 1

Figure 5-64.2.

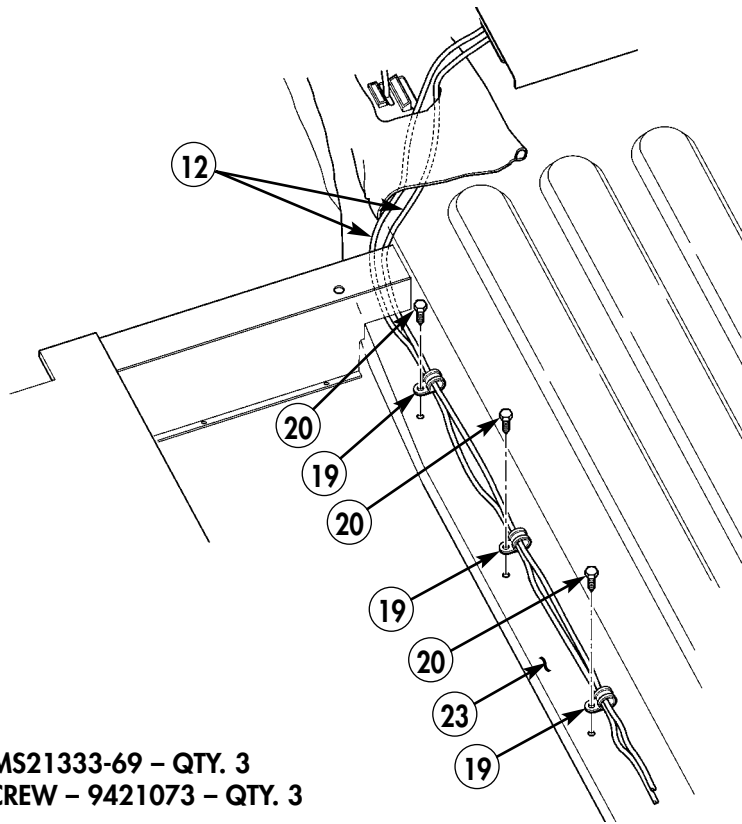

- 19. LOOP CLAMP – MS21333-69 – QTY. 3
- 20. SELF-TAPPING SCREW – 9421073 – QTY. 3

Figure 5-64.3.

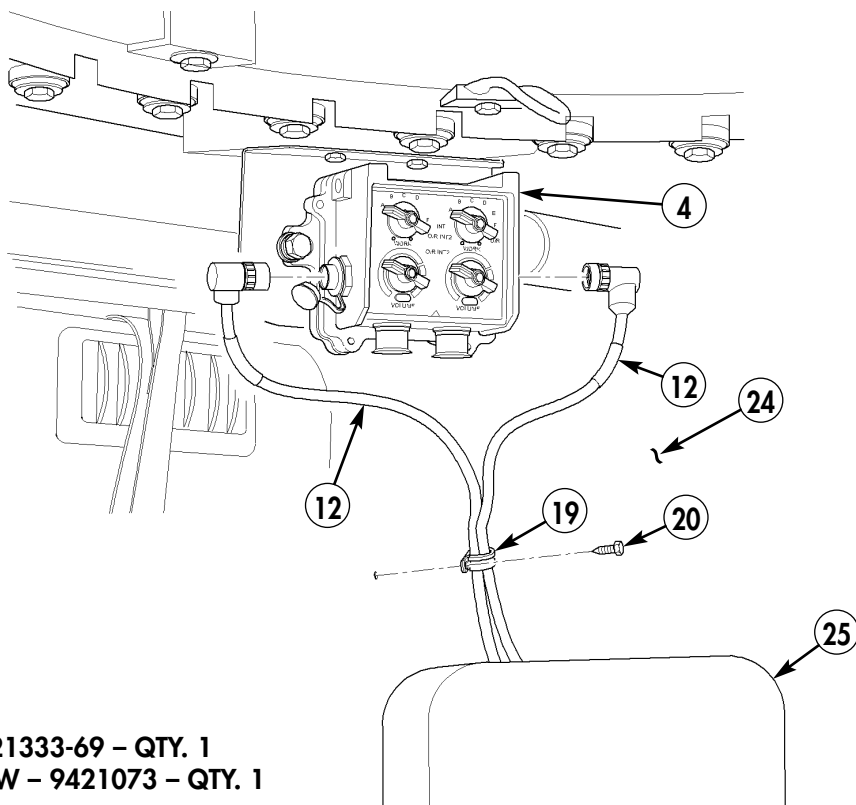

- 19. LOOP CLAMP – MS21333-69 – QTY. 1
- 20. SELF-TAPPING SCREW – 9421073 – QTY. 1

Figure 5-64.4.

Section XV. PLGR BRACKET INSTALLATION

15-1. Locate, mark, and drill two 0.218-in. diameter holes (2) in integrated rack (1).

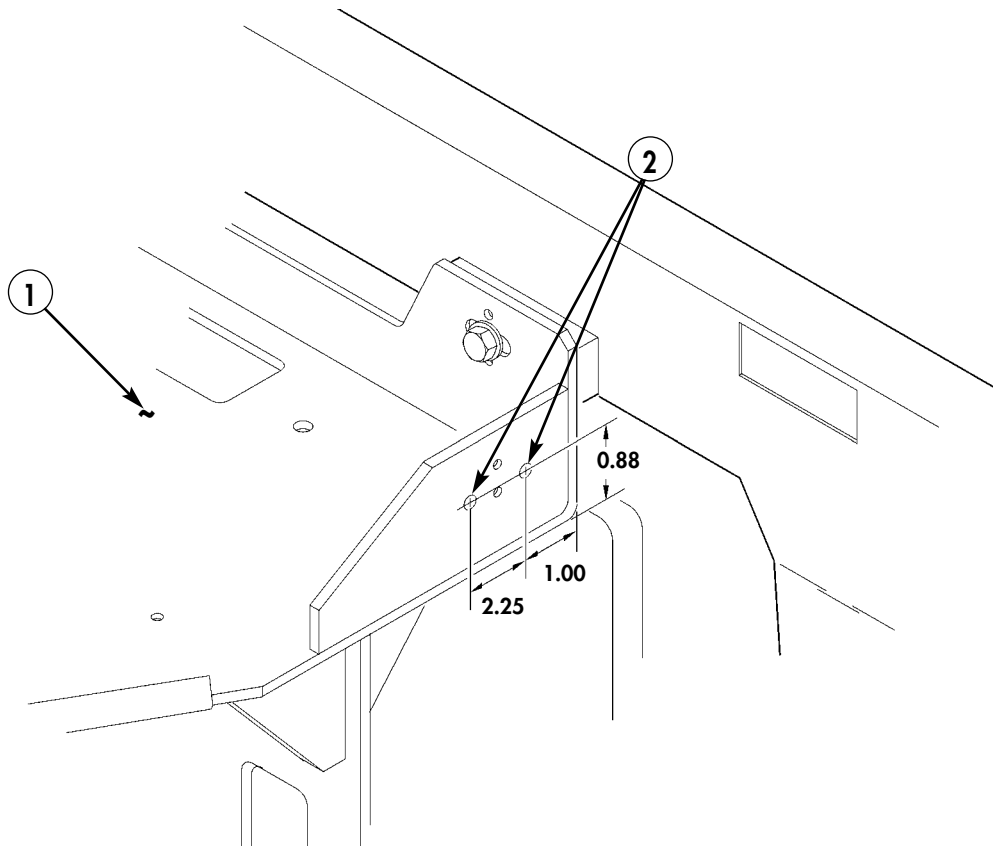
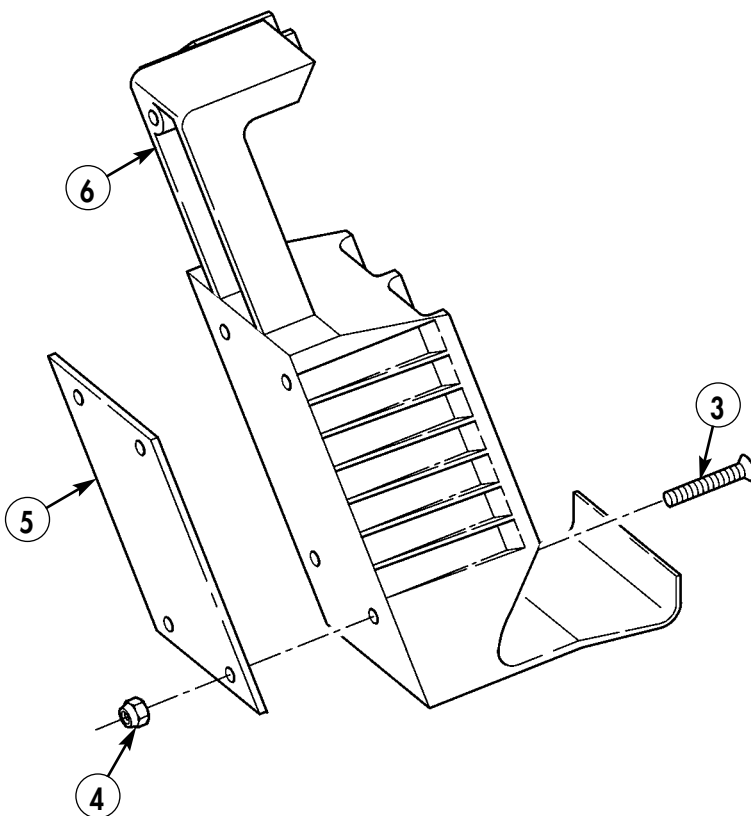

Figure 5-65.

15-2. Secure mounting bracket (5) to two lower holes in PLGR bracket (6) with two screws (3) and locknuts (4). Do not tighten locknuts (4).



- 3. SCREW – MS35206-266 – QTY. 2
- 4. LOCKNUT – MS17829-3C – QTY. 2
- 5. MOUNTING BRACKET – 12480575 – QTY. 1
- 6. PLGR BRACKET – 986-0645-001 – QTY.1

Figure 5-66.

15-3. Install PLGR mount assembly (7) on integrated rack (1) with two screws (3) and locknuts (4), using upper holes (8) only. Do not tighten locknuts (4).

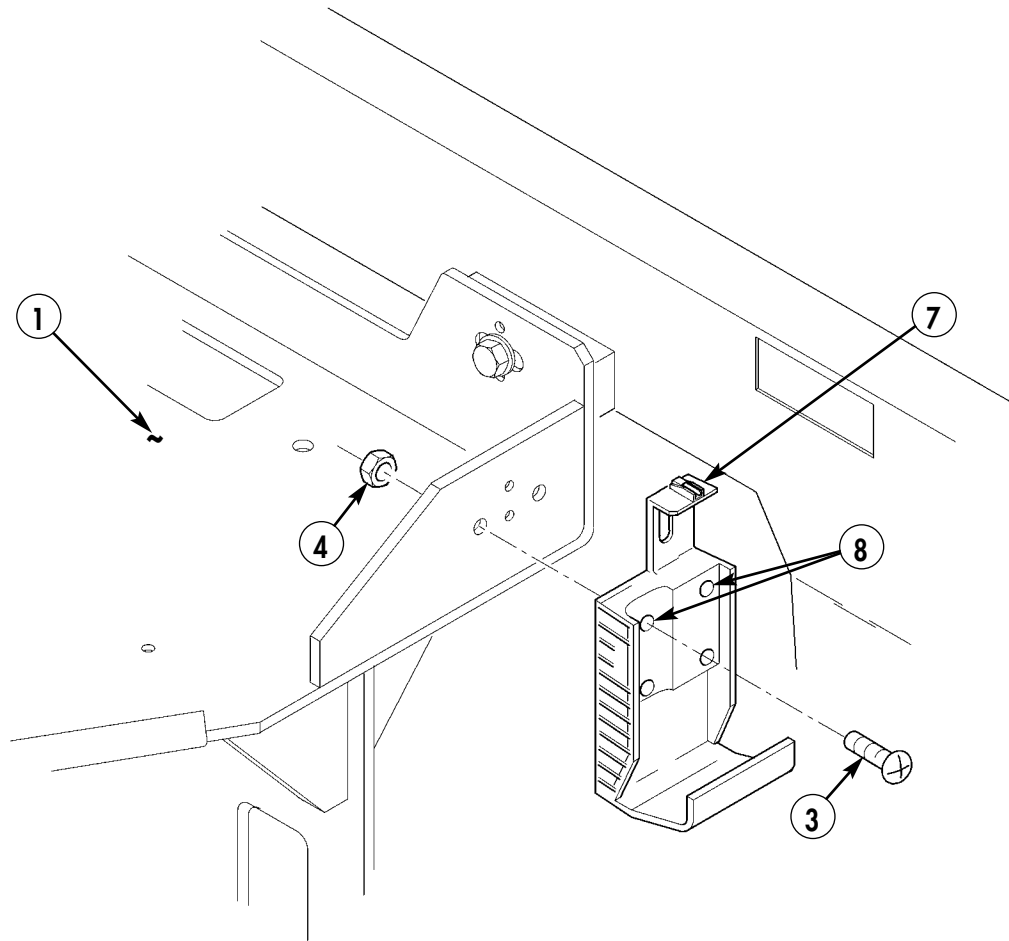

- 3. SCREW – MS35206-266 – QTY. 2
- 4. LOCKNUT – MS17829-3C – QTY. 2

Figure 5-67.

Section XVI. PLGR POWER CABLE INSTALLATION

16-1. Route PLGR power cable (2) from PLGR assembly (1) to B-beam (3).

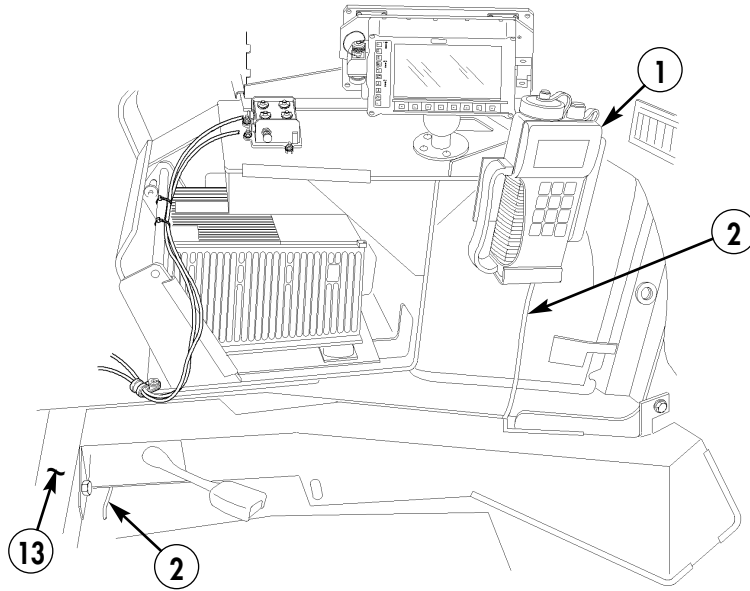

2. PLGR POWER CABLE – 9728558-10 – QTY. 1

Figure 5-68.

16-2. Attach shrink tubing (7) and terminal lugs (5) and (11) to PLGR power cable negative lead (10) and PLGR power cable positive lead (8). (Refer to TM 9-2320-387-24 for terminal connector repair.)

16-3. Attach PLGR power cable positive lead (8) to 24-volt terminal board stud (4) with existing nut (6).

16-4. Attach PLGR power cable negative lead (10) to ground strap stud (12) with existing nut (9).

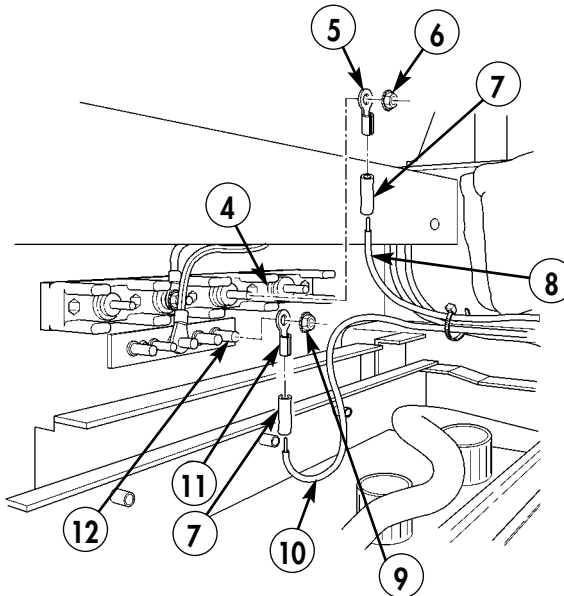

5. TERMINAL LUG – 7728780 – QTY. 1

7. SHRINK TUBING – MS23053/4-302-0 – QTY. A/R

11. TERMINAL LUG – 7728777 – QTY. 1

Figure 5-69.

Section XVII. PLGR ANTENNA AND CABLE INSTALLATION

- 17-1. Remove deep water fording intake stack. (Refer to TM 9-2320-387-24.)
- 17-2. Remove right windshield deflector. (Refer to TM 9-2320-387-24.)
- 17-3. Locate, mark, and drill two 0.147-in. diameter holes (2) in plenum (1).
- 17-4. Route PLGR antenna cable (3) along plenum (1) using two loop clamps (4) and self-tapping screws (5).

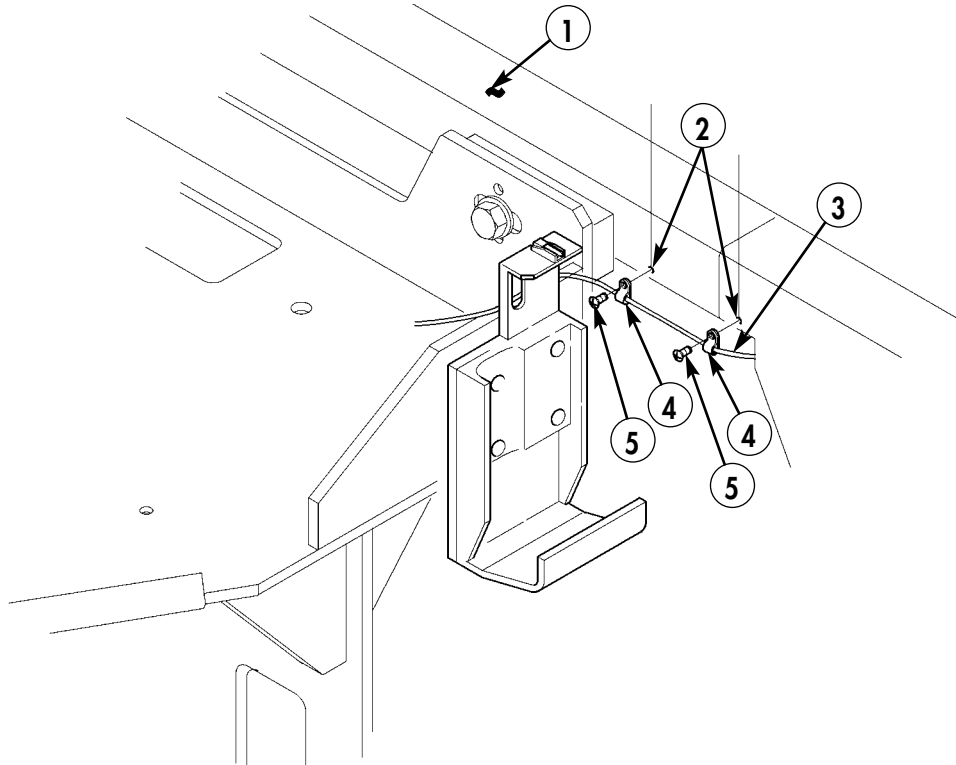

- 3. PLGR ANTENNA CABLE – 426-0141-050 – QTY. 1
- 4. LOOP CLAMP – MS21333-67 – QTY. 2
- 5. SELF-TAPPING SCREW – 9440025 – QTY. 2

Figure 5-70.

- 17-5. Cut grommet (6) to fit opening (8) and install in right windshield deflector (7).

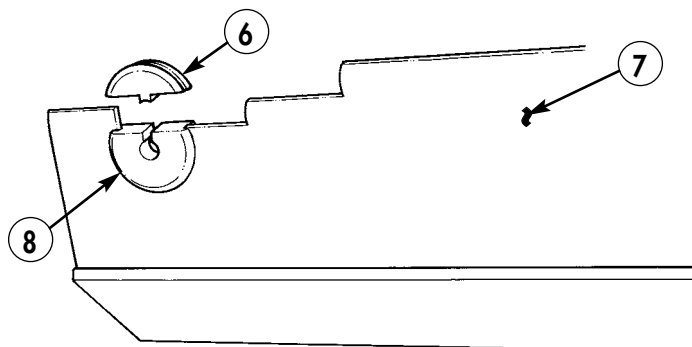

- 6. GROMMET – 12460299 – QTY. 1

Figure 5-71.

17-6. Locate, mark, and drill 0.562-in. diameter hole (11) in A-frame pillar (10).

NOTE

Wrap a section of PLGR antenna cable with tape to prevent PLGR antenna cable from being pulled into vehicle.

17-7. Split grommet (9) and insert PLGR antenna cable (3) and grommet (9) in hole (11) in A-frame pillar (10).

17-8. Apply RTV sealant around grommet (9).

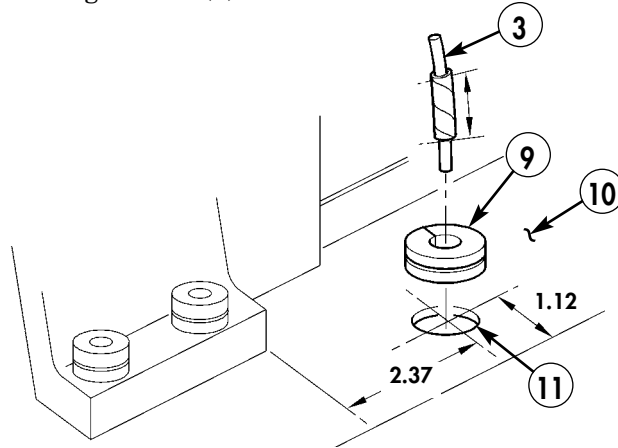

9. GROMMET – MS35489-31 – QTY. 1

Figure 5-72.

17-9. Attach PLGR antenna (14) to support bracket (15) with screw (12) and lockwasher (13).

17-10. Attach support bracket (15) to right windshield armor plate (23) with two existing screws (16), lockwashers (17), and washers (18).

17-11. Route PLGR antenna cable (3) along right windshield armor plate (23) with loop clamp (22), existing screw (19), lockwasher (20), and washer (21).

17-12. Connect PLGR antenna cable (3) to PLGR antenna (14).

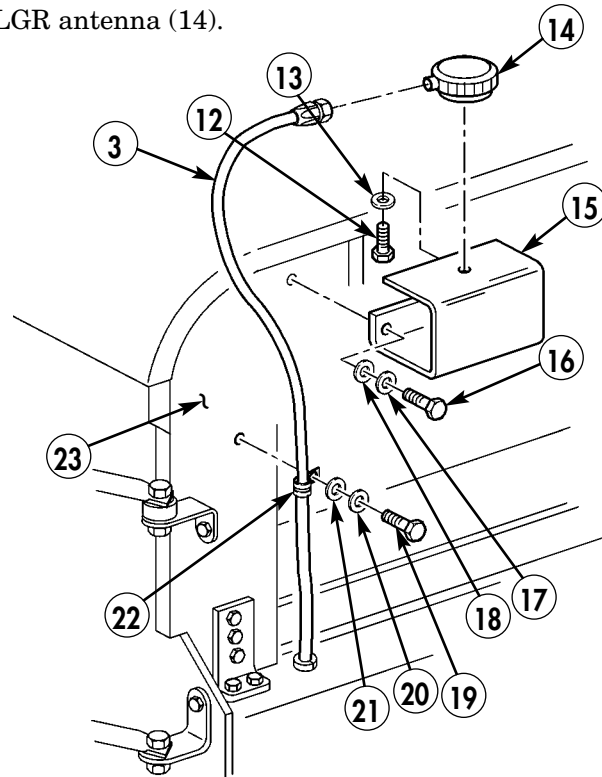

- 12. SCREW – MS35207-261 – QTY. 1
- 13. LOCKWASHER – MS35338-43 – QTY. 1
- 14. PLGR ANTENNA – AT575-030 – QTY. 1
- 15. SUPPORT BRACKET – 12460300 – QTY. 1
- 22. LOOP CLAMP – MS21333-96 – QTY. 1

Figure 5-73.

- 17-13. Secure PLGR power cable (27) and PLGR antenna cable (3) to PLGR mount assembly (24) with clamp (26), existing locknut (28), and screw (25). Tighten all locknuts (28).
- 17-14. Install right windshield deflector. (Refer to TM 9-2320-387-24.)
- 17-15. Install deep water fording stack. (Refer to TM 9-2320-387-24.)

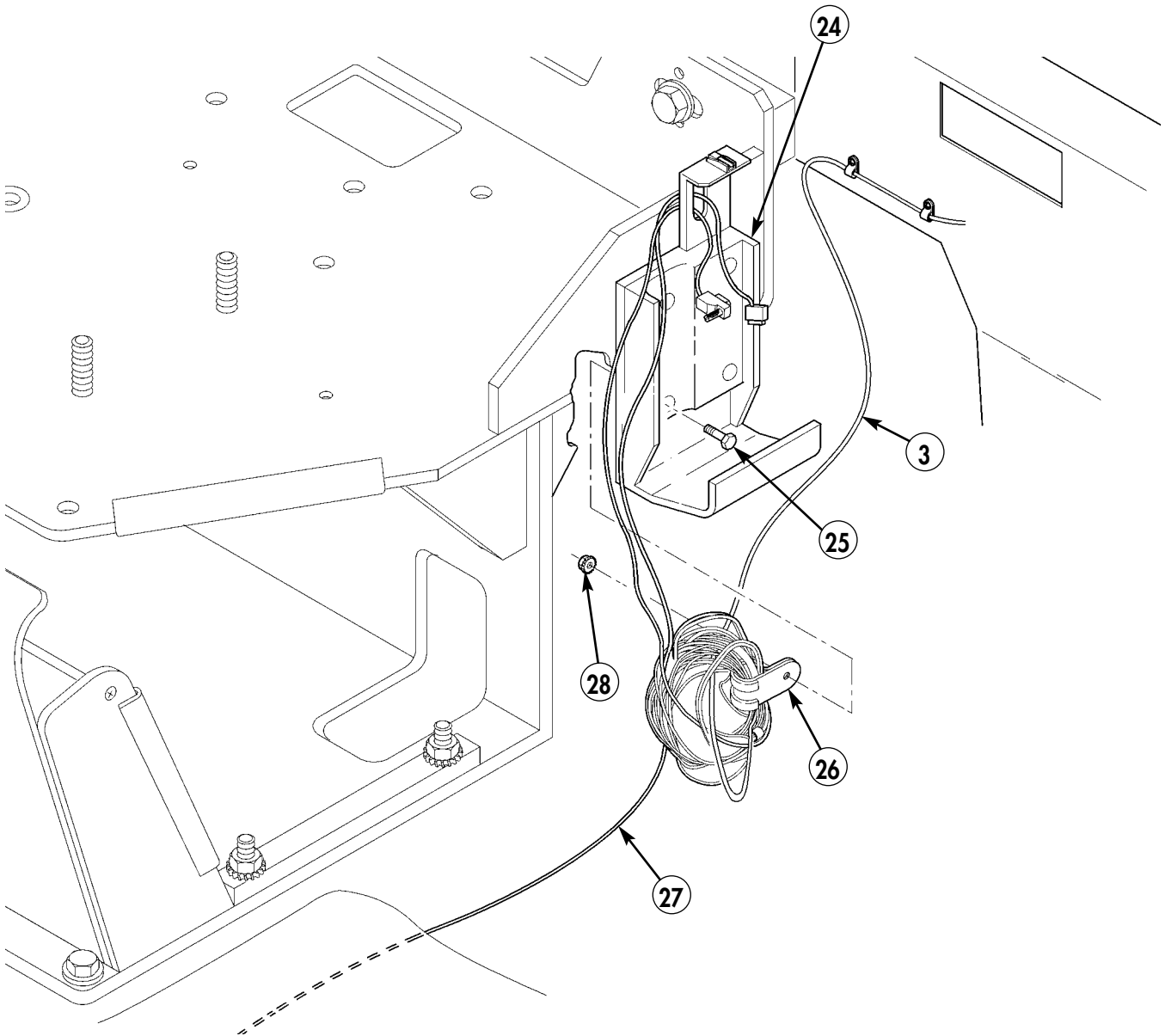

- 26. CLAMP – MS21333-78 – QTY. 1

Figure 5-74.

By Order of the Secretary of the Army:

PETER J. SCHOOMAKER
General, United States Army
Chief of Staff

Official:

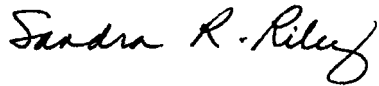

SANDRA R. RILEY
Administrative Assistant to the
Secretary of the Army
0520913

Distribution:

To be distributed in accordance with the Initial Distribution Number (IDN) 344826 requirements for TB 9-2320-387-35-1.

RECOMMENDED CHANGES TO PUBLICATIONS AND BLANK FORMS For use of this form, see AR 25-30; the proponent agency is ODISC4.	Use Part II (reverse) for Repair Parts and Special Tools Lists (RPSTL) and Supply Catalogs/Supply Manuals (SC/SM).	DATE: <p style="text-align: center;">5 Dec. 2005</p>
---	--	--

TO: <i>(Forward to proponent of publication or form) (include ZIP code)</i> AMSTA-LC-LPIT/Tech Pubs, TACOM-RI 1 Rock Island Arsenal Rock Island, IL 61299-7630	FROM: <i>(Activity and location) (include ZIP code)</i> <p style="text-align: center;">Co. B, 1st BN, 2nd Brigade Ft. Hood, TX 76445</p>
--	--

PART I - ALL PUBLICATIONS (EXCEPT RPSTL AND SC/SM) AND BLANK FORMS

PUBLICATION/FORM NUMBER <p style="text-align: center;">TB 9-2320-387-35-1</p>	DATE <p style="text-align: center;">17 OCT. 2005</p>	TITLE <p style="text-align: center;">TECHNICAL BULLETIN INSTALLATION INSTRUCTIONS</p>
---	--	---

ITEM NO.	PAGE NO.	PARA-GRAPH	LINE NO.*	FIGURE NO.	TABLE NO.	RECOMMENDED CHANGES AND REASON <i>(Provide exact wording of recommended changes, if possible)</i>
----------	----------	------------	-----------	------------	-----------	--

1	5-35			5-46		Grommet part number should be MS35498-149.
---	------	--	--	------	--	--

SAMPLE

**Reference to line numbers within the paragraph or subparagraph.*

TYPED NAME, GRADE, OR TITLE <p style="text-align: center;">Pat Smith</p>	TELEPHONE EXCHANGE/AUTOVON, PLUS EXTENSION <p style="text-align: center;">AV272-4162</p>	SIGNATURE <p style="text-align: center;"><i>Pat Smith</i></p>
--	---	--

TO: <i>(Forward direct to addressee listed in publication)</i> AMSTA-LC-LPIT/Tech Pubs, TACOM-RI 1 Rock Island Arsenal Rock Island, IL 61299-7630	FROM: <i>(Activity and location) (include ZIP code)</i>	DATE:
--	---	-------

PART II - REPAIR PARTS AND SPECIAL TOOLS LISTS AND SUPPLY CATALOGS/SUPPLY MANUALS

PUBLICATION/FORM NUMBER TB 9-2320-387-35-1	DATE 17 OCT. 2005	TITLE TECHNICAL BULLETIN INSTALLATION INSTRUCTIONS
---	----------------------	--

PAGE NO.	COLM NO.	LINE NO.	NATIONAL STOCK NUMBER	REFERENCE NO.	FIGURE NO.	ITEM NO.	TOTAL NO. OF MAJOR ITEMS SUPPORTED	RECOMMENDED ACTION
<h1>SAMPLE</h1>								

PART III - REMARKS *(Any general remarks or recommendations, or suggestions for improvement of publications and blank forms. Additional blank sheets may be used if more space is needed.)*

--	--	--

TYPED NAME, GRADE, OR TITLE	TELEPHONE EXCHANGE/AUTOVON, PLUS EXTENSION	SIGNATURE
-----------------------------	--	-----------

RECOMMENDED CHANGES TO PUBLICATIONS AND BLANK FORMS For use of this form, see AR 25-30; the proponent agency is ODISC4.				Use Part II (reverse) for Repair Parts and Special Tools Lists (RPSTL) and Supply Catalogs/Supply Manuals (SC/SM).		DATE:
TO: <i>(Forward to proponent of publication or form) (include ZIP code)</i> AMSTA-LC-LPIT/Tech Pubs, TACOM-RI 1 Rock Island Arsenal Rock Island, IL 61299-7630				FROM: <i>(Activity and location) (include ZIP code)</i>		
PART I - ALL PUBLICATIONS (EXCEPT RPSTL AND SC/SM) AND BLANK FORMS						
PUBLICATION/FORM NUMBER TB 9-2320-387-35-1			DATE 17 OCT. 2005		TITLE TECHNICAL BULLETIN INSTALLATION INSTRUCTIONS	
ITEM NO.	PAGE NO.	PARA-GRAPH	LINE NO.*	FIGURE NO.	TABLE NO.	RECOMMENDED CHANGES AND REASON <i>(Provide exact wording of recommended changes, if possible)</i>
<i>*Reference to line numbers within the paragraph or subparagraph.</i>						
TYPED NAME, GRADE, OR TITLE				TELEPHONE EXCHANGE/AUTOVON, PLUS EXTENSION		SIGNATURE

TO: <i>(Forward direct to addressee listed in publication)</i> AMSTA-LC-LPIT/Tech Pubs, TACOM-RI 1 Rock Island Arsenal Rock Island, IL 61299-7630	FROM: <i>(Activity and location) (include ZIP code)</i>	DATE:
---	--	--------------

PART II - REPAIR PARTS AND SPECIAL TOOLS LISTS AND SUPPLY CATALOGS/SUPPLY MANUALS

PUBLICATION/FORM NUMBER TB 9-2320-387-35-1	DATE 17 OCT. 2005	TITLE TECHNICAL BULLETIN INSTALLATION INSTRUCTIONS
--	-----------------------------	---

PAGE NO.	COLM NO.	LINE NO.	NATIONAL STOCK NUMBER	REFERENCE NO.	FIGURE NO.	ITEM NO.	TOTAL NO. OF MAJOR ITEMS SUPPORTED	RECOMMENDED ACTION

PART III - REMARKS *(Any general remarks or recommendations, or suggestions for improvement of publications and blank forms. Additional blank sheets may be used if more space is needed.)*

--

TYPED NAME, GRADE, OR TITLE	TELEPHONE EXCHANGE/AUTOVON, PLUS EXTENSION	SIGNATURE

RECOMMENDED CHANGES TO PUBLICATIONS AND BLANK FORMS For use of this form, see AR 25-30; the proponent agency is ODISC4.				Use Part II (reverse) for Repair Parts and Special Tools Lists (RPSTL) and Supply Catalogs/Supply Manuals (SC/SM).		DATE:
TO: <i>(Forward to proponent of publication or form) (include ZIP code)</i> AMSTA-LC-LPIT/Tech Pubs, TACOM-RI 1 Rock Island Arsenal Rock Island, IL 61299-7630				FROM: <i>(Activity and location) (include ZIP code)</i>		
PART I - ALL PUBLICATIONS (EXCEPT RPSTL AND SC/SM) AND BLANK FORMS						
PUBLICATION/FORM NUMBER TB 9-2320-387-35-1			DATE 17 OCT. 2005		TITLE TECHNICAL BULLETIN INSTALLATION INSTRUCTIONS	
ITEM NO.	PAGE NO.	PARA-GRAPH	LINE NO.*	FIGURE NO.	TABLE NO.	RECOMMENDED CHANGES AND REASON <i>(Provide exact wording of recommended changes, if possible)</i>
<i>*Reference to line numbers within the paragraph or subparagraph.</i>						
TYPED NAME, GRADE, OR TITLE				TELEPHONE EXCHANGE/AUTOVON, PLUS EXTENSION		SIGNATURE

TO: <i>(Forward direct to addressee listed in publication)</i> AMSTA-LC-LPIT/Tech Pubs, TACOM-RI 1 Rock Island Arsenal Rock Island, IL 61299-7630	FROM: <i>(Activity and location) (include ZIP code)</i>	DATE:
---	--	--------------

PART II - REPAIR PARTS AND SPECIAL TOOLS LISTS AND SUPPLY CATALOGS/SUPPLY MANUALS

PUBLICATION/FORM NUMBER TB 9-2320-387-35-1	DATE 17 OCT. 2005	TITLE TECHNICAL BULLETIN INSTALLATION INSTRUCTIONS
--	-----------------------------	---

PAGE NO.	COLM NO.	LINE NO.	NATIONAL STOCK NUMBER	REFERENCE NO.	FIGURE NO.	ITEM NO.	TOTAL NO. OF MAJOR ITEMS SUPPORTED	RECOMMENDED ACTION

PART III - REMARKS *(Any general remarks or recommendations, or suggestions for improvement of publications and blank forms. Additional blank sheets may be used if more space is needed.)*

--

TYPED NAME, GRADE, OR TITLE	TELEPHONE EXCHANGE/AUTOVON, PLUS EXTENSION	SIGNATURE