

TECHNICAL MANUAL UNIT MAINTENANCE

TRUCK, UTILITY: CARGO/TROOP CARRIER, 1-1/4 TON, 4X4, M998
(2320-01-107-7155) (EIC: BBD); M998A1 (2320-01-371-9577) (EIC: BBN);

TRUCK, UTILITY: CARGO/TROOP CARRIER, 1-1/4 TON, 4X4, W/WINCH,
M1038 (2320-01-107-7156) (EIC: BBE); M1038A1 (2320-01-371-9578) (EIC: BBP);

TRUCK, UTILITY: HEAVY VARIANT, 4X4, M1097 (2320-01-346-9317) (EIC: BBM);
M1097A1 (2320-01-371-9583) (EIC: BBU); M1097A2 (2320-01-380-8604) (EIC: BB6);
M1123 (2320-01-455-9593) (EIC: B6G);

TRUCK, UTILITY: TOW CARRIER, ARMORED, 1-1/4 TON, 4X4,
M966 (2320-01-107-7153) (EIC: BBC); M966A1 (2320-01-372-3932) (EIC: BBX);
M1121 (2320-01-456-1282) (EIC: B6H);

TRUCK, UTILITY: TOW CARRIER, ARMORED, 1-1/4 TON, 4X4, W/WINCH,
M1036 (2320-01-107-7154) (EIC: BBH);

TRUCK, UTILITY: TOW CARRIER, W/SUPPLEMENTAL ARMOR, 1-1/4 TON, 4X4,
M1045 (2320-01-146-7191); M1045A1 (2320-01-371-9580) (EIC: BBR);
M1045A2 (2320-01-380-8229) (EIC: BB5);

TRUCK, UTILITY: TOW CARRIER, W/SUPPLEMENTAL ARMOR, 1-1/4 TON, 4X4, W/WINCH,
M1046 (2320-01-146-7188); M1046A1 (2320-01-371-9582) (EIC: BBT);

TRUCK, UTILITY: ARMAMENT CARRIER, ARMORED, 1-1/4 TON, 4X4, M1025
(2320-01-128-9551) (EIC: BBF); M1025A1 (2320-01-371-9584) (EIC: BBV);
M1025A2 (2320-01-380-8233) (EIC: BB3);

TRUCK, UTILITY: ARMAMENT CARRIER, ARMORED, 1-1/4 TON, 4X4, W/WINCH,
M1026 (2320-01-128-9552) (EIC: BBG); M1026A1 (2320-01-371-9579) (EIC: BBQ);

TRUCK, UTILITY: ARMAMENT CARRIER, W/SUPPLEMENTAL ARMOR, 1-1/4 TON, 4X4,
M1043 (2320-01-146-7190); M1043A1 (2320-01-372-3933) (EIC: BBY);
M1043A2 (2320-01-380-8213) (EIC: BB4);

TRUCK, UTILITY: ARMAMENT CARRIER, W/SUPPLEMENTAL ARMOR, 1-1/4 TON, 4X4,
W/WINCH, M1044 (2320-01-146-7189); M1044A1 (2320-01-371-9581) (EIC: BBS);

TRUCK, UTILITY: S250 SHELTER CARRIER, 4X4, M1037 (2320-01-146-7193) (EIC: BBK);

TRUCK, UTILITY: S250 SHELTER CARRIER, 4X4, W/WINCH, M1042 (2320-01-146-7187);

TRUCK, AMBULANCE, 2-LITTER, ARMORED, 4X4, M996 (2310-01-111-2275)
(EIC: BBB); M996A1 (2310-01-372-3935) (EIC: BB2);

TRUCK, AMBULANCE, 4-LITTER, ARMORED, 4X4, M997 (2310-01-111-2274) (EIC: BBA);
M997A1 (2310-01-372-3934) (EIC: BBZ); M997A2 (2310-01-380-8225) (EIC: BB8);

TRUCK, AMBULANCE, 2-LITTER, SOFT TOP, 4X4, M1035 (2310-01-146-7194);
M1035A1 (2310-01-371-9585) (EIC: BBW); M1035A2 (2310-01-380-8290) (EIC: BB9).

BODY AND ACCESSORIES
MAINTENANCE 10-1

SPECIAL PURPOSE
BODIES MAINTENANCE 11-1

SPECIAL PURPOSE KITS
MAINTENANCE 12-1

PREPARATION FOR
STORAGE OR SHIPMENT 13-1

Approved for public release; distribution is unlimited.

HEADQUARTERS, DEPARTMENTS OF THE ARMY,
THE AIR FORCE, AND MARINE CORPS

JANUARY 1996

WARNING**EXHAUST GASES CAN KILL**

Brain damage or death can result from heavy exposure. Precautions must be followed to ensure crew safety when the personnel heater, main, or auxiliary engine of any vehicle is operated for any purpose.

1. Do not operate your vehicle engine in enclosed areas.
2. Do not idle vehicle engine with vehicle windows closed.
3. Be alert at all times for exhaust odors.
4. Be alert for exhaust poisoning symptoms. they are:
 - Headache
 - Dizziness
 - Sleepiness
 - Loss of muscular control
5. If you see another person with exhaust poisoning symptoms:
 - Remove person from area
 - Expose to open air
 - Keep person warm
 - Do not permit physical exercise
 - Administer artificial respiration, if necessary*
 - Notify a medic

*For artificial respiration, refer to FM 21-11.

6. BE AWARE, the field protective mask for nuclear, biological or chemical (NBC) protection will not protect you from carbon monoxide poisoning.

THE BEST DEFENSE AGAINST EXHAUST POISONING IS ADEQUATE VENTILATION.

WARNING SUMMARY

- Hood must be supported during removal and installation and hood prop rod and bracket replacement. Failure to support hood may cause injury to personnel or damage to equipment.
- Diesel fuel is highly flammable. Do not perform this procedure near fire, flames, or sparks. Severe injury or death will result.
- Do not touch hot exhaust system components with bare hands. Severe injury will result.
- Windshield must be supported during removal and installation. Failure to support windshield may cause injury to personnel or damage to equipment.
- Winch must be supported during removal and installation. Failure to support winch may cause severe injury to personnel or damage to equipment.
- Gloves must be worn whenever handling winch cable. Severe injury may result.
- Opening one end of cargo door before ensuring opposite end is securely closed will cause both ends to open simultaneously, resulting in injury to personnel or damage to equipment.
- Rear steps must be raised before disconnecting retractor lever from rear steps. Failure to do this may cause injury to personnel and damage to equipment.
- NBC contaminated filters must be handled and disposed of only by authorized and trained personnel. The unit commander or senior officer in charge of maintenance personnel must ensure that prescribed protective clothing (FM 3-4) is used, and prescribed safety measures and decontamination procedures (FM 3-5) are followed. The local unit SOP is responsible for final disposal of contaminated air filters. Failure to do this may cause severe injury to personnel.
- Seatbelts are to be replaced as a set. Failure to do this may cause injury to personnel or damage to equipment.
- Use eyeshields and gloves when removing and installing windshield. Glass could shatter causing injury.
- One assistant will be required to hold the cargo door open when either one or both gas springs are being removed and installed. Failure to do so may result in injury to personnel or damage to equipment.
- Direct all personnel to stand clear during any hoisting operations. A heavy, swinging load can be extremely dangerous. Failure to do so may cause injury to personnel or damage to equipment.

CHANGE
NO. 2

HEADQUARTERS,
DEPARTMENTS OF THE ARMY,
THE AIR FORCE, AND MARINE CORPS
WASHINGTON, D.C., 15 July 2004

TECHNICAL MANUAL
VOLUME 3 OF 3
UNIT MAINTENANCE

TRUCK, UTILITY: CARGO/TROOP CARRIER, 1-1/4 TON, 4X4,
M998 (2320-01-107-7155) (EIC: BBD); M998A1 (2320-01-371-9577) (EIC: BBN);
TRUCK, UTILITY: CARGO/TROOP CARRIER, 1-1/4 TON, 4X4, W/WINCH,
M1038 (2320-01-107-7156) (EIC: BBE); M1038A1 (2320-01-371-9578) (EIC: BBP);
TRUCK, UTILITY: HEAVY VARIANT, 4X4, M1097 (2320-01-346-9317) (EIC: BBM);
M1097A1 (2320-01-371-9583) (EIC: BBU); M1097A2 (2320-01-380-8604) (EIC: BB6); M1123 (2320-01-455-9593) (EIC: B6G);
TRUCK, UTILITY: TOW CARRIER, ARMORED, 1-1/4 TON, 4X4,
M966 (2320-01-107-7153) (EIC: BBC); M966A1 (2320-01-372-3932) (EIC: BBX); M1121 (2320-01-456-1282) (EIC: B6H);
TRUCK, UTILITY: TOW CARRIER, ARMORED, 1-1/4 TON, 4X4, W/WINCH,
M1036 (2320-01-107-7154) (EIC: BBH);
TRUCK, UTILITY: TOW CARRIER, W/SUPPLEMENTAL ARMOR, 1-1/4 TON, 4X4,
M1045 (2320-01-146-7191); M1045A1 (2320-01-371-9580) (EIC: BBR); M1045A2 (2320-01-380-8229) (EIC: BB5);
TRUCK, UTILITY: TOW CARRIER, W/SUPPLEMENTAL ARMOR, 1-1/4 TON, 4X4, W/WINCH,
M1046 (2320-01-146-7188); M1046A1 (2320-01-371-9582) (EIC: BBT);
TRUCK, UTILITY: ARMAMENT CARRIER, ARMORED, 1-1/4 TON, 4X4,
M1025 (2320-01-128-9551) (EIC: BBF); M1025A1 (2320-01-371-9584) (EIC: BBV); M1025A2 (2320-01-380-8233) (EIC: BB3);
TRUCK, UTILITY: ARMAMENT CARRIER, ARMORED, 1-1/4 TON, 4X4, W/WINCH,
M1026 (2320-01-128-9552) (EIC: BBG); M1026A1 (2320-01-371-9579) (EIC: BBQ);
TRUCK, UTILITY: ARMAMENT CARRIER, W/SUPPLEMENTAL ARMOR, 1-1/4 TON, 4X4,
M1043 (2320-01-146-7190); M1043A1 (2320-01-372-3933) (EIC: BBY); M1043A2 (2320-01-380-8213) (EIC: BB4);
TRUCK, UTILITY: ARMAMENT CARRIER, W/SUPPLEMENTAL ARMOR, 1-1/4 TON, 4X4, W/WINCH,
M1044 (2320-01-146-7189); M1044A1 (2320-01-371-9581) (EIC: BBS);
TRUCK, UTILITY: S250 SHELTER CARRIER, 4X4, M1037 (2320-01-146-7193) (EIC: BBK);
TRUCK, UTILITY: S250 SHELTER CARRIER, 4X4, W/WINCH, M1042 (2320-01-146-7187);
TRUCK, AMBULANCE, 2-LITTER, ARMORED, 4X4, M996 (2310-01-111-2275) (EIC: BBB); M996A1 (2310-01-372-3935) (EIC: BB2);
TRUCK, AMBULANCE, 4-LITTER, ARMORED, 4X4, M997 (2310-01-111-2274) (EIC: BBA);
M997A1 (2310-01-372-3934) (EIC: BBZ); M997A2 (2310-01-380-8225) (EIC: BB8);
TRUCK, AMBULANCE, 2-LITTER, SOFT TOP, 4X4,
M1035 (2310-01-146-7194); M1035A1 (2310-01-371-9585) (EIC: BBW); M1035A2 (2310-01-380-8290) (EIC: BB9).

TM 9-2320-280-20-3, 31 January 1996, is changed as follows:

1. Remove old pages and insert new pages as indicated below.
2. New or changed material is indicated by a vertical bar in the margin of the page.

Remove pages

A and B
i and ii
10-3 through 10-8
10-11 through 10-22
10-27 through 10-30
10-33 and 10-34
10-43 through 10-48
10-51 through 10-72
10-83 and 10-84
10-87 through 10-102
10-111 and 10-112
10-114.1 through 10-120
10-123 through 10-134
10-143 through 10-146
10-151 through 10-154.2
10-159 and 10-160
10-165 and 10-166
10-167 through 10-170

Insert pages

A through D
i and ii
10-3 through 10-8
10-11 through 10-22
10-27 through 10-30
10-33 and 10-34
10-43 through 10-48
10-51 through 10-72
10-83 and 10-84
10-87 through 10-102
10-111 and 10-112
10-114.1 through 10-120
10-123 through 10-134
10-143 through 10-146
10-151 through 10-154.2
10-159 and 10-160
10-165 and 10-166
10-167 through 10-170

Remove pages

10-175 through 10-195/(10-196 blank)
 11-5 through 11-22
 11-25 through 11-48
 11-49 and 11-50
 11-53 through 11-96
 11-99 through 11-108
 11-113 and 11-114
 11-117 through 11-134
 11-135 through 11-154
 11-157 through 11-172
 11-175 through 11-202
 11-207 through 11-216
 11-221 through 11-224
 11-227 and 11-228
 11-231 through 11-242
 11-245 through 11-248
 11-251 through 11-254
 11-257 through 11-274
 11-277 through 11-282
 11-285 and 11-286
 11-291 through 11-298
 11-301 through 11-304
 11-313 through 11-324
 12-1 through 12-4
 12-9 through 12-24
 12-27 through 12-32
 12-34.1 and 12-34.2
 12-37 and 12-38
 12-57 through 12-62.2
 12-65 through 12-72
 12-75 and 12-76
 12-85 through 12-90
 12-93 through 12-104
 12-107 through 12-110
 12-115 and 12-116
 12-119 and 12-120
 12-135 through 12-138
 12-141 through 12-146
 12-149 and 12-150
 12-153 and 12-154
 12-157 and 12-158
 12-161 and 12-162
 12-165 through 12-172
 12-175 and 12-176
 12-179 through 12-186
 12-189 and 12-190
 12-193 through 12-198
 12-202.1 through 12-204.2
 12-205 through 12-222
 12-223 through 12-232
 12-235 and 12-236
 12-239 through 12-242
 12-247 through 12-252
 12-255 through 12-274
 12-277 and 12-278
 12-281 and 12-282
 12-295 through 12-298
 12-301 and 12-302
 12-305 and 12-306
 12-309 through 12-312
 A-1 and A-2
 B-3 through B-27/(B-28 blank)
 D-23 through D-26
 D-46.1 and D-46.2
 D-69 through D-72
 G-1 through G-9/(G-10 blank)
 Index 7 through Index 35/
 (Index 36 blank)

Insert pages

10-175 through 10-204
 11-5 through 11-22
 11-25 through 11-48
 11-49 and 11-50
 11-53 through 11-96
 11-99 through 11-108
 11-113 and 11-114
 11-117 through 11-134
 11-135 through 11-154
 11-157 through 11-172
 11-175 through 11-202
 11-207 through 11-216
 11-221 through 11-224
 11-227 and 11-228
 11-231 through 11-242
 11-245 through 11-248
 11-251 through 11-254
 11-257 through 11-274
 11-277 through 11-282
 11-285 and 11-286
 11-291 through 11-298
 11-301 through 11-304
 11-313 through 11-324
 12-1 through 12-4
 12-9 through 12-24
 12-27 through 12-32
 12-34.1 and 12-34.2
 12-37 and 12-38
 12-57 through 12-62.2
 12-65 through 12-72
 12-75 and 12-76
 12-85 through 12-90
 12-93 through 12-104
 12-107 through 12-110
 12-115 and 12-116
 12-119 and 12-120
 12-135 through 12-138
 12-141 through 12-146
 12-149 and 12-150
 12-153 and 12-154
 12-157 and 12-158
 12-161 and 12-162
 12-165 through 12-172
 12-175 and 12-176
 12-179 through 12-186
 12-189 and 12-190
 12-193 through 12-198
 12-202.1 through 12-204.2
 12-205 through 12-222
 12-223 through 12-232
 12-235 and 12-236
 12-239 through 12-242
 12-247 through 12-252
 12-255 through 12-274
 12-277 and 12-278
 12-281 and 12-282
 12-295 through 12-298
 12-301 and 12-302
 12-305 and 12-306
 12-309 through 12-312
 A-1 and A-2
 B-3 through B-29/(B-30 blank)
 D-23 through D-26
 D-46.1 and D-46.2
 D-69 through D-72
 G-1 through G-12
 Index 7 through Index 35/
 (Index 36 blank)

3. File this change sheet in front of the publication for reference purposes.

By Order of the Secretary of the Army:

Peter J. Schoomaker
General, United States Army
Chief of Staff

Official:

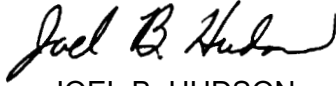

JOEL B. HUDSON
Administrative Assistant to the
Secretary of the Army
0223406

By Order of the Secretary of the Air Force:

RONALD R. FOGLEMAN
General, United States Air Force
Chief of Staff

Official:

HENRY VICCELLIO, JR.
General, United States Air Force
Commander, Air Force Materiel Command

By Order of the Marine Corps:

R. P. SHOCKEY
Director, Program Support
Marine Corps Systems Command

Distribution:

To be distributed in accordance with the initial distribution number (IDN) 380900, requirements for TM 9-2320-280-20-3.

CHANGE

NO. 1

HEADQUARTERS,
DEPARTMENTS OF THE ARMY,
THE AIR FORCE, AND MARINE CORPS
WASHINGTON, D.C., 30 JUNE 1999

TECHNICAL MANUAL
VOLUME 3 OF 3
UNIT MAINTENANCE

TRUCK, UTILITY: CARGO/TROOP CARRIER, 1-1/4 TON, 4X4,
M998 (2320-01-107-7155) (EIC: BBD); M998A1 (2320-01-371-9577) (EIC: BBN);
TRUCK, UTILITY: CARGO/TROOP CARRIER, 1-1/4 TON, 4X4, W/WINCH,
M1038 (2320-01-107-7156) (EIC: BBE); M1038A1 (2320-01-371-9578) (EIC: BBP);
TRUCK, UTILITY: HEAVY VARIANT, 4X4, M1097 (2320-01-346-9317) (EIC: BBM);
M1097A1 (2320-01-371-9583) (EIC: BBU); M1097A2 (2320-01-380-8604) (EIC: BB6); M1123 (2320-01-455-9593) (EIC: B6G);
TRUCK, UTILITY: TOW CARRIER, ARMORED, 1-1/4 TON, 4X4,
M966 (2320-01-107-7153) (EIC: BBC); M966A1 (2320-01-372-3932) (EIC: BBX); M1121 (2320-01-456-1282) (EIC: B6H);
TRUCK, UTILITY: TOW CARRIER, ARMORED, 1-1/4 TON, 4X4, W/WINCH,
M1036 (2320-01-107-7154) (EIC: BBH);
TRUCK, UTILITY: TOW CARRIER, W/SUPPLEMENTAL ARMOR, 1-1/4 TON, 4X4,
M1045 (2320-01-146-7191); M1045A1 (2320-01-371-9580) (EIC: BBR); M1045A2 (2320-01-380-8229) (EIC: BB5);
TRUCK, UTILITY: TOW CARRIER, W/SUPPLEMENTAL ARMOR, 1-1/4 TON, 4X4, W/WINCH,
M1046 (2320-01-146-7188); M1046A1 (2320-01-371-9582) (EIC: BBT);
TRUCK, UTILITY: ARMAMENT CARRIER, ARMORED, 1-1/4 TON, 4X4,
M1025 (2320-01-128-9551) (EIC: BBF); M1025A1 (2320-01-371-9584) (EIC: BBV); M1025A2 (2320-01-380-8233) (EIC: BB3);
TRUCK, UTILITY: ARMAMENT CARRIER, ARMORED, 1-1/4 TON, 4X4, W/WINCH,
M1026 (2320-01-128-9552) (EIC: BBG); M1026A1 (2320-01-371-9579) (EIC: BBQ);
TRUCK, UTILITY: ARMAMENT CARRIER, W/SUPPLEMENTAL ARMOR, 1-1/4 TON, 4X4,
M1043 (2320-01-146-7190); M1043A1 (2320-01-372-3933) (EIC: BBY); M1043A2 (2320-01-380-8213) (EIC: BB4);
TRUCK, UTILITY: ARMAMENT CARRIER, W/SUPPLEMENTAL ARMOR, 1-1/4 TON, 4X4, W/WINCH,
M1044 (2320-01-146-7189); M1044A1 (2320-01-371-9581) (EIC: BBS);
TRUCK, UTILITY: S250 SHELTER CARRIER, 4X4, M1037 (2320-01-146-7193) (EIC: BBK);
TRUCK, UTILITY: S250 SHELTER CARRIER, 4X4, W/WINCH, M1042 (2320-01-146-7187);
TRUCK, AMBULANCE, 2-LITTER, ARMORED, 4X4, M996 (2310-01-111-2275) (EIC: BBB); M996A1 (2310-01-372-3935) (EIC: BB2);
TRUCK, AMBULANCE, 4-LITTER, ARMORED, 4X4, M997 (2310-01-111-2274) (EIC: BBA);
M997A1 (2310-01-372-3934) (EIC: BBZ); M997A2 (2310-01-380-8225) (EIC: BB8);
TRUCK, AMBULANCE, 2-LITTER, SOFT TOP, 4X4,
M1035 (2310-01-146-7194); M1035A1 (2310-01-371-9585) (EIC: BBW); M1035A2 (2310-01-380-8290) (EIC: BB9).

TM 9-2320-280-20-3, 31 January 1996, is changed as follows:

1. Two new models have been added to the front cover. The new cover, located at the end of the change package, replaces the existing cover.
2. Remove old pages and insert new pages as indicated below.
3. New or changed material is indicated by a vertical bar in the margin of the page.

Remove pages

None
i and ii
10-1 and 10-2
10-7 through 10-10
None
10-15 and 10-16
10-33 and 10-34

Insert pages

A and B (after Warning d blank)
i and ii
10-1 and 10-2
10-7 through 10-10
10-14.1/(10-14.2 blank)
10-15 and 10-16
10-33 and 10-34

Approved for public release; distribution is unlimited.

Remove pages

10-37 and 10-38
10-45 and 10-46
10-57 and 10-58
10-81 through 10-84
10-93 and 10-94
10-111 and 10-112
10-115 and 10-116
10-123 through 10-128
10-145 and 10-146
10-149 through 10-156
10-159 through 10-168
10-171 through 10-176
10-179 and 10-180
10-187 and 10-188
10-191 through 10-193/(10-194 blank)
11-1 through 11-4
11-49 and 11-50
11-69 and 11-70
11-75 through 11-82
11-131 through 11-134
11-157 through 11-160
11-173 and 11-174
11-201 through 11-206
11-213 and 11-214
None
11-307 and 11-308
12-1 and 12-2
12-7 and 12-8
12-23 through 12-40
12-57 and 12-58
12-63 and 12-64
12-69 through 12-72
12-109 through 12-112
12-201 and 12-206
12-221 and 12-222
12-281 and 12-282
12-295/(12-296 blank)
A-1 and A-2
B-3 through B-27/(B-28 blank)
C-1 through C-7/(C-8 blank)
D-1 and D-2
D-9 and D-10
D-47 and D-48
D-65 and D-66
D-71 and D-72
D-77 through D-106
F-1 and F-2
G-1 through G-8
Index 1 through Index 33
cover

Insert pages

10-37 and 10-38
10-45 and 10-46
10-56.1 through 10-58
10-80.1 through 10-84
10-93 and 10-94
10-111 and 10-112
10-114.1/(10-114.2 blank) through 10-116
10-123 through 10-128
10-145 and 10-146
10-149 through 10-156
10-159 through 10-168
10-171 through 10-176.2
10-179 and 10-180
10-186.1 through 10-188
10-190.1 through 10-195/(10-196 blank)
11-1 through 11-4
11-48.1/(11-48.2 blank) through 11-50
11-69 and 11-70
11-75 through 11-82
11-131 through 11-134.1/(11-134.2 blank)
11-156.1 through 11-160
11-173 and 11-174
11-201 through 11-206
11-212.1 through 11-214
11-262.1/(11-262.2 blank)
11-307 and 11-308
12-1 and 12-2
12-7 and 12-8
12-23 through 12-40
12-57 and 12-58
12-62.1 through 12-64
12-69 through 12-72.1/(12-72.2 blank)
12-109 through 12-112
12-201 through 12-206
12-221 through 12-222.1/(12-222.2 blank)
12-281 and 12-282
12-295 through 12-317/(12-318 blank)
A-1 and A-2
B-3 through B-27/(B-28 blank)
C-1 through C-7/(C-8 blank)
D-1 and D-2
D-9 and D-10
D-46.1 through D-48
D-65 and D-66
D-71 and D-72
D-77 through D-116
F-1 and F-2
G-1 through G-9/ (G-10 blank)
Index 1 through Index 35/(Index 36 blank)
cover

4. File this change sheet in front of the publication for reference purposes.

By Order of the Secretary of the Army:

ERIC K. SHINSEKI
General, United States Army
Chief of Staff

Official:

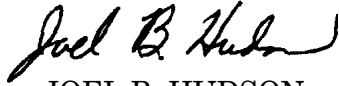

JOEL B. HUDSON
Administrative Assistant to the
Secretary of the Army
05692

By Order of the Secretary of the Air Force:

RONALD R. FOGLEMAN
General, United States Air Force
Chief of Staff

Official:

HENRY VICCELLIO, JR.
General, United States Air Force
Commander, Air Force Materiel Command

By Order of the Marine Corps:

D.R. BLOOMER
Colonel, USMC
Director, Program Support
Marine Corps Systems Command

Distribution:

To be distributed in accordance with the initial distribution number (IDN) 380900, requirements for TM 9-2320-280-20-3.

LIST OF EFFECTIVE PAGES

NOTE: The portion of the text affected by the changes is indicated by a vertical line in the outer margins of the page.

Dates of issue for original and changed pages of volume 3 are:

Original 031 January 1996

Change 130 June 1999

Change 2 **15 July** 2004

TOTAL NUMBER OF PAGES IN THIS PUBLICATION IS 1,170. CONSISTING OF THE FOLLOWING:

Page No.*Change No.	Page No.*Change No.	Page No.*Change No.
VOLUME 3		
a - b0	10-550	10-103 - 10-1100
A - B2	10-562	10-1112
C - D Added2	10-56.11	10-1121
i2	10-56.22	10-113 - 10-1140
ii1	10-571	10-114.12
10-1 - 10-21	10-582	10-114.2 Blank1
10-30	10-590	10-1151
10-42	10-60 - 10-612	10-116 - 10-1182
10-50	10-620	10-1190
10-62	10-632	10-1202
10-70	10-640	10-121 - 10-1230
10-82	10-65 - 10-662	10-124 - 10-1252
10-91	10-670	10-1261
10-10 - 10-110	10-682	10-1270
10-122	10-690	10-1282
10-130	10-702	10-1290
10-142	10-710	10-130 - 10-1332
10-14.12	10-722	10-134 - 10-1430
10-14.2 Blank1	10-73 - 10-800	10-1442
10-152	10-80.1 - 10-80.21	10-1450
10-161	10-811	10-1462
10-17 - 10-182	10-820	10-147 - 10-1490
10-19 - 10-200	10-82.1 - 10-82.21	10-1501
10-21 - 10-222	10-831	10-1510
10-23 - 10-260	10-842	10-1522
10-27 - 10-282	10-85 - 10-860	10-1531
10-290	10-87 - 10-882	10-1542
10-302	10-890	10-154.11
10-31 - 10-320	10-902	10-154.22
10-33 - 10-342	10-910	10-155 - 10-1561
10-35 - 10-360	10-92 - 10-932	10-157 - 10-1590
10-37 - 10-381	10-940	10-1602
10-39 - 10-430	10-95 - 10-962	10-1611
10-44 - 10-472	10-970	10-162 Blank1
10-48 - 10-500	10-982	10-163 - 10-1641
10-51 - 10-522	10-990	10-164.1 - 10-164.61
10-530	10-1002	10-1651
10-542	10-1010	10-1662
	10-1022	10-166.11

*Zero in this column indicates original page.

LIST OF EFFECTIVE PAGES (Contd)

Page No. *Change No.	Page No. *Change No.	Page No. *Change No.
10-166.2 Blank 1	11-40 - 11-41 2	11-144 - 11-149 2
10-167 - 10-170 2	11-42 0	11-150 0
10-171 0	11-43 - 11-49 2	11-151 2
10-172 1	11-50 1	11-152 0
10-172.1 - 10-172.4 1	11-51 - 11-52 0	11-153 - 11-154 2
10-173 1	11-53 - 11-58 2	11-155 - 11-156 0
10-174 0	11-59 0	11-156.1 - 11-156.6 1
10-175 2	11-60 - 11-65 2	11-157 1
10-176 1	11-66 0	11-158 2
10-176.1 2	11-67 2	11-159 1
10-176.2 1	11-68 0	11-160 2
10-177 2	11-69 - 11-70 2	11-160.1 - 11-160.2 Added . . . 2
10-178 0	11-71 0	11-161 0
10-179 - 10-186 2	11-72 - 11-80 2	11-162 - 11-166 2
10-186.1 - 10-186.4 2	11-81 1	11-167 0
10-186.5 - 10-186.6 Added . . . 2	11-82 - 11-83 2	11-168 - 11-170 2
10-187 - 10-190 2	11-84 - 11-85 0	11-171 0
10-190.1 - 10-190.2 2	11-86 2	11-172 2
10-191 - 10-195 2	11-87 0	11-173 - 11-174 1
10-196 - 10-204 Added 2	11-88 2	11-175 0
11-1 0	11-89 0	11-176 2
11-2 1	11-90 - 11-92 2	11-177 0
11-3 0	11-93 0	11-178 2
11-4 1	11-94 2	11-179 0
11-5 2	11-95 0	11-180 2
11-6 - 11-7 0	11-96 2	11-181 0
11-8 2	11-97 - 11-98 0	11-182 - 11-183 2
11-9 0	11-99 - 11-100 2	11-184 0
11-10 - 11-12 2	11-101 0	11-185 - 11-190 2
11-13 0	11-102 - 11-104 2	11-191 0
11-14 2	11-105 0	11-192 - 11-193 2
11-15 0	11-106 - 11-108 2	11-194 - 11-195 0
11-16 2	11-109 - 11-113 0	11-196 2
11-17 0	11-114 2	11-197 0
11-18 - 11-20 2	11-115 - 11-116 0	11-198 2
11-21 0	11-117 - 11-118 2	11-199 0
11-22 2	11-119 0	11-200 2
11-23 - 11-25 0	11-120 - 11-130 2	11-201 0
11-26 - 11-30 2	11-131 0	11-202 2
11-31 0	11-132 - 11-134 2	11-202.1 - 11-202.2 1
11-32 2	11-134.1 Added 1	11-203 - 11-205 1
11-33 0	11-134.2 Blank 1	11-206 - 11-207 0
11-34 - 11-35 2	11-135 2	11-208 2
11-36 0	11-136 0	11-209 0
11-37 - 11-38 2	11-137 - 11-142 2	11-210 - 11-212 2
11-39 0	11-143 0	11-212.1 2

*Zero in this column indicates original page.

LIST OF EFFECTIVE PAGES (Contd)

Page No. *Change No.	Page No. *Change No.	Page No. *Change No.
11-212.2 1	11-304 2	12-57 - 12-59 2
11-213 1	11-305 - 11-306 0	12-60 0
11-214 - 11-216 2	11-307 1	12-61 - 12-62 2
11-217 - 11-220 0	11-308 - 11-312 0	12-62.1 1
11-221 - 11-222 2	11-313 - 11-314 2	12-62.2 2
11-223 0	11-315 0	12-63 1
11-224 2	11-316 2	12-64 - 12-65 0
11-225 - 11-227 0	11-317 0	12-66 2
11-228 2	11-318 - 11-319 2	12-67 0
11-229 - 11-231 0	11-320 0	12-68 - 12-70 2
11-232 2	11-321 - 11-323 2	12-70.1 1
11-233 0	11-324 - 11-325 0	12-70.2 2
11-234 - 11-236 2	11-326 Blank 0	12-70.3 1
11-237 0	12-1 1	12-70.4 2
11-238 - 11-241 2	12-2 2	12-71 1
11-242 - 11-245 0	12-3 0	12-72 2
11-246 2	12-4 2	12-72.1 1
11-247 0	12-5 - 12-6 0	12-72.2 Blank 1
11-248 2	12-7 - 12-8 1	12-73 - 12-74 0
11-249 - 11-251 0	12-9 - 12-11 2	12-75 2
11-252 - 11-254 2	12-12 0	12-76 - 12-84 0
11-255 - 11-256 0	12-13 - 12-15 2	12-85 2
11-257 - 11-261 2	12-16 0	12-86 - 12-87 0
11-262 0	12-17 - 12-20 2	12-88 - 12-90 2
11-262.1 2	12-21 0	12-91 - 12-92 0
11-262.2 Blank 1	12-22 2	12-93 2
11-263 - 11-264 2	12-23 1	12-94 0
11-265 0	12-24 2	12-95 2
11-266 2	12-25 0	12-96 0
11-267 0	12-26 1	12-97 - 12-103 2
11-268 - 11-273 2	12-27 0	12-104 - 12-106 0
11-274 - 11-277 0	12-28 2	12-107 - 12-110 2
11-278 2	12-28.1 1	12-111 1
11-279 0	12-28.2 2	12-112 - 12-115 0
11-280 - 11-281 2	12-29 - 12-30 2	12-116 2
11-282 - 11-285 0	12-31 0	12-117 - 12-118 0
11-286 2	12-32 2	12-119 2
11-287 - 11-291 0	12-33 - 12-34 1	12-120 - 12-134 0
11-292 - 11-293 2	12-34.1 1	12-135 - 12-138 2
11-294 - 11-295 0	12-34.2 2	12-139 - 12-140 0
11-296 2	12-34.3 - 12-34.8 1	12-141 - 12-142 2
11-297 0	12-35 - 12-36 1	12-143 0
11-298 2	12-37 0	12-144 2
11-299 - 11-301 0	12-38 2	12-145 0
11-302 2	12-39 1	12-146 2
11-303 0	12-40 - 12-56 0	12-147 - 12-149 0

*Zero in this column indicates original page.

LIST OF EFFECTIVE PAGES (Contd)

Page No. *Change No.	Page No. *Change No.	Page No. *Change No.
12-150 2	12-230 2	D-1 - D-2 1
12-151 - 12-152 0	12-231 0	D-3 - D-9 0
12-153 2	12-232 2	D-10 1
12-154 - 12-157 0	12-233 - 12-235 0	D-11 - D-22 0
12-158 2	12-236 2	D-23 2
12-159 - 12-161 0	12-237 - 12-239 0	D-24 0
12-162 2	12-240 2	D-25 2
12-163 - 12-164 0	12-241 0	D-26 - D-46 0
12-165 - 12-168 2	12-242 2	D-46.1 - D-46.2 2
12-169 0	12-243 - 12-246 0	D-47 - D-48 1
12-170 2	12-247 - 12-250 2	D-49 - D-64 0
12-171 0	12-251 0	D-65 - D-66 1
12-172 2	12-252 2	D-67 - D-69 0
12-173 - 12-175 0	12-253 - 12-254 0	D-70 - D-71 2
12-176 2	12-255 - 12-266 2	D-72 - D-77 0
12-177 - 12-179 0	12-267 0	D-78 - D-116 1
12-180 2	12-268 2	E-1 - E-4 0
12-181 0	12-269 0	F-1 1
12-182 2	12-270 - 12-274 2	F-2 - F-12 0
12-183 0	12-275 - 12-276 0	G-1 0
12-184 2	12-277 - 12-278 2	G-2 - G-9 2
12-185 0	12-279 - 12-281 0	G-10 - G-12 Added 2
12-186 2	12-282 2	Index-1 - Index-7 1
12-187 - 12-189 0	12-283 - 12-294 0	Index-8 - Index-35 2
12-190 2	12-295 1	Index-36 Blank 1
12-191 - 12-193 0	12-296 2	FP-1 0
12-194 - 12-197 2	12-297 1	FP-2 Blank 0
12-198 - 12-200 0	12-298 2	FP-3 0
12-201 - 12-202 1	12-299 - 12-301 1	FP-4 Blank 0
12-202.1 2	12-302 2	FP-5 0
12-202.2 1	12-303 - 12-305 1	FP-6 Blank 0
12-203 1	12-306 2	FP-7 0
12-204 2	12-307 - 12-309 1	FP-8 Blank 0
12-204.1 1	12-310 - 12-312 2	FP-9 0
12-204.2 2	12-313 - 12-317 1	FP-10 Blank 0
12-204.3 - 12-204.4 1	12-318 Blank 1	FP-11 0
12-205 1	13-1 - 13-3 0	FP-12 Blank 0
12-206 - 12-214 2	13-4 Blank 0	FP-13 0
12-215 0	A-1 - A-2 2	FP-14 Blank 0
12-216 - 12-222 2	B-1 - B-3 0	FP-15 0
12-222.1 1	B-4 - B-27 2	FP-16 Blank 0
12-222.2 Blank 1	B-28 - B-29 Added 2	FP-17 0
12-223 - 12-225 2	B-30 Blank Added 2	FP-18 Blank 0
12-226 - 12-227 0	C-1 0	
12-228 2	C-2 - C-7 1	
12-229 0	C-8 Blank 0	

*Zero in this column indicates original page.

TECHNICAL MANUAL
NO. 9-2320-280-20-3
NO. 2320-20/7C

HEADQUARTERS,
DEPARTMENTS OF THE ARMY,
THE AIR FORCE, AND MARINE CORPS
WASHINGTON, D.C., 31 JANUARY 1996

TECHNICAL ORDER
NO. 36A12-1A-2092-1-3

TECHNICAL MANUAL VOLUME 3 OF 3

UNIT MAINTENANCE

- TRUCK, UTILITY: CARGO/TROOP CARRIER, 1-1/4 TON, 4X4, M998 (2320-01-107-7155) (EIC: BBD);
M998A1 (2320-01-371-9577) (EIC: BBN);
- TRUCK, UTILITY: CARGO/TROOP CARRIER, 1-1/4 TON, 4X4, W/WINCH, M1038 (2320-01-107-7156) (EIC: BBE);
M1038A1 (2320-01-371-9578) (EIC: BBP);
- TRUCK, UTILITY: HEAVY VARIANT, 4X4, M1097 (2320-01-346-9317) (EIC: BBM); M1097A1 (2320-01-371-9583) (EIC: BBU);
M1097A2 (2320-01-380-8604) (EIC: BB6); M1123 (2320-01-455-9593) (EIC: B6G);
- TRUCK, UTILITY: TOW CARRIER, ARMORED, 1-1/4 TON, 4X4, M966 (2320-01-107-7153) (EIC: BBC);
M966A1 (2320-01-372-3932) (EIC: BBX); M1121 (2320-01-456-1282) (EIC: B6H);
- TRUCK, UTILITY: TOW CARRIER, ARMORED, 1-1/4 TON, 4X4, W/WINCH, M1036 (2320-01-107-7154) (EIC: BBH);
- TRUCK, UTILITY: TOW CARRIER, W/SUPPLEMENTAL ARMOR, 1-1/4 TON, 4X4,
M1045 (2320-01-146-7191); M1045A1 (2320-01-371-9580) (EIC: BBR); M1045A2 (2320-01-380-8229) (EIC: BB5);
- TRUCK, UTILITY: TOW CARRIER, W/SUPPLEMENTAL ARMOR, 1-1/4 TON, 4X4, W/WINCH, M1046 (2320-01-146-7188);
M1046A1 (2320-01-371-9582) (EIC: BBT);
- TRUCK, UTILITY: ARMAMENT CARRIER, ARMORED, 1-1/4 TON, 4X4, M1025 (2320-01-128-9551) (EIC: BBF);
M1025A1 (2320-01-371-9584) (EIC: BBV); M1025A2 (2320-01-380-8233) (EIC: BB3);
- TRUCK, UTILITY: ARMAMENT CARRIER, ARMORED, 1-1/4 TON, 4X4, W/WINCH, M1026 (2320-01-128-9552) (EIC: BBG);
M1026A1 (2320-01-371-9579) (EIC: BBQ);
- TRUCK, UTILITY: ARMAMENT CARRIER, W/SUPPLEMENTAL ARMOR, 1-1/4 TON, 4X4, M1043 (2320-01-146-7190);
M1043A1 (2320-01-372-3933); M1043A2 (2320-01-380-8213) (EIC: BB4);
- TRUCK, UTILITY: ARMAMENT CARRIER, W/SUPPLEMENTAL ARMOR, 1-1/4 TON, 4X4, W/WINCH, M1044 (2320-01-146-
7189); M1044A1 (2320-01-371-9581);
- TRUCK, UTILITY: S250 SHELTER CARRIER, 4X4, M1037 (2320-01-146-7193) (EIC: BBK);
- TRUCK, UTILITY: S250 SHELTER CARRIER, 4X4, W/WINCH, M1042 (2320-01-146-7187);
- TRUCK, AMBULANCE, 2-LITTER, ARMORED, 4X4, M996 (2310-01-111-2275)
(EIC: BBB); M996A1 (2310-01-372-3935) (EIC: BB2);
- TRUCK, AMBULANCE, 4-LITTER, ARMORED, 4X4, M997 (2310-01-111-2274) (EIC: BBA);
M997A1 (2310-01-372-3934) (EIC: BBZ); M997A2 (2310-01-380-8225) (EIC: BB8);
- TRUCK, AMBULANCE, 2-LITTER, SOFT TOP, 4X4, M1035 (2310-01-146-7194);
M1035A1 (2310-01-371-9585) (EIC: BBW); M1035A2 (2310-01-380-8290) (EIC: BB9).

Approved for public release; distribution is unlimited.

REPORTING ERRORS AND RECOMMENDING IMPROVEMENTS

You can help improve this publication. If you find any mistakes or if you know of a way to improve the procedures, please let us know. Submit your DA Form 2028 (Recommended Changes to Publications and Blank Forms), through the Internet, on the Army Electronic Product Support (AEPS) website. The Internet address is <http://aeprs.ria.army.mil>. If you need a password, scroll down and click on "ACCESS REQUEST FORM." The DA Form 2028 is located in the ONLINE FORMS PROCESSING section of the AEPS. Fill out the form and click on SUBMIT. Using this form on the AEPS will enable us to respond quicker to your comments and better manage the DA Form 2028 program. You may also mail, fax or E-mail your letter or DA Form 2028 direct to: AMSTA-LC-CI Tech Pubs, TACOM-RI, 1 Rock Island Arsenal, Rock Island, IL 61299-7630. The E-mail address is TACOM-TECH-PUBS@ria.army.mil. The fax number is DSN 793-0726 or Commercial (309) 782-0726. (Marine Corps) Submit NAVMC 10772 to the Commanding General (826), MCLB, 814 Radford Blvd., Albany, GA 31704-1128.

This manual is published in three parts. TM 9-2320-280-20-1 contains chapters 1 and 2, TM 9-2320-280-20-2 contains chapters 3 through 9, and TM 9-2320-280-20-3 contains chapters 10 through 13 and Appendices A through G.

This manual contains a table of contents and alphabetized index for chapters 10 through 13.

* This publication supersedes TM 9-2320-280-20-3 dated 1 November 1993 and all changes.

VOLUME 3 OF 3

	Page
CHAPTER 10	10-1
BODY AND ACCESSORIES MAINTENANCE	
Section I.	10-1
I.	10-115
II.	10-179
III.	10-179
CHAPTER 11	11-1
SPECIAL PURPOSE BODIES MAINTENANCE	
Section I.	11-1
I.	11-161
II.	11-173
III.	11-173
CHAPTER 12	12-1
SPECIAL PURPOSE KITS MAINTENANCE	
Section I.	12-1
I.	12-19
II.	12-23
III.	12-36
IV.	12-104
V.	12-114
VI.	12-201
VII.	12-235
VIII.	12-251
IX.	12-254
X.	12-282
XI.	12-314
XII.	12-314
CHAPTER 13	13-1
PREPARATION FOR STORAGE OR SHIPMENT	
Section I.	13-1
I.	13-2
II.	13-2
APPENDIX A	A-1
APPENDIX B	B-1
APPENDIX C	C-1
APPENDIX D	D-1
APPENDIX E	E-1
APPENDIX F	F-1
APPENDIX G	G-1
INDEX	Index 1

CHAPTER 10

BODY AND ACCESSORIES MAINTENANCE

Section I. BODY MAINTENANCE

10-1. BODY MAINTENANCE TASK SUMMARY

TASK PARA.	PROCEDURES	PAGE NO.
10-2.	Fuel Filler Housing Replacement	10-3
10-3.	Hood Latch and Bracket Replacement	10-4
10-4.	Hood Prop Rod and Bracket Maintenance	10-6
10-5.	Hood and Hinge Replacement	10-8
10-6.	Outer Hood Seal Replacement	10-11
10-7.	Side Hood Stop Replacement	10-12
10-8.	Center Hood Stop Replacement	10-13
10-9.	Footman Loop and Strap Replacement	10-14
10-9.1.	Jack Retaining Strap Replacement	10-14.1
10-10.	Center Hood Stop Guide Replacement	10-15
10-11.	Front Hood Screen Replacement	10-16
10-12.	Hood Grille and Screen Replacement	10-17
10-13.	Door Handle Assembly Maintenance	10-18
10-14.	Fixed Rear Door Replacement	10-21
10-15.	Engine Access Cover Maintenance	10-22
10-16.	Engine Access Cover Flexible Latch and Holddown Strike Replacement	10-27
10-17.	Engine Left Splash Shield Maintenance	10-28
10-18.	Engine Left Splash Shield Access Cover Replacement	10-32
10-19.	3.5-Ton Jack Stowage Bracket and Cover Replacement	10-33
10-20.	Engine Right Splash Shield Maintenance	10-34
10-21.	Windshield Glass and Weatherstrip Replacement	10-38
10-22.	Windshield Ballistic Glass Replacement	10-40
10-23.	Windshield Assembly Maintenance	10-42
10-24.	Windshield Retention Bracket Replacement	10-44
10-25.	Left Outer Cowl Insulation Replacement	10-45
10-26.	Left Front Cowl Insulation Replacement	10-46
10-27.	Right Front Cowl Insulation Replacement	10-47
10-28.	Tunnel Interior Side Insulation Replacement	10-48
10-29.	Rear Seat Floor Insulation Replacement	10-50
10-30.	Right Inner Cowl Insulation Panel Replacement	10-51
10-31.	Left Inner Cowl Insulation Panel Replacement	10-52
10-31.1.	Cargo Floor Access Cover Maintenance (M1123)	10-56.2
10-32.	Driver's Seat Frame Replacement	10-58
10-33.	Driver's Seat and Seat Back Cushions Replacement	10-60

10-1. BODY MAINTENANCE TASK SUMMARY (Cont'd)

TASK PARA.	PROCEDURES	PAGE NO.
10-34.	Companion Seat Back Replacement	10-61
10-35.	Companion Seat and Battery Box Cover Replacement	10-62
10-36.	Battery Box Cover Latch Replacement	10-63
10-37.	Companion Seat and Seat Back Cushions Replacement	10-64
10-38.	Driver's Seat Assembly Replacement	10-65
10-39.	Driver's Seat Assembly Maintenance	10-66
10-40.	Battery Box Cover Catch Replacement	10-68
10-41.	Companion Seat Assembly and Battery Box Cover Replacement	10-69
10-42.	Companion Seat Assembly Maintenance	10-70
10-43.	Passenger Seat and Storage Compartment Cover Replacement	10-71
10-44.	Passenger Seat and Storage Compartment Latch Replacement	10-72
10-45.	Passenger Seat Back Replacement	10-73
10-46.	Passenger Seat and Seat Back Cushions Replacement	10-74
10-47.	Seatbelt Assembly Replacement	10-75
10-48.	Three Point Seatbelt Maintenance	10-76
10-48.1.	Three Point Seatbelt Maintenance (M996, M996A1, M997, M997A1, and M997A2)	10-80.2
10-49.	Three Point Seatbelt Brackets Replacement	10-82
10-49.1.	Three Point Seatbelt Brackets Replacement (M996, M996A1, M997, M997A1, and M997A2)	10-82.2
10-50.	Pioneer Tool Stowage Tray Maintenance	10-84
10-51.	Pioneer Tool Stowage Tray Mounting Bracket Replacement	10-86
10-52.	Pioneer Tool Stowage Tray Latch Striker Replacement	10-87
10-53.	Cargo Bulkhead Replacement	10-88
10-54.	Cargo Bulkhead Mounting Brackets Replacement	10-89
10-55.	Cargo Barrier Extension Maintenance	10-90
10-56.	Cargo Tiedown Replacement	10-92
10-57.	Fire Extinguisher Bracket Replacement	10-93
10-58.	Fire Extinguisher Support Replacement	10-94
10-59.	Driver's Seat Retainer Plate Assembly Replacement	10-95
10-60.	Tailgate Chain and Brackets Replacement	10-96
10-61.	Tailgate Replacement	10-98
10-62.	Tailgate Upper Hinge Replacement	10-100
10-63.	Mud Flap Installation	10-102
10-64.	Body Hinge Mount Replacement	10-103
10-65.	Airlift Bracket to Hood Seal Replacement	10-104
10-66.	Body Repair	10-105
10-67.	"B" Pillar Replacement	10-111
10-68.	M11 Decontamination Brackets Installation	10-112

10-2. FUEL FILLER HOUSING REPLACEMENT

This task covers:

a. Removal

b. Installation

INITIAL SETUP

Tools

General mechanic's tool kit
automotive (Appendix B, Item 1)

Manual Reference

TM 9-2320-280-24P

a. Removal

1. Remove filler cap "T" handle (1) and filler cap (2) from filler spout (6).
2. Remove three nuts (7), washers (4), capscrews (3), and washers (4) from filler housing (5) and filler spout (6).
3. Remove six screws (11) and washers (10) from fuel filler housing (5) and right outer wheelhouse panel (8).
4. Push filler cap (2) through filler housing (5) and remove filler housing (5).
5. Inspect speed nuts (9) for presence or damage. Replace if defective or missing.

b. Installation

1. Pull filler cap (2) through filler housing (5) and install housing (5) on right outer wheelhouse panel (8).
2. Secure filler housing (5) to right outer wheelhouse panel (8) with six washers (10) and screw (11).
Tighten screws (11) to 20 lb-in. (2 N•m).
3. Secure filler housing (5) to filler spout (6) with three washers (4), capscrews (3), washers (4), and nuts (7).
4. Install filler cap (2) on filler spout (6) with "T" bade (1).

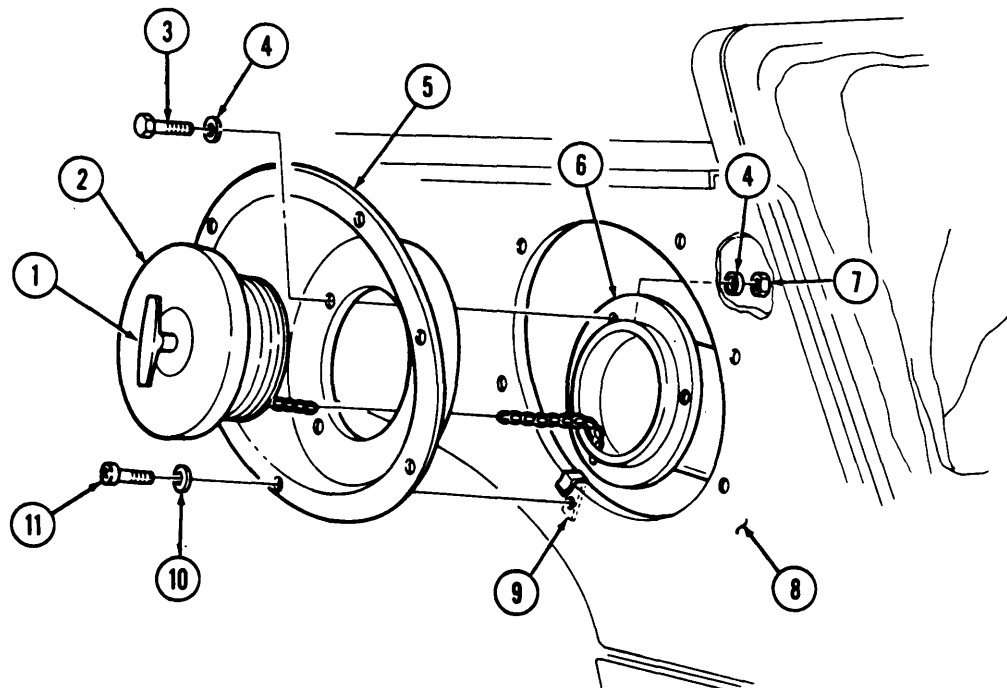

10-3. HOOD LATCH AND BRACKET REPLACEMENT

This task covers:

- | | |
|--|--|
| <ul style="list-style-type: none"> a. Removal b. Disassembly | <ul style="list-style-type: none"> c. Assembly d. Installation |
|--|--|

INITIAL SETUP:

Tools

General mechanic's tool kit:
automotive (Appendix B, Item 1)

Materials/Parts

Seven locknuts (Appendix G, Item 70)
Cotter pin (Appendix G, Item 16)
Spring pin (Appendix G, Item 298)

Manual References

TM 9-2320-280-10
TM 9-2320-280-24P

Equipment Condition

Hood raised and secured (TM 9-2320-280-10).

a. Removal

NOTE

If only the rubber latch is to be replaced, the spring pin does not have to be completely out of base.

1. Remove two locknuts (6), washers (4), capscrews (3), and washers (4) from base (7) and body (5). Discard locknuts (6).
2. Remove spring pin (2) from latch (10) and base (7).
3. Remove two locknuts (16), washers (17), capscrews (12), and latch bracket (13) from hood (15). Discard locknuts (16).
4. Remove three locknuts (18), washers (19), capscrews (21), latch stop bracket (20), and latch plate (14) from hood (15). Discard locknuts (18).

b. Disassembly

Remove cotter pin (1), pin (8), two rollers (9), and hood latch (11) from latch (10). Discard cotter pin (1).

c. Assembly

Install hood latch (11) on latch (10) with two rollers (9), pin (8), and cotter pin (1).

d. Installation

1. Install latch plate (14) and latch stop bracket (20) on hood (15) with three capscrews (21), washers (19), and locknuts (18).
2. Install latch bracket (13) on latch plate (14) with two capscrews (12), washers (17), and locknuts (16). Tighten locknuts (16) and (18) to 10 lb-ft (14 N·m).
3. Install latch (10) on base (7) with spring pin (2).
4. Install base (7) on body (5) with two washers (4), capscrews (3), washers (4), and locknuts (6). Tighten capscrews (3) to 6 lb-ft (8 N·m).

10-3. HOOD LATCH AND BRACKET REPLACEMENT (Cont'd)

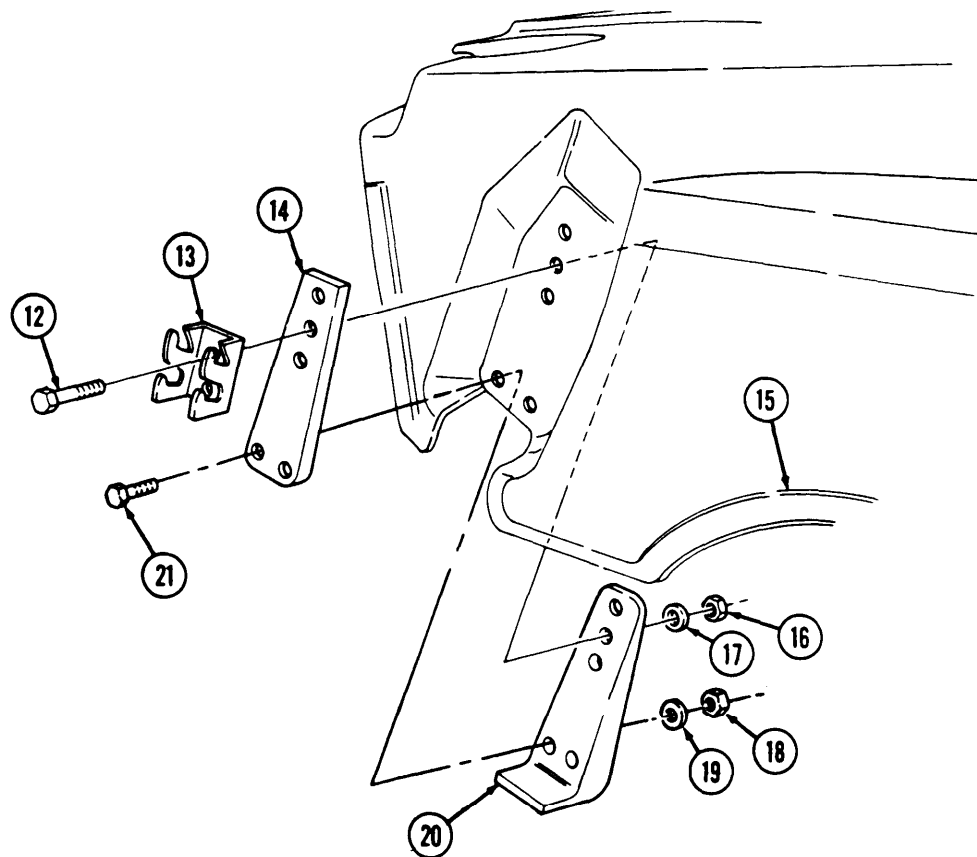
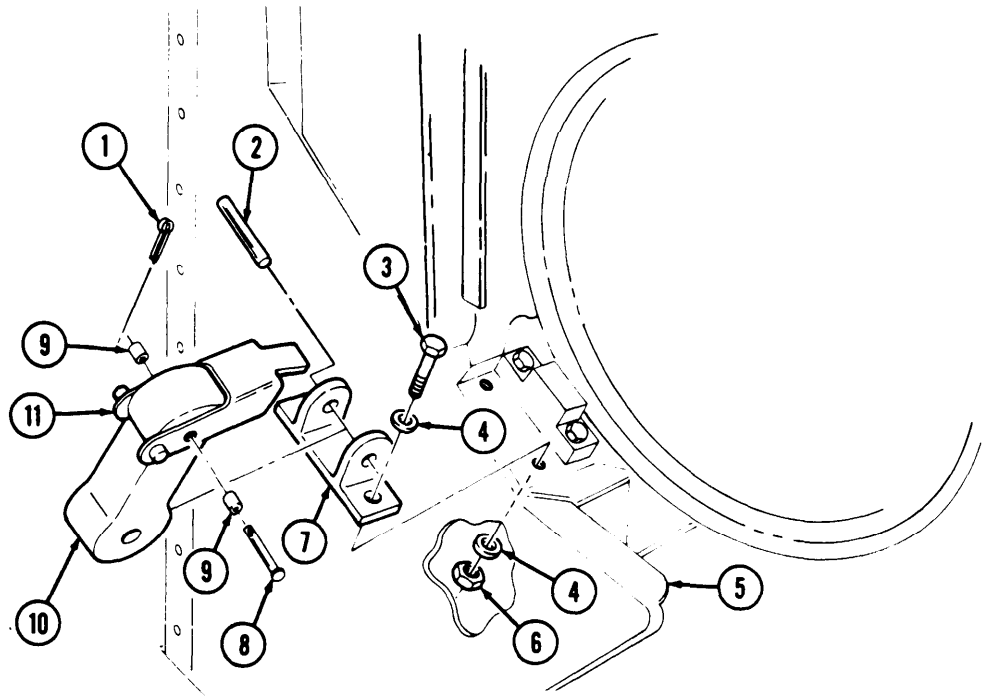

FOLLOW-ON TASK: **Lower and secure hood** (TM 9-2320-280-10).

10-4. HOOD PROP ROD AND BRACKET MAINTENANCE

This task covers:

- | | |
|---|--|
| <ul style="list-style-type: none"> a. Removal b. Disassembly c. Inspection | <ul style="list-style-type: none"> d. Assembly e. Installation |
|---|--|

INITIAL SETUP:

Tools

General mechanic's tool kit:
automotive (Appendix B, Item 1)

Materials/Parts

Four lockwashers (Appendix G, Item 135)
Locknut (Appendix G, Item 79)
Cotter pin (Appendix G, Item 12)

Manual References

TM 9-2320-280-10
TM 9-2320-280-24P

Equipment Condition

Hood raised and secured (TM 9-2320-280-10).

General Safety Instructions

Hood must be supported during hood prop rod and bracket replacement.

WARNING

Hood must be supported during hood prop rod and bracket replacement. Failure to support hood may cause injury to personnel or damage to equipment.

a. Removal

1. Remove cotter pin (4), washer (3), hood prop rod (2), and washer (3) from hood (1). Discard cotter pin (4).
2. Remove four screws (8), lockwashers (7), bracket (6), and hood prop rod (2) from airlift bracket (5). Discard lockwashers (7).

b. Disassembly

1. Remove hood prop rod (2) from eyebolt (15).
2. Remove locknut (9), washer (10), bushing (16), spring (11), eyebolt (15), and washer (14) from bracket (6). Discard locknut (9).
3. Remove snapping (12) and bushing (13) from bracket (6).

c. Inspection

Inspect bushing (13), bushing (16), and spring (11) for cracks, wear, or distortion. Replace bushing (13), (16), or spring (11) if cracked, worn, or distorted.

d. Assembly

1. Install bushing (13) on bracket (6) with snapping (12).

NOTE

Length of spring with bracket assembled is 2-1/4 in. (5.7 cm).

2. Install washer (14), eyebolt (15), and spring (11) on bracket (6) with bushing (16), washer (10), and locknut (9).
3. Install hood prop rod (2) into eyebolt (15).

10-4. HOOD PROP ROD AND BRACKET MAINTENANCE (Cont'd)

e.. Installation

1. Install hood prop rod (2) and bracket (6) on airlift bracket (5) with four lockwashers (7) and screws (8).
Tighten screws (8) to 6 lb-ft (8 N.m).
2. Install washer (3) and hood prop rod (2) on hood (1) with washer (3) and rotter pin (4).

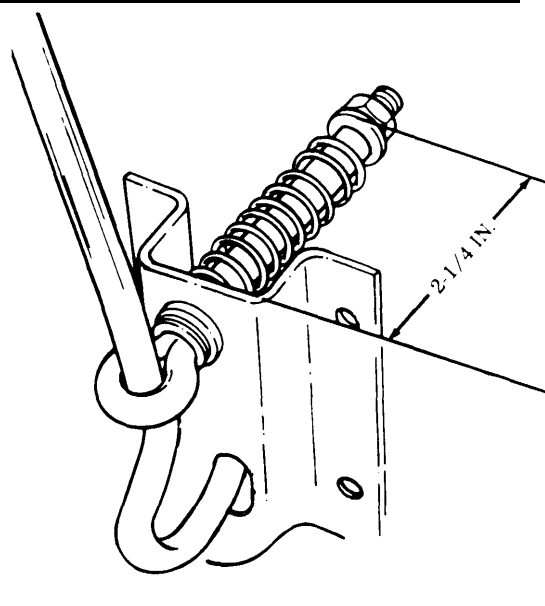
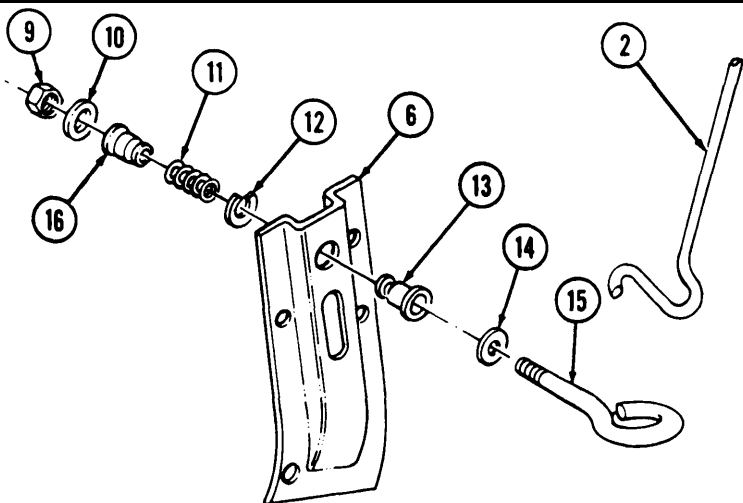
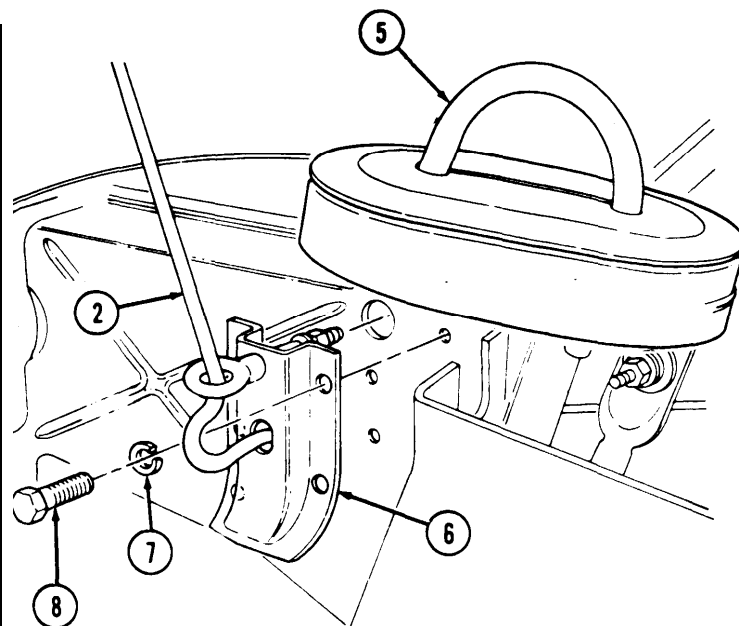
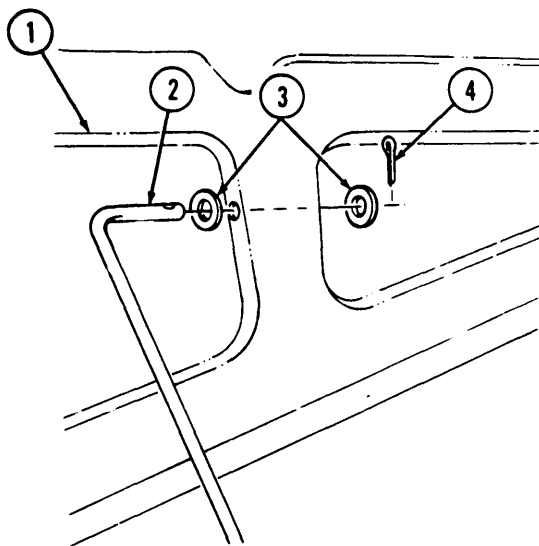

FOLLOW-ON TASK: Lower and secure hood (TM 9-2320-280-10).

10-5. HOOD AND HINGE REPLACEMENT

This task covers:

- | | |
|--|---------------------|
| <p>a. Removal</p> <p>b. Installation</p> | <p>c. Alignment</p> |
|--|---------------------|

INITIAL SETUP:

Tools

General mechanic's tool kit:
automotive (Appendix B, Item 1)

Materials/Parts

Sealing compound (Appendix C, Item 45)
Three cotter pins (Appendix G, Item 12)
Four locknuts (Appendix G, Item 98)

Personnel Required

One mechanic
One assistant

Manual References

TM 9-2320-280-10
TM 9-2320-280-24P
TM 43-0139

Equipment Condition

- Battery ground cable disconnected (para. 4-73).
- Hood raised and secured (TM 9-2320-280-10).

General Safety Instructions

Hood must be supported during removal and installation.

WARNING

Hood must be supported during removal and installation. Failure to support hood may cause injury to personnel and damage to equipment.

NOTE

Hood surface has a thin layer of gel coat that can seem cracked, in a spiderweb pattern, due to hood flexing. No repair is necessary. Any other cracks should be repaired to prevent further damage.

a. Removal

1. Disconnect connector plug (11) from connector receptacle (7).
2. Remove two cotter pins (1), washers (2), hinge pins (13), and washers (2) from two upper hinge halves (14) and lower hinge halves (12). Discard cotter pins (1).
3. Remove cotter pin (17), washer (18), hood prop rod (19), and washer (18) from hood (15). Discard cotter pin (17).
4. Remove hood (15).

NOTE

- Perform steps 5 and 6 if replacing hinges.
 - Note position of hinge halves prior to removal, for installation.
5. Remove four capscrews (4), washers (3), two upper hinge halves (14), and hinge plates (16) from hood (15).
 6. Remove four locknuts (9), two hinge plates (8), four capscrews (5), washers (6), and two lower hinge halves (12) from brackets (10). Discard locknuts (9).

b. Installation

NOTE

Perform steps 1 through 3 if hinges were removed.

1. Install two lower hinge halves (12) on brackets (10) with four washers (6), capscrews (5), two plates (8), and four locknuts (9). Do not tighten locknuts (9).
2. Apply sealing compound to hinge plates (16) and install hinge plates (16) to hood (15).

10-5. HOOD AND HINGE REPLACEMENT (Contd)

3. Install two upper hinge halves (14) on hood (15) with four washers (3) and capscrews (4). Tighten capscrews to 28 lb-ft (38 N·m).
4. Install hood (15) and align two upper hinge halves (14) with lower hinge halves (12).
5. Secure two upper hinge halves (14) to lower hinge halves (12) with washers (2), hinge pins (13), washers (2), and cotter pins (1).
6. Connect connector plug (11) to connector receptacle (7).
7. Install washer (18) and hood prop rod (19) on hood (15) with washer (18) and cotter pin (17).

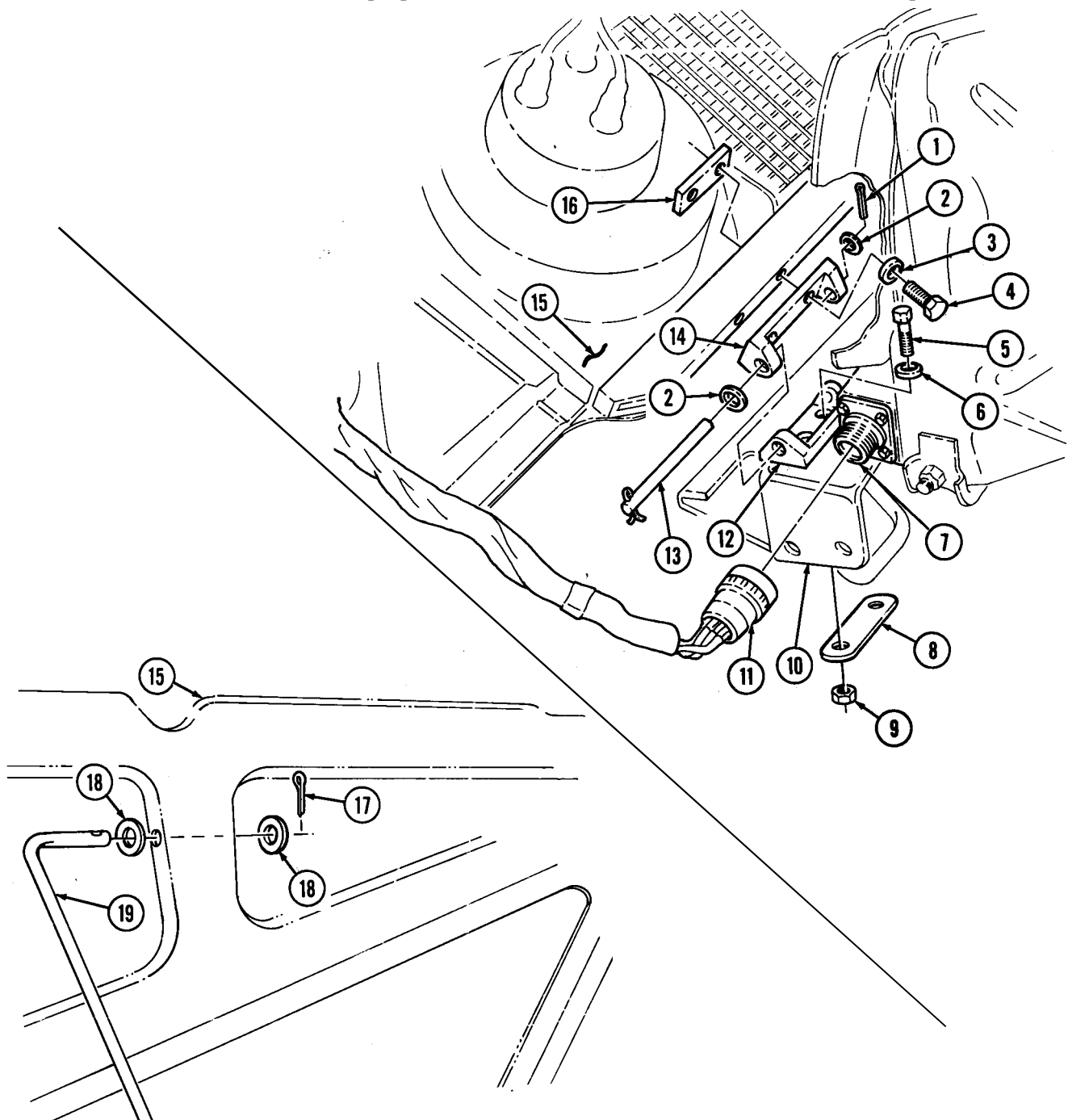

10-5. HOOD AND HINGE REPLACEMENT (Cont'd)

c. Alignment

1. Lower hood (4) and check alignment of hood stop guide (3) with center hood stop (2) on "A" pillar (1), and hood catch (5) with body latch (6).

NOTE

Upper and lower hinge halves contain slotted mounting holes to allow for adjustment.

2. With hood (4) lowered and secured and alignment correct, tighten four lower hinge half attaching locknuts (7) to 60 lb-ft (81 N·m).

NOTE

After hood alignment is completed, some contact may occur between hood and left mirror bracket. If contact exists, use file and trim about 1/4 in. (6.4 mm) off left corner and edge of hood. Trim until hood closes without hitting left mirror bracket. Touch up trim with paint (refer to TM 43-0139).

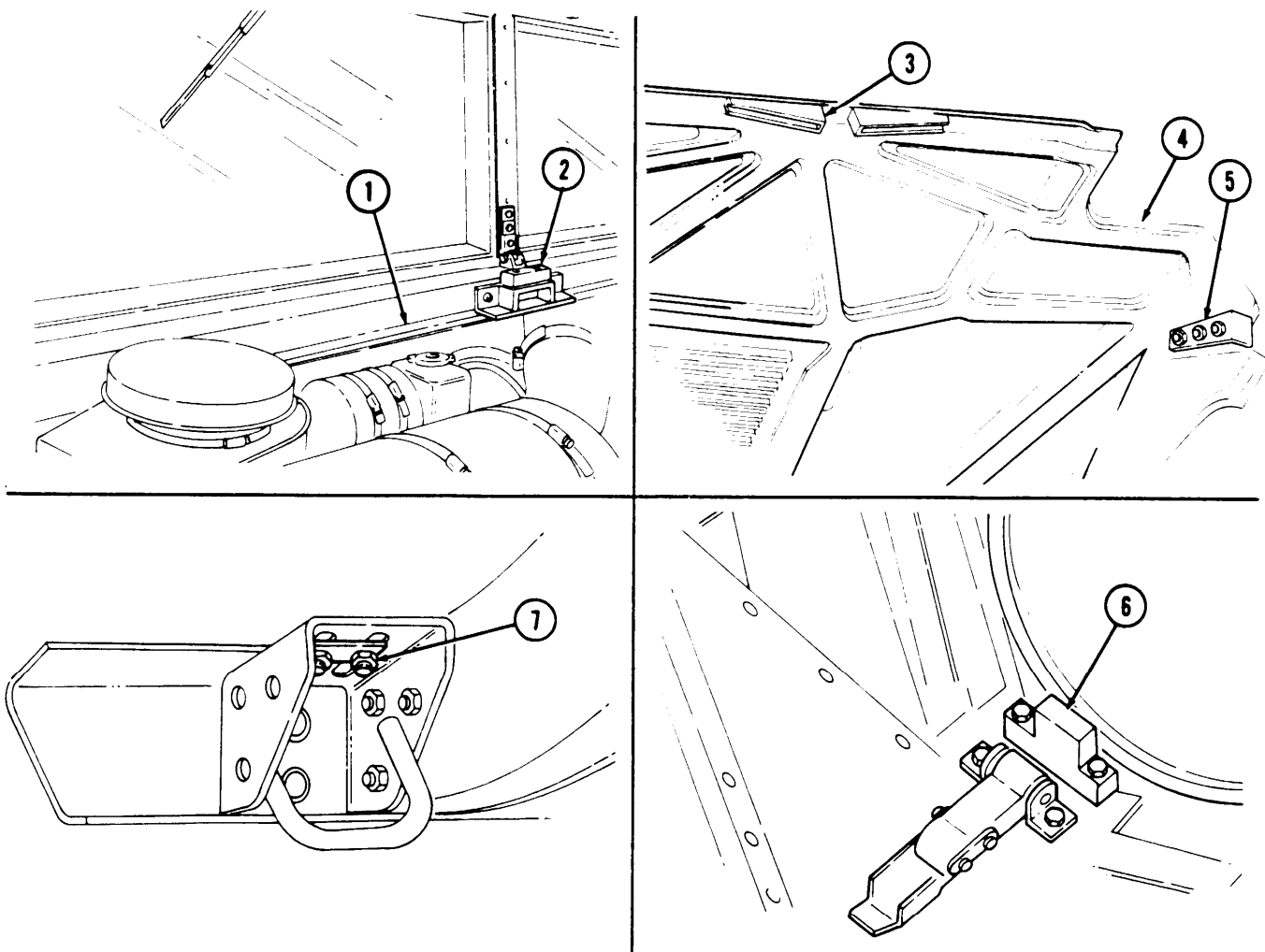

- FOLLOW-ON TASKS:**
- Lower and secure hood (TM 9-2320-280-10).
 - Connect battery ground cable (para. 4-73).

10-6. OUTER HOOD SEAL REPLACEMENT

This task covers:

a. Removal

b. Installation

INITIAL SETUP:

Tools

General mechanic's tool kit:
automotive (Appendix B, Item 1)

Equipment Condition

Hood raised and secured (TM 9-2320-280-10).

Manual References

TM 9-2320-280-10
TM 9-2320-280-24P

a. Removal

Remove two capscrews (4), seal retainer (3), and hood seal (2) from body (1).

b. Installation

Install hood seal (2) on body (1) with seal retainer (3) and two capscrews (4).

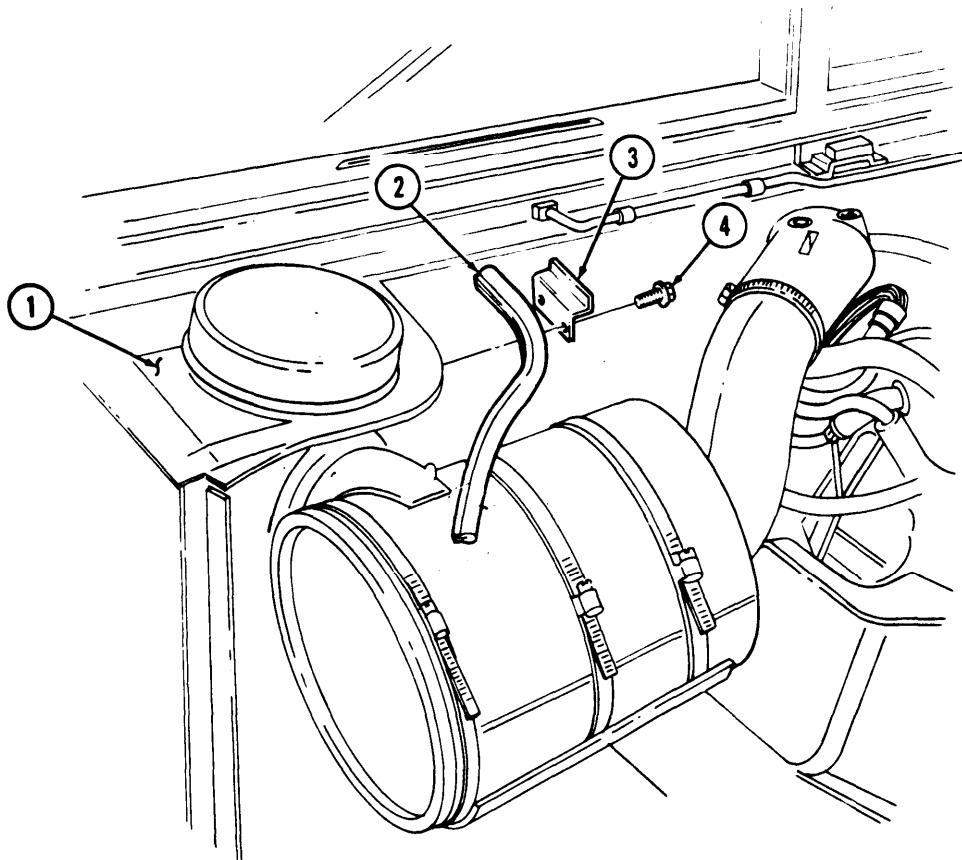

FOLLOW-ON TASK Lower and secure hood (TM 9-2320-280-10).

10-7. SIDE HOOD STOP REPLACEMENT

This task covers:

a. Removal

b. Installation

INITIAL SETUP:

Tools

General mechanic's tool kit:
automotive (Appendix B, Item 1)

Manual References

TM 9-2320-280-10
TM 9-2320-280-24P

Materials/Parts

Two locknuts (Appendix G, Item 70)

Equipment Condition

Hood raised and secured (TM 9-2320-280-10).

a. Removal

Remove two locknuts (6), washers (5), capscrews (3), washers (2), and side hood stop (1) from body (4). Discard locknuts (6).

b. Installation

Install side hood stop (1) on body (4) with two washers (2), capscrews (3), washers (5), and locknuts (6). Tighten capscrews (3) to 6 lb-ft (8 N·m).

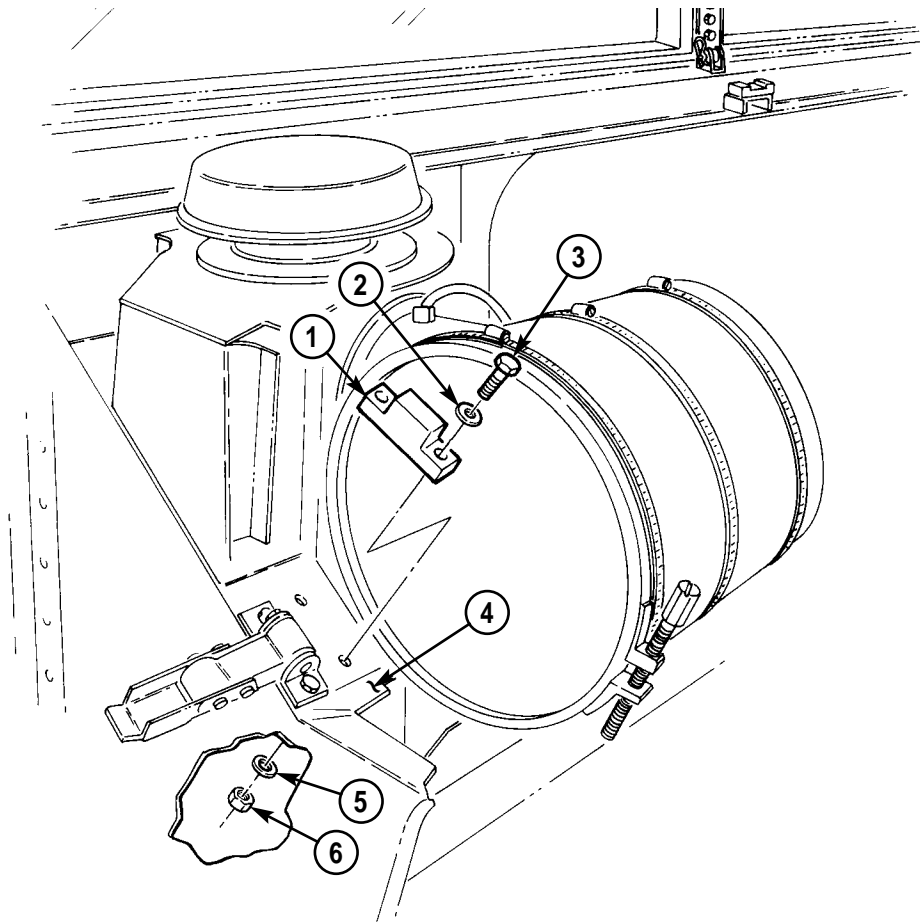

FOLLOW-ON TASK: Lower and secure hood (TM 9-2320-280-10).

10-8. CENTER HOOD STOP REPLACEMENT

This task covers:

a. Removal

b. Installation

INITIAL SETUP:

Tools

General mechanic's tool kit:
automotive (Appendix B, Item 1)

Equipment Condition

Hood raised and secured (TM 9-2320-280-10).

Manual References

TM 9-2320-280-10
TM 9-2320-280-24P

a. Removal

Remove two capscrews (1), washers (2), center hood stop (3), and plate (4) from "A" beam (5).

b. Installation

Install center hood stop (3) and plate (4) on "A" beam (5) with two washers (2) and capscrews (1). Tighten capscrews (1) to 12 lb-ft (16 N•m).

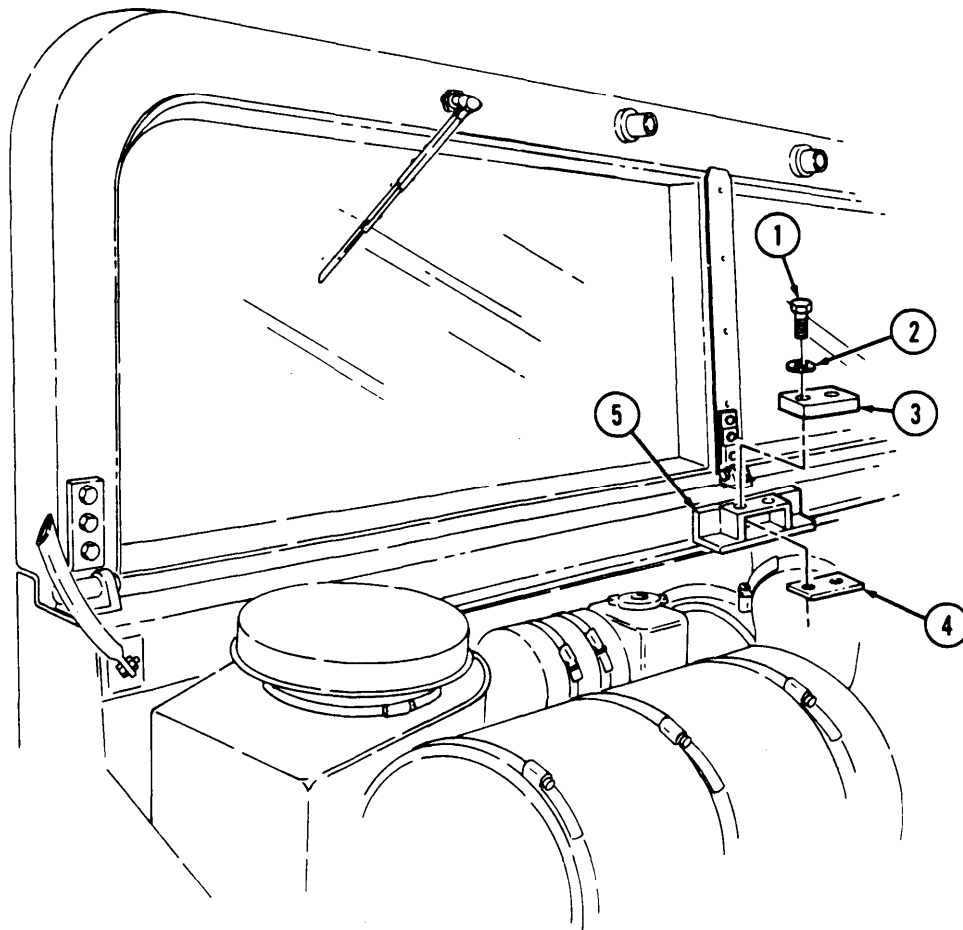

FOLLOW-ON TASK Lower and secure hood (TM 9-2320-280-10).

10-9. FOOTMAN LOOP AND STRAP REPLACEMENT

This task covers:

a. Removal

b. Installation

INITIAL SETUP:

Tools

General mechanic's tool kit:
automotive (Appendix B, Item 1)

Manual References

TM 9-2320-280-10
TM 9-2320-280-24P

Materials/Parts

Two locknuts (Appendix G, Item 74)

Equipment Condition

Rear end of cargo shell door raised
(TM 9-2320-280-10).

NOTE

All footman loops and straps for stowage and tiedowns are replaced basically the same. This procedure covers the night sight battery case footman loop and strap.

a. Removal

1. Remove two locknuts (4), screws (1), and footman loop (2) from wheelhouse (3). Discard locknuts (4).
2. Remove strap (5) from footman loop (2).

b. Installation

Install strap (5) on footman loop (2) and wheelhouse (3) with two screws (1) and locknuts (4). Tighten locknuts (4) to 16-30 lb-in. (2-3 N•m).

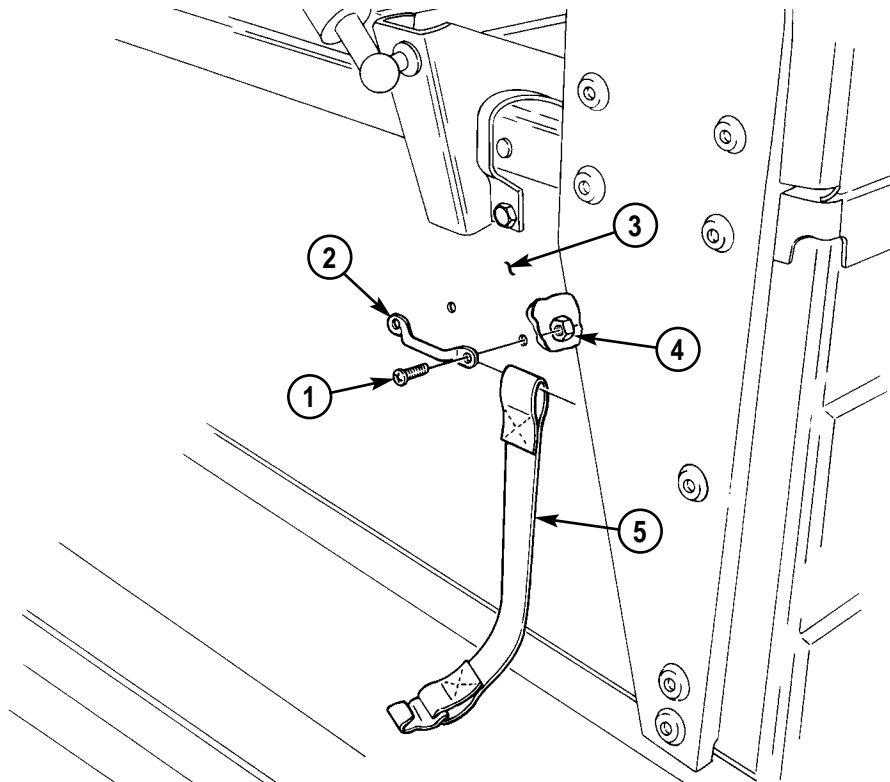

FOLLOW-ON TASK: Close cargo shell door (TM 9-2320-280-10).

10-9.1. JACK RETAINING STRAP REPLACEMENT

This task covers:

a. Removal

b. Installation

INITIAL SETUP:

Applicable Models

M1097A1, M1097A2, M1123

Tools

General mechanic's tool kit:
automotive (Appendix B, Item 1)

Materials/Parts

Four locknuts (Appendix G, Item 97)

Manual References

TM 9-2320-280-24P

a. Removal

1. Slide driver's seat (1) forward.
2. Remove four locknuts (7), washers (6), screws (4), two footman loops (2), and jack retaining strap (3) from vehicle floor (5). Discard locknuts (7).

b. Installation

1. Install jack retaining strap (3) and two footman loops (2) on vehicle floor (5) with four screws (4), washers (6), and locknuts (7).
2. Slide driver's seat (1) backward.

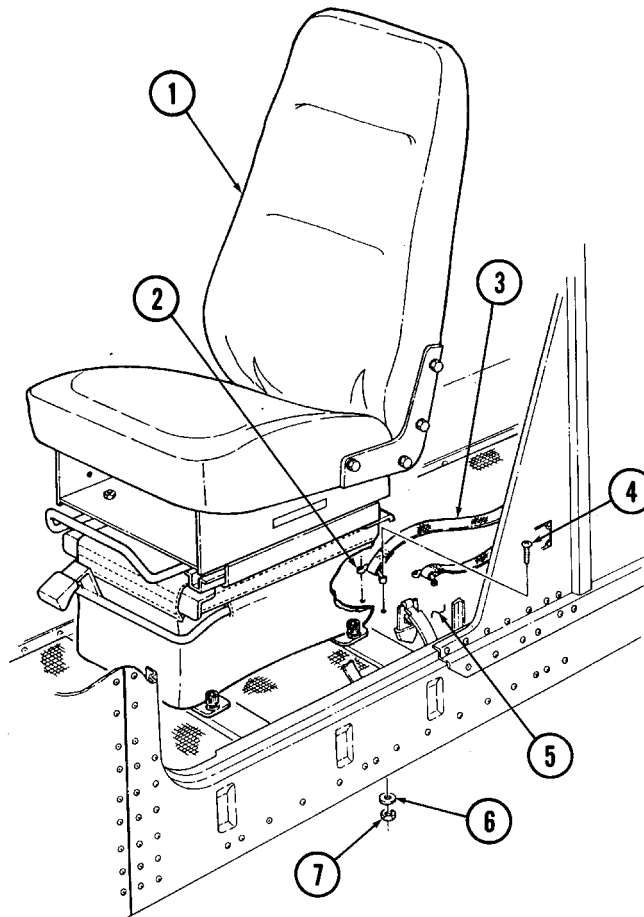

10-10. CENTER HOOD STOP GUIDE REPLACEMENT

This task covers:

a. Removal

b. Installation

INITIAL SETUP:

Tools

General mechanic's tool kit:
automotive (Appendix B, Item 1)

Manual References

TM 9-2320-280-10
TM 9-2320-280-24P

Materials/Parts

Six locknuts (Appendix G, Item 70)

Equipment Condition

Rear end of cargo shell door raised
(TM 9-2320-280-10).

a. Removal

Remove six locknuts (5), washers (2), capscrews (1), washers (2), two guide plates (3), and guide brackets (4) from hood (6). Discard locknuts (5).

b. Installation

Install two guide plates (3) and guide brackets (4) on hood (6) with six washers (2), capscrews (1), washers (2), and locknuts (5). Tighten locknuts (5) to 10 lb-ft (14 N·m).

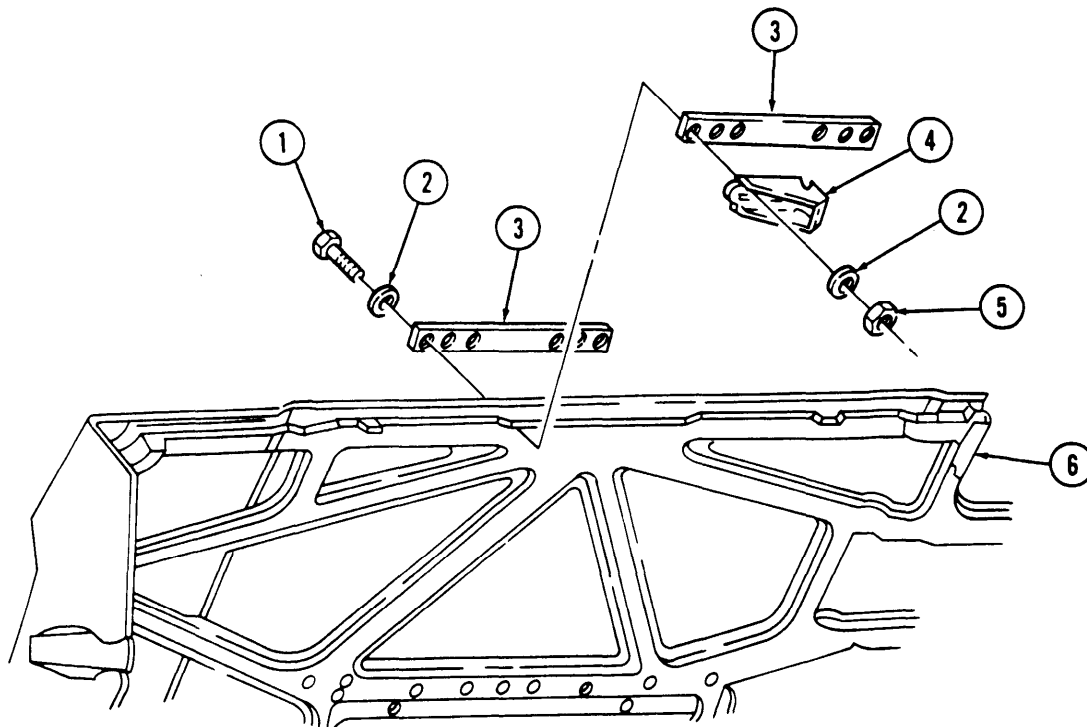

FOLLOW-ON TASK: Lower and secure hood (TM 9-2320-280-10).

10-11. FRONT HOOD SCREEN REPLACEMENT

This task covers:

a. Removal

b. Installation

INITIAL SETUP:

Applicable Models

M998, M998A1, M1035, M1035A1, M1035A2, M1037, M1038, M1038A1, M1042

Manual References

TM 9-2320-280-10
TM 9-2320-280-24P

Tools

General mechanic's tool kit:
automotive (Appendix B, Item 1)

Equipment Condition

Hood raised and secured (TM 9-2320-280-10).

Materials/Parts

Sealant (Appendix C, Item 38)

a. Removal

1. Remove three nuts (7), washers (6), and carriage bolts (8) from front hood screen (5) and hood (1).
2. Remove three capscrews (2), harness clamps (3), washers (4), and front hood screen (5) from hood (1).

b. Installation

1. Apply sealant to threads of capscrews (2).
2. Install front hood screen (5) on hood (1) with three washers (4), harness clamps (3), and capscrews (2). Tighten capscrews (2) to 20-30 lb-in. (2-3 N•m).
3. Secure front hood screen (5) to hood (1) with three carriage bolts (8), washers (6), and nuts (7). Tighten nuts (7) to 21 lb-ft (29 N•m).

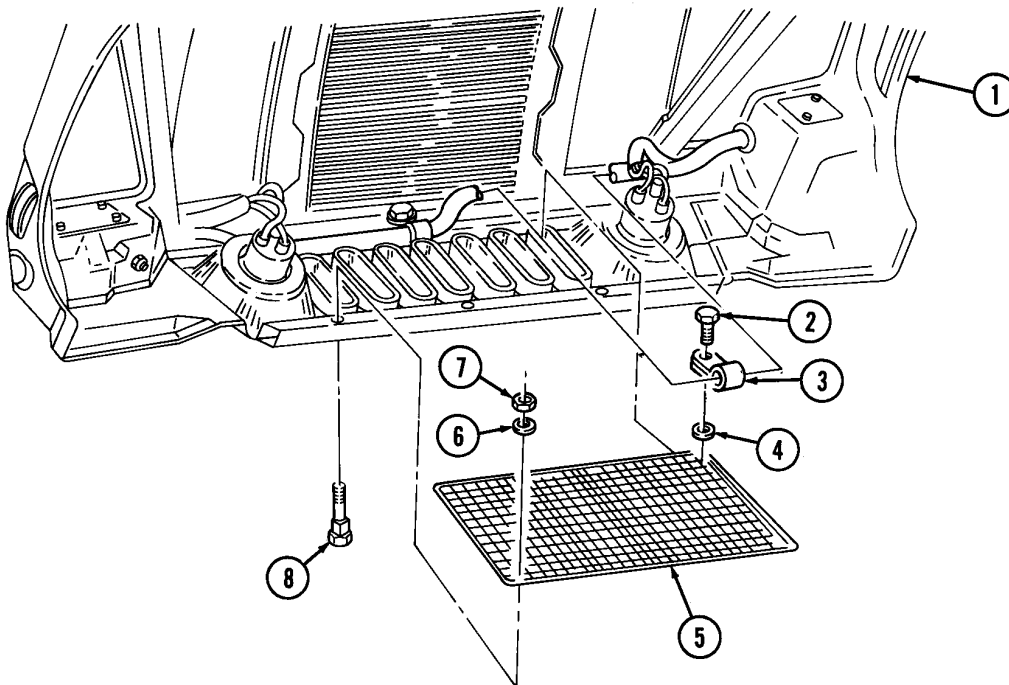

FOLLOW-ON TASK: Lower and secure hood (TM 9-2320-280-10).

10-12. HOOD GRILLE AND SCREEN REPLACEMENT

This task covers:

a. Removal

b. Installation

INITIAL SETUP:

Applicable Models

M998, M998A1, M1035, M1035A1, M1035A2,
M1037, M1038, M1038A1, M1042

Materials/Parts

Six locknuts (Appendix G, Item 70)
Six locknuts (Appendix G, Item 107)

Tools

General mechanic's tool kit:
automotive (Appendix B, Item 1)

Manual References

TM 9-2320-280-10
TM 9-2320-280-24P

Equipment Condition

Hood raised and secured (TM 9-2320-280-10).

a. Removal

1. Remove six locknuts (5), washers (2), capscrews (1), washers (2), and grille (3) from hood (4). Discard locknuts (5).
2. Remove six locknuts (7), washers (8), screws (10), washers (9), and screen (6) from grille (3). Discard locknuts (7).

b. Installation

1. Install screen (6) on grille (3) with six washers (9), screws (10), washers (8), and locknuts (7). Tighten locknuts (7) to 6 lb-ft (8 N·m).
2. Install grille (3) on hood (4) with six washers (2), capscrews (1), washers (2), and locknuts (5). Tighten locknuts (5) to 7 lb-ft (10 N·m).

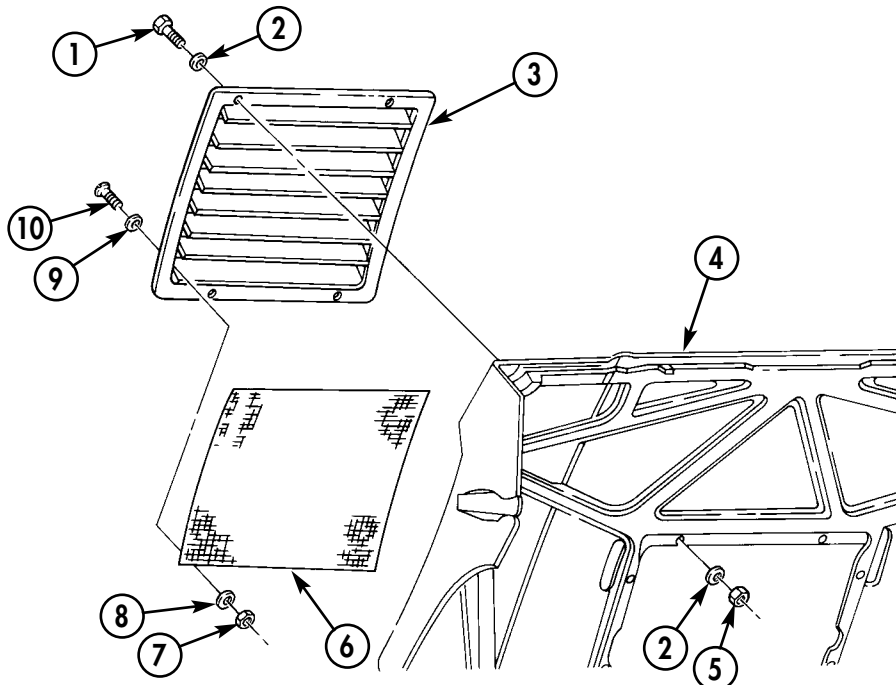

FOLLOW-ON TASK: Lower and secure hood (TM 9-2320-280-10).

10-13. DOOR HANDLE ASSEMBLY MAINTENANCE

This task covers:

- a. Removal
- b. Repair

c. Installation

INITIAL SETUP:

Applicable Models

M998, M998A1, M1035, M1035A1, M1035A2, M1037, M1038, M1038A1, M1042

Tools

General mechanic's tool kit:
automotive (Appendix B, Item 1)

Materials/Parts

Adhesive (Appendix C, Item 7)
Spring pin (Appendix G, Item 299)

Manual References

TM 9-2320-280-24P

NOTE

Some door handle assemblies may separate. To prevent or fix door handle assembly separation, perform step b.

a. Removal

1. Remove screw (5), inside door handle (4), and door handle spring (6) from door frame (7) and outside door handle (1).
2. Remove outside door handle (1) and washer (3) from door frame (7).

b. Repair

NOTE

Repair procedures for all door handle assemblies are basically the same. This procedure covers the left front door handle assembly.

1. Tighten screw (5) on inside door handle (4) to 15 lb-in. (1.7 N•m).

NOTE

- If screw will secure inside door handle, perform steps 2 and 3.
- If screw will not secure inside door handle, perform steps 4 through 10.

2. Locate, mark, and drill 0.125-in. (3.2-mm) diameter hole (9) through inside door handle (4) and outside door handle (1).
3. Install spring pin (8) through inside door handle (4) and outside door handle (1).

NOTE

Inside door handle can separate from outside door handle without removing screw.

4. Remove inside door handle (4) and door handle spring (6) from outside door handle (1) and door frame (7).
5. Remove outside door handle (1) and washer (3) from door frame (7).
6. Remove screw (5) and insert (2) from inside door handle (4).
7. Apply adhesive to outside of insert (2) and install insert (2) in outside door handle (1). Allow adhesive to cure for five minutes.
8. Install outside door handle (1) and washer (3) on door frame (7).
9. Install inside door handle spring (6) and inside door handle (4) on outside door handle (1) and door frame (7) with screw (5). Tighten screw (5) to 15 lb-in. (1.7 N•m).
10. Perform steps 2 and 3.

10-13. DOOR HANDLE ASSEMBLY MAINTENANCE (Cont'd)

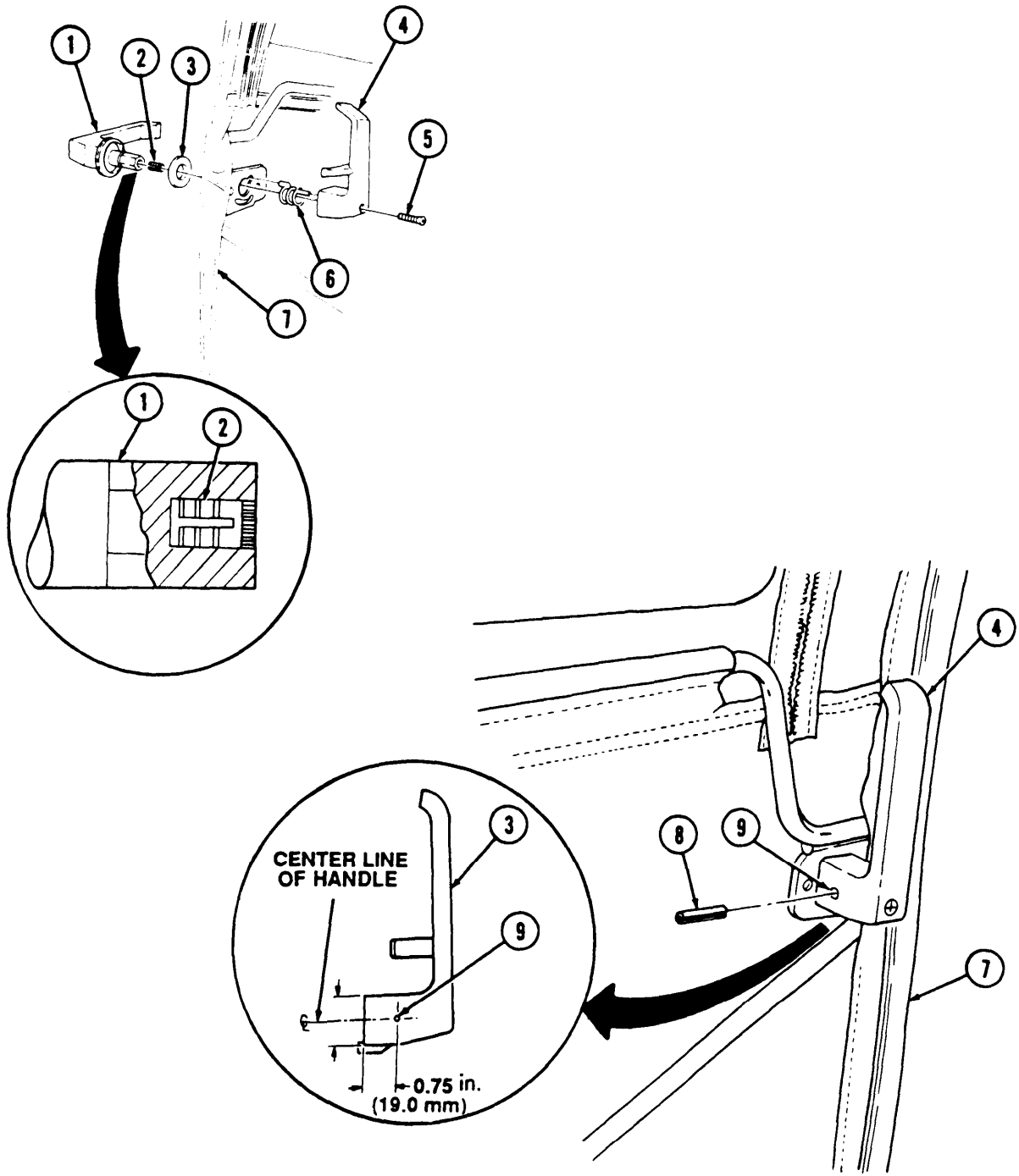

10-13. DOOR HANDLE ASSEMBLY MAINTENANCE (Cont'd)

c. Installation

1. Install washer (2) and outside door handle (1) on door frame (6).
2. Install door handle spring (5) and inside door handle (3) on outside door handle (1) in door frame (6).
3. Place outside door handle (1) in horizontal position, and place inside door handle (3) in vertical position with grip end of handle pointing to top of door.
4. Install inside door handle (3) on outside door handle (1) and door frame (6) with screw (4). Tighten screw (4) to 15 lb-in. (1.7 N•m).

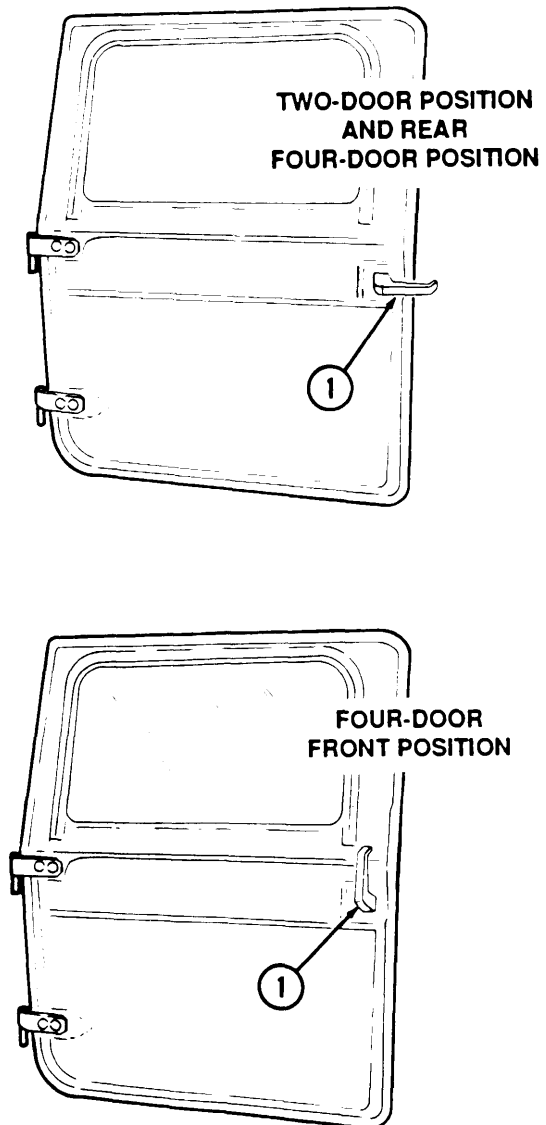
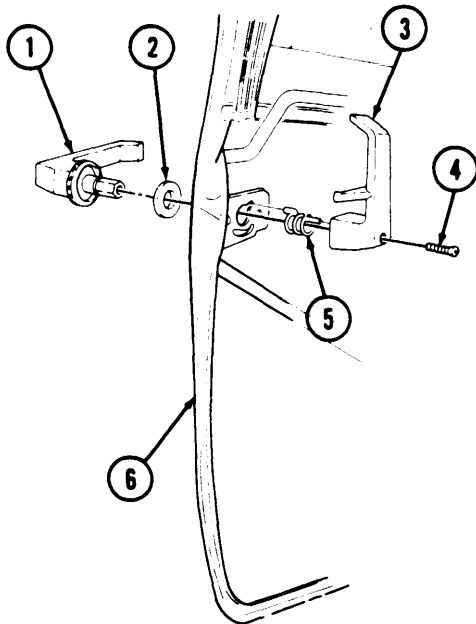

10-14. FIXED REAR DOOR REPLACEMENT

This task covers:

a. Removal

b. Installation

INITIAL SETUP:

Applicable Models

M998, M998A1, M1037, M1038, M1038A1,
M1042, M1097, M1097A1, M1097A2

Manual References

TM 9-2320-280-24P

Tools

General mechanic's tool kit:
automotive (Appendix B, Item 1)

Equipment Condition

Troop seat removed, if installed (para. 12-18).

Materials/Parts

Door seals (Appendix G, Item 27)

a. Removal

1. Remove four capscrews (6) and washers (7) from fixed rear door (4) and "B" pillar (1).
2. Remove locking pin (3) and fixed rear door (4) from body (2).
3. Remove seals (5) from fixed rear door (4). Discard seals (5).

b. Installation

1. Install seals (5) on fixed rear door (4).
2. Install fixed rear door (4) on body (2) with locking pin (3).
3. Install fixed rear door (4) on "B" pillar (1) with four washers (7) and capscrews (6). Tighten capscrews (6) to 6 lb-ft (8 N•m).

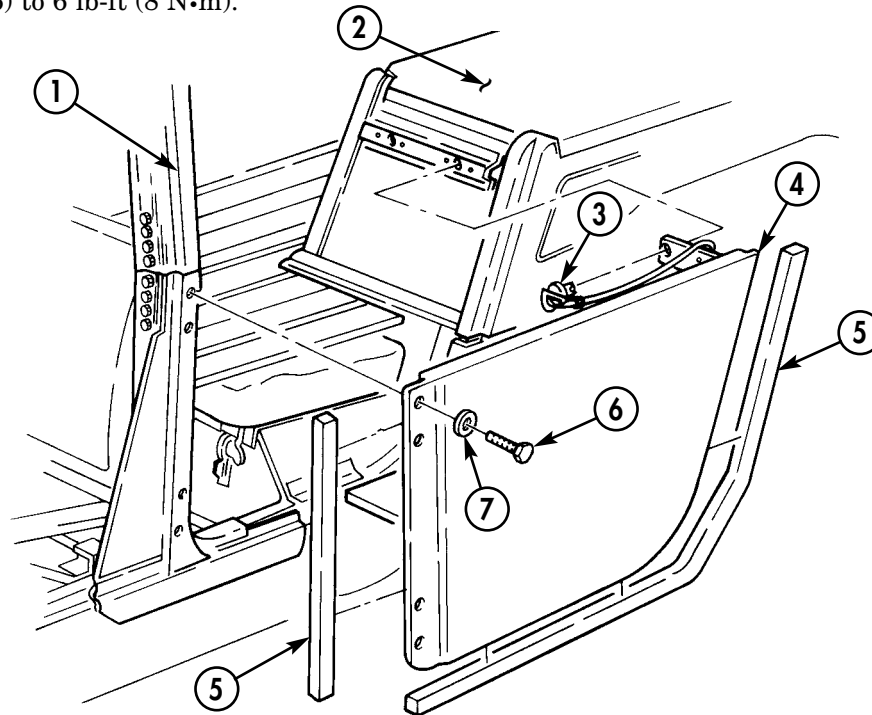

FOLLOW-ON TASK: Install troop seat, if removed (para. 12-18).

10-15. ENGINE ACCESS COVER MAINTENANCE

This task covers:

- | | |
|----------------|-----------------|
| a. Removal | c. Assembly |
| b. Disassembly | d. Installation |

INITIAL SETUP:

Tools

General mechanic's tool kit:
automotive (Appendix B, Item 1)

Materials/Parts

Two locknuts (Appendix G, Item 79)
Seven rivets (Appendix G, Item 236)
Two rivets (Appendix G, Item 238)
Two rivets (Appendix G, Item 249)
Four rivets (Appendix G, Item 266)

Manual References

TM 9-2320-280-24P

Equipment Condition

Front radio rack removed (para. 12-132).

a. Removal

1. Unlatch two flexible latches (1) from keepers (2) on engine access cover holddown brackets (3).
2. Unlatch two engine access cover holddown latches (6) from two engine access cover holddown strikes (7).
3. Turn two ring studs (5) and remove engine access cover (4).

b. Disassembly

NOTE

For rivet replacement instructions, refer to para. 10-66.

1. Remove seven rivets (10) and retainers (9) and remove insulation (11).
2. Remove seal (8) from access cover (4).

10-15. ENGINE ACCESS COVER MAINTENANCE (cont'd)

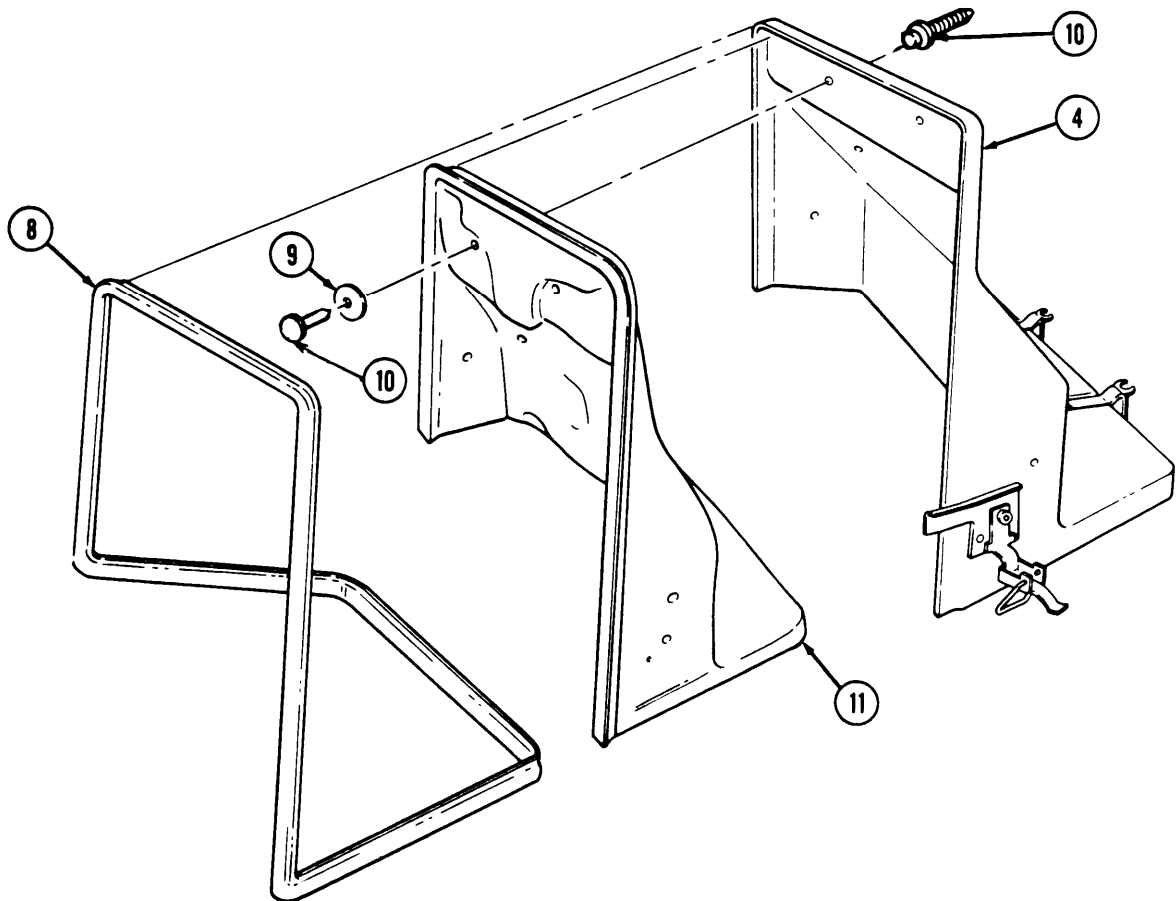
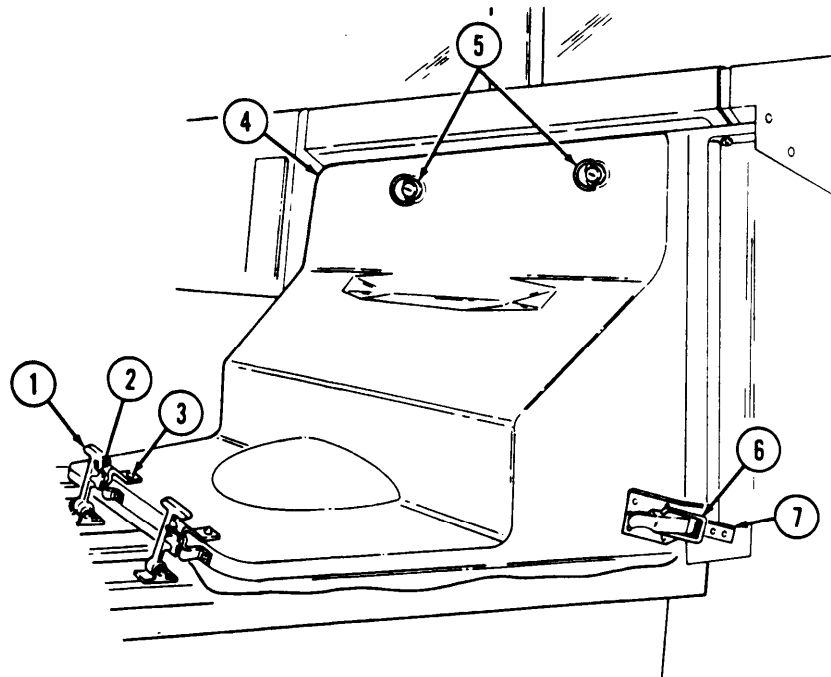

10-15. ENGINE ACCESS COVER MAINTENANCE (Cont'd)

3. Remove four retaining rings (8), two washers (7), ring studs (6), and washers (7) from access cover (5).
4. Remove two locknuts (9), shoulder bolts (13), and latches (14) from access cover (5). Discard locknuts (9).
5. Remove two rivets (12), backing plates (10), and guide plates (11) from access cover (5).
6. Remove two rivets (1) and keepers (2) from holddown brackets (3).
7. Remove four rivets (4), nuts (15), washers (16), capscrews (18), two holddown brackets (3), and backing plates (17) from access cover (5).

c. Assembly

1. Install two holddown brackets (3) and backing plates (17) on access cover (5) with four rivets (4), capscrews (18), washers (16), and nuts (15).
2. Install two keepers (2) on holddown brackets (3) with rivets (1).
3. Install two backing plates (10) and guide plates (11) on access cover (5) with rivets (12).
4. Install two latches (14) on plates (11) and access cover (5) with shoulder bolts (13) and locknuts (9).
5. Install two washers (7) and ring studs (6) on access cover (5) with washers (7) and four retaining rings (8).
6. Install seal (19) on access cover (5).
7. Install insulation (22) on access cover (5) with seven retainers (20) and rivets (21).

10-15. ENGINE ACCESS COVER MAINTENANCE (Cont'd)

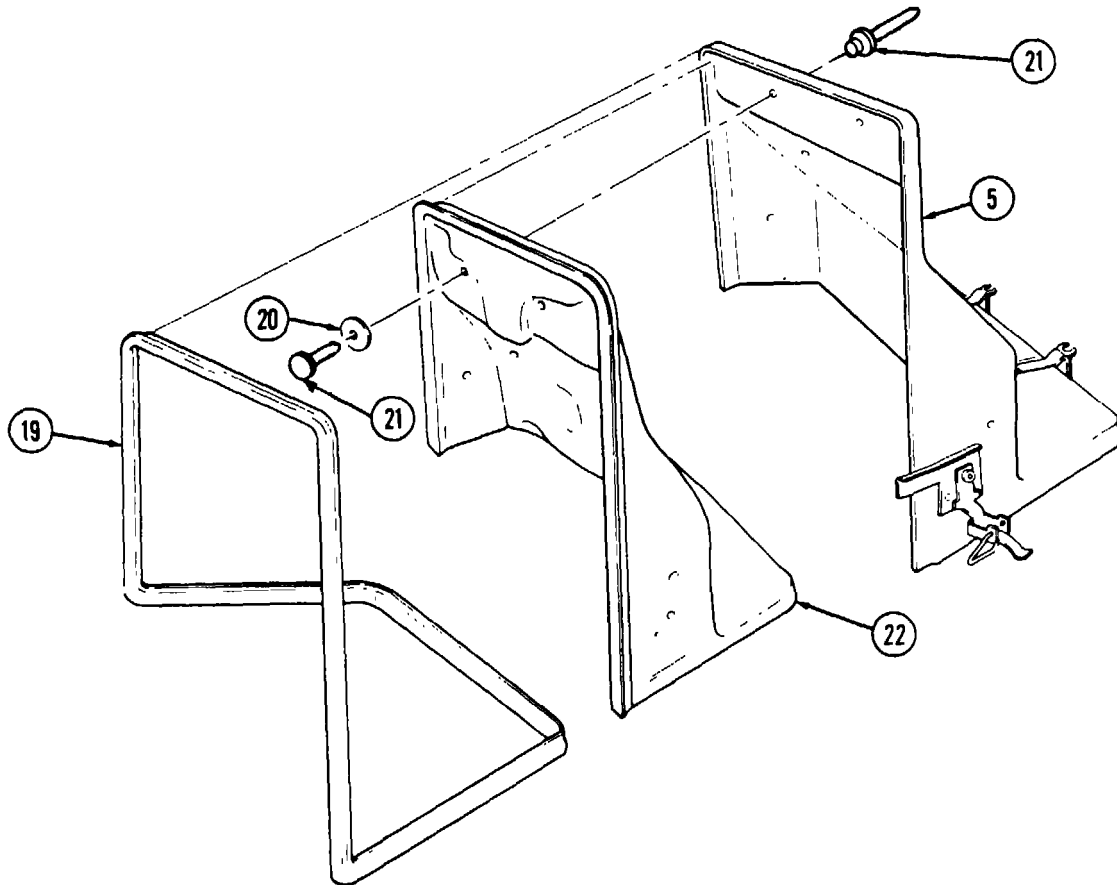
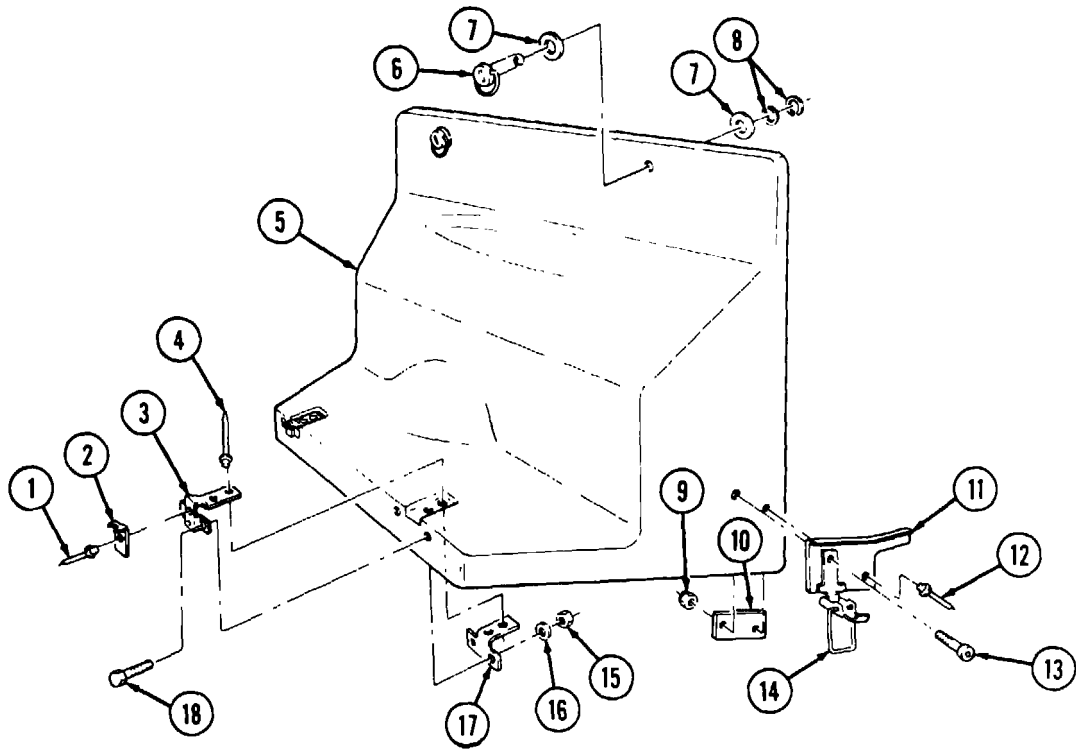

10-15. ENGINE ACCESS COVER MAINTENANCE (Cont'd)

d. Installation

1. Install access cover (4) with two ring studs (5).
2. Install two holddown latches (6) on holddown strikes (7).
3. Latch two flexible latches (1) to keepers (2) on access cover holddown brackets (3).

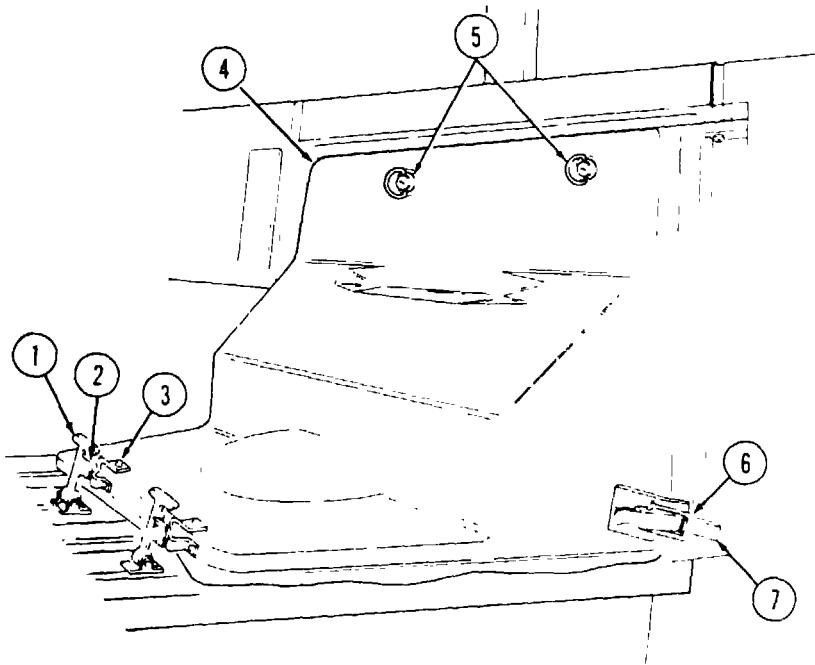

FOLLOW-ON TASK: Install front radio rack (para. 12-132).

10-16. ENGINE ACCESS COVER FLEXIBLE LATCH AND HOLDDOWN STRIKE REPLACEMENT

This task covers:

a. Removal

b. Installation

INITIAL SETUP:

Tools

General mechanic's tool kit:
automotive (Appendix B, Item 1)

Manual References

TM 9-2320-280-24P

Materials/Parts

Two rivets (Appendix G, Item 248)
Rivet (Appendix G, Item 240)
Rivet (Appendix G, Item 238)

Equipment Condition

Engine access cover removed (para. 10-15).

a. Removal

NOTE

For rivet replacement instructions, refer to para. 10-66.

1. Remove two rivets (5) and holddown strike (4) from body (3).
2. Remove two rivets (1) and flexible latch (2) from cargo floor (6).

b. Installation

1. Install flexible latch (2) on cargo floor (6) with two rivets (1).
2. Install holddown strike (4) on body (3) with two rivets (5).

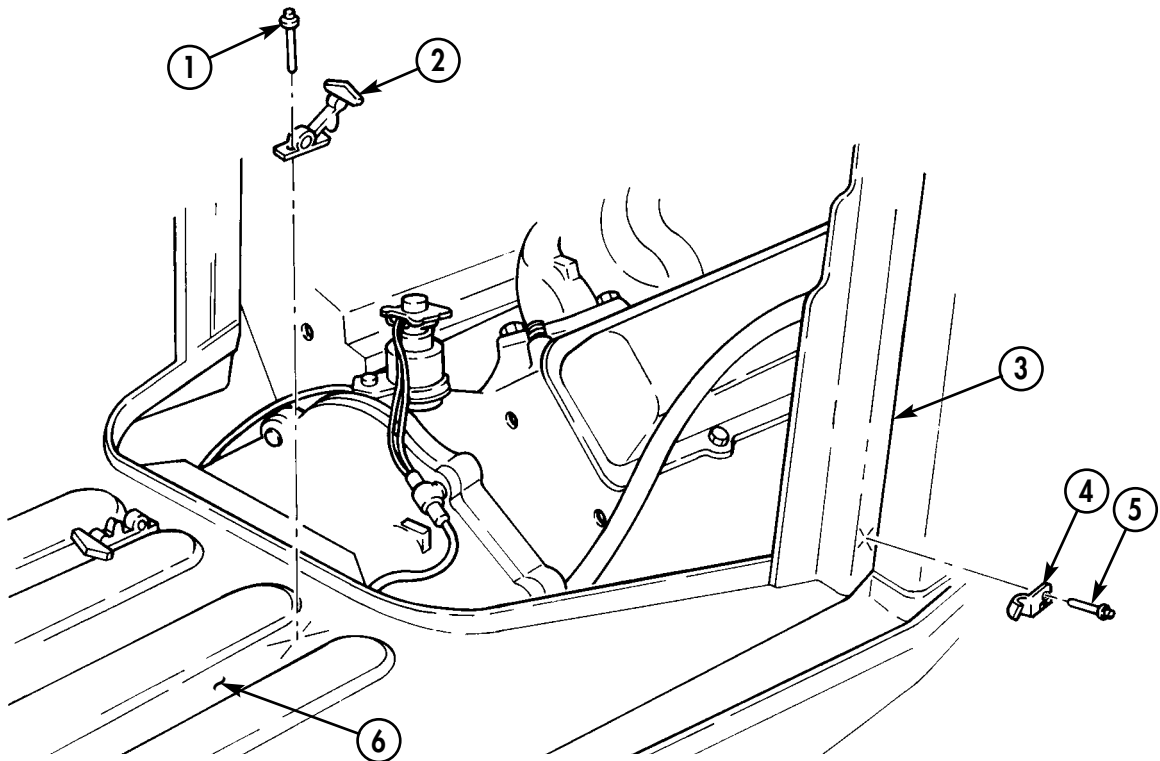

FOLLOW-ON TASK: Install engine access cover (para. 10-15).

10-17. ENGINE LEFT SPLASH SHIELD MAINTENANCE

This task covers:

- | | |
|--|--|
| <ul style="list-style-type: none"> a. Removal b. Disassembly | <ul style="list-style-type: none"> c. Assembly d. Installation |
|--|--|

Tools

General mechanic's tool kit:
automotive (Appendix B, Item 1)

Materials/Parts

Seven locknuts (Appendix G, Item 107)
Four lockwashers (Appendix G, Item 143)
Assembled locknut (Appendix G, Item 131)
Three locknuts (Appendix G, Item 79)
Two locknuts (Appendix G, Item 70)
Locknut (Appendix G, Item 128)
Lockwasher (Appendix G, Item 134)
Four rivets (Appendix G, Item 239)

Manual References

TM 9-2320-280-24P

Equipment Condition

- Battery ground cable disconnected (para. 4-73).
- Hood prop rod and bracket removed (para. 10-4).

General Safety Instructions

Hood must be supported during removal and installation.

WARNING

Hood must be supported during removal and installation. Failure to support hood may cause injury to personnel and damage to equipment.

NOTE

- Left splash shield maintenance is the same for all vehicles, except M998, M998A1, M1035, M1035A1, M1035A2, M1037, M1038, M1038A1, and M1042 vehicles do not have an armor plate attached to side of shield.
- The left splash shield can be modified with an access cover which will provide easier access to transmission oil cooler lines, at commander's discretion. Refer to appendix D, Figs. D-86 and D-87.

a. Removal

1. Disconnect hood harness (27) from connector receptacle (30).
2. Remove locknut (3), washer (2), capscrew (24), and washer (2) from splash shield (15) and support bracket (1). Discard locknut (3).
3. Remove locknut (10), washer (11), washer (12), capscrew (20), and washer (11) from splash shield (15) and airlift bracket (9). Discard locknut (10).
4. Remove capscrew (21), lockwasher (22), and washer (23) from splash shield (15) and airlift bracket (9). Discard lockwasher (22).
5. Remove four screws (28), lockwashers (29), and connector receptacle (30) from bracket (32). Discard lockwashers (29).
6. Remove assembled locknut (39) and screw (37) from harness and clamp (38) and splash shield (15). Discard assembled locknut (39).
7. Remove locknut (13), washer (14), capscrew (19), washer (14), and splash shield (15) from bracket (16). Discard locknut (13).

b. Disassembly

NOTE

Perform step 1 only if vehicle has an armor plate.

1. Remove locknut (33), washer (34), capscrew (36), washer (34), and armor plate (35) from splash shield (15). Discard locknut (31).

10-17. ENGINE LEFT SPLASH SHIELD MAINTENANCE (Cont'd)

2. Remove seven locknuts (8), washers (7), capscrews (6), seal retainers (4), and seal (5) from splash shield (15). Discard locknuts (8).
3. Remove two locknuts (25), washers (26), capscrews (31), washers (26), and bracket (32) from splash shield (15). Discard locknuts (25).

NOTE

For rivet replacement instructions refer to para. 10-66.

4. Remove four rivets (18) and bushing (17) from splash shield (15).

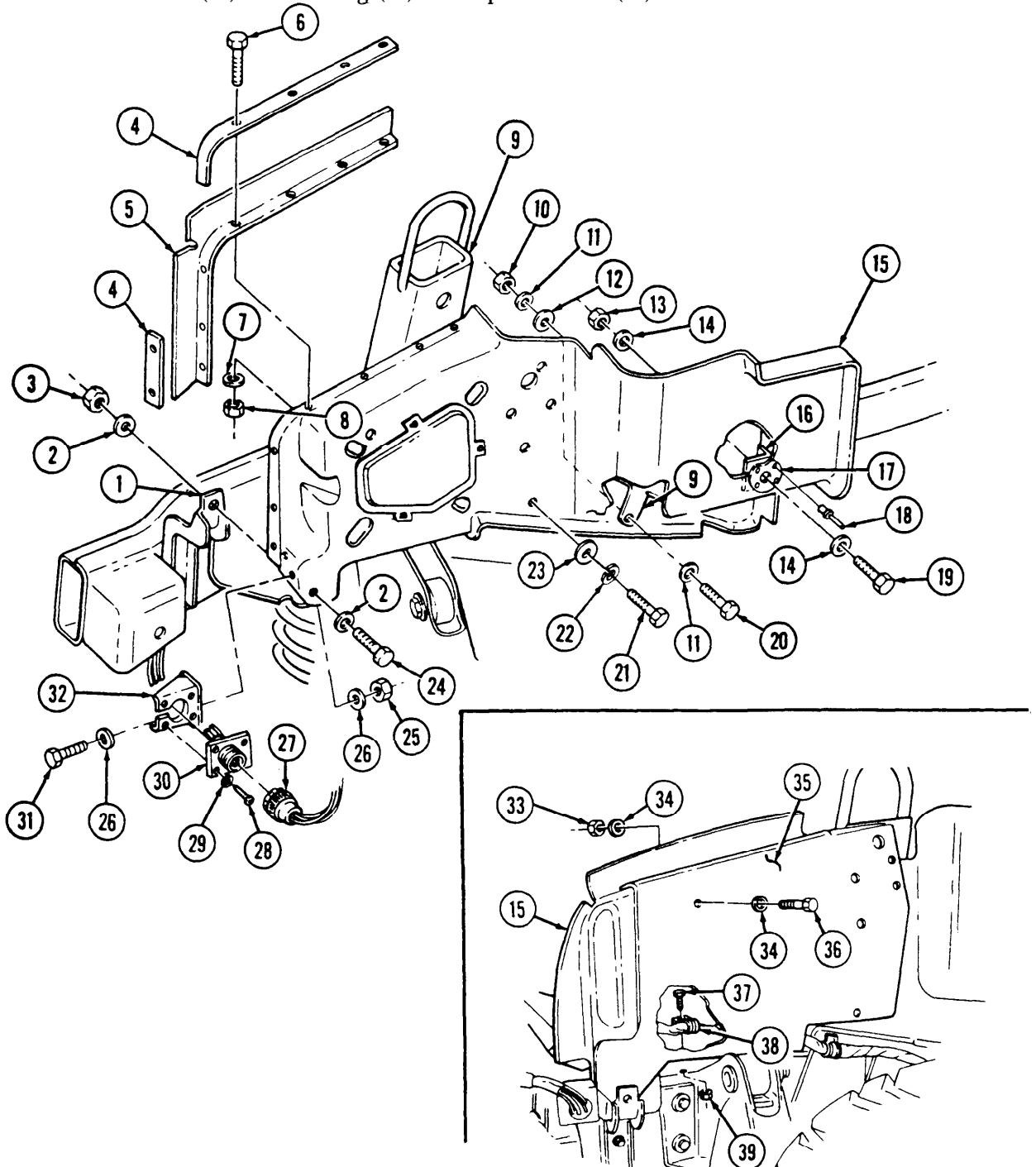

10-17. ENGINE LEFT SPLASH SHIELD MAINTENANCE (Cont'd)

c. Assembly

1. Install bushing (17) on splash shield (15) with four rivets (18).
2. Install bracket (32) on splash shield (15) with two washers (26), capscrews (31), washers (26), and locknuts (25). Tighten locknuts (25) to 6 lb-ft (8 N•m).
3. Install seal (5) and seal retainers (4) on splash shield (15) with seven capscrews (6), washers (7), and locknuts (8).

NOTE

Perform step 4 only if vehicle has an armor plate.

4. Install armor plate (35) on splash shield (15) with washer (34), capscrew (36), washer (34), and locknut (33). Tighten locknut (33) to 15 lb-ft (20 N•m).

d. Installation

1. Install splash shield (15) on bracket (16) with washer (14), capscrew (19), washer (14), and locknut (13).
- 2. Install harness and clamp (38) on splash shield (15) with screw (37) and assembled locknut (39).
3. Install connector receptacle (30) on bracket (32) with four lockwashers (29) and screws (28).
4. Install splash shield (15) to airlift bracket (9) with washer (23), lockwasher (22), and capscrew (21). Tighten capscrew (21) to 10 lb-ft (14 N•m).
5. Install splash shield (15) on airlift bracket (9) with washer (11), capscrew (20), washer (12), washer (11), and locknut (10). Tighten capscrew (20) to 10 lb-ft (14 N•m).
6. Install splash shield (15) on support bracket (1) with washer (2), capscrew (24), washer (2), and locknut (3). Tighten capscrew (24) to 6 lb-ft (8 N•m).
7. Connect hood harness (27) to connector receptacle (30).

10-17. ENGINE LEFT SPLASH SHIELD MAINTENANCE (Cont'd)

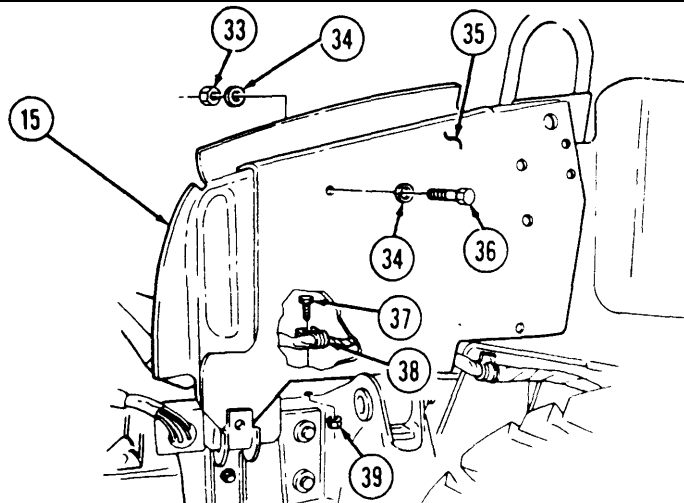
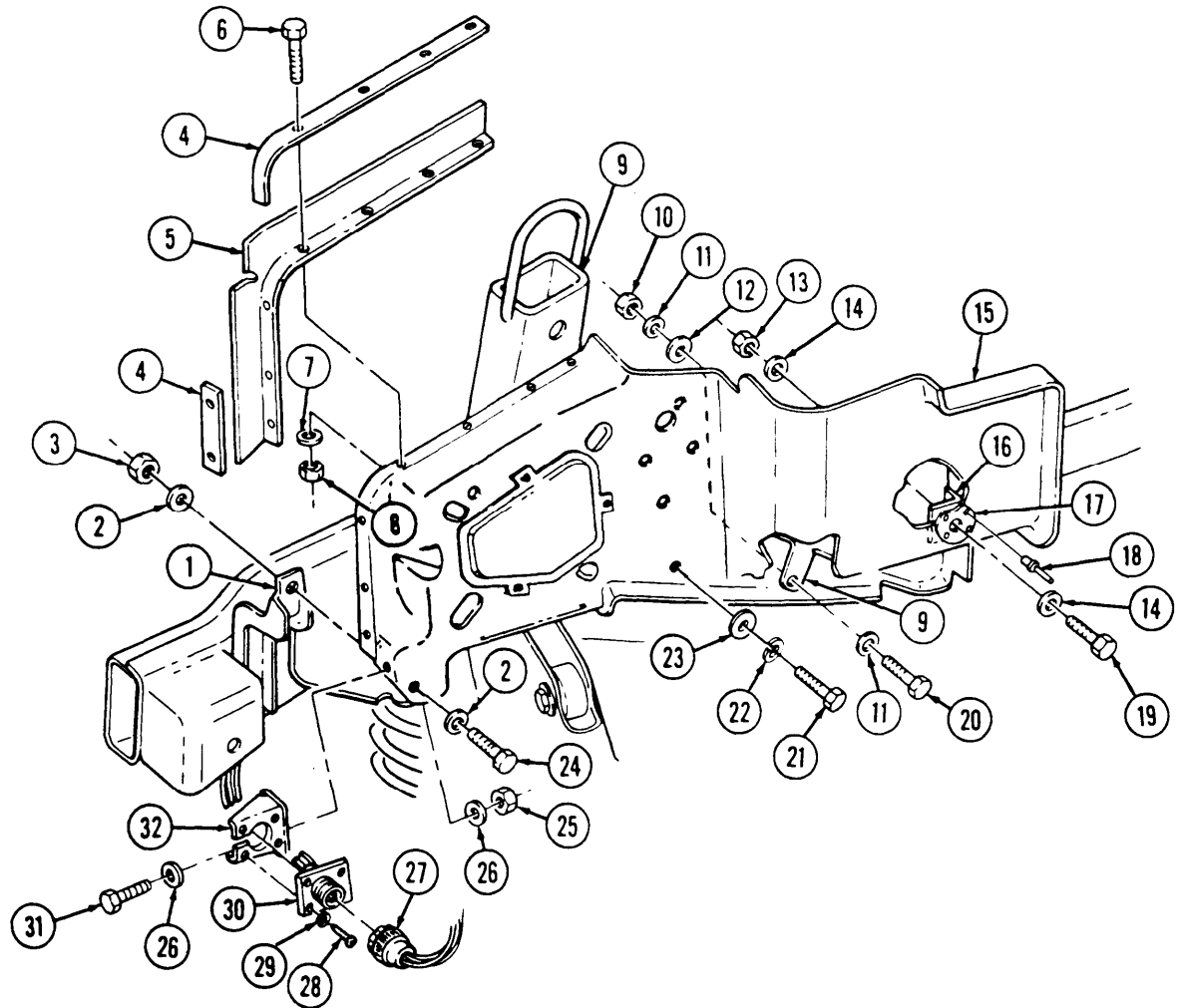

FOLLOW-ON TASKS: •Install hood prop rod and bracket (para. 10-4)
 •Connect battery ground cable (para. 4-73).

10-18. ENGINE LEFT SPLASH SHIELD ACCESS COVER REPLACEMENT

This task covers:

a. Removal

b. Installation

INITIAL SETUP:

Applicable Models

M997A2, M1025A2, M1035A2, M1043A2,
M1045A2, M1097A2 (or modified vehicles)

Manual References

TM 9-2320-280-10
TM 9-2320-280-24P

Tools

General mechanic's tool kit:
automotive (Appendix B, Item 1)

Equipment Condition

Hood raised and secured (TM 9-2320-280-10).

a. Removal

1. Remove three capscrews (4), washers (3), and splash shield access cover (5) from engine left splash shield (1).
2. Inspect spring nuts (2) for damage. Replace, if damaged.

b. Installation

Install splash shield access cover (5) to engine left splash shield (1) with three capscrews (4) and washers (3).

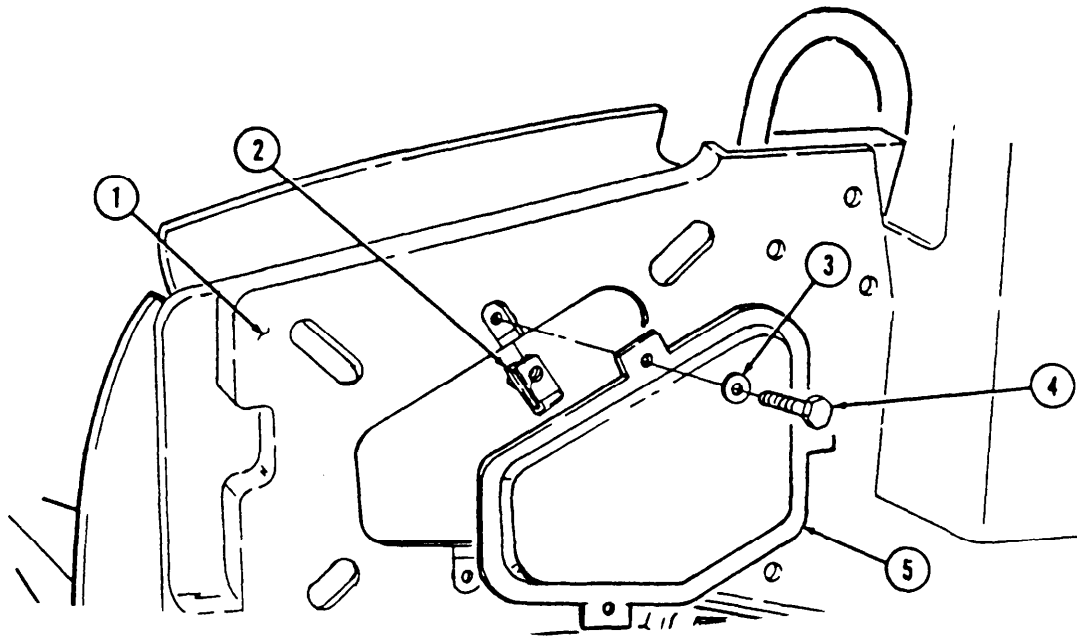

FOLLOW-ON TASK Lower and secure hood (TM 9-2320-280-10).

10-19. 3.5-TON JACK STOWAGE BRACKET AND COVER REPLACEMENT

This task covers:

a. Removal

b. Installation

INITIAL SETUP:

Applicable Models

M997A2, M1025A2, M1035A2, M1043A2,
M1045A2, M1097A2, M1123

Tools

General mechanic's tool kit:
automotive (Appendix B, Item 1)

Material/Parts

Two lockwashers (Appendix G, Item 135)

Manual References

TM 9-2320-280-10
TM 9-2320-280-24P

Equipment Condition

Hood raised and secured (TM 9-2320-280-10).

NOTE

The tools for the jack are stored behind the driver's seat.

a. Removal

1. Lift two latches (9) on cover (10) and remove cover (10) from bracket (5).
2. Remove two wing nuts (14), spacers (13), washers (12), and jack (11) from bracket (5).
3. Remove nut (6), washer (7), capscrew (8), and washer (7) from bracket (5).
4. Remove two capscrews (4), lockwashers (3), washers (2), and bracket (5) from splash shield (1). Discard lockwashers (3).

b. Installation

1. Install bracket (5) on splash shield (1) with two washers (2), lockwashers (3), and capscrews (4).
2. Install washer (7), capscrew (8), washer (7), and nut (6) on bracket (5).
3. Install jack (11) on bracket (5) with two washers (12), spacers (13), and wing nuts (14).
4. Install cover (10) on bracket (5).
5. Secure cover (10) on bracket (5) with two latches (9).

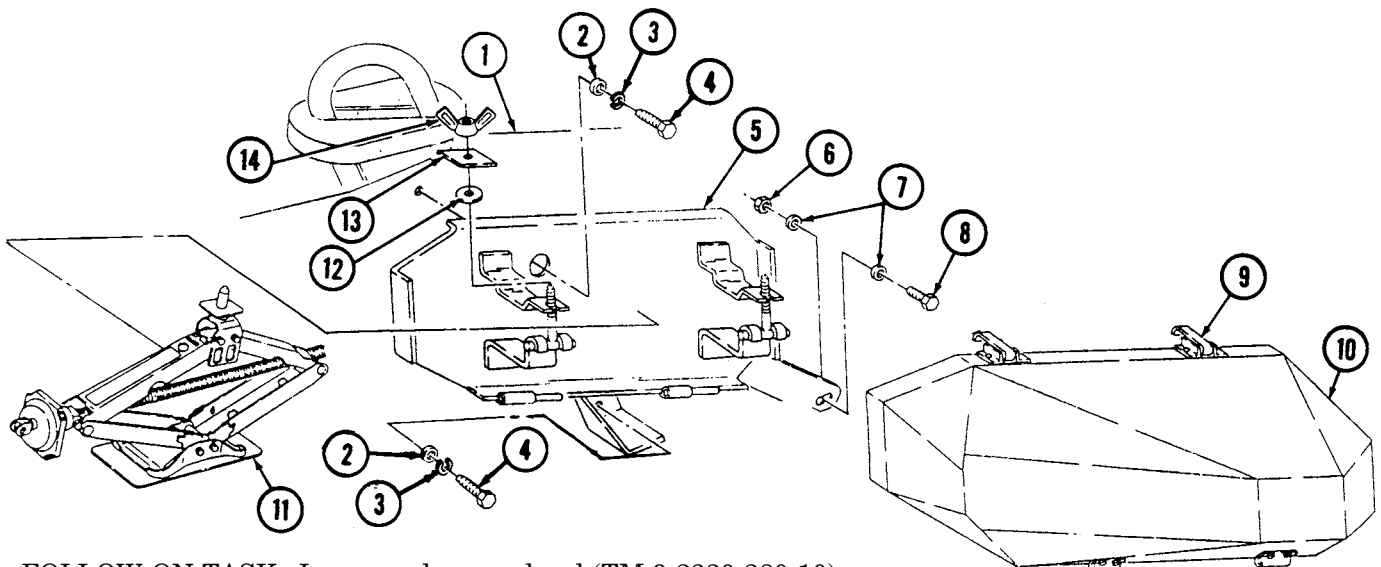

FOLLOW-ON TASK: Lower and secure hood (TM 9-2320-280-10).

10-20. ENGINE RIGHT SPLASH SHIELD MAINTENANCE

This task covers:

- | | |
|--|--|
| <ul style="list-style-type: none"> a. Removal b. Disassembly | <ul style="list-style-type: none"> c. Assembly d. Installation |
|--|--|

INITIAL SETUP:

Tools

General mechanic's tool kit:
automotive (Appendix B, Item 1)

Manual References

TM 9-2320-280-10
TM 9-2320-280-24P

Materials/Parts

Four locknuts (Appendix G, Item 79)
Three lockwashers (Appendix G, Item 134)
Seven locknuts (Appendix G, Item 107)
Locknut (Appendix G, Item 70)

Equipment Condition

- Hood raised and secured (TM 9-2320-280-10).
- 3.5-ton jack stowage bracket and cover removed (M1123 and "A2" series only) (para. 10-19).

NOTE

Right splash shield maintenance is the same for all vehicles, except M998, M998A1, M1035, M1035A1, M1035A2, M1037, M1038, M1038A1, and M1042 vehicles do not have an armor plate attached to side of shield.

a. Removal

1. Remove locknut (7), washer (6), capscrew (8), and washer (6) from splash shield (1) and support bracket (5). Discard locknut (7).
2. Remove locknut (15), washer (16), washer (17), capscrew (19), lockwasher (18), and washer (16) from splash shield (1) and airlift bracket (4). Discard locknut (15) and lockwasher (18).
3. Remove locknut (21), washer (20), capscrew (10), and fuel line clamp (22) from splash shield (1). Discard locknut (21).
4. Remove two screws (2), lockwashers (3), washers (9) (vehicles without armor plate), and splash shield (1) from airlift bracket (4). Discard lockwashers (3).

b. Disassembly

1. Remove locknut (14), washer (12), capscrew (11), washer (12), and support plate (13) from splash shield (1). Discard locknut (14).

10-20. ENGINE RIGHT SPLASH SHIELD MAINTENANCE (Cont'd)

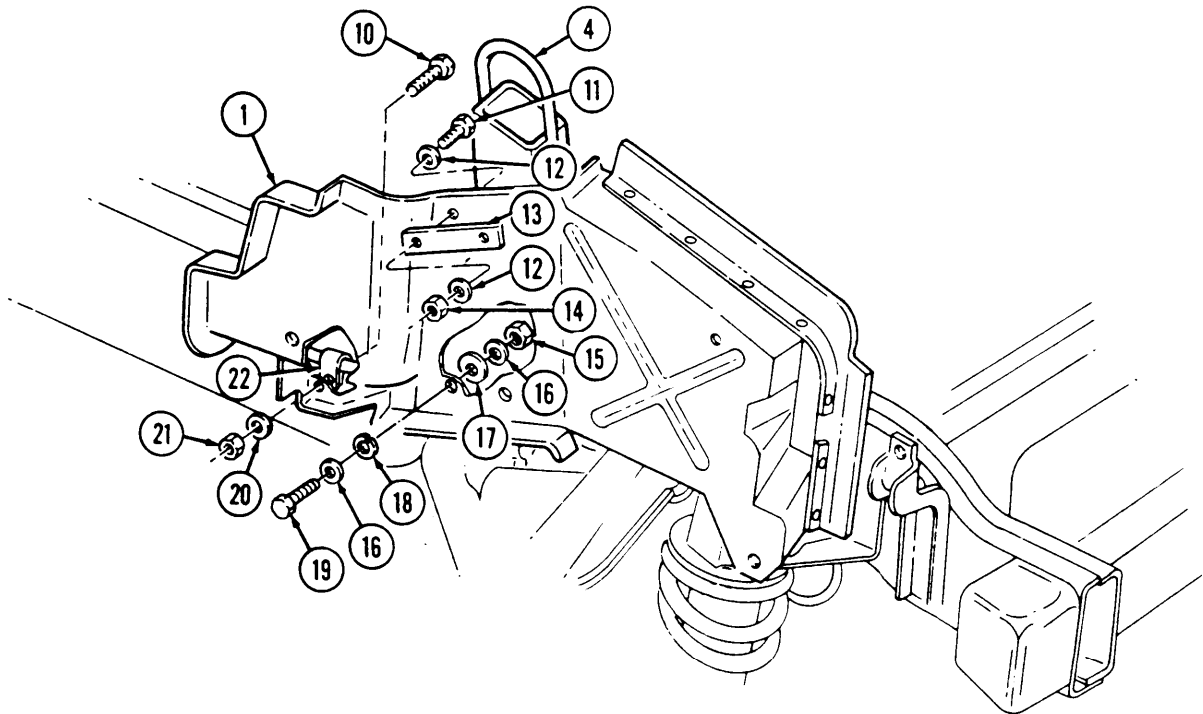
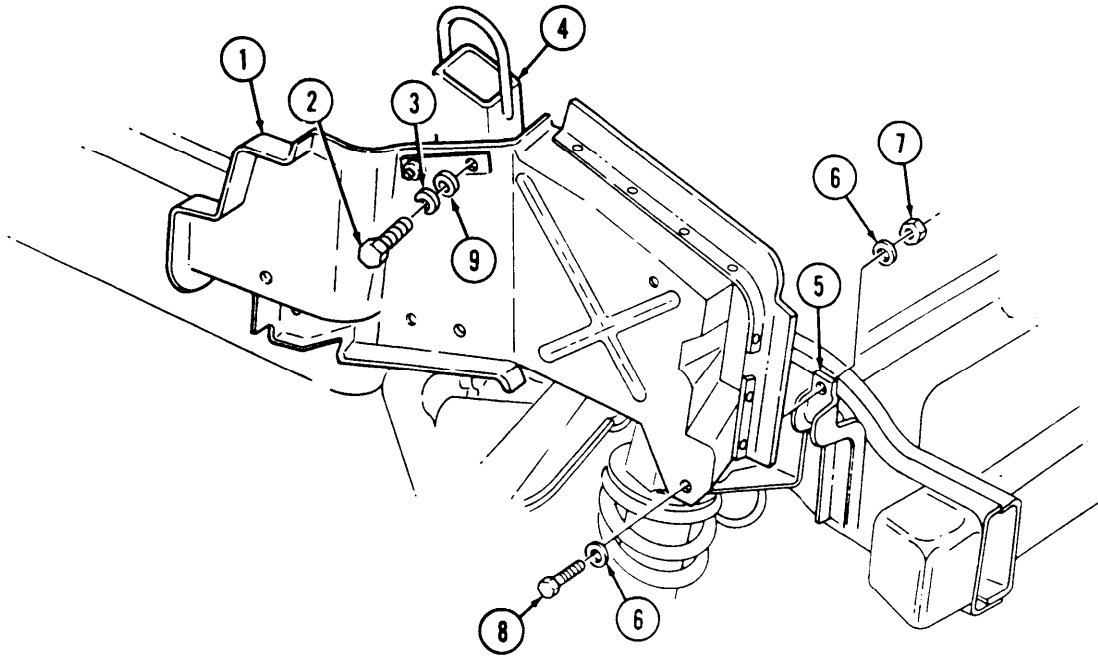

10-20. ENGINE RIGHT SPLASH SHIELD MAINTENANCE (Cont'd)

NOTE

Perform step 2 only if vehicle has an armor plate.

2. Remove locknut (2), washer (3), capscrew (4), washer (3), and armor plate (1) from splash shield (5). Discard locknut (2).
3. Remove seven locknuts (10), washers (9), capscrews (7), seal retainers (6), and seal (8) from splash shield (5). Discard locknuts (10).

c. Assembly

1. Install seal (8) and seal retainers (6) on splash shield (5) with seven capscrews (7), washers (9), and locknuts (10).

NOTE

Perform step 2 only if vehicle has an armor plate.

2. Install armor plate (1) on splash shield (5), ensuring capscrew holes align, and secure with washer (3), capscrew (4), washer (3), and locknut (2). Tighten locknut (2) to 15 lb-ft (20 N•m).
3. Install support plate (15) on splash shield (5), ensuring capscrew holes align, and secure with washer (14), capscrew (13), washer (14), and locknut (16).

d. Installation

1. Install splash shield (5) on airlift bracket (12) with two washers (31) (vehicles without armor plate), lockwashers (26), and screws (25).
2. Install fuel line clamp (24) on splash shield (5) with capscrew (11), washer (22), and locknut (23).
3. Secure splash shield (5) to airlift bracket (12) with lockwasher (20), washer (18), capscrew (21), washer (19), washer (18), and locknut (17). Tighten capscrew (21) to 10 lb-ft (14 N•m).
4. Secure splash shield (5) to support bracket (27) with washer (28), capscrew (30), washer (28), and locknut (29). Tighten capscrew (30) to 15 lb-ft (20 N•m).

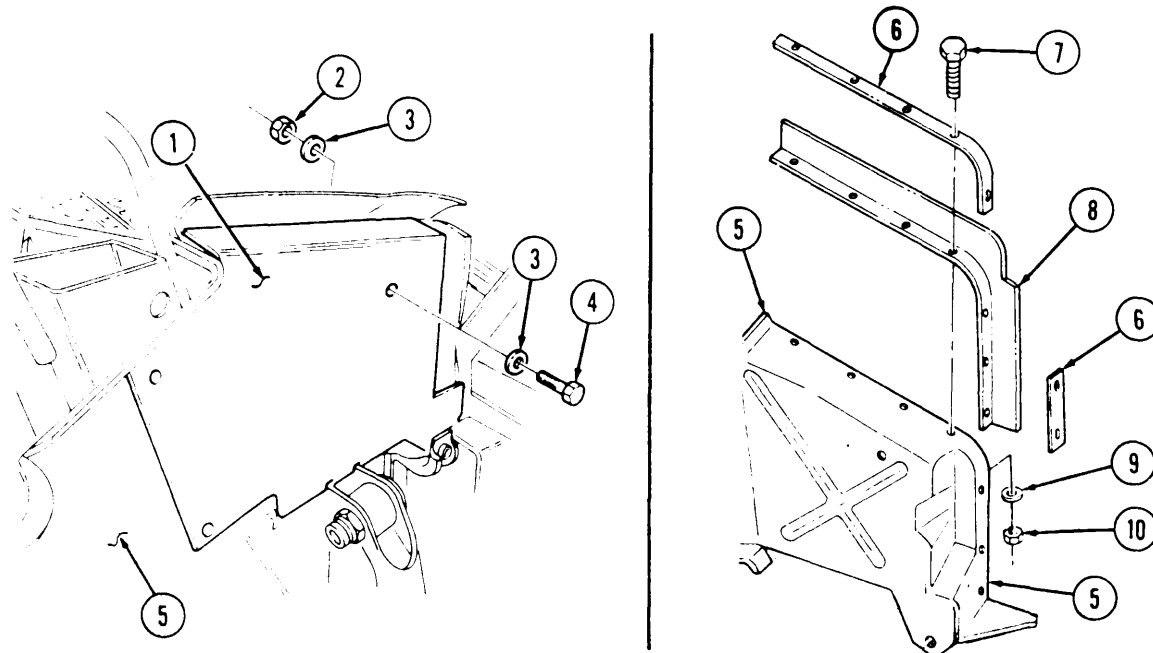

10-20. ENGINE RIGHT SPLASH SHIELD MAINTENANCE (Cont'd)

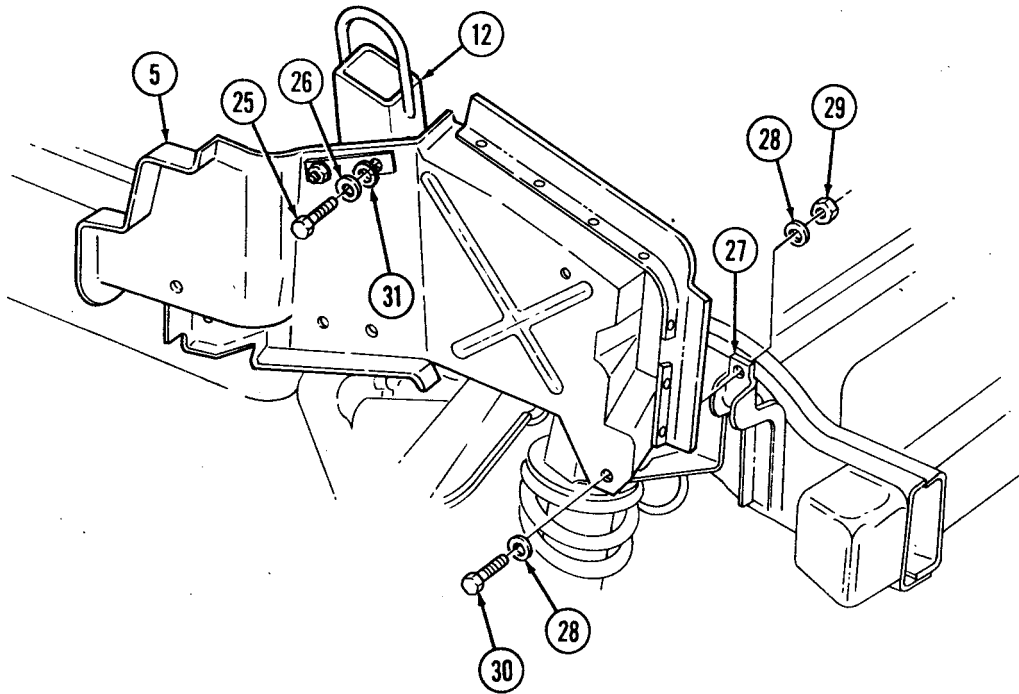
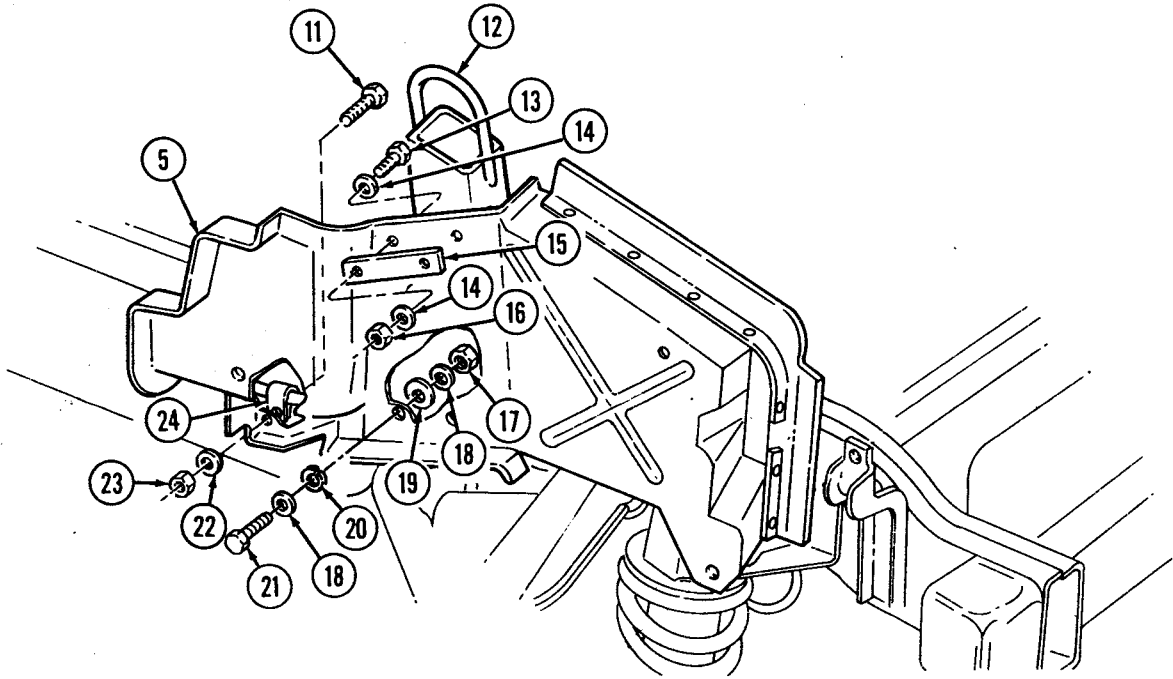

- FOLLOW-ON TASKS:**
- Install 3.5-ton jack stowage bracket and cover (M1123 and “A2” series only) (para. 10-19).
 - Lower and secure hood (TM 9-2320-280-10).

10-21. WINDSHIELD GLASS AND WEATHERSTRIP REPLACEMENT

This task covers:

a. Removal

b. Installation

INITIAL SETUP:

Applicable Models

M998, M998A1, M1035, M1035A1, M1035A2, M1037, M1038, M1038A1, M1042

Tools

General mechanic's tool kit:
automotive (Appendix B, Item 1)

Materials/Parts

Sealant (Appendix C, Item 38)

Manual References

TM 9-2320-280-24P

Equipment Condition

Windshield wiper blade and arm removed
(para. 10-70).

General Safety Instructions

Eyeshields and gloves are required when installing and removing windshield glass.

WARNING

Use eyeshields and gloves when removing and installing windshield. Glass could shatter causing injury.

a. Removal

1. Remove six capscrews (7) and upper retainer (3) from windshield frame (5).
2. Remove four capscrews (1) and center retainer (2) from windshield frame (5).
3. Remove weatherstrip (4) and glass (6) from windshield frame (5).
4. Clean sealant from windshield frame (5).

b. Installation

1. Apply a 1/8 inch (3 mm) bead of sealing compound to edge of glass (6) and to windshield frame (5).
2. Install weatherstrip (4) on glass (6).
3. Install glass (6) and weatherstrip (4) on windshield frame (5) with center retainer (2) and four capscrews (1).
4. Apply a thin bead of sealant to top edge of outside weatherstrip (4).
5. Install upper retainer (3) on windshield frame (5) with six capscrews (7).

10-21. WINDSHIELD GLASS AND WEATHERSTRIP REPLACEMENT (Cont'd)

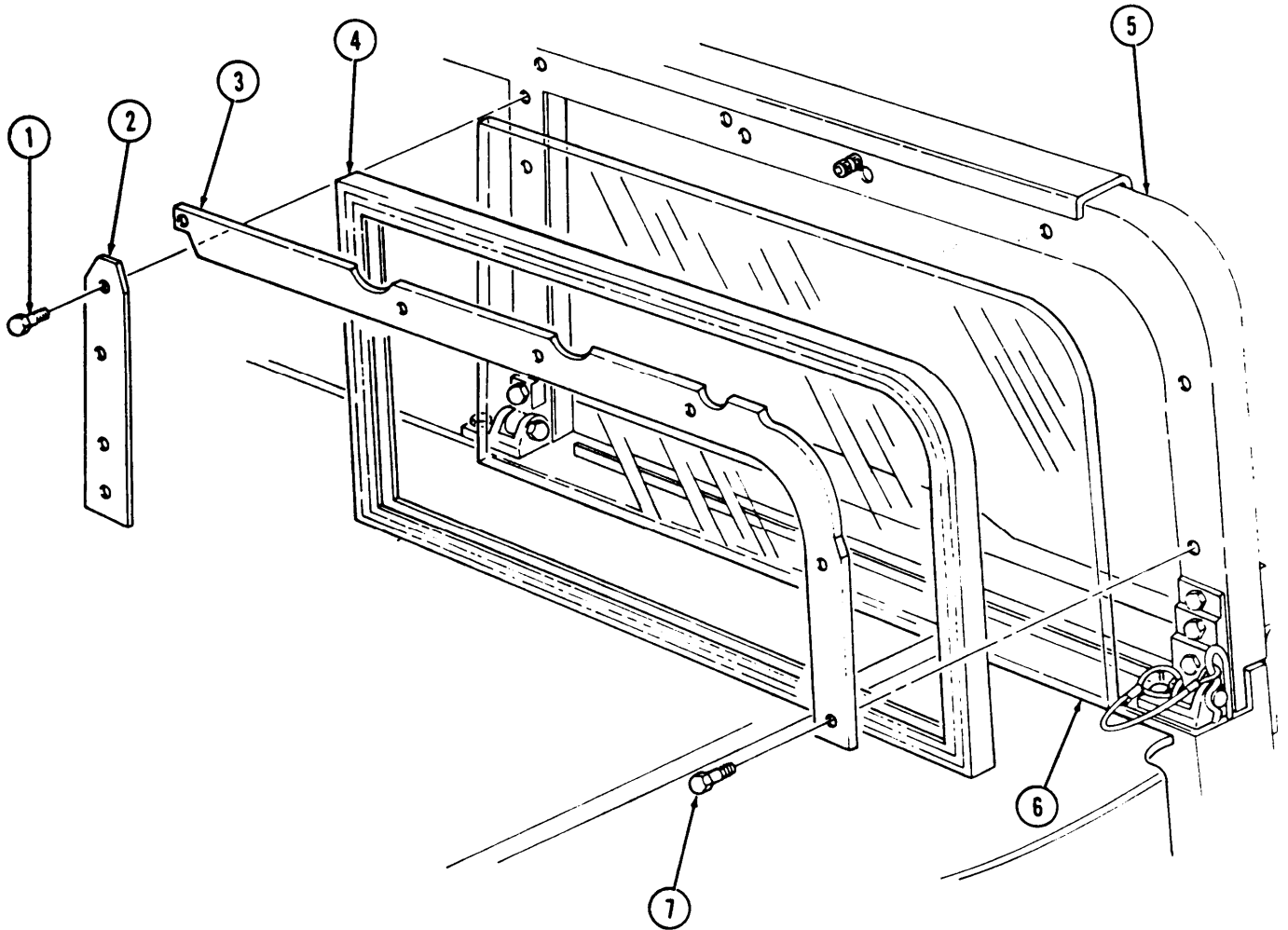

FOLLOW-ON TASK: Install windshield wiper blade and arm (para. 10-70).

10-22. WINDSHIELD BALLISTIC GLASS REPLACEMENT

I

This task covers:

a. Removal

b. Installation

INITIAL SETUP:**Applicable Models**

All except M998, M998A1, M1035, M1035A1, M1035A2, M1037, M1038, M1038A1, M1042

ToolsGeneral mechanic's tool kit:
automotive (Appendix B, Item 1)**Materials/Parts**

Sealing compound (Appendix C, Item 47)

Manual References

TM 9-2320-280-24P

Personnel RequiredOne mechanic
One assistant**Equipment Condition**Windshield wiper blade and arm removed
(para. 10-70).**General Safety Instructions**Eyeshields and gloves are required when installing
and removing windshield glass.

WARNING

Use eyeshields and gloves when removing and installing windshield glass. Glass could shatter causing injury.

a. Removal

1. Remove six screws (6) and upper retainer (5) from windshield frame (4).
2. Remove four screws (1) and center retainer (2) from windshield frame (4).
3. Remove ballistic glass (3) from windshield frame (4).
4. Clean sealing compound from windshield frame (4).

b. Installation

1. Apply a 1/8 in. (3 mm) bead of sealing compound around windshield frame (4).
2. Position ballistic glass (3) to windshield frame (4) with marking on weatherstrip facing inward.
3. Install center retainer (2) on windshield frame (4) with four screws (1).
4. Install upper retainer (5) on windshield frame (4) with six screws (6).

10-22. WINDSHIELD BALLISTIC GLASS REPLACEMENT (Cont'd)

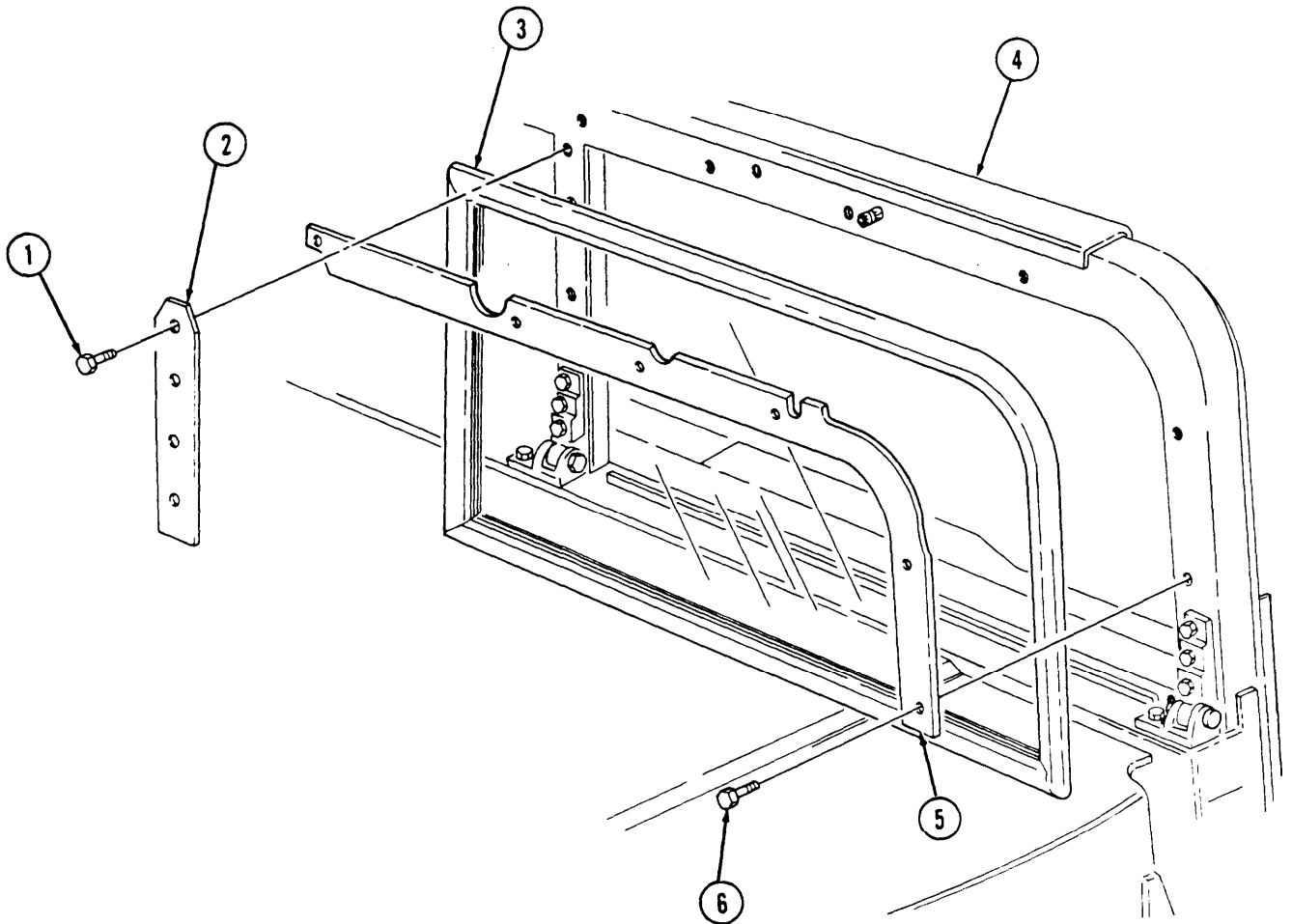

FOLLOW-ON TASK: Install windshield wiper blade and arm (para. 10-70).

10-23. WINDSHIELD ASSEMBLY MAINTENANCE

I

This task covers:

- | | |
|----------------|-----------------|
| a. Removal | c. Assembly |
| b. Disassembly | d. Installation |
-

INITIAL SETUP:

Applicable Models

M998, M998A1, M1035, M1035A1, M1035A2,
M1037, M1038, M1038A1, M1042

Tools

General mechanic's tool kit:
automotive (Appendix B, Item 1)

Personnel Required

One mechanic
One assistant

Manual References

TM 9-2320-280-10
TM 9-2320-280-24P

Equipment Condition

- Soft top enclosure removed, if install.
(TM 9-2320-280-10).
- Windshield wiper blade and arm removed
(para. 10-70).
- Windshield wiper linkage removed (para. 10-73).
- Windshield wiper arm pivots removed
(para. 10-74).

General Safety Instructions

Windshield must be supported during removal and installation.

WARNING

Windshield must be supported during removal and installation.
Failure to support windshield may cause injury to personnel or
damage to equipment.

a. Removal

1. Remove five hitch pins (5) from five hinge pins (6).
2. Remove five hinge pins (6) from upper hinge halves (2) and lower hinge halves (4).
3. Remove grommet (11) from "A" pillar (12) and remove jumper harness (10).
4. Remove windshield assembly (1) from "A" pillar (12).
5. Remove two seals (3) from windshield assembly (1).
6. Clean remains of seal (3) from windshield assembly (1).

b. Disassembly

1. Remove thirteen screws (9), former (8), and seal (7) from windshield assembly (1).
2. Clean remains of seal (7) from windshield assembly (1).

c. Assembly

1. Peel paper backing from seal (7) and install seal (7) on windshield assembly (1).
2. Install former (8) on seal (7) and windshield assembly (1) with thirteen screws (9).

d. Installation

1. Peel paper backing from two seals (3) and install seals (3) on windshield assembly (1).
2. Install windshield assembly (1) on "A" pillar (12).
3. Install jumper harness (10) on windshield center pillar (13) and install grommet (11) on "A" pillar (12).
4. Install upper hinge halves (2) on lower hinge halves (4) with five hinge pins (6).
5. Install five hitch pins (5) in hinge pins (6).

10-23. WINDSHIELD ASSEMBLY MAINTENANCE (Cont'd)

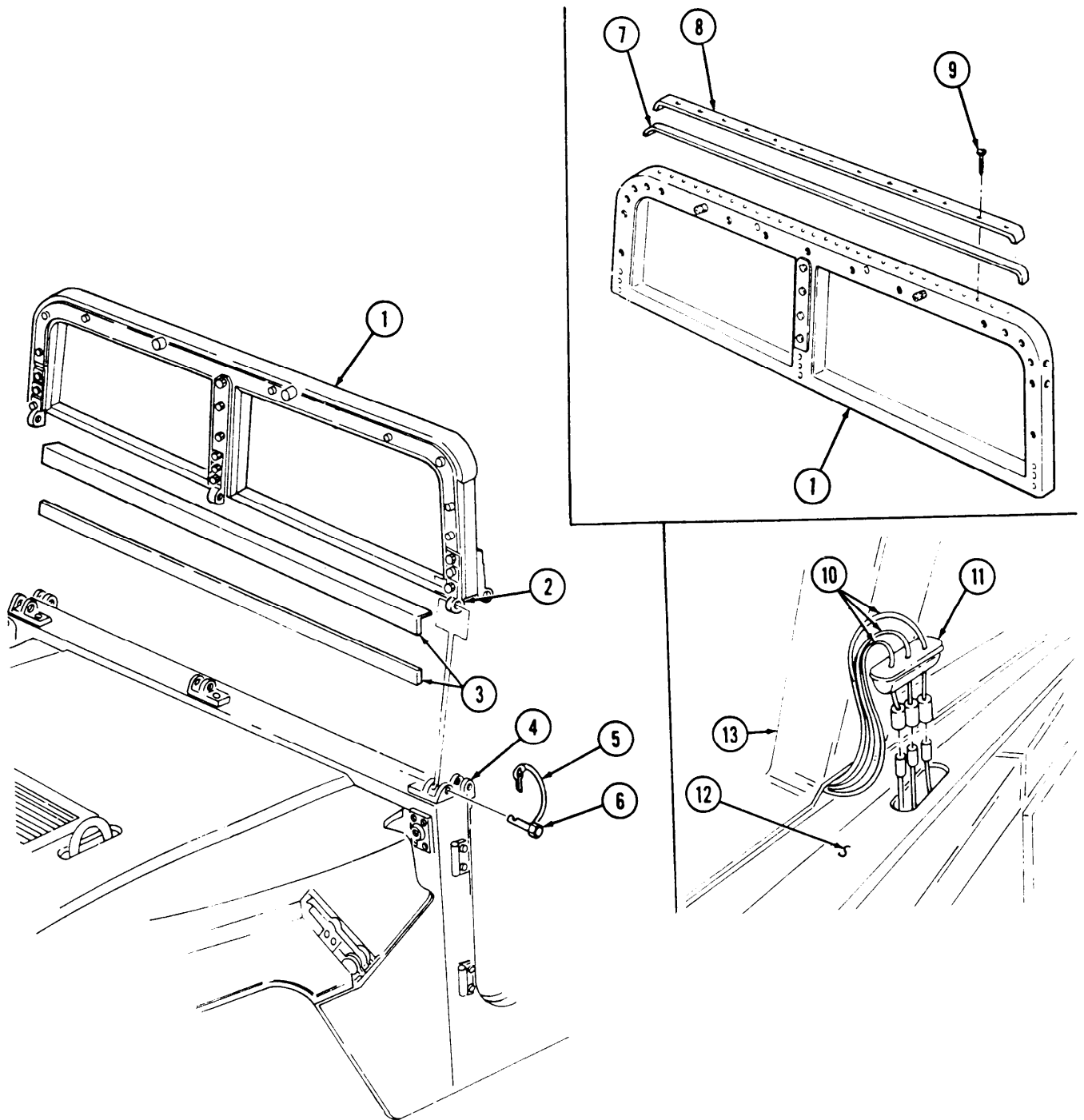

- FOLLOW-ON TASKS:
- Install windshield wiper arm pivots (para. 10-74).
 - Install windshield wiper linkage (para. 10-73).
 - Install windshield wiper blade and arm (para. 10-70).
 - Install soft top enclosure, if removed (TM 9-2320-280-10).

10-24. WINDSHIELD RETENTION BRACKET REPLACEMENT

This task covers:

a. Removal

b. Installation

INITIAL SETUP:

Applicable Models

M997A2, M1025A2, M1035A2,
M1043A2, M1045A2, M1097A2

Materials/Parts

Four lockwashers (Appendix G, Item 139)

Tools

General mechanic's tool kit:
automotive (Appendix B, Item 1)

Manual References

TM 9-2320-280-24P

a. Removal

1. Remove four capscrews (2), lockwashers (3), and retention bracket (1) from windshield frame (5). Discard lockwashers (3).
2. Inspect four nut inserts (4) for damage. Replace if damaged.

b. Installation

Install retention bracket (1) on windshield (5) with four lockwashers (3) and capscrews (2).

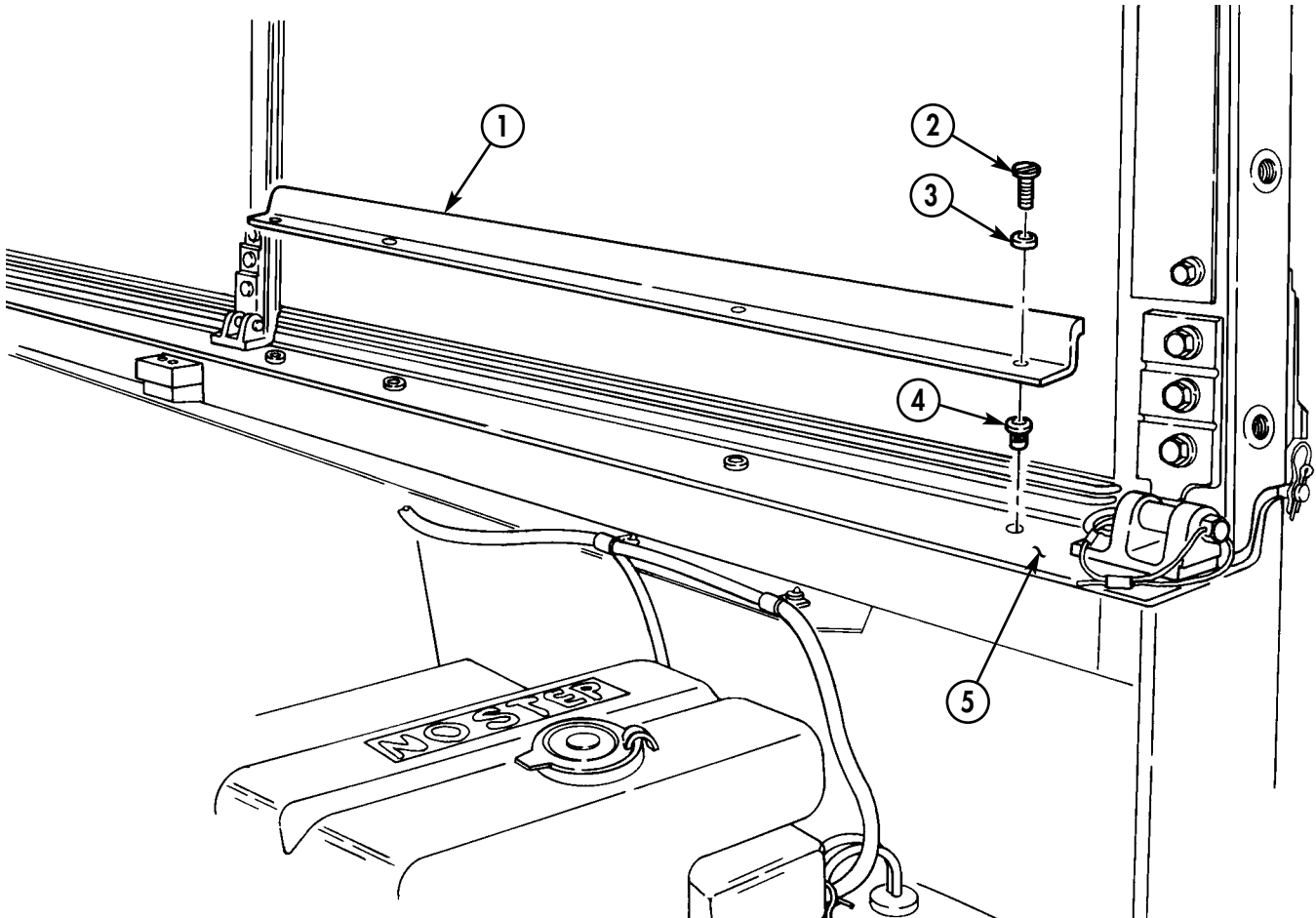

10-25. LEFT OUTER COWL INSULATION REPLACEMENT

This task covers:

a. Removal

b. Installation

INITIAL SETUP:

Tools

General mechanic's tool kit:
automotive (Appendix B, Item 1)

Manual References

TM 9-2320-280-24P

a. Removal

Remove nut (4), capscrew (1), washer (2), clamp (6), wiring harness (7), and insulation (3) from cowl (5). ■

b. Installation

Install insulation (3) and wiring harness (7) on cowl (5) with clamp (6), washer (2), capscrew (1), and nut (4). ■

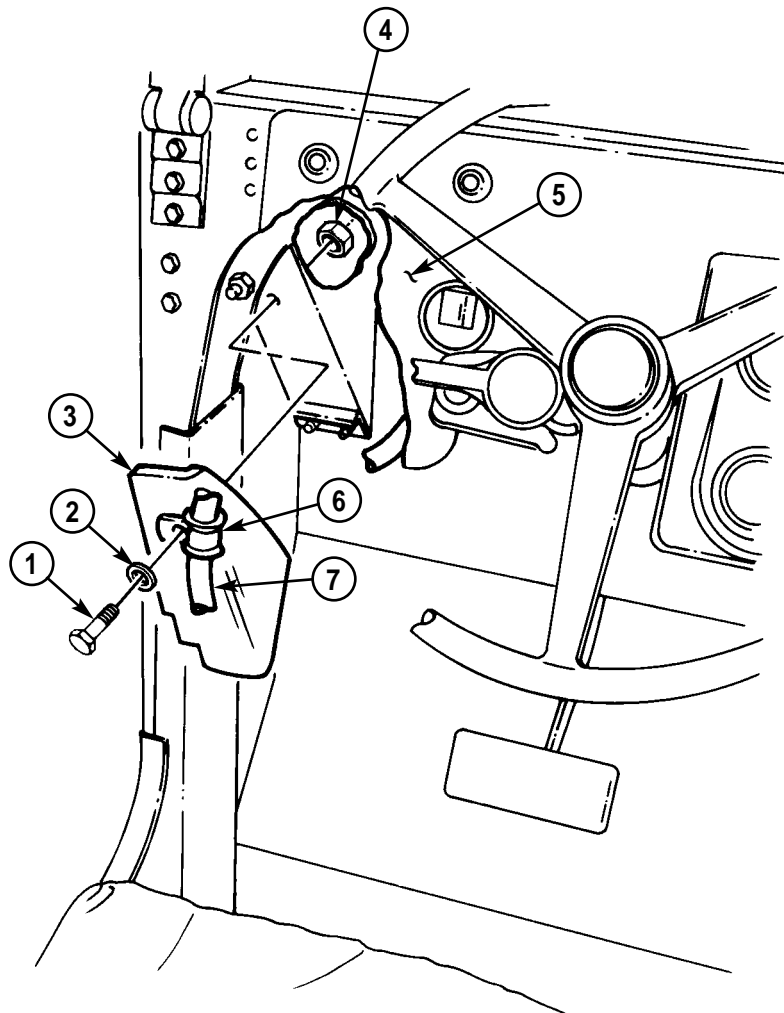

10-26. LEFT FRONT COWL INSULATION REPLACEMENT

This task covers:

a. Removal

b. Installation

INITIAL SETUP:

Tools

General mechanic's tool kit:
automotive (Appendix B, Item 1)

Manual References

TM 9-2320-280-24P

Materials/Parts

Four locknuts (Appendix G, Item 71)

Equipment Condition

Headlight beam selector switch removed
(para. 4-58).

a. Removal

1. Remove two nuts (1), capscrews (5), washers (1.1), and clamps (3) from wiring harness (2), insulation (9), and body (6).
2. Remove four locknuts (12), capscrews (7), washers (8), retainer (10), and insulation (9) from floor (11). Discard locknuts (12).

b. Installation

1. Install insulation (9) and retainer (10) on floor (11) with four washers (8), capscrews (7), and locknuts (12). Tighten locknuts (12) to 6 lb-ft (8 N·m).
2. Install wiring harness (2) and insulation (9) on body (6) with two clamps (3), capscrews (5), washers (1.1), and nuts (1).

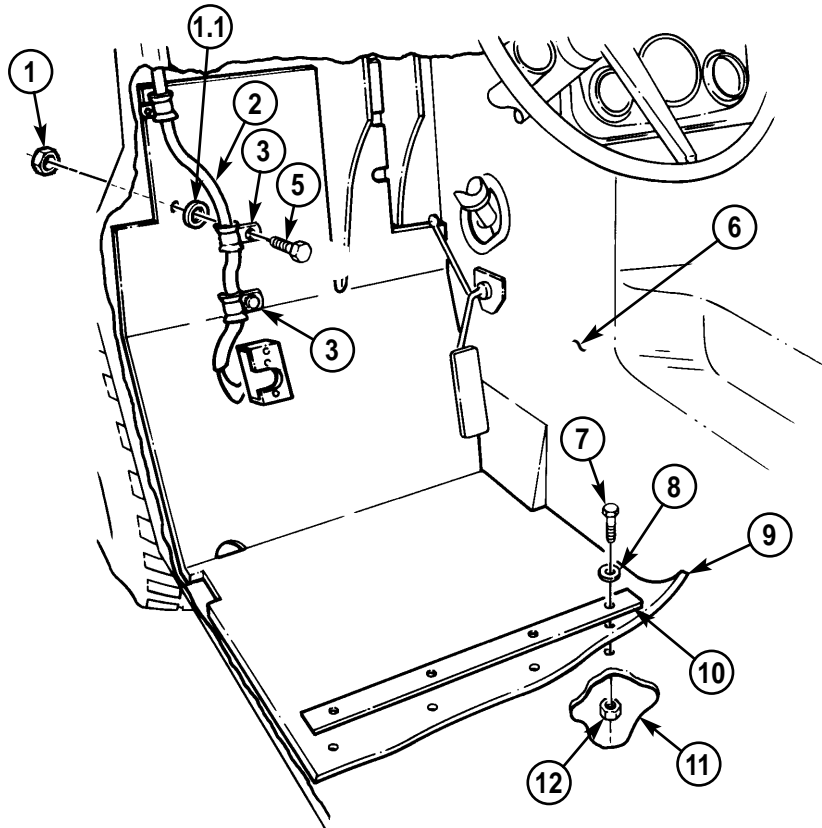

FOLLOW-ON TASK: Install headlight beam selector switch (para. 4-58).

10-27. RIGHT FRONT COWL INSULATION REPLACEMENT

This task covers:

a. Removal

b. Installation

INITIAL SETUP:

Tools

General mechanic's tool kit:
automotive (Appendix B, Item 1)

Manual References

TM 9-2320-280-24P

Materials/Parts

Four locknuts (Appendix G, Item 71)

Equipment Condition

Heater assembly removed (para. 10-87).

a. Removal

Remove four locknuts (6), capscrews (3), washers (2), retainer (1), and insulation (5) from floor (7). Discard locknuts (6).

b. Installation

1. Install insulation (5) and retainer (1) on floor (7) with four washers (2), capscrews (3), and locknuts (6). Tighten locknuts (6) to 6 lb-ft (8 N•m).
2. Press insulation (5) into place on cowl (4).

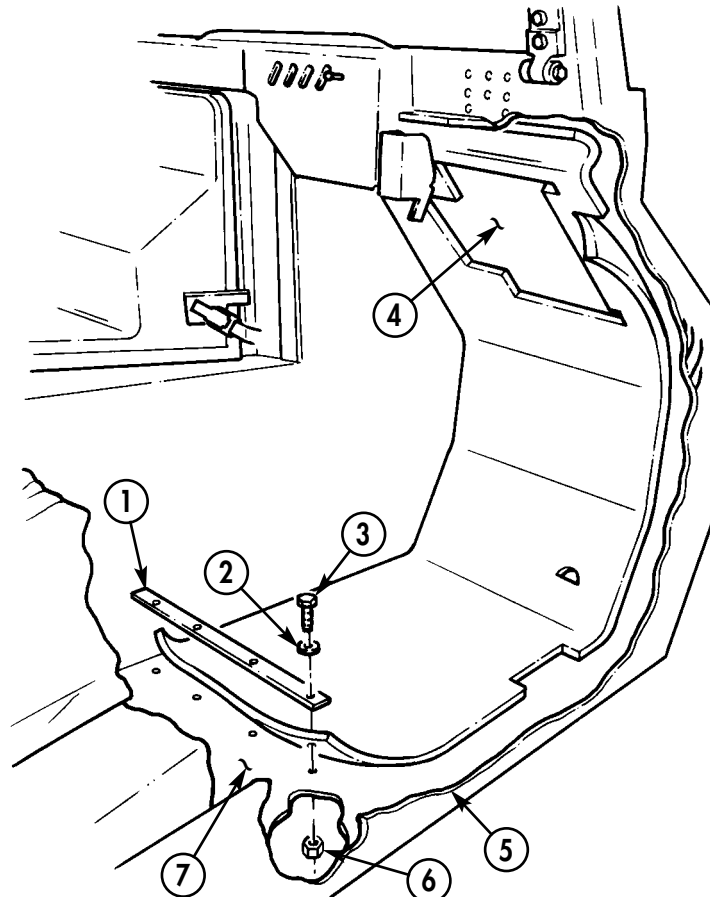

FOLLOW-ON TASK: Install heater assembly (para. 10-87).

10-28. TUNNEL INTERIOR SIDE INSULATION REPLACEMENT

This task covers:

a. Removal

b. Installation

INITIAL SETUP:

Tools

General mechanic's tool kit:
automotive (Appendix B, Item 1)

Equipment Condition

- Left front cowl insulation removed (para. 10-26).
- Front floorboard removed (para. 11-154).

Manual References

TM 9-2320-280-24P

NOTE

Removal and installation procedures for all tunnel interior side insulation are basically the same. This procedure covers the left front insulation.

a. Removal

1. Remove two screws (4) from retaining rod (5) and cargo floor (6).
2. Remove two screws (2) from retaining rod (3) and cargo floor (6).
3. Remove three screws (1) and retaining rod (8) from tunnel (7) and cargo floor (6).
4. Remove two screws (9) from retaining rod (10) and tunnel (7).
5. Remove two screws (14), retainer (12), and insulation (11) from floor (13).
6. Remove retaining rods (3), (5), and (10) from insulation (11).

b. Installation

1. Install retaining rods (10), (3), and (5) on insulation (11).
2. Position insulation (11) into place against floor (13), tunnel (7), and cargo floor (6).
3. Install insulation (11) and retainer (12) on floor (13) with two screws (14).
4. Install retaining rod (10) on tunnel (7) with two screws (9).
5. Install retaining rod (8) on tunnel (7) with three screws (1).
6. Install retaining rod (3) on cargo floor (6) with two screws (2).
7. Install retaining rod (5) on cargo floor (6) with two screws (4).

10-28. TUNNEL INTERIOR SIDE INSULATION REPLACEMENT (Cont'd)

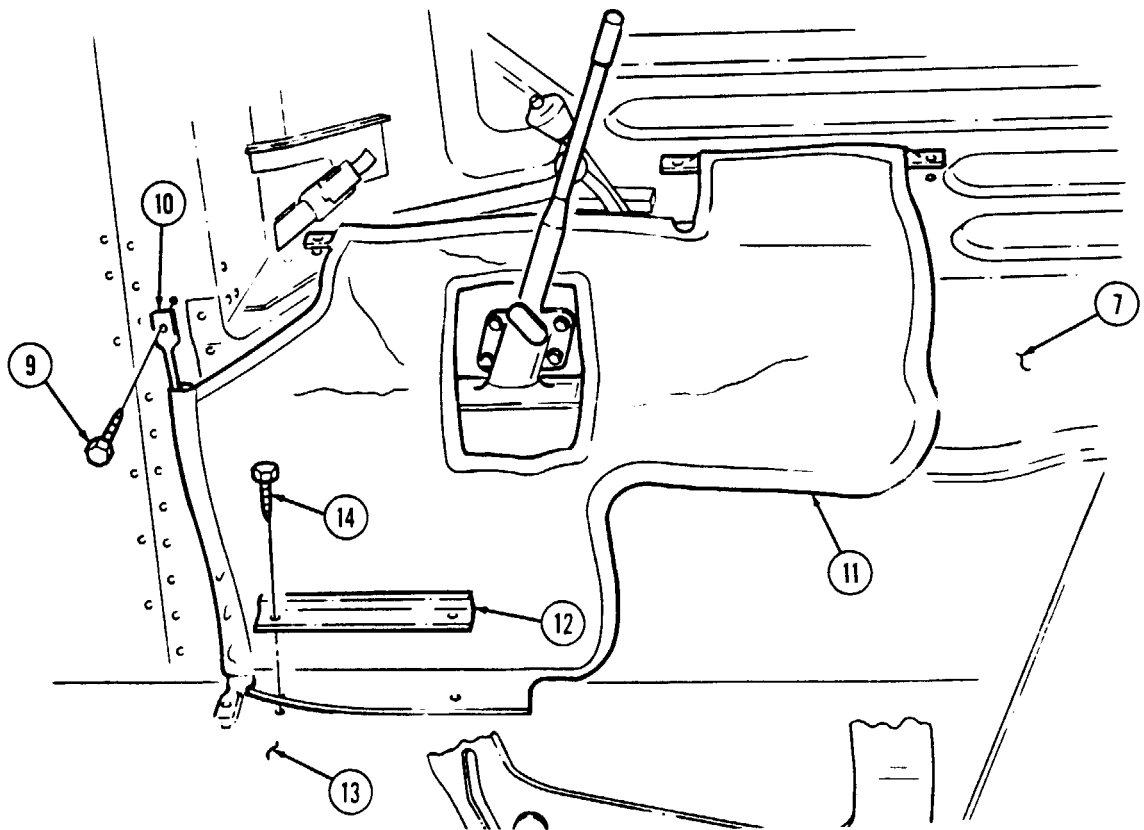
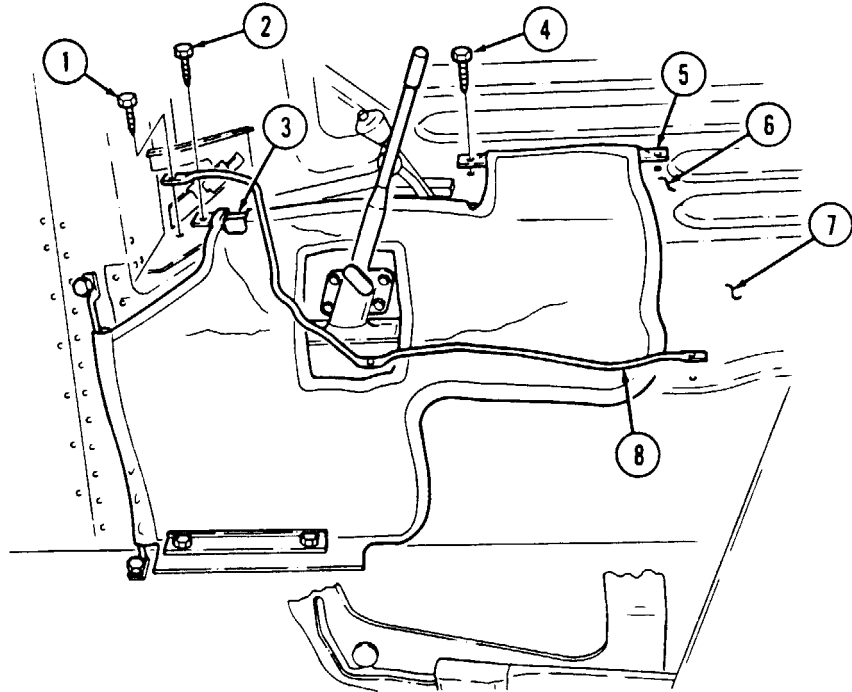

FOLLOW-ON TASKS: • Install left front cowl insulation (para. 10-26).
 • Install front floorboard (para. 11-154).

10-29. REAR SEAT FLOOR INSULATION REPLACEMENT

This task covers:

a. Removal

b. Installation

INITIAL SETUP:

Tools

General mechanic's tool kit
automotive (Appendix B, Item 1)

Manual References

TM 9-2320-280-24P

a. Removal

Remove insulation (1) from floor (2).

b. Installation

Install insulation (1) on floor (2).

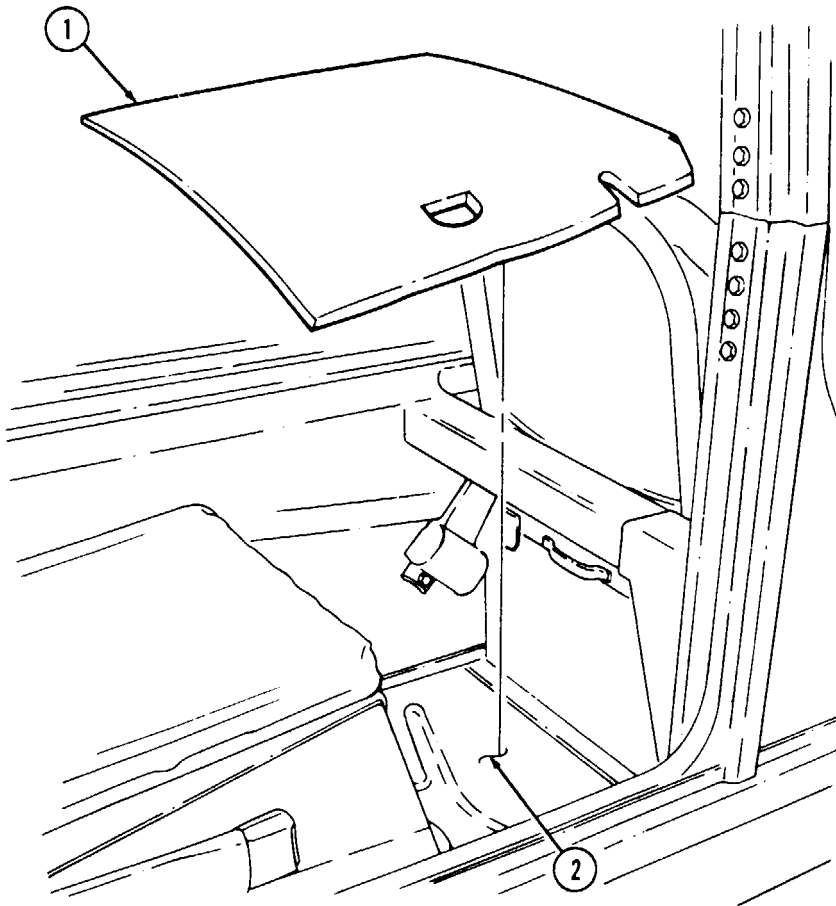

10-30. RIGHT INNER COWL INSULATION PANEL REPLACEMENT

This task covers:

a. Removal

b. Installation

INITIAL SETUP:

Tools

General mechanic's tool kit:
automotive (Appendix B, Item 1)

Manual References

TM 9-2320-280-10
TM 9-2320-280-24P

Materials/Parts

Three locknuts (Appendix G, Item 108)

Equipment Condition

Hood raised and secured (TM 9-2320-280-10). ■

a. Removal

Remove three locknuts (7), washers (4), capscrews (5), washers (4), retainer (3), insulation (2), and drain hose clamp (6) from cowl (1). Discard locknuts (7).

b. Installation

Install drain hose clamp (6), insulation (2), and retainer (3) on cowl (1) with three washers (4), capscrews (5), washers (4), and locknuts (7).

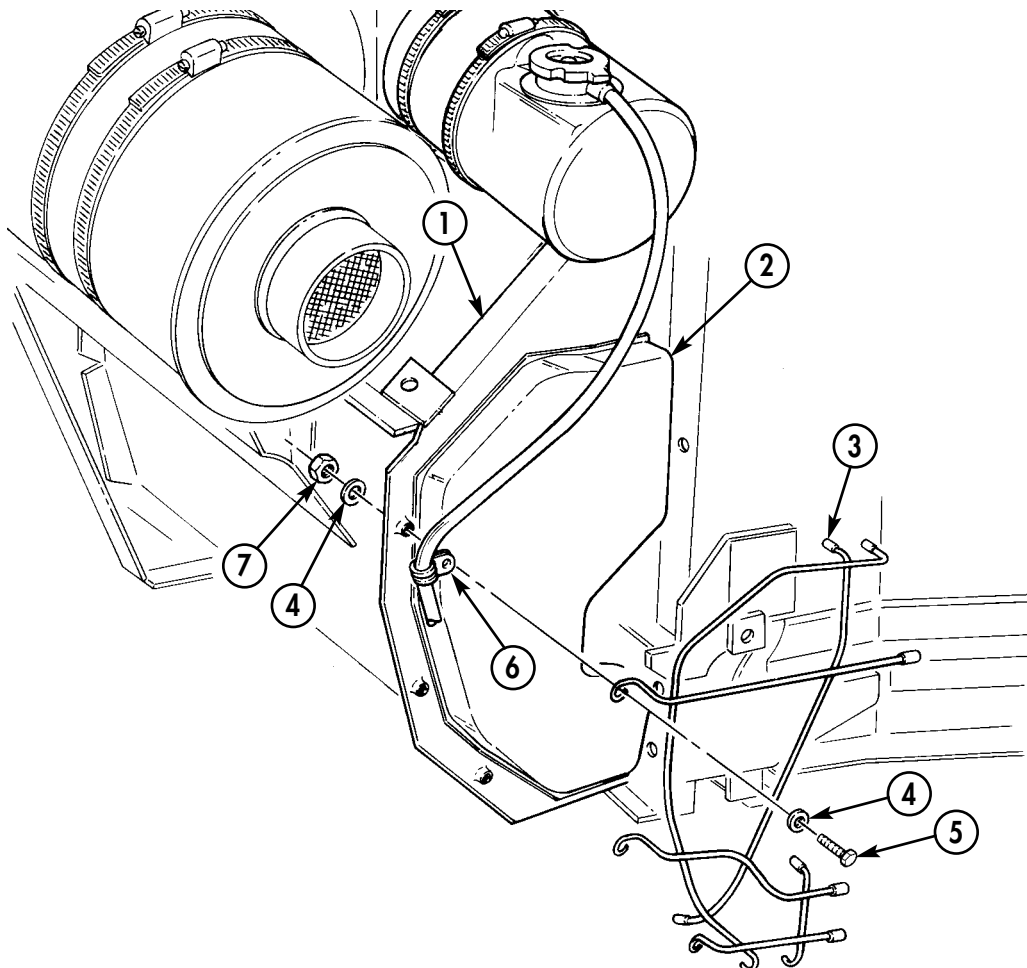

FOLLOW-ON TASK: Lower and secure hood (TM 9-2320-280-10).

10-31. LEFT INNER COWL INSULATION PANEL REPLACEMENT

This task covers:

a. Removal

b. Installation

INITIAL SETUP:

Tools

General mechanic's tool kit:
automotive (Appendix B, Item 1)

Personnel Required

One mechanic
One assistant

Materials/Parts

Cotter pin (Appendix G, Item 11)
Four locknuts (Appendix G, Item 112)
Three assembled locknuts
(Appendix G, Item 131)
O-ring (Appendix G, Item 216)

Manual References

TM 9-2320-280-10
TM 9-2320-280-24P

Equipment Condition

Hood raised and secured (TM 9-2320-280-10).

a. Removal

1. Remove four locknuts (5), washers (3), capscrews (2), and washers (3) from harness clamp (4), brake harness (8), retainer (1), and cowl (7). Discard locknuts (5).
2. Remove assembled locknut (10), capscrew (12), and harness clamp (9) from body harness (11), brake harness (8), and cowl (7). Discard assembled locknut (10).
3. Remove assembled locknut (15) and capscrew (13) from harness clamp (14) and cowl (7) and disconnect body harness (11) from cowl (7). Discard assembled locknut (15).
4. Remove upper insulation panel (6) by sliding up and out from between retainer (1) and cowl (7).
5. Remove assembled locknut (19) and capscrew (17) from clamp (18) and cowl (7). Discard assembled locknut (19).
6. Remove lower insulation panel (16) by sliding down between retainer (1) and cowl (7).

10-31. LEFT INNER COWL INSULATION PANEL REPLACEMENT (Cont'd)

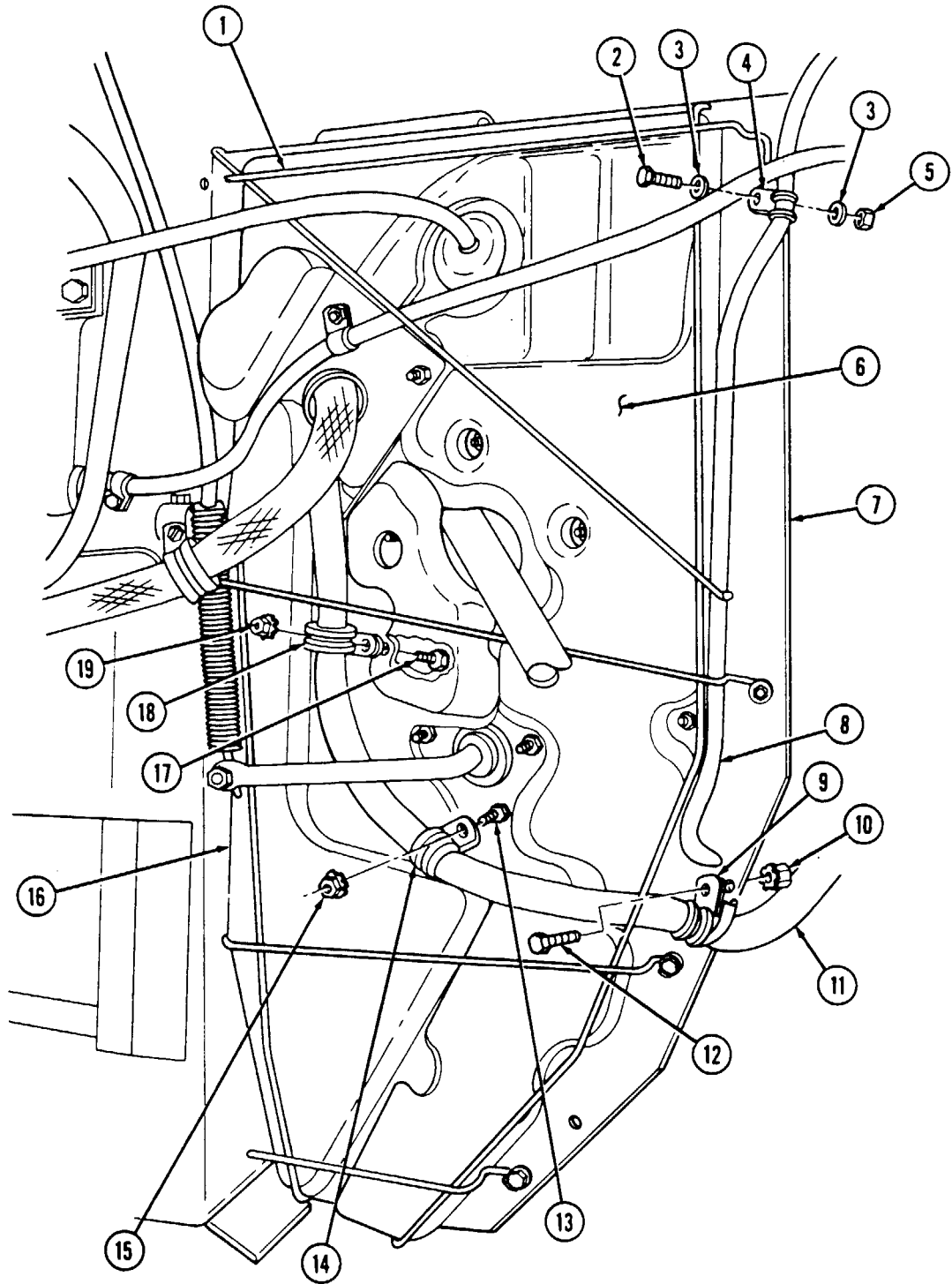

10-31. LEFT INNER COWL INSULATION PANEL REPLACEMENT (Cont'd)

7. Remove four screws (8) from instrument cluster (3) and dash panel (7) and pull instrument cluster (3) away for access to speedometer cable (2).
8. Remove speedometer cable (2) and O-ring (4) from speedometer (1). Discard O-ring (4).
9. Remove grommet (6) from cowl (5) and route speedometer cable (2) through cowl (5).
10. Remove cotter pin (14), washer (13), and accelerator cable (15) from linkage (12). Discard cotter pin (14).
11. Pull retainer (9) clear of linkage (12) and remove retainer (9) from between splash shield (10) and frame rail (11) by pulling forward and then down.

b. Installation

1. Install retainer (9) by sliding up between splash shield (10) and frame rail (11) forward of cowl (5), and then sliding back to mounting position on cowl (5).
2. Connect accelerator cable (15) to linkage (12) with washer (13) and cotter pin (14).
3. Route speedometer cable (2) through cowl (5). Install O-ring (4) into end of speedometer cable (2) and connect speedometer cable (2) to speedometer (1).
4. Install instrument cluster (3) on dash panel (7) with four screws (8).
5. Install grommet (6) on speedometer cable (2) in cowl (5).

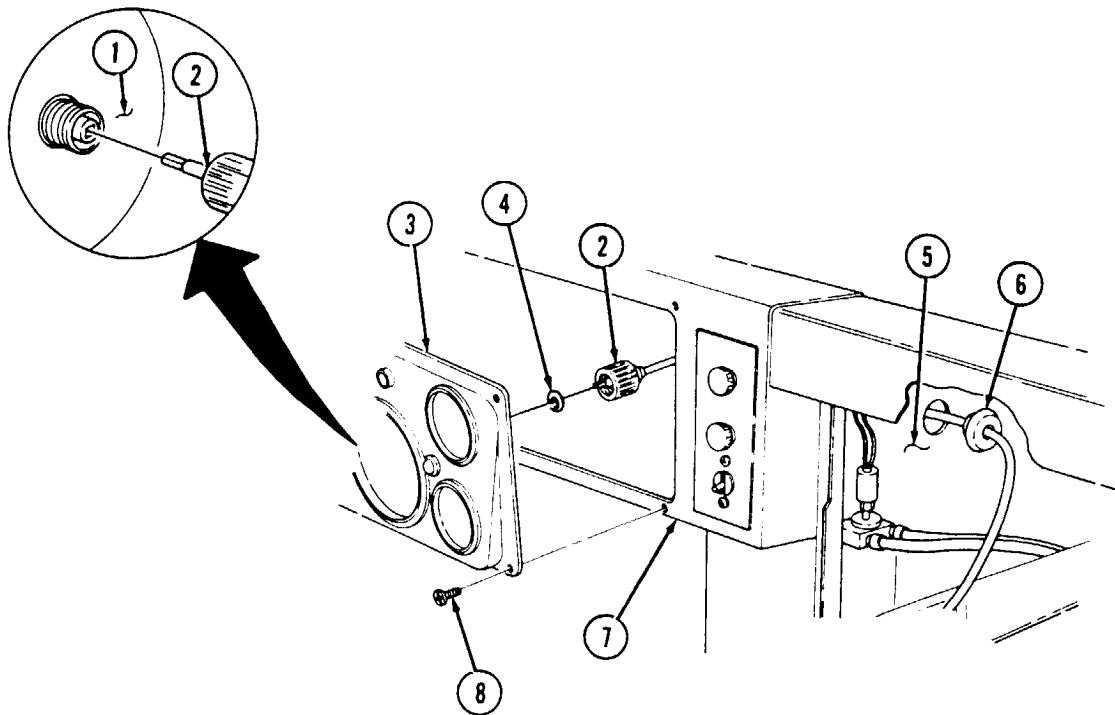

10-31. LEFT INNER COWL INSULATION PANEL REPLACEMENT (Cont'd)

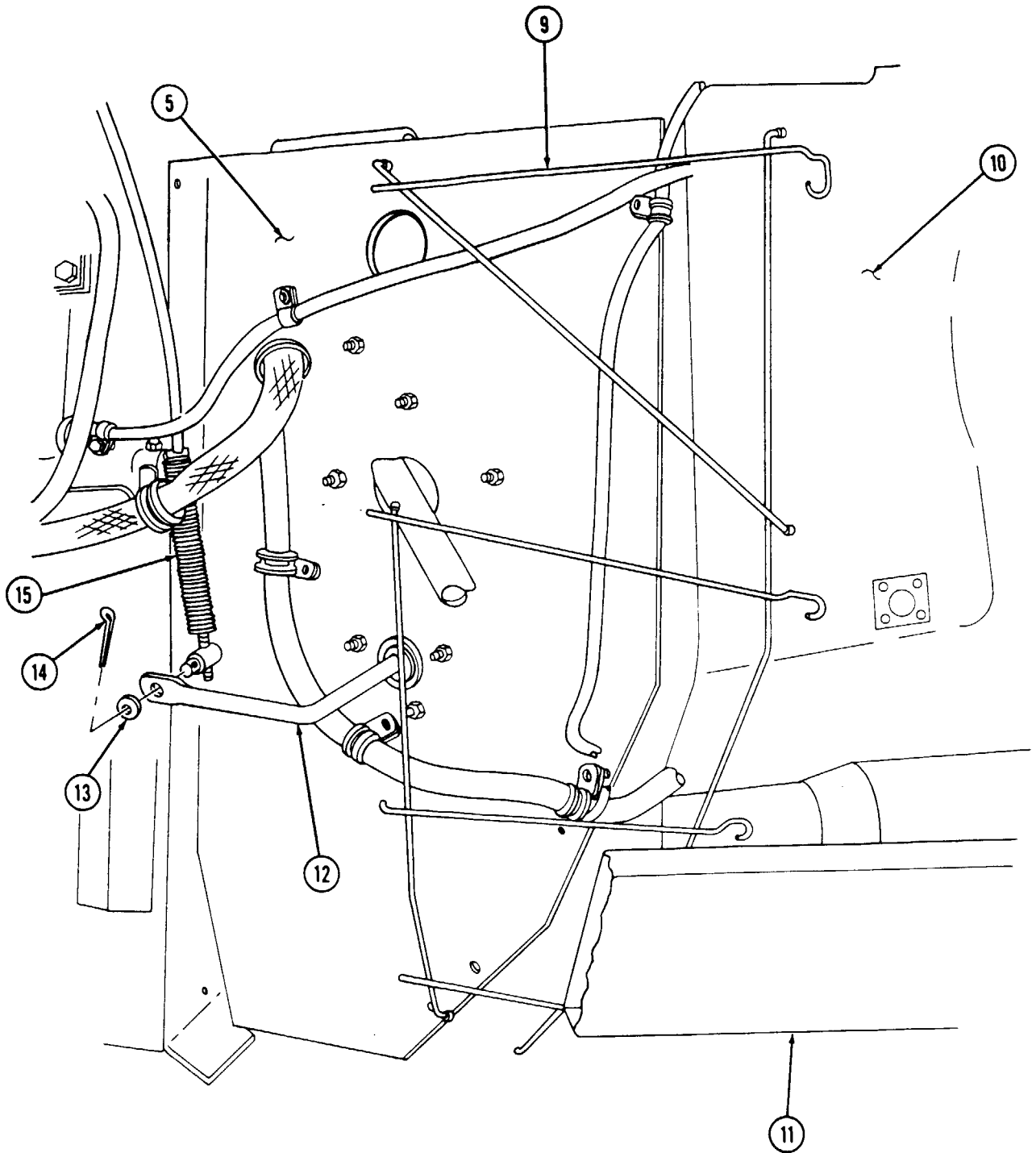

10-31. LEFT INNER COWL INSULATION PANEL REPLACEMENT (Cont'd)

6. Install lower insulation panel (14) by sliding up into position between retainer (2) and cowl (9).
- 7. Install clamp (19) on cowl (9) with capscrew (18) and assembled locknut (20).
8. Install upper insulation panel (8) by sliding down into position between retainer (2) and cowl (9).
- 9. Install clamp (15) and body harness (17) on cowl (9) with screw (13) and assembled locknut (16).
- 10. Install clamp (11) on brake harness (7) and body harness (17) on cowl (9) with capscrew (12) and assembled locknut (10).
11. Install retainer (2) and brake harness (7) on cowl (9), ensuring rear ends of retainer (2) are inserted in body holes (1), with harness clamp (5), four washers (4), capscrews (3), washers (4), and locknuts (6).

10-31. LEFT INNER COWL INSULATION PANEL REPLACEMENT (Cont'd)

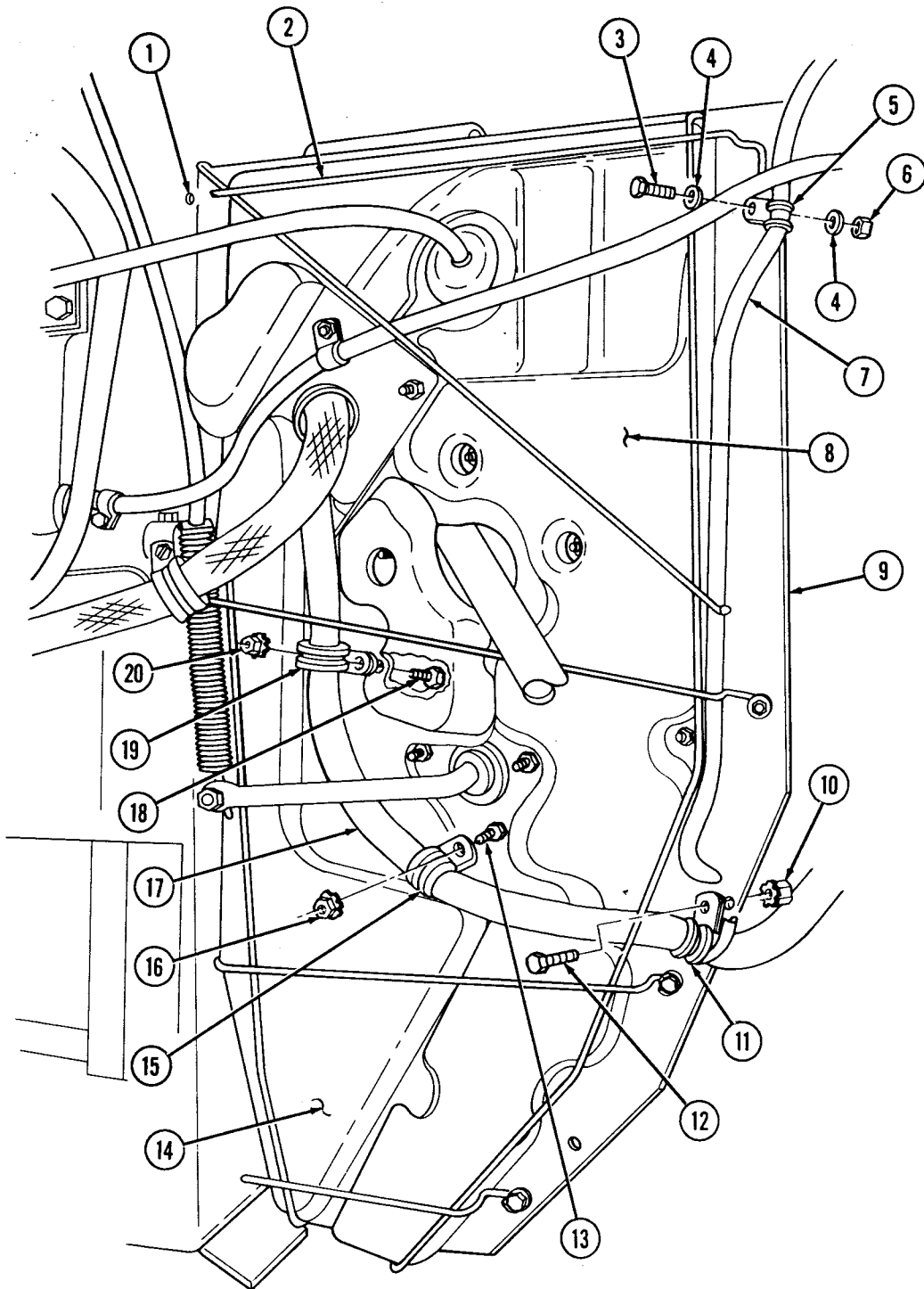

FOLLOW-ON TASK: Lower and secure hood (TM 9-2320-280-10).

10-31.1. CARGO FLOOR ACCESS COVER MAINTENANCE (M1123)

This task covers:

- a. Removal
- b. Inspection
- c. Installation

INITIAL SETUP:

Tools

General mechanic's tool kit:
automotive (Appendix B, Item 1)

Materials/Parts

Four lockwashers (Appendix G, Item 139)
Adhesive sealant (Appendix C, Item 9.1)

Manual References

TM 9-2320-280-24P

Equipment Condition

- Mortar ammo container removed, if equipped (para. 12-149).
- Rear radio rack removed, if equipped (para. 12-144).
- Troop/cargo winterization heater assembly removed, if equipped (para. 12-95).
- Troop/cargo winterization front cargo floor cover removed, if equipped (para. 12-110).
- S250 shelter removed, if equipped (para. 11-120).
- Ammo box tray (40 mm and 50 cal.) removed, if equipped (para. 11-105).
- Soft top ambulance litter assembly removed, if equipped (para. 11-124).

a. Removal

1. Remove four screws (2), lockwashers (3), washers (1), and cargo floor access cover (4) from cargo floor (5). Discard lockwashers (3).
2. Remove adhesive sealant from cargo floor access cover (4) and cargo floor (5).

b. Inspection

Inspect for missing or damaged insert nuts (6). Replace missing or damaged insert nuts (6) (para. 10-66).

c. Installation

1. Apply adhesive sealant to cargo floor (5) and cargo floor access cover (4).
2. Install cargo floor access cover (4) on cargo floor (5) with four washers (1), lockwashers (3), and screws (2).

10-31.1. CARGO FLOOR ACCESS COVER MAINTENANCE (M1123) (cont'd)

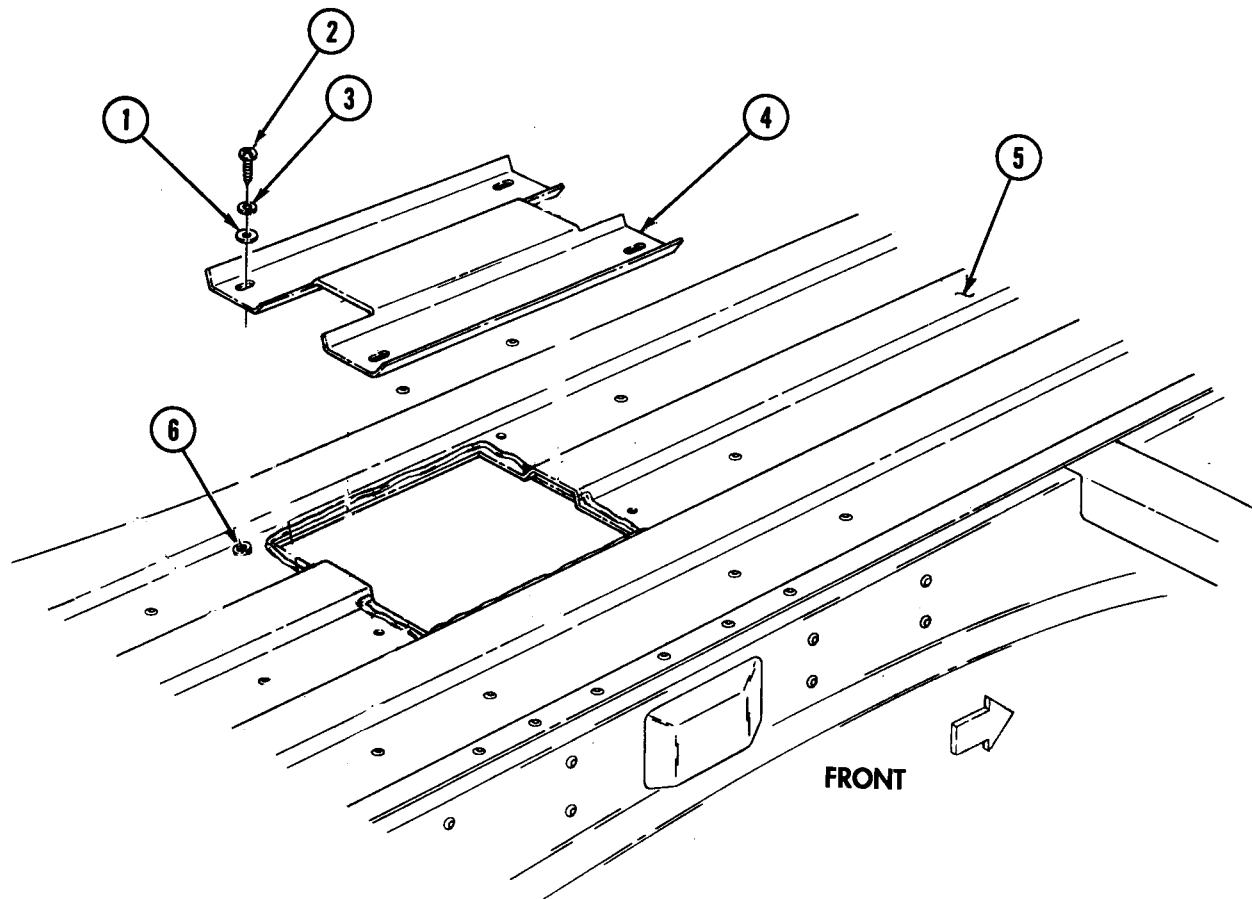

- FOLLOW-ON TASKS:**
- Install soft top ambulance litter, if removed (para. 11-124).
 - Install ammo box tray (40 mm and 50 cal.), if removed (para. 11-105).
 - Install S250 shelter, if removed (para. 11-120).
 - Install troop/cargo winterization front floor cover, if removed (para. 12-110).
 - Install troop/cargo winterization heater assembly, if removed (para. 12-95).
 - Install rear radio rack, if removed (para. 12-144).
 - Install mortar ammo container, if removed (para. 12-149).

10-32. DRIVER'S SEAT FRAME REPLACEMENT

This task covers:

a. Removal

b. Installation

INITIAL SETUP:

Applicable Models

M966, M996, M997, M998, M1025, M1026, M1035, M1036, M1037, M1038, M1042, M1043, M1044, M1045, M1046, M1097

Tools

General mechanic's tool kit:
automotive (Appendix B, Item 1)

Materials/Parts

Sixteen locknuts (Appendix G, Item 79)

Manual References

TM 9-2320-280-24P

Equipment Condition

Driver's seat and seat back cushions removed (para. 10-33).

NOTE

Ensure P/N 12338503-1 is used for replacement of driver's seat frame on vehicles equipped with three-point seatbelt.

a. Removal

1. Place driver's seat (1) in full forward position.
2. Remove sixteen locknuts (7), washers (4), capscrews (3), washers (4), and four adjuster brackets (5) from driver's seat bracket (8). Discard locknuts (7).
3. Lift up on driver's seat frame (2) and remove from driver's seat bracket (8).
4. Remove two spring pins (10) from inside retainers (9) and two rod and bushing assemblies (6) in seat frame (2) by sliding rod and bushing assemblies out from seat frame (2).

b. Installation

1. Install two rod and bushing assemblies (6) on seat frame (2) with two inside retainers (9) and spring pins (10).
2. Install driver's seat frame (2) on driver's seat bracket (8) with four adjuster brackets (5), sixteen washers (4), capscrews (3), washers (4), and locknuts (7). Tighten locknuts (7) to 21 lb-ft (29 N•m).
3. Adjust driver's seat (1) for desired position.

10-32. DRIVER'S SEAT FRAME REPLACEMENT (Cont'd)

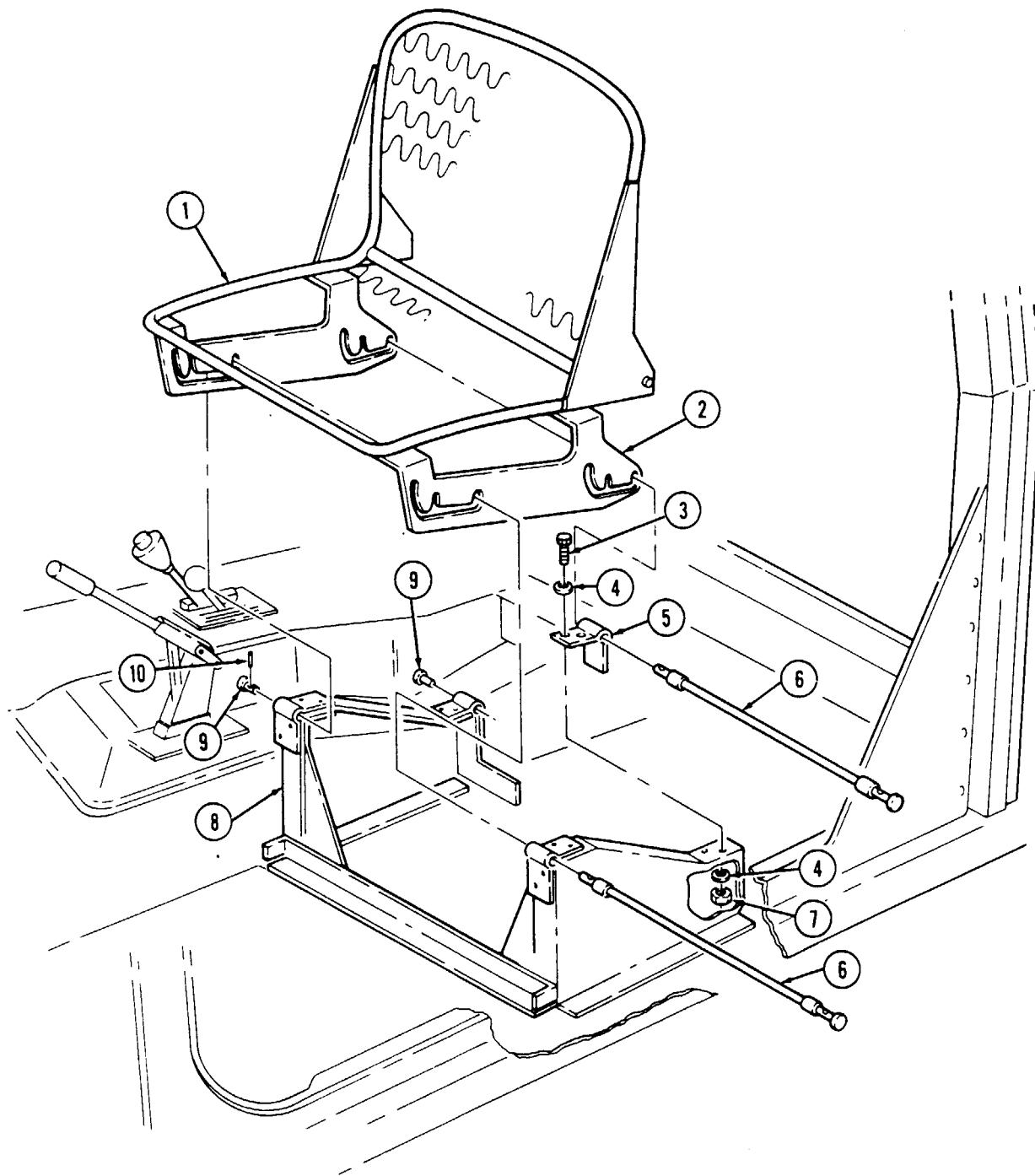

FOLLOW-ON TASK: Install driver's seat and seat back cushions (para. 10-33).

10-33. DRIVER'S SEAT AND SEAT BACK CUSHIONS REPLACEMENT

This task covers:

a. Removal

b. Installation

INITIAL SETUP:

Applicable Models

M966, M996, M997, M998, M1025, M1026, M1035, M1036, M1037, M1038, M1042, M1043, M1044, M1045, M1046, M1097

Materials/Parts

Four lock pins (Appendix G, Item 132)

Manual References

TM 9-2320-280-24P

Tools

General mechanic's tool kit:
automotive (Appendix B, Item 1)

a. Removal

1. Remove four lock pins (2) from seat holddown pins (5). Discard lock pins (2).
2. Remove four seat back cushion flaps (4) from holddown pins (5) and remove seat back cushion (3) from seat frame (7).
3. Remove two seat cushion straps (6) from holddown pins (5).
4. Remove front retainer strip (8) from seat frame (7) and remove seat cushion (1).

b. Installation

1. Install seat cushion (1) on seat frame (7) and install retainer strip (8) on seat frame (7).
2. Install two seat cushion straps (6) on holddown pins (5).
3. Install seat back cushion (3) on seat frame (7) and four flaps (4) on holddown pins (5).
4. Install four lock pins (2) on holddown pins (5).

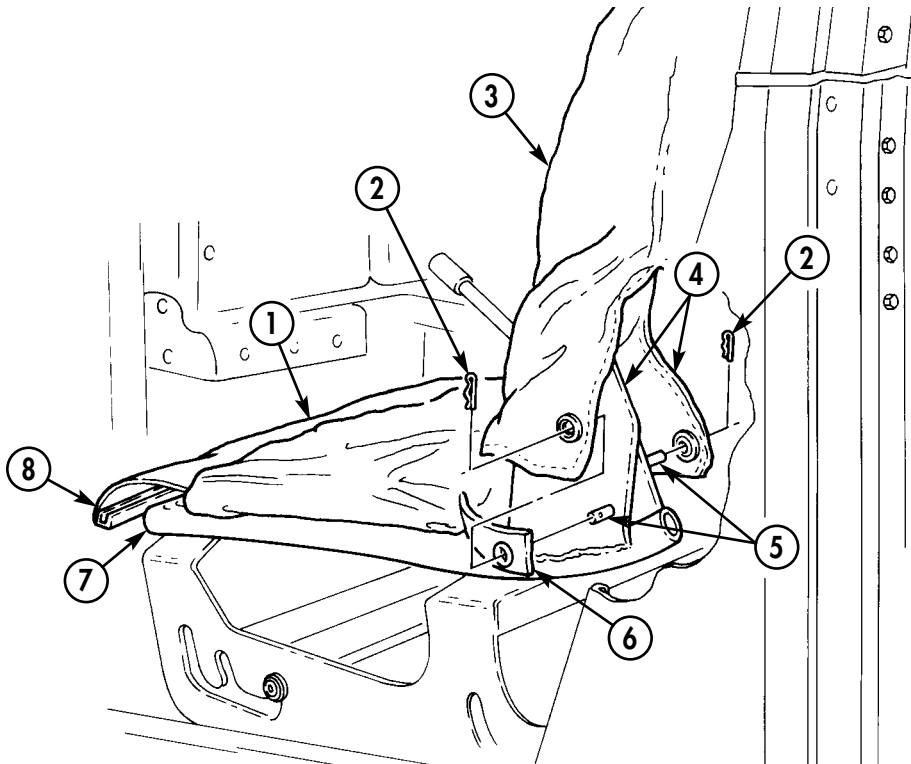

10-34. COMPANION SEAT BACK REPLACEMENT

This task covers:

a. Removal

b. Installation

INITIAL SETUP:

Applicable Models

M966, M996, M997, M998, M1025, M1026,
M1035, M1036, M1037, M1038, M1042,
M1043, M1044, M1045, M1046, M1097

Equipment Condition

Companion seat and battery box cover removed
(para. 10-35).

Tools

General mechanic's tool kit:
automotive (Appendix B, Item 1)

a. Removal

1. Remove four nuts (7), washers (5), capscrews (4), washers (5), and seat back (2) from body (6).
2. Remove four nuts (1), washers (8), and seat back cushion (3) from seat back (2).

b. Installation

1. Install seat back cushion (3) on seat back (2) with four washers (8) and nuts (1). Tighten nuts (1) to 15 lb-ft (20 N•m).
2. Install seat back (2) on body (6) with four washers (5), capscrews (4), washers (5), and nuts (7). Tighten capscrews (4) to 21 lb-ft (29 N•m).

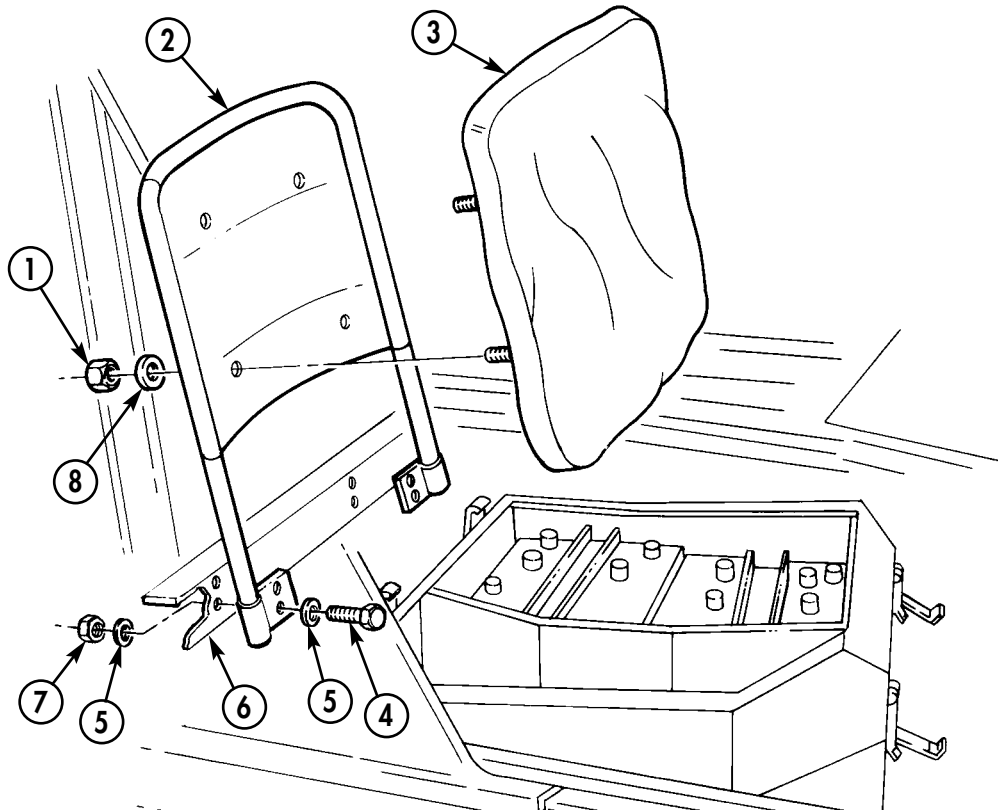

FOLLOW-ON TASK: Install companion seat and battery box cover (para. 10-35).

10-35. COMPANION SEAT AND BATTERY BOX COVER REPLACEMENT

This task covers:

- a. Removal b. Installation
-

INITIAL SETUP

Applicable Models

M966, M996, M997, M998, M1025, M1026,
M1035, M1036, M1037, M1038, M1042,
M1043, M1044, M1045, M1046, M1097

Tools

_General mechanic's tools kit:
_automotive (Appendix B, Item 1)

Manual References

TM 9-2320-280-24P

a. Removal

1. Release two latches (3) from companion seat and battery box cover (1).
2. Lift up and pull forward on companion seat and battery box cover (1) and remove from battery box (2).

b. Installation

Install companion seat and battery box cover (1) on battery box (2) with two latches (3).

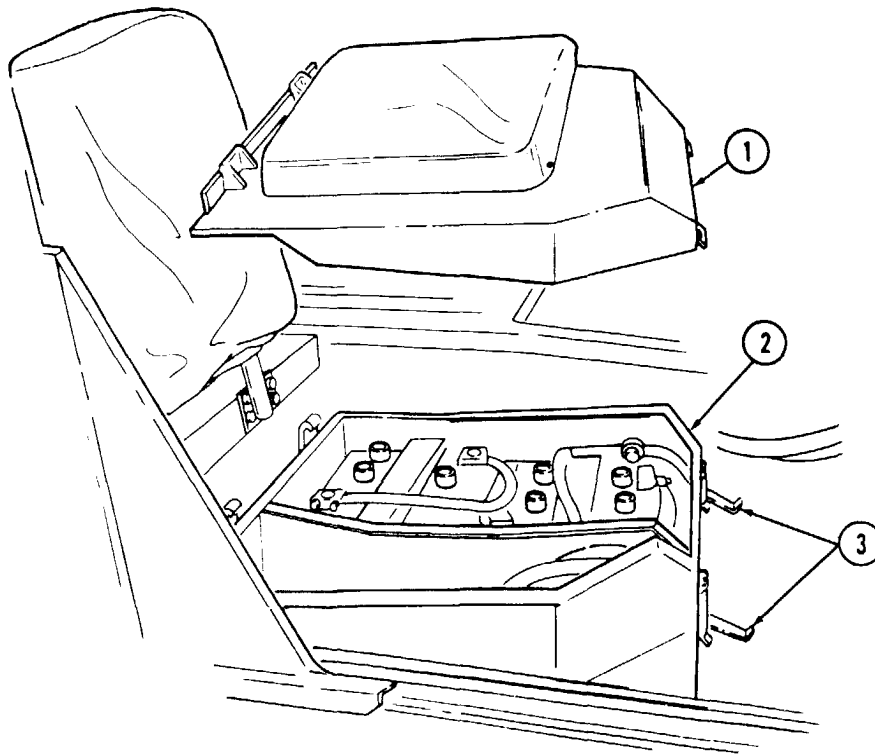

10-36. BATTERY BOX COVER LATCH REPLACEMENT

This task covers:

a. Removal

b. Installation

INITIAL SETUP:

Applicable Models

M966, M996, M997, M998, M1025, M1026,
M1035, M1036, M1037, M1038, M1042,
M1043, M1044, M1045, M1046, M1097

Tools

General mechanic's tool kit:
automotive (Appendix B, Item 1)

Materials/Parts

Two rivets (Appendix G, Item 240)
Two rivets (Appendix G, Item 241)

Manual References

TM 9-2320-280-24P

Equipment Condition

Batteries removed (para. 4-79).

NOTE

For instruction on replacement of rivets, refer to para. 10-66.

a. Removal

1. Remove two rivets (1) and striker latch (2) from battery box cover (3).
2. Remove two rivets (6) and tension latch (5) from battery box (4).

b. Installation

1. Install tension latch (5) on battery box (4) with two rivets (6).
2. Install striker latch (2) on battery box cover (3) with two rivets (1).

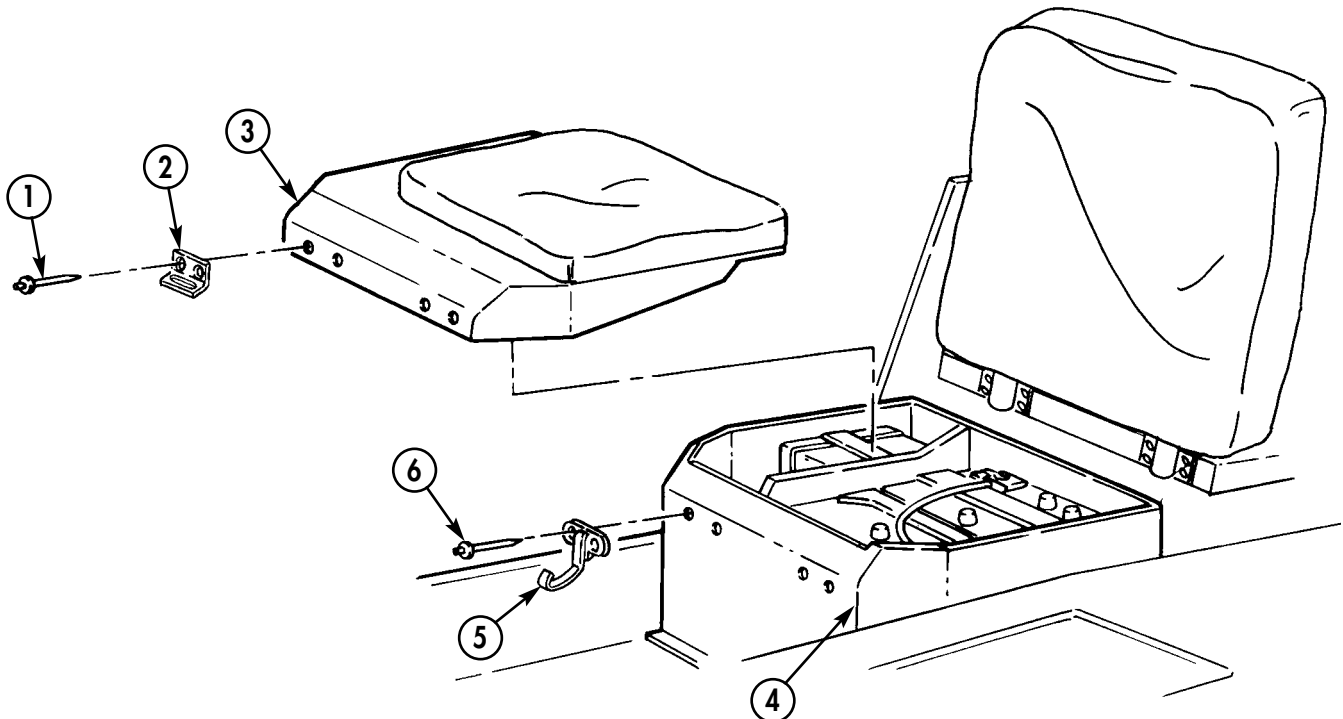

FOLLOW-ON TASK: Install batteries (para. 4-79).

10-37. COMPANION SEAT AND SEAT BACK CUSHIONS REPLACEMENT

This task covers:

a Removal

b. Installation

INITIAL SETUP

Applicable Models

M966, M996, M997, M998, M1025, M1026, M1035, M1036, M1037, M1038, M1042, M1043, M1044, M1045, M1046, M1097

Tools

General mechanic's tool kit
automotive (Appendix B, Item 1)

Manual References

TM 9-2320-280-24P

Equipment Condition

Companion seat and battery box cover removed
(para. 10-35).

a. Removal

1. Remove four nuts (7) and cushion (5) from battery box cover (6).
2. Remove four nuts (1), washers (2), and cushion (4) from seat back (3).

b. Installation

1. Install cushion (4) on seat back (3) with four washers (2) and nuts (1). Tighten nuts (1) to 15 lb-ft (20 N•m).
2. Install cushion (5) on battery box cover (6) with four nuts (7). Tighten nuts (7) to 15 lb-ft (20 N•m).

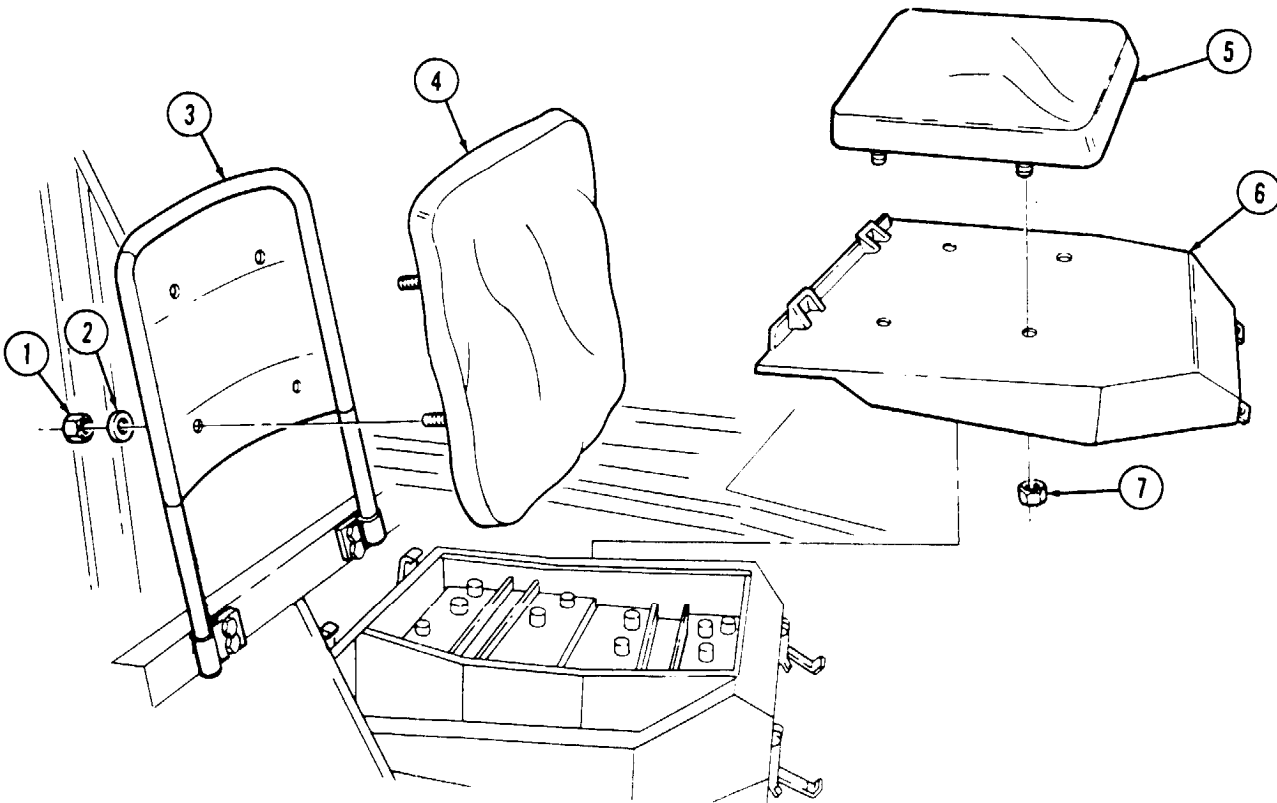

FOLLOW-ON TASK: Install companion seat and battery box cover (para. 10-35).

10-38. DRIVER'S SEAT ASSEMBLY REPLACEMENT

This task covers:

a. Removal

b. Installation

INITIAL SETUP:

Applicable Models

M966A1, M996A1, M997A1, M997A2,
M998A1, M1025A1, M1025A2, M1026A1,
M1035A1, M1035A2, M1038A1, M1043A1,
M1043A2, M1044A1, M1045A1, M1045A2,
M1046A1, M1097A1, M1097A2

Materials/Parts

Four lockwashers (Appendix G, Item 134)

Manual References

TM 9-2320-280-24P

Tools

General mechanic's tool kit:
automotive (Appendix B, Item 1)

a. Removal

1. Spread cover (6) to allow access to capscrews (2).
2. Remove four capscrews (2), lockwashers (3), spacers (4), cover (6), and seat assembly (1) from floor (5).

b. Installation

Install cover (6) and seat assembly (1) on floor (5) with four spacers (4), lockwashers (3), and capscrews (2).

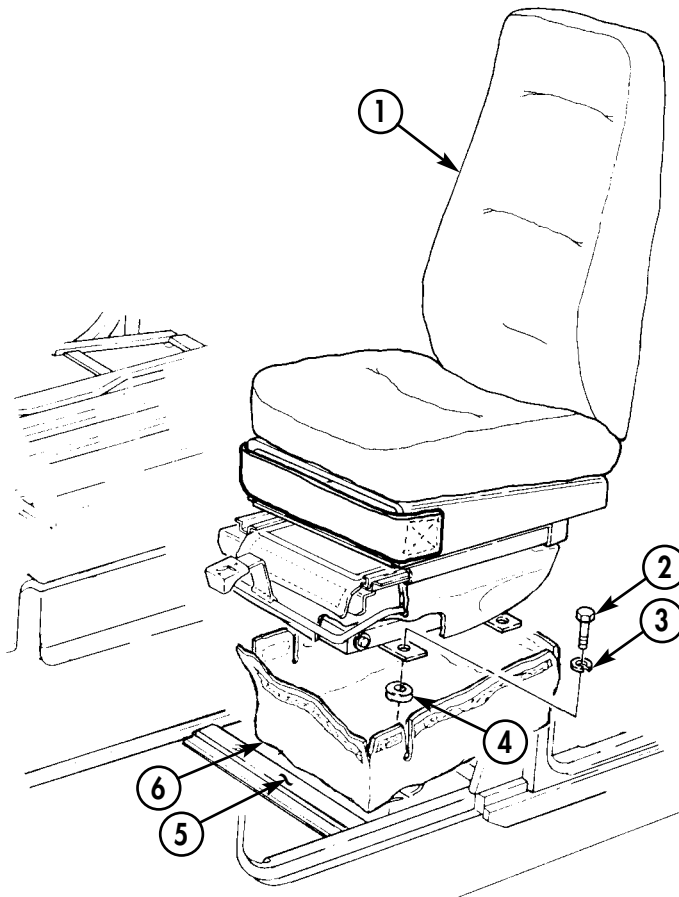

10-39. DRIVER'S SEAT ASSEMBLY MAINTENANCE

This task covers:

a. Disassembly

b. Assembly

INITIAL SETUP:

Applicable Models

M966A1, M996A1, M997A1, M997A2,
M998A1, M1025A1, M1025A2, M1026A1,
M1035A1, M1035A2, M1038A1, M1043A1
M1043A2, M1044A1, M1045A1, M1045A2,
M1046A1, M1097A1, M1097A2

Tools

General mechanic's tool kit:
automotive (Appendix B, Item 1)

Materials/Parts

Eight lockwashers (Appendix G, Item 149)
Four lockwashers (Appendix G, Item 134)

Manual References

TM 9-2320-280-24P

Equipment Condition

Driver's seat assembly removed (para. 10-38).

NOTE

Slide seat back and forth to gain access to slide set hardware.

a. Disassembly

1. Remove four nuts (12), lockwashers (11), capscrews (9), height adjuster (13), and cover (14) from slide set (10). Discard lockwashers (11).
2. Remove four nuts (8), lockwashers (16), and seat (2) from riser (6). Discard lockwashers (16).
3. Remove four nuts (3), lockwashers (4), capscrews (15), riser (6), and tray (5) from slide set (10). Discard lockwashers (4).
4. Remove two nuts (17), capscrews (19), loop (18), and strap (1) from riser (6).
5. Inspect velcro strip (7) on riser (6) for damage and replace if damaged.

b. Assembly

1. Install strap (1) and loop (18) on riser (6) with two capscrews (19) and nuts (17).
2. Install tray (5) and riser (6) on slide set (10) with four capscrews (15), lockwashers (4), and nuts (3).
3. Install seat (2) on riser (6) with four lockwashers (16) and nuts (8).
4. Install height adjuster (13) and cover (14) on slide set (10) with four capscrews (9), lockwashers (11), and nuts (12).

10-39. DRIVER'S SEAT ASSEMBLY MAINTENANCE (Cont'd)

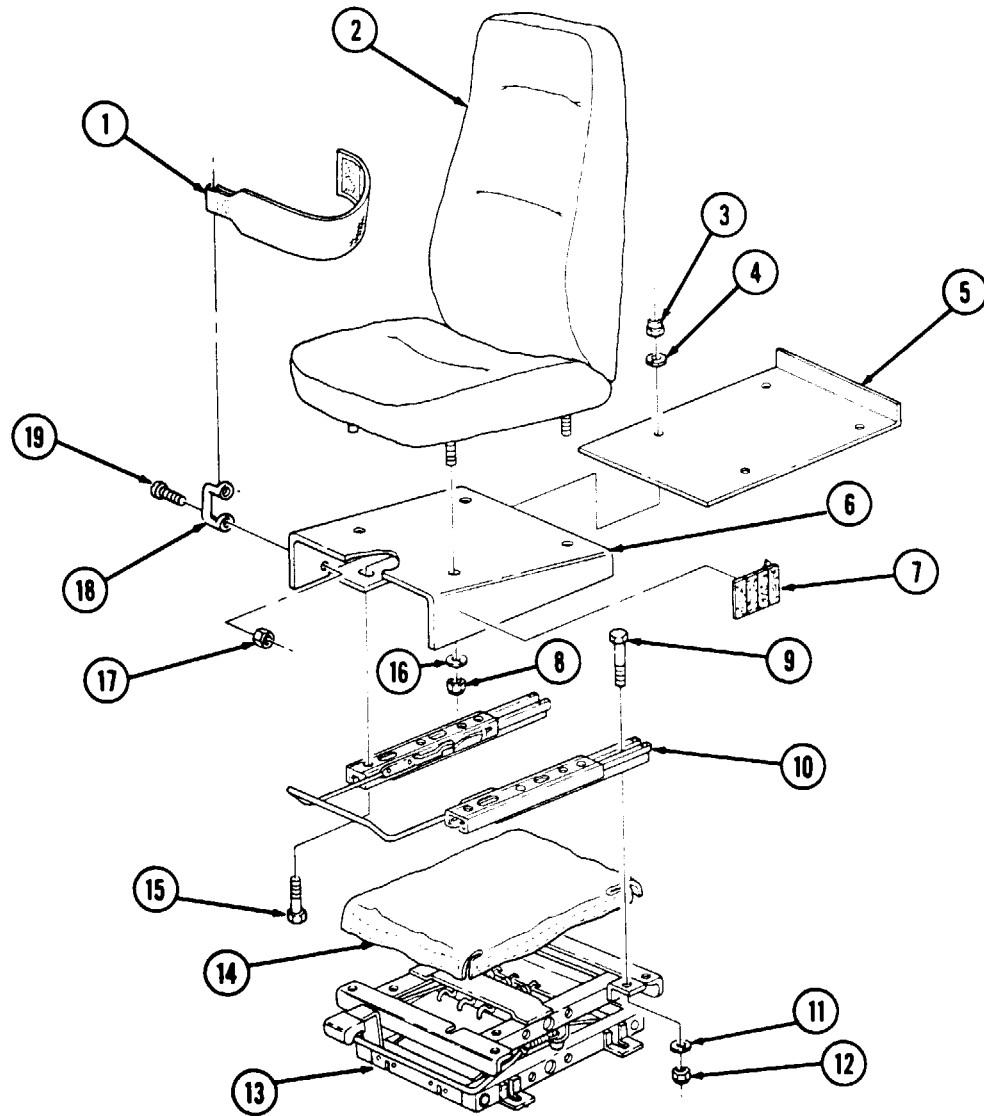

FOLLOW-ON TASK: Install driver's seat assembly (para. 10-38).

10-40. BATTERY BOX COVER CATCH REPLACEMENT

This task covers:

a. Removal

b. Installation

INITIAL SETUP:

Applicable Models

M966A1, M996A1, M997A1, M997A2,
M998A1, M1025A1, M1025A2, M1026A1,
M1035A1, M1035A2, M1038A1, M1043A1,
M1043A2, M1044A1, M1045A1, M1045A2,
M1046A1, M1097A1, M1097A2

Tools

General mechanic's tool kit:
automotive (Appendix B, Item 1)

Materials/Parts

Two rivets (Appendix G, Item 240)
Two rivets (Appendix G, Item 241)

Manual References

TM 9-2320-280-24P

Equipment Condition

Batteries removed (para. 4-79).

NOTE

For instruction on replacement of rivets, refer to para. 10-66.

a. Removal

1. Remove two rivets (1) and striker catch (2) from battery box cover (3) and bracket (7).
2. Remove two rivets (6) and clamping catch (5) from battery box (4).

b. Installation

1. Install clamping catch (5) on battery box (4) with two rivets (6).
2. Install striker catch (2) on battery box cover (3) and bracket (7) with two rivets (1).

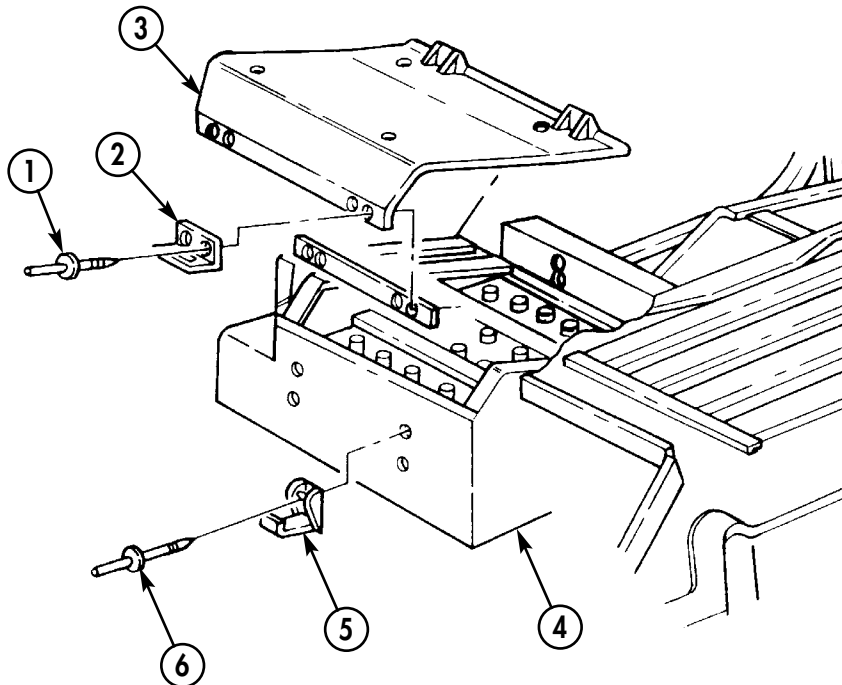

FOLLOW-ON TASK: Install batteries (para. 4-79).

10-41. COMPANION SEAT ASSEMBLY AND BATTERY BOX COVER REPLACEMENT

This task covers:

a Removal

b. Installation

INITIAL SETUP:

Applicable Models

M966A1, M996A1, M997A1, M997A2,
M998A1, M1025A1, M1025A2, M1026A1,
M1035A1, M1035A2, M1038A1, M1043A1,
M1043A2, M1044A1, M1045A1, M1045A2,
M1046A1, M1097A1, M1097A2

Tools

General mechanic's tool kit:
automotive (Appendix B, Item 1)

Manual References

TM 9-2320-280-24P

a. Removal

1. Release two latches (3) from companion seat and battery box cover (1).
2. Lift up and pull forward on companion seat and battery box cover (1) and remove from battery box (2).

b. Installation

Install companion seat and battery box cover (1) on battery box (2) with two latches (3)

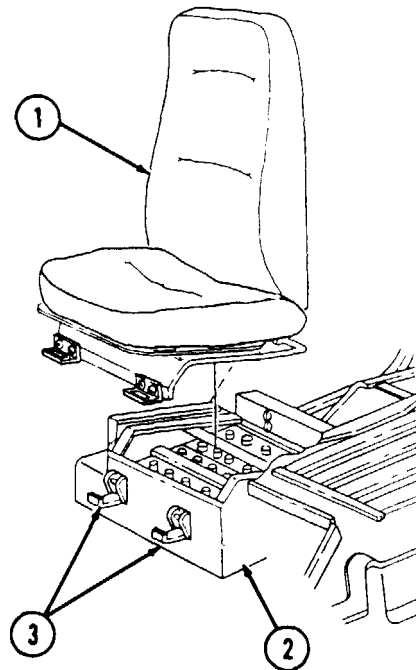

10-42. COMPANION SEAT ASSEMBLY MAINTENANCE

This task covers:

a. Disassembly

b. Assembly

INITIAL SETUP:

Applicable Models

M966A1, M996A1, M997A1, M997A2,
 M998A1, M1025A1, M1025A2, M1026A1,
 M1035A1, M1035A2, M1038A1, M1043A1,
 M1043A2, M1044A1, M1045A1, M1045A2,
 M1046A1, M1097A1, M1097A2

Tools

General mechanic's tool kit:
 automotive (Appendix B, Item 1)

Materials/Parts

Four lockwashers (Appendix G, Item 134)

Manual References

TM 9-2320-280-24P

Equipment Condition

Companion seat assembly and battery box cover removed (para. 10-41).

a. Disassembly

Remove four nuts (6), lockwashers (5), spacers (4), seat (1), and plate (2) from battery box cover (3).

b. Assembly

Install plate (2) and seat (1) on battery box cover (3) with four spacers (4), lockwashers (5), and nuts (6). Tighten nuts (6) to 15 lb-ft (20 N•m).

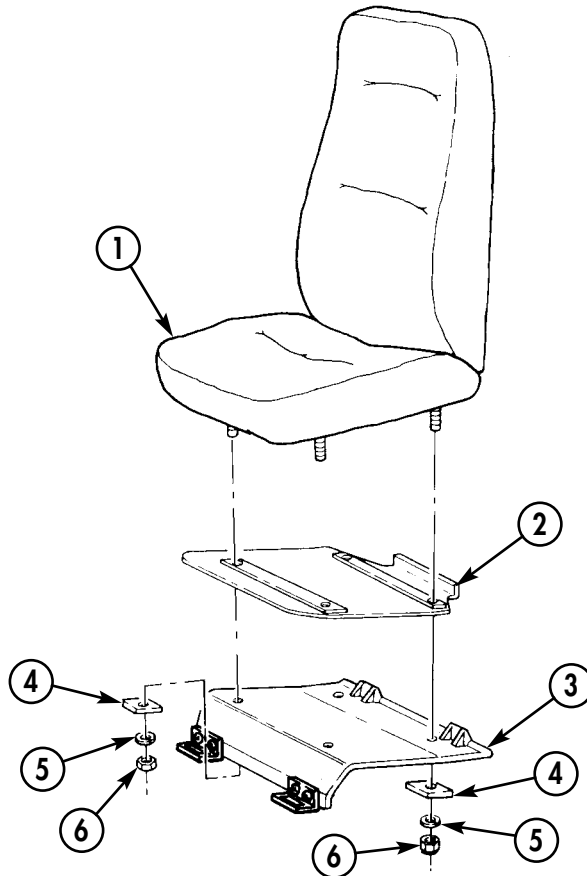

FOLLOW-ON TASK: Install companion seat assembly and battery box cover (para. 10-41).

10-43. PASSENGER SEAT AND STORAGE COMPARTMENT COVER REPLACEMENT

This task covers:

a Removal

b. Installation

INITIAL SETUP:**Applicable Models**

All except M996, M996A1, M997, M997A1,
M997A2, M1037, M1042

Manual References

TM 9-2320-280-24P

Tools

General mechanic's tool kit
automotive (Appendix B, Item 1)

a. Removal

Release two latches (3) and remove passenger seat and storage compartment cover (1) from storage compartment box (2).

b. Installation

Install passenger seat and storage compartment cover (1) on storage compartment box (2) with two latches (3).

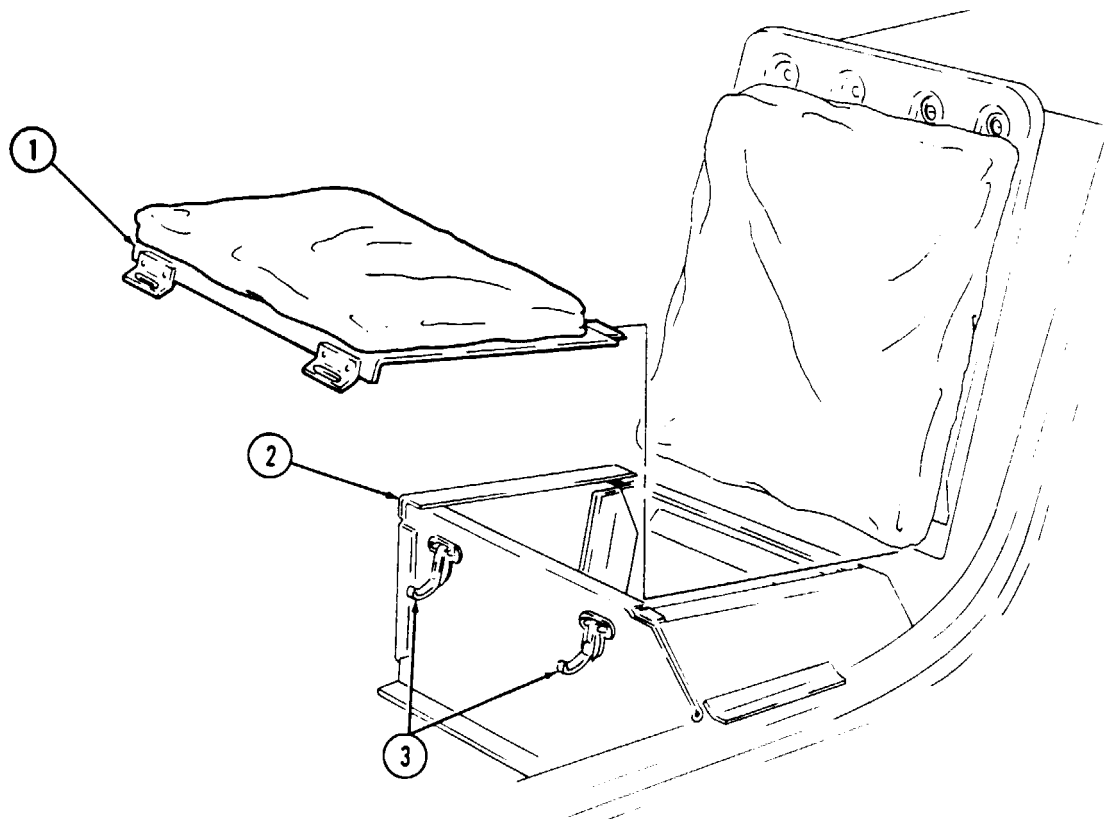

10-44. PASSENGER SEAT AND STORAGE COMPARTMENT LATCH REPLACEMENT

This task covers:

a. Removal

b. Installation

INITIAL SETUP:

Applicable Models

All except M996, M996A1, M997, M997A1, M997A2, M1037, M1042

Manual References

TM 9-2320-280-24P

Tools

General mechanic's tool kit:
automotive (Appendix B, Item 1)

Equipment Condition

Passenger seat and storage compartment cover removed (para. 10-43).

Materials/Parts

Two rivets (Appendix G, Item 240)
Two rivets (Appendix G, Item 241)

NOTE

For instructions on replacement of rivets, refer to para. 10-66.

a. Removal

1. Remove two rivets (1) and striker latch (2) from passenger seat and storage compartment cover (3).
2. Remove two rivets (6) and tension latch (5) from storage compartment box (4).

b. Installation

1. Install tension latch (5) on storage compartment box (4) with two rivets (6).
2. Install striker latch (2) on passenger seat and storage compartment cover (3) with two rivets (1).

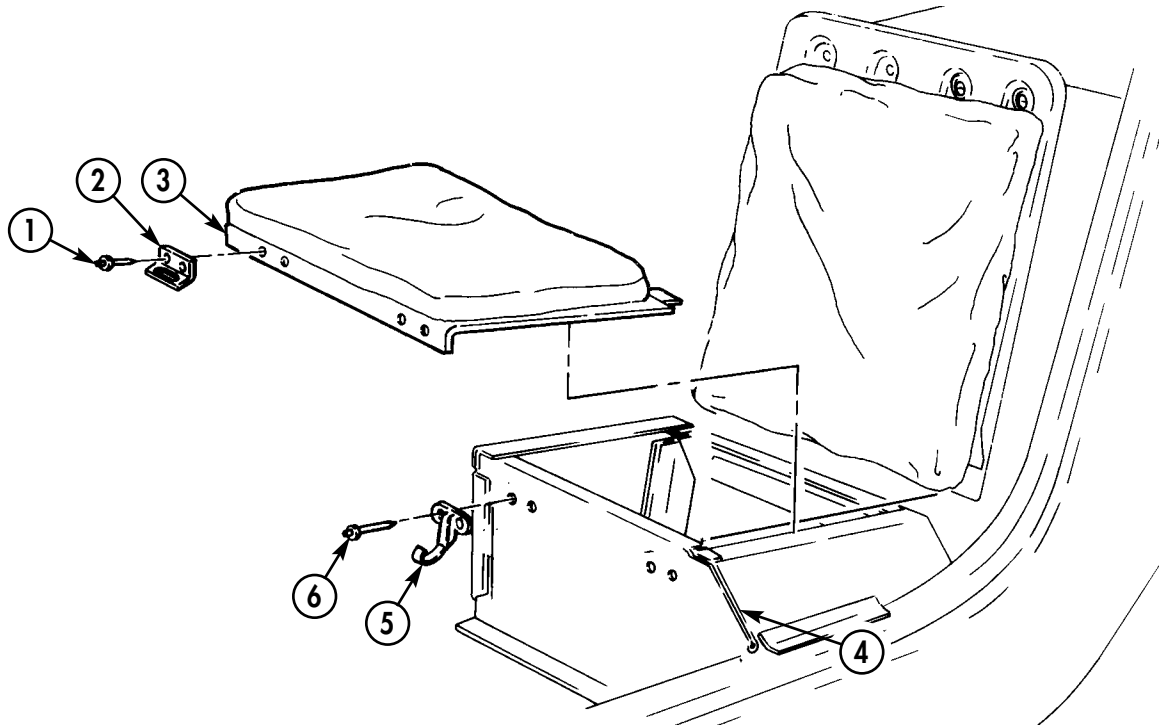

FOLLOW-ON TASK: Install passenger seat and storage compartment cover (para. 10-43).

10-45. PASSENGER SEAT BACK REPLACEMENT

This task covers:

a. Removal

b. Installation

INITIAL SETUP

Applicable Models

All except M996, M996A1, M997, M997A1,
M997A2, M1037, M1042

Manual References

TM 9-2320-280-24P

Tools

General mechanic's tool kit:
automotive (Appendix B, Item 1)

a. Removal

Remove two locking pins (1) and passenger seat back (2) from body (3).

b. Installation

Install passenger seat back (2) on body (3) with two locking pins (1).

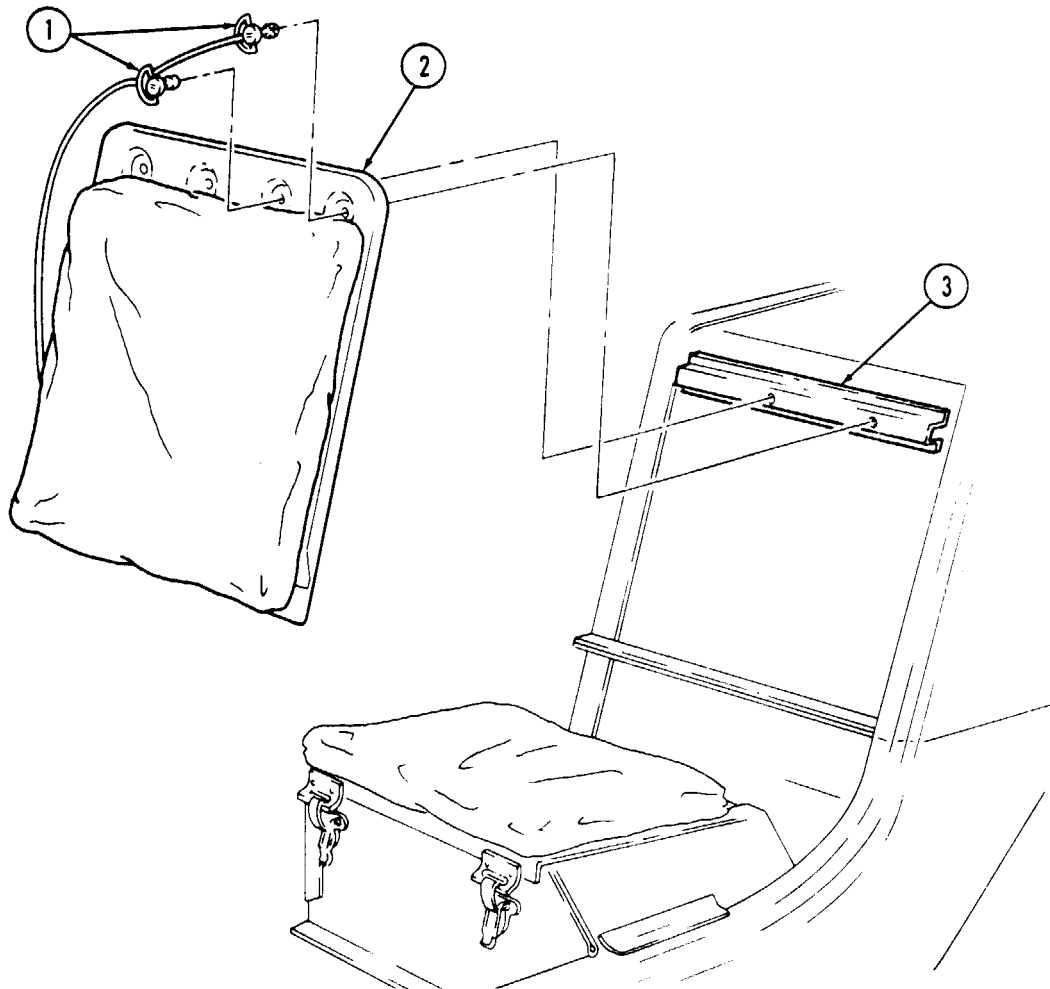

10-46. PASSENGER SEAT AND SEAT BACK CUSHIONS REPLACEMENT

This task covers:

- a. Removal b. Installation

INITIAL SETUP:

Applicable Models

All except M996, M996A1, M997, M997A1, M997A2, M1037, M1042

Tools

General mechanic's tool kit automotive (Appendix B, Item 1)

Manual References

TM 9-2320-280-24P

Equipment Condition

- Passenger seat and storage compartment cover removed (para. 10-43).
- Passenger seat back removed (para. 10-45).

a. Removal

1. Remove four nuts (7) and seat cushion (5) from storage compartment cover (6).
2. Remove four nuts (3), eight spacers (4), and seat back cushion (1) from seat back (2).

b. Installation

1. Install seat back cushion (1) on seat back (2) with eight spacers (4) and four nuts (3). Tighten nuts (3) to 15 lb-ft (20 N•m).
2. Install seat cushion (5) on storage compartment cover (6) with four nuts (7). Tighten nuts (7) to 15 lb-ft (20 N•m).

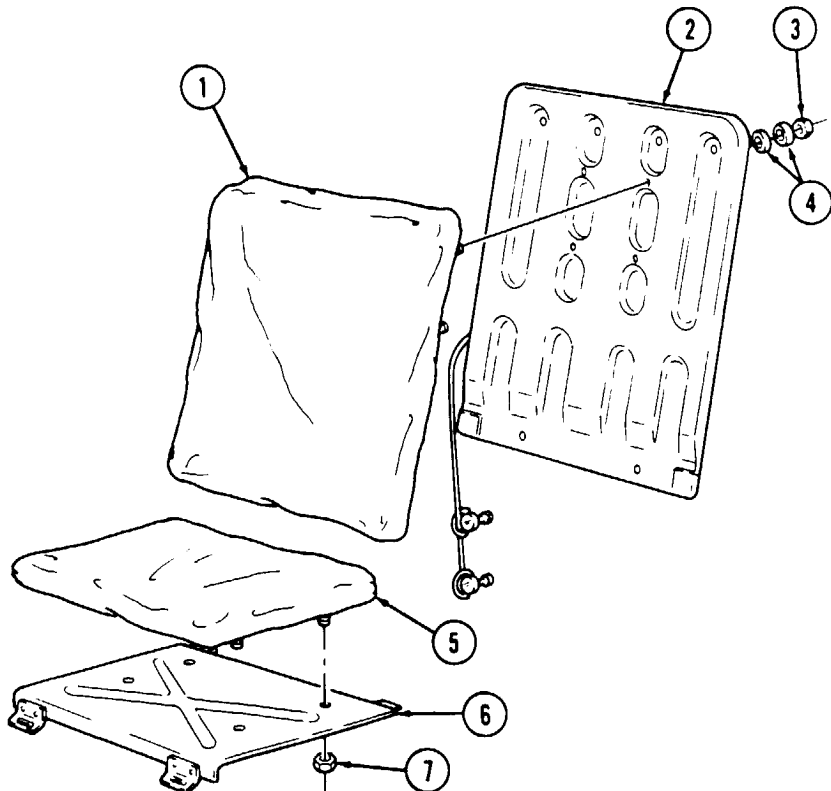

- FOLLOW-ON TASKS: • Install passenger seat and storage compartment cover (para. 10-43).
 • Install passenger seat back (para. 10-45).

10-47. SEATBELT ASSEMBLY REPLACEMENT

This task covers:

a Removal

b. Installation

INITIAL SETUP:

Tools

General mechanic's tool kit
automotive (Appendix B, Item 1)

Manual References

TM 9-2320-280-24P

Equipment Condition

- Passenger seat back removed, rear seatbelt only (para. 10-45).
- Companion seat and battery box cover removed, companion seatbelt only (para- 10-35).

General Safety Instructions

Seatbelts are to be replaced as a set.

WARNING

Seatbelts are to be replaced as a set. Failure to do this may cause injury to personnel or damage to equipment.

NOTE

- This procedure applies to all vehicles with serial numbers USBL Eff. 99,999 and below.
- All seatbelt removal and installation procedures are basically the same. This procedure covers the driver's seatbelt.

a. Removal

1. Remove anchor bolt (8), buckle assembly (7), and washer (6) from bracket (5).
2. Remove anchor bolt (4), connector assembly (3), and washer (2) from body (1).

b. Installation

1. Install washer (2) and connector assembly (3) on body (1) with anchor bolt (4). Tighten anchor bolt (4) to 35-40 lb-ft (47-54 **N•m**).
2. Install washer (6) and buckle assembly (7) on bracket (5) with anchor bolt (8). Tighten anchor bolt (8) to 35-40 lb-ft (47-54 **N•m**).

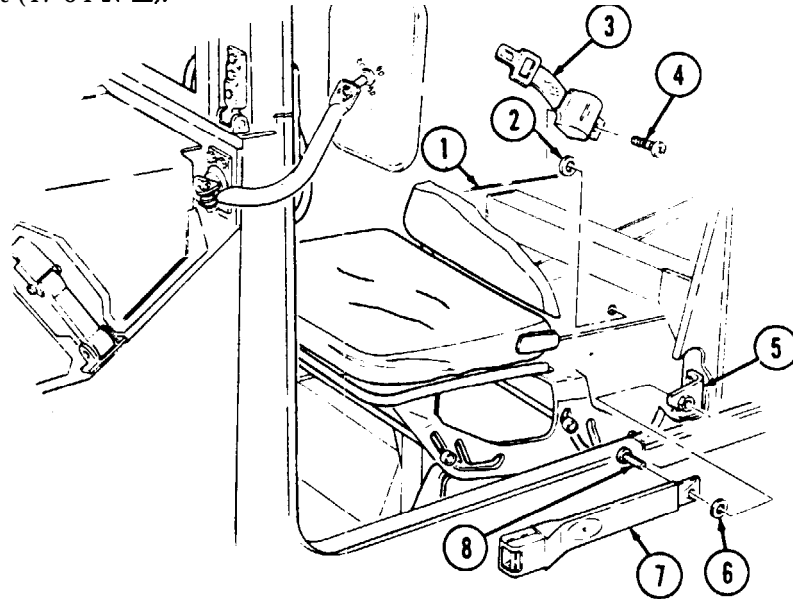

- FOLLOW-ON TASKS:**
- Install passenger seat back, rear seatbelt only (Pam. 10-45).
 - Install companion seat battery box cover, companion seatbelt only (para. 10-35).

10-48. THREE POINT SEATBELT MAINTENANCE

This task covers:

- | | |
|--------------------------------------|-------------------------------------|
| a. Front Seatbelt Removal | d. Rear Seatbelt Removal |
| b. Front Seatbelt Bracket Inspection | e. Rear Seatbelt Bracket Inspection |
| c. Front Seatbelt Installation | f. Rear Seatbelt Installation |

INITIAL SETUP:

Applicable Models

All models except M996, M996A1, M997, M997A1, M997A2

Tools

General mechanic's tool kit:
automotive (Appendix B, Item 1)

Manual References

TM 9-2320-280-10
TM 9-2320-280-24P

Equipment Condition

- Passenger seat back removed, rear seatbelt only (para. 10-45).
- Companion seat and battery box cover removed, companion seatbelt only (para. 10-35).
- Four-man soft top curtain removed, rear seatbelt only (TM 9-2320-280-10).
- Rear doors removed, armament vehicles only (para. 11-2).

General Safety Instructions

Seatbelts are to be replaced as a set.

WARNING

Seatbelts are to be replaced as a set. Failure to do this may cause injury to personnel or damage to equipment.

NOTE

Left and right seatbelt maintenance procedures are basically the same. This procedure covers the left seatbelt.

a. Front Seatbelt Removal

1. Remove capscrew (26), buckle assembly (25), and washer (24) from body (23).
2. Remove capscrew (22), connector assembly (21), and washer (20) from bracket (19).

NOTE

Steps 3 and 4 apply to all armament vehicles.

3. Remove two screws (7) and washers (8) from "B" pillar cover (12) and roof (6).
4. Remove two screws (14), washers (13), and "B" pillar cover (12) from "B" pillar (11).

NOTE

Step 5 applies to armament vehicles with serial numbers USBL Eff. 100,000 through 134,152 only.

5. Remove nut (9), washer (10), capscrew (1), "D" ring (2), washer (3), and bracket half (4) from "B" pillar (11).

NOTE

Step 6 applies to armament vehicles with serial numbers USBL Eff. 134,153 and above only. Steps 7 and 8 apply to all other vehicles.

6. Remove capscrew (1), "D" ring (2), washer (3), and bracket halves (4) and (5) from "B" pillar (11).
7. Remove capscrew (15), "D" ring (16), and washer (17) from upper bracket (18).
8. Remove capscrew (27), washer (28), and retractor (29) from lower bracket (30).

10-48. THREE POINT SEATBELT MAINTENANCE (Cont'd)

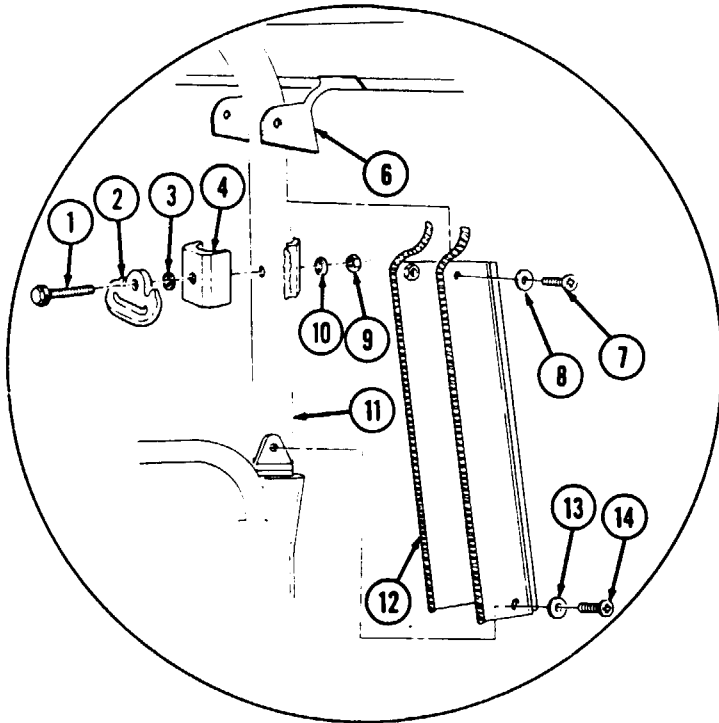

ARMAMENT VEHICLES OLD CONFIGURATION

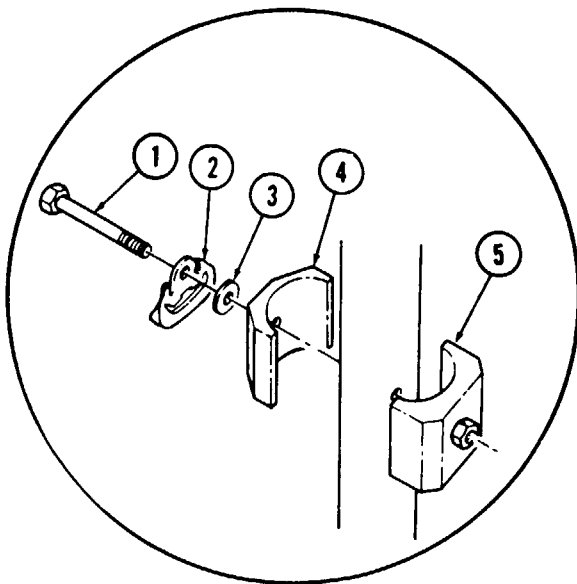

ARMAMENT VEHICLES NEW CONFIGURATION

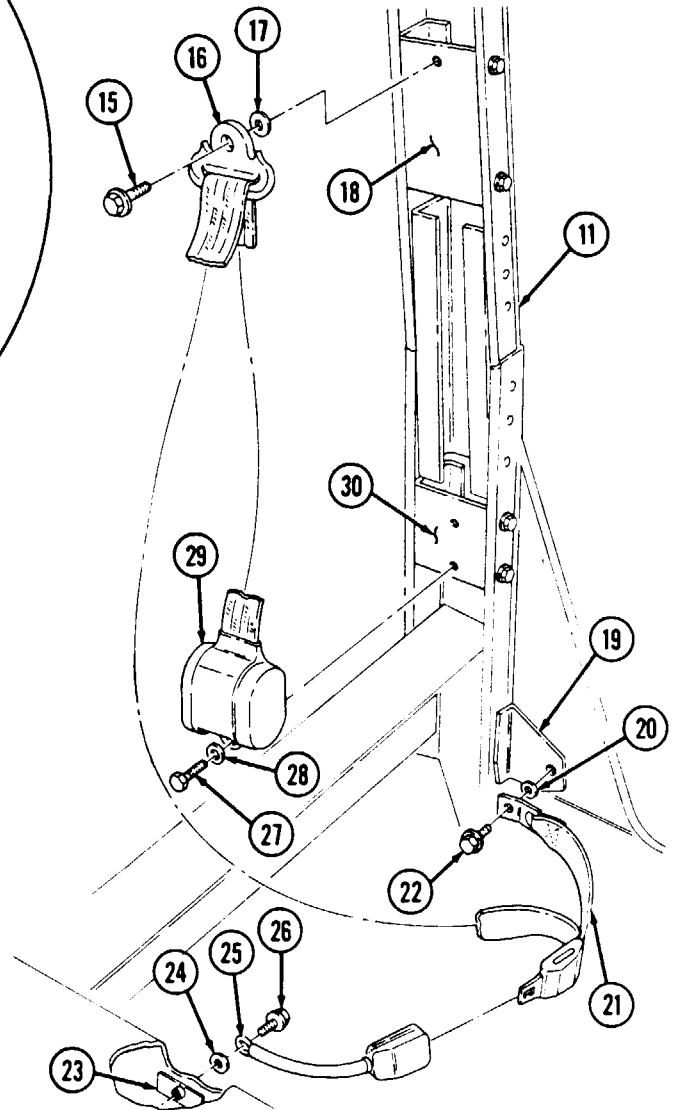

10-48. THREE POINT SEATBELT MAINTENANCE (Cont'd)

b. Front Seatbelt Bracket Inspection

NOTE

Step 1 applies to armament vehicles only. Step 2 applies to all other vehicles.

1. Inspect bracket halves (4) and (5) for bends, or cracks. Replace if broken, bent or cracked.
2. Inspect upper bracket (18) for breaks, bends, or cracks. Replace if broken, bent, or cracked, refer to **para. 10-49.**
3. Inspect lower bracket (30) for breaks, bends, or cracks. Replace if broken, bent, or cracked, refer to para. 10-49.

c. Front Seatbelt Installation

1. Install retractor (29) on lower bracket (30) with washer (28) and capscrew (27). Tighten capscrew (27) to 43-60 lb-ft (58-81 **N•m**).

NOTE

Step 2 applies to armament vehicles with serial numbers USBL Eff. 134,153 and above only.

2. Install "D" ring (2) and bracket halves (4) and (5) to "B" pillar (11) with washer (3) and capscrew (1).

NOTE

Step 3 applies to armament vehicles with serial numbers USBL Eff. 100,000 through 134,152 only.

3. Install bracket half (4), washer (3), and "D" ring (2) on "B" pillar (11) with capscrew (1), washer (10), and nut (9). Tighten nut (9) to 35-40 lb-ft (47-54 **N•m**).

NOTE

Steps 4 and 5 apply to all armament vehicles.

4. Install "B" pillar cover (12) on roof (6) with two washers (8) and screws (7).
5. Install "B" pillar cover (12) on "B" pillar (11) with two washers (13) and screws (14).
6. Install washer (17) and "D" ring (16) on upper bracket (18) with capscrew (15). Tighten capscrew (15) to 35-40 lb-ft (47-54 **N•m**).
7. Install washer (20) and connector assembly (21) on bracket (19) with capscrew (22). Tighten capscrew (22) to 35-40 lb-ft (47-54 **N•m**).
8. Install washer (24) and buckle assembly (25) on body (23) with capscrew (26). Tighten capscrew (26) to 35-40 lb-ft. (47-54 **N•m**).

10-48. THREE POINT SEATBELT MAINTENANCE (Cont'd)

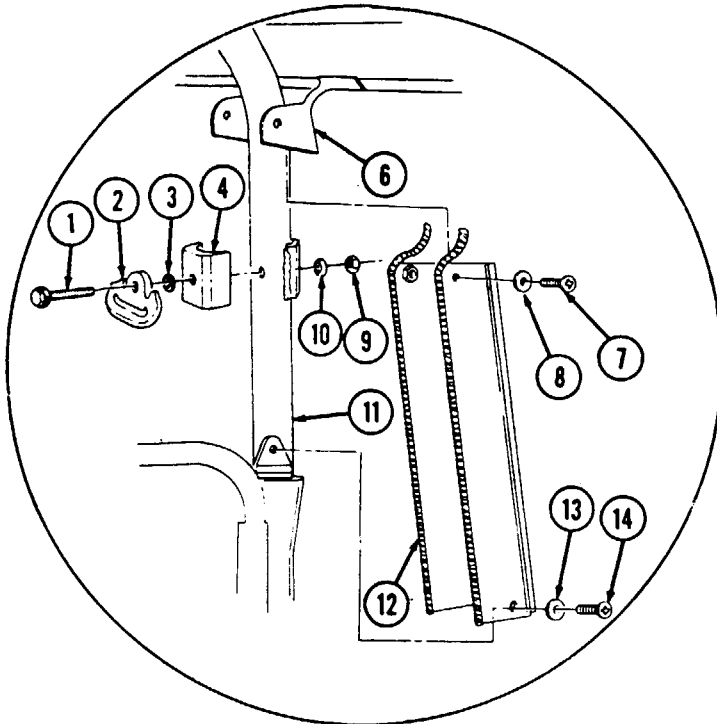

ARMAMENT VEHICLES OLD CONFIGURATION

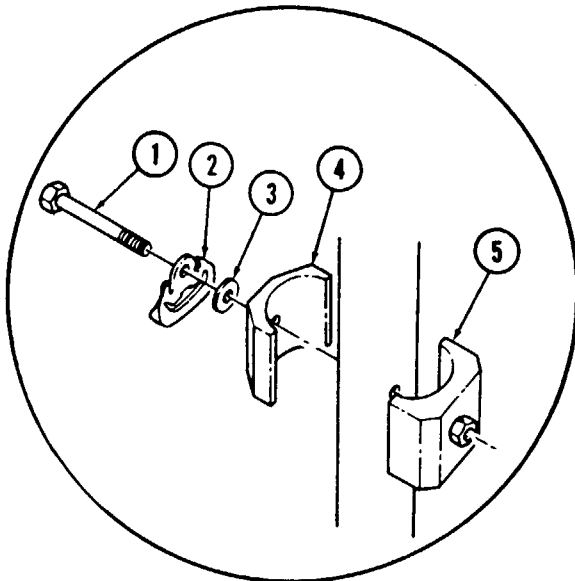

ARMAMENT VEHICLES NEW CONFIGURATION

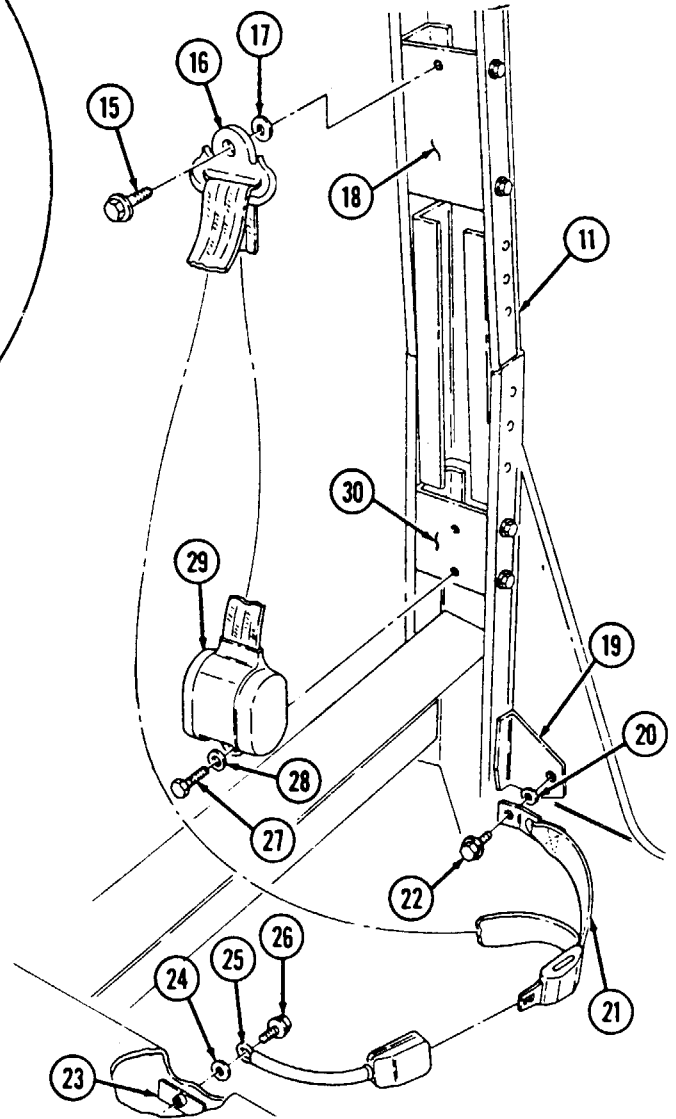

10-48. THREE POINT SEATBELT MAINTENANCE (Cont'd)

d. Rear Seatbelt Removal

NOTE

Left and right seatbelt maintenance procedures are basically the same. This procedure covers the right seatbelt.

1. Remove capscrew (22), buckle assembly (25), and washer (23) from body (24).
2. Remove capscrew (21), connector assembly (26), and washer (20) from bracket (27).

NOTE

Steps 3 and 4 apply to armament vehicles only. Steps 5 and 6 apply to all other vehicles.

3. Remove capscrew (4), "D" ring (5), and washer (6) from bracket (7).
4. Remove capscrew (1), washer (2), and retractor (3) from bracket (7).
5. Remove nut (17), washer (16), capscrew (12), "D" ring (13), and washer (14) from bracket (11).
6. Remove nut (18), washer (19), capscrew (8), washer (9), and retractor (10) from bracket (11).

e. Rear Seatbelt Bracket Inspection

NOTE

Rear seatbelt bracket inspection applies to all vehicles except armament vehicles.

1. Inspect bracket (11) for breaks, bends, or cracks. Replace if broken, bent, or cracked (refer to para. 10-49).
2. Inspect turnbutton (15) for bends, corrosion, or damage. Replace if bent, corroded, or damaged (refer to para. 10-66 for rivet removal).

f. Rear Seatbelt Installation

NOTE

Steps 1 and 2 apply to armament vehicles only. Steps 3 and 4 apply to all other vehicles.

1. Install retractor (3) on bracket (7) with washer (2) and capscrew (1). Tighten capscrew (1) to 35-40 lb-ft (47-54 **N•m**).
2. Install washer (6) and "D" ring (5) on bracket (7) with capscrew (4). Tighten capscrew (4) to 35-40 lb-ft (47-54 **N•m**).
3. Install retractor (10) on bracket (11) with washer (9), capscrew (8), washer (19), and nut (18). Tighten capscrew (8) to 43-60 lb-ft (58-81 **N•m**).
4. Install washer (14) and "n" ring (13) on bracket (11) with capscrew (12), washer (16), and nut (17). Tighten nut (17) to 35-40 lb-ft (47-54 **N•m**).
5. Install washer (20) and connector assembly (26) on bracket (27) with capscrew (21). Tighten capscrew (21) to 35-40 lb-ft (47-54 **N•m**).
6. Install washer (23) and buckle assembly (25) on body (24) with capscrew (22). Tighten capscrew (22) to 35-40 lb-ft (47-54 **N•m**).

10-48. THREE POINT SEATBELT MAINTENANCE (Cont'd)

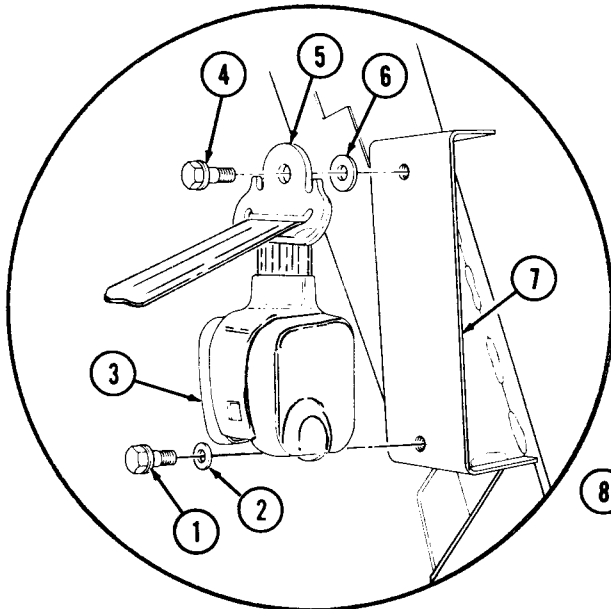

ARMAMENT VEHICLE

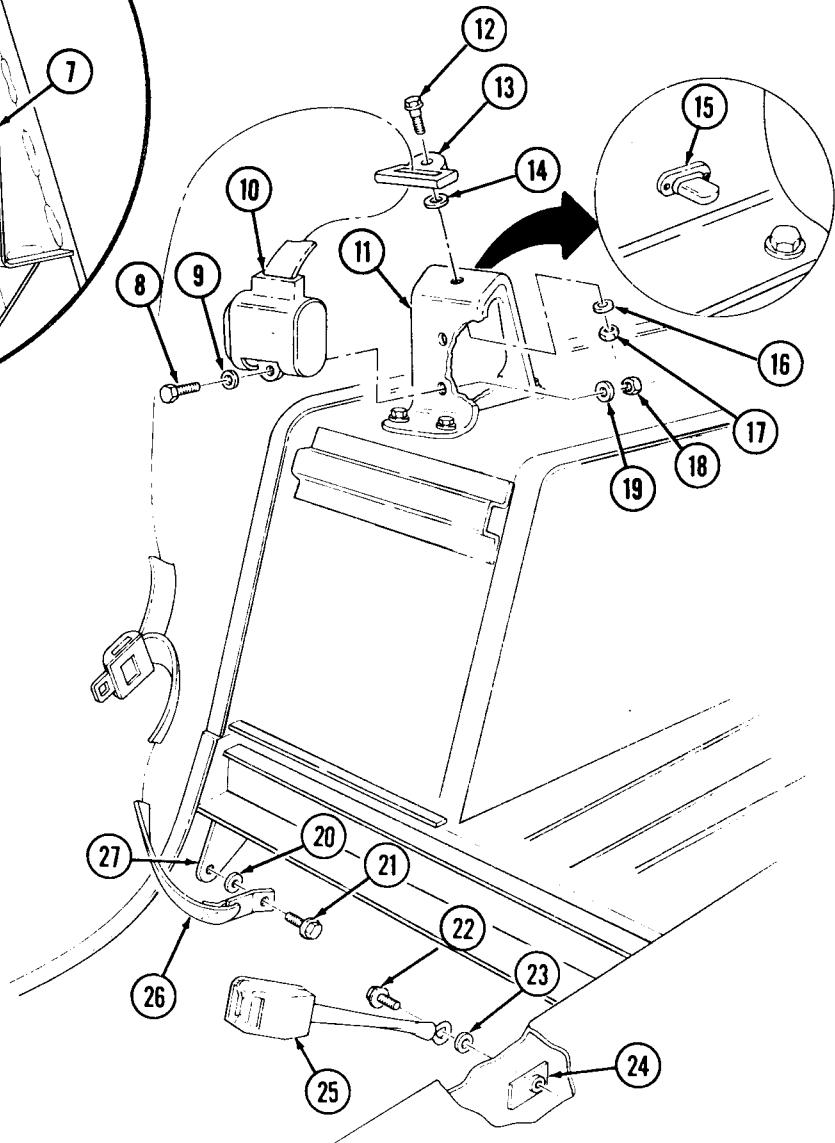

- FOLLOW-ON TASKS:**
- Install passenger seat back, rear seatbelt only (para. 10-45).
 - Install companion seat and battery box cover, companion seatbelt only (para. 10-35).
 - Install four-man soft top curtain, rear seatbelt only (TM 9-2320-280-10).
 - Install rear doors, armament vehicles only (para. 11-2).

10-48.1. THREE POINT SEATBELT MAINTENANCE (M996, M996A1, M997, M997A1, AND M997A2)

This task covers:

- a. Seatbelt Removal
- b. Seatbelt Bracket Inspection
- c. Seatbelt Installation

INITIAL SETUP:

Applicable Models

M996, M996A1, M997, M997A1, M997A2

Manual References

TM 9-2320-280-24P

Tools

General mechanic's tool kit:
automotive (Appendix B, Item 1)

Equipment Condition

Companion seat and battery box cover removed,
(companion seatbelt only) (para. 10-35).

WARNING

Seatbelts are to be replaced as a set. Failure to do this may cause injury to personnel or damage to equipment.

NOTE

Left and right seatbelt maintenance procedures are basically the same. This procedure covers the left seatbelt.

a. Seatbelt Removal

1. Remove capscrew (4), buckle assembly (3), and washer (2) from bracket (1).
2. Remove capscrew (8), connector assembly (5), and washer (7) from body (6).
3. Remove capscrew (9), D-ring (11), and washer (10) from bulkhead (12).
4. Remove capscrew (16), retractor (15), and washer (14) from bracket (13).

b. Seatbelt Bracket Inspection

Inspect brackets (1) and (13) for breaks, bends, or cracks. Replace if broken, bent, or cracked (para. 10-49.1).

c. Seatbelt Installation

1. Install washer (14) and retractor (15) on bracket (13) with capscrew (16). Tighten capscrew (16) to 35-40 lb-ft (47-54 N•m).
2. Install washer (10) and D-ring (11) on bulkhead (12) with capscrew (9). Tighten capscrew (9) to 35-40 lb-ft (47-54 N•m).
3. Install washer (7) and connector assembly (5) on body (6) with capscrew (8). Tighten capscrew (8) to 35-40 lb-ft (47-54 N•m).
4. Install washer (2) and buckle assembly (3) on bracket (1) with capscrew (4). Tighten capscrew (4) to 35-40 lb-ft (47-54 N•m).

10-48.1. THREE POINT SEATBELT MAINTENANCE (M996, M996A1, M997, M997A1, AND M997A2) (Cont'd)

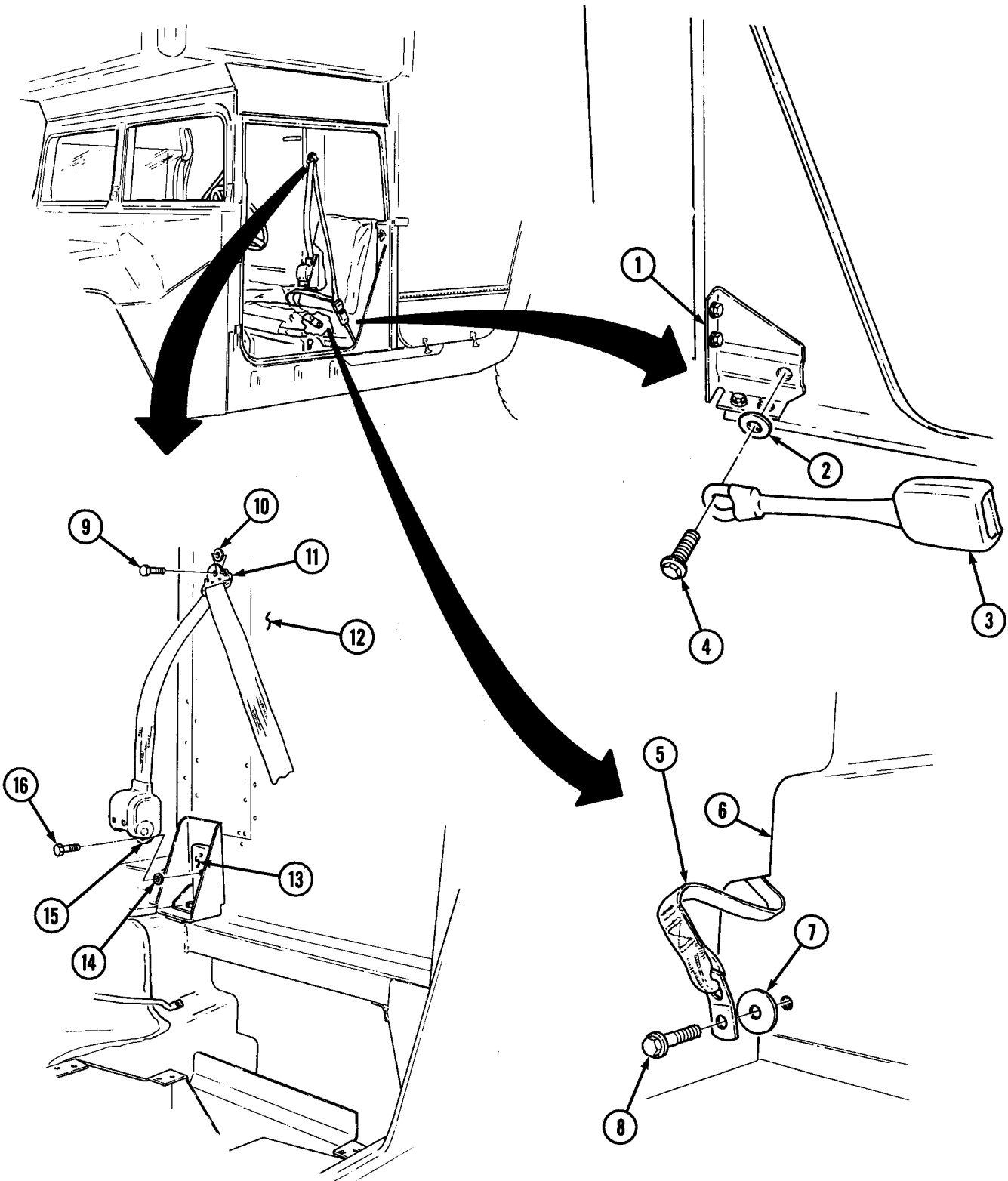

FOLLOW-ON TASK: Install companion seat and battery box cover (companion seatbelt only) (para. 10-35).

10-49. THREE POINT SEATBELT BRACKETS REPLACEMENT

This task covers:

- | | |
|--|---------------------------------------|
| a. Front Seatbelt Bracket Removal | c. Rear Seatbelt Bracket Removal |
| b. Front Seatbelt Bracket Installation | d. Rear Seatbelt Bracket Installation |
-

INITIAL SETUP:

Applicable Models

All models except M996, M996A1, M997, M997A1, M997A2

Tools

General mechanic's tool kit:
automotive (Appendix B, Item 1)

Manual References

TM 9-2320-280-24P

Equipment Condition

Three point seatbelt removed (para. 10-48).

NOTE

Left and right seatbelt brackets replacement procedures are basically the same. This procedure covers the left seatbelt bracket.

a. Front Seatbelt Bracket Removal

1. Remove four capscrews (3), washers (2), and upper bracket (1) from "B" pillar (4).
2. Remove four capscrews (6), washers (5), and lower bracket (7) from "B" pillar (4).

b. Front seatbelt Bracket Installation

1. Install lower bracket (7) on "B" pillar (4) with four washers (5) and capscrews (6). Tighten capscrews (6) to 15-21 lb-n (20-29 N•m).
2. Install upper bracket (1) on "B" pillar (4) with four washers (2) and capscrews (3). Tighten capscrews (3) to 15-21 lb-ft (20-29 N•m).

c. Rear Seatbelt Bracket Removal

NOTE

Left and right seatbelt brackets replacement procedures are basically the same. This procedure covers the right seatbelt bracket.

1. Remove two nuts (15), washers (14), capscrews (12), and washers (13) from bracket (10) and wheelhouse (16).
2. Remove two nuts (18), washers (17), capscrews (9), washers (8), and bracket (10) from wheelhouse (16).
3. Inspect turnbutton (11) for bends, corrosion, or damage. Replace if damaged, refer to para. 10-66 for rivet removal.

d. Rear seatbelt Bracket installation

1. Install bracket (10) on wheelhouse (16) with two washers (8), capscrews (9), washers (17), and nuts (18). Tighten capscrews (9) to 43-60 lb-ft (58-81 N•m).
2. Secure bracket (10) to wheelhouse (16) with two washers (13), capscrews (12), washers (14), and nuts (15). Tighten capscrews (12) to 43-60 lb-ft (58-81 N•m).

10-49. THREE POINT SEATBELT BRACKETS REPLACEMENT (Cont'd)

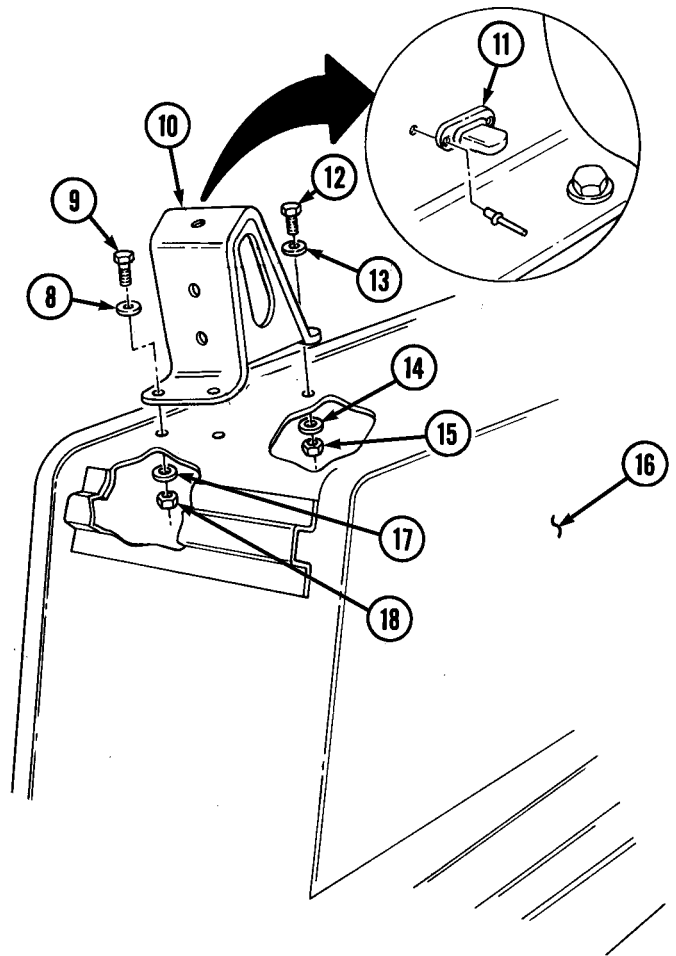
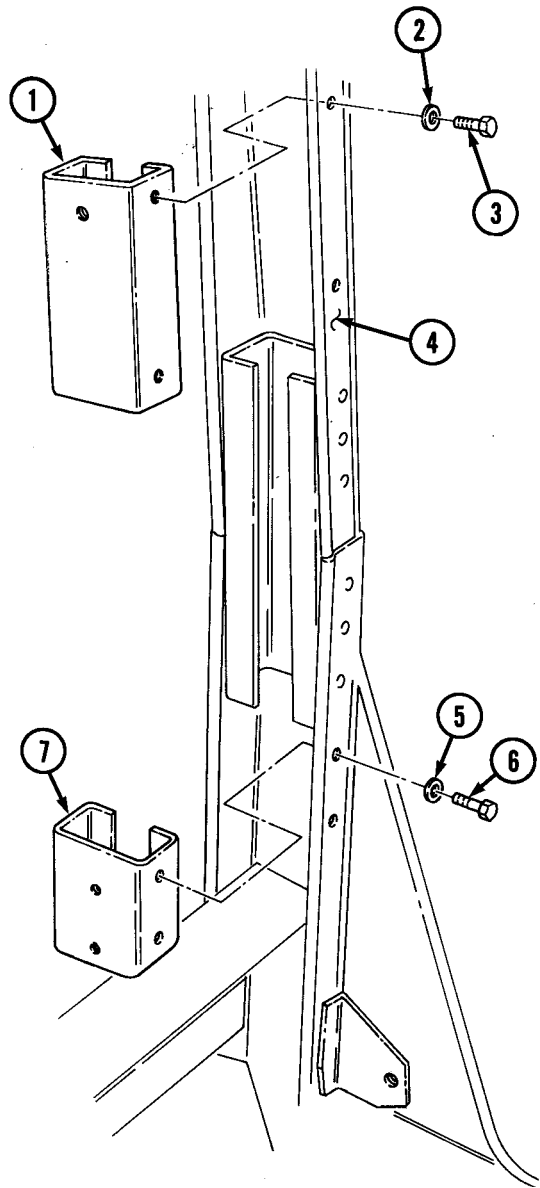

FOLLOW-ON TASK: Install three point seatbelt (para. 10-48).

10-49.1. THREE POINT SEATBELT BRACKETS REPLACEMENT (M996, M996A1, M997, M997A1, AND M997A2)

This task covers:

a. Removal

b. Installation

INITIAL SETUP:

Applicable Models

M996, M996A1, M997, M997A1, M997A2

Manual References

TM 9-2320-280-24P

Tools

General mechanic's tool kit:
automotive (Appendix B, Item 1)

Equipment Condition

Three point seatbelt removed (para. 10-48.1).

NOTE

Left and right seatbelt bracket replacement procedures are basically the same. This procedure covers the left seatbelt bracket.

a. Removal

1. Remove two nuts (6), capscrews (4) and (5), four washers (3), and bracket (2) from body (7) and "B" pillar (1).
2. Remove capscrew (11), washer (10), and bracket (8) from mount (9).

b. Installation

1. Install bracket (8) on mount (9) with washer (10) and capscrew (11). Tighten capscrew (11) to 90-95 lb-ft (122-129 N•m).
2. Install bracket (2) on body (7) and "B" pillar (1) with four washers (3), two capscrews (4) and (5), and nuts (6). Tighten capscrews (4) to 9-11 lb-ft (12-15 N•m) and capscrews (5) to 20-22 lb-ft (27-30 N•m).

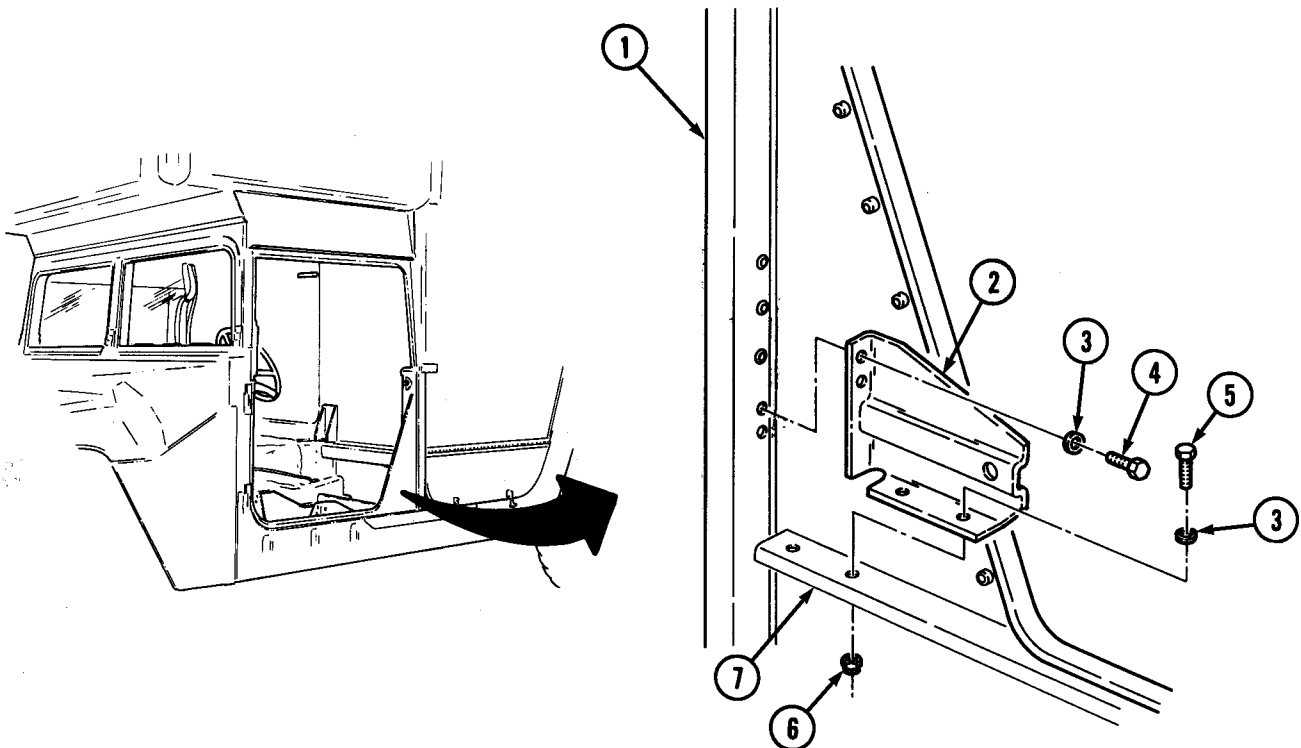

10-49.1. THREE POINT SEATBELT BRACKETS REPLACEMENT (M996, M996A1, M997, M997A1, AND M997A2) (Cont'd)

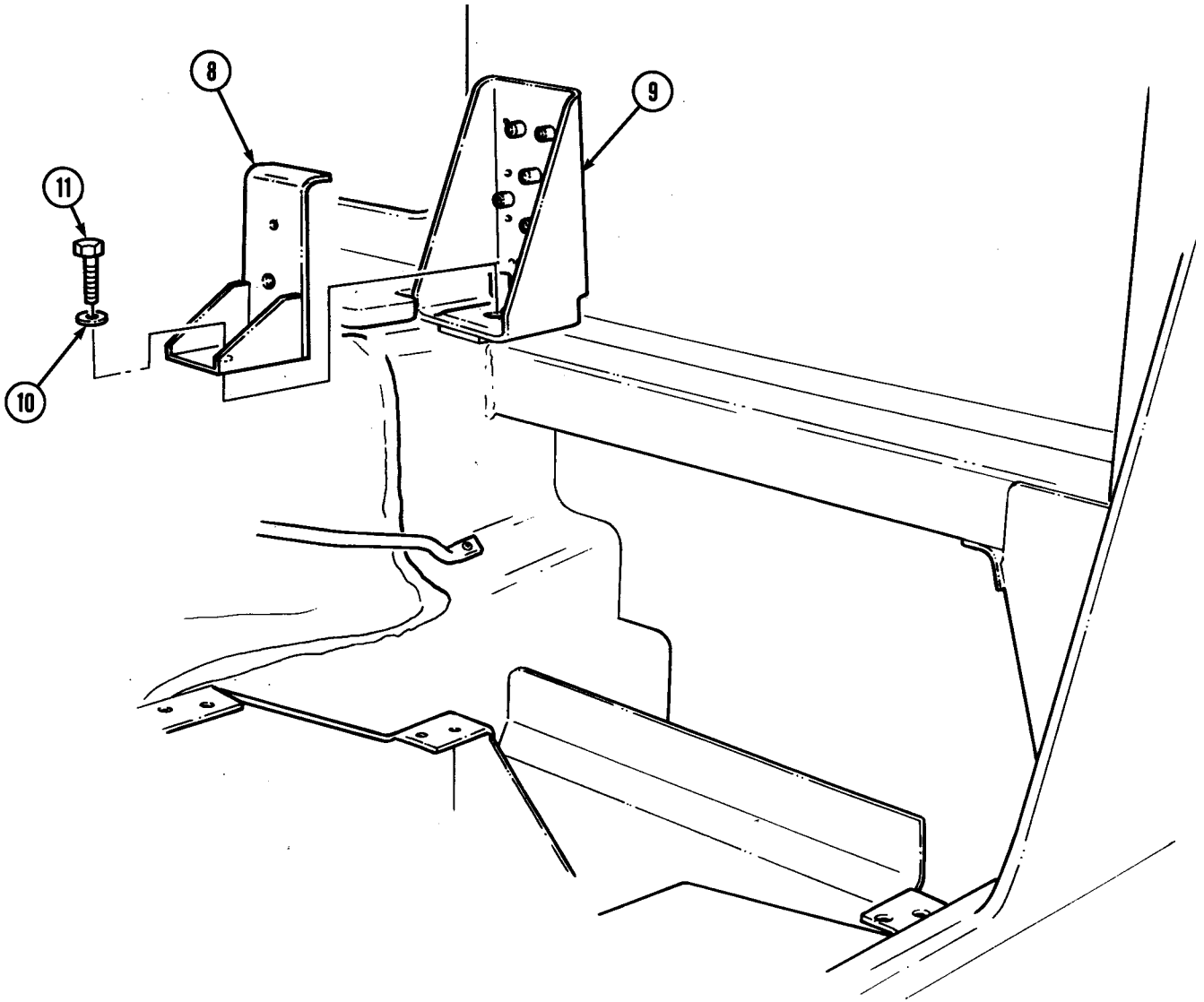

FOLLOW-ON TASK: Install three point seatbelt (para. 10-48.1).

10-50. PIONEER TOOL STOWAGE TRAY MAINTENANCE

This task covers:

a. Disassembly

b. Assembly

INITIAL SETUP:

Tools

General mechanic's tool kit:
automotive (Appendix B, Item 1)

Manual References

TM 9-2320-280-10
TM 9-2320-280-24P

Materials/Parts

Two lockwashers (Appendix G, Item 135)
Twelve lockwashers (Appendix G, Item 178)

Equipment Condition

Pioneer tool stowage tray removed
(TM 9-2320-280-10).

NOTE

- The procedures for disassembly and assembly of pioneer tool stowage trays for all vehicles are basically the same. The tray for M1037 and M1042 has tension latches mounted on angle brackets.
- Note position of straps for assembly.

a. Disassembly

1. Remove retainer (1) from pioneer tool stowage tray (14).
2. Remove eight nuts (5), lockwashers (4), screws (2), four footman loops (3), and two strap assemblies (6) from pioneer tool stowage tray (14). Discard lockwashers (4).
3. Remove two nuts (11), lockwashers (10), and two bumpers (13) from tool stowage tray (14). Discard lockwashers (10).
4. Remove four nuts (9), lockwashers (8), capscrews (12), and two latches (7) from pioneer tool stowage tray (14). Discard lockwashers (8).

b. Assembly

1. Install two latches (7) on pioneer tool stowage tray (14) with four capscrews (12), lockwashers (8), and nuts (9). Tighten nuts (9) to 16-30 lb-in. (2-3 N•m).
2. Install two bumpers (13) on pioneer tool stowage tray (14) with lockwashers (10) and nuts (11).
3. Install two strap assemblies (6) on pioneer tool stowage tray (14) with four footman loops (3), eight screws (2), lockwashers (4), and nuts (5). Tighten nuts (5) to 16-30 lb-in. (2-3 N•m).
4. Install retainer (1) on pioneer tool stowage tray (14).

10-50. PIONEER TOOL STOWAGE TRAY MAINTENANCE (Cont'd)

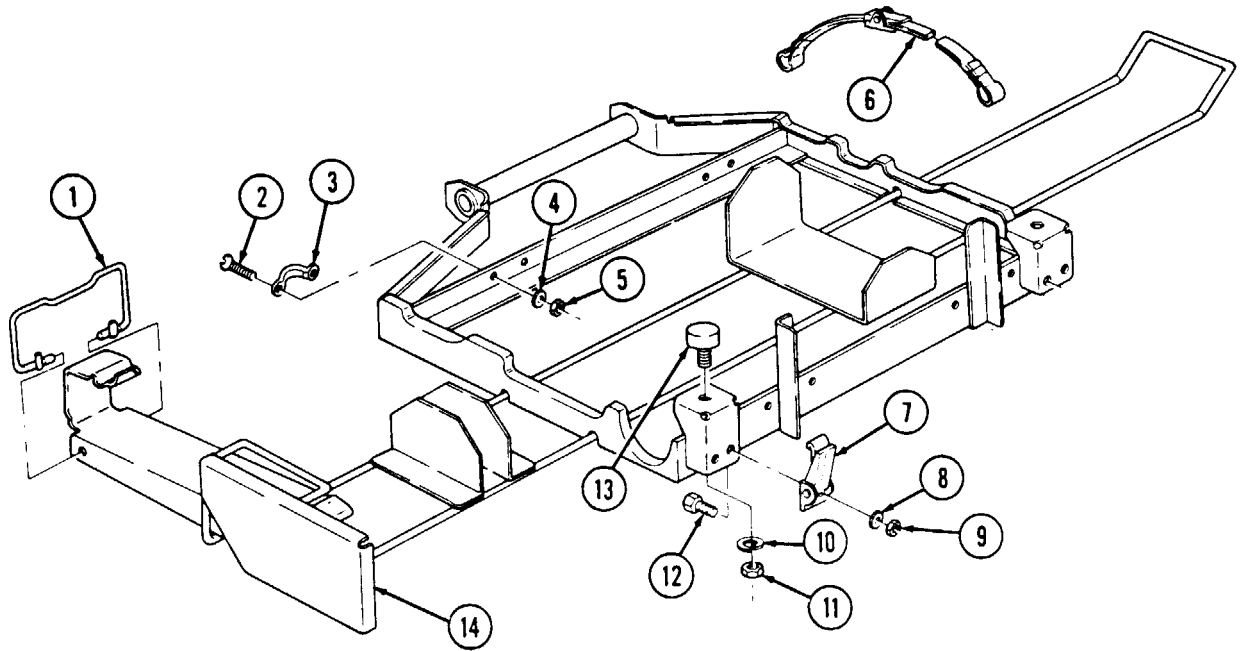

FOLLOW-ON TASK: Install pioneer tool stowage tray (TM 9-2320-280-10).

10-51. PIONEER TOOL STOWAGE TRAY MOUNTING BRACKET REPLACEMENT

This task covers:

a. Removal

b. Installation

INITIAL SETUP

Tools

General mechanic's tool kit:
automotive (Appendix B, Item 1)

Equipment Condition

Pioneer tool stowage tray removed
(TM 9-2320-280-10).

Manual References

TM 9-2320-280-10
TM 9-2320-280-24P

a. Removal

Remove two capscrews (2), washers (3), and mounting bracket (1) from rear crossmember (4).

b. Installation

Install bracket (1) on rear crossmember (4) with two washers (3) and capscrews (2). Tighten capscrews (2) to 37 lb-ft (50 N•m).

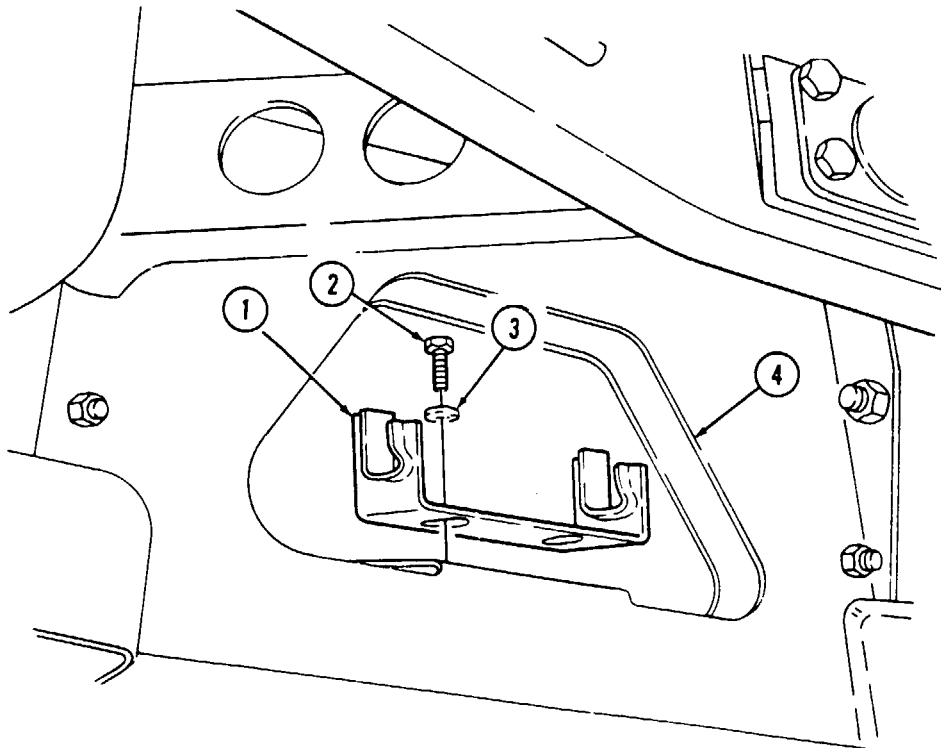

FOLLOW-ON TASK: Install pioneer tool stowage tray (TM 9-2320-280-10).

10-52. PIONEER TOOL STOWAGE TRAY LATCH STRIKER REPLACEMENT

This task covers:

a. Removal

b. Installation

INITIAL SETUP:

Tools

General mechanic's tool kit:
automotive (Appendix B, Item 1)

Manual References

TM 9-2320-280-10
TM 9-2320-280-24P

Materials/Parts

Two lockwashers (Appendix G, Item 178)

Equipment Condition

Pioneer tool stowage tray removed
(TM 9-2320-280-10).

a. Removal

Remove two nuts (5), lockwashers (4), capscrews (3), and tool tray latch striker (2) from frame (1). Discard lockwashers (4).

b. Installation

Install tool tray latch striker (2) on frame (1) with two capscrews (3), lockwashers (4), and nuts (5). Tighten nuts (5) to 16-30 lb-in. (2-3 N·m).

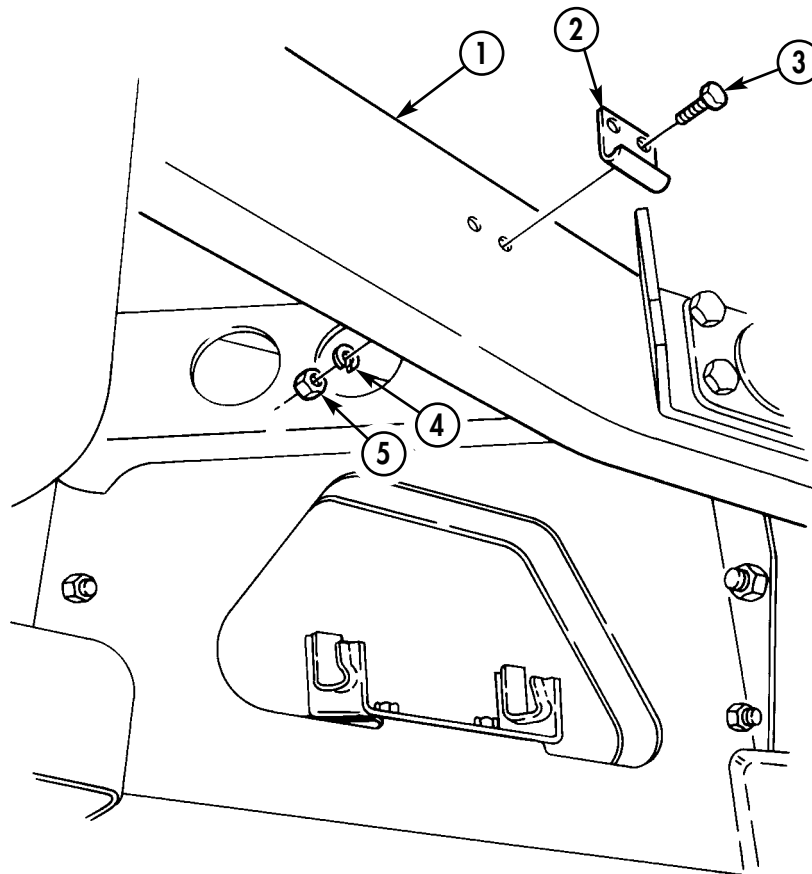

FOLLOW-ON TASK: Install pioneer tool stowage tray (TM 9-2320-280-10).

10-53. CARGO BULKHEAD REPLACEMENT

This task covers:

a. Removal

b. Installation

INITIAL SETUP:

Applicable Models

M998, M998A1, M1038, M1038A1, M1097, M1097A1, M1097A2

Materials/Parts

Four lockwashers (Appendix G, Item 152)

Tools

General mechanic's tool kit:
automotive (Appendix B, Item 1)

Manual References

TM 9-2320-280-24P

a. Removal

1. Remove two capscrews (7), lockwashers (8), washers (9), and cargo bulkhead bracket (10) from cargo floor (11). Discard lockwashers (8).
2. Remove two nuts (1), lockwashers (2), washers (3), capscrews (5), and washers (3) from cargo bulkhead (6) and "B" pillar (4). Discard lockwashers (2).
3. Remove cargo bulkhead (6) from vehicle.
4. Inspect anti-noise pads (12) for damage. Replace if damaged.

b. Installation

1. Install cargo bulkhead (6) on cargo floor (11).
2. Install cargo bulkhead (6) on "B" pillar (4) with two washers (3), capscrews (5), washers (3), lockwashers (2), and nuts (1).
3. Install cargo bulkhead bracket (10) on cargo floor (11) with two washers (9), lockwashers (8), and capscrews (7). Tighten capscrews (7) to 65 lb-ft (88 N·m).
4. Tighten nuts (1) to 15 lb-ft (20 N·m).

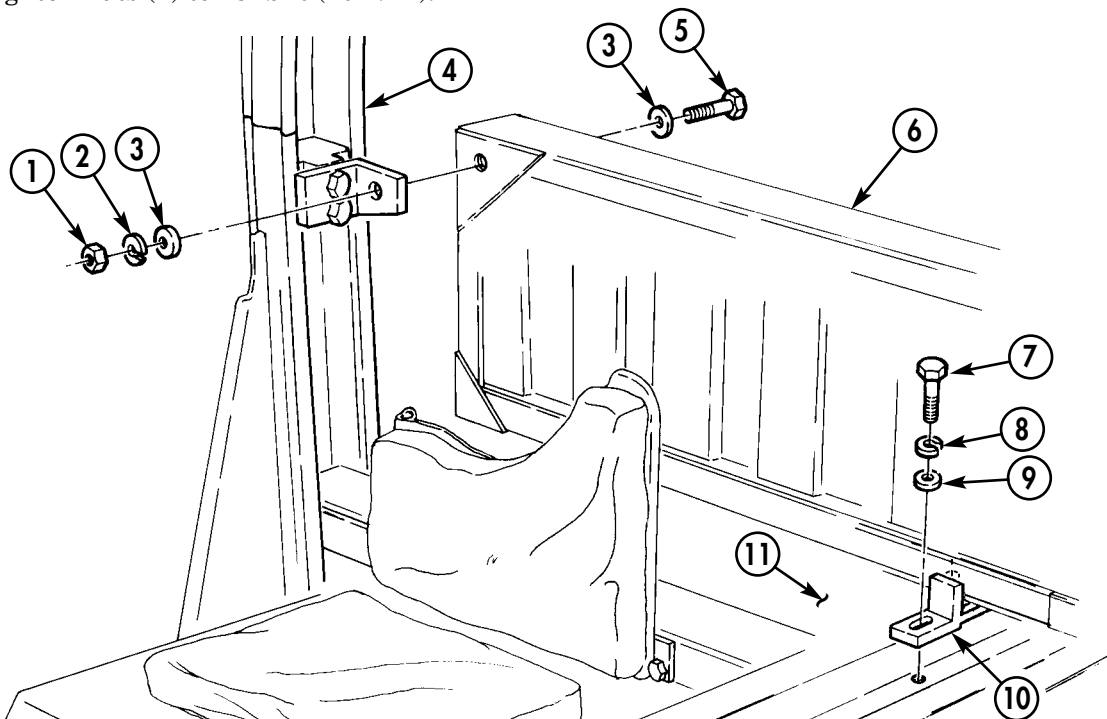

10-54. CARGO BULKHEAD MOUNTING BRACKETS REPLACEMENT

This task covers:

a. Removal

b. Installation

INITIAL SETUP:

Applicable Models

M998, M998A1, M1038, M1038A1, M1097,
M1097A1, M1097A2

Manual References

TM 9-2320-280-24P

Tools

General mechanic's tool kit:
automotive (Appendix B, Item 1)

Equipment Condition

Cargo bulkhead removed (para. 10-53).

a. Removal

1. Remove nut (6), washer (7), capscrew (10), washer (7), cargo bracket (9), and tiedown (8) from cargo floor (5).

NOTE

Note position of latch on "B" pillar for installation.

2. Remove two capscrews (4), latch (3), and latch retainer (2) from "B" pillar (1).

b. Installation

1. Install latch (3) and latch retainer (2) on "B" pillar (1) with two capscrews (4). Tighten capscrews (4) to 6 lb-ft (8 N•m)
2. Install tiedown (8) and bracket (9) on cargo floor (5) with washer (7), capscrew (10), washer (7), and nut (6). Tighten capscrews (10) to 26 lb-ft (35 N•m).

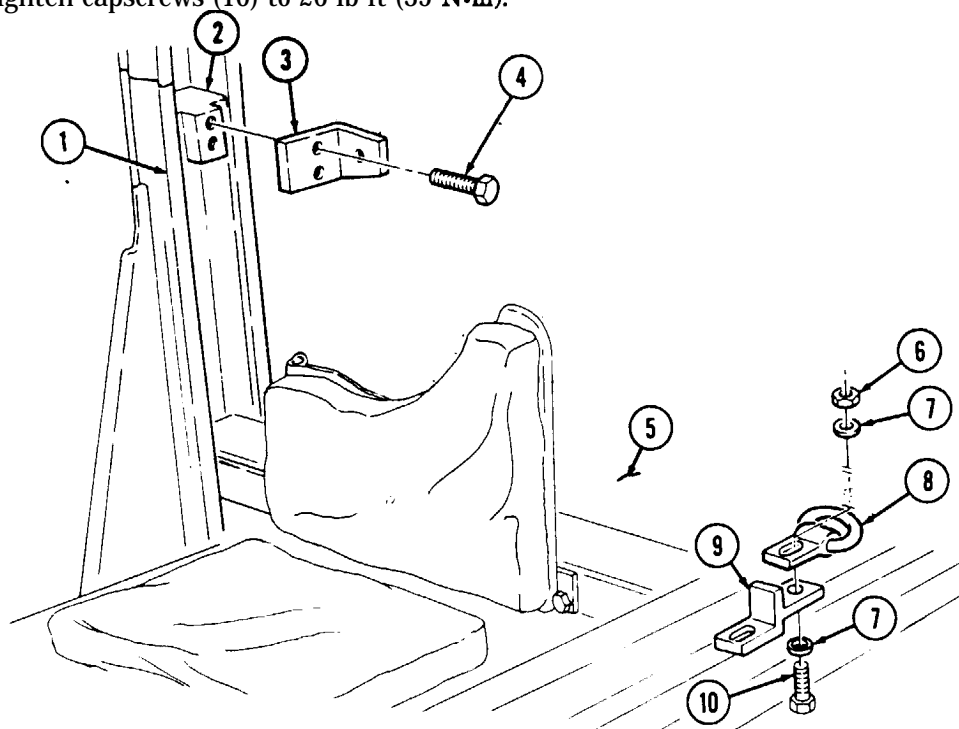

FOLLOW-ON TASK: Install cargo bulkhead (para. 10-53).

10-55. CARGO BARRIER EXTENSION MAINTENANCE

This task covers:

- | | |
|--|--|
| <ul style="list-style-type: none"> a. Removal b. Disassembly | <ul style="list-style-type: none"> c. Assembly d. Installation |
|--|--|

INITIAL SETUP:

Applicable Models

M998, M998A1, M1038, M1038A1, M1097, M1097A1, M1097A2

Tools

General mechanic's tool kit:
automotive (Appendix B, Item 1)

Materials/Parts

Eight locknuts (Appendix G, Item 86)

Manual References

TM 9-2320-280-24P

a. Removal

Remove quick release pin (12) from post assembly (4) and remove cargo barrier extension (5) from cargo bulkhead (13).

b. Disassembly

1. Remove screw (6) and lanyard (7) from post assembly (4).
2. Remove twenty-four screws (1), nut and washer assemblies (3), and three backboards (2) from four post assemblies (4).
3. Remove eight locknuts (11), washers (9), capscrews (8), washers (9), and four mounting brackets (10) from cargo bulkhead (13). Discard locknuts (11).

c. Assembly

1. Install lanyard (7) on post assembly (4) with screw (6).
2. Install three backboards (2) on post four assemblies (4) with twenty-four screws (1) and nut and washer assemblies (3).
3. Install four mounting brackets (10) on cargo bulkhead (13) with eight washers (9), capscrews (8), washers (9), and locknuts (11).

d. Installation

NOTE

When installing cargo barrier extension, ensure side rack pins on post assemblies slide into holes of cargo bulkhead.

Install cargo barrier extension (5) to cargo bulkhead (13) with quick release pin (12).

10-55. CARGO BARRIER EXTENSION MAINTENANCE (Cont'd)

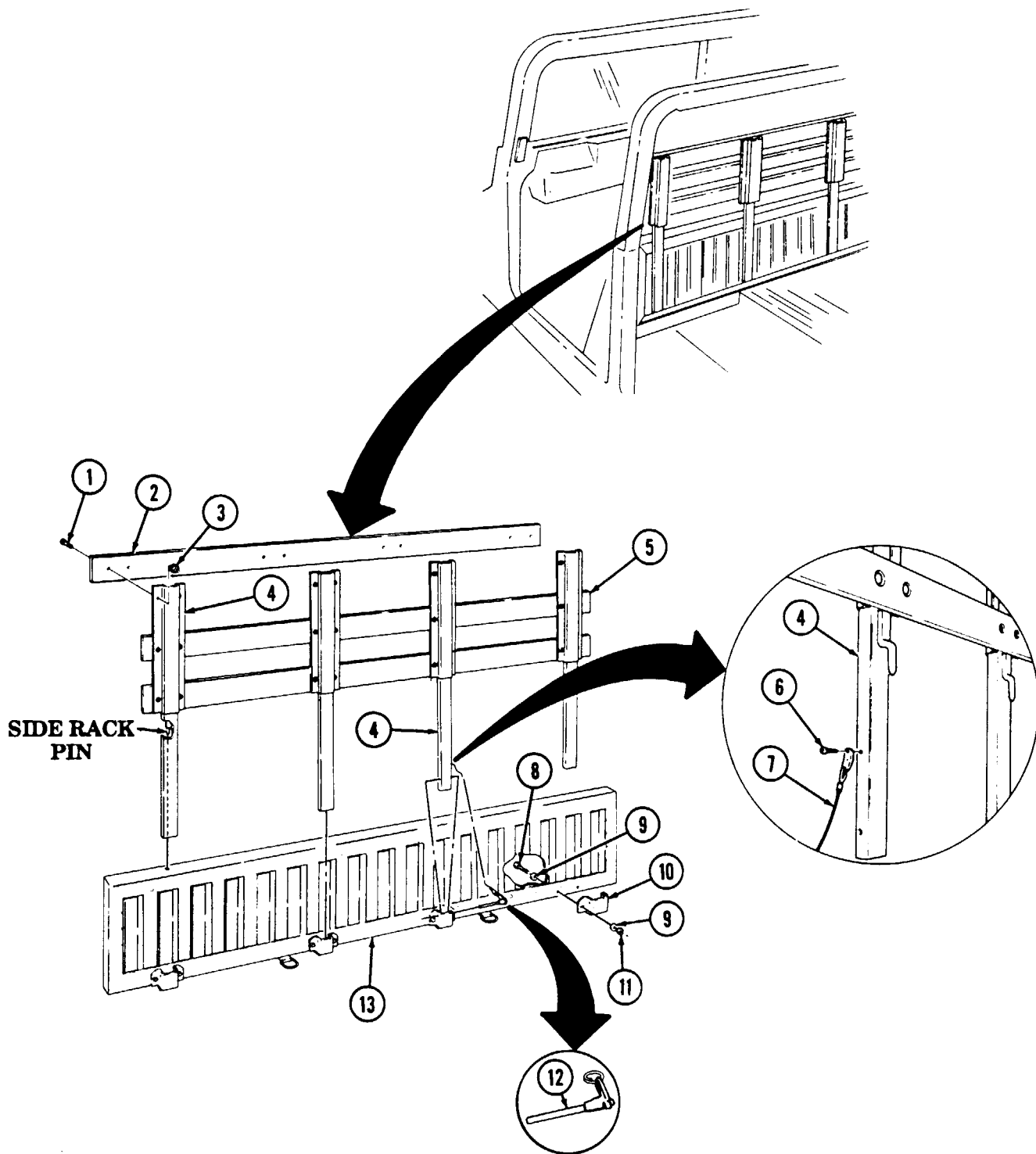

10-56. CARGO TIEDOWN REPLACEMENT

This task covers:

a. Removal

b. Installation

INITIAL SETUP:

Applicable Models

All except M996, M996A1, M997, M997A1, M997A2, M1037, M1042

Tools

General mechanic's tool kit:
automotive (Appendix B, Item 1)

Materials/Parts

Locknut (Appendix G, Item 79)

Manual References

TM 9-2320-280-24P

Personnel Required

One mechanic
One assistant

a. Removal

NOTE

- For removal of rear cargo tiedown, one assistant will be needed.
- Early production vehicles will have a capscrew in place of a hex head screw.

1. Remove hex head screw (1) and front cargo tiedown (2) from cargo floor (3).
2. Remove locknut (7), washer (6), hex head screw (4), and rear cargo tiedown (5) from cargo floor (3). Discard locknut (7).

b. Installation

NOTE

For installation of rear cargo tiedown, one assistant will be needed.

1. Install front cargo tiedown (2) on cargo floor (3) with hex head screw (1). Tighten hex head screw (1) to 65 lb-ft (88 N·m).
2. Install rear cargo tiedown (5) on cargo floor (3) with hex head screw (4), washer (6), and locknut (7). Tighten locknut (7) to 65 lb-ft (88 N·m).

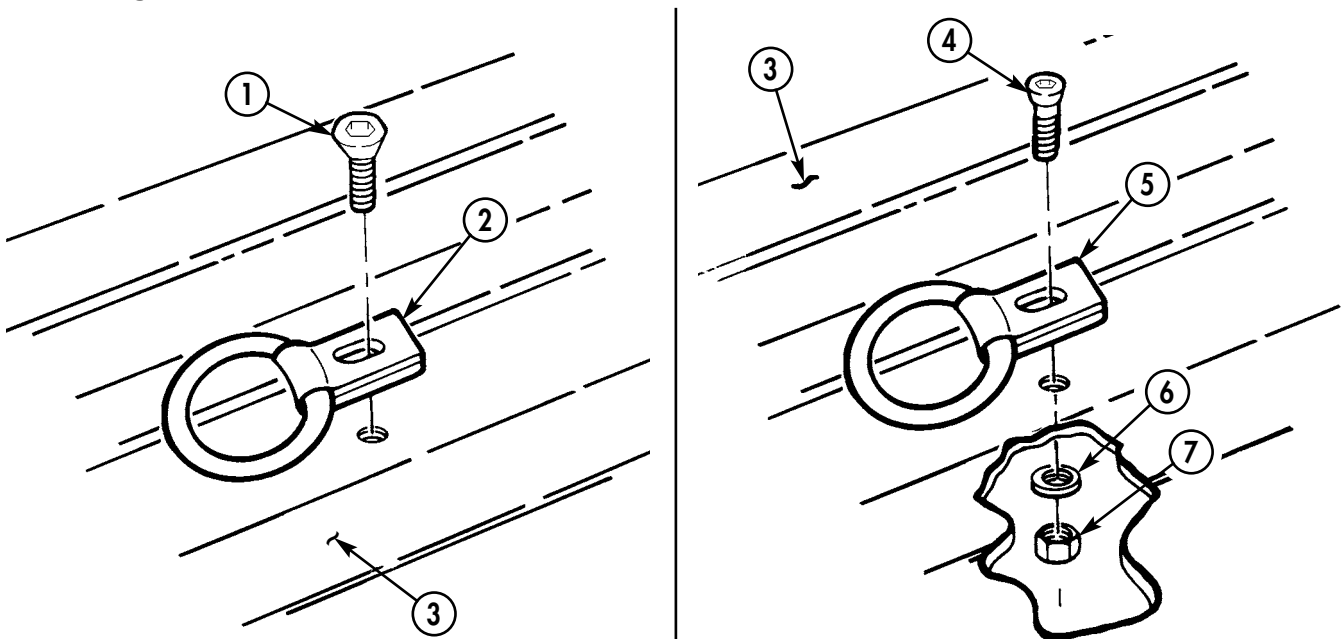

10-57. FIRE EXTINGUISHER BRACKET REPLACEMENT

This task covers:

a. Removal

b. Installation

INITIAL SETUP:

Tools

General mechanic's tool kit:
automotive (Appendix B, Item 1)

Manual References

TM 9-2320-280-24P

Materials/Parts

Four locknuts (Appendix G, Item 70)

NOTE

M1097A1, M1097A2, and M1123 models fire extinguisher bracket and retainer plate is mounted on the floor, left side of driver's seat, with capscrews securing retainer plate instead of wing head studs.

a. Removal

1. Turn two wing head studs (4) and remove driver's seat base retainer plate (7) from driver's seat base (3).
2. Remove four locknuts (1), washers (2), capscrews (6), washers (2), and fire extinguisher bracket (5) from driver's seat base retainer plate (7). Discard locknuts (1).

b. Installation

1. Install fire extinguisher bracket (5) on driver's seat base retainer plate (7) with four washers (2), capscrews (6), washers (2), and locknuts (1). Tighten locknuts (1) to 6 lb-ft (8 N·m).
2. Install driver's seat base retainer plate (7) on driver's seat base (3) with two wing head studs (4).

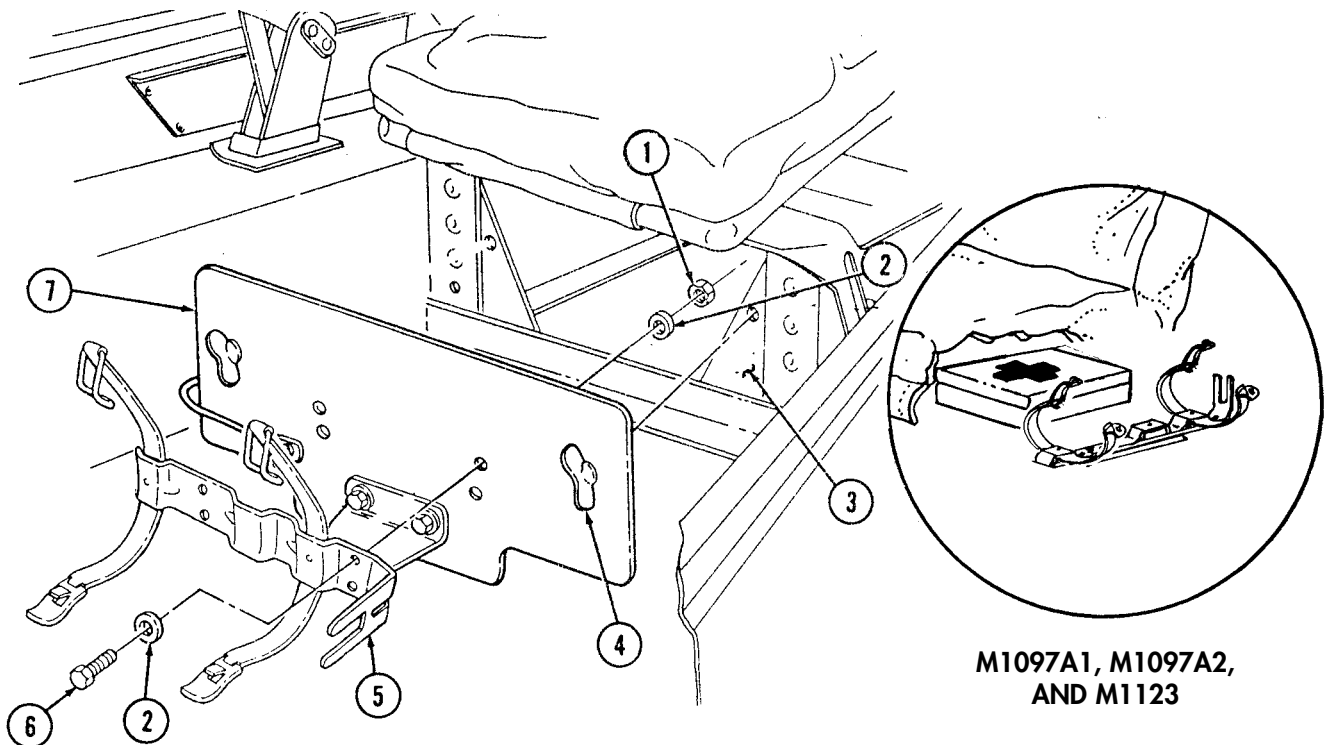

10-58. FIRE EXTINGUISHER SUPPORT REPLACEMENT

This task covers:

- a. Removal
- b. Installation

INITIAL SETUP:

Applicable Models

M966, M996, M997, M998, M1025, M1026,
M1035, M1036, M1037, M1038, M1042,
M1043, M1044, M1045, M1046

Manual References

TM 9-2320-280-24P

Equipment Condition

Fire extinguisher bracket removed (para. 10-57).

Tools

General mechanic's tool kit
automotive (Appendix B, Item 1)

a. Removal

Remove two nuts (4), washers (3), capscrews (1), washers (6), and fire extinguisher support (2) from driver's seat base retainer plate (5).

b. Installation

Install the extinguisher support (2) on driver's seat base retainer plate (5) with two washers (6), capscrews (1), washers (3), and nuts (4). Tighten nuts (4) to 21 lb-in. (2 N•m).

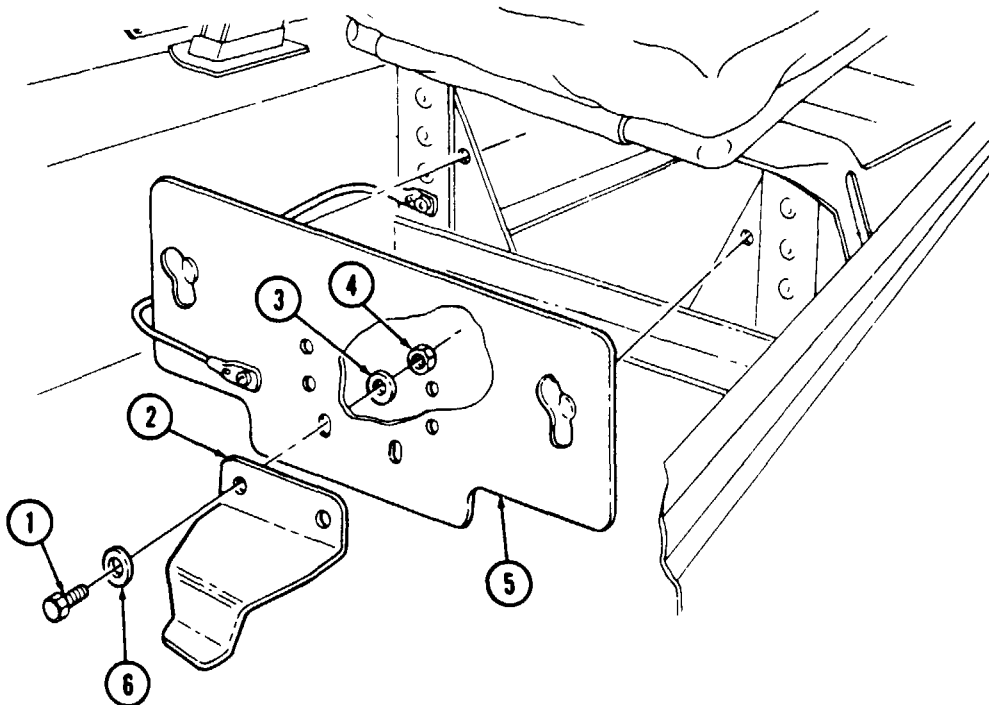

FOLLOW-ON TASK: Install fire extinguisher bracket (para. 10-57).

10-59. DRIVER'S SEAT RETAINER PLATE ASSEMBLY REPLACEMENT

This task covers:

a. Removal

b. Installation

INITIAL SETUP:

Applicable Models

M966, M996, M997, M998, M1025, M1026,
M1035, M1036, M1037, M1038, M1042,
M1043, M1044, M1045, M1046

Manual References

TM 9-2320-280-24P

Equipment Condition

Fire extinguisher support removed (para. 10-58).

Tools

General mechanic's tool kit:
automotive (Appendix B, Item 1)

Materials/Parts

Rivet (Appendix G, Item 253)

NOTE

For instructions on replacement of rivets, refer to para. 10-66.

a. Removal

Remove rivet (3) and retaining cable (2) from seat base (1) and remove driver's seat base retainer plate (4) and retaining cable (2).

b. Installation

Install driver's seat base retainer plate (4) and retaining cable (2) on driver's seat base (1) with rivet (3).

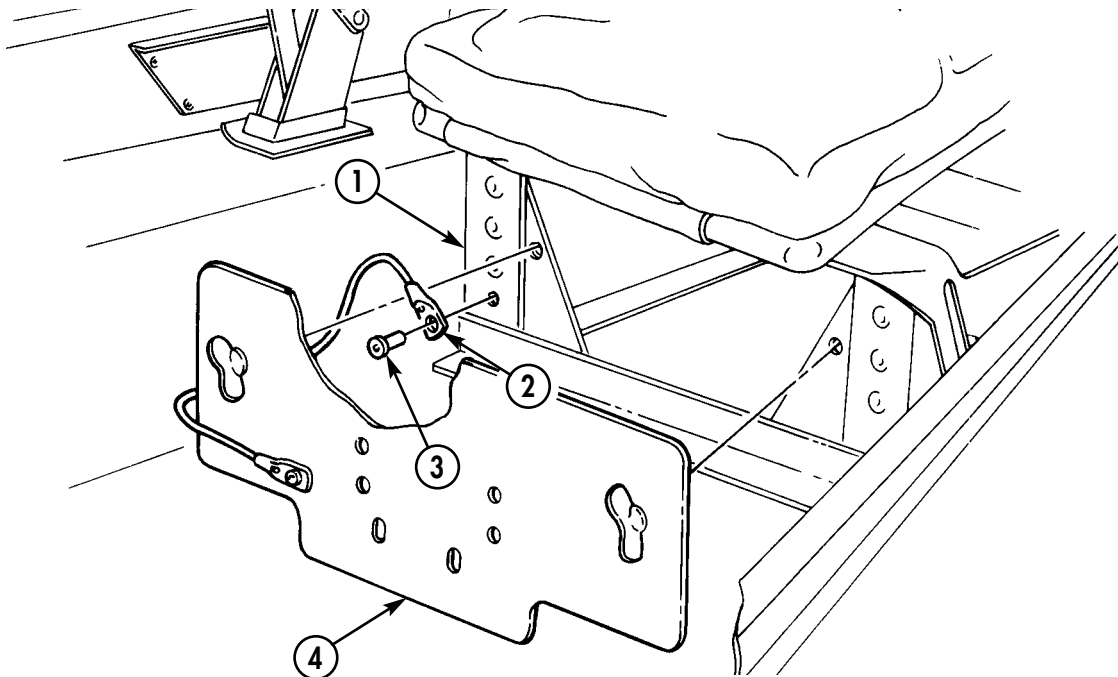

FOLLOW-ON TASK: Install fire extinguisher support (para. 10-58).

10-60. TAILGATE CHAIN AND BRACKETS REPLACEMENT

This task covers:

a. Removal

b. Installation

INITIAL SETUP:

Applicable Models

All models except M996, M996A1, M997, M997A1, M997A2

Manual References

TM 9-2320-280-10
TM 9-2320-280-24P

Tools

General mechanic's tool kit:
automotive (Appendix B, Item 1)

Equipment Condition

Tailgate lowered (TM 9-2320-280-10).

Materials/Parts

Four locknuts (Appendix G, Item 79)

a. Removal

1. Open tailgate chain cap link (6) and disconnect tailgate chain (7) from bracket (9).
2. Unhook tailgate chain (7) from tailgate chain bracket (4) and remove tailgate chain (7).
3. Remove four locknuts (1), washers (2), capscrews (5), washers (2), angle bracket (10), chain bracket (9), and latch bracket (4) from body (3). Discard locknuts (1).

NOTE

Perform step 4 only if tailgate chain cover is damaged.

4. Remove cover (8) from tailgate chain (7).

b. Installation

NOTE

Perform step 1 only if tailgate chain cover was removed.

1. Install cover (8) on tailgate chain (7).
2. Install angle bracket (10), chain bracket (9), and latch bracket (4) on body (3) with four washers (2), capscrews (5), washers (2), and locknuts (1). Tighten locknuts (1) to 15 lb-ft (20 N.m).
3. Hook tailgate chain (7) to tailgate chain bracket (4).
4. Connect tailgate chain cap link (6) to bracket (9) by closing chain cap link (6).

10-60. TAILGATE CHAIN AND BRACKETS REPLACEMENT (Cont'd)

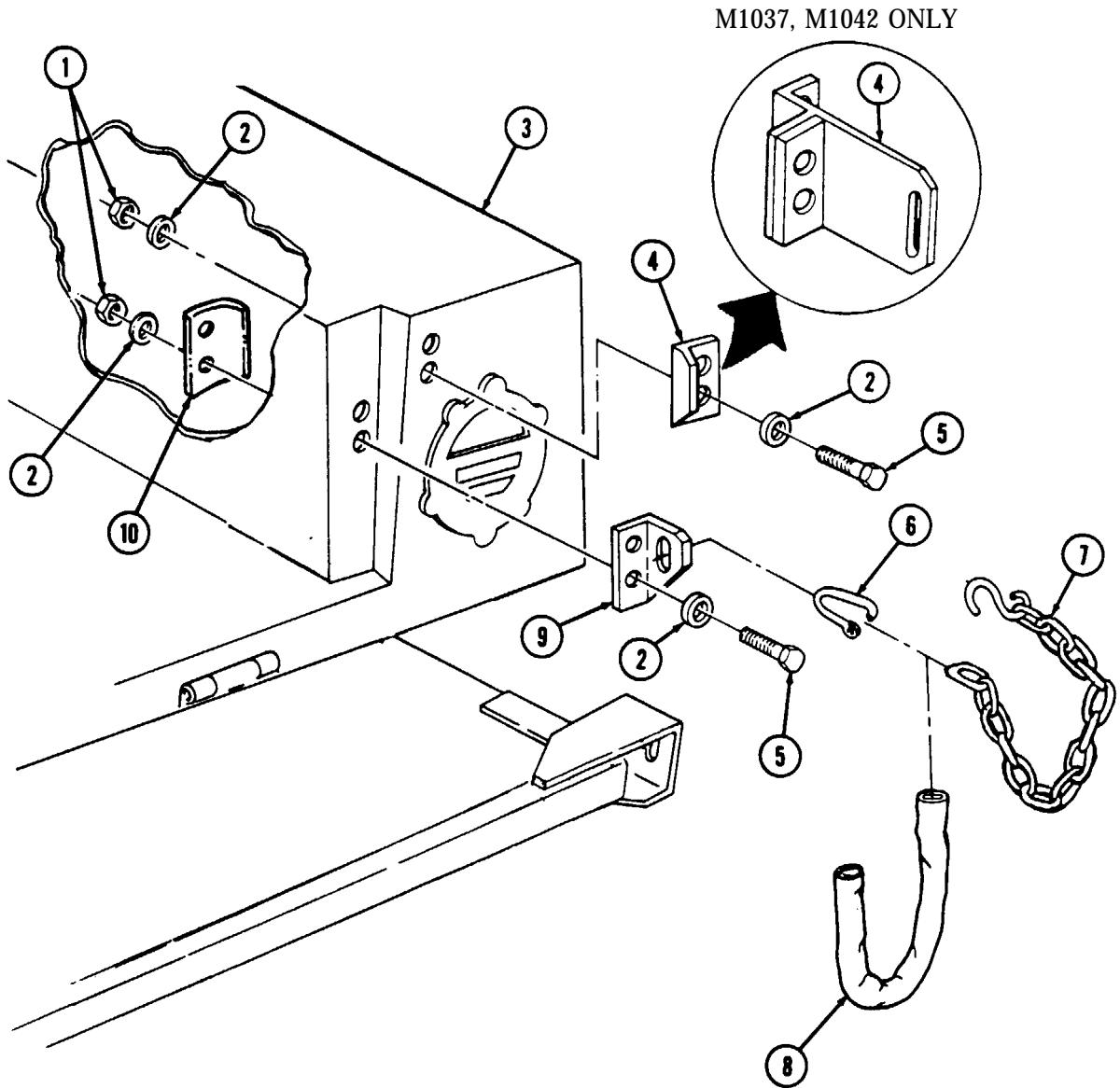

FOLLOW-ON TASK: Raise and secure tailgate (TM-9-2320-280-10).

10-61. TAILGATE REPLACEMENT

This task covers:

a. Removal

b. Installation

INITIAL SETUP:

Applicable Models

All models except M996, M996A1, M997, M997A1, M997A2, M1037, M1042

Tools

General mechanic's tool kit:
automotive (Appendix B, Item 1)

Materials/Parts

Six locknuts (Appendix G, Item 128)

Personnel Required

One mechanic
One assistant

Manual References

TM 9-2320-280-24P

Equipment Condition

M1025, M1025A1, M1025A2, M1026, M1026A1, M1036, M1043, M1043A1, M1043A2, M1044, M1044A1, M1045, M1045A1, M1045A2, M1046, and M1046A1 only:
Camouflage pack stowage straps removed (para. 10-9).

a. Removal

1. Remove six locknuts (10), washers (9), and capscrews (7) from tailgate (3) and body (2). Discard locknuts (10).
2. Disconnect two tailgate chains (1) from tailgate (3) and remove tailgate (3) and shims (8).

NOTE

- Perform step 3 if replacing seal(s).
- Seal across bottom of tailgate is used on TOW and armament carrier vehicles only.
- Vehicles equipped with tailgate upper hinge kit, P/N 12342446 will have a three-piece seal.

3. Remove seals (4) and (6) from tailgate (3).
4. Clean adhesive from tailgate (3).

b. Installation

NOTE

- Perform step 1 if replacing seal(s).
- Seal across bottom of tailgate is used on TOW and armament carrier vehicles only.
- Vehicles equipped with tailgate upper hinge kit, P/N 12342446, will have a three-piece seal.

1. Peel paper backing (5) from seals (4) and (6) and install seals (4) and (6) on tailgate (3).
2. Install shims (8) and tailgate (3) on body (2) with six capscrews (7), washers (9), and locknuts (10). Tighten locknuts (10) to 26 lb-ft (35 N•m).
3. Connect two tailgate chains (1) to tailgate (3).

10-61. TAILGATE REPLACEMENT (Cont'd)

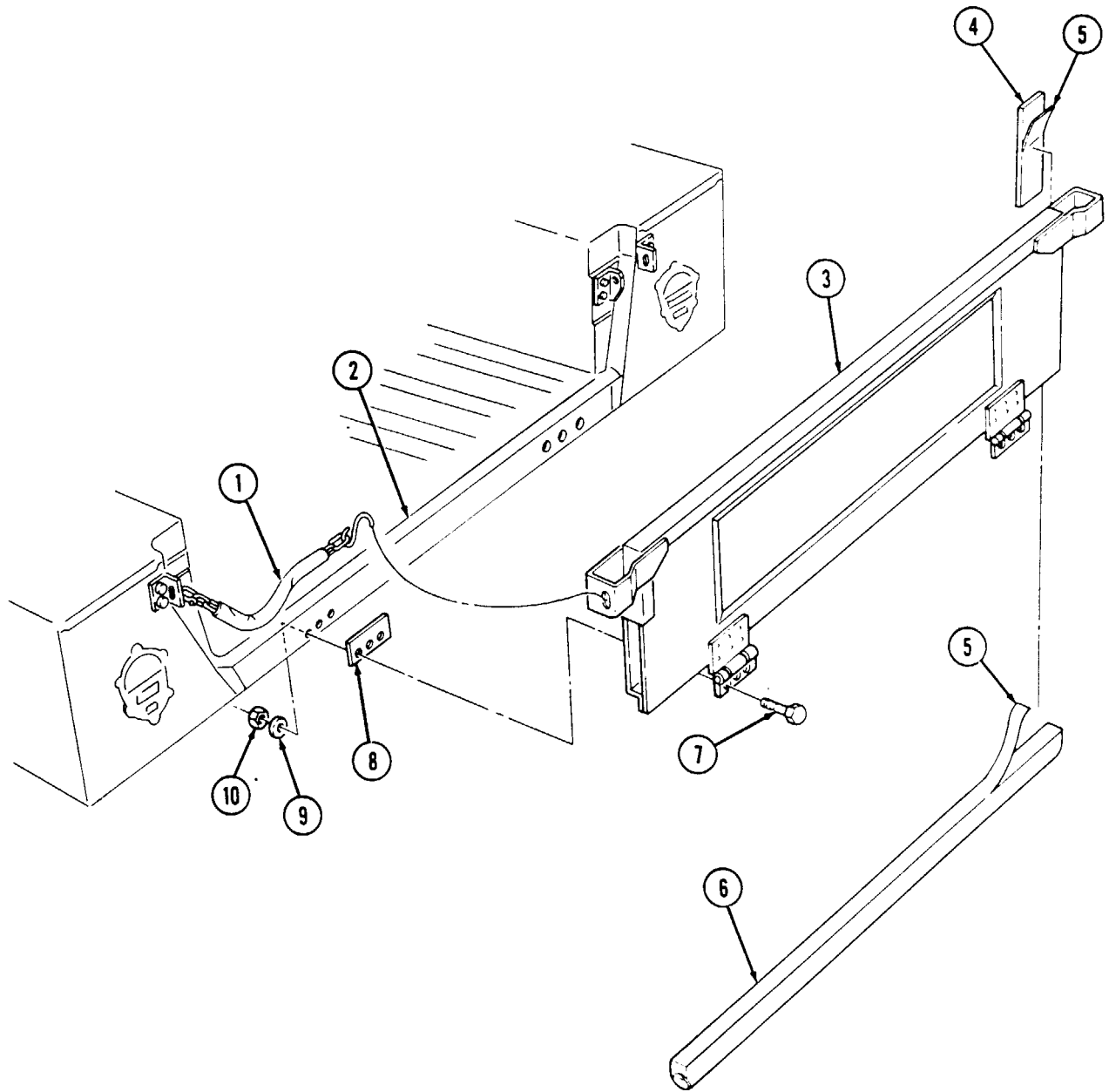

FOLLOW-ON TASK: M1025, M1025A1, M1025A2, M1026, M1026A1, M1036, M1043, M1043A1, M1043A2, M1044, M1044A1, M1045, M1045A1, M1045A2, M1046, and M1046A1 only
 Install camouflage pack stowage straps (para. 10-9).

10-62. TAILGATE UPPER HINGE REPLACEMENT

This task covers:

a. Removal

b. Installation

INITIAL SETUP:

Applicable Models

All models except M996, M996A1, M997, M997A1, M997A2, M1037, M1042

Tools

General mechanic's tool kit:
automotive (Appendix B, Item 1)

Materials/Parts

Eight locknuts (Appendix G, Item 122)

Personnel Required

One mechanic
One assistant

Manual References

TM 9-2320-280-24P

Equipment Condition

Tailgate removed (para. 10-61).

a. Removal

NOTE

- Left and right tailgate upper hinge replacement procedures are basically the same. This procedure covers the left tailgate upper hinge.
 - Seal across bottom of tailgate is used on TOW and armament carrier vehicles only. For access to capscrews, a small portion of the seal has to be removed.
 - The upper hinge is installed with rivets during manufacturing. A kit has been developed to repair the upper hinge. Use kit P/N 57K0107 for installation.
1. Remove seal (10) from tailgate (6) behind upper hinge (7).

NOTE

- Perform step 2 for TOW and armament carrier vehicles only. Perform step 3 for all other vehicles.
 - Note direction of capscrews for installation.
2. Remove two locknuts (8), washers (4), spacers (5), capscrews (3), and washers (4) from upper hinge (7) and tailgate (6). Discard locknuts (8).
 3. Remove three locknuts (8), washers (4), spacers (5), capscrews (3), and washers (4) from upper hinge (7) and tailgate (6). Discard locknuts (8).
 4. Remove three locknuts (9), washers (1), capscrews (2), washers (1), and upper hinge (7) from tailgate (6). Discard locknuts (9).
 5. Remove pin (12) and lower hinge (11) from upper hinge (7).

b. Installation

1. Install lower hinge (11) on upper hinge (7) with pin (12).
2. Install upper hinge (7) on tailgate (6) with three washers (1), capscrews (2), washers (1), and locknuts (9). Tighten locknuts (9) to 8 lb-ft (11 N•m).

NOTE

Perform step 3 for TOW and armament carrier vehicles only.
Perform step 4 for all other vehicles.

3. Secure upper hinge (7) to tailgate (6) with two washers (4), capscrews (3), spacers (5), washers (4), and locknuts (8). Tighten locknuts (8) to 8 lb-ft (11 N•m).

10-62. TAILGATE UPPER HINGE REPLACEMENT (Cont'd)

4. Secure upper hinge (7) to tailgate (6) with three washers (4), capscrews (3), spacers (5), washers (4), and locknuts (8). Tighten locknuts (8) to 8 lb-ft (11 N·m).
5. Install seal (10) on tailgate (6) behind upper hinge (7).

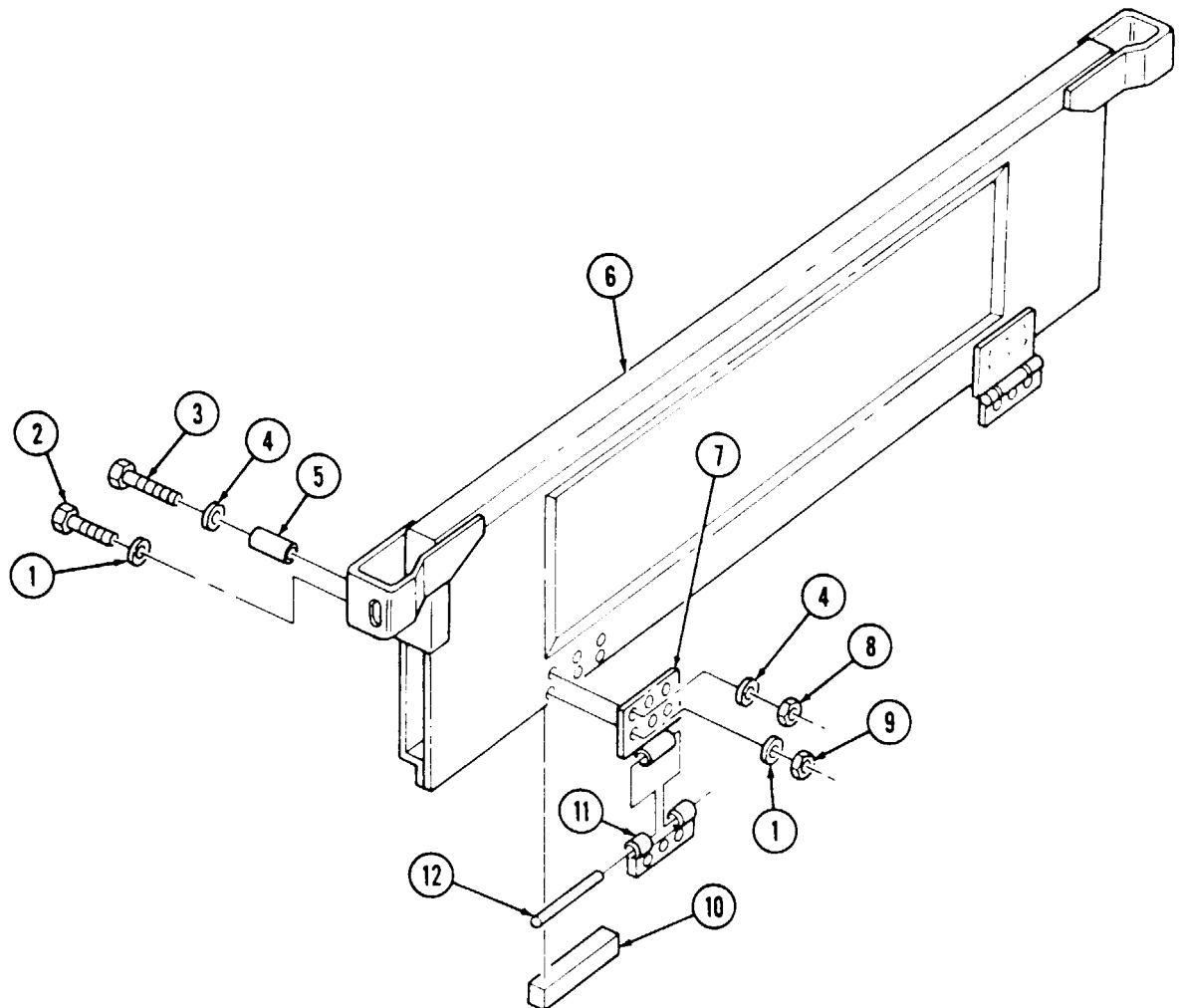

FOLLOW-ON TASK: Install tailgate (para. 10-61).

10-63. MUD FLAP INSTALLATION

This task covers:

Installation

INITIAL SETUP:

Tools

General mechanic's tool kit:
automotive (Appendix B, Item 1)

Manual References

TM 9-2320-280-24P

Installation

NOTE

Mud flap installation will prevent stones thrown by tires from hitting other vehicles. Installation is at commander's discretion. Refer to appendix D, Fig. D-88.

1. Remove two capscrews (4) and washers (3) from shield (5) and body (1).
2. Install mud flap assembly (2) on shield (5) and body (1) with two washers (3) and capscrews (4).
3. Repeat steps 1 and 2 for opposite side.

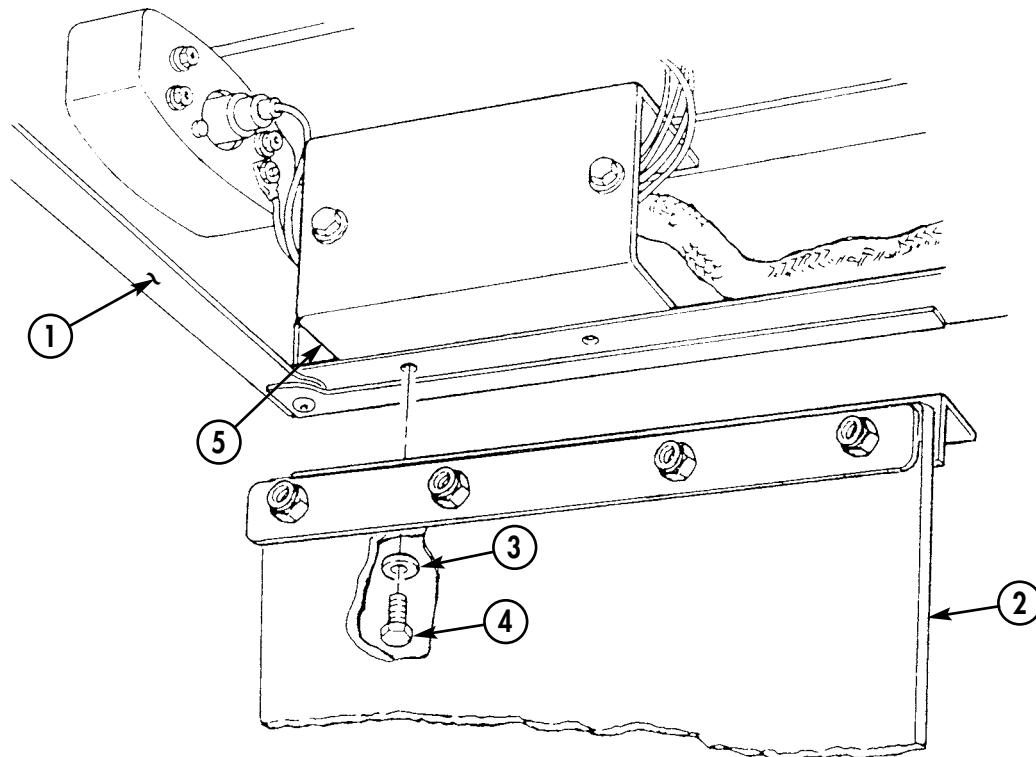

10-64. BODY HINGE MOUNT REPLACEMENT

This task covers:

a Removal

b. Installation

INITIAL SETUP:

Tools

General mechanic's tool kit:
automotive (Appendix B, Item 1)

Manual References

TM 9-2320-280-10
TM 9-2320-280-24P

Equipment Condition

M998, M998A1, M1035, M1035A1, M1035A2,
M1037, M1038, M1038A1, M1042 only:
• Soft top door removed (TM 9-2320-280-10).
M966, M966A1, M996, M996A1, M1025, M1025A1,
M1025A2, M1026, M1026A1, M1043, M1043A1,
M1043A2, M1044, M1044A1, M1045, M1045A1,
M1045A2, M1046 and M1046A1 only
• Ballistic crew door removed (para. 11-2).

a. Removal

NOTE

Perform step 1 for upper front body hinge removal.

1. Remove two nuts (1), washers (2), twelve-point screws (5), washers (4), and upper front body hinge mount (3) from body (6).

NOTE

Perform step 2 for lower front body hinge removal.

2. Remove two twelve-point screws (9), washers (8), and lower front body hinge mount (7) from body (6).

b. Installation

NOTE

Perform step 1 for lower and rear body hinge mount installation.

1. Install lower body hinge mount (7) on body (6) with two washers (8) and twelve-point screw (9). Tighten twelve-point screws (9) to 8 lb-ft (11 N•m).

NOTE

Perform step 2 for upper front body hinge installation.

2. Install upper body hinge mount (3) on body (6) with two washers (4), twelve-point screws (5), washers (2), and nuts (1). Tighten twelve-point screws (5) to 8 lb-ft (11 N•m).

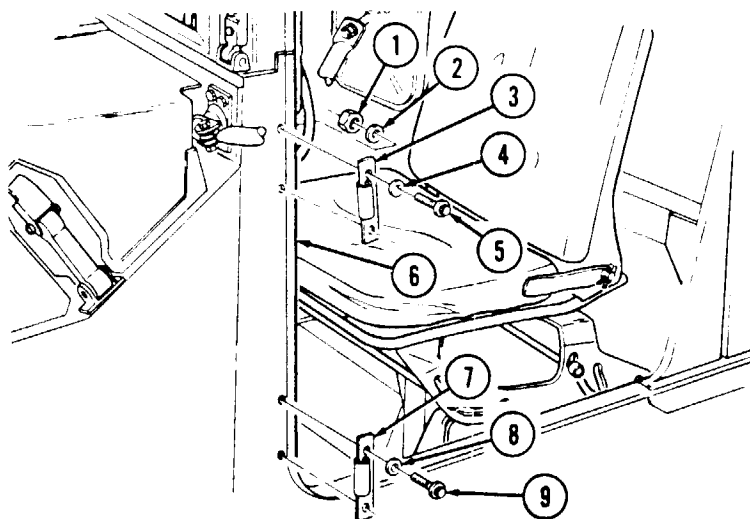

FOLLOW-ON TASKS: M998, M998A1, M1035, M1035A1, M1035A2, M1037, M1038, M1038A1, M1042 only
 • Install soft top door (TM 9-2320-280-10).
 M966, M966A1, M996, M996A1, M1025, M1025A1, M1025A2, M1026, M1026A1,
 M1043, M1043A1, M1043A2, M1044, M1044A1, M1045, M1045A1, M1045A2,
 M1046 and M1046A1 only:
 • Install ballistic crew door (para. 11-2).
 • Adjust soft top door (para. 10-102).

10-65. AIRLIFT BRACKET TO HOOD SEAL REPLACEMENT

This task covers:

a. Removal

b. Installation

INITIAL SETUP:

Tools

General mechanic's tool kit
automotive (Appendix B, Item 1)

Equipment Condition

Hood raised and secured (TM 9-2320-280-10).

Manual References

TM 9-2320-280-10
TM 9-2320-280-24P

a. Removal

Remove protector (1) and seal (2) from airlift bracket (3).

b. Installation

Install seal (2) and protector (1) on airlift bracket (3).

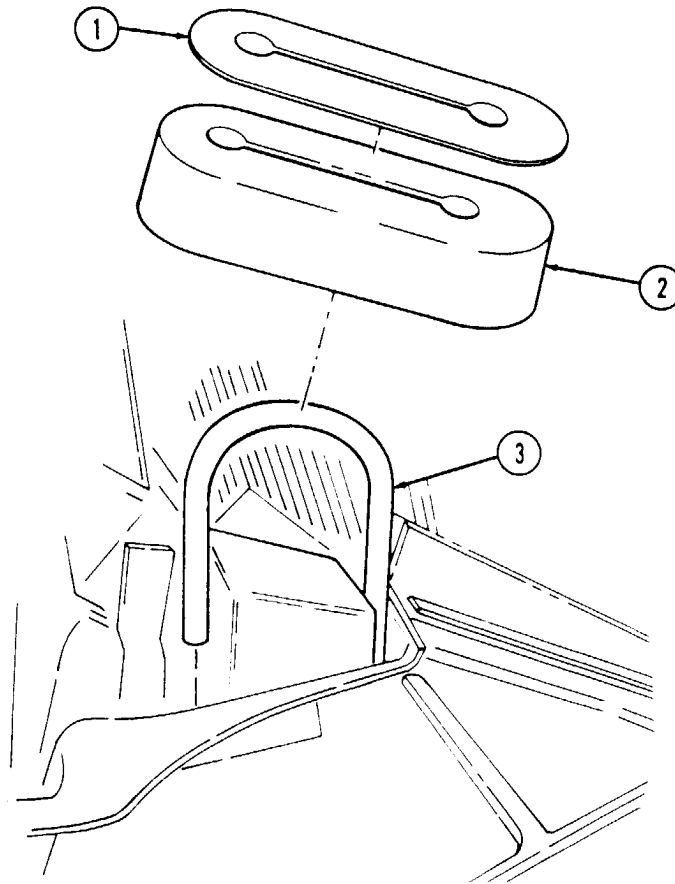

FOLLOW-ON TASK: Lower and secure hood (TM 9-2320-280-10).

10-66. BODY REPAIR

This task covers:

- | | |
|---------------|----------------------|
| a. General | c. Rivet Replacement |
| b. Inspection | |

INITIAL SETUP:

Tools

General mechanic's tool kit
automotive (Appendix B, Item 1)

Special Tools

Tool kit, riveter (Appendix B, Item 139)

Materials/Parts

Sealing compound (Appendix C, Item 40)

Manual References

TM 9-2320-280-24P

a. General

1. The M998 series body is constructed from aluminum alloys that have been heat treated to obtain high strength. Welding cannot be used to make body repairs. Heat generated in welding will reverse the heat treatment process and cause a great reduction in strength of material.
2. Solid 3/16 inch diameter aluminum rivets are the primary method of joining body components. Rivets are inserted into a hole through two pieces of metal and a second head is formed by manual or pneumatic impacting, or by squeezing the rivet. A bucking bar is used to backup the rivet to form rivet head. When making repairs, use blind rivets of the same size or oversize diameter with the appropriate grip length.
3. Blind structural aluminum rivets of 3/16 inch diameter are used in applications where there is access from only one side of the part. Blind rivets are installed using a tool that pulls on the rivet stem causing a bulbed head to form on the back side of the part. Fastening is complete when stem breaks off. High strength is obtained in blind structural rivets by mechanically locking the remaining stem inside rivet body. Blind pop rivets are used in locations where non-structural attachments such as latches, striker plates, etc., are attached to the body.
4. Steel pull-type lockbolt fasteners in 3/16 and 1/4-inch diameter are used where tension or high shear loads exist. Lockbolts are two-piece unthreaded fasteners. One part is a high-strength, steel-headed bolt-like part with aberrations on its shank. The mating part is a collar which is swaged over the serrations causing the fastener to be locked in place.
5. Rivnut/plusnut fasteners are tubular rivets with internal threads. Rivnut/plusnut fasteners are installed using a tool that engages the threads of the fastener and extends a pull, causing the shank to expand tightly against the material being fastened. This process is called "upsetting" a rivnut/plusnut.
6. Rivet and Lockbolt replacement.
To facilitate repairs to body, it is acceptable to replace lockbolts and rivets with 1/4 inch AN4 series bolts. Do not replace lockbolts with rivets. Standard threaded fasteners should not be used, as these will quickly wear the aluminum structure. Bolt lengths should be chosen so that the cylindrical portion of bolt is bearing on all members being joined. Bolts are designated as AN4-XX or AN4C-XX where XX defines grip length. Tighten all bolts to 70-75 lb-in. (8-9 N•m).
7. Fatigue strength of riveted joints and seams is increased by one part epoxy adhesive. This adhesive requires special material storage and metal preparation along with a low temperature heat cycle for curing. Because of its impracticality in field repairs, epoxy adhesive will not be used. Where possible, extra rivets and thicker metal gages should be used instead of adhesives. When making repairs, note epoxy exists and that parts may be difficult to separate, even after rivets are removed.

10-66. BODY REPAIR (Cont'd)

b. Inspection

1. The damaged area should be thoroughly cleaned and inspected to determine cause and extent of damage. Body parts should be inspected for holes, cracks, dents, distortion, or breaks. Fasteners should be inspected for breaks, stretching, looseness, cocked heads, or hole elongation. Seams, flanges, and joints should be inspected for straightness or local deformation as an indication that fasteners may have been stretched or holes elongated. It is possible for this to happen and fasteners still appear to be tight in their holes. In addition, make thorough inspection of adjacent areas to determine if high loads have been transmitted from the damaged area to other areas. This can result in secondary damage in the form of distorted panels or seams, loosened or sheared fasteners, elongated fastener holes, and cracks.
2. Signs of rivet failure include tipped heads, looseness, and sometimes chipped or cracked paint. If heads are tipped in the same direction and rivets are loose in consecutive groups, the joint has undergone excessive load. Rivet heads which are tipped in different directions and are not in groups may be improperly installed. With chipped or cracked paint, it may be necessary to remove paint to check true condition of rivets. Rivets subjected to critical loads but showing no distortion, should be inspected if failure is suspected. The head should be drilled off, and the shank should be carefully punched out. Failure is indicated by notched rivet shank and misaligned holes. Flush rivets showing head slippage within the dimple or countersink indicate either sheet bearing or rivet shear failure and must be removed for inspection and replacement. If failure of rivets cannot be detected by visual inspection, the joint can be checked by drilling and punching out several rivets. If rivet shanks are notched, rivets should be replaced with next larger size rivets. If rivet holes show elongation due to local failure in tearing of the sheet, next larger size rivet must be used in replacement. Any deformation of the sheet around the rivet, tear outs, or cracks between rivets usually indicates partially failed or damaged rivets. Complete repair of the joint will require replacement by next larger size rivets. Use the next 1/32 inch larger diameter rivet to obtain a tight joint when original hole has been enlarged. If original size rivet is installed, the rivet would not be able to carry its share of the shear load, and the joint would not meet its strength requirement.

c. Rivet Replacement

NOTE

When removing rivets, care should be taken to not enlarge rivet hole as this would require use of an oversize or larger rivet for replacement.

1. Solid Rivet Removal.
 - (a) File a flat surface on the manufactured head if accessible, It is always preferable to work on manufactured head rather than the one that is bucked over, since the former will always be more symmetrical about the shank.
 - (b) Indent center of the filed surface with a center punch.
 - (c) Drill through rivet head. Be sure to use a drill slightly smaller than diameter of rivet shank to avoid making rivet hole oversized.
 - (d) Shear weakened rivet head off with a sharp chisel. For this operation, support back side of rivet and cut rivet head along direction of rivet line or panel edge. This will prevent distortion of the panel.
 - (e) Firmly support the panel from the opposite side and drive out shank with a pin punch. If rivet is unduly tight because of swelling between sheets, drill rivet shank out with an undersize drill.
2. Blind Rivet Removal.
 - (a) File a small flat on rivet head.
 - (b) Center punch the flat. Support rivet backside, if possible.
 - (c) Using a small drill about the size of rivet pin, drill off tapered end of pin which forms the lock.

10-66. BODY REPAIR (Cont'd)

- (d) Shear lock using a pin punch to drive out pin.
 - (e) Pry out remainder of locking collar.
 - (f) Using a drill slightly smaller than rivet shank, drill almost through rivet head.
 - (g) Pry off rivet head with a pin punch.
 - (h) Tap out rivet shank with a pin punch.
3. Rivnut/Plusnut Removal.
- (a) Drill through rivnut head.
 - (b) Punch out shank.
4. Rivet Hole Drilling.
- (a) Center punch all new rivet locations. Center punch mark must be large enough to prevent drill from slipping out of position, yet it must not dent the surface of the material. To prevent denting, place a bucking bar behind material during punching.
 - (b) Make sure drill is the correct size (tables 10-1 and 10-2) and point is properly ground. A no. 10 drill is used to install standard 3/16-inch blind rivets.

Table 10-1. Drill Sues for Solid Shank Rivets

RIVET DIAMETER (INCH)	DRILL SIZE	DRILL DIAMETER (INCH)
1/16	#51	0.0670
3/32	#41	0.0960
1/8	#30	0.1285
5/32	#21	0.1590
3/16	#10	0.1910
1/4	F	0.2570
5/16	P	0.3230
3/8	W	0.3860

Table 10-2. Drill Sizes for Blind Rivets

NOMINAL DIAMETER (INCH)				OVERSIZE DIAMETER (INCH)			
RIVET DIAMETER	DRILL SIZE	MINIMUM	MAXIMUM	RIVET DIAMETER	DRILL SIZE	MINIMUM	MAXIMUM
1/8	#30	0.129	0.132	1/8	#27	0.143	0.146
5/32	#20	0.160	0.164	5/32	#16	0.176	0.180
3/16	#10	0.192	0.196	3/16	#5	0.205	0.209

- (c) Place drill in center mark for new rivet locations, or align drill with old hole when replacing old rivets with oversize rivets. When using a power drill, give the bit a few turns with fingers before starting motor. This will help assure that drill does not jump out of position when motor is started.

10-66. BODY REPAIR (Cont'd)

NOTE

- While drilling, hold drill at 90 degree angle to material surface. Avoid letting drill wobble, marking oblong holes.
- Avoid excessive pressure. Let drill bit do the cutting.
- Do not push drill through material.

- (d) Remove all burrs with a metal countersink or file.
- (e) Clean away all drill chips. Care must be taken to assure that no chips are trapped between sheets of metal.
- (f) Apply sealing compound to hole and surrounding area.

5. Hole Countersinking.

NOTE

Some rivet installations in the body require that rivet head be flush with the material surface. In these instances, countersunk or flush head rivets are used.

- (a) When using countersunk rivets, rivet holes must be countersunk with a tool having a 100° taper so rivet head will fit flush with surface.
- (b) When using a hand-operated countersink, the hole must be tried with a rivet so the recess will not be too deep or too shallow. It is best to use a countersink with a stop on it so depth of countersink can be controlled. Typical countersinking dimensions for blind rivets are shown in table 10-3. The minimum sheet thickness that can be machined for 100° countersink rivets is given in table 10-4.
- (c) Do not remove edge of hole on blind side of joint.

Table 10-3. Countersinking Dimensions for 100° Countersunk Blind Rivets

COUNTERSINKING DIMENSIONS (100°)		
← C →		
	010R. MIN.	
RIVET DIAMETER (INCH)	C (INCH)	
	MINIMUM	MAXIMUM
1/8	0.222	0.228
5/32	0.283	0.289
3/16	0.350	0.356

010R.
MIN.

Table 10-4. Minimum Sheet Gage & 100° Machine Countersink

RIVET SIZE (INCH)	3/32	1/8	5/32	3/16	1/4
GAGE (INCH)	0.040	0.050	0.064	0.072	0.072

10-66. BODY REPAIR (Cont'd)

6. Blind Rivet Driving Practices and Precautions.

- (a) Rivets should be inspected for proper installation. The grip length of each rivet is marked on top of its head to provide positive identification. Use of proper grip length will produce a rivet installation where locking collar is flush with top surface of rivet head. Tolerance limit on flushness is 0.020 in. (0.5 mm).
- (b) For proper rivet installation, it is imperative that holes be properly prepared, tools be in good working order, and rivets properly applied. When problems occur, the source of trouble could be in any of these areas.

7. Blind Rivet Installation.

NOTE

- Prior to installing blind rivets, the hole must be prepared, the parts aligned and clamped firmly in place. These steps are the same as for solid riveting operations. Proper drill sizes for standard and oversized blind rivets are given in table 10-2. Countersinking dimensions and minimum sheet gage for countersunk blind rivets are shown in tables 10-3 and 10-4.
- It is very important that the proper length rivet is selected for each application. Rivet lengths are sized by the range of material thickness that the rivet will grip. Selecting the proper rivet length is critical because rivets can tolerate only 1/16 inch variation in material thickness for each particular rivet length. Rivet grip lengths are called out as a "dash number" at the end of the manufacturer's part number. Grip lengths are determined as shown in table 10-5.
- For double dimpled sheets, add countersunk head height to materials thickness.
- Use rivet installation tool kit for all blind rivets.

Table 10-5. Rivet Grip Length Determination

MATERIAL THICKNESS RANGE (INCH)		RIVET GRIP NO.
MINIMUM	MAXIMUM	
	1/16	1
	1/8	2
1/8	3/16	3
3/16	1/4	4
1/4	5/16	5
5/16	3/8	6
3/8	7/16	7
7/16	1/2	8
1/2	9/16	9
9/16	5/8	10
5/8	11/16	11
11/16	3/4	12

10-66. BODY REPAIR (Cont'd)

- (a) Insert rivet stem into pulling head of rivet gun.
 - (b) Hold rivet gun in line with axis of rivet as accurately as possible.
 - (c) Apply a steady firm pressure against rivet head.
 - (d) Squeeze handles of manual gun. The rivet clamping action will pull sheets together, seat rivet head, and break stem flush with head of rivet.
8. Rivnut/Plusnut/Insertnut Installation.
- (a) Thread rivnut onto mandrel of installation tool.
 - (b) Insert rivnut into hole for installation.
 - (c) Apply steady firm pressure against rivnut head.
 - (d) Squeeze handles of tool to clinch rivnut shank against material.
 - (e) Remove mandrel from rivnut.

10-67. "B" PILLAR REPLACEMENT

This task covers:

a. Removal

b. Installation

INITIAL SETUP:

Applicable Models

M998, M998A1, M1035, M1035A1, M1035A2,
M1037, M1038, M1038A1, M1042

Manual References

TM 9-2320-280-10
TM 9-2320-280-24P

Tools

General mechanic's tool kit:
automotive (Appendix B, Item 1)

Equipment Condition

- Soft top removed, if installed (TM 9-2320-280-10).
- Soft top door strikers removed, if installed (para. 10-103).
- Three point seatbelt removed (para. 10-48 or 10-48.1).

Materials/Parts

Twelve locknuts (Appendix G, Item 86)

a. Removal

Remove twelve locknuts (5), washers (4), capscrews (2), and "B" pillar (1) from body (3). Discard locknuts (5).

b. Installation

Install "B" pillar (1) on body (3) with twelve capscrews (2), washers (4), and locknuts (5). Tighten locknuts (5) to 15 lb-ft (20 N•m).

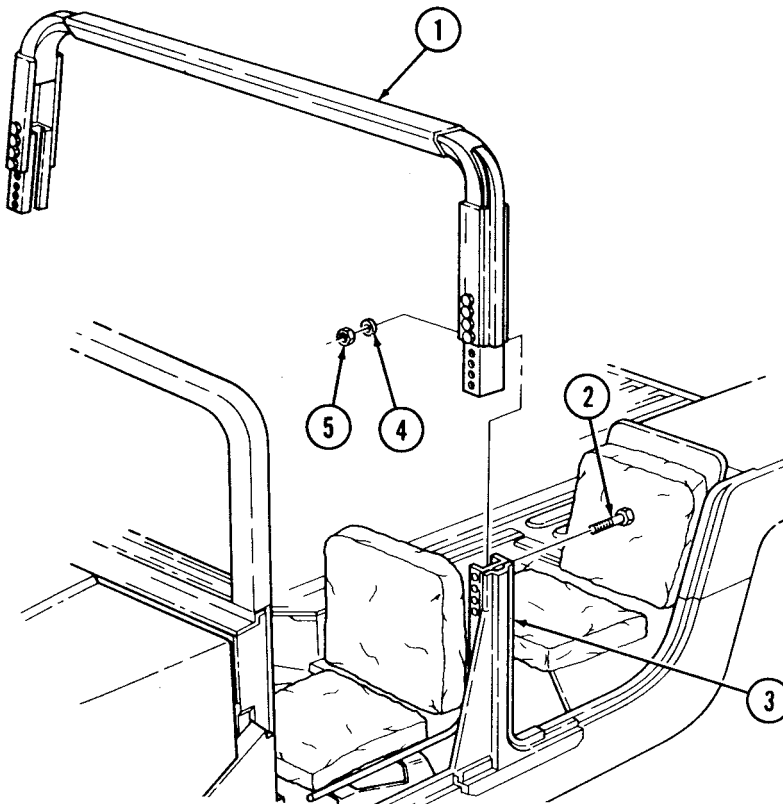

- FOLLOW-ON TASKS:
- Install soft top, if removed (TM 9-2320-280-10).
 - Install soft top door strikers, if removed (para. 10-103).
 - Install three point seatbelt (para. 10-48 or 10-48.1).

10-68. M11 DECONTAMINATION BRACKETS INSTALLATION

This task covers:

Installation

INITIAL SETUP:

Applicable Models

M966, M966A1, M998, M998A1, M1025, M1025A1, M1025A2, M1026, M1026A1, M1036, M1037, M1038, M1038A1, M1042, M1121

Tools

General mechanic's tool kit:
automotive (Appendix B, Item 1)

Manual References

TM 9-2320-280-10
TM 9-2320-280-24P

NOTE

The following procedure is for initial installation of apparatus (P/N D5-51-269). This apparatus is not included in TM 9-2320-280-24P.

Installation

NOTE

Perform steps 1 and 2 for models M966, M966A1, and M1036 vehicles only.

1. Using bracket (2) as a template, locate, mark, and drill four 0.281-inch (7.14 mm) diameter holes (1) in right wheel housing (4).
2. Install bracket (2) on right wheel housing (4) with four washers (3), screws (5), washers (3), and nuts (6).

NOTE

Perform steps 3 and 4 for models M998, M998A1, M1038, and M1038A1 vehicles only.

3. Using bracket (9) as a template, locate, mark, and drill four 0.281-inch (7.14 mm) diameter holes (10) in left wheel housing (11).
4. Install bracket (9) on left wheel housing (11) with four washers (7), screws (8), washers (7), and nuts (12).

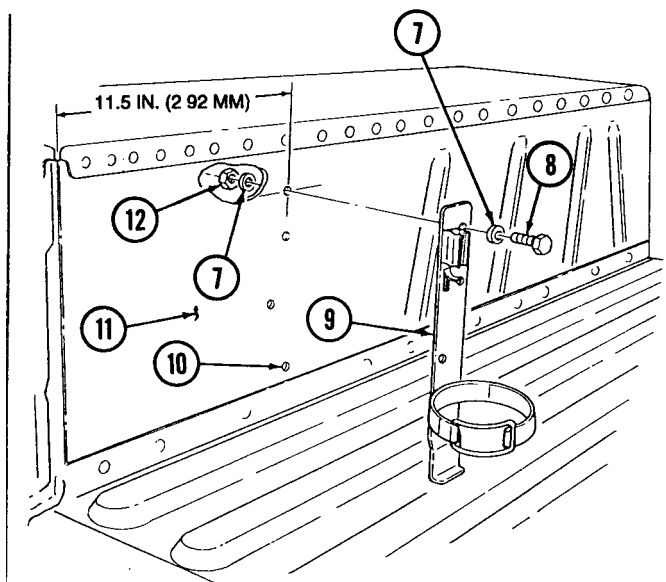
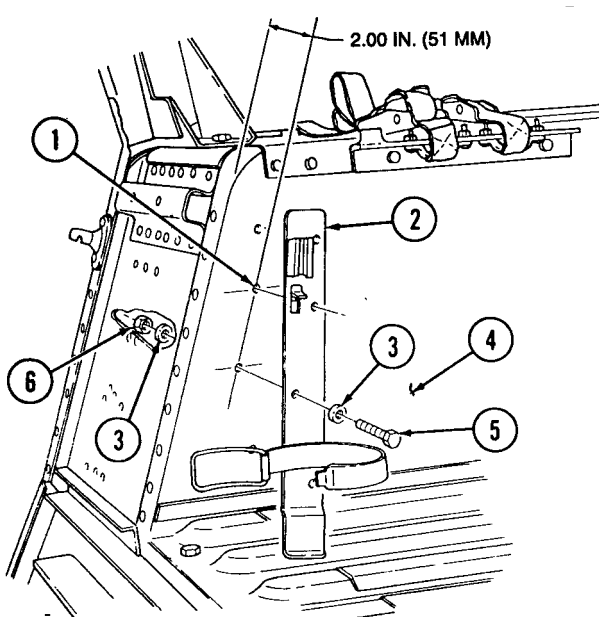

10-68. M11 DECONTAMINATION BRACKETS INSTALLATION (Cont'd)

NOTE

Perform steps 5 through 10 for models M1025, M1025A1, M1025A2, M1026, and M1026A1 vehicles only.

5. Using bracket (17) as a template, locate, mark, and drill a 0.281-inch (7.14 mm) diameter hole (22) through armor panel (13) and left wheel housing (25).
6. Install bracket (17) on armor panel (13) and left wheel housing (25) with washer (21), screw (20), washer (21), and nut (24). Do not tighten nut (24).
7. Position M11 decontaminating apparatus (19) in bracket (17) with handle (18) toward rear of vehicle.
8. Place top of M11 decontaminating apparatus (19) and bracket (17) between rear seat (16) and M13 decontamination mount bracket (23) in an upright position. Using bracket (17) as a template, scribe a reference line (14) on armor panel (13). Remove M11 decontaminating apparatus (19) from bracket (17).
9. Using marked reference line (14) on armor panel (13) and bracket (17) as a template, locate, mark, and drill two 0.281-inch (7.14mm) diameter holes (15).
10. Install bracket (17) on armor panel (13) with two washers (21), screws (20), washers (21), and nuts (24). Tighten screw (20) and nut (24) installed in step 6.

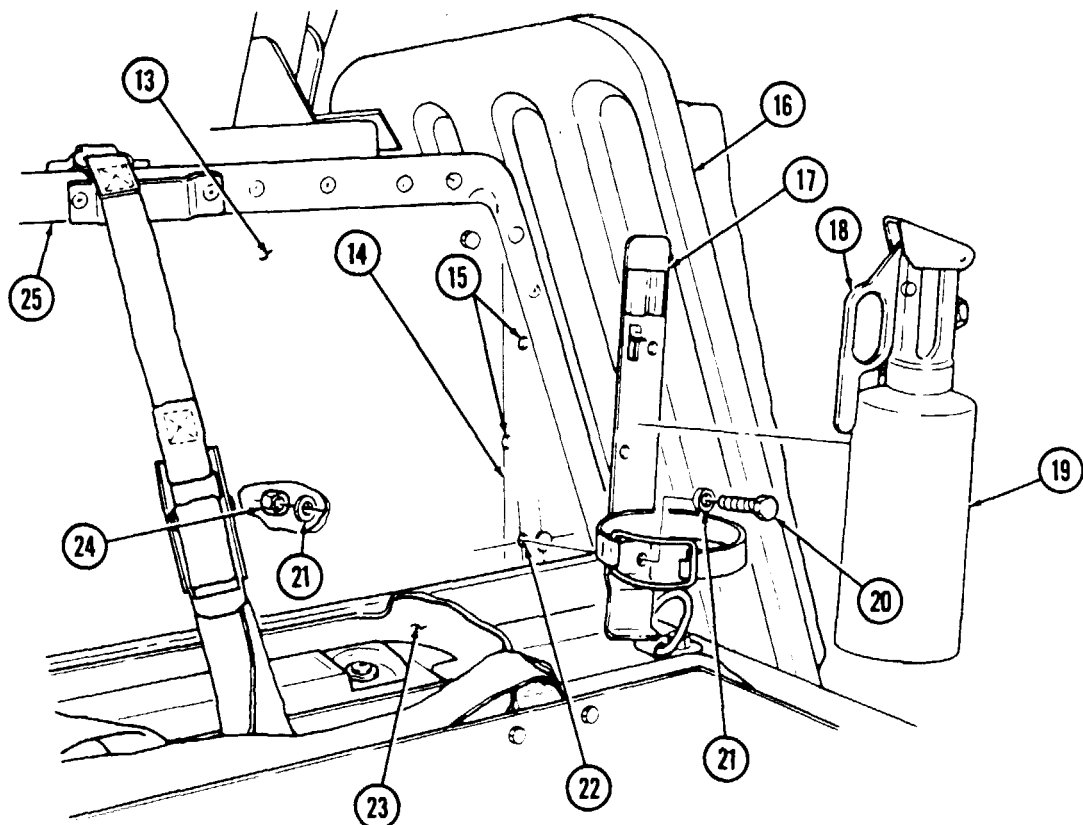

10-68. M11 DECONTAMINATION BRACKETS INSTALLATION (Cont'd)

NOTE

Perform steps 11 through 14 for model M1037 and M1042 vehicles only.

11. Remove left rear fixed door (1) (para. 10-14).
12. Using bracket (4) as a template, locate, mark, and drill four 0.281-inch (7.14 mm) diameter holes (5) in left rear fixed door (1).
13. Install bracket (4) on left rear fixed door (1) with four washers (2), screws (6), washers (2), and nuts (3).
14. Install left rear fixed door (1) (para. 10-14).

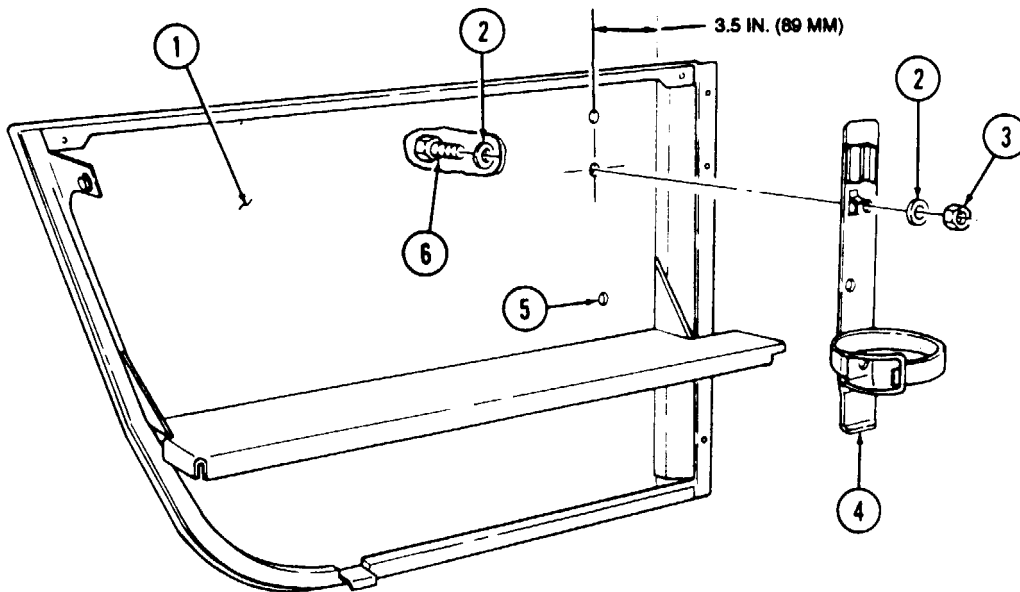

Section II. BODY ACCESSORIES MAINTENANCE

10-69. BODY ACCESSORIES MAINTENANCE TASK SUMMARY

TASK PARA.	PROCEDURES	PAGE NO.
10-70.	Windshield Wiper Blade and Arm Replacement	10-116
10-71.	Windshield Wiper Motor (SF5578716) Replacement	10-118
10-72.	Windshield Wiper Switch/Motor (12342501) Replacement	10-120
10-73.	Windshield Wiper Linkage Replacement	10-122
10-74.	Windshield Wiper Arm Pivot Replacement	10-123
10-75.	Windshield Washer Reservoir and Pump Assembly Replacement	10-124
10-76.	Windshield Washer Hoses Replacement	10-126
10-77.	Sun Visor Replacement	10-128
10-78.	Windshield Washer Nozzle Replacement	10-129
10-79.	Mirror Replacement	10-130
10-80.	Mirror Arm Assembly Replacement	10-131
10-81.	Mirror Mounting Bracket Replacement	10-132
10-82.	Rearview Mirror Maintenance	10-133
10-83.	Heater Shutoff Valve Replacement	10-137
10-84.	Heater Outlet/Inlet Piping Maintenance	10-138
10-85.	Heater Fan Switch Replacement	10-140
10-86.	Heater Fan Motor Resistor Assembly Replacement	10-142
10-87.	Heater Assembly Replacement	10-144
10-88.	Defrost Control Replacement	10-146
10-89.	Heater Control Replacement	10-148
10-90.	Heater Control Cable and Shutoff Valve Adjustment	10-150
10-91.	Heater Ducting Replacement	10-152
10-92.	Diverter Box Replacement (All except M998A2)	10-154
10-92.1.	Diverter Manifold and Housing Replacement	10-154.2 ■
10-93.	Defroster Ducting Replacement (All except M1097A2, M1123)	10-156
10-94.	Left Defroster Nozzle Replacement	10-160
10-94.1.	Heater Nozzle Deflector Replacement	10-163 ■
10-95.	Right Defroster Nozzle Replacement	10-164
10-96.	Heater Boot Replacement	10-164.1 ■
10-96.1.	Defroster Ducting Replacement (M1097A2, M1123)	10-164.2
10-96.2.	Heater Hose Replacement	10-164.4
10-96.3.	Diverter Box Cover Replacement	10-164.5
10-96.4.	Diverter Ducting Replacement	10-164.6
10-97.	Air Duct Assembly Replacement	10-165
10-97.1.	Diverter Box Replacement (M998A2)	10-166 ■
10-98.	“A” Pillar Former Assembly Replacement	10-167
10-99.	“C” Pillar Replacement	10-168

10-69. BODY ACCESSORIES MAINTENANCE TASK SUMMARY (Cont'd)
--

TASK PARA.	PROCEDURES	PAGE NO.
10-100.	Rear Bow Pivot Bracket Replacement	10-169
10-101.	Soft Top Door Hinge Replacement	10-170
10-102.	Soft Top Door Adjustment	10-172
10-102.1.	Soft Top Door Handle Repair	10-172.2
10-103.	Soft Top Door Striker Replacement	10-174
10-104.	Soft Top Repair	10-175
10-105.	"C" Pillar Reinforcement Brackets Installation	10-177

10-70. WINDSHIELD WIPER BLADE AND ARM MAINTENANCE

This task covers:

- | | |
|---|------------------------|
| <p>a. Removal</p> <p>b. Repair (Optional)</p> | <p>c. Installation</p> |
|---|------------------------|

INITIAL SETUP:

Tools

General mechanic's tool kit:
automotive (Appendix B, Item 1)

Manual References

TM 9-2320-280-10
TM 9-2320-280-24P

Materials/Parts

Spring (Appendix G, Item 299.1)

NOTE

Ensure windshield wiper motor switch is in OFF position. Note position of wiper arm for installation.

a. Removal

NOTE

Perform only if wiper blade and arm assembly is to be replaced.

1. Remove screw (1), nut (10), and blade assembly (8) from wiper arm (2).
2. Lift wiper arm (2) away from windshield (9).
3. Lift up latch (3) at base of wiper arm (2) and remove wiper arm (2) from splined shaft (4).

b. Repair (Optional)

NOTE

If spring inside wiper arm loses its tension, it can be replaced with spring as an alternate to replacing the wiper arm.

1. Remove wiper arm (2) and blade assembly (8). See task a.
2. Remove spring (7) from wiper arm (2). Discard spring (7).
3. Install spring (7) in second hole (6) of wiper arm tabs (5).
4. Install wiper arm (2) and blade assembly (8). See task c.

c. Installation

NOTE

- Perform only if wiper blade and arm assembly was removed.
- With motor switched OFF (parked position), mount wiper arm approximately 60° to vertical centerline, so that a sweep of approximately 120° will be achieved in operation.

1. Ensure wiper arm latch (3) is unlocked.
2. Install wiper arm (2) on splined shaft (4).
3. Install blade assembly (8) on wiper arm (2) with screw (1) and nut (10).

10-70. WINDSHIELD WIPER BLADE AND ARM MAINTENANCE (Cont'd)

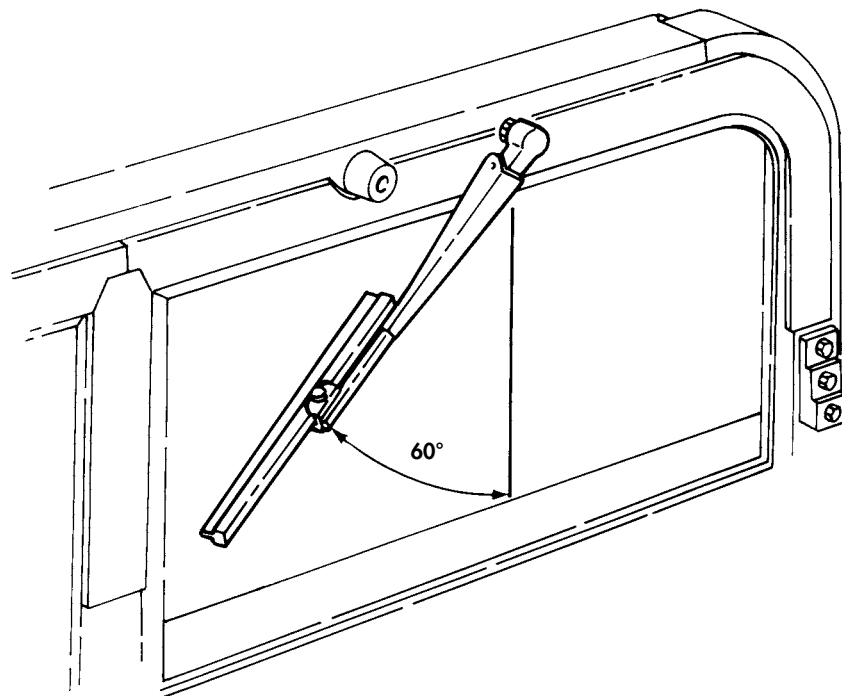
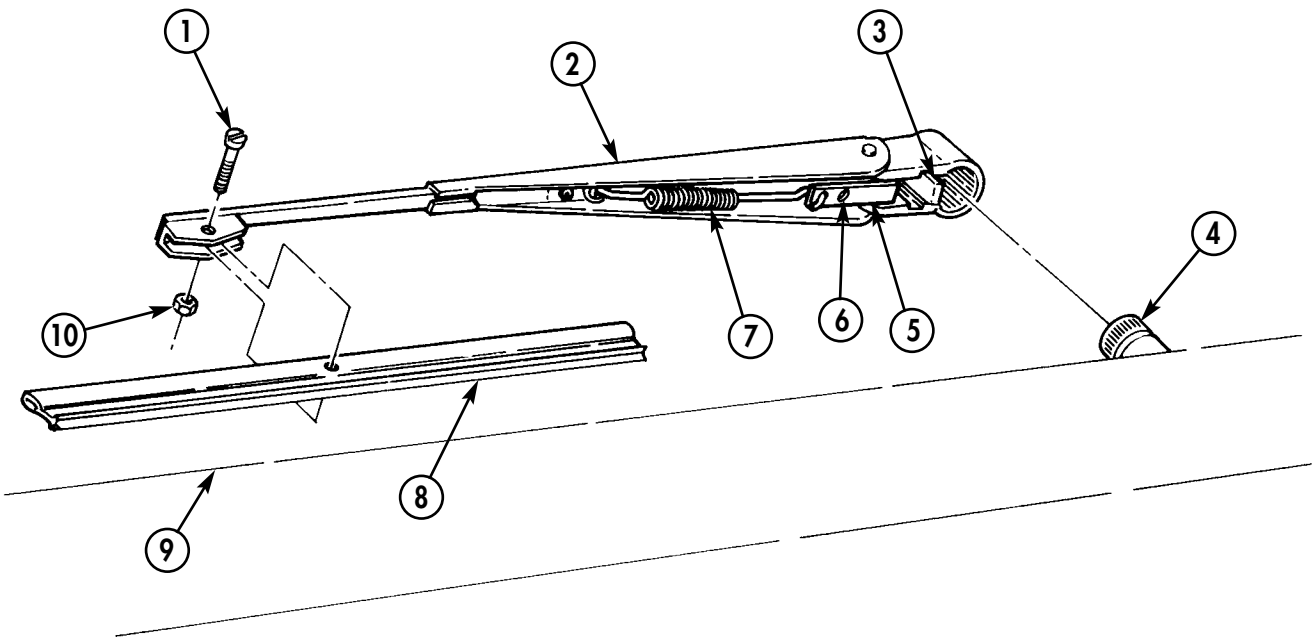

FOLLOW-ON TASK: Check windshield wiper for proper operation (TM 9-2320-280-10).

10-71. WINDSHIELD WIPER MOTOR (SF5578716) REPLACEMENT

This task covers:

a. Removal

b. Installation

INITIAL SETUP:

Tools

General mechanic's tool kit:
automotive (Appendix B, Item 1)

Manual References

TM 9-2320-280-10
TM 9-2320-280-24P

Materials/Parts

Adhesive-sealant (Appendix C, Item 10)
Two lockwashers (Appendix G, Item 175)
Gasket (Appendix G, Item 40.1)

Equipment Condition

Battery ground cable disconnected (para. 4-73).

a. Removal

NOTE

The windshield wiper motor for this application is no longer available. For replacement of a defective windshield wiper motor, refer to para. 10-72.

1. Disconnect connector (20) from wiper motor (15).
2. Remove screw (16) and washer (17) from wiper motor bracket (18) and windshield frame (1).
3. Remove screw (12), lockwasher (11), and ground lead 57G (10) from wiper motor (15). Discard lockwasher (11).
4. Remove three capscrews (9) and washers (8) from antenna cable clamp (7) (M996, M996A1, M997, M997A1, and M997A2 only), wiper motor mounting plate (4), and windshield frame (1).
5. Pull wiper motor mounting plate (4) and wiper motor (15) away from windshield frame (1) for access to cap screw (2).
6. Remove screw (14) and lockwasher (13) from wiper motor (15) and motor mounting plate (4), and separate wiper motor (15) and gasket (19) from motor mounting plate (4). Discard lockwasher (13) and gasket (19).
7. Remove cap screw (2) from motor drive lever assembly (3) and wiper motor (15), and remove wiper motor (15) and wiper motor mounting plate (4) from windshield frame (1).
8. Remove right access cover (6) from windshield frame (1).

b. Installation

NOTE

- Coat wiper motor and both sides of mounting plate with adhesive-sealant. Allow to dry approximately 2 hours.
 - To ease future wiper/motor removal and installation, the twelve point screws used in steps 1 and 3 may be discarded and replaced with hex head screws (NSN 5305-00-071-2505).
1. Install wiper motor (15) and gasket (19) on wiper motor mounting plate (4) with lockwasher (13) and screw (14).
 2. Position wiper motor mounting plate (4), gasket (19), and wiper motor (15) in windshield frame (1) and install motor drive lever assembly (3) on wiper motor (15) with cap screw (2).
 3. Install ground lead 57G (10) and wiper motor (15) on wiper motor mounting plate (4) with lockwasher (11) and screw (12).

10-71. WINDSHIELD WIPER MOTOR (SF5578716) REPLACEMENT (Cont'd)

8. Install wiper motor bracket (18) on windshield frame (1) with washer (17) and screw (16).
9. Install right access cover (6) on windshield frame (1).

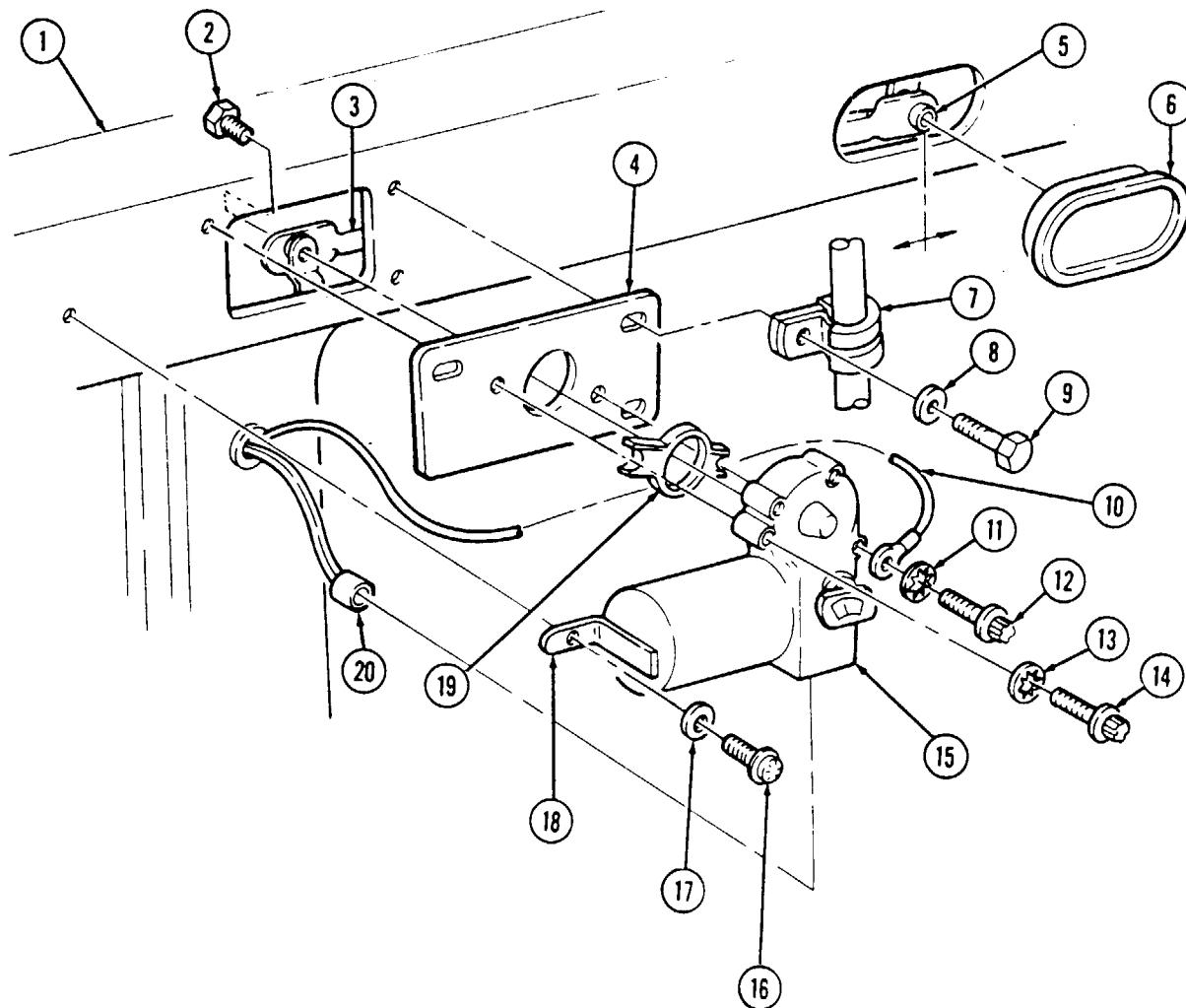

- FOLLOW-ON TASKS:**
- Connect battery ground cable (para 4-73).
 - Check wiper motor for proper operation (TM 9-2320-280-10).

10-72. WINDSHIELD WIPER SWITCH/MOTOR (12342501) REPLACEMENT

This task covers:

a. Removal

b. Installation

INITIAL SETUP:

Tools

General mechanic's tool kit:
automotive (Appendix B, Item 1)

Manual References

TM 9-2320-280-10
TM 9-2320-280-24P

Materials/Parts

Lockwasher (Appendix G, Item 176)
Lockwasher (Appendix G, Item 193)
Lockwasher (Appendix G, Item 175)

Equipment Condition

Battery ground cable disconnected (para. 4-73).

a. Removal

NOTE

Perform steps 1 through 4 for removal of wiper motor switch.
Proceed to step 5 for removal of wiper motor assembly.

1. Disconnect lead (12) from wiper switch (11).
2. Depress retaining clip on back of knob (15) and remove knob (15) from wiper switch (11).
3. Remove nut (14) and lockwasher (13) from wiper switch (11) and wiper motor mounting plate (10). Discard lockwasher (13).
4. Disconnect switch connector (9) from wiper motor (5) and remove wiper switch (11).
5. Remove screw (16) and lockwashers (17) and (19) from ground lead 57G (18) and wiper motor mounting plate (10). Discard lockwashers (17) and (19).
6. Remove three capscrews (8) and washers (7) from antenna cable clamp (6) (M996 and M997 only), wiper motor (5), and windshield frame (2).
7. Pull wiper motor (5) away from windshield frame (2) for access to clip (3).
8. Remove clip (3) and disconnect connecting links (1) and (4) from wiper motor (5) and remove wiper motor (5) from windshield frame (2).

b. Installation

NOTE

Perform steps 1 through 4 for installation of wiper motor switch.
Proceed to step 5 for installation of wiper motor assembly.

1. Install wiper switch (11) on wiper motor mounting plate (10) with lockwasher (13) and nut (14).
2. Depress retaining clip on back of knob (15) and install knob (15) on wiper switch (11).
3. Connect switch connector (9) to wiper motor (5).
4. Connect lead (12) to wiper switch (11).
5. Position wiper motor (5) in windshield frame (2) install connecting links (4) and (1) on wiper motor (5) with clip (3).
6. Install wiper motor (5) and antenna cable clamp (6) (M996 and M997 only) on windshield frame (2) with three washers (7) and capscrews (8).
7. Install ground lead 57G (18) on wiper motor mounting plate (10) with lockwashers (19) and (17) and screw (16).

10-72. WINDSHIELD WIPER SWITCH/MOTOR (12342501) REPLACEMENT (Cont'd)

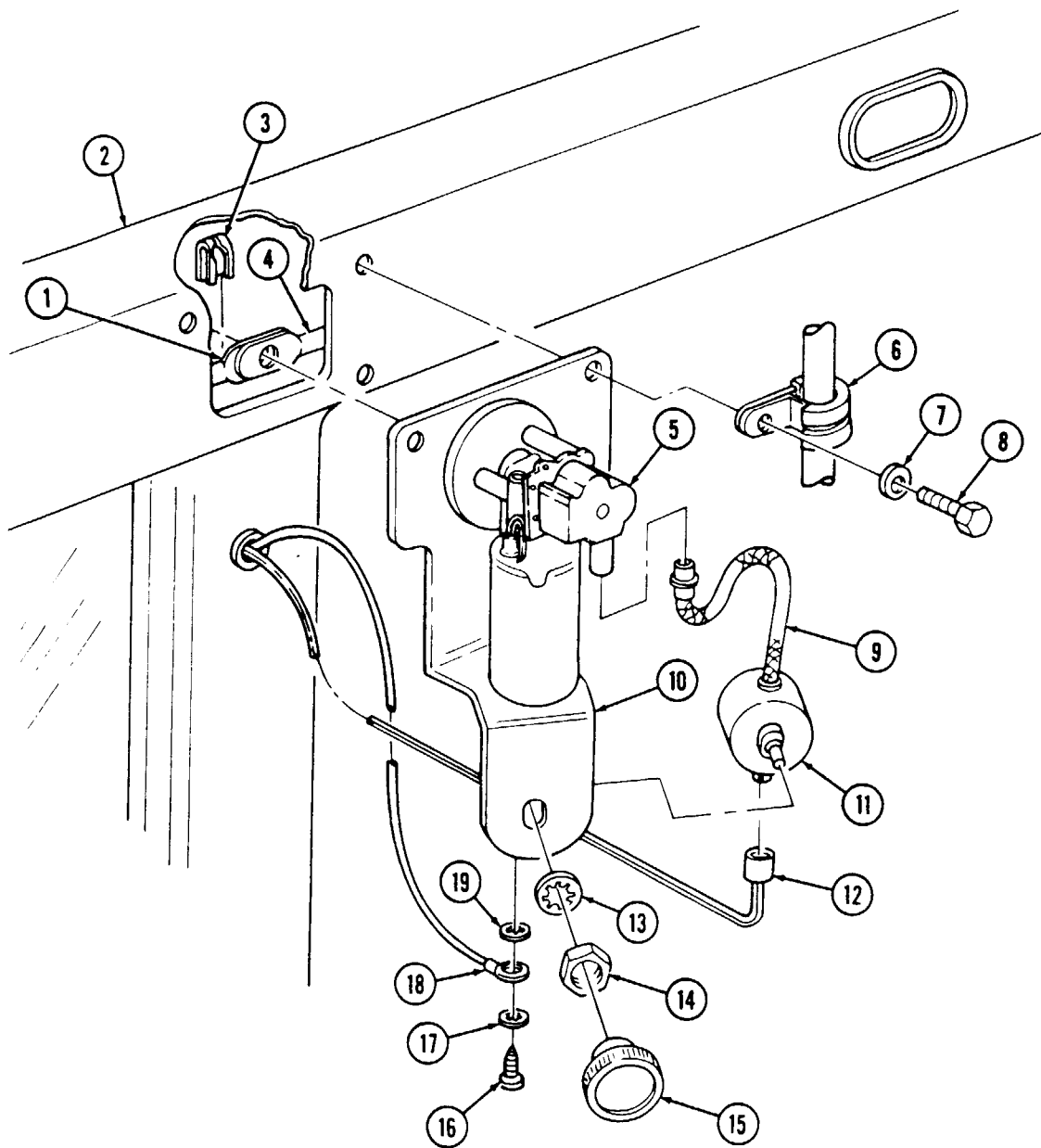

FOLLOW-ON TASKS: •Connect battery ground cable (para 4-73),
 •Check wiper motor for proper operation (TM 9-2320-280-10).

10-73. WINDSHIELD WIPER LINKAGE REPLACEMENT

This task covers:

a Removal

b. Installation

INITIAL SETUP:

Tools

General mechanic's tool kit:
automotive (Appendix B, Item 1)

Manual References

TM 9-2320-280-24P

Equipment Condition

- Windshield wiper switch/motor (12342501) removed (para. 10-72).
- Windshield wiper motor (SF5578716) removed (para. 10-71).

a. Removal

1. Remove two access covers (7) from windshield frame (1).
2. Pull connector arm retainer (3) from ball stud (5) and remove motor drive lever (6) from connector arms (4).
3. Disconnect connector arms (4) from wiper arm pivots (2) and remove connector arms (4) through center access in windshield frame (1).

b. Installation

CAUTION

Install the left (driver's) side connector arm first or damage to equipment will result.

1. Install connector arms (4) through center access on windshield frame (1) and connect connector arms (4) to wiper arm pivots (2).
2. Connect connector arms (4) together with motor drive lever (6) and connector arm retainer (3) on ball stud (5).
3. Install access covers (7) on windshield frame (1).

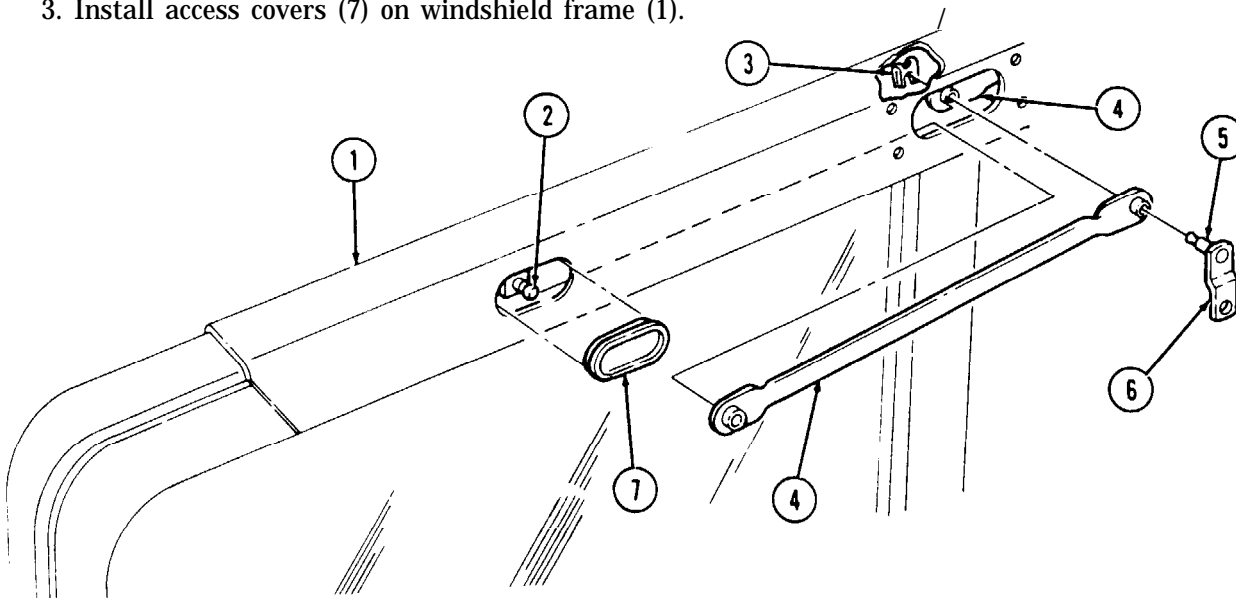

FOLLOW-ON TASK: • Install windshield wiper switch/motor (12342501) (para. 10-72).
• Install windshield wiper motor (SF5578716) (para. 10-71).

10-74. WINDSHIELD WIPER ARM PIVOT REPLACEMENT

This task covers:

- a. Repair (Optional)
- b. Removal

c Installation

INITIAL SETUP

Tools

General mechanic's tool kit
automotive (Appendix B, Item 1)

Manual References

TM 9-2320-280-24P

Equipment Condition

- Windshield wiper linkage removed (para. 10-73).
 - Windshield wiper blade and arm removed (para. 10-70).
-

a. Repair (Optional)

NOTE

- Steps 1 through 3 is an alternative repair for the windshield wiper arm pivot. The repair can be done at commander's discretion.
 - For easy handling, use of an old wiper arm as a hole guide is recommended. This will also protect the splined surface of the pivot.
 - Use roll pin (5315-01-027-4759) for repair.
1. Center punch the side of the wiper arm (1). Position the wiper arm (1) so it is horizontal for drilling
 2. Drill a 3/32 in. hole halfway through the center shaft (2). remove the old wiper arm (1), and continue drilling all the way through the shaft (2) and cap.
 3. Using a small hammer or punch drive a roll pin (3) into the hole until it is flush with the surface. Replace the original wiper arm.

b Removal

Remove nut (4), washer (5), seal (6), and pivot (8) from windshield frame (7).

c Installation

Install pivot (8) on windshield frame (7) with seal (6), washer (5), and nut (4).

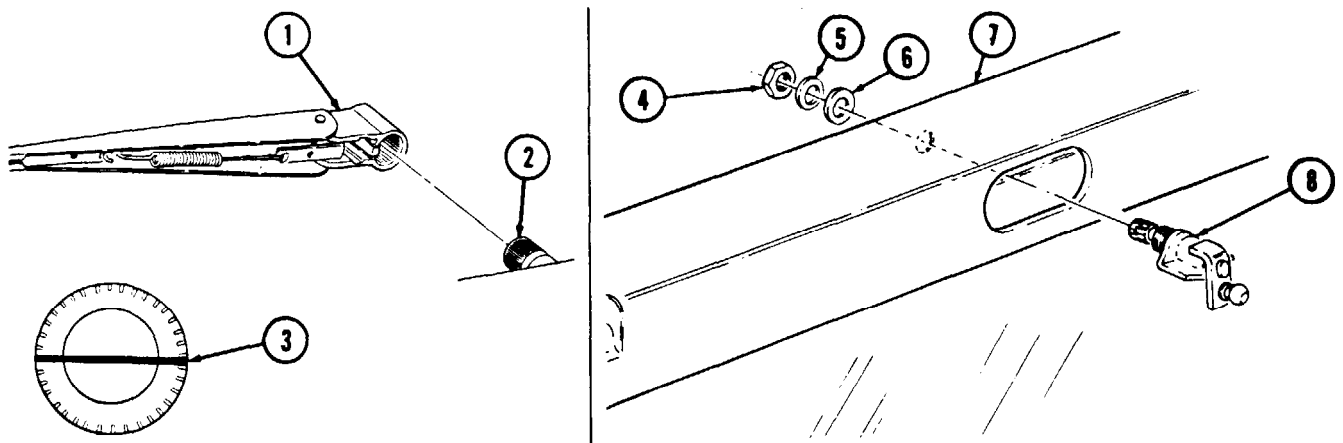

- FOLLOW-ON TASKS:
- Install windshield wiper blade and arm (para. 10-73).
 - Install windshield wiper linkage (para. 10-70).

10-75. WINDSHIELD WASHER RESERVOIR AND PUMP ASSEMBLY REPLACEMENT

This task covers:

a. Removal

b. Installation

INITIAL SETUP:

Tools

General mechanic's tool kit:
automotive (Appendix B, Item 1)

Manual References

TM 9-2320-280-10
TM 9-2320-280-24P

Materials/Parts

Two lockwashers (Appendix G, Item 135)
Lockwasher (Appendix G, Item 138)
Plain-assembled nut (Appendix G, Item 201)
Packing retainer (Appendix G, Item 229)

Equipment Condition

- Battery ground cable disconnected (para. 4-73).
- Hood raised and secured (TM 9-2320-280-10).

a. Removal

1. Disconnect harness leads 71C (6) and 57D (7) from pump leads (5) under dash panel and remove grommet (3) from cowl (10).
2. Loosen clamp (2) and disconnect windshield washer hose (1) from reservoir and pump assembly (4).

NOTE

Perform steps 3 and 4 for windshield washer reservoir with non-removable pump assembly only. Perform steps 5 through 7 for windshield washer reservoir with removable pump assembly only.

3. Remove plain-assembled nut (4.1), capscrew (1.1), and washer (1.2) from reservoir and pump assembly (4) and cowl (10). Discard plain-assembled nut (4.1).
4. Remove two nuts (12), lockwashers (11), capscrews (8), washers (9), and reservoir and pump assembly (4) from cowl (10). Discard lockwashers (11).
5. Remove two nuts (12), lockwashers (11), capscrews (8), washers (9), and reservoir (18) with pump assembly (4) from cowl (10). Discard lockwashers (11).
6. Remove nut (16), lockwasher (15), washer (14), capscrew (13), washer (14), and pump assembly (4) from reservoir (18). Discard lockwasher (15).
7. Remove packing retainer (17) from reservoir (18). Discard packing retainer (17).

b. Installation

NOTE

Perform steps 1 through 3 for windshield washer reservoir with removable pump assembly only. Perform steps 4 and 5 for windshield washer reservoir with non-removable pump assembly only.

1. Install packing retainer (17) on reservoir (18).
2. Install pump assembly (4) on windshield washer reservoir (18) with washer (14), capscrew (13), washer (14), lockwasher (15), and nut (16). Tighten nut (16) to 6-10 lb-ft (8-14 N•m).
3. Install reservoir (18) and pump assembly (4) on cowl (10) with two washers (9), capscrews (8), lockwashers (11), and nuts (12). Tighten nuts (12) to 8 lb-ft (11 N•m).
4. Install reservoir and pump assembly (4) on cowl (10) with two washers (9), capscrews (8), lockwashers (11), and nuts (12). Tighten nuts (12) to 8 lb-ft (11 N•m).
5. Install capscrew (1.1), washer (1.2), and plain-assembled nut (4.1) on reservoir and pump assembly (4) and cowl (10).
6. Connect windshield washer hose (1) to reservoir and pump assembly (4) and tighten clamp (2).
7. Connect harness leads 71C (6) and 57D (7) to pump leads (5) and install grommet (3) in cowl (10).

10-75. WINDSHIELD WASHER RESERVOIR AND PUMP ASSEMBLY REPLACEMENT (Cont'd)

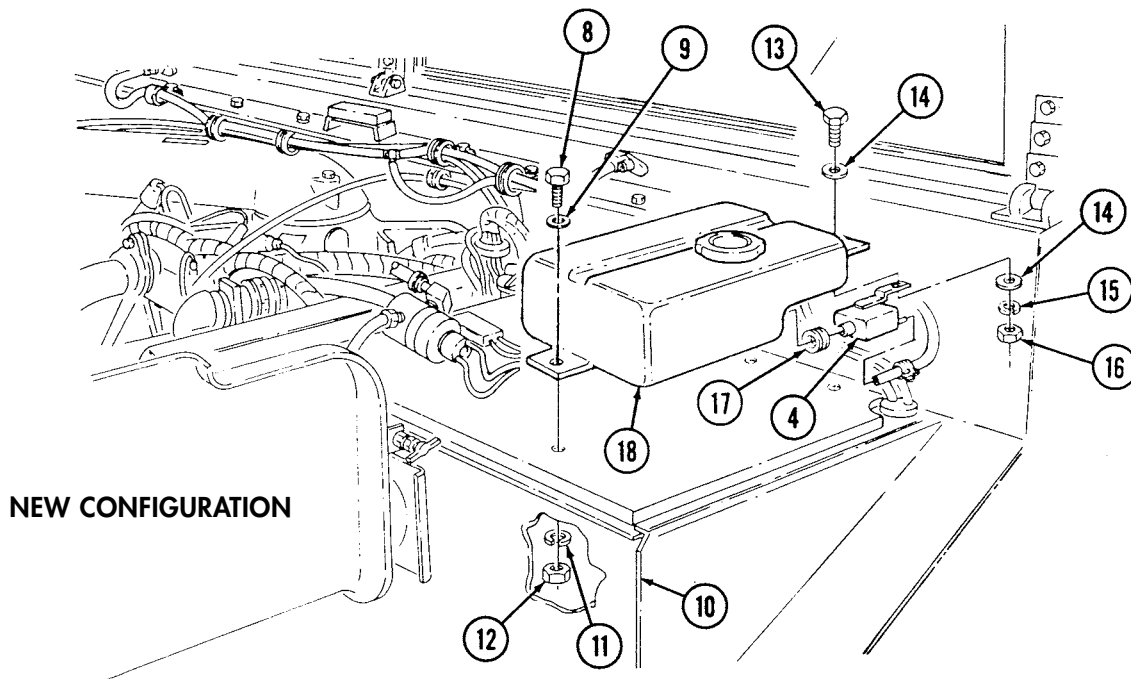
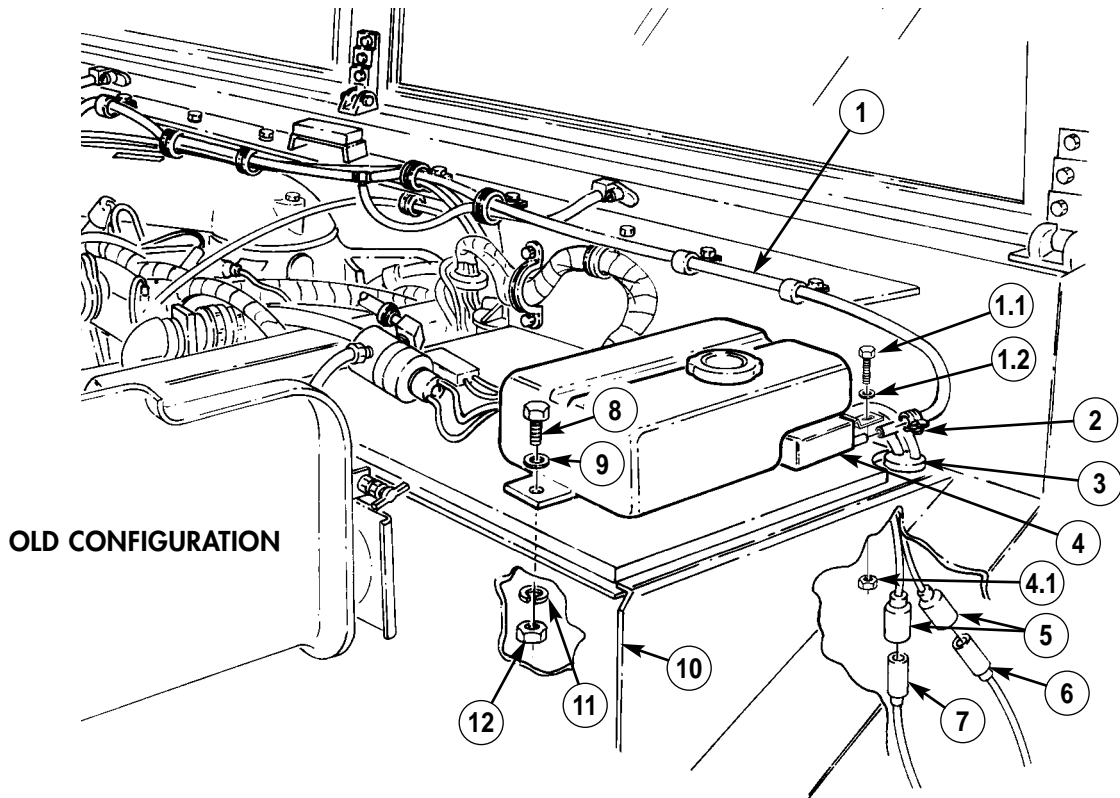

- FOLLOW-ON TASKS:**
- Fill reservoir (TM 9-2320-280-10).
 - Lower and secure hood (TM 9-2320-280-10).
 - Connect battery ground cable (para. 4-73).

10-76. WINDSHIELD WASHER HOSES REPLACEMENT

This task covers:

a. Removal

b. Installation

INITIAL SETUP:

Tools

General mechanic's tool kit:
automotive (Appendix B, Item 1)

Equipment Condition

Hood raised and secured (TM 9-2320-280-10).

Manual References

TM 9-2320-280-10
TM 9-2320-280-24P

a. Removal

1. Remove nut (18), washer (4), capscrew (5), and washer (4) from clamp (3), and remove washer hose (1) from body hood rail (13).
2. Remove two nuts (11), washers (10), capscrews (16), and washers (10) from clamps (9), and remove washer hose (12) from top of body hood rail (13).
3. Loosen clamp (14) and disconnect washer hose (12) from pump (15) and tee (6), and remove through clamp (17).
4. Disconnect washer hose (7) from tee (6) and nozzle (8) and remove through clamp (17).
5. Disconnect washer hose (1) from tee (6) and nozzle (2) and remove through clamp (17).

b. Installation

1. Install washer hose (1) through clamp (17) and connect to nozzle (2) and tee (6).
2. Install washer hose (7) through clamp (17) and connect to nozzle (8) and tee (6).
3. Install washer hose (12) through clamp (17) and connect to tee (6) and pump (15) and tighten clamp (14).

NOTE

When mounting the clamps, ensure they are positioned below the hood rest, so when the hood is closed it does not interfere with the clamps or hose.

4. Install washer hose (1) on body hood rail (13) and secure with clamp (3), washer (4), capscrew (5), washer (4), and nut (18).
5. Install washer hose (12) under body hood rail (13) and secure with two clamps (9), washers (10), capscrews (16), washers (10), and nuts (11).

10-76. WINDSHIELD WASHER HOSES REPLACEMENT (Cont'd)

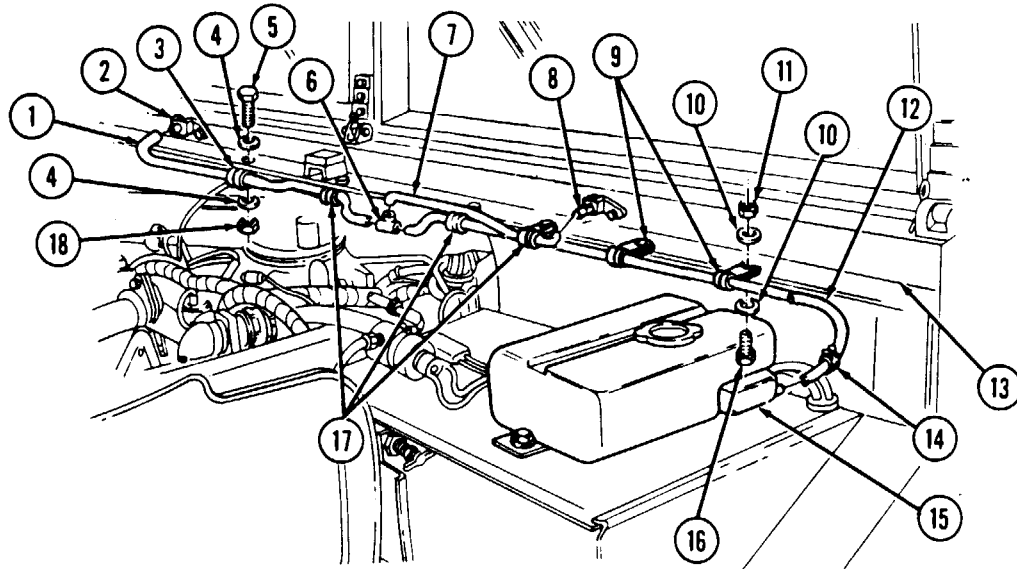

FOLLOW-ON TASK: Lower and secure hood (TM 8-2320-280-10).

10-77. SUN VISOR REPLACEMENT

This task covers:

a. Removal

b. Installation

INITIAL SETUP:

Applicable Models

M997A2, M1025A2, M1035A2,
M1043A2, M1045A2, M1097A2, M1123

Materials/Parts

Four lockwashers (Appendix G, Item 133)

Tools

General mechanic's tool kit:
automotive (Appendix B, Item 1)

Manual References

TM 9-2320-280-24P

NOTE

The procedure for left and right sun visors is basically the same.
This procedure covers the left sun visor.

a. Removal

1. Remove four capscrews (4), lockwashers (3), and sun visor (1) from windshield frame (2). Discard lockwashers (3).
2. Inspect four nut inserts (5) for damage. Replace if damaged.

b. Installation

Install sun visor (1) on windshield frame (2) with four lockwashers (3) and capscrews (4).

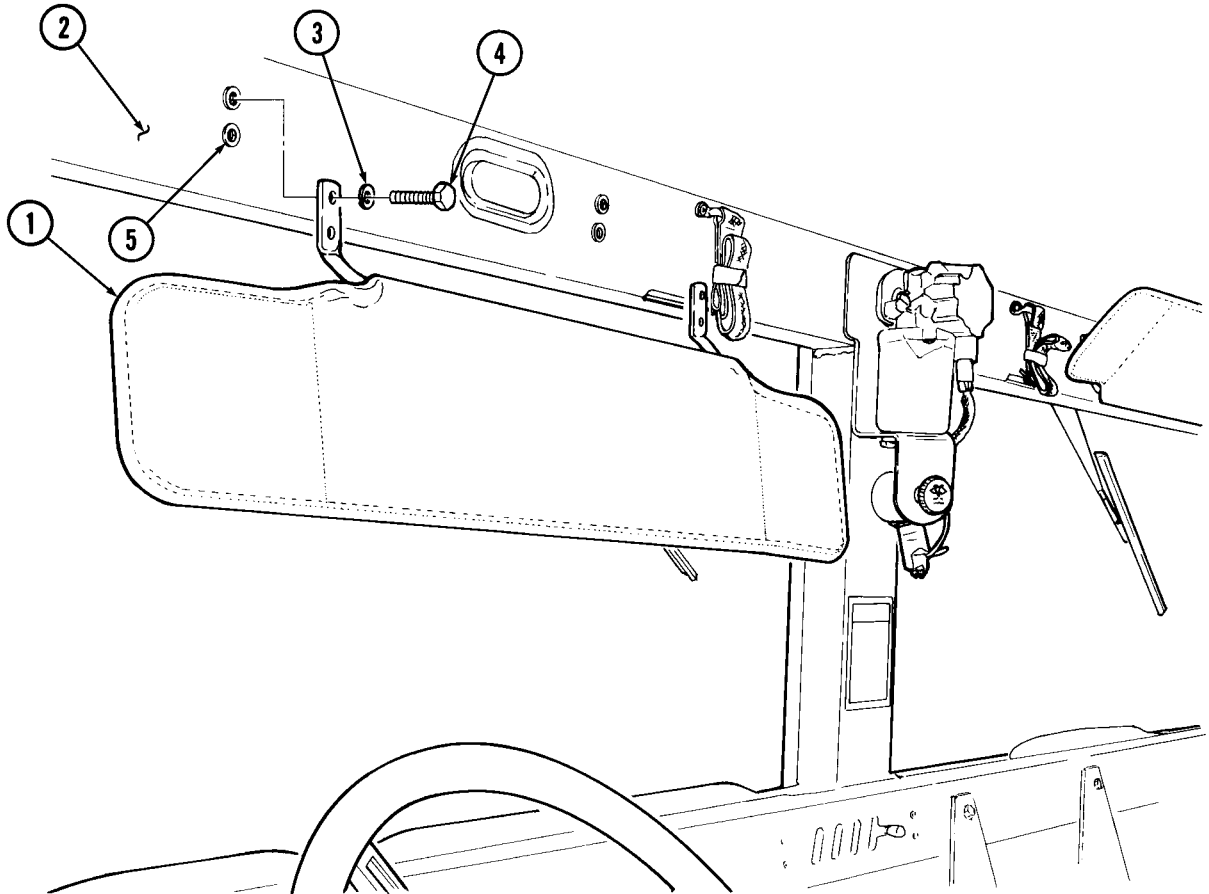

10-78. WINDSHIELD WASHER NOZZLE REPLACEMENT

This task covers:

a. Removal

b. Installation

INITIAL SETUP:

Tools

General mechanic's tool kit:
automotive (Appendix B, Item 1)

Equipment Condition

Hood raised and secured (TM 9-2320-280-10).

Manual References

TM 9-2320-280-10
TM 9-2320-280-24P

a. Removal

1. Disconnect hose (2) from nozzle (3).
2. Remove screw (1) and nozzle (3) from body (4).

b. Installation

1. Install nozzle (3) on body (4) with screw (1).
2. Connect hose (2) to nozzle (3).

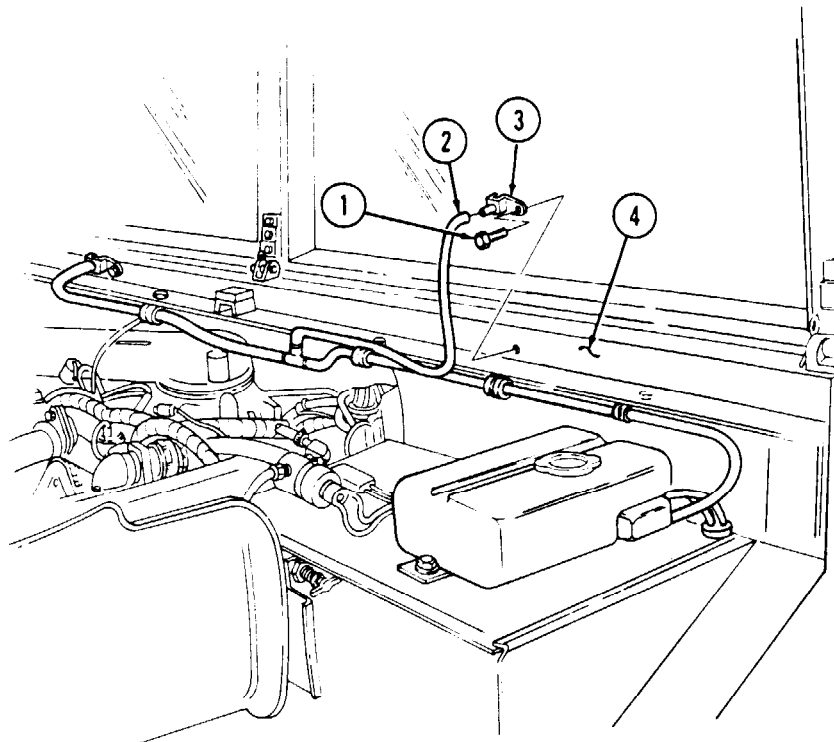

FOLLOW-ON TASK: Lower and secure hood (TM 9-2320-280-10).

10-79. MIRROR REPLACEMENT

This task covers:

a. Removal

b. Installation

INITIAL SETUP:

Tools

General mechanic's tool kit:
automotive (Appendix B, Item 1)

Manual References

TM 9-2320-280-24P

Materials/Parts

Locknut (Appendix G, Item 84)

a. Removal

Remove locknut (4), washer (3), and mirror (1) from arm assembly (2). Discard locknut (4).

b. Installation

Install mirror (1) on arm assembly (2) with washer (3) and locknut (4). Tighten locknut (4) to 6 lb-ft (8 N·m).

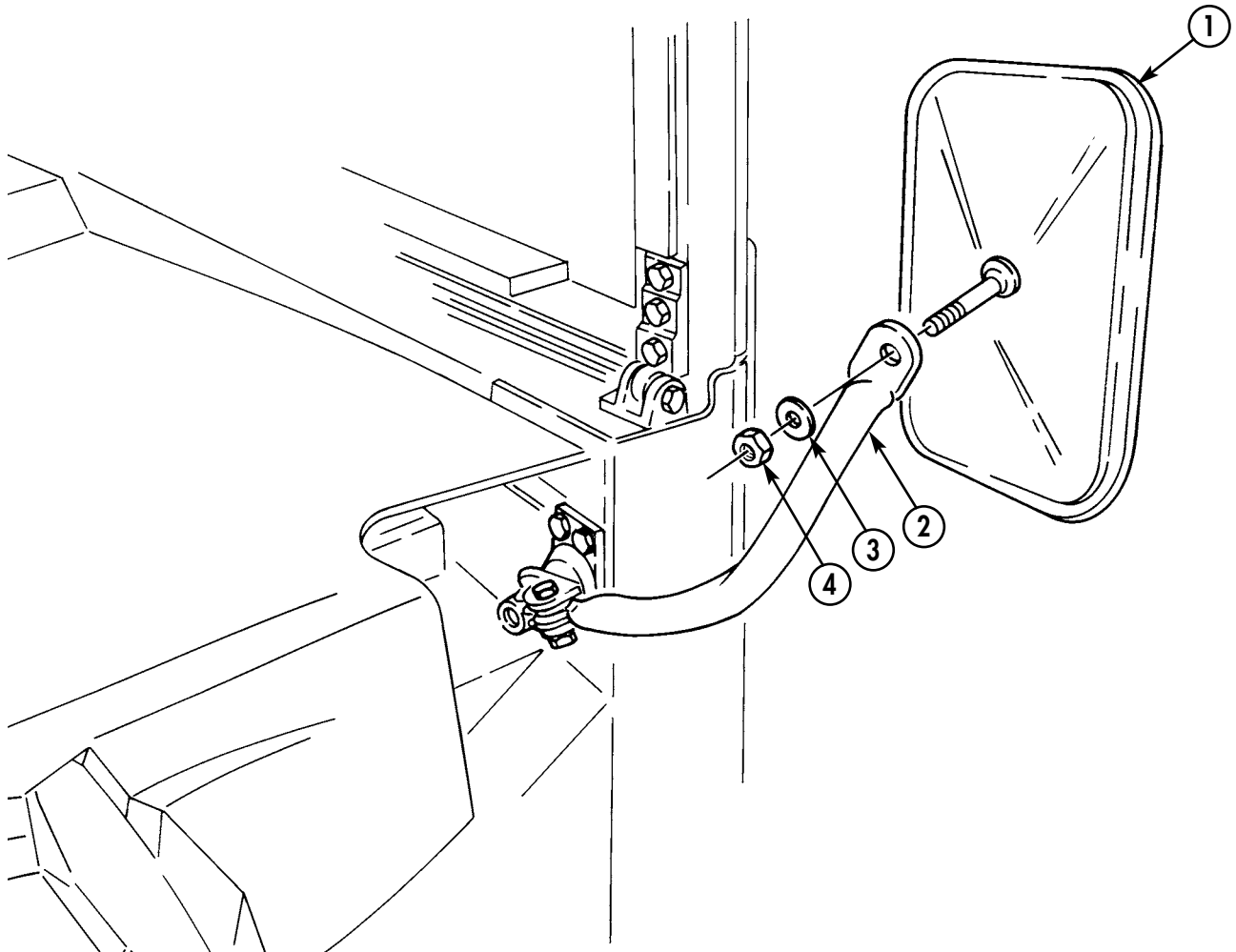

10-80. MIRROR ARM ASSEMBLY REPLACEMENT

This task covers:

a. Removal

b. Installation

INITIAL SETUP:

Tools

General mechanic's tool kit:
automotive (Appendix B, Item 1)

Manual References

TM 9-2320-280-24P

Materials/Parts

Lockwasher (Appendix G, Item 134)
Lockwasher (Appendix G, Item 133)
Flat washer (Appendix G, Item 39)

Equipment Condition

Mirror removed (para. 10-79).

a. Removal

1. Remove special nut (1), lockwasher (2), and washer (3) from pivot bracket (4) and mounting bracket (5). Discard lockwasher (2).
2. Remove mirror arm (7), pivot bracket (4), and flat washer (6) from mounting bracket (5). Discard flat washer (6).
3. Remove nut (10), lockwasher (11), capscrew (8), two spacers (9), and mirror arm (7) from pivot bracket (4). Discard lockwasher (11).

b. Installation

1. Install two spacers (9) and mirror arm (7) on pivot bracket (4) with capscrew (8), lockwasher (11), and nut (10). Tighten nut (10) to 15 lb-ft (20 N·m).
2. Install flat washer (6), pivot bracket (4), and mirror arm (7) on mounting bracket (5) with washer (3), lockwasher (2), and special nut (1).

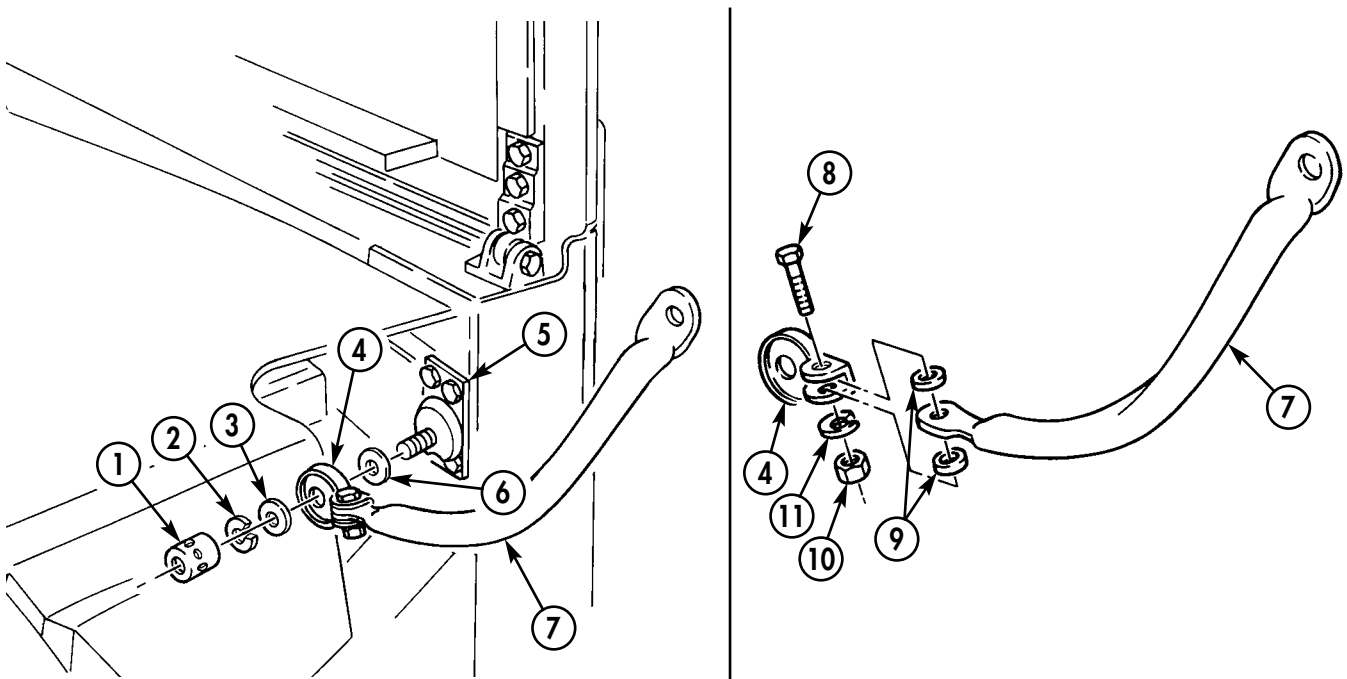

FOLLOW-ON TASK: Install mirror (para. 10-79).

10-81. MIRROR MOUNTING BRACKET REPLACEMENT

This task covers:

a. Removal

b. Installation

INITIAL SETUP:

Tools

General mechanic's tool kit:
automotive (Appendix B, Item 1)

Manual References

TM 9-2320-280-24P

Materials/Parts

Four locknuts (Appendix G, Item 79)

Equipment Condition

Mirror arm assembly removed (para. 10-80).

a. Removal

Remove four locknuts (5), capscrews (1), washers (2), and mounting bracket (3) from body (4). Discard locknuts (5).

b. Installation

Install mounting bracket (3) on body (4) with four washers (2), capscrews (1), and locknuts (5). Tighten capscrews (1) to 15 lb-ft (20 N•m).

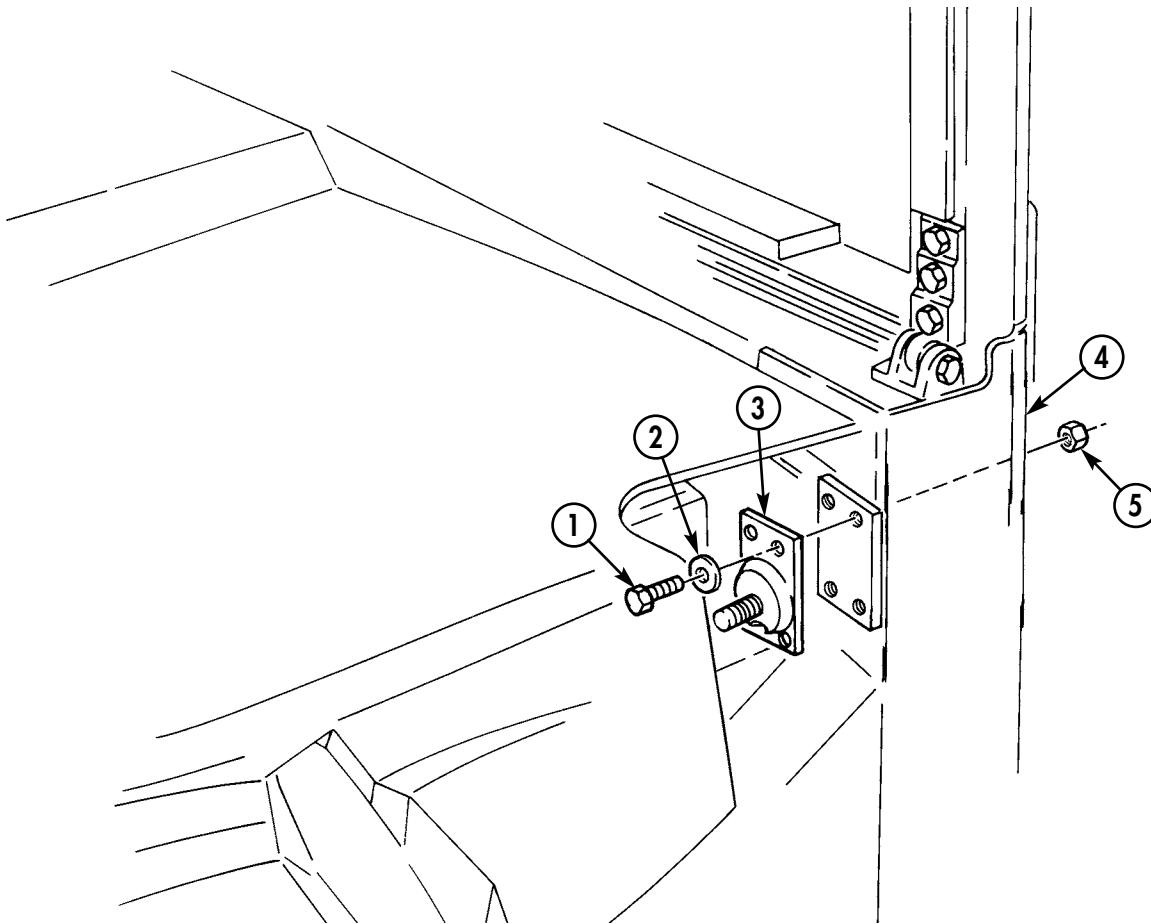

FOLLOW-ON TASK: Install mirror arm assembly (para. 10-80).

10-82. REARVIEW MIRROR MAINTENANCE

This task covers:

- | | |
|----------------|-----------------|
| a. Removal | d. Assembly |
| b. Inspection | e. Installation |
| c. Disassembly | |

INITIAL SETUP:

Tools

General mechanic's tool kit:
automotive (Appendix B, Item 1)

Manual References

TM 9-2320-280-24P

Materials/Parts

Three locknuts (Appendix G, Item 128)
Four lockwashers (Appendix G, Item 134)
Two locknuts (Appendix G, Item 79)

NOTE

Left and right rearview mirror removal procedures are basically the same. However, the left side rearview mirror upper mounting bracket may be mounted on the top (All A2 Series or M1123) or bottom (Basic/A1 Series) of the mirror assembly. This procedure covers the left rearview mirror.

a. Removal

Remove two capscrews (3), lockwashers (4), washers (5), upper mounting bracket (1), lower mounting bracket (6), and mirror assembly (2) from windshield frame (7). Discard lockwashers (4).

b. Inspection

NOTE

For inspection and removal of blind rivet or insertnut, refer to para. 10-66. Inspect blind rivet or insertnut (8) for damage. Replace with insertnut if damaged.

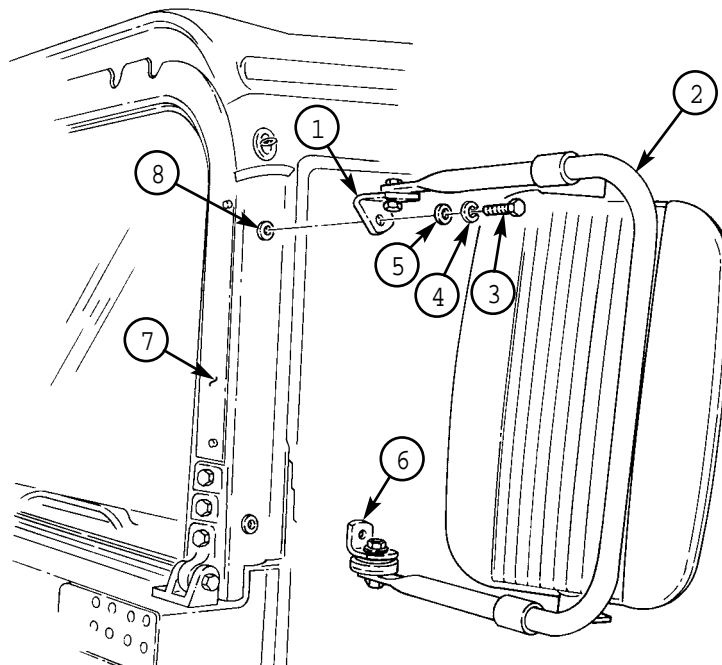

10-82. REARVIEW MIRROR MAINTENANCE (Cont'd)

c. Disassembly

1. Remove two capscrews (10), lockwashers (9), washers (8), spacers (6), and mirror head (5) from mirror brackets (7). Discard lockwashers (9).
2. Remove locknut (21), washer (22), nylon washers (23) and (2), capscrew (4) and upper mounting bracket (1) from mirror arm assembly (3). Discard locknut (21).
3. Remove locknut (20), washer (19), and lower mounting bracket (18) from mirror lock (17). Discard locknut (20).
4. Remove locknut (15), washer (16), and mirror lock (17) from arm assembly (3). Discard locknut (15).

NOTE

To remove clamps, slide clamps off mirror arm assembly.

5. Remove two locknuts (11), washers (12), capscrews (14), two clamps (13), and brackets (7) from mirror arm assembly (3). Discard locknuts (11).

d. Assembly

NOTE

- To install clamps, slide clamps on mirror arm assembly,
- Ensure clamps are positioned on mirror arm assembly to align with center of mirror head.

1. Install two clamps (13) and mirror brackets (7) on mirror arm assembly (3). Install mirror brackets (7) between clamps (13) with two capscrews (14), washers (12), and locknuts (11).
2. Install mirror lock (17) on mirror arm assembly (3) with washer (16) and locknut (15).
3. Install lower mounting bracket (18) on mirror lock (17) with washer (19) and locknut (20).
4. Install upper mounting bracket (1) on mirror arm assembly (3) with capscrew (4), nylon washers (2) and (23), washer (22), and locknut (21).

NOTE

Spacers must be positioned between mirror head and mirror brackets for proper installation,

5. Install mirror head (5) and two spacers (6) on mirror brackets (7) with washers (8), lockwashers (9), and capscrews (10).

10-82. REARVIEW MIRROR MOUNTING (Cont'd)

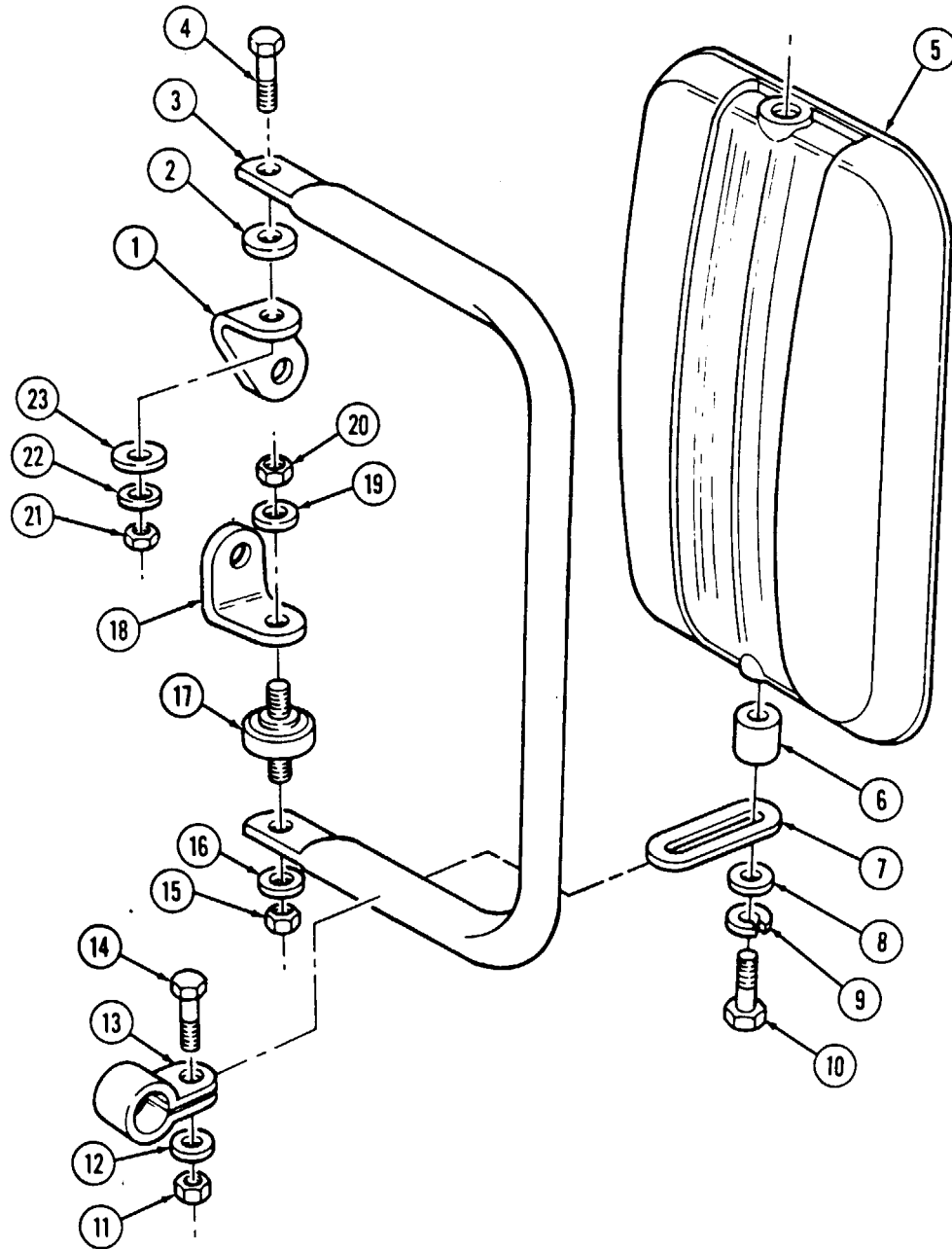

10-82. REARVIEW MIRROR MAINTENANCE (Cont'd)

e. Installation

Install mirror assembly (5) on windshield frame (1) with two washers (2), lockwashers (3), and capscrews (4).

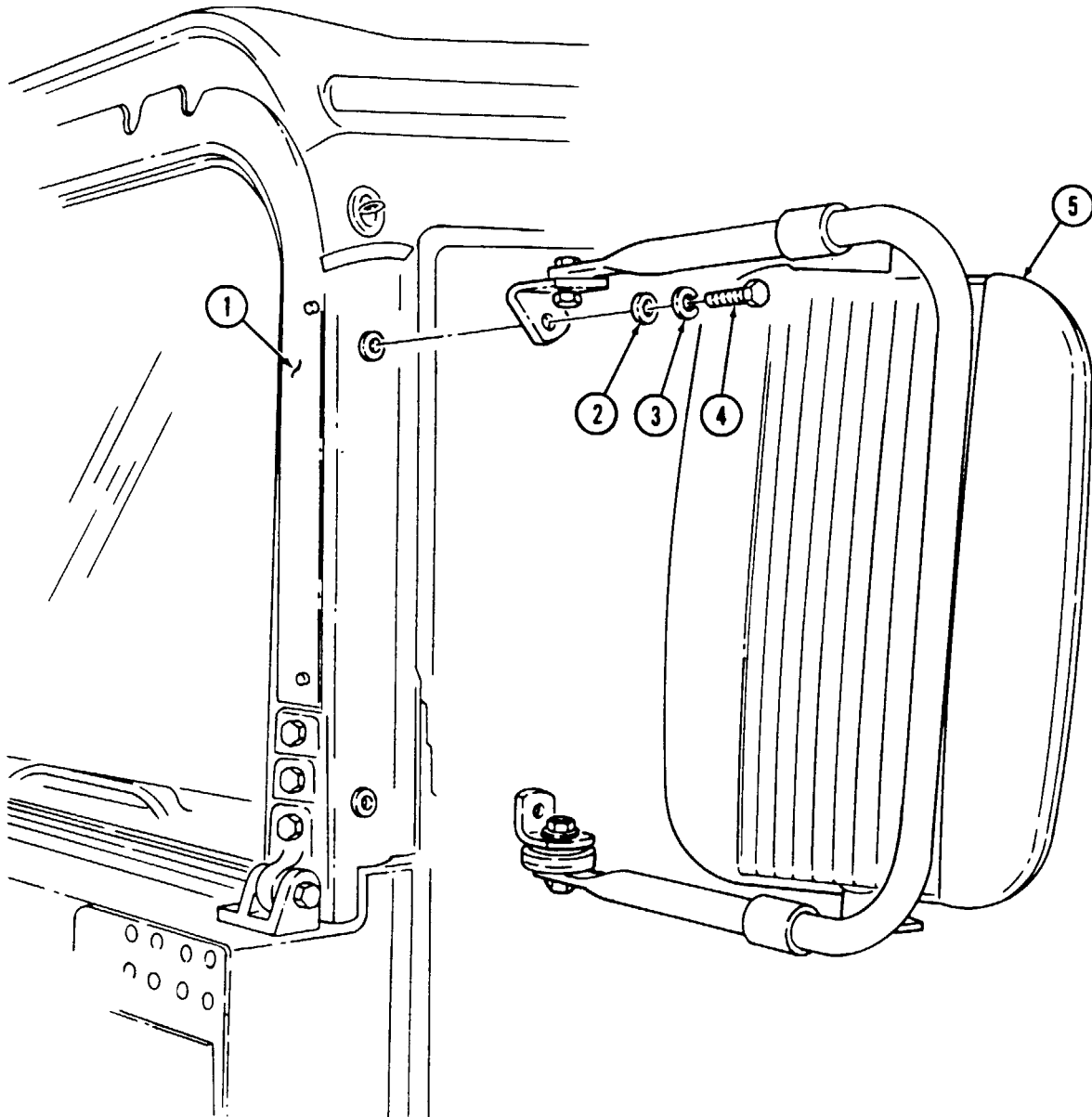

FOLLOW-ON TASK: Adjust rearview mirror (TM 9-2320-280-10).

10-83. HEATER SHUTOFF VALVE REPLACEMENT

This task covers:

a. Removal

b Installation

INITIAL SETUP:

Tools

General mechanic's tool kit
automotive (Appendix B, Item 1)

Equipment Condition

Cooling system drained as required (para. 3-60).

Manual References

TM 9-2320-280-10
TM 9-2320-280-24P

a. Removal

1. Remove screw (6) and clip (5) from shutoff valve (8).
2. Disconnect control wire (4) of heater control cable (7) from pin (3) of shutoff valve (8).
3. Loosen two clamps (2) and remove shutoff valve (8) from hoses (1).

b. Inspection

1. Connect shutoff valve (8) to two hoses (1) and tighten clamps (2).
2. Connect control wire (4) of heater control cable (7) to pin (3) of shutoff valve (8) with clip (5) and screw (6).

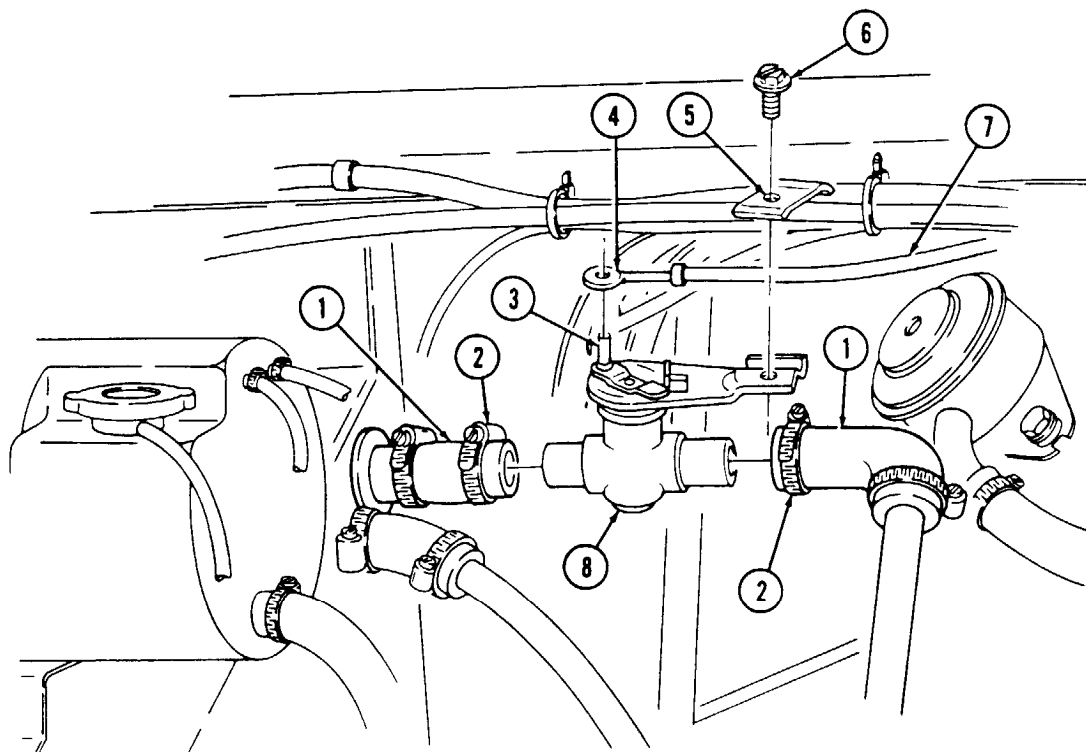

- FOLLOW-ON TASKS:
- Fill cooling system (para. 3-60).
 - Start engine (TM 9-2320-280-10) and check shutoff valve for leaks.

10-84. HEATER OUTLET/INLET PIPING MAINTENANCE

This task covers:

- a. Removal
- b. Inspection
- c. Installation

INITIAL SETUP:

Tools

General mechanic's tool kit:
automotive (Appendix B, Item 1)

Equipment Condition

Cooling system drained as required (para. 3-60).

Manual References

TM 9-2320-280-10
TM 9-2320-280-24P

NOTE

Procedures for installing and removing inlet and outlet piping are basically the same. This procedure covers the outlet piping.

a. Removal

1. Loosen clamp (9) from heater outlet hose (10) and water pump nipple (8) and disconnect outlet hose (10).
2. Remove nut (12), washer (7), capscrew (6), and washer (7) from inlet hose clamp (5) and outlet hose clamp (13).
3. Loosen clamp (2) and remove heater outlet hoses (3) and (10), and heater outlet tube (11) from vehicle.
4. Loosen two clamps (4) and remove heater outlet tube (11) from heater outlet hoses (3) and (10).
5. Remove clamps (2), (4), (13), and (9) from hoses (3) and (10).

b. Inspection

Inspect heater outlet port (1) and water pump nipple (8) for damage. Replace if damaged.

c. Installation

1. Install clamps (2), (4), (13), and (9) on hoses (3) and (10).
2. Connect two heater outlet hoses (3) and (10) to heater outlet tube (11) and tighten two clamps (4).
3. Install heater outlet hoses (3) and (10) and heater outlet tube (11) between heater outlet port (1) and water pump nipple (8).
4. Connect heater outlet hose (3) to heater outlet port (1) and tighten clamp (2).
5. Install outlet hose clamp (13) on inlet hose clamp (5) with washer (7), capscrew (6), washer (7), and nut (12).
6. Connect heater outlet hose (10) to water pump nipple (8) and tighten clamp (9).

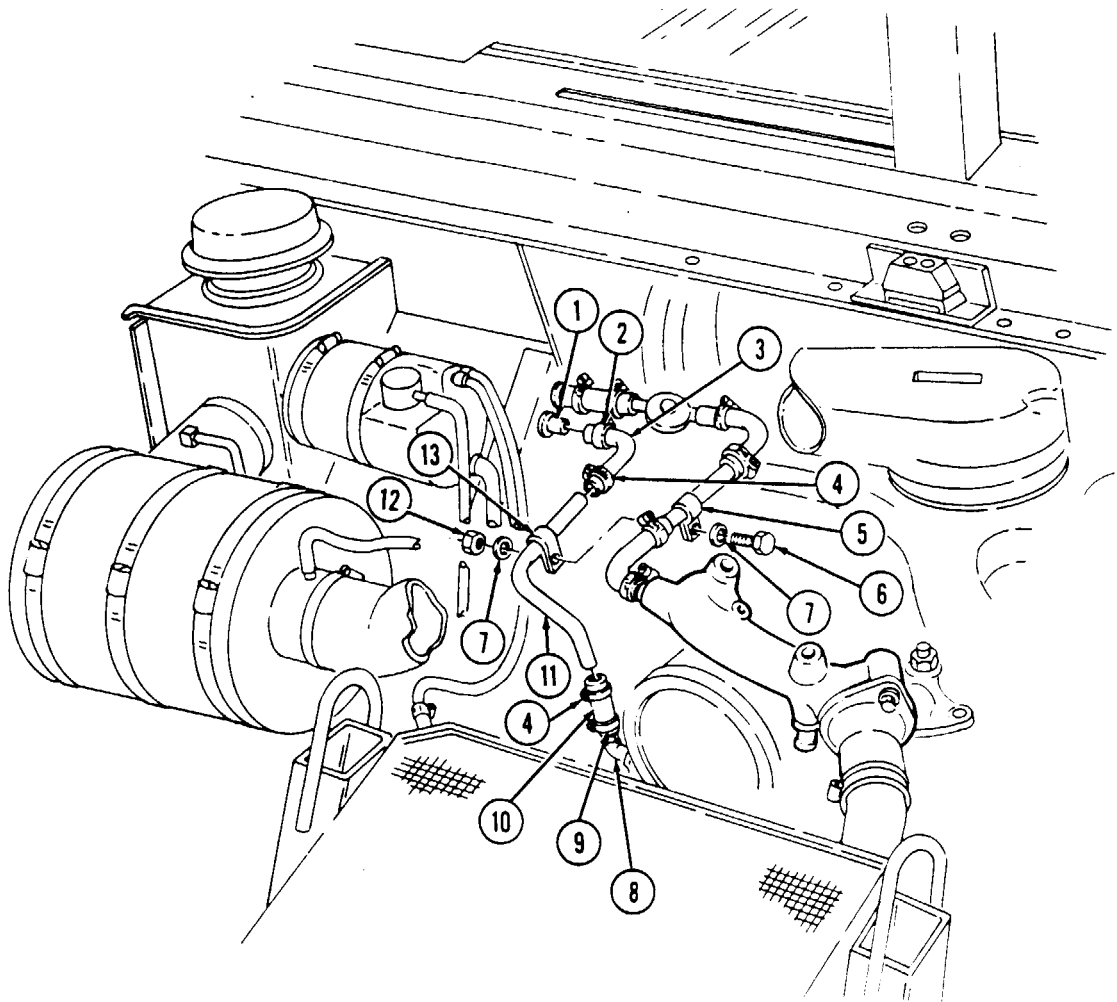
10-84. HEATER OUTLET/INLET PIPING MAINTENANCE (Cont'd)

- FOLLOW-ON TASKS:
- Fill cooling system (para. 3-60).
 - Start engine (TM 9-2320-280-10) and check outlet piping for leaks.

10-85. HEATER FAN SWITCH REPLACEMENT

This task covers:

- a. Removal b. Installation
-

INITIAL SETUP:

Tools

General mechanic's tool kit
automotive (Appendix B, Item 1)

Equipment Condition

Battery ground cable disconnected (para. 4-73).

Manual References

TM 9-2320-280-10
TM 9-2320-280-24P

a. Removal

1. Remove four capscrews (8) from instrument cluster (1) and instrument panel (6), and pull instrument cluster (1) away from panel (6) for access to fan switch (2).
2. Remove two screws (7) from fan switch (2) and panel (6).
3. Pull fan switch (2) out from behind panel (6).

NOTE

Prior to removal, tag leads for installation.

4. Disconnect leads 399 (3), 27D (4), and 400 (5) from fan switch (2) and remove fan switch (2).

b. Installation

1. Connect leads 399 (3), 27D (4), and 400 (5) to fan switch (2).
2. Install fan switch (2) on panel (6) with two screws (7).
3. Install instrument cluster (1) on panel (6) with four capscrews (8).

10-85. HEATER FAN SWITCH REPLACEMENT (Cont'd)

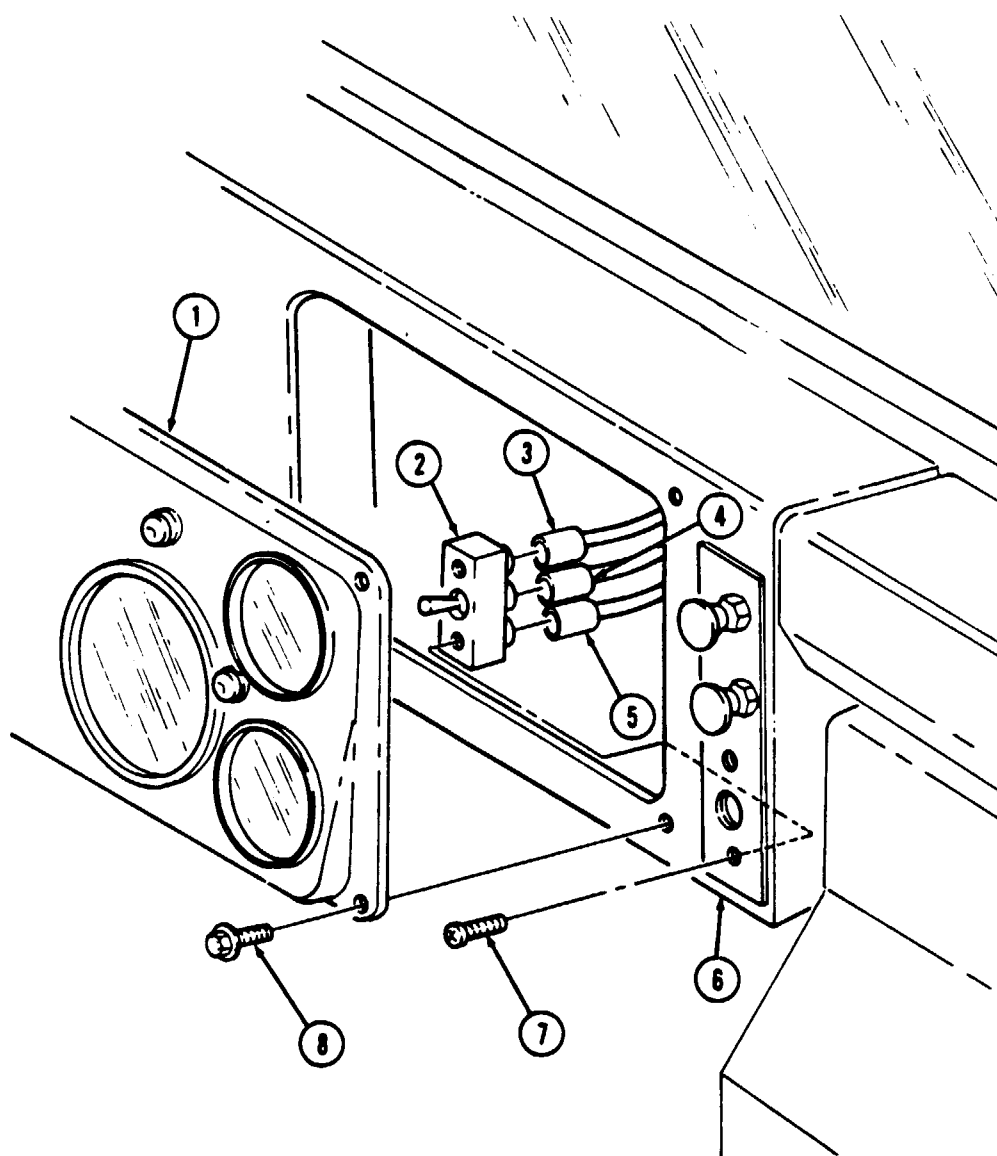

- FOLLOW-ON TASKS:
- Connect battery ground cable (para 4-73).
 - Check heater fan for proper operation (TM 9-2320-280-10).

10-86. HEATER FAN MOTOR RESISTOR ASSEMBLY REPLACEMENT

This task covers:

a. Removal

b. Installation

INITIAL SETUP

Tools

General mechanic's tool kit
automotive (Appendix B, Item 1)

Equipment Condition

Battery ground cable disconnected (para. 4-73).

Manual References

TM 9-2320-280-10
TM 9-2320-280-24P

a. Removal

1. Remove four capscrews (12) from instrument cluster (1) and instrument panel (2), and pull instrument cluster (1) away from panel (2) for access to resistor assembly (5).
2. Remove two screws (11) and heater fan switch (8) from panel (2). Pull heater fan switch (8) out from behind panel (2).

NOTE

Prior to removal, tag leads for installation.

3. Disconnect leads 399 (3) and 400 (6) from heater fan switch (8). Disconnect lead 400 (4) from harness lead 400D (7).
4. Loosen two screws (9) and nuts (10) and remove resistor assembly (5) from panel (2).

b. Installation

1. Connect lead 400 (4) to harness lead 400D (7). Connect leads 400 (6) and 399 (3) to heater fan switch (8).
2. Install resistor assembly (5) on panel (2) and tighten two screws (9) and nuts (10).
3. Install heater fan switch (8) on panel (2) with two screws (11).
4. Install instrument cluster (1) on panel (2) with four capscrews (12).

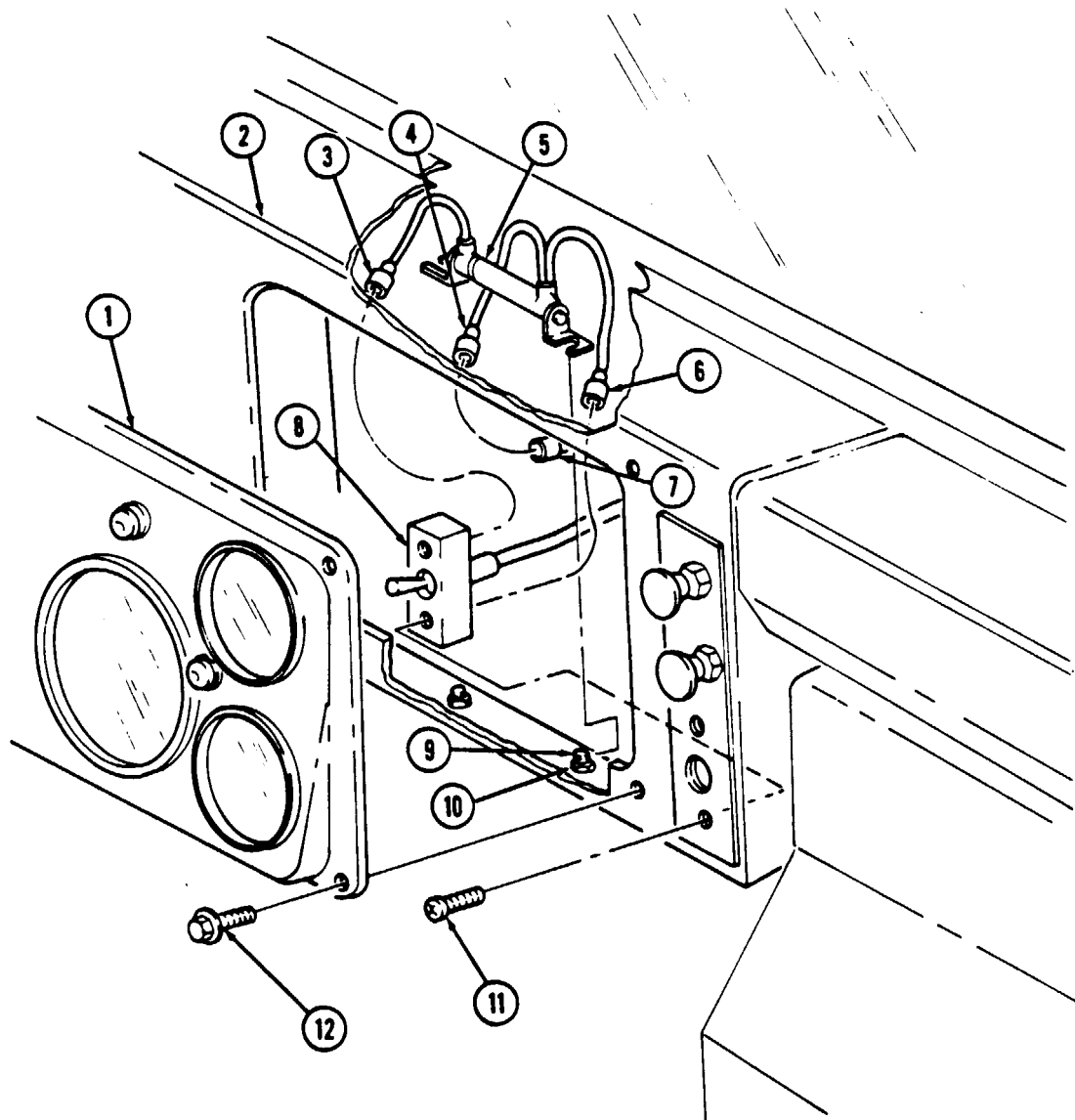
10-86. HEATER FAN MOTOR RESISTOR ASSEMBLY REPLACEMENT (Cont'd)

- FOLLOW-ON TASKS:
- Connect battery ground cable (para. 4-73).
 - Check heater fan for proper operation (TM 9-2320-280-10).

10-87. HEATER ASSEMBLY REPLACEMENT

This task covers:

a. Removal

b. Installation

INITIAL SETUP:

Tools

General mechanic's tool kit:
automotive (Appendix B, Item 1)

Manual References

TM 9-2320-280-10
TM 9-2320-280-24P

Materials/Parts

Four locknuts (Appendix G, Item 79)
Plain-assembled nut (Appendix G, Item 201)
Tiedown strap (Appendix G, Item 307)

Equipment Condition

- Battery ground cable disconnected (para. 4-73).
- Cooling system drained as required (para. 3-60).
- Weathercap removed (para. 3-18).
- Air cleaner assembly removed (para. 3-12).

a. Removal

1. Remove tiedown strap (11) from cable (12) and clamp (10). Discard tiedown strap (11).
2. Loosen clamp (10) and disconnect diverter box duct (8) from heater assembly (9).
3. Disconnect harness lead 400D (13) from heater assembly lead (14).
4. Remove plain-assembled nut (18) and lead 57E (19) from heater assembly (9). Discard plain-assembled nut (18).
5. Loosen two clamps (1) and disconnect heater inlet hose (2) and heater outlet hose (16) from inlet port (3) and outlet port (15).
6. Loosen clamp (21) and remove hose (20) from clamp (21) on heater assembly (9).
7. Remove three screws (23) and washers (24) from air intake neck (22) and cowl (25). Remove neck (22) for access to heater mounting hardware.
8. Remove four locknuts (4), washers (5), capscrews (6), and washers (5) from heater assembly (9) and body (7). Discard locknuts (4).
9. Remove ten clips (26) from heater boot (27) and heater assembly (9).
10. Slide heater assembly (9) right and away from firewall (17) to allow heater inlet port (3) and outlet port (15) to clear grommet openings in firewall (17) and remove heater assembly (9).

b. Installation

1. Install heater assembly (9) on firewall (17) and insert heater inlet port (3) and heater outlet port (15) through grommet openings in firewall (17).
2. Install heater boot (27) on heater assembly (9) with ten clips (26).
3. Install heater assembly (9) on body (7) with four washers (5), capscrews (6), washers (5), and locknuts (4). Tighten locknuts (4) to 15 lb-ft (20 N•m).
4. Install air intake neck (22) on cowl (25) with three washers (24) and capscrews (23). Tighten capscrews (23) to 6 lb-ft (8 N•m).
5. Connect heater inlet hose (2) and heater outlet hose (16) to heater assembly (9) inlet port (3) and outlet port (15) and tighten two clamps (1).
6. Install lead 57E (19) to heater assembly (9) with plain-assembled nut (18).
7. Connect harness lead 400D (13) to heater assembly lead (14).
8. Connect diverter box duct (8) to heater assembly (9) and tighten clamp (10).
9. Install hose (20) in clamp (21) on heater assembly (9) and tighten clamp (21).
10. Install cable (12) on clamp (10) with tiedown strap (11).

10-87. HEATER ASSEMBLY REPLACEMENT (Cont'd)

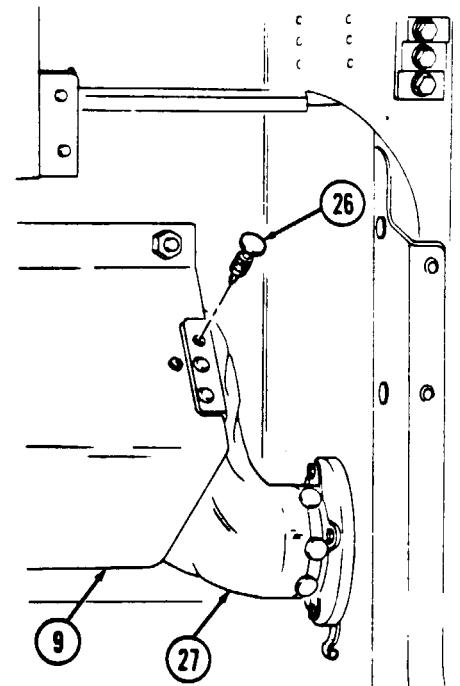
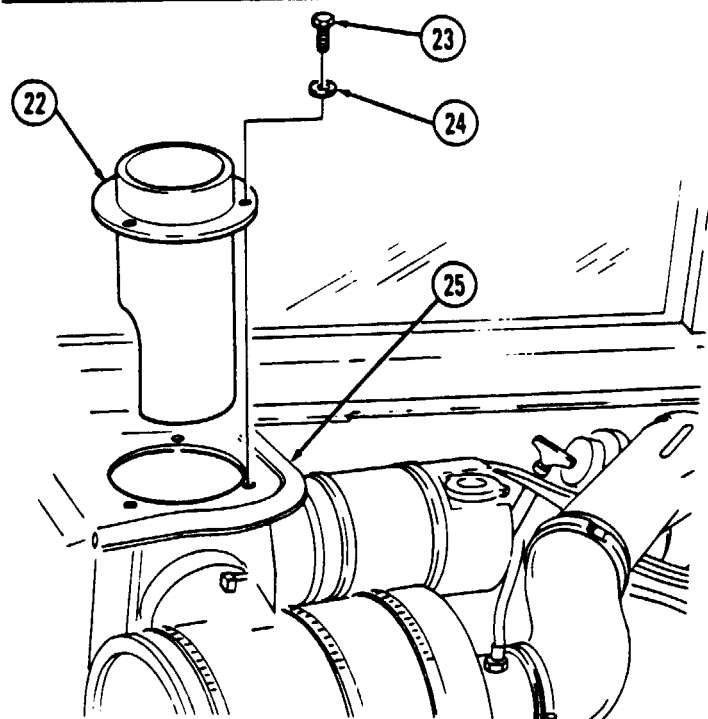
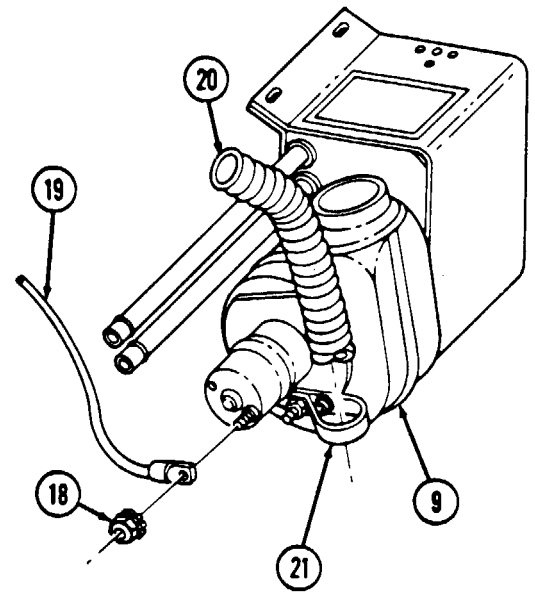
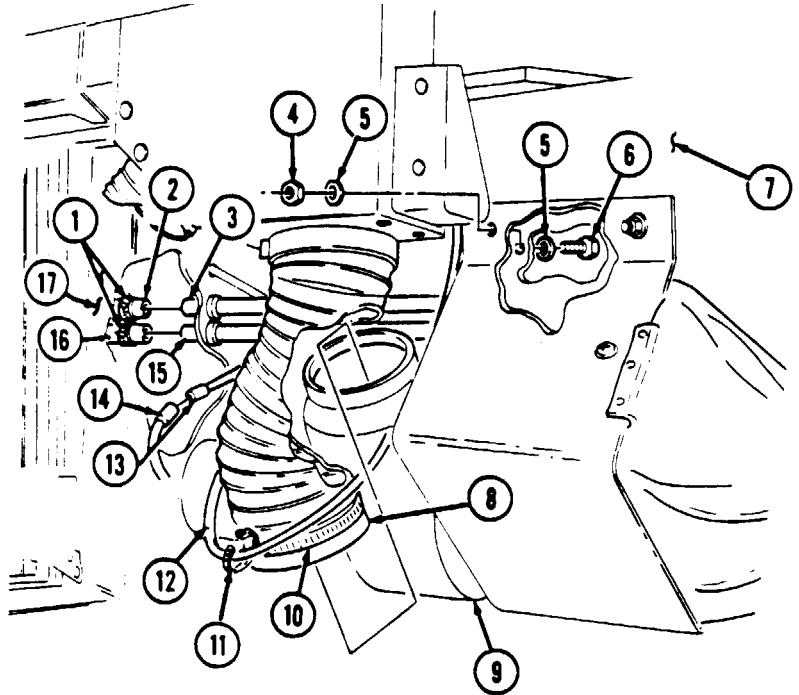

- FOLLOW-ON TASKS:
- Install weathercap (para. 3-18).
 - Install air cleaner assembly (para. 3-12).
 - Connect battery ground cable (para. 4-73).
 - Fill cooling system (para. 3-60).
 - Check heater assembly for proper operation (TM 9-2320-280-10).

10-88. DEFROST CONTROL REPLACEMENT

This task covers:

a. Removal

b. Installation

INITIAL SETUP:

Tools

General mechanic's tool kit:
automotive (Appendix B, Item 1)

Manual References

TM 9-2320-280-10
TM 9-2320-280-24P

Materials/Parts

Tiedown strap (Appendix G, Item 307)
Plug button (Appendix G, Item 8)
Lockwasher (Appendix G, Item 143)

Equipment Condition

- Hood raised and secured (TM 9-2320-280-10).
- Engine access cover removed (para. 10-15).

a. Removal

1. Remove four capscrews (2) from instrument cluster (5) and instrument panel (3).
2. Pull instrument cluster (5) away from panel (3).
3. Remove nut (15), lockwasher (16), screw (9), clamp (14), and control cable (6) from diverter box bracket (10). Discard lockwasher (16).
4. Remove plug button (12) from control wire (13) and baffle pin (11). Discard plug button (12).
5. Disconnect control wire (13) from baffle pin (11) on diverter box bracket (10).
6. Remove tiedown strap (18) from control cable (6) and hose clamp (17). Discard tiedown strap (18).
7. Pull control cable (6) through firewall (19) and three clamps (7) on "A" beam (8) and firewall (19).
8. Remove nut (4) from threaded shaft (1) and instrument panel (3) and pull control cable (6) through panel (3).

b. Installation

1. Feed control cable (6) through instrument panel (3) and install threaded shaft (1) on panel (3) with nut (4).
2. Route control cable (6) through three clamps (7) on "A" beam (8) and firewall (19).
3. Connect control wire (13) to baffle pin (11) on diverter box bracket (10) with plug button (12).

NOTE

Control wire and knob must be pushed in, and baffle pin must be in the upward position before securing control cable to diverter box.

4. Install clamp (14) on control cable (6) and diverter box bracket (10) with screw (9), lockwasher (16), and nut (15).
5. Install control cable (6) on hose clamp (17) with tiedown strap (18).
6. Install instrument cluster (5) on panel (3) with four capscrews (2).

10-88. DEFROST CONTROL REPLACEMENT (Cont'd)

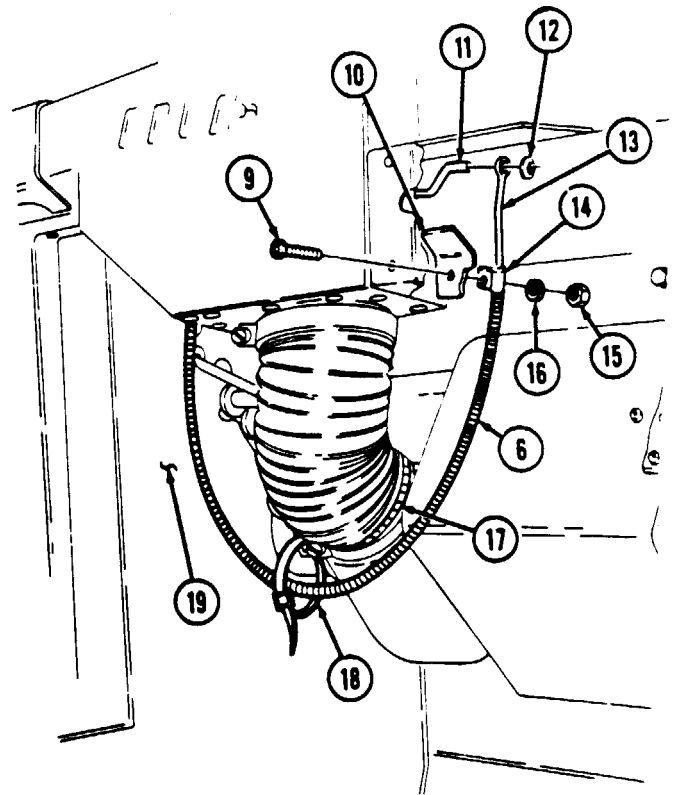
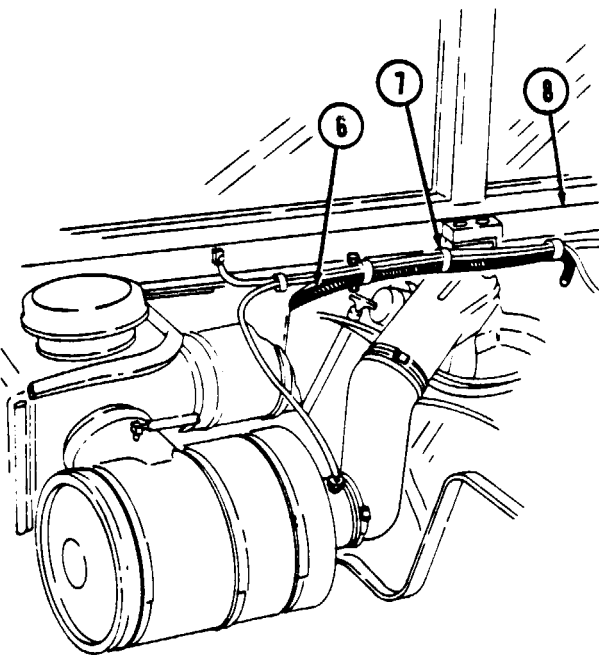
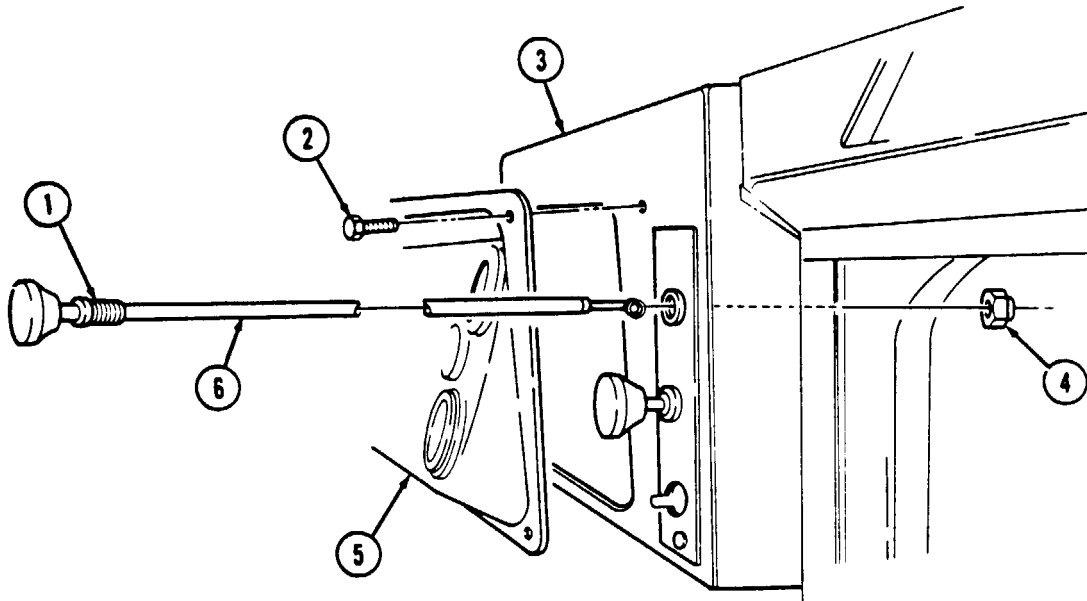

- FOLLOW-ON TASKS:**
- Lower and secure hood (TM 9-2320-280-10).
 - Install engine access cover (para. 10-15).
 - Check defroster control for proper operation (TM 9-2320-280-10).

10-89. HEATER CONTROL REPLACEMENT

This task covers:

- a. Removal b. Installation
-

INITIAL SETUP:

Tools

General mechanic's tool kit:
automotive (Appendix B, Item 1)

Equipment Condition

- Hood raised and secured (TM 9-2320-280-10).
- Engine access cover removed (pars. 10-15).

Manual References

TM 9-2320-280-10
TM 9-2320-280-24P

a. Removal

1. Remove screw (12) and clamp (11) from cable (7) and heater shutoff valve (15).
2. Remove control wire (10) from pin (9) on heater shutoff valve (15).
3. Carefully work cable (7) through three clips (13) along "A" beam (14).
4. Remove four capscrews (2) from instrument cluster (6) and instrument panel (3).
5. Pull instrument cluster (6) away from instrument panel (3).
6. Loosen nut (4) and slide along cable (7).
7. Pull cable (7) through nut (4) and instrument panel (3).

b. Installation

1. Feed cable (7) through instrument panel (3) and seat threaded shaft (1) in grommet (5).
2. Place nut (4) over cable (7) and secure threaded shaft (1) on instrument panel (3) by tightening nut (4).
3. Install instrument cluster (6) on instrument panel (3) with four capscrews (2).
4. Feed cable (7) carefully through three clips (13) along "A" beam (14).
5. Slip coiled end of control wire (10) over pin (9).

NOTE

Control wire and knob must be pushed in, and pin and lever rotated toward heater before anchoring cable to shutoff valve.

6. With control wire (10) and knob all the way in and pin (9) moved as close to heater (8) as possible, install cable (7) on shutoff valve (15) with clamp (11) and screw (12).

10-89. HEATER CONTROL REPLACEMENT (Cont'd)

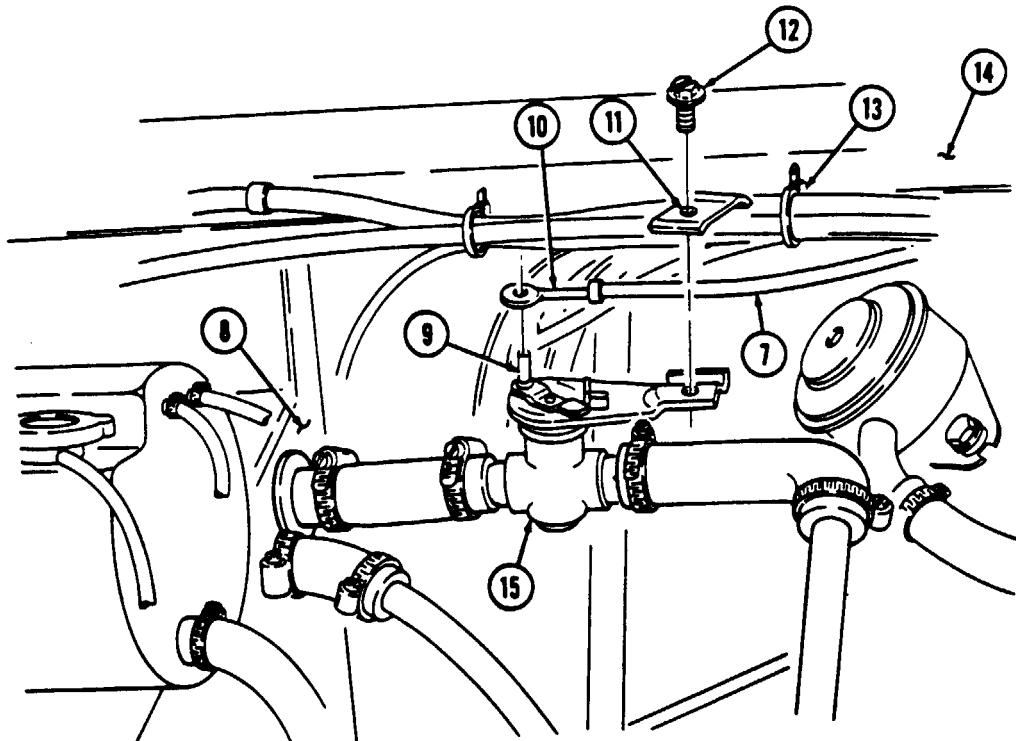
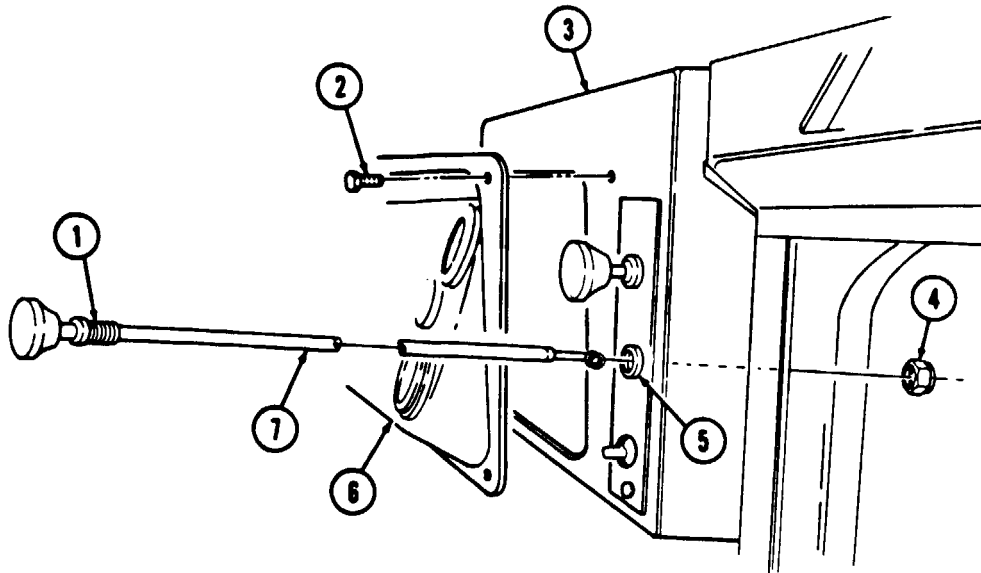

- FOLLOW-ON TASKS:
- Lower and secure hood (TM 9-2320-280-10).
 - Install engine access cover (para. 10-15).
 - Check heater control for proper operation (TM 9-2320-280-10).

10-90. HEATER CONTROL CABLE AND SHUTOFF VALVE ADJUSTMENT

This task covers:

Adjustment

INITIAL SETUP:

Tools

General mechanic's tool kit:
automotive (Appendix B, Item 1)

Manual References

TM 9-2320-280-10
TM 9-2320-280-24P

Materials/Parts

Lubricating oil (Appendix C, Item 32)

General Safety Instructions

Ensure engine is cool prior to performing this procedure.

NOTE

Perform the following procedure if the heater temperature control assembly is difficult to operate. The repositioning of the heater temperature control cable and heater shutoff valve will reduce cable bends and allow access for lubrication.

Adjustment

1. Push heater control knob (18) to "OFF" position.

WARNING

Ensure engine is cool prior to performing this procedure. Steam or hot coolant under pressure can cause injury to personnel.

2. Loosen two clamps (3) on hoses (4).
3. Rotate heater shutoff valve (1) and position heater shutoff valve lever (5) in the upward position.
4. Tighten two clamps (3) on hoses (4).
5. Loosen screw (14) and clip (13) and remove cable assembly (2) from heater shutoff valve (1).
6. Remove screw (8), washer (9), clamp (10), and crankcase depression regulator valve (11) from mounting bracket (12).
7. Install crankcase depression regulator valve (11) on mounting bracket (12) with screw (8) and washer (9).
8. Cut loop end (6) from spring wire (7). Cut as close to loop end (6) as possible.
9. Remove spring wire (7) from steel casing (16) and tube (15) by pulling heater control knob (18). Remove any kinks in spring wire (7).

NOTE

If control cable is 47.5 in. (1207 mm) in length, perform step 10.

10. Remove a 5 in. (127.0 mm) section from steel casing (16).
11. Route steel casing (16) through clamp (20).
12. Install spring wire (7) into steel casing (16) and tube (15).
13. Position end of steel casing (16) 0.75 in. (19.0 mm) from clip (13) and install steel casing (16) on heater shutoff valve (1) with clip (13) and screw (14).
14. Position heater control knob (18) 0.125 in. (3.18 mm) from instrument panel (17).
15. Turn spring wire (7) three turns around heater shutoff valve pin (21). Cut off any excess spring wire (7).
16. Pull out heater control knob (18) to "ON" position.
17. Apply lubricating oil to heater shutoff valve lever (5) and shutoff valve pin (21).
18. Apply lubricating oil to plunger (19).
19. Move heater control knob (18) to "OFF" and "ON" several times to distribute oil.
20. Check engine coolant level (TM 9-2320-280-10).
21. Start engine (TM 9-2320-280-10) and check heater shutoff valve (1) connections for leaks.

10-90. HEATER CONTROL CABLE AND SHUTOFF VALVE ADJUSTMENT (Cont'd)

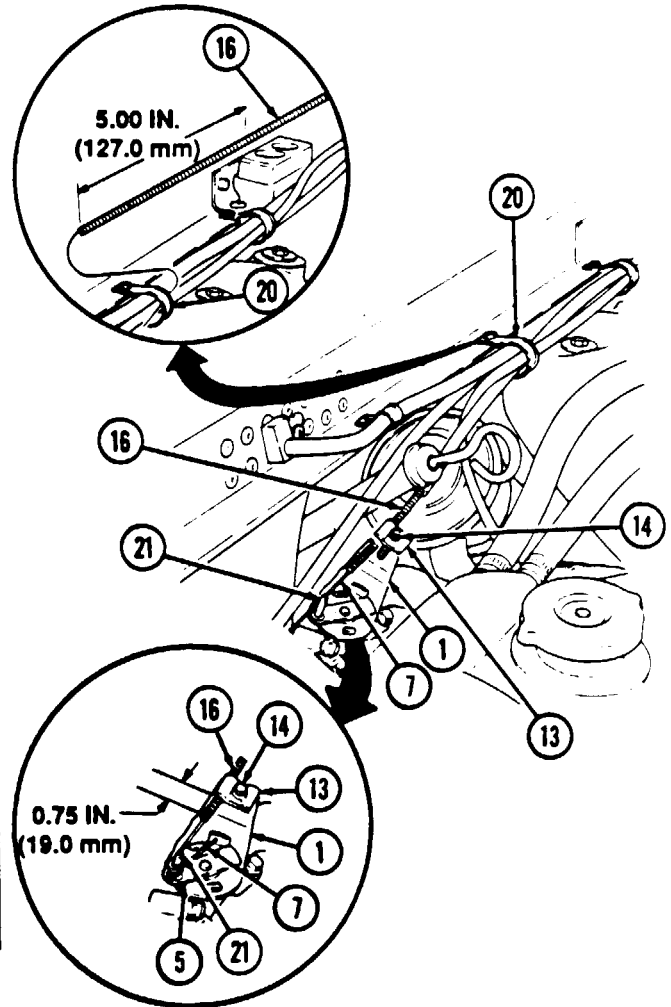
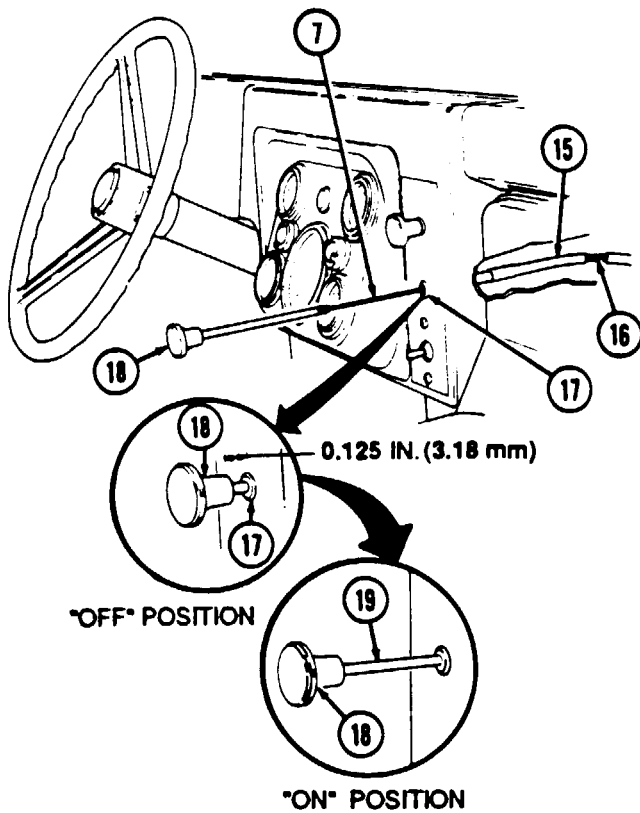
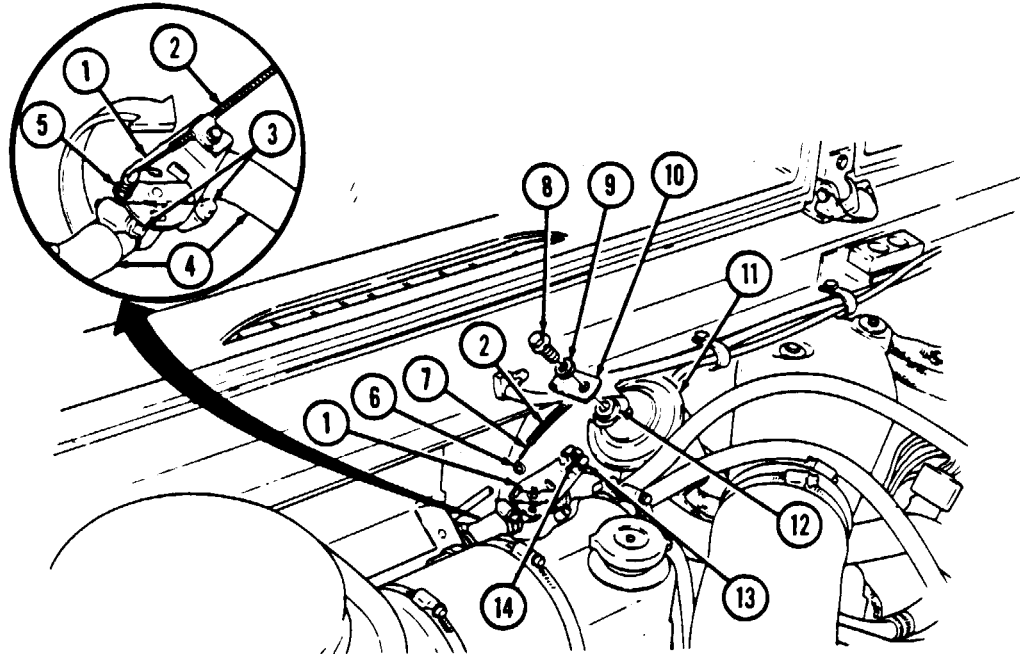

10-91. HEATER DUCTING REPLACEMENT

This task covers:

a. Removal

b. Installation

INITIAL SETUP:

Tools

General mechanic's tool kit:
automotive (Appendix B, Item 1)

Manual References

TM 9-2320-280-10
TM 9-2320-280-24P

Materials/Parts

Two locknuts (Appendix G, Item 70)

Equipment Condition

- Engine access cover removed (para. 10-15).
- Front radio rack assembly removed, if equipped (para. 12-132).

a. Removal

NOTE

- Perform steps 1 and 2 for vehicles with new configuration.
 - Proceed to step 3 for vehicles with old configuration.
1. Remove two capscrews (8.1) and washers (8.2) securing two radio rack upper mounting brackets (8.3) to plenum (7).
 2. Remove nine screws (8) securing plenum (7) to "A" beam (4).
 3. Remove nine screws (8), two capscrews (6), and washers (5) securing plenum (7) to "A" beam (4).
 4. Disconnect connector (23) from light switch (10).
 5. Remove two locknuts (25), washers (11), capscrews (12), and washers (11) securing instrument panel (9) to firewall (24). Discard locknuts (25).
 6. Remove nut (19), washer (18), capscrew (17), and washer (18) securing panel (9) and hand throttle bracket (15) to steering column bracket (20).
 7. Remove nut (13) and screw (16) securing hand throttle bracket (15) to instrument panel (9).
 8. Remove screw (14) securing panel (9) to firewall (24) and pull panel (9) away from "A" beam (4) for access to heat flex duct (1).
 9. Remove clamp (2) securing heat flex duct (1) to "A" beam (4) and plenum bracket (3).
 10. Remove clamp (22) securing heat flex duct (1) to steering column mount (21) and remove heat flex duct (1).

b. Installation

1. Install heat flex duct (1) to steering column mount (21) and secure with clamp (22).
2. Secure heat flex duct (1) to "A" beam (4) and plenum bracket (3) with clamp (2).
3. Place panel (9) back to "A" beam (4). Secure panel (9) to firewall (24) with screw (14).
4. Secure panel (9) and hand throttle bracket (15) to steering column bracket (20) with washer (18), capscrew (17), washer (18), and nut (19).
5. Secure hand throttle bracket (15) to instrument panel (9) with screw (16) and nut (13).
6. Secure panel (9) to firewall (24) with two washers (11), capscrews (12), washers (11), and locknuts (25).
7. Connect connector (23) to light switch (10).

NOTE

- Perform steps 8 and 9 for vehicles with new configuration.
 - Proceed to step 10 for vehicles with old configuration.
8. Install plenum (7) on "A" beam (4) with nine screws (8).
 9. Install two radio rack upper mounting brackets (8.3) to plenum (7) with two washers (8.2) and capscrews (8.1).
 10. Install plenum (7) on "A" beam (4) with nine screws (8), two washers (5), and capscrews (6).

10-91. HEATER DUCTING REPLACEMENT(Cont'd)

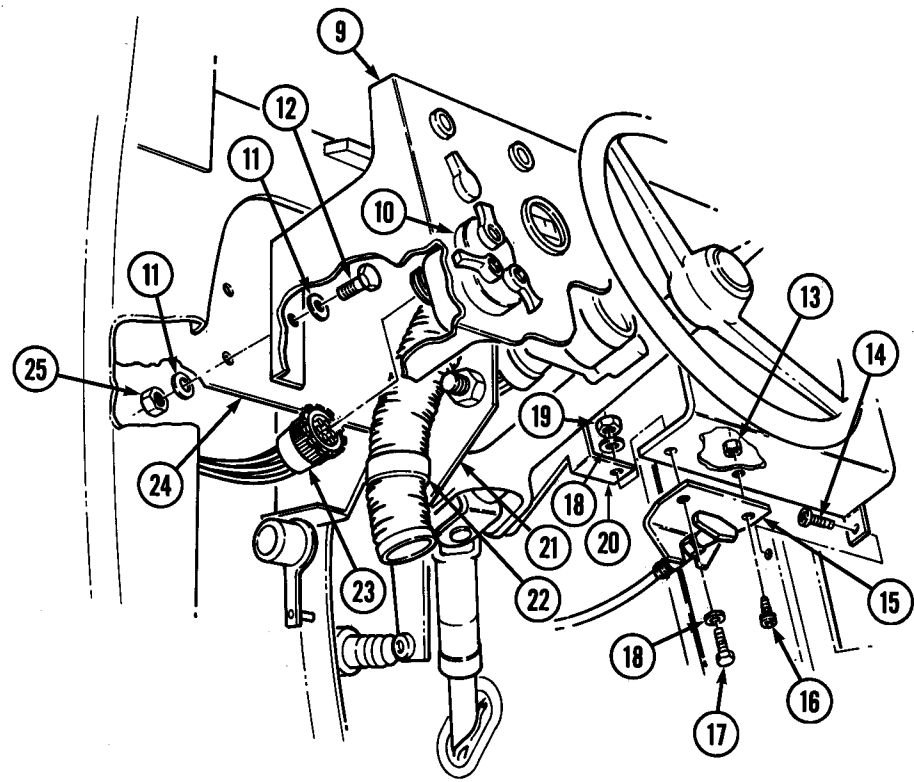
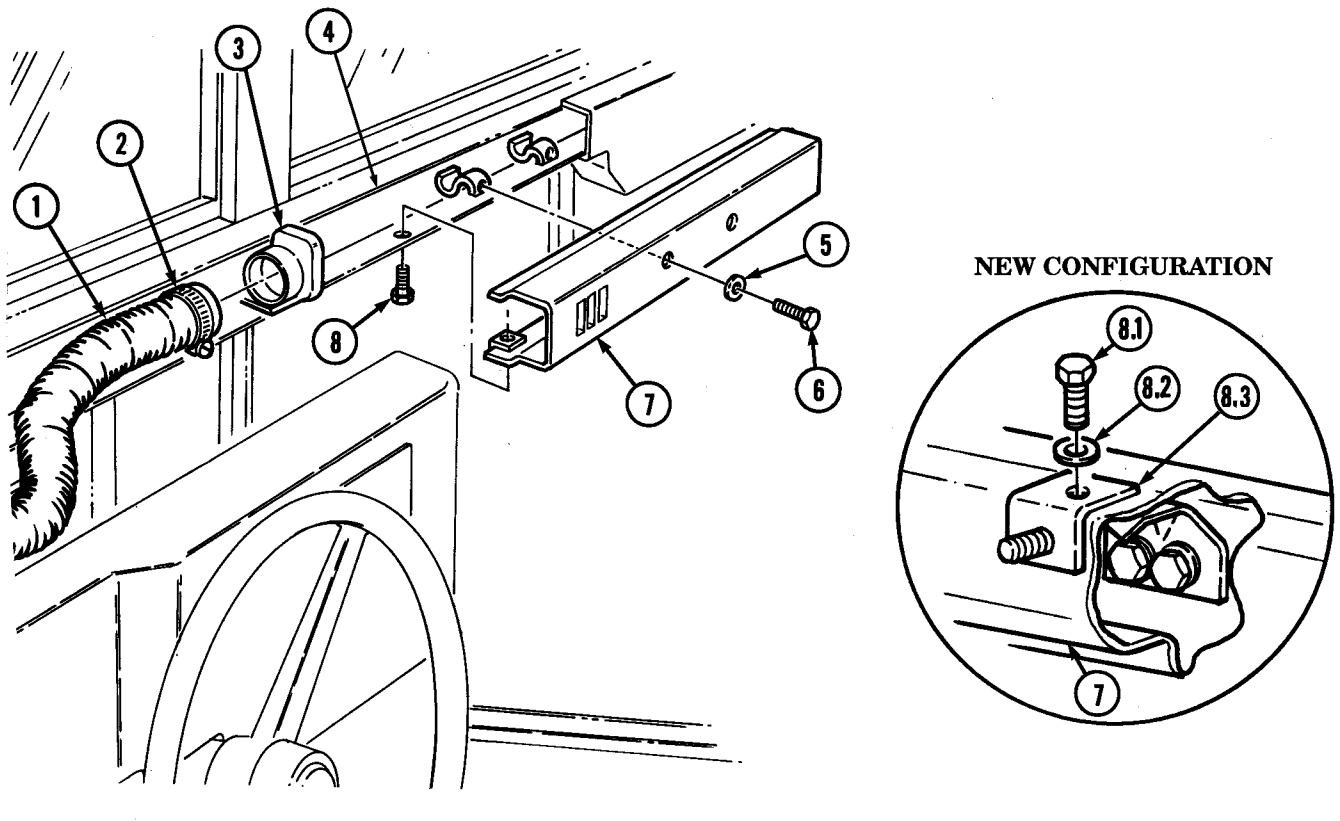

- FOLLOW-ON TASKS:**
- Install engine access cover (para. 10-15).
 - Install front radio rack assembly, if equipped (para. 12-132).

10-92. DIVERTER BOX REPLACEMENT (ALL EXCEPT M998A2)

This task covers:

a. Removal

b. Installation

INITIAL SETUP:

Applicable Models

All except M998A2 series and M1123

Tools

General mechanic's tool kit:
automotive (Appendix B, Item 1)

Materials/Parts

Lockwasher (Appendix G, Item 143)
Plug button (Appendix G, Item 8)

Manual References

TM 9-2320-280-24P

a. Removal

1. Loosen clamp (12) and disconnect heater flex duct (11) from bottom of diverter box (16).
2. Loosen clamp (15) and disconnect heater flex duct (14) from diverter box (16).
3. Remove nut (8), lockwasher (9), screw (13), and clip (10) from diverter box (16). Discard lockwasher (9).
4. Remove plug button (7) and disconnect cable core (6) from baffle pin (5). Discard plug button (7).
5. Remove three screws (17) from diverter box (16), right mounting bracket (3), and "A" beam (1).
6. Pull diverter box (16) away from "A" beam (1) and loosen two clamps (4) on defroster flex ducts (2) and remove diverter box (16).

b. Installation

1. Position diverter box (16) under "A" beam (1) and connect two defroster flex ducts (2) to diverter box (16) and tighten clamps (4).
2. Install diverter box (16) on "A" beam (1) and right mounting bracket (3) with three screws (17).
3. Connect defroster cable core (6) to baffle pin (5) with plug button (7).

NOTE

Control cable must be pushed in, and baffle pin must be in the upward position before installing control cable on diverter box.

4. Install clip (10) on diverter box (16) with screw (13), lockwasher (9), and nut (8).
5. Connect heater flex duct (11) to bottom of diverter box (16) and tighten clamp (12).
6. Connect heater flex duct (14) to diverter box (16) and tighten clamp (15).

10-92. DIVERTER BOX REPLACEMENT (ALL EXCEPT M998A2) (Cont'd)

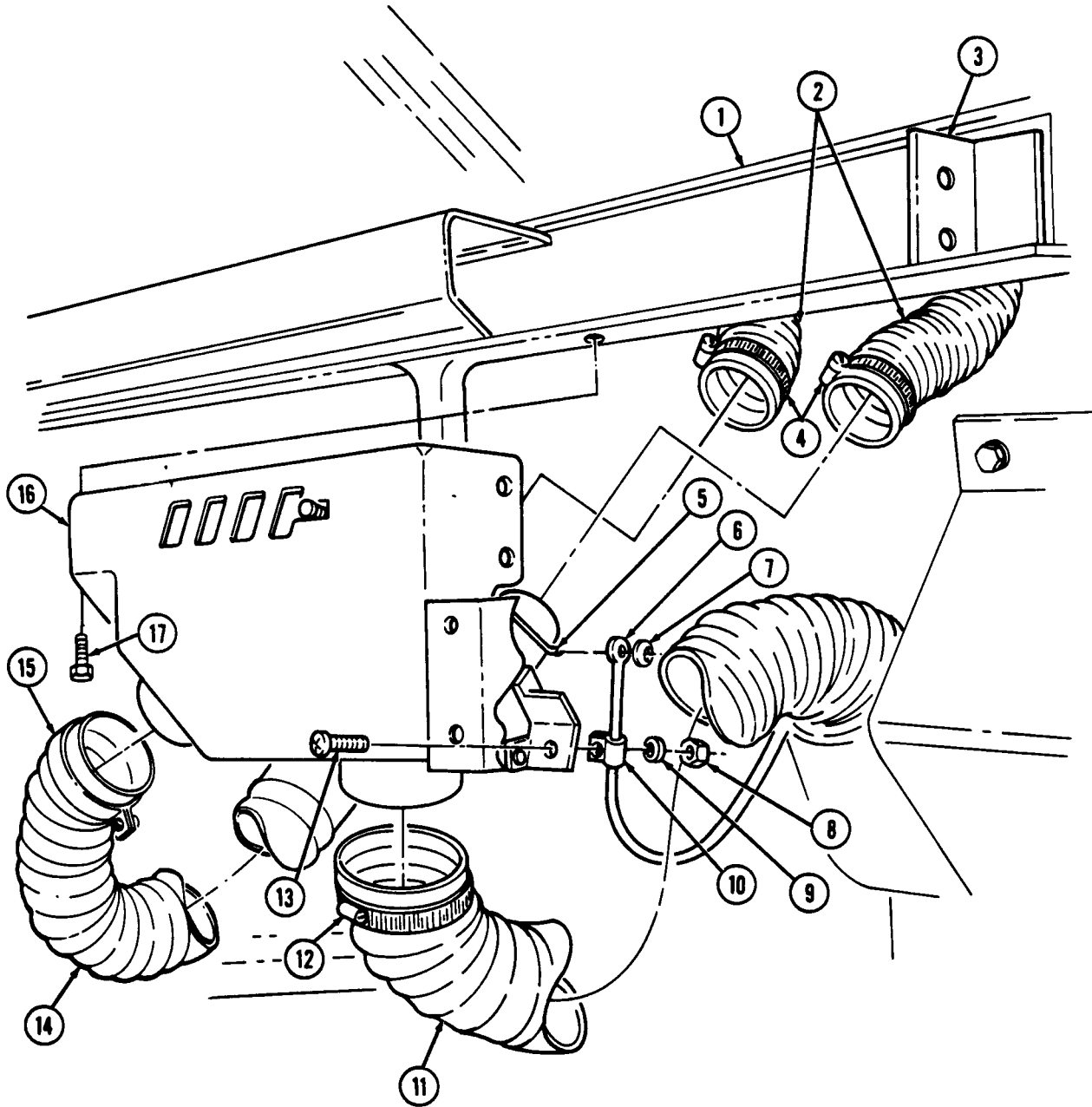

10-92.1. DIVERTER MANIFOLD AND HOUSING REPLACEMENT

This task covers:

a. Removal

b. Installation

INITIAL SETUP:

Applicable Models

M997A2, M1025A2, M1035A2, M1043A2,
M1045A2, M1097A2, M1123

Materials/Parts

Plug button (Appendix G, Item 8)
Four rivets (Appendix G, Item 258)

Tools

General mechanic's tool kit:
automotive (Appendix B, Item 1)

Manual References

TM 9-2320-280-24P

a. Removal

1. Remove four screws (16) and panel assembly (15) from right mounting bracket (3) and "A" beam (1).
2. Remove four rivets (14) from manifold and housing (9) and duct (13).
3. Remove two screws (8) from manifold and housing (9) and heater (7).
4. Remove screw (6) from clip (5) and manifold and housing (9).
5. Remove plug button (10) and disconnect defroster cable core (12) from baffle pin (11). Discard plug button (10).
6. Pull manifold and housing (9) away from "A" beam (1) and loosen two clamps (4) securing defroster flex ducts (2) to manifold and housing (9).
7. Remove manifold and housing (9) from heater (7).

b. Installation

1. Position manifold and housing (9) under "A" beam (1) and connect two defroster flex ducts (2) to manifold and housing (9) with two clamps (4).
2. Connect defroster cable core (12) to baffle pin (11) and install plug button (10).
3. Install duct (13) on manifold and housing (9) with four rivets (14).

NOTE

Ensure diverter control knob is pushed into cowl and baffle pin is in the downward position before securing control cable to diverter box.

4. Install clip (5) on manifold and housing (9) with screw (6).
5. Install manifold and housing (9) on heater (7) with two screws (8).
6. Install panel assembly (15) on "A" beam (1) and right mounting bracket (3) with four screws (16).

10-92.1. DIVERTER MANIFOLD AND HOUSING REPLACEMENT (Cont'd)

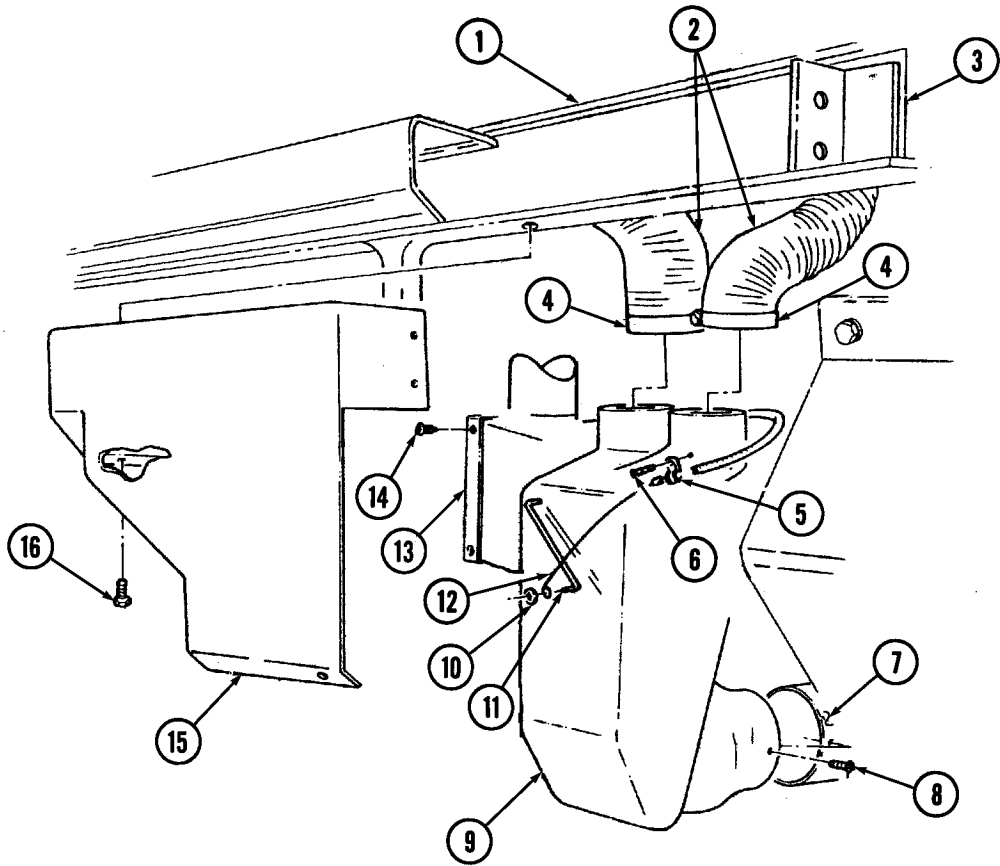

10-93. DEFROSTER DUCTING REPLACEMENT (ALL EXCEPT M1097A2, M1123)

This task covers:

a. Removal

b. Installation

INITIAL SETUP:

Applicable Models

All except M1097A2, M1123

Tools

General mechanic's tool kit:
automotive (Appendix B, Item 1)

Manual References

TM 9-2320-280-10
TM 9-2320-280-24P

Equipment Condition

- Hood raised and secured (TM 9-2320-280-10).
- Engine access cover removed (para. 10-15).

a. Removal

1. Remove eight screws (6) and retainer (7) from closeout panel (5) and "A" beam (4).
2. Remove three nuts (12), washers (9), capscrews (8), washers (9), clamps (10), and cable clamp (11) from closeout panel (5) and "A" beam (4).
3. Remove two screws (13) and closeout panel (5) from "A" beam (4).
4. Loosen clamp (2) and disconnect left flex duct (3) from left defroster nozzle (1).
5. Remove three screws (19) from diverter box (18) and "A" beam (4), and pull diverter box (18) away from "A" beam (4) for access to right defroster nozzle (14).
6. Loosen clamp (15) and disconnect right flex duct (16) from right defroster nozzle (14).
7. Loosen two clamps (17) and disconnect left flex duct (3) and right flex duct (16) from diverter box (18).

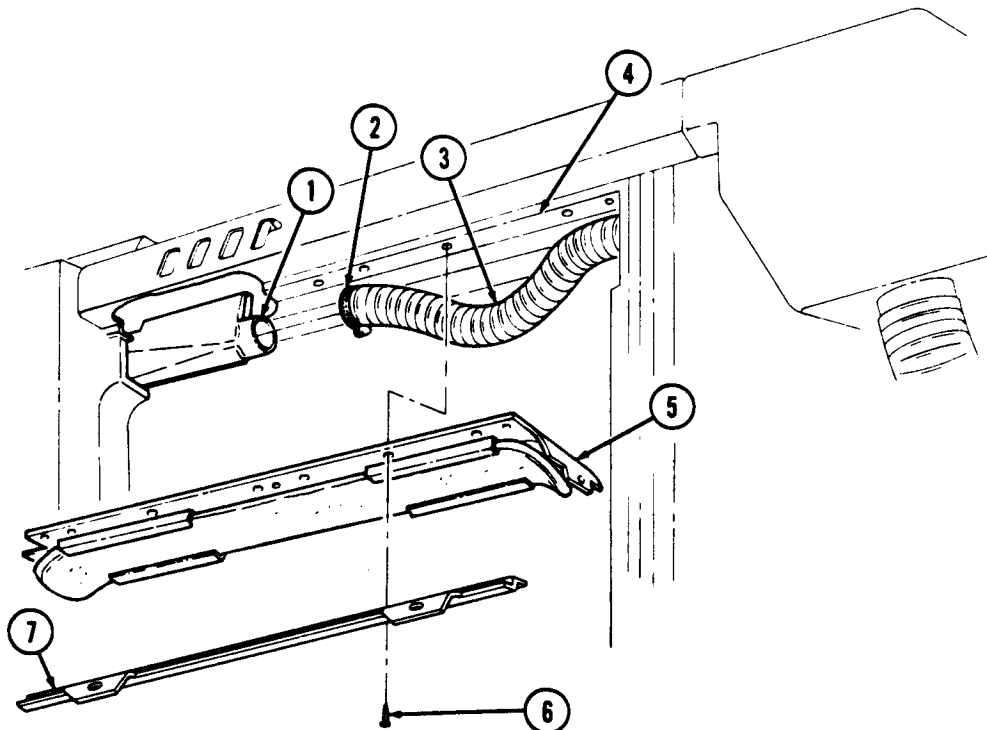

10-93. DEFROSTER DUCTING REPLACEMENT (Cont'd)

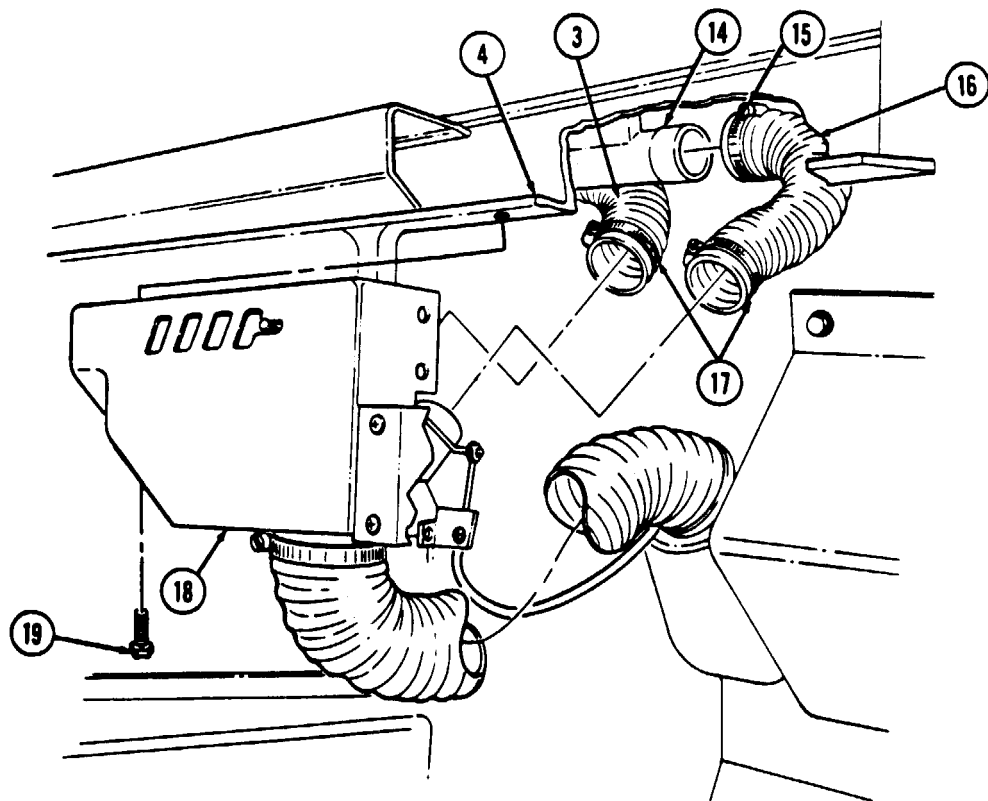
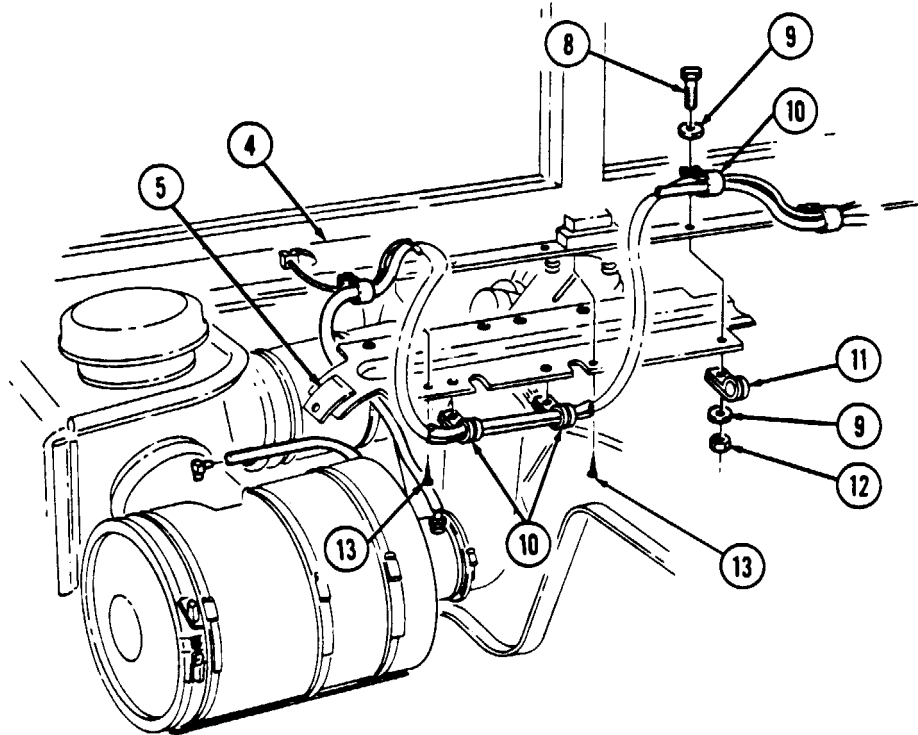

10-93. DEFROSTER DUCTING REPLACEMENT (Cont'd)

b. Installation

1. Connect left flex duct (2) and right flex duct (5) to diverter box (7) and tighten two clamps (6).
2. Connect right flex duct (5) to right defroster nozzle (3) and tighten clamp (4).
3. Install diverter box (7) on "A" beam (1) with three screws (8).
4. Connect left flex duct (2) to left defroster nozzle (9) and tighten clamp (10).
5. Install closeout panel (11) retainer (13) on "A" beam (1) with eight screws (12).
6. Secure closeout panel (11) to "A" beam (1) with two screws (19).
7. Install three clamps (16) and cable clamp (17) on closeout panel (11) and "A" beam (1) with three washers (15), capscrews (14), washers (15), and nuts (18).

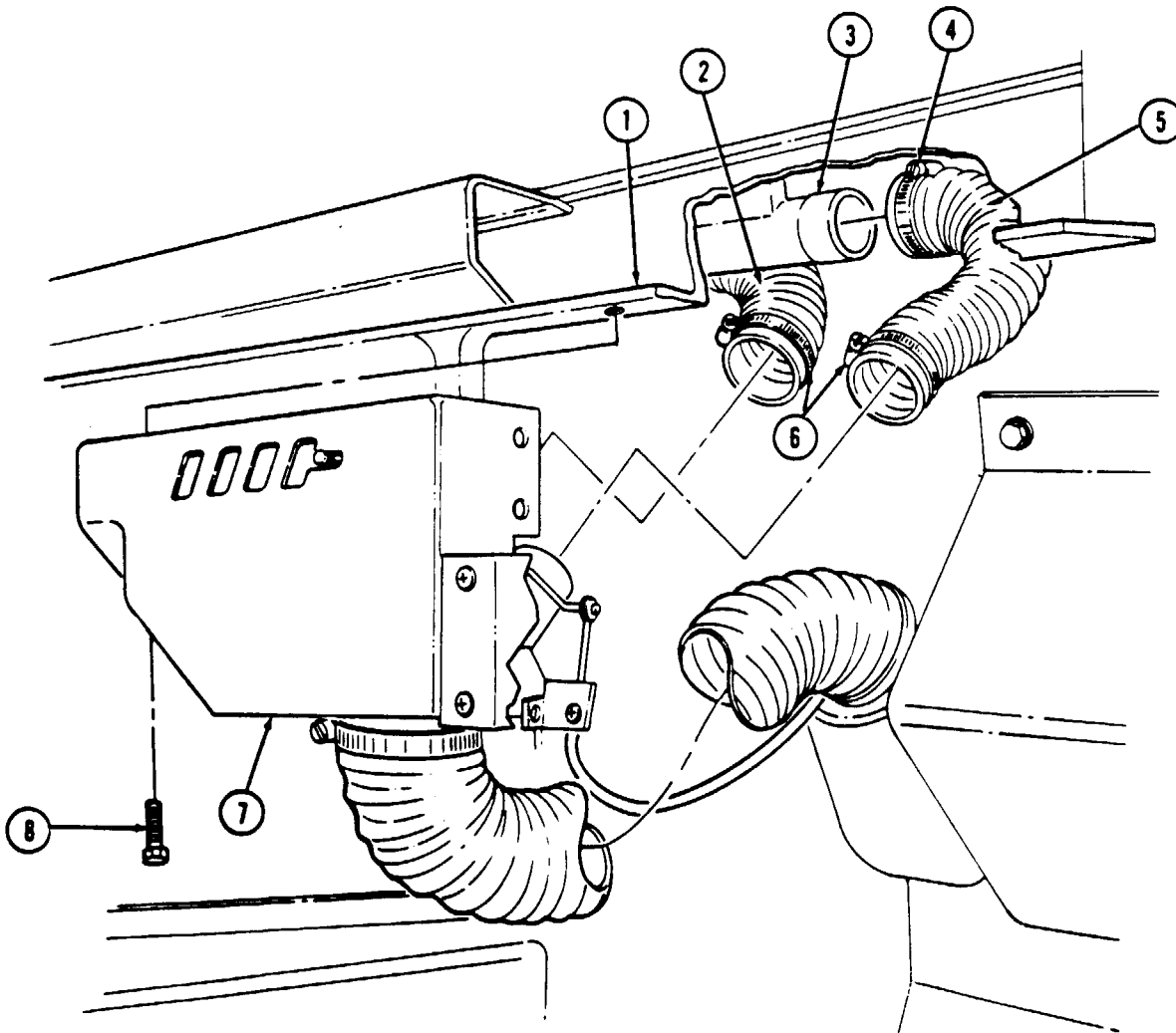

10-93. DEFROSTER DUCTING REPLACEMENT (Cont'd)

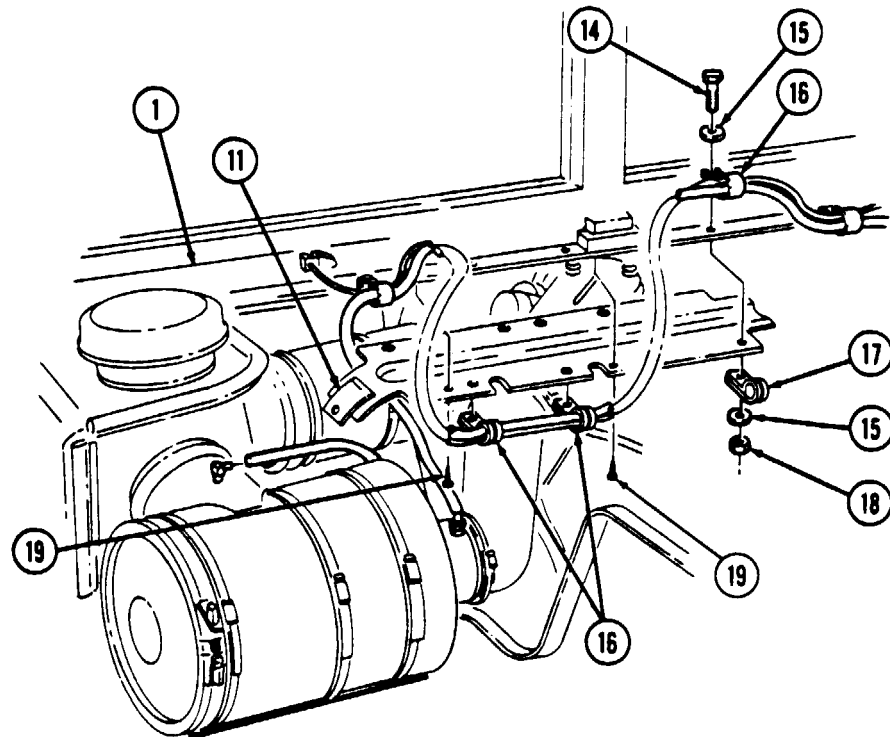
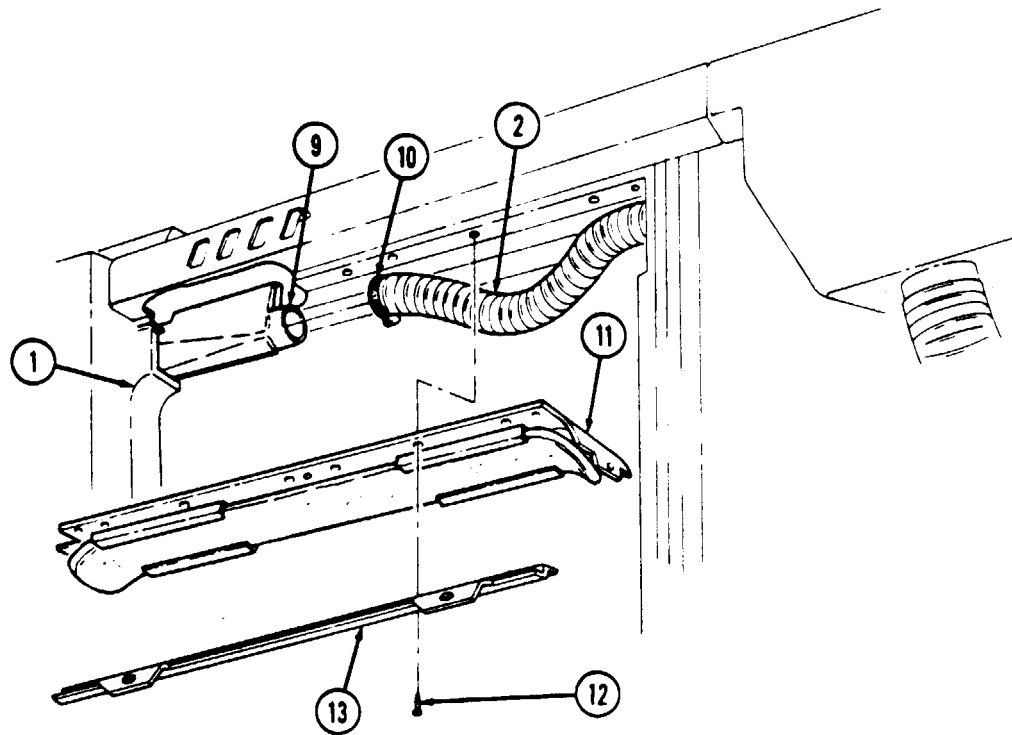

- FOLLOW-ON TASKS:
- Install engine access cover (para. 10-15).
 - Lower and secure hood (TM 9-2320-280-10).

10-94. LEFT DEFROSTER NOZZLE REPLACEMENT

This task covers:

a. Removal

b. Installation

INITIAL SETUP:

Tools

General mechanic's tool kit:
automotive (Appendix B, Item 1)

Manual References

TM 9-2320-280-10
TM 9-2320-280-24P

Materials/Parts

Lockwasher (Appendix G, Item 183)
Locknut (Appendix G, Item 128)
Locknut (Appendix G, Item 126)
Adhesive sealant (Appendix C, Item 10)

Equipment Condition

- Hood raised and secured (TM 9-2320-280-10).
- Engine access cover removed (para. 10-15).

a. Removal

1. Remove eight capscrews (5) and retainer (6) from closeout panel (4) and "A" beam (7).
2. Remove three nuts (20), washers (17), capscrews (16), and washers (17) from three clamps (18), cable clamp (19), closeout panel (4), and "A" beam (7).
3. Remove three screws (21) and closeout panel (4) from "A" beam (7).
4. Loosen clamp (2.1) and disconnect defroster duct (3) from defroster nozzle (2).
5. Remove locknut (9), lockwasher (10), washer (11), and pin (14) from steering column (15) and bracket (13), and lower steering column (15). Discard locknut (9) and lockwasher (10).

NOTE

Perform steps 5.1 and 5.2 for M1097A2 and M1123 series vehicles only.

- 5.1. Remove nut (15.1), screw (15.3), and ground wire 57C (15.2) from steering column (15).
- 5.2. Remove locknut (15.5), washer (15.6), capscrew (15.8), washer (15.7), and two brackets (15.4) from steering column (15). Discard locknut (15.5).
6. Remove retaining pin (12) from defroster nozzle (2) and bracket (13).

NOTE

Note position of defroster nozzle for installation.

7. Turn defroster nozzle (2) counterclockwise and remove from "A" beam (7).

b. Installation

1. Install defroster nozzle (2) on "A" beam (7).
2. Turn defroster nozzle (2) clockwise until defroster nozzle outlets (8) align with windshield frame louvers (1).
3. Install defroster nozzle (2) on bracket (13) with retaining pin (12).

NOTE

Perform steps 3.1 and 3.2 for M1097A2 and M1123 series vehicles only.

- 3.1. Install two brackets (15.4) on steering column (15) with washer (15.7), capscrew (15.8), washer (15.6), and locknut (15.5).
- 3.2. Install ground wire 57C (15.2), screw (15.3), and nut (15.1) on steering column (15).
4. Place steering column (15) in desired position, and install on bracket (13) with pin (14), washer (11), lockwasher (10), and locknut (9). Tighten locknut (9) to 31 lb-ft (42 N·m).
5. Apply adhesive and connect defroster duct (3) to defroster nozzle (2) and tighten clamp (2.1).

10-94. LEFT DEFROSTER NOZZLE REPLACEMENT (Cont'd)

6. Install retainer (6) and closeout panel (4) on "A" beam (7) with eight capscrews (5).
7. Secure closeout panel (4) to A-beam (7) with three capscrews (21).
8. Install closeout panel (4), three clamps (18), and cable clamp (19) on "A" beam (7) with three washers (17), capscrews (16), washers (17), and nuts (20).

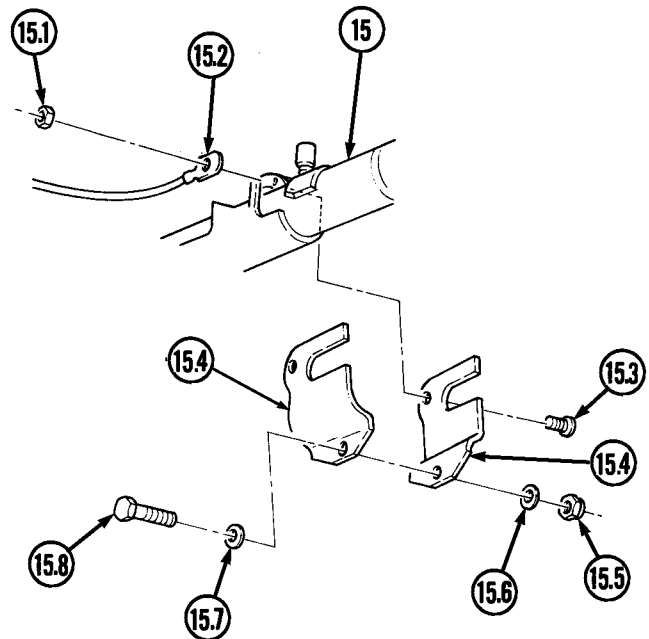
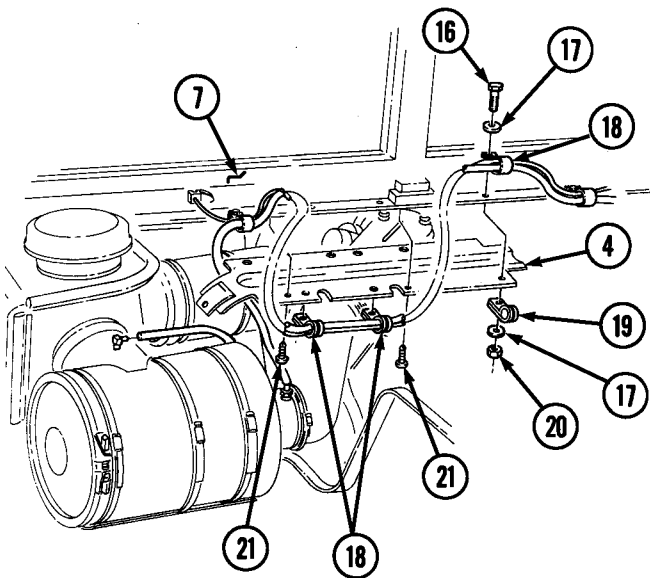
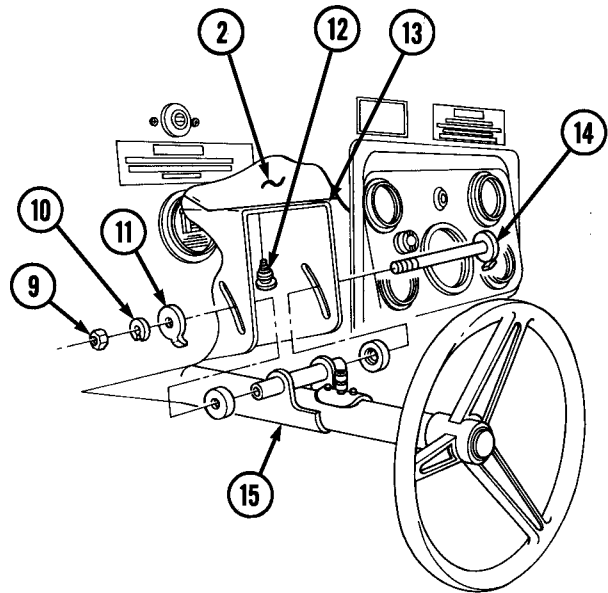
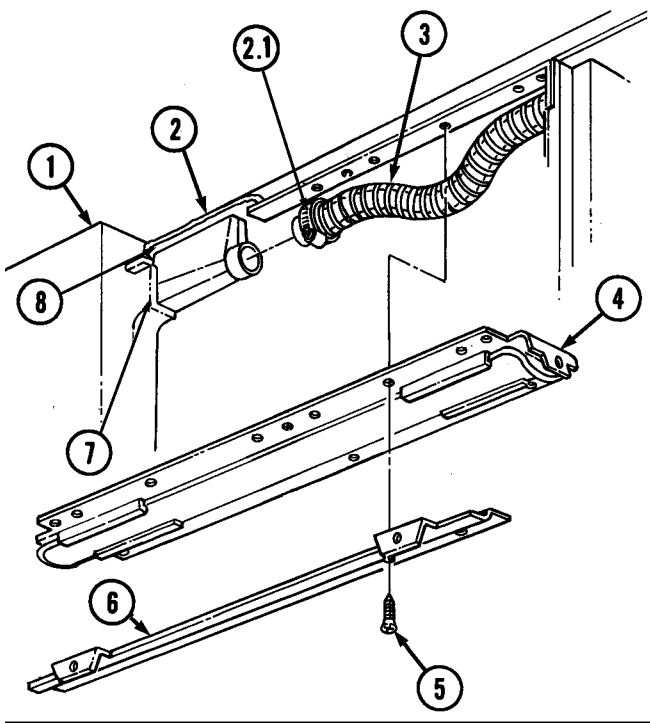

FOLLOW-ON TASKS: • Lower and secure hood (TM 9-2320-280-10).
 • Install engine access cover (para. 10-15).

10-94.1. HEATER NOZZLE DEFLECTOR REPLACEMENT

This task covers:

a. Removal

b. Installation

INITIAL SETUP:**Applicable Models**

M1097A2, M1123

Manual References

TM 9-2320-280-24P

Tools

General mechanic's tool kit:
automotive (Appendix B, Item 1)

a. Removal

Remove capscrews (3) and (4) and nozzle deflector (2) from left duct (1).

b. Installation

Install nozzle deflector (2) on left duct (1) with capscrews (3) and (4).

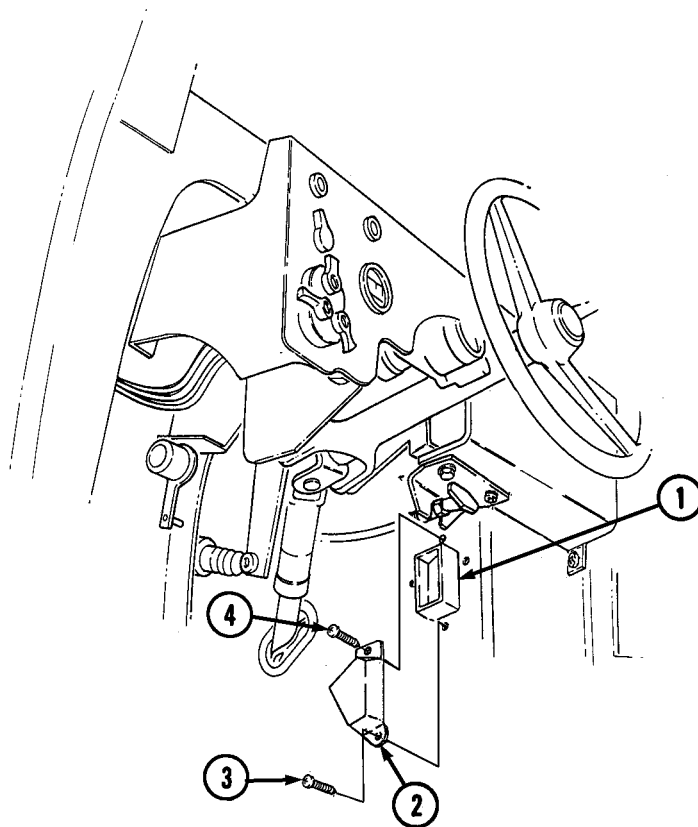

10-95. RIGHT DEFROSTER NOZZLE REPLACEMENT

This task covers:

a. Removal

b. Installation

INITIAL SETUP:

Tools

General mechanic's tool kit:
automotive (Appendix B, Item 1)

Equipment Condition

Defroster ducting removed (para. 10-93),
M1097A2 and M1123 (para. 10-96.1).

Manual References

TM 9-2320-280-24P

a. Removal

NOTE

Note position of defroster nozzle for installation.

Turn defroster nozzle (2) counterclockwise and remove from "A" beam (4).

b. Installation

Install defroster nozzle (2) on "A" beam (4) and turn defroster nozzle (2) clockwise until defroster nozzle outlets (1) align with windshield frame louvers (3).

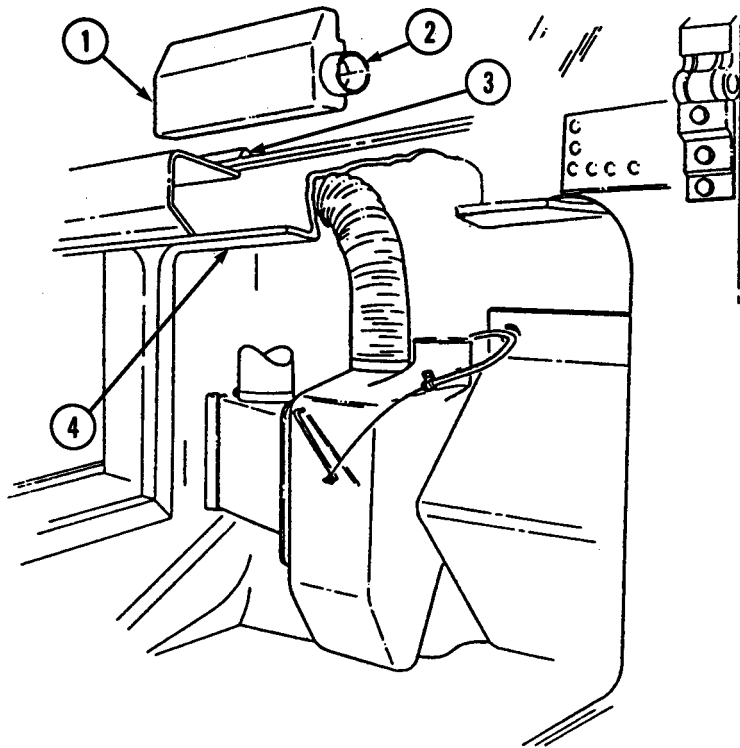

FOLLOW-ON TASK: Install defroster ducting (para. 10-93), M1097A2 and M1123 (para. 10-96.1).

10-96. HEATER BOOT REPLACEMENT

This task covers:

a. Removal

b. Installation

INITIAL SETUP:**Tools**

General mechanic's tool kit:
automotive (Appendix B, Item 1)

Manual References

TM 9-2320-280-24P

a. Removal

1. Remove ten clips (2) from heater boot (5) and heater assembly (1).
2. Remove six clips (4) and heater boot (5) from air duct retainer (3).

b. Installation

1. Install heater boot (5) on air duct retainer (3) with six clips (4).
2. Install heater boot (5) on heater assembly (1) with ten clips (2).

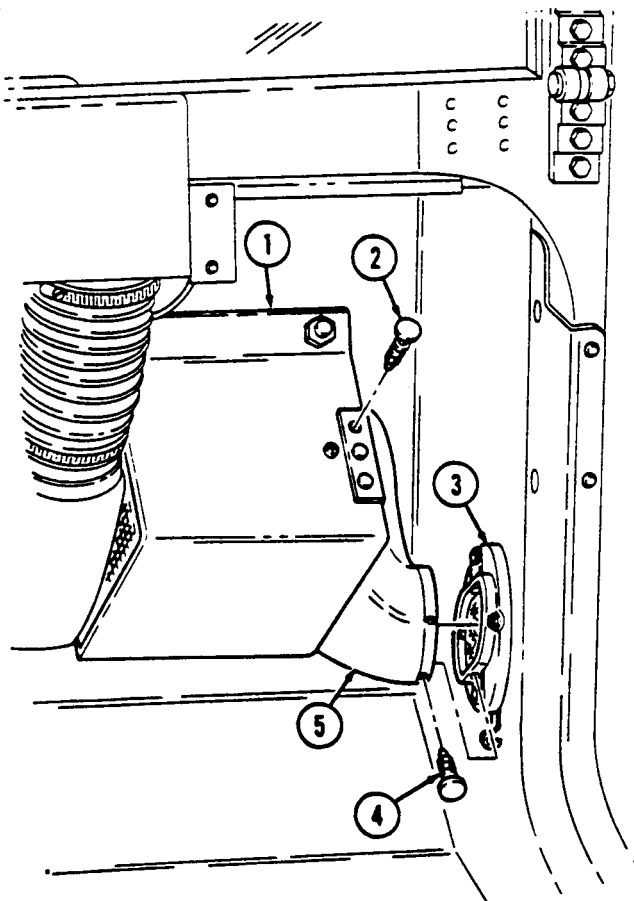

10-96.1. DEFROSTER DUCTING REPLACEMENT (M1097A2, M1123)

This task covers:

a. Removal

b. Installation

INITIAL SETUP:

Applicable Models

M1097A2, M1123

Tools

General mechanic's tool kit:
automotive (Appendix B, Item 1)

Materials/Parts

Adhesive sealant (Appendix C, Item 3)

Manual References

TM 9-2320-280-10
TM 9-2320-280-24P

Equipment Condition

- Hood raised and secured (TM 9-2320-280-10).
- Engine access cover removed (para. 10-15).

a. Removal

1. Remove eight screws (6), retainer (7), and closeout panel (5) from "A" beam (4).
2. Remove three nuts (12), washers (9), capscrews (8), and washers (9) from three clamps (10), cable clamp (11), closeout panel (5), and "A" beam (4).
3. Remove three screws (13) from closeout panel (5) and "A" beam (4).
4. Loosen clamp (2) and disconnect left flex duct (3) from left defroster nozzle (1).
5. Remove four screws (19) and diverter cover (18) from "A" beam (4).
6. Disconnect right flex duct (15) from right defroster nozzle (14).
7. Loosen two clamps (16) and disconnect left flex duct (3) and right flex duct (15) from diverter housing (17).

b. Installation

1. Connect left flex duct (3) and right flex duct (15) to diverter housing (17) and tighten two clamps (16).
2. Apply adhesive sealant and connect right flex duct (15) to right defroster nozzle (14).
3. Install diverter cover (18) on "A" beam (4) with four screws (19).
4. Apply adhesive and connect left flex duct (3) to left defroster nozzle (1) and tighten clamp (2).
5. Install closeout panel (5) and retainer (7) on "A" beam (4) with eight screws (6).
6. Secure closeout panel (5) to "A" beam (4) with three screws (13).
7. Install three clamps (10), cable clamp (11), and closeout panel (5) on "A" beam (4) with three washers (9), capscrews (8), washers (9), and nuts (12).

10-96.1. DEFROSTER DUCTING REPLACEMENT (M1097A2, M1123) (Cont'd)

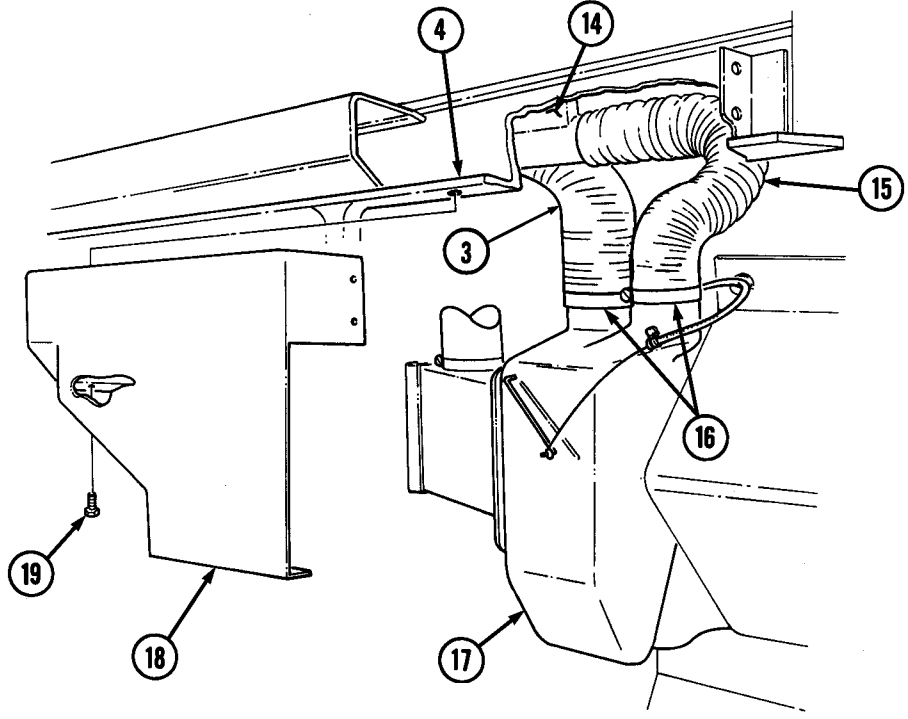
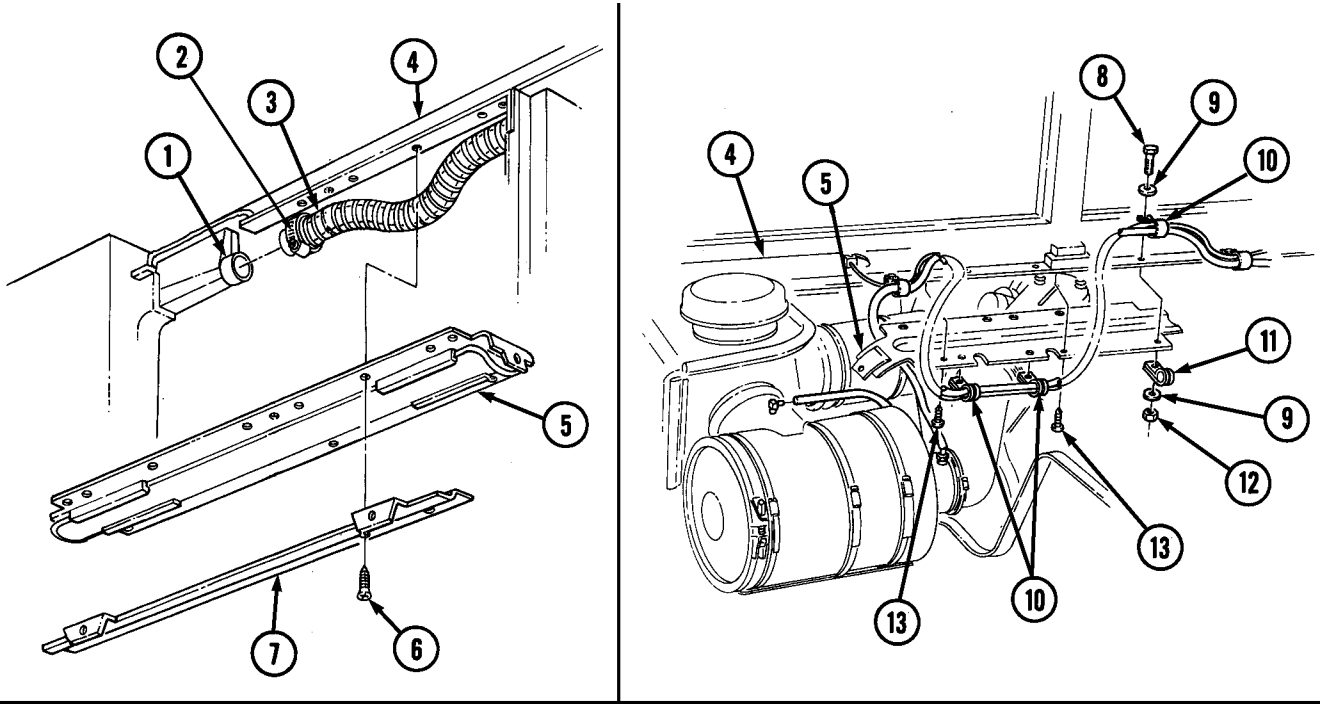

- FOLLOW-ON TASKS:**
- Install engine access cover (para. 10-15).
 - Lower and secure hood (TM 9-2320-280-10).

10-96.2. HEATER HOSE REPLACEMENT

This task covers:

a. Removal

b. Installation

INITIAL SETUP:

Applicable Models

M1097A2, M1123

Tools

General mechanic's tool kit:
automotive (Appendix B, Item 1)

Materials/Parts

Adhesive (Appendix C, Item 10)

Manual References

TM 9-2320-280-10
TM 9-2320-280-24P

Equipment Condition

- Hood raised and secured (TM 9-2320-280-10).
- Engine access cover removed (para. 10-15).

a. Removal

Disconnect heater hose (2) from left duct (1) and right duct (3), and remove heater hose (2).

b. Installation

Apply adhesive and connect heater hose (2) to left duct (1) and right duct (3).

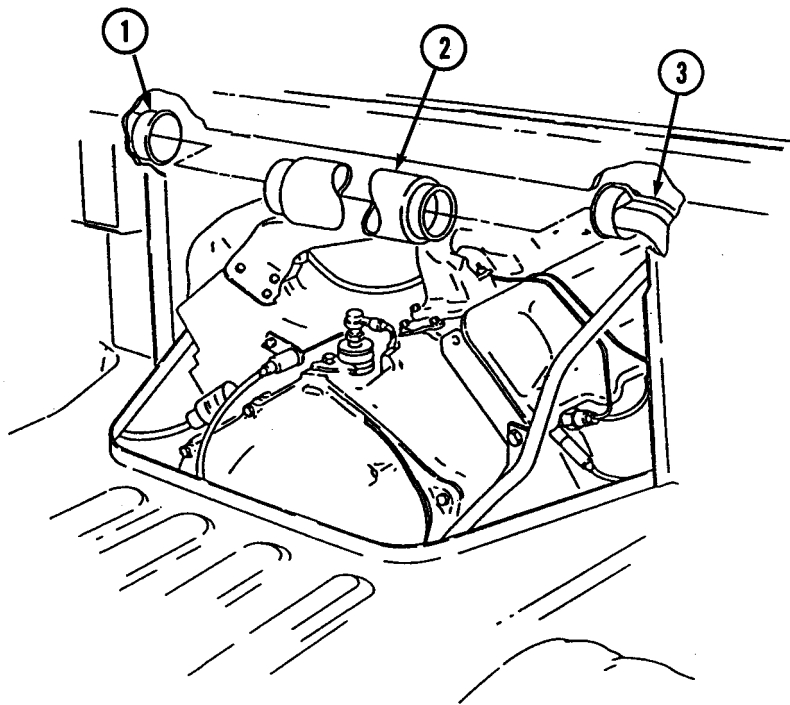

- FOLLOW-ON TASKS:
- Install engine access cover (para. 10-15).
 - Lower and secure hood (TM 9-2320-280-10).

10-96.3. DIVERTER BOX COVER REPLACEMENT

This task covers:

a. Removal

b. Installation

INITIAL SETUP:**Applicable Models**

M1097A2, M1123

Manual References

TM 9-2320-280-24P

Tools

General mechanic's tool kit:
automotive (Appendix B, Item 1)

a. Removal

Remove four screws (4) and diverter box cover (3) from right mounting bracket (2) and "A" beam (1).

b. Installation

Install diverter box cover (3) on right mounting bracket (2) and "A" beam (1) with four screws (4).

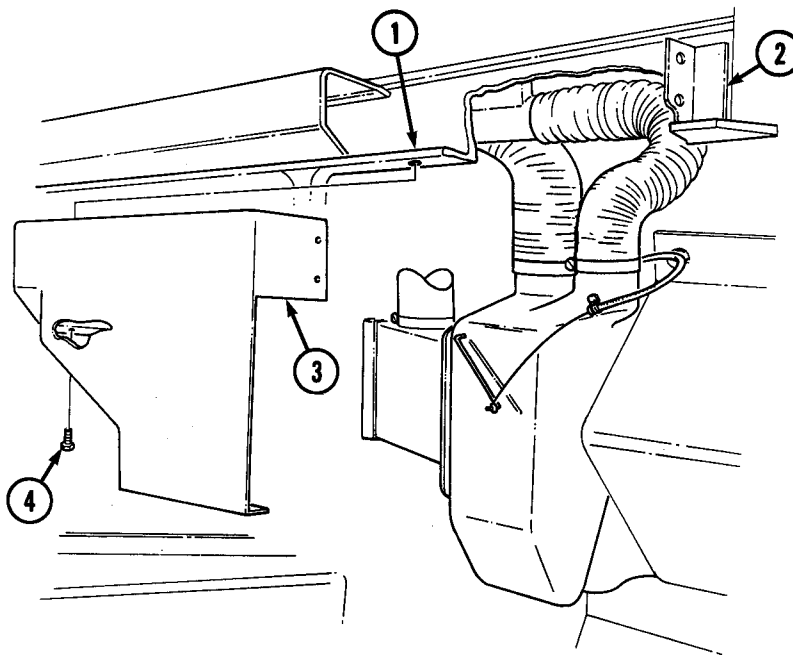

10-96.4. DIVERTER DUCTING REPLACEMENT

This task covers:

a. Removal

b. Installation

INITIAL SETUP:

Applicable Models

M1097A2, M1123

Manual References

TM 9-2320-280-24P

Tools

General mechanic's tool kit:
automotive (Appendix B, Item 1)

Manual Reference

Diverter box cover removed (para. 10-96.3).

a. Removal

Loosen clamp (1) and remove diverter ducting (2) from diverter duct (3).

b. Installation

Install diverter ducting (2) on diverter duct (3) and tighten clamp (1).

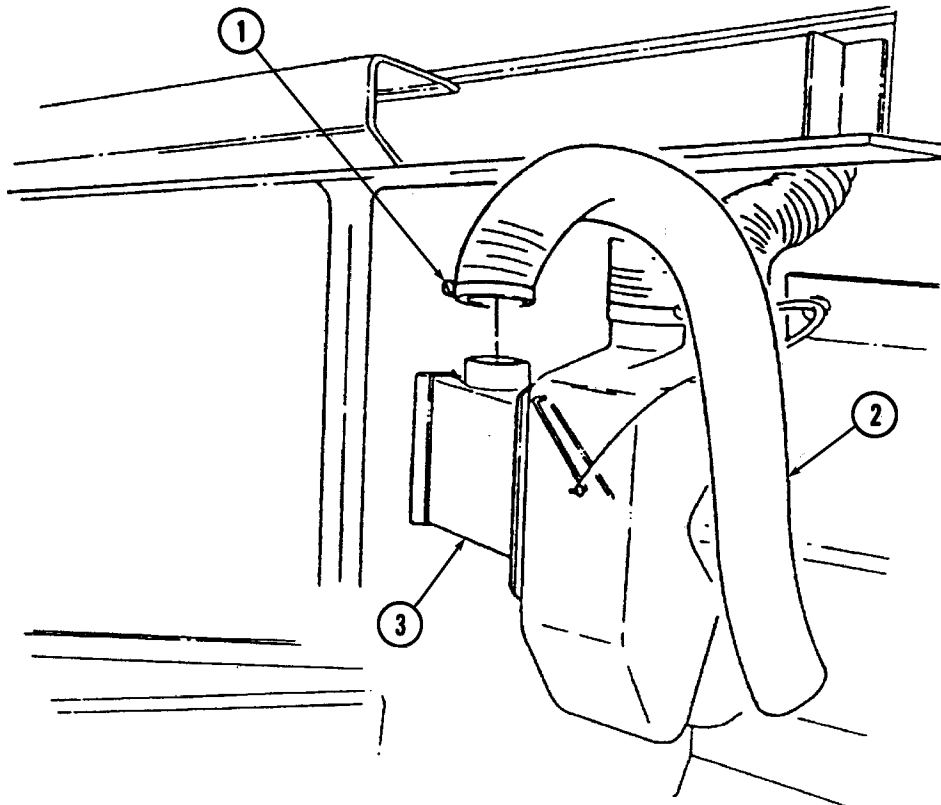

FOLLOW-ON TASK: Install diverter box cover (para. 10-96.3).

10-97. AIR DUCT ASSEMBLY REPLACEMENT

This task covers:

a. Removal

b. Installation

INITIAL SETUP:

Tools

General mechanic's tool kit:
automotive (Appendix B, Item 1)

Equipment Condition

- Arctic heater removed, if installed (para. 12-41).
- Heater boot removed (para. 10-96).

Manual References

TM 9-2320-280-24P

a. Removal

Remove four speed nuts (2), screws (5), air duct retainer (1), and grille assembly (3) from body (4).

b. Installation

Install grille assembly (3) and air duct retainer (1) on body (4) with four screws (5) and speed nuts (2).

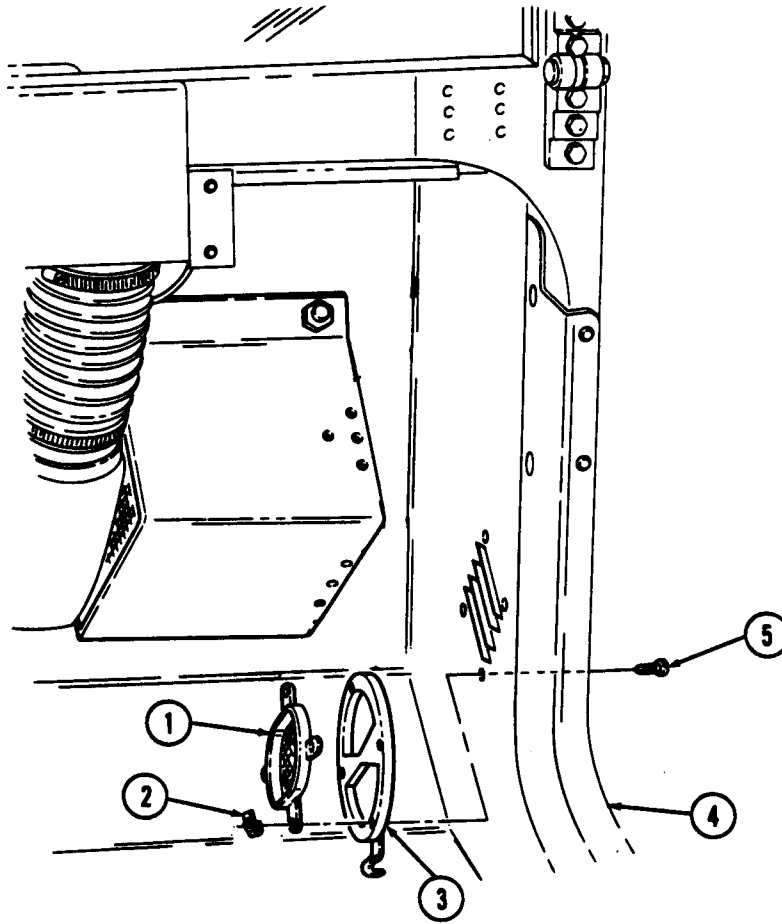

- FOLLOW-ON TASKS:
- Install arctic heater, if removed (para. 12-41).
 - Install heater boot (para. 10-96).

10-97.1. DIVERTER BOX REPLACEMENT (M998A2 SERIES)

This task covers:

a. Removal

b. Installation

INITIAL SETUP:

Applicable Models

M998A2 series

Tools

General mechanic's tool kit:
automotive (Appendix B, Item 1)

Manual References

TM 9-2320-280-24P

Materials/Parts

Two clips (Appendix G, Item 10)
Four rivets (Appendix G, Item 258)
Two rivets (Appendix G, Item 253)
Push on nut (Appendix G, Item 226)

Equipment Condition

- Diverter box cover removed (para. 10-96.3).
- Diverter ducting removed (para. 10-96.4).

a. Removal

1. Remove two clips (14) from transition diverter (12) and transition (13). Discard two clips (14).
2. Remove two screws (8) from diverter (9) and heater (7).
3. Remove screw (5) and clamp (4) from diverter (9).
4. Remove push on nut (11) and disconnect cable core (6) from baffle pin (10). Discard push on nut (11).
5. Pull diverter (9) away from "A" beam (1) and loosen two clamps (3) on defroster flex ducts (2) and remove diverter (9).
6. Remove four rivets (21) and transition diverter (15) from diverter (17).
7. Remove louver (16) from transition diverter (15).
8. Remove two rivets (19), flap (20), and bracket (18) from diverter (17).

b. Installation

1. Install flap (20) and bracket (18) on diverter (17) with two rivets (19).
2. Install louver (16) on transition diverter (15).
3. Install transition diverter (15) on diverter (17) with four rivets (21).
4. Position diverter (9) under "A" beam (1), connect two defroster flex ducts (2) to diverter (9), and tighten clamps (3).
5. Connect defroster cable core (6) to baffle pin (10) and install push on nut (11).
6. Install transition diverter (12) on transition (13) with two clips (14).

NOTE

Control cable must be pushed in, and baffle pin must be in the upward position before securing control cable to diverter box.

7. Install clamp (4) on diverter (9) with screw (5).
8. Install diverter (9) on heater (7) with two screws (8).

10-97.1. DIVERTER BOX REPLACEMENT (M998A2 SERIES) (Cont'd)

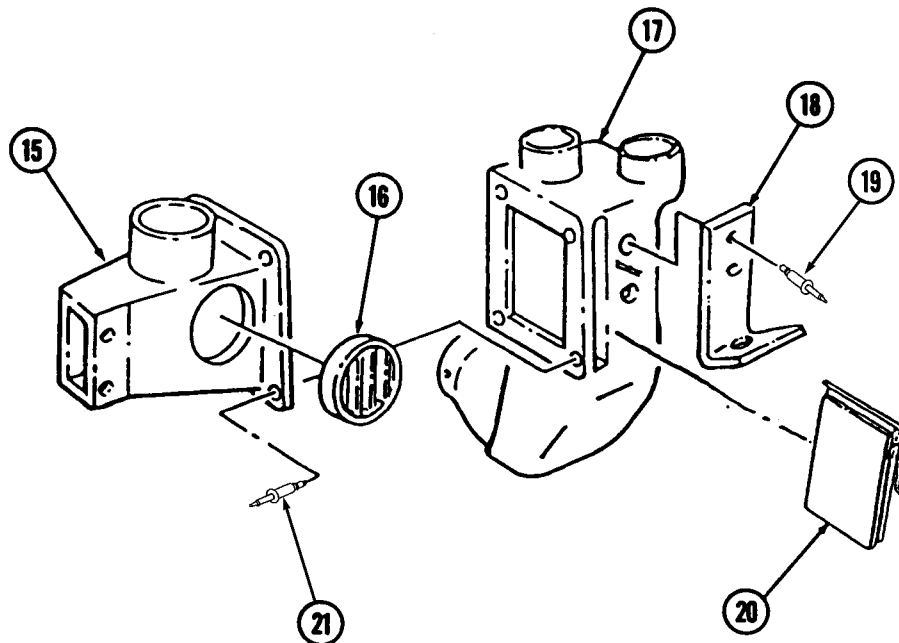
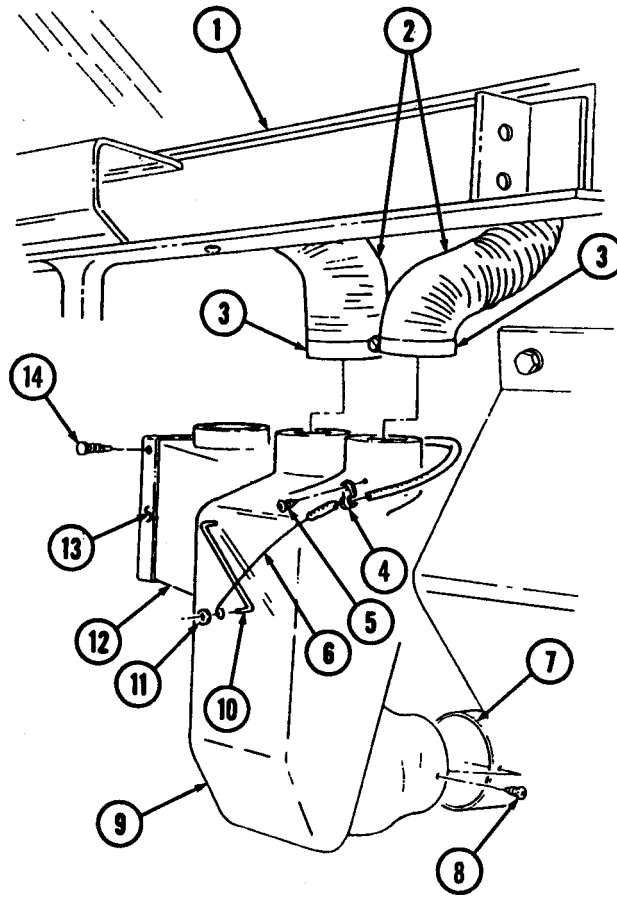

- FOLLOW-ON TASKS:
- Install diverter ducting (para. 10-96.4).
 - Install diverter box cover (para. 10-96.3).

10-98. "A" PILLAR FORMER ASSEMBLY REPLACEMENT

This task covers:

a. Removal

b. Installation

INITIAL SETUP:

Applicable Models

M998, M998A1, M1035, M1035A1, M1035A2,
M1037, M1038, M1038A1, M1042

Manual References

TM 9-2320-280-10
TM 9-2320-280-24P

Tools

General mechanic's tool kit:
automotive (Appendix B, Item 1)

Equipment Condition

Soft top removed (TM 9-2320-280-10).

Materials/Parts

Turnbutton stud (Appendix G, Item 303)

a. Removal

1. Remove thirteen screws (3) and "A" pillar former (2) from "A" pillar (1).
2. Clean weatherstrip from "A" pillar (1).
3. Inspect turnbutton stud (4) for damage. Replace if damaged.

b. Installation

1. Peel backing paper from "A" pillar former (2).
2. Install "A" pillar former (2) on "A" pillar (1) with thirteen screws (3).

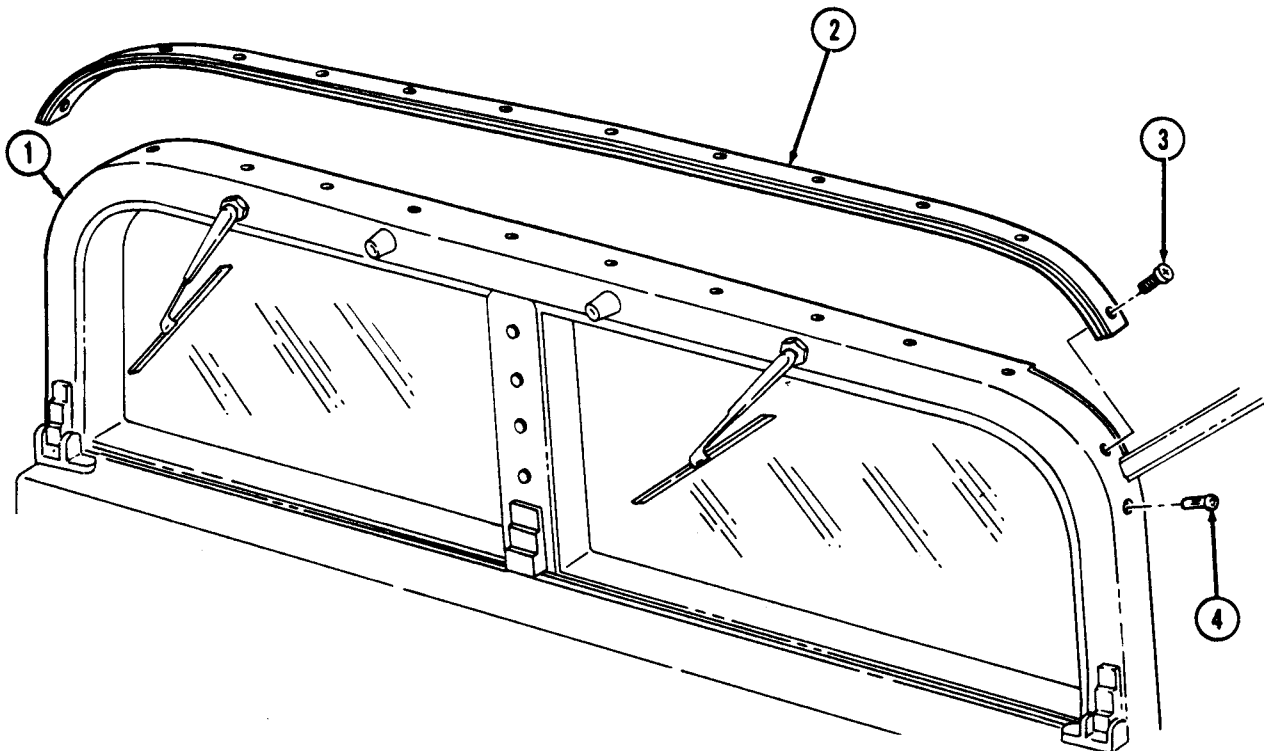

FOLLOW-ON TASK: Install soft top (TM 9-2320-280-10).

10-99. "C" PILLAR REPLACEMENT

This task covers:

a. Removal

b. Installation

INITIAL SETUP:

Applicable Models

M998, M998A1, M1035, M1035A1,
M1038, M1038A1

Tools

General mechanic's tool kit:
automotive (Appendix B, Item 1)

Materials/Parts

Four locknuts (Appendix G, Item 119)
Four locknuts (Appendix G, Item 71)
Eight rivets (Appendix G, Item 256)

Manual References

TM 9-2320-280-10
TM 9-2320-280-24P

Equipment Condition

Soft top removed (TM 9-2320-280-10).

a. Removal

1. Remove four locknuts (6), washers (5), capscrews (4), washers (5), eight rivets (2), and two braces (3) from "C" pillar (1) and wheelhouses (7). Discard locknuts (6).
2. Remove four locknuts (8), washers (9), capscrews (11), washers (9), two plates (10), and "C" pillar (1) from wheelhouses (7). Discard locknuts (8).
3. Inspect rivnut (12) for damage. Replace if damaged.

b. Installation

1. Install "C" pillar (1) on wheelhouses (7) with two plates (10), four washers (9), capscrews (11), washers (9), and locknuts (8). Tighten locknuts (8) to 6 lb-ft (8 N·m).
2. Install two braces (3) on wheelhouses (7) and "C" pillar (1) with four washers (5), capscrews (4), washers (5), locknuts (6), and eight rivets (2).

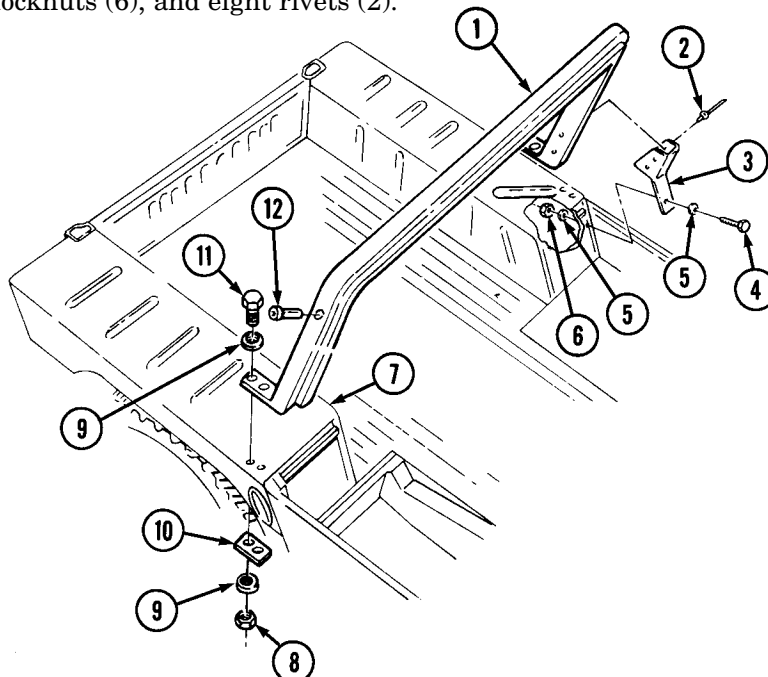

FOLLOW-ON TASK: Install soft top (TM 9-2320-280-10).

10-100. REAR BOW PIVOT BRACKET REPLACEMENT

This task covers:

a. Removal

b. Installation

INITIAL SETUP:

Applicable Models

M998, M998A1, M1035, M1035A1, M1035A2,
M1038, M1038A1, M1097, M1097A1,
M1097A2

Manual References

TM 9-2320-280-10
TM 9-2320-280-24P

Tools

General mechanic's tool kit:
automotive (Appendix B, Item 1)

Equipment Condition

Bows removed (TM 9-2320-280-10).

Materials/Parts

Two locknuts (Appendix G, Item 70)

a. Removal

Remove two locknuts (6), washers (5), capscrews (1), washers (2), bow pivot bracket (3), and plate (7) from body (4). Discard locknuts (6).

b. Installation

Install plate (7) and bow pivot bracket (3) on body (4) with two washers (2), capscrews (1), washers (5), and locknuts (6). Align bow pivot bracket (3) flush with side of body (4) and tighten two locknuts (6) to 6 lb-ft (8 N·m).

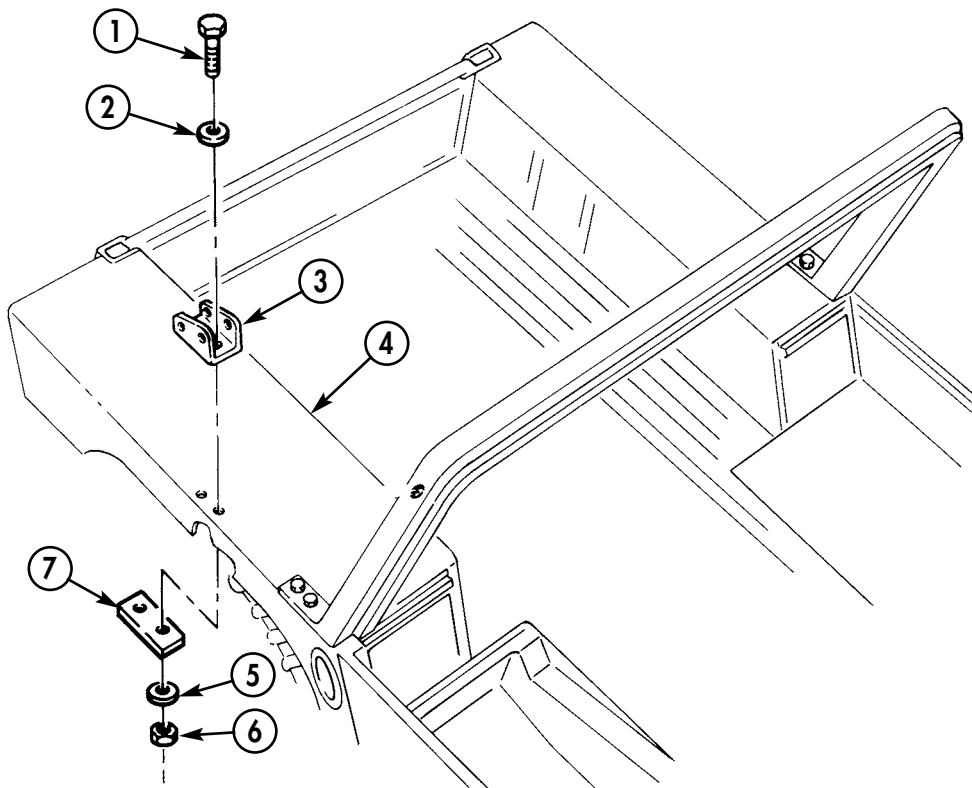

FOLLOW-ON TASK: Install bows (TM 9-2320-280-10).

10-101. SOFT TOP DOOR HINGE REPLACEMENT

This task covers:

a. Removal

b. Installation

INITIAL SETUP:

Applicable Models

M998, M998A1, M1035, M1035A1, M1035A2,
M1037, M1038, M1038A1, M1042, M1097,
M1097A1, M1097A2

Manual References

TM 9-2320-280-10
TM 9-2320-280-24P

Tools

General mechanic's tool kit:
automotive (Appendix B, Item 1)

Equipment Condition

Soft top door removed (TM 9-2320-280-10).

NOTE

Doorstrap brackets are attached to upper hinges only. This procedure covers the left door upper hinge.

a. Removal

- Remove two nuts (2), screws (5), hinge (4), and bracket (1) from door (3). Discard nuts (2).

b. Installation

- Install hinge (4) and bracket (1) on door (3) with two screws (5) and nuts (2). Tighten nuts (2) to 6 lb-ft (8 N•m).

10-101. SOFT TOP DOOR HINGE REPLACEMENT (Cont'd)

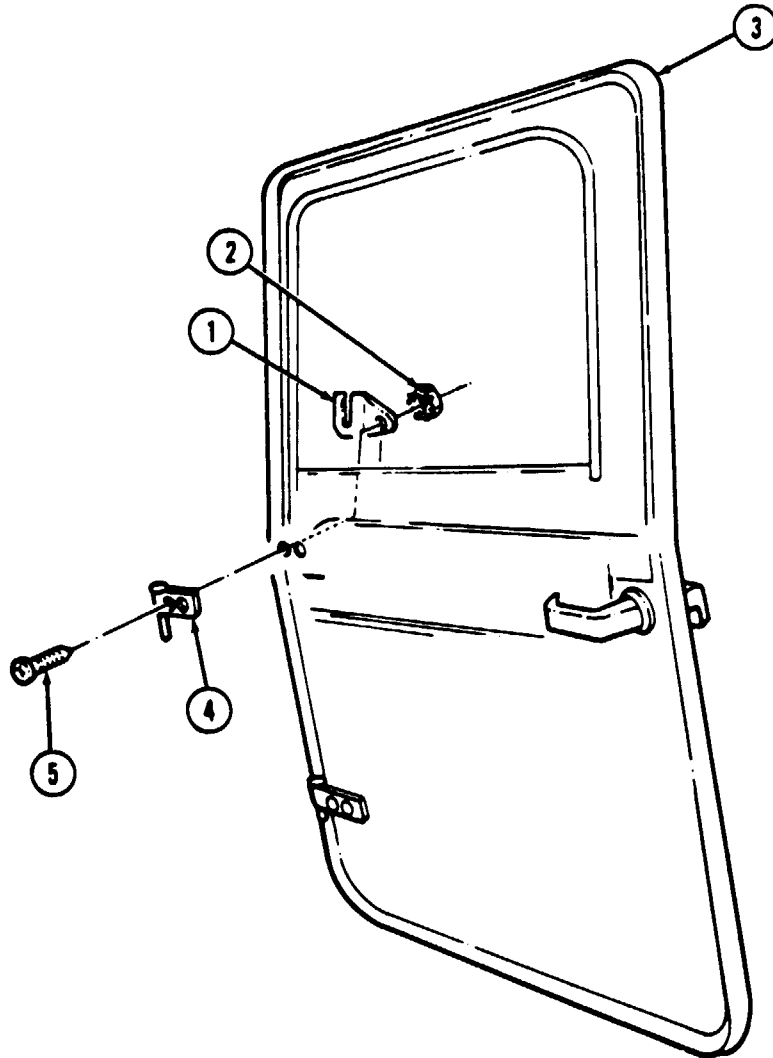

- FOLLOW-ON TASKS:
- Install door (TM 9-2320-280-10).
 - Adjust soft top door (para. 10-102).

10-102. SOFT TOP DOOR ADJUSTMENT

This task covers:

Adjustment

INITIAL SETUP:

Applicable Models

M998, M998A1, M1035, M1035A1, M1035A2,
M1037, M1038, M1038A1, M1042, M1097,
M1097A1, M1097A2, M1123

Personnel Required

One mechanic
One assistant

Tools

General mechanic's tool kit:
automotive (Appendix B, Item 1)

Manual References

TM 9-2320-280-10
TM 9-2320-280-24P

Adjustment

1. Open and close door (1) to check fit of door seal (2) to body (3). Door seal (2) should fit inside and contact door outline on body (3).
2. For vertical and horizontal adjustment of door (1), loosen four screws (4) on two hinges (5) and door (1). Slide door (1) to fit door outline on body (3). Hold door (1) in position, and tighten four screws (4) on two door hinges (5) and door (1).

NOTE

If additional vertical adjustment is needed, follow step 3. If no additional vertical adjustment is needed, go to step 4.

3. For additional vertical adjustment of door (1), remove door (1) from body (3) (TM 9-2320-280-10). Loosen four capscrews (7) on two body hinge mounts (6) and body (3) and slide body hinge mounts (6) up or down for adjustment. Hold body hinge mounts (6) in position, and tighten four capscrews (7) to 8 lb-ft (11 N•m). Install door (TM 9-2320-280-10).
4. For in and out adjustment of door (1), loosen two capscrews (8) on striker (10) and "B" pillar (11). With door (1) closed and door seal (2) pressed against body (3), slide striker (10) against inner door handle latch (9) and tighten two capscrews (8). Open door (1) and tighten two capscrews (8) to 15 lb-ft (20 N•m).
5. Close door (1) and check for fit of door seal (2) to door outline on body (3) and inner door handle latch (9) operation. Readjust door (1) if necessary.

10-102. SOFT TOP DOOR ADJUSTMENT (Cont'd)

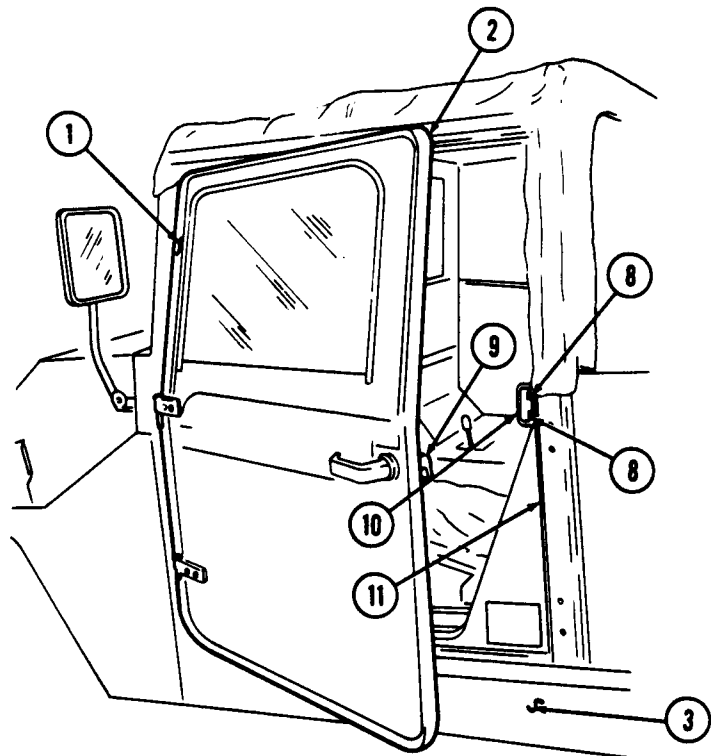
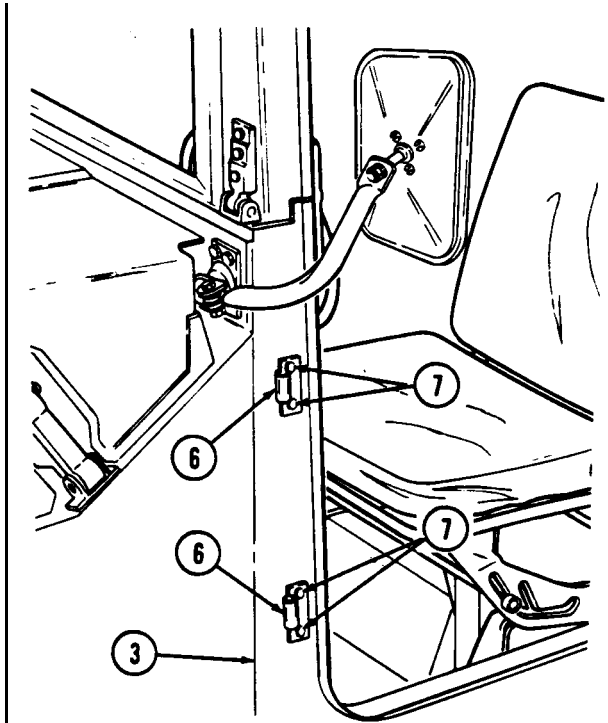
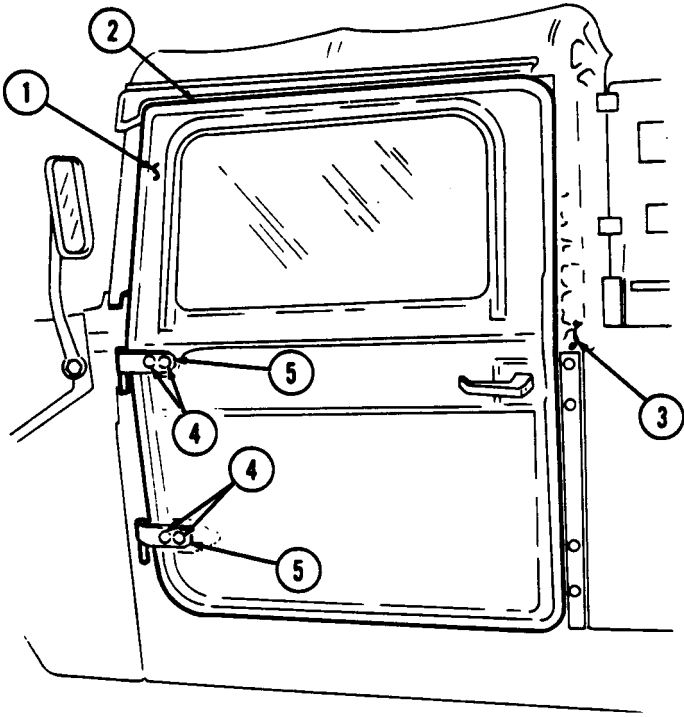

10-102.1. SOFT TOP DOOR HANDLE REPAIR

This task covers:

- a. Removal
- b. Repair
- c. Installation

INITIAL SETUP:

Applicable Models

M998, M998A1, M1035, M1035A1, M1035A2,
M1037, M1038, M1038A1, M1042, M1097,
M1097A1, M1097A2, M1123

Manual References

TM 9-2320-280-24P

Tools

General mechanic's tool kit:
automotive (Appendix B, Item 1)

a. Removal

1. Remove screw (5), inner (4) and outer (1) door handles, washer (7), and spring (6) from door (3).
2. Remove insert (2) from outer door handle (1) if present.

b. Repair

1. Drill 0.250-in. (6.35 mm) diameter hole through outer door handle (1).

NOTE

Countersink hole deep enough so screw is flush with surface of handle.

2. Using a 0.500-in. (12.7 mm) diameter drill bit, countersink outer handle (1).

CAUTION

Use tape or drill stop to ensure the proper depth is not exceeded when counterboring, or inner door handle may be damaged.

3. Counterbore inner door handle (4) to 0.238-in. (6.04 mm) diameter, 0.531-in. (13.49 mm) depth.

10-102.1. SOFT TOP DOOR HANDLE REPAIR (Cont'd)

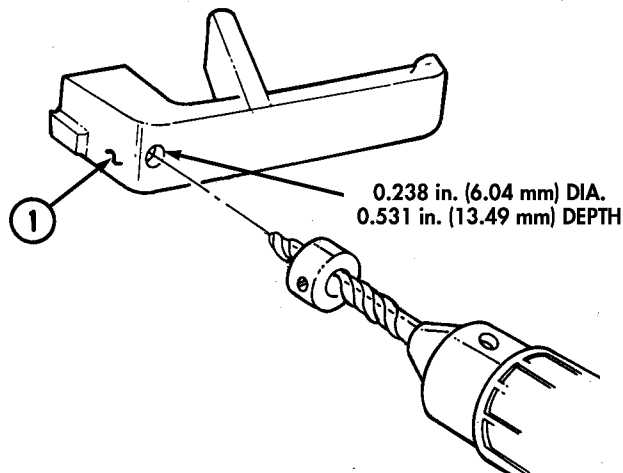
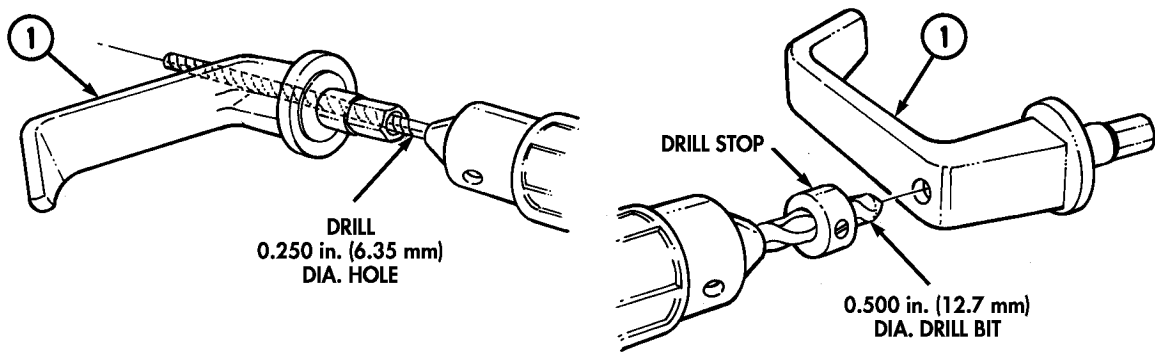
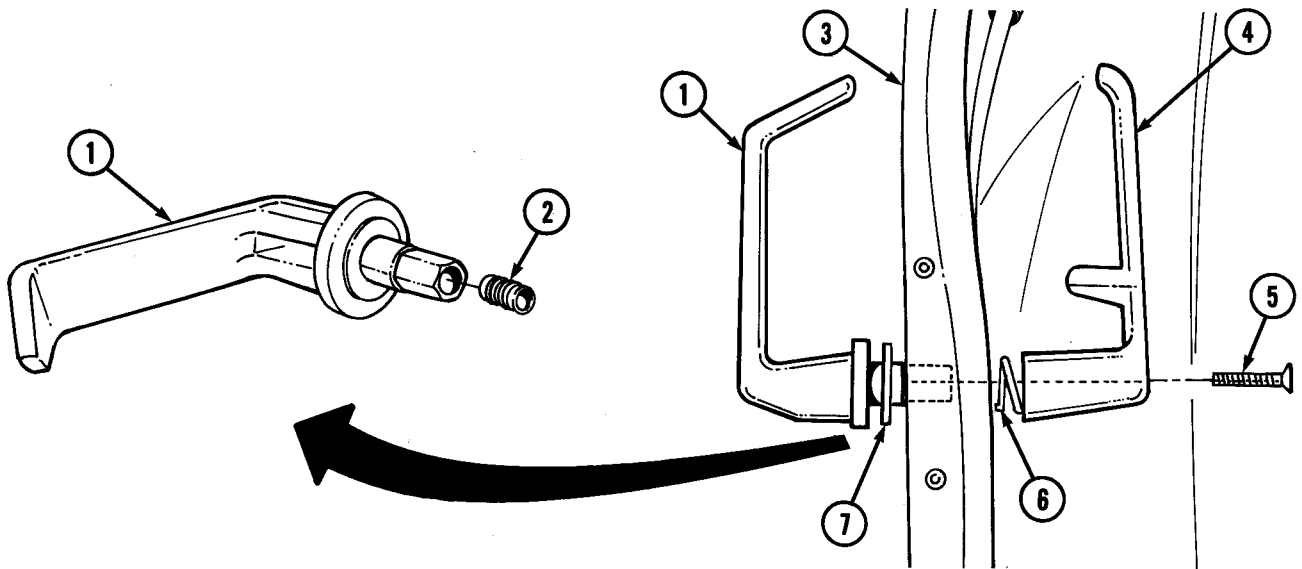

10-102.1. SOFT TOP DOOR HANDLE REPAIR (Cont'd)

c. Installation

1. Install two nuts (5), washers (3), and insert (2) on screw (4).
2. Install insert (2) with screw (4) into inner handle (1). Seat bottom washer (3) against handle surface (1).
3. Loosen two nuts (5) and remove screw (4), two nuts (5), and washers (3) from insert (2).
4. Assemble inner handle (1), washer (7), spring (6), and outer handle (8) with screw (4).
5. Measure length of screw (4) from insert (2).
6. Remove screw (4) and cut to measurement.
7. Install washer (7), outer handle (8), spring (6), and inner handle (1) on door (9) with screw (4).
8. Check door handle for proper operation.

10-102.1. SOFT TOP DOOR HANDLE REPAIR (Cont'd)

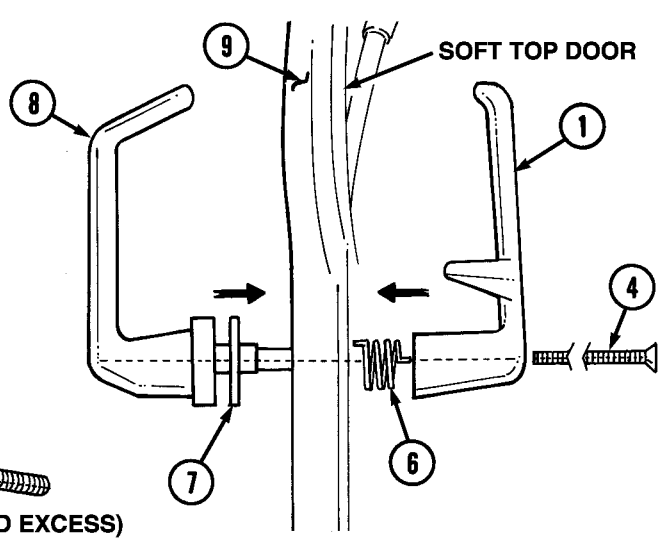
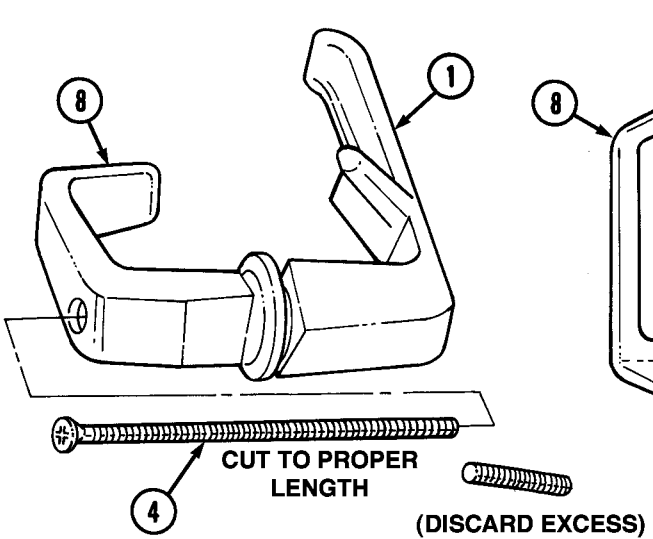
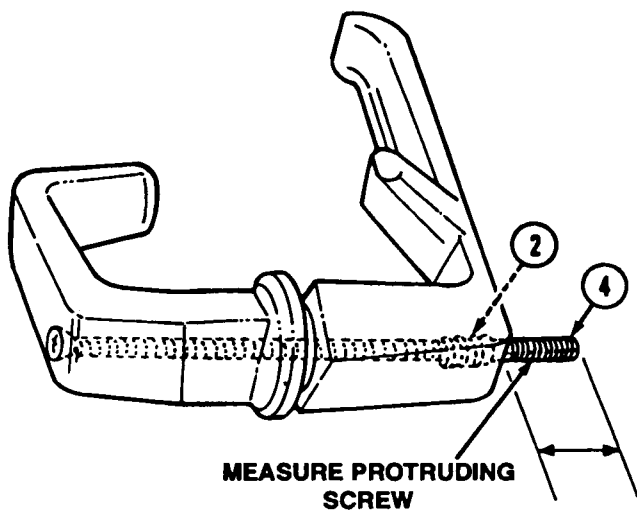
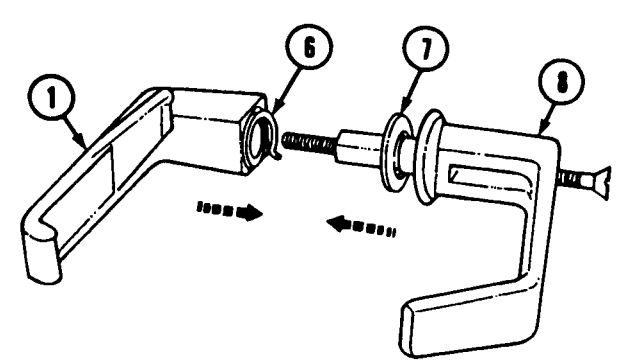
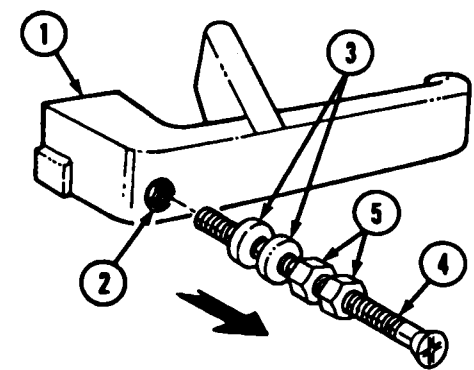
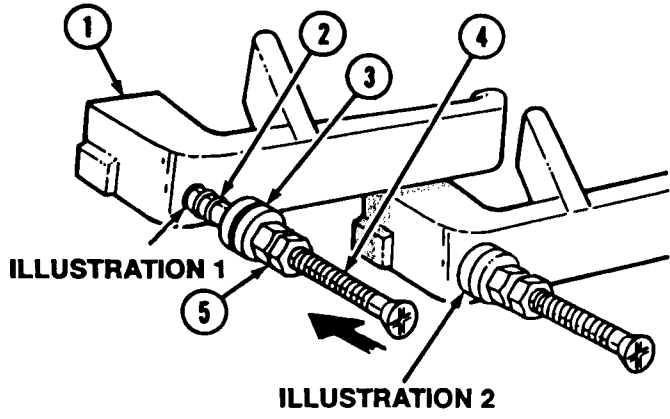

10-103. SOFT TOP DOOR STRIKER REPLACEMENT

This task covers:

- a. Removal
- b. Installation

INITIAL SETUP:

Applicable Models

M998, M998A1, M1035, M1035A1, M1035A2,
M1037, M1038, M1038A1, M1042, M1097,
M1097A1, M1097A2

Manual References

TM 9-2320-280-24P

Tools

General mechanic's tool kit
automotive (Appendix B, Item 1)

NOTE

Front door strikers are installed with washers and capscrews.
Rear door strikers are installed with star washers and capscrews.
This procedure covers a front door striker.

a. Removal

Remove two nuts (4), washers (2), capscrews (1), washers (2), and door striker (3) from body (5).

b. Installation

Install door striker (3) on body (5) with two washers (2), capscrews (1), washers (2), and nuts (4).
Tighten capscrews (1) to 15 lb-ft (20 N·m).

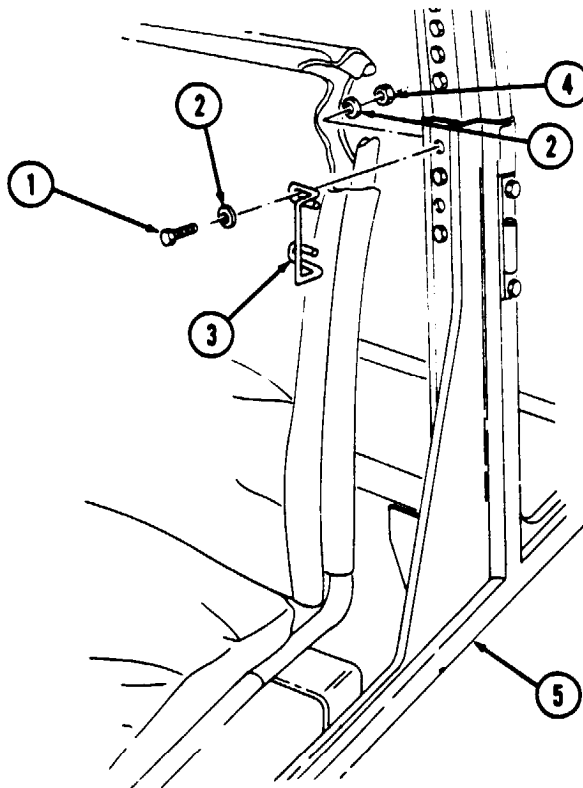

FOLLOW-ON TASK: Adjust soft top door (para. 10-102).

10-104. SOFT TOP REPAIR

This task covers:

- | | |
|--|---|
| <ul style="list-style-type: none"> a. Inspection and Cleaning b. Soft Top Material Repair c. Soft Top Window Repair | <ul style="list-style-type: none"> d. Soft Top Window Zipper Repair (Temporary) e. Soft Top Canvas Repair |
|--|---|

INITIAL SETUP:

Applicable Models

M998, M998A1, M1035, M1035A1, M1035A2,
M1037, M1038, M1038A1, M1042, M1097,
M1097A1, M1097A2, M1123

Manual Reference

FM 10-16
TM 9-2320-280-10
TM 9-2320-280-24P

Tools

General mechanic's tool kit:
automotive (Appendix B, Item 1)

Equipment Condition

Soft top enclosure removed, as required
(TM 9-2320-280-10).

Materials/Parts

Sealing compound (Appendix C, Item 42)
Hook and pile material (Appendix C, Item 52)
Two plastic sheets (Appendix D, Figure D-64)
Green plastic canvas
(Appendix D, Figure D-114)
Six socket turnbuttons (Appendix G, Item 293)
Six grommets (Appendix G, Item 63)
Twelve clinch plate turnbuttons
(Appendix G, Item 316)

a. Inspection and Cleaning

1. Inspect soft top doors and tops for pin holes and leaks around the seam areas.
2. Using soapy water solution and stiff brush, clean area to be sealed on the outer side of the canvas. Allow to dry.

b. Soft Top Material Repair

1. Apply sealing compound to cleaned area where leak occurred. Ensure sealing compound is pressed into stitching of seams.
2. Allow 20 minutes for sealing compound to cure.

10-104. SOFT TOP REPAIR (Cont'd)

c. Soft Top Window Repair

NOTE

The use of pressure-sensitive, adhesive-coated plastic sheets for temporary repair of small window cracks and holes should only be utilized if it does not hinder operator's vision. If damaged area is large enough so that plastic sheets will hinder operator's vision, door assembly should be replaced.

1. Ensure damaged area of window (1) is clean and dry.
2. Peel backing off plastic sheet (2) and apply to damaged area of window (1).
3. Peel backing off plastic sheet (3) and apply to other side of damaged area of window (1).

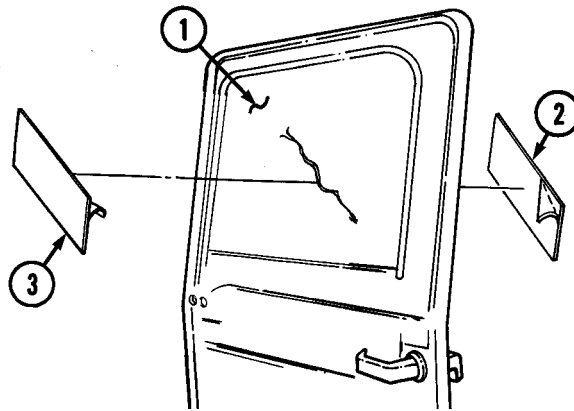

d. Soft Top Window Zipper Repair (Temporary)

NOTE

Use hook and pile material as a temporary measure to secure window with failed zipper until zipper or door can be replaced.

1. Apply half (5) of the self-adhesive hook and pile material on inside of door (4) around window (1).
2. Put mating half (6) of hook and pile material on window (1). Apply strips as required to firmly secure window.

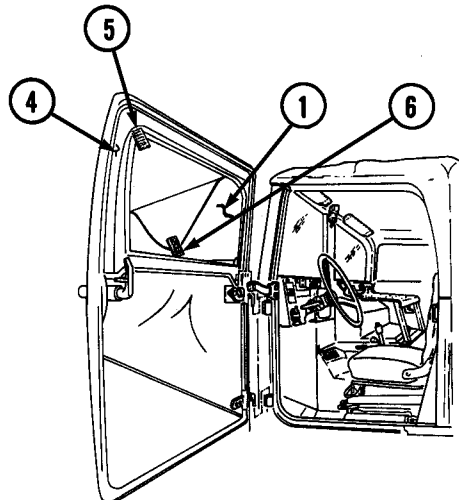

10-104. SOFT TOP REPAIR (Cont'd)

e. Soft Top Canvas Repair

NOTE

Since these procedures are a reinforcement guide, you can modify them to meet individual needs. These reinforcement procedures are helpful because:

- The securing straps reinforce the enclosure and reduce its “ballooning” action.
 - The extra wear, damage, and holes in the enclosure are reduced.
 - Any enclosure can be returned to a serviceable condition at a significantly lower cost than replacing the enclosure.
1. Secure six socket turnbuttons and grommets to canvas straps (2), (3), and (4) using twelve clinch plate turnbuttons, follow procedures found in FM 10-16, General Fabric Repair.
 2. Sew the eight canvas straps (2), (3), and (4) to inside of soft top enclosure (1). Follow procedures for sewing on straps as found in FM 10-16, General Fabric Repair. Attach straps in the following locations:
 - (a) Strap A (4) – On top front corners of soft top enclosure (1).
 - (b) Strap B (3) – Where the corners of second and third bows make contact with the enclosure (1).
 - (c) Strap C (2) – On the soft top enclosure (1) where second and third bows make contact with soft top enclosure (1).

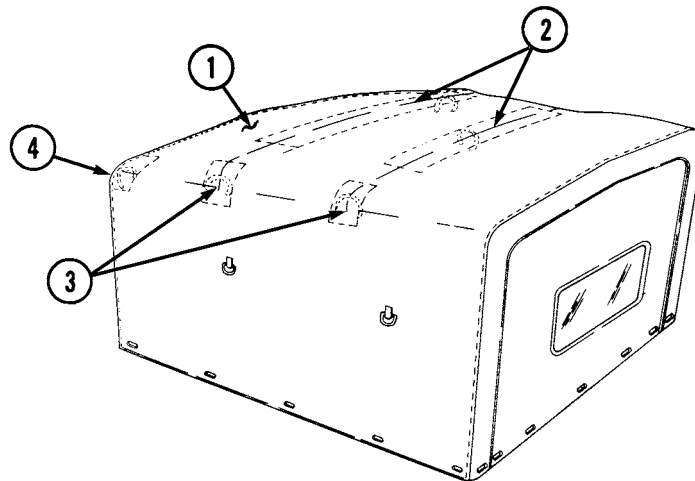

10-104. SOFT TOP REPAIR (Cont'd)

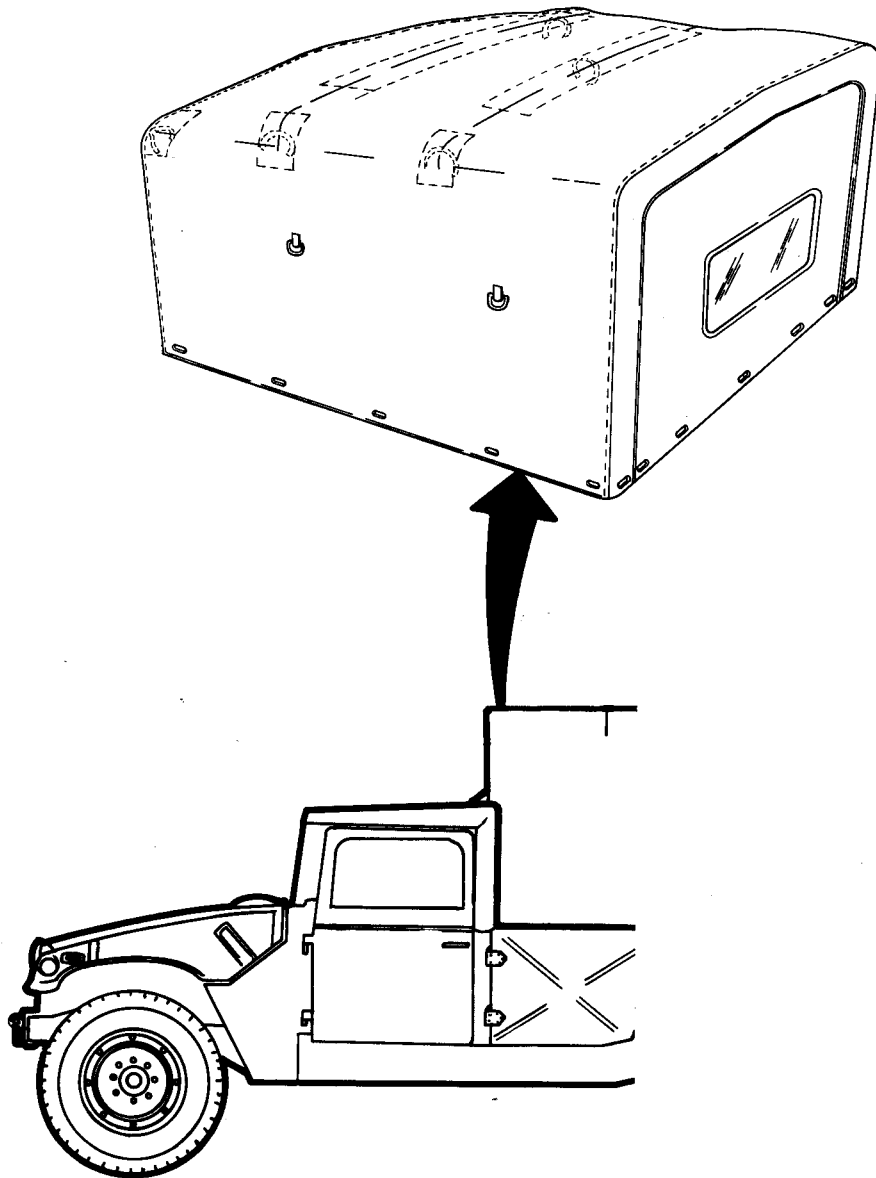

FOLLOW-ON TASK: Install soft top enclosure, as required, (TM 9-2320-280-10), ensuring straps are fastened around bows.

10-105. "C" PILLAR REINFORCEMENT BRACKETS INSTALLATION

This task covers:

Installation

INITIAL SETUP:

Tools

General mechanic's tool kit:
automotive (Appendix B, Item 1)

Materials/Parts

Two brackets (Appendix D, Fig. D-89)
Two locknuts (Appendix G, Item 119)
Eight rivets (Appendix G, Item 256)

Manual Reference

TM 9-2320-280-10
TM 9-2320-280-24P
TM 43-0139

Equipment Condition

Soft top removed as required (TM 9-2320-280-10).

Installation

NOTE

- The following procedure can be performed to prevent fatigue cracking of the "C" pillar mount brackets. Installation is at commander's discretion.
- For instructions on replacement of rivets, refer to para. 10-66.

1. Using 0.187-inch drill bit, remove rivet (5) from wheelhousing (4).
2. Scribe two reference lines (3) on "C" pillar (2).
3. Align reinforcement bracket (1) with reference lines (3) on "C" pillar (2).
4. Scribe hole location (5) on wheelhousing (4) onto reinforcement bracket (1).
5. Using reinforcement bracket as template, drill four 0.187-inch diameter holes through reinforcement bracket (1) and "C" pillar (2). Remove bracket (1).
6. Using 0.281-inch drill bit, enlarge hole (5) in wheelhousing (4).
7. Using hole location marked in step 4, drill 0.281-inch diameter hole in reinforcement bracket (1).
8. Spot paint reinforcement bracket (refer to TM 43-0139).

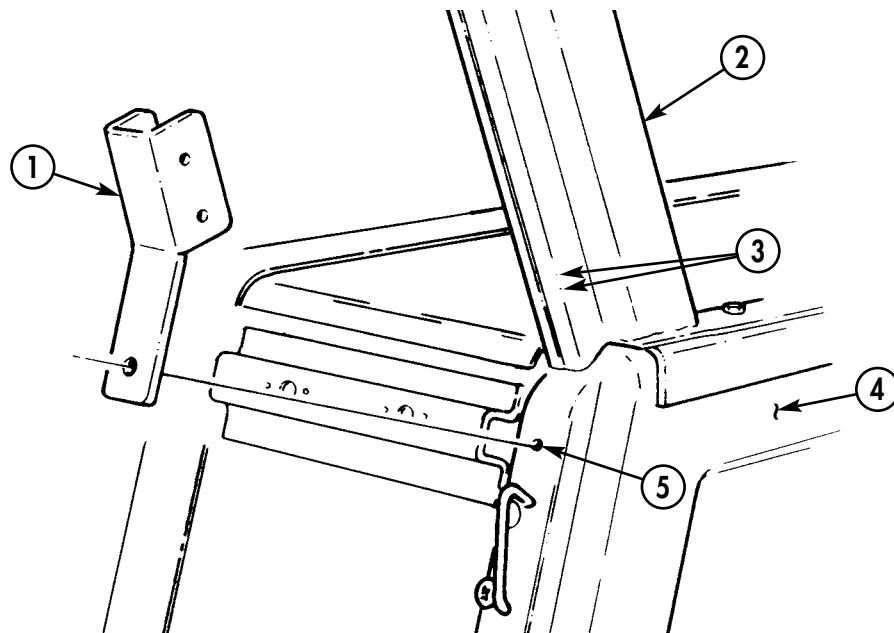

10-105. "C" PILLAR REINFORCEMENT BRACKETS INSTALLATION

9. Install reinforcement bracket (1) on "C" pillar (2) with four rivets (3).
10. Align mount hole (7) in reinforcement bracket (1) and hole in wheelhousing (4) and install washer (6), screw (8), washer (6), and locknut (5).
11. Spot paint as necessary (refer to TM 43-0139).

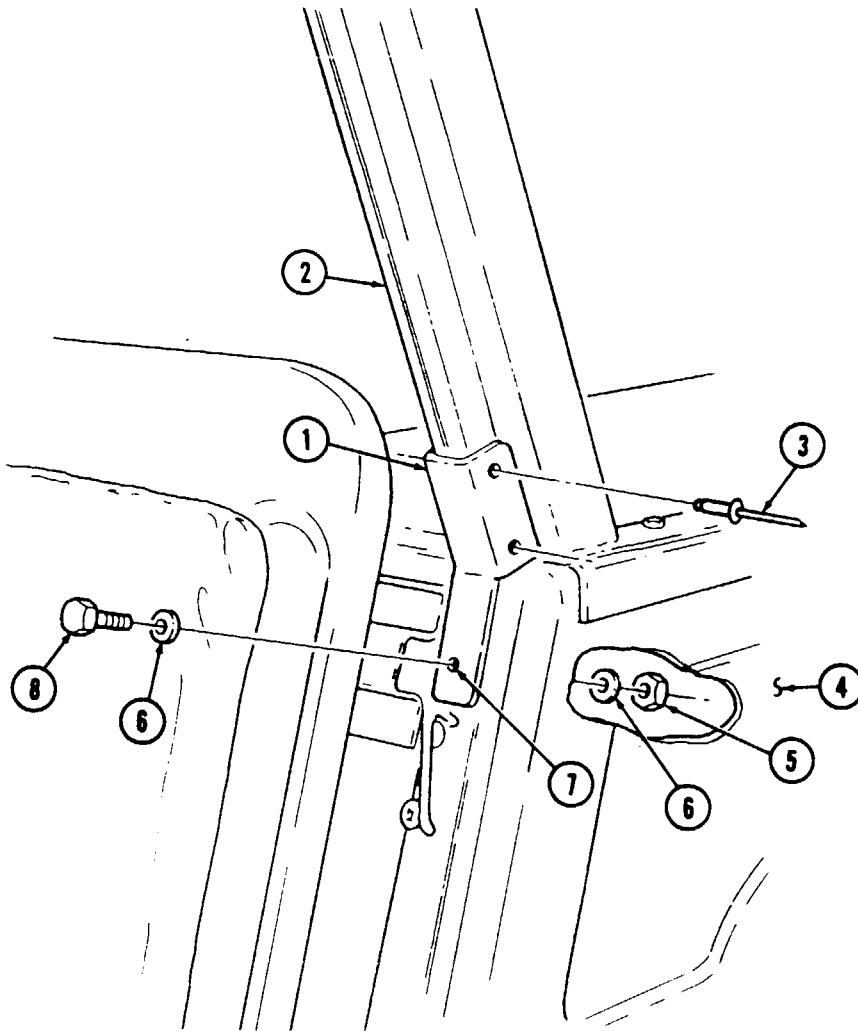

FOLLOW-ON TASK: Install soft top as required (TM 9-2320-280-10).

Section III. WINCH MAINTENANCE

10-106. WINCH MAINTENANCE TASK SUMMARY

TASK PARA.	PROCEDURES	PAGE NO.
10-107.	6,000 Lb Electric Winch Replacement	10-180
10-108.	9,000 Lb Electric Winch Replacement	10-184
10-108.1.	10,500 Lb Hydraulic Winch and Brackets Replacement	10-186.2
10-109.	6,000 Lb and 9,000 Lb Electric Winch Control Box Replacement	10-188
10-110.	6,000 Lb and 9,000 Lb Electric Winch Cable Replacement	10-190
10-110.1.	10,500 Lb Hydraulic Winch Cable Replacement	10-190.2
10-111.	6,000 Lb and 9,000 Lb Electric Winch Vent Line Replacement	10-192
10-112.	Fairlead Roller Bracket Assembly Replacement	10-193
10-113.	10,500 Lb Winch Hydraulic Hose Replacement	10-194
10-114.	10,500 Lb Hydraulic Winch Controller Plug Replacement	10-196

10-107. 6,000 LB ELECTRIC WINCH REPLACEMENT

This task covers:

a. Removal

b. Installation

INITIAL SETUP:

Applicable Models

M1026, M1026A1, M1036, M1038, M1038A1, M1042, M1044, M1044A1, M1046, M1046A1

Tools

General mechanic's tool kit:
automotive (Appendix B, Item 1)

Materials/Parts

Two lockwashers (Appendix G, Item 135)
Three tiedown straps (Appendix G, Item 307)
Assembled locknut (Appendix G, Item 131)
Lockwasher (Appendix G, Item 133)
Lockwasher (Appendix G, Item 137)

Personnel Required

One mechanic
One assistant

Manual References

TM 9-2320-280-10
TM 9-2320-280-24P

Equipment Condition

- Winch cable removed (para. 10-110).
- Battery ground cable disconnected (para. 4-73).
- Hood raised and secured (TM 9-2320-280-10).

General Safety Instructions

Winch must be supported during removal and installation.

WARNING

Winch must be supported during removal and installation.
Failure to support winch may result in injury to personnel or damage to equipment.

a. Removal

1. Remove nut (9) and lockwasher (10) and disconnect lead 7 (11) from starter terminal (8). Discard lockwasher (10).
2. Remove nut (7) and lockwasher (6) and disconnect lead 6 (4) from starter terminal (5). Discard lockwasher (6).
3. Remove assembled locknut (1) and clamp (3) from oil pan bracket screw (2). Discard assembled locknut (1).
4. Remove two capscrews (18), clamp (23), and bracket (19) from airlift bracket (20).
5. Remove nut (12), lockwasher (13), capscrew (15), and clamp (14) from frame bracket (29). Discard lockwasher (13). Pull cables (27) to front of vehicle.
6. Disconnect cable (35) from control cable (36) in winch control box (37) and remove grommet (34) and cable (35) from control box (37).
7. Disconnect vent line (24) from fitting (25) on winch motor (25.1) and remove three tiedown straps (26) from vent line (24) and power cables (27). Discard tiedown straps (26).
8. Remove four capscrews (30), washers (31), and nuts (32) from winch (33) and front bumper (38). Lower and remove winch (33) and power cables (27) from vehicle.
9. Measure length of power cables (27) from clamp (28) on winch (33) to clamp (21) on bracket (19) and record. Remove nut (17), lockwasher (16), capscrew (22), clamp (21), and bracket (19) from power cables (27). Discard lockwasher (16).

10-107. 6,000 LB ELECTRIC WINCH REPLACEMENT (Cont'd)

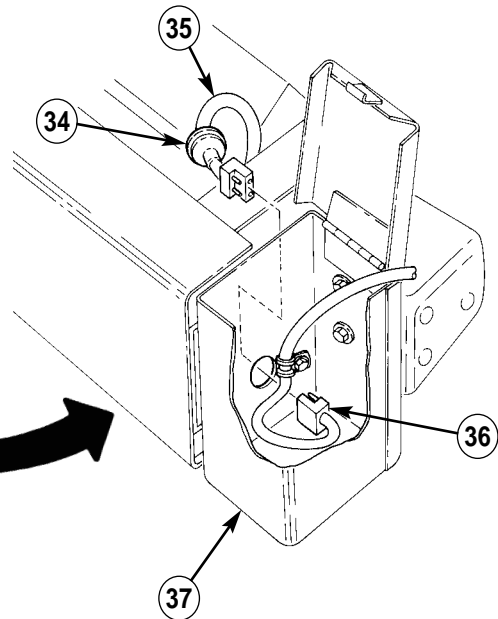
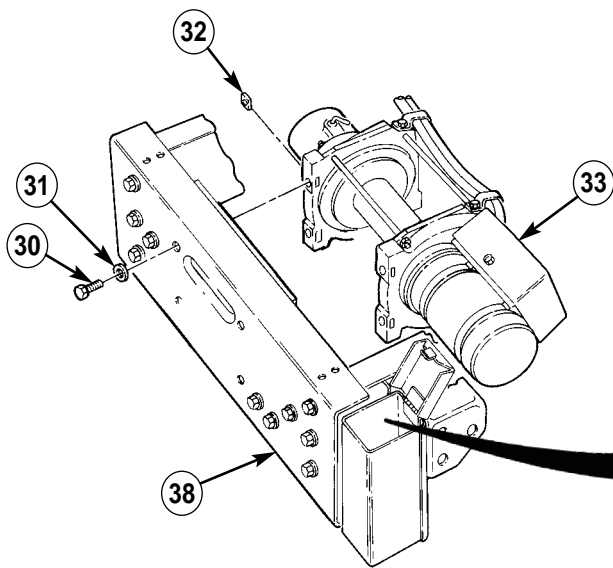
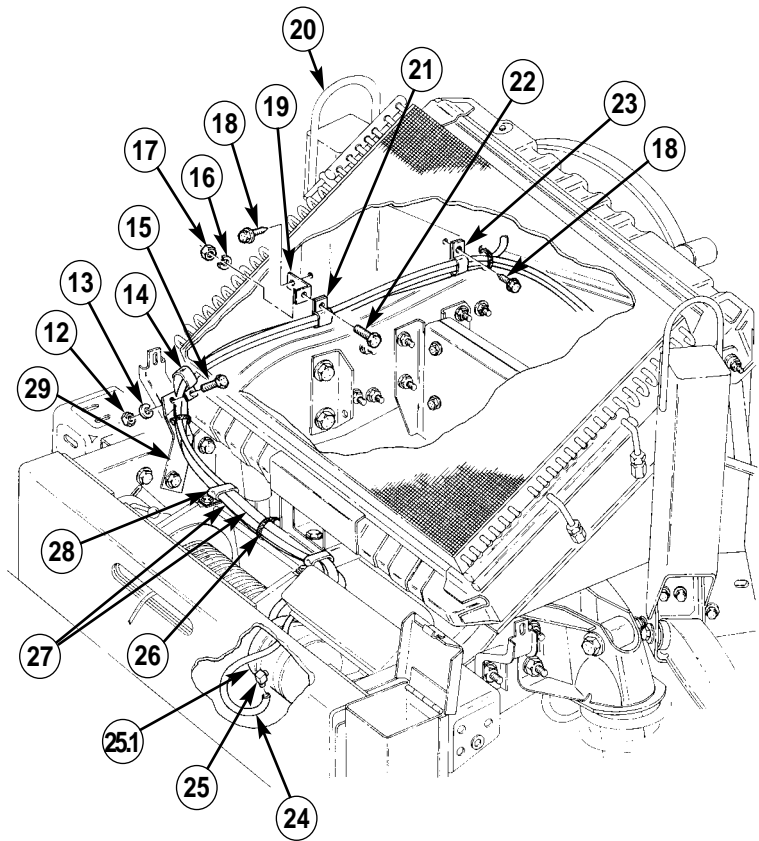
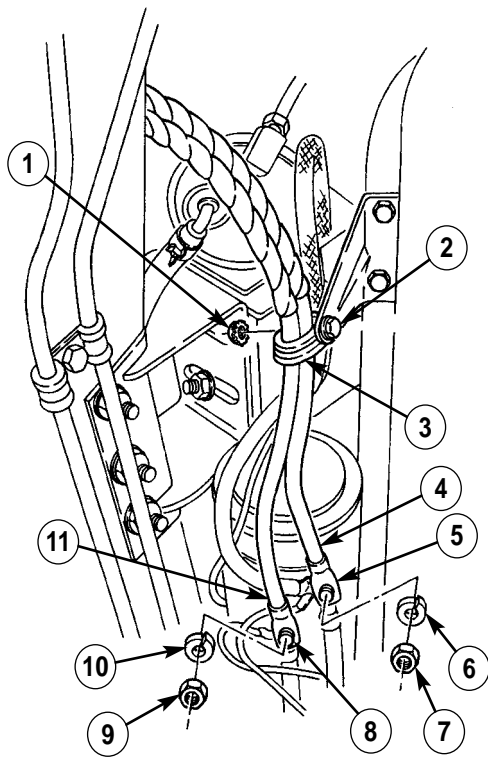

10-107. 6,000 LB ELECTRIC WINCH REPLACEMENT (Cont'd)

b. Installation

1. Install clamp (8) on power cables (15) at same distance from clamp (17) on winch (16) that was recorded in removal.
2. Install clamp (8) and bracket (6) on power cables (15) with capscrew (9), lockwasher (3), and nut (4).
3. Install winch (16) on front bumper (29) with four nuts (23), washers (22), and capscrews (21). Tighten capscrews (21) to 60 lb-ft (81 N·m).
4. Route cable (24) through opening (28) in control box (27) and connect to control cable (26). Install grommet (25) in opening (28).
5. Route power cables (15) in approximate mounting location in vehicle.
6. Install lead 7 (40) on starter terminal (37) with lockwasher (39) and nut (38). Tighten nut (38) to 15 lb-ft (20 N·m).
7. Install lead 6 (33) on starter terminal (34) with lockwasher (35) and nut (36). Tighten nut (36) to 25 lb-ft (34 N·m).
8. Install clamp (32) and power cables (15) on oil pan bracket screw (31) with assembled locknut (30).
9. Install clamp (10) on power cables (15) and airlift bracket (7) with capscrew (11).
10. Install bracket (6) on airlift bracket (7) with capscrew (5).
11. Install clamp (1) on power cables (15) and frame bracket (18) with capscrew (2), lockwasher (20), and nut (19).
12. Connect vent line (12) to fitting (13) on winch motor (11.1). Install vent line (12) on power cables (15) with three tiedown straps (14).

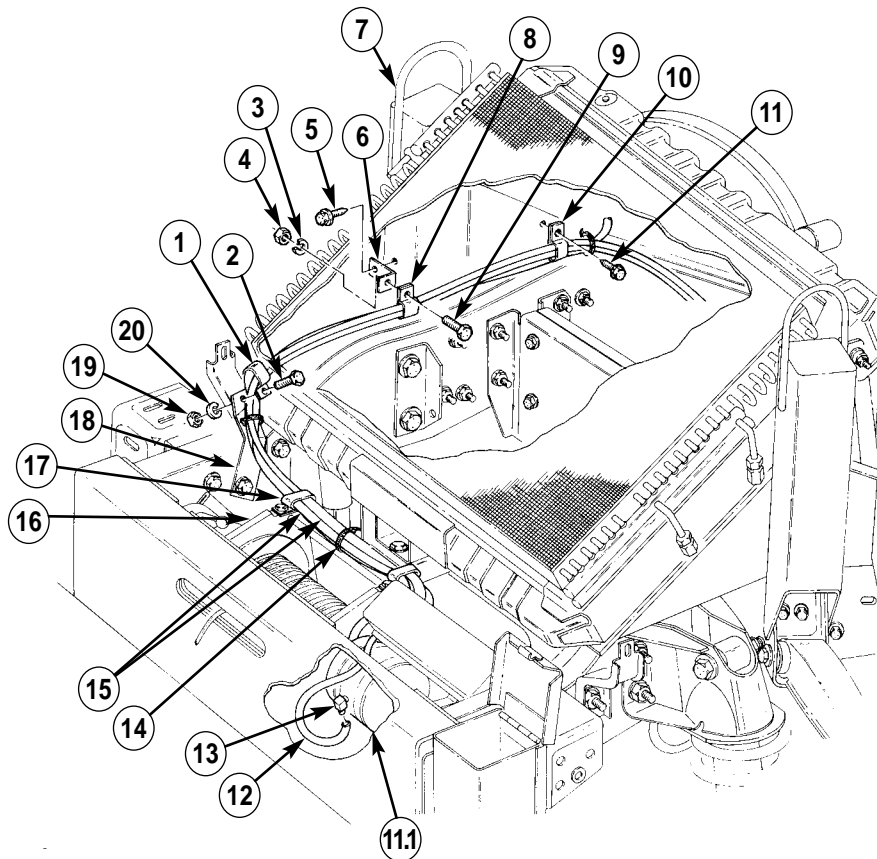

10-107. 6,000 LB ELECTRIC WINCH REPLACEMENT (Cont'd)

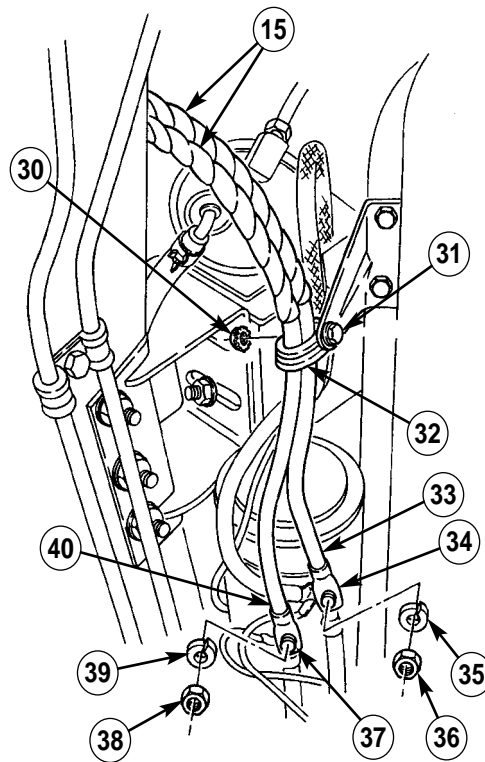
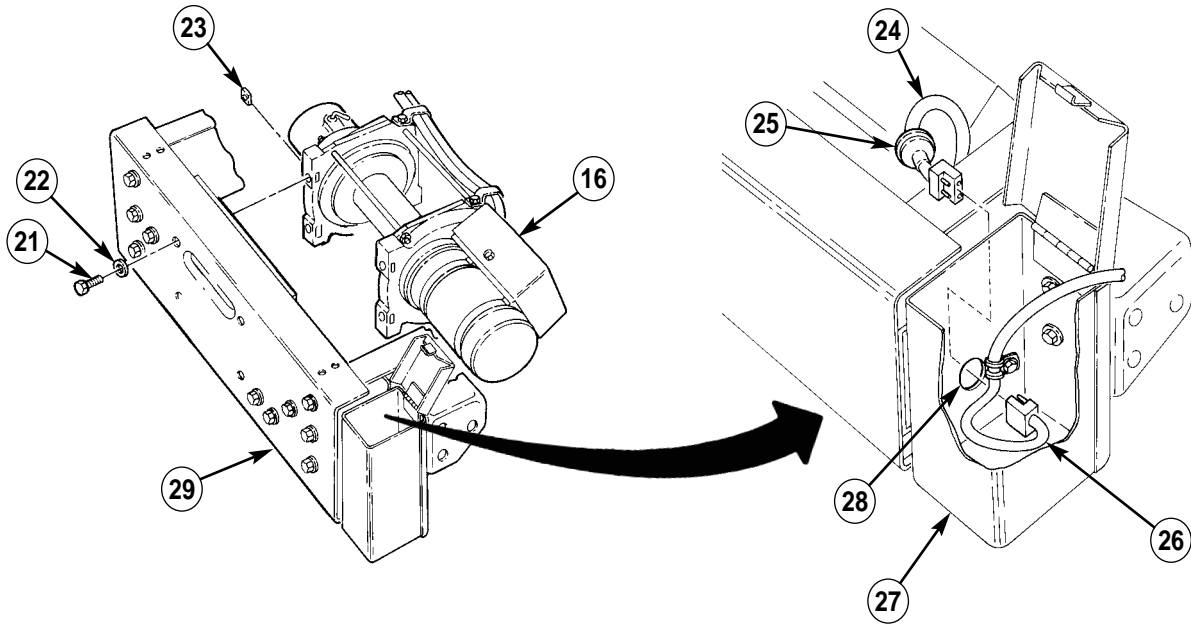

- FOLLOW-ON TASKS:**
- Connect battery ground cable (para. 4-73).
 - Install winch cable (para. 10-110).
 - Lower and secure hood (TM 9-2320-280-10).

10-108. 9,000 LB ELECTRIC WINCH REPLACEMENT

This task covers:

a. Removal

b. Installation

INITIAL SETUP:

Applicable Models

M997A2, M1025A2, M1035A2, M1043A2,
M1045A2, M1097A2

Tools

General mechanic's tool kit:
automotive (Appendix B, Item 1)

Materials/Parts

Two lockwashers (Appendix G, Item 164)
Lockwasher (Appendix G, Item 137)
Lockwasher (Appendix G, Item 194)
Four tiedown straps (Appendix G, Item 308)
Assembled locknut (Appendix G, Item 130)

Personnel Required

One mechanic
One assistant

Manual References

TM 9-2320-280-10
TM 9-2320-280-24P

Equipment Condition

- Battery ground cables disconnected (para. 4-73).
- Hood raised and secured (TM 9-2320-280-10).
- Engine right splash shield removed (para. 10-20).

General Safety Instructions

Winch must be supported during removal and installation.

WARNING

Winch must be supported during removal and installation. Failure to support winch may result in injury to personnel or damage to equipment.

a. Removal

1. Remove nut (9) and lockwasher (10) and disconnect lead 7 (11) from starter terminal (8). Discard lockwasher (10).
2. Remove nut (7) and lockwasher (6) and disconnect lead 6 (4) from starter terminal (5). Discard lockwasher (6).
3. Remove assembled locknut (1) and clamp (3) from oil pan bracket screw (2). Discard assembled locknut (1).
4. Remove two capscrews (18), clamp (23), and bracket (19) from airlift bracket (20).
5. Remove nut (12), lockwasher (13), capscrew (15), and clamp (14) from frame bracket (29). Discard lockwasher (13).
6. Disconnect vent line (24) from fitting (25) on winch motor (23.1) and remove four tiedown straps (26) and vent line (24) from power cables (27). Pull cables (27) to front of vehicle and discard tiedown straps (26).
7. Remove four retaining rings (35), two shafts (32), and rollers (34) from fairlead roller bracket (33). Pull cable (38) through bumper (31).
8. Remove two capscrews (31.2), washers (31.1), and fairlead roller bracket (33) from bumper (31) and winch (30).
9. Remove two capscrews (31.2) and washers (31.1) from winch (30) and front bumper (31). Lower and remove winch (30) and power cables (27) from vehicle.
10. Measure length of power cables (27) from clamp (28) on winch (30) to clamp (21) on bracket (19) and record. Remove nut (17), lockwasher (16), capscrew (22), clamp (21), and bracket (19) from power cables (27). Discard lockwasher (16).

10-108. 9,000 LB ELECTRIC WINCH REPLACEMENT (Cont'd)

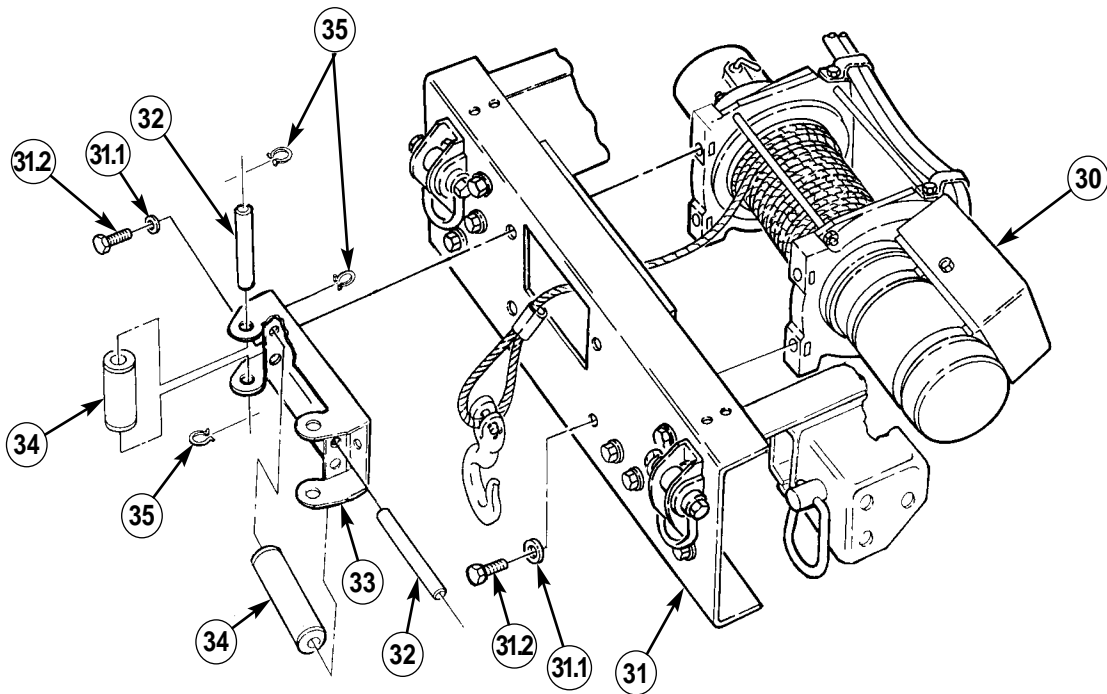
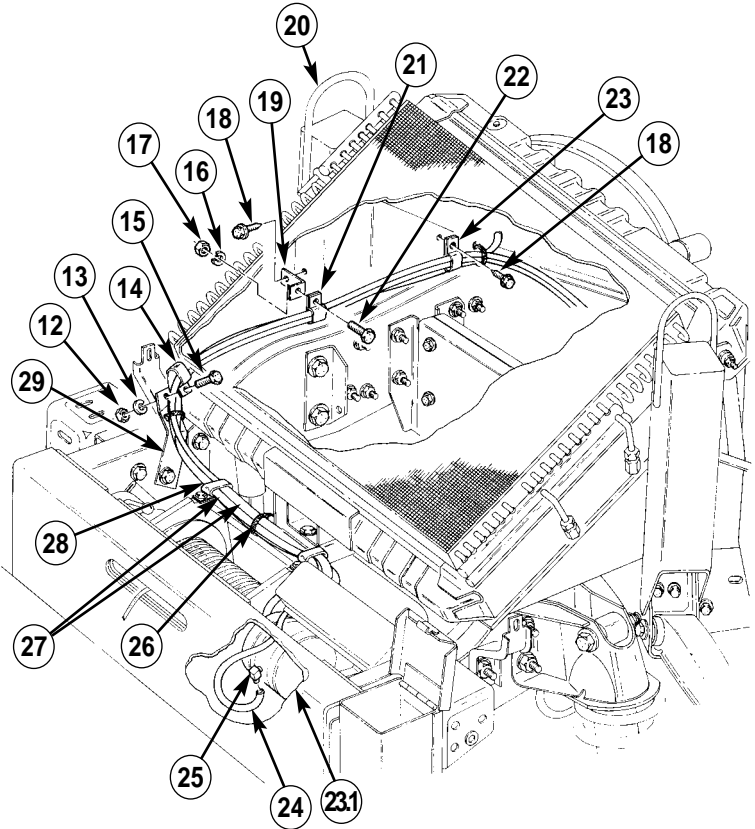
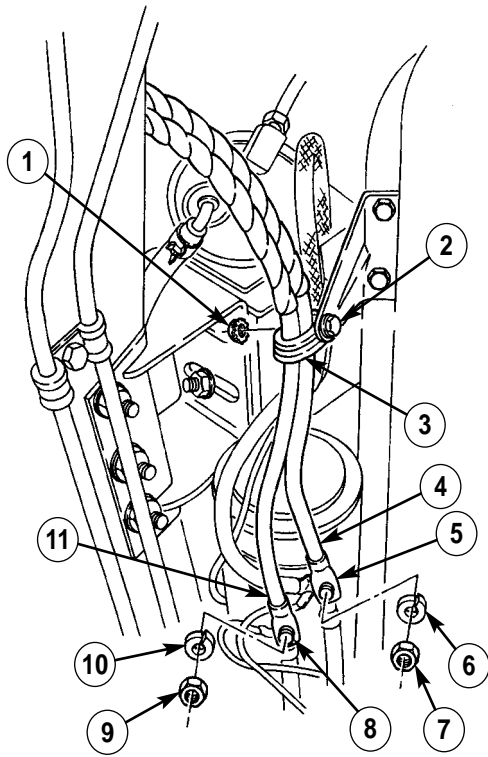

10-108. 9,000 LB ELECTRIC WINCH REPLACEMENT (Cont'd)

b. Installation

1. Position clamp (8) on power cables (15) at same distance from clamp (17) on winch (16) that was recorded in removal.
2. Install clamp (8) on power cables (15) and bracket (6) with capscrew (9), lockwasher (3), and nut (4).
3. Install winch (16) on bumper (21) with two washers (21.1) and capscrews (21.2). Tighten capscrews (21.2) to 35 lb-ft (47 N•m).
4. Install fairlead roller bracket (23) on bumper (21) and winch (16) with two washers (21.1) and capscrews (21.2). Feed cable (26) through bumper (21) and bracket (23). Tighten capscrews (21.2) to 35 lb-ft (47 N•m).
5. Install four rollers (24) and shafts (22) on fairlead roller bracket (23) with eight retaining rings (25).
6. Route power cables (15) in approximate mounting location in vehicle.
7. Install lead 7 (36) on starter terminal (33) with lockwasher (35) and nut (34). Tighten nut (34) to 15 lb-ft (20 N•m).
8. Install lead 6 (29) on starter terminal (30) with lockwasher (31) and nut (32). Tighten nut (32) to 25 lb-ft (34 N•m).
9. Install clamp (28) and power cables (15) on oil pan bracket screw (27) with assembled locknut (37).
10. Install clamp (10) on power cables (15) and airlift bracket (7) with capscrew (11).
11. Install bracket (6) on airlift bracket (7) with capscrew (5).
12. Install clamp (1) on power cables (15) and frame bracket (18) with capscrew (2), lockwasher (20), and nut (19).
13. Connect vent line (12) to fitting (13) on winch motor (11.1). Install vent line (12) on power cables (15) with four tiedown straps (14).

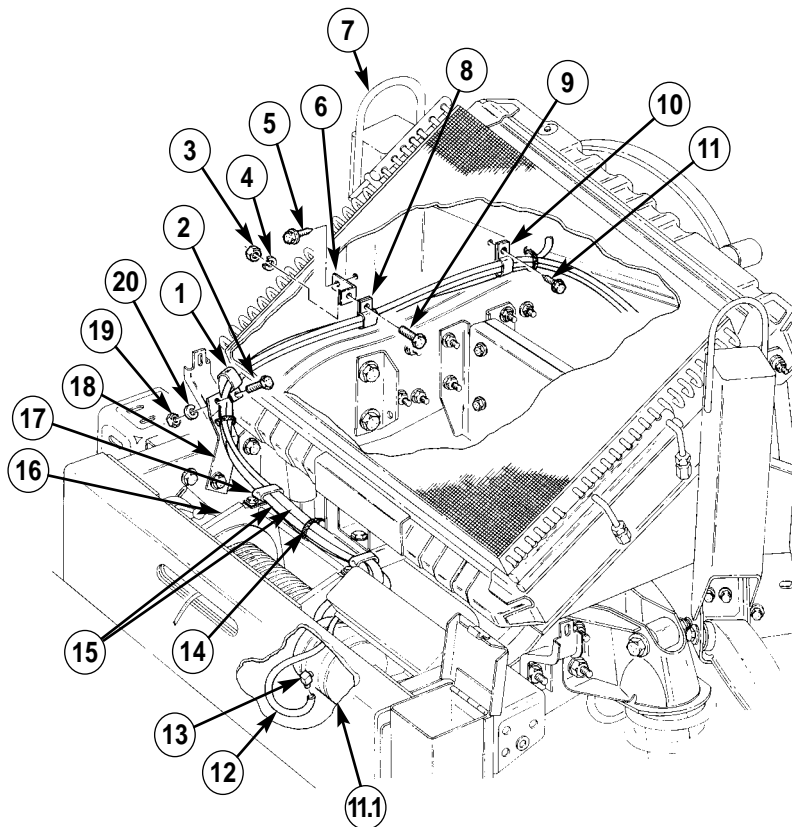

10-108. 9,000 LB ELECTRIC WINCH REPLACEMENT (Cont'd)

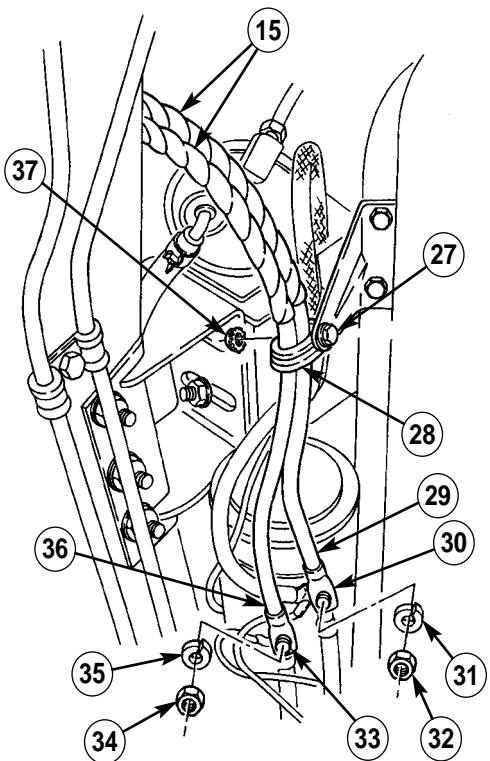
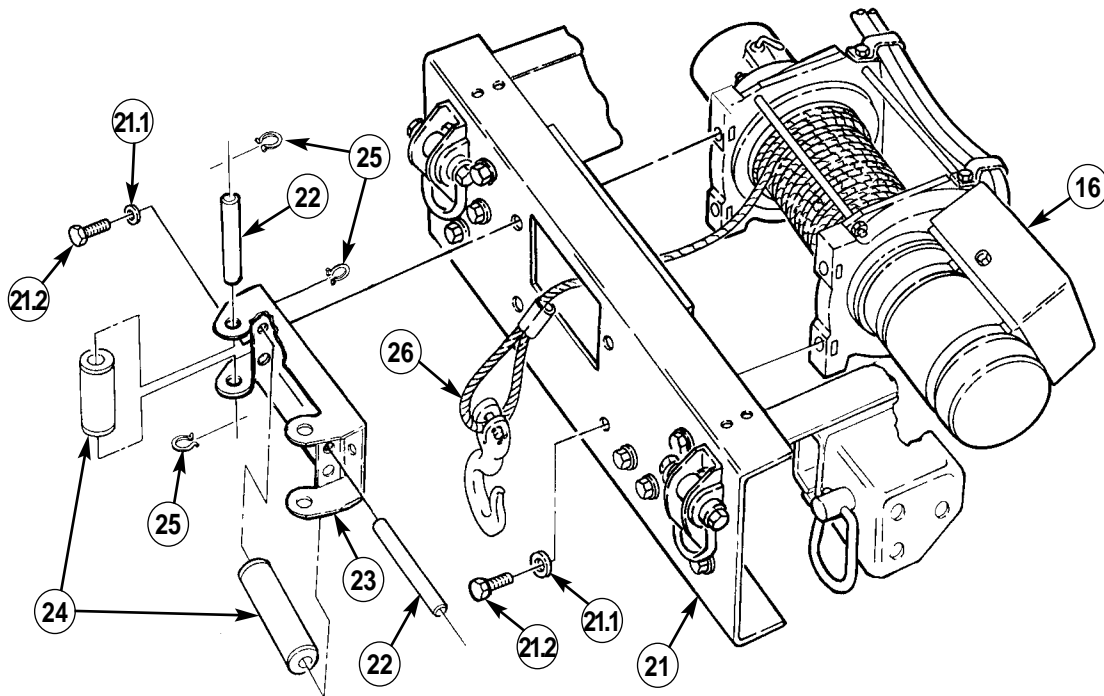

- FOLLOW-ON TASKS:**
- Install engine right splash shield (para. 10-20).
 - Connect battery ground cables (para. 4-73).
 - Lower and secure hood (TM 9-2320-280-10).

10-108.1. 10,500 LB HYDRAULIC WINCH AND BRACKETS REPLACEMENT

This task covers:

- | | |
|--|--|
| <p>a. Winch Removal</p> <p>b. Brackets Removal</p> | <p>c. Brackets Installation</p> <p>d. Winch Installation</p> |
|--|--|

INITIAL SETUP:

Applicable Models:

All vehicles except M996, M996A1, M997, M997A1, M997A2, M1035, M1035A1, M1035A2.

Tools

General mechanics tool kit: automotive (Appendix B, Item 1)
 Maintenance and repair shop equipment: automotive (Appendix B, Item 2)

Materials/Parts

Locknut (Appendix G, Item 70)
 Six locknuts (Appendix G, Item 80)
 Four locknuts (Appendix G, Item 81)
 Two locknuts (Appendix G, Item 89)

Manual References

TM 9-2320-280-10
 TM 9-2320-280-24P

Equipment Condition

- Parking brake applied (TM 9-2320-280-10)
- Battery ground cables disconnected (para. 4-73).
- Underbody protection kit removed (if applicable) (para. 12-186).
- Brake protection guards removed (if applicable) (para. 7-8.1).

General Safety Instructions

Support winch and bumper during winch replacement.

NOTE

Tag all leads prior to removal.

a. Winch Removal

1. Disconnect controller plug lead 758C (10) from winch lead 758C (9).
2. Disconnect controller plug lead 758A (8) from winch lead 758A (7).
3. Disconnect controller plug lead 758B (6) from lead wire 758B (5).
4. Remove locknut (14), washer (13), screw (11), and two clamps (12) with hydraulic hose assemblies (1) and (4) from winch and bumper assembly (15). Discard locknut (14).

CAUTION

- Tag hoses and connections prior to removal to assist in proper installation.
 - Cover or plug hoses and connections immediately after removal to prevent contamination. Remove all plugs prior to connecting hoses.
5. Disconnect hydraulic hose (1) from elbow (2) on bottom winch outlet port on winch (15) .
 6. Disconnect hydraulic hose (4) from elbow (3) on top winch inlet port on winch (15).

NOTE

If vehicle is to be operated with winch assembly removed, perform step 7.

7. Connect tube assembly (16) to hydraulic hose assemblies (1) and (4).

10-108.1. 10,500 LB HYDRAULIC WINCH AND BRACKETS REPLACEMENT (Cont'd)

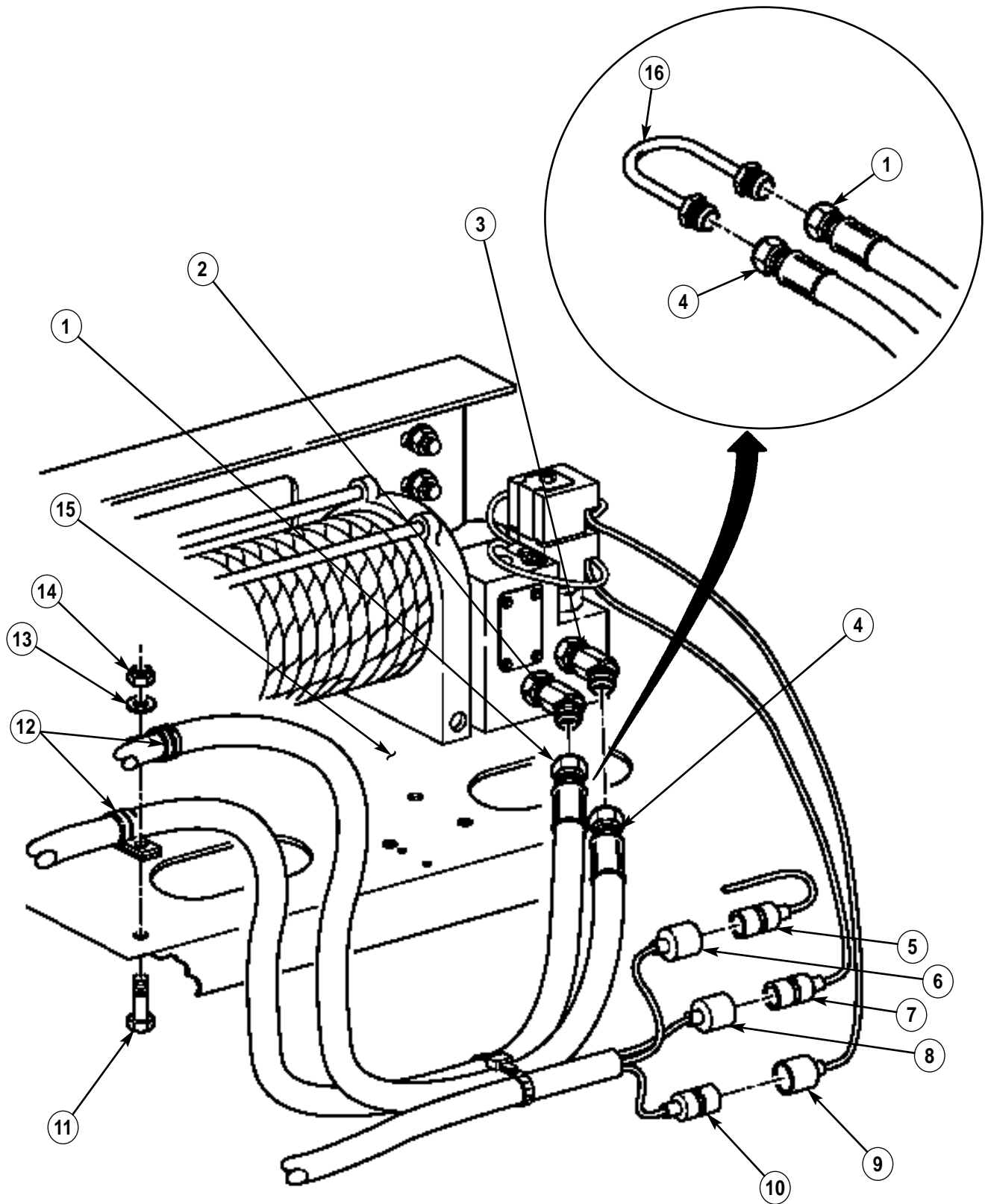

10-108.1. 10,500 LB HYDRAULIC WINCH AND BRACKETS REPLACEMENT (Cont'd)

WARNING

Winch and bumper must be supported with a floor jack during winch replacement. Failure to support winch may result in injury to personnel or damage to equipment.

8. Remove four locknuts (14), washers (10), capscrews (11), washers (10), and two tow brackets (9) from winch and bumper assembly (8) and left and right bracket assemblies (5). Discard locknuts (14).
9. Remove two locknuts (12), washers (13), and winch and bumper assembly (8) from left and right lower control arm screws (1). Discard locknuts (12).

b. Brackets Removal

NOTE

- Brackets may not require replacement. Replace brackets only when damaged.
 - The left and right side brackets are removed the same. This procedure covers the left side.
1. Remove three locknuts (3), washers (2), capscrews (15), and washers (2) from left hand bracket assembly (5) and frame rail (4.1). Discard locknuts (3).
 2. Remove capscrew (7), washer (6), and left hand bracket assembly (5) from grille extension (4).

c. Brackets Installation

1. Install left hand bracket assembly (5) on grille extension (4) with washer (6) and capscrew (7). Finger tighten capscrew (7).
2. Install left hand bracket assembly (5) on frame rail (4.1) with three washers (2), capscrews (15), washers (2), and locknuts (3). Tighten locknuts (3) to 225 lb-ft (303 N•m).

d. Winch Installation

WARNING

Winch and bumper must be supported with a floor jack during winch replacement. Failure to support winch may result in injury to personnel or damage to equipment.

1. Install winch and bumper assembly (8) on left and right lower control arm screws (1) with two washers (13) and locknuts (12). Finger tighten locknuts (12).
2. Secure winch and bumper assembly (8) and two tow brackets (9) on left and right bracket assemblies (5) with four washers (10), capscrews (11), washers (10), and locknuts (14).
3. Tighten capscrews (7) installed in step c.1. to 37 lb-ft (50 N•m).
4. Tighten locknuts (12) to 260 lb-ft (353 N•m).
5. Tighten locknuts (14) to 90 lb-ft (122 N•m).

10-108.1. 10,500 LB HYDRAULIC WINCH AND BRACKETS REPLACEMENT (Cont'd)

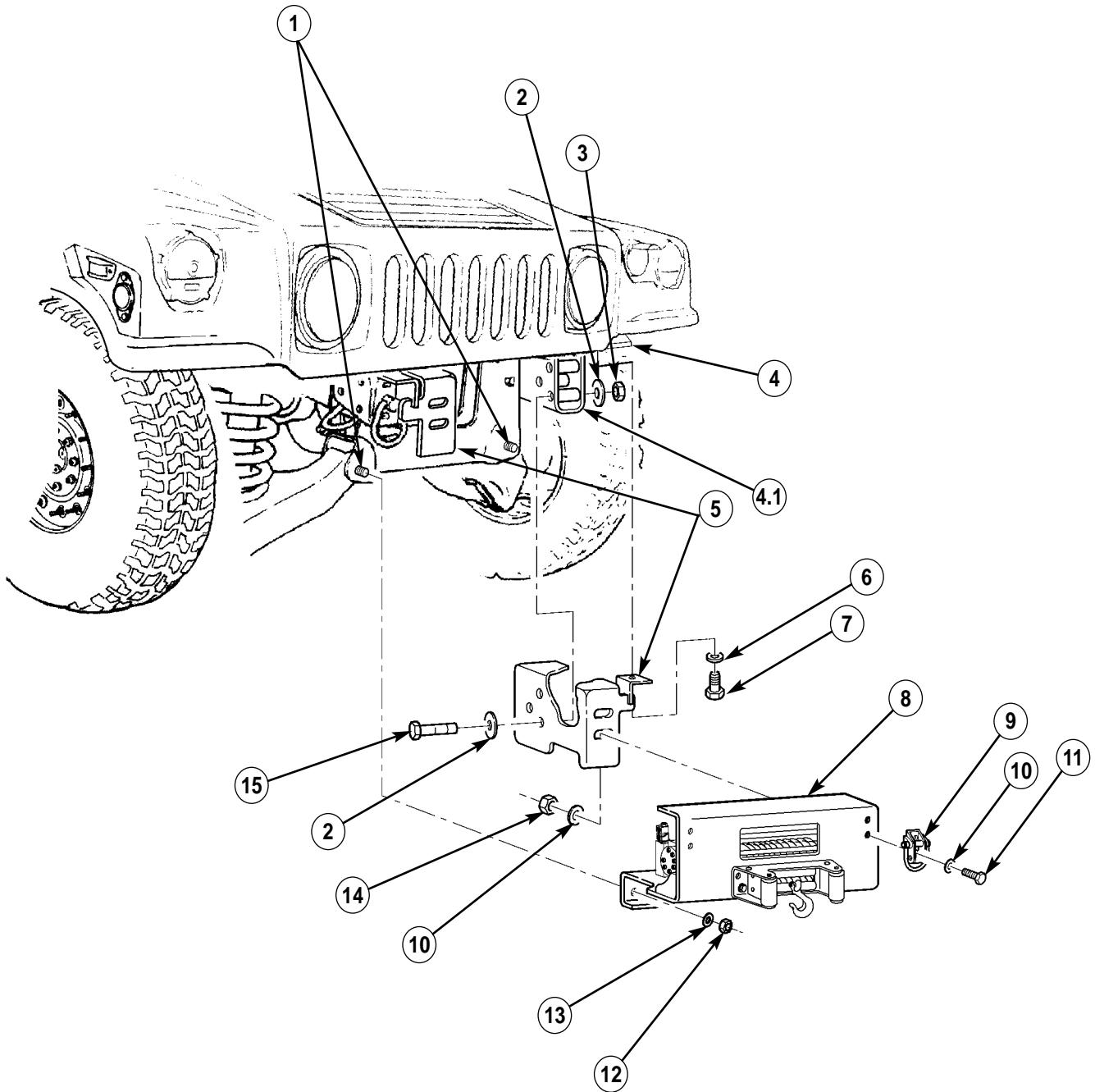

10-108.1. 10,500 LB HYDRAULIC WINCH AND BRACKETS REPLACEMENT (Cont'd)

NOTE

If tube assembly is installed, perform step 4.

4. Disconnect tube assembly (16) from hydraulic hose assemblies (1) and (4).
5. Connect hydraulic hose assembly (4) to elbow (3) on top winch inlet port on winch (15).
6. Connect hydraulic hose assembly (1) to elbow (2) on bottom winch outlet port on winch (15).
7. Install hydraulic hose assemblies (1) and (4) on winch and bumper assembly (15) with two clamps (12), capscrew (11), washer (13), locknut (14).
8. Connect controller plug lead 758B (6) to lead wire 785B (5).
9. Connect controller plug lead 758A (8) to winch lead 758A (7).
10. Connect controller plug lead 758C (10) to winch lead 758C (9).

10-108.1. 10,500 LB HYDRAULIC WINCH AND BRACKETS REPLACEMENT (Cont'd)

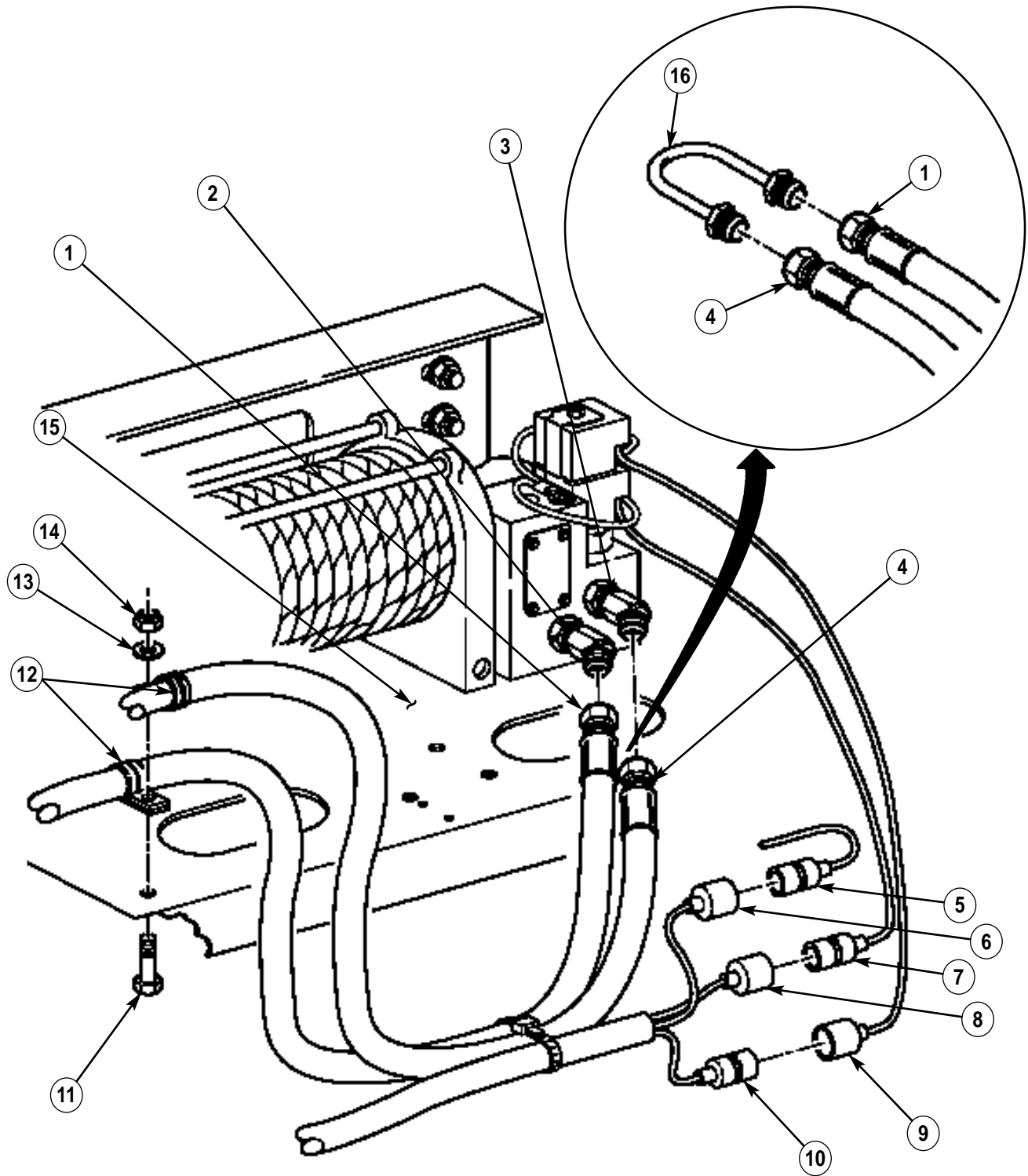

- FOLLOW-ON TASKS:**
- Install brake protection guards (if applicable) (para. 7-8.1).
 - Install underbody protection kit (if applicable) (para. 12-186).
 - Connect battery ground cables (para. 4-73).
 - Bleed power steering system (para. 8-29).

10-109. 6,000 LB AND 9,000 LB ELECTRIC WINCH CONTROL BOX REPLACEMENT

This task covers:

a. Removal

b. Installation

INITIAL SETUP:

Applicable Models

M1026, M1026A1, M1036, M1038, M1038A1, M1042, M1044, M1044A1, M1046, M1046A1

Tools

General mechanic's tool kit:
automotive (Appendix B, Item 1)

Materials/Parts

Lockwasher (Appendix G, Item 177)

Manual References

TM 9-2320-280-24P

Equipment Condition

Battery ground cable disconnected (para. 4-73).

a. Removal

1. Open winch control box (12) and pull control cable (8) out.
2. Remove capscrew (9), clamp (10), lockwasher (2), and nut (1) from control cable (8) and control box (12). Discard lockwasher (2).
3. Disconnect control cable (8) from cable (11) and remove control cable (8) from control box (12).
4. Remove two nuts (6), washers (5), capscrews (4), washers (5), and control box (12) from mounting bracket (7).
5. Slide cable (11) and grommet (3) out of control box (12).

b. Installation

1. Push cable (11) and grommet (3) into control box (12).
2. Install control box (12) on mounting bracket (7) with two washers (5), capscrews (4), and nuts (6). Tighten nuts (6) to 90 lb-ft (122 N•m).
3. Connect control cable (8) to cable (11).
4. Install control cable (8) on control box (12) with capscrew (9), clamp (10), lockwasher (2), and nut (1). Tighten nut (1) to 6 lb-ft (8 N•m). Close and secure control box (12).

**10-109. 6,000 LB AND 9,000 LB ELECTRIC WINCH CONTROL BOX
REPLACEMENT (Cont'd)**

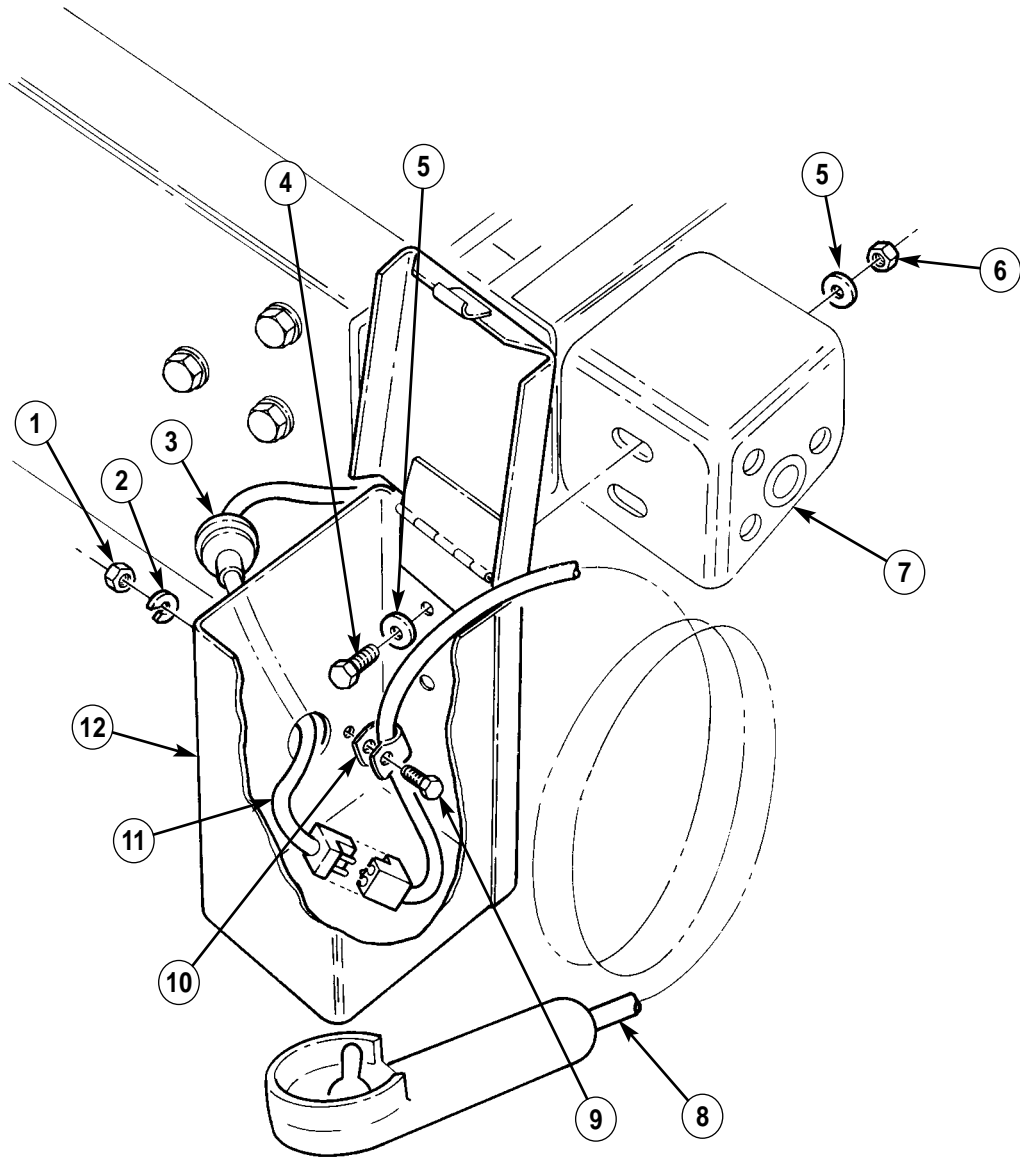

FOLLOW-ON TASK: Connect battery ground cable (para. 4-73).

10-110. 6,000 LB AND 9,000 LB ELECTRIC WINCH CABLE REPLACEMENT

This task covers:

a. Removal

b. Installation

INITIAL SETUP:

Applicable Models

M997A2, M1025A2, M1026, M1026A1, M1035A2, M1036, M1038, M1038A1, M1042, M1043A2, M1044, M1044A1, M1045A2, M1046, M1046A1, M1097A2

Tools

General mechanic's tool kit:
automotive (Appendix B, Item 1)

Materials/Parts

Cotter pin (Appendix G, Item 23)

Personnel Required

One mechanic
One assistant

Manual References

TM 9-2320-280-10
TM 9-2320-280-24P

General Safety Instruction

Wear leather gloves when handling winch cable.

WARNING

Gloves must be worn whenever handling winch cable. Severe injury may result.

a. Removal

1. Unwind winch cable (2) from drum assembly (1) (TM 9-2320-280-10).
2. Remove capscrew (5) and winch cable (2) from drum assembly (1).
3. Remove cotter pin (7), clevis pin (6), and hook (4) from winch cable (2). Discard cotter pin (7).

b. Installation

NOTE

If thimble is not installed on winch cable, or if wires are shearing or breaking, install thimble on winch cable. Refer to appendix D, fig. D-91 for instructions.

1. Install hook (4) on winch cable (2) with clevis pin (6) and cotter pin (7).
2. Install winch cable (2) on drum assembly (1) with capscrew (5).

CAUTION

- The winch cable must be spooled on the drum according to the direction of rotation label on the winch or the brake will not function.
 - Winch cable must be installed on drum under a load of at least 500 lbs (227 kg) or outer wraps will draw into inner wraps and damage winch cable.
3. Rewind winch cable (2) (TM 9-2320-280-10).

10-110. 6,000 LB AND 9,000 LB ELECTRIC WINCH CABLE REPLACEMENT (Cont'd)

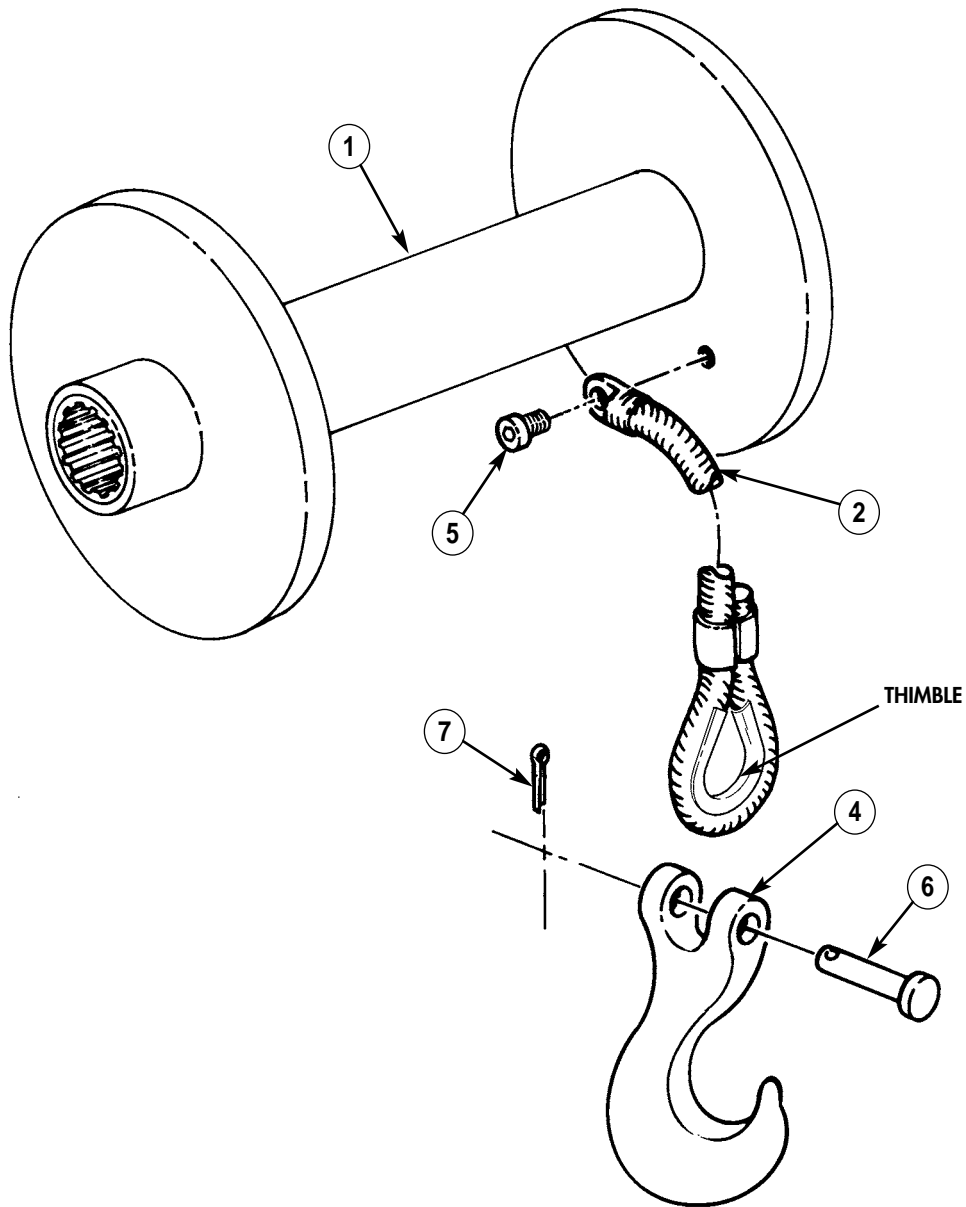

- FOLLOW-ON TASKS:
- Lubricate winch cable (TM 9-2320-280-10).
 - Check winch for proper operation (TM 9-2320-280-10).

10-110.1. 10,500 LB HYDRAULIC WINCH CABLE REPLACEMENT

This task covers:

a. Removal

b. Installation

INITIAL SETUP

Applicable Models:

All vehicles except M996, M996A1, M997, M997A1, M997A2, M1035, M1035A1, M1035A2

Tools

General mechanics tool kit: automotive (Appendix B, Item 1)

Materials/Parts

Cotter pin (Appendix G, Item 23)

Personnel Required

One mechanic
One assistant

Manual References

TM 9-2320-280-10
TM 9-2320-280-24P

General Safety Instructions

Wear leather gloves when handling winch cable.

WARNING

Gloves must be worn when handling winch cable or severe personnel injury may result.

a. Removal

1. Unwind winch cable (2) from drum assembly (1) (TM 9-2320-280-10).
2. Remove capscrew (4), terminal (3), and winch cable (2) from drum assembly (1).
3. Remove cotter pin (7), clevis pin (5), and hook (6) from winch cable (2). Discard cotter pin (7).

b. Installation

CAUTION

If wires on winch cable are shearing or breaking around thimble, repair can be performed. Refer to appendix D, fig. D-91 for instructions.

1. Install hook (6) on winch cable (2) with clevis pin (5) and cotter pin (7).

CAUTION

When installing cable on drum assembly, route cable in through fairlead assembly, under drum, and install on top of drum. Failure to do so may cause damage to cable and winch.

NOTE

It may be necessary to place the drumlock handles in FREE to route the winch cable through the rear winch mounting bracket, reinforcement plate, and roller assembly. Place drumlock handle back to ENGAGED position to prevent cable from unwrapping from drum.

2. Route winch cable (2) through fairlead assembly (8), under drum assembly (1), and install terminal (3) on drum assembly (1) with capscrew (4).

CAUTION

- The winch cable must be spooled on the drum according to the direction of rotation label on the winch or brake will not function.
- Winch cable must be installed on drum under a load of at least 500 lb (227 kg) or outer wraps will draw into inner wraps and damage winch cable.

3. Install winch cable (2) on drum assembly (1) (TM 9-2320-280-10).

10-110.1. 10,500 LB HYDRAULIC WINCH CABLE REPLACEMENT (Cont'd)

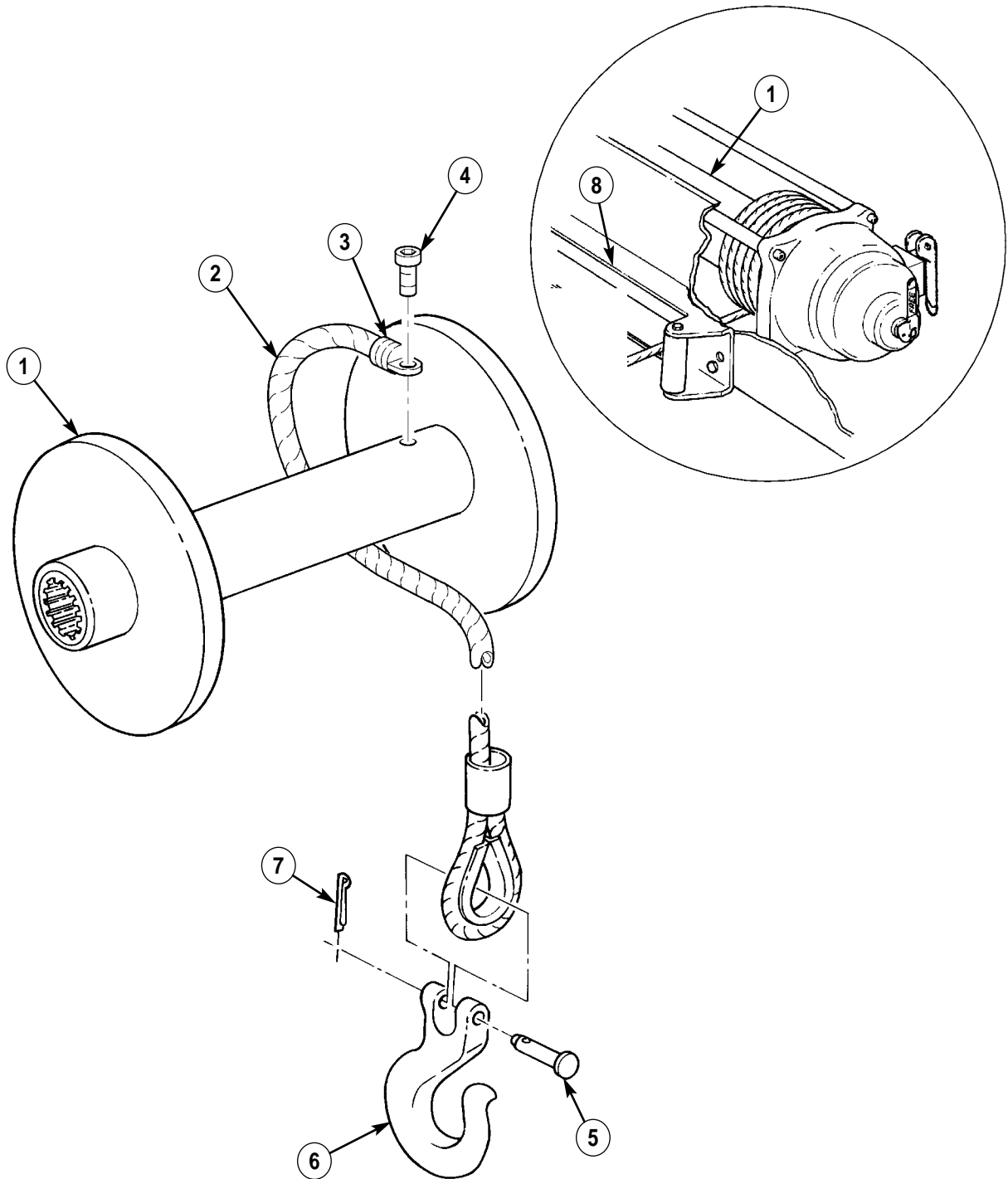

- FOLLOW ON TASKS:
- Lubricate winch cable (TM 9-2320-280-10).
 - Check winch for proper operation (TM 9-2320-280-10).

10-111. 6,000 LB AND 9,000 LB ELECTRIC WINCH VENT LINE REPLACEMENT

This task covers:

a. Removal

b. Installation

INITIAL SETUP:

Applicable Models

M997A2, M1025A2, M1026, M1026A1, M1035A2, M1036, M1038, M1038A1, M1042, M1043A2, M1044, M1044A1, M1045A2, M1046, M1046A1, M1097A2

Manual References

TM 9-2320-280-10
TM 9-2320-280-24P

Tools

General mechanic's tool kit:
automotive (Appendix B, Item 1)

Equipment Condition

- Hood raised and secured (TM 9-2320-280-10).
- Engine right splash shield removed (para. 10-20).

Materials/Parts

Four tiedown straps (Appendix G, Item 308)

a. Removal

1. Disconnect vent line (2) from winch fitting (4).
2. Remove three tiedown straps (5) and tiedown strap (6) (9,000 lb. winch only) from vent line (2) and cables (1). Discard tiedown straps (5) and (6).
3. Disconnect vent line (2) from tee fitting (3) and remove vent line (2).

b. Installation

1. Connect vent line (2) to tee fitting (3) and winch fitting (4).
2. Install vent line (2) on cables (1) with tiedown strap (6) (9,000 lb. winch only) and three tiedown straps (5).

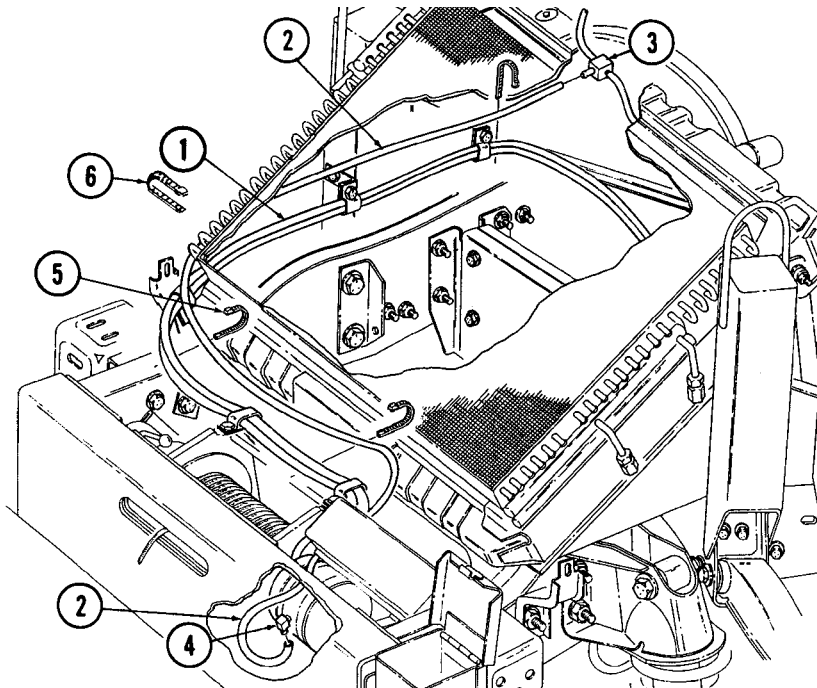

- FOLLOW-ON TASK:**
- Lower and secure hood (TM 9-2320-280-10).
 - Install engine right splash shield (para. 10-20).

10-112. FAIRLEAD ROLLER BRACKET ASSEMBLY REPLACEMENT

This task covers:

a. Removal

b. Installation

INITIAL SETUP

Applicable Models

All vehicles except M996, M996A1, M997, M997A1, M997A2, M1035, M1035A1, M1035A2

Tools

General mechanics tool kit:
automotive (Appendix B, Item 1)

Manual References

TM 9-2320-280-24P

General Safety Instructions

Winch must be supported during removal and installation.

WARNING

Winch must be supported during removal and installation.
Failure to support winch may result in injury to personnel or damage to equipment.

a. Removal

1. Remove four retaining rings (11), two shafts (3), and rollers (5) from bracket (4).
2. Remove four retaining rings (6), two shafts (10), and rollers (7) from bracket (4).
3. Remove two capscrews (8), washers (9), and bracket (4) from bumper (1) and winch (2).

b. Installation

1. Install bracket (4) on bumper (1) and winch (2) with two washers (9) and capscrews (8). Tighten capscrews (8) to 35 lb-ft (47 N·m).
2. Install two rollers (7) and shafts (10) in bracket (4) with four retaining rings (6).
3. Install two rollers (5) and shafts (3) in bracket (4) with four retaining rings (11).

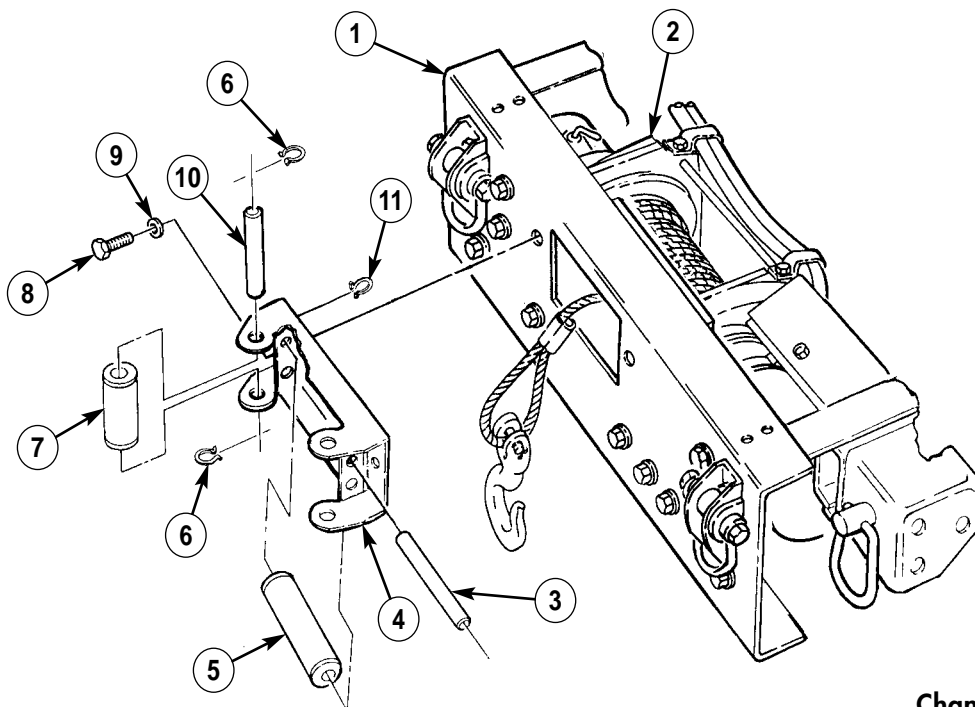

10-113. 10,500 LB WINCH HYDRAULIC HOSE REPLACEMENT

This task covers:

a. Removal

b. Installation

INITIAL SETUP:

Applicable Models:

All vehicles except M996, M996A1, M997, M997A1, M997A2, M1035, M1035A1, M1035A2

Tools

General mechanics tool kit: automotive (Appendix B, Item 1)

Materials/Parts

Lubricant (Appendix C, Item 33)
Two O-rings (Appendix G, Item 218)

Manual References

TM 9-2320-280-10
TM 9-2320-280-24P

Equipment Condition

Hood raised and secured (TM 9-2320-280-10)

a. Removal

CAUTION

Cover or plug power steering gear and hydro-boost connections immediately after removing hoses to prevent contamination. Remove all plugs prior to connecting hoses.

NOTE

Ensure area around power steering port is clean before removing hose.

1. Remove hydraulic hose (2) and O-ring (5) from power steering gear port (6). Discard O-ring (5).
2. Remove hydraulic hose (2) from winch outlet port (1) on winch (8).

NOTE

Ensure area around hydro-boost port is clean before removing hose.

3. Remove hydraulic hose (4) and O-ring (5) from hydro-boost port (3). Discard O-ring (5).
4. Remove hydraulic hose (4) from winch inlet port (7).

b. Installation

1. Apply lubricant to O-ring (5) and install O-ring (5) on hydraulic hose (4).
2. Install hydraulic hose (4) on hydro-boost port (3).
3. Route hydraulic hose (4) from hydro-boost port (3) to winch (8) and install hydraulic hose (4) to winch inlet port (7).
4. Apply lubricant to O-ring (5) and install O-ring (5) on hydraulic hose (2).
5. Install hydraulic hose (2) on power steering gear port (6).
6. Route hydraulic hose (2) from power steering gear port (6) along side hydraulic hose (4) and install hydraulic hose (2) on winch outlet port (1).

10-113. 10,500 LB WINCH HYDRAULIC HOSE REPLACEMENT (Cont'd)

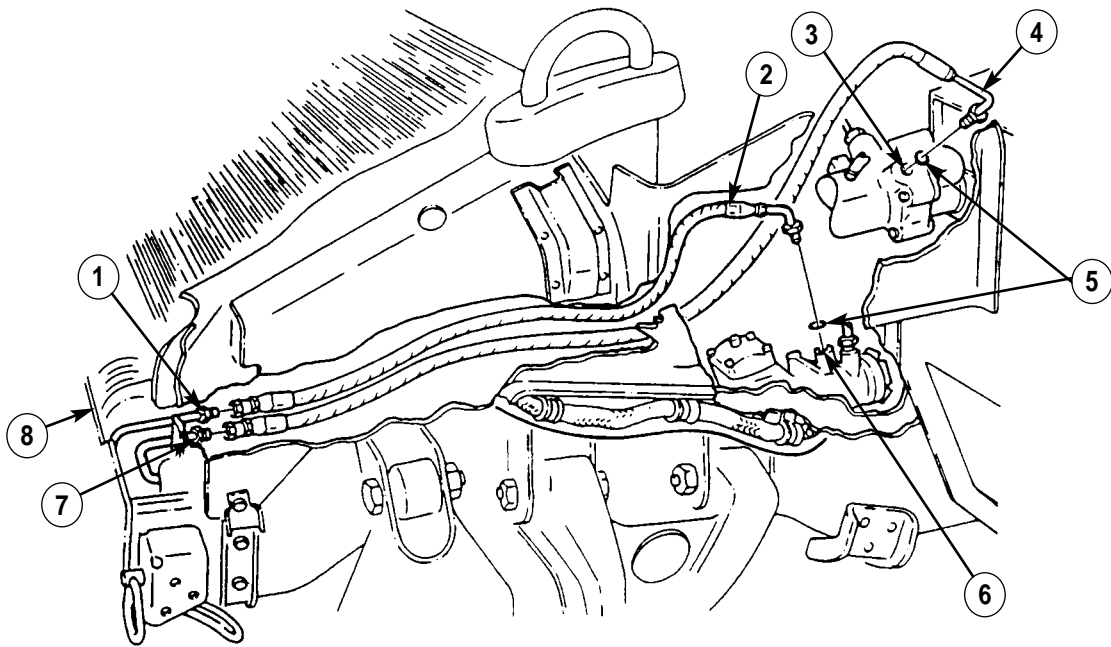

FOLLOW-ON TASK: Bleed power steering system (para. 8-29).

10-114. 10,500 LB HYDRAULIC WINCH CONTROLLER PLUG REPLACEMENT

This task covers:

a. Removal

b. Installation

INITIAL SETUP:

Applicable Models

All vehicles except M996, M996A1, M997, M997A1, M997A2, M1035, M1035A1, M1035A2

Tools

General mechanics tool kit: automotive (Appendix B, Item1)

Materials/Parts

Eight tiedown straps (Appendix G, Item 310)

Manual References

TM 9-2320-280-10
TM 9-2320-280-24P

Equipment Condition

- Hood raised and secured (TM 9-2320-280-10).
- Battery ground cables disconnected (para 4-73).
- Engine left splash shield removed (para 10-17).

a. Removal

1. Remove tiedown strap (5) from controller plug harness (1), body harness (3), lead wire (2), and two hydraulic hose assemblies (4). Discard tiedown strap (5).

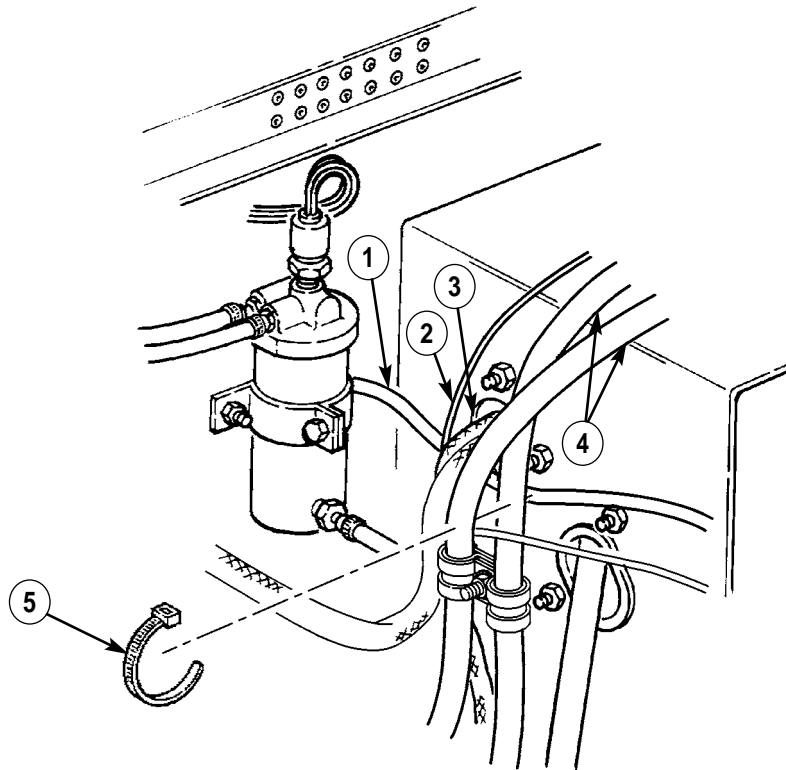

10-114. 10,500 LB HYDRAULIC WINCH CONTROLLER PLUG REPLACEMENT (Cont'd)

2. Remove four tiedown straps (5) from controller plug harness (1), lead wire (2), and two hydraulic hose assemblies (4). Discard tiedown straps (5).

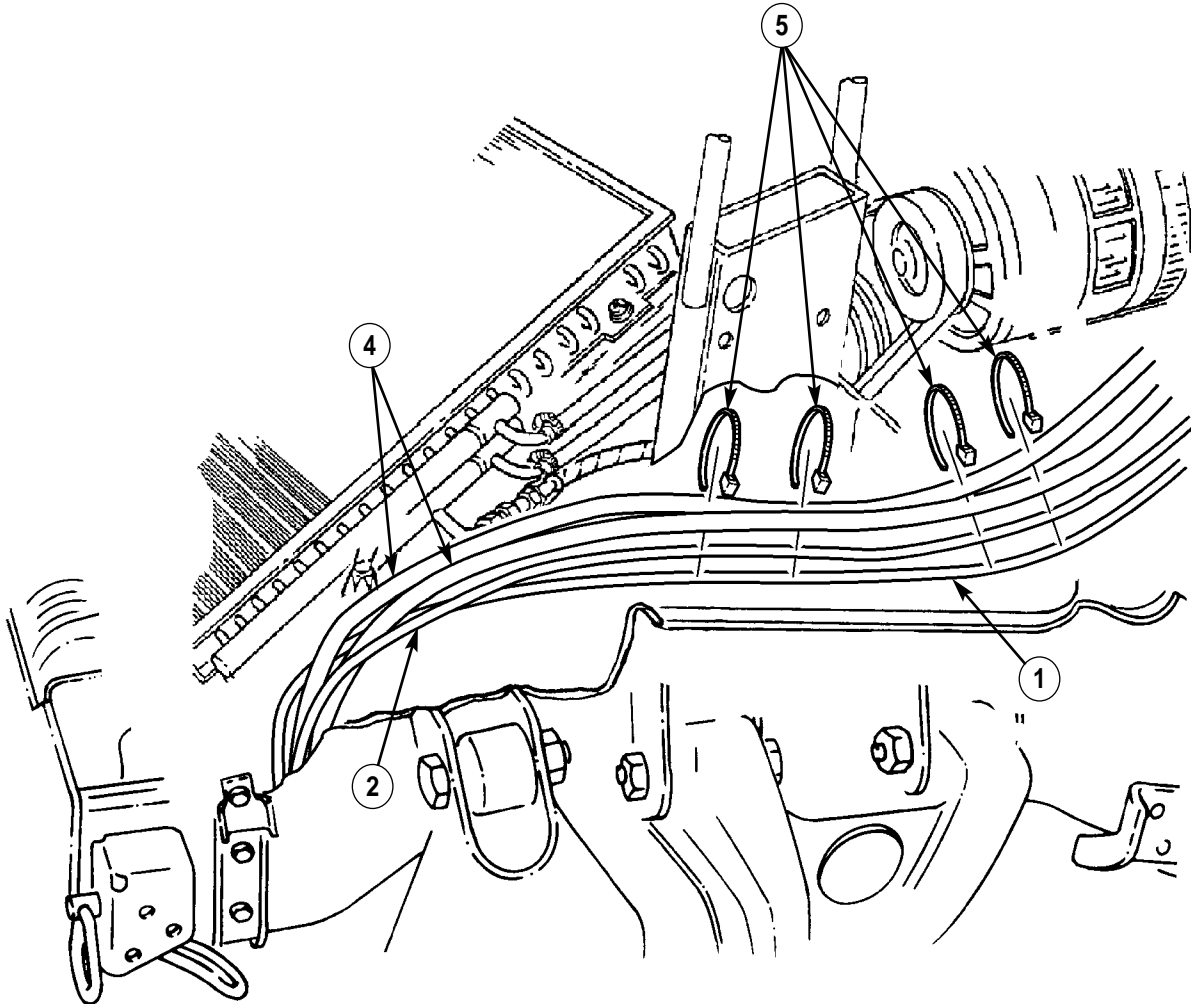

10-114. 10,500 LB HYDRAULIC WINCH CONTROLLER PLUG REPLACEMENT (Cont'd)

3. Remove three tiedown straps (8) from controller plug harness (9), lead wire (3), and two hydraulic hose assemblies (1). Discard tiedown straps (8).
4. Disconnect controller plug lead 785C (7) from winch lead 785C (6).
5. Disconnect controller plug lead 785A (4) from winch lead 785A (5).
6. Disconnect controller plug lead 785B (2) from lead wire 785B (3).

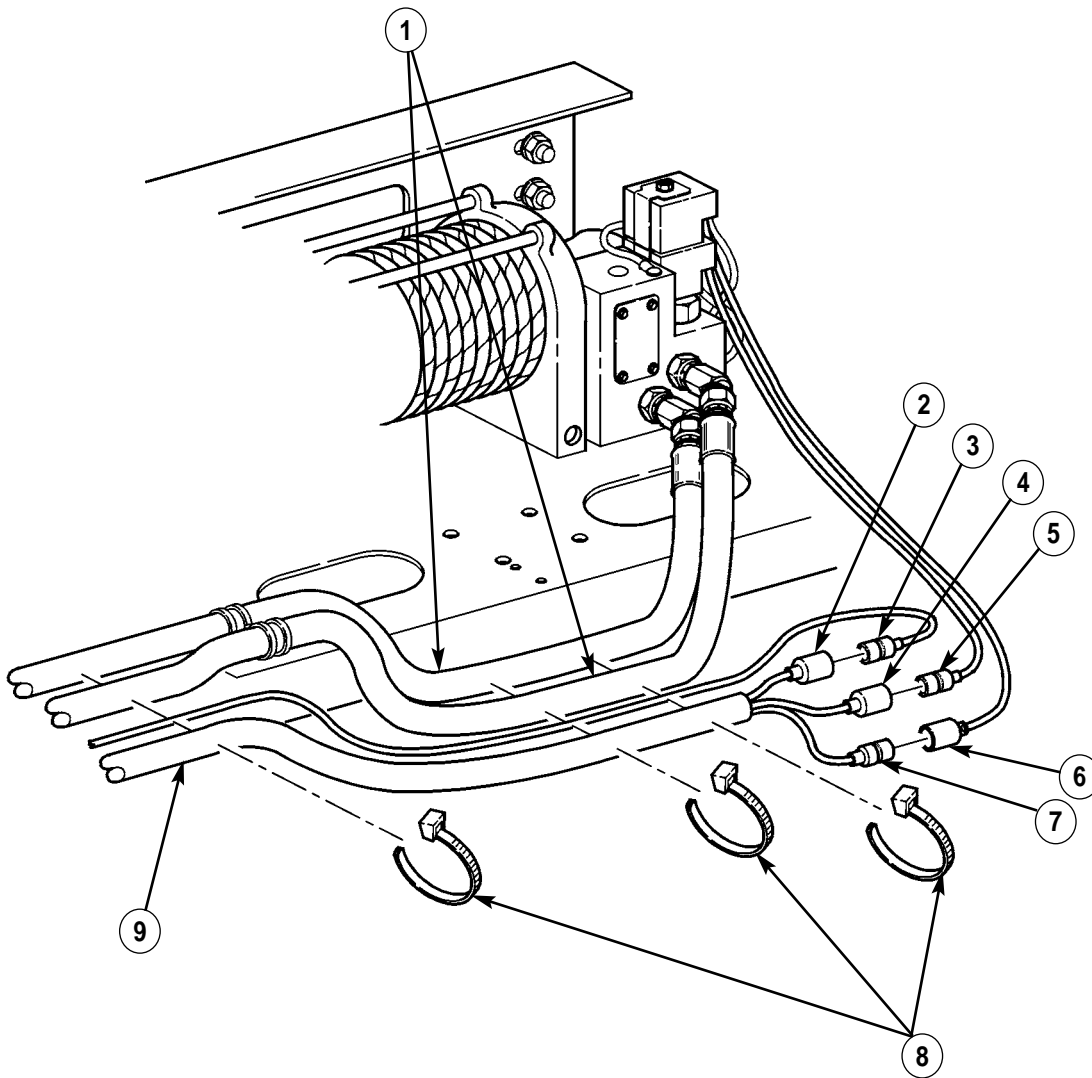

10-114. 10,500 LB HYDRAULIC WINCH CONTROLLER PLUG REPLACEMENT (Cont'd)

7. Remove four screws (12), controller plug (11), and cap with chain (13) from body panel (10).

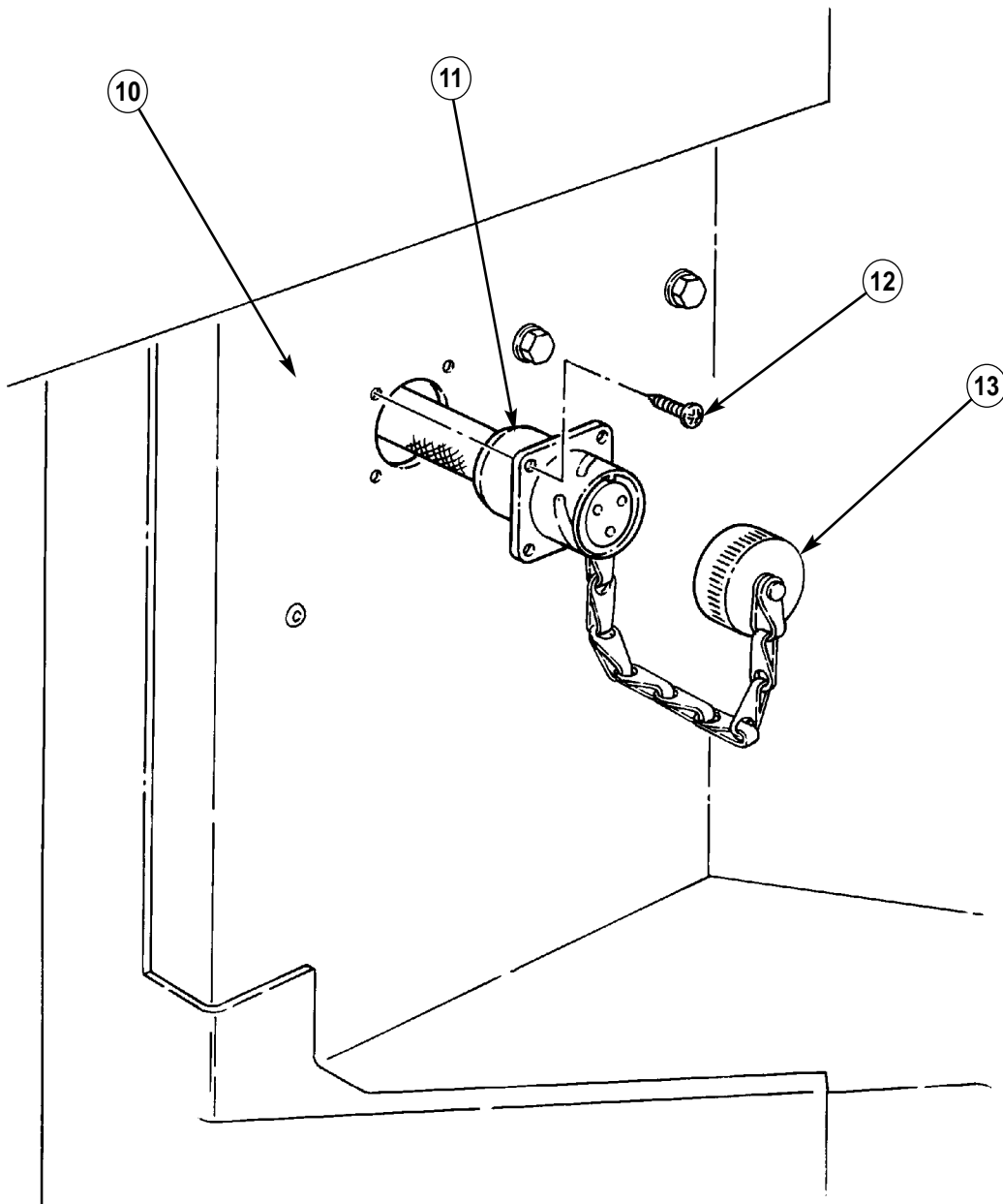

10-114. 10,500 LB HYDRAULIC WINCH CONTROLLER PLUG REPLACEMENT (Cont'd)

8. Move controller plug harness (1) away from frame rail (4) and from around fuel filter (2) and route controller plug harness (1) back through hole in body panel (3).

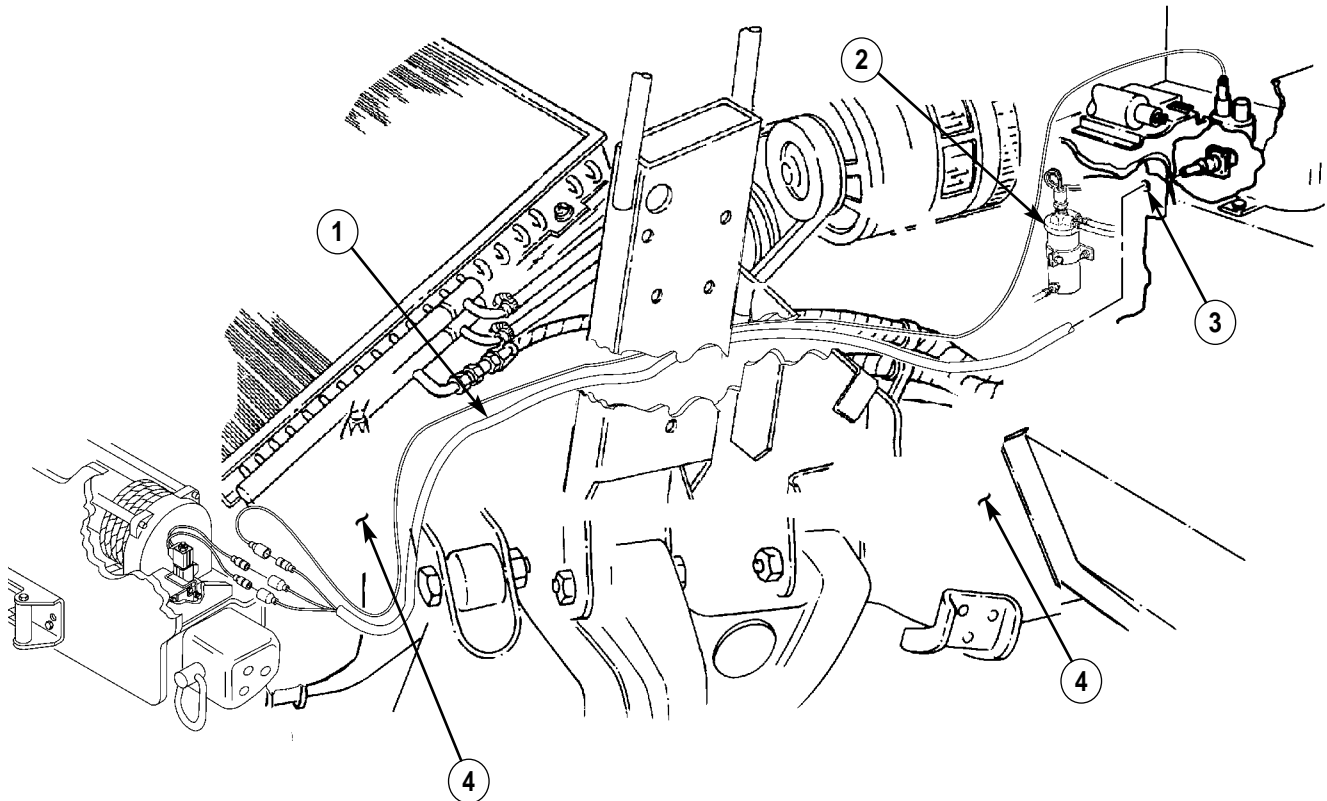

10-114. 10,500 LB HYDRAULIC WINCH CONTROLLER PLUG REPLACEMENT (Cont'd)**b. Installation****CAUTION**

Ensure controller plug harness does not contact any moving parts.

1. Route controller plug harness (1) through hole in body panel (3) into engine compartment (6).
2. Route controller plug harness (1) around fuel filter (2) and along body wiring harness (7) and lead wire (5) to frame rail (4) and then down to winch valve assembly (8).

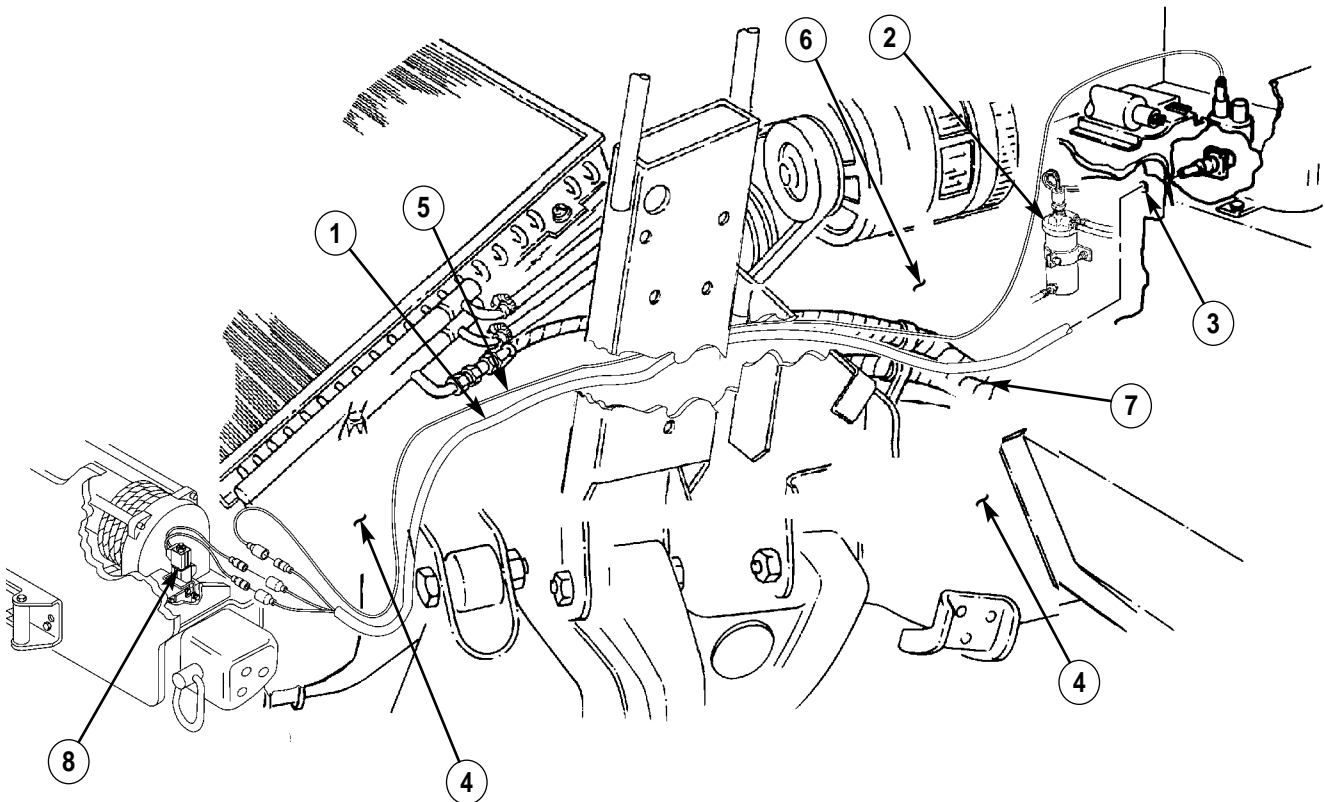

10-114. 10,500 LB HYDRAULIC WINCH CONTROLLER PLUG REPLACEMENT (Cont'd)

3. Align holes in controller plug (5) with holes (6) in body panel (1) and blind spline (3) at top position and install controller plug (5) and cap with chain (4) on body panel (1) with four screws (2).

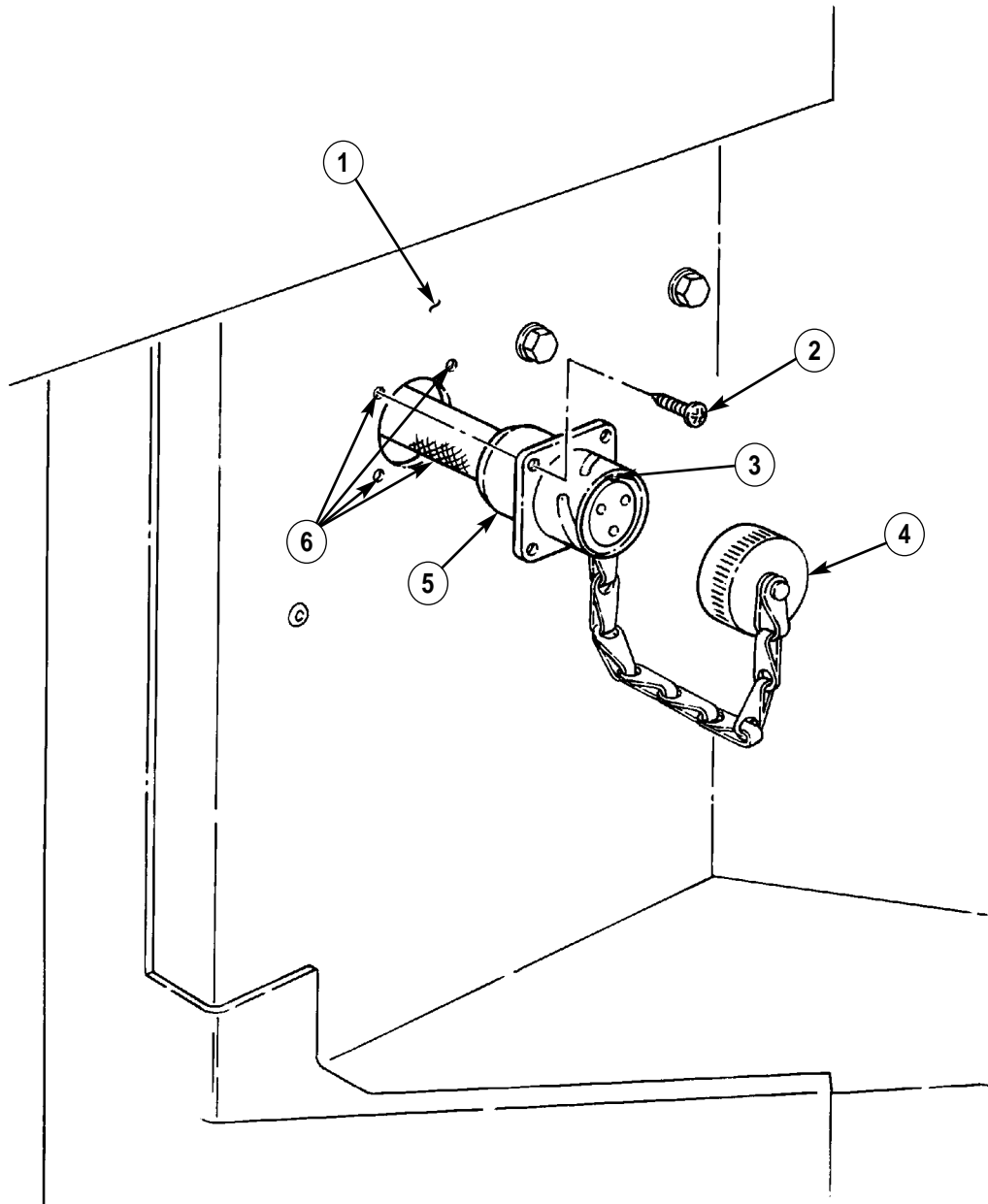

10-114. 10,500 LB HYDRAULIC WINCH CONTROLLER PLUG REPLACEMENT (Cont'd)

4. Connect lead wire 785B (9) to controller plug lead (8) 785B.
5. Connect controller plug lead 785A (10) to winch lead 785A (11).
6. Connect controller plug lead 785C (13) to winch lead 785C (12).
7. Secure controller plug harness (15) and lead wire (9) to two hydraulic hose assemblies (7) with three tiedown straps (14).

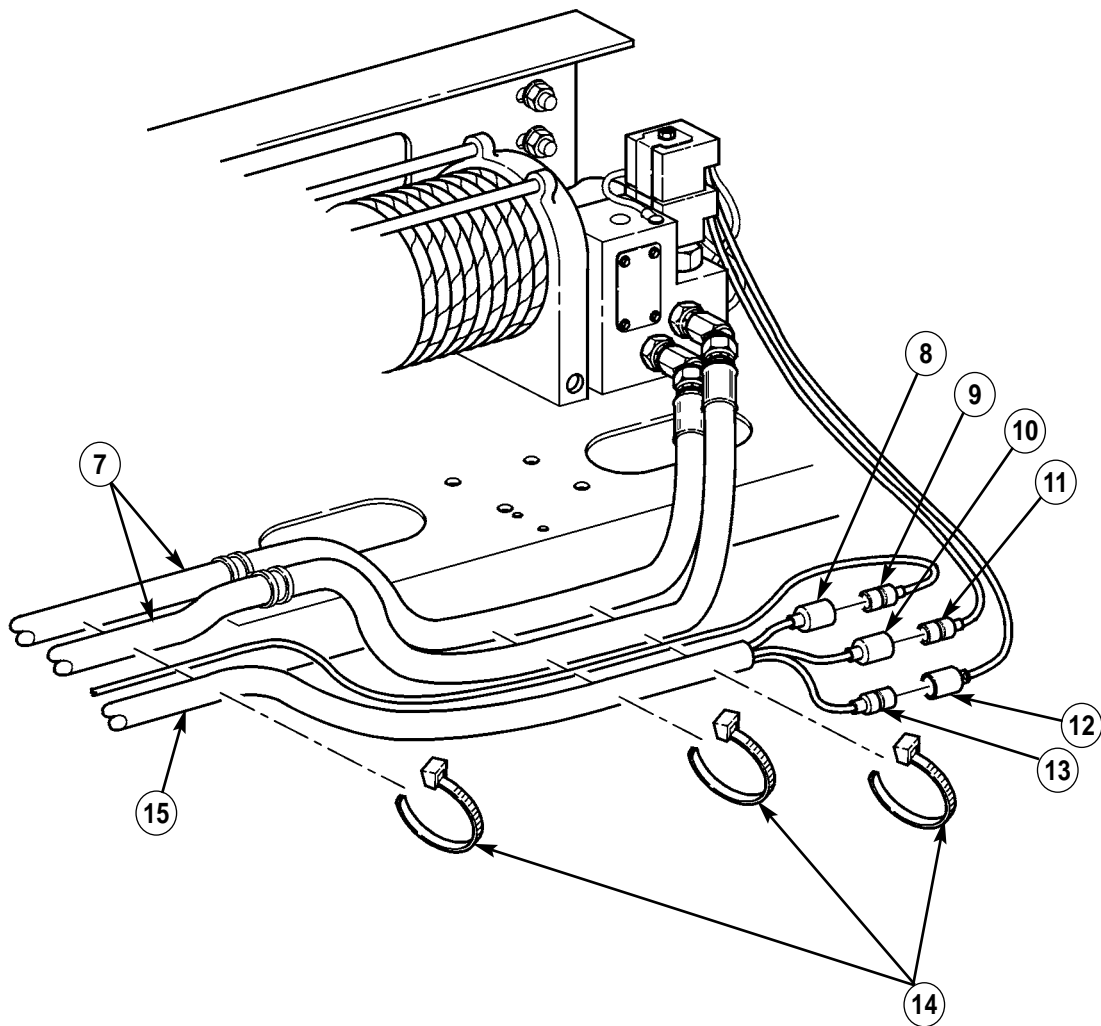

10-114. 10,500 LB HYDRAULIC WINCH CONTROLLER PLUG REPLACEMENT (Cont'd)

8. Secure lead wire (1) and controller plug harness (4) to two hydraulic hose assemblies (2) with four tiedown straps (3).
9. Secure controller plug harness (4), body harness (5), and lead wire (1) to two hydraulic hose assemblies (2) with tiedown strap (6).

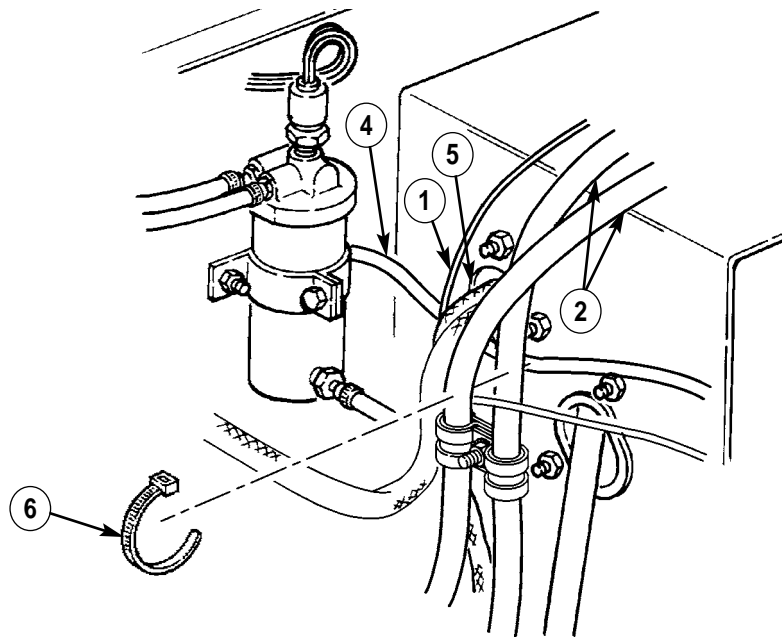
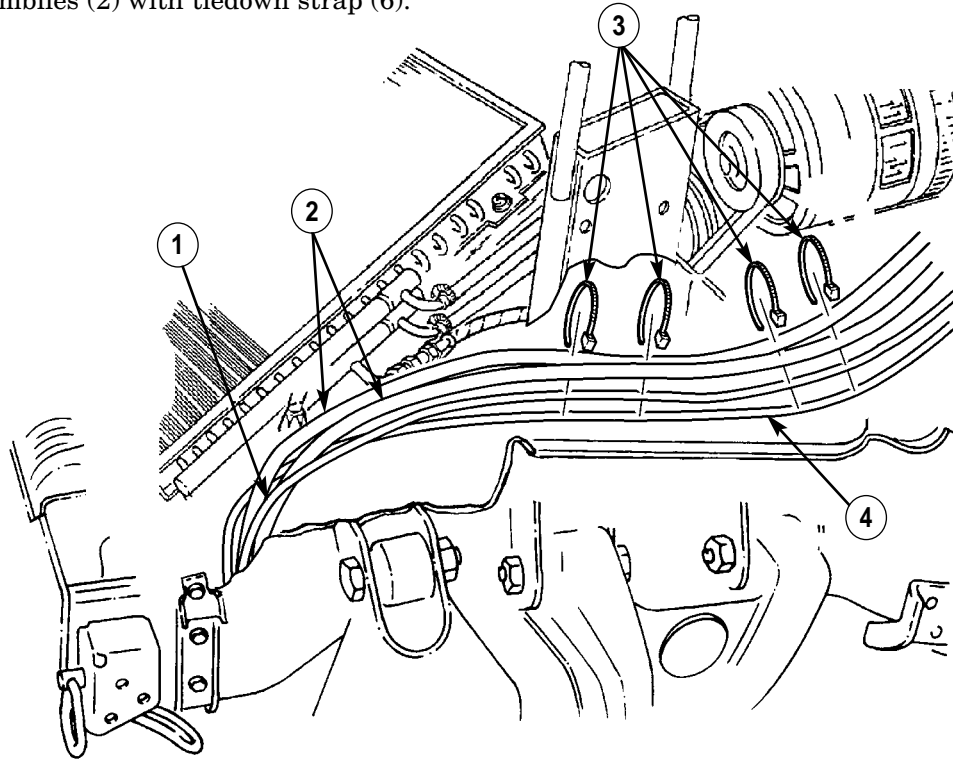

- FOLLOW-ON TASKS:**
- Install engine left splash shield. (para. 10-17).
 - Connect battery ground cables (para. 4-73).
 - Lower and secure hood (TM 9-2320-280-10).

CHAPTER 11 SPECIAL PURPOSE BODIES

Section I. WEAPON CARRIER BODY MAINTENANCE

11-1. WEAPON CARRIER BODY MAINTENANCE TASK SUMMARY

TASK PARA.	PROCEDURES	PAGE NO.
11-2.	Ballistic Crew Door Maintenance	11-5
11-3.	Ballistic Crew Door Hinge Replacement	11-8
11-4.	Ballistic Crew Door Rear Striker Plate Replacement	11-9
11-5.	Ballistic Crew Door Front Striker Plate Maintenance	11-10
11-6.	Ballistic Crew Door Paddle Lock Replacement	11-11
11-7.	Ballistic Crew Door Window Assembly Maintenance	11-12
11-8.	Ballistic Crew Door Window Protective Shield Replacement	11-14
11-9.	Ballistic Crew Door Window Stop Replacement	11-16
11-10.	Ballistic Crew Door Seal Replacement	11-17
11-11.	Ballistic Crew Door Latch Replacement	11-18
11-12.	Ballistic Crew Door Latch Tube Replacement	11-19
11-13.	Cargo Door Shell Door Maintenance	11-20
11-14.	Cargo Door Shell Door Wire Handle Lock Replacement	11-26
11-15.	Cargo Door Shell Door Grab Handle Replacement	11-27
11-16.	Cargo Door Shell Door Handle Latch Replacement	11-28
11-17.	Cargo Door Shell Door Latch Maintenance	11-29
11-18.	Cargo Door Shell Door Latch Rod Maintenance	11-30
11-19.	Cargo Door Shell Door Dovetail Assembly Maintenance	11-32
11-20.	Cargo Door Shell Door Retention Cable Replacement	11-34
11-21.	Cargo Door Shell Door Gas Spring Maintenance	11-35
11-22.	Cargo Door Shell Door Strap Replacement	11-40
11-23.	Cargo Door Shell Door Seal Protector Replacement	11-41

11-1. WEAPON CARRIER BODY MAINTENANCE TASK SUMMARY (Cont'd)

TASK PARA.	PROCEDURES	PAGE NO.
11-24.	Cargo Shell Door Seal Replacement	11-42
11-25.	Cargo Shell Door Front Striker Replacement	11-43
11-26.	Cargo Shell Door Rear Striker Replacement	11-44
11-27.	Cargo Shell Door Rear Striker Mounting Plate Replacement	11-45
11-28.	Cargo Shell Door Dovetail Spring Replacement	11-46
11-29.	Cargo Shell Door Gas Spring Mounting Bracket Replacement	11-47
11-30.	Cargo Shell Door Liner Replacement	11-48
■ 11-30.1.	"B" Pillar Padding Replacement	11-49
11-31.	Cargo Shell Roof Insulation Panel Replacement	11-50
11-32.	Hood Side Armor Plate Replacement	11-51
11-33.	Hood Center Armor Plate Replacement	11-52
11-34.	Hood Top Armored Grille Replacement	11-53
11-35.	Hood Front Armored Grille Replacement	11-54
11-36.	Right Cowl Armor Plate Replacement	11-55
11-37.	Left Cowl Armor Plate Replacement	11-56
11-38.	Footwell Armor Plate Replacement	11-57
11-39.	Right Wheelhouse Armor Plate Replacement	11-58
11-40.	Left Wheelhouse Armor Plate Replacement	11-60
11-41.	Tailgate Armor Plate Replacement	11-61
11-42.	Weapon Station Hatch Replacement	11-62
11-43.	Weapon Station Hatch Handle Replacement	11-63
11-44.	Weapon Station Hatch Hinge Pin Replacement	11-64
11-45.	Weapon Station Hatch Hinge Replacement	11-65
11-46.	Weapon Station Hatch Holddown Striker Replacement	11-67
11-47.	Weapon Station Tray Seal Replacement	11-68
11-48.	Weapon Station Bumper Pad Replacement	11-69
11-49.	Weapon Station Tray Lever Replacement	11-70
11-50.	Weapon Station Hatch Latch Replacement	11-71
11-51.	Weapon Station Hatch Tube Assembly Replacement	11-72
11-52.	Hinge Pivot Bracket and Gunner's Sling Replacement	11-73
11-53.	Gunner's Sling Hook Replacement	11-74
11-54.	Weapon Station Backrest Pad Replacement	11-75
11-55.	Turret Handle Replacement	11-76

11-1. WEAPON CARRIER BODY MAINTENANCE TASK SUMMARY (Cont'd)
--

TASK PARA.	PROCEDURES	PAGE NO.
11-56.	Turret Lock Replacement	11-77
11-57.	TOW Mount Pedestal Replacement	11-78
11-58.	TOW Mount Pedestal Cover Replacement	11-79
11-59.	TOW Missile Guidance System Pan Replacement	11-80
11-60.	Weapon Station Inclinometer Replacement	11-81
11-61.	Armament Mount Panel Replacement	11-82
11-62.	Armament Cover and Seal Replacement	11-83
11-63.	Gunner's Platform Replacement	11-84
11-64.	Gunner's Platform Assembly Maintenance	11-86
11-65.	Gunner's Platform Assembly Replacement	11-90
11-66.	Vehicle Power Conditioner (VPC) Mounting Bracket Replacement	11-91
11-67.	Tow Wiring Harness Replacement	11-92
11-68.	Cable Stowage Cleat Replacement	11-98
11-69.	Field Glasses Bracket Replacement	11-99
11-70.	Stowage Mount Bracket Replacement	11-100
11-71.	Stowage Pedestal Replacement	11-102
11-72.	Transversing Unit Mount Adapter Maintenance	11-103
11-73.	Elevation and Depression Stop Assembly Maintenance	11-104
11-74.	M16 Ammo Rack Assembly Replacement	11-106
11-75.	TOW Missile Rack Maintenance	11-107
11-76.	Water Can Bumper Replacement	11-117
11-77.	Missile Guidance Set (MGS) Battery Rack Assembly Replacement	11-118
11-78.	Tripod Mounting Bracket Replacement	11-120
11-79.	Tripod Head Mounting Bracket Replacement	11-121
11-80.	Fuel Can Tray and Hose Replacement	11-122
11-81.	Day Sight Stowage Bracket Replacement	11-123
11-82.	Night Sight Support Replacement	11-124
11-83.	Night Sight Coolant Base Replacement	11-125
11-84.	Front Night Sight Battery Bracket Replacement	11-126
11-85.	Rear Night Sight Battery Bracket Replacement	11-127
11-86.	Boresight Collimeter or Night Sight Mounting Spacers Replacement	11-128

11-1. WEAPON CARRIER BODY MAINTENANCE TASK SUMMARY (Cont'd)

TASK PARA.	PROCEDURES	PAGE NO.
11-87.	Launch Tube Stowage Brackets Replacement	11-129
11-88.	Antenna Blast Shield Replacement	11-130
11-89.	Gasoline Cook Stove Bracket Assembly Replacement	11-131
11-90.	Rifle Support Replacement	11-132
11-91.	Rifle Mounting Clamp Replacement	11-133
11-92.	Rifle Mounting Clamp Bracket Replacement	11-134
11-93.	Rifle Mounting Clamp Bracket Replacement (M16 A1 Rifle/M203 Grenade Launcher)	11-135
11-94.	Lower Rifle Mount Bracket Replacement	11-136
11-95.	Gun Adapter Plate Assembly Replacement	11-137
11-96.	Front Gun Mount Plate Assembly Replacement	11-138
11-97.	Rear Gun Mount Plate Assembly Replacement	11-139
11-98.	Gun Mount Support (Caliber .50) Replacement	11-140
11-99.	Gun Mount Support (40 MM) Replacement	11-141
11-100.	Machine Gun Stop Replacement	11-142
11-101.	Night Sight Retainer Replacement	11-143
11-102.	Tripod Bracket Replacement	11-144
11-103.	Double Ammo Box Tray (Caliber .50) Replacement	11-145
11-104.	Ammo Box tray (Caliber .50) Replacement	11-146
11-105.	Ammo Box tray (40 MM) and Caliber .50) Replacement	11-147
11-106.	Double Ammo Box Tray (40 MM) Replacement	11-148
11-107.	Triple Ammo Box Tray (40 MM) Replacement	11-149
11-108.	Water Can Tray Replacement	11-150
11-109.	Water Can/M13 Decon Can Bumper Replacement	11-151
11-110.	Rear Seat Stowage Compartment Net Brackets Replacement	11-152
11-111.	Cargo Bulkhead Replacement	11-153
11-112.	Weapon Station Tray and Bearing Seals Maintenance	11-154
■ 11-112.1.	Turret Cleaning	11-156.2
11-113.	Turret Bearing Maintenance	11-158

11-2. BALLISTIC CREW DOOR MAINTENANCE

This task covers:

- | | |
|---|--|
| <ul style="list-style-type: none"> a. Removal b. Installation | <ul style="list-style-type: none"> c. Inspection d. Adjustment |
|---|--|

INITIAL SETUP:

Applicable Models

All models except M998, M998A1, M1035, M1035A1, M1035A2, M1037, M1038, M1038A1, M1042, M1097, M1097A1, M1097A2

Tools

General mechanic's tool kit:
automotive (Appendix B, Item 1)

Materials/Parts

Six locknuts (Appendix G, Item 87)
Spacer plate, 0.125-in. (3.2-mm) thick
(Appendix G, Item 296)

Materials/Parts (Cont'd)

Spacer plate, 0.060-in. (1.5-mm) thick
(Appendix G, Item 231)
Spacer plate, hinge (Appendix G, Item 232)

Personnel Required

One mechanic
One assistant

Manual References

TM 9-2320-280-24P

a. Removal

1. Slide doorstrap (3) off doorstop bracket (2).
2. Open and hold crew door (1) straight out from vehicle. Lift up crew door (1) to remove door hinge pins (6) from body hinge mounts (5) and remove crew door (1) and washers (4) (if present).

b. Installation

1. Hold crew door (1) straight out from vehicle and insert washers (4) (if removed) and door hinge pins (6) on body hinge mounts (5).
2. Slide doorstrap (3) on doorstop bracket (2).

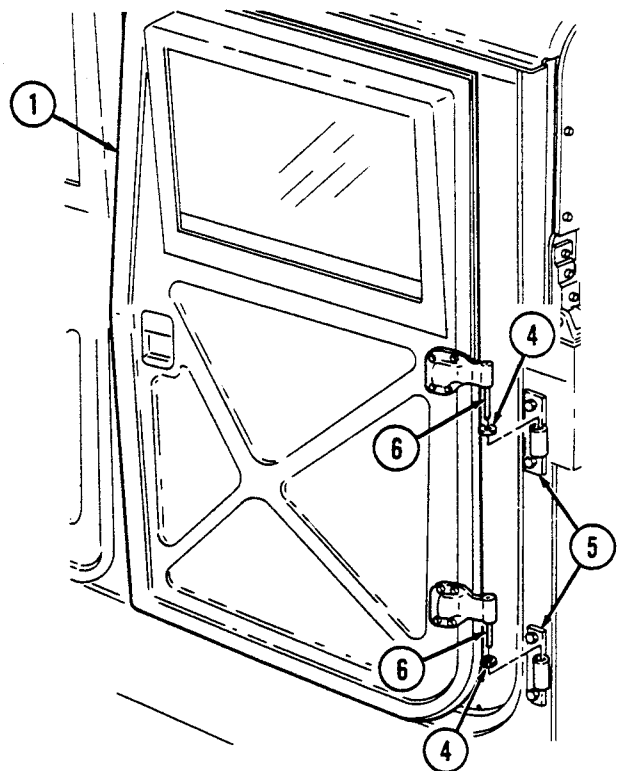
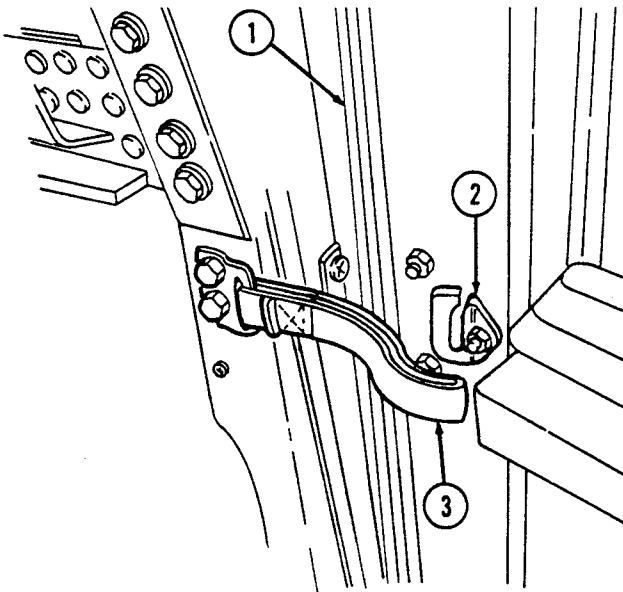

11-2. BALLISTIC CREW DOOR MAINTENANCE (Cont'd)

c. Inspection

1. Inspect crew door assembly (2) for proper alignment. Ensure door (2) is centered between pillar (7), roof (5), cargo shell (10), and lower side rail (8). If out-of-alignment condition exists, perform horizontal or vertical adjustment procedures.
2. Inspect crew door assembly (2) to ensure latch (1) is closing completely on striker (15) without extreme force. If latch (1) is out of adjustment, perform latch (1) adjustment procedures.
3. Inspect hinge (4) and latch (1) for adjustment. Insert a piece of paper (9) between crew door assembly (2) and pillar (7), and close door (2). Perform this test at four or five locations around the door (2). Door seals should offer some resistance when paper is pulled out. If door seal does not offer resistance, or resistance is excessive, perform hinge and latch adjustment procedures.
4. Inspect latch (1), hinge (4), and door handle (3) for loose, missing, or unserviceable parts.

d. Adjustment

NOTE

Perform steps 1 and 2 for horizontal adjustment. Perform steps 3 through 6 for vertical adjustment. Perform steps 7 through 18 for hinge adjustment and steps 19 through 23 for latch adjustment.

1. Loosen six screws (6) from two hinges (4) and crew door assembly (2).
2. Align and center crew door assembly (2) between pillar (7), roof (5), cargo shell (10), and lower side rail (8). Tighten six screws (6) to 6 lb-ft (8 N•m).
3. Remove door strap (11) from doorstop bracket (12).
4. Open crew door assembly (2) to approximately 45°, and lift and remove door (2) from body hinge mounts (14).
5. Install washer (13) on each door hinge (4), and install crew door assembly (2) on body hinge mounts (14).
6. Check vertical adjustment and repeat steps if necessary.
7. Remove door strap (11) from doorstop bracket (12).
8. Open crew door assembly (2) to approximately 45°, and lift door (2) and remove washers (13) (if installed) from body hinge mounts (14).
9. Remove locknut (19), washer (17), screw (16), washer (17), and doorstop bracket (12) from crew door assembly (2). Discard locknut (19).
10. Remove five locknuts (20), washers (21), screws (23), washers (21), two hinges (4), and spacer plates (18) (if installed) from crew door assembly (2). Discard locknuts (20).
11. To increase resistance to that portion of the door seal (22), install two hinge spacer plates (18) between door hinge (4) and outer side of crew door assembly (2).
12. To decrease resistance to that portion of the door seal (22), discard hinge spacer plate (18) between door hinge (4) and outer side of crew door assembly (2).
13. Install two spacer plates (18) (if required) and door hinges (4) on crew door assembly (2) with five washers (21), screws (23), washers (21), and locknuts (20).
14. Install doorstop bracket (12) on crew door assembly (2) with washer (17), screw (16), washer (17), and locknut (19).
15. Tighten locknuts (19) and (20) installed in steps 13 and 14 to 6 lb-ft (8 N•m).
16. Install two door hinge washers (13) (if removed), position crew assembly door (2) to approximately 45°, and install door hinges (4) on body hinge mounts (14).
17. Check hinge (4) adjustment and repeat steps if necessary.
18. Install door strap (11) on doorstop bracket (12).

11-2. BALLISTIC CREW DOOR MAINTENANCE (Cont'd)

19. Remove crew door latch (para. 11-11).

NOTE

- To increase resistance to door seal and adjust rear of crew door assembly, perform step 20.
- To decrease resistance to door seal and adjust rear of crew door assembly, perform step 21.

20. Discard spacer plate(s) (24) from crew door (2).

21. Add spacer plate (24) 0.125-in. (3.2-mm) thick or spacer plate (24) 0.060-in. (1.5-mm) thick to crew door (2).

22. Install crew door latch (para. 11-11).

23. Check door latch adjustment and repeat steps if necessary.

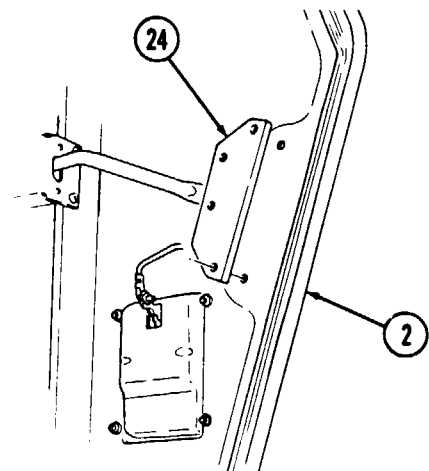
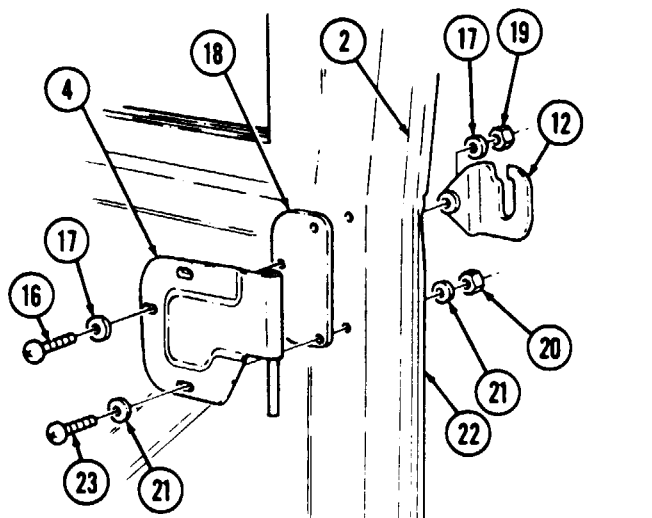
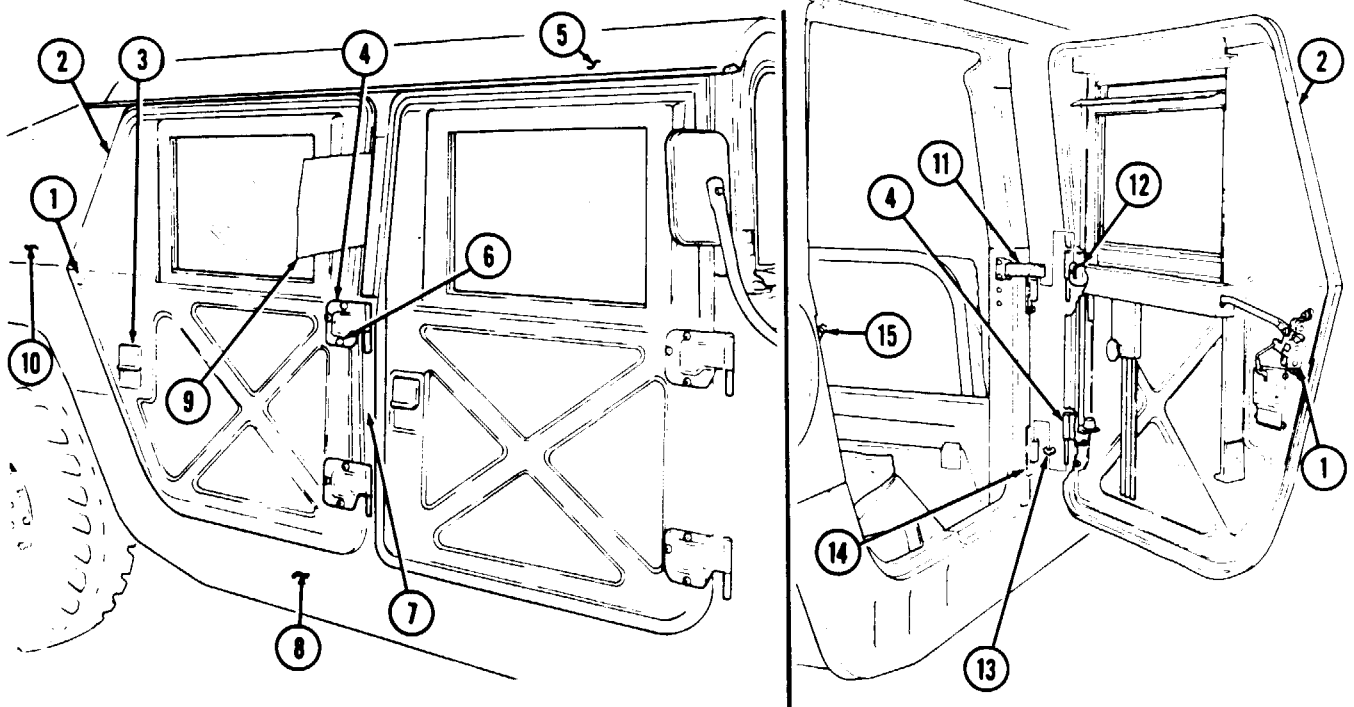

11-3. BALLISTIC CREW DOOR HINGE REPLACEMENT

This task covers:

a. Removal

b. Installation

INITIAL SETUP:

Applicable Models

All models except M998, M998A1, M1035, M1035A1, M1035A2, M1037, M1038, M1038A1, M1042, M1097, M1097A1, M1097A2

Materials/Parts

Three locknuts (Appendix G, Item 87)

Manual References

TM 9-2320-280-24P

Tools

General mechanic's tool kit:
automotive (Appendix B, Item 1)

Equipment Condition

Ballistic crew door removed (para. 11-2).

NOTE

- M966, M966A1, M996, M996A1, M997, M997A1, M997A2, M1025, M1025A1, M1025A2, M1026, M1026A1, and M1036 vehicles have one additional hinge shim on the inner door side of each door hinge mounting hardware.
- On top hinges, note position of doorstop bracket.

a. Removal

Remove three locknuts (5), washers (2), screws (1), washers (2), hinge (3), and shim(s) (4) from crew door (6). Discard locknuts (5).

b. Installation

Install shim(s) (4) and hinge (3) on crew door (6) with three washers (2), capscrews (1), washers (2), and locknuts (5). Tighten locknuts (5) to 6 lb-ft (8 N•m).

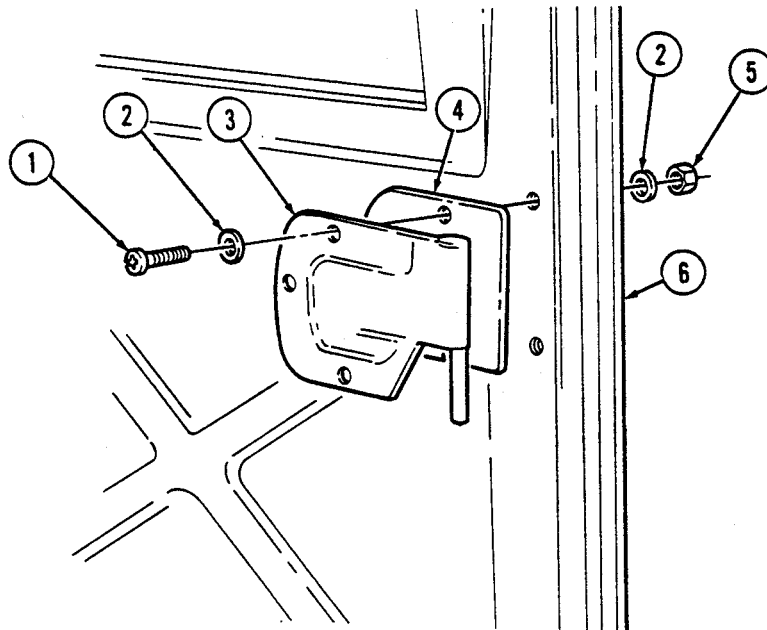

FOLLOW-ON TASK: Install ballistic crew door (para. 11-2).

11-4. BALLISTIC CREW DOOR REAR STRIKER PLATE REPLACEMENT

This task covers:

a. Removal

b. Installation

INITIAL SETUP:

Applicable Models

All models except M998, M998A1, M1035, M1035A1, M1035A2, M1037, M1038, M1038A1, M1042, M1097, M1097A1, M1097A2

Tools

General mechanic's tool kit:
automotive (Appendix B, Item 1)

Materials/Parts

Tape (Appendix C, Item 50)

Manual References

TM 9-2320-280-24P

a. Removal

Remove two capscrews (4), washers (3), and rear striker plate (2) from body (1). Remove tape from rear striker plate (2) and discard tape.

b. Installation

Apply tape to rear striker plate (2) mounting surface. Install rear striker plates (2) on body (1) with two washers (3) and capscrews (4). Tighten capscrews (4) to 8 lb-ft (11 N•m).

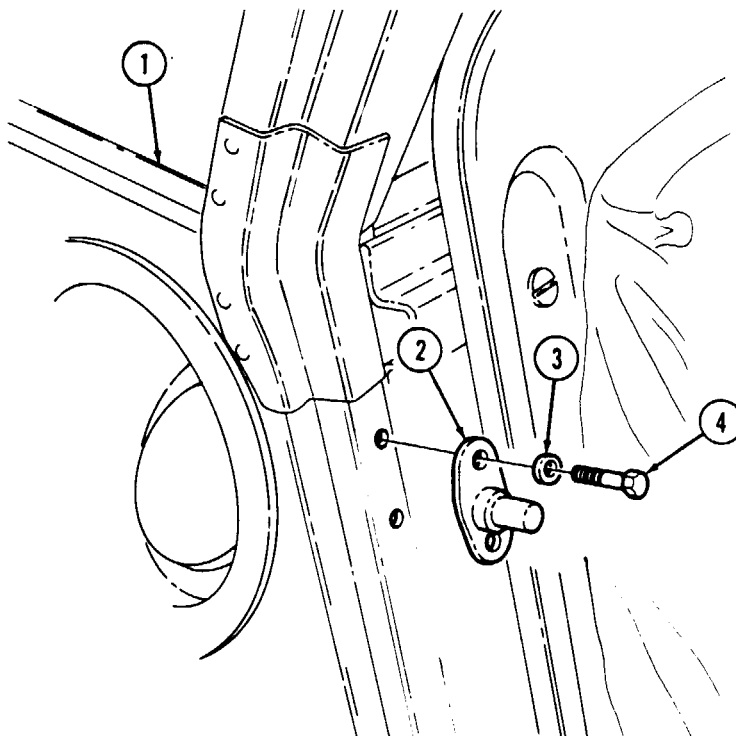

11-5. BALLISTIC CREW DOOR FRONT STRIKER PLATE MAINTENANCE

This task covers:

- a. Removal
- c. Adjustment
- b. Installation

INITIAL SETUP:

Applicable Models

All models except M998, M998A1, M1035, M1035A1, M1035A2, M1037, M1038, M1038A1, M1042, M1097, M1097A1, M1097A2

Tools

General mechanic's tool kit:
automotive (Appendix B, Item 1)

Materials/Parts

Tape (Appendix C, Item 50)
Two locknuts (Appendix G, Item 86)

Manual References

TM 9-2320-280-24P

a. Removal

Remove two locknuts (5), door strap (4), two capscrews (1), and front striker plate (2) from "B" pillar (3). Discard locknuts (5). Remove tape from front striker plate (2) and discard tape.

b. Installation

Apply tape to front striker plate (2) mounting surface. Install front striker plate (2) on "B" pillar (3) with two capscrews (1), door strap (4), and two locknuts (5). Finger tighten locknuts (5).

c. Adjustment

1. Close door (6) ensuring latch (7) latches on front striker plate (2).

NOTE

Front striker plates are slotted for vertical adjustment.

2. Press crew door (6) slightly inward and upward until seal (9) contacts body (8). Tighten locknuts (5) to 19 lb-ft (26 N•m).
3. Open and close crew door (6) several times to ensure proper latch (7) and front striker plate (2) alignment. If front striker plate (2) cannot be adjusted to align with latch (7), adjust crew door (6) (para. 11-2).

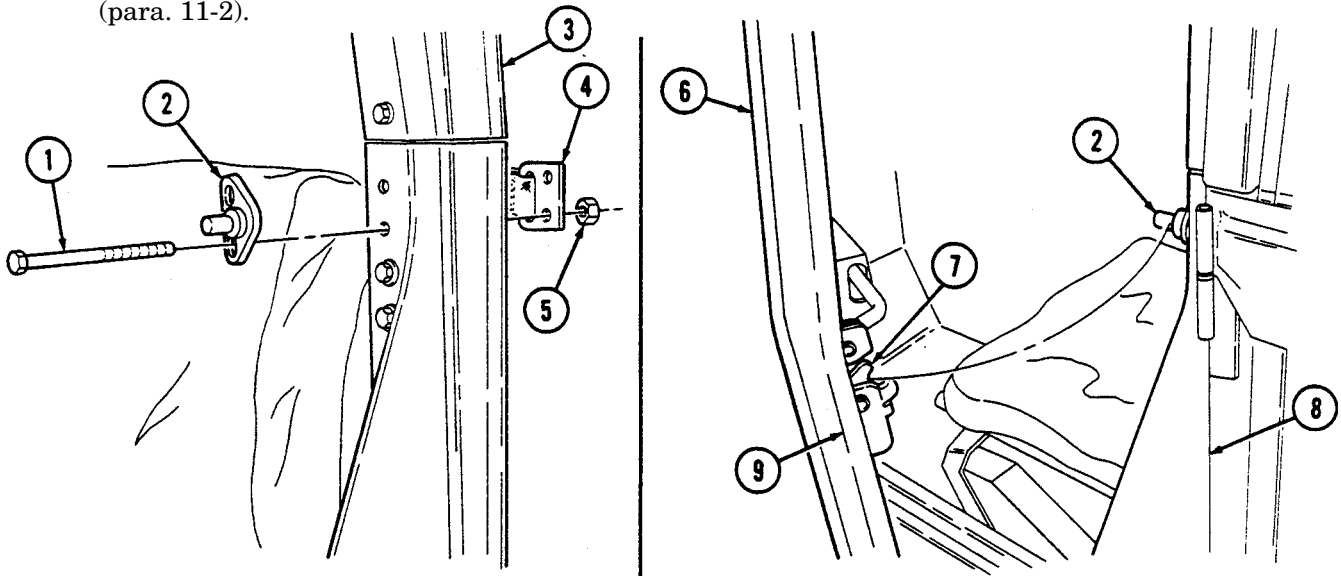

11-6. BALLISTIC CREW DOOR PADDLE LOCK REPLACEMENT

This task covers:

a. Removal

b. Installation

INITIAL SETUP:

Applicable Models

All models except M998, M998A1, M1035, M1035A1, M1035A2, M1037, M1038, M1038A1, M1042, M1097, M1097A1, M1097A2

Materials/Parts

Four locknuts (Appendix G, Item 85)

Manual References

TM 9-2320-280-24P

Tools

General mechanic's tool kit:
automotive (Appendix B, Item 1)

a. Removal

1. Release clevis clip (3) from hook (4) and remove hook (4) and clevis clip (3) from paddle lock (2).
2. Remove four locknuts (7), washers (6), screws (5), and paddle lock (2) from crew door (1). Discard locknuts (7).

b. Installation

1. Install paddle lock (2) on crew door (1) with four screws (5), washers (6), and locknuts (7). Tighten locknuts (7) to 12-17 lb-in. (1-2 N•m).
2. Connect hook (4) to paddle lock (2) with clevis clip (3).

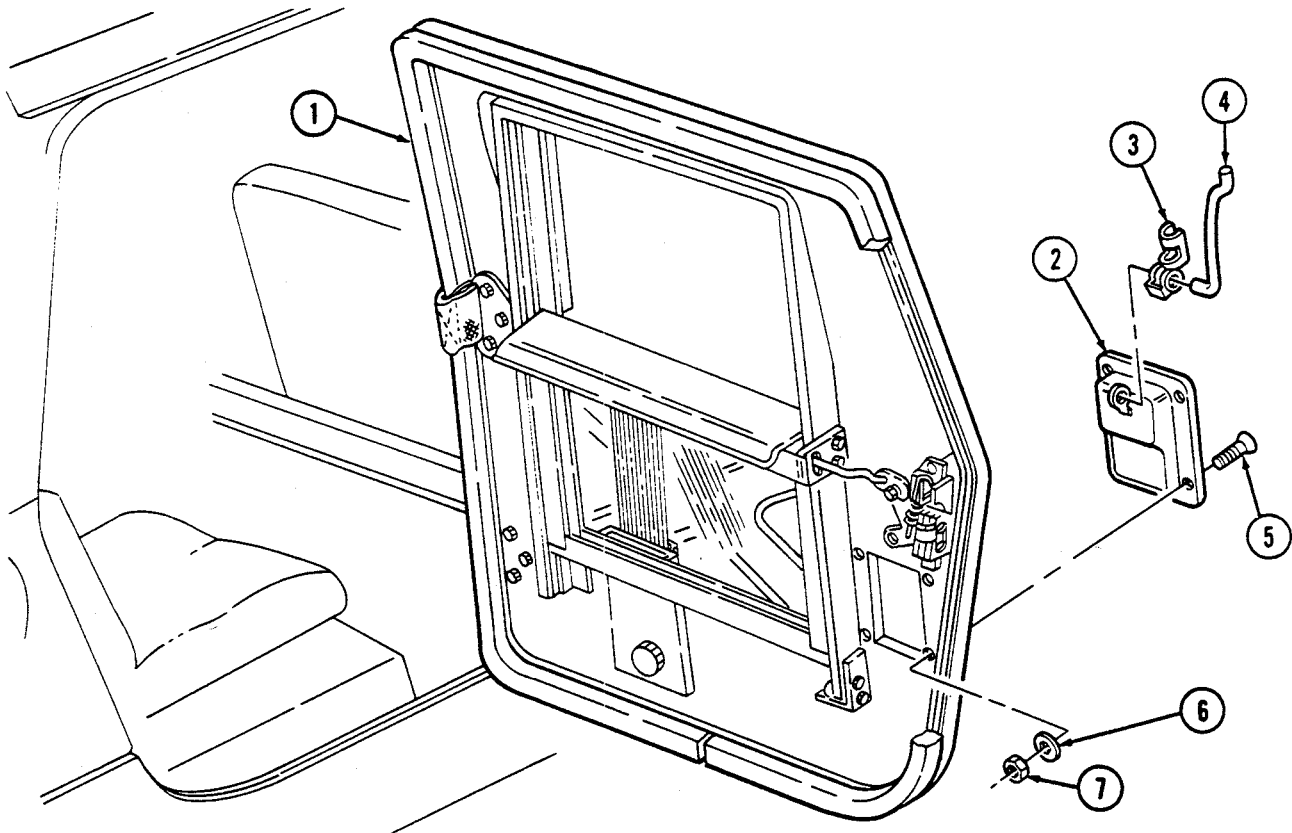

11-7. BALLISTIC CREW DOOR WINDOW ASSEMBLY MAINTENANCE

This task covers:

- | | |
|---|---|
| <p>a. Removal</p> <p>b. Disassembly</p> | <p>c. Assembly</p> <p>d. Installation</p> |
|---|---|

INITIAL SETUP:

Applicable Models

All models except M998, M998A1, M1035, M1035A1, M1035A2, M1037, M1038, M1038A1, M1042, M1097, M1097A1, M1097A2

Tools

General mechanic's tool kit:
automotive (Appendix B, Item 1)

Materials/Parts

Sealing compound (Appendix C, Item 43)
Retaining ring (Appendix G, Item 231)

Manual References

TM 9-2320-280-24P

Equipment Condition

- Window stops removed (para. 11-9).
- Latch tube removed (para. 11-12).

a. Removal

Pull out on window latch knob (4) and slide window (5) down and out from door side rails (1) and guide channel (2).

b. Disassembly

1. Remove latch knob (4) from pin (6).
2. Remove retaining ring (9), pin (6), and spring (10) from window latch (3). Discard retaining ring (9).
3. Remove four rollers (8) from guide pins (7).
4. Remove four guide pins (7) from window (5).

c. Assembly

1. Apply sealing compound to threads of guide pins (7) and install guide pins (7) on window (5) frame.
2. Install spring (10) and pin (6) on window latch (3) with retaining ring (9).
3. Apply sealing compound to threads of pin (6) and install latch knob (4) onto pin (6).
4. Install four rollers (8) on guide pins (7).

d. Installation

Align window latch (3) with window guide channel (2) and push window (5) up into guide channel (2) and door side rails (1).

11-7. BALLISTIC CREW DOOR WINDOW ASSEMBLY MAINTENANCE Cont'd)

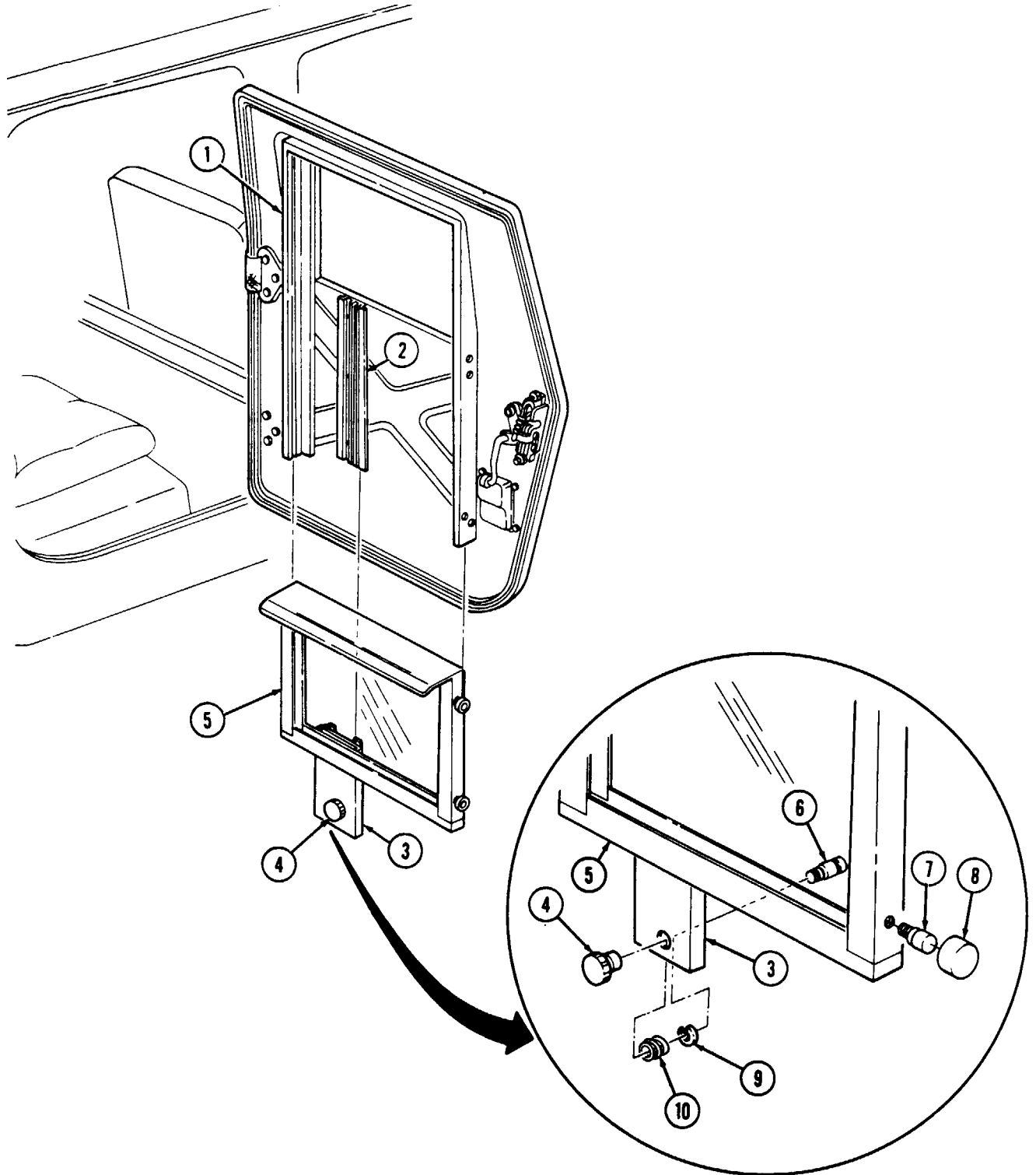

- FOLLOW-ON TASKS:
- Install latch tubs (para. 11-12).
 - Install window stops (para. 11-9).

11-8. BALLISTIC CREW DOOR WINDOW PROTECTIVE SHIELD REPLACEMENT

This task covers:

- | | |
|--|------------------------|
| <p>a. Initial Installation</p> <p>b. Removal</p> | <p>c. Installation</p> |
|--|------------------------|

INITIAL SETUP:

Applicable Models

All models except M998, M998A1, M1035, M1035A1, M1035A2, M1037, M1038, M1038A1, M1042, M1097, M1097A1, M1097A2

Materials/Parts (Cont'd)

Protective shield (Appendix D, Fig. D-65)
 Two blind rivets (Appendix G, Item 253)
 Two blind rivets (Appendix G, Item 251)

Tools

General mechanic's tool kit:
 automotive (Appendix B, Item 1)

Manual References

TM 43-0139
 TM 9-2320-280-24P

NOTE

- The following procedure can be performed to prevent damage to door glass. This task can be accomplished with the approval of the unit commander.
- Procedures for initial installation and replacement of the protective shields are basically the same for all windows. This procedure covers the left front protective shield.

a. Initial Installation

NOTE

Initial installation steps apply only to vehicles that have not been previously retrofitted with protective shields.

1. Position protective shield (3) on inside of ballistic door (1).
2. Using protective shield (3) as a template, locate and mark three top holes (2) and two bottom holes (5) on inside of ballistic door (1).

NOTE

Ensure window is closed tightly before drilling holes for the protective shield.

3. Drill three 0.156-in. (0.396-cm) diameter holes (8) through ballistic door frame (9).
4. Drill two 0.193-in. (0.490-cm) diameter holes (6) through ballistic door (1).
5. Install protective shield (3) on ballistic door frame (9) with three screws (4).

NOTE

Perform step 6 for M966, M966A1, M996, M996A1, M997, M997A1, M997A2, M1025, M1025A1, M1025A2, M1026, M1026A1, and M1036 vehicles. Perform step 7 for M1043, M1043A1, M1043A2, M1044, M1044A1, M1045, M1045A1, M1045A2, M1046, and M1046A1 vehicles.

6. Install protective shield (3) on ballistic door (1) with two 5/32-in. blind rivets (7).
7. Secure protective shield (3) to ballistic door (1) with two 3/16-in. blind rivets (7).
8. Spot paint ballistic door (1) and protective shield (3) as necessary. Refer to TM 43-0139.

11-8. BALLISTIC CREW DOOR WINDOW PROTECTIVE SHIELD REPLACEMENT (Cont'd)

b. Removal
NOTE

For instructions on replacement of rivets, refer to para. 11-66.

1. Remove two rivets (7) from protective shield (3) and ballistic door (1).
2. Remove three screws (4) and protective shield (3) from ballistic door frame (9).

c. Installation

1. Install protective shield (3) on ballistic doorframe (9) with three screws (4).

NOTE

Perform step 2 for M966, M966A1, M996, M996A1, M997, M997A1, M997A2, M1025, M1025A1, M1025A2, M1026, M1026A1, and M1036 vehicles. Perform step 3 for M1043, M1043A1, M1043A2, M1044, M1044A1, M1045, M1045A1, M1045A2, M1046, and M1046A1 vehicles,

2. Install protective shield (3) on ballistic door (1) with two 5/32-in. blind rivets (7).
3. Install protective shield (3) on ballistic door (1) with two 3/16-in. blind rivets (7).

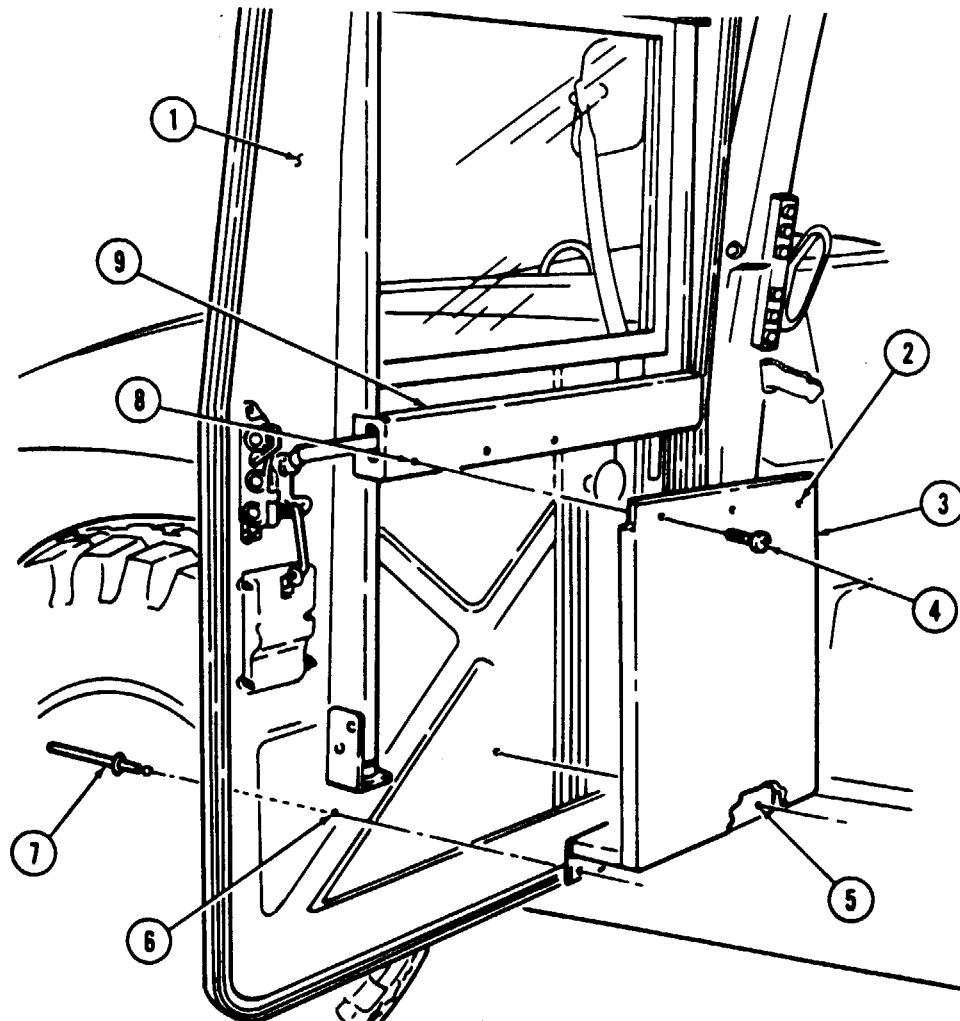

11-9. BALLISTIC CREW DOOR WINDOW STOP REPLACEMENT

This task covers:

a. Removal

b. Installation

INITIAL SETUP

Applicable Models

All models except M998, M998A1, M1035, M1035A1, M1035A2, M1037, M1038, M1038A1, M1042, M1097, M1097A1, M1097A2

Materials/Parts

Two locknuts (Appendix G, Item 87)
Locknut (Appendix G, Item 88)

Tools

General mechanic's tool kit:
automotive (Appendix B, Item 1)

Manual References

TM 9-2320-280-24P

CAUTION

If both window stops are being replaced, ensure ballistic window is locked in the full up position to prevent damage to window.

a. Removal

1. Remove two locknuts (2), screws (5), washers (4), and window stop bracket (6) from side rail (3). Discard locknuts (2).
2. Remove locknut (7), washer (8), screw (1), and pad (9) from window stop bracket (6). Discard locknut (7).

b. Installation

1. Install pad (9) on window stop bracket (6) with screw (1), washer (8), and locknut (7).
2. Install window stop bracket (6) on side rail (3) with two washers (4), screws (5), and locknuts (2).

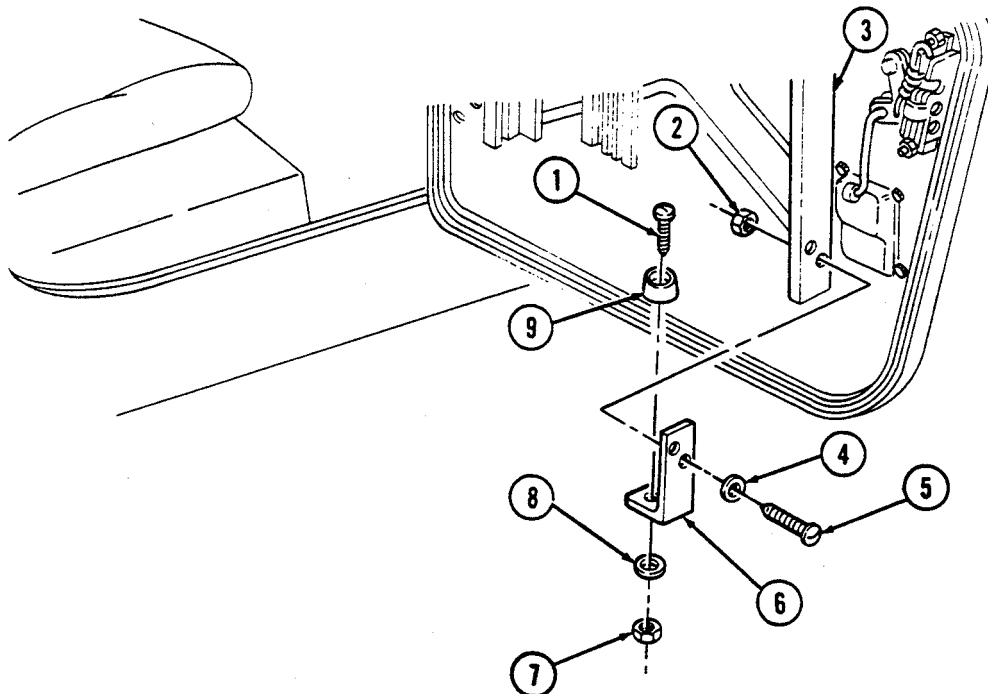

11-10. BALLISTIC CREW DOOR SEAL REPLACEMENT

This task covers:

a. Removal

b. Installation

INITIAL SETUP:

Applicable Models

All models except M998, M998A1, M1035, M1035A1, M1035A2, M1037, M1038, M1038A1, M1042, M1097, M1097A1, M1097A2

Materials/Parts

Detergent (Appendix C, Item 17)

Manual References

TM 9-2320-280-24P

Tools

General mechanic's tool kit:
automotive (Appendix B, Item 1)

a. Removal

1. Slide door strap (5) off doorstop bracket (4).
2. Start at end of seal (2) and pry seal (2) from seal retainer (3) around crew door (1).

b. Installation

1. Coat seal (2) with liquid detergent. Start at one end of seal (2) and press seal (2) into retainer (3) around door (1).
2. Slide door strap (5) on door stop bracket (4).

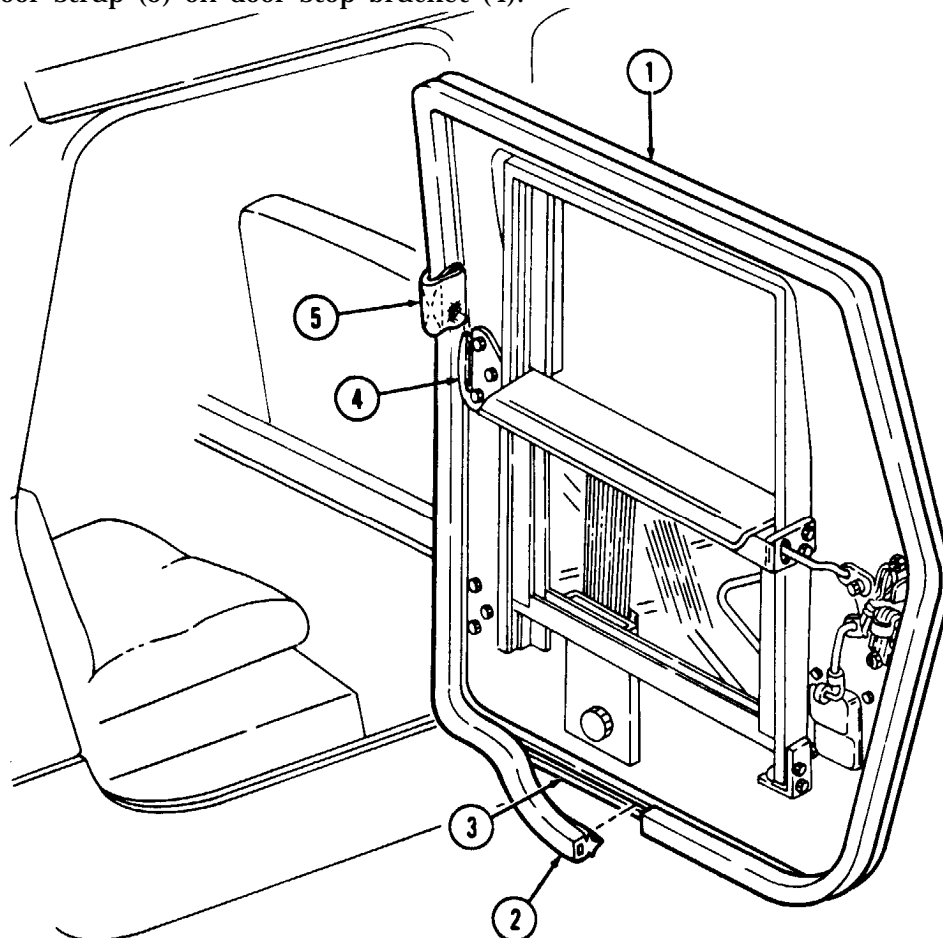

11-11. BALLISTIC CREW DOOR LATCH REPLACEMENT

This task covers:

a. Removal

b. Installation

INITIAL SETUP:

Applicable Models

All models except M998, M998A1, M1035, M1035A1, M1035A2, M1037, M1038, M1038A1, M1042, M1097, M1097A1, M1097A2

Tools

General mechanic's tool kit:
automotive (Appendix B, Item 1)

Materials/Parts

Lockbolt (Appendix G, Item 68)
Four locknuts (Appendix G, Item 87)

Manual References

TM 9-2320-280-24P

a. Removal

1. Remove clevis clip (6) and hook (7) from paddle lock (10) and disconnect hook (7) from door latch (14).
2. Disconnect spring (13) from top of latch (14).
3. Remove lockbolt (1), wave washer (2), latch tube (3), and washer (4) from latch arm (5). Discard lockbolt (1).
4. Remove four locknuts (15), washer (8), screws (9), latch (14), and spacer (12) from crew door (11). Discard locknuts (15).

b. Installation

1. Install spacer (12) and latch (14) on crew door (11) with four washers (8), screws (9), and locknuts (15). Tighten locknuts (15) to 6 lb-ft (8 N·m).
2. Connect spring (13) to top of latch (14).
3. Install washer (4) and latch tube (3) on latch arm (5) with wave washer (2) and lockbolt (1). Tighten lockbolt (1) to 6 lb-ft (8 N·m).
4. Install hook (7) on latch (14) and connect other end of hook (7) to paddle lock (10) with clevis clip (6).

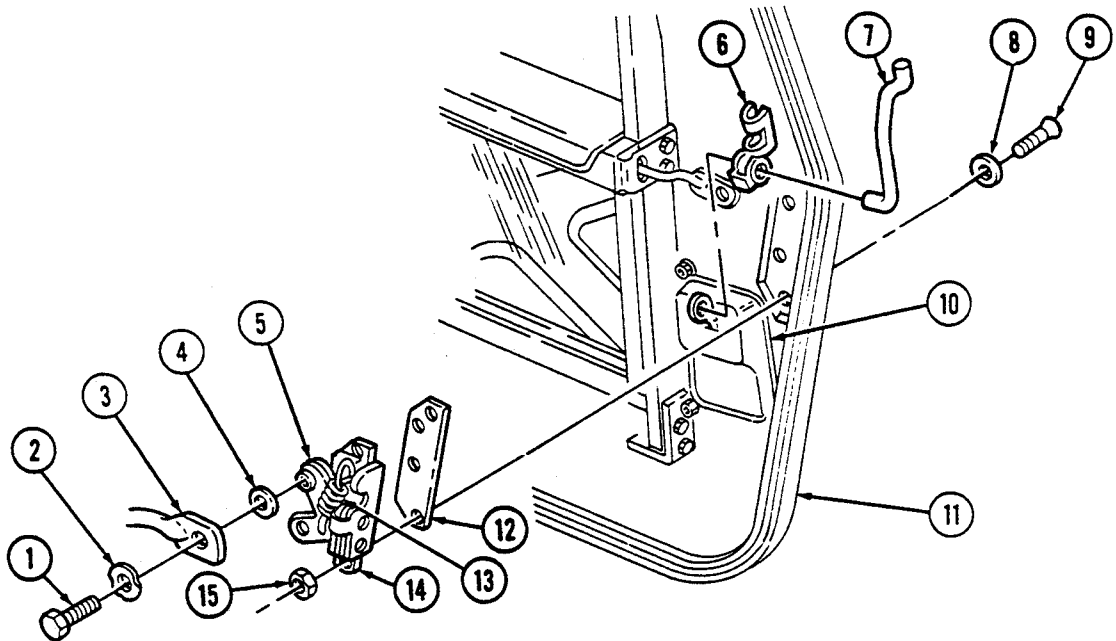

11-12. BALLISTIC CREW DOOR LATCH TUBE REPLACEMENT

This task covers:

a. Removal

b. Installation

INITIAL SETUP:

Applicable Models

All models except M998, M998A1, M1035, M1035A1, M1035A2, M1037, M1038, M1038A1, M1042, M1097, M1097A1, M1097A2

Tools

General mechanic's tool kit:
automotive (Appendix B, Item 1)

Materials/Parts

Lockbolt (Appendix G, Item 68)
Four screws (Appendix G, Item 282)

Manual References

TM 9-2320-280-24P

a. Removal

1. Remove lockbolt (9), wave washer (8), latch tube (7), and washer (3) from latch arm (4). Discard lockbolt (9).
2. Remove four screws (6), washers (5), and bracket (1) from side rails (2). Discard screws (6).
3. Remove two screws (12), washers (13), and guide (11) from bracket (1).
4. Slide latch tube (7) out of bracket (1).
5. Remove protector (10) from bracket (1).

b. Installation

1. Install protector (10) on bracket (1).
2. Slide latch tube (7) into bracket (1).
3. Install guide (11) on bracket (1) with two washers (13) and screws (12).
4. Install bracket (1) on side rails (2) with four washers (5) and screws (6).
5. Install washer (3) and latch tube (7) on latch arm (4) with wave washer (8) and lockbolt (9). Tighten capscrew (9) to 6 lb-ft (8 N·m).

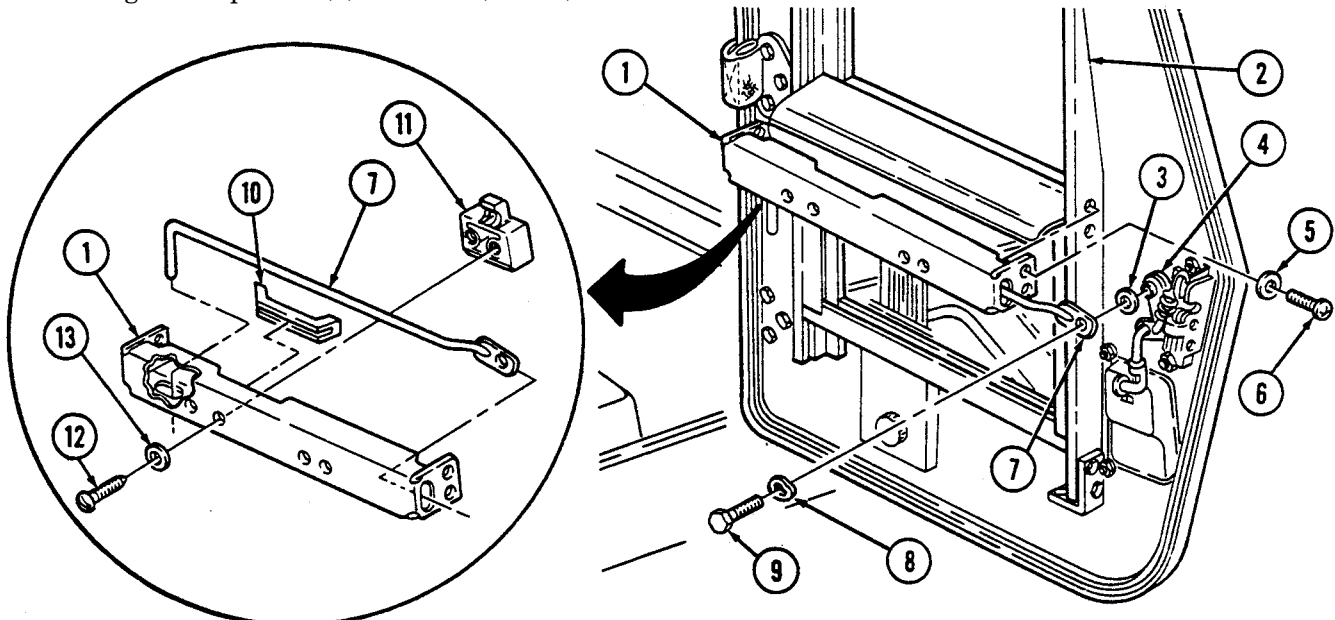

11-13. CARGO SHELL DOOR MAINTENANCE

This task covers:

- a. Removal
- c. Adjustment
- b. Installation

INITIAL SETUP:

Applicable Models

All models except M996, M996A1, M997, M997A1, M997A2, M998, M998A1, M1035, M1035A1, M1035A2, M1037, M1038, M1038A1, M1042, M1097, M1097A1, M1097A2

Tools

General mechanic's tool kit:
automotive (Appendix B, Item 1)

Materials/Parts

Two locknuts (Appendix G, Item 70)
Two assembled washer screws (Appendix G, Item 279)
Two locknuts (Appendix G, Item 79)

Personnel Required

One mechanic
One assistant

Manual References

TM 9-2320-280-10
TM 9-2320-280-24P

Equipment Condition

Rear end of cargo shell door raised (TM 9-2320-280-10).

General Safety Instructions

Never open one end of cargo shell door before ensuring opposite end is securely closed.

a. Removal

WARNING

Opening one end of cargo door before ensuring opposite end is fully closed will cause both ends to open simultaneously, resulting in injury to personnel or damage to equipment.

1. Remove two assembled washer screws (2) and footman loop (3) from strap (1) and cargo door (4). Discard assembled washer screws (2).
2. Lower cargo door (4) slightly, and remove two locknuts (5), washers (6), shoulder bolts (8), and retention cable (9) from two retention cable brackets (7). Discard locknuts (5).
3. Slowly raise cargo door (4) as far as possible to allow removal of gas springs (10) from cargo door (4).
4. Remove two locknuts (12), washers (11), and gas springs (10) from cargo door (4) and lay gas springs (10) inside vehicle. Discard locknuts (12).
5. Lower cargo door (4), release handle latch (13), and remove cargo door (4).

11-13. CARGO SHELL DOOR MAINTENANCE (Cont'd)

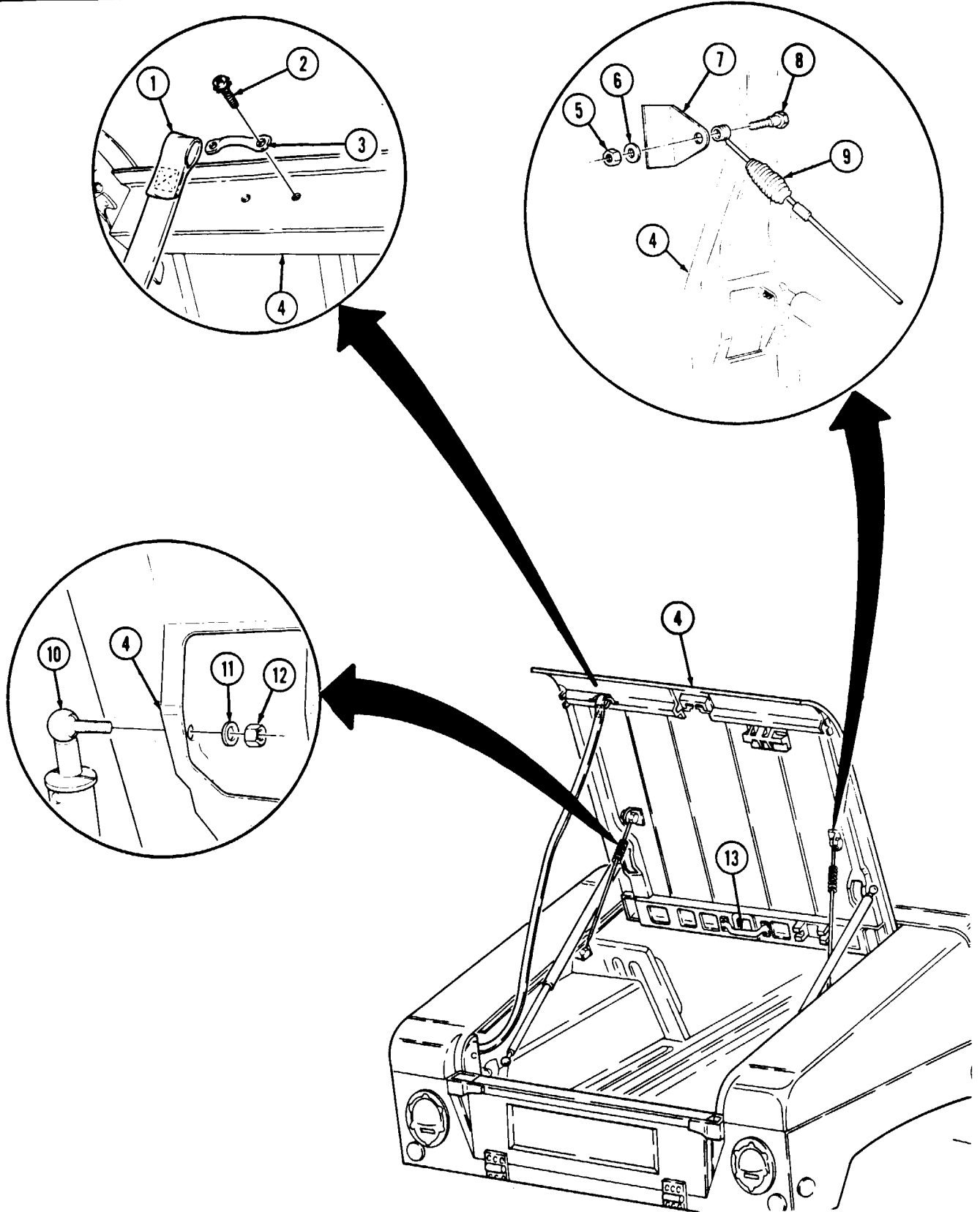

11-13. CARGO SHELL DOOR MAINTENANCE (Cont'd)

b. Installation

1. Install front latches (5) on front striker pins (6).
2. Push down on cargo door (4) edge to ensure front striker pins (6) are locked in front latches (5).
3. Slowly raise cargo door (4) as far as possible to allow installation of gas springs (1) on cargo door (4).
4. Connect two gas springs (1) to cargo door (4) with two washers (2) and locknuts (3). Tighten locknuts (3) to 15-20 lb-ft (20-27 N•m).
5. Connect two retention cables (14) to retention cable brackets (12) with two shoulder bolts (13), washers (11), and locknuts (10). Tighten locknuts (10) to 85-110 lb-in. (10-12 N•m).
6. Install strap (7) on cargo door (4) with footman loop (9) and two assembled washer screws (8).

NOTE

To assist closing cargo shell door, a grab loop may be added. Refer to cargo shell door strap replacement (para. 11-22).

7. Close cargo door (4), and ensure cargo door (4) is securely latched on rear striker pins (15).

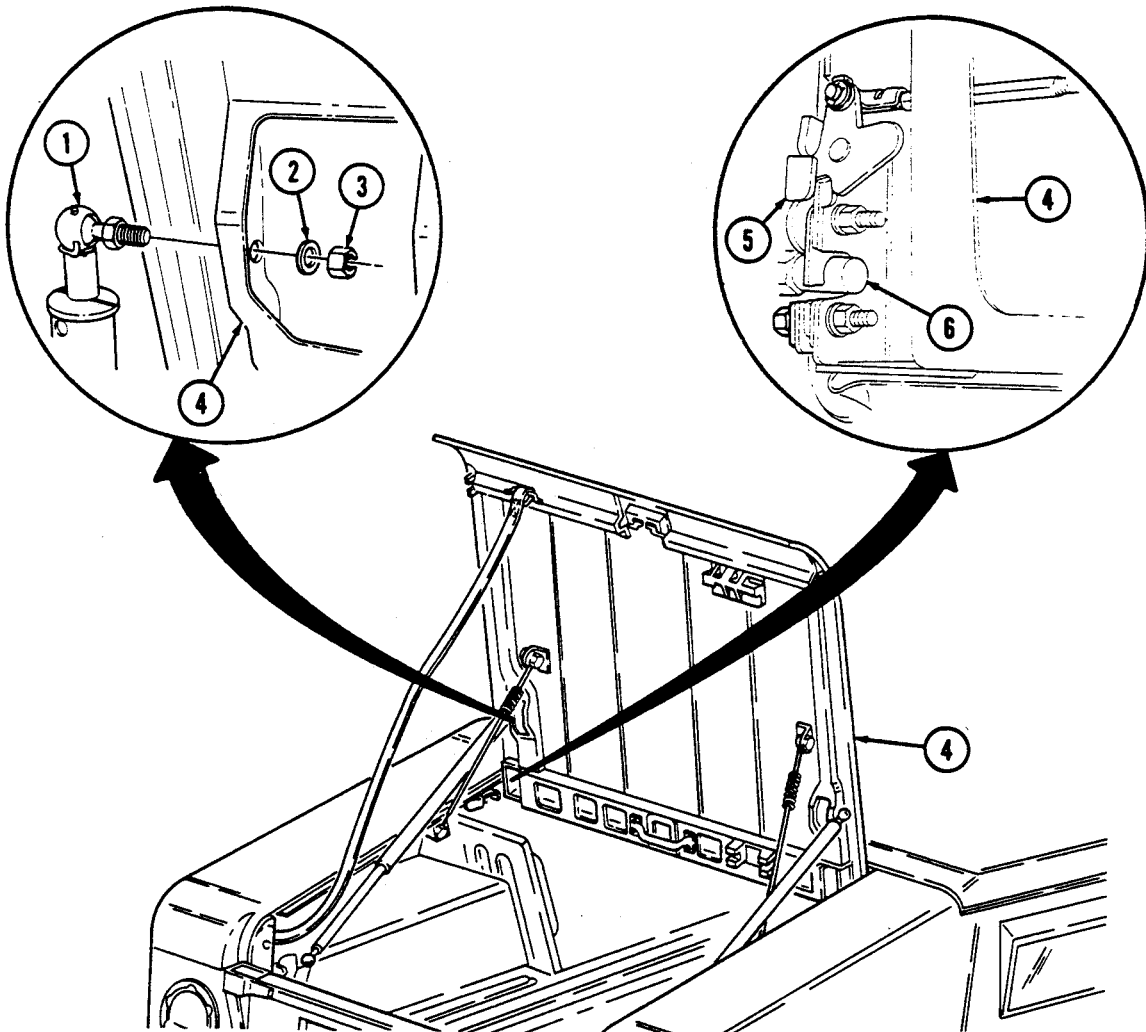

11-13. CARGO SHELL DOOR MAINTENANCE (Cont'd)

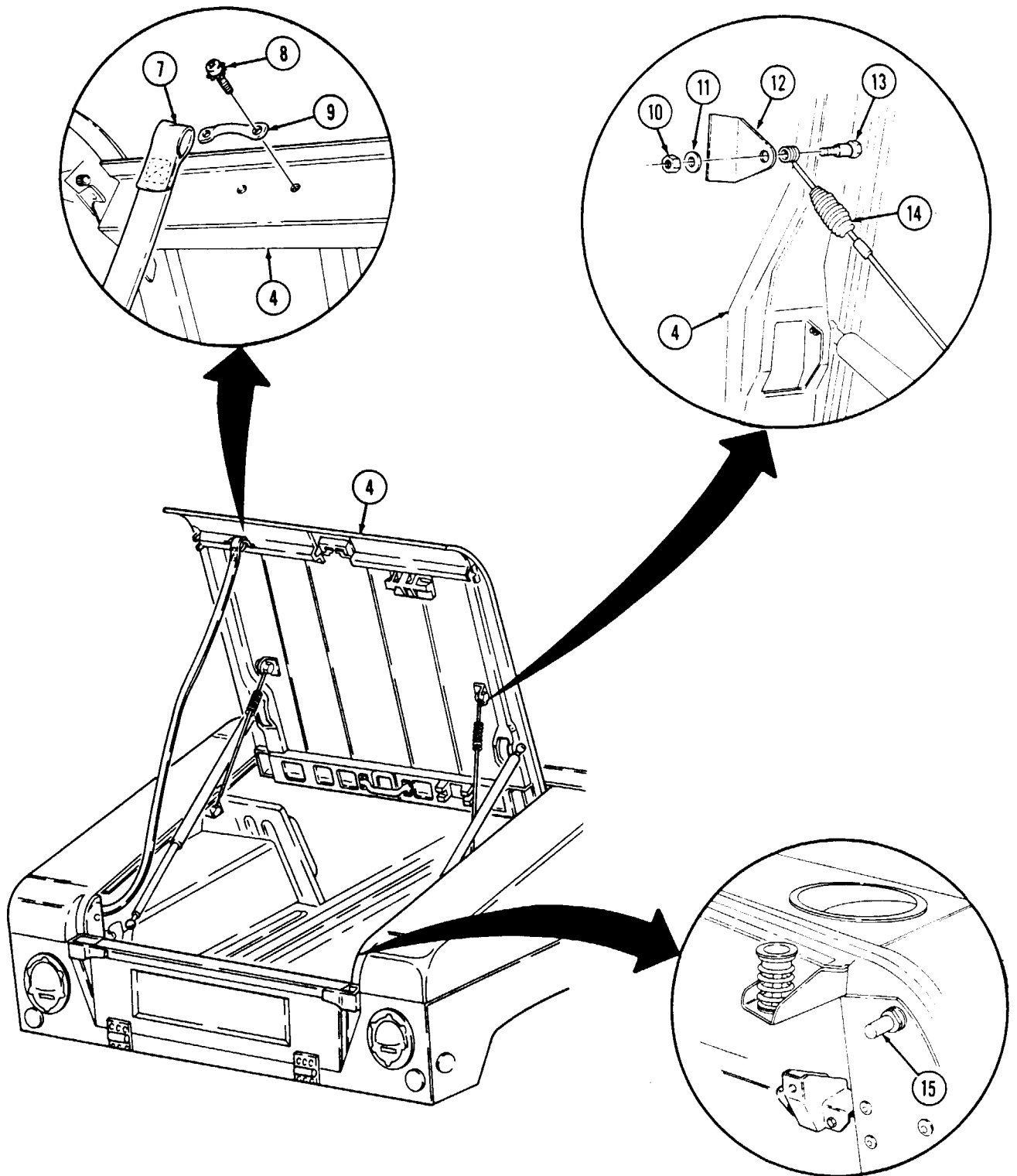

11-13. CARGO SHELL DOOR MAINTENANCE (Cont'd)

c. Adjustment

1. Pull rear wire handle (2) and raise rear end of cargo shell door (1).
2. Perform steps 1 through 4 of a., Removal.
3. Close cargo door (1).
4. Release handle latch (3) and push cargo door (1) open.
5. Loosen two front striker pin mounting nuts (5).
6. Loosen two countersunk screws (11) and nuts (10) to allow movement of male dovetail (9).
7. Close cargo door (1). Ensure front striker pins (7) are secured and centered in front latches (6).
8. Ensure male dovetail (9) is aligned with female dovetail (8).

NOTE

It maybe necessary to shim front striker pins for proper door alignment and operation.

9. Pull down on handle (4) to ensure cargo door (1) properly seals to cargo shell (12). With striker pins (7) properly adjusted, tighten striker pin mounting nuts (5) to 35-45 lb-ft (47-61 N•m).
10. Release handle latch (3) and push cargo door (1) open.
11. Tighten two nuts (10) on male dovetail (9) to 85-110 lb-in. (10-12 N•m).
12. Lower cargo door (1). Ensure front striker pins (7) are secured and centered in front latches (6).
13. Raise cargo door (1) from rear wire handle (2) and perform steps 3 through 6 of b., Installation.
14. Insert a piece of paper between door seals and door opening. With cargo door closed, seals should offer resistance when pulling out paper. If door seals do not offer resistance, readjust cargo door.

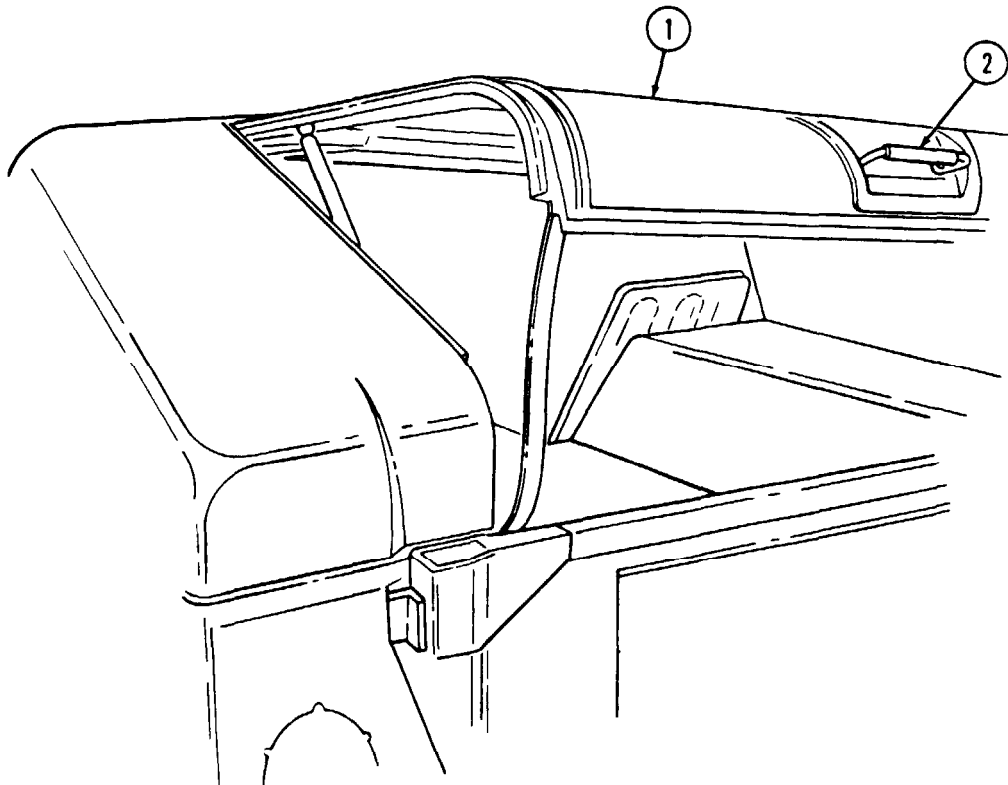

11-13. CARGO SHELL DOOR MAINTENANCE (Cont'd)

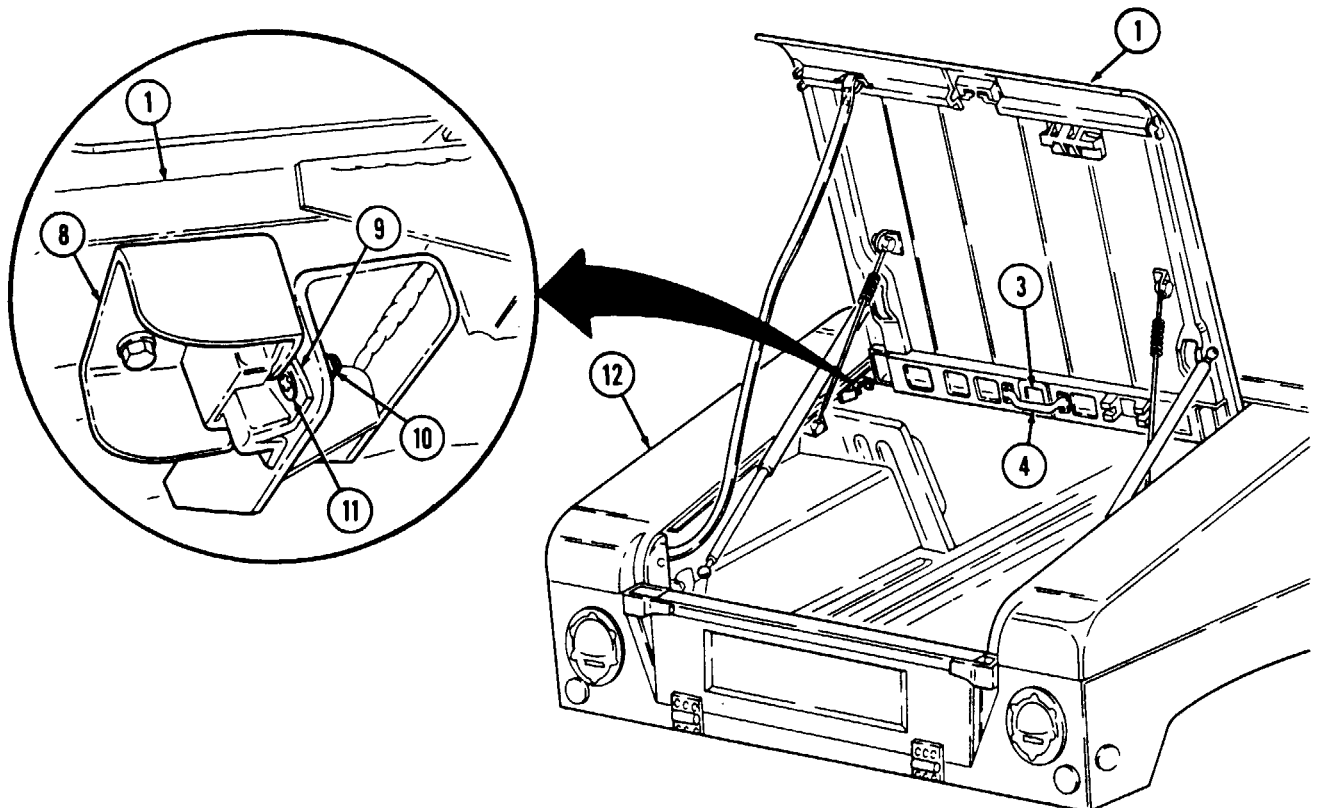
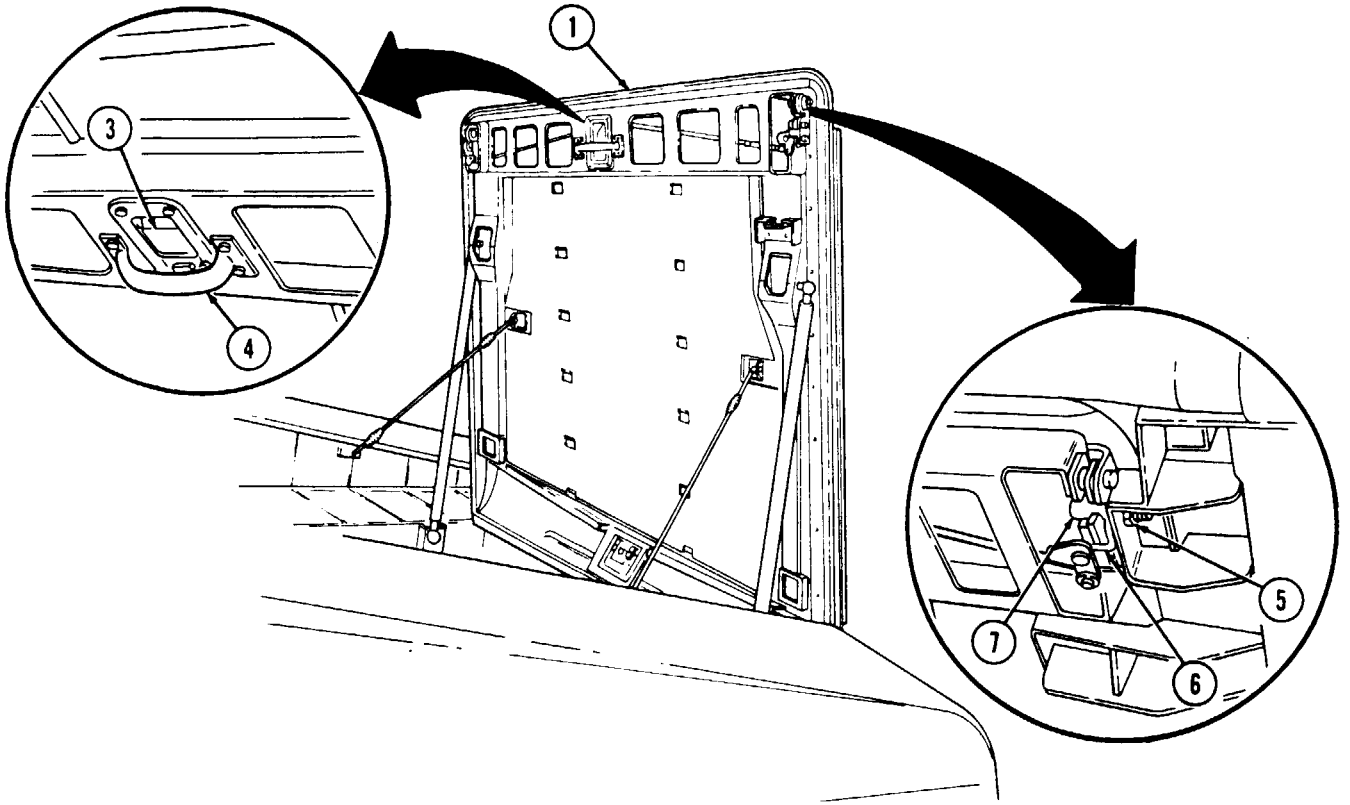

FOLLOW-ON TASK: Close cargo shell door (TM 9-2320-280-10).

11-14. CARGO SHELL DOOR WIRE HANDLE LOCK REPLACEMENT

This task covers:

a. Removal

b. Installation

INITIAL SETUP:

Applicable Models

All models except M996, M996A1, M997, M997A1, M997A2, M998, M998A1, M1035, M1035A1, M1035A2, M1037, M1038, M1038A1, M1042, M1097, M1097A1, M1097A2

Tools

General mechanic's tool kit:
automotive (Appendix B, Item 1)

Materials/Parts

Sealing compound (Appendix C, Item 45)
Two push on nuts (Appendix G, Item 228)

Manual References

TM 9-2320-280-10
TM 9-2320-280-24P

Equipment Condition

Tailgate lowered (TM 9-2320-280-10).

a. Removal

1. Remove two push on nuts (1), rod end clips (2), and latch rods (3) from wire handle lock pivot arms (4). Discard push on nuts (1).
2. Remove four nuts (5), washers (6), capscrews (8), washers (6), and wire handle lock (9) from cargo door (7).

b. Installation

1. Apply sealing compound to threads of capscrews (8).
2. Install wire handle lock (9) on cargo door (7) with four washers (6), capscrews (8), washers (6), and nuts (5).
3. Install two latch rods (3) on wire handle lock pivot arms (4) with rod end clips (2) and push on nuts (1).

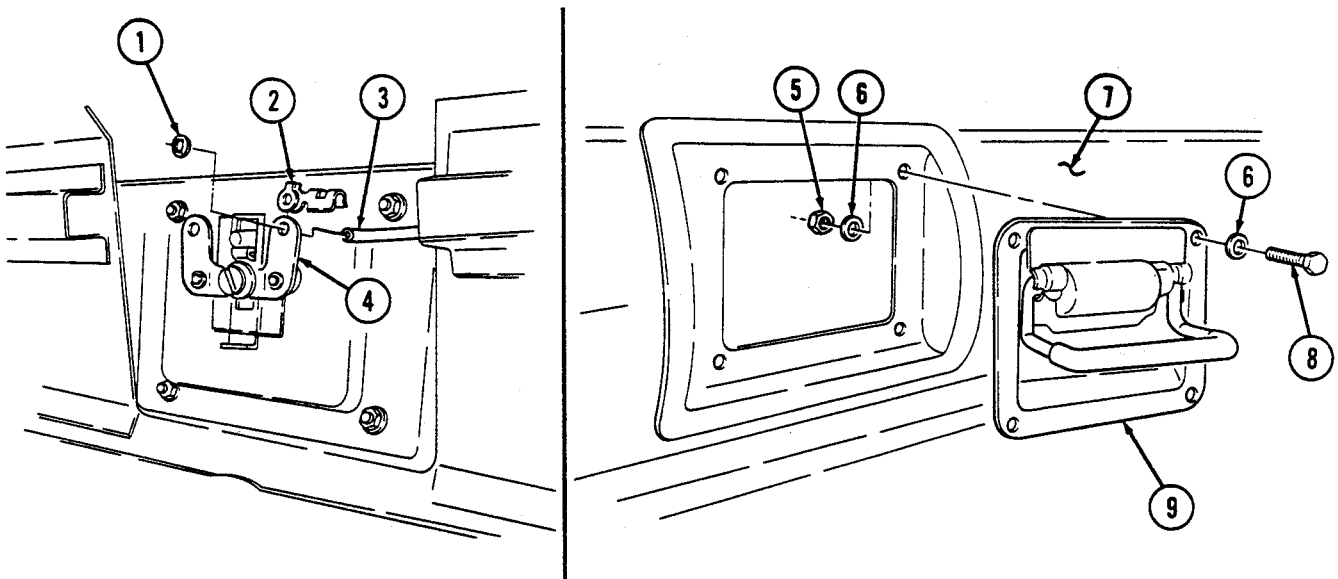

- FOLLOW-ON TASKS:**
- Raise and secure tailgate (TM 9-2320-280-10).
 - Check cargo shell door for proper operation (TM 9-2320-280-10).

11-15. CARGO SHELL DOOR GRAB HANDLE REPLACEMENT

This task covers:

a. Removal

b. Installation

INITIAL SETUP:

Applicable Models

All models except M996, M996A1, M997, M997A1, M997A2, M998, M998A1, M1035, M1035A1, M1035A2, M1037, M1038, M1038A1, M1042, M1097, M1097A1, M1097A2

Tools

General mechanic's tool kit:
automotive (Appendix B, Item 1)

Materials/Parts

Sealing compound (Appendix C, Item 45)
Four lockwashers (Appendix G, Item 173)

Manual References

TM 9-2320-280-10
TM 9-2320-280-24P

Equipment Condition

Forward end of cargo shell door raised
(TM 9-2320-280-10).

a. Removal

Remove four nuts (1), lockwashers (2), washers (3), countersunk screws (6), and grab handle (5) from cargo door (4). Discard lockwashers (3).

b. Installation

1. Apply sealing compound to threads of countersunk screw (6).
2. Install grab handle (5) on cargo door (4) with four countersunk screws (6), washers (3), lockwashers (2), and nuts (1).

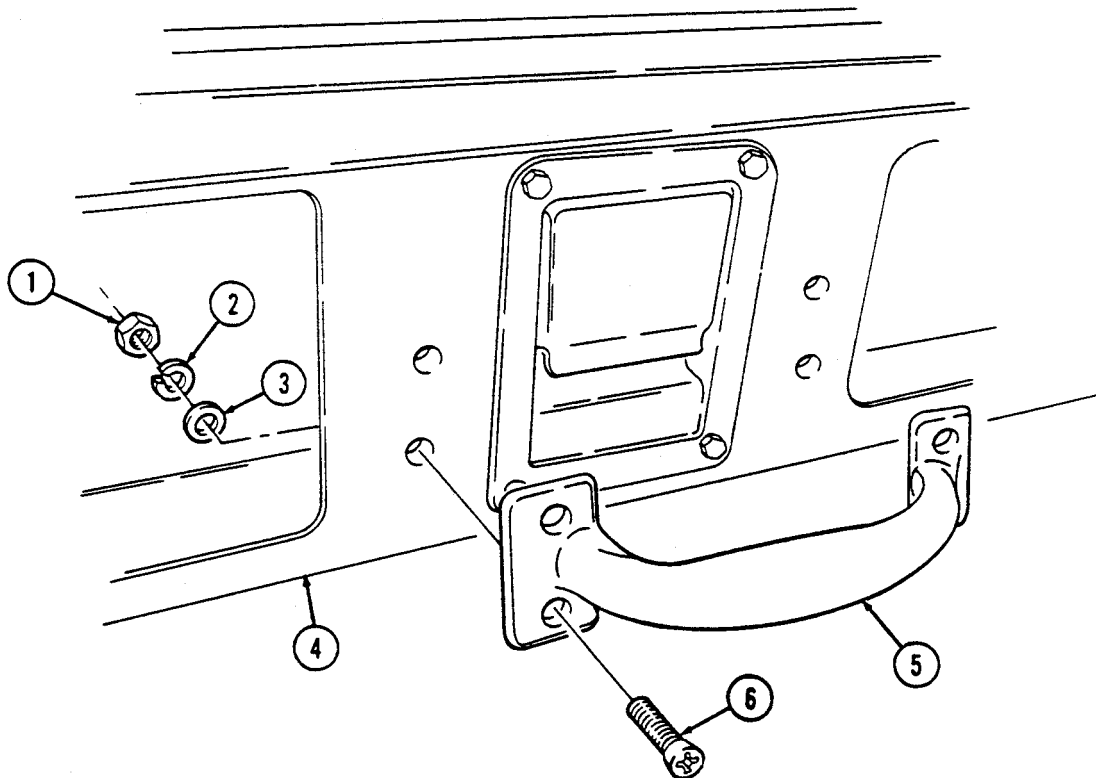

FOLLOW-ON TASK: Close cargo shell door (TM 9-2320-280-10).

11-16. CARGO SHELL DOOR HANDLE LATCH REPLACEMENT

This task covers:

a. Removal

b. Installation

INITIAL SETUP:

Applicable Models

All models except M996, M996A1, M997, M997A1, M997A2, M998, M998A1, M1035, M1035A1, M1035A2, M1037, M1038, M1038A1, M1042, M1097, M1097A1, M1097A2

Tools

General mechanic's tool kit:
automotive (Appendix B, Item 1)

Materials/Parts

Two push on nuts (Appendix G, Item 228)

Manual References

TM 9-2320-280-10
TM 9-2320-280-24P

Equipment Condition

Forward end of cargo shell door raised
(TM 9-2320-280-10).

a. Removal

1. Remove four nuts (4), washers (3), capscrews (5), and washers (3) from handle latch lock (1) and cargo door (2).
2. Pull handle latch (1) out and down until latch rods (6) are visible.
3. Remove two push on nuts (9), rod end clips (7), latch rods (6), and handle latch (1) from pivot arms (8). Discard push on nuts (9).

b. Installation

1. Position handle latch (1) to cargo door (2) until latch rods (6) can be connected to handle latch pivot arms (8) and secure latch rods (6) on pivot arms (8) with two rod end clips (7) and push on nuts (9).
2. Install handle latch (1) on cargo door (2) with four washers (3), capscrews (5), washers (3), and nuts (4).

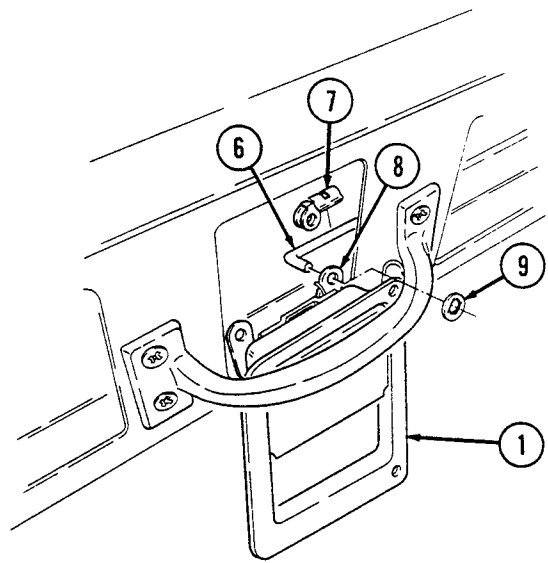
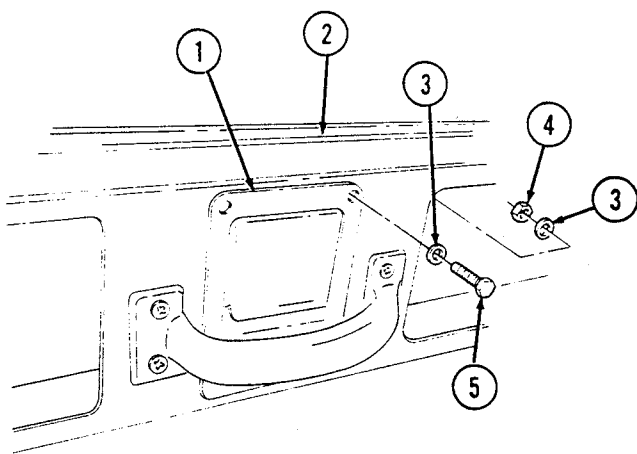

FOLLOW-ON TASK: Check cargo shell door for proper operation (TM 9-2320-280-10).

11-17. CARGO SHELL DOOR LATCH MAINTENANCE

This task covers:

- | | |
|---|---|
| <ul style="list-style-type: none"> a. Removal b. Installation | <ul style="list-style-type: none"> c. Adjustment |
|---|---|

INITIAL SETUP:

Applicable Models

All models except M996, M996A1, M997, M997A1, M997A2, M998, M998A1, M1035, M1035A1, M1035A2, M1037, M1038, M1038A1, M1042, M1097, M1097A1, M1097A2

Tools

General mechanic's tool kit:
automotive (Appendix B, Item 1)

Materials/Parts

Three lockwashers (Appendix G, Item 134)
Push on nut (Appendix G, Item 228)

Manual References

TM 9-2320-280-10
TM 9-2320-280-24P

Equipment Condition

Rear end of cargo shell door raised
(TM 9-2320-280-10).

a. Removal

1. Remove push on nut (6), rod end clip (7), and rod (8) from door latch (4). Discard push on nut (6).
2. Remove three nuts (1), lockwashers (2), capscrews (5), and door latch (4) from cargo door (3). Discard lockwashers (2).

b. Installation

Install door latch (4) on cargo door (3) with three capscrews (5), lockwashers (2), and nuts (1). Do not tighten nuts (1) all the way.

c. Adjustment

1. Loosen three nuts (1) from door latch (4) and cargo door (3).
2. Close cargo door (3) ensuring latch (4) is fully engaged on door striker pins (9).
3. Tighten three nuts (1) to 17 lb-ft (23 N·m).
4. Install rod (8) on latch (4) with rod end clip (7) and push on nut (6).

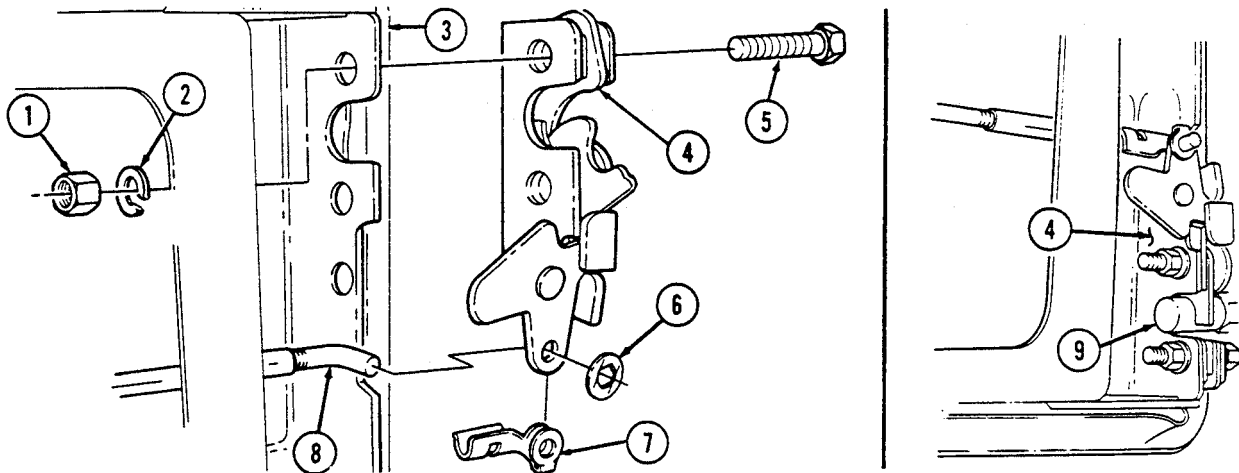

- FOLLOW-ON TASKS:
- Lubricate door latch (TM 9-2320-280-10).
 - Check cargo shell door for proper operation (TM 9-2320-280-10).

11-18. CARGO SHELL DOOR LATCH ROD MAINTENANCE

This task covers:

- | | |
|---|---|
| <ul style="list-style-type: none"> a. Removal b. Installation | <ul style="list-style-type: none"> c. Adjustment |
|---|---|

INITIAL SETUP:

Applicable Models

All models except M996, M996A1, M997, M997A1, M997A2, M998, M998A1, M1035, M1035A1, M1035A2, M1037, M1038, M1038A1, M1042, M1097, M1097A1, M1097A2

Tools

General mechanic's tool kit:
automotive (Appendix B, Item 1)

Materials/Parts

Two push on nuts (Appendix G, Item 228)

Manual References

TM 9-2320-280-10
TM 9-2320-280-24P

Equipment Condition

Forward end of cargo shell door raised (TM 9-2320-280-10).

NOTE

Maintenance procedures for all cargo shell door latch rods are basically the same. This procedure covers the left rear latch rod.

a. Removal

1. Remove push on nut (1), rod end clip (3), and latch rod (4) from pivot arm (2) on wire handle lock (5). Discard push on nut (1).
2. Remove push on nut (7), rod end clip (6), and latch rod (4) from door latch (8). Discard push on nut (7).

b. Installation

1. Connect latch rod (4) to door latch (8) with rod end clip (6).
2. Connect latch rod (4) to pivot arm (2) on wire handle lock (5) with rod end clip (3) and push on nut (1).
3. Close forward end of cargo door.

c. Adjustment

1. Open rear end of cargo door.
2. Close both rear door latches (8) to check latch action.
3. Gently pull wire handle lock (5) and observe movement of door latches (8). If both door latches (8) unlatch at the same time, install push on nut (7) on latch rod (4), no adjustment is necessary. If door latches (8) do not unlatch at the same time, go to step 4.
4. Remove rod end clip (6) from rod (4) and door latch (8). Rotate rod adjuster (9) in, if door latch (8) unlatches after opposite latch (8), or rotate rod adjuster (9) out, if door latch (8) unlatches before opposite door latch (8).
5. Repeat step 4 until door latches (8) unlatch at the same time.
6. Install latch rod (4) on door latch (8) with rod end clip (6) and push on nut (7).

11-18. CARGO SHELL DOOR LATCH ROD MAINTENANCE (Cont'd)

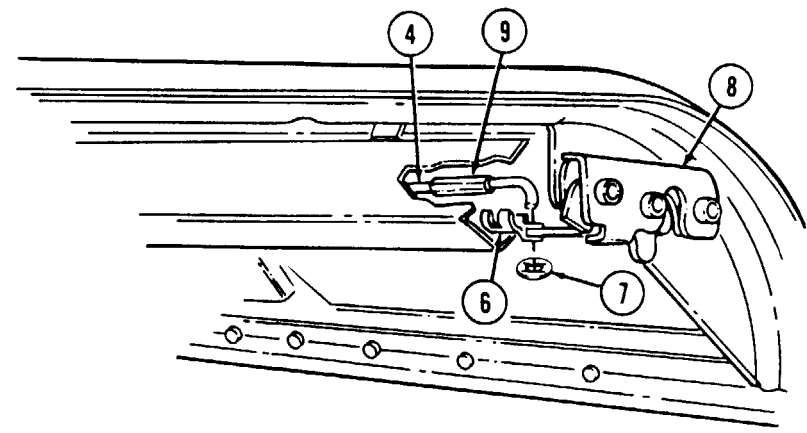
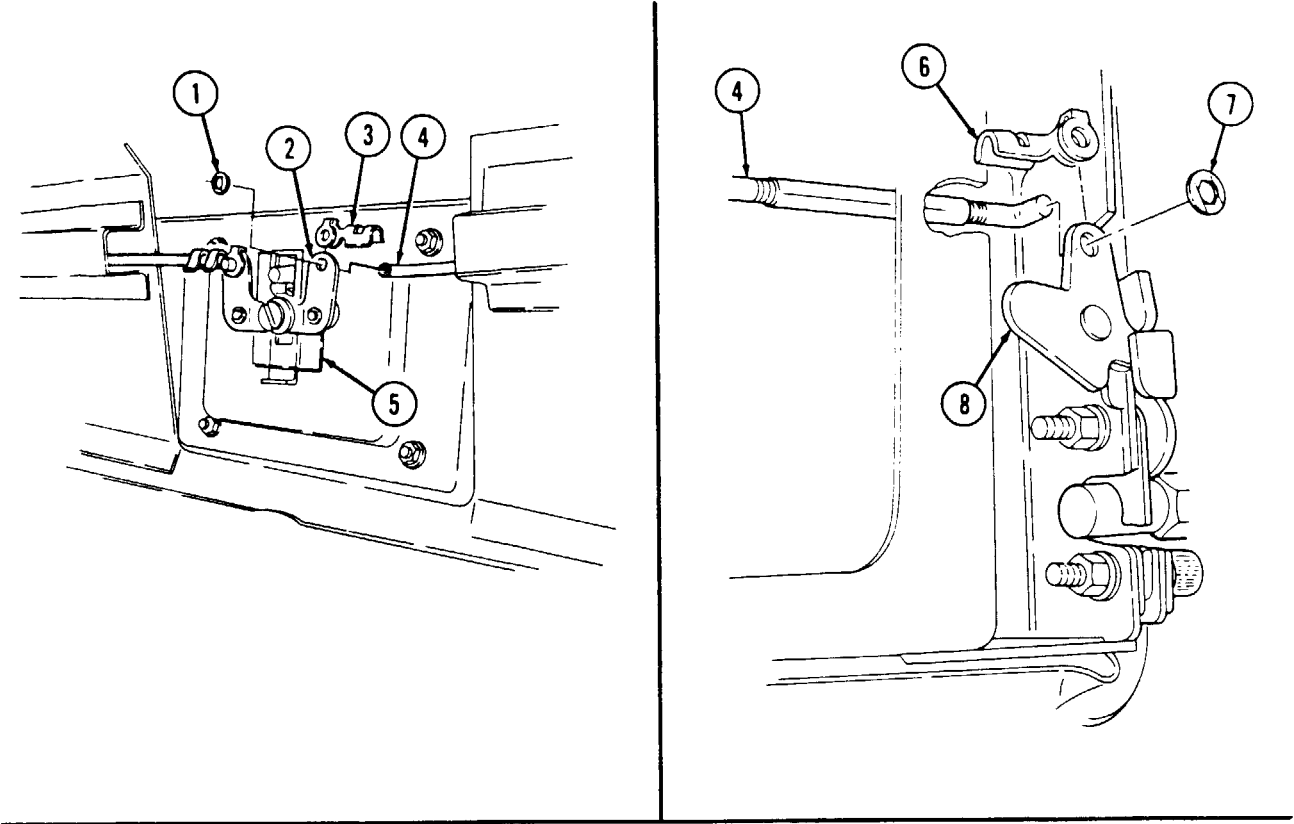

FOLLOW-ON TASK: Check cargo shell door for proper operation (TM 9-2320-280-10).

11-19. CARGO SHELL DOOR DOVETAIL ASSEMBLY MAINTENANCE

This task covers:

- | | |
|---|---|
| <ul style="list-style-type: none"> a. Removal b. Installation | <ul style="list-style-type: none"> c. Adjustment |
|---|---|

INITIAL SETUP:

Applicable Models

All models except M996, M996A1, M997, M997A1, M997A2, M998, M998A1, M1035, M1035A1, M1035A2, M1037, M 1038, M1038A1, M1042, M1097, M1097A1, M1097A2

Tools

General mechanic's tool kit:
automotive (Appendix B, Item 1)

Materials/Parts

Two locknuts (Appendix G, Item 70)
Two lockwashers (Appendix G, Item 175)

Manual References

TM 9-2320-280-24P

Equipment Condition

Rear end of cargo shell door raised
(TM 9-2320-280-10).

NOTE

The cargo shell door dovetail assembly is of two-piece construction. The female half is mounted on the cargo door. The male half is mounted on a bracket attached to the left cargo shell. Both halves are adjustable and function as a door alignment device.

a. Removal

1. Remove two capscrews (1), lockwashers (2), washers (3), and female dovetail (4) from cargo door (5). Discard lockwashers (2).
2. Remove two locknuts (6), washers (7), countersunk screws (11), male dovetail (10), and shim (9) from cargo shell bracket (8). Discard locknuts (6).

b. Installation

1. Install shim (9) and male dovetail (10) on cargo shell bracket (8) with two countersunk screws (11), washers (7), and locknuts (6). Leave male dovetail (10) loose enough to allow movement from left to right.
2. Install female dovetail (4) on cargo door (5) with two washers (3), lockwashers (2), and capscrews (1). Leave dovetail (4) loose enough to allow movement up and down.
3. Close rear end of cargo door (5).

c. Adjustment

1. Open forward end of cargo door (5).
2. Loosen two capscrews (1) from female dovetail (4) and cargo door (5) until female dovetail (4) will slide up and down.
3. Loosen two countersunk screws (11) and locknuts (6) from male dovetail (10) and cargo shell bracket (8) until male dovetail (10) can be moved from left to right.
4. Gently close cargo door (5) until male dovetail (10) and female dovetail (4) fully seat without interference. Once this condition exists, tighten mounting hardware of dovetails (4) and (10).
5. Open and close cargo door (5) several times to ensure proper dovetail (4) and (10) adjustment.
6. Tighten two capscrews (1) on female dovetail (4) to 10 lb-ft (14 N•m).
7. Tighten two locknuts (6) on male dovetail (10) to 85-100 lb-in. (10-11 N•m).

11-19. CARGO SHELL DOOR DOVETAIL ASSEMBLY MAINTENANCE (Cont'd)

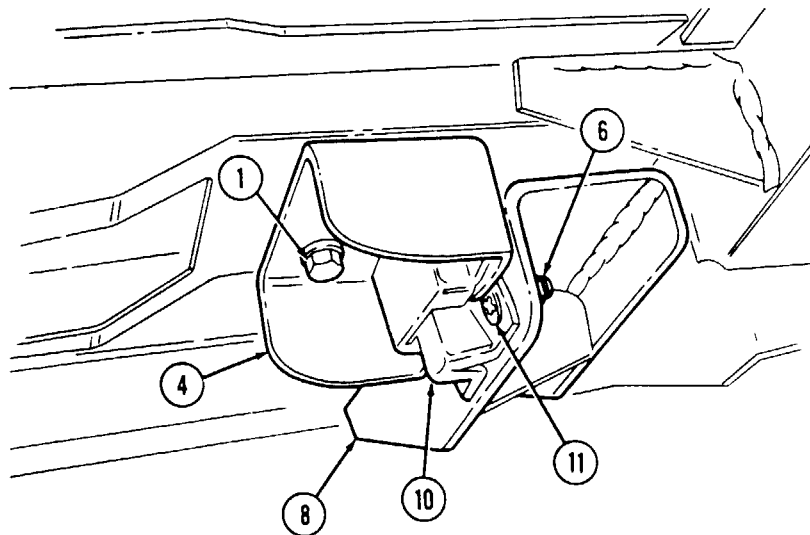
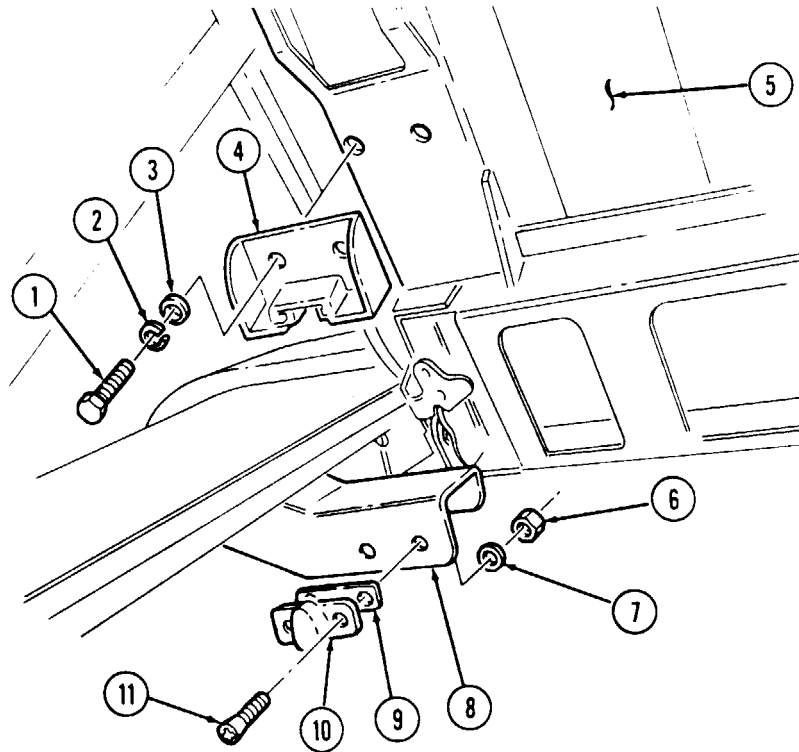

FOLLOW-ON TASK: Close cargo shell door (TM 9-2320-280-10).

11-20. CARGO SHELL DOOR RETENTION CABLE REPLACEMENT

This task covers:

a. Removal

b. Installation

INITIAL SETUP:

Applicable Models

All models except M996, M996A1, M997, M997A1, M997A2, M998, M998A1, M1035, M1035A1, M1035A2, M1037, M1038, M1038A1, M1042, M1097, M1097A1, M1097A2

Tools

General mechanic's tool kit:
automotive (Appendix B, Item 1)

Materials/Parts

Two locknuts (Appendix G, Item 70)

Manual References

TM 9-2320-280-10
TM 9-2320-280-24P

Equipment Condition

Forward end of cargo shell door raised
(TM 9-2320-280-10).

a. Removal

NOTE

It will be necessary to lower cargo shell door slightly to relieve cable tension during step 1.

1. Remove locknut (1), washer (2), shoulder bolt (4), and spring end of cable (5) from cargo door bracket (3). Discard locknut (1).
2. Remove locknut (8), washer (9), shoulder bolt (6), and cable (5) from left cargo shell bracket (7). Discard locknut (8).

b. Installation

1. Install cable (5) on cargo shell bracket (7) with shoulder bolt (6), washer (9), and locknut (8). Tighten locknut (8) to 85-110 lb-in. (10-12 N·m).
2. Install spring end of cable (5) on cargo door bracket (3) with shoulder bolt (4), washer (2), and locknut (1). Tighten locknut (1) to 85-110 lb-in. (10-12 N·m).

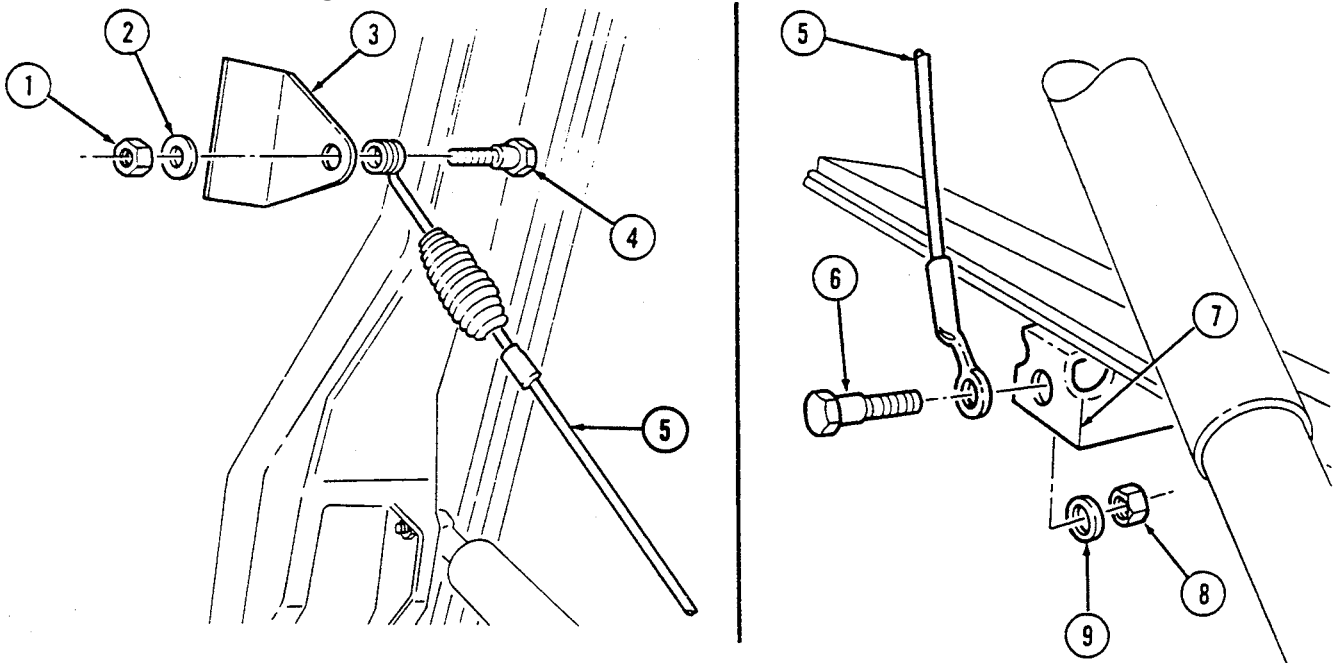

FOLLOW-ON TASK: Close cargo shell door (TM 9-2320-280-10).

11-21. CARGO SHELL DOOR GAS SPRING MAINTENANCE

This task covers:

- | | |
|----------------|-----------------|
| a. Rotating | d. Assembly |
| b. Removal | e. Installation |
| c. Disassembly | |

INITIAL SETUP:

Applicable Models

All models except M996, M996A1, M997, M997A1, M997A2, M998, M998A1, M1035, M1035A1, M1035A2, M1037, M1038, M1038A1, M1042, M1097, M1097A1, M1097A2

Tools

General mechanic's tool kit:
automotive (Appendix B, Item 1)

Materials/Parts

Grease (Appendix C, Item 22)
Two locknuts (Appendix G, Item 70)
Two retaining rings (Appendix G, Item 234)
Two assembled washer screws
(Appendix G, Item 279)
Two locknuts (Appendix G, Item 79)

Personnel Required

One mechanic
One assistant

Manual References

TM 9-2320-280-10
TM 9-2320-280-24P

Equipment Condition

Rear end of cargo shell door raised
(TM 9-2320-280-10).

General Safety Instructions

- Do not attempt to remove gas cylinders from spring rods.
- One assistant will be required to hold the cargo door open when either one or both gas springs are being removed or installed.

a. Rotating

NOTE

- Prior to starting any maintenance, ensure forward end of cargo shell door is locked.
- A 2 x 4 x 79.25 inch long board can be used to support cargo door in the open position.

1. Remove cargo shell door strap (para. 11-22).
2. Remove cargo shell door retention cable (para. 11-20).
3. Secure rear cargo door (1) in full open position.

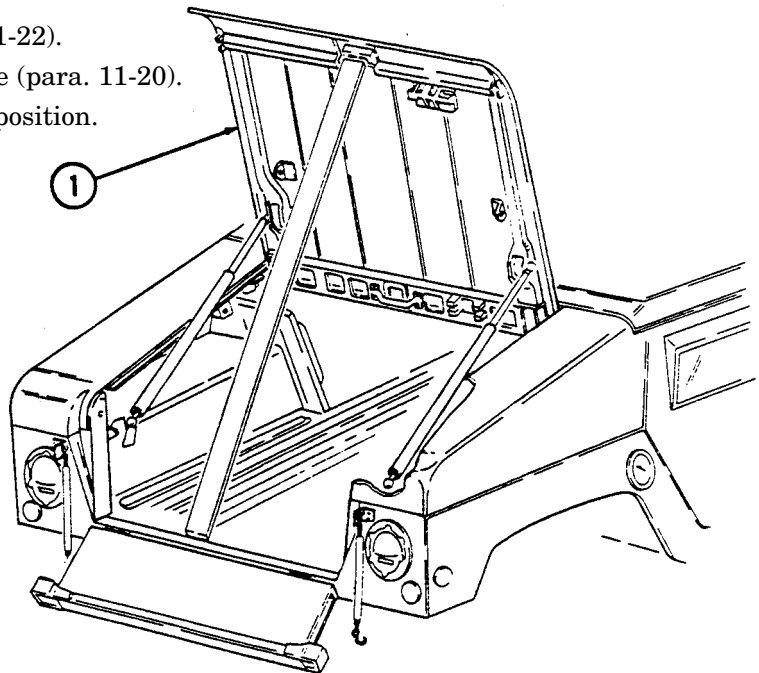

11-21. CARGO SHELL DOOR GAS SPRING MAINTENANCE (Cont'd)

4. Remove four retaining rings (1) from rod sockets (2) on two gas spring assemblies (5).

WARNING

Do not attempt to remove gas spring assemblies from ball studs until cargo door is supported in full open position. Failure to do so may result in injury to personnel or damage to equipment.

5. Remove left and right gas spring assemblies (5) from ball studs (3) on cargo door (4) and body bracket (6).
6. Invert left gas spring assembly (5) 180 degrees and position to right side of vehicle.
7. Invert right gas spring assembly (5) 180 degrees and position to left side of vehicle.
8. Install left and right gas spring assemblies (5) over ball studs (3) on cargo door (4) and body brackets (6).
9. Install four retaining rings (1) in rod sockets (2) on two gas springs (5).
10. Remove cargo door support.
11. Install cargo shell retention cable (para. 11-20).
12. Install cargo shell door strap (pars.. 11-22).
13. Check operation of cargo shell door (TM 9-2320-280-10).

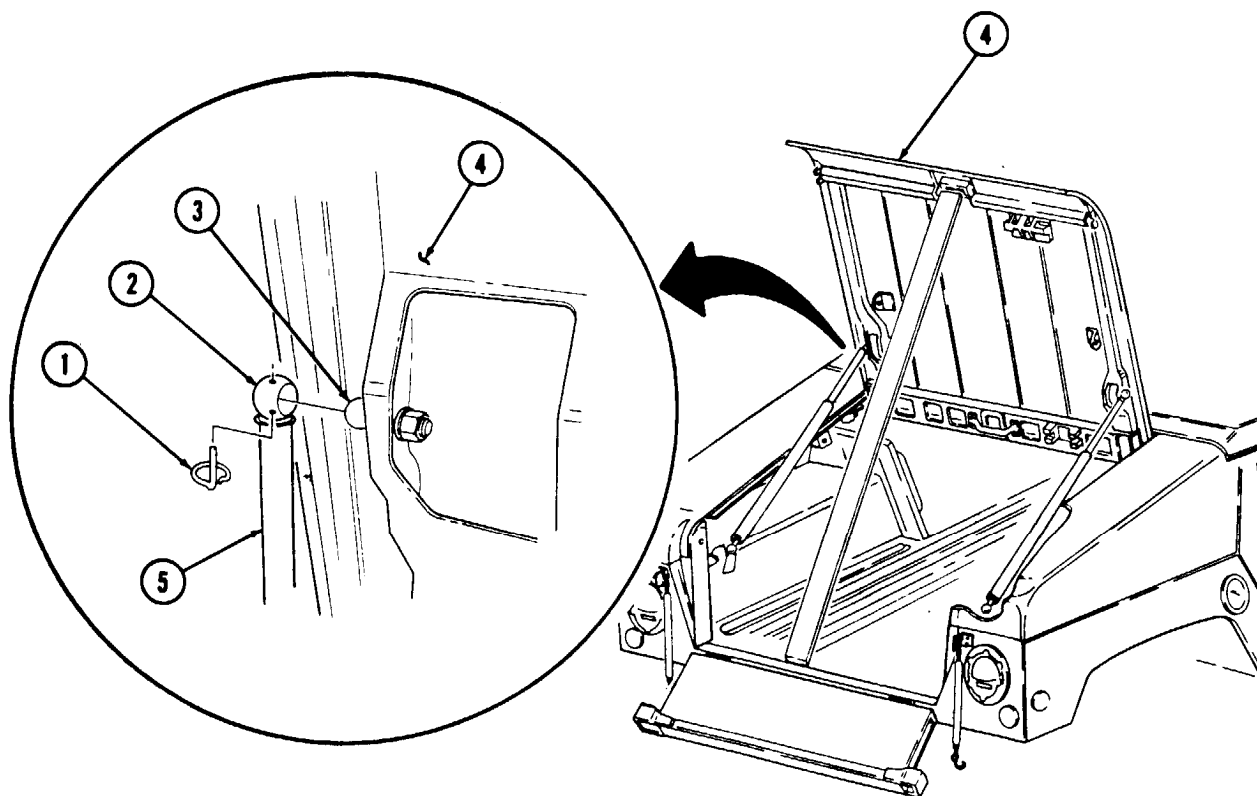

11-21. CARGO SHELL DOOR GAS SPRING MAINTENANCE (Cont'd)

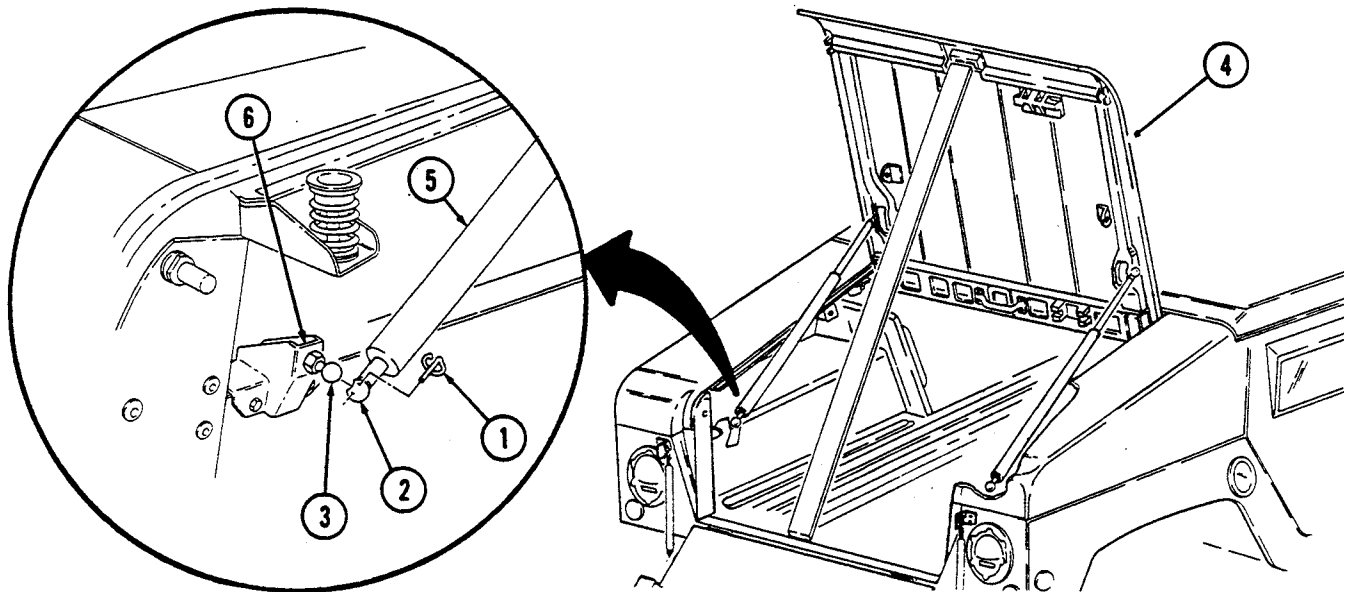

WARNING

One assistant will be required to hold the cargo door open when either one or both gas springs are being removed or installed. Failure to do so may result in injury to personnel or damage to equipment.

b. Removal

1. Remove two locknuts (1), washers (2), shoulder bolts (4), and retention cables (5) from cargo door (3). Discard locknuts (1).
2. Remove two assembled washer screws (6), footman loop (7), and cargo door strap (8) from cargo door (3). Discard assembled washer screws (6).

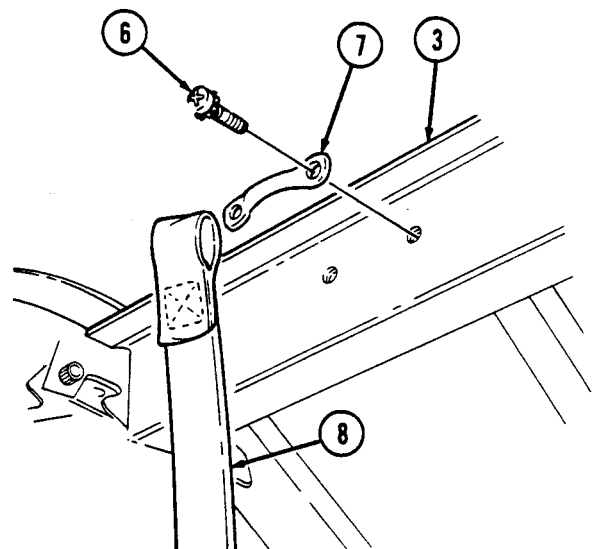
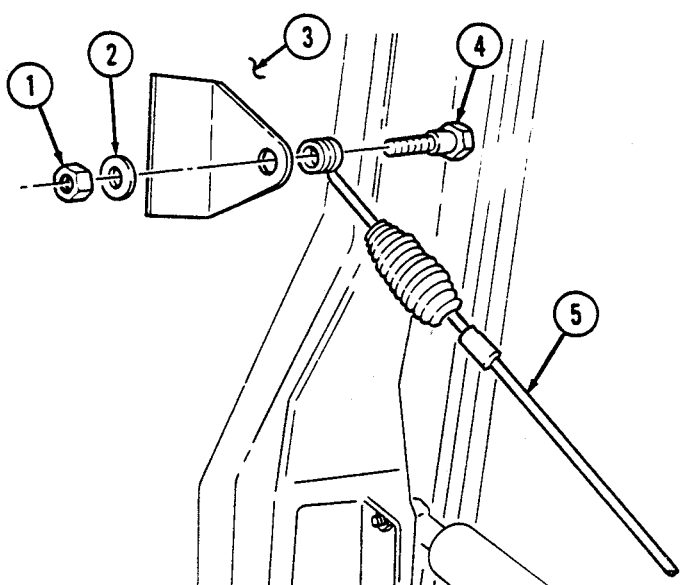

11-21. CARGO SHELL DOOR GAS SPRING MAINTENANCE (Cont'd)

3. Remove two locknuts (1), washers (2), and gas spring assembly (4) from cargo door (3) and body bracket (5). Discard locknuts (1).

c. Disassembly

1. Remove inner spring tube (6) from outer spring tube (13).
2. Remove two retaining rings (8) from ball studs (11) and rod sockets (12). Remove two ball studs (11) from rod sockets (12). Discard retaining rings (8).
3. Remove two clamps (10) from bushings (9) and spring rods (7) and (14). Pull spring rods (7) and (14) out of tubes (6) and (13) 1-inch (2.54 cm), and remove two bushings (9).

WARNING

Do not attempt to remove gas cylinders from inner spring rod or outer spring rod. High internal pressure will cause cylinder to explode, resulting in injury to personnel.

4. Pull inner spring rod (7) from inner tube (6) and outer spring rod (14) from outer tube (13).

d. Assembly

1. Install longer outer spring rod (14) on outer tube (13), leaving about 1-inch (2.54 cm) of the small diameter portion of the rod (14) exposed to install bushing (9).
2. Install bushing (9) on outer spring rod (14). Ensure bushing (9) is fully seated on outer tube (13) and rod socket (12) end is fully seated on bushing (9). Install and tighten clamp (10).
3. Place grease in rod end socket (12), and install ball stud (11) on socket (12) with retaining ring (8).
4. Repeat steps 1-3 for inner tube (6) and inner spring rod (7).
5. Install inner tube (6) into outer tube (13).

e. Installation

1. Install gas spring (4) on body bracket (5) and cargo door (3) with two washers (2) and locknuts (1). Tighten locknuts (1) to 15-20 lb-ft (20-27 N•m).
2. Install footman loop (16) and cargo door strap (17) on cargo door (3) with two assembled washer screws (15).
3. Install two retention cables (21) on cargo door (3) with two shoulder bolts (20), washers (19), and locknuts (18). Tighten locknuts (18) to 85-110 lb-in. (10-12 N•m).

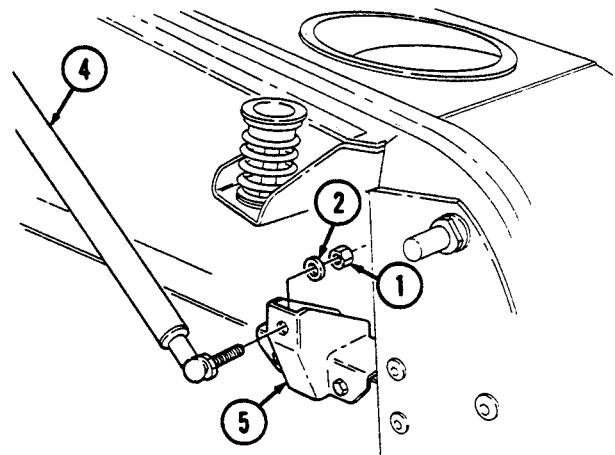
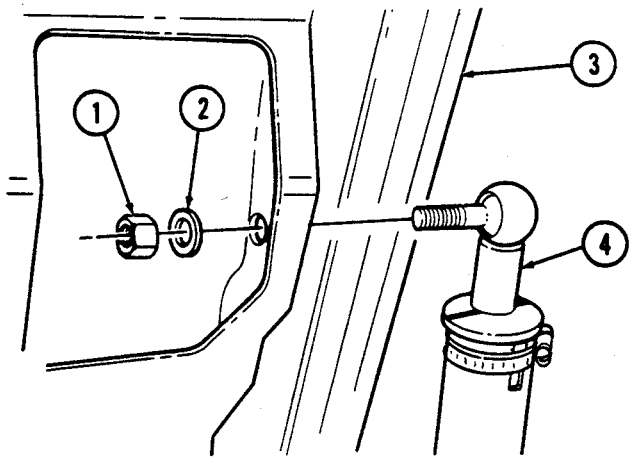

11-21. CARGO SHELL DOOR GAS SPRING MAINTENANCE (Cont'd)

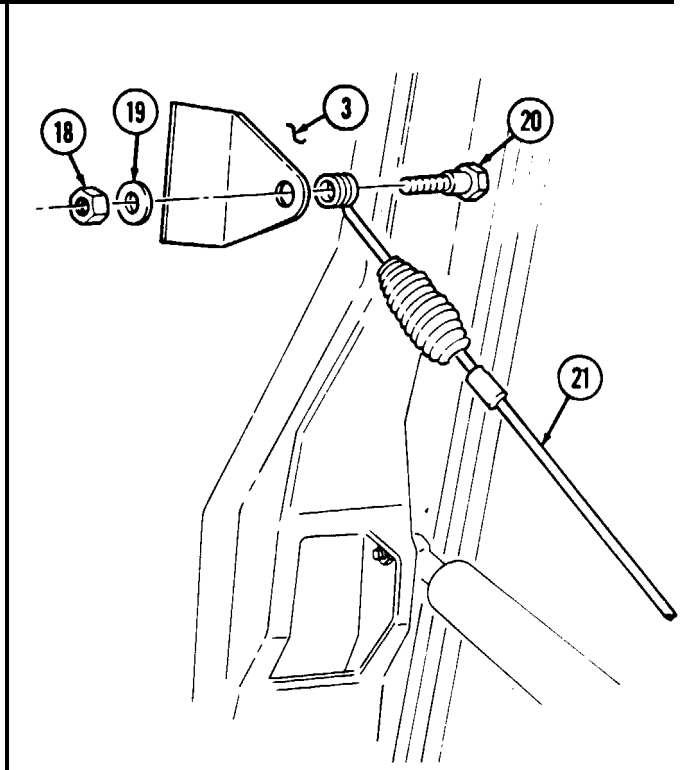
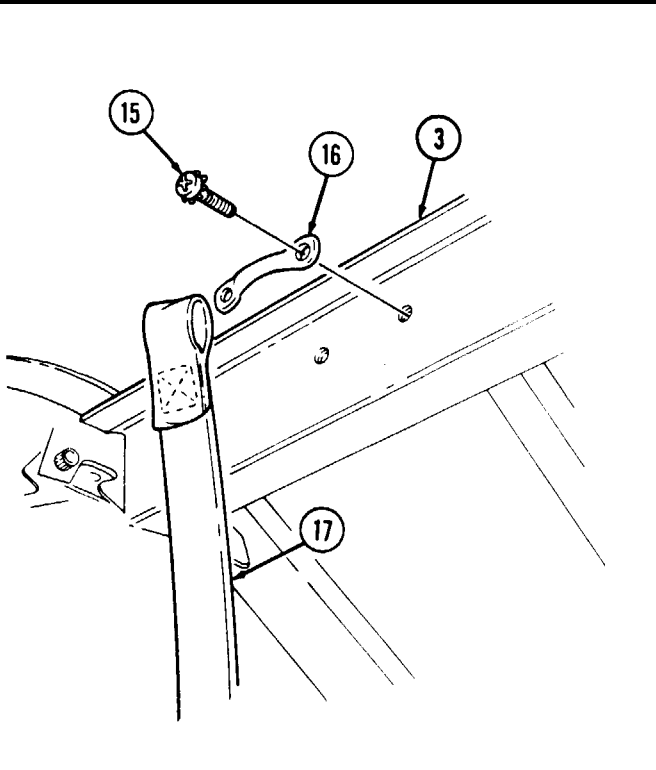
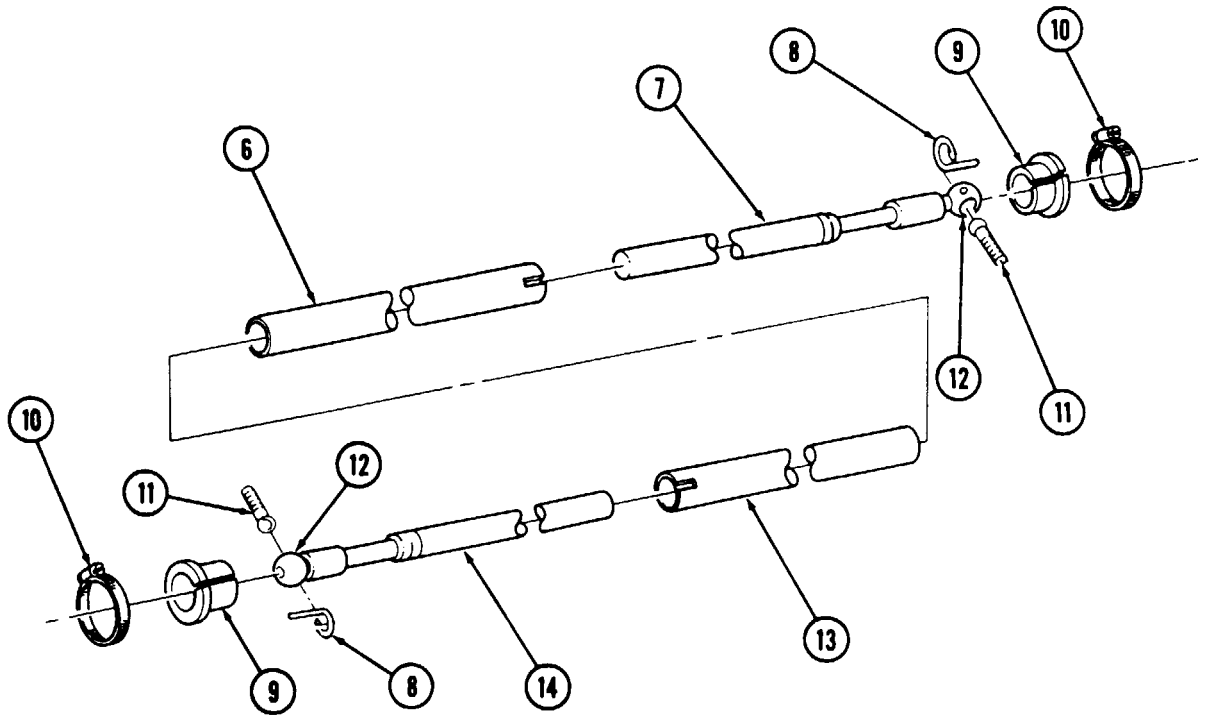

FOLLOW-ON TASK: Check cargo shell door for proper operation (TM 9-2320-280-10).

11-22. CARGO SHELL DOOR STRAP REPLACEMENT

This task covers:

a. Removal

b. Installation

INITIAL SETUP:

Applicable Models

All models except M996, M996A1, M997, M997A1, M997A2, M998, M998A1, M1035, M1035A1, M1035A2, M1037, M1038, M1038A1, M1042, M1097, M1097A1, M1097A2

Tools

General mechanic's tool kit:
automotive (Appendix B, Item 1)

Materials/Parts

Locknut (Appendix G, Item 128)
Two assembled washer screws
(Appendix G, Item 279)

Manual References

TM 9-2320-280-10
TM 9-2320-280-24P

Equipment Condition

Rear end of cargo shell door raised
(TM 9-2320-280-10).

a. Removal

1. Remove two assembled washer screws (3), footman loop (2), and strap (1) from cargo door (4). Discard assembled washer screws (3).
2. Remove locknut (5), washer (6), capscrew (7), and strap (1) from left striker mounting plate (8). Discard locknut (5).

b. Installation

NOTE

To assist closing cargo shell door, a grab loop may be added. Refer to appendix D, figure D-83.

1. Install strap (1) on left striker mounting plate (8) with capscrew (7), washer (6), and locknut (5). Tighten locknut (5) to 25-30 lb-ft (34-41 N•m).
2. Install strap (1) and footman loop (2) on cargo door (4) with two assembled washer screws (3).

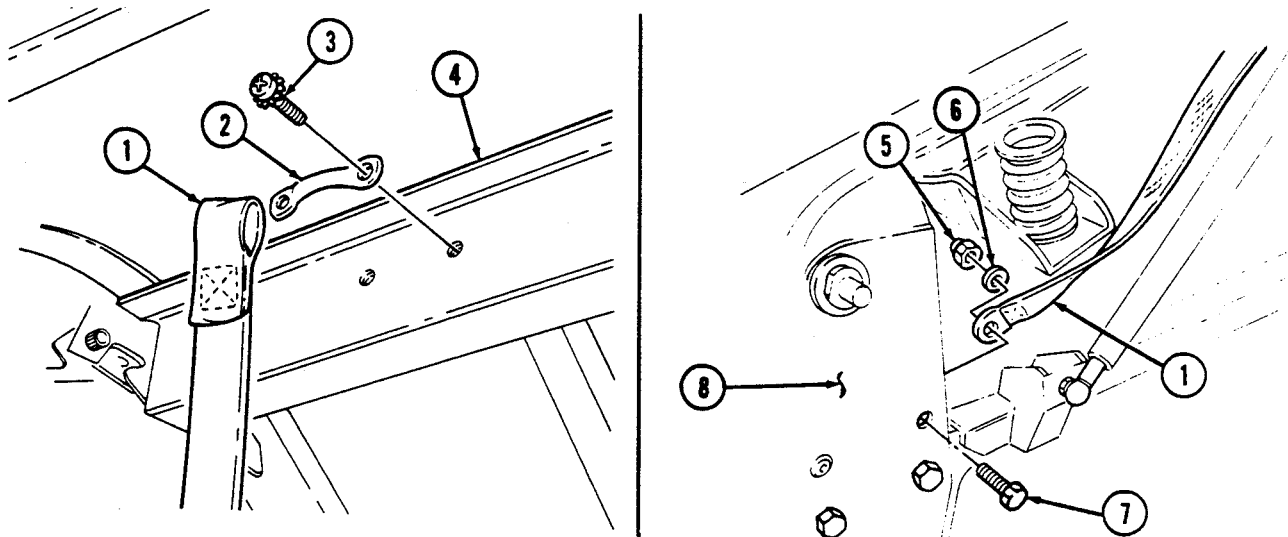

FOLLOW-ON TASK: Close cargo shell door (TM 9-2320-280-10).

11-23. CARGO SHELL DOOR SEAL PROTECTOR REPLACEMENT

This task covers:

a. Removal

b. Installation

INITIAL SETUP:

Applicable Models

All models except M996, M996A1, M997, M997A1, M997A2, M998, M998A1, M1035, M1035A1, M1035A2, M1037, M1038, M1038A1, M1042, M1097, M1097A1, M1097A2

Tools

General mechanic's tool kit:
automotive (Appendix B, Item 1)

Materials/Parts

Thirteen locknuts (Appendix G, Item 70)

Manual References

TM 9-2320-280-10
TM 9-2320-280-24P

Equipment Condition

Rear end of cargo shell door raised
(TM 9-2320-280-10).

a. Removal

Remove thirteen locknuts (4), washers (5), capscrews (2), washers (5), and seal protector (1) from cargo door (3). Discard locknuts (4).

b. Installation

Install seal protector (1) on cargo door (3) with thirteen washers (5), capscrews (2), washers (5), and locknuts (4). Tighten locknuts (4) to 85-100 lb-in. (10-12 N·m).

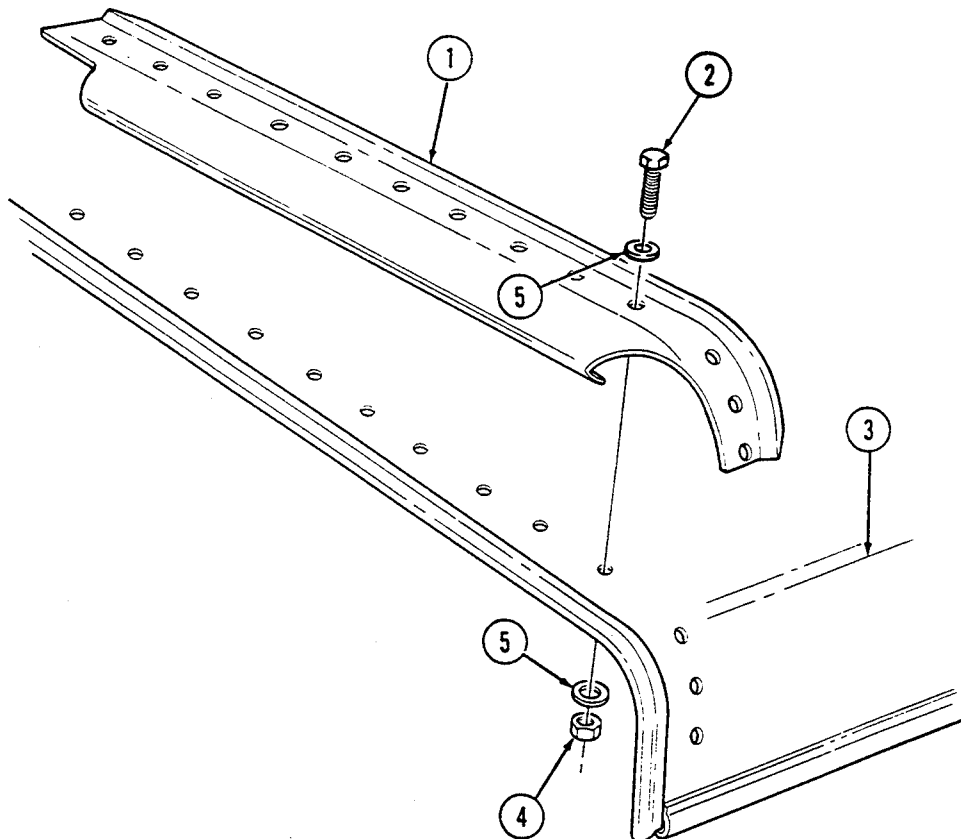

FOLLOW-ON TASK: Close cargo shell door (TM 9-2320-280-10).

11-24. CARGO SHELL DOOR SEAL REPLACEMENT

This task covers:

a. Removal

b. Installation

INITIAL SETUP:

Applicable Models

All models except M998, M998A1, M997, M997A1, M997A2, M998, M998A1, M1035, M1035A1, M1035A2, M1037, M1038, M1038A1, M1042, M1097, M1097A1, M1097A2

Tools

General mechanic's tool kit:
automotive (Appendix B, Item 1)

Materials/Parts

Sealing compound (Appendix C, Item 40)

Manual References

TM 9-2320-280-24P

Equipment Condition

Cargo shell door seal protector removed (para. 11-23).

a. Removal

Remove seal (1) from cargo door (2). Clean edge around cargo door (2) to remove dirt, corrosion, or *remaining* adhesive.

b. Installation

1. Install seal (1) on cargo door (2), making sure seal (1) is fully seated.
2. Detach seal (1) at rear edge of cargo door (2) only, and apply sealing compound in seal (1) channel the entire length of rear edge of cargo door (2).
3. Install seal (1) on rear edge of cargo door (2), making sure seal (1) is fully seated.

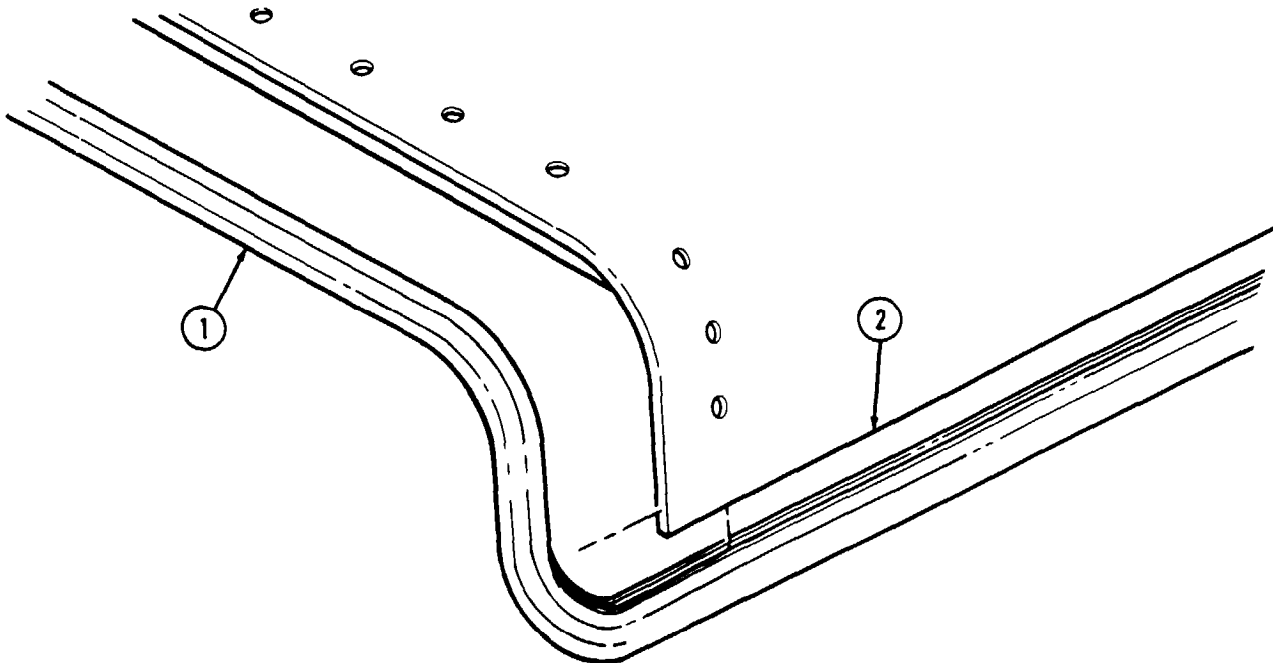

FOLLOW-ON TASK: Install cargo shell door seal protector (para. 11-23).

11-25. CARGO SHELL DOOR FRONT STRIKER REPLACEMENT

This task covers:

a. Removal

b. Installation

INITIAL SETUP:

Applicable Models

All models except M996, M996A1, M997, M997A1, M997A2, M998, M998A1, M1035, M1035A1, M1035A2, M1037, M1038, M1038A1, M1042, M1097, M1097A1, M1097A2

Tools

General mechanic's tool kit:
automotive (Appendix B, Item 1)

Materials/Parts

Locknut (Appendix G, Item 105)

Manual References

TM 9-2320-280-10
TM 9-2320-280-24P

Equipment Condition

Forward end of cargo shell door raised
(TM 9-2320-280-10).

a. Removal

Remove locknut (4), washer (2), front striker (3), and washer (2) from body bracket (1). Discard locknut (4).

b. Installation

Install washer (2) and front striker (3) on body bracket (1) with washer (2) and locknut (4). Tighten locknut (4) to 35-45 lb-ft (47-61 N•m).

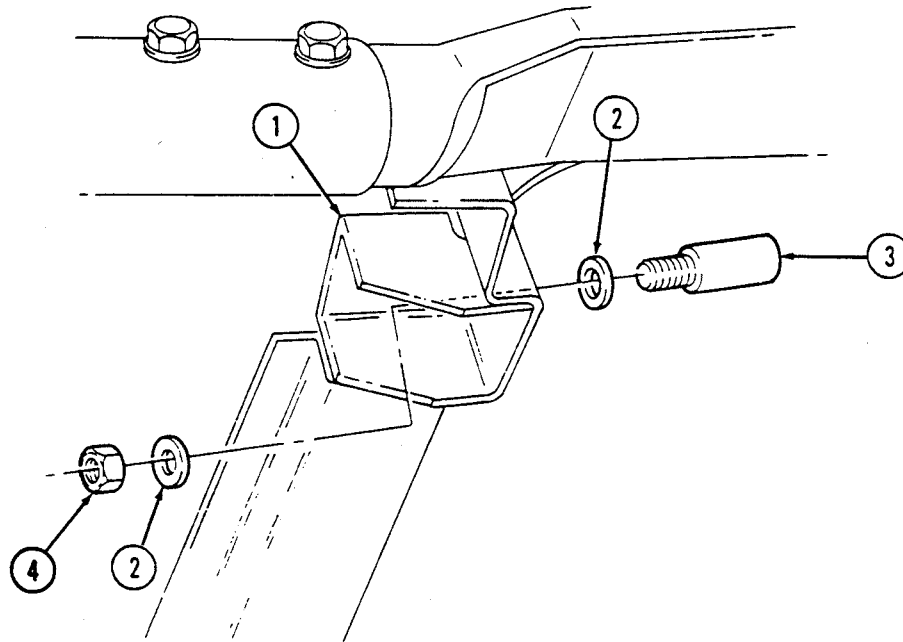

FOLLOW-ON TASK: Adjust cargo shell door (para. 11-13).

11-26. CARGO SHELL DOOR REAR STRIKER REPLACEMENT

This task covers:

a. Removal

b. Installation

INITIAL SETUP:

Applicable Models

All models except M996, M996A1, M997, M997A1, M997A2, M998, M998A1, M1035, M1035A1, M1035A2, M1037, M1038, M1038A1, M1042, M1097, M1097A1, M1097A2

Tools

General mechanic's tool kit:
automotive (Appendix B, Item 1)

Materials/Parts

Locknut (Appendix G, Item 105)

Personnel Required

One mechanic
One assistant

Manual References

TM 9-2320-280-10
TM 9-2320-280-24P

Equipment Condition

- Tailgate lowered (TM 9-2320-280-10).
- Rear end of cargo shell door raised (TM 9-2320-280-10).

a. Removal

Remove locknut (4), washer (3), striker (1), and spacer (2) from striker plate (6) and wheelhouse (5). Discard locknut (4).

b. Installation

Install spacer (2) and striker (1) on striker plate (6) and wheelhouse (5) with washer (3) and locknut (4). Tighten locknut (4) to 190-210 lb-ft (258-285 N·m).

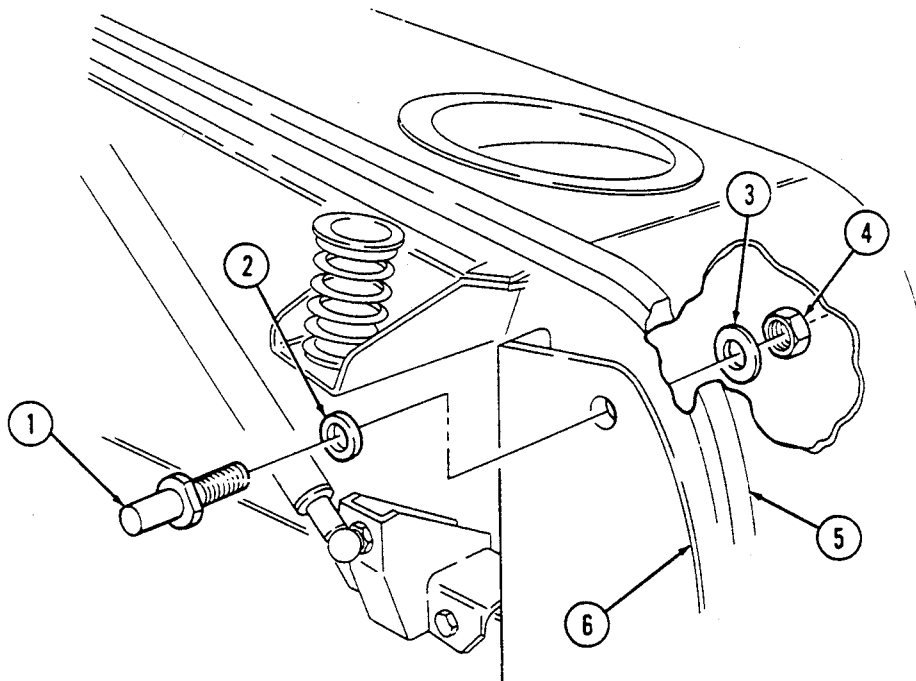

- FOLLOW-ON TASKS:**
- Raise and secure tailgate (TM 9-2320-280-10).
 - Close cargo shell door (TM 9-2320-280-10).

11-27. CARGO SHELL DOOR REAR STRIKER MOUNTING PLATE REPLACEMENT

This task covers:

a. Removal

b. Installation

INITIAL SETUP:

Applicable Models

All models except M996, M996A1, M997, M997A1, M997A2 M998, M998A1, M1035, M1035A1, M1035A2, M1037, M1038, M1038A1, M1042, M1097, M1097A1, M1097A2

Tools

General mechanic's tool kit:
automotive (Appendix B, Item 1)

Materials/Parts

Six locknuts (Appendix G, Item 128)

Personnel Required

One mechanic
One assistant

Manual References

TM 9-2320-280-10
TM 9-2320-280-24P

Equipment Condition

- Rear striker removed (para. 11-26).
- Cargo shell door strap removed (left side only) (para. 11-22).

a. Removal

1. Remove locknut (5), washer (4), and socket head screw (2) from striker mounting plate (3) and wheelhouse (8). Discard locknut (5).
2. Remove five locknuts (6), washers (7), capscrews (1), washers (9), and striker mounting plate (3) from wheelhouse (8). Discard locknuts (6).

b. Installation

1. Install striker mounting plate (3) on wheelhouse (8) with five washers (9), capscrews (1), washers (7), and locknuts (6).
2. Secure striker mounting plate (3) to wheelhouse (8) with socket head screw (2), washer (4), and locknut (5). Tighten locknuts (5) and (6) to 25-30 lb-ft (34-41 N•m).

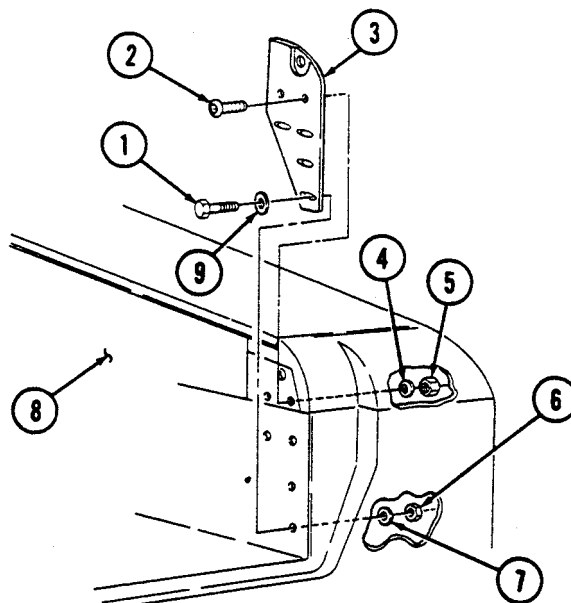

- FOLLOW-ON TASKS:
- Install cargo shell door strap (left side only) (para. 11-22).
 - Install rear striker (para. 11-26).

11-28. CARGO SHELL DOOR DOVETAIL SPRING REPLACEMENT

This task covers:

a. Removal

b. Installation

INITIAL SETUP:

Applicable Models

All models except M996, M996A1, M997, M997A1, M997A2, M998, M998A1, M1035, M1035A1, M1035A2, M1037, M1038, M1038A1, M1042, M1097, M1097A1, M1097A2

Tools

General mechanic's tool kit:
automotive (Appendix B, Item 1)

Materials/Parts

Two locknuts (Appendix G, Item 101)
Lockwasher (Appendix G, Item 178)

Manual References

TM 9-2320-280-10
TM 9-2320-280-24P

Equipment Condition

- Rear end of cargo shell door raised (TM 9-2320-280-10).
- Tailgate lowered (TM 9-2320-280-10).

a. Removal

Remove locknut (8), lockwasher (7), washer (6), cup (9), spring (3), locknut (2), retainer (10), and head bolt (1) from cargo shell dovetail (5). Discard locknuts (2) and (8) and lockwasher (7).

b. Installation

1. Install retainer (10) and locknut (2) on head bolt (1) and position locknut (2) to end of threads on head bolt (1).
2. Install cup (9) and head bolt (1) on dovetail (5).
3. Lower cargo door.
4. Hold locknut (2) and adjust head bolt (1) up until head bolt (1) touches bottom of cargo door (4).
5. Raise cargo door.
6. Remove head bolt (1) from dovetail (5).
7. Install spring (3), cup (9), and head bolt (1) on dovetail (5) with washer (6), lockwasher (7), and locknut (8). Tighten locknut (8) to 55 lb-ft (75 N•m).

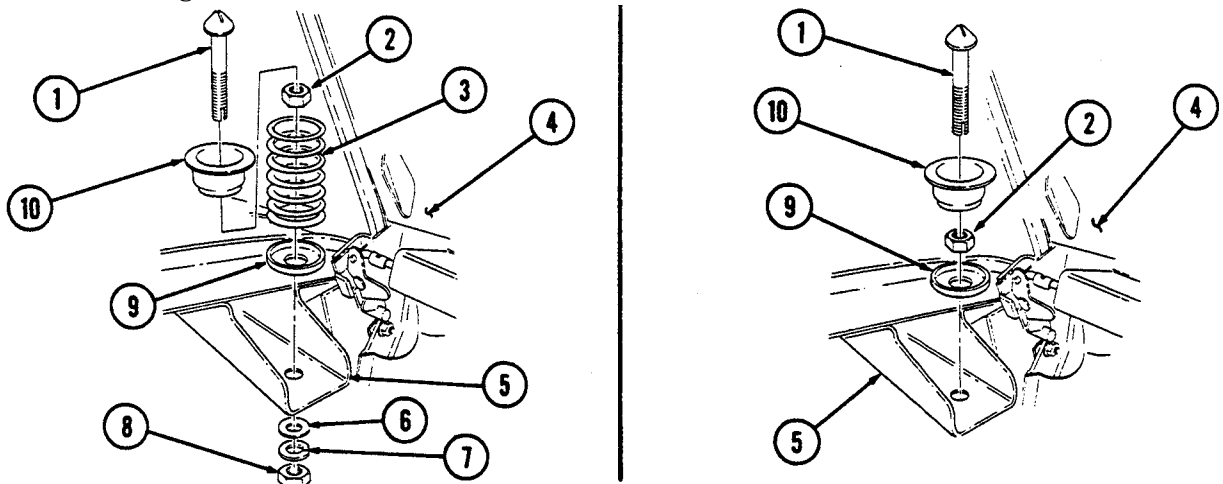

- FOLLOW-ON TASKS:
- Close cargo shell door (TM 9-2320-280-10).
 - Raise and secure tailgate (TM 9-2320-280-10).

11-29. CARGO SHELL DOOR GAS SPRING MOUNTING BRACKET REPLACEMENT

This task covers:

a. Removal

b. Installation

INITIAL SETUP:

Applicable Models

All models except M996, M996A1, M997, M997A1, M997A2, M998, M998A1, M1035, M1035A1, M1035A2, M1037, M1038, M1038A1, M1042, M1097, M1097A1, M1097A2

Tools

General mechanic's tool kit:
automotive (Appendix B, Item 1)

Materials/Parts

Tape (Appendix C, Item 50)
Four locknuts (Appendix G, Item 70)

Personnel Required

One mechanic
One assistant

Manual References

TM 9-2320-280-10
TM 9-2320-280-24P

Equipment Condition

- Tailgate lowered (TM 9-2320-280-10).
- Gas spring removed (para. 11-21).

a. Removal

1. Remove two locknuts (9), washers (1), capscrews (2), and washers (1) from bracket (3) and wheelhouse (6). Discard locknuts (9).
2. Remove two locknuts (8), washers (4), backing plate (7), capscrews (5), washers (4), and bracket (3) from wheelhouse (6). Discard locknuts (8). Remove tape from bracket (3) and discard tape.

b. Installation

1. Apply tape to bracket (3) mounting surfaces. Install bracket (3) on wheelhouse (6) with two washers (4), capscrews (5), backing plate (7), washers (4), and locknuts (8). Tighten locknuts (8) to 8 lb-ft (11 N•m).
2. Secure bracket (3) to wheelhouse (6) with two washers (1), capscrews (2), washers (1), and locknuts (9). Tighten locknuts (9) to 8 lb-ft (11 N•m).

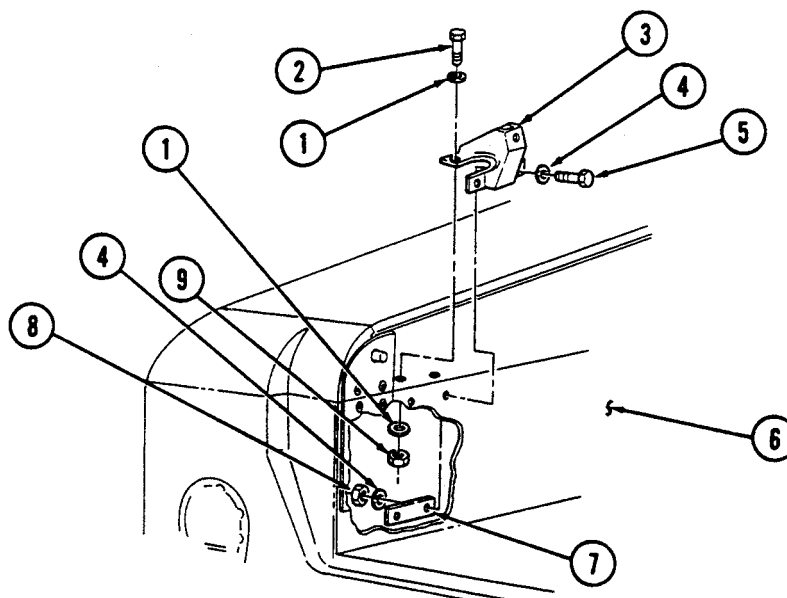

- FOLLOW-ON TASKS:
- Install gas spring (para. 11-21).
 - Raise and secure tailgate (TM 9-2320-280-10).

11-30. CARGO SHELL DOOR LINER REPLACEMENT

This task covers:

a. Removal

b. Installation

INITIAL SETUP:

Applicable Models

M966, M966A1, M1025, M1025A1, M1025A2, M1026, M1026A1, M1036

Personnel Required

One mechanic
One assistant

Tools

General mechanic's tool kit:
automotive (Appendix B, Item 1)

Manual References

TM 9-2320-280-10
TM 9-2320-280-24P

Materials/Parts

Twelve spring tension fasteners
(Appendix G, Item 30)

Equipment Condition

Rear end of cargo shell door raised
(TM 9-2320-280-10).

a. Removal

1. Remove ten screws (6), washers (5), clips (4), and two retainers (7) from cargo shell door (1).
2. Remove twelve spring tension fasteners (8) from liner (3) and door (1). Discard spring tension fasteners (8).
3. Remove liner (3) and three sound dampeners (2) from door (1).
4. Clean cargo door (1) to remove adhesive.

b. Installation

NOTE

Ensure surface is free of dirt and oil before applying adhesive backing.

1. Apply three sound dampeners (2) to door (1).
2. Place four spring tension fasteners (8) in two top and two bottom holes of liner (3). Ensure heads of spring tension fasteners (8) are on side of liner (3) without adhesive.
3. Peel paper backing (9) from liner (3).
4. Align liner (3) with door (1), ensuring top and bottom spring tension fasteners (8) in liner (3) align with top and bottom holes in door (1), and install liner (3) on door (1) with top and bottom spring tension fasteners (8). Press entire surface of liner (3) to ensure adhesion.
5. Install eight remaining spring tension fasteners (8) through liner (3) into door (1).
6. Install two retainers (7) on door (1) with ten clips (4), washers (5), and screws (6).

11-30. CARGO SHELL DOOR LINER REPLACEMENT(Cont'd)

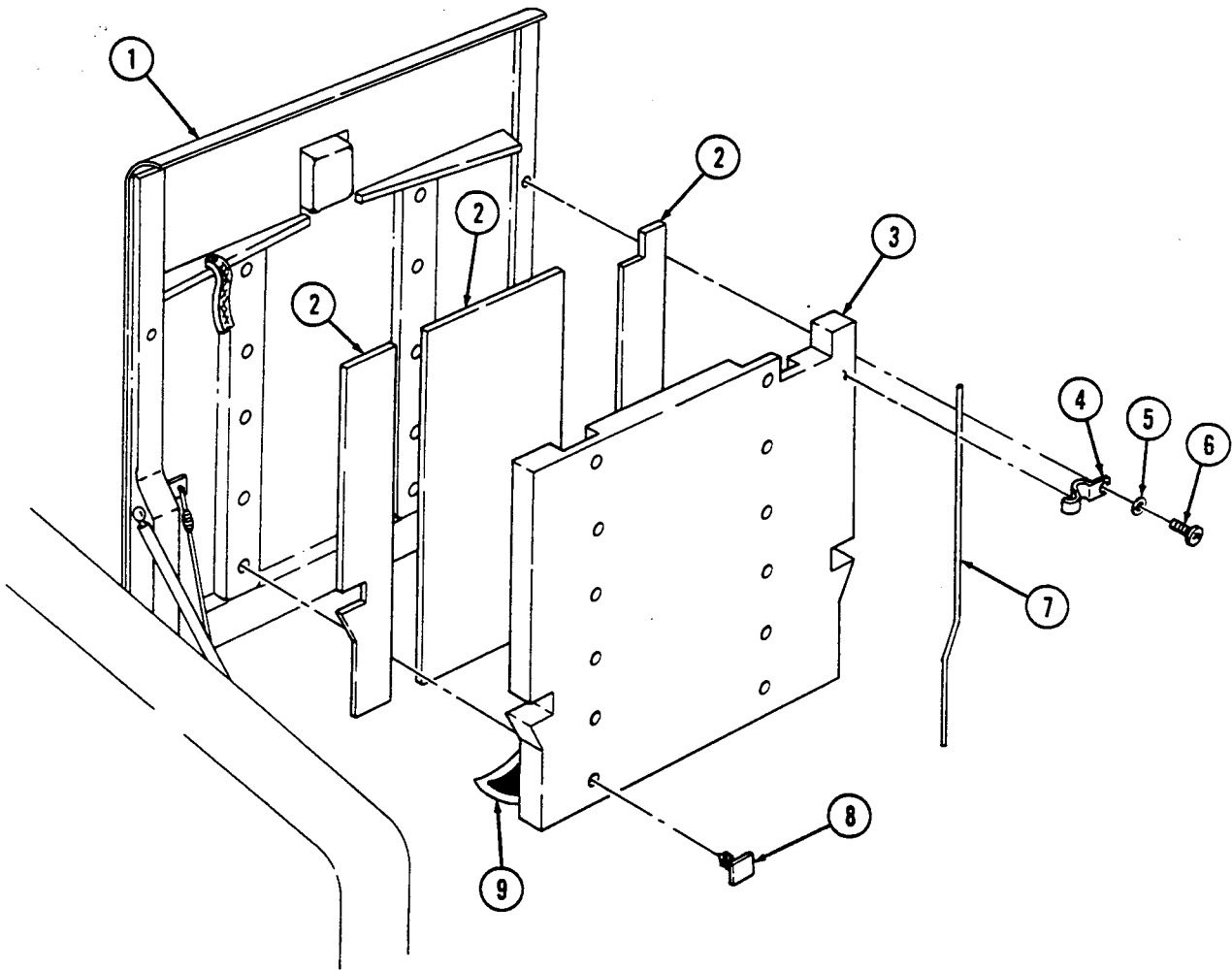

FOLLOW-ON TASK: Close cargo shell door (TM 9-2320-280-10).

11-30.1. "B" PILLAR PADDING REPLACEMENT

This task covers:

a. Removal

b. Installation

INITIAL SETUP:

Applicable Models

M966, M1025, M1026, M1036, M1043,
M1044, M1045, M1046, M1121

Manual References

TM 9-2320-280-24P

Materials/Parts

Two locknuts (Appendix G, Item 122)

Equipment Condition

Remove rifle mounting clamp bracket (if equipped)
(para. 11-92).

a. Removal

1. Remove locknut (8), washer (7), capscrew (6), and washer (7) from padding (3) and "B" pillar (11). Discard locknut (8).
2. Remove locknut (10), washer (4), capscrew (5), and washer (4) from padding (3) and "B" pillar (11). Discard locknut (10).
3. Remove screw (1), washer (2), and padding (3) from "B" pillar (11).
4. Remove edge trim (9) from "B" pillar (11).

b. Installation

1. Install edge trim (9) on "B" pillar (11).
2. Install padding (3) on "B" pillar (11) with washer (2) and screw (1).
3. Secure padding (3) to "B" pillar (11) with washer (4), capscrew (5), washer (4), and locknut (10).
4. Secure padding (3) to "B" pillar (11) with washer (7), capscrew (6), washer (7), and locknut (8).

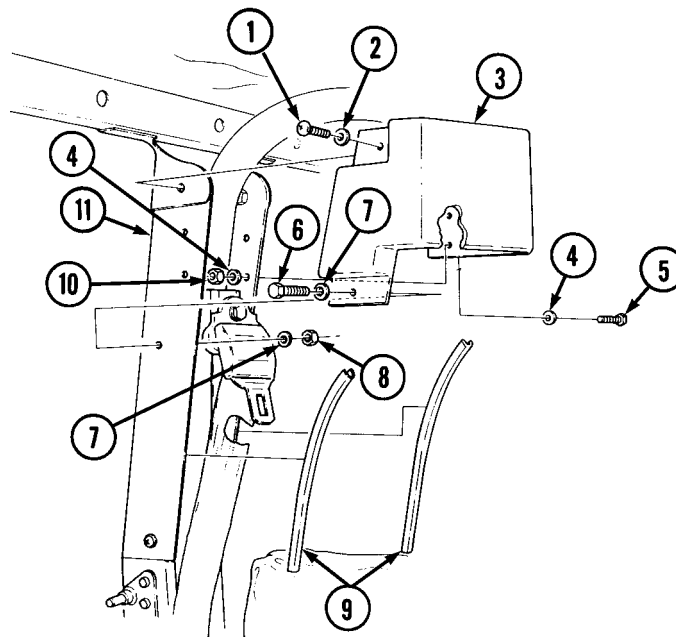

FOLLOW-ON TASK: Install rifle mounting clamp bracket (if removed) (para. 11-92).

11-31. CARGO SHELL ROOF INSULATION PANEL REPLACEMENT

This task covers:

a. Removal

b. Installation

INITIAL SETUP:

Applicable Models

M966, M966A1, M1025, M1025A1,
M1025A2, M1026, M1026A1, M1036,
M1121

Tools

General mechanic's tool kit:
automotive (Appendix B, Item 1)

Materials/Parts

Primer adhesive (Appendix C, Item 35)

Manual References

TM 9-2320-280-24P

a. Removal

1. Remove insulation panel (2) from roof (1).
2. Clean roof (1) surface to remove adhesive.

b. Installation

1. Spray primer adhesive on roof (1), peel paper backing (3) from panel (2), and install panel (2) on roof (1).
2. Press panel (2) surface to ensure adhesion.

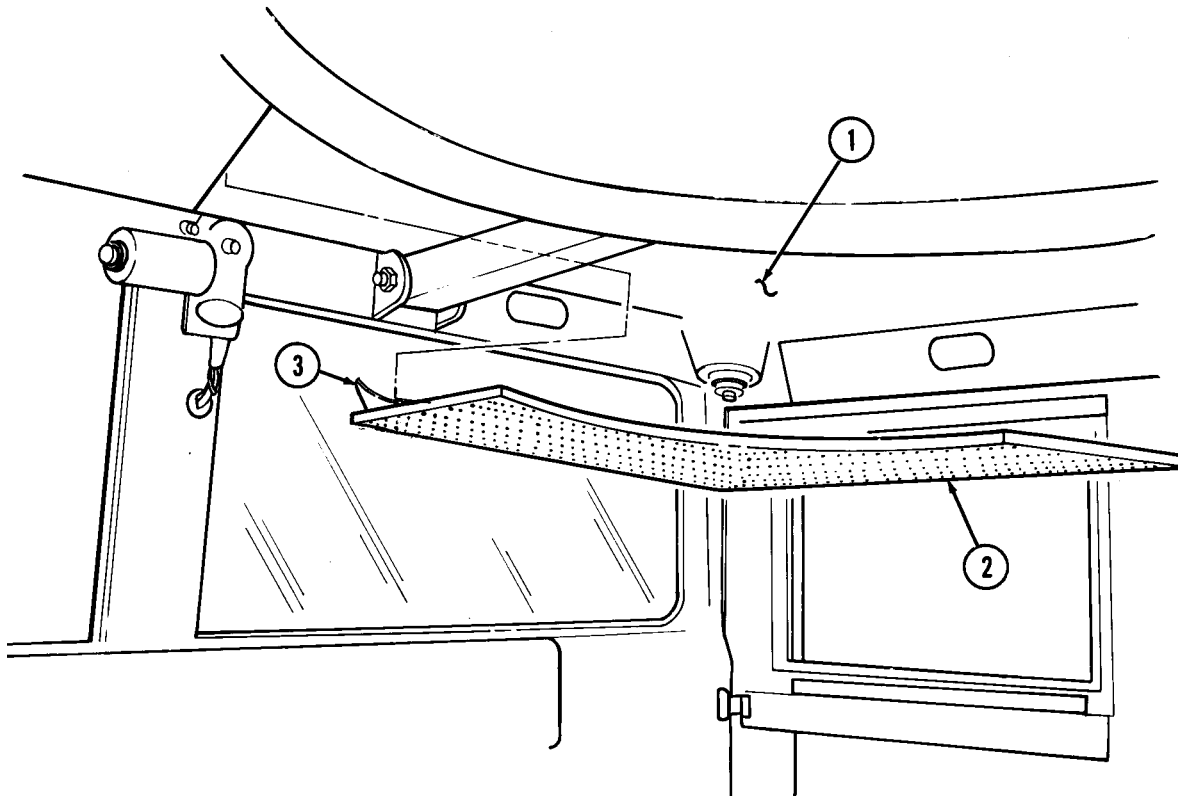

11-32. HOOD SIDE ARMOR PLATE REPLACEMENT

This task covers:

a. Removal

b. Installation

INITIAL SETUP:

Applicable Models

All models except M998, M998A1, M1035, M1035A1, M1035A2, M1037, M1038, M1038A1, M1042, M1097, M1097A1, M1097A2

Manual References

TM 9-2320-280-10
TM 9-2320-280-24P

Tools

General mechanic's tool kit:
automotive (Appendix B, Item 1)

Equipment Condition

Hood raised and secured (TM 9-2320-280-10).

a. Removal

Remove four capscrews (4), washers (5), and armor plate (1) from hood (2).

b. Installation

Slide narrow end of armor plate (1) between radiator-to-hood seal (3) and hood (2) until holes align, and install on hood (2) with four washers (5) and capscrews (4). Tighten capscrews (4) to 15-20 lb-in. (2 N·m).

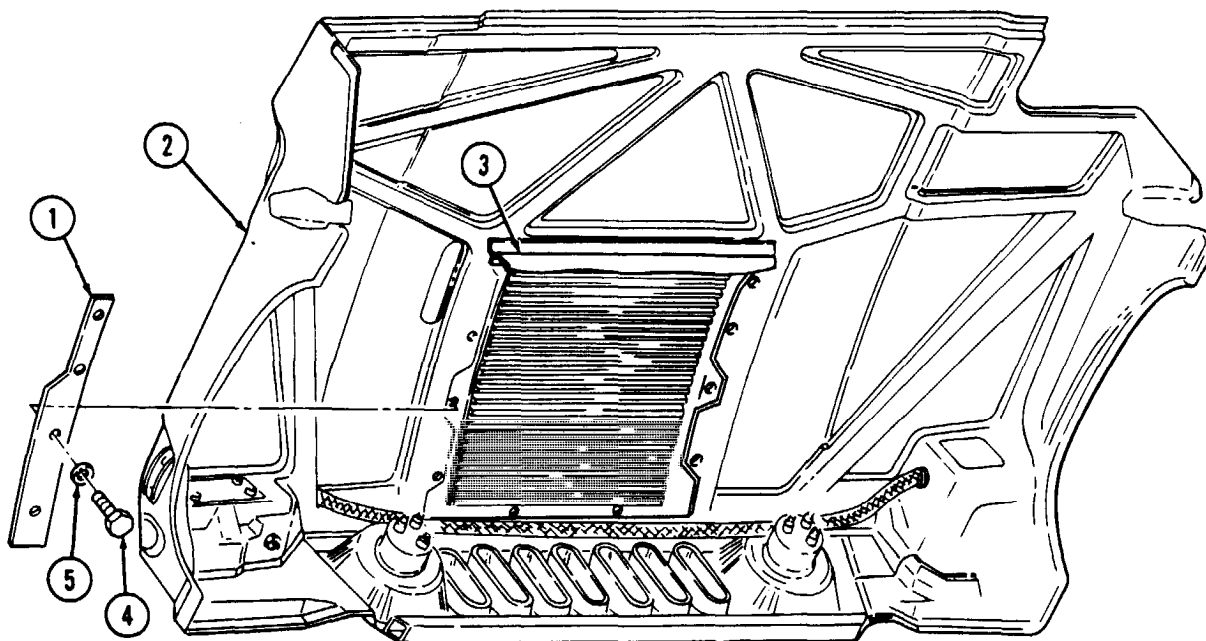

FOLLOW-ON TASK: Lower and secure hood (TM 9-2320-280-10).

11-33. HOOD CENTER ARMOR PLATE REPLACEMENT

This task covers:

- a. Removal
- b. Installation

INITIAL SETUP:

Applicable Models

All models except M998, M998A1, M1035, M1035A1, M1035A2, M1037, M1038, M1038A1, M1042, M1097, M1097A1, M1097A2

Manual References

TM 9-2320-280-10
TM 9-2320-280-24P

Tools

General mechanic's tool kit:
automotive (Appendix B, Item 1)

Equipment Condition

Hood raised and secured (TM 9-2320-280-10).

a. Removal

Remove nine capscrews (5), washers (6), hood seal retainer (4), hood-to-radiator seal (3), and armor plate (2) from hood (1).

b. Installation

Install armor plate (2), hood-to-radiator seal (3), and hood seal retainer (4) on hood (1) with nine washers (6) and capscrews (5). Tighten capscrews (5) to 15-20 lb-in. (2 N•m).

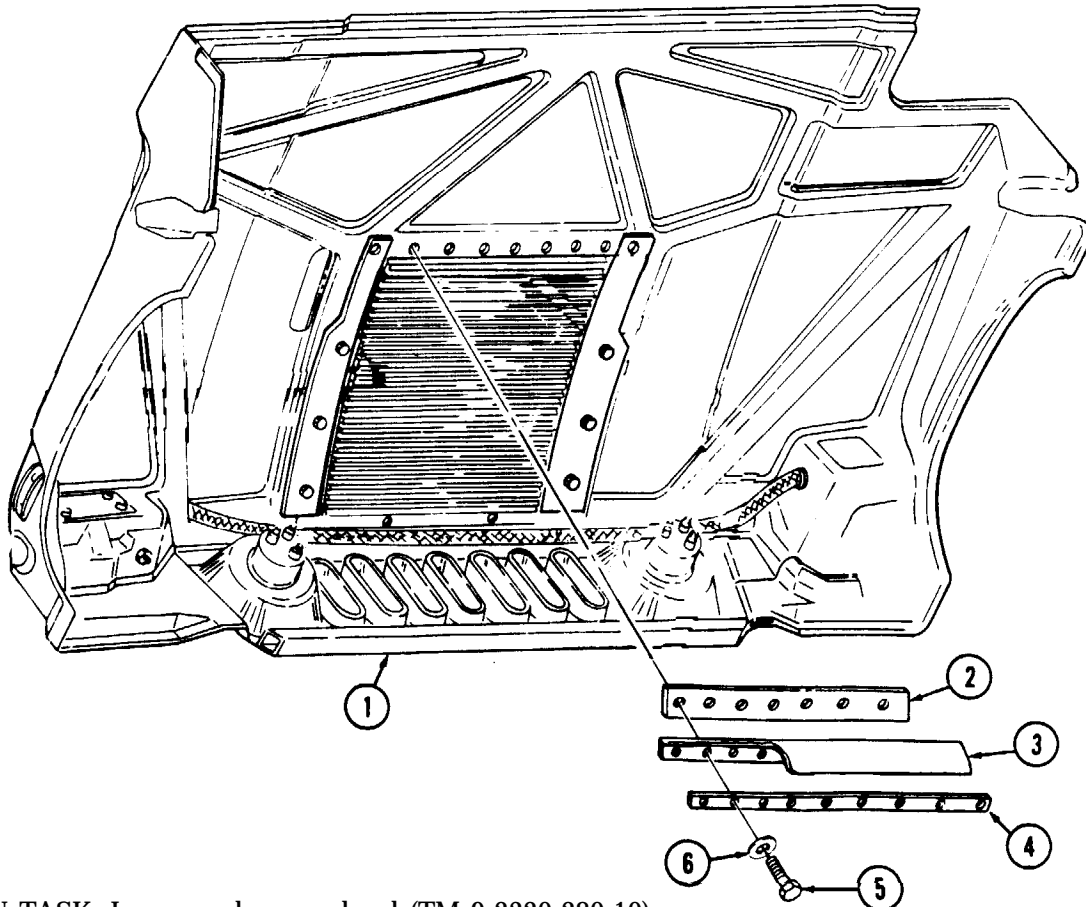

FOLLOW-ON TASK: Lower and secure hood (TM 9-2320-280-10).

11-34. HOOD TOP ARMORED GRILLE REPLACEMENT

This task covers:

a. Removal

b. Installation

INITIAL SETUP:

Applicable Models

All models except M998, M998A1, M1035, M1035A1, M1035A2, M1037, M1038, M1038A1, M1042, M1097, M1097A1, M1097A2

Tools

General mechanic's tool kit:
automotive (Appendix B, Item 1)

Materials/Parts

Four locknuts (Appendix G, Item 70)

Personnel Required

One mechanic
One assistant

Manual References

TM 9-2320-280-10
TM 9-2320-280-24P

Equipment Condition

Hood raised and secured (TM 9-2320-280-10).

a. Removal

Remove four locknuts (5), washers (2), capscrews (3), washers (2), and top grille (1) from hood (4). Discard locknuts (5).

b. Installation

Install grille (1) on hood (4) with four washers (2), capscrews (3), washers (2), and locknuts (5). Tighten locknuts (5) to 6 lb-ft (8 N·m).

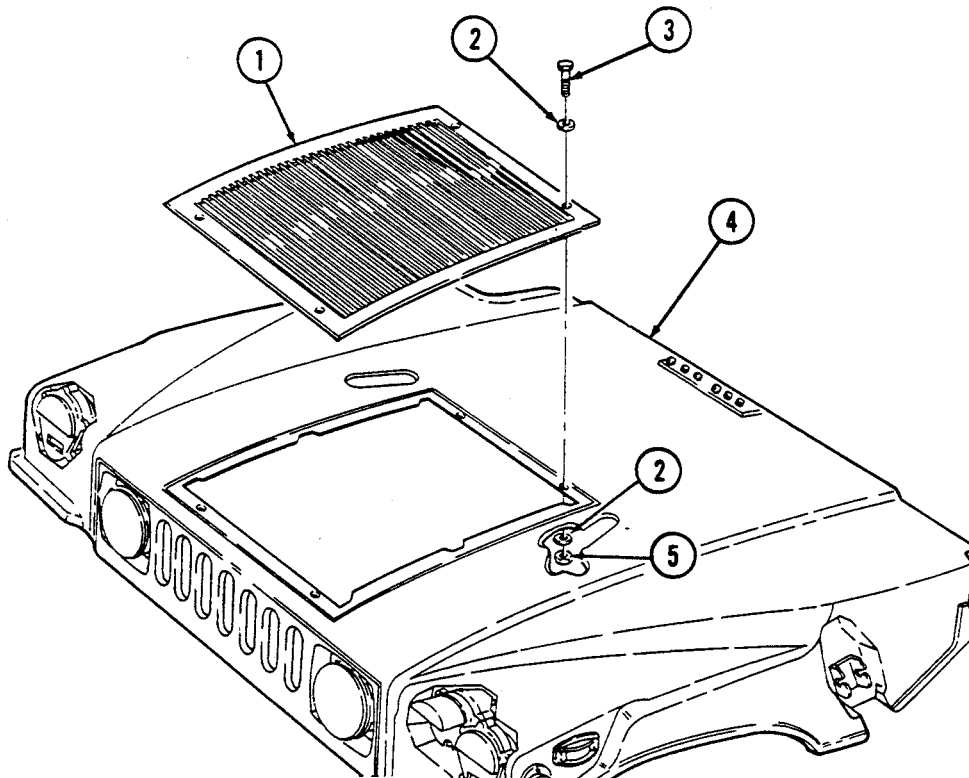

FOLLOW-ON TASK: Lower and secure hood (TM 9-2320-280-10).

11-35. HOOD FRONT ARMORED GRILLE REPLACEMENT

This task covers:

a. Removal

b. Installation

INITIAL SETUP:

Applicable Models

All models except M998, M998A1, M1035, M1035A1, M1035A2, M1037, M1038, M1038A1, M1042, M1097, M1097A1, M1097A2

Tools

General mechanic's tool kit:
automotive (Appendix B, Item 1)

Materials/Parts

Three locknuts (Appendix G, Item 83)
Three lockwashers (Appendix G, Item 157)

Manual References

TM 9-2320-280-10
TM 9-2320-280-24P

Equipment Condition

Hood raised and secured (TM 9-2320-280-10).

a. Removal

1. Remove three locknuts (5), washers (4), and carriage bolts (2) from front grille (3) and hood (1). Discard locknuts (5).
2. Remove three capscrews (6), harness clamps (7), lockwashers (8), washers (9), and grille (3) from hood (1). Discard lockwashers (8).

b. Installation

1. Install front grille (3) on hood (1) with three washers (9), lockwashers (8), harness clamps (7), and capscrews (6).
2. Secure grille (3) to hood (1) with three carriage bolts (2), washers (4), and locknuts (5).
3. Tighten locknuts (5) to 21 lb-ft (29 N·m). Tighten capscrews (6) to 20-30 lb-in. (2-3 N·m).

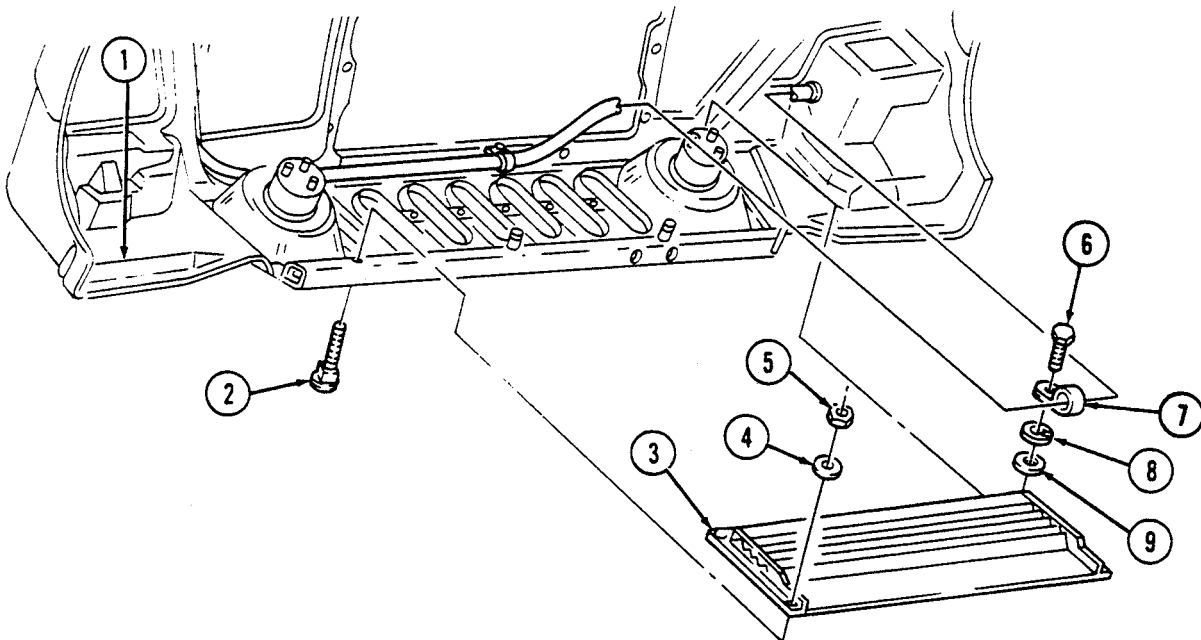

FOLLOW-ON TASK: Lower and secure hood (TM 9-2320-280-10).

11-36. RIGHT COWL ARMOR PLATE REPLACEMENT

This task covers:

a. Removal

b. Installation

INITIAL SETUP:

Applicable Models

All models except M998, M998A1, M1035, M1035A1, M1035A2, M1037, M1038, M1038A1, M1042, M1097, M1097A1, M1097A2

Tools

General mechanic's tool kit:
automotive (Appendix B, Item 1)

Materials/Parts

Four locknuts (Appendix G, Item 70)

Manual References

TM 9-2320-280-24P

Equipment Condition

Ballistic crew door removed (para. 11-2).

a. Removal

Remove four locknuts (2), washers (1), screws (5), washers (4), and armor plate (6) from cowl (3).
Discard locknuts (2).

b. Installation

Install armor plate (6) on cowl (3) with four washers (4), screws (5), washers (1), and locknuts (2).
Tighten locknuts (2) to 6 lb-ft (8 N•m).

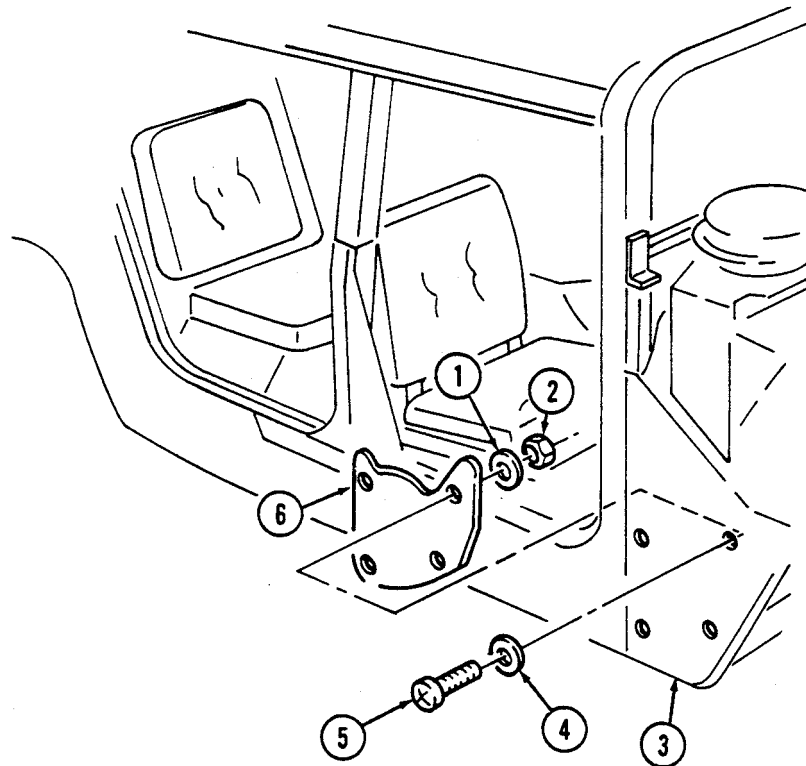

FOLLOW-ON TASK: Install ballistic crew door (para. 11-2).

11-37. LEFT COWL ARMOR PLATE REPLACEMENT

This task covers:

a. Removal

b. Installation

INITIAL SETUP:

Applicable Models

All models except M998, M998A1, M1035, M1035A1, M1035A2, M1037, M1038, M1038A1, M1042, M1097, M1097A1, M1097A2

Materials/Parts

Seven locknuts (Appendix G, Item 70)

Manual References

TM 9-2320-280-24P

Tools

General mechanic's tool kit:
automotive (Appendix B, Item 1)

Equipment Condition

Ballistic crew door removed (para. 11-2).

a. Removal

Remove seven locknuts (1), washers (2), screws (4), washers (5), and armor plate (3) from cowl (6). Discard locknuts (1).

b. Installation

Install armor plate (3) on cowl (6) with seven washers (5), screws (4), washers (2), and locknuts (1). Tighten locknuts (1) to 6 lb-ft (8 N•m).

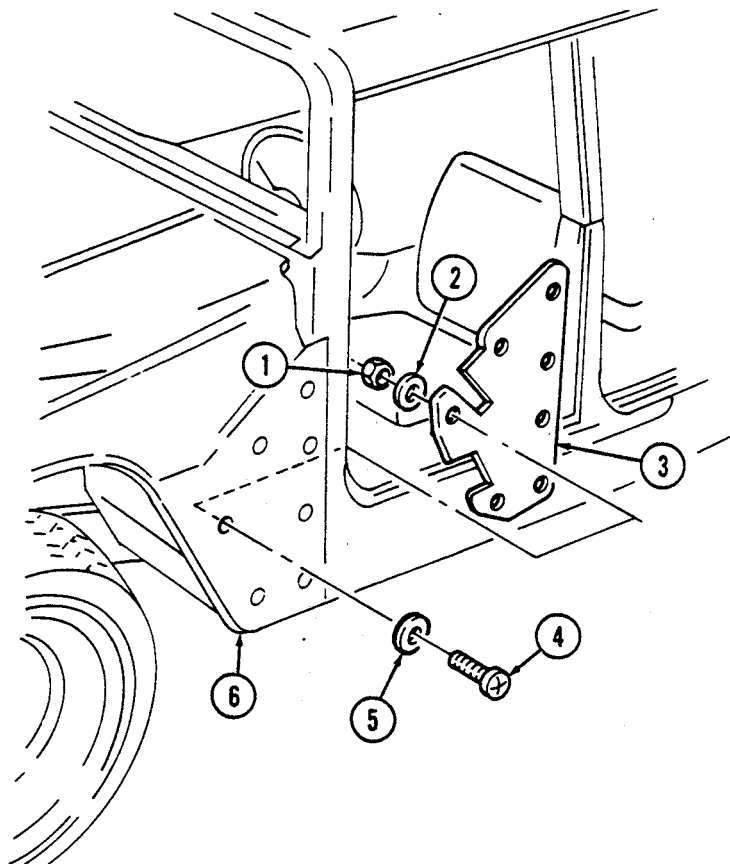

FOLLOW-ON TASK: Install ballistic crew door (para. 11-2).

11-38. FOOTWELL ARMOR PLATE REPLACEMENT

This task covers:

a. Removal

b. Installation

INITIAL SETUP:

Applicable Models

All models except M998, M998A1, M1035, M1035A1, M1035A2, M1037, M1038, M1038A1, M1042, M1097, M1097A1, M1097A2

Materials/Parts

Four locknuts (Appendix G, Item 70)

Manual References

TM 9-2320-280-24P

Tools

General mechanic's tool kit:
automotive (Appendix B, Item 1)

a. Removal

Remove four locknuts (3), washers (2), screws (6), washers (5), armor plate (1), and four spacers (7) from body (4). Discard locknuts (3).

b. Installation

Install four spacers (7) and armor plate (1) on body (4) with four washers (5), screws (6), washers (2), and locknuts (3). Tighten locknuts (3) to 6 lb-ft (8 N·m).

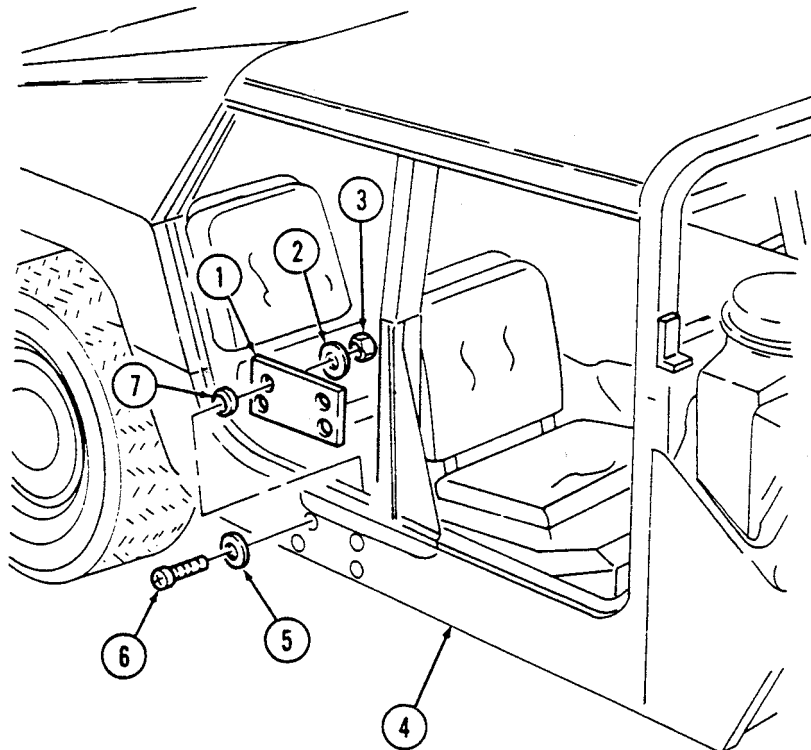

11-39. RIGHT WHEELHOUSE ARMOR PLATE REPLACEMENT

This task covers:

a. Removal

b. Installation

INITIAL SETUP:

Applicable Models

M1025, M1025A1, M1025A2, M1026, M1026A1, M1043, M1043A1, M1043A2, M1044, M1044A1, M1045, M1045A1, M1045A2, M1046, M1046A1

Tools

General mechanic's tool kit:
automotive (Appendix B, Item 1)

Materials/Parts

Fourteen locknuts (Appendix G, Item 70)
Sound dampener (Appendix G, Item 294)

Personnel Required

One mechanic
One assistant

Manual References

TM 9-2320-280-10
TM 9-2320-280-24P

Equipment Condition

- Rear end of cargo shell door raised (TM 9-2320-280-10).
M1045, M1045A1, M1045A2, M1046, and M1046A1 only:
- Night sight support assembly removed (para. 11-82).
M1043, M1043A1, M1043A2, M1044, and M1044A1 only:
- Machine gun stop removed (para. 11-100).

a. Removal

1. Remove four locknuts (7), washers (6), screws (9), and two footman loops (8) from wheelhouse (3). Discard locknuts (7).
2. Remove ten locknuts (5), washers (4), capscrews (10), washers (4), armor plate (1), and sound dampener (2) from wheelhouse (3). Discard locknuts (5) and sound dampener (2).
3. Clean armor plate (1) to remove adhesive.

b. Installation

1. Peel paper backing (11) from sound dampener (2) and install sound dampener (2) on armor plate (1).
2. Install armor plate (1) on wheelhouse (3) with ten washers (4), capscrews (10), washers (4), and locknuts (5). Tighten capscrews (10) to 6 lb-ft (8 N•m).
3. Install two footman loops (8) on wheelhouse (3) with four screws (9), washers (6), and locknuts (7).

11-39. RIGHT WHEELHOUSE ARMOR PLATE REPLACEMENT (Cont'd)

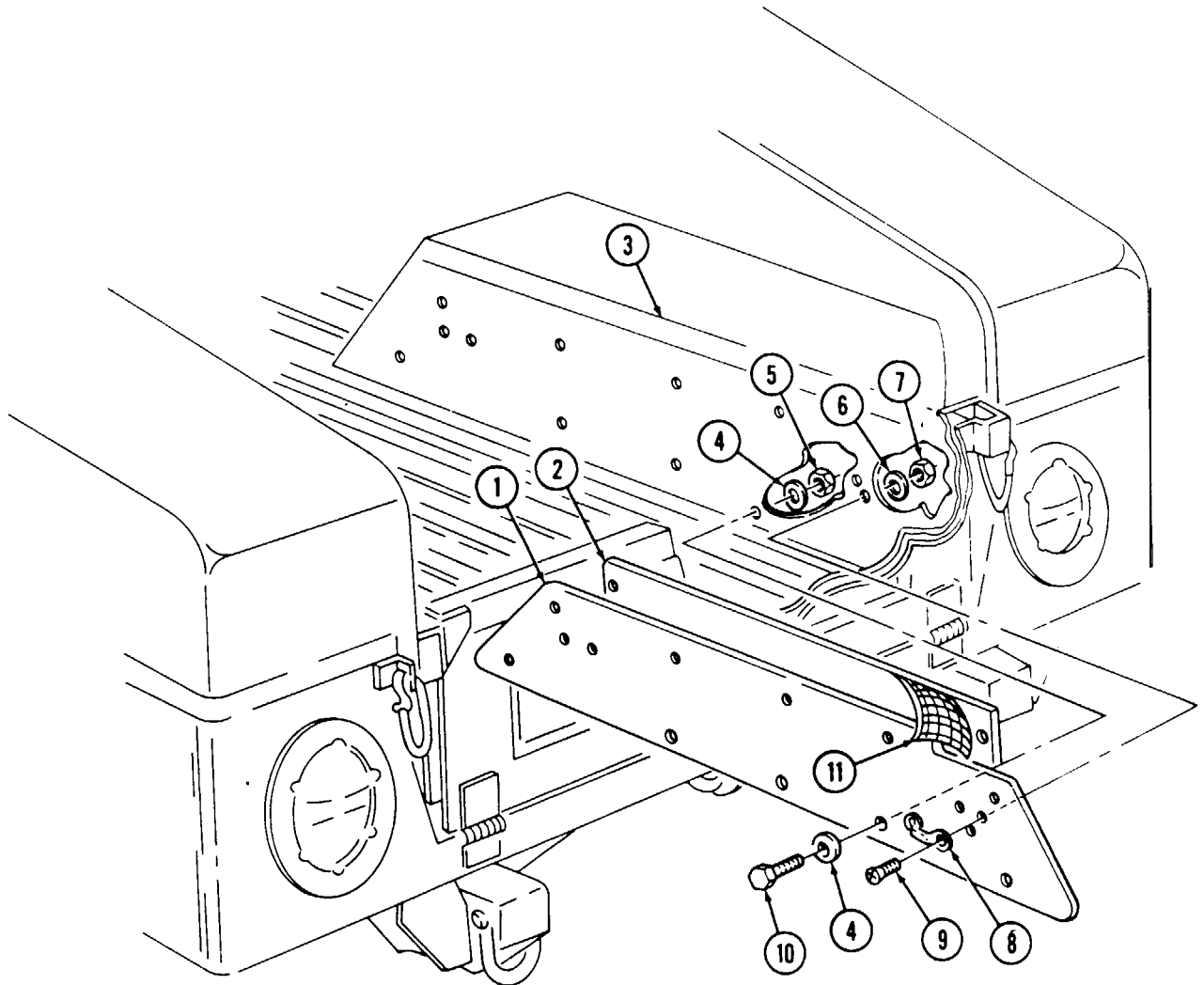

- FOLLOW-ON TASKS:** M1043, M1043A1, M1043A2, M1044, and M1044A1 only:
- Install machine gun stop (para. 11-100).
- M1045, M1045A1, M1045A2, M1046, and M1046A1 only:
- Install night sight support assembly (para. 11-82).
 - Close cargo shell door (TM 9-2320-280-10).

11-40. LEFT WHEELHOUSE ARMOR PLATE REPLACEMENT

This task covers:

a. Removal

b. Installation

INITIAL SETUP:

Applicable Models

M1025, M1025A1, M1025A2, M1026, M1026A1, M1043, M1043A1, M1043A2, M1044, M1044A1, M1045, M1045A1, M1045A2, M1046, M1046A1

Tools

General mechanic's tool kit:
automotive (Appendix B, Item 1)

Materials/Parts

Ten locknuts (Appendix G, Item 70)
Sound dampener (Appendix G, Item 294)

Personnel Required

One mechanic
One assistant

Manual References

TM 9-2320-280-10
TM 9-2320-280-24P

Equipment Condition

- Rear end of cargo shell door raised (TM 9-2320-280-10).
- M1045, M1045A1, M1045A2, M1046, and M1046A1 only:
- Tripod head mounting bracket removed (para. 11-79).
- M1043, M1043A1, M1043A2, M1044, and M1044A1 only:
- Water can bumper removed (para. 11-109).

a. Removal

1. Remove ten locknuts (2), washers (3), capscrews (7), washers (3), armor plate (5), and sound dampener (4) from wheelhouse (1). Discard locknuts (2) and sound dampener (4).
2. Clean armor plate (5) to remove adhesive.

b. Installation

1. Peel paper backing (6) from sound dampener (4) and install sound dampener (4) on armor plate (5).
2. Install armor plate (5) on wheelhouse (1) with ten washers (3), capscrews (7), washers (3), and locknuts (2). Tighten capscrews (7) to 6 lb-ft (8 N·m).

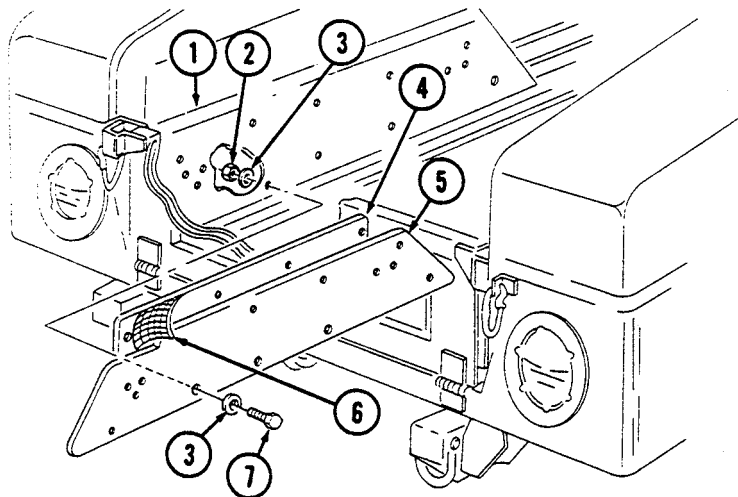

- FOLLOW-ON TASKS:** M1043, M1043A1, M1043A2, M1044, and M1044A1 only:
- Install water can bumper (para. 11-109).
- M1045, M1045A1, M1045A2, M1046, and M1046A1 only:
- Install tripod head mounting bracket (para. 11-79)
 - Close cargo shell door (TM 9-2320-280-10).

11-41. TAILGATE ARMOR PLATE REPLACEMENT

This task covers:

a. Removal

b. Installation

INITIAL SETUP:

Applicable Models

All models except M996, M996A1, M997, M997A1, M997A2, M998, M998A1, M1035, M1035A1, M1035A2, M1037, M1038, M1038A1, M1042, M1097, M1097A1, M1097A2

Tools

General mechanic's tool kit:
automotive (Appendix B, Item 1)

Materials/Parts

Nine lockwashers (Appendix G, Item 135)
Sound dampener (Appendix G, Item 295)

Manual References

TM 9-2320-280-10
TM 9-2320-280-24P

Equipment Condition

Tailgate lowered (TM 9-2320-280-10).

a. Removal

1. Remove nine capscrews (3), lockwashers (2), armor plate (1), and sound dampener (4) from tailgate (5). Discard lockwashers (2) and sound dampener (4).
2. Clean armor plate (1) to remove adhesive.

b. Installation

1. Peel paper backing (6) from sound dampener (4) and install sound dampener (4) on armor plate (1).
2. Install armor plate (1) on tailgate (5) with nine lockwashers (2) and capscrews (3). Tighten capscrews (3) to 6 lb-ft (8 N•m).

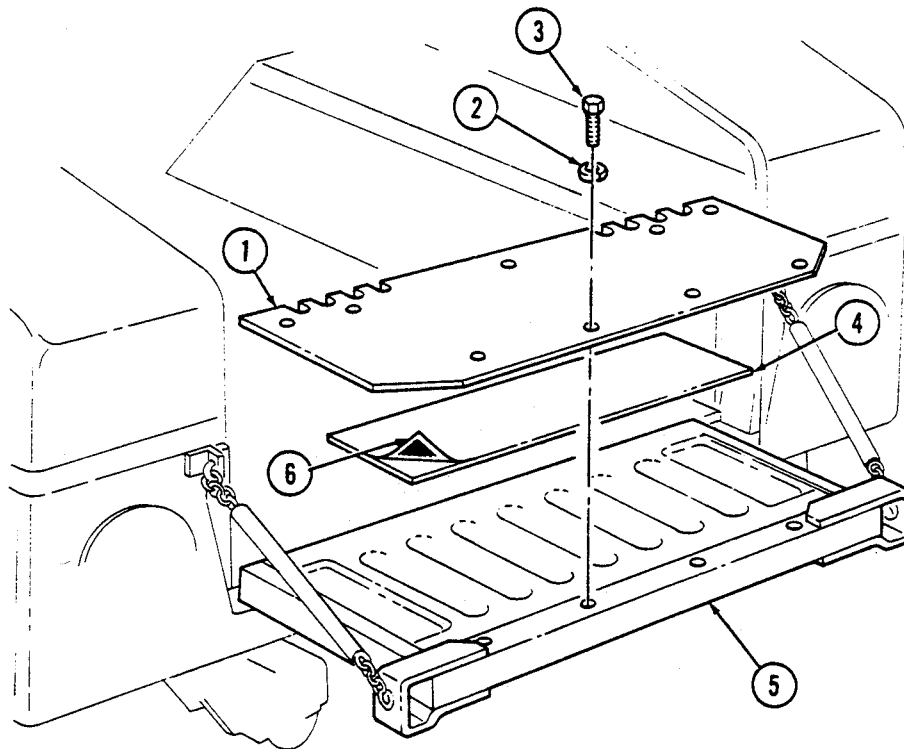

FOLLOW-ON TASK: Raise and secure tailgate (TM 9-2320-280-10).

11-42. WEAPON STATION HATCH REPLACEMENT

This task covers:

a. Removal

b. Installation

INITIAL SETUP:

Applicable Models

All models except M996, M996A1, M997, M997A1, M997A2, M998, M998A1, M1035, M1035A1, M1035A2, M1037, M1038, M1038A1, M1042, M1097, M1097A1, M1097A2

Materials/Parts

RTV Sealant (Appendix C, Item 38)
Locknut (Appendix G, Item 128)

Manual References

TM 9-2320-280-24P

Tools

General mechanic's tool kit:
automotive (Appendix B, Item 1)

a. Removal

1. Remove capscrew (6) and washer (7) from hatch pivot bracket (9) and weapon station (1).
2. Remove locknut (10), washer (5), capscrew (4), washer (5), and hatch pivot bracket (9) from weapon station (1). Discard locknut (10).
3. Slide hatch hinge pin (3) out from hatch pivot bracket (2) and remove weapon station hatch (8).

b. Installation

NOTE

Some hatches may leak water. To prevent water leaks, install NSN 5330-01-190-2227 seal on hatch with RTV sealant.

1. Install weapon station hatch (8) with hatch hinge pin (3) in hatch pivot bracket (2).
2. Install hatch pivot bracket (9) on weapon station (1) with washer (5), capscrew (4), washer (5), and locknut (10).
3. Install hatch pivot bracket (9) on weapon station (1) with washer (7) and capscrew (6). Tighten locknut (10) and capscrew (6) to 37 lb-ft (50 N·m).

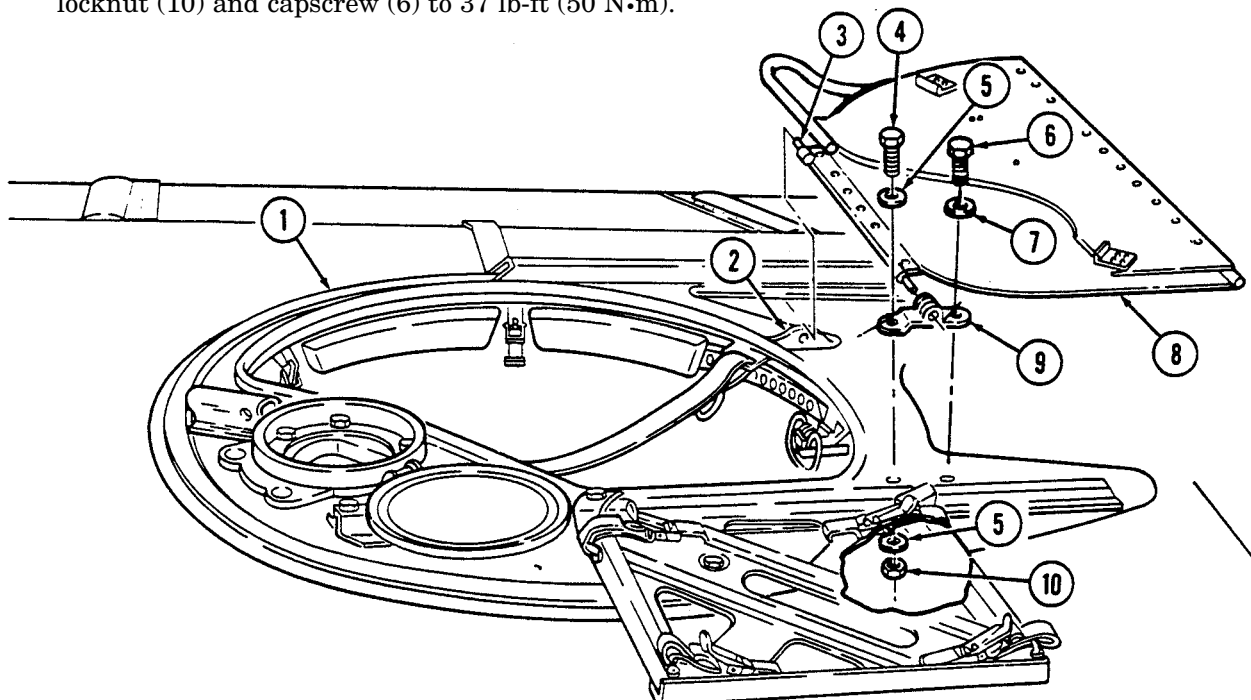

11-43. WEAPON STATION HATCH HANDLE REPLACEMENT

This task covers:

a. Removal

b. Installation

INITIAL SETUP:

Applicable Models

All models except M996, M996A1, M997, M997A1, M997A2, M998, M998A1, M1035, M1035A1, M1035A2, M1037, M1038, M1038A1, M1042, M1097, M1097A1, M1097A2

Materials/Parts

Two locknuts (Appendix G, Item 107)

Manual References

TM 9-2320-280-24P

Tools

General mechanic's tool kit:
automotive (Appendix B, Item 1)

a. Removal

Remove two locknuts (1), washers (2), capscrews (5), large washers (4), and handle (6) from hatch (3). Discard locknuts (1).

b. Installation

Install handle (6) on hatch (3) with two large washers (4), capscrews (5), washers (2), and locknuts (1). Tighten locknuts to 6 lb-ft (8 N·m).

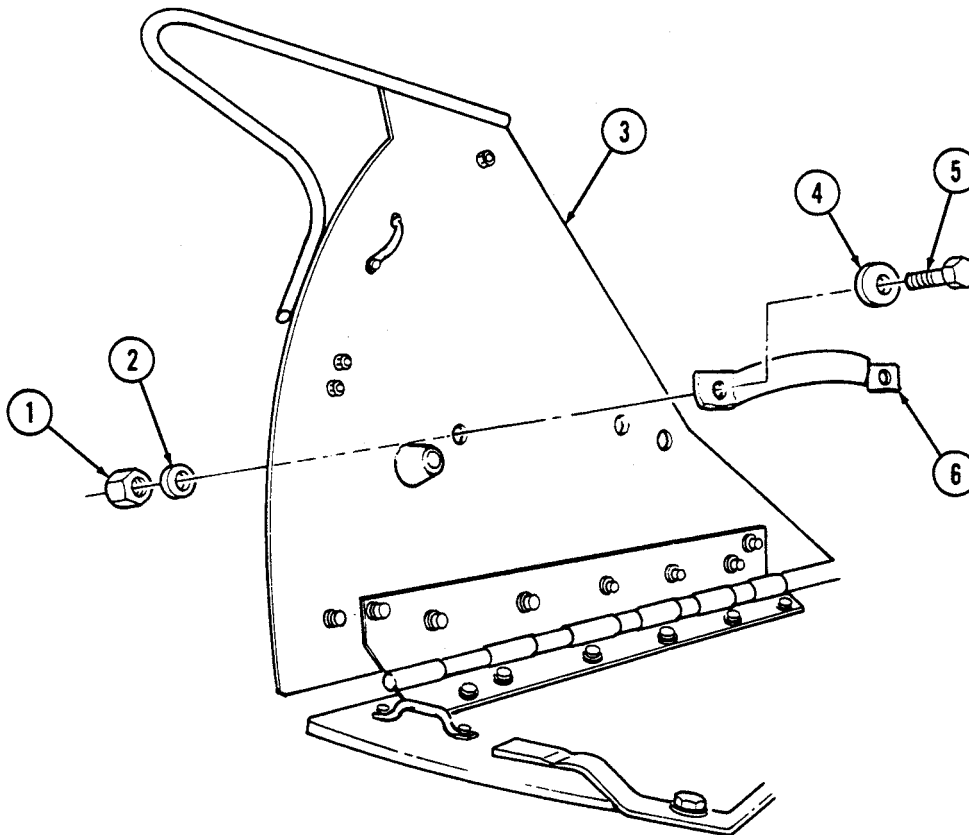

11-44. WEAPON STATION HATCH HINGE PIN REPLACEMENT

This task covers:

a. Removal

b. Installation

INITIAL SETUP:

Applicable Models

All models except M996, M996A1, M997, M997A1, M997A2, M998, M998A1, M1035, M1035A1, M1035A2, M1037, M1038, M1038A1, M1042, M1097, M1097A1, M1097A2

Materials/Parts

Two locknuts (Appendix G, Item 70)

Manual References

TM 9-2320-280-24P

Tools

General mechanic's tool kit:
automotive (Appendix B, Item 1)

a. Removal

1. Remove two locknuts (3), washers (4), capscrews (7), and washers (4) from hatch hinge pin (5) and hatch panel (1). Discard locknuts (3).

NOTE

Spacer not required on M1043, M1043A1, M1043A2, M1044, M1044A1, M1045, M1045A1, M1045A2, M1046, and M1046A1 vehicles.

2. Remove hatch hinge pin (5) and two spacers (2) from hinge pivot bracket (6) and hatch panel (1).

b. Installation

1. Install hatch hinge pin (5) on hatch panel (1) and slide into hinge pivot bracket (6). Slide two spacers (2) between hatch panel (1) and hinge pin (5) on top side of hatch panel (1).
2. Secure hatch hinge pin (5) to hatch panel (1) with two washers (4), capscrews (7), washers (4), and locknuts (3). Tighten locknuts (3) to 6 lb-ft (8 N•m).

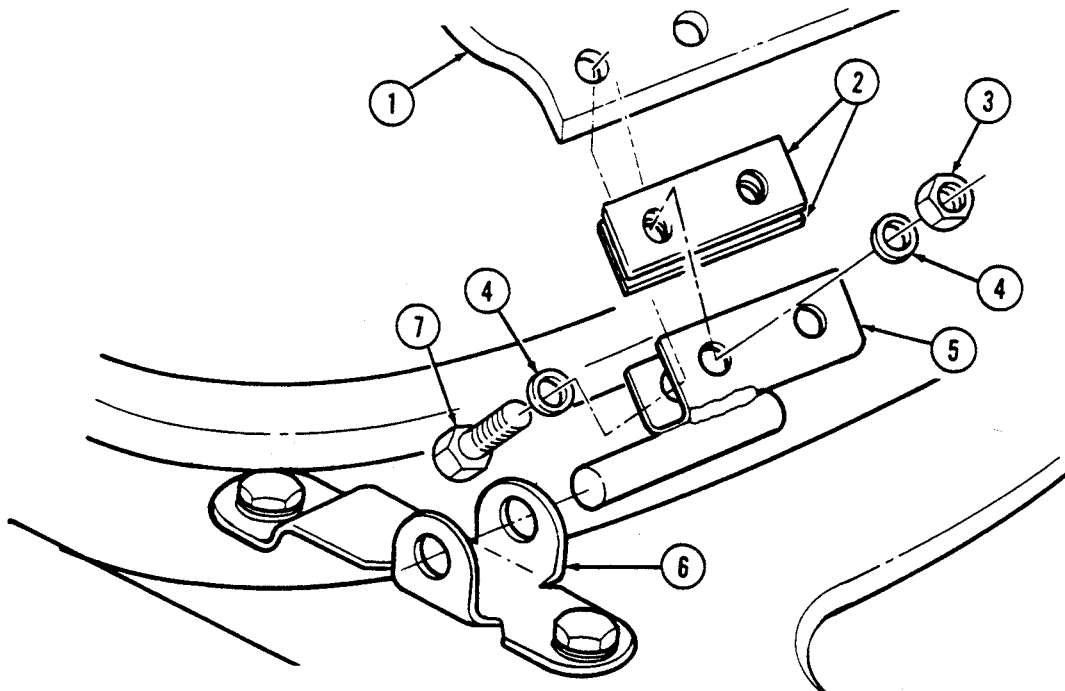

11-45. WEAPON STATION HATCH HINGE REPLACEMENT

This task covers:

a. Removal

b. Installation

INITIAL SETUP:

Applicable Models

All models except M996, M996A1, M997, M997A1, M997A2, M998, M998A1, M1035, M1035A1, M1035A2, M1037, M1038, M1038A1, M1042, M1097, M1097A1, M1097A2

Materials/Parts

Sixteen locknuts (Appendix G, Item 70)

Manual References

TM 9-2320-280-24P

Tools

General mechanic's tool kit:
automotive (Appendix B, Item 1)

a. Removal

1. Remove seven locknuts (5), washers (2), capscrews (3), washers (2), right hatch panel (1), and hinge (4) from left hatch panel (6). Discard locknuts (5).
2. Remove nine locknuts (11), washers (7), capscrews (8), washers (7), retainer (10), seal (9), and hinge (4) from right hatch panel (1). Discard locknuts (11).
3. Inspect seal (9) for damage. Replace if damaged.

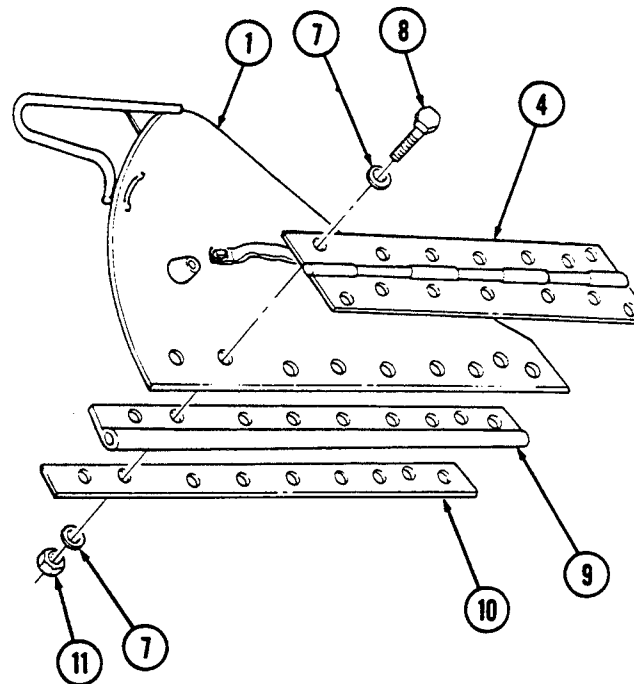
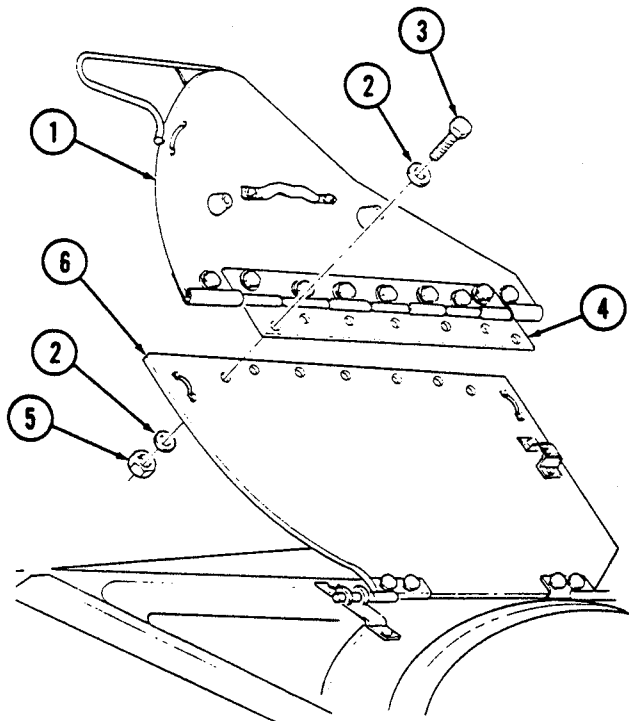

11-45. WEAPON STATION HATCH HINGE REPLACEMENT (Cont'd)

b. Installation

1. Install hinge (4), seal (5), and retainer (6) on right hatch panel (1) with nine washers (2), capscrews (3), washers (2), and locknuts (7). Tighten locknuts (7) to 6 lb-ft (8 N•m).
2. Install hinge (4) and right hatch panel (1) on left hatch panel (11) with seven washers (8), capscrews (9), washers (8), and locknuts (10). Tighten locknuts (10) to 6 lb-ft (8 N•m).

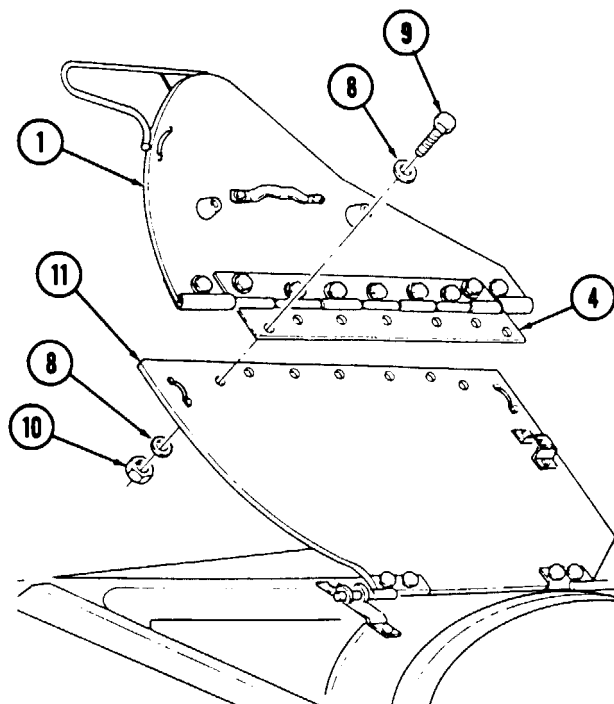
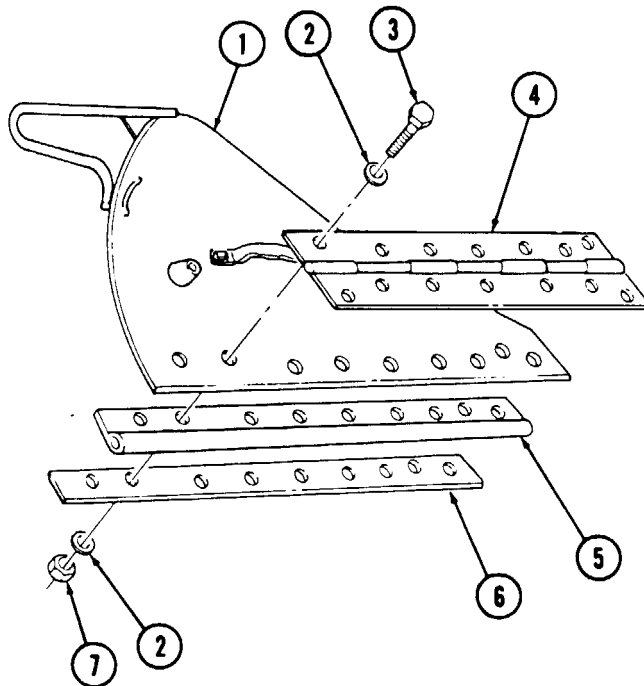

11-46. WEAPON STATION HATCH HOLDDOWN STRIKER REPLACEMENT

This task covers:

a. Removal

b. Installation

INITIAL SETUP:

Applicable Models

All models except M996, M996A1, M997, M997A1, M997A2, M998, M998A1, M1035, M1035A1, M1035A2, M1037, M1038, M1038A1, M1042, M1097, M1097A1, M1097A2

Tools

General mechanic's tool kit:
automotive (Appendix B, Item 1)

Materials/Parts

Two locknuts (Appendix G, Item 70)
Two locknuts (Appendix G, Item 107)

Manual References

TM 9-2320-280-24P

a. Removal

NOTE

This task covers the left hatch panel holddown striker. The right hatch panel holddown striker is mounted directly on the panel.

1. Remove two locknuts (5), washers (4), screws (1), and holddown striker (2) from bracket (3). Discard locknuts (5).
2. Remove two locknuts (7), washers (8), capscrews (9), washers (8), and bracket (3) from left hatch panel (6). Discard locknuts (7).

b. Installation

1. Install striker (2) on bracket (3) with two screws (1), washers (4), and locknuts (5).
2. Install bracket (3) on left hatch panel (6) with two washers (8), capscrews (9), washers (8), and locknuts (7). Tighten locknuts (7) to 6 lb-ft (8 N·m).

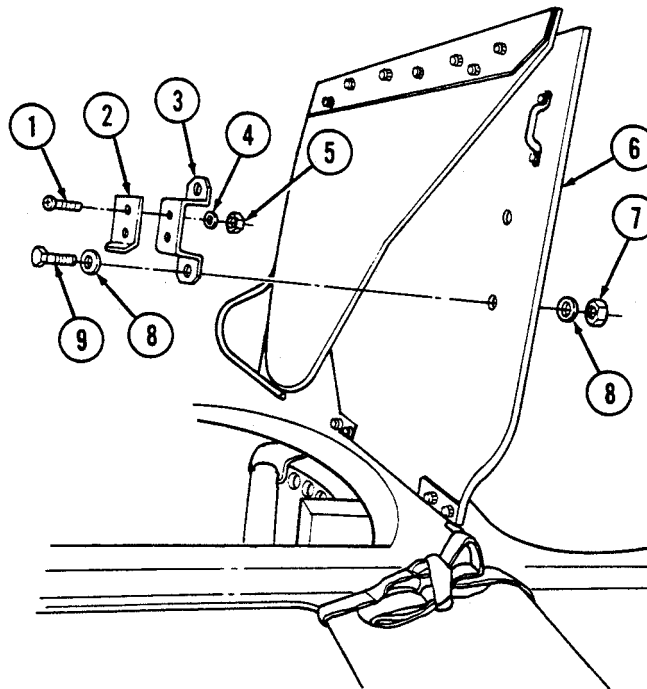

11-47. WEAPON STATION TRAY SEAL REPLACEMENT

This task covers:

a. Removal

b. Installation

INITIAL SETUP:

Applicable Models

All models except M996, M996A1, M997, M997A1 M997A2, M998, M998A1, M1035, M1035A1, M1035A2, M1037, M1038, M1038A1, M1042, M1097, M1097A1, M1097A2

Materials/Parts

Adhesive (Appendix C, Item 3)

Manual References

TM 9-2320-280-24P

Tools

General mechanic's tool kit:
automotive (Appendix B, Item 1)

a. Removal

1. Remove seal (1) from weapon station (2).
2. Thoroughly clean the edge of weapon station (2).

b. Installation

1. Measure and cut required length of seal (1).
2. Apply a 1/16-in. (1.6 mm) to 1/8-in. (3.2 mm) bead of adhesive to seal (1) lip.
3. Starting somewhere other than at a corner, press seal over the lip of the weapon station (2) tray hatch opening.
4. Allow seal (1) to set and cure undisturbed, for about one hour.

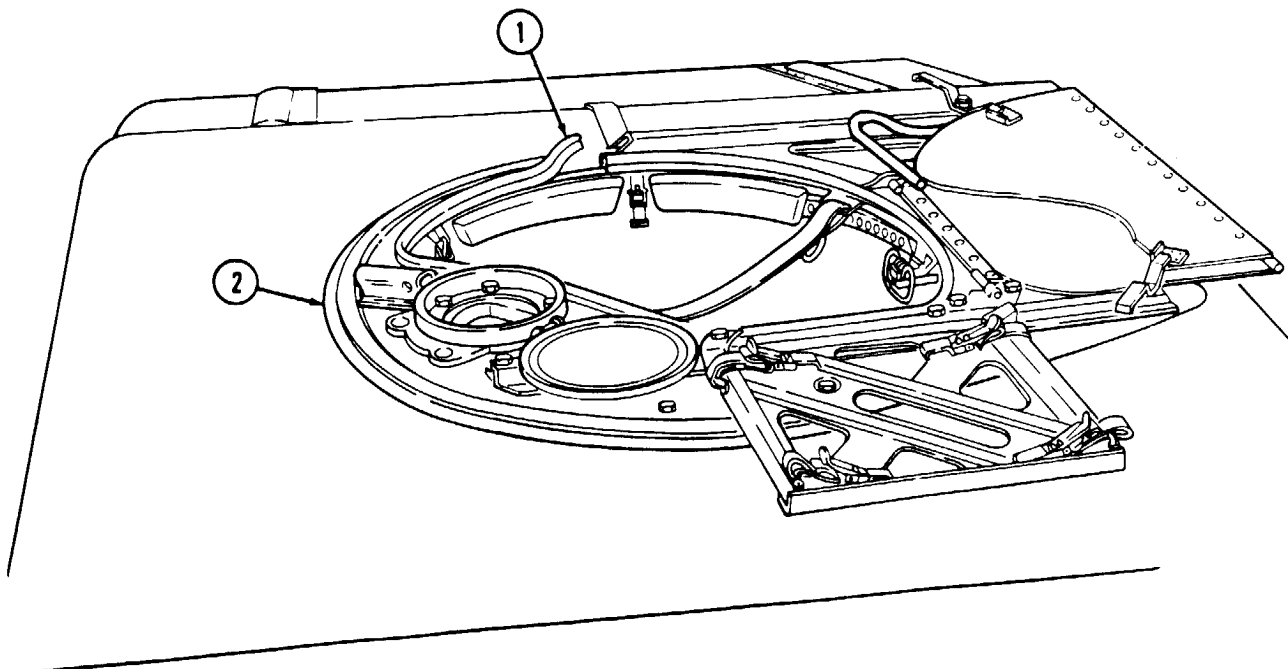

11-48. WEAPON STATION BUMPER PAD REPLACEMENT

This task covers:

a. Removal

b. Installation

INITIAL SETUP:

Applicable Models

All models except M996, M996A1, M997, M997A1, M997A2, M998, M998A1, M1035, M1035A1, M1035A2, M1037, M1038, M1038A1, M1042, M1097, M1097A1, M1097A2, M1123

Tools

General mechanic's tool kit:
automotive (Appendix B, Item 1)

Materials/Parts

Locknut (Appendix G, Item 107)

Manual References

TM 9-2320-280-24P

NOTE

Bumper pads for both sides of hatch are installed basically the same. This procedure covers the right side.

a. Removal

Remove locknut (5), washer (4), screw (3), and bumper pad (2) from hatch (1). Discard locknut (5).

b. Installation

Install bumper pad (2) on hatch (1) with screw (3), washer (4), and locknut (5).

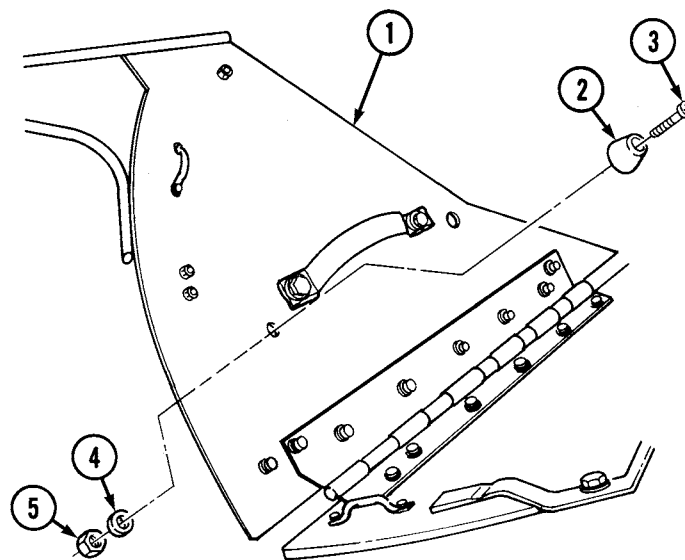

11-49. WEAPON STATION TRAY LEVER REPLACEMENT

This task covers:

- a. Removal
- b. Installation

INITIAL SETUP:

Applicable Models

All models except M996, M996A1, M997, M997A1, M997A2, M998, M998A1, M1035, M1035A1, M1035A2, M1037, M1038, M1038A1, M1042, M1097, M1097A1, M1097A2, M1123

Materials/Parts

Four spring tension washers
(Appendix G, Item 320)
Sealing compound (Appendix C, Item 40)

Manual References

TM 9-2320-280-24P

Tools

General mechanic's tool kit:
automotive (Appendix B, Item 1)

a. Removal

Remove capscrew (4), washer (3), two spring tension washers (2), tray lever (1), two spring tension washers (2), and washer (3) from weapon station (5). Discard spring tension washers (2).

b. Installation

NOTE

Apply sealing compound to threads on capscrew.

Install washer (3), two spring tension washers (2), and tray lever (1) on weapon station (5) with two spring tension washers (2), washer (3), and capscrew (4). Tighten capscrew (4) to 6 lb-ft (8 N·m).

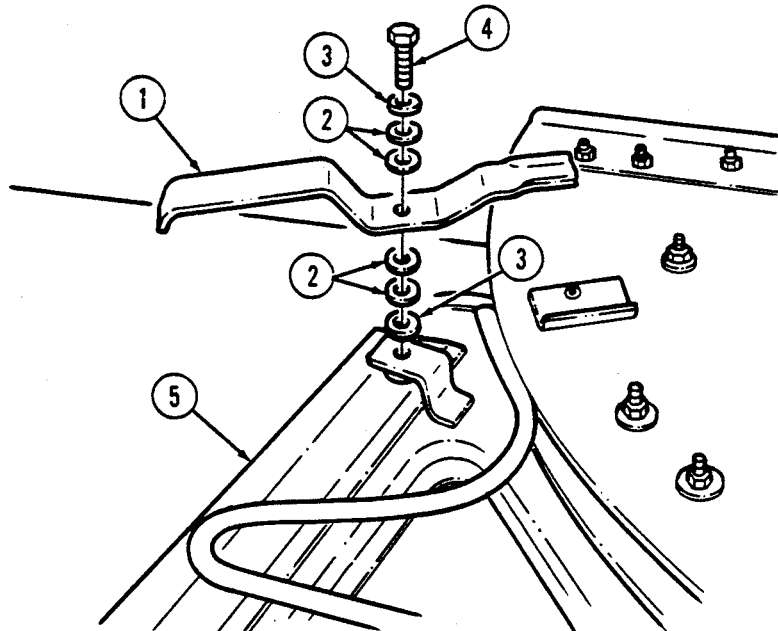

11-50. WEAPON STATION HATCH LATCH REPLACEMENT

This task covers:

a. Removal

b. Installation

INITIAL SETUP:

Applicable Models

All models except M996, M996A1, M997, M997A1, M997A2, M998, M998A1, M1035, M1035A1, M1035A2, M1037, M1038, M1038A1, M1042, M1097, M1097A1, M1097A2

Tools

General mechanic's tool kit
automotive (Appendix B, Item 1)

Manual References

TM 9-2320-280-24P

NOTE

- Procedures for replacing the three hatch latches are basically the same, except the hatch latch opposite the backrest side of weapon station has a spacer. This procedure covers the hatch latch with spacer.
- To increase latch tension, 3/8-in. (9.5 mm) flat washers may be added between bottom of weapon station and any of the three hatch latches.

a. Removal

Remove capscrew (2), washer(1), hatch latch (5), and spacer (4) from weapon station (3).

b. Installation

Install spacer (4) and hatch latch (5) on weapon station (3) with washer (1) and capscrew (2). Tighten capscrew (2) to 37 lb-ft (50 N•m).

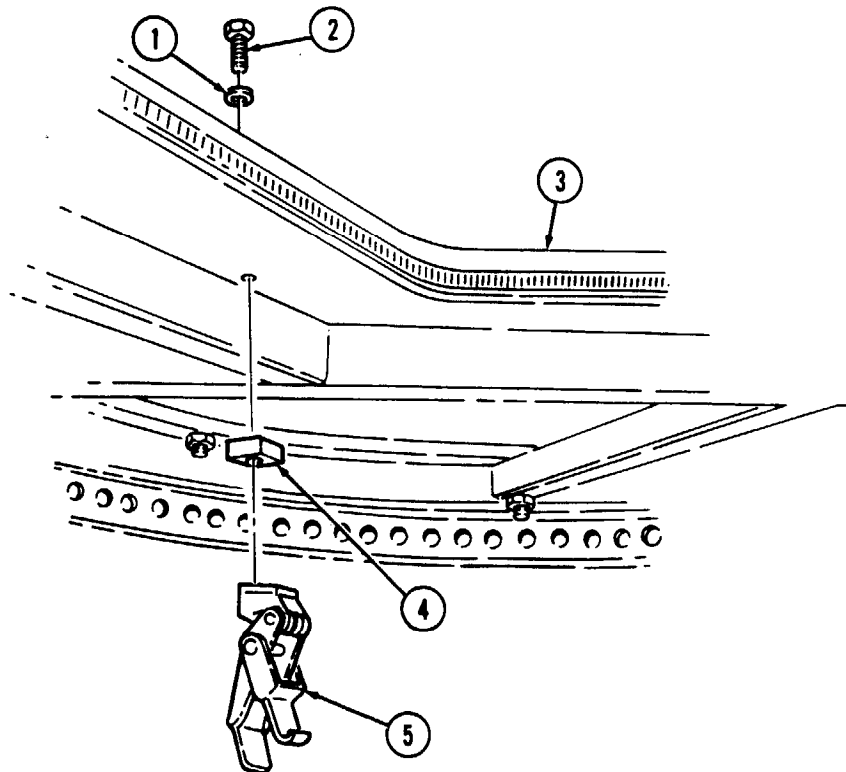

11-51. WEAPON STATION HATCH TUBE ASSEMBLY REPLACEMENT

This task covers:

a. Removal

b. Installation

INITIAL SETUP:

Applicable Models

All models except M996, M996A1, M997, M997A1, M997A2, M998, M998A1, M1035, M1035A1, M1035A2, M1037, M1038, M1038A1, M1042, M1097, M1097A1, M1097A2

Tools

General mechanic's tool kit:
automotive (Appendix B, Item 1)

Materials/Parts

Ten locknuts (Appendix G, Item 128)

Manual References

TM 9-2320-280-24P

a. Removal

NOTE

- Note locations of capscrews for installation.
- Later production vehicles are equipped with spacers.

Remove ten locknuts (5), washers (1), capscrews (2), washers (1), hatch tube (4), and five spacers (6), if installed, from weapon station (3). Discard locknuts (5).

b. Installation

NOTE

TOW mount pedestal and TOW MGS pan/armament cover and armament mount panel must be in place prior to installing weapon station hatch tube assembly.

Install five spacers (6), if removed, and hatch tube (4) on weapon station (3) with ten washers (1), capscrews (2), washers (1), and locknuts (5). Tighten locknuts (5) to 37 lb-ft (50 N•m).

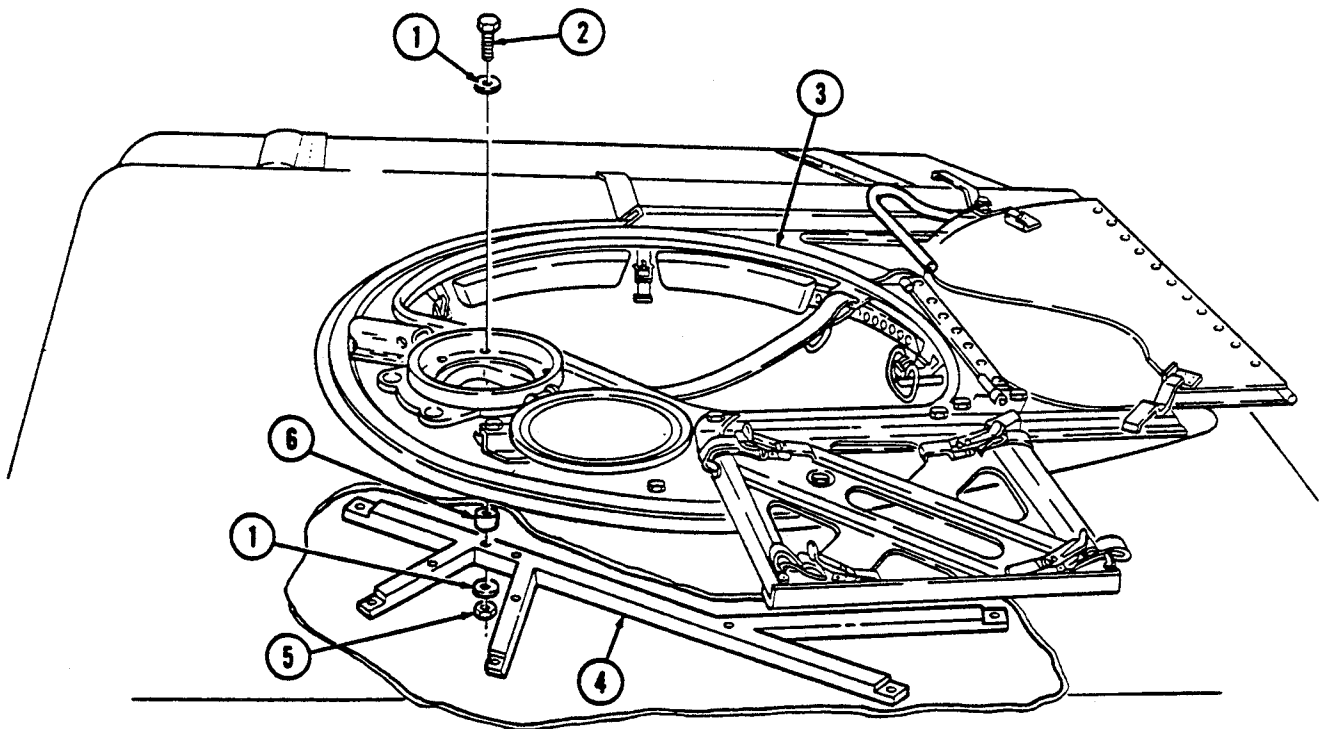

11-52. HINGE PIVOT BRACKET AND GUNNER'S SLING REPLACEMENT

This task covers:

a. Removal

b. Installation

INITIAL SETUP:

Applicable Models

All models except M996, M996A1, M997, M997A1, M997A2, M998, M998A1, M1035, M1035A1, M1035A2, M1037, M1038, M1038A1, M1042, M1097, M1097A1, M1097A2

Materials/Parts

Locknut (Appendix G, Item 128)

Manual References

TM 9-2320-280-24P

Tools

General mechanic's tool kit:
automotive (Appendix B, Item 1)

a. Removal

1. Remove locknut (8), washer (2), capscrew (3), washer (2), gunner's sling (9), and hinge pivot bracket (6) from weapon station (1). Discard locknut (8).
2. Remove capscrew (4), washer (5), and hinge pivot bracket (6) from weapon station (1) and rear hinge pin (7).

b. Installation

1. Install hinge pivot bracket (6) on rear hinge pin (7).
2. Install hinge pivot bracket (6) on weapon station (1) with washer (5) and capscrew (4). Tighten capscrew (4) to 37 lb-ft (50 N·m).
3. Install hinge pivot bracket (6) and gunner's sling (9) on weapon station (1) with washer (2), capscrew (3), washer (2), and locknut (8). Tighten locknut (8) to 37 lb-ft (50 N·m).

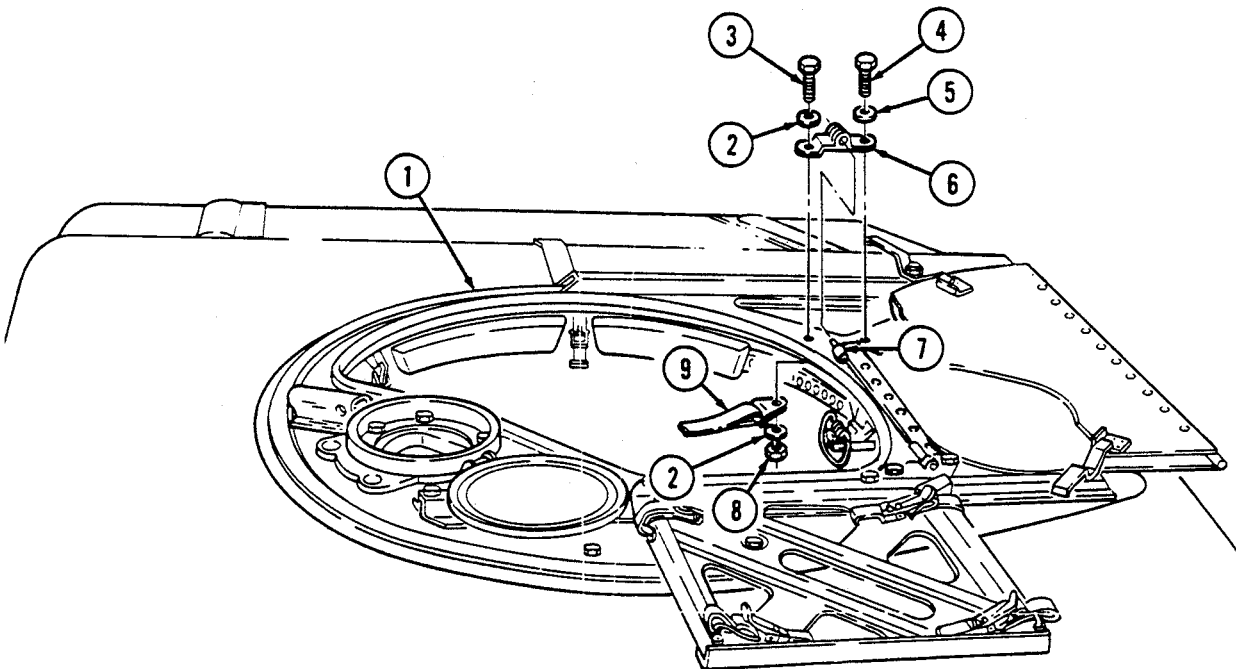

11-53. GUNNER'S SLING HOOK REPLACEMENT

This task covers:

a. Removal

b. Installation

INITIAL SETUP:

Applicable Models

All models except M996, M996A1, M997, M997A1, M997A2, M998, M998A1, M1035, M1035A1, M1035A2, M1037, M1038, M1038A1, M1042, M1097, M1097A1, M1097A2

Materials/Parts

Locknut (Appendix G, Item 128)

Manual References

TM 9-2320-280-24P

Tools

General mechanic's tool kit:
automotive (Appendix B, Item 1)

a. Removal

Remove locknut (5), washer (2), capscrew (1), washer (2), and gunner's sling hook (4) from weapon station (3). Discard locknut (5).

b. Installation

Install gunner's sling hook (4) on weapon station (3) with washer (2), capscrew (1), washer (2), and locknut (5). Tighten locknut (5) to 37 lb-ft (50 N·m).

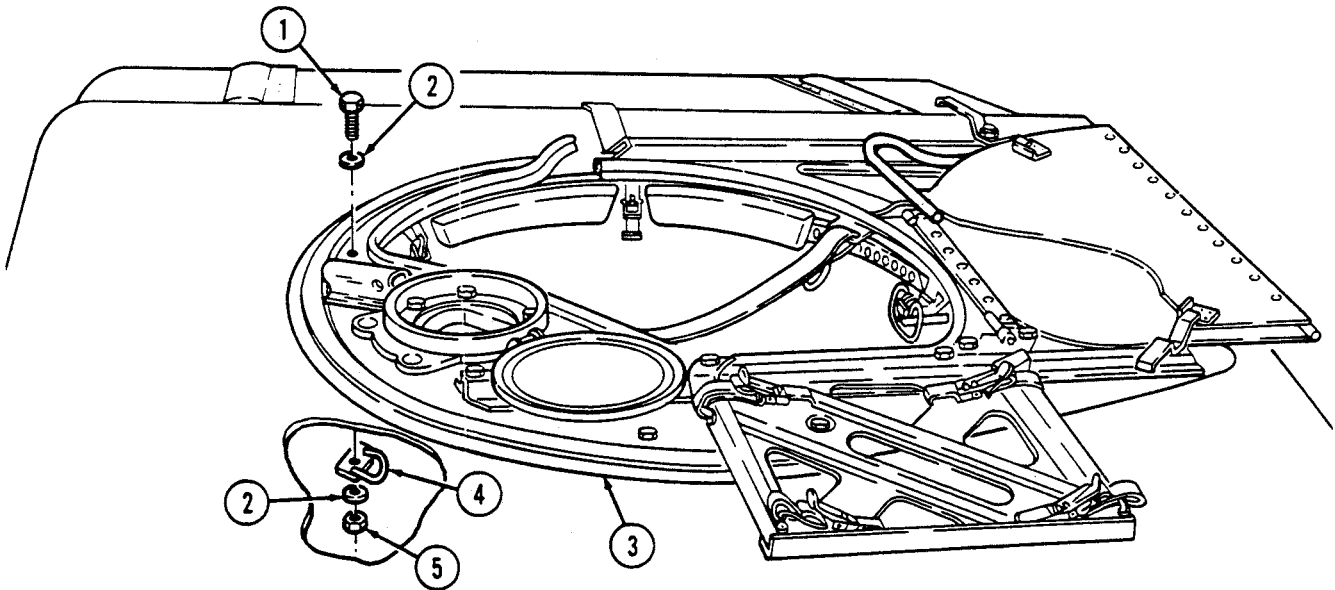

11-54. WEAPON STATION BACKREST PAD REPLACEMENT

This task covers:

a. Removal

b. Installation

INITIAL SETUP:

Applicable Models

All models except M996, M996A1, M997, M997A1, M997A2, M998, M998A1, M1035, M1035A1, M1035A2, M1037, M1038, M1038A1, M1042, M1097, M1097A1, M1097A2, M1123

Tools

General mechanic's tool kit:
automotive (Appendix B, Item 1)

Materials/Parts

Three locknuts (Appendix G, Item 128)

Manual References

TM 9-2320-280-24P

NOTE

The procedure for removing and installing left and right backrest pads is the same. This procedure covers right backrest pad.

a. Removal

Remove three locknuts (4), washers (2), capscrews (3), washers (2), and backrest pad (5) from weapon station (1). Discard locknuts (4).

b. Installation

Install backrest pad (5) on weapon station (1) with three washers (2), capscrews (3), washers (2), and locknuts (4). Tighten locknuts (4) to 37 lb-ft (50 N·m).

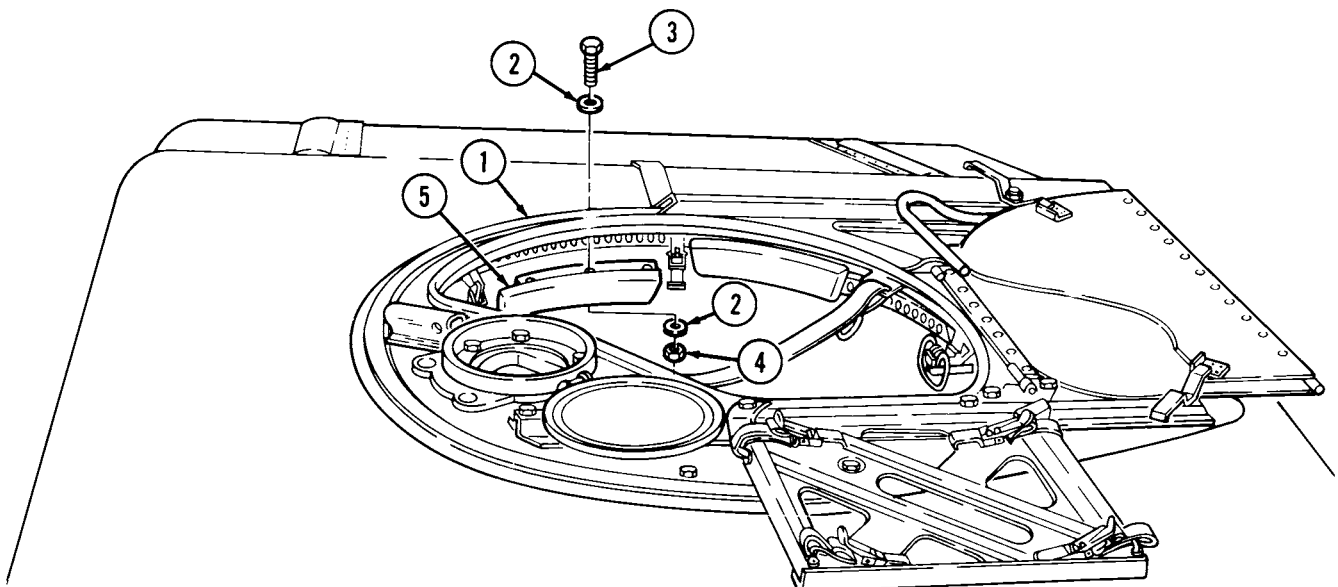

11-55. TURRET HANDLE REPLACEMENT

This task covers:

a. Removal

b. Installation

INITIAL SETUP:

Applicable Models

All models except M996, M996A1, M997, M997A1, M997A2, M998, M998A1, M1035, M1035A1, M1035A2, M1037, M1038, M1038A1, M1042, M1097, M1097A1, M1097A2, M1123

Materials/Parts

Four locknuts (Appendix G, Item 86)

Manual References

TM 9-2320-280-24P

Tools

General mechanic's tool kit:
automotive (Appendix B, Item 1)

NOTE

- Fabrication instructions are available to replace the turret handle. Refer to appendix D (fig. D-95).
- The following procedure is for replacement of turret handle that has been previously removed and installed in accordance with the fabrication instructions.

a. Removal

Remove four locknuts (4), washers (2), capscrews (1), washers (2), and turret handle (3) from weapon station tray (5). Discard locknuts (4).

b. Installation

Install turret handle (3) on weapon station tray (5) with four washers (2), capscrews (1), washers (2), and locknuts (4).

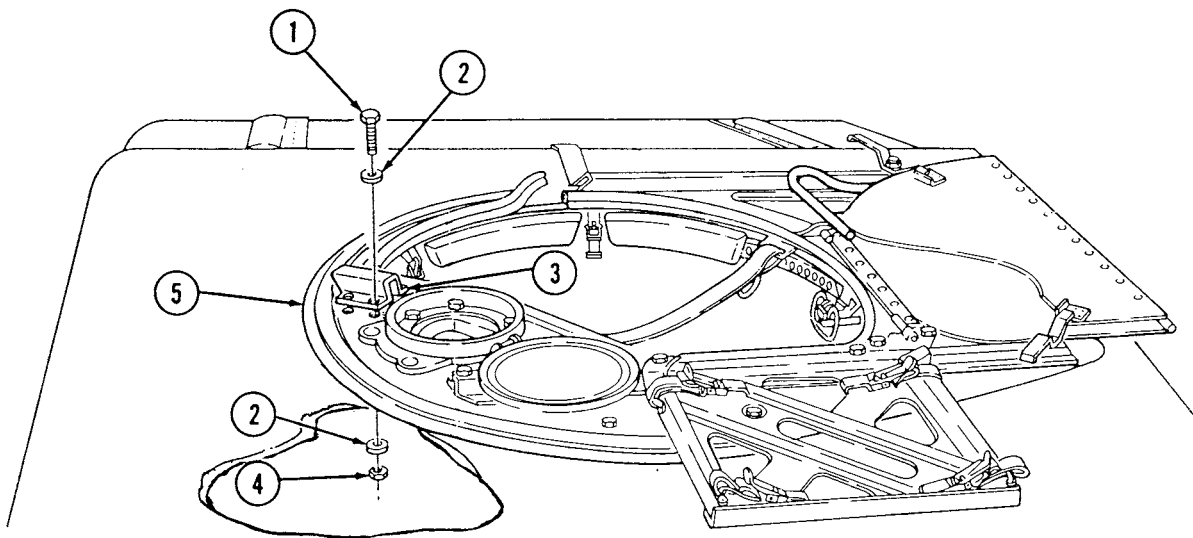

11-56. TURRET LOCK REPLACEMENT

This task covers:

a. Removal

b. Installation

INITIAL SETUP:

Applicable Models

All models except M996, M996A1, M997, M997A1, M997A2, M998, M998A1, M1035, M1035A1, M1035A2, M1037, M1038, M1038A1, M1042, M1097, M1097A1, M1097A2

Materials/Parts

Two locknuts (Appendix G, Item 128)

Manual References

TM 9-2320-280-24P

Tools

General mechanic's tool kit:
automotive (Appendix B, Item 1)

a. Removal

Remove two locknuts (6), washers (1), capscrews (2), washers (1), turret lock (5), and spacer(s) (4) from weapon station (3). Discard locknuts (6).

b. Installation

NOTE

Install same amount of spacers that were removed between bottom of weapon station and turret lock. Amount of spacers may be adjusted to correct lock handle binding. Refer to TM 9-2320-280-24P if more spacers are needed.

Install spacer(s) (4) and turret lock (5) on weapon station (3) with two washers (1), capscrews (2), washers (1), and locknuts (6). Tighten locknuts (6) to 37 lb-ft (50 N·m).

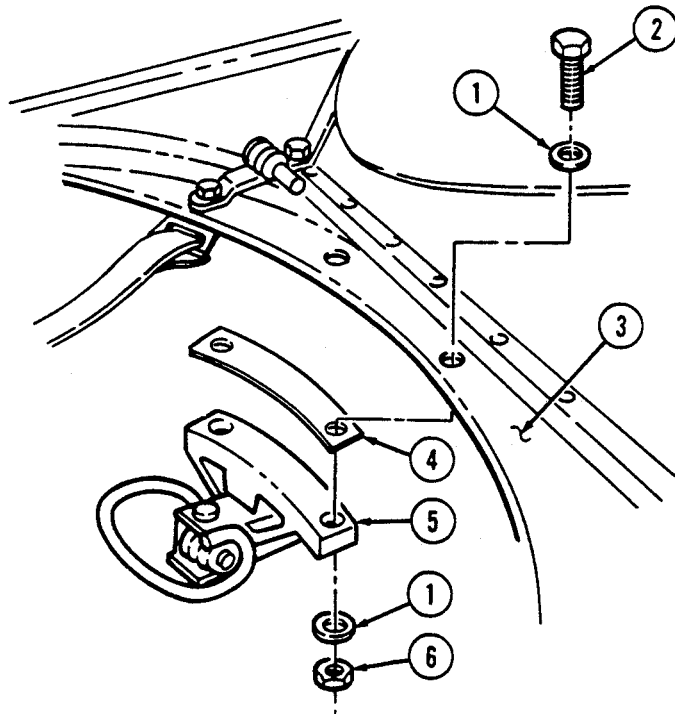

11-57. TOW MOUNT PEDESTAL REPLACEMENT

This task covers:

a. Removal

b. Installation

INITIAL SETUP:

Applicable Models

M966, M966A1, M1036, M1045, M1045A1, M1045A2, M1046, M1046A1, M1121

Tools

General mechanic's tool kit:
automotive (Appendix B, Item 1)

Materials/Part

Eight locknuts (Appendix G, Item 128)

Manual References

TM 9-2320-280-24P

a. Removal

NOTE

Note locations of capscrews for installation.

Remove eight locknuts (4), washers (2), capscrews (3), washers (2), and pedestal mount (1) from weapon station (5). Discard locknuts (4).

b. Installation

Install pedestal mount (1) on weapon station (5) with eight washers (2), capscrews (3), washers (2), and locknuts (4). Tighten locknuts (4) to 37 lb-ft (50 N·m).

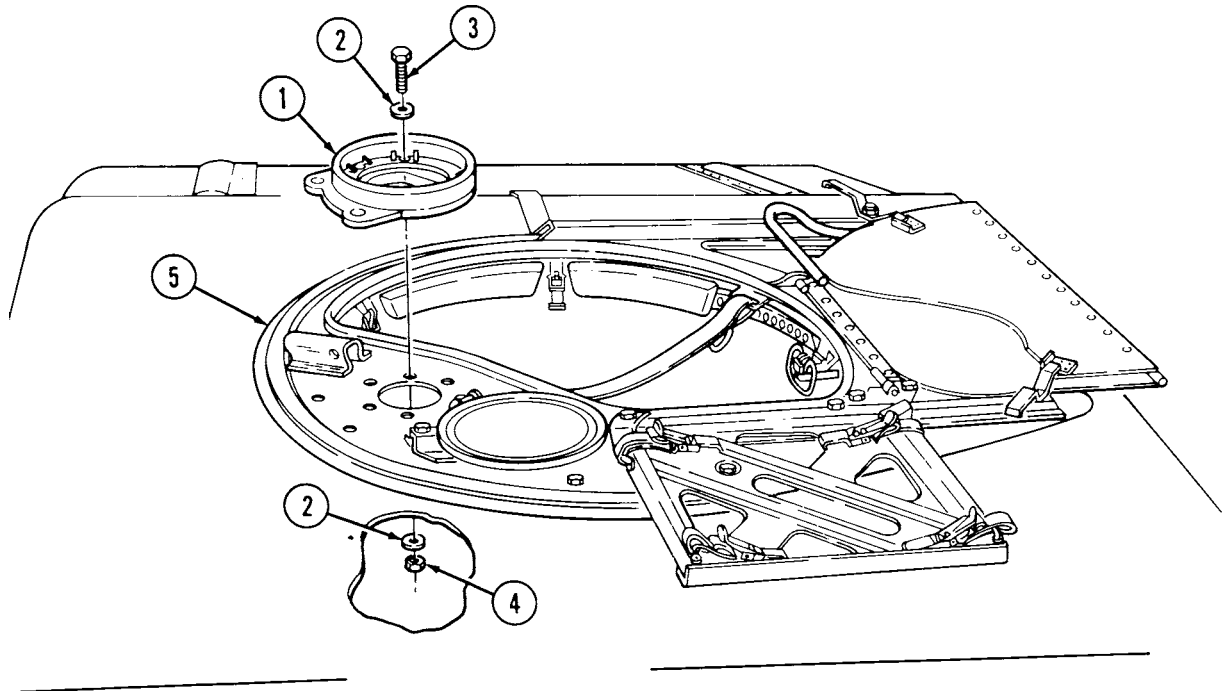

11-58. TOW MOUNT PEDESTAL COVER REPLACEMENT

This task covers:

a. Removal

b. Installation

INITIAL SETUP:

Applicable Models

M966, M966A1, M1036, M1045,
M1045A1, M1045A2, M1046, M1046A1, M1121

Materials/Parts

Two locknuts (Appendix G, Item 70)

Tools

General mechanic's tool kit:
automotive (Appendix B, Item 1)

Manual References

TM 9-2320-280-20P

a. Removal

Remove two locknuts (5), washers (1), capscrews (2), washers (1), and TOW mount pedestal cover (3) from weapon station (4). Discard locknuts (5).

b. Installation

Install TOW mount pedestal cover (3) on weapon station (4) with two washers (1), capscrews (2), washers (1), and locknuts (5). Tighten locknuts (5) to 65 lb-in. (7 N•m).

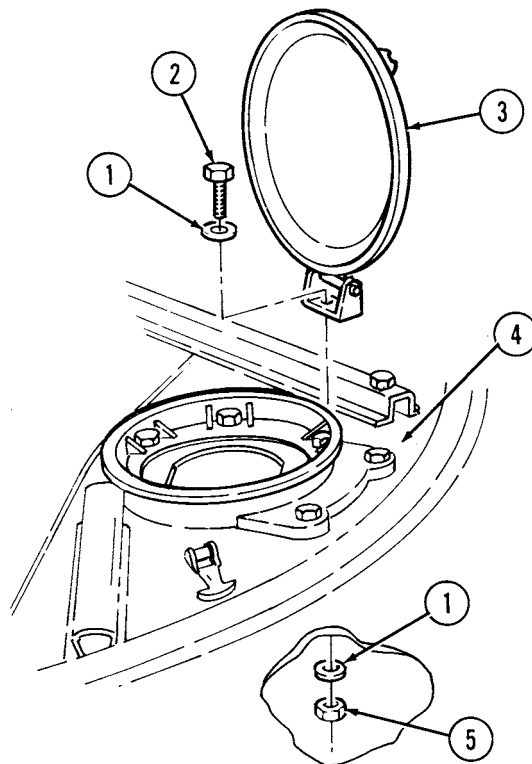

11-59. TOW MISSILE GUIDANCE SYSTEM PAN REPLACEMENT

This task covers:

a. Removal

b. Installation

INITIAL SETUP:

Applicable Models

M966, M966A1, M1036, M1045, M1045A1, M1045A2, M1046, M1046A1, M1121

Materials/Parts

Five locknuts (Appendix G, Item 128)

Tools

General mechanic's tool kit:
automotive (Appendix B, Item 1)

Manual References

TM 9-2320-280-24P

a. Removal

NOTE

Note locations of capscrews for installation.

1. Remove locknut (7), washer (6), washer (5), capscrew (4), and washer (3) from TOW MGS pan (12) and weapon station (8). Discard locknut (7).
2. Remove four locknuts (9), washers (10), capscrews (2), washers (1), TOW MGS pan (12), and three washers (11) from weapon station (8). Discard locknuts (9).

b. Installation

1. Install three washers (11) and TOW MGS pan (12) on weapon station (8) with four washers (1), capscrews (2), washers (10), and locknuts (9).
2. Secure TOW MGS pan (12) to weapon station (8) with washer (3), capscrew (4), washer (5), washer (6), and locknut (7).
3. Tighten locknuts (9) and (7) to 12 lb-ft (16 N·m).

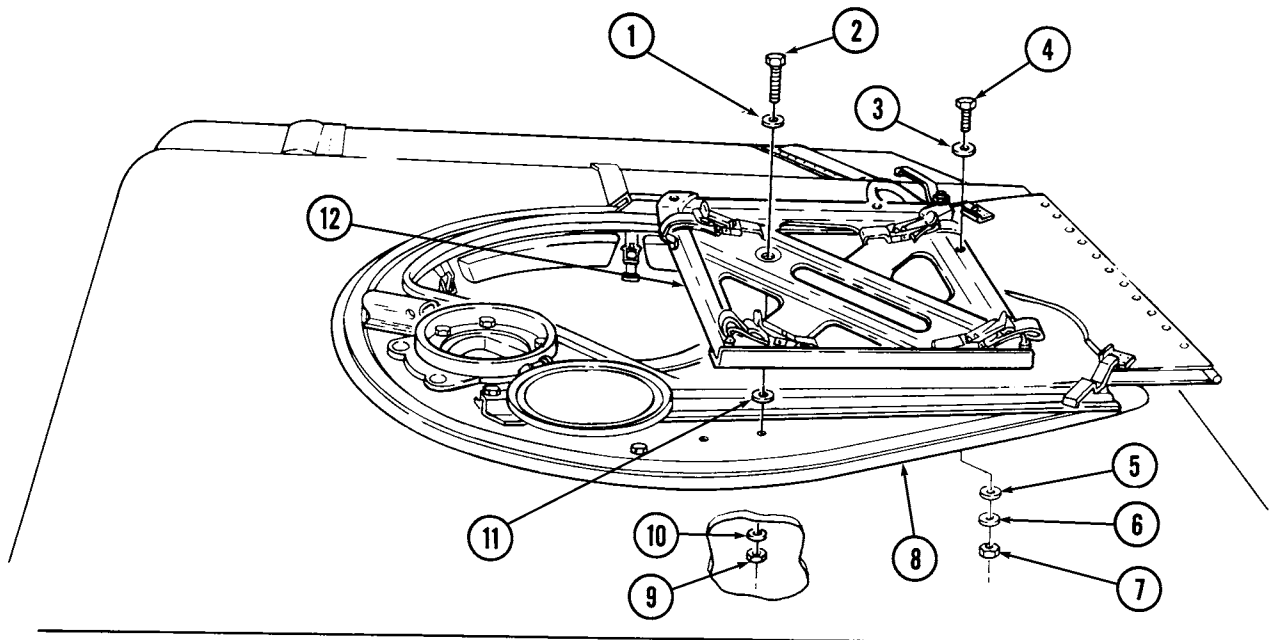

11-60. WEAPON STATION INCLINOMETER REPLACEMENT

This task covers:

a. Removal

b. Installation

INITIAL SETUP:

Applicable Models

M966, M966A1, M1036, M1045, M1045A1,
M1045A2, M1046, M1046A1, M1121

Manual References

TM 9-2320-280-24P

Tools

General mechanic's tool kit:
automotive (Appendix B, Item 1)

a. Removal

Remove two screws (4), washers (3), and inclinometer (1) from weapon station (2).

b. Installation

Install inclinometer (1) on weapon station (2) with two washers (3) and screws (4).

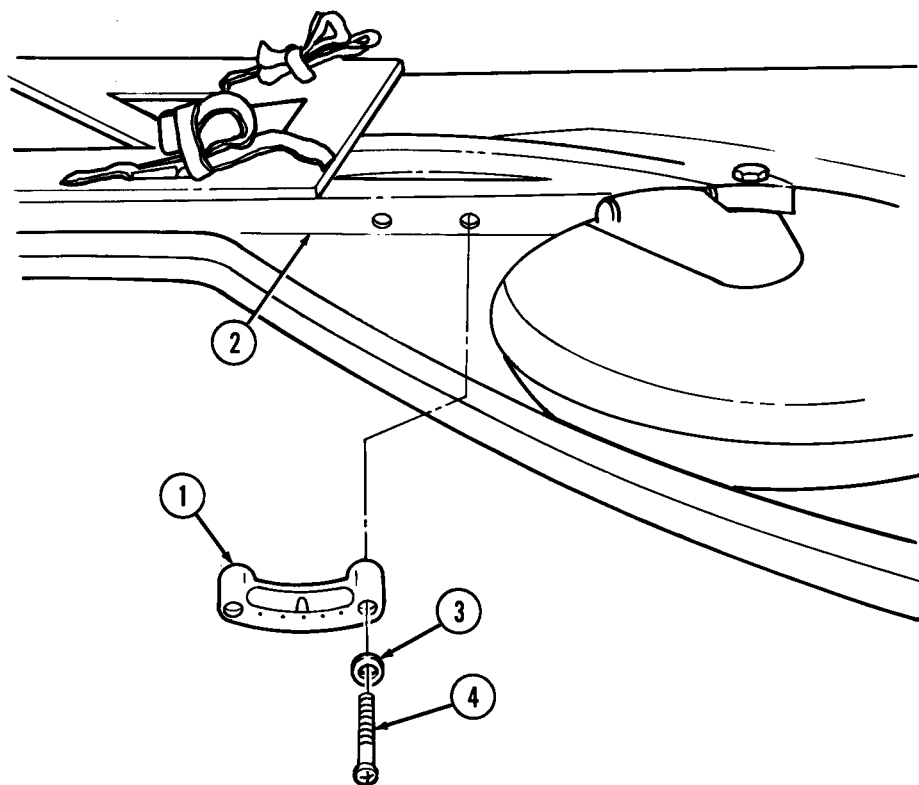

11-61. ARMAMENT MOUNTING ASSEMBLY REPLACEMENT

This task covers:

a. Removal

b. Installation

INITIAL SETUP:

Applicable Models

M1025, M1025A1, M1025A2, M1026, M1026A1,
M1043, M1043A1, M1043A2, M1044, M1044A1

Materials/Parts

Six locknuts (Appendix G, Item 128)

Tools

General mechanic's tool kit:
automotive (Appendix B, Item 1)

Manual References

TM 9-2320-280-24P

a. Removal

NOTE

- Note locations of capscrews for installation.
- Later production vehicles are equipped with a spacer.

1. Remove pin (7) and adapter (3) from armament mounting assembly (4).
2. Remove six locknuts (5), washers (1), capscrews (2), washers (1), armament mounting assembly (4), and spacers (6), if installed, from weapon station (8). Discard locknuts (5).

b. Installation

1. Install six spacers (6), if removed, and armament mounting assembly (4) on weapon station (8) with six washers (1), capscrews (2), washers (1), and locknuts (5). Tighten locknuts (5) to 37 lb-ft (50 N•m).
2. Install adapter (3) on armament mounting assembly (4) with pin (7).

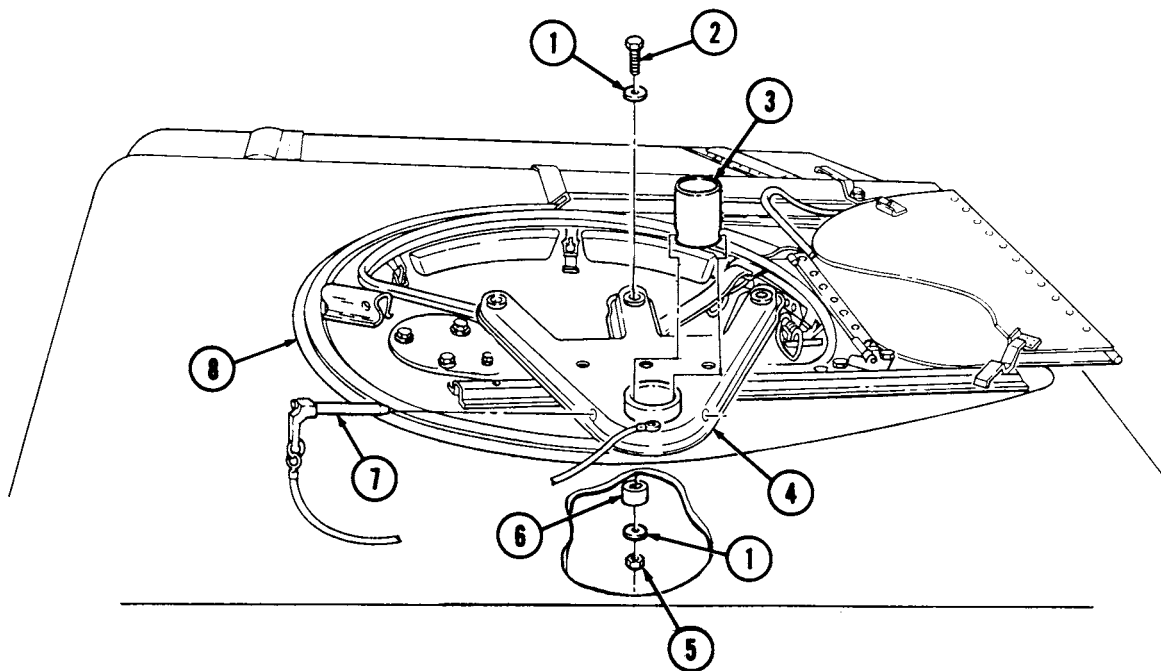

11-62. ARMAMENT COVER AND SEAL REPLACEMENT

This task covers:

a. Removal

b. Installation

INITIAL SETUP:

Applicable Models

M1025, M1025A1, M1025A2, M1026, M1026A1,
M1043, M1043A1, M1043A2, M1044, M1044A1

Materials/Parts

Three locknuts (Appendix G, Item 128)
Locknut (Appendix G, Item 70)

Tools

General mechanic's tool kit:
automotive (Appendix B, Item 1)

Manual References

TM 9-2320-280-24P

a. Removal

NOTE

Note locations of capscrews for installation.

1. Remove locknut (6), washer (4), capscrew (3), and washer (4) from armament cover (5) and weapon station (8). Discard locknut (6).
2. Remove three locknuts (7), washers (1), capscrews (2), washers (1), and armament cover (5) from weapon station (8). Discard locknuts (7).
3. Remove seal (10) from armament cover (5). Clean armament cover (5) to remove adhesive.

b. Installation

1. Peel paper backing (9) from seal (10) and apply seal (10) to armament cover (5).
2. Install armament cover (5) on weapon station (8) with three washers (1), capscrews (2), washers (1), and locknuts (7).
3. Secure armament cover (5) to weapon station (8) with washer (4), capscrew (3), washer (4), and locknut (6).
4. Tighten locknut (6) to 65 lb-in. (7 N·m). Tighten locknuts (7) to 12 lb-ft (16 N·m).

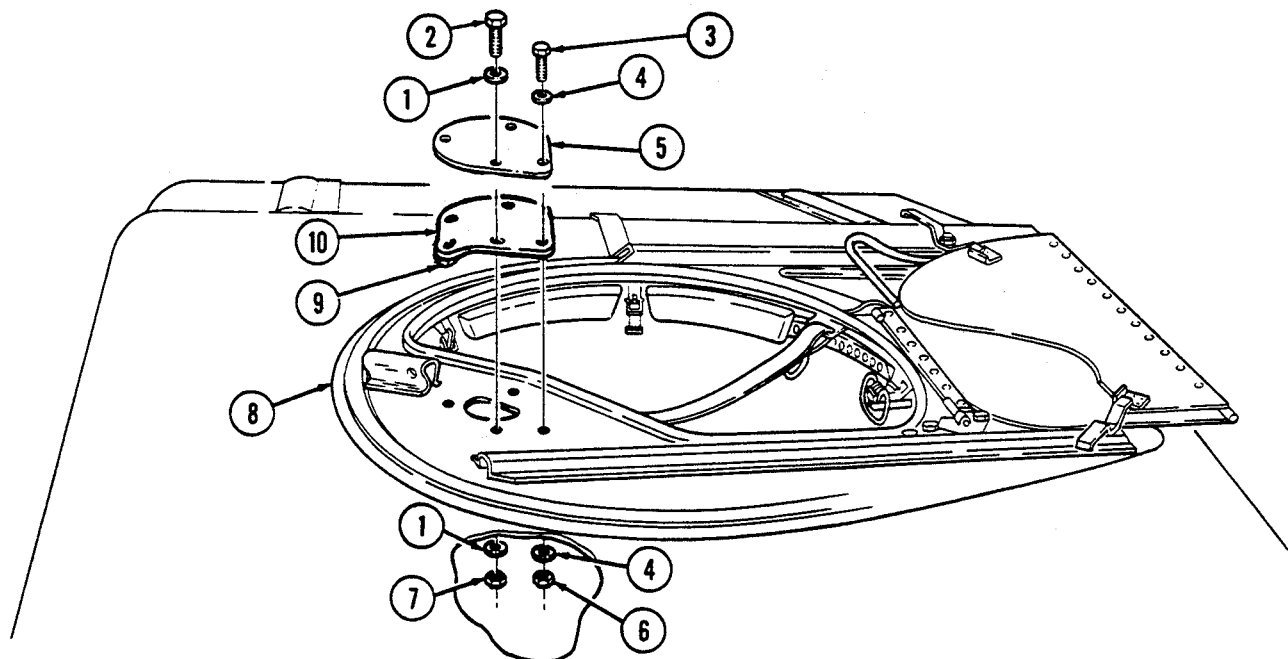

11-63. GUNNER'S PLATFORM REPLACEMENT

This task covers:

a. Removal

b. Installation

INITIAL SETUP:

Applicable Models

All models except M996, M996A1, M997, M997A1, M997A2, M998, M998A1, M1035, M1035A1, M1035A2, M1037, M1038, M1038A1, M1042, M1097, M1097A1, M1097A2

Manual References

TM 9-2320-280-10
TM 9-2320-280-24P

Tools

General mechanic's tool kit:
automotive (Appendix B, Item 1)

a. Removal

1. Remove four capscrews (3) and washers (2) from two guides (7) and remove four channel nuts (6) from gunner's platform (1).
2. Remove two pins (4) from gunner's platform (1).

NOTE

Tag location of guides for installation.

3. Slowly lift front of gunner's platform (1) and remove two guides (7) and four channel nuts (6) from pin receptacles (8) on forward risers (5).
4. Tilt gunner's platform (1) all the way back.
5. Remove two nuts (10), washers (11), and shoulder bolts (13) from rear brackets (12) and rear risers (9) and remove gunner's platform (1).
6. Remove footman loops and straps (para. 10-9) from gunner's platform (1).

b. Installation

1. Install footman loops and straps (para. 10-9) on gunner's platform (1).
2. Install rear brackets (12) on rear risers (9) and install gunner's platform (1) with two shoulder bolts (13), washers (11), and nuts (10). Tighten nuts (10) to 10-15 lb-ft (14-20 N•m).
3. Slide two channel nuts (6) in guides (7), align with front hole in guide (7), and hold in place.
4. Align two guides (7) with front holes in gunner's platform (1). Place two washers (2) on capscrews (3) and install capscrews (3) through front holes in gunner's platform (1) and guides (7) into channel nuts (6). Tighten capscrews (3) finger tight.
5. Slide two pin receptacles (8) into guides (7).
6. Slide two rear channel nuts (6) into rear of guides (7), align with rear holes in gunner's platform (1) by moving front of gunner's platform (1) slightly up and down, and install washers (2) and capscrews (3) in channel nuts (6).
7. Install two pins (4) on rear side holes, and tighten four capscrews (3) to 6 lb-ft (8 N•m).

11-63. GUNNER'S PLATFORM REPLACEMENT (Cont'd)

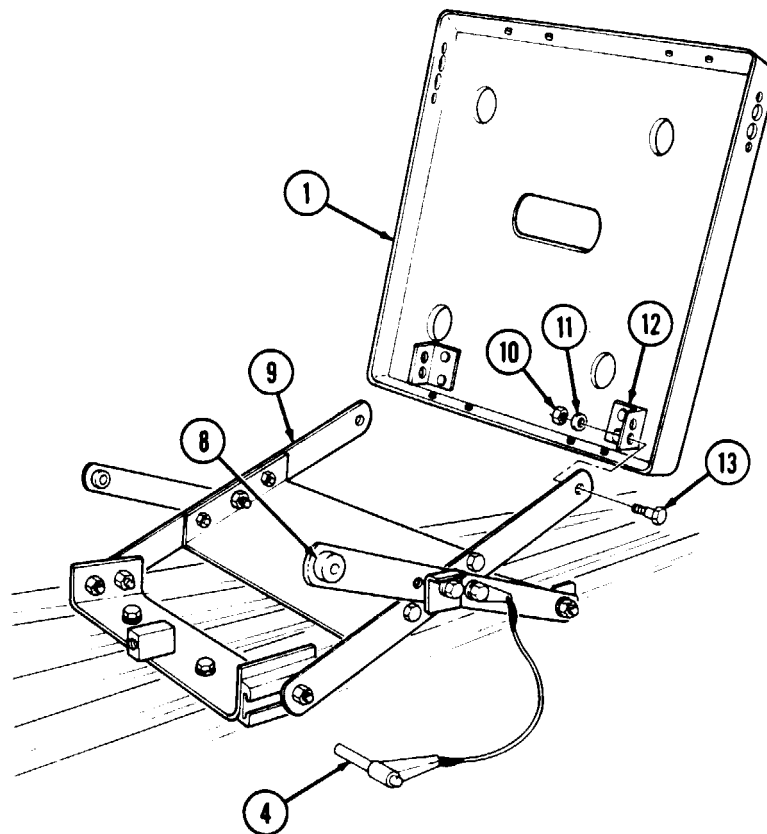
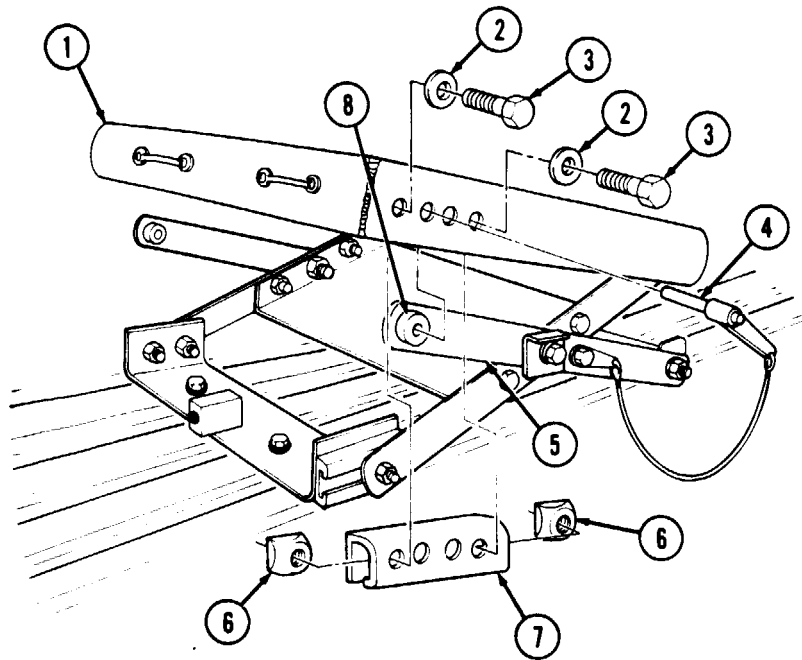

FOLLOW-ON TASK: Check operation of gunner's platform (TM 9-2320-280-10).

11-64. GUNNER'S PLATFORM ASSEMBLY MAINTENANCE

This task covers:

a. Disassembly

b. Assembly

INITIAL SETUP:

Applicable Models

All models except M996, M996A1, M997, M997A1, M997A2, M998, M998A1, M1035, M1035A1, M1035A2, M1037, M1038, M1038A1, M1042, M1097, M1097A1, M1097A2

Tools

General mechanic's tool kit:
automotive (Appendix B, Item 1)

Materials/Parts

Six locknuts (Appendix G, Item 111)
Four locknuts (Appendix G, Item 109)
Two locknuts (Appendix G, Item 110)

Personnel Required

One mechanic
One assistant

Manual References

TM 9-2320-280-24P

Equipment Condition

- Gunner's platform removed (para. 11-63).
- Gunner's platform assembly removed (para. 11-65).

a. Disassembly

1. Remove two locknuts (5), washers (4), shoulder bolts (2), and outer risers (3) from rear mounting bracket (6). Discard locknuts (5).
2. Remove riser assembly (1) from front mounting bracket (7).
3. Remove two locknuts (9), washers (10), capscrews (17), spacers (12), outer risers (3), and latches (18) from inner risers (11). Discard locknuts (9).
4. Remove two locknuts (13), washers (14), capscrews (16), and two pin-and-lanyard assemblies (15) from outer risers (3). Discard locknuts (13).
5. Remove four locknuts (24), washers (23), capscrews (19), and inner risers (11) from stiffener plate (8). Discard locknuts (24).
6. Remove two locknuts (20), washers (21), and guide pin bolts (22) from inner risers (11). Discard locknuts (20).

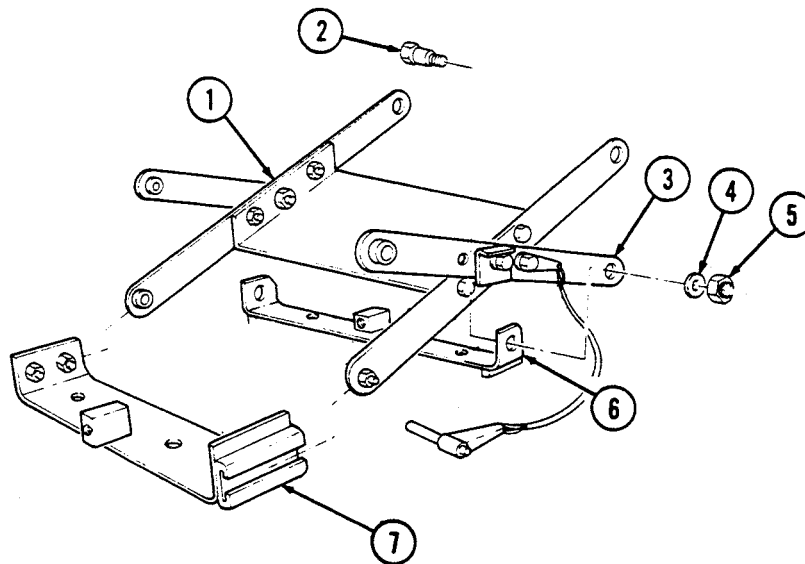

11-64. GUNNER'S PLATFORM ASSEMBLY MAINTENANCE (Cont'd)

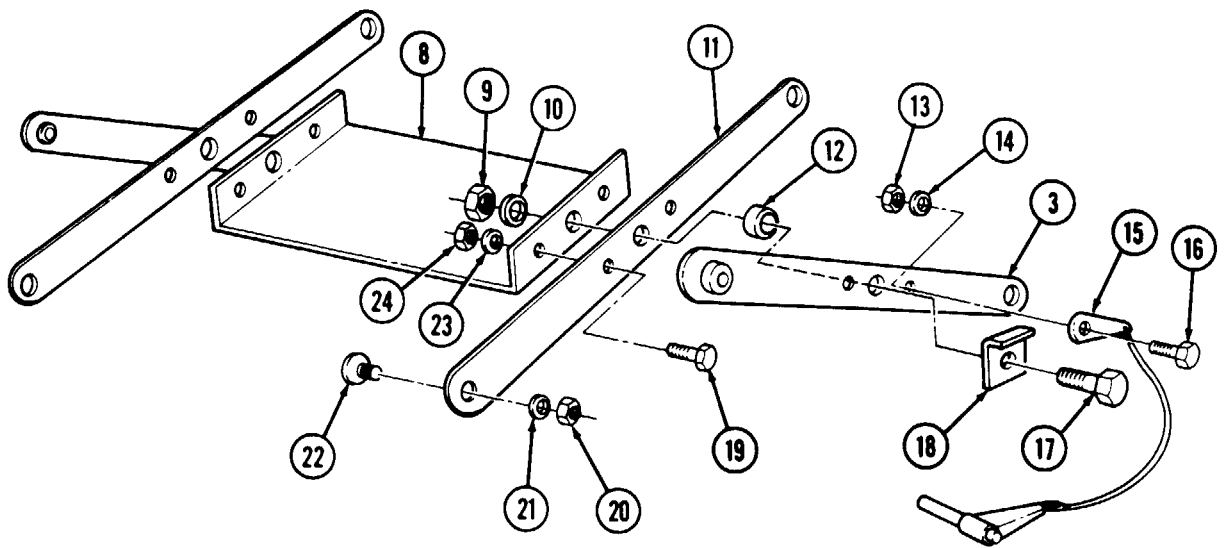

11-64. GUNNER'S PLATFORM ASSEMBLY MAINTENANCE (Cont'd)

b. Assembly

1. Install two guide pin bolts (17) on inner risers (4) with two washers (16) and locknuts (15). Tighten locknuts (15) to 10-15 lb-ft (14-20 N•m).

NOTE

Make sure heads of guide pin bolts are installed inward, facing each other.

2. Install inner risers (4) on stiffener plate (1) with four capscrews (14), washers (18), and locknuts (19). Tighten locknuts (19) to 6 lb-ft (8 N•m).
3. Install two pin-and-lanyard assemblies (8) on outer risers (12), on same side as pin receptacles (13), with two capscrews (9), washers (7), and locknuts (6). Tighten locknuts (6) to 6 lb-ft (8 N•m).
4. Install two spacers (5), outer risers (12), and latches (11) on inner risers (4) ensuring pin receptacles (13) are facing outward, with two capscrews (10), washers (3), and locknuts (2). Tighten locknuts (2) to 6 lb-ft (8 N•m), then back off locknuts 1/4 to 1/2 turn to allow outer risers (12) to pivot freely.
5. Install guide pin bolts (17) on front mounting bracket (24) tracks, and install outer risers (12) on rear mounting bracket (21) with two shoulder bolts (20), washers (22), and locknuts (23). Tighten locknuts (23) to 10-15 lb-ft (14-20 N•m).

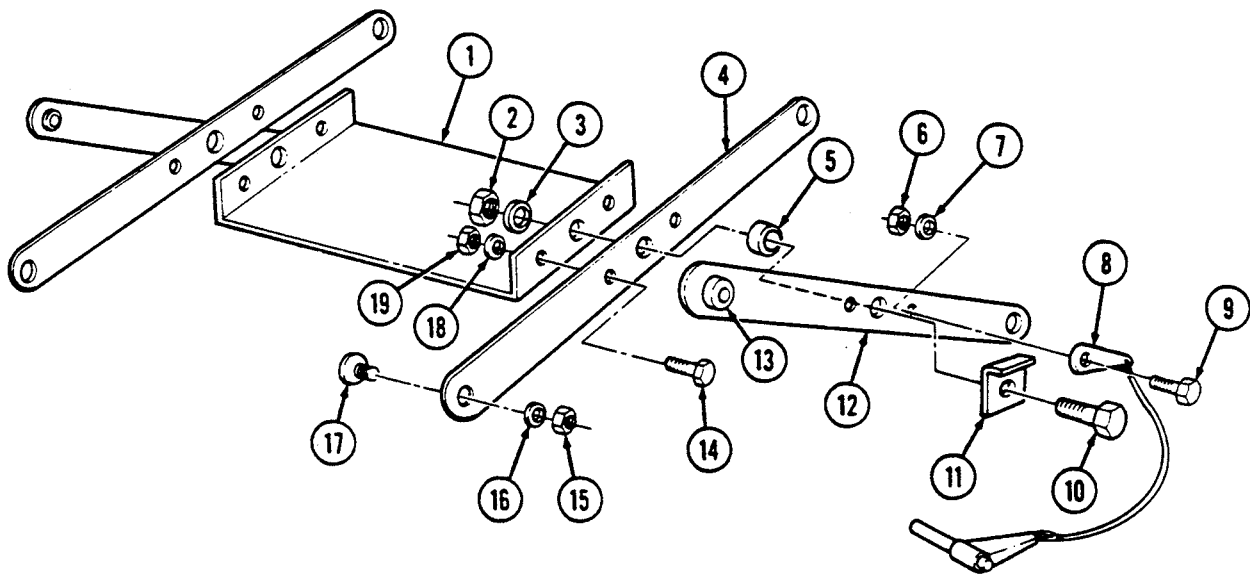

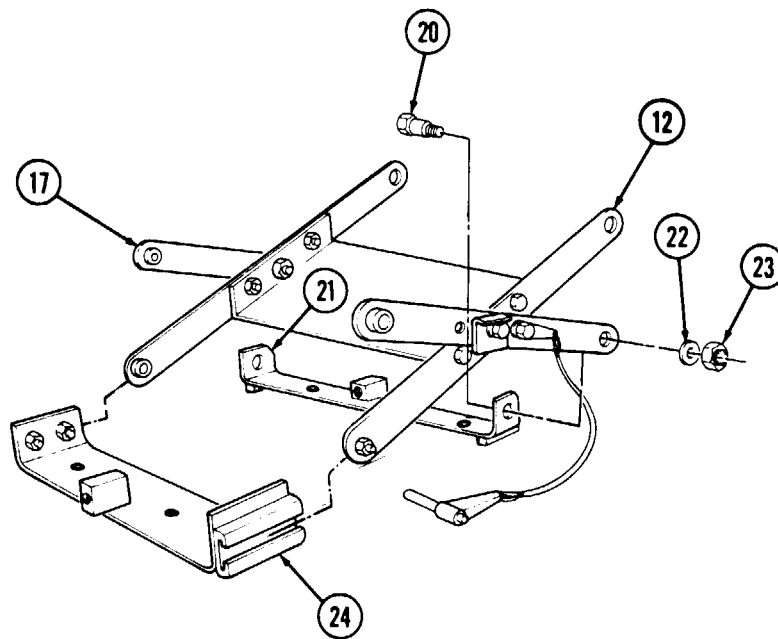
11-64. GUNNER'S PLATFORM ASSEMBLY MAINTENANCE (Cont'd)

- FOLLOW-ON TASKS:**
- Install gunner's platform (para. 11-63).
 - Install gunner's platform assembly (para. 11-65).

11-65. GUNNER'S PLATFORM ASSEMBLY REPLACEMENT

This task covers:

a. Removal

b. Installation

INITIAL SETUP:

Applicable Models

All models except M996, M996A1, M997, M997A1, M997A2, M998, M998A1, M1035, M1035A1, M1035A2, M1037, M1038, M1038A1, M1042, M1097, M1097A1, M1097A2

Tools

General mechanic's tool kit:
automotive (Appendix B, Item 1)

Materials/Parts

Five locknuts (Appendix G, Item 90)

Personnel Required

One mechanic
One assistant

Manual References

TM 9-2320-280-24P

a. Removal

1. Remove two locknuts (11), washers (9), reinforcement brackets (10), capscrews (8), and washers (9) from front gunner's platform bracket (7) and cargo floor (5). Discard locknuts (11).
2. Remove three locknuts (6), washers (3), capscrews (2), washers (3), gunner's platform assembly (1), and rear gunner's bracket (4) from cargo floor (5). Discard locknuts (6).

b. Installation

1. Install gunner's platform assembly (1) and rear gunner's platform bracket (4) on cargo floor with three washers (3), capscrews (2), washers (3), and locknuts (6).
2. Install front bracket (7) on cargo floor (5) with two washers (9), capscrews (8), reinforcement brackets (10), washers (9), and locknuts (11). Tighten capscrews (2) and (8) to 21 lb-ft (29 N·m).

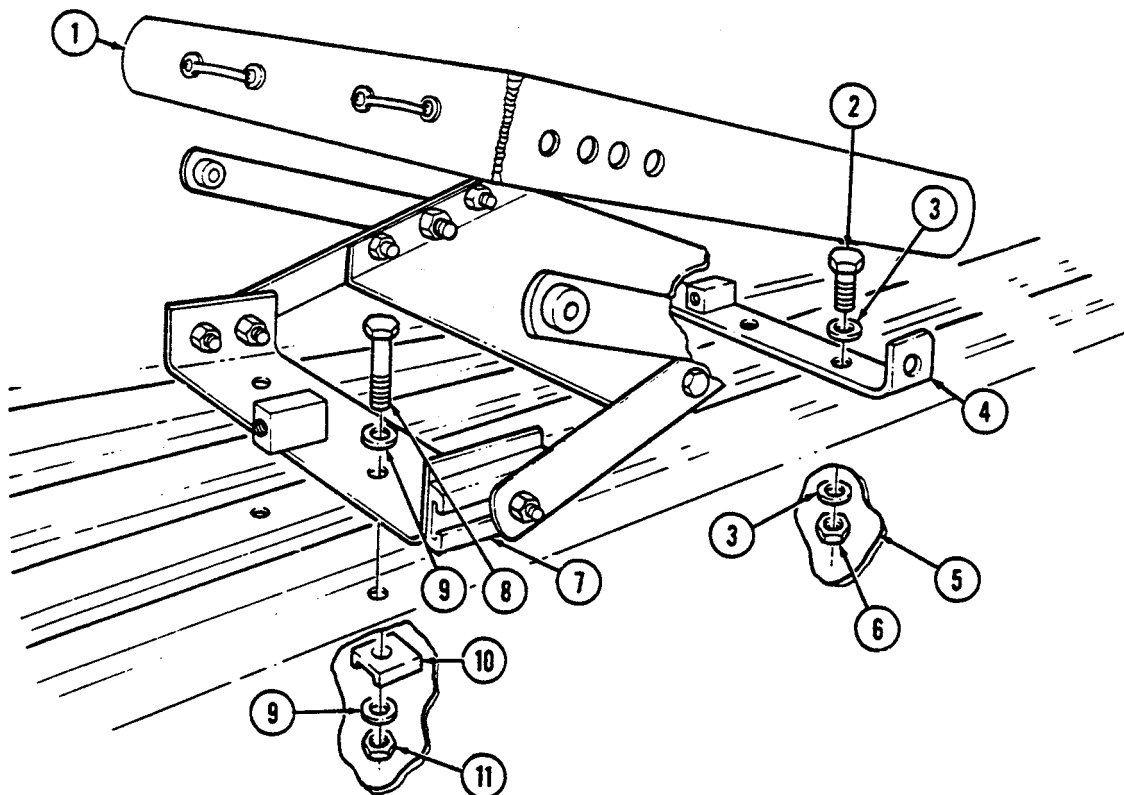

11-66. VEHICLE POWER CONDITIONER (VPC) MOUNTING BRACKET REPLACEMENT

This task covers:

a. Removal

b. Installation

INITIAL SETUP:

Applicable Models

M966, M966A1, M1036, M1045, M1045A1,
M1045A2, M1046, M1046A1

Tools

General mechanic's tool kit:
automotive (Appendix B, Item 1)

Materials/Parts

Four locknuts (Appendix G, Item 96)

Manual References

TM 9-2320-280-24P

a. Removal

Remove four locknuts (5), washers (4), screws (1), and vehicle power conditioner (VPC) mounting bracket (3) from underside of radio rack (2). Discard locknuts (5).

b. Installation

Install VPC mounting bracket (3) on underside of radio rack (2) with four screws (1), washers (4), and locknuts (5). Tighten locknuts (5) to 6 lb-ft (8 N·m).

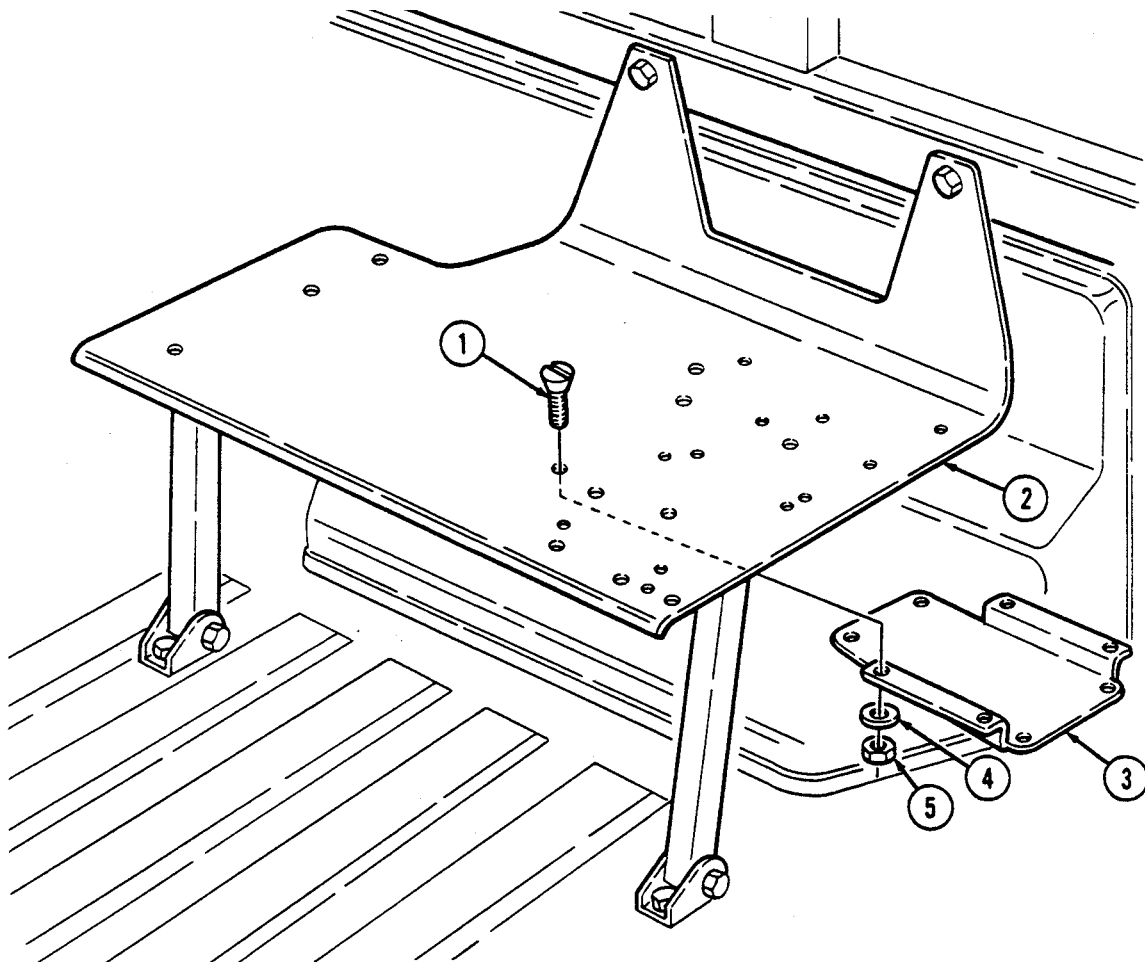

11-67. TOW WIRING HARNESS REPLACEMENT

This task covers:

a. Removal

b. Installation

INITIAL SETUP:

Applicable Models

M966, M966A1, M1036, M1045, M1045A1, M1045A2, M1046, M1046A1

Tools

General mechanic's tool kit:
automotive (Appendix B, Item 1)

Materials/Parts

Grease (Appendix C, Item 24)
Two lockwashers (Appendix G, Item 133)
Eight plain-assembled nuts (Appendix G, Item 201)
Lockwasher (Appendix G, Item 148)
Lockwasher (Appendix G, Item 141)
Four plain-assembled nuts (Appendix G, Item 202)

Manual References

TM 43-0139
TM 9-2320-280-24P

Equipment Condition

Battery ground cable disconnected (para. 4-73).

a. Removal

NOTE

Perform steps 1 through 3 for vehicles with serial numbers 99,999 and below and step 4 for vehicles with serial numbers 100,000 and above.

1. Uncoil TOW wiring harness (9) and MGS power cable (7) from cable stowage cleat (10).
2. Remove plain-assembled nut (3) and clamp (2) from TOW wiring harness (9), MGS power cable (7), and support assembly (4). Discard plain-assembled nut (3).
3. Remove two plain-assembled nuts (6), screws (1), and clamps (5) from TOW wiring harness (9), MGS power cable (7), and "B" pillar (8). Discard plain-assembled nuts (6).
4. Uncoil TOW wiring harness (9) and MGS power cable (7) from cable stowage cleat (10).
5. Disconnect VPC cable (11) from connector receptacle (12).
6. Remove four plain-assembled nuts (13), screws (16), cover (15), and connector receptacle (12) from bracket (14). Discard plain-assembled nuts (13).
7. Remove two plain-assembled nuts (17), screws (19), and clamps (18) from TOW wiring harness (9) and battery box (20). Discard plain-assembled nuts (17).

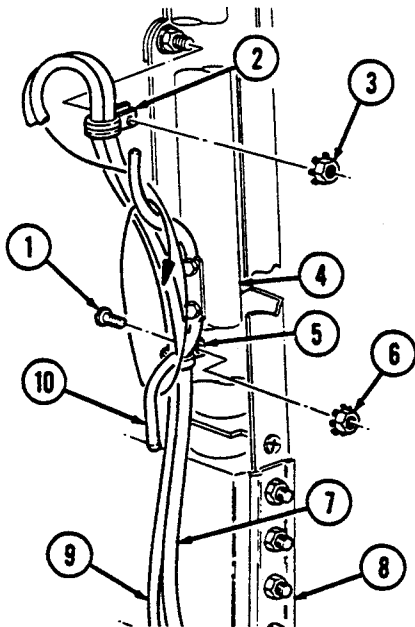

OLD CONFIGURATION

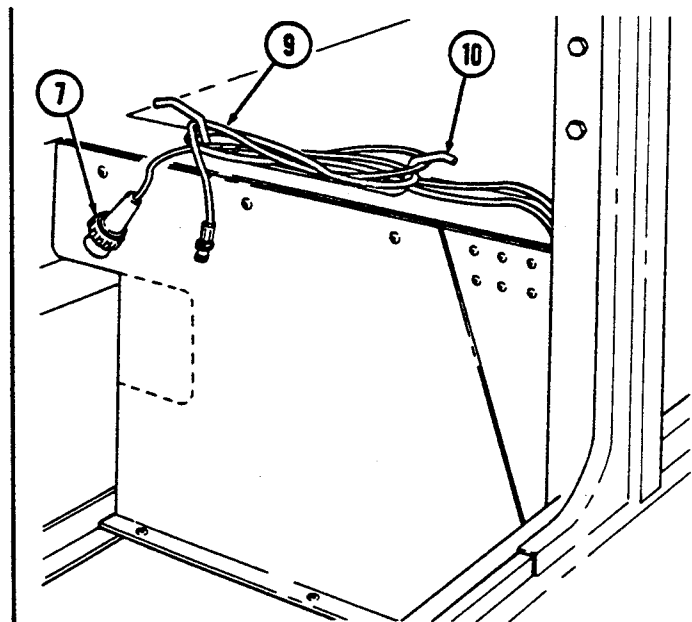

NEW CONFIGURATION

11-67. TOW WIRING HARNESS REPLACEMENT (Cont'd)

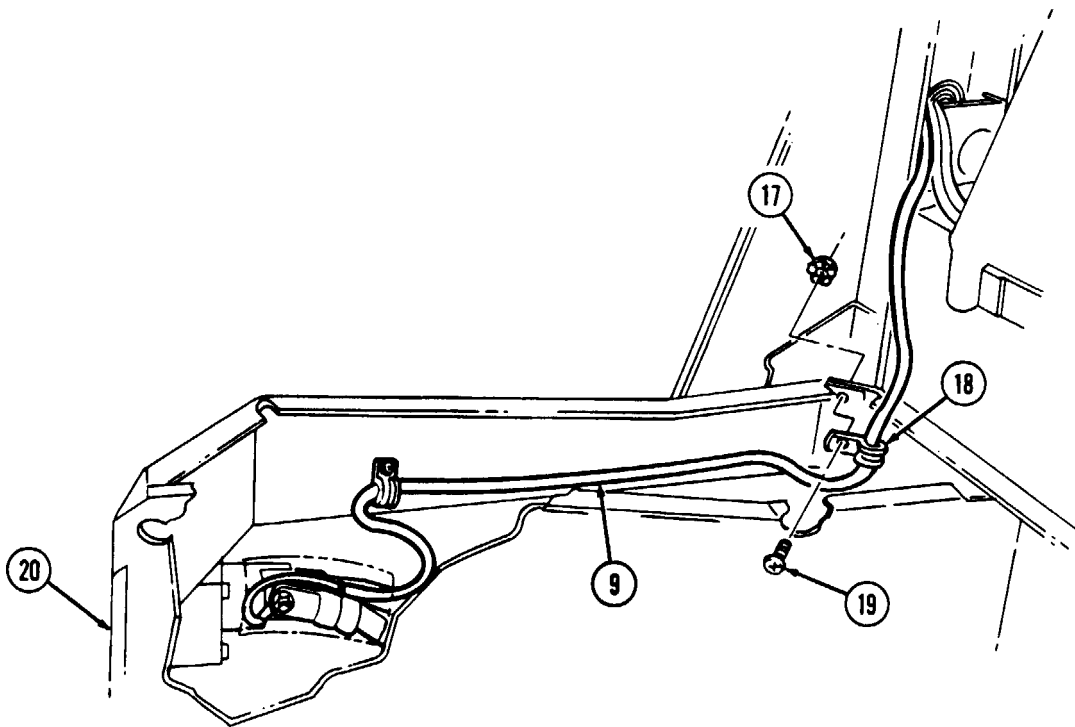
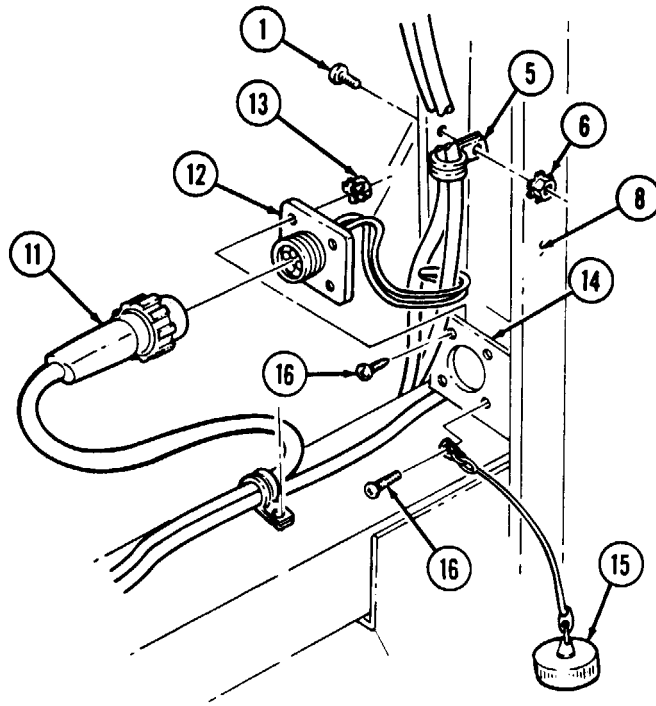

11-67. TOW WIRING HARNESS REPLACEMENT (Cont'd)

NOTE

Perform steps 8 through 10 and 14 and 15 for vehicles with serial numbers 99,999 and below, and steps 11 through 15 for vehicles with serial numbers 100,000 and above with kits 5705623 and 5705624 installed.

8. Slide rubber boot (9) back to allow access to slave receptacle (3) connections.
9. Remove capscrew (1), lockwasher (2), slave positive cable (10), and lead 49B (11) from slave receptacle (3). Discard lockwasher (2).
10. Remove capscrew (5), lockwasher (4), slave negative cable (6), and lead 50B (7) from slave receptacle (3). Remove TOW wiring harness (8) from vehicle. Discard lockwasher (4).
11. Remove plain-assembled nut (21), screw (23), and clamp (22) from TOW wiring harness (8) and battery box (18). Discard plain-assembled nut (21).
12. Remove capscrew (12), lockwasher (13), lead 50B (7), slave negative cable (6), and battery negative cable (14) from shunt (15). Discard lockwasher (13).
13. Remove nut (20), lockwasher (19), lead 49B (11), cables (17), and slave positive cable (10) from power stud (16). Discard lockwasher (19).
14. Remove two plain-assembled nuts (32), screws (24), and clamps (25) from MGS power cable (26), VPC cable (31), and body (27). Discard plain-assembled nuts (32).
15. Remove two screws (29) from retainer (30) and body (27) and pull back insulation (28). Remove MGS power cable (26) and VPC cable (31) from vehicle.

b. Installation

1. Install MGS power cable (26) and VPC cable (31) on approximate mounting location in vehicle.
2. Install insulation (28) over MGS power cable (26) and VPC cable (31) and install retainer (30) to body (27) with two screws (29).
3. Install VPC cable (31) and MGS power cable (26) on body (27) with two clamps (25), screws (24), and plain-assembled nuts (32).
4. Install TOW wiring harness (8) in approximate mounting location on vehicle.

NOTE

Perform steps 5 through 7 and 11 for vehicles with serial numbers 99,999 and below, and steps 8 through 10 for vehicles with serial numbers 100,000 and above with kits 5705623 and 5705624 installed.

5. Connect lead 50B (7) and slave negative cable (6) to slave receptacle (3) with lockwasher (4) and capscrew (5).
6. Connect lead 49B (11) and slave positive cable (10) to slave receptacle (3) with lockwasher (2) and capscrew (1).
7. Using grease, coat receptacle (3) terminals and all exposed metal on rear of receptacle (3) and area under cap on front of receptacle (3).
8. Install lead 49B (11), slave positive cable (10), and cables (17) on power stud (16) with lockwasher (19) and nut (20). Apply grease to power stud (16) and all exposed metal.
9. Install battery negative cable (14), slave negative cable (6), and lead 50B (7) on shunt (15) with lockwasher (13) and capscrew (12).
10. Install TOW wiring harness (8) on battery box (18) with clamp (22), screw (23), and plain-assembled nut (21).
11. Slide rubber boot (9) to cover slave receptacle (3) connections.

11-67. TOW WIRING HARNESS REPLACEMENT (Cont'd)

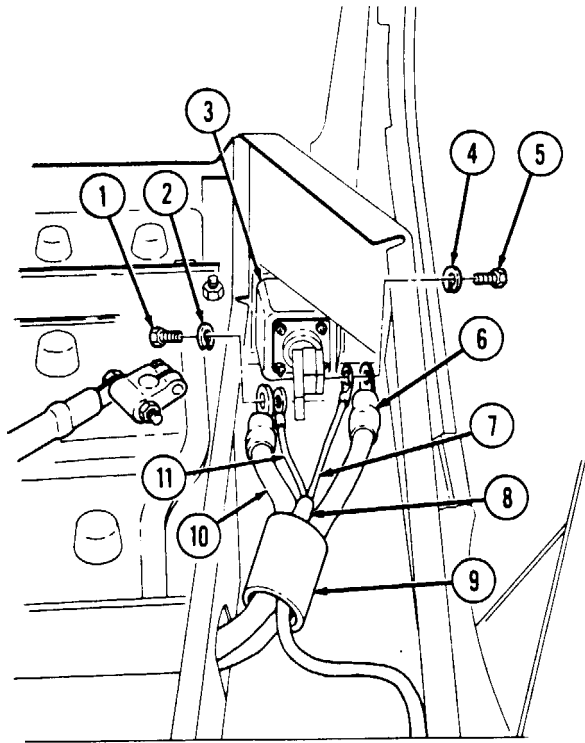

OLD CONFIGURATION

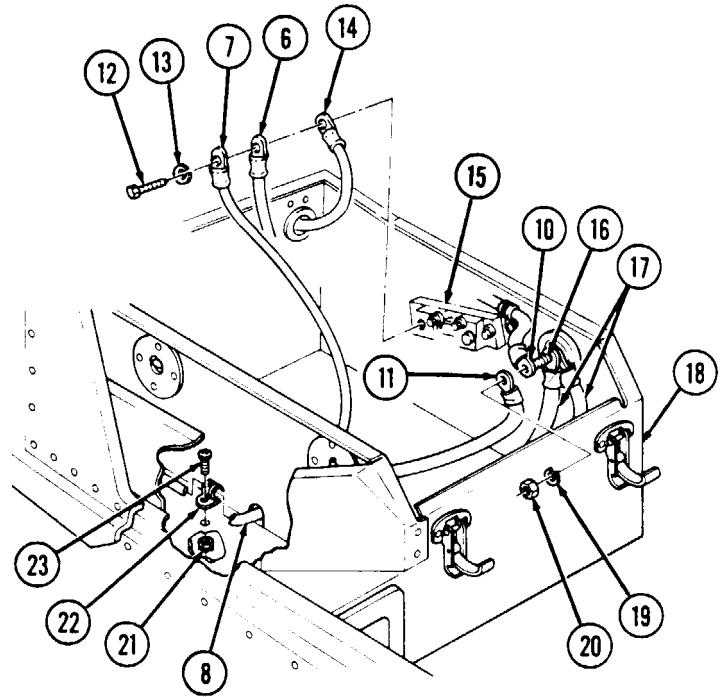

NEW CONFIGURATION

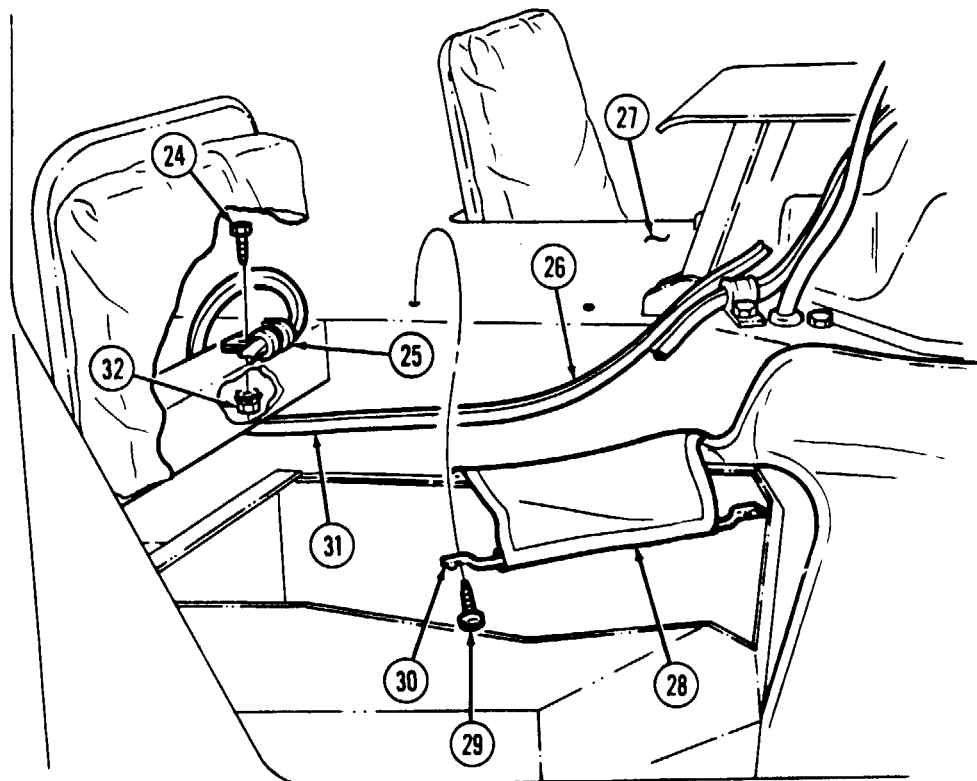

11-67. TOW WIRING HARNESS REPLACEMENT (Cont'd)

WARNING

The battery box on some HMMWV TOW carrier models M966, M966A1, M1045, M1045A1, M1045A2, M1046, or M1046A1 with serial numbers 1 through 19,410 has cut through the TOW power cable. A cut TOW power cable can cause a fire or battery explosion.

12. Inspect battery box (5) at corner where TOW wiring harness (2) exits battery box (5).
13. If the top edge of battery box (5) forms two "points" where the wiring harness (2) exits battery box (5), (before), cut off the pointed corners and file round. Spot paint, if necessary (refer to TM 43-0139). Battery box (5) should resemble (after) illustration when completed.
14. Install TOW wiring harness (2) on battery box (5) with two clamps (3), screws (4), and plain-assembled nuts (1).

NOTE

Cover chain is installed under lower right screw.

15. Install connector receptacle (7) and cover (15) on bracket (13) with four screws (16) and plain-assembled nuts (8).
16. Connect VPC cable (6) to connector receptacle (7).

NOTE

Perform steps 18 through 20 for vehicles with serial numbers 99,999 and below and step 17 for vehicles with serial numbers 100,000 and above.

17. Coil TOW wiring harness (2) and MGS power cable (10) around cable cleat (20).
18. Install TOW wiring harness (2) and MGS power cable (10) on "B" pillar (14) with two clamps (11), screws (9), and plain-assembled nuts (12).
19. Install TOW wiring harness (2) and MGS power cable (10) on support assembly (19) with clamp (17) and plain-assembled nut (18).
20. Coil TOW wiring harness (2) and MGS power cable (10) around cable stowage cleat (20).

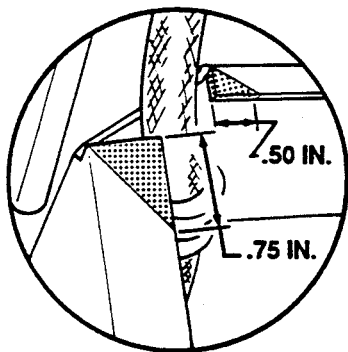

BEFORE

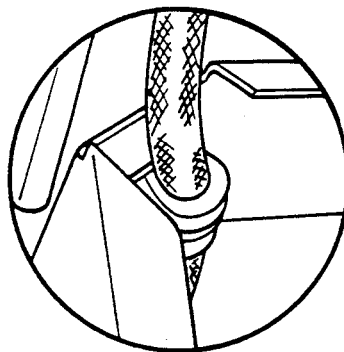

AFTER

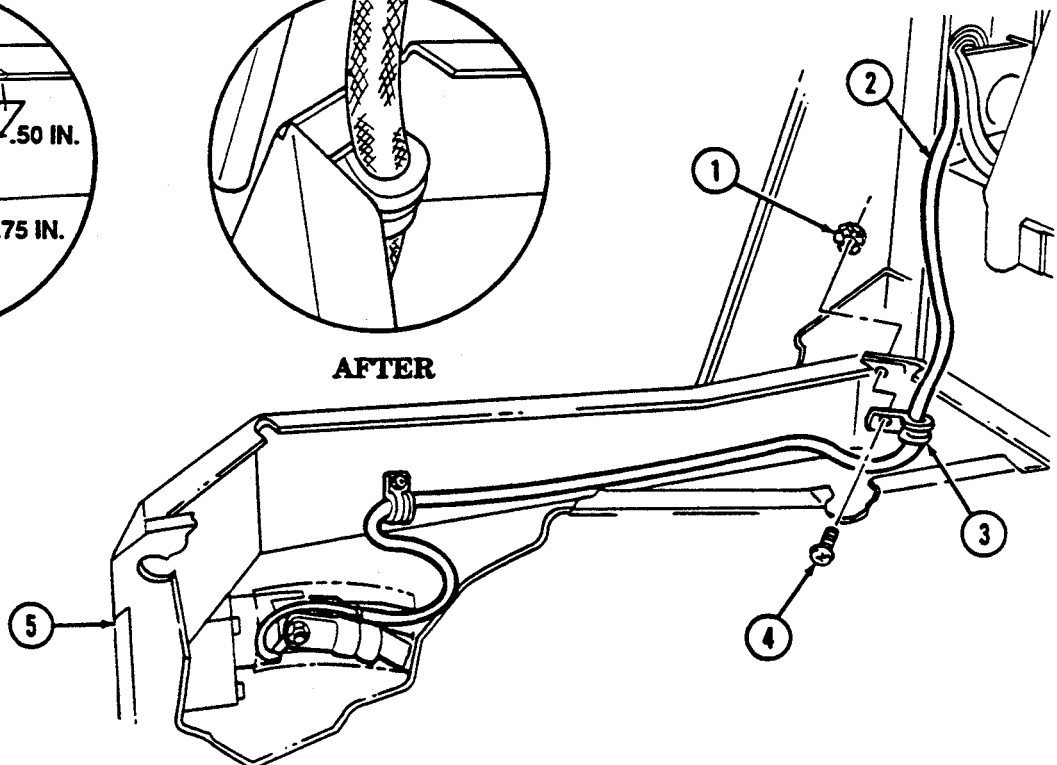

11-67. TOW WIRING HARNESS REPLACEMENT (Cont'd)

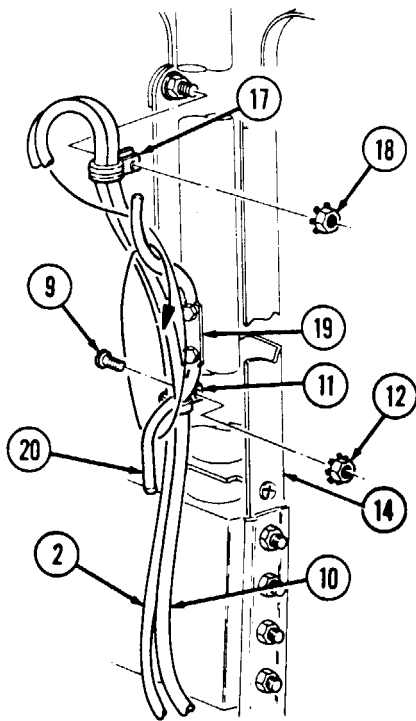
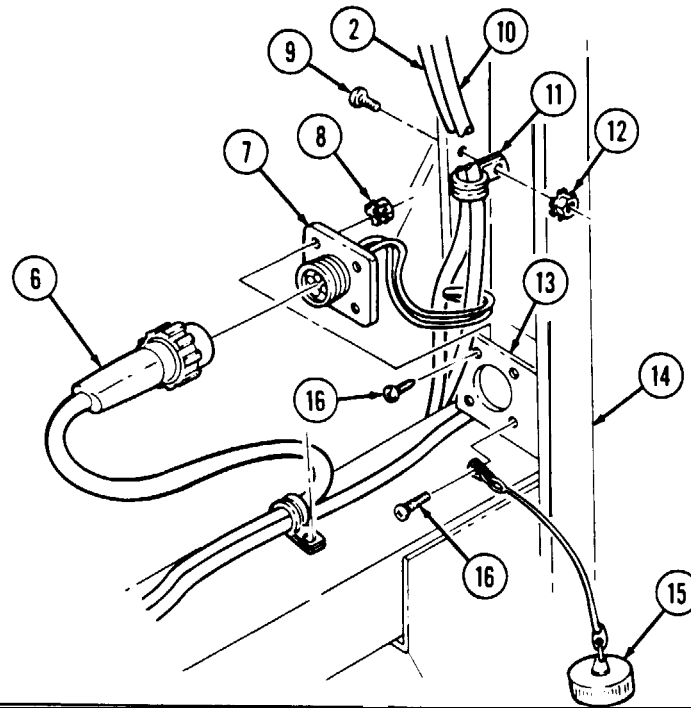

OLD CONFIGURATION

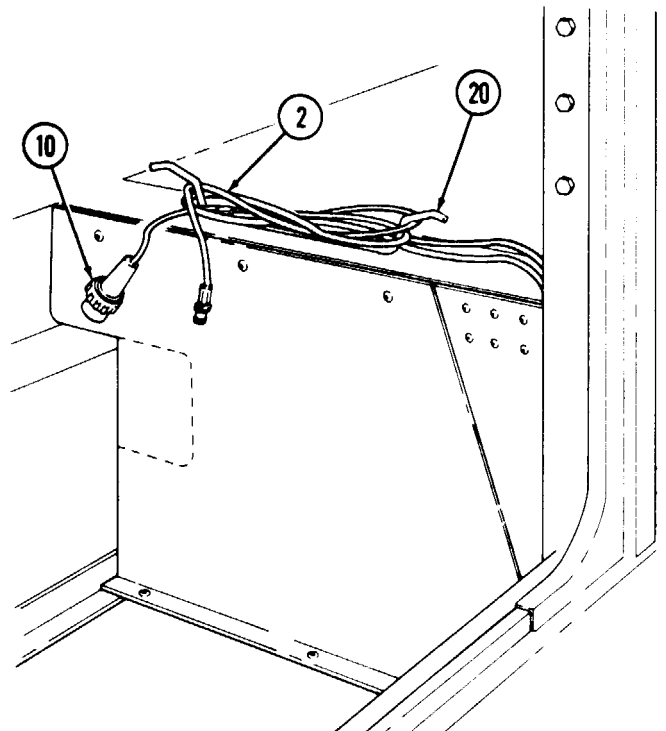

NEW CONFIGURATION

FOLLOW-ON TASK: Connect battery ground cable (para. 4-73).

11-68. CABLE STORAGE CLEAT REPLACEMENT

This task covers:

- a. Removal b. Installation

INITIAL SETUP:

Applicable Models

M966, M966A1, M1036, M1045, M1045A1,
M1045A2, M1046, M1046A1

Manual References

TM 9-2320-280-24P

Tools

General mechanic's tool kit:
automotive (Appendix B, Item 1)

a. Removal

NOTE

The cable storage cleat for vehicles with serial numbers 100,000 and above is located behind the companion seat. Removal and installation procedures are basically the same.

1. Uncoil TOW wiring harness (1) and MGS power cable (2) from cable storage cleat (6).
2. Remove two capscrews (4), washers (5), and cable storage cleat (6) from support assembly (3).

b. Installation

1. Install cable storage cleat (6) on support assembly (3) with two washers (5) and capscrews (4). Tighten capscrews (4) to 6 lb-ft (8 N·m).
2. Coil TOW wiring harness (1) and MGS power cable (2) around cable storage cleat (6).

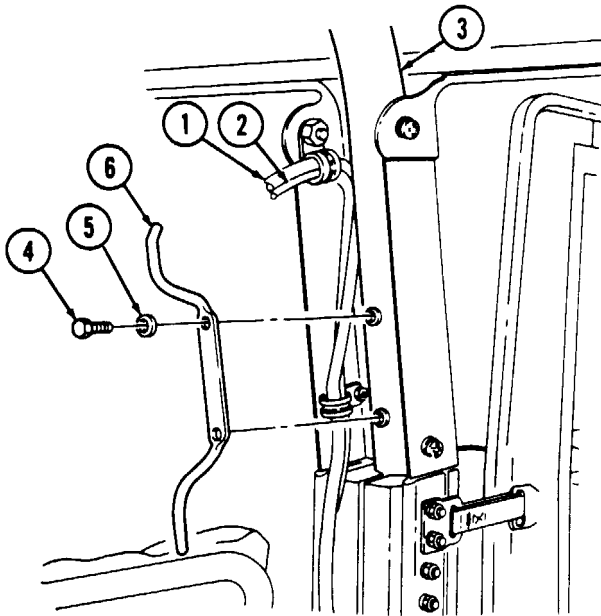

OLD CONFIGURATION

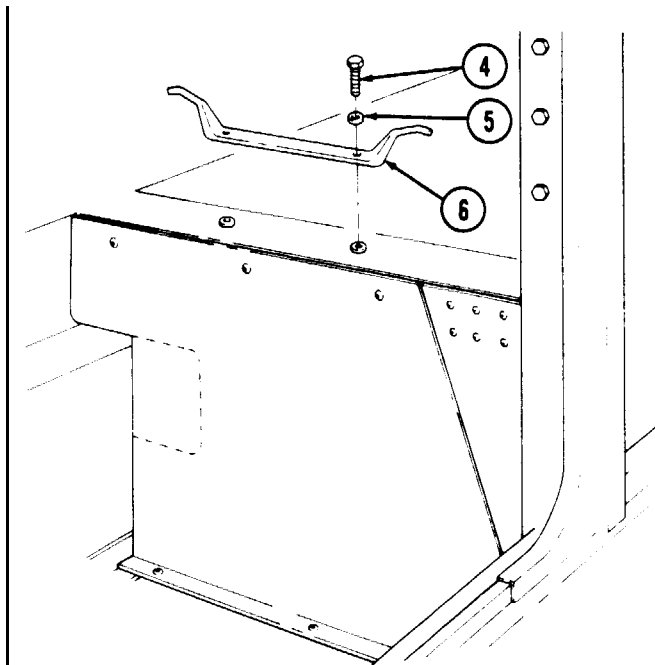

NEW CONFIGURATION

11-69. FIELD GLASSES BRACKET REPLACEMENT

This task covers:

a. Removal

b. Installation

INITIAL SETUP:

Applicable Models

M966, M966A1, M1036, M1045, M1045A1,
M1045A2, M1046, M1046A1

Tools

General mechanic's tool kit:
automotive (Appendix B, Item 1)

Materials/Parts

Three locknuts (Appendix G, Item 96)

Manual References

TM 9-2320-280-24P

a. Removal

Remove three locknuts (4), washers (5), screws (2), and field glasses bracket (1) from radio rack assembly (3). Discard locknuts (4).

b. Installation

Install field glasses bracket (1) on radio rack assembly (3) with three screws (2), washers (5), and locknuts (4). Tighten locknuts (4) to 6 lb-ft (8 N•m).

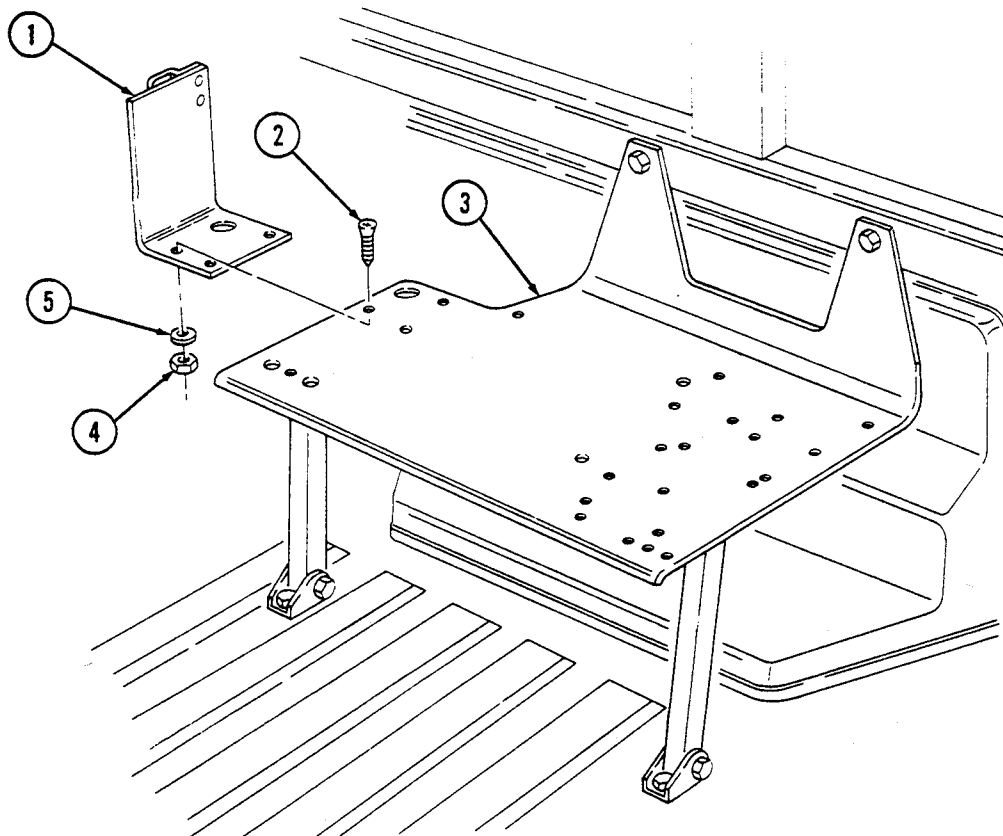

11-70. STOWAGE MOUNT BRACKET REPLACEMENT

This task covers:

a. Removal

b. Installation

INITIAL SETUP:

Applicable Models

M966, M966A1, M1036, M1045, M1045A1, M1045A2, M1046, M1046A1

Personnel Required

One mechanic
One assistant

Tools

General mechanic's tool kit:
automotive (Appendix B, Item 1)

Manual References

TM 9-2320-280-24P

Materials/Parts

Two locknuts (Appendix G, Item 70)

Equipment Condition

- Stowage pedestal removed (para. 11-71).
- Fuel tank removed (para. 3-24).

a. Removal

1. Remove two locknuts (5), washers (4), capscrews (17), and washers (4) from stowage mount bracket (3) and support bracket (12). Discard locknuts (5).
2. Remove capscrew (8), washer (9), and tiedown (10) from stowage bracket (3) and cargo floor (16).
3. Slide plate (18) in "B" beam (14) to allow access to nut (13).
4. Remove nut (13), capscrew (6), and washer (7) from stowage bracket (3), spacer (11), and cargo floor (16).
5. Remove nut (15), capscrew (2), washer (1), stowage bracket (3), and spacer (11) from cargo floor (16).

b. Installation

1. Install spacer (11) and stowage bracket (3) on cargo floor (16) with washer (1), capscrew (2), and nut (15). Tighten capscrew (2) to 37 lb-ft (50 N•m).
2. Install stowage bracket (3) on cargo floor (16) with washer (7), capscrew (6), and nut (13). Tighten capscrew (6) to 37 lb-ft (50 N•m).
3. Close plate (18) in "B" beam (14).
4. Secure stowage bracket (3) and tiedown (10) to cargo floor (16) with washer (9) and capscrew (8). Tighten capscrew (8) to 75 lb-ft (102 N•m).
5. Install stowage bracket (3) on support bracket (12) with two washers (4), capscrews (17), washers (4), and locknuts (5). Tighten locknuts (5) to 6 lb-ft (8 N•m).

11-70. STOWAGE MOUNT BRACKET REPLACEMENT (Cont'd)

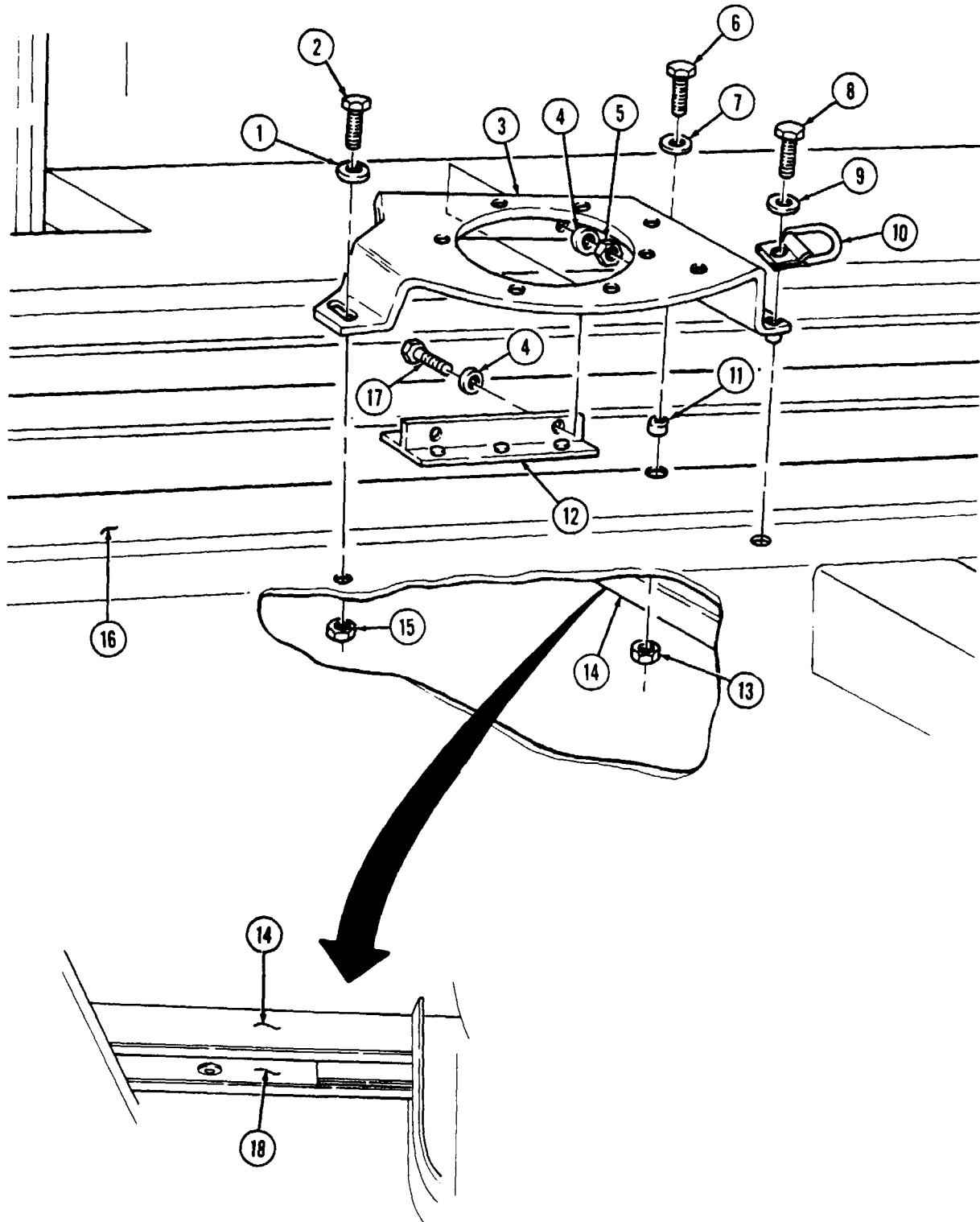

- FOLLOW-ON TASKS:
- Install fuel tank (para. 3-24).
 - Install stowage pedestal (para. 11-71).

11-71. STOWAGE PEDESTAL REPLACEMENT

This task covers:

a. Removal

b. Installation

INITIAL SETUP:

Applicable Models

M966, M966A1, M1036, M1045, M1045A1,
M1045A2, M1046, M1046A1

Manual References

TM 9-1425-450-12
TM 9-1425-472-12
TM 9-2320-280-24P

Tools:

General mechanic's tool kit:
automotive (Appendix B, Item 1)

Equipment Condition

Traversing unit mount adapter removed
(TM 9-1425-450-12, TM 9-1425-472-12).

Materials/Parts

Eight locknuts (Appendix G, Item 128)

a. Removal

Remove eight locknuts (5), washers (3), capscrews (2), washers (3), and stowage pedestal (1) from stowage mount bracket (4). Discard locknuts (5).

b. Installation

Install stowage pedestal (1) on stowage mount bracket (4) with eight washers (3), capscrews (2), washers (3), and locknuts (5). Tighten capscrews (2) to 31 lb-ft (42 N•m).

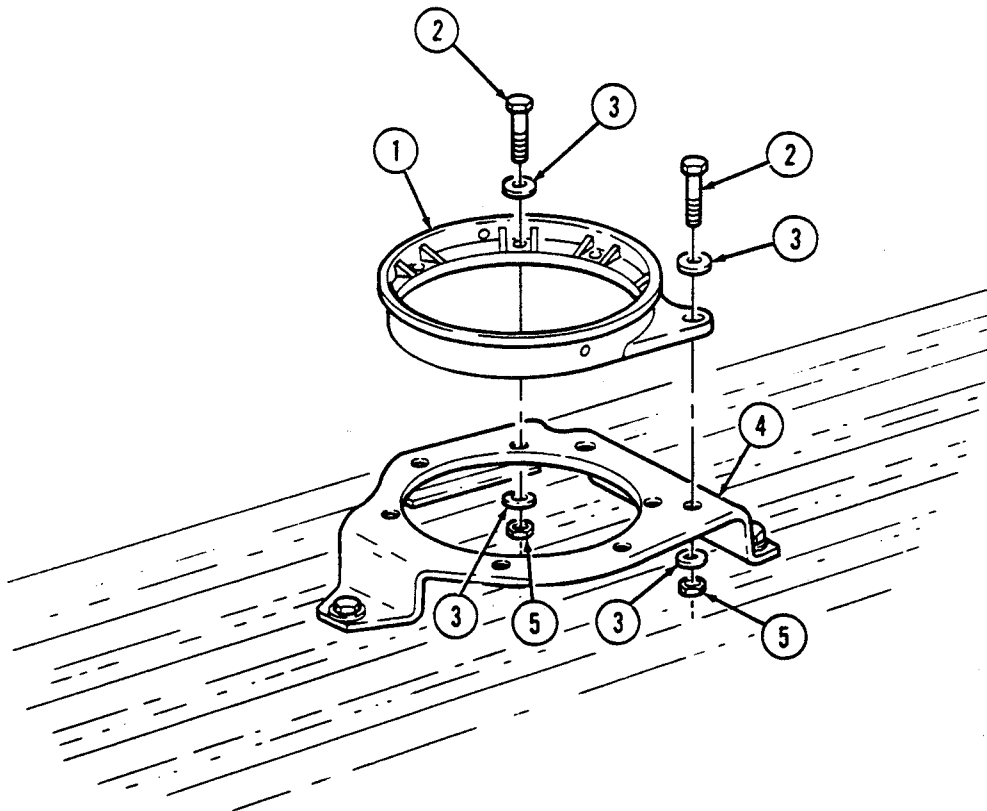

FOLLOW-ON TASK: Install traversing unit mount adapter (TM 9-1425-450-12, TM 9-1425-472-12).

11-72. TRAVERSING UNIT MOUNT ADAPTER MAINTENANCE

This task covers:

a. Disassembly

b. Assembly

INITIAL SETUP:

Applicable Models

M966, M966A1, M1036, M1045, M1045A1,
M1045A2, M1046, M1046A1

Manual References

TM 9-1425-450-12
TM 9-1425-472-12
TM 9-2320-280-24P

Tools

General mechanic's tool kit:
automotive (Appendix B, Item 1)

Equipment Condition

Traversing unit mount adapter removed
(TM 9-1425-450-12, TM 9-1425-472-12).

Materials/Parts

Six locknuts (Appendix G, Item 70)

NOTE

- Upper coupling clamp and lower coupling clamp are removed and installed the same. This procedure covers the upper coupling clamp.
- Note position of coupling clamp for installation.

a. Disassembly

Remove six locknuts (3), washers (4), capscrews (5), three retainers (6), and coupling clamp (1) from traversing unit mount adapter (2). Discard locknuts (3).

b. Assembly

Install coupling clamp (1) on traversing unit mount adapter (2) with three retainers (6), capscrews (5), washers (4), and locknuts (3). Tighten locknuts (3) to 6 lb-ft (8 N·m).

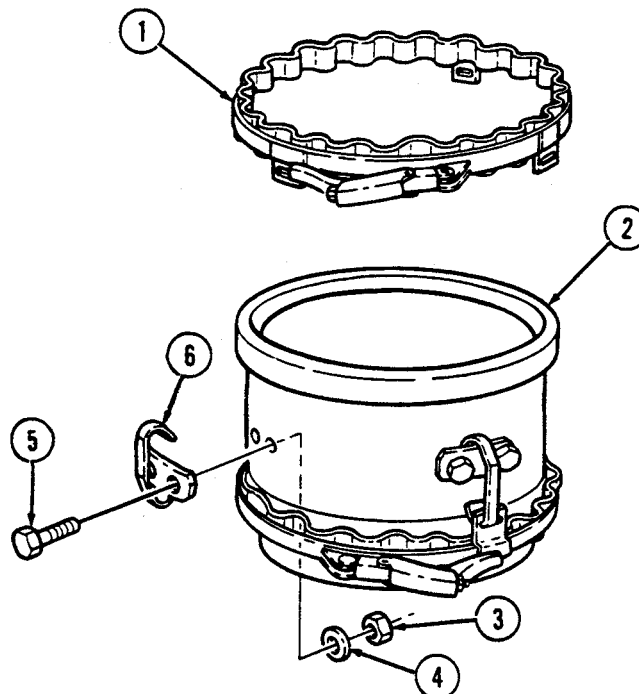

FOLLOW-ON TASK: Install traversing unit mount adapter (TM 9-1425-450-12, TM 9-1425-472-12).

11-73. ELEVATION AND DEPRESSION STOP ASSEMBLY MAINTENANCE

This task covers:

a. Disassembly

b. Assembly

INITIAL SETUP:

Applicable Models

M966, M966A1, M1036, M1045, M1045A1, M1045A2, M1046, M1046A1

Tools

General mechanic's tool kit:
automotive (Appendix B, Item 1)

Materials/Parts

Three retaining rings (Appendix G, Item 235)

Manual References

TM 9-2320-280-24P

General Safety Instructions

Note position of downward stop and upward stop for assembly.

WARNING

Note position of elevation and depression downward stop and upward stop for assembly. Injury to personnel and/or damage to equipment will result if stops are not properly assembled.

a. Disassembly

1. Remove retaining ring (3), clevis pin (15), cable end of pin assembly (14), and return spring (1) from upward stop strap (4). Discard retaining ring (3).
2. Remove pin assembly (14) and upward stop bracket (2) from upward stop strap (4).
3. Remove retaining ring (6), clevis pin (9), cable end of pin assembly (10), and return spring (8) from downward stop strap (11). Discard retaining ring (6).
4. Remove pin assembly (10) and downward stop bracket (7) from downward stop strap (11).
5. Remove retaining ring (16), clevis pin (5), socket head screw (12), and washer (13) from stop straps (4) and (11). Discard retaining ring (16).

b. Assembly

1. Install stop straps (4) and (11) together with clevis pin (5), retaining ring (16), washer (13), and socket head screw (12).
2. Install downward stop bracket (7) on downward stop strap (11) with pin assembly (10) through upper holes of downward stop bracket (7) and downward stop strap (11).
3. Install return spring (8), downward stop bracket (7), and cable end of pin assembly (10) on downward stop strap (11) with clevis pin (9) and retaining ring (6).
4. Install upward stop bracket (2) on upward stop strap (4) with pin assembly (14) through upper holes of upward stop bracket (2) and upward stop strap (4).
5. Install return spring (1), upward stop bracket (2), and cable end of pin assembly (14) on upward stop strap (4) with clevis pin (15) and retaining ring (3).

11-73. ELEVATION AND DEPRESSION STOP ASSEMBLY MAINTENANCE (Cont'd)

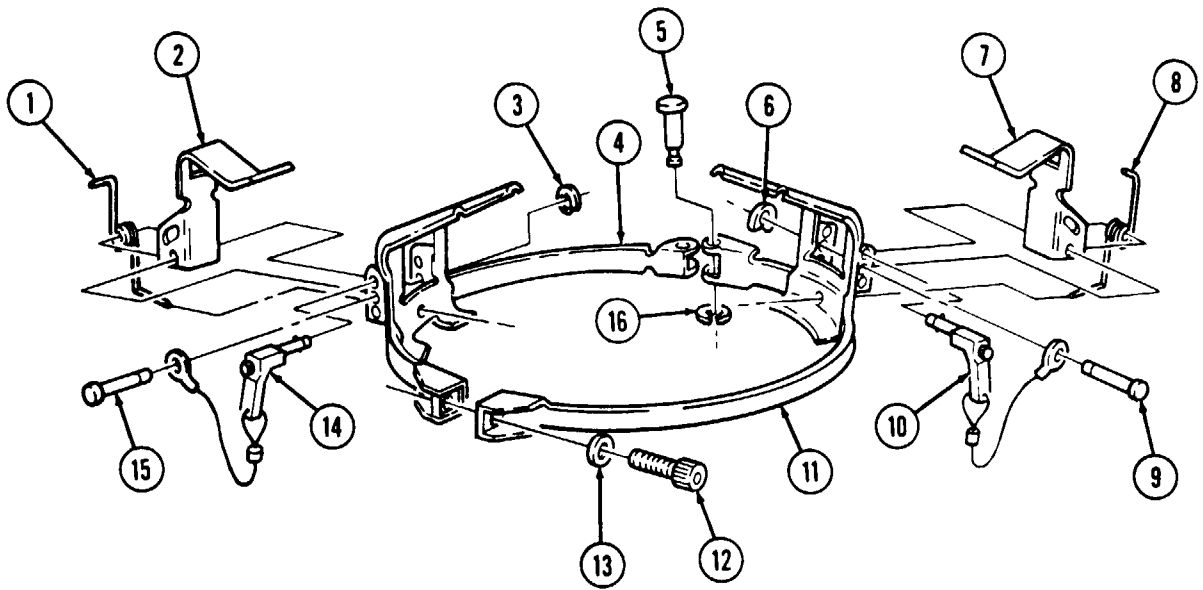

11-74. M16 AMMO RACK ASSEMBLY REPLACEMENT

This task covers:

a. Removal

b. Installation

INITIAL SETUP:

Applicable Models

M966, M966A1, M1036, M1045, M1045A1, M1045A2, M1046, M1046A1

Personnel Required

One mechanic
One assistant

Tools

General mechanic's tool kit:
automotive (Appendix B, Item 1)

Manual References

TM 9-2320-280-10
TM 9-2320-280-24P

Materials/Parts

Four locknuts (Appendix G, Item 70)
Two locknuts (Appendix G, Item 74)

Equipment Condition

Rear end of cargo shell door raised
(TM 9-2320-280-10).

a. Removal

1. Remove four locknuts (7), washers (6), two reinforcement brackets (5), and four screws (4) from M16 ammo rack (2) and wheelhouse (1). Discard locknuts (7).
2. Remove two locknuts (8), washers (9), reinforcement brackets (10), screws (3), and M16 ammo rack (2) from wheelhouse (1). Discard locknuts (8).

b. Installation

1. Install M16 ammo rack (2) on wheelhouse (1) with two screws (3), reinforcement brackets (10), washers (9), and locknuts (8).
2. Secure M16 ammo rack (2) to wheelhouse (1) with four screws (4), two reinforcement brackets (5), four washers (6), and locknuts (7).
3. Tighten locknuts (7) and (8) to 6 lb-ft (8 N•m).

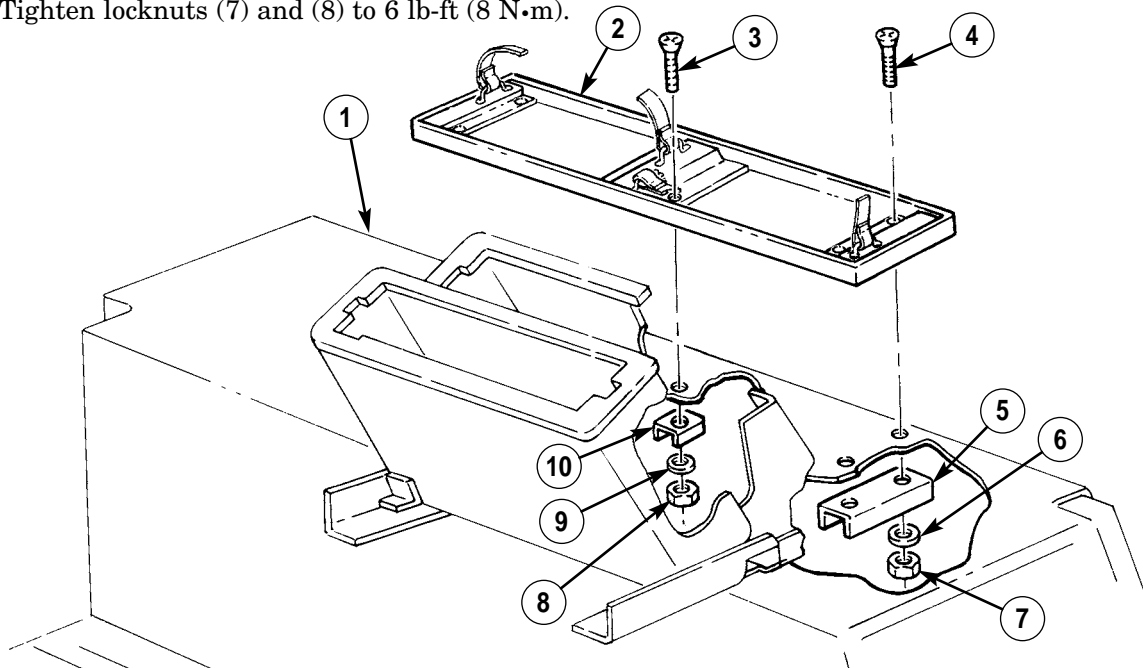

FOLLOW-ON TASK: Close cargo shell door (TM 9-2320-280-10).

11-75. TOW MISSILE RACK MAINTENANCE

This task covers:

- | | |
|----------------|-----------------|
| a. Removal | d. Assembly |
| b. Disassembly | e. Installation |
| c. Inspection | |

INITIAL SETUP:

Applicable Models

M966, M966A1, M1036, M1045, M1045A1, M1045A2, M1046, M1046A1

Tools

General mechanic's tool kit:
automotive (Appendix B, Item 1)

Materials/Parts

Adhesive (Appendix C, Item 1)
Eight cotter pins (Appendix G, Item 16)
Eighteen locknuts (Appendix G, Item 70)
Three locknuts (Appendix G, Item 81)
Sixteen locknuts (Appendix G, Item 107)
Eight cotter pins (Appendix G, Item 12)
Two locknuts (Appendix G, Item 79)

Personnel Required

One mechanic
One assistant

Manual References

TM 9-2320-280-10
TM 9-2320-280-24P

Equipment Condition

- Rear end of cargo shell door raised (TM 9-2320-280-10).
- Tailgate lowered (TM 9-2320-280-10).
- Footman loop and strap removed (para. 10-9).

a. Removal

1. Remove two locknuts (16), washers (1), capscrews (2), and washers (1) from MGS battery rack (3) and missile rack (4). Discard locknuts (16).
2. Remove three locknuts (7), washers (6), capscrews (5), and washers (6) from missile rack (4) and cargo floor (8). Discard locknuts (7).
3. Remove two locknuts (13), washers (14), reinforcements (12), capscrews (15), and washers (14) from missile rack (4) and cargo floor (8). Discard locknuts (13).
4. Remove capscrew (9), washer (10), missile rack (4), and tiedown (11) from cargo floor (8).

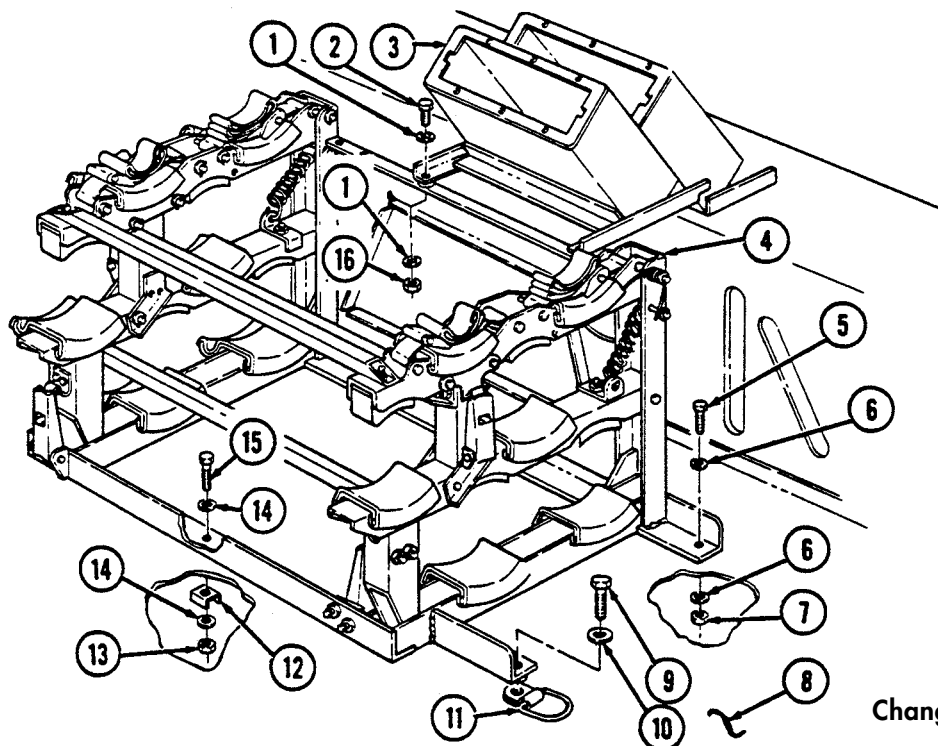

11-75. TOW MISSILE RACK MAINTENANCE (Cont'd)**b. Disassembly**

1. Remove eight cotter pins (7), washers (8), pins (10), and four strap assemblies (9) from upper rack assembly (4). Discard cotter pins (7).
2. Remove two locknuts (11), washers (12), capscrews (15), washers (12), spacers (13), and lanyard (24) from upper rack assembly (4) and base assembly (21). Discard locknuts (11).
3. Release two tension latches (30) and raise upper rack assembly (4). Remove two cotter pins (17), washers (18), pins (20), washers (18), torsion springs (19), washers (18), four washers (14), and upper rack assembly (4) from base assembly (21). Discard cotter pins (17).

NOTE

Shims are installed under each bumper on front end of missile rack, but only as needed under bumpers on rear end of missile rack.

4. Remove four locknuts (6), washers (5), capscrews (31), washers (5), four bumpers (41), and shims (42) from upper rack assembly (4). Discard locknuts (6).
5. Remove four locknuts (43), washers (2), screws (1), washers (2), and two latch strikes (3) from upper rack assembly (4). Discard locknuts (43).
6. Remove two cotter pins (32), washers (33), pins (40), and washers (33) from extension springs (35) and base assembly (21). Disconnect extension springs (35) from spring brackets (34). Discard cotter pins (32).
7. Remove two cotter pins (36), washers (39), pins (37), and upper supports (29) from intermediate rack assemblies (25). Discard cotter pins (36).
8. Remove four locknuts (28), washers (23), screws (22), washers (23), and two tension latches (30) from upper supports (29). Discard locknuts (28).
9. Remove two locknuts (26), washers (27), capscrews (16), washers (27), and connector bar (38) from upper supports (29). Discard locknuts (26).

11-75. TOW MISSILE RACK MAINTENANCE (Cont'd)

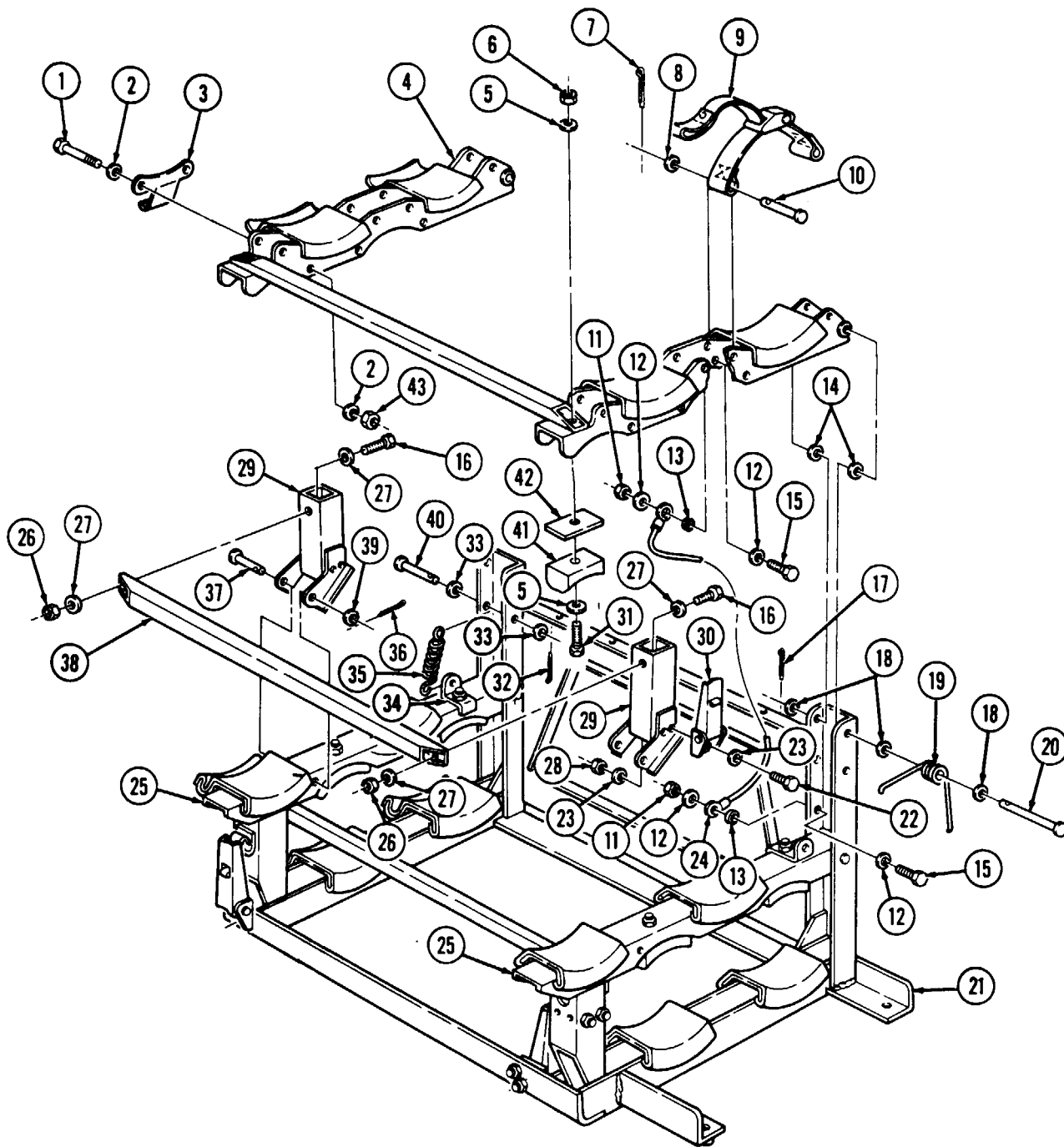

11-75. TOW MISSILE RACK MAINTENANCE (Cont'd)

10. Remove two cotter pins (16), washers (17), and pins (18) from intermediate supports (6). Release two tension latches (21) and remove intermediate supports (6) and washers (13) from base assembly (27). Discard cotter pins (16).

NOTE

Shims are installed under each bumper on front end of missile rack, but only as needed under bumpers on rear end of missile rack.

11. Remove four locknuts (7), washers (8), capscrews (12), washers (8), bumpers (11), shims (10), and two spring brackets (9) (outer side only) from intermediate supports (6). Discard locknuts (7).
12. Remove four locknuts (29), washers (2), screws (1), washers (2), and two latch strikes (3) from intermediate rack assemblies (6). Discard locknuts (29).
13. Remove two locknuts (14), washers (5), capscrews (4), washers (5), and connector bar (15) from intermediate rack assemblies (6). Discard locknuts (14).
14. Remove two locknuts (26), washers (24), capscrews (23), washers (24), and bracket (22) from base assembly (27). Discard locknuts (26).
15. Remove four locknuts (19), washers (20), screws (25), washers (20), and two tension latches (21) from base assembly (27) and bracket (22). Discard locknuts (19).

NOTE

- Perform steps b. 16 and d. 1 if replacing missile pads.
- Procedures for replacing all missile pads are the same. Steps b. 16 and d. 1 cover replacement of one base assembly missile pad,

16. Remove pad (28) from base assembly (27), and clean remaining adhesive from base assembly (27) mounting surface.

c. Inspection

1. Inspect base assembly (27), intermediate rack assemblies (6), and connector bars (15) for cracks, broken welds, and damage. Replace any component if damaged.
2. Inspect bumpers (11) and missile pads (28) for cracks, tears, and deterioration. Replace any component if damaged.

11-75. TOW MISSILE RACK MAINTENANCE (Cont'd)

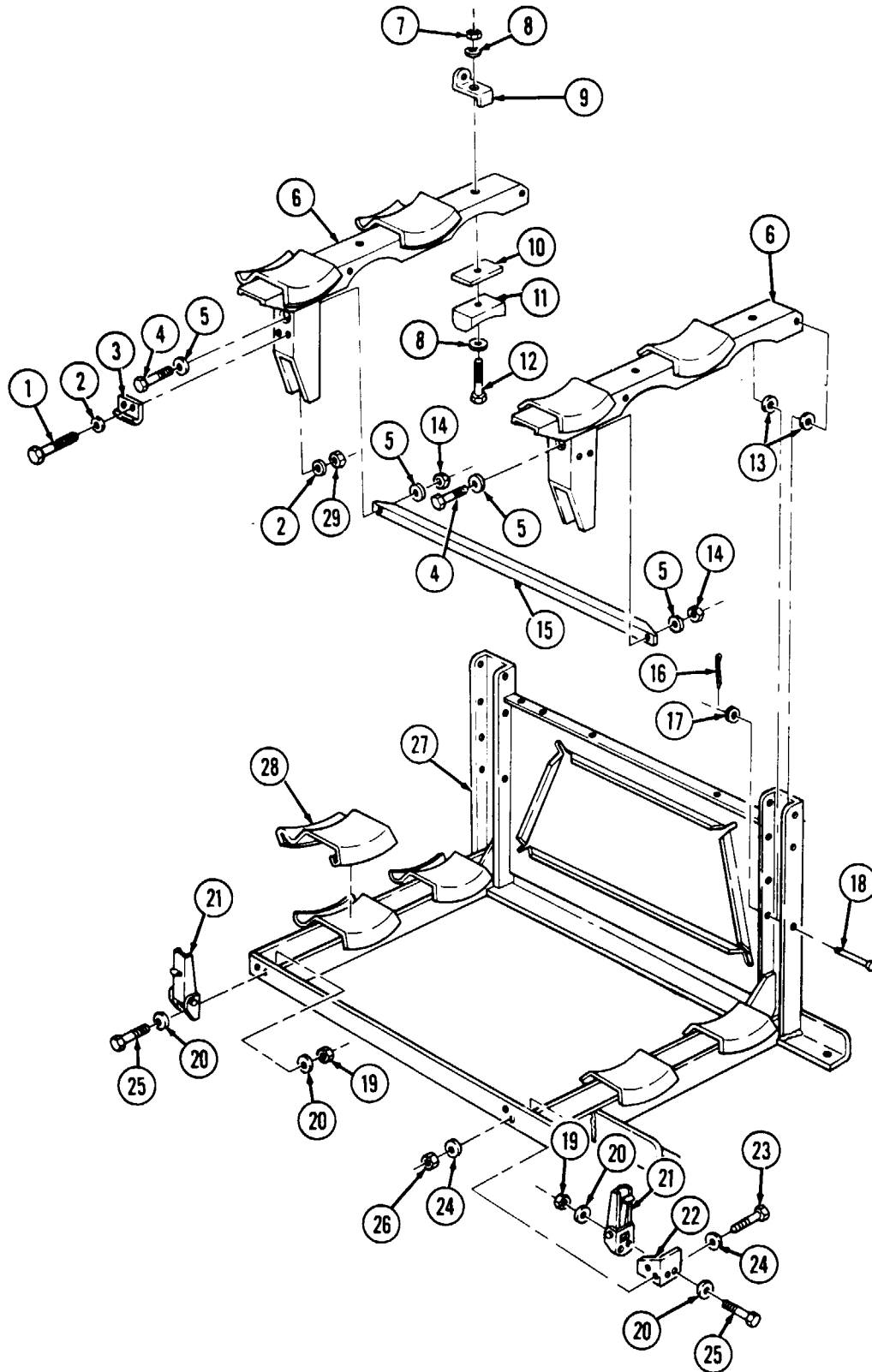

11-75. TOW MISSILE RACK MAINTENANCE (Cont'd)

3. Inspect upper rack assembly (1) and upper supports (2) for cracks, broken welds, and damage. Replace any component if damaged.

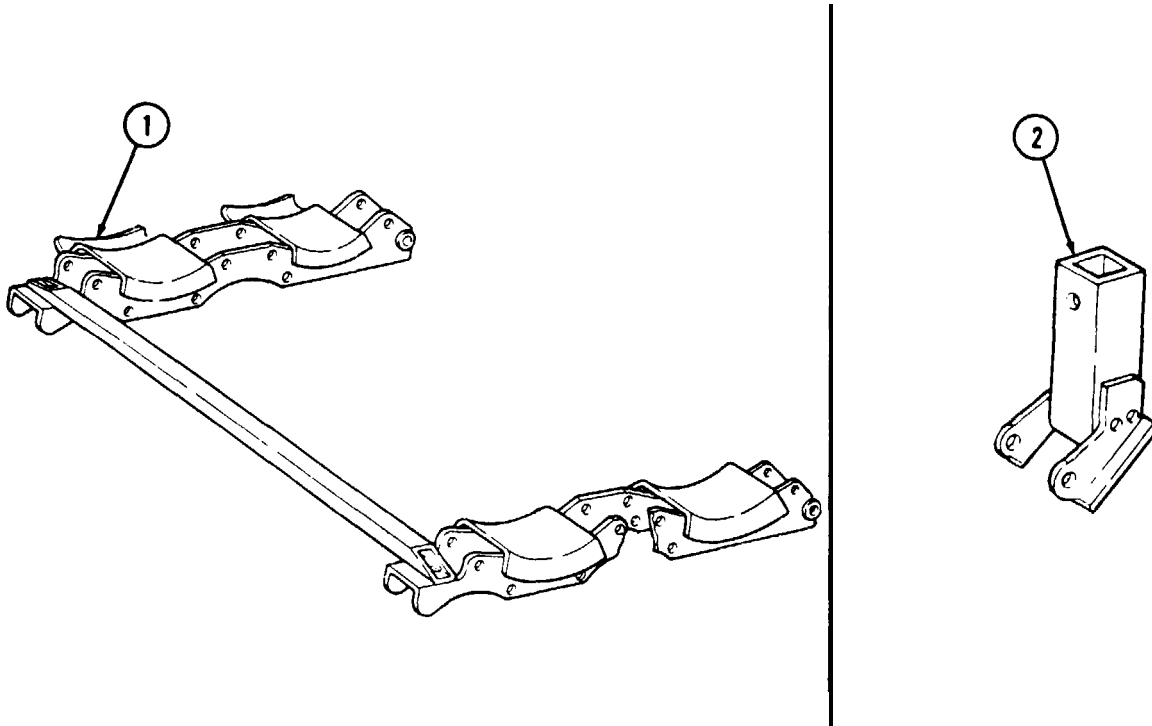

d. Assembly

1. Apply adhesive to base assembly (29) pad mounting surface and install missile pad (28) on base assembly (29).
2. Install two tension latches (22) on base assembly (29) and bracket (23) with four washers (21), screws (26), washers (21), and locknuts (20).
3. Install bracket (23) on base assembly (29) with two washers (25), capscrews (24), washers (25), and locknuts (27). Tighten locknuts (27) to 6 lb-ft (8 N•m).
4. Install connector bar (16) on two intermediate rack assemblies (8) with washers (7), capscrews (6), washers (7), and locknuts (15). Tighten locknuts (15) to 6 lb-ft (8 N•m).
5. Install two latch strikes (5) on intermediate rack assemblies (8) with four washers (4), screws (3), washers (4), and locknuts (30).

NOTE

Shims are installed under each bumper on front end of missile rack, but only as needed under bumpers on rear end of missile rack.

6. Install shims (12), four bumpers (13), and two spring brackets (9) (outer side only) on intermediate rack assemblies (8) with four washers (11), capscrews (31), washers (11), and locknuts (10).
7. Install intermediate rack assemblies (8) and four washers (14) on base assembly (29) with two pins (19), washers (18), and cotter pins (17). It maybe necessary to slowly install pins (19) while installing washers (14) between intermediate rack assembly (8) sides and base assembly (29) channels.

11-75. TOW MISSILE RACK MAINTENANCE (Cont'd)

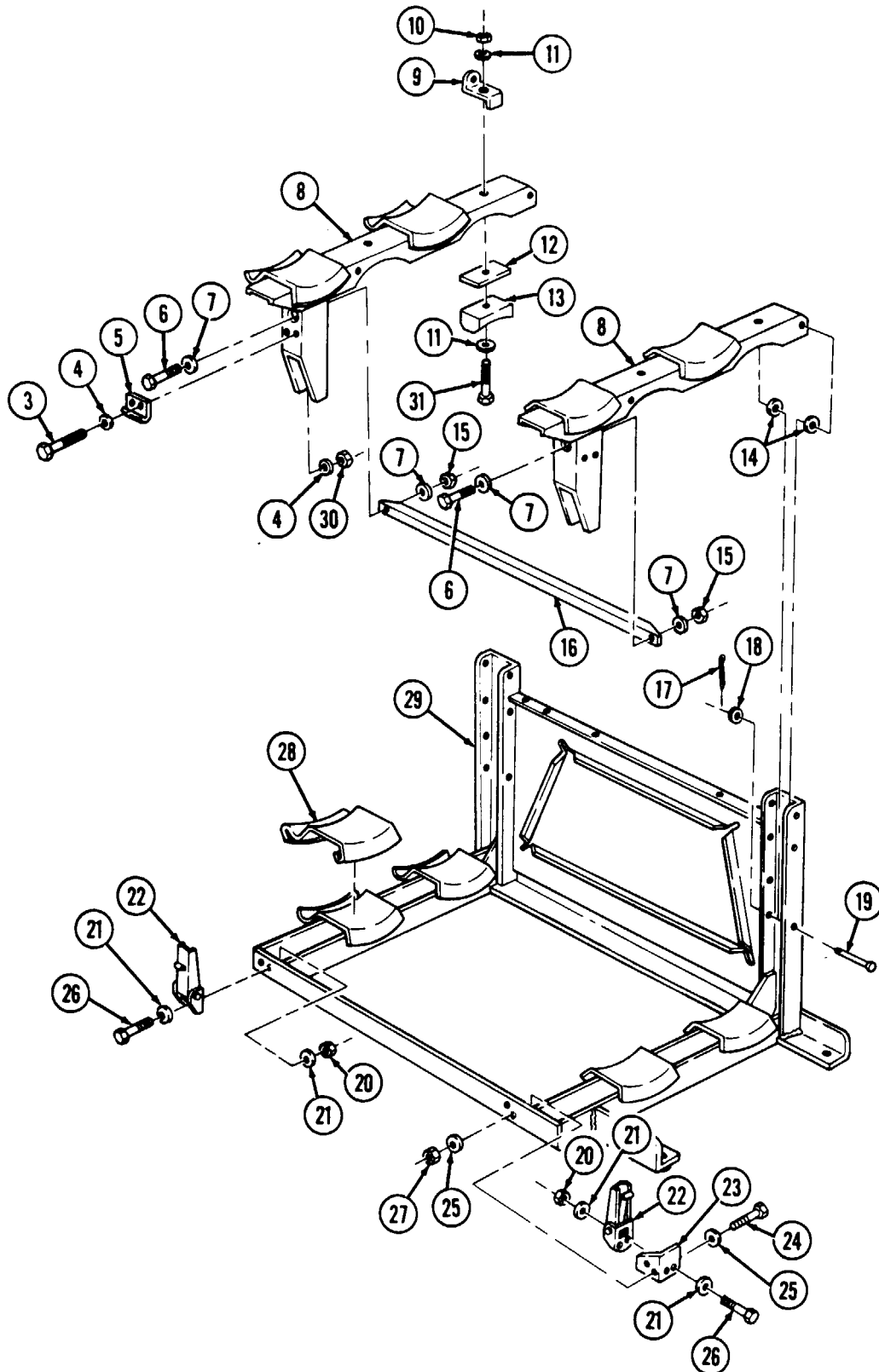

11-75. TOW MISSILE RACK MAINTENANCE (Cont'd)

8. Connect two extension springs (36) to spring brackets (35). Extend springs (36) to base assembly (21) and install with two washers (34), pins (41), washers (34), and cotter pins (33). Install intermediate supports (25) on base assembly (21) with two lower tension latches (30).
9. Install connector bar (37) on upper supports (29) with two washers (27), capscrews (31), washers (27), and locknuts (26). Tighten locknuts (26) to 6 lb-ft (8 N•m).
10. Install two tension latches (30) on upper supports (29) with four washers (23), screws (22), washers (23), and locknuts (28).
11. Install upper supports (29) on intermediate rack assemblies (25) with two pins (38), washers (40), and cotter pins (39).

NOTE

Shims are installed under each bumper on front end of missile rack, but only as needed under bumpers on rear end of missile rack.

12. Install shims (43) and four bumpers (42) on upper rack assembly (4) with four washers (5), capscrews (32), washers (5), and locknuts (6).
13. Install two latch strikes (3) on upper rack assembly (4) with four washers (2), screws (1), washers (2), and locknuts (44).
14. Install upper rack assembly (4) and four washers (12) on base assembly (21) with two washers (18), pins (20), torsion springs (19), washers (18), and cotter pins (17). It may be necessary to slowly install pins (20) while installing washers (12) between upper rack assembly (4) sides and base assembly (21) channels.
15. Install lanyard (24) on upper rack assembly (4) and base assembly (21) with two washers (14), capscrews (16), spacers (15), washers (14), and locknuts (13).
16. Install four strap assemblies (9) on upper rack assembly (4) with eight pins (10), washers (8), and cotter pins (7).
17. Lift upper rack assembly (4) all the way up, and place one end of torsion springs (19) underneath pad supports (11), and other end of torsion springs (19) on inner rack side of pins (41), ensuring washers (34) are on outside of spring (19) ends. Lower upper rack assembly (4) and secure with two tension latches (30).

11-75. TOW MISSILE RACK MAINTENANCE (Cont'd)

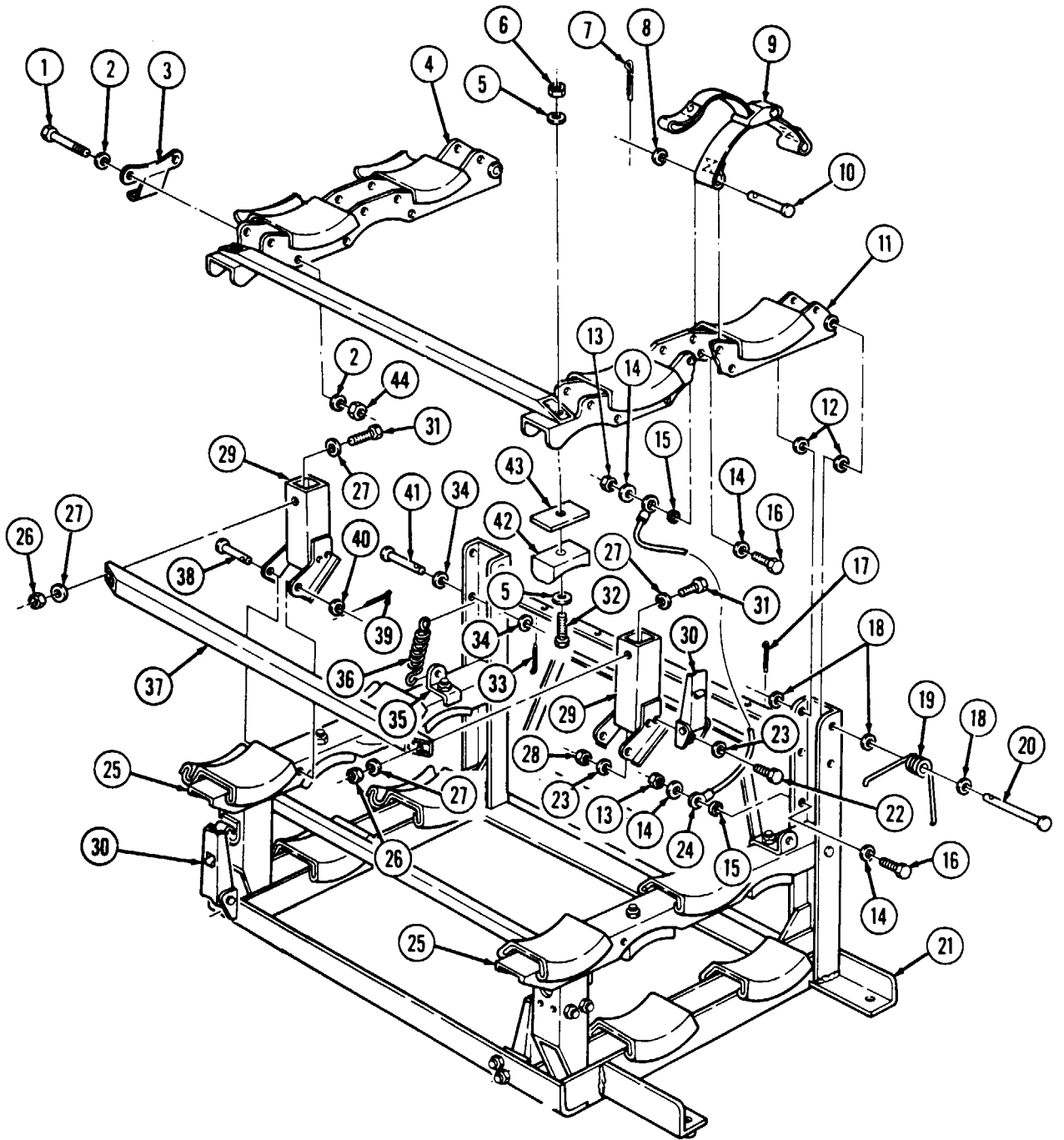

11-75. TOW MISSILE RACK MAINTENANCE (Cont'd)

e. Installation

1. Install tiedown (11) and missile rack (4) on cargo floor (8) with washer (10) and capscrew (9). Do not tighten capscrew (9).
2. Secure missile rack (4) to cargo floor (8) with three washers (6), capscrews (5), washers (6), and locknuts (7). Do not tighten capscrews (5).
3. Secure missile rack (4) to cargo floor (8) with two washers (13), capscrews (15), reinforcements (12), washers (13), and locknuts (14). Do not tighten capscrews (15).
4. Install MGS battery rack (3) on missile rack (4) with two washers (1), capscrews (2), washers (1), and locknuts (16). Tighten capscrews (2) to 6 lb-ft (8 N•m).
5. Tighten capscrews (5) and (15) to 21 lb-ft (28 N•m). Tighten capscrew (9) to 90 lb-ft (122 N•m).

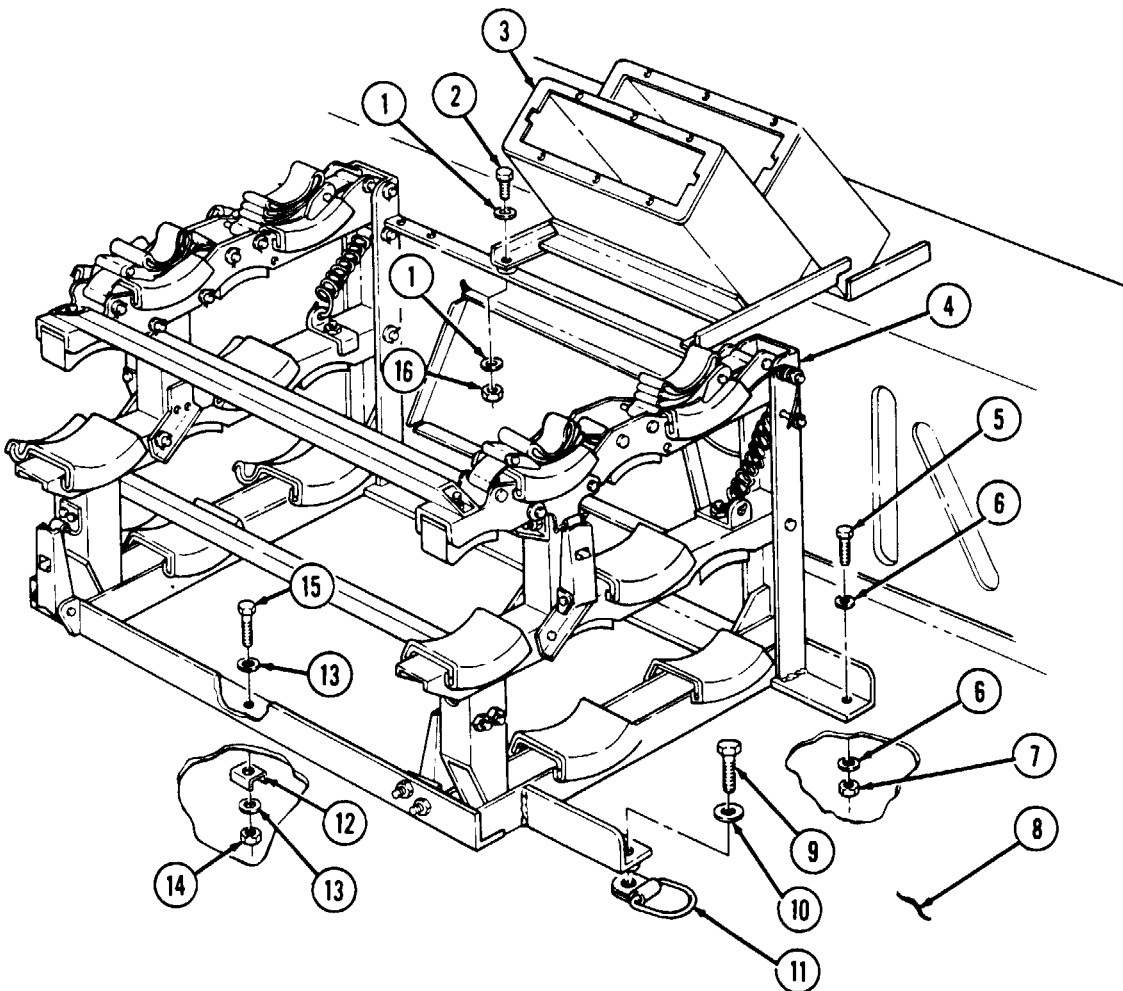

- FOLLOW-ON TASKS:
- Install footman loop and strap (para. 10-9).
 - Raise and secure tailgate (TM 9-2320-280-10).
 - Close cargo shell door (TM 9-2320-280-10).

11-76. WATER CAN BUMPER REPLACEMENT

This task covers:

a. Removal

b. Installation

INITIAL SETUP:

Applicable Models

M966, M966A1, M1036, M1045, M1045A1,
M1045A2, M1046, M1046A1

Manual References

TM 9-2320-280-10
TM 9-2320-280-24P

Tools

General mechanic's tool kit:
automotive (Appendix B, Item 1)

Equipment Condition

Rear end of cargo shell door raised
(TM 9-2320-280-10).

Materials/Parts

Two locknuts (Appendix G, Item 70)

a. Removal

Remove two locknuts (2), washers (3), capscrews (6), washers (3), water can bumper (5), and water can bumper bracket (4) from MGS battery rack assembly (1). Discard locknuts (2).

b. Installation

Install water can bumper bracket (4) and water can bumper (5) on MGS battery rack assembly (1) with two washers (3), capscrews (6), washers (3), and locknuts (2). Tighten locknuts (2) to 6 lb-ft (8 N·m).

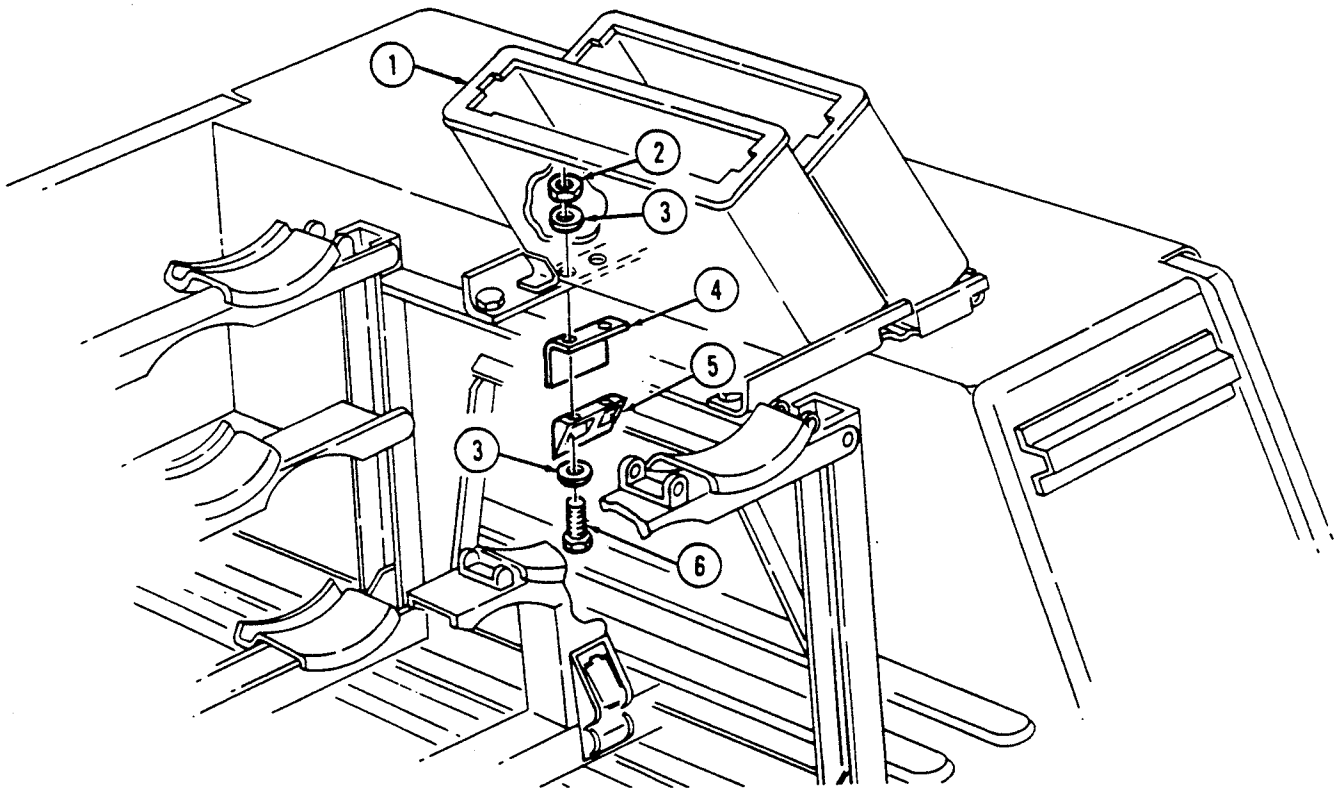

FOLLOW-ON TASK: Close cargo shell door (TM 9-2320-280-10).

11-77. MISSILE GUIDANCE SET (MGS) BATTERY RACK ASSEMBLY REPLACEMENT

This task covers:

a. Removal

b. Installation

INITIAL SETUP:

Applicable Models

M966, M966A1, M1036, M1045, M1045A1, M1045A2, M1046, M1046A1

Personnel Required

One mechanic
One assistant

Tools

General mechanic's tool kit:
automotive (Appendix B, Item 1)

Manual References

TM 9-2320-280-10
TM 9-2320-280-24P

Materials/Parts

Six locknuts (Appendix G, Item 70)

Equipment Condition

- Rear end of cargo shell door raised (TM 9-2320-280-10).
- Water can bumper removed (para. 11-76).

a. Removal

1. Remove two locknuts (11), washers (2), capscrews (3), and washers (2) from MGS battery rack (4) and missile rack (1). Discard locknuts (11).
2. Remove four locknuts (9), washers (5), reinforcement brackets (8) and (10), capscrews (6), washers (5), and MGS battery rack (4) from wheelhouse (7). Discard locknuts (9).
3. Remove footman loop and strap (para. 10-9) from MGS battery rack (4).

b. Installation

1. Install footman loop and strap (para. 10-9) on MGS battery rack (4).
2. Install MGS battery rack (4) on wheelhouse (7) with four washers (5), capscrews (6), reinforcement brackets (8) and (10), washers (5), and locknuts (9).
3. Install MGS battery rack (4) on missile rack (1) with two washers (2), capscrews (3), washers (2), and locknuts (11). Tighten capscrews (3) and locknuts (9) to 6 lb-ft (8 N•m).

11-77. MISSILE GUIDANCE SET (MGS) BATTERY RACK ASSEMBLY REPLACEMENT (Cont'd)

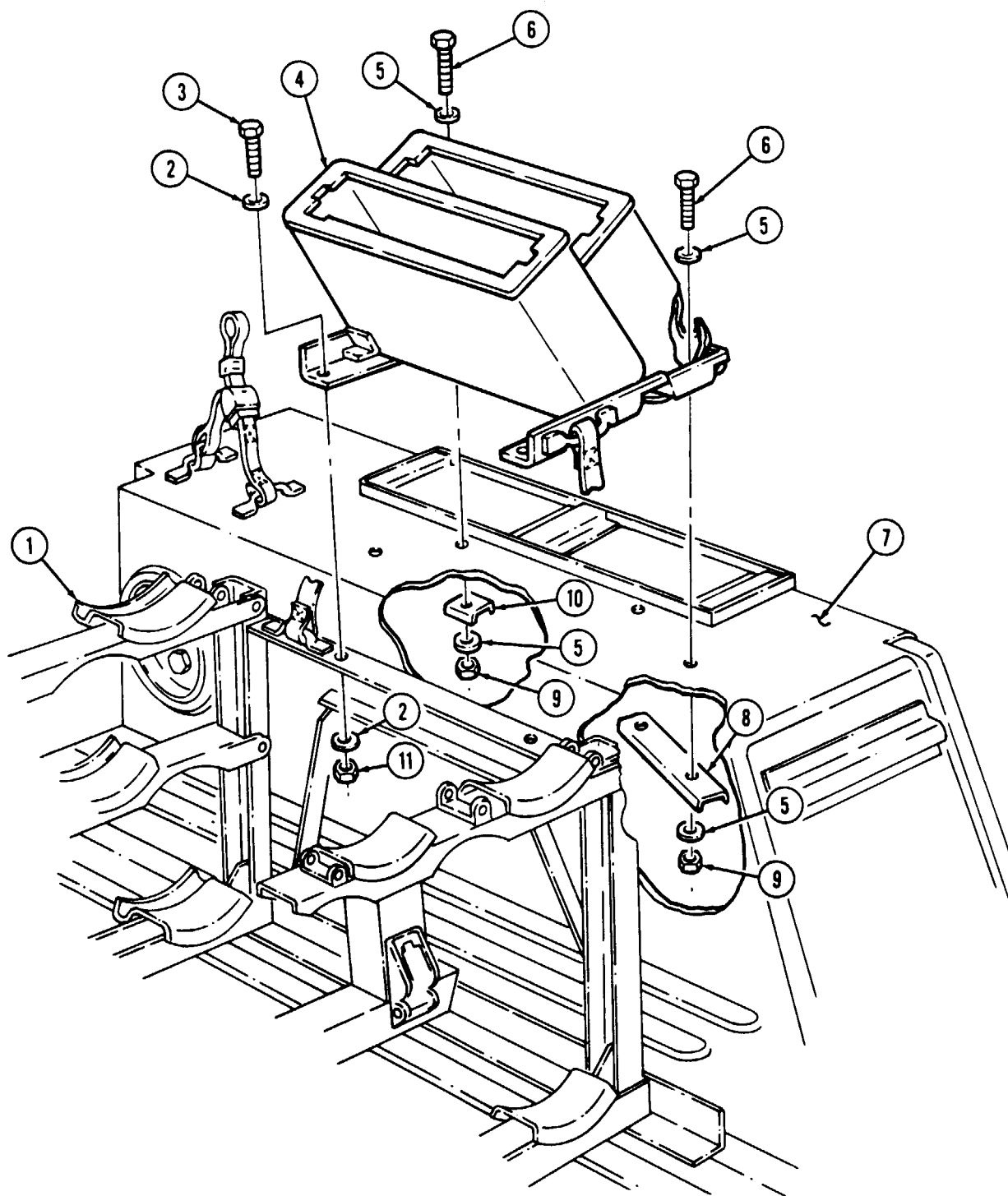

FOLLOW-ON TASKS:

- Close cargo shell door (TM 9-2320-280-10).
- Install water can bumper (para. 11-76).

11-78. TRIPOD LEG MOUNTING BRACKET REPLACEMENT

This task covers:

a. Removal

b. Installation

INITIAL SETUP:

Applicable Models

M966, M966A1, M1036, M1045, M1045A1, M1045A2, M1046, M1046A1

Personnel Required

One mechanic
One assistant

Tools

General mechanic's tool kit:
automotive (Appendix B, Item 1)

Manual References

TM 9-2320-280-10
TM 9-2320-280-24P

Materials/Parts

Three locknuts (Appendix G, Item 70)

Equipment Condition

- Rear end of cargo shell door raised (TM 9-2320-280-10).
- Pioneer tool rack removed (TM 9-2320-280-10).

a. Removal

1. Remove three locknuts (9), washers (5), capscrews (6), washers (5), tripod leg bracket (4), and spacers (10) from cargo floor (7). Discard locknuts (9).
2. Remove two nuts (11), washers (2), capscrews (1), washers (2), strap bracket (8), and strap (3) from tripod leg bracket (4).

b. Installation

1. Install strap bracket (8) and strap (3) on tripod leg bracket (4) with two washers (2), capscrews (1), washers (2), and nuts (11).
2. Install three spacers (10) and tripod leg bracket (4) on cargo floor (7) with three washers (5), capscrews (6), washers (5), and locknuts (9).
3. Tighten front and rear locknuts (9) and center capscrew (6) to 6 lb-ft (8 N•m).

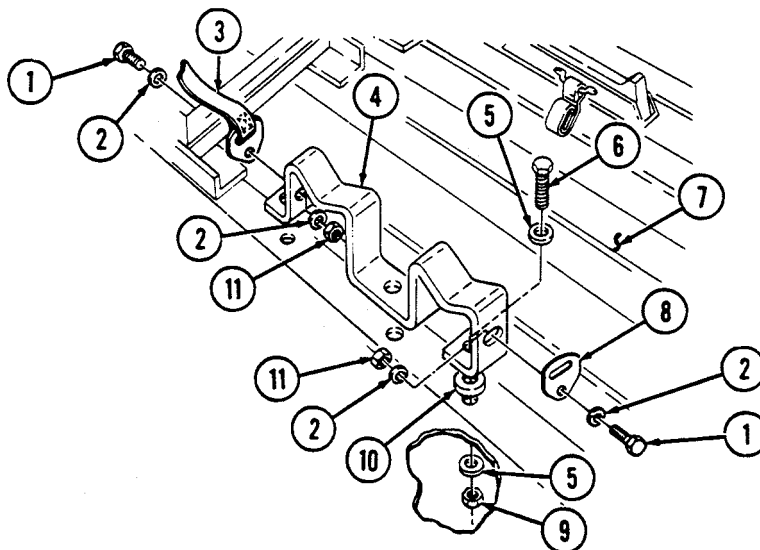

- FOLLOW-ON TASKS:**
- Close cargo shell door (TM 9-2320-280-10).
 - Install pioneer tool rack (TM 9-2320-280-10).

11-79. TRIPOD HEAD MOUNTING BRACKET REPLACEMENT

This task covers:

a. Removal

b. Installation

INITIAL SETUP:

Applicable Models

M966, M966A1, M1036, M1045, M1045A1, M1045A2, M1046, M1046A1

Tools

General mechanic's tool kit:
automotive (Appendix B, Item 1)

Materials/Parts

Three locknuts (Appendix G, Item 70)

Manual References

TM 9-2320-280-10
TM 9-2320-280-24P

Equipment Condition

- Rear end of cargo shell door raised (TM 9-2320-280-10).
- Tailgate lowered (TM 9-2320-280-10).

a. Removal

NOTE

On M1045, M1045A1, M1045A2, M1046, and M1046A1 models, there is an additional washer between the wheelhouse and the wheelhouse armor.

1. Remove three locknuts (7), washers (6), and plate assembly (5) from wheelhouse (8). Discard locknuts (7).
2. Remove three capscrews (1), washers (2), tripod head bracket (3), and three spacers (4) from wheelhouse (8)

b. Installation

1. Install three spacers (4) and tripod head bracket (3) on wheelhouse (8) with three washers (2) and capscrews (1).
2. Install plate assembly (5) on wheelhouse (8) with three washers (6) and locknuts (7). Tighten locknuts (7) to 6 lb-ft (8 N·m).

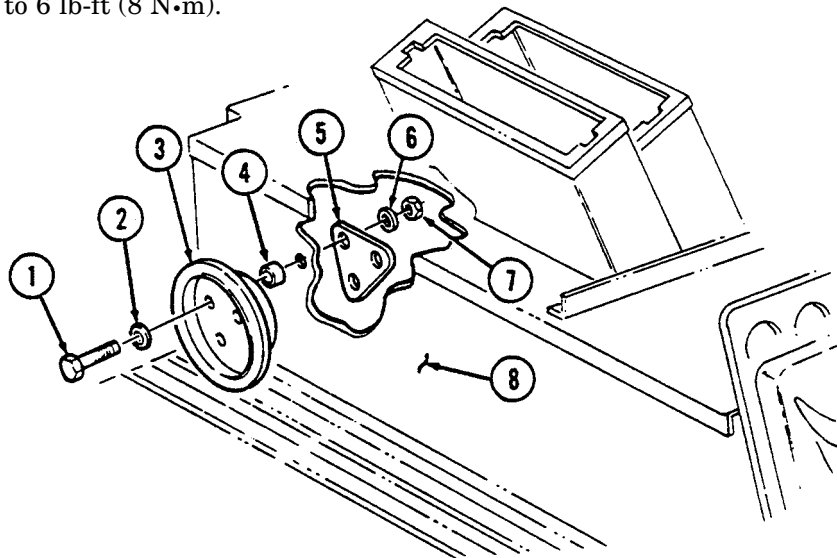

- FOLLOW-ON TASKS:
- Raise and secure tailgate (TM 9-2320-280-10).
 - Close cargo shell door (TM 9-2320-280-10).

11-80. FUEL CAN TRAY AND HOSE REPLACEMENT

This task covers:

a. Removal

b. Installation

INITIAL SETUP:

Applicable Models

M966, M966A1, M1036, M1045, M1045A1,
M1045A2, M1046, M1046A1

Manual References

TM 9-2320-280-10
TM 9-2320-280-24P

Tools

General mechanic's tool kit:
automotive (Appendix B, Item 1)

Equipment Condition

Rear of cargo shell door raised
(TM 9-2320-280-10).

Materials/Parts

Screw (Appendix G, Item 284)

a. Removal

1. Remove screw (8) and hose clamp (6) from frame (5) and remove hose (7) from fuel can tray (3). Discard screw (8).
2. Remove four screws (1), washers (2), and fuel can tray (3) from cargo floor (4).

b. Installation

1. Install fuel can tray (3) on cargo floor (4) with four washers (2) and screws (1). Tighten screws (1) to 6 lb-ft (8 N·m).
2. Connect hose (7) to fuel can tray (3).
3. Install hose (7) on frame (5) with clamp (6) and screw (8). Tighten screw (8) to 7 lb-ft (10 N·m).

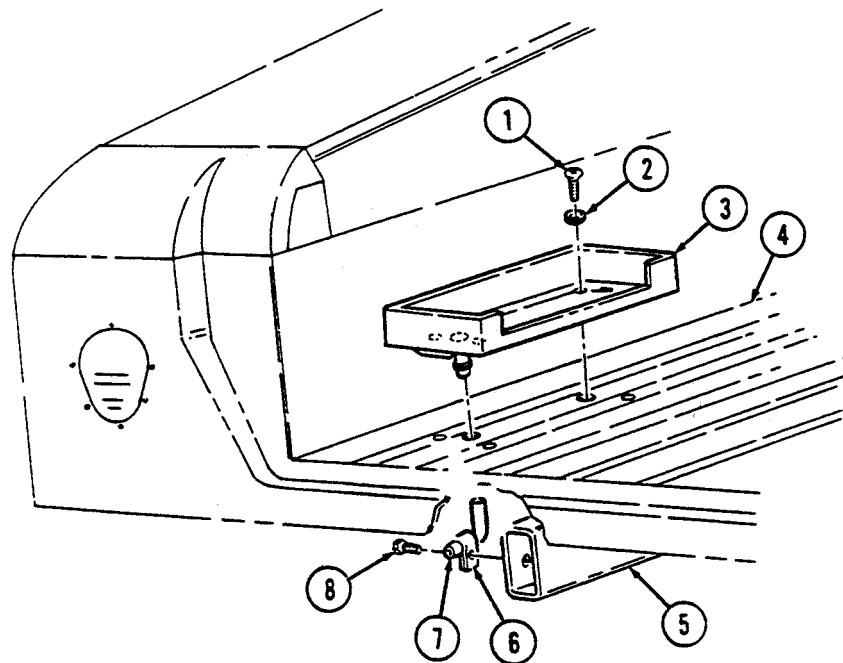

FOLLOW-ON TASK: Close cargo shell door (TM 9-2320-280-10).

11-81. DAY SIGHT STOWAGE BRACKET REPLACEMENT

This task covers:

a. Removal

b. Installation

INITIAL SETUP:

Applicable Models

M966, M966A1, M1036, M1045, M1045A1,
M1045A2, M1046, M1046A1

Tools

General mechanic's tool kit:
automotive (Appendix B, Item 1))

Materials/Parts

Detergent (Appendix C, Item 17)
Four locknuts (Appendix G, Item 70)
Seven locknuts (Appendix G, Item 76)

Personnel Required

One mechanic
One assistant

Manual References

TM 9-2320-280-10
TM 9-2320-280-24P

Equipment Condition

Rear end of cargo shell door raised
(TM 9-2320-280-10).

a. Removal

1. Remove four locknuts (6), washers (5), capscrews (10), and bracket (2) from cargo floor (9). Discard locknuts (6).
2. Remove seven locknuts (3), washers (4), capscrews (8), and two pads (1) from bracket (2). Discard locknuts (3).
3. Inspect four spacers (7) in cargo floor (9) for damage. Replace any spacer (7) if damaged.

b. Installation

1. Lubricate pads (1) with detergent and install on bracket (2) with seven capscrews (8), washers (4), and locknuts (3). Tighten locknuts (3) to 6 lb-ft (8 N•m).
2. Install bracket (2) on cargo floor (9) with four capscrews (10), washers (5), and locknuts (6). Tighten locknuts (6) to 6 lb-ft (8 N•m).

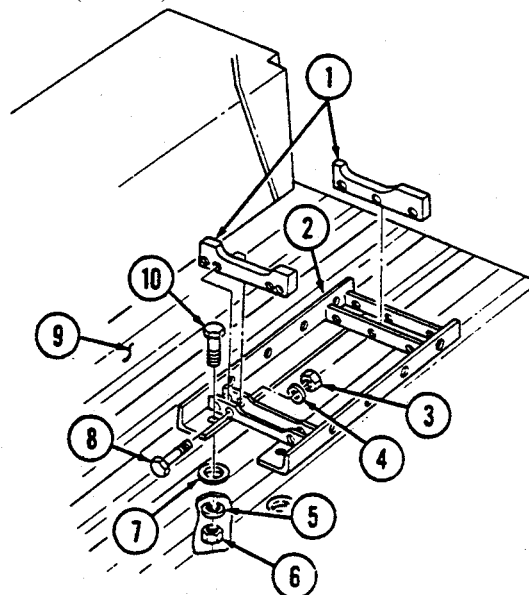

FOLLOW-ON TASK: Close cargo shell door (TM 9-2320-280-10).

11-82. NIGHT SIGHT SUPPORT REPLACEMENT

This task covers:

a. Removal

b. Installation

INITIAL SETUP:

Applicable Models

M966, M966A1, M1036, M1045, M1045A1, M1045A2, M1046, M1046A1

Personnel Required

One mechanic
One assistant

Tools

General mechanic's tool kit:
automotive (Appendix B, Item 1)

Manual References

TM 9-2320-280-10
TM 9-2320-280-24P

Materials/Parts

Two locknuts (Appendix G, Item 70)

Equipment Condition

Rear end of cargo shell door raised
(TM 9-2320-280-10).

a. Removal

Remove two locknuts (2), washers (3), capscrews (5), washers (3), and night sight support (4) from wheelhouse (1). Discard locknuts (2).

b. Installation

Install night sight support (4) on wheelhouse (1) with two washers (3), capscrews (5), washers (3), and locknuts (2). Tighten locknuts (2) to 6 lb-ft (8 N·m).

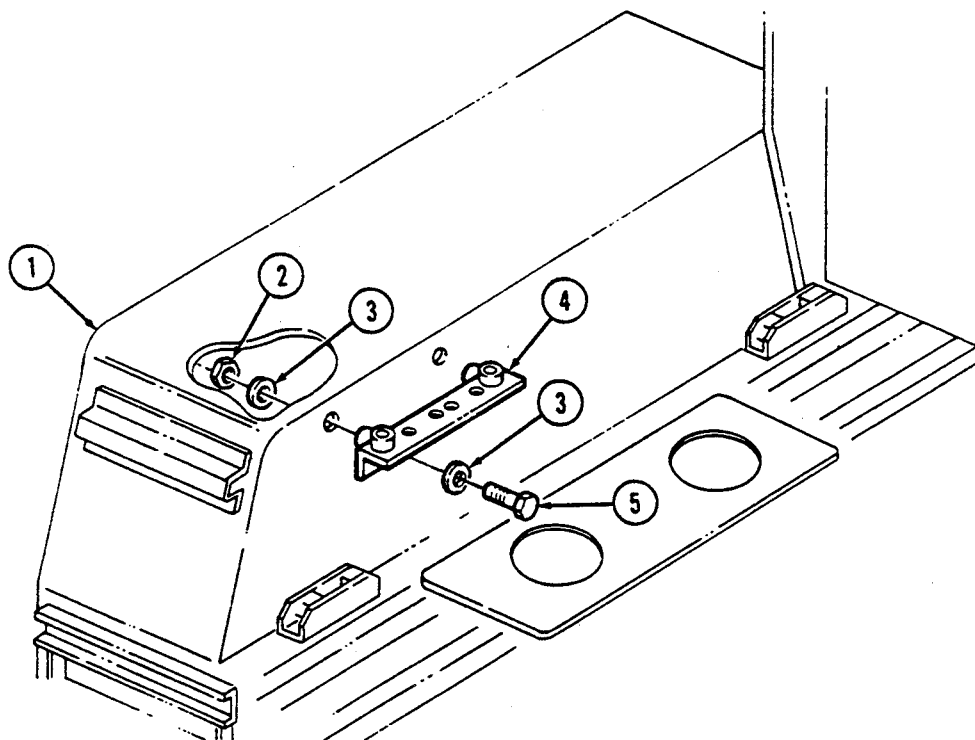

FOLLOW-ON TASK: Close cargo shell door (TM 9-2320-280-10).

11-83. NIGHT SIGHT COOLANT BASE REPLACEMENT

This task covers:

a. Removal

b. Installation

INITIAL SETUP:

Applicable Models

M966, M966A1, M1036, M1045, M1045A1,
M1045A2, M1046, M1046A1

Personnel Required

One mechanic
One assistant

Tools

General mechanic's tool kit:
automotive (Appendix B, Item 1)

Manual References

TM 9-2320-280-10
TM 9-2320-280-24P

Materials/Parts

Six locknuts (Appendix G, Item 70)

Equipment Condition

Rear end of cargo shell door raised
(TM 9-2320-280-10).

a. Removal

1. Remove two locknuts (9), washers (6), spacers (8), capscrews (5), and washers (6) from night sight coolant base (4) and cargo floor (7). Discard locknuts (9).
2. Remove two locknuts (10), washers (11), and screws (3) from coolant base (4) and cargo floor (7). Discard locknuts (10).
3. Remove two locknuts (12), washers (1), capscrews (2), washers (1), and coolant base (4) from cargo floor (7). Discard locknuts (12).

b. Installation

1. Install coolant base (4) on cargo floor (7) with two washers (1), capscrews (2), washers (1), and locknuts (12).
2. Secure coolant base (4) to cargo floor (7) with two screws (3), washers (11), and locknuts (10).
3. Secure coolant base (4) to cargo floor (7) with two washers (6), capscrews (5), spacers (8), washers (6), and locknuts (9).
4. Tighten locknuts (10) to 50 lb-in. (6 N·m). Tighten locknuts (9) and (12) to 72 lb-in. (8 N·m).

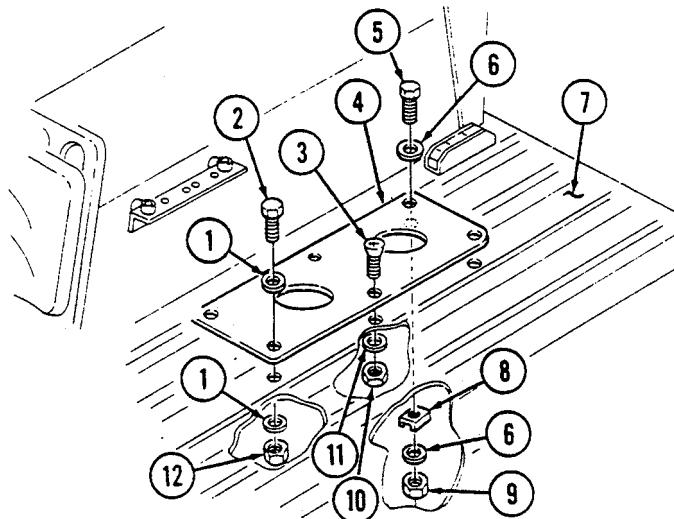

FOLLOW-ON TASK: Close cargo shell door (TM 9-2320-280-10).

11-84. FRONT NIGHT SIGHT BATTERY BRACKET REPLACEMENT

This task covers:

a. Removal

b. Installation

INITIAL SETUP:

Applicable Models

M966, M966A1, M1036, M1045, M1045A1, M1045A2, M1046, M1046A1

Personnel Required

One mechanic
One assistant

Tools

General mechanic's tool kit:
automotive (Appendix B, Item 1)

Manual References

TM 9-2320-280-10
TM 9-2320-280-24P

Materials/Parts

Locknut (Appendix G, Item 70)
Lockwasher (Appendix G, Item 177)

Equipment Condition

Rear end of cargo shell door raised
(TM 9-2320-280-10).

a. Removal

1. Remove locknut (8), washer (1), reinforcement bracket (7), capscrew (2), and washer (1) from bracket (5) and cargo floor (6). Discard locknut (8).
2. Remove capscrew (4), lockwasher (3), and bracket (5) from cargo floor (6). Discard lockwasher (3).

b. Installation

1. Install bracket (5) on cargo floor (6) with washer (1), capscrew (2), reinforcement bracket (7), washer (1), and locknut (8).
2. Secure bracket (5) to cargo floor (6) with lockwasher (3) and capscrew (4).
3. Tighten capscrew (4) to 4 lb-ft (5 N·m). Tighten locknut (8) to 6 lb-ft (8 N·m).

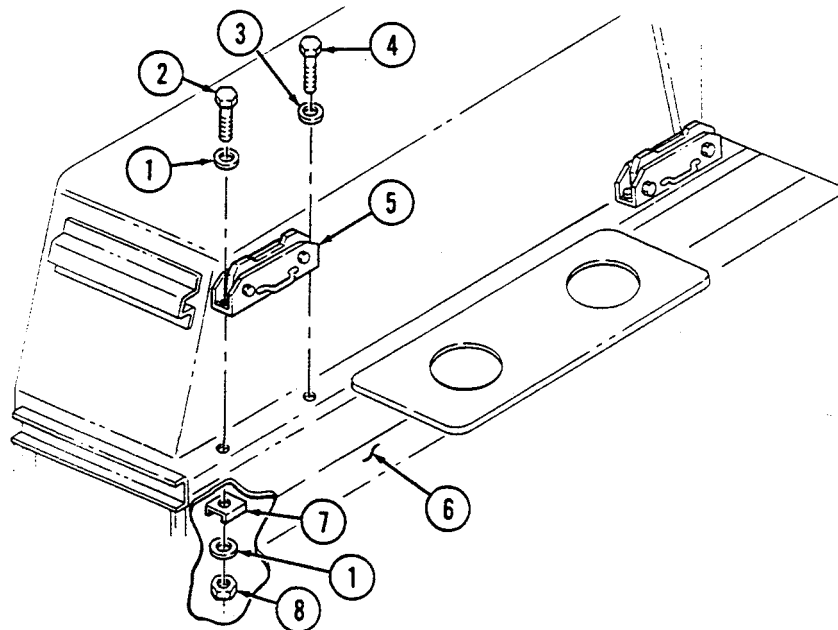

FOLLOW-ON TASK: Close cargo shell door (TM 9-2320-280-10).

11-85. REAR NIGHT SIGHT BATTERY BRACKET REPLACEMENT

This task covers:

a. Removal

b. Installation

INITIAL SETUP:

Applicable Models

M966, M966A1, M1036, M1045, M1045A1,
M1045A2, M1046, M1046A1

Personnel Required

One mechanic
One assistant

Tools

General mechanic's tool kit:
automotive (Appendix B, Item 1)

Manual References

TM 9-2320-280-10
TM 9-2320-280-24P

Materials/Parts

Two locknuts (Appendix G, Item 70)

Equipment Condition

Rear end of cargo shell door raised
(TM 9-2320-280-10).

a. Removal

1. Remove locknut (7), washer (4), large washer (6), capscrew (3), and washer (4) from bracket (5) and cargo floor (9). Discard locknut (7).
2. Remove locknut (8), washer (1), capscrew (2), washer (1), and bracket (5) from cargo floor (9). Discard locknut (8).

b. Installation

1. Install bracket (5) on cargo floor (9) with washer (1), capscrew (2), washer (1), and locknut (8).
2. Secure bracket (5) to cargo floor (9) with washer (4), capscrew (3), large washer (6), washer (4), and locknut (7). Tighten locknuts (7) and (8) to 6 lb-ft (8 N·m).

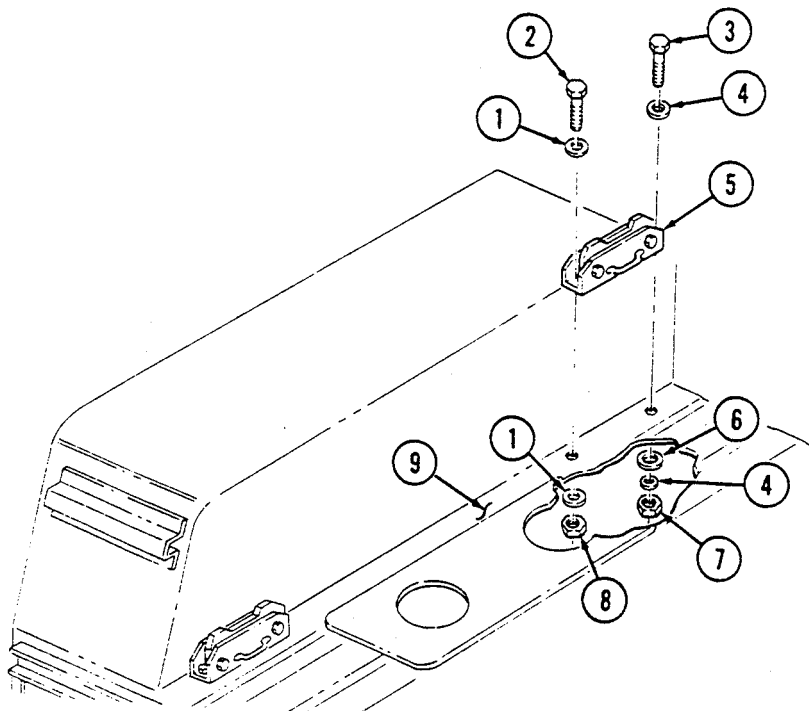

FOLLOW-ON TASK: Close cargo shell door (TM 9-2320-280-10).

11-86. BORESIGHT COLLIMATOR OR NIGHT SIGHT MOUNTING SPACERS REPLACEMENT

This task covers:

a. Removal

b. Installation

INITIAL SETUP:

Applicable Models

M966, M966A1, M1036, M1045, M1045A1, M1045A2, M1046, M1046A1

Personnel Required

One mechanic
One assistant

Tools

General mechanic's tool kit:
automotive (Appendix B, Item 1)

Manual References

TM 9-2320-280-10
TM 9-2320-280-24P

Materials/Parts

Four locknuts (Appendix G, Item 70)

Equipment Condition

Rear end of cargo shell door raised (TM 9-2320-280-10).

NOTE

Boresight collimator mounting spacers and night sight support assembly mounting spacers are replaced the same. This procedure covers the boresight collimator mounting spacers.

a. Removal

Remove four locknuts (5), washers (4), screws (1), and boresight collimator mounting spacers (2) from wheelhouse (3). Discard locknuts (5).

b. Installation

Install four boresight collimator mounting spacers (2) on wheelhouse (3) with screws (1), washers (4), and locknuts (5). Tighten locknuts (5) to 6 lb-ft (8 N·m).

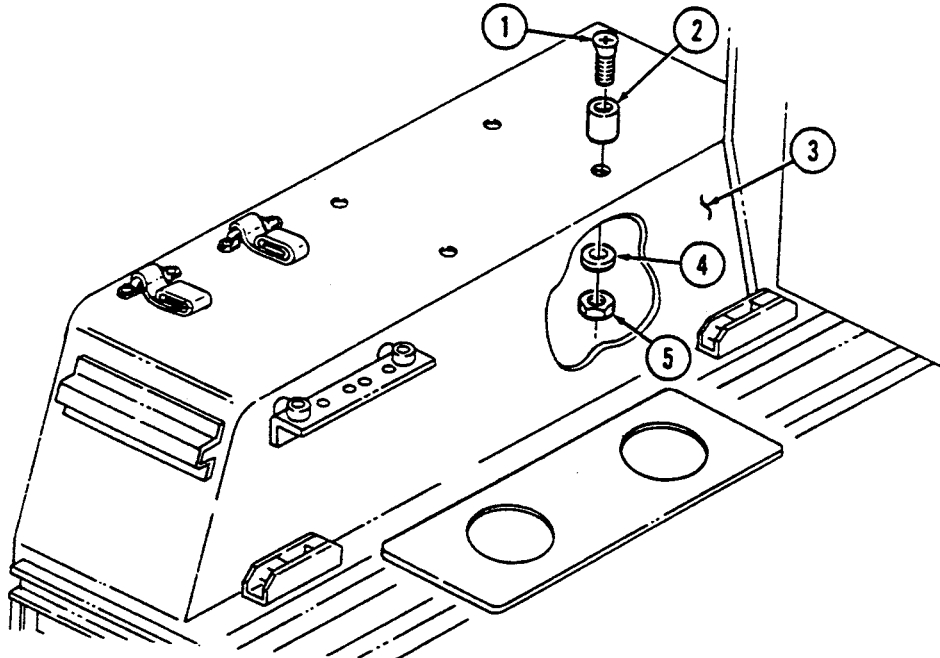

FOLLOW-ON TASK: Close cargo shell door (TM 9-2320-280-10).

11-87. LAUNCH TUBE STOWAGE BRACKETS REPLACEMENT

This task covers:

a. Removal

b. Installation

INITIAL SETUP:

Applicable Models

M966, M966A1, M1036, M1045, M1045A1,
M1045A2, M1046, M1046A1

Manual References

TM 9-2320-280-10
TM 9-2320-280-24P

Tools

General mechanic's tool kit:
automotive (Appendix B, Item 1)

Equipment Condition

Rear end of cargo shell door raised
(TM 9-2320-280-10).

Materials/Parts

Sealing compound (Appendix C, Item 45)
Four lockwashers (Appendix G, Item 134)
Two cotter pins (Appendix G, Item 23)
Four locknuts (Appendix G, Item 79)

a. Removal

1. Remove two cotter pins (5), pins (8), and strap (6) from front launch tube bracket (7). Discard cotter pins (5).
2. Remove four locknuts (4), washers (3), front launch tube bracket (7), and plate (2) from cargo door (1). Discard locknuts (4).
3. Remove four capscrews (9), lockwashers (10), and rear launch tube bracket (11) from cargo door (1). Discard lockwashers (10).

b. Installation

1. Apply sealing compound to threads of four capscrews (9). Install rear launch tube bracket (11) on cargo door (1) with four lockwashers (10) and capscrews (9). Tighten capscrews (9) to 10 lb-ft (14 N·m).
2. Install plate (2) and front launch tube bracket (7) on cargo door (1) with four washers (3) and locknuts (4). Tighten locknuts (4) to 10 lb-ft (14 N·m).
3. Install strap (6) on front launch tube bracket (7) with two pins (8) and cotter pins (5).

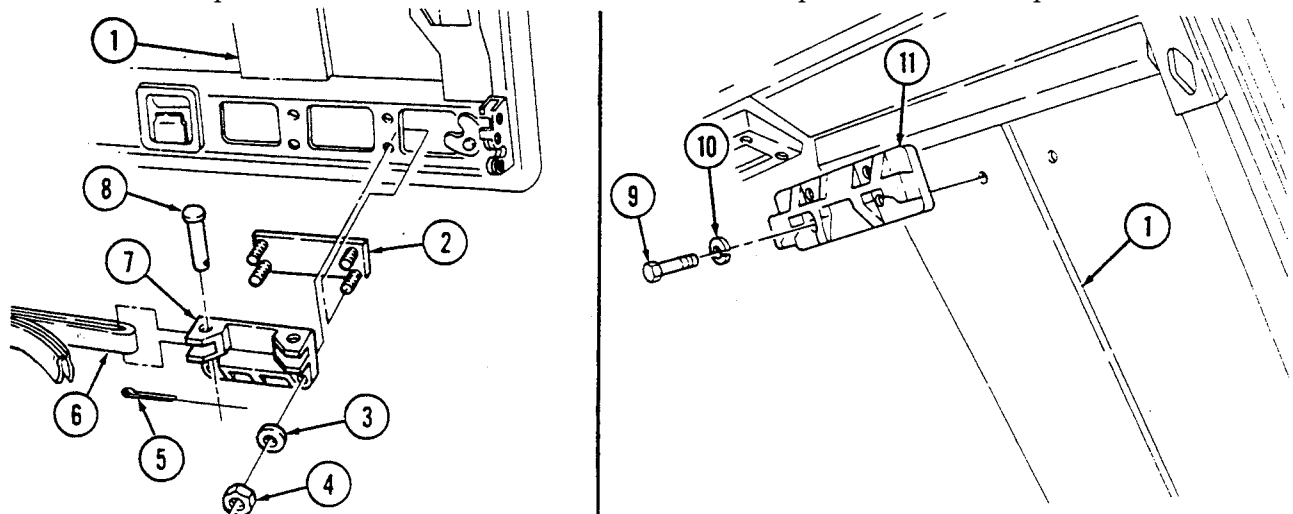

FOLLOW-ON TASK: Close cargo shell door (TM 9-2320-280-10).

11-88. ANTENNA BLAST SHIELD REPLACEMENT

This task covers:

a. Removal

b. Installation

INITIAL SETUP:

Applicable Models

M966, M966A1, M1036, M1045, M1045A1, M1045A2, M1046, M1046A1

Manual References

TM 9-2320-280-10
TM 9-2320-280-24P

Tools

General mechanic's tool kit:
automotive (Appendix B, Item 1)

Equipment Condition

Rear end of cargo shell door raised
(TM 9-2320-280-10).

Materials/Parts

Four locknuts (Appendix G, Item 70)

a. Removal

Remove four locknuts (5), washers (4), capscrews (2), washers (3), and blast shield (1) from cargo shell (6). Discard locknuts (5).

b. Installation

Install blast shield (1) on cargo shell (6) with four washers (3), capscrews (2), washers (4), and locknuts (5). Tighten locknuts (5) to 85-110 lb-in. (10-12 N·m).

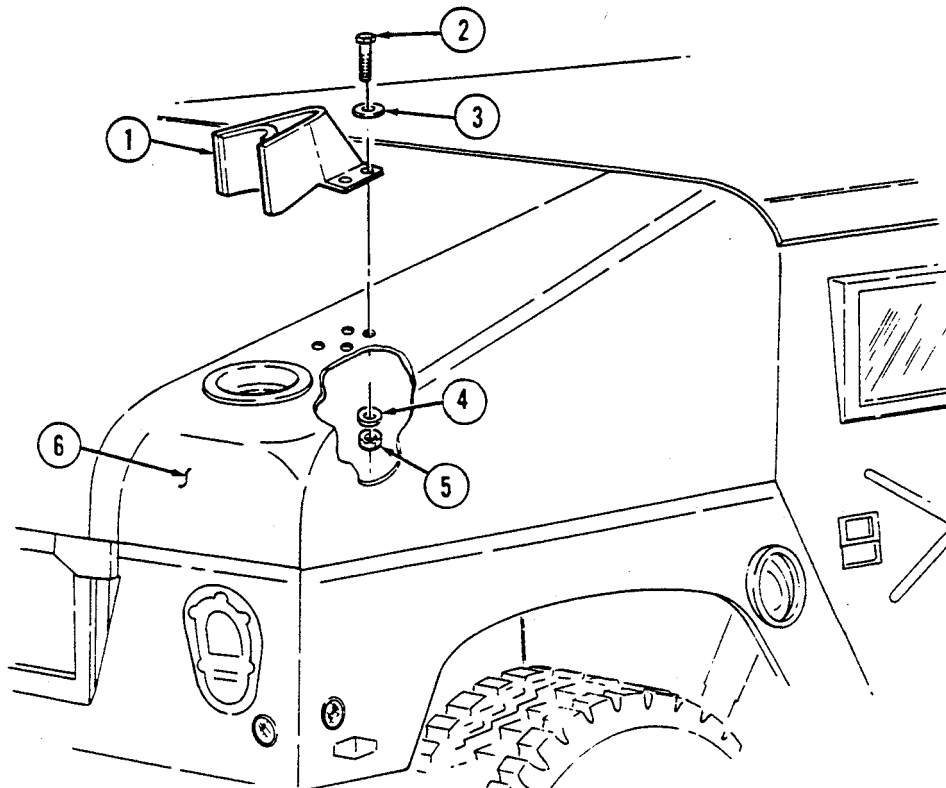

FOLLOW-ON TASK: Close cargo shell door (TM 9-2320-280-10).

11-89. GASOLINE COOK STOVE BRACKET ASSEMBLY REPLACEMENT

This task covers:

a. Removal

b. Installation

INITIAL SETUP:

Applicable Models

M966, M966A1, M1025, M1025A1, M1025A2,
M1026, M1026A1, M1036, M1045, M1045A1,
M1045A2, M1046, M1046A1

Tools

General mechanic's tool kit:
automotive (Appendix B, Item 1)

Materials/Parts

Sealing compound (Appendix C, Item 45)

Manual References

TM 9-2320-280-24P

Equipment Condition

Remove engine right splash shield (para. 10-20).

a. Removal

Remove two capscrews (3), washers (2), and bracket assembly (1) from right airlift bracket (4).

b. Installation

1. Apply sealing compound to threads of two capscrews (3).
2. Install bracket assembly (1) on right airlift bracket (4) with two washers (2) and capscrews (3).
Tighten capscrews (3) to 6 lb-ft (8 N•m).

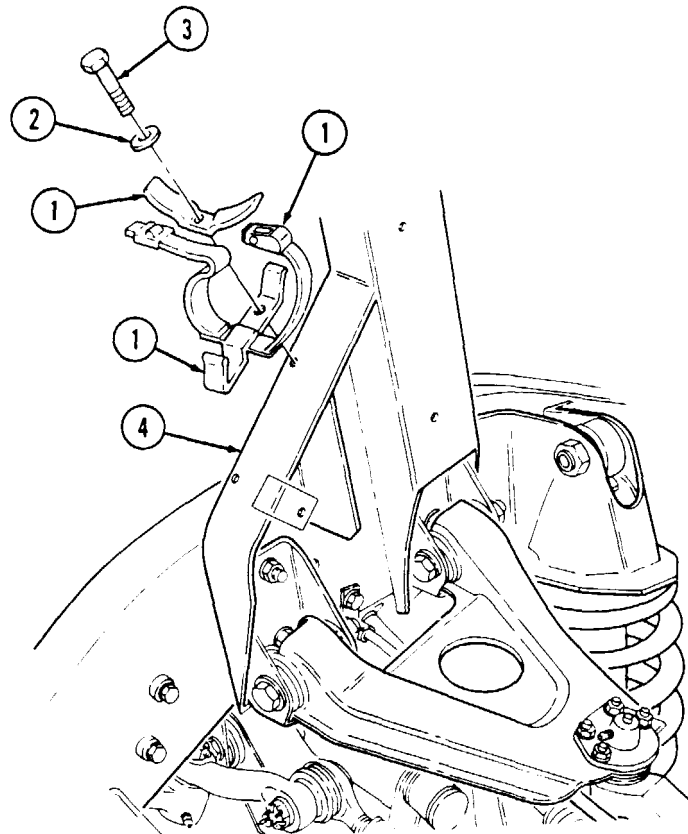

FOLLOW-ON TASK: Install engine right splash shield (para. 10-20).

11-90. RIFLE SUPPORT REPLACEMENT

This task covers:

a. Removal

b. Installation

INITIAL SETUP:

Applicable Models

All models except M996, M996A1, M997, M997A1, M997A2, M998, M998A1, M1035, M1035A1, M1035A2, M1037, M1038, M1038A1, M1042, M1097, M1097A1, M1097A2, M1123

Tools

General mechanic's tool kit:
automotive (Appendix B, Item 1)

Materials/Parts

Three locknuts (Appendix G, Item 79)

Personnel Required

One mechanic
One assistant

Manual References

TM 9-2320-280-24P

a. Removal

Remove three locknuts (5), washers (2), capscrews (1), washers (2), and rifle support (3) from floor panel (4). Discard locknuts (5).

b. Installation

Install rifle support (3) on floor panel (4) with three washers (2), capscrews (1), washers (2), and locknuts (5). Tighten locknuts (5) to 12-17 lb-ft (16-23 N·m).

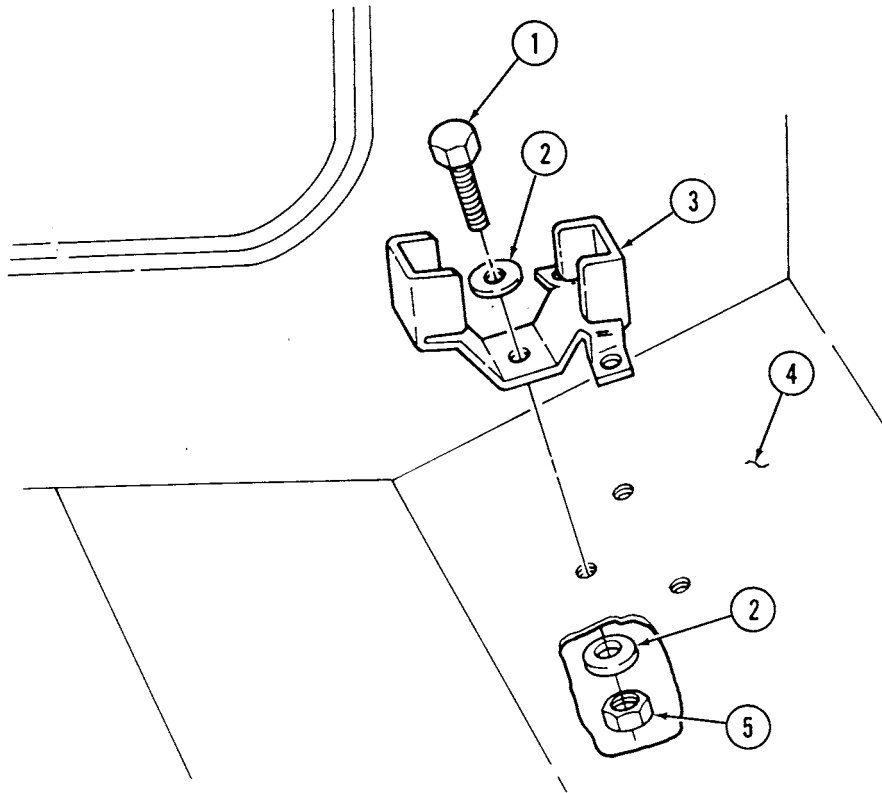

11-91. RIFLE MOUNTING CLAMP REPLACEMENT

This task covers:

a. Removal

b. Installation

INITIAL SETUP:

Applicable Models

All models except M996, M996A1, M997, M997A1, M997A2, M998, M998A1, M1035, M1035A1, M1035A2, M1037, M1038, M1038A1, M1042, M1097, M1097A1, M1097A2, M1123

Tools

General mechanic's tool kit:
automotive (Appendix B, Item 1)

Materials/Parts

Two locknuts (Appendix G, Item 91)
Two locknuts (new configuration)
(Appendix G, Item 92)

Manual References

TM 9-2320-280-24P

NOTE

- Procedures for replacing the left and right rifle mounting clamps are basically the same. This procedure covers the right rifle mounting clamp.
- Vehicle may be equipped with new rifle mounting clamp bracket configuration for M16 rifle or M203 grenade launcher.

a. Removal

Remove two locknuts (2), washers (3), screws (4), washers (3), and clamp (5) from clamp bracket (1). Discard locknuts (2).

b. Installation

Install clamp (5) on clamp bracket (1), with moveable finger (6) inboard, with two washers (3), screws (4), washers (3), and locknuts (2).

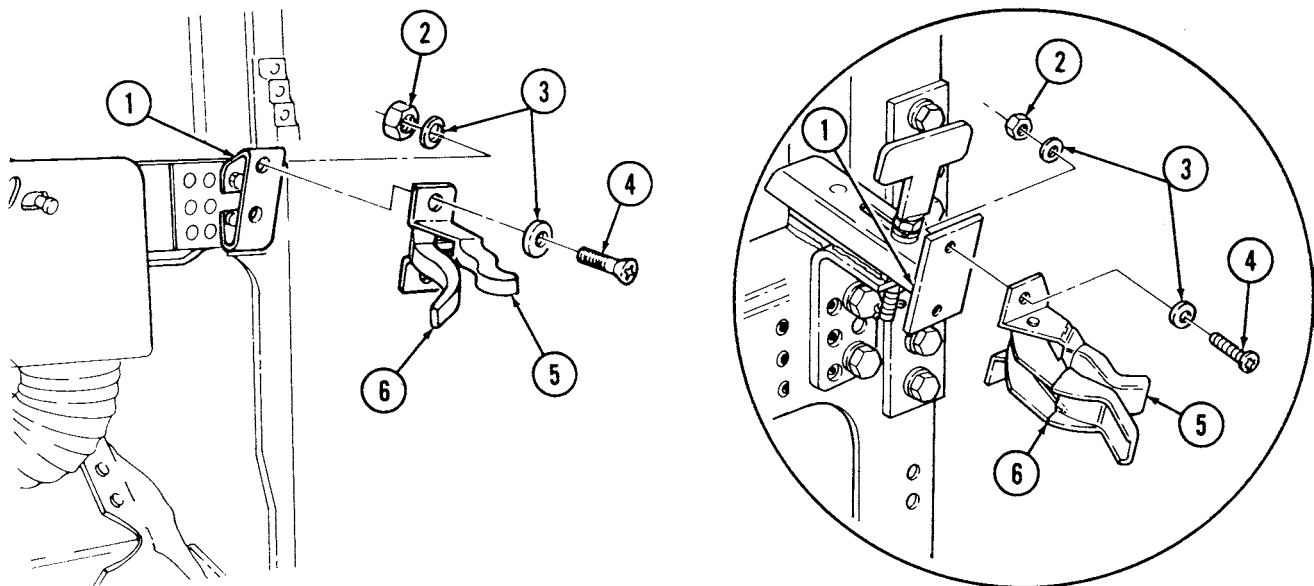

11-92. RIFLE MOUNTING CLAMP BRACKET REPLACEMENT

This task covers:

a. Removal

b. Installation

INITIAL SETUP:

Applicable Models

All models except M996, M996A1, M997, M997A1, M997A2, M998, M998A1, M1035, M1035A1, M1035A2, M1037, M1038, M1038A1, M1042, M1097, M1097A1, M1097A2, M1123

Tools

General mechanic's tool kit:
automotive (Appendix B, Item 1)

Materials/Parts

Two locknuts (Appendix G, Item 70)
Two locknuts (Appendix G, Item 122)

Manual References

TM 9-2320-280-24P

Equipment Condition

Rifle mounting clamp removed (para. 11-91).

NOTE

Replacement procedures for the front and rear (rear bracket installed on M1025, M1025A1, M1025A2, M1026, M1026A1, M1043, M1043A1, M1043A2, M1044, and M1044A1 vehicles only) rifle mounting clamp brackets are basically the same. This procedure covers the right front and right rear bracket (M1025A2 only).

a. Removal

1. Remove two locknuts (5), washers (3), capscrews (4), washers (3), and clamp bracket (2) from "A" beam (1). Discard locknuts (5).

NOTE

Perform step 2 for M1025A2 vehicles only.

2. Remove two locknuts (6), washers (7), capscrews (9), washers (7), and clamp bracket (8) from "B" pillar (10). Discard locknuts (6).

b. Installation

1. Install clamp bracket (2) on "A" beam (1) with two washers (3), capscrews (4), washers (3), and locknuts (5).

NOTE

Perform step 2 for M1025A2 vehicles only.

2. Install clamp bracket (8) on "B" pillar (10) with two washers (7), capscrews (9), washers (7), and locknuts (6).

11-92. RIFLE MOUNTING CLAMP BRACKET REPLACEMENT (Cont'd)

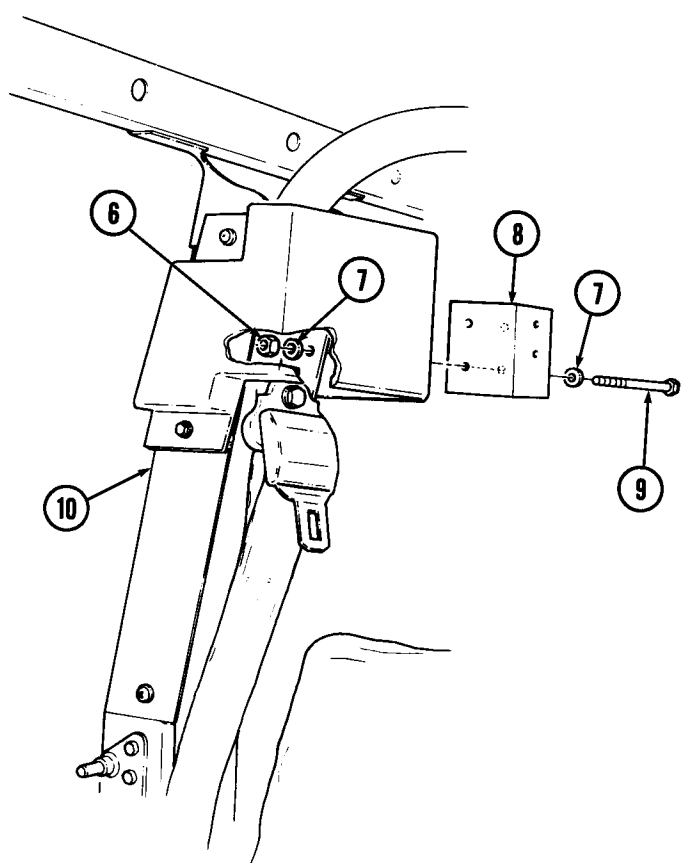
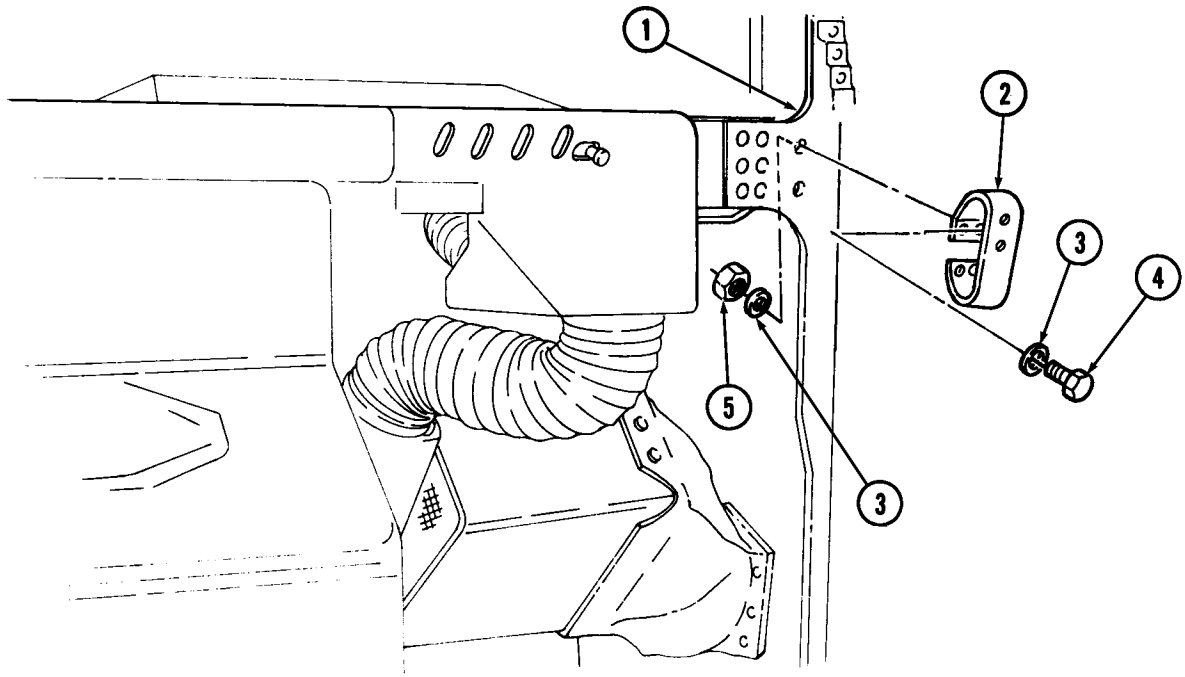

FOLLOW-ON TASK: Install rifle mounting clamp (para. 11-91).

11-93. RIFLE MOUNTING CLAMP BRACKET REPLACEMENT (M16 A1 RIFLE/M203 GRENADE LAUNCHER)

This task covers:

a. Removal

b. Installation

INITIAL SETUP:

Applicable Models

All models except M996, M996A1, M997, M997A1, M997A2, M998, M998A1, M1035, M1035A1, M1035A2, M1037, M1038, M1038A1, M1042, M1097, M1097A1, M1097A2

Tools

General mechanic's tool kit:
automotive (Appendix B, Item 1)

Materials/Parts

Cotter pin (Appendix G, Item 24)
Lockwasher (Appendix G, Item 135)
Two locknuts (Appendix G, Item 70)

Manual References

TM 9-2320-280-24P

Equipment Condition

Rifle mounting clamp removed (para. 11-91).

NOTE

Replacement procedures for left and right rifle mounting clamp brackets are basically the same. This procedure covers the right rifle mounting clamp bracket.

a. Removal

1. Remove cotter pin (7) from handle (5). Discard cotter pin (7).
2. Remove handle (5), lockwasher (4), washer (3), and clamp bracket (2) from mounting bracket (6). Discard lockwasher (4).
3. Remove two locknuts (10), washers (8), capscrews (9), washers (8), and mounting bracket (6) from "A" beam (1). Discard locknuts (10).

b. Installation

1. Install mounting bracket (6) on "A" beam (1) with two washers (8), capscrews (9), washers (8), and locknuts (10).
2. Install clamp bracket (2) on mounting bracket (6) with washer (3), lockwasher (4), and handle (5).
3. Install cotter pin (7) on handle (5).

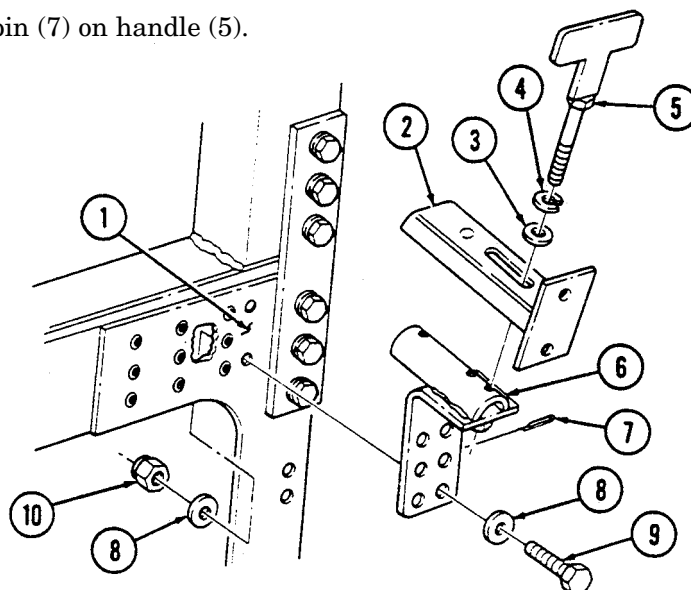

FOLLOW-ON TASK: Install rifle mounting clamp (para. 11-91).

11-94. LOWER RIFLE MOUNT BRACKET REPLACEMENT

This task covers:

a. Removal

b. Installation

INITIAL SETUP:

Applicable Models

M1025, M1025A1, M1025A2, M1026,
M1026A1, M1043, M1043A1, M1043A2,
M1044, M1044A1,

Tools

General mechanic's tool kit:
automotive (Appendix B, Item 1)

Manual References

TM 9-2320-280-24P

a. Removal

Remove two screws (4), washers (3), and lower rifle mount bracket (2) from "B" beam (1).

b. Installation

Install rifle mount bracket (2) on "B" beam (1) with two washers (3) and screws (4).

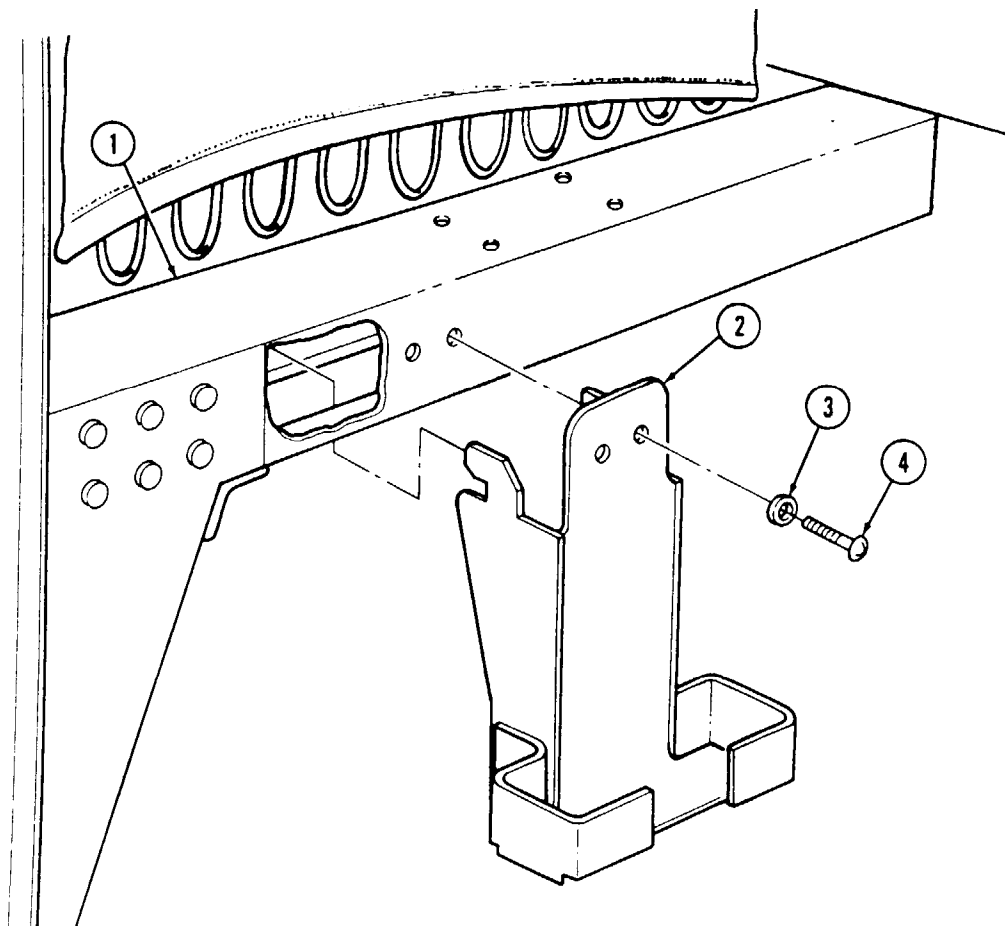

11-95. GUN ADAPTER PLATE ASSEMBLY REPLACEMENT

This task covers:

a. Removal

b. Installation

INITIAL SETUP:

Applicable Models

M1043, M1043A1, M1043A2, M1044,
M1044A1

Personnel Required

One mechanic
One assistant

Tools

General mechanic's tool kit:
automotive (Appendix B, Item 1)

Manual References

TM 9-2320-280-24P

Materials/Parts

Two locknuts (Appendix G, Item 70)

a. Removal

1. Remove two capscrews (2) and washers (1) from adapter plate (5) and cargo floor (11).
2. Remove locknut (14), washer (4), capscrew (3), and washer (4) from adapter plate (5) and cargo floor (11). Discard locknut (14).
3. Remove locknut (12), washer (6), reinforcement bracket (13), capscrew (7), and washer (6) from adapter plate (5) and cargo floor (11). Discard locknut (12).
4. Remove capscrew (8), washer (9), adapter plate (5), and cargo tiedown (10) from cargo floor (11).

b. Installation

1. Install cargo tiedown (10) and adapter plate (5) on cargo floor (11) with washer (9) and capscrew (8).
2. Install adapter plate (5) on cargo floor (11) with washer (6), capscrew (7), reinforcement bracket (13), washer (6), and locknut (12).
3. Secure adapter plate (5) to cargo floor (11) with washer (4), capscrew (3), washer (4), and locknut (14).
4. Secure adapter plate (5) to cargo floor (11) with two washers (1) and capscrews (2).
5. Tighten capscrews (2), (7), and (3) to 6 lb-ft (8 N·m). Tighten capscrew (8) to 75 lb-ft (102 N·m).

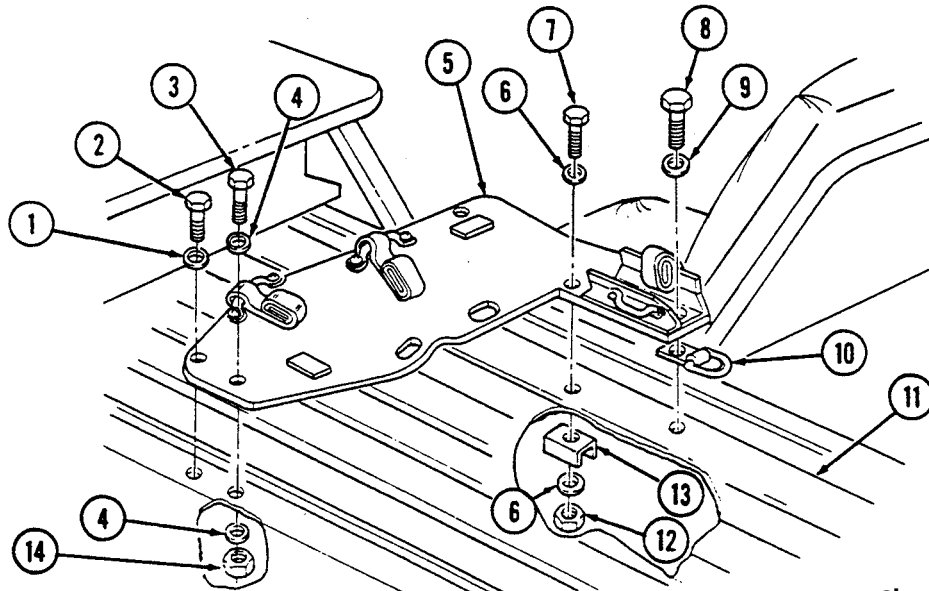

11-96. FRONT GUN MOUNT PLATE ASSEMBLY REPLACEMENT

This task covers:

a. Removal

b. Installation

INITIAL SETUP:

Applicable Models

M1025, M1025A1, M1025A2, M1026,
M1026A1, M1043, M1043A1, M1043A2,
M1044, M1044A1

Tools

General mechanic's tool kit:
automotive (Appendix B, Item 1)

Materials/Parts

Five locknuts (Appendix G, Item 128)

Personnel Required

One mechanic
One assistant

Manual References

TM 9-2320-280-10
TM 9-2320-280-24P

Equipment Condition

- Rear end of cargo shell door raised (TM 9-2320-280-10).
- Fuel tank removed (para 3-24).

a. Removal

1. Remove five locknuts (5), washers (2), capscrews (1), washers (2), and front plate assembly (3) from cargo floor (4). Discard locknuts (5).
2. Remove 40 mm gun mount support (para. 11-99) and caliber .50 gun mount support (para. 11-98) from front plate assembly (3).

b. Installation

1. Install caliber .50 gun mount support (para. 11-98) and 40 mm gun mount support (para. 11-99) on front plate assembly (3).
2. Install front plate assembly (3) on cargo floor (4) with five washers (2), capscrews (1), washers (2), and locknuts (5). Tighten capscrews (1) to 26 lb-ft (35 N•m).

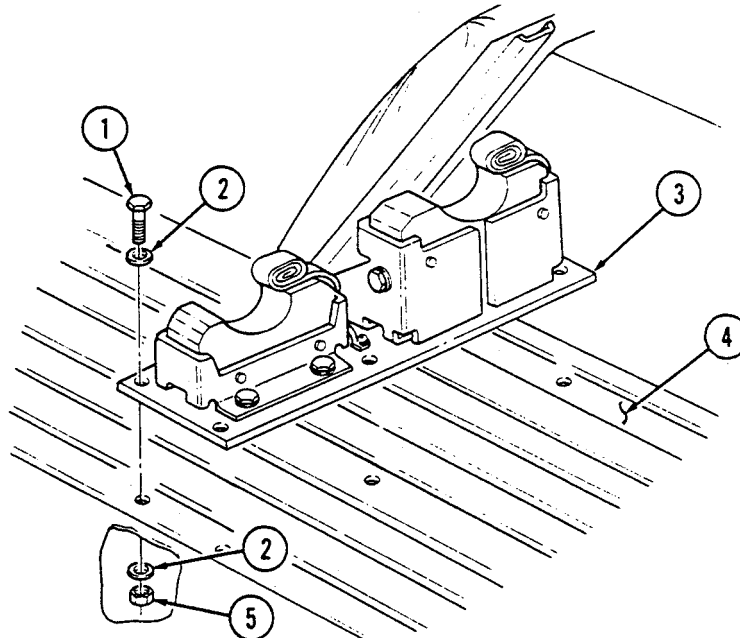

FOLLOW-ON TASKS: • Close cargo shell door (TM 9-2320-280-10).
• Install fuel tank (para. 3-24).

11-97. REAR GUN MOUNT PLATE ASSEMBLY REPLACEMENT

This task covers:

a. Removal

b. Installation

INITIAL SETUP:

Applicable Models

M1025, M1025A1, M1025A2, M1026,
M1026A1, M1043, M1043A1, M1043A2,
M1044, M1044A1

Tools

General mechanic's tool kit:
automotive (Appendix B, Item 1)

Materials/Parts

Six locknuts (Appendix G, Item 128)

Personnel Required

One mechanic
One assistant

Manual References

TM 9-2320-280-10
TM 9-2320-280-24P

Equipment Condition

Rear end of cargo shell door raised
(TM 9-2320-280-10).

a. Removal

1. Remove three locknuts (7), washers (3), reinforcement brackets (6), capscrews (2), and washers (3) from rear plate assembly (4) and cargo floor (5). Discard locknuts (7).
2. Remove three locknuts (8), washers (9), capscrews (1), washers (9), and rear plate assembly (4) from cargo floor (5). Discard locknuts (8).
3. Remove 40 mm gun mount support (para. 11-99) and caliber .50 gun mount support (para. 11-98) from rear plate assembly (4).

b. Installation

1. Install caliber .50 gun mount support (para. 11-98) and 40 mm gun mount support (para. 11-99) on rear plate assembly (4).
2. Install rear plate assembly (4) on cargo floor (5) with three washers (3), capscrews (2), reinforcement brackets (6), washers (3), and locknuts (7).
3. Secure rear plate assembly (4) to cargo floor (5) with three washers (9), capscrews (1), washers (9), and locknuts (8). Tighten capscrews (1) and (2) to 26 lb-ft (35 N·m).

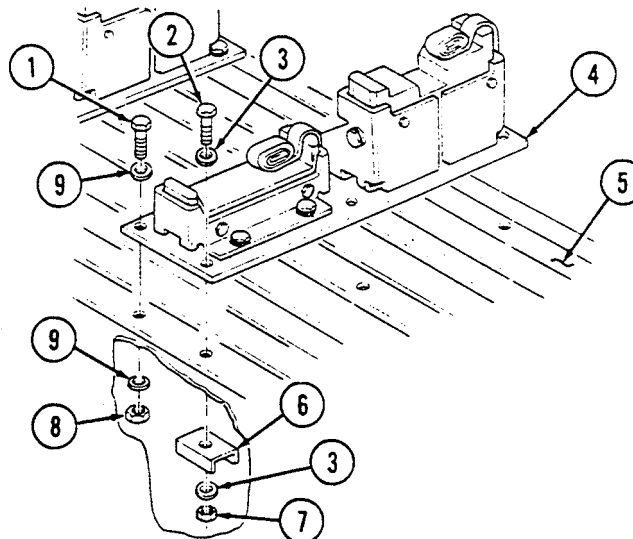

FOLLOW-ON TASK: Close cargo shell door (TM 9-2320-280-10).

11-98. GUN MOUNT SUPPORT (CALIBER .50) REPLACEMENT

This task covers:

a. Removal

b. Installation

INITIAL SETUP:

Applicable Models

M1025, M1025A1, M1025A2, M1026,
M1026A1, M1043, M1043A1, M1043A2,
M1044, M1044A1

Tools

General mechanic's tool kit:
automotive (Appendix B, Item 1)

Materials/Parts

Two locknuts (Appendix G, Item 70)

Manual References

TM 9-2320-280-10
TM 9-2320-280-24P

Equipment Condition

Rear end of cargo shell door raised
(TM 9-2320-280-10).

a. Removal

1. Remove two locknuts (1), washers (2), capscrews (7), washers (2), and pad (3) from bracket (6). Discard locknuts (1).
2. Remove four capscrews (5), washers (4), and bracket (6) from mounting plate (8).

b. Installation

1. Install bracket (6) on mounting plate (8) with four washers (4) and capscrews (5). Tighten capscrews (5) to 26 lb-ft (35 N·m).
2. Install pad (3) on bracket (6) with two washers (2), capscrews (7), washers (2), and locknuts (1). Tighten locknuts (1) to 6 lb-ft (8 N·m).

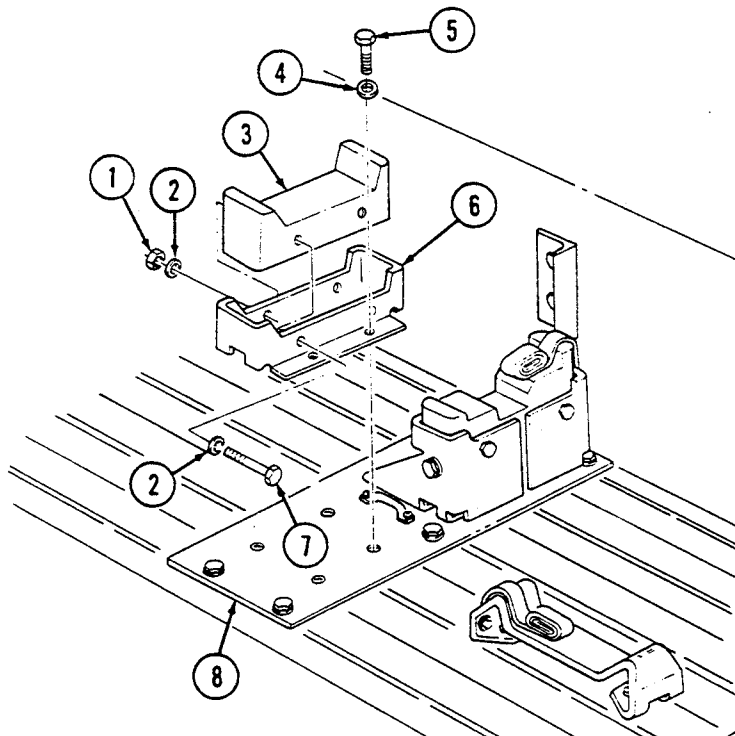

FOLLOW-ON TASK: Close cargo shell door (TM 9-2320-280-10).

11-99. GUN MOUNT SUPPORT (40 MM) REPLACEMENT

This task covers:

a. Removal

b. Installation

INITIAL SETUP:

Applicable Models

M1025, M1025A1, M1025A2, M1026,
M1026A1, M1043, M1043A1, M1043A2,
M1044, M1044A1

Tools

General mechanic's tool kit:
automotive (Appendix B, Item 1)

Materials/Parts

Four locknuts (Appendix G, Item 70)

Manual References

TM 9-2320-280-10
TM 9-2320-280-24P

Equipment Condition

Rear end of cargo shell door raised
(TM 9-2320-280-10).

a. Removal

1. Remove four capscrews (11), washers (10), and bracket (12) from mounting plate (7).
2. Remove two locknuts (8), washers (3), capscrews (4), washers (3), and pad (1) from brace (9) and bracket (12). Discard locknuts (8).
3. Remove two locknuts (2), washers (6), screws (5), and brace (9) from bracket (12). Discard locknuts (2).

b. Installation

1. Install brace (9) on bracket (12) with two screws (5), washers (6), and locknuts (2). Tighten locknuts (2) to 6 lb-ft (8 N·m).
2. Install pad (1) on bracket (12) and brace (9) with two washers (3), capscrews (4), washers (3), and locknuts (8). Tighten locknuts (8) to 6 lb-ft (8 N·m).
3. Install bracket (12) on mounting plate (7) with four washers (10) and capscrews (11). Tighten capscrews (11) to 26 lb-ft (35 N·m).

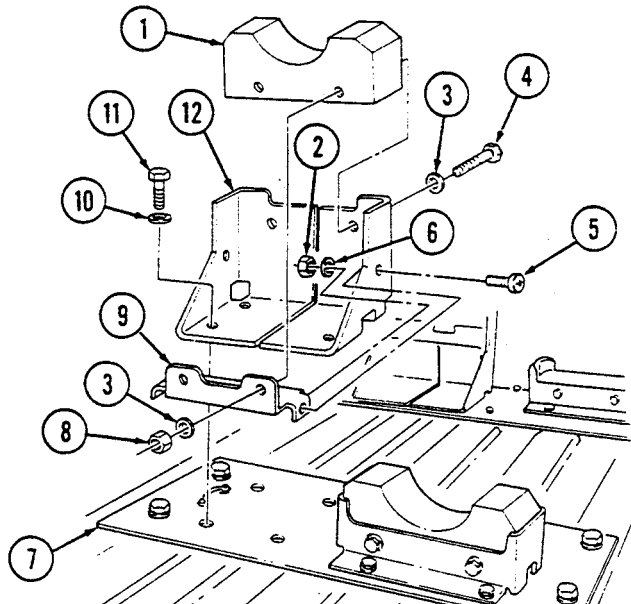

FOLLOW-ON TASK: Close cargo shell door (TM 9-2320-280-10).

11-100. MACHINE GUN STOP REPLACEMENT

This task covers:

a. Removal

b. Installation

INITIAL SETUP:

Applicable Models

M1025, M1025A1, M1025A2, M1026,
M1026A1, M1043, M1043A1, M1043A2,
M1044, M1044A1

Tools

General mechanic's tool kit:
automotive (Appendix B, Item 1)

Materials/Parts

Two locknuts (Appendix G, Item 70)

Personnel Required

One mechanic
One assistant

Manual References

TM 9-2320-280-10
TM 9-2320-280-24P

Equipment Condition

Rear end of cargo shell door raised
(TM 9-2320-280-10).

a. Removal

Remove two locknuts (4), washers (2), capscrews (1), washers (2), and stop (3) from wheelhouse (5). Discard locknuts (4).

b. Installation

Install stop (3) on wheelhouse (5) with two washers (2), capscrews (1), washers (2), and locknuts (4). Tighten locknuts (4) to 6 lb-ft (8 N•m).

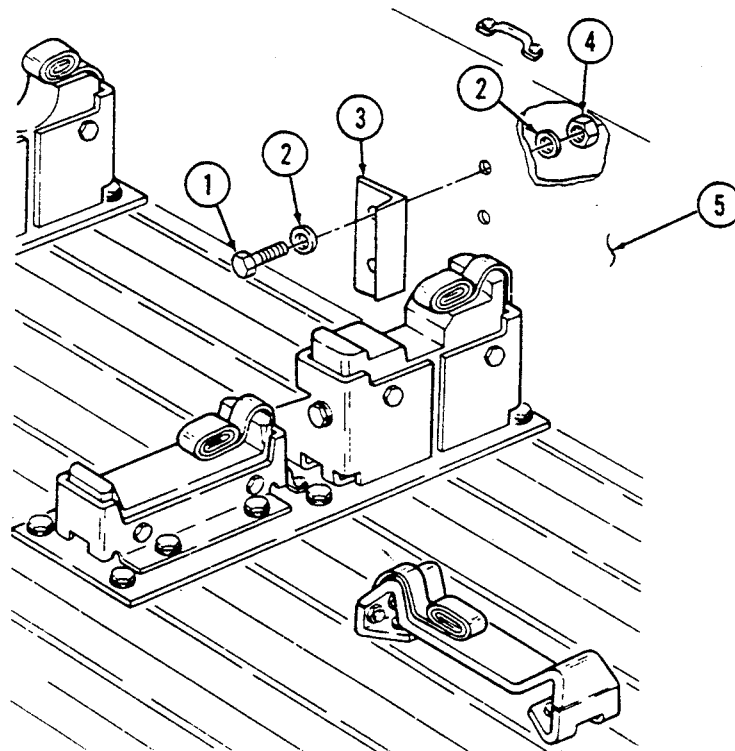

FOLLOW-ON TASK: Close cargo shell door (TM 9-2320-280-10).

11-101. NIGHT SIGHT RETAINER REPLACEMENT

This task covers:

a. Removal

b. Installation

INITIAL SETUP:

Applicable Models

M1025, M1025A1, M1025A2, M1026,
M1026A1, M1043, M1043A1, M1043A2,
M1044, M1044A1

Tools

General mechanic's tool kit:
automotive (Appendix B, Item 1)

Manual References

TM 9-2320-280-10
TM 9-2320-280-24P

Equipment Condition

Rear end of cargo shell door raised
(TM 9-2320-280-10).

a. Removal

Remove two screws (3), footman loop (2), and retainer (1) from wheelhouse (4).

b. Installation

Install retainer (1) and footman loop (2) on wheelhouse (4) with two screws (3).

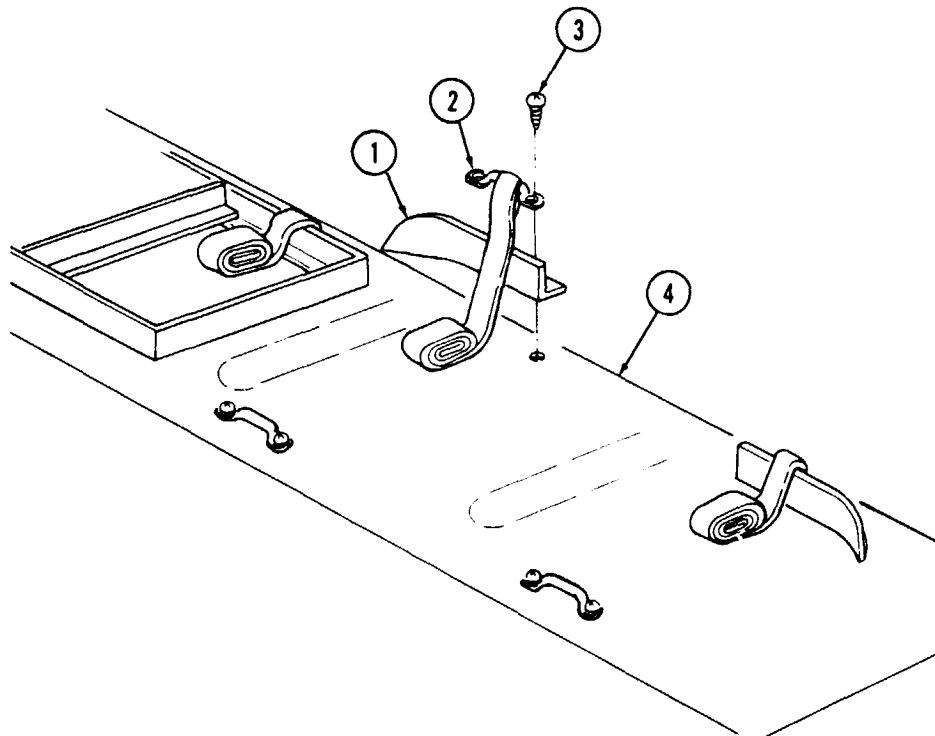

FOLLOW-ON TASK: Close cargo shell door (TM 9-2320-280-10).

11-102. TRIPOD BRACKET REPLACEMENT

This task covers:

a. Removal

b. Installation

INITIAL SETUP:

Applicable Models

M1025, M1025A1, M1025A2, M1026,
M1026A1, M1043, M1043A1, M1043A2,
M1044, M1044A1

Personnel Required

One mechanic
One assistant

Tools

General mechanic's tool kit:
automotive (appendix B, Item 1)

Manual References

TM 9-2320-280-10
TM 9-2320-280-24P

Materials/Parts

Two locknuts (Appendix G, Item 70)

Equipment Condition

Rear end of cargo shell door raised
(TM 9-2320-280-10).

a. Removal

1. Remove locknut (8), washer (4), large washer (7), capscrew (3), and washer (4) from tripod bracket (5) and cargo floor (6). Discard locknut (8).
2. Remove locknut (9), washer (1), capscrew (2), washer (1), and tripod bracket (5) from cargo floor (6). Discard locknut (9).

b. Installation

1. Install tripod bracket (5) on cargo floor (6) with washer (1), capscrew (2), washer (1), and locknut (9).
2. Secure tripod bracket (5) to cargo floor (6) with washer (4), capscrew (3), large washer (7), washer (4), and locknut (8). Tighten locknuts (8) and (9) to 6 lb-ft (8 N·m).

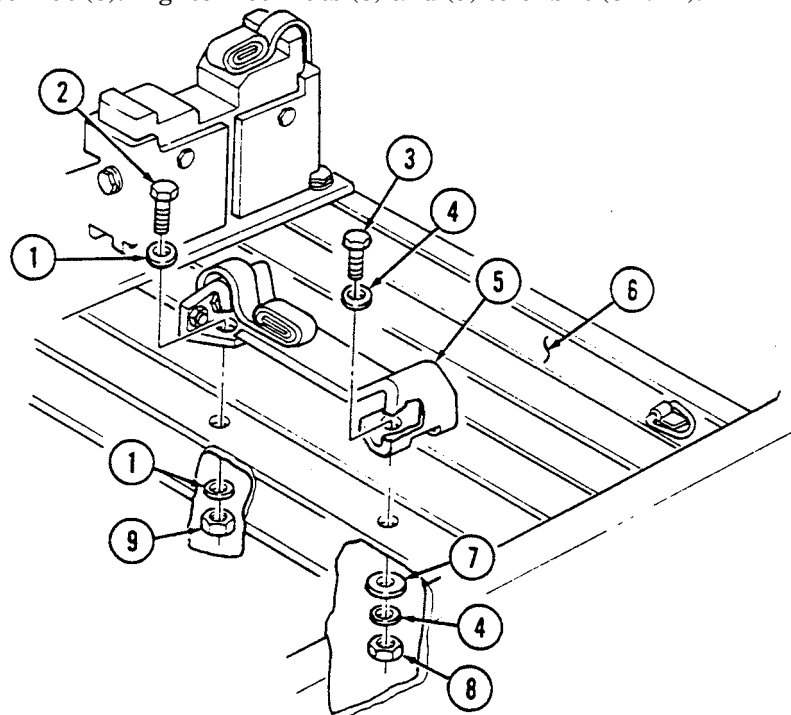

FOLLOW-ON TASK: Close cargo shell door (TM 9-2320-280-10).

11-103. DOUBLE AMMO BOX TRAY (CALIBER .50) REPLACEMENT

This task covers:

a. Removal

b. Installation

INITIAL SETUP:

Applicable Models

M1025, M1025A1, M1025A2, M1026,
M1026A1, M1043, M1043A1, M1043A2,
M1044, M1044A1

Tools

General mechanic's tool kit:
automotive (Appendix B, Item 1)

Materials/Parts

Four locknuts (Appendix G, Item 70)

Personnel Required

One mechanic
One assistant

Manual References

TM 9-2320-280-10
TM 9-2320-280-24P

Equipment Condition

Rear end of cargo shell door raised
(TM 9-2320-280-10).

a. Removal

1. Remove two locknuts (9), washers (2), capscrews (3), and washers (2) from ammo box tray (1) and wheelhouse (6). Discard locknuts (9).
2. Remove two locknuts (8), washers (5), reinforcement brackets (7), capscrews (4), washers (5), and ammo box tray (1) from wheelhouse (6). Discard locknuts (8).

b. Installation

1. Install ammo box tray (1) on wheelhouse (6) with two washers (5), capscrews (4), reinforcement brackets (7), washers (5), and locknuts (8).
2. Secure ammo box tray (1) to wheelhouse (6) with two washers (2), capscrews (3), washers (2), and locknuts (9). Tighten locknuts (9) and (8) to 6 lb-ft (8 N·m).

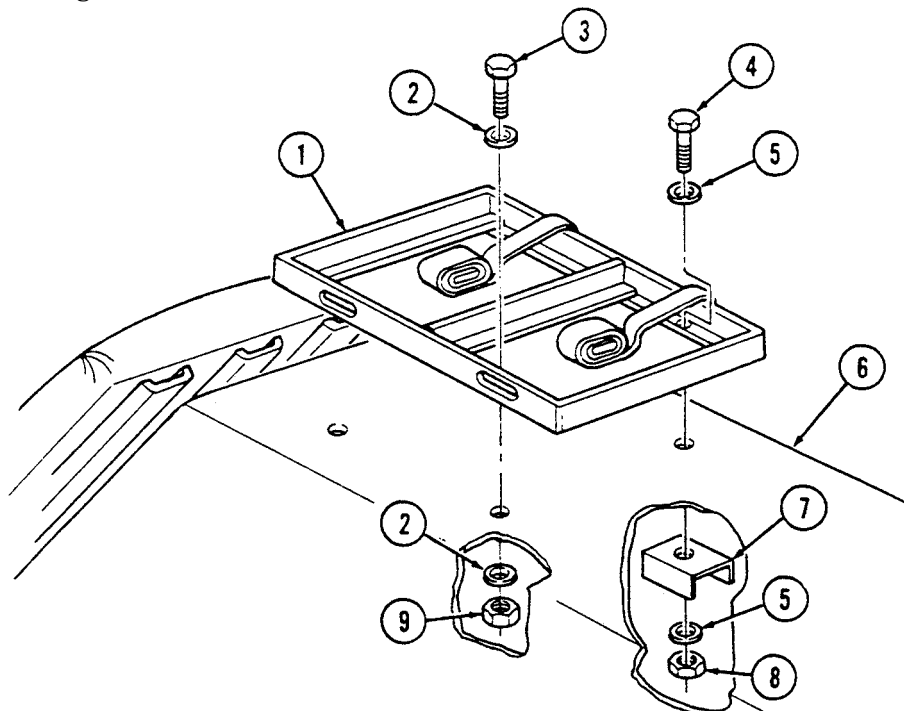

FOLLOW-ON TASK: Close cargo shell door (TM 9-2320-280-10).

11-104. AMMO BOX TRAY (CALIBER .50) REPLACEMENT

This task covers:

a. Removal

b. Installation

INITIAL SETUP:

Applicable Models

M1025, M1025A1, M1025A2, M1026,
M1026A1, M1043, M1043A1, M1043A2,
M1044, M1044A1

Personnel Required

One mechanic
One assistant

Tools

General mechanic's tool kit:
automotive (Appendix B, Item 1)

Manual References

TM 9-2320-280-10
TM 9-2320-280-24P

Materials/Parts

Four locknuts (Appendix G, Item 70)

Equipment Condition

Rear end of cargo shell door raised
(TM 9-2320-280-10).

a. Removal

Remove four locknuts (6), washers (3), reinforcement brackets (5), capscrews (4), washers (3), and ammo box tray (2) from wheelhouse (1). Discard locknuts (6).

b. Installation

Install ammo box tray (2) on wheelhouse (1) with four washers (3), capscrews (4), reinforcement brackets (5), washers (3), and locknuts (6). Tighten capscrews (4) to 6 lb-ft (8 N•m).

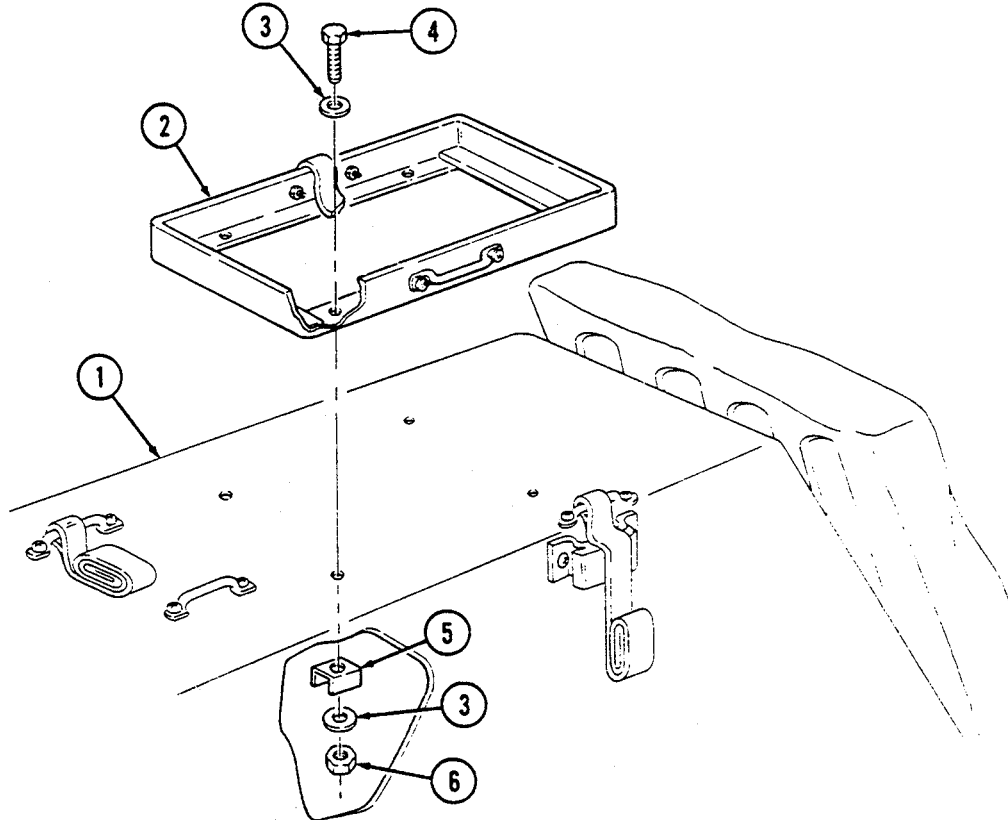

FOLLOW-ON TASK: Close cargo shell door (TM 9-2320-280-10).

11-105. AMMO BOX TRAY (40 MM AND CALIBER .50) REPLACEMENT

This task covers:

a. Removal

b. Installation

INITIAL SETUP:

Applicable Models

M1025, M1025A1, M1025A2, M1026,
M1026A1, M1043, M1043A1, M1043A2,
M1044, M1044A1

Tools

General mechanic's tool kit:
automotive (appendix B, item 1)

Materials/Parts

Four locknuts (Appendix G, Item 70)

Personnel Required

One mechanic
One assistant

Manual References

TM 9-2320-280-10
TM 9-2320-280-24P

Equipment Condition

Rear end of cargo shell door raised
(TM 9-2320-280-10).

a. Removal

1. Remove locknut (7), washer (2), reinforcement bracket (8), capscrew (3), and washer (2) from ammo box tray (1) and cargo floor (9). Discard locknut (7).
2. Remove three locknuts (6), washers (5), capscrews (4), washers (5), and ammo box tray (1) from cargo floor (9). Discard locknuts (6).

b. Installation

NOTE

Longer capscrews go in right side mounting holes.

1. Install ammo box tray (1) on cargo floor (9) with washer (2), capscrew (3), reinforcement bracket (8), washer (2), and locknut (7).
2. Secure ammo box tray (1) to cargo floor (9) with three washers (5), capscrews (4), washers (5), and locknuts (6). Tighten capscrews (4) and (3) to 6 lb-ft (8 N·m).

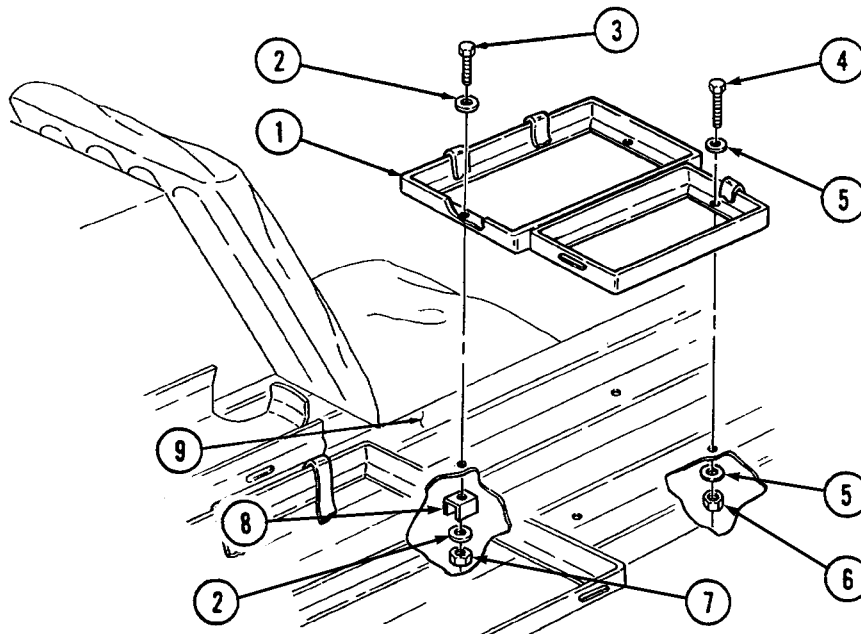

FOLLOW-ON TASK: Close cargo shell door (TM 9-2320-280-10).

11-106. DOUBLE AMMO BOX TRAY (40 MM) REPLACEMENT

This task covers:

a. Removal

b. Installation

INITIAL SETUP:

Applicable Models

M1025, M1025A1, M1025A2, M1026,
M1026A1, M1043, M1043A1, M1043A2,
M1044, M1044A1

Personnel Required

One mechanic
One assistant

Tools

General mechanic's tool kit:
automotive (Appendix B, Item 1)

Manual References

TM 9-2320-280-10
TM 9-2320-280-24P

Materials/Parts

Eight locknuts (Appendix G, Item 70)

Equipment Condition

Rear end of cargo shell door raised
(TM 9-2320-280-10).

a. Removal

Remove eight locknuts (5), washers (2), reinforcement brackets (4), capscrews (3), washers (2), and ammo box tray (1) from cargo floor (6). Discard locknuts (5).

b. Installation

Install ammo box tray (1) on cargo floor (6) with eight washers (2), capscrews (3), reinforcement brackets (4), washers (2), and locknuts (5). Tighten capscrews (3) to 6 lb-ft (8 N·m).

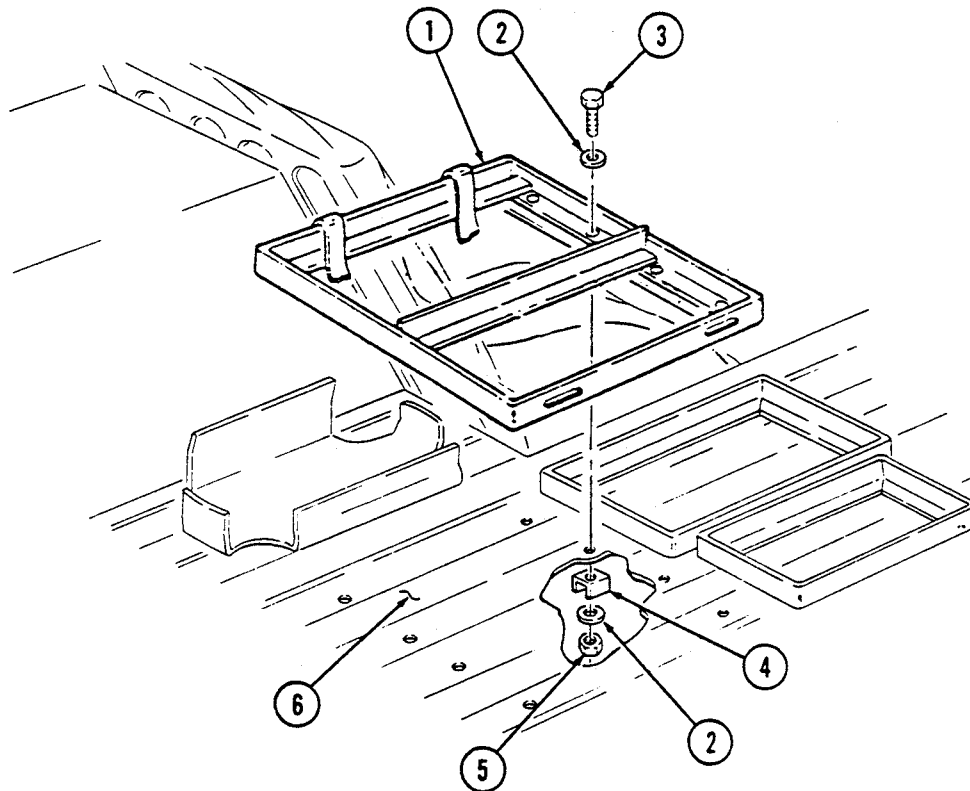

FOLLOW-ON TASK: Close cargo shell door (TM 9-2320-280-10).

11-107. TRIPLE AMMO BOX TRAY (40 MM) REPLACEMENT

This task covers:

a. Removal

b. Installation

INITIAL SETUP:

Applicable Models

M1025, M1025A1, M1025A2, M1026,
M1026A1, M1043, M1043A1, M1043A2,
M1044, M1044A1

Tools

General mechanic's tool kit:
automotive (Appendix B, Item 1)

Materials/Parts

Six locknuts (Appendix G, Item 70)

Personnel Required

One mechanic
One assistant

Manual References

TM 9-2320-280-10
TM 9-2320-280-24P

Equipment Condition

Rear end of cargo shell door raised
(TM 9-2320-280-10).

a. Removal

1. Remove three locknuts (8), washers (2), capscrews (3), and washers (2) from ammo box tray (1) and cargo floor (9). Discard locknuts (8).
2. Remove three locknuts (7), washers (4), reinforcement brackets (6), capscrews (5), washers (4), and ammo box tray (1) from cargo floor (9). Discard locknuts (7).

b. Installation

1. Install ammo box tray (1) on cargo floor (9) with three washers (4), capscrews (5), reinforcement brackets (6), washers (4), and locknuts (7).
2. Secure ammo box tray (1) to cargo floor (9) with three washers (2), capscrews (3), washers (2), and locknuts (8). Tighten capscrews (3) and (5) to 6 lb-ft (8 N·m).

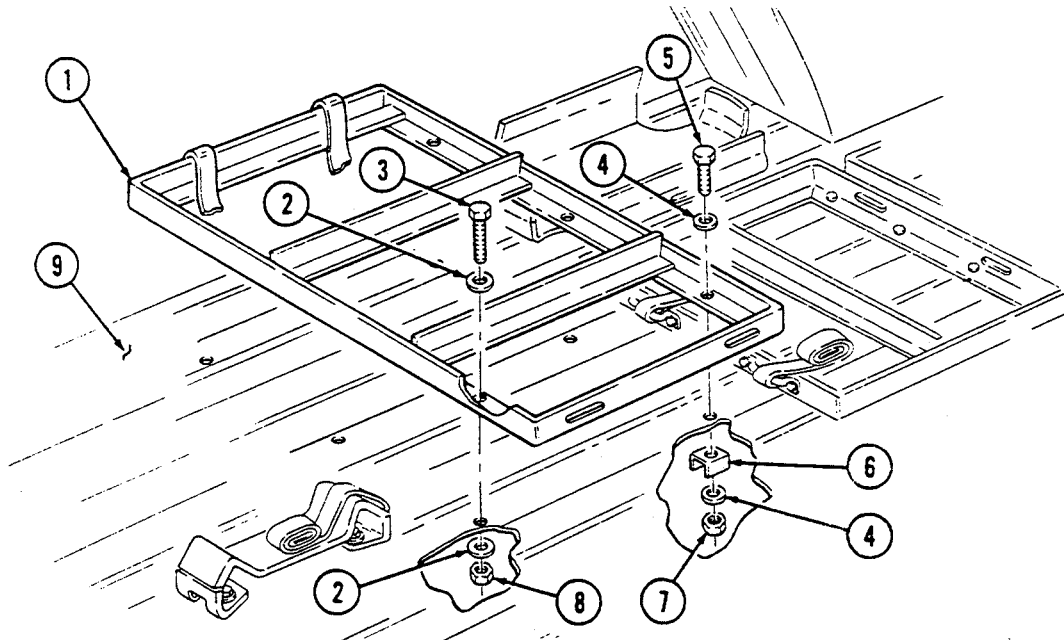

FOLLOW-ON TASK: Close cargo shell door (TM 9-2320-280-10).

11-108. WATER CAN TRAY REPLACEMENT

This task covers:

- a. Removal
- b. Installation

INITIAL SETUP:

Applicable Models

M1025, M1025A1, M1025A2, M1026,
M1026A1, M1043, M1043A1, M1043A2,
M1044, M1044A1

Tools

General mechanic's tool kit:
automotive (Appendix B, Item 1)

Personnel Required

One mechanic
One assistant

Manual References

TM 9-2320-280-10
TM 9-2320-280-24P

Equipment Condition

Rear of cargo shell door raised
(TM 9-2320-280-10).

a. Removal

NOTE

For M1025; M1025A1, M1025A2, M1026, and M1026A1 vehicles,
go to step 2.

1. Remove four screws (2), washers (3), and water can tray (1) from cargo floor (5).
2. Remove three screws (2), washers (3), and water can tray (1) from cargo floor (5).
3. Inspect rivnuts (4) for damage. Replace if damaged.

b. Installation

NOTE

For M1025, M1025A1, M1025A2, M1026, and M1026A1 vehicles,
go to step 2.

1. Install water can tray (1) on cargo floor (5) with four washers (3) and screws (2). Tighten screws (2) to 6 lb-ft (8 N·m).
2. Install water can tray (1) on cargo floor (5) with three washers (3) and screws (2). Tighten screws (2) to 6 lb-ft (8 N·m).

M1025, M1025A1, M1025A2,
M1026, M1026A1

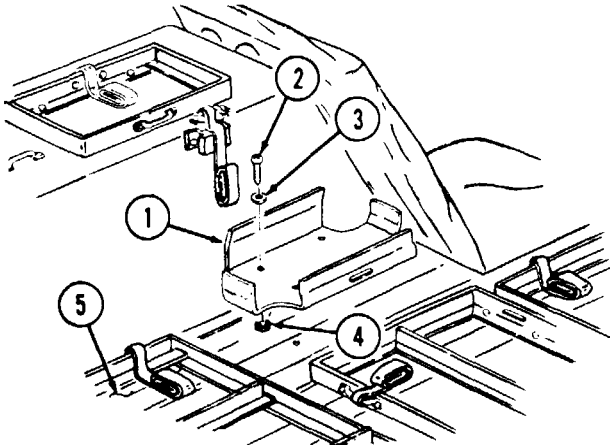

M1043, M1043A1, M1043A2,
M1044, M1044A1

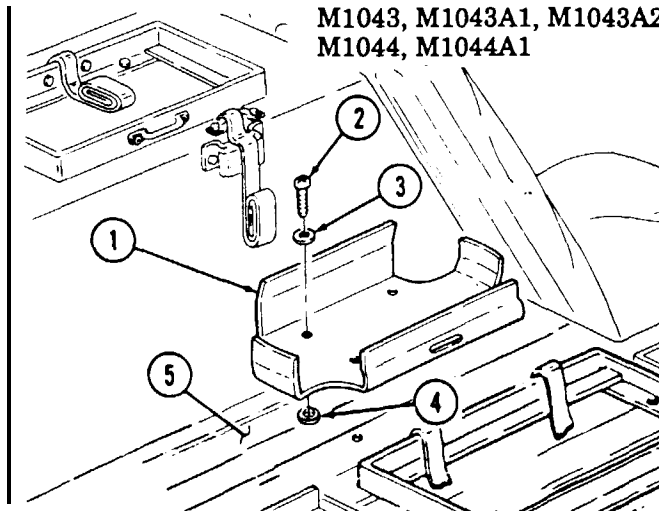

FOLLOW-ON TASK: Close cargo shell door (TM 9-2320-280-10).

11-109. WATER CAN/M13 DECON CAN BUMPER REPLACEMENT

This task covers:

a. Removal

b. Installation

INITIAL SETUP:

Applicable Models

M1025, M1025A1, M1025A2, M1026,
M1026A1, M1043, M1043A1, M1043A2,
M1044, M1044A1

Tools

General mechanic's tool kit:
automotive (appendix B, Item 1)

Materials/Parts

Two plain-assembled nuts
(Appendix G, Item 201)

Personnel Required

One mechanic
One assistant

Manual References

TM 9-2320-280-24P
TM 9-2320-280-10

Equipment Condition

Rear of cargo shell door raised
(TM 9-2320-280-10).

NOTE

- M1025, M1025A1, M1025A2, M1026, and M1026A1 vehicles have both a water can and M13 decon can bumpers.
- M1043, M1043A1, M1043A2, M1044, and M1044A1 vehicles have only a water can bumper.

a. Removal

Remove two plain-assembled nuts (4), screws (3), and water can bumper (2) from wheelhouse (1). Discard plain-assembled nuts (4).

b. Installation

Install water can bumper (2) on wheelhouse (1) with two screws (3) and plain-assembled nuts (4).

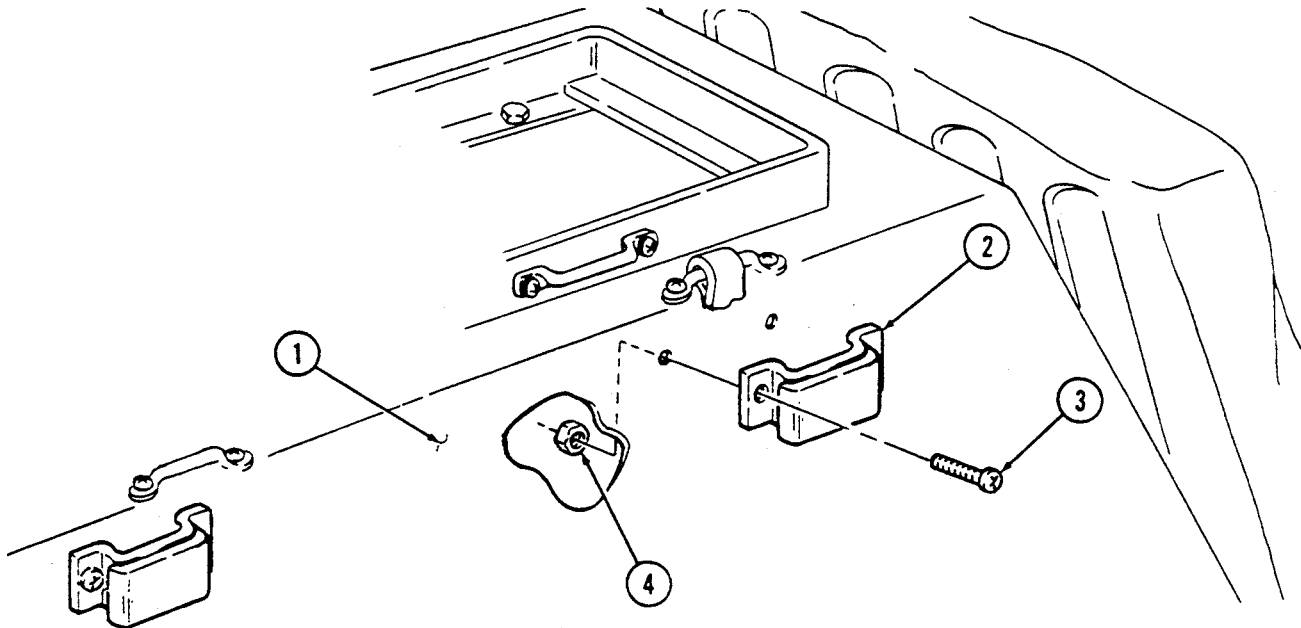

FOLLOW-ON TASK: Close cargo shell door (TM 9-2320-280-10).

11-110. REAR SEAT STOWAGE COMPARTMENT NET BRACKETS REPLACEMENT

This task covers:

- | | |
|------------|-----------------|
| a. Removal | b. Installation |
|------------|-----------------|

INITIAL SETUP:

Applicable Models

M1025A2, M1043A2

Tools

General mechanic's tool kit:
automotive (Appendix B, Item 1)

Manual References

TM 9-2320-280-10
TM 9-2320-280-24P

Equipment Condition

Rear seat stowage compartment net removed
(TM-9-2320-280-10).

a. Removal

1. Remove two nuts (5), capscrews (7), and bracket (6) from support (4).
2. Remove two nuts (8), capscrews (3), washers (2), and bracket (1) from support (4).

b. Installation

1. Install bracket (1) on support (4) with two washers (2), capscrews (3), and nuts (8).
2. Install bracket (6) on support (4) with two capscrews (7) and nuts (5).

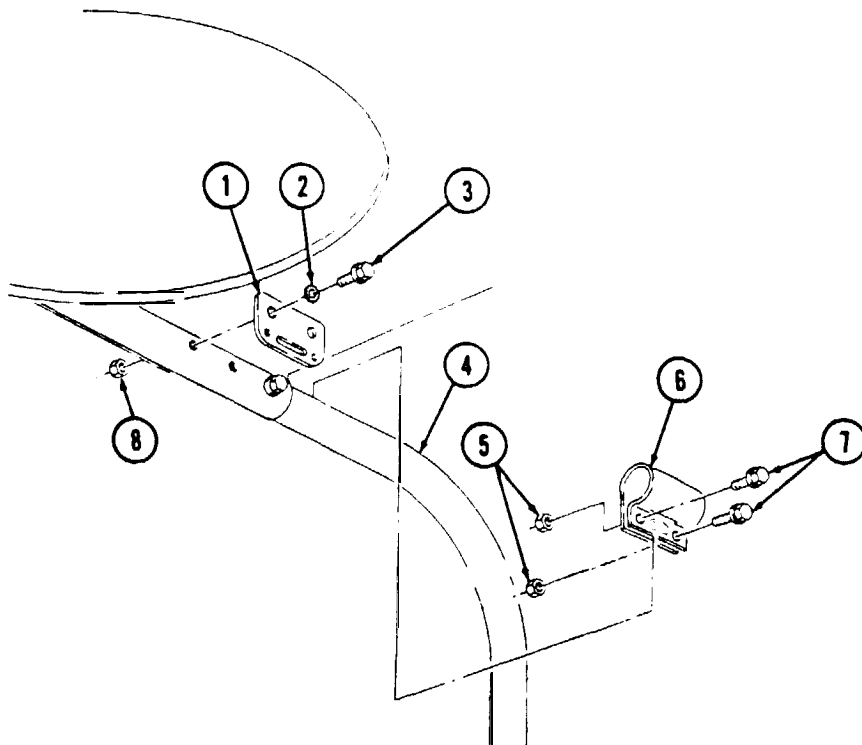

FOLLOW-ON TASK: Install rear seat stowage compartment net (TM-9-2320-280-10).

11-111. CARGO BULKHEAD REPLACEMENT

This task covers:

a. Removal

b. Installation

INITIAL SETUP:

Applicable Models

M1025A2, M1043A2

Tools

General mechanic's tool kit:
automotive (Appendix B, Item 1)

Materials/Parts

Four locknuts (Appendix G, Item 128)

Manual References

TM 9-2320-280-10
TM 9-2320-280-24P

Equipment Condition

Stowage compartment net removed
(TM 9-2320-280-10).

a. Removal

1. Remove cargo bulkhead (4) from two channels (5).
2. Remove four locknuts (2), hex head screws (3), and two channels (5) from wheel housings (1). Discard locknuts (2).

b. Installation

1. Install two channels (5) on wheel housings (1) with four hex head screws (3) and locknuts (2).
2. Tighten locknuts (2) to 15 lb-ft (20 N·m).
3. Install cargo bulkhead (4) in two channels (5).

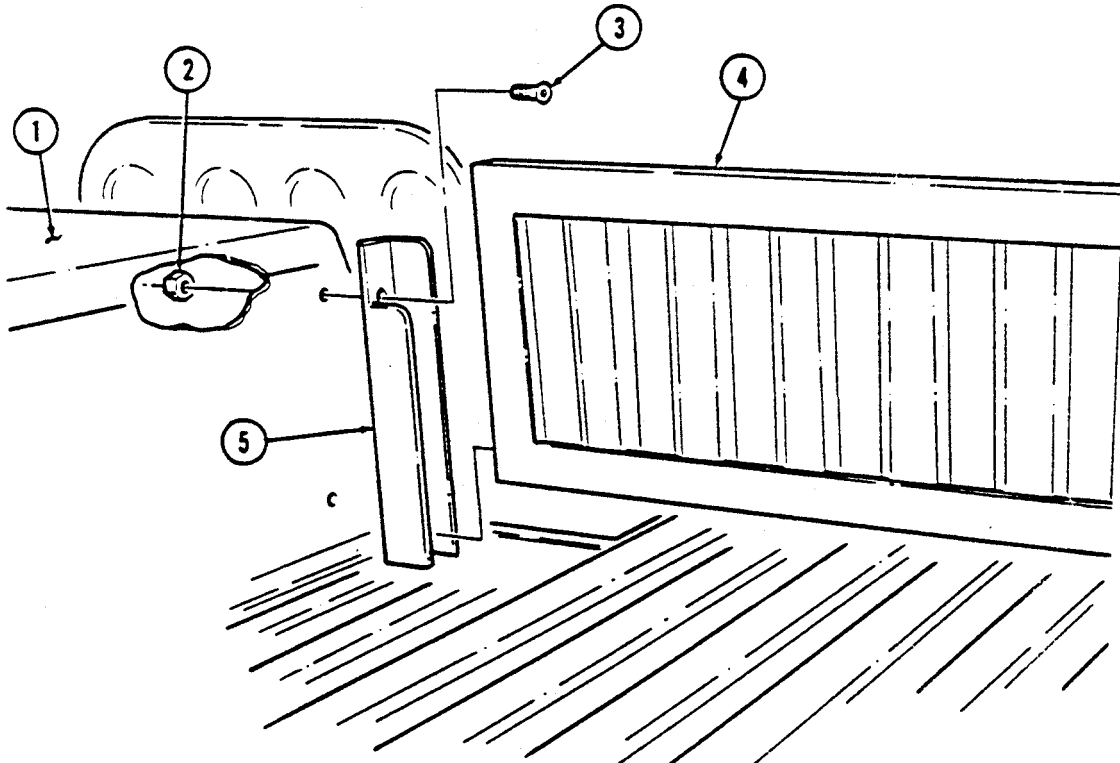

FOLLOW-ON TASK: Install stowage compartment net (TM 9-2320-280-10).

11-112. WEAPON STATION TRAY AND BEARING SEALS MAINTENANCE

This task covers:

- | | |
|--|----------------------|
| <p>a. Removal</p> <p>b. Installation</p> | <p>c. Adjustment</p> |
|--|----------------------|

INITIAL SETUP:

Applicable Models

All models except M996, M996A1, M997, M997A1, M997A2, M998, M998A1, M1035, M1035A1, M1035A2, M1037, M1038, M1038A1, M1042, M1097, M1097A1, M1097A2

Tools

General mechanic's tool kit:
automotive (Appendix B, Item 1)

Materials/Parts

Adhesive (Appendix C, Item 3)
Three locknuts (Appendix G, Item 128)
Seal (Appendix G, Item 285)

Personnel Required

One mechanic
One assistant

Manual References

TM 9-2320-280-10
TM 9-2320-280-24P

Equipment Condition

- Weapon station hatch removed (para. 11-42).
- Hinge pivot bracket and gunner's sling removed (para. 11-52).
- Gunner's sling hook removed (para. 11-53).
- Weapon station backrest pads removed (para. 11-54).
- Weapon station hatch latch removed (para. 11-50).
- Weapon station hatch tube removed (para. 11-51).
- Turret lock removed (para. 11-56).

M966, M966A1, M1036, M1045, M1045A1, M1045A2, M1046, and M1046A1 Only:

- TOW mount pedestal removed (para. 11-57).
- TOW mount pedestal cover removed (para. 11-58).
- Weapon station inclinometer removed (para. 11-60).
- TOW MGS pan removed (para. 11-59).

M1025, M1025A1, M1025A2, M1026, M1026A1, M1043, M1043A1, M1043A2, M1044, and M1044A1 only:

- Armament cover and seal removed (para. 11-62).
- Armament mount panel removed (para. 11-61).

M1043, M1043A1, M1043A2, M1044, and M1044A1 only:

- Traversing bar removed (para. 12-161).

NOTE

Note location of attaching hardware for installation.

a. Removal

1. Remove three locknuts (7), washers (3), capscrews (2), washers (3), and weapon station tray (1) from bearing (5). Discard locknuts (7).

NOTE

- The upper and lower turret bearing seals are basically the same. Steps 2 and 3 apply to the lower bearing seal.
- Replace turret bearing seals that are damaged, separated, or peeled out.

2. Remove eighteen capscrews (10), washers (11), and three turret locking sections (9) from support assembly (8).
3. Remove turret bearing seal (12) from support assembly (8) and remove remains of adhesive from grooves in support assembly (8).

11-112. WEAPON STATION TRAY AND BEARING SEALS MAINTENANCE (Cont'd)

b. Installation

NOTE

- Perform steps 1 and 2 only if installing new turret bearing seals.
 - New seal broad side fits into groove.
1. Apply adhesive to grooves in support assembly (8) and install turret bearing seal (12) into support assembly (8).
 2. Install three turret **lockring** sections (9) on support assembly (8) with eighteen washers (11) and capscrews (10). Tighten capscrews (10) to 37 lb-ft (50 N·m).
 3. Install weapon station tray (1) on bearing (5).
 4. Ensure all mounting hardware capscrew holes (4) in weapon station tray (1) are aligned with mounting hardware capscrew holes (6) in bearing (5).
 5. Install weapon station tray (1) on bearing (5) with three washers (3), capscrews (2), washers (3), and locknuts (7). Tighten locknuts (7) to 37 lb-ft (50 N·m).

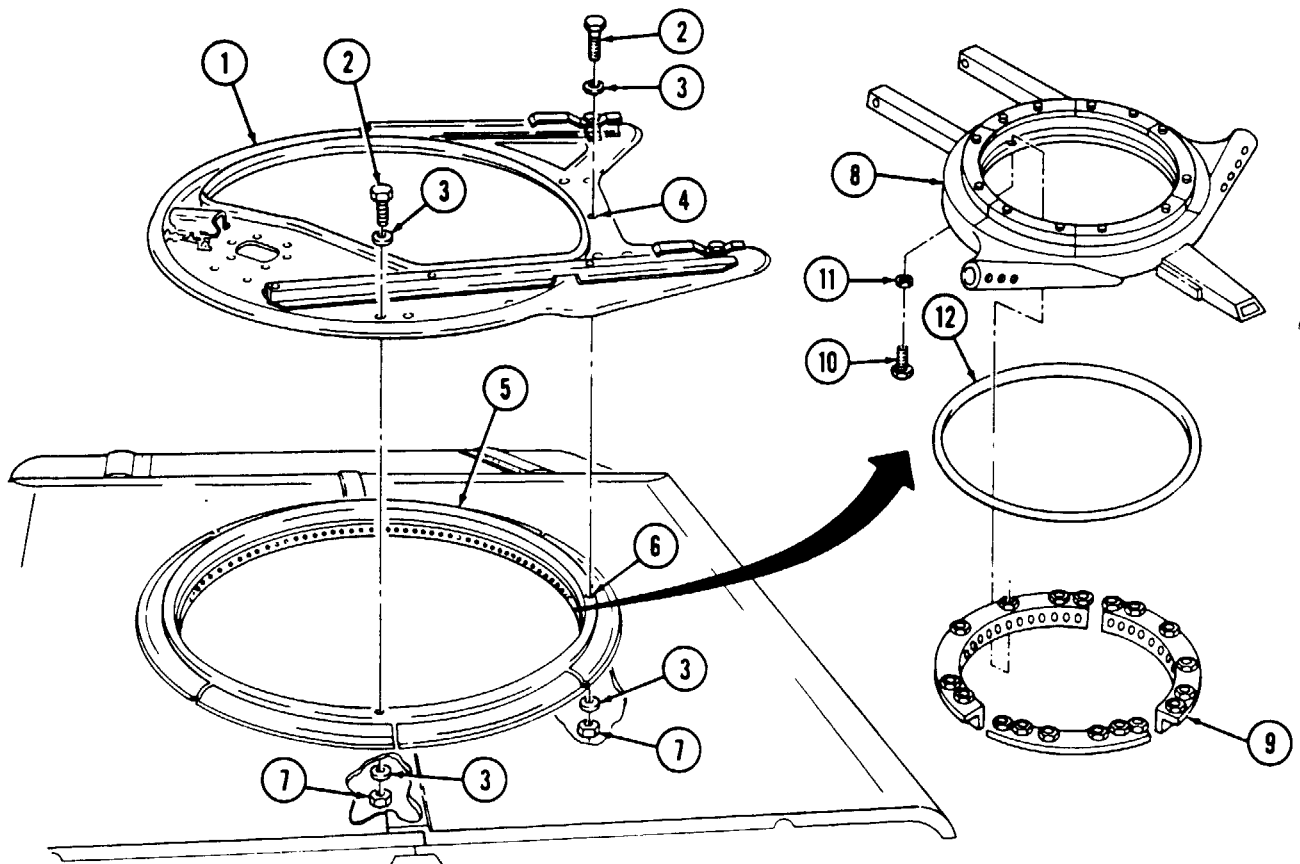

11-112. WEAPON STATION TRAY AND BEARING SEALS MAINTENANCE (Cont'd)

c. Adjustment

NOTE

- Do not adjust weapon station tray if loose or damaged.
- Weapon station tray needs adjustment if it binds, sticks, or does not rotate freely.

1. Loosen capscrew (6) securing support ring (1) to "C" pillar support bracket (7).
2. Check the gap between "C" pillar support bracket (7) and support ring (1).

NOTE

- If gap is the thickness of a slotted washer or greater, proceed to step 4.
- If no gap exists, proceed to step 3.

3. Remove one slotted washer (8) at a time, as required, and rotate weapon station tray (9) to check for binding. If there is no improvement, proceed to step 5.
4. Add one slotted washer (8) at a time, as required, and rotate weapon station tray (9) to check for binding. If there is no improvement, proceed to step 5.
5. Loosen eight capscrews (3) securing two clevises (5) to windshield (2). Rotate weapon station tray (9) to check for binding.
6. If weapon station tray (9) rotation has improved, position adjustment slots (4) in clevises (5) where weapon station tray (9) operated freely and tighten eight capscrews (3) and capscrew (6).

NOTE

If weapon station tray rotation has not improved after adjustment procedures, remove turret bearing assembly.

7. Install primary weapon system and check operation of weapon station tray (10). Refer to TM 9-2320-280-10.

11-112. WEAPON STATION TRAY AND BEARING SEALS MAINTENANCE (Cont'd)

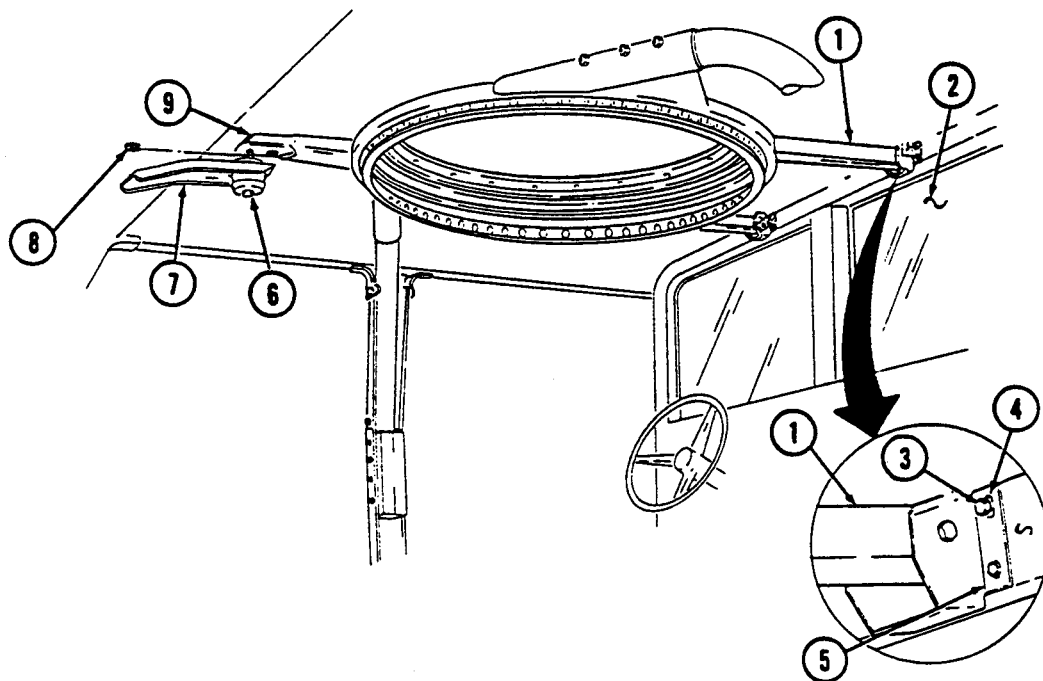

- FOLLOW-ON TASKS:**
- Install weapon station hatch tube (para. 11-51).
 - Install weapon station hatch latch (para. 11-50).
 - Install weapon station backrest pads (para. 11-54).
 - Install gunner's sling hook (para. 11-53).
 - Install hinge pivot bracket and gunner's sling (para. 11-52).
 - Install weapon station hatch (para. 11-42).
 - Install turret lock (para. 11-56).
 - Check weapon station for proper operation (TM 9-2320-280-10).

M966, M966A1, M1036, M1045, M1045A1, M1045A2, M1046, M1046A1, and M1121
Only:

- Install TOW mount pedestal (para. 11-57).
- Install TOW mount pedestal cover (para. 11-58).
- Install TOW MGS pan (para. 11-59).
- Install weapon station inclinometer (para. 11-60).

M1025, M1025A1, M1025A2, M1026, M1026A1, M1043, M1043A1, M1043A2,
M1044, and M1044A1 Only:

- Install armament cover and seal (para. 11-62).
- Install armament mount panel (para. 11-61).

M1043, M1043A1, M1043A2, M1044, and M1044A1 Only:

- Install traversing bar (para. 12-161).

11-112.1. TURRET CLEANING

This task covers:

a. Turret Modification

b. Cleaning

INITIAL SETUP:

Applicable Models

All models except M996, M996A1, M997, M997A1, M997A2, M998, M998A1, M1035, M1035A1, M1035A2, M1037, M1038, M1038A1, M1042, M1097, M1097A1, M1097A2, M1123

Materials/Parts

Hose (Appendix D, Fig. D-119)
 Fixture (Appendix D, Fig. D-117)
 Bushing (Appendix D, Fig. D-118)

Manual References

TM 9-2320-280-24P

Tools

General mechanic's tool kit:
 automotive (Appendix B, Item 1)

NOTE

If not previously accomplished, perform task a. to allow use of hose to clean turret.

a. Turret Modification

NOTE

The following optional procedure will aid in turret cleaning. Have your commander's concurrence before performing any modification to the vehicle.

1. Locate and mark the position to drill hole (2) in inner bearing (1).
2. Remove weapon station tray and seal (para. 11-112).
3. Secure fixture (3) to inner bearing (1) with centerline of hole (4) aligned with mark on inner bearing (1).
4. Position 0.339-in. drill bit (5) (letter R drill bit) four inches from drill chuck jaws (6).

11-112.1. TURRET CLEANING (Cont'd)

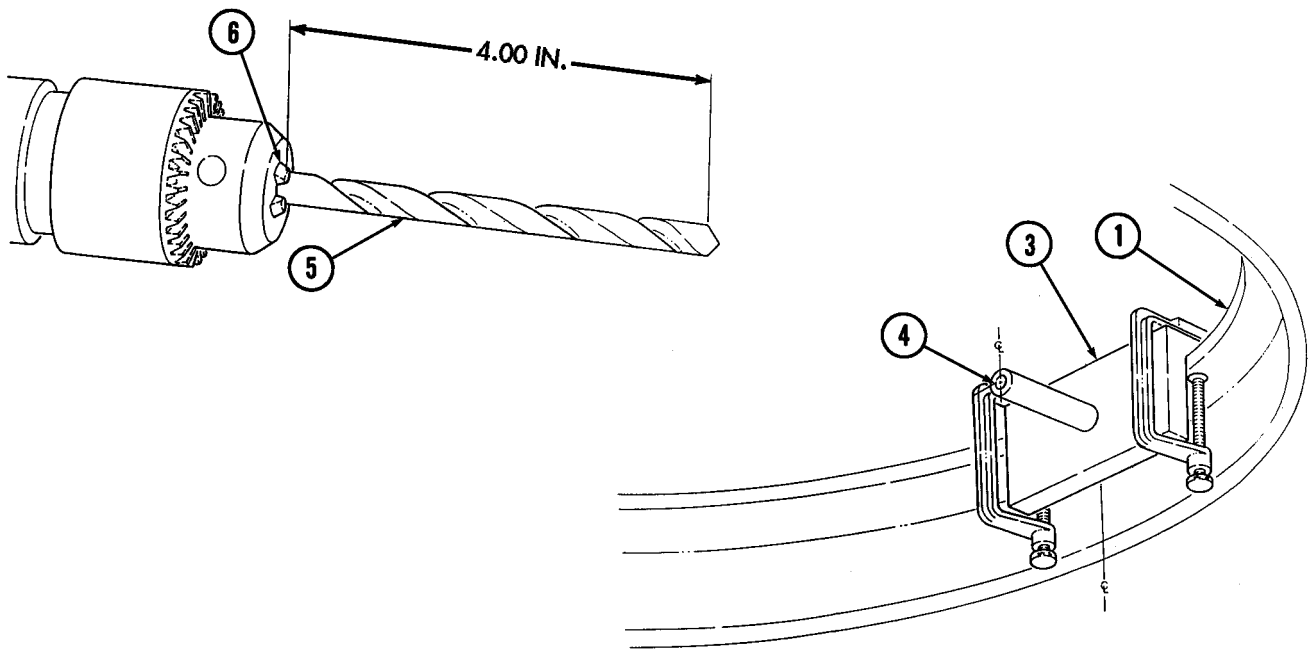
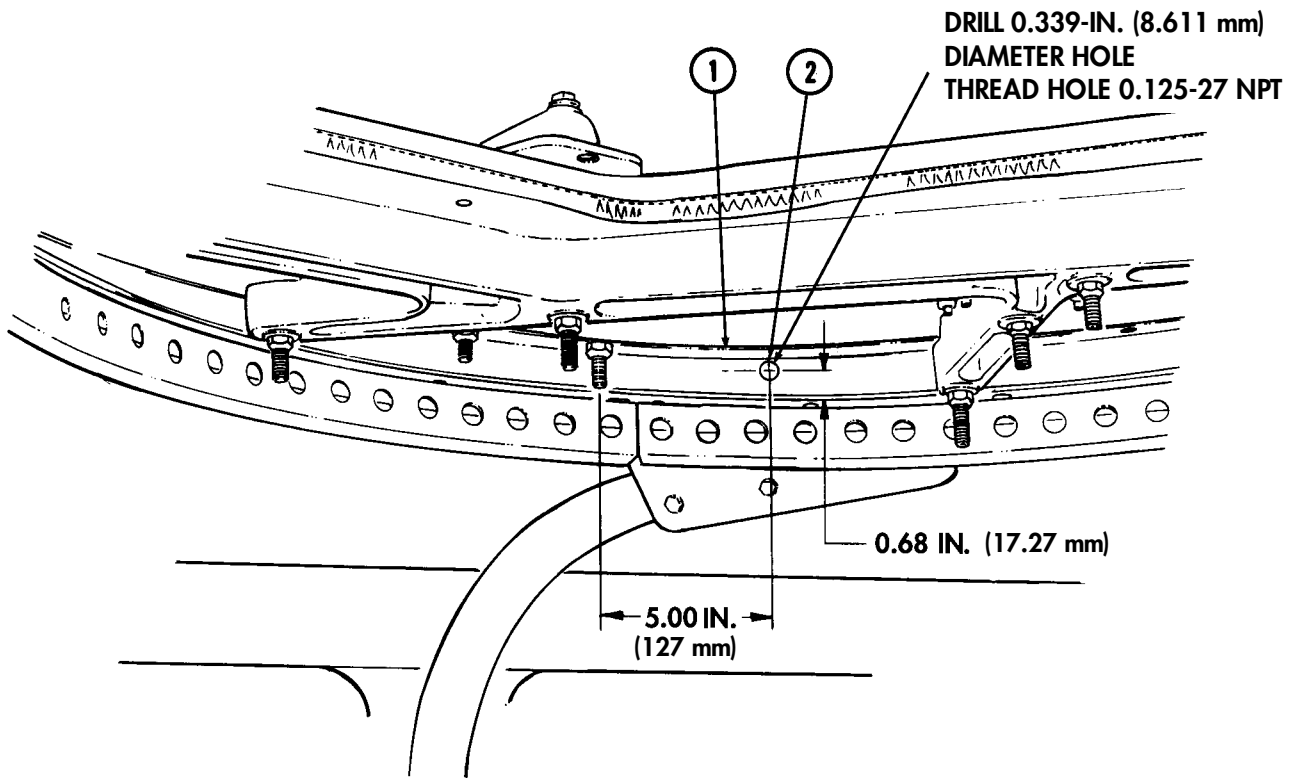

11-112.1. TURRET CLEANING (Cont'd)

5. Using fixture (2), drill 0.339-in. (8.611mm) diameter hole (3) in inner bearing (1).
6. Remove fixture (2) from inner bearing (1).

CAUTION

Ensure bearings are spread apart where drill bit will come through inner bearing, or drill bit may damage bearing

7. Using hole drilled in step 5, drill 0.234-in. (5.944 mm) diameter hole (4) through inner bearing (1) only.

NOTE

After threading inner bearing hole, clean metal shavings

8. Using 0.125-27 NPT standard tap, thread hole (5).

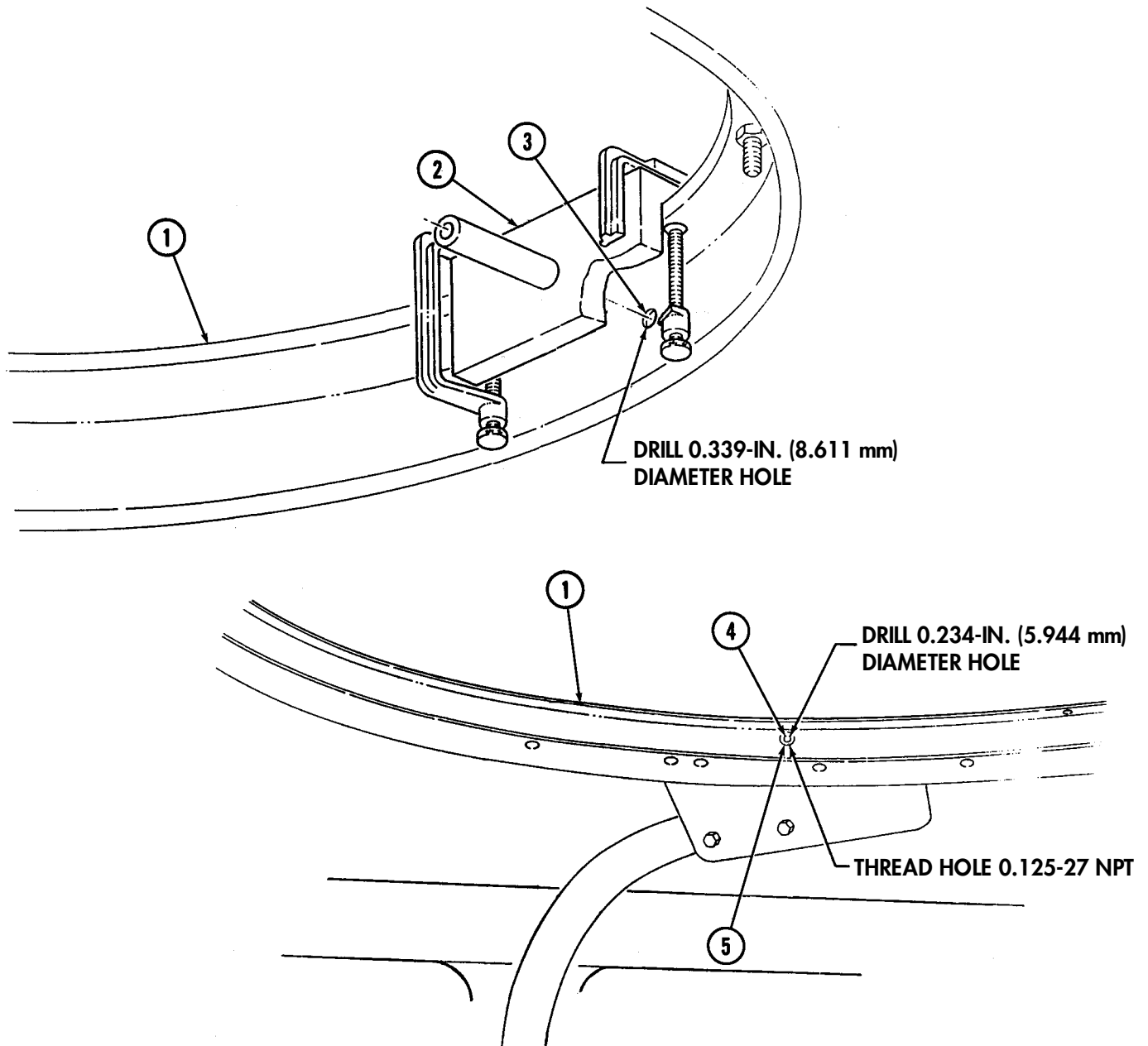

11-112.1. TURRET CLEANING (Cont'd)

9. Remove tapered end (6) on 0.125-27 NPT standard tap (7).
10. Using modified 0.125-27 NPT tap, finish threading hole (5).
11. Install weapon station tray and seal (para. 11-112).

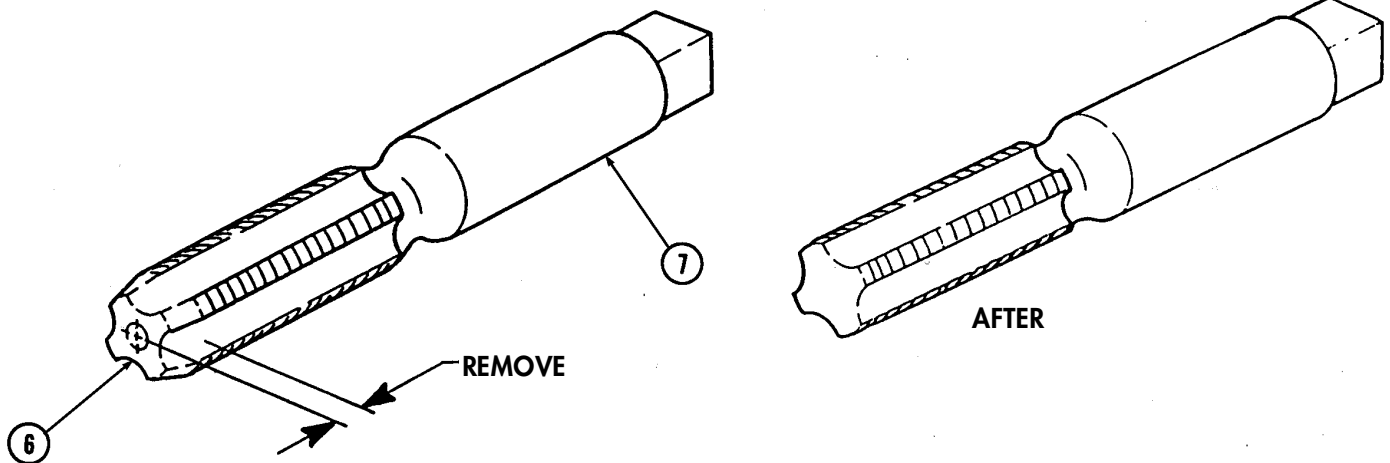

11-112.1. TURRET CLEANING (Cont'd)

b. Cleaning

1. Install hose (4) in hole (2) on inner bearing (1).
2. Connect low-pressure water hose (5) to hose (4).
3. Turn water on and rotate weapon station tray (3) several full rotations.

NOTE

Allow water to force out any dirt or grit within turret bearing.

4. Turn water off when cleaning is completed.
5. Disconnect low-pressure water hose (5) from hose (4).

NOTE

Hose assembly may either be stowed in place on weapon station tray or removed.

6. Remove hose (4) from hole (2) on inner bearing (1).

11-112.1. TURRET CLEANING (Cont'd)

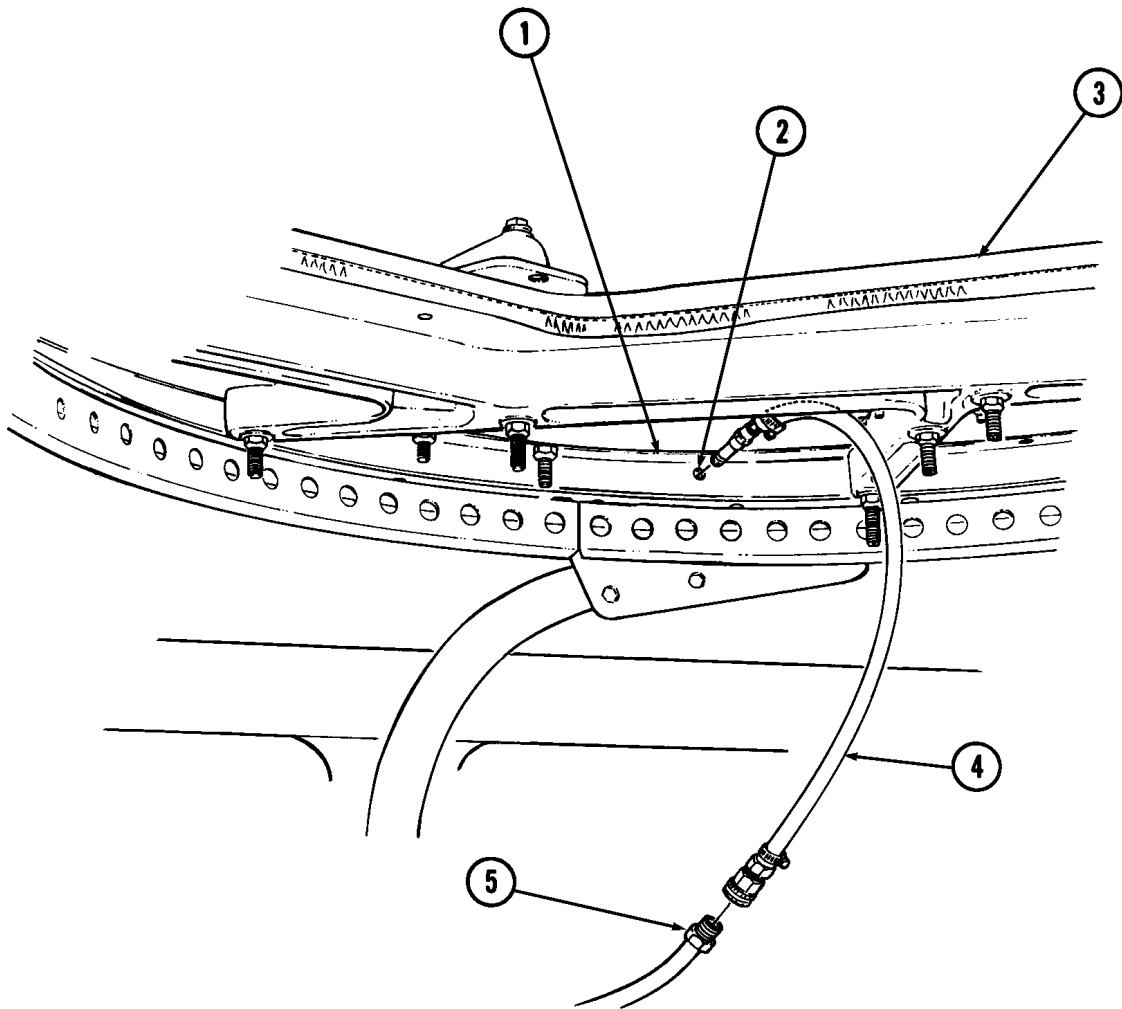

11-113. TURRET BEARING MAINTENANCE

This task covers:

- | | |
|--|--|
| <ul style="list-style-type: none"> a. Removal b. Cleaning and Inspection | <ul style="list-style-type: none"> c. Installation d. Adjustment |
|--|--|

INITIAL SETUP:

Applicable Models

All vehicles except: M996, M996A1, M997, M997A1, M997A2, M998, M998A1, M1035, M1035A1, M1035A2, M1037, M1038, M1038A1, M1042, M1097, M1097A1, M1097A2, M1123

Tools

General mechanic's tool kit:
automotive (Appendix B, Item 1)

Materials/Parts

Drycleaning solvent (Appendix C, Item 18)
Sealant (Appendix C, Item 38)
Detergent (Appendix C, Item 17)
Two turret bearing seals
(Appendix D, Fig. D-90)
Twelve locknuts (Appendix G, Item 128)
Seal (Appendix G, Item 285)

Personnel Required

One mechanic
One assistant

Manual References

TM 9-2320-280-24P

Equipment Condition

Weapon station tray and bearing seals removed
(para. 11-112).

General Safety Instructions

- Drycleaning solvent is flammable and will not be used near an open flame. A fire extinguisher will be kept nearby when the solvent is used. Use only in well-ventilated places.
- Compressed air used for cleaning purposes will not exceed 30 psi (207 kPa). Use only with effective chip guarding and personal protective equipment (goggles/shield, gloves, etc.).

WARNING

Drycleaning solvent is flammable and will not be used near an open flame. A fire extinguisher will be kept nearby when the solvent is used. Use only in well-ventilated places. Failure to do this will result in injury to personnel and/or damage to equipment.

NOTE

Drycleaning solvent may be used to assist in loosening the sealant during removal.

a. Removal

1. Remove twelve locknuts (4), washers (5), and capscrews (2) from roof retainers (1), bearing assembly (3), and support ring (6). Discard locknuts (4).
2. Remove twelve roof retainers (1) and bearing assembly (3) from support ring (6).

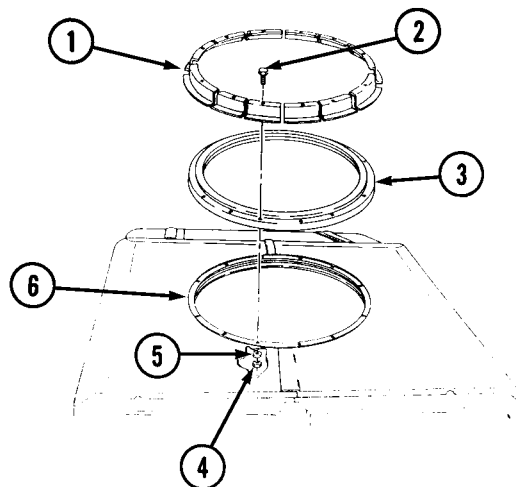

11-113. TURRET BEARING MAINTENANCE (Cont'd)

b. Cleaning and Inspection

1. Remove two seals (7) from grooves (8) in bearing assembly (3). Discard seals (7).
2. Remove old sealant from grooves (8) and surface of races (9) on bearing assembly (3).
3. Using high pressure water or steam directed between races (9), clean ball bearings (10) in bearing assembly (3) with mild detergent.

WARNING

Compressed air used for cleaning purposes will not exceed 30 psi (207 kPa). Use only with effective chip guarding and personal protective equipment (goggles/shield, gloves, etc.).

4. Using compressed air, blow out moisture from ball bearings (10) in bearing assembly (3).
5. Place and rotate bearing assembly (3) on a flat surface, and ensure it rotates freely with a maximum of 6 lb pull on the outer race (9).
6. If bearing assembly (3) does not rotate freely, send bearing assembly (3) to direct support maintenance.
7. If bearing assembly (3) rotates freely, proceed to step 8.
8. Cut an 11-foot piece of seal (7).

NOTE

- Stretch seal during installation to ensure seal is fully installed in groove.
 - The broad side of new seal fits into the groove.
 - Ensure sealant is not used on ball bearings or races.
9. Place bearing assembly (3) on a flat surface, apply sealant into groove (8), and install seal (7).
 10. Apply sealant to ends of seal (7) on bearing assembly (3).

NOTE

Allow to dry approximately 15 minutes before handling bearing assembly.

11. Turn bearing assembly (3) over, apply sealant into groove (8), and install second seal (7).
12. Apply sealant to ends of seal (7) on bearing assembly (3).

NOTE

Allow to dry one hour before installation.

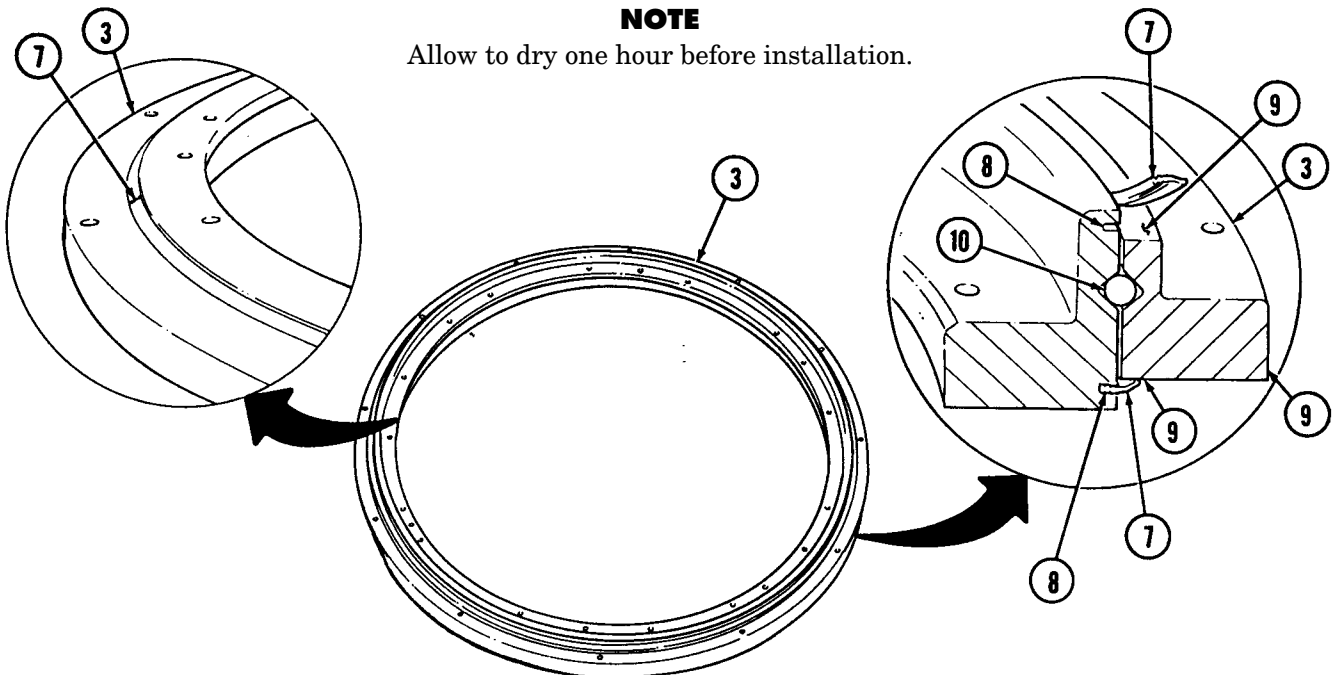

11-113. TURRET BEARING MAINTENANCE (Cont'd)

c. Installation

1. Install bearing assembly (3) on support ring (9).

NOTE

Step 2 is to prevent roof leaks.

2. Using sealant, fill front and rear roof seams (6) and (4) (where left and right roof halves join together and overlap).
3. Secure bearing assembly (3) to support ring (9) with twelve roof retainers (1), capscrews (2), washers (8), and locknuts (7). Tighten locknuts (7) to 37 lb-ft (50 N·m).
4. Inside vehicle, apply sealant along area where support ring (9) and roof (5) meet.

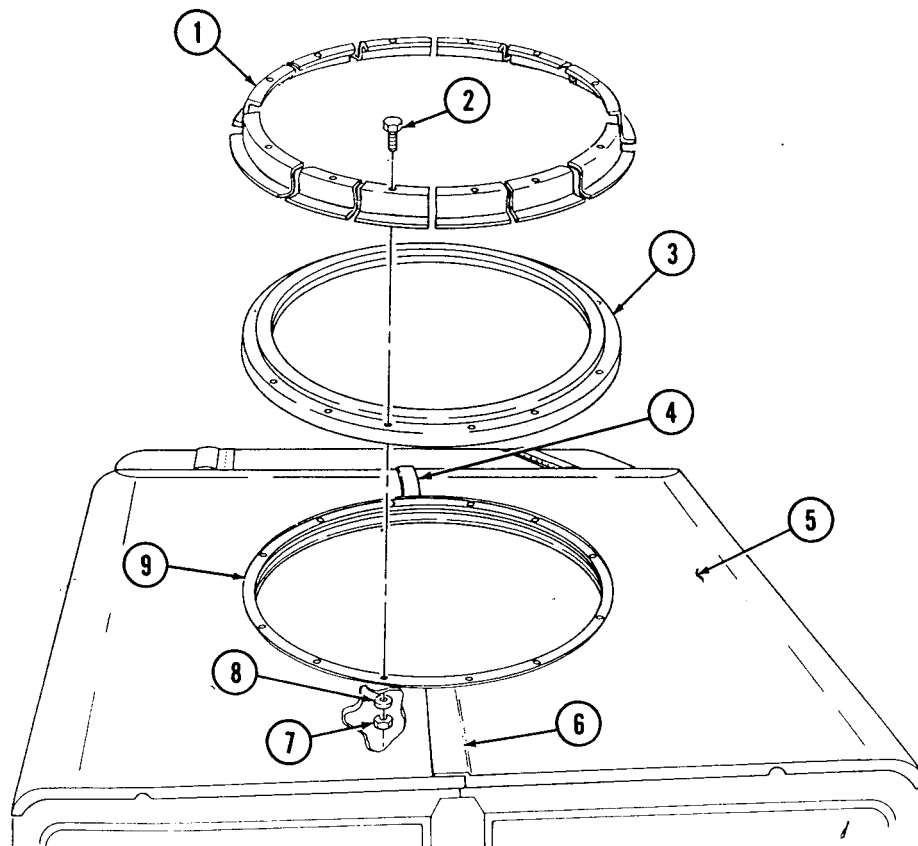

11-113. TURRET BEARING MAINTENANCE (Cont'd)

d. Adjustment

1. Inspect, tighten, or replace any loose, missing, or damaged parts on weapon station turret (1) area.

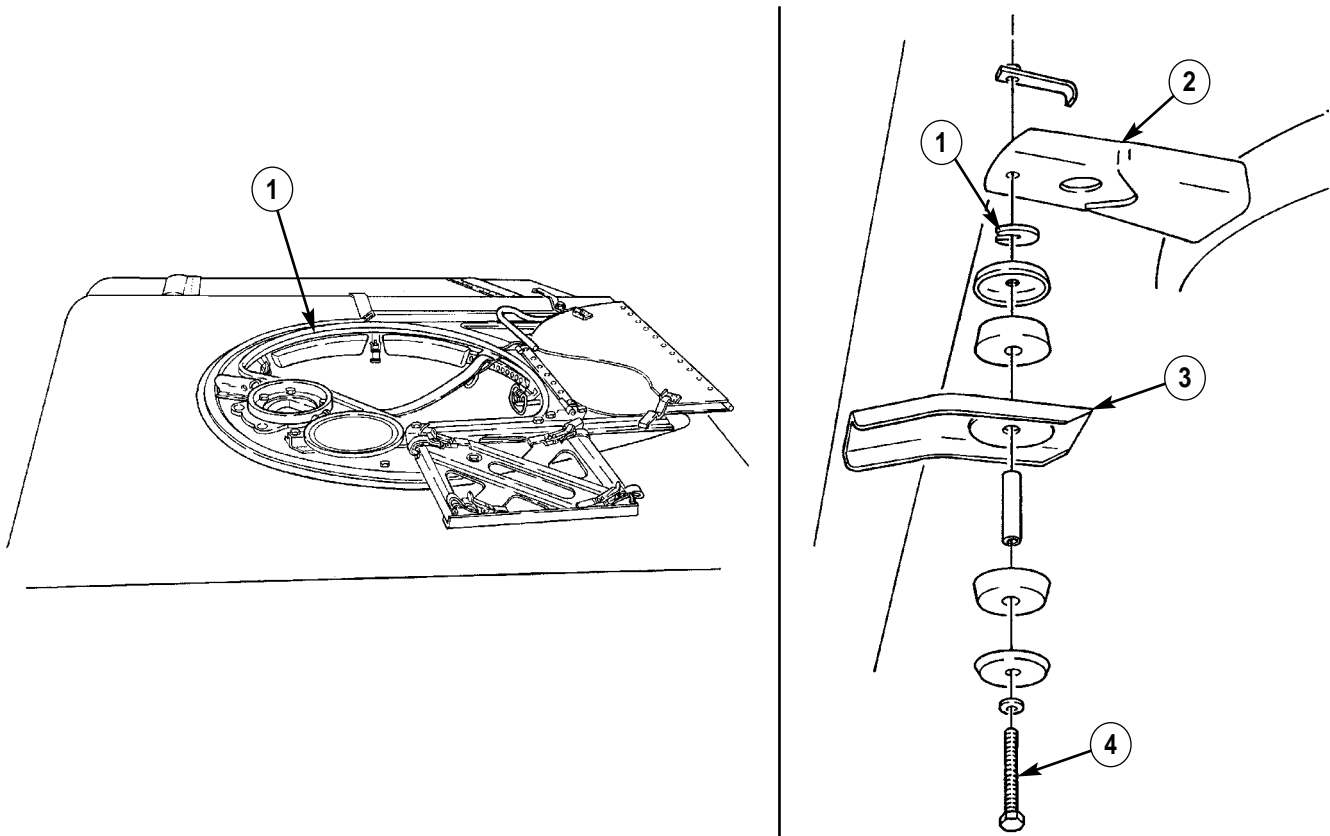

2. If weapon station turret rotation has not improved, loosen bolt (4), securing rear of support ring (2) to "C" pillar support bracket (3).
3. Check gap between "C" pillar support bracket (3) and rear support ring (2).

NOTE

If no gap exists, proceed to step 4.

If gap is the thickness of a slotted washer or greater, proceed to step 5.

4. Remove slotted washers (1), one at a time, as required, and rotate turret to check for binding. If there is no improvement, proceed to step 6.
5. Add slotted washers (1), one at a time, as required, and rotate turret to check to see if it rotates freely. If there is no improvement, proceed to step 6.

11-113. TURRET BEARING MAINTENANCE (Cont'd)

6. Loosen eight clevis retaining bolts (3), securing front ring assembly supports (1) to windshield assembly (2). Rotate turret and check to see if it rotates freely.

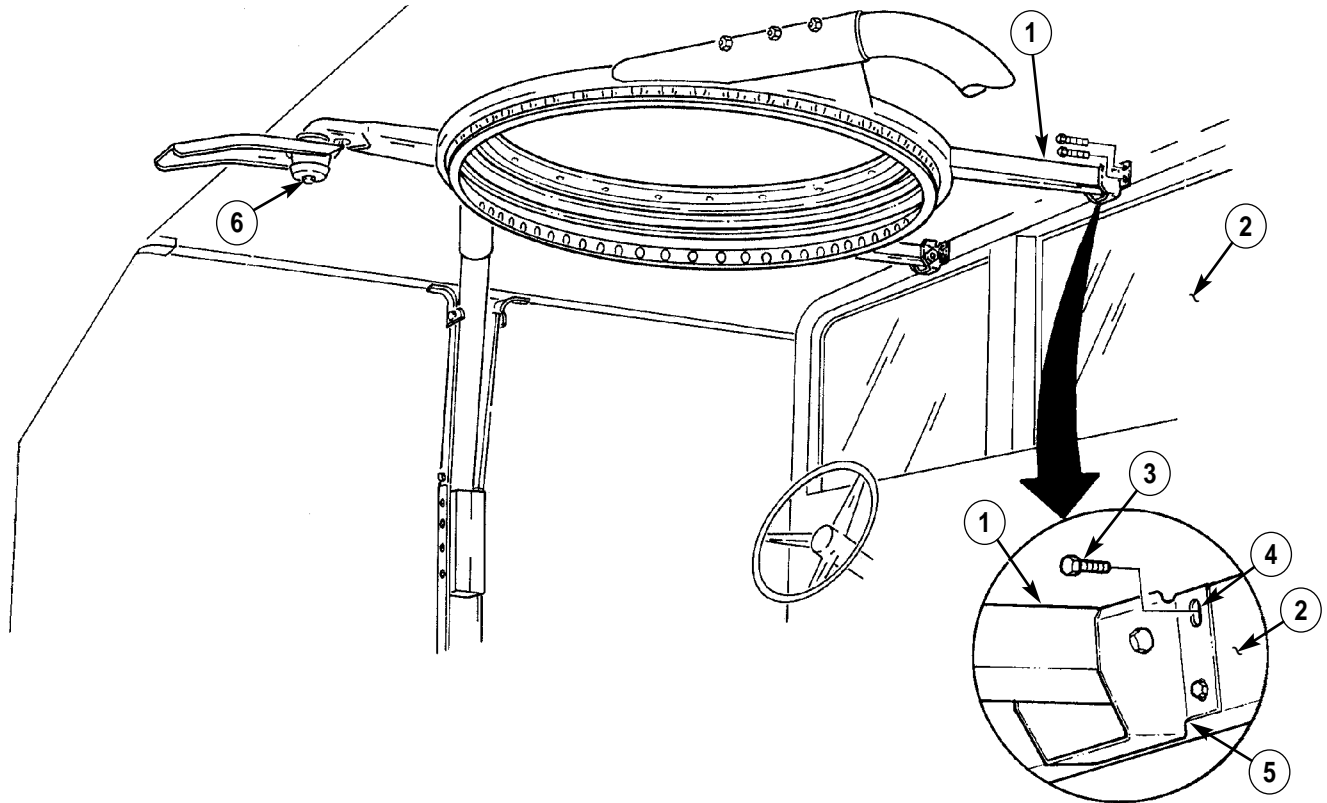

7. If turret rotation has improved, position adjustment slots (4) in clevis (5) where turret operates freely, and tighten eight clevis retaining bolts (3) and rear support ring bolt (6).
8. Install weapon station tray and bearing seals (para. 11-112).
9. Install primary weapon system and check operation of weapon station turret (TM 9-2320-280-10).
10. If turret rotation has not improved as a result of adjustment, replace turret bearing assembly.

Section II. S250 SHELTER CARRIER BODY MAINTENANCE

11-114. S250 SHELTER CARRIER BODY MAINTENANCE TASK SUMMARY

TASK PARA.	PROCEDURES	PAGE NO.
11-115.	Shelter Support Reinforcement Replacement	11-162
11-116.	Shelter Mounting Bracket Replacement	11-163
11-117.	Shelter Carrier Tailgate Replacement	11-164
11-118.	Shelter Carrier Tailgate Bracket Replacement	11-165
11-119.	Shelter Carrier Tailgate Chain Maintenance	11-166
11-120.	Shelter Replacement	11-168
11-121.	Shelter Support Assembly Replacement	11-170
11-122.	Cab Enclosure Panel Replacement	11-172

11-115. SHELTER SUPPORT REINFORCEMENT REPLACEMENT

This task covers:

a. Removal

b. Installation

INITIAL SETUP:

Applicable Models

M1037, M1042, M1097, M1097A1, M1097A2

Manual References

TM 9-2320-280-10
 TM 9-2320-280-24P

Tools

General mechanic's tool kit:
 automotive (Appendix B, Item 1)

Equipment Condition

Tailgate lowered (TM 9-2320-280-10).

Materials/Parts

Two lockbolts (Appendix G, Item 69)
 Two lockwashers (Appendix G, Item 179)

a. Removal

NOTE

It may be necessary to detach cab rear panel straps and turnbuttons and roll cab rear panel upward to gain access to front support reinforcements.

Remove two lockbolts (7), lockwashers (6), washers (5), reinforcement (4), and shims (3) (if installed) from mounting bracket (2). Discard lockbolts (7) and lockwashers (6).

b. Installation

NOTE

Ensure correct positioning of shims, if installed, upon installation of lockbolts.

Install shims (3) (if installed) and reinforcement (4) on support assembly (1) and mounting bracket (2) with two lockbolts (7), lockwashers (6), and washers (5). Tighten lockbolts (7) to 90 lb-ft (122 N·m).

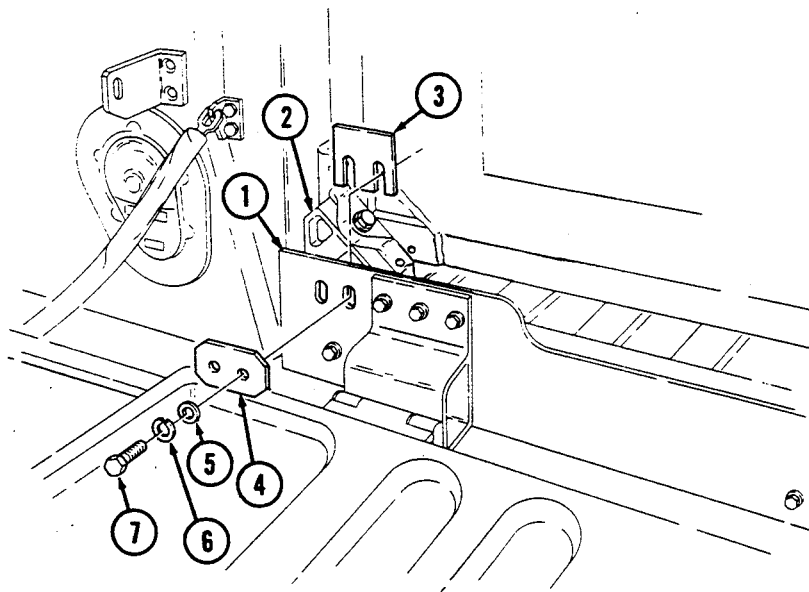

FOLLOW-ON TASK: Raise and secure tailgate (TM 9-2320-280-10).

11-116. SHELTER MOUNTING BRACKET REPLACEMENT

This task covers:

a. Removal

b. Installation

INITIAL SETUP:

Applicable Models

M1037, M1042, M1097, M1097A1, M1097A2

Manual References

TM 9-2320-280-24P

Tools

General mechanic's tool kit: automotive
(Appendix B, Item 1)

Equipment Condition

Shelter removed (para. 11-120).

Materials/Parts

Bolt (Appendix G, Item 6)
Lockwasher (Appendix G, Item 180)

a. Removal

Remove bolt (5), lockwasher (4), washer (3), and mounting bracket (1) from shelter (2). Discard bolt (5) and lockwasher (4).

b. Installation

Install mounting bracket (1) on shelter (2) with bolt (5), lockwasher (4), and washer (3). Do not tighten bolt (5) until shelter (2) is installed.

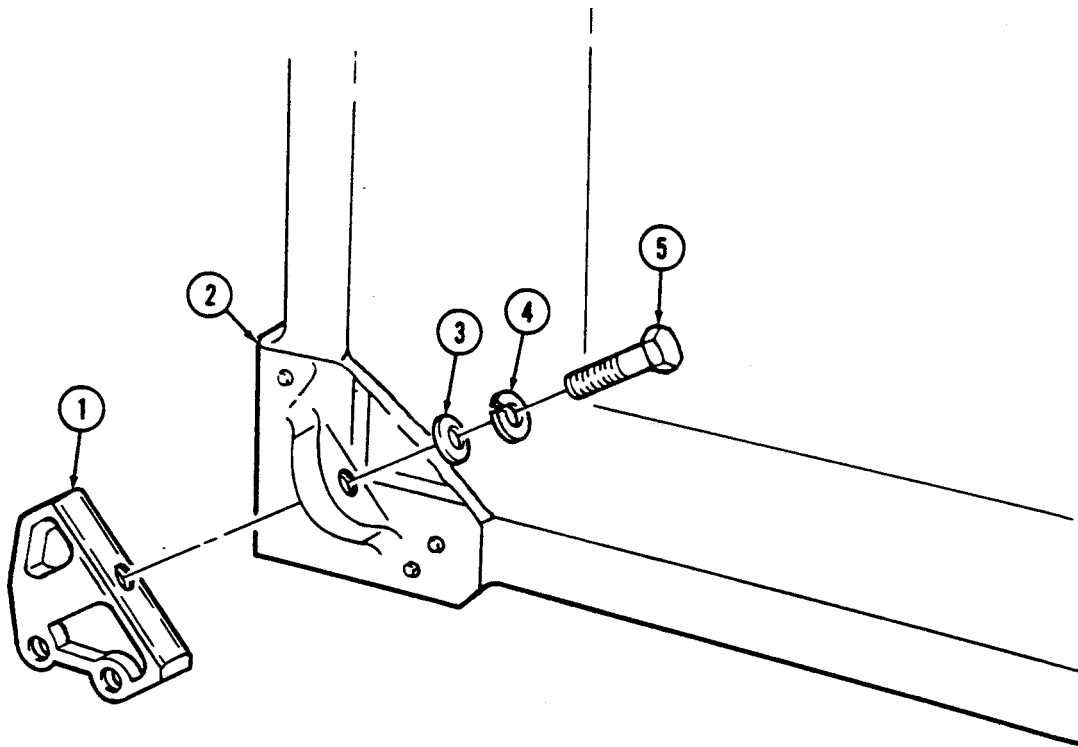

FOLLOW-ON TASK: Install shelter (para. 11-120).

11-117. SHELTER CARRIER TAILGATE REPLACEMENT

This task covers:

a. Removal

b. Installation

INITIAL SETUP:

Applicable Models

M1037, M1042, M1097, M1097A1, M1097A2

Personnel Required

One mechanic
One assistant

Tools

General mechanic's tool kit:
automotive (Appendix B, Item 1)

Manual References

TM 9-2320-280-24P

Materials/Parts

Four locknuts (Appendix G, Item 79)

a. Removal

1. Remove four locknuts (9), washers (2), capscrews (1), and washers (2) from right and left tailgate chain assemblies (10) and tailgate (8). Discard locknuts (9).
2. Remove six nuts (3), washers (4), capscrews (7), tailgate (8), and shims (6) from tailgate mounting brackets (5).

b. Installation

1. Install shims (6) and tailgate (8) on tailgate mounting brackets (5) with six capscrews (7), washers (4), and nuts (3). Tighten capscrews (7) to 26 lb-ft (35 N•m).
2. Install right and left tailgate chain assemblies (10) on tailgate (8) with four washers (2), capscrews (1), washers (2), and locknuts (9). Tighten capscrews (1) to 15 lb-ft (20 N•m).

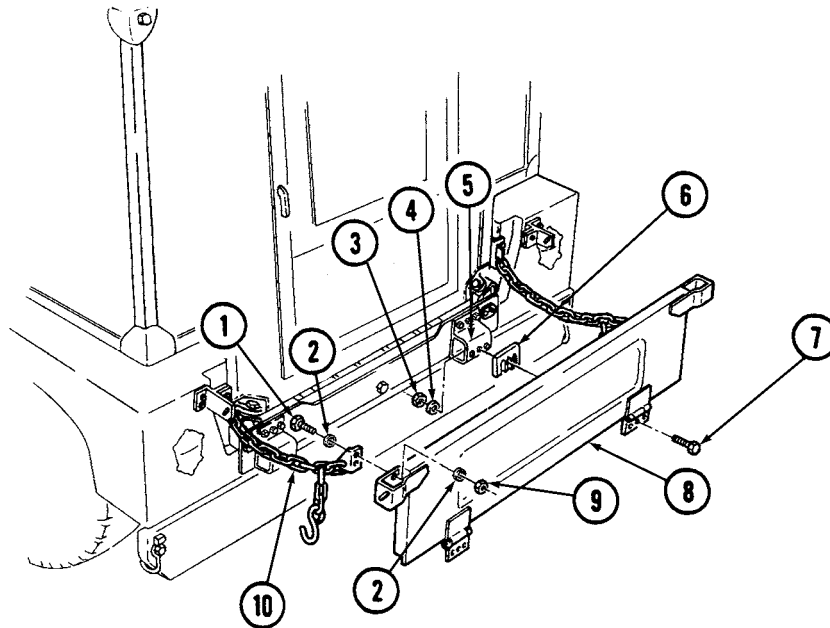

11-118. SHELTER CARRIER TAILGATE BRACKET REPLACEMENT

This task covers:

a. Removal

b. Installation

INITIAL SETUP:

Applicable Models

M1037, M1042, M1097, M1097A1, M1097A2

Manual References

TM 9-2320-280-24P

Tools

General mechanic's tool kit:
automotive (Appendix B, Item 1)

Equipment Condition

Shelter carrier tailgate removed (para. 11-117).

Materials/Parts

Three locknuts (Appendix G, Item 128)

NOTE

The procedure for replacement of right and left tailgate brackets is basically the same. This procedure covers the right bracket.

a. Removal

1. Remove nut (7), washer (6), capscrew (5), and washer (6) from tailgate bracket (8) and shelter support assembly (3).
2. Remove three locknuts (4), washers (2), capscrews (1), washers (2), and tailgate bracket (8) from shelter support assembly (3). Discard locknuts (4).

b. Installation

1. Install tailgate bracket (8) on shelter support assembly (3) with three washers (2), capscrews (1), washers (2), and locknuts (4).
2. Secure tailgate bracket (8) to shelter support assembly (3) with washer (6), capscrew (5), washer (6), and nut (7). Tighten nut (7) to 65 lb-ft (88 N·m). Tighten capscrews (1) to 26 lb-ft (35 N·m).

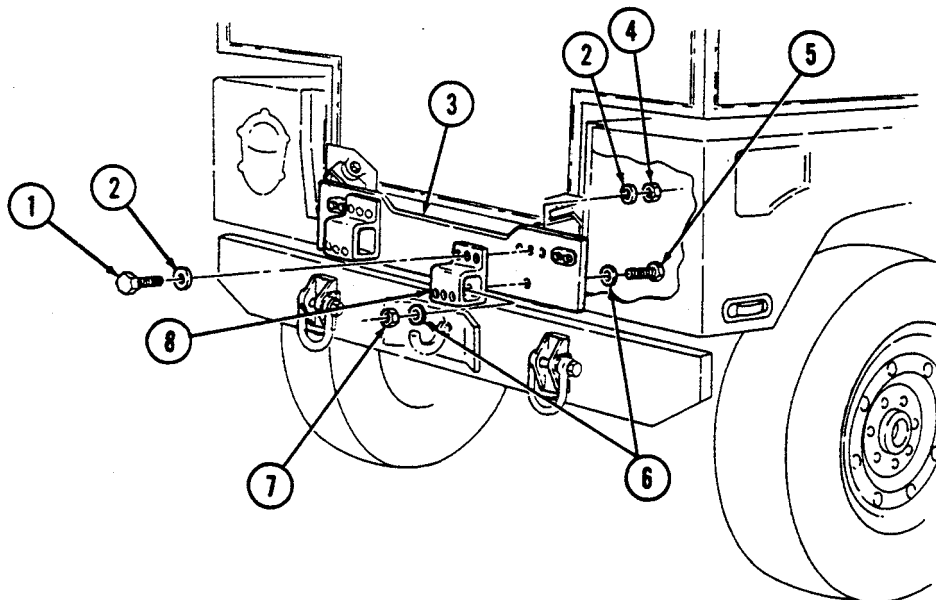

FOLLOW-ON TASK: Install shelter carrier tailgate (para. 11-117).

11-119. SHELTER CARRIER TAILGATE CHAIN MAINTENANCE

This task covers:

- | | |
|--|--|
| <ul style="list-style-type: none"> a. Removal b. Disassembly | <ul style="list-style-type: none"> c. Assembly d. Installation |
|--|--|

INITIAL SETUP:

Applicable Models

M1037, M1042, M1097, M1097A1, M1097A2

Manual References

TM 9-2320-280-10
TM 9-2320-280-24P

Tools

General mechanic's tool kit:
automotive (Appendix B, Item 1)

Equipment Condition

Tailgate lowered (TM 9-2320-280-10).

Materials/Parts

Four locknuts (Appendix G, Item 79)

NOTE

The procedure for replacement of right and left tailgate chain assemblies is basically the same. This procedure covers the left tailgate assembly.

a. Removal

1. Remove two locknuts (1), washers (2), capscrews (5), washers (2), reinforcing bracket (3), and tailgate chain assembly (10) from body (11). Discard locknuts (1).
2. Remove two locknuts (9), washers (7), capscrews (6), washers (7), and tailgate chain assembly (10) from tailgate (8). Discard locknuts (9).

b. Disassembly

1. Pry two chain links (12) apart and remove two chain mounting brackets (4) from chain (16).
2. Pry apart "S" hook (15) and remove "S" hook (15) from chain (14).
3. Pry apart chain link (13) and remove chain (14) from chain (16).

c. Assembly

1. Install chain (14) on chain (16) with chain link (13).
2. Install "S" hook (15) on chain (14) and bend "S" hook (15) closed.
3. Install two chain mounting brackets (4) to chain (16) with two chain links (12).

d. Installation

1. Install tailgate chain assembly (10) and reinforcing bracket (3) on body (11) with two washers (2), capscrews (5), washers (2), and locknuts (1). Tighten locknuts (1) to 15 lb-ft (20 N•m).
2. Install tailgate chain assembly (10) on tailgate (8) with two washers (7), capscrews (6), washers (7), and locknuts (9). Tighten capscrews (6) to 15 lb-ft (20 N•m).

11-119. SHELTER CARRIER TAILGATE CHAIN MAINTENANCE (Cont'd)

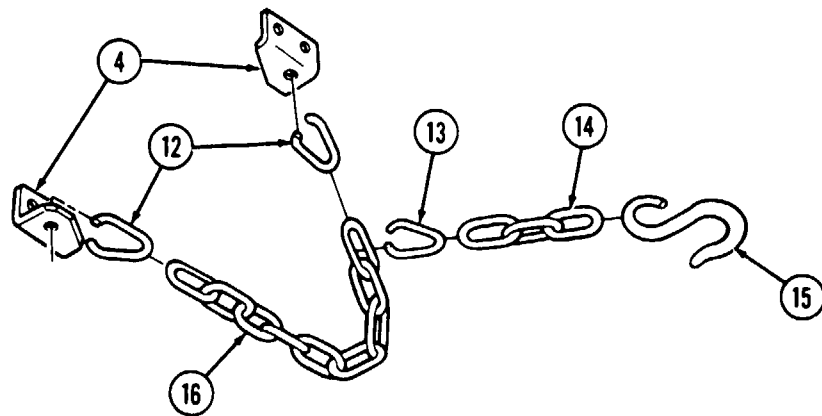
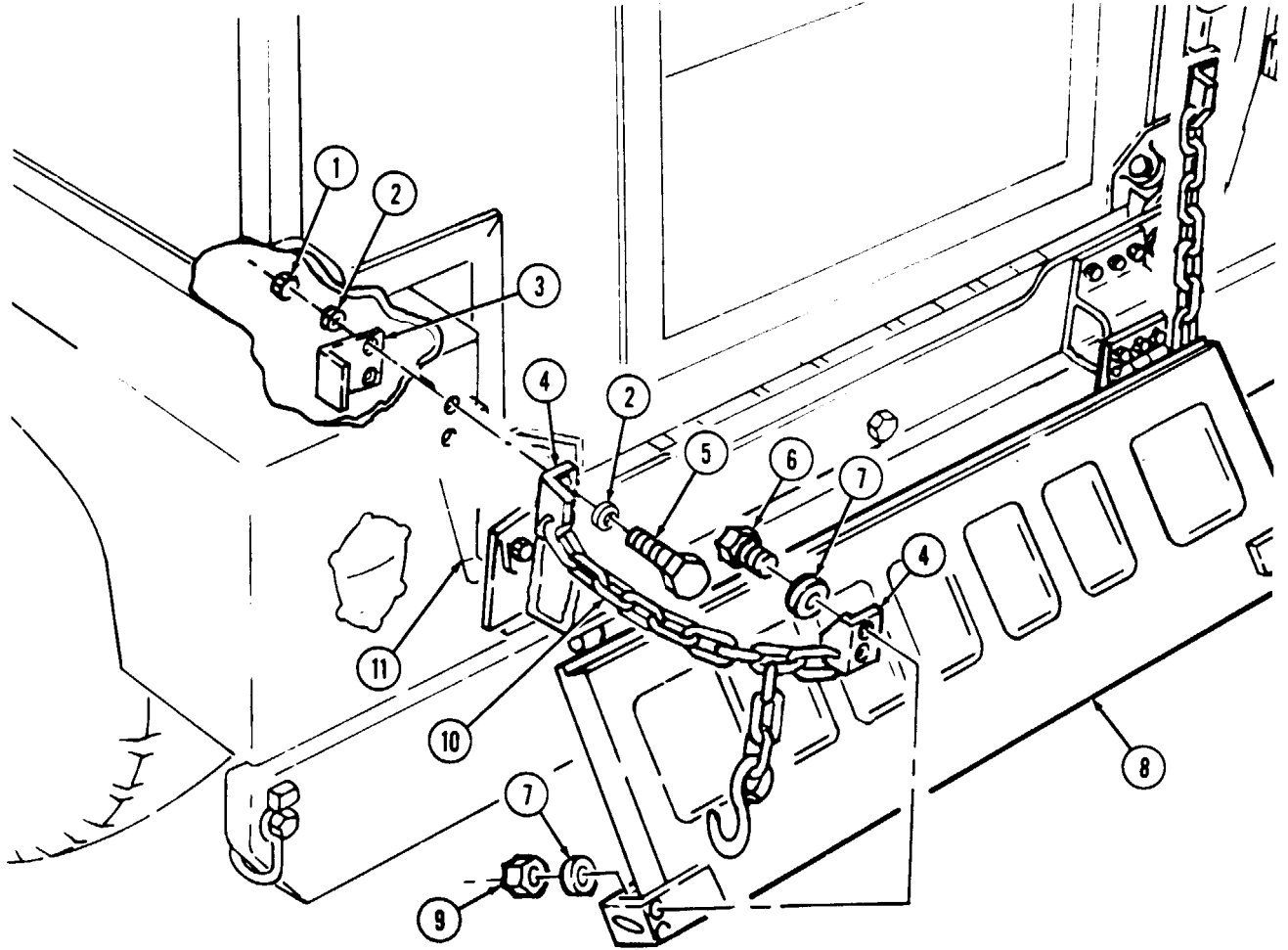

FOLLOW-ON TASK: Raise and secure tailgate (TM 9-2320-280-10).

11-120. SHELTER REPLACEMENT

This task covers:

a. Removal

b. Installation

INITIAL SETUP:

Applicable Models

M1037, M1042, M1097, M1097A1, M1097A2

Tools

General mechanic's tool kit:
automotive (Appendix B, Item 1)

Materials/Parts

Eight lockbolts (Appendix G, Item 69)
Eight lockwashers (Appendix G, Item 179)

Personnel Required

One mechanic
One assistant

Manual References

TM 9-2320-280-10
TM 9-2320-280-24P

Equipment Condition

Tailgate lowered (TM 9-2320-280-10).

General Safety Instructions

Direct all personnel to stand clear during hoisting operations.

a. Removal

WARNING

Direct all personnel to stand clear during hoisting operations. A heavy, swinging load can be extremely dangerous.

1. Position chain hoist (2) over top of shelter (3).
2. Connect lifting chains (1) to chain hoist (2) and four corners of shelter (3).

NOTE

It may be necessary to detach cab rear panel straps and turnbuttons and roll cab rear panel upward to gain access to front mounting brackets.

3. Remove eight lockbolts (12), lockwashers (11), washers (10), and four reinforcements (9) from four mounting brackets (6) and support assembly (4), and remove shims (7), if present. Discard lockbolts (12) and lockwashers (11).
4. Remove shelter (3) from support assembly (4) and vehicle body with chain hoist (2).
5. Remove mounting brackets (para. 11-116).

b. Installation

WARNING

Direct all personnel to stand clear during hoisting operations. A heavy, swinging load can be extremely dangerous.

1. Install mounting brackets (para. 11-116).
2. Install shelter (3) over support assembly (4) and gradually lower shelter (3) into position on support assembly (4).

NOTE

Shelter should be tightly fitted to front of support assembly and centered from side to side. Shims should only be added to rear shelter mounts.

3. Position shelter (3) on support assembly (4) and front mounting points (5) and install front of shelter (3) on front of support assembly (4) with two reinforcements (9), four washers (10), lockwashers (11), and lockbolts (12). Tighten lockbolts (12) to 90 lb-ft (122 N•m) and bolts (8) to 60 lb-ft (81 N•m).

11-120. SHELTER REPLACEMENT (Cont'd)

4. Install rear of shelter (3) on support assembly (4) with two reinforcements (9), four washers (10), lockwashers (11), and lockbolts (12). Do not tighten lockbolts (12).
5. Add shims (7), as necessary, to rear shelter mounts to ensure snug fit between mounting brackets (6) and support assembly (4). Tighten lockbolts (12) to 90 lb-ft (122 N•m) and bolts (8) to 60 lb-ft (81 N•m).
6. Disconnect lifting chains (1) from shelter (3).

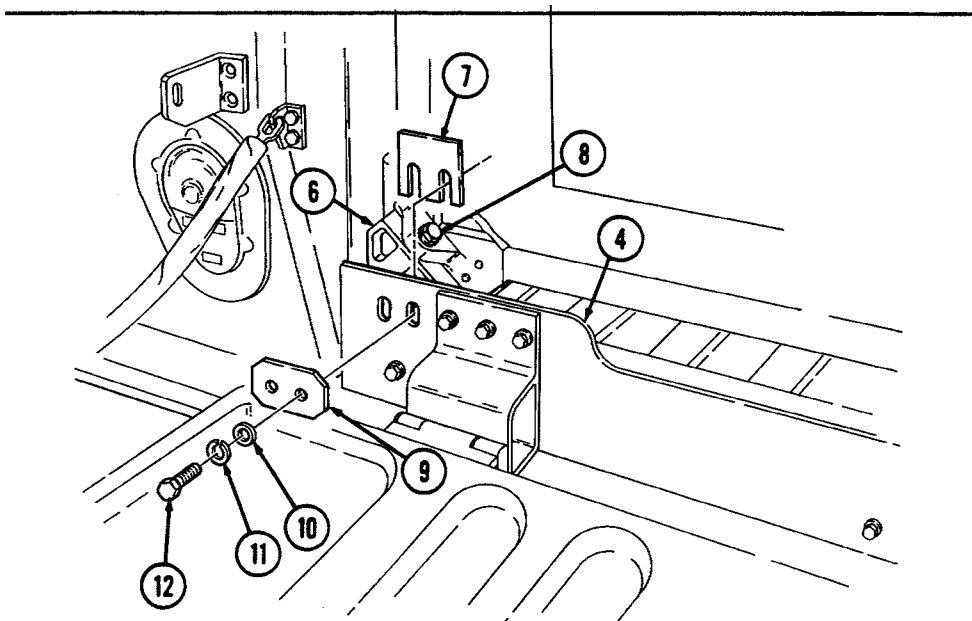
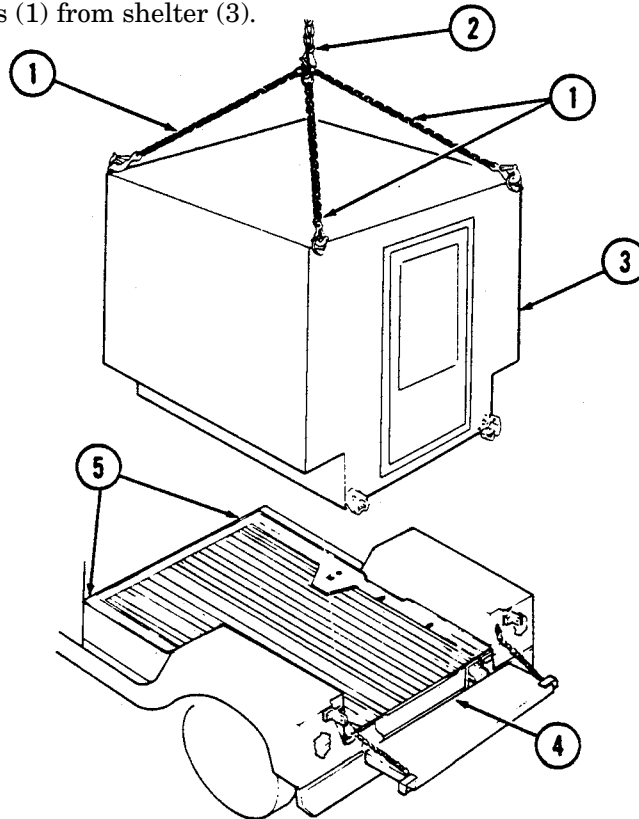

FOLLOW-ON TASK: Raise and secure tailgate (TM 9-2320-280-10).

11-121. SHELTER SUPPORT ASSEMBLY REPLACEMENT

This task covers:

a. Removal

b. Installation

INITIAL SETUP:

Applicable Models

M1037, M1042, M1097, M1097A1, M1097A2

Tools

General mechanic's tool kit:
automotive (Appendix B, Item 1)

Materials/Parts

Locknut (Appendix G, Item 70)
Thirteen locknuts (Appendix G, Item 81)
Four locknuts (Appendix G, Item 128)

Personnel Required

One mechanic
One assistant

Manual References

TM 9-2320-280-10
TM 9-2320-280-24P

Equipment Condition

- Shelter carrier tailgate brackets removed (para. 11-118).
- Cab enclosure panels removed (para. 11-122).
- Fuel filler housing removed (para. 10-2).
- Rear soft top curtain rolled up (TM 9-2320-280-10).
- Shelter removed (para. 11-120).

a. Removal

1. Remove two locknuts (24), washers (2), capscrews (4), washers (5), and spacers (6) from support assembly (27) and cargo floor (22). Discard locknuts (24)
2. Remove six locknuts (24), washers (2), reinforcement plates (23) and (25), six capscrews (3), washers (2), and spacers (1) from support assembly (27) and "B" beam (26). Discard locknuts (24).
3. Remove two locknuts (21), washers (7), capscrews (9), and washers (10) from support assembly (27) and cargo floor (22). Discard locknuts (21).
4. Remove locknut (34), washer (33), capscrew (29), washer (30), clamp (32), and fuel filler spout (28) from body (31) and pull fuel filler spout (28) away for access to locknut (21). Discard locknut (34).
5. Remove two locknuts (21), washers (7), capscrews (8), and washers (7) from support assembly (27) and cargo floor (22). Discard locknuts (21).
6. Remove four locknuts (19), washers (14), capscrews (13), and washers (14) from support assembly and cargo floor (22). Discard locknuts (19).
7. Remove three nuts (20), washers (15), capscrews (16), and washers (15) from support assembly (27) and "D" beam (17).
8. Remove locknut (18), washer (12), capscrew (11), washer (12), and support assembly (27) from cargo floor (22) and "D" beam (17). Discard locknut (18).

b. Installation

1. Install support assembly (27) on cargo floor (22) and "D" beam (17) with washer (12), capscrew (11), washer (12), and locknut (18).
2. Secure support assembly (27) to "D" beam (17) with three washers (15), capscrews (16), washers (15), and nuts (20).
3. Secure support assembly (27) to cargo floor (22) with four washers (14), capscrews (13), washers (14), and locknuts (19).
4. Secure support assembly (27) to cargo floor (22) with two washers (7), capscrews (8), washers (7), and locknuts (21).
5. Install support assembly (27) on "B" beam (26) with six spacers (1), washers (2), capscrews (3), two reinforcement plates (23) and (25), six washers (2), and locknuts (24).

11-121. SHELTER SUPPORT ASSEMBLY REPLACEMENT (Cont'd)

6. Secure support assembly (27) to cargo floor (22) with two spacers (6), washers (5), capscrews (4), washers (2), and locknuts (24).
7. Secure support assembly (27) to cargo floor (22) with two washers (10), capscrews (9), washers (7), and locknuts (21).
8. Tighten four locknuts (19) to 26 lb-ft (35 N•m).
9. Tighten capscrews (3), (4), (8), (9), (11), and (16) to 65 lb-ft (88 N•m).
10. Install fuel filler spout (28) and clamp (32) on body (31) with washer (30), capscrew (29), washer (33), and locknut (34).

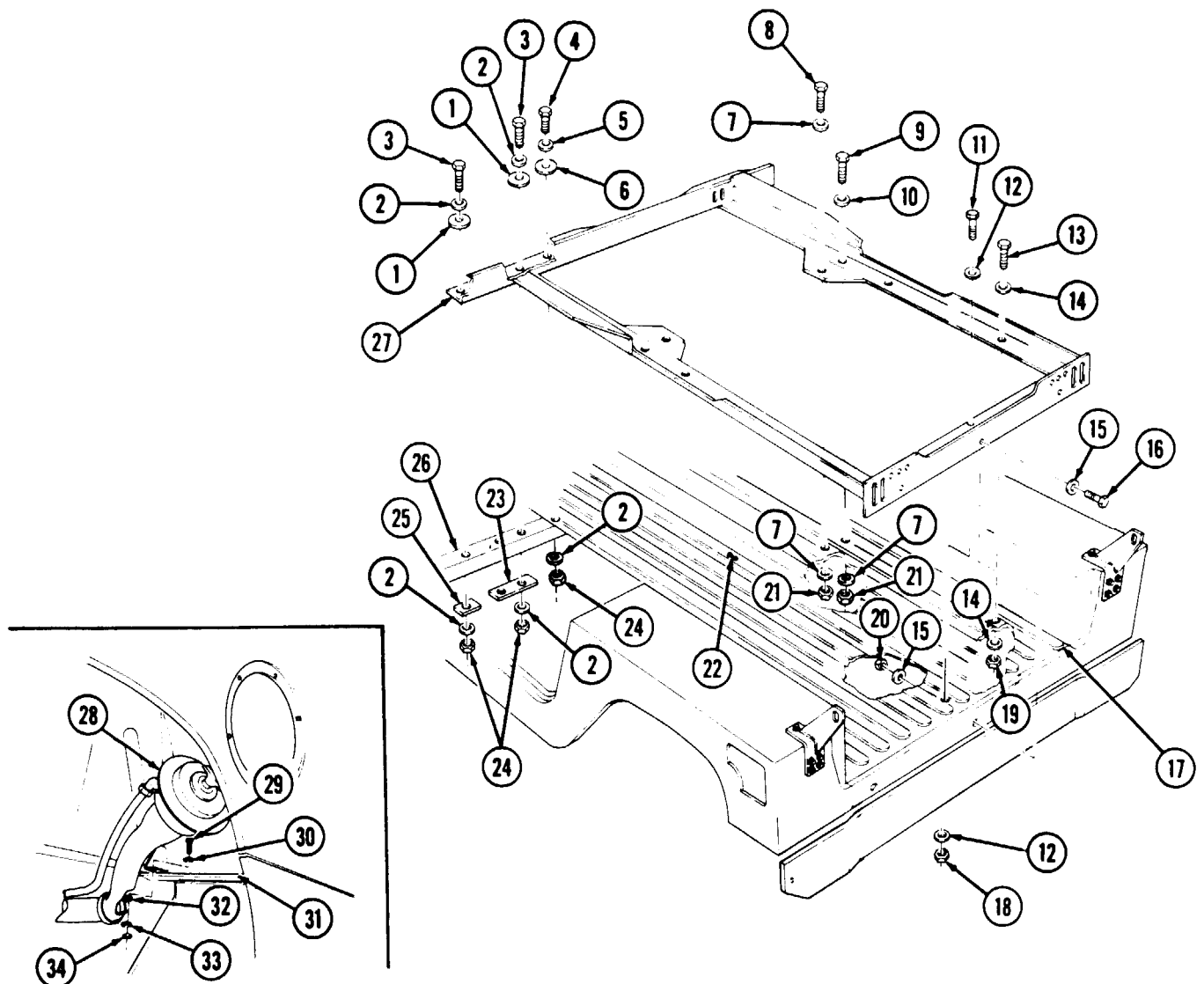

- FOLLOW-ON TASKS:**
- Install cab enclosure panels (para. 11-122).
 - Install shelter carrier tailgate brackets (para. 11-118).
 - Install fuel filler housing (para. 10-2).
 - Roll down rear soft top curtain (TM 9-2320-280-10).
 - Install shelter (para. 11-120).

11-122. CAB ENCLOSURE PANEL REPLACEMENT

This task covers:

a. Removal

b. Installation

INITIAL SETUP:

Applicable Models

M1037, M1042, M1097, M1097A1, M1097A2

Personnel Required

One mechanic
One assistant

Tools

General mechanic's tool kit:
automotive (Appendix B, Item 1)

Manual References

TM 9-2320-280-24P

Materials/Parts

Three lockwashers (Appendix G, Item 113)

Equipment Condition

Fixed rear door removed (para. 10-14).

a. Removal

1. Remove three nuts (5), lockwashers (4), and capscrews (7) from panel (1) and footwell (6). Discard lockwashers (4).
2. Remove three screws (2) and panel (1) from "B" beam (3).

b. Installation

1. Install panel (1) on "B" beam (3) with three screws (2).
2. Install panel (1) on footwell (6) with three capscrews (7), lockwashers (4), and nuts (5). Tighten nuts (5) to 15-20 lb-in. (2 N·m).

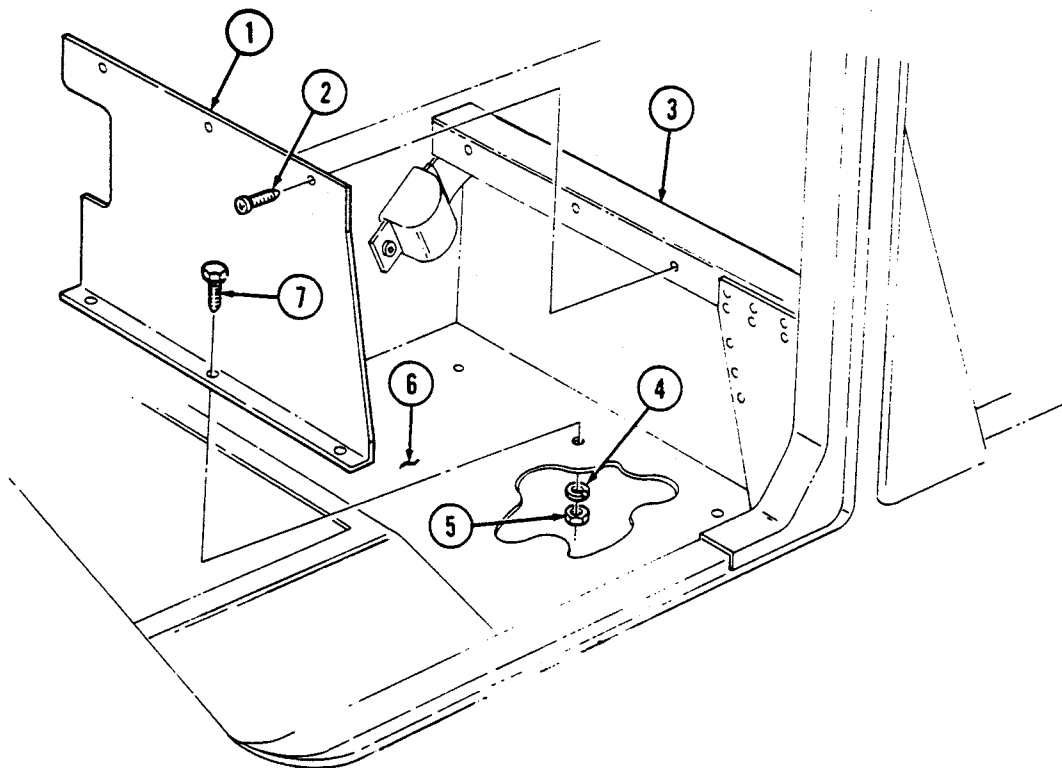

FOLLOW-ON TASK: Install fixed rear door (para. 10-14).

Section III. AMBULANCE BODY MAINTENANCE

11-123. AMBULANCE BODY MAINTENANCE TASK SUMMARY

TASK PARA.	PROCEDURES	PAGE NO.
11-124.	Soft Top Ambulance Litter Assembly Maintenance	11-176
11-125.	Rear Door Maintenance	11-183
11-126.	Rear Door Hinge Replacement	11-185
11-127.	Rear Door Handles Replacement	11-186
11-128.	Rear Door Latch Assembly and Guide Replacement	11-187
11-129.	Rear Door Seal Protector Replacement	11-188
11-130.	Rear Door Seals Replacement	11-189
11-131.	Rear Door Latch Rod Striker Guides and Brackets Maintenance	11-190
11-132.	Rear Door Holder Assembly Replacement	11-192
11-133.	Rear Steps Hinge Replacement	11-193
11-134.	Rear Steps Striker and Bracket Maintenance	11-194
11-135.	Rear Steps Latch Assembly Replacement	11-196
11-136.	Rear Steps Retaining Cable Maintenance	11-198
11-137.	Rear Steps Retractor Replacement	11-200
11-138.	Rear Steps Maintenance	11-202
11-139.	Upper Litter Rack Striker Replacement	11-206
11-140.	Upper Litter Rack Replacement	11-207
11-141.	Upper Litter Rack Striker Support Brackets Replacement	11-208
11-142.	Upper Litter Rack Latch Replacement	11-210
11-143.	Upper Litter Rack Latch Bracket Replacement	11-211
11-144.	Upper Litter Rack Support Bracket Replacement	11-212
11-145.	Upper Litter Rack Strap and Ring Replacement	11-212.1
11-145.1.	Litter Skid Tracks Edge Trim Replacement	11-212.2
11-146.	Litter Skid Pad Replacement	11-214
11-147.	Litter Handle Bumper Replacement	11-215
11-148.	Spineboard Mounting Bracket Replacement	11-216
11-149.	IV Bag Strap Replacement	11-218
11-150.	IV Bag Hook Replacement	11-219
11-151.	Stowage Box Turnbutton Replacement	11-220
11-152.	Stowage Door Replacement	11-221
11-153.	Ambulance Compartment Mat Replacement	11-222
11-154.	Front Floorboard Replacement	11-223
11-155.	Bulkhead Door Replacement	11-224
11-156.	Bulkhead Door Latch Replacement	11-228
11-157.	Attendant Seat Maintenance	11-232
11-158.	Attendant Seat Guide Rail Replacement	11-234
11-159.	Litter Stowage Door Replacement	11-235
11-160.	Litter Stowage Tray Support and Strap Replacement	11-236

11-123. AMBULANCE BODY MAINTENANCE TASK SUMMARY (Cont'd)

TASK PARA.	PROCEDURES	PAGE NO.
11-161.	Litter Rail Extension Replacement	11-238
11-162.	NBC Compartment Door Replacement (M997, M997A1, M997A2)	11-240
11-163.	NBC Compartment Door Latch Replacement	11-241
11-164.	NBC Heater Replacement	11-242
11-165.	NBC Heater Brackets Replacement	11-243
11-166.	NBC Air Line Piping Maintenance	11-244
11-167.	NBC Gas Filter and Bracket Replacement	11-246
11-168.	NBC Precleaner, Particulate Filter Assembly, and Bracket Replacement	11-248
11-169.	Intercom and Brackets Replacement	11-250
11-170.	Rear Drip Rail Replacement	11-252
11-171.	Radio Antenna Mount Replacement (M996, M996A1)	11-253
11-172.	Radio Antenna Mount Replacement (M997, M997A1, M997A2)	11-254
11-173.	Stowage Net Assembly Replacement	11-255
11-174.	Red Cross Placard Retaining Clip Replacement	11-256
11-175.	Red Cross Placard Replacement	11-257
11-176.	Exterior Stowage Door Replacement	11-258
11-177.	Attendant Seat Stowage Brackets Replacement	11-259
11-178.	Rear Door Vent Assembly Replacement	11-260
11-179.	Medical Stowage Cover and Latch Replacement	11-261
11-180.	Edge Protector Replacement	11-262
11-180.1.	Spreader Bar Tiedown Replacement	11-262.1
11-181.	Ambulatory Patient Seat Maintenance	11-263
11-182.	Ambulatory Patient Seat Rear Closeout Panel Replacement	11-265
11-183.	NBC Door Maintenance (M996, M996A1)	11-266
11-184.	Air Intake Compartment Panels Replacement	11-268
11-185.	Air Intake Duct Door Replacement	11-269
11-186.	Air Inlet/Outlet Grille Replacement	11-270
11-187.	Front Cover Panel Replacement	11-271
11-188.	Rear Cover Panel Replacement	11-272
11-189.	Heater Exhaust Pipe Replacement (M997, M997A1, M997A2)	11-273
11-190.	Heater Replacement (M997, M997A1, M997A2)	11-274
11-191.	Heater Outlet Hose Replacement (M997, M997A1, M997A2)	11-276
11-192.	Heater Fuel Filter Replacement	11-278
11-193.	Heater Fuel Lines Replacement	11-280
11-194.	Heater Fuel Pump Replacement	11-286
11-195.	Heater Fuel System Bleeding	11-288
11-196.	Floor Heat Duct Louver Replacement	11-290
11-197.	Blower Motor Resistor Replacement	11-291
11-198.	Blower Motor and Housing Maintenance	11-292

11-123. AMBULANCE BODY MAINTENANCE TASK SUMMARY (Cont'd)

TASK PARA.	PROCEDURES	PAGE NO.
11-199.	Duct Door Control Cables Maintenance	11-296
11-200.	Evaporator Drain Tube Replacement	11-302
11-201.	Condenser Cooling Fan Replacement	11-304
11-202.	Compressor Belt Maintenance	11-306
11-203.	Air-Conditioning Duct Louver Replacement	11-308
11-204.	Heater Compartment Panel Replacement (M996, M996A1)	11-309
11-205.	Air Intake Filter Maintenance	11-310
11-206.	Heater Outlet/Blower Fan Hose Replacement (M996, M996A1)	11-312
11-207.	Heater Exhaust Pipe Replacement (M996, M996A1)	11-313
11-208.	Heater Mounting Bracket Assembly Replacement (M996, M996A1)	11-314
11-209.	Heater Replacement (M996, M996A1)	11-316
11-210.	Blower Outlet Deflector Replacement	11-318
11-211.	Heat/Air-Conditioning Duct Maintenance	11-319
11-212.	Blower Assembly Replacement	11-321
11-213.	Air Diverter Replacement (M996, M996A1)	11-323
11-214.	Panel Insulation Replacement	11-324
11-215.	Ambulance Spreader Bar Maintenance	11-325

11-124. SOFT TOP AMBULANCE LITTER ASSEMBLY MAINTENANCE

This task covers:

- | | |
|---|--|
| <ul style="list-style-type: none"> a. Removal b. Disassembly c. Inspection | <ul style="list-style-type: none"> d. Assembly e. Installation |
|---|--|

INITIAL SETUP:

Applicable Models

M1035, M1035A1, M1035A2

Tools

General mechanic's tool kit:
automotive (Appendix B, Item 1)

Special Tools

Torque adapter (Appendix B, Item 145)

Materials/Parts

Eleven locknuts (Appendix G, Item 70)
Twenty-two locknuts (Appendix G, Item 128)
Six lockwashers (Appendix G, Item 133)
Eight locknuts (Appendix G, Item 112)
Eight blind rivets (Appendix G, Item 245)
Two lockwashers (Appendix G, Item 135)

Personnel Required

One mechanic
One assistant

Manual References

TM 9-2320-280-10
TM 9-2320-280-24P

Equipment Condition

Tailgate lowered (TM 9-2320-280-10).

NOTE

For instructions on replacement of rivets, refer to para. 10-66.

a. Removal

1. Remove two capscrews (22) and washers (21) from litter assembly (1), spacers (20), and cargo floor (26).
2. Remove two locknuts (11), washers (12), capscrews (24), and washers (12) from litter assembly (1), spacers (25), and cargo floor (26). Discard locknuts (11).
3. Remove four locknuts (13), washers (14), capscrews (19), washers (14), and shims (17) from litter assembly (1) and wheelhouses (10). Discard locknuts (13).
4. Remove four locknuts (15), washers (16), capscrews (23), washers (16), and shims (18) from litter assembly (1) and wheelhouses (10). Discard locknuts (15).
5. Remove two nuts (9), washers (5), capscrews (4), and washers (5) from spacers (6), litter assembly (1), and cargo floor (26).
6. Remove two locknuts (8), washers (3), capscrews (2), and washers (3) from spacers (7), litter assembly (1), and cargo floor (26). Discard locknuts (8).
7. Remove litter assembly (1) from vehicle.

NOTE

Note position of spacers for installation.

8. Remove spacers (6), (7), (20), and (25) from cargo floor (26).

11-124. SOFT TOP AMBULANCE LITTER ASSEMBLY MAINTENANCE (Cont'd)

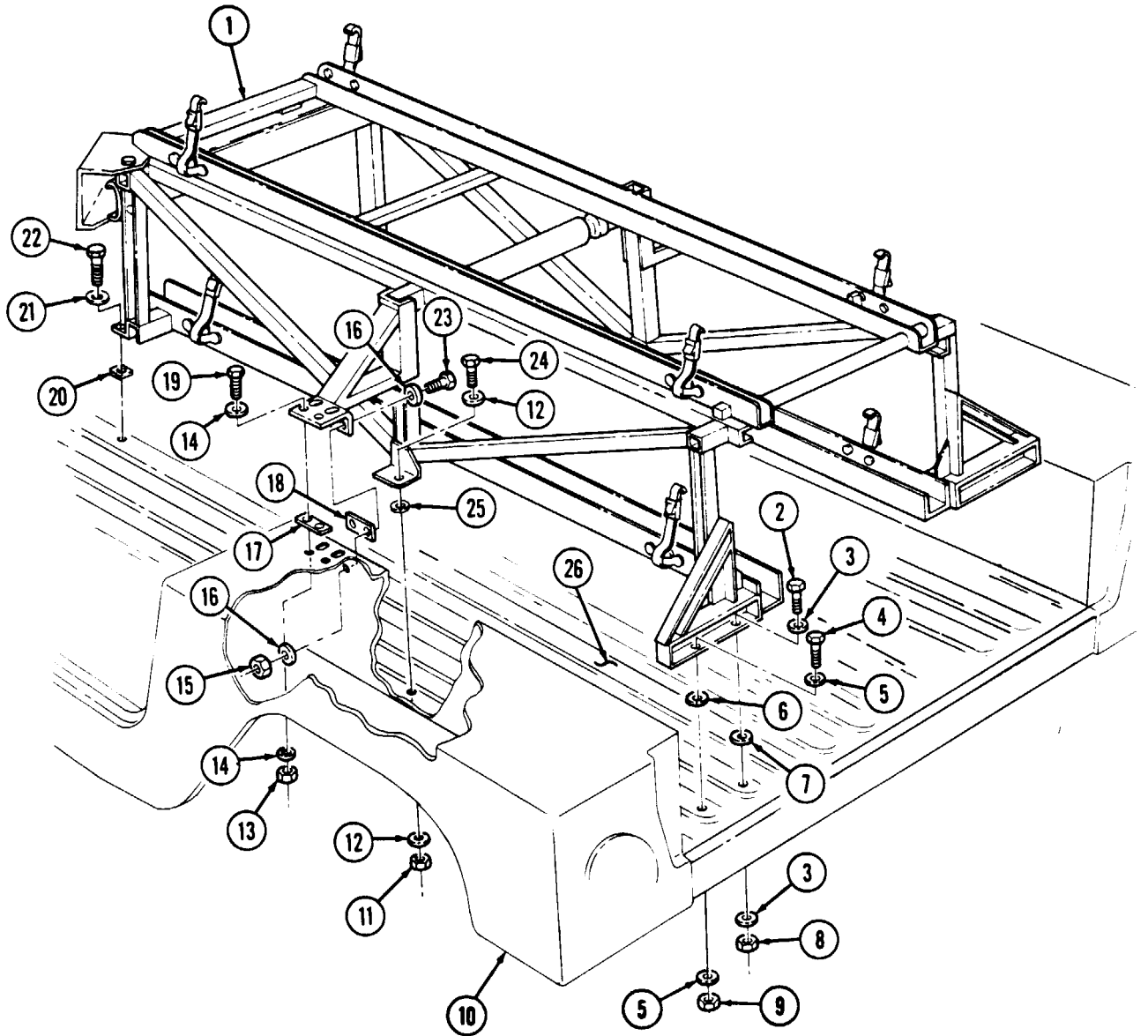

11-124. SOFT TOP AMBULANCE LITTER ASSEMBLY MAINTENANCE (Cont'd)**b. Disassembly**

1. Remove six locknuts (17), washers (16), capscrews (25), and washers (16) from rear gusset supports (20) and track assemblies (47). Discard locknuts (17).
2. Remove two locknuts (23), washers (19), capscrews (18), washers (19), and rear gusset supports (20) from track assemblies (47). Discard locknuts (23).
3. Remove six locknuts (29), washers (27), capscrews (26), washers (27), and two wheelhouse gusset supports (28) from track assemblies (47). Discard locknuts (29).
4. Remove two capscrews (14), lockwashers (13), and washers (12) from camrol stops (48) and track assemblies (47). Unlatch and raise litter tray (4) to remove camrol stops (48) from track assemblies (47). Discard lockwashers (13).
5. Remove litter tray (4) from track assemblies (47).
6. Remove two camrols (6) and washers (5) from litter tray (4).
7. Remove two nuts (43), lockwashers (42), washers (41), socket head shoulder bolts (1), and torsion springs (2) from bumper support plates (40). Discard lockwashers (42).
8. Remove four screws (3) and two bumper support plates (40) from litter tray (4).
9. Remove two capscrews (30), lockwashers (31), washers (32), round support (11), and tube roller (10) from track assemblies (47). Discard lockwashers (31).
10. Remove eight screws (44) and two shields (45) from tray assembly bumper (46) and track assemblies (47).
11. Remove three locknuts (52), washers (51), capscrews (50), and stop (49) from track assembly (47) (right side only). Discard locknuts (52).
12. Remove two capscrews (35), lockwashers (36), washers (37), and tray assembly bumper (46) from track assemblies (47). Discard lockwashers (36).
13. Remove four locknuts (33), washers (34), capscrews (38), washers (34), and cross gusset bracket (39) from track assemblies (47). Discard locknuts (33).
14. Remove eight rivets (8), four footman loops (9), and straps (7) from litter tray (4).
15. Remove eight locknuts (15), screws (22), four footman loops (21), and straps (24) from track assemblies (47). Discard locknuts (15).

c. Inspection

1. Inspect litter tray (4), track assemblies (47), rear gusset supports (20), and wheelhouse gusset supports (28) for cracks, broken welds, and distortion. Replace any component if damaged.
2. Inspect tube roller (10), round support (11), and camrols (6) for warping and damage. Replace any component if damaged.
3. Inspect torsion springs (2), socket head shoulder bolts (1), footman loops (9) and (21), and straps (24) and (7) for damage. Replace any component if damaged.

11-124. SOFT TOP AMBULANCE LITTER ASSEMBLY MAINTENANCE (Cont'd)

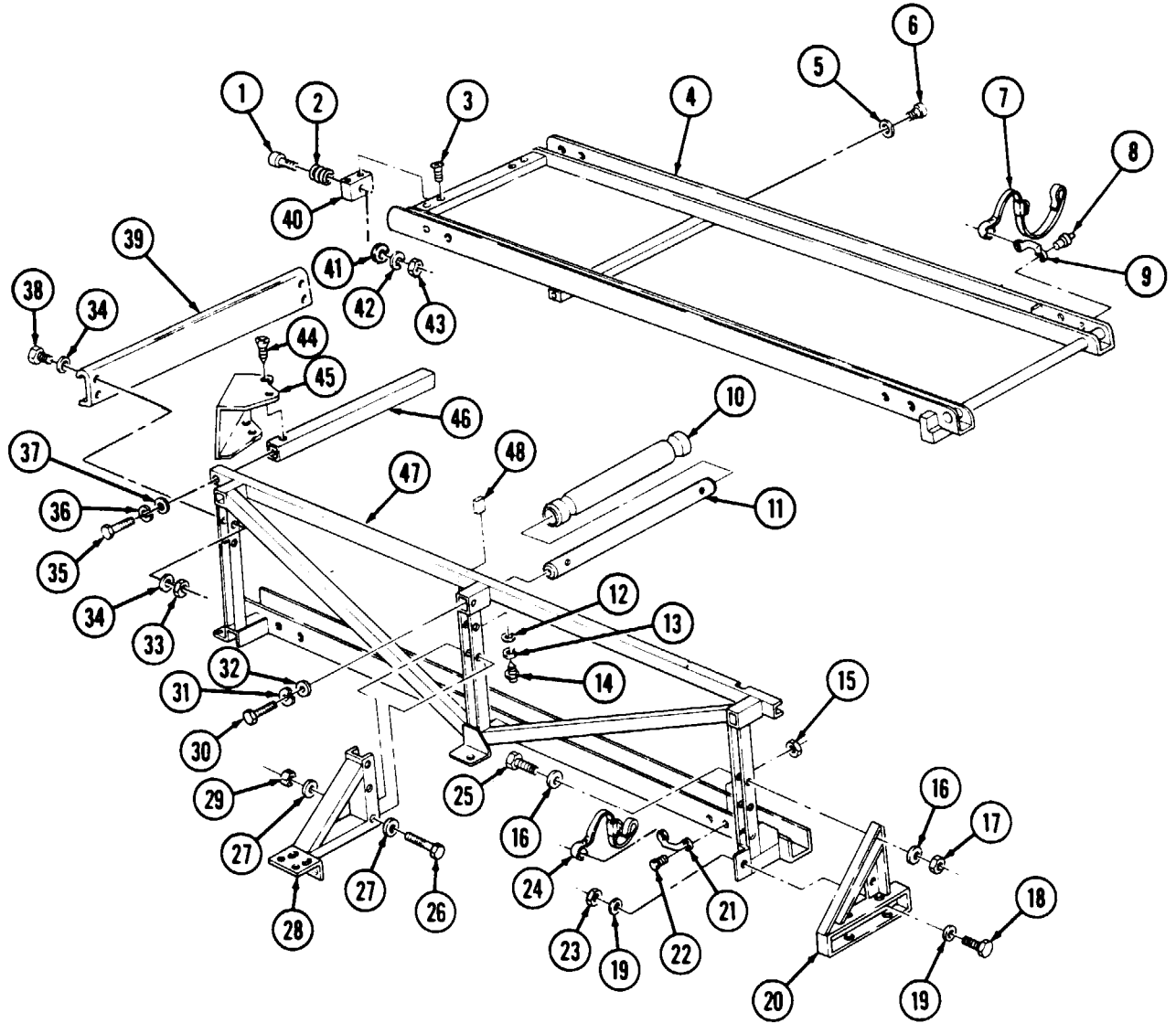

RIGHT FRONT LOWER CORNER

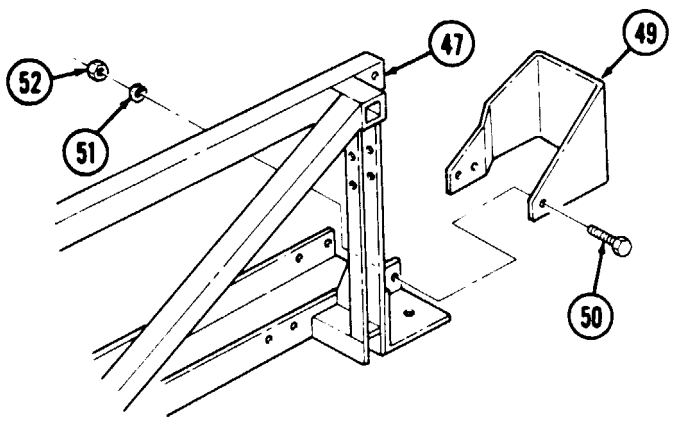

11-124. SOFT TOP AMBULANCE LITTER ASSEMBLY MAINTENANCE (Cont'd)
--

d. Assembly

1. Install four straps (24) and footman loops (21) on two track assemblies (47) with eight screws (22) and locknuts (15).
2. Install four straps (7) and footman loops (9) on litter tray (4) with eight rivets (8).
3. Install cross gusset bracket (39) on two track assemblies (47) with four washers (34), capscrews (38), washers (34), and locknuts (33). Tighten capscrews (38) to 31 lb-ft (42 N•m).
4. Install tray assembly bumper (46) on two track assemblies (47) with two washers (37), lockwashers (36), and capscrews (35). Tighten capscrews (35) to 31 lb-ft (42 N•m).
5. Install stop (49) on track assembly (47) (right side only) with three capscrews (50), washers (51), and locknuts (52). Tighten capscrews (50) to 6 lb-ft (8 N•m).
6. Install two shields (45) on track assemblies (47) and tray assembly bumper (46) with eight screws (44).
7. Install tube roller (10) on round support (11). Install round support (11) on two track assemblies (47) with washers (32), lockwashers (31), and capscrews (30). Tighten capscrews (30) to 31 lb-ft (42 N•m).
8. Install two wheelhouse gusset supports (28) on track assemblies (47) with six washers (27), capscrews (26), washers (27), and locknuts (29). Tighten locknuts (29) to 31 lb-ft (42 N•m).
9. Install two rear gusset supports (20) on track assemblies (47) with six washers (16), capscrews (25), washers (16), and locknuts (17). Do not tighten locknuts (17).
10. Secure rear gusset supports (20) to track assemblies (47) with two washers (19), capscrews (18), washers (19), and locknuts (23). Tighten capscrews (18) and locknuts (17) to 31 lb-ft (42 N•m).
11. Install two bumper support plates (40) on litter tray (4) with four screws (3).

CAUTION

Do not overtighten shoulder bolts.

12. Install two torsion springs (2) on socket head shoulder bolts (1) and install two socket head shoulder bolts (1) on bumper support plates (40) with two washers (41), lockwashers (42), and nuts (43). Tighten nuts (43) to end threads on socket head shoulder bolts (1).
13. Install two washers (5) and camrols (6) on litter tray (4).
14. Install litter tray (4) on track assembly (47) channels, and slide litter tray (4) toward tray assembly bumper (46) until camrols (6) are past wheelhouse gusset supports (28).
15. Raise litter tray (4) to install two camrol stops (48) on track assemblies (47) and install camrol stops (48) with two washers (12), lockwashers (13), and capscrews (14). Tighten capscrews (14) to 6 lb-ft (8 N•m).

11-124. SOFT TOP AMBULANCE LITTER ASSEMBLY MAINTENANCE (Cont'd)

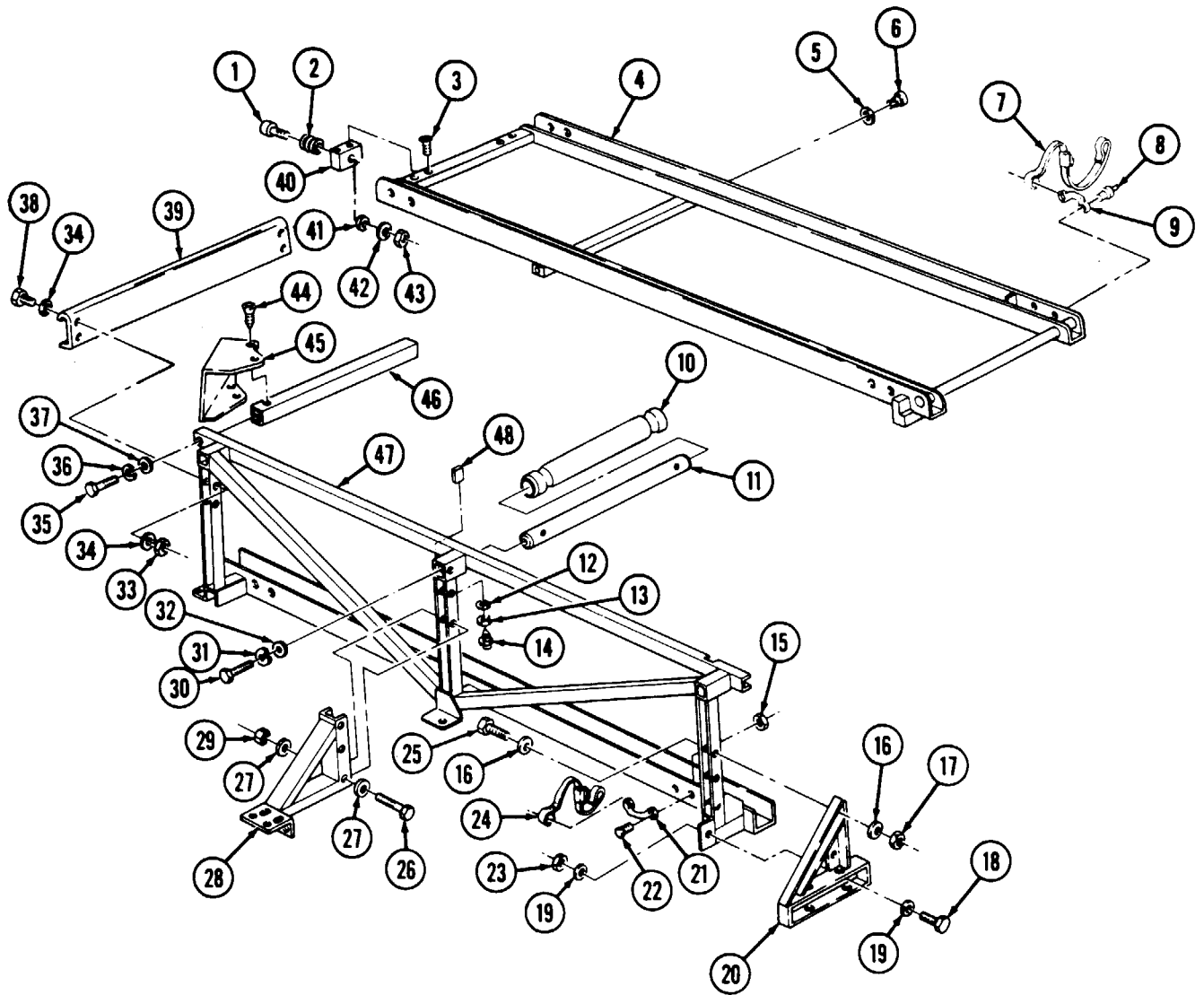

RIGHT FRONT LOWER CORNER

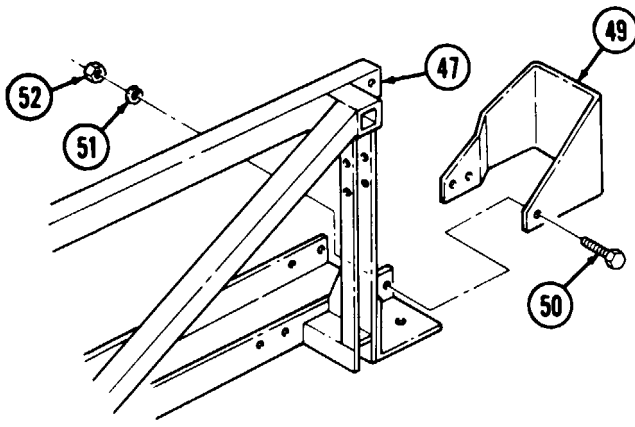

11-124. SOFT TOP AMBULANCE LITTER ASSEMBLY MAINTENANCE (Cont'd)

e. Installation

1. Install litter assembly (1) in vehicle and install spacers (25), (20), (7), and (6) on mounting locations between cargo floor (26) and litter assembly (1).
2. Secure litter assembly (1) to cargo floor (26) with two washers (3), capscrews (2), washers (3), and locknuts (8). Do not tighten capscrews (2).
3. Secure litter assembly (1) to cargo floor (26) with two washers (5), capscrews (4), washers (5), and nuts (9). Do not tighten capscrews (4).
4. Secure litter assembly (1) to cargo floor (26) with two washers (12), capscrews (24), washers (12), and locknuts (11). Do not tighten capscrews (24).
5. Install shims (18) between litter assembly (1) and side of wheelhouses (10) and install litter assembly (1) on wheelhouses (10) with four washers (16), capscrews (23), washers (16), and locknuts (15). Do not tighten capscrews (23).
6. Install shims (17) between litter assembly (1) and top of wheelhouses (10) and install litter assembly (1) on wheelhouses (10) with four washers (14), capscrews (19), washers (14), and locknuts (13). Do not tighten capscrews (19).
7. Secure litter assembly (1) to cargo floor (26) with two washers (21) and capscrews (22). Tighten capscrews (22) to 75 lb-ft (102 N·m).
8. Tighten capscrews (19) and (23) to 6 lb-ft (8 N·m). Tighten capscrews (24) and (2) to 31 lb-ft (42 N·m). Using torque adapter, tighten capscrews (4) to 75 lb-ft (102 N·m).

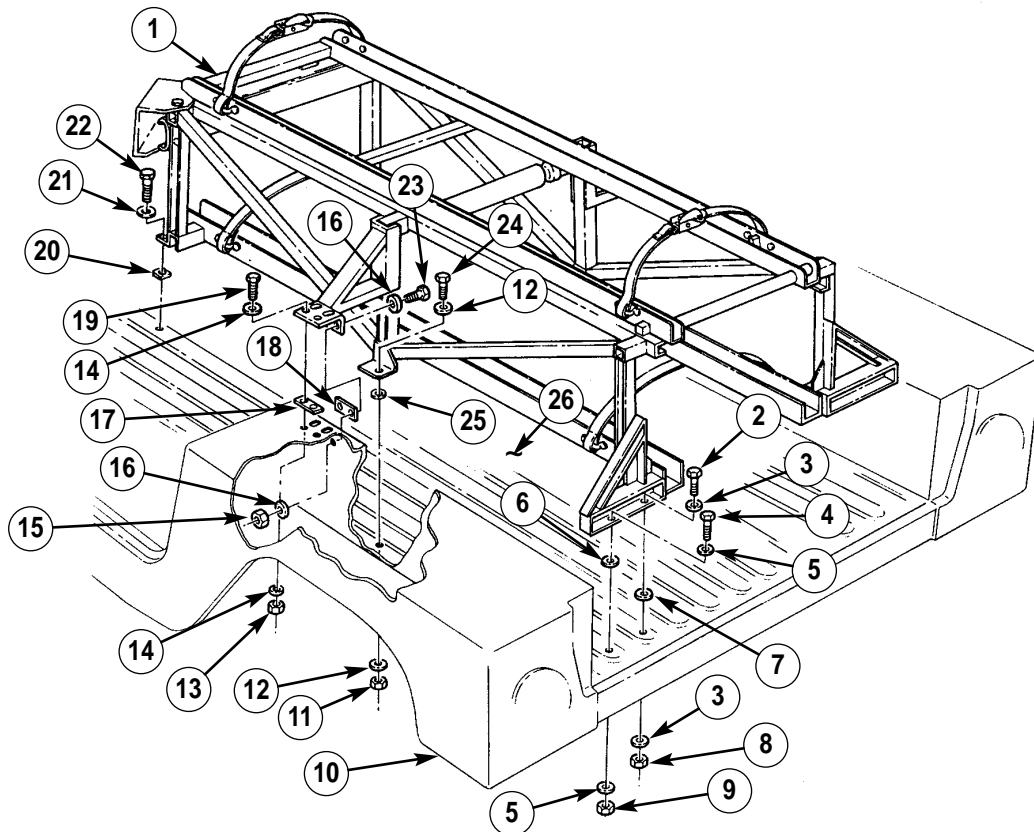

FOLLOW-ON TASK: Raise and secure tailgate (TM 9-2320-280-10).

11-125. REAR DOOR MAINTENANCE

This task covers:

- a. Removal
- b. Installation
- c. Adjustment

INITIAL SETUP:

Applicable Models

M996, M996A1, M997, M997A1, M997A2

Tools

General mechanic's tool kit:
automotive (Appendix B, Item 1)

Materials/Parts

Six locknuts (Appendix G, Item 79)

Personnel Required

One mechanic
One assistant

Manual References

TM 9-2320-280-10
TM 9-2320-280-24P

Equipment Condition

Rear doors opened (TM 9-2320-280-10).

a. Removal

Remove six locknuts (2), washers (3), capscrews (6), washers (3), door (5), and shims (4), if present, from hinges (1). Discard locknuts (2).

b. Installation

Install door (5) and shims (4), if removed, on two hinges (1) with six washers (3), capscrews (6), washers (3), and locknuts (2). Tighten locknuts (2) to 15 lb-ft (20 N·m).

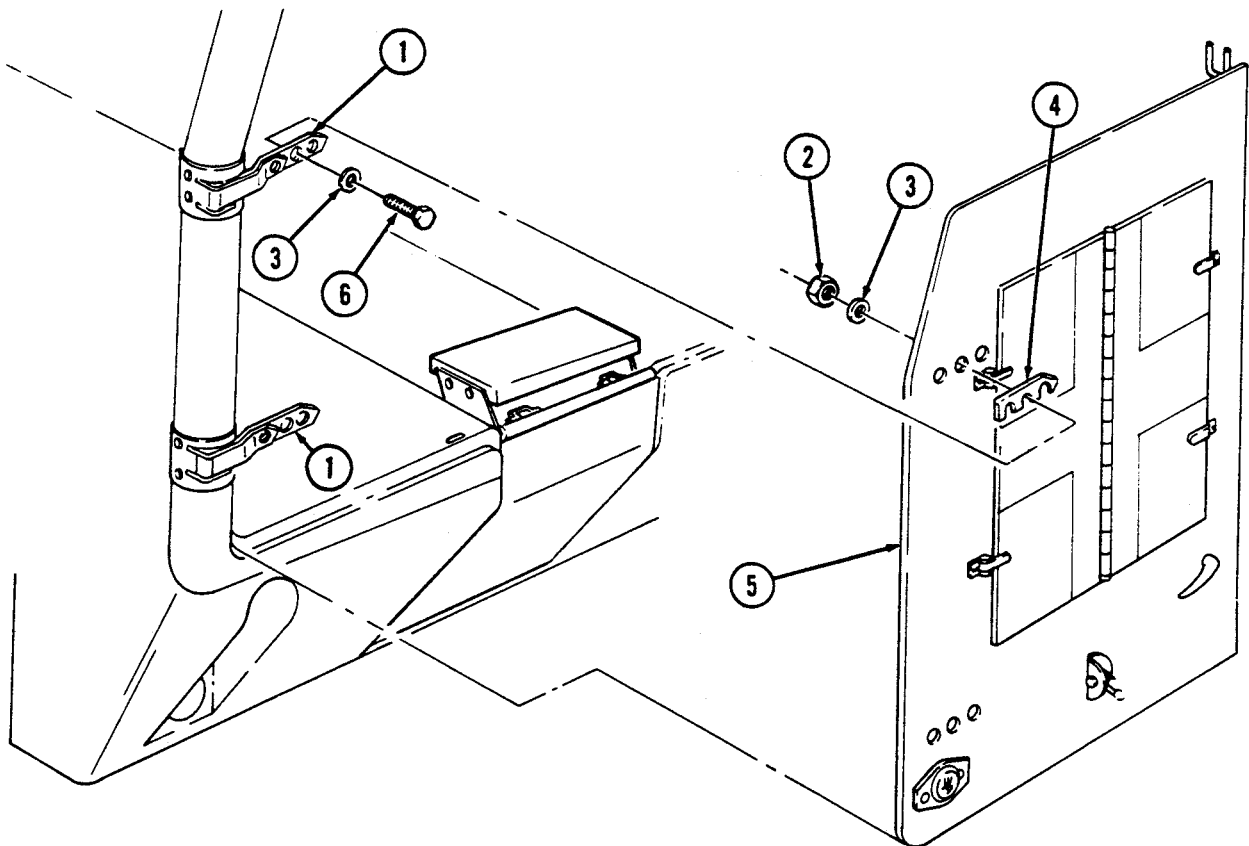

11-125. REAR DOOR MAINTENANCE (Cont'd)

c. Adjustment

1. Check adjustment and sealing of door (9) by inserting a sheet of paper between bottom edge of door (9) and seal (3) on door frame (4), and closing both doors (9). Door seal (3) should offer resistance when pulling out paper. If door seal (3) does not offer resistance, proceed to step 3.
2. Open door (9). Repeat step 1 for top edge and both side edges of door (9). If door seal (3) offers resistance at all four sides of door (9), doors are adjusted correctly.
3. For vertical adjustment of door (9), loosen eight capscrews (12) securing hinges (1) to body (2). Slide door (9) and hinges (1) up or down as required, hold door (9) in place, and tighten capscrews (12) to 15 lb-ft (20 N•m).
4. For outer edge of door (9) adjustment, loosen six locknuts (5) and capscrews (11) and remove or add shims (6) as required between door (9) and hinge (1). Tighten locknuts (5) to 15 lb-ft (20 N•m).
5. If inner edges of doors (9) do not seal properly check for worn or damaged latch assembly rods (8), left door seal (7), or latch rod catches (10). Replace latch rod catches (10) (para. 11-131), door seal (7) (para. 11-130), or latch assembly (8) (para. 11-128) if damaged or worn.
6. Repeat steps 1 and 2 to ensure proper adjustment and sealing.

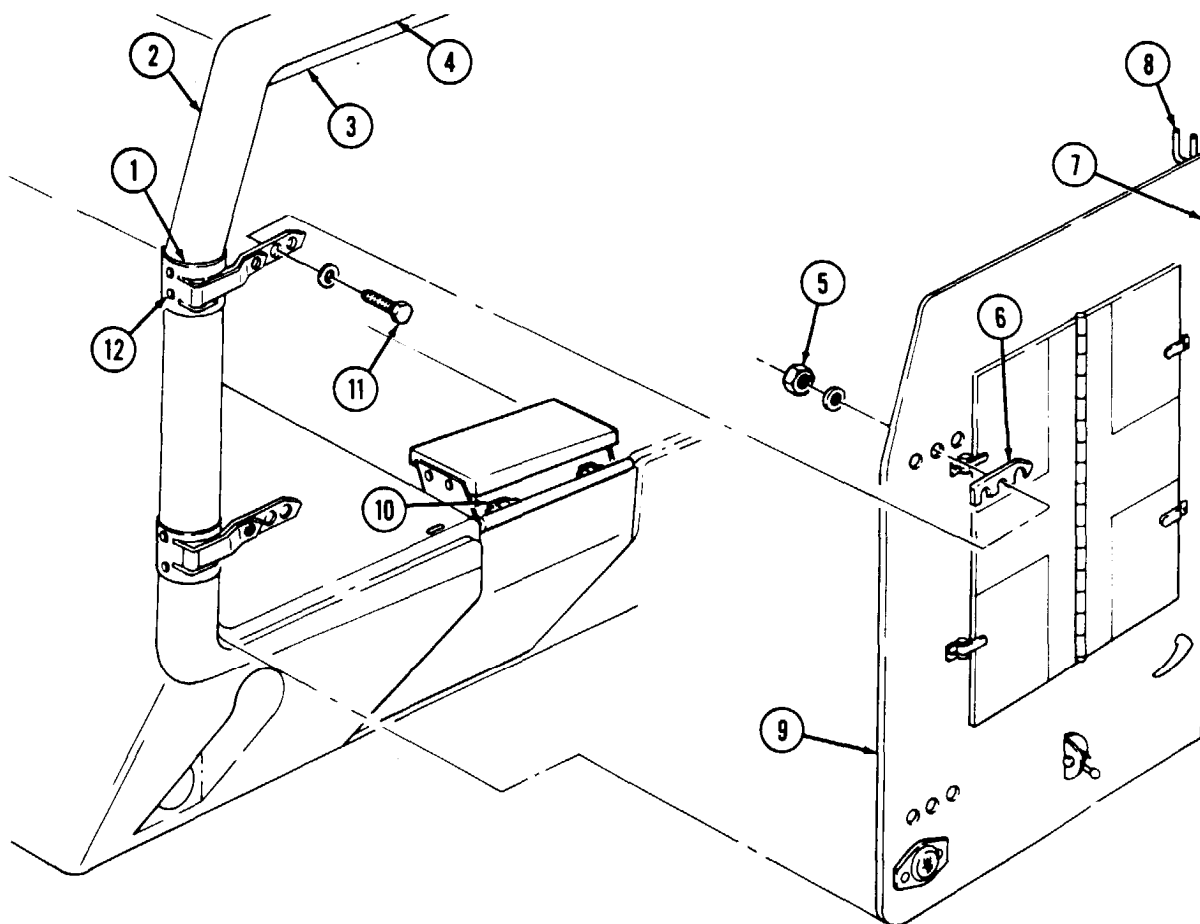

FOLLOW-ON TASKS: • Adjust latch rod catches (para. 11-131).
 • Close rear doors (TM 9-2320-280-10).

11-126. REAR DOOR HINGE REPLACEMENT

This task covers:

a. Removal

b. Installation

INITIAL SETUP:

Applicable Models

M996, M996A1, M997, M997A1, M997A2

Manual References

TM 9-2320-280-24P

Tools

General mechanic's tool kit:
automotive (Appendix B, Item 1)

Equipment Condition

Rear door removed (para. 11-125).

Materials/Parts

Four lockwashers (Appendix G, Item 134)

a. Removal

Remove four capscrews (4), lockwashers (3), and hinge (2) from body (1). Discard lockwashers (3).

b. Installation

Install hinge (2) on body (1) with four lockwashers (3) and capscrews (4). Tighten capscrews (4) to 15 lb-ft (20 N·m).

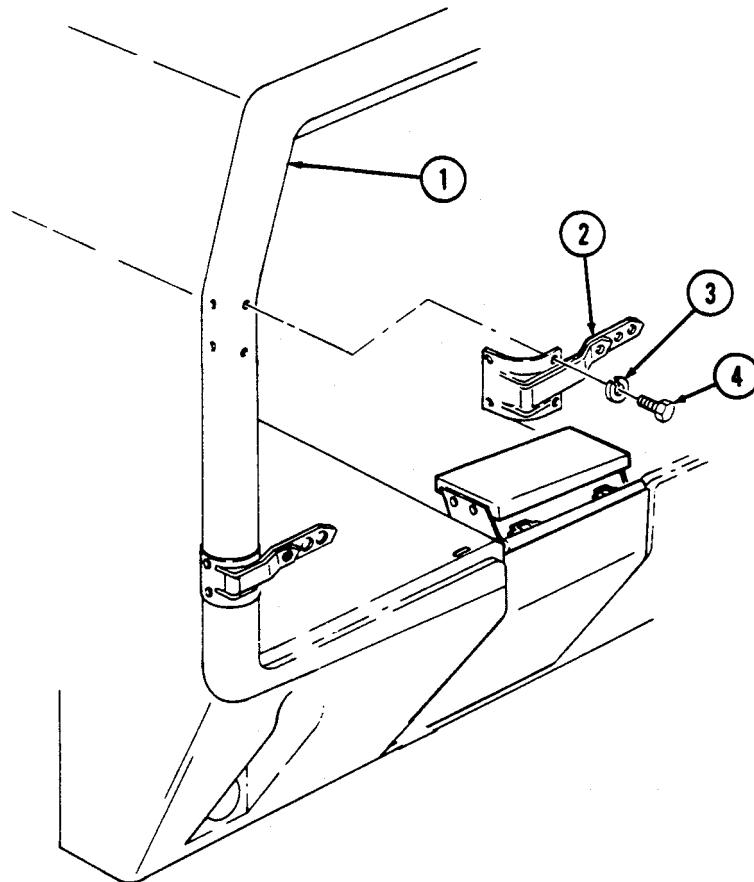

FOLLOW-ON TASK: Install rear door (para. 11-125).

11-127. REAR DOOR HANDLES REPLACEMENT

This task covers:

a. Removal

b. Installation

INITIAL SETUP:

Applicable Models

M996, M996A1, M997, M997A1, M997A2

Manual References

TM 9-2320-280-10
TM 9-2320-280-24P

Tools

General mechanic's tool kit:
automotive (Appendix B, Item 1)

Equipment Condition

Rear door opened (TM 9-2320-280-10).

Materials/Parts

Grease (Appendix C, Item 25)
Sealing compound (Appendix C, Item 41)
Four locknuts (Appendix G, Item 70)

a. Removal

1. Remove setscrew (9) and inner handle (1) from outer handle assembly (3) and door (5).
2. Remove four locknuts (8), washers (7), capscrews (4), and outer handle assembly (3) from latch assembly (6). Discard locknuts (8).

b. Installation

1. Apply a thin bead of sealing compound around inner plate of outer handle assembly (3).
2. Lubricate outer handle shaft (2) with grease.
3. Install outer handle assembly (3) on door (5) and latch assembly (6) with four capscrews (4), washers (7), and locknuts (8). Tighten locknuts (8) to 10 lb-ft (14 N•m).
4. Install inner handle (1) on outer handle assembly (3) with setscrew (9).

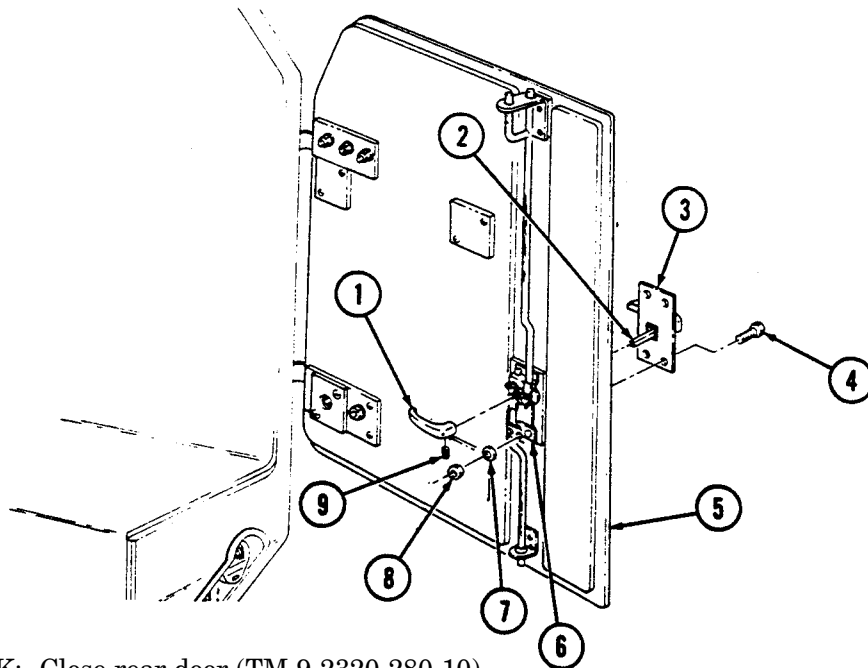

FOLLOW-ON TASK: Close rear door (TM 9-2320-280-10).

11-128. REAR DOOR LATCH ASSEMBLY AND GUIDE REPLACEMENT

This task covers:

a. Removal

b. Installation

INITIAL SETUP:

Applicable Models

M996, M996A1, M997, M997A1, M997A2

Manual References

TM 9-2320-280-24P

Tools

General mechanic's tool kit:
automotive (Appendix B, Item 1)

Equipment Condition

Rear door handles removed (para. 11-127).

Materials/Parts

Four solid rivets (Appendix G, Item 269)

NOTE

For instructions in replacement of rivets, refer to para. 10-66.

a. Removal

1. Slide latch assembly (7) down until upper latch rod (8) is out of upper guide (2). Slide latch assembly (7) up until lower latch rod (6) is out of lower guide (5).
2. Remove four rivets (1), latch guide (2), and shims (3), if present, from door (4).

b. Installation

1. Install latch guide (2) and shims (3), if removed, on door (4) with four rivets (1).
2. Slide lower latch rod (6) into lower guide (5).
3. Insert upper latch rod (8) into upper guide (2) and slide latch assembly (7) up to mounting position.

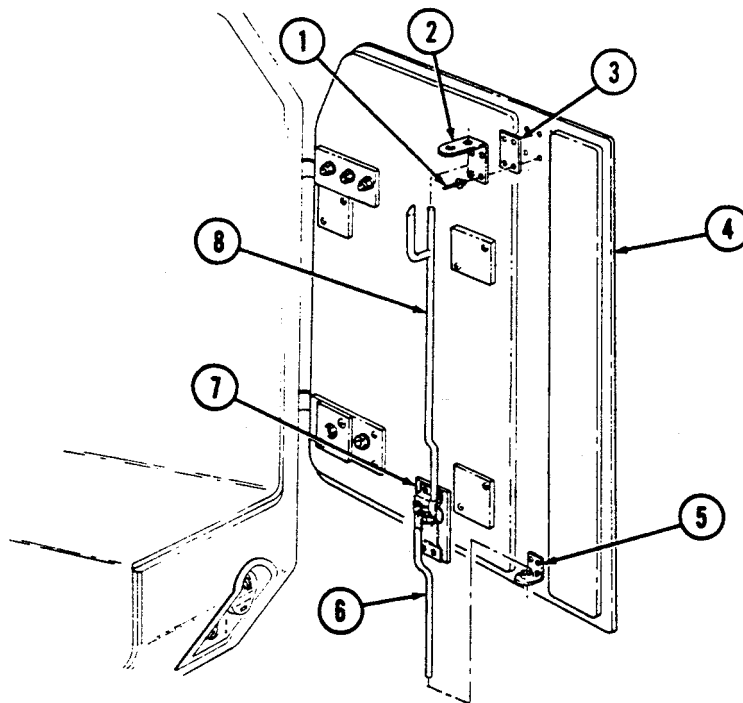

FOLLOW-ON TASKS: • Install rear door handles (para. 11-127).
• Adjust latch rod brackets (para. 11-131).

11-129. REAR DOOR SEAL PROTECTOR REPLACEMENT

This task covers:

a. Removal

b. Installation

INITIAL SETUP:

Applicable Models

M996, M996A1, M997, M997A1, M997A2

Tools

General mechanic's tool kit:
automotive (Appendix B, Item 1)

Materials/Parts

Five blind rivets (Appendix G, Item 242)

Manual References

TM 9-2320-280-10
TM 9-2320-280-24P

Equipment Condition

Rear doors opened (TM 9-2320-280-10).

NOTE

For instructions on replacement of rivets, refer to para. 10-66.

a. Removal

Remove five rivets (2) and seal protector (3) from body (1).

b. Installation

Install seal protector (3) on body (1) with five rivets (2).

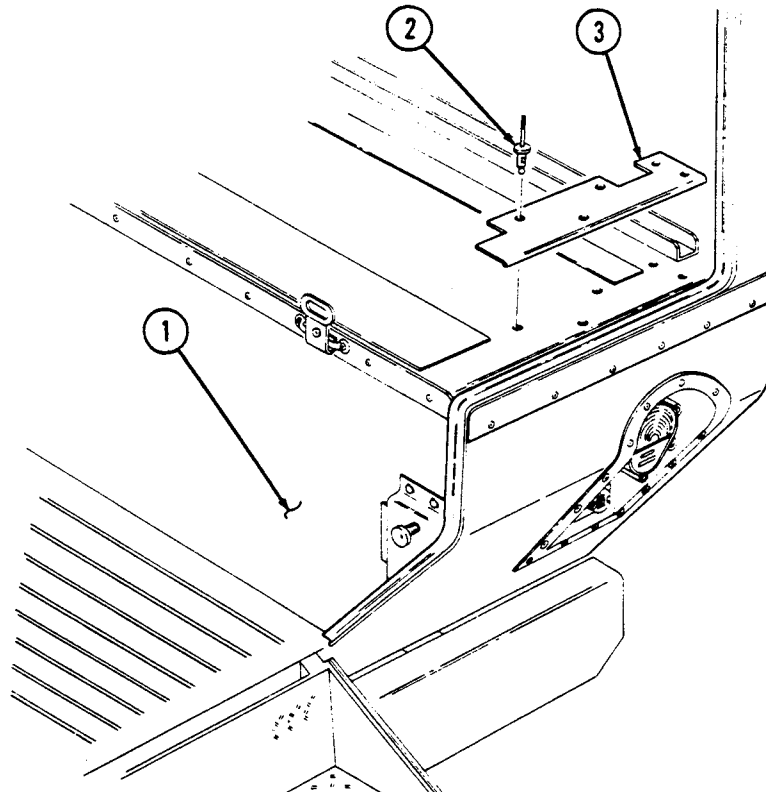

FOLLOW-ON TASK: Close rear doors (TM 9-2320-280-10).

11-130. REAR DOOR SEALS REPLACEMENT

This task covers:

a. Removal

b. Installation

INITIAL SETUP:

Applicable Models

M996, M996A1, M997, M997A1, M997A2

Tools

General mechanic's tool kit:
automotive (Appendix B, Item 1)

Materials/Parts

Two blind rivets (Appendix G, Item 257)

Manual References

TM 9-2320-280-10
TM 9-2320-280-24P

Equipment Condition

- Rear steps lowered (TM 9-2320-280-10).
- Rear door seal protector removed (para. 11-129).

NOTE

For instructions on replacement of rivets, refer to para. 10-66.

a. Removal

1. Pry seal (1) from body channel (2) and remove seal (1).
2. Remove two rivets (5), step seal (3), and retainer (4) from body (6).
3. Pry seal (8) from door (7) and remove plug (9) from seal (8).

b. Installation

1. Install plug (9) into seal (8) and install seal (8) on door (7).
2. Install step seal (3) and retainer (4) on body (6) with two rivets (5).
3. Install seal (1) by seating seal (1) into body channel (2).

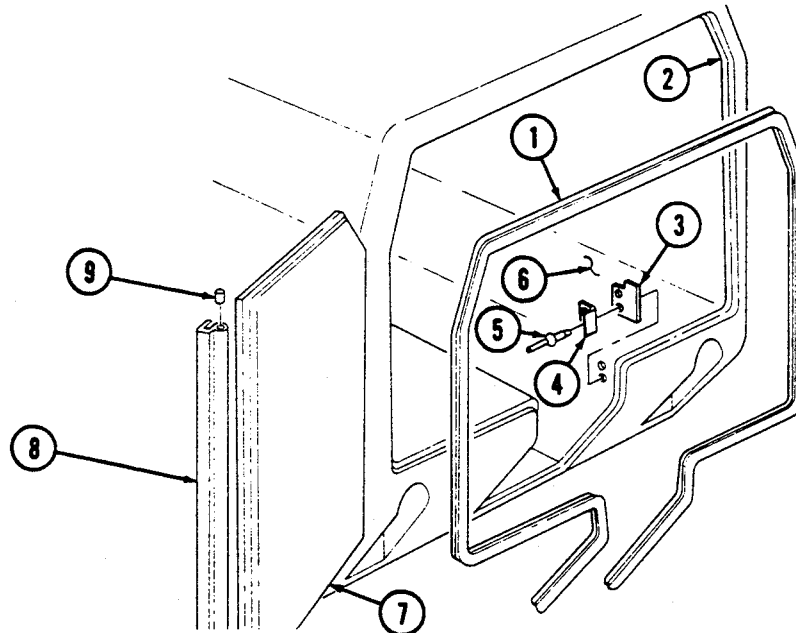

- FOLLOW-ON TASKS:
- Raise rear steps (TM 9-2320-280-10).
 - Install rear door seal protector (para. 11-129).
 - Adjust rear door (para. 11-125).

11-131. REAR DOOR LATCH ROD STRIKER GUIDES AND BRACKETS MAINTENANCE

This task covers:

- | | |
|---|--|
| <ul style="list-style-type: none"> a. Striker Guide Removal b. Striker Guide Installation c. Bracket Removal | <ul style="list-style-type: none"> d. Bracket Installation e. Striker Guide Adjustment |
|---|--|

INITIAL SETUP:

Applicable Models

M996, M996A1, M997, M997A1, M997A2

Tools

General mechanic's tool kit:
automotive (Appendix B, Item 1)

Materials/Parts

Three blind rivets (Appendix G, Item 259)

Manual References

TM 9-2320-280-10
TM 9-2320-280-24P

Equipment Condition

- Rear doors opened (TM 9-2320-280-10).
- Rear door blackout switch bracket removed (para. 4-93).

NOTE

Upper and lower striker guides and brackets are replaced basically the same. This procedure covers the upper striker guide and bracket.

a. Striker Guide Removal

Remove two nuts (7), washers (5), screws (4), washers (5), and striker guide (6) from bracket (2).

b. Striker Guide Installation

1. Install striker guide (6) on bracket (2) with two washers (5), screws (4), washers (5), and nuts (7). Do not tighten nuts (7).
2. Proceed to Adjustment, e.2.

c. Bracket Removal

NOTE

For instructions on replacement of rivets, refer to para. 10-66.

1. Remove striker guide (step a. above).
2. Remove three rivets (3) and bracket (2) from body (1).

d. Bracket Installation

1. Install bracket (2) on body (1) with three rivets (3).
2. Install striker guide (step b. above).

e. Striker Guide Adjustment

1. Check all four striker guides (6) for proper clearance from latch rods (8). Clearance should be 1/8 in. (3 mm) from end of latch rods (8) to surface of striker guides (6). If clearance of any striker guide (6) is not within specifications, loosen two locknuts (7) from striker guide (6) and bracket (2).
2. Install striker guide (6) 1/8 in. (3 mm) from end of latch rod (8), hold in place, and tighten two nuts (7).

11-131. REAR DOOR LATCH ROD STRIKER GUIDES AND BRACKETS
MAINTENANCE (Cont'd)

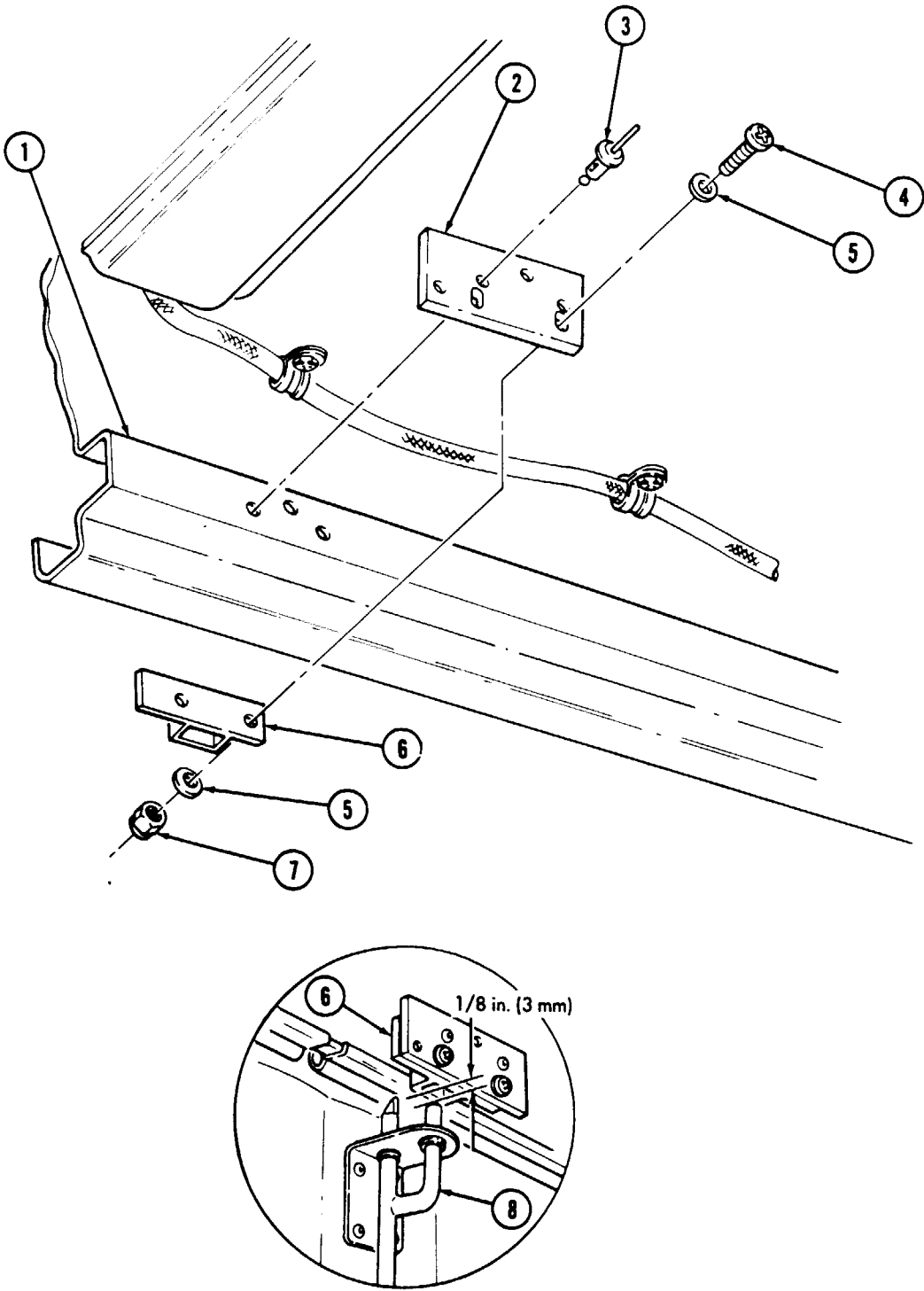

FOLLOW-ON TASKS • Install rear door blackout light switch bracket (para. 4-93).
• Close rear doors (TM 9-2320-280-10).

11-132. REAR DOOR HOLDER ASSEMBLY REPLACEMENT

This task covers:

a. Removal

b. Installation

INITIAL SETUP:

Applicable Models

M996, M996A1, M997, M997A1, M997A2

Tools

General mechanic's tool kit:
automotive (Appendix B, Item 1)

Materials/Parts

Two solid rivets (Appendix G, Item 269) (M996 series)
Two blind rivets (Appendix G, Item 260) (M997 series)

Manual References

TM 9-2320-280-24P

NOTE

- For instructions on replacement of rivets, refer to para. 10-66.
- Holder and guide must be replaced together; both parts are considered to be one assembly.

a. Removal

1. Remove two rivets (1) and guide (2) from door (3).
2. Remove screw (5) and holder (4) from body (6).

b. Installation

1. Install holder (4) on body (6) with screw (5).
2. Install guide (2) on door (3) with two rivets (1).

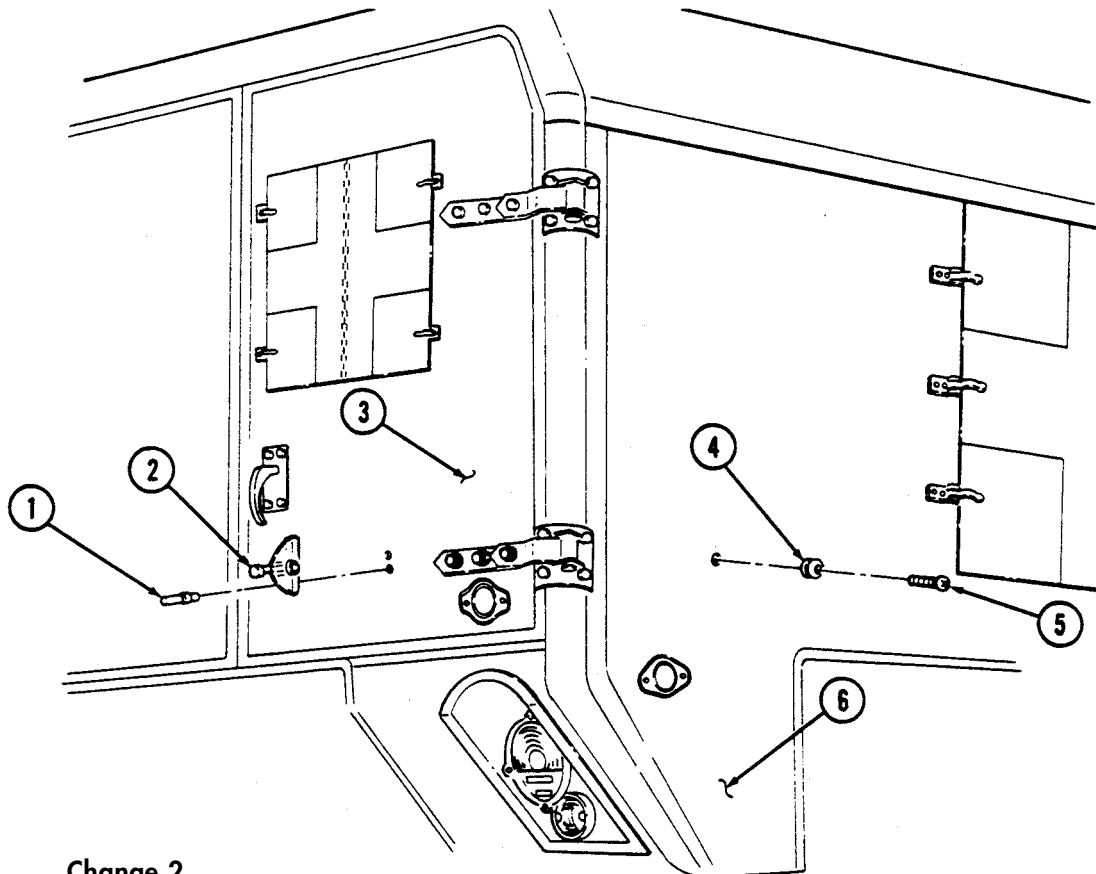

11-133. REAR STEPS HINGE REPLACEMENT

This task covers:

a. Removal

b. Installation

INITIAL SETUP:

Applicable Models

M996, M996A1, M997, M997A1, M997A2

Tools

General mechanic's tool kit:
automotive (Appendix B, Item 1)

Materials/Parts

Two locknuts (Appendix G, Item 79)

Manual References

TM 9-2320-280-10
TM 9-2320-280-24P

Equipment Condition

Rear steps lowered (TM 9-2320-280-10).

a. Removal

1. Remove two locknuts (1), washers (2), capscrews (8), and washers (2) from hinge (5) and rear steps (3). Discard locknuts (1).
2. Remove two capscrews (7), washers (6), and hinge (5) from doorsill (4).

b. Installation

1. Install hinge (5) on doorsill (4) with two capscrews (7) and washers (6). Tighten capscrews (7) to 15 lb-ft (20 N·m).
2. Install hinge (5) on rear steps (3) with two washers (2), capscrews (8), washers (2), and locknuts (1). Tighten locknuts (1) to 15 lb-ft (20 N·m).

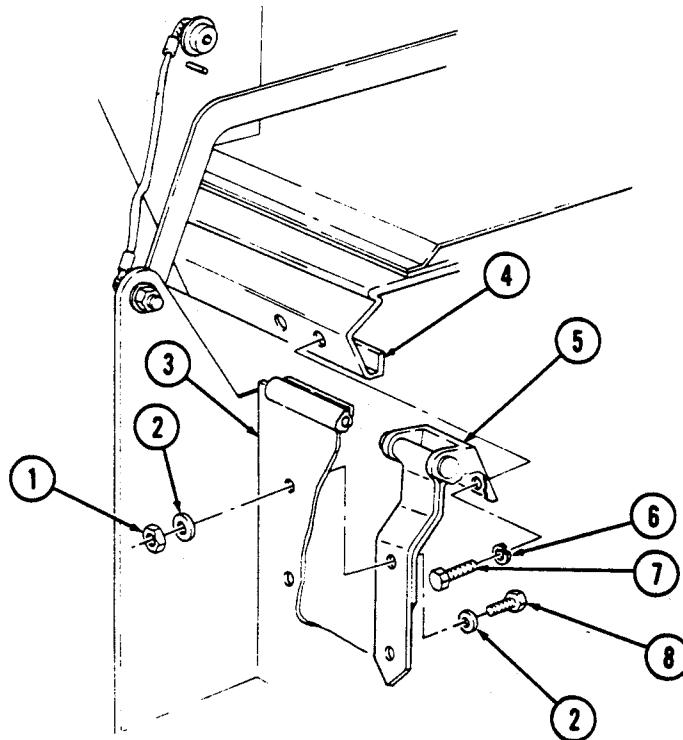

FOLLOW-ON TASK: Raise rear steps (TM 9-2320-280-10).

11-134. REAR STEPS STRIKER AND BRACKET MAINTENANCE

This task covers:

- | | |
|---|--|
| <ul style="list-style-type: none"> a. Striker Removal b. Striker Installation c. Bracket Removal | <ul style="list-style-type: none"> d. Bracket Installation e. Bracket Adjustment |
|---|--|

INITIAL SETUP:

Applicable Models

M996, M996A1, M997, M997A1, M997A2

Tools

General mechanic's tool kit:
automotive (Appendix B, Item 1)

Personnel Required

One mechanic
One assistant

Manual References

TM 9-2320-280-10
TM 9-2320-280-24P

Equipment Condition

Rear steps lowered (TM 9-2320-280-10).

a. Striker Removal

Remove striker (5) from bracket (4).

b. Striker Installation

Install striker (5) on bracket (4). Tighten striker (5) to 60 lb-ft (81 N•m).

c. Bracket Removal

Remove four capscrews (1), washers (2), and bracket (4) from body (3).

d. Bracket Installation

Install bracket (4) on body (3) with four capscrews (1) and washers (2). Do not tighten capscrews (1).

e. Bracket Adjustment

1. Loosen four capscrews (1) from bracket (4) and body (3) on opposite bracket (4) replaced.
2. Raise rear steps (TM 9-2320-280-10) and ensure rear step latches are engaged on strikers (5).
3. Press rear step assembly firmly against body (3), hold in place, and tighten eight capscrews (1) on two brackets (4) and body (3).
4. Lower rear steps (TM 9-2320-280-10). Tighten eight capscrews (1) to 6 lb-ft (8 N•m).

11-134. REAR STEPS STRIKER AND BRACKET MAINTENANCE (Cont'd)

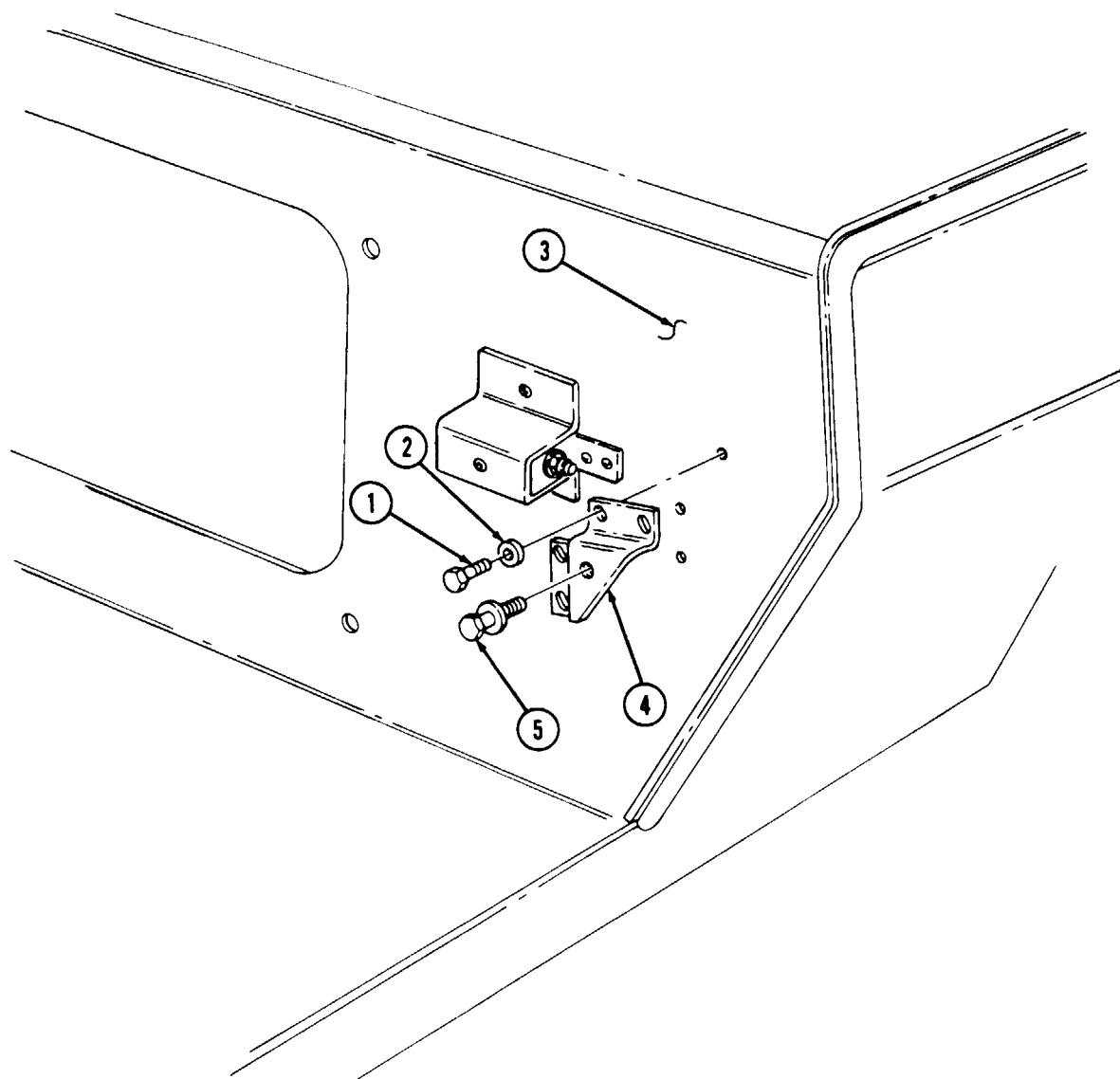

FOLLOW-ON TASK: Raise rear steps (TM 9-2320-280-10).

11-135. REAR STEPS LATCH ASSEMBLY MAINTENANCE

This task covers:

- | | |
|---|---|
| <ul style="list-style-type: none"> a. Removal b. Installation | <ul style="list-style-type: none"> c. Adjustment |
|---|---|

INITIAL SETUP:

Applicable Models

M996, M996A1, M997, M997A1, M997A2

Tools

General mechanic's tool kit:
automotive (Appendix B, Item 1)

Materials/Parts

Three locknuts (Appendix G, Item 70)

Manual References

TM 9-2320-280-10
TM 9-2320-280-24P

Equipment Condition

Rear steps lowered (TM 9-2320-280-10).

NOTE

The procedure for replacing left and right latch assemblies is basically the same. This procedure covers the right latch assembly.

a. Removal

1. Open split ring (7) from release cable (8) and latch (5).
2. Remove three locknuts (2), washers (3), capscrews (6), shim (4), and latch (5) from step frame (9). Discard locknuts (2).

b. Installation

1. Install shim (4) and latch (5) on step frame (9) with three capscrews (6), washers (3), and locknuts (2). Tighten locknuts (2) to 6 lb-ft (8 N•m).
2. Install release cable (8) on latch (5) with split ring (7) and close split ring (7).

c. Adjustment

1. Loosen six locknuts (2) on latch (5) from step frame (9).
2. Raise rear steps (TM 9-2320-280-10) and ensure step latches (5) are engaged on strikers (1).
3. Press rear step assembly firmly against body (10), hold in place, and tighten six locknuts (2) on latches (5) and step frame (9).
4. Lower rear steps (TM 9-2320-280-10) and tighten six locknuts (2) to 6 lb-ft (8 N•m).
5. If latches (5) do not center on strikers (1), add or remove shims (4).

11-135. REAR STEPS LATCH ASSEMBLY MAINTENANCE (Cont'd)

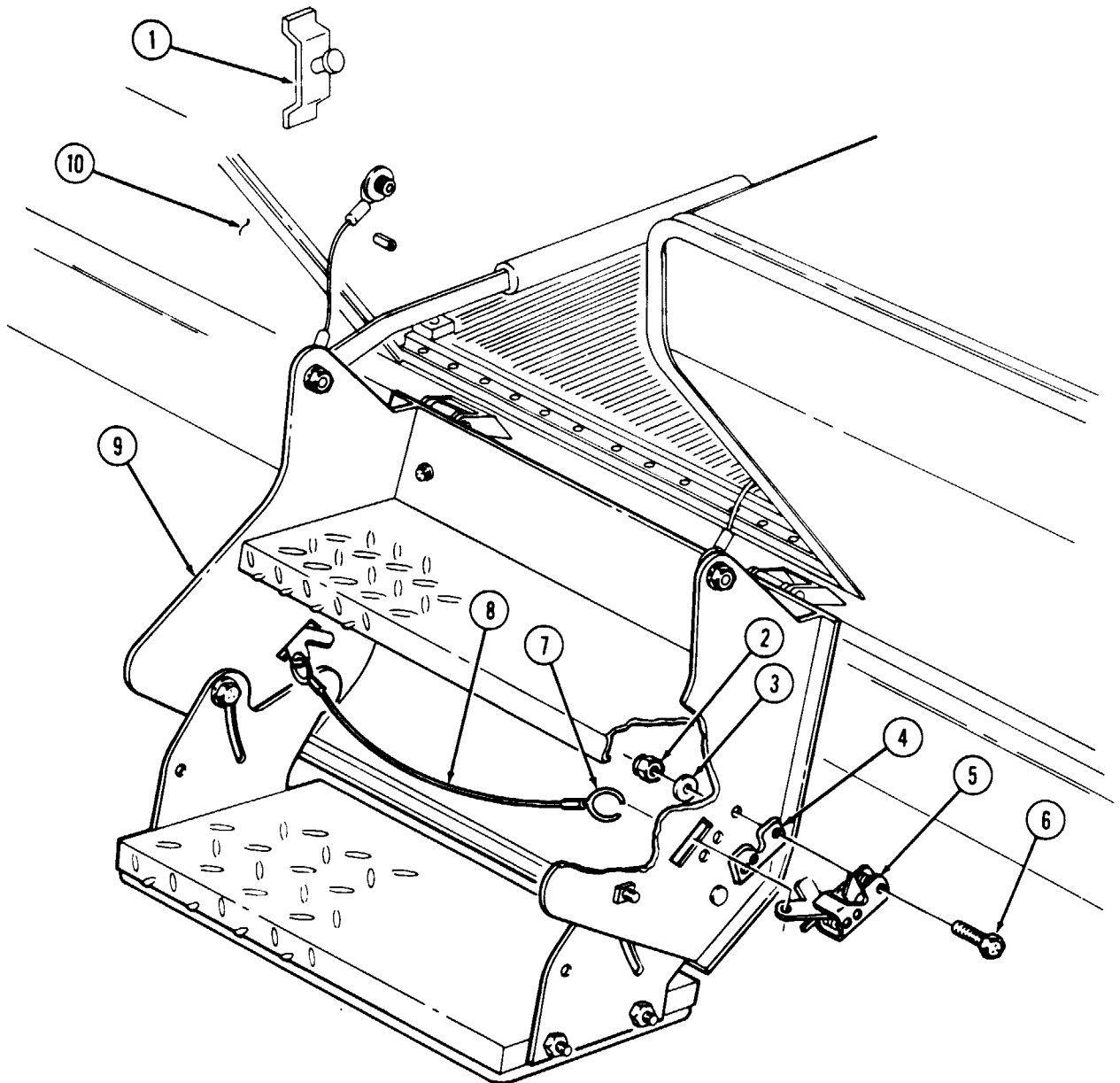

FOLLOW-ON TASK: Raise rear steps (TM 9-2320-280-10).

11-136. REAR STEPS RETAINING CABLE REPLACEMENT

This task covers:

a. Removal

b. Installation

INITIAL SETUP:

Applicable Models

M996, M996A1, M997, M997A1, M997A2

Tools

General mechanic's tool kit:
automotive (Appendix B, Item 1)

Materials/Parts

Two locknuts (Appendix G, Item 128)

Manual References

TM 9-2320-280-10
TM 9-2320-280-24P

Equipment Condition

- Rear steps raised (TM 9-2320-280-10).
- Litter stowage door open (TM 9-2320-280-10).

General Safety Instructions

Rear steps must be raised before disconnecting retractor lever from rear steps.

WARNING

Rear steps must be raised before disconnecting retractor lever from rear steps. Failure to do this may cause injury to personnel and damage to equipment.

NOTE

The procedure for replacing left and right retaining cables are basically the same. This procedure covers the left retaining cable.

a. Removal

1. Remove locknut (6), washer (7), socket head screw (11), large washer (10), retaining cable (3), and retractor lever (9) from rear steps (8). Discard locknut (6).
2. Lower rear steps (TM 9-2320-280-10).
3. Remove locknut (1), washer (2), socket head screw (5), large washer (4), and retaining cable (3) from body (12). Discard locknut (1).

b. Installation

1. Install retaining cable (3) on body (12) with large washer (4), socket head screw (5), washer (2), and locknut (1). Tighten screw (5) to 37 lb-ft (50 N•m).
2. Raise rear steps (TM 9-2320-280-10).
3. Install retractor lever (9) and retaining cable (3) on rear steps (8) with large washer (10), socket head screw (11), washer (7), and locknut (6). Tighten screw (11) to 31 lb-ft (42 N•m).

11-136. REAR STEPS RETAINING CABLE REPLACEMENT (Cont'd)

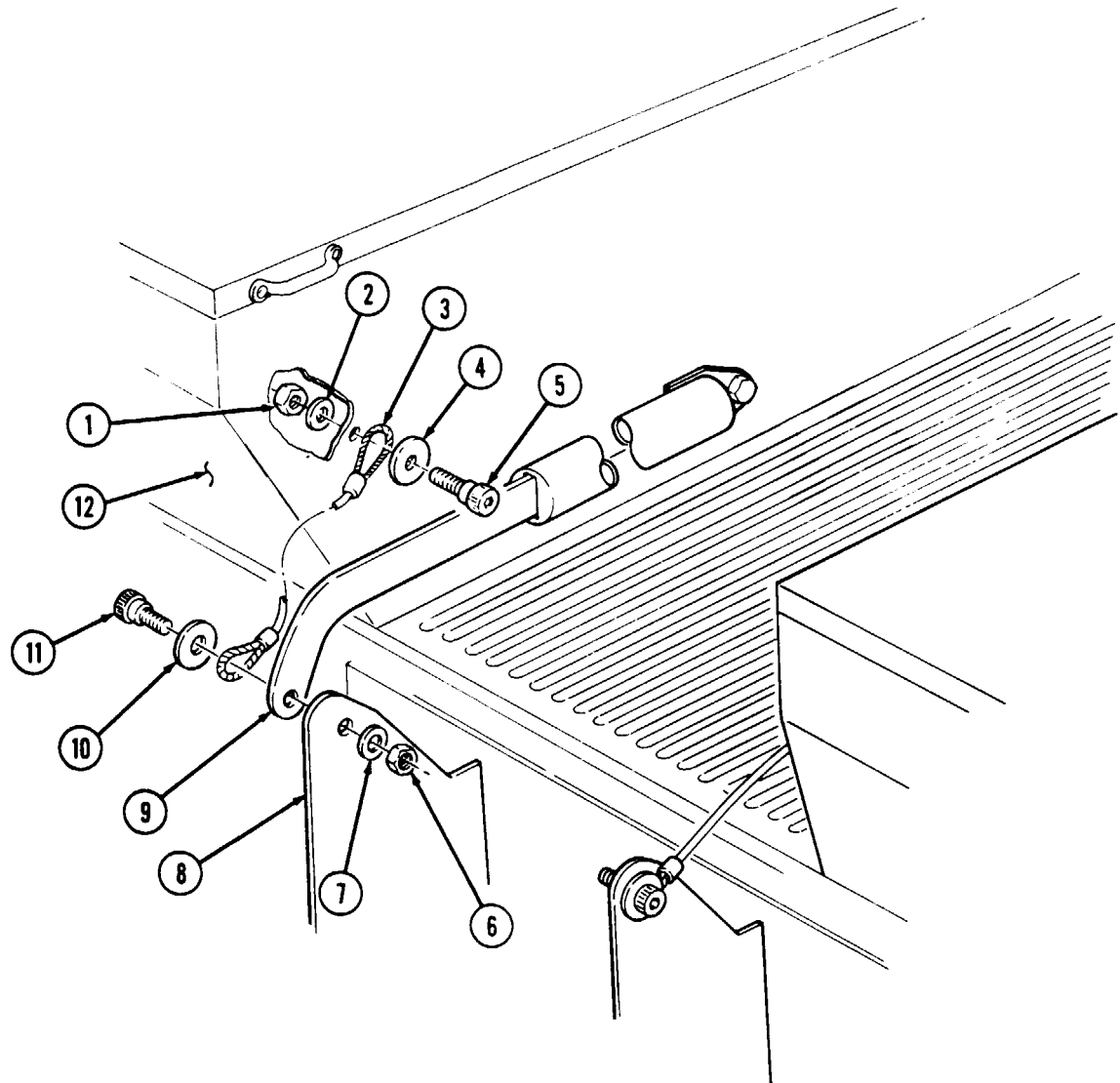

FOLLOW-ON TASK: Close litter stowage door (TM 9-2320-280-10).

11-137. REAR STEPS RETRACTOR REPLACEMENT

This task covers:

a. Removal

b. Installation

INITIAL SETUP:

Applicable Models

M996, M996A1, M997, M997A1, M997A2

Tools

General mechanic's tool kit:
automotive (Appendix B, Item 1)

Materials/Parts

Two locknuts (Appendix G, Item 128)

Manual References

TM 9-2320-280-10
TM 9-2320-280-24P

Equipment Condition

- Rear steps raised (TM 9-2320-280-10). M997, M997A1, and M997A2 only:
- Litter rail extension and litters removed from stowage compartment (TM 9-2320-280-10).

General Safety Instructions

Rear steps must be raised before disconnecting retractor lever from rear steps.

WARNING

Rear steps must be raised before disconnecting retractor lever from rear steps. Failure to do this may cause injury to personnel and damage to equipment.

NOTE

The procedure for replacing rear steps retractor is similar for M996, M996A1, M997, M997A1, and M997A2 ambulances.

a. Removal

1. Remove locknut (9), washer (11), socket head screw (1), large washer (2), retractor (8), and retaining cable (3) from rear steps (10). Discard locknut (9).
2. Lower rear steps (TM 9-2320-280-10).
3. Remove locknut (5), washer (6), capscrew (7), and retractor (8) from body (4). Discard locknut (5).

b. Installation

1. Install retractor (8) and retaining cable (3) on rear steps (10) with large washer (2), socket head screw (1), washer (11), and locknut (9). Tighten screw (1) to 31 lb-ft (42 N•m).
2. Raise rear steps (TM 9-2320-280-10).
3. Install retractor (8) on body (4) with capscrew (7), washer (6), and locknut (5). Tighten capscrew (7) to 37 lb-ft (50 N•m).

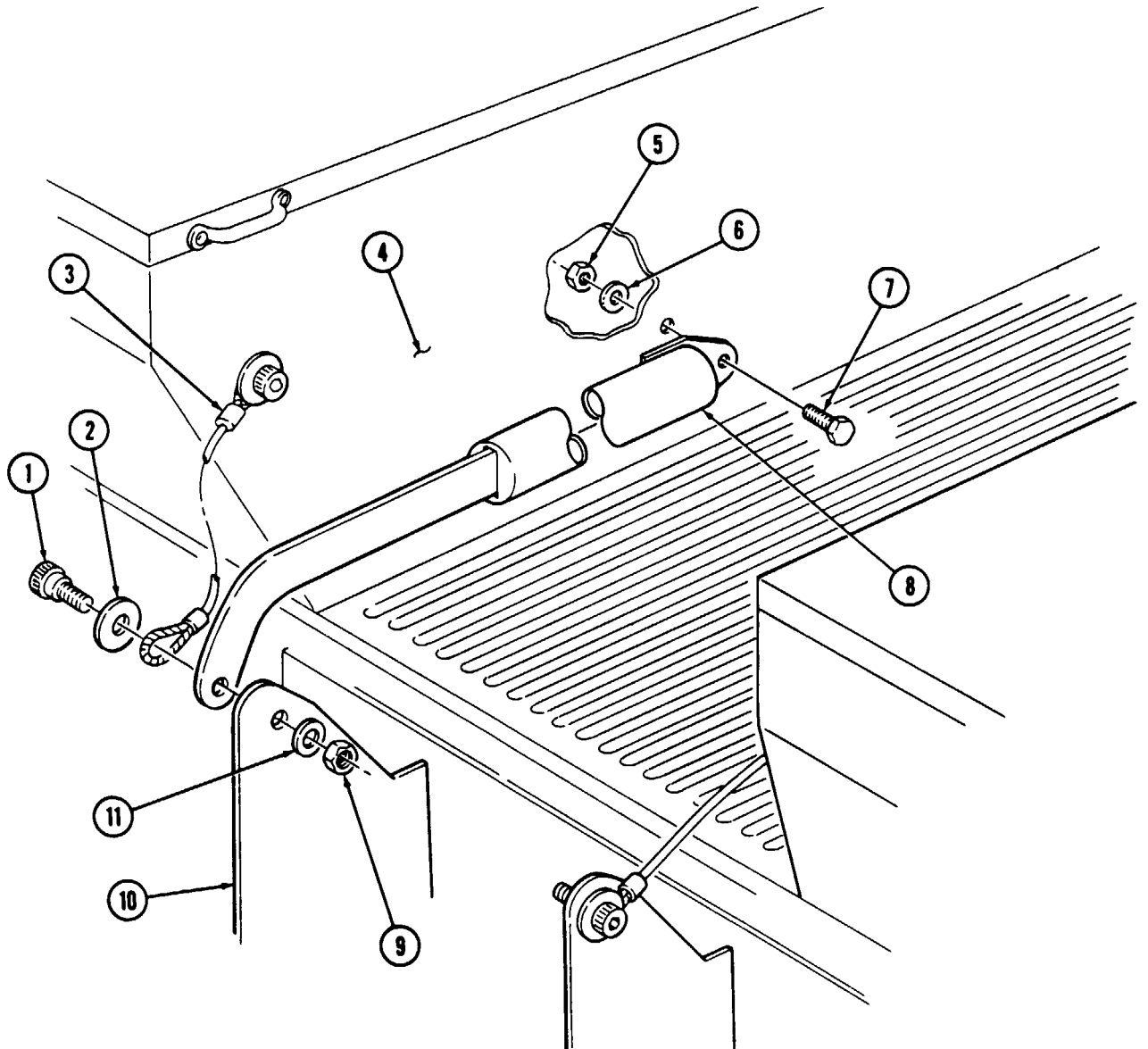
11-137. REAR STEPS RETRACTOR REPLACEMENT (Cont'd)

FOLLOW-ON TASK: M997, M997A1, and M997A2 only

Install litter rail extension and litters in stowage compartment (TM 9-2320-280-10).

11-138. REAR STEPS MAINTENANCE

This task covers:

- | | |
|--|--|
| <ul style="list-style-type: none"> a. Removal b. Disassembly | <ul style="list-style-type: none"> c. Assembly d. Installation |
|--|--|

INITIAL SETUP:

Applicable Models

M996, M996A1, M997, M997A1, M997A2

Tools

General mechanic's tool kit:
automotive (Appendix B, Item 1)

Materials/Parts

Adhesive (Appendix C, Item 3)
Ten locknuts (Appendix G, Item 128)
Four locknuts (Appendix G, Item 79)
Three cotter pins (Appendix G, Item 16)
Cotter pin (Appendix G, Item 25)
Six blind rivets (Appendix G, Item 259)
Two blind rivets (Appendix G, Item 250)

Personnel Required

One mechanic
One assistant

Manual References

TM 9-2320-280-10
TM 9-2320-280-24P

Equipment Condition

Rear steps raised (TM 9-2320-280-10).

General Safety Instructions

Rear steps must be raised before disconnecting retractor lever from rear steps.

WARNING

Rear steps must be raised before disconnecting retractor lever from rear steps. Failure to do this may cause injury to personnel and damage to equipment.

a. Removal

1. Remove two locknuts (5), washers (4), socket head screws (6), large washers (7), retaining cables (8), and retractor lever (9) from rear step (3). Discard locknuts (5).
2. Lower rear steps (TM 9-2320-280-10).
3. Remove rear steps latches (para. 11-135).
4. Remove four locknuts (1), washers (2), capscrews (11), washers (12), and rear step (3) from two hinges (10). Discard locknuts (1).

11-138. REAR STEPS MAINTENANCE(Cont'd)

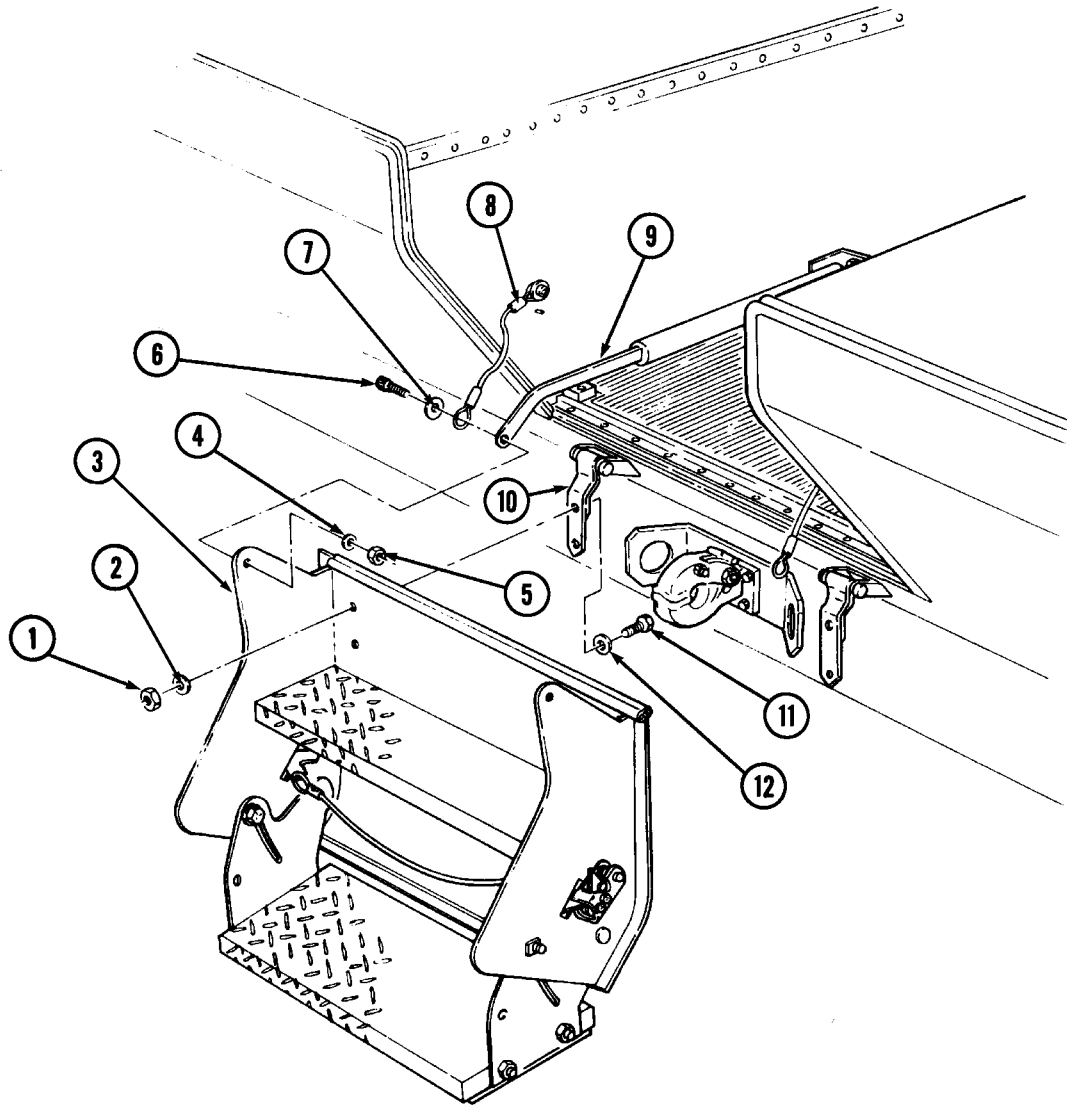

11-138. REAR STEPS MAINTENANCE (Cont'd)

NOTE

For instructions on replacement of rivets, refer to para. 10-66.

b. Disassembly

1. If damaged, remove two rubber seals (25), from sides of step frame (2).
2. Remove two seals (1) from edges of step frame (2).
3. Remove four screws (20) from seat (18) and lower tread plate (19), and pry up on seat (18) to remove from tread plate (19). Clean remaining adhesive from lower tread plate (19).
4. Remove four locknuts (6), washers (5), capscrews (12), washers (5), and upper tread plate (21) from step frame (2). Discard locknuts (6).
5. Remove four locknuts (14), washers (15), capscrews (17), washers (15), and lower tread plate (19) from step frame (2) and two side plates (16). Discard locknuts (14).

NOTE

Cotter pins and washers may not be installed on all vehicles.

6. Remove cotter pin (23), washer (24), and knob (22) from side plate (16) and step frame (2). Discard cotter pin (23).
7. Remove three cotter pins (7), washers (9), spring washers (10), clevis pins (13), and washers (9) from two side plates (16) and step frame (2). Discard cotter pins (7).
8. Remove two rivets (3) and angle bracket (4) from step frame (2).
9. Remove six rivets (11) and two latch striker guide support brackets (8) from step frame (2).

c. Assembly

1. Install two latch striker guide support brackets (8) on step frame (2) with six rivets (11).
2. Install angle bracket (4) on step frame (2) with two rivets (3).

NOTE

Cotter pins and washers may not be installed on all vehicles.

3. Install two side plates (16) on step frame (2) with three washers (9), clevis pins (13), spring washers (10), washers (9), and cotter pins (7).
4. Install side plate (16) on step frame (2) with knob (22), washer (24), and cotter pin (23).
5. Install upper tread plate (21) on step frame (2) with four washers (5), capscrews (12), washers (5), and locknuts (6). Tighten locknuts (6) to 26 lb-ft (35 N•m).
6. Install lower tread plate (19) on side plates (16) with four washers (15), capscrews (17), washers (15), and locknuts (14). Tighten locknuts (14) to 26 lb-ft (35 N•m).
7. Apply adhesive to back of seat (18). Install seat (18) on lower tread plate (19) with four screws (20).
8. Install two seals (1) on edges of step frame (2).
9. Install two rubber seals (25) on step frame (2) sides, if removed.

11-138. REAR STEPS MAINTENANCE (Cont'd)

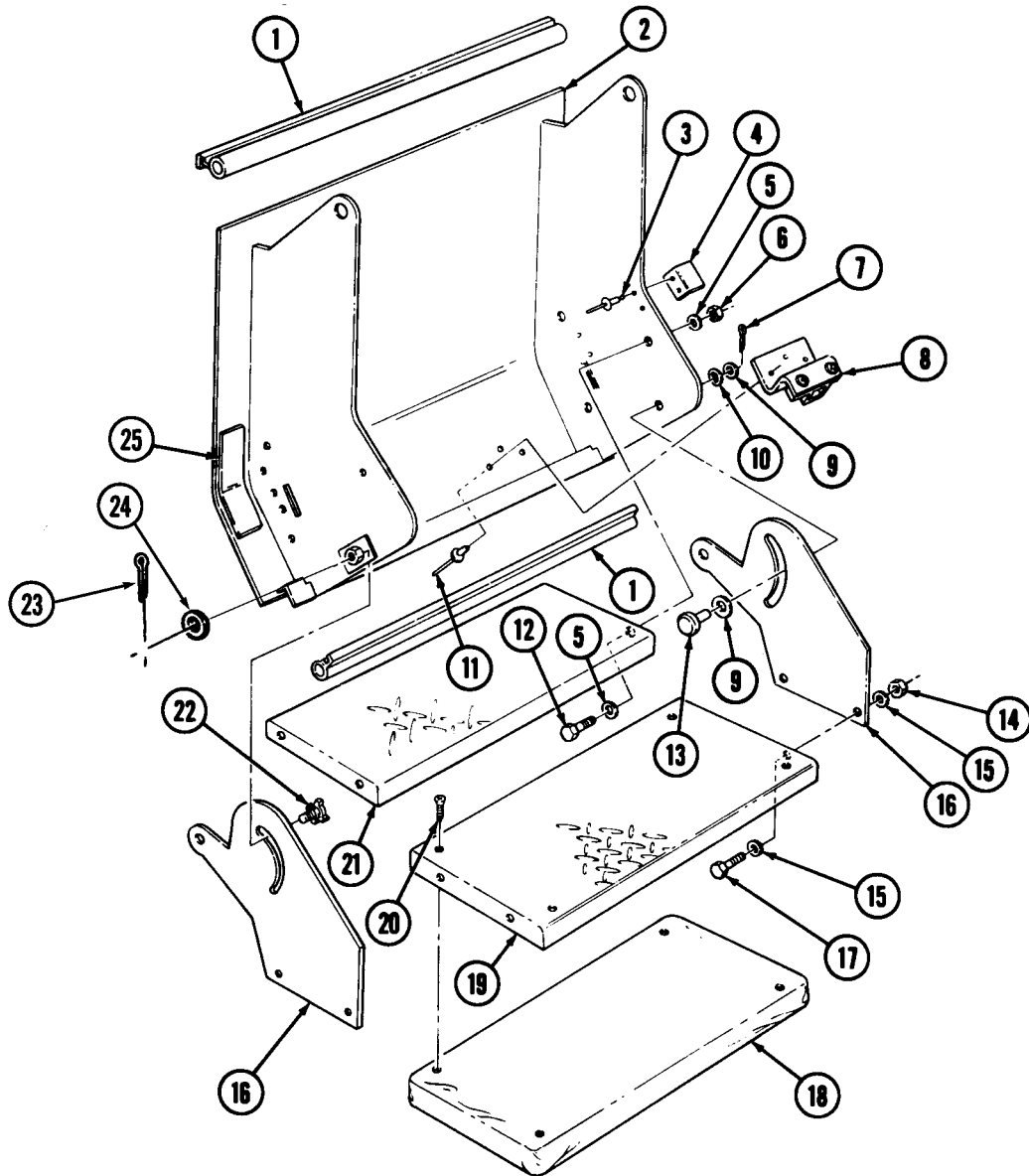

11-138. REAR STEPS MAINTENANCE (Cont'd)

d. Installation

1. Install rear step (6) on two hinges (11) with four washers (5), capscrews (4), washers (8), and locknuts (7). Raise steps and push in and down on steps while tightening capscrews (4).
2. Lower steps (TM 9-2320-280-10) and tighten locknuts (7) to 15 lb-ft (20 N·m).
3. Install and adjust rear step latches (para. 11-135).
4. Raise rear steps (TM 9-2320-280-10).
5. Install retractor lever (3) and two retaining cables (2) on rear step (6) with two large washers (1), socket-head screws (12), washers (9), and locknuts (10). Tighten screws (12) to 31 lb-ft (42 N·m).

11-138. REAR STEPS MAINTENANCE (Cont'd)

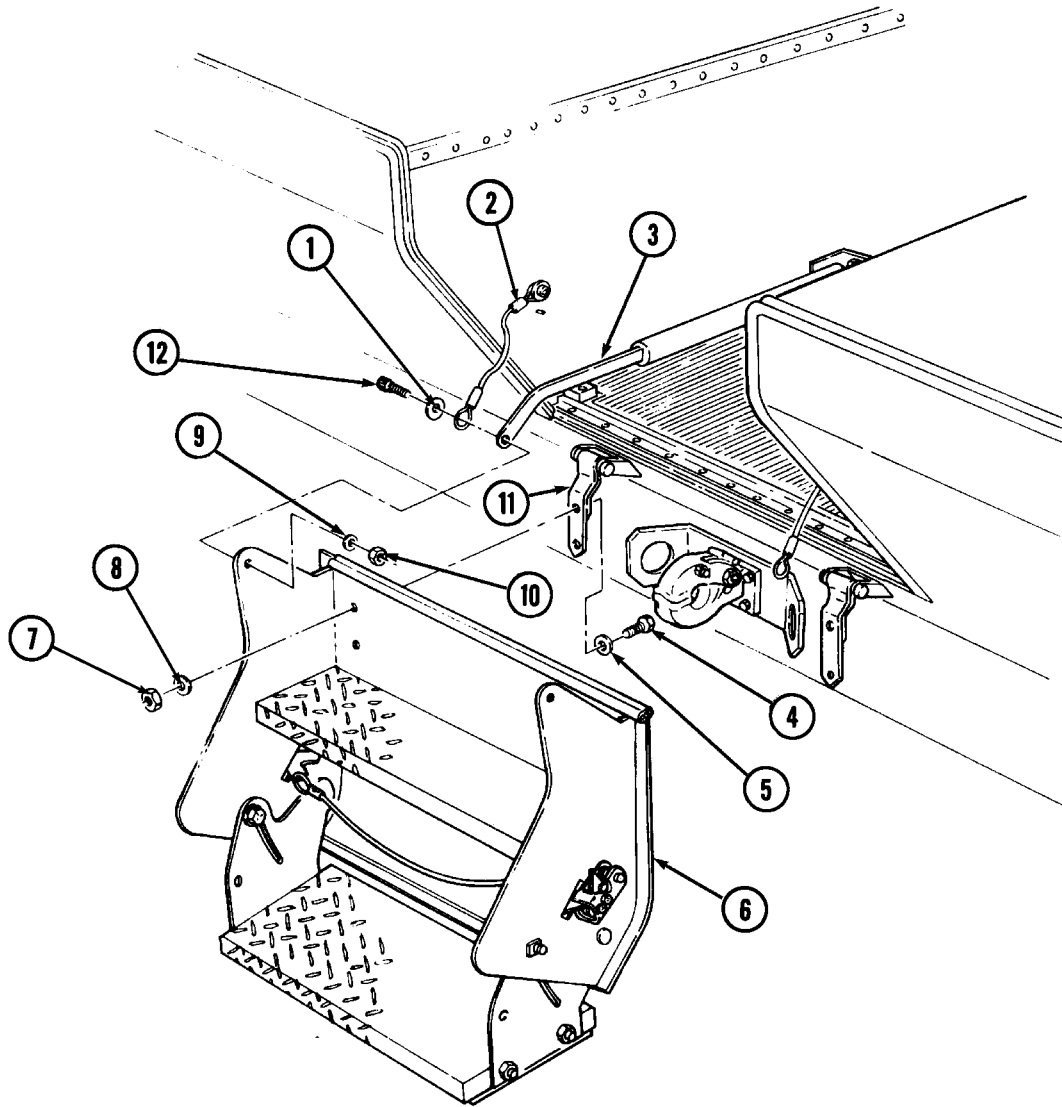

11-139. UPPER LITTER RACK STRIKER REPLACEMENT

This task covers:

a. Removal

b. Installation

INITIAL SETUP:

Applicable Models

M997, M997A1, M997A2

Tools

General mechanic's tool kit
automotive (Appendix B, Item 1)

Manual References

TM 9-2320-280-10
TM 9-2320-280-24P

Equipment Condition

Upper litter rack placed in backrest position
(TM 9-2320-280-10).

a. Removal

Remove nut (1) and striker (2) from support (3).

b. Installation

Install striker (2) on support (3) with nut (1).

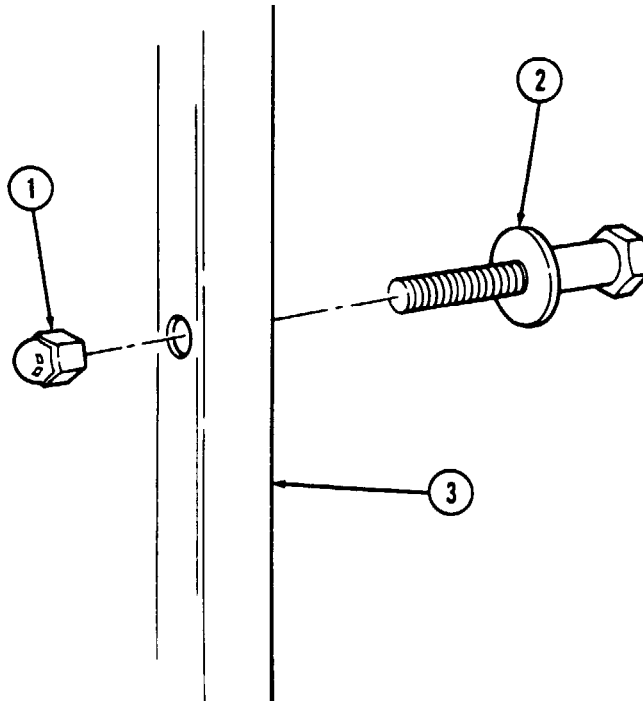

FOLLOW-ON TASK: Raise upper litter rack (TM 9-2320-280-10).

11-140. UPPER LITTER RACK REPLACEMENT

This task covers:

a. Removal

b. Installation

INITIAL SETUP:

Applicable Models

M997, M997A1, M997A2

Manual References

TM 9-2320-280-10

TM 9-2320-280-24P

Tools

General mechanic's tool kit:
automotive (Appendix B, Item 1)

Equipment Condition

Upper litter rack placed in the backrest position
(TM 9-2320-280-10).

a. Removal

1. Remove two hitch pins (4), washers (5), retaining pins (2), four nylon washers (6), and upper litter rack (1) from front and middle support brackets (3).
2. Release latch lock (8) and latch (9), and remove upper litter rack (1) from rear litter bracket (7) and ambulance body (10).

b. Installation

1. Install upper litter rack (1) on ambulance body (10) and rear litter bracket (7) by locking latch (9) and latch lock (8).
2. Install upper litter rack (1) on front and middle support brackets (3) with four nylon washers (6), two retaining pins (2), washers (5), and hitch pins (4).

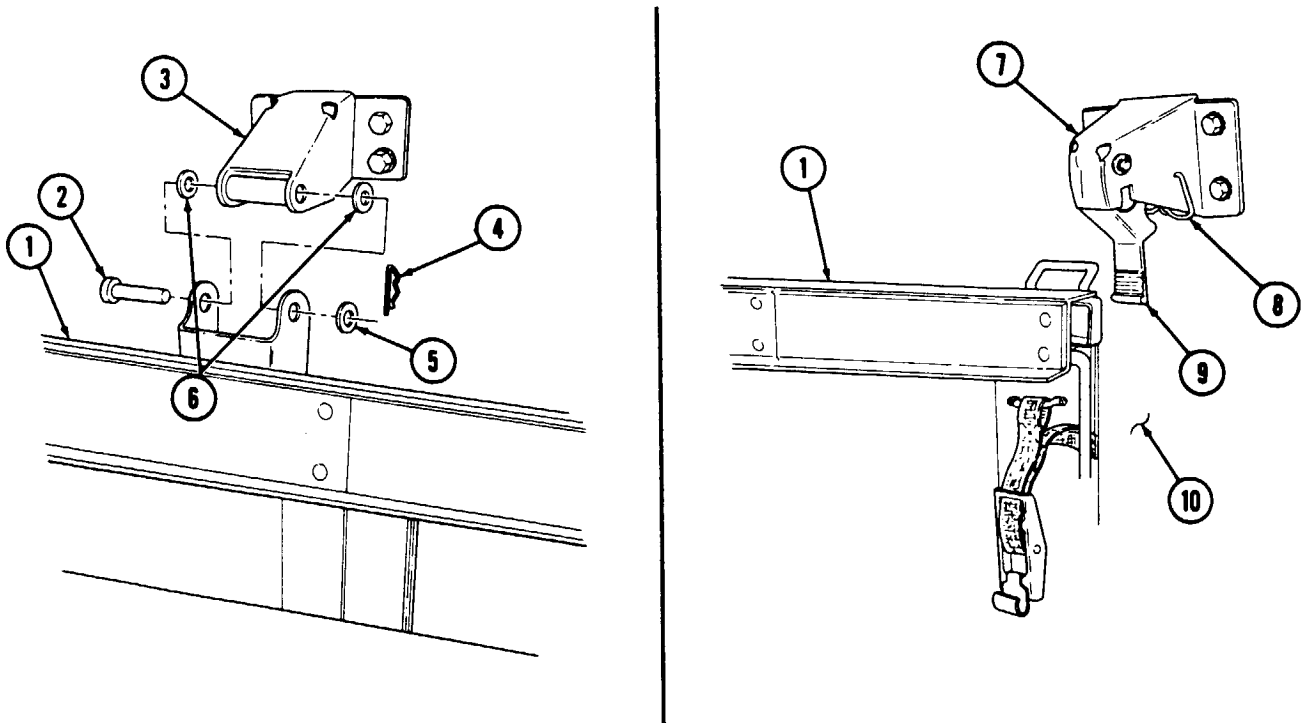

FOLLOW-ON TASK: Raise upper litter rack (TM 9-2320-280-10).

11-141. UPPER LITTER RACK STRIKER SUPPORT BRACKETS REPLACEMENT

This task covers:

a. Removal

b. Installation

INITIAL SETUP:

Applicable Models

M997, M997A1, M997A2

Manual References

TM 9-2320-280-24P

Tools

General mechanic's tool kit:
automotive (Appendix B, Item 1)

Equipment Condition

Upper litter rack striker removed (para. 11-139).

Materials/Parts

Two blind rivets (Appendix G, Item 260)
Four blind rivets (Appendix G, Item 259)
Eight blind rivets (Appendix G, Item 244)

NOTE

For instructions on replacement of rivets, refer to para. 10-66.

a. Removal

1. Remove two rivets (8) from upper bracket (1) and roof (2).
2. Remove four rivets (5) and support (3) with brackets (1) and (6) from roof (2) and body (4).
3. Remove four rivets (9) and upper bracket (1) from support (3).
4. Remove four rivets (7) and lower bracket (6) from support (3).

b. Installation

1. Install lower bracket (6) on support (3) with four rivets (7).
2. Install upper bracket (1) on support (3) with four rivets (9).
3. Install upper bracket (1) and support (3) on roof (2) with two rivets (8).
4. Install lower bracket (6) and support (3) on body (4) with four rivets (5).

11-141. UPPER LITTER RACK STRIKER SUPPORT BRACKETS REPLACEMENT (Cont'd)

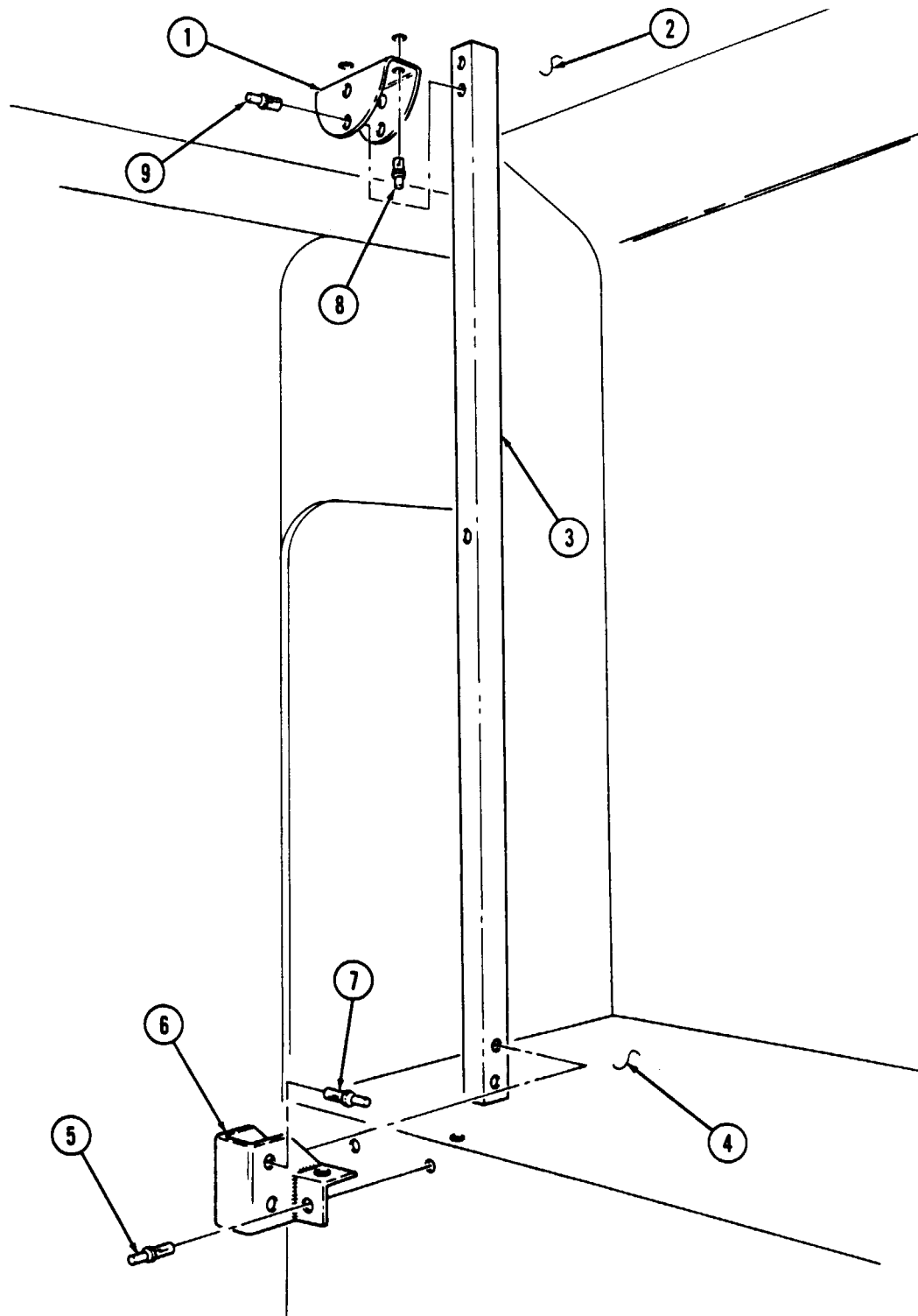

FOLLOW-ON TASK: Install upper litter rack striker (para. 11-139).

11-142. UPPER LITTER RACK LATCH MAINTENANCE

This task covers:

- a. Removal
- c. Adjustment
- b. Installation

INITIAL SETUP:

Applicable Models

M997, M997A1, M997A2

Tools

General mechanic's tool kit:
automotive (Appendix B, Item 1)

Materials/Parts

Three locknuts (Appendix G, Item 70)

Manual References

TM 9-2320-280-10
TM 9-2320-280-24P

Equipment Condition

Upper litter rack placed in backrest position (TM 9-2320-280-10).

a. Removal

Remove three locknuts (4), capscrews (3), and latch (2) from litter rack (1). Discard locknuts (4).

b. Installation

Install latch (2) on litter rack (1) with three capscrews (3) and locknuts (4). Do not tighten capscrews (3).

c. Adjustment

1. Raise upper litter rack (1) (TM 9-2320-280-10), and ensure latch (2) is engaged on striker.
2. Hold litter rack (1) in place, and tighten three capscrews (3) to 10 lb-ft (14 N•m).

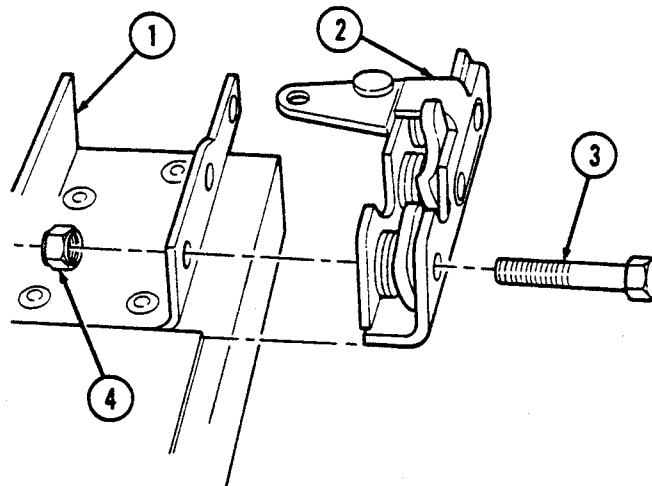

11-143. UPPER LITTER RACK LATCH BRACKET REPLACEMENT

This task covers:

a. Removal

b. Installation

INITIAL SETUP:

Applicable Models

M997, M997A1, M997A2

Manual References

TM 9-2320-280-24P

Tools

General mechanic's tool kit:
automotive (Appendix B, Item 1)

Equipment Condition

Upper litter rack latch removed (para. 11-142).

Materials/Parts

Four blind rivets (Appendix G, Item 244)

NOTE

For instructions on replacement of rivets, refer to para. 10-66.

a. Removal

Remove four rivets (2) and bracket (1) from upper litter tray (3).

b. Installation

Install bracket (1) on upper litter tray (3) with four rivets (2).

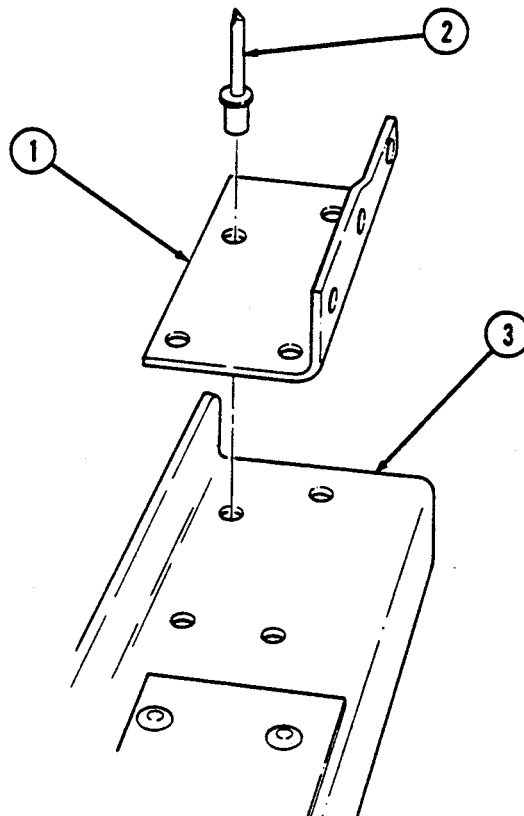

FOLLOW-ON TASK: Install upper litter rack latch (para. 11-142).

11-144. UPPER LITTER RACK SUPPORT BRACKET REPLACEMENT

This task covers:

a. Removal

b. Installation

INITIAL SETUP:

Applicable Models

M997, M997A1, M997A2

Tools

General mechanic's tool kit:
automotive (Appendix B, Item 1)

Materials/Parts

Four lockwashers (Appendix G, Item 134)

Manual References

TM 9-2320-280-10
TM 9-2320-280-24P

Equipment Condition

Upper litter rack placed in backrest position
(TM 9-2320-280-10).

a. Removal

1. Remove hitch pin (5), washer (7), retaining pin (9), two nylon washers (6), and litter rack (8) from support bracket (3).
2. Remove four capscrews (1), lockwashers (2), and support bracket (3) from body (4). Discard lockwashers (2).

b. Installation

1. Install support bracket (3) on body (4) with four lockwashers (2) and capscrews (1). Tighten capscrews (1) to 21 lb-ft (29 N·m).
2. Install litter rack (8) on support bracket (3) with two nylon washers (6), retaining pin (9), washer (7), and hitch pin (5).

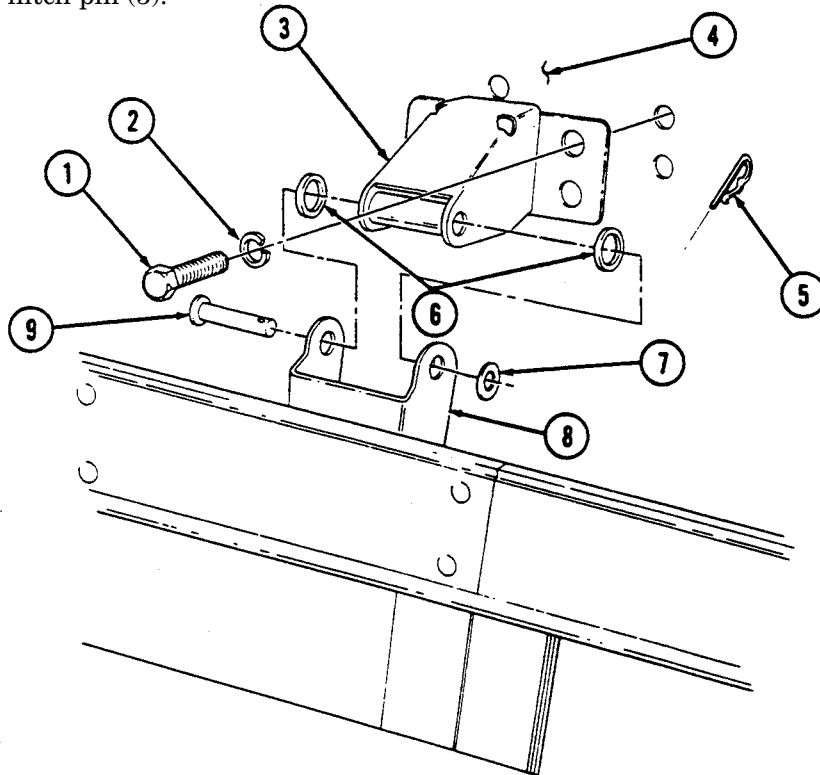

FOLLOW-ON TASK: Raise litter rack (TM 9-2320-280-10).

11-145. UPPER LITTER RACK STRAP AND RING REPLACEMENT

This task covers:

a. Removal

b. Installation

INITIAL SETUP:

Applicable Models

M997, M997A1, M997A2

Tools

General mechanic's tool kit:
automotive (Appendix B, Item 1)

Materials/Parts

Two lockwashers (Appendix G, Item 135)

Materials/Parts (Cont'd)

Two plain-assembled nuts (Appendix G, Item 201)
Two capscrews (Appendix G, Item 9)
Two solid rivets (Appendix G, Item 270)

Manual References

TM 9-2320-280-24P

Equipment Condition

Remove duct assembly (para. 4-103).

a. Removal

1. Remove two capscrews (4), lockwashers (3), and strap bracket (2) from roof (1). Discard lockwashers (3).
2. Remove strap (5) from upper litter rack (6).

NOTE

- Some vehicles may have capscrews and plain-assembled nuts instead of rivets securing the ring assembly.
- For replacement of rivets, refer to para. 10-66.

3. Remove two rivets (8) and ring assembly (9) from upper litter rack (6).

b. Installation

1. Install ring assembly (9) on upper litter rack (6) with two capscrews (7) and plain-assembled nuts (10).
2. Install strap bracket (2) on roof (1) with two lockwashers (3) and capscrews (4). Tighten capscrews (4) to 10 lb-ft (14 N·m).
3. Connect strap (5) to upper litter rack (6) and tighten strap (5) to support upper litter rack (6).

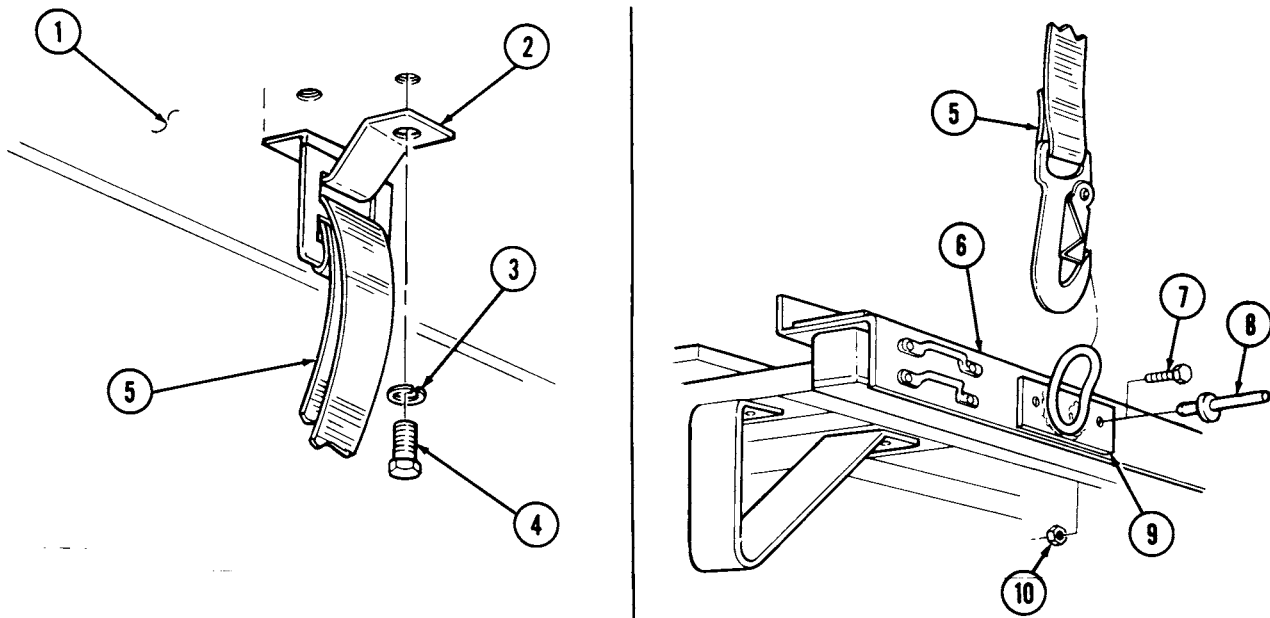

FOLLOW-ON TASK: Install duct assembly (para. 4-103).

11-145.1. LITTER SKID TRACKS EDGE TRIM REPLACEMENT

This task covers:

a. Removal

b. Installation

INITIAL SETUP:

Applicable Models

M996, M996A1, M997, M997A1, M997A2,
M1035, M1035A1, M1035A2

Materials/Parts

Sealant, RTV (Appendix C, Item 3)

Tools

General mechanic's tool kit:
automotive (Appendix B, Item 1)

Manual References

TM 9-2320-280-24P

NOTE

- No NSN is assigned to edge trim. It will need to be ordered directly from the vendor (2L480). The part number (SD1276) is for 500-feet (150 m) bulk edging. When ordering, specify how many feet are needed.
- M996 and M996A1 vehicles require approximately 30 ft (19 m) of trim; M997, M997A1, and M997A2 vehicles require approximately 58 ft (18 m) of trim; and M1035, M1035A1, and M1035A2 vehicles require approximately 59 ft (18 m) of trim.

a. Removal

1. Remove edge trim (2) from track edge (3).
2. Clean any remaining adhesive from track edge (3).

b. Installation

NOTE

- Edge trim must be cut to allow for interferences along tracks.
 - Edge trim length must be shortened .50 in. (12.7 mm) at each end to allow room for adhesive sealant application.
1. Measure length of skid track (1) and cut edge trim (2) to size.

NOTE

To prevent drying of adhesive sealant before edge trim can be installed, install edge trim to only one track at a time.

2. Apply thin bead of adhesive sealant along full length of litter skid track edge (3).

NOTE

When installing edge trim sections on litter track edges, ensure grip is positioned on outside of track edge to prevent edge trim from loosening when litter is being used.

3. Install edge trim (2) on track edge (3).
4. Apply adhesive sealant to ends of edge trim (2) and smooth between track (1) and edge trim (2).

11-145.1. LITTER SKID TRACKS EDGE TRIM REPLACEMENT (Cont'd)

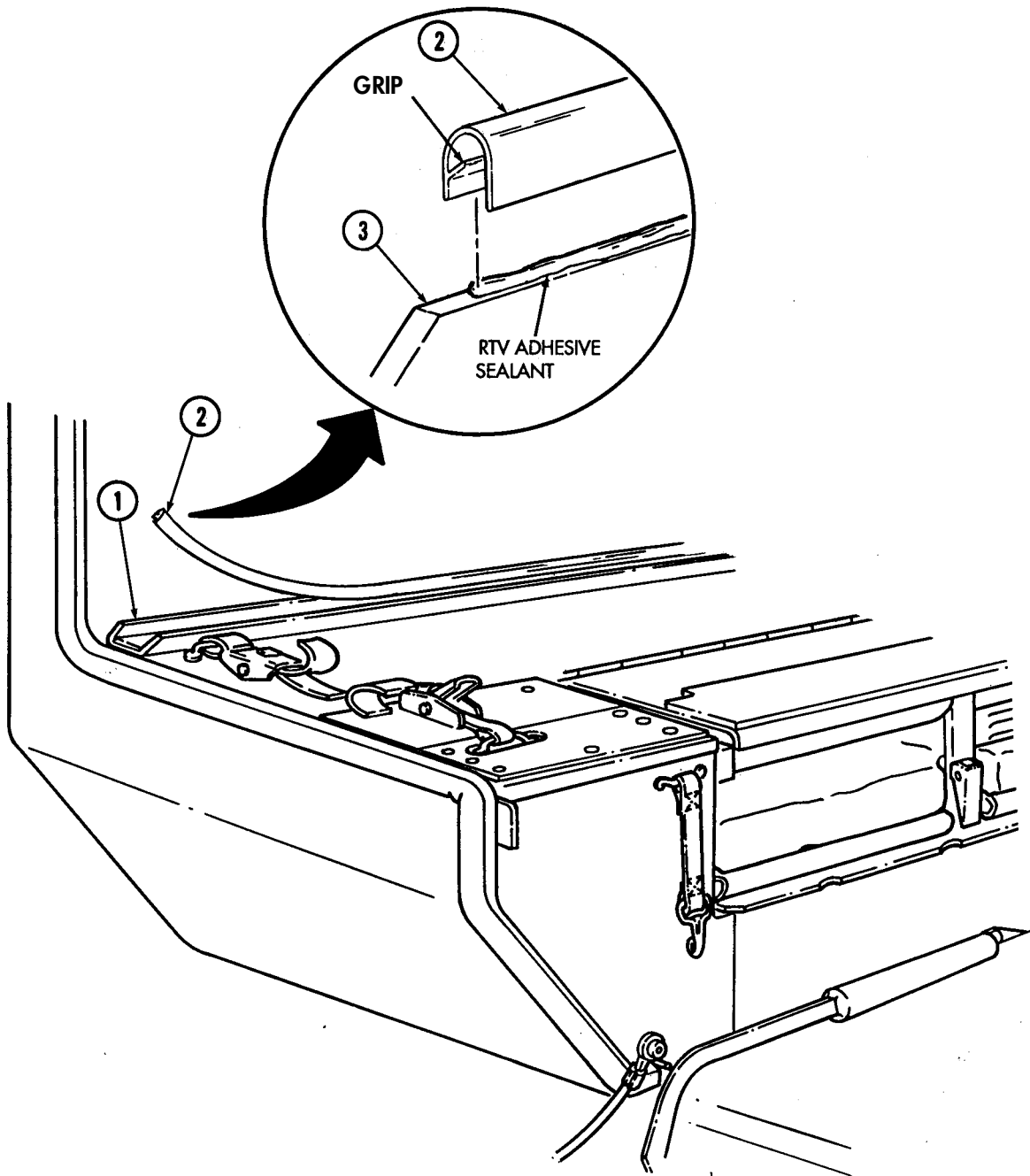

11-146. LITTER SKID PAD REPLACEMENT

This task covers:

a. Removal

b. Installation

INITIAL SETUP:

Applicable Models

M996, M996A1, M997, M997A1, M997A2

Manual References

TM 9-2320-280-24P

Tools

General mechanic's tool kit:
automotive (Appendix B, Item 1)

Equipment Condition

Litter strap removed (para. 11-160).

Materials/Parts

Nineteen blind rivets (Appendix G, Item 261)

NOTE

- Skid pads are removed and installed basically the same for both M996, M996A1, M997, M997A1, and M997A2 ambulances. This procedure covers lower skid pad replacement for M997, M997A1, and M997A2 ambulances.
- For instructions on replacement of rivets, refer to para. 10-66.

a. Removal

Remove nineteen rivets (2) and skid pad (3) from body (1).

b. Installation

Install skid pad (3) on body (1) with nineteen rivets (2).

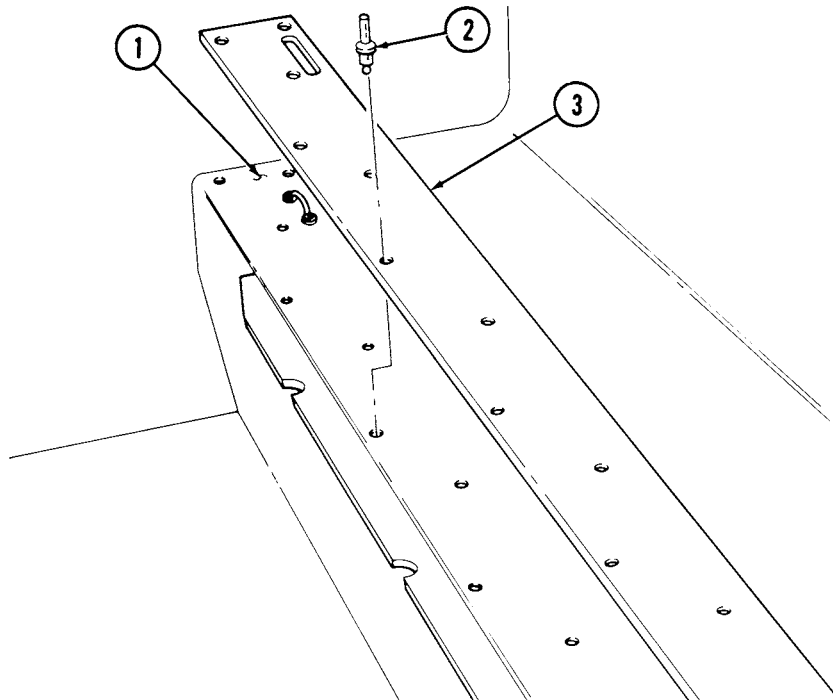

FOLLOW-ON TASK: Install litter strap (para. 11-160).

11-147. LITTER HANDLE BUMPER REPLACEMENT

This task covers:

a. Removal

b. Installation

INITIAL SETUP:

Applicable Models

M996, M996A1, M997, M997A1, M997A2

Tools

General mechanic's tool kit:
automotive (Appendix B, Item 1)

Materials/Parts

Two blind rivets (Appendix G, Item 258)

Manual References

TM 9-2320-280-10
TM 9-2320-280-24P

Equipment Condition

Rear door opened (TM 9-2320-280-10).

NOTE

- The procedure for replacing litter handle bumpers are basically the same for M996, M996A1, M997, M997A1, and M997A2 ambulances. This procedure covers the rear door litter handle bumpers replacement for M997, M997A1, and M997A2 ambulances.
- For instructions on replacement of rivets, refer to para. 10-66.

a. Removal

1. Remove two rivets (1) and upper bumper (2) from rear door (3).
2. Remove two screws (5) and lower bumper (4) from rear door (3).

b. Installation

1. Install lower bumper (4) on rear door (3) with two screws (5).
2. Install upper bumper (2) on rear door (3) with two rivets (1).

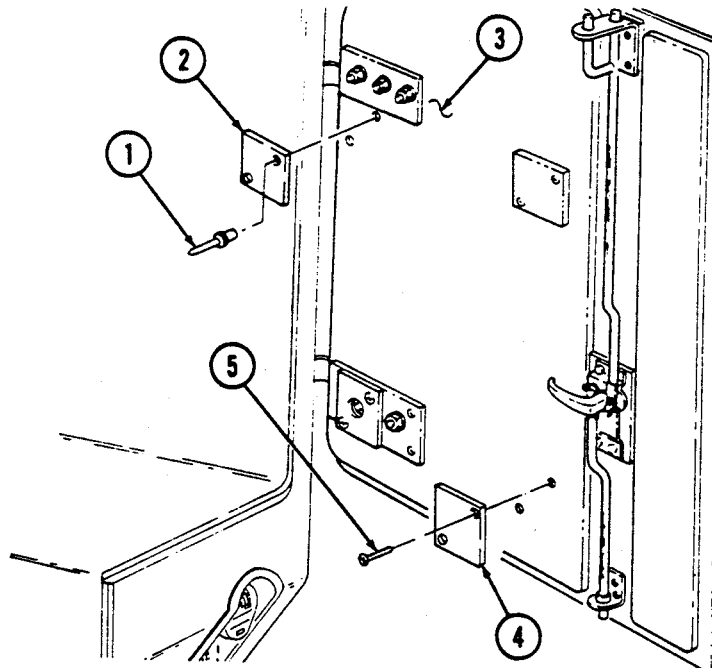

FOLLOW-ON TASK: Close rear door (TM 9-2320-280-10).

11-148. SPINEBOARD MOUNTING BRACKET REPLACEMENT

This task covers:

a. Removal

b. Installation

INITIAL SETUP:

Applicable Models

M996, M996A1, M997, M997A1, M997A2

Materials/Parts

Two lockwashers (Appendix G, Item 138)

Tools

General mechanic's tool kit:
automotive (Appendix B, Item 1)

Manual References

TM 9-2320-280-24P

NOTE

The procedure for replacing the left and right spineboard mounting brackets are basically the same for M996, M996A1, M997, M997A1, and M997A2 ambulances. This procedure covers replacement of a right spineboard bracket on M997, M997A1, and M997A2 ambulances.

a. Removal

1. Remove spineboard from stowage position.
2. Remove six screws (1), footman loops (3) and (6), and vertical strap assembly (4) from body (2).
3. Remove four screws (11), washers (10), washers (9), and two brackets (8) from body (2).
4. Remove two nuts (7), lockwashers (14), screws (13), footman loop (12), and horizontal strap assembly (5) from bracket (8). Discard lockwashers (14).

b. Installation

1. Install horizontal strap assembly (5) and footman loop (12) on bracket (8) with two screws (13), lockwashers (14), and nuts (7).
2. Install two brackets (8) on body (2) with four screws (11), washers (10), and washers (9).
3. Install vertical strap (4), footman loop (6), and footman loop (3) on body (2) with six screws (1).
4. Install spineboard and adjust brackets (8) by loosening screws (11) and sliding brackets (8) so that spineboard is held securely and tighten screws (11). Install and tighten strap assemblies (5) and (4) on spineboard.

11-148. SPINEBOARD MOUNTING BRACKET REPLACEMENT (Cont'd)

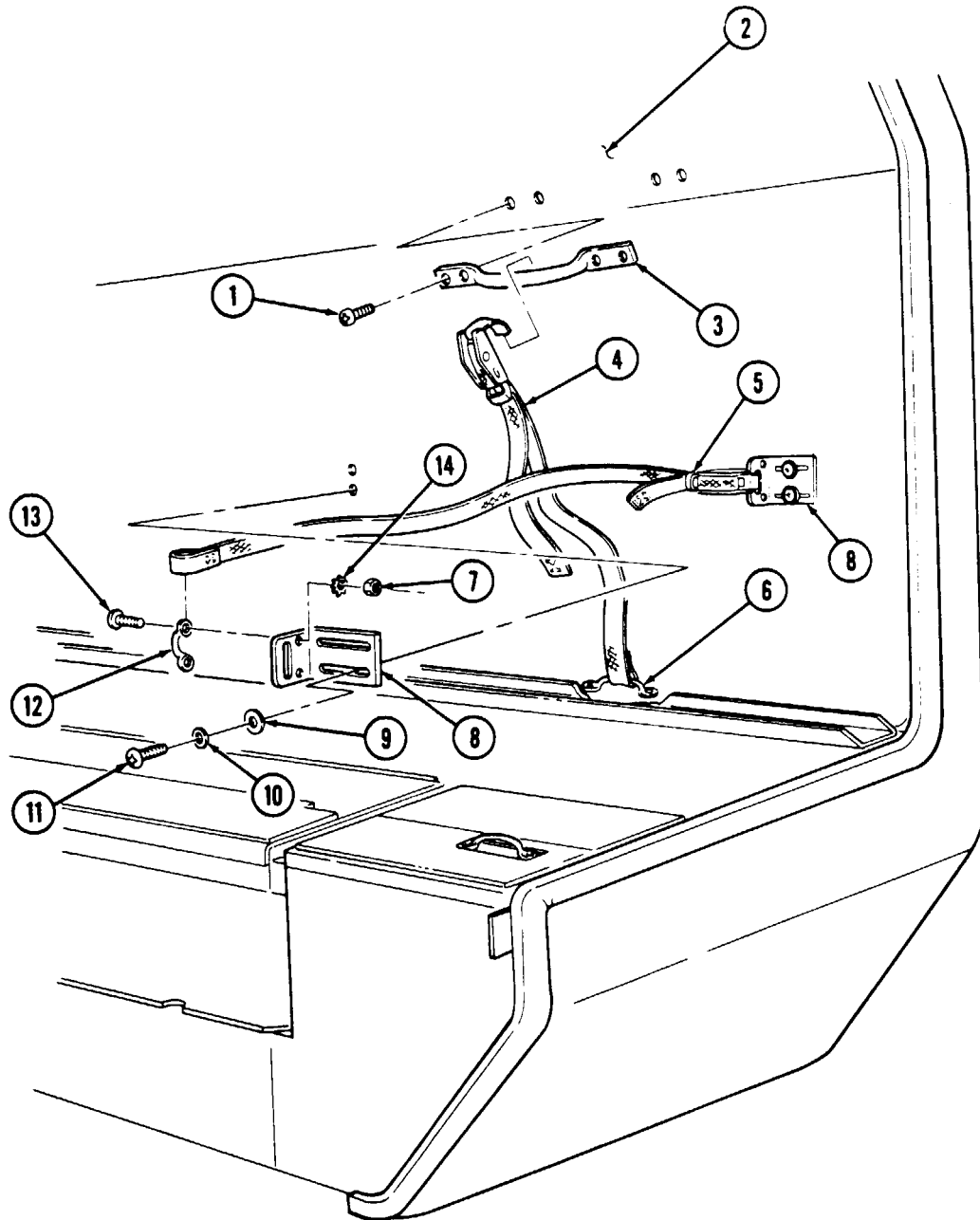

11-149. IV BAG STRAP REPLACEMENT

This task covers:

a. Removal

b. Installation

INITIAL SETUP:

Applicable Models

M996, M996A1, M997, M997A1, M997A2

Manual References

TM 9-2320-280-24P

Tools

General mechanic's tool kit:
automotive (Appendix B, Item 1)

a. Removal

Remove screw (3) and strap (2) from body (1).

b. Installation

Install strap (2) on body (1) with screw (3).

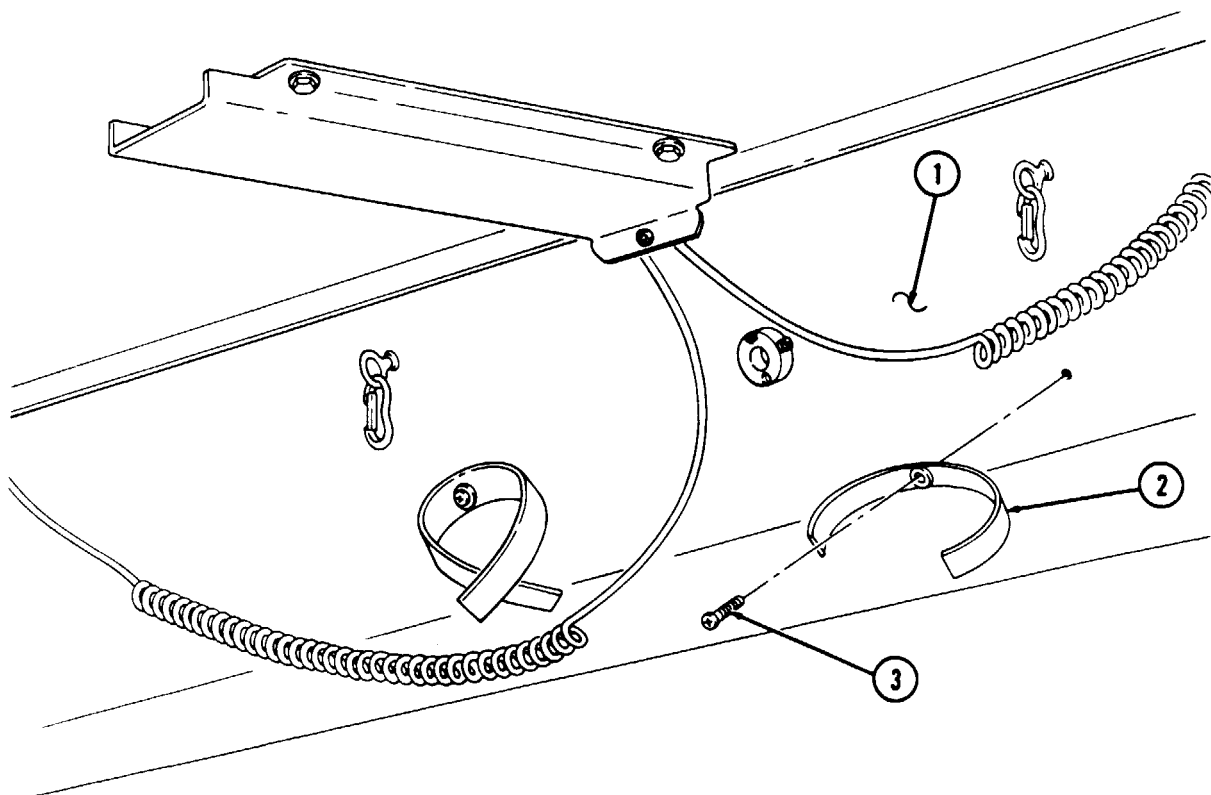

11-150. IV BAG HOOK REPLACEMENT

This task covers:

a. Removal

b. Installation

INITIAL SETUP:

Applicable Models

M996, M996A1, M997, M997A1, M997A2

Manual References

TM 9-2320-280-24P

Tools

General mechanic's tool kit:
automotive (Appendix B, Item 1)

a. Removal

Remove eyebolt (1) from body (2) and remove hook (3) from eyebolt (1).

b. Installation

Install hook (3) on eyebolt (1) and install eyebolt (1) into body (2).

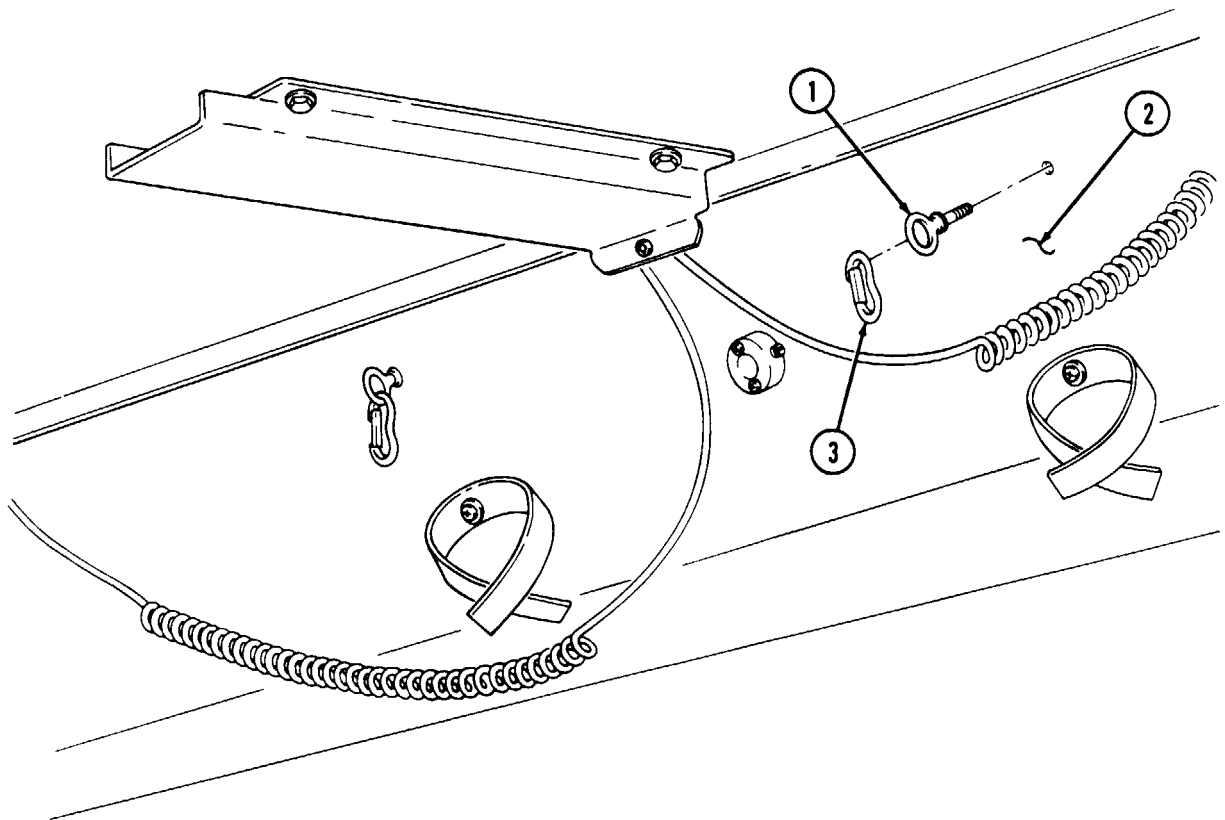

11-151. STOWAGE BOX TURNBUTTON REPLACEMENT

This task covers:

a. Removal

b. Installation

INITIAL SETUP:

Applicable Models

M997, M997A1, M997A2

Manual References

TM 9-2320-280-24P

Tools

General mechanic's tool kit:
automotive (Appendix B, Item 1)

a. Removal

1. Remove curtain eyelet (1) from turnbutton (2) on stowage box (3).
2. Remove turnbutton (2) from stowage box (3).

b. Installation

1. Install turnbutton (2) on stowage box (3).
2. Install curtain eyelet (1) on turnbutton (2) on stowage box (3).

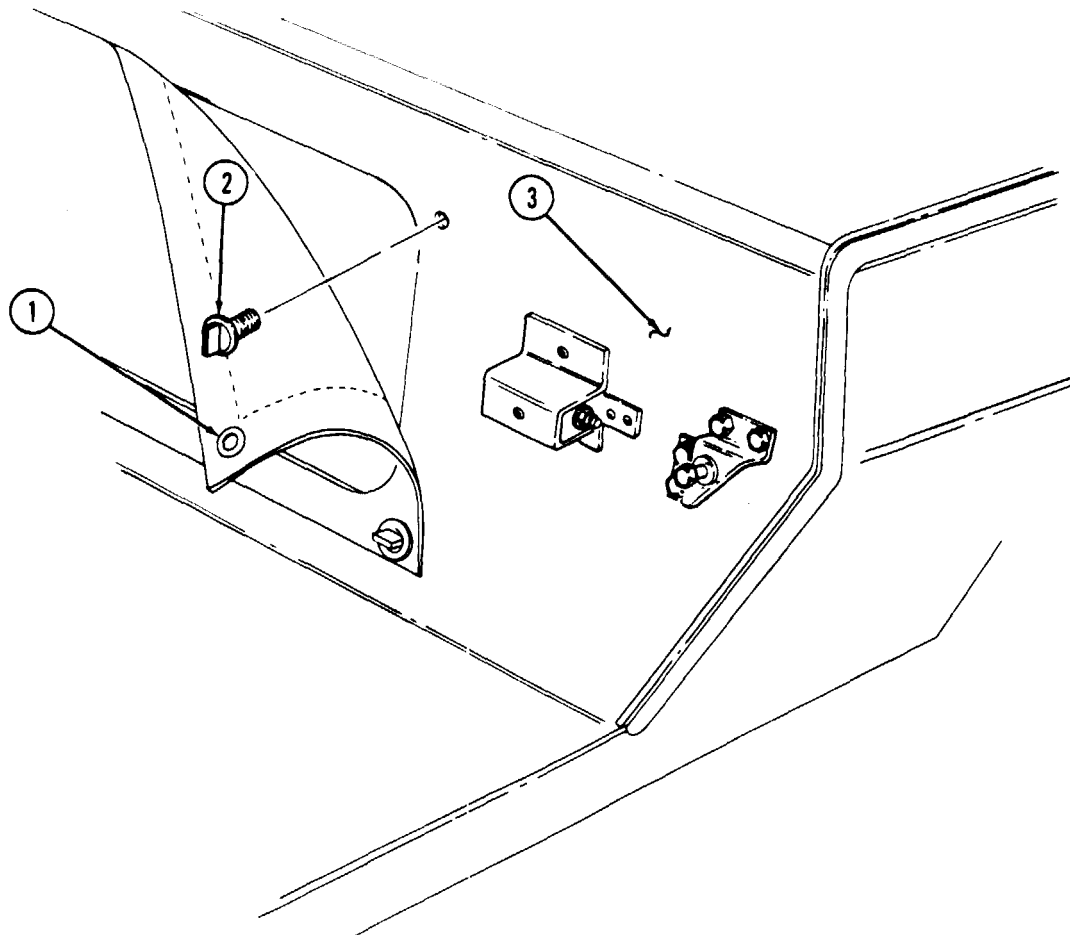

11-152. STOWAGE DOOR REPLACEMENT

This task covers:

a. Removal

b. Installation

INITIAL SETUP:

Applicable Models

M997, M997A1, M997A2

Tools

General mechanic's tool kit:
automotive (Appendix B, Item 1)

Materials/Parts

Five solid rivets (Appendix G, Item 271)
Three blind rivets (Appendix G, Item 260)
Four solid rivets (Appendix G, Item 272)

Manual References

TM 9-2320-280-24P

NOTE

- Upper and lower stowage doors are removed and installed basically the same. This procedure covers the lower stowage door.
- For instructions on replacement of rivets, refer to para. 10-66.

a. Removal

1. Remove seal (4), if damaged, from door (8).
2. Remove three rivets (3) and door (8) from hinge (2).
3. Remove three rivets (1) and hinge (2) from bulkhead (6).
4. Remove two rivets (5) and hasp (7) from bulkhead (6).
5. Remove four rivets (10) and staple (9) from door (8).

b. Installation

1. Install hasp (7) on bulkhead (6) with two rivets (5).
2. Install staple (9) on door (8) with four rivets (10).
3. Install hinge (2) on bulkhead (6) with three rivets (1).
4. Install door (8) on hinge (2) with three rivets (3).
5. Install seal (4) on door (8), if removed.

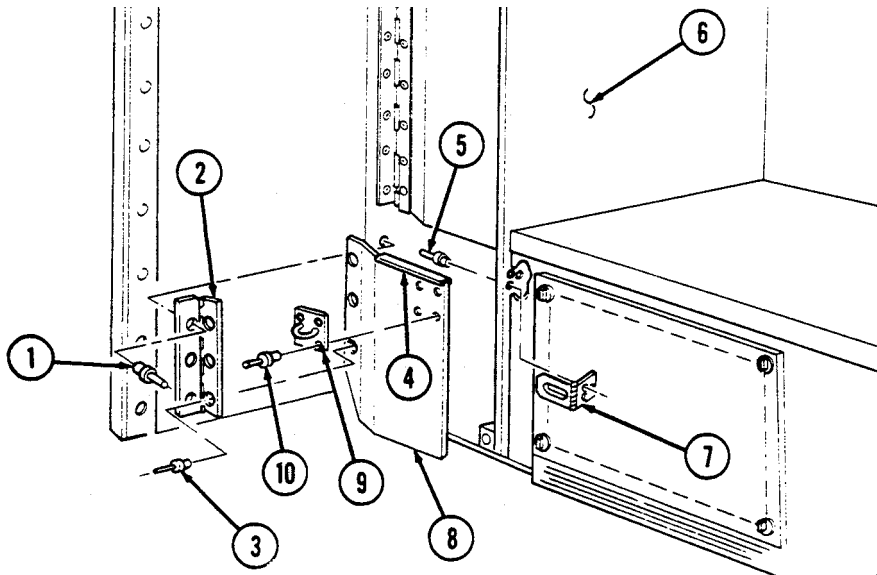

11-153. AMBULANCE COMPARTMENT MAT REPLACEMENT

This task covers:

a. Removal

b. Installation

INITIAL SETUP:

Applicable Models

M996, M996A1, M997, M997A1, M997A2

Manual References

TM 9-2320-280-10
 TM 9-2320-280-24P

Tools

General mechanic's tool kit:
 automotive (Appendix B, Item 1)

Equipment Condition

Rear steps lowered (TM 9-2320-280-10).

Materials/Parts

Nine blind rivets (Appendix G, Item 244)
 Nine blind rivets (Appendix G, Item 254)

NOTE

For instructions on replacement of rivets, refer to para. 10-66.

a. Removal

1. Remove nine rivets (6) and front mat retainer (5) from mat (1) and floor (4).
2. Remove nine rivets (3), rear mat retainer (2), and floor mat (1) from floor (4).

b. Installation

1. Install floor mat (1) and front mat retainer (5) on floor (4) with nine rivets (6).
2. Install rear mat retainer (2) on floor (4) with nine rivets (3).

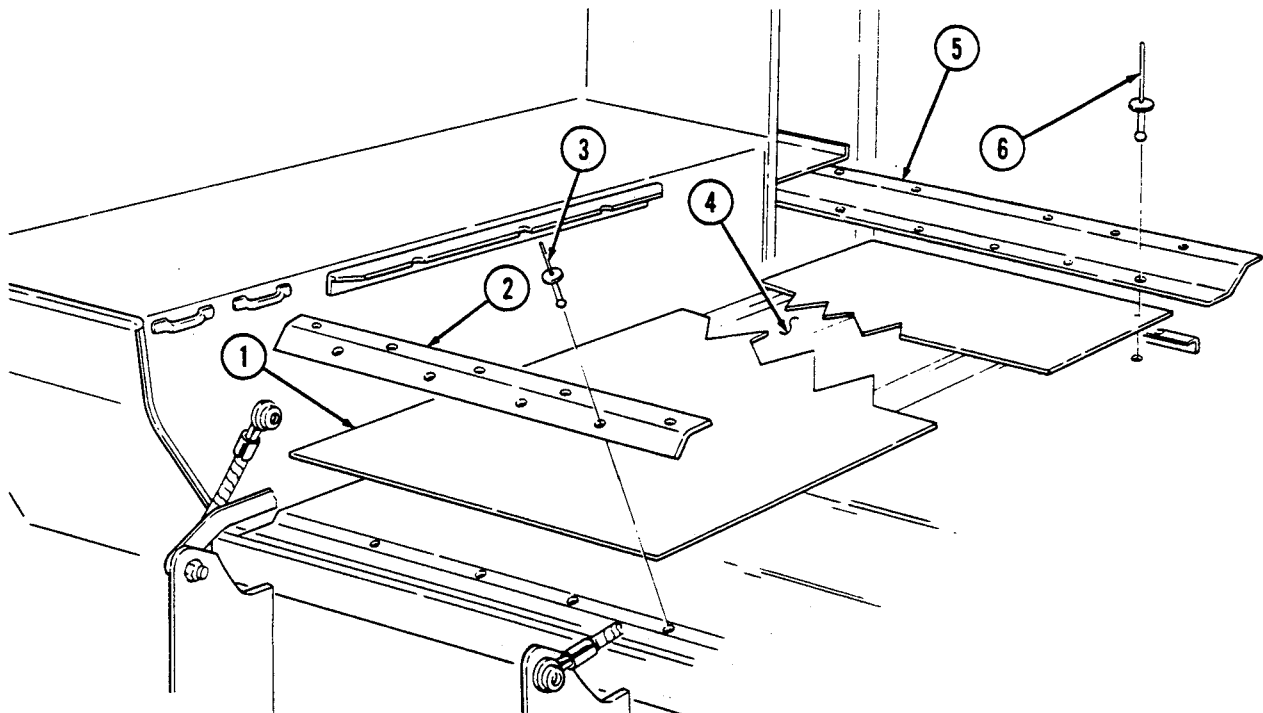

FOLLOW-ON TASK: Raise rear steps (TM 9-2320-280-10).

11-154. FRONT FLOORBOARD REPLACEMENT

This task covers:

a. Removal

b. Installation

INITIAL SETUP:

Applicable Models

M996, M996A1, M997, M997A1, M997A2,
M998, M998A1, M1038, M1038A1

Manual References

TM 9-2320-280-24P

Tools

General mechanic's tool kit:
automotive (Appendix B, Item 1)

NOTE

The procedure to remove and install the front and rear floorboards are basically the same. The following procedure is for the front floorboard.

a. Removal

Remove four screws (2) and floorboard (1) from floor (3).

b. Installation

Install floorboard (1) on floor (3) with four screws (2).

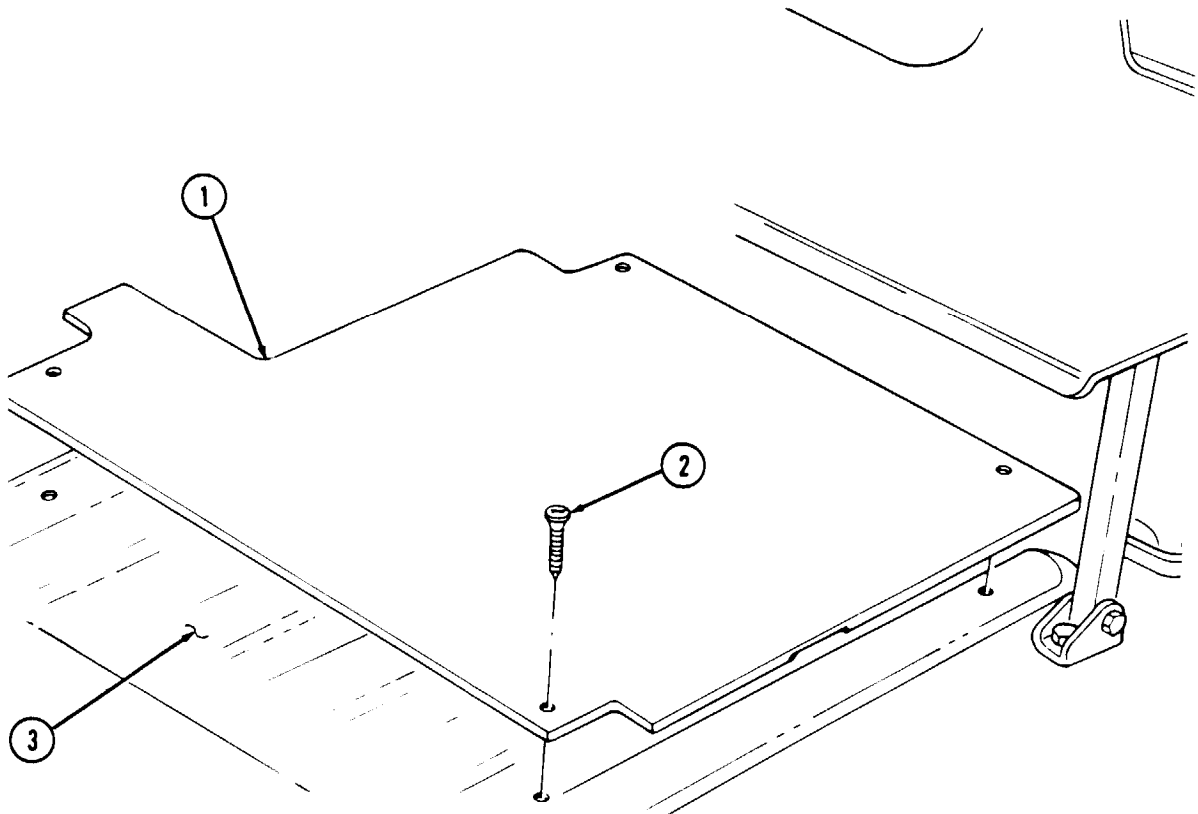

11-155. BULKHEAD DOOR REPLACEMENT

This task covers:

a. Removal

b. Installation

INITIAL SETUP:

Applicable Models

M996, M996A1, M997, M997A1, M997A2

Tools

General mechanic's tool kit:
automotive (Appendix B, Item 1)

Materials/Parts

Twenty blind rivets (Appendix G, Item 237)
Twenty-four blind rivets (Appendix G, Item 257)
Twelve blind rivets (Appendix G, Item 243)
Fourteen blind rivets (Appendix G, Item 250)
Twenty blind rivets (Appendix G, Item 244)

Manual References

TM 9-2320-280-24P

NOTE

- For instructions on replacement of rivets, refer to para. 10-66.
- M996, M996A1, M997, M997A1, and M997A2 bulkhead doors are replaced basically the same, except for the following:
 - Forty-eight rivets are used to mount M996 and M996A1 bulkhead doors to bulkhead.
 - Ten rivets are used to mount M996 and M996A1 door retainer to door.
 - Bulkhead door striker placement is different for M996, M996A1, M997, M997A1, and M997A2 ambulances.
- This procedure covers M997, M997A1, and M997A2 bulkhead door replacement.

a. Removal

1. Starting at top of door opening (1), pry seal (2) from around door opening (1) and remove seal (2).
2. Pry seal (37) from right door retainer (36) and remove seal (37).

NOTE

Step 3 applies to M996 and M996A1 vehicles only.

3. Remove two screws (34) from strap assembly (35) and right door (29).
4. Remove thirty-four rivets (11), two hinges (12), and doors (4) and (29) from body (3).
5. Remove thirty-four rivets (11) and two hinges (12) from doors (4) and (29).
6. Remove two screws (8), doughnut washers (7), handle (5), and doughnut washers (6) from left door (4).
7. Remove eight rivets (10) and two strikers (9) from doors (4) and (29).
8. Remove fourteen rivets (33) and door retainer (36) from right door (29).
9. Remove four screws (22), washers (23), two rod guide cover plates (24), and plusnuts (25) from right door (29).
10. Remove screw (28), washer (27), and blackout switch pin (26) from right door (29).
11. Remove setscrew (31), handle (32), and washer (30) from right door (29).
12. Remove four screws (39), washers (38), and handle cover plate (19) from right door (29).
13. Remove three nuts (21), washers (20), screws (16), washers (17), and handle (18) from cover plate (19).
14. Remove four rivets (13) and two catch assemblies (14) from stowage shelves (15).

11-155. BULKHEAD DOOR REPLACEMENT (Cont'd)

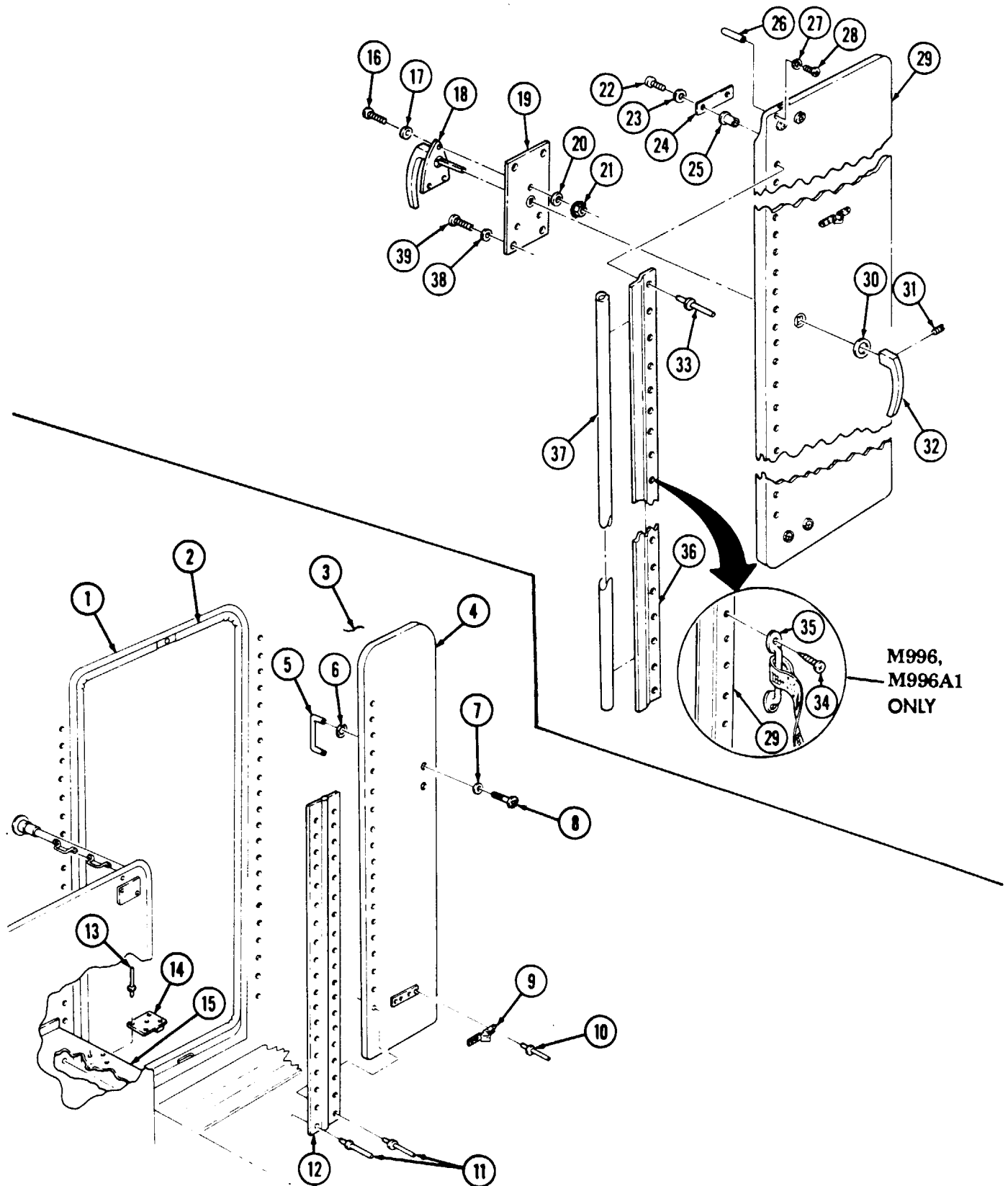

11-155. BULKHEAD DOOR REPLACEMENT (Cont'd)

b. Installation

1. Install handle (18) on handle cover plate (19) with three washers (17), screws (16), washers (20), and nuts (21).
2. Install handle cover plate (19) on right door (29) with four washers (38) and screws (39).
3. Install washer (30) and handle (32) on right door (29) with setscrew (31).
4. Install blackout switch pin (26) on right door (29) with washer (27) and screw (28).
5. Install two plusnuts (25) and rod guide cover plates (24) on right door (29) with four washers (23) and screws (22).
6. Install door retainer (36) on right door (29) with fourteen rivets (33).
7. Install two strikers (9) on doors (4) and (29) with eight rivets (10).
8. Install handle (5) and two doughnut washers (6) on left door (4) with two screws (8) and doughnut washers (7).
9. Install two hinges (12) on doors (4) and (29) with thirty-four rivets (11).

NOTE

Step 10 applies to M996 and M996A1 vehicles only.

10. Install strap assembly (35) on right door (29) with two screws (34).
11. Install hinges (12) on body (3) with thirty-four rivets (11).
12. Install two catch assemblies (14) on stowage shelves (15) with four rivets (13).
13. Install seal (37) on right door retainer (36) by pushing into place.
14. Install seal (2) by starting at top of door opening (1) and pushing seal (2) into place around door opening (1).

11-155. BULKHEAD DOOR REPLACEMENT (Cont'd)

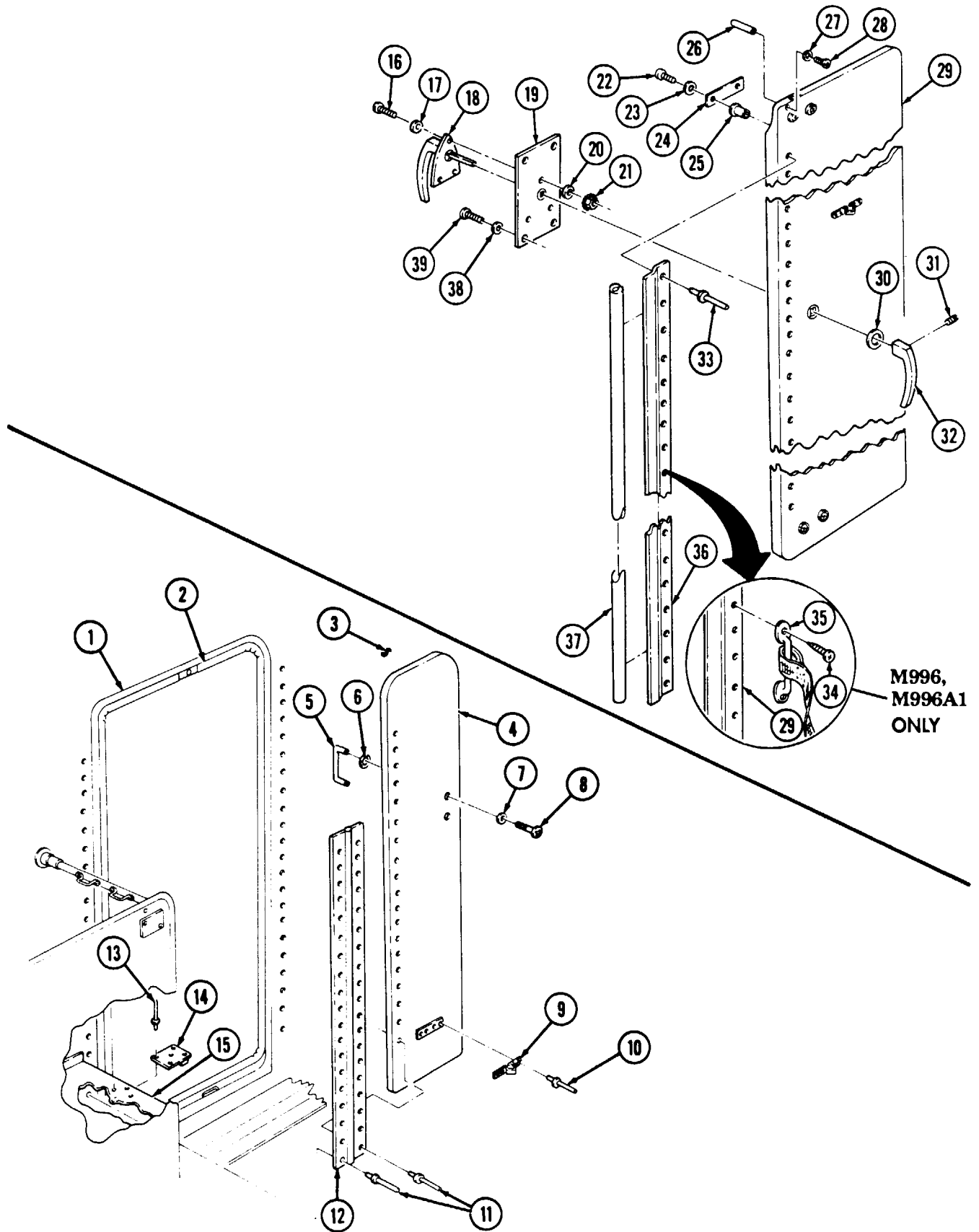

11-156. BULKHEAD DOOR LATCH REPLACEMENT

This task covers:

a. Removal

b. Installation

INITIAL SETUP:

Applicable Models

M996, M996A1, M997, M997A1, M997A2

Tools

General mechanic's tool kit:
automotive (Appendix B, Item 1)

Materials/Parts

Twelve blind rivets (Appendix G, Item 243)

Manual References

TM 9-2320-280-24P

a. Removal

NOTE

- For instructions on replacement of rivets, refer to para. 10-66.
- Perform step 1 for M996 and M996A1 vehicles.

1. Remove twelve rivets (3) and right bulkhead door (1) from hinge (2).
2. Remove four screws (9), washers (10), and two rod guide cover plates (8) from door (1).
3. Remove four nuts (7), washers (6), screws (4), washers (6), and two rod guides (5) from door (1).

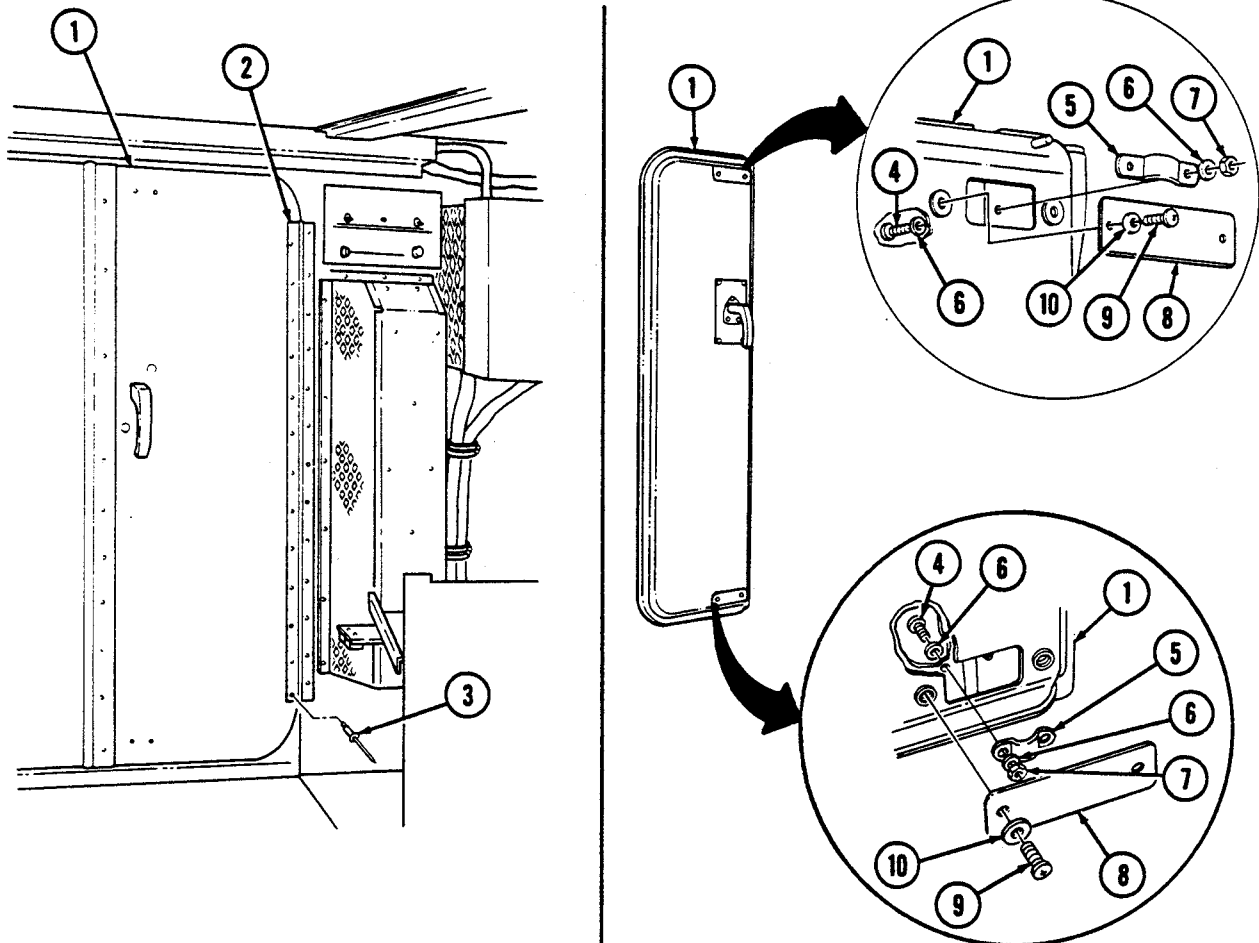

11-156. BULKHEAD DOOR LATCH REPLACEMENT (Cont'd)

4. Remove setscrew (11), handle (12), and washer (13) from door (1).
5. Remove four screws (16), washers (15), cover plate (14), and handle (17) from door (1).
6. Remove four nuts (23), washers (20), screws (19), and washers (20) from latch assembly (22) and door (1).
7. Rotate latch assembly (22) to horizontal position and disconnect rods (21) and (24), then remove latch assembly (22).

NOTE

Perform step 8 for M996 and M996A1 vehicles. Perform step 9 for M997, M997A1, and M997A2 vehicles.

8. Remove upper rod (21) through rod opening (18) at top of door (1), and lower rod (24) through rod opening (26) at bottom of door (1).
9. Remove upper rod (21) and lower rod (24) through latch opening (25) in door (1),

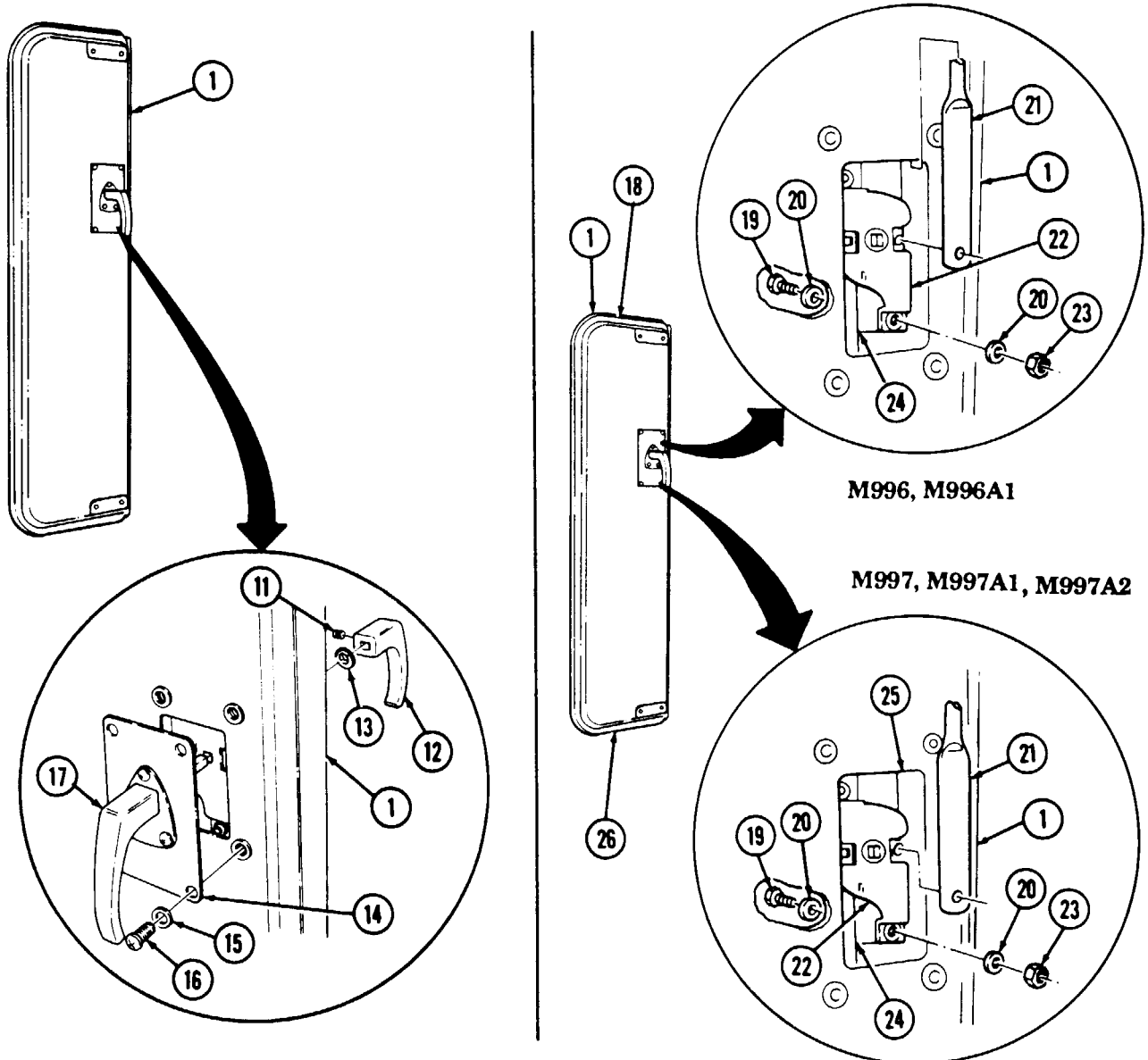

11-156. BULKHEAD DOOR LATCH REPLACEMENT (Cont'd)

b. Installation

NOTE

Perform step 1 for M996 and M996A1 vehicles. Perform step 2 for M997, M997A1, and M997A2 vehicles.

1. Install upper rod (5) through rod opening (2) at top of bulkhead door (1), and lower rod (8) through rod opening (10) at bottom of door (1).
2. Install upper rod (5) and lower rod (8) through latch opening (9) in door (1).
3. Install latch assembly (6) through latch opening in door (1), rotate latch assembly (6) to a horizontal position, and connect rods (5) and (8) to latch assembly (6).
4. Rotate latch assembly (6) to a vertical position and install two washers (4), screws (3), washers (4), and nuts (7).
5. Install cover plate (14) and handle (17) on door (1) with four washers (15) and screws (16).
6. Install washer (13) and handle (12), on handle (17) with setscrew (11).

M996, M996A1

M997, M997A1, M997A2

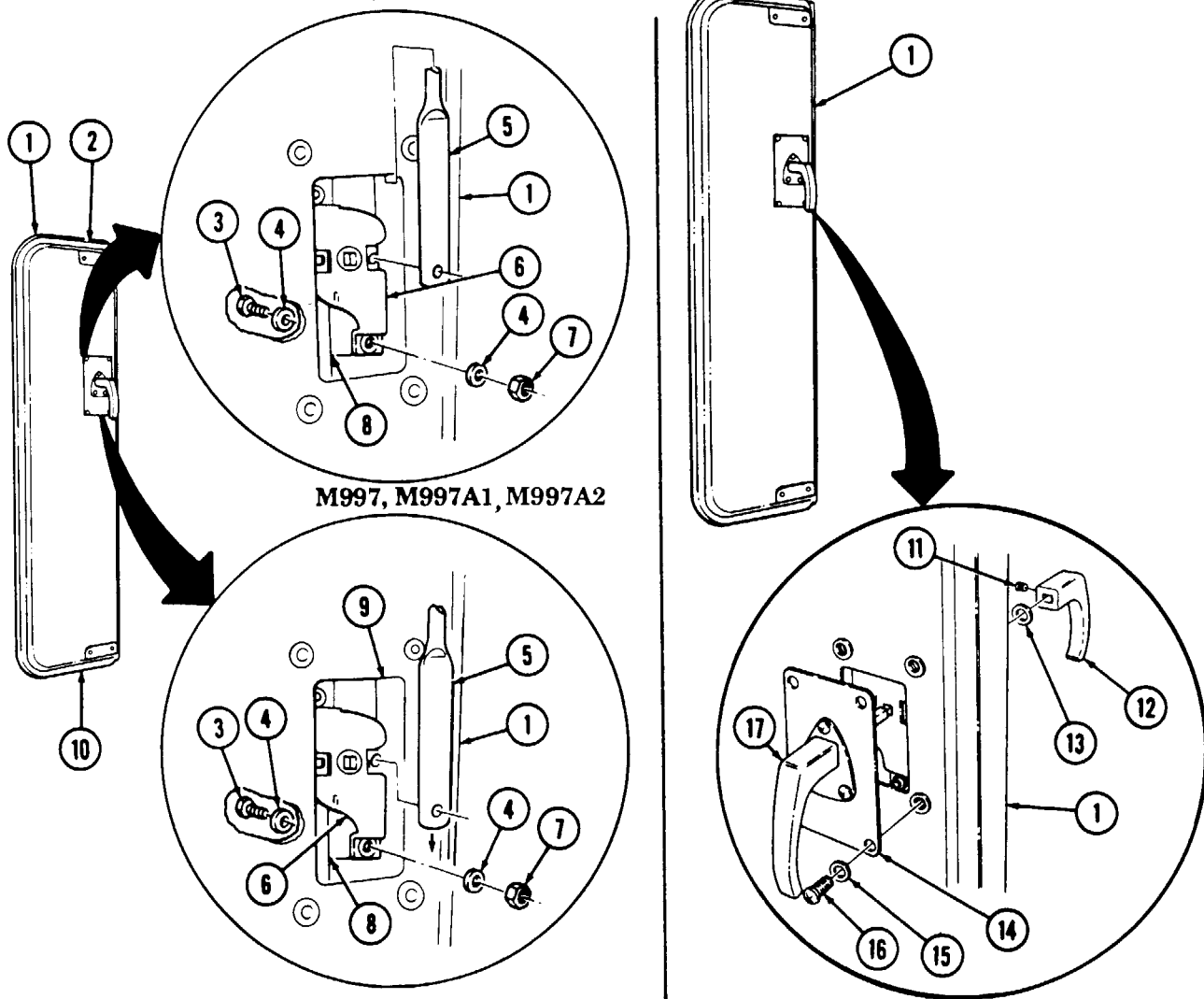

11-156. BULKHEAD DOOR LATCH REPLACEMENT (Cont'd)

7. Install two rod guides (19) on door (1) with four washers (20), screws (18), washers (20), and nuts (21).
8. Install two rod guide cover plates (22) on door (1) with four washers (24) and screws (23).

NOTE

Perform step 9 for M996 and M996A1 vehicles.

9. Install door (1) on hinge (25) with twelve rivets (26).

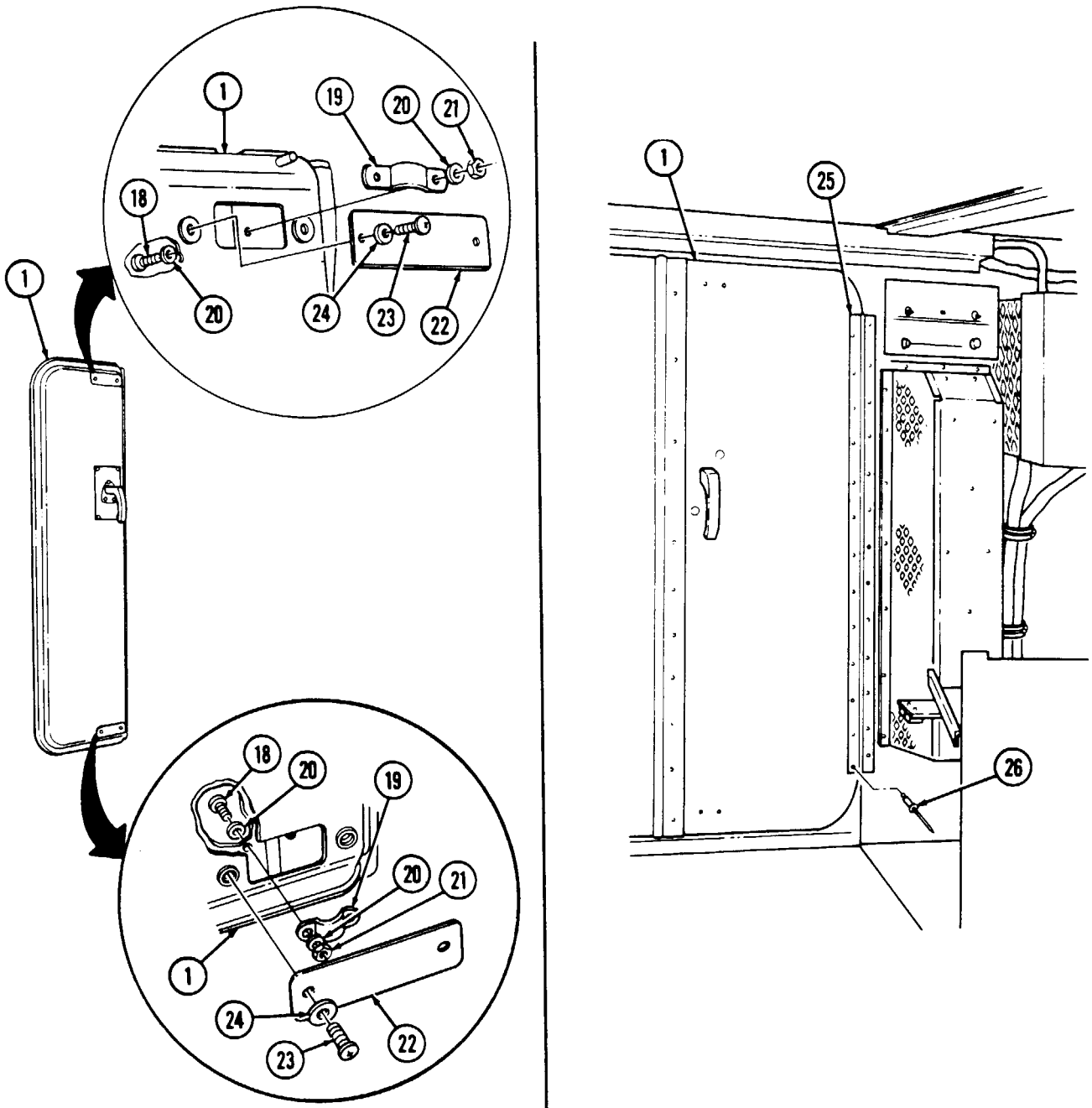

11-157. ATTENDANT SEAT MAINTENANCE

This task covers:

- | | |
|---|---|
| <p>a. Removal</p> <p>b. Disassembly</p> | <p>c. Assembly</p> <p>d. Installation</p> |
|---|---|

INITIAL SETUP:

Applicable Models

M996, M996A1, M997, M997A1, M997A2

Tools

General mechanic's tool kit:
automotive (Appendix B, Item 1)

Materials/Parts

Two cotter pins (Appendix G, Item 24)
Two locknuts (Appendix G, Item 93)

Manual References

TM 9-2320-280-24P

a. Removal

NOTE

- The attendant seat assemblies are similar for M996, M996A1, M997, M997A1, and M997A2 ambulances with the following exceptions:
 - The M996 and M996A1 ambulance attendant seat must be removed from forward ends of attendant seat rails.
 - The M997, M997A1, and M997A2 ambulance attendant seat must be removed from rearward ends of attendant seat rails.

Push seat latch (3) to release locking mechanism and slide seat (1) to end of seat rails (2). Remove seat (1) from rails (2).

b. Disassembly

1. Remove two locknuts (7), capscrews (6), and seatbelt (4) from seat base (8). Discard locknuts (7).
2. Remove socket head screw (15), washer (16), washer (17), handle (18), and nylon washer (11) from seat base (8).
3. Remove two cotter pins (12), washers (14), clevis pins (10), and handle (18) from latch rods (9). Discard cotter pins (12).
4. Disconnect spring (13) from handle (18) and seat base (8) and remove spring (13).
5. Remove four screws (19) and cushion (5) from seat base (8).

c. Assembly

1. Install cushion (5) on seat base (8) with four screws (19).
2. Install latch rods (9) on seat base (8).
3. Connect latch rods (9) to handle (18) with two clevis pins (10), washers (14), and cotter pins (12).
4. Install handle (18) and nylon washer (11) on seat base (8) with washer (17), washer (16), and socket head screw (15).
5. Connect spring (13) to handle (18) and seat base (8).
6. Install seatbelt (4) on seat base (8) with two capscrews (6) and locknuts (7). Tighten locknuts (7) to 60 lb-ft (81 N•m).

11-157. ATTENDANT SEAT MAINTENANCE (Cont'd)

d. Installation

NOTE

- The M996 and M996A1 ambulance attendant seat must be installed at forward ends of attendant seat rails.
- The M997, M997A1, and M997A2 ambulance attendant seat must be installed at rearward ends of attendant seat rails.

Install seat (1) on ends of seat rails (2) and slide seat (1) onto seat rails (2).

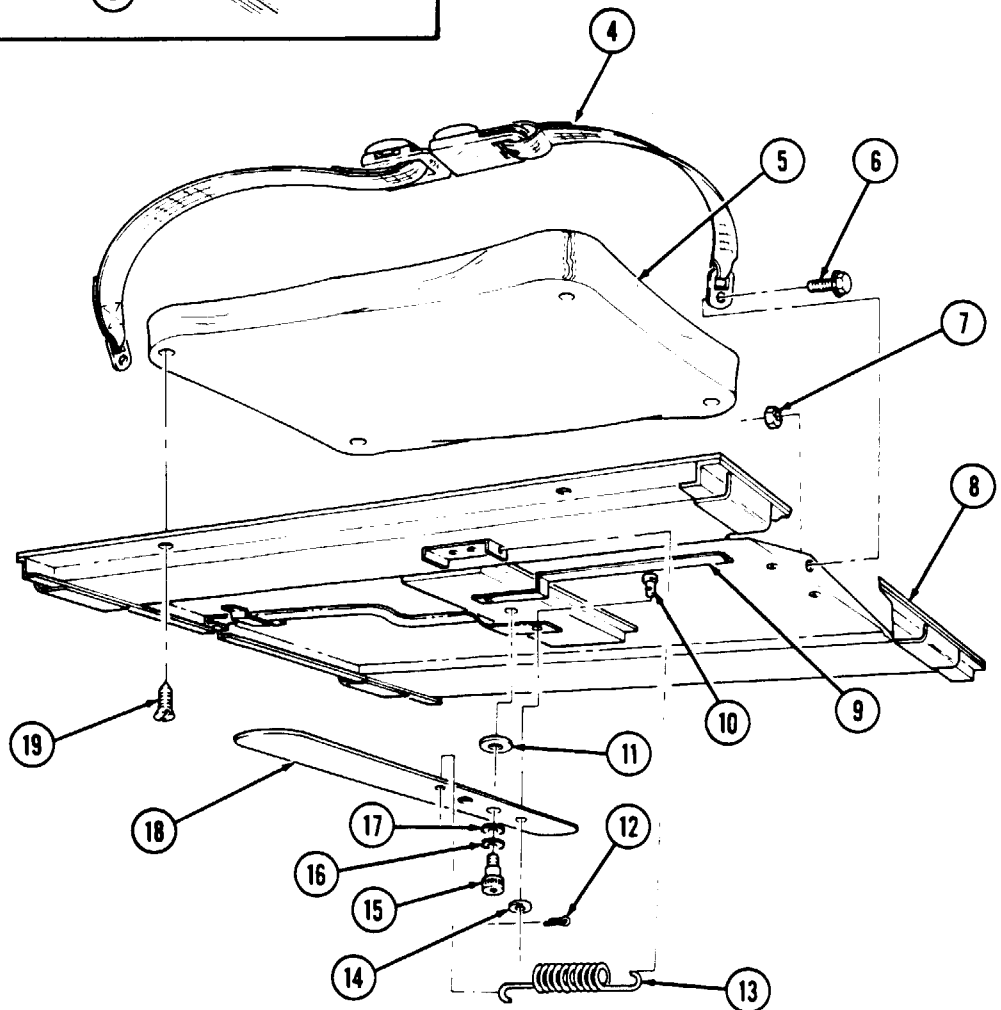
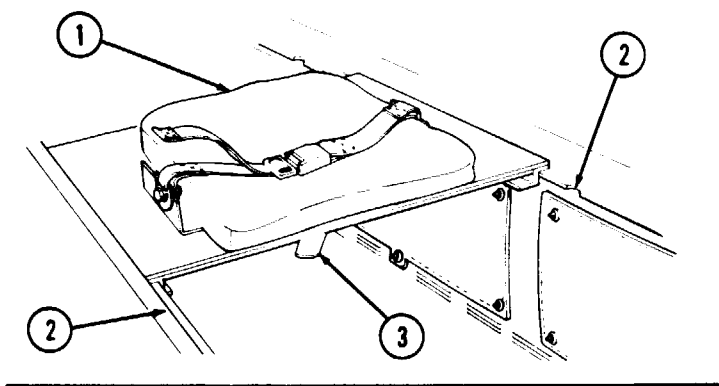

11-158. ATTENDANT SEAT GUIDE RAIL REPLACEMENT

This task covers:

a. Removal

b. Installation

INITIAL SETUP:

Applicable Models

M996, M996A1, M997, M997A1, M997A2

Manual References

TM 9-2320-280-24P

Tools

General mechanic's tool kit:
automotive (Appendix B, Item 1)

Equipment Condition

Attendant seat removed (para. 11-157).

Materials/Parts

Twenty solid rivets (Appendix G, Item 271)

NOTE

- For instructions on replacement of rivets, refer to para. 10-66.
- The procedures for replacing the left and right attendant seat guide rails are basically the same for M996, M996A1, M997, M997A1, and M997A2 ambulances. This procedure covers replacement of the left attendant seat guide rail on M997, M997A1, and M997A2 ambulance.
- M996 and M996A1 have seventeen rivets securing guide rail.

a. Removal

Remove twenty rivets (1) and guide rail (2) from ambulance body (3).

b. Installation

Install guide rail (2) on ambulance body (3) with twenty rivets (1).

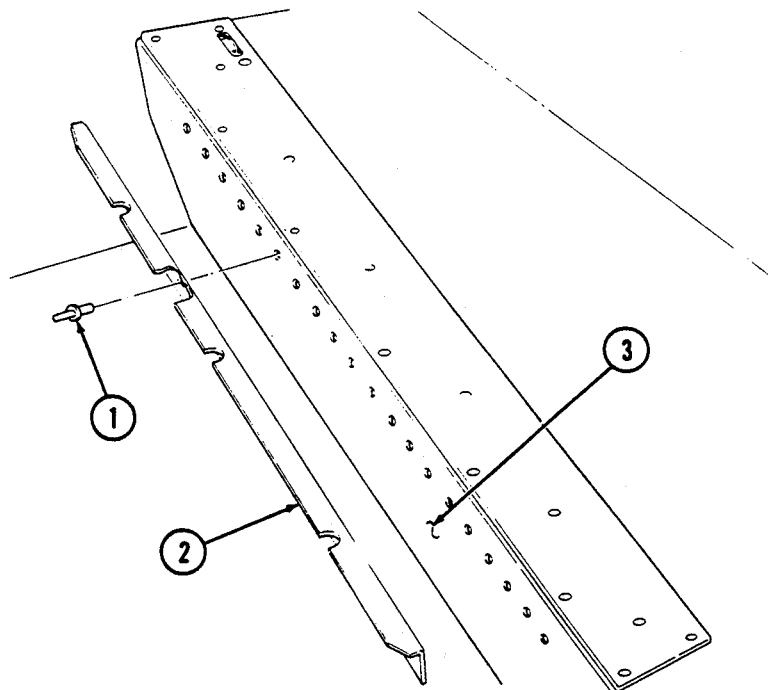

FOLLOW-ON TASK: Install attendant seat (para. 11-157).

11-159. LITTER STOWAGE DOOR REPLACEMENT

This task covers:

a. Removal

b. Installation

INITIAL SETUP:

Applicable Models

M996, M996A1, M997, M997A1, M997A2

Tools

General mechanic's tool kit:
automotive (Appendix B, Item 1)

Materials/Parts

Seven blind rivets (Appendix G, Item 251)
Seven blind rivets (Appendix G, Item 250)

Manual References

TM 9-2320-280-24P

NOTE

For instructions on replacement of rivets, refer to para. 10-66.

a. Removal

1. Remove five rivets (6) and door (9) from hinge (8).
2. Remove two rivets (5) and latch (4) from door (9).
3. Remove five rivets (7) and hinge (8) from body (1).
4. Remove two rivets (3) and catch (2) from body (1).
5. Remove seal (10), if damaged, from body (1).

b. Installation

1. Install seal (10), if removed, on body (1).
2. Install catch (2) on body (1) with two rivets (3).
3. Install hinge (8) on body (1) with five rivets (7).
4. Install latch (4) on door (9) with two rivets (5).
5. Install door (9) on hinge (8) with five rivets (6).

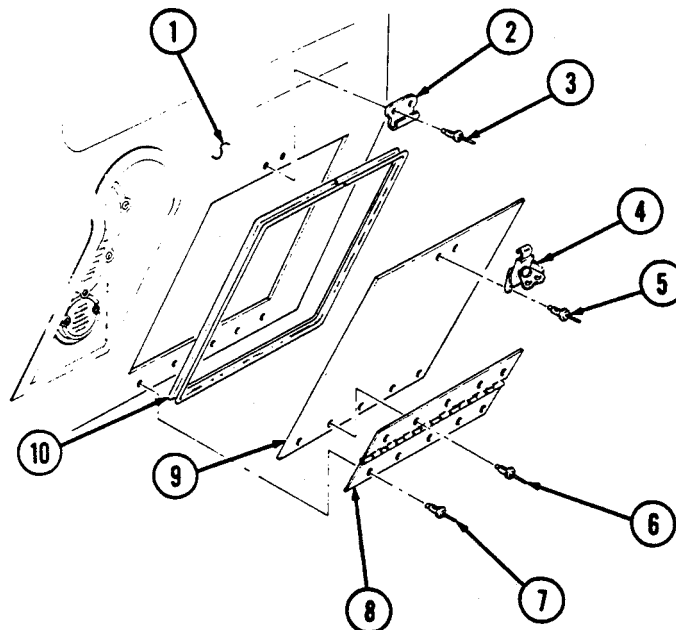

11-160. LITTER STOWAGE TRAY SUPPORT AND STRAP REPLACEMENT

This task covers:

- | | |
|---------------------|------------------------|
| a. Leg Removal | c. Straps Removal |
| b. Leg Installation | d. Straps Installation |

INITIAL SETUP:

Applicable Models

M996, M996A1, M997, M997A1, M997A2

Manual References

TM 9-2320-280-10
 TM 9-2320-280-24P

Tools

General mechanic's tool kit:
 automotive (Appendix B, Item 1)

Equipment Condition

Litter stowage door opened (TM 9-2320-280-10).

Materials/Parts

Four blind rivets (Appendix G, Item 257)

NOTE

Steps a. and b. apply to M997, M997A1, and M997A2 vehicles only.

a. Leg Removal

1. Remove spring (5) from litter tray support (3) and litter tray (2).

NOTE

For instruction on replacement of rivets, refer to para. 10-66.

2. Remove four rivets (1), two brackets (4), and litter tray support (3) from litter tray (2).

b. Leg Installation

1. Install litter tray support (3) and two brackets (4) on litter tray (2) with four rivets (1).
2. Install spring (5) on litter tray (2) and support (3).

NOTE

Steps c. and d. apply to M996 and M996A1 vehicles only.

c. Straps Removal

Remove two screws (7), footman loop (9), and straps (8) from body (6).

NOTE

If rivnuts are damaged, refer to para. 10-66 for replacement.

d. Straps Installation

Install straps (8) and footman loop (9) on body (6) with two screws (7).

11-160. LITTER STOWAGE TRAY SUPPORT AND STRAP REPLACEMENT (Cont'd)

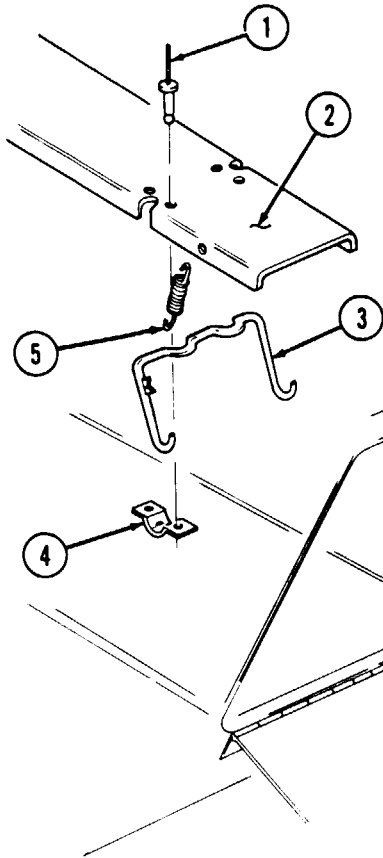

M997, M997A1, M997A2

M996, M996A1

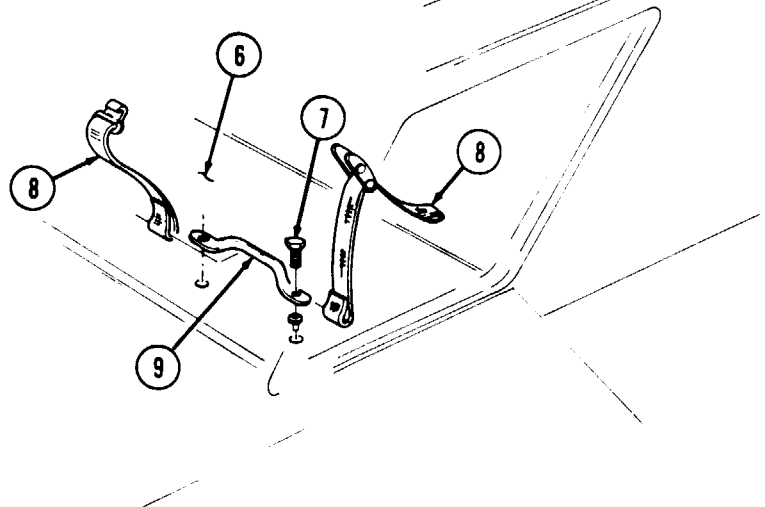

FOLLOW-ON TASK: Close litter stowage door (TM 9-2320-280-10).

11-161. LITTER RAIL EXTENSION REPLACEMENT

This task covers:

a. Disassembly

b. Assembly

INITIAL SETUP:

Applicable Models

M996, M996A1, M997, M997A1, M997A2

Tools

General mechanic's tool kit:
automotive (Appendix B, Item 1)

Materials/Parts

Four locknuts (Appendix G, Item 128)
Eight locknuts (Appendix G, Item 70)
Twenty-two solid rivets (Appendix G, Item 267)
Four solid rivets (Appendix G, Item 268)
Four locknuts (Appendix G, Item 79)
Eight blind rivets (Appendix G, Item 261)
Eight solid rivets (Appendix G, Item 273)

Manual References

TM 9-2321-280-10
TM 9-2320-280-24P

Equipment Condition

Litter rail extension removed from stowage compartment (TM 9-2320-280-10).

NOTE

For instructions on replacement of rivets, refer to para. 10-66.

a. Disassembly

1. Remove two locknuts (18), washers (15), capscrews (14), washers (15), support feet (17), and tubes (16) from support legs (12). Discard locknuts (18).
2. Remove four locknuts (21), washers (22), capscrews (24), washers (22), and strap assembly (23) from two support legs (12). Discard locknuts (21).

NOTE

Note locations of capscrews for installation.

3. Remove four locknuts (20), washers (19), capscrews (26), washers (19), and hinge braces (25) from support legs (12). Discard locknuts (20).
4. Remove four locknuts (30), washers (29), capscrews (27), and two hinges (28) from four hinge braces (25). Discard locknuts (30).
5. Remove two locknuts (10), washers (8), capscrews (7), washers (8), support legs (12), and tubes (9) from rails (6). Discard locknuts (10).
6. Remove four rivets (13) and two leg stops (11) from support legs (12).
7. Remove eight rivets (1) from ends of two extension rail skids (2). Remove twenty-two rivets (3) and two skids (2) from extension rails (6).
8. Remove eight rivets (5) and two hooks (4) from extension rails (6).

b. Assembly

1. Install two hooks (4) and ends of skids (2) on extension rails (6) with eight rivets (5).
2. Install two skids (2) to extension rails (6) and secure to ends with eight rivets (1).
3. Install skids (2) on extension rails (6) with twenty-two rivets (3).
4. Install two leg stops (11) on support legs (12) with four rivets (13).
5. Install two support legs (12) and tubes (9) on rails (6) with two washers (8), capscrews (7), washers (8), and locknuts (10). Tighten locknuts (10) to 6 lb-ft (8 N•m).

11-161. LITTER RAIL EXTENSION REPLACEMENT (Cont'd)

6. Install four hinge braces (25) on two hinges (28) with four capscrews (27), washers (29), and locknuts (30).
7. Install four hinge braces (25) on two support legs (12) with four washers (19), capscrews (26), washers (19), and locknuts (20). Tighten locknuts (20) to 15 lb-ft (20 N·m).
8. Install strap assembly (23) on two support legs (12) with four washers (22), capscrews (24), washers (22), and locknuts (21). Tighten locknuts (21) to 6 lb-ft (8 N·m).
9. Install two support feet (17) and tubes (16) on support legs (12) with two washers (15), capscrews (14), washers (15), and locknuts (18). Tighten locknuts (18) to 6 lb-ft (8 N·m).

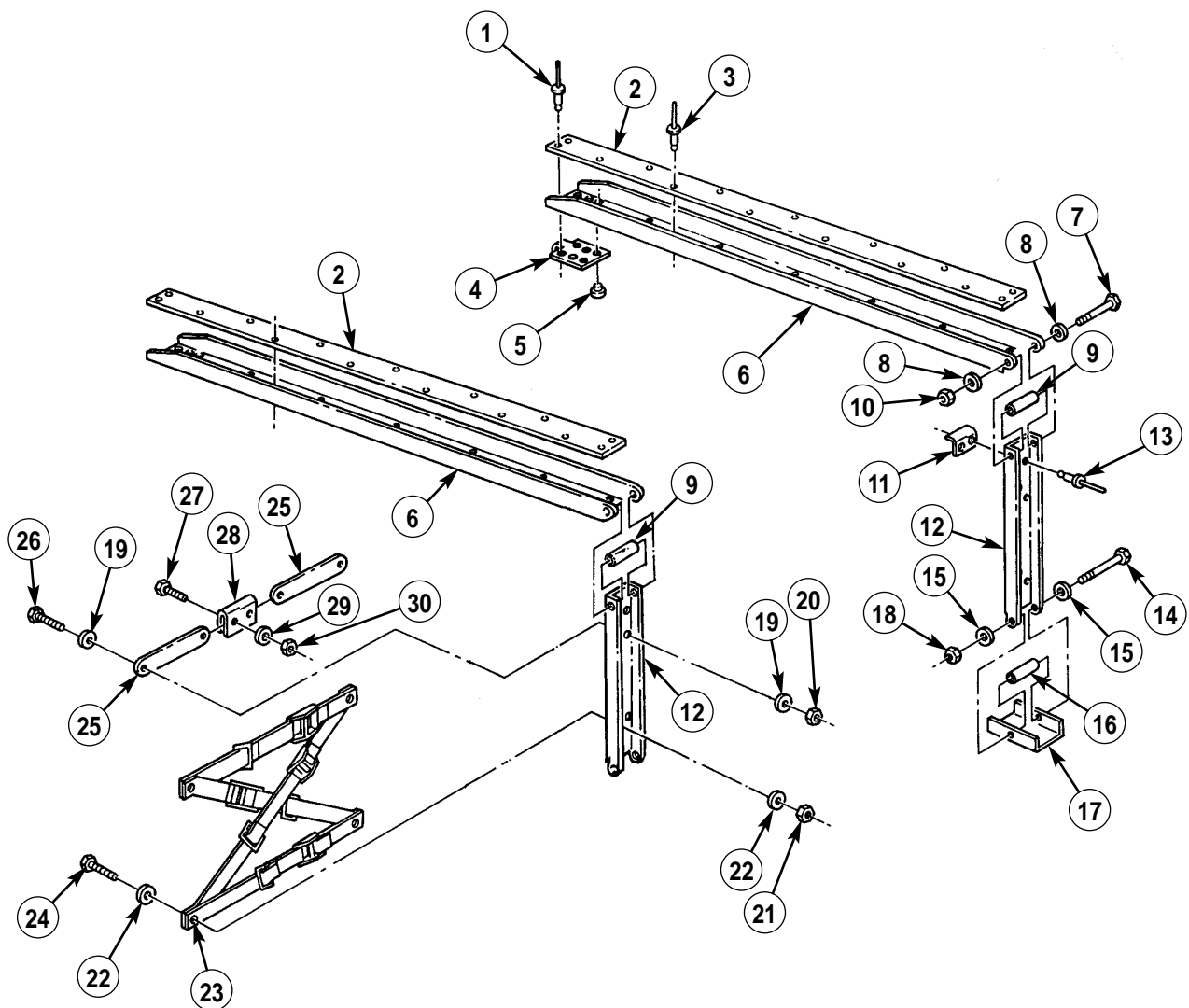

FOLLOW-ON TASK: Install litter rail extension in stowage compartment (TM 9-2320-280-10).

11-162. NBC COMPARTMENT DOOR REPLACEMENT (M997, M997A1, M997A2)

This task covers:

a. Removal

b. Installation

INITIAL SETUP:

Applicable Models

M997, M997A1, M997A2

Tools

General mechanic's tool kit:
automotive (Appendix B, Item 1)

Materials/Parts

Lockwasher (Appendix G, Item 144)
Eighteen blind rivets (Appendix G, Item 250)

Manual References

TM 9-2320-280-24P

NOTE

For instructions on replacement of rivets, refer to para. 10-66.

a. Removal

1. Remove nine rivets (3) and door (4) from hinge (2).
2. Remove nine rivets (1) and hinge (2) from body (5).
3. Remove nut (6), lockwasher (8), retainer (9), and paddle lock (11) from door (4). Discard lockwasher (8).
4. Remove jamnut (10) from paddle lock (11).

b. Installation

1. Install jamnut (10) on paddle lock (11).
2. Install paddle lock (11) on door (4) with retainer (9), lockwasher (8), and nut (6).
3. Install hinge (2) on body (5) with nine rivets (1).
4. Install door (4) on hinge (2) with nine rivets (3).

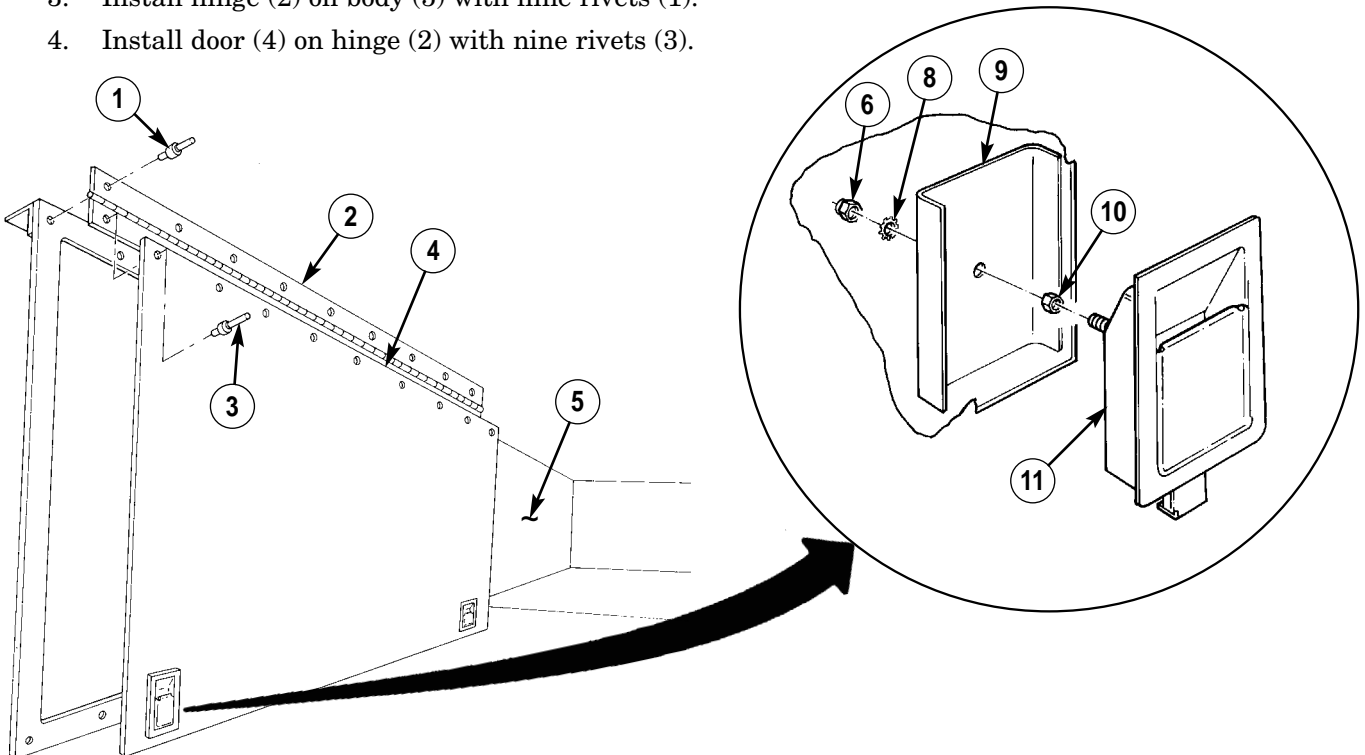

11-163. NBC COMPARTMENT DOOR LATCH REPLACEMENT

This task covers:

a. Removal

b. Installation

INITIAL SETUP:

Applicable Models

M997, M997A1, M997A2

Tools

General mechanic's tool kit:
automotive (Appendix B, Item 1)

Materials/Parts

Four assembled washer screws
(Appendix G, Item 278)

Manual References

TM 9-2320-280-24P

a. Removal

Remove four assembled washer screws (3) and latch (1) from ceiling (2). Discard assembled washer screws (3).

b. Installation

Install latch (1) on ceiling (2) with four assembled washer screws (3).

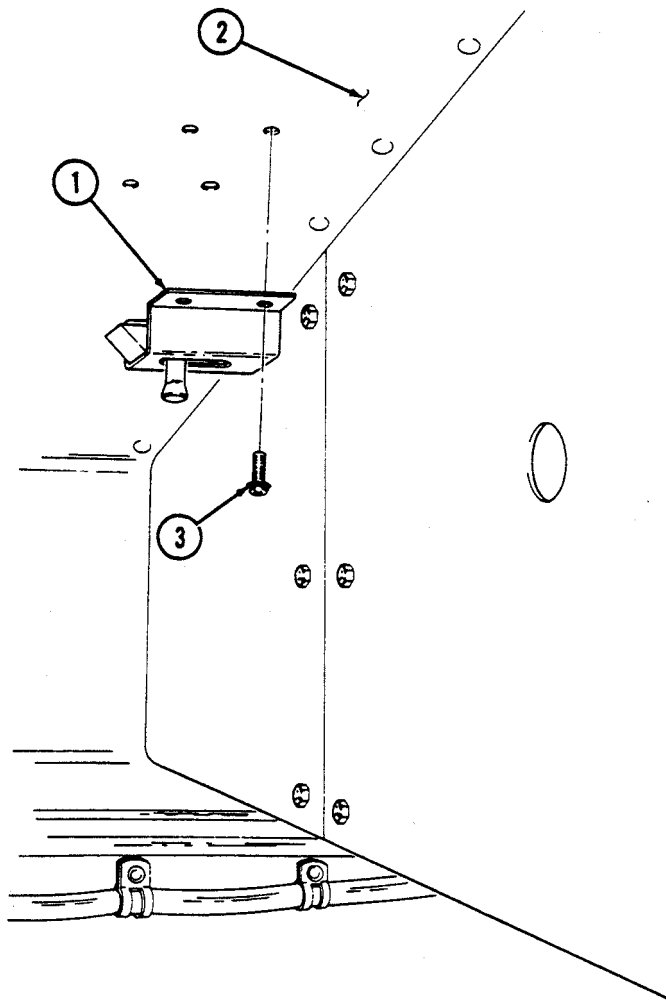

11-164. NBC HEATER REPLACEMENT

This task covers:

- a. Removal
- b. Installation

INITIAL SETUP:

Applicable Models

M996, M996A1, M997, M997A1, M997A2

Manual References

TM 9-2320-280-10
 TM 9-2320-280-24P

Tools

General mechanic's tool kit
 automotive (Appendix B, Item 1)

Equipment Condition

Battery ground cable disconnected (para. 4-73).

NOTE

- The procedure for replacing NBC heaters in M996, M996A1, M997, M997A1, and M997A2 ambulances is basically the same. This procedure covers the driver's NBC heater in the M997, M997A1, and M997A2 ambulances.
- Prior to removal, tag all leads for installation.

a. Removal

1. Disconnect lead 786 (10) from heater (1).
2. Loosen clamp (6) on heater (1) and NBC pipe connector (5).
3. Remove four nuts (9), washers (8), capscrews (4), washers (3), heater (1), and ground lead (7) from body (2).

b. Installation

1. Install heater (1) and ground lead (7) on body (2) with four washers (3), capscrews (4), washers (8), and nuts (9).
2. Install NBC pipe connector (5) to heater (1) with clamp (6).
3. Install lead 786 (10) to heater (1).

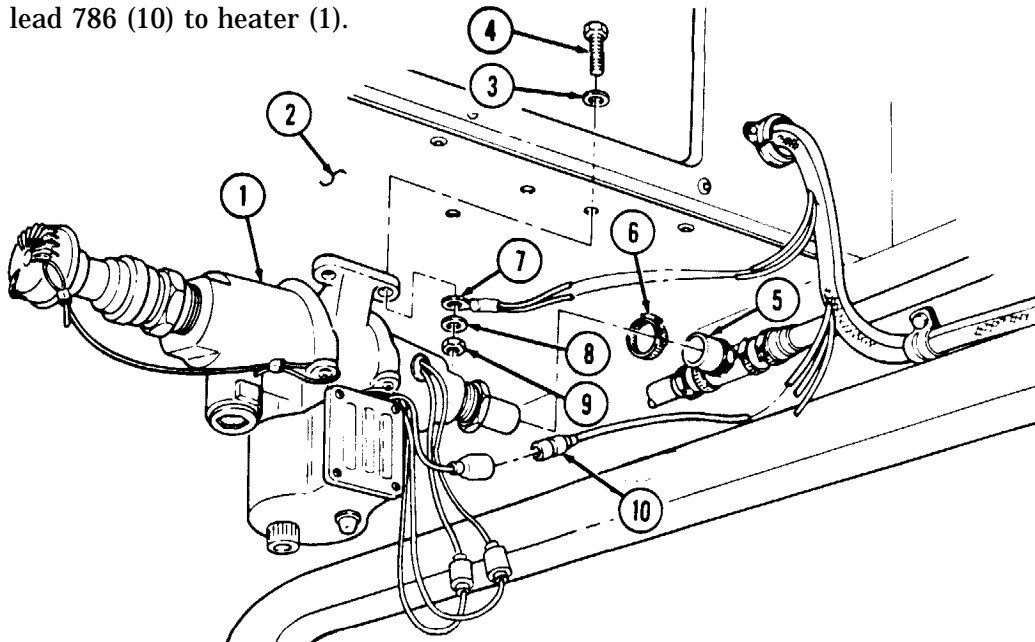

- FOLLOW-ON TASKS:**
- Check operation of NBC heater (TM 9-2320-280-10).
 - Connect battery ground cable (para. 4-73).

11-165. NBC HEATER BRACKETS REPLACEMENT

This task covers:

a. Removal

b. Installation

INITIAL SETUP:

Applicable Models

M997, M997A1, M997A2

Manual References

TM 9-2320-280-24P

Tools

General mechanic's tool kit:
automotive (Appendix B, Item 1)

Equipment Condition

NBC heaters removed (para. 11-164).

NOTE

Left and right NBC heater brackets are replaced basically the same. This procedure covers replacement of left heater brackets.

a. Removal

1. Remove NBC piping (6) from two clamps (7).
2. Remove four capscrews (9), washers (8), and NBC heater mounting bracket (5) from bulkhead brackets (1).
3. Remove four capscrews (4), washers (3), and two bulkhead brackets (1) from bulkhead (2).

b. Installation

1. Install two bulkhead brackets (1) on bulkhead (2) with four washers (3) and capscrews (4).
2. Install NBC heater mounting bracket (5) on two bulkhead brackets (1) with four washers (8) and capscrews (9).
3. Install NBC piping (6) in two clamps (7).

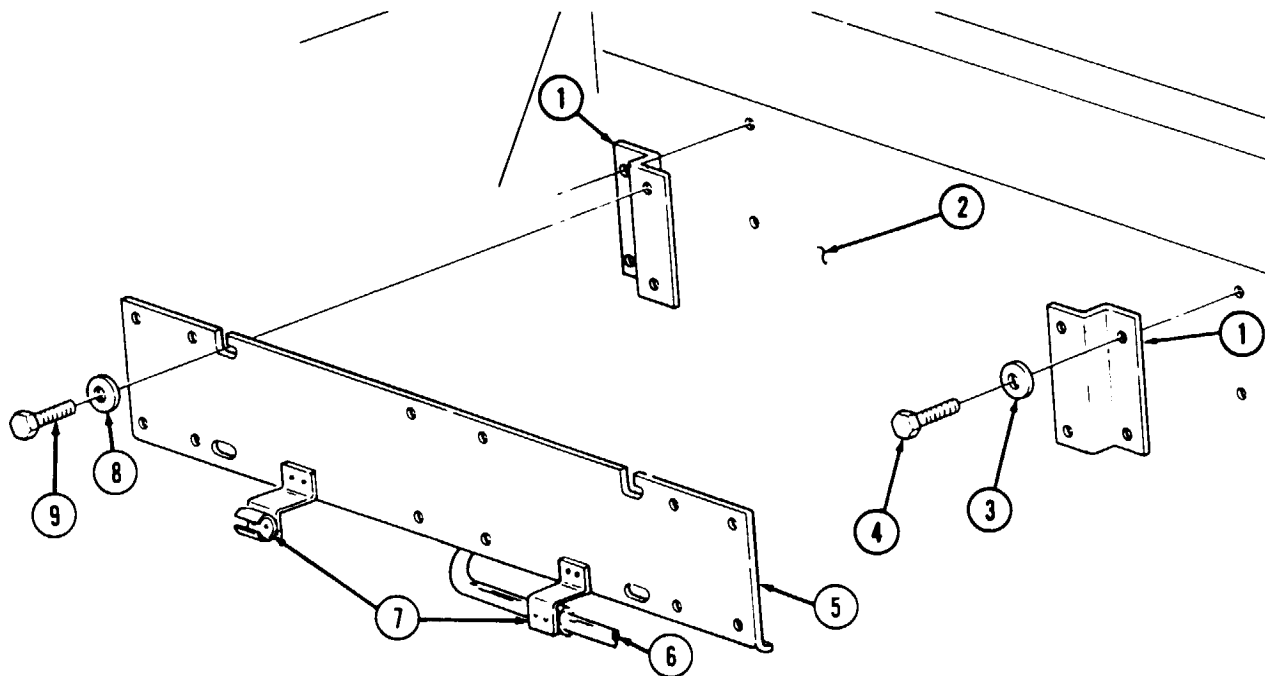

FOLLOW-ON TASK: Install NBC heaters (para. 11-164).

11-166. NBC AIR LINE PIPING MAINTENANCE

This task covers:

- | | |
|--------------------------------|-----------------|
| a. Removal | c. Installation |
| b. Air Line Piping Fabrication | |
-

INITIAL SETUP:

Applicable Models

M996, M996A1, M997, M997A1, M997A2

Materials/Parts

Adhesive (Appendix C, Item 6)

Tools

General mechanic's tool kit:
automotive (Appendix B, Item 1)

Manual References

TM 9-2320-280-10
TM 9-2320-280-24P

NOTE

- Replacement and repair for NBC air lines in M996, M996A1, M997, M997A1, and M997A2 ambulances are basically the same. This procedure gives general guidelines for repair or replacement of PVC pipe.
- The PVC pipe used in ambulance NBC air lines is made up of tees, elbows, connectors, and miscellaneous lengths of straight pipe. All of these are connected and sealed with PVC adhesive. Before beginning a repair or replacement procedure, ensure that you have all necessary pipe, connectors, and PVC adhesive.

a. Removal

Remove section of damaged pipe (6). Damaged pipe section (6) will have to be cut from system because pipe joints cannot be separated without damaging components.

b. Air Line Piping Fabrication

1. Cut a section of new pipe (2) 1/16 in. (1.6 mm) smaller than damaged pipe section (6).

NOTE

Perform steps 2 and 3 before applying PVC adhesive.

2. Install two connectors (3) on new pipe section (2).
3. Install connectors (3) and new pipe section (2) on pipe ends (4) to ensure correct fit and then remove connectors (3) and new pipe section (2).

NOTE

Clean ends of pipe with emery cloth before applying adhesive.

4. Apply PVC adhesive to one end of connectors (3) and both ends of new pipe section (2).
5. Install two connectors (3) with PVC adhesive coated ends inward, to new pipe section (2) and twist components 70-90°. If an elbow (1) or tee (5) is being installed, twist components together 70-90° and then turn components to their proper orientation. Allow PVC adhesive to dry.
6. Apply PVC adhesive to connectors (3) and pipe ends (4).

c. Installation

Install connectors (3) and new pipe section (2) on pipe ends (4) and twist 70-90°. Allow PVC adhesive to dry.

11-166. NBC AIR LINE PIPING MAINTENANCE (Cont'd)

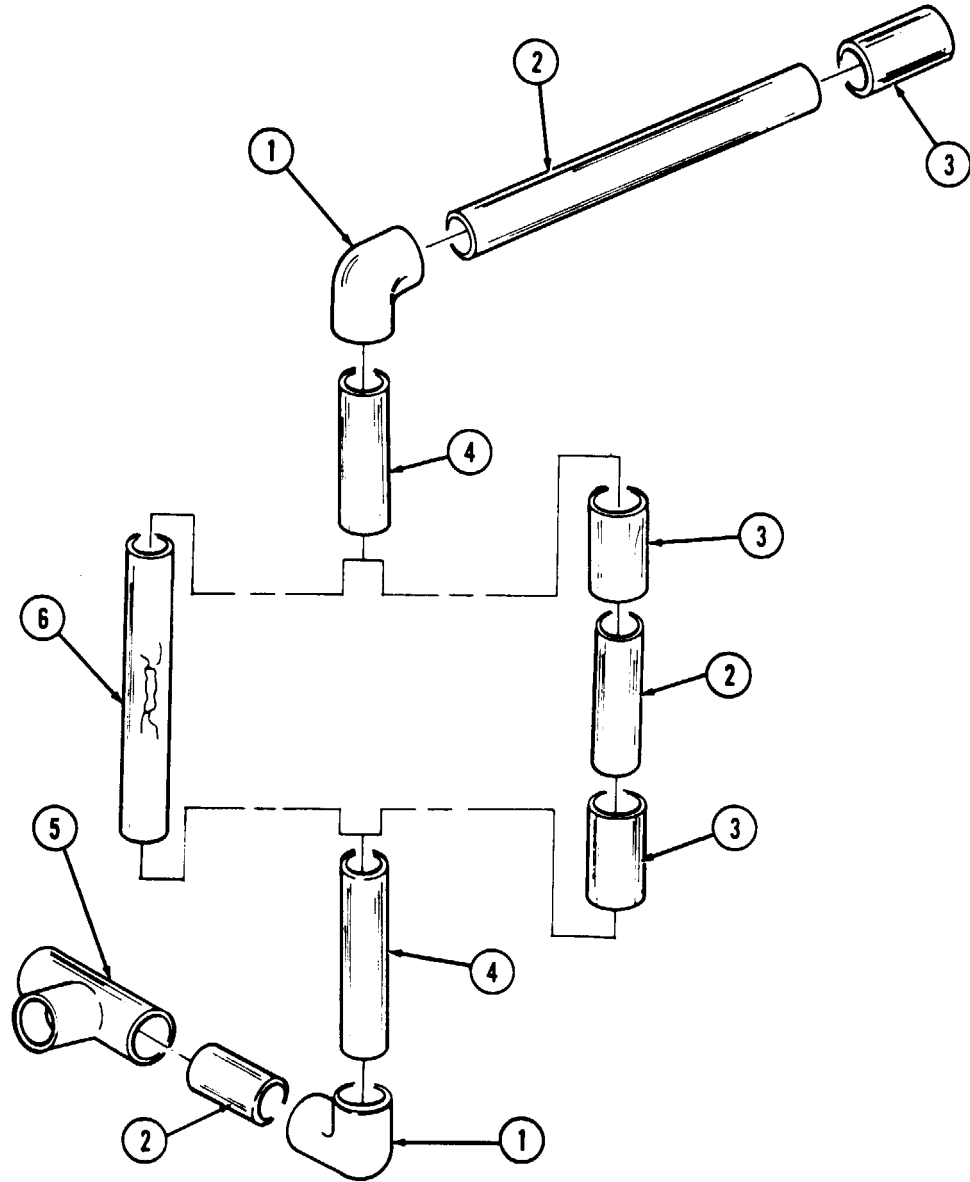

FOLLOW-ON TASK: Operate NBC system and check for leaks (TM 9-2320-280-10).

11-167. NBC GAS FILTER AND BRACKET REPLACEMENT

This task covers:

a. Removal

b. Installation

INITIAL SETUP:

Applicable Models

M996, M996A1, M997, M997A1, M997A2

Tools

General mechanic's tool kit:
automotive (Appendix B, Item 1)

Materials/Parts

Four lockwashers (Appendix G, Item 135)
Four blind rivets (Appendix G, Item 251)

Manual References

TM 9-2320-280-10
TM 9-2320-280-24P
FM 3-4
FM 3-5

Equipment Condition

NBC access door opened (TM 9-2320-280-10).

General Safety Instructions

If filter has been used in a nuclear, biological, or chemical (NBC) environment, special precautions must be taken.

WARNING

NBC contaminated filters must be handled and disposed of only by authorized and trained personnel. The unit commander or senior officer in charge of maintenance personnel must ensure that prescribed protective clothing (FM 3-4) is used, and prescribed safety measures and decontamination procedures (FM 3-5) are followed. The local unit SOP is responsible for final disposal of contaminated air filters.

NOTE

- For instructions on replacement of rivets, refer to para. 10-66.
- The procedures for replacing the NBC gas filter and bracket are basically the same for M996, M996A1, M997, M997A1, and M997A2 ambulances. This procedure covers NBC filter and bracket in M997, M997A1, and M997A2 ambulances. The basic differences in M996 and M996A1 ambulances are:
 - PVC air line is replaced by flex tube.
 - Bracket is installed on NBC door and secured with four rivets and eight washers.
- Note direction of gas filter air flow arrow for installation.

a. Removal

1. Loosen two clamps (1) on ends of gas filter (9) and connectors (2).
2. Unhook two latches (8) from bracket (5) on gas filter (9).
3. Remove gas filter (9) from connectors (2) and bracket (5).

NOTE

Perform step 4 for M997, M997A1, and M997A2 vehicles only.

4. Remove four capscrews (7), lockwashers (6), bracket (5), and two spacers (4) from body (3). Discard lockwashers (6).

11-167. NBC GAS FILTER AND BRACKET REPLACEMENT (Cont'd)

NOTE

Perform step 5 for M996 and M996A1 vehicles only.

- Remove four rivets (10), eight washers (11), and bracket (5) from NBC door (12).

b. Installation

NOTE

Perform step 1 for M996 and M996A1 vehicles only.

- Install bracket (5) on NBC door (12) with eight washers (11) and four rivets (10).

NOTE

Perform step 2 for M997, M997A1, and M997A2 vehicles only.

- Intall two spacers (4) and bracket (5) on body (3) with four lockwashers (6) and capscrews (7).
- Install gas filter (9) on connectors (2) and bracket (5) with latches (8).
- Install ends of gas filter (9) on connectors (2) and tighten two clamps (1).

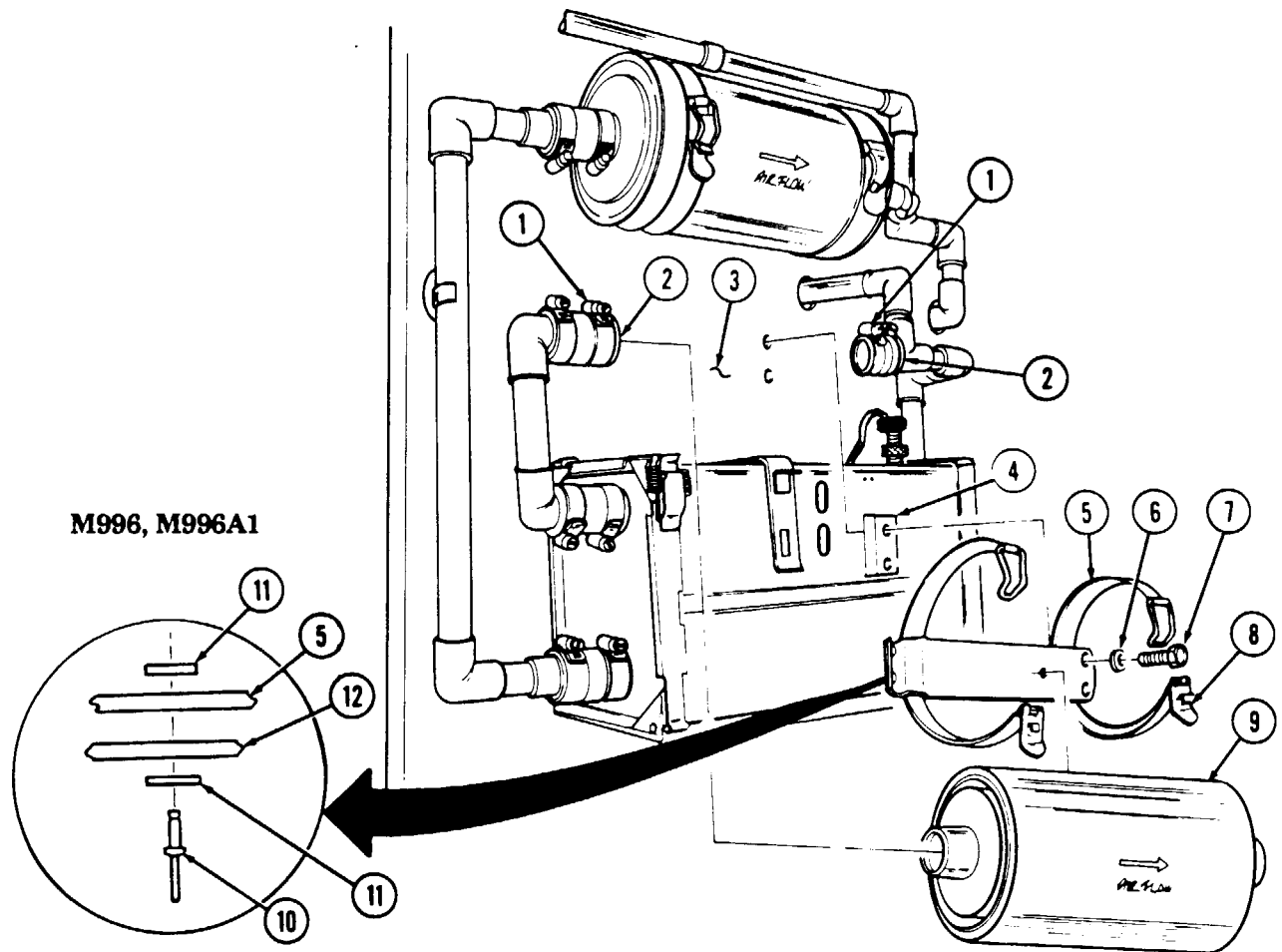

FOLLOW-ON TASK: Close NBC access door (TM 9-2320-280-10).

11-168. NBC PRECLEANER, PARTICULATE FILTER ASSEMBLY, AND BRACKET REPLACEMENT

This task covers:

a. Removal

b. Installation

INITIAL SETUP:

Applicable Models

M996, M996A1, M997, M997A1, M997A2

Tools

General mechanic's tool kit:
automotive (Appendix B, Item1)

Materials/Parts

Four lockwashers (Appendix G, Item 181)
Four lockwashers (Appendix G, Item 135)
Four lockwashers (Appendix G, Item 185)
Filter (Appendix G, Item 34)

Manual References

TM 9-2320-280-10
TM 9-2320-280-24P
FM 3-4
FM 3-5

Equipment Condition

NBC access door opened (TM 9-2320-280-10).

General Safety Instructions

NBC contaminated filters must be handled and disposed of only by trained personnel.

WARNING

MNBC contaminated filters must be handled and disposed of only by authorized and trained personnel. The unit commander or senior officer in charge of maintenance personnel must ensure that prescribed protective clothing (FM 3-4) is used, and prescribed safety measures and decontamination procedures (FM 3-5) are followed. The local unit SOP is responsible for final disposal of contaminated air filters.

NOTE

The procedures for replacing precleaner and particulate filter and filter assembly and bracket are basically the same for M996, M996A1, M997, M997A1, and M997A2 ambulances. This procedure covers precleaner and particulate filter and bracket in M997, M997A1, and M997A2 ambulances. The basic differences in M996 and M996A1 ambulance are:

- The rigid PVC air line is replaced by flex tube and plastic clamps.
- Bracket is mounted on the floor of the NBC compartment and is secured by four capscrews, washers, lockwashers, and nuts.

a. Removal

1. Disconnect lead and connector (para. 4-101).
2. Loosen two clamps (1) on precleaner and particulate filter assembly (7) and connectors (2).
3. Remove latch (9) and arms (10) on precleaner and particulate filter assembly (7) from bracket (6).
4. Remove precleaner and particulate filter assembly (7) from connectors (2) and bracket (6).

NOTE

Perform step 5 for M997, M997A1, and M997A2 vehicles only.

5. Remove four capscrews (5), lockwashers (4), and bracket (6) from body (3). Discard lockwashers (4).

NOTE

Perform step 6 for M996 and M996A1 vehicles only.

6. Remove four nuts (11), lockwashers (12), capscrews (14), washers (13), and bracket (6) from floor (15) of NBC compartment. Discard lockwashers (12).
7. For shipping or decontamination purposes, slide clip (8) over intake holes in precleaner and particulate filter assembly (7).

11-168. NBC PRECLEANED, PARTICULATE FILTER ASSEMBLY, AND BRACKET REPLACEMENT (Cont'd)

8. Remove four screws (19), lockwashers (20), and manifold (16) from housing (18). Discard lockwashers (20).
9. Remove filter (17) from filter housing (18).

b. Installation

NOTE

Perform step 1 for M997, M997A1, and M997A2 vehicles only.

1. Install bracket (6) on body (3) with four lockwashers (4) and capscrews (5).

NOTE

Perform step 2 for M996 and M996A1 vehicles only.

2. Install bracket (6) on floor (15) of NBC compartment with four washers (13), capscrews (14), lockwashers (12), and nuts (11).
3. Install filter (17) into filter housing (18).
4. Install manifold (16) on filter housing (18) with four lockwashers (20) and screws (19).
5. Slide clip (8) away from air intake holes in precleaned and particulate filter assembly (7).
6. Install precleaned and particulate filter assembly (7) on connectors (2) and bracket (6) with arms (10) and latch (9).
7. Tighten two clamps (1) on precleaned and particulate assembly (7) and connectors (2).
8. Connect lead and connector (para. 4-101).

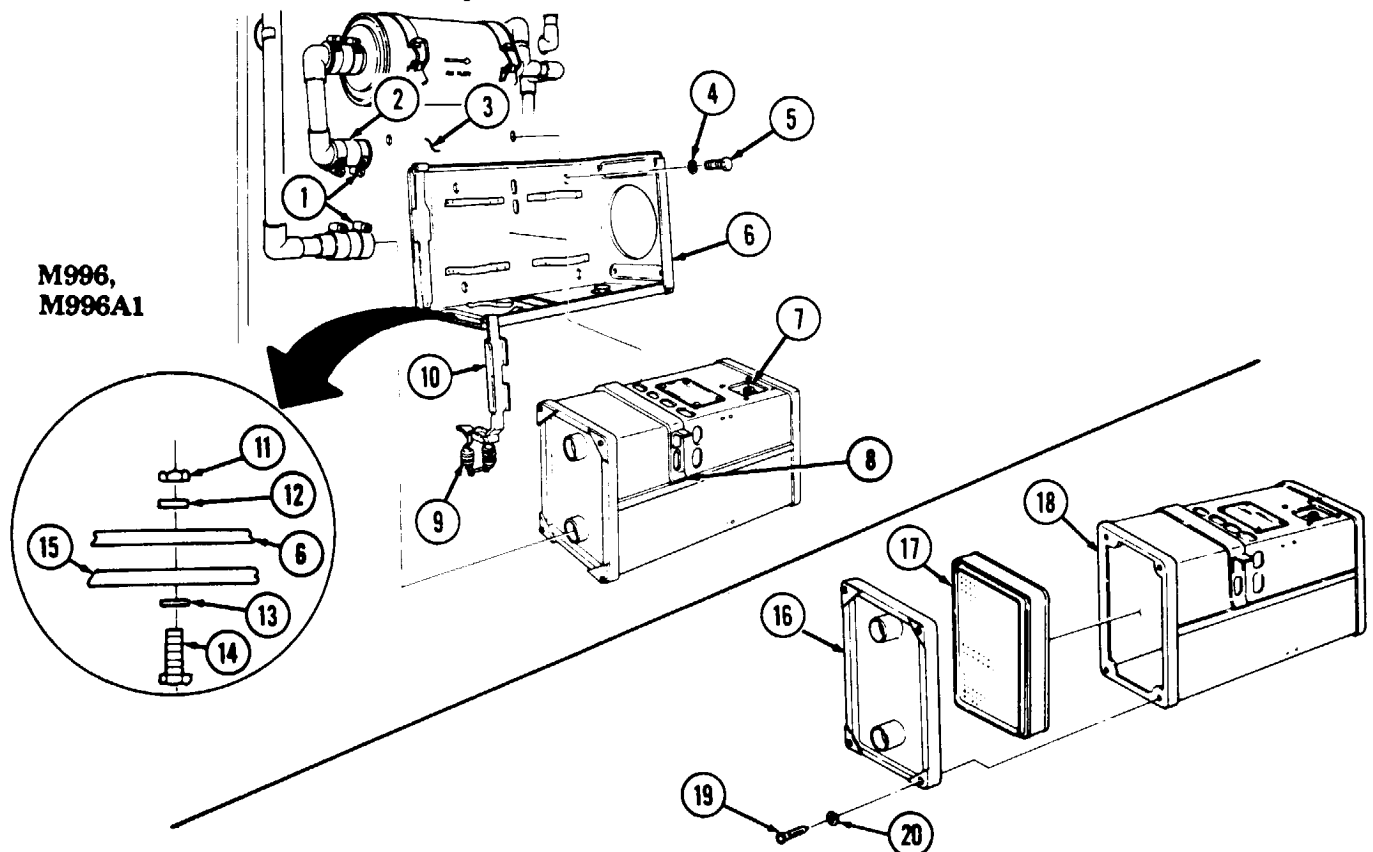

FOLLOW-ON TASK: Close NBC access door (TM 9-2320-280-10).

11-169. INTERCOM AND BRACKETS REPLACEMENT

This task covers:

a. Removal

b. Installation

INITIAL SETUP:

Applicable Models

M996, M996A1, M997, M997A1, M997A2

Manual References

TM 9-2320-280-24P

Tools

General mechanic's tool kit:
automotive (Appendix B, Item 1)

a. Removal

1. Disconnect intercom cable (11) from intercom control (10).
2. Remove two nuts (17), washers (16), capscrews (12), washers (13), and intercom control (10) from intercom mounting bracket (6).
3. Disconnect cable (7) from audio amplifier (8).
4. Remove four nuts (3), washers (4), capscrews (9), washers (4), and audio amplifier (8) from intercom mounting bracket (6).
5. Remove two nuts (14), washers (15), capscrews (20), and washers (21) from intercom mounting bracket (6) and radio rack support (5).
6. Remove two nuts (18), washers (19), screws (2), and intercom mounting bracket (6) from radio rack (1).

NOTE

Perform step 7 for M996 and M996A1 vehicles only.

7. Disconnect intercom cable (11) from intercom control (22). Remove two capscrews (24), washers (25), and intercom control (22) from wall (23).

NOTE

Perform step 8 for M997, M997A1, and M997A2 vehicles only.

8. Disconnect intercom cable (11) from intercom control (26). Remove two nuts (29), washers (28), reinforcement bracket (27), two capscrews (32), washers (31), and intercom control (26) from body (30).

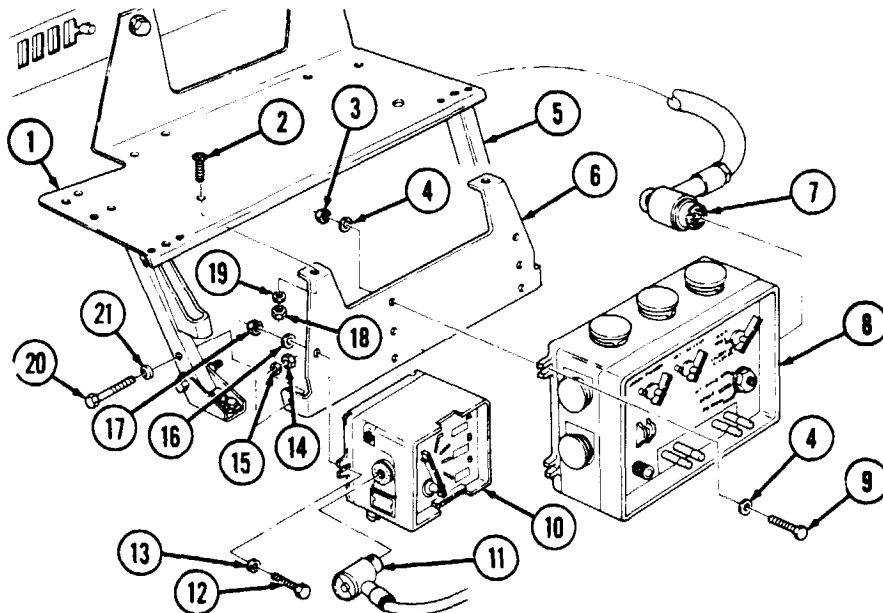

11-169. INTERCOM AND BRACKETS REPLACEMENT (Cont'd)

b. Installation

NOTE

Perform step 1 for M997, M997A1, and M997A2 vehicles only.

1. Install intercom control (26) and reinforcement bracket (27) on body (30) with two washers (31), capscrews (32), washers (28), and nuts (29). Connect intercom cable (11) to intercom control (26).

NOTE

Perform step 2 for M996 and M996A1 vehicles only.

2. Install intercom control (22) on body (23) with two washers (25) and capscrews (24). Connect intercom cable (11) to intercom control (22).
3. Install intercom mounting bracket (6) on radio rack support (5) with two washers (21), capscrews (20), washers (15), and nuts (14).
4. Install intercom mounting bracket (6) on radio rack (1) with two screws (2), washers (19), and nuts (18).
5. Install audio amplifier (8) on intercom mounting bracket (6) with four washers (4), capscrews (9), washers (4), and nuts (3). Connect cable (7) to audio amplifier (8).
6. Install intercom control (10) on intercom mounting bracket (6) with two washers (13), capscrews (12), washers (16), and nuts (17). Connect intercom cable (11) to intercom control (10).

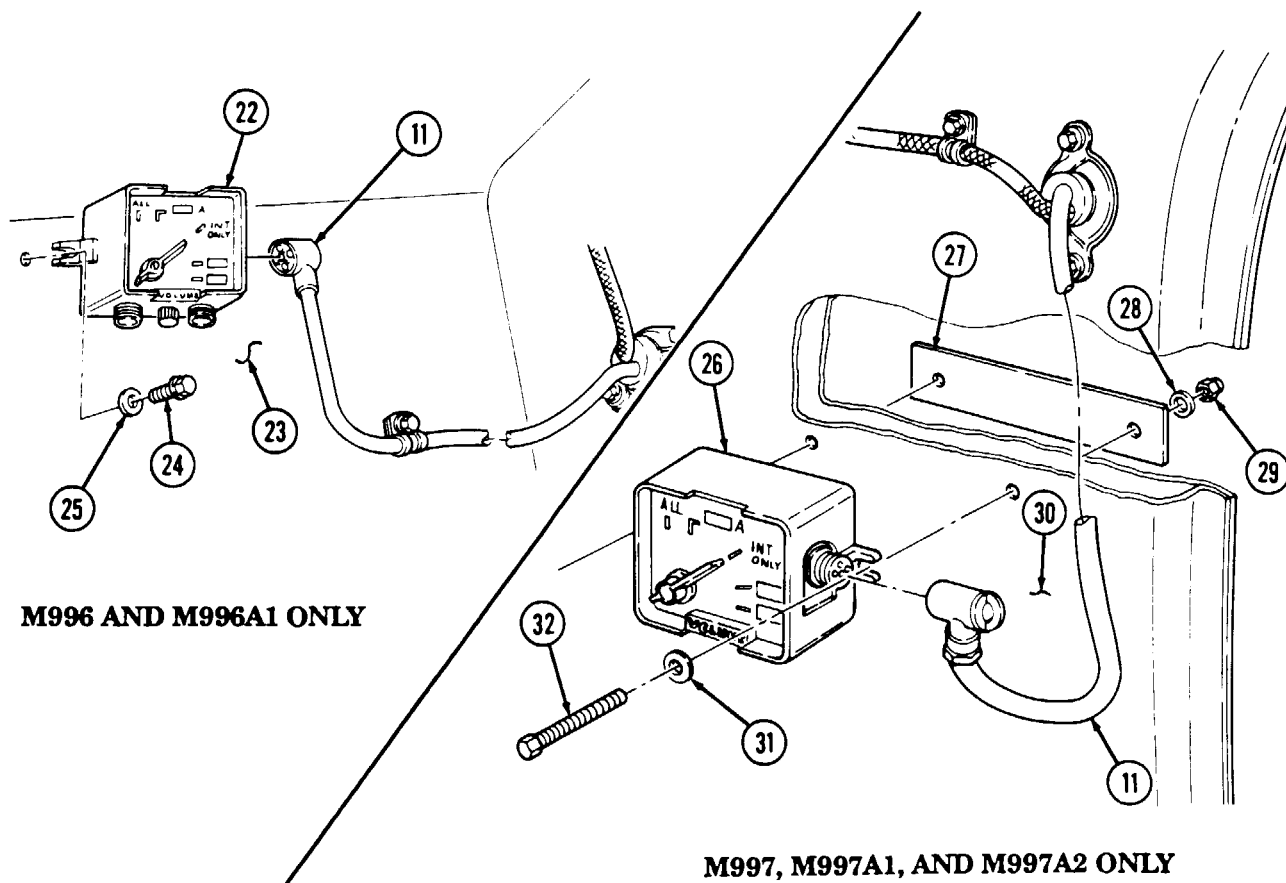

M996 AND M996A1 ONLY

M997, M997A1, AND M997A2 ONLY

11-170. REAR DRIP RAIL REPLACEMENT

This task covers:

a. Removal

b. Installation

INITIAL SETUP:

Applicable Models

M996, M996A1, M997, M997A1, M997A2

Tools

General mechanic's tool kit:
automotive (Appendix B, Item 1)

Materials/Parts

Sealant (Appendix C, Item 38)
Nine blind rivets (Appendix G, Item 254)

Manual References

TM 9-2320-280-24P

NOTE

For instructions on replacement of rivets, refer to para. 10-66.

a. Removal

Remove nine rivets (2) and drip rail (3) from body (1).

b. Installation

Apply sealant to drip rail (3) and install drip rail (3) on body (1) with nine rivets (2).

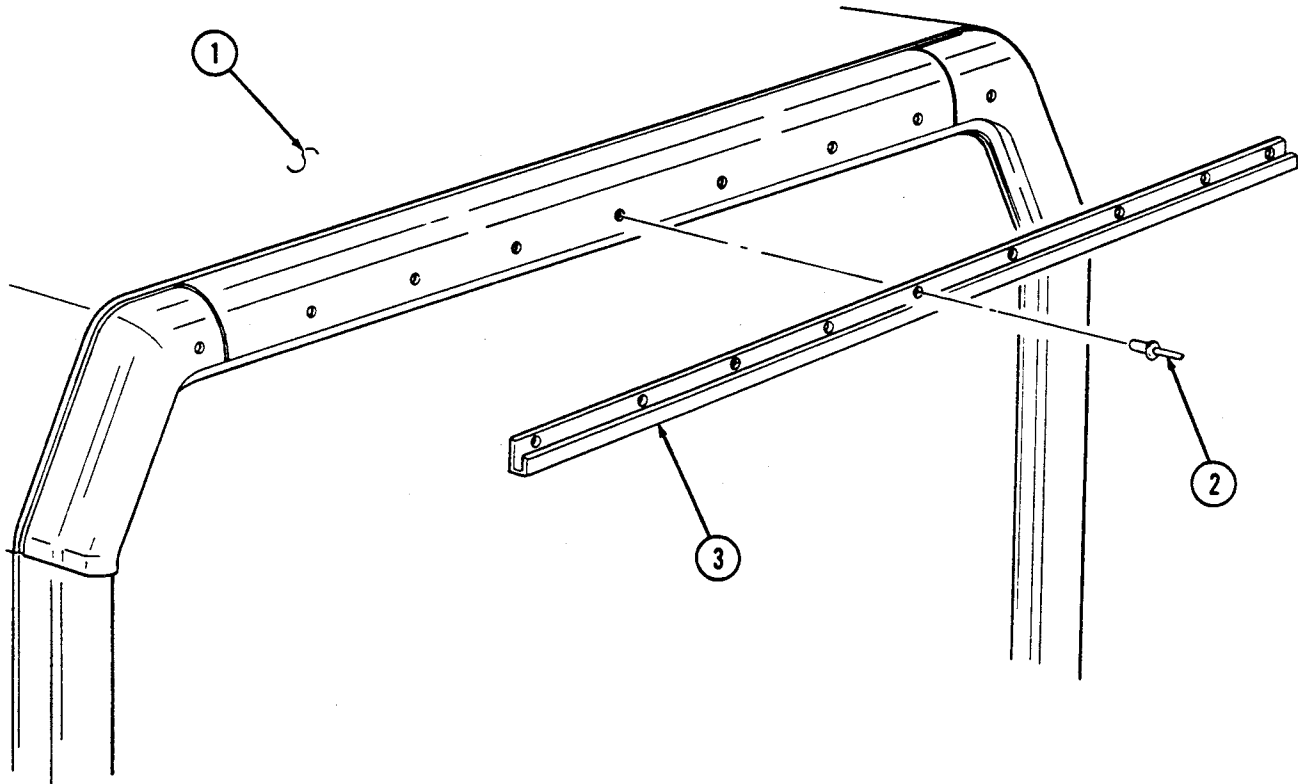

11-171. RADIO ANTENNA MOUNT REPLACEMENT (M996, M996A1)

This task covers:

a. Removal

b. Installation

INITIAL SETUP:

Applicable Models

M996, M996A1

Manual References

TM 9-2320-280-24P

Tools

General mechanic's tool kit:
automotive (Appendix B, Item 1)

Equipment Condition

Antenna removed (para. 12-137).

Materials/Parts

Six lockwashers (Appendix G, Item 134)

a. Removal

Remove six capscrews (2), lockwashers (1), antenna mount (3), and seal (4) from roof (5). Discard lockwashers (1).

b. Installation

Install seal (4) and antenna mount (3) on roof (5) with six lockwashers (1) and capscrews (2).

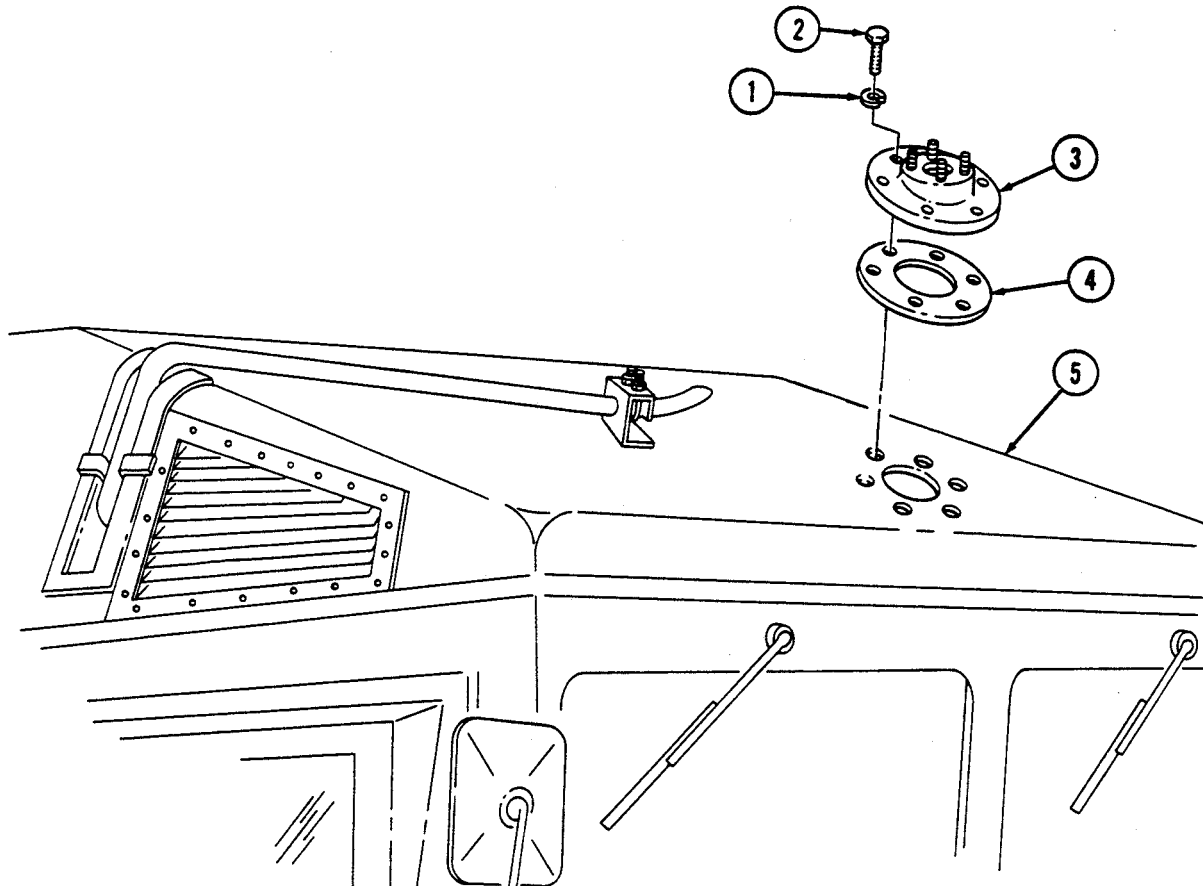

FOLLOW-ON TASK: Install antenna (para. 12-137).

11-172. RADIO ANTENNA MOUNT REPLACEMENT (M997, M997A1, M997A2)

This task covers:

a. Removal

b. Installation

INITIAL SETUP:

Applicable Models

M997, M997A1, M997A2

Manual References

TM 9-2320-280-24P

Tools

General mechanic's tool kit:
automotive (Appendix B, Item 1)

Equipment Condition

Antenna removed (para. 12-137).

Materials/Parts

Two lockwashers (Appendix G, Item 158)
Lockwasher (Appendix G, Item 144)

a. Removal

1. Remove capscrew (7), lockwasher (8), seal (2), cable clip (9), and ground strap (6) from antenna mount (1) and roof (10). Discard lockwasher (8).
2. Remove two capscrews (5), lockwashers (4), washers (3), antenna mount (1), and seal (2) from roof (10). Discard lockwashers (4).

b. Installation

NOTE

Clean ground strap at point of interior body contact to bare metal to ensure good antenna ground.

1. Install seal (2) and antenna mount (1) on roof (10) with two washers (3), lockwashers (4), and capscrews (5).
2. Install cable clip (9), ground strap (6), seal (2), and antenna mount (1) on roof (10) with lockwasher (8) and capscrew (7).

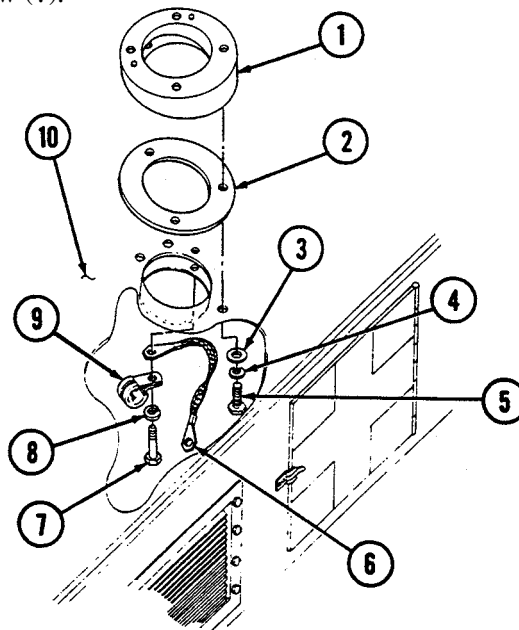

FOLLOW-ON TASK: Install antenna (para. 12-137).

11-173. STOWAGE NET ASSEMBLY REPLACEMENT

This task covers:

a. Removal

b. Installation

INITIAL SETUP:

Applicable Models

M997, M997A1, M997A2

Manual References

TM 9-2320-280-24P

Tools

General mechanic's tool kit:
automotive (Appendix B, Item 1)

a. Removal

1. Slide two spring-loaded caps (4) on front support bar (7) inward, away from wall mounts (5), and slide flange (8) up and out of wall mounts (5).
2. Remove five stowage strap hooks (1) from footman loops (6) and remove stowage net (2) and front support bar (7).
3. Unfasten two straps (3) and remove stowage net (2) from front support bar (7).

b. Installation

1. Install stowage net (2) on front support bar (7) with two straps (3).
2. Install five stowage strap hooks (1) on footman loops (6).
3. Slide two spring-loaded caps (4) inward, along front support bar (7), and install flange (8) on wall mounts (5).

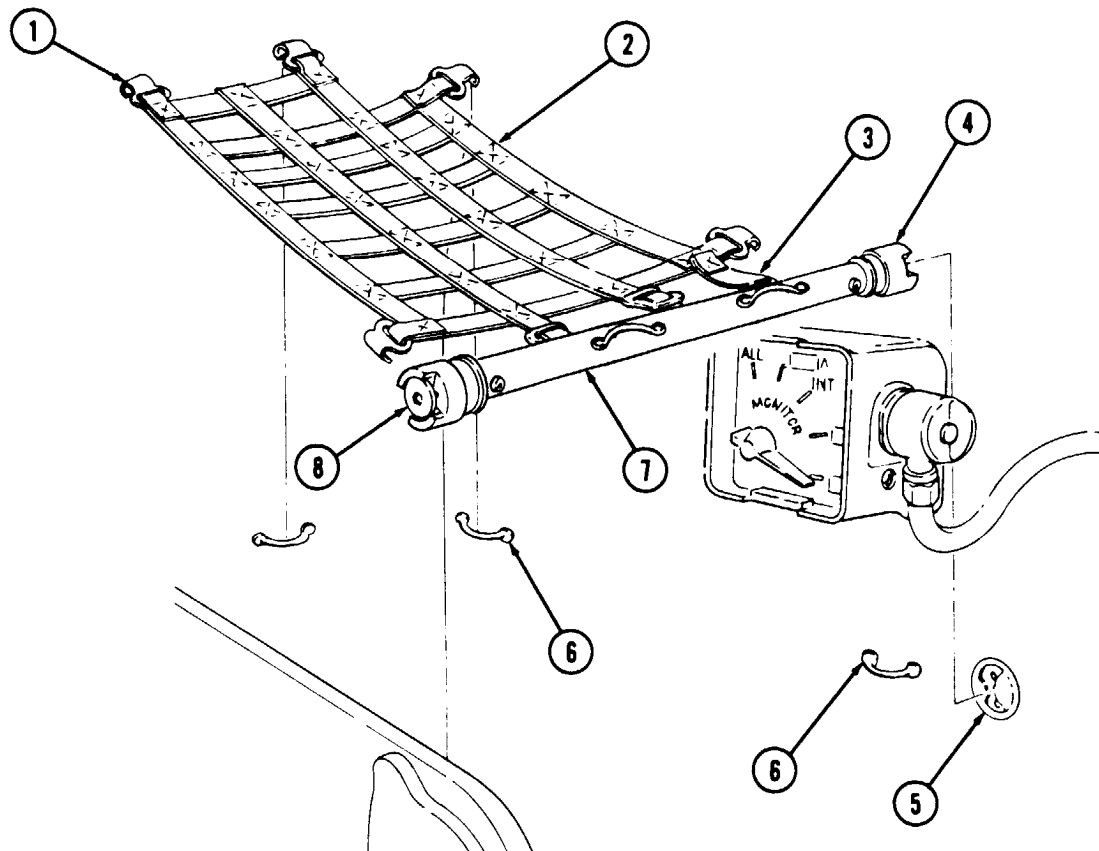

11-174. RED CROSS PLACARD RETAINING CLIP REPLACEMENT

This task covers:

a. Removal

b. Installation

INITIAL SETUP:

Applicable Models

M996, M996A1, M997, M997A1, M997A2

Manual References

TM 9-2320-280-24P

Tools

General mechanic's tool kit:
automotive (Appendix B, Item 1)

a. Removal

Remove two capscrews (1) and retaining clip (2) from body (3).

b. Installation

Install retaining clip (2) on body (3) with two capscrews (1).

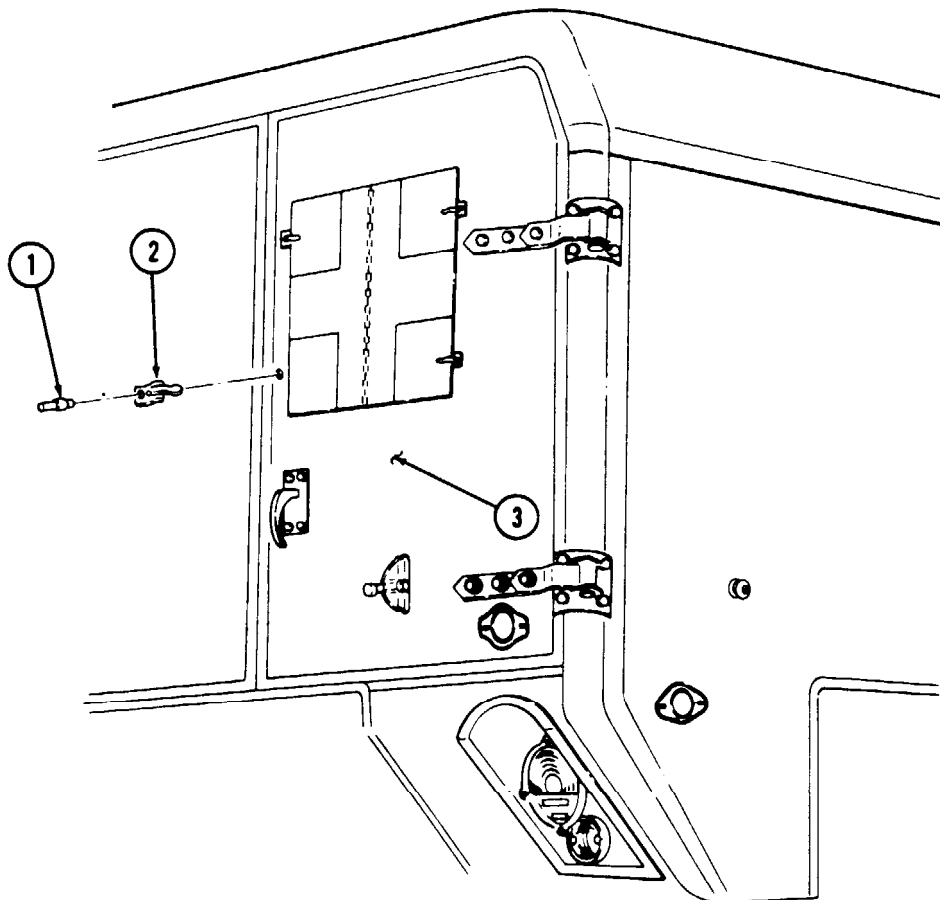

11-175. RED CROSS PLACARD REPLACEMENT

This task covers:

a. Removal

b. Installation

INITIAL SETUP:

Applicable Models

M996, M996A1, M997, M997A1, M997A2

Tools

General mechanic's tool kit:
automotive (Appendix B, Item 1)

Materials/Parts

Seven blind rivets (Appendix G, Item 251)
Five blind rivets (Appendix G, Item 250)

Manual References

TM 9-2320-280-24P

NOTE

- Rear door, body side, body top, and front red cross placards are removed and installed basically the same. This procedure covers an M997, M997A1, and M997A2 rear door red cross placard.
- For instructions on replacement of rivets, refer to para. 10-66.

a. Removal

Remove twelve rivets (1) and red cross placard (2) from rear door (3).

b. Installation

Install red cross placard (2) to rear door (3) with twelve rivets (1).

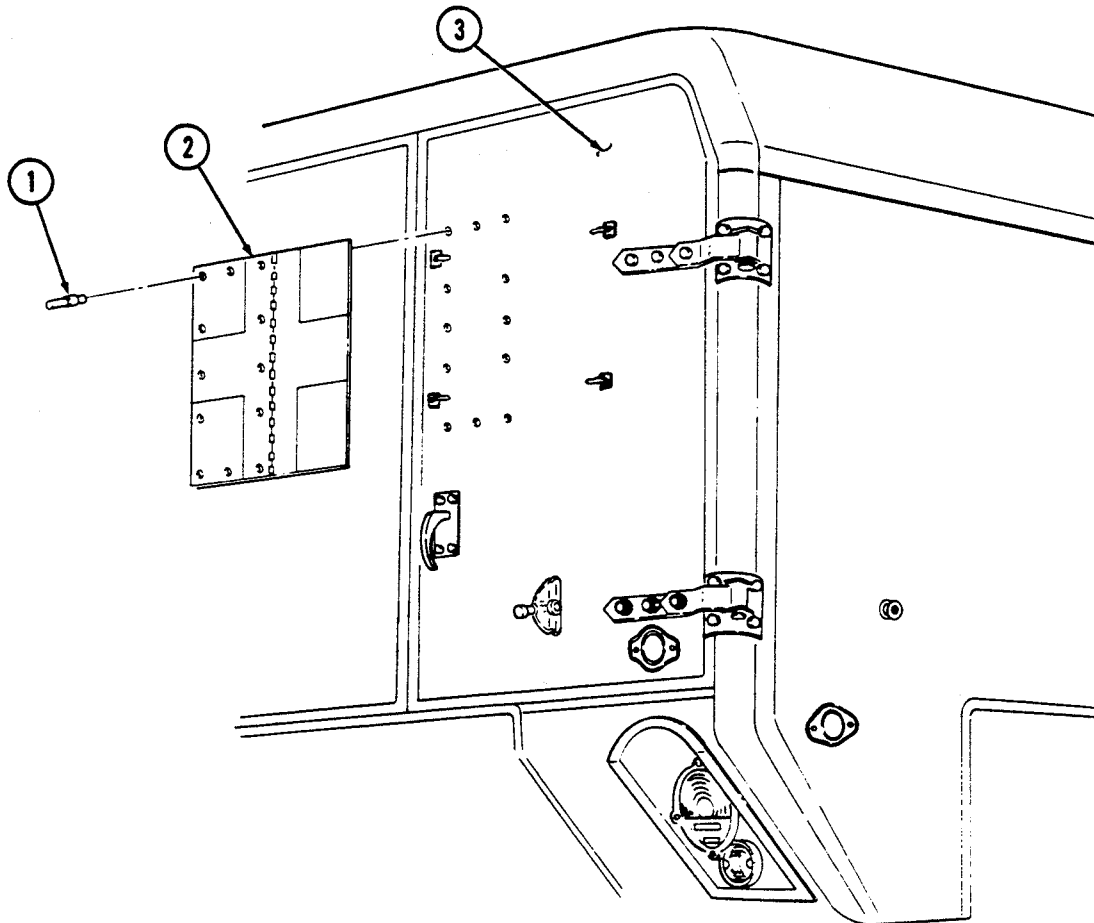

11-176. EXTERIOR STOWAGE DOOR REPLACEMENT

This task covers:

a. Removal

b. Installation

INITIAL SETUP:

Applicable Models

M996, M996A1, M997, M997A1, M997A2

Tools

General mechanic's tool kit:
automotive (Appendix B, Item 1)

Materials/Parts

Adhesive (Appendix C, Item 3)
Fourteen blind rivets (Appendix G, Item 250)
Twelve blind rivets (Appendix G, Item 253)

Manual References

TM 9-2320-280-24P

NOTE

- For instructions on replacement of rivets, refer to para. 10-66.
- Replacement procedures for left and right exterior stowage doors are basically the same. This procedure covers the left stowage door.

a. Removal

1. Remove seven rivets (2), hinge (6), and door (8) from body (5).
2. Remove seven rivets (1) and hinge (6) from door (8).
3. Remove four rivets (11) and two rubber latches (10) from door (8).
4. Remove four rivets (9) and two brushguards (12) from door (8).
5. Remove four rivets (3) and two catches (4) from body (5).
6. Remove seal (7) from door (8). Discard seal (7) if damaged.

b. Installation

1. Apply adhesive to seal (7) and install seal (7) on door (8).
2. Install two catches (4) on body (5) with four rivets (3).
3. Install two brushguards (12) on door (8) with four rivets (9).
4. Install two rubber latches (10) on door (8) with four rivets (11).
5. Install hinge (6) on door (8) with seven rivets (1).
6. Install hinge (6) and door (8) on body (5) with seven rivets (2).

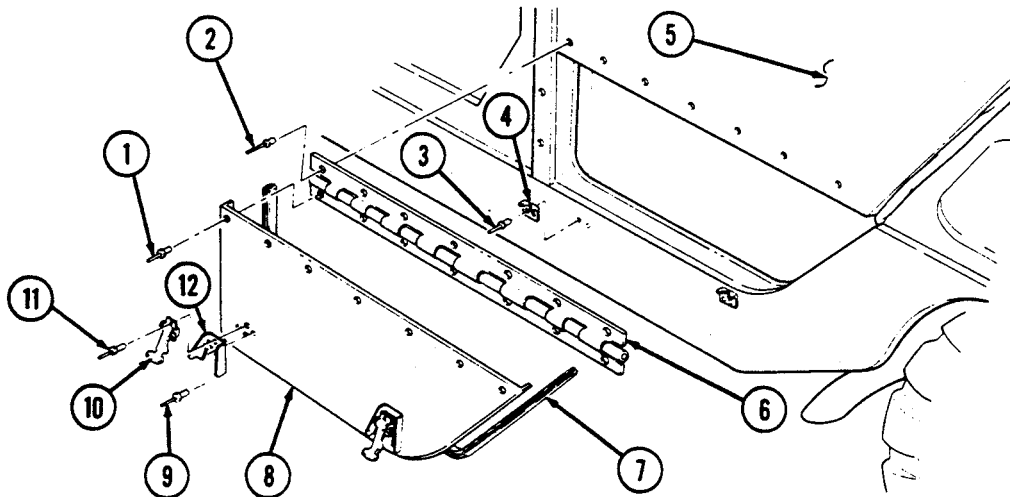

11-177. ATTENDANT SEAT STOWAGE BRACKETS REPLACEMENT

This task covers:

a. Removal

b. Installation

INITIAL SETUP:

Applicable Models

M996, M996A1, M997, M997A1, M997A2

Tools

General mechanic's tool kit:
automotive (Appendix B, Item 1)

Materials/Parts

Eight blind rivets (Appendix G, Item 251)

Manual References

TM 9-2320-280-10
TM 9-2320-280-24P

Equipment Condition

Attendant seat removed from stowed position
(TM 9-2320-280-10).

NOTE

- For instructions on replacement of rivets, refer to para. 10-66.
- Replacement procedures for attendant seat stowage brackets are basically the same for M996, M996A1, M997, M997A1, and M997A2 ambulances, with the exception of the strap assembly. The strap assembly is mounted in a vertical position on the body of the M996 and M996A1 ambulance. This procedure covers the attendant seat stowage brackets in the M997, M997A1, and M997A2 ambulances.

a. Removal

1. Remove four screws (3) and two footman loops (5) from body (1), and remove strap assembly (2) from footman loops (5).
2. Remove eight rivets (6) and two brackets (7) from body (1).
3. Inspect blind rivet (4) for damage. Replace if damaged.

b. Installation

1. Install two brackets (7) on body (1) with eight rivets (6).
2. Install strap assembly (2) on two footman loops (5) and install footman loops (5) on body (1) with four screws (3).

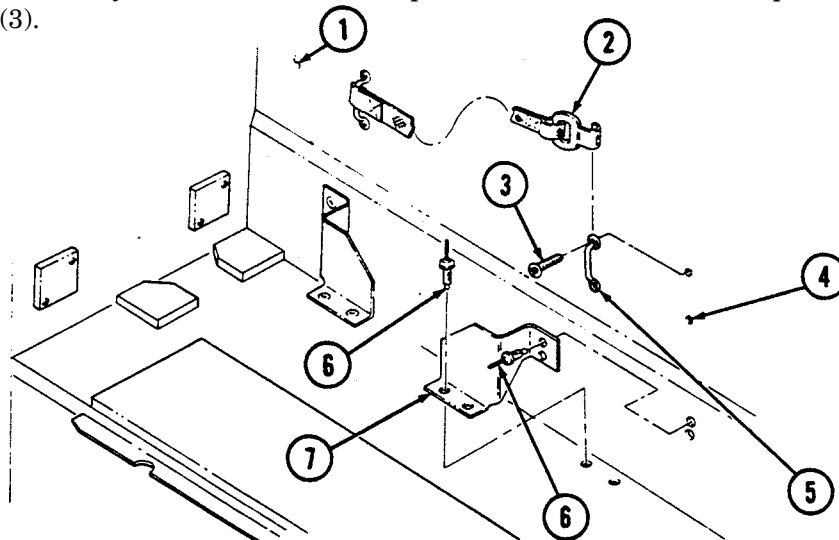

FOLLOW-ON TASK: Stow attendant seat (TM 9-2320-280-10).

11-178. REAR DOOR VENT ASSEMBLY REPLACEMENT

This task covers:

a. Removal

b. Installation

INITIAL SETUP:

Applicable Models

M996, M996A1

Tools

General mechanic's tool kit:
automotive (Appendix B, Item 1)

Materials/Parts

Fourteen blind rivets (Appendix G, Item 250)
Blind rivet (Appendix G, Item 257)
Blind rivet (Appendix G, Item 253)

Manual References

TM 9-2320-280-24P

NOTE

For instructions on replacement of rivets, refer to para. 10-66.

a. Removal

1. Remove two rivets (1) and retaining clip (2) from door (3).
2. Remove fourteen rivets (5) and vent assembly (4) from door (3).

b. Installation

1. Install vent assembly (4) on door (3) with fourteen rivets (5).
2. Install retaining clip (2) on door (3) with two rivets (1).

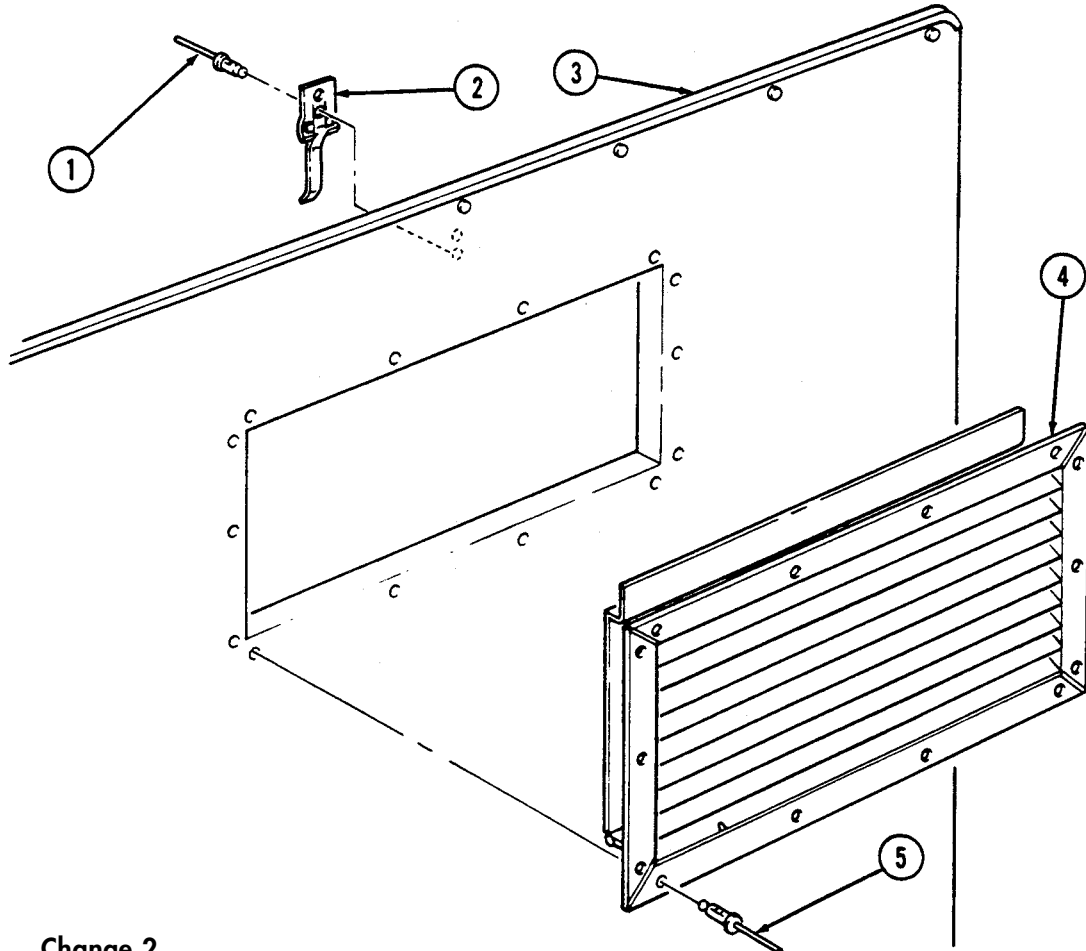

11-179. MEDICAL STOWAGE COVER AND LATCH REPLACEMENT

This task covers:

a. Removal

b. Installation

INITIAL SETUP:

Applicable Models

M996, M996A1

Tools

General mechanic's tool kit:
automotive (Appendix B, Item 1)

Materials/Parts

Nine blind rivets (Appendix G, Item 237)
Two blind rivets (Appendix G, Item 240)
Two blind rivets (Appendix G, Item 250)

Manual References

TM 9-2320-280-24P

NOTE

For instructions on replacement of rivets, refer to para. 10-66.

a. Removal

1. Remove nine rivets (7) and cover and hinge assembly (1) from body (6).
2. Remove two rivets (3) and catch (2) from body (6).
3. Remove two rivets (5) and latch (4) from cover and hinge assembly (1).

b. Installation

1. Install latch (4) on cover and hinge assembly (1) with two rivets (5).
2. Install catch (2) on body (6) with two rivets (3).
3. Install cover and hinge assembly (1) on body (6) with nine rivets (7).

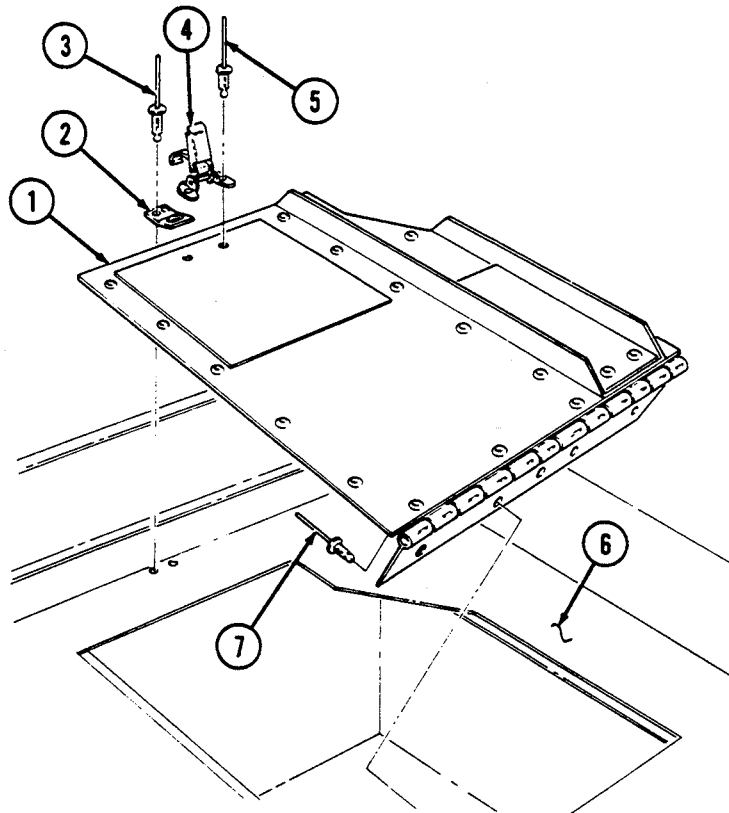

11-180. EDGE PROTECTOR REPLACEMENT

This task covers:

a. Removal

b. Installation

INITIAL SETUP:

Applicable Models

M996, M996A1, M997, M997A1, M997A2

Manual References

TM 9-2320-280-24P

Tools

General mechanic's tool kit:
automotive (Appendix B, Item 1)

a. Removal

Pry edge protector (2) from bulkhead (1) and remove edge protector (2).

b. Installation

Install edge protector (2) by pressing edge protector (2) onto bulkhead (1).

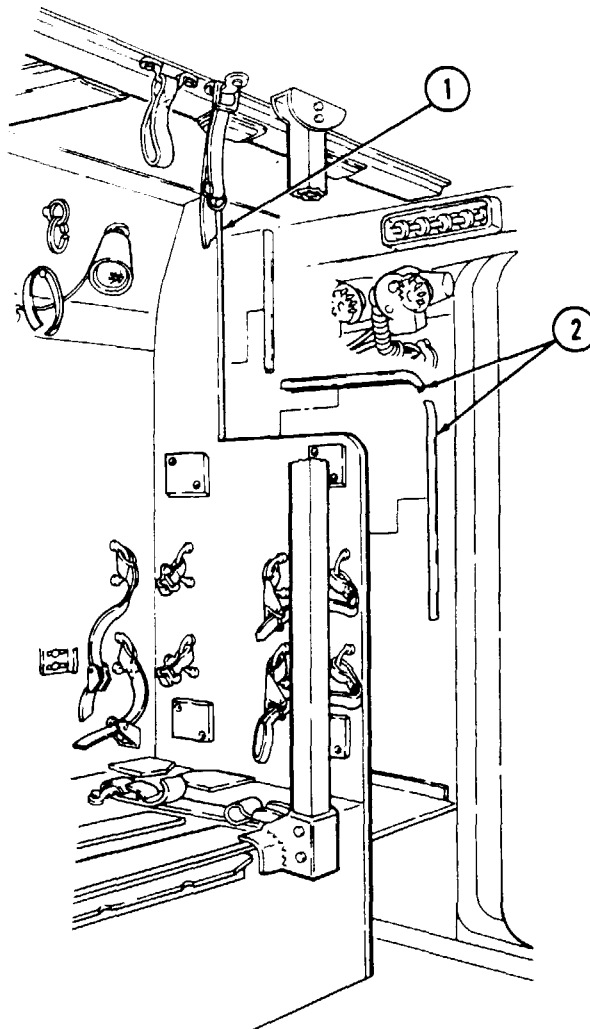

11-180.1. SPREADER BAR TIEDOWN REPLACEMENT

This task covers:

a. Removal

b. Installation

INITIAL SETUP:

Applicable Models

M996, M996A1, M997, M997A1,
M997A2

Materials/Parts

Lockwasher (Appendix G, Item 140)
Adhesive sealant (Appendix C, Item 38)

Tools

General mechanic's tool kit
automotive (Appendix B, Item 1)

a. Removal

Remove capscrew (4), lockwasher (3), and spreader bar tiedown (2) from body (1). Discard lockwasher (3).

b. Installation

Apply adhesive sealant to capscrew (4) and install spreader bar tiedown (2) on body (1) with lockwasher (3) and capscrew (4). Tighten capscrew (4) to 45-55 lb-ft (61-75 N·m).

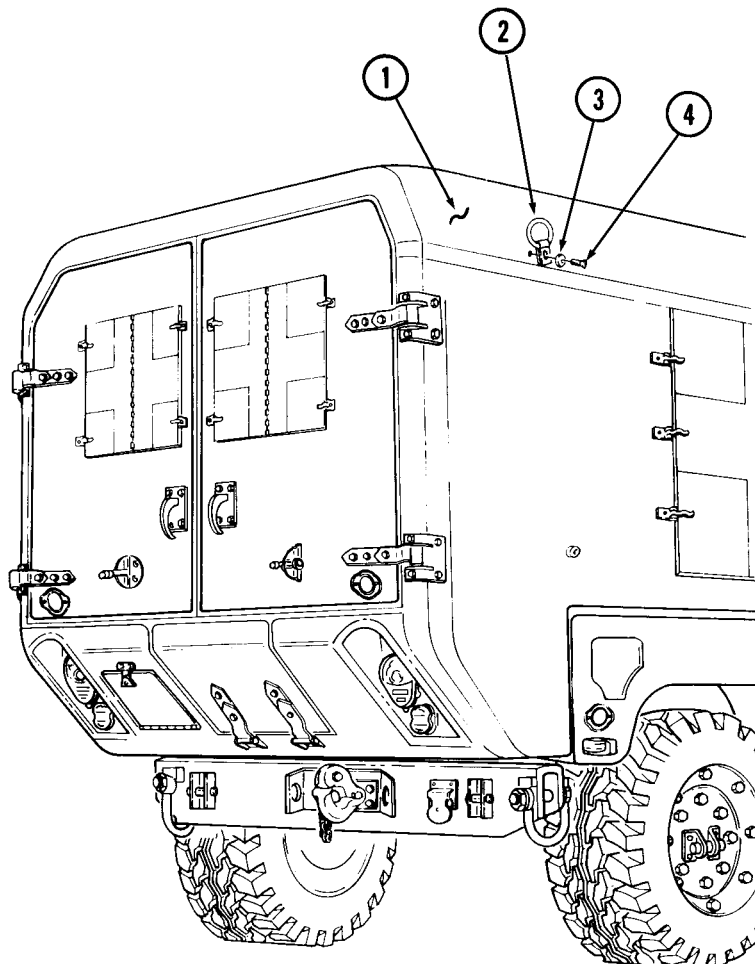

11-181. AMBULATORY PATIENT SEAT REPLACEMENT

This task covers:

a. Removal

b. Installation

INITIAL SETUP:

Applicable Models

M996, M996A1

Tools

General mechanic's tool kit:
automotive (Appendix B, Item 1)

Materials/Parts

Four blind rivets (Appendix G, Item 252)
Two locknuts (Appendix G, Item 70)
Two solid rivets (Appendix G, Item 271)
Blind rivnut (Appendix G, Item 274)

Manual References

TM 9-2320-280-10
TM 9-2320-280-24P

Equipment Condition

Ambulatory patient seat opened
(TM 9-2320-280-10).

NOTE

For instructions on replacement of rivets, refer to para. 10-66.

a. Removal

1. Remove two screws (6) from seat brace (2) and seat frame (1).
2. Remove two locknuts (5), screws (3), and seat brace (2) from seatback (4). Discard locknuts (5).
3. Inspect blind rivnut (7) for damage. Replace if damaged.
4. Remove four blind rivets (12) and seat support (8) from seatback (4).
5. Remove two solid rivets (11), latch (9), and shim (10) from seat support (8).

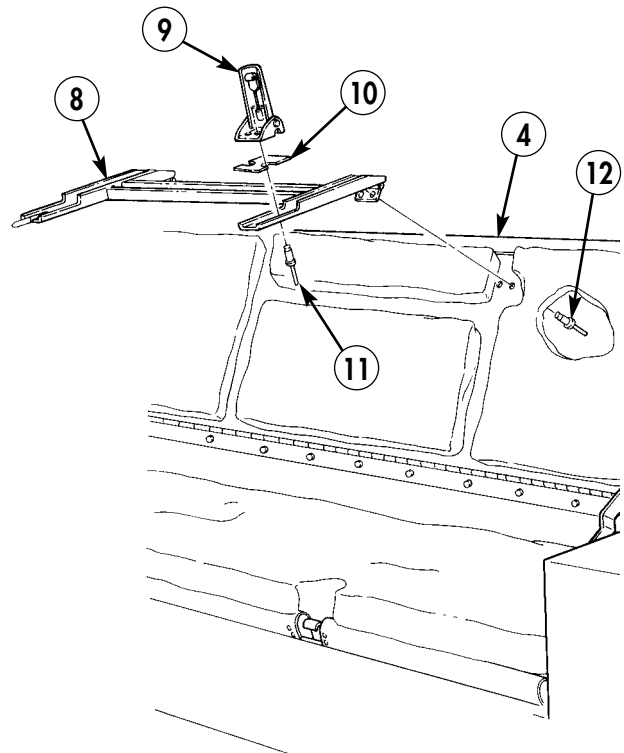
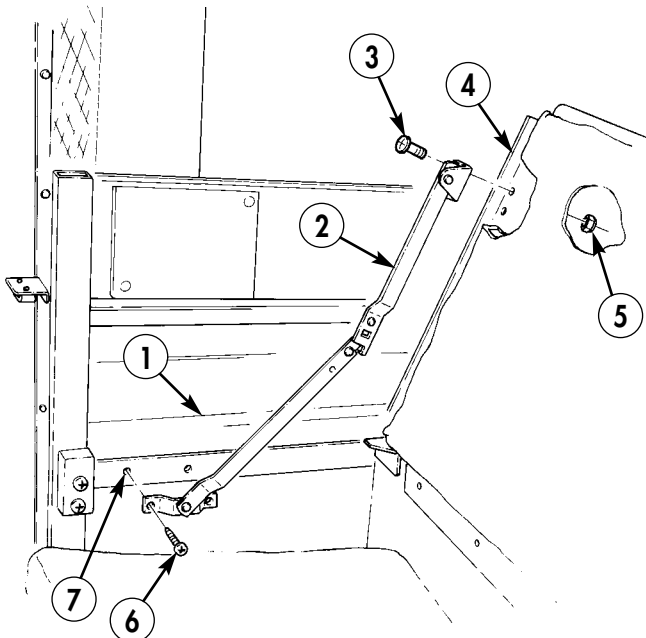

11-181. AMBULATORY PATIENT SEAT REPLACEMENT (Cont'd)

6. Remove eight screws (8) and two end cushions (2) from seatback (1).
7. Remove four screws (8) and two middle cushions (3) from seatback (1).
8. Remove twelve nuts (5), washers (6), and seat cushion (4) from seat base (7).

b. Installation

1. Install seat cushion (4) on seat base (7) with twelve washers (6) and nuts (5).
2. Install two middle cushions (3) on seatback (1) with four screws (8).
3. Install two end cushions (2) on seatback (1) with eight screws (8).
4. Install latch (15) and shim (16) on seat support (14) with two solid rivets (17).
5. Install seat support (14) on seatback (1) with four blind rivets (18).
6. Install seat brace (10) on seatback (1) with two screws (11) and locknuts (12).
7. Install seat brace (10) on seat frame (9) with two screws (13).

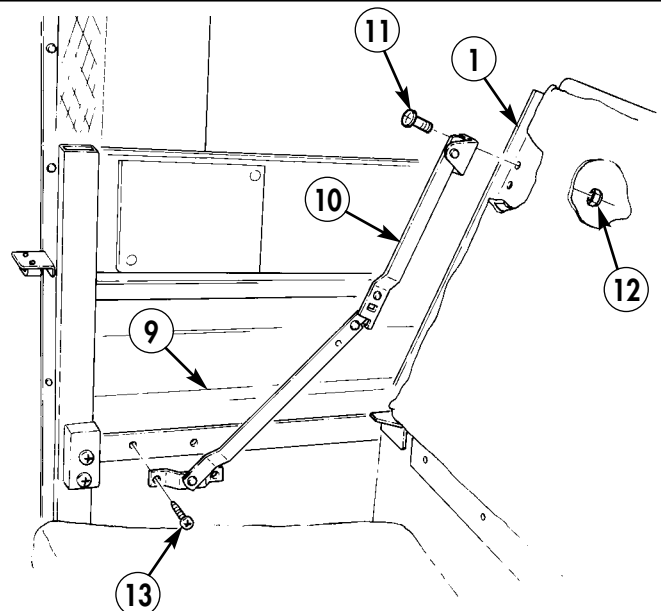
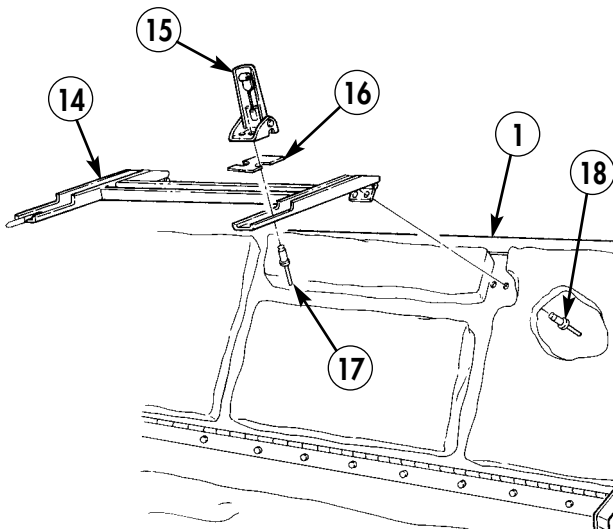
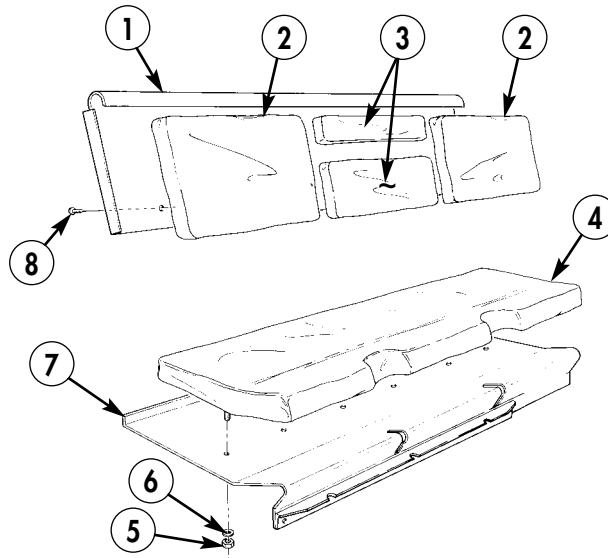

FOLLOW-ON TASK: Close ambulatory patient seat (TM 9-2320-280-10).

11-182. AMBULATORY PATIENT SEAT REAR CLOSEOUT PANEL REPLACEMENT

This task covers:

a. Removal

b. Installation

INITIAL SETUP:

Applicable Models

M996, M996A1

Manual References

TM 9-2320-280-24P

Tools

General mechanic's tool kit:
automotive (Appendix B, Item 1)

a. Removal

1. Remove two screws (9) from seat brace assembly (1) and closeout panel (4). Push seat brace assembly (1) up and out of way.
2. Remove two screws (7), washers (6), and seat stop (5) from closeout panel (4) and litter rack (2).
3. Remove three screws (8) and (3) and closeout panel (4) from litter rack (2).

b. Installation

1. Install closeout panel (4) on litter rack (2) with three screws (8) and (3).
2. Install seat stop (5) on closeout panel (4) with two washers (6) and screws (7).
3. Install seat brace (1) on closeout panel (4) with two screws (9).

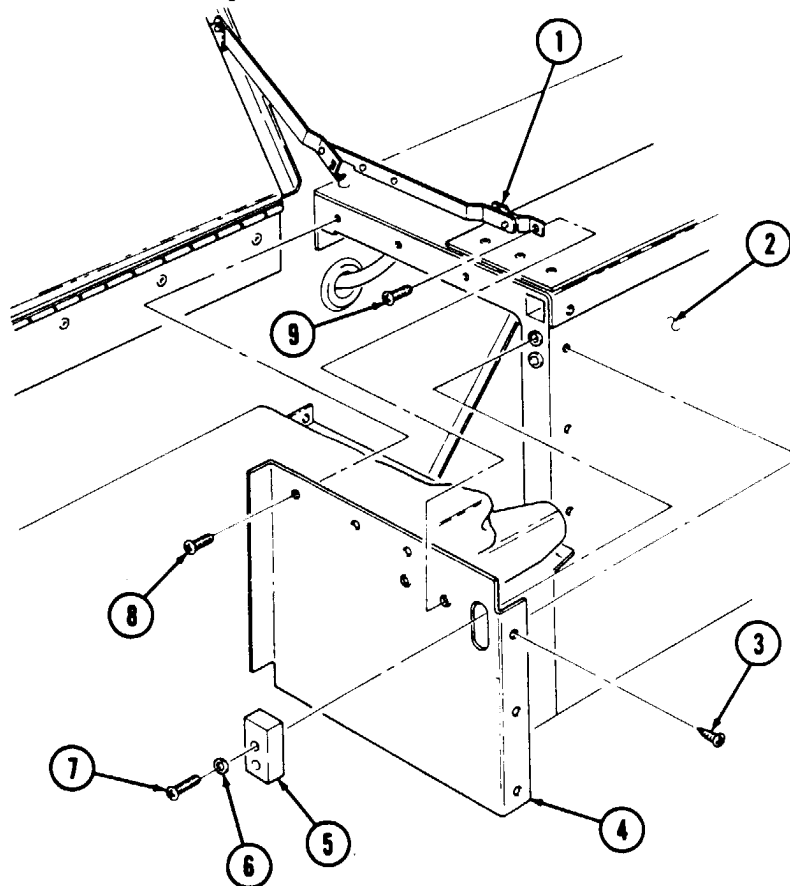

11-183. NBC DOOR REPLACEMENT (M996, M996A1)

This task covers:

a. Removal

b. Installation

INITIAL SETUP:

Applicable Models

M996, M996A1

Manual References

TM 9-2320-280-24P

Tools

General mechanic's tool kit:
automotive (Appendix B, Item 1)

Equipment Condition

NBC gas filters and brackets removed
(para. 11-167).

Materials/Parts

Ten blind rivets (Appendix G, Item 250)

NOTE

For instructions on replacement of rivets, refer to para. 10-66.

a. Removal

1. Remove five rivets (13), door (10), and hinge (12) from body (1).
2. Remove five rivets (11) and hinge (12) from door (10).
3. Remove two screws (7), nut (3), footman loop (9), and strap (8) from door (10).
4. Remove two wing head screws (6) and retainers (4) from door (10). Inspect retainers (4) for damage, replace if damaged.
5. Remove seals (2) and (5) from door (10).

b. Installation

1. Install seals (2) and (5) on door (10).
2. Install two wing head screws (6) on door (10) with retainers (4).
3. Install strap (8) and footman loop (9) on door (10) with two screws (7) and nut (3).
4. Install hinge (12) on door (10) with five rivets (11).
5. Install door (10) and hinge (12) on body (1) with five rivets (13).

11-183. NBC DOOR REPLACEMENT (M996, M996A1) (Cont'd)

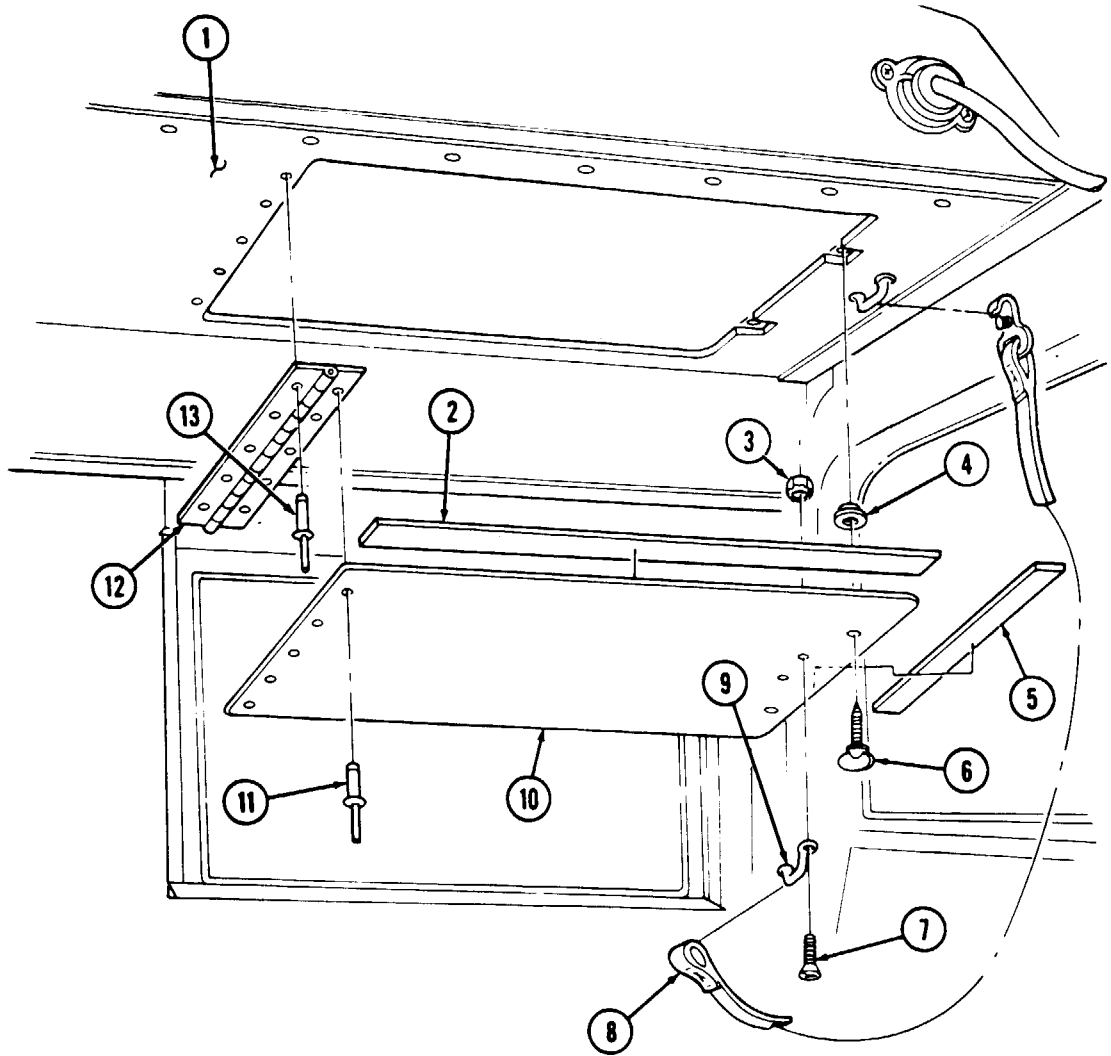

FOLLOW-ON TASK: Install NBC gas filters and brackets (para. 11-167).

11-184. AIR INTAKE COMPARTMENT PANELS REPLACEMENT

This task covers:

a. Removal

b. Installation

INITIAL SETUP:

Applicable Models

M997, M997A1, M997A2

Tools

General mechanic's tool kit:
automotive (Appendix B, Item 1)

Materials/Parts

Two lockwashers (Appendix G, Item 182)
Two tapping screws (Appendix G, Item 283)

Manual References

TM 9-2320-280-24P

Equipment Condition

- Blower housing opened (para. 11-198).
- Front cover panel removed (para. 11-187).

a. Removal

1. Remove six screws (2) from panel (3) and condenser fan housing (4).
2. Remove three screws (5) and panel (3) from panel (7).
3. Remove two tapping screws (1) from panel (7) and air intake assembly (14). Discard tapping screws (1).
4. Remove two nuts (13), washers (12), screws (8), washers (10), lockwashers (9), and panel (7) from body (11). Discard lockwashers (9).

b. Installation

1. Install panel (7) on body (11) and air intake assembly (14) with two washers (10), lockwashers (9), screws (8), washers (12), and nuts (13).
2. Install panel (7) on air intake assembly (14) with two tapping screws (1).
3. Install panel (3) on panel (7) and fan housing (4) with three screws (5).
4. Secure panel (3) to fan housing (4) with six screws (2).

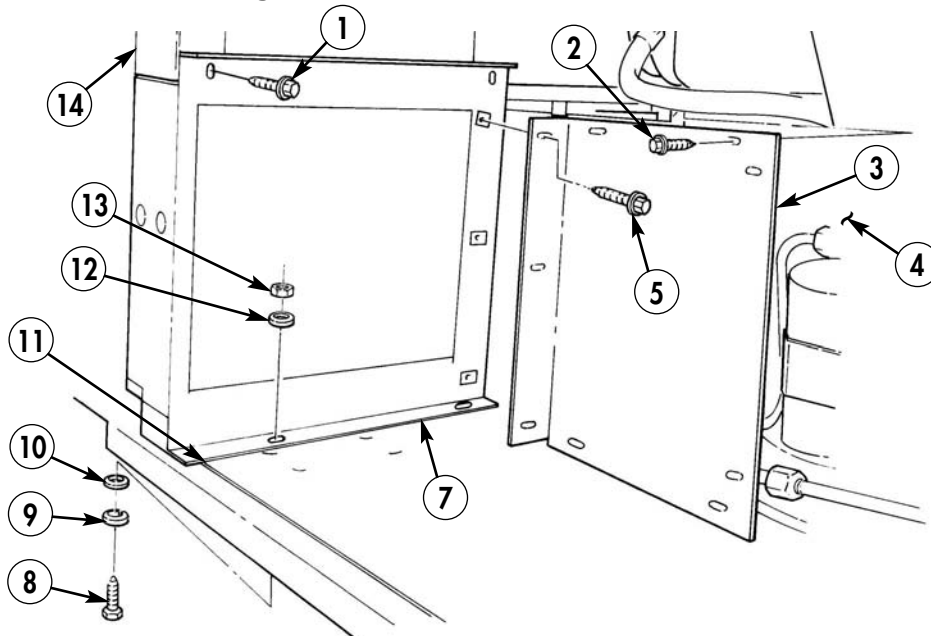

- FOLLOW-ON TASKS:
- Close blower housing (para. 11-198).
 - Install front cover panel (para. 11-187).

11-185. AIR INTAKE DUCT DOOR REPLACEMENT

This task covers:

a. Removal

b. Installation

INITIAL SETUP:

Applicable Models

M997, M997A1, M997A2

Tools

General mechanic's tool kit:
automotive (Appendix B, Item 1)

Materials/Parts

Push on nut (Appendix G, Item 227)
Two lockwashers (Appendix G, Item 134)

Manual References

TM 9-2320-280-10
TM 9-2320-280-24P

Equipment Condition

- Air intake filter removed (TM 9-2320-280-10).
- Blower housing opened (para. 11-198).

NOTE

Evaporator intake duct door and heater intake duct door are replaced basically the same. This procedure covers the evaporator duct door.

a. Removal

1. Remove push on nut (6) and slide control cable (5) off arm (7). Discard push on nut (6).
2. Remove two capscrews (4) and lockwashers (3) from duct door (2) and intake duct (8). Discard lockwashers (3).
3. Slide duct door (2) right, and remove duct door (2) and bushing (1) from intake duct (8) and bracket (9).

b. Installation

1. Install bushing (1) on bracket (9).
2. Install arm (7) through intake duct (8) and slide duct door (2) left into bushing (1).
3. Install duct door (2) on intake duct (8) with two lockwashers (3) and capscrews (4).
4. Slide control cable (5) onto arm (7) with push on nut (6).

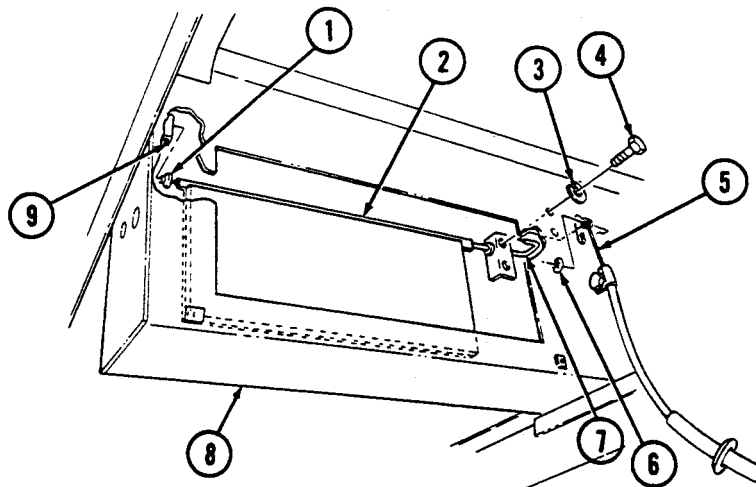

- FOLLOW-ON TASKS:
- Install air intake filter (TM 9-2320-280-10).
 - Adjust duct door control cable (para. 11-199).

11-186. AIR INLET/OUTLET GRILLE REPLACEMENT

This task covers:

a. Removal

b. Installation

INITIAL SETUP:

Applicable Models

M997, M997A1, M997A2

Tools

General mechanic's tool kit:
automotive (Appendix B, Item 1)

Materials/Parts

Adhesive (Appendix C, Item 3)
Gasket (Appendix G, Item 49)
Ten lockwashers (Appendix G, Item 144)

Manual References

TM 9-2320-280-24P

NOTE

Procedures for replacing inlet and outlet grilles are basically the same. This procedure covers the outlet grille.

a. Removal

Remove ten screws (3), lockwashers (4), washers (5), grille (6), and gasket (1) from body (2). Discard gasket (1) and lockwashers (4). Clean grille (6) to remove remaining adhesive.

b. Installation

NOTE

Ensure outer louvers on grille are angled downward for installation.

Apply adhesive to grille (6) at gasket (1) mating surface. Install gasket (1) and grille (6) on body (2) with ten washers (5), lockwashers (4), and screws (3).

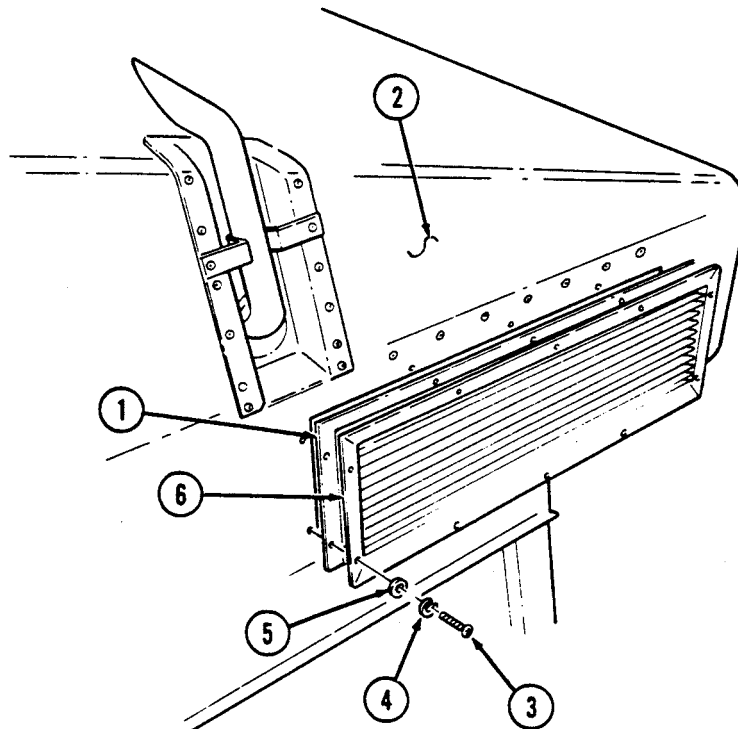

11-187. FRONT COVER PANEL REPLACEMENT

This task covers:

a. Removal

b. Installation

INITIAL SETUP:

Applicable Models

M997, M997A1, M997A2

Materials/Parts

Six lockwashers (Appendix G, Item 144)

Tools

General mechanic's tool kit:
automotive (Appendix B, Item 1)

Manual References

TM 9-2320-280-24P

a. Removal

1. Remove two capscrews (1), lockwashers (2), and washers (3) from panel (9) and panel (4). Discard lockwashers (2).
2. Remove four screws (8), lockwashers (7), washers (6), and panel (9) from body (5). Discard lockwashers (7).

b. Installation

1. Install panel (9) on body (5) with four washers (6), lockwashers (7), and screws (8).
2. Install panel (9) on panel (4) with two washers (3), lockwashers (2), and capscrews (1).

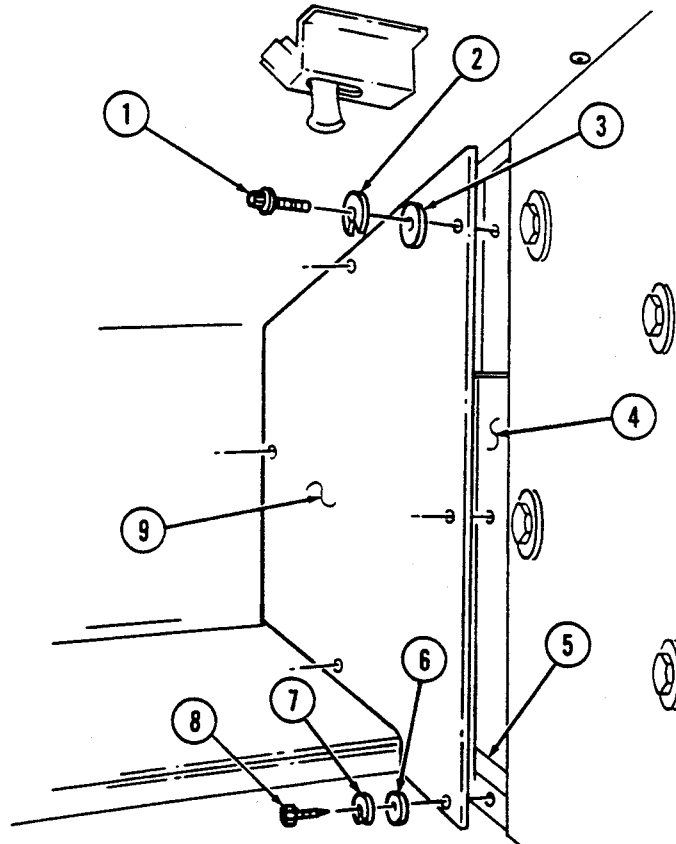

11-188. REAR COVER PANEL REPLACEMENT

This task covers:

a. Removal

b. Installation

INITIAL SETUP:

Applicable Models

M997, M997A1, M997A2

Tools

General mechanic's tool kit:
automotive (Appendix B, Item 1)

Materials/Parts

Nine lockwashers (Appendix G, Item 144)

Manual References

TM 9-2320-280-24P

a. Removal

1. Remove four capscrews (7) and washers (8) from panel (1) and blower housing (6).
2. Remove nine screws (5), lockwashers (4), washers (3), and panel (1) from body (2). Discard lockwashers (4).

b. Installation

1. Install panel (1) on body (2) with nine washers (3), lockwashers (4), and screws (5).
2. Install panel (1) on blower housing (6) with four washers (8) and capscrews (7).

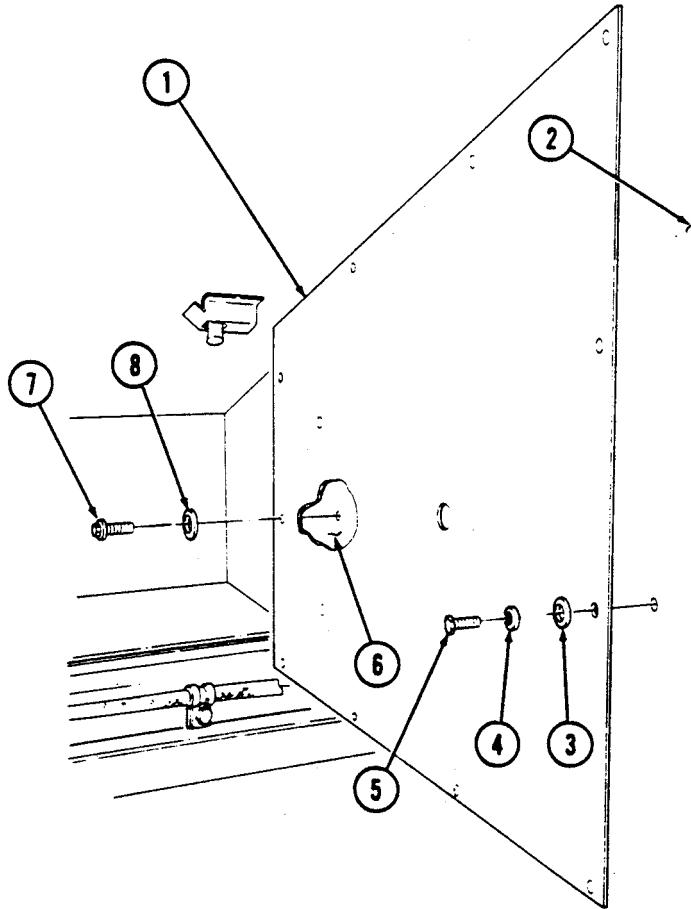

11-189. HEATER EXHAUST PIPE REPLACEMENT (M997, M997A1, M997A2)

This task covers:

a. Removal

b. Installation

INITIAL SETUP:

Applicable Models

M997, M997A1, M997A2

Manual References

TM 9-2320-280-24P

Tools

General mechanic's tool kit:
automotive (Appendix B, Item 1)

General Safety Instructions

Do not touch hot exhaust system with bare hands.

Materials/Parts

Two blind rivets (Appendix G, Item 250)

WARNING

Do not touch hot exhaust system components with bare hands.
Severe injury will result.

NOTE

For instructions on replacement of rivets, refer to para. 10-66.

a. Removal

1. Remove two rivets (5) from exhaust pipe (1) and body (2).
2. Remove exhaust pipe (1) from opening (3) in body (2)

b. Installation

1. Install exhaust pipe (1) on opening (3) in body (2) and onto heater exhaust outlet (4).
2. Install exhaust pipe (1) on body (2) with two rivets (5).

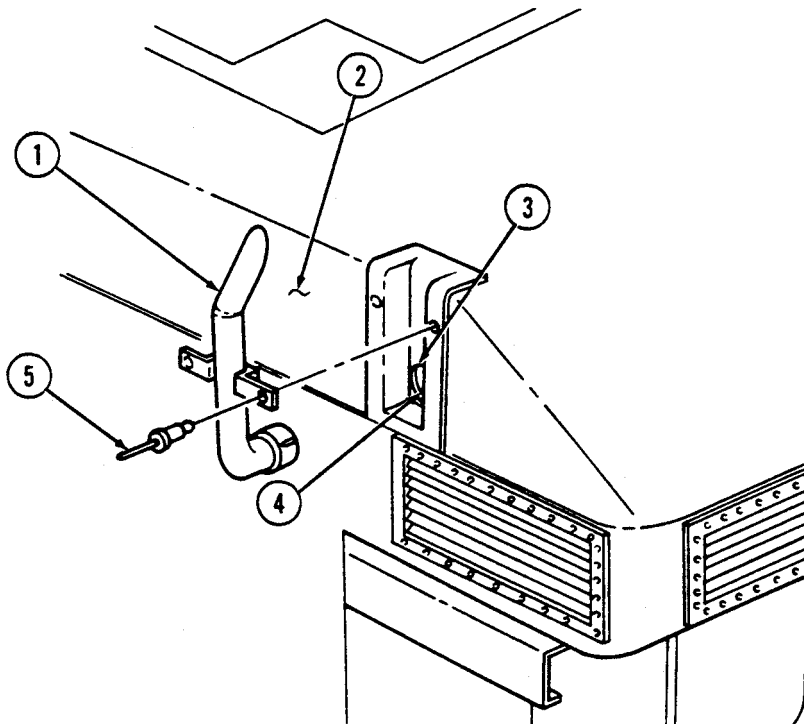

11-190. HEATER REPLACEMENT (M997, M997A1, M997A2)

This task covers:

- a. Removal b. Installation
-

INITIAL SETUP:

Applicable Models

M997, M997A1, M997A2

Tools

General mechanic's tool kit:
automotive (Appendix B, Item 1)

Personnel Required

One mechanic
One assistant

Manual References

TM 9-2320-280-24P

Equipment Condition

- Blower housing open (para. 11-198).
- Battery ground cable disconnected (para. 4-73).

General Safety Instructions

Diesel fuel is highly flammable. Do not perform this procedure near fire, flames, or sparks.

WARNING

Diesel fuel is highly flammable. Do not perform this procedure near fire, flames, or sparks. Severe injury or death may result.

NOTE

- Have drainage container ready to catch fuel.
- Cover or plug all open connections immediately after disconnection to prevent contamination. Remove all covers or plugs prior to connection.

a. Removal

1. Disconnect plug (11) from heater receptacle (12).
2. Loosen clamp (8) and disconnect hose (9) from heater outlet (7).
3. Disconnect fuel line (13) from heater (14) and allow fuel to drain into container.
4. Remove two clamps (2) from heater (14) and mounting brackets (4).
5. Turn two dzus fasteners (16) and remove cover (15) from heater (14).
6. Remove heater (14) by lifting rear of heater (14) up and pulling heater (14) out from exhaust pipe (6) and sliding heater (14) to the right and out of intake assembly (1).
7. Inspect seal (5) for presence and damage. Replace if missing or damaged.
8. Remove four screws (10) and outlet (7) from heater (14).

b. Installation

1. Install outlet (7) on heater (14) with four screws (10).
2. Install two clamps (2) on mounting brackets (4).
3. Install heater (14) on mounting brackets (4), ensuring heater exhaust outlet (3) is installed into exhaust pipe (6), and clamps (2) are wrapped around heater (14).
4. Slide heater (14) into intake assembly (1) opening and on mounting brackets (4) with two clamps (2).
5. Connect fuel line (13) to heater (14).
6. Connect hose (9) to heater outlet (7) and tighten clamp (8).
7. Connect plug (11) to heater receptacle (12).
8. Install cover (15) on heater (14) with two dzus fasteners (16).

11-190. HEATER REPLACEMENT (M997, M997A1, M997A2) (Cont'd)

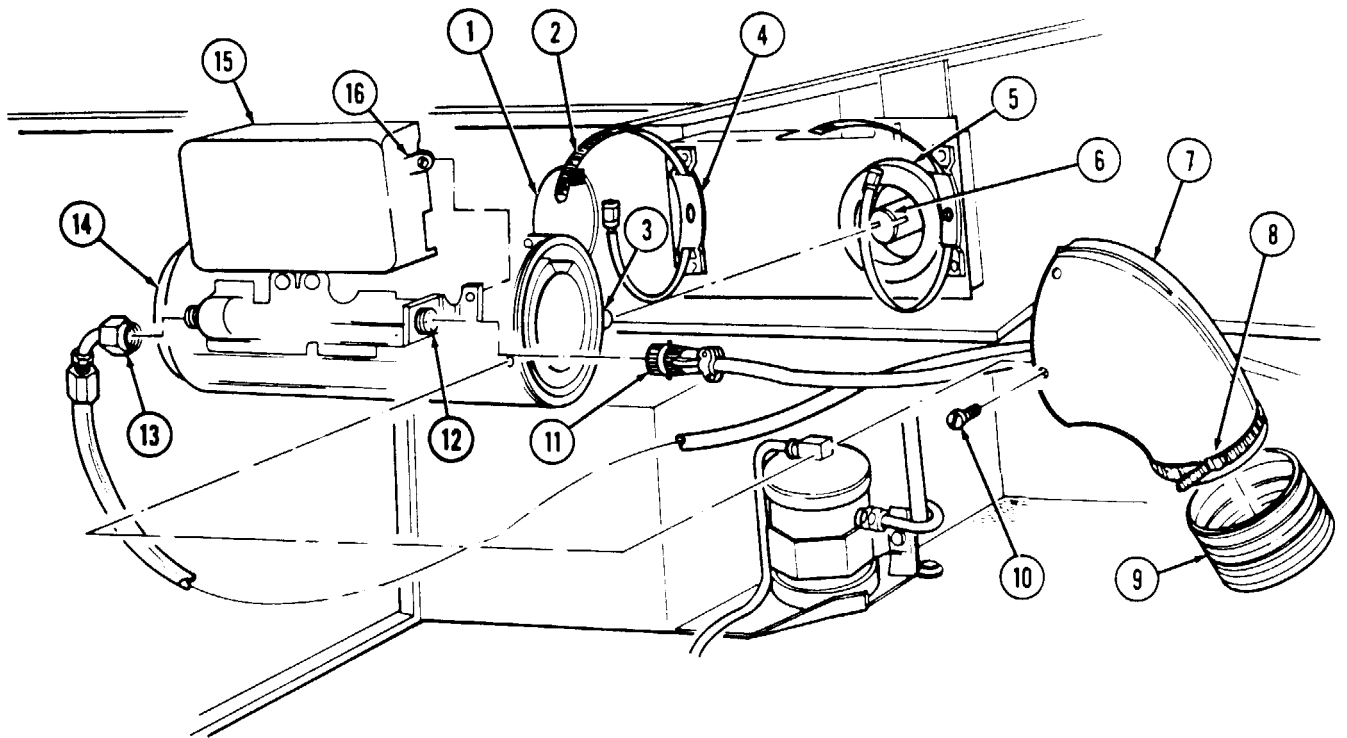

- FOLLOW-ON TASKS:
- Close blower housing (para 11-198).
 - Connect battery ground cable (para. 4-73).

11-191. HEATER OUTLET HOSE REPLACEMENT (M997, M997A1, M997A2)

This task covers:

a. Removal

b. Installation

INITIAL SETUP:

Applicable Models

M997, M997A1, M997A2

Manual References

TM 9-2320-280-24P

Tools

General mechanic's tool kit:
automotive (Appendix B, Item 1)

Equipment Condition

Blower housing open (para. 11-198).

a. Removal

1. Loosen clamp (5) and disconnect hose (4) from heater outlet (1).
2. Loosen clamp (2) and disconnect hose (4) from heat duct (3).
3. Remove hose (4) by pulling out from behind and over top of heater (6).
4. Remove clamps (2) and (5) from hose (4).

b. Installation

1. Install clamps (2) and (5) on hose (4).
2. Route hose (4) over top of and behind heater (6) in mounting position.
3. Connect hose (4) to heat duct (3) and tighten clamp (2).
4. Connect hose (4) to heater outlet (1) and tighten clamp (5).

11-191. HEATER OUTLET HOSE REPLACEMENT (M997, M997A1, M997A2) (Cont'd)

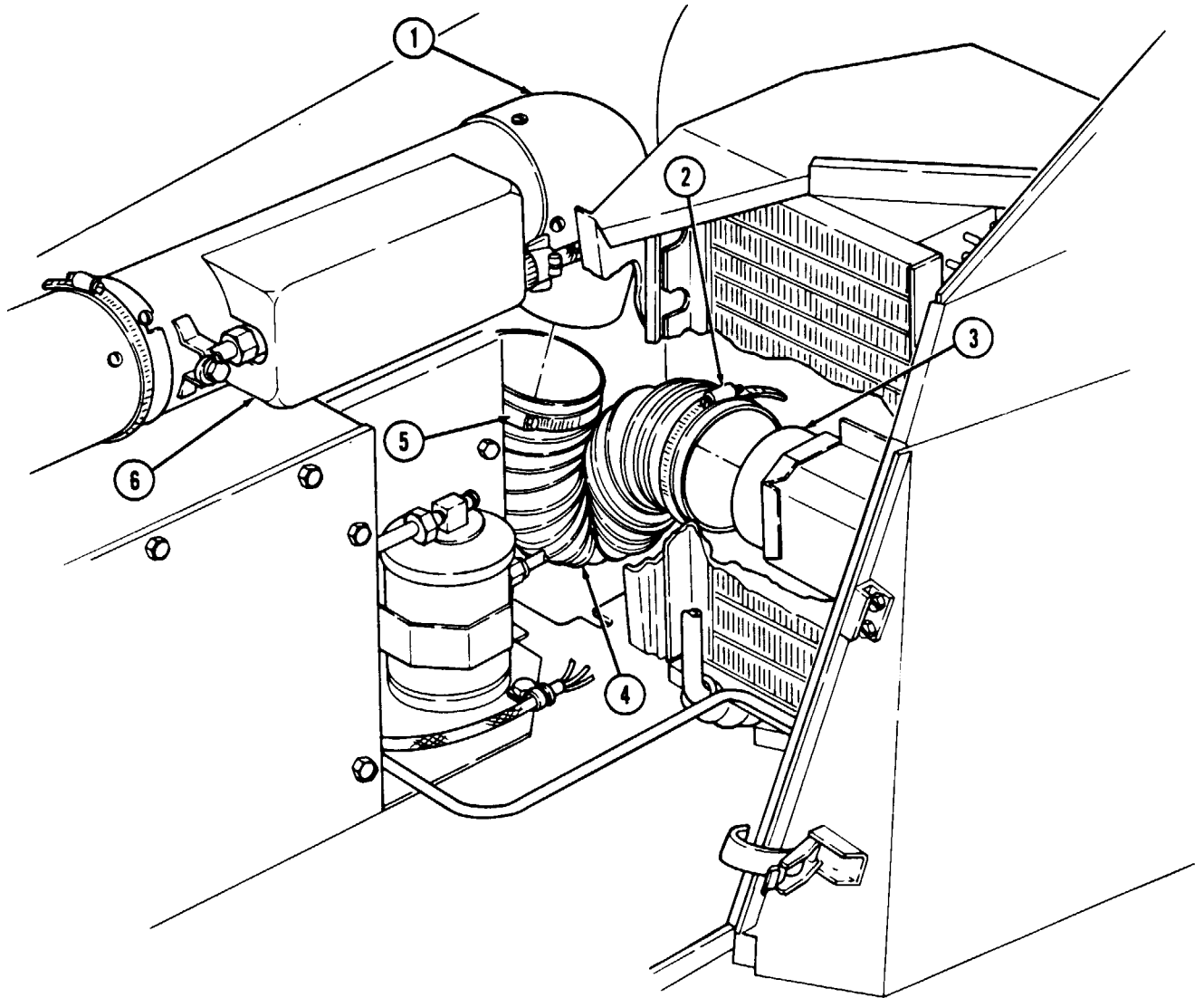

FOLLOW-ON TASK: Close blower housing (para. 11-198).

11-192. HEATER FUEL FILTER REPLACEMENT

This task covers:

a. Removal

b. Installation

INITIAL SETUP:

Applicable Models

M996, M996A1, M997, M997A1, M997A2

Tools

General mechanic's tool kit:
automotive (Appendix B, Item 1)

Materials/Parts

Sealing compound (Appendix C, Item 44)
Two lockwashers (Appendix G, Item 138)

Manual Reference

TM 9-2320-280-10
TM 9-2320-280-24P

Equipment Condition

- Stowage compartment door open (TM 9-2320-280-10).
- Close fuel shut-off valve (TM 9-2320-280-10).

General Safety Instructions

Diesel fuel is highly flammable. Do not perform this procedure near fire, flames, or sparks.

WARNING

Diesel fuel is highly flammable. Do not perform this procedure near fire, flames, or sparks. Severe injury or death will result.

NOTE

- Have drainage container ready to catch fuel.
- Cover or plug all open connections immediately after disconnection to prevent contamination. Remove all covers or plugs prior to connection.

a. Removal

1. Disconnect two fuel lines (5) from filter (7) and allow fuel to drain.
2. Remove two nuts (4), lockwashers (3), washers (2), screws (8), filter (7), and spacers (1) from panel (6). Discard lockwashers (3).

b. Installation

NOTE

Apply sealing compound to threads of all fuel line joints before installation.

1. Install two spacers (1) and filter (7) on panel (6) with two screws (8), washers (2), lockwashers (3), and nuts (4).
2. Connect two fuel lines (5) to filter (7).

11-192. HEATER FUEL FILTER REPLACEMENT (Cont'd)

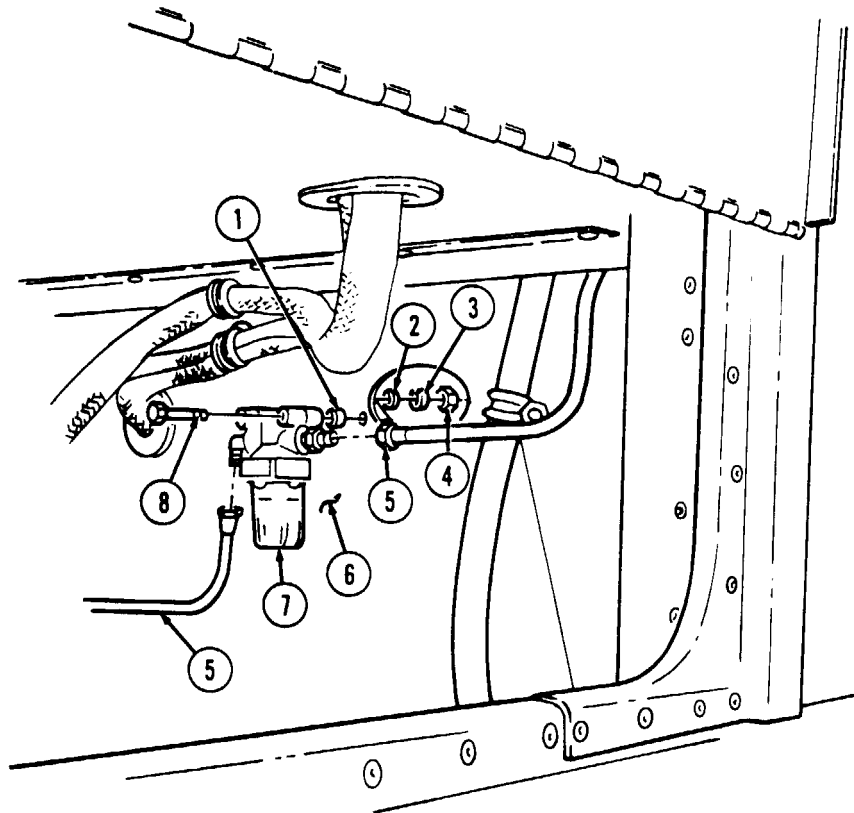

- FOLLOW-ON TASKS:
- Open fuel shut-off valve (TM 9-2320-280-10).
 - Bleed heater fuel system (para. 11-195).
 - Close stowage compartment door (TM 9-2320-280-10).

11-193. HEATER FUEL LINES REPLACEMENT

This task covers:

- | | |
|---|---|
| <ul style="list-style-type: none"> a. Heater Fuel Line Replacement b. Cab Fuel Line Replacement c. Shutoff Valve Replacement d. "B" Beam Fuel Line Replacement e. Filter Fuel Line Replacement | <ul style="list-style-type: none"> f. Bulkhead Coupling Replacement g. Bulkhead Fuel Line Replacement h. Pump Fuel Line Replacement i. Tank Fuel Line and Supply Tube Replacement |
|---|---|

INITIAL SETUP:

Applicable Models

M996, M996A1, M997, M997A1, M997A2

Manual References

TM 9-2320-280-24P

Tools

General mechanic's tool kit:
automotive (Appendix B, Item 1)

General Safety Instructions

Do not perform this procedure near fire, flames, or sparks.

Materials/Parts

Sealing compound (Appendix C, Item 44)
Tiedown strap (Appendix G, Item 308)

WARNING

Diesel fuel is highly flammable. Do not perform this procedure near fire, flames, or sparks. Severe injury or death will result.

NOTE

- Fuel line replacement is basically the same on M996, M996A1, M997, M997A1, and M997A2 vehicles. This procedure covers M997, M997A1, and M997A2 vehicles.
- Have drainage container ready to catch fuel.
- Apply sealing compound to threads of all fuel line joints before installation.
- Cover or plug all open connections immediately after removal to prevent contamination. Remove all covers or plugs prior to connection.

a. Heater Fuel Line Replacement

1. Open blower housing (para. 11-198).
2. Disconnect fuel line (1) from heater (2) and allow fuel to drain. Remove tiedown strap (3) from fuel line (1) and control cables (4). Discard tiedown strap (3).
3. Disconnect fuel line (1) from cab fuel line (8), allow fuel to drain, and remove fuel line (1).
4. Install fuel line (1) through grommet (14) and connect to cab fuel line (8).
5. Connect fuel line (1) to heater (2).
6. Install fuel line (1) on control cables (4) with tiedown strap (3).
7. Close blower housing (para. 11-198).

b. Cab Fuel Line Replacement

1. Remove capscrew (11), harness clamp (12), and clamp (6) from A/C lines (5), body (13), and fuel line (8).
2. Disconnect fuel line (8) from shutoff valve (7) and allow fuel to drain.
3. Disconnect fuel line (8) from heater fuel line (1) and remove fuel line (8) from vehicle.
4. Install fuel line (8) in vehicle and connect to heater fuel line (1).

11-193. HEATER FUEL LINES REPLACEMENT (Cont'd)

5. Connect fuel line (8) to shutoff valve (7).
6. Install clamp (6) on A/C lines (5), fuel line (8), and body (13) with harness clamp (12) and capscrew (11).

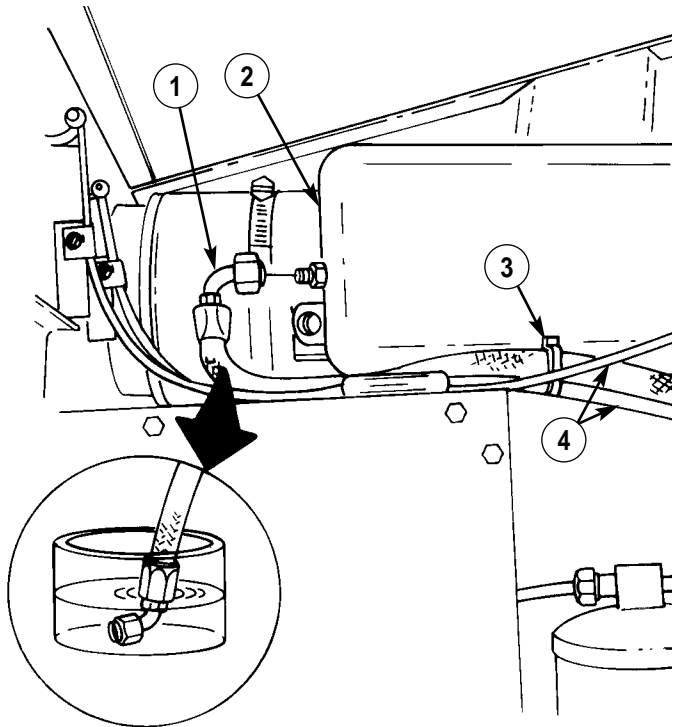
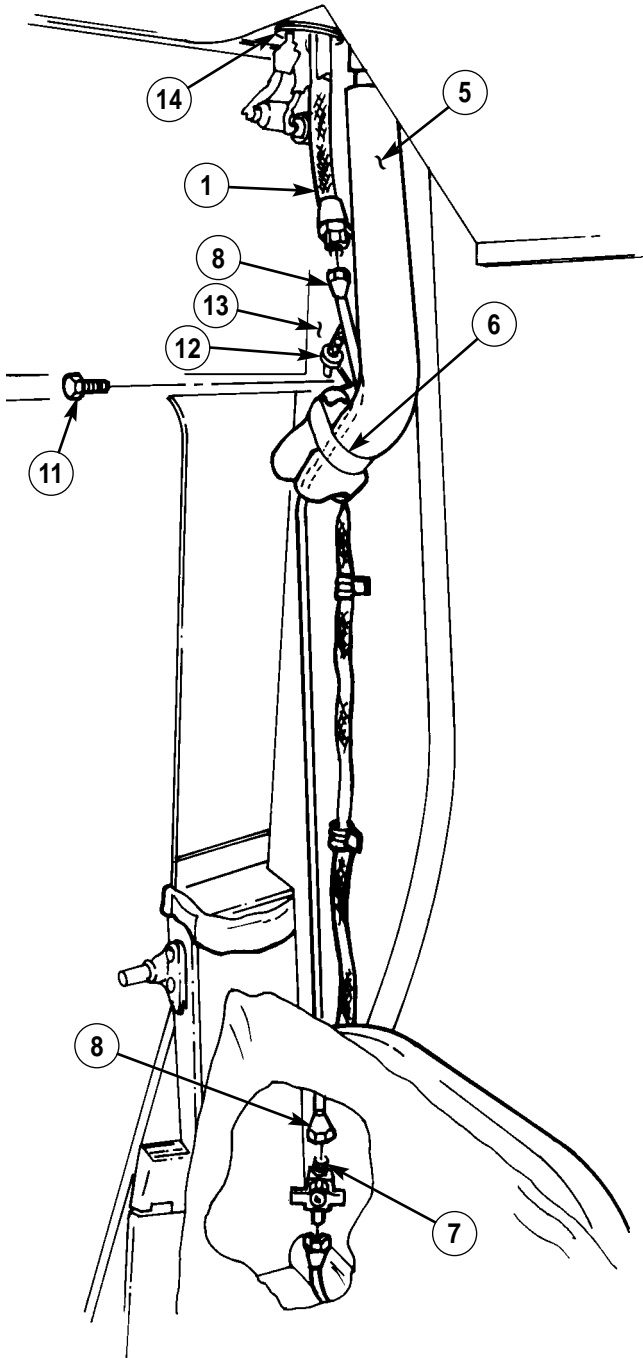

11-193. HEATER FUEL LINES REPLACEMENT (Cont'd)

c. Shutoff Valve Replacement

1. Disconnect cab fuel line (1) from shutoff valve (2) and allow fuel to drain.
2. Close shutoff valve (2), disconnect "B" beam fuel line (3) from shutoff valve (2), and remove shutoff valve (2).
3. Connect "B" beam fuel line (3) to shutoff valve (2).
4. Connect cab fuel line (1) to shutoff valve (2) and open valve (2).

d. "B" Beam Fuel Line Replacement

1. Close shutoff valve (2) and disconnect fuel line (3) from shutoff valve (2).
2. Disconnect fuel line (3) from filter (6), allow fuel to drain, and remove fuel line (3).
3. Connect fuel line (3) between "B" beam (5) and seal (4) and connect to filter (6).
4. Connect fuel line (3) to shutoff valve (2) and open valve (2).

e. Filter Fuel Line Replacement

1. Disconnect fuel line (7) from filter (6) and allow fuel to drain.
2. Disconnect fuel line (7) from bulkhead connector (13).
3. Connect fuel line (7) to bulkhead connector (13).
4. Connect fuel line (7) to filter (6).

f. Bulkhead Coupling Replacement

1. Remove fuel tank (para. 3-24).
2. Disconnect filter fuel line (7) from bulkhead connector (13) and allow fuel to drain.
3. Disconnect bulkhead fuel line (8) from elbow (9).
4. Remove elbow (9) from coupling half (12).
5. Remove coupling nut (10), washer (11), and coupling half (12) from tunnel (14).
6. Remove bulkhead connector (13) from coupling half (12).
7. Install bulkhead connector (13) on coupling half (12).
8. Install coupling half (12) to tunnel (14) with washer (11) and coupling nut (10).
9. Install elbow (9) on coupling half (12).
10. Connect bulkhead fuel line (8) to elbow (9).
11. Connect filter fuel line (7) to bulkhead connector (13).
12. Install fuel tank (para. 3-24).

11-193. HEATER FUEL LINES REPLACEMENT (Cont'd)

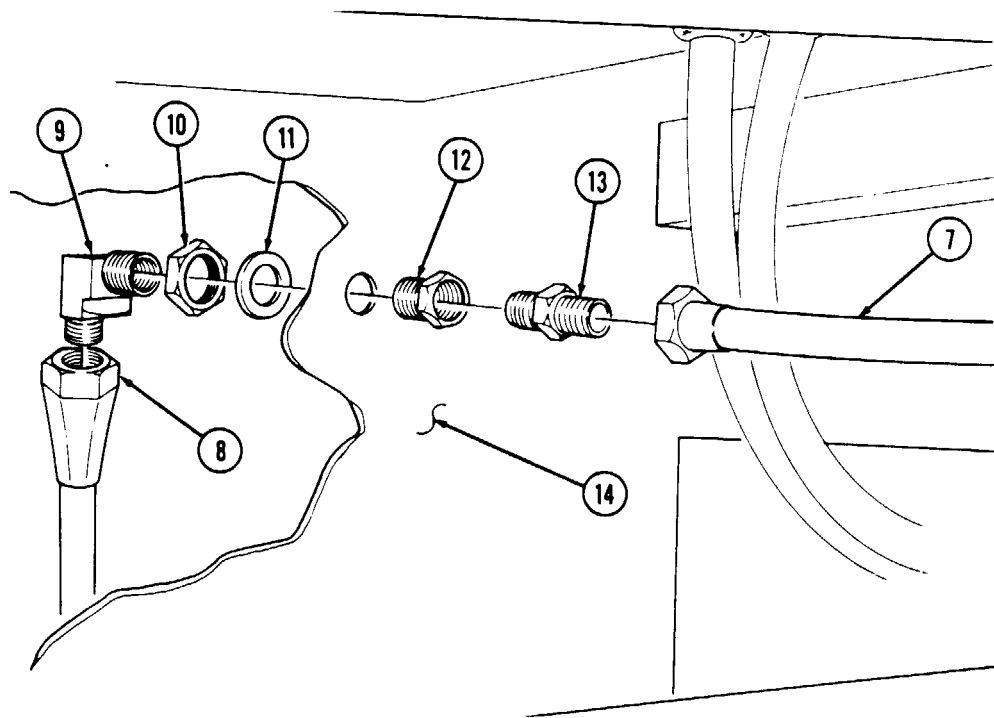
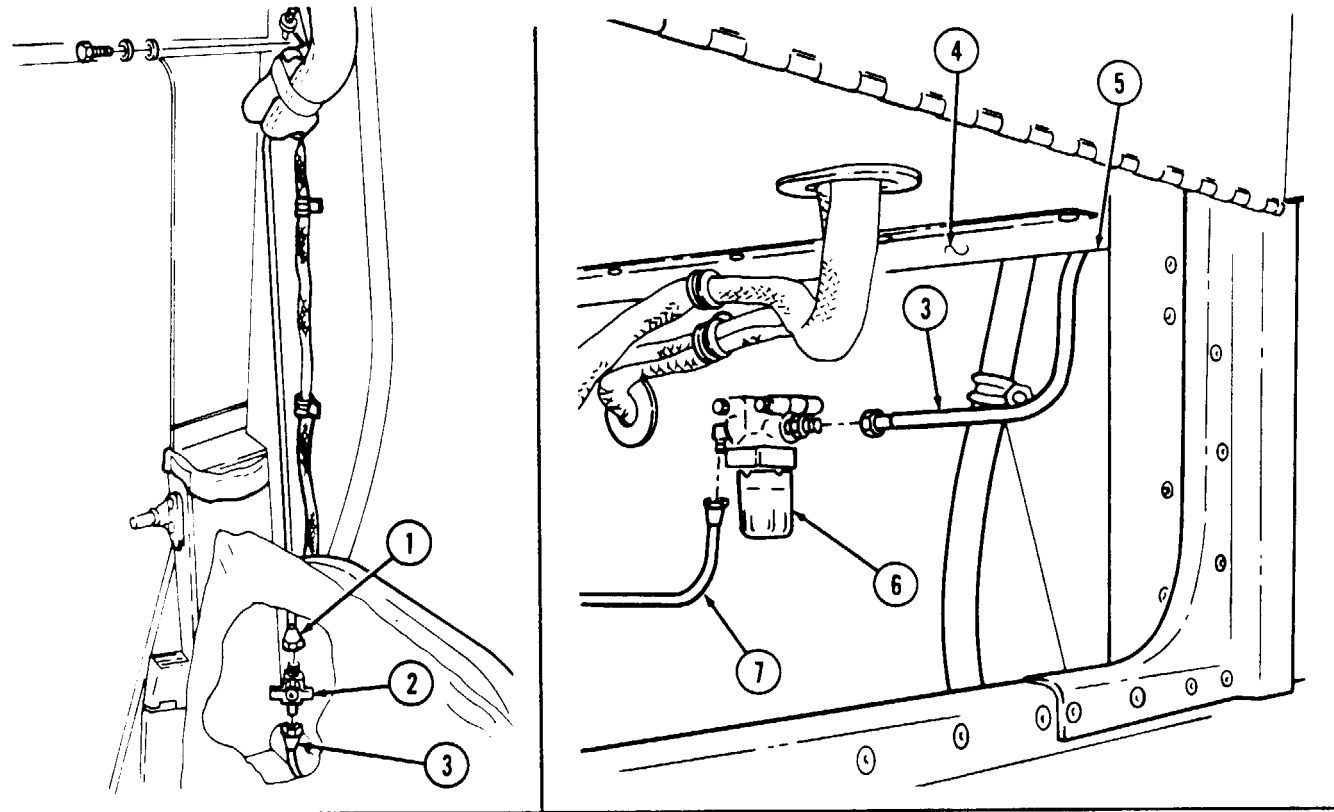

11-193. HEATER FUEL LINES REPLACEMENT (Cont'd)

1

g. Bulkhead Fuel Line Replacement

1. Remove fuel tank (para. 3-24).
2. Disconnect fuel line (2) from elbow (6) and allow fuel to drain.
3. Disconnect fuel line (2) from pump (1) and remove fuel line (2).
4. Connect fuel line (2) to pump (1).
5. Connect fuel line (2) to elbow (6).
6. Install fuel tank (para. 3-24).

h. Pump Fuel Line Replacement

1. Loosen clamp (4) and disconnect hose (5) from fuel line (3). Allow fuel to drain.
2. Disconnect fuel line (3) from pump (1).
3. Connect fuel line (3) to pump (1).
4. Connect hose (5) to fuel line (3) and tighten clamp (4).

i. Tank Fuel Line and Supply Tube Replacement

1. Remove fuel tank (para. 3-24).
2. Remove capscrew (10) clamp (11) and fuel line (9) from tank (8).
3. Remove fuel line (9) from supply tube (7).
4. Remove supply tube (7) from tank (8).
5. Install supply tube (7) on tank (8).
6. Connect fuel line (9) to supply tube (7).
7. Install clamp (11) on fuel line (9) and tank (8) with capscrew (10).
8. Install fuel tank (para. 3-24).

11-193. HEATER FUEL LINES REPLACEMENT (Cont'd)

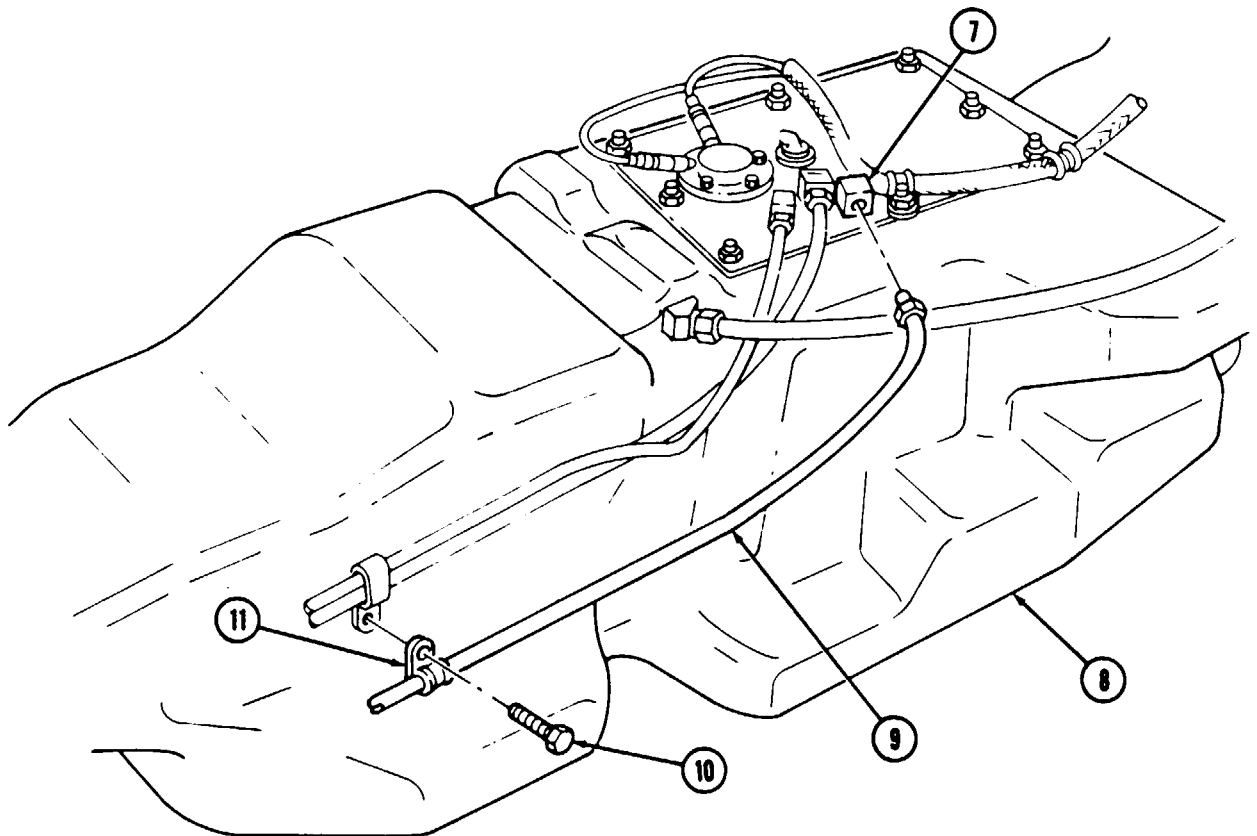
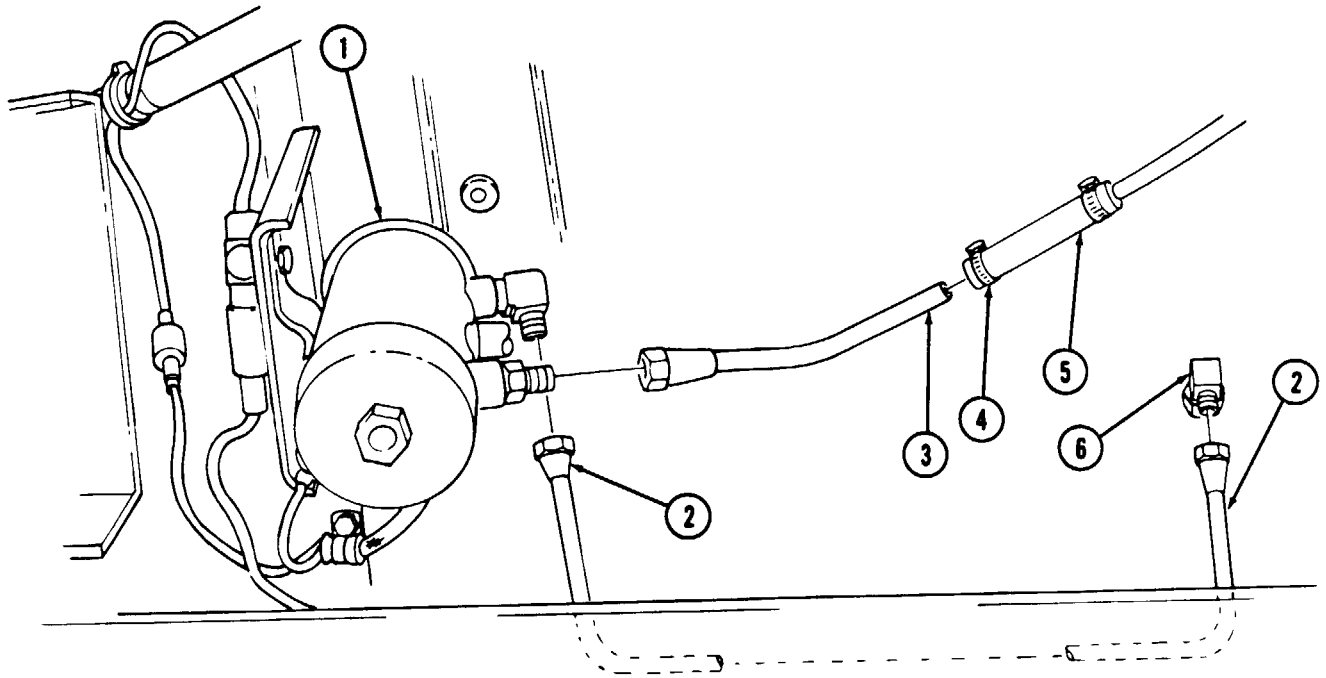

FOLLOW-ON TASK: Bleed heater fuel system (para. 11-195).

11-194. HEATER FUEL PUMP REPLACEMENT

This task covers:

a. Removal

b. Installation

INITIAL SETUP:

Applicable Models

M996, M996A1, M997, M997A1, M997A2

Tools

General mechanic's tool kit:
automotive (Appendix B, Item 1)

Materials/Parts

Sealing compound (Appendix C, Item 44)
Two locknuts (Appendix G, Item 70)
Tiedown strap (Appendix G, Item 308)

Manual References

TM 9-2320-280-24P

Equipment Condition

Battery ground cable disconnected (para. 4-73).

General Safety Instructions

Do not perform this procedure near fire, flames, or sparks.

WARNING

Diesel fuel is highly flammable. Do not perform this procedure near fire, flames, or sparks. Severe injury or death will result.

NOTE

- Have drainage container ready to catch fuel.
- Cover or plug all open connections immediately after disconnection to prevent contamination. Remove covers or plugs prior to connection.
- Apply sealing compound to threads of all fuel line joints before installation.

a. Removal

1. Disconnect two fuel lines (8) from elbow (7) and fitting (9) and allow fuel to drain.
2. Remove tiedown strap (1) from fuel pump lead (13) and dipstick tube (2). Discard tiedown strap (1).
3. Disconnect fuel pump lead (13) from control box lead (12).
4. Remove two locknuts (11), washers (3), capscrews (4), washers (3), fuel pump (6), and ground terminal (5) from capacitor clamp (14) and bracket (10). Discard locknuts (11).
5. Remove elbow (7) and fitting (9) from fuel pump (6).

b. Installation

1. Install elbow (7) and fitting (9) on fuel pump (6).
2. Install fuel pump (6) on bracket (10) and capacitor clamp (14) with ground terminal (5), two washers (3), capscrews (4), washers (3), and locknuts (11).
3. Connect two fuel lines (8) to elbow (7) and fitting (9).
4. Connect fuel pump lead (13) to control box lead (12) and install fuel pump lead (13) on dipstick tube (2) with tiedown strap (1).

11-194. HEATER FUEL PUMP REPLACEMENT (Cont'd)

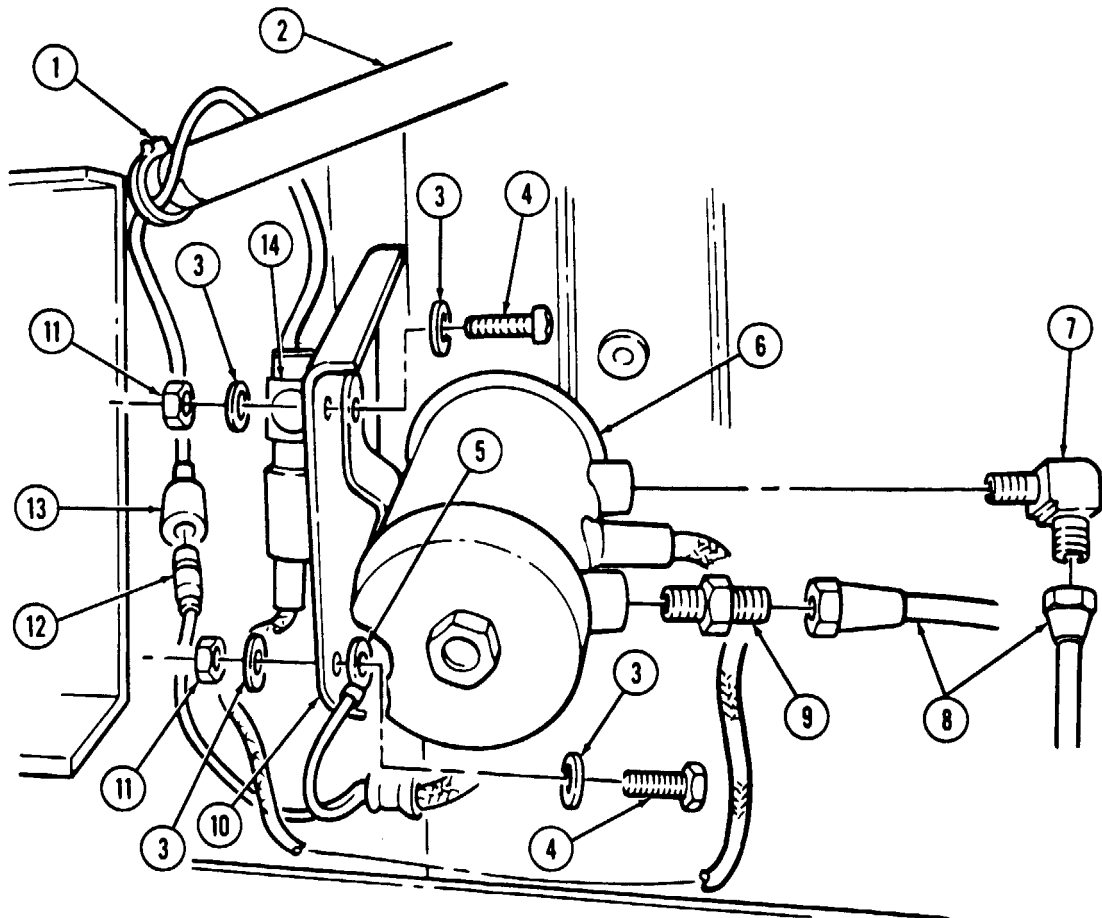

- FOLLOW-ON TASKS:
- Connect battery ground cable (para. 4-73).
 - Bleed heater fuel system (para. 11-195).

11-195. HEATER FUEL SYSTEM BLEEDING

This task covers:

Bleeding

INITIAL SETUP:

Applicable Models

M997, M997A1, M997A2

Tools

General mechanic's tool kit:
automotive (Appendix B, Item 1)

Materials/Parts

Sealing compound (Appendix C, Item 45)

Personnel Required

One mechanic
One assistant

Manual References

TM 9-2320-280-24P

Equipment Condition

Blower housing open (para. 11-198).

General Safety Instructions

Do not perform this procedure near fire, flames, or sparks.

WARNING

Diesel fuel is highly flammable. Do not perform this procedure near fire, flames, or sparks. Severe injury or death will result.

NOTE

- Have drainage container ready to catch fuel.
- Apply compound to threads of all fuel line joints before **installation**.

Bleeding

1. Disconnect heater fuel line (4) from heater (3).
2. Place end of fuel line (4) in drainage container.
3. Place heater rotary switch (1) on control box (2) to "RUN" position. Hold switch (1) in "RUN" position until fuel flows free of air bubbles.
4. Place switch (1) to "OFF" position.
5. Connect fuel line (4) to heater (3).

11-195. HEATER FUEL SYSTEM BLEEDING (Cont'd)

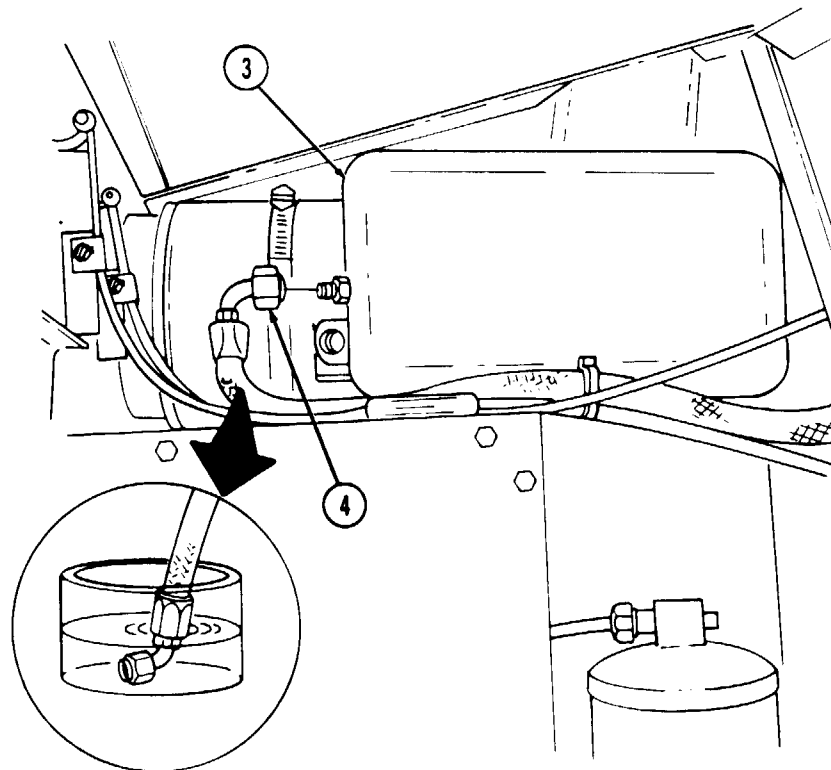
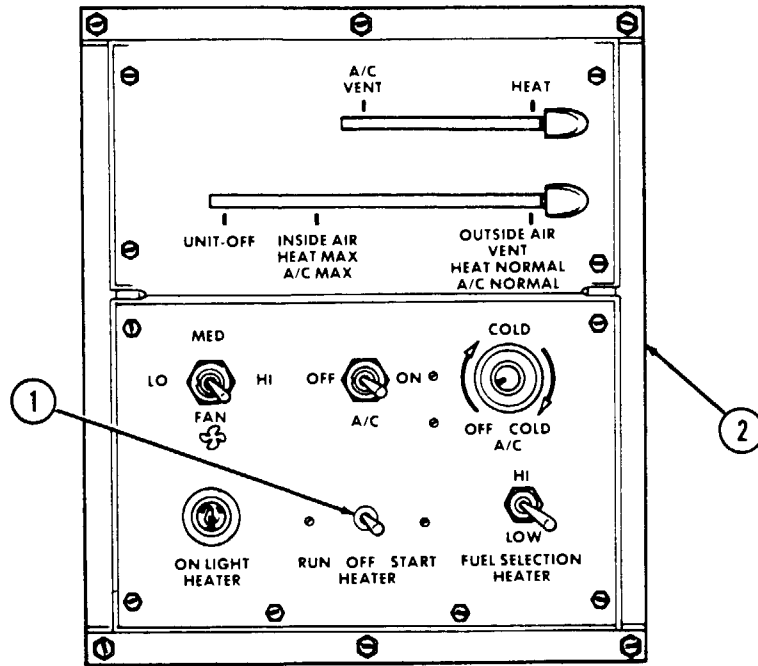

FOLLOW-ON TASK: Close blower housing (para. 11-198).

11-196. FLOOR HEAT DUCT LOUVER REPLACEMENT

This task covers:

a. Removal

b. Installation

INITIAL SETUP:

Applicable Models

M997, M997A1, M997A2

Manual Reference

TM 9-2320-280-24P

Tools

General mechanic's tool kit:
automotive (Appendix B, Item 1)

a. Removal

Remove four screws (3) and louver (2) from floor heat duct (1).

b. Installation

Install louver (2) on floor heat duct (1) with four screws (3).

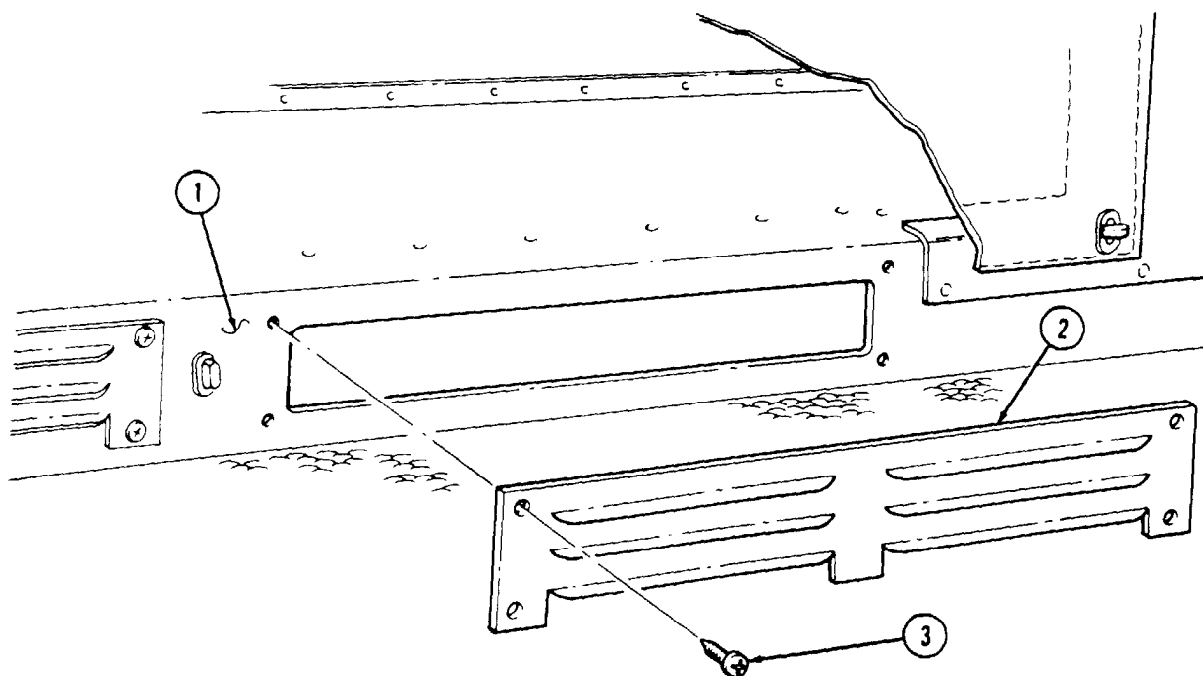

11-197. BLOWER MOTOR RESISTOR REPLACEMENT

This task covers:

a. Removal

b. Installation

INITIAL SETUP:

Applicable Models

M996, M996A1, M997, M997A1, M997A2

Tools

General mechanic's tool kit:
automotive (Appendix B, Item 1)

Manual References

TM 9-2320-280-24P

Equipment Condition

- Battery ground cable disconnected (para. 4-73).
- Blower housing open (para. 11-198).
- Heater compartment panel removed (M996 and M996A1 vehicles only) (para. 11-204).

NOTE

M996, M996A1, M997, M997A1, and M997A2 blower motor resistors are replaced basically the same. This procedure covers M997, M997A1, and M997A2 vehicles only.

a. Removal

1. Disconnect plug (1) from resistor (3).
2. Remove two screws (4) and resistor (3) from blower housing (2).

b. Installation

1. Install resistor (3) on blower housing (2) with two screws (4).
2. Connect plug (1) to resistor (3).

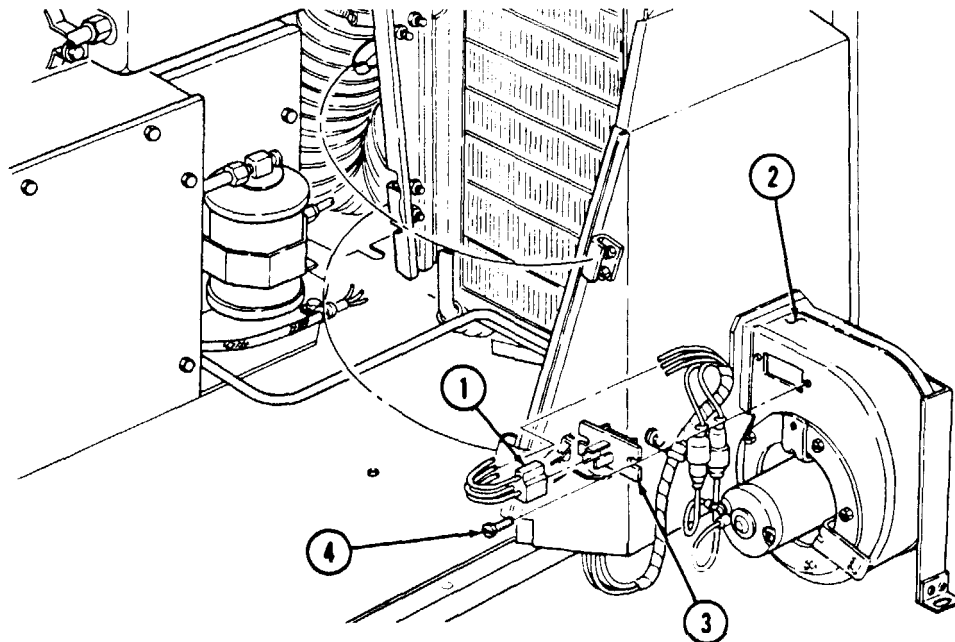

- FOLLOW-ON TASKS:
- Close blower housing (para. 11-198).
 - Connect battery ground cable (para. 4-73).
 - Heater compartment panel installed (M996 and M996A1 vehicles only) (para. 11-204).

11-198. BLOWER MOTOR AND HOUSING MAINTENANCE

This task covers:

- | | |
|---|---|
| <ul style="list-style-type: none"> a. Opening Blower Housing b. Closing Blower Housing c. Blower Housing Removal | <ul style="list-style-type: none"> d. Blower Housing Installation e. Blower Motor Removal f. Blower Motor Installation |
|---|---|

INITIAL SETUP:

Applicable Models

M997, M997A1, M997A2

Manual References

TM 9-2320-280-24P

Tools

General mechanic's tool kit:
automotive (Appendix B, Item 1)

Equipment Condition

- Rear cover panel removed (para. 11-188).
- Battery ground cable disconnected (para. 4-73).

Materials/Parts

Six lockwashers (Appendix G, Item 159)
Plain-assembled nut (Appendix G, Item 201)
Plain-assembled nut (Appendix G, Item 204)

a. Opening Blower Housing

1. Remove plain-assembled nut (3) and capscrew (11) from blower housing (2) and body (13). Discard plain-assembled nut (3).
2. Release two latches (14) from blower housing (2) and evaporator duct (1) and swing blower housing (2) open.

b. Closing Blower Housing

1. Swing blower housing (2) closed and secure to evaporator duct (1) with two latches (14).
2. Install blower housing (2) on body (13) with capscrew (11) and plain-assembled nut (3).

c. Blower Housing Removal

1. Perform step a.

NOTE

Prior to removal, tag leads for installation.

2. Disconnect four control box leads (6) from blower motor leads (5).
3. Remove plain-assembled nut (12.1), capscrew (10), and clamp (7) from blower housing (2). Discard plain-assembled nut (12.1).
4. Remove two capscrews (19) and lockwashers (18) from plate (20) and evaporator duct (1). Discard lockwashers (18).
5. Remove two screws (21), lockwashers (15), and plate (20) from blower housing (2) and evaporator duct (1). Discard lockwashers (15).
6. Remove four capscrews (16), washers (17), and blower housing (2) from evaporator duct (1).

d. Blower Housing Installation

1. Install blower housing (2) on evaporator duct (1) with four lockwashers (17) and capscrews (16).
2. Install plate (20) on blower housing (2) and evaporator duct (1) with two lockwashers (15) and screws (21).
3. Install plate (20) on evaporator duct (1) with two lockwashers (18) and capscrews (19).
4. Install clamp (7) and control box harness (12) on blower housing (2) with capscrew (10) and plain-assembled nut (12.1).

11-198. BLOWER MOTOR AND HOUSING MAINTENANCE (Cont'd)

5. Connect four control box leads (6) to blower motor leads (5).
6. Perform step b.

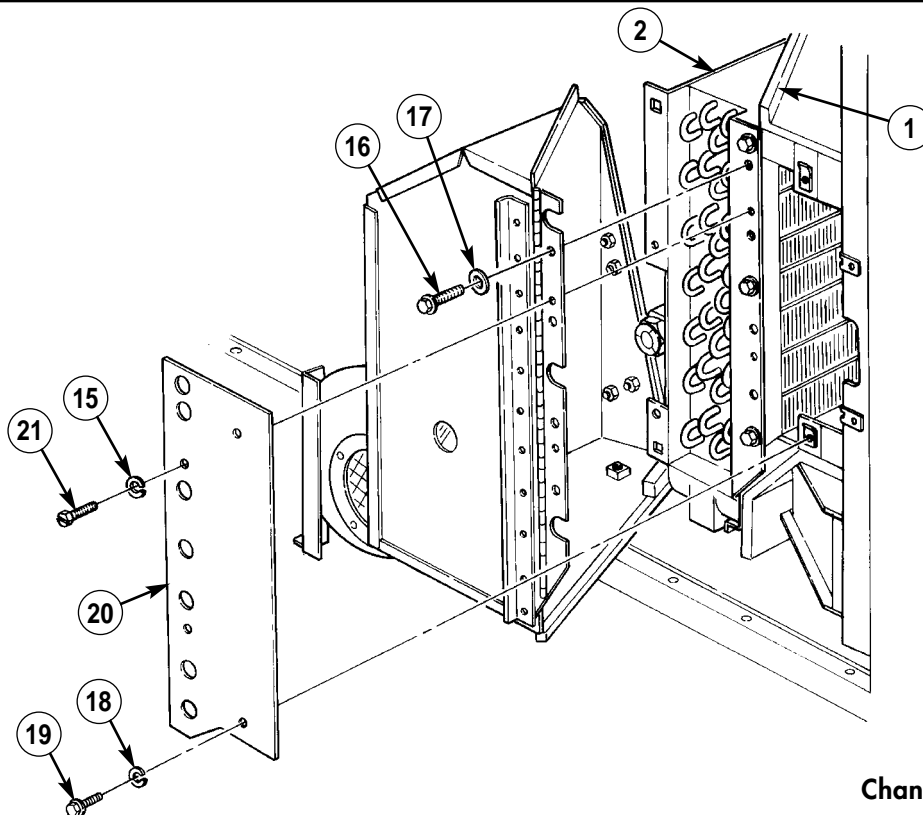
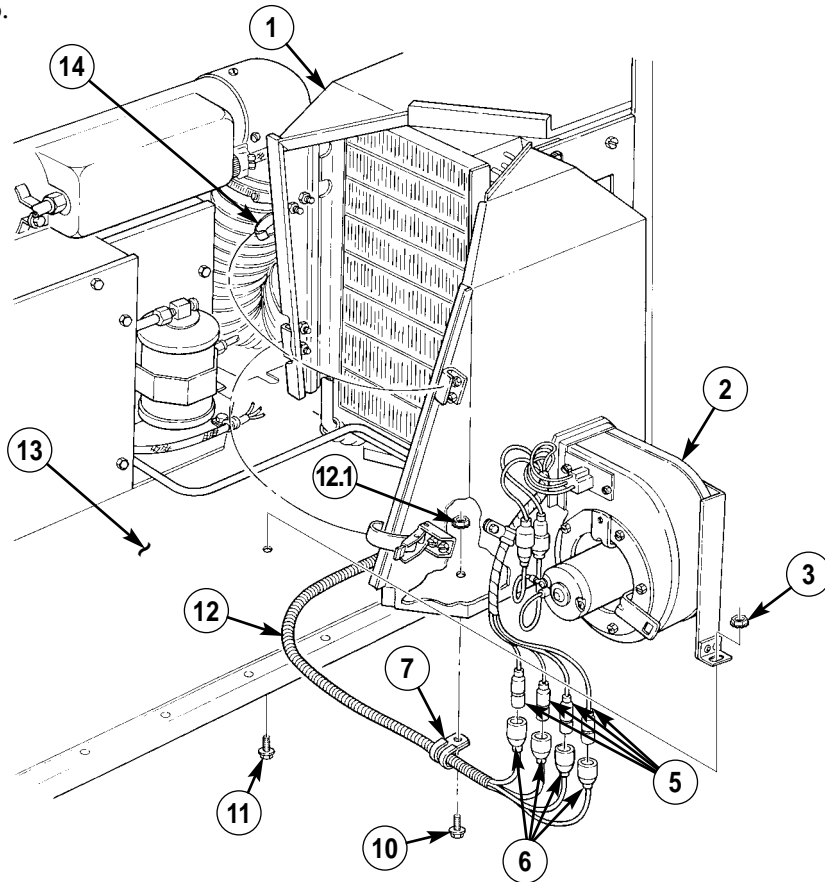

11-198. BLOWER MOTOR AND HOUSING MAINTENANCE (Cont'd)

a Blower Motor Removal

1. Perform step a.

NOTE

Prior to removal, tag leads for installation.

2. Disconnect two blower motor leads (10) from leads (1).
3. Remove five screws (8), blower motor (9), and bracket (7) from housing (2).
4. Remove setscrew (4) and fan (3) from motor (9).
5. Remove two nuts (5), lockwashers (6), and motor (9) from motor bracket (7). Discard lockwashers (6).

f. Blower Motor Installation

1. Install motor (9) on motor bracket (7) with two lockwashers (6) and nuts (5).
2. Install fan (3) on motor (9) with setscrew (4).

NOTE

Ensure fan rotates freely before securing.

3. Install blower motor (9) on housing (2) with five screws (8).
4. Connect two blower motor leads (10) to leads (1).
5. Perform step b.

11-198. BLOWER MOTOR AND HOUSING MAINTENANCE (Cont'd)

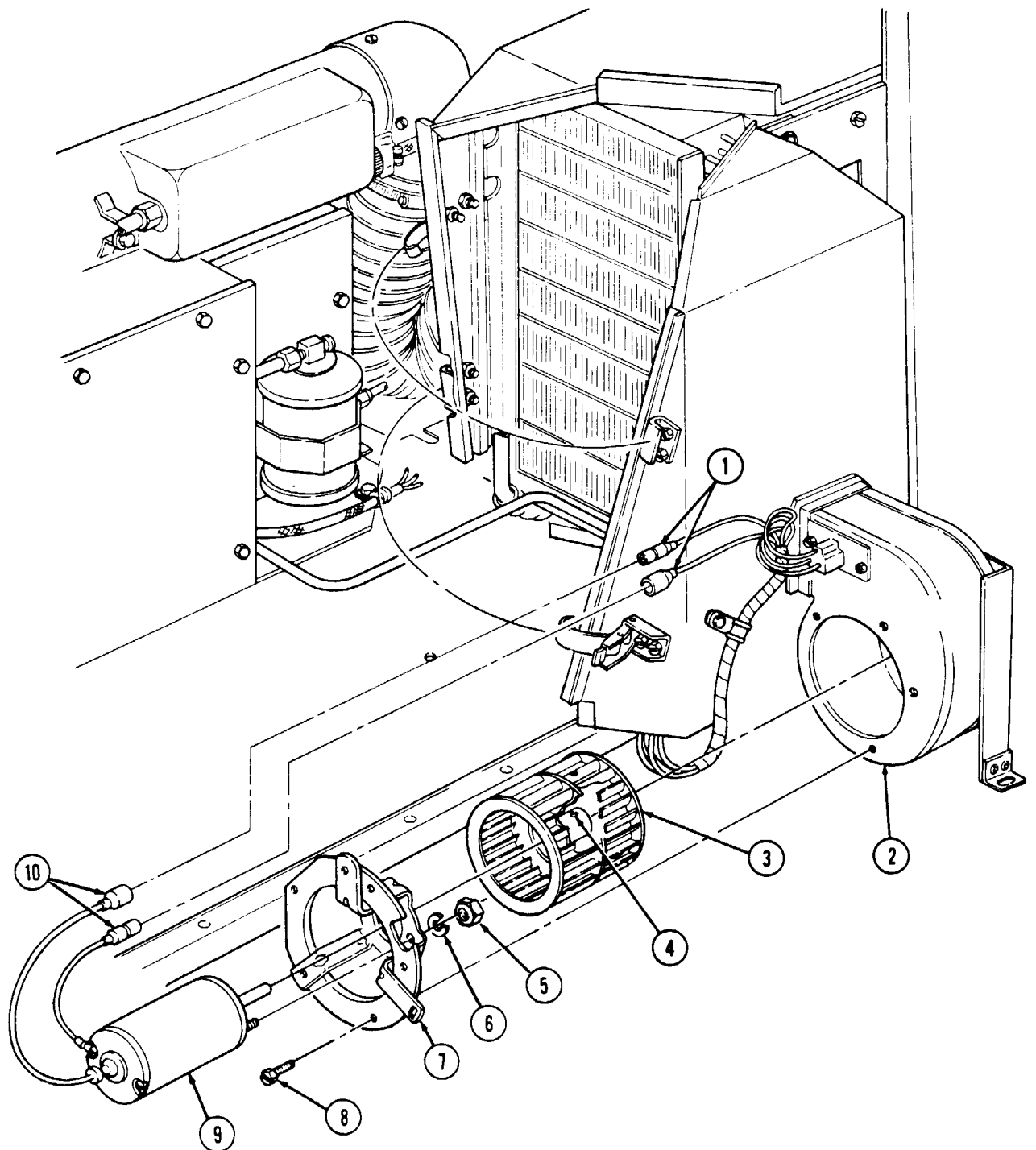

FOLLOW-ON TASKS:

- Install rear cover panel (para. 11-188).
- Connect battery ground cable (para. 4-73).

11-199. DUCT DOOR CONTROL CABLES MAINTENANCE

This task covers:

- | | |
|--|--|
| <ul style="list-style-type: none"> a. Evaporator Intake Cable Removal b. Evaporator Intake Cable Installation c. Heater/Air-Conditioning Outlet Cable Removal d. Heater/Air-Conditioning Outlet Cable Installation | <ul style="list-style-type: none"> e. Heater Intake Cable Removal f. Heater Intake Cable Installation g. Cable Adjustment |
|--|--|

INITIAL SETUP:

Applicable Models

M997, M997A1, M997A2

Tools

General mechanic's tool kit:
automotive (Appendix B, Item 1)

Materials/Parts

Six lockwashers (Appendix G, Item 138)
Two push on nuts (Appendix G, Item 226)
Four lockwashers (Appendix G, Item 159)
Four push on nuts (Appendix G, Item 227)

Manual References

TM 9-2320-280-10
TM 9-2320-280-24P

Equipment Condition

- Blower housing open (para. 11-198).
- Battery ground cable disconnected (para. 4-73).
- Control box levers positioned to UNIT OFF and A/C-VENT (TM 9-2320-280-10).

a. Evaporator Intake Cable Removal

1. Remove push on nut (3) and disconnect cable loop (5) from duct door arm (6). Discard push on nut (3).
2. Remove screw (1), lockwasher (2), and cable (7) from intake assembly (4). Discard lockwasher (2).
3. Remove push on nut (9) from cable loop (8) and control lever pin (10). Discard push on nut (9).
4. Remove screw (12), lockwasher (13), and cable (7) from control box bracket (11), and disconnect cable loop (8) from control lever pin (10). Discard lockwasher (13).

b. Evaporator Intake Cable Installation

1. Connect cable loop (8) on control lever pin (10) with push on nut (9).

NOTE

It may be necessary to adjust turnbuckle on cable to align control cable clamp with control box bracket.

2. Install cable (7) on control box bracket (11) with lockwasher (13) and screw (12).
3. Connect cable loop (5) on duct door arm (6) with push on nut (3).
4. Install cable (7) on intake assembly (4) with lockwasher (2) and screw (1).
5. Proceed to Cable Adjustment, g. 2.

11-199. DUCT DOOR CONTROL CABLES MAINTENANCE (Cont'd)

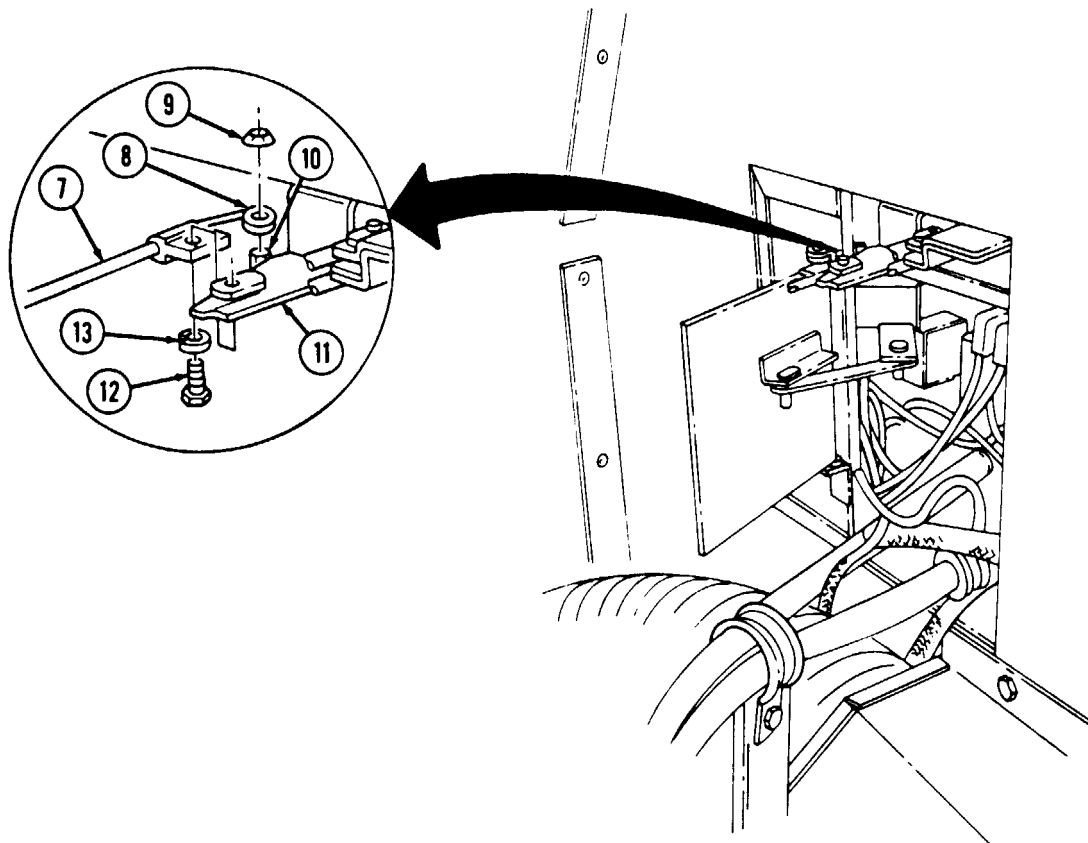
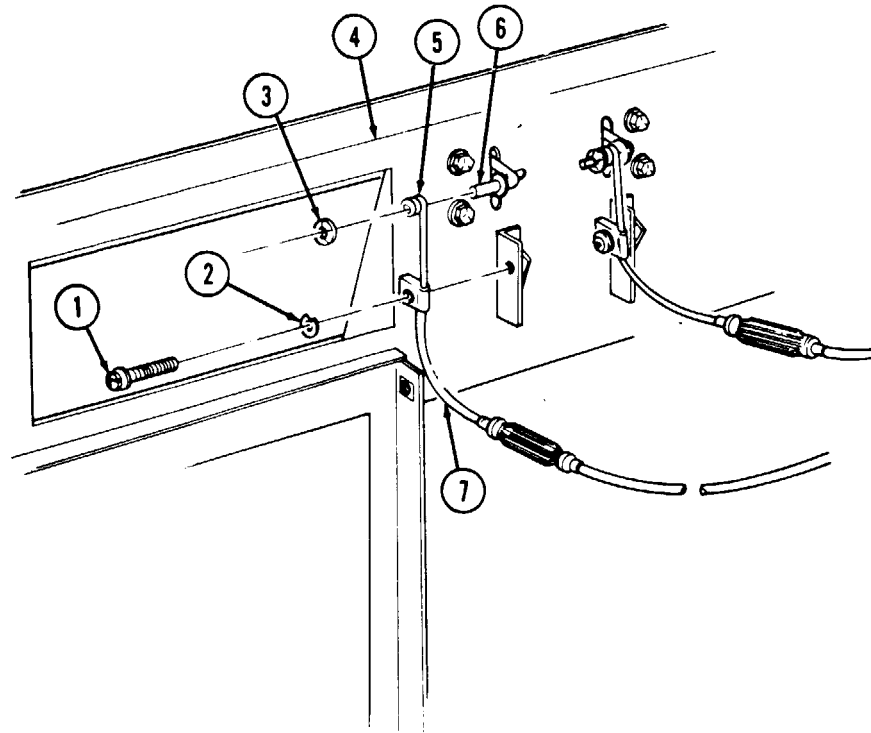

11-199. DUCT DOOR CONTROL CABLES MAINTENANCE (Cont'd)

c. Heater/Air-Conditioning Outlet Cable Removal

1. Remove two screws (4) and lockwashers (3) from plate (2) and evaporator duct (1). Discard lockwashers (3).
2. Remove two capscrews (7), lockwashers (8), and plate (2) from evaporator duct (1). Discard lockwashers (8).
3. Remove screw (6) and lockwasher (9) from cable (10) and evaporator duct (1). Discard lockwasher (9).
4. Remove push on nut (5) and cable loop (11) from duct door arm (12). Discard push on nut (5).
5. Remove push on nut (23) from cable loop (22) and control lever pin (21). Discard push on nut (23).
6. Remove screw (25) and lockwasher (24) from cable (10) and control box bracket (20), and disconnect cable loop (22) from control lever pin (21). Discard lockwasher (24).

d. Heater/Air-Conditioning Outlet Cable Installation

1. Connect cable loop (22) on control lever pin (21) with push on nut (23).

NOTE

It may be necessary to adjust turnbuckle on cable to align control cable clamp with control box bracket.

2. Install cable (10) on control box bracket (20) with lockwasher (24) and screw (25).
3. Install cable (10) on evaporator duct (1) with lockwasher (9) and screw (6).
4. Connect cable loop (11) on duct door arm (12) with push on nut (5).
5. Proceed to Cable Adjustment, g. 3 (c).

e. Heater Intake Cable Removal

1. Remove push on nut (13) and cable loop (14) from duct door arm (15). Discard push on nut (13).
2. Remove screw (19), lockwasher (18), and cable (17) from intake assembly (16). Discard lockwasher (18).
3. Remove push on nut (23) and cable loop (22) from control lever pin (21). Discard push on nut (23).
4. Remove screw (25), lockwasher (24), and cables (10) and (17) from control box bracket (20) and disconnect cable loop (22) from control lever pin (21). Discard lockwasher (24).
5. Disconnect cable loop (26) from control lever pin (21) and slide cable (17) out from bracket (20).

f. Heater Intake Cable Installation

1. Slide cable (17) through bracket (20) and connect cable loop (26) on control lever pin (21).
2. Connect cable loop (22) to control lever pin (21) with push on nut (23).

NOTE

It may be necessary to adjust turnbuckle on cable to align control cable clamp with control box bracket.

3. Install cable (10) on control box bracket (20) and install cables (10) and (17) with lockwasher (24) and screw (25).
4. Connect cable loop (14) on duct door arm (15) with push on nut (13).
5. Install cable (17) on intake assembly (16) with lockwasher (18) and screw (19).
6. Proceed to Cable Adjustment, g. 1.

11-199. DUCT DOOR CONTROL CABLES MAINTENANCE (Cont'd)

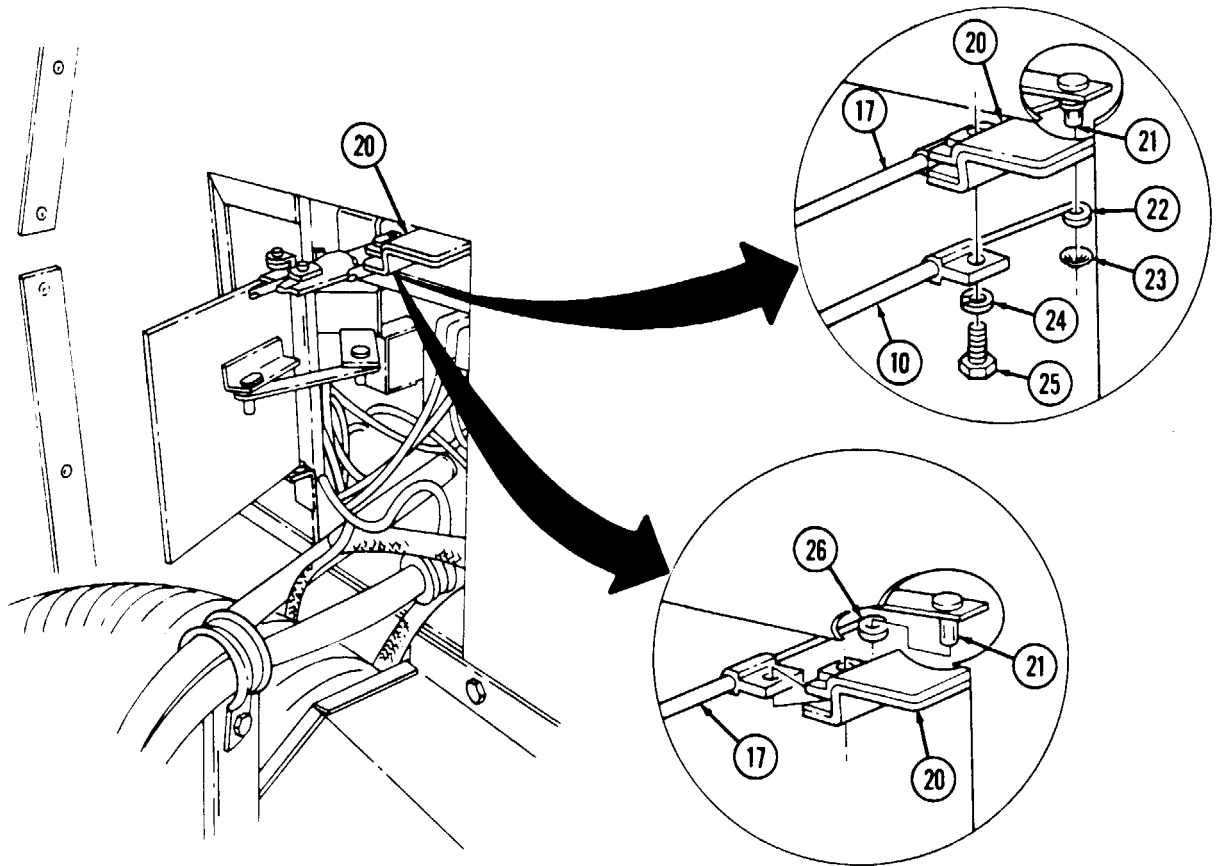
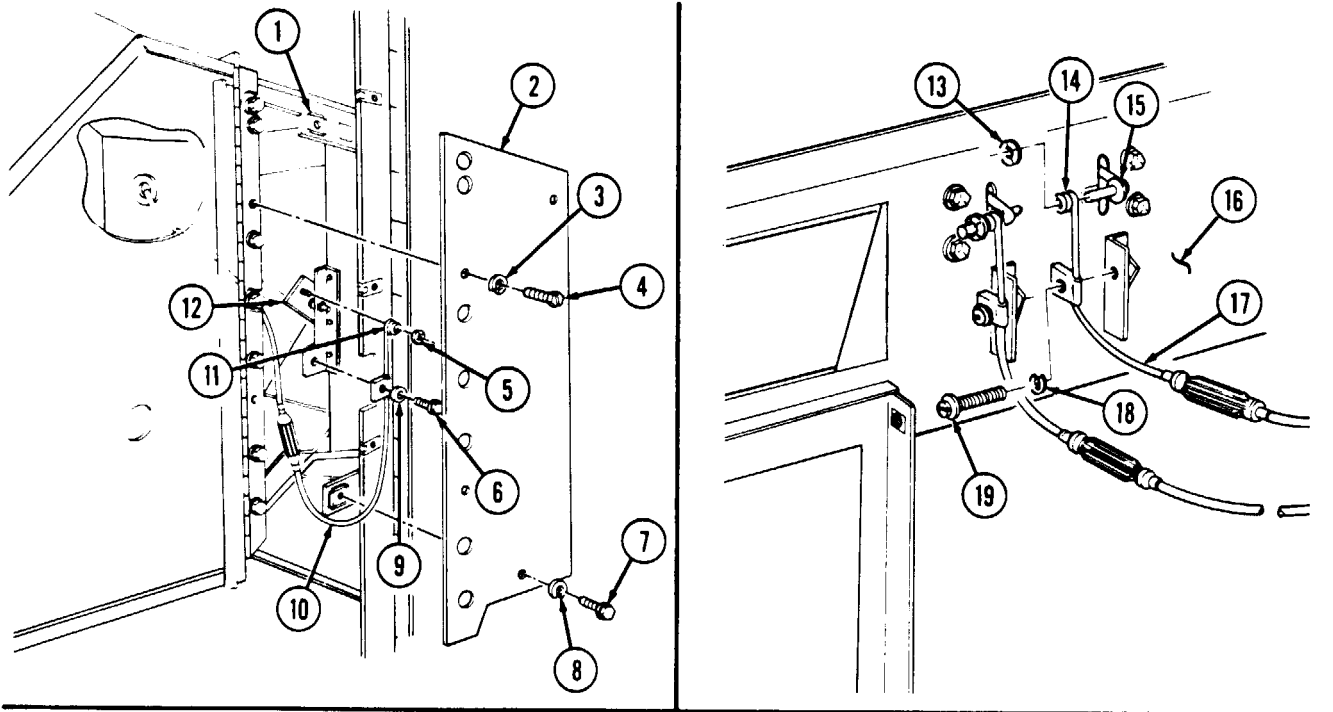

11-199. DUCT DOOR CONTROL CABLES MAINTENANCE (Cont'd)

g. Cable Adjustment

1. Heater intake cable adjustment.
 - (a) Place top lever (2) on control box (1) in A/C-VENT position.
 - (b) Adjust turnbuckle (6) on cable (7) until duct door arm (5) is all the way up (duct door fully closed).
2. Evaporator intake cable adjustment.
 - (a) Place bottom lever (3) on control box (1) in UNIT OFF position.
 - (b) Adjust turnbuckle (8) on cable (9) until duct door arm (4) is all the way up (duct door fully closed).
3. Heater/air-conditioning outlet cable adjustment.
 - (a) Remove two screws (13) and lockwashers (12) from plate (11) and evaporator duct (10). Discard lockwashers (12).
 - (b) Remove two capscrews (14), lockwashers (15), and plate (11) from evaporator duct (10). Discard lockwashers (15).
 - (c) Place top lever (2) on control box (1) in HEAT position.
 - (d) Adjust turnbuckle (17) on control cable (16) until duct door arm (18) is all the way down (duct door all the way up).
 - (e) Place top lever (2) on control box (1) in A/C-VENT position.
 - (f) Adjust turnbuckle (17) on control cable (16) until duct door arm (18) is all the way up (duct door all the way down).
 - (g) Install plate (11) on evaporator duct (10) with two lockwashers (15) and capscrews (14).
 - (h) Install plate (11) on evaporator duct (10) with two lockwashers (12) and screws (13).

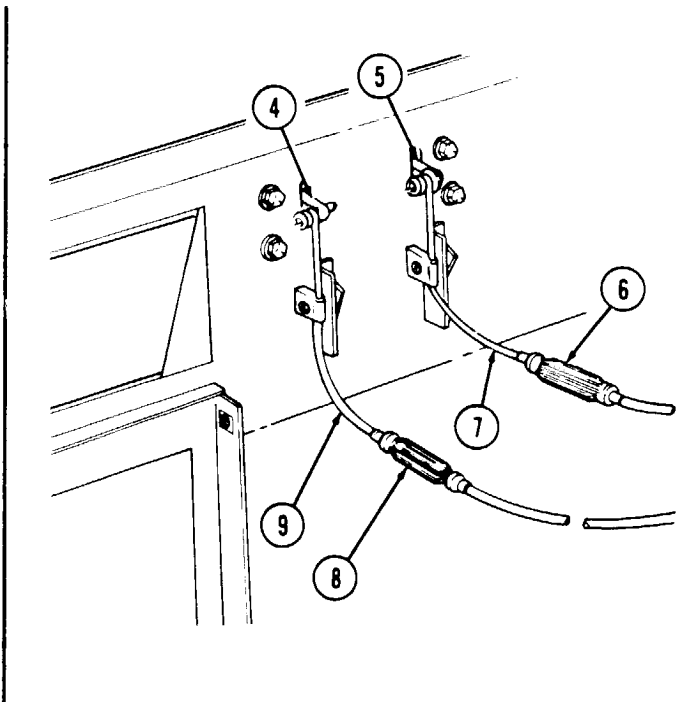
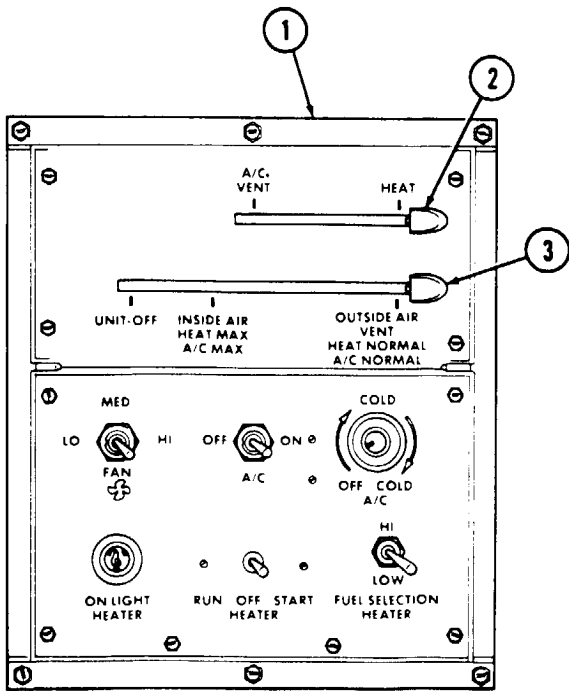

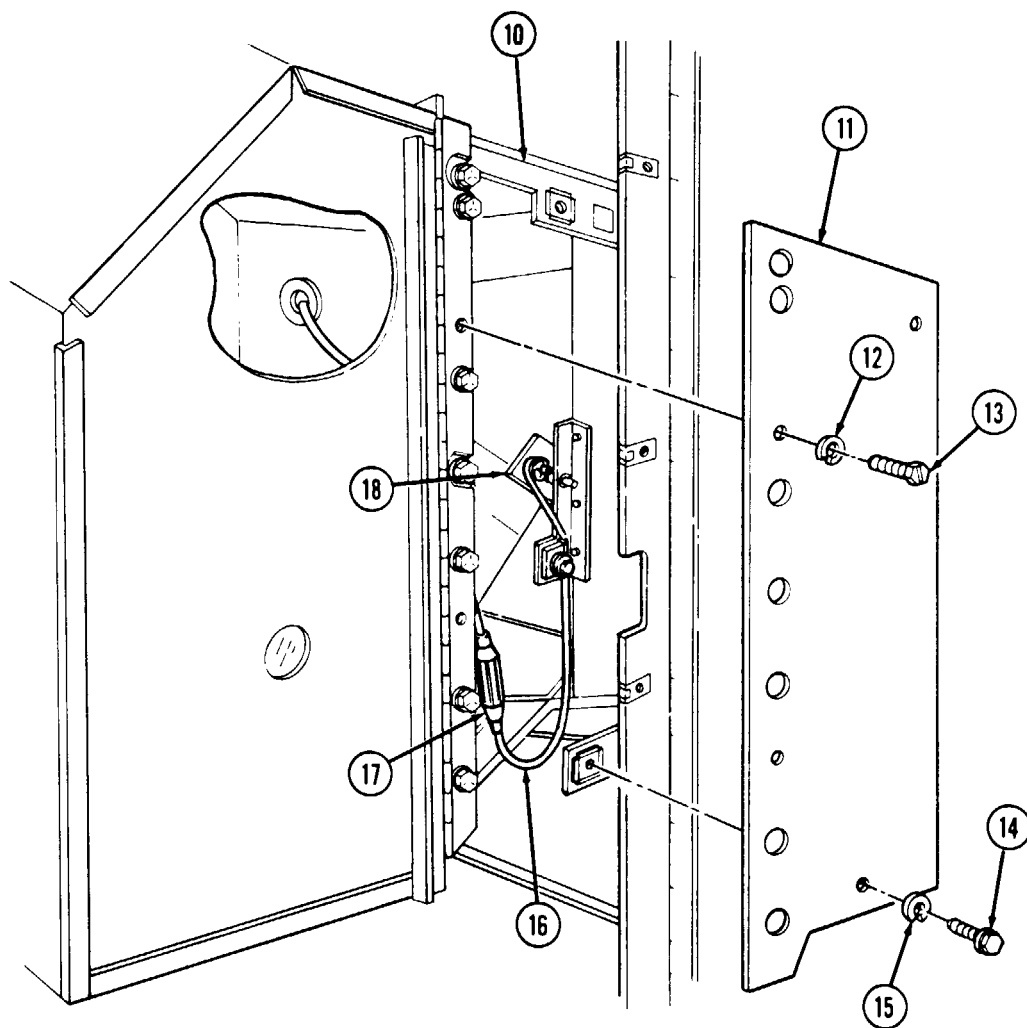
11-199. DUCT DOOR CONTROL CABLES MAINTENANCE (Cont'd)

FOLLOW-ON TASKS:

- Close blower housing (para. 11-198).
- Connect battery ground cable (para. 4-73).

11-200. EVAPORATOR DRAIN TUBE REPLACEMENT

This task covers:

a. Removal

b. Installation

INITIAL SETUP:

Applicable Models

M997, M997A1, M997A2

Materials/Parts

Tiedown strap (Appendix G, Item 309)

Tools

General mechanic's tool kit:
automotive (Appendix B, Item 1)

Manual References

TM 9-2320-280-24P

Equipment Condition

Blower housing open (para. 11-198).

a. Removal

NOTE

Perform steps 1 through 3 for old configuration only.

1. Disconnect flex tube (2) from evaporator drain pan (1).
2. Disconnect flex tube (2) from nipple (3).
3. Remove clamp (4) and nipple (3) from drain tube (5).

NOTE

Perform steps 4 through 8 for new configuration only.

4. Remove clamp (10) from drain tube (5).
5. Remove elbow (9) from drain tube (5).
6. Remove clamps (6) and (7) from hose (8).
7. Remove elbow (9) from hose (8).
8. Disconnect hose (8) from evaporator drain pan (1).
9. Remove tiedown strap (12) from harness (13) and drain tube (5). Discard tiedown strap (12).
10. Remove screw (14), clamp (17), and drain tube (5) from body (15).
11. Pull drain tube (5) through cab ceiling grommet (11) and cab floor grommet (16).

b. Installation

1. Install drain tube (5) through cab floor grommet (16) and cab ceiling grommet (11). Allow approximately 2 in. (5 cm) of drain tube (5) to extend through cab floor grommet (16).
2. Install drain tube (5) on body (15) with clamp (17) and screw (14).
3. Install drain tube (5) on harness (13) with tiedown strap (12).

NOTE

Perform steps 4 through 6 for new configuration only.

4. Connect hose (8) to evaporator drain pan (1) with clamp (7).
5. Install elbow (9) on hose (8) with clamp (6).
6. Install elbow (9) on drain tube (5) with clamp (10).

NOTE

Perform steps 7 through 9 for old configuration only.

7. Install nipple (3) in drain tube (5) with clamp (4).
8. Connect flex tube (2) to nipple (3).
9. Connect flex tube (2) to evaporator drain pan (1).

11-200. EVAPORATOR DRAIN TUBE REPLACEMENT (Cont'd)

OLD CONFIGURATION

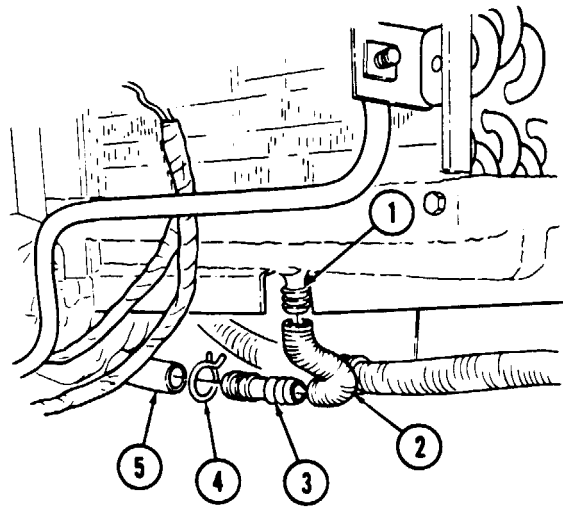

NEW CONFIGURATION

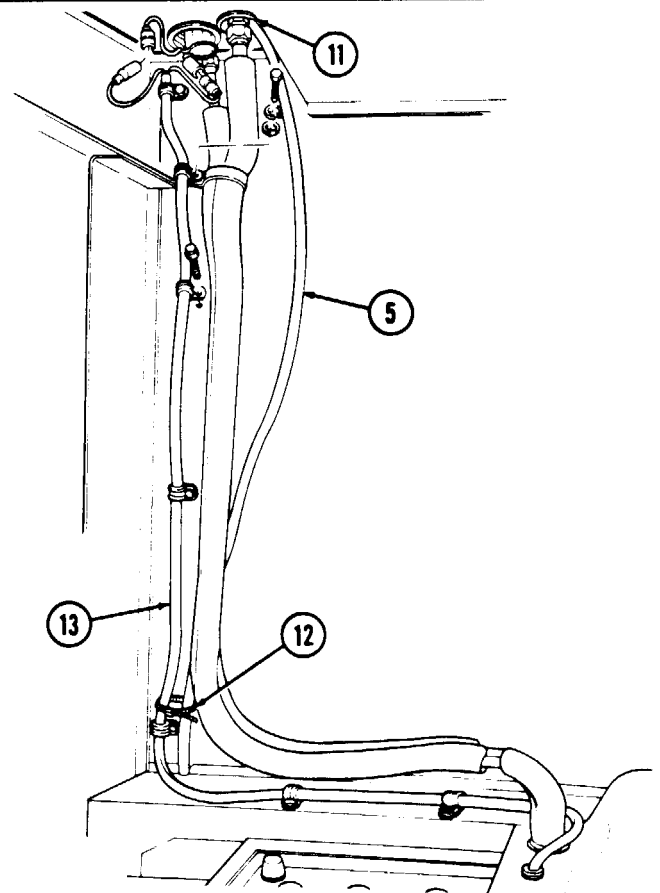
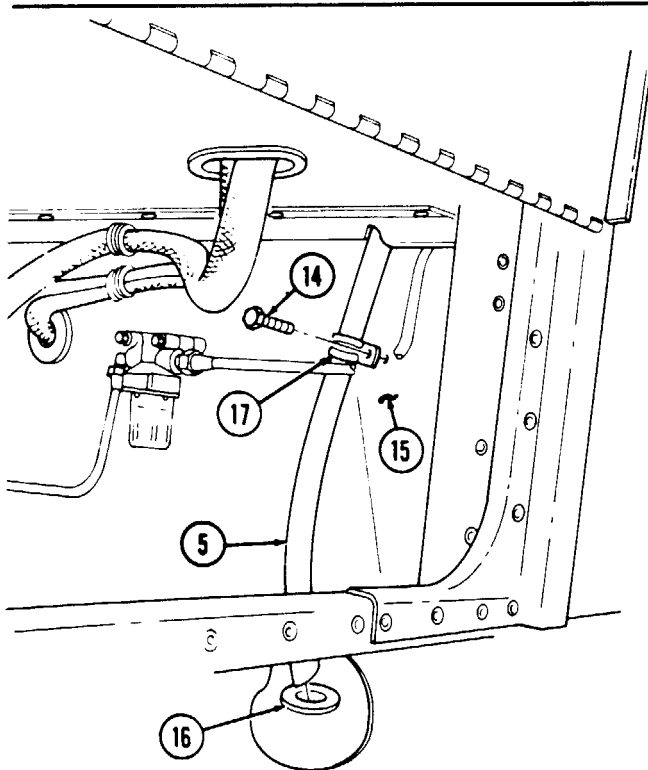
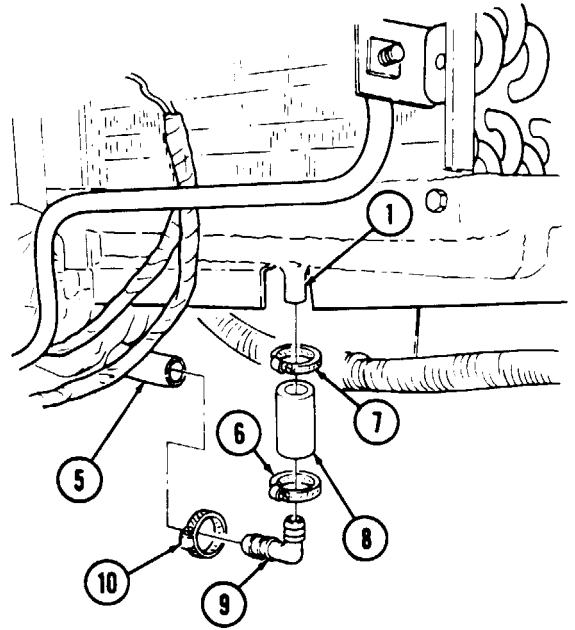

FOLLOW-ON TASK: Close blower housing (para. 11-198).

11-201. CONDENSER COOLING FAN REPLACEMENT

This task covers:

a. Removal

b. Installation

INITIAL SETUP:

Applicable Models

M997, M997A1, M997A2

Manual References

TM 9-2320-280-24P

Tools

General mechanic's tool kit:
automotive (Appendix B, Item 1)

Equipment Condition

- Air intake compartment panels removed (para. 11-184).
- Battery ground cable disconnected (para. 4-73).

Materials/Parts

Lockwasher (Appendix G, Item 182)

a. Removal

NOTE

Prior to removal, tag leads for installation.

1. Disconnect two harness leads (5) from fan motor leads (6).
2. Remove nut (8), capscrew (2), lockwasher (3), motor clamp (4), and fan motor (11) from bracket (7). Discard lockwasher (3).
3. Remove rubber mount (12) from fan motor (11).
4. Remove set screw (9) and fan blade (1) from motor shaft (10).

b. Installation

1. Install fan blade (1) on motor shaft (10) with set screw (9).
2. Install rubber mount (12) on fan motor (11).
3. Install fan motor (11) on bracket (7) so that rubber mount (12) is centered on bracket (7), and further-most corner edges of fan blades (1) are approximately 0.4 in. (10 mm) from fan shroud facing (13).
4. Install motor clamp (4) to bracket (7) and fan motor (11) with lockwasher (3), capscrew (2), and nut (8).
5. Connect two harness leads (5) to fan motor leads (6).

11-201. CONDENSER COOLING FAN REPLACEMENT (Cont'd)

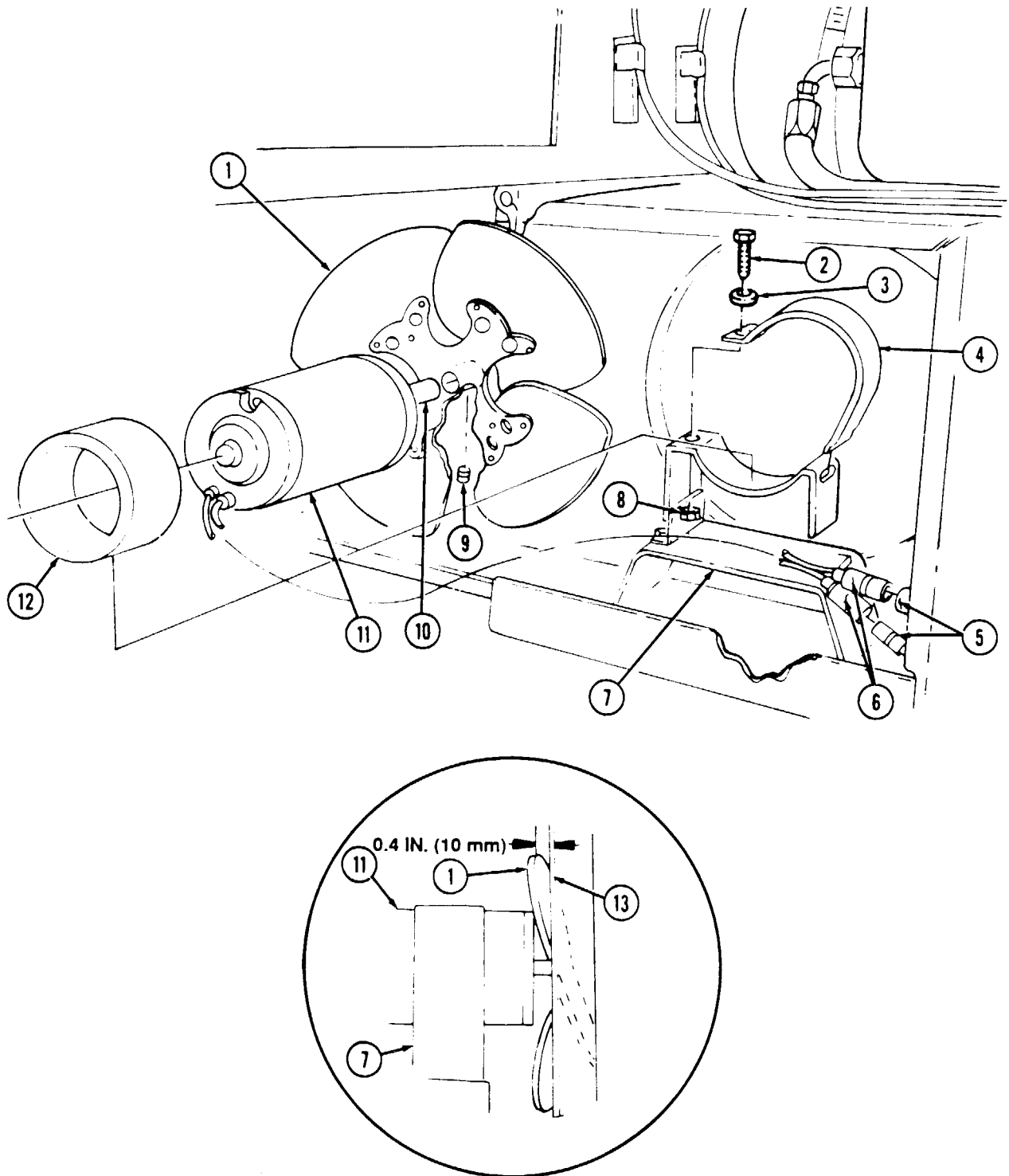

- FOLLOW-ON TASKS:
- Install air intake compartment panels (para. 11-184).
 - Connect battery ground cable (para. 4-73).

11-202. COMPRESSOR BELT MAINTENANCE

This task covers:

- a. Removal
- c. Adjustment
- b. Installation

INITIAL SETUP:

Applicable Models

M997, M997A1, M997A2

Tools

General mechanic's tool kit:
automotive (Appendix B, Item 1)

Special Tools

Belt tension gauge (Appendix B, Item 67)
Crowfoot, 14 mm (Appendix B, Item 152)

Personnel Required

One mechanic
One assistant

Manual References

TM 9-2320-280-24P

Equipment Condition

- Engine right splash shield removed (para. 10-20).
- Engine access cover removed (para. 10-15).
- Serpentine drivebelt removed ("A2" series only) (para. 3-83).

a. Removal

1. Loosen two capscrews (10) from compressor (11) and support bracket (12).
2. Loosen two nuts (1) and capscrew (7) from adjusting bracket (5) and mounting ears (6).
3. Loosen nut (2) on adjusting bracket (5) and timing cover bolt (3), and push compressor (11) toward timing chain cover (4) to loosen belt (9).
4. Disconnect fan drive hose (15) from fan drive assembly (17).
5. Remove belt (9) from compressor pulley (8), water pump pulley (14), crankshaft pulley (16), and over fan blades (13).

b. Installation

Install belt (9) over fan blades (13) and place belt (9) on crankshaft pulley (16), water pump pulley (14), and compressor pulley (8).

c. Adjustment

NOTE

If belt was replaced, go to step 2.

1. Perform Removal, steps a.1 through a.4.

CAUTION

Do not pry against compressor housing with pry bar when adjusting belt tension. Compressor may be damaged.

2. Pull compressor (11) away from timing chain cover (4) and position pry bar between rear mounting ear (6) and support bracket (12) to adjust belt tension.
3. Using belt tension gauge, check belt (9) for proper tension (refer to table 11-1).

Table 11-1. Compressor Belt Tension Requirements

NOTE		
A "used" belt is one that has run at least fifteen minutes or fifteen miles (24 kilometers).		
APPLICATION	NEW BELT	USED BELT
Compressor belt	105 ± 5 lbs (467 ± 22 N)	90 ± 5 lbs (400 ± 22 N)

11-202. COMPRESSOR BELT MAINTENANCE (Cont'd)

4. If belt (9) tension is correct, tighten nut (2), two capscrews (10), capscrew (7), and two nuts (1).
5. Repeat step (3). If belt (9) tension cannot be properly adjusted, replace belt (9).
6. Tighten nut (2) to 40 lb-ft (54 N·m). Using crowfoot on front capscrew (10), tighten two capscrews (10) to 26 lb-ft (35 N·m). Tighten two nuts (1) to 26 lb-ft (35 N·m).
7. Connect fan drive hose (15) to fan drive assembly (17).

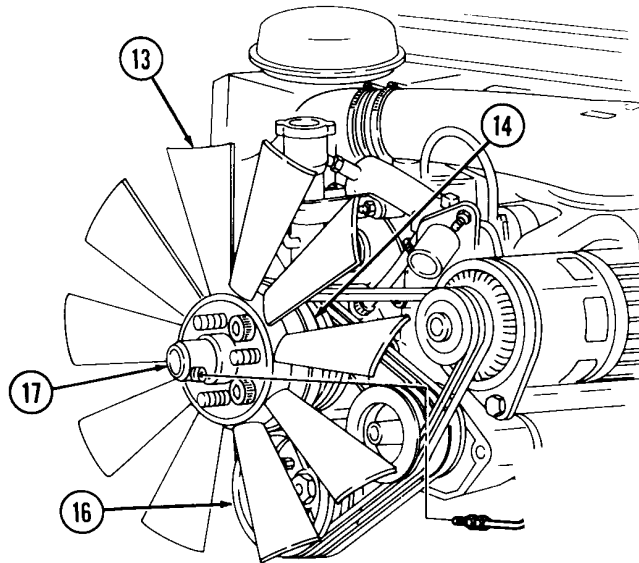
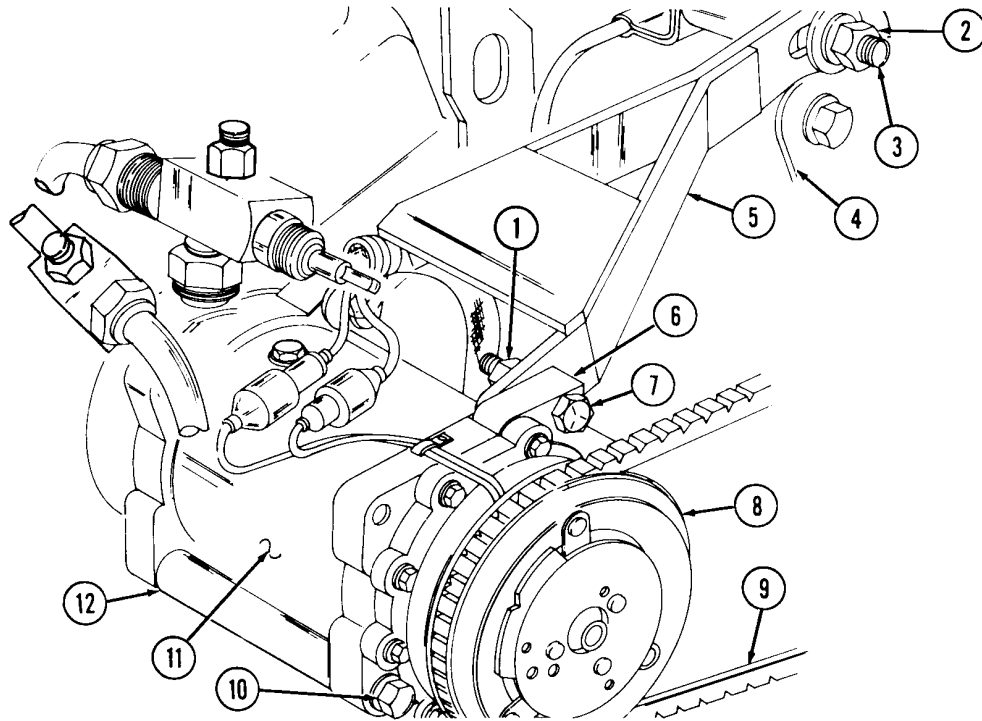

- FOLLOW-ON TASKS:**
- Install engine right splash shield (para. 10-20).
 - Install engine access cover (para. 10-15).
 - Install serpentine drivebelt (A2 series only) (para. 3-83).

11-203. AIR-CONDITIONING DUCT LOUVER REPLACEMENT

This task covers:

a Removal

b. Installation

INITIAL SETUP:

Applicable Models

M997, M997A1, M997A2

Manual References

TM 9-2320-280-24P

Tools

General mechanic's tool kit:
automotive (Appendix B, Item 1)

a. Removal

Pry duct louver (2) from air-conditioning duct (1) and remove duct louver (2).

b. Installation

Push duct louver (2) into opening in air-conditioning duct (1).

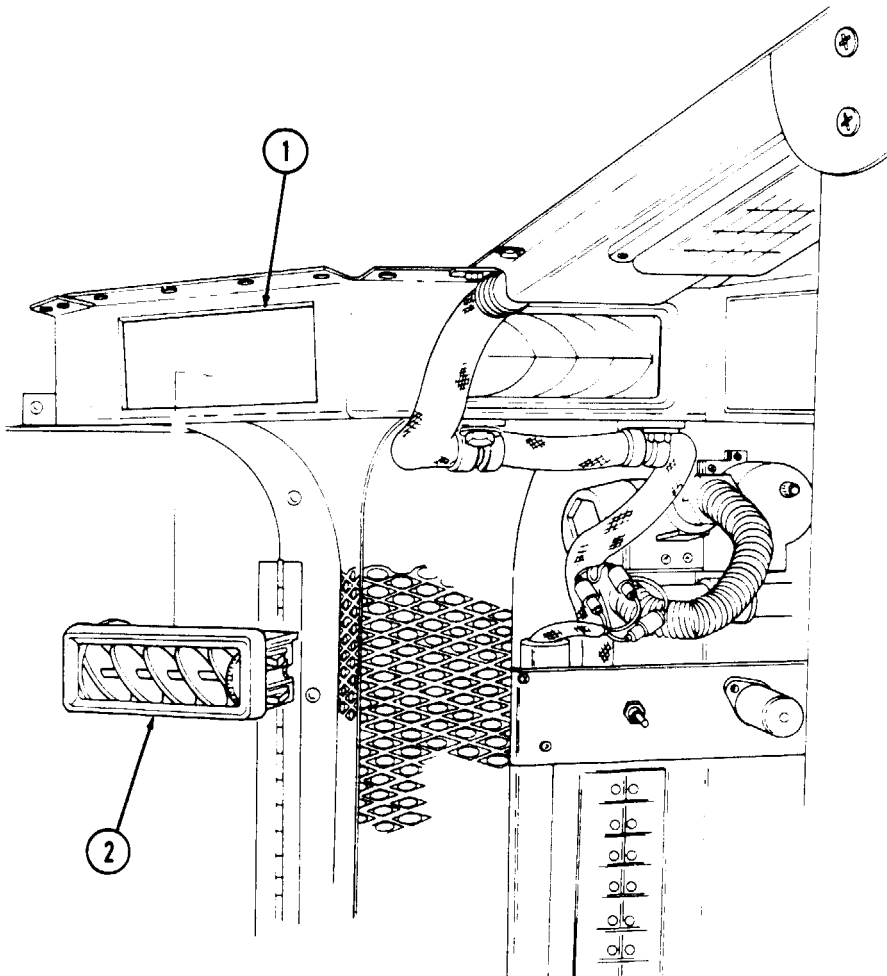

11-204. HEATER COMPARTMENT PANEL REPLACEMENT (M996, M996A1)

This task covers:

a. Removal

b. Installation

INITIAL SETUP:**Applicable Models**

M996, M996A1

Manual References

TM 9-2320-280-24P

Tools

General mechanic's tool kit:
automotive (Appendix B, Item 1)

a. Removal

1. Loosen seven wing bolts (1) and remove panel (2) from body (3).
2. Inspect seven retaining washers (4) on wing bolts (1) for presence and damage. Replace retaining washers (4) if missing or damaged.

b. Installation

Install panel (2) to body (3) with seven wing bolts (1).

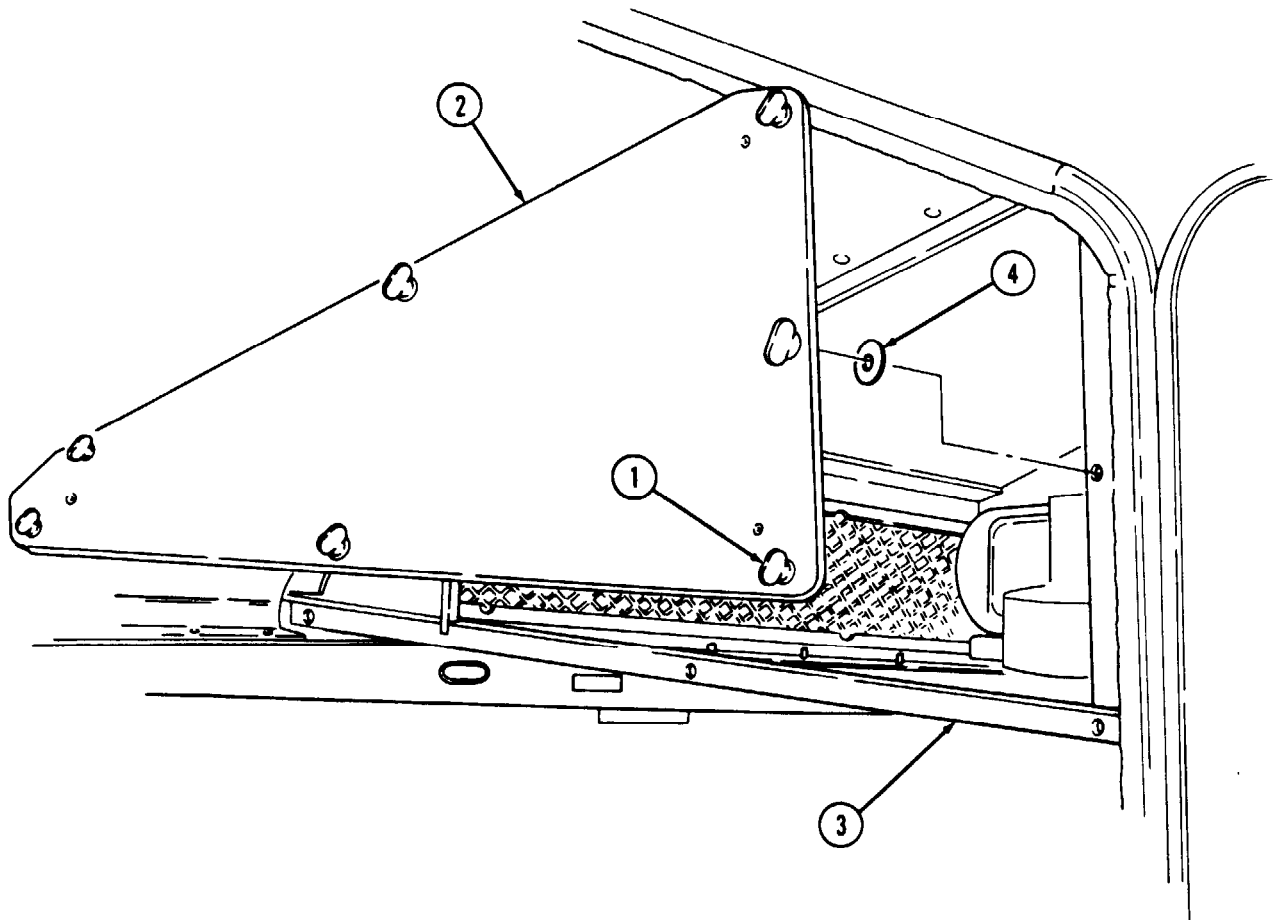

11-205. AIR INTAKE FILTER MAINTENANCE

This task covers

a. Inspection

b. Cleaning

INITIAL SETUP:

Applicable Models

M996, M996A1, M997, M997A1, M997A2

Took

General mechanic's tool kit:
automotive (Appendix B, Item 1)

Manual References

TM 9-2320-280-10
TM 9-2320-280-24P
FM 3-4
FM 3-5

Materials/Parts

Detergent (Appendix C, Item (17))

Equipment Condition

Air intake filters removed (TM 9-2320-280-10).

General Safety Instructions

- NBC contaminated filters must be handled and disposed of only by trained personnel.
- Compressed air used for cleaning purposes will not exceed 30 psi (207 kPa).

WARNING

NBC contaminated filters must be handled and disposed of only by authorized and trained personnel. The unit commander or senior officer in charge of maintenance personnel must ensure that prescribed protective clothing (FM 3-4) is used, and prescribed safety measures and decontamination procedures (FM 3-5) are followed. The local unit SOP is responsible for final disposal of contaminated air filters,

a. Inspection

Inspect filters (1) for tears, rips, contaminants, or other damage. Inspect filter frames (2) and supports (3) for cracks, bends, or other damage. If filters (1), frames (2), or support (3) are damaged, replace.

b. Cleaning

1. Cleaning with detergent.

Remove oily dirt from filter (1) by gently hand washing in warm water and non-sudsing detergent. Gently rinse filter (1) with warm water. Allow filter to dry.

2. Cleaning with compressed air.

WARNING

Compressed air used for cleaning purposes will not exceed 30 psi (207 kPa). Use only with effective chip guarding and personnel protective equipment (goggles/shield, gloves, etc.).

Remove oily dirt and dust from filter (1) by directing air stream at an angle and approximately 6 in. (152.4 mm) from filter (1). Blow away loosened dirt or dust from both sides of filter (1).

11-205. AIR INTAKE FILTER MAINTENANCE (Cont'd)

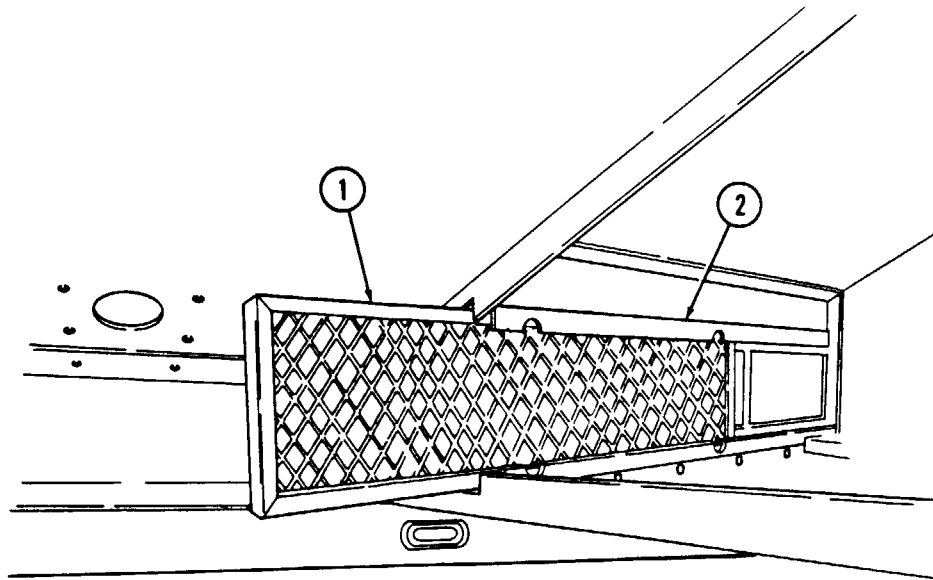

M996, M996A1 ONLY

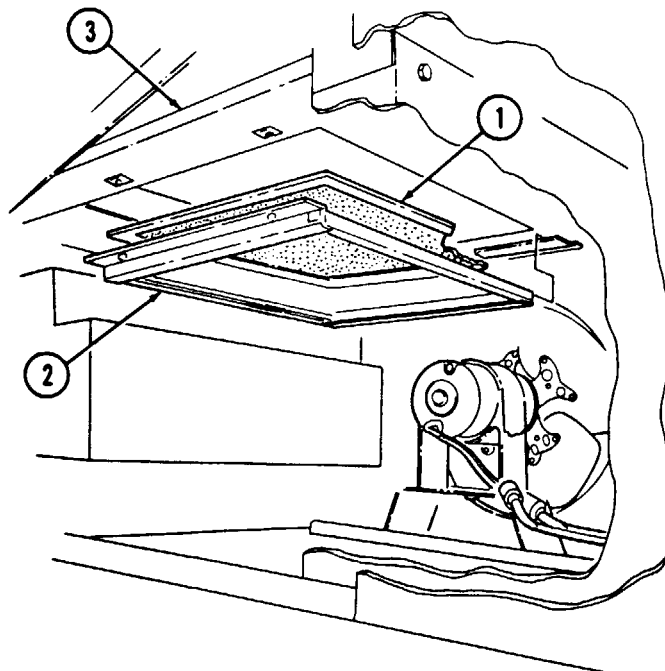

M997, M997A1, M997A2 ONLY

FOLLOW-ON TASK: Install air intake filter (TM 9-2320-280-10).

11-206. HEATER OUTLET/BLOWER FAN HOSE REPLACEMENT (M996, M996A1)

This task covers:

a. Removal

b. Installation

INITIAL SETUP:

Applicable Models

M996, M996A1

Manual References

TM 9-2320-280-24P

Tools

General mechanic's tool kit:
automotive (Appendix B, Item 1)

Equipment condition

Heater compartment panel removed (para. 11-204).

NOTE

Heater outlet hose and blower fan hose replacement procedures are basically the same. This procedure covers the heater outlet hose.

a. Removal

Loosen two clamps (3) and remove hose (2) from heater (1) and blower duct (4).

b. Installation

Install hose (2) on blower duct (4) and heater (1) and tighten two clamps (3).

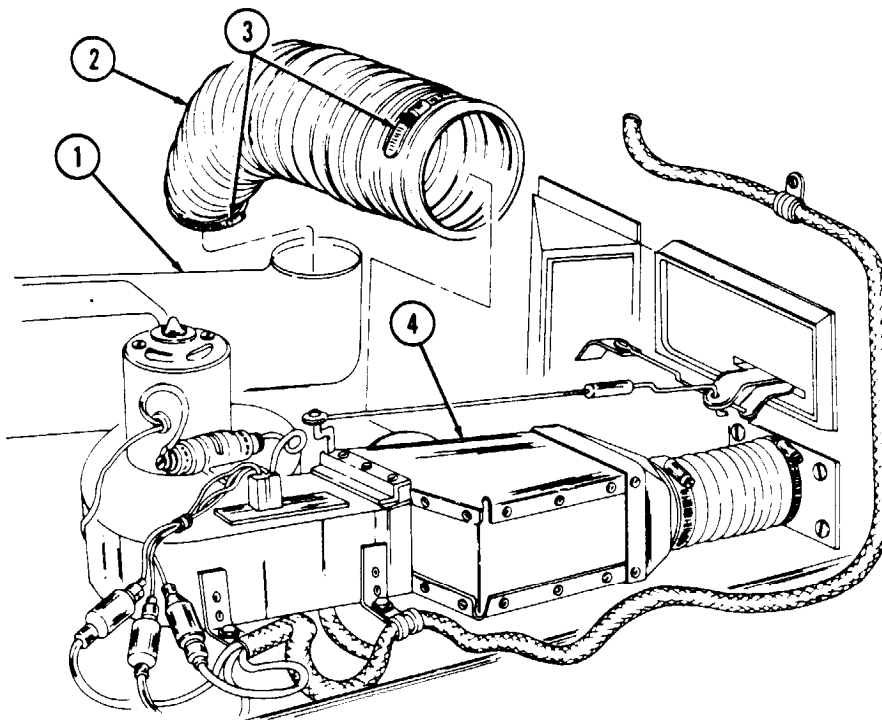

FOLLOW-ON TASK: Install heater compartment panel (para. 11-204).

11-207. HEATER EXHAUST PIPE REPLACEMENT (M996, M996A1)

This task covers:

a. Removal

b. Installation

INITIAL SETUP:

Applicable Models

M996, M996A1

Manual References

TM 9-2320-280-24P

Tools

General mechanic's tool kit:
automotive (Appendix B, Item)

General Safety Instructions

Do not touch hot exhaust system components with bare hands.

Materials/Parts

Two lockwashers (Appendix G, Item 144)

WARNING

Do not touch hot exhaust system components with bare hands.
Severe injury will result.

a. Removal

1. Remove two screws (1) from exhaust pipe bracket (2) and body (7).
2. Remove two capscrews (5) and lockwashers (6) from support bracket (4) and body (7). Discard lockwashers (6).
3. Remove exhaust pipe (3) and support bracket (4) by sliding out of exhaust outlet (8).
4. Remove two nuts (9), U-bolt (10), clamp (11), and support bracket (4) from exhaust pipe (3).

b. Installation

1. Install support bracket (4) and clamp (11) on exhaust pipe (3) with U-bolt (10) and two nuts (9). Do not tighten nuts (9).
2. Install exhaust pipe (3) and support bracket (4) on body (7), ensuring end of exhaust pipe (3) is fully seated on exhaust outlet (8).
3. Install exhaust pipe bracket (2) on body (7) with two screws (1).
4. Install support bracket (4) on body (7) with two lockwashers (6) and capscrews (5). Tighten capscrews (5) to 15 lb-ft (20 N·m).
5. Tighten two nuts (9) to 15 lb-ft (20 N·m).

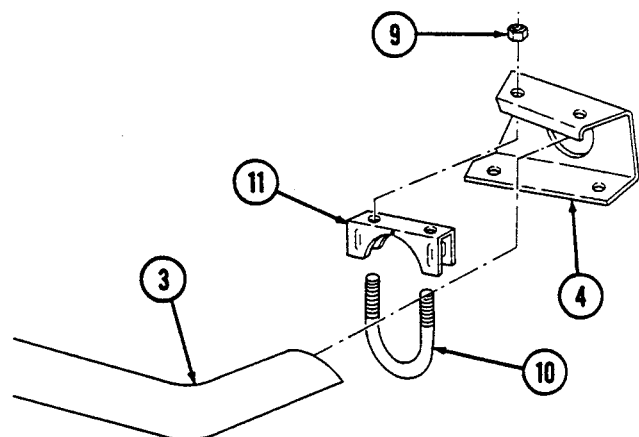
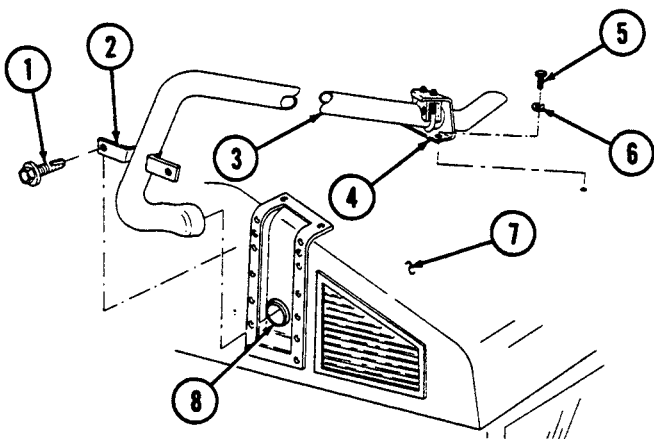

11-208. HEATER MOUNTING BRACKET ASSEMBLY REPLACEMENT (M996, M996A1)

This task covers:

a. Removal

b. Installation

INITIAL SETUP:

Applicable Models

M996, M996A1

Manual References

TM 9-2320-280-24P

Tools

General mechanic's tool kit:
automotive (Appendix B, Item 1)

Equipment Condition

Heater removed (para. 11-209).

Materials/Parts

Eight blind rivets (Appendix G, Item 241)

NOTE

For instructions on replacement of rivets, refer to para. 10-66.

a. Removal

1. Remove two screws (1), clamps (2), and fuel line (3) from bracket (4).
2. Remove six screws (8) from NBC control box (9) and body (7), and pull control box (9) away for access.
3. Remove eight rivets (6) and bracket (4) from body (5).

b. Installation

1. Install bracket (4) on body (5) with eight rivets (6).
2. Install fuel line (3) and two clamps (2) on bracket (4) with two screws (1).
3. Install NBC control box (9) on body (7) with six screws (8).

11-208. HEATER MOUNTING BRACKET ASSEMBLY REPLACEMENT (M996, M996A1) (Cont'd)

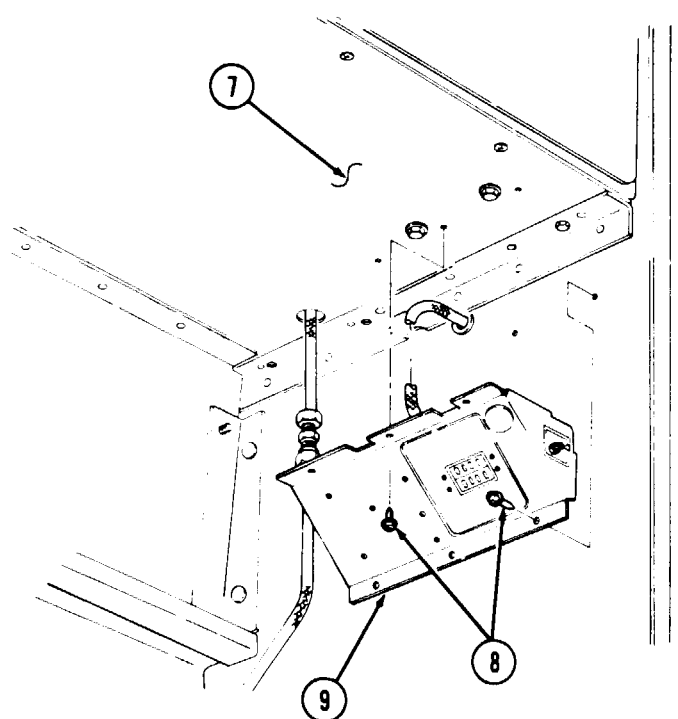
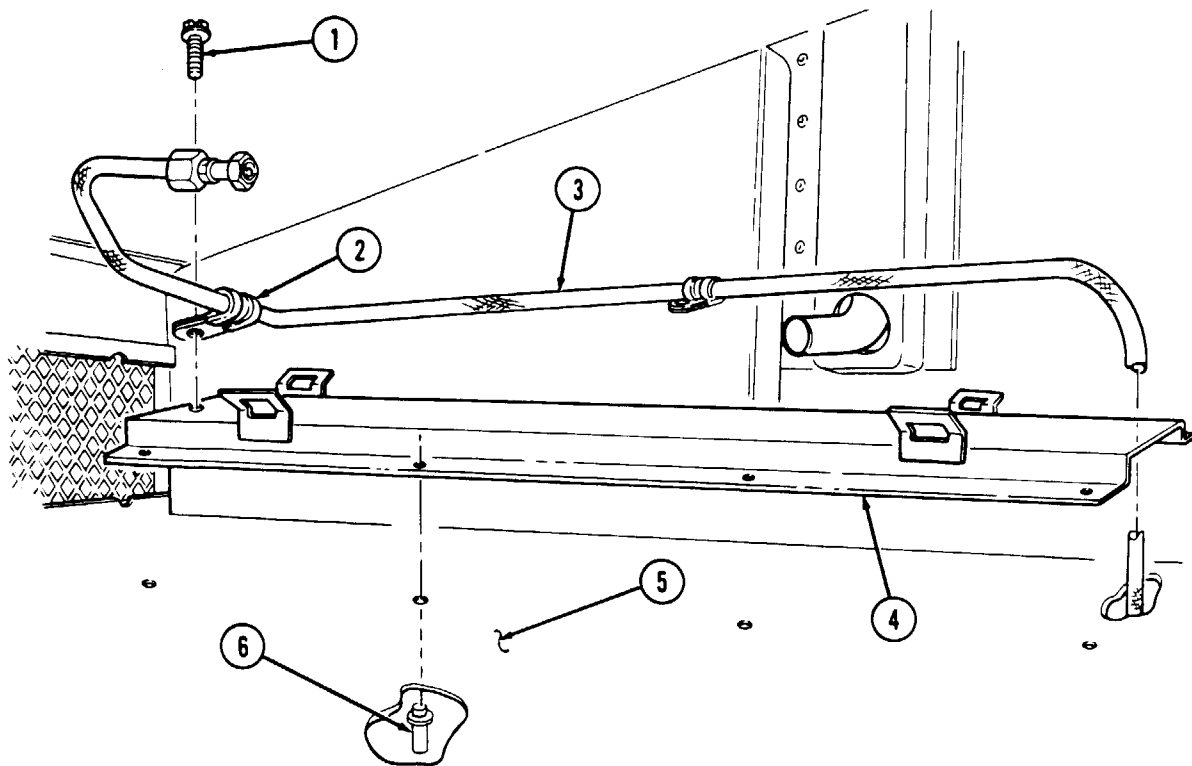

FOLLOW-ON TASK: Install heater (para. 11-209).

11-209. HEATER REPLACEMENT (M996, M996A1)

This task covers:

a. Removal

b. Installation

INITIAL SETUP:

Applicable Models

M996, M996A1

Tools

General mechanic's tool kit:
automotive (Appendix B, Item 1)

Materials/Parts

Sealing compound (Appendix C, Item 44)
Two assembled washer screws
(Appendix G, Item 280)

Personnel Required

One mechanic
One assistant

Manual References

TM 9-2320-280-24P

Equipment Condition

- Blower assembly removed (para. 11-212).
- Heater outlet hose removed (para. 11-206).

General Safety Instructions

Do not perform this procedure near fire, flames, or sparks.

WARNING

Diesel fuel is highly flammable. Do not perform this procedure near fire, flames, or sparks. Severe injury or death will result.

NOTE

- Have drainage container ready to catch fuel.
- Cover or plug all open connections immediately after disconnection to prevent contamination. Remove all covers or plugs prior to connection.
- Apply sealing compound to threads of all fuel line joints before installation.

a. Removal

1. Disconnect fuel line (11) from heater (2) and allow fuel to drain.
2. Disconnect control box plug (7) from heater receptacle (1).
3. Remove two clamps (9) and heater (2) from mounting brackets (10).
4. Remove four screws (8) and outlet (5) from heater (2).
5. Remove two assembled washer screws (6), exhaust tube (4), and seal (3) from heater (2). Discard assembled washer screws (6).
6. Inspect seal (3) for damage, replace if damaged.

b. Installation

1. Install seal (3) and exhaust tube (4) on heater (2) with two assembled washer screws (6).
2. Install outlet (5) on heater (2) with four screws (8).
3. Install two clamps (9) on mounting brackets (10).

NOTE

Have assistant guide exhaust outlet into exhaust pipe from outside of vehicle. Install heater exhaust outlet in first for proper clearance.

4. Install heater (2) on mounting brackets (10) with clamps (9).

11-210. BLOWER OUTLET DEFLECTOR REPLACEMENT

This task covers:

a. Removal

b. Installation

INITIAL SETUP:

Applicable Models

M996, M996A1

Materials/Parts

Nineteen blind rivets (Appendix G, Item 250)

Tools

General mechanic's tool kit:
automotive (Appendix B, Item 1)

Manual References

TM 9-2320-280-24P

NOTE

For instructions on replacement of rivets, refer to para. 10-66.

a. Removal

1. Remove two rivets (3) from deflector (1) and bracket (4).
2. Remove seventeen rivets (5) and deflector (1) from body (2).

b. Installation

1. Install deflector (1) on body (2) with seventeen rivets (5).
2. Install deflector (1) on bracket (4) with two rivets (3).

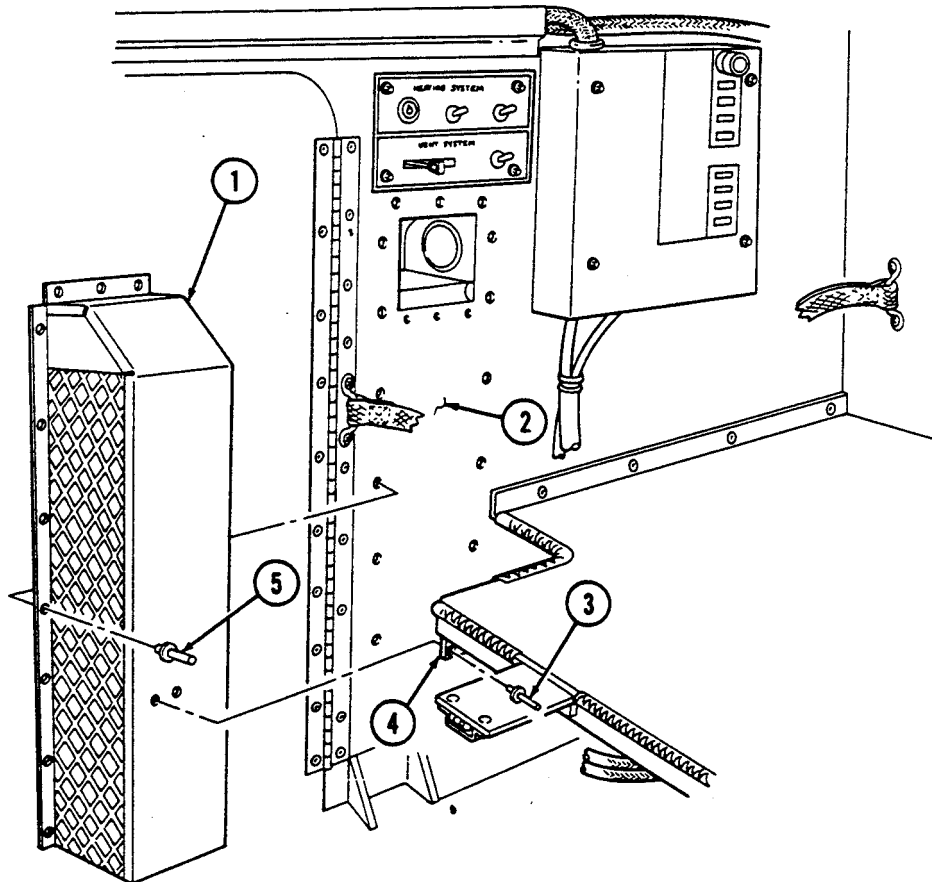

11-211. HEAT/AIR-CONDITIONING DUCT MAINTENANCE

This task covers:

- | | |
|----------------|-----------------|
| a. Removal | c. Assembly |
| b. Disassembly | d. Installation |

INITIAL SETUP:

Applicable Models

M997, M997A1, M997A2

Tools

General mechanic's tool kit:
automotive (Appendix B, Item 1)

Materials/Parts

Fourteen blind rivets (Appendix G, Item 250)
Twenty blind rivets (Appendix G, Item 251)
Eight blind rivets (Appendix G, Item 237)
Six blind rivets (Appendix G, Item 262)

Manual References

TM 9-2320-280-24P

Equipment Condition

- Control box assembly removed (para. 4-96).
- Upper and lower stowage doors removed (para. 11-152).
- NBC heater bracket removed (para. 11-165).

NOTE

For instructions on replacement of rivets, refer to para. 10-66.

a. Removal

1. Remove two screws (8), clamps (3), and light harness (18), from duct (17).
2. Remove eight rivets (7) and three stowage shelves (6) from duct (17).
3. Remove twenty rivets (9) from duct (17) and body (4).
4. Remove eight screws (14) and floor duct (13) from duct (17) and floor tunnel (11).
5. Remove eight rivets (1) and duct (17) from air-conditioning outlet (2).

b. Disassembly

1. Remove six rivets (12), washers (15), and guard (5) from duct (17).
2. Remove six rivets (10) and three reinforcement plates (16) from duct (17).

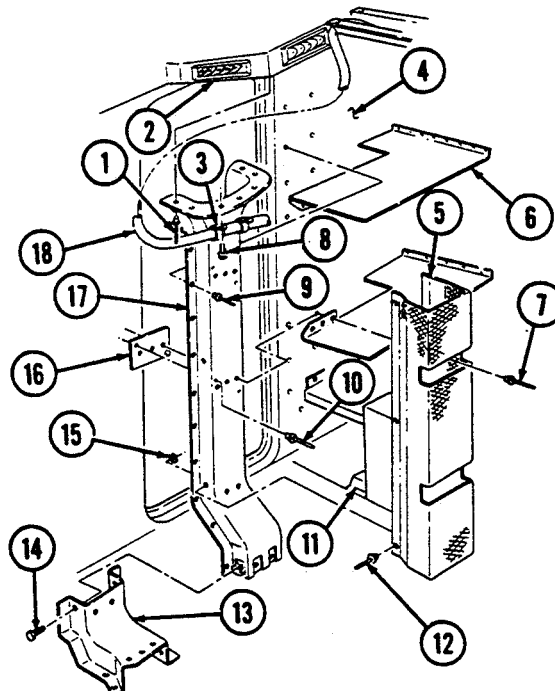

11-211. HEAT/AIR-CONDITIONING DUCT MAINTENANCE (Cont'd)

c. Assembly

1. Install three reinforcement plates (16) on duct (17) with six rivets (10).
2. Install guard (5) on duct (17) with six washers (15) and rivets (12).

d. Installation

1. Install duct (17) on air-conditioning outlet (2) with eight rivets (1).
2. Install floor duct (13) on duct (17) and floor tunnel (11) with eight screws (14).
3. Install duct (17) on body (4) with twenty rivets (9).
4. Install three stowage shelves (6) on duct (17) with eight rivets (7).
5. Install two clamps (3) and light harness (18) on duct (17) with two screws (8).

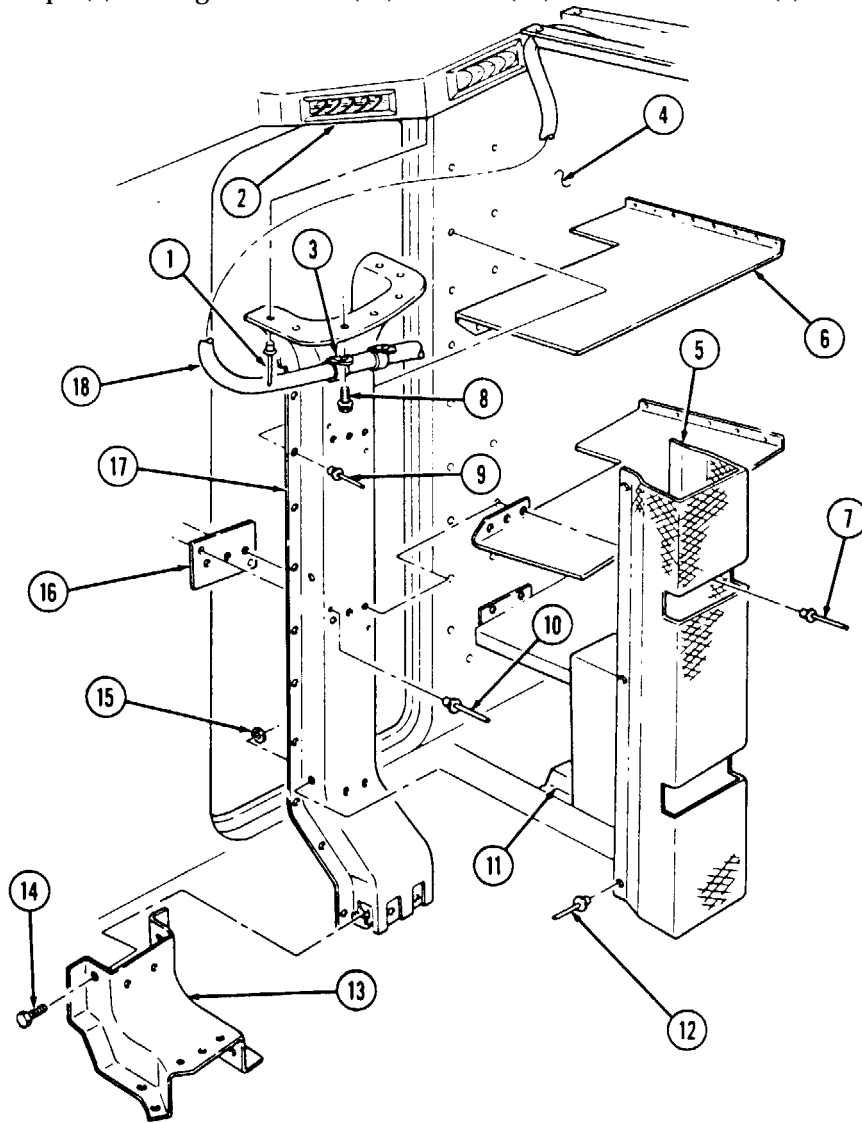

- FOLLOW-ON TASKS:
- Install NBC heater bracket (para. 11-165).
 - Install upper and lower stowage doors (para. 11-152).
 - Install control box assembly (para. 4-96).

11-212. BLOWER ASSEMBLY REPLACEMENT

This task covers:

a. Removal

b. Installation

INITIAL SETUP:

Applicable Models

M996, M996A1

Tools

General mechanic's tool kit:
automotive (Appendix B, Item 1)

Materials/Parts

Four blind rivnuts (Appendix G, Item 274)
Push on nut (Appendix G, Item 227)
Four blind rivets (Appendix G, Item 264)

Manual References

TM 9-2320-280-10
TM 9-2320-280-24P

Equipment Condition

- Battery ground cable disconnected (para. 4-73).
- Heater compartment panel removed (para. 11-204).

NOTE

For instructions on replacement of rivets, refer to para. 10-66.

a. Removal

1. Loosen two clamps (5) and disconnect hose ducts (2) from diverter box (8).
2. Remove push on nut (3) and disconnect control linkage (4) from diverter box arm (17). Discard push on nut (3).

NOTE

Prior to removal tag leads for installation.

3. Disconnect harness leads 770 (12), 771 (13), and 772 (14) from blower motor leads (11).
4. Remove four rivnuts (10), capscrews (6), washers (7), harness clamp (9), two ground terminals (15), and blower assembly (1) from bracket (16). Discard rivnuts (10).
5. Remove four rivets (20), diverter box (9), and foot (19) from blower assembly (1).

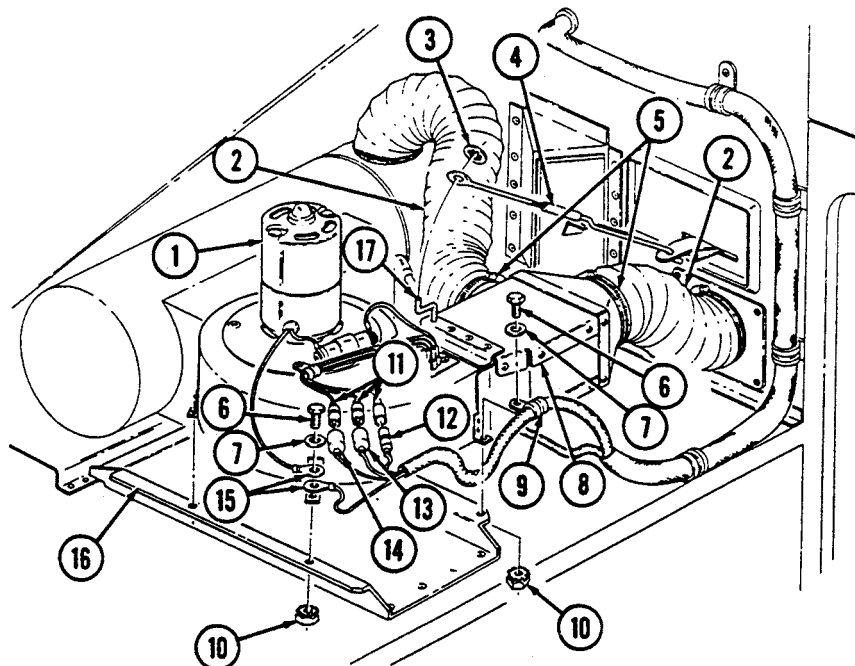

11-212. BLOWER ASSEMBLY REPLACEMENT (Cont'd)

b. Installation

1. Install diverter box (9) and foot (19) on blower assembly (1) with four rivets (20).
2. Install blower assembly (1), harness clamp (10), and two ground terminals (16) on bracket (17) with four washers (8), capscrews (7), and rivnuts (11).
3. Connect leads 770 (13), 771 (14), and 772 (15) to blower motor leads (12).
4. Place lever on heat/vent control panel in UNIT OFF position (TM 9-2320-280-10). Turn adjustable end (3) of control linkage (5) so that diverter box arm (18) is installed all the way forward (toward blower motor) when adjustable end (3) is installed on diverter box arm (18).
5. Install control linkage (5) on diverter box arm (18) with push on nut (4).
6. Install two hose ducts (2) on diverter box (9) and tighten clamps (6).

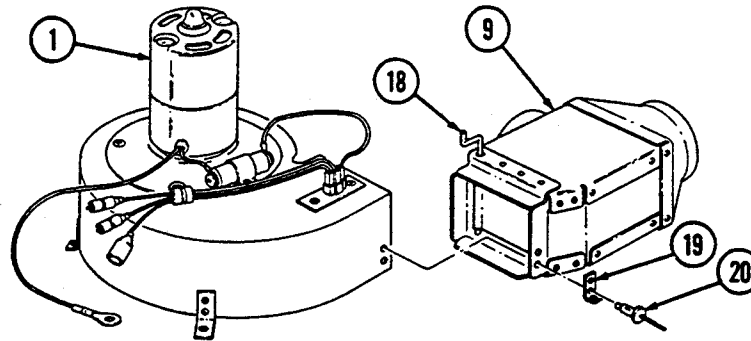
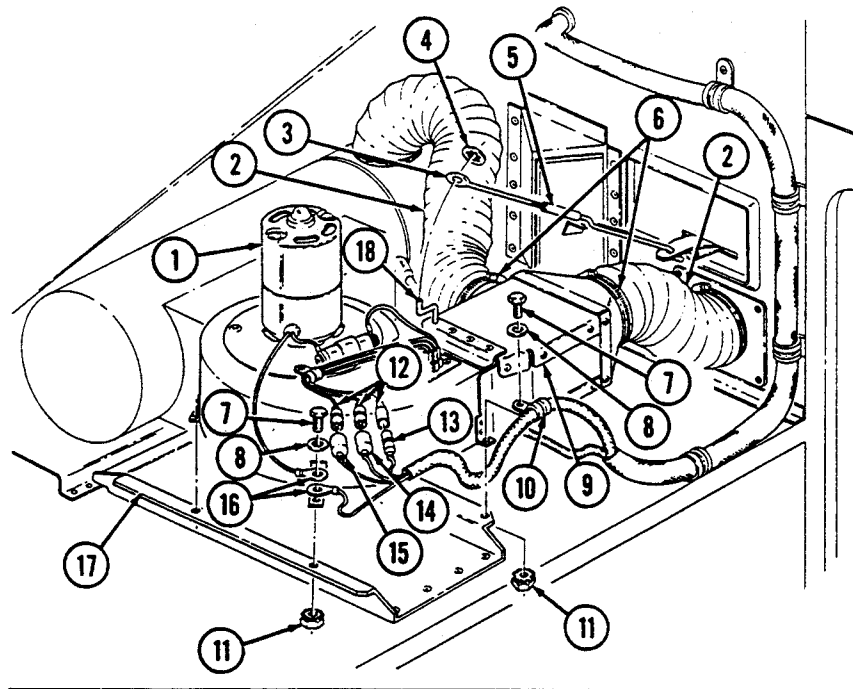

- FOLLOW-ON TASKS:**
- Install heater compartment panel (para. 11-204).
 - Connect battery ground cable (para. 4-73).
 - Check blower for proper operation (TM 9-2320-280-10).

11-213. AIR DIVERTER REPLACEMENT (M996, M996A1)

This task covers:

a. Removal

b. Installation

INITIAL SETUP:

Applicable Models

M996, M996A1

Manual References

TM 9-2320-280-24P

Tools

General mechanic's tool kit:
automotive (Appendix B, Item 1)

Equipment Condition

Blower assembly removed (para. 11-212).

Materials/Parts

Nine blind rivets (Appendix G, Item 265)
Lockwasher (Appendix G, Item 160)

NOTE

For instructions on replacement of rivets, refer to para. 10-66.

a. Removal

1. Remove lockwasher (4) and control linkage (5) from diverter door arm (6). Discard lockwasher (4).
2. Remove nine rivets (1) and diverter (3) from body (2).

b. Installation

1. Install diverter (3) on body (2) with nine rivets (1).
2. Connect control linkage (5) on diverter door arm (6) with lockwasher (4).

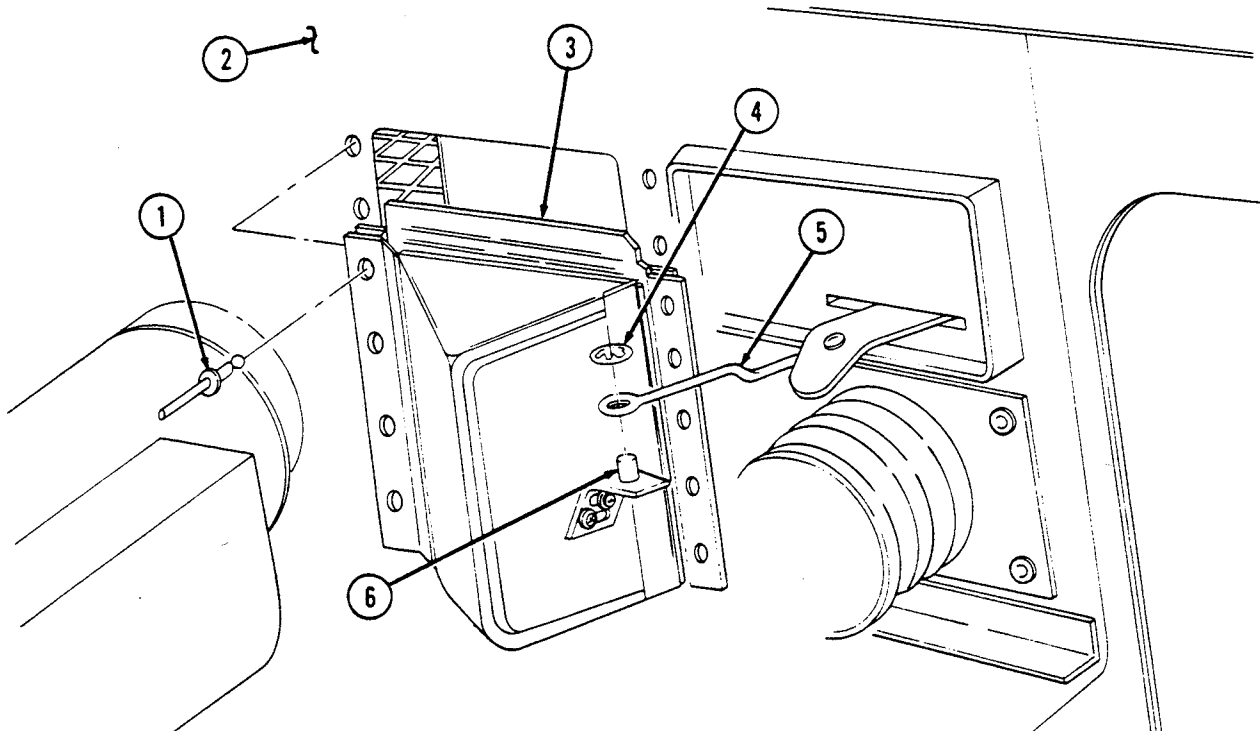

FOLLOW-ON TASK: Install blower assembly (para. 11-212).

11-214. PANEL INSULATION REPLACEMENT

This task covers:

a. Removal

b. Installation

INITIAL SETUP:

Applicable Models

M997, M997A1 M997A2

Manual References

TM 9-2320-280-24P

Tools

General mechanic's tool kit:
automotive (Appendix B, Item 1)

Equipment Condition

Blower housing opened (para. 11-198).

NOTE

Replacement of all air-conditioning insulation panels is basically the same. This procedure covers the air intake compartment insulation panel.

a. Removal

Remove insulation (3) from air intake compartment panel (1). Clean panel (1) to remove remaining adhesive.

b. Installation

Peel paper backing (2) from insulation (3) and install insulation (3) on air intake compartment panel (1).

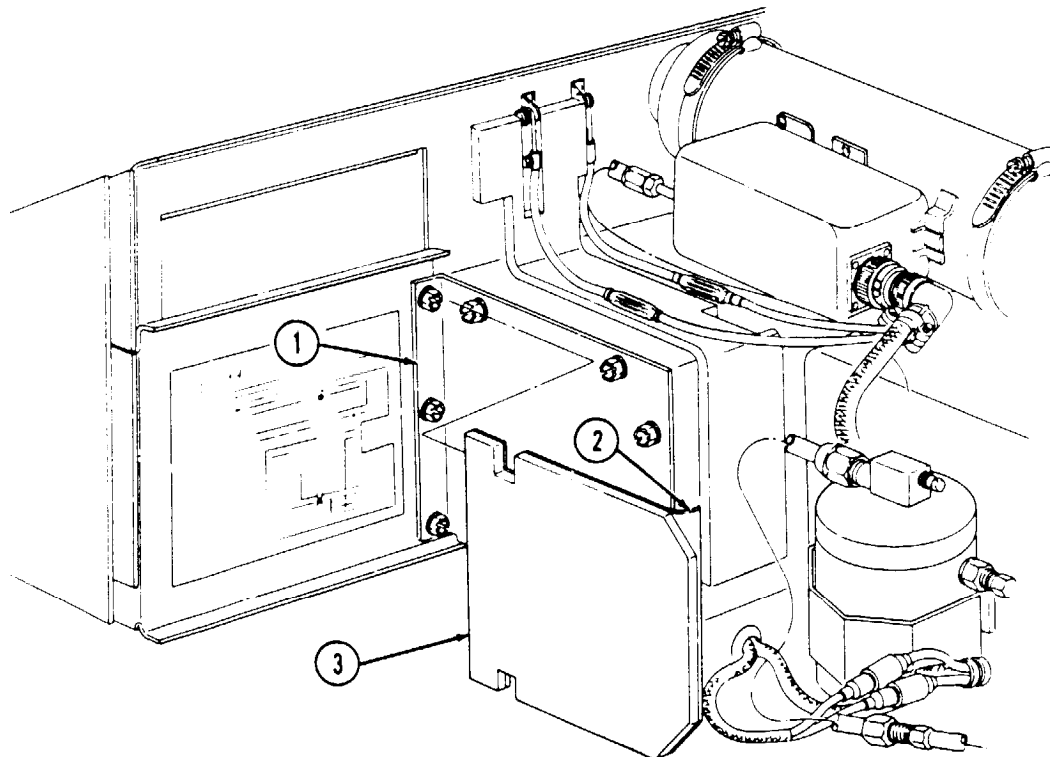

FOLLOW-ON TASK: Close blower housing (para. 11-198).

11-215. AMBULANCE SPREADER BAR MAINTENANCE

This task covers:

- | | |
|----------------|-----------------|
| a. Removal | c. Assembly |
| b. Disassembly | d. Installation |

INITIAL SETUP:

Applicable Models

M996, M996A1, M997, M997A1, M997A2

Manual References

TM 9-2320-280-24P

Tools

General mechanic's tool kit:
automotive (Appendix B, Item 1)

a. Removal

1. Remove three pins (3) and extension bar (1) from ambulance.
2. Remove two links (7) from extension bar (1).

b. Disassembly

1. Remove six ferrules (2) and three cables (4) from extension bar (1) and three pins (3).
2. Disconnect two cable assemblies (6) from links (7).
3. Disconnect two snap hooks (5) from cable assemblies (6).

c. Assembly

1. Connect two snap hooks (5) to cable assemblies (6).
2. Connect two cable assemblies (6) to links (7).
3. Install six ferrules (2) and three cables (4) on extension bar (1) and three pins (3).

d. Installation

1. Install two links (7) on extension bar (1).
2. Install extension bar (1) on ambulance with three pins (3).

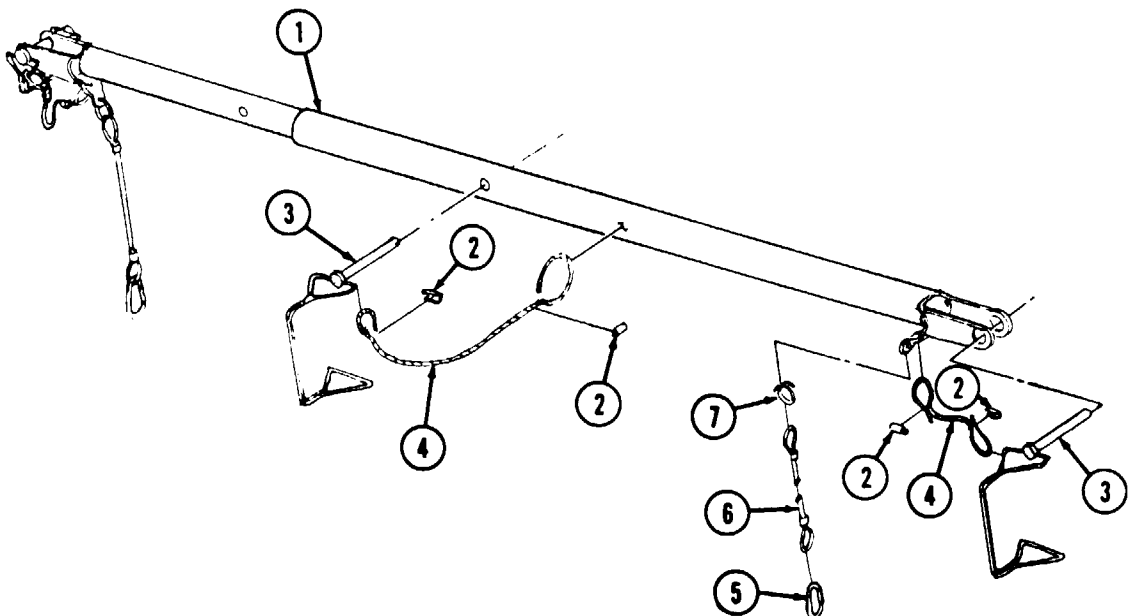

CHAPTER 12 SPECIAL PURPOSE KITS MAINTENANCE

Section I. DEEP WATER FORDING KIT MAINTENANCE

12-1. DEEP WATER FORDING KIT MAINTENANCE TASK SUMMARY

TASK PARA.	PROCEDURES	PAGE NO.
12-2.	Deep Water Fording Kit Exhaust Assembly Maintenance	12-2
12-3.	Deep Water Fording Kit Air Intake Assembly Replacement	12-4
12-4.	Air Cleaner Extension Elbow Maintenance	12-5
12-5.	Windshield Mounting Bracket Replacement	12-7
12-6.	Air Cleaner Dust Cap Maintenance	12-8
12-7.	Air Cleaner to Selector Valve Vent Line Replacement	12-9
12-8.	Fuel Tank Vent Stack Tube Replacement	12-10
12-9.	Selector Valve Replacement	12-11
12-10.	CDR Valve Vent Line Replacement	12-13
12-11.	Hydro-Boost Vent Line Replacement	12-14
12-12.	Deep Water Fording Sensor Cup Replacement	12-15
12-13.	Sensor Cup Vent Line Replacement	12-16
12-14.	Power Steering Vent Line Replacement	12-17
12-15.	Exhaust Reinforcement Bracket Replacement	12-18

12-2. DEEP WATER FORDING KIT EXHAUST ASSEMBLY MAINTENANCE

This task covers:

- | | |
|---|---|
| <ul style="list-style-type: none"> a. Removal b. Inspection | <ul style="list-style-type: none"> c. Installation |
|---|---|

INITIAL SETUP:

Applicable Models

All models except M966, M966A1, M1025, M1025A1, M1025A2, M1026, M1026A1

Manual References

TM 9-2320-280-10
TM 9-2320-280-24P

Tools

General mechanic's tool kit:
automotive (Appendix B, Item 1)

General Safety Instructions

Do not touch hot exhaust system components with bare hands.

Materials/Parts

Gasket (Appendix G, Item 42)
Five locknuts (Appendix G, Item 128)
Locknut (Appendix G, Item 79)

WARNING

Do not touch hot exhaust system components with bare hands.
Severe injury will result.

a. Removal

1. Remove three locknuts (1), washers (2), capscrews (10), washers (2), exhaust assembly (9), and gasket (11) from muffler (3). Discard locknuts (1) and gasket (11).
2. Remove two locknuts (4), washers (5), exhaust assembly (9), and two spacers (8) from wheel house (7). Discard locknuts (4).

NOTE

Perform steps 3 through 5 for M997, M997A1, and M997A2 models only.

3. Remove two bolts (18), washers (16), and exhaust extension (17) from upper body (25).
4. Remove locknut (19), washer (20), noise damper (21), exhaust reinforcement bracket (24), isolator (22), noise damper (23), and bolt (13) from exhaust extension (17). Discard locknut (19).
5. Remove two isolators (15) and spacers (14) from bracket (24).

b. Inspection

1. Inspect two insulators (6) for breaks, cracks, or deterioration. Replace if damaged.

NOTE

Perform step 2 for M997, M997A1, and M997A2 models only.

2. Inspect two rivnuts (12) for thread damage or deterioration. Replace if damaged.

12-2. DEEP WATER FORDING KIT EXHAUST ASSEMBLY MAINTENANCE (Cont'd)

c. Installation

NOTE

Perform steps 1 through 3 for M997, M997A1, and M997A2 models only.

1. Install two spacers (14) and isolators (15) on bracket (24).
2. Install bolt (13), bracket (24), isolator (22), and noise damper (23) on exhaust extension (17) with noise damper (21), washer (20), and locknut (19). Tighten locknut (19) to 17 lb-ft (23 N•m).
3. Install exhaust extension (17) on upper body (25) with two washers (16) and bolts (18).
4. Install two spacers (8) and exhaust assembly (9) on wheelhouse (7) with two washers (5) and locknuts (4). Tighten locknuts (4) to 37 lb-ft (50 N•m).
5. Install exhaust assembly (9) and gasket (11) on muffler (3) with three washers (2), capscrews (10), washers (2), and locknuts (1). Tighten locknuts (1) to 26 lb-ft (35 N•m).

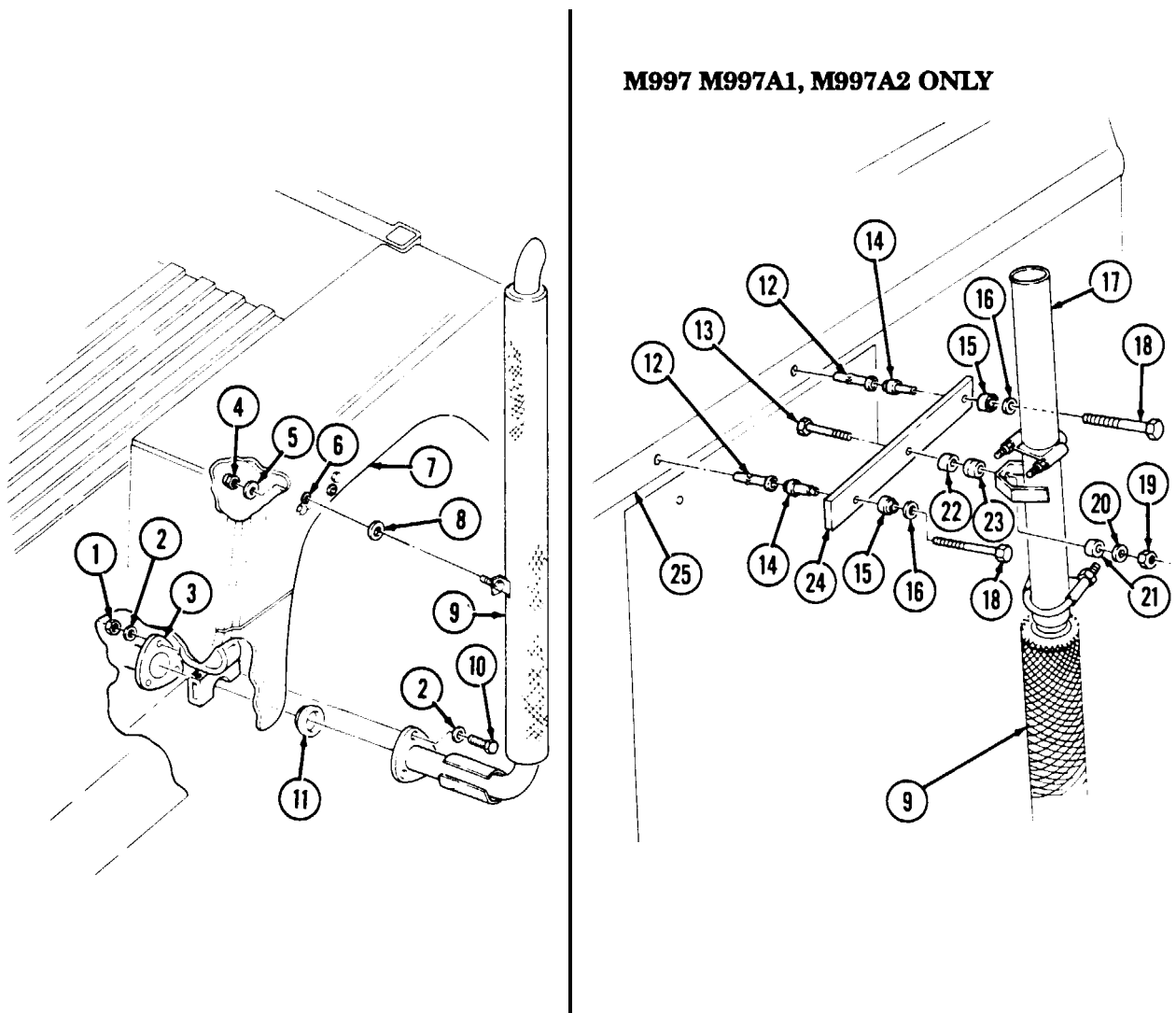

FOLLOW-ON TASK: Start engine (TM 9-2320-280-10) and check for exhaust leaks.

12-3. DEEP WATER FORDING KIT AIR INTAKE ASSEMBLY REPLACEMENT

This task covers:

a. Removal

b. Installation

INITIAL SETUP:

Applicable Models

All models except M966, M966A1, M1025, M1025A1, M1025A2, M1026, M1026A1

Tools

General mechanic's tool kit:
automotive (Appendix B, Item 1)

Materials/Parts

Locknut (Appendix G, Item 105)

Manual References

TM 9-2320-280-24P

Equipment Condition

- Weathercap removed (para. 3-18).
- Fuel tank vent stack tube removed (para. 12-8).

a. Removal

1. Remove locknut (5), washer (3), capscrew (2), and washer (3) from air intake assembly (1) and windshield mounting bracket (4). Discard locknut (5).
2. Loosen clamp (6) and remove air intake assembly (1) from air cleaner extension elbow (7).

b. Installation

1. Install air intake assembly (1) into air cleaner extension elbow (7) with clamp (6). Tighten clamp (6) to 45-50 lb-in. (5-6 N•m).
2. Install air intake assembly (1) on windshield mounting bracket (4) with washer (3), capscrew (2), washer (3), and locknut (5). Tighten capscrew (2) to 43 lb-ft (58 N•m).

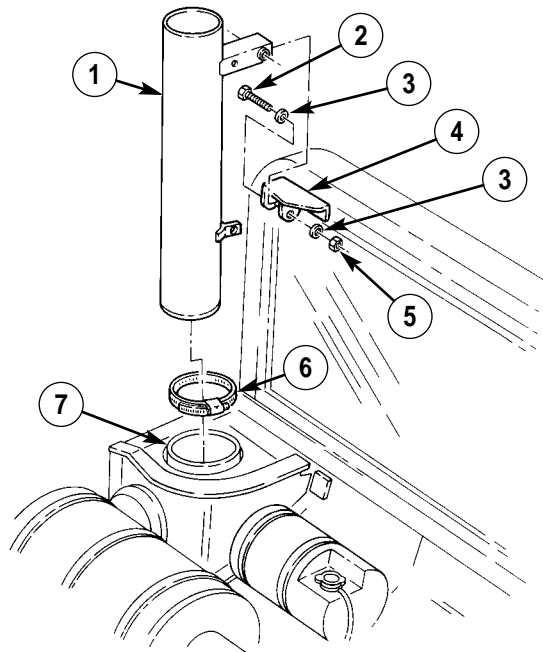

- FOLLOW-ON-TASKS:
- Install weather cap (para. 3-18).
 - Install fuel tank vent stack tube (para. 12-8).

12-4. AIR CLEANER EXTENSION ELBOW MAINTENANCE

This task covers:

- | | |
|---------------|-----------------|
| a. Removal | c. Installation |
| b. Inspection | |

INITIAL SETUP:

Applicable Models

All models except M966, M966A1, M1025, M1025A1, M1025A2, M1026, M1026A1

Manual References

TM 9-2320-280-24P

Tools

General mechanic's tool kit
automotive (Appendix B, Item 1)

Equipment Condition

Deep water fording kit removed (para. 12-3).

a. Removal

1. Loosen clamp (3) and disconnect air horn-to-air cleaner elbow (4) from air cleaner assembly (6).
2. Disconnect air cleaner-to-selector valve vent line (2) from air cleaner assembly (6).
3. Disconnect air restriction gauge hose (5) from air cleaner assembly (6).
4. Loosen two outer clamps (7) from air cleaner assembly (6) and support brackets (11).
5. Remove air cleaner assembly (6), gasket (8), and air cleaner extension elbow (10) from air induction box (1).
6. Loosen clamp (9) and remove air cleaner extension elbow (10) from air cleaner assembly (6).

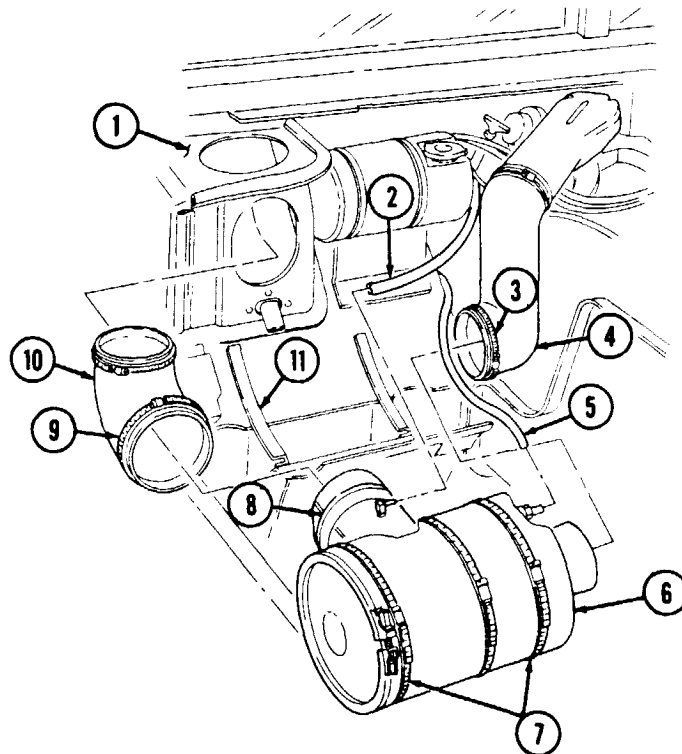

12-4. AIR CLEANER EXTENSION ELBOW MAINTENANCE (Cont'd)

b. Inspection

Inspect gasket (8) for breaks or cracks. Replace if broken or cracked.

c. Installation

1. Install air cleaner extension elbow (10) on air cleaner assembly (6). Tighten clamp (9) to 45-50 lb-in. (5-6 N•m).
2. Install air cleaner extension elbow (10) on air induction box (1),
3. Install air cleaner assembly (6) on support brackets (11) with two outer clamps (7). Tighten clamps (7) to 35-40 lb-in. (4-5 N•m).
4. Connect air restriction gauge hose (5) to air cleaner assembly (6).
5. Connect air cleaner-to-selector valve vent line (2) to air cleaner assembly (6).
6. Connect air horn-to-air cleaner elbow (4) to air cleaner assembly (6). Tighten clamp (3) to 45-50 lb-in. (5-6 N•m).

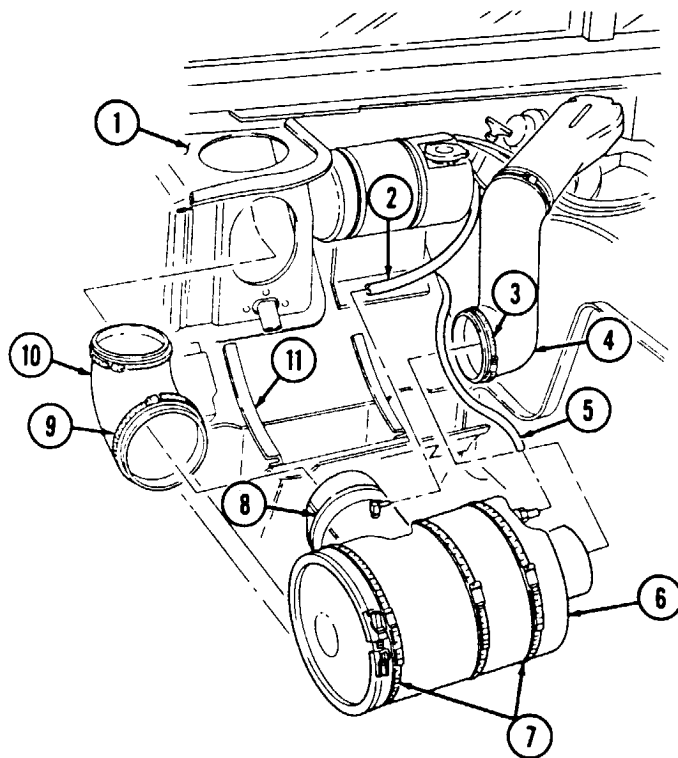

FOLLOW-ON TASK: Install air intake assembly (para. 12-3).

12-5. WINDSHIELD MOUNTING BRACKET REPLACEMENT

This task covers:

a. Removal

b. Installation

INITIAL SETUP:

Applicable Models

All models except M966, M966A1, M1025, M1025A1, M1025A2, M1026, M1026A1, M1121

Manual References

TM 9-2320-280-24P

Equipment Condition

Deep water fording kit removed (para. 12-3).

Tools

General mechanic's tool kit:
automotive (Appendix B, Item 1)

a. Removal

Remove two capscrews (1), washers (2), and windshield mounting bracket (3) from windshield (4).

b. Installation

Install windshield mounting bracket (3) on windshield (4) with two washers (2) and capscrews (1). Tighten capscrews (1) to 6 lb-ft (8 N·m).

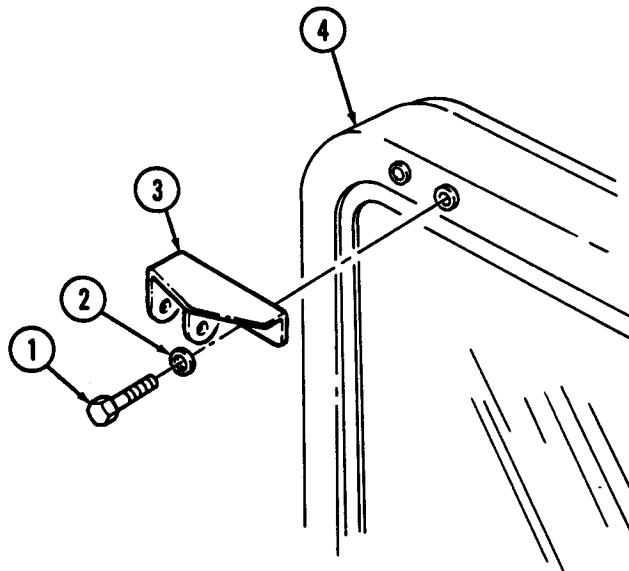

FOLLOW-ON TASK: Install air intake assembly (para. 12-3).

12-6. AIR CLEANER DUST CAP MAINTENANCE

This task covers:

- a. Removal
- b. Inspection
- c. Installation

INITIAL SETUP:

Applicable Models

All models except M966, M966A1, M1025, M1025A1, M1025A2, M1026, M1026A1, M1121

Manual References

TM 9-2320-280-10
TM 9-2320-280-24P

Tools

General mechanic's tool kit:
automotive (Appendix B, Item 1)

Equipment Condition

Hood raised and secured (TM 9-2320-280-10).

a. Removal

1. Remove four screws (5) and dust unloader cover plate (4) from air cleaner bracket (6).
2. Remove clamp (2) and air cleaner dust cap (3) from air cleaner assembly (1).

b. Inspection

Inspect air cleaner dust cap (3) for cuts, tears, obstructions, or enlarged gap. Replace if cut, torn, worn, missing, or if center opening exceeds 0.125 in. (3.18 mm).

c. Installation

1. Install dust cap (3) on air cleaner assembly (1) with clamp (2). Tighten clamp (2) to 45-50 lb-in. (5-6 N·m).
2. Install dust unloader cover plate (4) on air cleaner bracket (6) with four screws (5).

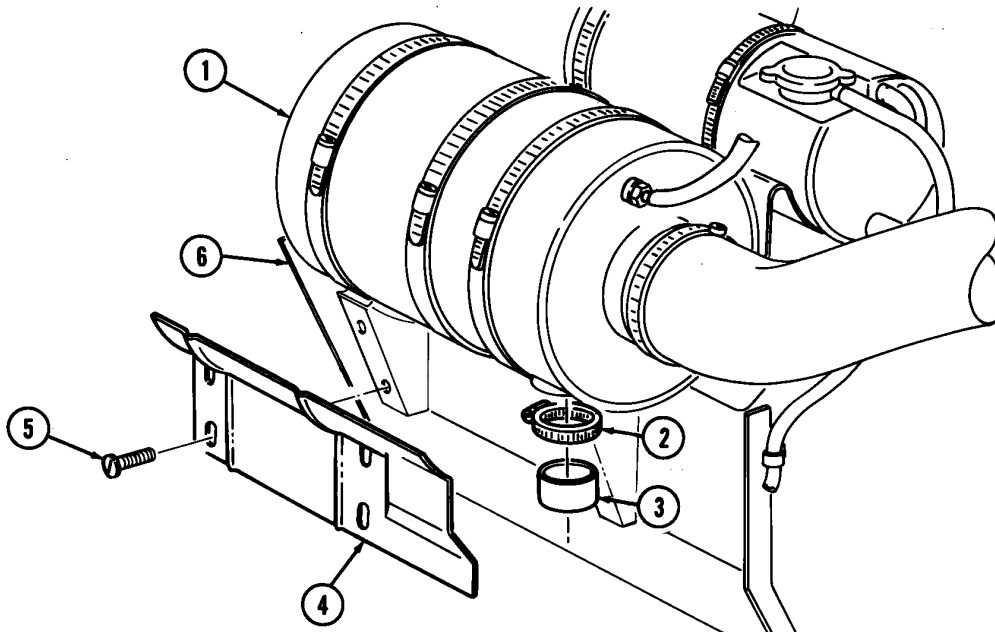

FOLLOW-ON TASK: Lower and secure hood (TM 9-2320-280-10).

12-7. AIR CLEANER TO SELECTOR VALVE VENT LINE REPLACEMENT

This task covers:

a. Removal

b. Installation

INITIAL SETUP:

Applicable Models

All models except M966, M966A1, M1025, M1025A1, M1025A2, M1026, M1026A1

Manual References

TM 9-2320-280-10
TM 9-2320-280-24P

Tools

General mechanic's tool kit:
automotive (Appendix B, Item 1)

Equipment Condition

Hood raised and secured (TM 9-2320-280-10).

Materials/Parts

Three tiedown straps (Appendix G, Item 314)

a. Removal

1. Disconnect air cleaner-to-selector valve vent line (2) from air cleaner assembly fitting (1).
2. Remove three tiedown straps (3) and vent line (2) from existing hoses (4) on "A" beam (5). Discard tiedown straps (3).
3. Remove air cleaner-to-selector valve vent line (2) from selector valve (6).

b. Installation

1. Connect air cleaner-to-selector valve vent line (2) to selector valve (6).
2. Route vent line (2) along "A" beam (5) and secure to existing hoses (4) with three tiedown straps (3).
3. Connect air cleaner-to-selector vent line (2) to air cleaner assembly fitting (1).

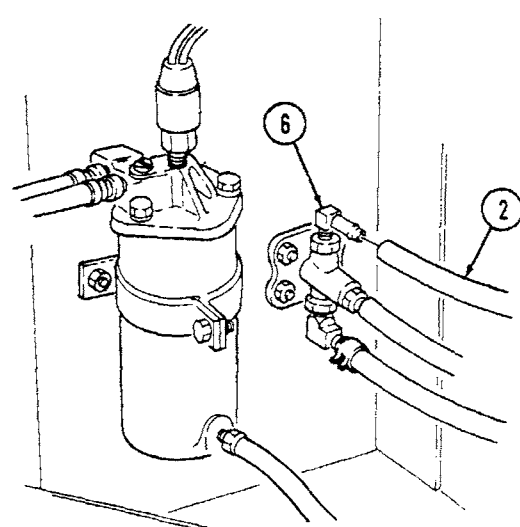
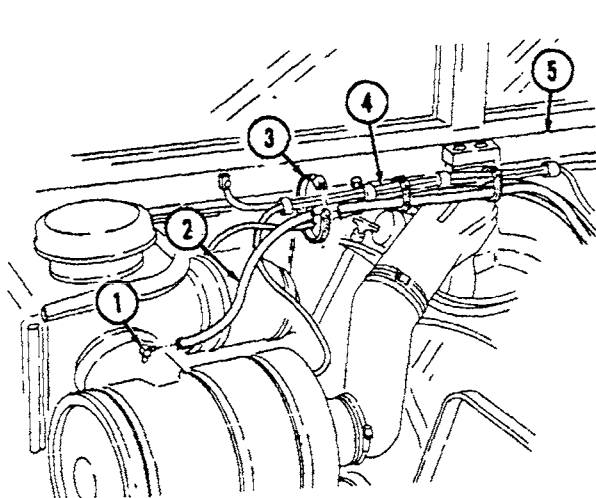

FOLLOW-ON TASK: Lower and secure hood (TM 9-2320-280-10).

12-8. FUEL TANK VENT STACK TUBE REPLACEMENT

This task covers:

a. Removal

b. Installation

INITIAL SETUP:

Applicable Models

All models except M966, M966A1, M1025, M1025A1, M1025A2, M1026, M1026A1, M1097, M1097A1, M1097A2

Manual References

TM 9-2320-280-10
TM 9-2320-280-24P

Tools

General mechanic's tool kit:
automotive (Appendix B, Item 1)

Equipment Condition

Hood raised and secured (TM 9-2320-280-10).

Materials/Parts

Two lockwashers (Appendix G, Item 183)

a. Removal

1. Disconnect fuel tank vent line (8) from fuel tank vent stack tube (2).
2. Remove nut (10), lockwasher (9), screw (7), and clamp (6) from fuel tank vent stack tube (2) and air intake assembly (1). Discard lockwasher (9).
3. Remove screw (5), lockwasher (4), fuel tank vent stack tube (2), and clamp (3) from air intake assembly (1). Discard lockwasher (4).

b. Installation

1. Install fuel tank vent stack tube (2) and clamp (3) on air intake assembly (1) with lockwasher (4) and screw (5).
2. Install fuel tank vent stack tube (2) and clamp (6) on air intake assembly (1) with lockwasher (9), screw (7), and nut (10).
3. Connect vent line (8) to vent stack tube (2).

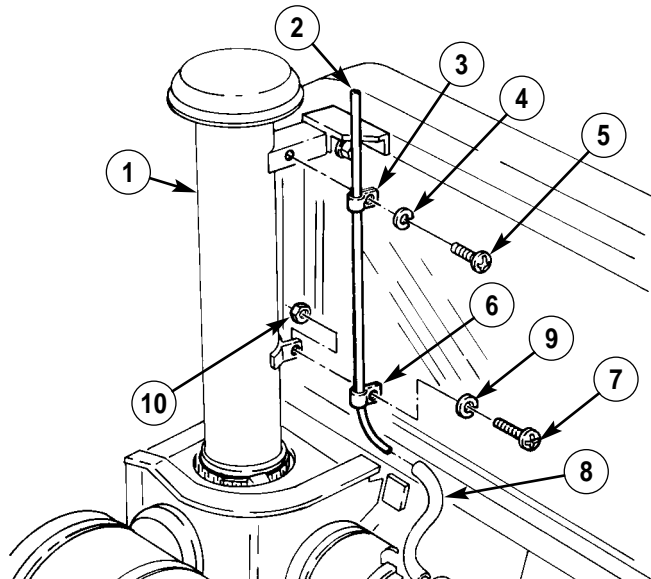

FOLLOW-ON TASK: Lower and secure hood (TM 9-2320-280-10).

12-9. SELECTOR VALVE REPLACEMENT

This task covers:

a. Removal

b. Installation

INITIAL SETUP:

Applicable Models

All models except M966, M966A1, M1025, M1025A1, M1025A2, M1026, M1026A1, M1097, M1097A1, M1097A2

Tools

General mechanic's tool kit:
automotive (Appendix B, Item 1)

Materials/Parts

Two locknuts (Appendix G, Item 70)

Manual References

TM 9-2320-280-10
TM 9-2320-280-24P

Equipment Condition

- Hood raised and secured (TM 9-2320-280-10).
- Engine access cover removed (para. 10-15).

a. Removal

1. Remove screw (1) and selector control (2) from selector valve (4).
2. Remove two locknuts (9), washers (13), capscrews (14), and washers (13) from selector valve (4) and body (3). Discard locknuts (9).

NOTE

Prior to removal, tag vent lines for installation.

3. Disconnect air cleaner-to-selector valve vent line (6) from elbow (5).
4. Disconnect selector valve-to-union tee vent line (8) from connector (7).
5. Loosen clamp (11) and disconnect CDR valve vent line (10) from elbow (12).
6. Remove elbow (5), connector (7), and elbow (12) from selector valve (4).

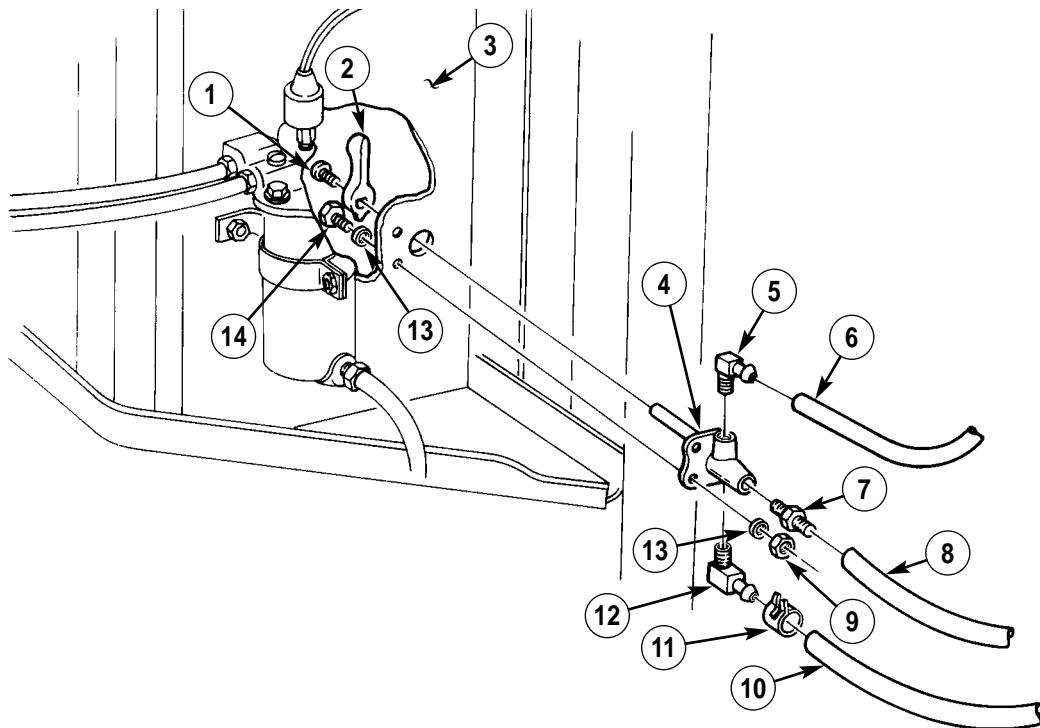

12-9. SELECTOR VALVE REPLACEMENT (Cont'd)

b. Installation

1. Install elbow (12), connector (7), and elbow (5) on selector valve (4).
2. Connect CDR valve vent line (10) to selector elbow (12) with clamp (11).
3. Connect selector valve-to-union tee vent line (8) to connector (7).
4. Connect air cleaner-to-selector valve vent line (6) to elbow (5).
5. Install selector valve (4) on body (3) with two washers (13), capscrews (14), washers (13), and locknuts (9). Tighten locknuts (9) to 10 lb-ft (14 N•m).
6. Install selector control (2) on selector valve (4) with screw (1).

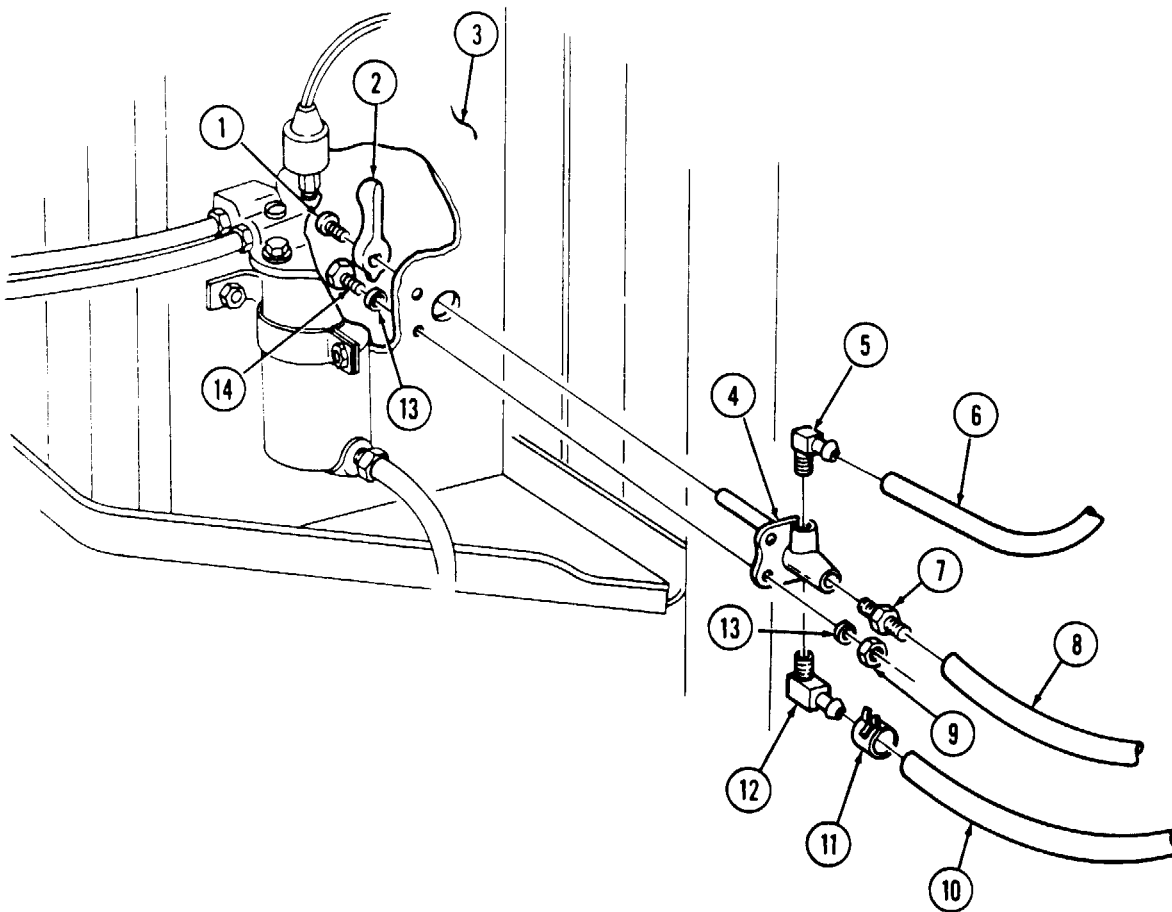

- FOLLOW-ON TASKS:**
- Install engine access cover (para. 10-15).
 - Lower and secure hood (TM 9-2320-280-10).

12-10. CDR VALVE VENT LINE REPLACEMENT

This task covers:

a. Removal

b. Installation

INITIAL SETUP:

Applicable Models

All models except M966, M966A1, M1025, M1025A1, M1025A2, M1026, M1026A1, M1097, M1097A1, M1097A2

Tools

General mechanic's tool kit:
automotive (Appendix B, Item 1)

Materials/Parts

Two tiedown straps (Appendix G, Item 314)

Manual References

TM 9-2320-280-10
TM 9-2320-280-24P

Equipment Condition

Hood raised and secured (TM 9-2320-280-10).

a. Removal

1. Loosen clamp (2) and disconnect CDR valve vent line (3) from CDR valve (1).
2. Remove two tiedown straps (5) from vent line (3) and existing hoses (6) on "A" beam (4). Discard tiedown straps (5).
3. Loosen clamp (2) and remove vent line (3) from elbow (8) on selector valve (7).
4. Remove clamps (2) from vent line (3).

b. Installation

1. Install clamps (2) on vent line (3).
2. Connect vent line (3) to elbow (8) on selector valve (7) with clamp (2).
3. Install vent line (3) along "A" beam (4) on existing hoses (6) with two tiedown straps (5).
4. Connect vent line (3) to CDR valve (1) with clamp (2).

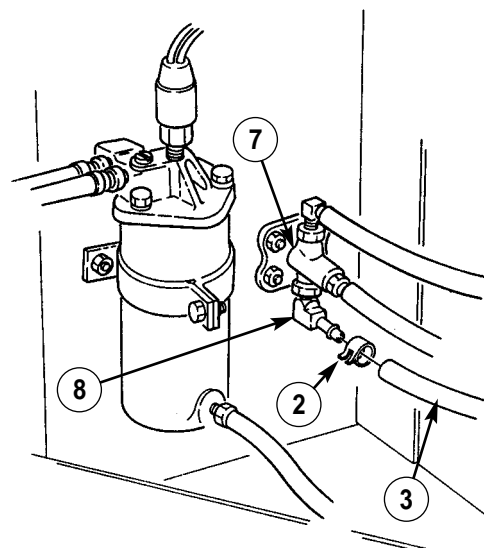
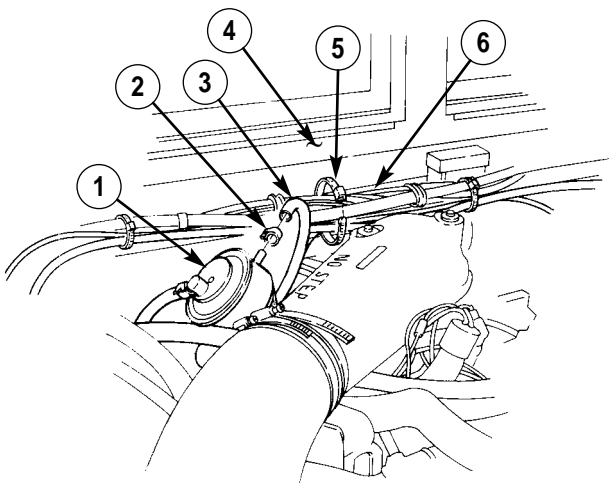

FOLLOW-ON TASK: Lower and secure hood (TM 9-2320-280-10).

12-11. HYDRO-BOOST VENT LINE REPLACEMENT

This task covers:

a. Removal

b. Installation

INITIAL SETUP:

Applicable Models

All models except M966, M966A1, M1025, M1025A1, M1025A2, M1026, M1026A1, M1097, M1097A1, M1097A2

Manual References

TM 9-2320-280-24P

Equipment Condition

Engine left splash shield removed (para. 10-17).

Tools

General mechanic's tool kit:
automotive (Appendix B, Item 1)

Materials/Parts

Locknut (Appendix G, Item 70)
Plain-assembled nut
(Appendix G, Item 201)

a. Removal

1. Disconnect hydro-boost vent line (2) from hydro-boost (1).
2. Remove plain-assembled nut (3), capscrew (10), clamp (4), harness clamp (9), and vent line (2) from body (11). Discard plain-assembled nut (3).
3. Remove locknut (6), washer (7), capscrew (8), washer (7), clamp (5), and vent line (2) from body (11). Discard locknut (6).
4. Remove two clamps (4) and (5) from vent line (2).

b. Installation

1. Install two clamps (4) and (5) on vent line (2).
2. Install vent line (2) and clamp (5) on body (11) with washer (7), capscrew (8), washer (7), and locknut (6). Tighten capscrew (8) to 6 lb-ft (8 N•m).
3. Install vent line (2), harness clamp (9), and clamp (4) on body (11) with capscrew (10) and plain-assembled nut (3).
4. Connect vent line (2) to hydro-boost (1).

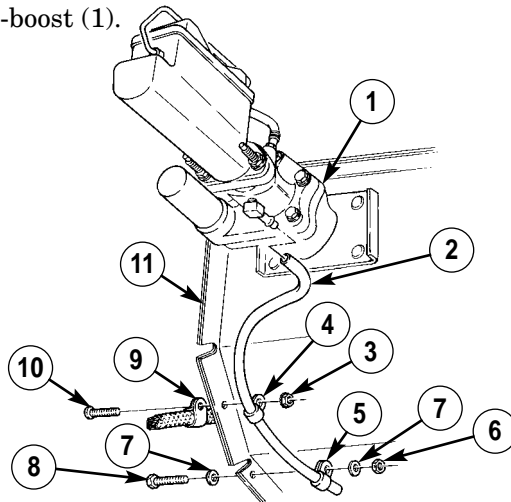

FOLLOW-ON TASK: Install engine left splash shield (para. 10-17).

12-12. DEEP WATER FORDING SENSOR CUP REPLACEMENT

This task covers:

a. Removal

b. Installation

INITIAL SETUP:

Applicable Models

All models except M966, M966A1, M1025, M1025A1, M1025A2, M1026, M1026A1

Manual References

TM 9-2320-280-24P

Tools

General mechanic's tool kit:
automotive (Appendix B, Item 1)

Equipment Condition

Engine access cover removed (para. 10-15).

Materials/Parts

Two locknuts (Appendix G, Item 70)

a. Removal

1. Loosen clamp (3) and disconnect sensor cup vent line (2) from sensor cup (4).
2. Remove two locknuts (1), washers (6), capscrews (5), washers (6), and sensor cup (4) from body (7). Discard locknuts (1).

b. Installation

1. Install sensor cup (4) on body (7) with two washers (6), capscrews (5), washers (6), and locknuts (1). Tighten locknuts (1) to 6 lb-ft (8 N·m).
2. Connect sensor cup vent line (2) to sensor cup (4) with clamp (3).

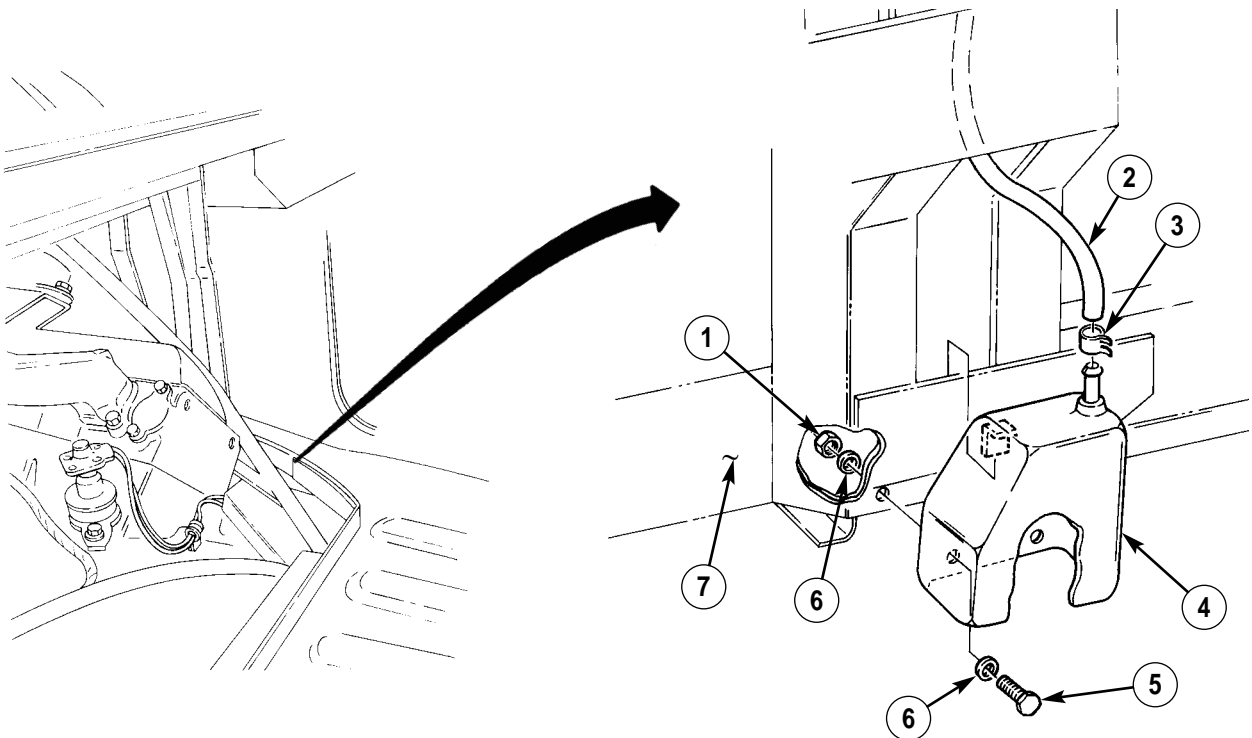

FOLLOW-ON TASK: Install engine access cover (para. 10-15).

12-13. SENSOR CUP VENT LINE REPLACEMENT

This task covers:

a. Removal

b. Installation

INITIAL SETUP:

Tools

General mechanic's tol kit:
automotive (Appendix B, Item 1)

Equipment Condition

- Hood raised and secured (TM 9-2320-280-10).
- Engine access cover removed (paa. 10-15).

Manual References

TM 9-2320-280-10
TM 9-2320-20-24P

a. Removal

1. Loosen clamp (3) and disconnect sensor cup vent line (1) from CDR valve (2).
2. Loosen clamp (6) and remove vent line (1) from sensor cup (5).
3. Remove two clamps (3) and (6) from vent line (1).

b. Installation

1. Install two clamps (3) and (6) on vent line (1).
2. Route vent line (1) through "A" beam (4).
3. Connect vent line (1) to sensor cup (5) with clamp (6).
4. Connect vent line (1) to CDR valve (2) with clamp (3).

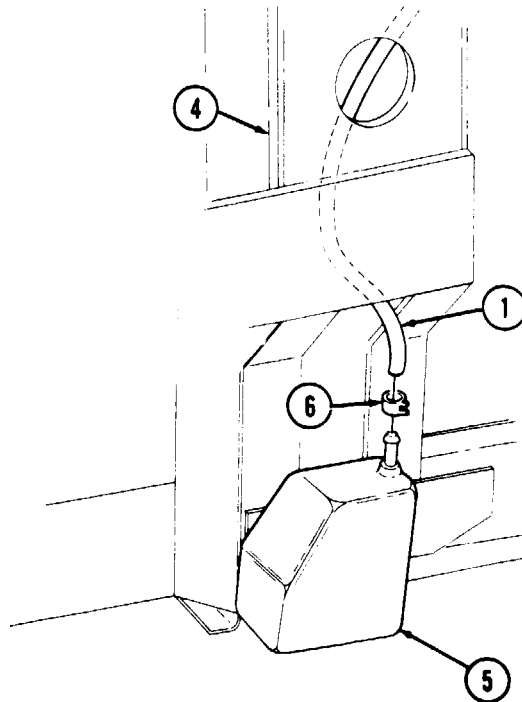
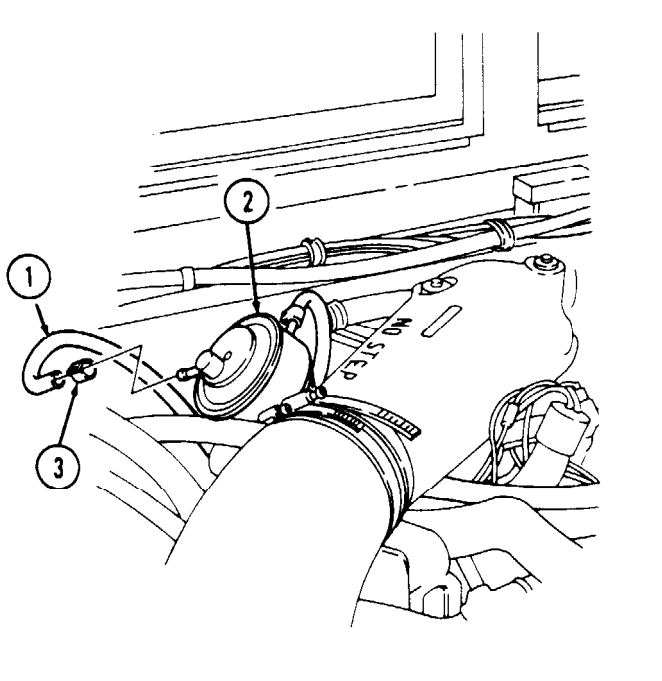

FOLLOW-ON TASKS: • Install engine access cover (para. 10-15).
• Lower and secure hood (TM 9-2320-280-10).

12-14. POWER STEERING VENT LINE REPLACEMENT

This task covers:

a. Removal

b. Installation

INITIAL SETUP:

Applicable Models

All models except M966, M966A1, M1025, M1025A1, M1025A2, M1026, M1026A1, M1097, M1097A1, M1097A2

Manual References

TM 9-2320-280-10
TM 9-2320-280-24P

Tools

General mechanic's tool kit:
automotive (Appendix B, Item 1)

Equipment Condition

Hood raised and secured (TM 9-2320-280-10).

a. Removal

Loosen two clamps (3) and remove power steering vent line (1) from power steering pump cap (4) and tee fitting (2).

b. Installation

Connect vent line (1) to power steering cap (4) and tee fitting (2) with two clamps (3).

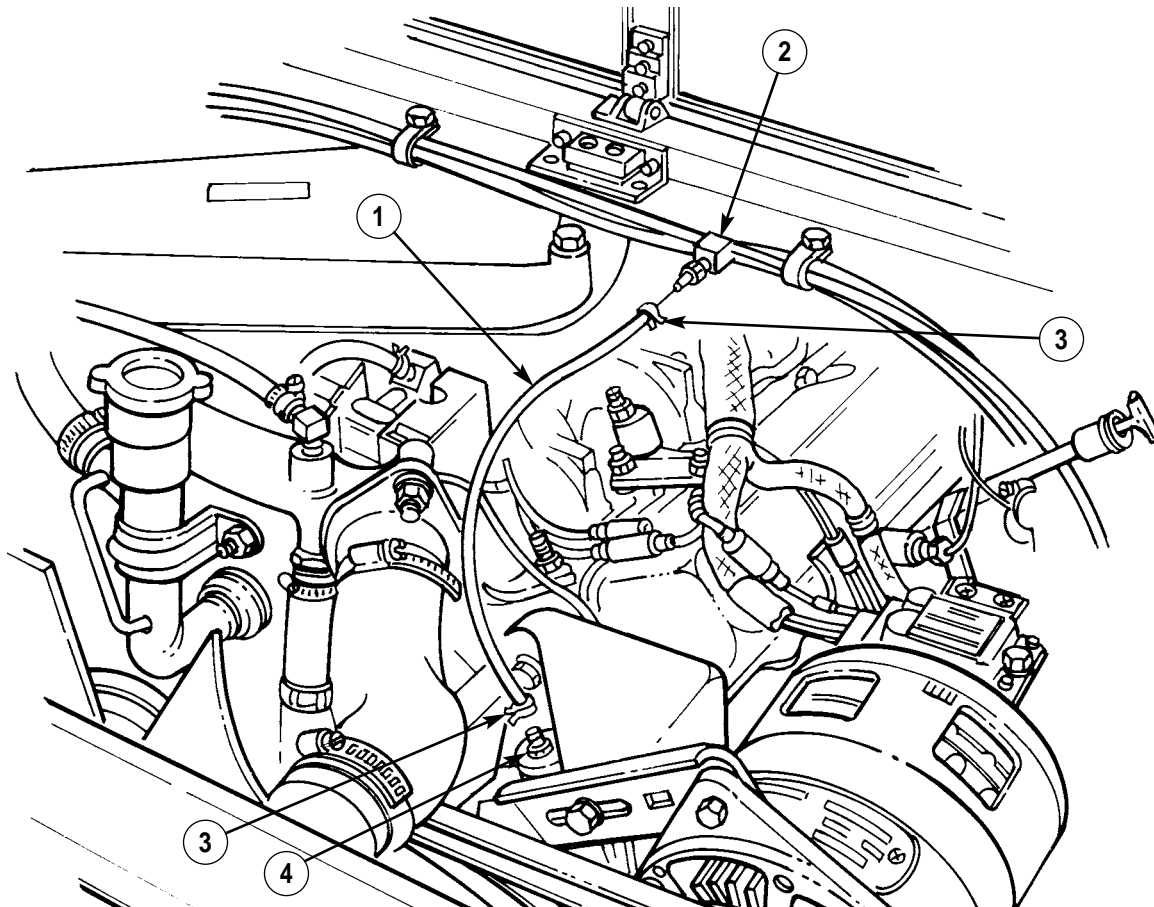

FOLLOW-ON TASK: Lower and secure hood (TM 9-2320-280-10).

12-15. EXHAUST REINFORCEMENT BRACKET REPLACEMENT

This task covers:

a. Removal

b. Installation

INITIAL SETUP:

Tools

General mechanic's tool kit:
automotive (Appendix B, Item 1)

Manual References

TM 9-2320-280-24P

Materials/Parts

Eight locknuts (Appendix G, Item 70)

Equipment Condition

Deep water fording kit exhaust assembly removed
(para. 12-2).

a. Removal

1. Remove two isolators (4) from wheelhouse (3) and reinforcement bracket (5).
2. Remove eight locknuts (6), washers (1), capscrews (2), washers (1), and reinforcement bracket (5) from wheelhouse (3). Discard locknuts (6).

b. Installation

1. Install reinforcement bracket (5) on wheelhouse (3) with eight washers (1), capscrews (2), washers (1), and locknuts (6). Tighten capscrews (2) to 6 lb-ft (8 N•m).
2. Install two isolators (4) on wheelhouse (3) and reinforcement bracket (5).

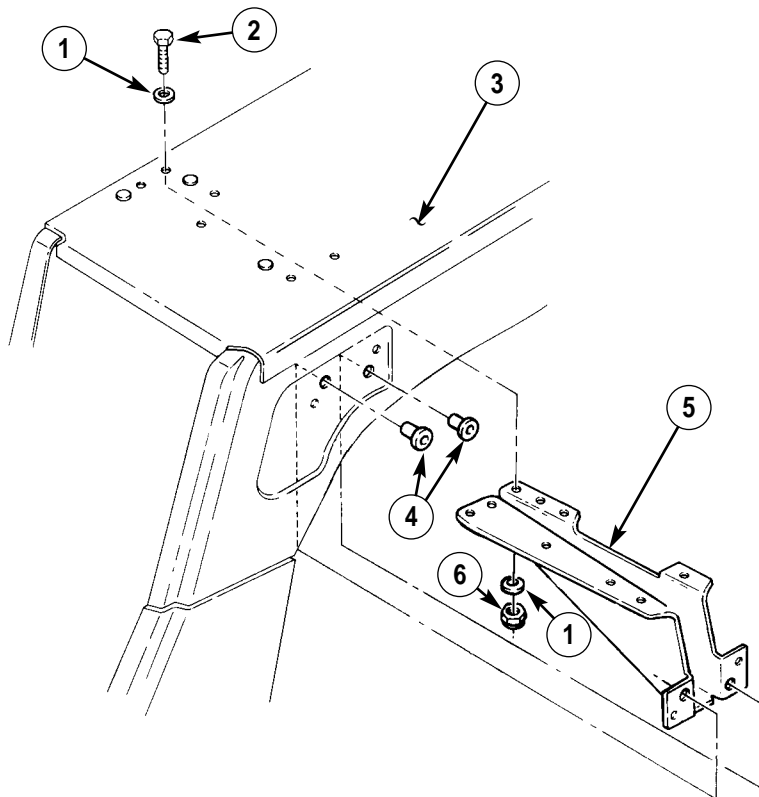

FOLLOW-ON TASK: Install deep water fording kit exhaust assembly (para. 12-2).

Section II. TROOP SEAT KIT MAINTENANCE

12-16. TROOP SEAT KIT MAINTENANCE TASK SUMMARY

TASK PARA.	PROCEDURES	PAGE NO.
12-17.	Seat Support Replacement	12-19
12-18.	Troop Seat Kit Replacement	12-20
12-19.	Troop Seat Board Replacement	12-22

12-17. SEAT SUPPORT REPLACEMENT

This task covers:

a. Removal

b. Installation

INITIAL SETUP:

Applicable Models

M998, M998A1, M1038, M1038A1, M1097, M1097A1, M1097A2

Materials/Parts

Three cotter pins (Appendix G, Item 19)

Tools

General mechanic's tool kit:
automotive (Appendix B, Item 1)

Manual References

TM 9-2320-280-24P

a. Removal

1. Remove two lockpins (1) from troop seat (2).
2. Lower seat support (4).
3. Remove three cotter pins (6), clevis pins (5), and seat support (4) from back support (3). Discard cotter pins (6).

b. Installation

1. Install seat support (4) on back support (3) with three clevis pins (5) and cotter pins (6).
2. Raise seat support (4) and install two lockpins (1) on troop seat (2).

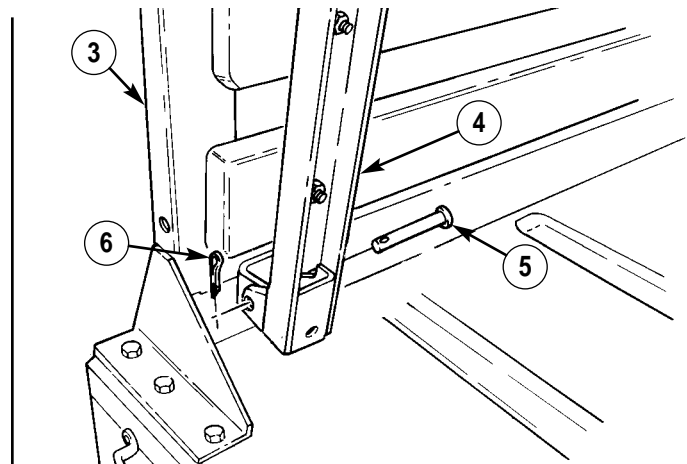
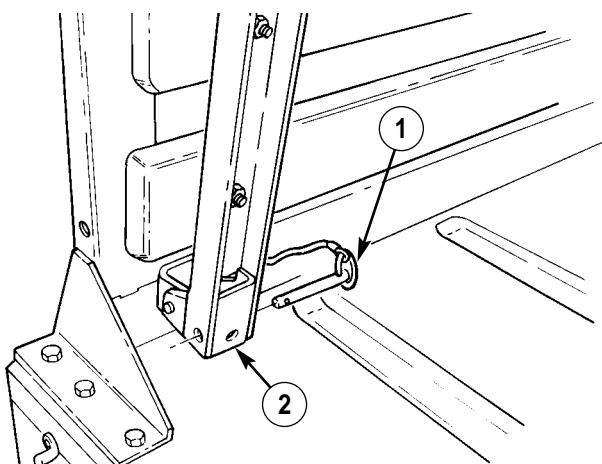

12-18. TROOP SEAT KIT REPLACEMENT

This task covers:

a. Removal

b. Installation

INITIAL SETUP:

Applicable Models

M998, M998A1, M1038, M1038A1, M1097, M1097A1, M1097A2

Personnel Required

One mechanic
One assistant

Tools

General mechanic's tool kit:
automotive (Appendix B, Item 1)

Manual References

TM 9-2320-280-24P

Materials/Parts

Nine locknuts (Appendix G, Item 70)
Two locknuts (Appendix G, Item 71)
Three locknuts (Appendix G, Item 86)

a. Removal

1. Remove three locknuts (16), washers (2), capscrews (3), washers (2), and rear angle bracket (18) from wheelhouse (1). Discard locknuts (16).
2. Remove two locknuts (13), washers (14), capscrews (17), washers (14), and rear bracket retainer plate (15) from wheelhouse (1). Discard locknuts (13).
3. Remove two nuts (9), washers (7), capscrews (8), washers (7), and support bracket (6) from wheelhouse (1).
4. Remove six locknuts (12), washers (5), capscrews (4), washers (5), three reinforcement plates (11), and main channel (10) from wheelhouse (1). Discard locknuts (12).
5. Remove troop seat (19).
6. Remove three locknuts (22), washers (21), capscrews (24), and channel support (23) from "B" pillar (20). Discard locknuts (22).

b. Installation

1. Install channel support (23) on "B" pillar (20) with three capscrews (24), washers (21), and locknuts (22). Tighten locknuts (22) to 15 lb-ft (20 N•m).
2. Install troop seat (19) on wheelhouse (1).
3. Install main channel (10) and three reinforcement plates (11) on wheelhouse (1) with six washers (5), capscrews (4), washers (5), and locknuts (12). Tighten capscrews (4) to 15 lb-ft (20 N•m).
4. Install support bracket (6) on wheelhouse (1) with two washers (7), capscrews (8), washers (7), and nuts (9). Tighten nuts (9) to 43 lb-ft (58 N•m).
5. Install rear bracket retainer plate (15) on wheelhouse (1) with two washers (14), capscrews (17), washers (14), and locknuts (13). Tighten locknuts (13) to 6 lb-ft (8 N•m).
6. Install rear angle bracket (18) on wheelhouse (1) with three washers (2), capscrews (3), washers (2), and locknuts (16). Tighten locknuts (16) to 6 lb-ft (8 N•m).

12-18. TROOP SEAT KIT REPLACEMENT (Cont'd)

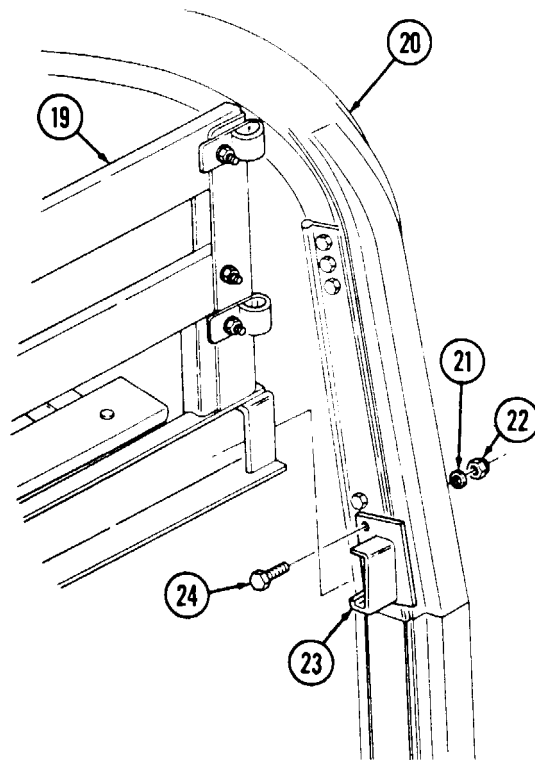
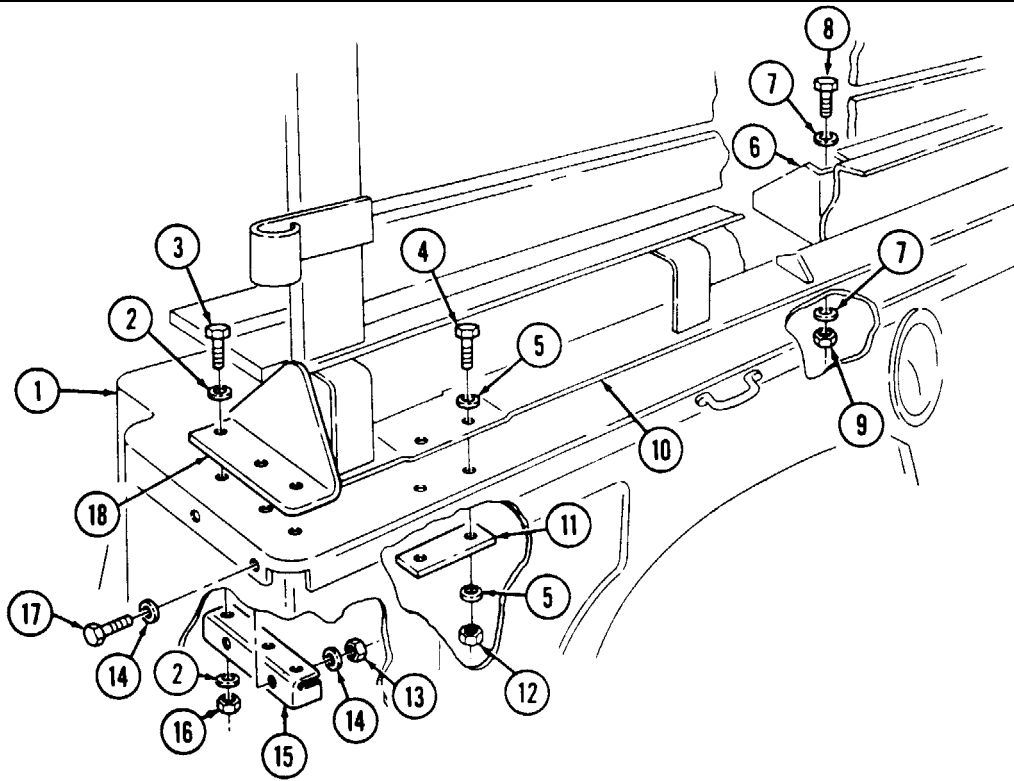

12-19. TROOP SEAT BOARD REPLACEMENT

This task covers:

a. Removal

b. Installation

INITIAL SETUP:

Applicable Models

M998, M998A1, M1038, M1038A1, M1097, M1097A1, M1097A2

Materials/Parts

Three plain-assembled nuts (Appendix G, Item 205)

Tools

General mechanic's tool kit: automotive (Appendix B, Item 1)

Manual References

TM 9-2320-280-24P

NOTE

The procedure for replacing seat boards and back boards is basically the same. This procedure covers seat boards.

a. Removal

Remove three carriage bolts (1), plain-assembled nuts (3), and seat board (2) from channel assembly (4). Discard plain-assembled nuts (3).

b. Installation

Install seat board (2) on channel assembly (4) with three carriage bolts (1) and plain-assembled nuts (3).

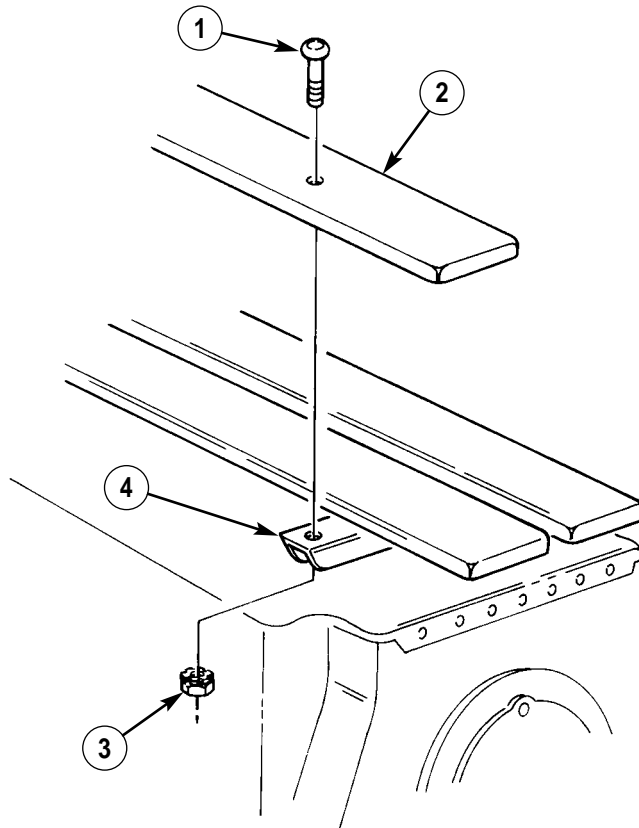

Section III. 100 AMPERE ALTERNATOR KIT MAINTENANCE

12-20. 100 AMPERE ALTERNATOR MAINTENANCE TASK SUMMARY

TASK PARA.	PROCEDURES	PAGE NO.
12-21.	100 Ampere Regulator (R027096300) Replacement	12-24
12-22.	100 Ampere Regulator (12342944, N3106) Replacement	12-28
12-22.1.	100 Ampere Alternator Cable (12446821-2) Replacement	12-28.2
12-23.	100 Ampere Alternator (12340912) Replacement	12-30
12-24.	100 Ampere Alternator (12342944) Replacement	12-32
12-24.1.	100/200 Ampere Dual Voltage Alternator and Regulator Conversion	12-34.2

12-21. 100 AMPERE REGULATOR (R027096300) REPLACEMENT

This task covers:

a. Removal

b. Installation

INITIAL SETUP:

Applicable Models

All models except M996, M996A1, M1026, M1026A1, M1097, M1097A1, M1097A2, M1123

Tools

General mechanic's tool kit: automotive (Appendix B, Item 1)

Materials/Parts

Antiseize compound (Appendix C, Item 13)
 Adhesive sealant (Appendix C, Item 9)
 Silicone (Appendix C, Item 48)
 Six lockwashers (Appendix G, Item 184)
 Two lockwashers (Appendix G, Item 142)
 Lockwasher (Appendix G, Item 134)

Manual References

TM 9-2320-280-10
 TM 9-2320-280-24P

Equipment Condition

- Battery ground cable disconnected (para. 4-73).
- Hood raised and secured (TM 9-2320-280-10).

NOTE

- Prior to removal, tag leads for installation.
- Older model regulators have two screws securing regulator cover and terminals are sealed with sealant. Newer model regulators have four screws securing regulator cover and no sealant. Identify which type is on vehicle and follow particular model steps as noted.

a. Removal

1. Remove capscrew (11), lockwasher (10), and lead 3B (8) from regulator (9). Discard lockwasher (10).

NOTE

Perform steps 2 and 3 for older model regulators and step 4 for newer models.

2. Remove two screws (3), lockwashers (2), and cover (1) from regulator (9). Discard lockwashers (2).
3. Remove sealant from cover (1), leads (4), (5), and (7), and regulator (9).
4. Remove four screws (3), lockwashers (2), cover (18), gasket (17) and sealing wedge (16) from regulator (9) and leads (4), (5), and (7). Discard lockwashers (2).
5. Remove nut (13), lockwasher (12), and lead 5A (4) from regulator (9). Discard lockwasher (12).
6. Remove nut (15), lockwasher (14), and lead 2A (5) from regulator (9). Discard lockwasher (14).
7. Disconnect regulator lead 568 (7) from engine harness lead 568A (6).
8. Loosen two clamp nuts (23) and remove clamp pins (22) and guard (21) from regulator slots (19).
9. Unscrew connector plug (24) and remove regulator (9) from alternator (20).

12-21. 100 AMPERE REGULATOR (R027096300) REPLACEMENT (Cont'd)

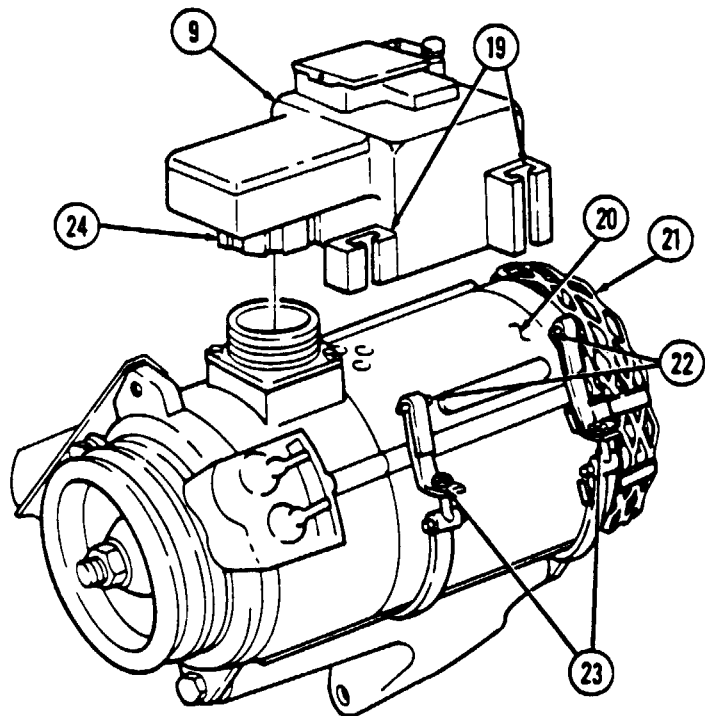
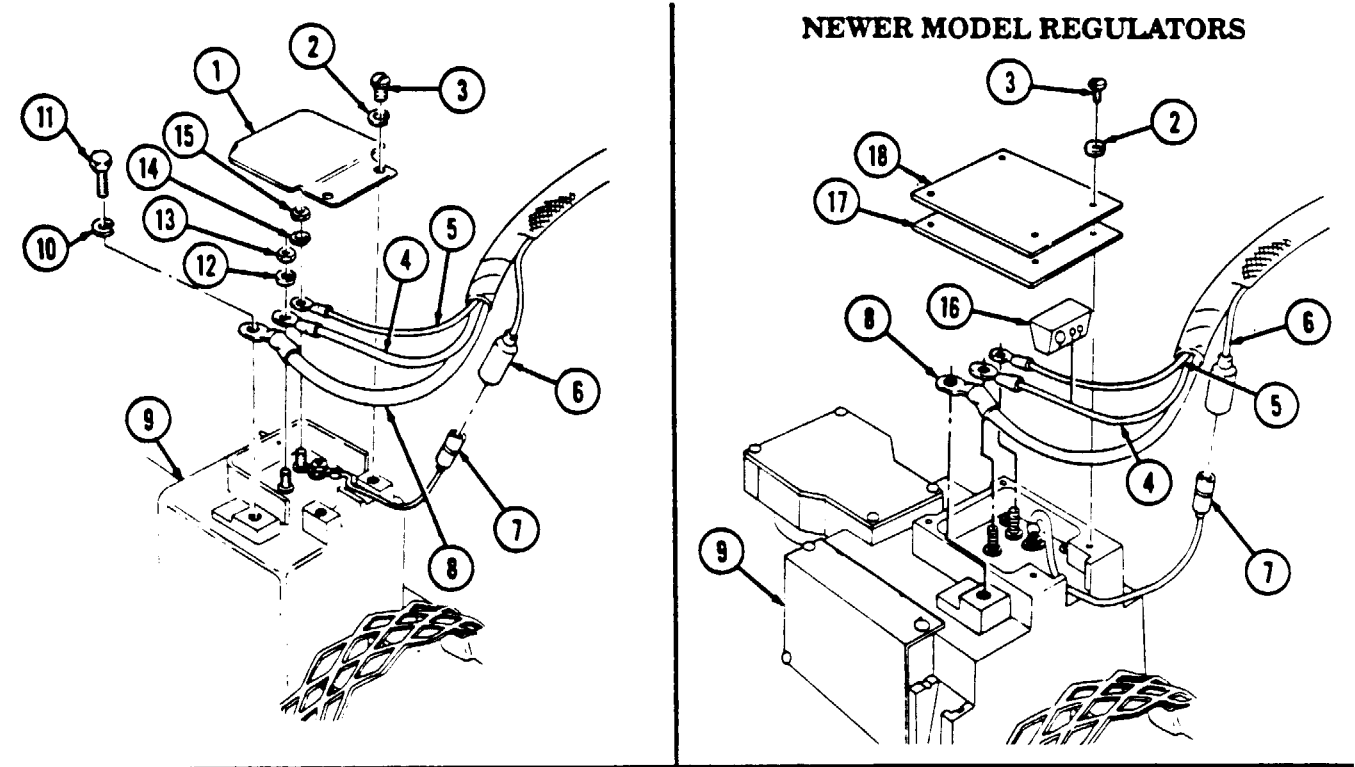

12-21. 100 AMPERE REGULATOR (R027096300) REPLACEMENT(Cont'd)

b. Installation

1. Fill alternator receptacle (8) with silicone. Install regulator (1) on alternator (3) and tighten connector plug (9) between alternator (3) and regulator (1).
2. Ensure guard (4) is positioned in rear clamp (5). Install clamp pins (7) into regulator slots (2). Tighten two clamp nuts (6) to 35-45 lb-in. (4-5 N·m).

NOTE

Ensure terminals are clean before connections are made.

3. Connect engine harness lead 568A (15) to regulator lead 568 (16).
4. Connect lead 2A (14) to regulator (1) with lockwasher (23) and nut (24). Tighten nut (24) to 20 lb-in. (2.3 N·m).
5. Connect lead 5A (13) to regulator (1) with lockwasher (21) and nut (22). Tighten nut (22) to 50 lb-in. (5.6 N·m).

NOTE

Perform steps 6 and 7 for older model regulators, and steps 8 and 9 for newer model regulators.

6. Completely fill regulator cavity (18) with sealant to form a water tight seal. Sealant should extrude from side of cover (10) when installed.
7. Install cover (10) to regulator (1) and secure with two lockwashers (11) and screws (12).
8. Insert leads (13), (14), and (17) into sealing wedge (29) and install sealing wedge (29) in regulator cavity (18).
9. Install gasket (25) and cover (26) on regulator (1) with four lockwashers (28) and screws (27).
10. Apply antiseize compound to contact surface of lead 3B (17). Install lead 3B (17) on regulator (1) with lockwasher (19) and capscrew (20). Tighten capscrew (20) to 90 lb-in. (10 N·m).

12-21. 100 AMPERE REGULATOR (R027096300) REPLACEMENT (Cont'd)

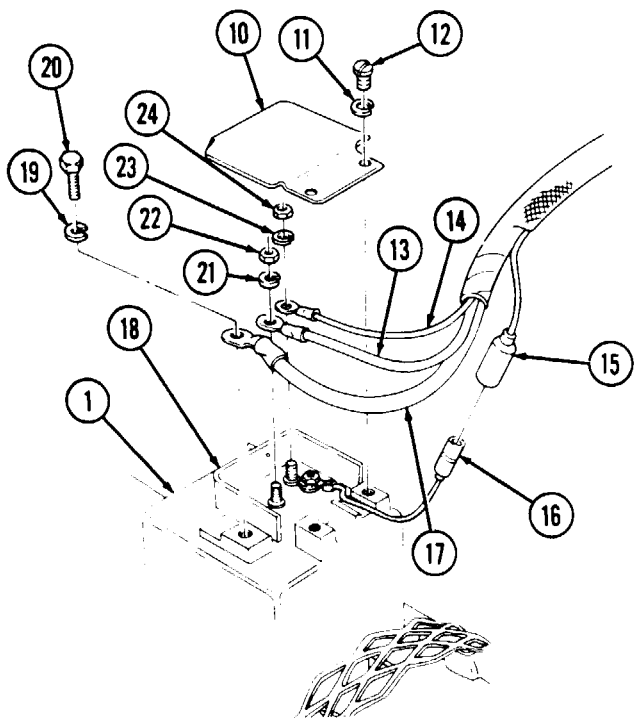
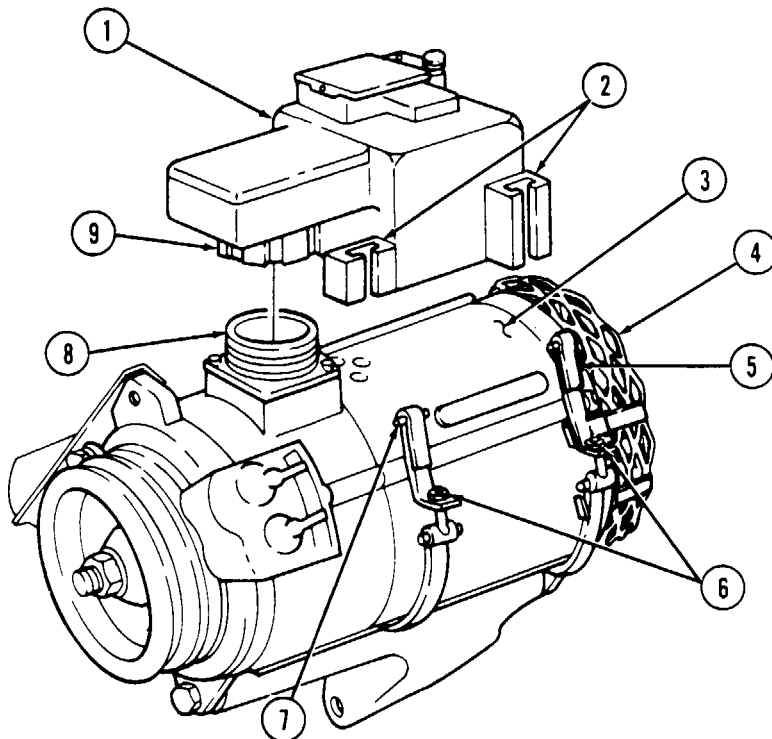

NEWER MODEL REGULATORS

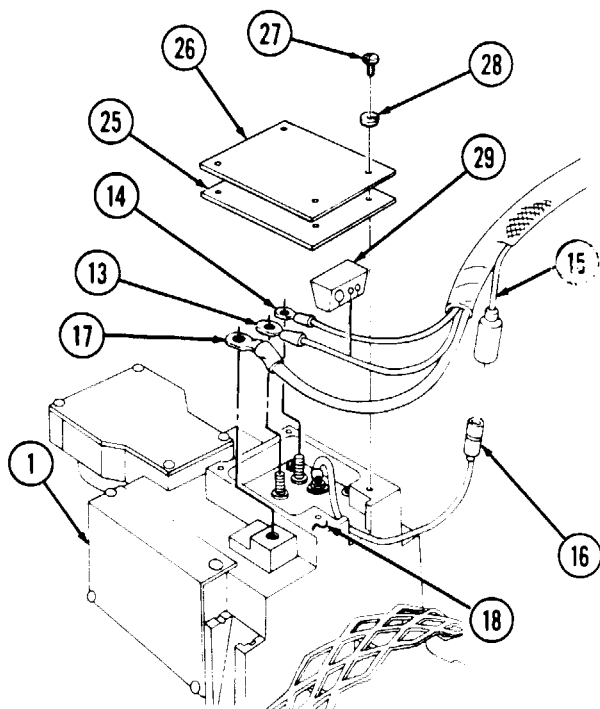

- FOLLOW-ON TASKS: Ž Lower and secure hood (TM 9-2320-280-10).
 • Connect battery ground cable (para. 4-73).
 Ž Start engine (TM 9-2320-280-10) and observe voltmeter for proper reading.

12-22. 100 AMPERE REGULATOR (12342944, N3106) REPLACEMENT

This task covers:

a. Removal

b. Installation

INITIAL SETUP:

Applicable Models

All models except M996, M996A1, M1026, M1026A1, M1097, M1097A1, M1097A2, M1123

Tools

General mechanic's tool kit:
automotive (Appendix B, Item 1)

Materials/Parts

Sealing compound (Appendix C, Item 45)
Three lockwashers (Appendix G, Item 138)

Manual References

TM 9-2320-280-10
TM 9-2320-280-24P

Equipment Condition

- Battery ground cables disconnected (para. 4-73).
- Hood raised and secured (TM 9-2320-280-10).

a. Removal

NOTE

Prior to removal, tag leads for installation.

1. Disconnect regulator plug (1) from voltage regulator (4).
2. Slide back rubber boot (21) and remove nut (22), lead 5A (23), and washer (24) from red (energize) terminal (25).
3. Slide back rubber boot (18) and remove nut (17), lead 2A (16), and washer (15) from yellow (AC) terminal (14).

NOTE

Perform steps 4 and 5 for M1025A2, M1035A2, M1043A2, and M1045A2 vehicles only.

4. Slide back rubber boot (12) and remove nut (11), lead (10), and washer (9) from terminal (8).
5. Disconnect regulator connector (20) from alternator connector (19).
6. Remove two screws (5), lockwashers (6), and washers (7) securing voltage regulator (4) to alternator (13). Discard lockwashers (6).
7. Remove capscrew (3), lockwasher (2), and voltage regulator (4) from alternator (13). Discard lockwasher (2).

b. Installation

1. Apply sealing compound to threads of capscrew (3).
2. Install voltage regulator (4) on alternator (13) with lockwasher (2) and capscrew (3). Tighten capscrew (3) to 88-94 lb-in. (10-11 N•m).
3. Install two washers (7), lockwashers (6), and screws (5) on voltage regulator (4) and alternator (13). Tighten screws (5) to 30-34 lb-in. (3-4 N•m).

NOTE

Perform steps 4 and 5 for M1025A2, M1035A2, M1043A2, and M1045A2 vehicles only.

4. Install washer (9), lead (10), and nut (11) on terminal (8). Tighten nut (11) to 18-22 lb-in. (2.0-2.5 N•m). Slide rubber boot (12) over terminal (8).
5. Connect regulator connector (20) to alternator connector (19).
6. Install washer (24), lead 5A (23), and nut (22) on red (energize) terminal (25). Tighten nut (22) to 23-27 lb-in. (2.6-3.0 N•m). Slide rubber boot (21) over terminal (25).

12-22. 100 AMPERE REGULATOR (12342944, N3106) REPLACEMENT (6nt'd)

7. Install washer (15), lead 2A (16), and nut (17) on yellow (AC) terminal (14). Tighten nut (17) to 18-22 lb-in. (2.0-2.5 N·m). Slide rubber boot (18) over terminal (14).
8. Connect regulator plug (1) to voltage regulator (4).

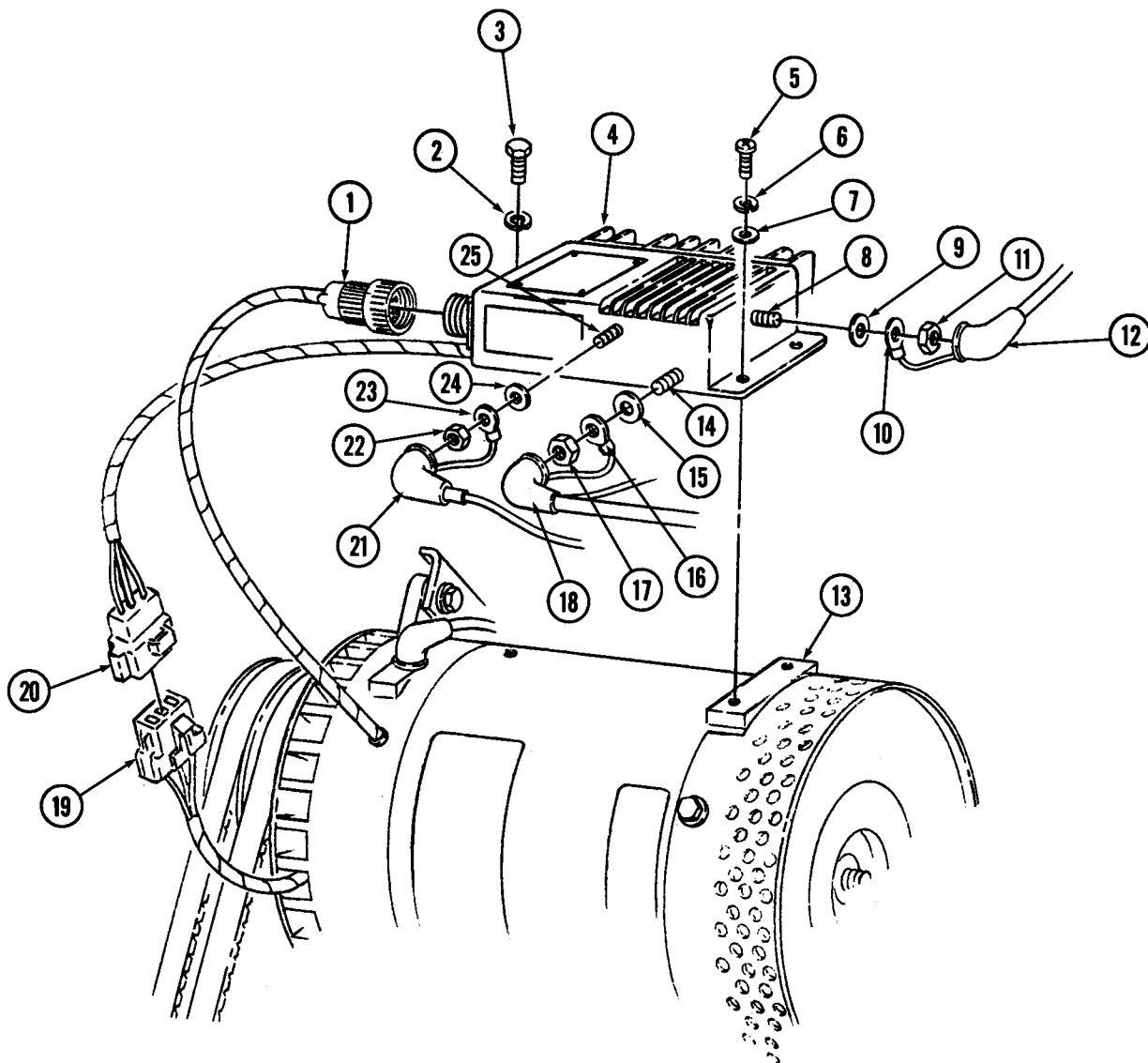

- FOLLOW-ON TASKS:
- Lower and secure hood (TM 9-2320-280-10).
 - Connect battery ground cables (para. 4-73).

12-22.1. 100 AMPERE ALTERNATOR CABLE (12446821-2) REPLACEMENT

This task covers:

a. Removal

b. Installation

INITIAL SETUP:

Applicable Models

All models except M996, M996A1, M1026, M1026A1, M1097, M1097A1, M1097A2, M1123

Tools

General mechanic's tool kit:
automotive (Appendix B, Item 1)

Materials/Parts

Lockwasher (Appendix G, Item 150)
Adhesive sealant (Appendix C, Item 9)

Manual References

TM 9-2320-280-10
TM 9-2320-280-24P

Equipment Condition

- Battery ground cables disconnected (para. 4-73).
- Hood raised and secured (TM 9-2320-280-10).
- Engine access cover removed (para. 10-15).

a. Removal

1. Slide back rubber boot (1) and remove nut (3), washer (5), fuse (2), insulator (6), cable (7), and bushing (8) from positive stud (9).
2. Remove capscrew (11), clamp (12), and cable (7) from bracket (10).
3. Remove nut (17), lockwasher (16), washer (15), and cable (7) from buss bar (14). Discard lockwasher (16).
4. Remove cable (7) through grommet (18) and from battery box (13).

b. Installation

NOTE

Ensure terminals are clean before connections are made.

1. Route cable (7) through grommet (18) on battery box (13), and install cable (7) on buss bar (14) with washer (15), lockwasher (16), and nut (17).
2. Route cable (7) in approximate mounting location over heat shield, and secure cable (7) and clamp (12) on bracket (10) with capscrew (11).
3. Apply sealant to positive stud (9) and cable (7) so all exposed metallic surfaces are coated.
4. Install bushing (8), cable (7), fuse (2), and insulator (6) on positive stud (9) with washer (5) and nut (3). Tighten nut (3) to 10-15 lb-ft (14-20 N•m). Slide rubber boot (1) over nut (3).

12-22.1. 100 AMPERE ALTERNATOR CABLE (12446821-2) REPLACEMENT (Cont'd)

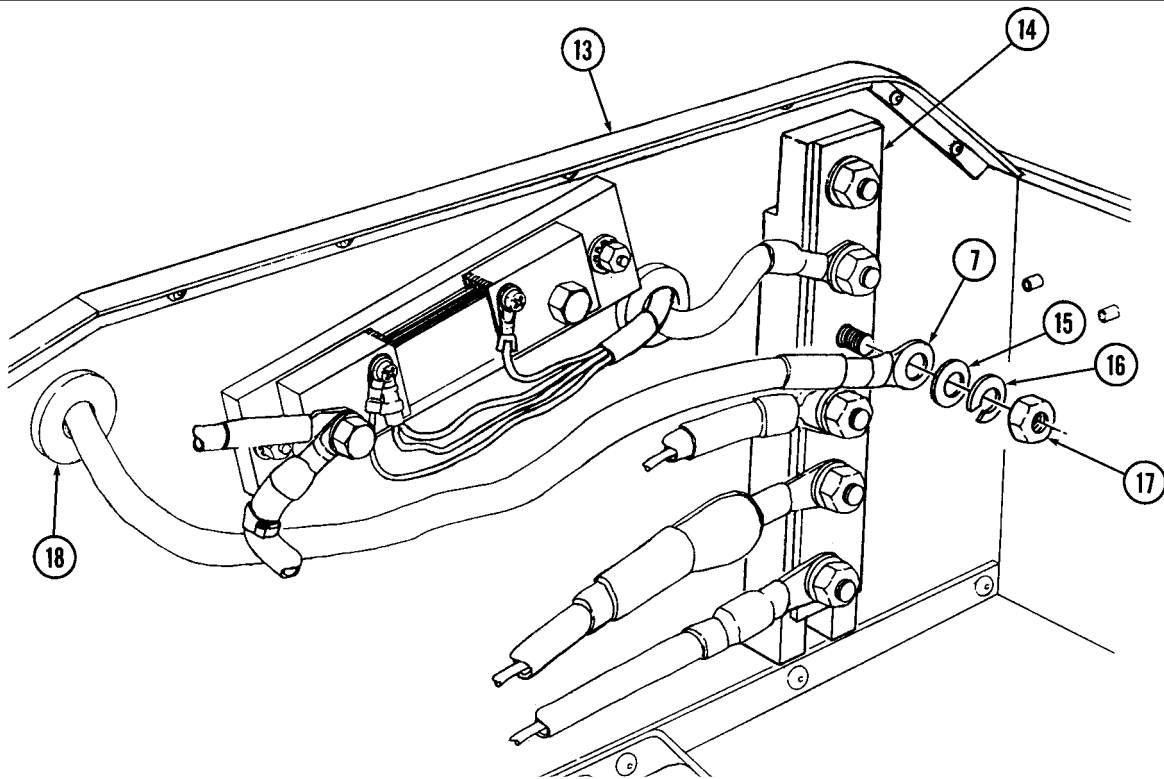
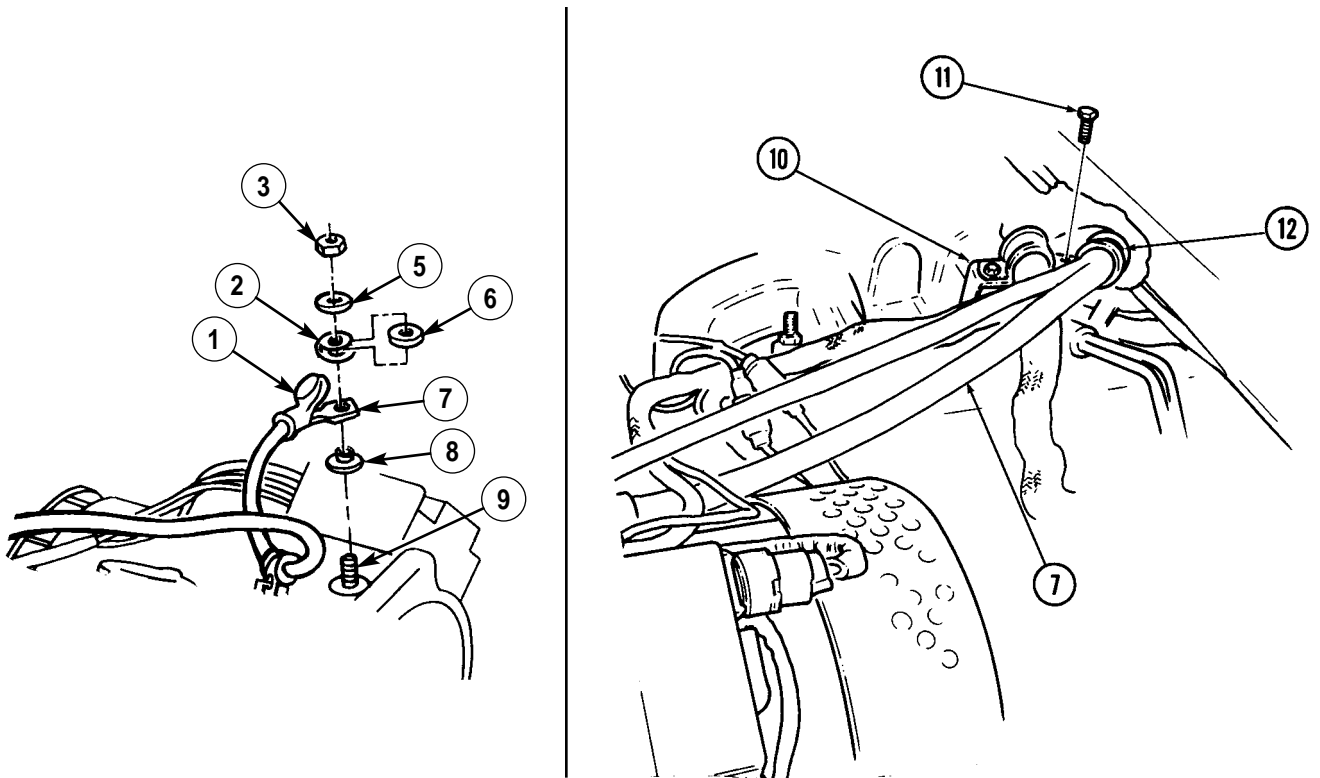

- FOLLOW-ON TASKS:**
- Install engine access cover (para. 10-15).
 - Lower and secure hood (TM 9-2320-280-10).
 - Connect battery ground cables (para. 4-73).
 - Start engine and check operation of voltmeter gauge (TM 9-2320-280-10).

12-23. 100 AMPERE ALTERNATOR (12340912) REPLACEMENT

This task covers:

a. Removal

b. Installation

INITIAL SETUP:

Tools

General mechanic's tool kit:
automotive (Appendix B, Item 1)

Materials/Parts

Silicone (Appendix C, Item 48)
Two lockwashers (Appendix G, Item 188)
Lockwasher (Appendix G, Item 133)

Personnel Required

One mechanic
One assistant

Manual References

TM 9-2320-280-10
TM 9-2320-280-24P

Equipment Condition

- Battery ground cable disconnected (para. 4-73).
- Hood raised and secured (TM 9-2320-280-10).

General Safety Instructions

Alternator must be supported during removal and installation.

a. Removal

1. Loosen two clamp nuts (12) and remove clamp pins (7) from regulator slots (6).
2. Loosen connector plug (4) and remove regulator (5) from alternator (13) and position regulator (5) out of the way.
3. Loosen capscrew (20) on alternator adjusting bracket (19), and two capscrews (10) on alternator mounting bracket (18) and support bracket (17).
4. Remove two drivebelts (1) from alternator pulley (2).

WARNING

Alternator must be supported during removal and installation. Failure to do this may cause injury to personnel or damage to equipment.

5. Remove capscrew (14), lockwasher (15), and washer (16) from alternator (13) and adjusting bracket (19). Discard lockwasher (15).

NOTE

- Perform step 7 for vehicles with new alternator support bracket configuration.
- In some cases, a thru-bolt and nut may be present on mounting bracket instead of standard capscrews and washers.

6. Remove two capscrews (10), lockwashers (11), and alternator (13) from mounting bracket (18) and support bracket (17). Discard lockwashers (11).
7. Remove two capscrews (10), lockwashers (11), washer (22), spacer (24), and alternator (13) from power steering lines bracket (23), support bracket (17), and mounting bracket (18). Discard lockwashers (11).
8. Remove guard (9) and two clamp straps (8) from alternator (13).
9. Remove alternator pulley (2) (para. 4-3).

b. Installation

1. Install alternator pulley (2) (para. 4-3).
2. Install two clamp straps (8) and guard (9) on alternator (13).

NOTE

- Perform step 4 for vehicles with new alternator support bracket configuration.
- In some cases, a thru-bolt and nut may be present on mounting bracket instead of standard capscrews and washers.

3. Install alternator (13) on mounting bracket (18) and support bracket (17) with two lockwashers (11) and capscrews (10). Tighten capscrews (10) finger tight.

12-23. 100 AMPERE ALTERNATOR (12340912) REPLACEMENT (Cont'd)

4. Position alternator (13) on mounting bracket (18) (with support bracket (17) and power steering lines bracket (23) on the outside of alternator mounting flange (21)) and install spacer (24), washer (22), two lockwashers (11), and capscrews (10).
5. Align alternator (13) with hole in adjusting bracket (19), and install washer (16), lockwasher (15), and capscrew (14). Tighten capscrew (14) finger tight.
6. Install two drivebelts (1) on alternator pulley (2).
7. Fill alternator receptacle (3) with silicone.
8. Install regulator (5) on alternator (13) and secure connector plug (4) between alternator (13) and regulator (5).
9. Ensure guard (9) is positioned in rear clamp (8). Install clamp pins (7) into regulator slots (6). Tighten two clamp nuts (12) to 40 lb-in. (4.5 NZm).

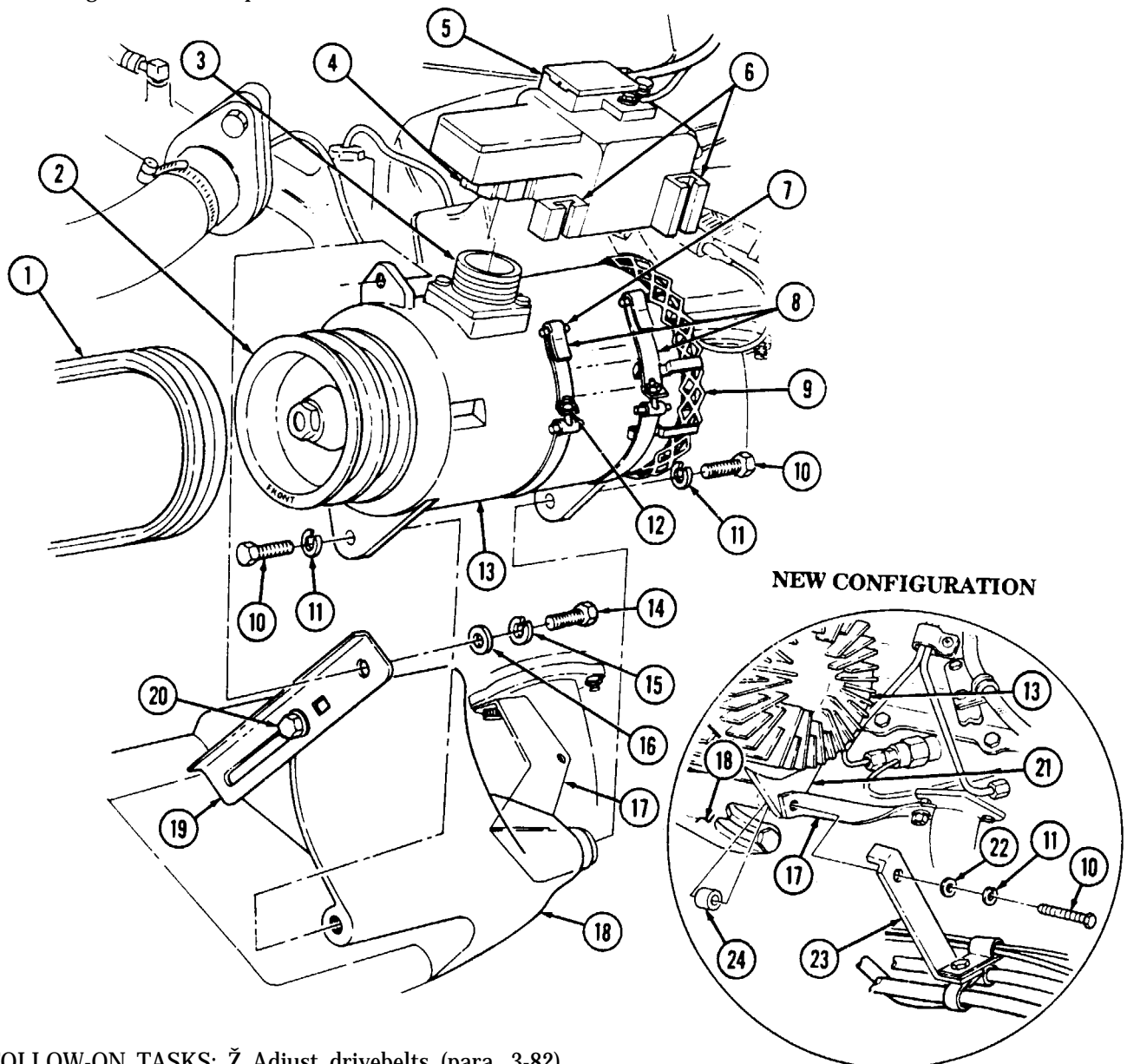

FOLLOW-ON TASKS: Ž Adjust drivebelts (para. 3-82).

Ž Connect battery ground cable (para. 4-73).

12-24. 100 AMPERE ALTERNATOR (12342944) REPLACEMENT

This task covers:

a. Removal

b. Installation

INITIAL SETUP:

Applicable Models

All models except M996, M996A1, M1026, M1026A1, M1097, M1097A1, M1097A2, M1123

Tools

General mechanic's tool kit:
 automotive (Appendix B, Item 1)
 Breaker bar, 3/8 in. (Appendix B, Item 2)

Materials/Parts

Lockwasher (Appendix G, Item 133)
 Lockwasher (Appendix G, Item 186)
 Lockwasher (Appendix G, Item 187)
 Two lockwashers (Appendix G, Item 188)

Personnel Required

One mechanic
 One assistant

Manual References

TM 9-2320-280-10
 TM 9-2320-280-24P

Equipment Condition

- Battery ground cable removed (para. 4-73).
- Hood raised and secured (TM 9-2320-280-10).
- Voltage regulator removed (para. 12-22).

General Safety Instructions

Alternator must be supported during removal and installation.

a. Removal

NOTE

Prior to removal, tag leads for installation.

1. Slide back rubber boot (4) and remove capscrew (1), lockwasher (2), washer (3), and ground cable (5) from alternator (6). Discard lockwasher (2).
2. Slide back rubber boot (18) and remove nut (21), lockwasher (20), washer (19), alternator positive cable (17), nut (16.2), and washer (16.1) from positive stud (16). Discard lockwasher (20).

NOTE

- Perform steps 3 and 4 for 6.2 L engine only.
- Perform step 5 for 6.5 L engine only.
- In some cases, a thru-bolt and nut may be present on mounting bracket instead of standard capscrews and washers.

3. Loosen capscrews (11) and (13) on alternator adjusting bracket (8) and two capscrews (23) from alternator (6), alternator mounting bracket (25), and support bracket (24).

NOTE

All "A2" models except the M997A2 are equipped with serpentine belts.

4. Remove two drivebelts (7) from alternator pulley (14).
5. Position 3/8-inch breaker bar on belt tensioner (22), move tensioner (22) clockwise, and remove drivebelt (7) from alternator pulley (14).

WARNING

Alternator must be supported during removal and installation. Failure to support alternator may cause injury to personnel or damage to equipment.

6. Remove capscrew (11), lockwasher (10), and washer (9) from alternator (6) and adjusting bracket (8). Discard lockwasher (10).

12-24. 100 AMPERE ALTERNATOR (12342944) REPLACEMENT (Cont'd)

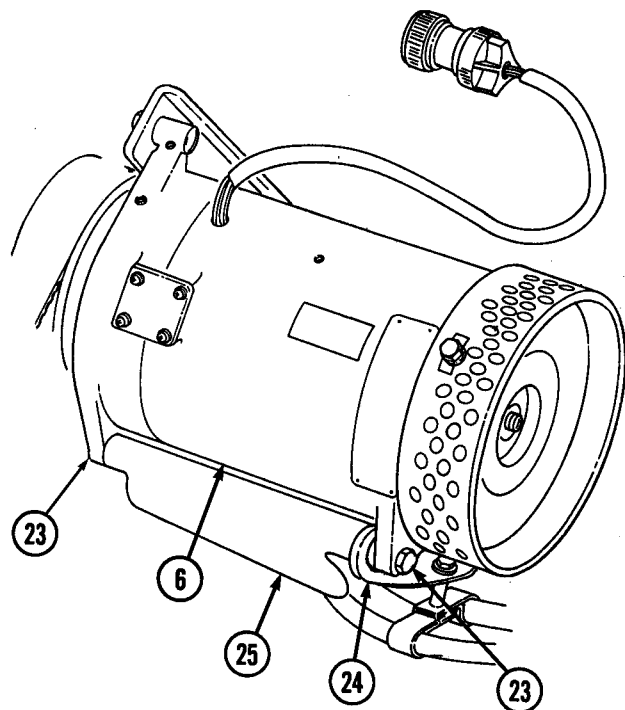
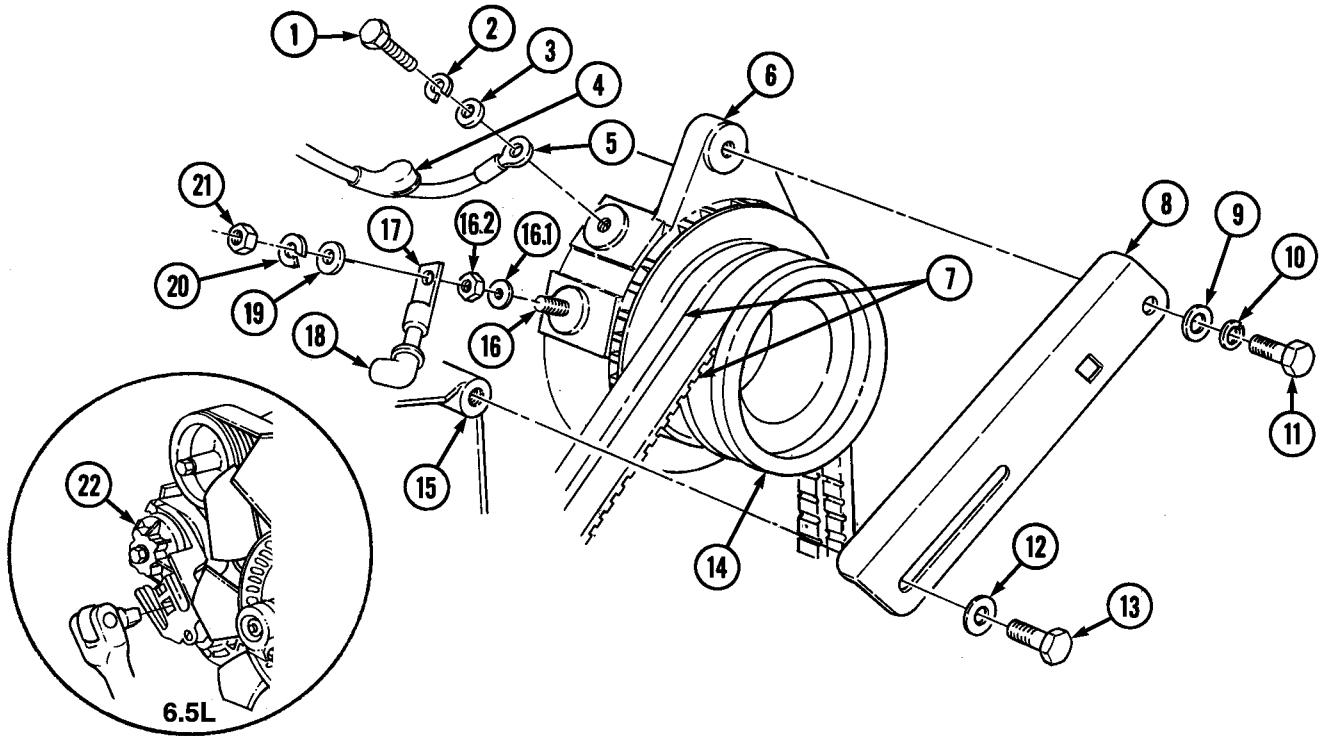

12-24. 100 AMPERE ALTERNATOR (12342944) REPLACEMENT (Cont'd)

7. Remove capscrew (13), washer (12), and alternator adjusting bracket (8) from alternator mounting bracket (25).
8. Remove two capscrews (4), lockwashers (5), washers (6), and spacer (10) from alternator (12), power steering lines bracket (7), support bracket (8), and alternator mounting bracket (11). Discard lockwashers (5).
9. Remove alternator (12).
10. Remove three capscrews (1), washers (2), bushings (13), and fan guard assembly (3) from alternator (12).
11. Remove alternator pulley (25) (para. 4-3).

b. Installation

1. Install alternator pulley (25) (para. 4-3).
2. Install fan guard assembly (3) on alternator (12) with three bushings (13), washers (2), and capscrews (1).

NOTE

In some cases, a thru-bolt and nut may be present on mounting bracket instead of standard capscrews and washers.

3. Position alternator (12) on alternator mounting bracket (11) (with support bracket (8) and power steering lines bracket (7) on the outside of alternator mounting flange (9) and install spacer (10), two washers (6), lockwashers (5), and capscrews (4).
4. Install alternator adjusting bracket (19) on alternator mounting bracket (11) with washer (20), lockwasher (21), and capscrew (22).

NOTE

Perform step 4.1 for 6.2L only.

- 4.1. Tighten capscrew (22) to 40 lb-ft (54 N·m).

NOTE

Perform step 5 for 6.2L only.

5. Align alternator (12) with adjusting bracket (19) and install washer (23), and capscrew (24). Do not tighten capscrew (24) on 6.2 L only. On 6.5 L tighten capscrew (24) to 40 lb-ft (54 N·m).

NOTE

Ensure terminals are clean before connections are made.

6. Install washer (26.1), nut (26.2), and positive cable (27) on positive stud (26) with washer (29), lockwasher (30), and nut (31). Tighten nut (31) to 10-15 lb-ft (14-20 N·m).
7. Install ground cable (17) on alternator (12) with washer (15), lockwasher (14), and capscrew (32). Tighten capscrew (32) to 8-12 lb-ft (11-16 N·m).

NOTE

- Perform step 8 for 6.2L only.
- Perform step 9 for 6.5L only.

8. Install two drivebelts (18) on alternator pulley (25).
9. Position 3/8-in. breaker bar on belt tensioner (33), move tensioner (33) clockwise and install belt (18) on alternator pulley (25).
10. Install rubber boots (16) and (28) over cables (17) and (27).

12-24. 100 AMPERE ALTERNATOR (12342944) REPLACEMENT (Cont'd)

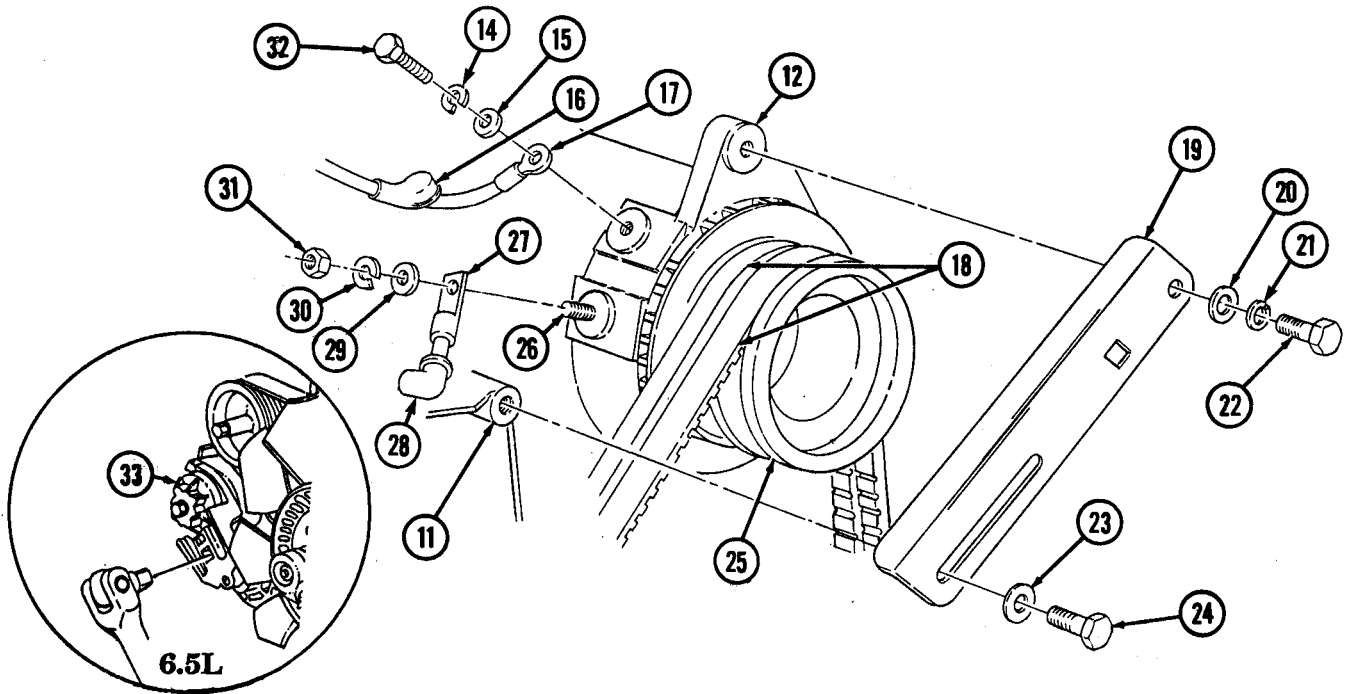
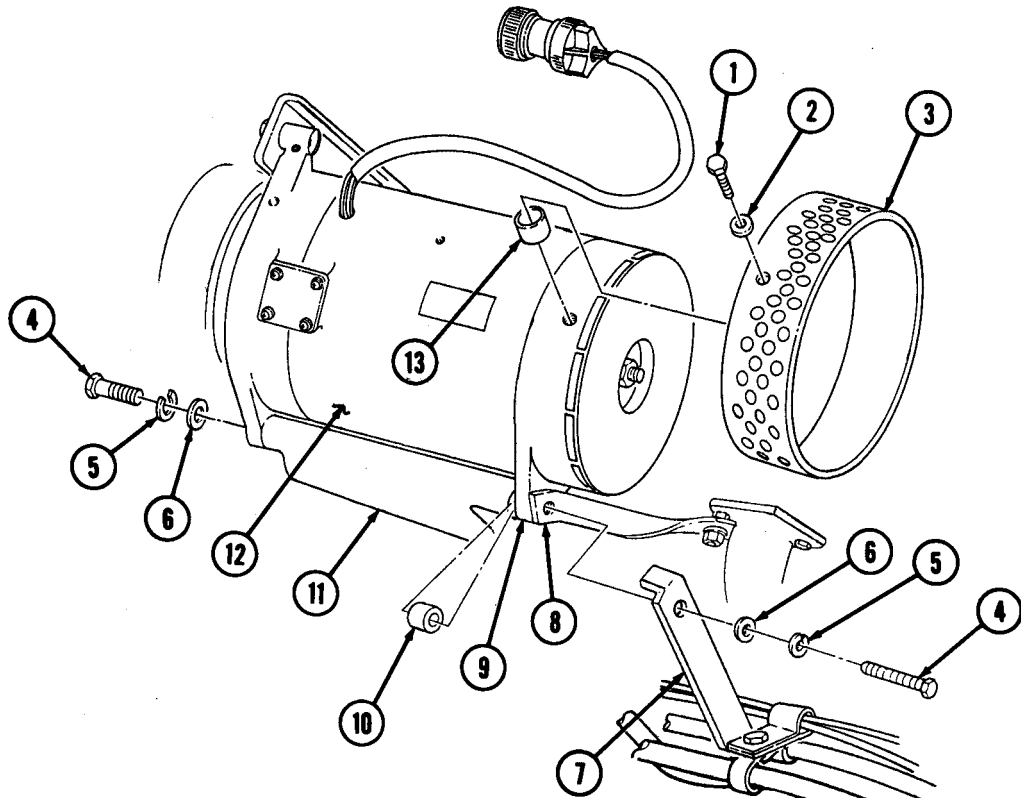

- FOLLOW-ON TASKS:**
- Install voltage regulator (para. 12-22).
 - Adjust alternator belts (para. 3-81) (All except "A2" vehicles).
 - Battery ground cable installed (para. 4-73).
 - Lower and secure hood (TM 9-2320-280-10).

12-24.1. 100/200 AMPERE DUAL VOLTAGE ALTERNATOR AND REGULATOR CONVERSION

This task covers:

- a. Part Fabrication
- b. 100 Ampere Dual Voltage Alternator and Regulator Installation
- c. 200 Ampere Dual Voltage Alternator and Regulator Installation

INITIAL SETUP:

Tools

General mechanic's tool kit:
automotive (Appendix B, Item 1)

Materials/Parts

Grease (Appendix C, Item 25)
Sealant (Appendix C, Item 38)
Alternator (NSN 2920-01-907-0532)
Lockwasher (Appendix G, Item 134)
Lockwasher (Appendix G, Item 185)
Lockwasher (Appendix G, Item 186)
Lockwasher (Appendix G, Item 187)
Tiedown strap (Appendix G, Item 313)

Manual References

TM 9-2320-280-10
TM 9-2320-280-24P

Equipment Condition

- Battery ground cable disconnected (para. 4-73).
- Hood raised and secured (TM 9-2320-280-10).
- Regulator removed (para. 12-22).
- Alternator removed (para. 12-23).

NOTE

This task is for single voltage vehicle systems (basic and "A1" models) only.

a. Part Fabrication

Refer to appendix D, figure D-121.

b. 100 Ampere Dual Voltage Alternator and Regulator Installation

1. Remove nut (1), washer (2), and pulley (3) from shaft (6) on alternator assembly (5).
2. Remove nut (1) and washer (2) from shaft (6) of replacement 100 ampere alternator assembly (5).
3. Install previously removed pulley (3) on woodruff key (4) and shaft (6) with washer (2) and nut (1).
4. Place alternator assembly (5) in a soft-jawed vise and tighten nut (1) to 120 lb-ft (163 N•m).
Remove alternator assembly (5) from vise.

12-24.1. 100/200 AMPERE DUAL VOLTAGE ALTERNATOR AND REGULATOR
CONVERSION (Cont'd)

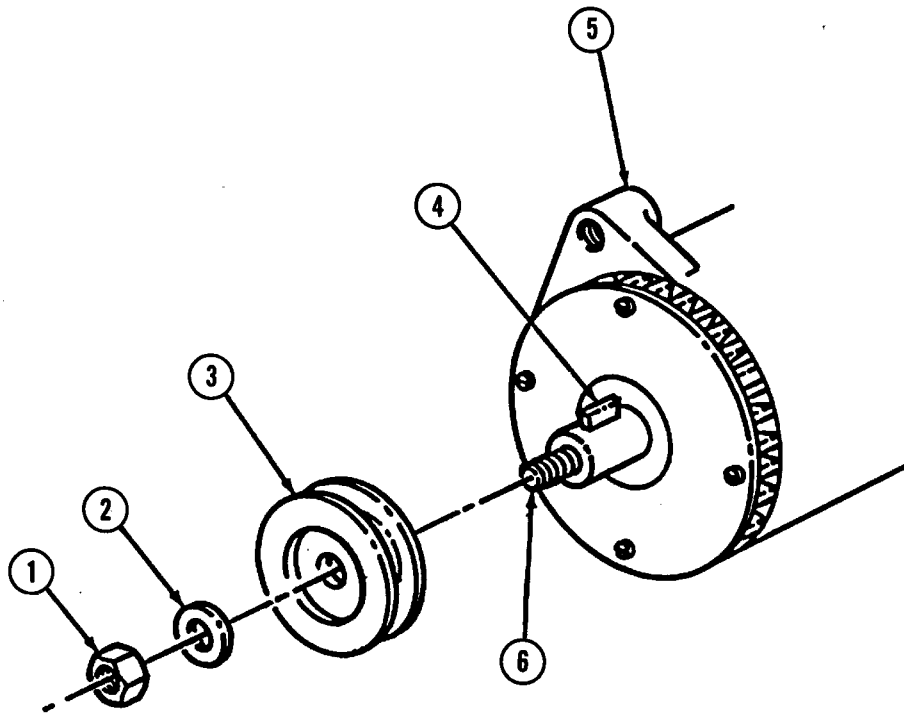

12-24.1 100/200 AMPERE DUAL VOLTAGE ALTERNATOR AND REGULATOR CONVERSION (Cont'd)

NOTE

Do not connect electrical connections when performing step 5.

5. Install alternator assembly (para. 12-23).
6. Remove screw (3), lockwasher (2), and washer (1) from regulator (16). Discard lockwasher (2).
7. Install ground wire (6), washer (1), lockwasher (2), and screw (3) on regulator (16). Tighten screw (3) to 88-94 lb-in. (10-11 N•m).
8. Route ground wire (6) around regulator (16) to 14-volt stud (7), remove nut (8) from stud (7), and install ground wire (6) on stud (7) with nut (8). Tighten nut (8) to 45-55 lb-ft (5-6 N•m).
9. Apply sealant to nut (8) and stud (7).
10. Remove screw (24), lockwasher (23), and washer (22) from ground point (25) on alternator assembly (17). Discard lockwasher (23).
11. Install lead 3B (5), washer (22), lockwasher (23), and screw (24) to ground point (25) on alternator assembly (17). Tighten screw (24) to 75-85 lb-in. (8-10 N•m).
12. Remove nut (21) and washer (20) from positive terminal (18) on alternator assembly (17).
13. Install red boot (19) on lead 5A (4).
14. Install lead 5A (4) on positive terminal (18) on alternator assembly (17) with washer (20) and nut (21). Tighten nut (21) to 65-70 lb-in. (7-8 N•m).
15. Apply grease to positive terminal (18) and lead 5A (4), and slide boot (19) over positive terminal (18).
16. Remove nut (13) from IGN terminal (9).
17. Install black boot (12) on lead 568A (11).
18. Install lead 568A (11) and nut (13) on IGN terminal (9). Tighten nut (13) to 23-27 lb-in. (2-3 N•m).
19. Apply grease to IGN terminal (9), lead 568A (11), and inside of boot (12), and slide boot (12) over IGN terminal (9).
20. Remove nut (14) from AC terminal (15).
21. Install black boot (12) on lead 2A (10).
22. Install lead 2A (10) and nut (14) on AC terminal (15). Tighten nut (14) to 18-22 lb-in. (2-3 N•m).
23. Apply grease to AC terminal (15), lead 2A (10), and inside of black boot (12), and slide boot (12) over AC terminal (15).
24. Connect battery ground cable (para. 4-73).

12-24.1. 100/200 AMPERE DUAL VOLTAGE ALTERNATOR AND REGULATOR
CONVERSION (Cont'd)

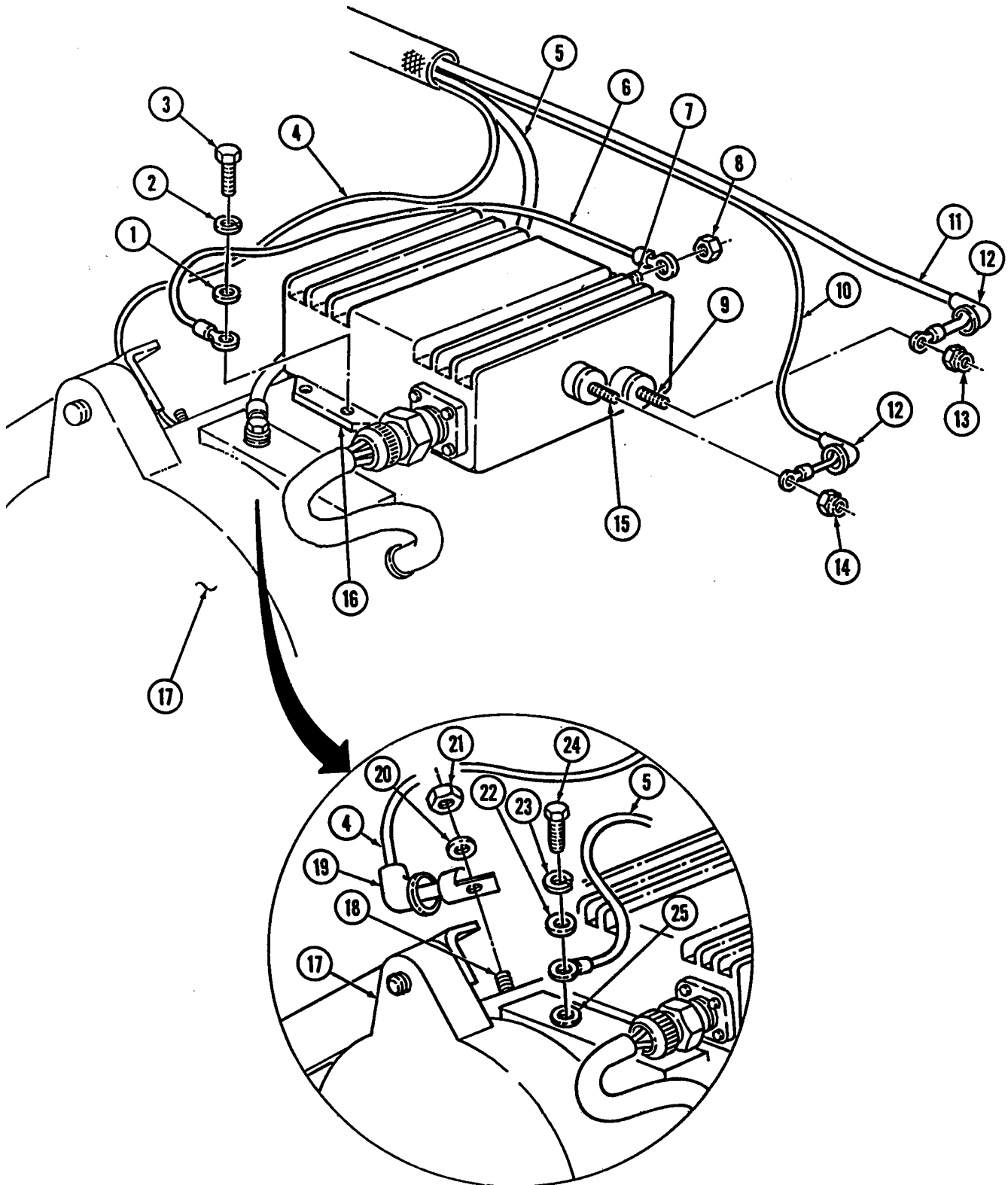

12-24.1. 100/200 AMPERE DUAL VOLTAGE ALTERNATOR AND REGULATOR CONVERSION (Cont'd)

c. 200 Ampere Dual Voltage Alternator and Regulator Installation

1. Remove nut (1) and washer (2) from shaft (6) of alternator assembly (5).
2. Install previously removed pulley (3) on woodruff key (4) and shaft (6) with washer (2) and nut (1).
3. Place alternator assembly (5) in a soft-jawed vise, and tighten nut (1) to 115-125 lb-ft (156-170 N•m).

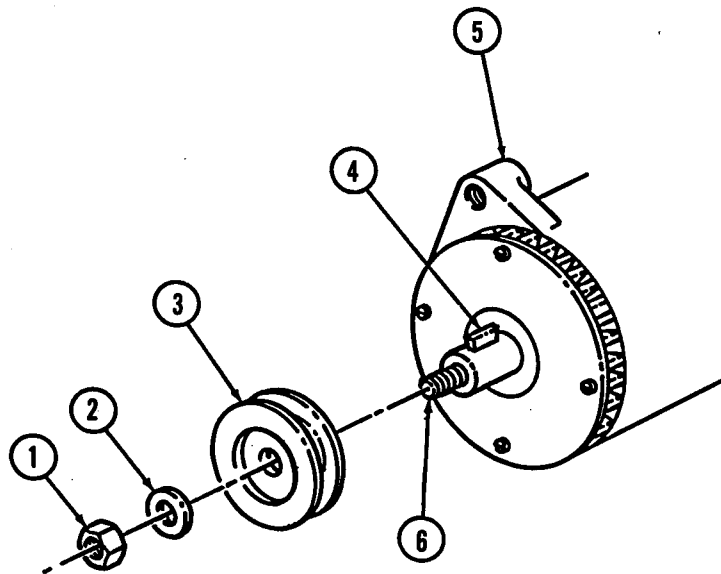

12-24.1. 100/200 AMPERE DUAL VOLTAGE ALTERNATOR AND REGULATOR CONVERSION (Cont'd)

NOTE

Do not connect electrical connections when performing step 4.

4. Install alternator assembly (para. 12-23).
5. Remove screw (13), lockwasher (14), and washer (15) from regulator (19). Discard lockwasher (14).
6. Install ground wire (16), washer (15), lockwasher (14), and screw (13) on regulator (19). Tighten screw (13) to 88-94 lb-in. (10-11 N·m).
7. Route ground wire (16) around regulator (19) to 14-volt stud (18), remove nut (17) from stud (18), and install ground wire (16) on stud (18) with nut (17). Tighten nut (17) to 45-55 lb-in. (5-6 N·m).
8. Apply sealant to nut (17) and stud (18).
9. Assemble dummy plug (7) by installing plug (8) in shell (9).
10. Remove lead 568 (20) from lead 568A (11). Discard lead 568 (20).
11. Install dummy plug assembly (7) in lead 568A (11).
12. Secure lead 568A (11) to electrical harness (12) with tiedown strap (10).

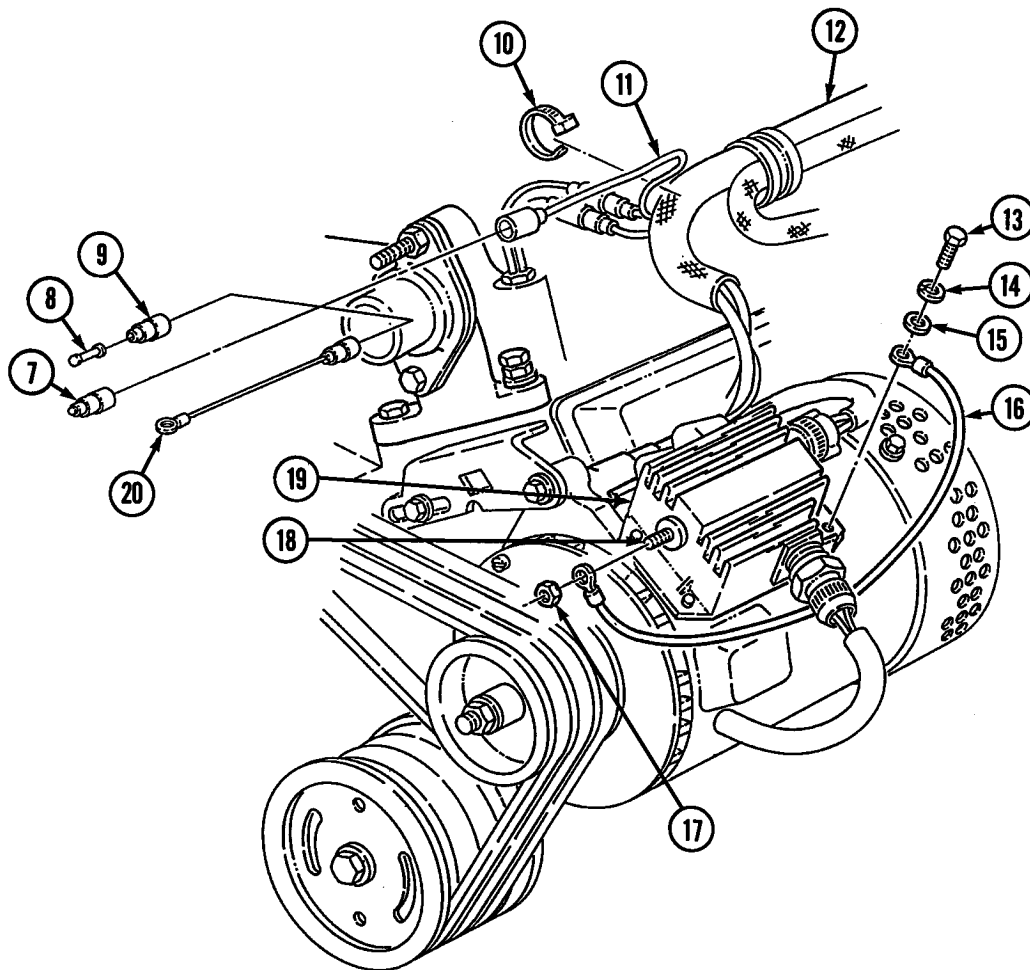

**12-24.1. 100/200 AMPERE DUAL VOLTAGE ALTERNATOR AND REGULATOR
CONVERSION (Cont'd)**

13. Remove nut (12), lockwasher (11), and washer (10) from ground stud (7) on alternator assembly (6). Discard lockwasher (11).
14. Install ground strap (8), lead 3B (9), washer (10), lockwasher (11), and nut (12) on alternator assembly (6).
15. Remove nut (2) and washer (3) from positive terminal (5).
16. Install lead 6 (4), washer (3), and nut (2) to positive terminal (5) on alternator assembly (6).
17. Apply grease to positive terminal (5), lead 6 (4), and inside of boot (1), and slide boot (1) over positive terminal (5).

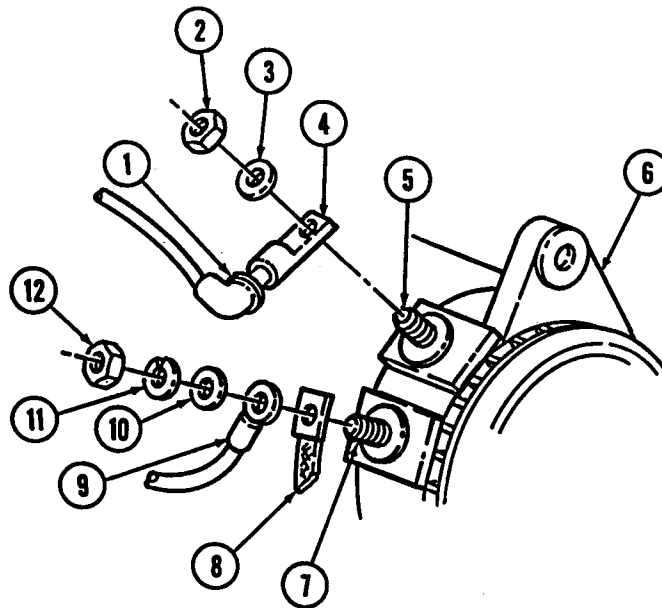

12-24.1. 100/200 AMPERE DUAL VOLTAGE ALTERNATOR AND REGULATOR CONVERSION (Cont'd)

18. Remove nut (15) from IGN terminal (14) on regulator (13).
19. Install boot (17) on lead 5A (16).
20. Install lead 5A (16) to IGN terminal (14) on regulator (13) with nut (15). Tighten nut (15) to 23-27 lb-in. (2-3 N•m).
21. Apply grease to IGN terminal (14), lead 5A (16), and inside of boot (17), and slide boot (17) over IGN terminal (2).
22. Remove nut (18) from AC terminal (21) on regulator (13).
23. Install boot (20) on lead 2A (19).
24. Install lead 2A (19) to AC terminal (21) on regulator (13) with nut (18). Tighten nut (18) to 18-22 lb-in. (2-3 N•m).
25. Apply grease to AC terminal (21), lead 2A (19), and inside of boot (20), and slide boot (20) over AC terminal (21).

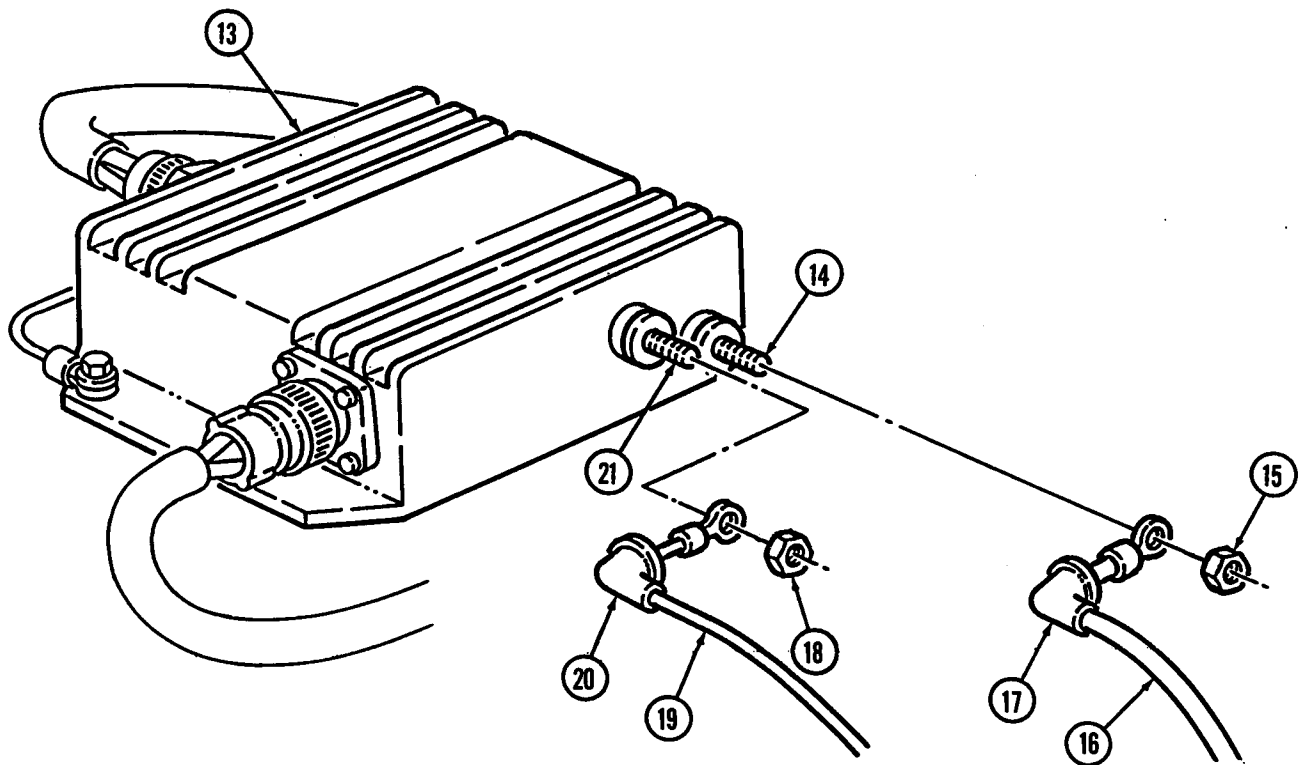

- FOLLOW-ON TASKS:**
- Connect battery ground cable (para. 4-73).
 - Lower and secure hood (TM 9-2320-280-10).

Section IV. ARCTIC WINTERIZATION KITS MAINTENANCE

12-25. ARCTIC WINTERIZATION KITS MAINTENANCE TASK SUMMARY

TASK PARA.	PROCEDURES	PAGE NO.
12-26.	Arctic Heater Fuel Pump Replacement	12-38
12-27.	Arctic Heater Fuel Filter Assembly Replacement	12-40
12-28.	Arctic Heater Fuel Supply Tube Assembly Replacement	12-42
12-29.	Arctic Heater Tank-to-Hose Fuel Supply Line Replacement	12-43
12-30.	Arctic Heater Fuel Supply Hose Replacement	12-44
12-31.	Arctic Heater Pump-to-Hose Fuel Supply Line Replacement	12-45
12-32.	Arctic Heater Pump-to-Bulkhead Fuel Supply Line Replacement	12-46
12-33.	Arctic Heater Fuel Supply Line Bulkhead Coupling Replacement	12-48
12-34.	Arctic Heater Filter-to-Bulkhead Fuel Supply Line Replacement	12-50
12-35.	Arctic Heater Filter-to-Heater Fuel Supply Hose Replacement	12-52
12-36.	Arctic Heater CDR Valve Tube Assembly Replacement	12-53
12-37.	Arctic Heater Plenum Assembly Replacement	12-55
12-38.	Arctic Heater Plenum Hose Replacement	12-56
12-39.	Arctic Heater Plenum Cover Replacement	12-57
12-40.	Arctic Heater Regulator Replacement	12-58
12-41.	Arctic Heater Assembly Replacement	12-59
12-42.	Arctic Heater Control Box Assembly Replacement	12-61
12-42.1.	Arctic Heater Control Cable Maintenance	12-62.2
12-43.	Arctic Heater Control Box Assembly Maintenance	12-64
12-44.	Arctic Heater Bracket Assembly Replacement	12-66
12-45.	Arctic Heater Battery Box Plugs Replacement	12-67
12-46.	Arctic Heater Front Cowl Insulation Replacement	12-68
12-47.	Arctic Heater Diverter Box Cover Replacement	12-69
12-48.	Arctic Heater Exhaust Diverter Cable Assembly Maintenance	12-70
12-48.1.	Arctic Heater Ducting Replacement	12-70.2
12-48.2.	Arctic Heater Oil Pan Shroud Replacement	12-70.4
12-49.	Arctic Diverter Box Maintenance	12-72
12-50.	Arctic Defroster Ducting Replacement	12-73
12-51.	Arctic Left Defroster Nozzle Replacement	12-75
12-52.	Arctic Right Defroster Nozzle Replacement	12-78
12-53.	Arctic Heater Nozzle Replacement	12-79
12-54.	Arctic Heater Hose Replacement	12-80
12-55.	Arctic Diverter Box Cover Replacement	12-81
12-56.	Arctic Diverter Ducting Replacement	12-82

Section IV. ARCTIC WINTERIZATION KITS MAINTENANCE

12-25. ARCTIC WINTERIZATION KITS MAINTENANCE TASK SUMMARY (Cont'd)

TASK PARA.	PROCEDURES	PAGE NO.
12-57.	Swingfire Heater Water Jacket Replacement	12-83
12-58.	Swingfire Heater U-Clamps Replacement	12-85
12-59.	Swingfire Heater Brushguard and Shield Assembly Replacement	12-86
12-60.	Swingfire Heater Exhaust Pipe Assembly Replacement	12-87
12-61.	Swingfire Heater Windshield Washer Reservoir Plate Replacement	12-88
12-62.	Swingfire Heater Hood Guard Replacement	12-89
12-63.	Swingfire Heater Radiator Lower Tube Assembly Replacement	12-90
12-64.	Swingfire Heater Inlet Hose and Tee Replacement	12-92
12-65.	Swingfire Heater Pump Assembly, Bracket, and Lower Hose Replacement	12-93
12-66.	Swingfire Heater Water Jacket to Pump and Tee Hoses Replacement	12-95
12-67.	Swingfire Relay and Harness Assembly Replacement	12-97
12-68.	Swingfire Heater Harness Assembly Replacement	12-99
12-69.	Swingfire Circuit Breaker and Harness Lead Replacement	12-102
12-70.	Swingfire Windshield Washer Pump Harness Extension Replacement	12-103

12-26. ARCTIC HEATER FUEL PUMP REPLACEMENT

This task covers:

a. Removal

b. Installation

INITIAL SETUP:

Applicable Models

M966, M966A1, M996, M996A1, M997, M997A1, M997A2, M998, M998A1, M1025, M1025A1, M1025A2, M1037, M1038, M1038A1, M1121

Tools

General mechanic's tool kit:
automotive (Appendix B, Item 1)

Materials/Parts

Sealing compound (Appendix C, Item 44)
Two locknuts (Appendix G, Item 70)
Lockwasher (Appendix G, Item 175)

Manual References

TM 9-2320-280-10
TM 9-2320-280-24P

Equipment Condition

Battery ground cable disconnected (para. 4-73).

General Safety Instructions

Do not perform this procedure near fire, flames, or sparks.

WARNING

Diesel fuel is highly flammable. Do not perform this procedure near fire, flames, or sparks. Severe injury or death will result.

a. Removal

CAUTION

Cover or plug all open hoses and connections immediately after disconnection to prevent contamination. Remove all covers or plugs prior to connection.

NOTE

- Have drainage container ready to catch fuel.
- Prior to removal, tag leads for installation.
- Fuel pump is located under right rear passenger seat floor along frame.

1. Disconnect lead 402A (13) from wiring harness lead (14).
2. Disconnect pump-to-tank fuel supply line (11) from connector (12).
3. Remove connector (12) from fuel pump inlet (11.1).

NOTE

Proceed to step 5 for M996, M996A1, M997, M997A1, M997A2, M998, M998A1, M1038, and M1038A1 models only. Perform step 4 for all other models.

4. Remove cap (7) and connector (6) from fuel pump tee (5).
5. Remove fuel supply line (8) and connector (6) from fuel pump tee (5).
6. Disconnect tube assembly (10) from connector (9).
7. Remove connector (9) from fuel pump tee (5).
8. Remove two locknuts (17), washers (2), ground lead 416A (16), lockwasher (15), clamp (18), two capscrews (3), washers (2), and fuel pump (4) from mounting bracket (1). Discard locknuts (17) and lockwasher (15).
9. Remove fuel pump tee (5) from fuel pump outlet (4.1).
10. Inspect connectors (6), (9), and (12) for damaged threads or cracks. Replace if cracked or damaged.

12-26. ARCTIC HEATER FUEL PUMP REPLACEMENT(Cont'd)

b. Installation

1. Install fuel pump (4) and ground lead 416A (16) on mounting bracket (1) with washer (2), capscrew (3), lockwasher (15), washer (2), and locknut (17). Tighten locknut (17) to 8 lb-ft (11 N•m).
2. Install fuel pump (4) on mounting bracket (1) with washer (2), capscrew (3), clamp (18), washer (2), and locknut (17). Tighten locknut (17) to 8 lb-ft (11 N•m).
3. Apply sealing compound to threads of fuel pump inlet (11.1) and install connector (12) on fuel pump inlet (11.1).
4. Apply sealing compound to threads of connector (12) and connect pump-to-tank fuel supply line (11) to connector (12).
5. Connect lead 402A (13) to wiring harness lead (14).
6. Apply sealing compound to threads of fuel pump outlet (4.1) and install fuel pump tee (5) on fuel pump outlet (4.1).
7. Apply sealing compound to threads of fuel pump tee (5) and install connector (9) on fuel pump tee (5).
8. Apply sealing compound to threads of connector (9) and install tube assembly (10) on connector (9).

NOTE

Proceed to step 11 for M996, M996A1, M997, M997A1, M997A2, M998, M998A1, M1038, and M1038A1 models. Perform steps 9 and 10 for all other models.

9. Apply sealing compound to threads of connector (6) and install connector (6) on fuel pump tee (5).
10. Install cap (7) on connector (6).
11. Apply sealing compound to threads of connector (6) and install connector (6) on fuel pump tee (5) and fuel supply line (8).

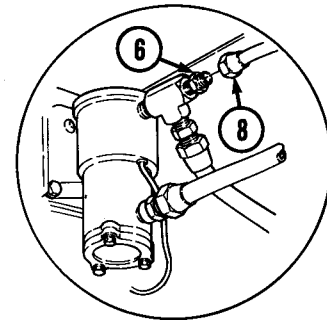
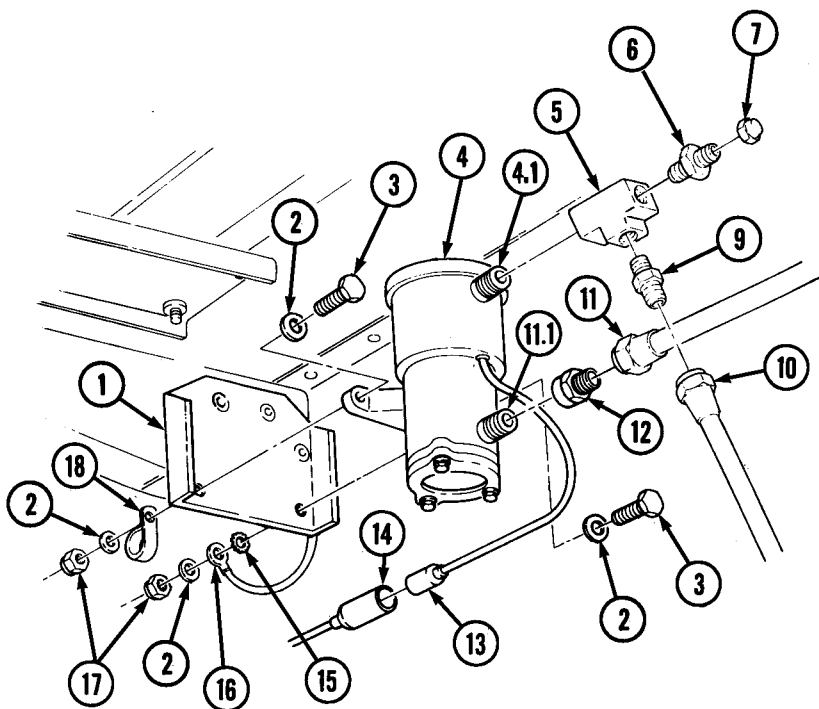

FOR M996, M996A1, M997, M997A1, M997A2, M998, M998A1, M1038, AND M1038A1 MODELS

- FOLLOW-ON TASKS:
- Connect battery ground cable (para. 4-73).
 - Operate arctic heater (TM 9-2320-280-10) and check for fuel leaks.

12-27. ARCTIC HEATER FUEL FILTER ASSEMBLY REPLACEMENT

This task covers

a. Removal

b. Installation

INITIAL SETUP:

Tools

General mechanic's tool kit:
automotive (Appendix B, Item 1)

Manual References

TM 9-2320-280-10
TM 9-2320-280-24P

Materials/Parts

Sealing compound (Appendix C, Item 44)

General Safety Instructions

Do not perform this procedure near fire, flames, or sparks.

WARNING

Diesel fuel is highly flammable. Do not perform this procedure near fire, flames, or sparks. Severe injury or death will result.

a. Removal

CAUTION

Cover or plug all open hoses and connections immediately after disconnection to prevent contamination. Remove all covers or plugs prior to connection.

NOTE

Have drainage container ready to catch fuel.

1. Disconnect fuel supply line (12) from elbow (9).
2. Loosen clamp (2) and disconnect filter-to-heater fuel supply hose (1) from connector (7).
3. Remove two nuts (11), capscrews (3), washers (4), shield (10), filter assembly (8), and spacer (5) from body (6).
4. Remove elbow (9) and connector (7) from filter assembly (8).
5. Inspect elbow (9) and connector (7) for damaged threads or cracks. Replace if cracked or damaged.

b. Installation

1. Apply sealing compound to threaded ends of elbow (9) and connector (7) and install elbow (9) and connector (7) on filter assembly (8).
2. Install spacer (5), filter assembly (8), and shield (10) on body (6) with two washers (4), capscrews (3), and nuts (11). Tighten nuts (11) to 16-30 lb-in. (2-3 NŹm).
3. Connect filter-to-heater fuel supply hose (1) to connector (7) with clamp (2).
4. Connect fuel supply line (12) to elbow (9).

12-27. ARCTIC HEATER FUEL FILTER ASSEMBLY REPLACEMENT (Cont'd)

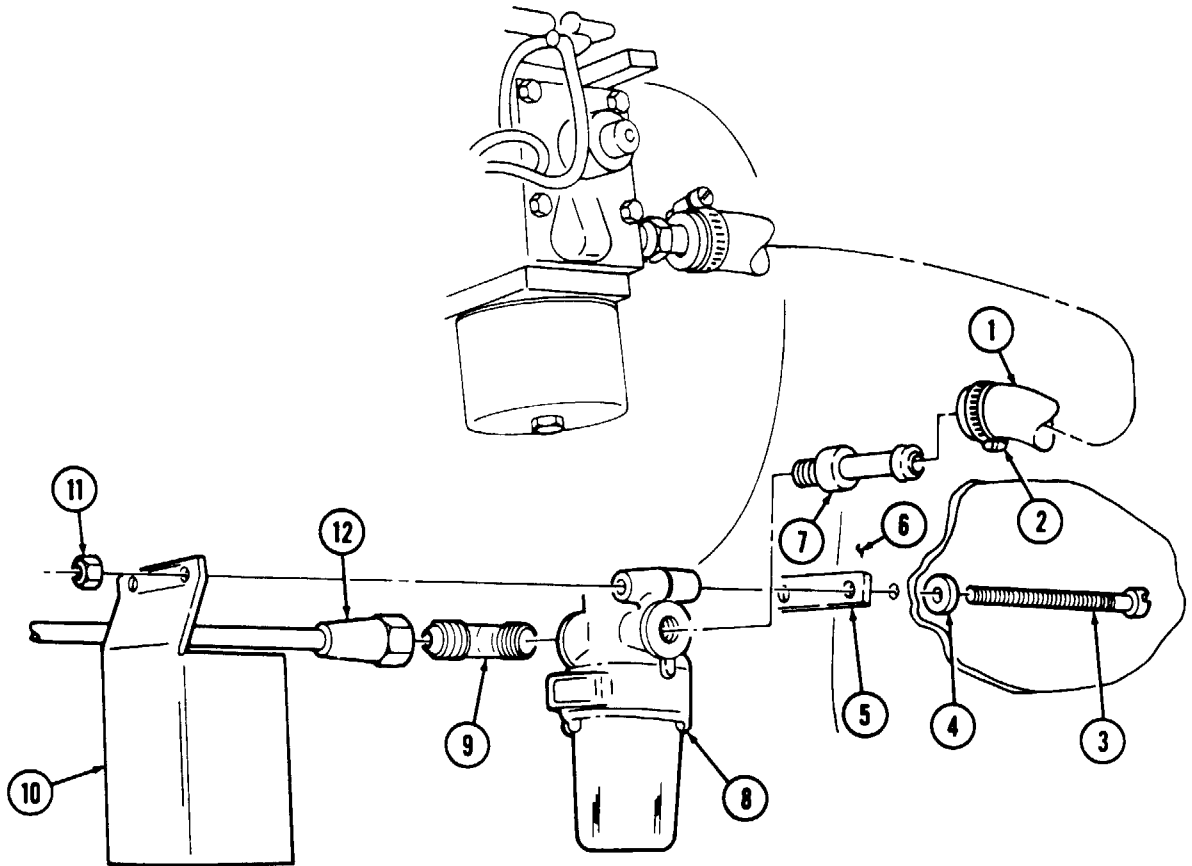

FOLLOW-ON TASK: Operate arctic heater (TM 9-2320-280-10) and check for fuel leaks.

12-28. ARCTIC HEATER FUEL SUPPLY TUBE ASSEMBLY REPLACEMENT

This task covers:

a. Removal

b. Installation

INITIAL SETUP:

Tools

General mechanic's tool kit:
automotive (Appendix B, Item 1)

Manual References

TM 9-2320-280-10
TM 9-2320-280-24P

Materials/Parts

Sealing compound (Appendix C, Item 44)

Equipment Condition

Fuel tank removed (para. 3-24).

a. Removal

1. Mark position of fuel supply tube assembly (2) on access cover (3).
2. Disconnect arctic fuel supply line (4) from fuel supply tube assembly (2).
3. Remove tube assembly (2) from fuel tank (1).

b. Installation

1. Apply sealing compound to threads of fuel supply tube assembly (2) and install fuel supply tube assembly (2) on fuel tank (1).
2. Apply sealing compound to fuel supply line (4) and connect fuel supply line (4) to fuel supply tube assembly (2).

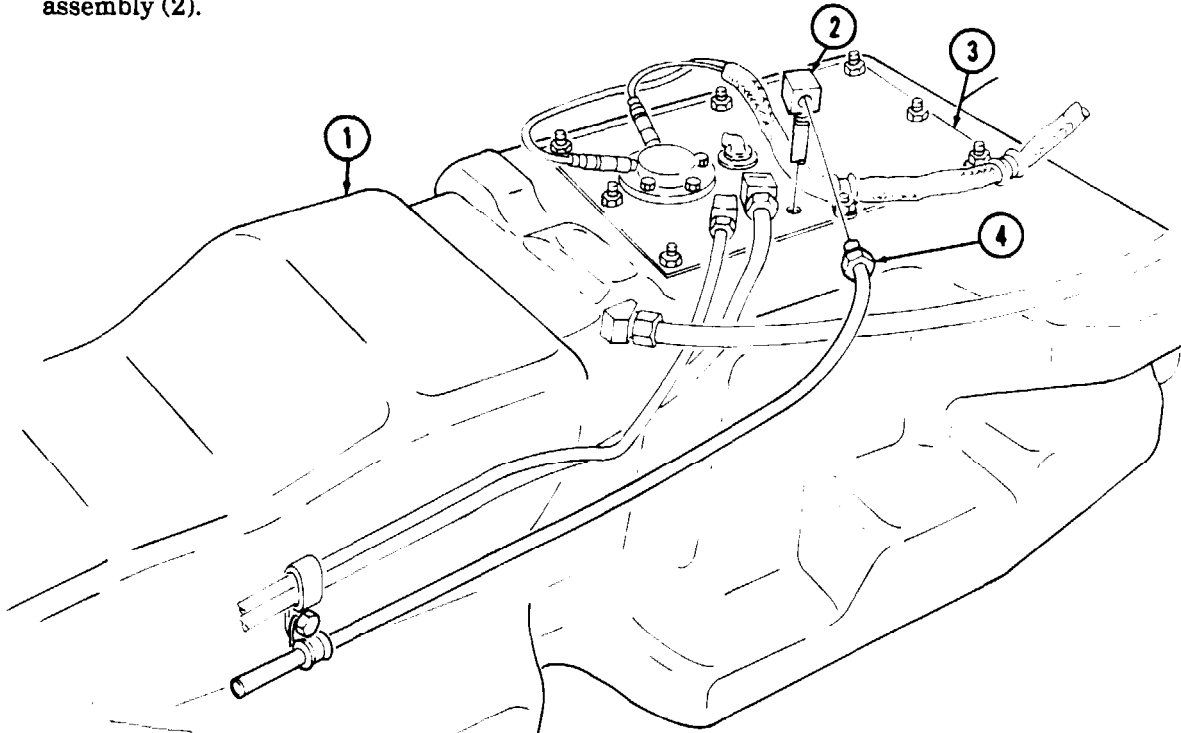

FOLLOW-ON TASKS: Ž Install fuel tank (para. 3-24).

Ž Operate arctic heater (TM 9-2320-280-10) and check for fuel leaks.

12-29. ARCTIC HEATER TANK-TO-HOSE FUEL SUPPLY LINE REPLACEMENT

This task covers:

a. Removal

b. Installation

INITIAL SETUP:

Tools

General mechanic's tool kit:
automotive (Appendix B, Item 1)

Materials/Parts

Sealing compound (Appendix C, Item 44)

Manual References

TM 9-2320-280-10
TM 9-2320-280-24P

Equipment Condition

Fuel tank removed (para. 3-24).

General Safety Instructions

Do not perform this procedure near fire, flames, or sparks.

WARNING

Diesel fuel is highly flammable. Do not perform this procedure near fire, flames, or sparks. Severe injury or death will result.

a. Removal

CAUTION

Cover or plug all open hoses and connections immediately after disconnection to prevent contamination. Remove all covers or plugs prior to connection.

NOTE

Have drainage container ready to catch fuel.

1. Disconnect tank-to-hose fuel supply line (3) from fuel supply tube assembly (2).
2. Remove capscrew (4), clamp (5), and tank-to-hose fuel supply line (3) from fuel tank (1).

b. Installation

1. Apply sealing compound to threads of tank-to-hose fuel supply line (3) and connect fuel supply line (3) to fuel supply tube assembly (2).
2. Install tank-to-hose fuel supply line (3) on fuel tank (1) with clamp (5) and capscrew (4).

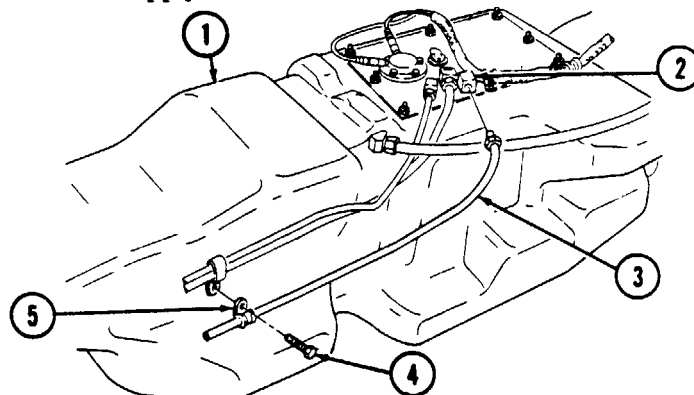

FOLLOW-ON TASKS: \bar{Z} Install fuel tank (para. 3-24).
 \bar{Z} Operate arctic heater (TM 9-2320-280-10) and check for fuel leaks.

12-30. ARCTIC HEATER FUEL SUPPLY HOSE REPLACEMENT

This task covers:

- a. Removal b. Installation

INITIAL SETUP:

Tools

General mechanic's tool kit:
automotive (Appendix B, Item 1)

General Safety Instructions

Do not perform this procedure near fire, flames, or sparks.

Manual References

TM 9-2320-280-10
TM 9-2320-280-24P

WARNING

Diesel fuel is highly flammable. Do not perform this procedure near fire, flames, or sparks. Severe injury or death will result.

a. Removal

CAUTION

Cover or plug all open hoses and connections immediately after disconnection to prevent contamination. Remove all covers or plugs prior to connection.

NOTE

Have drainage container ready to catch fuel.

Loosen two clamps (4) and remove fuel supply hose (3) from tank-to-hose fuel supply line (2) and pump-to-hose fuel supply line (1).

b. Installation

1. Connect hose (3) to tank-to-hose fuel supply line (2) with clamp (4).
2. Connect hose (3) to pump-to-hose fuel supply line (1) with clamp (4).

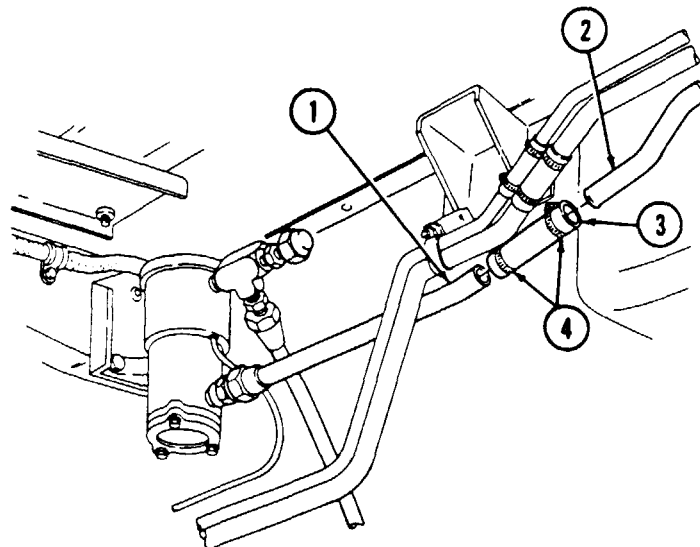

FOLLOW-ON TASKS: Operate arctic heater (TM 9-2320-280-10) and check for fuel leaks.

12-31. ARCTIC HEATER PUMP-TO-HOSE FUEL SUPPLY LINE REPLACEMENT

This task covers:

a. Removal

b. Installation

INITIAL SETUP:

Tools

General mechanic's tool kit
automotive (Appendix B, Item 1)

Manual References

TM 9-2320-280-10
TM 9-2320-280-24P

Materials/Parts

Sealing compound (Appendix C, Item 44)

General Safety Instructions

Do not perform this procedure near fire, flames, or sparks.

WARNING

Diesel fuel is highly flammable. Do not perform this procedure near fire, flames, or sparks. Severe injury or death will result.

a. Removal

CAUTION

Cover or plug all open hoses and connections immediately after disconnection to prevent contamination. Remove all covers or plugs prior to connection.

NOTE

Have drainage container ready to catch fuel.

1. Loosen clamp (5) and disconnect fuel supply hose (4) from pump-to-hose fuel supply line (3).
2. Remove pump-to-hose fuel supply line (3) from connector (2) on fuel pump (1).
3. Inspect connector (2) for damaged threads or cracks. Replace if cracked or damaged.

b. Installation

1. Apply sealing compound to threads of connector (2) and connect pump-to-hose fuel supply line (3) to connector (2) on fuel pump (1).
2. Connect fuel supply hose (4) to pump-to-hose fuel supply line (3) with clamp (5).

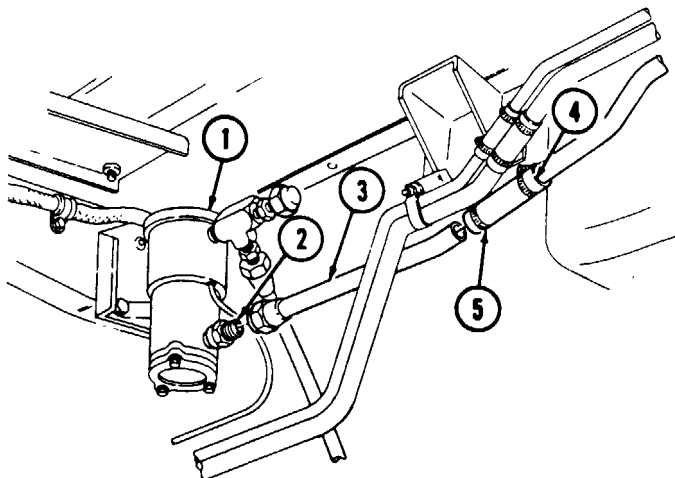

FOLLOW-ON TASK: Operate arctic heater (TM 9-2320-280-10) and check for fuel leaks.

12-32. ARCTIC HEATER PUMP-TO-BULKHEAD FUEL SUPPLY LINE REPLACEMENT

This task covers:

- a. Removal b. Installation

INITIAL SETUP:

Tools

General mechanic's tool kit:
automotive (Appendix B, Item 1)

Manual References

TM 9-2320-280-10
TM 9-2320-280-24P

Materials/Parts

Sealing compound (Appendix C, Item 44)

General Safety Instructions

Do not perform this procedure near fire, flames, or sparks.

WARNING

Diesel fuel is highly flammable. Do not perform this procedure near fire, flames, or sparks. Severe injury or death will result.

a. Removal

CAUTION

Cover or plug all open hoses and connections immediately after disconnection to prevent contamination. Remove all covers or plugs prior to connection.

NOTE

Have drainage container ready to catch fuel.

1. Disconnect pump-to-bulkhead fuel supply line (2) from connector (1).
2. Remove pump-to-bulkhead fuel supply line (2) from bulkhead coupling elbow (3).

NOTE

Perform steps 3 and 4 for M996, M996A1, M997, M997A1, M997A2, M998, M998A1, M1038, and M1038A1 models only.

3. Disconnect rear pump-to-bulkhead fuel supply line (5) from connector (4).
4. Remove rear pump-to-bulkhead fuel supply line (5) from rear bulkhead coupling elbow (6).
5. Inspect connectors (1) and (4) and bulkhead coupling elbows (3) and (6) for damaged threads or cracks. Replace if cracked or damaged.

b. Installation

NOTE

Perform steps 1 and 2 for M996, M996A1, M997, M997A1, M997A2, M998, M998A1, M1038 and M1038A1 models only.

1. Apply sealing compound to threads of connector (4) and install rear pump-to-bulkhead fuel supply line (5) on connector (4).
2. Apply sealing compound to threads of rear bulkhead coupling elbow (6) and connect rear pump-to-bulkhead fuel supply line (5) to rear bulkhead coupling elbow (6).
3. Apply sealing compound to threads of connector (1) and install pump-to-bulkhead fuel supply line (2) on connector (1).
4. Apply sealing compound to threads of bulkhead Coupling elbow (3) and connect pump-to-bulkhead fuel supply line (2) to bulkhead coupling elbow (3).

12-32. ARCTIC HEATER PUMP-TO-BULKHEAD FUEL SUPPLY LINE REPLACEMENT (Cont'd)

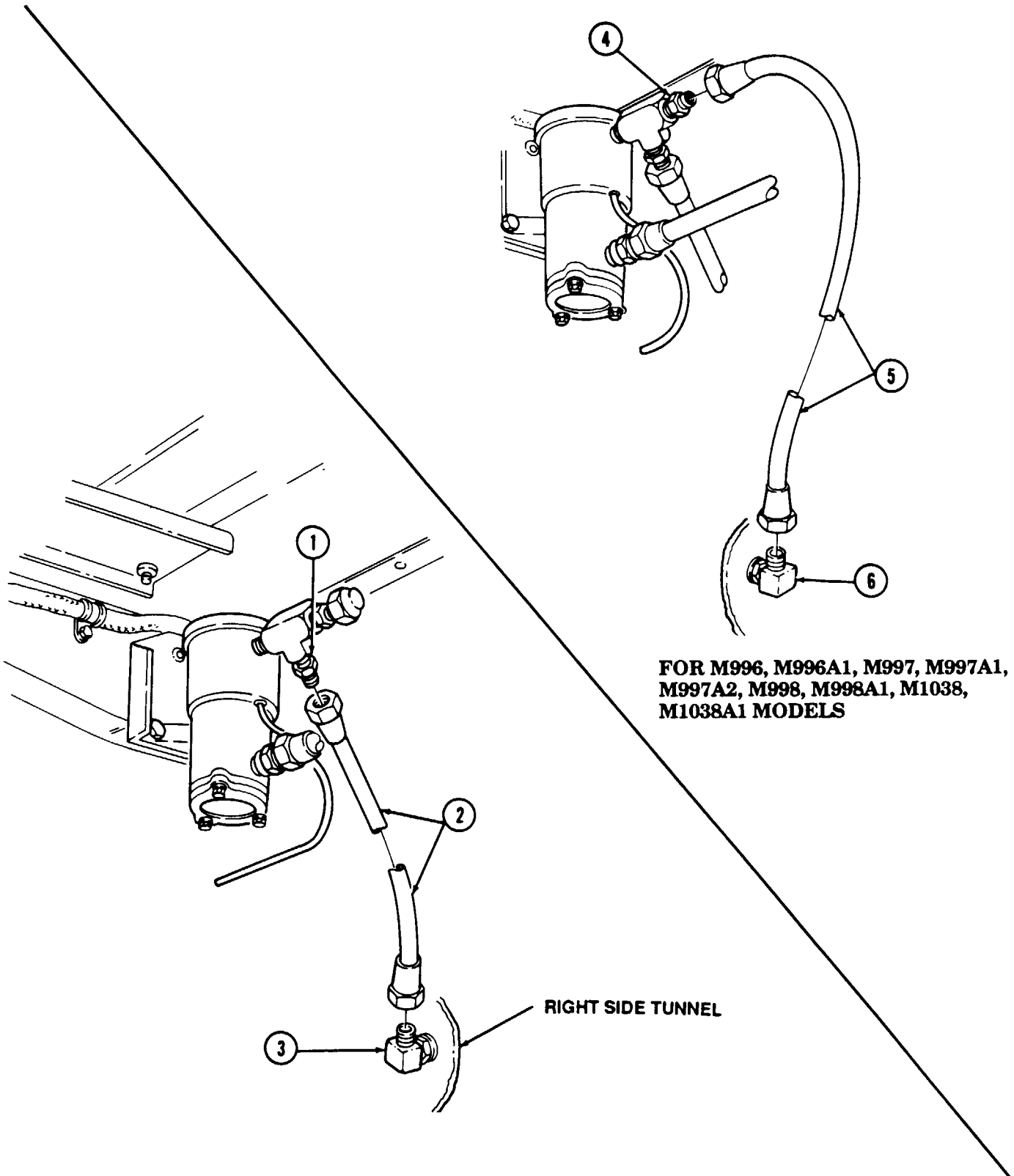

FOR M996, M996A1, M997, M997A1, M997A2, M998, M998A1, M1038, M1038A1 MODELS

FOLLOW-ON TASK: Operate arctic heater (TM 9-2320-280-10) and check for fuel leaks.

12-33. ARCTIC HEATER FUEL SUPPLY LINE BULKHEAD COUPLING REPLACEMENT

This task covers:

- a. Removal b. Installation

INITIAL SETUP:

Tools

General mechanic's tool kit:
automotive (Appendix B, Item 1)

Manual References

TM 9-2320-280-10
TM 9-2320-280-24P

Materials/Parts

Sealing compound (Appendix C, Item 44)

General Safety Instructions

Do not perform this procedure near fire, flames, or sparks.

WARNING

Diesel fuel is highly flammable. Do not perform this procedure near fire, flames, or sparks. Severe injury or death will result.

a. Removal

CAUTION

Cover or plug all open hoses and connections immediately after disconnection to prevent contamination. Remove all covers or plugs prior to connection.

NOTE

Have drainage container ready to catch fuel.

1. Disconnect pump-to-bulkhead fuel supply line (1) from elbow (2).
2. Disconnect elbow (2) from coupling half (5).
3. Remove coupling nut (3) and washer (4) from bulkhead (8) and coupling half (5).
4. Disconnect filter-to-bulkhead fuel supply line (7) from elbow (6).
5. Remove coupling half (5) from elbow (6).
6. Inspect elbows (2) and (6) and coupling half (5) for damaged threads or cracks. Replace if cracked or damaged.

b. Installation

1. Apply sealing compound to threads of elbows (2) and (6).
2. Connect elbow (6) to coupling half (5).
3. Connect filter-to-bulkhead fuel supply line (7) to elbow (6).
4. Install coupling half (5) on bulkhead (8) with washer (4) and coupling nut (3).
5. Connect elbow (2) to coupling half (5).
6. Connect pump-to-bulkhead fuel supply line (1) to elbow (2).

12-33. ARCTIC HEATER FUEL SUPPLY LINE BULKHEAD COUPLING REPLACEMENT (Cont'd)

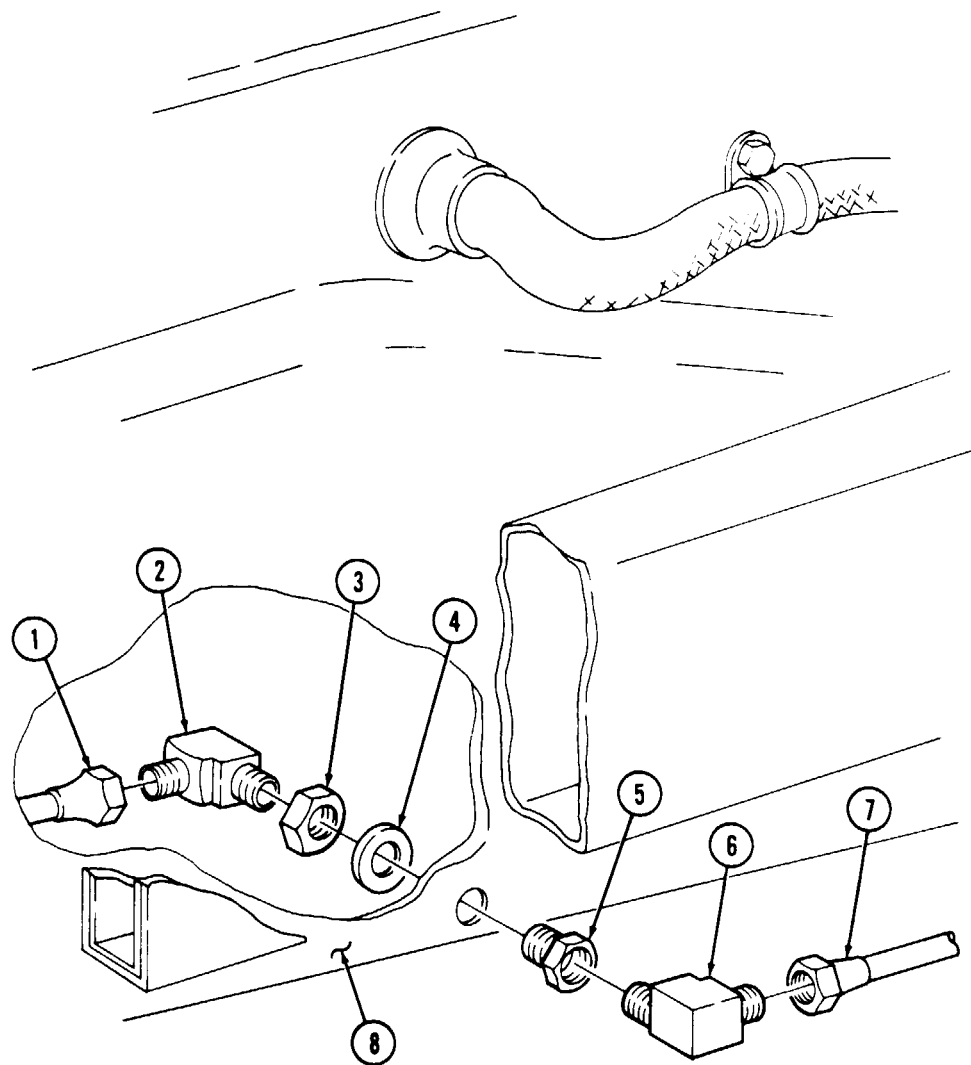

FOLLOW-ON TASK: Operate arctic heater (TM 9-2320-280-10) and check for fuel leaks.

12-34. ARCTIC HEATER FILTER-TO-BULKHEAD FUEL SUPPLY LINE REPLACEMENT

This task covers

a. Removal

b. Installation

INITIAL SETUP:

Tools

General mechanic's tool kit:
automotive (Appendix B, Item 1)

Manual References

TM 9-2320-280-10
TM 9-2320-280-24P

Materials/Parts

Sealing compound (Appendix C, Item 44)

General Safety Instructions

Do not perform this procedure near fire, flames, or sparks.

WARNING

Diesel fuel is highly flammable. Do not perform this procedure near fire, flames, or sparks. Severe injury or death will result.

a. Removal

CAUTION

Cover or plug all open hoses and connections immediately after disconnection to prevent contamination. Remove all covers or plugs prior to connection.

NOTE

Have drainage container ready to catch fuel.

1. Disconnect filter-to-bulkhead fuel supply line (2) from bulkhead elbow (8).
2. Disconnect fuel supply line (2) from filter elbow (3).
3. Remove nut (7), washer (5), capscrew (4), washer (5), clamp (6), and fuel supply line (2) from plenum (1).
4. Inspect filter elbow (3) and bulkhead elbow (8) for damaged threads or cracks. Replace if cracked or damaged.

b. Installation

1. Apply sealing compound to threads of filter elbow (3) and install fuel supply line (2) on filter elbow (3).
2. Apply sealing compound to threads of bulkhead elbow (8) and connect fuel supply line (2) to bulkhead elbow (8).
3. Connect fuel supply line (2) to plenum (1) with clamp (6), washer (5), capscrew (4), washer (5), and nut (7). Tighten capscrew (4) to 8 lb-ft (11 N·m).

12-34. ARCTIC HEATER FILTER-TO-BULKHEAD FUEL SUPPLY LINE REPLACEMENT (Cont'd)

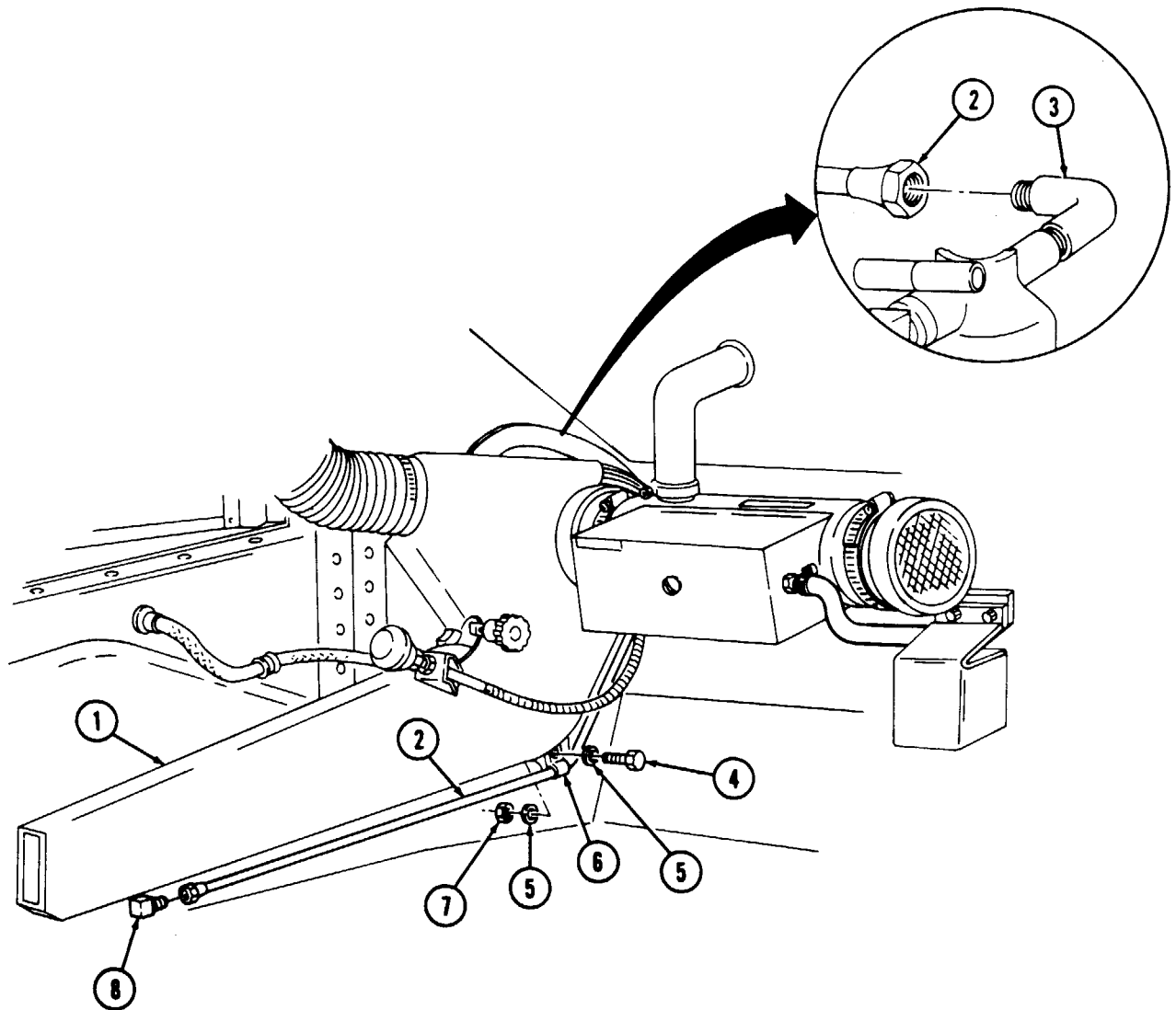

FOLLOW-ON TASK: Operate arctic heater (TM 9-2320-280-10) and check for fuel leaks.

12-35. ARCTIC HEATER FILTER-TO-HEATER FUEL SUPPLY HOSE REPLACEMENT

This task covers:

- a. Removal
- b. Installation

INITIAL SETUP:

Tools

General mechanic's tool kit:
 automotive (Appendix B, Item 1)

General Safety Instructions

Do not perform this procedure near fire, flames, or sparks.

Manual References

TM 9-2320-280-10
 TM 9-2320-280-24P

WARNING

Diesel fuel is highly flammable. Do not perform this procedure near fire, flames, or sparks. Severe injury or death will result.

a. Removal

CAUTION

Cover or plug all open hoses and connections immediately after disconnection to prevent contamination. Remove all plugs prior to connection.

NOTE

Have drainage container ready to catch fuel.

1. Remove two clamps (2) and hose (3) from filter connector (4) and heater connector (1).
2. Inspect filter connector (4) and heater connector (1) for damage. Replace if damaged.

b. Installation

1. Install clamps (2) on hose (3).
2. Install hose (3) on heater connector (4) and heater connector (1) with clamps (2).

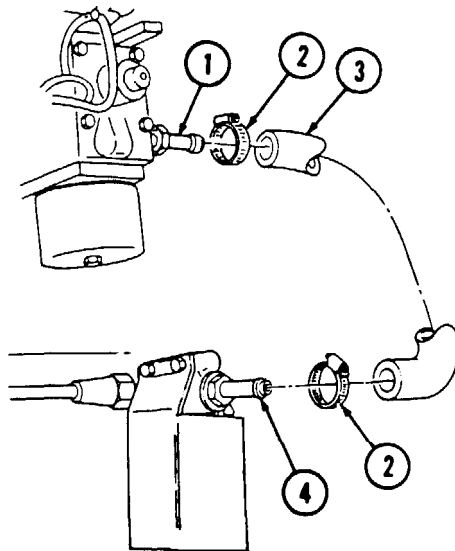

FOLLOW-ON TASK: Operate arctic heater (TM 9-2320-280-10) and check for fuel leaks.

12-36. ARCTIC HEATER CDR VALVE TUBE ASSEMBLY REPLACEMENT

This task covers:

a. Removal

b. Installation

INITIAL SETUP:

Tools

General mechanic's tool kit:
automotive (Appendix B, Item 1)

Equipment Condition

Ž Cooling system drained, as required (para. 3-60).
Ž Air horn removed (para. 3-14).

Manual References

TM 9-2320-280-24P

a. Removal

1. Remove clamp (1) and disconnect heater inlet elbow hose (2) from CDR valve tube assembly (19).
2. Remove clamp (4) and disconnect hose (5) from CDR valve (3).
3. Remove clamp (12) and disconnect hose (13) from oil filter tube (11).
4. Remove clamp (9) and disconnect hose (14) from water pump fitting (10). Remove tube assembly (15).
5. Remove nut (18), two washers (6), clamps (17), and capscrew (7) from heater inlet tube (16) and tube assembly (19).
6. Remove three clamps (8) and hoses (5), (14), and (13) from tube assembly (15).

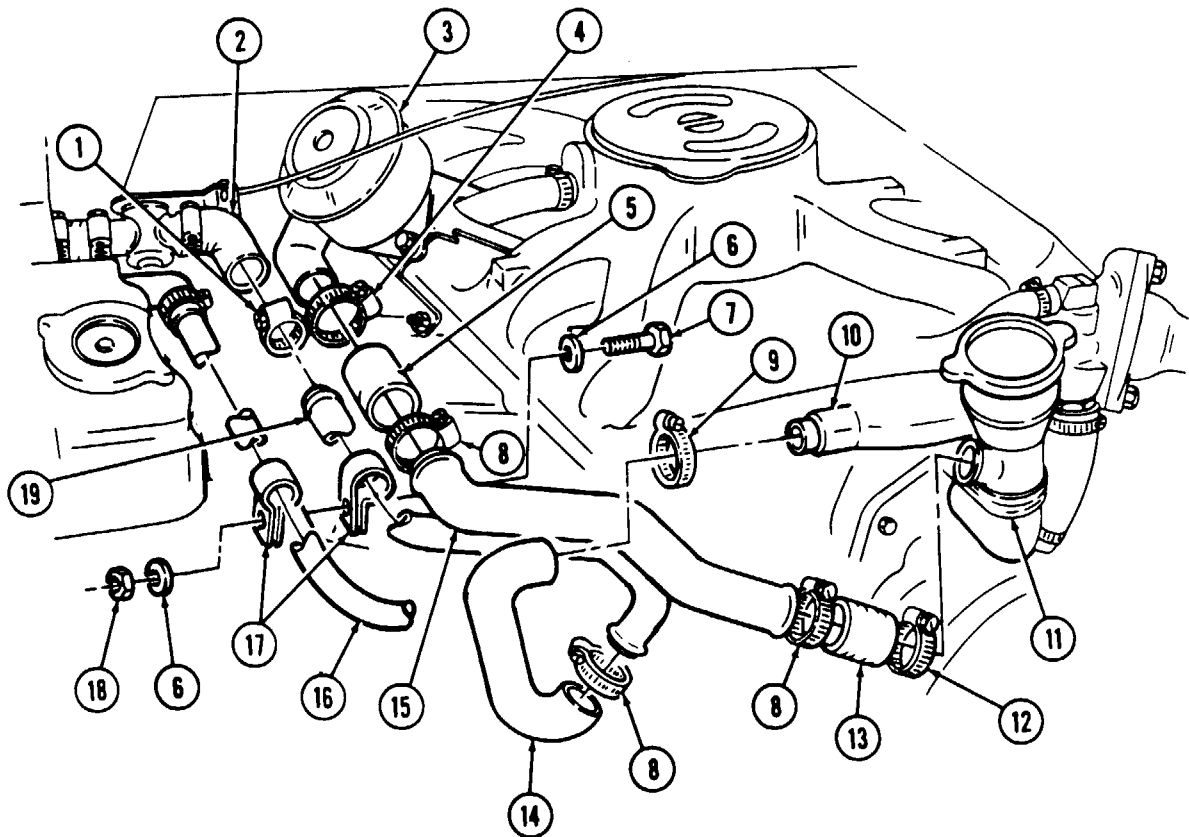

12-36. ARCTIC HEATER CDR VALVE TUBE ASSEMBLY REPLACEMENT (Cont'd)

b. Installation

1. Install three clamps (8) on hoses (5), (14), and (13). Install three hoses (5), (14), and (13) on tube assembly (15) with three clamps (8).
2. Install two clamps (17) on heater inlet tube (16) and tube assembly (19) with two washers (6), capscrew (7), and nut (18).
3. Install clamp (9) on hose (14), and connect hose (14) to water pump fitting (10) with clamp (9).
4. Install clamp (12) on hose (13), and connect hose (13) to oil filler tube (11) with hose (13) and clamp (12).
5. Install clamp (4) on hose (5) and connect hose (5) to CDR valve (3) with clamp (4).
6. Install clamp (1) on heater inlet elbow hose (2) and connect heater inlet elbow hose (2) to tube assembly (19) with clamp (1).

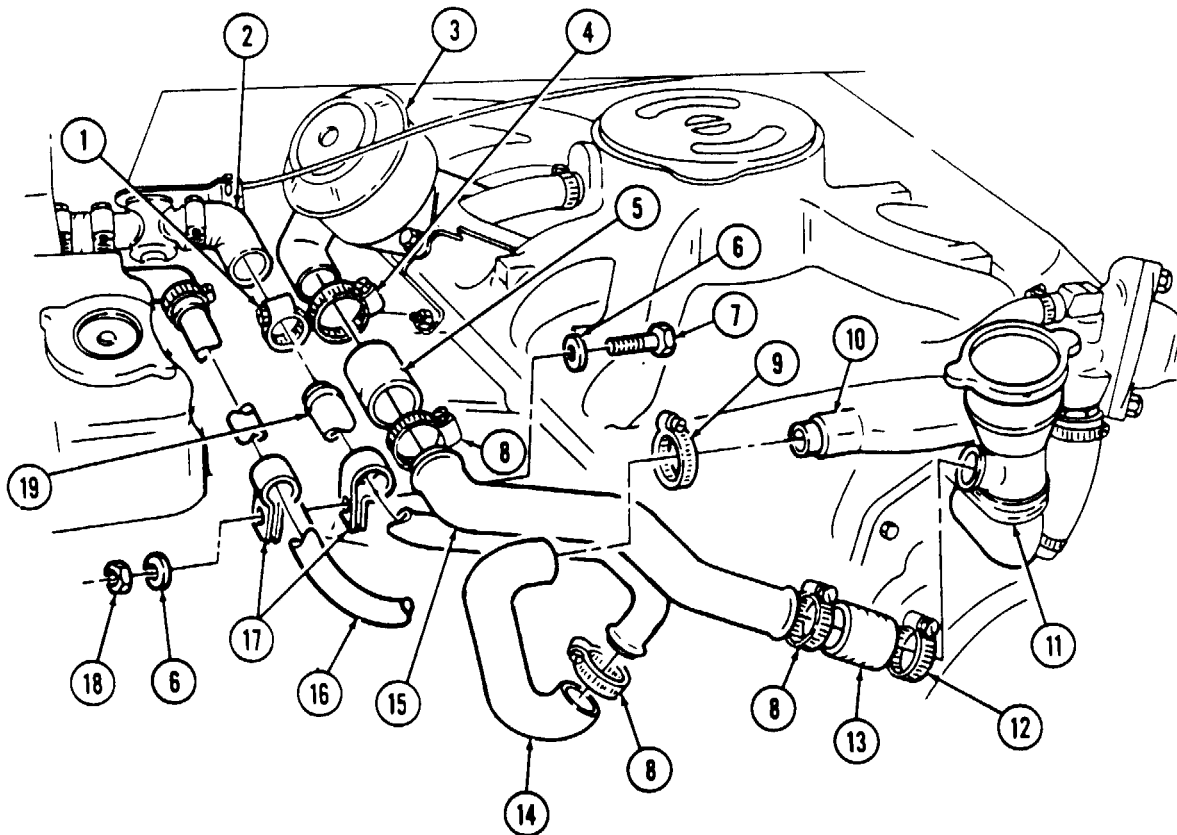

FOLLOW-ON TASKS: Ž Install air horn (para. 3-14).
 Ž Fill cooling system (para. 3-60).

12-37. ARCTIC HEATER PLENUM ASSEMBLY REPLACEMENT

This task covers:

a. Removal

b. Installation

INITIAL SETUP:

Tools

General mechanic's tool kit:
automotive (Appendix B, Item 1)

Equipment Condition

Arctic heater assembly removed (para. 12-41).

Manual References

TM 9-2320-280-24P

a. Removal

1. Remove nut (9), washer (10), capscrew (11), washer (10), and clamp (12) from fuel supply line (13) and plenum (15).
2. Loosen nut (8) and remove knob (1) and nut (8) from cable assembly core (4).
3. Remove nut (7), washer (6), and cable assembly core (4) from plenum bracket (5).
4. Loosen clamp (3) and remove hose (2) from plenum (15).
5. Remove plenum (15) from receptacle assembly (14).

b. Installation

1. Slide plenum (15) into receptacle assembly (14).
2. Connect hose (2) to plenum (15) with clamp (3).
3. Connect cable assembly core (4) to plenum bracket (5) with washer (6) and nut (7).
4. Install nut (8) and knob (1) on cable assembly core (4).
5. Install clamp (12) and fuel supply line (13) on plenum (15) with washer (10), capscrew (11), washer (10), and nut (9).

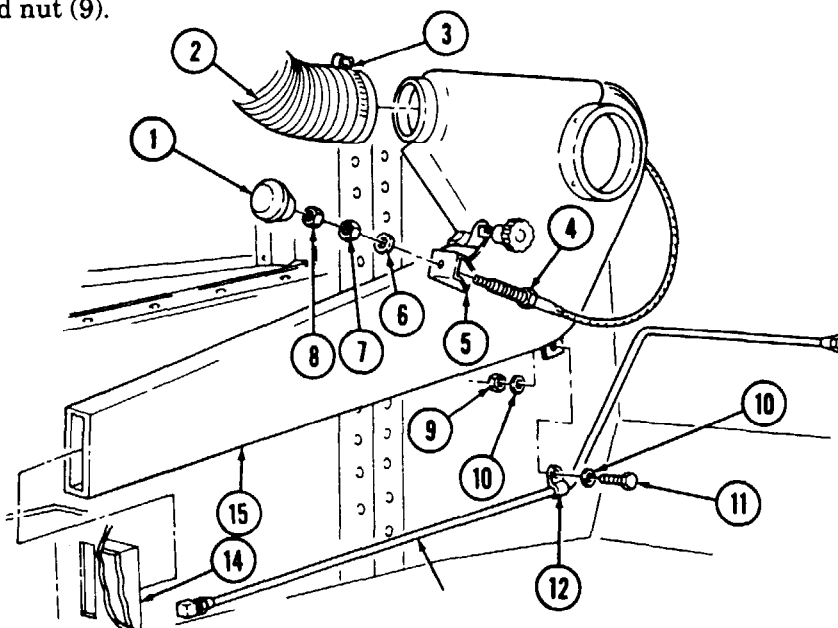

FOLLOW-ON TASKS: \checkmark Install arctic heater assembly (para. 12-41).
 \checkmark Adjust exhaust diverter cable (para. 12-48).

12-38. ARCTIC HEATER PLENUM HOSE REPLACEMENT

This task covers:

a. Removal

b. Installation

INITIAL SETUP:

Tools

General mechanic's tool kit:
automotive (Appendix B, Item 1)

Manual References

TM 9-2320-280-24P

a. Removal

Remove two clamps (2) and plenum hose (1) from adapter (3) and plenum (4).

b. Installation

Connect plenum hose (1) to plenum (4) and adapter (3) with two clamps (2).

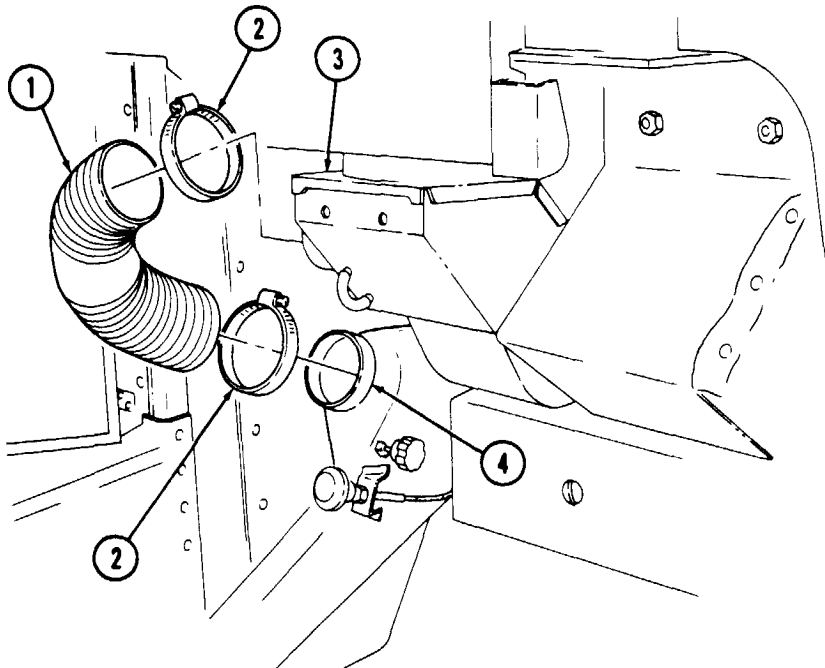

12-39. ARCTIC HEATER PLENUM COVER REPLACEMENT

This task covers:

a. Removal

b. Installation

INITIAL SETUP:

Tools

General mechanic's tool kit:
automotive (Appendix B, Item 1)

Manual References

TM 9-2320-280-24P

Materials/Parts

Six blind rivets (Appendix G, Item 255)

a. Removal

1. Remove three rivets (1) and retainer (2) from plenum (6).
2. Remove three rivets (5) and retainer (4) from plenum (6).
3. Peel cover (3) back and remove from plenum (6).
4. Clean remaining adhesive from surface of plenum (6).

b. Installation

NOTE

Ensure surface is free of dirt and oil before applying adhesive backed cover.

1. Peel backing paper from adhesive-backed cover (3).

NOTE

Ensure cover is attached to all bends and corners.

2. Install cover (3) on plenum (6) by pressing cover (3) firmly in place.

NOTE

Refer to para. 10-66 for rivet installation.

3. Install retainer (4) on plenum (6) with three rivets (5).
4. Install retainer (2) on plenum (6) with three rivets (1).

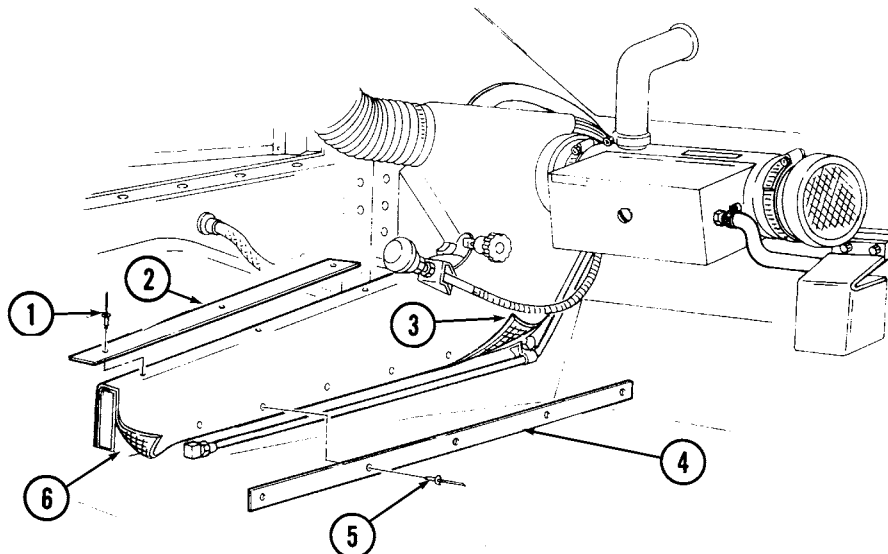

12-40. ARCTIC HEATER REGULATOR REPLACEMENT

This task covers:

a. Removal

b. Installation

INITIAL SETUP:

Tools

General mechanic's tool kit:
automotive (Appendix B, Item 1)

Manual References

TM 9-2320-280-24P

Materials/Parts

Seal (Appendix G, Item 287)
Four locknuts (Appendix G, Item 79)

Equipment Condition

Arctic heater diverter box cover removed
(para. 12-47).

a. Removal

1. Loosen clamp (15) and disconnect plenum hose (14) from regulator (1).
2. Remove four locknuts (9), washers (10), capscrews (11), and washers (10) from heater assembly (13) and cowl panel (12) and pull heater assembly (13) away from cowl panel (12). Discard locknuts (9).
3. Loosen two clamps (5) and remove two heater pipes (7) from inlet hose (4), outlet hose (3), and two cowl grommets (6).
4. Disconnect regulator (1) from heat duct (8) and remove regulator (1) from heater assembly (13).
5. Remove seal (2) from regulator (1). Discard seal (2).

b. Installation

1. Install seal (2) on regulator (1).
2. Install regulator (1) on heat duct (8) and heater assembly (13).
3. Route two heater pipes (7) through two cowl grommets (6).
4. Install heater assembly (13) on cowl panel (12) with four capscrews (11), washers (10), locknuts (9), and washers (10). Tighten locknuts (9) to 17 lb-ft (23 N·m).
5. Install inlet hose (4) and outlet hose (3) on heater pipes (7) with two clamps (5).
6. Install plenum hose (14) on regulator (1) with clamp (15).

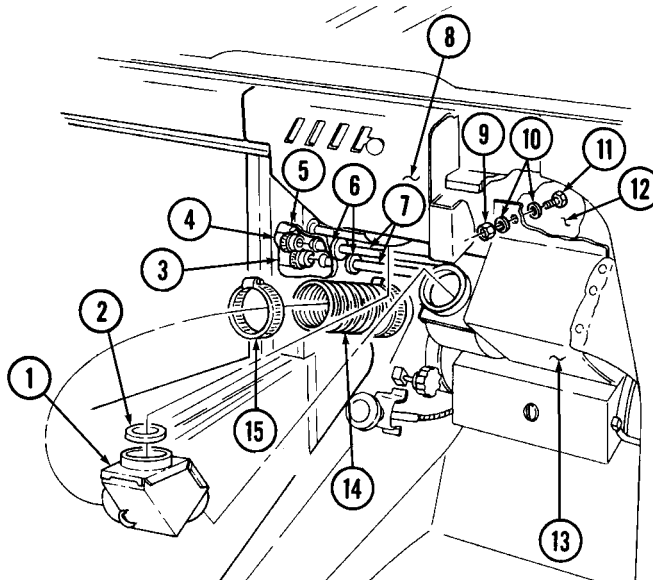

FOLLOW-ON TASK: Install arctic heater diverter box cover (para. 12-47).

12-41. ARCTIC HEATER ASSEMBLY REPLACEMENT

This task covers:

a. Removal

b. Installation

INITIAL SETUP:

Tools

General mechanic's tool kit:
automotive (Appendix B, Item 1)

Materials/Parts

Thermaseal (Appendix G, Item 304)
Four locknuts (Appendix G, Item 78)
Cotter pin (Appendix G, Item 13)

Manual References

TM 9-2320-280-24P

Equipment Condition

- Heater boot removed (para. 10-96).
- Arctic heater fuel filter removed (para. 12-27).
- Arctic heater filter-to-heater fuel supply hose removed (para. 12-35).

General Safety Instructions

Do not perform this procedure near fire, flames, or sparks.

WARNING

Diesel fuel is highly flammable. Do not perform this procedure near fire, flames, or sparks. Severe injury or death will result.

a. Removal

CAUTION

Cover or plug all open hoses and connections immediately after disconnection to prevent contamination. Remove all covers or plugs prior to connection.

NOTE

Have drainage container ready to catch fuel.

1. Disconnect electrical connector (6) from heater assembly (3).
2. Remove setscrew (8) from heater assembly (3) and plenum assembly input port (9).
3. Open two clamps (5) and slide heater assembly (3) from plenum assembly (7) and exhaust pipe (1) from cowl flange (2). Remove heater assembly (3) and exhaust pipe (1) from mounting bracket assemblies (4).
4. Remove three capscrews (16) and dust unloader cover plate (15) from air cleaner bracket (17).
5. Remove cotter pin (12) from elbow (11) and exhaust pipe elbow (14). Discard cotter pin (12).
6. Remove four locknuts (13), elbow (11), and thermaseal (10) from cowl (18). Discard thermaseal (10) and locknuts (13).

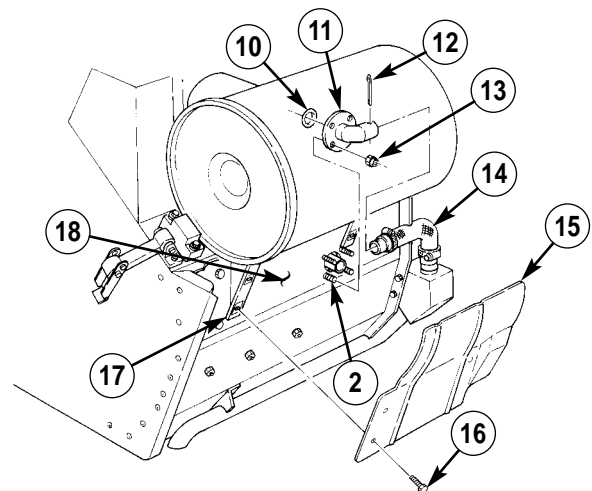
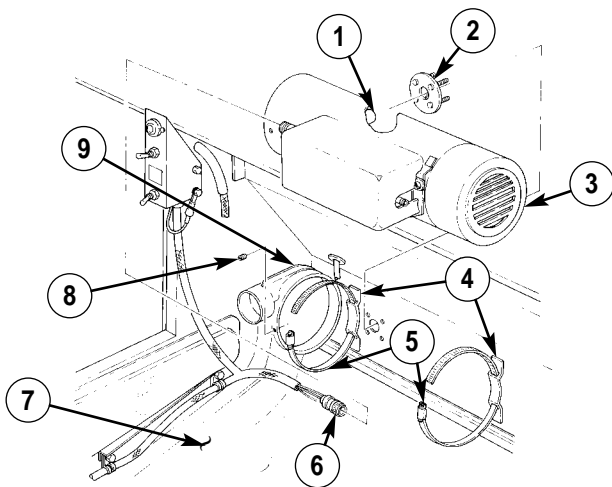

12-41. ARCTIC HEATER ASSEMBLY REPLACEMENT (Cont'd)

b. Installation

1. Install heater assembly (4) and exhaust pipe (2) on mounting bracket assemblies (5) with two clamps (6) finger tight.
2. Align heater assembly outlet port (1) with plenum assembly input port (9) and exhaust pipe (2) with cowl flange (3). Install heater assembly (4) on plenum assembly input port (9) with setscrew (8).
3. Connect electrical connector (7) to heater assembly (4).
4. Tighten two clamps (6).
5. Install elbow (11) on exhaust pipe elbow (14) with cotter pin (12).
6. Install thermaseal (10) on exhaust pipe (2).
7. Install elbow (11) on cowl (18) with four locknuts (13).
8. Install dust unloader cover plate (15) on air cleaner bracket (17) with three capscrews (16).

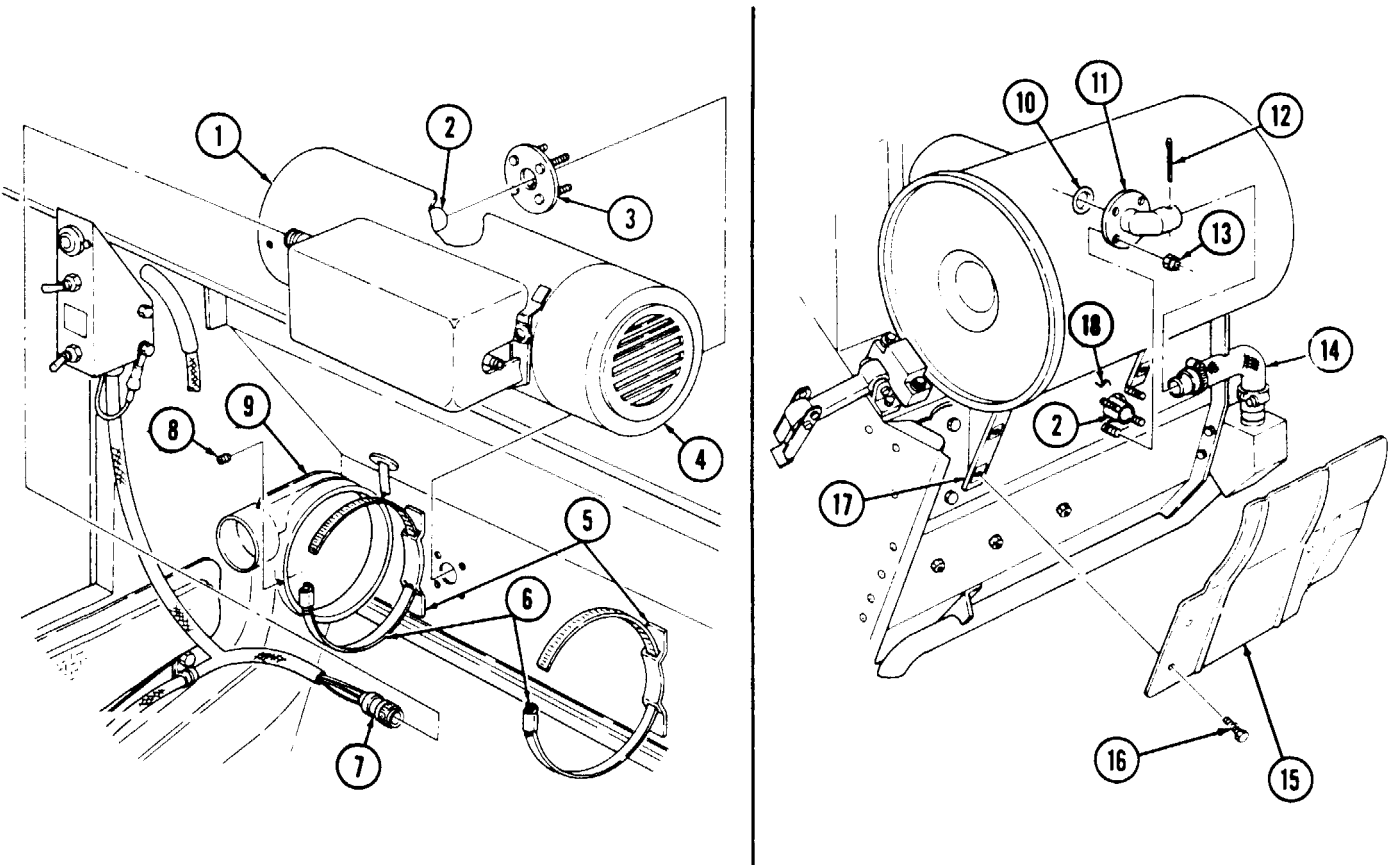

- FOLLOW-ON TASKS: \checkmark Install arctic heater fuel filter (para. 12-27).
 \checkmark Install arctic heater filter-to-heater fuel supply hose (para. 12-35).
 \checkmark Install heater boot (para. 10-96).

12-42. ARCTIC HEATER CONTROL BOX ASSEMBLY REPLACEMENT

This task covers:

a. Removal

b. Installation

INITIAL SETUP:

Tools

General mechanic's tool kit:
automotive (Appendix B, Item 1)

Materials/Parts

Locknut (Appendix G, Item 70)
Lockwasher (Appendix G, Items 175)
Two lockwashers (Appendix G, Item 178)

Personnel Required

One mechanic
One assistant

Manual References

TM 9-2320-280-24P

Equipment Condition

Battery ground cable disconnected (para. 4-73).

a. Removal

1. Remove nut (6), washer (7), capscrew (11), and washer (7) and disconnect ground lead 416A (9) from fuel pump bracket (10).

NOTE

Perform step 2 for vehicles not equipped with troop/cargo winterization kit. Perform step 3 for vehicles equipped with troop/cargo winterization kit.

2. Disconnect lead 402 (4) from fuel pump lead 402A (5).
3. Disconnect lead 402 (26) from fuel pump jumper lead (25).
4. Remove nut (19), lockwasher (18), and washer (17) and disconnect leads 6B (20), 6C (21), and 400 (22) from power stud (8). Discard lockwasher (18).
5. Remove nut (12) and lockwasher (13), and disconnect leads 416 (15) and 416A (14) from shunt (16). Discard lockwasher (13).
6. Remove locknut (23), capscrew (1), and clamp (2) from heater control box cable (3) and tunnel (24). Discard locknut (23).

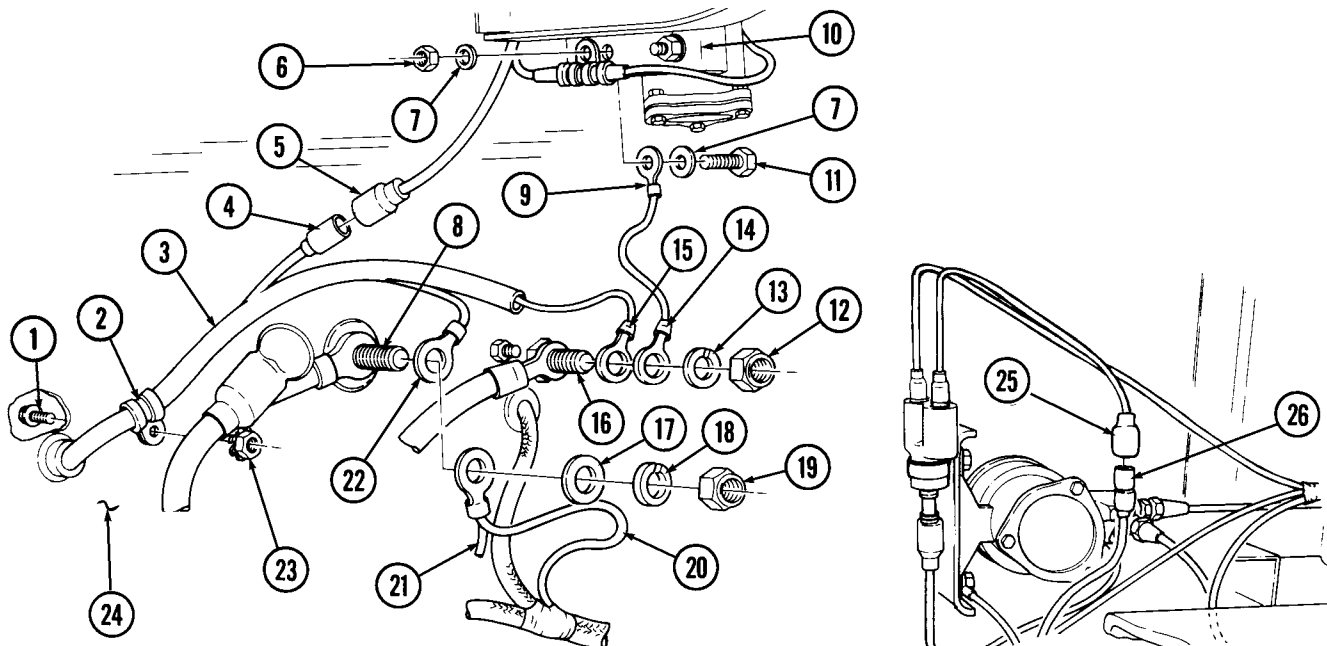

12-42. ARCTIC HEATER CONTROL BOX ASSEMBLY REPLACEMENT (Cont'd)

7. Remove grommets (25) and (40) from tunnel (24) and battery box (39), and pull heater control box cable (3) through tunnel (24) and battery box (39).
8. Remove two screws (37) and clamps (38) from heater control box cable (3) and retainer (41).
9. Disconnect electrical connector (36) from heater (35).
10. Remove screw (34), retaining rod (33), and heater control box cable (3) from tunnel (24).
11. Remove two screws (30), lockwasher (31), heater control box (28), and ground lead 416B (29) from cowl (32). Discard lockwasher (31).

b. Installation

1. Install heater control box (28) and ground lead 416B (29) on cowl (32) with lockwasher (31) and two screws (30).
2. Connect electrical connector (36) to heater (35).
3. Install heater control box cable (3) on retainer (41) with two clamps (38) and screws (37).
4. Install heater control box cable (3) on tunnel (24) with retaining rod (33) and screw (34).
5. Push heater control box cable (3) through battery box (39) and tunnel (24), and install grommets (25) and (40).
6. Install heater control box cable (3) on tunnel (24) with clamp (2), capscrew (1), and locknut (23).
7. Connect leads 416 (15) and 416A (14) to shunt (16) with lockwasher (13) and nut (12).
8. Connect leads 6B (20), 6C (21), and 400 (22) to power stud (8) with washer (17), lockwasher (18), and nut (19).

NOTE

Perform step 9 for vehicles not equipped with troop/cargo winterization kit. Perform step 10 for vehicles equipped with troop/cargo winterization kit.

9. Connect lead 402 (4) to fuel pump lead 402A (5).
10. Connect lead 402 (27) to fuel pump jumper lead (26).
11. Connect ground lead 416A (9) to fuel pump bracket (10) with washer (7), capscrew (11), washer (7), and nut (6).

12-42. ARCTIC HEATER CONTROL BOX ASSEMBLY REPLACEMENT(Cont'd)

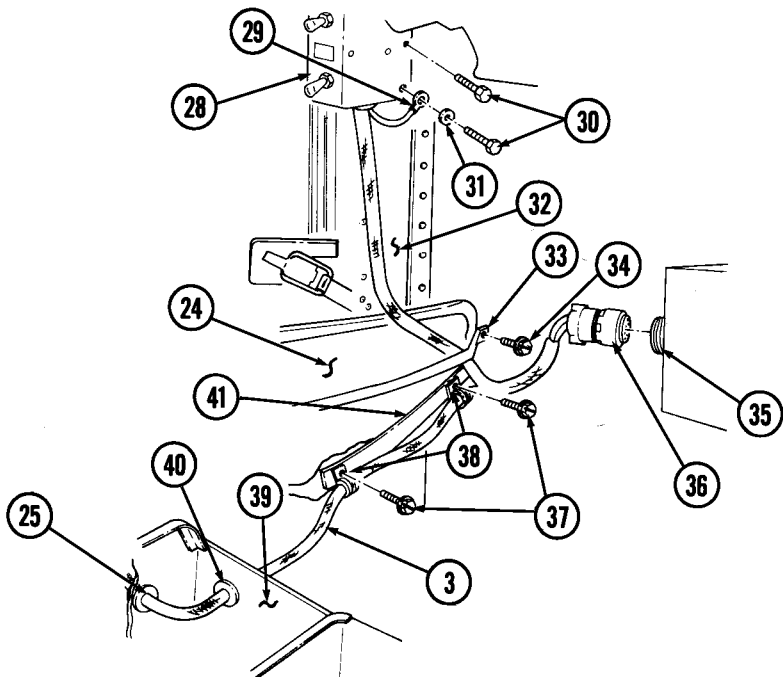
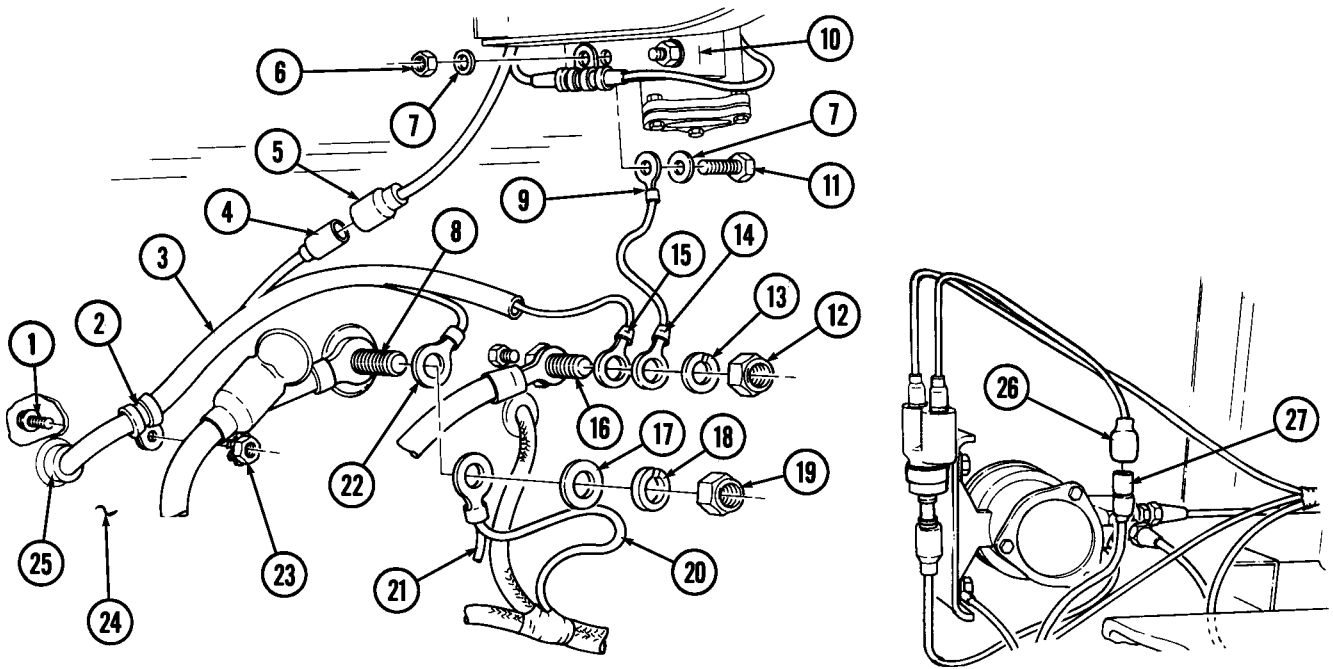

FOLLOW-ON TASK: Connect battery ground cable (para. 4-73).

12-42.1. ARCTIC HEATER CONTROL CABLE MAINTENANCE

This task covers:

- | | |
|--|----------------------|
| <p>a. Removal</p> <p>b. Installation</p> | <p>c. Adjustment</p> |
|--|----------------------|

INITIAL SETUP:

Tools

General mechanic's tool kit:
automotive (Appendix B, Item 1)

Materials/Parts

Cotter pin (Appendix G, Item 26)

Manual References

TM 9-2320-280-10
TM 9-2320-280-24P

Equipment Condition

- Hood raised and secured (TM 9-2320-280-10).
- Engine right splash shield removed (para. 10-20).
- Arctic heater assembly removed (para. 12-41).

a. Removal

1. Loosen nut (2) and remove knob (1) and nut (2) from control cable core (6).
2. Remove nut (3), washer (4), and control cable (9) from plenum bracket (5).
3. Remove grommet (8) from cowl opening (7) and push control cable (9) through cowl opening (7).
4. Remove capscrew (15), washer (16), and control cable bracket (17) from diverter box (18).
5. Remove cotter pin (11) and washer (10) from control cable pin (13) and exhaust diverter lever (12). Discard cotter pin (11).
6. Disconnect cable pin (13) from exhaust diverter lever (12) and remove control cable (9).

b. Installation

1. Install control cable pin (13) on exhaust diverter lever (12) with washer (10) and cotter pin (11).
2. Install control cable bracket (17) on diverter box (18) with washer (16) and capscrew (15).
3. Push control cable (9) through cowl opening (7) and install grommet (8) on cowl opening (7).
4. Connect control cable (9) to plenum bracket (5) with washer (4) and nut (3).
5. Install nut (2) and knob (1) on control cable core (6) and tighten nut (2).

c. Adjustment

1. Loosen screw (14) on control cable pin (13).
2. Ensure knob (1) is pushed all the way in (exhaust position).
3. Ensure exhaust diverter lever (12) on diverter box (18) is in the full vertical position (exhaust position).
4. Tighten screw (14) on control cable pin (13).

12-42.1 ARCTIC HEATER CONTROL CABLE MAINTENANCE (Cont'd)

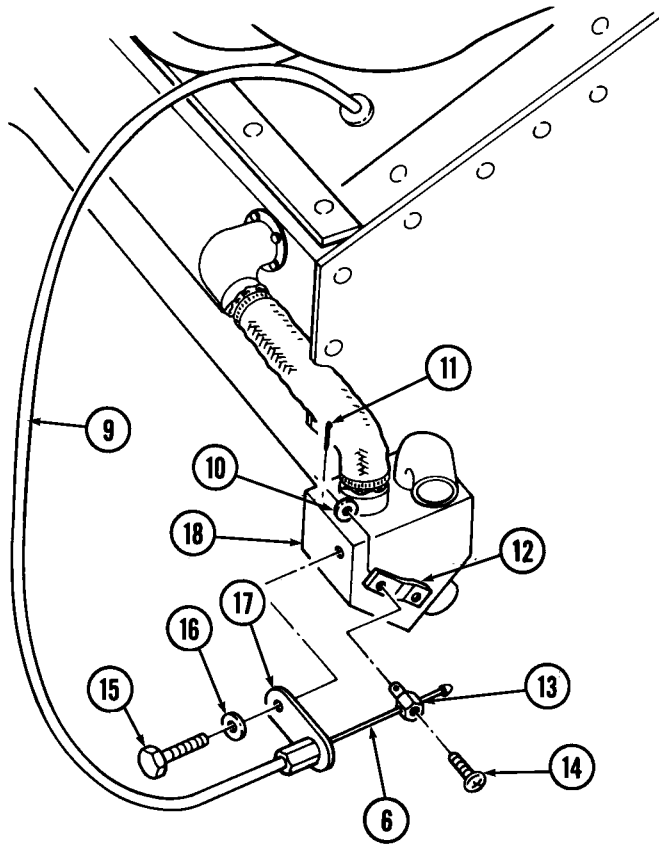
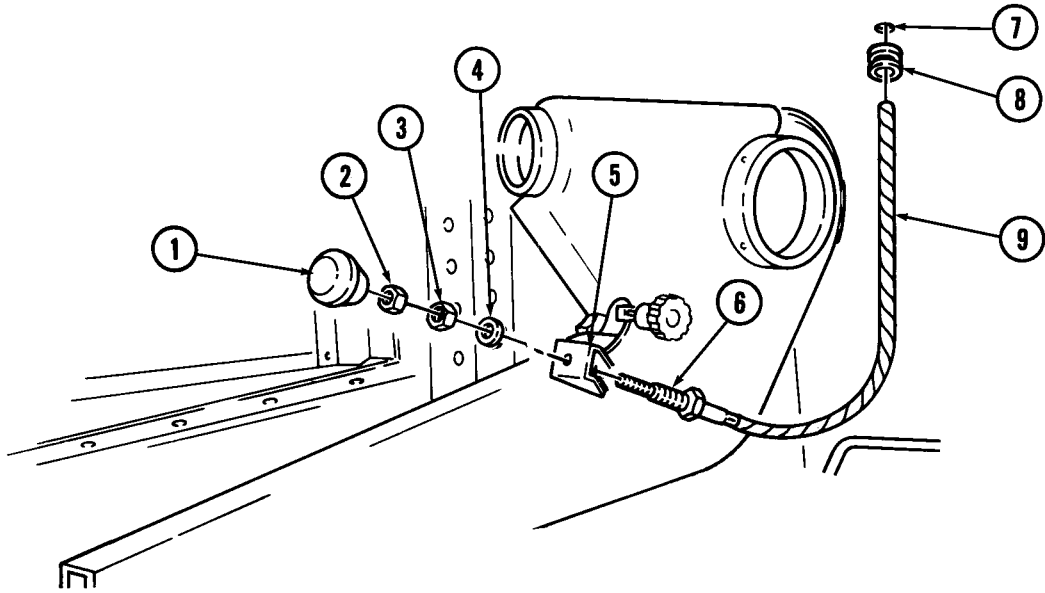

- FOLLOW-ON TASKS:
- Install arctic heater assembly (para. 12-41).
 - Install engine right splash shield (para. 10-20).
 - Lower and secure hood (TM 9-2320-280-10).

12-43. ARCTIC HEATER CONTROL BOX ASSEMBLY MAINTENANCE

This task covers:

a. Disassembly

b. Assembly

INITIAL SETUP:**Tools**

General mechanic's tool kit:
automotive (Appendix B, Item 1)

Equipment Condition

Arctic heater control box assembly removed
(para. 12-42).

Manual References

TM 9-2320-280-24P

a. Disassembly**NOTE**

Prior to removal, tag all leads for installation.

1. Remove nut (6), washer (4), and toggle switch (5) from control box (9). Disconnect leads (16), (19), and (22) from toggle switch (5).
2. Remove two screws (21) and circuit breaker (20) from control box (9). Disconnect leads (15), (14), and (13) from circuit breaker (20).
3. Remove nut (8), washer (7), and toggle switch (10) from control box (9). Disconnect leads (22), (12) (13), (24), and (23) from toggle switch (10).
4. Remove grommet (18) and harness (17) from control box (9).
5. Remove two screws (2) and LED assembly (1) from control box (9).
6. Remove name plate (3) from control box (9).

b. Assembly

1. Install name plate (3) on control box (9).
2. Install LED assembly (1) on control box (9) with two screws (2).
3. Install grommet (18) and harness (17) on control box (9). Ensure lead (11) and LED assembly (1) are installed through grommet (18) and out of control box (9).
4. Connect leads (12), (24), (13), (22), and (23) to toggle switch (10). Install toggle switch (10) on control box (9) with washer (7) and nut (8).
5. Connect leads (15), (14), and (13) to circuit breaker (20). Install circuit breaker (20) on control box (9) with two screws (21).
6. Connect leads (16), (19), and (22) to toggle switch (5). Install toggle switch (5) on control box (9) with washer (4) and nut (6).

12-43. ARCTIC HEATER CONTROL BOX ASSEMBLY MAINTENANCE (Cont'd)

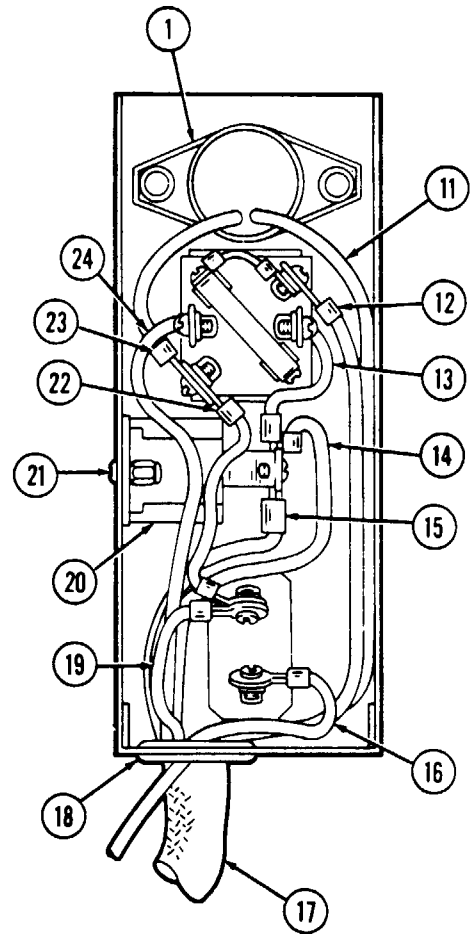
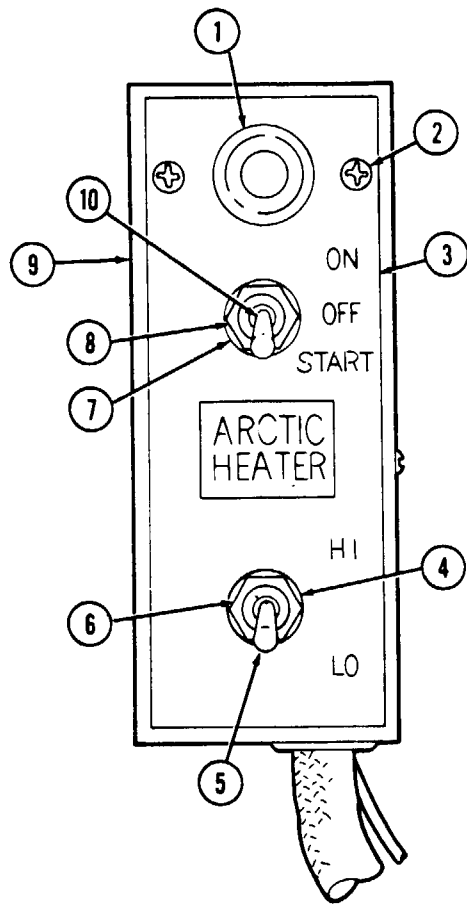

FOLLOW-ON TASK: Install arctic heater control box assembly (para. 12-42).

12-44. ARCTIC HEATER BRACKET ASSEMBLY REPLACEMENT

This task covers:

a. Removal

b. Installation

INITIAL SETUP:

Tools

General mechanic's tool kit:
automotive (Appendix B, Item 1)

Personnel Required

One mechanic
One assistant

Materials/Parts

Two lockwashers (Appendix G, Item 135)

Equipment Condition

- Hood raised and secured (TM 9-2320-280-10).
- Arctic heater assembly removed (para. 12-41).

Manual References

TM 9-2320-280-10
TM 9-2320-280-24P

a. Removal

1. Remove two capscrews (5), lockwashers (4), washers (3), and bracket assembly (2) from cowl (6). Discard lockwashers (4).
2. Remove clamp (1) from bracket assembly (2).

b. Installation

1. Install clamp (1) on bracket assembly (2).
2. Install bracket assembly (2) on cowl (6) with two washers (3), lockwashers (4), and capscrews (5). Tighten capscrews (5) to 8 lb-ft (11 N•m).

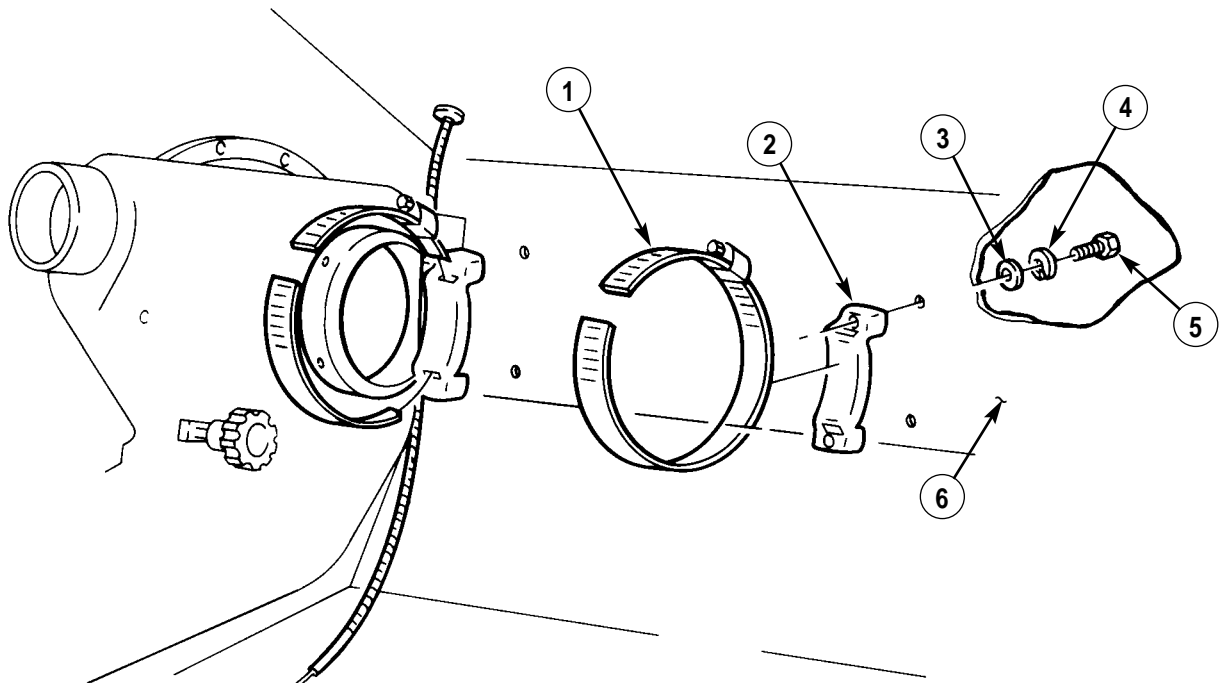

- FOLLOW-ON TASKS:**
- Install arctic heater (para. 12-41).
 - Lower and secure hood (TM 9-2320-280-10).

12-45. ARCTIC HEATER BATTERY BOX PLUGS REPLACEMENT

This task covers:

a. Removal

b. Installation

INITIAL SETUP:

Tools

General mechanic's tool kit
automotive (Appendix B, Item 1)

Equipment Condition

Battery box cover removed (TM 9-2320-280-10).

Manual References

TM 9-2320-280-10
TM 9-2320-280-24P

a. Removal

Remove three plugs (2) from openings (1) in battery box (3).

b. Installation

Install three plugs (2) on openings (1) in battery box (3).

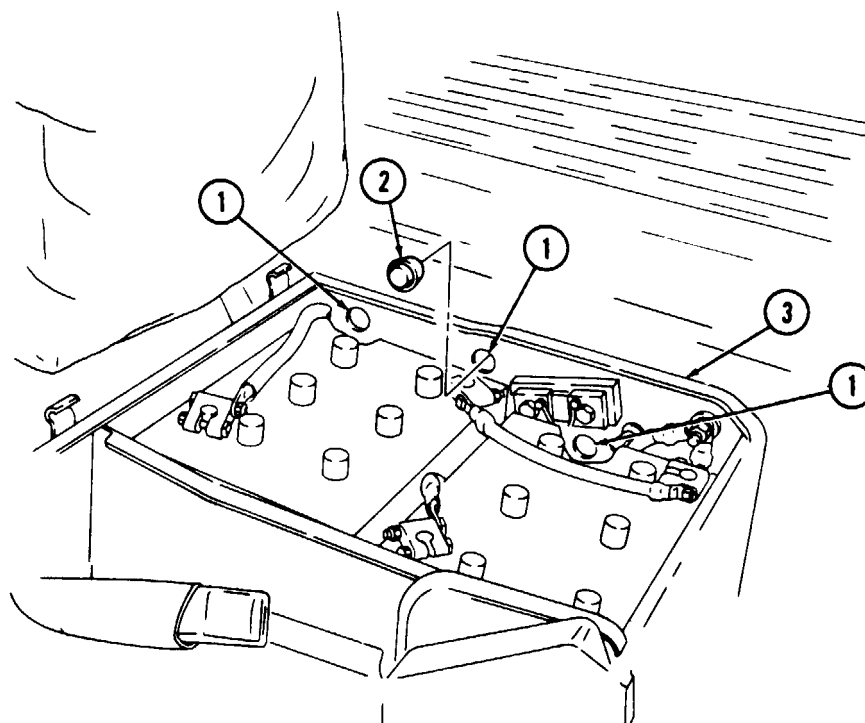

FOLLOW-ON TASK: Install battery box cover (TM 9-2320-280-10).

12-46. ARCTIC HEATER FRONT COWL INSULATION REPLACEMENT

This task covers:

a. Removal

b. Installation

INITIAL SETUP:

Tools

General mechanic's tool kit:
automotive (Appendix B, Item 1)

Manual References

TM 9-2320-280-24P

Materials/Parts

Eight locknuts (Appendix G, Item 70)

NOTE

Right and left front cowl insulation is removed and installed basically the same. This procedure covers the right front cowl insulation.

a. Removal

1. Remove four locknuts (11), washers (9), capscrews (8), and retainer (10) from cowl (4). Discard locknuts (11).
2. Remove four locknuts (7), washers (6), capscrews (5), washers (6), and retainer (3) from cowl (4). Discard locknuts (7).
3. Starting at base of battery box (1), peel back insulation (2) and work forward.
4. Remove insulation (2) from cowl (4).
5. Clean remaining adhesive from cowl (4).

b. Installation

NOTE

Ensure surface is free of dirt and oil before applying adhesive backing.

1. Peel backing paper from adhesive-backed insulation (2).
2. Install insulation (2) on cowl (4) and work toward battery box (1), pressing insulation (2) firmly in place.
3. Install retainer (10) on cowl (4) with four washers (9), capscrews (8), and locknuts (11).
4. Install retainer (3) on cowl (4) with four washers (6), capscrews (5), washers (6), and locknuts (7).

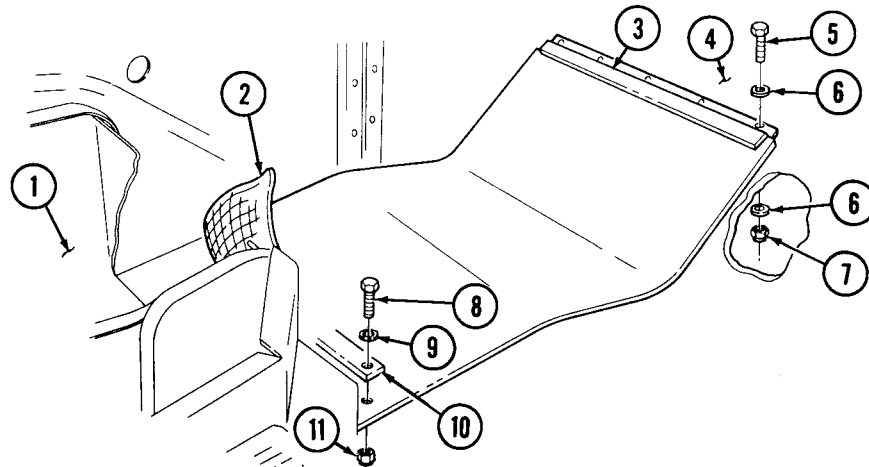

12-47. ARCTIC HEATER DIVERTER BOX COVER REPLACEMENT

This task covers:

a. Removal

b. Installation

INITIAL SETUP:

Tools

General mechanic's tool kit:
automotive (Appendix B, Item 1)

Manual References

TM 9-2320-280-24P

Materials/Parts

Adhesive (Appendix C, Item 3)
Five blind rivets (Appendix G, Item 254)

NOTE

For rivet replacement instructions, refer to para. 10-66.

a. Removal

1. Remove five rivets (4) and washers (3) from cover (1) and diverter box (2).
2. Peel back cover (1) and remove from diverter box (2).
3. Clean remaining adhesive, dirt, and oil from diverter box (2).

b. Installation

1. Apply adhesive to surface of diverter box (2) and rough surface of cover (1).
2. Install cover (1) on diverter box (2), pressing firmly in place.
3. Secure cover (1) to diverter box (2) with five washers (3) and rivets (4).
4. Ensure cover (1) is attached at all bends and corners of diverter box (2).
5. Remove backing from two data plates (6) and install data plates (6) on cover (1).
6. Remove backing from warning plate (5) and install warning plate (5) on cover (1).

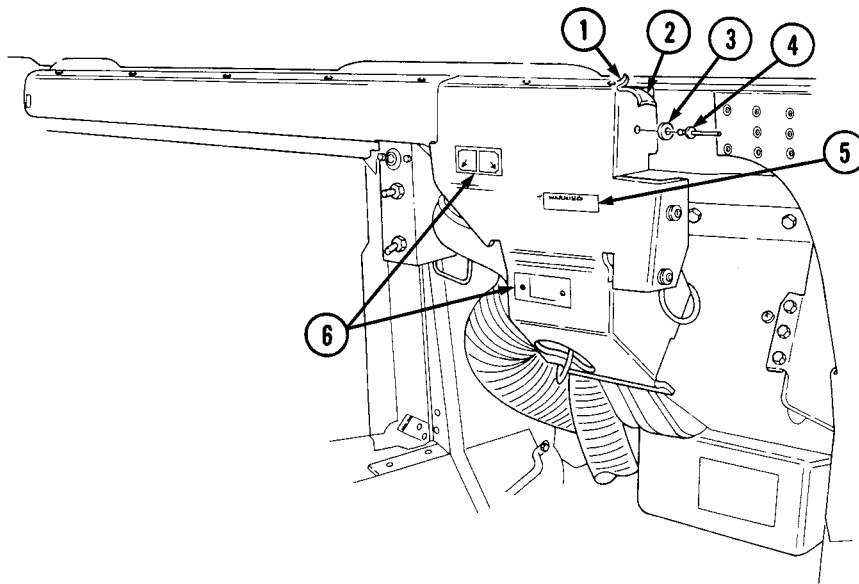

12-48. ARCTIC HEATER EXHAUST DIVERTER CABLE ASSEMBLY MAINTENANCE

This task covers:

- | | |
|--|----------------------|
| <p>a. Removal</p> <p>b. Installation</p> | <p>c. Adjustment</p> |
|--|----------------------|

INITIAL SETUP:

Tools

General mechanic's tool kit:
automotive (Appendix B, Item 1)

Materials/Parts

Cotter pin (Appendix G, Item 26)

Manual References

TM 9-2320-280-10
TM 9-2320-280-24P

Equipment Condition

- Hood raised and secured (TM 9-2320-280-10).
- Engine right splash shield removed (para. 10-20).
- Arctic heater assembly removed (para. 12-41).

a. Removal

1. Loosen nut (2) and remove knob (1) and nut (2) from cable assembly core (6).
2. Remove nut (3), washer (4), and cable assembly (9) from plenum bracket (5).
3. Remove grommet (8) from cowl opening (7) and pull cable assembly (9) through cowl opening (7).
4. Remove capscrew (15), washer (16), and cable bracket (17) from diverter box (18).
5. Remove cotter pin (11) and washer (10) from cable pin (13) and exhaust diverter lever (12). Disconnect cable pin (13) from exhaust diverter lever (12) and remove cable assembly (9). Discard cotter pin (11).

b. Installation

1. Install cable pin (13) on exhaust diverter lever (12) with washer (10) and cotter pin (11).
2. Install cable bracket (17) on diverter box (18) with washer (16) and capscrew (15).
3. Push cable assembly (9) through cowl opening (7) and install grommet (8) on cowl opening (7).
4. Connect cable assembly (9) to plenum bracket (5) with washer (4) and nut (3).
5. Install nut (2) and knob (1) on cable assembly core (6) and tighten nut (2) on knob (1).

c. Adjustment

1. Loosen screw (14) on cable assembly core (6) to cable pin (13).
2. Ensure knob (1) is pushed all the way in (exhaust position).
3. Ensure exhaust diverter lever (12) on diverter box (18) is in the full vertical position (exhaust position).
4. Tighten screw (14) on cable assembly core (6) on cable pin (13).

12-48. ARCTIC HEATER EXHAUST DIVERTER CABLE ASSEMBLY MAINTENANCE (Cont'd)

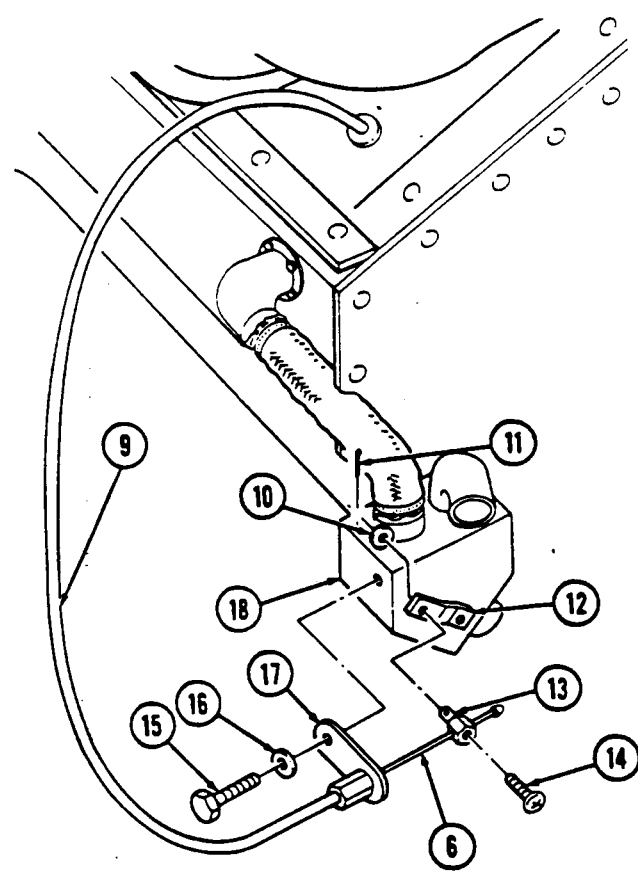
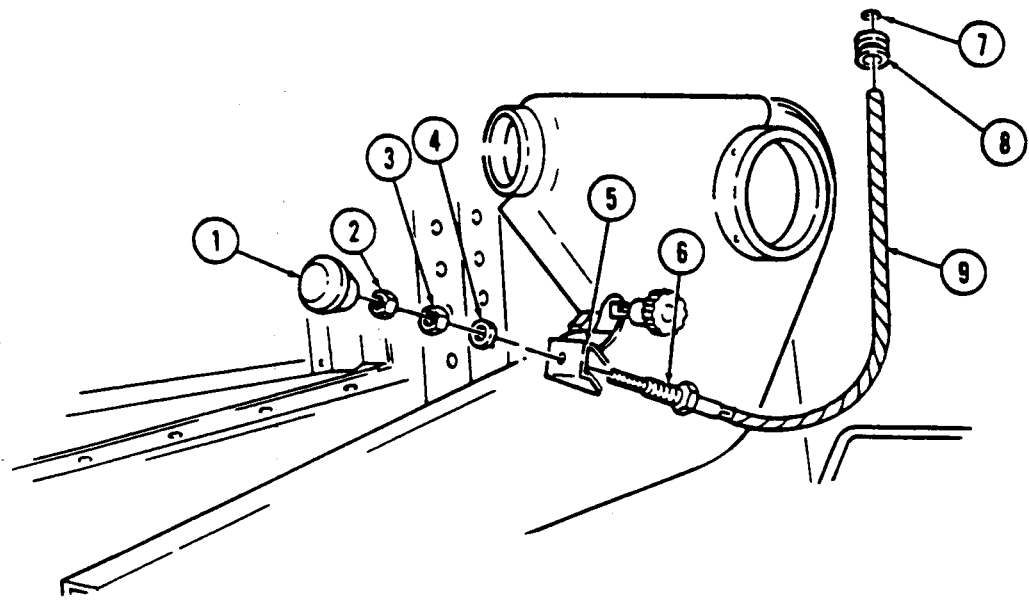

- FOLLOW-ON TASKS:
- Install arctic heater assembly (para. 12-41).
 - Install engine right splash shield (para. 10-20).
 - Lower and secure hood (TM 9-2320-280-10).

12-48.1 ARCTIC HEATER DUCTING REPLACEMENT

This task covers:

a. Removal

b. Installation

INITIAL SETUP:

Applicable Models

M997A2, M1025A2, M1043A2,
M1045A2, M1097A2, M1123

Manual References

TM 9-2320-280-10
TM 9-2320-280-24P

Tools

General mechanic's tool kit:
automotive (Appendix B, Item 1)

Equipment Condition

- Engine access cover removed (para. 10-15).
- Front radio rack assembly removed, if equipped (para. 12-132).

Materials/Parts

Two locknuts (Appendix G, Item 70)
Two blind rivets (Appendix G, Item 264)

a. Removal

1. Remove two capscrews (4), washers (5), and two radio rack mounting brackets (6) from plenum panel (7).
2. Remove nine screws (9), retainer (8), and plenum panel (7) from "A" beam (2).
3. Disconnect connector (25) from light switch (12).
4. Remove two locknuts (27), washers (13), capscrews (14), and washers (13) securing instrument panel (11) to firewall (26). Discard locknuts (27).
5. Remove nut (21), washer (20), capscrew (19), washer (20) from hand throttle bracket (17), steering column bracket (22), and instrument panel (11).
6. Remove nut (15), screw (18), and hand throttle bracket (17) from instrument panel (11).
7. Remove screw (16) securing panel (11) to firewall (26) and pull panel (11) away from "A" beam (2) for access to air duct (1).

NOTE

Refer to para. 10-66 for rivet removal.

8. Remove two rivets (10) securing air duct (1) to diverter assembly (3).
9. Remove clamp (24) and air duct (1) from steering column mount (23).

b. Installation

1. Install air duct (1) on steering column mount (23) with clamp (24).

NOTE

Refer to para. 10-66 for rivet installation.

2. Install air duct (1) on diverter assembly (3) with two rivets (10).
3. Install panel (11) on firewall (26) with screw (16).
4. Secure panel (11) and hand throttle bracket (17) to steering column bracket (22) with washer (20), capscrew (19), washer (20), and nut (21).
5. Install hand throttle bracket (17) on instrument panel (11) with screw (18) and nut (15).
6. Secure panel (11) to firewall (26) with two washers (13), capscrews (14), washers (13), and locknuts (27).
7. Connect connector (25) to light switch (12).
8. Install plenum panel (7) and retainer on "A" beam (2) with nine screws (9).
9. Install two radio rack mounting brackets (6) on plenum panel (7) with two washers (5) and capscrews (4).

12-48.1. ARCTIC HEATER DUCTING REPLACEMENT(Cont'd)

NEW CONFIGURATION

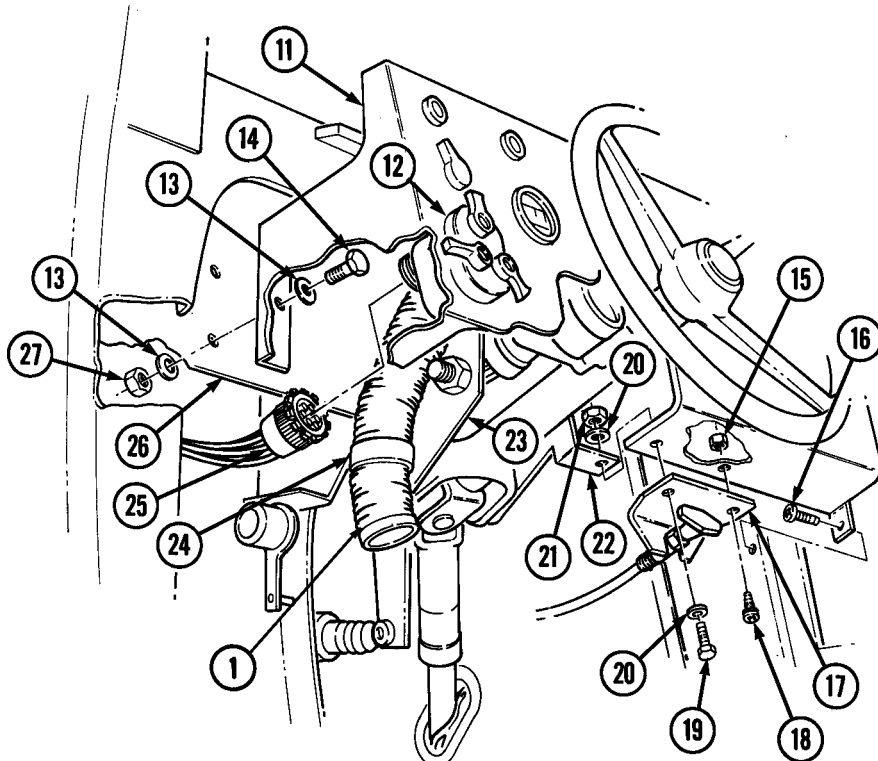
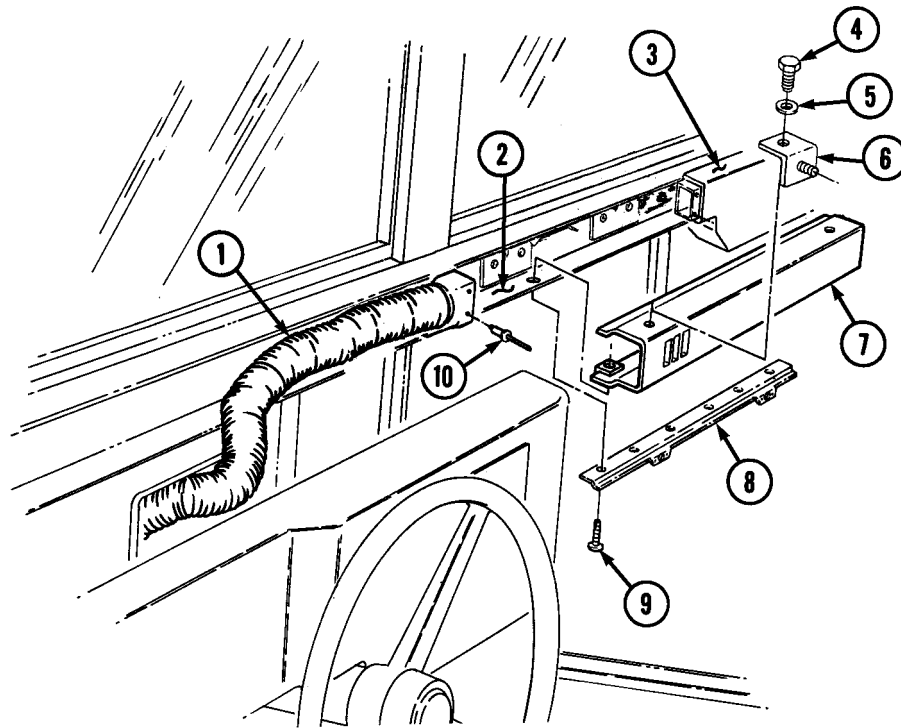

- FOLLOW-ON TASKS:
- Install engine access cover (para. 10-15).
 - Install front radio rack assembly, if equipped (para. 12-132).

12-48.2. ARCTIC HEATER OIL PAN SHROUD REPLACEMENT

This task covers:

a. Removal

b. Installation

INITIAL SETUP:

Applicable Models

M966, M966A1, M997, M997A1, M997A2, M998, M998A1, M1025, M1025A1, M1025A2, M1037, M1038, M1038A1, M1121

Tools

General mechanic's tool kit:
automotive (Appendix B, Item 1)

Materials/Parts

Cotter pin (Appendix G, Item 13)
Nine locknuts (Appendix G, Item 129)

Manual References

TM 9-2320-280-20
TM 9-2320-280-24P

General Safety Instructions

Do not touch hot exhaust system with bare hands.

WARNING

Do not touch hot exhaust system components with bare hands.
Severe injury may result.

a. Removal

1. Remove cotter pin (8) and flex tube (7) from oil pan shroud (6). Discard cotter pin (8).
2. Remove two locknuts (5), washers (4), starter cable bracket (3), and washer (2) from oil pan (1). Discard locknuts (5).
3. Remove seven locknuts (9), washers (10), and oil pan shroud (6) from oil pan (1). Discard locknuts (9).

b. Installation

1. Install oil pan shroud (6) on oil pan (1) with seven washers (10) and locknuts (9).
2. Install washer (2) and starter cable bracket (3) on oil pan (1) with two washers (4) and locknuts (5).
3. Connect flex tube (7) to oil pan shroud (6) with cotter pin (8).

12-48.2. ARCTIC HEATER OIL PAN SHROUD REPLACEMENT(Cont'd)

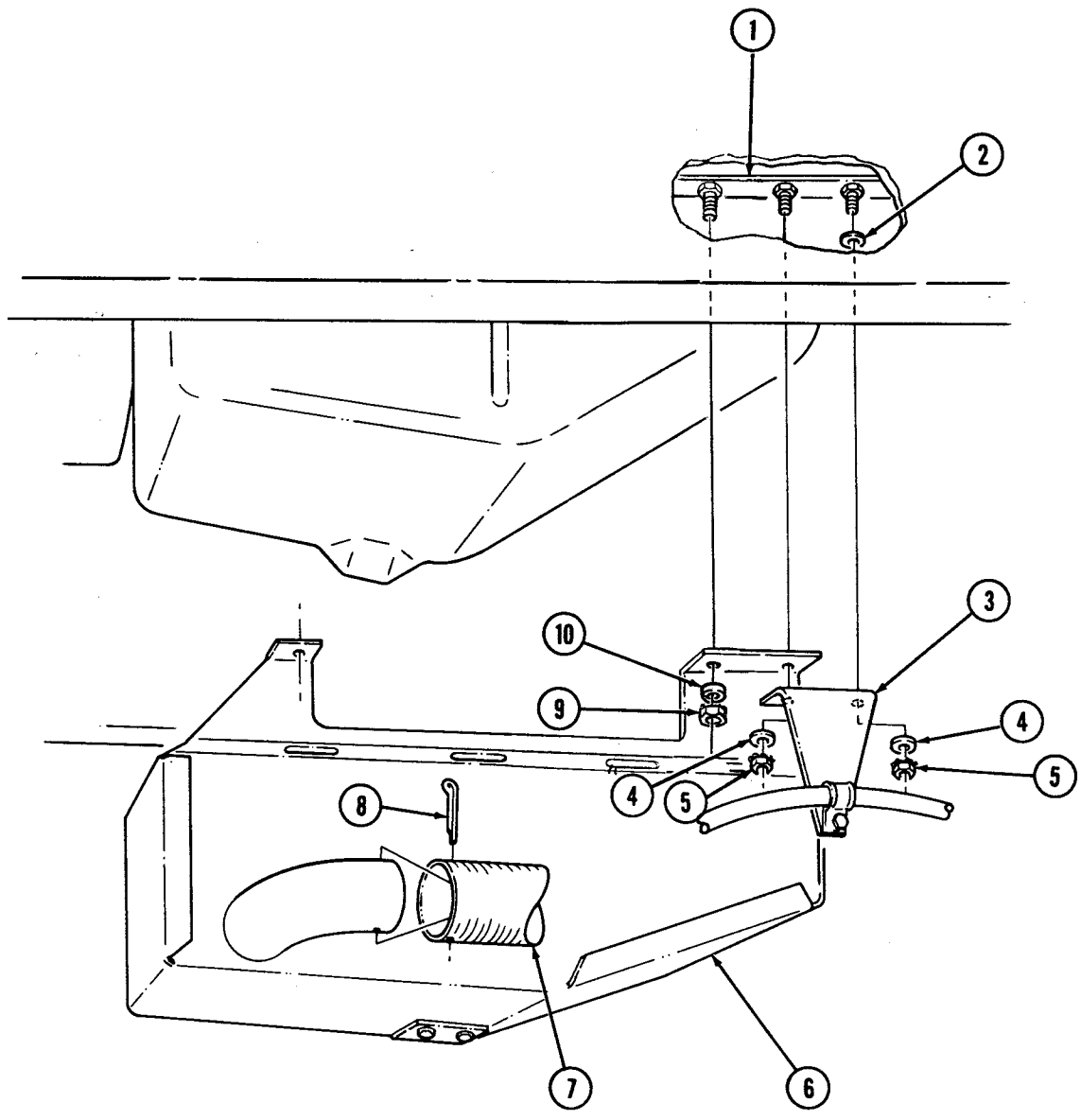

12-49. ARCTIC DIVERTER BOX MAINTENANCE

This task covers:

- | | |
|--|--|
| <ul style="list-style-type: none"> a. Removal b. Disassembly | <ul style="list-style-type: none"> c. Assembly d. Installation |
|--|--|

INITIAL SETUP:

Applicable Models

M997A2, M1025A2, M1035A2, M1043A2,
M1045A2, M1097A2, M1123

Tools

General mechanic's tool kit:
automotive (Appendix B, Item 1)

Materials/Parts

Plug button (Appendix G, Item 8)
Two blind rivets (Appendix G, Item 253)
Four blind rivets (Appendix G, Item 258)

Equipment Condition

Arctic diverter ducting removed (para. 12-56).

a. Removal

1. Remove two screws (14) from transition diverter (12) and transition (13).
2. Remove two screws (8) from diverter (9) and heater (7).
3. Remove screw (5) and clamp (4) from diverter (9)
4. Remove plug button (11) and disconnect defroster cable core (6) from baffle pin (10). Discard plug button (11).
5. Pull diverter (9) away from "A" beam (1), loosen two clamps (3), and remove diverter (9) from defroster flex ducts (2).

b. Disassembly

NOTE

Refer to para. 10-66 for rivet removal.

1. Remove four rivets (21) and transition diverter (12) from diverter (9).
2. Remove screw (15), spring (16), and louver (17) from transition diverter (12).
3. Remove two rivets (19), flap (20), and bracket (18) from diverter (9).

c. Assembly

NOTE

Refer to para. 10-66 for rivet installation.

1. Install flap (20) and bracket (18) on diverter (9) with two rivets (19).
2. Install louver (17) on transition diverter (12) with spring (16) and screw (15).
3. Install transition diverter (12) on diverter (9) with four rivets (21).

d. Installation

1. Position diverter (9) under "A" beam (1) and connect two defroster flex ducts (2) on diverter (9).
2. Secure flex ducts (2) to diverter (9) with two clamps (3).
3. Connect defroster cable core (6) on baffle pin (10) with plug button (11).
4. Install transition diverter (12) on transition (13) with two screws (14).

NOTE

Control cable must be pushed in, and baffle pin must be in the upward position before securing control cable to diverter box.

5. Install clamp (4) on diverter (9) with screw (5).
6. Install diverter (9) on heater (7) with two screws (8).

12-49. ARCTIC DIVERTER BOX MAINTENANCE (Cont'd)

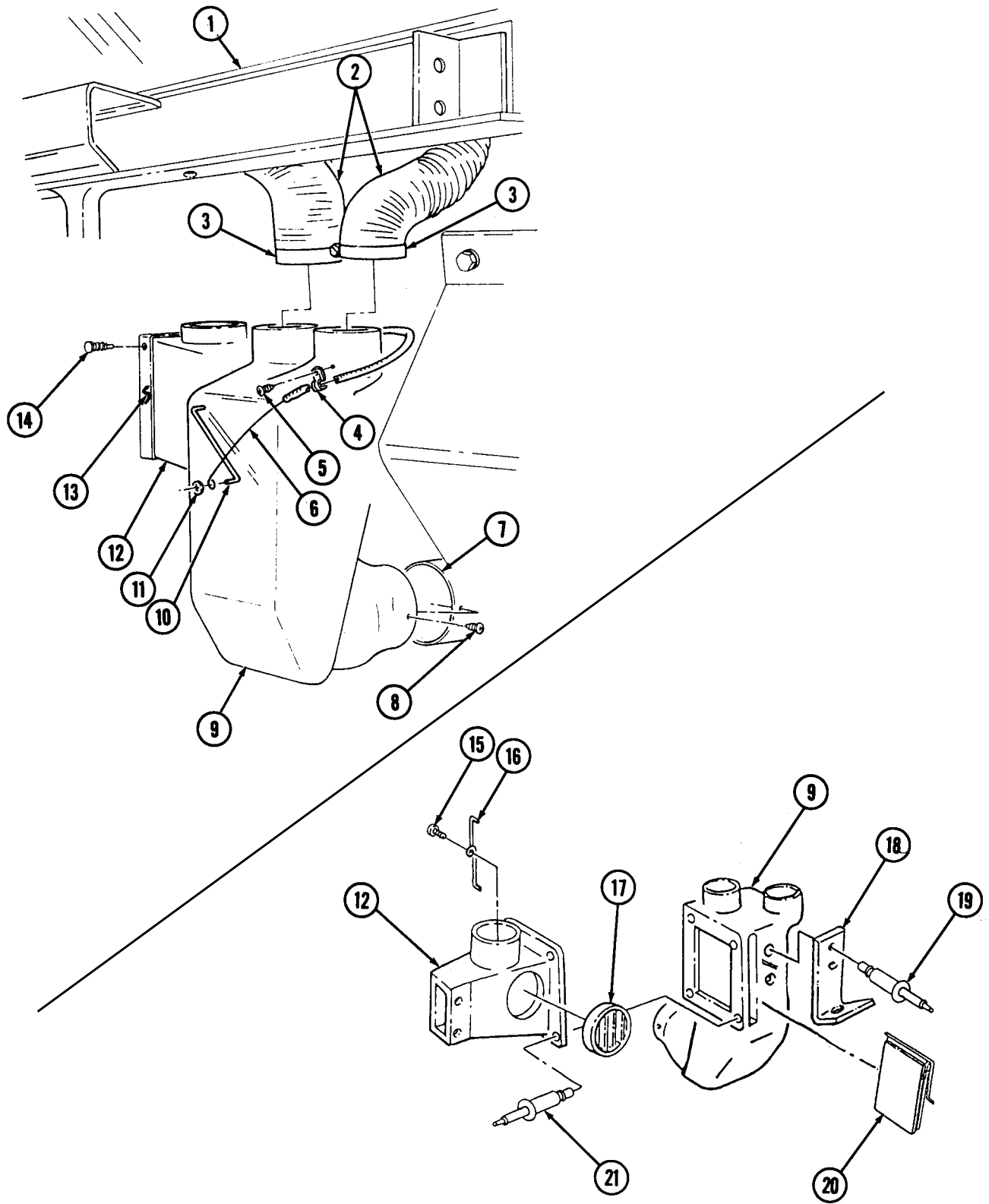

FOLLOW-ON TASK: Install arctic diverter ducting (para. 12-56).

12-50. ARCTIC DEFROSTER DUCTING REPLACEMENT

This task covers:

a. Removal

b. Installation

INITIAL SETUP:

Applicable Models

M997A2, M1025A2, M1035A2,
M1043A2, M1045A2, M1097A2

Manual References

TM 9-2320-280-10
TM 9-2320-280-24P

Tools

General mechanic's tool kit
automotive (Appendix B, Item 1)

Equipment Condition

⌚ Hood raised and secured (TM 9-2320-280-10).
⌚ Engine access cover removed (para. 10-15).

Materials/Parts

Adhesive sealant (Appendix C, Item 10)

a. Removal

1. Remove six screws (5), retainer (6), and closeout panel (4) from "A" beam (3).
2. Remove three nuts (11), washers (8), capscrews (7), and washers (8) from three clamps (9), cable clamp (10), closeout panel (4), and "A" beam (3).
3. Remove three screws (12) from closeout panel (4) and "A" beam (3).
4. Disconnect left flex duct (2) from left defroster nozzle (1).
5. Remove four screws (18) from panel assembly (17) and "A" beam (3) and pull panel assembly (17) away from "A" beam (3) for access to right defroster nozzle (13).
6. Disconnect right flex duct (14) from right defroster nozzle (13).
7. Loosen two clamps (15) and disconnect left flex duct (2) and right flex duct (14) from diverter housing (16).

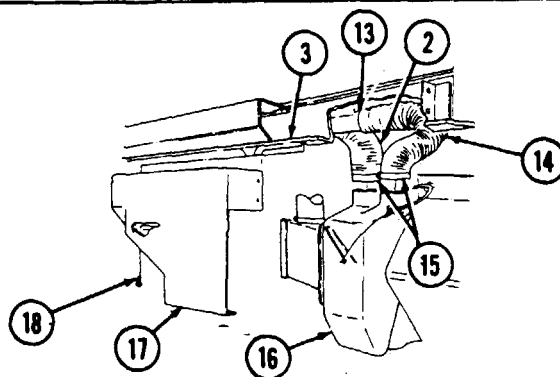
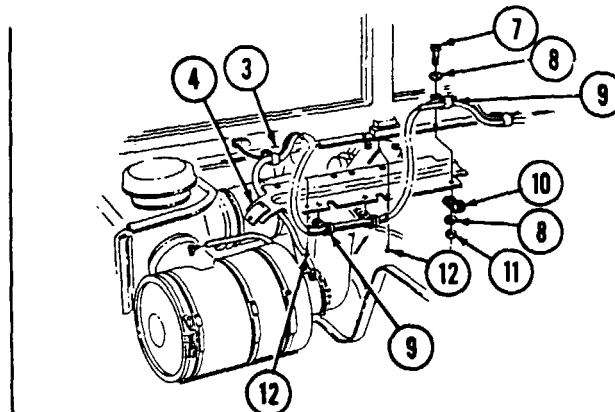
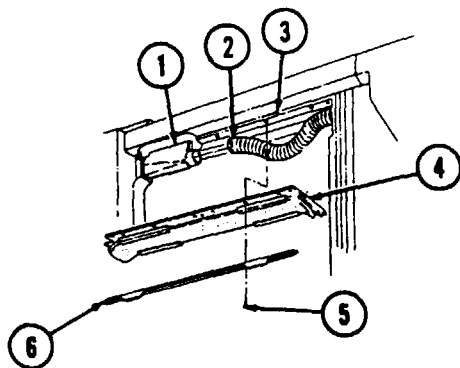

12-50. ARCTIC DEFROSTER DUCTING REPLACEMENT (Cont'd)

b. Installation

1. Connect left flex duct (2) and right flex duct (4) to diverter housing (6) with two clamps (5).
2. Apply adhesive sealant and connect right flex duct (4) to right defroster nozzle (3).
3. Install panel assembly (7) on "A" beam (1) with four screws (8).
4. Apply adhesive sealant and connect left flex duct (2) to left defroster nozzle (9).
5. Install retainer (12) and closeout panel (10) on "A" beam (1) with six screws (11).
6. Secure closeout panel (10) to "A" beam (1) with three screws (18).
7. Install three clamps (15), cable clamp (16), and closeout panel (10) on "A" beam (1) with three washers (14), capscrews (13), washers (14), and nuts (17).

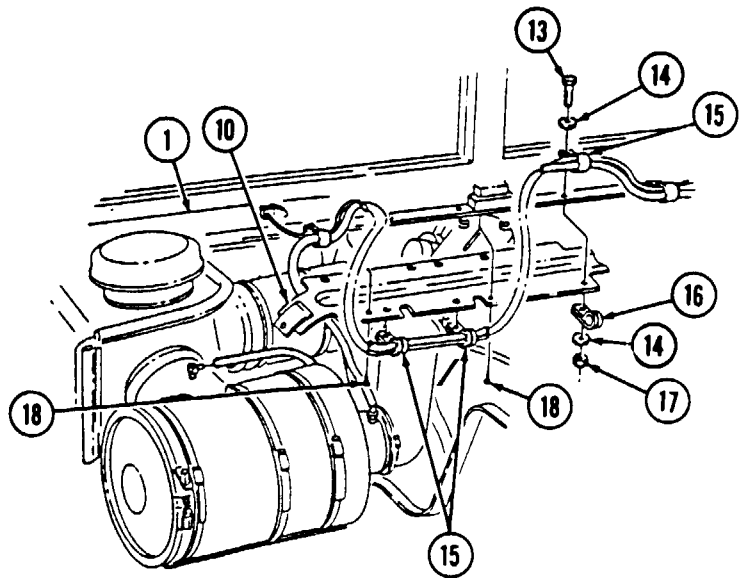
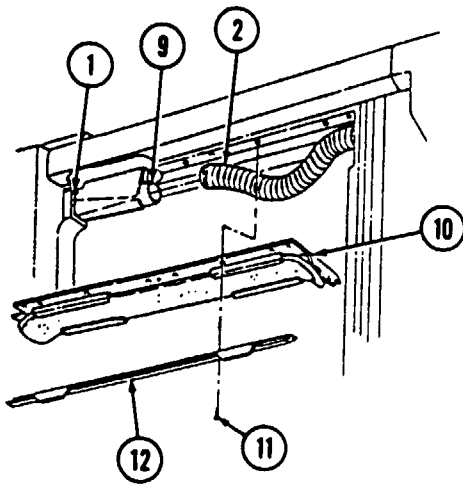
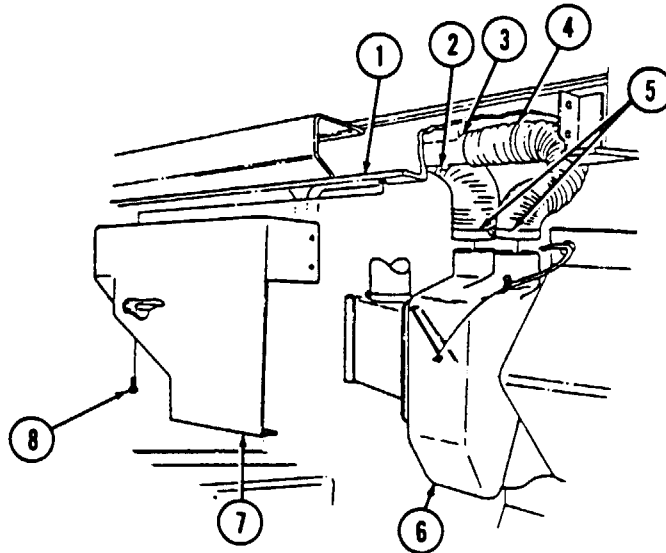

FOLLOW-ON TASKS: \checkmark Install engine access cover (para. 10-15).
 \checkmark Lower and secure hood (TM 9-2320-280-10).

12-51. ARCTIC LEFT DEFROSTER NOZZLE REPLACEMENT

This task covers:

a. Removal

b. Installation

INITIAL SETUP:

Applicable Models

M997A2, M1025A2, M1035A2,
M1043A2, M1045A2, M1097A2

Tools

General mechanic's tool kit:
automotive (Appendix B, Item 1)

Materials/Parts

Adhesive sealant (Appendix C, Item 10)
Lockwasher (Appendix G, Item 133)
Locknut (Appendix G, Item 128)

Manual References

TM 9-2320-280-10
TM 9-2320-280-24P

Equipment Condition

- Hood raised and secured (TM 9-2320-280-10).
- Engine access cover removed (para. 10-15).

a. Removal

1. Remove six screws (4) and retainer (5) from closeout panel (3) and "A" beam (6).
2. Remove three nuts (11), washers (8), capscrews (7), and washers (8) from three clamps (9), cable clamp (10), closeout panel (3) and "A" beam (6).
3. Remove three screws (12) and closeout panel (3) from "A" beam (6).
4. Disconnect defroster duct (2) from defroster nozzle (1).

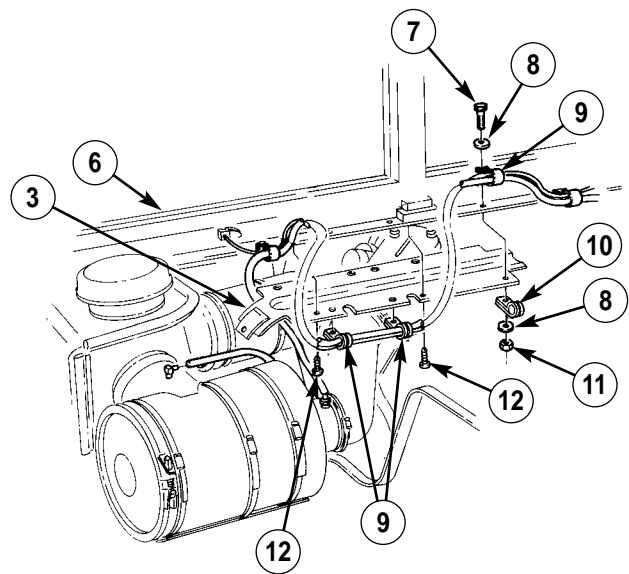
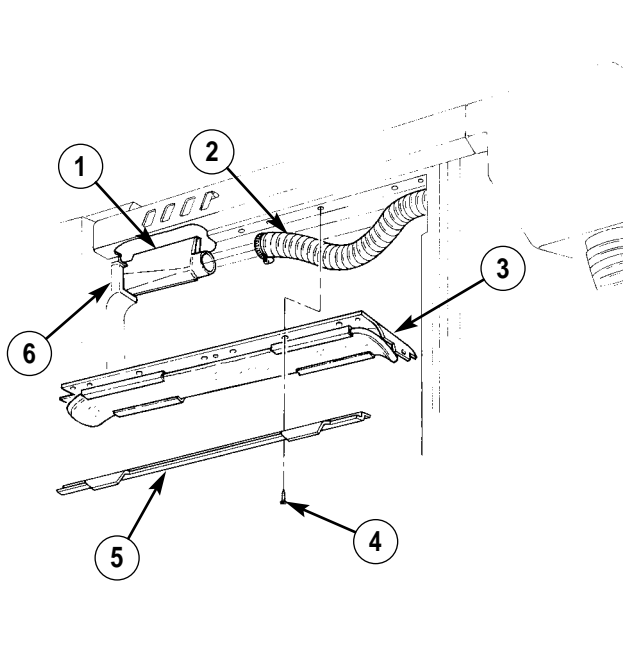

12-51. ARCTIC LEFT DEFROSTER NOZZLE REPLACEMENT (Cont'd)

5. Remove locknut (9), lockwasher (10), washer (11), and pin (14) from steering column (15) and bracket (13), and lower steering column (15). Discard locknut (9) and lockwasher (10).
6. Remove retaining pin (12) from defroster nozzle (2) and bracket (13).

NOTE

Note position of defroster nozzle for installation.

7. Turn defroster nozzle (2) counterclockwise and remove from "A" beam (7).

b. Installation

1. Install defroster nozzle (2) on "A" beam (7).
2. Turn defroster nozzle (2) clockwise until defroster nozzle outlets (8) align with windshield frame louvers (1).
3. Install defroster nozzle (2) on steering column bracket (13) with retaining pin (12).
4. Place steering column (15) in desired position, and install on bracket (13) with pin (14), washer (11), lockwasher (10), and locknut (9). Tighten locknut (9) to 31 lb-ft (42 N·m).
5. Apply adhesive sealant and connect defroster duct (3) to defroster nozzle (2).
6. Install retainer (6) and closeout panel (4) on "A" beam (7) with six screws (5).
7. Secure closeout panel (4) to "A" beam (7) with three screws (22).
8. Install closeout panel (4), three clamps (18), and cable clamp (19) on "A" beam (7) with three washers (17), capscrews (16), washers (17), and nuts (20).

12-51. ARCTIC LEFT DEFROSTER NOZZLE REPLACEMENT (Cont'd)

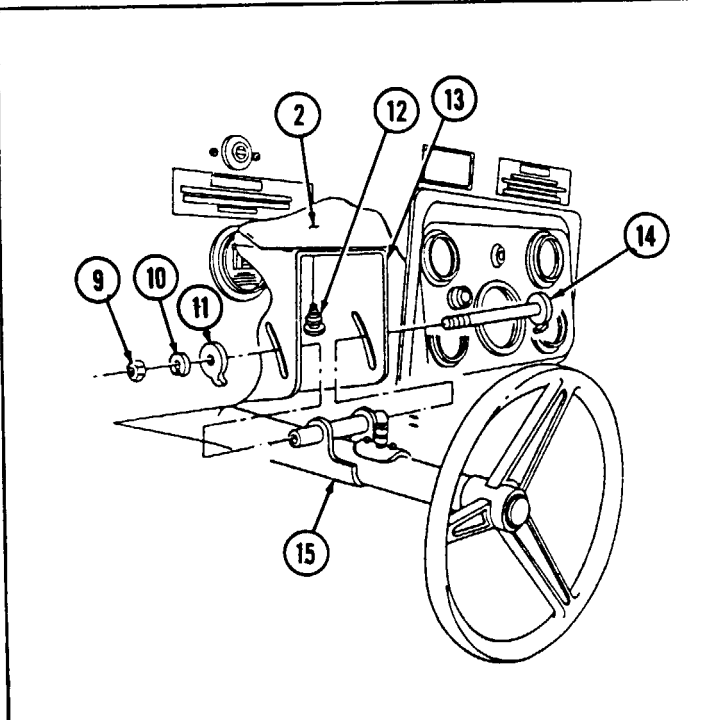
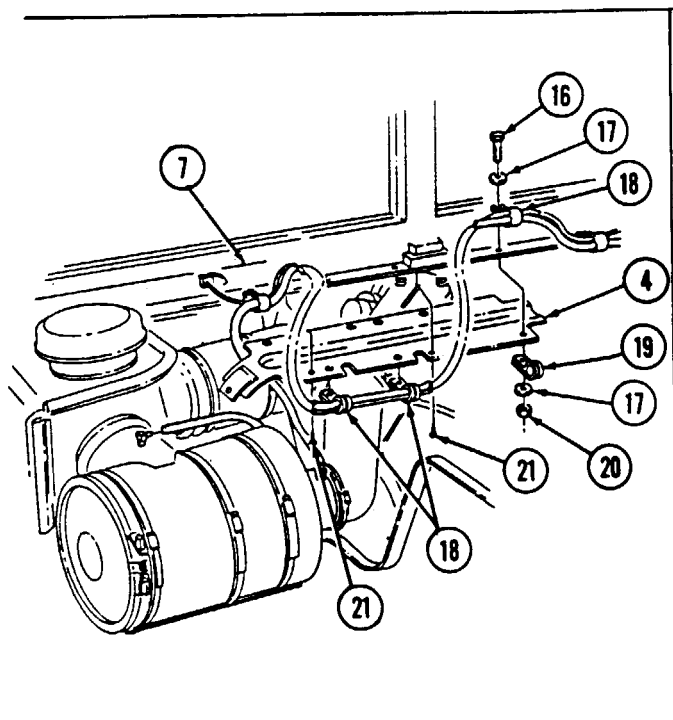
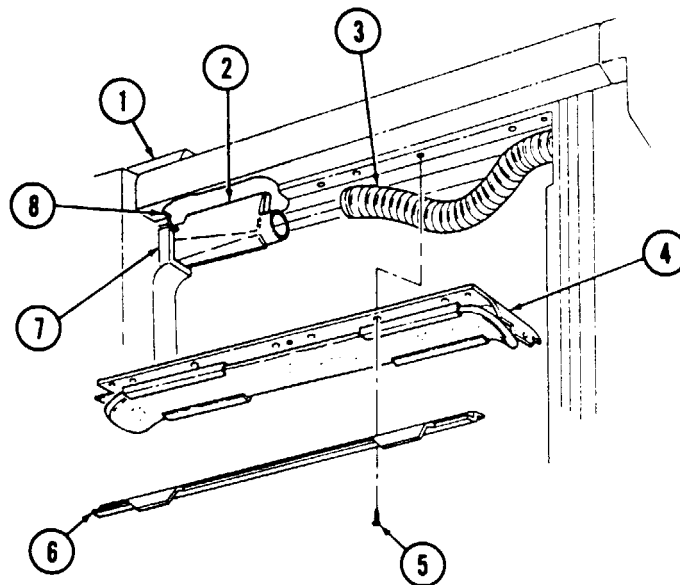

FOLLOW-ON TASKS: Ž Lower and secure hood (TM 9-2320-280-10).
 Ž Install engine access cover (para. 10-15).

12-52. ARCTIC RIGHT DEFROSTER NOZZLE REPLACEMENT

This task covers:

- a. Removal
- b. Installation

INITIAL SETUP:

Applicable Models

M997A2, M1025A2, M1035A2,
M1043A2, M1045A2, M1097A2

Manual References

TM 9-2320-280-24P

Tools

General mechanic's tool kit:
automotive (Appendix B, Item 1)

Equipment Condition

Defroster ducting removed (para. 12-50).

a. Removal

NOTE

Note position of defroster nozzle for installation.

Turn defroster nozzle (2) counterclockwise and remove from "A" beam (4).

b. Installation

Install defroster nozzle (2) on "A" beam (4) and turn defroster nozzle (2) clockwise until defroster nozzle outlets (1) align with windshield frame louvers (3).

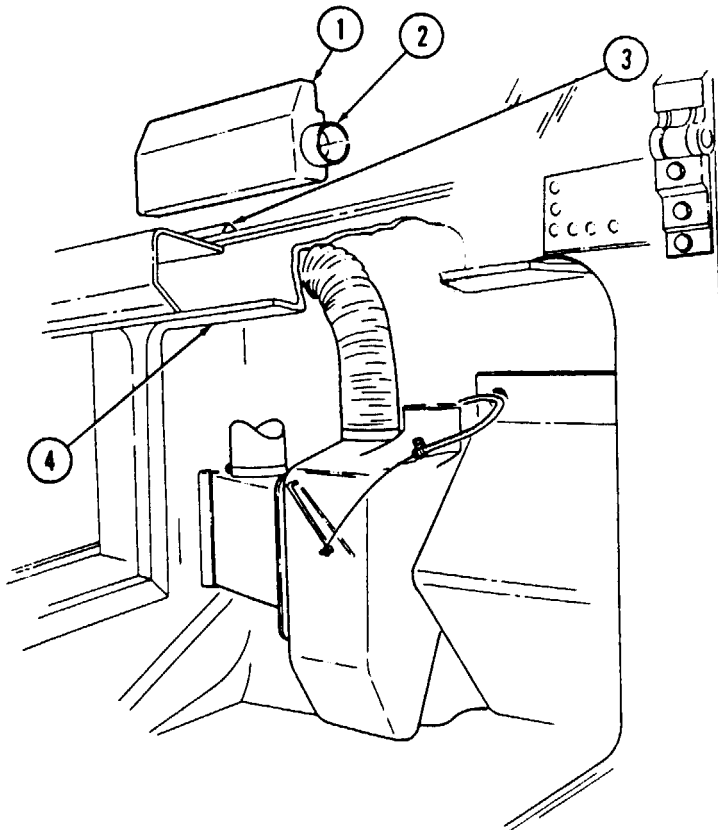

FOLLOW-ON TASK: Install defroster ducting (para. 12-50).

12-53. ARCTIC HEATER NOZZLE REPLACEMENT

This task covers:

a. Removal

b. Installation

INITIAL SETUP:**Applicable Models**

M997A2, M1025A2, M1035A2,
M1043A2, M1045A2, M1097A2

Manual References

TM 9-2320-280-24P

Tools

General mechanic's tool kit
automotive (Appendix B, Item 1)

a. Removal

Remove capscrews (3) and (4) and nozzle (2) from left transition (1).

b. Installation

Install nozzle (2) on left transition (1) with capscrews (3) and (4).

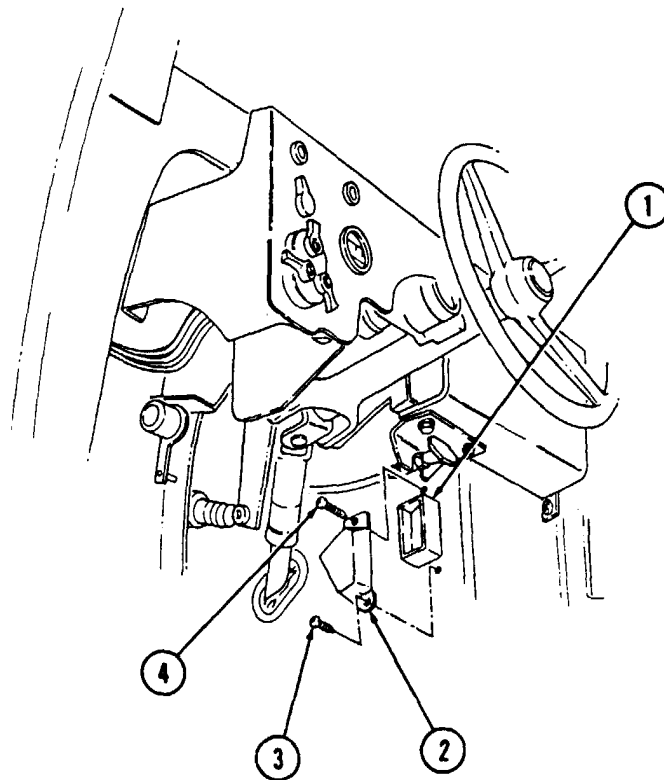

12-54. ARCTIC HEATER HOSE REPLACEMENT

This task covers:

a. Removal

b. Installation

INITIAL SETUP:

Applicable Models

M997A2, M1025A2, M1035A2,
M1043A2, M1045A2, M1097A2

Manual References

TM 9-2320-280-10
TM 9-2320-280-24P

Tools

General mechanic's tool kit:
automotive (Appendix B, Item 1)

Equipment Condition

Ž Hood raised and secured (TM 9-2320-280-10).
Ž Engine access cover removed (pars. 10-15).

Materials/Parts

Adhesive sealant (Appendix C, Item 9)

a. Removal

Disconnect heater hose (2) from left transition (1) and right transition (3), and remove heater hose (2).

b. Installation

Apply adhesive sealant and connect heater hose (2) to left transition (1) and right transition (3).

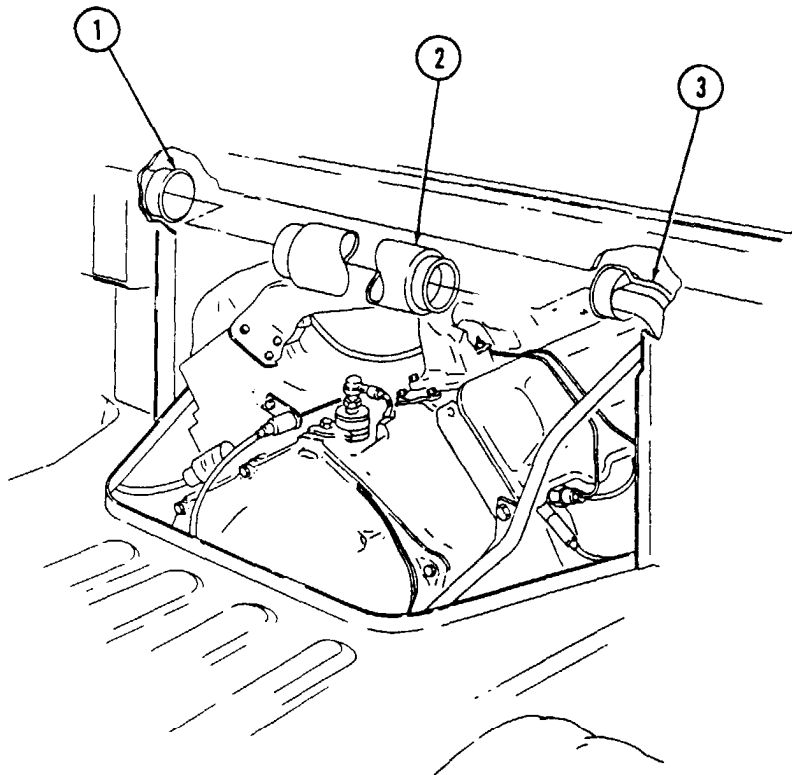

FOLLOW-ON TASKS: Ž Install engine access cover (para. 10-15).
Ž Lower and secure hood (TM 9-2320-280-10).

12-55. ARCTIC DIVERTER BOX COVER REPLACEMENT

This task covers:

a. Removal

b. Installation

INITIAL SETUP:

Applicable Models

M997A2, M1025A2, M1035A2,
M1043A2, M1045A2, M1097A2

Manual References

TM 9-2320-280-24P

Tools

General mechanic's tool kit
automotive (Appendix B, Item 1)

a. Removal

Remove three capscrews (4) and diverter box cover (3) from right mounting bracket (2) and "A" beam (1).

b. Installation

Install diverter box cover (3) on right mounting bracket (2) and "A" beam (1) with three capscrews (4).

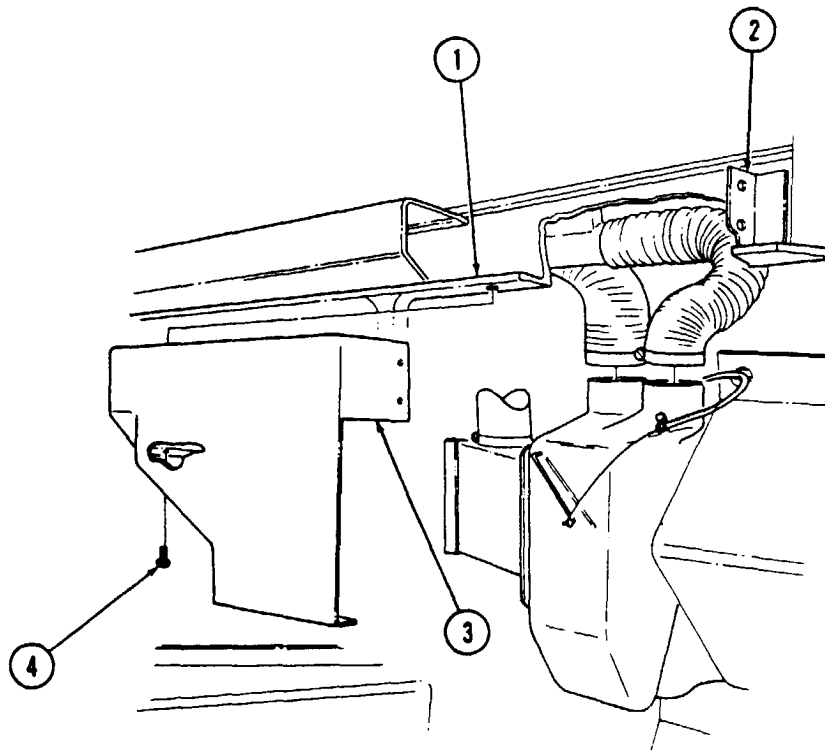

12-56. ARCTIC DIVERTER DUCTING REPLACEMENT

This task covers:

a. Removal

b. Installation

INITIAL SETUP:

Applicable Models

M997A2, M1025A2, M1035A2,
M1043A2, M1045A2, M1097A2

Manual References

TM 9-2320-280-24P

Tools

General mechanic's tool kit:
automotive (Appendix B, Item 1)

Manual Reference

Diverter box cover removed (para. 12-55).

a. Removal

Loosen clamp (1) and remove diverter ducting (2) from diverter transition (3).

b. Installation

Install diverter ducting (2) to diverter transition (3) and tighten clamp (1).

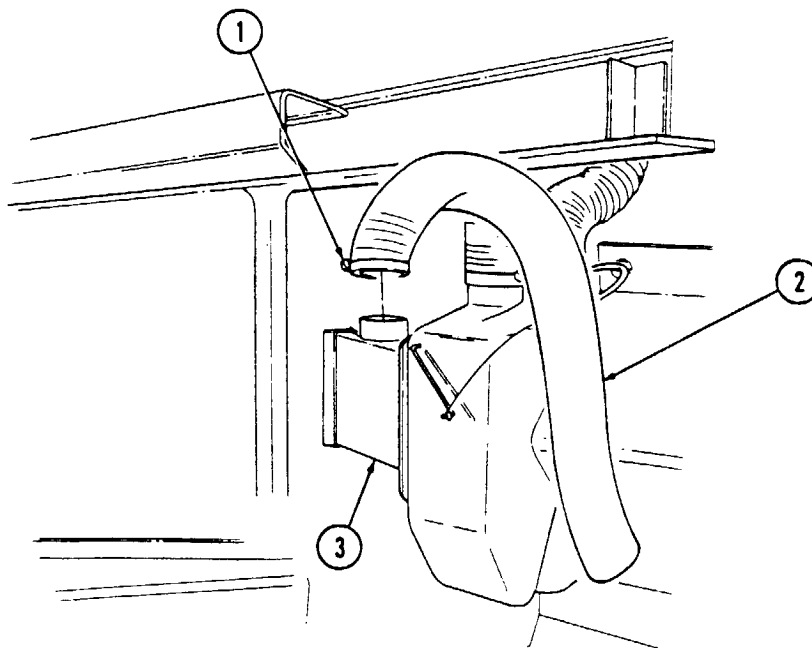

FOLLOW-ON TASK: Install diverter box cover (para. 12-55).

12-57. SWINGFIRE HEATER WATER JACKET REPLACEMENT

This task covers:

a. Removal

b. Installation

INITIAL SETUP:

Applicable Models

M966, M966A1, M996, M996A1, M997,
M997A1, M997A2, M998, M998A1, M1025,
M1025A1, M1025A2, M1037, M1038, M1038A1

Tools

General mechanic's tool kit:
automotive (Appendix B, Item 1)

Manual References

TM 9-2320-280-24P

Equipment Condition

⌞ Battery ground cable disconnected (para. 4-73).
⌞ Cooling system drained as required (para. 3-60).

a. Removal

1. Remove clamp (2) and inlet hose (1) from water jacket (3).
2. Remove clamp (6) and outlet hose (4) from water jacket (3).
3. Remove nut (10), washer (9), washer (11) and chain retainer (8) from U-clamp assembly (7).
4. Remove three nuts (12), washers (13), two U-bolts (5), and water jacket (3) from two U-clamp assemblies (7).

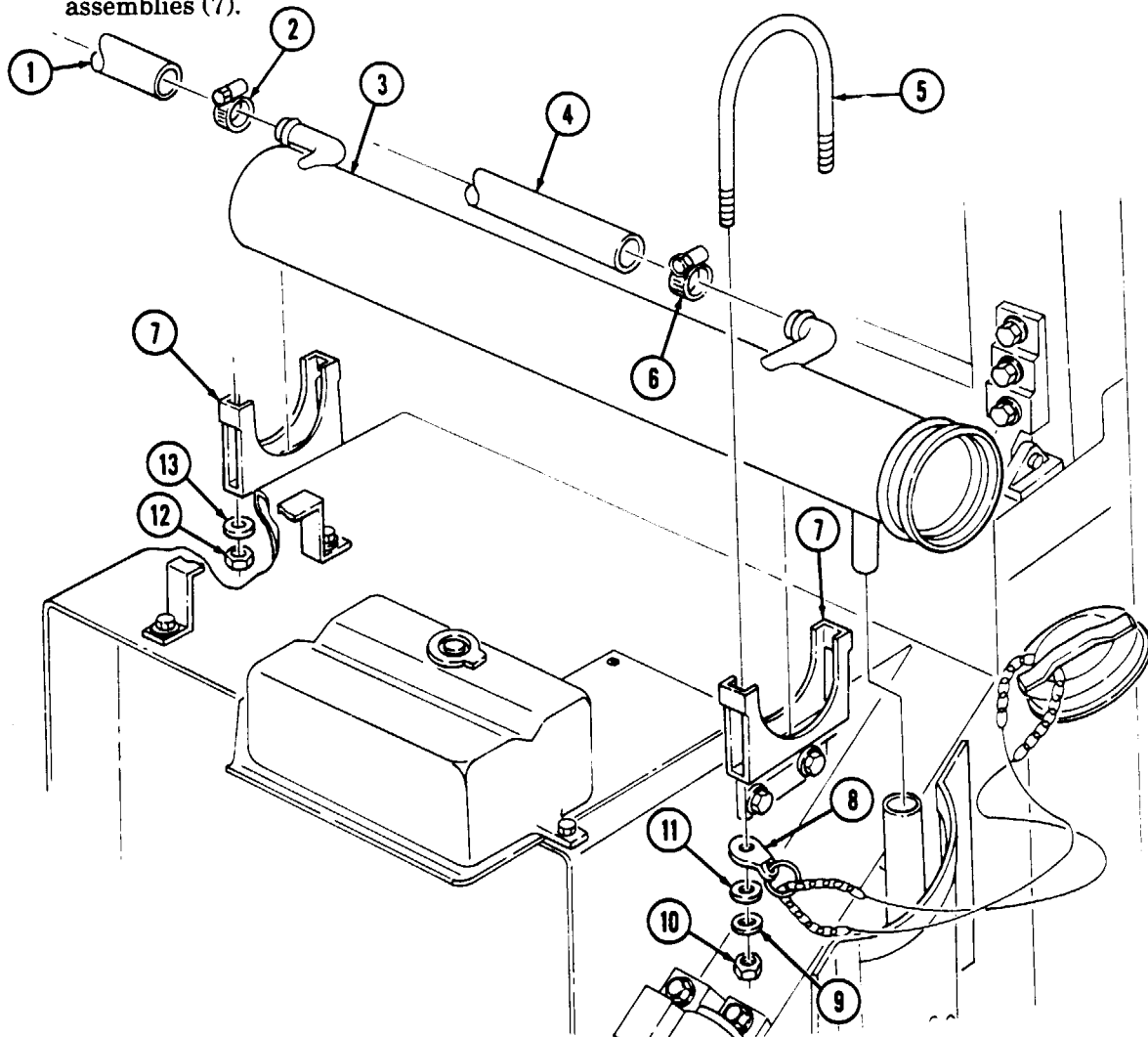

12-57. SWINGFIRE HEATER WATER JACKET REPLACEMENT (Cont'd)

b. Installation

1. Install water jacket (3) on two U-clamp assemblies (7) with two U-bolts (5), three washers (13), and nuts (12).
2. Install chain retainer (8) on U-clamp assembly (7) with washer (11), washer (9), and nut (10).
3. Install outlet hose (4) on water jacket (3) with clamp (6).
4. Install inlet hose (1) on water jacket (3) with clamp (2).

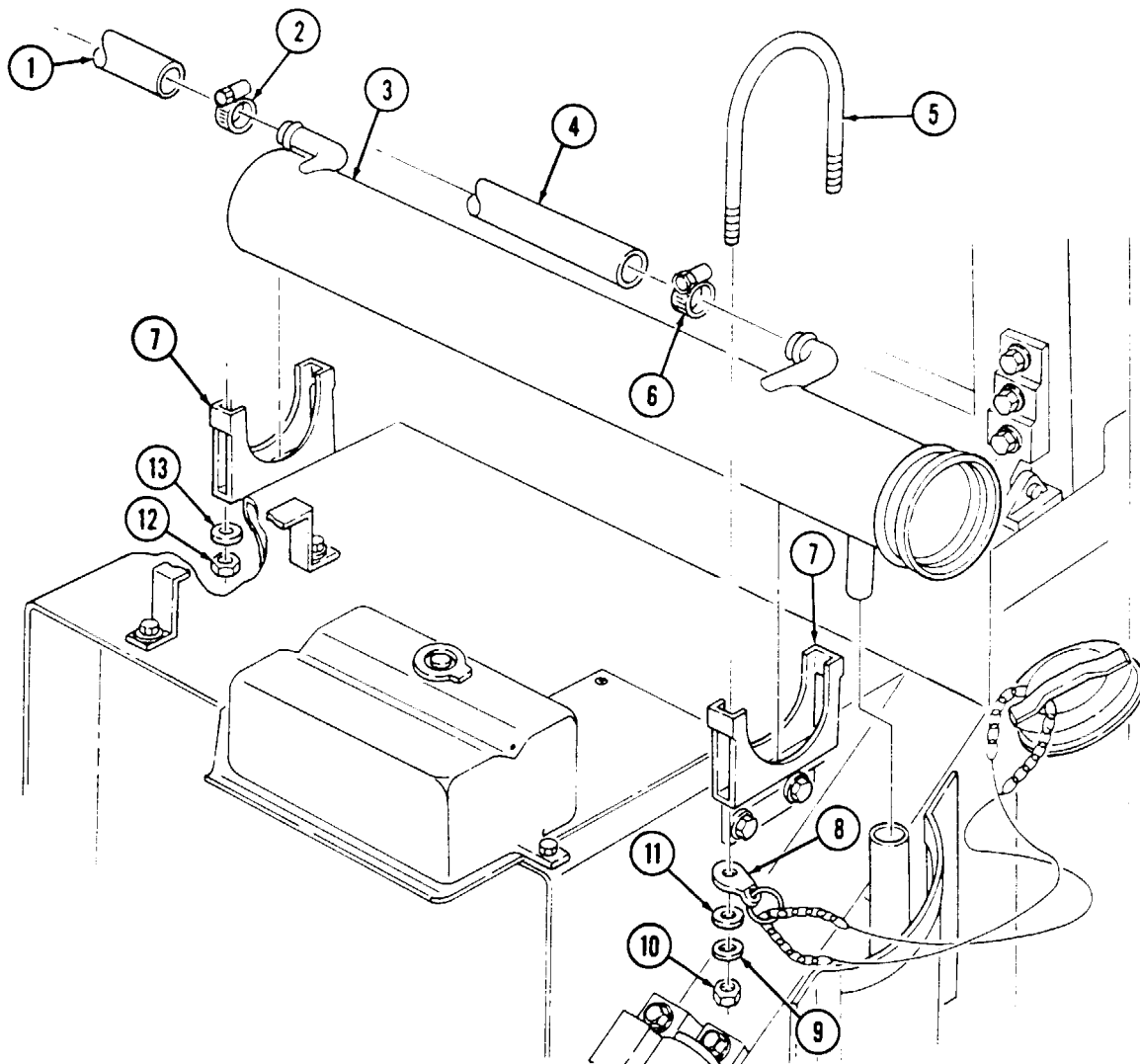

FOLLOW-ON TASKS: Ž Fill cooling system (para. 3-60).
 Ž Connect battery ground cable (para. 4-73).

12-58. SWINGFIRE HEATER U-CLAMPS REPLACEMENT

This task covers:

a. Removal

b. Installation

INITIAL SETUP:

Applicable Models

M966, M966A1, M996, M996A1, M997, M997A1, M997A2, M998, M998A1, M1025, M1025A1, M1025A2, M1037, M1038, M1038A1

Tools

General mechanic's tool kit:
automotive (Appendix B, Item 1)

Materials/Parts

Four lockwashers (Appendix G, Item 133)

Personnel Required

One mechanic
One assistant

Manual References

TM 9-2320-280-24P

Equipment Condition

- Water jacket removed (para. 12-57).
- Wiring harness and relay disconnected (para. 12-67).

a. Removal

1. Remove two capscrews (8), lockwashers (7), bracket (5), and U-clamp assembly (6) from cowl (9). Discard lockwashers (7).
2. Remove two capscrews (1), lockwashers (2), plate (4), and U-clamp assembly (3) from cowl (9). Discard lockwashers (2).

b. Installation

1. Install U-clamp assembly (3) and plate (4) on cowl (9) with two lockwashers (2) and capscrews (1).
2. Install U-clamp assembly (6) and bracket (5) on cowl (9) with two lockwashers (7) and capscrews (8).

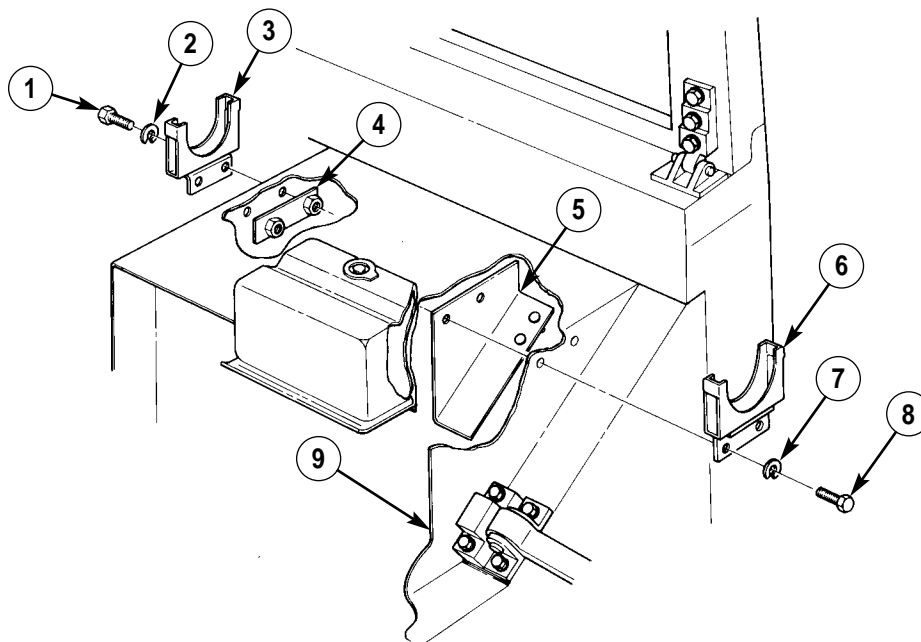

FOLLOW-ON TASKS: • Connect wiring harness and relay (para. 12-67).
• Install water jacket (para. 12-57).

12-59. SWINGFIRE HEATER BRUSHGUARD AND SHIELD ASSEMBLY REPLACEMENT

This task covers:

a. Removal

b. Installation

INITIAL SETUP:

Applicable Models

M966, M966A1, M996, M996A1, M997,
M997A1, M997A2, M998, M998A1, M1025,
M1025A1, M1025A2, M1037, M1038, M1038A1

Tools

General mechanic's tool kit:
automotive (Appendix B, Item 1)

Manual References

TM 9-2320-280-24P

Personnel Required

One mechanic
One assistant

General Safety Instructions

Do not touch hot exhaust system components
with bare hands.

WARNING

Do not touch hot exhaust system components with bare hands.
Severe injury will result.

a. Removal

Remove eight nuts (3), capscrews (1), washers (2), and brushguard and shield assembly (4) from cowl (5).

b. Installation

Install brushguard and shield assembly (4) on cowl (5) with eight washers (2), capscrews (1), and nuts (3).

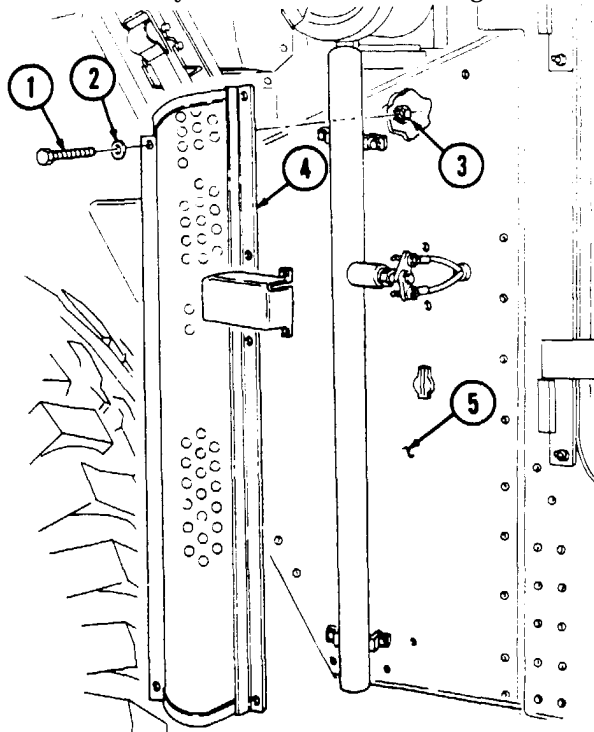

12-60. SWINGFIRE HEATER EXHAUST PIPE ASSEMBLY REPLACEMENT

This task covers:

a. Removal

b. Installation

INITIAL SETUP:

Applicable Models

M966, M966A1, M996, M996A1, M997,
M997A1, M997A2, M998, M998A1, M1025,
M1025A1, M1025A2, M1037, M1038, M1038A1

Tools

General mechanic's tool kit:
automotive (Appendix B, Item 1)

Manual References

TM 9-2320-280-24P

Equipment Condition

- Ž Brushguard and shield assembly removed (para. 12-59).
- Ž Battery ground cable disconnected (para. 4-73).

General Safety Instructions

Do not touch hot exhaust system components with bare hands.

WARNING

Do not touch hot exhaust system components with bare hands.
Severe injury will result.

a. Removal

1. Remove two screws (6) and harness leads 81B (5) and 81E (4) from thermal switch (7).
2. Remove four nuts (3), washers (2), capscrews (1), and exhaust pipe (8) from cowl (9).
3. Remove thermal switch (7) from exhaust pipe (8).

b. Installation

1. Install thermal switch (7) on exhaust pipe (8).
2. Install exhaust pipe (8) on cowl (9) with four capscrews (1), washers (2), and nuts (3).
3. Connect harness leads 81E (4) and 81B (5) to thermal switch (7) with two screws (6).

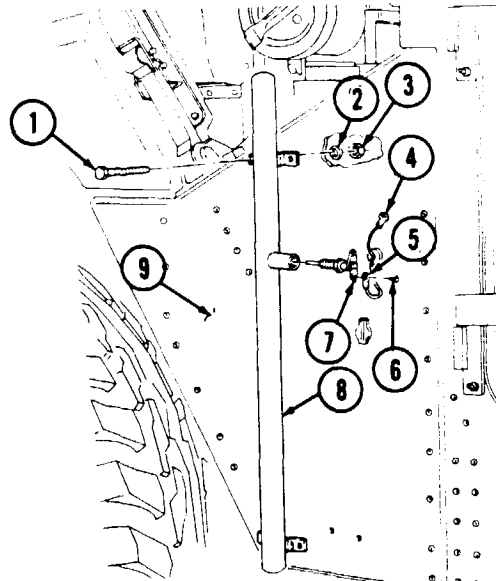

FOLLOW-ON TASKS: Ž Install brushguard and shield assembly (para. 12-59).
Ž Connect battery ground cable (para. 4-73).

12-61. SWINGFIRE HEATER WINDSHIELD WASHER RESERVOIR PLATE REPLACEMENT

This task covers:

a. Removal

b. Installation

INITIAL SETUP:

Applicable Models

M966, M966A1, M996, M996A1, M997, M997A1, M997A2, M998, M998A1, M1025, M1025A1, M1025A2, M1037, M1038, M1038A1

Tools

General mechanic's tool kit:
automotive (Appendix B, Item 1)

Materials/Parts

Two blind rivets (Appendix G, Item 257)

Manual References

TM 9-2320-280-24P

Equipment Condition

- Protective control box removed (para. 4-5).
- Windshield washer reservoir removed (para. 10-75).

NOTE

For instructions on replacement of rivets, refer to para. 10-66.

a. Removal

Remove two rivets (1) and plate (2) from cowl (3).

b. Installation

Install plate (2) on cowl (3) with two rivets (1).

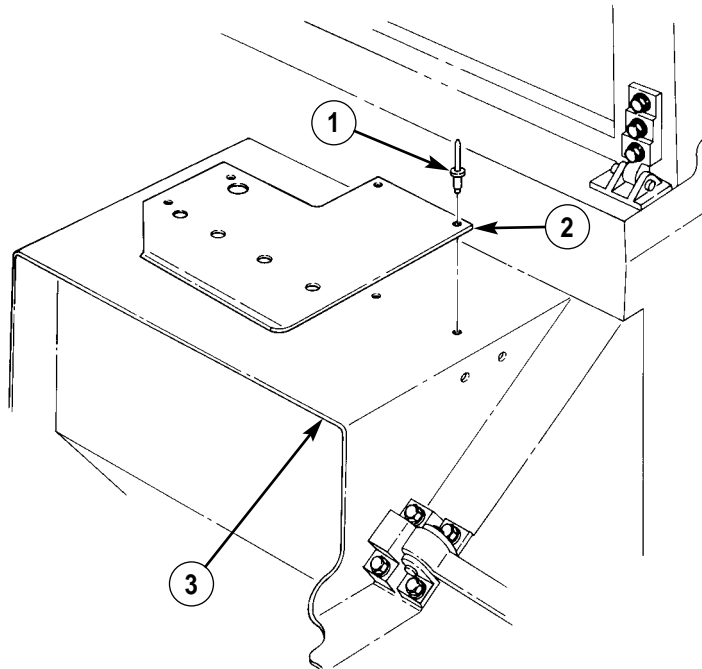

- FOLLOW-ON TASKS:**
- Install windshield washer reservoir (para. 10-75).
 - Install protective control box (para. 4-5).

12-62. SWINGFIRE HEATER HOOD GUARD REPLACEMENT

This task covers:

a. Removal

b. Installation

INITIAL SETUP:

Applicable Models

M966, M966A1, M996, M996A1, M997,
M997A1, M997A2, M998, M998A1, M1025,
M1025A1, M1025A2, M1037, M1038, M1038A1

Materials/Parts

Eleven blind rivets (Appendix G, Item 258)

Manual References

TM 9-2320-280-24P

Tools

General mechanic's tool kit:
automotive (Appendix B, Item 1)

NOTE

For instructions on replacement of rivets, refer to para. 10-66.

a. Removal

Remove eleven rivets (1) and guard (2) from hood (3).

b. Installation

Install guard (2) on hood (3) with eleven rivets (1).

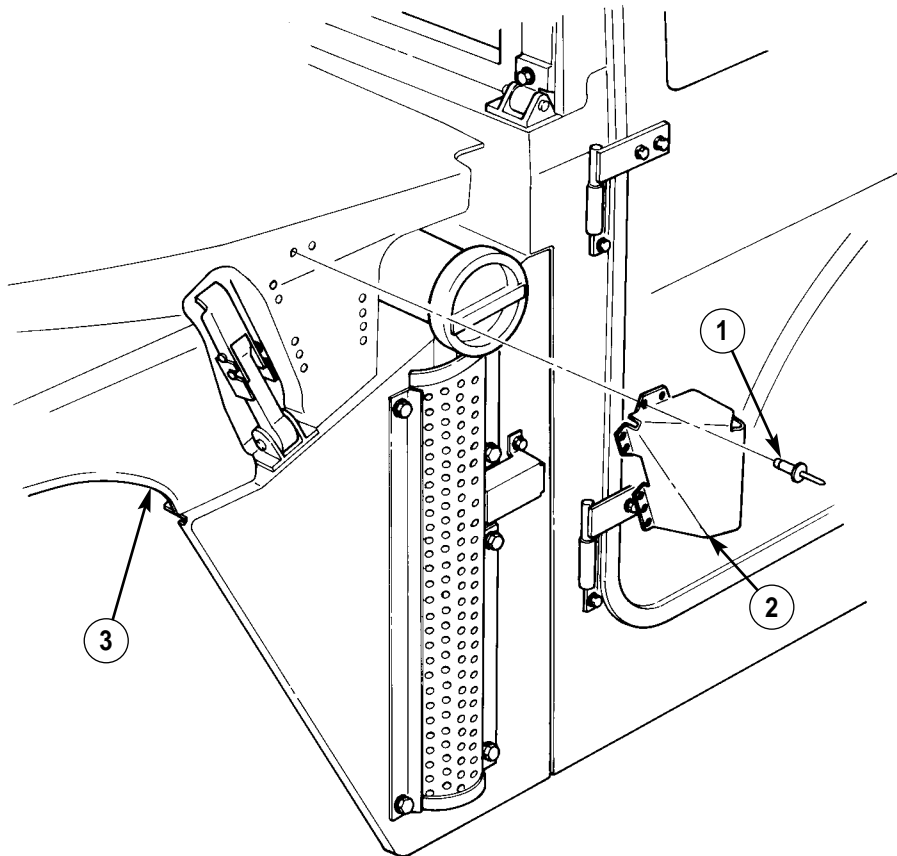

12-63. SWINGFIRE HEATER RADIATOR LOWER TUBE ASSEMBLY REPLACEMENT

This task covers:

a. Removal

b. Installation

INITIAL SETUP:

Applicable Models

M966, M966A1, M996, M996A1, M997, M997A1, M997A2, M998, M998A1, M1025, M1025A1, M1025A2, M1037, M1038, M1038A1

Tools

General mechanic's tool kit:
automotive (Appendix B, Item 1)

Materials/Parts

Two locknuts (Appendix G, Item 70)

Manual References

TM 9-2320-280-24P

Equipment Condition

Cooling system drained (para. 3-60).

a. Removal

1. Remove two locknuts (5), washers (3), capscrews (2), and washers (3) from radiator lower tube assembly (12) and frame bracket (4). Discard locknuts (5).
2. Loosen clamp (9) and disconnect water pump inlet hose (8) from radiator lower tube assembly (12).
3. Loosen clamp (6) and disconnect swingfire heater pump hose (7) from radiator lower tube assembly (12).
4. Loosen clamp (11) and disconnect surge tank hose (10) from radiator lower tube assembly (12).
5. Loosen clamp (13) and disconnect lower radiator hose (1) from radiator lower tube assembly (12).
6. Remove radiator lower tube assembly (12).
7. Remove clamps (9), (6), (11), and (13) from water pump inlet hose (8), swingfire heater pump hose (7), surge tank hose (10), and lower radiator hose (1).

b. Installation

1. Install clamps (9), (6), (11), and (13) on water pump inlet hose (8), swingfire heater pump hose (7), surge tank hose (10), and lower radiator hose (1).
2. Connect lower radiator hose (1) to radiator lower tube assembly (12) with clamp (13).
3. Connect surge tank hose (10) to radiator lower tube assembly (12) with clamp (11).
4. Connect swingfire heater pump hose (7) to radiator lower tube assembly (12) with clamp (6).
5. Connect water pump inlet hose (8) to radiator lower tube assembly (12) with clamp (9).
6. Connect radiator lower tube assembly (12) to bracket (4) with two washers (3), capscrews (2), washers (3), and locknuts (5).

12-63. SWINGFIRE HEATER RADIATOR LOWER TUBE ASSEMBLY REPLACEMENT (Cont'd)

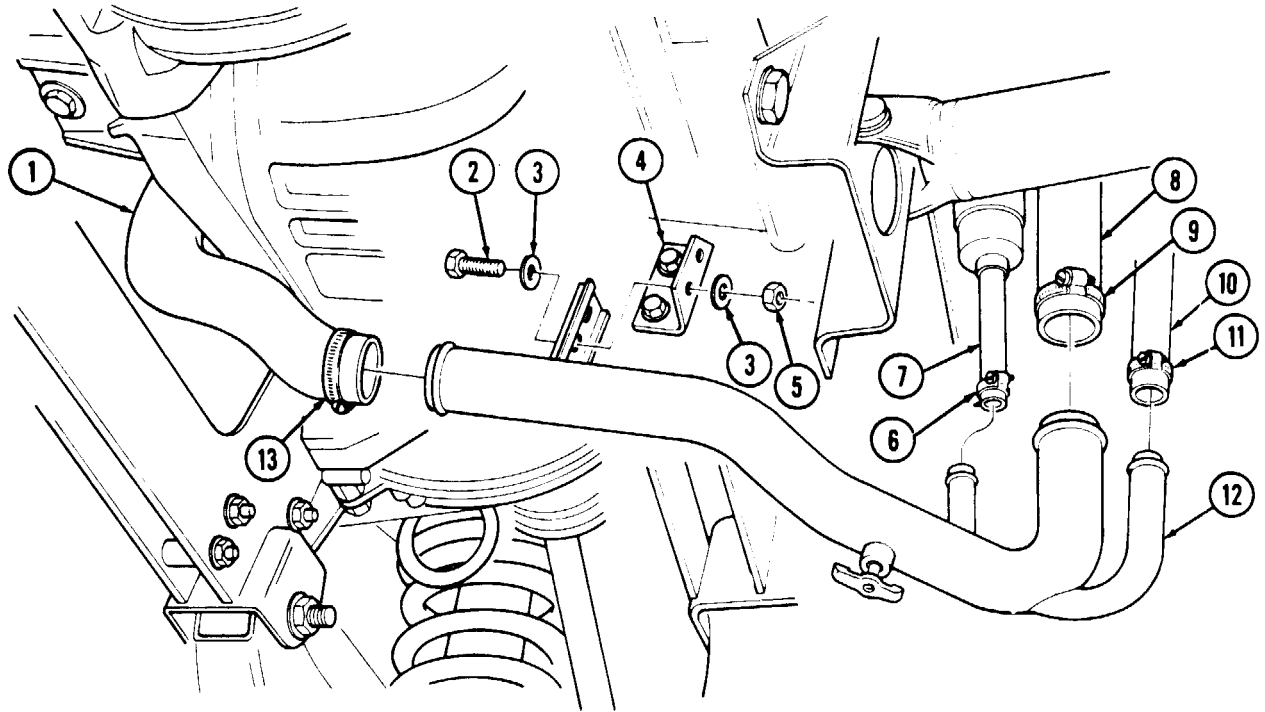

FOLLOW-ON TASKS: Fill cooling system (para. 3-60).

12-64. SWINGFIRE HEATER INLET HOSE AND TEE REPLACEMENT

This task covers:

- a. Removal
- b. Installation

INITIAL SETUP:

Applicable Models

M966, M966A1, M996, M996A1, M997, M997A1, M997A2, M998, M998A1, M1025, M1025A1, M1025A2, M1037, M1038, M1038A1

Tools

General mechanic's tool kit:
automotive (Appendix B, Item 1)

Manual References

TM 9-2320-280-24P

Equipment Condition

- ⌘ Battery ground cable disconnected (para. 4-73).
- ⌘ Air horn removed (para. 3-14).
- ⌘ Cooling system drained as required (para. 3-60).

a. Removal

1. Loosen clamp (2) and disconnect heater inlet hose (1) from tee (3).
2. Loosen clamps (11) and (4) and remove tee (3) from connector hose (10) and hose (5).
3. Loosen clamp (9) and disconnect connector hose (10) from CDR valve tube (8).
4. Loosen clamp (6) and disconnect hose (5) from water crossover nipple (7).
5. Remove clamps (9), (11), (4), (2), and (6) from connector hose (10), hose (5), and inlet hose (1).

b. Installation

1. Install clamps (9), (11), (4), (2), and (6) on connector hose (10), hose (5), and inlet hose (1).
2. Install connector hose (10) on CDR valve tube (8) with clamp (9).
3. Install hose (5) on water crossover nipple (7) with clamp (6).
4. Install tee (3) on connector hose (10) and hose (5) with clamps (4) and (11).
5. Install heater inlet hose (1) on tee (3) with clamp (2).

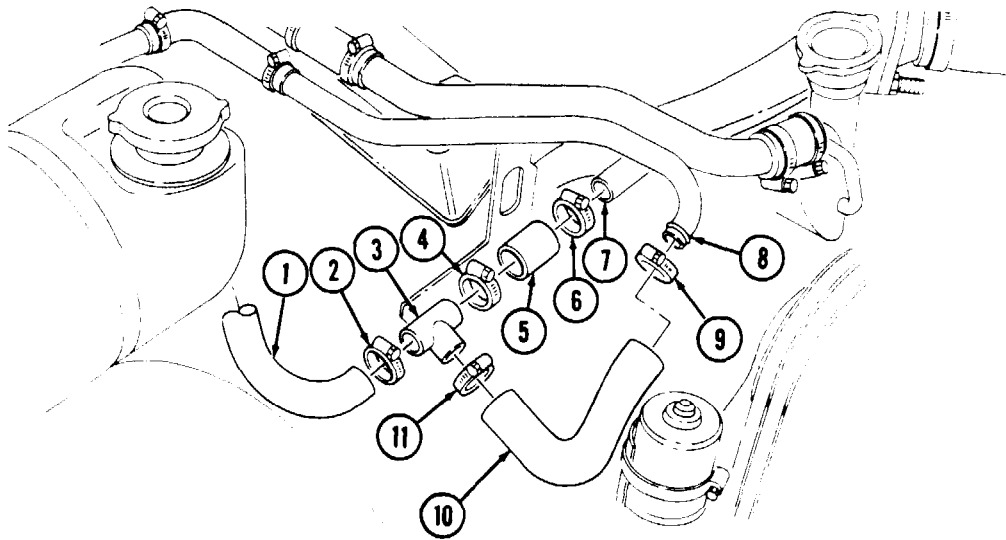

- FOLLOW-ON TASKS:**
- ⌘ Install air horn (para. 3-14).
 - ⌘ Fill cooling system (para. 3-60).
 - ⌘ Connect battery ground cable (para. 4-73).

12-65. SWINGFIRE HEATER PUMP ASSEMBLY, BRACKET, AND LOWER HOSE REPLACEMENT

This task covers:

a. Removal

b. Installation

INITIAL SETUP:

Applicable Models

M966, M966A1, M996, M996A1, M997, M997A1, M997A2, M998, M998A1, M1025, M1025A1, M1025A2, M1037, M1038, M1038A1

Tools

General mechanic's tool kit:
automotive (Appendix B, Item 1)

Materials/Parts

Two lockwashers (Appendix G, Item 191)

Manual References

TM 9-2320-280-24P

Equipment Condition

- Battery ground cable disconnected (para. 4-73).
- Cooling system drained as required (para. 3-60).

NOTE

Prior to removal, tag leads for installation.

a. Removal

1. Disconnect lead 81G (2) and ground wire lead (1) from heater pump leads (3).
2. Loosen clamp (9) and disconnect outlet hose (10) from heater pump (4).
3. Loosen clamps (5) and (7) and disconnect inlet hose (6) from heater pump (4) and radiator lower tube assembly (8).
4. Remove clamps (5) and (7) from inlet hose (6).
5. Remove clamp (11) and heater pump (4) from bracket (15).
6. Remove two nuts (14), lockwashers (13), and bracket (15) from water pump studs (12). Discard lockwashers (13).

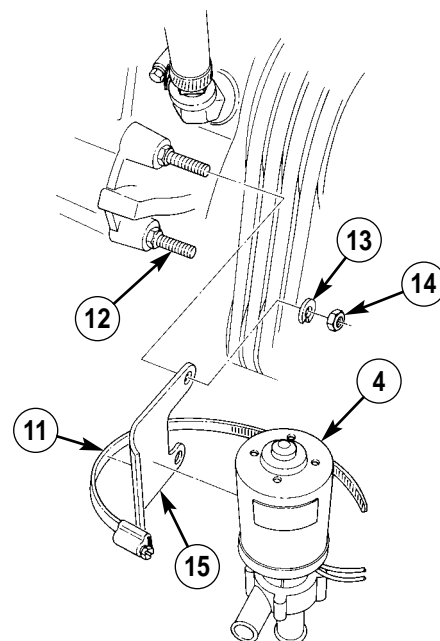
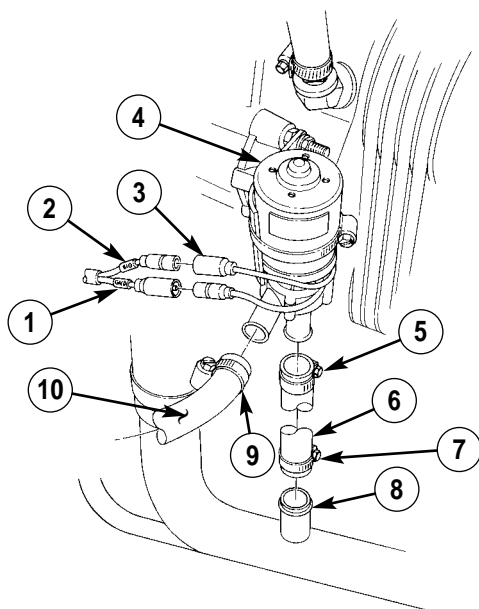

12-65. SWINGFIRE HEATER PUMP ASSEMBLY, BRACKET, AND LOWER HOSE REPLACEMENT (Cont'd)

b. Installation

1. Install bracket (5) on water pump studs (1) with two lockwashers (2) and nuts (3).
2. Install heater pump (4) on bracket (5) with clamp (6).
3. Install clamps (9) and (11) on inlet hose (10).
4. Install inlet hose (10) on radiator lower tube assembly (12) and heater pump (4) with clamps (9) and (11).
5. Install clamp (14) on outlet hose (13). Connect outlet hose (13) to heater pump (4) with clamp (14).
6. Connect ground wire lead (15) and lead 81G (7) to heater pump leads (8).

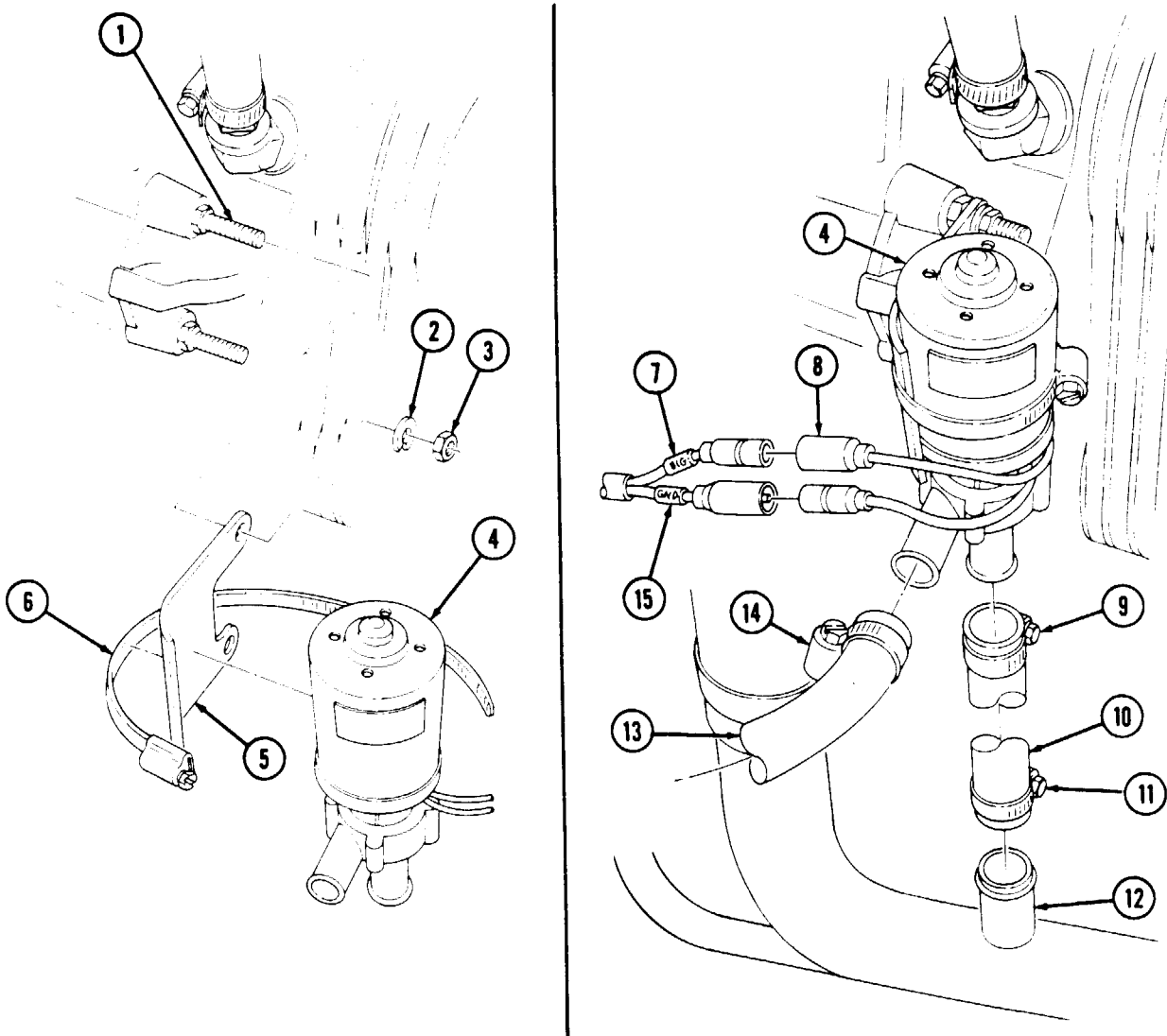

FOLLOW-ON TASKS: \checkmark Fill cooling system (para. 3-60).
 \checkmark Connect battery ground cable (para. 4-73).

12-66. SWINGFIRE HEATER WATER JACKET TO PUMP AND TEE HOSES REPLACEMENT

This task covers:

a. Removal

b. Installation

INITIAL SETUP:

Applicable Models

M966, M966A1, M996, M996A1, M997, M997A1, M997A2, M998, M998A1, M1025, M1025A1, M1025A2, M1037, M1038, M1038A1

Tools

General mechanic's tool kit:
automotive (Appendix B, Item 1)

Materials/Parts

Three tiedown straps (Appendix G, Item 312)

Manual References

TM 9-2320-280-24P

Equipment Condition

- Cooling system drained as required (para. 3-60).
- Air horn removed (para. 3-14).

a. Removal

1. Remove three tiedown straps (5) from inlet hose (8) and outlet hose (6). Discard tiedown straps (5).
2. Remove nut (15) and screw (4) from two clamps (16), inlet hose (8), outlet hose (6) and support (2).
3. Remove screw (3) and support (2) from "A" beam (1).
4. Remove clamp (7) and outlet hose (6) from water jacket (10).
5. Remove clamp (9) and inlet hose (8) from water jacket (10).
6. Remove clamp (12) and outlet hose (6) from tee (11).
7. Remove clamp (14) and inlet hose (8) from heater pump (13).
8. Remove clamps (9), (12), (7), (14), and (16) from inlet and outlet hoses (6) and (8).

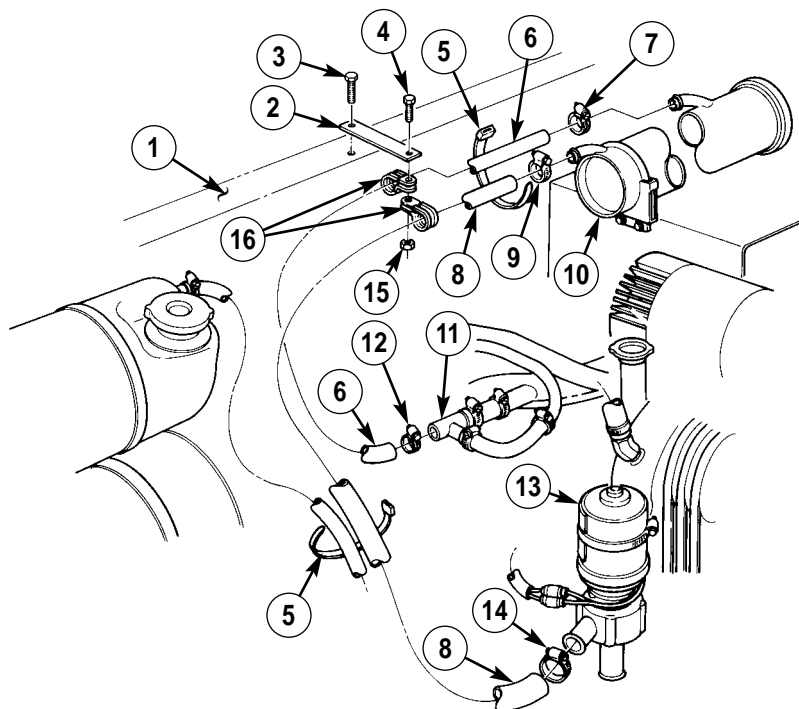

**12-66. SWINGFIRE HEATER WATER JACKET TO PUMP AND TEE HOSES REPLACEMENT
(Cont'd)**

b. Installation

1. Install clamps (16), (14), (7), (12), and (9) on inlet and outlet hoses (6) and (8).
2. Install outlet hose (8) on heater pump (13) with clamp (14).
3. Install inlet hose (6) on tee (11) with clamp (12).
4. Connect inlet hose (6) to water jacket (10) with clamp (7).
5. Connect outlet hose (8) to water jacket (10) with clamp (9).
6. Install support (2) on "A" beam (1) with screw (3).
7. Connect inlet and outlet hoses (6) and (8) with clamps (16) on support (2) with screw (4) and nut (15).
8. Install three tiedown straps (5) on inlet and outlet hoses (6) and (8).

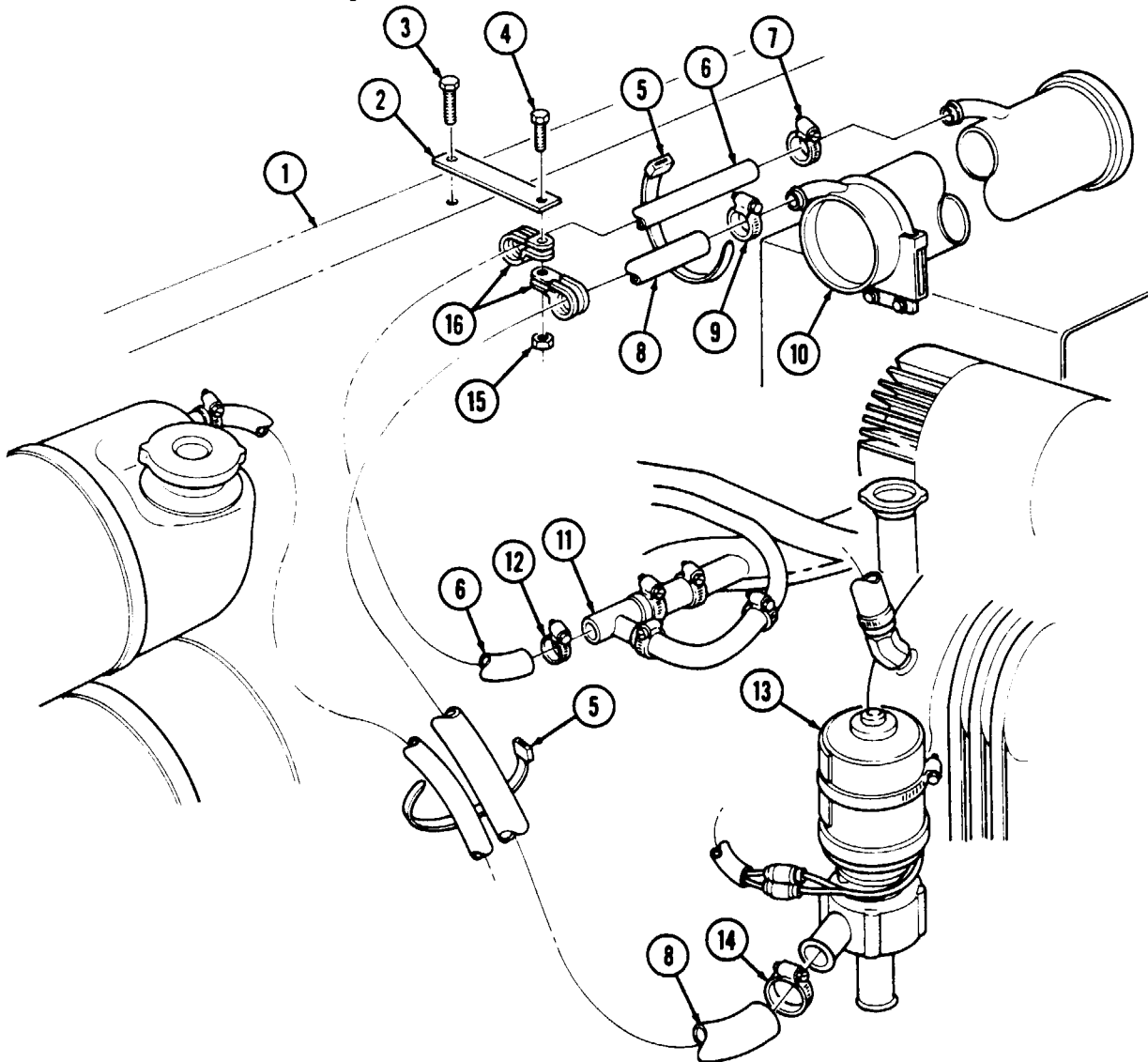

FOLLOW-ON TASKS: Ž Fill cooling system (para. 3-60).
 Ž Install air horn (para. 3-14).

12-67. SWINGFIRE RELAY AND HARNESS ASSEMBLY REPLACEMENT

This task covers:

a. Removal

b. Installation

INITIAL SETUP:

Applicable Models

M966, M966A1, M996, M996A1, M997, M997A1, M997A2, M998, M998A1, M1025, M1025A1, M1025A2, M1037, M1038, M1038A1

Tools

General mechanic's tool kit:
automotive (Appendix B, Item 1)

Materials/Parts

Lockwasher (Appendix G, Item 161)

Manual References

TM 9-2320-280-24P

Equipment Condition

- Battery ground cable disconnected (para. 4-73).
- Brushguard and shield assembly removed (para. 12-59).

a. Removal

CAUTION

Use care when removing harness. Failure to do so will cause damage to harness.

NOTE

Prior to removal, tag leads for installation.

1. Remove screw (16) and body wiring harness (17) from bracket (15).
2. Remove two screws (6) and leads 81E (8) and 81B (10) from relay (7).
3. Remove two screws (12) and leads 81B (11) and GND (9) from relay (7).
4. Remove two nuts (5) and relay (7) from bracket (15).
5. Remove two screws (1) and leads 81E (26) and 81B (2) from thermal switch (3).
6. Disconnect lead 81B (18) from connector (20).
7. Disconnect lead 81B (13) from lead 81A (14) and remove harness assembly (4).
8. Remove nipple (19) from lead 81B (18).
9. Remove nut (21), lockwasher (22), and connector (20) from cover (25). Discard lockwasher (22).
10. Remove grommet (23) from cowl (24).

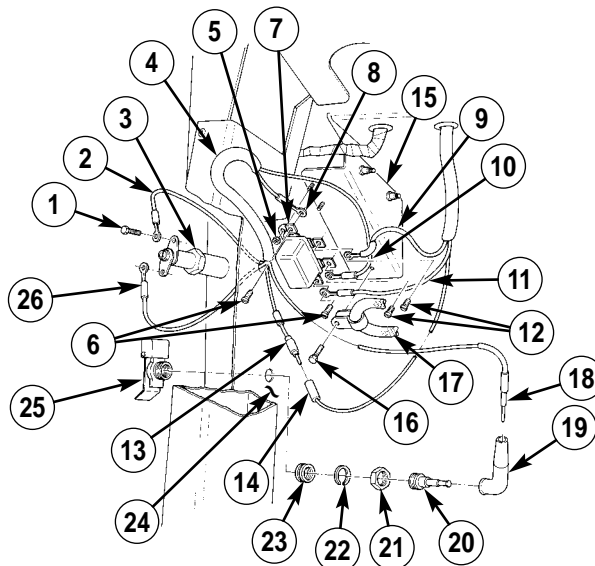

12-67. SWINGFIRE RELAY AND HARNESS ASSEMBLY REPLACEMENT (Cont'd)

b. Installation

1. Install grommet (23) to cowl (24).
2. Install cover (25) and connector (20) with lockwasher (22) and nut (21).
3. Install nipple (19) on lead 81B (18).

CAUTION

Use care when routing harness. Failure to do so will cause damage to harness.

4. Install harness assembly (4) inside cowl (24) and connect lead 81B (13) to 81A (14).
5. Route leads 81E (26) and 81B (2) through cowl (24).
6. Connect lead 81B (18) to connector (20).
7. Connect leads 81B (2) and 81E (26) to thermal switch (3) with two screws (1).
8. Install relay (7) on bracket (15) with two nuts (5).
9. Connect leads 81G (11) and GND (9) to relay (7) with two screws (12).
10. Connect leads 81B (10) and 81E (8) to relay (7) with two screws (6).
11. Connect body wiring harness (17) to bracket (15) with screw (16).

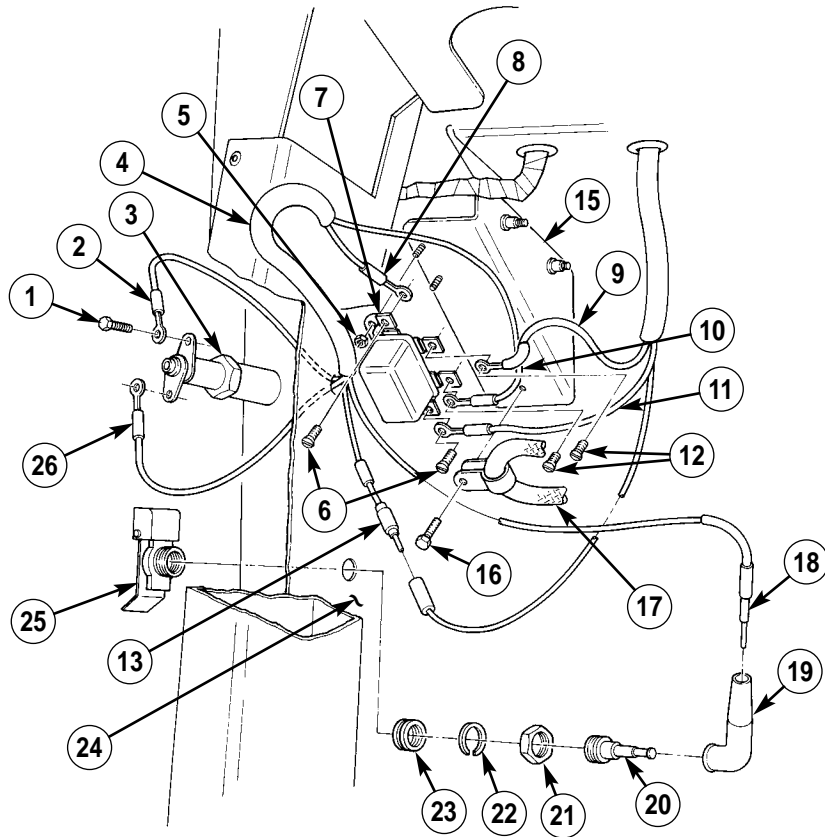

- FOLLOW-ON TASKS:
- Install brushguard and shield assembly (para. 12-59).
 - Connect battery ground cable (para. 4-73).

12-68. SWINGFIRE HEATER HARNESS ASSEMBLY REPLACEMENT

This task covers:

a. Removal

b. Installation

INITIAL SETUP:

Applicable Models

M966, M966A1, M996, M996A1, M997, M997A1, M997A2, M998, M998A1, M1025, M1025A1, M1025A2, M1037, M1038, M1038A1

Tools

General mechanic's tool kit:
automotive (Appendix B, Item 1)

Materials/Parts

Four tiedown straps (Appendix G, Item 312)

Manual References

TM 9-2320-280-24P

Equipment Condition

- Battery ground cable disconnected (para. 4-73).
- Air horn removed (para. 3-14).

a. Removal

CAUTION

Use care when removing harness. Failure to do so will cause damage to harness.

NOTE

Prior to removal, tag leads for installation.

1. Remove two screws (9) and disconnect lead 81G (8) and GND (4) from relay (1).
2. Disconnect lead 81A (6) from lead 81B (7).
3. Pull harness assembly (5) out through cowl (2).
4. Remove grommet (3) from cowl (2).
5. Remove three tiedown straps (10) from harness assembly (5) and "A" beam (11). Discard tiedown straps (10).
6. Remove tiedown strap (14) from harness assembly (5) and air horn bracket (13). Discard tiedown strap (14).
7. Disconnect lead 81G (8) and GND (4) from heater pump leads (12).

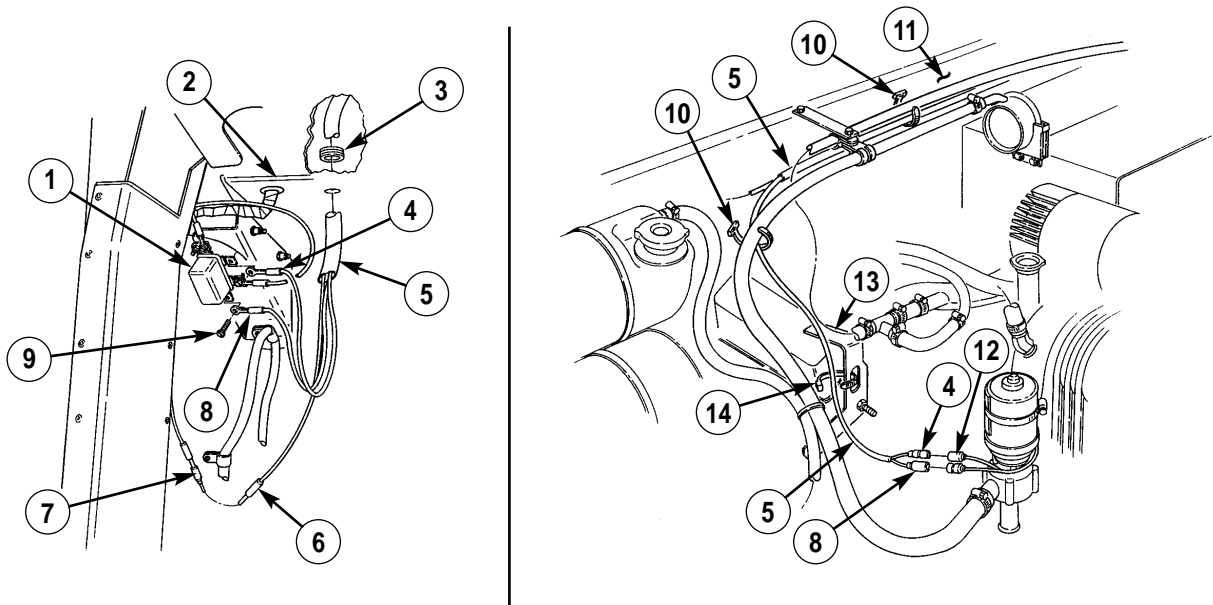

12-68. SWINGFIRE HEATER HARNESS ASSEMBLY REPLACEMENT (Cont'd)

- 8. Deleted.
- 9. Remove nut (19) from lead GND (4) and negative battery terminal (18) inside battery box (17).
- 10. Disconnect GND (4) from negative battery terminal (18) and lead 81A (6) from circuit breaker (20).
- 11. Guide harness assembly (5) out through hole in battery box (17) and remove harness assembly (5) from vehicle.

b. Installation

CAUTION

Use care when routing harness. Failure to do so will cause damage to harness.

- 1. Position harness assembly (5) on right hand cowl (16) along right hand frame rail and vent line.
- 2. Guide harness assembly (5) through hole in battery box (17) and connect lead 81A (6) to circuit breaker (20) inside battery box (17).
- 3. Connect GND (4) to negative battery terminal (18) with nut (19).
- 4. Connect GND (4) and lead 81G (8) to heater pump leads (12).
- 5. Install harness assembly (5) under air horn bracket (13) with tiedown strap (14).
- 6. Install harness assembly (5) across "A" beam (11) with three tiedown straps (10).
- 7. Install grommet (3) to cowl (2).
- 8. Guide harness assembly (5) through grommet (3).
- 9. Connect lead 81A (6) to lead 81B (7).
- 10. Connect GND (4) and lead 81G (8) to relay (1) with two screws (9).

12-68. SWINGFIRE HEATER HARNESS ASSEMBLY REPLACEMENT (Cont'd)

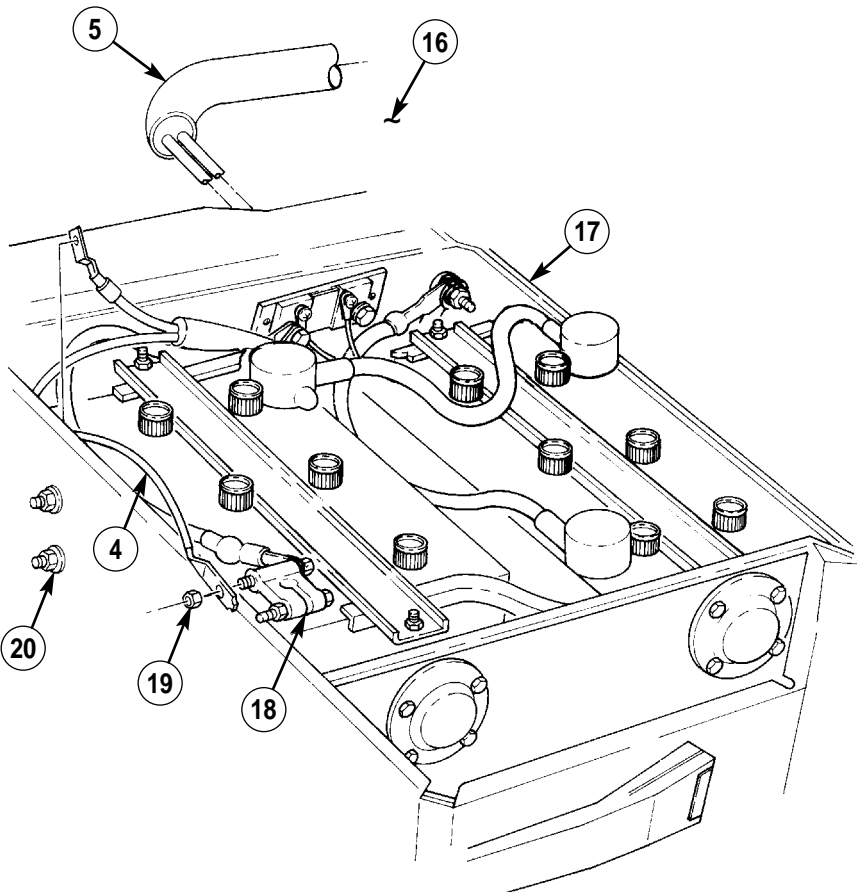
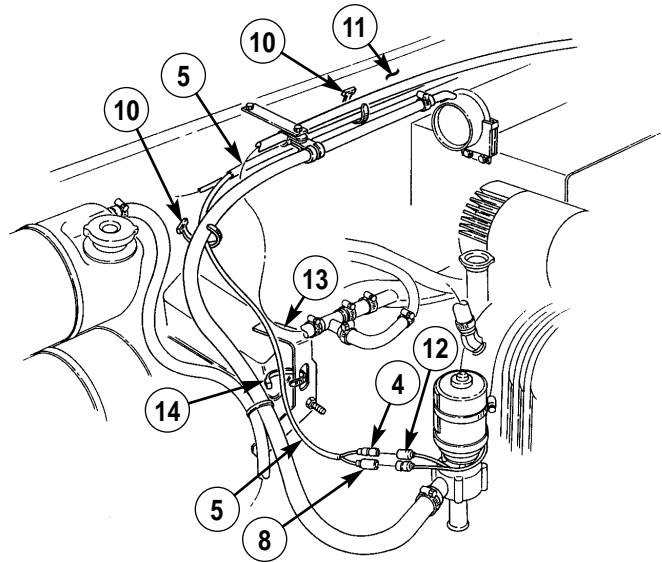
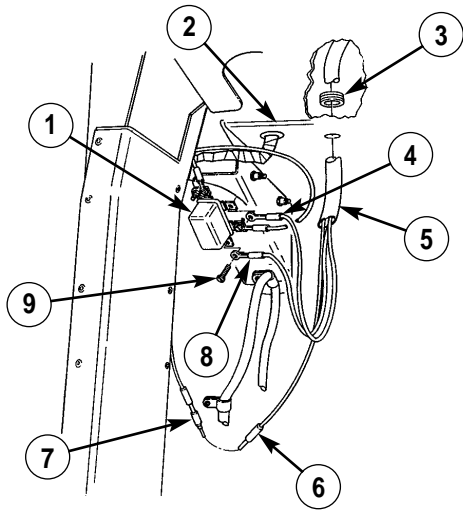

- FOLLOW-ON TASKS:**
- Install air horn (para. 3-14).
 - Lower and secure hood (TM 9-2320-280-10).
 - Connect battery ground cable (para. 4-73).

12-69. SWINGFIRE CIRCUIT BREAKER AND HARNESS LEAD REPLACEMENT

This task covers:

a. Removal

b. Installation

INITIAL SETUP:

Applicable Models

M966, M966A1, M996, M996A1, M997, M997A1, M997A2, M998, M998A1, M1025, M1025A1, M1025A2, M1037, M1038, M1038A1

Tools

General mechanic's tool kit:
automotive (Appendix B, Item 1)

Materials/Parts

Two lockwashers (Appendix G, Item 136)
Lockwasher (Appendix G, Item 141)

Manual References

TM 9-2320-280-24P

Equipment Condition

Battery ground cable disconnected (para. 4-73).

NOTE

Prior to removal, tag leads for installation.

a. Removal

1. Disconnect harness leads 81A (3) and 81A (4) from circuit breaker (1) inside battery box (9).
2. Remove two nuts (11), lockwashers (10), screws (2), and circuit breaker (1) from battery box (9). Discard lockwashers (10).
3. Remove nut (7), lockwasher (6), washer (5) and harness lead 81A (3) from power feed through stud (8). Discard lockwashers (6).

b. Installation

1. Install harness lead 81A (3) on power feed through stud (8) with washer (5), lockwasher (6), and nut (7).
2. Install circuit breaker (1) on battery box (9) with two screws (2), lockwashers (10), and nuts (11).
3. Connect harness leads 81A (3) and 81A (4) to circuit breaker (1).

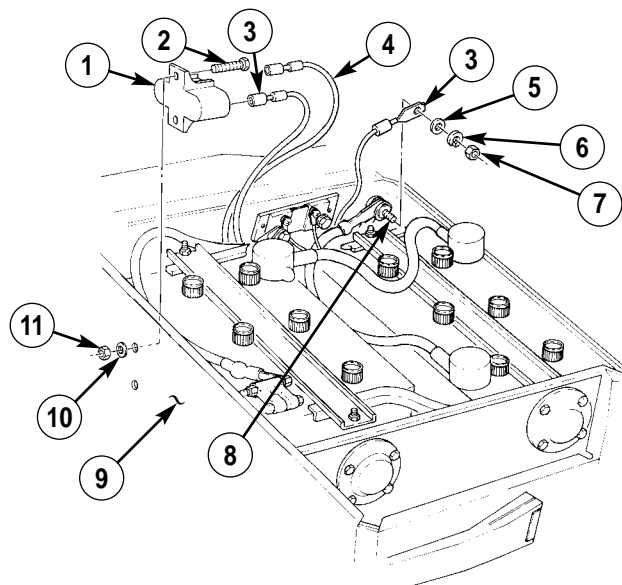

FOLLOW-ON TASK: Connect battery ground cable (para. 4-73).

12-70. SWINGFIRE WINDSHIELD WASHER PUMP HARNESS EXTENSION REPLACEMENT

This task covers:

a. Removal

b. Installation

INITIAL SETUP:

Applicable Models

M966, M966A1, M996, M996A1, M997, M997A1, M997A2, M998, M998A1, M1025, M1025A1, M1025A2, M1037, M1038, M1038A1

Tools

General mechanic's tool kit:
automotive (Appendix B, Item 1)

Materials/Parts

Tiedown strap (Appendix G, Item 312)

Manual References

TM 9-2320-280-10
TM 9-2320-280-24P

Equipment Condition

- Battery ground cable disconnected (para. 4-73).
- Hood raised and secured (TM 9-2320-280-10).

a. Removal

NOTE

Prior to removal, tag leads for installation.

1. Remove tiedown strap (8) from harness extension (7) and protective control box wiring harness (9). Discard tiedown strap (8).
2. Disconnect leads 71C (3) and 57D (6) from windshield washer pump leads 71C (2) and 57D (1).
3. Disconnect leads 71C (3) and 57D (6) from body wiring harness (4) under dash panel.
4. Pull harness extension (7) out through cowl (5) and remove harness extension (7) from vehicle.

b. Installation

1. Guide harness extension (7) through cowl (5).
2. Connect leads 71C (3) and 57D (6) to body wiring harness (4) under dash panel.
3. Connect leads 57D (6) and 71C (3) to windshield washer pump leads 71C (2) and 57D (1).
4. Install harness extension (7) on protective control box wiring harness (9) with tiedown strap (8).

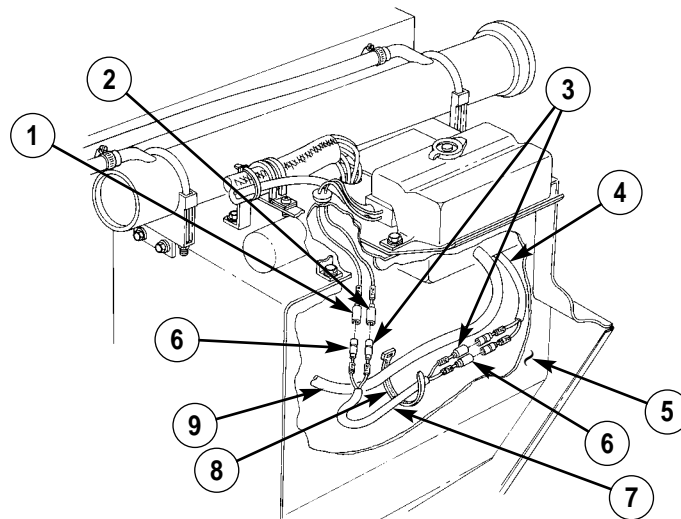

- FOLLOW-ON TASKS:
- Lower and secure hood (TM 9-2320-280-10).
 - Connect battery ground cable (para. 4-73).

Section V. ARCTIC WINTERIZATION CREW TOP KITS MAINTENANCE

12-71. ARCTIC WINTERIZATION CREW TOP KITS MAINTENANCE TASK SUMMARY

TASK PARA.	PROCEDURES	PAGE NO.
12-72.	Arctic Top Cover Assembly Replacement	12-105
12-73.	Arctic Curtain Assembly Replacement	12-106
12-74.	Arctic Curtain Angle Assembly Replacement	12-107
12-75.	Arctic Window Replacement	12-108
12-76.	Arctic Curtain Channel Assembly Replacement (2-Man Crew)	12-109
12-77.	Arctic Curtain Channel Assembly Replacement (4-Man Crew)	12-110
12-78.	Arctic Curtain Fastener Tape Hook Replacement	12-112
12-79.	Arctic Foam Insulation Strip Replacement	12-113

12-72. ARCTIC TOP COVER ASSEMBLY REPLACEMENT

This task covers:

a. Removal

b. Installation

INITIAL SETUP:

Applicable Models

M998, M998A1, M1037, M1038, M1038A1,
M1097, M1097A1, M1097A2

Manual References

TM 9-2320-280-24P

Tools

General mechanic's tool kit:
automotive (Appendix B, Item 1)

a. Removal

1. Unfasten eleven turnbuttons (8) from top cover (6) and "B" pillar (7).
2. Unfasten two turnbuttons (9) from top cover flaps (2) and "B" pillar (7).
3. Unfasten six turnbuttons (10) from top cover flaps (2) and horizontal rails (11).
4. Unfasten two turnbuttons (3) from top cover flaps (2) and windshield frame (4).
5. Fold top cover (6) toward front of vehicle and slide front bead (1) of top cover (6) from "A" pillar former assembly (5) and remove top cover (6).

b. Installation

1. Install top cover (6) by sliding front bead (1) of top cover (6) into "A" pillar former assembly (5).
2. Unfold top cover (6) toward rear of vehicle.
3. Install top cover flaps (2) on horizontal rails (11) with six turnbuttons (10).
4. Install top cover flaps (2) on "B" pillar (7) with two turnbuttons (9).
5. Install top cover (6) on "B" pillar (7) with eleven turnbuttons (8).
6. Install two top cover flaps (2) on windshield frame (4) with two turnbuttons (3).

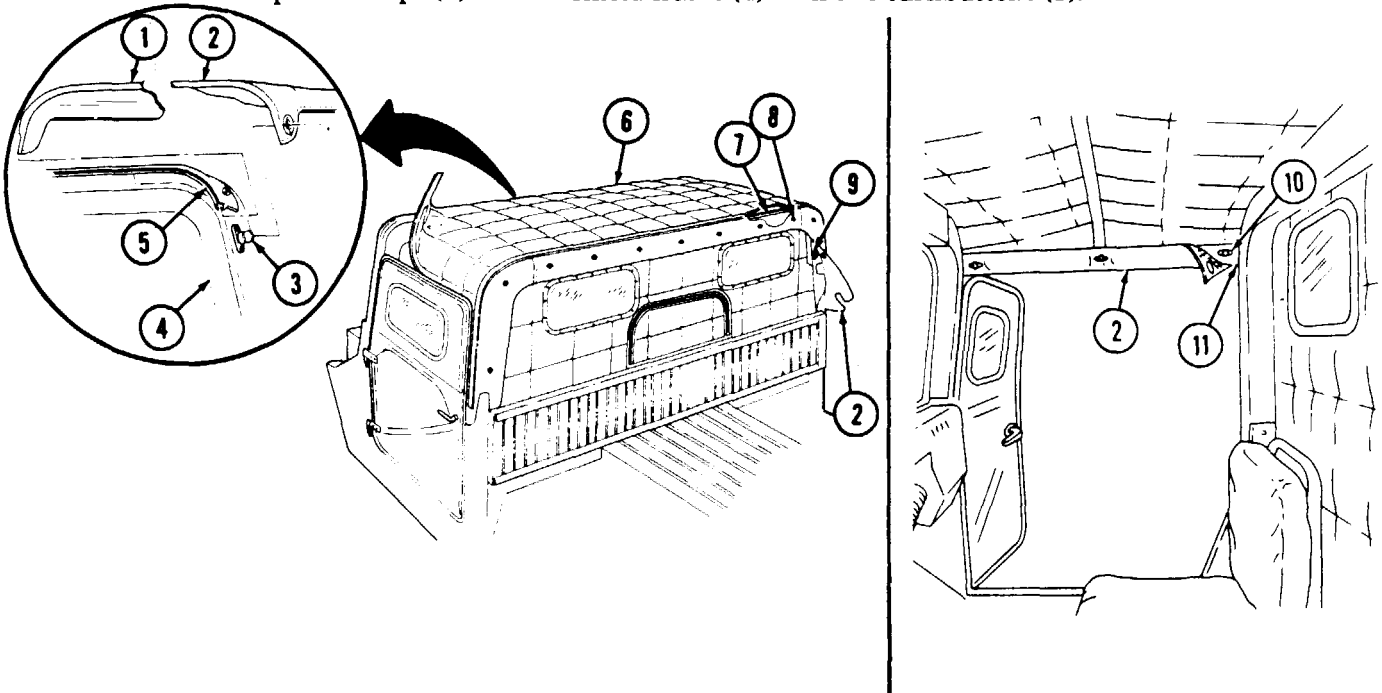

12-73. ARCTIC CURTAIN ASSEMBLY REPLACEMENT

This task covers:

a. Removal

b. Installation

INITIAL SETUP:

Applicable Models

M998, M998A1, M1037, M1038, M1038A1,
M1097, M1097A1, M1097A2

Manual References

TM 9-2320-280-24P

Tools

General mechanic's tool kit:
automotive (Appendix B, Item 1)

Equipment Condition

Ž Companion seat back removed (para. 10-34).
Ž Arctic top cover assembly removed (para. 12-72).

a. Removal

1. Peel curtain (3) back from fastener tape (4) on angle assembly (6).
2. Release two straps (7), remove curtain (3) from channel assembly (8), and peel curtain (3) back from fastener tape (4) on channel assembly (8).
3. Peel curtain (3) back from fastener tape (4) on tunnel (5) and "B" pillar (1).
4. Unfasten twelve turnbuttons (2) and remove curtain (3) from "B" pillar (1).

b. Installation

1. Install curtain (3) on "B" pillar (1) with twelve turnbuttons (2).
2. Attach curtain (3) to fastener tape (4) on "B" pillar (1) and tunnel (5).
3. Attach curtain (3) to fastener tape (4) on channel assembly (8) with two straps (7).
4. Attach curtain (3) to fastener tape (4) on angle assembly (6).

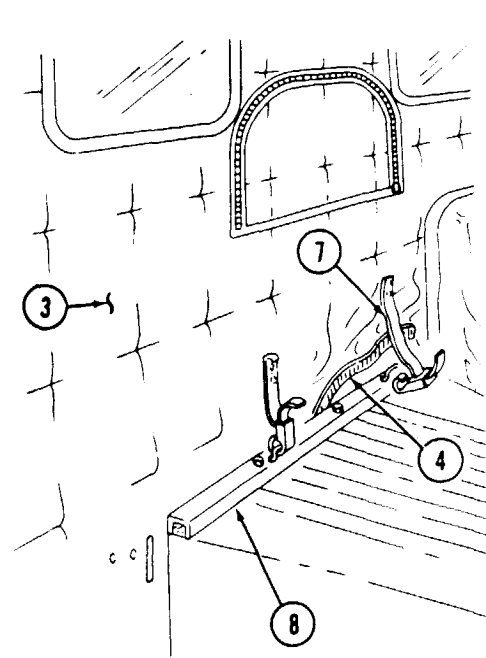
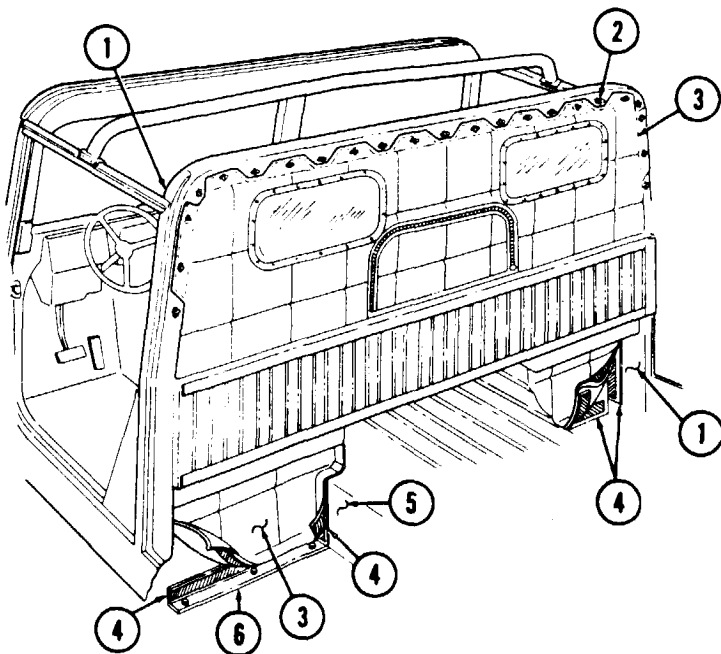

FOLLOW-ON TASKS: Ž Install arctic top cover assembly (para. 12-72).
Ž Install companion seat back (para. 10-34).

12-74. ARCTIC CURTAIN ANGLE ASSEMBLY REPLACEMENT

This task covers:

a. Removal

b. Installation

INITIAL SETUP:

Applicable Models

M998, M998A1, M1037, M1038, M1038A1,
M1097, M1097A1, M1097A2

Personnel Required

One mechanic
One assistant

Tools

General mechanic's tool kit:
automotive (Appendix B, Item 1)

Manual References

TM 9-2320-280-24P

Materials/Parts

Adhesive-sealant (Appendix C, Item 10)
Three locknuts (Appendix G, Item 94)

a. Removal

1. Peel curtain (2) back from fastener tape (1) on angle assembly (4).
2. Remove three locknuts (8), washers (9), capscrews (5), washers (6), and angle assembly (4) from cargo floor (7). Discard locknuts (8).
3. Peel fastener tape (1) from angle assembly (4).
4. Clean remaining adhesive from angle assembly (4) surface.

b. Installation

NOTE

Ensure surface is free of dirt and oil before applying adhesive backing.

1. Peel paper backing (3) from fastener tape (1) and install fastener tape (1) to angle assembly (4).
2. Install angle assembly (4) on cargo floor (7) with three washers (6), capscrews (5), washers (9), and locknuts (8). Tighten locknuts (8) to 17 lb-ft (23 N·m).
3. Attach curtain (2) to fastener tape (1) on angle assembly (4).

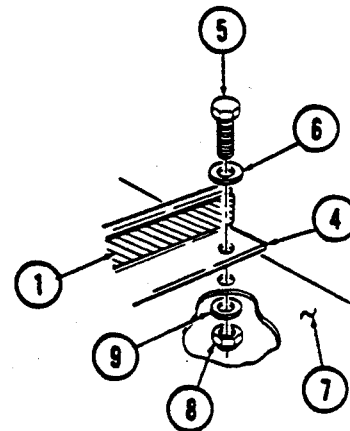
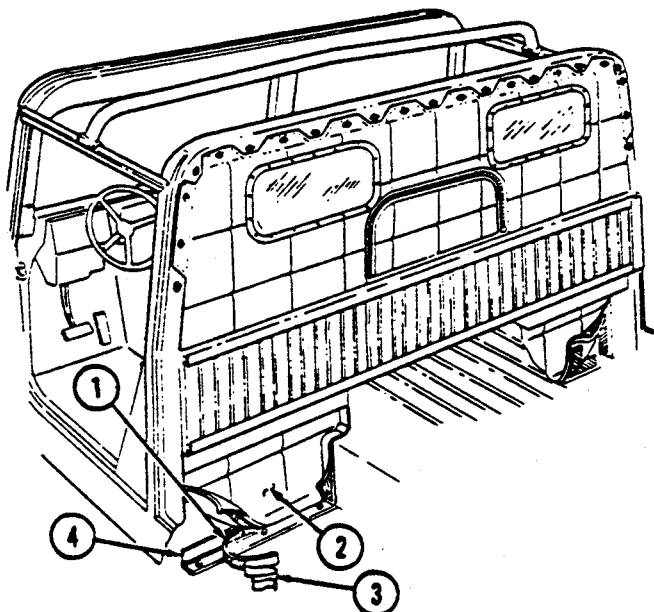

12-75. ARCTIC WINDOW REPLACEMENT

This task covers:

a. Removal

b. Installation

INITIAL SETUP:

Applicable Models

M998, M998A1, M1037, M1038, M1038A1, M1042, M1097, M1097A1, M1097A2

Personnel Required

One mechanic
One assistant

Tools

General mechanic's tool kit:
automotive (Appendix B, Item 1)

Manual References

TM 9-2320-280-24P

Materials/Parts

Adhesive-sealant (Appendix C, Item 10)
Eighteen locknuts (Appendix G, Item 95)

a. Removal

1. Remove eighteen locknuts (1), screws (7), two retainers (2), inner window (3), and outer window (6) from arctic curtain (4). Discard locknuts (1).
2. Remove adhesive-sealant from edge of outer window (6).

b. Installation

1. Apply adhesive-sealant around edge of outer window (6) between screw holes.
2. Insert outer window (6) into curtain flaps (5), ensuring surface without adhesive-sealant faces outside of vehicle.
3. Insert inner window (3) into curtain flaps (5) from inside of vehicle, and align inner window (3) and outer window (6) screw holes.
4. Secure inner window (3) and outer window (6) to arctic curtain flaps (5) with two retainers (2), eighteen screws (7), and locknuts (1).

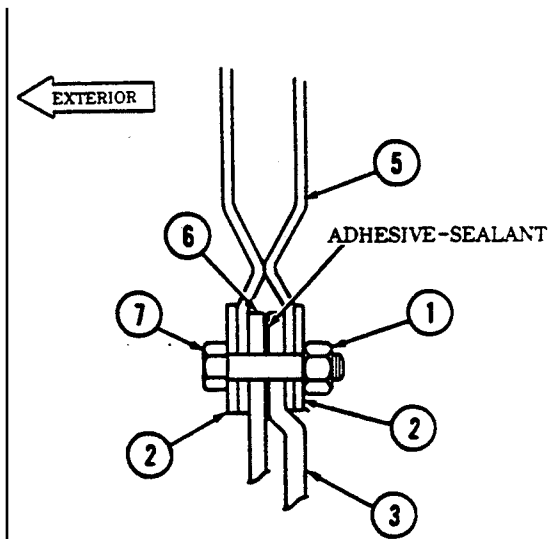
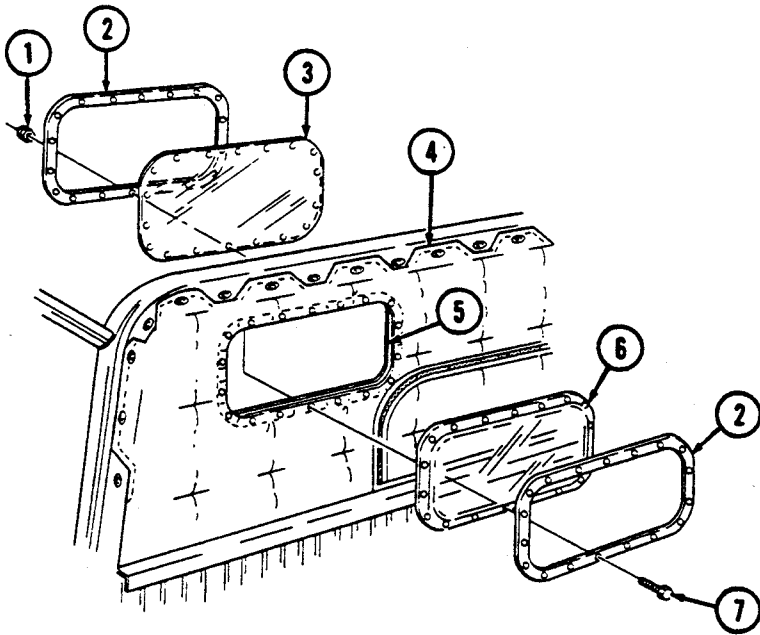

12-76. ARCTIC CURTAIN CHANNEL ASSEMBLY REPLACEMENT (2-MAN CREW)

This task covers:

a. Removal

b. Installation

INITIAL SETUP:

Applicable Models

M998, M998A1, M1037, M1038, M1038A1,
M1097, M1097A1, M1097A2

Manual References

TM 9-2320-280-24P

Tools

General mechanic's tool kit:
automotive (Appendix B, Item 1)

a. Removal

1. Peel curtain (13) back from fastener tape (7) on channel assembly (8).
2. Open two straps (1) from curtain (13) and channel assembly (8).
3. Remove four capscrews (4), washers (5), and channel assembly (8) from cargo floor (12).
4. Peel and remove fastener tape (7) from channel assembly (8).
5. Remove seal (9) from channel assembly (8).
6. Remove four nuts (11), washers (10), screws (3), and two footman loops (2) from channel assembly (8).

b. Installation

NOTE

Ensure surface is free of dirt and oil before applying adhesive backing.

1. Install two footman loops (2) on channel assembly (8) with four screws (3), washers (10), and nuts (11).
2. Install seal (9) into channel assembly (8).
3. Peel paper backing (6) from fastener tape (7) and install fastener tape (7) on channel assembly (8).
4. Install channel assembly (8) on cargo floor (12) with four washers (5) and capscrews (4).
5. Install curtain (13) on channel assembly (8) with two straps (1).
6. Secure curtain (13) to channel assembly (8) with fastener tape (7).

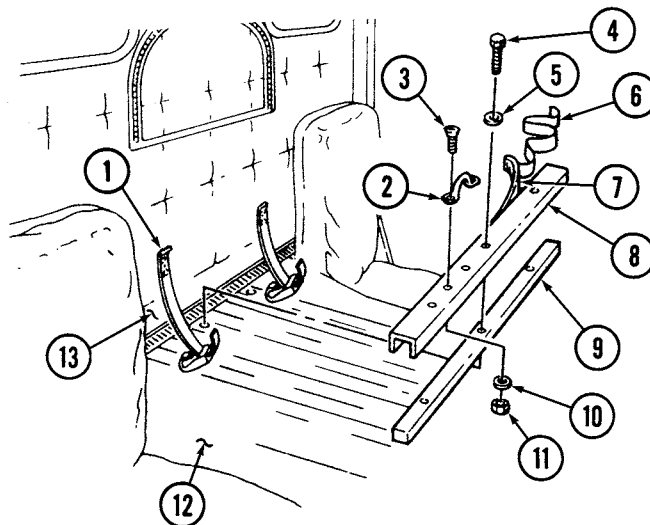

12-77. ARCTIC CURTAIN CHANNEL ASSEMBLY MAINTENANCE (4-MAN CREW)

This task covers:

- | | |
|---|---|
| <ul style="list-style-type: none"> a. Removal b. Inspection | <ul style="list-style-type: none"> c. Installation |
|---|---|

INITIAL SETUP:

Applicable Models

M998, M998A1, M1038, M1038A1, M1097, M1097A1, M1097A2, M1123

Tools

General mechanic's tool kit:
automotive (Appendix B, Item 1)

Materials/Parts

Twelve locknuts (Appendix G, Item 118)
Ten locknuts (Appendix G, Item 71)

Manual References

TM 9-2320-280-24P

a. Removal

1. Release two straps (2) from curtain (3) and wheelhousing channel assemblies (1) and (22).
2. Release four straps (4) from curtain (3) and cargo floor channel assembly (11).
3. Pull curtain (3) back from fastener tape (10) on wheelhousing channel assemblies (1) and (22), and cargo floor channel assembly (11).
4. Remove six capscrews (8), washers (9), and cargo floor channel assembly (11) from cargo floor (14).
5. Remove seal (12) from cargo floor channel assembly (11).
6. Remove eight locknuts (13), washers (12.1), screws (7), and four footman loops (6) from cargo floor channel assembly (11). Discard locknuts (13).
7. Remove ten locknuts (21), twenty washers (16), ten capscrews (15), and wheelhousing channel assemblies (1) and (22) from wheel housings (20). Discard locknuts (21).
8. Remove four locknuts (19), screws (17), and two footman loops (18) from wheelhousing channel assemblies (1) and (22). Discard locknuts (19).

b. Inspection

1. Inspect thirty-one turnbuttons (23) on soft top for bends, corrosion, or damage. Replace if bent, corroded, or damaged (refer to para. 10-66).
2. Inspect six rivnuts (5) on cargo floor for looseness, cracks, wearing, or damage. Replace if loose, cracked, worn, or damaged (refer to para. 10-66).
3. Inspect fastener tape (10) on wheelhousing channel assemblies (1) and (22) and cargo floor channel assembly (11) for tearing or damage. Replace if torn or damaged (refer to para. 12-78).

c. Installation

1. Install two footman loops (18) on wheelhousing channel assemblies (1) and (22) with four screws (17) and locknuts (19).
2. Install wheelhousing channel assemblies (1) and (22) on wheel housings (20) with twenty washers (16), ten capscrews (15), and locknuts (21).
3. Install four footman loops (6) on cargo floor channel assembly (11) with eight screws (7), washers (12.1), and locknuts (13).
4. Install seal (12) in cargo floor channel assembly (11).
5. Install cargo floor channel assembly (11) on cargo floor (14) with six washers (9) and capscrews (8).
6. Install curtain (3) on wheelhousing channel assemblies (1) and (22) and cargo floor channel assembly (11) with fastener tape (10).
7. Secure curtain (3) to cargo floor channel assembly (11) with four straps (4).
8. Secure curtain (3) to wheelhousing channel assemblies (1) and (22) with two straps (2).

12-77. ARCTIC CURTAIN CHANNEL ASSEMBLY REPLACEMENT (4-MAN CREW)(Cont'd)

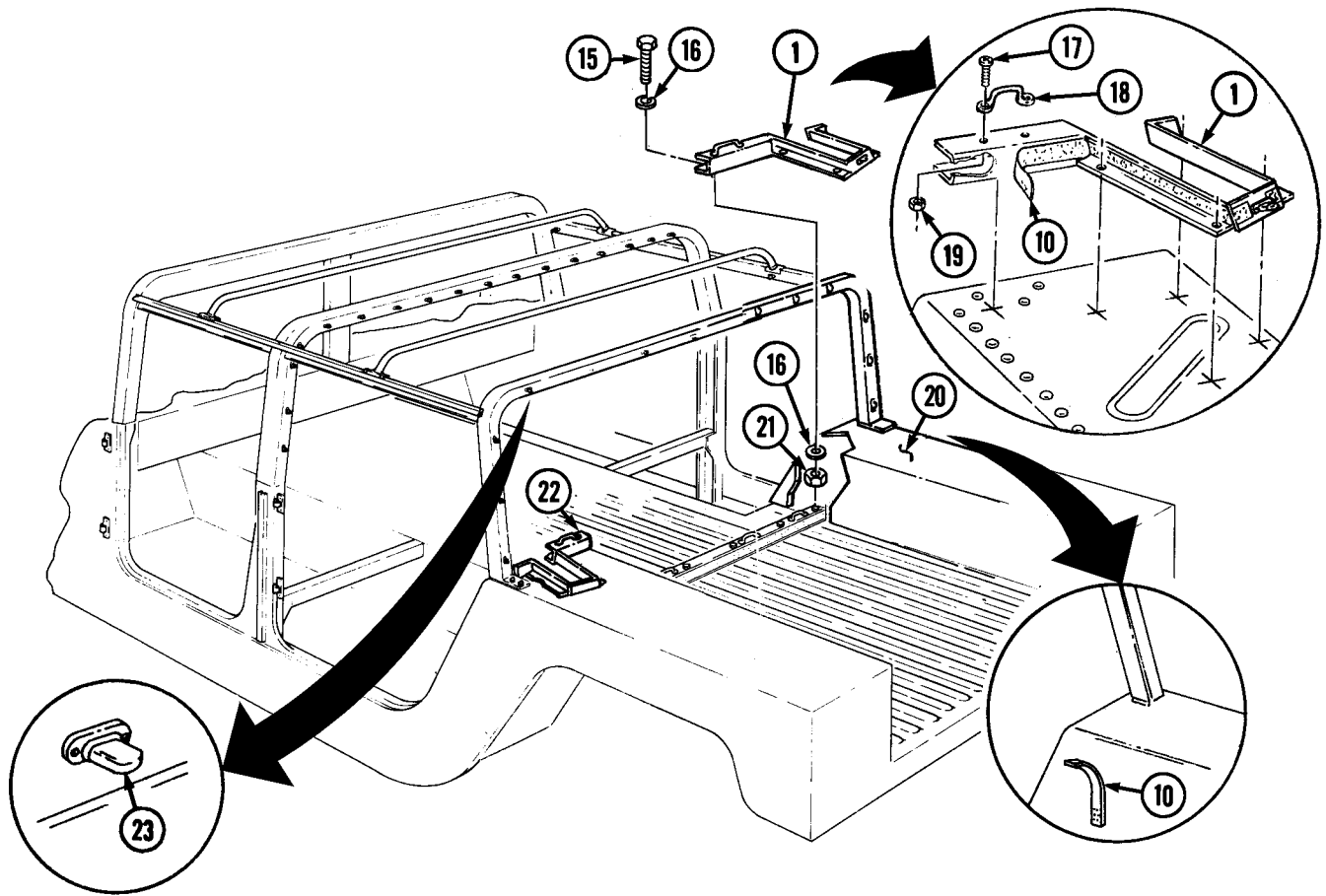
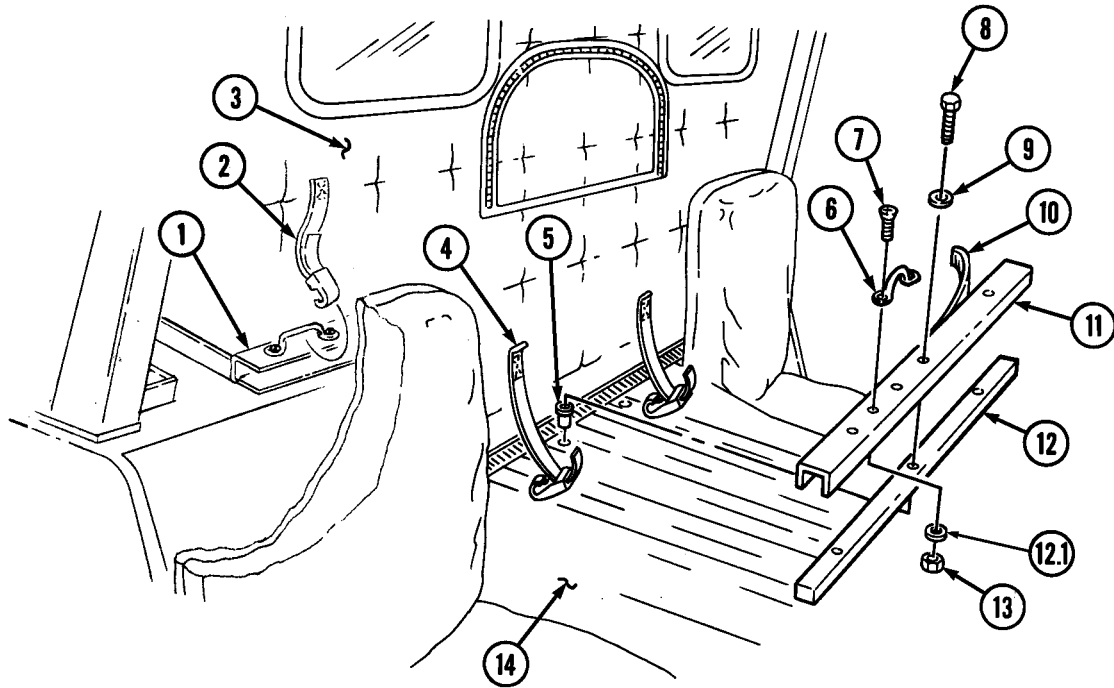

12-78. ARCTIC CURTAIN FASTENER TAPE HOOK REPLACEMENT

This task covers:

a. Removal

b. Installation

INITIAL SETUP:

Applicable Models

M998, M998A1, M1037, M1038, M1038A1,
M1097, M1097A1, M1097A2

Manual References

TM 9-2320-280-24P

Tools

General mechanic's tool kit:
automotive (Appendix B, Item 1)

Equipment Condition

Arctic curtain assembly removed (para. 12-73).

NOTE

All fastener tape is removed and installed the same. This procedure covers the "B" pillar fastener tape.

a. Removal

1. Peel fastener tape (3) from "B" pillar (2).
2. Clean remaining adhesive from "B" pillar (2).

b. Installation

1. Ensure "B" pillar surface (2) is free of dirt and oil.
2. Peel paper backing (1) from fastener tape (3).
3. Apply fastener tape (3) to "B" pillar (2) and press firmly in place.

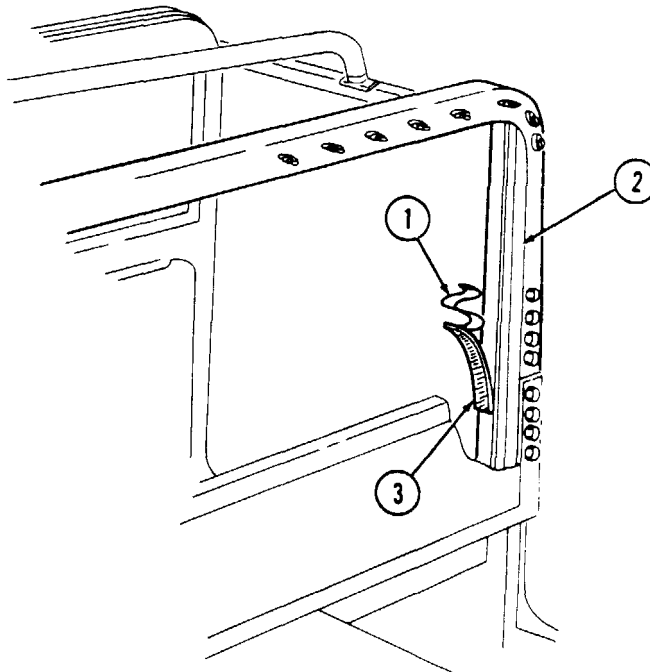

FOLLOW-ON TASK: Install arctic curtain assembly (para. 12-73).

12-79. ARCTIC FOAM INSULATION STRIP REPLACEMENT

This task covers:

a. Removal

b. Installation

INITIAL SETUP:

Applicable Models

M998, M998A1, M1037, M1038, M1038A1,
M1097, M1097A1, M1097A2

Manual References

TM 9-2320-280-24P

Tools

General mechanic's tool kit:
automotive (Appendix B, Item 1)

a. Removal

1. Peel foam insulation strip (3) from "A" pillar (1).
2. Clean remaining adhesive from "A" pillar surface (1).

b. Installation

NOTE

Ensure "A" pillar surface is free of dirt and oil before applying foam insulation strip.

1. Peel paper backing (2) from foam insulation strip (3).
2. Install foam insulation strip (3) on "A" pillar (1) and press firmly in place.

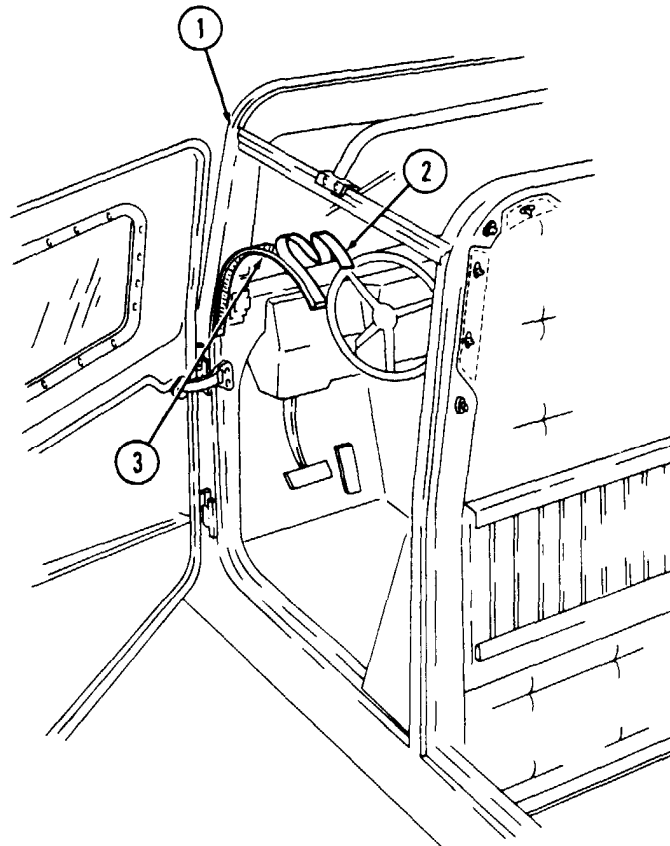

Section VI. TROOP/CARGO WINTERIZATION KIT MAINTENANCE

12-80. TROOP/CARGO WINTERIZATION KIT MAINTENANCE TASK SUMMARY

TASK PARA.	PROCEDURES	PAGE NO.
12-81.	Troop/Cargo Winterization Heater Fuel Pump Replacement	12-116
12-82.	Troop/Cargo Winterization Heater Fuel Filter Assembly Replacement	12-119
12-83.	Troop/Cargo Winterization Heater Fuel Supply Tube Assembly Replacement	12-121
12-84.	Troop/Cargo Winterization Heater Tank-to-Hose Fuel Supply Line Replacement	12-122
12-85.	Troop/Cargo Winterization Heater Fuel Supply Hose Replacement	12-123
12-86.	Troop/Cargo Winterization Heater Pump-to-Hose Fuel Supply Line Replacement	12-124
12-87.	Troop/Cargo Winterization Heater Pump-to-Bulkhead Fuel Supply Line Replacement	12-125
12-88.	Troop/Cargo Winterization Heater Bulkhead Fuel Supply Hose Replacement	12-127
12-89.	Troop/Cargo Winterization Heater Bulkhead Hose-to-Bulkhead Coupling Fuel Supply Line Replacement	12-128
12-90.	Troop/Cargo Winterization Heater Fuel Supply Line Bulkhead Coupling Replacement	12-129
12-91.	Troop/Cargo Winterization Heater Filter-to-Bulkhead Coupling Fuel Supply Hose Replacement	12-131
12-92.	Troop/Cargo Winterization Heater Filter-to-Heater Fuel Supply Hose Replacement	12-133
12-93.	Troop/Cargo Winterization Heater Guard Assembly Replacement	12-135
12-94.	Troop/Cargo Winterization Heat Deflector Replacement	12-136
12-95.	Troop/Cargo Winterization Heater Assembly Replacement	12-137
12-96.	Troop/Cargo Winterization Heater Diverter Assembly Replacement	12-140
12-97.	Troop/Cargo Winterization Heater Air Intake Assembly Replacement	12-141
12-98.	Troop/Cargo Winterization Heater Base Assembly Replacement	12-142
12-99.	Troop/Cargo Winterization Floor Bracket Replacement	12-143
12-100.	Troop/Cargo Winterization Heater Control Box and Angle Bracket Replacement	12-144
12-101.	Troop/Cargo Winterization Heater Wiring Harness Replacement	12-146
12-102.	Troop/Cargo Winterization Heater Wiring Harness Adapter Replacement	12-150
12-103.	Troop/Cargo Winterization Circuit Breaker Replacement	12-152
12-104.	Troop/Cargo Winterization Blackout Curtain Replacement	12-153
12-105.	Troop/Cargo Winterization Blackout/Dome Light Wiring Harness Replacement	12-154

12-80. TROOP/CARGO WINTERIZATION KIT MAINTENANCE TASK SUMMARY (Cont'd)

TASK PARA.	PROCEDURES	PAGE NO.
12-106.	Troop/Cargo Winterization Blackout/Dome Light Switch Replacement	12-156
12-107.	Troop/Cargo Winterization Blackout/Dome Light Door Switch Replacement	12-158
12-108.	Troop/Cargo Winterization Blackout/Dome Light Assembly Replacement	12-160
12-109.	Troop/Cargo Winterization Blackout/Dome Light Lamp Replacement	12-161
12-110.	Troop/Cargo Winterization Front and Rear Cargo Floor Cover Replacement	12-162
12-111.	Troop/Cargo Winterization Cargo Floor Skid Strips Replacement	12-164
12-112.	Troop/Cargo Winterization Seat Back Cover Replacement	12-165
12-113.	Troop/Cargo Winterization Fixed Door Cover Replacement	12-166
12-114.	Troop/Cargo Winterization Side Floor Cover Replacement	12-167
12-115.	Troop/Cargo Winterization Wheelhousing Covers Replacement	12-168
12-116.	Troop/Cargo Winterization Door Adjustment	12-170
12-117.	Troop/Cargo Winterization Door and Frame Assembly Replacement	12-172
12-118.	Troop/Cargo Winterization End Closure Replacement	12-176
12-119.	Troop/Cargo Winterization Top Cover Assembly Replacement	12-180
12-120.	Troop/Cargo Winterization Top Enclosure Assembly Replacement	12-186
12-121.	Troop/Cargo Winterization Troop Seat Assembly and Bow Replacement	12-190
12-122.	Troop/Cargo Winterization Rear Step Assembly Replacement	12-194
12-123.	Troop/Cargo Winterization Handle Assembly Replacement	12-195
12-124.	Troop/Cargo Winterization Fuel Can Mounting Bracket Replacement	12-196
12-125.	Troop/Cargo Winterization Antenna Mounting Bracket Replacement	12-197
12-126.	Troop/Cargo Winterization Rear Reflector Replacement	12-198
12-127.	Troop/Cargo Winterization Rear Composite Light Housing Replacement	12-199
12-128.	Troop/Cargo Winterization Data Plate Replacement	12-200

12-81. TROOP/CARGO WINTERIZATION HEATER FUEL PUMP REPLACEMENT

This task covers:

a. Removal

b. Installation

INITIAL SETUP:

Applicable Models

M998, M998A1, M1038, M1038A1

Tools

General mechanic's tool kit:
automotive (Appendix B, Item 1)

Materials/Parts

Sealing compound (Appendix C, Item 44)
Two locknuts (Appendix G, Item 70)
Lockwasher (Appendix G, Item 175)
Four blind rivets (Appendix G, Item 257)

Manual References

TM 9-2320-280-10
TM 9-2320-280-24P

Equipment Condition

Battery ground cable disconnected (para. 4-73).

General Safety Instructions

Do not perform this procedure near fire, flames, or sparks.

WARNING

Diesel fuel is highly flammable. Do not perform this procedure near fire, flames, or sparks. Severe injury or death will result.

a. Removal

CAUTION

Cover or plug all open hoses and connections immediately after disconnection to prevent contamination. Remove all plugs prior to connection.

NOTE

- Have drainage container ready to catch fuel.
 - Prior to removal, tag leads for installation.
1. Disconnect fuel pump lead (2) from electrical connector (3).
 2. Disconnect pump-to-hose fuel supply line (6) from connector (7).
 3. Remove connector (7) from fuel pump (1).
 4. Disconnect pump-to-bulkhead fuel supply line (8) from connector (9).

NOTE

Perform step 5 if vehicle is equipped with front arctic heater.
Perform step 6 if vehicle is not equipped with front arctic heater.

5. Disconnect arctic heater fuel supply line (5) from connector (4).
6. Remove cap (11) from connector (4).
7. Remove two locknuts (15), washers (14), lockwasher (12), two capscrews (17), washers (14), fuel pump (1), and ground lead 799B (13) from bracket (16). Discard locknuts (15) and lockwasher (12).

NOTE

For instructions on replacement of rivets, refer to para. 10-66.

8. Inspect four rivets (19) on bracket (16) and crossmember (18) and replace rivets (19), if damaged.
9. Remove connectors (9) and (4) and tee (10) from fuel pump (1).

12-81. TROOP/CARGO WINTERIZATION HEATER FUEL PUMP REPLACEMENT (Cont'd)

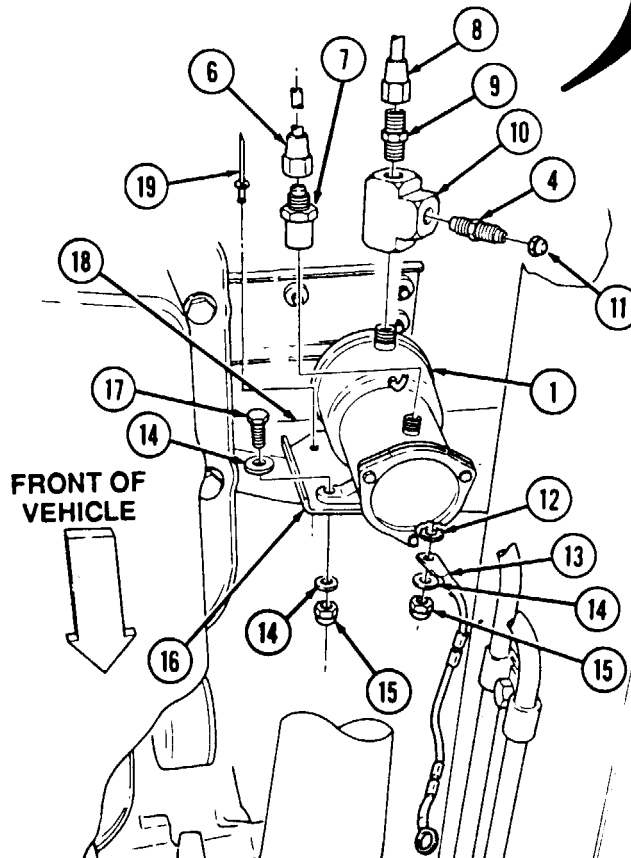
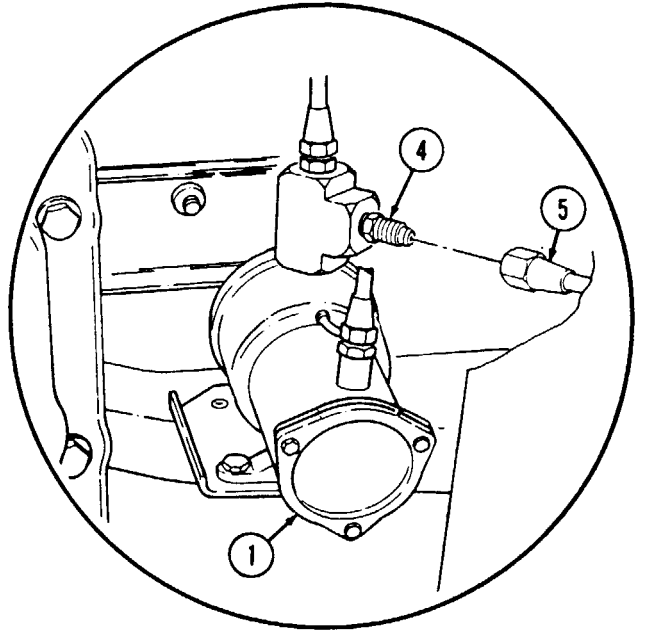
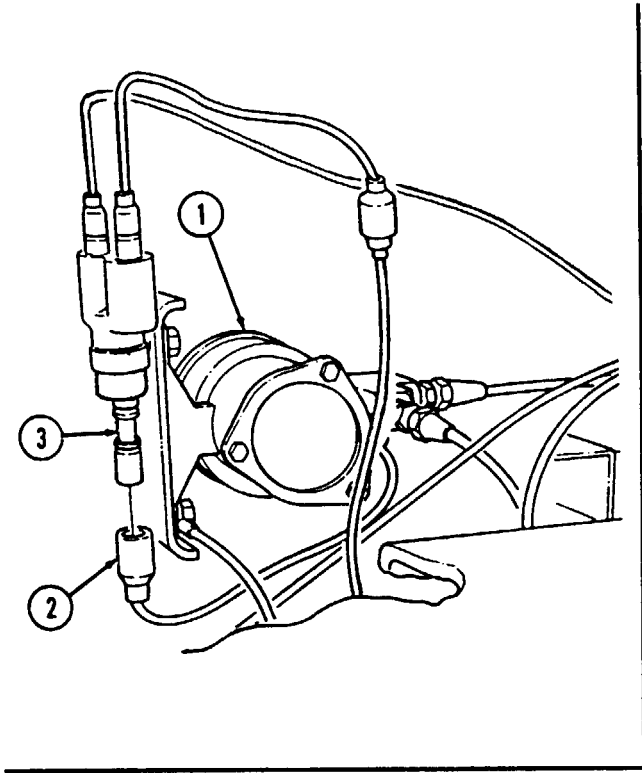

12-81. TROOP/CARGO WINTERIZATION HEATER FUEL PUMP REPLACEMENT (Cont'd)

b. Installation

1. Apply sealing compound to threads of connectors (9) and (4) and install connectors (9) and (4) on tee (10).
2. Apply sealing compound to threads of fuel pump (1) and install connector (7) and tee (10) on fuel pump (1).
3. Install fuel pump (1) and ground lead 799B (13) on bracket (16) with two washers (14), capscrews (17), lockwasher (12), two washers (14), and locknuts (15).
4. Apply sealing compound to threads of connector (9) and connect pump-to-bulkhead fuel supply line (8) to connector (9).

NOTE

Perform step 5 if vehicle is equipped with front arctic heater.
 Perform step 6 if vehicle is not equipped with front arctic heater.

5. Apply sealing compound to threads of connector (4) and connect arctic heater fuel supply line (5) to connector (4).
6. Apply sealing compound to threads of connector (4) and install cap (11) on connector (4).
7. Apply sealing compound to threads of connector (7) and connect pump-to-hose fuel supply line (6) to connector (7).
8. Connect fuel pump lead (2) to electrical connector (3).

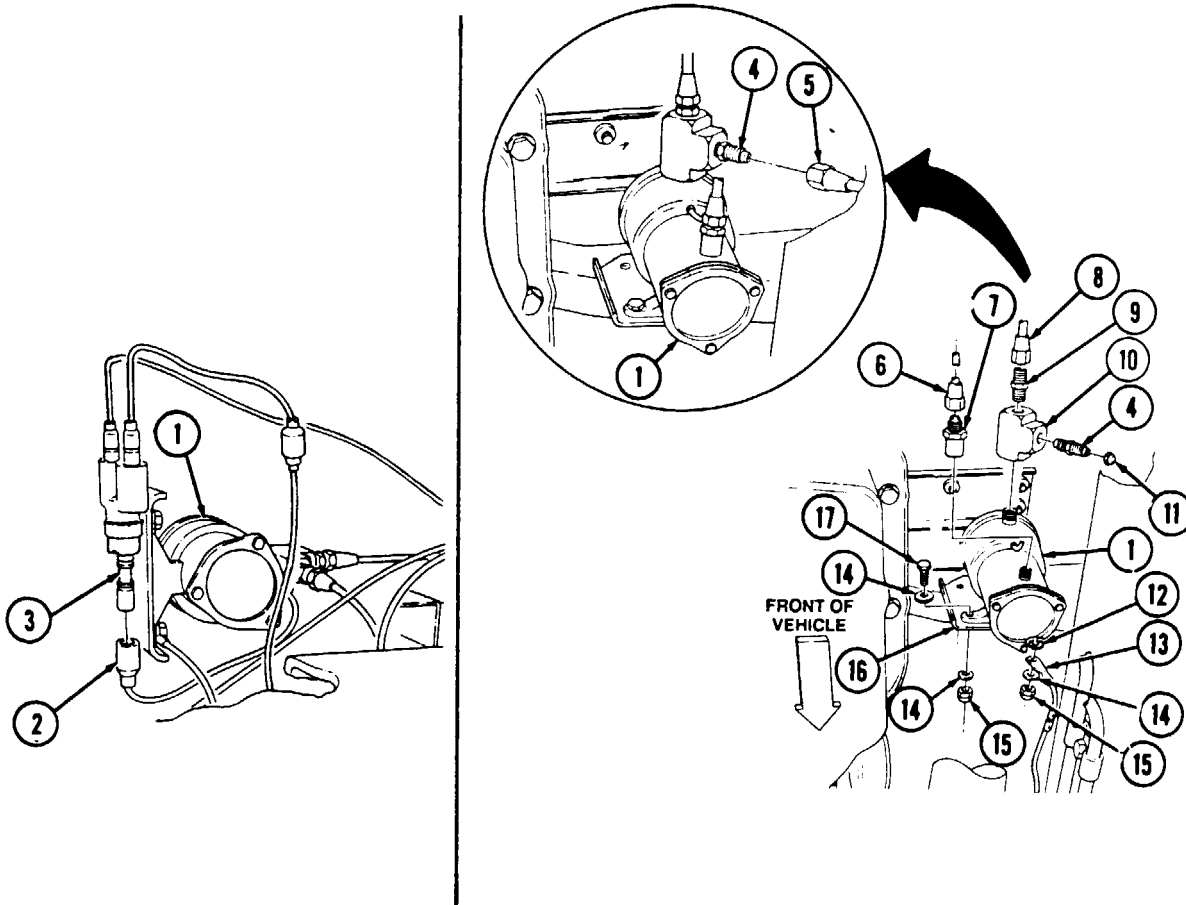

FOLLOW-ON TASKS: \bar{Z} Connect battery ground cable (para. 4-73).
 \bar{Z} Operate troop/cargo heater (TM 9-2320-280-10) and check for fuel leaks.

12-82. TROOP/CARGO WINTERIZATION HEATER FUEL FILTER ASSEMBLY REPLACEMENT

This task covers:

a. Removal

b. Installation

INITIAL SETUP:

Applicable Models

M998, M998A1, M1038, M1038A1

Tools

General mechanic's tool kit:
automotive (Appendix B, Item 1)

Materials/Parts

Sealing compound (Appendix C, Item 44)
Two locknuts (Appendix G, Item 117)

Manual References

TM 9-2320-280-10
TM 9-2320-280-24P

Equipment Condition

Heater guard assembly removed
(para. 12-93).

General Safety Instructions

Do not perform this procedure near fire, flames, or sparks.

WARNING

Diesel fuel is highly flammable. Do not perform this procedure near fire, flames, or sparks. Severe injury or death will result.

a. Removal

CAUTION

Cover or plug all open hoses and connections immediately after disconnection to prevent contamination. Remove all plugs prior to connection.

NOTE

Have drainage container ready to catch fuel.

1. Loosen clamp (3) and disconnect filter-to-heater fuel supply hose (2) from filter elbow (4).
2. Loosen clamp (9) and disconnect filter-to-bulkhead coupling fuel supply hose (8) from filter connector (10).
3. Remove two locknuts (1) and capscrews (7) from filter assembly (5), spacers (11), and heater base assembly (6). Discard locknuts (1).
4. Remove filter elbow (4) and connector (10) from filter assembly (5).

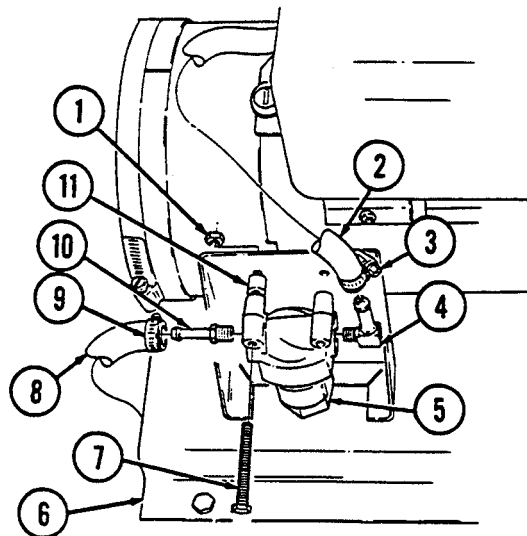

12-82. TROOP/CARGO WINTERIZATION HEATER FUEL FILTER ASSEMBLY REPLACEMENT (Cont'd)

b. Installation

1. Apply sealing compound to threads of filter elbow (4) and connector (10) and install filter elbow (4) and connector (10) on filter assembly (5).
2. Install two spacers (11) and filter assembly (5) on heater base assembly (6) with two capscrews (7) and locknuts (1).
3. Connect filter-to-bulkhead coupling fuel supply hose (8) to filter connector (10) with clamp (9).
4. Connect filter-to-heater fuel supply hose (2) to filter elbow (4) with clamp (3).

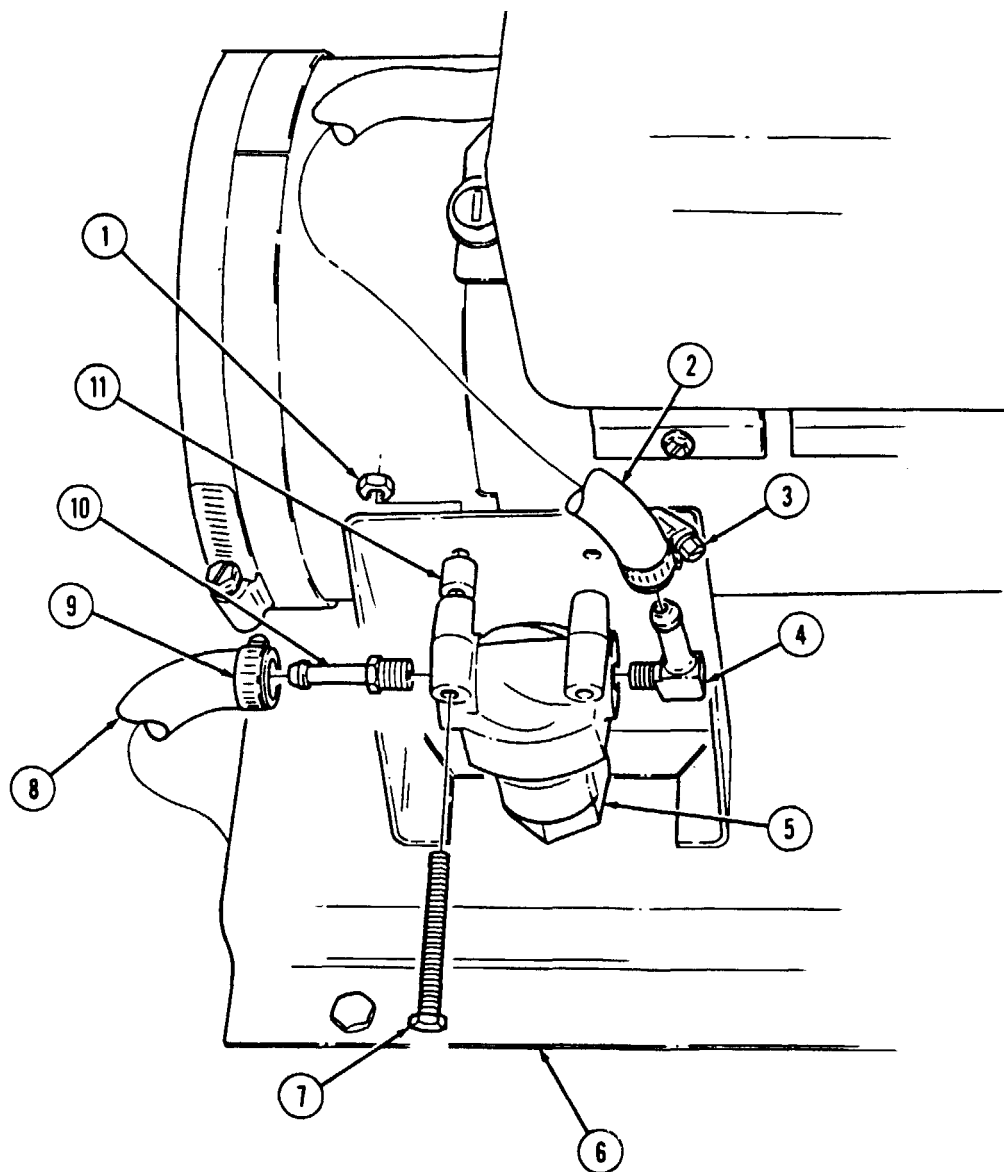

FOLLOW-ON TASKS: \checkmark Install heater guard assembly (para. 12-93).
 \checkmark Operate troop/cargo heater (TM 9-2320-280-10) and check for fuel leaks.

12-83. TROOP/CARGO WINTERIZATION HEATER FUEL SUPPLY TUBE ASSEMBLY REPLACEMENT

This task covers:

a. Removal

b. Installation

INITIAL SETUP:

Applicable Models

M998, M998A1, M1038, M1038A1

Tools

General mechanic's tool kit:
automotive (Appendix B, Item 1)

Materials/Parts

Sealing compound (Appendix C, Item 44)

Manual References

TM 9-2320-280-10
TM 9-2320-280-24P

Equipment Condition

Fuel tank removed (para. 3-24).

General Safety Instructions

Do not perform this procedure near fire, flames, or spar .

WARNING

Diesel fuel is highly flammable. Do not perform this procedure near fires, flames, or sparks. Severe injury or death will result.

a. Removal

1. Mark position of fuel supply tube assembly (2) on access cover (3).

CAUTION

Cover or plug all open hoses and connections immediately after disconnection to prevent contamination. Remove all plugs prior to connection.

NOTE

Have drainage container ready to catch fuel.

2. Disconnect tank-to-hose fuel supply line (4) from fuel supply tube assembly (2).
3. Remove fuel supply tube assembly (2) from fuel tank (1).

b. Installation

1. Apply sealing compound to threads of fuel supply tube assembly (2) and install tube assembly (2) on fuel tank (1).
2. Apply sealing compound to tank-to-hose fuel supply line (4) and connect fuel supply line (4) to fuel supply tube assembly (2).

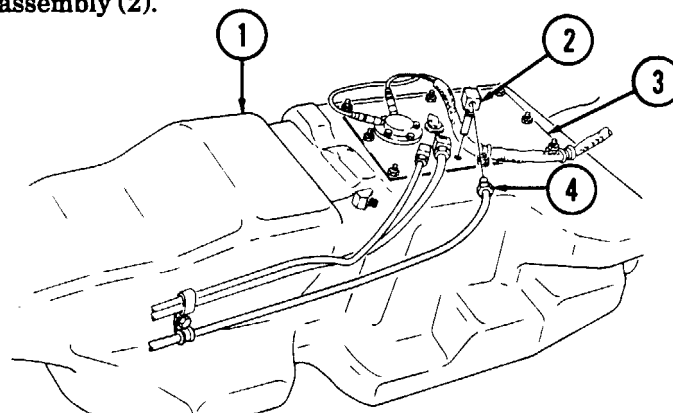

FOLLOW-ON TASKS: Ž Install fuel tank (para. 3-24).

Ž Operate troop/cargo heater (TM 9-2320-280-10) and check for fuel leaks.

12-84. TROOP/CARGO WINTERIZATION HEATER TANK-TO-HOSE FUEL SUPPLY LINE REPLACEMENT

This task covers:

a. Removal

b. Installation

INITIAL SETUP:

Applicable Models

M998, M998A1, M1038, M1038A1

Manual References

TM 9-2320-280-10
TM 9-2320-280-24P

Tools

General mechanic's tool kit:
automotive (Appendix B, Item 1)

Equipment Condition

Fuel tank removed (para. 3-24).

Materials/Parts

Sealing compound (Appendix C, Item 44)

General Safety Instructions

Do not perform this procedure near fire, flames, or sparks.

WARNING

Diesel fuel is highly flammable. Do not perform this procedure near fire, flames, or sparks. Severe injury or death will result.

a. Removal

CAUTION

Cover or plug all open hoses and connections immediately after disconnection to prevent contamination. Remove all plugs prior to connection.

NOTE

Have drainage container ready to catch fuel.

1. Disconnect tank-to-hose fuel supply line (3) from tube assembly (2).
2. Remove capscrew (4), clamp (5), and tank-to-hose fuel supply line (3) from fuel tank (1).

b. Installation

1. Apply sealing compound to threads of tank-to-hose fuel supply line (3) and connect tank-to-hose fuel supply line (3) to tube assembly (2).
2. Install tank-to-hose fuel supply line (3) on fuel tank (1) with clamp (5) and capscrew (4).

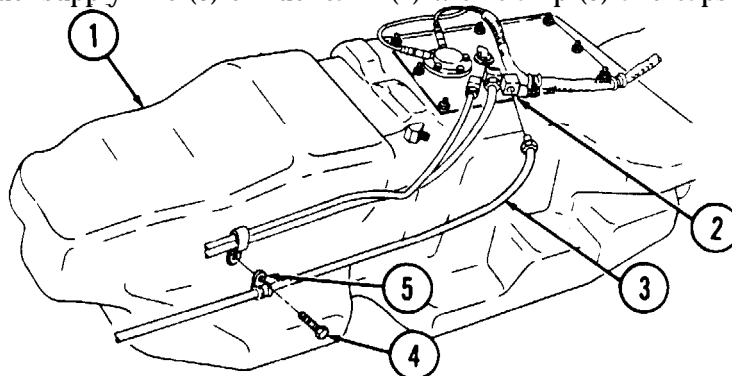

- FOLLOW-ON TASKS:**
- ⌘ Install fuel tank (para. 3-24).
 - ⌘ Operate troop/cargo heater (TM 9-2320-280-10) and check for fuel leaks.

12-85. TROOP/CARGO WINTERIZATION HEATER FUEL SUPPLY HOSE REPLACEMENT

This task covers:

a. Removal

b. Installation

INITIAL SETUP:

Applicable Models

M998, M998A1, M1038, M1038A1

Tools

General mechanic's tool kit:
automotive (Appendix B, Item 1)

Manual References

TM 9-2320-280-10
TM 9-2320-280-24P

General Safety Instructions

Do not perform this procedure near fire, flames, or sparks.

WARNING

Diesel fuel is highly flammable. Do not perform this procedure near fire, flames, or sparks. Severe injury or death will result.

a. Removal

CAUTION

Cover or plug all open hoses and connections immediately after disconnection to prevent contamination. Remove all plugs prior to connection.

NOTE

Have drainage container ready to catch fuel.

Remove two clamps (4) and fuel supply hose (3) from tank-to-hose fuel supply line (2) and pump-to-hose fuel supply line (1).

b. Installation

1. Connect fuel supply hose (3) to tank-to-hose fuel supply line (2) with clamp (4).
2. Connect fuel supply hose (3) to pump-to-hose fuel supply line (1) with clamp (4).

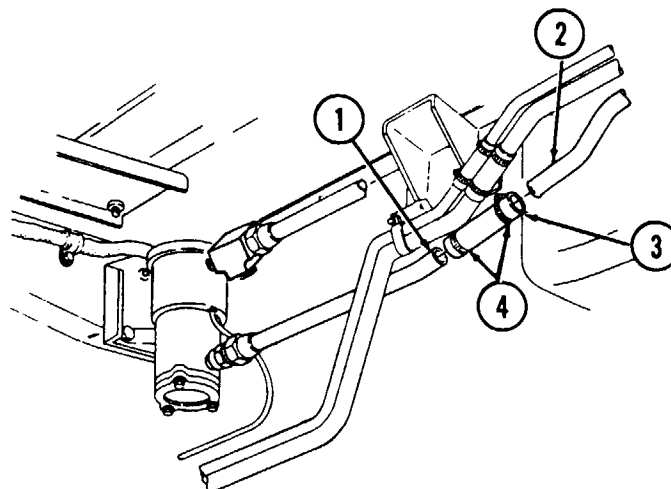

FOLLOW-ON TASK: Operate troop/cargo heater (TM 9-2320-280-10) and check for fuel leaks.

12-86. TROOP/CARGO WINTERIZATION HEATER PUMP-TO-HOSE FUEL SUPPLY LINE REPLACEMENT

This task covers:

a Removal

b. Installation

INITIAL SETUP:

Applicable Models

M998, M998A1, M1038, M1038A1

Manual References

TM 9-2320-280-10

TM 9-2320-280-24P

Tools

General mechanic's tool kit:
automotive (Appendix B, Item 1)

General Safety Instructions

Do not perform this procedure near fire, flames, or sparks.

Materials/Parts

Sealing compound (Appendix C, Item 44)

WARNING

Diesel fuel is highly flammable. Do not perform this procedure near fire, flames, or sparks. Severe injury or death will result.

a. Removal

CAUTION

Cover or plug all open hoses and connections immediately after disconnection to prevent contamination. Remove all plugs prior to connection.

NOTE

Have drainage container ready to catch fuel.

1. Loosen clamp (5) and disconnect fuel supply hose (4) from pump-to-hose fuel supply line (3).
2. Disconnect pump-to-hose fuel supply line (3) from connector (2) on fuel pump (1).
3. Inspect connector (2) for damaged threads or cracks. Replace if cracked or damaged.

b. Installation

1. Apply sealing compound to threads of connector (2) and connect pump-to-hose fuel supply line (3) to connector (2) on fuel pump (1).
2. Connect fuel supply hose (4) to pump-to-hose fuel supply line (3) with clamp (5).

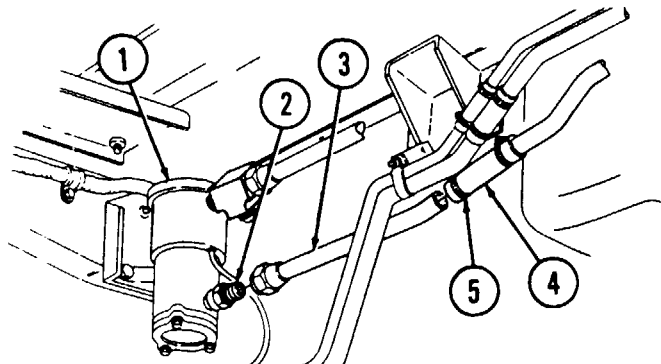

FOLLOW-ON TASK: Operate troop/cargo heater (TM 9-2320-280-10) and check for fuel leaks.

12-87. TROOP/CARGO WINTERIZATION HEATER PUMP-TO-BULKHEAD FUEL SUPPLY LINE REPLACEMENT

This task covers:

a. Removal

b. Installation

INITIAL SETUP:

Applicable Models

M998, M998A1, M1038, M1038A1

Tools

General mechanic's tool kit:
automotive (Appendix B, Item 1)

Materials/Parts

Sealing compound (Appendix C, Item 44)

Manual References

TM 9-2320-280-10
TM 9-2320-280-24P

General Safety Instructions

Do not perform this procedure near fire, flames, or sparks.

WARNING

Diesel fuel is highly flammable. Do not perform this procedure near fire, flames, or sparks. Severe injury or death will result.

a. Removal

CAUTION

Cover or plug all open hoses and connections immediately after disconnection to prevent contamination. Remove all plugs prior to connection.

NOTE

Have drainage container ready to catch fuel.

1. Disconnect pump-to-bulkhead fuel supply line (3) from connector (2).
2. Remove clamp (5) and bulkhead hose (4) from pump-to-bulkhead fuel supply line (3).

NOTE

If vehicle is equipped with front arctic heater unit, cap will not be installed on connector.

3. Inspect connector (2), tee (1), connector (6), and cap (7) for damaged threads or cracks. Replace if cracked or damaged.

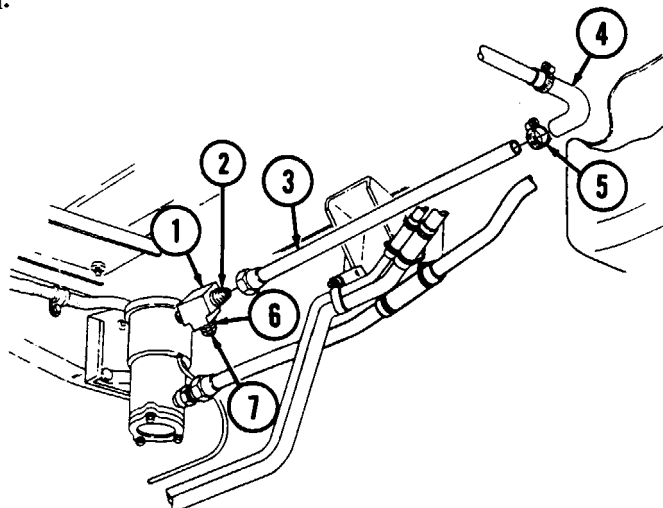

12-87. TROOP/CARGO WINTERIZATION HEATER PUMP-TO-BULKHEAD FUEL SUPPLY LINE REPLACEMENT (Cont'd)

b. Installation

1. Connect bulkhead hose (4) to pump-to-bulkhead fuel supply line (3) with clamp (5).
2. Apply sealing compound to threads of connector (2) on tee (1) and connect pump-to-bulkhead fuel supply line (3) to connector (2).

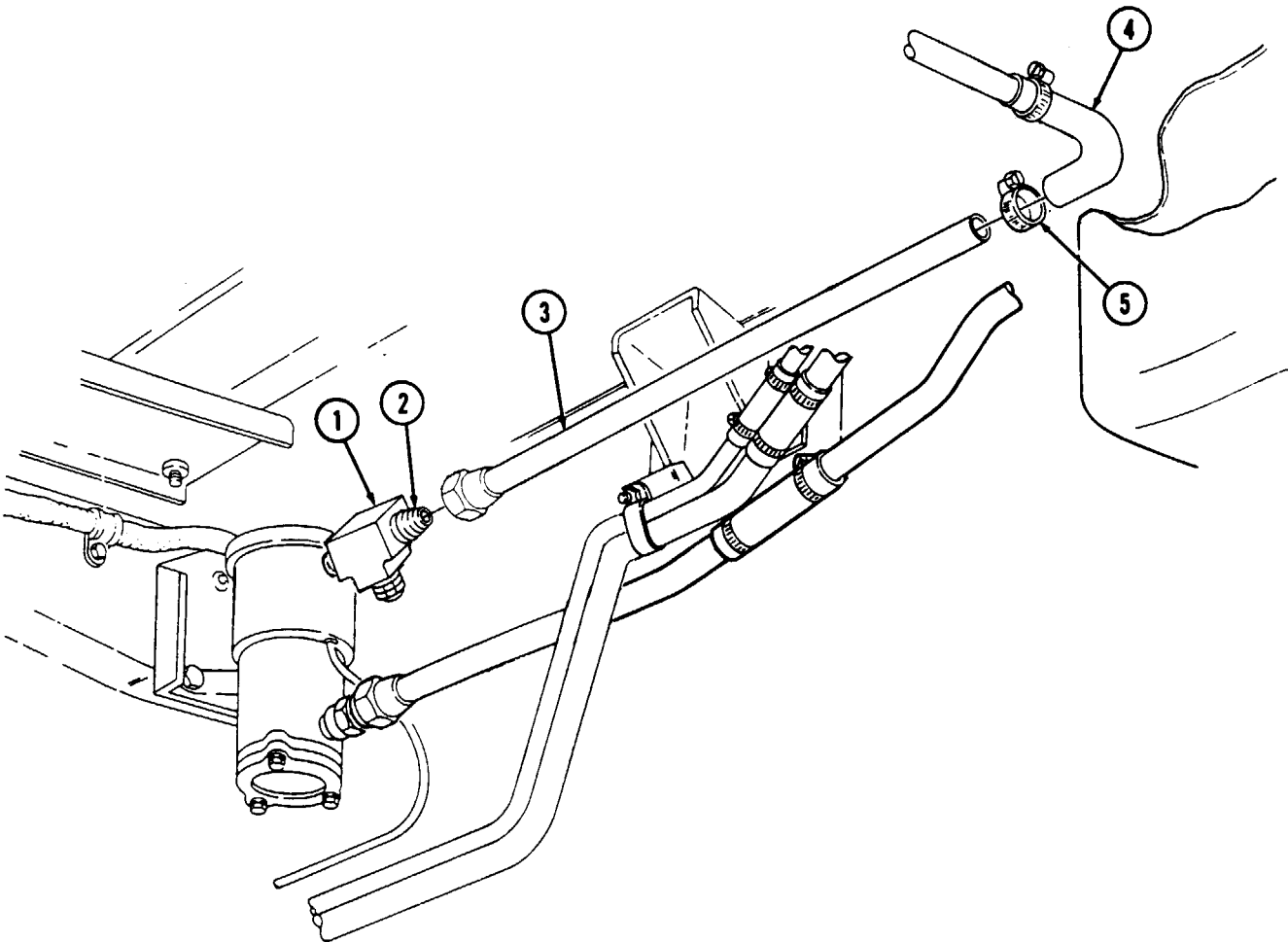

FOLLOW-ON TASK: Operate troop/cargo heater (TM 9-2320-280-10) and check for fuel leaks.

12-88. TROOP/CARGO WINTERIZATION HEATER BULKHEAD FUEL SUPPLY HOSE REPLACEMENT

This task covers:

a. Removal

b. Installation

INITIAL SETUP:

Applicable Models

M998, M998A1, M1038, M1038A1

Tools

General mechanic's tool kit:
automotive (Appendix B, Item 1)

Manual References

TM 9-2320-280-10
TM 9-2320-280-24P

General Safety Instructions

Do not perform this procedure near fire, flames, or sparks.

WARNING

Diesel fuel is highly flammable. Do not perform this procedure near fire, flames, or sparks. Severe injury or death will result.

a. Removal

CAUTION

Cover or plug all open hoses and connections immediately after disconnection to prevent contamination. Remove all plugs prior to connection.

NOTE

Have drainage container ready to catch fuel.

Remove two clamps (2) and bulkhead fuel supply hose (4) from pump-to-bulkhead fuel supply line (1) and bulkhead hose-to-bulkhead coupling supply line (3).

b. Installation

Connect bulkhead fuel supply hose (4) to pump-to-bulkhead fuel supply line (1) and bulkhead hose-to-bulkhead coupling supply line (3) with two clamps (2).

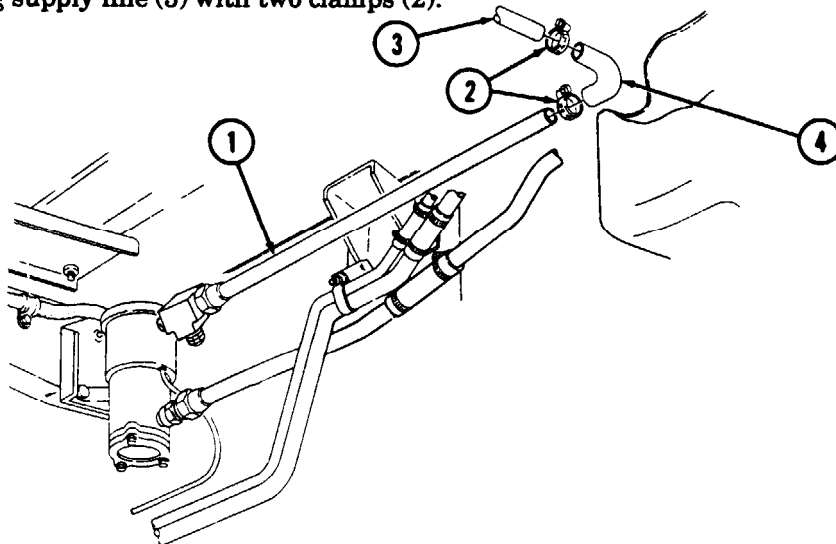

FOLLOW-ON TASK: Operate troop/cargo heater (TM 9-2320-280-10) and check for fuel leaks.

12-89. TROOP/CARGO WINTERIZATION HEATER BULKHEAD HOSE-TO-BULKHEAD COUPLING FUEL SUPPLY LINE REPLACEMENT

This task covers:

- a. Removal b. Installation

INITIAL SETUP:

Applicable Models

M998, M998A1, M1038, M1038A1

Tools

General mechanic's tool kit:
automotive (Appendix B, Item 1)

Materials/Parts

Sealing compound (Appendix C, Item 44)

Manual References

TM 9-2320-280-10
TM 9-2320-280-24P

General Safety Instructions

Do not perform this procedure near fire, flames, or sparks.

WARNING

Diesel fuel is highly flammable. Do not perform this procedure near fire, flames, or sparks. Severe injury or death will result.

a. Removal

CAUTION

Cover or plug all open hoses and connections immediately after disconnection to prevent contamination. Remove all plugs prior to connection.

NOTE

Have drainage container ready to catch fuel.

1. Loosen clamp (2) and disconnect bulkhead hose (1) from bulkhead hose-to-bulkhead coupling fuel supply line (3).
2. Disconnect bulkhead hose-to-bulkhead coupling fuel supply line (3) from elbow (4) and remove bulkhead hose-to-bulkhead coupling fuel supply line (3).

b. Installation

1. Apply sealing compound to threads of elbow (4) and connect bulkhead hose-to-bulkhead coupling fuel supply line (3) to elbow (4).
2. Connect bulkhead hose (1) to bulkhead hose-to-bulkhead coupling fuel supply line (3) with clamp (2).

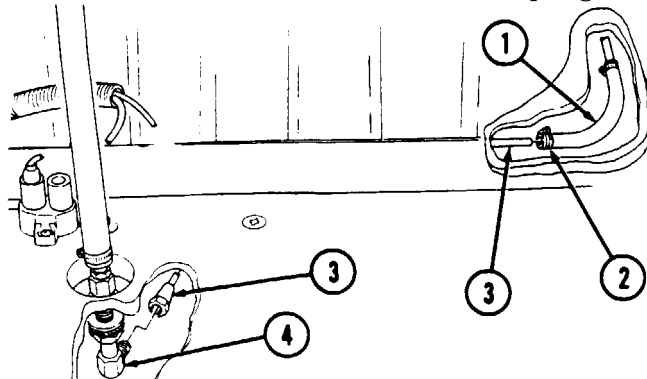

FOLLOW-ON TASK: Operate troop/cargo heater (TM 9-2320-280-10) and check for fuel leaks.

12-90. TROOP/CARGO WINTERIZATION HEATER FUEL SUPPLY LINE BULKHEAD COUPLING REPLACEMENT

This task covers:

a. Removal

b. Installation

INITIAL SETUP:

Applicable Models

M998, M998A1, M1038, M1038A1

Tools

General mechanic's tool kit:
automotive (Appendix B, Item 1)

Materials/Parts

Sealing compound (Appendix C, Item 44)

Manual References

TM 9-2320-280-10

TM 9-2320-280-24P

General Safety Instructions

Do not perform this procedure near fire, flames, or sparks.

WARNING

Diesel fuel is highly flammable. Do not perform this procedure near fire, flames, or sparks. Severe injury or death will result.

a. Removal

CAUTION

Cover or plug all open hoses and connections immediately after disconnection to prevent contamination. Remove all plugs prior to connection.

NOTE

Have drainage container ready to catch fuel.

1. Disconnect bulkhead hose-to-bulkhead coupling fuel supply line (7) from elbow (8).
2. Remove elbow (8) from nipple (9).
3. Remove nut (10) and washers (11) and (6) from coupling half (12) and cargo floor (5).
4. Pull remaining fittings up through cargo floor (5).
5. Loosen clamp (1) and disconnect filter-to-bulkhead coupling fuel supply hose (2) from connector (3).
6. Remove connector (3) from adapter (4).
7. Remove adapter (4) from coupling half (12).
8. Remove nipple (9) from coupling half (12).

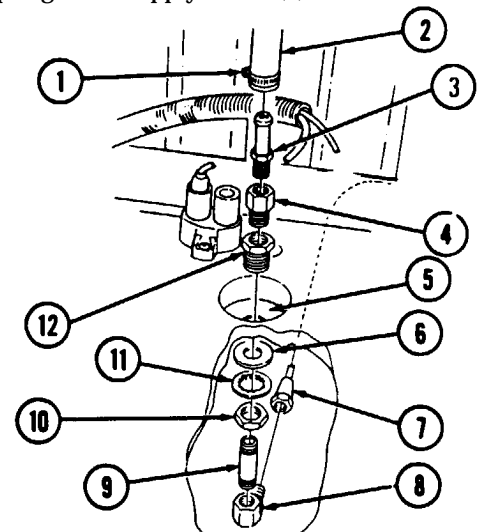

12-90. TROOP/CARGO WINTERIZATION HEATER FUEL SUPPLY LINE BULKHEAD COUPLING REPLACEMENT (Cont'd)

b. Installation

1. Apply sealing compound to threads of nipple (9) and install nipple (9) on coupling half (12).
2. Apply sealing compound to threads of adapter (4) and install adapter (4) on coupling half (12).
3. Apply sealing compound to threads of connector (3) and install connector (3) on adapter (4).
4. Connect filter-to-bulkhead coupling fuel supply hose (2) to connector (3) with clamp (1).
5. Insert nipple (9), coupling half (12), adapter (4), and connector (3) through cargo floor (5).
6. Secure coupling half (12) to cargo floor (5) with washers (6) and (11) and nut (10).
7. Apply sealing compound to threads of nipple (9) and install elbow (8) on nipple (9).
8. Apply sealing compound to threads of elbow (8) and connect bulkhead hose-to-bulkhead coupling fuel supply line (7) to elbow (8).

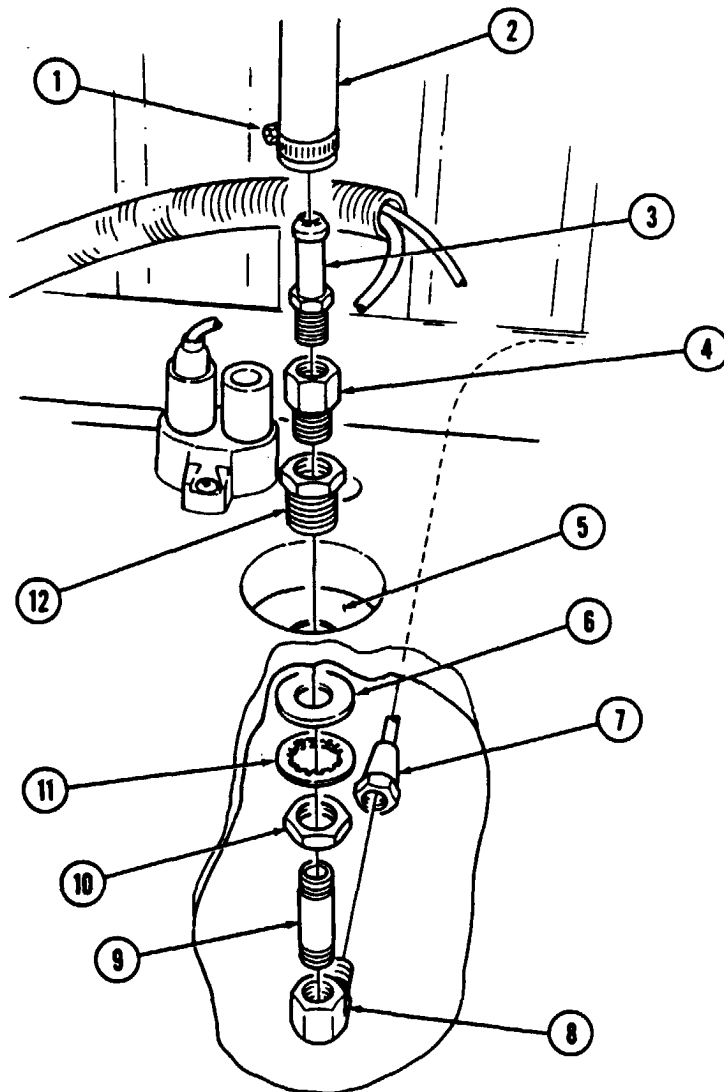

FOLLOW-ON TASK: Operate troop/cargo heater (TM 9-2320-280-10) and check for fuel leaks.

12-91. TROOP/CARGO WINTERIZATION HEATER FILTER-TO-BULKHEAD COUPLING FUEL SUPPLY HOSE REPLACEMENT

This task covers:

a. Removal

b. Installation

INITIAL SETUP:

Applicable Models

M998, M998A1, M1038, M1038A1

Tools

General mechanic's tool kit:
automotive (Appendix B, Item 1)

Materials/Parts

Sealing compound (Appendix C, Item 44)

Manual References

TM 9-2320-280-10
TM 9-2320-280-24P

Equipment Condition

Heater guard assembly removed
(para. 12-93).

General Safety Instructions

Do not perform this procedure near tire, flames, or sparks.

WARNING

Diesel fuel is highly flammable. Do not perform this procedure near fire, flames, or sparks. Severe injury or death will result.

a. Removal

CAUTION

Cover or plug all open hoses and connections immediately after disconnection to prevent contamination. Remove all plugs prior to connection.

NOTE

Have drainage container ready to catch fuel.

1. Loosen clamp (2) and disconnect filter-to-bulkhead coupling fuel supply hose (1) from filter connector (3).
2. Loosen clamp (4) and remove filter-to-bulkhead coupling fuel supply hose (1) from bulkhead coupling connector (5).
3. Inspect filter connector (3) and bulkhead coupling connector (5) for damage. Replace if cracked or damaged.

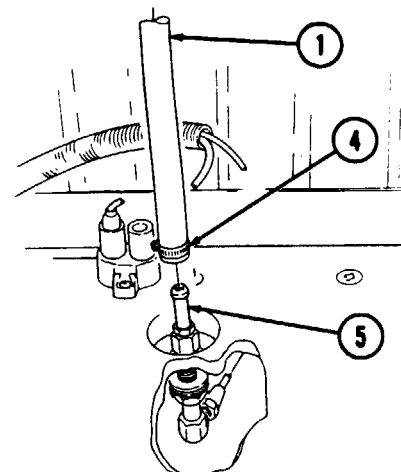
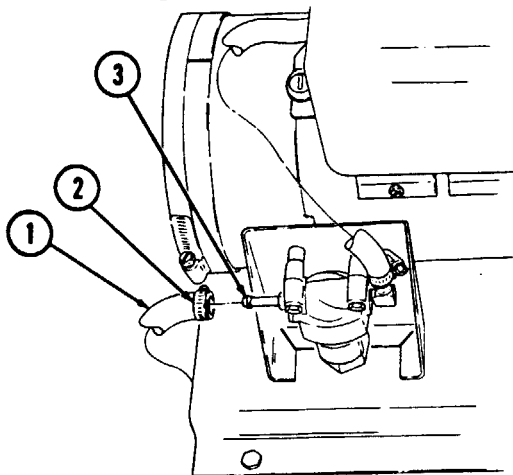

12-91. TROOP/CARGO WINTERIZATION HEATER FILTER-TO-BULKHEAD COUPLING FUEL SUPPLY HOSE REPLACEMENT (Cont'd)

b. Installation

1. Connect filter-to-bulkhead coupling fuel supply hose (1) to bulkhead coupling connector (5) with clamp (4).
2. Connect filter-to-bulkhead coupling fuel supply hose (1) to filter connector (3) with clamp (2).

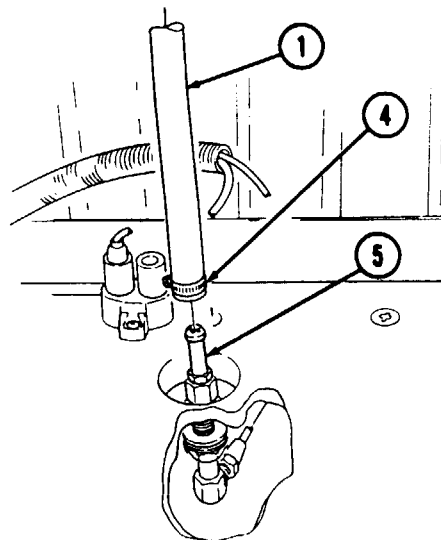
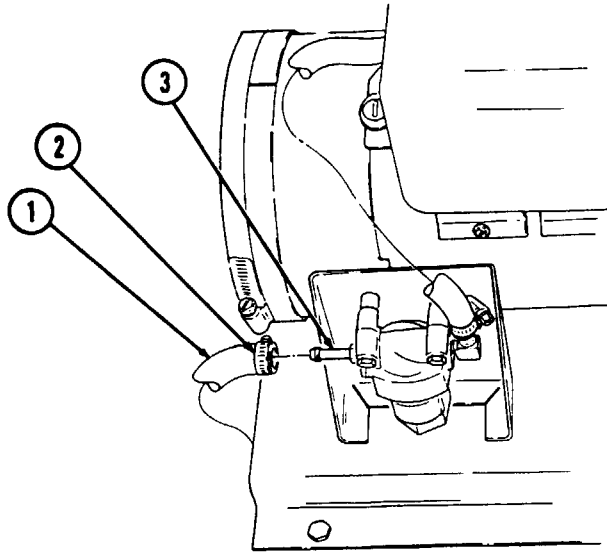

FOLLOW-ON TASKS: Ž Install heater guard assembly (para. 12-93).
Ž Operate troop/cargo heater (TM 9-2320-280-10) and check for fuel leaks.

12-92. TROOP/CARGO WINTERIZATION HEATER FILTER-TO-HEATER FUEL SUPPLY HOSE REPLACEMENT

This task covers:

a. Removal

b. Installation

INITIAL SETUP:

Applicable Models

M998, M998A1, M1038, M1038A1

Tools

General mechanic's tool kit:
automotive (Appendix B, Item 1)

Materials/Parts

Sealing compound (Appendix C, Item 44)

Manual References

TM 9-2320-280-10
TM 9-2320-280-24P

Equipment Condition

Heater guard assembly removed
(para. 12-93).

General Safety Instructions

Do not perform this procedure near fire, flames, or sparks.

WARNING

Diesel fuel is highly flammable. Do not perform this procedure near fire, flames, or sparks. Severe injury or death will result.

a. Removal

CAUTION

Cover or plug all open hoses and connections immediately after disconnection to prevent contamination. Remove all plugs prior to connection.

NOTE

Have drainage container ready to catch fuel.

1. Loosen clamp (4) and disconnect filter-to-heater fuel supply hose (1) from filter elbow (5).
2. Loosen clamp (2) and disconnect filter-to-heater fuel supply hose (1) from heater connector (3).
3. **Inspect filter elbow (5) and heater connector (3) for damage. Replace if damaged.**

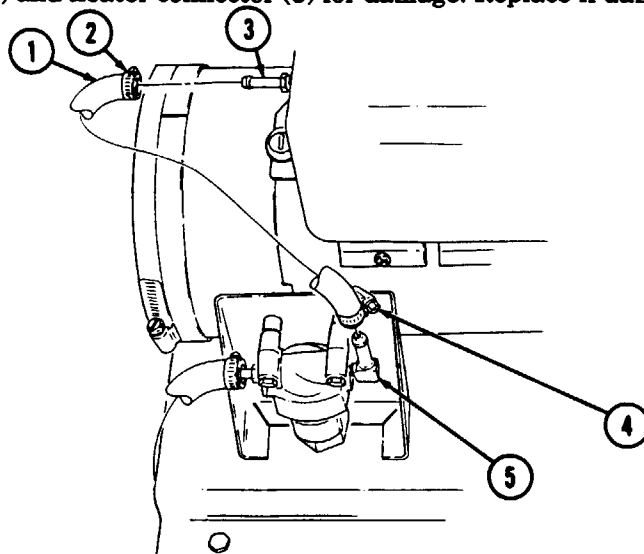

12-92. TROOP/CARGO WINTERIZATION HEATER FILTER-TO-HEATER FUEL SUPPLY HOSE REPLACEMENT (Cont'd)

b. Installation

1. Connect filter-to-heater fuel supply hose (1) to heater connector (3) with clamp (2).
2. Install filter-to-heater fuel supply hose (1) on filter elbow (5) with clamp (4).

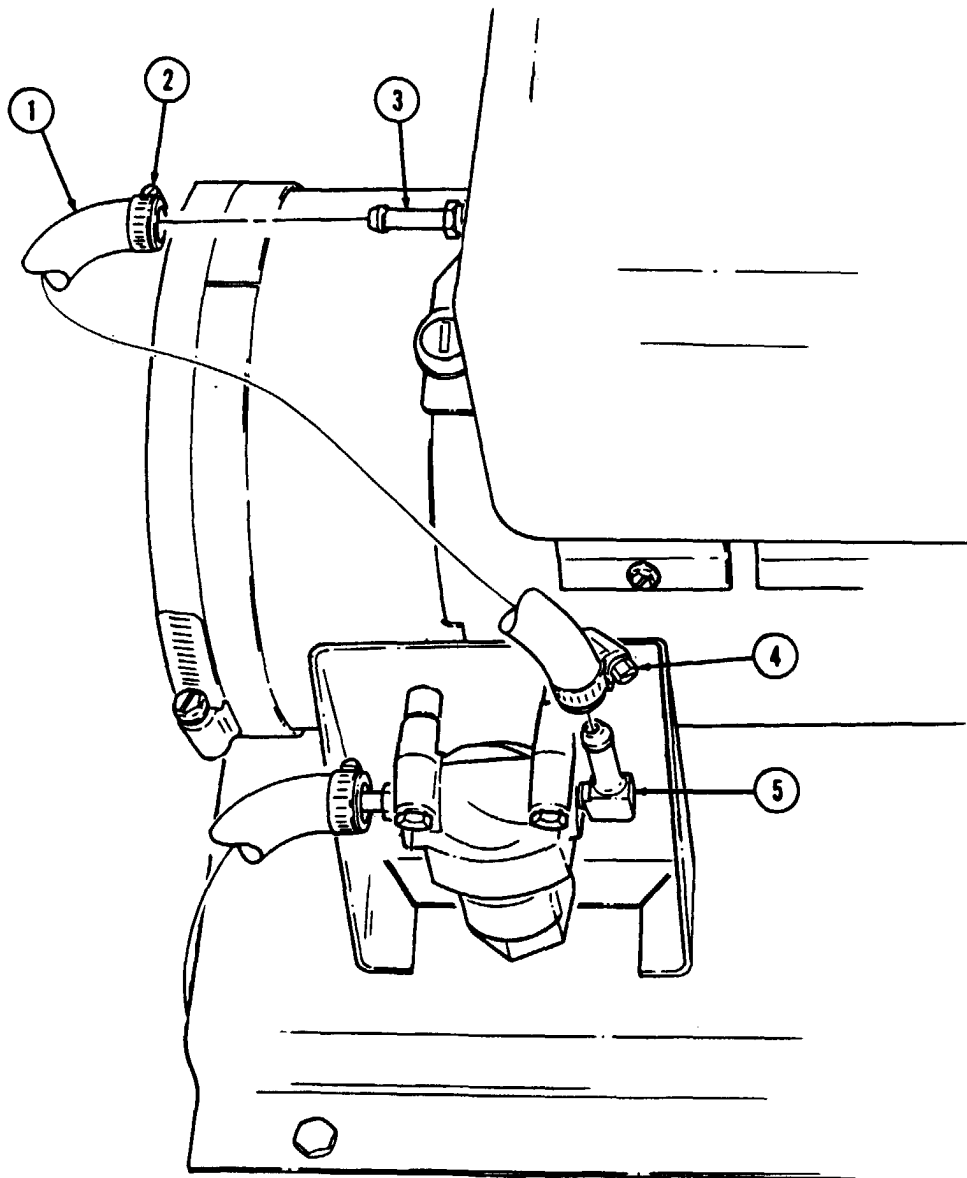

- FOLLOW-ON TASKS:
- Ž Install heater guard assembly (para. 12-93).
 - Ž Operate troop/cargo heater (TM 9-2320-280-10) and check for fuel leaks.

12-93. TROOP/CARGO WINTERIZATION HEATER GUARD ASSEMBLY REPLACEMENT

This task covers:

a. Removal

b. Installation

INITIAL SETUP:

Applicable Models

M998, M998A1, M1038, M1038A1

Tools

General mechanic's tool kit:
automotive (Appendix B, Item 1)

Materials/Parts

Four lockwashers (Appendix G, Item 162)

Manual References

TM 9-2320-280-24P

a. Removal

Remove four capscrews (3), lockwashers (2), and guard assembly (1) from heater base assembly (4). Discard lockwashers (2).

b. Installation

Install guard assembly (1) on heater base assembly (4) with four lockwashers (2) and capscrews (3).

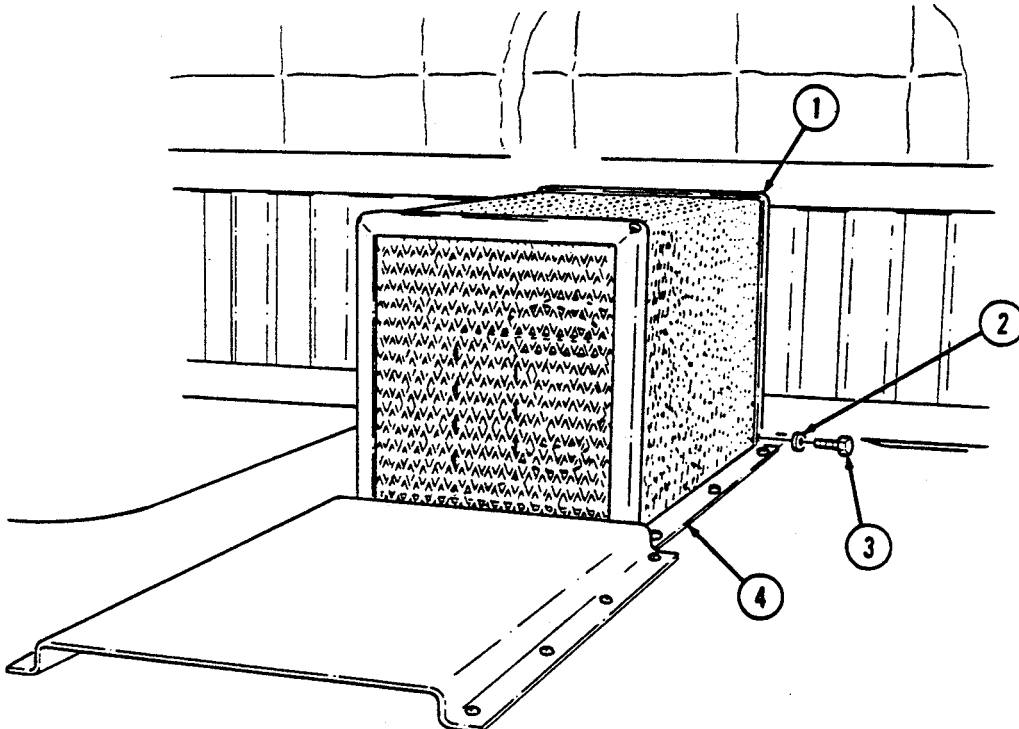

12-94. TROOP/CARGO WINTERIZATION HEAT DEFLECTOR REPLACEMENT

This task covers:

a. Removal

b. Installation

INITIAL SETUP:

Applicable Models

M998, M998A1, M1038, M1038A1

Manual References

TM 9-2320-280-24P

Tools

General mechanic's tool kit:
automotive (Appendix B, Item 1)

Equipment Condition

Heater guard assembly removed (para. 12-93).

Materials/Parts

Four lockwashers (Appendix G, Item 163)

a. Removal

Remove four capscrews (3), lockwashers (4), and heat deflector (1) from heater base assembly (2). Discard lockwashers (4).

b. Installation

Install heat deflector (1) on heater base assembly (2) with four lockwashers (4) and capscrews (3).

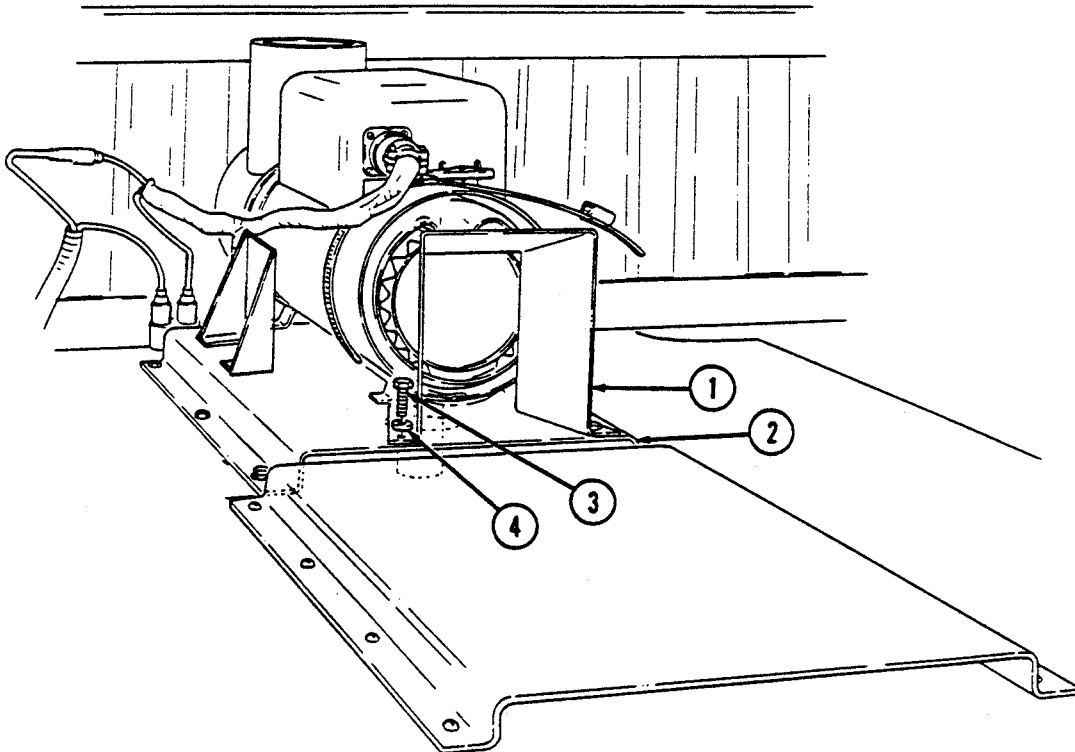

FOLLOW-ON TASK: Install heater guard assembly (para. 12-93).

12-95. TROOP/CARGO WINTERIZATION HEATER ASSEMBLY REPLACEMENT

This task covers:

a. Removal

b. Installation

INITIAL SETUP:

Applicable Models

M998, M998A1, M1038, M1038A1

Tools

General mechanic's tool kit:
automotive (Appendix B, Item 1)

Materials/Parts

Adhesive sealant (Appendix C, Item 10)
Sealing compound (Appendix C, Item 42)
O-ring (Appendix G, Item 222)

Manual References

TM 9-2320-280-10
TM 9-2320-280-24P

Equipment Condition

- Battery ground cable disconnected (para. 4-73).
- Heater guard assembly removed (para. 12-93).

General Safety Instructions

- Do not perform this procedure near fire, flames or sparks.
- Ensure handle on diverter assembly is facing toward left side of vehicle.

WARNING

Diesel fuel is highly flammable. Do not perform this procedure near fire, flames, or sparks. Severe injury or death will result.

a. Removal

CAUTION

Cover or plug all open hoses and connections immediately after disconnection to prevent contamination. Remove all plugs prior to connection.

NOTE

Have drainage container ready to catch fuel.

1. Loosen clamp (2) and disconnect filter-to-heater fuel supply hose (1) from connector (3).
2. Remove connector (3) from heater inlet port (4).
3. Remove clamp (6) and diverter assembly (7) from air inlet adapter (5).

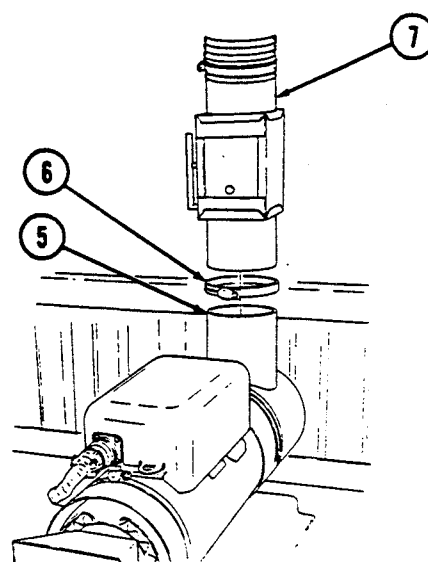
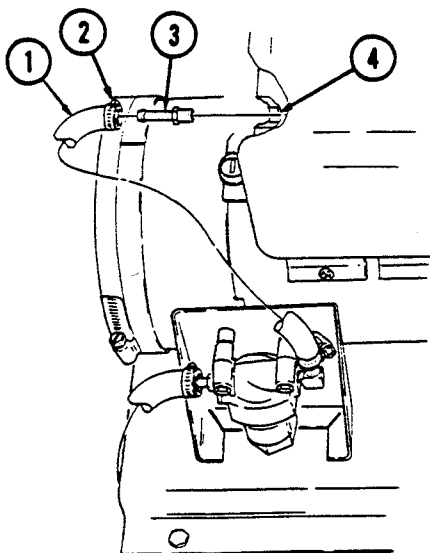

12-95. TROOP/CARGO WINTERIZATION HEATER ASSEMBLY REPLACEMENT (Cont'd)

4. Disconnect cannon plug (2) from heater (3).
5. Remove two clamps (1) and heater (3) from heater base assembly (4) .
6. Remove air inlet adapter (5) from heater (3).
7. Remove O-ring (6) and washer (7) from heater (3). Discard O-ring (6).
8. Remove exhaust extension (8) from heater base assembly (4).

b. Installation

NOTE

When installing exhaust extension into heater base assembly, ensure tab on exhaust extension and notch in heater base assembly are aligned.

1. Apply sealant to underside surface of flange on exhaust extension (8), and install exhaust extension (8) on heater base assembly (4).
2. Install washer (7) and O-ring (6) on heater (3).
3. Install air inlet adapter (5) on heater (3).
4. Install heater (3) on heater base assembly (4) with two clamps (1).
5. Connect cannon plug (2) to heater (3).

WARNING

Ensure handle on diverter assembly is facing toward left side of vehicle. Improper installation of the diverter assembly may cause serious injury to personnel.

6. Install diverter assembly (10) on air inlet adapter (5) with clamp (9).
7. Apply sealing compound to threads of connector (13) and install connector (13) on heater inlet port (14).
8. Connect filter-to-heater fuel supply hose (11) to connector (13) with clamp (12).

12-95. TROOP/CARGO WINTERIZATION HEATER ASSEMBLY REPLACEMENT (Cont'd)

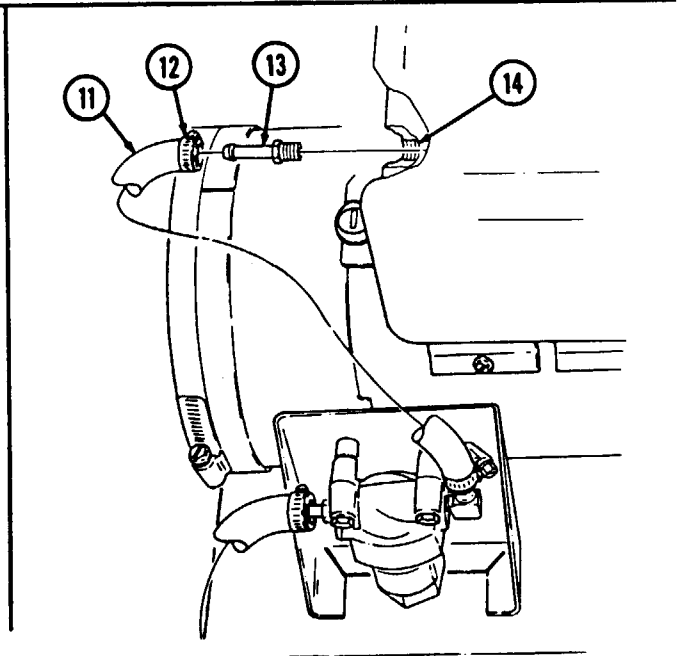
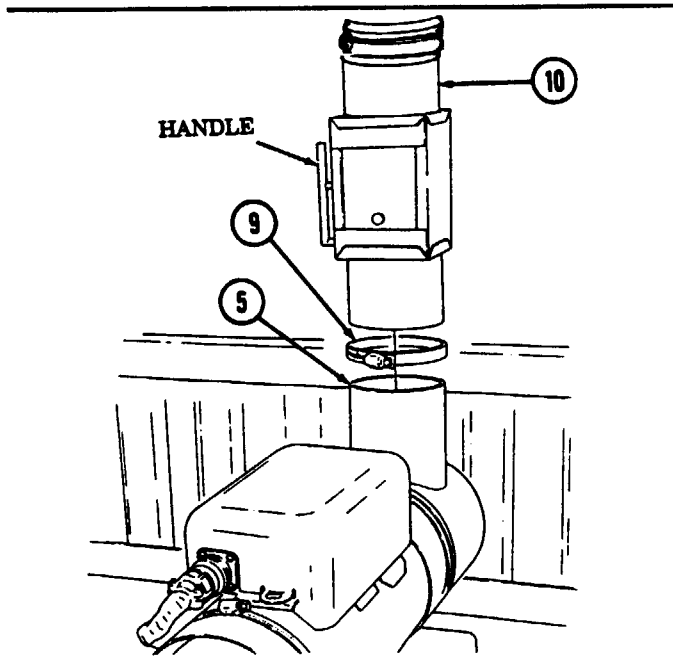
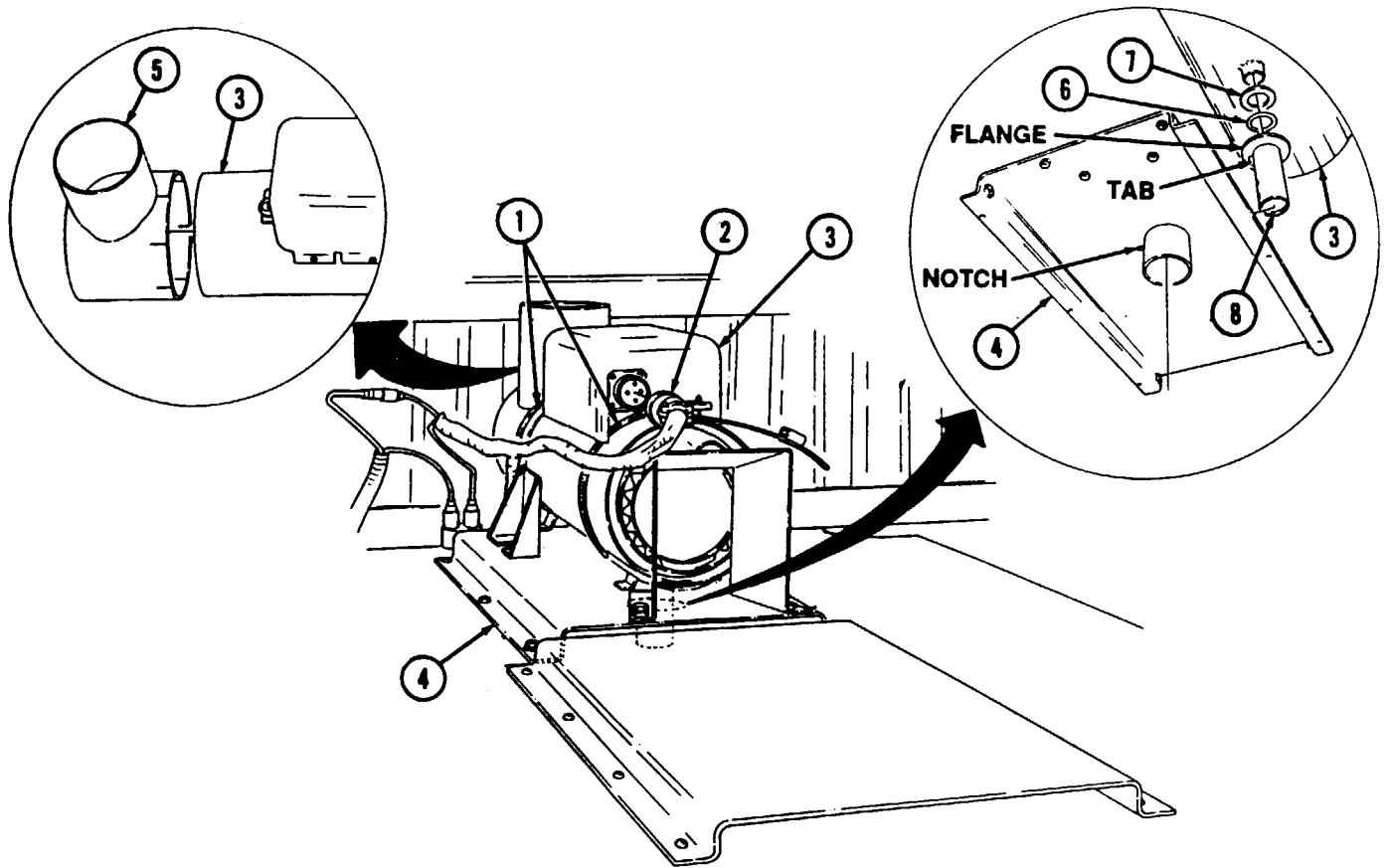

- FOLLOW-ON TASKS:
- ☒ Install heater guard assembly (para. 12-93).
 - ☒ Connect battery ground cable (para. 4-73).
 - ☒ Operate troop/cargo heater (TM 9-2320-280-10) and check for fuel leaks.

12-96. TROOP/CARGO WINTERIZATION HEATER DIVERTER ASSEMBLY REPLACEMENT

This task covers:

- a. Removal
- b. Installation

INITIAL SETUP:

Applicable Models

M998, M998A1, M1038, M1038A1

Manual References

TM 9-2320-280-24P

Tools

General mechanic's tool kit:
automotive (Appendix B, Item 1)

General Safety Instructions

Ensure handle on diverter assembly is facing toward left side of vehicle.

a. Removal

1. Remove clamp (2) and flex duct (3) from diverter assembly (1).
2. Remove clamp (5) and diverter assembly (1) from air inlet adapter (4).

b. Installation

WARNING

Ensure handle on diverter assembly is facing toward left side of vehicle. Improper installation of the diverter assembly may cause serious injury to personnel.

1. Install diverter assembly (1) on air inlet adapter (4) with clamp (5).
2. Install flex duct (3) on diverter assembly (1) with clamp (2).

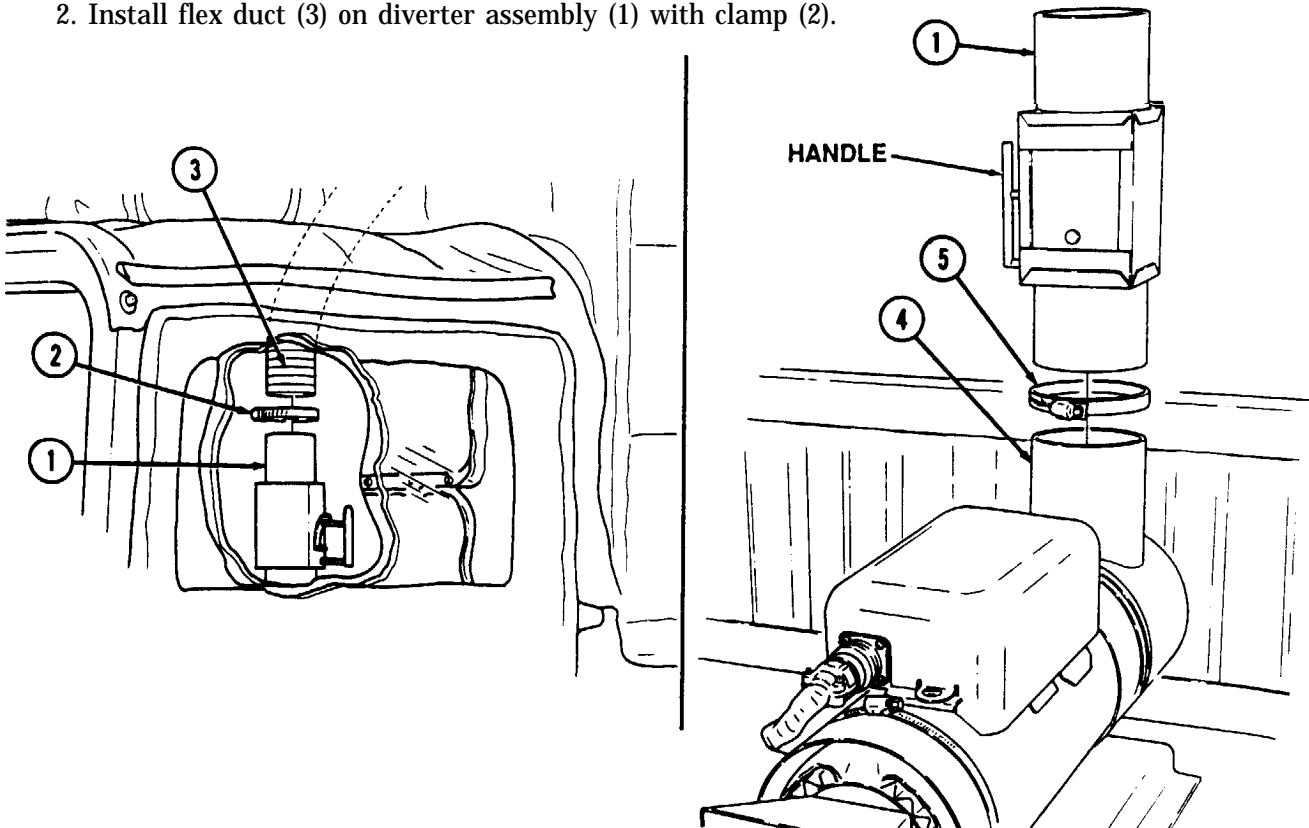

12-97. TROOP/CARGO WINTERIZATION HEATER AIR INTAKE ASSEMBLY REPLACEMENT

This task covers:

a. Removal

b. Installation

INITIAL SETUP:

Applicable Models

M998, M998A1, M1038, M1038A1

Tools

General mechanic's tool kit:
automotive (Appendix B, Item 1)

Materials/Parts

Three locknuts (Appendix G, Item 78)
Four locknuts (Appendix G, Item 117)

Manual References

TM 9-2320-280-24P

a. Removal

1. Remove two clamps (9) and flex duct (11) from diverter assembly (10) and adapter (7).
2. Remove three locknuts (5), capscrews (3), and hood (2), from top cover assembly (1) and plate (4). Discard locknuts (5).
3. Remove four locknuts (8), screws (12), adapter (7), and screen (6) from plate (4). Discard locknuts (8).

b. Installation

1. Install screen (6) and adapter (7) on plate (4) with four screws (12) and locknuts (8).
2. Install hood (2) on top cover assembly (1) and plate (4) with three capscrews (3) and locknuts (5).
3. Install flex duct (11) on adapter (7) and diverter assembly (10) with two clamps (9).

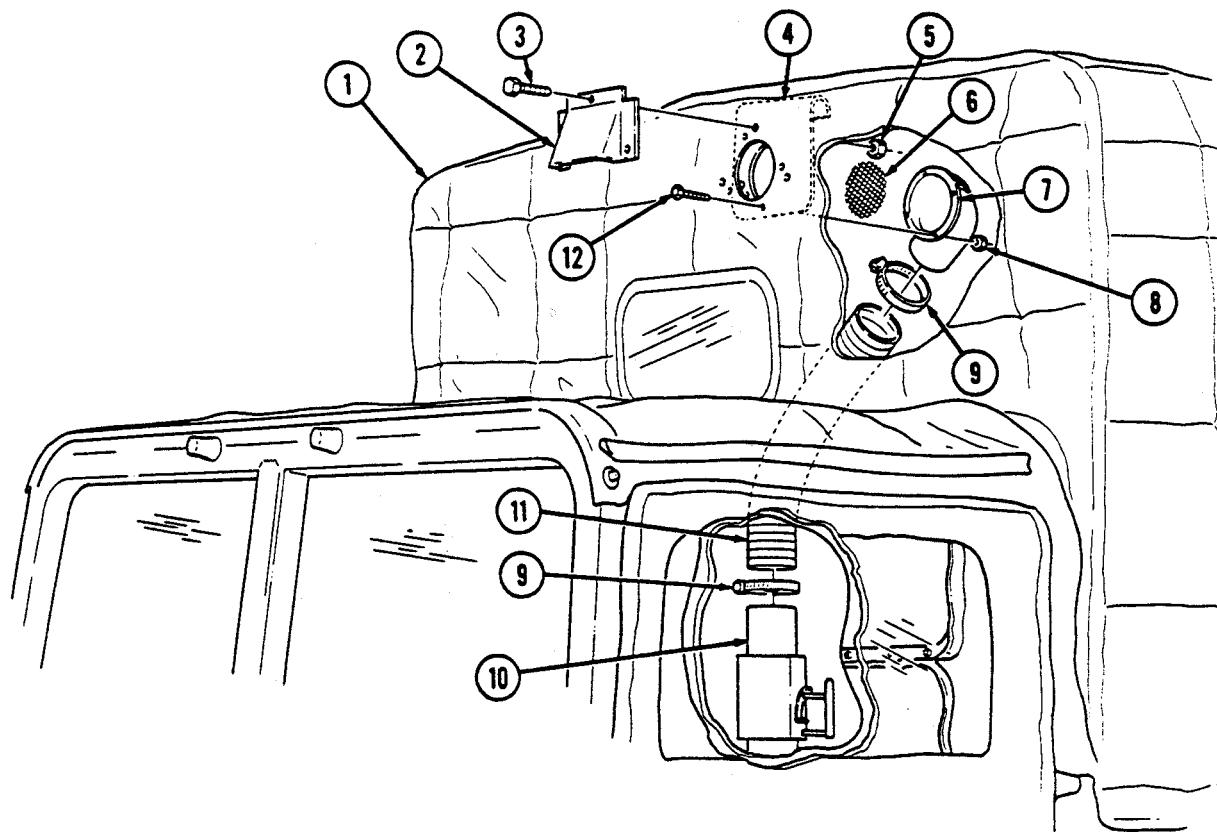

12-98. TROOP/CARGO WINTERIZATION HEATER BASE ASSEMBLY REPLACEMENT

This task covers:

a. Removal

b. Installation

INITIAL SETUP:

Applicable Models

M998, M998A1, M1038, M1038A1

Manual References

TM 9-2320-280-24P

Tools

General mechanic's tool kit:
automotive (Appendix B, Item 1)

Equipment Condition

- Heater assembly removed (para. 12-95).
- Heater fuel filter assembly removed (para. 12-82).
- Heat deflector removed (para. 12-94).

Materials/Parts

Gasket (Appendix G, Item 52)
Six lockwashers (Appendix G, Item 163)

a. Removal

1. Remove six capscrews (2), lockwashers (1), and heater base assembly (3) from cargo floor cover (4). Discard lockwashers (1).
2. Remove gasket (5) from heater base assembly (3). Discard gasket (5).

b. Installation

1. Install gasket (5) on heater base assembly (3).
2. Install heater base assembly (3) on cargo floor cover (4) with six lockwashers (1) and capscrews (2).

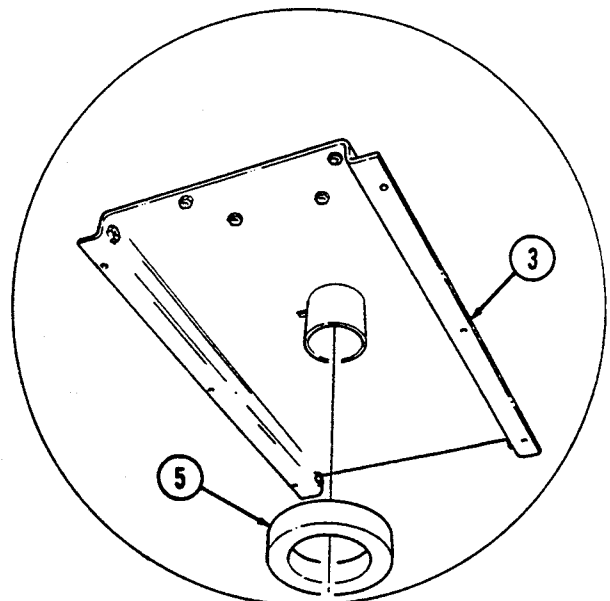
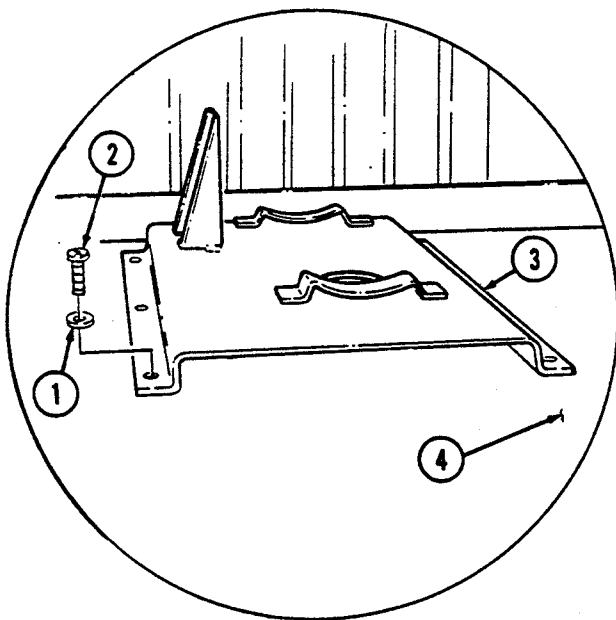

- FOLLOW-ON TASKS:**
- Install heat deflector (para. 12-94).
 - Install fuel filter assembly (para. 12-82).
 - Install heater assembly (para. 12-95).

12-99. TROOP/CARGO WINTERIZATION FLOOR BRACKET REPLACEMENT

This task covers:

a. Removal

b. Installation

INITIAL SETUP:

Applicable Models

M998, M998A1, M1038, M1038A1

Manual References

TM 9-2320-280-24P

Tools

General mechanic's tool kit:
automotive (Appendix B, Item 1)

a. Removal

Remove eight screws (2) and floor bracket (1) from front cargo floor cover (3).

b. Installation

Install floor bracket (1) on front cargo floor cover (3) with eight screws (2).

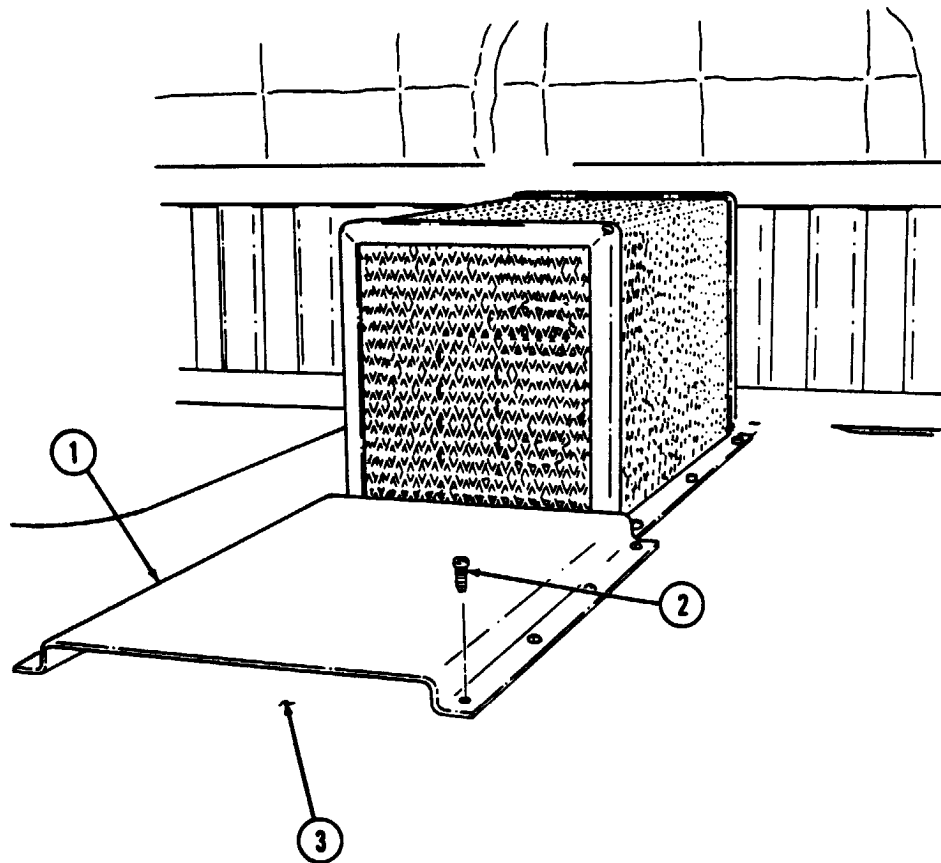

12-100. TROOP/CARGO WINTERIZATION HEATER CONTROL BOX AND ANGLE BRACKET REPLACEMENT

This task covers:

a. Removal

b. Installation

INITIAL SETUP:

Applicable Models

M998, M998A1, M1038, M1038A1

Tools

General mechanic's tool kit:
automotive (Appendix B, Item 1)

Materials/Parts

Adhesive (Appendix C, Item 7)
Two locknuts (Appendix G, Item 78)
Two lockwashers (Appendix G, Item 189)
Tiedown strap (Appendix G, Item 313)

Manual References

TM 9-2320-280-10
TM 9-2320-280-24P

Equipment Condition

Battery ground cable disconnected (para. 4-73).

a. Removal

1. Disconnect control box lead 400 (7) from harness lead 1C (8).
2. Remove tiedown strap (6) from ground lead 2C (3), ground lead (2), control box lead 400 (7), and heater wiring harness (10). Discard tiedown strap (6).
3. Disconnect cannon plug (11) from inner shell (13).
4. Remove two screws (12) and control box inner shell (13) from outer shell (14),
5. Remove two crown nuts (4), nuts (5), lockwashers (1), capscrews (9), ground lead 2C (3), ground lead (2), and outer shell (14) from angle bracket (15). Discard lockwashers (1).
6. Remove two locknuts (18), washers (17), capscrews (19), and angle bracket (15) from cargo bulkhead (16). Discard locknuts (18).

b. Installation

1. Install angle bracket (15) on cargo bulkhead (16) with two capscrews (19), washers (17), and locknuts (18).
2. Install outer shell (14), ground lead (2), and ground lead 2C (3) to angle bracket (15) with two capscrews (9), lockwashers (1), and nuts (5).
3. Apply adhesive to exposed threads of two capscrews (9) and install two crown nuts (4) on capscrews (9).
4. Install inner shell (13) on outer shell (14) with two screws (12).
5. Connect cannon plug (11) to inner shell (13).
6. Connect control box lead 400 (7) to harness lead 1C (8).
7. Install tiedown strap (6) on ground lead 2C (3), ground lead (2), control box lead 400 (7), and heater wiring harness (10).

12-100. TROOP/CARGO WINTERIZATION HEATER CONTROL BOX AND ANGLE BRACKET REPLACEMENT (Cont'd)

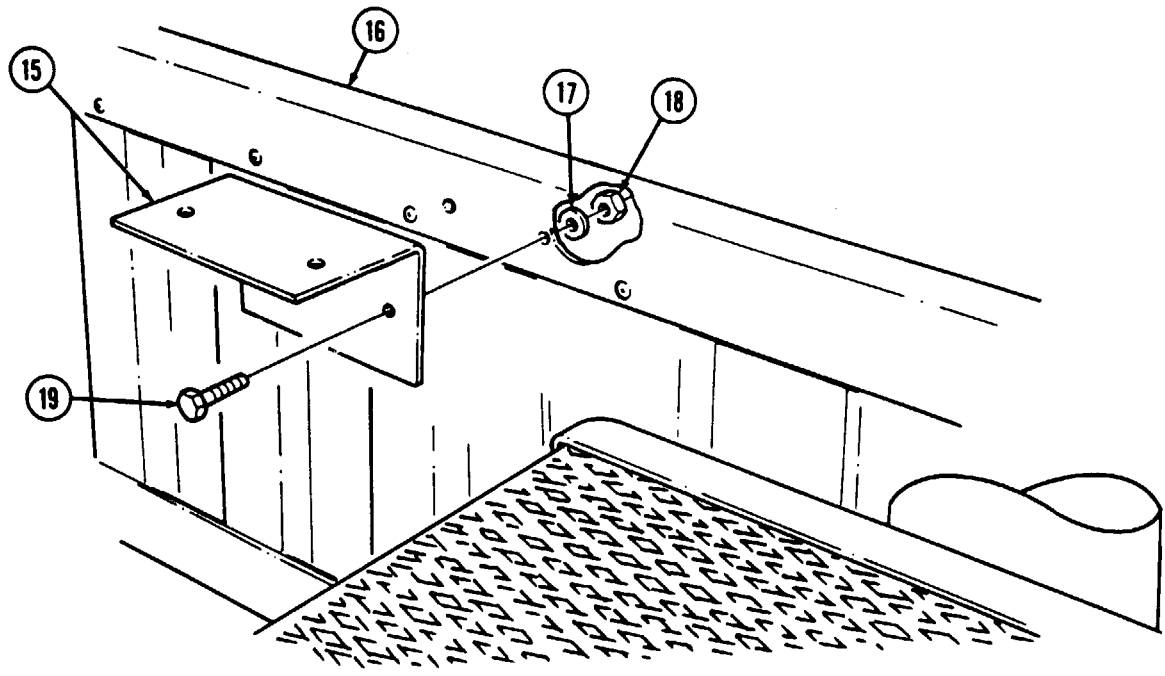
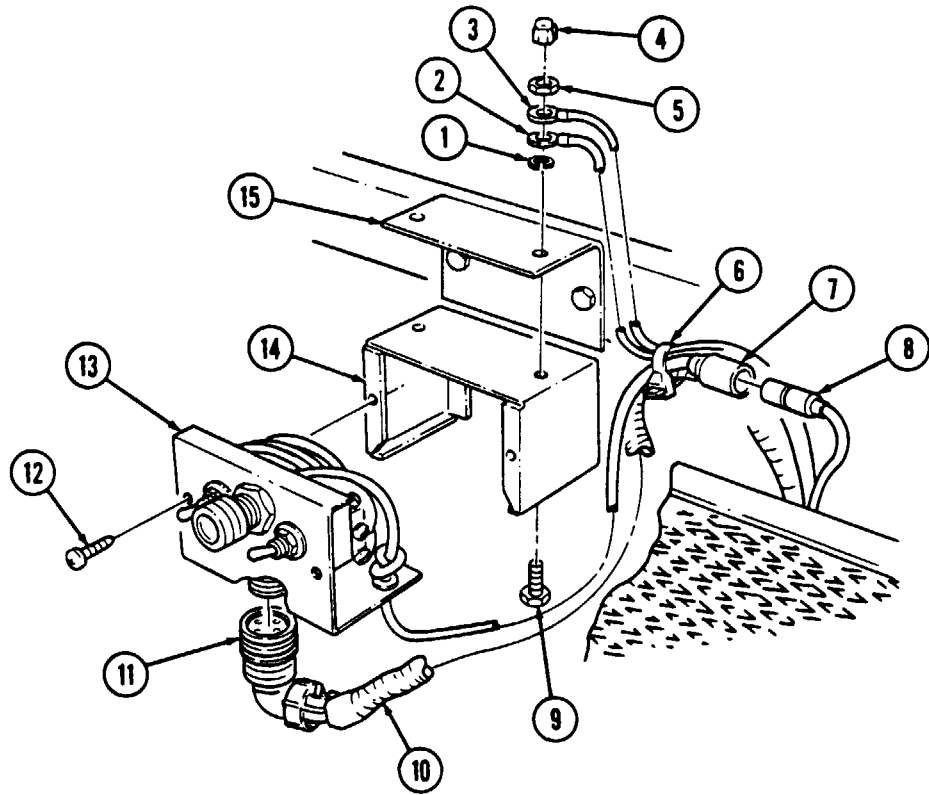

FOLLOW-ON TASKS:
 Ž Connect battery ground cable (para. 4-73).
 Ž Check for proper operation of troop/cargo heater (TM 9-2320-280-10).

12-101. TROOP/CARGO WINTERIZATION HEATER WIRING HARNESS REPLACEMENT

This task covers:

a. Removal

b. Installation

INITIAL SETUP:

Applicable Models

M998, M998A1, M1038, M1038A1

Tools

General mechanic's tool kit:
automotive (Appendix B, Item 1)

Materials/Parts

Adhesive (Appendix C, Item 7)
Two lockwashers (Appendix G, Item 178)
Lockwasher (Appendix G, Item 189)
Tiedown strap (Appendix G, Item 309)
Tiedown strap (Appendix G, Item 313)

Manual References

TM 9-2320-280-10
TM 9-2320-280-24P

Equipment Condition

Battery ground cable disconnected (para. 4-73).

a. Removal

NOTE

- Depending on what kits are installed on the vehicle, there may be unidentified leads on the shunt stud and power stud. These leads must remain on the studs.
- Prior to removal, tag leads for installation.

1. Remove nut (6), lockwasher (7), fuel pump ground lead 799B (10) and lead 2A (8) from shunt stud (9). Discard lockwasher (7).
2. Remove nut (15), lockwasher (14), starter cable (13), and lead 1A (12) from power stud (11). Discard lockwasher (14).
3. Disconnect lead FP (1) from adapter (2).
4. Remove tiedown strap (4) and heater wiring harness (3) from transmission vacuum line (5). Discard tiedown strap (4).
5. Disconnect cannon plug (25) from control box inner shell (27).
6. Remove two screws (26) and control box inner shell (27) from outer shell (28).
7. Remove crown nut (19), nut (20), lockwasher (16), capscrew (24), ground lead 2C (18), and ground lead (17) from angle bracket (29). Discard lockwasher (16).
8. Disconnect lead 1C (23) from control box lead 400 (22).
9. Remove tiedown strap (21) from ground lead 2C (18), ground lead (17), control box lead 400 (22), and heater wiring harness (3). Discard tiedown strap (21).
10. Disconnect lead 2B (31) from lead 2A (30).
11. Disconnect lead 1B (36) from circuit breaker (35).
12. Disconnect cannon plug (32) from heater (33) and remove heater wiring harness (3).
13. Remove plastic sleeve (34) from heater wiring harness (3).

12-101. TROOP/CARGO WINTERIZATION HEATER WIRING HARNESS REPLACEMENT (Cont'd)

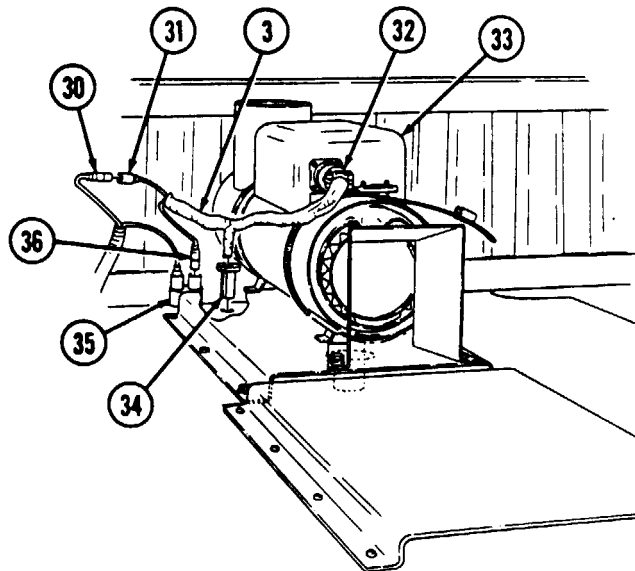
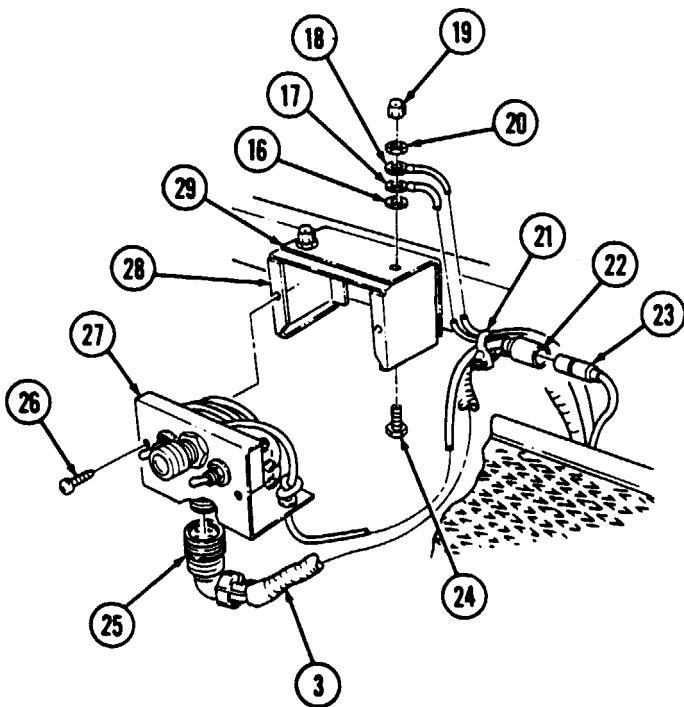
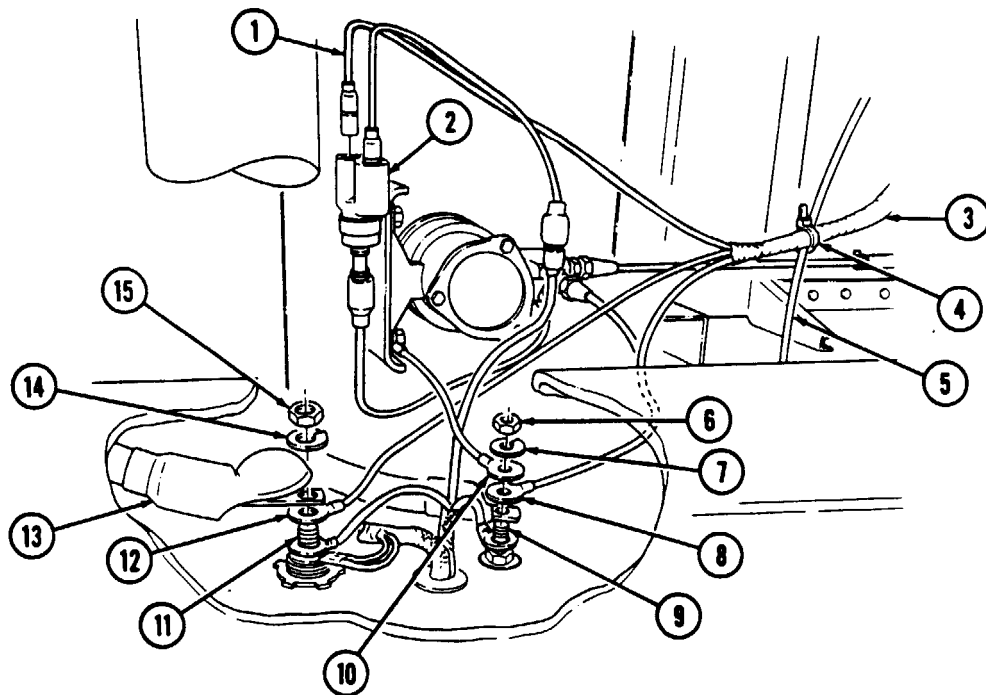

12-101. TROOP/CARGO WINTERIZATION HEATER WIRING HARNESS REPLACEMENT
(Cont'd)

b. Installation

1. Install heater wiring harness (3) through cargo floor (7), and position plastic sleeve (6) around harness (3). Insert plastic sleeve (6) into cargo floor (7).
2. Connect cannon plug (4) to heater (5).
3. Connect lead 1B (9) to circuit breaker (8).
4. Connect lead 2B (2) to lead 2A (1).
5. Connect lead 1C (17) to control box lead 400 (16).
6. Install ground lead (11) and ground lead 2C (12) on angle bracket (23) with capscrew (18), lockwasher (10), and nut (14).
7. Apply adhesive to exposed threads of capscrew (18) and install crown nut (13) on capscrew (18).
8. Install control box inner shell (21) on outer shell (22) with two screws (20).
9. Connect cannon plug (19) to control box inner shell (21).
10. Install tiedown strap (15) on ground lead 2C (12), ground lead (11), control box lead 400 (16), and heater wiring harness (3).
11. Connect lead FP (24) to adapter (25).
12. Install lead 1A (34) and starter cable (35) on power stud (33) with lockwasher (36) and nut (37).
13. Install lead 2A (30) and fuel pump ground lead 799B (32) on shunt stud (31) with lockwasher (29) and nut (28).
14. Install heater wiring harness (3) to transmission vacuum line (27) with tiedown strap (26).

12-101. TROOP/CARGO WINTERIZATION HEATER WIRING HARNESS REPLACEMENT (Cont'd)

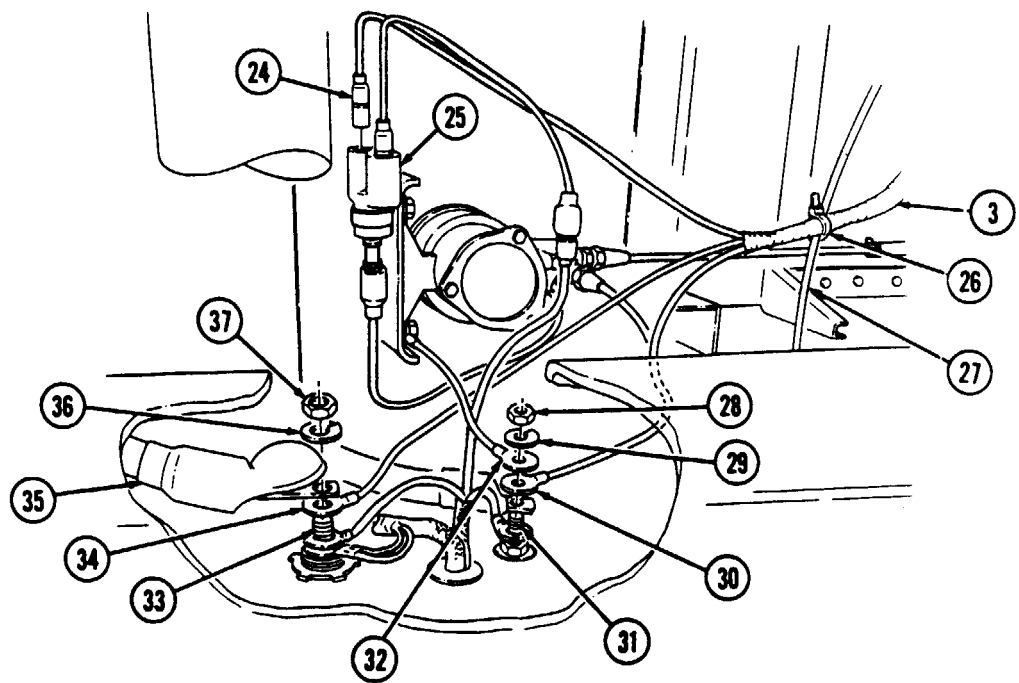
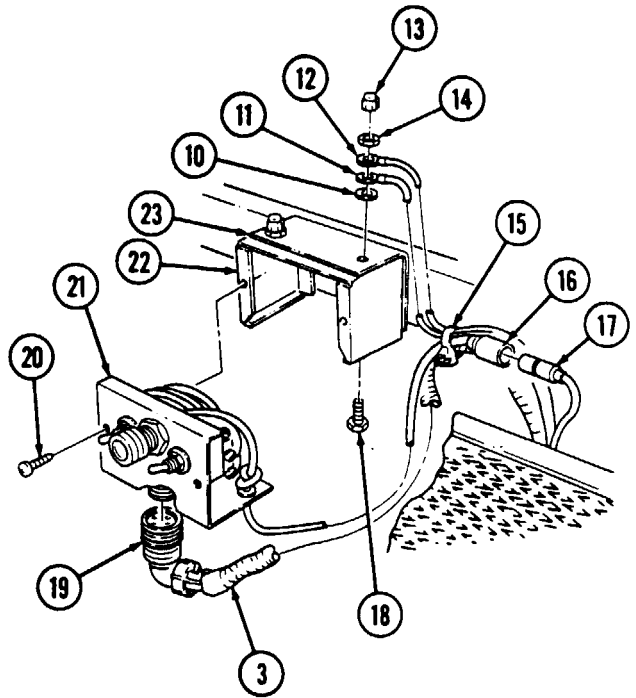
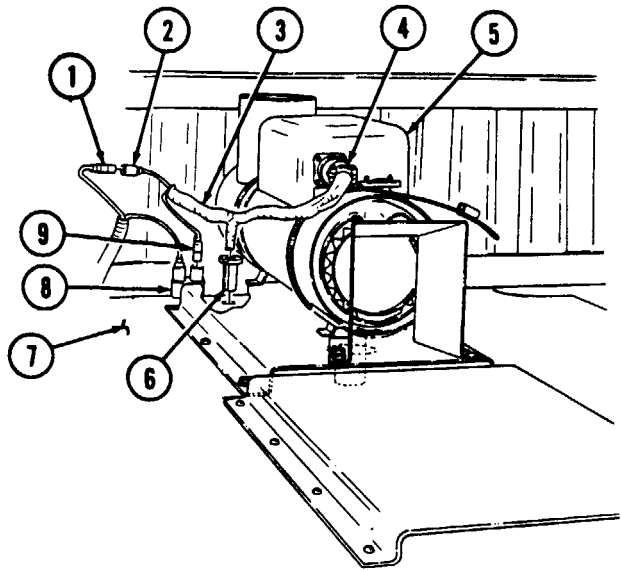

FOLLOW-ON TASKS:
 Ž Connect battery ground cable (para. 4-73).
 Ž Check for proper operation of troop/cargo heater (TM 9-2320-280-10).

12-102. TROOP/CARGO WINTERIZATION HEATER WIRING HARNESS ADAPTER REPLACEMENT

This task covers:

a. Removal

b. Installation

INITIAL SETUP:

Applicable Models

M998, M998A1, M1038, M1038A1

Tools

General mechanic's tool kit:
automotive (Appendix B, Item 1)

Materials/Parts

Locknut (Appendix G, Item 70)

Manual References

TM 9-2320-280-10
TM 9-2320-280-24P

Equipment Condition

Battery ground cable disconnected (para. 4-73).

a. Removal

1. Disconnect fuel pump lead (11) from connector (5).
2. Disconnect connector (5) from adapter (4).
3. Disconnect lead FP (1) from adapter (4).

NOTE

Perform step 4 if vehicle is equipped with front arctic heater.
Perform step 5 if vehicle is not equipped with front arctic heater.

4. Disconnect fuel pump jumper lead (6) from adapter (4).
5. Disconnect plug (2) and plug shell (3) from adapter (4).
6. Remove locknut (13), washer (14), capscrew (9), washer (8), fuel pump (10), clamp (12), and adapter (4) from bracket (7). Discard locknut (13).
7. Remove clamp (12) from adapter (4).

b. Installation

1. Install clamp (12) on adapter (4).
2. Install fuel pump (10), clamp (12), and adapter (4) on bracket (7) with washer (8), capscrew (9), washer (14), and locknut (13).

NOTE

Perform step 3 if vehicle is equipped with front arctic heater.
Perform step 4 if vehicle is not equipped with front arctic heater.

3. Connect fuel pump jumper lead (6) to adapter (4).
4. Connect plug shell (3) and plug (2) to adapter (4).
5. Connect lead FP (1) to adapter (4).
6. Connect connector (5) to adapter (4).
7. Connect fuel pump lead (11) to connector (5).

12-102. TROOP/CARGO WINTERIZATION HEATER WIRING HARNESS ADAPTER REPLACEMENT (Cont'd)

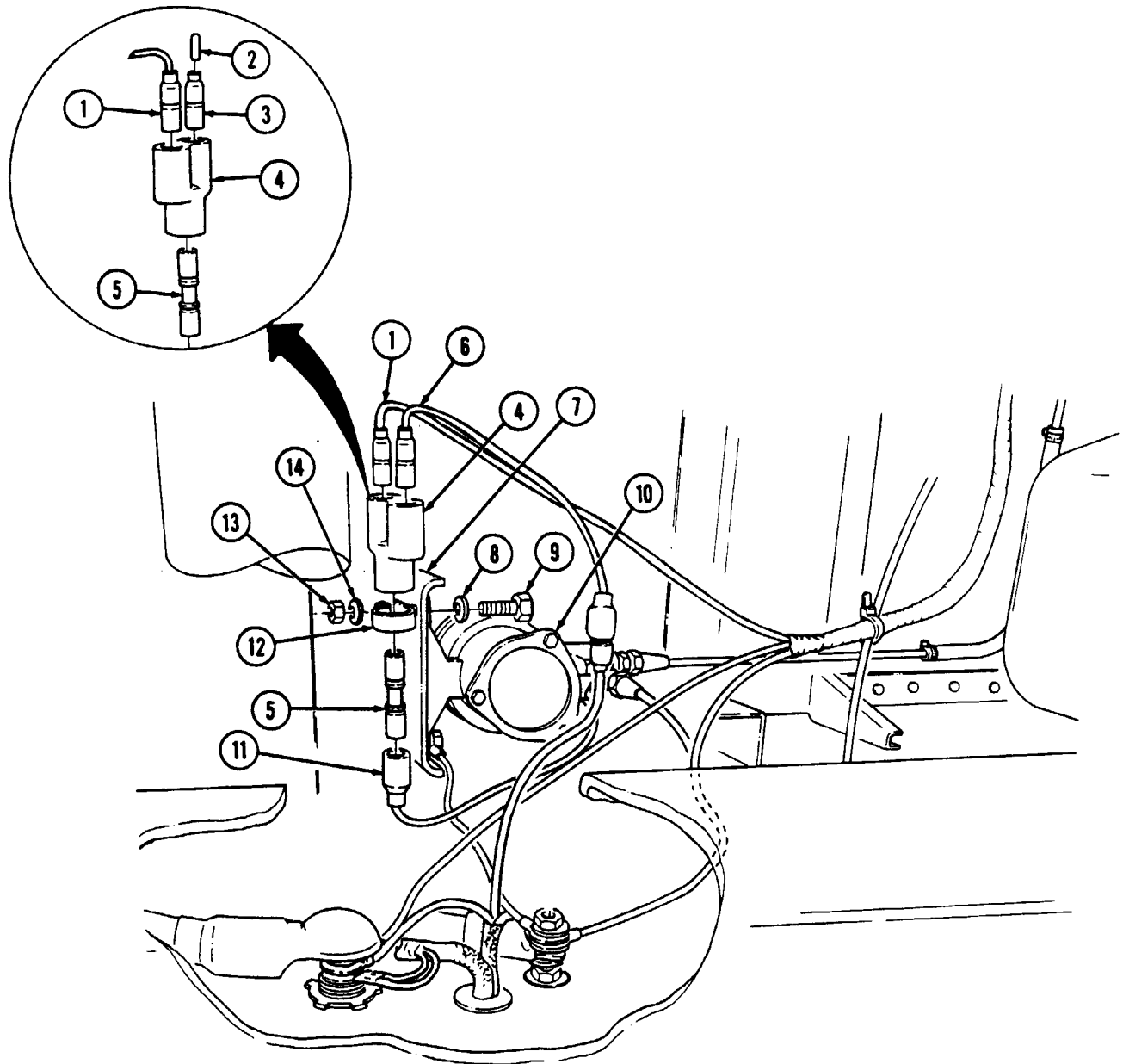

FOLLOW-ON TASKS:
 Ž Connect battery ground cable (para. 4-73).
 Ž Check for proper operation of troop/cargo heater (TM 9-2320-280-10).

12-103. TROOP/CARGO WINTERIZATION CIRCUIT BREAKER REPLACEMENT

This task covers:

- a. Removal
- b. Installation

INITIAL SETUP:

Applicable Models

M998, M998A1, M1038, M1038A1

Manual References

TM 9-2320-280-10
 TM 9-2320-280-24P

Tools

General mechanic's tool kit:
 automotive (Appendix B, Item 1)

Equipment Condition

Battery ground cable disconnected (para. 4-73).

NOTE

Prior to removal, tag leads for installation.

a. Removal

1. Disconnect heater harness lead 1B (2) from circuit breaker (4).
2. Disconnect blackout/dome light harness lead 1A (1) from circuit breaker (4).
3. Remove two screws (3) and circuit breaker (4) from front cargo floor cover (5).

b. Installation

1. Install circuit breaker (4) on front cargo floor cover (5) with two screws (3).
2. Connect blackout/dome light harness lead 1A (1) to circuit breaker (4).
3. Connect heater harness lead 1B (2) to circuit breaker (4).

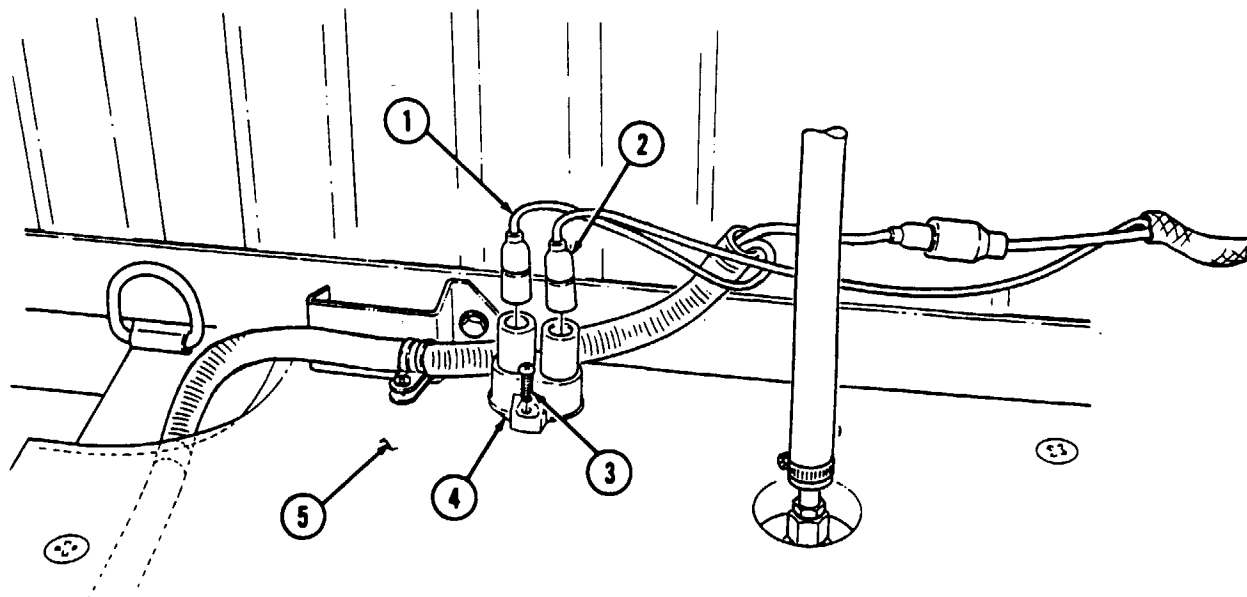

- FOLLOW-ON TASKS:**
- ⌘ Connect battery ground cable (para. 4-73).
 - ⌘ Check for proper operation of troop/cargo heater (TM 9-2320-280-10).

12-104. TROOP/CARGO WINTERIZATION BLACKOUT CURTAIN REPLACEMENT

This task covers:

a. Removal

b. Installation

INITIAL SETUP:

Applicable Models

M998, M998A1, M1038, M1038A1

Materials/Parts

Eighteen locknuts (Appendix G, Item 95)

Tools

General mechanic's tool kit:
automotive (Appendix B, Item 1)

Manual References

TM 9-2320-280-10
TM 9-2320-280-24P

NOTE

There are two blackout curtains located in the driver's compartment. There is also a blackout curtain located above the driver's compartment on the troop/cargo enclosure assembly. This blackout curtain opens from inside the enclosure assembly. The replacement procedures for all blackout curtains are basically the same. The following replacement instructions cover the right blackout curtain in the driver's compartment.

a. Removal

Remove eighteen locknuts (2), blackout curtain (3), and retainer (1) from arctic curtain (4). Discard locknuts (2).

b. Installation

Install blackout curtain (3) and retainer (1) on arctic curtain (4) with eighteen locknuts (2).

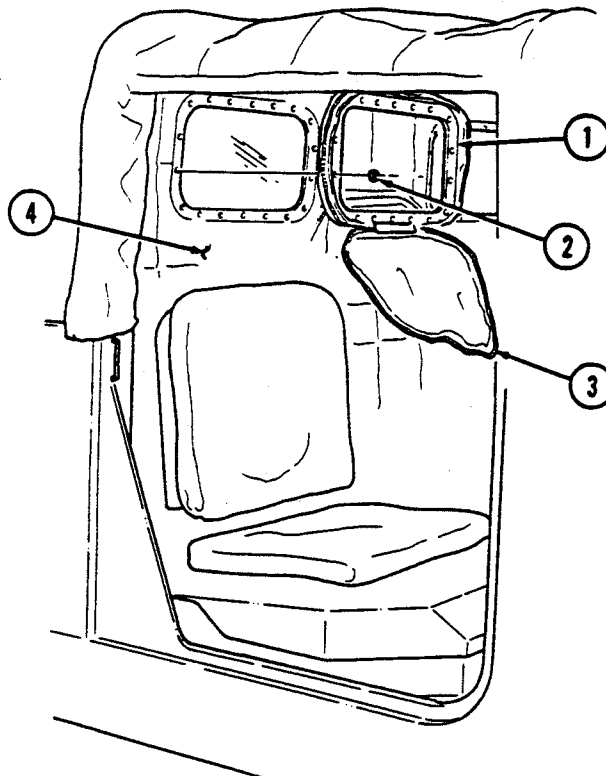

12-105. TROOP/CARGO WINTERIZATION BLACKOUT/DOME LIGHT WIRING HARNESS REPLACEMENT

This task covers:

- a. Removal
- b. Installation

INITIAL SETUP:

Applicable Models

M998, M998A1, M1038, M1038A1

Tools

General mechanic's tool kit:
automotive (Appendix B, Item 1)

Manual References

TM 9-2320-280-10
TM 9-2320-280-24P

Equipment Condition

- ⌘ Battery ground cable disconnected (para. 4-73).
- ⌘ Cargo floor cover removed (para. 12-110).
- ⌘ Blackout/dome light switch removed (para. 12-106).
- ⌘ Blackout/dome light door switch removed (para. 12-107).

NOTE

Prior to removal, tag leads for installation.

a. Removal

1. Remove four screws (22) and upper side channel (23) from left end closure (24).
2. Remove ten screws (26) and lower side channel (25) from left end closure (24).
3. Remove four screws (19) and right blackout/dome light assembly (1) from right end closure (27).
4. Disconnect harness leads 712C (7) and 719C (6) from dome light leads 711/712 (8) and 719 (9).
5. Disconnect harness leads 711C (2) and 2C (3) from blackout light leads 711/712 (5) and 717 (4).
6. Remove four screws (21) and left blackout/dome light assembly (10) from left end closure (24).
7. Disconnect harness leads 712B (13) and 719B (14) from dome light leads 711/712 (12) and 719 (11).
8. Disconnect harness leads 711B (16) and 2B (15) from blackout light leads 711/712 (17) and 717 (18) and remove wiring harness (20).

b. Installation

1. Connect harness leads 711B (16) and 2B (15) to blackout light leads 711/712 (17) and 717 (18).
2. Connect harness leads 712B (13) and 719B (14) to dome light leads 711/712 (12) and 719 (11).
3. Install left blackout/dome light assembly (10) on left end closure (24) with four screws (21).
4. Connect harness leads 711C (2) and 2C (3) to blackout light leads 711/712 (5) and 717 (4).
5. Connect harness leads 712C (7) and 719C (6) to dome light leads 711/712 (8) and 719 (9).
6. Install right blackout/dome light assembly (1) on right end closure (27) with four screws (19).
7. Install wiring harness (20) under lower side channel (25) and install lower side channel (25) to left end closure (24) with ten screws (26).
8. Install wiring harness (20) under upper side channel (23) and install upper side channel (23) to left end closure (24) with four screws (22).

12-105. TROOP/CARGO WINTERIZATION BLACKOUT/DOME LIGHT WIRING HARNESS REPLACEMENT (Cont'd)

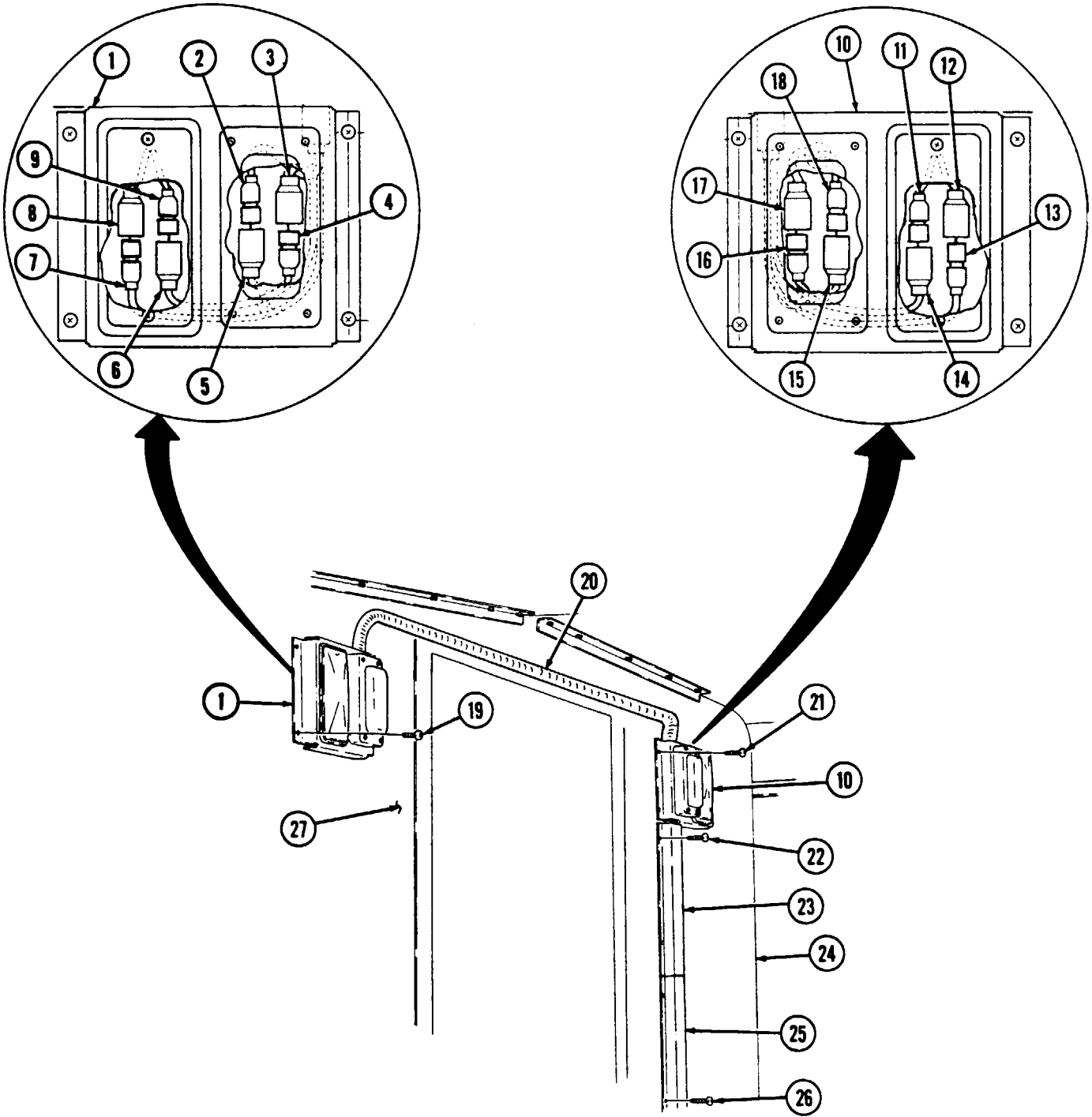

- FOLLOW-ON TASKS:
- Ž Install blackout/dome light door switch (para. 12-107).
 - Ž Install blackout/dome light switch (para. 12-106).
 - Ž Install cargo floor cover (para. 12-110).
 - Ž Connect battery ground cable (para. 4-73).
 - Ž Check blackout light and dome light for proper operation (TM 9-2320-280-10).

12-106. TROOP/CARGO WINTERIZATION BLACKOUT/DOME LIGHT SWITCH REPLACEMENT

This task covers:

a. Removal

b. Installation

INITIAL SETUP:

Applicable Models

M998, M998A1, M1038, M1038A1

Manual References

TM 9-2320-280-10
TM 9-2320-280-24P

Tools

General mechanic's tool kit:
automotive (Appendix B, Item 1)

Equipment Condition

Battery ground cable disconnected (para. 4-73).

a. Removal

1. Remove nut (7) from box (3).
2. Remove two screws (2), box (3), and switch (9) from upper side channel (1) and lower side channel (4).
3. Inspect decal (8) and remove from box (3) if decal (8) is damaged or illegible.

NOTE

Prior to removal, tag leads for installation.

4. Remove three screws (5), washers (11), and leads 711A (6), 1B (12), and 712A (10) from switch (9).

b. Installation

NOTE

Ensure lead 711A is positioned on top switch contact, and keyway is on bottom of switch.

1. Install leads 711A (6), 1B (12), and 712A (10) on switch (9) with three washers (11) and screws (5).
Do not tighten screws (5).
2. Install decal (8) on box (3), if removed.

NOTE

Ensure keyway in switch is toward the "BLACKOUT" position on box when installed.

3. Install switch (9) on box (3) with nut (7).
4. Tighten three screws (5) installed in step 1.

NOTE

Ensure electrical harness lead are not binding during box installation.

5. Install box (3) on upper side channel (1) and lower side channel (4) with two screws (2).

12-106. TROOP/CARGO WINTERIZATION BLACKOUT/DOME LIGHT SWITCH REPLACEMENT (Cont'd)

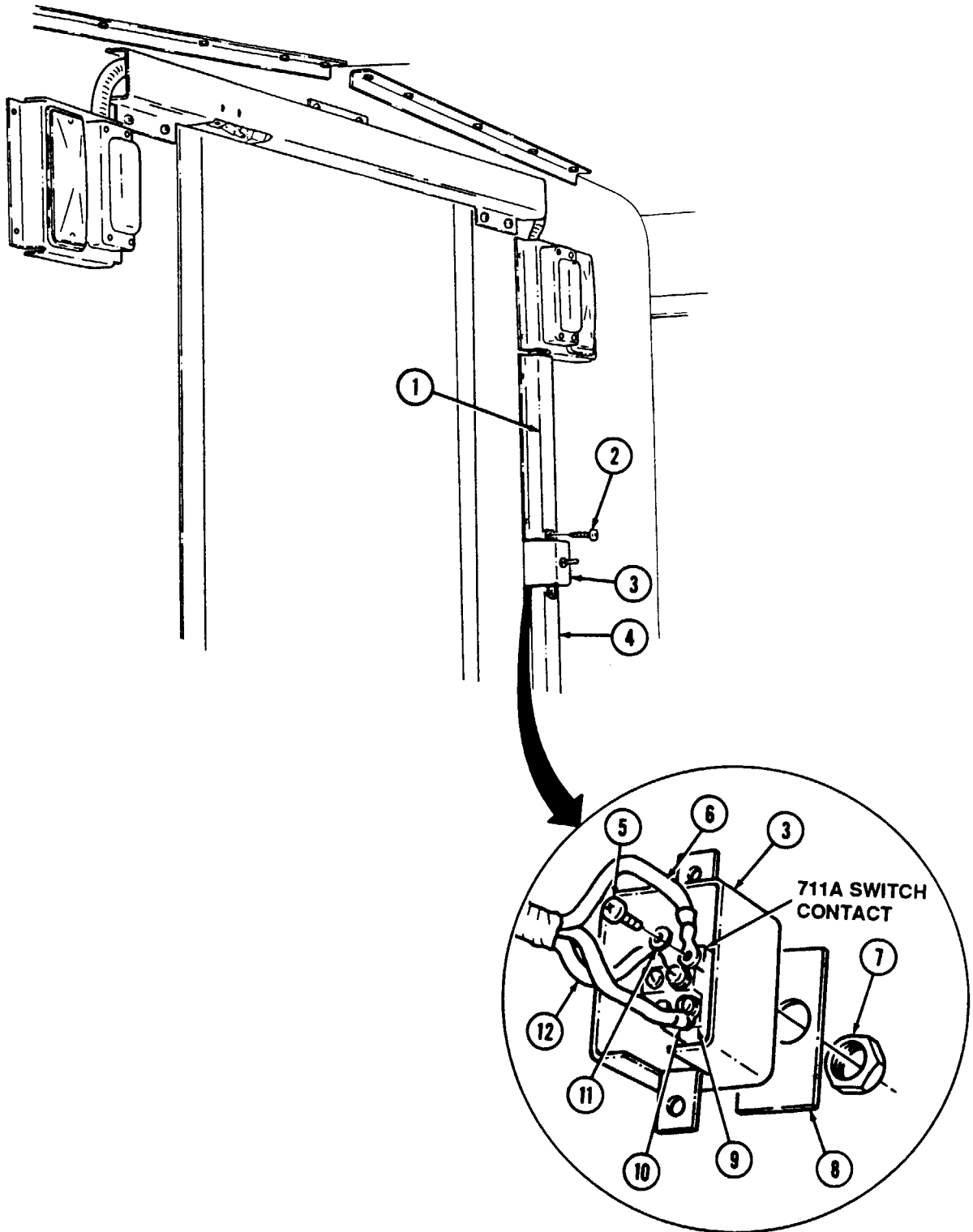

- FOLLOW-ON TASKS:
- Ž Connect battery ground cable (para. 4-73).
 - Ž Check blackout light and dome light for proper operation (TM 9-2320-280-10).

12-107. TROOP/CARGO WINTERIZATION BLACKOUT/DOME LIGHT DOOR SWITCH REPLACEMENT

This task covers:

a. Removal

b. Installation

INITIAL SETUP:

Applicable Models

M998, M998A1, M1038, M1038A1

Tools

General mechanic's tool kit:
automotive (Appendix B, Item 1)

Materials/Parts

Four locknuts (Appendix G, Item 117)

Manual References

TM 9-2320-280-10
TM 9-2320-280-24P

Equipment Condition

Battery ground cable disconnected (para. 4-73).

a. Removal

1. Remove six screws (2) and top channel (1) from left end closure (3) and right end closure (4).
2. Remove four screws (7), locknuts (5), four clamps (6), and wiring harness (11) from top channel (1). Discard locknuts (5).
3. Remove two screws (12), nuts (8), washers (9), and switch (10) from top channel (1).

NOTE

Prior to removal, tag leads for installation.

4. Remove two screws (16), washers (15), and leads 719A (14) and 2D (13) from switch (10).

b. Installation

1. Install leads 719A (14) and 2D (13) on switch (10) with two washers (15) and screws (16).
2. Install switch (10) on top channel (1) with two screws (12), washers (9), and nuts (8).
3. Install four clamps (6) and wiring harness (11) on top channel (1) with four screws (7) and locknuts (5).
4. Install top channel (1) on left end closure (3) and right end closure (4) with six screws (2).

12-107. TROOP/CARGO WINTERIZATION BLACKOUT/DOME LIGHT DOOR SWITCH REPLACEMENT (Cont'd)

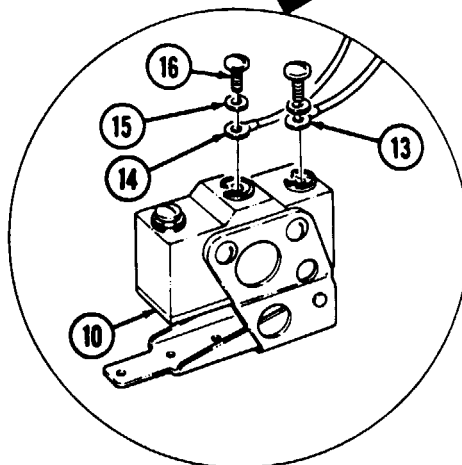
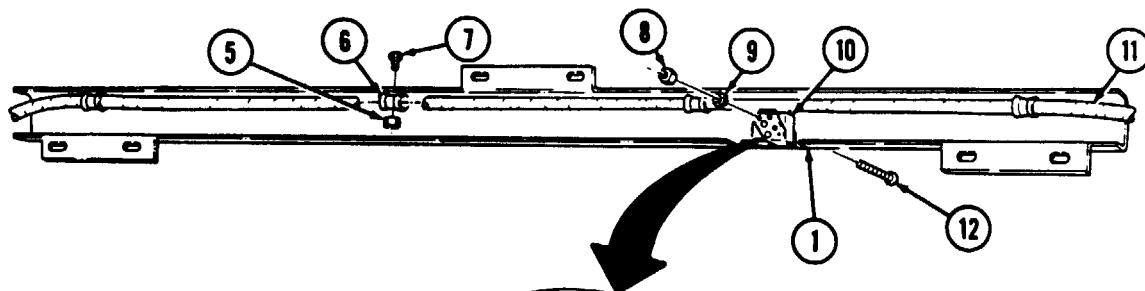
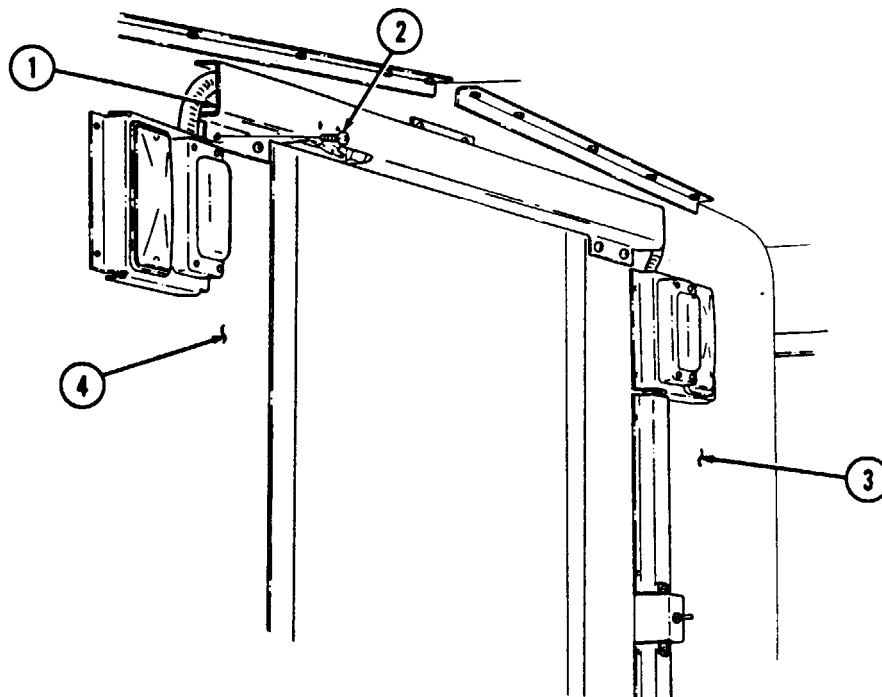

FOLLOW-ON TASKS: \checkmark Connect battery ground cable (para. 4-73).
 \checkmark Check blackout light and dome light for proper operation (TM 9-2320-280-10).

12-108. TROOP/CARGO WINTERIZATION BLACKOUT/DOME LIGHT ASSEMBLY REPLACEMENT

This task covers:

- a Removal
- b. Installation

INITIAL SETUP:

Applicable Models

M998, M998A1, M1038, M1038A1

Tools

General mechanic's tool kit:
automotive (Appendix B, Item 1)

Manual References

TM 9-2320-280-10
TM 9-2320-280-24P

Equipment Condition

Battery ground cable disconnected (para. 4-73).

NOTE

Ž Replacement instructions for left and right blackout/dome light assemblies are the same. This procedure covers right blackout/dome light assembly.

Ž Prior to removal, tag leads for installation.

a. Removal

1. Remove four screws (1) from blackout/dome light assembly (3) and right end closure (2).
2. Disconnect blackout light leads 717 (8) and 711/712 (9) from leads 2C (7) and 711C (6).
3. Disconnect dome light leads 719 (5) and 711/712 (4) from leads 719C (10) and 712C (11) and remove blackout/dome light assembly (3).

b. Installation

1. Connect dome light leads 719 (5) and 711/712 (4) to leads 719C (10) and 712C (11).
2. Connect blackout light leads 717 (8) and 711/712 (9) to leads 2C (7) and 711C (6).
3. Install blackout/dome light assembly (3) on right end closure (2) with four screws (1).

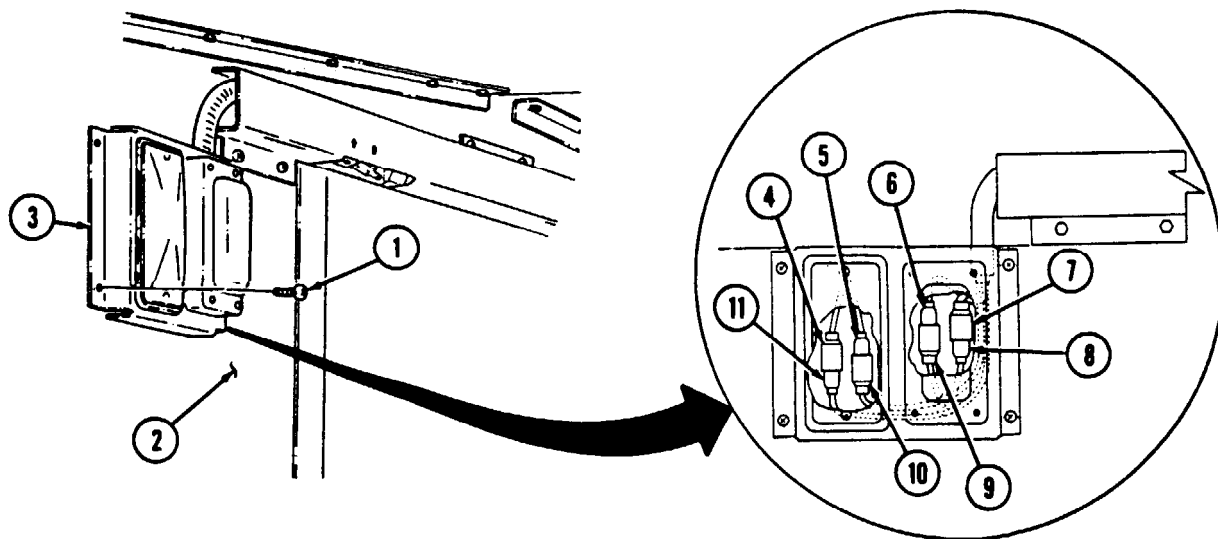

- FOLLOW-ON TASKS:**
- Ž Connect battery ground cable (para. 4-73).
 - Ž Check blackout light and dome light for proper operation (TM 9-2320-280-10).

12-109. TROOP/CARGO WINTERIZATION BLACKOUT/DOME LIGHT LAMP REPLACEMENT

This task covers:

a Removal

b. Installation

INITIAL SETUP:

Applicable Models

M998, M998A1, M1038, M1038A1

Manual References

TM 9-2320-280-10
TM 9-2320-280-24P

Tools

General mechanic's tool kit:
automotive (Appendix B, Item 1)

Equipment Condition

Battery ground cable disconnected (para. 4-73).

a. Removal

NOTE

Perform steps 1 and 2 for blackout light lamp removal. Perform steps 3 and 4 for dome light lamp removal.

1. Remove four screws (5) and blackout light cover and lens assembly (3) from light body (2).
2. Remove lamp (4) from light body (2).
3. Remove two screws (7) and dome light cover and lens assembly (6) from light body (1).
4. Remove lamp (8) from light body(1).

b. Installation

NOTE

Perform steps 1 and 2 for blackout light lamp installation. Perform steps 3 and 4 for dome light lamp installation.

1. Install lamp (4) in light body (2).
2. Install blackout light cover and lens assembly (3) on light body (2) with four screws (5).
3. Install lamp (8) in light body (1).
4. Install dome light cover and lens assembly (6) on light body (1) with two screws (7).

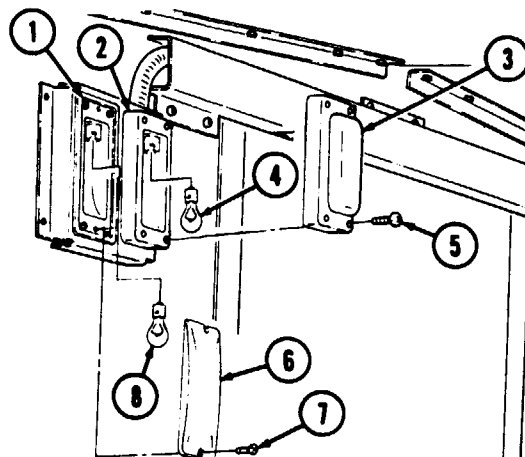

FOLLOW-ON TASKS: \bar{Z} Connect battery ground cable (para. 4-73).
 \bar{Z} Check blackout light and dome light for proper operation (TM 9-2320-280-10).

12-110. TROOP/CARGO WINTERIZATION FRONT AND REAR CARGO FLOOR COVER REPLACEMENT

This task covers:

a. Removal

b. Installation

INITIAL SETUP:

Applicable Models

M998, M998A1, M1038, M1038A1

Manual References

TM 9-2320-280-24P

Tools

General mechanic's tool kit:
automotive (Appendix B, Item 1)

Equipment Condition

- Heater base assembly removed (para. 12-98).
- Heater wiring harness removed (para. 12-101).
- Circuit breaker removed (para. 12-103).
- Skid strips removed (para. 12-111).
- Side wheelhousing covers removed (para. 12-115).

Materials/Parts

Four locknuts (Appendix G, Item 120)
Six platenuts (Appendix G, Item 225)
Nine rivnuts (Appendix G, Item 275)

a. Removal

1. Remove screw (1) and clamp (2) from blackout/dome light wiring harness (3) and front cargo floor cover (4).
2. Remove two locknuts (11), washers (10), and screws (8) from door and frame assembly (9), rear cargo floor cover (7), cargo floor (15), and "D" beam (14). Discard locknuts (11).
3. Remove two locknuts (12), washers (13), and capscrews (16) from door and frame assembly (9), rear cargo floor cover (7), cargo floor (15), and "D" beam (14). Discard locknuts (12).
4. Remove two screws (5) and step latch strip (6) from rear cargo floor cover (7).
5. Remove nine screws (17), front cargo floor cover (4), and rear cargo floor cover (7) from cargo floor (15).
6. Inspect nine rivnuts (18) for damage. Replace if damaged.
7. Inspect six platenuts (19) for damage. Replace if damaged.

b. Installation

NOTE

Ensure position markers on blackout/dome light wiring harness extend beyond the front and rear cargo floor covers.

1. Install front cargo floor cover (4) and rear cargo floor cover (7) on cargo floor (15) with nine screws (17).
2. Install step latch strip (6) on rear cargo floor cover (7) with two screws (5).
3. Install door and frame assembly (9) and rear cargo floor cover (7) on cargo floor (15) and "D" beam (14) with two capscrews (16), washers (13), and locknuts (12).
4. Secure door and frame assembly (9) and rear cargo floor cover (7) to cargo floor (15) and "D" beam (14) with two screws (8), washers (10), and locknuts (11).
5. Install blackout/dome light wiring harness (3) on front cargo floor (4) with clamp (2) and screw (1).

12-110. TROOP/CARGO WINTERIZATION FRONT AND REAR CARGO FLOOR COVER REPLACEMENT (Cont'd)

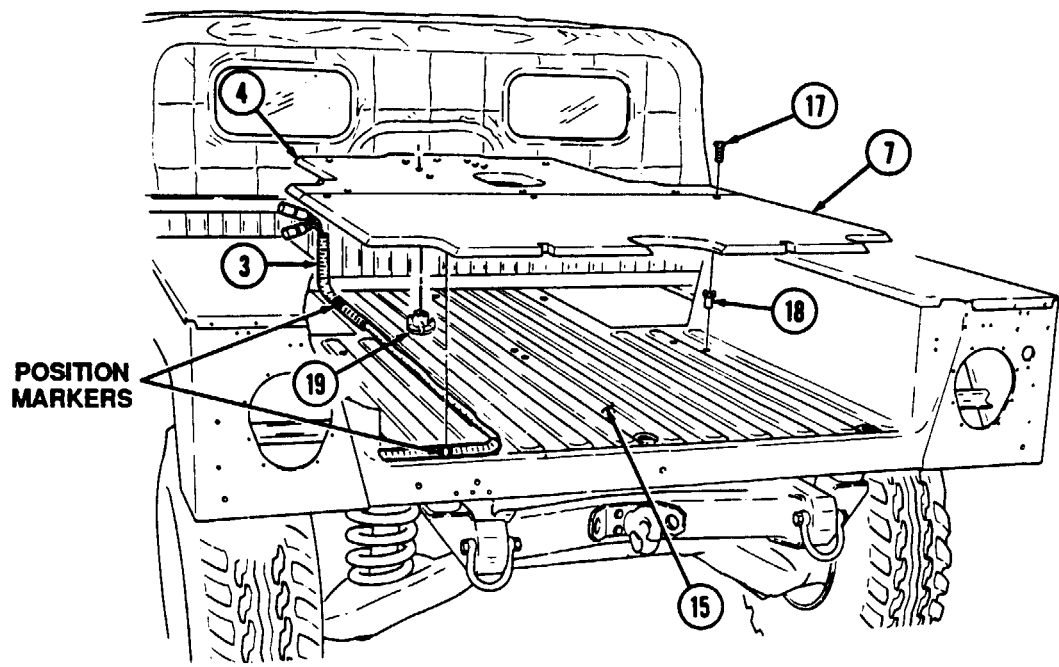
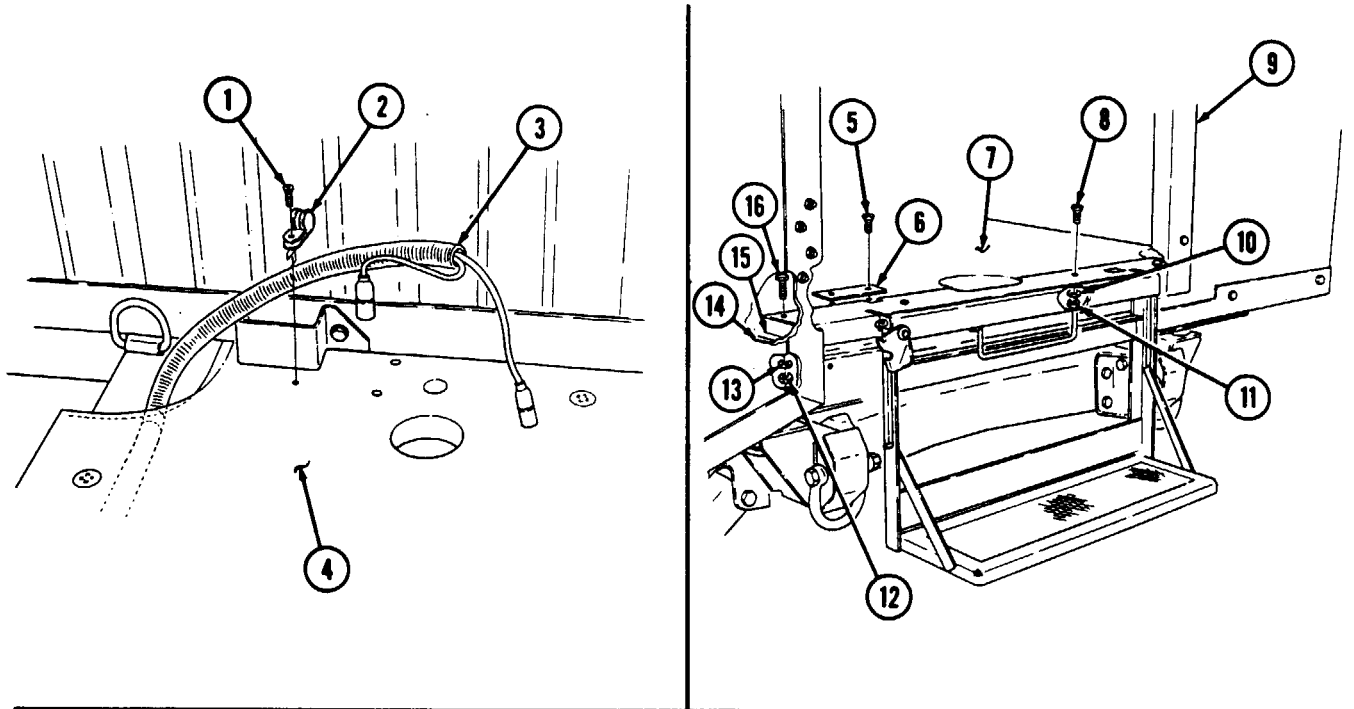

- FOLLOW-ON TASKS:
- Ž Install side wheelhousing covers (para. 12-115).
 - Ž Install skid strips (para. 12-111).
 - Ž Install circuit breaker (para. 12-103).
 - Ž Install heater wiring harness (para. 12-101).
 - Ž Install heater base assembly (para. 12-98).

12-111. TROOP/CARGO WINTERIZATION CARGO FLOOR SKID STRIPS REPLACEMENT

This task covers:

- a. Removal
- b. Installation

INITIAL SETUP:

Applicable Models

M998, M998A1, M1038, M1038A1

Manual References

TM 9-2320-280-24P

Tools

General mechanic's tool kit:
automotive (Appendix B, Item 1)

Equipment Condition

Floor bracket removed (para. 12-99).

a. Removal

1. Remove fourteen screws (4) and two skid strips (3) from front cargo floor cover (1) and rear cargo floor cover (6).
2. Remove five screws (2) and skid strip (5) from rear cargo floor cover (6).

b. Installation

1. Install skid strip (5) on rear cargo floor cover (6) with five screws (2).
2. Install two skid strips (3) to front cargo floor cover (1) and rear cargo floor cover (6) with fourteen screws (4).

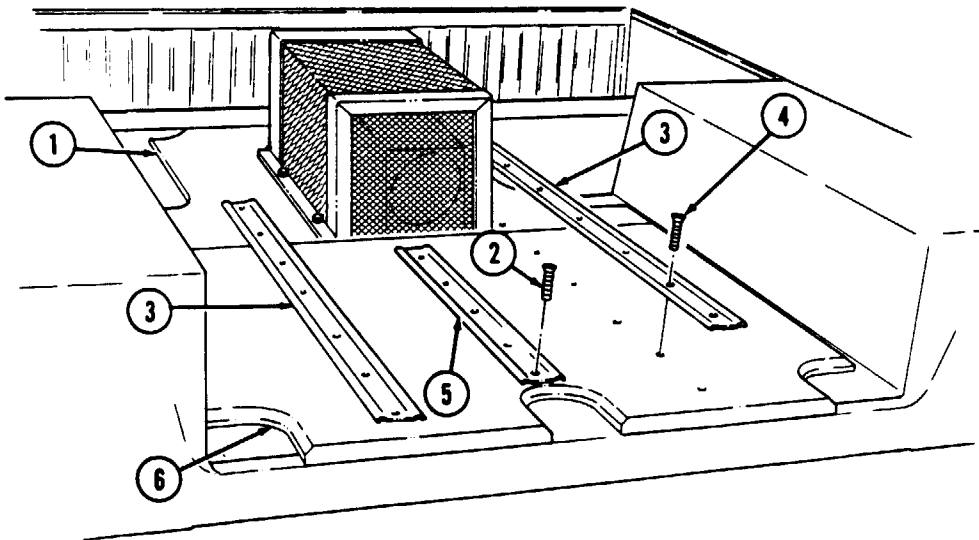

FOLLOW-ON TASK: Install floor bracket (para. 12-99).

12-112. TROOP/CARGO WINTERIZATION SEAT BACK COVER REPLACEMENT

This task covers:

a. Removal

b. Installation

INITIAL SETUP:

Applicable Models

M998, M998A1, M1038, M1038A1

Materials/Parts

Four locknuts (Appendix G, Item 120)

Tools

General mechanic's tool kit:
automotive (Appendix B, Item 1)

Manual References

TM 9-2320-280-24P

NOTE

Replacement instructions for left and right seat back covers are the same. This procedure covers right seat back cover.

a. Removal

1. Remove two turn screws (1) and seat back (4) from body (7).
2. Remove four locknuts (6), washers (5), screws (2), and seat back cover (3) from seat back (4). Discard locknuts (6).

b. Installation

1. Install seat back cover (3) on seat back (4) with four screws (2), washers (5), and locknuts (6).
2. Install seat back (4) on body (7) with two turn screws (1).

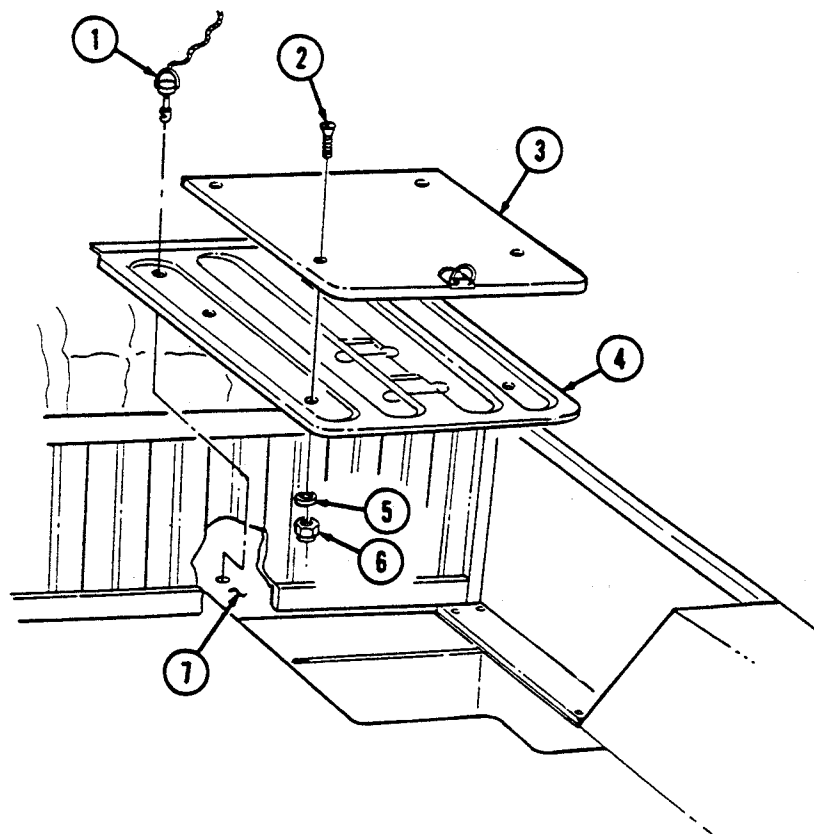

12-113. TROOP/CARGO WINTERIZATION FIXED DOOR COVER REPLACEMENT

This task covers:

a. Removal

b. Installation

INITIAL SETUP:

Applicable Models

M998, M989A1, M1038, M1038A1

Materials/Parts

Two locknuts (Appendix G, Item 119)

Tools

General mechanic's tool kit:
automotive (Appendix B, Item 1)

Manual References

TM 9-2320-280-24P

NOTE

Replacement instructions for left and right fixed door covers are the same. This procedure covers right fixed door cover.

a. Removal

Remove two locknuts (3), washers (2), screws (4), and fixed door cover (1) from fixed door (5). Discard locknuts (3).

b. Installation

Install fixed door cover (1) on fixed door (5) with two screws (4), washers (2), and locknuts (3).

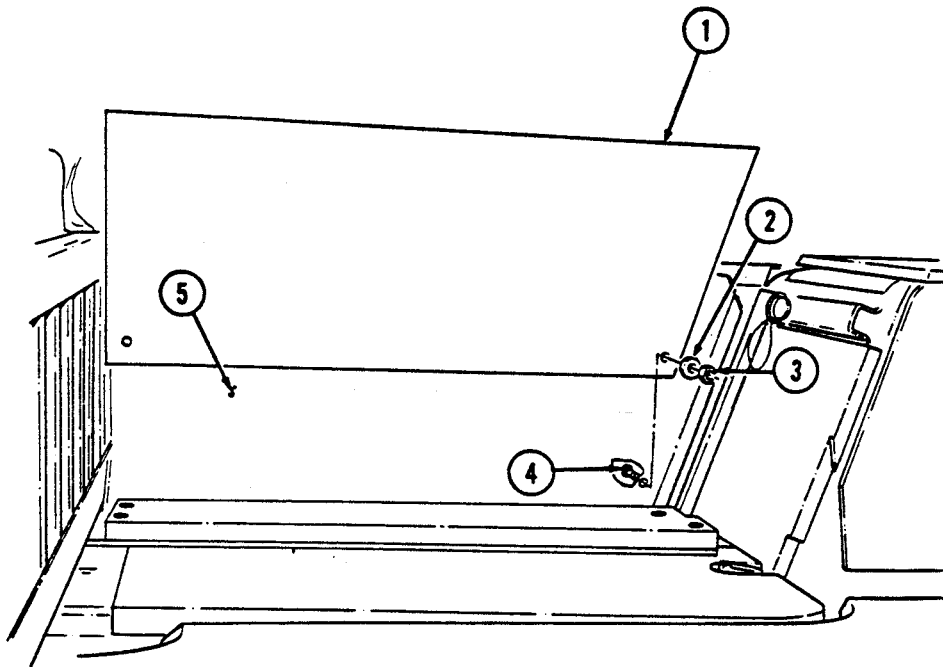

12-114. TROOP/CARGO WINTERIZATION SIDE FLOOR COVER REPLACEMENT

This task covers:

a. Removal

b. Installation

INITIAL SETUP:

Applicable Models

M998, M998A1, M1038, M1038A1

Materials/Parts

Four locknuts (Appendix G, Item 120)

Tools

General mechanic's tool kit:
automotive (Appendix B, Item 1)

Manual References

TM 9-2320-280-24P

NOTE

Replacement instructions for left and right side floor covers are the same. This procedure covers right side floor cover.

a. Removal

1. Remove two turn screws (1) and seat back (2) from body (8).
2. Remove four locknuts (6), washers (7), screws (4), and side floor cover (3) from cargo floor (5). Discard locknuts (6).

b. Installation

1. Install side floor cover (3) on cargo floor (5) with four screws (4), washers (7), and locknuts (6).
2. Install seat back (2) on body (8) with two turn screws (1).

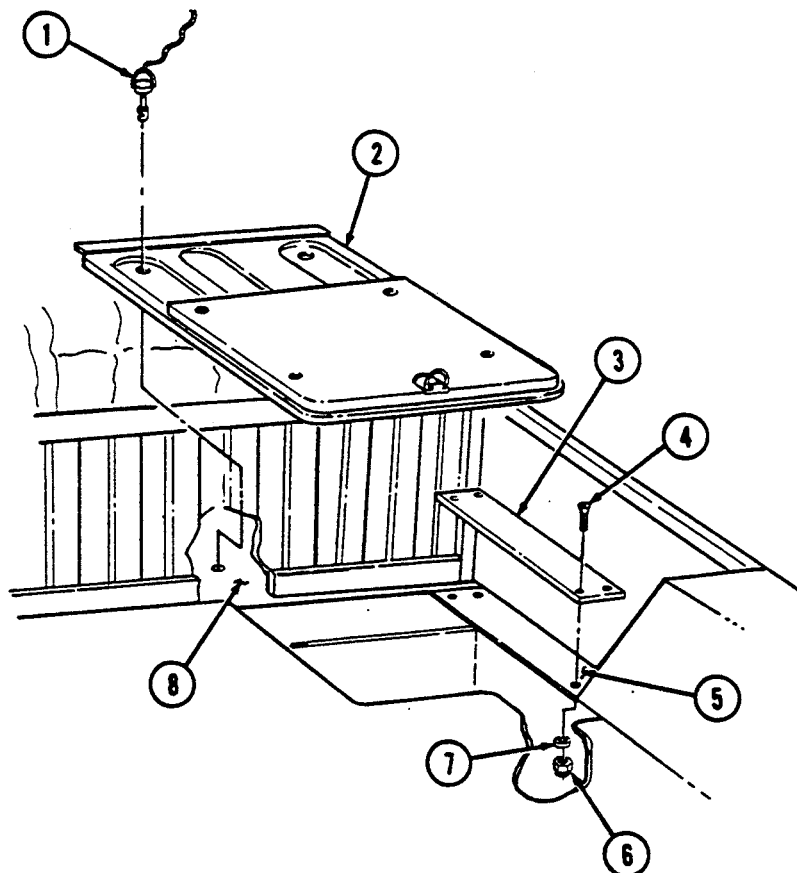

12-115. TROOP/CARGO WINTERIZATION WHEELHOUSING COVERS REPLACEMENT

This task covers:

a. Removal

b. Installation

INITIAL SETUP:

Applicable Models

M998, M998A1, M1038, M1038A1

Manual References

TM 9-2320-280-24P

Tools

General mechanic's tool kit:
automotive (Appendix B, Item 1)

Equipment Condition

Troop seat removed (para. 12-121).

Materials/Parts

Twenty-two locknuts (Appendix G, Item 119)

NOTE

Replacement instructions for left and right wheelhousing covers are the same. This procedure covers right wheelhousing covers.

a. Removal

1. Remove four locknuts (2), washers (3), screws (5), and front cover (1) from wheelhousing (4). Discard locknuts (2).
2. Remove twelve locknuts (7), washers (6), screws (9), and side cover (8) from wheelhousing (4). Discard locknuts (7).
3. Remove six locknuts (12), washers (13), screws (11), and top cover (10) from wheelhousing (4). Discard locknuts (12).
4. Remove six screws (14) and six spacers (15) from top cover (10).

b. Installation

1. Install six spacers (15) on top cover (10) with six screws (14).
2. Install top cover (10) on wheelhousing (4) with six screws (11), washers (13), and locknuts (12).
3. Install side cover (8) on wheelhousing (4) with twelve screws (9), washers (6), and locknuts (7).
4. Install front cover (1) on wheelhousing (4) with four screws (5), washers (3), and locknuts (2).

12-115. TROOP/CARGO WINTERIZATION WHEELHOUSING COVERS REPLACEMENT (Cont'd)

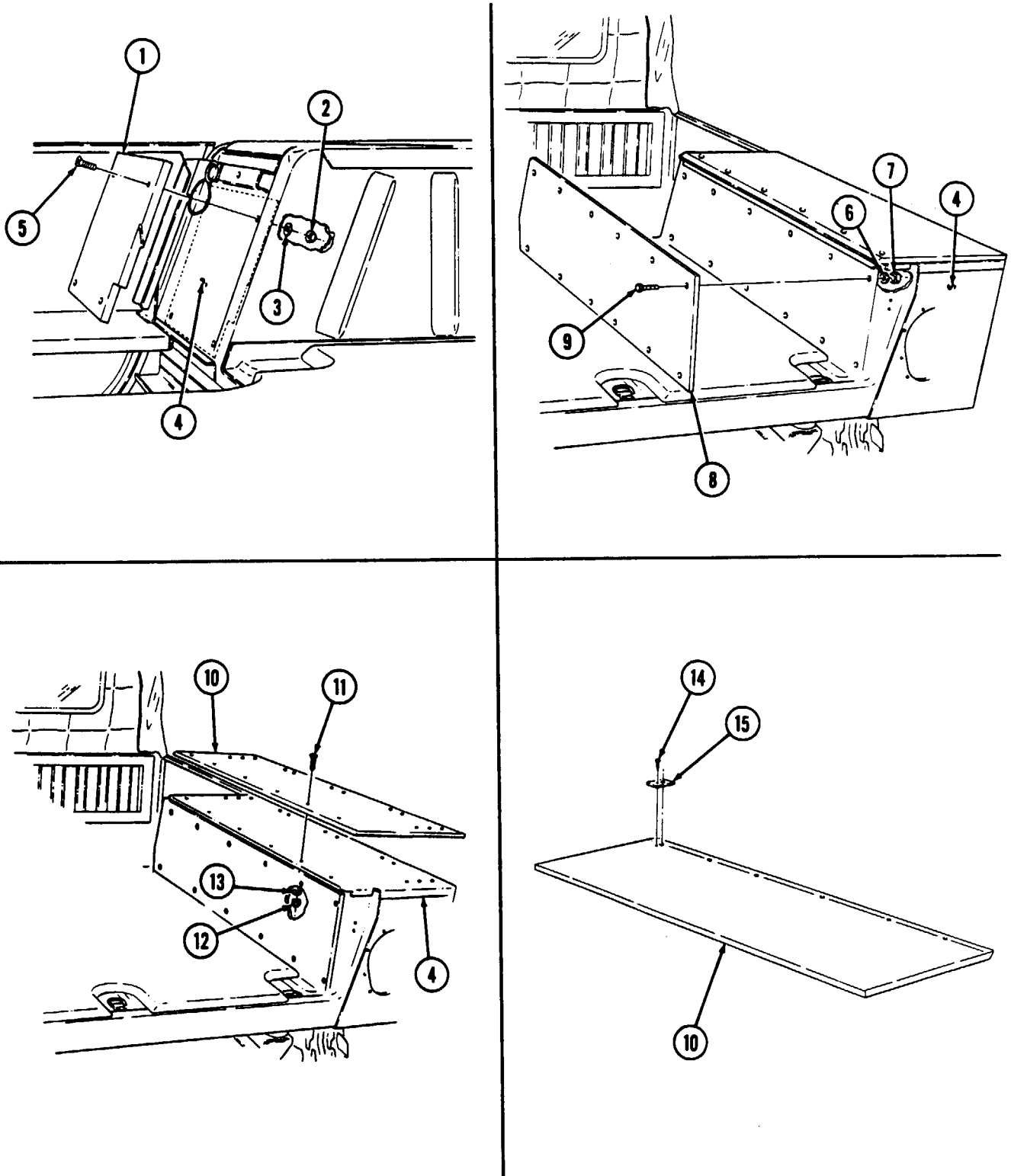

FOLLOW-ON TASK: Install troop seat (para. 12-121).

12-116. TROOP/CARGO WINTERIZATION DOOR ADJUSTMENT

This task covers:

Adjustment

INITIAL SETUP:

Applicable Models

M998, M998A1, M1038, M1038A1

Tools

General mechanic's tool kit:
automotive (Appendix B, Item 1)

Materials/Parts

Eight locknuts (Appendix G, Item 121)

Personnel Required

One mechanic
One assistant

Manual References

TM 9-2320-280-10
TM 9-2320-280-24P

Adjustment

NOTE

- Adjustment of door and frame assembly may be required if door is not centered or binds during opening or closing.
 - Ensure door has an equal distance around frame assembly in both vertical and horizontal directions.
 - For vertical or horizontal door adjustment, perform step 1.
 - For lateral door adjustment, perform steps 2 and 3.
 - For dome light on/off adjustment, perform steps 4 through 10.
1. Loosen eight nuts (14) and capscrews (11) from two hinges (2) and frame assembly (3) and lift or lower door (1) as required. Tighten nuts (14) to 85-90 lb-ft (115-122 N•m).
 2. Remove eight locknuts (13) from door (1) and two hinges (2). Discard locknuts (13).
 3. Add or remove shims (12) from door (1), as required. Install and tighten locknuts (13) to 50-55 lb-ft (68-75 N•m).
 4. Place dome light switch in "DOME LIGHT" position (TM 9-2320-280-10).
 5. With door (1) in open position, loosen upper jamnut (6) and lower jamnut (7) to maximum outward position on control rod (8).
 6. Close and fasten door (1).
 7. Align rod (10) of actuator light control (9) with center of control arm (5) on door switch assembly (4).
 8. Engage control arm (5) by adjusting lower jamnut (7) upward on control arm (5) and actuator light control (9) until dome lights are on.
 9. Adjust lower jamnut (7) 0.25 in. (6.4 mm) beyond initial adjustment made in step 8.
 10. Adjust upper jamnut (6) on control rod (8) down on actuator light control (9) and tighten jamnut (6).

12-116. TROOP/CARGO WINTERIZATION DOOR ADJUSTMENT (Cont'd)

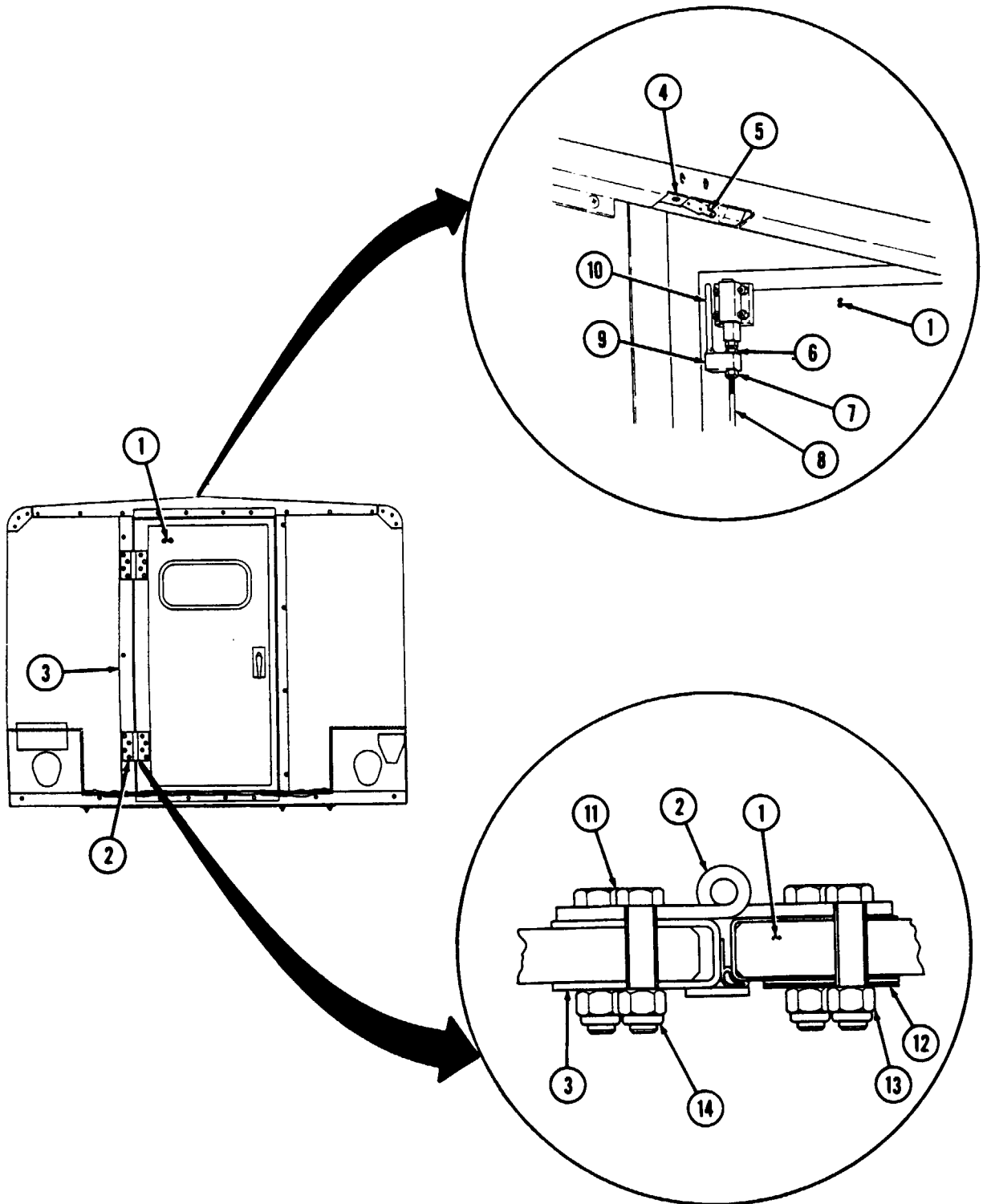

12-117. TROOP/CARGO WINTERIZATION DOOR AND FRAME ASSEMBLY REPLACEMENT

This task covers:

a. Removal

b. Installation

INITIAL SETUP:

Applicable Models

M998, M998A1, M1038, M1038A1

Tools

General mechanic's tool kit:
automotive (Appendix B, Item 1)

Materials/Parts

Twelve locknuts (Appendix G, Item 119)
Four locknuts (Appendix G, Item 120)
Twelve locknuts (Appendix G, Item 121)

Personnel Required

One mechanic
One assistant

Manual References

TM 9-2320-280-24P

Equipment Condition

- End closures removed (para. 12-118).
- Rear step assembly removed (para. 12-122).

a. Removal

1. Shut door (1) and close latch (2).
2. Remove eight nuts (6) capscrews (5), and shims (if installed) from two hinges (3) and frame assembly (4).
3. Open latch (2) and remove door (1) and two hinges (3) from frame assembly (4).
4. Remove two locknuts (17) and screws (15) from channel (9) and top enclosure plate support (16). Discard locknuts (17).
5. Remove eight locknuts (21), screws (19), and washers (18) from channel (9) and top enclosure assembly (20). Discard locknuts (21).
6. Remove two locknuts (26), washers (27), and capscrews (22) from frame assembly (4), rear floor cover (30), cargo floor (29), and "D" beam (28). Discard locknuts (26).
7. Remove two locknuts (25), washers (24), and screws (23) from frame assembly (4), rear floor cover (30), cargo floor (29), and "D" beam (28). Discard locknuts (25).
8. Remove four locknuts (11), washers (12), capscrews (14), washers (13), and frame assembly (4) from support (10). Discard locknuts (11).
9. Remove two locknuts (35) and capscrews (34) from trailer mount bracket (36) and support (10). Discard locknuts (35).
10. Remove four locknuts (31), washers (32), capscrews (33), and support (10) from "D" beam (28). Discard locknuts (31).
11. Remove four locknuts (8), capscrews (7), and frame assembly (4) from channel (9). Discard locknuts (8).

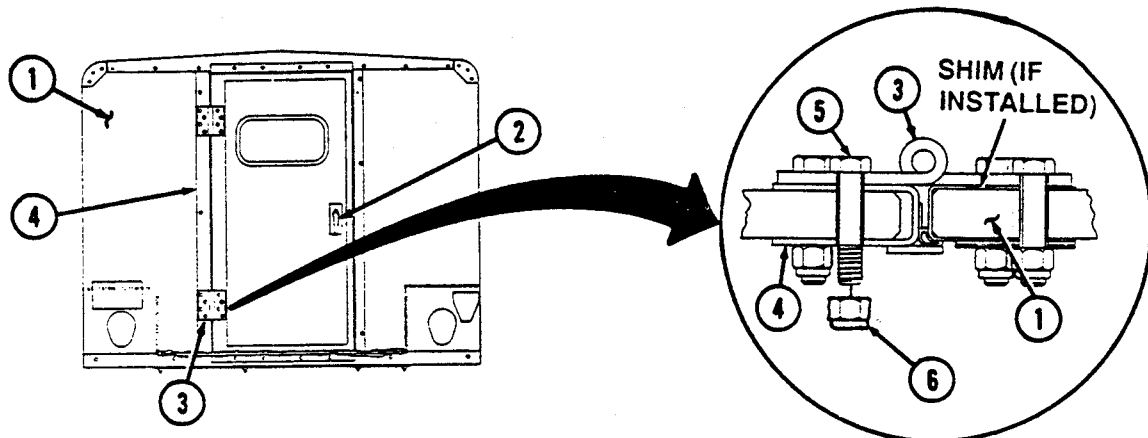

12-117. TROOP/CARGO WINTERIZATION DOOR AND FRAME ASSEMBLY REPLACEMENT (Cont'd)

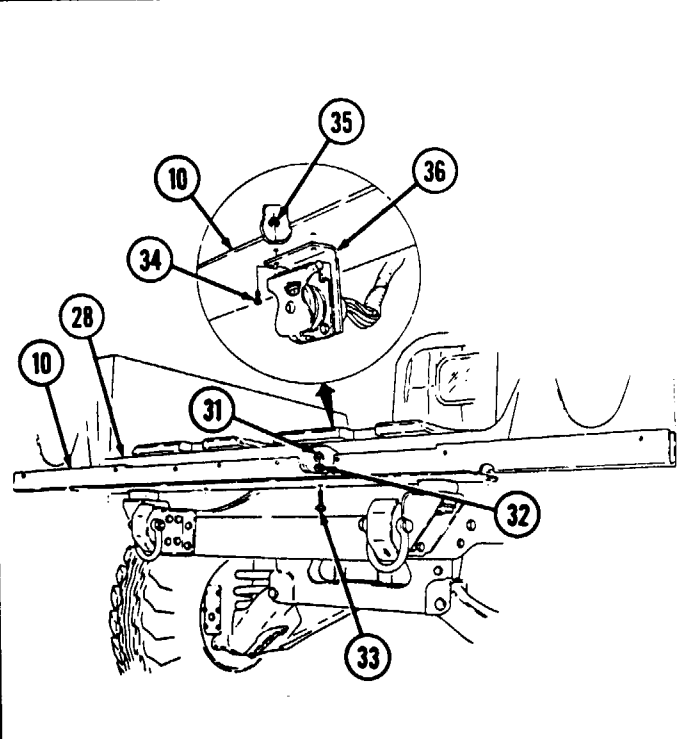
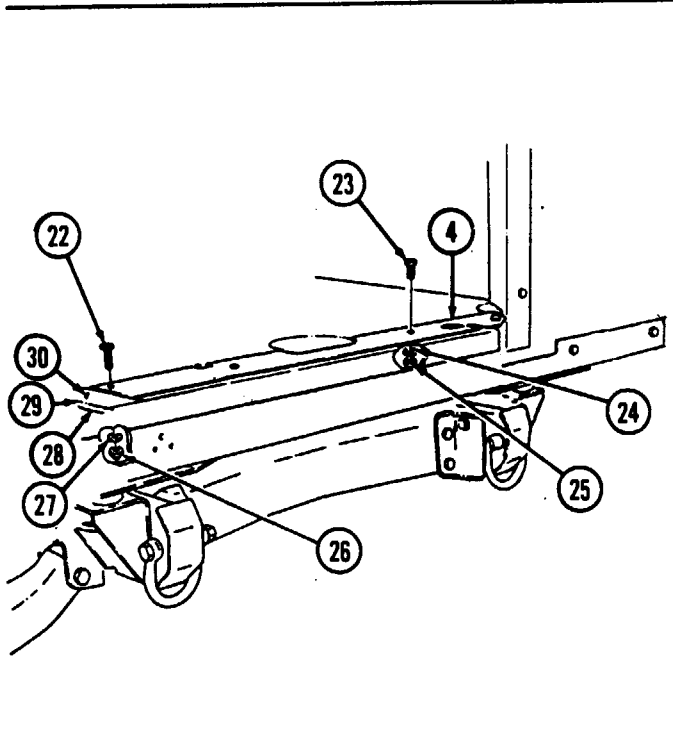
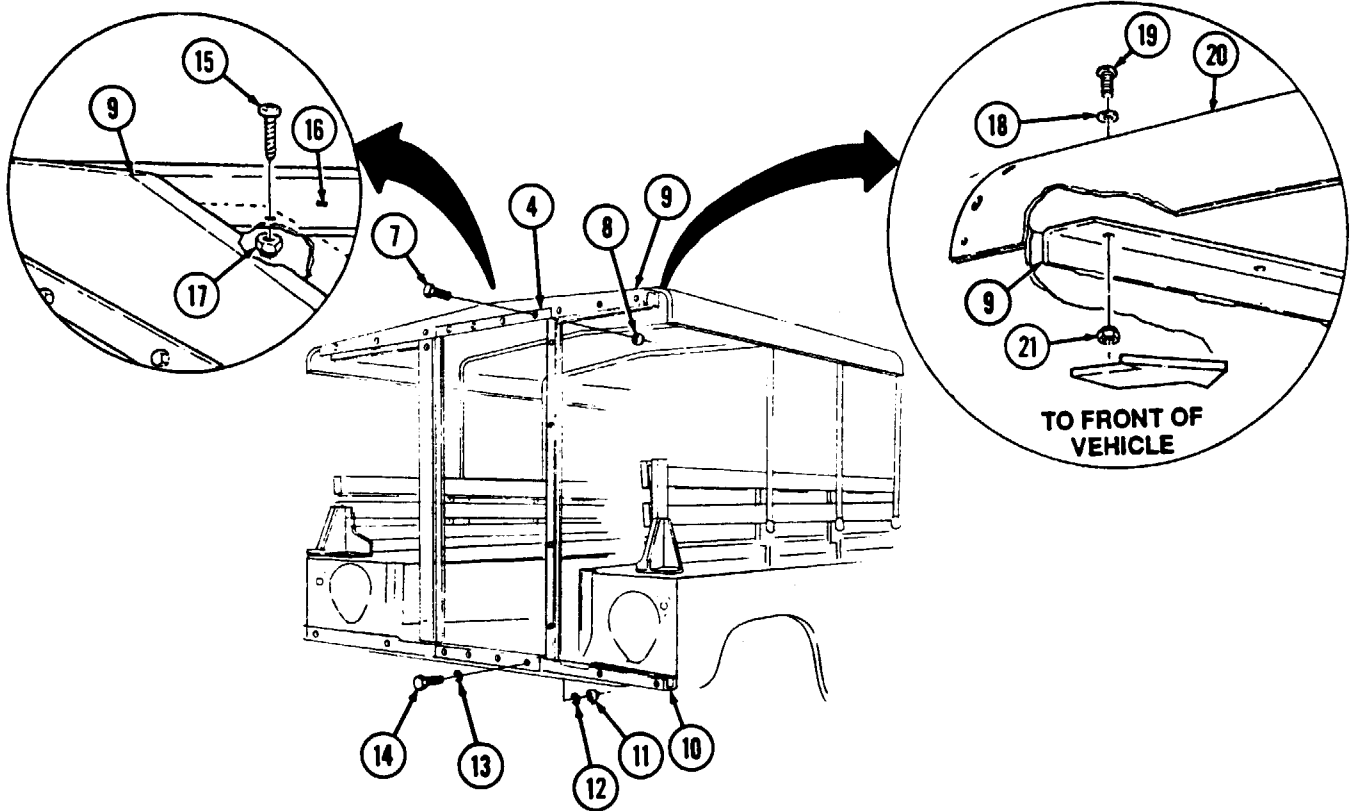

**12-117. TROOP/CARGO WINTERIZATION DOOR AND FRAME ASSEMBLY
REPLACEMENT (Cont'd)**

b. Installation

1. Install support (4) on "D" beam (5) with four capscrews (3), washers (2), and locknuts (1).
2. Install trailer mount bracket (8) on support (4) with two capscrews (6) and locknuts (7).
3. Install frame assembly (11) on channel (20) with four capscrews (18) and locknuts (19).
4. Install frame assembly (11) and channel (20) on support (4) with four washers (23), capscrews (24), washers (22), and locknuts (21).
5. Install frame assembly (11) on rear floor cover (17), cargo floor (16), and "D" beam (5) with two screws (10), washers (12), and locknuts (13).
6. Secure frame assembly (11) to rear floor cover (17), cargo floor (16), and "D" beam (5) with two capscrews (9), washers (15), and locknuts (14).
7. Install channel (20) on top enclosure assembly (30) with eight washers (28), screws (29), and locknuts (31).
8. Install channel (20) on top enclosure plate support (26) with two screws (25) and locknuts (27).

NOTE

Ensure shims are added as required.

9. Install door (32) and two hinges (33) on frame assembly (11) with eight capscrews (34) and nuts (35). Tighten nuts (35) to 85-90 lb-ft (115-122 NZm).

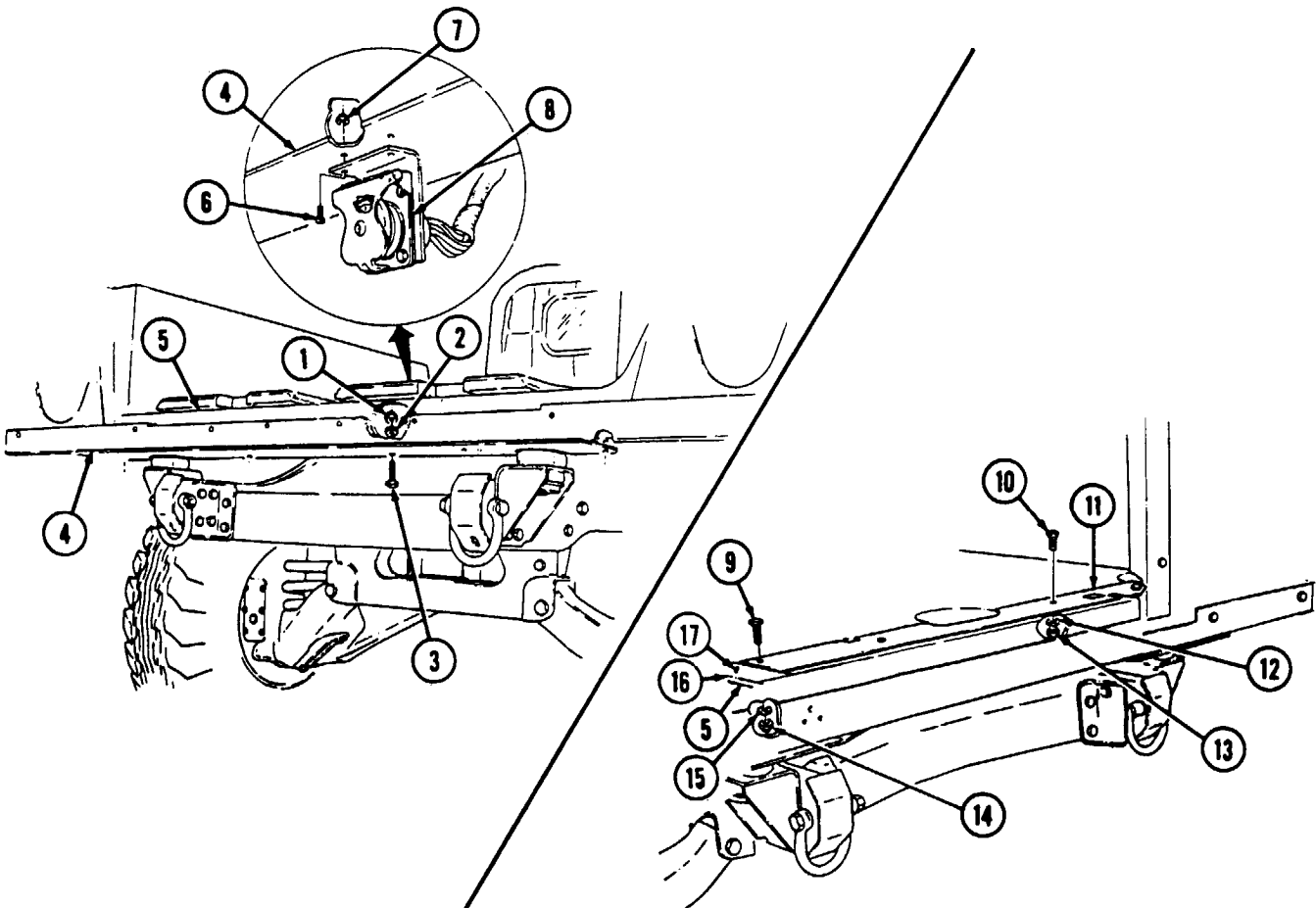

12-117. TROOP/CARGO WINTERIZATION DOOR AND FRAME ASSEMBLY REPLACEMENT (Cont'd)

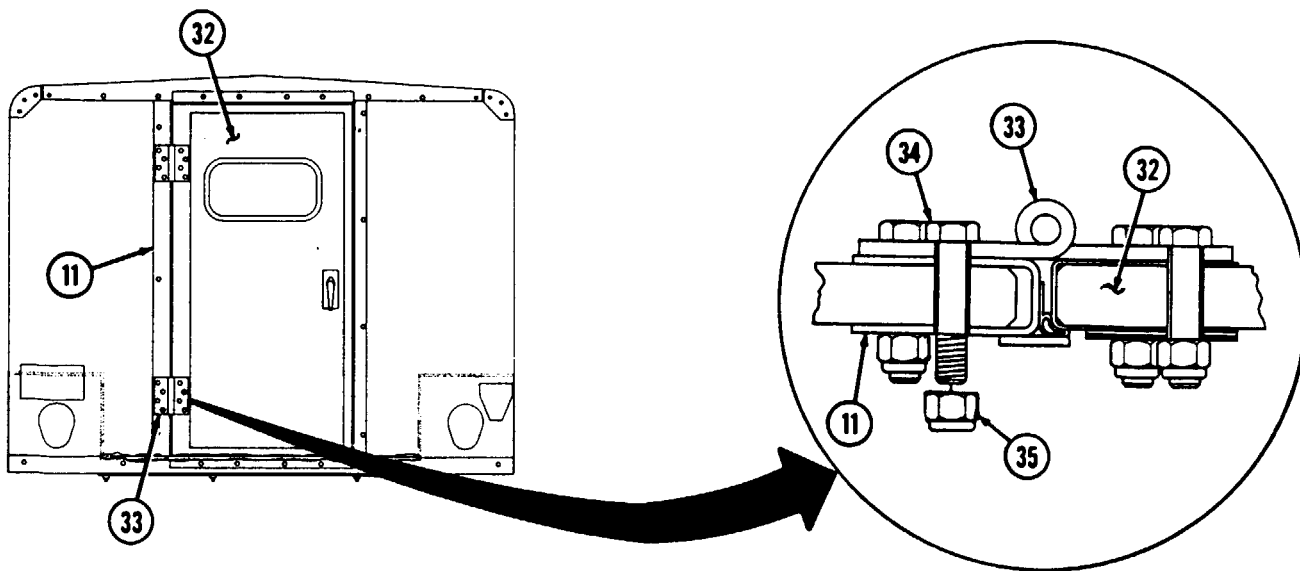
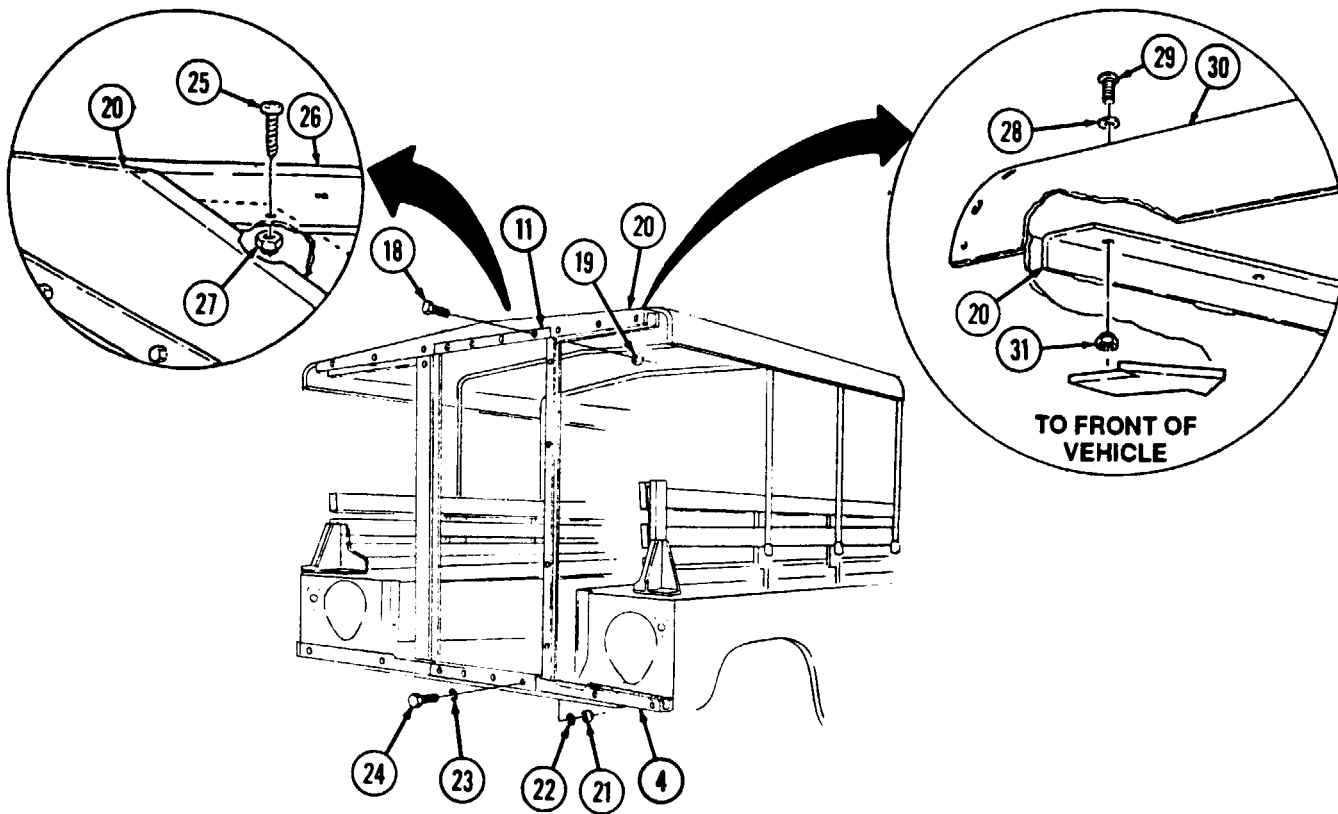

FOLLOW-ON TASKS: Ž Install rear step assembly (para. 12-122).
 Ž Install end closures (para. 12-118).
 Ž Adjust door (para. 12-116).

12-118. TROOP/CARGO WINTERIZATION END CLOSURE REPLACEMENT

This task covers:

a. Removal

b. Installation

INITIAL SETUP:

Applicable Models

M998, M998A1, M1038, M1038A1

Tools

General mechanic's tool kit:
automotive (Appendix B, Item 1)

Materials/Parts

Twelve locknuts (Appendix G, Item 121)

Personnel Required

One mechanic
One assistant

Manual References

TM 9-2320-280-24P

Equipment Condition

- Rear reflector removed (para. 12-126).
- Rear composite light housing removed para. 12-127).
- Handle assembly removed (right end closure only) (para. 12-123).
- Antenna mounting bracket removed (right end closure only) (para. 12-125).
- Fuel can mounting bracket removed (left end closure only) (para. 12-124).
- Blackout/dome light wiring harness removed (para. 12-105).

a. Removal

NOTE

Replacement instructions for left and right end closures are basically the same. This procedure covers right end closure.

1. Remove seven screws (1) and clamping strip (9) from top cover assembly (5), channel (10), and right end closure (6).
2. Remove three screws (2) and clamping strip (3) from top cover assembly (5), outside corner plate (4), and right end closure (6).
3. Remove eight screws (8) and clamping strip (7) from top cover assembly (5), and right end closure (6).
4. Remove screw (14) from clamping strip (15), top cover assembly (5) and right end closure (6).
5. Remove eight nuts (11), capscrews (13), clamping strip (15), and top cover assembly (5) from right rear vehicle body (12).

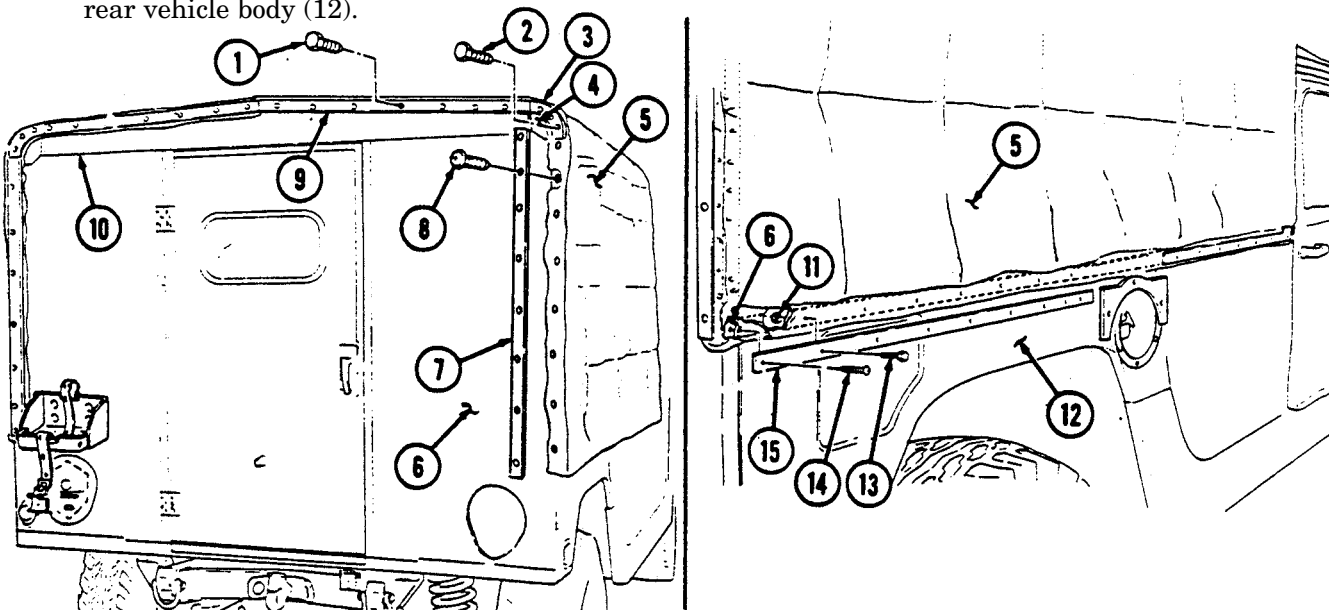

12-118. TROOP/CARGO WINTERIZATION END CLOSURE REPLACEMENT (Cont'd)

6. Remove three locknuts (27), screws (26), and outside corner plate (4) from inside corner bracket (28), and right end closure (6). Discard locknuts (27).
7. Remove locknut (18) and screw (17) from right end closure (6) and channel (10). Discard locknut (18).
8. Remove two locknuts (19) and capscrews (16) from right end closure (6) and channel (10). Discard locknuts (19).
9. Remove four locknuts (21) and capscrews (25) from right end closure (6) and door and frame assembly (20). Discard locknuts (21).
10. Remove two locknuts (23), capscrews (24), and right end closure (6) from support assembly (22). Discard locknuts (23).

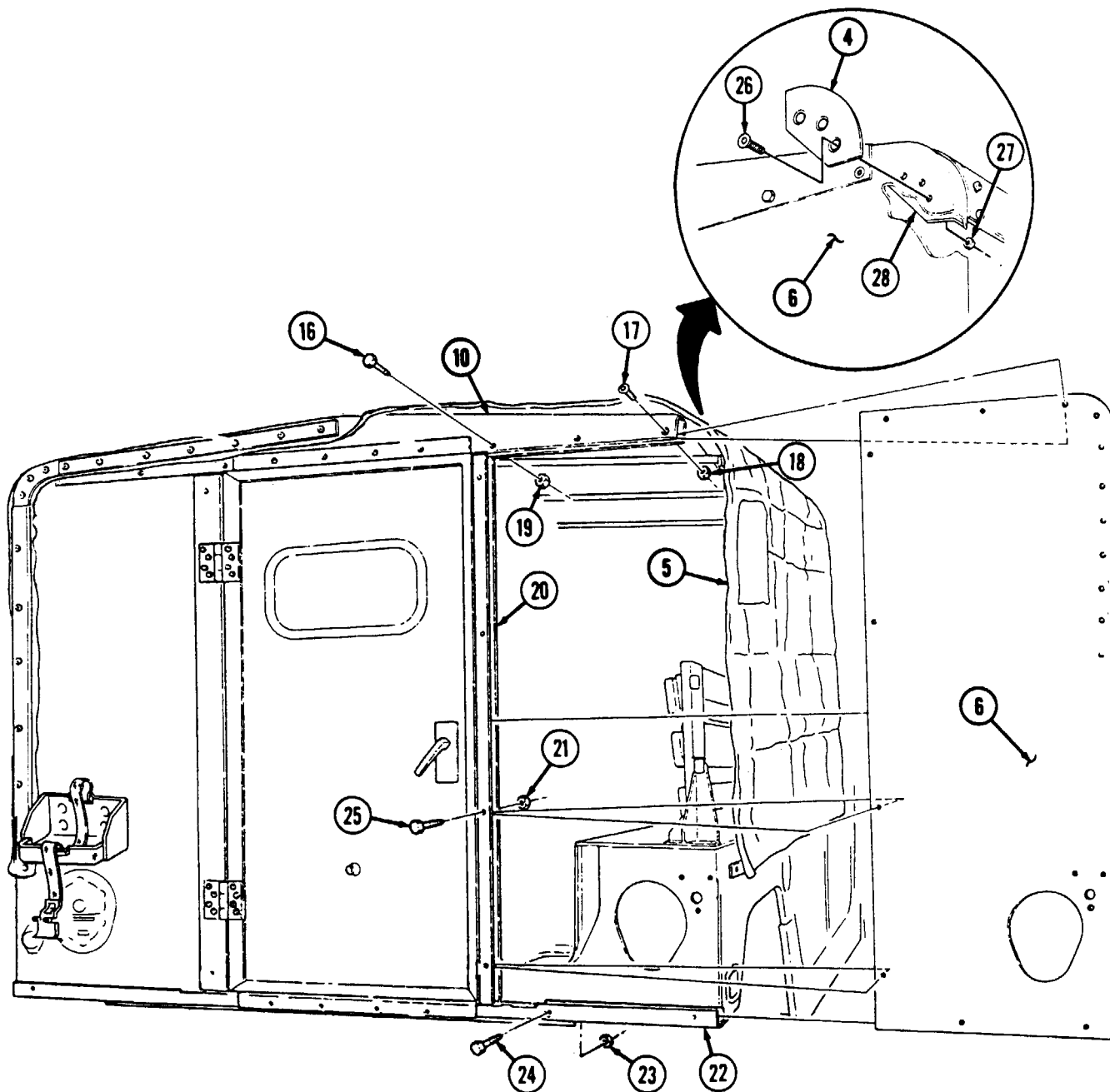

12-118. TROOP/CARGO WINTERIZATION END CLOSURE REPLACEMENT (Cont'd)

b. Installation

NOTE

Ensure lower right corner of end closure is flush with support assembly.

1. Position right end closure (9) on support assembly (10), door and frame assembly (7), and channel (1).
2. Secure right end closure (9) to support assembly (10) with two capscrews (12) and locknuts (11).
3. Install right end closure (9) on door and frame assembly (7) with four capscrews (13) and locknuts (8).
4. Install right end closure (9) on channel (1) with two capscrews (2) and locknuts (5).
5. Secure right end closure (9) to channel (1) with screw (3) and locknut (4).
6. Install outside corner plate (14) on right end closure (9) and inside corner bracket (16) with three screws (17) and locknuts (15).

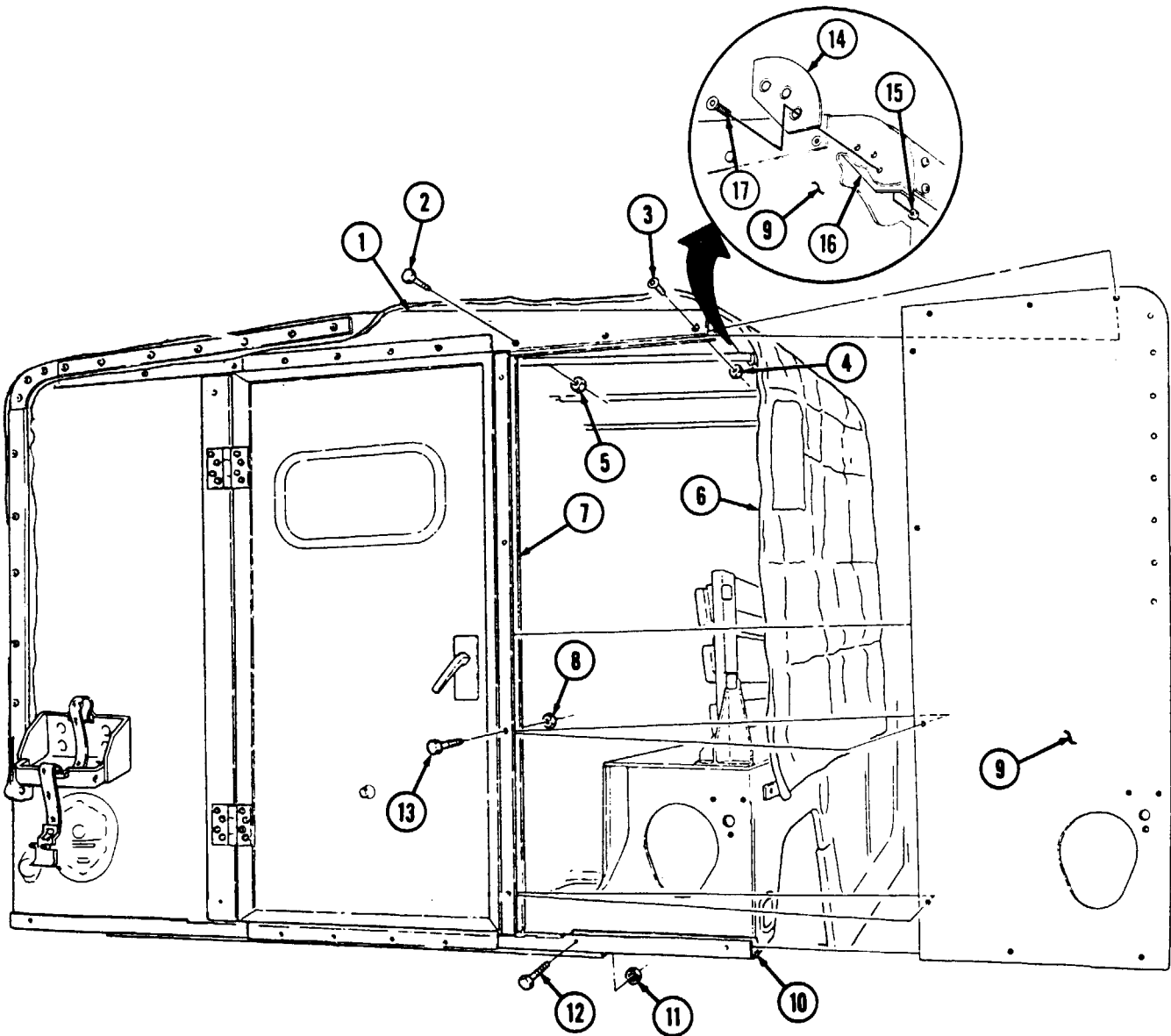

12-118. TROOP/CARGO WINTERIZATION END CLOSURE REPLACEMENT (Cont'd)

7. Install top cover assembly (6) on right rear vehicle body (19) with strip (22), eight capscrews (20), and nuts (18).
8. Install top cover assembly (6) on right end closure (9) with strip (22) and screw (21).
9. Secure top cover assembly (6) to right end closure (9) with strip (26) and eight screws (27).
10. Install top cover assembly (6) on outside corner plate (14) and right end closure (9) with strip (25) and three screws (24).
11. Install top cover assembly (6) on channel (1) and right end closure (9) with strip (28) and seven screws (23).

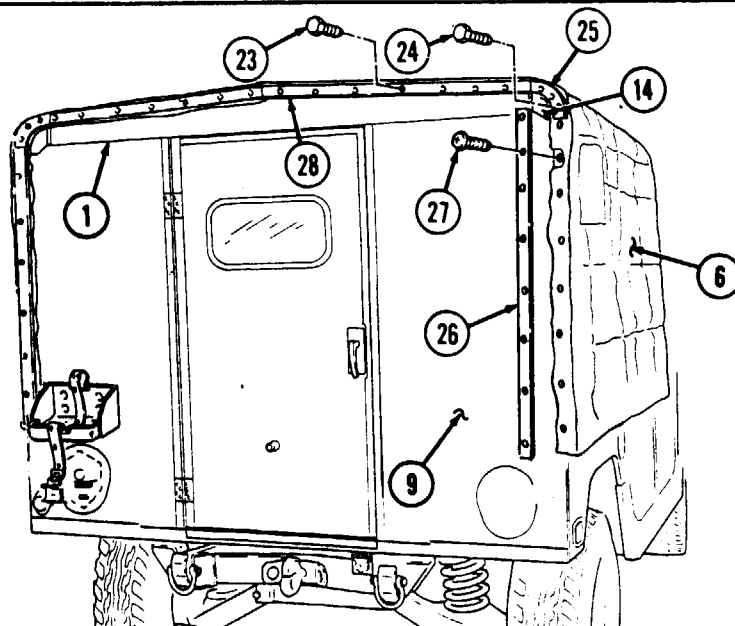
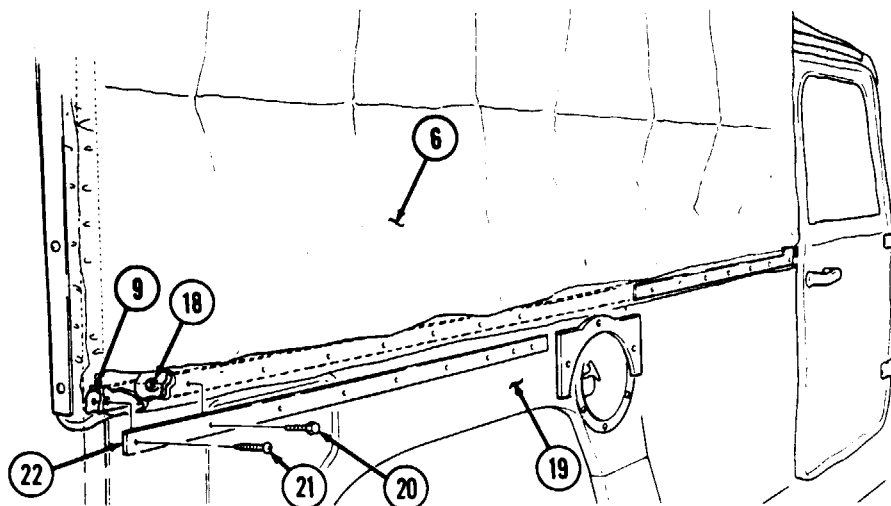

- FOLLOW-ON TASKS:
- Ž Install blackout/dome light wiring harness (para. 12-105).
 - Ž Install fuel can mounting bracket (left end closure only) (para. 12-124).
 - Ž Install antenna mounting bracket (right end closure only) (para. 12-125).
 - Ž Install handle assembly (right end closure only) (para. 12-123).
 - Ž Install rear composite light housing (para. 12-127).
 - Ž Install rear reflector (para. 12-126).

12-119. TROOP/CARGO WINTERIZATION TOP COVER ASSEMBLY REPLACEMENT

This task covers:

a. Removal

b. Installation

INITIAL SETUP:

Applicable Models

M998, M998A1, M1038, M1038A1

Tools

General mechanic's tool kit:
automotive (Appendix B, Item 1)

Materials/Parts

Adhesive spray (Appendix C, Item 8)
Adhesive sealant (Appendix C, Item 10)
Two rubber strips (Appendix G, Item 300)
Two rubber strips (Appendix G, Item 301)
Two rubber strips (Appendix G, Item 302)
Two seals (Appendix G, Item 289)

Personnel Required

One mechanic
One assistant

Manual References

TM 9-2320-280-24P

Equipment Condition

Air intake assembly removed (para. 12-97).

a. Removal

1. Remove nut (2) and capscrew (1) from clamping strip (16), top cover assembly (5), rubber strip (13), and left rear fixed door (12).
2. Remove six nuts (14), capscrews (15), and clamping strip (16) from top cover assembly (5), rubber strip (13), and left rear fixed door (12).
3. Remove screw (9) from clamping strip (11), top cover assembly (5), rubber strip (13), and left end closure (7).
4. Remove ten nuts (6), capscrews (10), and clamping strip (11) from top cover assembly (5), rubber strip (13), and left rear vehicle body (8).
5. Remove and discard rubber strip (13).
6. Remove nut (19) and capscrew (22) from clamping strip (23), top cover assembly (5), rubber strip (35), and right rear fixed door (24).
7. Remove six nuts (18), capscrews (25), and clamping strip (23) from top cover assembly (5), rubber strip (35), and right rear fixed door (24).
8. Remove three screws (26), spring nuts (17), (if damaged) and plate assembly (27) from top cover assembly (5), rubber strip (35), fuel tank filler (28), and right rear vehicle body (32).
9. Remove screw (31) from clamping strip (29), top cover assembly (5), rubber strip (35), and right end closure (33).
10. Remove eight nuts (34), capscrews (30), clamping strip (29), top cover assembly (5), and rubber strip (35) from right rear vehicle body (32). Discard rubber strip (35).
11. Remove sixteen screws (47), two clamping strips (46), and two rubber strips (44) from rear end closure assembly (45) and top cover (5). Discard rubber strips (44).
12. Remove six screws (36), two clamping strips (37), seals (43), and outside corner plates (42) from rear end closure assembly (45) and top cover (5). Discard seals (43).
13. Remove fourteen screws (39), two clamping strips (38), and rubber strips (41) from channel (40), top cover (5), and two rear end closure assemblies (45). Discard rubber strips (41).
14. Detach eight fastener straps (3) from bow assemblies (4).
15. Detach top cover assembly fastener strip (21) from cab top cover strip (20).
16. Remove top cover assembly (5).

12-119. TROOP/CARGO WINTERIZATION TOP COVER ASSEMBLY REPLACEMENT
(Cont'd)

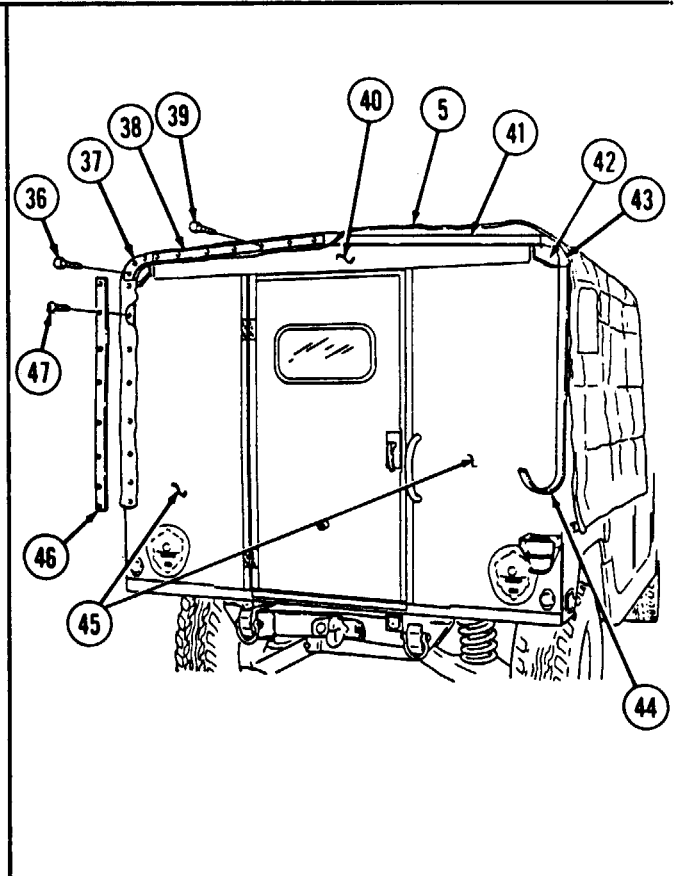
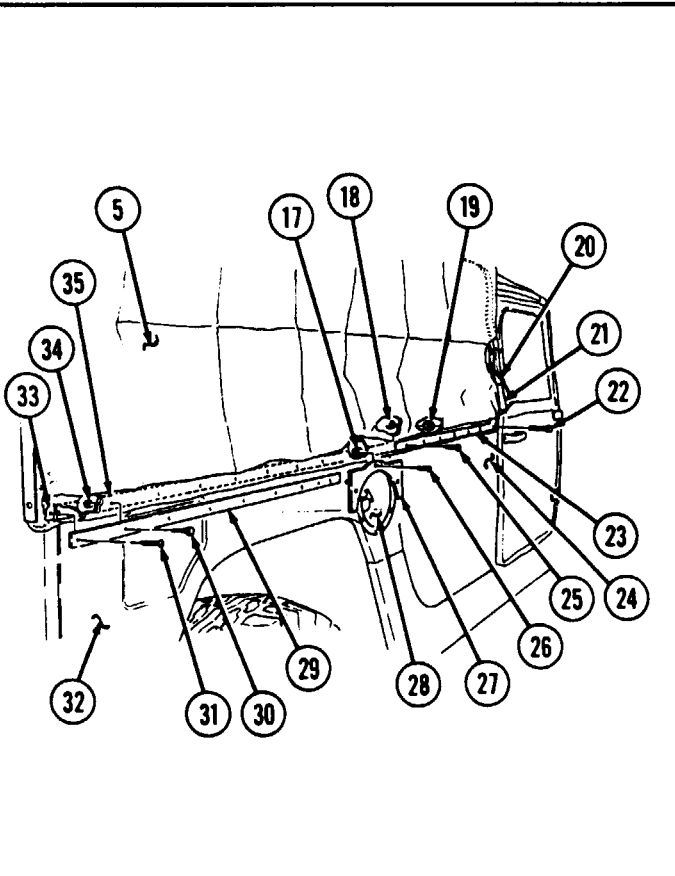
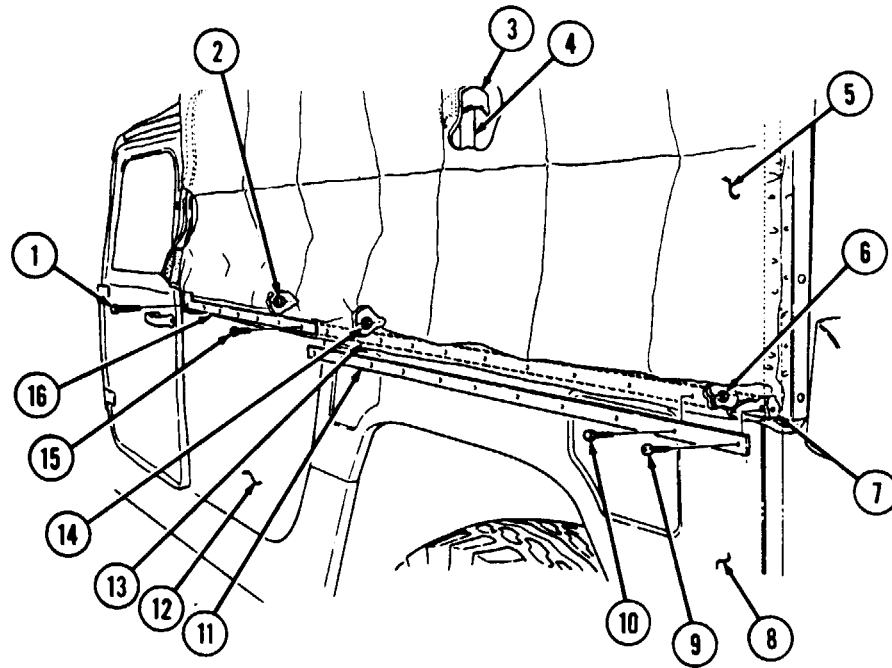

**12-119. TROOP/CARGO WINTERIZATION TOP COVER ASSEMBLY REPLACEMENT
(Cont'd)**

b. Installation

1. Apply adhesive spray to channel (3) and mating surfaces of two rubber strips (2) and install rubber strips (2) on channel (3).
2. Apply adhesive spray to outside corner plates (4) and mating surfaces of two seals (1) and install seals (1) on outside corner plates (4).
3. Apply adhesive spray to two rear end closure assemblies (6) and mating surfaces of rubber strips (5) and install rubber strips (5) on rear end closure assembly (6).
4. Apply adhesive spray to right side of vehicle (8) and mating surface of rubber strip (7) and install rubber strip (7) on right side of vehicle (8).
5. Apply adhesive spray to left side of vehicle (10) and mating surface of rubber strip (9) and install rubber strip (9) on left side of vehicle (10).
6. Apply an even coat of sealant to two top enclosure assemblies (13), rear end closure assemblies (17), corner edges (19), and other shaded areas.
7. Apply sealant to top enclosure assembly clamps (11), plates (14), and screws (12).

NOTE

If raised edges or gaps exist around areas of outside corner plates and rear end closure assembly, fill with sealant.

8. Apply sealant to outside corner plates (15) and channel assembly (16).
9. Apply sealant to any open gaps on rear end closure assembly (17) and vehicle body (18).

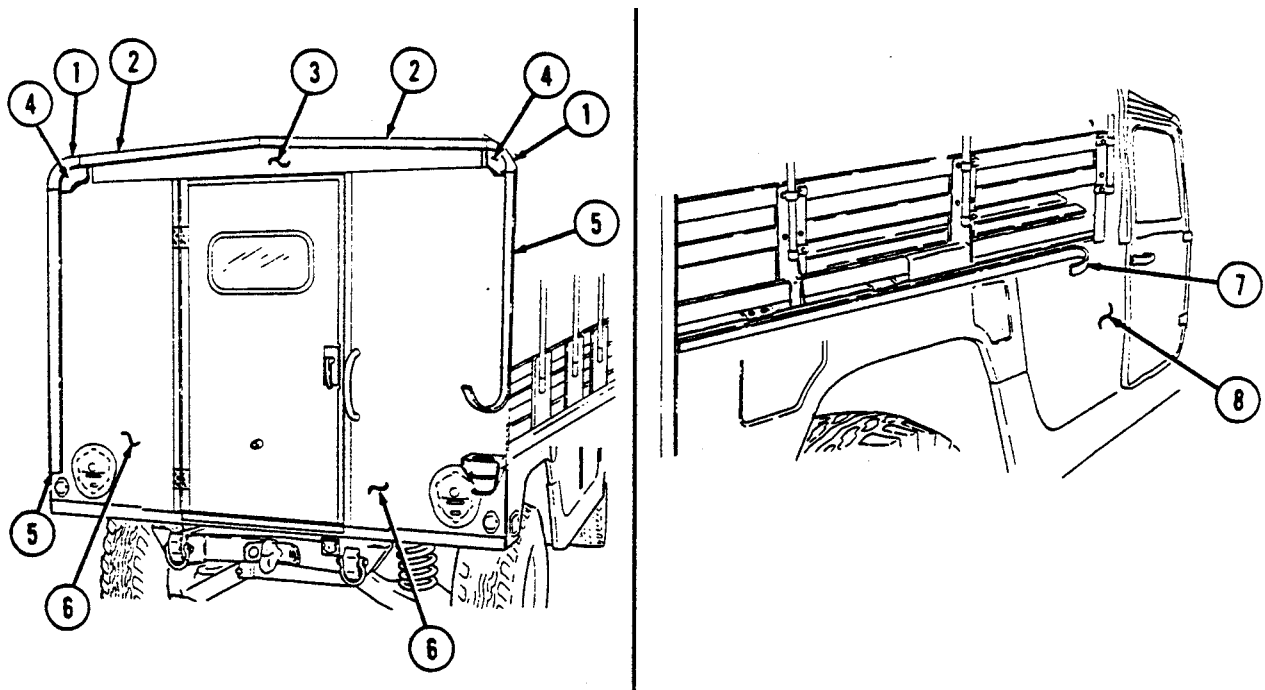

12-119. TROOP/CARGO WINTERIZATION TOP COVER ASSEMBLY REPLACEMENT
(Cont'd)

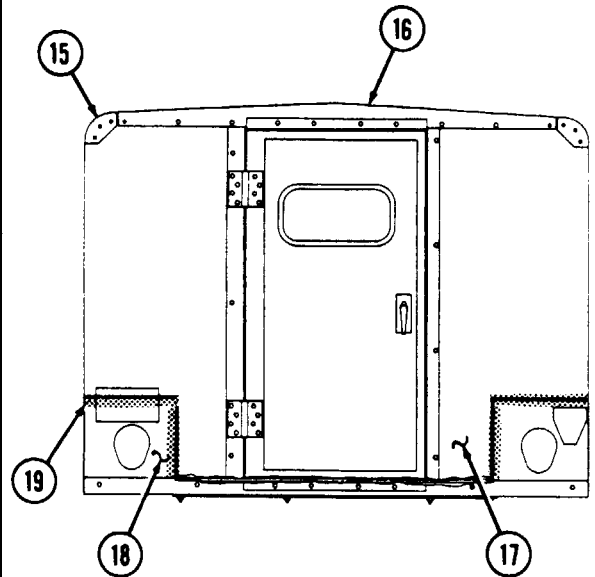
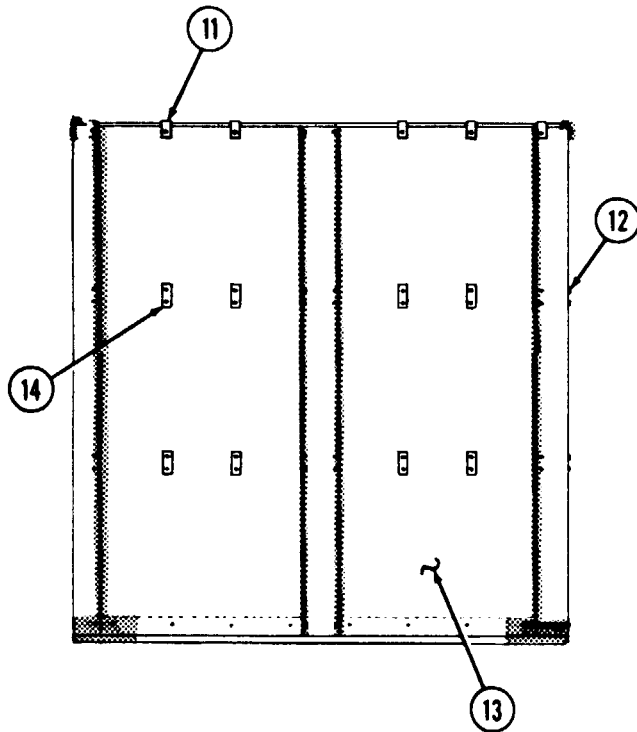
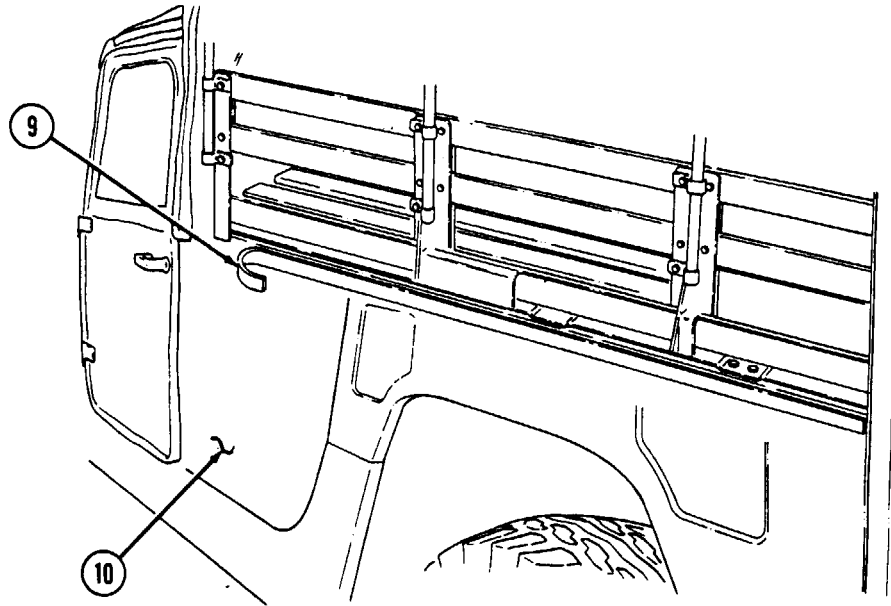

**12-119. TROOP/CARGO WINTERIZATION TOP COVER ASSEMBLY REPLACEMENT
(Cont'd)**

NOTE

When installing top cover assembly, ensure fastener straps are installed on inside of enclosure.

10. Center and install top cover assembly (6) over top enclosure assembly (7), rear end closure assemblies (13), and vehicle body (12).
11. Attach top cover assembly fastener strip (20) to cab top cover strip (19).
12. Install eight fastener straps (37) on bow assemblies (38).

NOTE

Top cover assembly is oversized to allow for shrinkage for proper fit.

- 13. Install top cover assembly (6) and two clamping strips (3) on two rubber strips (8), channel (5), and rear end closure assemblies (13) with fourteen screws (4).
14. Install top cover assembly (6) and two clamping strips (2) on two seals (10), outside corner plates (9), and rear end closure assemblies (13) with six screws (1).
- 15. Install top cover assembly (6) and two clamping strips (14) on two rubber strips (11) and rear end closure assemblies (13) with sixteen screws (15).
- 16. Install top cover assembly (6) and clamping strip (28) on rubber strip (34) and right rear vehicle body (31) with eight capscrews (29) and nuts (33).
- 17. Secure top cover assembly (6) and clamping strip (28) to rubber strip (34) and right end closure (32) with screw (30).
- 18. Install top cover assembly (6) and plate assembly (26) on rubber strip (34), fuel tank filler (27), and right rear vehicle body (31) with three screws (25) and spring nuts (16) (if removed).
- 19. Install top cover assembly (6) and clamping strip (22) on rubber strip (34) and right rear fixed door (23) with six capscrews (24) and nuts (17).
- 20. Secure top cover assembly (6) and clamping strip (22) to rubber strip (34) and right rear fixed door (23) with capscrew (21) and nut (18).
- 21. Install top cover assembly (6) and clamping strip (44) on rubber strip (46) and left rear vehicle body (41) with ten capscrews (43) and nuts (39).
- 22. Install top cover assembly (6) and clamping strip (44) on rubber strip (46) and left end closure (40) with screw (42).
- 23. Install top cover assembly (6) and clamping strip (49) on rubber strip (46) and left rear fixed door (45) with six capscrews (48) and nuts (47).
- 24. Secure top cover assembly (6) and clamping strip (49) to rubber strip (46) and left rear fixed door (45) with capscrew (35) and nut (36).

12-119. TROOP/CARGO WINTERIZATION TOP COVER ASSEMBLY REPLACEMENT (Cont'd)

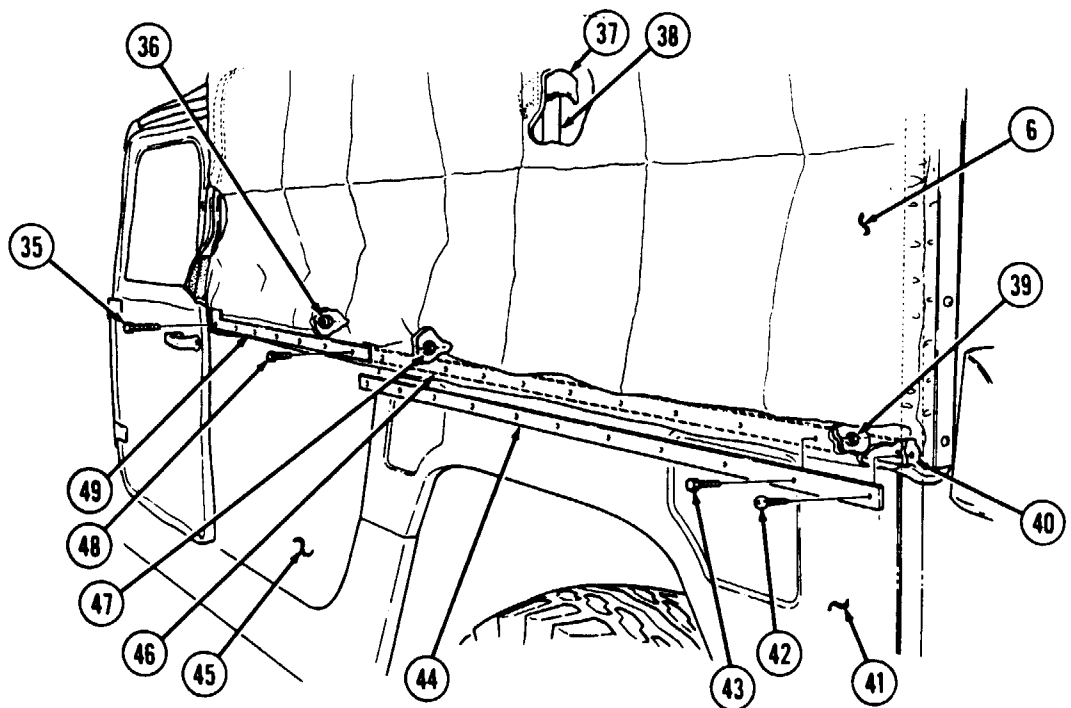
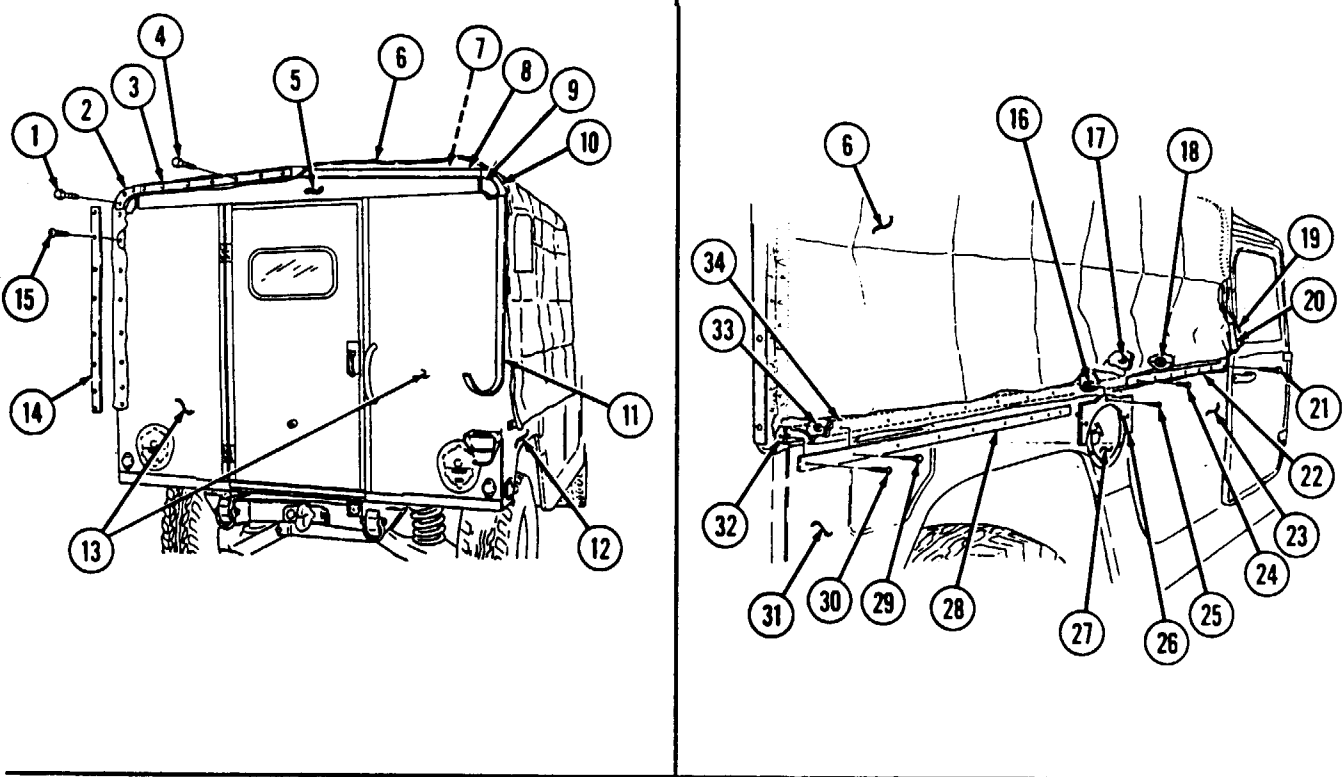

FOLLOW-ON TASK: Install air intake assembly (para. 12-97).

12-120. TROOP/CARGO WINTERIZATION TOP ENCLOSURE ASSEMBLY REPLACEMENT

This task covers:

a. Removal

b. Installation

INITIAL SETUP:

Applicable Models

M998, M998A1, M1038, M1038A1

Tools

General mechanic's tool kit:
automotive (Appendix B, Item 1)

Materials/Parts

Adhesive (Appendix C, Item 7)
Eighteen locknuts (Appendix G, Item 119)
Six locknuts (Appendix G, Item 121)

Personnel Required

One mechanic
One assistant

Manual References

TM 9-2320-280-24P

Equipment Condition

Top cover assembly removed (para. 12-119).

a. Removal

1. Remove safety caps (2) as required from top enclosure assembly mounting screws (1).
2. Remove six locknuts (9) and screws (5), and two outside plates (4) from inside corner brackets (6), and end enclosures (8). Discard locknuts (9).

NOTE

For installation, note size and location of inside corner bracket mounting screws.

3. Remove four locknuts (7) and screws (11) from two inside corner brackets (6) and supports (3). Discard locknuts (7).
4. Remove four locknuts (10) and screws (12) from two inside corner brackets (6) and supports (3). Discard locknuts (10).
5. Remove two locknuts (17) and screws (15) from plate (14), channel (13), and two supports (16). Discard locknuts (17).
6. Remove eight locknuts (20), screws (19), and washers (18) from two supports (3) and channel (13). Discard locknuts (20).
7. Remove sixteen nuts (38), screws (40), and eight clamps (39) from two supports (21), supports (3), rear bow (24), and middle bow (23).
8. Remove four nuts (35), screws (37), clamps (36), two supports (21), and supports (3) from front bow (22).
9. Remove sixteen nuts (31), screws (28), eight support plates (29), and clamps (30) from two supports (16), rear bow (24), and middle bow (23).
10. Remove six nuts (34), screws (32), and clamps (33) from two supports (16), plate (14), and front bow (22).
11. Remove eight nuts (27), screws (25), four clamps (26), two supports (16), and plate (14) from rear bow (24) and middle bow (23).

12-120. TROOP/CARGO WINTERIZATION TOP ENCLOSURE ASSEMBLY REPLACEMENT (Cont'd)

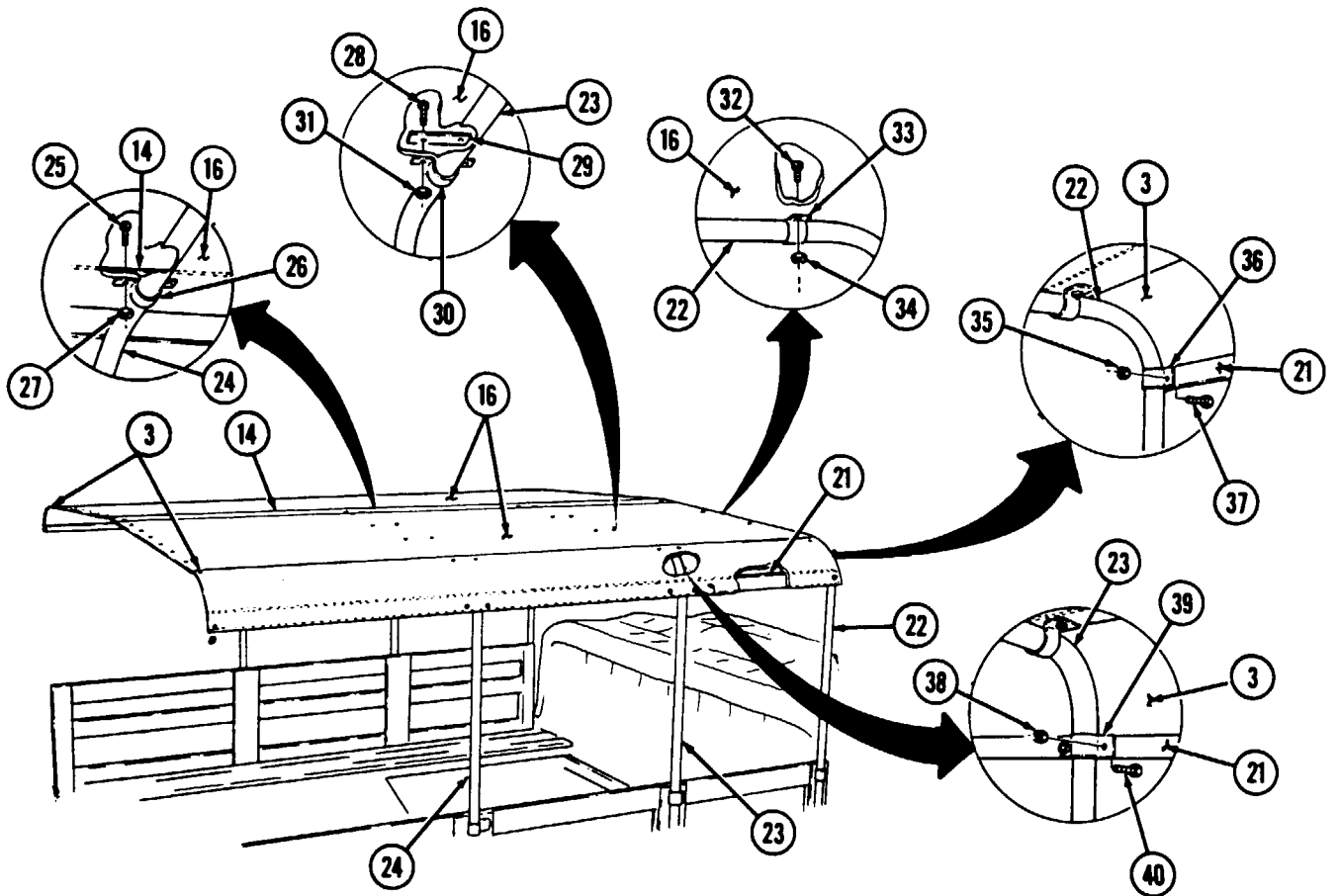
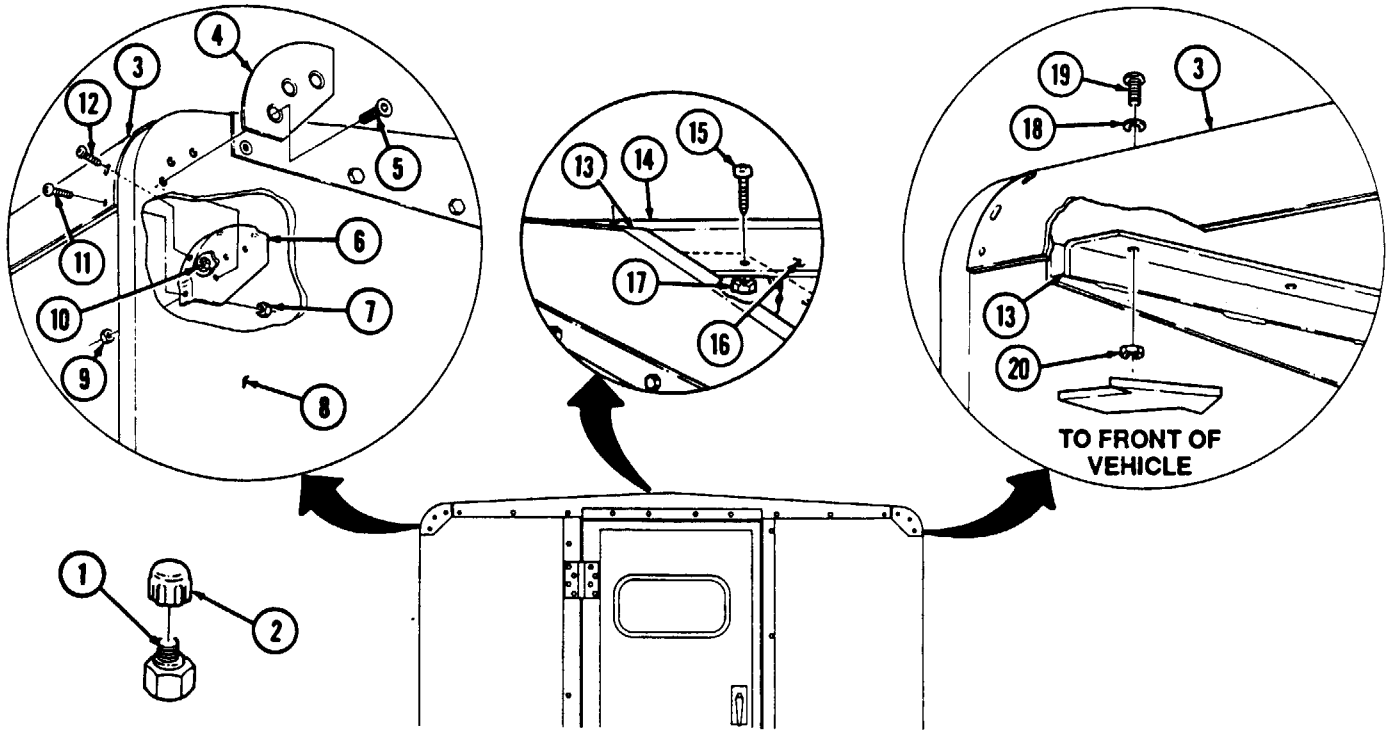

**12-120. TROOP/CARGO WINTERIZATION TOP ENCLOSURE ASSEMBLY REPLACEMENT
(Cont'd)**

b. Installation

1. Install plate (2) and two supports (3) on front bow (5), middle bow (6), and rear bow (7) with four clamps (9), eight screws (8) and nuts (10).
2. Secure plate (2) and two supports (3) to front bow (5) with six clamps (16), screws (15), and nuts (17).
3. Install two supports (3) on rear bow (7) and middle bow (6) with eight clamps (13), support plates (12), sixteen screws (11), and nuts (14).
4. Install two supports (4) and supports (1) on front bow (5), middle bow (6), and rear bow (7) with four clamps (19), screws (20), and nuts (18).
5. Install two supports (4) and supports (1) on rear bow (7) and middle bow (6) with eight clamps (22), sixteen screws (23), and nuts (21).
6. Install two supports (1) on channel (33) with eight washers (36), screws (37), and locknuts (38).
7. Install plate (2) on channel (33) and two supports (16) with two screws (34) and locknuts (35).
8. Install two outside plates (24) and inside corner brackets (26) on two end closures (28) with six screws (25) and locknuts (29).
9. Install two inside corner brackets (26) on two supports (1) with four screws (32) and locknuts (30).
10. Secure two inside corner brackets (26) to two supports (1) with four screws (31) and locknuts (27).
11. Apply adhesive to exposed threads of top enclosure assembly mounting screws (39) and install safety caps (40) on screws (39) as required.

**12-120. TROOP/CARGO WINTERIZATION TOP ENCLOSURE ASSEMBLY REPLACEMENT
(Cont'd)**

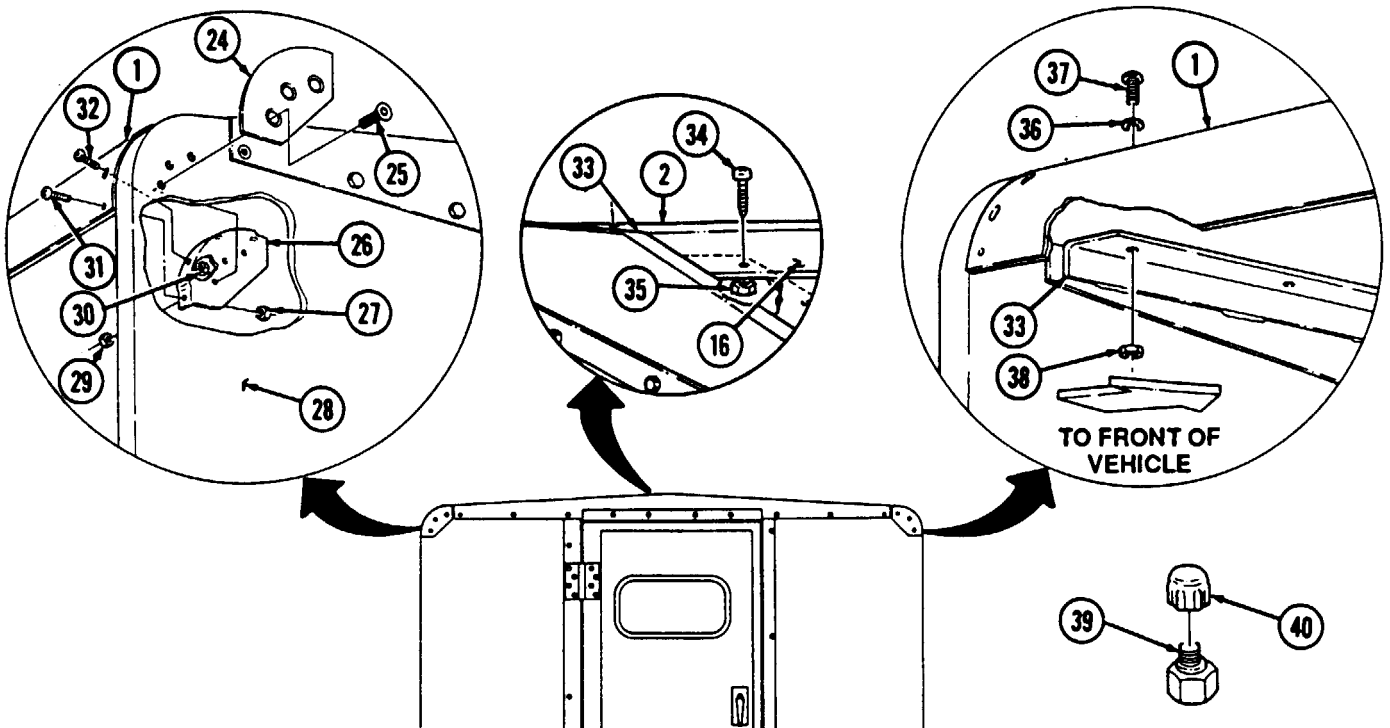
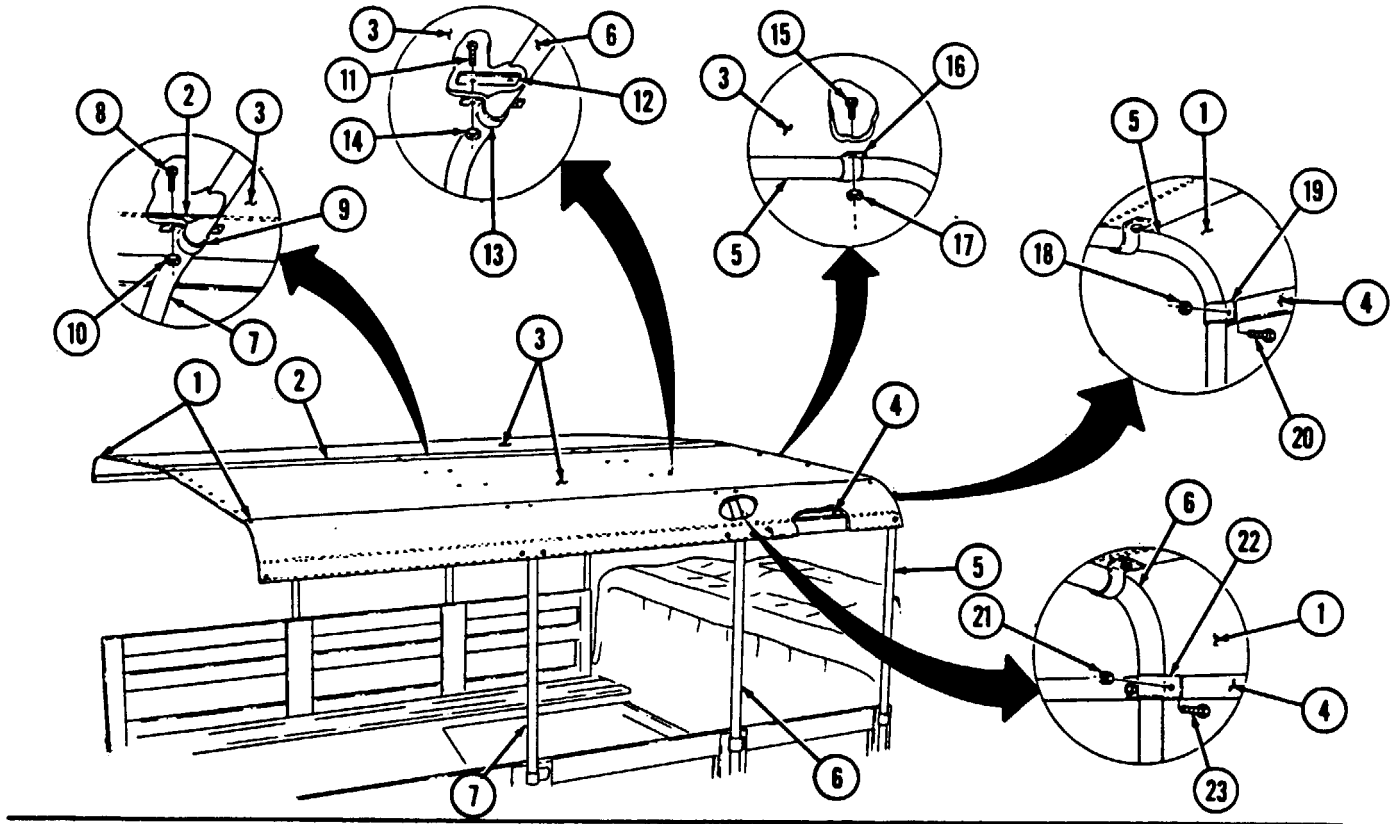

FOLLOW-ON TASK: Install top cover assembly (para. 12-119).

12-121. TROOP/CARGO WINTERIZATION TROOP SEAT ASSEMBLY AND BOW REPLACEMENT

This task covers:

a. Removal

b. Installation

INITIAL SETUP:

Applicable Models

M998, M998A1, M1038, M1038A1

Tools

General mechanic's tool kit:
automotive (Appendix B, Item 1)

Materials/Parts

Nine locknuts (Appendix G, Item 122)
Two locknuts (Appendix G, Item 123)
Two locknuts (Appendix G, Item 119)
Three locknuts (Appendix G, Item 86)

Personnel Required

One mechanic
One assistant

Manual References

TM 9-2320-280-24P

Equipment Condition

Top enclosure assembly removed (para. 12-120).

NOTE

Replacement instructions for left and right troop seat assemblies are the same. This procedure covers left troop seat assembly.

a. Removal

1. Remove plate (1) from front bow (20).
2. Remove front bow (20), middle bow (2), and rear bow (3) from troop seat assembly (9).
3. Remove six locknuts (11), washers (10), capscrews (13), and washers (12) from troop seat assembly (9) and wheelhousing (14). Discard locknuts (11).
4. Remove three locknuts (25), washers (26), capscrews (28), and washers (27) from rear corner troop seat bracket (29) and wheelhousing (14). Discard locknuts (25).
5. Remove two locknuts (24), washers (23), and capscrews (21) from front wheelhousing bracket (22) and wheelhousing (14). Discard locknuts (24).
6. Remove troop seat assembly (9) from wheelhousing (14) and support assembly (16).
7. Remove three locknuts (19), washers (18), and capscrews (15) from support assembly (16) and "B" pillar (17). Discard locknuts (19).
8. Remove two locknuts (8), washers (7), screws (5), and block (6) from cargo bulkhead (4).

12-121. TROOP/CARGO WINTERIZATION TROOP SEAT ASSEMBLY AND BOW REPLACEMENT (Cont'd)

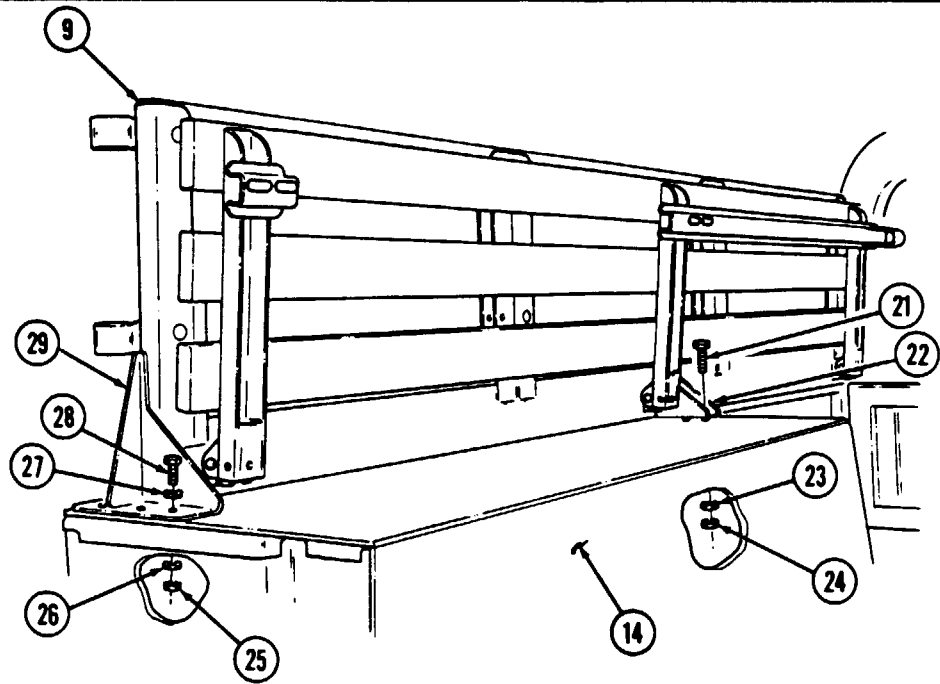
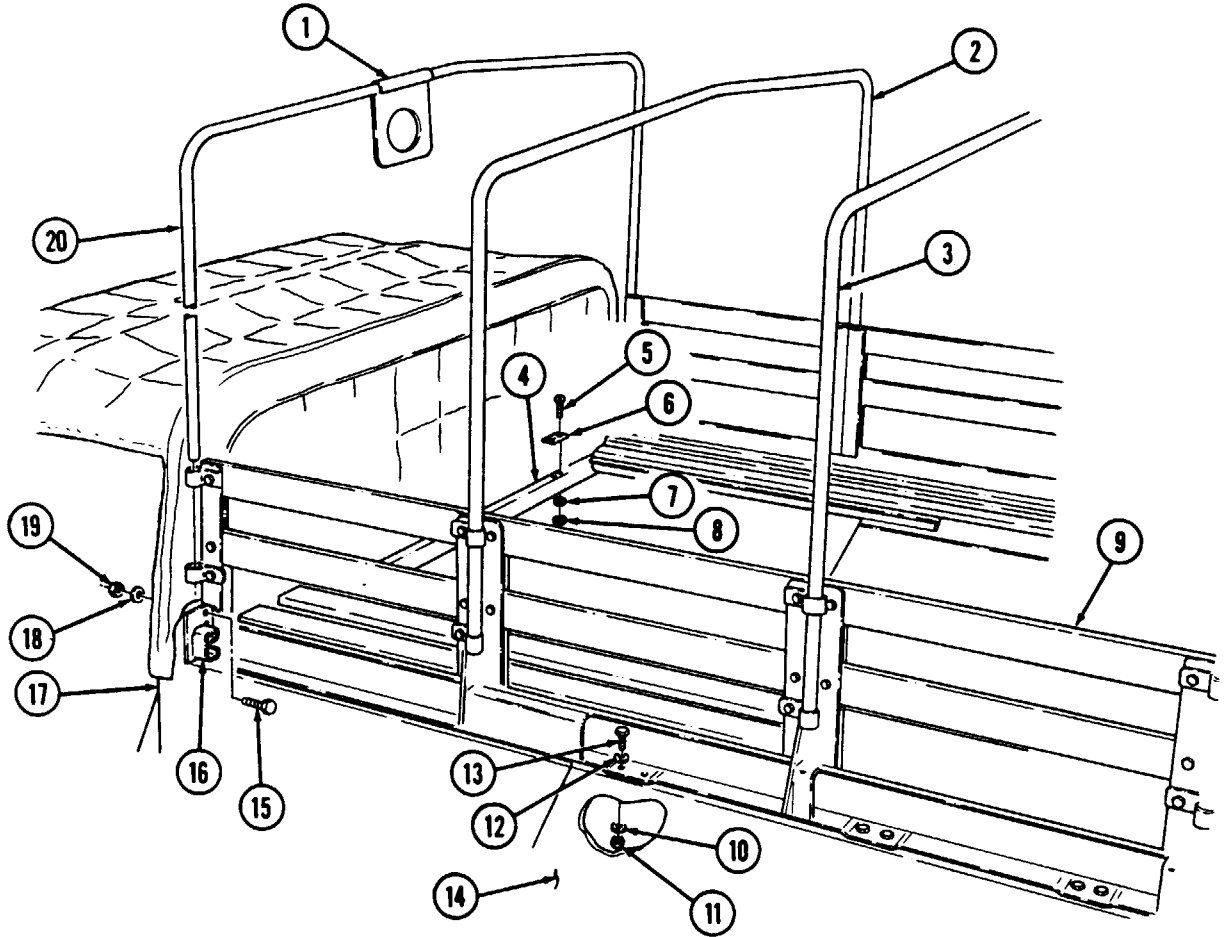

12-121. TROOP/CARGO WINTERIZATION TROOP SEAT ASSEMBLY AND BOW REPLACEMENT (Cont'd)

b. Installation

1. Install block (6) on cargo bulkhead (4) with two screws (5), washers (7), and locknuts (8).

NOTE

Support assembly must be installed with narrow offset to outside of vehicle and rounded side up.

2. Install support assembly (16) on "B" pillar (17) with three capscrews (15), washers (18), and locknuts (19).
3. Install troop seat assembly (9), folded in stowed position, into support assembly (16) and on wheelhousing (14).
4. Install front wheelhousing bracket (22) on wheelhousing (14) with two capscrews (21), washers (23), and locknuts (24). Tighten locknuts (24) to 49 lb-ft (66 N \bar{Z} m).
5. Install rear corner troop seat bracket (29) on wheelhousing (14) with three washers (27), capscrews (28), washers (26), and locknuts (25). Tighten locknuts (25) to 96 lb-in. (11 N \bar{Z} m).
6. Install troop seat assembly (9) on wheelhousing (14) with six washers (12), capscrews (13), washers (10), and locknuts (11). Tighten locknuts (11) to 96 lb-in. (11 N \bar{Z} m).
7. Install front bow (20), middle bow (2), and rear bow (3) on slots on outside of troop seat assembly (9).
8. Install plate (1) on front bow (20).

12-121. TROOP/CARGO WINTERIZATION TROOP SEAT ASSEMBLY AND BOW REPLACEMENT (Cont'd)

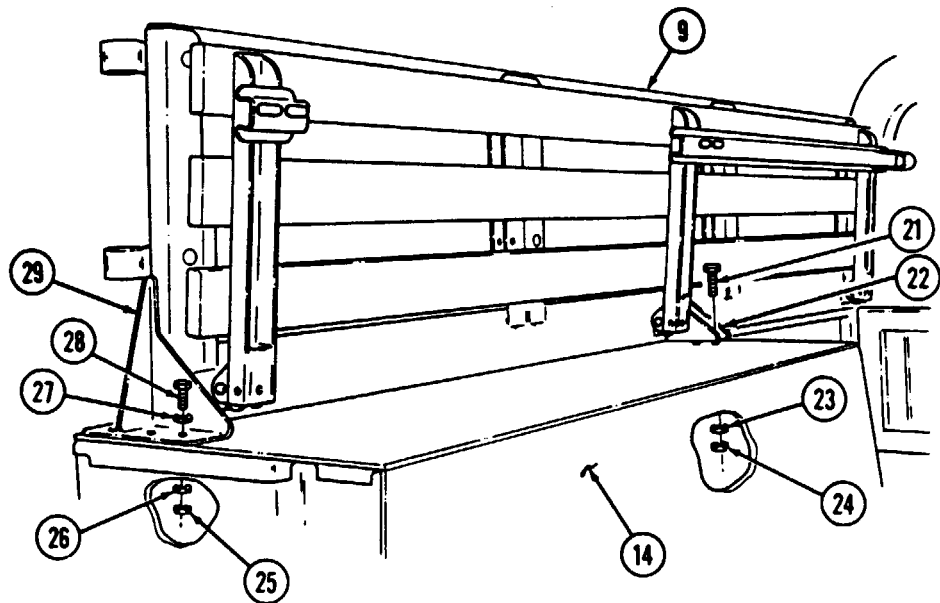
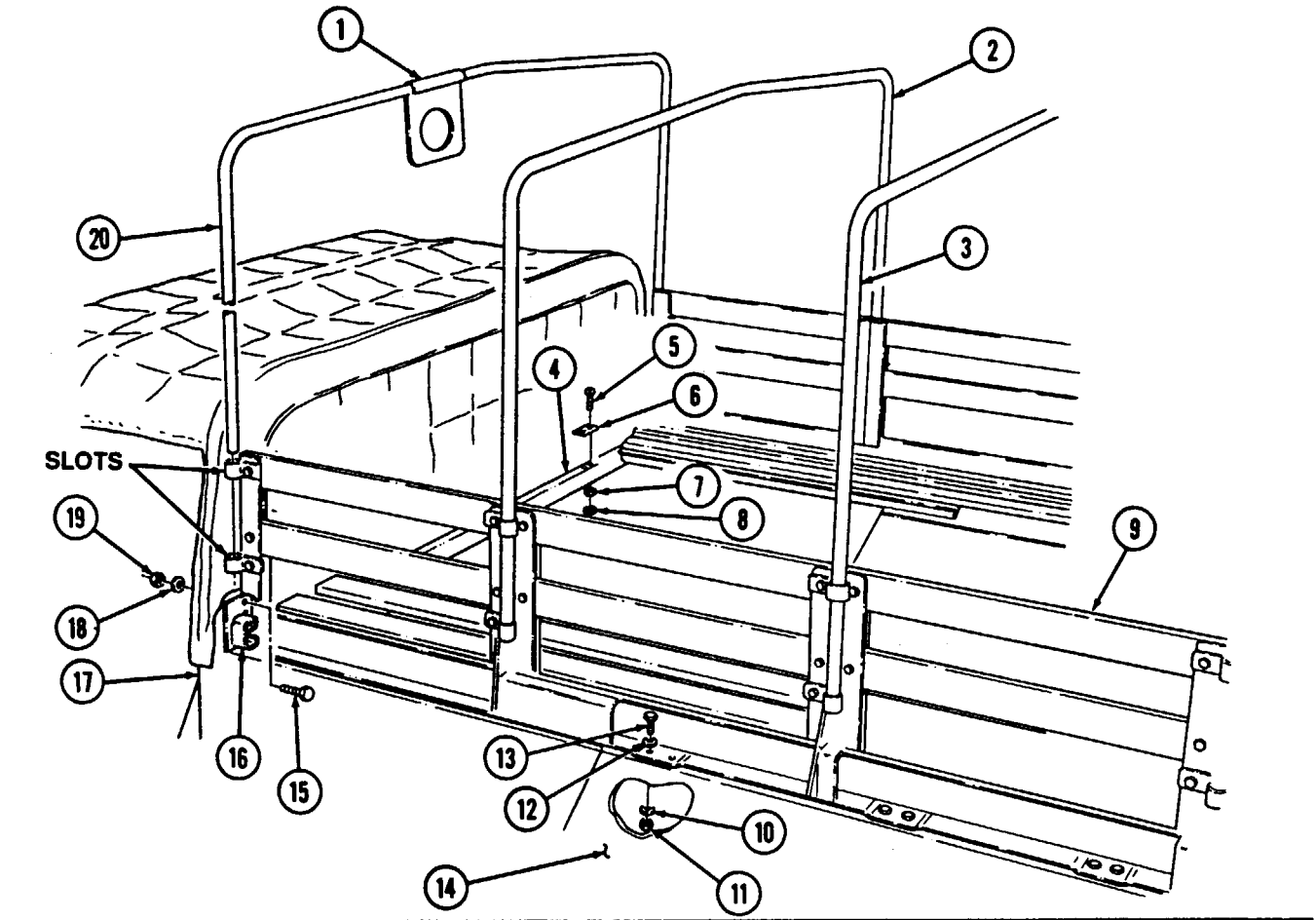

FOLLOW-ON TASK: Install top enclosure assembly (para. 12-120).

12-122. TROOP/CARGO WINTERIZATION REAR STEP ASSEMBLY REPLACEMENT

This task covers:

a. Removal

b. Installation

INITIAL SETUP:

Applicable Models

M998, M998A1, M1038, M1038A1

Materials/Parts

Two cotter pins (Appendix G, Item 12)

Tools

General mechanic's tool kit:
automotive (Appendix B, Item 1)

Manual References

TM 9-2320-280-24P

a. Removal

1. Remove two cotter pins (7), clevis pins (6), and step assembly (5) from door and frame assembly (4). Discard cotter pins (7).
2. Remove two screws (1) and step latch strip (2) from cargo floor cover (3).

b. Installation

1. Install step latch strip (2) on cargo floor cover (3) with two screws (1).
2. Install step assembly (5) on door and frame assembly (4) with two clevis pins (6) and cotter pins (7).

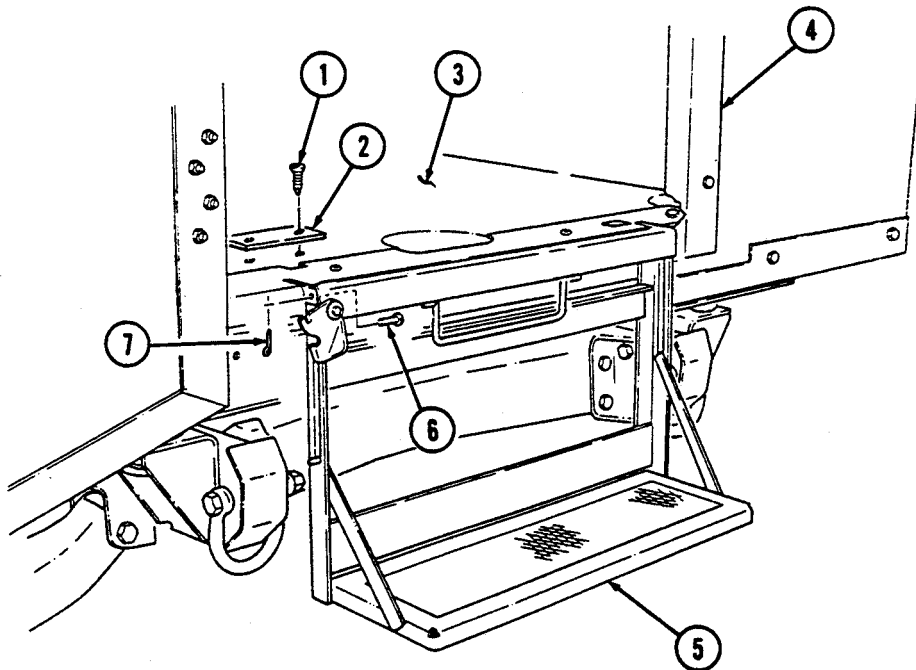

12-123. TROOP/CARGO WINTERIZATION HANDLE ASSEMBLY REPLACEMENT

This task covers:

a. Removal

b. Installation

INITIAL SETUP:

Applicable Models

M998, M998A1, M1038, M1038A1

Tools

General mechanic's tool kit:
automotive (Appendix B, Item 1)

Materials/Parts

Adhesive (Appendix C, Item 7)
Two locknuts (Appendix G, Item 124)

Manual References

TM 9-2320-280-24P

a. Removal

Remove two safety caps (4), locknuts (3), washers (2), handle assembly (6) and two washers (1) from right end closure (5). Discard locknuts (3).

b. Installation

1. Install two washers (1) and handle assembly (6) on right end closure (5) with two washers (2) and locknuts (3).
2. Apply adhesive to exposed threads of handle assembly (6) and install two safety caps (4) on handle assembly (6).

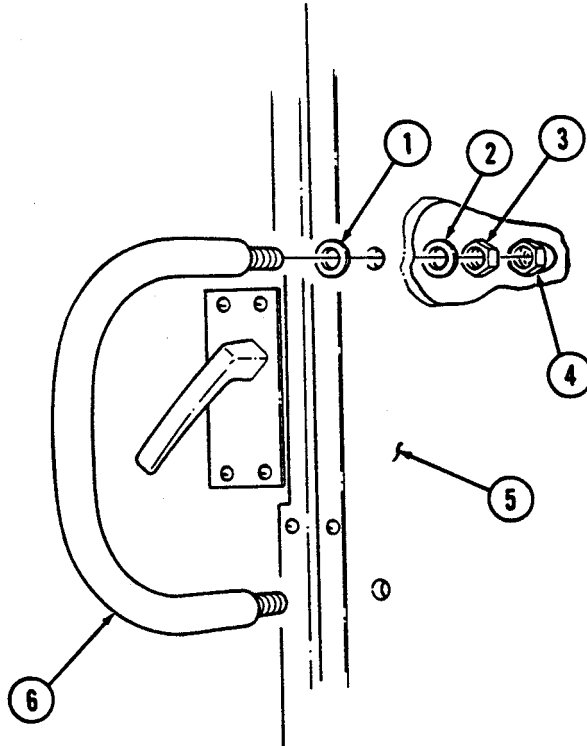

12-124. TROOP/CARGO WINTERIZATION FUEL CAN MOUNTING BRACKET REPLACEMENT

This task covers:

a. Removal

b. Installation

INITIAL SETUP:

Applicable Models

M998, M998A1, M1038, M1038A1

Materials/Parts

Four locknuts (Appendix G, Item 120)

Tools

General mechanic's tool kit:
automotive (Appendix B, Item 1)

Manual References

TM 9-2320-280-24P

a. Removal

1. Remove two locknuts (1), plate (2), and two capscrews (4) from fuel can mounting bracket (5) and left end closure (7). Discard locknuts (1).
2. Remove two locknuts (10), washers (9), capscrews (6), and fuel can mounting bracket (5) from left end closure (7). Discard locknuts (10).
3. Remove two spacers (8) from lower mounting holes (3) in left end closure (7).

b. Installation

1. Install two spacers (8) in lower mounting holes (3) in left end closure (7).
2. Install fuel can mounting bracket (5) on left end closure (7) with two capscrews (6), washers (9), and locknuts (10).
3. Secure fuel can mounting bracket (5) and plate (2) to left end closure (7) with two capscrews (4) and locknuts (1).
4. Tighten two locknuts (1) and locknuts (10) to 34 lb-ft (46 N•m).

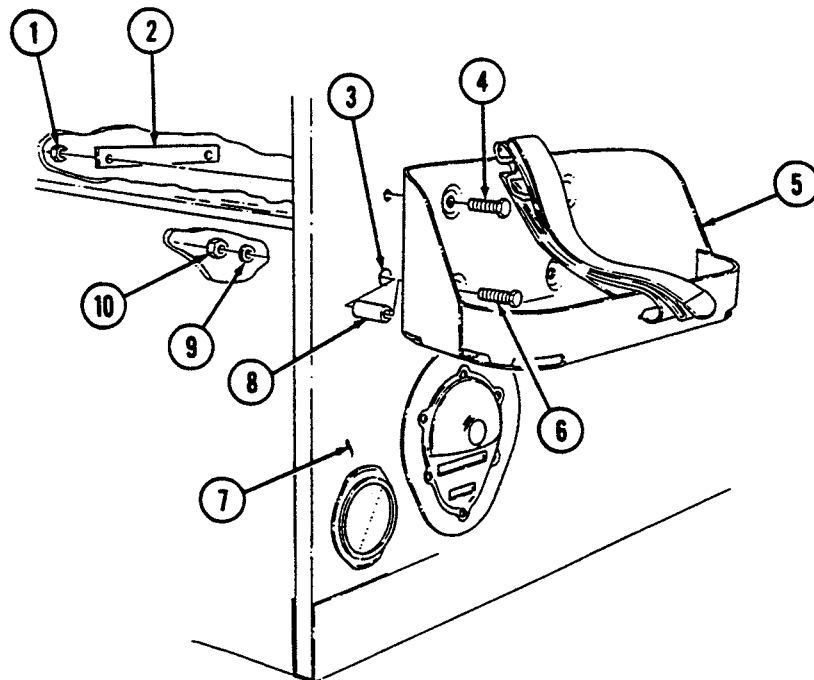

12-125. TROOP/CARGO WINTERIZATION ANTENNA MOUNTING BRACKET REPLACEMENT

This task covers:

a. Removal

b. Installation

INITIAL SETUP:

Applicable Models

M998, M998A1, M1038, M1038A1

Manual References

TM 9-2320-280-24P

Tools

General mechanic's tool kit:
automotive (Appendix B, Item 1)

Equipment Condition

- AS 1729/VRC antenna removed (para. 12-137), if installed.
- AB-652/GR antenna removed (para. 12-139), if installed.

Materials/Parts

Three locknuts (Appendix G, Item 125)

a. Removal

1. Remove three locknuts (4), washers (3), capscrews (8), washers (6), and antenna mounting bracket (2) from right end closure (7). Discard locknuts (4).
2. Remove three spacers (5) from right end closure (7).
3. Remove grommet (1) from antenna mounting bracket (2).

b. Installation

1. Install grommet (1) on antenna mounting bracket (2).
2. Install three spacers (5) on right end closure (7).
3. Install antenna mounting bracket (2) on right end closure (7) with three washers (6), capscrews (8), washers (3), and locknuts (4). Tighten locknuts (4) to 15 lb-ft (20 N·m).

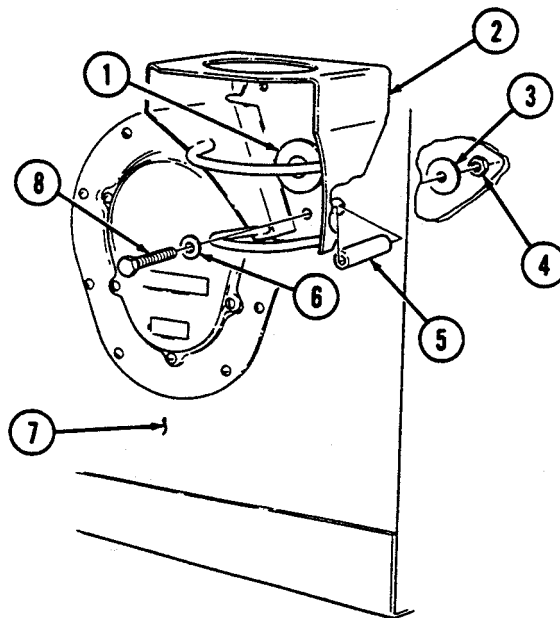

- FOLLOW-ON TASKS:
- Install AS 1729/VRC antenna (para. 12-137), if removed.
 - Install AB-652/GR antenna (para. 12-139), if removed.

12-126. TROOP/CARGO WINTERIZATION REAR REFLECTOR REPLACEMENT

This task covers:

a. Removal

b. Installation

INITIAL SETUP:

Applicable Models

M998, M998A1, M1038, M1038A1

Manual References

TM 9-2320-280-24P

Tools

General mechanic's tool kit:
automotive (Appendix B, Item 1)

NOTE

Replacement instructions for left and right rear reflectors are the same. This procedure covers right rear reflector.

a. Removal

Remove two screws (3) and reflector (2) from right end closure (1).

b. Installation

Install reflector (2) on right end closure (1) with two screws (3).

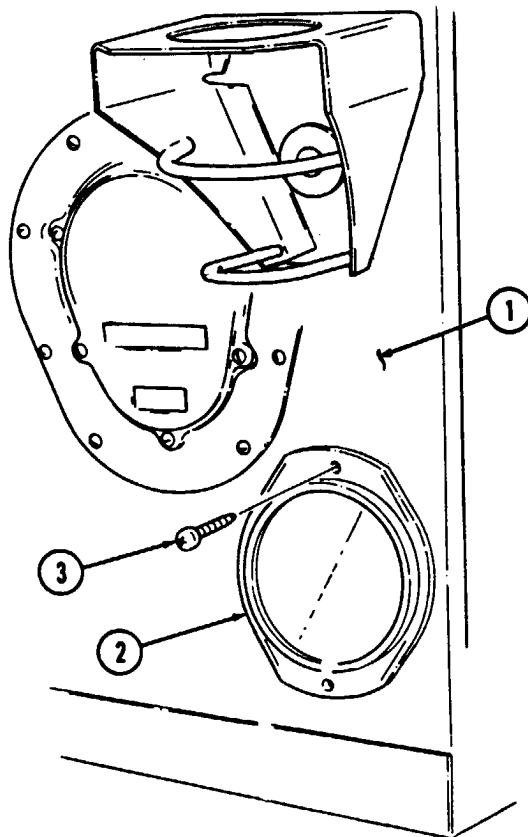

12-127. TROOP/CARGO WINTERIZATION REAR COMPOSITE LIGHT HOUSING REPLACEMENT

This task covers:

a. Removal

b. Installation

INITIAL SETUP:

Applicable Models

M998, M998A1, M1038, M1038A1

Manual References

TM 9-2320-280-24P

Tools

General mechanic's tool kit:
automotive (Appendix B, Item 1)

Equipment Condition

Rear composite light assembly removed
(para. 4-56).

NOTE

Replacement instructions for left and right rear composite light housings are the same. This procedure covers right rear composite light housing.

a. Removal

Remove eight screws (3) and rear composite light housing (1) from right end closure (2).

b. Installation

Install rear composite light housing (1) on right end closure (2) with eight screws (3).

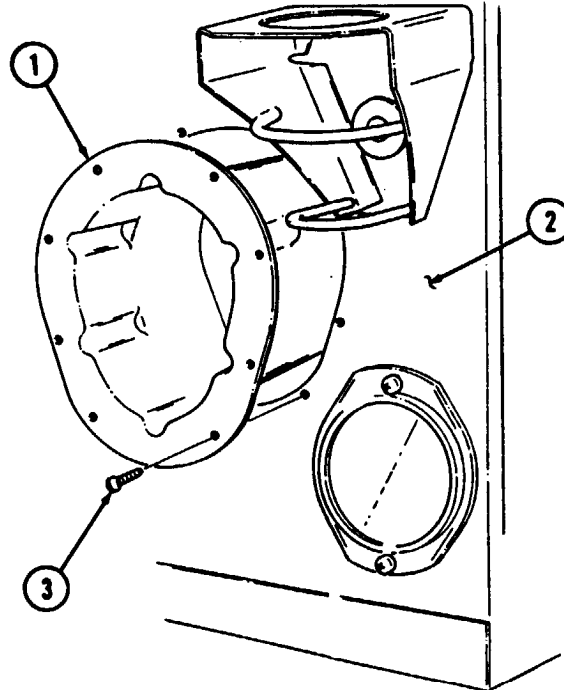

FOLLOW-ON TASK: Install rear composite light housing (para. 4-56).

12-128. TROOP/CARGO WINTERIZATION DATA PLATE REPLACEMENT

This task covers:

a. Removal

b. Installation

INITIAL SETUP:

Applicable Models

M998, M998A1, M1038, M1038A1

Manual References

TM 9-2320-280-24P

Tools

General mechanic's tool kit:
automotive (Appendix B, Item 1)

a. Removal

Remove four screws (3) and data plate (1) from left end closure (2).

b. Installation

Install data plate (1) on left end closure (2) with four screws (3).

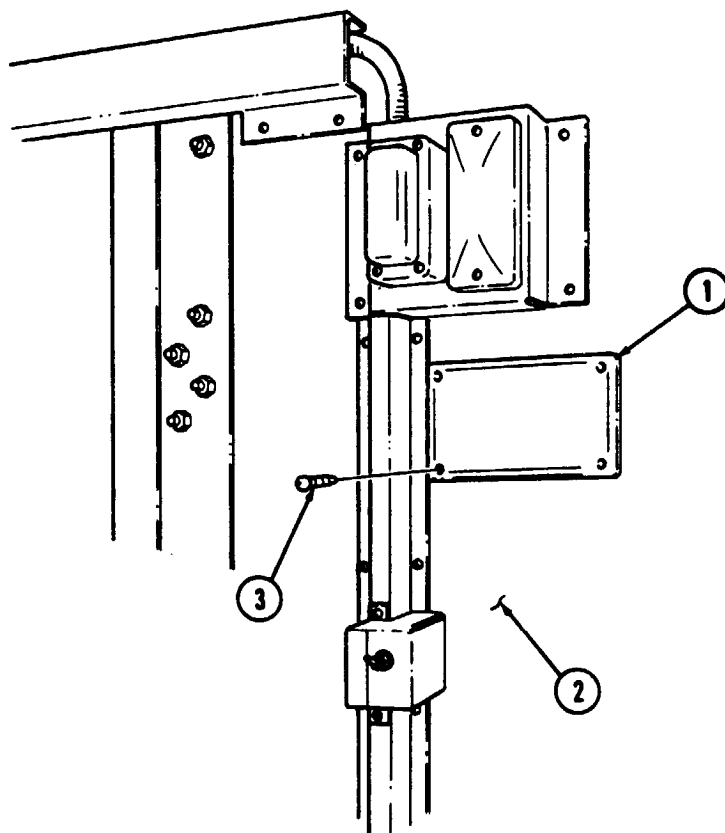

Section VII. COMMUNICATIONS KITS MAINTENANCE

12-129. COMMUNICATIONS KITS MAINTENANCE TASK SUMMARY

TASK PARA.	PROCEDURES	PAGE NO.
12-130.	Front Radio Rack Mounting Bracket Replacement	12-202
12-131.	Auxiliary Shelf Replacement	12-202.1
12-131.1.	Front Radio Rack Upper Mounting Brackets Replacement	12-202.2
12-132.	Front Radio Rack Replacement	12-204
12-132.1.	Installation of New Configuration Front Radio Rack Bracket	12-204.2
12-133.	Front Lower Radio Rack Replacement	12-206
12-134.	Dual TSEC/KY-57 Mounting Bracket and Control Switch Bracket Replacement	12-207
12-135.	Speaker Stop Replacement	12-208
12-136.	Antenna Ground Strap Replacement	12-209
12-137.	AS 1729/VRC Antenna Replacement	12-211
12-138.	Rear Antenna Mounting Bracket Replacement	12-212
12-139.	AB-652/GR Antenna Replacement	12-213
12-140.	Rear Antenna Cables Replacement	12-214
12-141.	Front Radio Rack Power Cable Replacement	12-221
12-142.	Headphone Mounting Bracket Replacement	12-223
12-143.	Handset Bracket Replacement	12-224
12-144.	Rear Radio Rack Maintenance	12-225
12-145.	Rear Radio Rack Antenna Tower Maintenance	12-228
12-146.	Rear Radio Rack to Tower Antenna Cables Replacement	12-230
12-147.	Rear Radio Rack Power Cable Replacement	12-232

12-130. FRONT RADIO RACK MOUNTING BRACKET REPLACEMENT

This task covers:

a. Removal

b. Installation

INITIAL SETUP:

Applicable Models

All models except M996, M996A1, M997, M997A1, M997A2, M1037, M1042, M1097, M1097A1, M1097A2, M1123

Tools

General mechanic's tool kit:
automotive (Appendix B, Item 1)

Personnel Required

One mechanic
One assistant

Manual References

TM 9-2320-280-24P

Equipment Condition

Radio rack assembly removed (para. 12-132).

a. Removal

NOTE

Brace is attached under the floor and secured by four capscrews holding the two radio rack mounting brackets to the cargo floor.

1. Remove two capscrews (2), washers (1), and radio rack mounting bracket (3) from cargo floor (4).

NOTE

Perform step 2 for vehicles with new configuration.

2. Remove two capscrews (7), washers (6), and radio rack mounting bracket (5) from cargo floor (4).

b. Installation

1. Install radio rack mounting bracket (3) on cargo floor (4) with two washers (1) and capscrews (2). Tighten capscrews (2) to 96 lb-in. (11 N•m).

NOTE

Perform step 2 for vehicles with new configuration.

2. Install radio rack mounting bracket (5) on cargo floor (4) with two washers (6) and capscrews (7). Tighten capscrews (7) to 96 lb-in. (11 N•m).

NEW CONFIGURATION

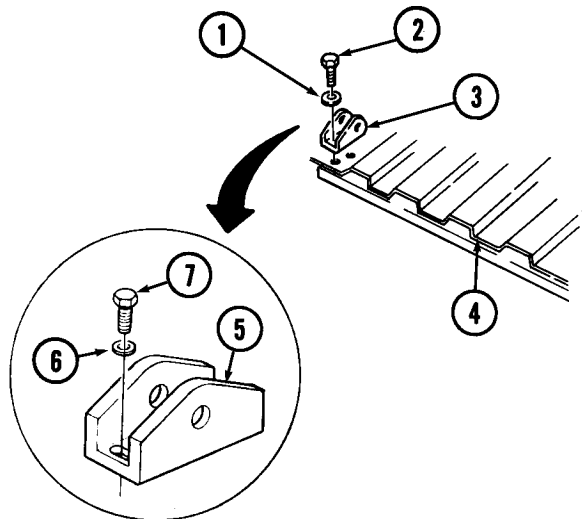

FOLLOW-ON TASK: Install radio rack assembly (para. 12-132).

12-131. AUXILIARY SHELF REPLACEMENT

This task covers:

a. Removal

b. Installation

INITIAL SETUP:

Applicable Models

M998, M998A1, M1038, M1038A1

Tools

General mechanic's tool kit:
automotive (Appendix B, Item 1)

Materials/Parts

Four locknuts (Appendix G, Item 70)

Manual References

TM 9-2320-280-24P

Equipment Condition

Speaker stop removed (para. 12-135).

a. Removal

1. Remove two locknuts (7), washers (8), screws (2), from auxiliary shelf (6) and radio rack (1). Discard locknuts (7).
2. Remove two locknuts (5), washers (4), capscrews (3), and auxiliary shelf (6) from radio rack (1). Discard locknuts (5).

b. Installation

1. Install auxiliary shelf (6) on radio rack (1) with two capscrews (3), washers (4), and locknuts (5).
2. Install radio rack (1) on auxiliary shelf (6) with two screws (2), washers (8), and locknuts (7).

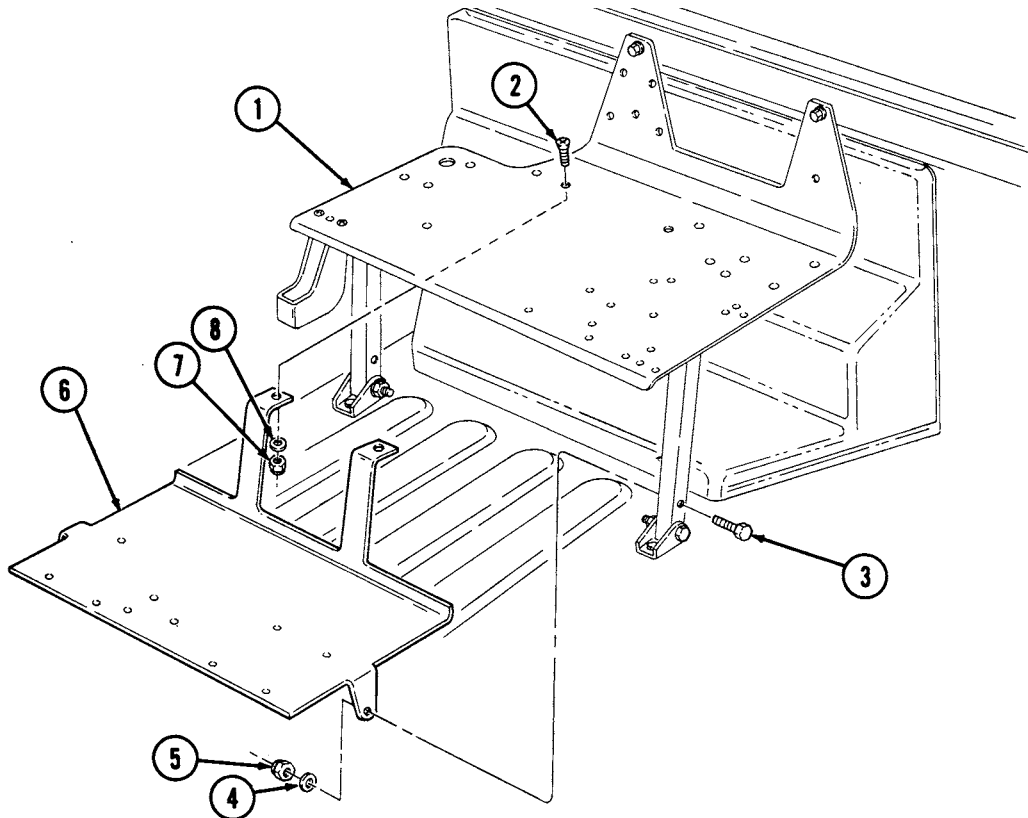

FOLLOW-ON TASK: Install speaker stop (para. 12-135).

12-131.1. FRONT RADIO RACK UPPER MOUNTING BRACKETS REPLACEMENT

This task covers:

a. Removal

b. Installation

INITIAL SETUP:

Applicable Models

M966, M998, M1025, M1026, M1036, M1038,
M1043, M1044, M1045, M1046, M1121

Manual References

TM 9-2320-280-24P

Tools

General mechanic's tool kit:
automotive (Appendix B, Item 1)

Equipment Condition

Radio rack assembly removed (para. 12-132).

Personnel Required

One mechanic
One assistant

a. Removal

1. Remove two capscrews (4), washers (5), and radio rack mounting brackets (6) from plenum (7).
2. Remove nine screws (9), retainer (8), and plenum (7) from "A" beam (10).
3. Remove four capscrews (3), washers (2), and two radio rack upper mounting brackets (1) from "A" beam (10).

b. Installation

1. Install two radio rack upper mounting brackets (1) on "A" beam (10) with four washers (2) and capscrews (3).
2. Install retainer (8) and plenum (7) on "A" beam (10) with nine screws (9).
3. Install two radio rack mounting brackets (6) on plenum (7) with two washers (5) and capscrews (4).

12-131.1. FRONT RADIO RACK UPPER MOUNTING BRACKETS REPLACEMENT (6nt'd)

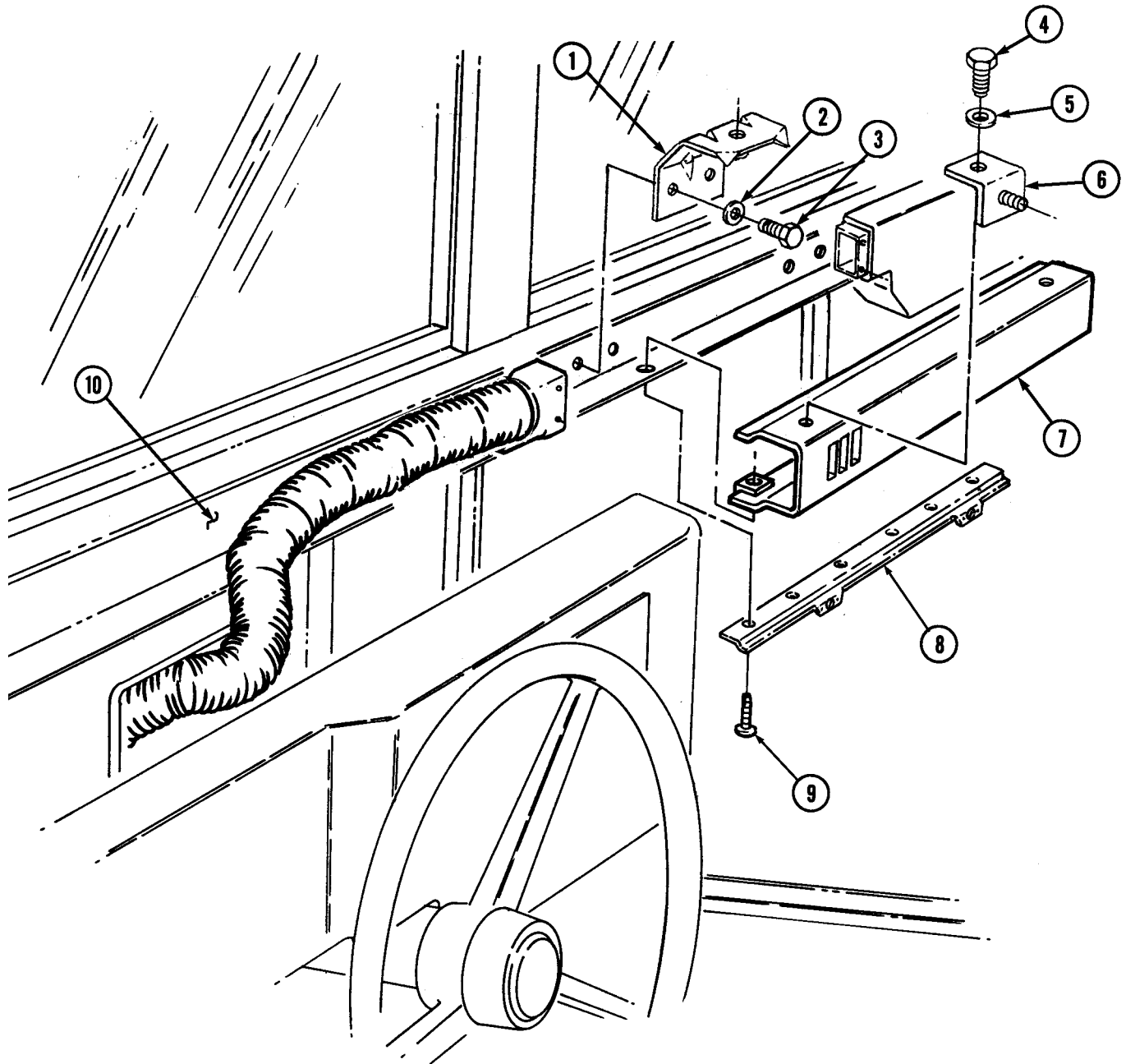

FOLLOW-ON TASK: Install radio rack assembly (para. 12-132).

12-132. FRONT RADIO RACK REPLACEMENT

This task covers:

a. Removal

b. Installation

INITIAL SETUP:

Applicable Models

All models except M996, M996A1, M997, M997A1, M997A2, M1037, M1042, M1097, M1097A1, M1097A2, M1123

Tools

General mechanic's tool kit:
automotive (Appendix B, Item 1)

Materials/Parts

Antiseize compound (Appendix C, Item 13)
Four locknuts (Appendix G, Item 78)
Two plain-assembled nuts
(Appendix G, Item 201)
Two locknuts (Appendix G, Item 128)

Manual References

TM 9-2320-280-24P

Equipment Condition

- Headphone mounting bracket removed (para. 12-142).
- Dual TSEC/KY-57 mounting bracket and control switch bracket removed (para. 12-134) if installed.
- Auxiliary shelf removed (para. 12-131) if installed.

M966, M966A1, M1036, M1045, M1045A1, M1045A2, M1046, M1046A1, M1121 only:

- Vehicle power conditioner (VPC) mounting bracket removed (para. 11-66).
- Field glasses bracket removed (para. 11-69).

a. Removal

1. Remove two plain-assembled nuts (8), screws (5), two clamps (6), and cables (7) from radio rack (4). Discard plain-assembled nuts (8).
2. Remove two capscrews (1) and washers (2) from radio rack (4) and "A" beam (3).

NOTE

Perform steps 2.1 and 2.2 for vehicles with new configuration.

- 2.1. Remove two locknuts (15) and washers (14) from radio rack (4) and two radio rack upper brackets (13). Discard locknuts (15).
- 2.2. Remove two locknuts (18), washers (17), capscrews (16), and radio rack (4) from two radio rack mounting brackets (19) and remove radio rack (4). Discard locknuts (18).
3. Remove two locknuts (12), washers (11), capscrews (9), and radio rack (4) from radio rack mounting brackets (10). Discard locknuts (12).

b. Installation

1. Install radio rack (4) on radio rack mounting brackets (10) with two capscrews (9), washers (11), and locknuts (12). Tighten locknuts (12) to 8-10 lb-ft (11-14 N•m).

NOTE

Perform steps 1.1 and 1.2 for vehicles with new configuration.

- 1.1. Install radio rack (4) on two radio rack mounting brackets (19) with capscrews (16), washers (17), and locknuts (18). Tighten locknuts (18) to 8-10 lb-ft (11-14 N•m).
- 1.2. Install radio rack (4) on two radio rack upper brackets (13) with washers (14) and locknuts (15). Tighten locknuts (15) to 8-10 lb-ft (11-14 N•m).
2. Install radio rack (4) on "A" beam (3) with two washers (2) and capscrews (1). Tighten capscrews (1) to 6 lb-ft (8 N•m).
3. Install cables (7) and two clamps (6) on radio rack (4) with two screws (5) and plain-assembled nuts (8).

12-132. FRONT RADIO RACK REPLACEMENT(Cont'd)

NEW CONFIGURATION

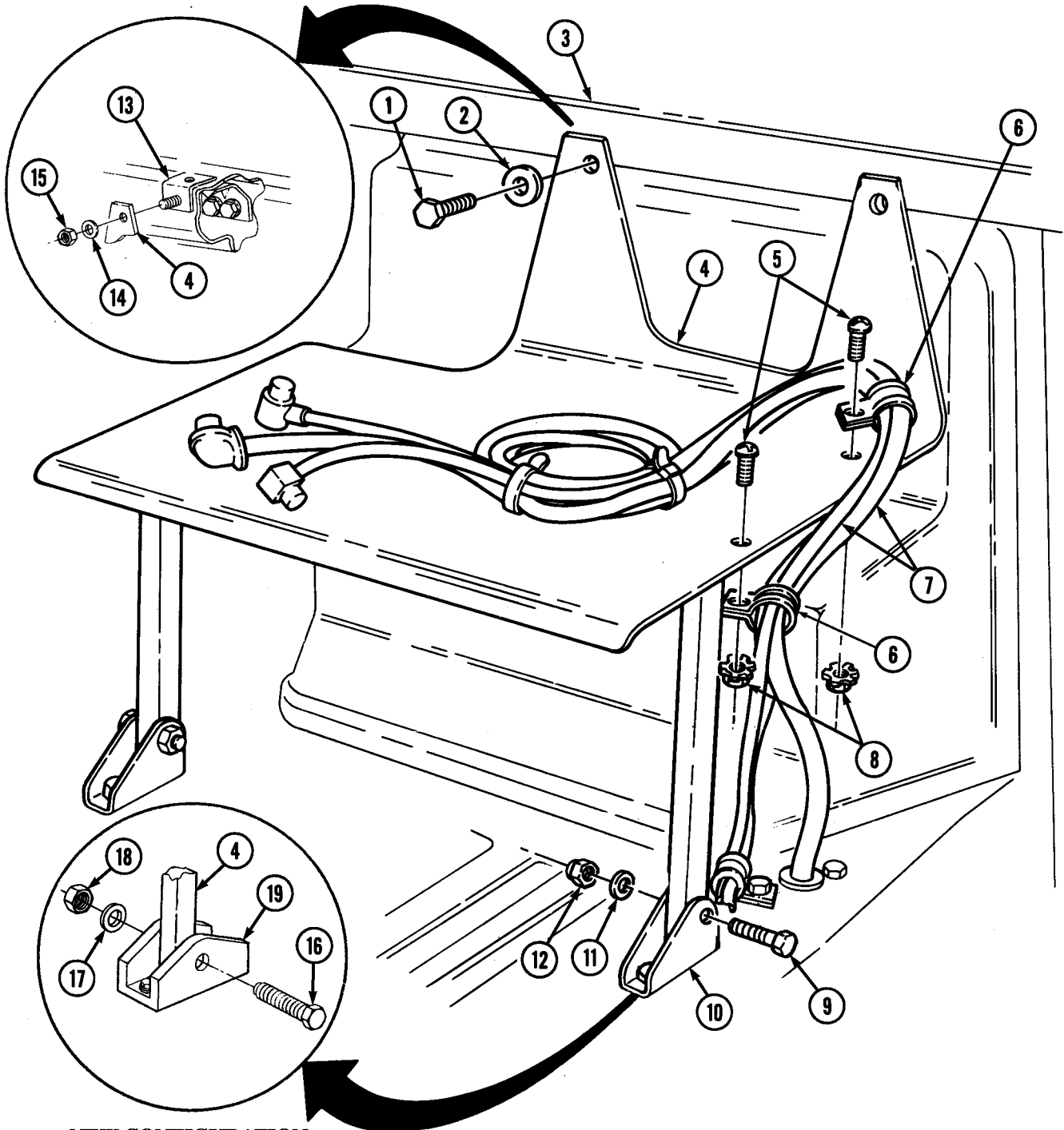

NEW CONFIGURATION

- FOLLOW-ON TASKS:**
- Install headphone mounting bracket (para. 12-142).
 - Install dual TSEC/KY-57 mounting bracket and control switch bracket, (para. 12-134) if removed.
 - Install auxiliary shelf (para. 12-131) if removed.
M966, M966A1, M1036, M1045, M1045A1, M1045A2, M1046, M1046A1, and M1121 only.
 - Install vehicle power conditioner (VPC) mounting bracket (para. 11-66).
 - Install field glasses bracket (para. 11-69).

12-132.1. INSTALLATION OF NEW CONFIGURATION FRONT RADIO RACK BRACKET

This task covers:

a. Vehicle Preparation

b. Installation

INITIAL SETUP:

Applicable Models

All models except M996, M996A1, M997, M997A1, M997A2, M1037, M1042, M1097, M1097A1, M1097A2, M1123

Tools

General mechanic's tool kit:
automotive (Appendix B, Item 1)

Materials/Parts

Four locknuts (Appendix G, Item 71)
Four locknuts (Appendix G, Item 128)
Two blind rivets (Appendix G, Item 237)
Sealant (Appendix C, Item 38)

Manual References

TM 9-2320-280-24P

Equipment Condition

- Front radio rack removed (para. 12-132).
- Front floorboard removed (para. 11-154).
- Front radio rack mounting bracket removed (para. 12-130).
- Engine access cover removed (para. 10-15).

a. Vehicle Preparation

NOTE

Refer to para. 10-66 for rivet removal.

1. Remove nine screws (7), plenum panel (11), and engine shroud mount (6) from "A" beam (1).
2. Remove four nuts (5), washers (4), screws (2), and two mounting brackets (3) from "A" beam (1).
3. Remove two rivets (10) and radio rack brace (8) from tunnel floor (9).

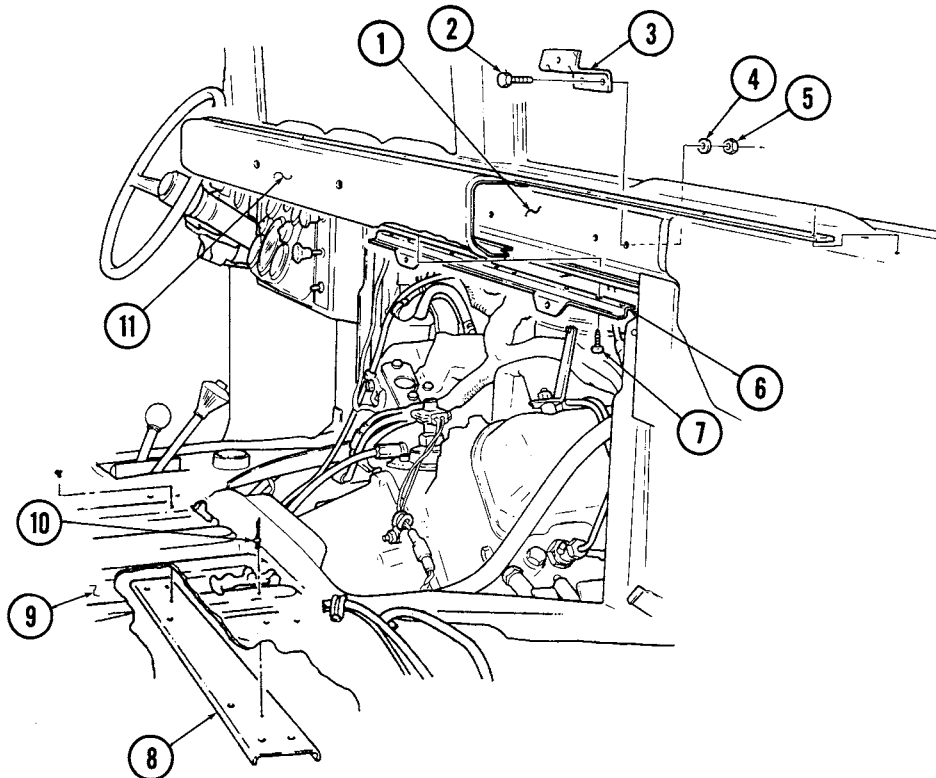

12-132.1. INSTALLATION OF NEW CONFIGURATION FRONT RADIO RACK BRACKET (Cont'd)

b. Installation

1. Locate, mark, and drill two 0.440-in. (11.18 mm) diameter holes (12) in plenum panel (11).
2. Locate, mark, and drill four 0.281-in. (7.1 mm) diameter holes (13) in "A" beam (1).
3. Cut two 0.75-in. (2 mm) square holes (15) in floor mat (14) on top of tunnel floor (9).
4. Using two radio rack mounting brackets (17) as a template, locate, mark, and drill two 0.313-in. (8 mm) diameter holes (16) in top of tunnel floor (9).
5. Apply sealant to two holes (12) and two existing holes on plenum panel (11) and four holes (13) on "A" beam (1).

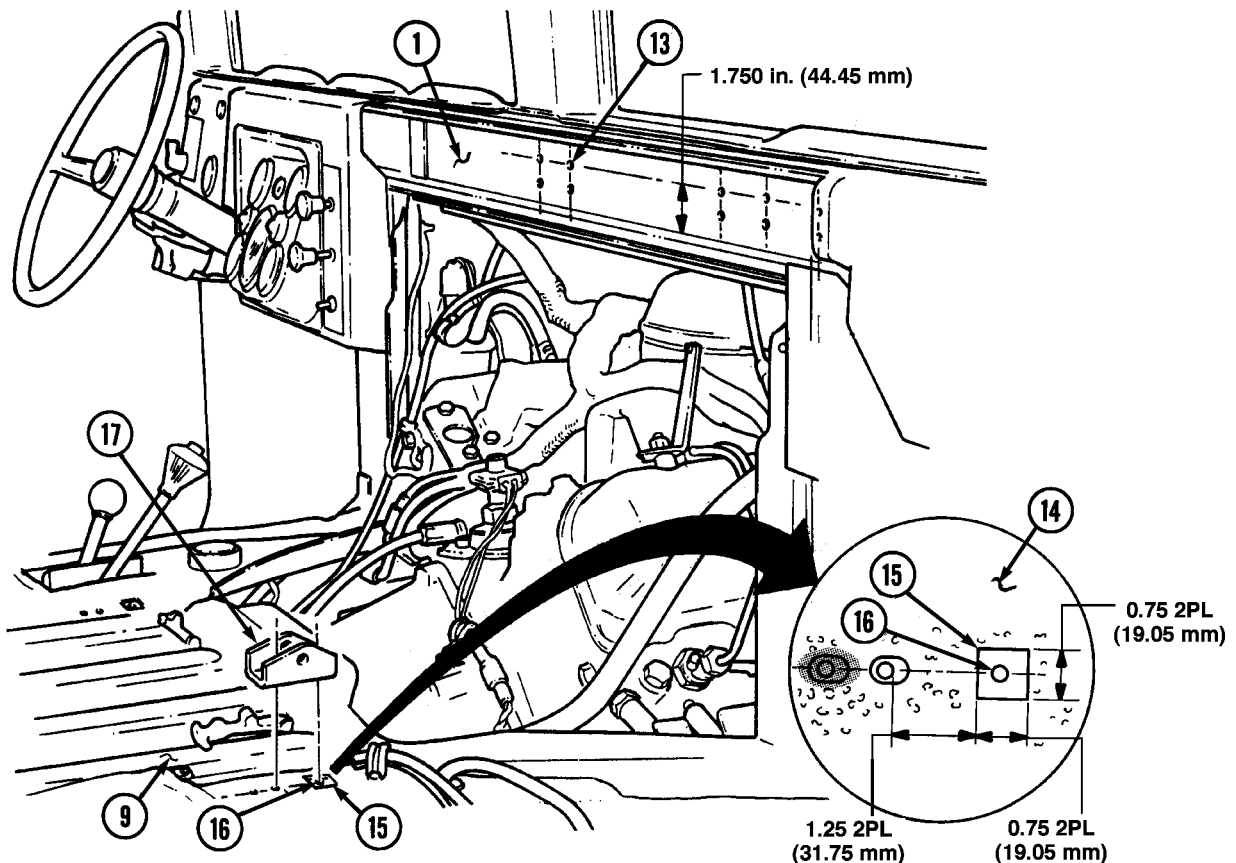
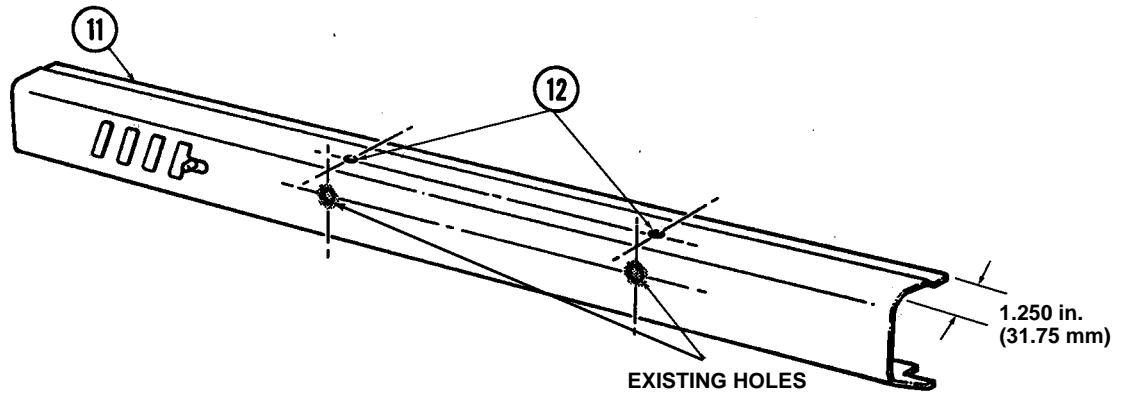

12-132.1. INSTALLATION OF NEW CONFIGURATION FRONT RADIO RACK BRACKET (Cont'd)

6. Position radio rack brace (13) under tunnel floor (15) and two radio rack mounting brackets (12) on tunnel floor (15).
7. Install radio rack brace (13) and two radio rack mounting brackets (12) on tunnel floor (15) with four screws (17) and washers (16).
8. Install plenum panel (1) and engine shroud mount (11) on "A" beam (5) with nine screws (10).
9. Using two holes (14) in tunnel floor (15) as a template, drill two 0.172-inch (4.3 mm) diameter holes through radio rack brace (13).

NOTE

Refer to para. 10-66 for rivet installation.

10. Install two rivets (27) in tunnel floor (15) and radio rack brace (13).
11. Install front floorboard (para. 11-154).
12. Install engine access cover (para. 10-15).
13. Install two radio mounting brackets (7) on "A" beam (5) with four screws (6), washers (8), and locknuts (9).
14. Install two upper radio rack brackets (2) on plenum panel (1) with two screws (3) and washers (4).
15. Install front radio rack (26) on two radio rack mounting brackets (12) with two screws (23), washers (24), and locknuts (25).
16. Install front radio rack (26) on plenum panel (1) and upper radio rack brackets (2) with two washers (19) and locknuts (18).
17. Install two screws (20) and nuts (21) through "P" clamps (22) and front radio rack (26).

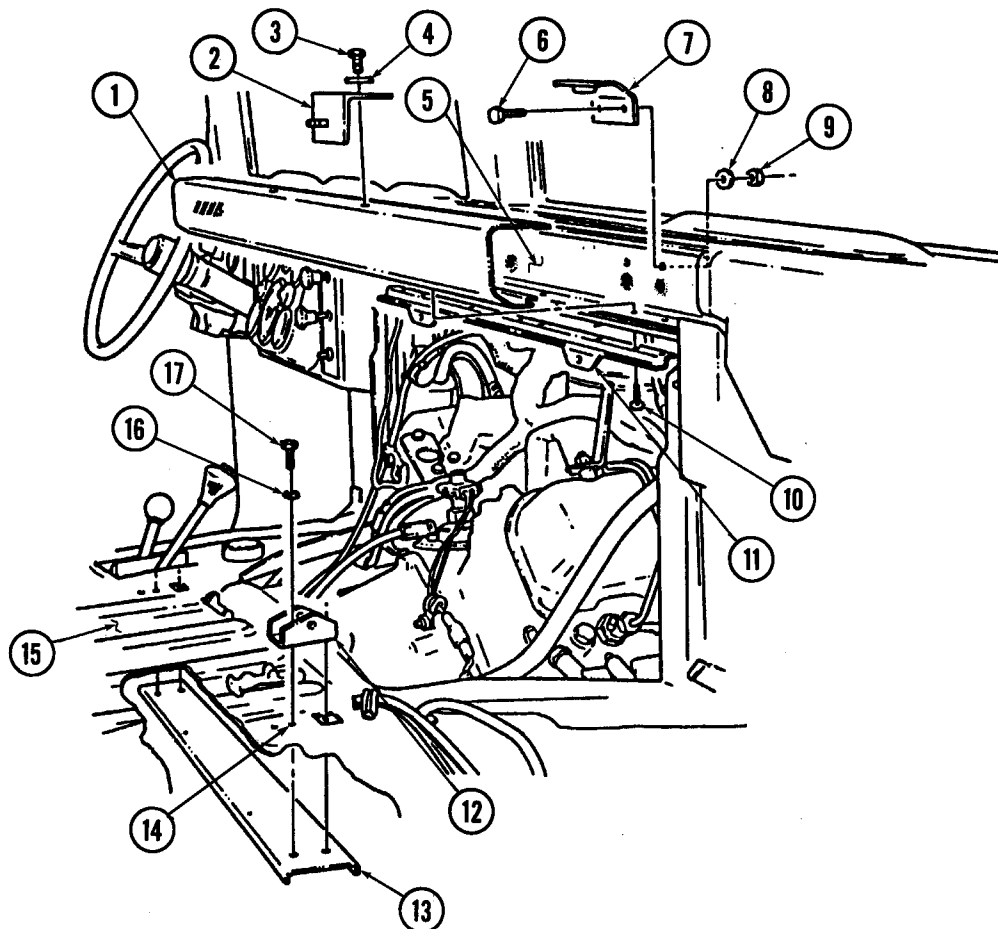

12-132.1. INSTALLATION OF NEW CONFIGURATION FRONT RADIO RACK BRACKET (Cont'd)

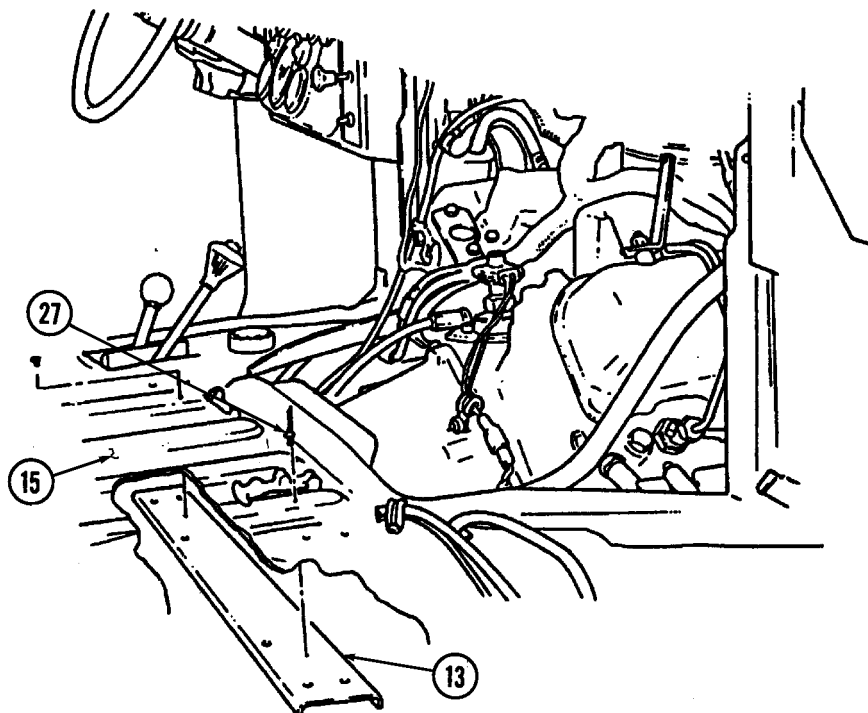
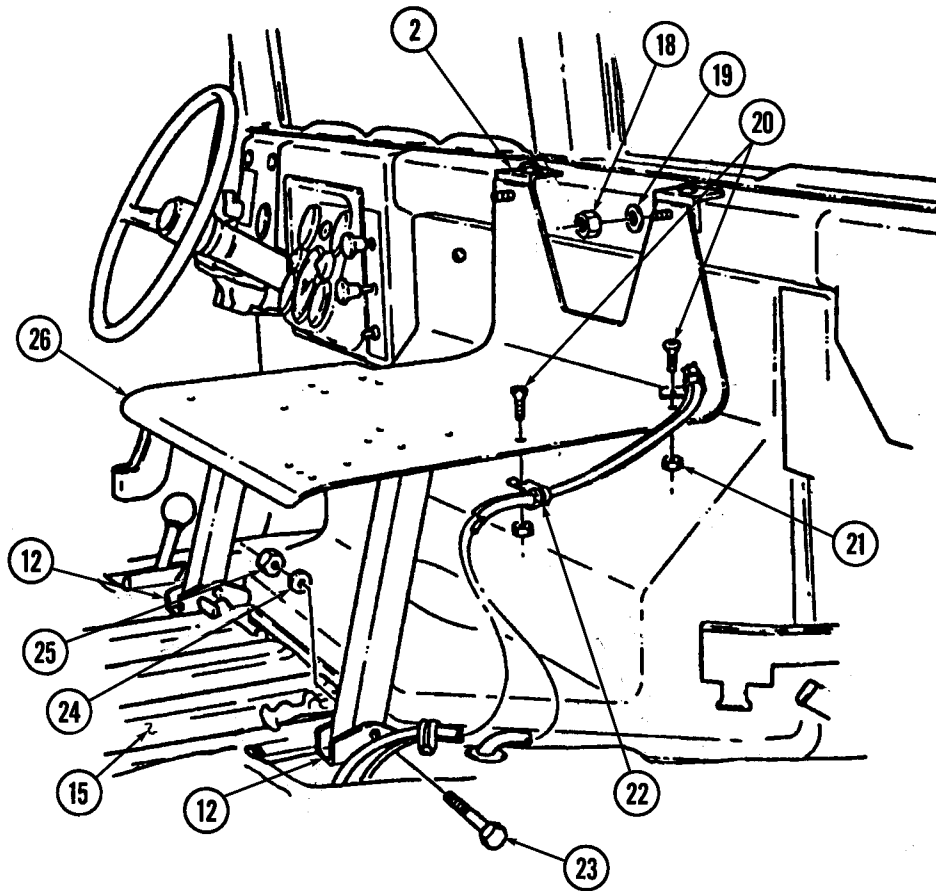

12-133. FRONT LOWER RADIO RACK REPLACEMENT

This task covers:

a. Removal

b. Installation

INITIAL SETUP:

Applicable Models

M998, M998A1, M1038, M1038A1

Tools

General mechanic's tool kit:
automotive (Appendix B, Item 1)

Materials/Parts

Six locknuts (Appendix G, Item 70)
Four locknuts (Appendix G, Item 128)

Manual References

TM 9-2320-280-24P

a. Removal

1. Remove two capscrews (2) and washers (3) from upper radio rack (1) and plenum (4).
2. Remove two locknuts (6), washers (5), and screws (12) from lower radio rack (8) and upper radio rack (1). Discard locknuts (6).
3. Remove two locknuts (11), washers (10), capscrews (7), and upper radio rack (1) from mounting brackets (9). Discard locknuts (11).
4. Remove four locknuts (19), washers (14), capscrews (13), washers (14), and mounting brackets (9) from lower radio rack (8). Discard locknuts (19).
5. Remove two locknuts (18), washers (15), capscrews (16), and lower radio rack (8) from mounting brackets (17). Discard locknuts (18).

b. Installation

1. Install lower radio rack (8) on mounting brackets (17) with two capscrews (16), washers (15), and locknuts (18). Tighten locknuts (18) to 8-10 lb-ft (11-14 N·m).
2. Install two mounting brackets (9) on lower radio rack (8) with four washers (14), capscrews (13), washers (14), and locknuts (19). Finger tighten locknuts (19).
3. Install upper radio rack (1) on mounting brackets (9) with two capscrews (7), washers (10), and locknuts (11). Tighten locknuts (11) to 8-10 lb-ft (11-14 N·m).
4. Install upper radio rack (1) on lower radio rack (8) with two screws (12), washers (5), and locknuts (6).
5. Install upper radio rack (1) on plenum (4) with two washers (3) and capscrews (2). Tighten capscrews (2) to 6 lb-ft (8 N·m).
6. Tighten four locknuts (19) on mounting brackets (9) and lower radio rack (8).

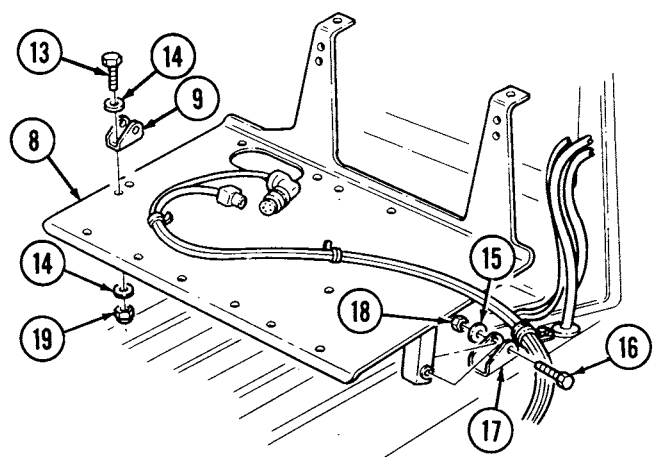
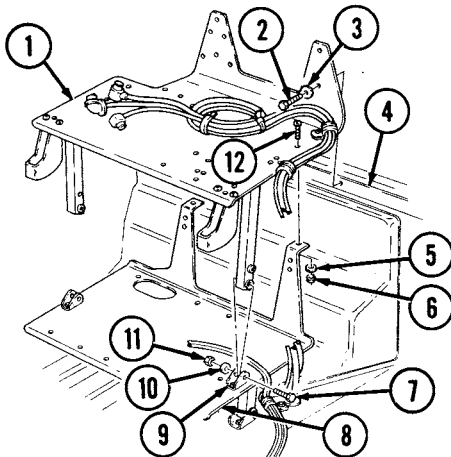

12-134. DUAL TSEC/KY-57 MOUNTING BRACKET AND CONTROL SWITCH BRACKET REPLACEMENT

This task covers:

a. Removal

b. Installation

INITIAL SETUP:

Applicable Models

M998, M998A1, M1038, M1038A1, M1097, M1097A1, M1097A2

Tools

General mechanic's tool kit:
automotive (Appendix B, Item 1)

Materials/Parts

Four locknuts (Appendix G, Item 86)

Manual References

TM 9-2320-280-24P

a. Removal

Remove four locknuts (6), washers (3), capscrews (2), washers (3), dual TSEC/KY-57 mounting bracket (4) and control switch bracket (5) from radio rack (1). Discard locknuts (6).

b. Installation

Install switch bracket (5) and mounting bracket (4) on radio rack (1) with four washers (3), capscrews (2), washers (3), and locknuts (6).

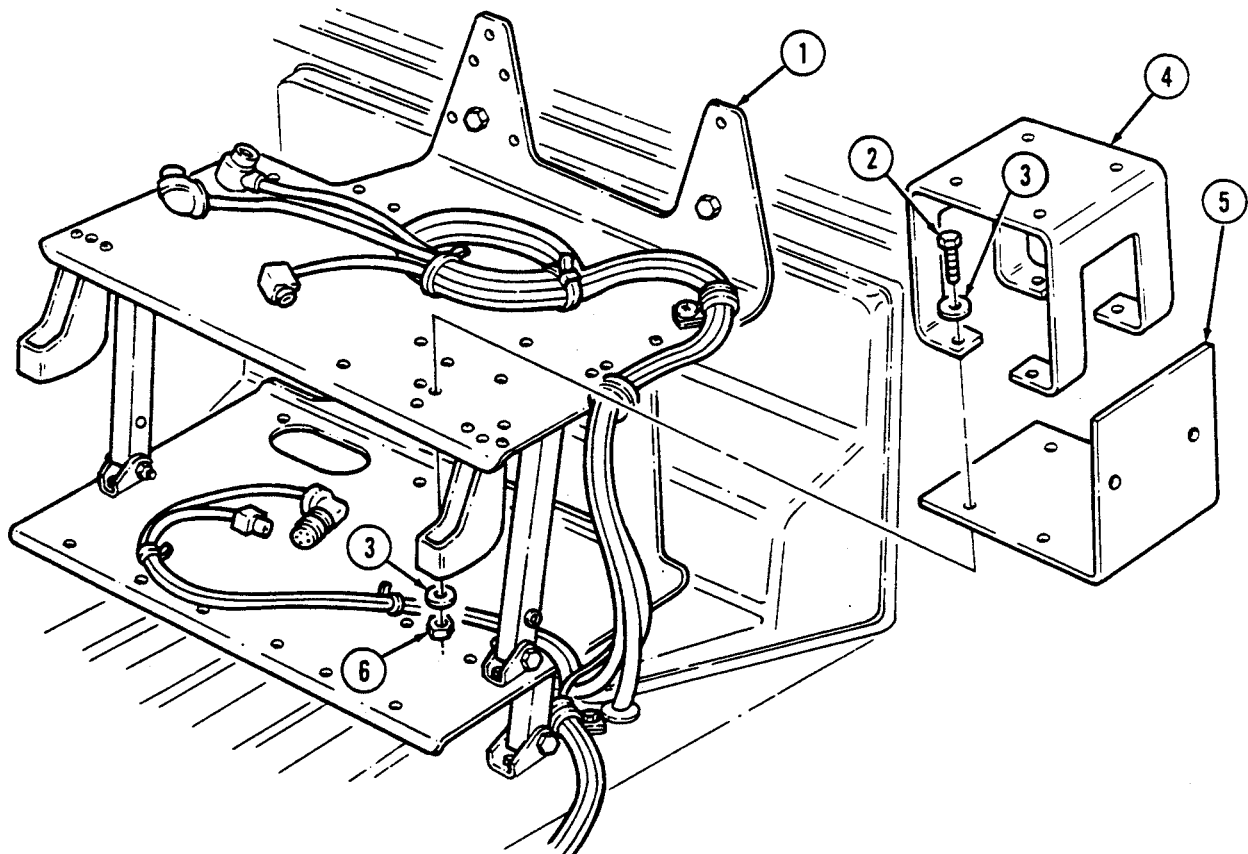

12-135. SPEAKER STOP REPLACEMENT

This task covers:

a. Removal

b. Installation

INITIAL SETUP:

Applicable Models

M998, M998A1, M1038, M1038A1

Tools

General mechanic's tool kit:
automotive (Appendix B, Item 1)

Materials/Parts

Two locknuts (Appendix G, Item 70)

Manual References

TM 9-2320-280-24P

a. Removal

Remove two locknuts (4), washers (2), capscrews (1), washers (2), and speaker stop (3) from auxiliary shelf (5). Discard locknuts (4).

b. Installation

Install speaker stop (3) on auxiliary shelf (5) with two washers (2), capscrews (1), washers (2), and locknuts (4).

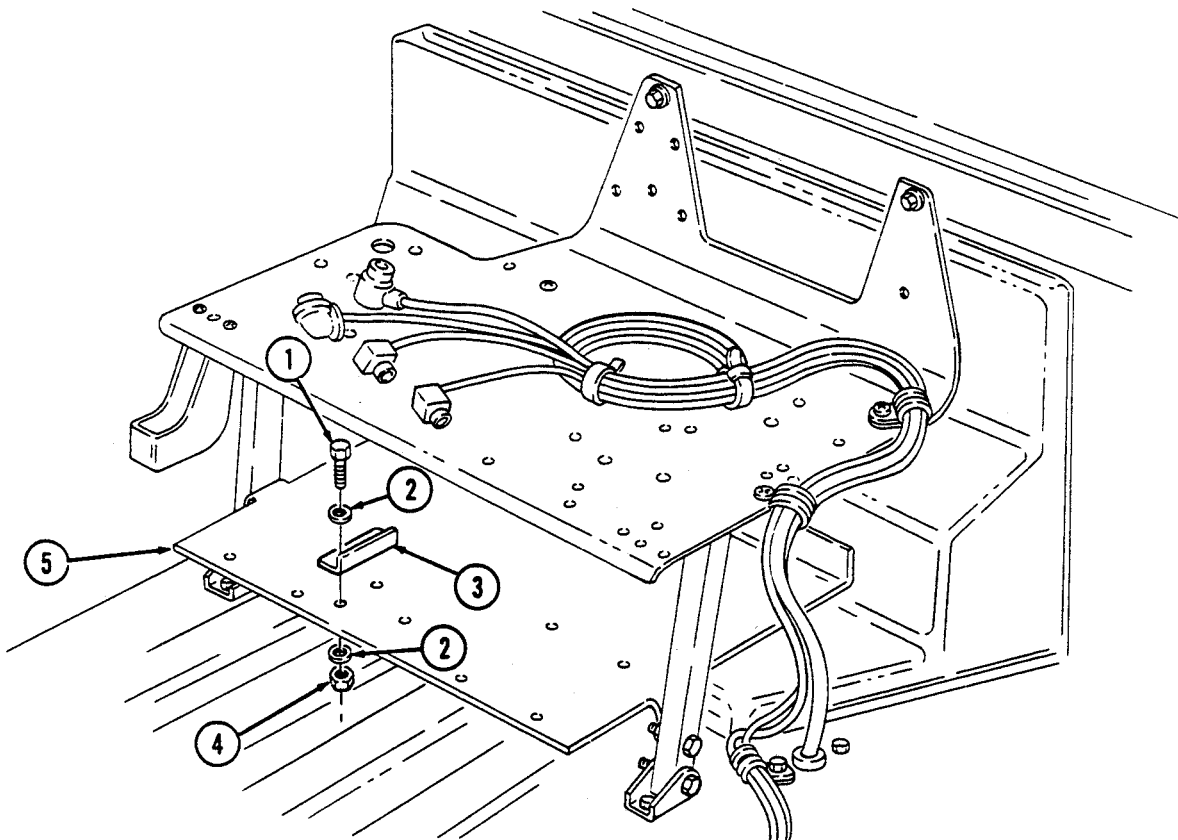

12-136. ANTENNA GROUND STRAP REPLACEMENT

This task covers:

a. Removal

b. Installation

INITIAL SETUP:

Applicable Models

All models except M996, M996A1, M997, M997A1, M997A2, M1036, M1037, M1042, M1097, M1097A1, M1097A2

Tools

General mechanic's tool kit:
automotive (Appendix B, Item 1)

Materials/Parts

Antiseize compound (Appendix C, Item 13)
Two lockwashers (Appendix G, Item 138)
Locknut (Appendix G, Item 128)
Plain-assembled nut (Appendix G, Item 201)

Manual References

TM 9-2320-280-10
TM 9-2320-280-24P

Equipment Condition

- Battery ground cable disconnected (para. 4-73). M966, M966A1, M1025, M1025A1, M1025A2, M1026, M1026A1, M1043, M1043A1, M1043A2, M1044, M1044A1, M1045, M1045A1, M1045A2, M1046, and M1046A1 only:
- Cargo shell door raised (TM 9-2320-280-10).

a. Removal

1. Remove screw (6), lockwasher (7), and ground strap (3) from antenna base (2). Discard lockwasher (7).

NOTE

Perform step 2 for M998, M998A1, M1035, M1035A1, M1035A2, M1038, and M1038A1 models only.

2. Remove plain-assembled nut (4), lockwasher (5), screw (8), and ground strap (3) from antenna mounting bracket assembly (1). Discard plain-assembled nut (4) and lockwasher (5).

NOTE

Perform step 3 for M966, M966A1, M1025, M1025A1, M1025A2, M1026, M1026A1, M1043, M1043A1, M1043A2, M1044, M1044A1, M1045, M1045A1, M1045A2, M1046, and M1046A1 models only.

3. Remove locknut (13), washer (10), capscrew (9), washer (10), ground strap (3), and lockwasher (12) from cargo shell (11). Discard locknut (13) and lockwasher (12).

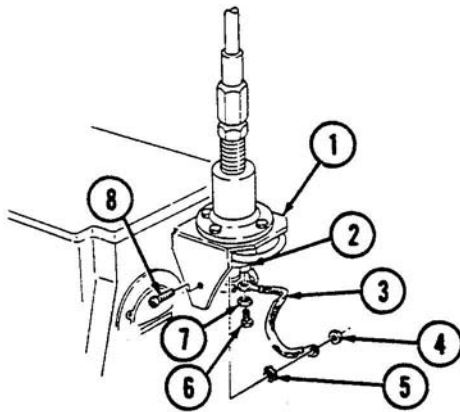

**M998, M998A1, M1035,
M1035A1, M1035A2, M1038,
M1038A1**

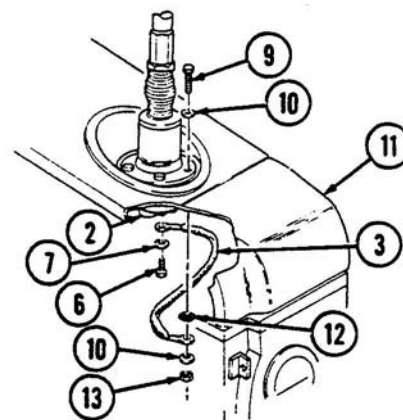

**M966, M966A1, M1025, M1025A1,
M1025A2, M1026, M1026A1, M1043,
M1043A1, M1043A2, M1044, M1044A1,
M1045, M1045A1, M1045A2, M1046,
M1046A1**

12-136. ANTENNA GROUND STRAP REPLACEMENT (Cont'd)

b. Installation

NOTE

Perform step 1 for M966, M966A1, M1025, M1025A1, M1025A2, M1026, M1026A1, M1045A2, M1043, M1043A1, M1043A2, M1044, M1044A1, M1045, M1045A1, M1046, and M1046A1 models only.

1. Install lockwasher (12) and ground strap (3) on cargo shell (11) with washer (10), capscrew (9), washer (10), and locknut (13). Tighten locknut (13) to 31 lb-ft (42 N·m).

NOTE

Perform steps 2 and 3 for M998, M998A1, M1035, M1035A1, M1035A2, M1038, and M1038A1 models only.

2. Apply antiseize compound to screw (8) threads.
3. Install lockwasher (5) and ground strap (3) on antenna mounting bracket assembly (1) with screw (8) and plain-assembled nut (4).
4. Install ground strap (3) on antenna base (2) with lockwasher (7) and screw (6).

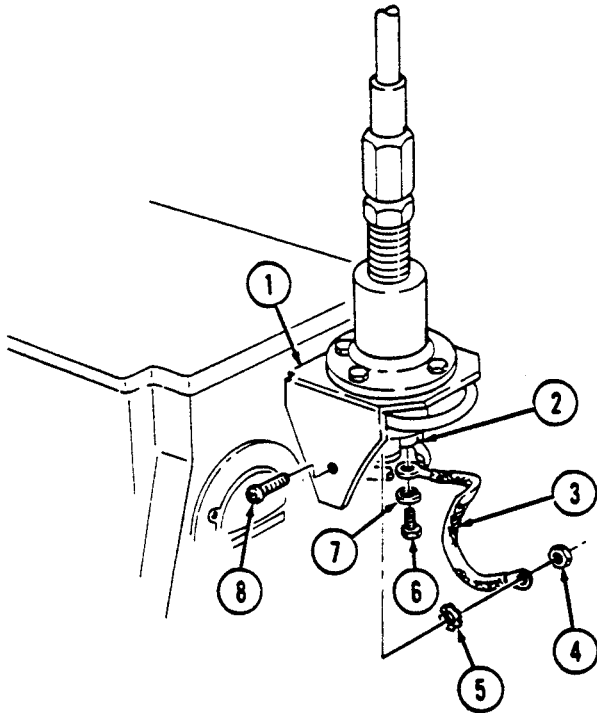

**M998, M998A1, M1035,
M1035A1, M1035A2, M1038,
M1038A1**

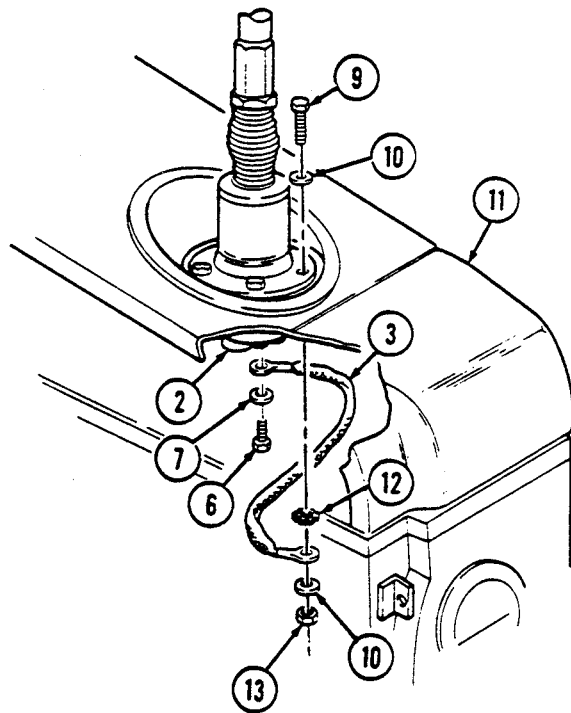

**M966, M966A1, M1025, M1025A1,
M1025A2, M1026, M1026A1, M1043,
M1043A1, M1043A2, M1044, M1044A1,
M1045, M1045A1, M1045A2, M1046,
M1046A1**

FOLLOW-ON TASKS: • Connect battery ground cable (para. 4-73).

M966, M966A1, M1025, M1025A1, M1025A2, M1026, M1026A1, M1043, M1043A1, M1043A2, M1044, M1044A1, M1045, M1045A1, M1045A2, M1046, and M1046A1 only:

- Lower cargo shell door (TM 9-2320-280-10).

12-137. AS 1729/VRC ANTENNA REPLACEMENT

This task covers:

a. Removal

b. Installation

INITIAL SETUP:

Applicable Models

All models except M996, M996A1, M1036, M1037, M1042, M1097, M1097A1, M1097A2

Tools

General mechanic's tool kit:
automotive (Appendix B, Item 1)

Materials/Parts

Three locknuts (Appendix G, Item 128)

Manual References

TM 9-2320-280-24P

Equipment Condition

Antenna ground strap removed (para. 12-136)
(except M997, M997A1, M997A2)

NOTE

Antenna replacement is basically the same for all models except the M998, M998A1, M1038, and M1038A1 which use an external antenna mounting bracket. This procedure covers the M966, M966A1, M997, M997A1, M997A2, M1025, M1025A1, M1025A2, M1026, M1026A1, M1035, M1035A1, M1035A2, M1043, M1043A1, M1043A2, M1044, M1044A1, M1045, M1045A1, M1045A2, M1046, and M1046A1 models.

a. Removal

1. Disconnect radio antenna cable (3) and antenna control cable (2) from antenna (1).
2. Remove three locknuts (6), washers (5), capscrews (4), washers (5), and antenna (1) from cargo shell (7). Discard locknuts (6).

b. Installation

1. Install antenna (1) on cargo shell (7) with three washers (5), capscrews (4), and locknuts (6). Tighten locknuts (6) to 26 lb-ft (35 N•m).
2. Connect antenna control cable (2) and radio antenna cable (3) on antenna (1).

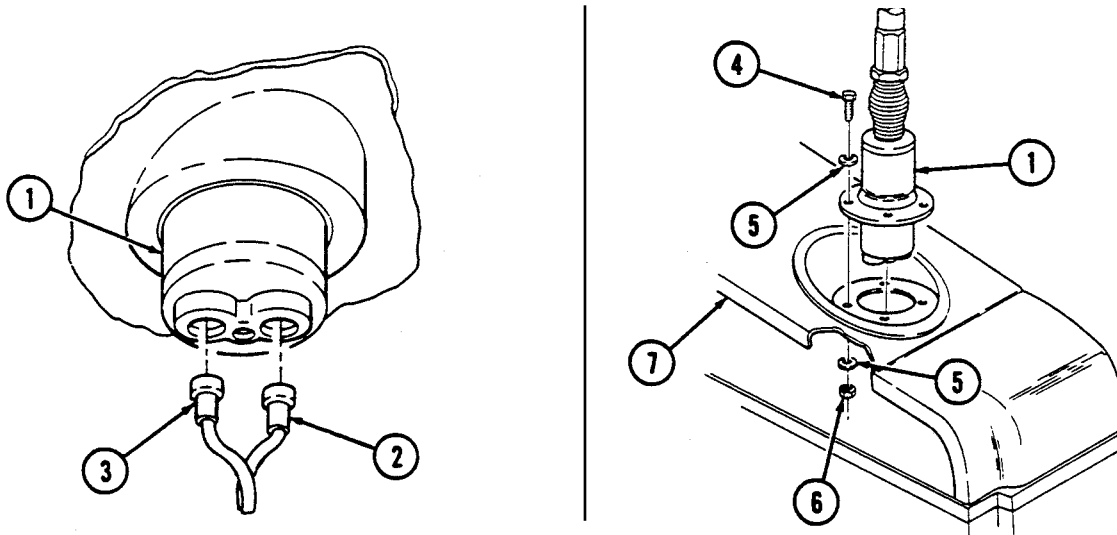

FOLLOW-ON TASK: Install antenna ground strap (para. 12-136).

12-138. REAR ANTENNA MOUNTING BRACKET REPLACEMENT

This task covers:

a. Removal

b. Installation

INITIAL SETUP:

Applicable Models

M998, M998A1, M1038, M1038A1

Tools

General mechanic's tool kit:
automotive (Appendix B, Item 1)

Special Tools

Crowfoot, 3/8 in. (Appendix B, Item 151)
Socket adapter, 3/8 in. (Appendix B, Item 146)

Materials/Parts

Three locknuts (Appendix G, Item 113)

Manual References

TM 9-2320-280-24P

Equipment Condition

- AS 1729/VRC antenna removed (para. 12-137) if installed.
- AB-652/GR antenna removed (para. 12-139) if installed.

a. Removal

1. Remove grommet (3).

NOTE

Note position of washers and clamp for installation.

2. Remove three locknuts (8), washers (7), capscrews (4), washers (5), antenna mounting bracket (2), and clamp (6) from body (1). Discard locknuts (8).

b. Installation

1. Install antenna mounting bracket (2) and clamp (6) on body (1) with three washers (5), capscrews (4), washers (7), and locknuts (8). Using crowfoot, tighten locknuts (8) to 15 lb-ft (20 N·m).
2. Install grommet (3).

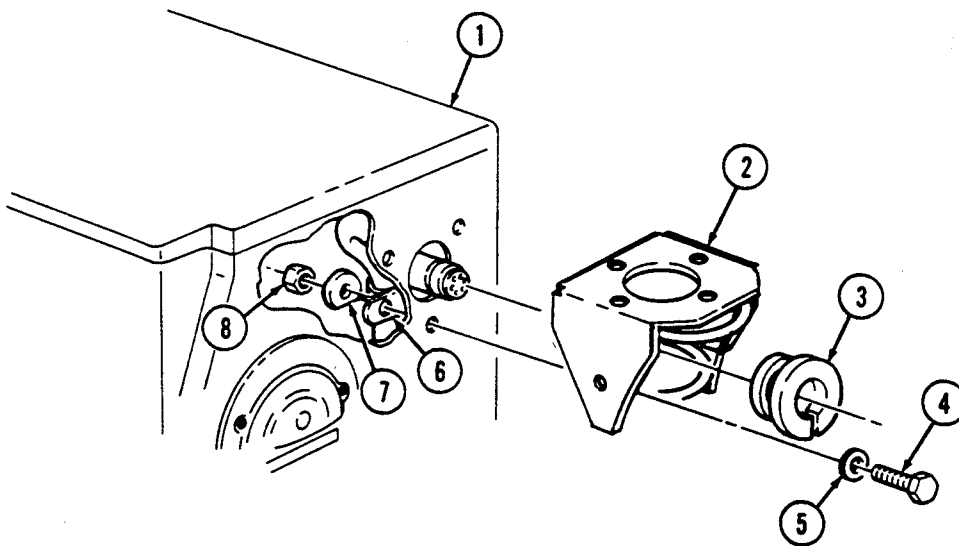

- FOLLOW-ON TASKS:**
- Install AS 1729/VRC antenna (para. 12-137) if removed.
 - Install AB-652/GR antenna (para. 12-139) if removed.

12-139. AB-652/GR ANTENNA REPLACEMENT

This task covers:

a. Removal

b. Installation

INITIAL SETUP:

Applicable Models

M998, M998A1, M1038, M1038A1

Tools

General mechanic's tool kit:
automotive (Appendix B, Item 1)

Materials/Parts

Four locknuts (Appendix G, Item 128)

Manual References

TM 9-2320-280-24P

Equipment Condition

Battery ground cable disconnected
(para. 4-73).

a. Removal

1. Disconnect antenna cable (7) from adapter (8).
2. Loosen ground clamp (9) and remove from adapter (8).
3. Remove adapter (8) from lower insulator (10).
4. Remove antenna (1), rubber washer (13), ground ring (12), rubber washer (11), and lower insulator (10) from antenna mounting bracket (5).
5. Remove four locknuts (6), washers (3), capscrews (2), washers (3), and adapter (4) from antenna mounting bracket (5). Discard locknuts (6).

b. Installation

1. Install adapter (4) on antenna mounting bracket (5) with four washers (3), capscrews (2), washers (3), and locknuts (6).
2. Install lower insulator (10), rubber washer (11), ground ring (12), rubber washer (13), and antenna (1) on mounting bracket (5).
3. Install adapter (8) on lower insulator (10).
4. Install ground clamp (9) on adapter (8) and tighten.
5. Connect antenna cable (7) to adapter (8).

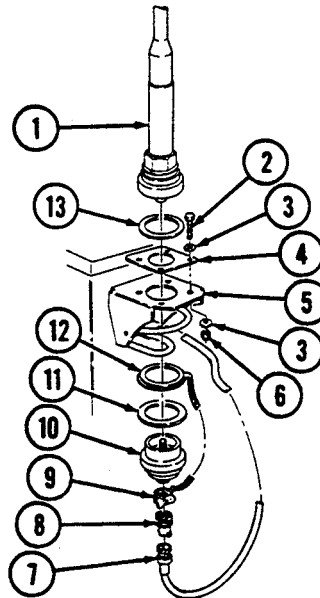

FOLLOW-ON TASK: Connect battery ground cable (para. 4-73).

12-140. REAR ANTENNA CABLES REPLACEMENT

This task covers:

a. Removal

b. Installation

INITIAL SETUP:

Applicable Models

All models except M996, M996A1, M997, M997A1, M997A2, M1037, M1042, M1097, M1097A1, M1097A2

Tools

General mechanic's tool kit:
automotive (Appendix B, Item 1)

Materials/Parts

Two tiedown straps (Appendix G, Item 307)
Nine plain-assembled nuts
(Appendix G, Item 201)
Four assembled locknuts (Appendix G, Item 130)
Two lockwashers (Appendix G, Item 146)
Locknut (Appendix G, Item 70)

Personnel Required

One mechanic
One assistant

Manual References

TM 9-2320-280-10
TM 9-2320-280-24P

Equipment Condition

- Battery ground cable disconnected (para. 4-73).
 - Right rear passenger seat back removed (para. 10-45).
 - Dual TSEC/KY-57 mounting bracket and control switch bracket removed (para. 12-134) if installed.
 - Front floorboard removed (para. 11-154).
- M966, M966A1, M1025, M1025A1, M1025A2, M1026, M1026A1, M1043, M1043A1, M1043A2, M1044, M1044A1, M1045, M1045A1, M1045A2, M1046, and M1046A1 models only:
- Cargo shell door raised (TM 9-2320-280-10).

NOTE

- Left and right rear antenna cables are replaced basically the same, except the left antenna cables have an additional six clamps securing cables across rear of vehicle. This procedure covers the right rear antenna cables.
- Perform steps 1 through 5 for front radio rack, and steps 6 and 7 for rear radio rack.

a. Removal

1. Remove two tiedown straps (6) from antenna cables (4). Discard tiedown straps (6).
2. Remove two plain-assembled nuts (5), screws (2), two clamps (3), and antenna cables (4) from front radio rack (1). Discard plain-assembled nuts (5).
3. Remove plain-assembled nut (11), capscrew (8), clamp (9) from two antenna cables (4), and grommet (10). Discard plain-assembled nut (11).
4. Remove two screws (12) and insulation retainer (13) from cargo floor (7) and pull away from cargo floor (7).
5. Remove three screws (26), clamps (27), and two antenna cables (4) from body (19).
6. Remove two capscrews (23), washers (24), clamps (25), and antenna cables (18) from rear radio rack (22) and cargo floor (7).
7. Remove two screws (20), clamps (21), and antenna cables (18) from body (19) and remove clamps (21) from antenna cables (18).
8. Remove plain-assembled nut (28), screw (17), and clamp (29) from two antenna cables (4) and body (19). Discard plain-assembled nut (28).
9. Remove two assembled locknuts (14), capscrews (30), antenna cables (4), grommet (16), and retainer (15) from body (19). Discard assembled locknuts (14).

12-140. REAR ANTENNA CABLES REPLACEMENT (Cont'd)

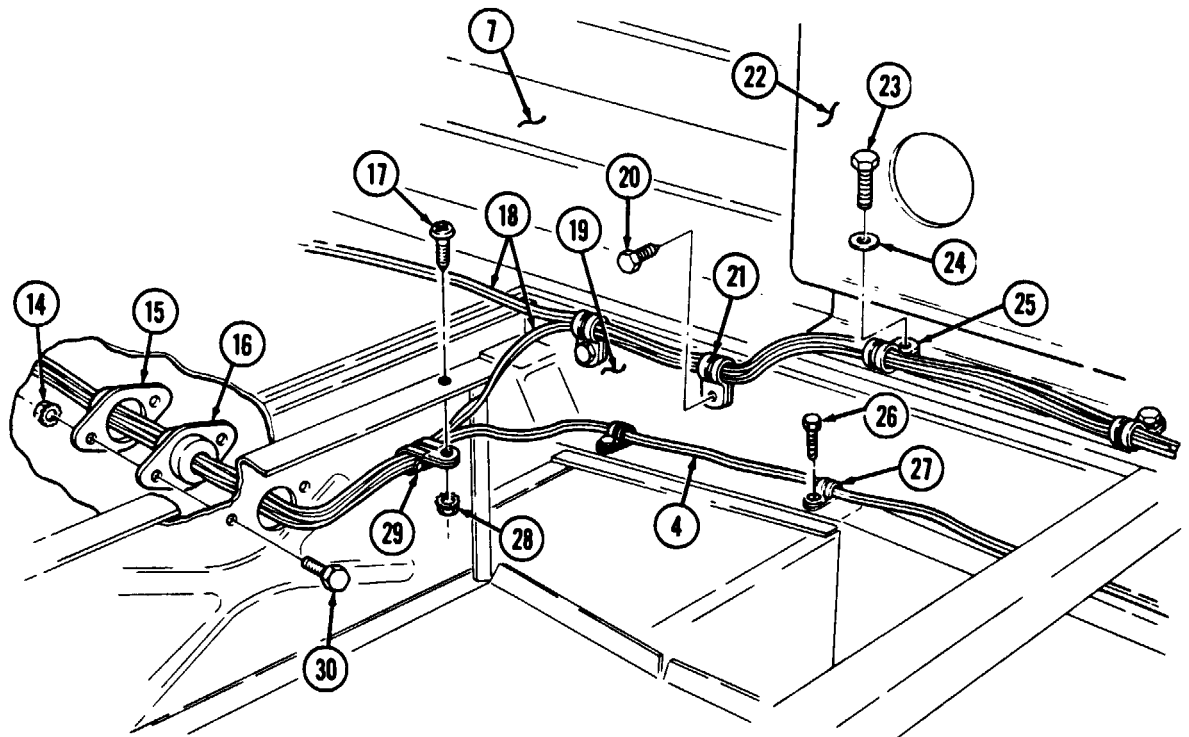
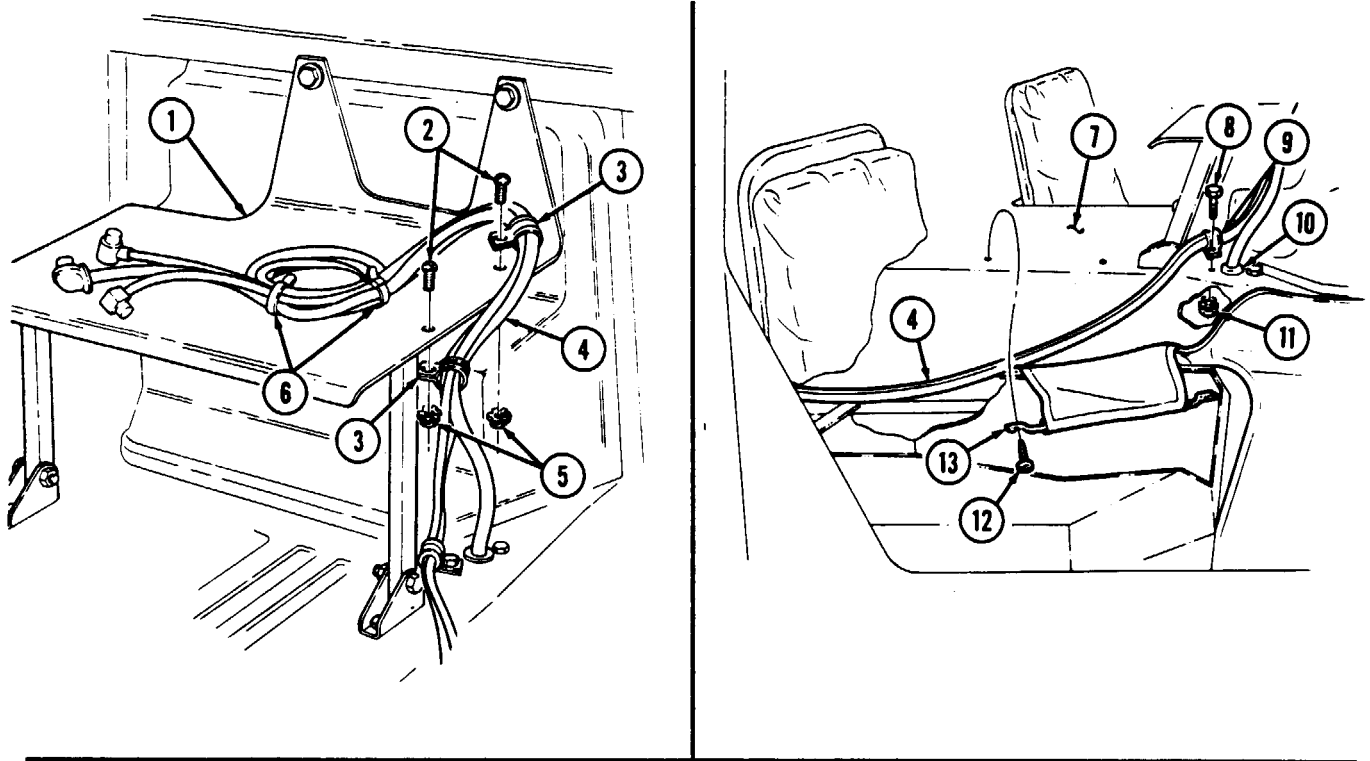

12-140. REAR ANTENNA CABLES REPLACEMENT (Cont'd)

10. Remove five screws (7), clamps (3), and two antenna cables (1) from underbody (2).
11. Remove locknut (5), washer (4), capscrew (9), washer (4), and filler pipe clamp (8) from underbody (2) and filler pipe (6). Discard locknut (5).

NOTE

Perform steps 12 through 15 for M966, M966A1, M1025, M1025A1, M1025A2, M1026, M1026A1, M1043, M1043A1, M1043A2, M1044, M1044A1, M1045, M1045A1, M1045A2, M1046, and M1046A1 models only.

12. Remove two plain-assembled nuts (10), screws (12), clamps (11), and antenna cables (1) from wheelhouse (13). Discard plain-assembled nuts (10).
13. Remove two assembled locknuts (18), capscrews (15), two antenna cables (1), grommet (17), and retainer (16) from wheelhouse (13). Discard assembled locknuts (18).
14. Disconnect two antenna cables (1) from antenna base (14) and remove antenna cables (1).
15. Remove ten clamps (3) and two clamps (11) from antenna cables (1).

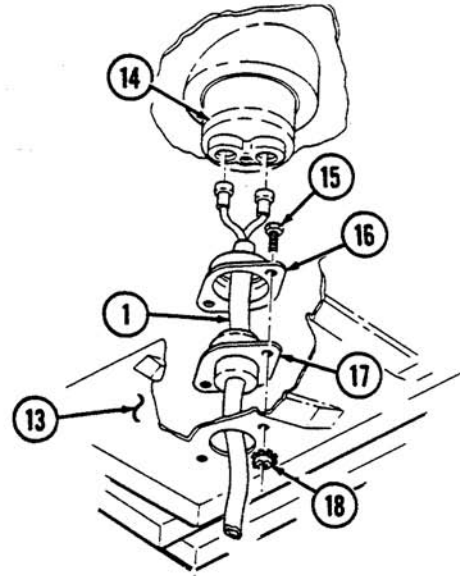
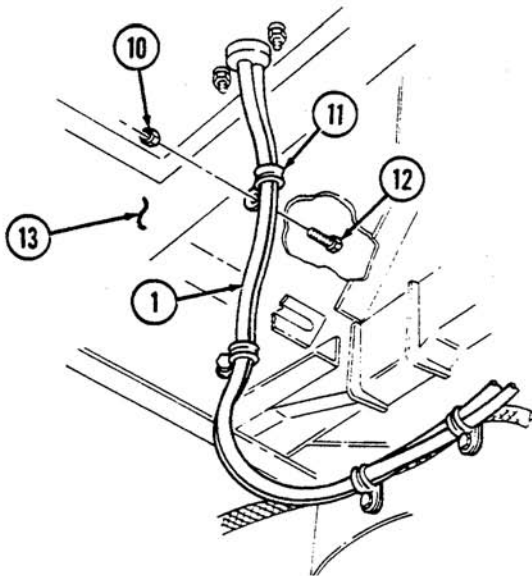
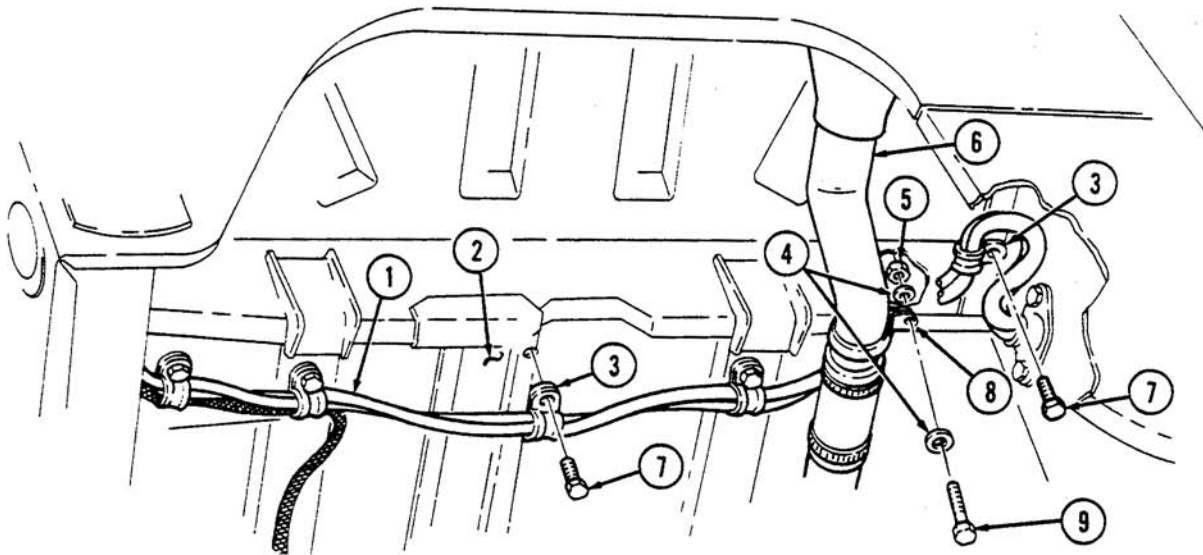

12-140. REAR ANTENNA CABLES REPLACEMENT (Cont'd)

NOTE

Perform steps 16 through 22 for M998, M998A1, M1038, and M1038A1 models only.

16. Remove plain-assembled nut (23), capscrew (25), clamp (26), two antenna cables (1), and body harness (24) from body (22). Discard plain-assembled nut (23).
17. Remove two capscrews (28) and lockwashers (27) from cable shield (21) and body (22). Pull cable shield (21) away from body (22) to allow access to clamps (30). Discard lockwashers (27).
18. Remove two plain-assembled nuts (29), capscrews (20), clamps (30), antenna cables (1), and body harness (24) from cable shield (21). Discard plain-assembled nuts (29).

NOTE

Note position of clamp for installation.

19. Remove nut (18), clamp (31), and two antenna cables (1) from antenna mounting bracket cap-screw (19).
20. Disconnect two antenna cables (1) from antenna base (14), and push grommet (33) and antenna cables (1) through grommet opening (32) in body (22). Remove grommet (33) from antenna cables (1).
21. Remove antenna cables (1).
22. Remove clamps from two antenna cables (1) and body harness (24) as required.

b. Installation

1. Install two antenna cables (1) in approximate mounting location.
2. Install clamps and grommet (33) on two antenna cables (1) and body harness (24) as required.

NOTE

Perform steps 3 through 8 for M998, M998A1, M1038, and M1038A1 models only.

3. Insert antenna cables (1) through grommet opening (32) and install grommet (33) in body (22).
4. Connect antenna cables (1) to antenna base (14).
5. Install two antenna cables (1) on antenna mounting bracket cap-screw (19) with clamp (31) and nut (18).
6. Install two antenna cables (1) and body harness (24) on shield (21) with two clamps (30), capscrews (20), and plain-assembled nuts (29).
7. Install shield (21) on body (22) with two lockwashers (27) and capscrews (28).
8. Secure two antenna cables (1) and body harness (24) to body (22) with clamp (26), capscrew (25), and plain-assembled nut (23).

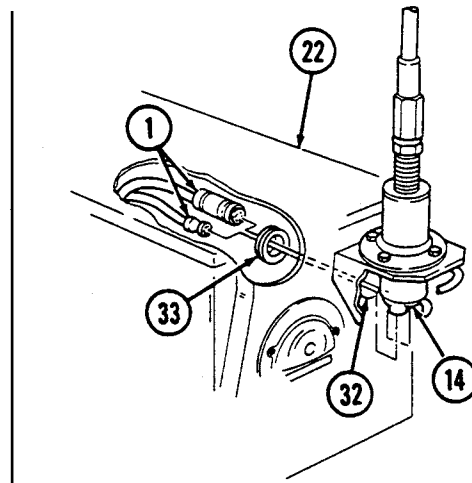
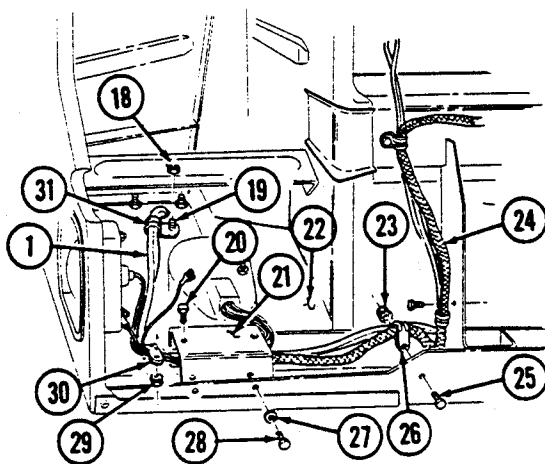

12-140. REAR ANTENNA CABLES REPLACEMENT (Cont'd)

NOTE

Perform steps 9 through 12 for M966, M966A1, M1025, M1025A1, M1025A2, M1026, M1026A1, M1043, M1043A1, M1043A2, M1044, M1044A1, M1045, M1045A1, M1045A2, M1046, and M1046A1 models only.

9. Connect two antenna cables (4) to antenna base (1).
10. Install grommet (5) and retainer (7) on antenna cables (4).
11. Install two antenna cables (4), grommet (5), and retainer (7) on wheelhouse (6) with two capscrews (2) and assembled locknuts (3).
12. Install two antenna cables (4) on wheelhouse (6) with two clamps (9), screws (10), and plain-assembled nuts (8).
13. Install two antenna cables (4) on underbody (12) with clamp (11) and screw (23).
14. Position clamp (20) over yellow locator tape (22) on two antenna cables (4) and install on underbody (12) with screw (21).
15. Secure two antenna cables (4) to underbody (12) with three clamps (16) and screws (15).
16. Install clamp (17) on filler spout (19) and underbody (12) with washer (13), capscrew (18), washer (13), and locknut (14).

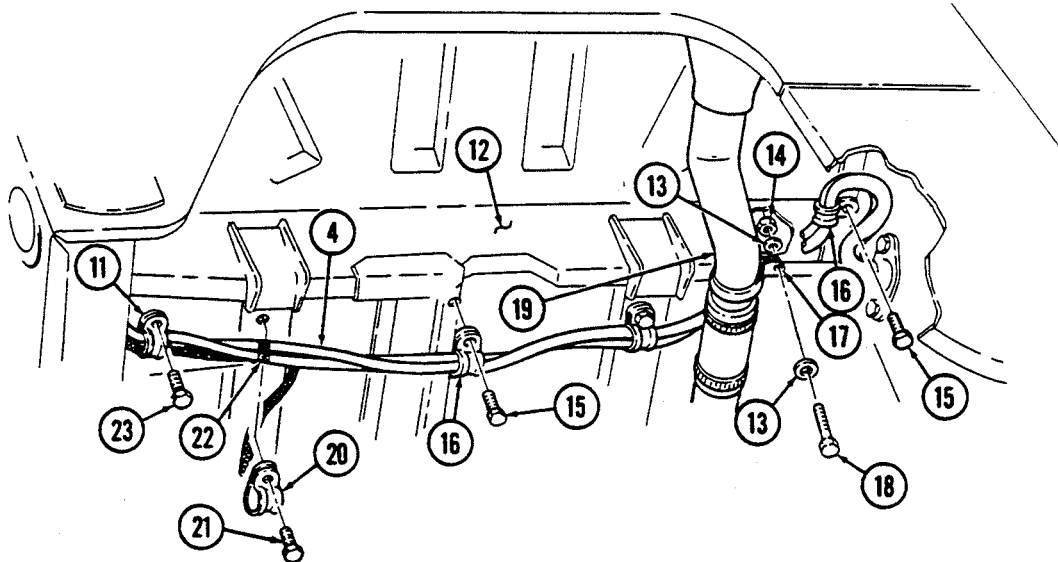
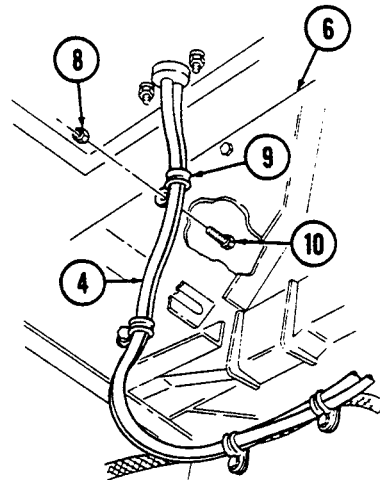
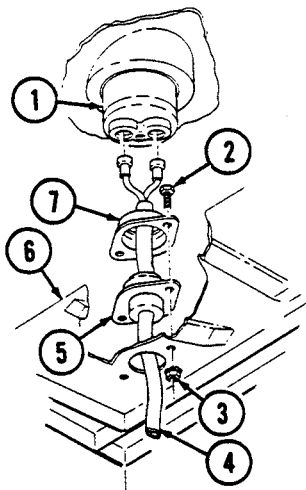

12-140. REAR ANTENNA CABLES REPLACEMENT (Cont'd)

17. Install grommet (25) and retainer (24) on two antenna cables (4).
18. Install two antenna cables (4), grommet (25), and retainer (24) on body (28) with two capscrews (40) and assembled locknuts (41).
19. Install two antenna cables (4) on body (28) with clamp (26), screw (27), and plain-assembled nut (39).

NOTE

Perform steps 20 and 21 for rear radio rack, and steps 22 through 27 for front radio rack.

20. Install antenna cables (29) and (32) on body (28) with two clamps (31) and screws (30).
21. Install antenna cables (29) and (32) on rear radio rack (36) with two clamps (35), washers (34), and capscrews (33). Tighten capscrews (33) to 15 lb-ft (20 N•m).
22. Secure two antenna cables (4) to body (28) with three clamps (38) and screws (37).

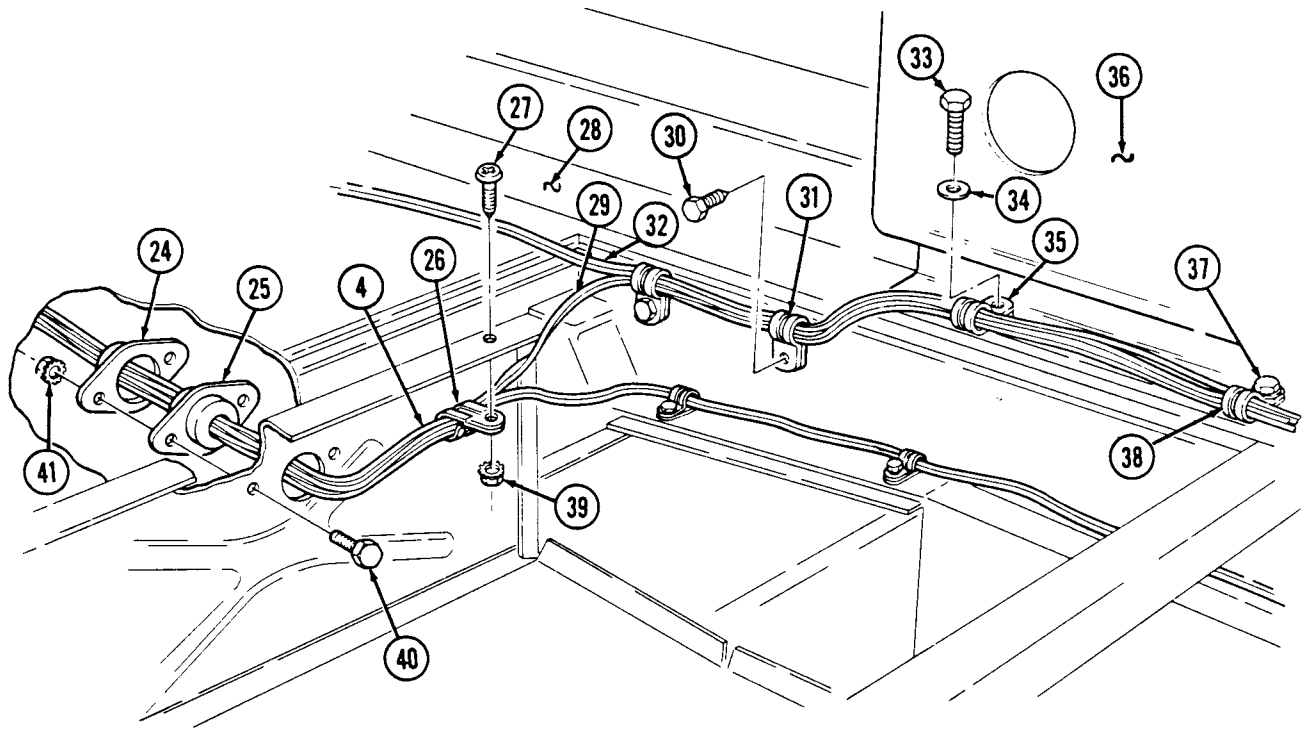

12-140. REAR ANTENNA CABLES REPLACEMENT (Cont'd)

23. Route two antenna cables (9) under insulation (6) along cargo floor (1).
24. Install insulation retainer (8) on cargo floor (1) with two screws (7).
25. Install two antenna cables (9) and grommet (4) on cargo floor (1) with clamp (2), capscrew (3), and plain-assembled nut (5).
26. Install two antenna cables (9) and power cable (14) on front radio rack (10) with two clamps (12), screws (11), and plain-assembled nuts (13).
27. Secure two antenna cables (9) to radio power cable (14) with two tiedown straps (15).

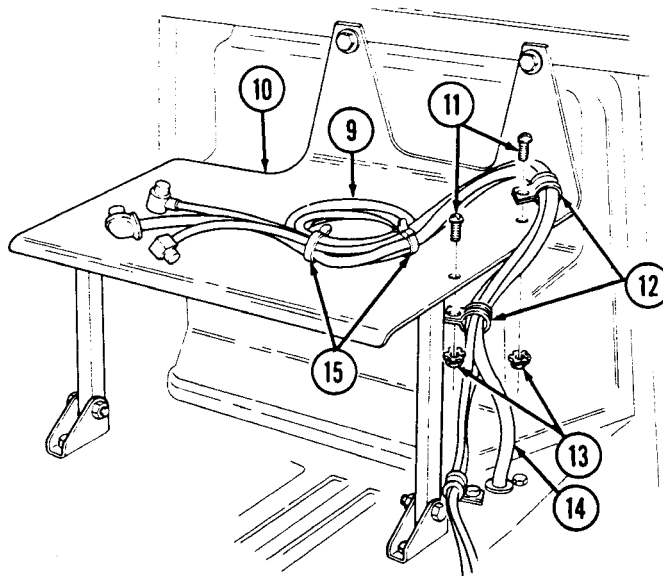
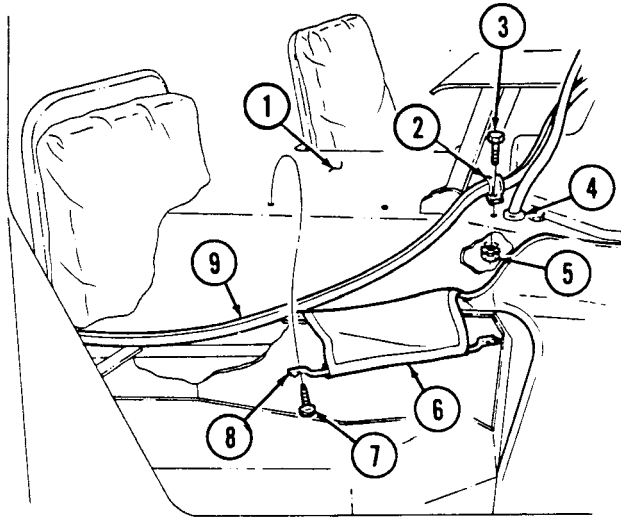

- FOLLOW-ON TASKS:**
- Install right rear passenger seat back (para. 10-45).
 - Connect battery ground cable (para. 4-73).
 - Install dual TSEC/KY-57 mounting bracket and control switch bracket (para. 12-134), if removed.
 - Install front floorboard (para. 11-154).
M966, M966A1, M1025, M1025A1, M1025A2, M1026, M1026A1, M1043, M1043A1, M1043A2, M1044, M1044A1, M1045, M1045A1, M1045A2, M1046, and M1046A1 models only:
 - Lower cargo shell door (TM 9-2320-280-10).

12-141. FRONT RADIO RACK POWER CABLE REPLACEMENT

This task covers:

a. Removal

b. Installation

INITIAL SETUP:

Applicable Models

All models except M996, M996A1, M997, M997A1, M997A2, M1037, M1042, M1097, M1097A1, M1097A2, M1123

Tools

General mechanic's tool kit:
automotive (Appendix B, Item 1)

Materials/Parts

Two plain-assembled nuts (Appendix G, Item 201)
Lockwasher (Appendix G, Item 165)
Two tiedown straps (Appendix G, Item 307)
Two locknuts (Appendix G, Item 78)
Lockwasher (Appendix G, Item 178)
Two assembled locknuts (Appendix G, Item 130)

Manual References

TM 9-2320-280-24P

Equipment Condition

Battery ground cable disconnected (para. 4-73).

a. Removal

1. Remove two tiedown straps (16) from power cable (9) and antenna cables (4). Discard tiedown straps (16).
2. Remove two plain-assembled nuts (8), screws (5) clamps (7), and power cable (9) from radio rack (1). Discard plain-assembled nuts (8).
3. Remove two capscrews (2) and washers (3) from radio rack (1) and "A" beam (6). Pull radio rack (1) away from "A" beam (6).

NOTE

Perform step 3.1 for vehicles with new configuration.

- 3.1. Remove two locknuts (29), washers (28), radio rack (1), capscrews (26), washers (27), and radio rack upper brackets (30) from "A" beam (6). Discard locknuts (29).
4. Remove engine access cover (para. 10-15).
5. Remove two assembled locknuts (12) and capscrews (15) from clamp (14), retainer (11), grommet (10), power cable (9), and body (13). Discard assembled locknuts (12).
6. Remove nut (20), lockwasher (19), washer (18), and positive lead (17) from stud (25). Discard lockwasher (19).
7. Remove nut (21), lockwasher (22), and negative lead (23) from shunt (24). Discard lockwasher (22).
8. Remove power cable (9).

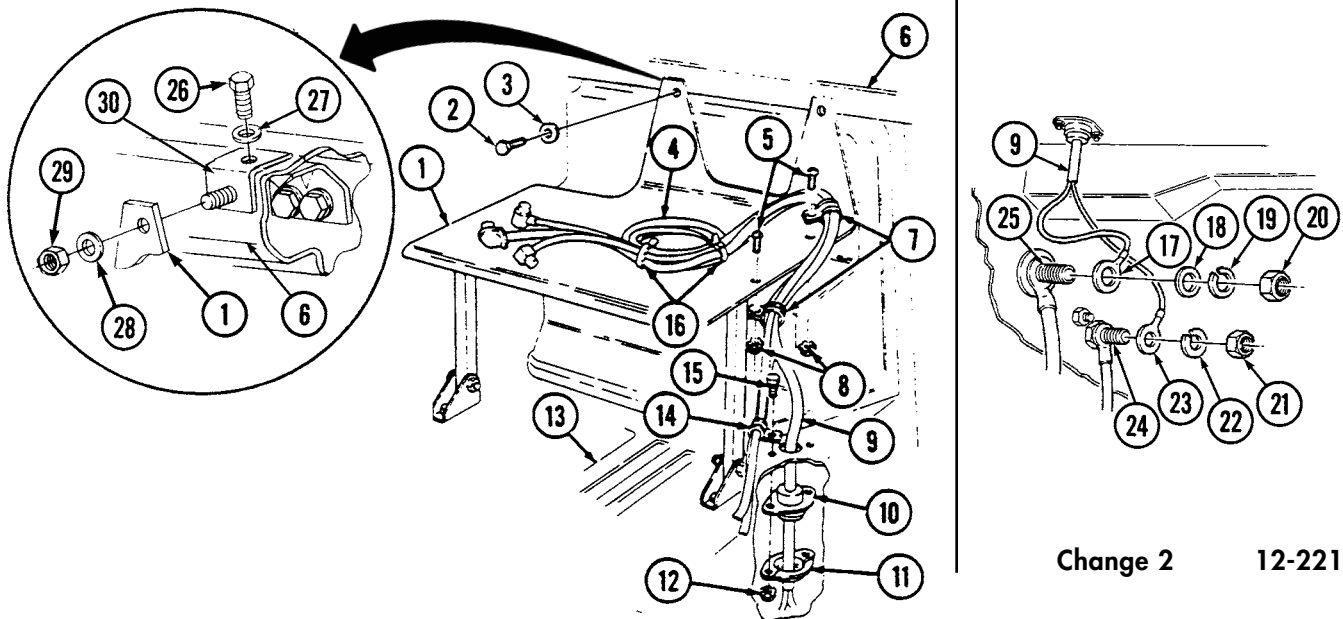

12-141. FRONT RADIO RACK POWER CABLE REPLACEMENT (Cont'd)

b. Installation

1. Position power cable (9) in approximate location.
2. Install negative lead (23) to shunt (24) with lockwasher (22) and nut (21). Tighten nut (21) to 75 lb-ft (102 N·m).
3. Install positive lead (17) on power stud (25) with washer (18), lockwasher (19), and nut (20). Tighten nut (20) to 26 lb-ft (35 N·m).
4. Install grommet (10), retainer (11), clamp (14), and power cable (9) on body (13) with two capscrews (15) and assembled locknuts (12). Tighten capscrews (15) to 5 lb-ft (7 N·m).
5. Install engine access cover (para. 10-15).

NOTE

Perform step 5.1 for vehicles with new configuration.

- 5.1. Install radio rack (1) and two radio rack upper brackets (30) on "A" beam (6) with two washers (28), locknuts (29), washers (27), and capscrew (26).
6. Install radio rack (1) on "A" beam (6) with two washers (3) and capscrews (2). Tighten capscrews (2) to 6 lb-ft (8 N·m).
7. Install power cable (9) on antenna cables (4) with two tiedown straps (16).
8. Install power cable (9) on radio rack (1) with two clamps (7), screws (5), and plain-assembled nuts (8).

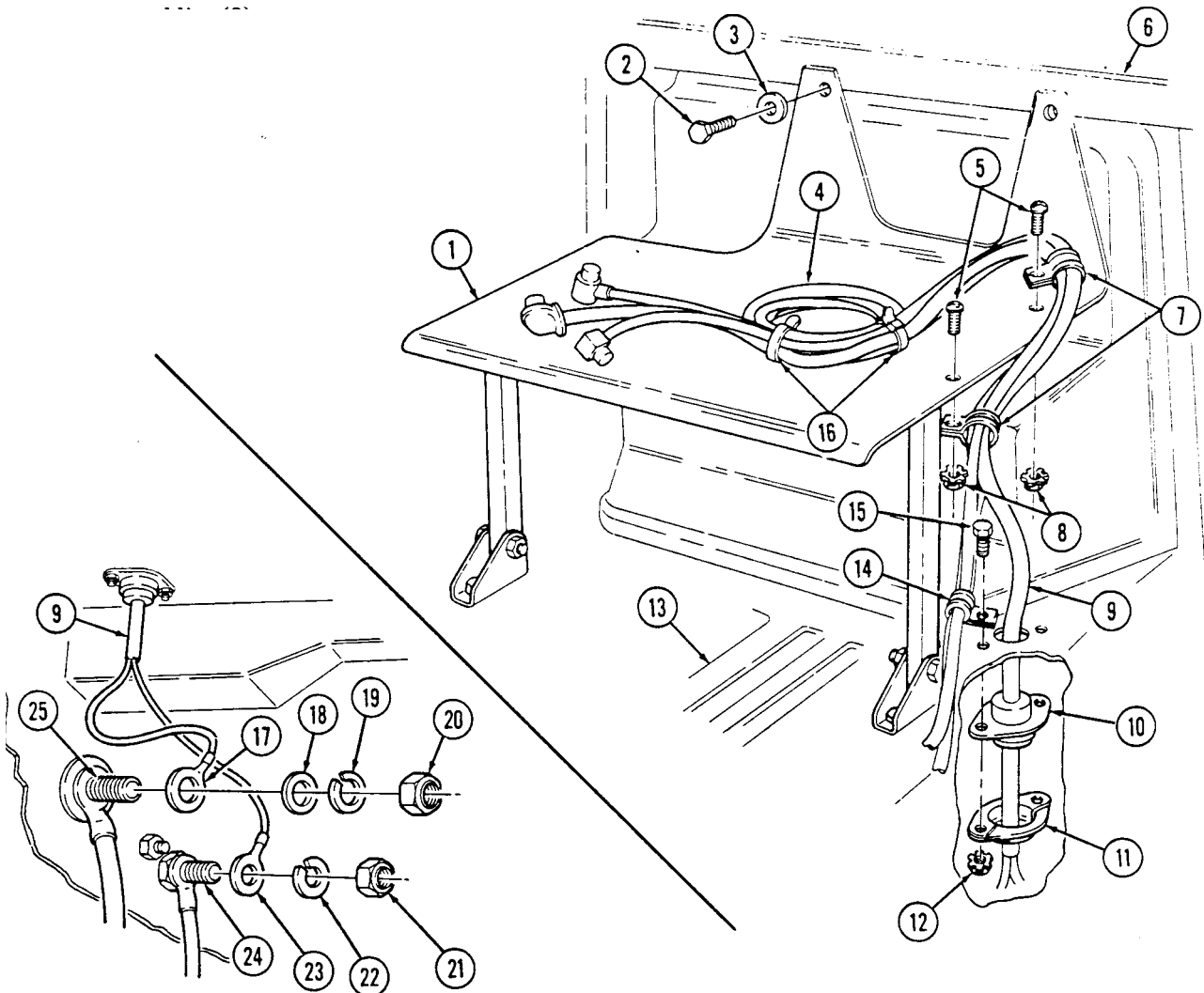

12-141. FRONT RADIO RACK POWER CABLE REPLACEMENT (6n1'd)

NEW CONFIGURATION

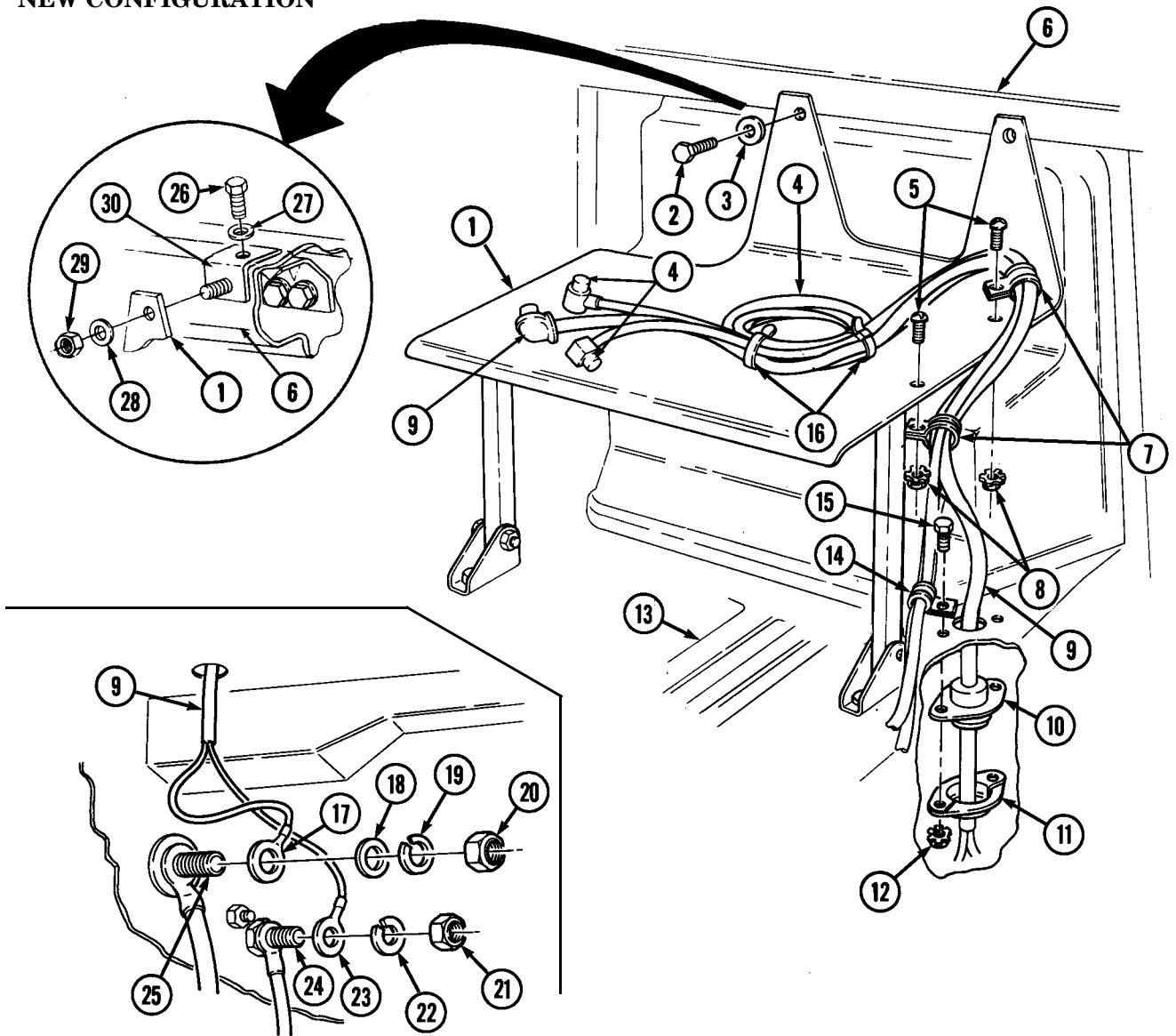

FOLLOW-ON TASK: Connect battery ground cable (para. 4-73).

12-142. HEADPHONE MOUNTING BRACKET REPLACEMENT

This task covers:

a. Removal

b. Installation

INITIAL SETUP:**Tools**

General mechanic's tool kit:
automotive (Appendix B, Item 1)

Manual References

TM 9-2320-280-24P

Materials/Parts

Two locknuts (Appendix G, Item 70)

a. Removal

Remove two locknuts (4), washers (3), screws (1), and headphone mounting bracket (5) from radio rack (2). Discard locknuts (4).

b. Installation

Install headphone mounting bracket (5) on radio rack (2) with two screws (1), washers (3), and locknuts (4). Tighten locknuts (4) to 6 lb-ft (8 N•m).

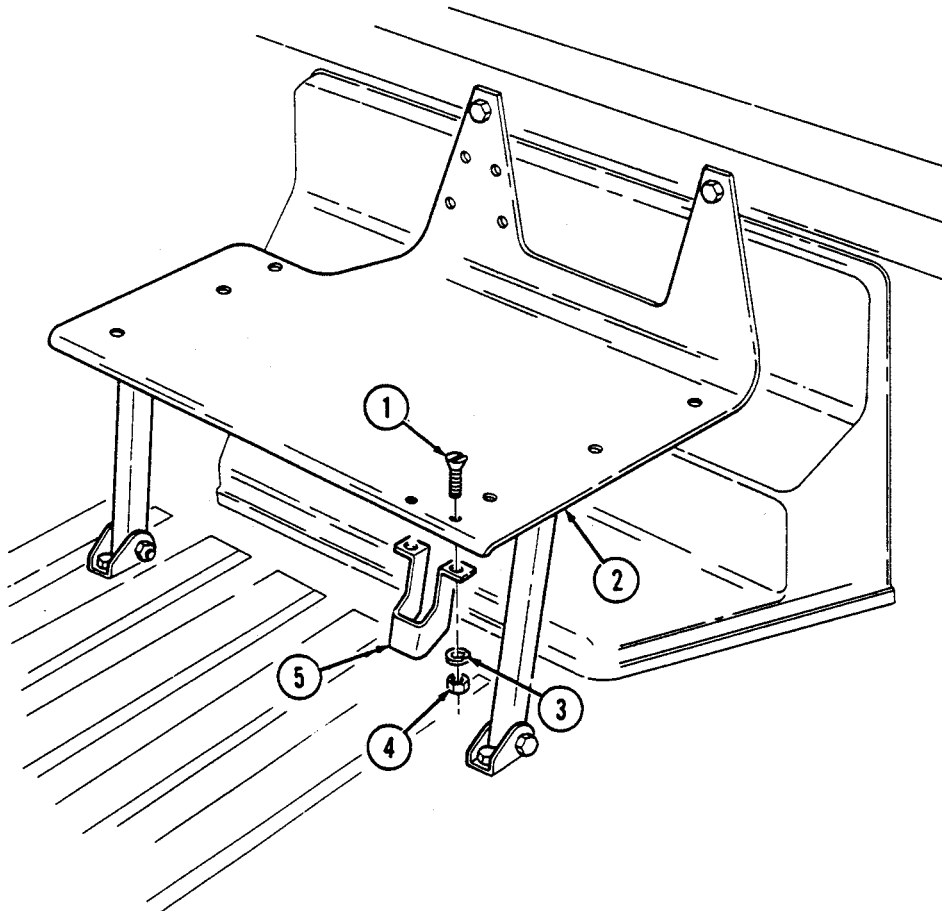

12-143. HANDSET BRACKET REPLACEMENT

This task covers:

a. Removal

b. Installation

INITIAL SETUP:

Applicable Models

M998, M998A1, M1038, M1038A1

Materials/Parts

Two locknuts (Appendix G, Item 70)

Tools

General mechanic's tool kit:
automotive (Appendix B, Item 1)

Manual References

TM 9-2320-280-24P

a. Removal

Remove two locknuts (5), washers (3), capscrews (2), washers (3), and handset bracket (4) from upper shelf (1). Discard locknuts (5).

b. Installation

Install handset bracket (4) on upper shelf (1) with two washers (3), capscrews (2), washers (3), and locknuts (5). Tighten locknuts (5) to 8 lb-ft (11 N·m).

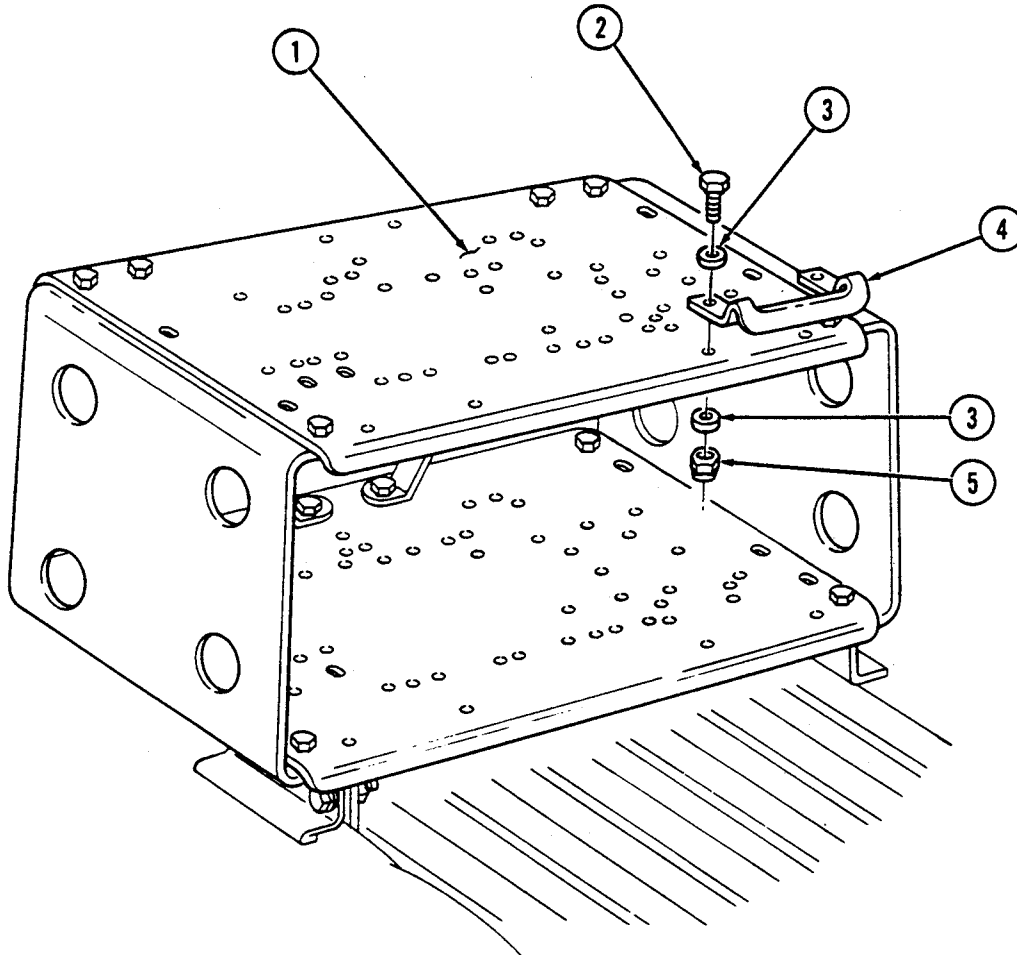

12-144. REAR RADIO RACK MAINTENANCE

This task covers:

- | | |
|----------------|-----------------|
| a. Removal | c. Assembly |
| b. Disassembly | d. Installation |

INITIAL SETUP:

Applicable Models

M998, M998A1, M1038, M1038A1

Manual References

TM 9-2320-280-24P

Tools

General mechanic's tool kit:
automotive (Appendix B, Item 1)

Equipment Condition

- Speaker stop removed (para. 12-135) if installed.
- Handset brackets removed (para. 12-143).

Materials/Parts

Fifteen locknuts (Appendix G, Item 79)
Three locknuts (Appendix G, Item 70)

a. Removal

1. Remove two locknuts (9), washers (10), capscrews (12), washers (10), and insulation retainer (11) from radio rack (2). Discard locknuts (9).
2. Remove two screws (16), retainer (15), and insulation (14) from cargo floor (8) and left brace (13), and pull insulation (14) and two left antenna cables (1), if present, away from radio rack (2).
3. Remove two locknuts (7), washers (4), capscrews (5), washers (4), power cable (3), and two clamps (6) from radio rack (2). Discard locknuts (7).

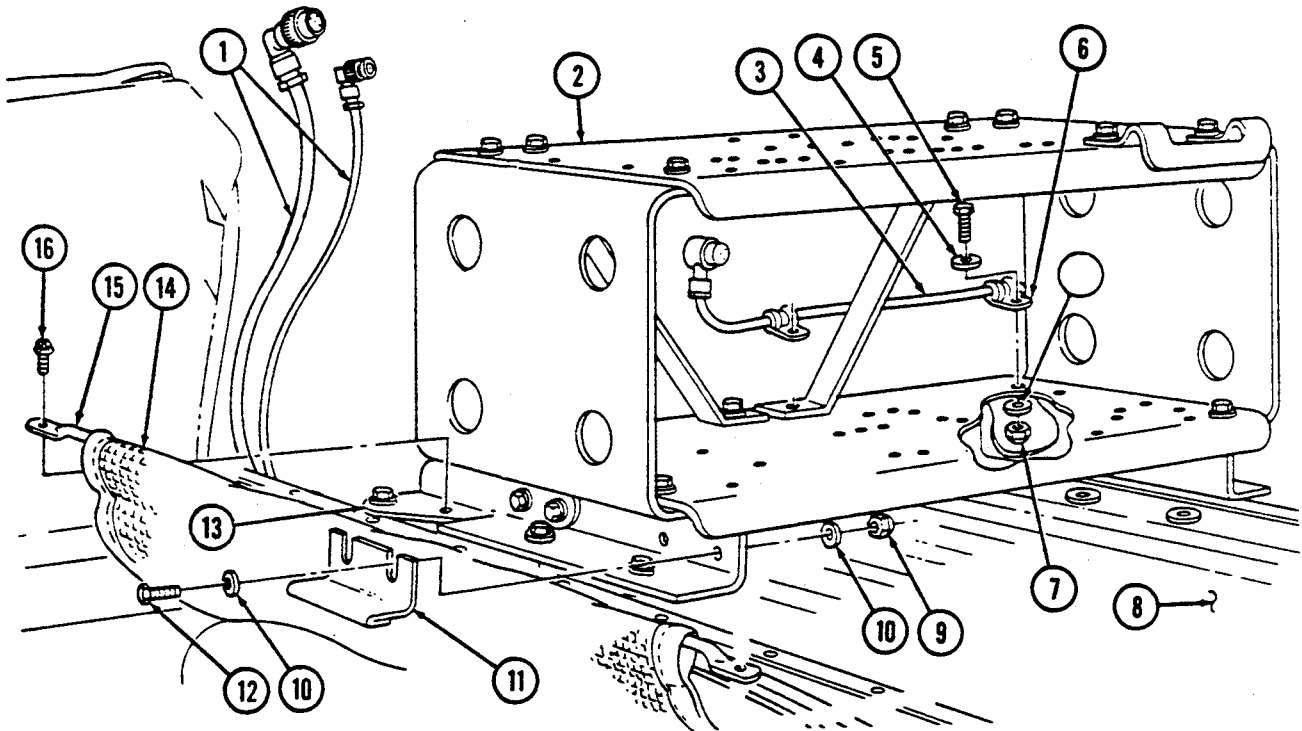

12-144. REAR RADIO RACK MAINTENANCE (Cont'd)

4. Remove two capscrews (36), washers (37), antenna cables (14), clamps (38), and radio rack (17) from cargo floor (23).
5. Remove two capscrews (35), washers (34), cargo tiedowns (33), and radio rack braces (29) from cargo floor (23).
6. Remove two capscrews (16), washers (15), and radio rack (17) from cargo floor (23).

b. Disassembly

1. Remove four locknuts (7), washers (8), capscrews (10), washers (8), and two braces (9) from supports (6). Discard locknuts (7).
2. Remove three locknuts (12), washers (4), capscrews (3), washers (4), and two braces (13) from shelves (5). Discard locknuts (12).
3. Remove seven locknuts (11), washers (1), capscrews (2), washers (1), and two shelves (5) from supports (6). Discard locknuts (11).

c. Assembly

NOTE

Assemble shelves to supports with holes designated "A" facing in the same direction.

1. Install two shelves (5) on supports (6) with seven washers (1), capscrews (2), washers (1), and locknuts (11). Tighten locknuts (11) to 15 lb-ft (20 NŹm).
2. Install two braces (13) on shelves (5) with three washers (4), capscrews (3), washers (4), and locknuts (12). Tighten locknuts (12) to 8 lb-ft (11 NŹm).
3. Install two braces (9) on supports (6) with four washers (8), capscrews (10), washers (8), and locknuts (7). Do not tighten locknuts (7).

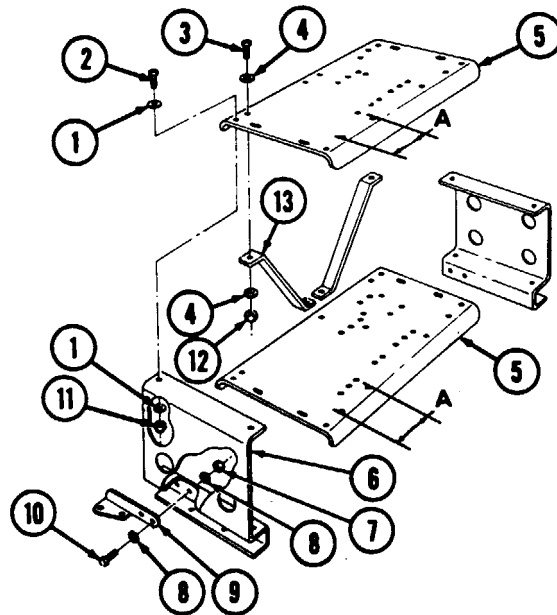

12-144. REAR RADIO RACK MAINTENANCE (Cont'd)

d. Installation

1. Install radio rack (17) on cargo floor (23) with two washers (15) and capscrews (16). Do not tighten capscrews (16).
2. Secure two radio rack braces (29) to cargo floor (23) with two cargo tiedowns (33), washers (34), and capscrews (35). Do not tighten capscrews (35).
3. Install two clamps (38) and antenna cables (14) on radio rack (17) with two washers (37) and capscrews (36).
4. Tighten capscrews (36) and (16) securely. Tighten capscrews (26) to 15 lb-ft (20 NŹm). Tighten capscrews (35) to 65 lb-ft (88 NŹm).
5. Install two clamps (21) and power cable (18) on radio rack (17) with two washers (19), capscrews (20), washers (19), and locknuts (22). Tighten capscrews (20) to 15 lb-ft (20 NŹm).
6. Ensure left antenna cable(s) (14), if present, are routed under insulation (30). Install retainer (31) and insulation (30) on cargo floor (23) and left brace (29) with two screws (32).
7. Install insulation retainer (27) on radio rack (17) with two washers (25), capscrews (28), washers (25), and locknuts (24). Tighten capscrews (28) to 15 lb-ft (20 NŹm).

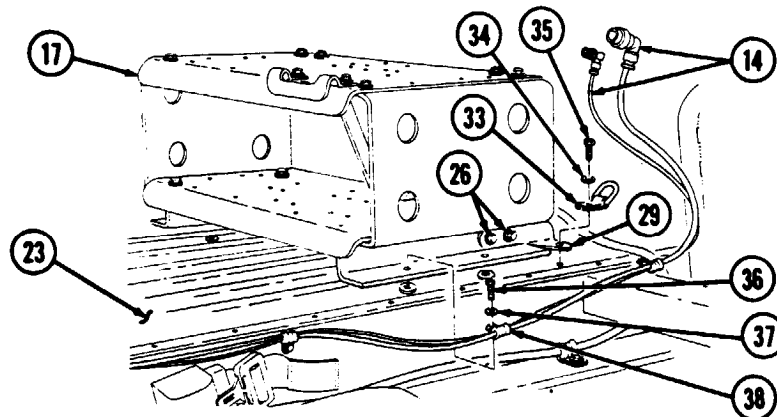
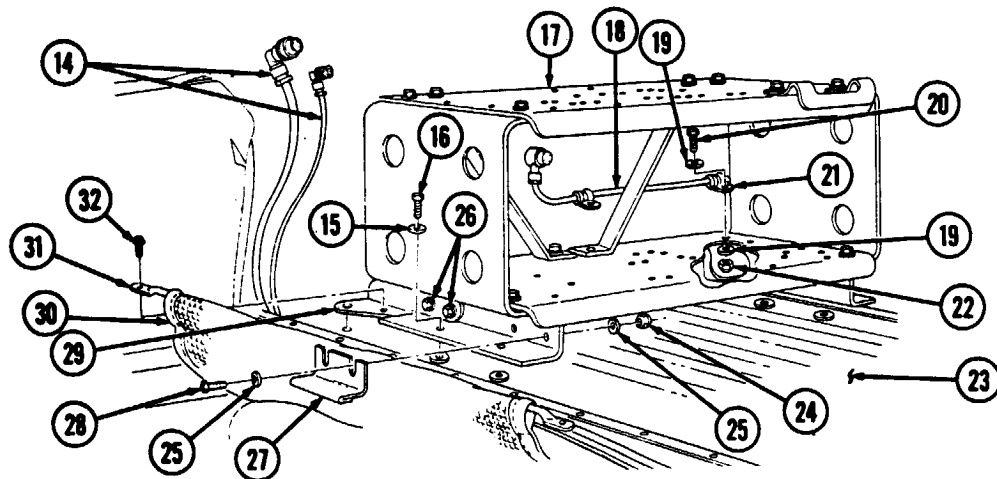

FOLLOW-ON TASK: \checkmark Install handset brackets (para. 12-143).
 \checkmark Install speaker stop (para. 12-135) if removed.

12-145. REAR RADIO RACK ANTENNA TOWER MAINTENANCE

This task covers:

- | | |
|----------------|-----------------|
| a. Removal | c. Assembly |
| b. Disassembly | d. Installation |

INITIAL SETUP:

Applicable Models

M998, M998A1, M1038, M1038A1

Manual References

TM 9-2320-280-24P

Tools

General mechanic's tool kit:
automotive (Appendix B, Item 1)

Equipment Condition

Antenna removed (para. 12-137 or 12-139).

Materials/Parts

Ten lockwashers (Appendix G, Item 135)

a. Removal

1. Remove three nuts (12), lockwashers (13), three clamps (14), and two antenna cables (17) from capscrews (2). Discard lockwashers (13).

NOTE

If cargo soft top is installed, it will be necessary to unfasten and roll up side for access to antenna tower mounting hardware.

2. Remove three nuts (11), washers (10), capscrews (18), washers (10), from tower (4) and wheelhouse (7).
3. Remove two nuts (9), washers (6), half moon washers (8), capscrews (5), washers (6), and tower (4) from wheelhouse (7).

b. Disassembly

Remove seven nuts (15), lockwashers (16), washers (3), capscrews (2), washers (3), and reinforcement (1) from tower (4). Discard lockwashers (16).

c. Assembly

Install reinforcement (1) on tower (4) with seven washers (3), capscrews (2), washers (3), lockwashers (16), and nuts (15). Tighten nuts (15) to 5 lb-ft (7 N•m).

d. Installation

1. Install antenna tower (4) on wheelhouse (7) with two washers (6), capscrews (5), half moon washers (8), washers (6), and nuts (9). Tighten nuts (9) to 5 lb-ft (7 N•m).
2. Secure antenna tower (4) to wheelhouse (7) with three washers (10), capscrews (18), washers (10), and nuts (11). Tighten nuts (11) to 45 lb-ft (61 N•m).
3. Install two antenna cables (17) on wheelhouse (7) and capscrews (2) with three clamps (14), lockwashers (13), and nuts (12).

12-145. REAR RADIO RACK ANTENNA TOWER MAINTENANCE (Cont'd)

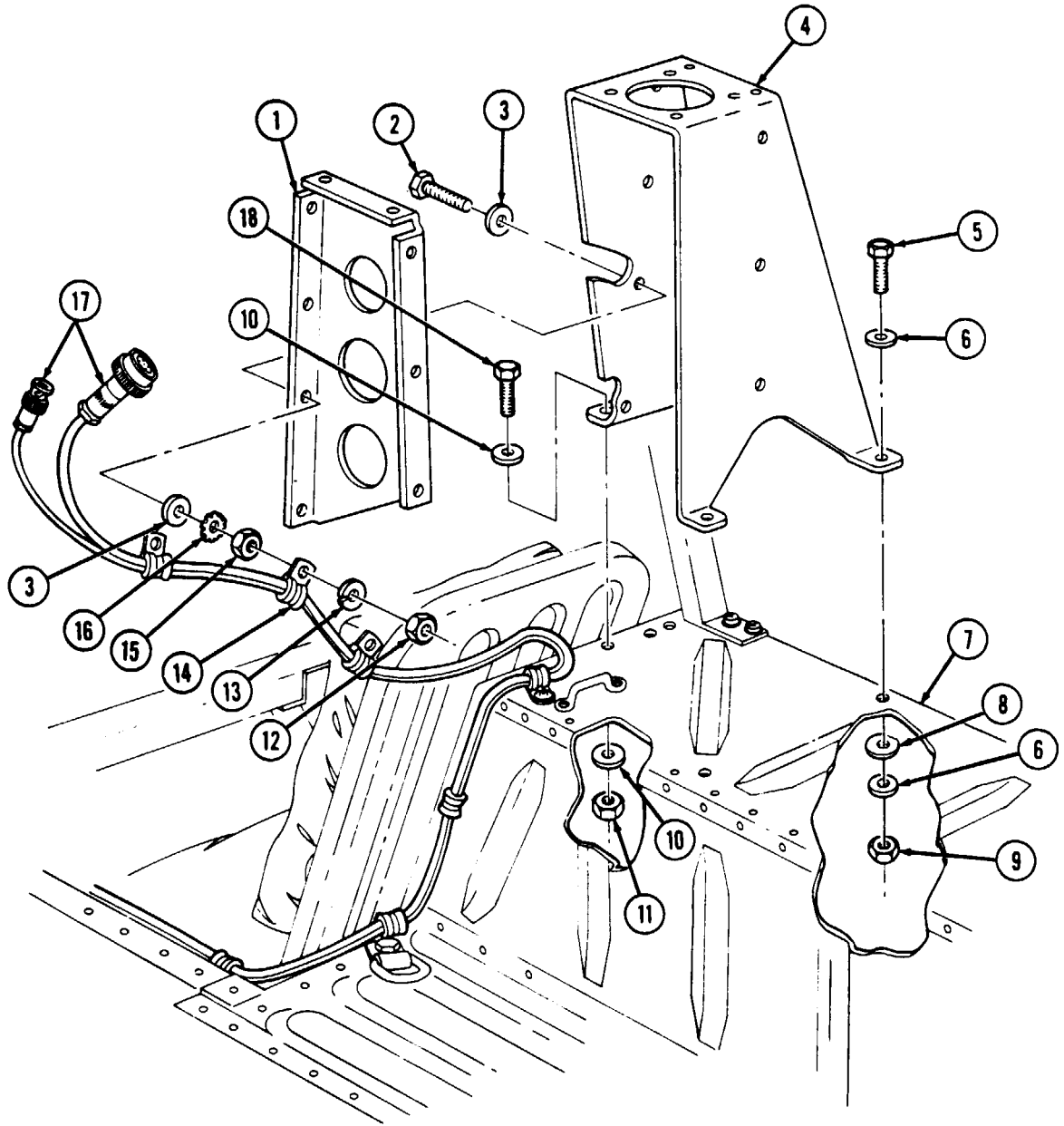

FOLLOW-ON TASK: Install antenna (para. 12-137 or 12-139).

12-146. REAR RADIO RACK TO TOWER ANTENNA CABLES REPLACEMENT

This task covers:

a. Removal

b. Installation

INITIAL SETUP:

Applicable Models

M998, M998A1, M1038, M1038A1

Tools

General mechanic's tool kit:
automotive (Appendix B, Item 1)

Materials/Parts

Two locknuts (Appendix G, Item 79)
Three lockwashers (Appendix G, Item 135)

Manual References

TM 9-2320-280-24P

a. Removal

NOTE

Antenna cables from rear radio rack to left or right antenna towers are replaced basically the same. This procedure covers the left antenna cables.

1. Remove two locknuts (7), washers (8), capscrews (10), washers (8), and insulation retainer (9) from radio rack (5). Discard locknuts (7).
2. Remove two screws (1) and retainer (2) from cargo floor (6) and left brace (11) and pull insulation (3) away from radio rack (5).
3. Remove three screws (13), clamps (14), and two antenna cables (4) from wheelhouse (16) and cargo floor (6).
4. Remove three nuts (17), lockwashers (18), clamps (15), and two antenna cables (4) from tower capscrews (19). Discard lockwashers (18).
5. Disconnect two antenna cables (4) from antenna (12).

b. Installation

1. Connect two antenna cables (4) to antenna (12) and route in approximate mounting location.
2. Install three clamps (15) and antenna cables (4) on tower capscrews (19) with three lockwashers (18) and nuts (17).
3. Install three clamps (14) on two antenna cables (4) and install three clamps (14) on wheelhouse (16) with screws (13).
4. Route antenna cables (4) under insulation (3) and install insulation (3) and retainer (2) on cargo floor (6) and left brace (11) with two screws (1).
5. Install insulation retainer (9) on radio rack (5) with two washers (8), capscrews (10) washers (8), and locknuts (7). Tighten capscrews (10) to 15 lb-ft (20 N•m).

12-146. REAR RADIO RACK TO TOWER ANTENNA CABLES REPLACEMENT (Cont'd)

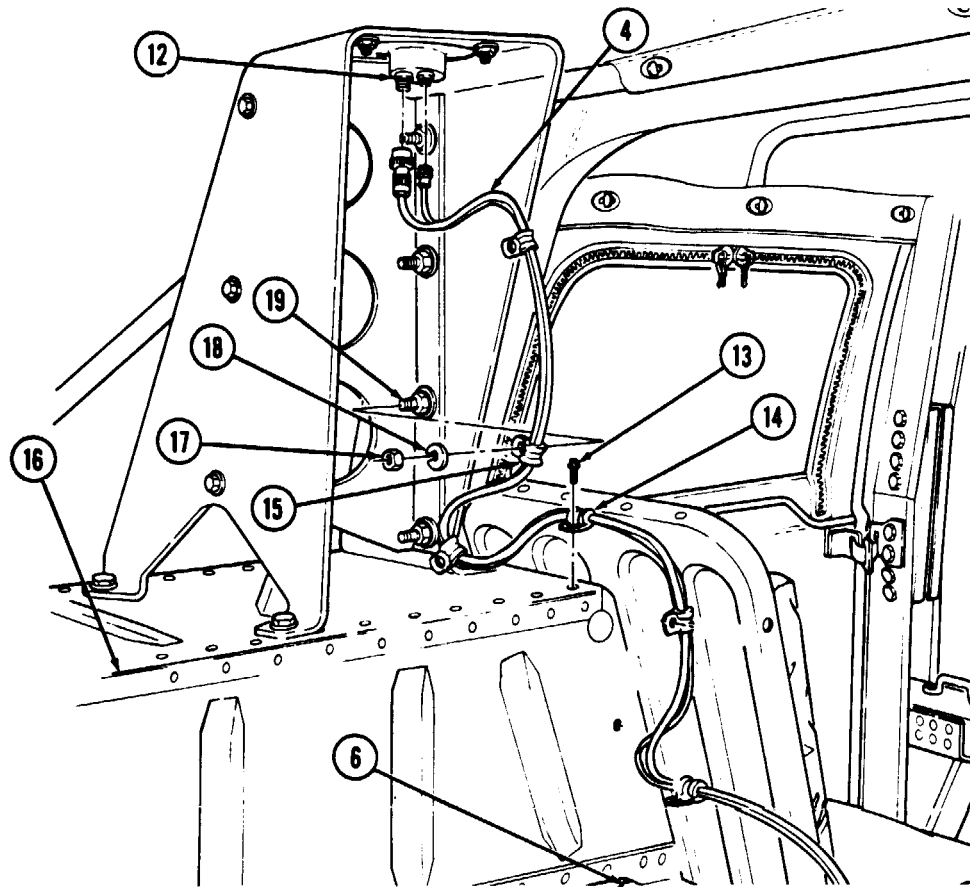
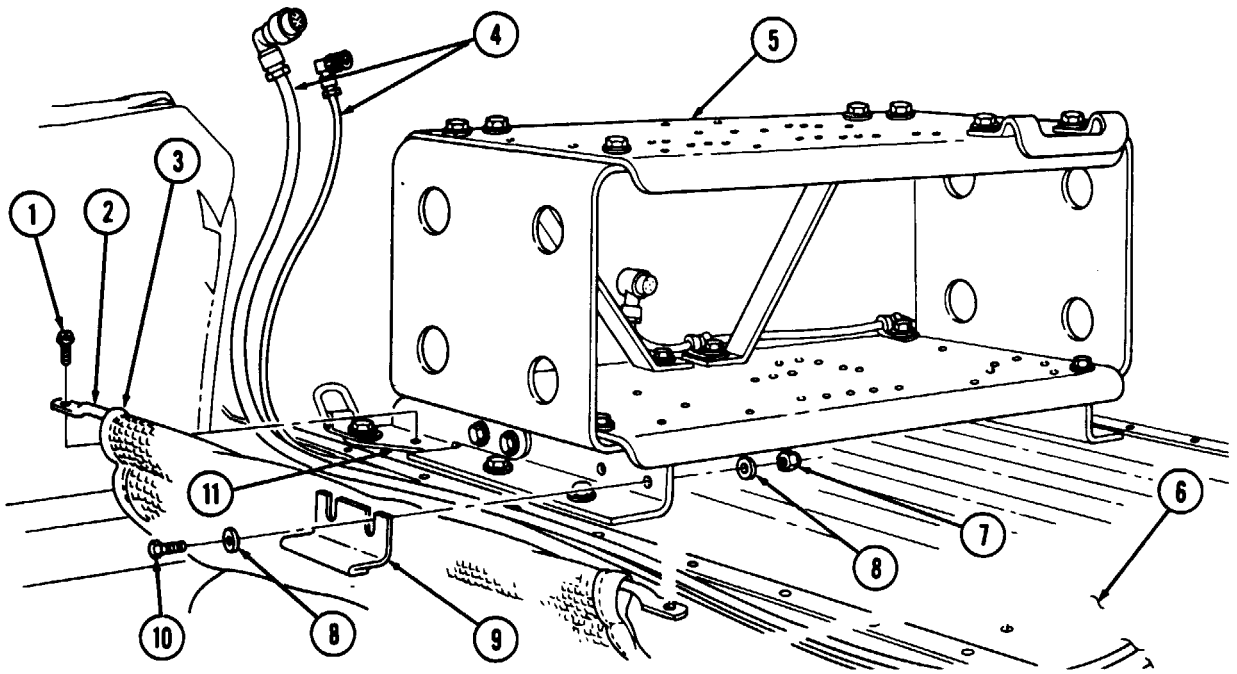

12-147. REAR RADIO RACK POWER CABLE REPLACEMENT

This task covers:

a. Removal

b. Installation

INITIAL SETUP:

Applicable Models

M998, M998A1, M1038, M1038A1

Tools

General mechanic's tool kit:
automotive (Appendix B, Item 1)

Materials/Parts

Two lockwashers (Appendix G, Item 178)
Two locknuts (Appendix G, Item 79)
Lockwasher (Appendix G, Item 141)

Personnel Required

One mechanic
One assistant

Manual References

TM 9-2320-280-24P

Equipment Condition

Battery ground cable disconnected (para. 4-73).

a. Removal

1. Remove two locknuts (6), washers (4), capscrews (3), washers (4), power cable (1), and clamps (2) from radio rack (5). Discard locknuts (6).
2. Remove two screws (8), clamps (7), power cable (1), and two antenna cables (12), if present, from tunnel (11).
3. Remove grommet (9) from body (10) and power cable (1).

NOTE

It may be necessary to loosen front shunt mounting bolt to remove capscrew from shunt.

4. Remove nut (13), lockwasher (14), negative starter cable (15), nut (16), lockwasher (17), capscrew (24), and power cable negative terminal (19) from shunt (18). Discard lockwashers (14) and (17).
5. Remove nut (23), lockwasher (22), and power cable positive terminal (21) from power stud (20). Discard lockwasher (22).

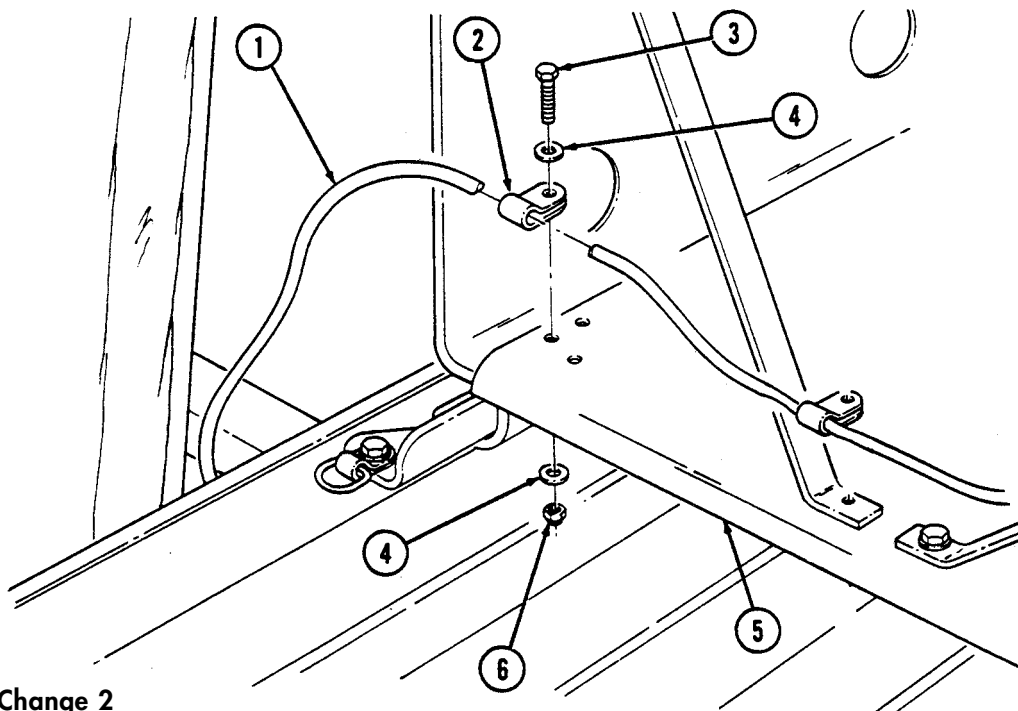

12-147. REAR RADIO RACK POWER CABLE REPLACEMENT (Cont'd)

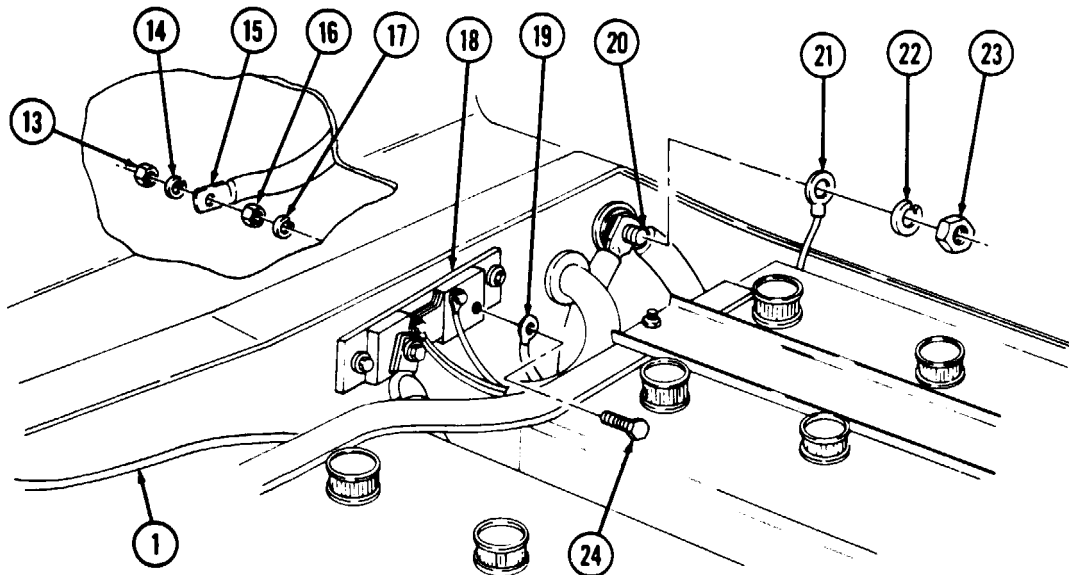
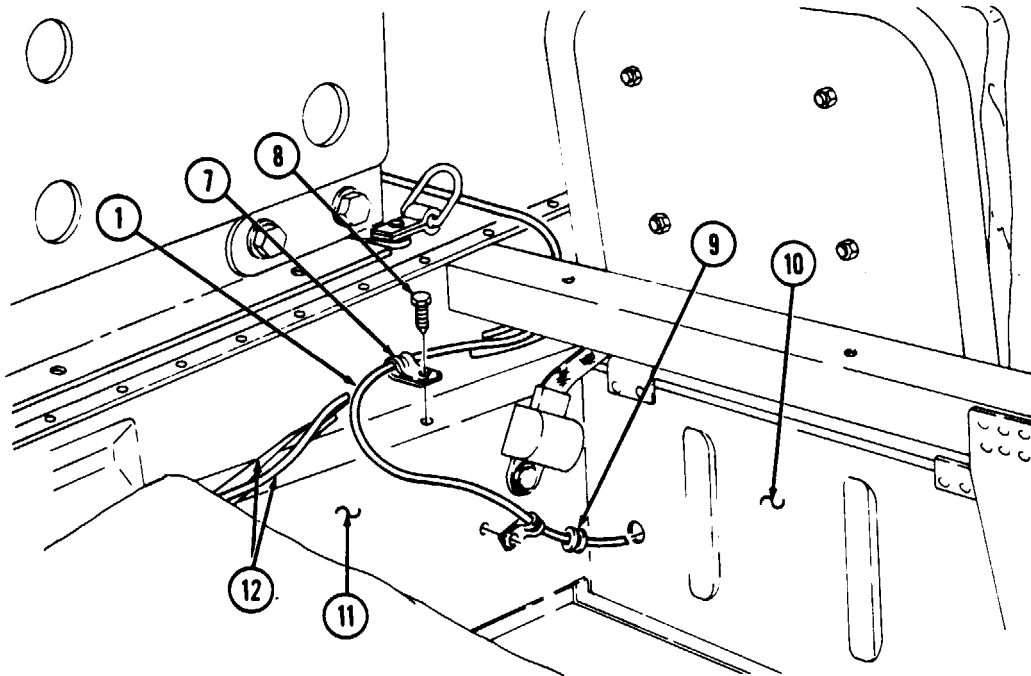

12-147. REAR RADIO RACK POWER CABLE REPLACEMENT (Cont'd)

b. Installation

1. Install power cable (1) on approximate mounting location. Install locator tape (5) on power cable (1) in grommet (4), and install grommet (4) on body (6).
2. Install positive terminal (17) on power stud (16) with lockwasher (18) and nut (19). Tighten nut (19) to 26 lb-ft (35 NŹm).
3. Install negative terminal (15) on shunt (14) with capscrew (20), lockwasher (13), and nut (12). Tighten nut (12) to 75 lb-ft (102 NŹm).
4. Install negative starter cable (11) to capscrew (20) with lockwasher (10) and nut (9). Tighten nut (9) to 75 lb-ft (102 NŹm).
5. Install two clamps (2) on power cable (1) and two antenna cables (8), if present, and install on tunnel (7) with two screws (3).
6. Install two clamps (21) on power cable (1) and install on radio rack (24) with two washers (23), capscrews (22), washers (23), and locknuts (25). Tighten capscrews (22) to 15 lb-ft (20 NŹm).

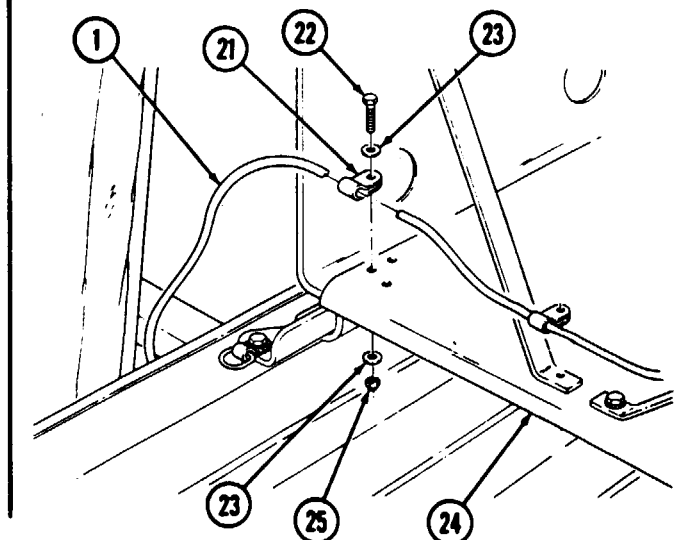
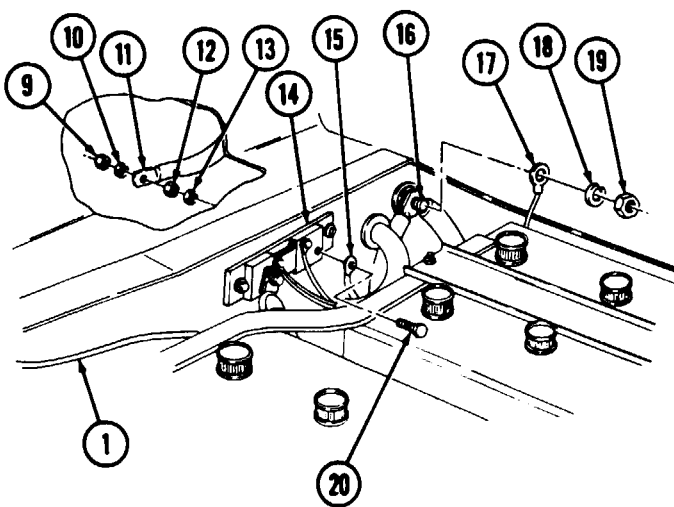
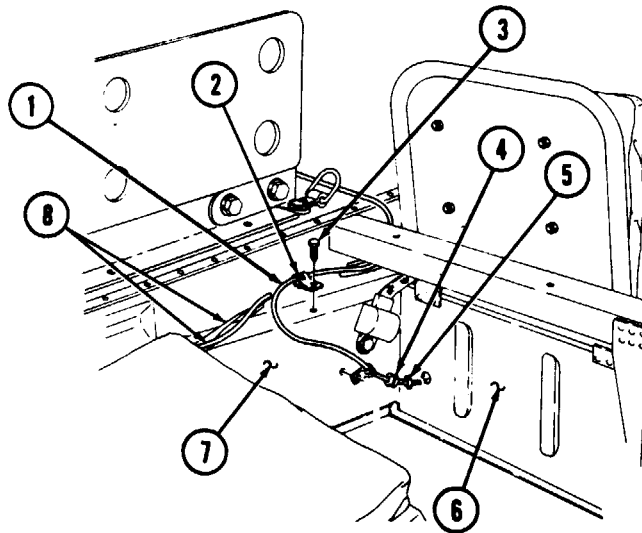

FOLLOW-ON TASK: Connect battery ground cable (para. 4-73).

Section VIII. 81 MM MORTAR KIT MAINTENANCE

12-148. 81 MM MORTAR KIT MAINTENANCE TASK SUMMARY

TASK PARA.	PROCEDURES	PAGE NO.
12-149.	Mortar Ammo Container Maintenance	12-236
12-150.	Base Plate Strap Replacement	12-240
12-151.	Cleaning Staff Stowage Clip Replacement	12-241
12-152.	Bipod Stowage Tray Maintenance	12-242
12-153.	Ready Rack Replacement	12-244
12-154.	Ready Rack Strap Replacement	12-245
12-155.	Ready Rack Hand Guard Replacement	12-246
12-156.	Equipment Rack Replacement	12-247
12-157.	Tool Chest Strap Replacement	12-248
12-158.	Troop Seat Support Pad Replacement	12-249
12-159.	Mortar Barrel Stowage Bracket Replacement	12-250

12-149. MORTAR AMMO CONTAINER MAINTENANCE

This task covers:

- | | |
|----------------|-----------------|
| a. Removal | c. Assembly |
| b. Disassembly | d. Installation |

INITIAL SETUP:

Applicable Models

M998, M998A1, M1038, M1038A1

Tools

General mechanic's tool kit:
automotive (Appendix B, Item 1)

Materials/Parts

Tape (Appendix C, Item 50)
Sixteen locknuts (Appendix G, Item 79)
Twenty-six locknuts (Appendix G, Item 81)
Thirty locknuts (Appendix G, Item 70)

Personnel Required

One mechanic
One assistant

Manual References

TM 9-2320-280-10
TM 9-2320-280-24P

Equipment Condition

- Ready rack straps removed (para. 12-154).
- Base plate strap removed (para. 12-150).
- Tailgate lowered (TM 9-2320-280-10).
- Cargo bulkhead removed (para. 10-53).

a. Removal

1. Remove four capscrews (3) and washers (4) from ammo container (2) and cargo floor (6).
2. Remove two locknuts (7), washers (8), capscrews (1), and washers (8) from ammo container (2) and cargo floor (6). Discard locknuts (7).
3. Remove ammo container (2) and twenty-four washers (5) from cargo floor (6).
4. Remove tape from ammo container (2).

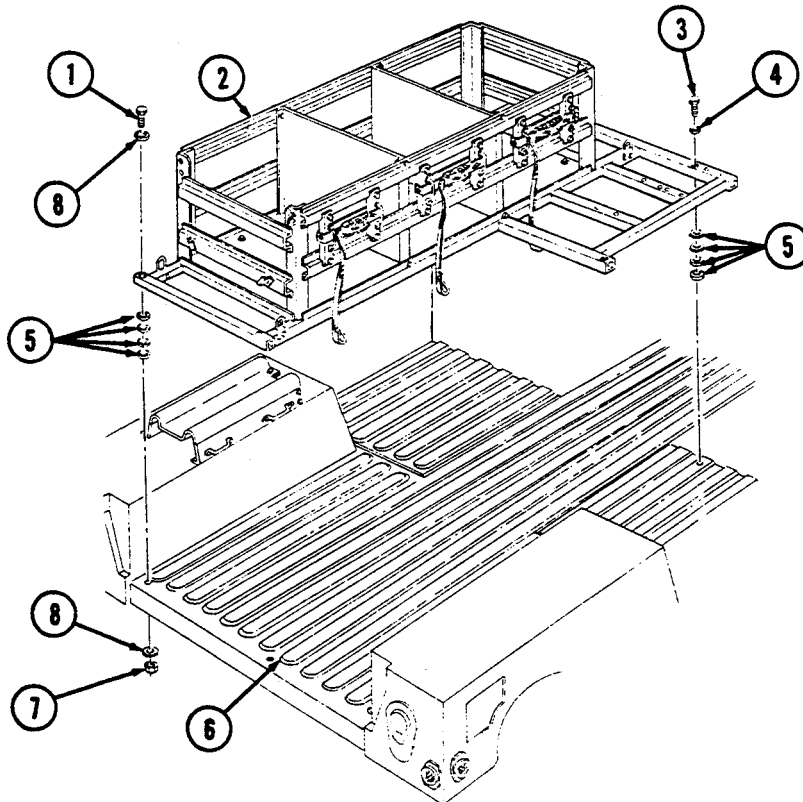

12-149. MORTAR AMMO CONTAINER MAINTENANCE (Cont'd)

b. Disassembly

1. Remove twelve locknuts (23), washers (21), capscrews (20), washers (21), and six footman loops (19) from ammo container supports (17). Discard locknuts (23).
2. Remove twelve locknuts (15), washers (16), capscrews (18), washers (16), six ammo container supports (17), and three straps (19) from ammo container (2). Discard locknuts (15).
3. Remove two locknuts (38), washers (37), capscrews (35), and strap bracket (36) from ammo container (2). Discard locknuts (38).
4. Remove four locknuts (31), washers (32), capscrews (34), and two base plate brackets (33) from ammo container (2). Discard locknuts (31).
5. Remove four locknuts (30), washers (29), capscrews (27), and four tiedown brackets (28) from ammo container base (25). Discard locknuts (30).
6. Remove twenty locknuts (10), washers (11), capscrews (24), and two ammo container reinforcements (9) from ammo container (2). Discard locknuts (10).
7. Remove sixteen locknuts (26), washers (13), capscrews (12), washers (13), ammo container floor (14), and ammo container (2) from ammo base (25). Discard locknuts (26).

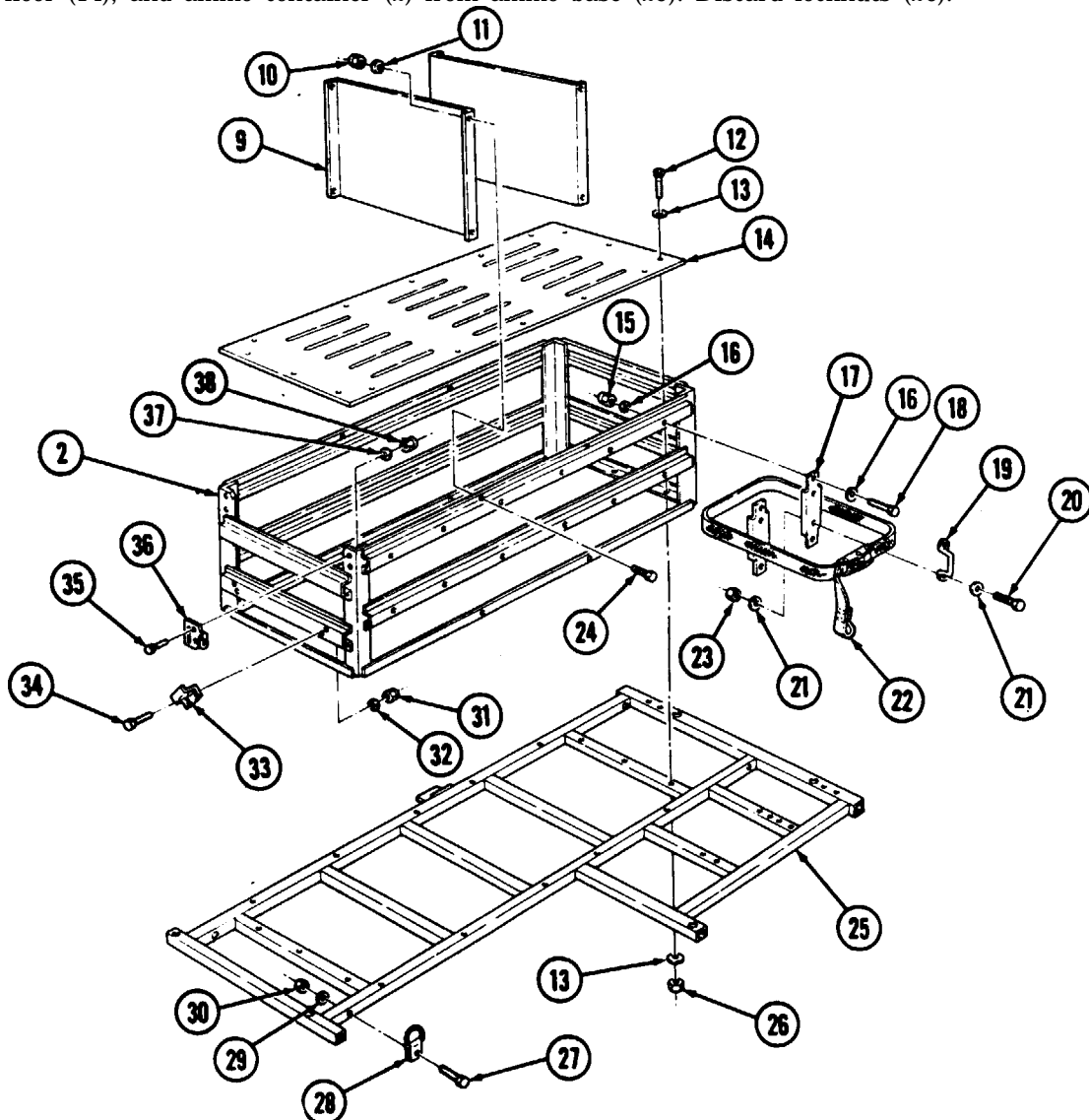

12-149. MORTAR AMMO CONTAINER MAINTENANCE (Cont'd)

c. Assembly

1. Install ammo container (29) and ammo container floor (6) on ammo container base (16) with sixteen washers (5), capscrews (4), washers (5), and locknuts (17). Tighten locknuts (17) to 15 lb-ft (20 N·m).
2. Install two ammo container reinforcements (1) on ammo container (29) with twenty capscrews (7), washers (3), and locknuts (2). Tighten locknuts (2) to 6 lb-ft (8 N·m).
3. Install four tiedown brackets (19) on ammo container base (16) with four washers (20), capscrews (18), and locknuts (21).
4. Install two base plate brackets (24) on ammo container (29) with two capscrews (25), washers (23), and locknuts (22). Tighten locknuts (22) to 6 lb-ft (8 N·m).
5. Install strap bracket (27) on ammo container (29) with two capscrews (26), washers (30), and locknuts (31). Tighten locknuts (31) to 6 lb-ft (8 N·m).
6. Install three straps (14) and ammo container supports (8) on ammo container (29) with twelve washers (9), capscrews (10), washers (9), and locknuts (28). Tighten locknuts (28) to 6 lb-ft (8 N·m).
7. Install six footman loops (13) and three straps (14) on ammo container supports (8) with twelve washers (12), capscrews (11), washers (12), and locknuts (15). Tighten locknuts (15) to 6 lb-ft (8 N·m).

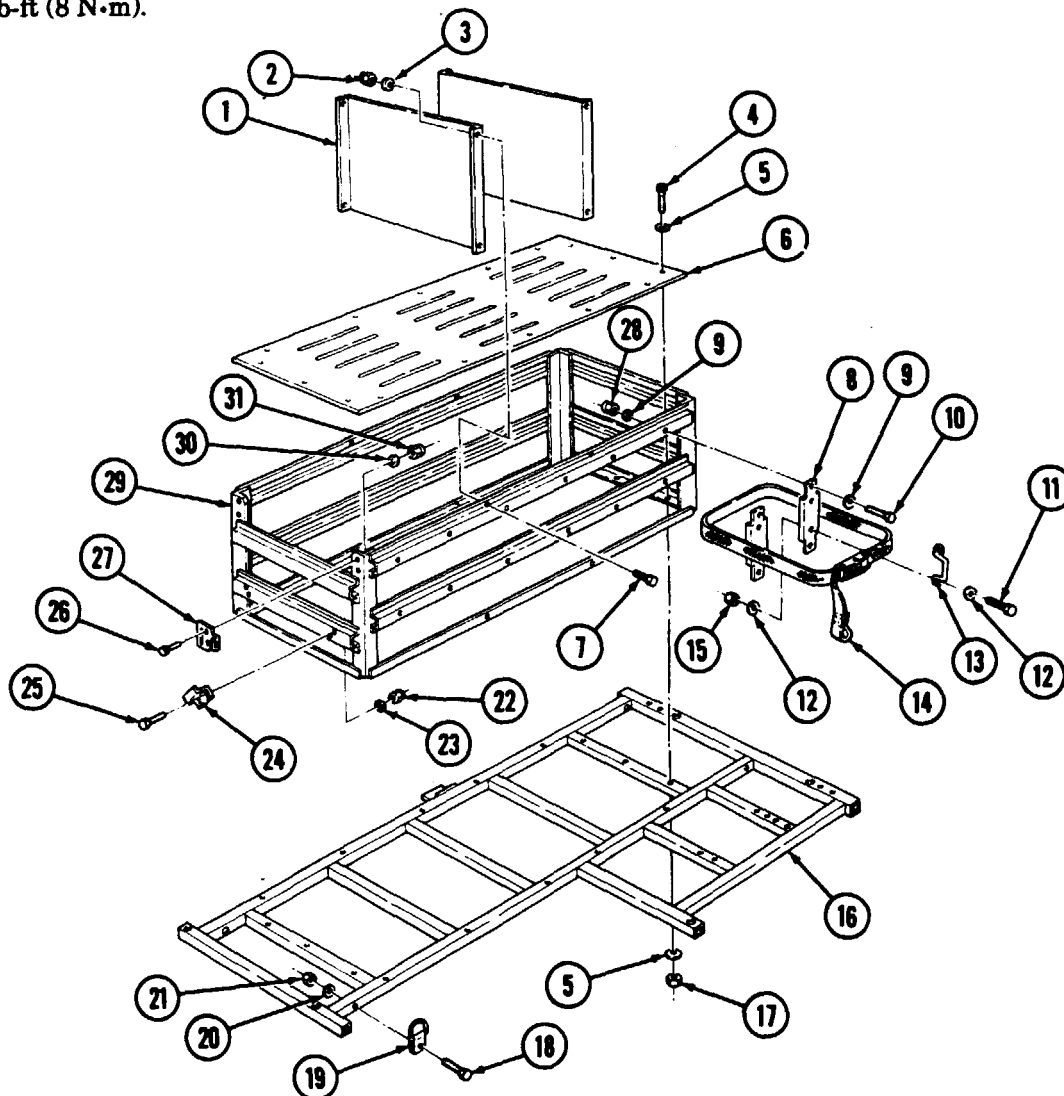

12-149. MORTAR AMMO CONTAINER MAINTENANCE (Cont'd)

d. Installation

1. Install twenty-four washers (36) and ammo container (33) on vehicle.
2. Install two washers (39), capscrews (32), washers (39), locknuts (38), and ammo container (33) on cargo floor (37). Tighten capscrews (32) to 65 lb-ft (88 NŹm).
3. Install four washers (35), capscrews (34), and ammo container (33) on cargo floor (37). Tighten capscrews (34) to 65 lb-ft (88 NŹm).

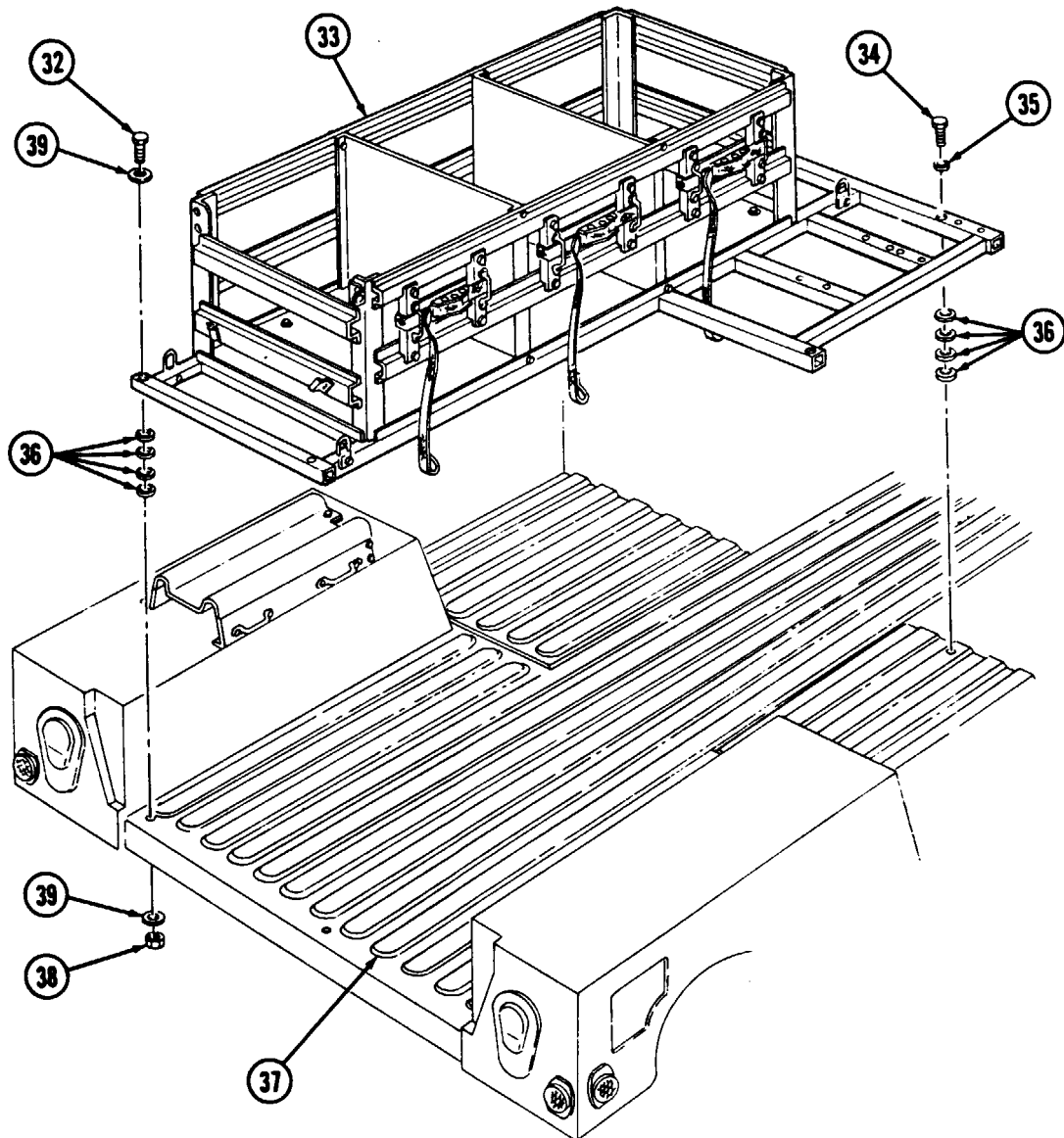

- FOLLOW-ON TASKS:
- Ź Install cargo bulkhead (para. 10-53).
 - Ź Install base plate strap (para. 12-150).
 - Ź Install ready rack straps (para. 12-154).
 - Ź Raise tailgate (TM 9-2320-280-10).

12-150. BASE PLATE STRAP REPLACEMENT

This task covers:

a. Removal

b. Installation

INITIAL SETUP:

Applicable Models

M998, M998A1, M1038, M1038A1

Tools

General mechanic's tool kit:
automotive (Appendix B, Item 1)

Materials/Parts

Two locknuts (Appendix G, Item 70)

Manual References

TM 9-2320-280-10
TM 9-2320-280-24P

Equipment Condition

Tailgate lowered (TM 9-2320-280-10).

a. Removal

1. Unlatch strap (7) from bracket (6).
2. Remove two locknuts (4), washers (2), capscrews (1), washers (2), footman loop (3), and strap (7) from ammo rack container (5). Discard locknuts (4).

b. Installation

1. Install footman loop (3) and strap (7) on ammo rack container (5) with two washers (2), capscrews (1), washers (2), and locknuts (4). Tighten locknuts (4) to 6 lb-ft (8 N·m).
2. Latch strap (7) to bracket (6).

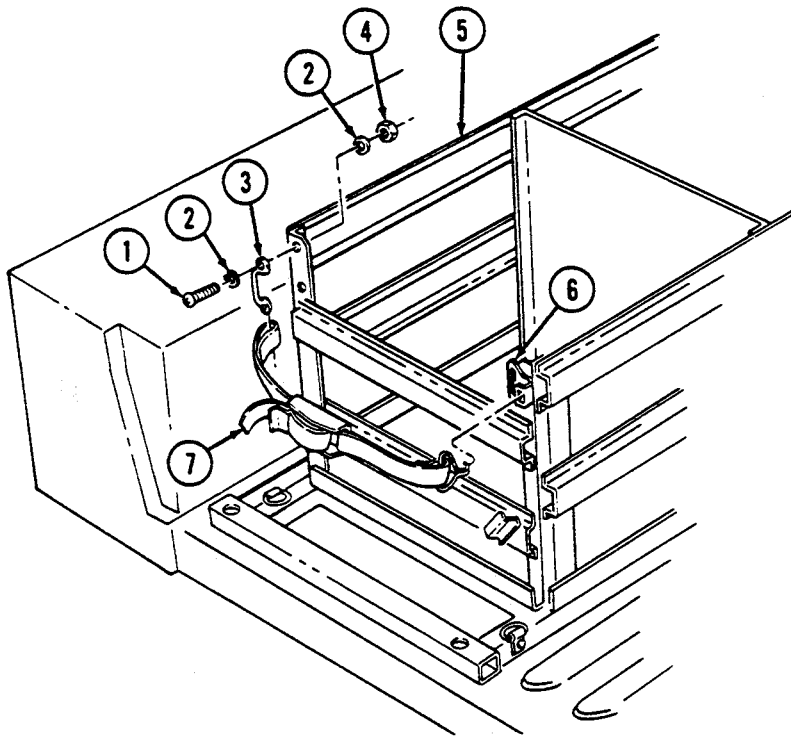

FOLLOW-ON TASK: Raise tailgate (TM 9-2320-280-10).

12-151. CLEANING STAFF STOWAGE CLIP REPLACEMENT

This task covers:

a. Removal

b. Installation

INITIAL SETUP:

Applicable Models

M998, M998A1, M1038, M1038A1

Tools

General mechanic's tool kit:
automotive (Appendix B, Item 1)

Materials/Parts

Tape (Appendix C, Item 50)

Manual References

TM 9-2320-280-10
TM 9-2320-280-24P

Equipment Condition

Tailgate lowered (TM 9-2320-280-10).

NOTE

A shim is installed under front stowage clip.

a. Removal

1. Remove two screws (1) and clip (2) from cargo floor (3).
2. Remove tape from bottom of clip (2) (or bottom of shim for front clip).

b. Installation

1. Apply tape on bottom of clip (2) (or bottom of shim for front clip).
2. Install clip (2) on cargo floor (3) with two screws (1).

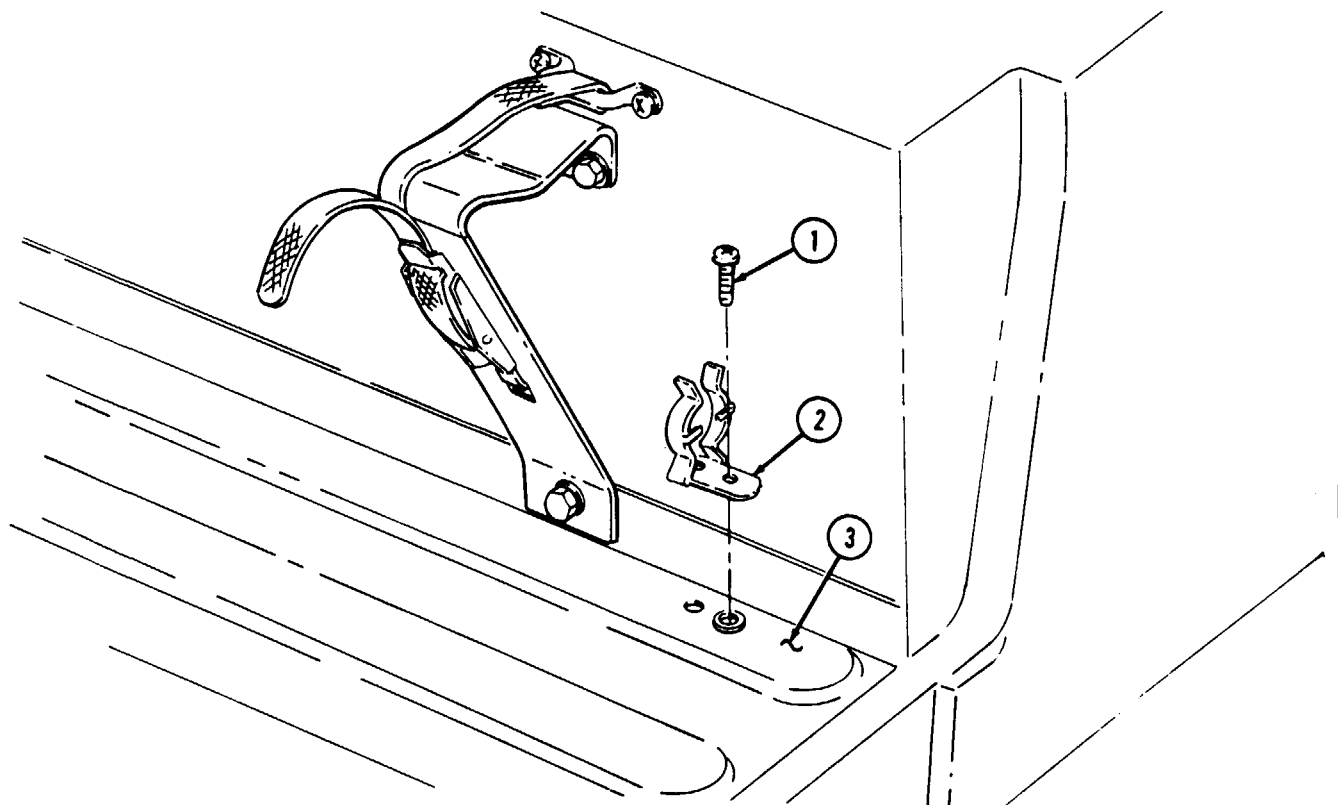

FOLLOW-ON TASK: Raise tailgate (TM 9-2320-280-10).

12-152. BIPOD STOWAGE TRAY MAINTENANCE

This task covers:

- | | |
|--|--|
| <ul style="list-style-type: none"> a. Removal b. Disassembly | <ul style="list-style-type: none"> c. Assembly d. Installation |
|--|--|

INITIAL SETUP:

Applicable Models

M998, M998A1, M1038, M1038A1

Tools

General mechanic's tool kit:
automotive (Appendix B, Item 1)

Materials/Parts

Tape (Appendix C, Item 50)
Thirteen locknuts (Appendix G, Item 88)
Six locknuts (Appendix G, Item 70)
Three lockwashers (Appendix G, Item 135)

Personnel Required

One mechanic
One assistant

Manual References

TM 9-2320-280-24P

a. Removal

1. Remove five locknuts (7), washers (8), capscrews (1), and washers (8) from bipod stowage tray (2) and wheelhouse (3). Discard locknuts (7).
2. Remove three capscrews (6), lockwashers (5), washers (4), and bipod stowage tray (2) from wheelhouse (3). Discard lockwashers (5).
3. Remove tape from bipod stowage tray (2).

b. Disassembly

1. Remove six locknuts (15), washers (13), capscrews (12), washers (13), and support bracket (14) from tray (16). Discard locknuts (15).
2. Unlatch straps (9) from footman loops (21).
3. Remove four locknuts (18), washers (17), screws (11), two footman loops (10), and straps (9) from tray (16). Discard locknuts (18).
4. Remove four locknuts (19), washers (20), screws (22), and two footman loops (21) from tray (16). Discard locknuts (19).

c. Assembly

1. Install two footman loops (21) on tray (16) with four screws (22), washers (20), and locknuts (19).
2. Install two footman loops (10) on two straps (9) and tray (16) with four screws (11), washers (17), and locknuts (18).
3. Latch straps (9) to footman loops (21).
4. Install support bracket (14) on tray (16) with six washers (13), capscrews (12), washers (13), and locknuts (15). Tighten locknuts (15) to 6 lb-ft (8 N•m).

d. Installation

1. Apply tape to bipod stowage tray (2).
2. Install bipod stowage tray (2) on wheelhouse (3) with three washers (4), lockwashers (5), and capscrews (6). Tighten capscrews (6) to 6 lb-ft (8 N•m).
3. Secure bipod stowage tray (2) to wheelhouse (3) with five washers (8), capscrews (1), washers (8), and locknuts (7). Tighten locknuts (7) to 6 lb-ft (8 N•m).

12-152. BIPOD STORAGE TRAY MAINTENANCE (Cont'd)

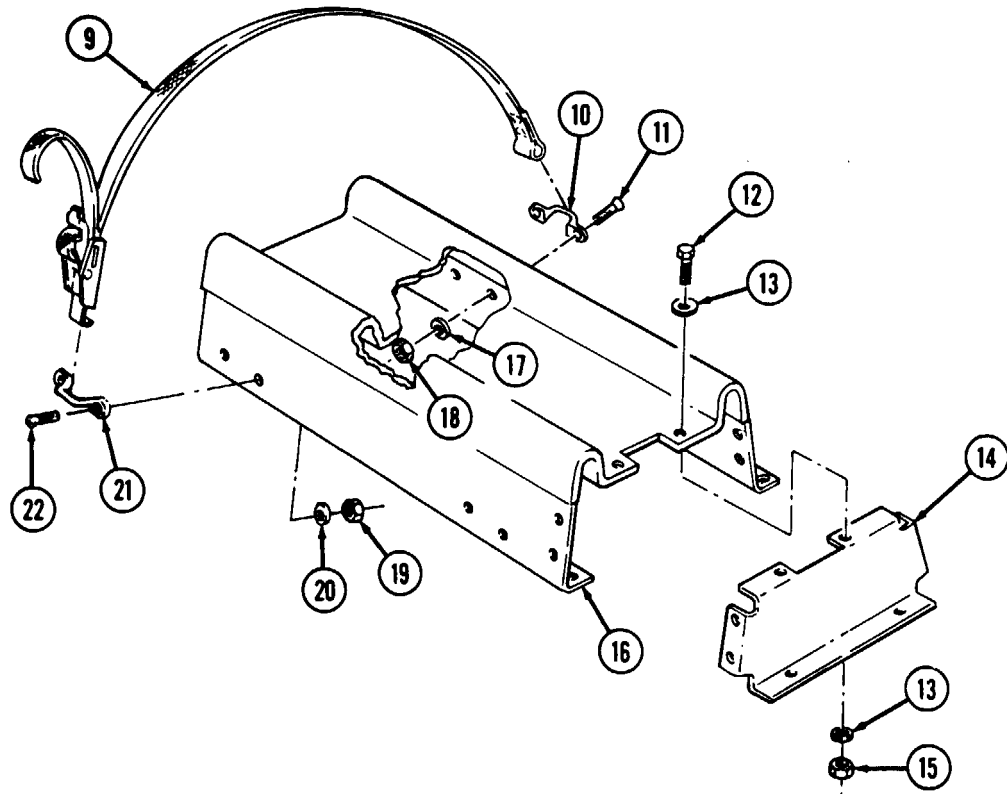
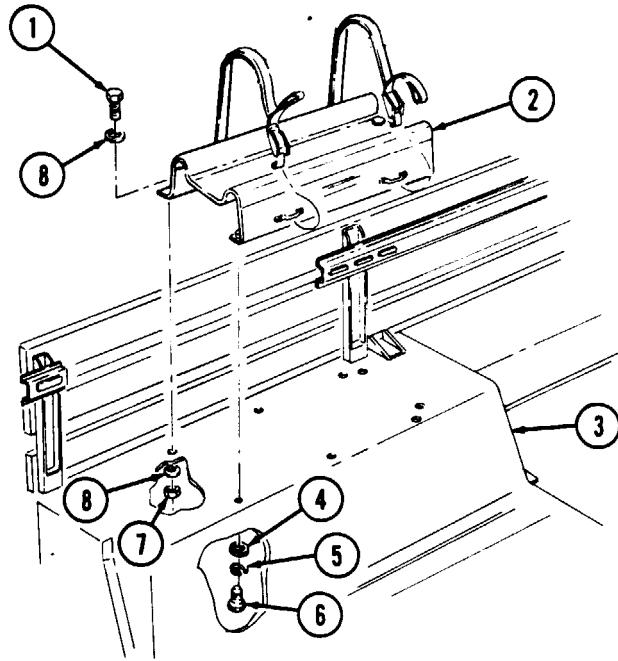

12-153. READY RACK REPLACEMENT

This task covers:

a. Removal

b. Installation

INITIAL SETUP:

Applicable Models

M998, M998A1, M1038, M1038A1

Manual References

TM 9-2320-280-24P

Tools

General mechanic's tool kit:
automotive (Appendix B, Item 1)

a. Removal

Unlatch two straps (2) and remove ready rack (1) from cargo floor (3).

b. Installation

Install ready rack (1) on cargo floor (3) with two straps (2).

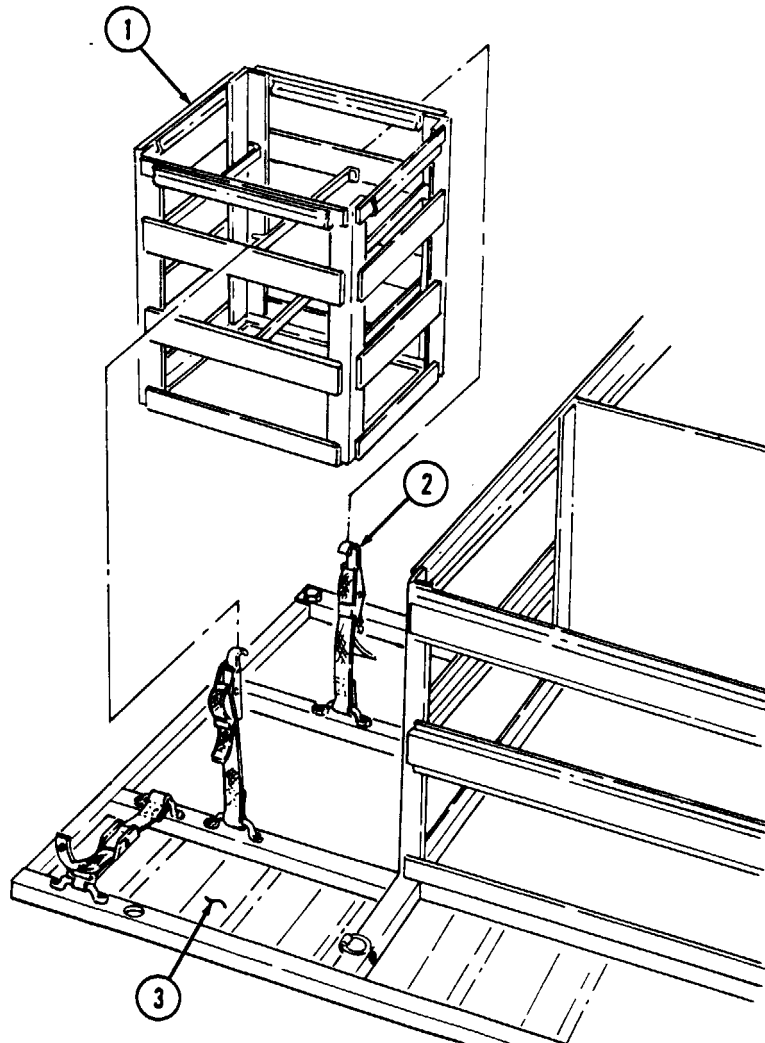

12-154. READY RACK STRAP REPLACEMENT

This task covers:

a. Removal

b. Installation

INITIAL SETUP:

Applicable Models

M998, M998A1, M1038, M1038A1

Manual References

TM 9-2320-280-24P

Tools

General mechanic's tool kit:
automotive (Appendix B, Item 1)

Equipment Condition

Ready rack removed (para. 12-153).

a. Removal

Remove two screws (2) securing footman loop (4) and strap (1) to ammo container (3) and remove footman loop (4) from strap (1).

b. Installation

Install footman loop (4) and strap (1) on ammo container (3) with two screws (2).

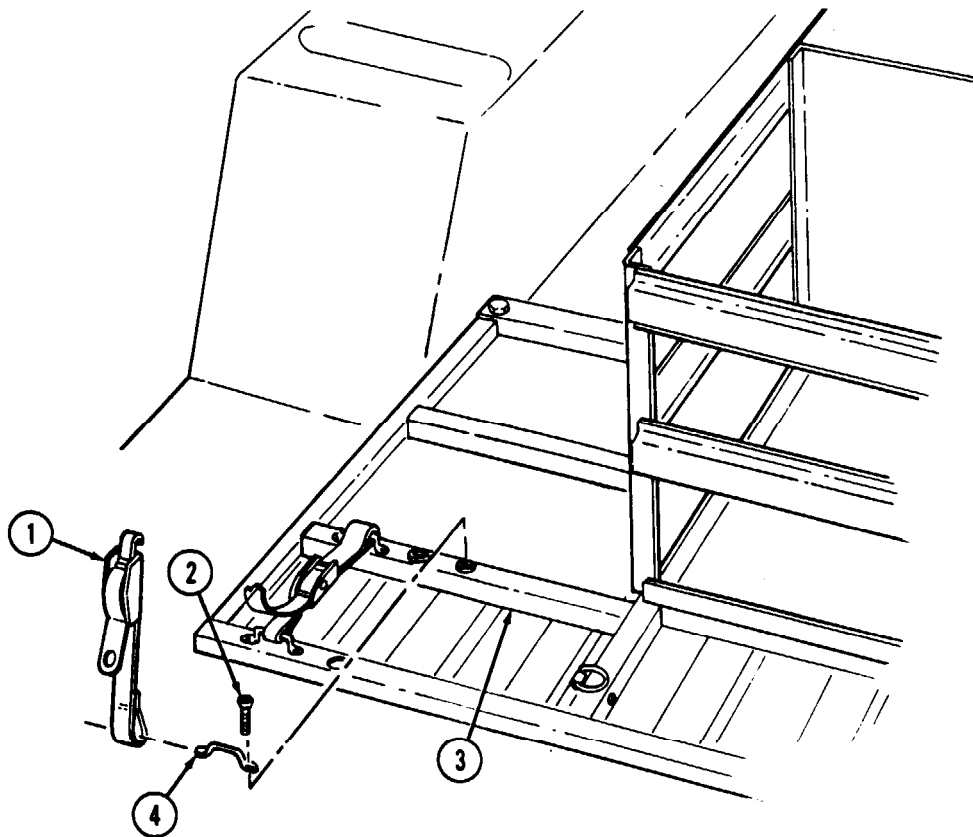

FOLLOW-ON TASK: Install ready rack (para. 12-153).

12-155. READY RACK HAND GUARD REPLACEMENT

This task covers:

a. Removal

b. Installation

INITIAL SETUP:

Applicable Models

M998, M998A1, M1038, M1038A1

Manual References

TM 9-2320-280-24P

Tools

General mechanic's tool kit:
automotive (Appendix B, Item 1)

Equipment Condition

Ready rack removed (para. 12-153).

Materials/Parts

Adhesive (Appendix C, Item 2)

a. Removal

1. Remove hand guard (2) from ready rack (1).
2. Clean adhesive from ready rack (1).

b. Installation

Apply adhesive to hand guard (2) and ready rack (1). Install hand guard (2) on ready rack (1).

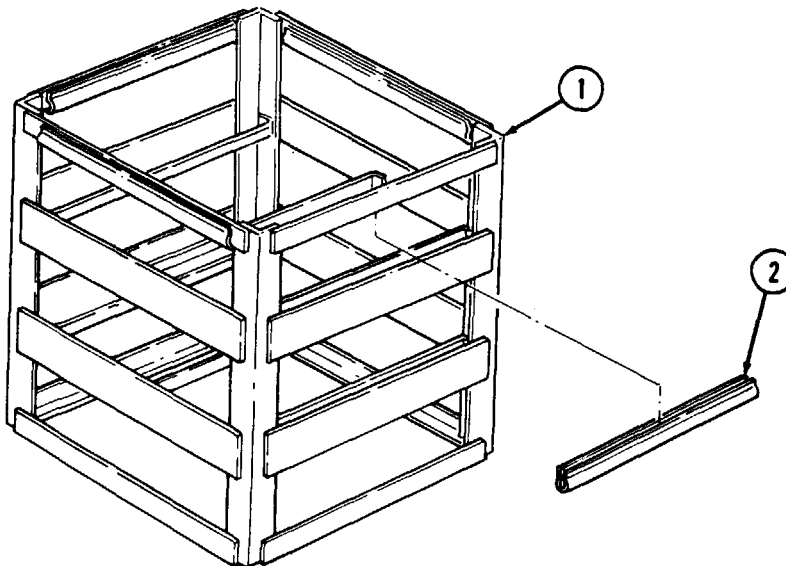

FOLLOW-ON TASK: Install ready rack (para. 12-153).

12-156. EQUIPMENT RACK REPLACEMENT

This task covers:

a. Removal

b. Installation

INITIAL SETUP:

Applicable Models

M998, M998A1, M1038, M1038A1

Manual References

TM 9-2320-280-24P

Tools

General mechanic's tool kit:
automotive (Appendix B, Item 1)

Equipment Condition

- Tool chest straps removed (para. 12-157).
- Troop seat support pad removed (para. 12-158).

Materials/Parts

Tape (Appendix C, Item 50)
Six lockwashers (Appendix G, Item 134)
Two locknuts (Appendix G, Item 88)

a. Removal

1. Remove six capscrews (3), lockwashers (4), and equipment rack (5) from cargo floor (6). Discard lockwashers (4).
2. Remove two locknuts (1), washers (8), screws (7), and retainer bracket (2) from equipment rack (5). Discard locknuts (1).
3. Remove tape from equipment rack (5).

b. Installation

1. Apply tape to equipment rack (5).
2. Install retainer bracket (2) on equipment rack (5) with two washers (8), screws (7), and locknuts (1).
3. Install equipment rack (5) on cargo floor (6) with six lockwashers (4) and capscrews (3). Tighten capscrew (3) to 15 lb-ft (20 N·m).

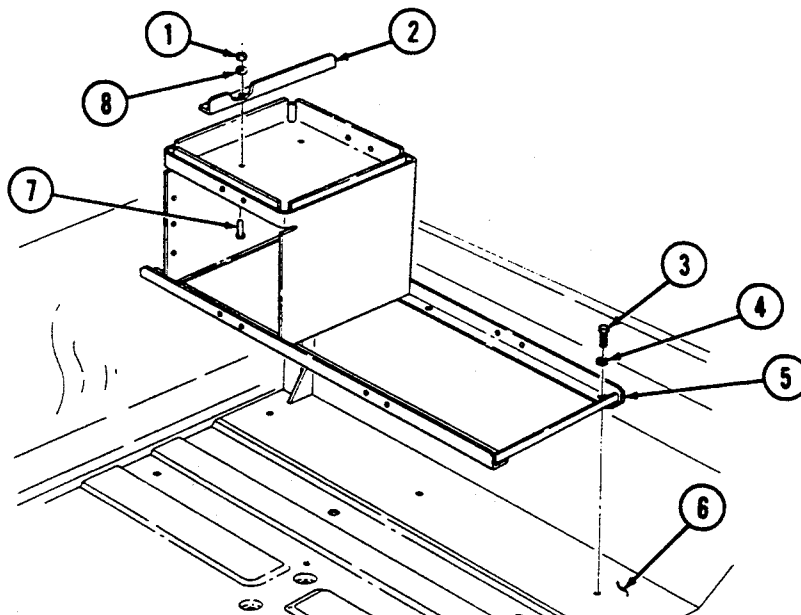

- FOLLOW-ON TASKS:
- Install troop seat support pad (para. 12-158).
 - Install tool chest straps (para. 12-157).

12-157. TOOL CHEST STRAP REPLACEMENT

This task covers:

a. Removal

b. Installation

INITIAL SETUP:

Applicable Models

M998, M998A1, M1038, M1038A1

Tools

General mechanic's tool kit:
automotive (Appendix B, Item 1)

Materials/Parts

Four locknuts (Appendix G, Item 88)

Manual References

TM 9-2320-280-10
TM 9-2320-280-24P

Equipment Condition

Right troop seat raised (TM 9-2320-280-10).

a. Removal

NOTE

The tool chest strap, M14 chest strap, and M166 chest strap are replaced basically the same. This procedure covers tool chest strap replacement.

Remove four locknuts (5), screws (4), two footman loops (3), and strap (2) from equipment rack (1). Discard locknuts (5).

b. Installation

Install two footman loops (3) and strap (2) on equipment rack (1) with four screws (4) and locknuts (5).

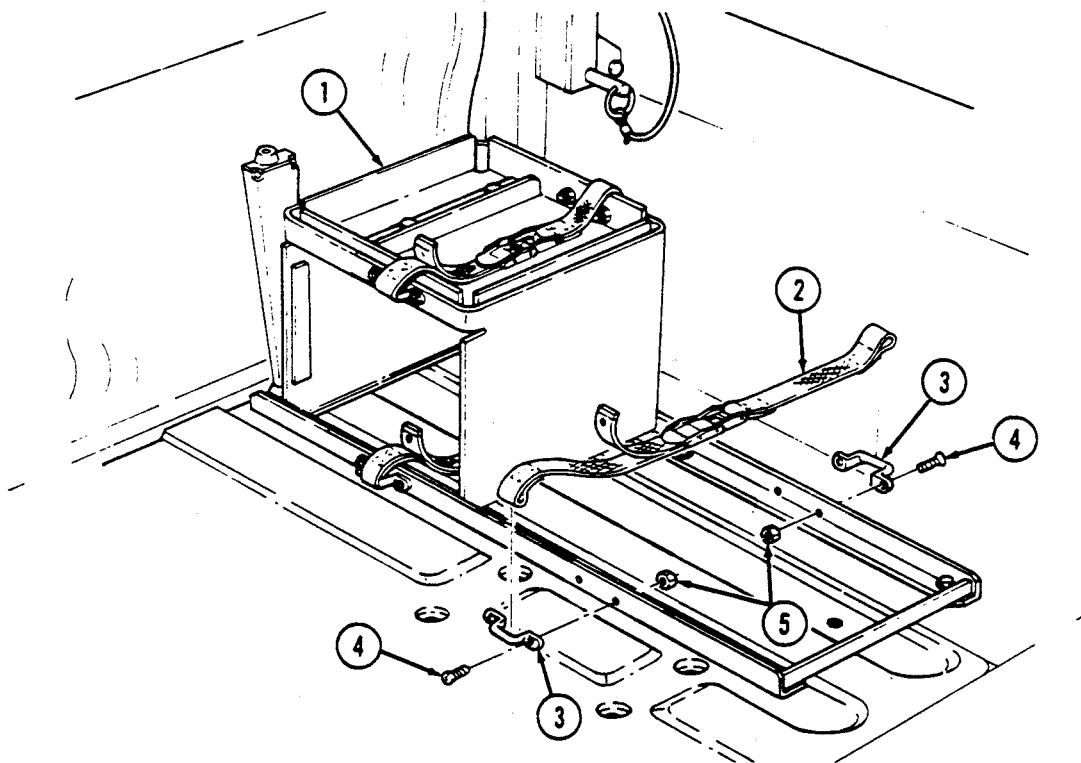

FOLLOW-ON TASK: Lower right troop seat (TM 9-2320-280-10).

12-158. TROOP SEAT SUPPORT PAD REPLACEMENT

This task covers:

a. Removal

b. Installation

INITIAL SETUP:

Applicable Models

M998, M998A1, M1038, M1038A1

Tools

General mechanic's tool kit:
automotive (Appendix B, Item 1)

Materials/Parts

Two locknuts (Appendix G, Item 70)

Manual References

TM 9-2320-280-10
TM 9-2320-280-24P

Equipment Condition

Right troop seat raised (TM 9-2320-280-10).

a. Removal

Remove two locknuts (5), washers (3), capscrews (4), washers (3), and pad (2) from wheelhouse (1). Discard locknuts (5).

b. Installation

Install pad (2) on wheelhouse (1) with two washers (3), capscrews (4), washers (3), and locknuts (5).

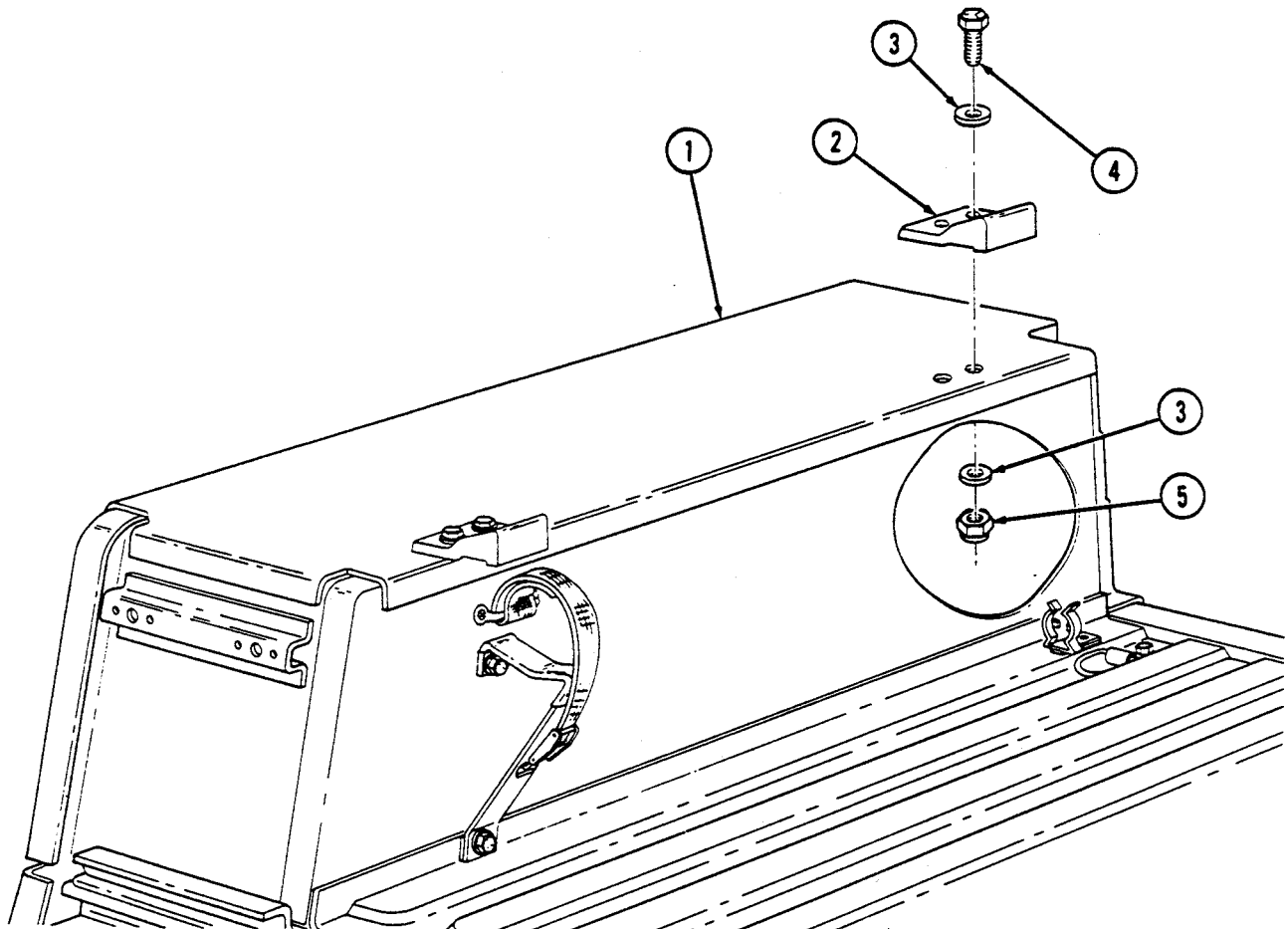

FOLLOW-ON TASK: Lower right troop seat (TM 9-2320-280-10).

12-159. MORTAR BARREL STOWAGE BRACKET REPLACEMENT

This task covers:

a. Removal

b. Installation

INITIAL SETUP:

Applicable Models

M998, M998A1, M1038, M1038A1

Tools

General mechanic's tool kit:
automotive (Appendix B, Item 1)

Materials/Parts

Tape (Appendix C, Item 50)
Three locknuts (Appendix G, Item 70)

Personnel Required

One mechanic
One assistant

Manual References

TM 9-2320-280-10
TM 9-2320-280-24P

Equipment Condition

Tailgate lowered (TM 9-2320-280-10).

a. Removal

1. Unlatch strap (1) from bracket (6).
2. Remove three locknuts (4), washers (3), capscrews (7), washers (3), bracket (6), and washer (5) from wheelhouse (2). Discard locknuts (4).
3. Remove tape from bracket (6).

b. Installation

1. Apply tape to bracket (6).
2. Install washer (5) and bracket (6) on wheelhouse (2) with three washers (3), capscrews (7), washers (3), and locknuts (4). Tighten locknuts (4) to 6 lb-ft (8 N•m).
3. Latch strap (1) to bracket (6).

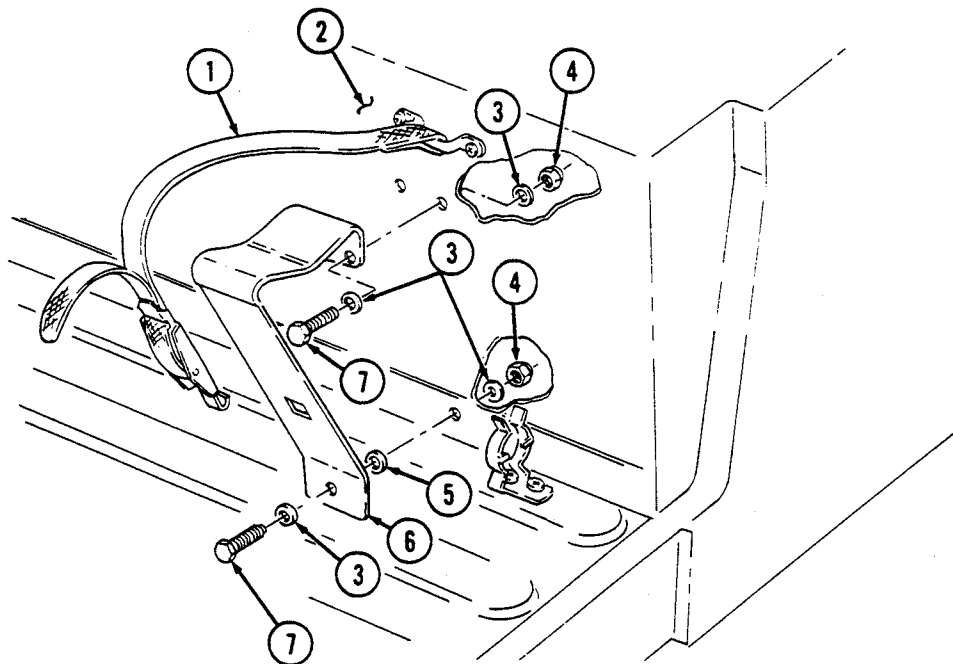

FOLLOW-ON TASK: Raise tailgate (TM 9-2320-280-10).

Section IX. TRAVERSING BAR KIT MAINTENANCE

12-160. TRAVERSING BAR KIT MAINTENANCE TASK SUMMARY

TASK PARA.	PROCEDURES	PAGE NO.
12-161.	Traversing Bar Kit Maintenance	12-252

12-161. TRAVERSING BAR KIT MAINTENANCE

This task covers:

a. Removal

b. Installation

INITIAL SETUP:

Applicable Models

M1043, M1043A1, M1043A2, M1044, M1044A1

Manual References

TM 9-2320-280-24P

Tools

General mechanic's tool kit:
automotive (Appendix B, Item 1)

Equipment Condition

Hatch opened (TM 9-2320-280-10).

Materials/Parts

Six locknuts (Appendix G, Item 128)

NOTE

- This task covers the MK64 tri-mount and the .50 cal. machine gun mount.
- Perform steps 1 and 2 for the MK64 mount only.

a. Removal

1. Remove two locknuts (12), washers (13), capscrews (1), washers (13), and traversing bar (2) from upper mounts (6). Discard locknuts (12).
2. Remove four locknuts (3), washers (4), capscrews (7), washers (4), and upper mounts (6) from lower mount (5). Discard locknuts (3).

NOTE

Perform steps 3 and 4 for the .50 cal. machine gun mount only.

3. Remove two locknuts (12), washers (13), capscrews (1), washers (13), and traversing bar (2) from lower mount (5). Discard locknuts (12).
4. Remove three locknuts (9), washers (10), capscrews (11), washers (10), and lower mount (5) from armament panel (8). Discard locknuts (9).

b. Installation

NOTE

Perform steps 1 and 2 for the .50 cal. machine gun mount only.

1. Install lower mount (5) on armament panel (8) with three washers (10), capscrews (11), washers (10), and locknuts (9). Tighten locknuts (9) to 37 lb-ft (50 N•m).
2. Install traversing bar (2) on lower mount (5) with two washers (13), capscrews (1), washers (13), and locknuts (12). Tighten locknuts (12) to 37 lb-ft (50 N•m).

NOTE

Perform steps 3 and 4 for the MK64 mount only.

3. Install upper mounts (6) on lower mount (5) with four washers (4), capscrews (7), washers (4), and locknuts (3). Tighten locknuts (3) to 37 lb-ft (50 N•m).
4. Install traversing bar (2) on upper mount (6) with two washers (13), capscrews (1), washers (13), and locknuts (12). Tighten locknuts (12) to 37 lb-ft (50 N•m).

12-161. TRAVERSING BAR KIT MAINTENANCE (Cont'd)

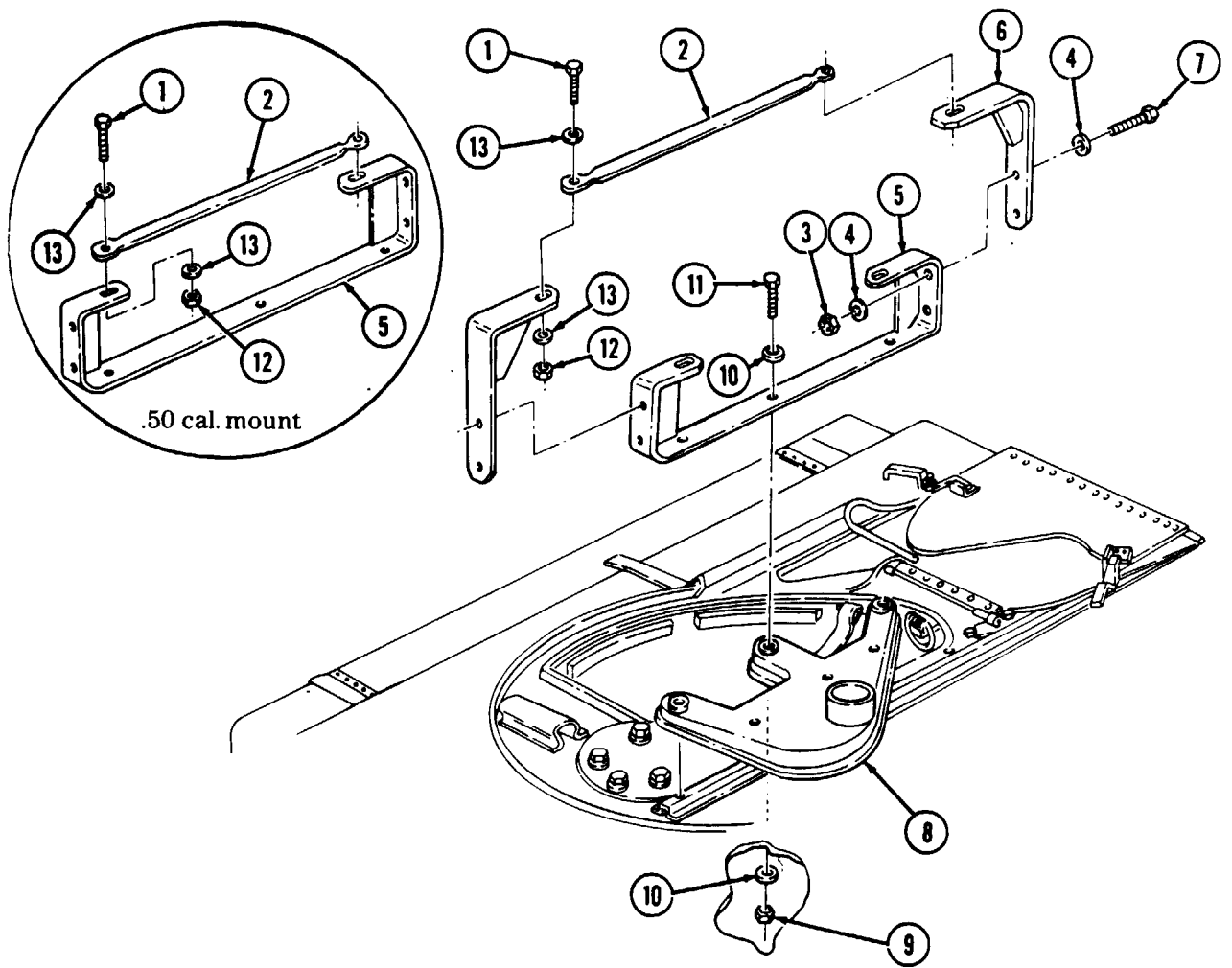

FOLLOW-ON TASK: Close hatch (TM 9-2320-280-10).

Section X. M1097, M1097A1, and M1097A2 SPECIAL PURPOSE KITS MAINTENANCE

12-162. M1097, M1097A1, AND M1097A2 SPECIAL PURPOSE KITS MAINTENANCE TASK SUMMARY
--

TASK PARA.	PROCEDURES	PAGE NO.
12-163.	Trailer Connector and Wiring Harness Replacement (L119)	12-255
12-164.	Rear Bumper Replacement (L119)	12-257
12-165.	Rear Bumper Brace Bracket Replacement (L119)	12-258
12-166.	Rear Bumper Outer Brace Replacement (L119)	12-259
12-167.	Rear Bumper Outer Mounting Bracket Replacement (L119)	12-260
12-168.	Rear Bumper Inner Brace Replacement (L119)	12-261
12-169.	Rear Bumper Inner Mounting Bracket Replacement (L119)	12-262
12-170.	Pioneer Tool Stowage Rack Latch Strike Replacement (L119)	12-263
12-171.	Rear Bumper Lifting Shackle Replacement (L119)	12-264
12-172.	Rear Tiedown Bracket Replacement (L119)	12-265
12-173.	Ammo Tiedown Strap Replacement (L119)	12-266
12-174.	Ammo Divider Replacement (L119)	12-267
12-175.	Telephone Strap Replacement (L119)	12-268
12-176.	Section Chest Strap Replacement (L119)	12-269
12-177.	Tripod Strap Replacement (L119)	12-270
12-178.	Gun Display Unit Battery Strap Replacement (L119)	12-271
12-179.	Sight Box Straps Replacement (L119)	12-272
12-180.	Water/Fuel Can Strap Replacement (L119)	12-273
12-181.	Ammo Rack Maintenance (L119)	12-274
12-182.	M60 Machine Gun Strap Replacement (L119)	12-277
12-183.	Camouflage Rack Maintenance	12-278

12-163. TRAILER CONNECTOR AND WIRING HARNESS REPLACEMENT (L119)

This task covers:

a. Removal

b. Installation

INITIAL SETUP:

Applicable Models

M1097, M1097A1, M1097A2

Manual References

TM 9-2320-280-24P

Tools

General mechanic's tool kit:
automotive (Appendix B, Item 1)

Equipment Condition

Battery ground cable disconnected (para. 4-73).

Materials/Parts

Four assembled locknuts
(Appendix G, Item 130)

NOTE

Prior to removal, tag leads for installation.

a. Removal

1. Remove four assembled locknuts (13), capscrews (1), and receptacle cover (2) from mounting bracket (4). Discard assembled locknuts (13).
2. Remove screw (11) and clamp (9) from D-beam (6).
3. Disconnect receptacle assembly (3) from body wiring harness (10) and remove receptacle assembly (3).
4. Deleted.

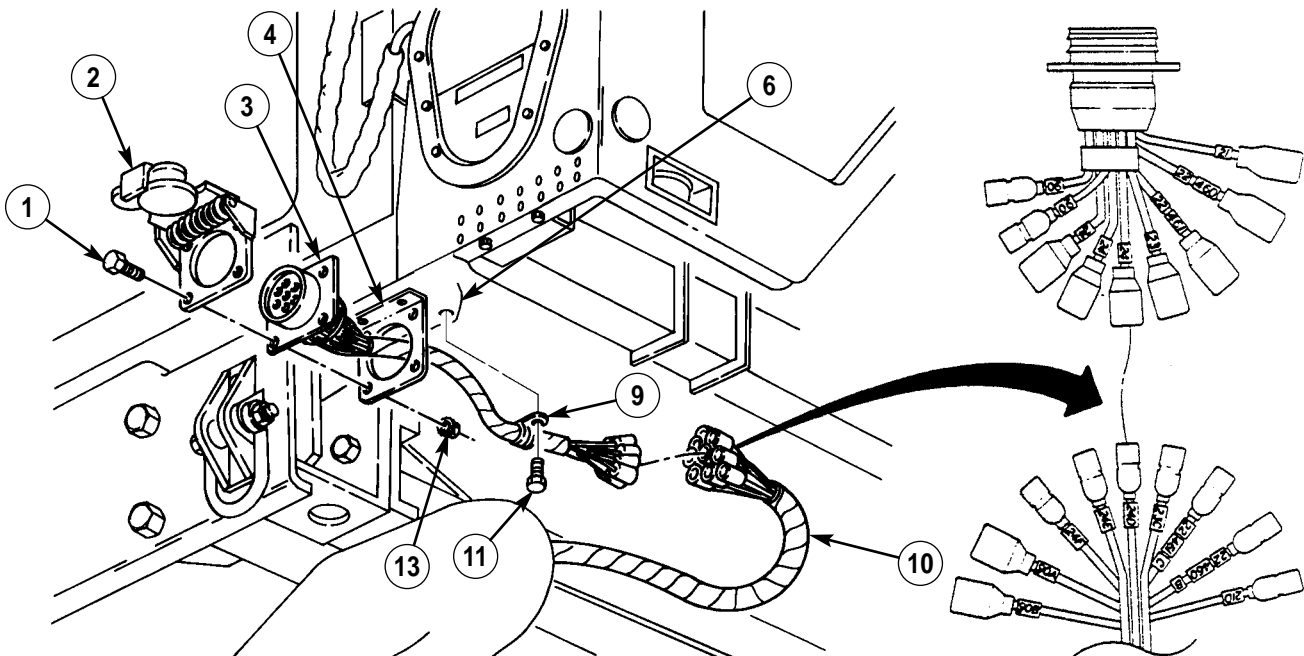

12-163. TRAILER CONNECTOR AND WIRING HARNESS REPLACEMENT (L119) (Cont'd)

b. Installation

1. Feed receptacle assembly (3) leads through bracket (4) and connect receptacle assembly (3) to body wiring harness (10).
2. Install clamp (9) on D-beam (6) with screw (11).
3. Install receptacle assembly (3) and receptacle cover (2) on mounting bracket (4) with four capscrews (1) and assembled locknuts (13).

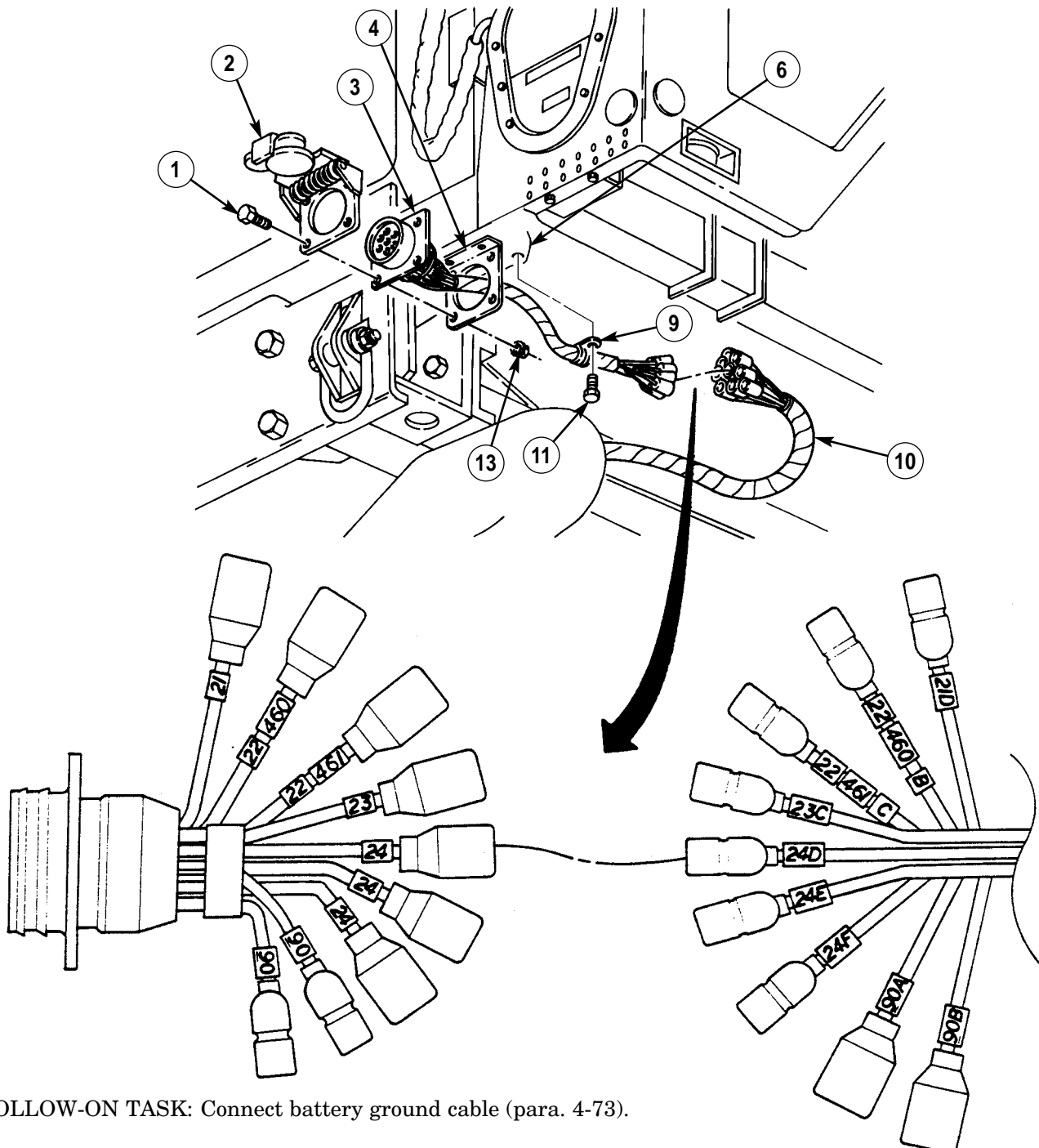

FOLLOW-ON TASK: Connect battery ground cable (para. 4-73).

12-164. REAR BUMPER REPLACEMENT (L119)

This task covers:

a. Removal

b. Installation

INITIAL SETUP:

Applicable Models

M1097, M1097A1, M1097A2

Tools

General mechanic's tool kit:
automotive (Appendix B, Item 1)

Materials/Parts

Four locknuts (Appendix G, Item 81)

Equipment Condition

- Towing pintle removed (para 9-12).
- Rear tiedown brackets (L119) removed (para 12-172).

a. Removal

Remove four locknuts (6), washers (5), capscrews (3), washers (2), and bumper (4) from two inner mounting brackets (1). Discard locknuts (6).

b. Installation

Install bumper (4) on two inner mounting brackets (1) with four washers (2), capscrews (3), washers (5), and locknuts (6). Tighten locknuts (6) to 90 lb-ft (122 N·m).

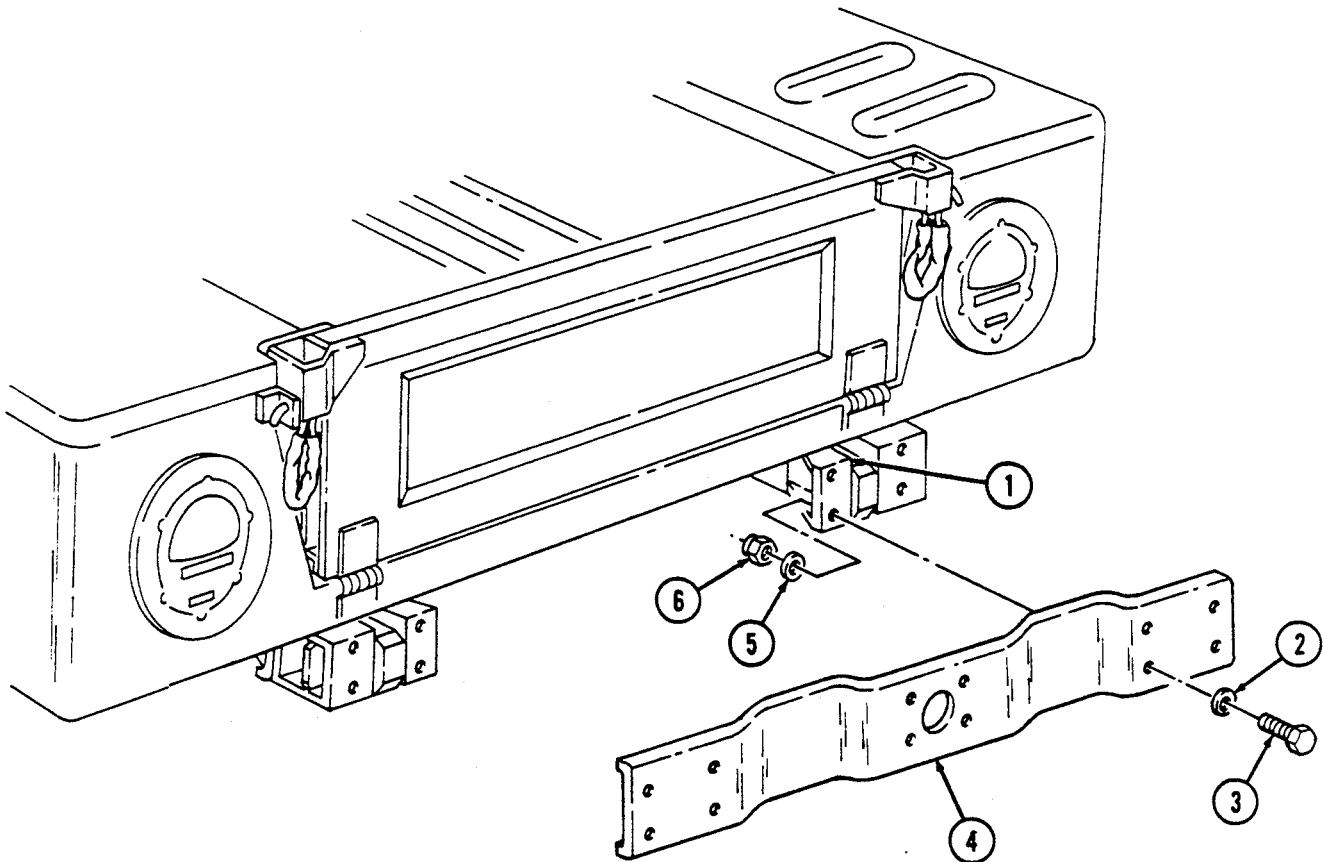

FOLLOW-ON TASKS: • Install rear tiedown brackets (L119) (para 12-172).
• Install towing pintle (para 9-12).

12-165. REAR BUMPER BRACE BRACKET REPLACEMENT (L119)

This task covers:

a. Removal

b. Installation

INITIAL SETUP:

Applicable Models

M1097, M1097A1, M1097A2

Manual References

TM 9-2320-280-10

Tools

General mechanic's tool kit:
automotive (Appendix B, Item 1)

Equipment Condition

- Pioneer tool stowage rack removed (TM 9-2320-280-10).
- Towing pintle removed (para 9-12).

Materials/Parts

Four locknuts (Appendix G, Item 81)

a. Removal

Remove four locknuts (6), washers (5), capscrews (3), washers (2) and brace bracket (4) from rear bumper (7) and two inner braces (1). Discard locknuts (6).

b. Installation

1. Install brace bracket (4) on rear bumper (7) and two inner braces (1).
2. Secure brace bracket (4) to two inner braces (1) with four washers (2), capscrews (3), washers (5), and locknuts (6). Tighten locknuts (6) to 90 lb-ft (122 N·m).

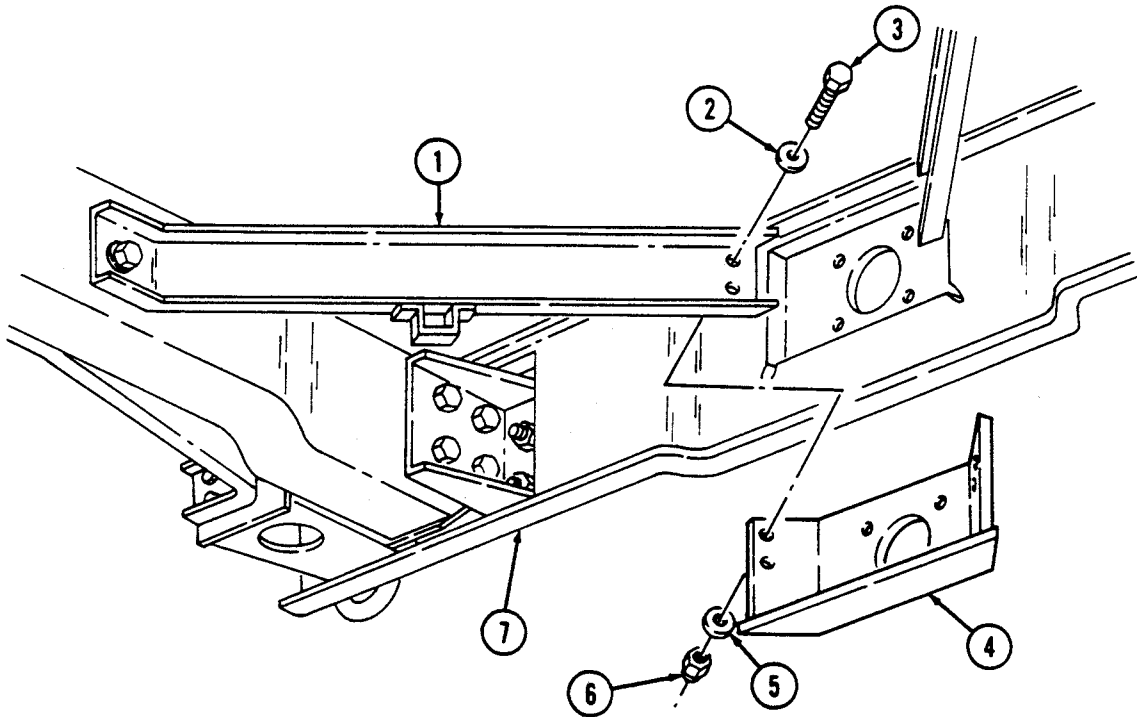

- FOLLOW-ON TASKS:**
- Install towing pintle (para 9-12).
 - Install pioneer tool stowage rack (TM 9-2320-280-10).

12-166. REAR BUMPER OUTER BRACE REPLACEMENT (L119)

This task covers:

a. Removal

b. Installation

INITIAL SETUP:

Applicable Models

M1097, M1097A1, M1097A2

Materials/Parts

Three locknuts (Appendix G, Item 81)

Tools

General mechanic's tool kit:
automotive (Appendix B, Item 1)

Manual References

TM 9-2320-280-24P

a. Removal

1. Remove locknut (7), washer (8), capscrew (10), and washer (9) from outer brace (4) and frame (11). Discard locknut (7).
2. Remove two locknuts (2), washers (3), capscrews (6), washers (5), and outer brace (4) from outer mounting bracket (1). Discard locknuts (2).

b. Installation

1. Install outer brace (4) on outer mounting bracket (1) with two washers (5), capscrews (6), washers (3), and locknuts (2). Tighten locknuts (2) to 90 lb-ft (122 N·m).
2. Install outer brace (4) on frame (11) with washer (9), capscrew (10), washer (8), and locknut (7). Tighten locknut (7) to 90 lb-ft (122 N·m).

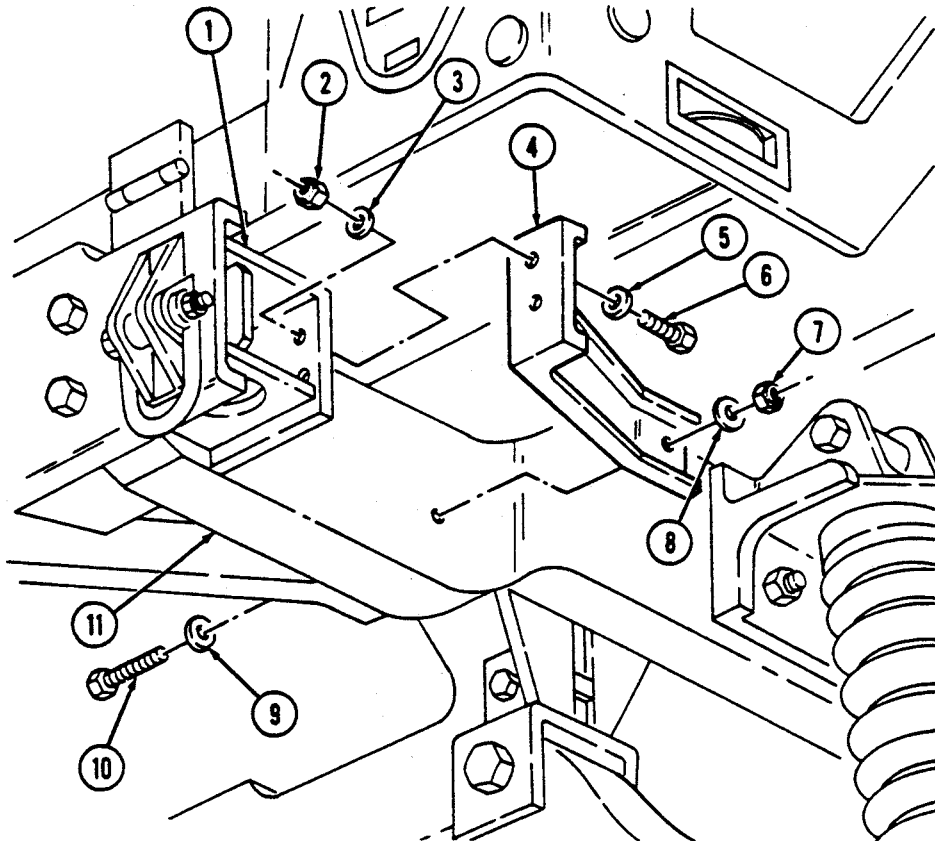

12-167. REAR BUMPER OUTER MOUNTING BRACKET REPLACEMENT (L119)

This task covers:

a. Removal

b. Installation

INITIAL SETUP:

Applicable Models

M1097, M1097A1, M1097A2

Manual References

TM 9-2320-280-24P

Tools

General mechanic's tool kit:
automotive (Appendix B, Item 1)

Equipment Condition

Rear tiedown bracket removed (para 12-172).

Materials/Parts

Six locknuts (Appendix G, Item 81)

a. Removal

1. Remove two locknuts (2), washers (3), capscrews (7), and washers (6) from outer mounting bracket (1) and outer brace (9). Discard locknuts (2).
2. Loosen locknut (8) from outer brace (9) and frame (10).
3. Remove four locknuts (11), washers (12), capscrews (4), washers (5), outer mounting bracket (1) and spacer (13) from frame (10). Discard locknuts (11).

b. Installation

1. Install outer mounting bracket (1) and spacer (13) on frame (10) with four washers (5), capscrews (4), washers (12), and locknuts (11). Tighten locknuts (11) to 90 lb-ft (122 N·m).
2. Install outer mounting bracket (1) on outer brace (9) with two washers (6), capscrews (7), washers (3), and locknuts (2). Tighten locknuts (2) to 90 lb-ft (122 N·m).
3. Tighten locknut (8) on outer brace (9) to 90 lb-ft (122 N·m).

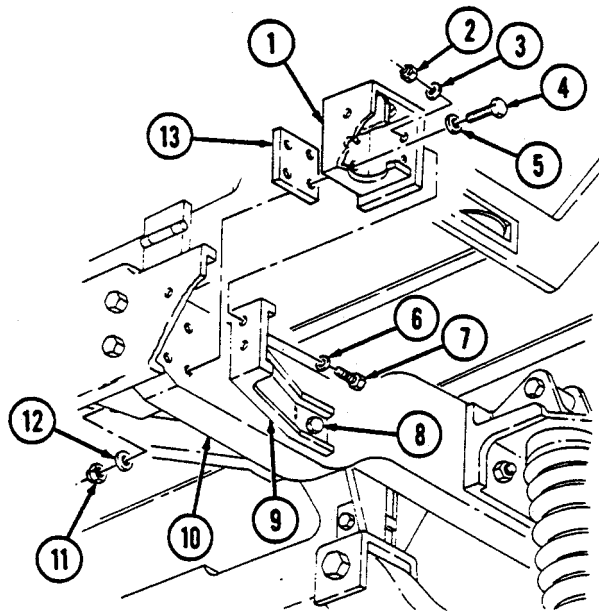

FOLLOW-ON TASKS: Install rear tiedown bracket (para 12-172).

12-168. REAR BUMPER INNER BRACE REPLACEMENT (L119)

This task covers:

a. Removal

b. Installation

INITIAL SETUP:

Applicable Models

M1097, M1097A1, M1097A2

Tools

General mechanic's tool kit:
automotive (Appendix B, Item 1)

Materials/Parts

Three locknuts (Appendix G, Item 81)

Manual References

TM 9-2320-280-10
TM 9-2320-280-24P

Equipment Condition

- Pioneer tool stowage rack removed (TM 9-2320-280-10).
- Pioneer tool stowage rack latch strike removed (para. 12-170).

a. Removal

1. Remove locknut (5), washer (4), capscrew (8), and washer (7) from inner brace (9) and frame (6). Discard locknut (5).
2. Remove two locknuts (3), washers (2), capscrews (10), washers (11), and inner brace (9) from brace bracket (1). Discard locknuts (3).

b. Installation

1. Install inner brace (9) on brace bracket (1) with two washers (11), capscrews (10), washers (2), and locknuts (3). Tighten locknuts (3) to 90 lb-ft (122 N·m).
2. Install inner brace (9) on frame (6) with washer (7), capscrew (8), washer (4), and locknut (5). Tighten locknut (5) to 90 lb-ft (122 N·m).

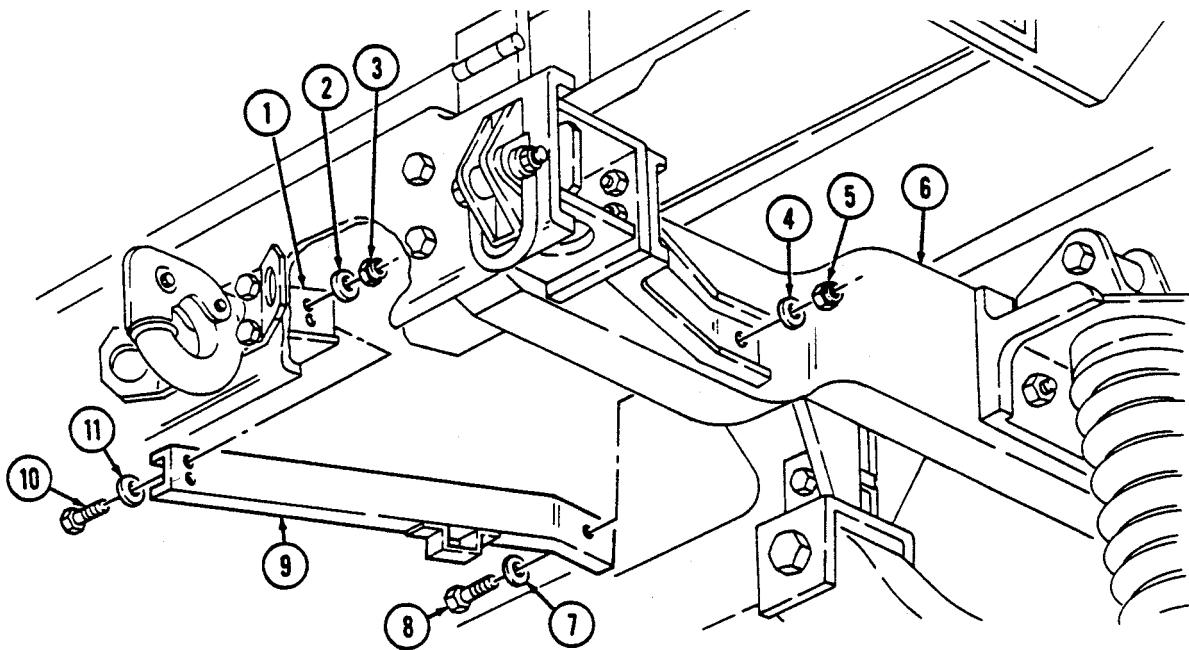

- FOLLOW-ON TASKS:
- Install pioneer tool stowage rack latch strike (para. 12-170).
 - Install pioneer tool stowage rack (TM 9-2320-280-10).

12-169. REAR BUMPER INNER MOUNTING BRACKET REPLACEMENT (L119)

This task covers:

a. Removal

b. Installation

INITIAL SETUP:

Applicable Models

M1097, M1097A1, M1097A2

Tools

General mechanic's tool kit:
automotive (Appendix B, Item 1)

Materials/Parts

Six locknuts (Appendix G, Item 81)

Manual References

TM 9-2320-280-10
TM 9-2320-280-24P

Equipment Condition

Pioneer tool stowage rack removed
(TM 9-2320-280-10).

a. Removal

1. Remove two locknuts (7), washers (8), capscrews (1), and washers (2) from inner mounting bracket (10) and bumper (13). Discard locknuts (7).
2. Remove four locknuts (11), washers (12), capscrews (4), washers (3), inner mounting bracket (10), and spacers (9) and (6) from frame (5).

b. Installation

1. Install inner mounting bracket (10) and spacers (9) and (6) on frame (5) with four washers (3), capscrews (4), washers (12), and locknuts (11). Tighten locknuts (11) to 90 lb-ft (122 N-m).
2. Install inner mounting bracket (10) on bumper (13) with two washers (2), capscrews (1), washers (8), and locknuts (7). Tighten locknuts (7) to 90 lb-ft (122 N-m).

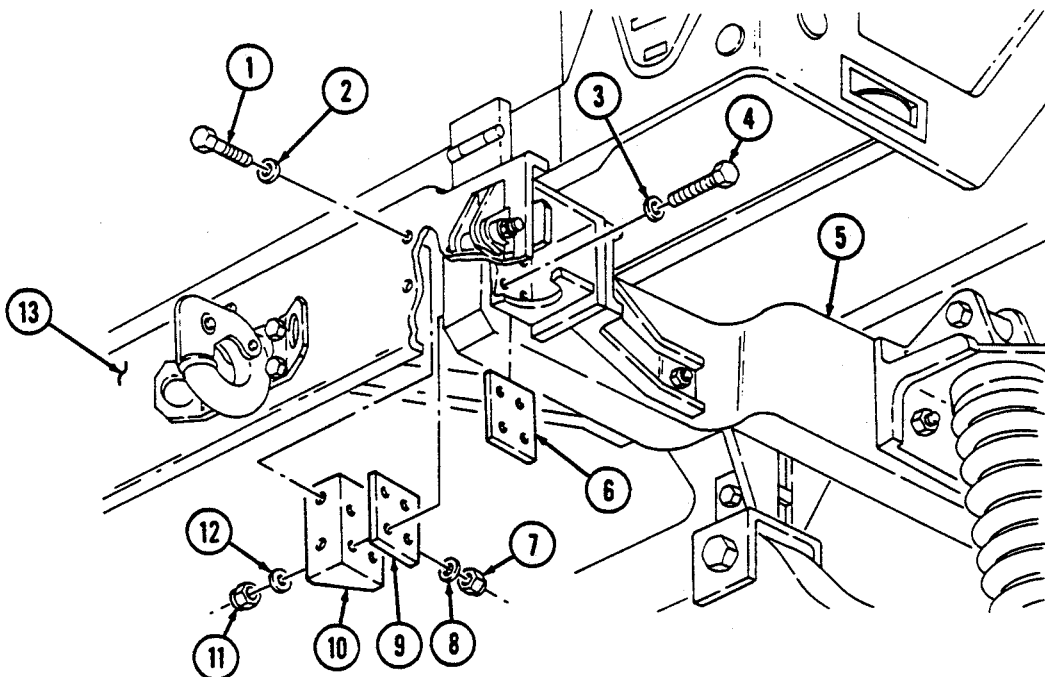

FOLLOW-ON TASK: Install pioneer stowage rack (TM 9-2320-280-10).

12-170. PIONEER TOOL STOWAGE RACK LATCH STRIKE REPLACEMENT (L119)

This task covers:

a. Removal

b. Installation

INITIAL SETUP:

Applicable Models

M1097, M1097A1, M1097A2

Tools

General mechanic's tool kit:
automotive (Appendix B, Item 1)

Materials/Parts

Two lockwashers (Appendix G, Item 138)

Manual References

TM 9-2320-280-10
TM 9-2320-280-24P

Equipment Condition

Pioneer tool stowage rack removed
(TM 9-2320-280-10).

a. Removal

Remove two nuts (5), lockwashers (4), screws (2), and latch strike (3) from rear bumper inner brace (1). Discard lockwashers (4).

b. Installation

Install latch strike (3) on rear bumper inner brace (1) with two screws (2), lockwashers (4), and nut (5).

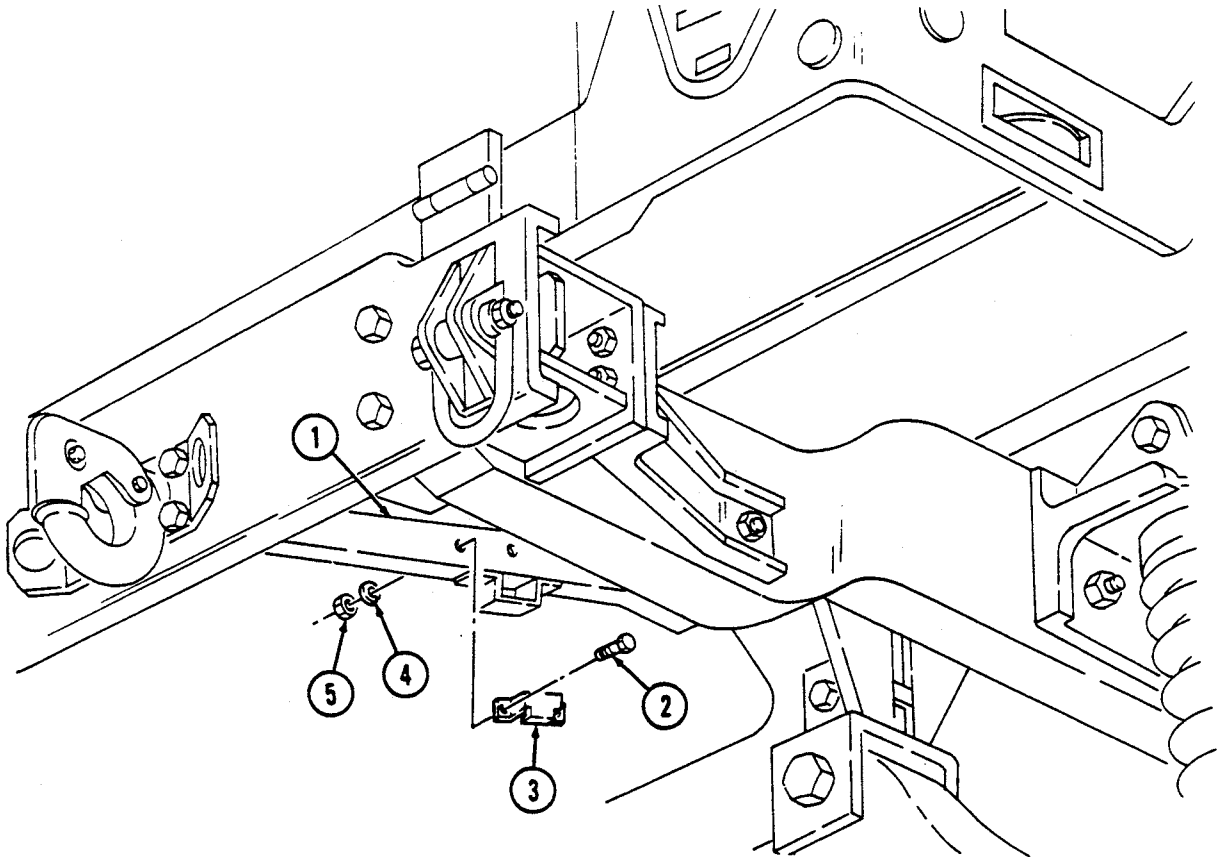

FOLLOW-ON TASK: Install pioneer tool stowage rack (TM 9-2320-280-10).

12-171. REAR BUMPER LIFTING SHACKLE REPLACEMENT (L119)

This task covers:

a. Removal

b. Installation

INITIAL SETUP:

Applicable Models

M1097, M1097A1, M1097A2

Materials/Parts

Cotter pin (Appendix G, Item 14)

Tools

General mechanic's tool kit:
automotive (Appendix B, Item 1)

Manual References

TM 9-2320-280-24P

a. Removal

Remove cotter pin (6), slotted nut (1), spring washer (5), capscrew (3), and shackle (4) from tiedown bracket (2). Discard cotter pin (6).

b. Installation

1. Install shackle (4) on tiedown bracket (2) with capscrew (3), spring washer (5), and slotted nut (1). Tighten slotted nut (1) enough to allow movement of shackle (4).
2. Install cotter pin (6) on slotted nut (1).

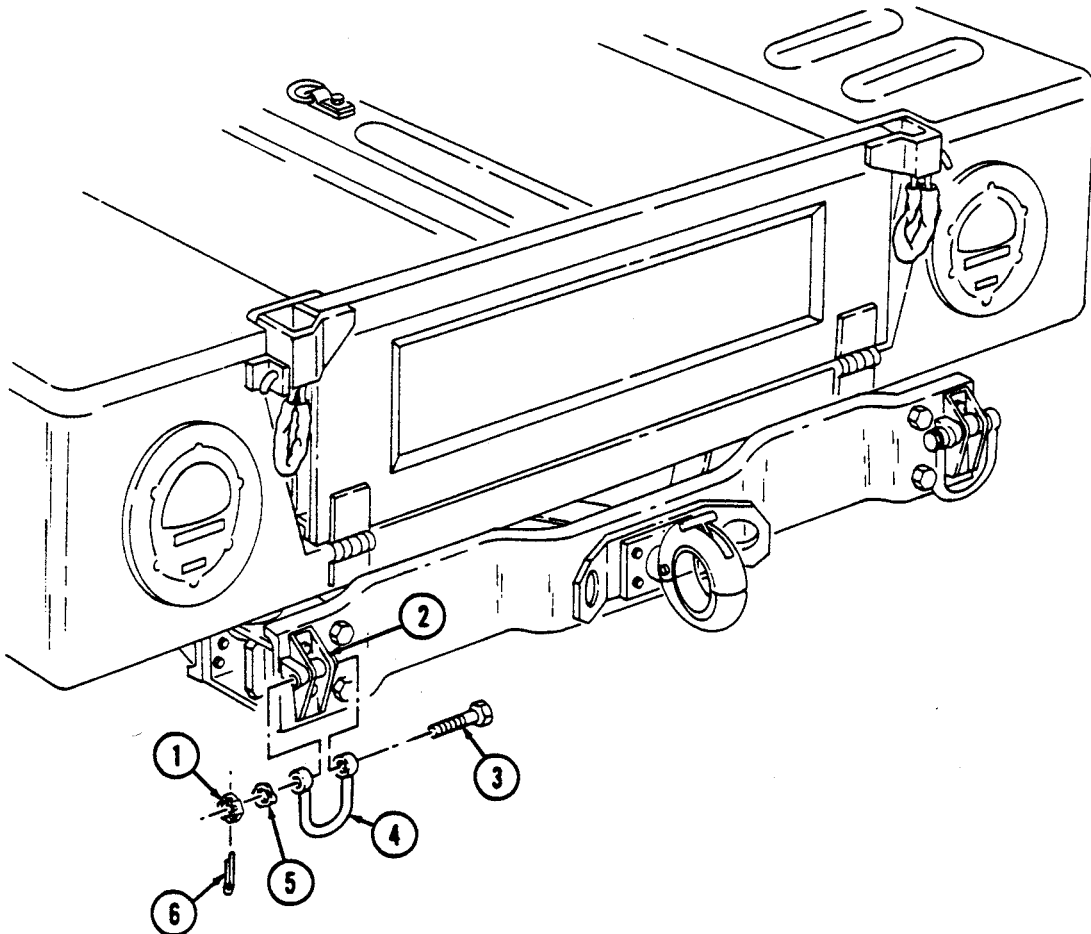

12-172. REAR TIEDOWN BRACKET REPLACEMENT (L119)

This task covers:

a. Removal

b. Installation

INITIAL SETUP:

Applicable Models

M1097, M1097A1, M1097A2

Tools

General mechanic's tool kit:
automotive (Appendix B, Item 1)

Materials/Parts

Two locknuts (Appendix G, Item 81)

Manual References

TM 9-2320-280-24P

Equipment Condition

Rear bumper lifting shackle (L119) removed
(para. 12-171).

a. Removal

Remove two locknuts (4), washers (3), capscrews (6), washers (5), and tiedown bracket (2) from rear bumper (1).

b. Installation

Install tiedown bracket (2) on rear bumper (1) with two washers (5), capscrews (6), washers (3), and locknuts (4). Tighten locknuts (4) to 90 lb-ft (122 N·m).

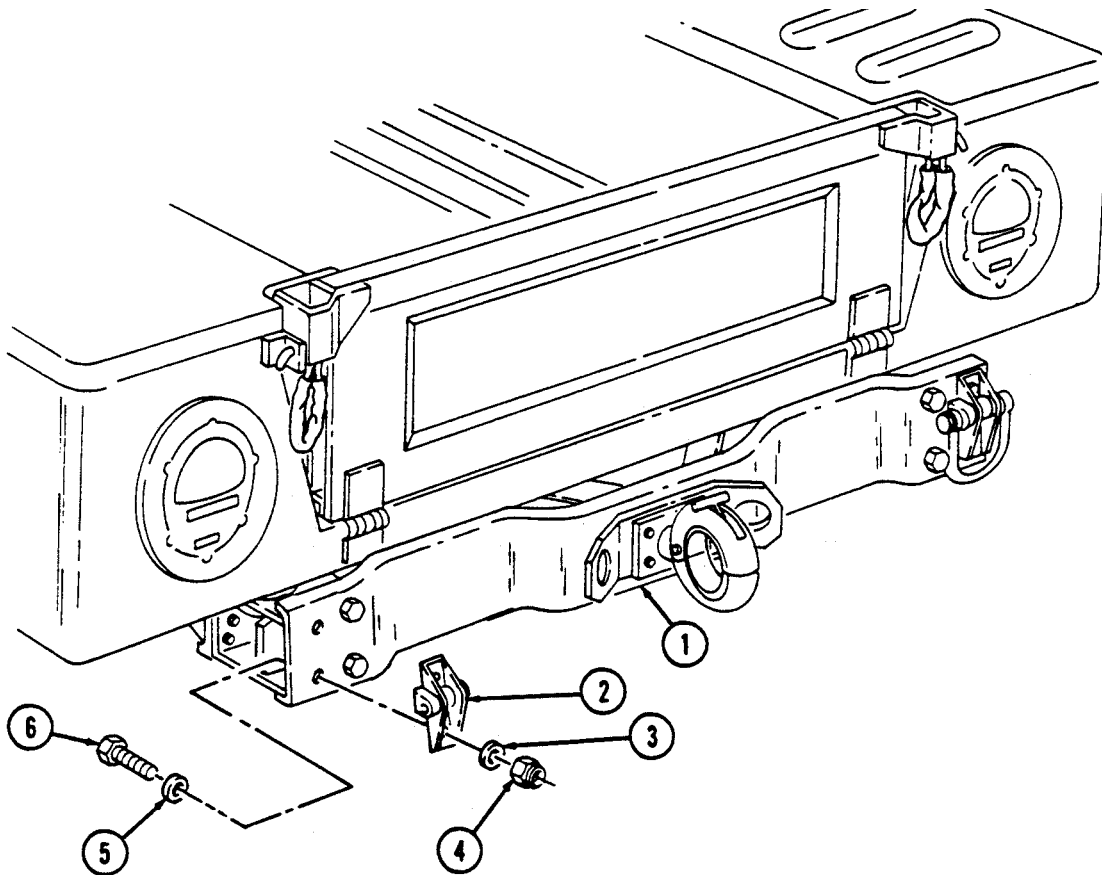

FOLLOW-ON TASK: Install rear bumper lifting shackle (L119) (para. 12-171).

12-173. AMMO TIEDOWN STRAP REPLACEMENT (L119)

This task covers:

a. Removal

b. Installation

INITIAL SETUP:

Applicable Models

M1097, M1097A1, M1097A2

Tools

General mechanic's tool kit:
automotive (Appendix B, Item 1)

Materials/Parts

Two locknuts (Appendix G, Item 70)

Manual References

TM 9-2320-280-24P

Personnel Required

One mechanic
One assistant

a. Removal

1. Remove two locknuts (1), washers (9), reinforcement (11), screws (8), washers (9), and footman loop (10) from strap (5) and wheelhouse (2). Discard locknuts (1).
2. Slide strap (5) through footman loop (3) on wedge (4).
3. Remove strap hook (6) from slot in ammo rack assembly (7) and remove strap (5).

b. Installation

1. Slide strap (5) on footman loop (10). Install footman loop (10) and strap (5) on wheelhouse (2) with two washers (9), screws (8), reinforcement (11), washers (9), and locknuts (1).
2. Install strap (5) through footman loop (3) on wedge (4).
3. Attach strap hook (6) to slot in ammo rack assembly (7).

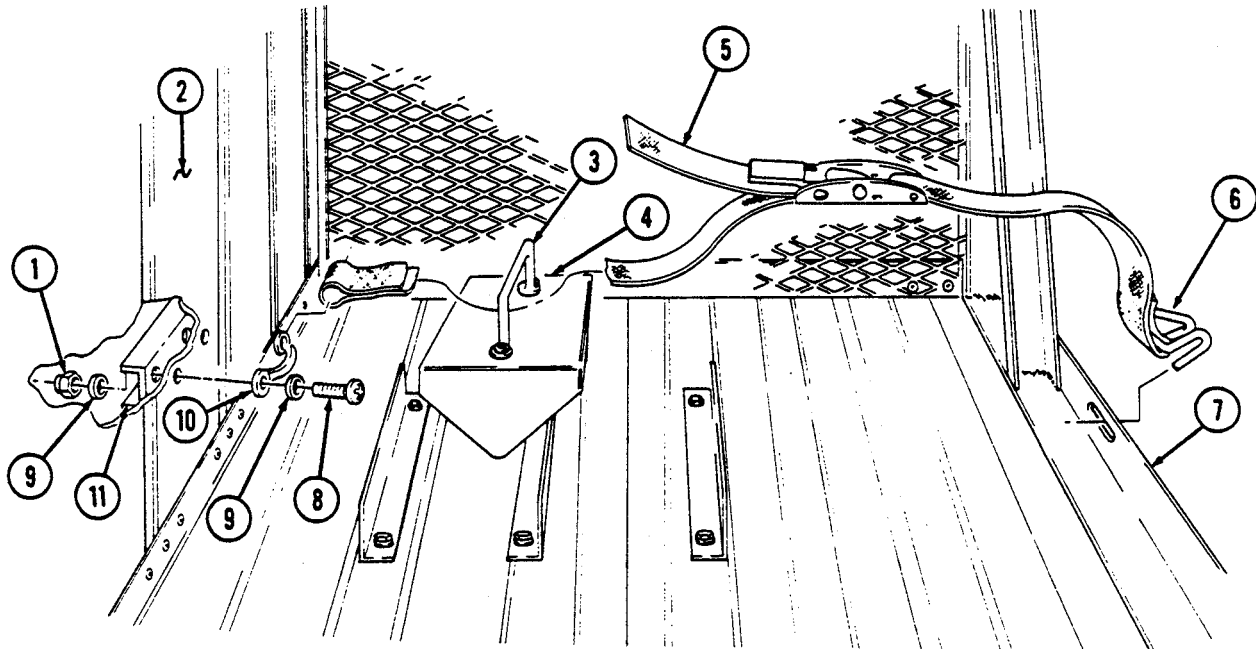

12-174. AMMO DIVIDER REPLACEMENT (L119)

This task covers:

a. Removal

b. Installation

INITIAL SETUP:

Applicable Models

M1097, M1097A1, M1097A2

Manual References

TM 9-2320-280-24P

Tools

General mechanic's tool kit:
automotive (Appendix B, Item 1)

Equipment Condition

Ammo tiedown strap removed (para. 12-173).

a. Removal

Remove two capscrews (2), washers (1), and ammo divider (3) from cargo floor (4).

b. Installation

Install ammo divider (3) on cargo floor (4) with two washers (1) and capscrews (2).

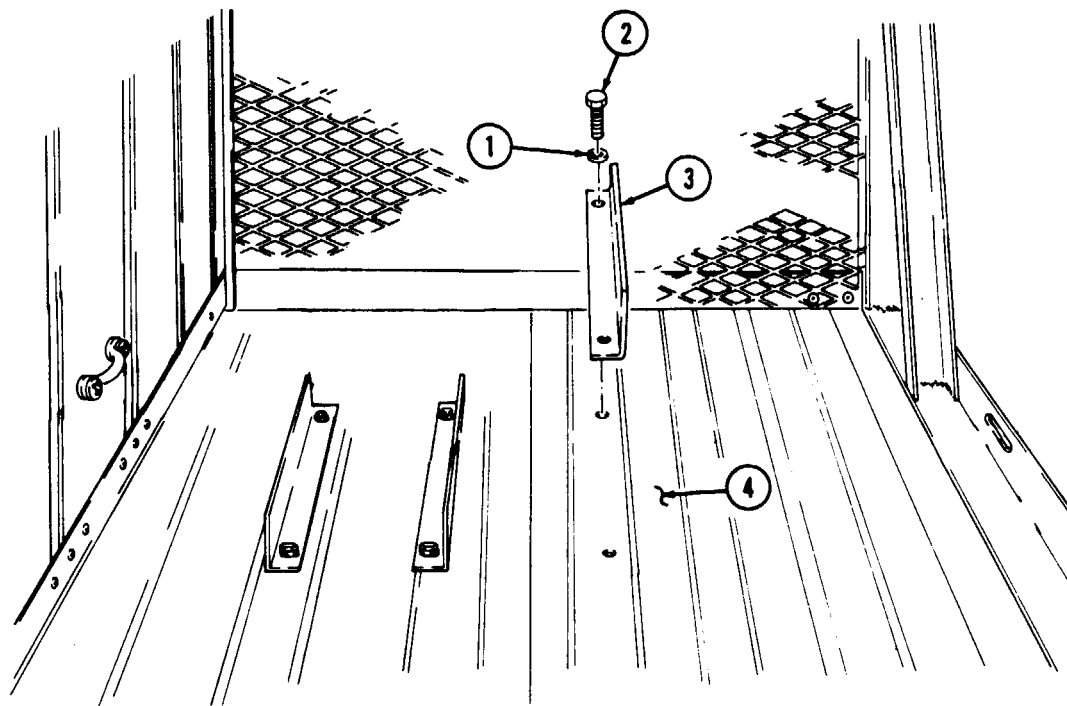

FOLLOW-ON TASK: Install ammo tiedown strap (para. 12-173).

12-175. TELEPHONE STRAP REPLACEMENT (L119)

This task covers:

a. Removal

b. Installation

INITIAL SETUP:

Applicable Models

M1097, M1097A1, M1097A2

Tools

General mechanic's tool kit:
automotive (Appendix B, Item 1)

Materials/Parts

Two locknuts (Appendix G, Item 96)

Personnel Required

One mechanic
One assistant

Manual References

TM 9-2320-280-10
TM 9-2320-280-24P

Equipment Condition

Troop seat (R.H.) raised (TM 9-2320-280-10).

NOTE

The telephone strap, remote strap, and cable reel strap are replaced basically the same. This procedure covers the telephone strap replacement.

a. Removal

1. Remove two locknuts (8), washers (7), and screws (4) footman loop (5), and strap (3) from fixed door (6). Discard locknuts (8).
2. Remove strap hook (1) from footman loop (2) and remove strap (3).

b. Installation

1. Slide strap (3) onto footman loop (5). Install footman loop (5) and strap (3) on fixed door (6) with two screws (4), washers (7), and locknuts (8).
2. Attach strap hook (1) on footman loop (2).

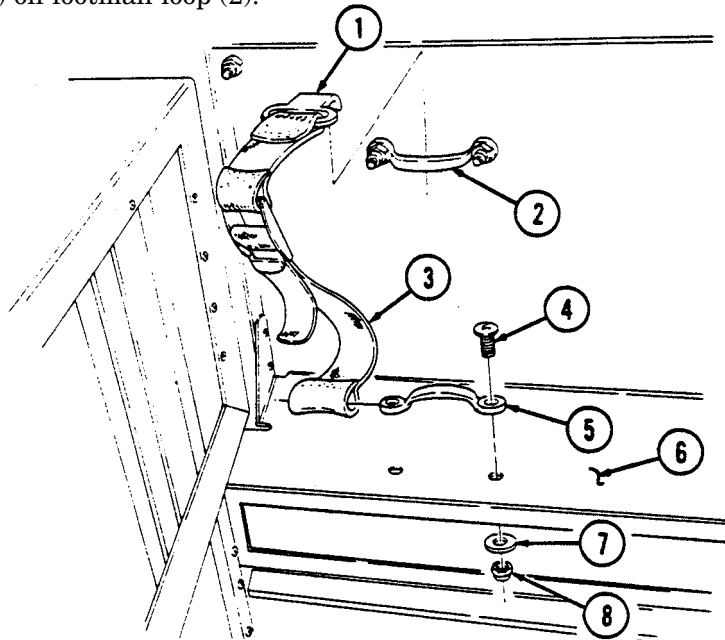

FOLLOW-ON TASK: Lower right troop seat (TM 9-2320-280-10).

12-176. SECTION CHEST STRAP REPLACEMENT (L119)

This task covers:

a. Removal

b. Installation

INITIAL SETUP:

Applicable Models

M1097, M1097A1, M1097A2

Manual References

TM 9-2320-280-24P

Tools

General mechanic's tool kit:
automotive (Appendix B, Item 1)

NOTE

The section chest straps, aiming post straps, and spade straps are replaced basically the same. This procedure covers the section chest strap.

a. Removal

Remove two screws (1), footman loop (2), and strap (4) from body (3) and remove footman loop (2) from strap (4).

b. Installation

Slide strap (4) onto footman loop (2). Install footman loop (2) and strap (4) on body (3) with two screw (1).

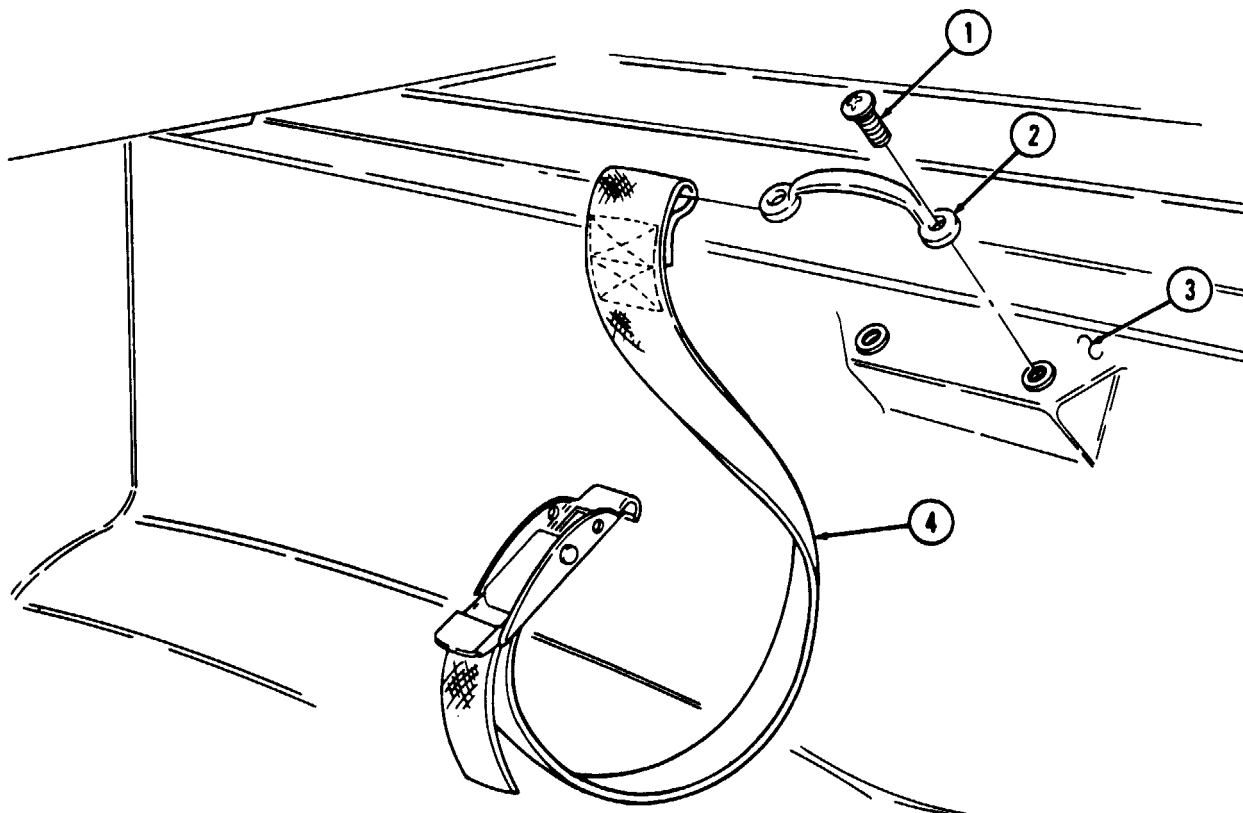

12-177. TRIPOD STRAP REPLACEMENT (L119)

This task covers:

a. Removal

b. Installation

INITIAL SETUP:

Applicable Models

M1097, M1097A1, M1097A2

Manual References

TM 9-2320-280-10
 TM 9-2320-280-24P

Tools

General mechanic's tool kit:
 automotive (Appendix B, Item 1)

Equipment Condition

Troop seat (R.H.) raised (TM 9-2320-280-10).

Materials/Parts

Four locknuts (Appendix G, Item 97)

a. Removal

1. Remove strap hook (7) from strap buckle (5).
2. Remove four locknuts (4), screws (1), two footman loops (3), and straps (6) from troop seat (2). Discard locknuts (4).

b. Installation

1. Slide straps (6) onto two footman loops (3). Install footman loops (3) and straps (6) on troop seat (2) with four screws (1) and locknuts (4).
2. Attach strap hook (7) on strap buckle (5).

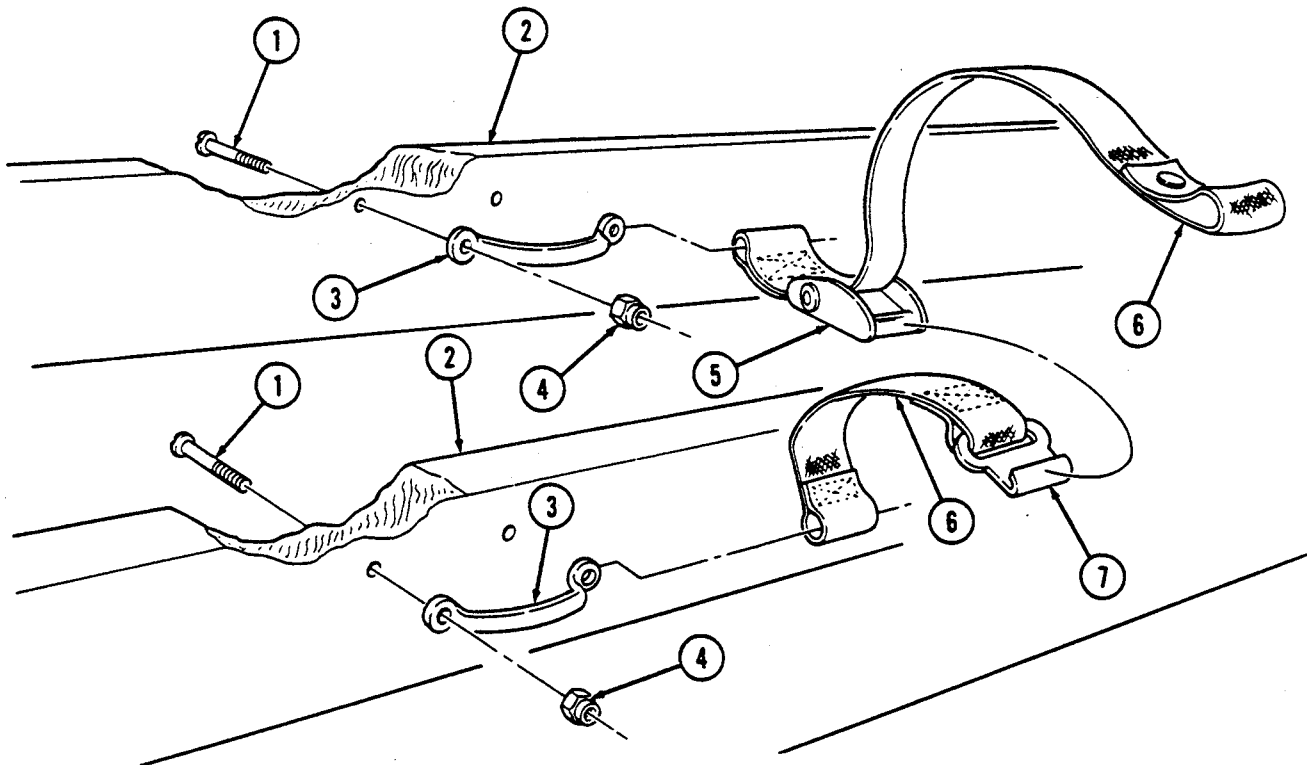

FOLLOW-ON TASK: Lower right troop seat (TM 9-2320-280-10).

12-178. GUN DISPLAY UNIT BATTERY STRAP REPLACEMENT (L119)

This task covers:

a. Removal

b. Installation

INITIAL SETUP:

Applicable Models

M1097, M1097A1, M1097A2

Tools

General mechanic's tool kit:
automotive (Appendix B, Item 1)

Materials/Parts

Four locknuts (Appendix G, Item 97)

Personnel Required

One mechanic
One assistant

Manual References

TM 9-2320-280-10
TM 9-2320-280-24P

Equipment Condition

Left troop seat raised (TM 9-2320-280-10).

NOTE

The G.D.U. battery strap and G.D.U. strap are replaced basically the same. This procedure covers the G.D.U. battery strap.

a. Removal

1. Remove strap hook (3) from strap buckle (2).
2. Remove two locknuts (7), screws (5), washers (4), footman loop (6), and strap (1) from fixed door (8). Discard locknuts (7).
3. Remove two locknuts (9), screws (11), footman loop (10), and strap (1) from fixed door (8). Discard locknuts (9).

b. Installation

1. Slide strap (1) onto footman loop (6). Install footman loop (6) and strap (1) on fixed door (8) with two washers (4), screws (5), and locknuts (7).
2. Slide strap (1) onto footman loop (10). Install footman loop (10) and strap (1) on fixed door (8) with two screws (11) and locknuts (9).
3. Attach strap hook (3) to strap buckle (2).

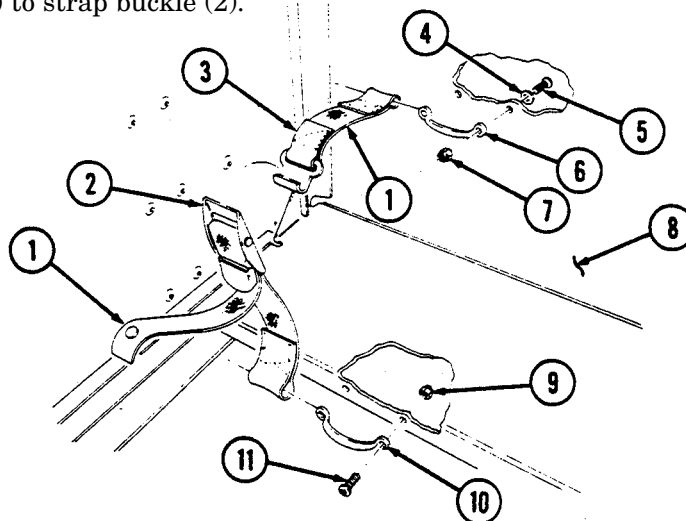

FOLLOW-ON TASK: Lower left troop seat (TM 9-2320-280-10).

12-179. SIGHT BOX STRAPS REPLACEMENT (L119)

This task covers:

a. Removal

b. Installation

INITIAL SETUP:

Applicable Models

M1097, M1097A1, M1097A2

Materials/Parts

Six locknuts (Appendix G, Item 97)

Tools

General mechanic's tool kit:
automotive (Appendix B, Item 1)

Manual References

TM 9-2320-280-24P

NOTE

The sight box #1 straps and the sight box #2 strap are replaced basically the same. This procedure covers the sight box #1 straps.

a. Removal

1. Remove strap hooks (5) from strap buckles (6).
2. Remove four locknuts (4), screws (1), two footman loops (3), and straps (7) and (16) from ammo rack (2). Discard locknuts (4).
3. Remove two locknuts (10), screws (8), footman loop (9), and strap (7) from "C" beam (11). Discard locknuts (10).
4. Remove two screws (15), washers (14), flat footman loop (13), and strap (16) from cargo floor (12). Remove strap (16).

b. Installation

1. Slide strap (16) onto flat footman loop (13). Install flat footman loop (13) and strap (16) on cargo floor (12) with two screws (15) and washers (14).
2. Slide strap (7) onto footman loop (9). Install footman loop (9) and strap (7) on "C" beam (11) with two screws (8) and locknuts (10).
3. Slide straps (7) and (16) onto two footman loops (3). Install footman loops (3) and straps (7) and (16) on ammo rack (2) with four screws (1) and locknuts (4).
4. Attach strap hooks (5) on strap buckles (6).

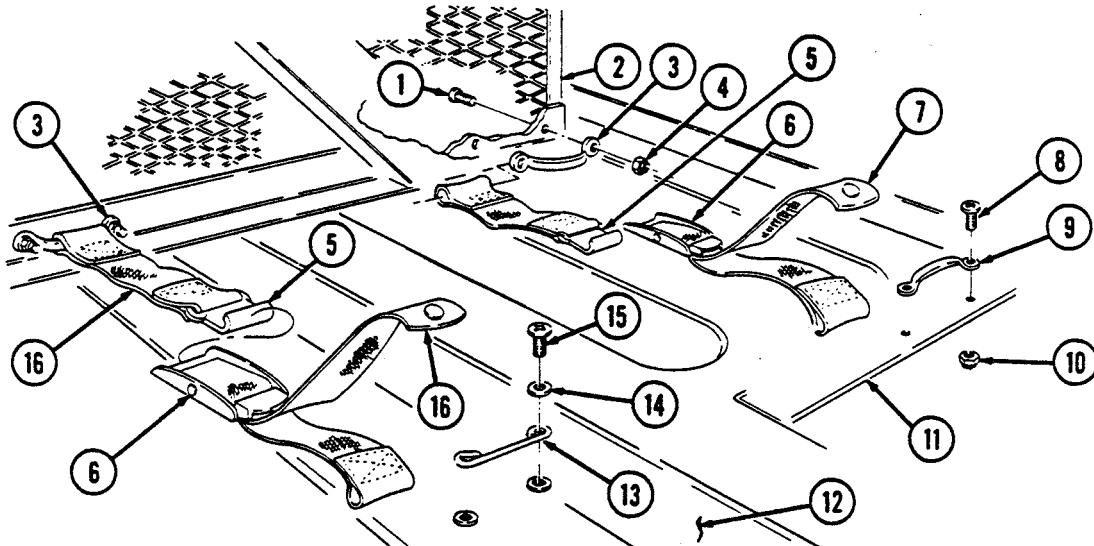

12-180. WATER/FUEL CAN STRAP REPLACEMENT (L119)

This task covers:

a. Removal

b. Installation

INITIAL SETUP:

Applicable Models

M1097, M1097A1, M1097A2

Tools

General mechanic's tool kit:
automotive (Appendix B, Item 1)

Materials/Parts

Two locknuts (Appendix G, Item 97)

Manual References

TM 9-2320-280-24P

Personnel Required

One mechanic
One assistant

a. Removal

1. Remove two locknuts (7), washers (6), screws (4), footman loop (5), and strap (3) from footwell (8). Discard locknuts (7).
2. Remove strap hook (2) from flat footman loop (1).

b. Installation

1. Slide strap (3) onto footman loop (5). Install footman loop (5) and strap (3) on footwell (8) with two screws (4), washers (6), and locknuts (7).
2. Attach strap hook (2) to flat footman loop (1).

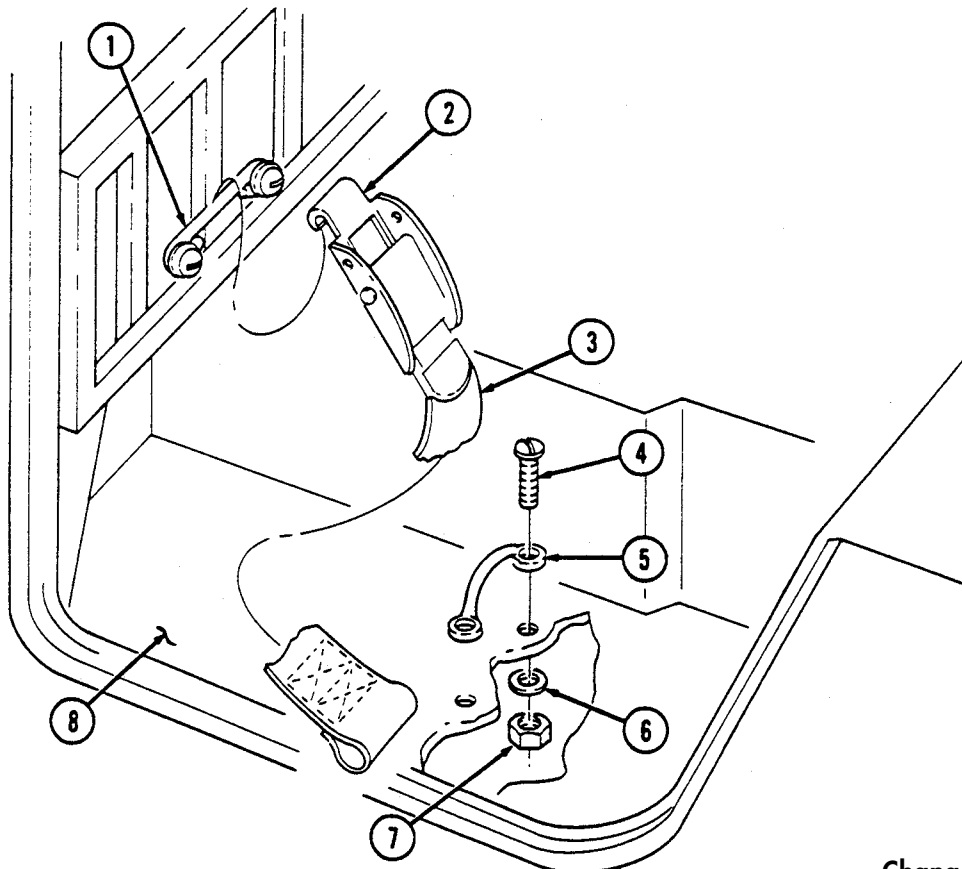

12-181. AMMO RACK MAINTENANCE (L119)

This task covers:

- | | |
|----------------|-----------------|
| a. Removal | c. Assembly |
| b. Disassembly | d. Installation |

INITIAL SETUP:

Applicable Models

M1097, M1097A1, M1097A2

Tools

General mechanic's tool kit:
automotive (Appendix B, Item 1)

Materials/Parts

Twelve locknuts (Appendix G, Item 70)
Twelve locknuts (Appendix G, Item 97)
Locknut (Appendix G, Item 81)
Four lockwashers (Appendix G, Item 135)

Personnel Required

One mechanic
One assistant

Manual References

TM 9-2320-280-10
TM 9-2320-280-24P

Equipment Condition

- Tailgate lowered (TM 9-2320-280-10).
- Troop seat (L.H.) raised (TM 9-2320-280-10).
- Sight box straps removed (para. 12-179).
- M60 machine gun straps removed (para. 12-182).

a. Removal

1. Remove twelve locknuts (9), washers (8), capscrews (5), and washers (6) from ammo rack assembly (3), two plates (7), and wheelhouse (10). Discard locknuts (9).
2. Remove locknut (14), washer (15), capscrew (2), and washer (1) from ammo rack assembly (3) and "D" beam (16). Discard locknut (14).
3. Remove six capscrews (12) and washers (13) from ammo rack assembly (3) and cargo floor (11).
4. Remove ammo tiedown strap hook (4) from ammo rack assembly (3).
5. Remove ammo rack assembly (3).

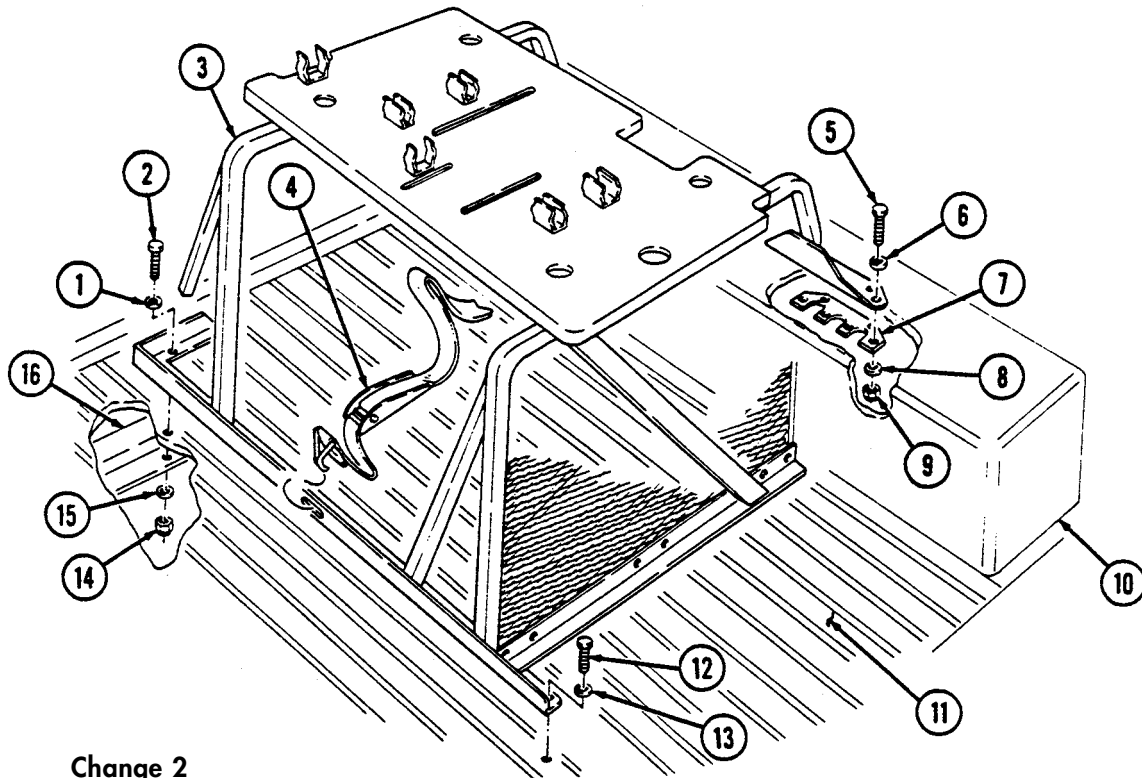

12-181. AMMO RACK MAINTENANCE (L119) (Cont'd)

b. Disassembly

1. Remove four locknuts (28), washers (29), screws (18), and two strut spring clips (17) from ammo rack top tray (21). Discard locknuts (28).
2. Remove eight locknuts (26), washers (27), screws (19), and four spike spring clips (20) from ammo rack top tray (21). Discard locknuts (26).
3. Remove four capscrews (22), lockwashers (23), washers (24), and ammo rack top tray (21) from ammo rack (25). Discard lockwashers (23).

c. Assembly

1. Install ammo rack top tray (21) on ammo rack (25) with four washers (24), lockwashers (23), and capscrews (22).
2. Install four spike spring clips (20) on ammo rack top tray (21) with eight screws (19), washers (27), and locknuts (26).
3. Install two strut spring clips (17) on ammo rack top tray (21) with four screws (18), washers (29), and locknuts (28).

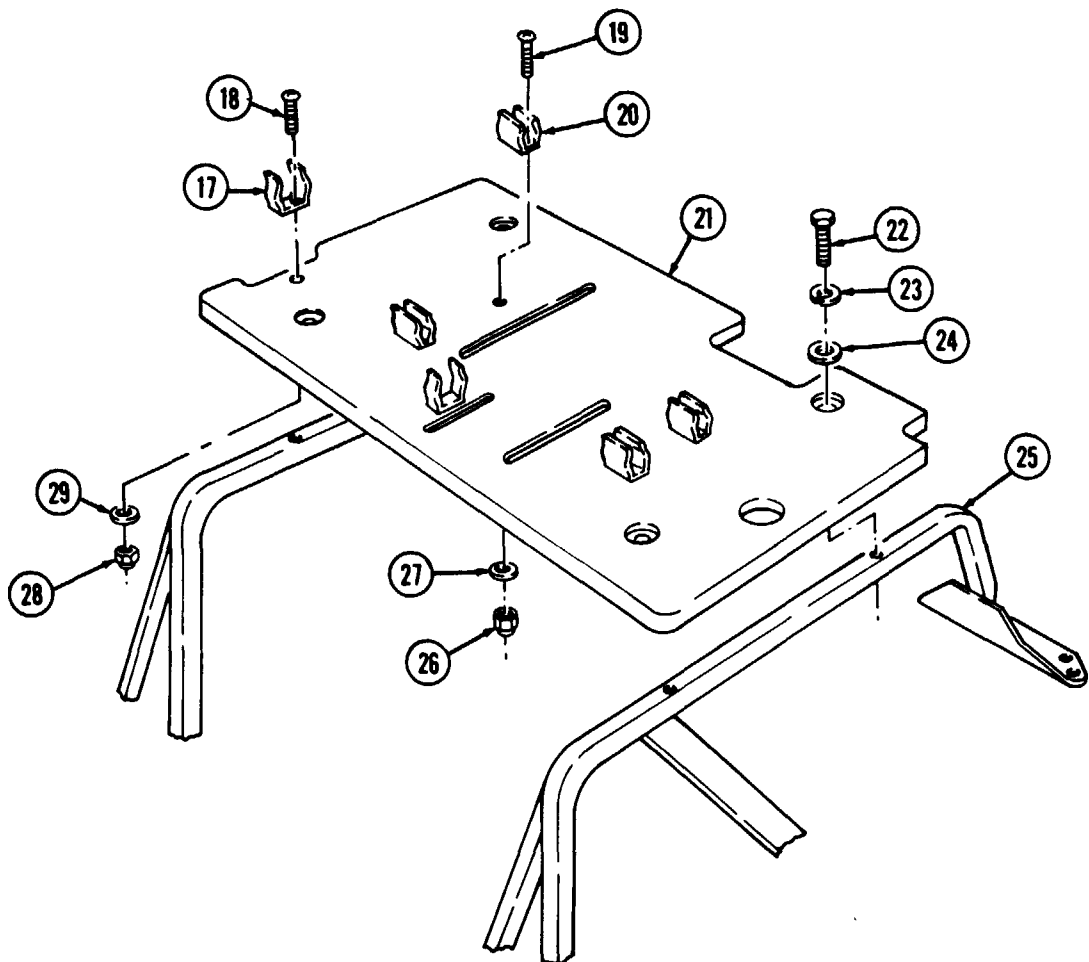

12-181. AMMO RACK MAINTENANCE (L119) (Cont'd)

d. Installation

1. Install ammo rack assembly (3) on cargo floor (11) with six washers (13) and capscrews (12).
2. Install ammo rack assembly (3) on "D" beam (16) with washer (1), capscrew (2), washer (15), and locknut (14).
3. Install ammo rack assembly (3) and two plates (7) on wheelhouse (10) with twelve washers (6), capscrews (5), washers (8), and locknuts (9).
4. Attach ammo tiedown strap hook (4) to ammo rack assembly (3).

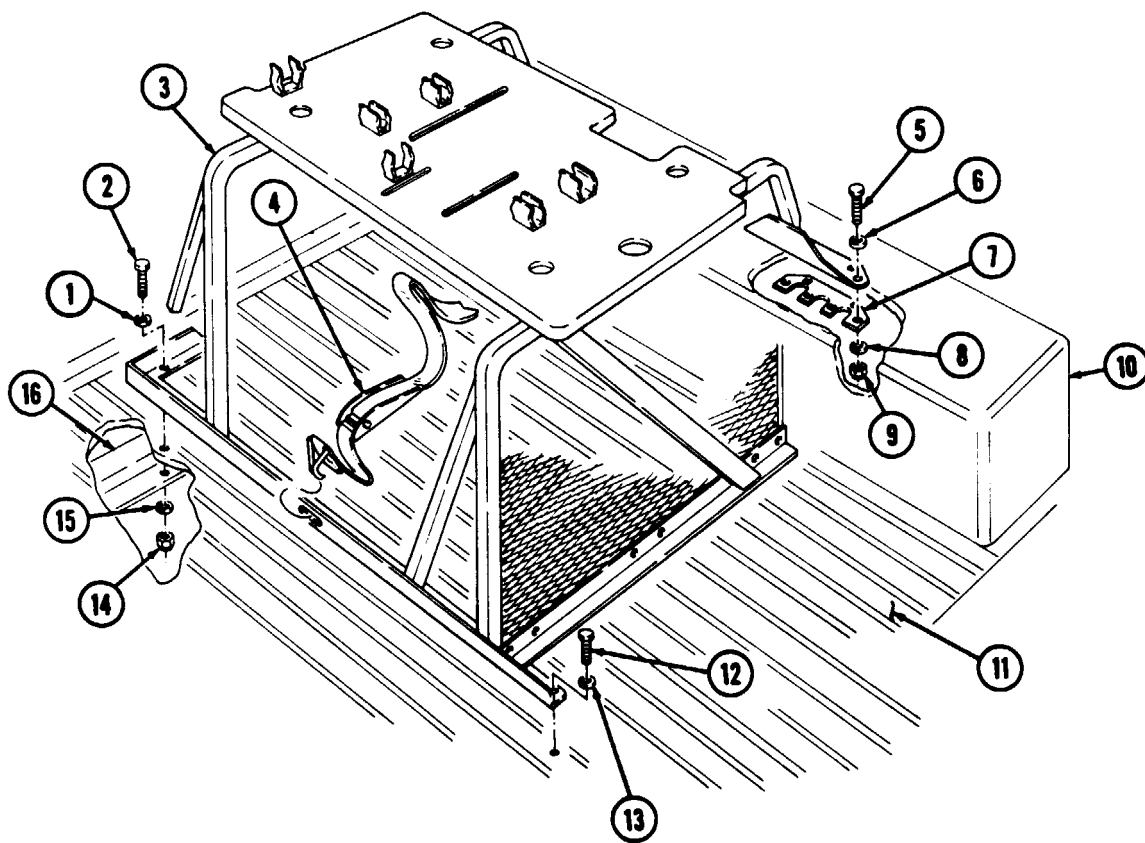

- FOLLOW-ON TASKS:
- Ž Install M60 machine gun straps (para. 12-182).
 - Ž Install sight box straps (para. 12-179).
 - Ž Lower troop seat (L. H.) (TM 9-2320-280-10).
 - Ž Raise tailgate (TM 9-2320-280-10).

12-182. M60 MACHINE GUN STRAP REPLACEMENT (L119)

This task covers:

a. Removal

b. Installation

INITIAL SETUP:

Applicable Models

M1097, M1097A1, M1097A2,

Materials/Parts

Two locknuts (Appendix G, Item 97)

Tools

General mechanic's tool kit:
automotive (Appendix B, Item 1)

Manual References

TM 9-2320-280-24P

a. Removal

1. Remove strap hook (4) from footman loop (3).
2. Remove two locknuts (7), washers (8), screws (2), footman loops (3) and (6), and strap (5) from ammo rack top tray (1). Remove strap (5) from loop (6). Discard locknuts (7).

b. Installation

1. Install strap (5) on loop (6) and footman loops (3) and (6) on ammo rack top tray (1) with two screws (2), washers (8), and locknuts (7).
2. Attach strap hook (4) to footman loop (3).

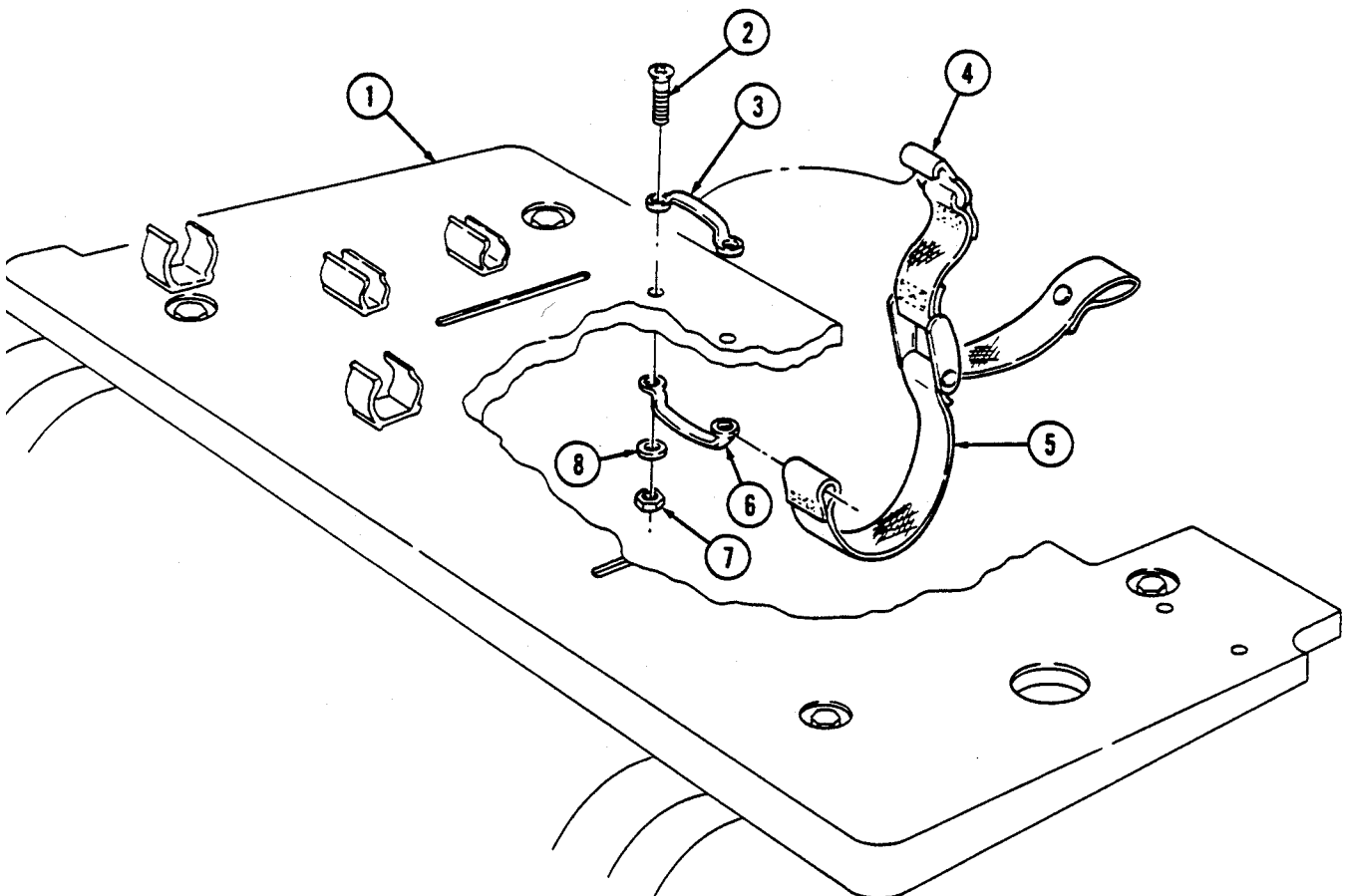

12-183. CAMOUFLAGE RACK MAINTENANCE

This task covers:

- | | |
|----------------|-----------------|
| a. Removal | c. Assembly |
| b. Disassembly | d. Installation |

INITIAL SETUP:

Applicable Models

M1097, M1097A1, M1097A2

Tools

General mechanic's tool kit:
automotive (Appendix B, Item 1)

Materials/Parts

Twelve locknuts (Appendix G, Item 70)
Eight locknuts (Appendix G, Item 79)
Six locknuts (Appendix G, Item 128)

Manual References

TM 9-2320-280-24P

Personnel Required

One mechanic
One assistant

a. Removal

1. Remove two access covers (17) from windshield (10).
2. Disconnect connector arms (16) from wiper arm pivots (15).
3. Remove four locknuts (7), washers (6), two brackets (9), lower front mounting brackets (5), and spacers (8) from windshield (10). Discard locknuts (7).
4. Remove two capscrews (12), washers (11), locknuts (2), washers (3), and two rear mounting brackets (1) and plates (13) from "B" pillar (14). Discard locknuts (2).
5. Remove camouflage rack (4) from vehicle.

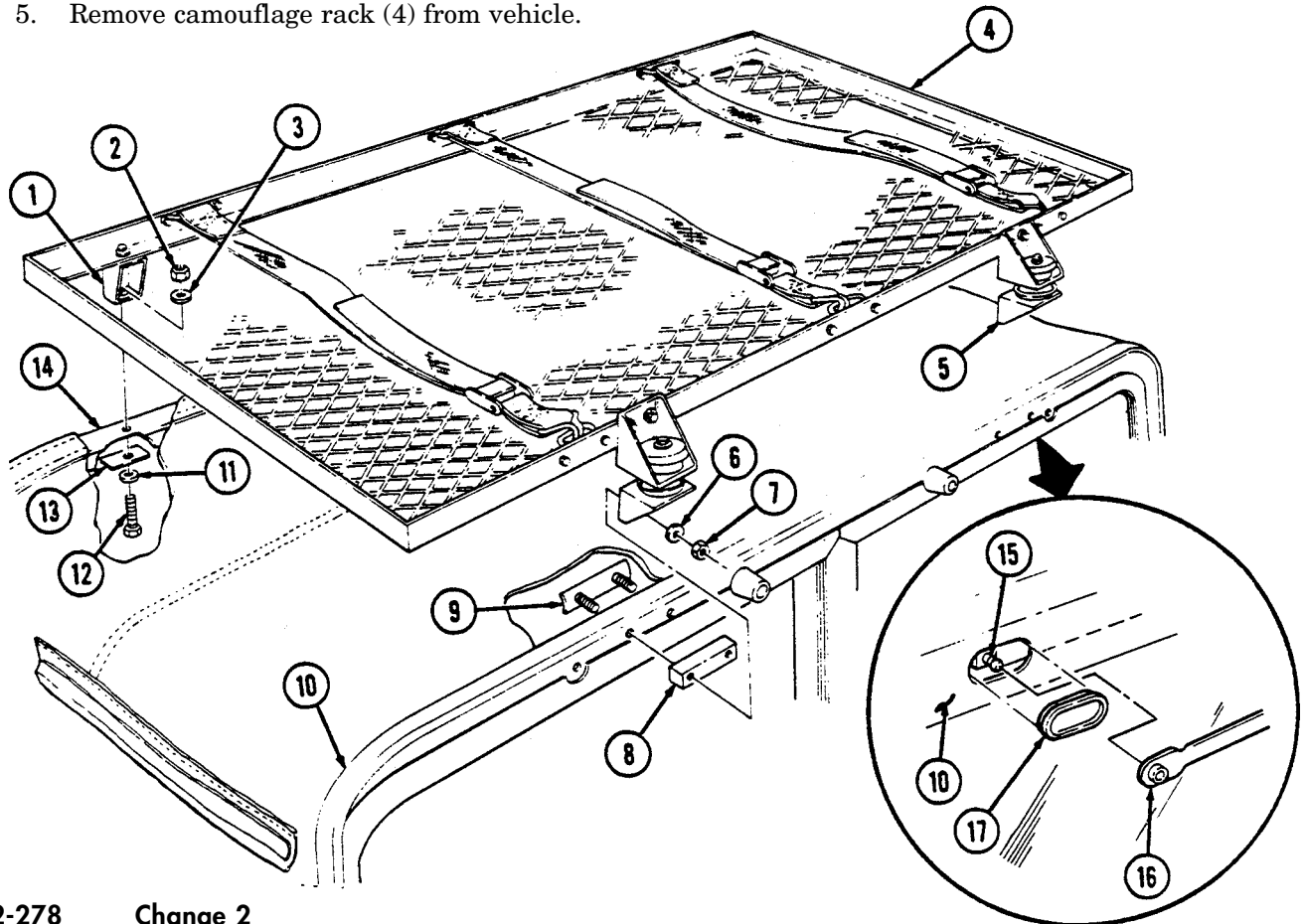

12-183. CAMOUFLAGE RACK MAINTENANCE (Cont'd)

b. Disassembly

1. Remove two locknuts (38), washers (37), capscrews (26), washers (27), snubber plates (35), mounts (34), spacers (30), mounts (29), snubber plates (28), and two lower front mounting brackets (36) from upper front mounting brackets (31). Discard locknuts (38).
2. Remove four locknuts (42), washers (41), capscrews (33), washers (32), and two upper front mounting brackets (31) from camouflage rack (4). Discard locknuts (42).
3. Remove two locknuts (47), washers (46), capscrews (19), washers (18), and two rear mounting brackets (1) from camouflage rack (4). Discard locknuts (47).
4. Remove six locknuts (24), washers (23), capscrews (20), washers (21), three rear footman loops (22), and three straps (24) from camouflage rack (4). Discard locknuts (24).
5. Remove six locknuts (46), washers (45), capscrews (39), washers (40), three front footman loops (43), and six washers (44) from camouflage rack (4). Discard locknuts (46).

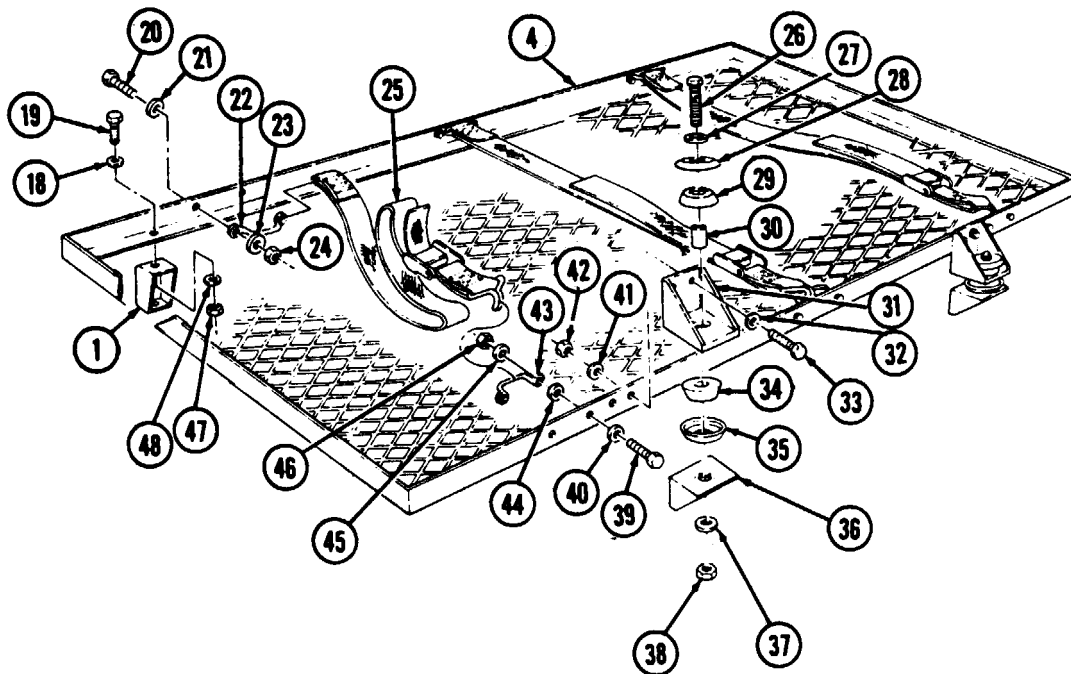

12-183. CAMOUFLAGE RACK MAINTENANCE (Cont'd)

c. Assembly

1. Install two rear mounting brackets (33) on camouflage rack (9) with two washers (1), capscrews (2), washers (32), and locknuts (31). Tighten locknuts (31) to 37 lb-ft (50 NŽm).
2. Install two upper front mounting brackets (15) on camouflage rack (9) with four washers (16), capscrews (17), washers (25), and locknuts (26). Tighten locknuts (26) to 21 lb-ft (29 NŽm).
3. Install two snubber plates (12), mounts (13), spacers (14), mounts (18), snubber plates (19), and lower front mounting brackets (20) on upper front mounting bracket (15) with two washers (11), capscrews (10), washers (21), and locknuts (22). Tighten locknuts (22) to 37 lb-ft (50 NŽm).
4. Install three rear footman loops (5) and three straps (8) on camouflage rack (9) with six washers (4), capscrews (3), washers (6), and locknuts (7). Tighten locknuts (7) to 6 lb-ft (8 NŽm).
5. Install six washers (28) and three front footman loops (27) on camouflage rack (9) with six washers (24), capscrews (23), washers (29), and locknuts (30). Tighten locknuts (30) to 6 lb-ft (8 NŽm).

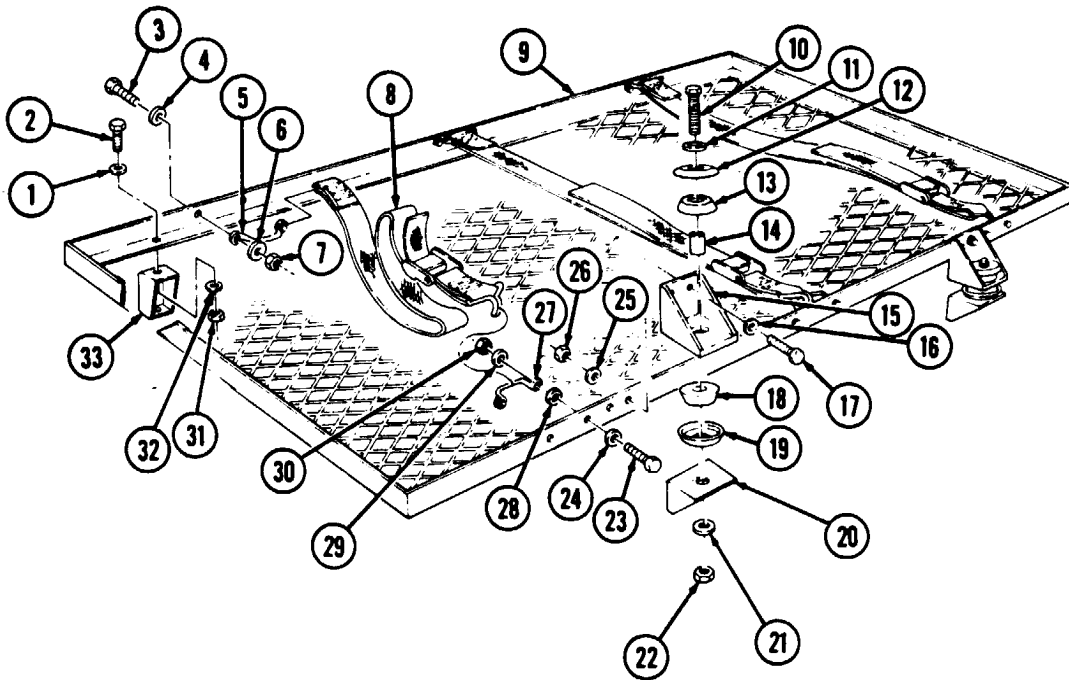

12-183. CAMOUFLAGE RACK MAINTENANCE

d. Installation

1. Install camouflage rack (9) on vehicle.
2. Install two rear mounting brackets (33) and plates (44) on "B" pillar (45) with two washers (42), capscrews (43), washers (35), and locknuts (34). Tighten locknuts (34) to 37 lb-ft (50 N·m).
3. Install two brackets (40), lower front mounting brackets (36), and spacers (39) on windshield (41) with four washers (37) and locknuts (38). Tighten locknuts (38) to 15 lb-ft (20 N·m).
4. Connect connector arms (47) on wiper arm pivots (46).
5. Install access covers (48) on windshield (41).

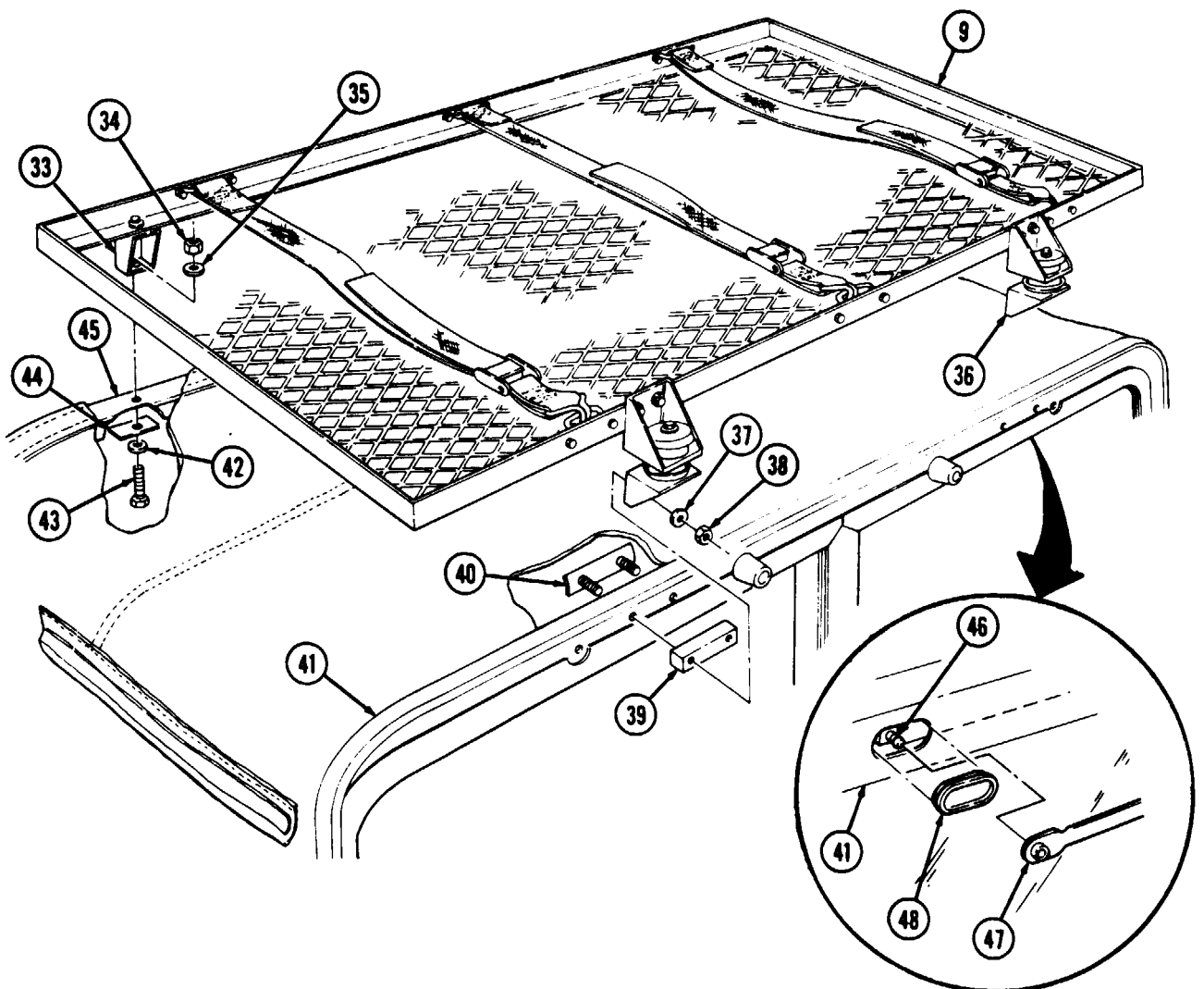

Section XI. ACCESSORY KITS INSTALLATION

12-184. ACCESSORY KITS INSTALLATION TASK SUMMARY

TASK PARA.	PROCEDURES	PAGE NO.
12-185.	Siren and Warning Light Installation	12-282
12-186.	Underbody Protection Kit Replacement	12-296
12-187.	Brushguard Assembly Replacement	12-310
12-188.	Floor Drain Hole Plate Installation	12-312

12-185. SIREN AND WARNING LIGHT INSTALLATION

This task covers:

- | | |
|---|--|
| <ul style="list-style-type: none"> a. Manufactured Items b. Warning Light Assembly Installation c. Siren Assembly Installation d. Circuit Breaker and Relay Installation e. Siren and Warning Light Switch and Indicator Installation | <ul style="list-style-type: none"> f. Siren Electrical Wires Installation g. Passenger's Side Siren Switch and Driver's Side Siren Switch Installation h. Warning Light Assembly Electrical Wires Installation i. Siren Battery Wires Installation |
|---|--|

INITIAL SETUP:

Applicable Models

M1025, M1025A1, M1025A2, M1026, M1026A1

Tools

General mechanic's tool kit: automotive (Appendix B, Item 1)

Materials/Parts

- Adhesive (Appendix C, Item 1)
- Adhesive-sealant (Appendix C, Item 10)
- Siren mounting bracket (Appendix D, Fig. 68)
- Warning light mounting bracket (Appendix D, Fig. 69)
- Wire "D" (Appendix D, Fig. 70)
- Wire "F" (Appendix D, Fig. 71)
- Wire "G" (Appendix D, Fig. 72)
- Wire "L" (Appendix D, Fig. 73)
- Wire "K" (Appendix D, Fig. 74)
- Wire "I" (Appendix D, Fig. 75)
- Wire "N" (Appendix D, Fig. 76)
- Wire "H" (Appendix D, Fig. 77)
- Wire "J" (Appendix D, Fig. 78)

Material/Parts (Cont'd)

- Wire "A" (Appendix D, Fig. 79)
- Wire "B" (Appendix D, Fig. 80)
- Wire "M" (Appendix D, Fig. 81)
- Relay Connector (Appendix D, Fig. 82)
- Locknut (Appendix G, Item 126)
- Two lockwashers (Appendix G, Item 189)
- Eight lockwashers (Appendix G, Item 136)
- Ten locknuts (Appendix G, Item 127)
- Lockwasher (Appendix G, Item 141)
- Six lockwashers (Appendix G, Item 176)
- Lockwasher (Appendix G, Item 178)
- Packing (Appendix G, Item 223)
- Ten tiedown straps (Appendix G, Item 310)

Manual References

TM 9-2320-280-24P

Equipment Condition

- Batteries removed (para. 4-79).
- Engine access cover removed (para. 10-15).

a. Manufactured Items

NOTE

Prior to installing the siren and warning light, assemble required materials listed in "Materials/Parts".

12-185. SIREN AND WARNING LIGHT INSTALLATION (Cont'd)

b. Warning Light Assembly Installation

1. Using fabricated warning light bracket (1) as a template, locate, mark, and drill four 0.343-in. (8.7-mm) diameter holes (5) in left side of roof (7).
2. Locate, mark, and drill 0.750-in. (19.1-mm) diameter hole (6) in left side of roof (7).
3. Cut roof panel insulation (8) away for access to mounting hardware.
4. Install warning light bracket (1) on roof (7) with four washers (3), screws (4), and locknuts (2).
5. Install shell (21), washer (20), and terminal (19) on red lead (22) of warning light assembly (9).
6. Install shell (17), sleeve (16), and terminal (15) on black lead (18) of warning light assembly (9).
7. Install nipple (14) on plate (11).
8. Align studs (10) of warning light assembly (9) to holes in plate (11) and install three washers (12) and nuts (13).
9. Install warning light assembly (9) on warning light bracket (1).

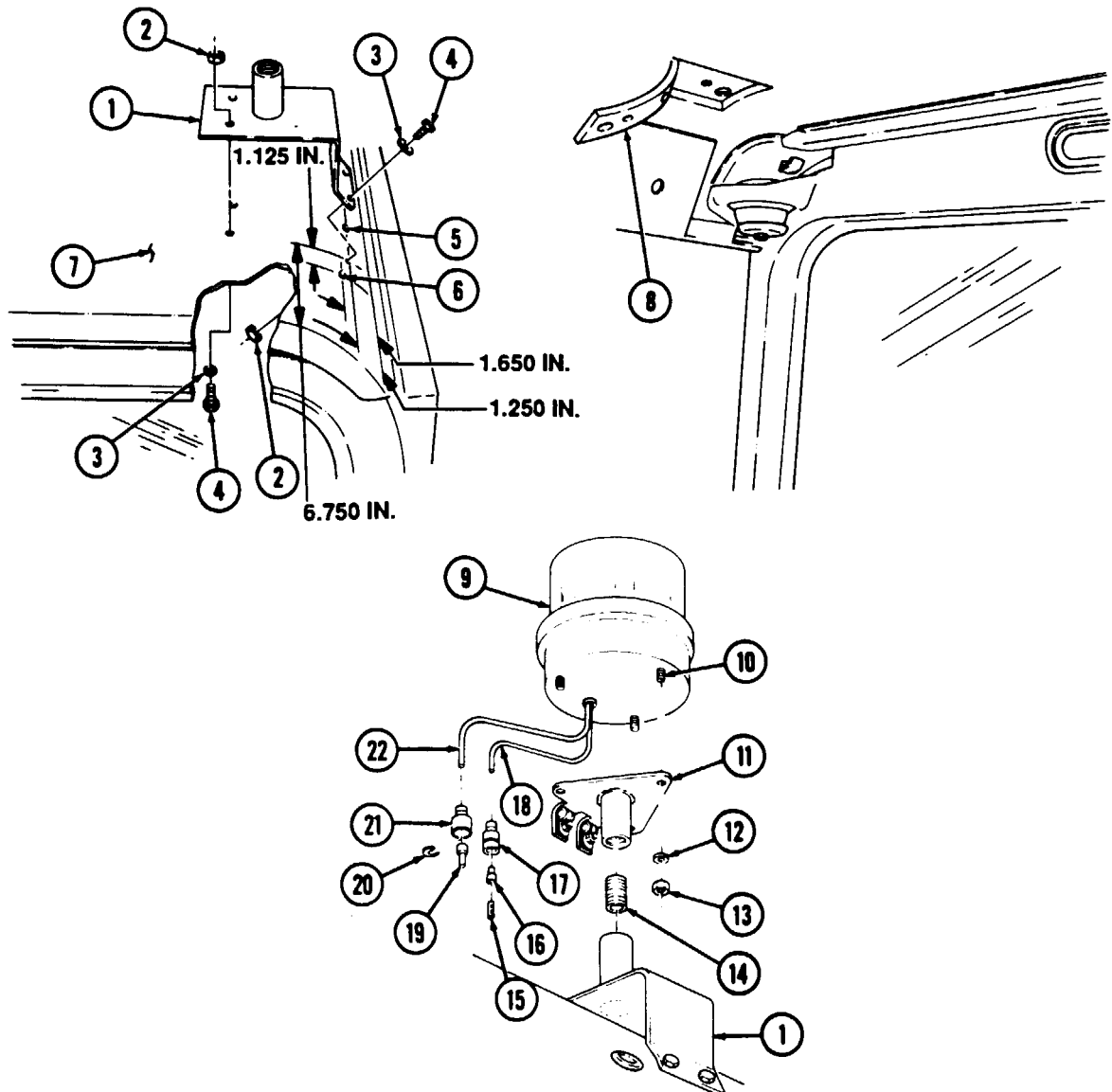

12-185. SIREN AND WARNING LIGHT INSTALLATION (Cont'd)

c. Siren Assembly Installation

1. Using fabricated siren bracket (1) as a template, locate, mark, and drill six 0.343-in. (8.7-mm) diameter holes (2) in right side of roof (3).
2. Locate, mark, and drill 0.75-in. (19-mm) diameter hole (4) in right side of roof (3).
3. Cut roof panel insulation (5) away for access to mounting hardware.
4. Cut siren lead (28) to a length of 5.0 in. (12.7 cm).
5. Install shell (27), sleeve (26), and terminal (25) on siren lead (28).
6. Install gasket (11), plate (10), and panel (15) on siren bracket (1) with four capscrews (16), lockwashers (8), and nuts (7).
7. Install siren assembly (6) and fabricated ground wire "I" (9) on siren bracket (1) with two capscrews (16), lockwashers (8), and nuts (7).
8. Install siren bracket assembly (1) on roof (3) with four screws (14), two screws (18), six washers (13), and locknuts (12).
9. Connect connector (24) of fabricated wire "H" (23) to siren lead (28) and route wire "H" (23) and ground wire "I" (9) through hole (4).
10. Split grommet (20) and install grommet (20) in hole (4).
11. Install siren wires (23) and (9) on siren bracket (1) with clamp (19), washer (22), screw (21), and nut (17).

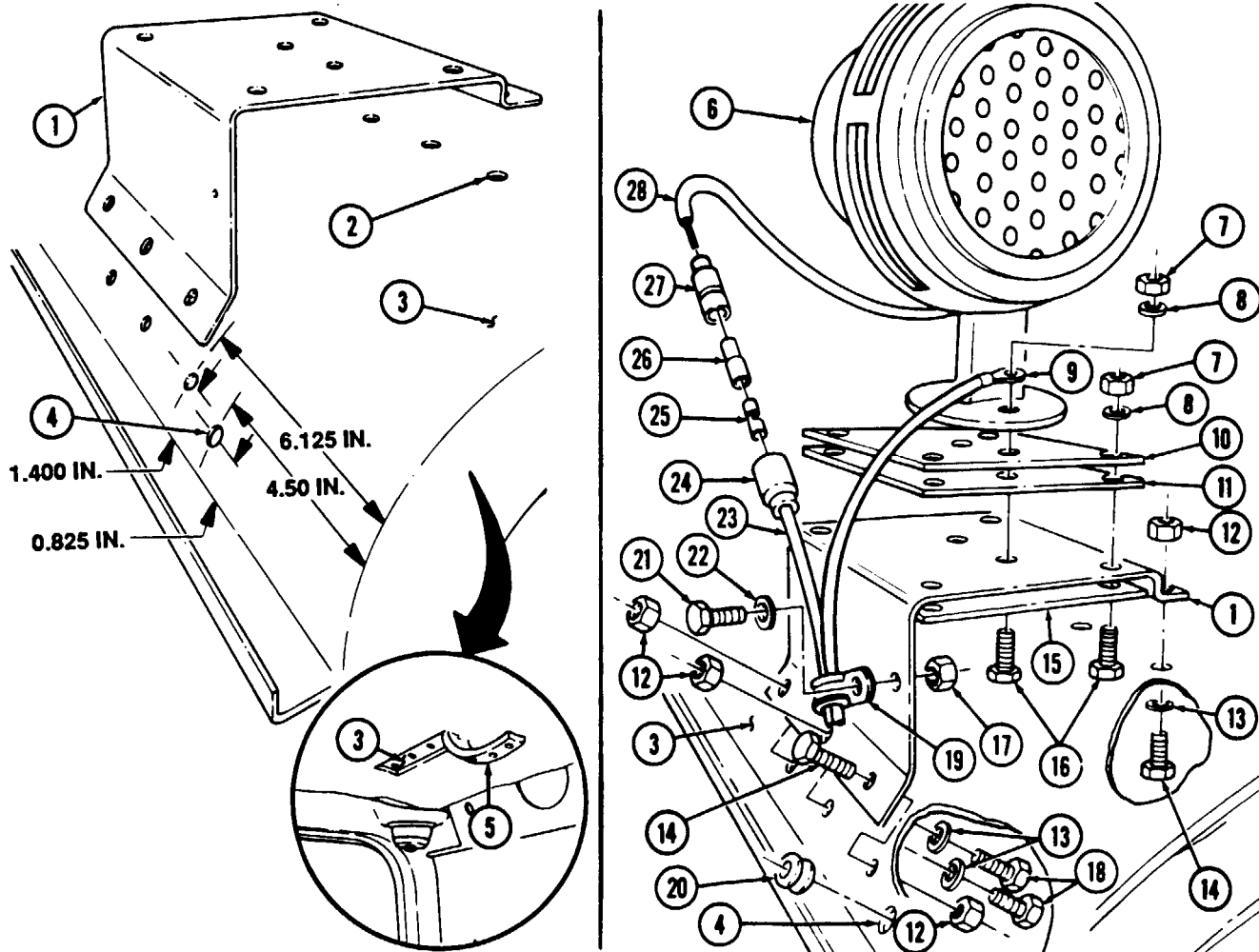

12-185. SIREN AND WARNING LIGHT INSTALLATION (Cont'd)

d Circuit Breaker and Relay Installation

1. Locate, mark, and drill two 0.187-in. (4.8-mm) diameter holes (2) in battery box panel (1).
2. Install circuit breaker (5) on battery box panel (1) with two screws (6), lockwashers (3), and nuts (4).
3. Locate, mark and drill two 0.281-in (7.1-mm) diameter holes (7) in body side panel (8).

NOTE

Note location of external-tooth lockwashers to top relay mounting screw when installing wires "I", "J", and "K" to relay mounting ground.

4. Install relay (18) on body side panel (8) with two washers (17), screws (19), lockwashers (20), and nuts (16). Finger tighten top nut (16).
5. Cut lead 467(A) (9) from main light switch connector (21) and install two shells (10), sleeves (11), and terminals (12) on ends of cut leads 467(A) (9).
6. Connect adapter connector "C" (15) to two leads 467(A) (9).
7. Connect relay connector (14) to relay (18).
8. Connect relay lead "A" (13) to adapter "C" (15).

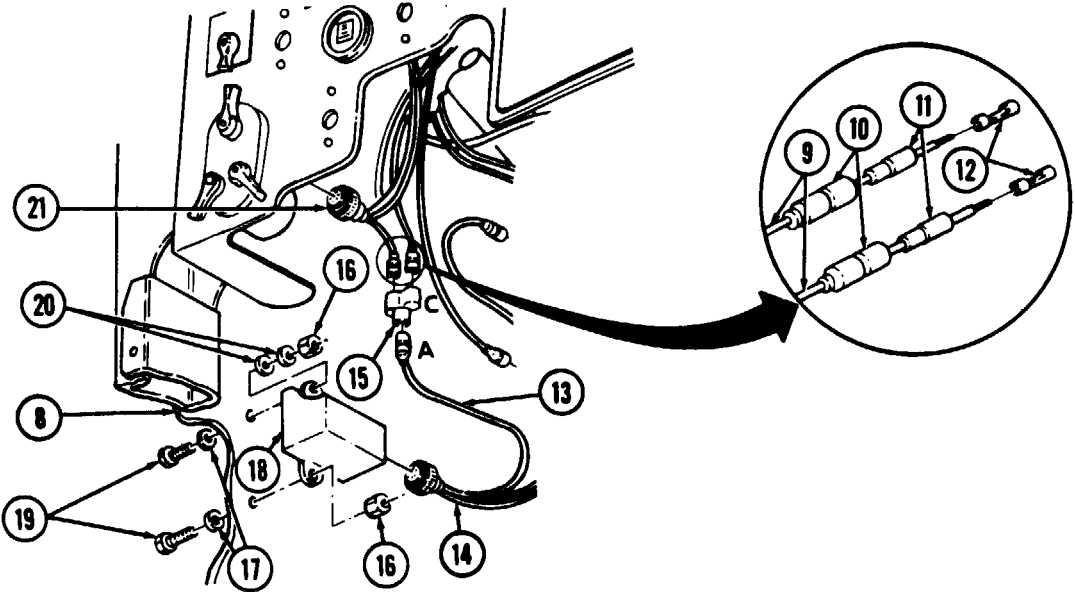
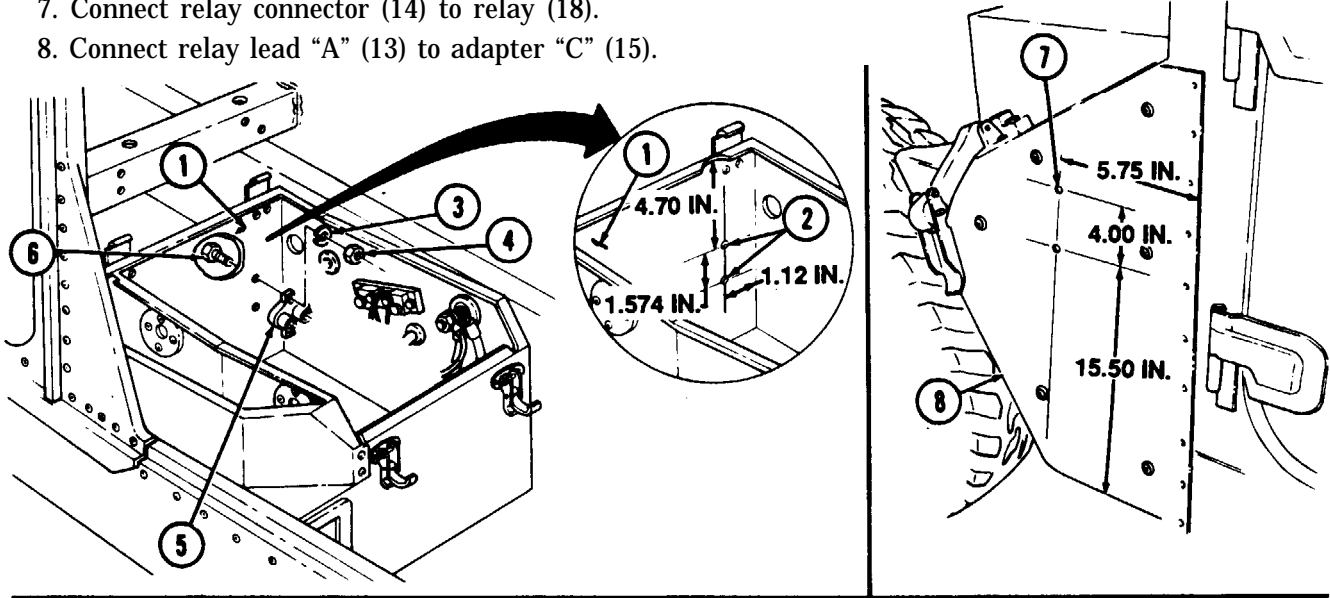

12-185. SIREN AND WARNING LIGHT INSTALLATION (Cont'd)

e. Siren and Warning Light Switch and Indicator Installation

1. Loosen nut (1) and lower steering column (2).
2. Locate, mark, and drill six 0.187-in. (4.8-mm) diameter holes (3) in dash panel (5).
3. Locate, mark, and drill three 0.750-in. (19-mm) diameter holes (4) in dash panel (5).
4. Install warning light switch (11) on dash panel (5) with two lockwashers (10) and screws (9).
5. Install lamp (13) on indicator lamp assembly (12) and install indicator lamp assembly (12) on dash panel (5) with two screws (6).
6. Install packing (8) and lens (7) on dash panel (5).

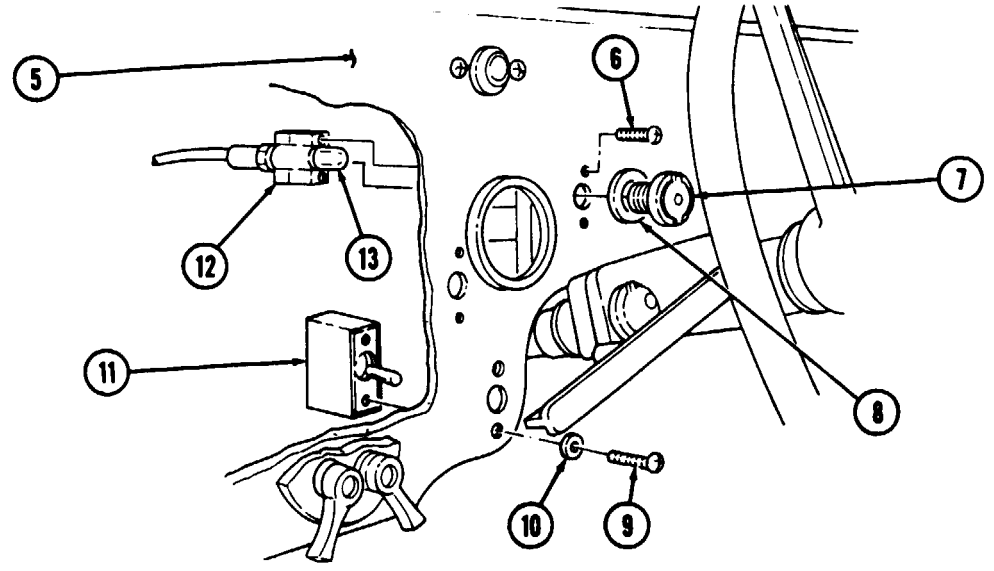
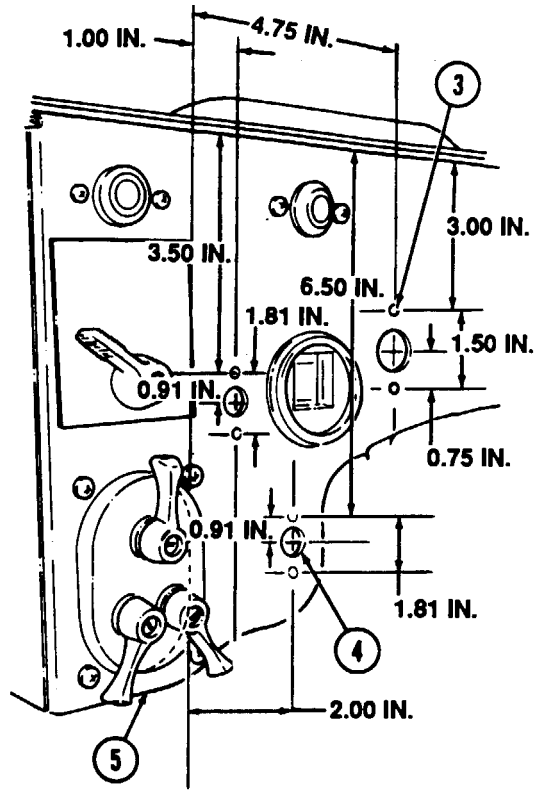
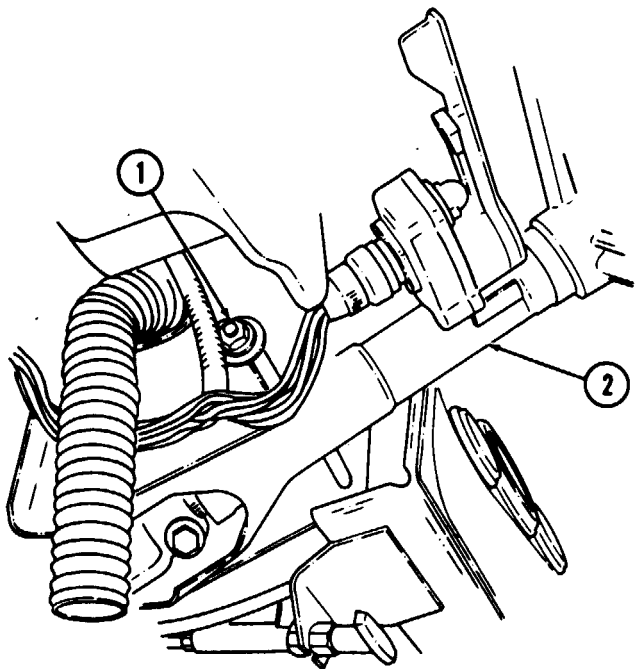

12-185. SIREN AND WARNING LIGHT INSTALLATION (Cont'd)

f. Siren and Electrical Wires Installation

1. Locate, mark, and drill 0.625-in. (15.9-mm) diameter hole (1) in left side of dash panel (2).
2. Route siren wires "H" (4) and "I" (5) along top, and down left side, of windshield frame (3).
3. Route siren wires "H" (4) "I" (5) through hole (1) in left side of dash panel (2).
4. Split grommet (6) and install grommet (6) in hole (1).
5. Connect siren wire "H" (4) to adapter connector "E" (7).
6. Remove top nut (8) and lockwasher (11) from relay (9) and install siren wire "I" (5) on top mounting screw (10) of relay (9).

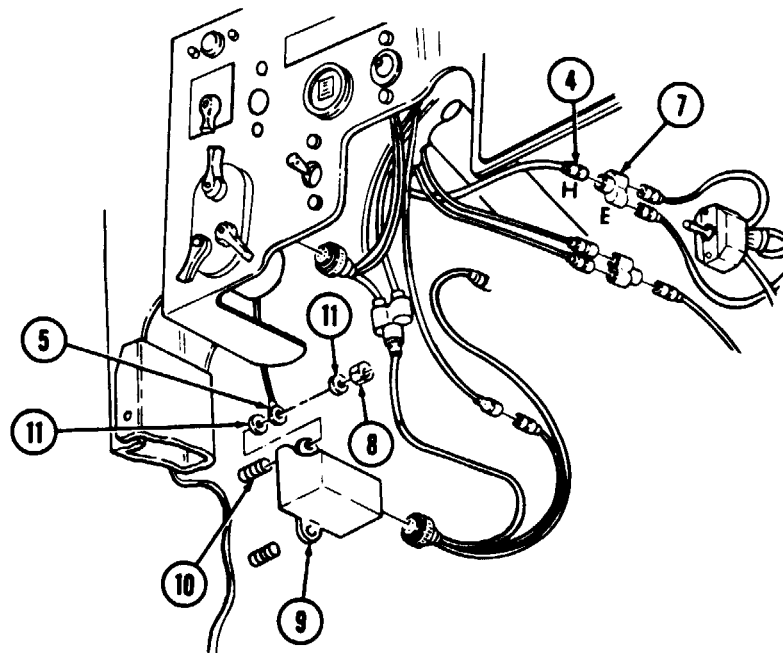
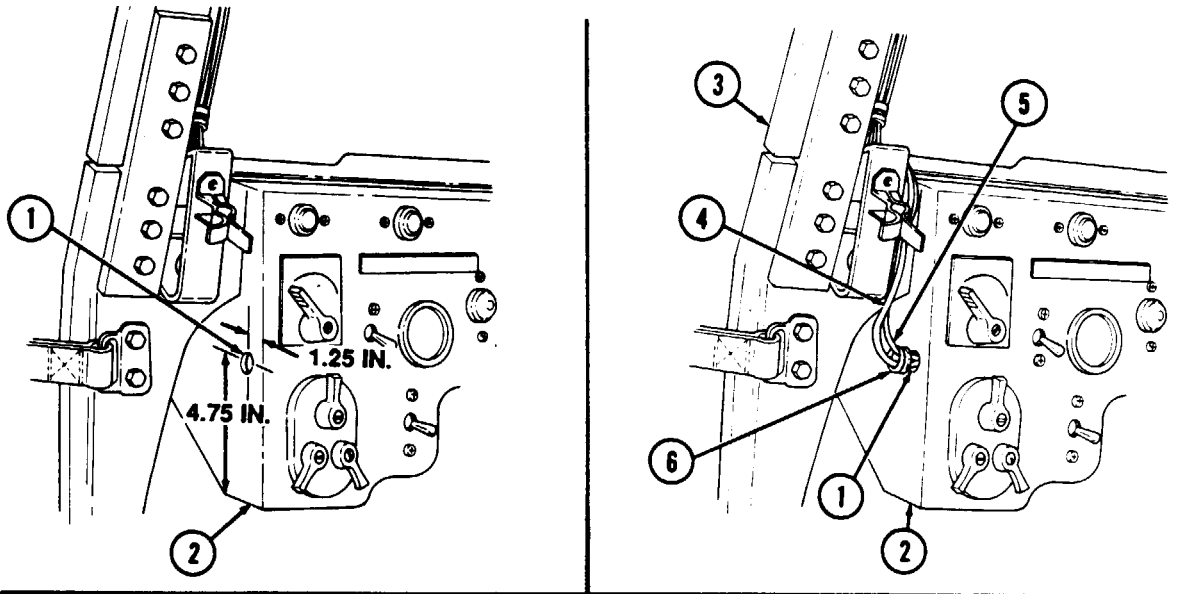

12-185. SIREN AND WARNING LIGHT INSTALLATION (Cont'd)

g. Passenger's Side Siren Switch and Driver's Side Siren Switch Installation

1. Install two shells (3), washers (4), and terminals (5) on leads (2) of passenger's side siren switch (1).
2. Tape and secure two unused leads (6) of passenger's siren switch (1).

NOTE

Passenger's side and driver's side siren switch are the same.
Repeat steps 1 and 2 for driver's side switch.

3. Locate, mark, and drill two 0.187-in. (4.8-mm) diameter holes (8) and 0.750-in. (19-mm) diameter hole (7) on "A" beam (9).
4. Install passenger's side siren switch (1) on "A" beam (9) with two lockwashers (10) and screws (11).

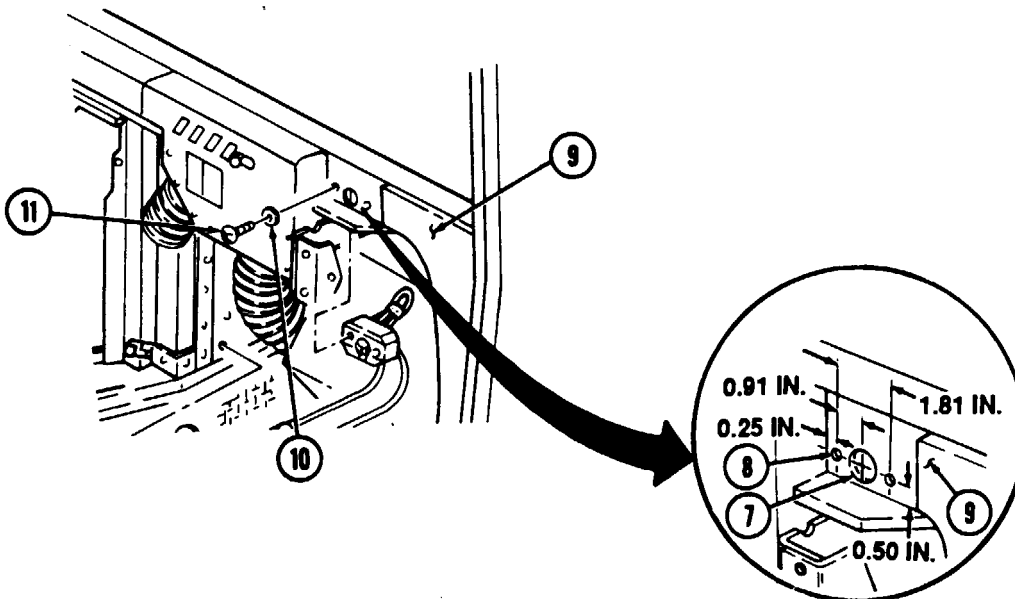
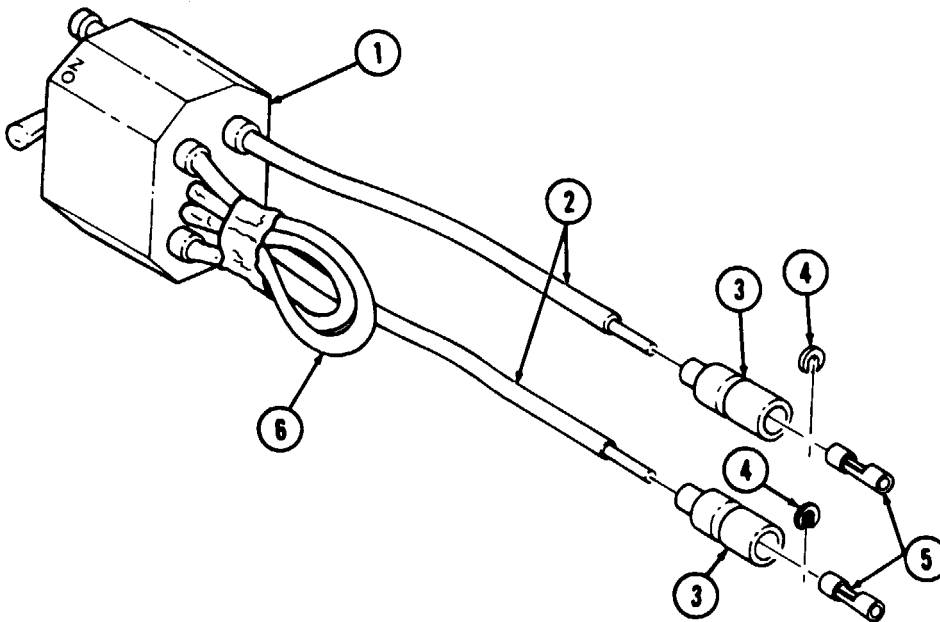

12-185. SIREN AND WARNING LIGHT INSTALLATION (Cont'd)

5. Install driver's side siren switch (15) on dash panel (14) with two lockwashers (12) and screws (13).
6. Route fabricated wire "G" (17) along tunnel (27) and connect connector (24) to lead (22) of passenger's side siren switch.
7. On driver's side, connect wire "G" (17) connector (30) to adapter connector "E" (28).
8. Connect lead (29) of driver's side siren switch (15) to adapter connector "E" (28).
9. Connect lead (31) of driver's side siren switch (15) to adapter connector "B" (32).
10. On driver's side, connect one end of fabricated wire "D" (33) to adapter "B" (32), and the other end to adapter connector "A" (34).
11. On driver's side, connect lead "B" (35) of relay (36) to adapter "A" (34).
12. Route fabricated wire "F" (16) along tunnel (27), and connect connector (25) to lead (23) of passenger's side siren switch (21).
13. On driver's side, connect wire "F" (16) to adapter connector "B" (32).
14. Locate, mark, and drill three 0.146-in. (3.7-mm) diameter holes (20) in right side engine panel (19) and vehicle tunnel (27).
15. Install wires "F" (16) and "G" (17) on panel (19) with clamp (26) and screw (18).
16. Install wires "F" (16) and "G" (17) on tunnel (27) with five clamps (26) and screws (18).
17. Tuck exposed wires under vehicle insulation on tunnel (27).

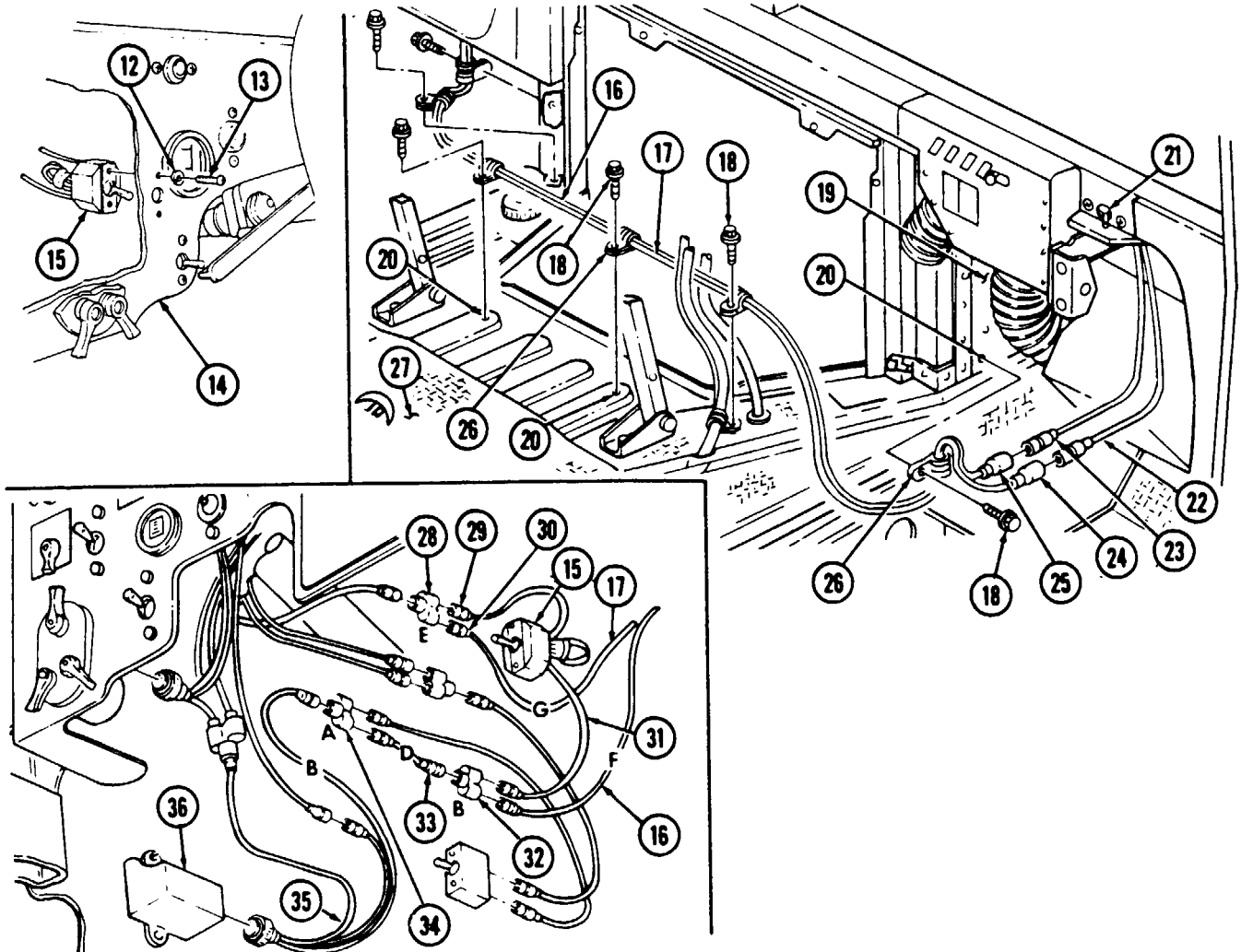

12-185. SIREN AND WARNING LIGHT INSTALLATION (Cont'd)

h. Warning Light Assembly Electrical Wires Installation

1. Install and connect fabricated wire "M" (11) to red lead (10), and wire "J" (1) to black lead (2) of warning light assembly (3).
2. Install fabricated wires "M" (11) and "J" (1) on bracket (4) with clamp (5), washer (7), screw (6), and locknut (8).
3. Route fabricated wires "M" (11) and "J" (1) in roof (9).
4. Route fabricated wires "M" (11) and "J" (1) downward along windshield frame (12).

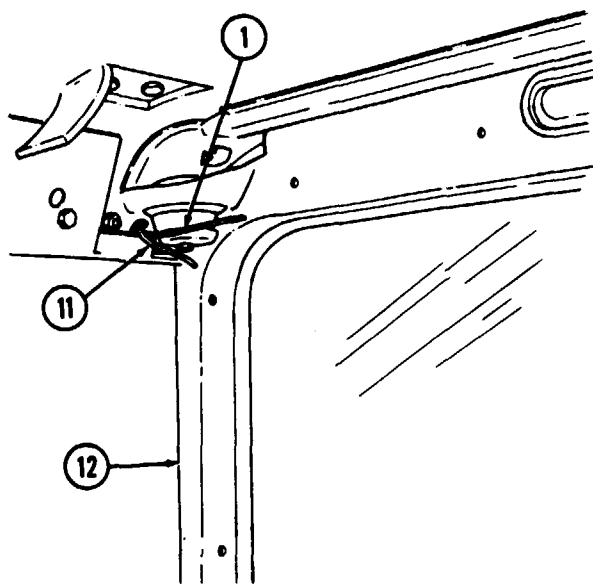
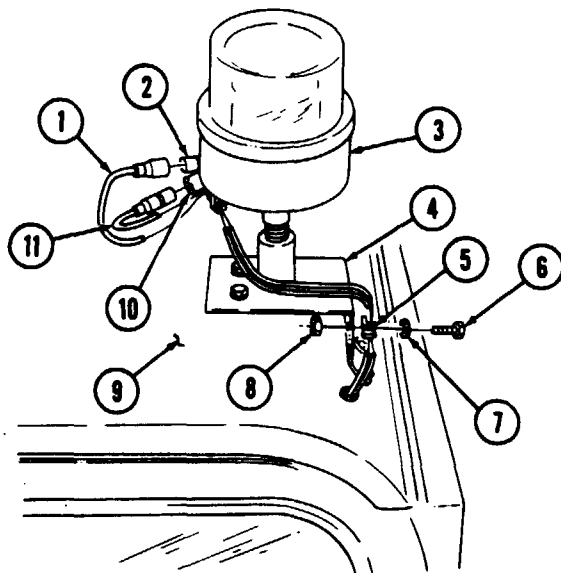

12-185. SIREN AND WARNING LIGHT INSTALLATION (Cont'd)

5. Route fabricated wires "M" (11) and "J" (1) through grommet (14) and hole in left side dash panel (13).
6. Connect fabricated wire "M" (11) to adapter (15).
7. Install fabricated wire "J" (1) on top mounting screw (23) of relay (22).
8. Connect indicator light lead (17) to adapter "D" (15).
9. Connect fabricated wire "A" (16) to adapter "D" (15) and connector (19) to light switch (20).
10. Connect fabricated wire "B" (18) to adapter "A" (21) and warning light switch (20).
11. Split grommet (24) and install grommet (24) on roof (9). Apply adhesive-sealant RTV on **grommet (24)**.

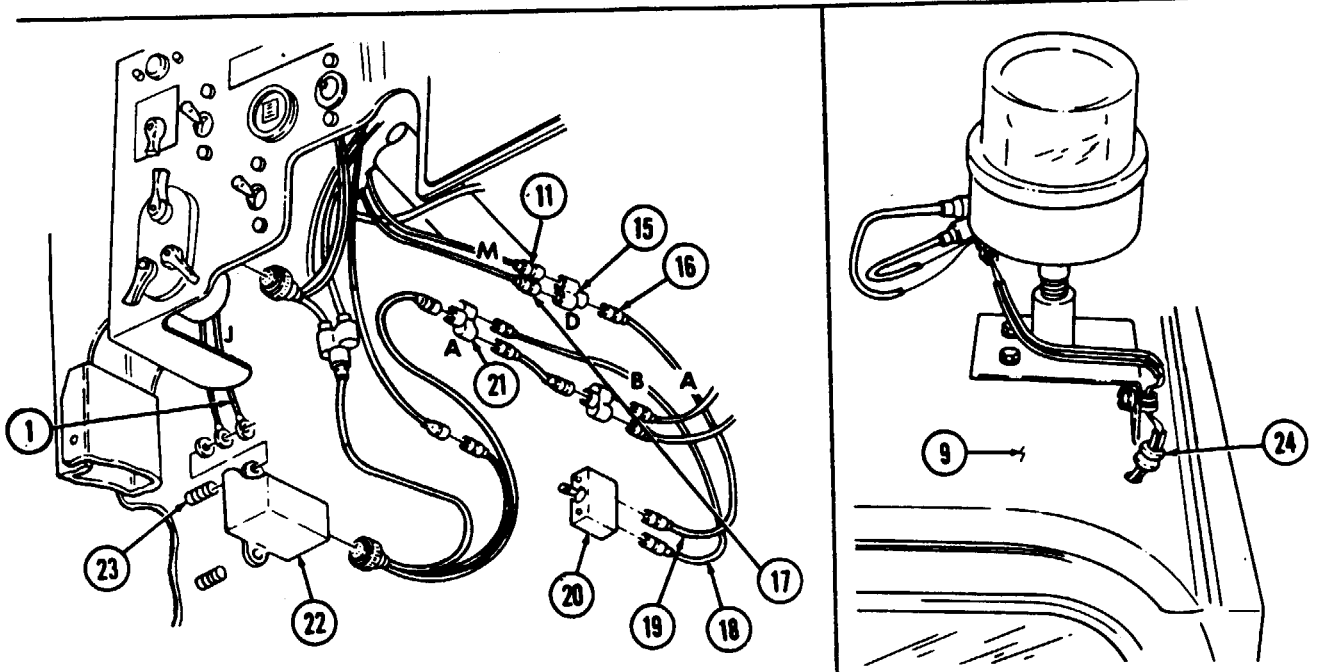
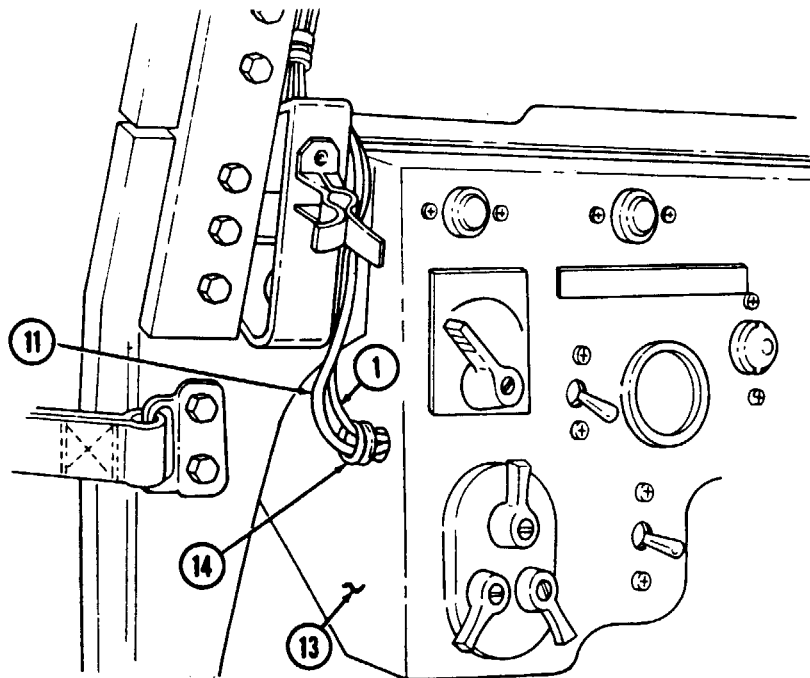

12-185. SIREN AND WARNING LIGHT INSTALLATION (Cont'd)

i. Siren Battery Wires Installation

1. Install fabricated wire "K" (1) on top mounting screw (6) of relay (5) with washer (7) and nut (2).
2. Install fabricated wire "L" (3) on lead "C" (4) of relay (5).
3. Route wires "K" (1) and "L" (3) through grommet opening (8) in firewall (9).
4. Route wires (10) along cable harness (11) in engine compartment (12).
5. Raise steering column (14) and tighten nut (13).

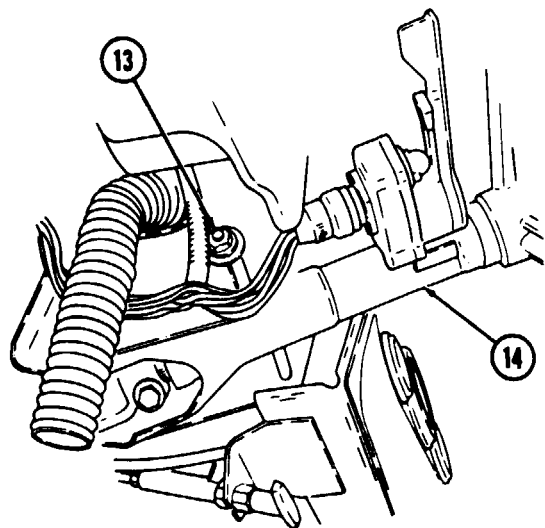
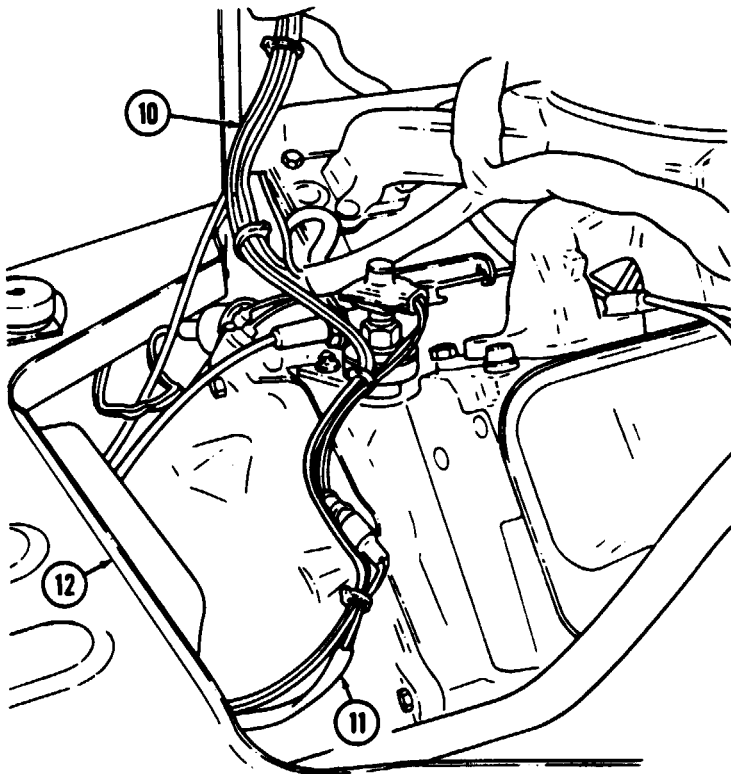
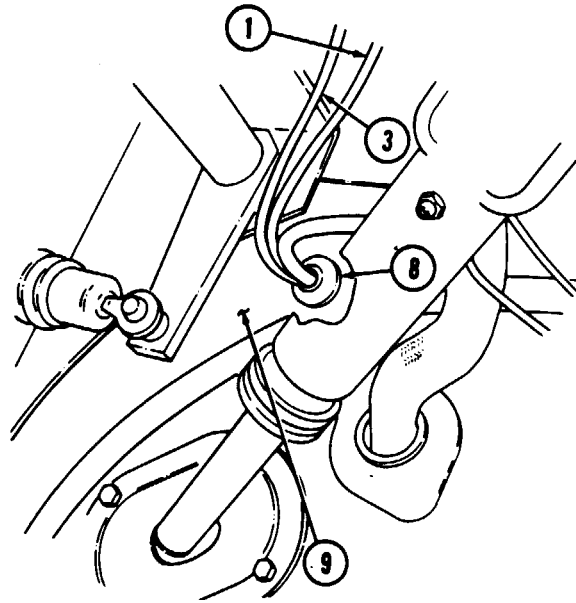
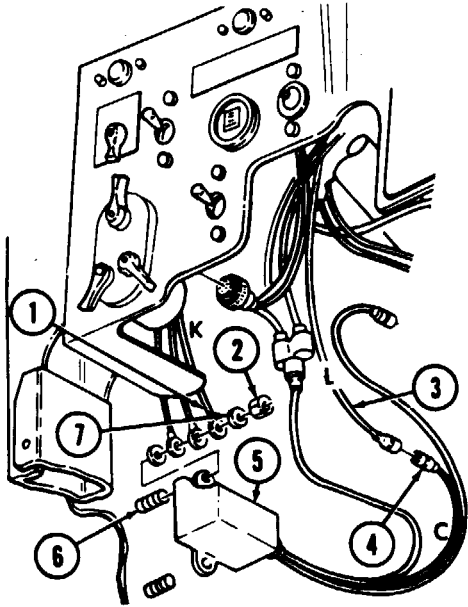

12-185. SIREN AND WARNING LIGHT INSTALLATION (Cont'd)

6. Route wire "L" (3) through grommet (16) in battery box (15).
7. Connect wire "L" (3) to circuit breaker (25).
8. Remove nut (19) and lockwasher (20) from ground stud (18). Discard lockwasher (20). Connect fabricated wire "K" (1) to ground stud (18) on vehicle body (17) and install wire "K" (1) with lockwasher (20) and nut (19).
9. Remove nut (24) and lockwasher (23) from positive power stud (21). Discard lockwasher (23). Connect fabricated wire "N" (22) to circuit breaker (25) and power stud (21). Install wire "N" (22) on stud (21) with lockwasher (23) and nut (24).

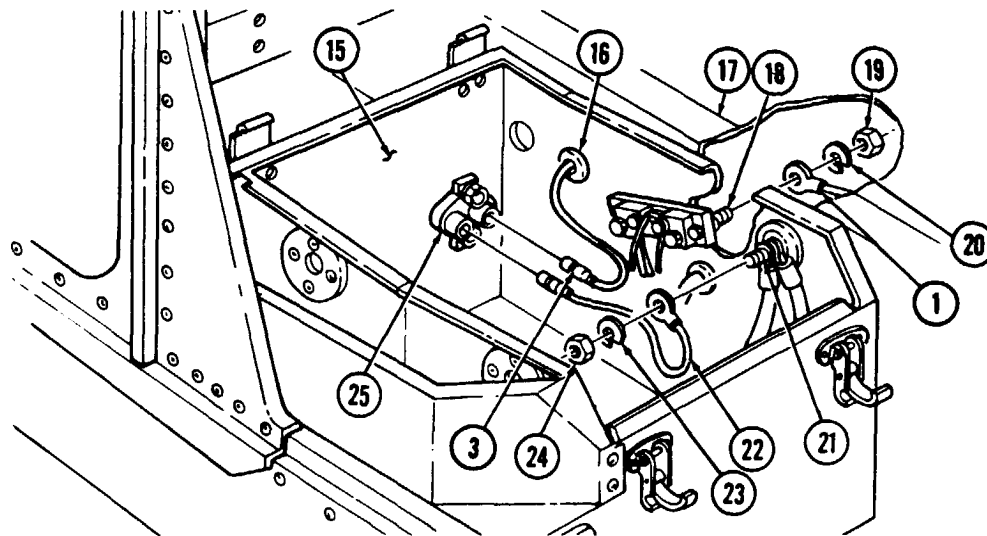

12-185. SIREN AND WARNING LIGHT INSTALLATION (Cont'd)

10. Locate, mark, and drill two 0.146-in. (3.7-mm) diameter holes (6), equally spaced, in left side windshield frame (8) and four 0.146-in. (3.7-mm) diameter holes (5), equally spaced, along top of windshield frame (3).
11. Install wires (4) and warning light wires (9) on left side windshield frame (8) and along top of windshield frame (3) with six clamps (2) and screws (1).
12. Install warning light wires (9) on wiring harness under dash (7) and engine compartment (10) with ten tiedown straps (11).
13. Apply adhesive to right and left side roof panel insulation (12), and install on roof (13).

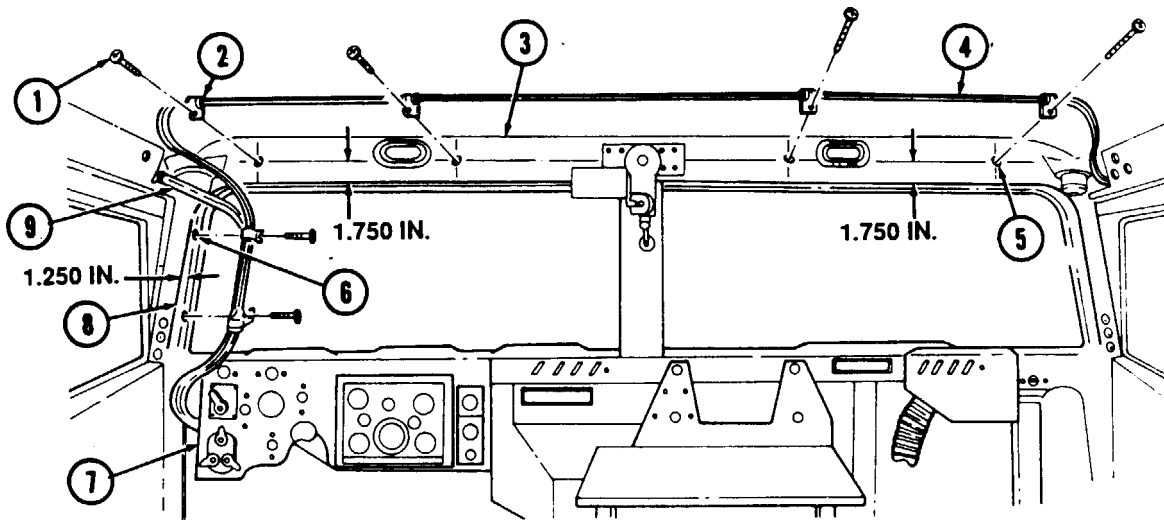

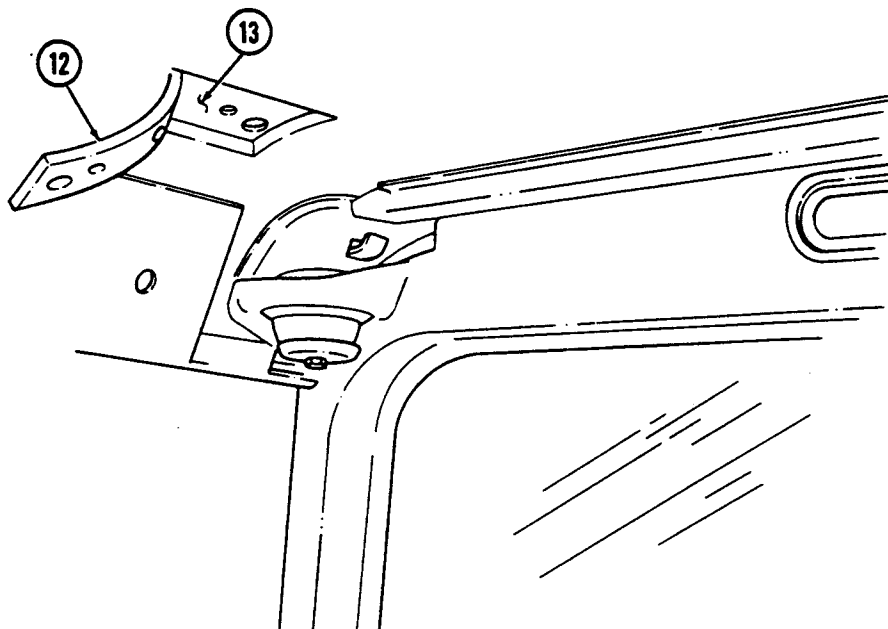
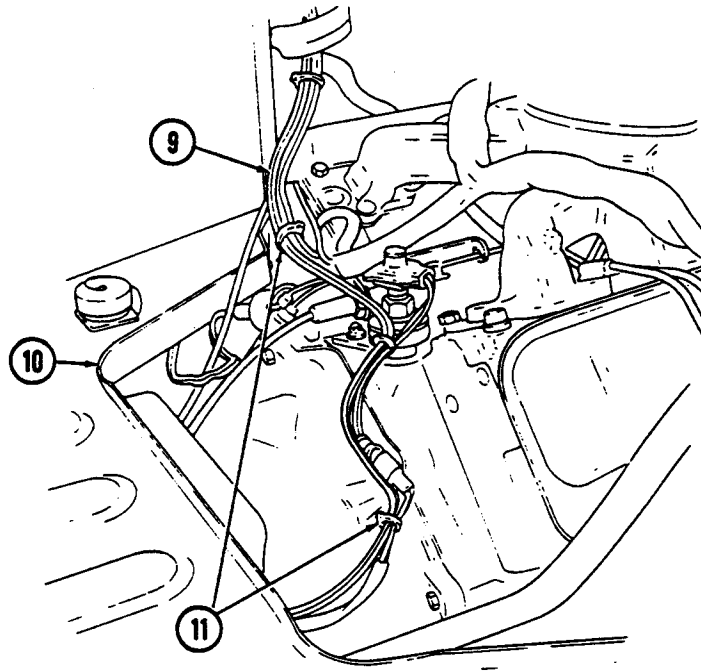
12-185. SIREN AND WARNING LIGHT INSTALLATION (Cont'd)

- FOLLOW-ON TASKS:
- Install engine access cover (para. 10-15).
 - Install batteries (para. 4-79).
 - Check siren and warning light for proper operation.

12-186. UNDERBODY PROTECTION KIT REPLACEMENT

This task covers:

- | | |
|---------------------------------|--------------------------------------|
| a. Front Skid Plate Removal | g. Fuel Tank Shield Installation |
| b. Front Shield Removal | h. Rear Shield Installation |
| c. Intermediate Shield Removal | i. Transfer Case Shield Installation |
| d. Transfer Case Shield Removal | j. Intermediate Shield Installation |
| e. Rear Shield Removal | k. Front Shield Installation |
| f. Fuel Tank Shield Removal | l. Front Skid Plate Installation |

INITIAL SETUP:

Applicable Models

M997A2, M1025A2, M1035A2, M1043A2,
M1045A2, M1097A2, M1123

Manual References

TM 9-2320-280-10
TM 9-2320-280-24P

Tools

General mechanic's tool kit: automotive
(Appendix B, Item 1)

General Safety Instructions

- Do not perform this procedure near fire, flames or sparks.
- Fuel tank must be supported during removal and installation.

Materials/Parts

Four flat washers (Appendix G, Item 36)
Twenty-five locknuts (Appendix G, Item 128)
Two locknuts (Appendix G, Item 81)
Seventeen locknuts (Appendix G, Item 79)

a. Front Skid Plate Removal

1. Remove three locknuts (9), six washers (2), three capscrews (7), and front skid plate (6) from front shield (8). Discard locknuts (9).
2. Remove three locknuts (5), six washers (3), three capscrews (4), and front skid plate (6) from front bumper (1). Discard locknuts (5).

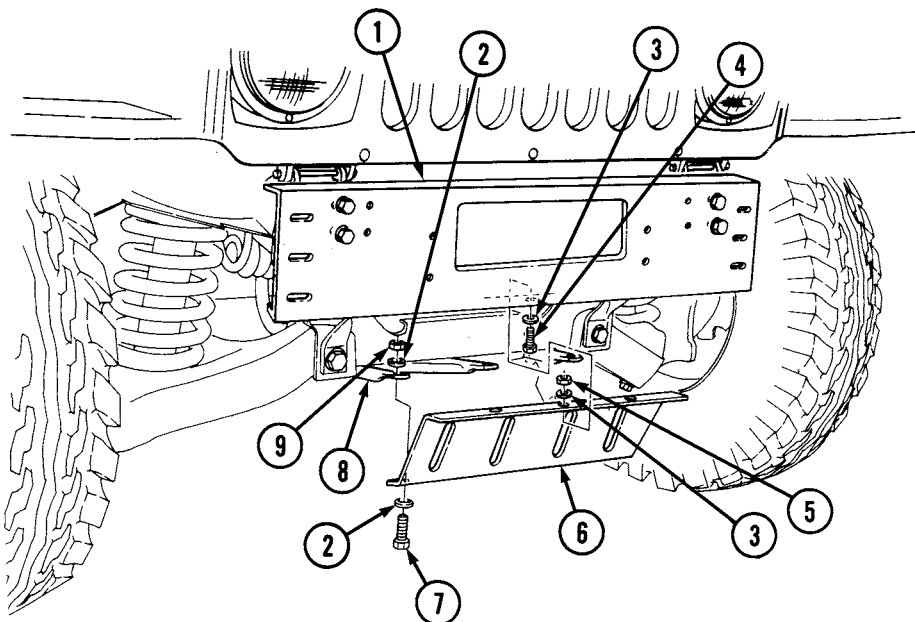

12-186. UNDERBODY PROTECTION KIT REPLACEMENT (Cont'd)**b. Front Shield Removal**

1. Remove three locknuts (16), six washers (17), and three capscrews (18) from front shield (14), front crossmember (15), and intermediate shield (19). Discard locknuts (16).
2. Remove three locknuts (13), six washers (12), three capscrews (11), and front shield (14) from front skid plate (10). Discard locknuts (13).

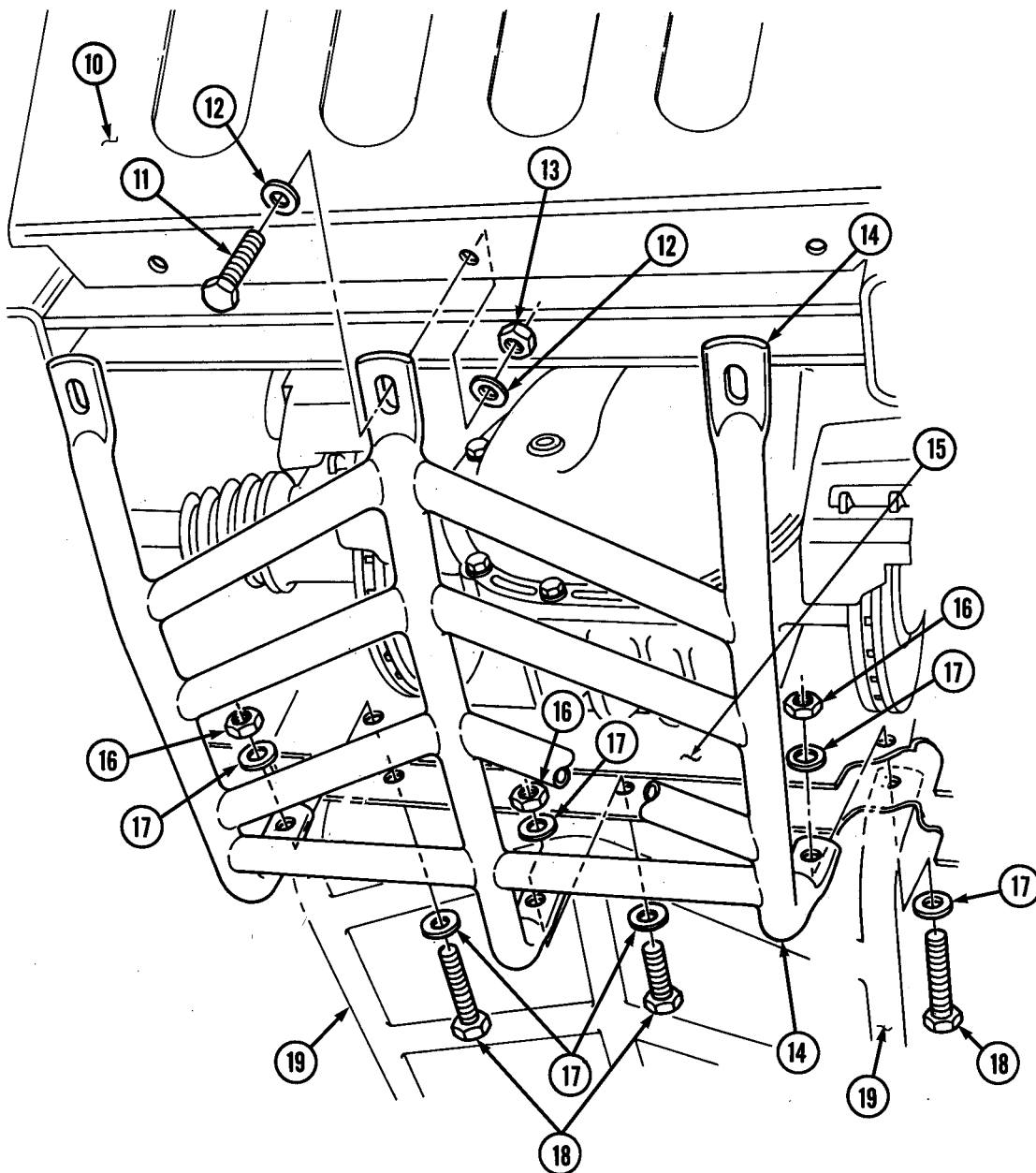

12-186. UNDERBODY PROTECTION KIT REPLACEMENT (Cont'd)

c. Intermediate Shield Removal

1. Remove six locknuts (6), twelve washers (2), six capscrews (3), four flat washers (5), and two transmission support brackets (4) from intermediate shield (1) and transmission mount cross-member (7). Discard locknuts (6) and flat washers (5).
2. Remove locknut (8), two washers (9), and capscrew (10) from right support bracket (15) and right side frame rail (16). Discard locknut (8).
3. Remove locknut (22), two washers (19), and capscrew (18) from left support bracket (24), engine mount bracket (17), and left side frame rail (23). Discard locknut (22).
4. Remove four locknuts (14), eight washers (12), four capscrews (11), and right side support bracket (15) from right side mounting bracket (13). Discard locknuts (14).
5. Remove four locknuts (26), eight washers (21), four capscrews (20), and left side support bracket (24) from left side mounting bracket (25). Discard locknuts (26).
6. Remove two locknuts (29), four washers (30), two capscrews (31), and intermediate shield (1) from front crossmember (27) and front shield (28). Discard locknuts (29).

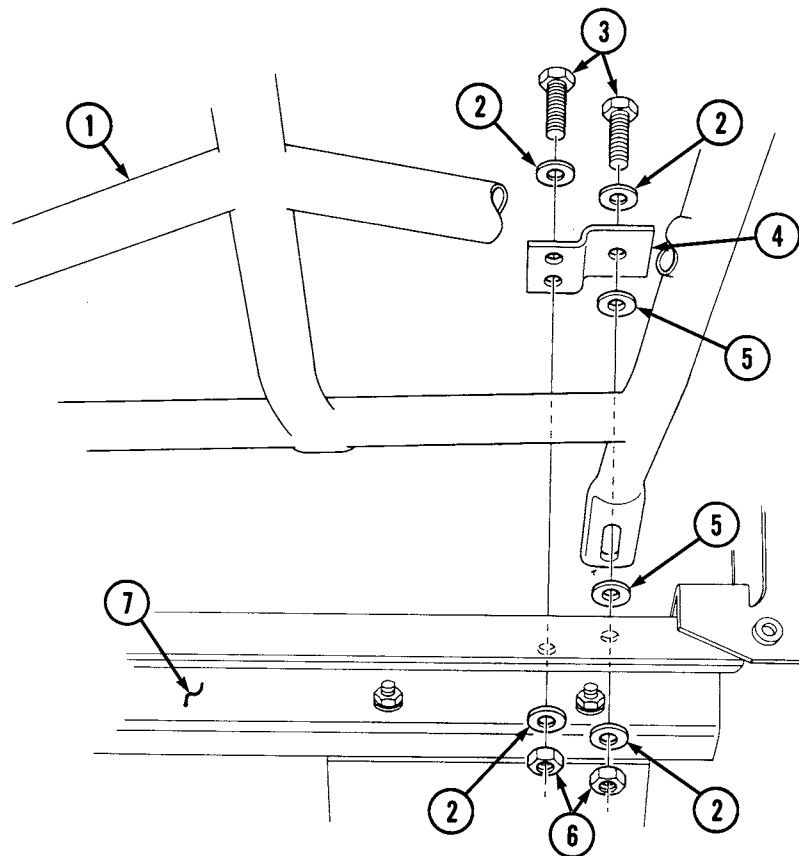

12-186. UNDERBODY PROTECTION KIT REPLACEMENT (Cont'd)

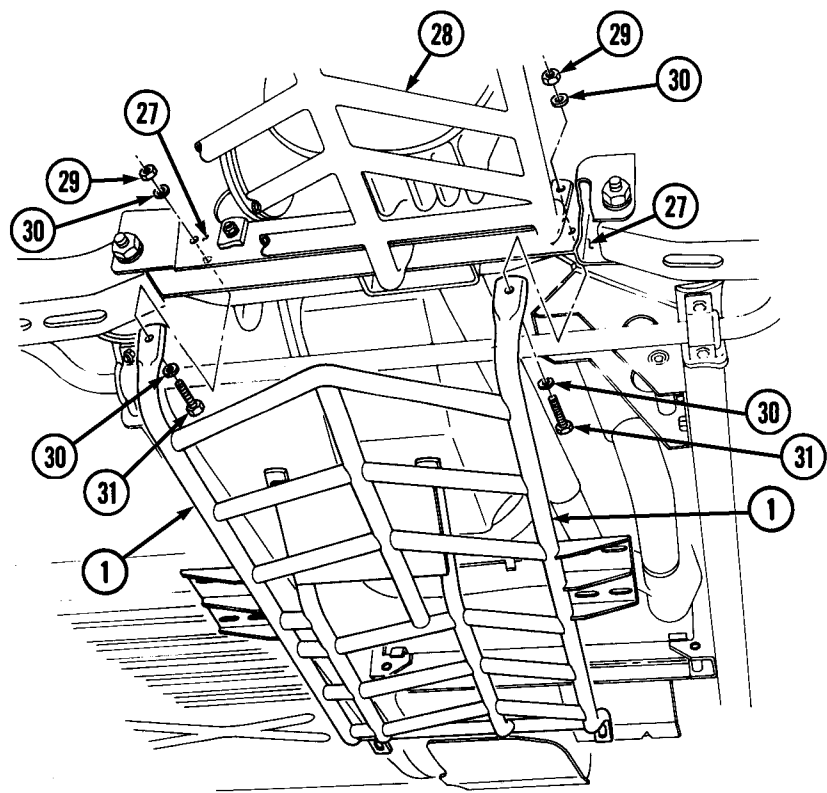
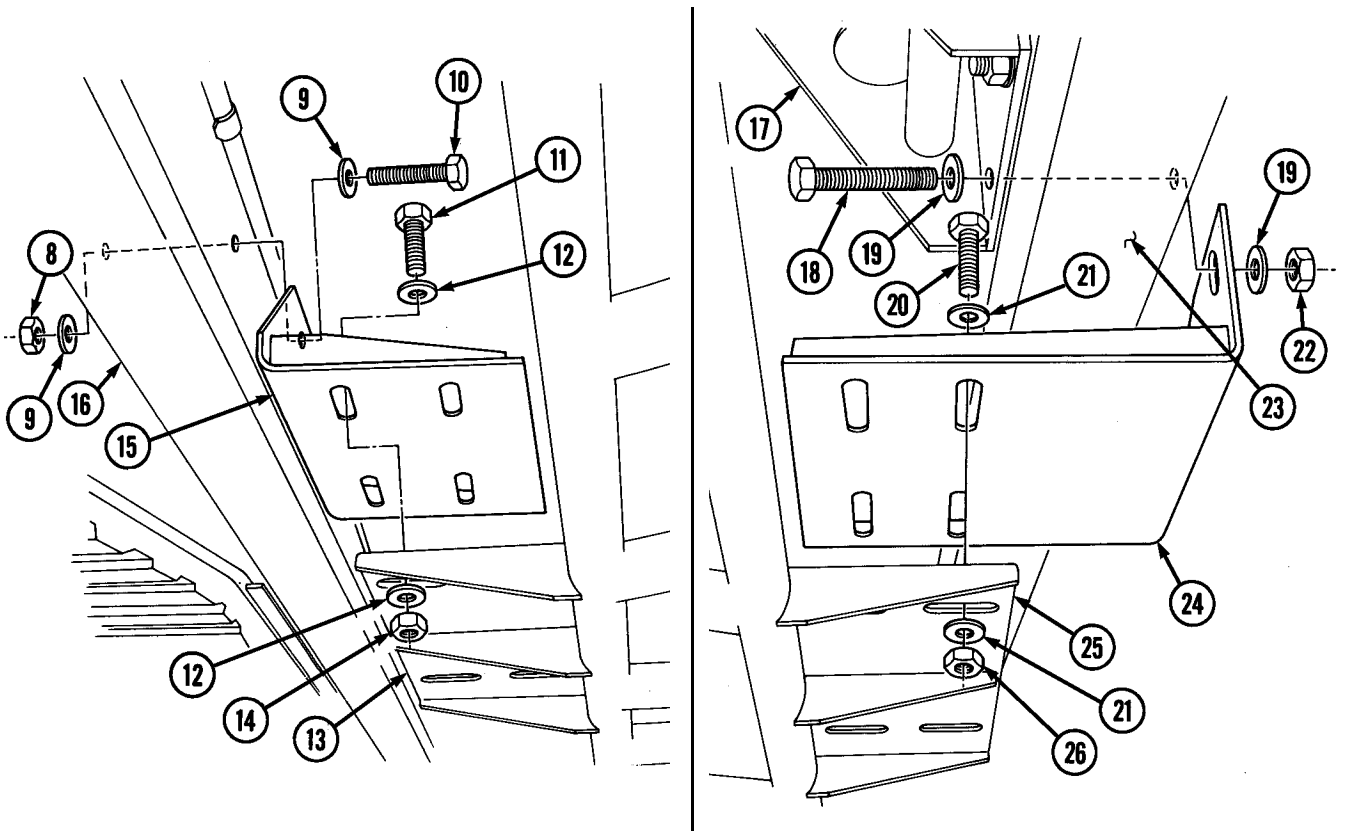

12-186. UNDERBODY PROTECTION KIT REPLACEMENT (Cont'd)

d. Transfer Case Shield Removal

Remove two locknuts (1), four washers (2), two capscrews (4), and transfer case shield (5) from cross-member (3). Discard locknuts (1).

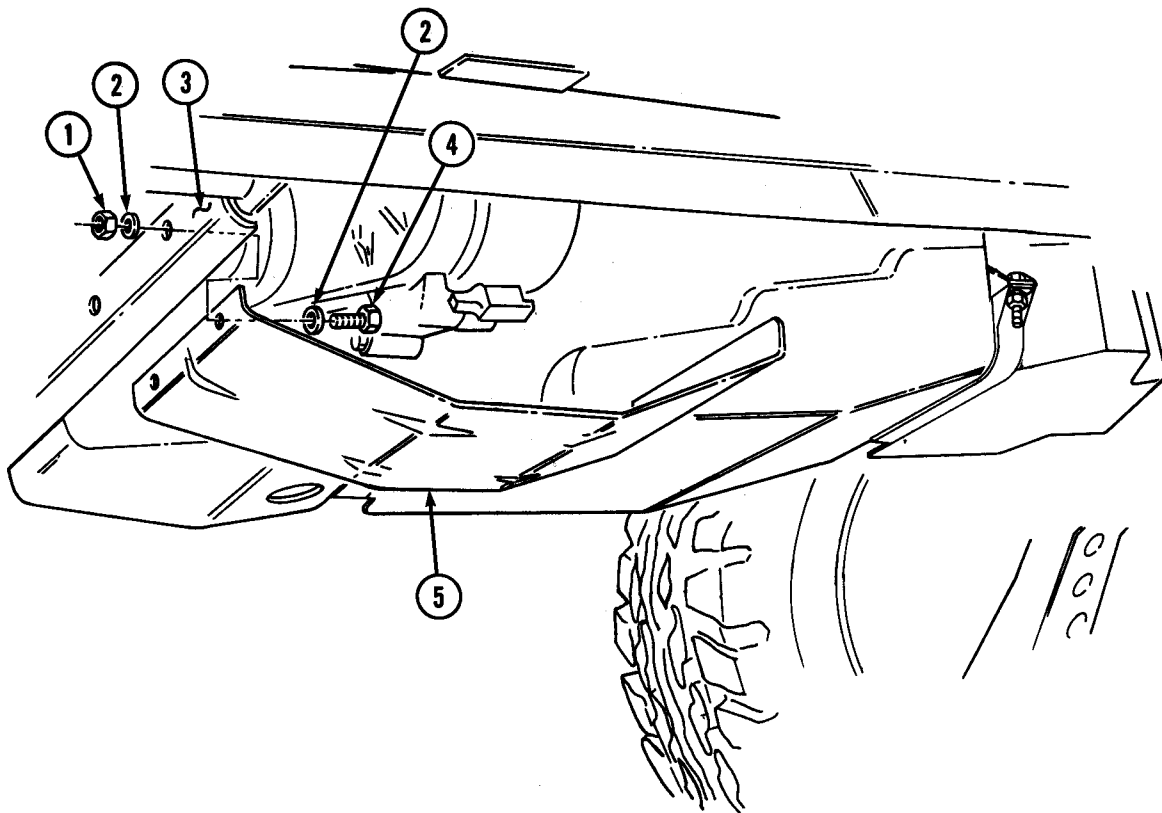

12-186. UNDERBODY PROTECTION KIT REPLACEMENT (Cont'd)

e. Rear Shield Removal

1. Remove three locknuts (18), six washers (16), three capscrews (15), and spacers (17) from rear shield (19) and rear-front crossmember (14). Discard locknuts (18).
2. Remove three locknuts (10), six washers (11), three capscrews (13), and rear shield (19) from three mounting brackets (12). Discard locknuts (19).
3. Remove six locknuts (9), twelve washers (7), six capscrews (6), spacers (20), and three mounting brackets (12) from rear-rear crossmember (8). Discard locknuts (9).

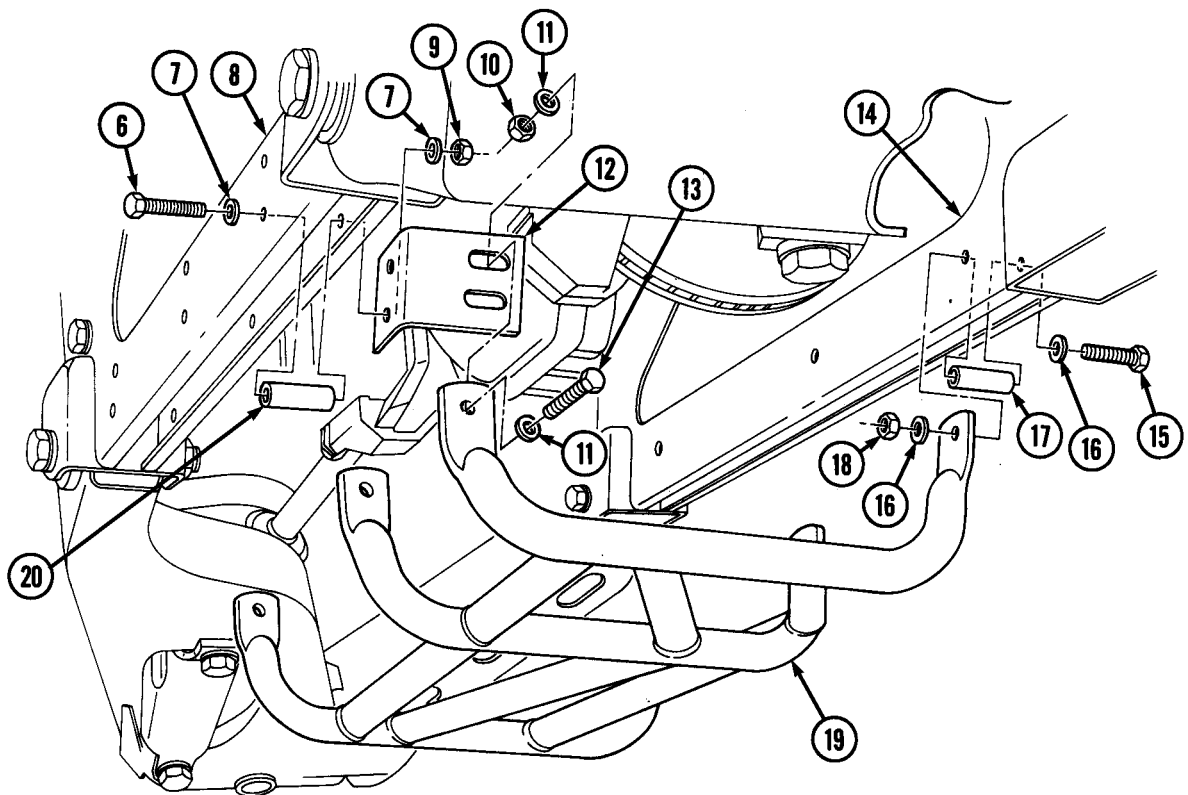

12-186. UNDERBODY PROTECTION KIT REPLACEMENT (Cont'd)

f. Fuel Tank Shield Removal

WARNING

- Fuel tank must be supported during removal and installation; failure to do so may cause damage to fuel tank or injury to personnel.
 - Diesel fuel is highly flammable. Do not perform this task near fire, flames, or sparks. Severe injury or death may result.
1. Drain fuel tank (1) (refer to para. 3-24).
 2. Remove two nuts (6), four washers (2), two capscrews (3), and support straps (5) from upper straps (4).
 3. Swing support straps (5) down and remove fuel tank shield (7).

g. Fuel Tank Shield Installation

WARNING

- Fuel tank must be supported during removal and installation; failure to do so may cause damage to fuel tank or injury to personnel.
 - Diesel fuel is highly flammable. Do not perform this task near fire, flames, or sparks. Severe injury or death may result.
1. Position fuel tank shield (7) on fuel tank (1) and raise support straps (5).

NOTE

Maintain 0.50 in. (13mm) clearance between upper and lower straps when tightening locknuts.

2. Install support straps (5) to upper straps (4) with two capscrews (3), four washers (2), and two nuts (6). Tighten nuts (6) to 37 lb-ft (50 N•m).
3. Fill fuel tank (1) (refer to TM 9-2320-280-10).

12-186. UNDERBODY PROTECTION KIT REPLACEMENT (Cont'd)

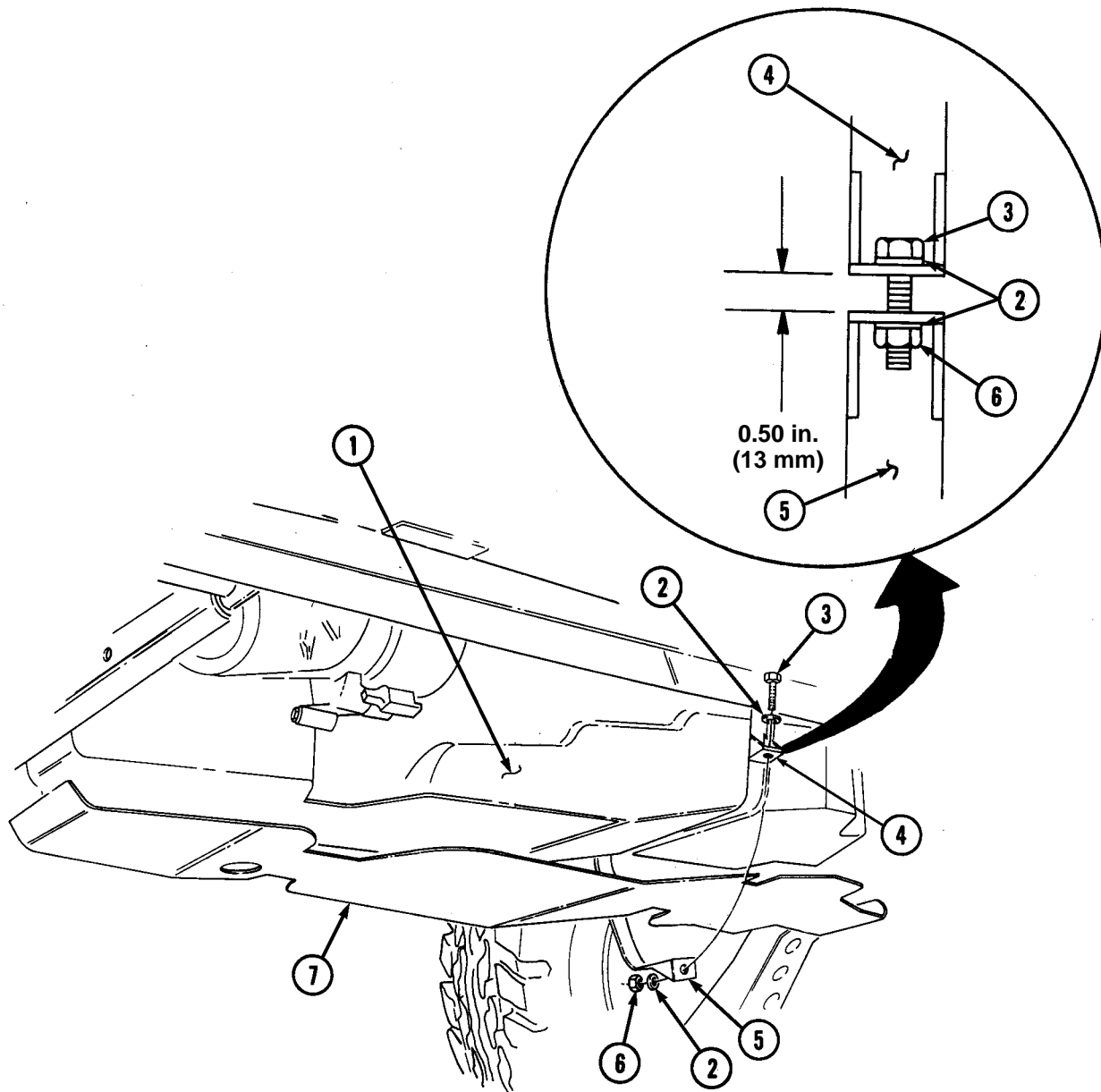

12-186. UNDERBODY PROTECTION KIT REPLACEMENT (Cont'd)

h. Rear Shield Installation

1. Install rear shield (14) to rear-front crossmember (9) with three spacers (12), capscrews (10), six washers (11), and three locknuts (13). Tighten locknuts (13) to 44 lb-ft (60 N•m).
2. Install rear shield (14) on three mounting brackets (7) with three capscrews (8), six washers (6), and three locknuts (5). Do not tighten locknuts (5).
3. Install three mounting brackets (7) on rear-rear crossmember (3) with six spacers (15), capscrews (1), twelve washers (2), and six locknuts (4). Tighten locknuts (4) to 24 lb-ft (33 N•m).
4. Tighten three locknuts (5) to 24 lb-ft (33 N•m).

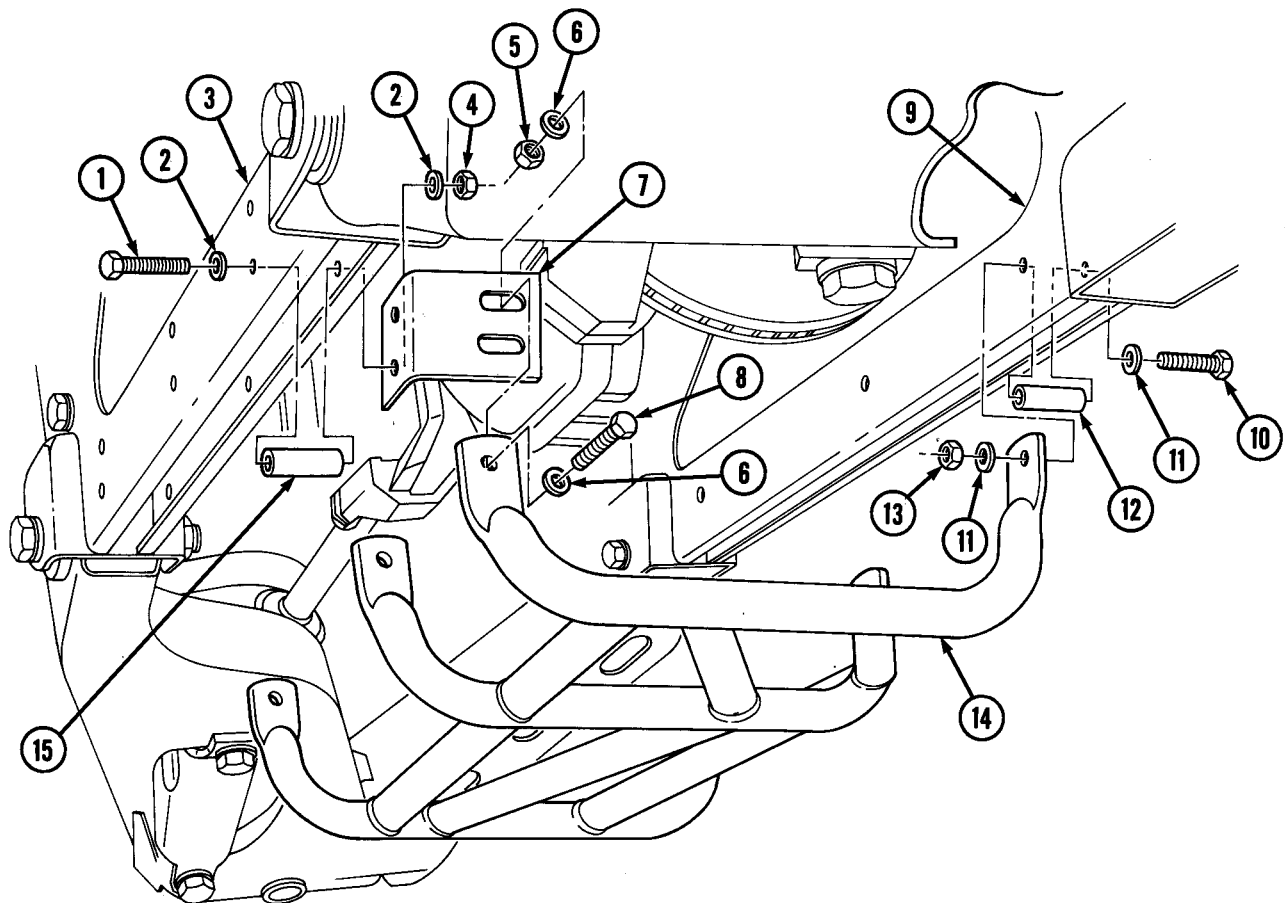

12-186. UNDERBODY PROTECTION KIT REPLACEMENT (Cont'd)**i. Transfer Case Shield Installation**

Install transfer case shield (20) on crossmember (18) with two capscrews (19), four washers (17), and two locknuts (16).

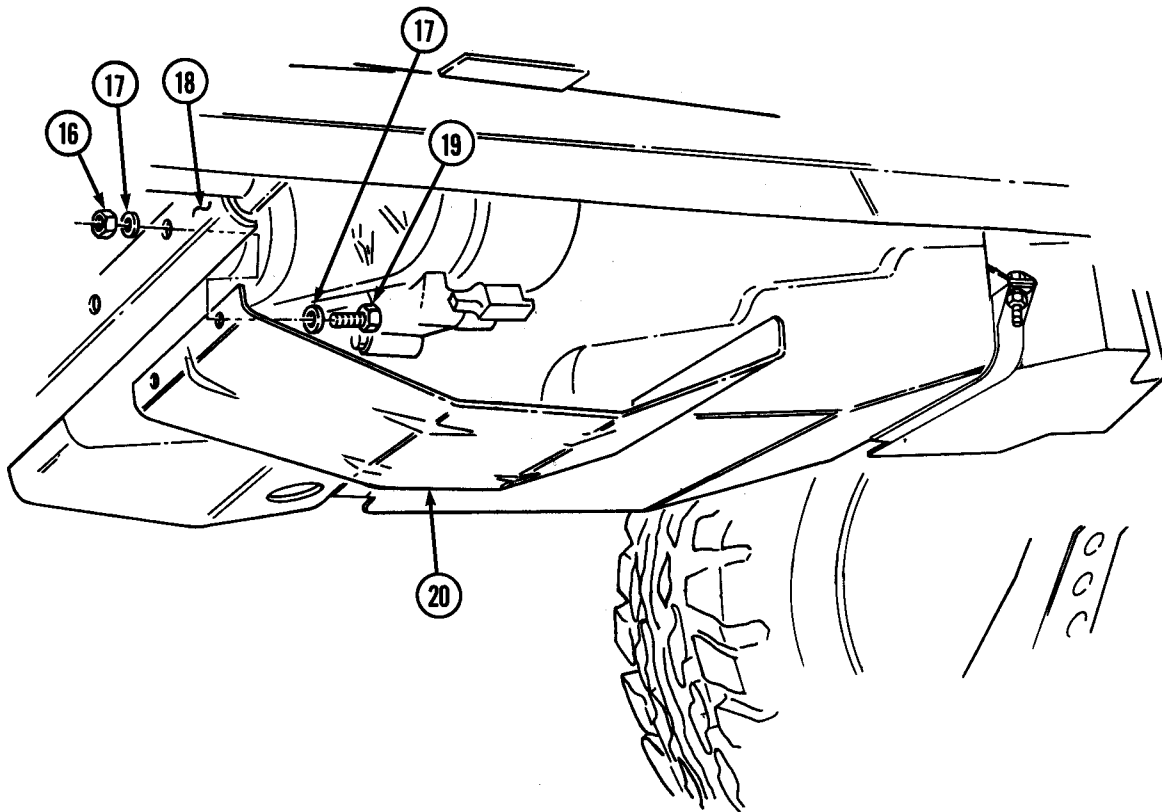

12-186. UNDERBODY PROTECTION KIT REPLACEMENT (Cont'd)

j. Intermediate Shield Installation

1. Install intermediate shield (6) and front shield (2) on front crossmember (1) with four washers (4), two capscrews (5), and locknuts (3). Tighten locknuts (3) to 44 lb-ft (60 N•m).
2. Install left side support bracket (14) on left side mounting bracket (15) with eight washers (11), four capscrews (10), and locknuts (16). Do not tighten locknuts (16).
3. Install right side support bracket (24) on right side mounting bracket (22) with eight washers (21), four capscrews (20), and locknuts (23). Do not tighten locknuts (23).
4. Install left side support bracket (14) on engine mount bracket (7) and left side frame rail (13) with two washers (9), capscrew (8), and locknut (12). Tighten locknut (12) to 105 lb-ft (142 N•m).
5. Install right side support bracket (24) on right side frame rail (25) with two washers (18), capscrew (19), and locknut (17). Tighten locknut (17) to 105 lb-ft (142 N•m).
6. Install two transmission support brackets (28) on intermediate shield (6) and transmission mount crossmember (31) with twelve washers (26), four flat washers (29), six capscrews (27), and locknuts (30). Tighten locknuts (30) to 30 lb-in. (3 N•m).
7. Tighten locknuts (16) and (23) to 24 lb-ft (33 N•m).

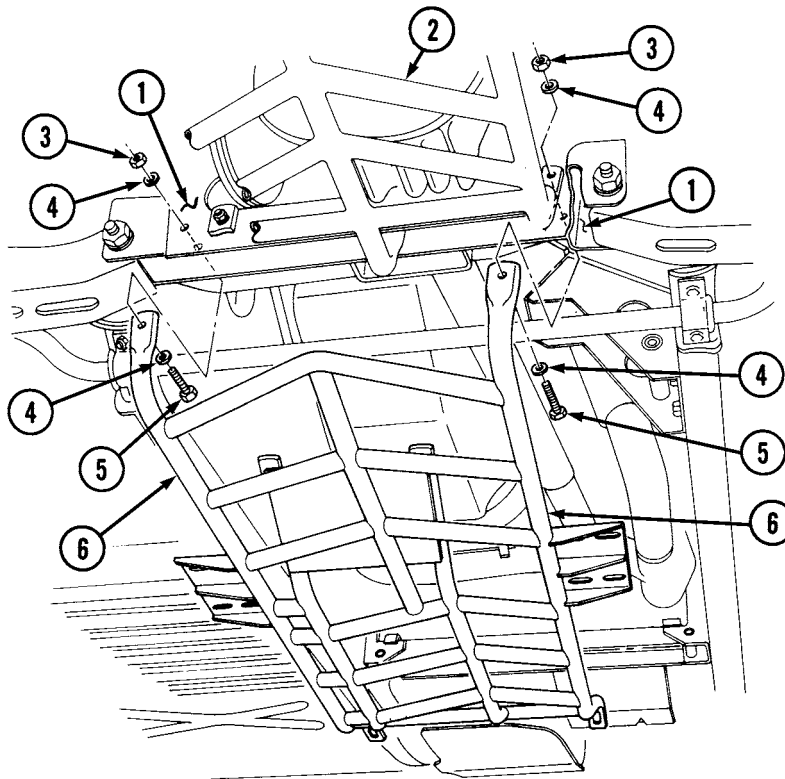

12-186. UNDERBODY PROTECTION KIT REPLACEMENT (Cont'd)

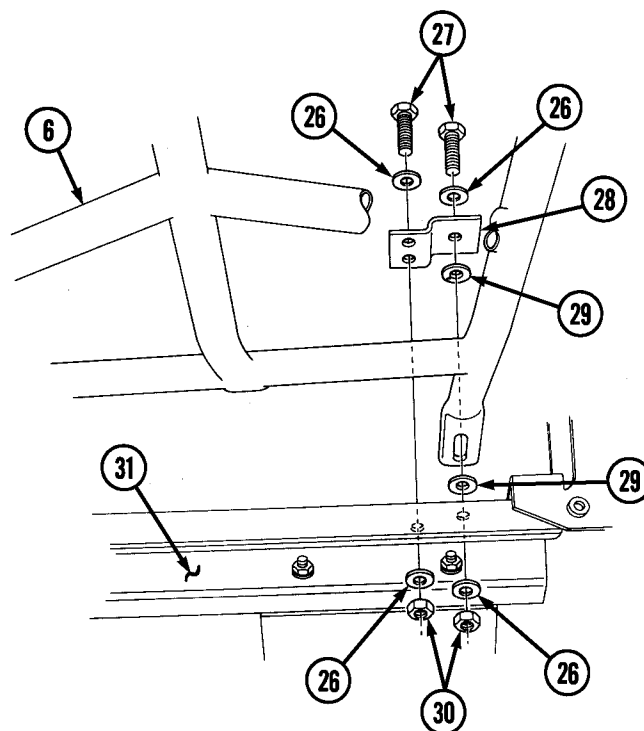
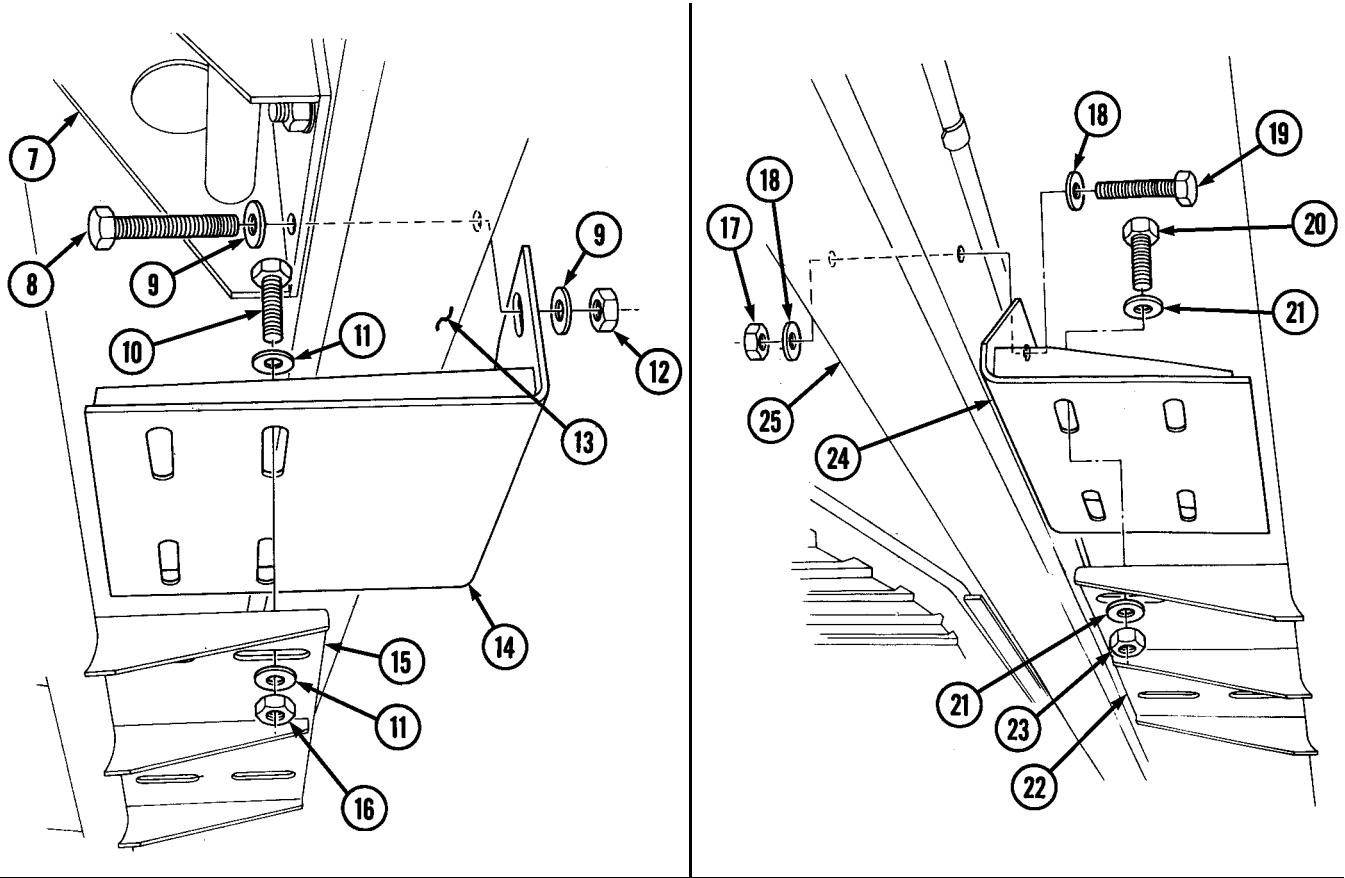

12-186. UNDERBODY PROTECTION KIT REPLACEMENT (Cont'd)

k. Front Shield Installation

1. Install front shield (5) on front skid plate (1) with six washers (3), three capscrews (2), and locknuts (4). Do not tighten locknuts (4).
2. Install front shield (5) on front crossmember (6) and intermediate shield (9) with six washers (8), three capscrews (10), and locknuts (7).
3. Tighten locknuts (4) and (7) to 44 lb-ft (60 N·m).

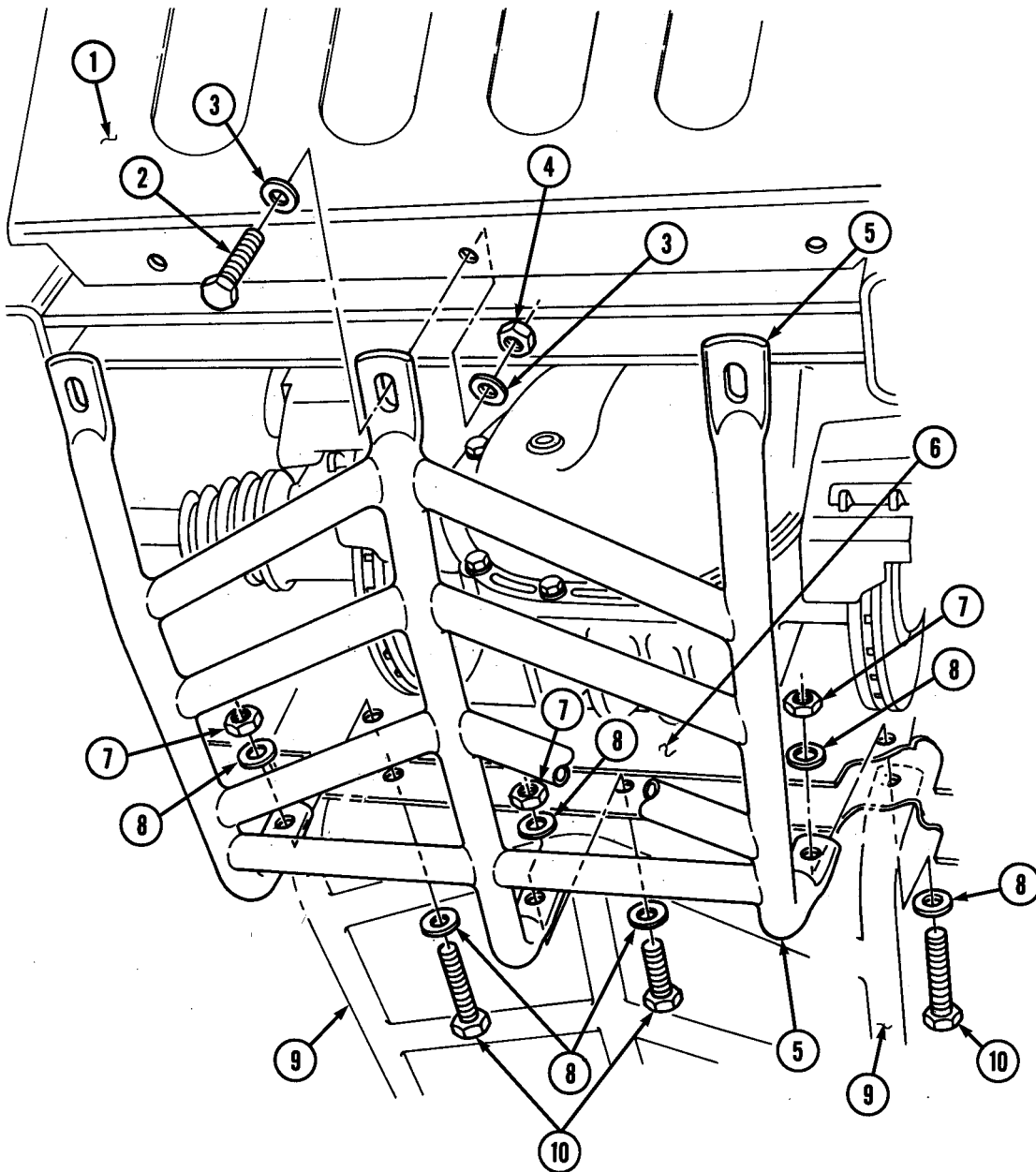

12-186. UNDERBODY PROTECTION KIT REPLACEMENT (Cont'd)**1. Front Skid Plate Installation**

1. Install front skid plate (16) on front bumper (11) with six washers (13), three capscrews (14), and locknuts (15). Tighten locknuts (15) to 24 lb-ft (33 N·m).
2. Install front skid plate (16) on front shield (18) with six washers (12), three capscrews (17), and locknuts (19). Tighten locknuts (19) to 44 lb-ft (60 N·m).

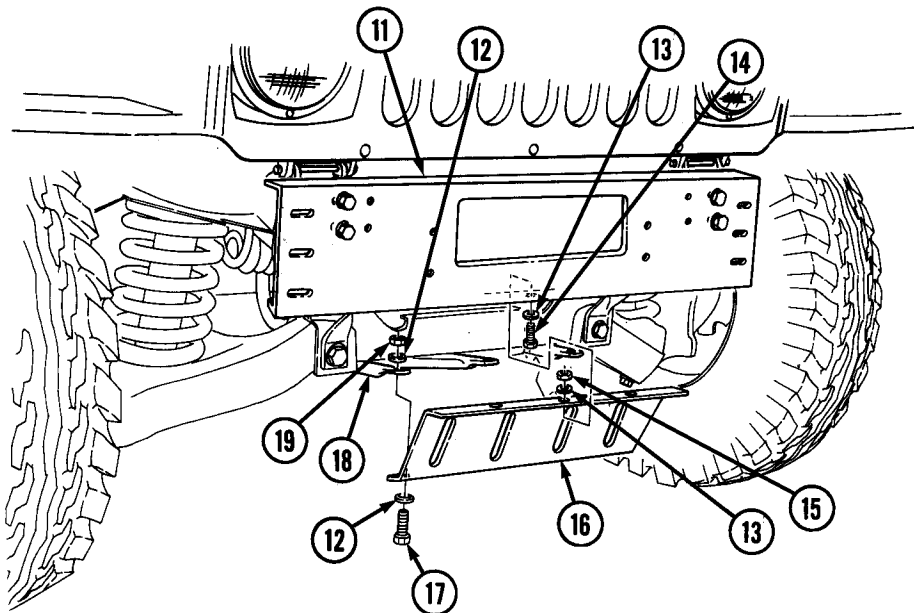

12-187. BRUSHGUARD ASSEMBLY REPLACEMENT

This task covers:

- | | |
|------------------------------------|------------------------------------|
| a. Brushguard Assembly Replacement | d. Quick-Release Brace Replacement |
| b. Tube Assembly Replacement | e. Lanyard Replacement |
| c. Pivot Brace Replacement | |

INITIAL SETUP:

Applicable Models

M997A2, M1025A2, M1035A2, M1043A2,
M1045A2, M1097A2, M1123

Manual References

TM 9-2320-280-24P

Tools

General mechanic's tool kit:
automotive (Appendix B, Item 1)

a. Brushguard Assembly Replacement

1. Remove two nuts (15), washers (16), capscrews (20), and washers (16) from pivot brace (13).
2. Remove two pins (18) from brushguard assembly (4) and quick-release brace (19) and remove brushguard assembly (4) from pivot brace (13).
3. Position brushguard assembly (4) on pivot brace (13) and install two pins (18) through brushguard assembly (4) on quick-release brace (19).
4. Install two washers (16), capscrews (20), washers (16), and nuts (15) on pivot brace (13).

b. Tube Assembly Replacement

NOTE

Perform these steps for three-piece brushguard only.

1. Remove two nuts (22), washers (2), capscrews (3), washers (2), and tube assembly (1) from brushguard assembly (4). Repeat step for other side.
2. Install tube assembly (1) on brushguard assembly (4) with two washers (2), capscrews (3), washers (2), and nuts (22). Repeat step for other side.

c. Pivot Brace Replacement

1. Remove brushguard assembly (4) (task a).
2. Remove two nuts (11), washers (12), capscrews (14), washers (12), and pivot brace (13) from bumper (8).
3. Install pivot brace (13) on bumper (8) with two washers (12), capscrews (14), washers (12), and nuts (11).
4. Install brushguard assembly (4) (task a).

d. Quick-Release Brace Replacement

1. Remove two pins (18) from brushguard assembly (4) and quick-release brace (13) and lower brushguard assembly (4).

NOTE

Vehicles equipped with winch will not have nuts and washers as indicated in steps 2 and 3.

2. Remove two nuts (9), washers (10), capscrews (17), washers (10), and brace (19) from bumper (8).
3. Install brace (19) on bumper (8) with two washers (10), capscrews (17), washers (10), and nuts (9).
4. Raise brushguard assembly (4) and install two pins (18) through brushguard assembly (4) and brace (19).

12-187. BRUSHGUARD ASSEMBLY REPLACEMENT (Cont'd)

e. Lanyard Replacement

1. Remove nut (21), screw (7), washer (6), lanyard (5), and pin (18) from brushguard assembly (4). Repeat step for other side.
2. Install pin (18) and lanyard (5) on brushguard assembly (4) with washer (6), screw (7), and nut (21). Repeat step for other side.

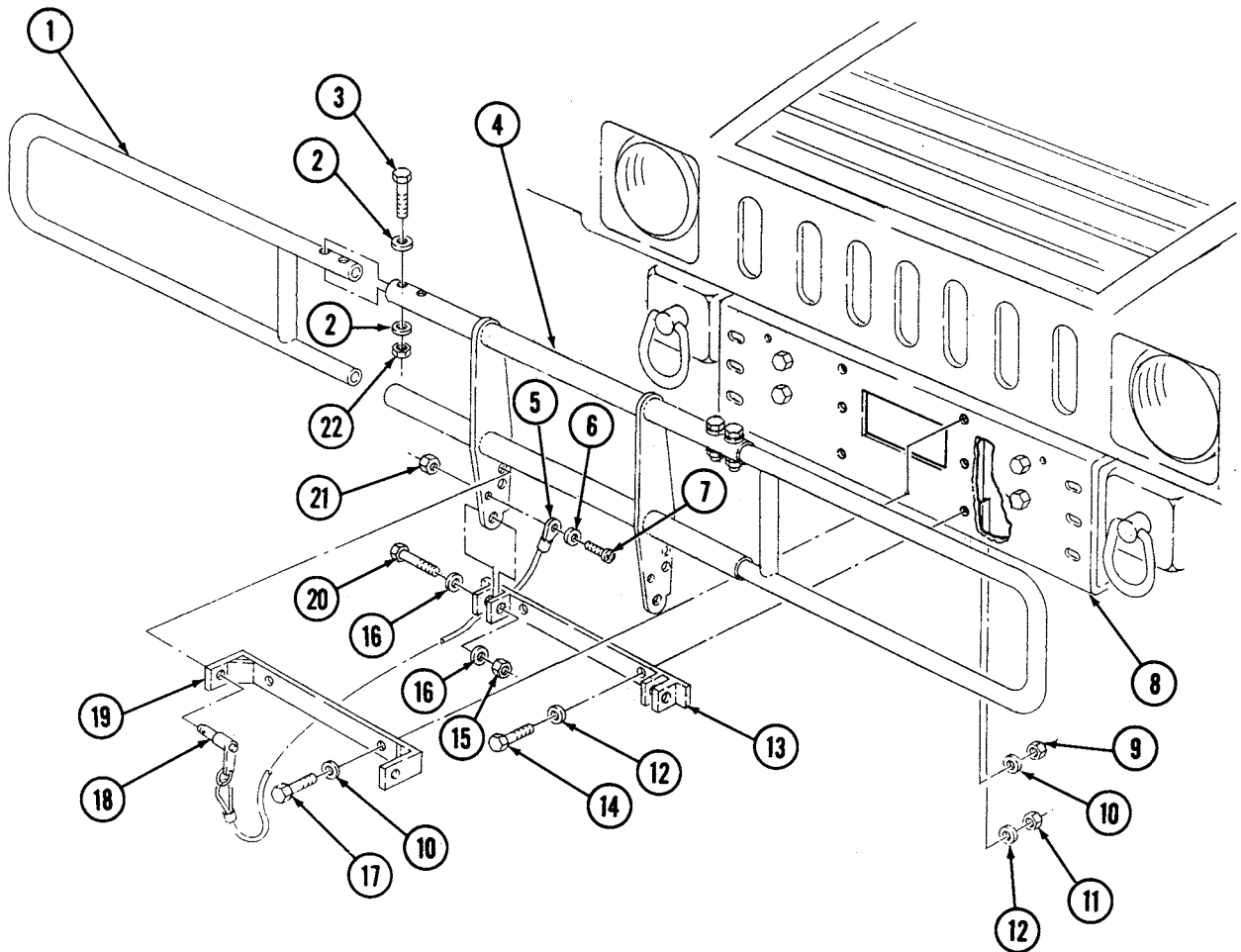

12-188. FLOOR DRAIN HOLE PLATE INSTALLATION

This task covers:

Installation

INITIAL SETUP:

Tools

General mechanic's tool kit:
automotive (Appendix B, Item 1)

Manual References

TM 9-2320-280-24P
TM 43-0139

Materials/Parts

Adhesive sealant (Appendix C, Item 2.1)
Blind rivet (Appendix G, Item 243)
Blind rivet (Appendix G, Item 244)

Installation

NOTE

All drain hole plates are installed basically the same. This procedure covers one drain hole plate.

1. Mark on outline at drain hole (3) on floor panel (4).
2. Cut and remove drain hole material (1) from floor panel (4), and remove sharp edges and burrs from floor panel (4).
3. Mark underside of floor panel (4) with two lines centered over damaged floor drain area.
4. Using a 0.187-inch diameter drill, remove rivet (2) securing floor panel (4) to side body panel (6).

NOTE

- It may be necessary to bend or shape the drain hole plate to the contour of the floor panel.
 - When installed, the drain hole plate opening faces toward the center of the vehicle.
5. Position drain hole plate (5) to underside of floor panel (4). Bend or shape drain hole plate (5) to the contour of the floor panel (4).
 6. Using drain hole plate (5) as a template, locate, mark, and drill seven 0.187-in (4.8 mm) diameter holes on floor panel (4).
 7. Apply approximately 0.125 in. (3.175 mm) thickness of adhesive sealant to shaded mating surface on drain hole plate (5).
 8. Apply approximately 0.125 in. (3.175 mm) thickness of adhesive sealant to shaded mating surface on underside of floor panel (4) and side body panel (6).
 9. Position drain hole plate (5) to underside of floor panel (4) and install seven rivets (2) on floor panel (4) and drain hole plate (5).
 10. Using rivet hole drilled in step 4 as a template, drill 0.187-in. diameter hole through drain hole plate (5).
 11. Install rivet (2) on floor panel (4), side body panel (6), and drain hole plate (5).
 12. Remove adhesive and clean edges on floor panel (4) and drain hole plate (5).
 13. Spot paint floor panel (4) and drain hole plate (5) (TM 43-0139).

12-188. FLOOR DRAIN HOLE PLATE INSTALLATION (Contd)

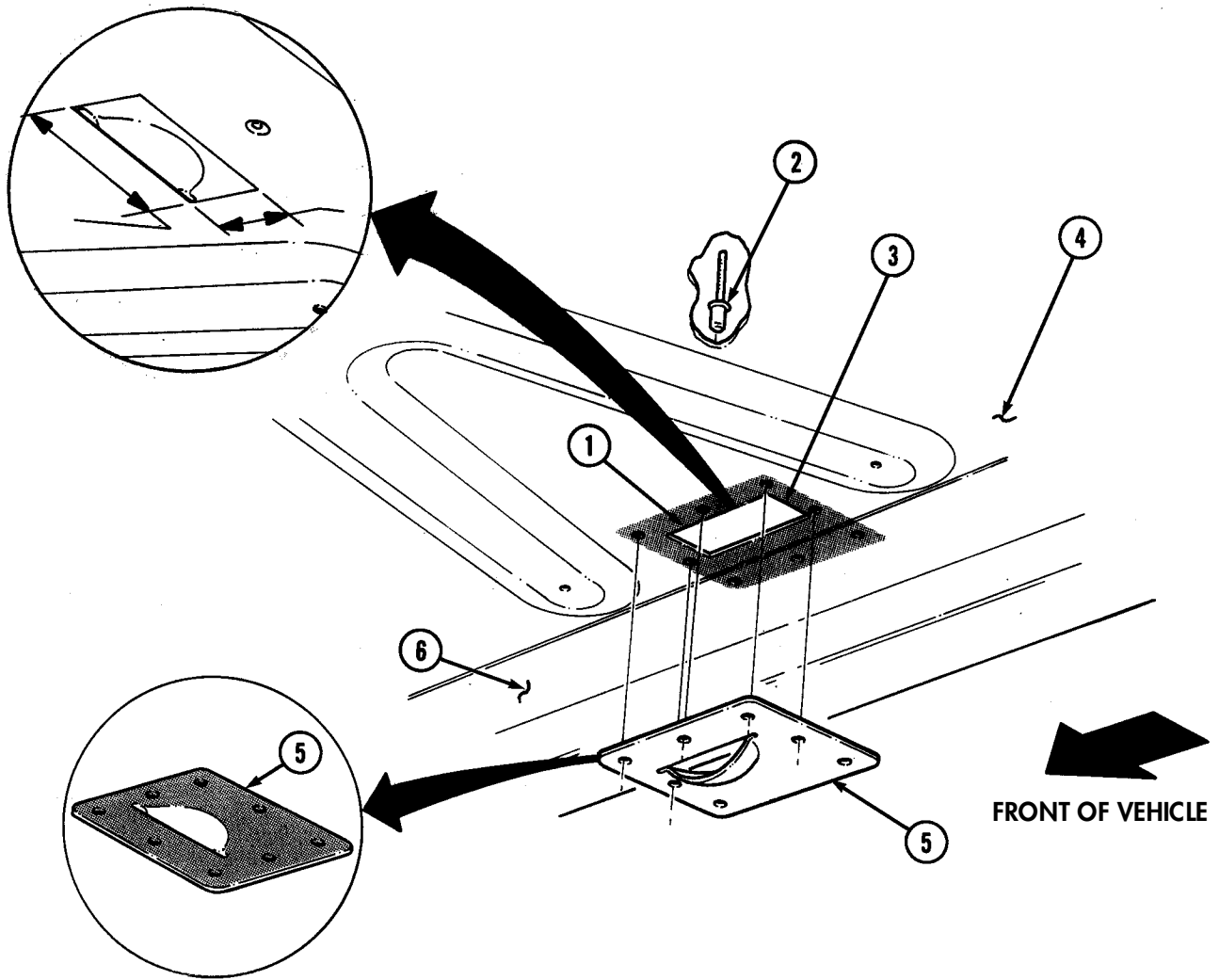

Section XII. CARGO BARRIER AND NET KIT MAINTENANCE

12-189. CARGO BARRIER AND NET KIT MAINTENANCE TASK SUMMARY

TASK PARA.	PROCEDURES	PAGE NO.
12-190.	Cargo Barrier Channel Replacement	12-314
12-191.	Antiskid Strip Replacement	12-316

12-190. CARGO BARRIER CHANNEL REPLACEMENT

This task covers:

- a. Removal
- b. Installation

INITIAL SETUP:

Applicable Models

M1025, M1025A1, M1026, M1026A1

Manual References

TM 9-2320-280-10
 TM 9-2320-280-24P

Tools

General mechanics's tool kit:
 automotive (Appendix B, Item 1)

Equipment Condition

Cargo barrier and net removed (TM 9-2320-280-10).

NOTE

Replacement procedure for left and right cargo barrier channels are the same. This procedure covers the left cargo barrier channel.

a. Removal

Remove two nuts (2), washers (3), screws (5), and channel (4) from armor plate (6) and wheelhouse (1).

b. Installation

Install channel (4) on armor plate (6) and wheelhouse (1) with two screws (5), washers (3), and nuts (2).

12-190. CARGO BARRIER CHANNEL REPLACEMENT (Cont'd)

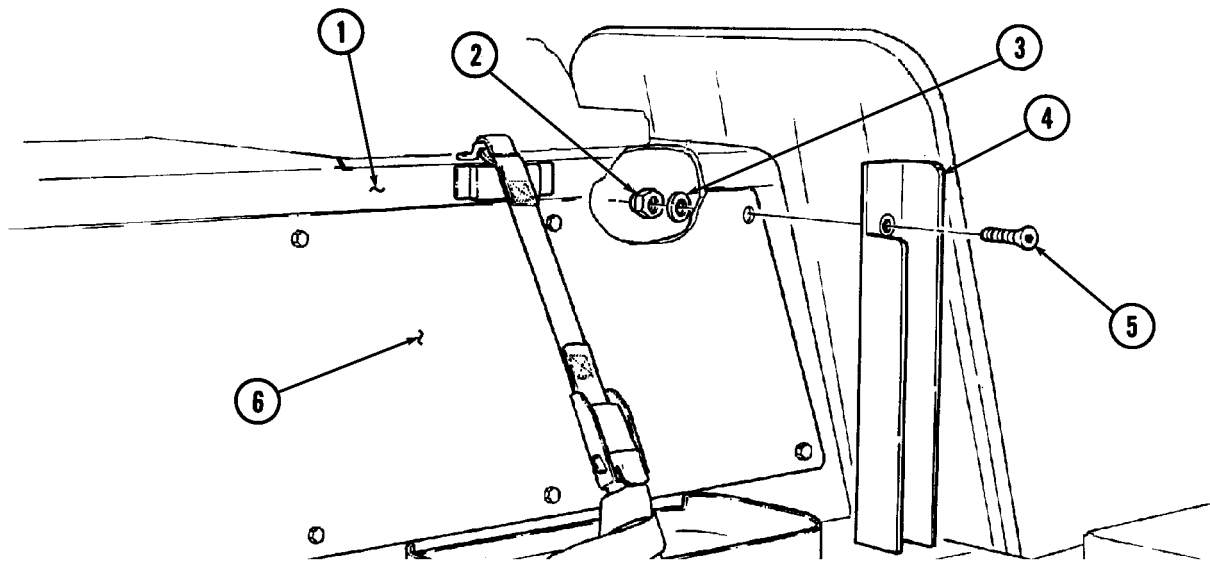

FOLLOW-ON TASK: Install cargo barrier and net (TM 9-2320-280-10).

12-191. ANTISKID STRIP REPLACEMENT

This task covers:

a. Removal

b. Installation

INITIAL SETUP:

Applicable Models

M1025, M1025A1, M1026, M1026A1

Tools

General mechanic's tool kit:
automotive (Appendix B, Item 1)

Manual References

TM 9-2320-280-10
TM 9-2320-280-24P

Equipment Condition

Stowage compartment net removed
(TM 9-2320-280-10).

a. Removal

1. Remove antiskid strip (4) from cargo floor (3).
2. Clean remaining adhesive from cargo floor (3).
3. Inspect plugs (1) in cargo floor (3) and right wheelhouse (2), and replace plugs (1) if damaged.

b. Installation

1. Ensure surface of cargo floor (3) is free of dirt and oil.
2. Peel paper backing (5) from antiskid strip (4) and press antiskid strip (4) firmly onto cargo floor (3).

12-191. ANTISKID STRIP REPLACEMENT (Cont'd)

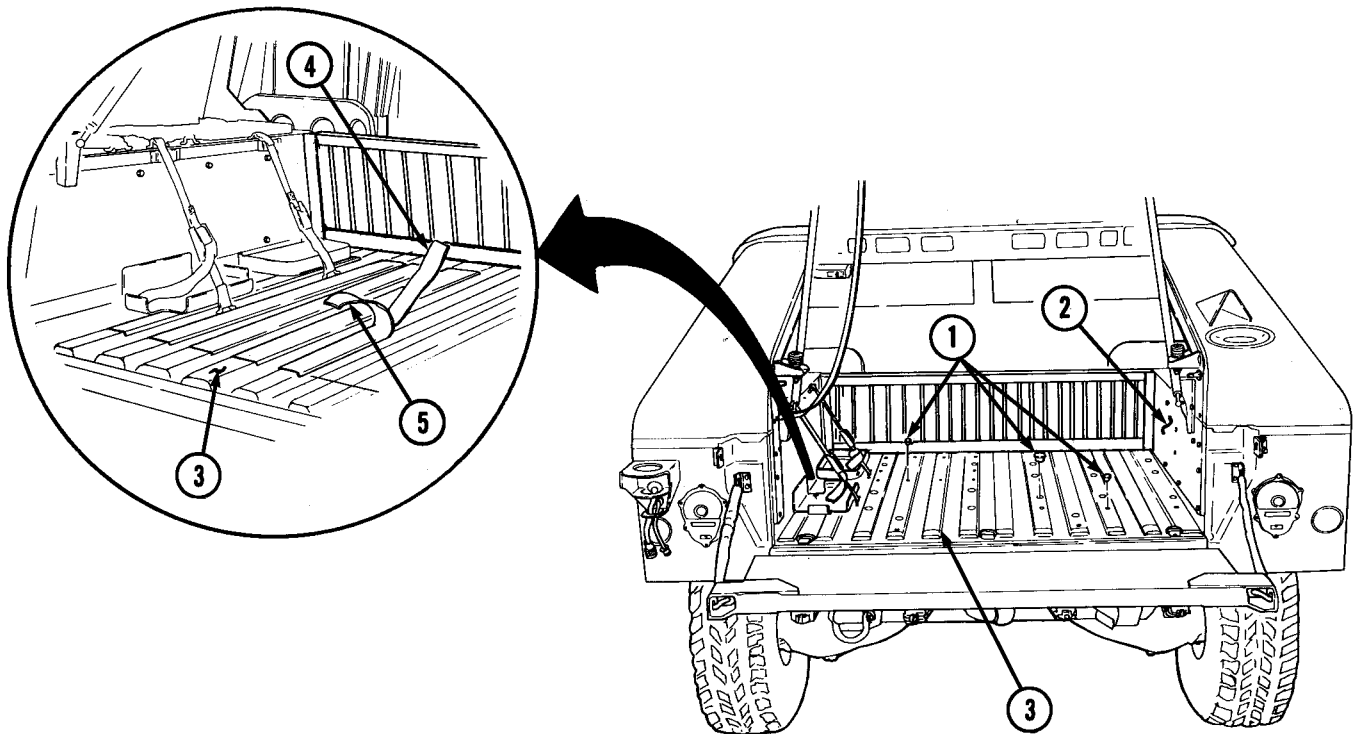

FOLLOW-ON TASK: Install stowage compartment net (TM 9-2320-280-10).

CHAPTER 13

PREPARATION FOR STORAGE OR SHIPMENT

Section I. GENERAL INSTRUCTIONS

13-1. SCOPE

- a. This chapter describes requirements for preparation of M998 series vehicles and components for shipment and limited storage.
- b. When vehicles are shipped or stored, the officer in charge is responsible for preparing the vehicles in a properly maintained and serviceable condition. Vehicles must be properly cleaned, preserved, painted, and lubricated. Vehicles, componentry, and BII must be prepared and protected to prevent corrosion, deterioration, and physical damage.

13-2. ADMINISTRATIVE STORAGE

- a. Administrative storage is the placement of a unit's organic material in a limited care and preservation status for short periods of time.
- b. Instructions and requirements pertaining to administrative storage are found in DA PAM 738-750.

13-3. SECURITY

- a. Equipment and vehicle security requirements are covered in AR 190-13 and AR 190-51.
- b. Cryptographic materials or COMSEC equipment will not be shipped with vehicles or remain in vehicles in storage. Refer to (C) AR 380-40 for information concerning COMSEC materials.
- c. Access to materiel in storage should be strictly controlled to prevent unauthorized cannibalization or pilferage. Refer to AR 750-1.

13-4. SPECIAL PACKAGING AND SHIPPING REQUIREMENTS

- a. When required, wrap, pack, mark, and stow uninstalled government furnished equipment and BII in accordance with MIL-B-12841, MIL-STD-129, MIL-V-62038, and TM 746-10.
- b. Height and width of vehicles prepared for rail transportation must not exceed the limitations of AR 700-15. Whenever possible, local transportation personnel must be consulted about limitations of particular railroad lines to be used for movement in order to avoid delays, dangerous conditions, or damage to equipment.
- c. Loading and blocking procedures must be in accordance with pamphlet no. MD-7, Rules Governing the Loading of Defense Material on Open-Top Cars, of Association of American Railroads.
- d. Loading and blocking of vehicles for highway shipment must be in accordance with Interstate Commerce Commission Publication "Motor Carrier Safety Regulations."
- e. For specific instructions concerning loading and blocking of M998 series vehicles for air, land, or sea shipment, refer to TM 55-2320-280-14.

Section II. PREPARATION FOR STORAGE AND SHIPMENT

13-5. GENERAL STORAGE AND SHIPPING INFORMATION

- a. Storage procedures will be such that the vehicle can be returned to service and operated with minimum delay. Disassembly should be limited to that necessary to clean and preserve exposed surfaces and equipment and to the maximum extent consistent with safe storage. The vehicle will be placed in storage in as nearly a completely assembled condition as practical.
- b. Storage site selection should offer maximum protection from the environment and provide access for inspection, maintenance, and vehicle exercise if necessary.
- c. For long term storage refer to MIL-V-62038 for information concerning preparation of vehicles and components.

13-6. CLEANING

- a. Before applying preservatives, thoroughly clean all vehicle surfaces of corrosion, soil, grease, damaged paint, or other foreign materials. Refer to TM 9-2320-280-10 for M998 series vehicles cleaning instructions.

WARNING

- Drycleaning solvent is flammable and will not be used near an open flame. A fire extinguisher will be kept nearby when the solvent is used. Use only in well-ventilated places. Failure to do this may result in injury to personnel and/or damage to equipment.
- Protective gloves, clothing, and/or respiratory equipment must be worn whenever caustic, toxic, or flammable cleaning solutions are used. Failure to do this may result in injury to personnel and/or damage to equipment.

CAUTION

- Do not allow cleaning compounds to come into contact with rubber, leather, vinyl, or canvas materials. Damage to equipment will result.
- Do not use compressed air when cleaning vehicle interiors. Damage to equipment can result.

- b. Descriptions and uses of cleaning compounds, solvents, drycleaning solutions, and corrosion removing compounds are found in TM 9-247. Refer to TM 9-2320-280-10 as a general guide of cleaning materials used in removing contaminants from M998 series vehicles.

13-7. INSPECTIONS, STOWAGE, AND INVENTORY

- a. Perform a semiannual (S) PMCS on vehicles intended for limited storage or shipment. (See table 2-1 in chapter 2.)
- b. Apply all urgent MWO's to vehicle and equipment (DA PAM 25-30).
- c. Inventory the vehicle and components (TM 9-2320-280-10-HR) and ensure proper stowage of components and BII (TM 9-2320-280-10).
- d. Prepare uninstalled BII and government furnished equipment in accordance with para. 13-4a.

13-8. REPAIR, PAINTING, AND PRESERVATION

- a.** All equipment deficiencies noted during inspections should be repaired in accordance with vehicle TM's.
- b.** All unpainted metal surfaces must be protected during storage or shipment. Inspect, clean, and spot paint metal surfaces as required in TM 9-2320-280-10. Unpainted exposed machined surfaces must be prepared with corrosion-preventive compounds or oil and grease as referenced in TM 9-2320-280-10. Be sure to select preservatives that will not harm vehicle interior components.
- c.** Sunlight, heat, moisture, and dirt accelerate deterioration. Install all covers authorized for the equipment. Close and secure all openings except those required for venting and drainage. Seal all openings to prevent the entry of rain, snow, or dust.
- d.** Inflate tires to a maximum of 30 psi (207 kPa).

13-9. LUBRICATION

Lubricate vehicles in accordance with TM 9-2320-280-10 and TM 9-2320-280-20-1 before shipment or storage.

13-10. RECORDS AND REPORTS

Maintenance records required by AR 750-1 will be maintained and reports submitted in accordance with DA PAM 738-750 and AR 220-1.

APPENDIX A REFERENCES

A-1. SCOPE

This appendix lists all forms, field manuals, technical manuals, and other publications required for use with this manual.

A-2. PUBLICATIONS INDEX

The following index should be consulted frequently for latest changes or revisions and for new publications relating to materiel covered in this manual.

Consolidated Index of Army Publications and Blank Forms DA PAM 25-30

A-3. FORMS

Recommended Changes to Publications and Blank Forms DA Form 2028
 Recommended Changes to Equipment Technical Publications DA Form 2028-2
 Hand Receipt/Annex Number DA Form 2062
 Exchange Tag DA Form 2402
 Equipment Inspection and Maintenance Worksheet DA Form 2404
 Maintenance Request DA Form 2407
 The Army Maintenance Management System (TAMMS) DA PAM 738-750
 Preventive Maintenance Schedule and Record DD Form 314
 Processing and Deprocessing Record for Shipping, Storage,
 and Issue of Vehicles and Spare Engines DD Form 1397
 Quality Deficiency Report Standard Form 368

A-4. FIELD MANUALS

NBC Protection FM 3-4
 NBC Decontamination FM 3-5
 Operation and Maintenance of Ordnance Materiel in Cold Weather (0° to -65°F) FM 9-207
 First Aid for Soldiers FM 21-11
 Manual for the Wheeled Vehicle Driver FM 21-305
 Browning Machinegun Caliber .50 HB, M2 FM 23-65
 Machinegun 7.62-MM, M60 FM 23-67
 Basic Cold Weather Manual FM 31-70
 Northern Operations FM 31-71
 Army Motor Transport Units and Operations FM 55-30
 Mountain Operations FM 90-6
 General Fabric Repair FM 10-16

A-5. TECHNICAL MANUALS

Inspection, Care and Maintenance of Antifriction Bearings TM 9-214
 Materials Used for Cleaning, Preserving, Abrading, and Cementing Ordnance
 Materiel and Related Materials (Including Chemicals) TM 9-247
 Operator's Manual for Machinegun, Caliber .50 Browning, M2 TM 9-1005-213-10
 Operator's Manual for M60, 7.62-MM Machinegun TM 9-1005-224-10

A-5. TECHNICAL MANUALS (Cont'd)

Operator's and Organizational Maintenance Manual for
TOW 2 Weapon System, Guided Missile System TM 9-1425-450-12

Operator's and Organizational Maintenance Manual for
TOW Weapon System, Guided Missile System TM 9-1425-472-12

■ Tactical Wheeled Vehicles: Repair of Frames TM 9-2300-247-40

Operator's Manual for Truck, 1-1/4 Ton, 4X4, M998 Series TM 9-2320-280-10

Unit, Direct Support and General Support Maintenance Repair Parts and
Special Tools List TM 9-2320-280-24P

Operator's, Unit, Direct Support and General Support Maintenance Manual For
Care, Maintenance, Repair and Inspection of Pneumatic Tires,
Inner Tubes, and Radial Tires TM 9-2610-200-14

Operator's, Organizational, Direct Support and
General Support Maintenance Manual for Lead-Acid Storage Batteries TM 9-6140-200-14

Marking, Packaging and Supplies and Equipment:
General Packaging Instructions for Field Use TM 746-10

Procedures for Destruction of Tank Automotive Equipment to Prevent Enemy Use . . . TM 750-244-6

Cooling Systems: Tactical Vehicles TM 750-254

Principles of Automotive Vehicles TM 9-8000

Painting Instructions for Army Materiel TM 43-0139

A-6. TECHNICAL BULLETINS

Solder and Soldering TB SIG-222

Security of Tactical Wheeled Vehicles TB 9-2300-422-20

■ Equipment Improvement Report and Maintenance Digest TB 43-0001-62

Use of Antifreeze Solutions and Cleaning Compounds
in Engine Cooling Systems TB 750-651

Corrosion Prevention and Control TB 43-0213

A-7. ARMY REGULATIONS

Identification and Distribution of DA Publications and Issue of
Agency and Command Administrative Publication AR 310-2

Dictionary of United States Army Terms AR 310-25

A-8. OTHER PUBLICATIONS

Army Acquisition Policy AR 70-1

The Army Physical Security Program AR 190-13

Security of Unclassified Army Properties AR 190-51

Unit Status Reporting AR 220-1

Policy for Safeguarding and Controlling Comsec Material AR 380-40

Prevention of Motor Vehicle Accidents AR 385-55

Packaging of Material AR 700-15

Army Material Maintenance Policy and Retail Maintenance Operation AR 750-1

Expendable/Durable Items (Except: Medical, Class V, Repair Parts and Heraldic Items) . . . CTA 50-970

■ Operator's Manual for Welding Theory and Application TC 9-237

Hand Receipt for Truck, 1-1/4 Ton, 4X4, M998 Series TM 9-2320-280-10 HR

Transportability Guidance TM 55-2320-280-14

APPENDIX B MAINTENANCE ALLOCATION CHART

Section I. INTRODUCTION

B-1. THE ARMY MAINTENANCE SYSTEM (MAC)

- a.** This section provides a general explanation of all maintenance and repair functions authorized at various maintenance levels under the standard Army Maintenance System Concept.
- b.** The Maintenance Allocation Chart (MAC) in section II designates overall authority and responsibility for the performance of maintenance functions on the identified end item or component. The application of the maintenance functions to the end item or component will be consistent with the capacities and capabilities of the designated maintenance levels, which are shown on the MAC in column (4) as:
- Unit - includes two subcolumns, C (operator/crew) and O (unit) maintenance.
 - Direct Support - includes an F subcolumn.
 - General Support - includes an H subcolumn.
 - Depot - includes a D subcolumn.
- c.** Section III lists the tools and test equipment (both special tools and common tool sets) required for each maintenance function as referenced from section II.
- d.** Section IV contains supplemental instructions and explanatory notes for a particular maintenance function.

B-2. MAINTENANCE FUNCTIONS

Maintenance functions will be limited to and defined as follows:

- a. Inspect.** To determine the serviceability of an item by comparing its physical, mechanical, and/or electrical characteristics with established standards through examination (e.g., by sight, sound, or feel).
- b. Test.** To verify serviceability by measuring the mechanical, pneumatic, hydraulic, or electrical characteristics of an item and comparing those characteristics with prescribed standards.
- c. Service.** Operations required periodically to keep an item in proper operating condition, i.e., to clean (includes decontaminate, when required), to preserve, to drain, to paint, or to replenish fuel, lubricants, chemical fluids, or gases.
- d. Adjust.** To maintain or regulate, within prescribed limits, by bringing into proper or exact position, or by setting the operating characteristics to specified parameters.
- e. Align.** To adjust specified variable elements of an item to bring about optimum or desired performance.
- f. Calibrate.** To determine and cause corrections to be made or to be adjusted on instruments or test, measuring, and diagnostic equipment used in precision measurement. Consists of comparisons of two instruments, one of which is a certified standard of known accuracy, to detect and adjust any discrepancy in the accuracy of the instrument being compared.
- g. Remove/Install.** To remove and install the same item when required to perform service or other maintenance functions. Install may be the act of emplacing, seating, or fixing into position a spare, repair part, or module (component or assembly) in a manner to allow the proper functioning of an equipment or system.
- h. Replace.** To remove an unserviceable item and install a serviceable counterpart in its place. "Replace" is authorized by the MAC and is shown as the 3d position code of the SMR code.

i. Repair. The application of maintenance services, including fault location/troubleshooting, removal/installation, and disassembly/assembly procedures, and maintenance actions to identify troubles and restore serviceability to an item by correcting specific damage, fault, malfunction, or failure in a part, subassembly, module (component or assembly), end item, or system.

j. Overhaul. That maintenance effort (service/action) prescribed to restore an item to a completely serviceable/operational condition as required by maintenance standards in appropriate technical publications (i.e., DMWR). Overhaul is normally the highest degree of maintenance performed by the Army. Overhaul does not normally return an item to like-new condition.

k. Rebuild. Consists of those services/actions necessary for the restoration of unserviceable equipment to a like-new condition in accordance with original manufacturing standards. Rebuild is the highest degree of materiel maintenance applied to Army equipment. The rebuild operation includes the act of returning to zero those age measurements (hours/ miles, etc.) considered in classifying Army equipment/components.

B-3. EXPLANATION OF COLUMNS IN THE MAC, SECTION II

a. Column (1)-Group Number. Column 1 lists functional group code numbers, the purpose of which is to identify maintenance significant components, assemblies, subassemblies, and modules with the next higher assembly.

b. Column (2)-Component/Assembly. Column 2 contains the names of components, assemblies, subassemblies, and modules for which maintenance is authorized.

c. Column (3)-Maintenance Function. Column 3 lists the functions to be performed on the item listed in Column 2. (For detailed explanation of these functions, see para. B-2.)

d. Column (4)-Maintenance Category. Column 4 specifies, by the listing of a work time figure in the appropriate subcolumn(s), the category of maintenance authorized to perform the function listed in Column 3. This figure represents the active time required to perform that maintenance function at the indicated category of maintenance. If the number of complexity of the tasks within the listed maintenance function vary at different maintenance categories, appropriate work time figures will be shown for each category. The work time figure represents the average time required to restore an item (assembly, subassembly, component, module, end item, or system) to a serviceable condition under typical field operating conditions. This time includes preparation time (including any necessary disassembly/assembly time) troubleshooting/fault location time, and quality assurance/quality control time in addition to the time required to perform the specific tasks identified for the maintenance functions authorized in the maintenance allocation chart. The symbol designations for the various maintenance categories are as follows:

NOTE

When a complete replace or repair task performed at higher level maintenance includes lower level maintenance tasks (equipment condition/follow-on tasks), the lower level work time figures in the MAC must be added to the higher level work time shown in the MAC to determine the total time to accomplish that maintenance function.

- C Operator or crew
- O Unit maintenance
- F Direct Support maintenance
- H General Support maintenance
- D Depot maintenance

e. Column (5)-Tools and Equipment. Column 5 specifies, by code, those common tool sets (not individual tools) and special tools, TMDE, and support equipment required to perform the designated function.

f. Column (6)-Remarks. This column shall, when applicable, contain a letter code, in alphabetic order, which shall be keyed to the remarks contained in Section IV.

B-4. EXPLANATION OF COLUMNS IN TOOL AND TEST EQUIPMENT REQUIREMENTS, SECTION III

- a. **Column (1)-Reference Code.** The tool and test equipment reference code correlates with a code used in the MAC, Section II, Column 5.
- b. **Column (2)-Maintenance Category.** The lowest category of maintenance authorized to use the tool or test equipment.
- c. **Column (3)-Nomenclature.** Name or identification of the tool or test equipment.
- d. **Column (4)-National Stock Number.** The National stock number of the tool or test equipment.
- e. **Column (5)-Tool Number.** The manufacturer's part number.

B-5. EXPLANATION OF COLUMNS IN REMARKS, SECTION IV

- a. **Column (1)-Remarks Code.** The code recorded in column 6, Section II.
- b. **Column (2)-Remarks.** This column lists information pertinent to the maintenance function being performed as indicated in the MAC, Section II.

Section II. MAINTENANCE ALLOCATION CHART (Cont'd)

(1) Group Number	(2) Component/Assembly	(3) Maintenance Function	(4) Maintenance Level					(5) Tools and Equipment Ref Code	(6) Remarks Code
			Unit		Direct Support	General Support	Depot		
			C	O	F	H	D		
01	ENGINE								
0100	Engine Assembly	Inspect Test Service Adjust Replace Repair	0.2	0.7	1.0			1,20,21,22,26 1,2 41,42 25,145 1,7,10,43-45	G
	Mount, Engine	Inspect Replace		0.1		16.0		2,144,145 1,2,144- 146,149	
0101	Cylinder Head	Replace Repair			3.0	5.0		1,6 1,6,8,12-18	
	Block, Cylinder	Repair				10.0		1,6-8,12-18	
0102	Crankshaft	Replace				4.0		1	
	Pulley, Crankshaft	Replace			0.5			1,6	
	Damper, Vibration	Replace			0.5			1,6	
	Bearings, Crankshaft	Replace				4.0		1	
	Oil Seals, Crankshaft, Front	Replace			2.0			1	
	Oil Seals, Crankshaft, Rear	Replace			2.0			1,6,46	
0103	Flywheel	Replace			3.5			1,6	
0104	Pistons, Connecting Rods								
	Rods, Connecting	Replace				8.0		1,6	
	Bearings, Connecting Rod	Replace				2.0		1,6	
	Pistons	Replace				8.0		1,6	
	Rings, Piston	Replace				7.0		1,6,10	
0105	Valves, Camshaft, and Timing System								
	Cover, Rocker Arm	Replace			1.0			1,6	
	Valves, Intake and Exhaust	Replace Repair				3.0 3.0		6 6,8	
	Rocker Arm Assembly	Replace			2.1			1,6	
	Springs, Valve	Test Replace			0.5 2.3			1,8 1,6	
	Rods, Push	Replace			3.0			1	
	Lifters	Replace			6.0			1	

Section II. MAINTENANCE ALLOCATION CHART (Cont'd)

(1) Group Number	(2) Component/Assembly	(3) Maintenance Function	(4) Maintenance Level					(5) Tools and Equipment Ref Code	(6) Remarks Code
			Unit		Direct Support	General Support	Depot		
			C	O	F	H	D		
0106	Gears and Chain, Timing	Replace			4.0			1,6,10	
	Camshaft	Replace				4.0		1,6,10	
	Bearings, Camshaft	Replace				4.0		1,6,45,47	
	Engine Lubrication System								
	Pan, Oil	Replace		2.0				1,2	
	Pump, Oil	Replace			2.5			1,6	
	Filter, Oil	Replace		0.5				1,2	
	Dipstick and Tube	Replace		0.2				1,2,156	
	Oil Cooler Assembly	Inspect		0.1				1,2	
		Replace		0.5				1	
	Repair			1.0					
	Lines, Oil Cooler	Inspect		0.2					
		Replace		1.8				1	
	Valve, Crankcase Depression Regulator	Inspect		0.1					
		Test		0.3					L
		Service		0.3				1	
		Replace		0.3				1,2	
0108	Manifold, Intake	Replace			3.0			1,6	
	Manifold, Exhaust	Replace		3.0				1,146, 150,156	
03	FUEL SYSTEM								
0301	Injector Nozzle, Fuel	Test			0.5			1,9	
		Replace			0.7			1,6,49,134, 146,153	
0302	Lines, Injection Pump	Inspect		0.1					
		Replace			2.0			1,147,148	
	Pump, Injection	Inspect		0.1					
		Calibrate				A		1,9,59-65	A
		Replace			4.0			1,147	
		Repair			0.6	5.0		1,9,50-57, 158-161	O
	Fuel Pump	Test		0.3				1,2	
		Replace		1.0				1,2	
0304	Cleaner Assembly, Air	Inspect	0.2						
		Service	0.2	0.5				1	
		Replace		0.2				1	
	Horn, Air Induction	Inspect	0.1						
		Replace		0.3				1,2	
0306	Lines and Fittings, Fuel	Inspect		0.2					
		Replace		3.2				1	
	Tank, Fuel	Inspect		0.1					
		Replace		2.6				1,2	

Section II. MAINTENANCE ALLOCATION CHART (Cont'd)

(1) Group Number	(2) Component/Assembly	(3) Maintenance Function	(4) Maintenance Level					(5) Tools and Equipment Ref Code	(6) Remarks Code
			Unit		Direct Support	General Support	Depot		
			C	O	F	H	D		
0309	Filter Assembly, Fuel	Inspect Service Replace	0.1	0.1 0.5 0.5				1 2	B
0311	Glow Plugs	Test Replace		0.3 0.7				2 1,2,48,155	
0312	Accelerator Linkage	Inspect Adjust Replace		0.2 0.2 0.8				1 1,2	
	Hand Throttle	Inspect Adjust Replace	0.1	0.1 0.2 0.5				1 1,2	
04	EXHAUST SYSTEM								
0401	Muffler	Inspect Replace		0.2 1.9				1,2	
	Crossover Pipe	Inspect Replace		0.2 1.2				1,2,145, 150	
	Tailpipe	Inspect Replace		0.2 0.5				1,2	
05	COOLING SYSTEM								
0501	Radiator	Inspect Test Replace Repair	0.1	0.2 0.5 4.3	3.0			2,66 1 1	
	Surge Tank	Inspect Service Replace	0.1 0.1	0.5 0.6				1,2 1	C
0502	Shroud, Fan	Inspect Replace Repair		0.1 4.4 F				1	F,M
0503	Hoses, Lines, and Clamps	Inspect Replace	0.1	0.1 2.5				1	
	Thermostat	Test Replace		0.2 0.3				1,2	
0504	Pump, Water	Replace		3.5				1,6	
0505	Fan	Inspect Replace	0.1	0.1 1.0				1,2,161	
	Fan Drive	Repair			4.7			1,6	
	Pulley, Water Pump	Replace		4.8				1,157	

Section II. MAINTENANCE ALLOCATION CHART (Cont'd)

(1) Group Number	(2) Component/Assembly	(3) Maintenance Function	(4) Maintenance Level					(5) Tools and Equipment Ref Code	(6) Remarks Code
			Unit		Direct Support	General Support	Depot		
			C	O	F	H	D		
06 0601	Belts, Drive	Inspect	0.1						
		Adjust		0.5				1,2,67	
		Replace		1.0				1,2,67	
0603	ELECTRICAL SYSTEM								
	Alternator (60 Ampere)	Inspect		0.1					
		Test		0.3				2,166	
0607	Pulley, Alternator	Adjust		0.3				1,163	
		Replace		1.0				1,2	
		Replace		1.2				1,2,67	
0608	Starter	Inspect		0.2					
		Test		0.3				2	
		Replace		1.9				1,2,145, 146,149	
0609	Instrument Panel	Repair			8.3			1,9	
		Switches		0.3				1	
		Instruments, Gages	0.1	0.5				1	
0610	Circuit Breakers	Replace		0.5				1	
		Control, Directional Signal	0.1						
		Inspect		0.3				1	
0611	Protective Control Box	Inspect		0.1					
		Replace		0.3				1	
		Headlight	0.1						
0612	Headlight	Inspect		0.2				1,2	
		Adjust		0.5				1	
		Replace							
0613	Lights, Composite, Front and Rear	Inspect	0.1						
		Replace		0.1				1	
		Sending Units and Warning Switches	Test		0.1				2
0614	Sending Units and Warning Switches	Replace		0.1				1	
		Horn Assembly	0.1						
		Inspect		0.2				2	
0615	Horn Assembly	Test		0.3				1	
		Replace							
		Switch, Horn	Test		0.2				2
0616	Switch, Horn	Replace		0.2				1	
		Battery	0.1						
		Inspect		0.5				2	
0617	Battery	Test		0.2				1	
		Service		1.6				1	
		Replace							
0618	Cables, Battery	Inspect	0.2						
		Replace		0.8				1	
		Repair		0.5				1,2	

Section II. MAINTENANCE ALLOCATION CHART (Cont'd)

(1) Group Number	(2) Component/Assembly	(3) Maintenance Function	(4) Maintenance Level					(5) Tools and Equipment Ref Code	(6) Remarks Code
			Unit		Direct Support	General Support	Depot		
			C	O	F	H	D		
0613	Wiring Harnesses								
	Wiring Harness, Engine	Inspect		0.3					
		Replace			4.5			1,6	
		Repair		0.5				1,2	
	Wiring Harness, STE/ICE-R	Inspect		0.3					
		Replace			3.7			1,6	
		Repair		0.5				1,2	
	Wiring Harness, Body	Inspect		0.4					
		Replace			3.5			1,6	
		Repair		0.5				1,2	
	Wiring Harness, Hood	Inspect		0.2					
		Replace		1.0				1	
		Repair		0.5				2	
	0615	Ambulance Electrical System							
		Spotlight and Ceiling	Inspect	0.1					
Light Bulbs		Replace		0.1				1	
Spotlight and Ceiling Light Assemblies		Inspect	0.1						
		Replace		0.2				1	
Blackout Light Switches		Inspect	0.1						
		Replace		0.2				1	
Backup Lights		Replace		0.3				1	
Control Box		Inspect	0.1						
		Replace		2.5				1	
Control Box Relays, Switches, Fuse Blocks		Replace		0.3				1	
Heat/Vent Control Panel (M996)		Replace		0.3				1	
Heat, Vent, and A/C Control Box (M997)		Replace			10.0			1	
Heat, Vent, and A/C Switches and Relays		Replace		0.3				1	
200 Ampere Alternator		Inspect		0.2					
	Test		0.3				2,166		
	Replace		1.1				1		
	Adjust		0.3						
	Repair			4.0					
Lighting Wiring Harness	Replace		3.5				1		
NBC Control Box and Wiring Harness	Replace		4.3						

Section II. MAINTENANCE ALLOCATION CHART (Cont'd)

(1) Group Number	(2) Component/Assembly	(3) Maintenance Function	(4) Maintenance Level					(5) Tools and Equipment Ref Code	(6) Remarks Code
			Unit		Direct Support	General Support	Depot		
			C	O	F	H	D		
07	TRANSMISSION (3L80)								
0705	Shift Control and Linkage	Inspect Adjust Replace Repair	0.1	0.2 0.5 1.5 1.0				1 1,2 6	
	Modulator, Mechanical	Adjust Replace		0.1 0.6				2 2	
	Switch Neutral Start	Replace		0.5				1	
	Detent Solenoid	Replace			1.7			1,2	
0708	Torque Converter	Replace			3.3			1,2	
0710	Transmission Assembly	Inspect Test Service Replace Repair	0.1		0.5 0.2 5.8			2,6,145 1,2 1,6,144 1,6,70,80	
	Transmission Mount	Inspect Replace		0.2 1.0				1,6	
	Gear Unit	Replace Repair				1.5 1.3		1,6,70-73 1,6,72-75	
0713	Forward Clutch	Replace Repair				2.0 0.6		1,6,70-73 1,6,76,77	
	Direct Clutch	Replace Repair				2.0 0.8		1,6,70-73,79 1,6,76,77	
	Intermediate Clutch	Replace Repair				2.0 0.8		1,6,70-73 1,6,74,75,79	
0714	Rear Servo	Replace Repair				1.0 0.3		1,6,78 1,6,78	
	Front Servo	Replace Repair				1.0 1.0		1,6 1,6	
	Band, Front and Rear	Replace				2.5		1,6,70-73,79	
	Governor	Inspect Replace			0.2 0.5			1,6	
	Control Valve	Replace Repair				1.3 1.0		1,6 1,6,10	
0721	Oil Pump, Transmission	Replace Repair				1.0 1.6		1,6,70,71,73,80 1,6,73-75	
	Seal, Oil Pump	Replace			0.3			1,6,80	
	Oil Filter, Transmission	Replace		1.5				1,2	
	Oil Cooler Lines	Inspect Replace		0.2 1.0				1	

Section II. MAINTENANCE ALLOCATION CHART (Cont'd)

(1) Group Number	(2) Component/Assembly	(3) Maintenance Function	(4) Maintenance Level					(5) Tools and Equipment Ref Code	(6) Remarks Code
			Unit		Direct Support	General Support	Depot		
			C	O	F	H	D		
0705	TRANSMISSION (4L80-E) Shift Control and Linkage	Inspect	0.1	0.2					
		Adjust		0.5				1	
		Replace		1.5				1,2	
		Repair		1.0				1,2	
	Throttle Position Sensor	Adjust		0.1				1,63,166,173	
		Replace		0.6				1,63,166,173	
	Switch, Neutral Start	Replace		0.5				1	
0708	Torque Converter	Replace			3.3			1,2	
0710	Transmission Assembly	Inspect	0.1						
		Test			0.5			1,2,6, 93.1,93.2, 145,166,173	
		Service		0.2				1,2	
		Replace			5.8			1,2,6,144	
		Repair				4.0		1,6,70,71,81	
		Overhaul				13.5		1,6,70-73, 79,81-84, 92,93,95,172	
	Transmission Mount	Inspect		0.2					
		Replace		1.0				1,2	
	Gear Unit	Replace				1.5		1,6,84	
		Repair				1.3		1,6,84	
0713	Forward Clutch	Replace				2.0		1,6,85, 87,88,172	
		Repair				0.6		1,6,85-88, 172	
	Direct Clutch	Replace				2.0		1,6,79, 87,88, 172	
		Repair				0.8		1,6,79, 86-88	
	Intermediate Clutch	Replace				2.0		1,6,84	
		Repair				0.8		1,6,79,84	
	Fourth Clutch	Replace				2.0		1,6,86-88	
		Repair				0.8		1,6,87-89	
	Turbine Shaft and Overdrive Carrier	Replace				2.0		1,6	
		Repair				0.8		1,6,79,86,90	
0714	Rear Servo	Replace				1.0		1,6	
		Repair				0.3		1,6	
	Front Servo	Replace				1.0		1,6	
		Repair				1.0		1,6	
	Band, Front and Rear	Replace				2.5		1,6,92,93	
	Governor	Inspect			0.2				
		Replace			0.5			1,6	
	Control Valve	Replace				1.3		1,6	
		Repair				1.0		1,6,10	

Section II. MAINTENANCE ALLOCATION CHART (Cont'd)

(1) Group Number	(2) Component/Assembly	(3) Maintenance Function	(4) Maintenance Level					(5) Tools and Equipment Ref Code	(6) Remarks Code
			Unit		Direct Support	General Support	Depot		
			C	O	F	H	D		
0721	Oil Pump, Transmission	Replace Repair				1.0 1.6	1,6,83 1,6,83,91		
	Seal, Oil Pump	Replace			0.3		1,6,80		
	Oil Filter, Transmission	Replace		1.5			1,2		
	Lines, Oil Cooler	Inspect Replace		0.2 1.0			1,2		
08	TRANSFER								
0801	Transfer Case	Inspect Service Replace Repair Overhaul		0.1 0.5	5.2	5.7 10.0	2 1,6,144 1,6,75,94-106 1,6,10,75 94,106,144	P	
	Seal, Oil, Input and Output Shaft	Replace		1.3			1,2,94		
	Yokes, Front and Rear	Replace		1.2			1,2		
	Bearings, Output Shaft	Replace				3.0	1,2,75,95-100		
	Gear, Speedometer Driven	Replace		0.5			1,2,107		
0803	Shift Control and Linkage	Inspect Adjust Replace Repair	0.1	0.2 0.5 1.0		1.0	1 1,2 1,2	D	
09	PROPELLER SHAFTS								
0900	Shafts, Propeller, Front	Service Replace Repair		0.2 1.0 0.5	1.2		1,2 1,2 1,2,6	E	
	Shaft, Propeller, Rear	Service Replace Repair		0.2 1.0 1.2			1,2 1,2 1,2		
	Joints, Universal	Inspect Service Replace		0.1 0.3 1.5			2 1,2		
10	FRONT AXLE								
1000	Halfshaft	Inspect Replace Repair		0.2 2.2 1.0			1,2 1,2		

Section II. MAINTENANCE ALLOCATION CHART (Cont'd)

(1) Group Number	(2) Component/Assembly	(3) Maintenance Function	(4) Maintenance Level					(5) Tools and Equipment Ref Code	(6) Remarks Code	
			Unit		Direct Support	General Support	Depot			
			C	O	F	H	D			
1002	Differential Assembly	Inspect		0.1						
		Service		0.5					1,2	
		Replace			5.0				1,2	
		Repair				10.2			1,7,75,94, 117-124	
1004	Seal, Output Shaft, Differential	Replace			1.0				1,6,117	
		Seal, Pinion, Differential	Replace			0.3			1,6,94	
		Differential Cover	Replace		0.5				1,2	H
		Knuckle and Geared Hub	Inspect		0.1					
Service			0.5					1,2		
Replace				2.0				1,2,167		
Repair				1.2				1,2,6,75, 126-128,129	K	
1004	Bearing, Spindle, Geared Hub	Adjust		0.9				1,2,127		
		Seal, Input, Geared Hub	Replace		2.0			1,2,75,126		
		Seal, Spindle, Geared Hub	Replace		1.0			1,2,75,127,128	I	
		Steering Stop	Adjust		0.5			2		
1004	Upper Control Arm	Replace		0.3				2		
		Inspect		0.1						
		Replace		1.0				1,2		
		Repair			1.0			1,2		
1004	Lower Control Arm	Inspect		0.1						
		Replace		2.6				1,2		
		Repair			1.0			1,2		
		Ball Joint, Upper and Lower	Replace		0.6				1,2,129,146, 151	
11	REAR AXLE									
1100	Halfshaft	Inspect		0.2						
		Replace		1.8				1,2		
		Repair		1.0				1,2		
1102	Differential Assembly	Inspect		0.1						
		Service		0.5				1,2		
		Replace			5.0			1,2		
		Repair				10.0		1,7,75,94, 117-124		
1102	Seal, Output Shaft, Differential	Replace			1.0			1,6,117		
		Seal, Pinion, Differential	Replace			0.3		1,6,94		

Section II. MAINTENANCE ALLOCATION CHART (Cont'd)

(1) Group Number	(2) Component/Assembly	(3) Maintenance Function	(4) Maintenance Level					(5) Tools and Equipment Ref Code	(6) Remarks Code
			Unit		Direct Support	General Support	Depot		
			C	O	F	H	D		
1104	Knuckle and Geared Hub	Inspect		0.1				2,167 1,2,75,126, 128,129 1,2,127 1,2,75,126 1,2,75,127, 128 1,2 1,2 1,2 1,2 1,2,129,146, 151	K
		Service		0.5					
		Replace			2.0				
		Repair			1.2				
	Bearing, Spindle, Geared Hub	Adjust		0.9					
		Seal, Input, Geared Hub	Replace			2.0			
	Seal, Spindle, Geared Hub	Replace		1.0					
		Upper Control Arm	Inspect		0.1				
	Lower Control Arm	Replace		1.0					
		Repair			1.0				
Ball Joint, Upper and Lower	Inspect		0.1						
	Replace		2.6		1.0				
12	BRAKES	Repair		0.6					
		1201	Parking Brake Lever	Adjust	0.3				
Replace		1.0							
Parking Brake Cable	Adjust			0.5					
	Replace			1.0					
Parking Disc Brake Pad	Inspect			0.2					
	Replace			1.0					
Dual Service/Parking Brake Cable, Right Rear	Adjust			0.5					
	Replace			0.7					
Dual Service/Parking Brake Cable, Left Rear	Adjust			0.5					
	Replace			0.5					
Dual Service/Parking Calipers, Rear	Inspect	0.1							
	Replace		1.0						
Dual Service/Parking Pads, Rear	Inspect		0.2						
	Replace		1.0						
1202	Service Brakes	Test	0.1						
		Calipers, Front and Rear	Replace		1.0				
	Repair			0.5					
	Pads, Front and Rear	Inspect		0.2					
Rotor, Front and Rear	Replace		1.0						
	Inspect		0.1						
Replace		1.2							
Repair			1.5						

Section II. MAINTENANCE ALLOCATION CHART (Cont'd)

(1) Group Number	(2) Component/Assembly	(3) Maintenance Function	(4) Maintenance Level					(5) Tools and Equipment Ref Code	(6) Remarks Code
			Unit		Direct Support	General Support	Depot		
			C	O	F	H	D		
1204	Master Cylinder	Inspect Service Replace	0.1	0.2 0.5				2 1,2	
	Brake Lines	Inspect Replace		0.2 1.5				1	
	Proportioning Valve	Replace		0.6				1,2	
1205	Hydro-Boost	Replace		1.3				1,2	
1206	Pedal, Brake	Replace		1.0				1,2,146,153	
13	WHEELS AND TIRES								
1301	Front Wheel Toe-In	Align		0.5				1	
	Rear Wheel Toe-Out	Align		0.5				1	
1311	Wheel and Tire Assembly	Inspect Service Replace Repair	0.1 0.2 0.4	0.1 0.1 0.5				1,2 1,2,130	N
	Runflat Assembly	Replace		2.2				1,2,4,144, 154,131	J
14	STEERING								
1401	Mechanical Steering								
	Wheel, Steering	Replace		0.7				1,2	
	Column, Steering	Inspect Replace		0.1 1.8				1,2	
	Intermediate Shaft, Steering	Service Replace		0.2 0.5				1,2 1,2	
	Tie Rod Assembly	Inspect Service Adjust Replace		0.1 0.2 0.5 0.5				1,2 1,2,167 1,2,129	
	Center Link	Inspect Replace		0.1 0.3				1,2 1,2,167	
	Pitman Arm	Inspect Replace		0.1 1.0				1,2,129	
	Idler Arm	Inspect Replace		0.1 0.3				1,2,129	
	Camber/castor	Adjustment				2.2		1,138.1	
1407	Gear, Power Steering	Inspect Replace Repair		0.2 0.5	3.7			1,2 1,6,132, 133,135	

Section II. MAINTENANCE ALLOCATION CHART (Cont'd)

(1) Group Number	(2) Component/Assembly	(3) Maintenance Function	(4) Maintenance Level					(5) Tools and Equipment Ref Code	(6) Remarks Code
			Unit		Direct Support	General Support	Depot		
			C	O	F	H	D		
1410	Pump, Power Steering	Inspect Test	0.1	0.1 0.5				1,2, 136-138	
		Service Replace Repair		0.2 1.0 1.0				1,2 1,2 1,2	
	Pulley, Power Steering Pump	Replace		0.5				1,2,137	
1411	Hoses, Lines, and Fittings Power Steering	Inspect Replace		0.2 1.0				1	
15	FRAME								
1501	Frame Assembly	Inspect Repair		0.5		F		1,5	F
	Crossmember, Transmission	Replace		2.0				1	
	Crossmember, Suspension, Front, Brackets, and Supports	Inspect Replace Repair		0.2	4.5 2.0			1,6 1,5	
	Crossmember, Rear	Replace		2.0				1,2	
	Bumpers	Replace		0.5				1,2	
1503	Pintle, Towing	Inspect Service Replace Repair	0.1	0.1 1.0 0.2				1 1,2 1,2	
16	SPRINGS AND SHOCK ABSORBERS								
1601	Springs	Inspect Replace		0.1 1.0				1,2	
1604	Absorbers, Shock	Inspect Replace	0.1	0.1 0.8				1,2	
1605	Rod, Stabilizer	Replace		1.5				1,2	
	Rod, Radius	Inspect Replace Repair		0.1 1.0 0.5				1,2 1,2	
18	BODY AND HOOD								
1801	Body	Inspect Service Replace Repair	0.1	1.0		F F		1 1,6 1,2,139,140	F F
	Hood	Inspect Replace Repair	0.1	1.3	F			1,2 1,6	F

Section II. MAINTENANCE ALLOCATION CHART (Cont'd)

(1) Group Number	(2) Component/Assembly	(3) Maintenance Function	(4) Maintenance Level					(5) Tools and Equipment Ref Code	(6) Remarks Code
			Unit		Direct Support	General Support	Depot		
			C	O	F	H	D		
1802	Doors, Rear	Inspect Replace Repair	0.1	0.2	F			1 1,5,139	F
	Cover, Engine Access	Inspect Replace Repair	0.1	0.1	F			1 1,5,139	F
	Windshield Assembly, Folding	Inspect Replace Repair	0.1	2.0	F			1,2 1,5,139	F
	Windshield Assembly, Fixed	Inspect Replace Repair	0.1		2.0 F			1,6 1,5,139	F
1806	Windshield Glass	Inspect Replace	0.1	1.0					
	Seats	Inspect Replace Repair	0.1	1.0 1.0				1,2 1,2	
1808	Seatbelts	Inspect Replace	0.1	0.8				1,2	
	Stowage Racks, Boxes, and Straps	Inspect Replace Repair	0.1	F F				1,2 1,2	F F
1812	Tailgate	Inspect Replace Repair	0.1	0.4	1.0			1,2 1,5,139	
	TOW Carrier and Armament Carrier (M966, M966A1, M1025, M1025A1, M1025A2, M1026, M1026A1, M1036, M1043, M1043A1, M1043A2, M1044, M1044A1, M1045, M1045A1, M1045A2, M1046, M1046A1, M1121)								
	Doors, Crew	Inspect Adjust Replace Repair	0.1	0.3 0.2	F			1,2 1 1,5,139	F
	Door, Cargo Shell	Inspect Adjust Replace Repair	0.1	0.3 2.5 F				1,2 1,2 1,2,139	F
	Glass, Door	Inspect Replace	0.1	1.0				1	
	Weapon Station	Inspect Replace	0.1	1.5				1,6	
	Gunners Platform	Inspect Replace	0.1	0.5				1	

Section II. MAINTENANCE ALLOCATION CHART (Cont'd)

(1) Group Number	(2) Component/Assembly	(3) Maintenance Function	(4) Maintenance Level					(5) Tools and Equipment Ref Code	(6) Remarks Code
			Unit		Direct Support	General Support	Depot		
			C	O	F	H	D		
	S250 Shelter Carrier (M1037, M1042)								
	Support, Shelter	Inspect Replace	0.1	2.0				1,2	
	Sling, Tiedown	Inspect Replace	0.1	0.3				1	
	Soft Top Ambulance (M1035, M1035A1)								
	Rack, Litter	Inspect Replace	0.1	1.5				1,2,	
	Ambulance – 2-Litter (M996, M996A1), 4-Litter (M997, M997A1 M997A2)								
	Door, Rear	Inspect Adjust Replace	0.1	0.4 0.3				1,2 1,2	
	Door Latch and Handles, Rear	Inspect Replace	0.1 0.5						
	Steps, Rear	Inspect Replace Repair	0.1	0.5 0.6				1,2 1,2	
	Litter Rack, Upper	Inspect Replace	0.1	1.5				1,2	
	Doors, Stowage	Inspect Replace	0.1	1.0				1,2,139	
	Doors, Bulkhead	Inspect Replace	0.1	2.0				1,2,139	
	Extension Rails, Litter	Repair		1.2				1,2	
	NBC Heaters and Brackets	Inspect Replace	0.1	0.8				1,2	
	NBC Filters and Brackets	Inspect Replace	0.1	0.7				1,2	
	Ambulatory Patient Seat	Inspect Replace	0.1	0.6				1,2	
	Heat/Vent Panel (M996, M996A1)	Replace		0.3				1,2	
	Heater (M996, M996A1)	Adjust Replace Repair		1.5 0.8 3.5				1,6 1,2 1,6	
	Heater (M997, M997A1, M997A2)	Adjust Replace Repair		1.5 0.8 3.5				1,6 1,2 1,6	

Section II. MAINTENANCE ALLOCATION CHART (Cont'd)

(1) Group Number	(2) Component/Assembly	(3) Maintenance Function	(4) Maintenance Level					(5) Tools and Equipment Ref Code	(6) Remarks Code
			Unit		Direct Support	General Support	Depot		
			C	O	F	H	D		
20	WINCH								
2001	Winch Assembly	Service Replace Repair		0.2 0.6				1,2 1,9,159	
	Cable, Winch	Inspect Service Replace	0.5		4.0			1 1,2	
	Control Assembly, Winch	Inspect Replace	0.1		0.1			1,2	
22	BODY ACCESSORY ITEMS								
2201	Bows	Inspect Service Replace Repair	0.5	0.1 1.0 0.5				1 1	
	Cover, 2-Door Cab	Inspect Service Replace Repair	0.5	0.1 0.5	F			1 1,7	
	Cover, 4-Door Cab	Inspect Service Replace Repair	0.5	0.1 1.5	F			1 1,7	
	Cover, 2-Door Cargo	Inspect Service Replace Repair	0.5	0.1 1.0	F			1 1,7	
	Cover, 4-Door Cargo	Inspect Service Replace Repair	0.5	0.1 1.0	F			1 1,7	
	Door, Front	Inspect Service Adjust Replace Repair	0.1 0.1					1,2 1 1,7	
	Cover, Rear Door	Inspect Service Replace Repair	0.1 0.1		F			1 1,7	
	Curtain, Body Cover	Inspect Service Replace Repair	0.5	0.1 1.0	F			1 1,7	

Section II. MAINTENANCE ALLOCATION CHART (Cont'd)

(1) Group Number	(2) Component/Assembly	(3) Maintenance Function	(4) Maintenance Level					(5) Tools and Equipment Ref Code	(6) Remarks Code
			Unit		Direct Support	General Support	Depot		
			C	O	F	H	D		
2202	Motor, Windshield Wiper	Test		0.3				2	
		Replace		0.5				1,2	
	Arm Assembly, Wiper	Inspect	0.1						
		Replace		0.2				1,2	
	Linkage, Wiper	Replace		0.5				1	
	Motor and Reservoir Assembly, Washer	Test		0.2				2	
		Service		0.2				1	
		Replace		0.1				1,2	
	Nozzle, Washer	Replace		0.5				1	
	Mirror, Rearview	Inspect	0.1						
	Adjust	0.1							
	Replace		0.2				1,2		
	Reflectors	Replace		0.2			1		
	Steering Wheel Lock	Replace		1.0			1,139		
2207	Ducting, Defroster and Heater	Replace		1.0			1		
	Controls, Defroster and Heater	Replace		1.0			1		
	Heater Assembly	Replace		1.4			1,2		
2210	Data Plates	Replace		0.5			1,139		
33	SPECIAL PURPOSE KITS								
3303	Arctic Winterization Kit	Install			8.0			6,139-142	
	Arctic Heater Kit	Install			8.0			6,139-142	
	Pump and Lines, Fuel	Inspect	0.1	0.2					
		Replace		1.0				1,2	
	Heater	Inspect	0.1						
		Replace		0.2				1	
	Control, Heater	Replace		0.5				1	
		Repair		1.0				1	
	2-Man Crew Top Kit	Install			2.0			139	
	Cover, 2-Door Cab	Inspect	0.1						
	Replace		0.5				1		
	Repair			F			7	F	
	Curtain, Body Cover	Inspect	0.1						
		Replace		0.5			1		
		Repair			F		7	F	
3305	Deep Water Fording Kit	Install		4.0				1,2	
	Snorkel, Intake and Exhaust	Inspect	0.2	0.2					
		Install	2.0						
		Replace		1.5				2	
	Venting	Inspect	0.1	0.1					
	Replace		1.0				1		

Section II. MAINTENANCE ALLOCATION CHART (Cont'd)

(1) Group Number	(2) Component/Assembly	(3) Maintenance Function	(4) Maintenance Level					(5) Tools and Equipment Ref Code	(6) Remarks Code
			Unit		Direct Support	General Support	Depot		
			C	O	F	H	D		
3307	100 AMP Alternator Kit	Inspect		0.2					
		Test		0.3					4
		Install		2.5					2
		Replace		1.0					2
		Repair			1.0				9
	Troop Seat Kit	Inspect	0.1						
		Install		2.0					1,2
		Replace		0.8					2
	Communications Kit	Repair		1.0					4
		Install		3.0					1,2
			Replace		F				1
	47	GAGES (NON-ELECTRICAL)							
4701	Speedometer	Replace		0.2					1
	Cable and Housing	Replace		0.5					1
4702	Gage, Air Restriction	Inspect	0.1						
		Replace		0.1					1
52	AIR CONDITIONER								
	Ambulance (M997, M997A1, M997A2)								
5203	Compressor, A/C	Replace			1.5				1,2,19,19.1
		Repair			3.0				1,2,143
		Replace			0.4				1
5205	Service Valve, A/C	Replace			0.6			2,19,19.1	
5217	A/C Lines and Fittings	Inspect		0.1					
		Replace			1.5				1,6,19,19.1
		Inspect	0.1						
	Air Conditioner	Test		0.3					
		Service			1.6				2,19,19.1,143
5230	Coil, Condensor	Replace			1.6				2,19
5241	Coil, Evaporator	Replace			2.0				2,19
		Repair			0.4				2
5243	Blower Motor, Condenser	Replace		0.8					1
	Blower Motor, Evaporator	Replace		1.0					1
		Repair		0.6					
5246	Bottle, Dryer	Replace			0.3				1

Section III. TOOL AND TEST EQUIPMENT REQUIREMENTS

(1) Reference Code	(2) Maintenance Category	(3) Nomenclature	(4) National/NATO Stock Number	(5) Tool Number	
1	O	Tool Kit, General Mechanic's Automotive	5180-00-177-7033	SC5180-90-CL-N26	■
2	O	Shop Equipment, Automotive Maintenance and Repair: Organizational Maintenance, Common #1, Less Power	4910-00-754-0654	SC4910-95-CLA74	■
3	O	Shop Equipment, Automotive Maintenance and Repair: Organizational Maintenance, Supplemental #1, Less Power	4910-00-754-0653	SC4910-95-CLA73	■
4	O	Shop Equipment, Automotive Maintenance and Repair: Organizational Maintenance, Common #2, Less Power	4910-00-754-0650	SC4910-95-CLA72	■
5	O	Tool Kit, Body and Fender	5180-00-754-0643	SC5180-90-N34	■
6	F	Shop Equipment, Automotive Maintenance and Repair: Field Maintenance, Basic, Less Power	4910-00-754-0705	SC4910-95-CLA31	■
7	F	Shop Equipment, Automotive Maintenance and Repair: Field Maintenance, Supplemental #1, Less Power	4910-00-754-0706	SC4910-95-CLA62	■
8	F	Shop Equipment, Automotive Maintenance and Repair: Field Maintenance, Supplemental #2, Less Power	4910-00-754-0707	SC4910-95-CLA63	■
9	F	Shop Equipment, Fuel and Electrical System Engine: Field Maintenance, Basic, Less Power	4940-00-754-0714	SC4910-95-CLA01	■
10	F	Shop Equipment, Automotive Maintenance and Repair: Field Maintenance, Wheeled Vehicles, Post, Camp and Station, Set A	4910-00-348-7696	SC4910-95-CLA02	■
11	O	Special Tool Kit, Organizational	5180-01-387-5455	57K0267	
11.1	O	Special Tool Kit, Organizational, Supplemental ("A2" series only)	5180-01-410-8467	57K3219	■
12	F	Special Tool Kit, Direct Support	5180-01-389-7560	57K0268	
13	H	Special Tool Kit, General Support	5180-01-389-7561	57K0266	
13.1	H	Special Tool Kit, General Support, Supplemental ("A2" series only)	5180-01-408-7050	57K3218	■
13.2	H	Special Tool Kit, General Support, Supplemental Transmission	5180-01-357-9692	57K0236	■

Section III. TOOL AND TEST EQUIPMENT REQUIREMENTS

(1) Reference Code	(2) Maintenance Category	(3) Nomenclature	(4) National/NATO Stock Number	(5) Tool Number
NOTE The optional metric tool sets listed below are required for maintenance of this vehicle.				
14	O	Metric Wrench Set, 10-32 mm, Open End/Box End	5120-01-119-0010	OEXM719K
15	O	Metric Socket Set, 6-26 mm, Std., 6 pt., 3/8 in. Drive	5120-01-117-3876	221FSMY
16	F	Metric Socket Set, Std., 6 pt., 3/8 in. Drive, Deep Reach	5120-01-112-9543	B107.5
17	F	Metric Allen Wrench Kit	5120-01-046-5079	B18.3.2M
18	F	Metric Tap and Die Kit	5136-01-119-0005	TDM99117
19	F	Tool Kit, Service Refrigeration Unit	5180-00-596-1474	SC5180-90-CL-N18
19.1	F	Parts Kit, FR-12 Refrigerant	4130-01-452-8773	57K3534
01 ENGINE				
20	F	Adapter, Compression Gage	4910-01-238-2551	J 26999-30
21	F	Quick Disconnect	4730-01-842-5266	J 25209
22	F	90° Elbow	4730-00-985-4804	MS51815-4P
23	F	Remover, Hydraulic Valve Lifter	5120-01-209-6870	J 29834
24		DELETED		
25	F	Engine Lifting Sling	4910-01-193-7808	J 33139
26	F	Tester, Engine Compression	4910-00-785-6437	J 6692A
27		DELETED		
28		DELETED		
29		DELETED		
30		DELETED		
31		DELETED		
32		DELETED		
33		DELETED		
34		DELETED		
35		DELETED		
36		DELETED		
37		DELETED		

Section III. TOOL AND TEST EQUIPMENT REQUIREMENTS

(1) Reference Code	(2) Maintenance Category	(3) Nomenclature	(4) National/NATO Stock Number	(5) Tool Number
38		DELETED		
39		DELETED		
40		DELETED		
41	F	Gauge, Timing	6620-01-231-3671	MT95
42	F	Meter, Dynamic Timing	5180-01-186-3114	J 33127
43		DELETED		
44	H	Stand – Engine Repair	4910-00-506-0037	1725A
45		DELETED		
46	H	Installer, Crankshaft Rear Oil Seal (6.2L)	5120-01-210-8792	J 33153
	H	Installer, Crankshaft Rear Oil Seal (6.5L)	5120-01-422-0334	J 39084
47	H	Remover and Installer, Camshaft Bearings	5120-01-206-3818	J 35178
48	O	Pliers, Needle Nose, 90°	5120-01-174-4496	497ACP
		03 FUEL SYSTEM		
49	F	Remover, Fuel Injection Nozzle	5120-01-171-5233	J 29873
50	H	Installer, Drive Shaft Bearing	5120-01-208-7771	23805
51	H	Installer, Drive Shaft Seal	5120-01-208-7752	22727
52	H	Kit, Throttle and Shutoff Shaft Bushing	5180-01-189-0448	18411
53	H	Socket, Torx Drive, T27	5120-01-367-3534	FTX27A
54	H	Support, Governor Weight	5120-01-197-0236	16313
55	H	Wrench, End Cap	5120-01-207-5563	20548
56	H	Roller to Roller Setting Tool	5120-01-200-4526	19969
57	H	Fixture, Holding	5120-01-208-7753	23615
58	H	Mandrel, Pilot Tube	5120-01-208-1767	16314
59	H	Extractor, Delivery Valve Test Set	5120-00-816-7059	26081
60		DELETED		
61	H	Linkage Gap Tool	5210-01-249-0370	23080
62	H	Indicator, Automatic Advance	5210-01-249-0368	23745
63	O	Block, Throttle Lever Gauge	4820-01-179-4869	J 33043
64	H	Protractor	6675-01-247-2286	22089

Section III. TOOL AND TEST EQUIPMENT REQUIREMENTS

(1) Reference Code	(2) Maintenance Category	(3) Nomenclature	(4) National/NATO Stock Number	(5) Tool Number
65	H	Gage, Air Timing	5220-01-247-0361	23715
66	O	05 COOLING SYSTEM Tester, Radiator	4910-00-728-8227	ST255A
67	O	Gage, Belt Tension	6635-01-093-3710	J 23600B
68	F	06 ELECTRICAL SYSTEM Socket, Torx	5120-01-227-3159	TLE60
69	O	Starter Pinion Core Shaft Nut Driver	9530-00-236-7723	MS14267C001
70	H	07 TRANSMISSION (3L80) Fixture, Transmission Holding	5120-01-198-7583	J 8763-02
71	H	Base, Transmission Holding Fixture	5120-01-144-4484	J 3289-20
72	H	Holding Tool, Transmission Gear Unit Assembly	4910-01-178-8865	J 21795-02
73	H	Adapter, Slide Hammer, 3/8-16	5120-01-130-8865	J 6471-2
74	H	Bushing Service Set	5180-01-195-9777	J 21465-01
75	O	Driver Handle	5120-00-677-2259	J8092
76	H	Compressor, Clutch Spring	5120-01-210-8793	J 4670-01
77	H	Adapter, Clutch Spring Compressor	4910-01-210-1318	J 21664
78	H	Gage, Band Apply Selector	4910-01-178-0722	J 21370
79	H	Alignment Tool, Intermediate Clutch Pack	4910-01-209-0729	J 24396
80	F	Installer, Oil Pump Seal	5120-01-176-1845	J 21359A
81	H	07 TRANSMISSION (4L80-E) Adapter, Holding Tool, Use W/J 8763-02	5120-01-422-1326	J 38655
82	H	Adapter, Torque, 3/8	5120-01-367-3536	FTX40A
83	H	Removal/Installer Tool, Oil Pump	5120-01-422-1308	J 37789-A
84	H	Installer/Remover, Gear Unit	5120-01-422-1300	J 38868-A
85	H	Adapter, Clutch Compressor Spring , Use W/J 23327	5120-01-422-1329	J 38734

Section III. TOOL AND TEST EQUIPMENT REQUIREMENTS

(1) Reference Code	(2) Maintenance Category	(3) Nomenclature	(4) National/NATO Stock Number	(5) Tool Number
86	H	Seal Protectors, Forward Clutch Piston, Kit Includes J 38732-1 and J 21362-1	5120-01-422-1301	J 38732
87	H	Compressor, Clutch Spring	4910-01-178-0724	J 23327
88	H	Adapter, Compressor, Clutch Spring, Use W/J 23327	5120-01-410-8216	J 25018-A
89	H	Seal Piston and Housing, Fourth Clutch, Includes J38731-1, J38731-2, J38731-3	5180-01-422-0138	J 38731
90	H	Installer/Sizer/Pusher, Turbine Shaft Seal, Includes J38736-1, J38736-2, J38736-3, J38736-4, J38736-5, J38736-6	5120-01-422-7051	J 38736
91	H	Installer/Sizer/Pusher, Oil Pump Seal Ring J 38739-1, J 38739-2, J 38739-3	5180-01-422-1294	J 38739
92	H	Gauge Pin, Band Apply, Use W/J 38737	5120-01-422-0032	J 21370-10
93	H	Tool Pin Checking, Band Apply	5120-01-422-1313	J 38737
93.1	O	Jumper, Throttle Position Sensor Adjustment	6150-01-412-7774	12460120
93.2	O	Case, Transmission Diagnostic Cable	5120-01-408-8173	12460136
93.3	O	Diagnostic Switch Cable	6150-01-410-8215	12460137
		08 TRANSFER (218)		
94	O	Installer, Yoke Seal	4910-01-179-5530	J 29162
95	H	Adapter, Slide Hammer	5120-01-391-5131	J 6471-8
96	H	Installer, Front Output Shaft Rear Bearing	5120-01-195-2721	J 29163
97	H	Installer, Rear Output Shaft Bearing	5120-01-196-0084	J 29166
98	H	Installer, Front Output Shaft Front Bearing	5120-01-170-3278	J 29167
99	H	Remover, Front Output Shaft Front Bearing	5120-01169-4876	J 29168
100	H	Remover, Universal Bearing and Bushing	5120-01-201-7857	J 29369
101	H	Remover, Input Gear Bearing	5120-01-195-4551	J 29170
102	H	Installer, Input Gear Bearing	5120-01-185-7955	J 29169

Section III. TOOL AND TEST EQUIPMENT REQUIREMENTS

(1) Reference Code	(2) Maintenance Category	(3) Nomenclature	(4) National/NATO Stock Number	(5) Tool Number
103	H	Installer, Rear Retainer Bearing	5120-01-185-8024	J 7818
104	H	Installer, Main Shaft Bearing	5120-01-265-4872	J 36307
105	H	Remover, Annulus Gear Bushing	5120-01-185-7956	J 29185
106	H	Installer, Annulus Gear Bushing	5120-01-247-6629	J 29185-2
107	O	Mirror, Inspection	5120-00-618-6902	J 35219
08 TRANSFER (242)				
108	H	Installer, Bushing Remover/Bearing	5120-01-357-3633	J 33826
109	H	Installer, Mainshaft Pilot Bearing	5120-01-389-9992	J 39636
110	H	Installer, Input Gear Seal	5120-01-357-3632	J 33831
111	H	Installer, Output Shaft Front Bearing	5120-01-357-3630	J 33833
112	H	Installer, Output Shaft Seal	5120-01-227-1680	J 22661
113	H	Remover, Extension Housing Bushing	5120-01-357-3631	J 33839
114	H	Bearing Tool	5120-01-357-9123	J 9276-3
115	H	Installer, Extension Housing Seal	5120-01-361-3101	J 33843
116	H	Installer, Bearing and Bushing	5120-01-185-7960	J 29174
116.1	O	Installer, Inserter	5120-01-144-1849	J 38869
116.2	O	Installer, Seal	5120-01-437-0480	6888
116.3	O	Handle, Drive	5120-01-026-1666	C-4171
116.4	H	Installer, Output Shaft, Rear Bearing	5120-01-477-6860	J 33832 or 5742628
10 AND 11 FRONT AND REAR AXLE				
117	F	Installer, Axle Shaft and Seal	5120-01-187-3659	J 33142
118	H	Adapters, Axle Holding Fixture	5120-01-218-8235	J 33149-A
119	H	Spreader, Differential Housing	4910-00-105-2823	W129
120	H	Remover, Pinion Rear Bearing Cup	5120-01-185-7957	J 21786
121	H	Remover, Pinion Front Bearing Cup	5120-01-187-3660	J21787
122	H	Installer, Pinion Rear Bearing Cup	5120-01-185-7962	J 8608
123	H	Installer, Pinion Front Bearing Cup	5120-01-185-7964	J 8611-01
124	H	Set, Pinion Setting Gage	5180-01-216-8643	J 35199
125	H	Set, Pinion Setting Gauge	5180-01-363-8079	J 39524
126	O	Installer, Geared Hub Input Seal	5120-01-187-3607	J 33143

Section III. TOOL AND TEST EQUIPMENT REQUIREMENTS

(1) Reference Code	(2) Maintenance Category	(3) Nomenclature	(4) National/NATO Stock Number	(5) Tool Number
127	O	Wrench, Geared Hub Locknut	5120-01-185-7963	J 33144
128	O	Installer, Geared Hub Spindle Seal	5120-01-229-0842	J 35184
129	O	Pickle Fork	5120-00-880-4268	11595179
13 WHEELS AND TIRES				
130	O	Bubble Balancer	4910-01-093-0167	MIL-B-45989
131	O	Runflat Compressor	5120-01-335-5847	J 39250 or 528236
14 STEERING SYSTEM				
132	F	Remover and Installer, Adjuster Plug Bearing	5120-01-185-7965	J 6221
133	F	Remover and Installer, Pitman Shaft Bearing	5120-01-082-6447	J 6278
134	F	Wrench, Spanner	5120-01-082-6436	J 7624
135	F	Arbor, Rack Piston	5120-01-179-1032	J 21552
136	O	Analyzer, Power Steering	4910-01-185-7966	12342943
137	O	Installer, Power Steering Pump Pulley	4910-01-179-2517	J 25033-B
138	O	Adapter	5120-01-231-1709	J 33141
138.1	H	Equipment, Alignment	4910-01-154-1820	DFP 134
18 BODY AND HOOD				
139	O	Tool Kit, Riveter	5180-01-201-4978	D-100-MIL-1
140	F	Puller, Head, Right Angle	5130-01-044-7196	H763-456
141	F	Puller, Head, Offset	5130-01-329-0509	H781-456
142	F	Puller, Head, Straight	5130-01-104-5370	H749A-456
52 AIR CONDITIONER				
143	F	Tool Kit, Compressor	5180-01-267-2907	J 29642-C
MULTIPURPOSE TOOLS				
144	O	Adapter, Torque, 9/16 in.	5120-01-367-3582	SRES 18

Section III. TOOL AND TEST EQUIPMENT REQUIREMENTS

(1) Reference Code	(2) Maintenance Category	(3) Nomenclature	(4) National/NATO Stock Number	(5) Tool Number
145	O	Adapter, Torque, 3/4 in.	5120-01-367-3585	SRES 24
146	O	Adapter, Socket, 3/8 in. to 1/2 in. Drive	5120-00-240-8702	11655788-2
147	F	Crowfoot, 3/8 in. Drive, 16 mm	5120-01-242-8165	J 35159
148	F	Crowfoot, 1/2 in. Drive, 19 mm	5120-01-230-9421	J 35160
149	O	Crowfoot, 3/8 in. Drive, 5/8 in.	5120-00-184-8398	FC20
150	O	Crowfoot, 3/8 in. Drive, 9/16 in.	5120-01-335-1094	FC 18A
151	O	Crowfoot, 3/8 in. Drive, 15/16 in.	5120-01-335-1100	FC-30A
152	O	Crowfoot, 3/8 in. Drive, 14 mm	5120-01-079-8023	FCOM14
153	O	Crowfoot, 3/8 in. Drive, 7/8 in.	5120-01-335-1099	FC-28A
154	O	Crowfoot, 3/8 in. Drive, 11/16 in.	5120-01-335-1096	FC-22A
155	O	Socket, Deep Well, 12 pt., 3/8 in.	5120-00-277-1463	FVS121
156	O	Driver, Hex-Head, 8 mm	5120-01-053-4159	FAM8A
157	O	Driver, Hex-Head, 6 mm	5120-01-055-1308	FAM6A
158	O	Driver, Hex-Head, 1/8 in.	5120-01-016-9202	J 35171
159	F	Driver, Hex-Head, 5/32 in.	5120-01-367-3456	FA5A
160	O	Driver, Hex-Head, 1/4 in.	5120-00-596-8508	FA8A
161	O	Driver, Hex-Head, 5/16 in.	5120-00-683-8602	FA10B
162	O	Driver, Hex-Head, 7 mm	5120-01-437-3658	FAM 7
163	O	Driver, Hex-Head, 3/16 in.	5120-00-683-8597	FA6A
164	O	"C" Clamp	5120-01-180-0908	A-A-429
165	O	Connector Repair Kit	5180-00-876-9336	7550526
166	O	Multimeter	6625-01-139-2512	AN/PSM-45
167	O	Puller, Mechanical	5120-01-011-7938	C-3894-A
168	O	Socket, 1-1/2 in. Drive 3/4 in.	5120-00293-0094	47148
169	O	Puller, Steering Wheel	5120-00-620-0020	6200020
170	O	Vice Insert	5120-00-221-1506	404-4
171	O	Universal Joint Bearing Kit	5120-01-210-4096	7057
172	F	Indicator, Dial	5120-00-277-8840	196A
173	F	Gauge, Pressure, Dial	6685-00-880-8753	8030176
174	F	Center Support Thread Reamer		J39919

Section IV. REMARKS

(1) REMARKS CODE	(2) REMARKS
A	Calibration time will be established when support equipment requirements are identified.
B	Operator drains water from fuel filter assembly. All other service is performed at unit level.
C	Operator replenishes coolant. All other service is performed at unit level.
D	Operator inspects shift lever. All other inspections are performed at unit level.
E	Direct support maintenance repairs coupling shaft by replacing center bearing. All other repair is performed at unit level.
F	In this category, no specific times can be established. Time required for repair will depend on the extent of repair required for damaged components.
G	Simplified test equipment/internal combustion engine (STE/ICE-R) testing times may vary depending on the type of tests being performed.
H	For vehicles with new brake adapters, P/N 10453002.
I	It is authorized to remove spindle to replace the seal. All other repair is performed at direct support level.
J	Runflat compressor to be used with rubber runflat.
K	If the puller kit is not available at unit level, it can be found in the GSA catalogue, Blind Hole Puller Set, NSN 5120-00-140-3557.
L	This tool can be found in the MCRL or GSA catalogue, Manometer, U-Tube, NSN 6685-00-857-4895.
M	Fan shroud repair is limited to repairs that can be made using fiberglass repair kit (Appendix C, Item 50). Only these repairs that can be made while the shroud is installed on the vehicle are authorized.
N	Operator can remove and replace wheel assembly, but must notify unit maintenance to tighten lug nuts to proper torque as soon as possible.
O	Direct support replaces fuel injection pump governor cover gasket, shut-off solenoid, and cold advance solenoid.
P	Direct support can reseal transfer case and rear transfer case housing with silicone sealant (RTV), NSN 6850-01-159-4844.

APPENDIX C

EXPENDABLE/DURABLE SUPPLIES AND MATERIALS LIST

SECTION I. INTRODUCTION

C-1. SCOPE

This appendix lists expendable/durable supplies and materials you will need to maintain the M998 series vehicles. These items are authorized to you by CTA 50-970, Expendable Items (Except Medical, Class V, Repair Parts, and Heraldic Items).

C-2. EXPLANATION OF COLUMNS

- a. Column (1)-Item Number.** This number is assigned to each entry in the listing and is referenced in “Initial Setup” of applicable tasks under the heading of “Materials/Parts.”
- b. Column (2)-Level.** This column identifies the lowest level of maintenance that requires the listed item.
- C — Operator/Crew
 - O — Unit Maintenance
- c. Column (3) – National Stock Number.** This is the National stock number assigned to the item; use it to request or requisition the item.
- d. Column (4) – Description.** Indicates the Federal item name and, if required, a description to identify the item. The last line for each item listing indicates the Commercial and Government Entity Code (CAGEC) in parentheses followed by the part number.
- e. Column (5) – Unit of Measure (U/M).** Indicates the measure used in performing the actual maintenance function. This measure is expressed by an alphabetical abbreviation (QT, GAL.). If the unit of measure differs from the unit of issue, requisition the lowest unit of issue that will satisfy your requirements.

Section II. EXPENDABLE/DURABLE SUPPLIES AND MATERIALS LIST

(1) ITEM NUMBER	(2) LEVEL	(3) NATIONAL STOCK NUMBER	(4) DESCRIPTION	(5) U/M
1	O	8040-01-126-1422	ADHESIVE: plastic cement (04963) 1099 1 Quart Can	QT
2	O	8040-00-826-3535	ADHESIVE: ethyl-2-cyanoacrylate, low viscosity (81349) MIL-A-46050C 1 Ounce Bottle	OZ
2.1	O	8030-01-347-0964	ADHESIVE: sealant, gray, Uniroyal (89619) SILAPRENE M6325-11 11 Ounce Cartridge	OZ
3	O	8040-00-865-8991	ADHESIVE: silicone, black (01139) RTV-103 12 Ounce Cartridge	OZ
4	O	8040-00-165-8614	ADHESIVE: synthetic, rubber (GA100AJ1) 1 Quart Can	QT
5	O	8040-00-938-1535	ADHESIVE: silicone, RTV (81349) MIL-A-46164 12 Ounce Cartridge	OZ
6	O	8040-00-573-1502	ADHESIVE: plumbing, solvent cement (81349) MIL-A-22010 1 Pint Container	PT
7	O	8040-01-167-2613	ADHESIVE: type II, class II (80244) MIL-A-46050-C 5 Ounce Tube	OZ
		8040-01-090-9320	1 Pint	PT
8	O	8040-01-215-3426	ADHESIVE: general trim, spray (04963) 051135 08080 24 Ounce Can	OZ
9	O	N/A	ADHESIVE SEALANT: RTV silicone rubber, clear (71984) SILASTIC 737 RTV 3 Ounce Tube	OZ
		N/A	10.3 Ounce Cartridge	OZ
		N/A	5.5 Gallon Pail	GAL.
9.1	O	8040-00-078-9774	ADHESIVE: (71984) 732 RTV 6 Ounce Cartridge	OZ

Section II. EXPENDABLE/DURABLE SUPPLIES AND MATERIALS LIST (Cont'd)

(1) ITEM NUMBER	(2) LEVEL	(3) NATIONAL STOCK NUMBER	(4) DESCRIPTION	(5) U/M
10	O	8040-00-833-9563	ADHESIVE-SEALANT: silicone, RTV, general purpose (80244) MIL-A-46106, type I 5 Ounce Tube	OZ
11	C	6850-00-174-1806	ANTIFREEZE: arctic-type (81349) MIL-A-11755 55 Gallon Drum	GAL.
12	C	6850-00-181-7929	ANTIFREEZE: ethylene glycol, inhibited heavy-duty, single package (81349) MIL-A-46153 1 Gallon Container	GAL.
		6850-00-181-7933	5 Gallon Container	GAL.
13	O	8030-00-059-2761	ANTISEIZE COMPOUND: conductive (81349) MIL-A-907 1 Pound Can	LB
14	C	9150-01-102-9455	BRAKE FLUID: silicone, automotive, all weather, operational and preservative (81349) MIL-B-46176 1 Gallon Can	GAL.
		9150-01-123-3152	5 Gallon Can	GAL.
15		7510-00-223-6701	CHALK, MARKING: (81348) SS-C-255 1 Gross	GR.
16	O	6850-00-003-5295	CLEANING AND LUBRICATING COMPOUND: electrical (81349) MIL-C-83360 16 Ounce Can	OZ
17	C	7930-00-282-9699	DETERGENT: general purpose, liquid (81349) MIL-D-16791 1 Gallon Container	GAL.
17.1	C	7930-00-985-6904	DETERGENT: laundry (81348) PD-245 20 oz. box	OZ
18	C	6850-00-110-4498	DRYCLEANING SOLVENT: (81348) P-D-680, type II 1 Pint Can	PT
		6850-00-274-5421	5 Gallon Drum	GAL.
		6850-00-285-8011	55 Gallon Drum	GAL.
		6850-00-637-6135	Bulk	GAL.

Section II. EXPENDABLE/DURABLE SUPPLIES AND MATERIALS LIST (Cont'd)

(1) ITEM NUMBER	(2) LEVEL	(3) NATIONAL STOCK NUMBER	(4) DESCRIPTION	(5) U/M
19	C		FUEL OIL: diesel, regular, DF-2 (81348) VV-F-800	
		9140-00-286-5295	5 Gallon Can	GAL.
		9140-00-286-5296	55 Gallon Drum	GAL.
20	C		FUEL OIL: diesel, winter, DF-1 (81348) VV-F-800	
		9140-00-286-5287	5 Gallon Drum	GAL.
		9140-00-286-5288	55 Gallon Drum	GAL.
21	C		FUEL OIL: diesel, arctic, DF-A (81348) VV-F-800	
		9140-00-286-5282	5 Gallon Can	GAL.
		9140-00-286-5284	55 Gallon Drum	GAL.
22	C		GREASE: automotive and artillery (81349) MIL-G-10924	
		9150-00-935-1017	14 Ounce Cartridge	OZ
		9150-00-190-0904	1-3/4 Pound Can	LB
23	O		GREASE: ball and roller bearing (73219) 18901	
		9150-01-095-5512	Case, 24/14 Ounce Cans	OZ
24	O		GREASE: dielectric colloid (72872) 112X	
		N/A	1 Gallon Container	GAL.
25	O		GREASE: lithium base w/molybdenum disulfide (60218) LS2267	
		9150-01-015-1542	14.5 Ounce Cartridge	OZ
26	C		HYDRAULIC FLUID: transmission (24617) Dexron® II	
		9150-00-698-2382	1 Quart Can	QT
		9150-00-657-4959	5 Gallon Can	GAL.
27	C		HYDRAULIC FLUID: transmission (24617) Dexron® III	
		9150-01-353-4799	1 Quart Can	QT
		1950-01-114-9968	55 Gallon Drum	GAL.
27.1	O		LUBRICANT: run flat (62161) 12460308-1 55 Gallon Drum	GAL.

Section II. EXPENDABLE/DURABLE SUPPLIES AND MATERIALS LIST (Cont'd)

(1) ITEM NUMBER	(2) LEVEL	(3) NATIONAL STOCK NUMBER	(4) DESCRIPTION	(5) U/M
28	C		LUBRICATING OIL: gear, multipurpose, GO 75 (81349) MIL-L-2105	
		9150-01-035-5390	1 Quart Can	QT
		9150-01-035-5391	5 Gallon Drum	GAL.
29	C		LUBRICATING OIL: gear, multipurpose, GO 80/90 (81349) MIL-L-2105	
		9150-01-035-5392	1 Quart Can	QT
		9150-01-035-5393	5 Gallon Drum	GAL.
30	C		LUBRICATING OIL: internal combustion engine, arctic, OEA (81349) MIL-L-46167	
		9150-00-402-4478	1 Quart Can	QT
		9150-00-402-2372	5 Gallon Drum	GAL.
31	C	9150-00-491-7197	55 Gallon Drum	GAL.
			LUBRICATING OIL: internal combustion engine, tactical service, OE/HDO 10 (81349) MIL-L-2104	
		9150-00-189-6727	1 Quart Can	QT
32	C	9150-00-186-6668	5 Gallon Can	GAL.
		9150-00-191-2772	55 Gallon Drum	GAL.
			LUBRICATING OIL: internal combustion engine, tactical service, OE/HDO 30 (81349) MIL-L-2104	
33	O	9150-00-186-6681	1 Quart Can	QT
		9150-00-188-9858	5 Gallon Drum	GAL.
		9150-00-189-6729	55 Gallon Drum	GAL.
34	C		LUBRICATING OIL: general purpose, corrosion resistant and oxidation resistant (92895) PQRUSTPREVENTIVENO172	
		9150-00-273-2389	4 Ounce Can	OZ
			LUBRICATING OIL: internal combustion engine, tactical service, OE/HDO 15/40 (81349) MIL-L-2104	
		9150-01-152-4117	1 Quart Can	QT
		9150-01-152-4118	5 Gallon Drum	GAL.
		9150-01-152-4119	55 Gallon Drum	GAL.

Section II. EXPENDABLE/DURABLE SUPPLIES AND MATERIALS LIST (Cont'd)

(1) ITEM NUMBER	(2) LEVEL	(3) NATIONAL STOCK NUMBER	(4) DESCRIPTION	(5) U/M
35	C	8010-01-826-3535	PRIMER, ADHESIVE: spray (81349) MIL-A-46050C 15 Ounce Can	OZ
36	C	7920-00-205-1711	RAG: wiping, cotton and cotton-synthetic (58536) A-A-531 50 Pound Bale	LB
37	O	2090-00-372-6064	REPAIR KIT, Glass Reinforcement Plastic Laminate (81349) MIL-R-19907D 1 Kit	KT
38	O	6850-01-159-4844	SEALANT: silicone, RTV (11862) 1052734 8-1/2 Ounce Tube	OZ
39	O	8030-01-374-3504	SEALING COMPOUND (05972) 51831 50 Milliliter Tube	ML
		8030-01-374-2338	300 Milliliter Cartridge	ML
40	O	8030-01-347-0964	SEALING COMPOUND: adhesive, elastomeric (00333) M6325-11OZ 11 Ounce Cartridge	OZ
41	O	8030-01-171-7628	SEALING COMPOUND: anaerobic, adhesive/sealant (05972) 272-40 50 CC Bottle	CC
42	O	8040-01-010-8758	SEALING COMPOUND: canvas (81349) MIL-A-46106 1 Quart	QT
43	O	8030-00-009-5023	SEALING COMPOUND: corrosion-resistant (81349) MIL-S-81733, type II Kit	EA
44	O	8030-01-054-0740	SEALING COMPOUND: pipe, anaerobic, with teflon (05972) 59231 50 Milliliter Tube	ML
45	O	8030-00-148-9833	SEALING COMPOUND: thread-locking, high strength (80244) MIL-S-46163, type I, grade K 10 CC Bottle	CC

Section II. EXPENDABLE/DURABLE SUPPLIES AND MATERIALS LIST (Cont'd)

(1) ITEM NUMBER	(2) LEVEL	(3) NATIONAL STOCK NUMBER	(4) DESCRIPTION	(5) U/M
46	O	8030-01-025-1692	SEALING COMPOUND: thread-locking, medium strength (80244) MIL-S-46163, type II, grade N 250 CC Bottle	CC
47	O	8030-00-165-6547	SEALING COMPOUND: windshield (04963) 847H 1 Quart Container	QT
47.1	O	8030-01-328-0574	SEALING COMPOUND: electrical components silicone rubber, clear (71984) RTV 737 3 Ounce Cartridge	OZ
48	O	6850-00-880-7616 6850-00-295-7685	SILICONE COMPOUND: dielectric colloid, non-melting, heat stable, NATO code no. S-736 (81349) MIL-S-8660 8 Ounce Tube 10 Pound Can	OZ LB
49	O	6810-00-264-6618 6810-00-290-5574	SODIUM BICARBONATE: technical (baking soda) (81348) O-S-576 1 Pound Box 100 Pound Bag	LB LB
50	O	7510-00-149-0732	TAPE: pressure-sensitive adhesive, polyester film, transparent, 1 in. wide, 2 mil thick (80063) SMA597833-3 72 Yard Roll	YD
51	O	7510-00-283-0612	TAPE: pressure-sensitive adhesive, masking, flat, 1 in. width (19203) 8790710 60 Yard Roll	YD
52	O	8315-01-115-7617	TAPE: hook and pile material (81349) MIL-F-211840	YD
53	O	4020-00-291-5901	TWINES: fibrous, cotton (string) 16-ply (81348) T-T-871 375 Yard Spool	YD

APPENDIX D ILLUSTRATED LIST OF MANUFACTURED ITEMS

Section I. INTRODUCTION

D-1. SCOPE

This appendix includes complete instructions for making items authorized to be manufactured or fabricated at unit maintenance.

D-2. GENERAL

- a. A part number index in alphanumeric order is provided for cross-referencing the part number of the item to be manufactured to the figure which covers fabrication criteria.
- b. All bulk materials needed for manufacture of an item are listed by part number or specification number in a tabular list on the illustration.

Table D-1. Manufactured Items Part Number Index.

PART NO.	FIGURE NO.	PART NO.	FIGURE NO.	PART NO.	FIGURE NO.
MS51331-1	D-88	5573534	D-35	5584373	D-37
MT161A	D-90	5574986	D-21	5584383	D-15
M23053/1-204-0	D-61	5575468	D-24	5584707	D-21
M23053/7-204-2	D-61	5577552	D-35	5584813	D-22
M23053/4-303-0	D-1	5578874	D-39	5584836	D-22
M23053/4-303-2	D-1	5578875	D-39	5584892	D-39
M232053/4-304-2	D-2	5578876	D-39	5584893	D-39
RR-C-271	D-15.1	5578877	D-39	5588617-7.5	D-33
RR-C-271-6	D-3	5578878	D-39	5588618-13	D-32
SF5575898	D-7	5578887	D-9	5588698	D-8
SF5585243	D-16	5578910	D-10	5588767	D-11
SF5585245	D-16	5578911	D-11	5589086	D-29
SF5585258	D-16	5578940	D-30	5589275	D-31
SF5589035	D-4	5578999	D-12	5590023	D-14
SF5589036	D-4	5579007	D-11	5590024	D-14
SF5589037	D-5	5579008	D-10	5590025	D-14
SF5590706	D-26	5579997	D-13	5591157	D-37
SF5591372	D-6	5581213	D-27	5591158	D-37
SF5591612	D-25	5581366	D-34	5591159	D-37
SF5592748	D-4	5582451	D-62	5591161	D-37
12338591-1	D-94	5582479	D-14	5591168	D-37
12342947	D-94	5582641	D-37	5591180	D-15
12446730	D-95	5582642	D-37	5591210	D-36
12446770	D-86	5582643	D-37	5591253	D-37
12446771	D-87	5582645	D-37	5591482	D-37
12446821	D-62.1	5582646	D-37	5591483	D-37
14066306	D-18	5582648	D-15	5591681	D-15
15667	D-91	5582649	D-15	5591707	D-37
15847	D-38	5583183	D-14	5591937	D-14
15848	D-38	5583855	D-15	5591938	D-14
1775-826	D-17	5584173	D-37	5592085	D-58
23500024	D-11	5584188	D-28	5594083	D-36
23500084	D-19	5584372	D-15	5594278	D-23

Table D-1. Manufactured Items Part Number Index (Cont'd).

PART NO.	FIGURE NO.	PART NO.	FIGURE NO.	PART NO.	FIGURE NO.
5595995	D-23	5597995	D-59	5598815	D-54
5597214	D-60	5597997	D-59	5598816	D-45
5597215	D-60	5597998	D-59	5598817	D-46
5597216	D-60	5597999	D-59	5598818	D-48
5597217	D-60	5598000	D-59	5598819	D-41
5597218	D-60	5598029	D-59	5598820	D-47
5597219	D-60	5598030	D-59	5598821	D-53
5597220	D-60	5598031	D-59	5598825	D-63
5597221	D-60	5598032	D-59	5598826	D-63
5597222	D-60	5598033	D-59	5598827	D-64
5597223	D-60	5598034	D-59	5598828	D-65
5597224	D-60	5598035	D-59	5598829	D-66
5597225	D-60	5598036	D-59	5598830	D-67
5597226	D-60	5598061	D-59	5598832	D-68
5597227	D-60	5598062	D-59	5598833	D-69
5597228	D-60	5598063	D-59	5598834	D-70
5597229	D-60	5598064	D-59	5598835	D-71
5597230	D-60	5598065	D-59	5598836	D-72
5597231	D-60	5598132	D-60	5598837	D-73
5597232	D-60	5598133	D-60	5598838	D-74
5597722	D-60	5598134	D-60	5598839	D-75
5597723	D-60	5598236	D-44	5598840	D-76
5597724	D-60	5598237	D-43	5598841	D-77
5597725	D-60	5598238	D-40	5598842	D-78
5597726	D-60	5598239	D-57	5598843	D-79
5597727	D-60	5598240	D-55	5598844	D-80
5597728	D-60	5598241	D-49	5598845	D-81
5597730	D-60	5598242	D-50	5598846	D-82
5597957	D-60	5598243	D-56	5598847	D-83
5597958	D-60	5598245	D-52	5740702	D-10
5597970	D-60	5598813	D-42	8434398	D-114
5597994	D-59	5598814	D-51		

Section II. ILLUSTRATED MANUFACTURING INSTRUCTIONS

MATERIAL BLOCK		
STOCK SIZE	DESCRIPTION	SPECIFICATION
0.470 IN. INSIDE DIAMETER	INSULATION SLEEVING, HEAT SHRINK	MIL-I-23053

HEAT SHRINK INSULATION SLEEVING		
INSULATION PART NUMBER	CUT LENGTH (INCHES)	MANUFACTURED FROM PART NUMBER (CAGEC)
M23053/4-303-0	1.5	M23053/4-303-0 (81349)
M23053/4-303-2	1.5	M23053/4-303-2 (81349)

Figure D-1. Heat Shrink Insulation Sleeving

INSTRUCTIONS:

Cut insulation to length shown.

MATERIAL BLOCK		
STOCK SIZE	DESCRIPTION	SPECIFICATION
0.940 IN. INSIDE DIAMETER	INSULATION SLEEVING, HEAT SHRINK	MIL-I-23053

HEAT SHRINK INSULATION SLEEVING		
INSULATION PART NUMBER	CUT LENGTH (INCHES)	MANUFACTURED FROM PART NUMBER (CAGEC)
M23053/4-304-2	2.0	M23053/4-304-2 (81349)

Figure D-2. Heat Shrink Insulation Sleeving

INSTRUCTIONS:

Cut insulation to length shown.

Section II. ILLUSTRATED MANUFACTURING INSTRUCTIONS (Cont'd)

MATERIAL BLOCK		
STOCK SIZE	DESCRIPTION	SPECIFICATION
10 LINKS	CHAIN, WELDLESS	RR-C-271, TYPE II, CLASS 2

TOWING PINTLE LOCK CHAIN		
CHAIN PART NUMBER	CUT LENGTH	MANUFACTURED FROM NSN
RR-C-271-6	6 LINKS	4010-00-129-3321

Figure D-3. Towing Pintle Lock Chain

INSTRUCTIONS:

Cut chain to length shown.

MATERIAL BLOCK		
STOCK SIZE	DESCRIPTION	SPECIFICATION
20 IN. INSIDE DIAMETER	DUCT, FLEX	ASTM D 1149

DEFROSTER FLEX DUCTING			
ITEM NO.	DUCTING PART NUMBER	CUT LENGTH (INCHES)	MANUFACTURED FROM PART NUMBER (CAGEC)
1	SF5589035	37	FLX4001-16057600 (16632)
2	SF5589036	7	FLX4001-16057600 (16632)
3	SF5592748	19	FLX4001-16057600 (16632)

Figure D-4. Defroster Flex Ducting

INSTRUCTIONS:

Determine ducting part number needed from RPSTL and cut ducting to length shown.

Section II. ILLUSTRATED MANUFACTURING INSTRUCTIONS (Cont'd)

MATERIAL BLOCK		
STOCK SIZE	DESCRIPTION	SPECIFICATION
1.50 IN. INSIDE DIAMETER	DUCT, FLEX	ASTM D1149

DEFROSTER FLEX DUCTING		
DUCTING PART NUMBER	CUT LENGTH (INCHES)	MANUFACTURED FROM PART NUMBER (CAGEC)
SF5589037	33-1/2	FLX4001-12057600 (16632)

Figure D-5. Defroster Flex Ducting

INSTRUCTIONS:

Cut duct to length shown.

MATERIAL BLOCK		
STOCK SIZE	DESCRIPTION	SPECIFICATION
3.00 IN. INSIDE DIAMETER	DUCT, FLEX	ASTM D1149

DEFROSTER FLEX DUCTING		
DUCTING PART NUMBER	CUT LENGTH (INCHES)	MANUFACTURED FROM PART NUMBER (CAGEC)
SF5591372	8.50	FLX4001-24057600 (16632)

Figure D-6. Defroster Flex Ducting

INSTRUCTIONS:

Cut duct to length shown.

Section II. ILLUSTRATED MANUFACTURING INSTRUCTIONS (Cont'd)

MATERIAL BLOCK		
STOCK SIZE	DESCRIPTION	SPECIFICATION
0.200 IN. HEIGHT 0.162 IN. WIDTH 0.085 IN. OPENING	GROMMET, NONMETALLIC	ASTM D-4066

BATTERY CABLE EDGE PROTECTOR		
EDGE PROTECTOR PART NUMBER	CUT LENGTH (INCHES)	MANUFACTURED FROM NSN
SF5575898	3-7/8	5325-00-074-3301

Figure D-7. Battery Cable Edge Protector

INSTRUCTIONS:

Cut edge protector to length shown.

MATERIAL BLOCK		
STOCK SIZE	DESCRIPTION	SPECIFICATION
0.312 IN. ± 0.016 IN. INSIDE DIAMETER 0.562 IN. ± 0.023 IN. OUTSIDE DIAMETER	HOSE	GM-6165-M

ARCTIC/AMBULANCE HEATER FUEL SUPPLY HOSE		
HOSE PART NUMBER	CUT LENGTH (INCHES)	MANUFACTURED FROM: PART NUMBER (CAGEC)
5588698	2-13/16	9438306 (11862)

Figure D-8. Arctic/Ambulance Heater Fuel Supply Hose

INSTRUCTIONS:

Cut hose to length shown.

Section II. ILLUSTRATED MANUFACTURING INSTRUCTIONS (Cont'd)

MATERIAL BLOCK		
STOCK SIZE	DESCRIPTION	SPECIFICATION
0.500 IN. INSIDE DIAMETER 0.750 IN. OUTSIDE DIAMETER	HOSE, NONMETALLIC	GM06147-M

FUEL CAN DRAIN HOSE		
HOSE PART NUMBER	CUT LENGTH (INCHES)	MANUFACTURED FROM PART NUMBER (CAGEC)
5578887	10-1/2	9436581 (11862)

Figure D-9 Fuel Can Drain Hose

INSTRUCTIONS:

Cut hose to length shown.

MATERIAL BLOCK		
STOCK SIZE	DESCRIPTION	SPECIFICATION
0.375 IN. ± 0.016 IN. INSIDE DIAMETER 0.625 IN. ± 0.023 IN. OUTSIDE DIAMETER	HOSE, NONMETALLIC	GM-6165-M

FUEL SUPPLY HOSE			
ITEM NO.	HOSE PART NUMBER	CUT LENGTH (INCHES)	MANUFACTURED FROM NSN
1	5578910	6-1/2	4720-01-159-5796
2	5579008	2-13/16	4720-01-159-5796
3	5740702	10	4720-01-185-9473

Figure D-10. Fuel Supply Hose

INSTRUCTIONS:

Determine hose part number needed from RPSTL and cut hose to length shown.

Section II. ILLUSTRATED MANUFACTURING INSTRUCTIONS (Cont'd)

MATERIAL BLOCK		
STOCK SIZE	DESCRIPTION	SPECIFICATION
0250 IN. ± 0.016 IN. INSIDE DIAMETER 0.500 IN. ± 0.023 IN. OUTSIDE DIAMETER	HOSE, NONMETALLIC	GM-6165-M

FUEL HOSE			
ITEM NO.	HOSE PART NUMBER	CUT LENGTH (INCHES)	MANUFACTURED FROM NSN
1	23500024	22	4720-01-155-7784
2	5578911	9	4720-01-155-7784
3	5579007	2-13/16	4720-01-155-7784
4	5588767	26	4720-01-155-7784

Figure D-11. Fuel Hose

INSTRUCTIONS:

Determine hose part number needed from RPSTL and cut hose to length shown.

MATERIAL BLOCK		
STOCK SIZE	DESCRIPTION	SPECIFICATION
0.290 IN. ± 0.040 IN. INSIDE DIAMETER	HOSE, NONMETALLIC	ASTM D2000

OVERFLOW HOSE		
HOSE PART NUMBER	CUT LENGTH (INCHES)	MANUFACTURED FROM NSN
5578999	18-5/16	4720-01-185-6673

Figure D-12. Overflow Hose

INSTRUCTIONS:

Cut hose to length shown.

Section II. ILLUSTRATED MANUFACTURING INSTRUCTIONS (Cont'd)

MATERIAL BLOCK		
STOCK SIZE	DESCRIPTION	SPECIFICATION
0.62 IN. INSIDE DIAMETER 0.94 IN. OUTSIDE DIAMETER	HOSE, NONMETALLIC	SAE 20R3, CLASS D-1

HEATER HOSE		
HOSE PART NUMBER	CUT LENGTH (INCHES)	MANUFACTURED FROM NSN
5579997	2-1/2	4720-00-241-4435

Figure D-13. Heater Hose

INSTRUCTIONS:

Cut hose to length shown.

MATERIAL BLOCK		
STOCK SIZE	DESCRIPTION	SPECIFICATION
0.367 IN. ± 0.023 IN. INSIDE DIAMETER 0.656 IN. ± 0.031 IN. OUTSIDE DIAMETER	HOSE, NONMETALLIC	GM-6210-M

CONNECTOR HOSES			
ITEM NO.	HOSE PART NUMBER	CUT LENGTH (INCHES)	MANUFACTURED FROM NSN
1	5582479	3	4720-01-186-2358
2	5583183	19	4720-01-186-2358
3	5590023	23	4720-01-186-2358
4	5590024	41	4720-01-297-0255
5	5590025	27	4720-01-271-6955
6	5591937	7-1/4	4720-01-186-2358
7	5591938	10	4720-01-186-2358

Figure D-14. Transmission Cooling Lines Connector Hoses and Steering Hydraulic System Hoses

INSTRUCTIONS:

Determine hose part number needed from RPSTL and cut hose to length shown.

Section II. ILLUSTRATED MANUFACTURING INSTRUCTIONS (Cont'd)

MATERIAL BLOCK		
STOCK SIZE	DESCRIPTION	SPECIFICATION
0.250 IN. INSIDE DIAMETER 0.500 IN. OUTSIDE DIAMETER	HOSE, NONMETALLIC	N/A

VENT LINE HOSE PART NUMBER			
ITEM NO.	HOSE PART NUMBER	CUT LENGTH (INCHES)	MANUFACTURED FROM NSN
1	5582648	4	4720-00-289-9625
2	5582649	25	4720-01-325-0204
3	5583855	42	4720-00-289-9625
4	5584372	8	4720-00-289-9625
5	5584383	32	4720-00-289-9625
6	5591180	2	4720-00-289-9625
7	5591681	18	4720-00-289-9625

Figure D-15. Vent Line Hose.

INSTRUCTIONS:

Determine hose part number needed from RPSTL and cut hose to length shown.

MATERIAL BLOCK		
STOCK SIZE	DESCRIPTION	SPECIFICATION
BULK	CHAIN, WELDLESS	RR-C-271, TYPE II, CLASS 7-16

FUEL CAP CHAIN		
PART NUMBER	CUT LENGTH (INCHES)	MANUFACTURED FROM NSN
RR-C-271	8	4010-00-958-0633

Figure D-15.1. Fuel Cap Chain.

INSTRUCTIONS:

Cut chain to length shown.

Section II. ILLUSTRATED MANUFACTURING INSTRUCTIONS (Cont'd)

MATERIAL BLOCK		
STOCK SIZE	DESCRIPTION	SPECIFICATION
0.190 IN. INSIDE DIAMETER	HOSE, NONMETALLIC	ASTM D1149

WINDSHIELD WASHER HOSE			
ITEM NO.	HOSE PART NUMBER	CUT LENGTH (INCHES)	MANUFACTURED FROM PART NUMBER (CAGEC)
1	SF5585243	16	846-50 (11288)
2	SF5585245	36	846-50 (11288)
3	SF5585258	27	846-50 (11288)

Figure D-16. Windshield Washer Hose

INSTRUCTIONS:

Determine hose part number needed from RPSTL and cut hose to length shown.

MATERIAL BLOCK		
STOCK SIZE	DESCRIPTION	SPECIFICATION
0.125 IN. INSIDE DIAMETER 0.25 IN. INSIDE DIAMETER	HOSE, NONMETALLIC	N/A

AIR RESTRICTION HOSE		
HOSE PART NUMBER	CUT LENGTH (INCHES)	MANUFACTURED FROM NSN
1775-826	84	4720-01-188-3190

Figure D-17. Air Restriction Hose

INSTRUCTIONS:

Cut hose to length shown.

Section II. ILLUSTRATED MANUFACTURING INSTRUCTIONS (Cont'd)

MATERIAL BLOCK		
STOCK SIZE	DESCRIPTION	SPECIFICATION
0.156 IN. INSIDE DIAMETER 0.281 IN. OUTSIDE DIAMETER	HOSE, NONMETALLIC	N/A

FUEL DRAIN BACK HOSE		
HOSE PART NUMBER	CUT LENGTH (INCHES)	MANUFACTURED FROM NSN
14066306	7	4720-01-184-0432

Figure D-18. Fuel Drain Back Hose

INSTRUCTIONS:

Cut hose to length shown.

MATERIAL BLOCK		
STOCK SIZE	DESCRIPTION	SPECIFICATION
0.750 IN. INSIDE DIAMETER 1.00 IN. OUTSIDE DIAMETER	HOSE, NONMETALLIC	N/A

THERMOSTAT BYPASS HOSE		
HOSE PART NUMBER	CUT LENGTH (INCHES)	MANUFACTURED FROM NSN
23500084	5	4720-01-845-9211

Figure D-19. Thermostat Bypass Hose

INSTRUCTIONS:

Cut hose to length shown.

Section II. ILLUSTRATED MANUFACTURING INSTRUCTIONS (Cont'd)

MATERIAL BLOCK		
STOCK SIZE	DESCRIPTION	SPECIFICATION
0.25 IN. INSIDE DIAMETER 0.50 IN. OUTSIDE DIAMETER	HOSE, NONMETALLIC	GM-6163-M

FUEL DRAIN BACK HOSE		
HOSE PART NUMBER	CUT LENGTH (INCHES)	MANUFACTURED FROM NSN
9439363	7	4720-01-163-7833

Figure D-20. Fuel Drain Back Hose

INSTRUCTIONS:

Cut hose to length shown.

MATERIAL BLOCK		
STOCK SIZE	DESCRIPTION	SPECIFICATION
0.280 IN. WIDTH 0.370 IN. HEIGHT	PAD, CUSHIONING	N/A

EDGE PROTECTOR			
ITEM NO.	EDGE PROTECTOR PART NUMBER	CUT LENGTH (INCHES)	MANUFACTURED FROM NSN
1	5574986	5-11/16	2590-01-196-7281
2	5584707	8-7/8	2590-01-196-7281

Figure D-21. Handle Edge Protector

INSTRUCTIONS:

Determine edge protector part number needed from RPSTL and cut edge protector to length shown.

Section II. ILLUSTRATED MANUFACTURING INSTRUCTIONS (Cont'd)

MATERIAL BLOCK		
STOCK SIZE	DESCRIPTION	SPECIFICATION
0.75 IN. ± 0.09 IN., SQUARE	RUBBER, NEOPRENE	N/A

FIXED DOOR SEAL			
ITEM NO.	SEAL PART NUMBER	CUT LENGTH (INCHES)	MANUFACTURED FROM PART NUMBER (CAGEC)
1	5584813	49-7/16	R-421-N (82942)
2	5584836	21-15/16	R-421-N (82942)

Figure D-22. Fixed Door Seal

INSTRUCTIONS:

Determine seal part number needed from RPSTL and cut seal to length shown.

MATERIAL BLOCK		
STOCK SIZE	DESCRIPTION	SPECIFICATION
0.56 IN. WIDTH 1.00 IN. HEIGHT	CHANNEL, NONMETALLIC	N/A

EDGE PROTECTOR			
ITEM NO.	EDGE PROTECTOR PART NUMBER	CUT LENGTH (INCHES)	MANUFACTURED FROM PART NUMBER (CAGEC)
1	5594278	6-1/2	ZX-4295 (76385)
2	5595995	8-1/2	

Figure D-23. Handle Edge Protector

INSTRUCTIONS:

Determine edge protector part number needed from RPSTL and cut edge protector to length shown.

Section II. ILLUSTRATED MANUFACTURING INSTRUCTIONS (Cont'd)

MATERIAL BLOCK		
STOCK SIZE	DESCRIPTION	SPECIFICATION
0.10 IN. THICK	RUBBER STRIP	N/A

ANTI-NOISE PAD		
PAD PART NUMBER	CUT (INCHES)	MANUFACTURED FROM NSN
5575468	1-1/2 X 1-3/16	5330-01-198-3521

Figure D-24. Anti-Noise Pad

INSTRUCTIONS:

Cut pad to size shown.

MATERIAL BLOCK		
STOCK SIZE	DESCRIPTION	SPECIFICATION
0.250 IN. THICK 0.50 IN. WIDTH	SEAL	ASTM D 1056 ASTM D-903

WINDSHIELD LOWER SEAL		
SEAL PART NUMBER	CUT LENGTH (INCHES)	MANUFACTURED FROM PART NUMBER (CAGEC)
SF5591612	83-1/2	68-412121-2 (82942)

Figure D-25. Windshield Lower Seal

INSTRUCTIONS:

Cut seal to length shown.

Section II. ILLUSTRATED MANUFACTURING INSTRUCTIONS (Cont'd)

MATERIAL BLOCK		
STOCK SIZE	DESCRIPTION	SPECIFICATION
0.188 IN. THICK 0.50 IN. WIDTH	SEAL	ASTM D-1056 ASTM D-903

WINDSHIELD LOWER SEAL		
SEAL PART NUMBER	CUT LENGTH (INCHES)	MANUFACTURED FROM PART NUMBER (CAGEC)
SF5590706	80-1/2	68-412121-1 (82942)

Figure D-26. Windshield Lower Seal

INSTRUCTIONS:

Cut seal to length shown.

MATERIAL BLOCK		
STOCK SIZE	DESCRIPTION	SPECIFICATION
N/A	SEAL, RUBBER	N/A

RUBBER LOWER SEAL		
SEAL PART NUMBER	CUT LENGTH (INCHES)	MANUFACTURED FROM NSN
5581213	17-1/4	5330-01-288-7822

Figure D-27. Rubber Lower Seal

INSTRUCTIONS:

Determine seal part number needed from RPSTL and cut seal to length shown.

Section II. ILLUSTRATED MANUFACTURING INSTRUCTIONS (Cont'd)

MATERIAL BLOCK		
STOCK SIZE	DESCRIPTION	SPECIFICATION
0.520 IN. THICK 1.136 IN. WIDTH	SEAL, NONMETALLIC	ASTM D 1056

TRAY ASSEMBLY SEAL		
SEAL PART NUMBER	CUT LENGTH (INCHES)	MANUFACTURED FROM NSN
5584188	100	5330-01-202-8360

Figure D-28. Tray Assembly Seal

INSTRUCTIONS:

Cut seal to length shown.

MATERIAL BLOCK		
STOCK SIZE	DESCRIPTION	SPECIFICATION
1.00 IN. THICK 1.75 IN. WIDTH	SEAL, RUBBER	MIL-I-14511B

ARCTIC CURTAIN SEAL		
SEAL PART NUMBER	CUT LENGTH (INCHES)	MANUFACTURED FROM PART NUMBER (CAGEC)
5589086	30	1C-100-01 (55674)

Figure D-29. Arctic Curtain Seal

INSTRUCTIONS:

Cut seal to length shown.

Section II. ILLUSTRATED MANUFACTURING INSTRUCTIONS (Cont'd)

MATERIAL BLOCK		
STOCK SIZE	DESCRIPTION	SPECIFICATION
0.50 IN. INSIDE DIAMETER	CHAFE GUARD, SPIRAL WRAP	N/A

SPIRAL WRAP CHAFE GUARD		
GUARD PART NUMBER	CUT LENGTH (INCHES)	MANUFACTURED FROM PART NUMBER (CAGEC)
5578940	3	25FT2661-16P-120.00 (98441)

Figure D-30. Spiral Wrap Chafe Guard

INSTRUCTIONS:

Cut chafe guard to length shown.

MATERIAL BLOCK		
STOCK SIZE	DESCRIPTION	SPECIFICATION
0.25 IN. THICK 0.50 IN. WIDTH	STRIP FOAM, INSULATION	MIL-I-14511B

FOAM INSULATION STRIP		
INSULATION PART NUMBER	CUT LENGTH (INCHES)	MANUFACTURED FROM PART NUMBER (CAGEC)
5589275	12	1C-025-02 (55674)

Figure D-31. Foam Insulation Strip

INSTRUCTIONS:

Cut insulation to length shown.

Section II. ILLUSTRATED MANUFACTURING INSTRUCTIONS (Cont'd)

MATERIAL BLOCK		
STOCK SIZE	DESCRIPTION	SPECIFICATION
3.0 IN. WIDTH	TAPE, ADHESIVE	N/A

RUN FLAT LUBE PACKAGE TAPE		
TAPE PART NUMBER	CUT LENGTH (INCHES)	MANUFACTURED FROM PART NUMBER (CAGEC)
5588618-13	13	Y-9485 (04963)

Figure D-32. Run Flat Lube Package Tape

INSTRUCTIONS:

Cut tape to length shown.

Section II. ILLUSTRATED MANUFACTURING INSTRUCTIONS [Cont'd)

MATERIAL BLOCK		
STOCK SIZE	DESCRIPTION	SPECIFICATION
0.75 IN. WIDE	TAPE, FILAMENT	N/A

FILAMENT TAPE		
TAPE PART NUMBER	CUT LENGTH (INCHES)	MANUFACTURED FROM NSN
5588617-7.5	7.5	7510-00-802-8311

Figure D-33. Filament Tape

INSTRUCTIONS:

Cut tape to length shown,

MATERIAL BLOCK		
STOCK SIZE	DESCRIPTION	SPECIFICATION
0.75 IN. WIDTH 0.045 IN. THICK	TAPE, FOAM	N/A

FOAM TAPE		
TAPE PART NUMBER	CUT LENGTH (INCHES)	MANUFACTURED FROM NSN
5581366	81-1/2	9320-01-155-2369

Figure D-34. Foam Tape

INSTRUCTIONS:

Cut tape to length shown.

Section II. ILLUSTRATED MANUFACTURING INSTRUCTIONS (Cont'd)

MATERIAL BLOCK		
STOCK SIZE	DESCRIPTION	SPECIFICATION
0.375 IN. INSIDE DIAMETER 0.50 IN. OUTSIDE DIAMETER	TUBING, NONMETALLIC	SAE J844

FUEL SYSTEM VENT LINE			
ITEM NO.	VENT LINE PART NUMBER	CUT LENGTH (INCHES)	MANUFACTURED FROM NSN
1	5573534	27	4720-01-003-6706
2	5577552	43	4720-01-003-6706

Figure D-35. Fuel System Vent Line

INSTRUCTIONS:

Determine vent line part number needed from RPSTL and cut vent line to length shown.

MATERIAL BLOCK		
STOCK SIZE	DESCRIPTION	SPECIFICATION
0.312 IN. INSIDE DIAMETER 0.375 IN. OUTSIDE DIAMETER	TUBING, NONMETALLIC	SAE J844

FUEL SYSTEM VENT LINE			
ITEM NO.	VENT LINE PART NUMBER	CUT LENGTH (INCHES)	MANUFACTURED FROM PART NUMBER (CAGEC)
1	5591210	11	PFT-6B (87373)
2	5594083	91	PFT-6B (87373)

Figure D-36. Fuel Tank Vent Line

INSTRUCTIONS:

Cut vent line to length shown.

Section II. ILLUSTRATED MANUFACTURING INSTRUCTIONS (Cont'd)

MATERIAL BLOCK		
STOCK SIZE	DESCRIPTION	SPECIFICATION
0.180 IN. INSIDE DIAMETER 0.250 IN. OUTSIDE DIAMETER	TUBING, NONMETALLIC	SAE J844, TYPE A

VENT LINE TUBE			
ITEM NO.	TUBE PART NUMBER	CUT LENGTH (INCHES)	MANUFACTURED FROM NSN
1	5582641	4	4720-01-071-4042
2	5582642	11	4720-01-071-4042
3	5582643	15	4720-01-071-4042
4	5582645	24	4720-01-071-4042
5	5582646	32	4710-01-347-6368
6	5584173	8	4720-01-071-4042
7	5584373	26	4720-01-071-4042
8	5591157	40	4720-01-071-4042
9	5591158	35-1/2	4720-01-071-4042
10	5591159	7	4720-01-071-4042
11	5591161	10	4720-01-071-4042
12	5591168	64	4720-01-071-4042
13	5591253	41	4720-01-071-4042
14	5591482	12	4720-01-071-4042
15	5591483	14	4720-01-071-4042
16	5591707	70	4120-01-071-4042

Figure D-37. Vent Line Tube

INSTRUCTIONS:

Determine tube part number needed from RPSTL and cut tube to length shown.

Section II. ILLUSTRATED MANUFACTURING INSTRUCTIONS (Cont'd)

MATERIAL BLOCK		
STOCK SIZE	DESCRIPTION	SPECIFICATION
4 IN. GAGE, TYPE 1, CLASS A	WIRE, ELECTRICAL	MIL-C-13486

WINCH BATTERY CABLE					
ITEM NO.	CABLE PART NUMBER	CUT LENGTH (INCHES)	MANUFACTURED FROM NSN	END TERMINALS NSN	END INSULATOR
1	15847	74	6145-00-538-8219	5940-00-520-2447 5940-00-197-3664	M23053/03-0 (81349)
2	15848	87-1/2	6145-00-538-8219	5940-00-520-2447 5940-00-197-3664	M23053/03-0 (81349)

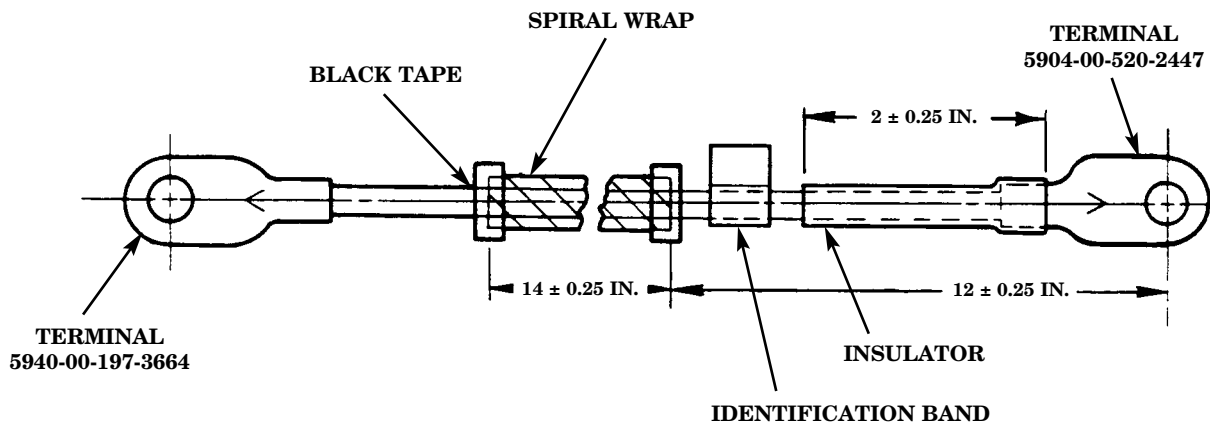

Figure D-38. Winch Battery Cable

INSTRUCTIONS:

1. Determine cable number needed from RPSTL and cut cable 6145-00-538-8219 to length as shown.
2. Select and solder proper end terminals to cable ends as shown. (Refer to TC 9-237 for soldering instructions.)
3. Install insulator as shown.
4. Cut 14 inches of spiral wrap from bulk 25 FT 2661-8P (98441) and install as shown. Spiral wrap is held in position with black tape at both ends.
5. Mark and install identification band using old cable as reference.

Section II. ILLUSTRATED MANUFACTURING INSTRUCTIONS (Cont'd)

MATERIAL BLOCK		
STOCK SIZE	DESCRIPTION	SPECIFICATION
"0" GAGE	WIRE, ELECTRICAL	MIL-C-13486

BATTERY CABLE ASSEMBLY					
ITEM NO.	CABLE PART NUMBER	CUT LENGTH (INCHES)	MANUFACTURED FROM NSN	END TERMINALS NSN	END INSULATORS NSN
1	5578874	21	6145-00-705-6674	5940-00-705-6732 5940-00-705-6732	5970-01-174-9449 5970-01-174-9449
2	5578875	25	6145-00-705-6674	5940-00-735-5520 5940-00-705-6732	5970-01-174-9449 5970-01-174-9449
3	5578876	13	6145-00-705-6674	5940-00-705-6732 5940-00-705-6732	5970-01-174-9449 5970-01-174-9449
4	5578877	36	6145-00-705-6674	5940-00-735-5520 5940-00-705-6732	5970-01-174-9449 5970-01-174-9449
5	5578878	32	6145-00-705-6674	5940-00-705-6732 5940-00-705-6732	5970-01-174-9449 5970-01-174-9449
6	5584892	31	6145-00-705-6674	5940-00-735-5520 5940-00-735-5520	5970-01-174-9449 5975-01-208-9618
7	5584893	31	6145-00-705-6674	5940-00-735-5520 5940-00-705-6732	5970-01-174-9449 5970-01-174-9449

Section II. ILLUSTRATED MANUFACTURING INSTRUCTIONS (Cont'd)

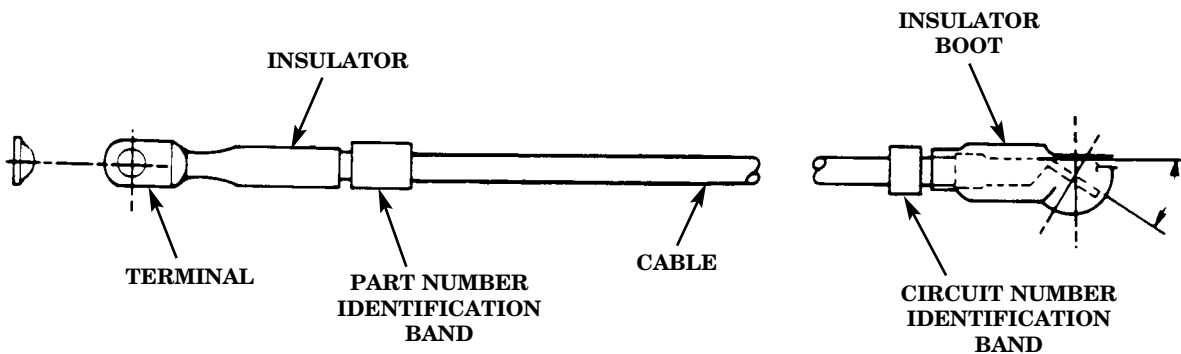

Figure D-39. Battery Cable Assembly

INSTRUCTIONS:

1. Determine cable number needed from RPSTL and cut wire 6154-00-705-6674 to length as shown.

NOTE

- Items 1, 4, 5, 6, and 7: flat of terminals to be 90° offset as shown without wire twist.
- Item 6: one terminal end is bent 30°.

2. Select and solder proper end terminals to cable ends as shown. (Refer to TC 9-237 for soldering instructions.)

NOTE

Insulator boot 5582481 is installed on 30° bent terminal end of item 6.

3. Select and install proper insulators as shown.
4. Mark and install circuit number identification band and part number identification band using old cable as reference.

Section II. ILLUSTRATED MANUFACTURING INSTRUCTIONS (Cont'd)

MATERIAL BLOCK		
STOCK SIZE	DESCRIPTION	SPECIFICATION
1.00 THICK	FOAM, ACOUSTIC	ASTM D-903 UL 94 HF-1

AIR CONDITIONING COMPARTMENT INSULATION		
INSULATION PART NUMBER	CUT (INCHES)	MANUFACTURED FROM PART NUMBER (CAGEC)
5598238	13 X 10.55	C 540 B H52 (28818)

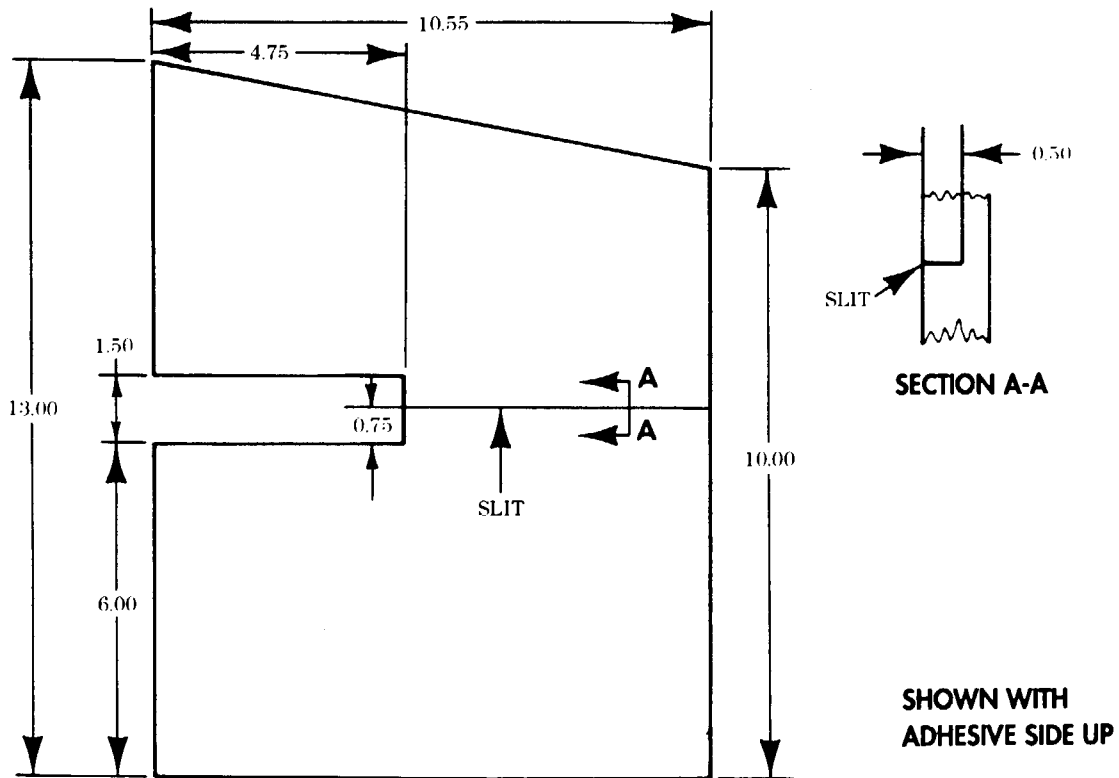

Figure D-40. A/C Compartment Side Front Insulation

INSTRUCTIONS:

Cut insulation to dimensions shown.

Section II. ILLUSTRATED MANUFACTURING INSTRUCTIONS (Cont'd)

MATERIAL BLOCK		
STOCK SIZE	DESCRIPTION	SPECIFICATION
1.00 THICK	FOAM, ACOUSTIC	ASTM D-903 UL 94 HF-1

AIR CONDITIONING COMPARTMENT INSULATION		
INSULATION PART NUMBER	CUT (INCHES)	MANUFACTURED FROM PART NUMBER (CAGEC)
5598819	21.80 X 29.50	C 540 B H52 (28818)

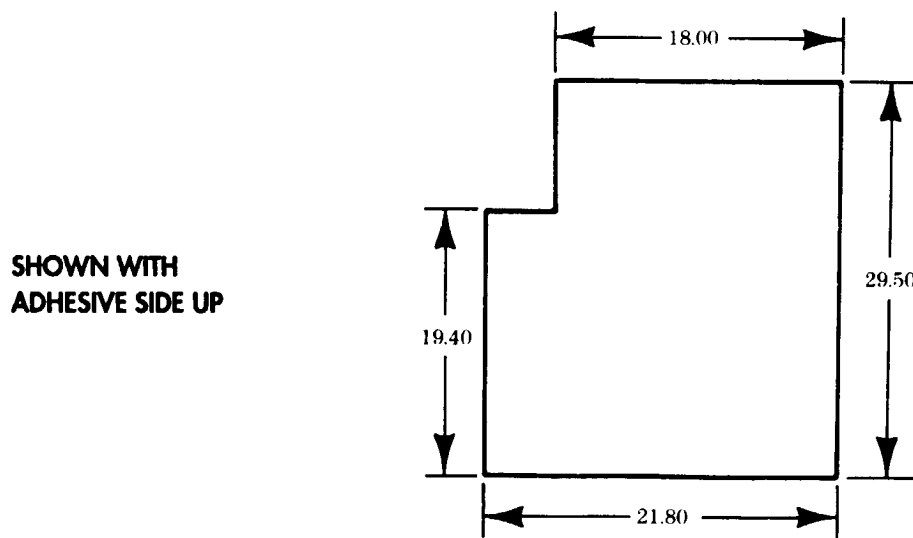

Figure D-41. A/C Compartment Passenger Side Ceiling Insulation

INSTRUCTIONS:

Cut insulation to dimensions shown.

Section II. ILLUSTRATED MANUFACTURING INSTRUCTIONS (Cont'd)

MATERIAL BLOCK		
STOCK SIZE	DESCRIPTION	SPECIFICATION
1.00 THICK	FOAM, ACOUSTIC	ASTM D-903 UL 94 HF-1

AIR CONDITIONING COMPARTMENT INSULATION		
INSULATION PART NUMBER	CUT (INCHES)	MANUFACTURED FROM PART NUMBER (CAGEC)
5598813	24.55 X 13.50	C 540 B H52 (28818)

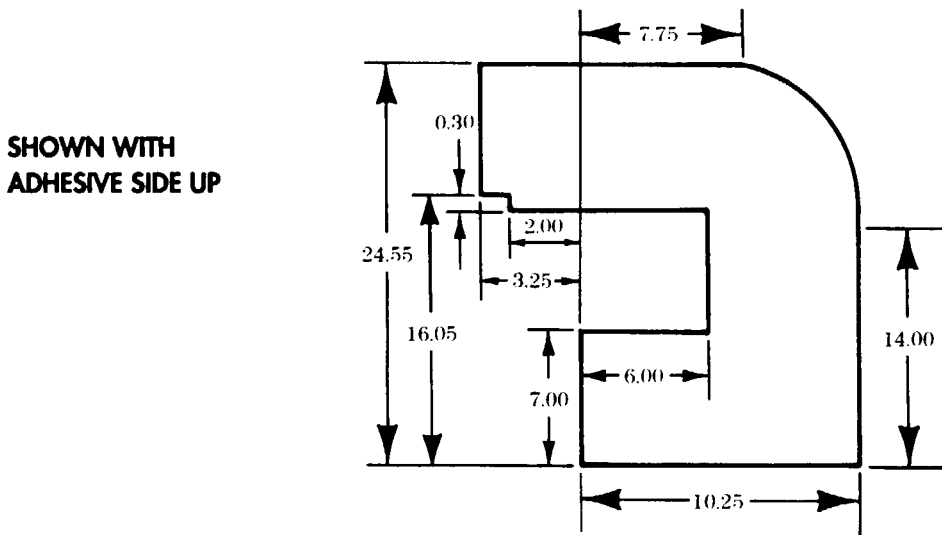

Figure D-42. A/C Compartment Bulkhead Outboard Insulation

INSTRUCTIONS:

Cut insulation to dimensions shown.

Section II. ILLUSTRATED MANUFACTURING INSTRUCTIONS (Cont'd)

MATERIAL BLOCK		
STOCK SIZE	DESCRIPTION	SPECIFICATION
1.00 THICK	FOAM, ACOUSTIC	ASTM D-903 UL 94 HF-1

AIR CONDITIONING COMPARTMENT INSULATION		
INSULATION PART NUMBER	CUT (INCHES)	MANUFACTURED FROM PART NUMBER (CAGEC)
5598237	28.90 X 12.00	C 540 B H52 (28818)

SHOWN WITH
ADHESIVE SIDE UP

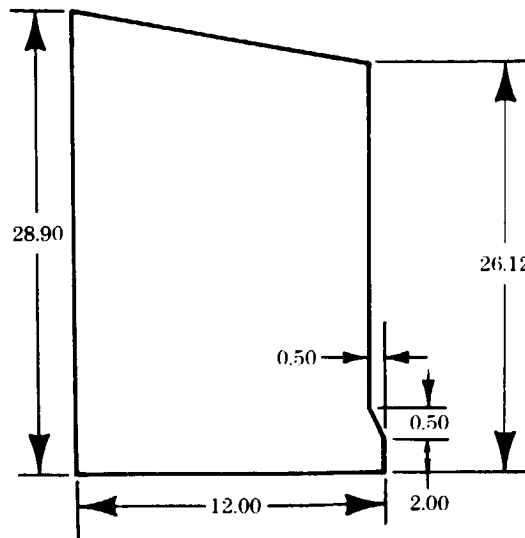

Figure D-43. A/C Compartment Side Rear Insulation

INSTRUCTIONS:

Cut insulation to dimensions shown.

Section II. ILLUSTRATED MANUFACTURING INSTRUCTIONS (Cont'd)

MATERIAL BLOCK		
STOCK SIZE	DESCRIPTION	SPECIFICATION
1.00 THICK	FOAM, ACOUSTIC	ASTM D-903 UL 94 HF-1

AIR CONDITIONING COMPARTMENT INSULATION		
INSULATION PART NUMBER	CUT (INCHES)	MANUFACTURED FROM PART NUMBER (CAGEC)
5598236	28.50 X 22.00	C 540 B H52 (28818)

SHOWN WITH
ADHESIVE SIDE UP

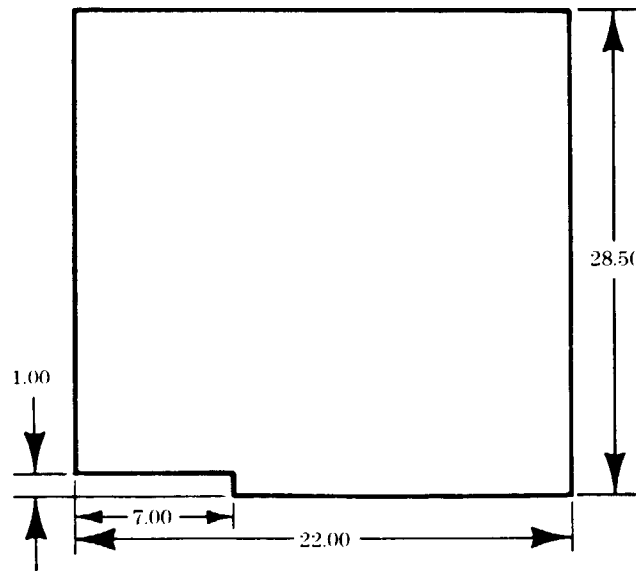

Figure D-44. A/C Compartment Roof Insulation

INSTRUCTIONS:

Cut insulation to dimensions shown.

Section II. ILLUSTRATED MANUFACTURING INSTRUCTIONS (Cont'd)

MATERIAL BLOCK		
STOCK SIZE	DESCRIPTION	SPECIFICATION
1.00 THICK	FOAM, ACOUSTIC	ASTM D-903 UL 94 HF-1

AIR CONDITIONING COMPARTMENT INSULATION		
INSULATION PART NUMBER	CUT (INCHES)	MANUFACTURED FROM PART NUMBER (CAGEC)
5598816	12.80 X 10.75	C 540 B H52 (28818)

Figure D-45. A/C Compartment Front Closeout Insulation

INSTRUCTIONS:

Cut insulation to dimensions shown.

MATERIAL BLOCK		
STOCK SIZE	DESCRIPTION	SPECIFICATION
1.00 THICK	FOAM, ACOUSTIC	ASTM D-903 UL 94 HF-1

AIR CONDITIONING COMPARTMENT INSULATION		
INSULATION PART NUMBER	CUT (INCHES)	MANUFACTURED FROM PART NUMBER (CAGEC)
5598817	23.70 X 18.50	C 540 B H52 (28818)

Figure D-46. A/C Compartment Front Ceiling Insulation

INSTRUCTIONS:

Cut insulation to dimensions shown.

Section II. ILLUSTRATED MANUFACTURING INSTRUCTIONS (Cont'd)

MATERIAL BLOCK		
STOCK SIZE	DESCRIPTION	SPECIFICATION
1.00 THICK	FOAM, ACOUSTIC	ASTM D-903 UL 94 HF-1

AIR CONDITIONING COMPARTMENT INSULATION		
INSULATION PART NUMBER	CUT (INCHES)	MANUFACTURED FROM PART NUMBER (CAGEC)
5598820	9.40 X 33.70	C 540 B H52 (28818)

Figure D-47. A/C Compartment Driver Compartment Above Door Insulation

INSTRUCTIONS:

Cut insulation to dimensions shown.

Section II. ILLUSTRATED MANUFACTURING INSTRUCTIONS (Cont'd)

MATERIAL BLOCK		
STOCK SIZE	DESCRIPTION	SPECIFICATION
1.00 THICK	FOAM, ACOUSTIC	ASTM D-903 UL 94 HF-1

AIR CONDITIONING COMPARTMENT INSULATION		
INSULATION PART NUMBER	CUT (INCHES)	MANUFACTURED FROM PART NUMBER (CAGEC)
5598818	32.90 X 24.80	C 540 B H52 (28818)

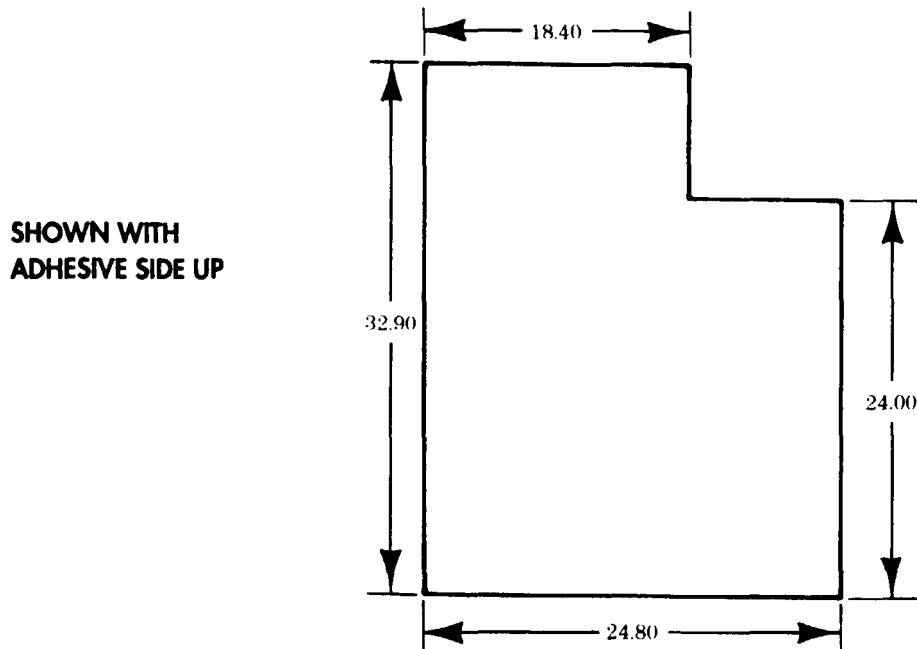

Figure D-48. A/C Compartment Driver Side Ceiling Insulation

INSTRUCTIONS:

Cut insulation to dimensions shown.

Section II. ILLUSTRATED MANUFACTURING INSTRUCTIONS (Cont'd)

MATERIAL BLOCK		
STOCK SIZE	DESCRIPTION	SPECIFICATION
1.00 THICK	FOAM, ACOUSTIC	ASTM D-903 UL 94 HF-1

AIR CONDITIONING COMPARTMENT INSULATION		
INSULATION PART NUMBER	CUT (INCHES)	MANUFACTURED FROM PART NUMBER (CAGEC)
5598241	14.75 X 4.20	C 540 B H52 (28818)

SHOWN WITH
ADHESIVE SIDE UP

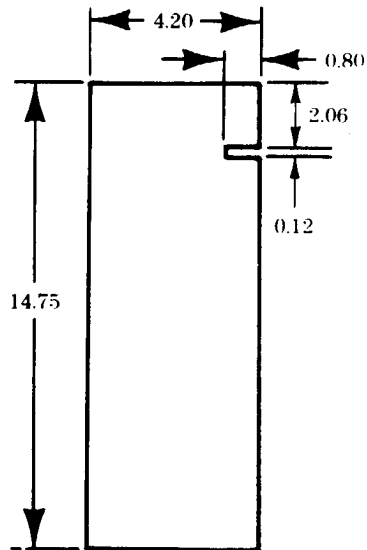

Figure D-49. A/C Compartment Condenser Top Outer Insulation

INSTRUCTIONS:

Cut insulation to dimensions shown.

Section II. ILLUSTRATED MANUFACTURING INSTRUCTIONS (Cont'd)

MATERIAL BLOCK		
STOCK SIZE	DESCRIPTION	SPECIFICATION
1.00 THICK	FOAM, ACOUSTIC	ASTM D-903 UL 94 HF-1

AIR CONDITIONING COMPARTMENT INSULATION		
INSULATION PART NUMBER	CUT (INCHES)	MANUFACTURED FROM PART NUMBER (CAGEC)
5598242	12.50 X 19.80	C 540 B H52 (28818)

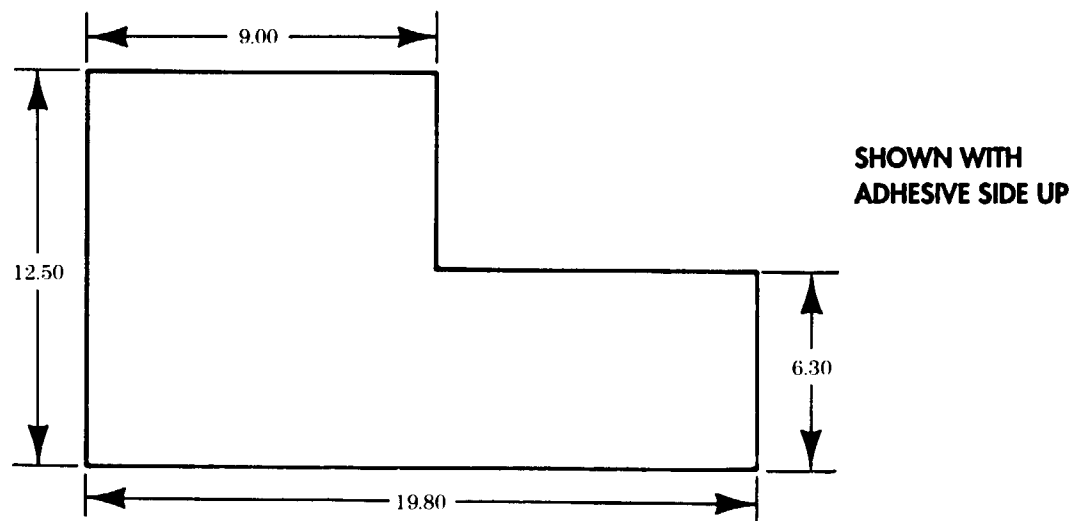

Figure D-50. A/C Compartment Condenser Top Inner Insulation

INSTRUCTIONS:

Cut insulation to dimensions shown.

Section II. ILLUSTRATED MANUFACTURING INSTRUCTIONS (Cont'd)

MATERIAL BLOCK		
STOCK SIZE	DESCRIPTION	SPECIFICATION
1.00 THICK	FOAM, ACOUSTIC	ASTM D-903 UL 94 HF-1

AIR CONDITIONING COMPARTMENT INSULATION		
INSULATION PART NUMBER	CUT (INCHES)	MANUFACTURED FROM PART NUMBER (CAGEC)
5598814	10.00 X 13.50	C 540 B H52 (28818)

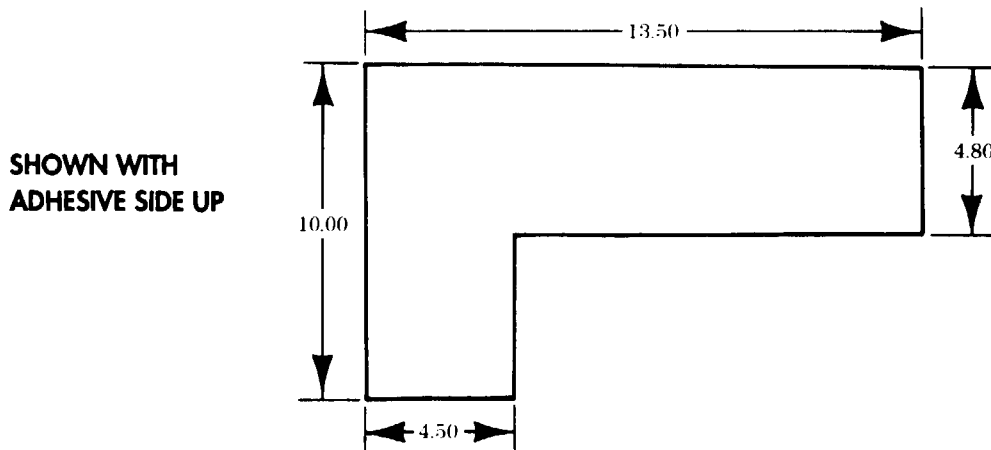

Figure D-51. A/C Compartment Bulkhead Upper Inboard Insulation

INSTRUCTIONS:

Cut insulation to dimensions shown.

Section II. ILLUSTRATED MANUFACTURING INSTRUCTIONS (Cont'd)

MATERIAL BLOCK		
STOCK SIZE	DESCRIPTION	SPECIFICATION
1.00 THICK	FOAM, ACOUSTIC	ASTM D-903 UL 94 HF-1

AIR CONDITIONING COMPARTMENT INSULATION		
INSULATION PART NUMBER	CUT (INCHES)	MANUFACTURED FROM PART NUMBER (CAGEC)
5598245	22.62 X 26.20	C 540 B H52 (28818)

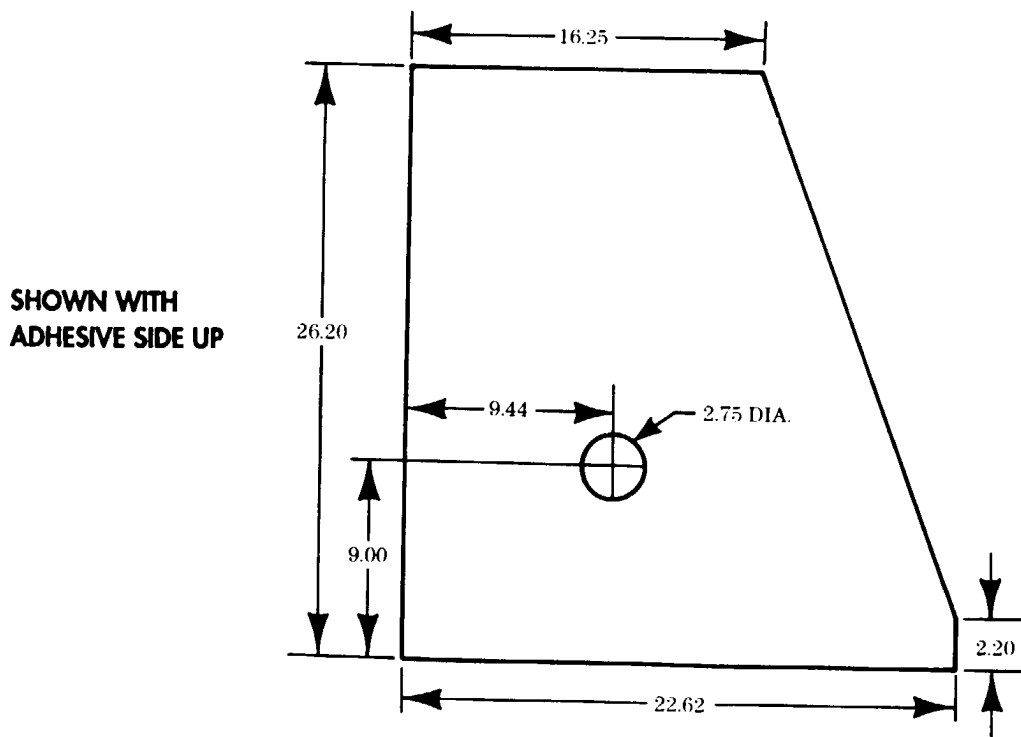

Figure D-52. A/C Compartment Access Door Insulation

INSTRUCTIONS:

Cut insulation to dimensions shown.

Section II. ILLUSTRATED MANUFACTURING INSTRUCTIONS (Cont'd)

MATERIAL BLOCK		
STOCK SIZE	DESCRIPTION	SPECIFICATION
1.00 THICK	FOAM, ACOUSTIC	ASTM D-903 UL 94 HF-1

AIR CONDITIONING COMPARTMENT INSULATION		
INSULATION PART NUMBER	CUT (INCHES)	MANUFACTURED FROM PART NUMBER (CAGEC)
5598821	7.80 X 5.60	C 540 B H52 (28818)

Figure D-53. A/C Compartment Access Door Insulation

INSTRUCTIONS:

Cut insulation to dimensions shown.

Section II. ILLUSTRATED MANUFACTURING INSTRUCTIONS (Cont'd)

MATERIAL BLOCK		
STOCK SIZE	DESCRIPTION	SPECIFICATION
1.00 THICK	FOAM, ACOUSTIC	ASTM D-903 UL 94 HF-1

AIR CONDITIONING COMPARTMENT INSULATION		
INSULATION PART NUMBER	CUT (INCHES)	MANUFACTURED FROM PART NUMBER (CAGEC)
5598815	5.70 X 12.30	C 540 B H52 (28818)

SHOWN WITH
ADHESIVE SIDE UP

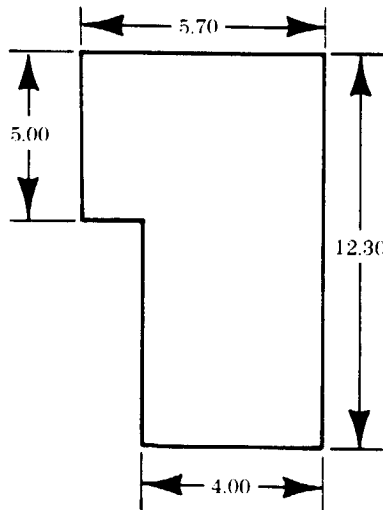

Figure D-54. A/C Compartment Condenser Side Inner Insulation

INSTRUCTIONS:

Cut insulation to dimensions shown.

Section II. ILLUSTRATED MANUFACTURING INSTRUCTIONS (Cont'd)

MATERIAL BLOCK		
STOCK SIZE	DESCRIPTION	SPECIFICATION
1.00 THICK	FOAM, ACOUSTIC	ASTM D-903 UL 94 HF-1

AIR CONDITIONING COMPARTMENT INSULATION		
INSULATION PART NUMBER	CUT (INCHES)	MANUFACTURED FROM PART NUMBER (CAGEC)
5598240	6.50 X 12.10	C 540 B H52 (28818)

SHOWN WITH
ADHESIVE SIDE UP

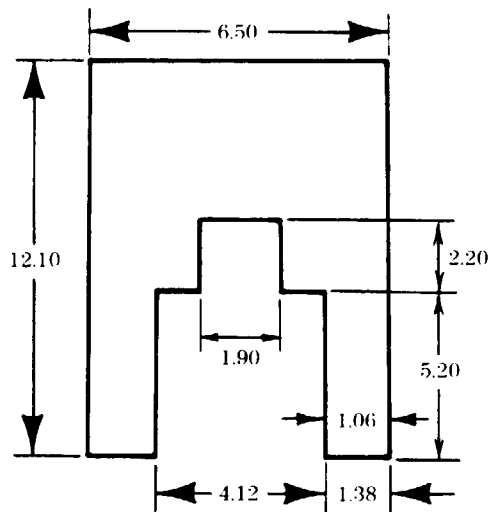

Figure D-55. A/C Compartment Condenser Side Insulation

INSTRUCTIONS:

Cut insulation to dimensions shown.

Section II. ILLUSTRATED MANUFACTURING INSTRUCTIONS (Cont'd)

MATERIAL BLOCK		
STOCK SIZE	DESCRIPTION	SPECIFICATION
1.00 THICK	FOAM, ACOUSTIC	ASTM D-903 UL 94 HF-1

AIR CONDITIONING COMPARTMENT INSULATION		
INSULATION PART NUMBER	CUT (INCHES)	MANUFACTURED FROM PART NUMBER (CAGEC)
5598243	8.75 X 11.25	C 540 B H52 (28818)

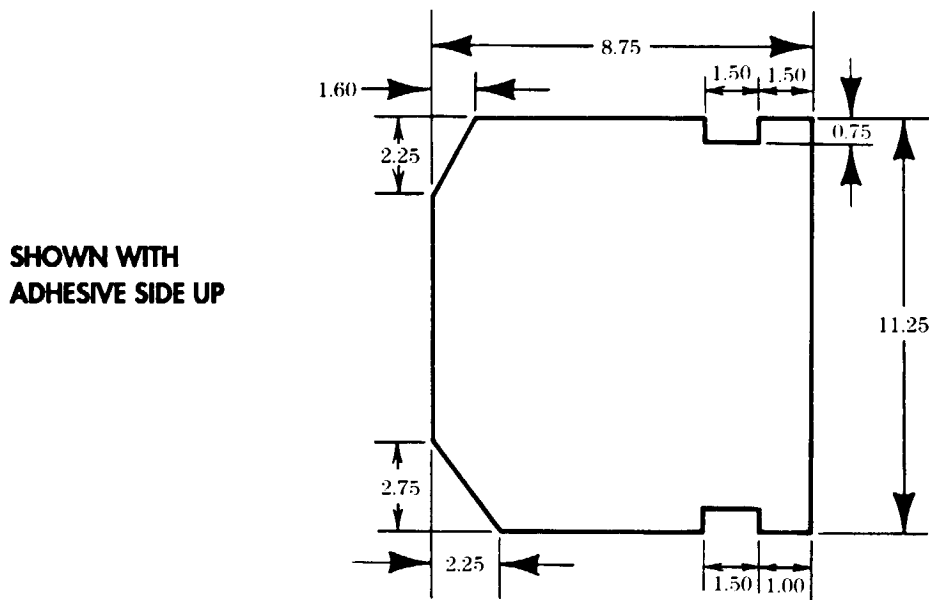

Figure D-56. A/C Compartment Condenser Closeout Panel Insulation

INSTRUCTIONS:

Cut insulation to dimensions shown.

Section II. ILLUSTRATED MANUFACTURING INSTRUCTIONS (Cont'd)

MATERIAL BLOCK		
STOCK SIZE	DESCRIPTION	SPECIFICATION
1.00 THICK	FOAM, ACOUSTIC	ASTM D-903 UL 94 HF-1

AIR CONDITIONING COMPARTMENT INSULATION		
INSULATION PART NUMBER	CUT (INCHES)	MANUFACTURED FROM PART NUMBER (CAGEC)
5598239	11 X 10.50	C 540 B H52 (28818)

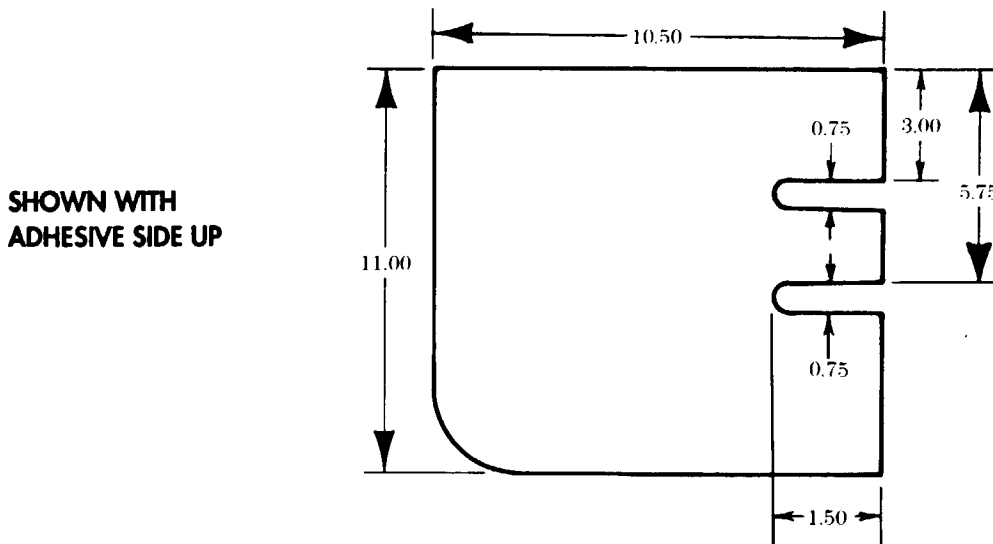

Figure D-57. A/C Compartment Condenser Side Insulation

INSTRUCTIONS:

Cut insulation to dimensions shown.

Section II. ILLUSTRATED MANUFACTURING INSTRUCTIONS (Cont'd)

MATERIAL BLOCK		
STOCK SIZE	DESCRIPTION	SPECIFICATION
0.38 THICK 0.42 WIDE	WEATHERSEAL	MIL-STD-1180

LITTER STOWAGE DOOR SEAL		
INSULATION PART NUMBER	CUT LENGTH (INCHES)	MANUFACTURED FROM PART NUMBER (CAGEC)
5592085	48	ZX-2004 (76385)

Figure D-58. Litter Stowage Door Seal

INSTRUCTIONS:

Cut seal to length shown.

Section II. ILLUSTRATED MANUFACTURING INSTRUCTIONS (Cont'd)

MATERIAL BLOCK		
STOCK SIZE	DESCRIPTION	SPECIFICATION
0.060 THICK 0.50 WIDE	SEAL, RUBBER	ASTM D 1056 MIL-STD-1180

NBC DOOR AND ACCESS PANEL SEALS			
ITEM NO.	SEAL PART NUMBER	CUT LENGTH (INCHES)	MANUFACTURED FROM PART NUMBER (CAGEC)
1	5597994	14.70	R-495-T (79101)
2	5597995	16.98	R-495-T (79101)
3	5597997	33.56	R-495-T (79101)
4	5597998	4.72	R-495-T (79101)
5	5597999	31.28	R-495-T (79101)
6	5598000	11.56	R-495-T (79101)
7	5598029	10.62	R-495-T (79101)
8	5598030	18.92	R-495-T (79101)
9	5598031	16.66	R-495-T (79101)
10	5598032	13.76	R-495-T (79101)
11	5598033	4.38	R-495-T (79101)
12	5598034	29.86	R-495-T (79101)
13	5598035	29.42	R-495-T (79101)
14	5598036	24.50	R-495-T (79101)
15	5598061	5.56	R-495-T (79101)
16	5598062	7.56	R-495-T (79101)
17	5598063	3.28	R-495-T (79101)
18	5598064	2.50	R-495-T (79101)
19	5598065	3.72	R-495-T (79101)

Figure D-59. NBC Door and Access Panel Seals

INSTRUCTIONS:

Determine seal part number needed from RPSTL and cut seal to length shown.

Section II. ILLUSTRATED MANUFACTURING INSTRUCTIONS (Cont'd)

MATERIAL BLOCK		
STOCK SIZE	DESCRIPTION	SPECIFICATION
0.75 INSIDE DIAMETER	TUBING, PVC	ASTM 1784 ASTM D 2846 FMVSS-302

NBC SYSTEM PVC TUBING			
ITEM NO.	TUBING PART NUMBER	CUT LENGTH (INCHES)	MANUFACTURED FROM NSN
1	5597214	1.62	4710-00-112-8626
2	5597215	1.81	4710-00-112-8626
3	5597216	2.00	4710-00-112-8626
4	5597217	2.12	4710-00-112-8626
5	5597218	2.38	4710-00-112-8626
6	5597219	3.75	4710-00-112-8626
7	5597220	3.25	4710-00-112-8626
8	5597221	4.62	4710-00-112-8626
9	5597222	4.25	4710-00-112-8626
10	5597223	4.38	4710-00-112-8626
11	5597224	4.75	4710-00-112-8626
12	5597225	5.25	4710-00-112-8626
13	5597226	6.87	4710-00-112-8626
14	5597227	10.62	4710-00-112-8626
15	5597228	15.31	4710-00-112-8626
16	5597229	15.88	4710-00-112-8626
17	5597230	30.12	4710-00-112-8626
18	5597231	31.38	4710-00-112-8626
19	5597232	6.81	4710-00-112-8626
20	5597722	1.31	4710-00-112-8626
21	5597723	8.75	4710-00-112-8626
22	5597724	5.80	4710-00-112-8626
23	5597725	1.38	4710-00-112-8626
24	5597726	1.75	4710-00-112-8626
25	5597727	4.65	4710-00-112-8626
26	5597728	7.45	4710-00-112-8626
27	5597730	6.12	4710-00-112-8626
28	5597957	2.70	4710-00-112-8626

Figure D-60. NBC System PVC Tubing

Section II. ILLUSTRATED MANUFACTURING INSTRUCTIONS (Cont'd)

NBC SYSTEM PVC TUBING (Cont'd)			
ITEM NO.	TUBING PART NUMBER	CUT LENGTH (INCHES)	MANUFACTURED FROM NSN
29	5597958	7.50	4710-00-112-8626
30	5597970	14.12	4710-00-112-8626
31	5598132	10.28	4710-00-112-8626
32	5598133	2.88	4710-00-112-8626
33	5598134	3.03	4710-00-112-8626

Figure D-60. NBC System PVC Tubing (Cont'd)

INSTRUCTIONS:

NOTE

Make sure tubing is cut square at ends, and ends are free of nicks, burrs, and cracks.

Determine tubing part number needed from RPSTL and cut tube to length shown.

MATERIAL BLOCK		
STOCK SIZE	DESCRIPTION	SPECIFICATION
0.625 IN. INSIDE DIAMETER	INSULATION SLEEVING, HEAT SHRINK	MIL-I-23053

HEAT SHRINK INSULATION SLEEVING		
INSULATION PART NUMBER	CUT LENGTH (INCHES)	MANUFACTURED FROM PART NUMBER (CAGEC)
M23053/1-204-0	2.0	M23053/1-204-0 (81349)
M23053/1-204-2	2.0	M23053/1-204-2 (81349)

Figure D-61. Heat Shrink Insulation Sleeving

INSTRUCTIONS:

Cut insulation to length shown.

Section II. ILLUSTRATED MANUFACTURING INSTRUCTIONS (Cont'd)

MATERIAL BLOCK		
STOCK SIZE	DESCRIPTION	SPECIFICATION
"O" GAGE	WIRE, ELECTRICAL	MIL-C-13486

200 AMP ALTERNATOR CABLE ASSEMBLY				
CABLE PART NUMBER	CUT LENGTH (INCHES)	MANUFACTURED FROM NSN	END TERMINAL NSN	END INSULATOR NSN
5582451	58	6145-00-705-6674	5940-00-735-5520	5970-00-174-9449

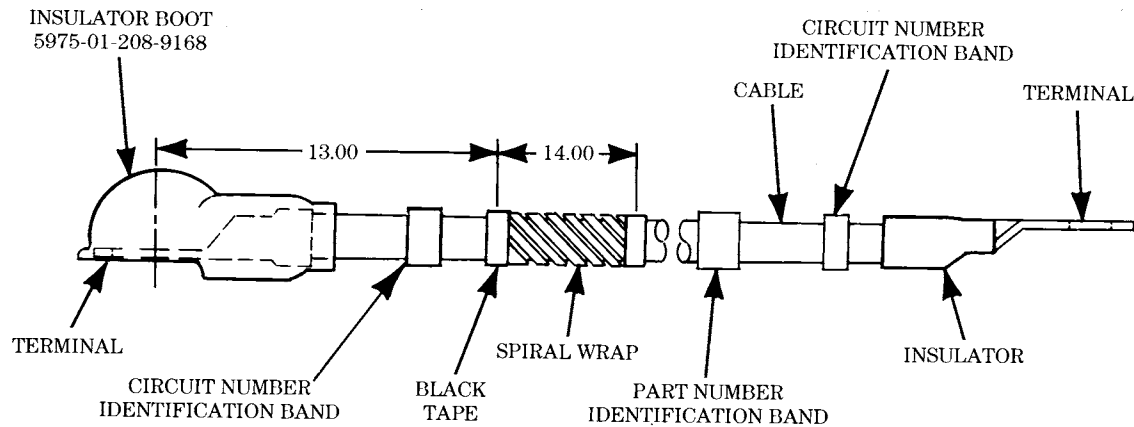

Figure D-62. 200 Amp Alternator Cable Assembly.

INSTRUCTIONS:

1. Cut cable to length as shown.
2. Cut 14 inches of spiral wrap from bulk and install as shown. Secure spiral wrap in position with black tape at both ends.
3. Select and solder proper end terminals to cable ends as shown. (Refer to TC 9-237 for soldering instructions.)
4. Install insulator and insulator boot to cable ends as shown.
5. Mark and install identification bands using old cable as reference.

Section II. ILLUSTRATED MANUFACTURING INSTRUCTIONS (Cont'd)

MATERIAL BLOCK		
STOCK SIZE	DESCRIPTION	SPECIFICATION
"O" GAGE	WIRE, ELECTRICAL	MIL-C-13486

12 VOLT ALTERNATOR CABLE ASSEMBLY				
CABLE PART NUMBER	CUT LENGTH (INCHES)	MANUFACTURED FROM P/N	END TERMINAL PART NUMBER	END INSULATOR PART NUMBER
12446821	102	M13486/1-9	MS20659-108	12460417

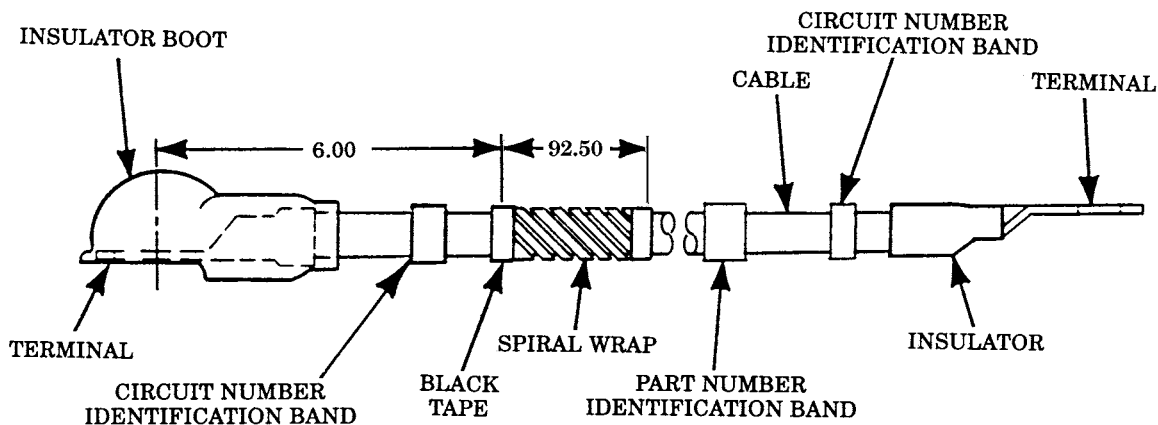

Figure D-62.1. 12 Volt Alternator Cable Assembly.

INSTRUCTIONS:

1. Cut cable to length as shown.
2. Cut of 92.50 inches spiral wrap from bulk and install as shown. Secure spiral wrap in position with tape at both ends.
3. Select and solder proper end terminals to cable ends as shown. (Refer to TC 9-237 for soldering instructions.)
4. Install insulator and insulator boot to cable ends as shown.
5. Mark and install identification bands using old cable as reference.

Section II. ILLUSTRATED MANUFACTURING INSTRUCTIONS (Cont'd)

MATERIAL BLOCK		
STOCK SIZE	DESCRIPTION	SPECIFICATION
0.250-IN. DIAMETER	TUBE, METALLIC	MIL-T-6845
0.250-IN. (NOM) INSIDE DIAMETER 0.438-IN. (NOM) OUTSIDE DIAMETER	HOSE, NONMETALLIC	MIL-H-13444

FUEL FILTER BLEEDER TOOL			
ITEM NO.	TOOL PART NUMBER	CUT LENGTH (INCHES)	MANUFACTURED FROM NSN
1	5598825	1-1/2	4710-00-825-5894
2	5598826	24	4720-00-542-3304

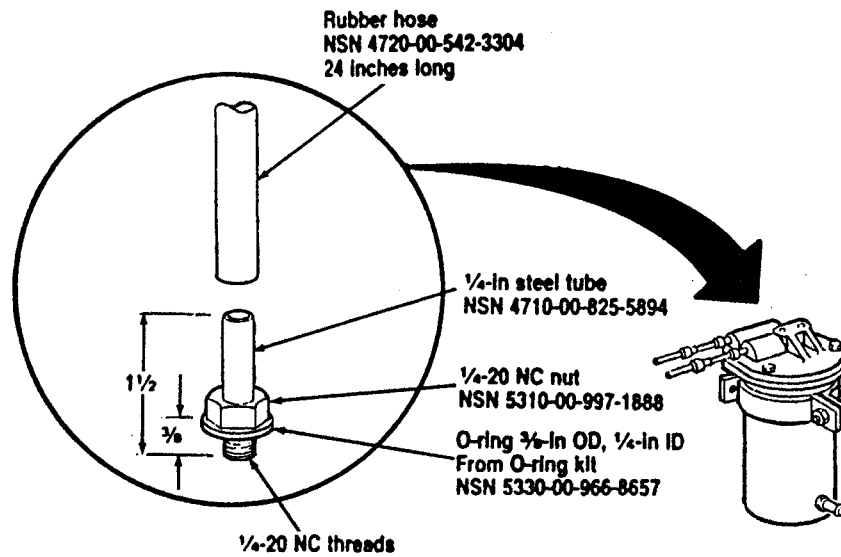

Figure D-63. Fuel Filter Bleeder Tool.

INSTRUCTIONS:

1. Cut steel tube, NSN 4710-00-825-5894, to length as shown.
2. Thread one end of the tube 5/8 inch.
3. Install nut, NSN 5310-00-997-1888, and O-ring, NSN 5330-00-966-8657, on threaded end of tube.
4. Install 24-inch rubber hose, NSN 4720-00-542-3304, to the other end of the tube.

Section II. ILLUSTRATED MANUFACTURING INSTRUCTIONS (Cont'd)

MATERIAL BLOCK		
STOCK SIZE	DESCRIPTION	SPECIFICATION
1. .125 IN. THICK	FLAT STEEL	N/A
2. .375 IN. DIAMETER	ROUND STEEL	N/A

GLOW PLUG TOOL		
ITEM NO.	CUT LENGTH (INCHES)	MANUFACTURED FROM PART NUMBER (FSCM)
1	as shown	9515-00-204-3994
2	as shown	9510-00-189-0652

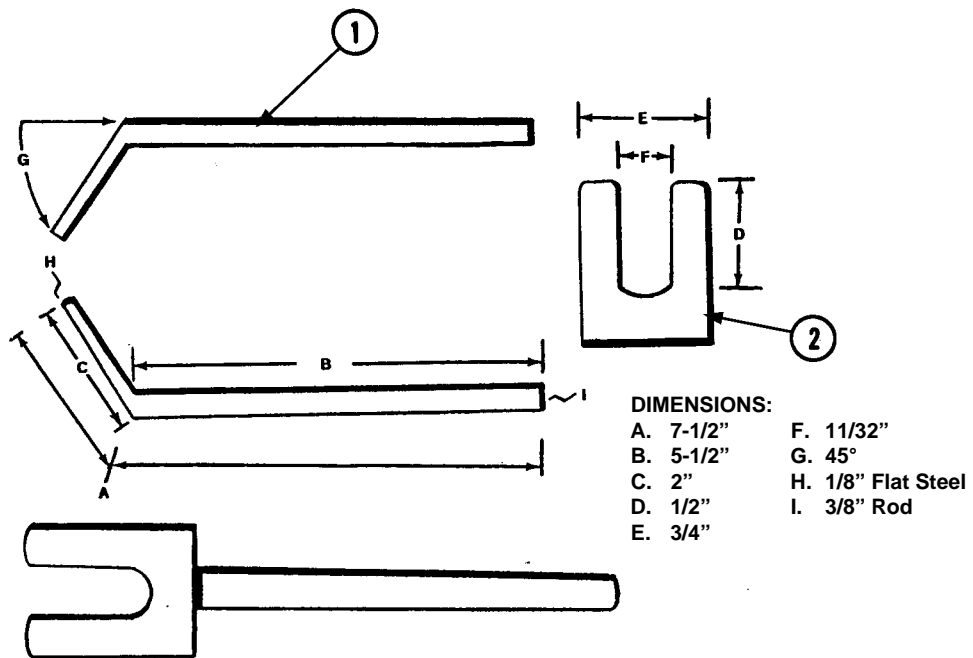

Figure D-63.1. Glow Plug Tool Assembly.

INSTRUCTIONS:

1. Cut steel to lengths as shown.
2. Weld flat steel and round steel together at angle as shown.
3. Forked end (dimension F) must fit behind hex-head of glow plug. Thickness may have to be ground down from .125 inch to .0625 inch to insure proper fit.

Section II. ILLUSTRATED MANUFACTURING INSTRUCTIONS (Cont'd)

MATERIAL BLOCK		
STOCK SIZE	DESCRIPTION	SPECIFICATION
0.002-IN. (NOM) THICK 26-IN. (NOM) WIDTH	PLASTIC SHEET, PRESS	N/A

PLASTIC SHEET		
PLASTIC SHEET PART NUMBER	CUT LENGTH (INCHES)	MANUFACTURED FROM NSN
5598827	AS REQUIRED	9330-00-618-7214

Figure D-64. Plastic Sheet

INSTRUCTIONS:

Cut two pieces of plastic large enough to cover small hole or crack with enough to overlap about 1/4 in. around damaged area of window.

Section II. ILLUSTRATED MANUFACTURING INSTRUCTIONS (Cont'd)

MATERIAL BLOCK		
STOCK SIZE	DESCRIPTION	SPECIFICATION
12 x 4-FT SHEET 0.060 THICK	ALUMINUM ALLOY TEMPER T-4	ASTM B 209-90

PROTECTIVE SHIELD		
PROTECTIVE SHIELD PART NUMBER	CUT TO SIZE (INCHES)	MANUFACTURED FROM NSN
5598828	AS SHOWN	9535-00-541-7194

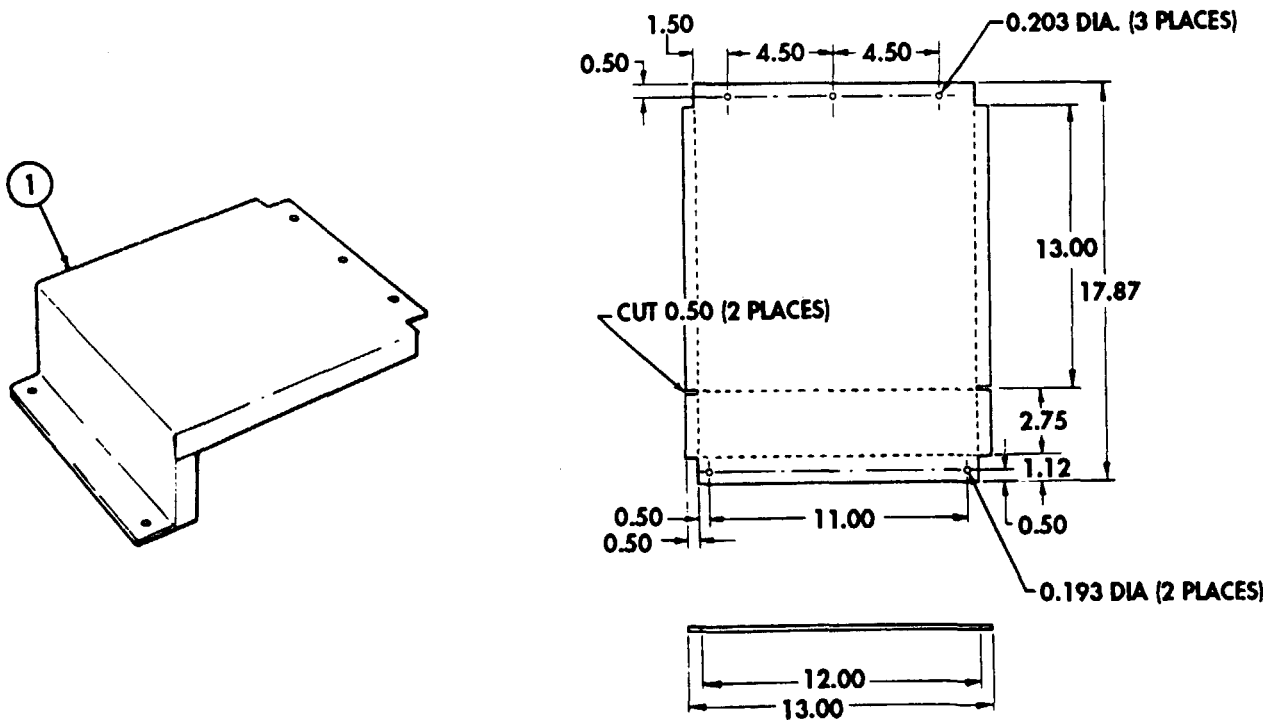

Figure D-65. Protective Shield

INSTRUCTIONS:

1. Cut aluminum sheet metal to size as shown.
2. Locate, mark, and drill two 0.193-in. diameter holes in protective shield (1).
3. Locate, mark, and drill three 0.203-in. diameter holes in protective shield (1).
4. Make two 0.50-in. relief cuts in sides of protective shield (1).
5. Bend edges (90° bend along dotted lines) on protective shield (1).
6. Remove all burrs and sharp edges.
7. Paint protective shield (1) as required. Refer to TM 43-0139.

Section II. ILLUSTRATED MANUFACTURING INSTRUCTIONS (Cont'd)

MATERIAL BLOCK		
STOCK SIZE	DESCRIPTION	SPECIFICATION
0.750-IN. THICK	PLYWOOD, 4 X 8 FT. SHEET	MIL-STD-731A

PROTECTIVE ENGINE COVER		
COVER PART NUMBER	CUT (INCHES)	MANUFACTURED FROM PART NUMBER NSN
5598829	34 X 60	N/A

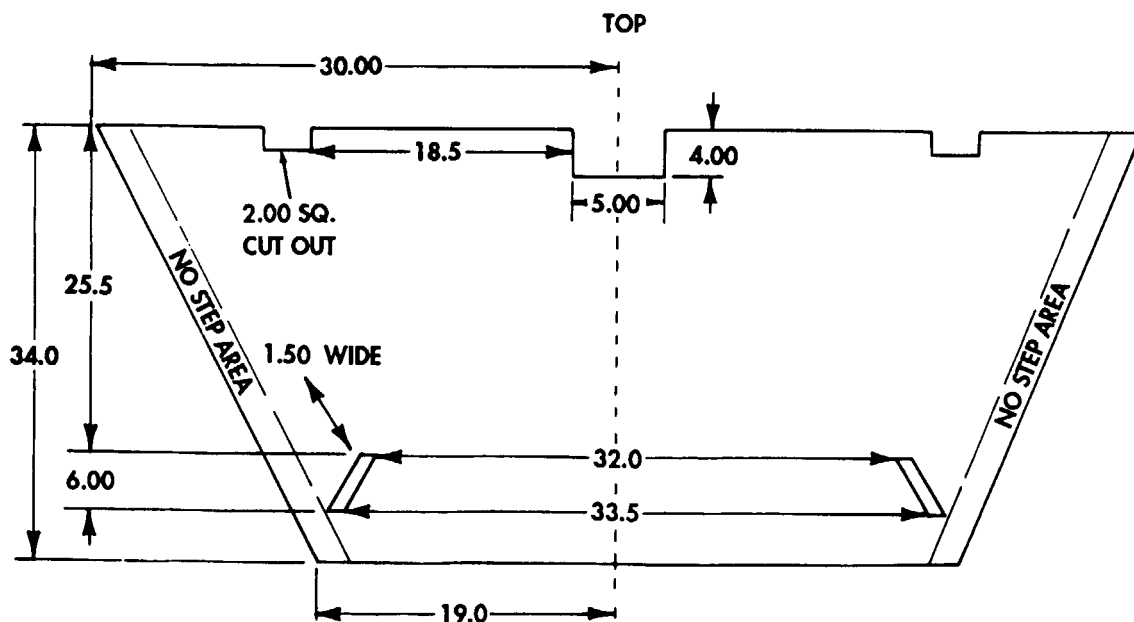

Figure D-66. Protective Engine Cover

INSTRUCTIONS:

1. Cut plywood to dimensions shown. If necessary, modify plywood for proper fit.
2. Paint cover and outline with yellow safety boarder, 4-inches wide on outside edges.
3. Stencil "NO STEP AREA" caution on outside edges.
4. Prior to installing protective engine cover, remove both plate covers and seals from airlift brackets.
5. Store flat or hang on wall to prevent warpage.

Section II. ILLUSTRATED MANUFACTURING INSTRUCTIONS (Cont'd)

MATERIAL BLOCK		
STOCK SIZE	DESCRIPTION	SPECIFICATION
0.750-IN. THICK	PLYWOOD, 4 X 8 FT. SHEET	MIL-STD-731A

PROTECTIVE ENGINE COVER		
COVER PART NUMBER	CUT (INCHES)	MANUFACTURED FROM PART NUMBER NSN
5598830	40.0 x 46.5	N/A

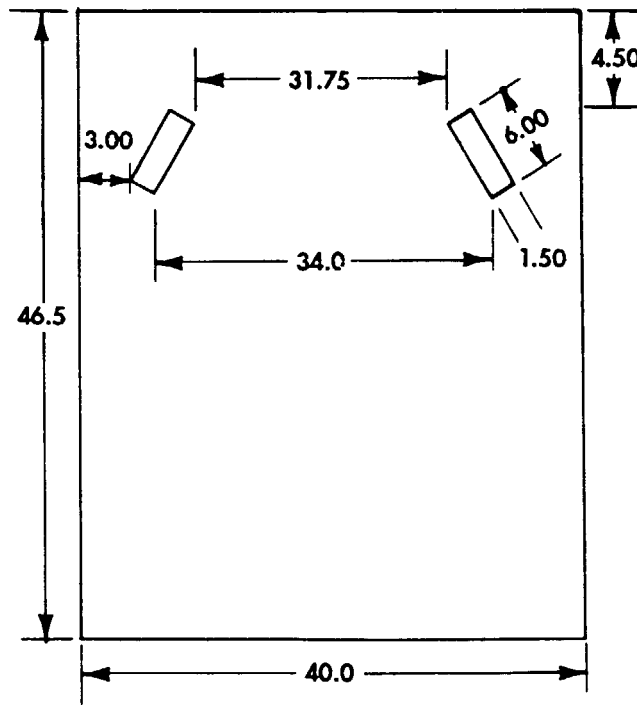

Figure D-67. Cooler Fin Protective Cover

INSTRUCTIONS:

1. Cut plywood to dimensions shown. If necessary, modify plywood for proper fit.
2. Never use cover with engine running; engine damage will occur.
3. Stencil "NO STEP" caution to top of cover.
4. Prior to installing cooler fin protective cover, remove both plate covers and seals from airlift bracket.
5. Store flat or hang on wall to prevent warpage.

Section II. ILLUSTRATED MANUFACTURING INSTRUCTIONS (Cont'd)

MATERIAL BLOCK		
STOCK SIZE	DESCRIPTION	SPECIFICATION
.1196-IN. THICK	STEEL, CARBON HR, CQ, P&O	ASTM A569

SHEET		
PART NUMBER	CUT LENGTH (INCHES)	MANUFACTURED FROM NSN
5598832	AS SHOWN	N/A

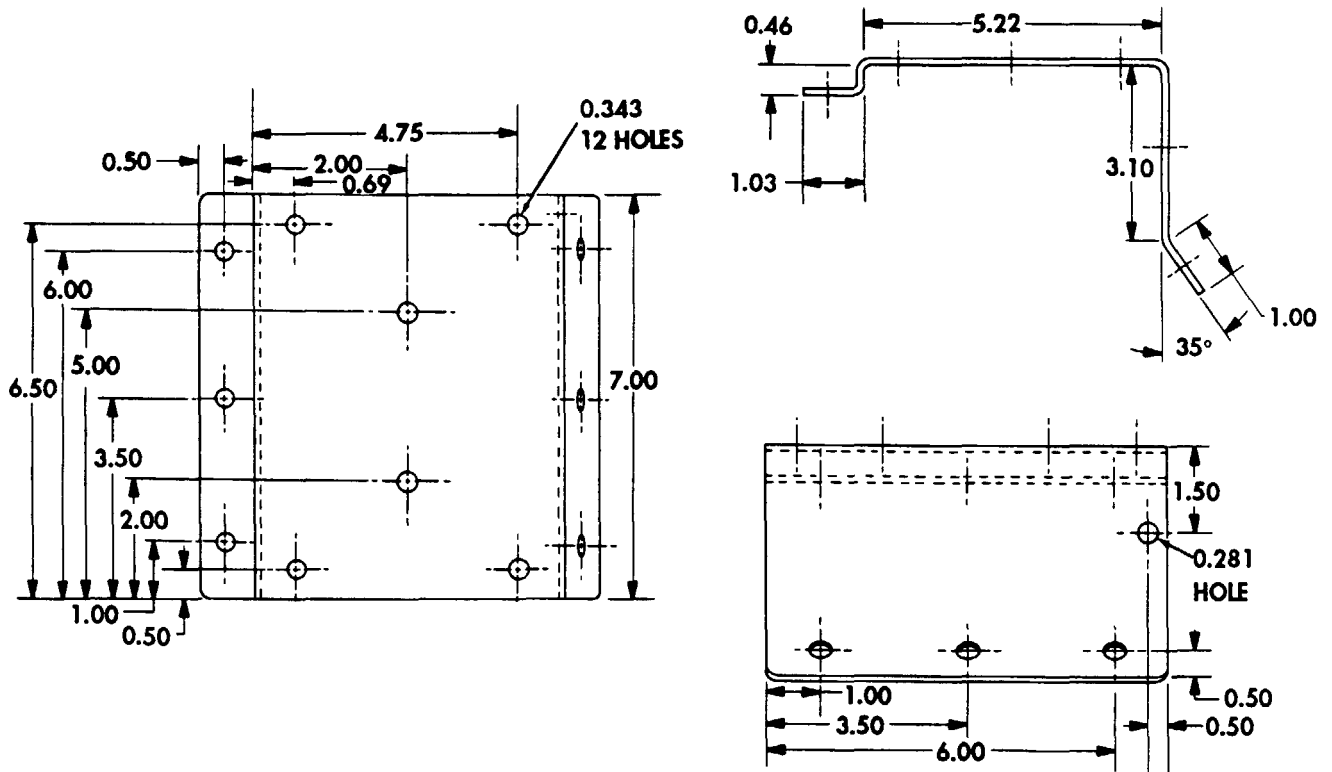

Figure D-68. Siren Mounting Bracket

INSTRUCTIONS:

1. Fabricate siren mounting bracket according to dimensions shown.
2. Remove all burrs and sharp edges.
3. Clean per SPEC TT-C-490. Treat per SPEC Type I or II, or SPEC TT-C-490.
4. Prime per SPEC MIL-P-52192, MIL-P-53022, or MIL-P-53030.
5. Finish-paint per SPEC MIL-C-46168.

Section II. ILLUSTRATED MANUFACTURING INSTRUCTIONS (Cont'd)

MATERIAL BLOCK		
STOCK SIZE	DESCRIPTION	SPECIFICATION
.1196-IN. THICK	STEEL, CARBON HR, CQ, P&O	ASTM A569

SHEET		
PART NUMBER	CUT LENGTH (INCHES)	MANUFACTURED FROM NSN
5598833	AS SHOWN	N/A

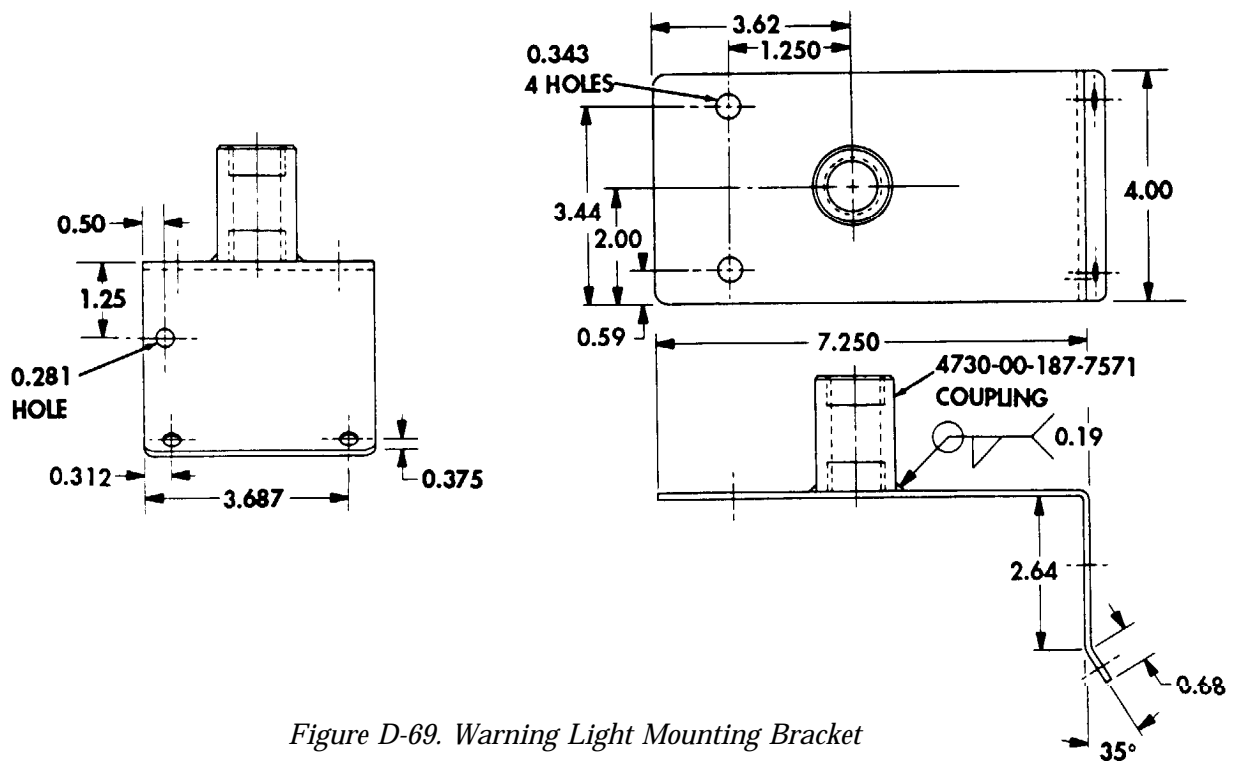

Figure D-69. Warning Light Mounting Bracket

INSTRUCTIONS:

1. Fabricate warning light mounting bracket according to dimensions shown.
2. Weld sizes are minimum. Weld per SPEC MIL-STD-1261.
3. Remove all burrs and sharp edges.
4. Clean per SPEC TT-C-490. Treat per SPEC Type I or II, or SPEC TT-C-490.
5. Prime per SPEC MIL-P-52192, MIL-P-53022, or MIL-P-53030.
6. Finish-paint per SPEC MIL-C-46168.

Section II. ILLUSTRATED MANUFACTURING INSTRUCTIONS (Cont'd)

MATERIAL BLOCK		
STOCK SIZE	DESCRIPTION	SPECIFICATION
12 AWG	WIRE, ELECTRICAL	MIL-C-13486

WIRE "D"		
WIRE PART NUMBER	CUT LENGTH (INCHES)	MANUFACTURED FROM NSN
5598834	5.0	2. 6145-00-705-6678
SHELL NSN	TERMINAL INSULATOR NSN	WASHER NSN
1. 2590-00-695-9076 (2 EACH)	4. 5940-00-399-6676 (2 EACH)	3. 5310-00-298-8903 (2 EACH)

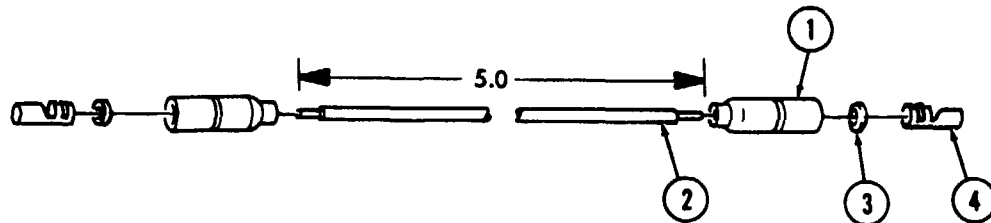

Figure D-70. Wire "D" - Adapter "A" to Adapter Connector "B"

MATERIAL BLOCK		
STOCK SIZE	DESCRIPTION	SPECIFICATION
12 AWG	WIRE, ELECTRICAL	MIL-C-13486

WIRE "F"		
WIRE PART NUMBER	CUT LENGTH (INCHES)	MANUFACTURED FROM NSN
5598835	123.0	4. 6145-00-705-6678
SHELL NSN	TERMINAL INSULATOR NSN	WASHER NSN
1. 5935-00-695-9077 5. 2590-00-695-9076	3. 5999-00-925-6495 7. 5940-00-399-6676	2. 5310-00-595-7044 6. 5310-00-298-8903

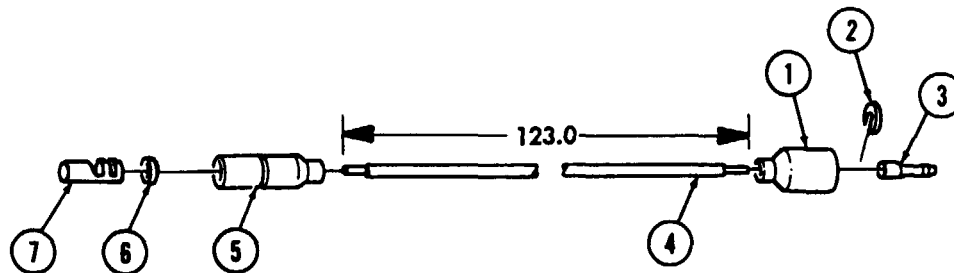

Figure D-71. Wire "F" - Passenger Side Siren Switch to Adapter Connector "B"

Section II. ILLUSTRATED MANUFACTURING INSTRUCTIONS (Cont'd)

MATERIAL BLOCK		
STOCK SIZE	DESCRIPTION	SPECIFICATION
12 AWG	WIRE, ELECTRICAL	MIL-C-13486

WIRE "G"		
WIRE PART NUMBER	CUT LENGTH (INCHES)	MANUFACTURED FROM NSN
5598836	117.0	4. 6145-00-705-6678
SHELL NSN 1. 5935-00-695-9077 5. 2590-00-695-9076	TERMINAL INSULATOR NSN 3. 5999-00-925-6495 7. 5940-00-399-6676	WASHER NSN 2. 5310-00-595-7044 6. 5310-00-298-8903

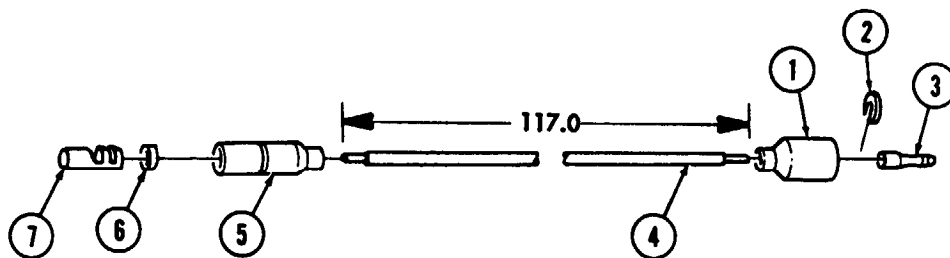

Figure D-72. Wire "G" - Passenger Side Siren Switch Adapter Connector "E"

MATERIAL BLOCK		
STOCK SIZE	DESCRIPTION	SPECIFICATION
12 AWG	WIRE, ELECTRICAL	MIL-C-13486

WIRE "L"		
WIRE PART NUMBER	CUT LENGTH (INCHES)	MANUFACTURED FROM NSN
5598837	113.0	4. 6145-00-705-6678
SHELL NSN 1. 5935-00-695-9077 5. 2590-00-695-9076	TERMINAL INSULATOR NSN 3. 5999-00-925-6495 7. 5940-00-399-6676	WASHER NSN 2. 5310-00-595-7044 6. 5310-00-298-8903

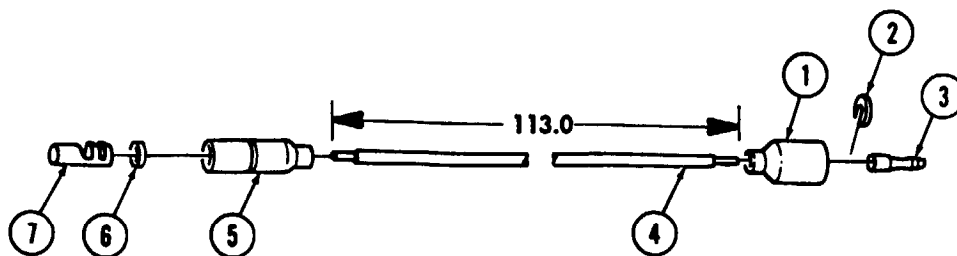

Figure D-73. Wire "L" - Relay Lead "C" to Circuit Breaker in Battery Box

Section II. ILLUSTRATED MANUFACTURING INSTRUCTIONS (Cont'd)

MATERIAL BLOCK		
STOCK SIZE	DESCRIPTION	SPECIFICATION
12 AWG	WIRE, ELECTRICAL	MIL-C-13486

WIRE "K"		
WIRE PART NUMBER	CUT LENGTH (INCHES)	MANUFACTURED FROM NSN
5598838	104.0	2. 6145-00-705-6678
	TERMINAL INSULATOR NSN 1. 5940-00-682-2445 3. 5940-00-113-8183	

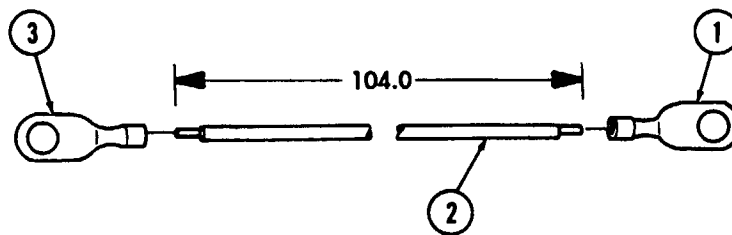

Figure D-74. Wire "K" - Battery Ground Stud by Relay Mounting Ground

MATERIAL BLOCK		
STOCK SIZE	DESCRIPTION	SPECIFICATION
12 AWG	WIRE, ELECTRICAL	MIL-C-13486

WIRE "I"		
WIRE PART NUMBER	CUT LENGTH (INCHES)	MANUFACTURED FROM NSN
5598839	127.0	2. 6145-00-705-6678
	TERMINAL INSULATOR NSN 1. 5940-00-113-8183 (2 EACH)	

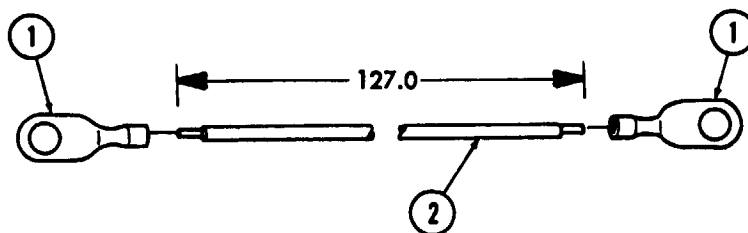

Figure D-75. Wire "I" - Siren Assembly Mount to Relay Mounting Ground

Section II. ILLUSTRATED MANUFACTURING INSTRUCTIONS (Cont'd)

MATERIAL BLOCK		
STOCK SIZE	DESCRIPTION	SPECIFICATION
12 AWG	WIRE, ELECTRICAL	MIL-C-13486

WIRE "N"		
WIRE PART NUMBER	CUT LENGTH (INCHES)	MANUFACTURED FROM NSN
5598840	22.0	2. 6145-00-705-6678
SHELL NSN 3. 2590-00-695-9076	TERMINAL INSULATOR NSN 1. 5940-00-682-2445 5. 5940-00-399-6676	WASHER NSN 4. 5310-00-298-8903

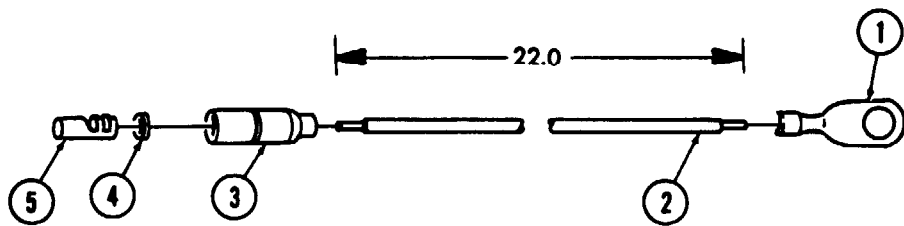

Figure D-76. Wire "N" - Circuit Breaker to Battery Stud (Positive)

MATERIAL BLOCK		
STOCK SIZE	DESCRIPTION	SPECIFICATION
14 AWG	WIRE, ELECTRICAL	MIL-C-13486

WIRE "H"		
WIRE PART NUMBER	CUT LENGTH (INCHES)	MANUFACTURED FROM NSN
5598841	120.0	4. 6145-00-152-6499
SHELL NSN 1. 5970-00-906-0159 5. 5935-00-833-8561	TERMINAL INSULATOR NSN 3. 5995-00-057-2929 7. 1015-00-798-2997	SLEEVE/WASHER NSN 2. 5310-00-833-8567 6. 5970-00-833-8562

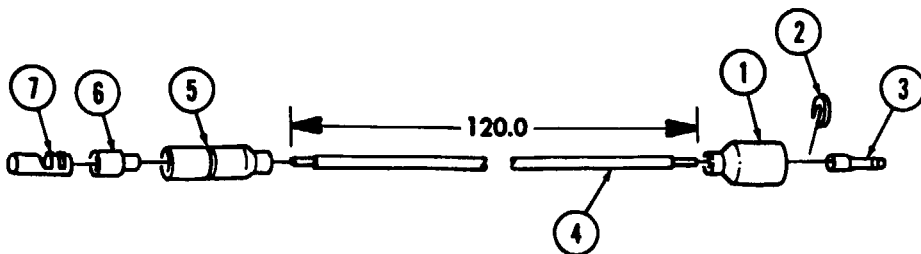

Figure D-77. Wire "H" - Siren Hot Side to Adapter Connector "E" .

Section II. ILLUSTRATED MANUFACTURING INSTRUCTIONS (Cont'd)

MATERIAL BLOCK		
STOCK SIZE	DESCRIPTION	SPECIFICATION
14 AWG	WIRE, ELECTRICAL	MIL-C-13486

WIRE "J"		
WIRE PART NUMBER	CUT LENGTH (INCHES)	MANUFACTURED FROM NSN
5598842	57.0	4. 6145-00-152-6499
SHELL NSN 1. 5970-00-906-0159	TERMINAL INSULATOR NSN 5. 5940-00-283-5281 3. 5995-00-057-2929	WASHER NSN 2. 5310-00-833-8567

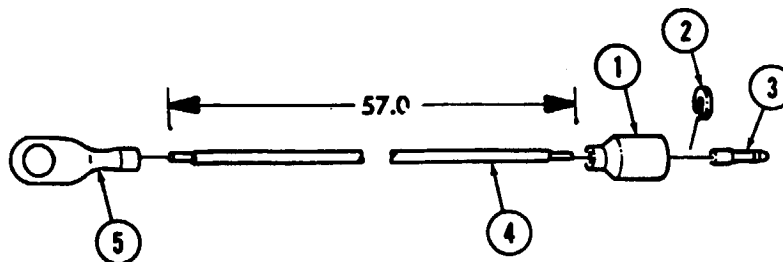

Figure D-78. Wire "J" - Warning Light Black Lead to Relay Mounting Ground

MATERIAL BLOCK		
STOCK SIZE	DESCRIPTION	SPECIFICATION
14 AWG	WIRE, ELECTRICAL	MIL-C-13486

WIRE "A"		
WIRE PART NUMBER	CUT LENGTH (INCHES)	MANUFACTURED FROM NSN
5598843	6.75	1. 6145-00-152-6499
SHELL NSN 2. 5933-00-833-8561 (2 EACH)	TERMINAL INSULATOR NSN 4. 1015-00-748-2997 (2 EACH)	SLEEVE NSN 3. 5970-00-833-8562 (2 EACH)

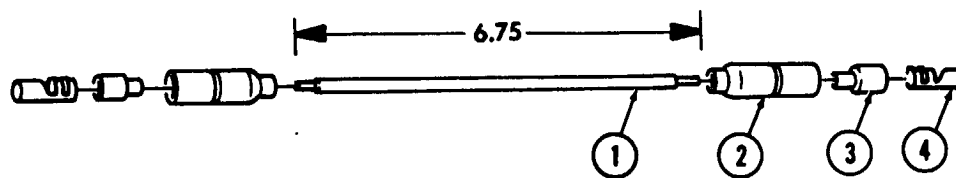

Figure D-79. Wire "A" - Light Toggle Switch to Adapter Connector "D"

Section II. ILLUSTRATED MANUFACTURING INSTRUCTIONS (Cont'd)

MATERIAL BLOCK		
STOCK SIZE	DESCRIPTION	SPECIFICATION
14 AWG	WIRE, ELECTRICAL	MIL-C-13486

WIRE "B"		
WIRE PART NUMBER	CUT LENGTH (INCHES)	MANUFACTURED FROM NSN
5598844	9.50	1. 6145-00-152-6499
SHELL NSN 2. 5933-00-833-8561 (2 EACH)	TERMINAL INSULATOR NSN 4. 1015-00-748-2997 (2 EACH)	SLEEVE NSN 3. 5970-00-833-8562 (2 EACH)

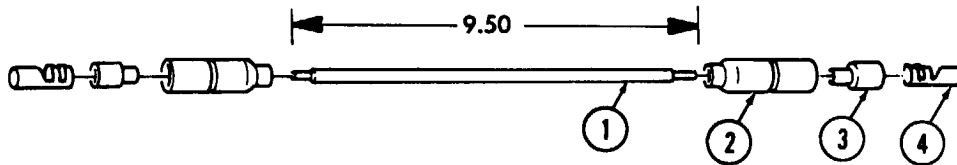

Figure D-80. Wire "B" - Light Toggle Switch Adapter Connector "A"

MATERIAL BLOCK		
STOCK SIZE	DESCRIPTION	SPECIFICATION
14 AWG	WIRE, ELECTRICAL	MIL-C-13486

WIRE "M"		
WIRE PART NUMBER	CUT LENGTH (INCHES)	MANUFACTURED FROM NSN
5598845	47.0	1. 6145-00-152-6499
SHELL NSN 2. 5933-00-833-8561 (2 EACH)	TERMINAL INSULATOR NSN 4. 1015-00-748-2997 (2 EACH)	SLEEVE NSN 3. 5970-00-833-8562 (2 EACH)

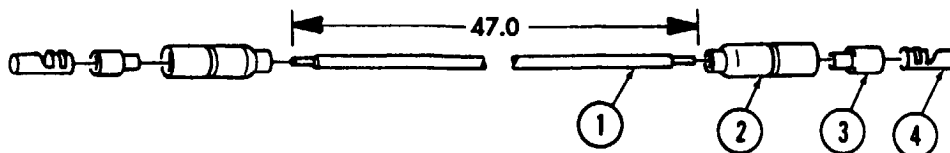

Figure D-81. Wire "M" - Warning Light Red Lead to Adapter Connector "D"

Section II. ILLUSTRATED MANUFACTURING INSTRUCTIONS (Cont'd)

MATERIAL BLOCK		
STOCK SIZE	DESCRIPTION	SPECIFICATION
A=14 AWG, B=12 AWG	WIRE, ELECTRICAL	MIL-C-13486

RELAY CONNECTOR		
WIRE PART NUMBER	CUT LENGTH (INCHES)	MANUFACTURED FROM NSN
5598846	5. A 17.0 6. B 15.0, AND 10.0	6. 6145-00-705-6678 5. 6145-00-152-6499
SHELL ASSEMBLY/SHELL NSN 1. 5935-00-686-2609 7. 5935-00-833-8561 12. 2590-00-695-9076 (2 EACH)	TERMINAL INSULATOR NSN 9. 1015-00-798-2997 10. 5940-00-399-6676 (2 EACH)	SLEEVE/WASHER NSN 8. 5970-00-833-8562 11. 5310-00-298-8903 (2 EACH)
NUT NSN 3. 5310-00-655-9860 4. 5935-00-335-9414		GROMMET 2. 5365-00-752-7633

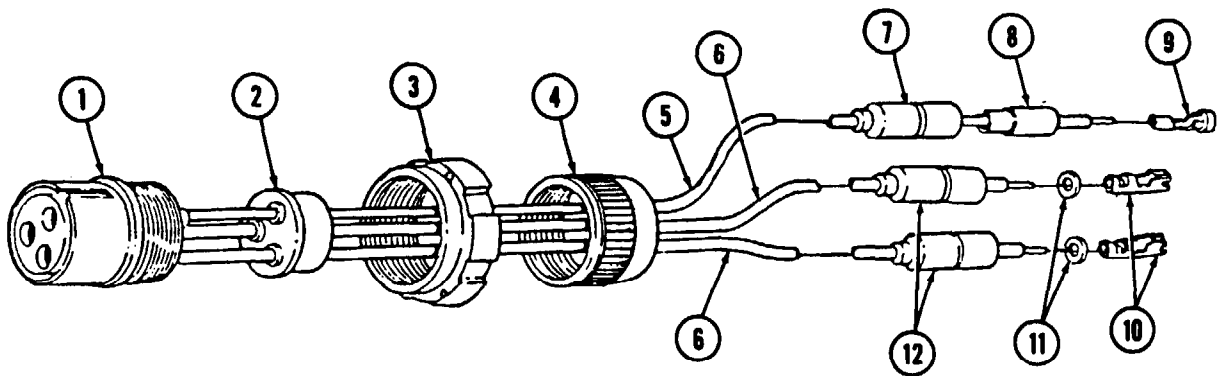

Figure D-82. - Relay Connector

Section II. ILLUSTRATED MANUFACTURING INSTRUCTIONS (Cont'd)

MATERIAL BLOCK		
STOCK SIZE	DESCRIPTION	SPECIFICATION
	STRAP WEBBING	N/A
N/A	THREAD	N/A

GRAB LOOP		
GRAB LOOP PART NUMBER	CUT LENGTH (INCHES)	MANUFACTURED FROM NSN
5598847	12 in.	8315-00-634-3304

INSTRUCTIONS:

1. Remove cargo shell door strap from vehicle. Refer to para. 11-22.
2. Position grab loop one-third of the way down strap. Fold strap into thirds and mark top fold.
3. Secure grab loop to strap with thread using box stitch and string. Refer to FM 10-16.
4. Install cargo shell door strap on vehicle with grab loop facing the rear. Refer to para. 11-22.

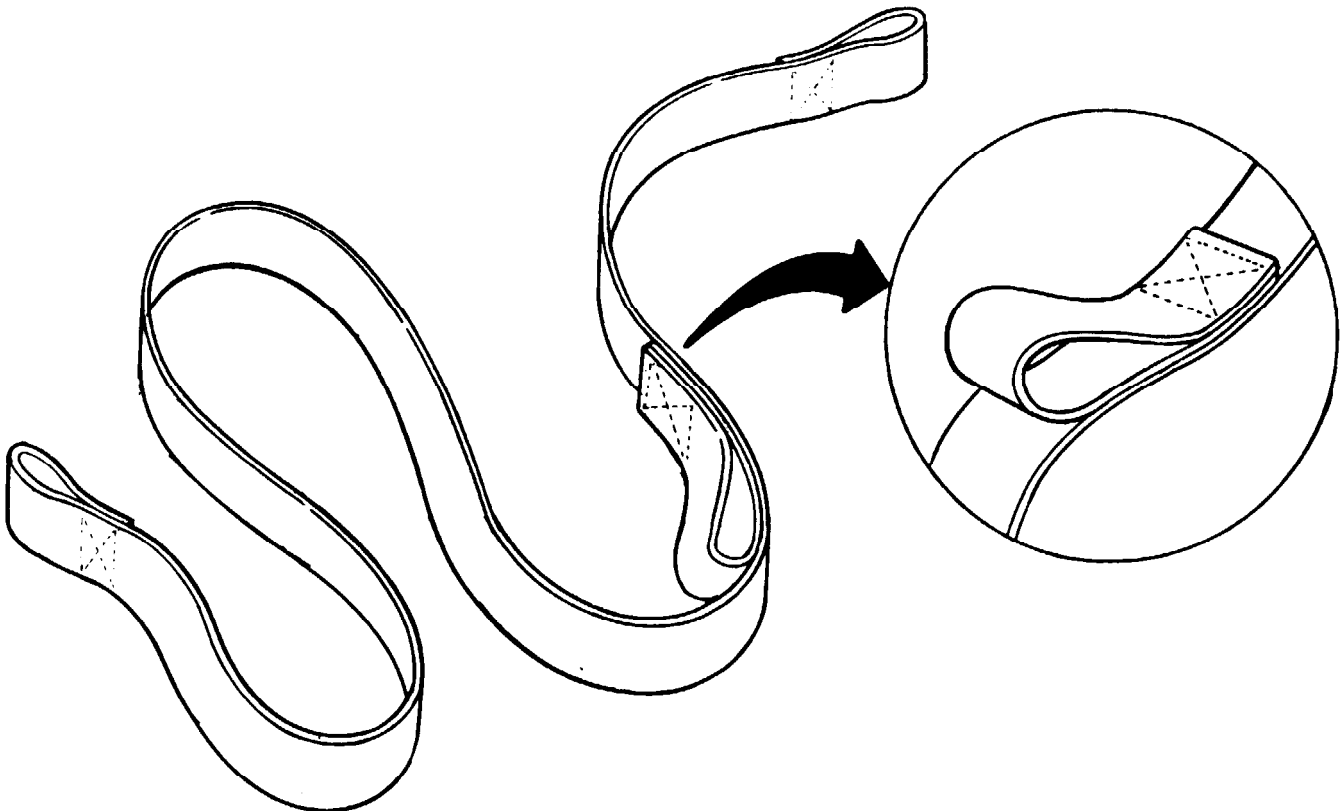

Figure D-83. Grab Loop

Section II. ILLUSTRATED MANUFACTURING INSTRUCTIONS (Cont'd)

MATERIAL BLOCK		
STOCK SIZE	DESCRIPTION	SPECIFICATION
100 FT.	FELT, MECHANICAL	MILG20241

NOTE:
ALL DIMENSIONS ARE IN INCHES

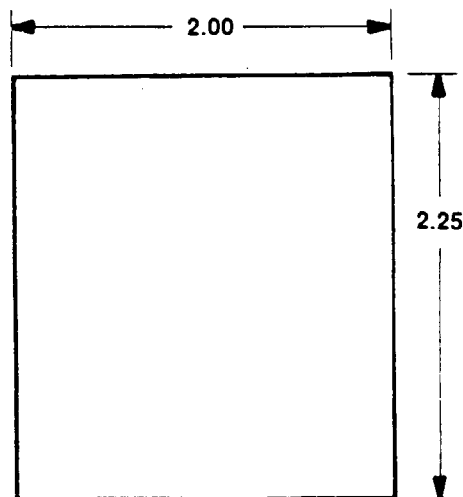

Figure D-84. Felt Sheet

INSTRUCTIONS:

Cut felt to dimensions shown.

Section II. ILLUSTRATED MANUFACTURING INSTRUCTIONS (Cont'd)

MATERIAL BLOCK		
STOCK SIZE	DESCRIPTION	SPECIFICATION
0.63 THICK	HEAT SHIELD	N/A

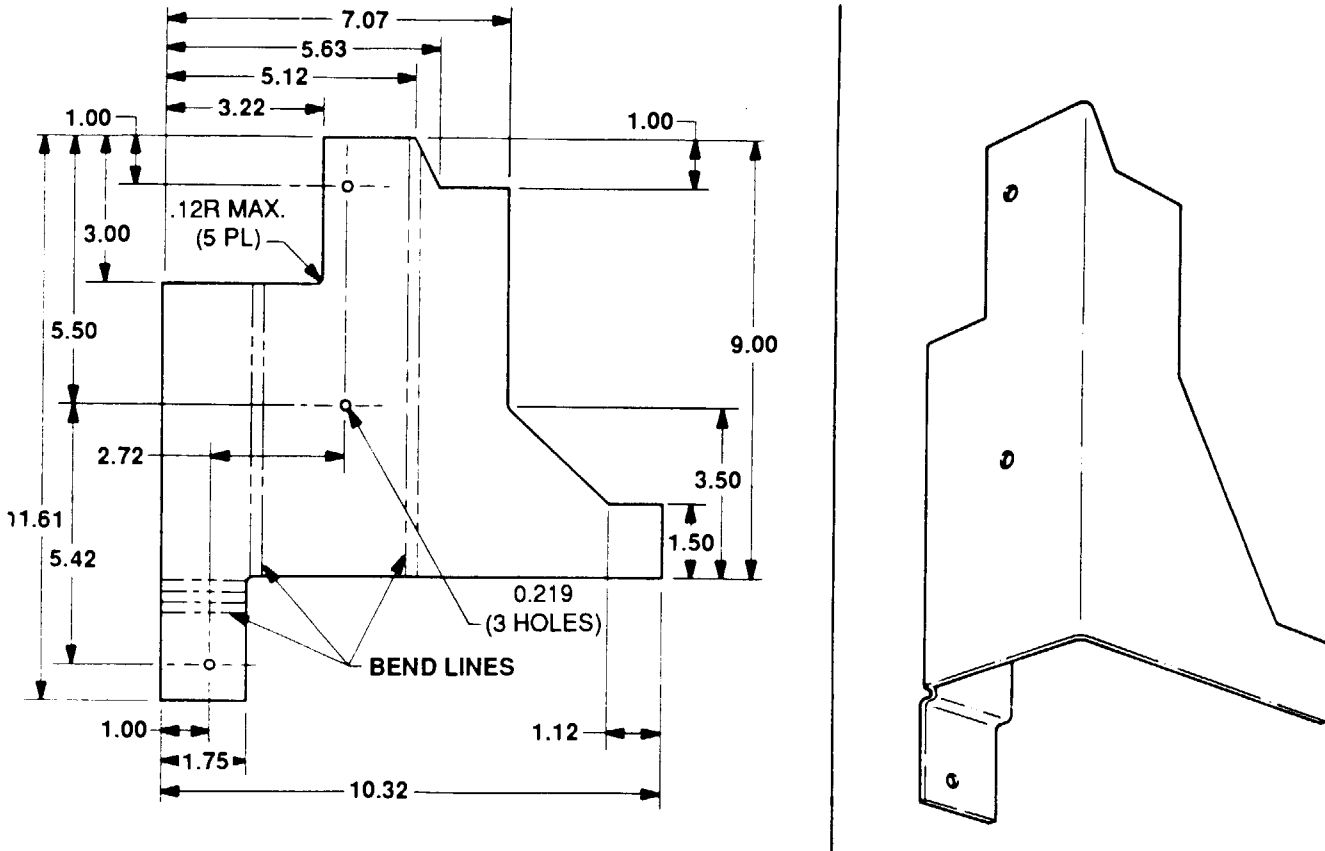

NOTE: All dimensions are in inches.

Figure D-85. Heat Shield Extension

INSTRUCTIONS:

All inside bend radius to 6.12 unless otherwise specified.

Section II. ILLUSTRATED MANUFACTURING INSTRUCTIONS (Cont'd)

MATERIAL BLOCK		
STOCK SIZE	DESCRIPTION	SPECIFICATION
10 X 12-FT SHEET. 0.08 IN. THICK	ALUMINUM ALLOY 6061-T6	IAW QQ-A-225/8

LEFT SPLASH SHIELD ACCESS COVER		
ACCESS COVER PART NUMBER	CUT TO SIZE (INCHES)	MANUFACTURED FROM NSN
12446770	AS SHOWN	9530-01-071-2140

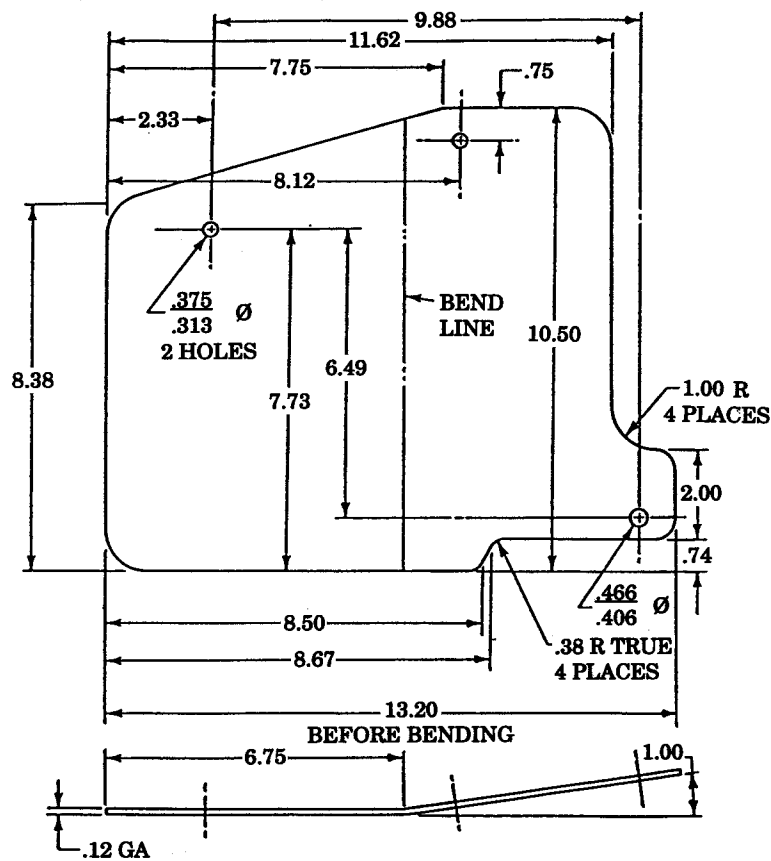

Figure D-86. Left Splash Shield Access Cover.

INSTRUCTIONS:

1. Cut aluminum sheet metal to size as shown.
2. Locate, mark, and drill two .313-.375-in. diameter holes in left splash shield access cover as shown.
3. Locate, mark, and drill one .406-.466-in. diameter hole in left splash shield access cover as shown.
4. Remove all burrs and sharp edges.
5. Paint left splash shield access cover as required. (Refer to TM 43-0139.)

Section II. ILLUSTRATED MANUFACTURING INSTRUCTIONS (Cont'd)

LEFT SPLASH SHIELD		
SPLASH SHIELD PART NUMBER	CUT (INCHES)	MANUFACTURED FROM PART NUMBER
12446771	AS SHOWN	12340361

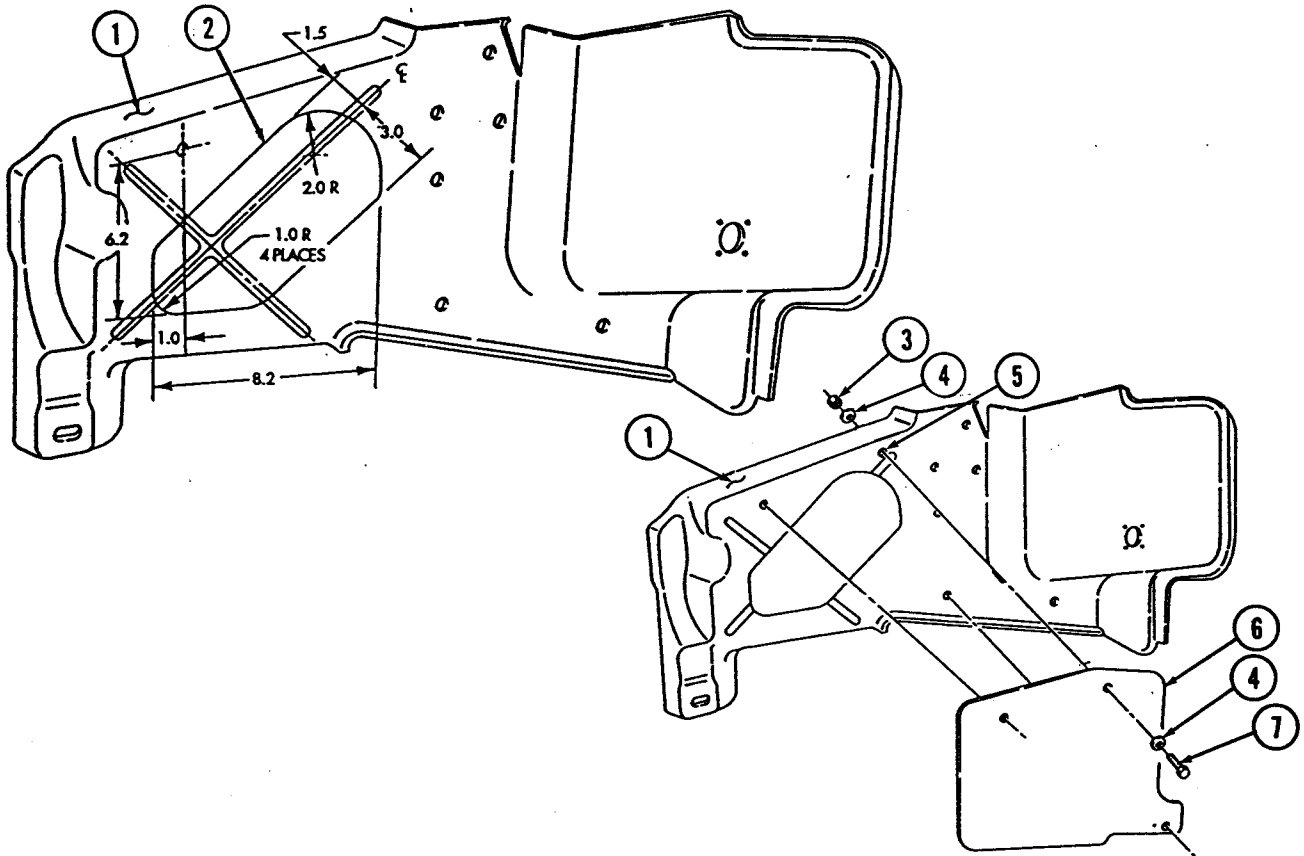

Figure D-87. Left Splash Shield.

INSTRUCTIONS:

1. Remove left splash shield. (Refer to para. 10-17.)
2. Cut hole (2) in left splash shield (1) as shown.
3. Using fabricated access cover (6) as a template, locate, mark, and drill a 0.312-inch diameter hole (5) through left splash shield (1) as shown.

NOTE

Existing mounting hardware is used to secure bottom right-hand hole.

4. Secure top two holes of access cover (6) to left splash shield (1) with two NSN 5306-00-225-8499 washers (4), NSN 5306-00-225-8499 screws (7), NSN 5310-00-087-7493 washers (4), and NSN 5310-00-814-0673 nuts (3) as shown.
5. Install modified left splash shield. (Refer to para. 10-17.)

Section II. ILLUSTRATED MANUFACTURING INSTRUCTIONS (Cont'd)

MATERIAL BLOCK		
STOCK SIZE	DESCRIPTION	SPECIFICATION
0.125 IN. THICK	ALUMINUM ALLOY TEMPER 6061	QQ-A-250/11

VEHICULAR SPLASH GUARD NSN 1. 2540-00-843-7043 (2 EACH)	CAPSCREWS NSN 6. 5305-00-269-3241 (4 EACH)	WASHERS NSN 3. 5310-00-087-7493 (4 EACH)
LOCKNUTS NSN 4. 5310-00-959-1488 (4 EACH)	90° ANGLE BRACKET NSN 5. 9540-00-140-2417 (2 EACH)	

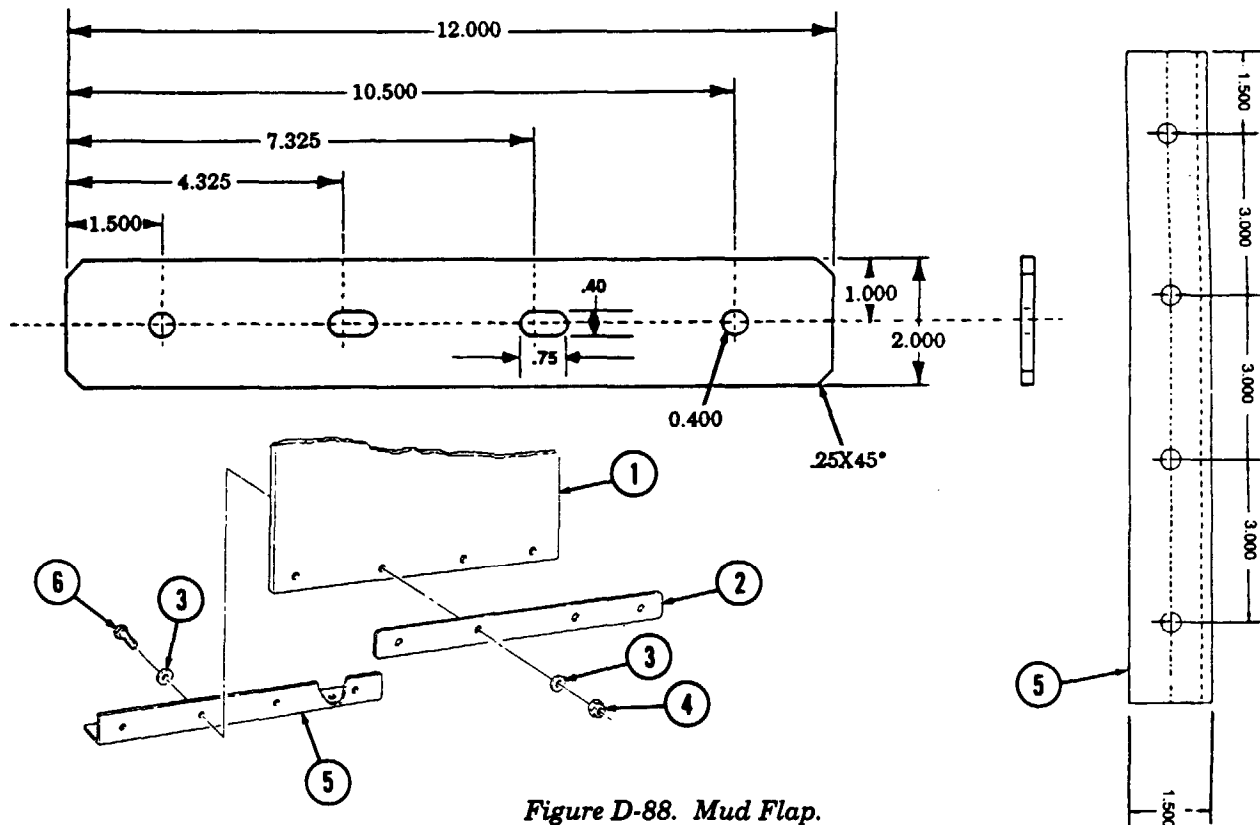

Figure D-88. Mud Flap.

INSTRUCTIONS:

1. Cut aluminum sheet metal to size as shown.
2. Locate, mark, and drill two .75 X .40 in. slots in mud flap plate.
3. Locate, mark, and drill two .40 in. diameter holes in mud flap plate.
4. Remove all burrs and sharp edges.
5. Locate, mark, and drill eight holes in angle bracket (5) as shown.
6. Paint as required. Refer to TM 43-0139.
7. Install mud flap (1) between mounting bracket (2) and angle bracket plate (5) with four washers (3), capscrews (6), washers (3), and locknuts (4).

Section II. ILLUSTRATED MANUFACTURING INSTRUCTIONS (Cont'd)

MATERIAL BLOCK		
STOCK SIZE	DESCRIPTION	SPECIFICATION
0.0500 IN. THICK	ALUMINUM ALLOY TEMPER	QQ-A-250/11

REINFORCEMENT BRACKET		
PART NUMBER	CUT TO SIZE (INCHES)	MANUFACTURED FROM NSN
N/A	AS SHOWN	9535-00-541-7194

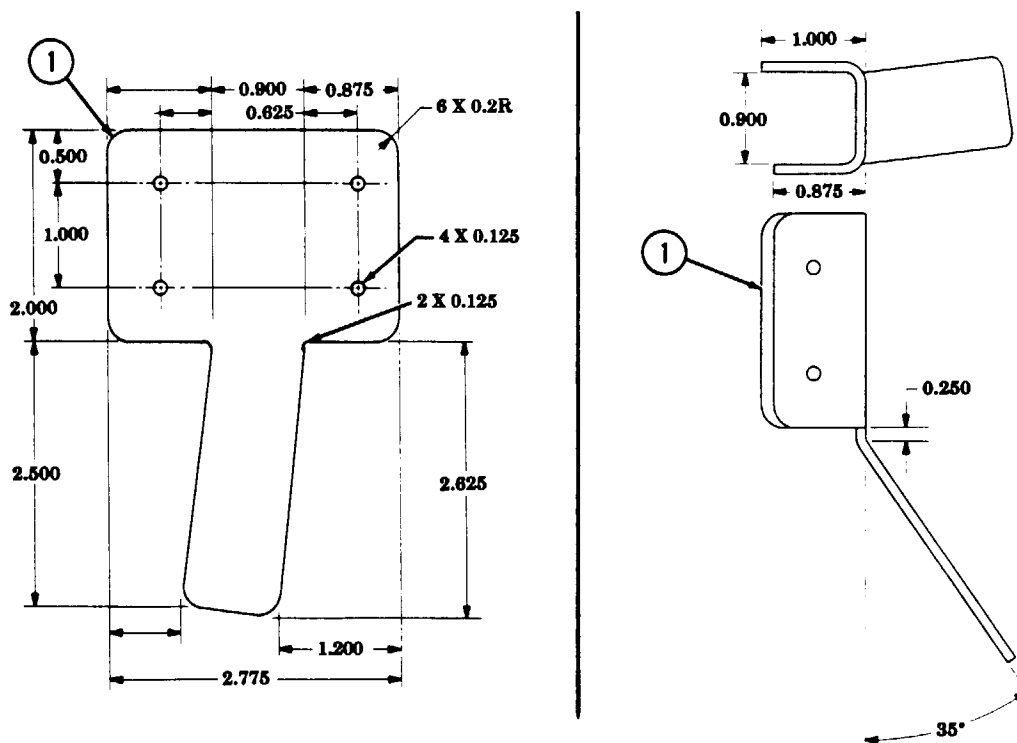

Figure D-89. "C" Pillar Reinforcement Bracket.

INSTRUCTIONS:

1. Cut two pieces of aluminum sheet metal to size as shown.
2. Locate, mark, and drill four 0.125-inch diameter holes in reinforcement brackets (1).
3. Bend left reinforcement bracket (1).
4. Bend right reinforcement bracket (1) in opposite direction.

Section II. ILLUSTRATED MANUFACTURING INSTRUCTIONS (Cont'd)

MATERIAL BLOCK		
STOCK SIZE	DESCRIPTION	SPECIFICATION
N/A	SEAL, NONMETALLIC	N/A

TURRET BEARING SEAL		
SEAL PART NUMBER	CUT LENGTH (FEET)	MANUFACTURED FROM NSN
MT161A	22	5330-01-282-2213

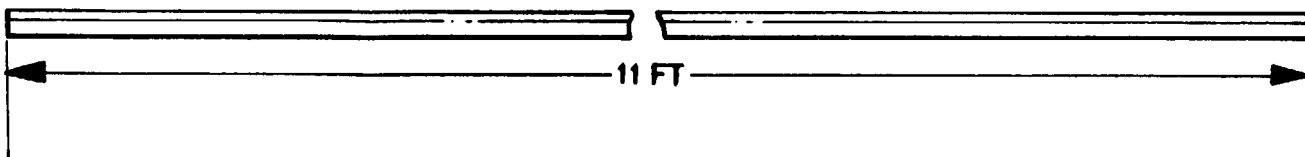

Figure D-90. Turret Bearing Seal.

INSTRUCTIONS:

1. Cut seal to length shown.

Section II. ILLUSTRATED MANUFACTURING INSTRUCTIONS (Cont'd)

WINCH WIRE ROPE ASSEMBLY					
ASSEMBLY PART NUMBER	CUT LENGTH (INCHES)	MANUFACTURED FROM PART NUMBER (CAGEC)	TERMINAL PART NUMBER (CAGEC)	CLAMP PART NUMBER (CAGEC)	THIMBLE PART NUMBER (CAGEC)
15667	1200.0	21451 (27647)	16464 (27647)	MS16843-5 (96906)	G-408-3/8 (75535)

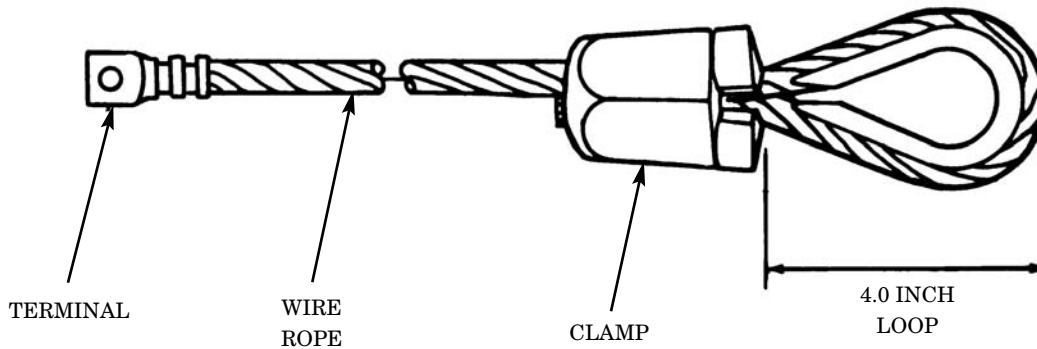

Figure D-91, Winch Wire Rope Assembly

INSTRUCTIONS:

1. (a) Properly seize wire rope end before cutting. To seize wire rope end, follow these instructions.

NOTE

- Ensure each wrap is tight to the preceding wrap.
- Ensure the length of the seizing is not less than the diameter of the wire rope.

- (1) Wrap the seizing wire around the wire rope as tight as possible.
- (2) Twist the ends of the seizing together by hand counterclockwise so that the twist is near the middle of the seizing.

NOTE

Do not try to tighten the seizing by twisting.

- (3) Tighten the twist just enough to take up the slack.
 - (4) Tighten the seizing by prying the twist away from the axis of the wire rope.
 - (5) Tighten the twist again as described in step (3).
 - (6) Repeat the process until the seizing can not be pryed away from the axis of the wire rope.
 - (7) Cut off wire ends and pound the twist into contact with the seizing.
- (b) Cut wire rope to length as shown and install part of clamp with nut on wire rope.

Section II. ILLUSTRATED MANUFACTURING INSTRUCTIONS (Cont'd)

2. Position rope after seizing in a suitable fixture to make a loop, leaving enough rope to wrap around thimble and enclose in clamp.
3. Insert thimble and close jaws of fixture to enable rope to conform to groove of thimble.
4. Place one half of clamp in position and adjust rope accordingly. The seized portion of the wire rope should equal one rope diameter and protrude entirely beyond the threaded end of the clamp half.
5. Install clamp nut. Holding both threaded halves in position, push the nut into both halves through the first two threads. Ensure proper alignment of both threaded halves, and that there is no cross-threading.
6. Remove rope, clamp and thimble while still connected.
7. Hold opposing flats of clamp halves in suitable fixture and properly lubricate exposed threads with high-viscosity lubricating oil.
8. Using a permanent marker, mark one flat nut to ensure the same opposing flats are checked before and after tightening the clamp.
9. Using calipers, measure 1/8 inch across the flat nut from the bottom and note measurement.
10. Check to make sure clamp halves are properly secured in fixture, and tighten with appropriate wrench.
11. Using calipers, again take measurement of the same flat nuts as was done before tightening of the nut. If the increment dilation is between 0.004 and 0.007 inches, clamp is tight.
12. Using arbor press, crimp terminal to opposite end of wire rope.

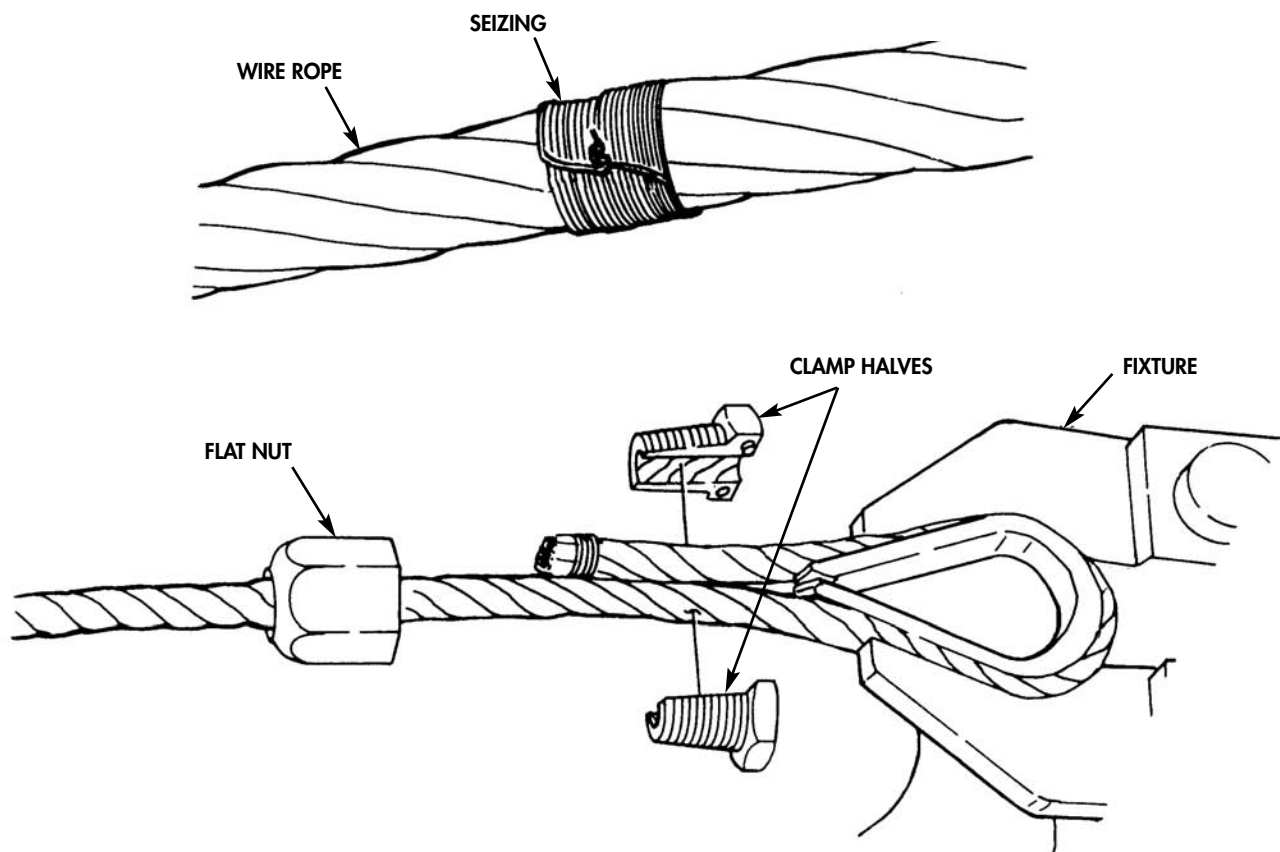

Section II. ILLUSTRATED MANUFACTURING INSTRUCTIONS (Cont'd)

MATERIAL BLOCK		
STOCK SIZE	DESCRIPTION	SPECIFICATION
.050 X 36 IN. THICK	ALUMINUM ALLOY 6061-T6	QQ-A-250/11

RETAINER		
SEAL PART NUMBER	CUT LENGTH (FEET)	MANUFACTURED FROM NSN
N/A	8	9535-00-250-6503

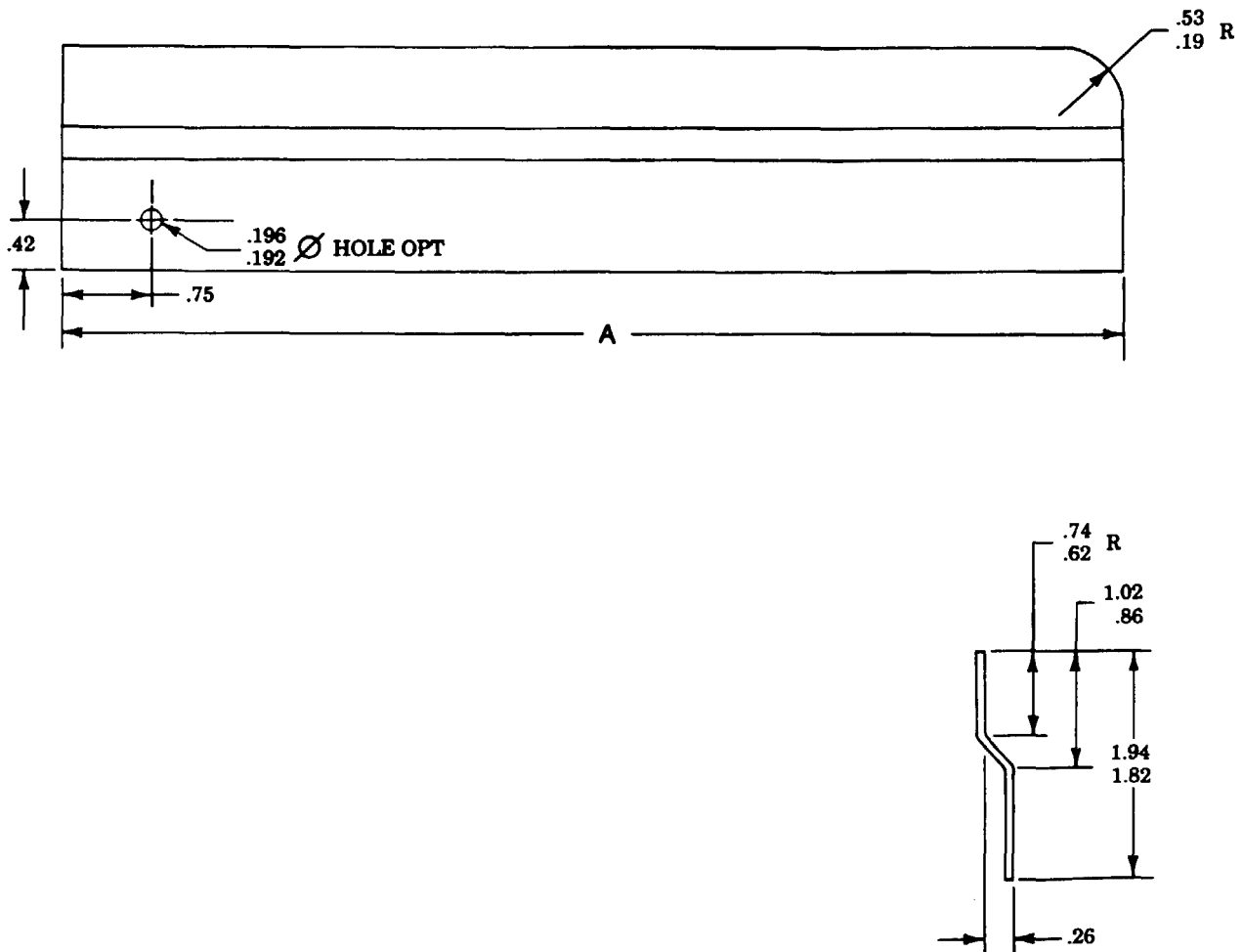

Figure D-92. Ambulance Bulkhead Door Retainer.

INSTRUCTIONS:

1. Cut retainer to length shown.
2. Remove all burrs and sharp edges.

Section II. ILLUSTRATED MANUFACTURING INSTRUCTIONS (Cont'd)

MATERIAL BLOCK		
STOCK SIZE	DESCRIPTION	NSN
N/A	1/4 IN. CAPSCREW	5305-00-068-0515
N/A	1/4 IN. NUT	5310-00-768-0319
N/A	1/4 IN. LOCKWASHER	5310-00-582-5965
N/A	CLAMP	5340-01-159-1321
N/A	CHAIN, CUT TO DESIRED LENGTH	4010-00-129-3221

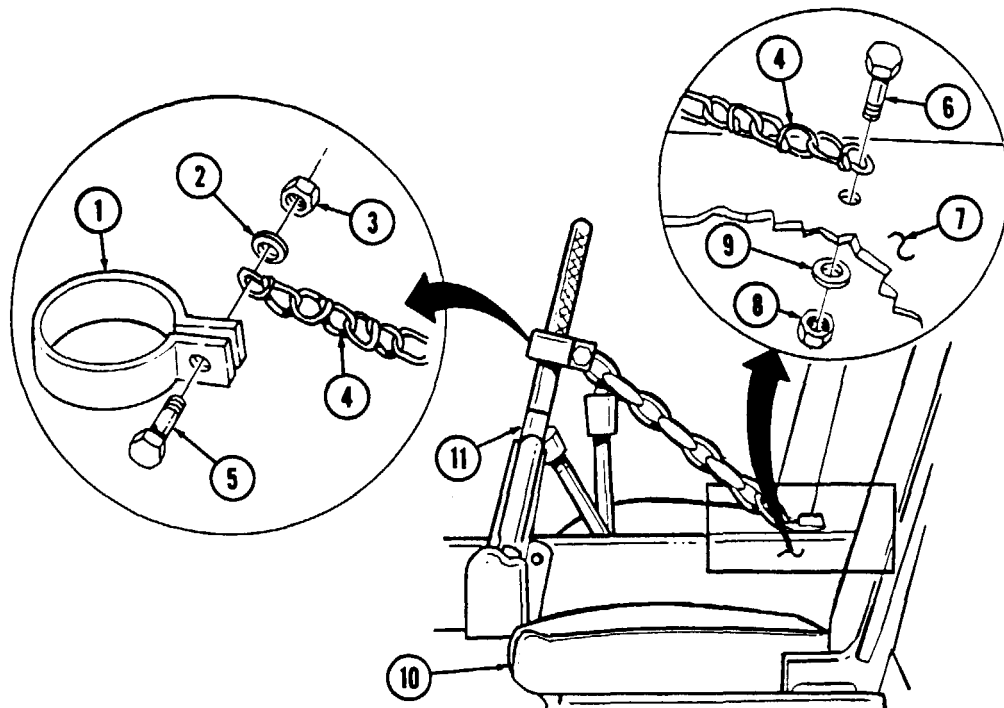

Figure D-93. Parking Brake Lever.

INSTRUCTIONS:**CAUTION**

When drilling through the transmission cowl, be careful not to drill into the transmission housing.

NOTE

The location of the mounting hole will vary depending on vehicle configuration. Locate the hole in a suitable place, near the driver's seat

1. Drill a 1/4-in. hole in the transmission cowl (7), near the driver's seat (10).
2. Cut chain (4) to desired length and install the clamp (1) on chain (4) with cap screw (5), lockwasher (2), and nut (3).
3. Install chain (4) on transmission cowl (7) with cap screw (6), lockwasher (9), and nut (8).
4. With the parking brake applied, slip clamp (1) over lever (11) to lock it in place. When not in use, stow the chain lock out of the way.
5. Paint chain lock red for easy identification.

Section II. ILLUSTRATED MANUFACTURING INSTRUCTIONS (Cont'd)

MATERIAL BLOCK		
13. HOSE, NON-METALLIC 4720-01-394-3747	15. FITTING 4730-00-278-3721	14. QUICK-DISCONNECT 4730-01-399-0241

INSTRUCTIONS:

1. Disconnect battery ground cable (Refer to para. 4-73).

NOTE

Have container available to catch fluid drainage from hydraulic hoses.

2. Remove clamp (4) and hydraulic hose (5) from elbow fitting (2).
3. Disconnect fan drive hydraulic hose (11) from fitting (12).
4. Remove elbow fitting (2) from adapter bushing (9).
5. Remove nut (3), washer (6), and washer (8) securing adapter bushing (9) to fan shroud (7).
6. Remove fan drive hydraulic hose (11) from elbow fitting (10).
7. Remove fitting (12) from fan drive (1).

NOTE

Apply sealing compound (appendix C, item 44) to all pipe threads during installation.

8. Install hose (13) on elbow fitting (10).
9. Install quick-disconnect (14) on fitting (15).
10. Install fan drive hydraulic hose (13) in quick-disconnect (14).
11. Install fitting (15) in fan drive (1).
12. Install adapter bushing (9) and washer (8) in fan shroud (7) with washer (6) and nut (3).
13. Install elbow fitting (2) in adapter bushing (9).
14. Install hydraulic hose (5) on elbow fitting (2) with clamp (4).
15. Connect battery ground cable (para. 4-73).
16. Bleed power steering system (para. 8-29).

Section II. ILLUSTRATED MANUFACTURING INSTRUCTIONS (Cont'd)

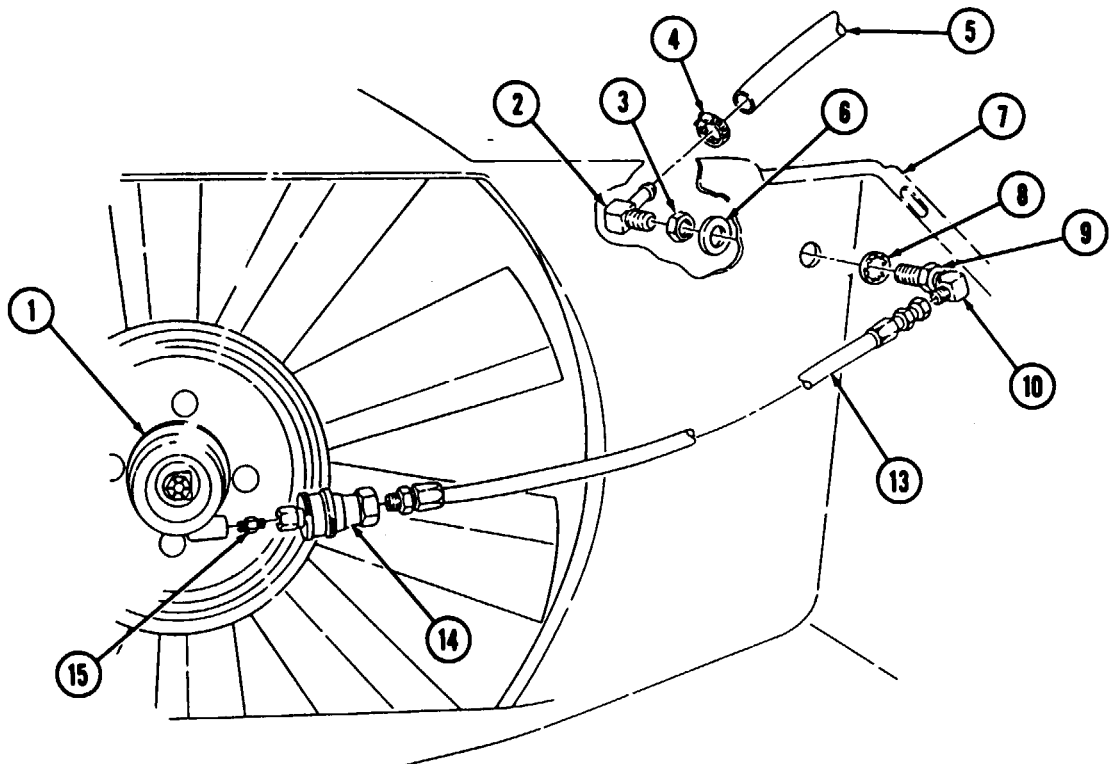
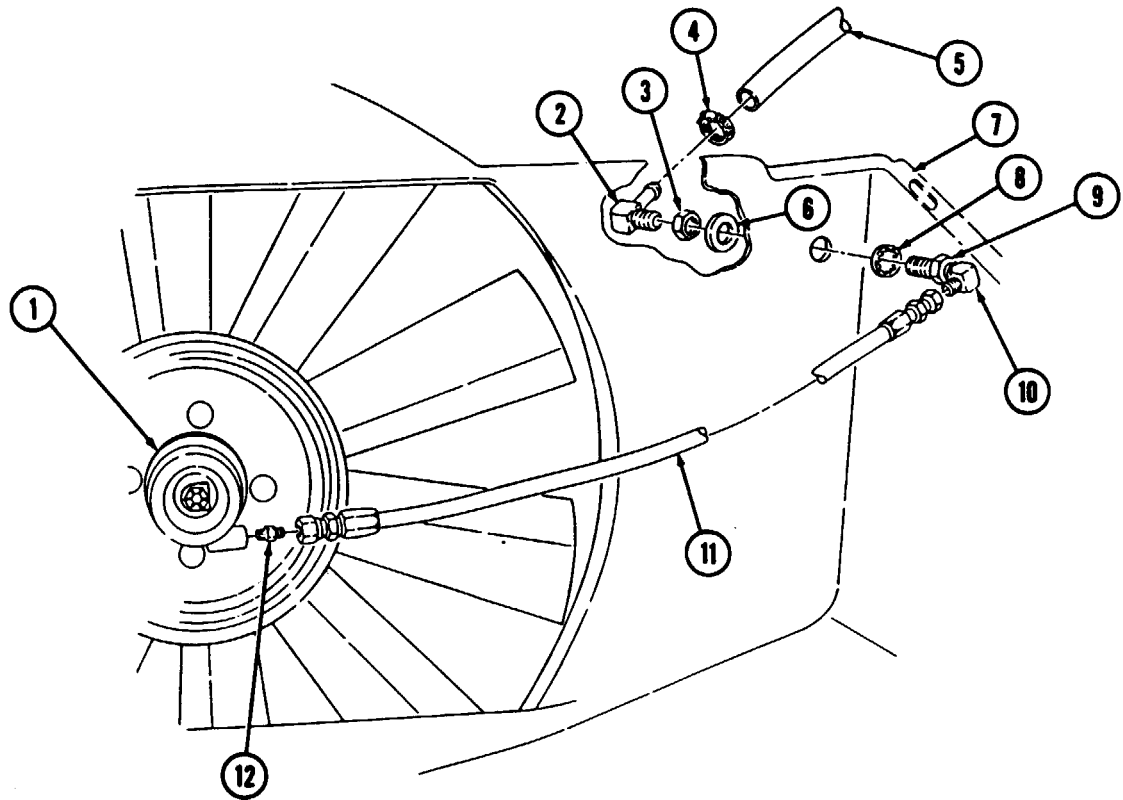

Figure D-94. Fan Drive Quick-Disconnect.

Section II. ILLUSTRATED MANUFACTURING INSTRUCTIONS (Cont'd)

MATERIAL BLOCK		
STOCK SIZE	DESCRIPTION	NSN
N/A	LOCKNUT	5310-00-241-6658
N/A	WASHER	5310-01-119-1024
N/A	BOLT	5306-00-050-1237
N/A	HANDLE	P/N 12446730

INSTRUCTIONS:

1. Using existing turret handle (1) as a template, scribe two reference lines (2) on weapon station (4).
2. Locate and mark the center of six spot welds (3) on turret handle (1).

NOTE

Ensure drill does not penetrate weapon station.

3. Using 0.313-inch diameter drill bit, drill out six spot welds (3) in turret handle (1).
4. Using chisel, remove turret handle (1) from weapon station (4).

NOTE

When grinding weapon station, ensure that the two reference lines are not removed.

5. Grind off any remaining spot weld (3) material flush with weapon station (4).
6. Using two reference lines (2) marked in step 1, position turret handle (5) on weapon station (4).
7. Using turret handle (5) as a template, drill four 0.344-inch diameter holes (6) in weapon station (4).
8. Spot paint weapon station (4) (refer to TM 43-0139).
9. Install turret handle (5) on weapon station (4) with four washers (8), capscrews (7), washers (8), and locknuts (9).
10. Spot paint capscrews (7) and locknuts (9) (refer to TM 43-0139).

Section II. ILLUSTRATED MANUFACTURING INSTRUCTIONS (Cont'd)

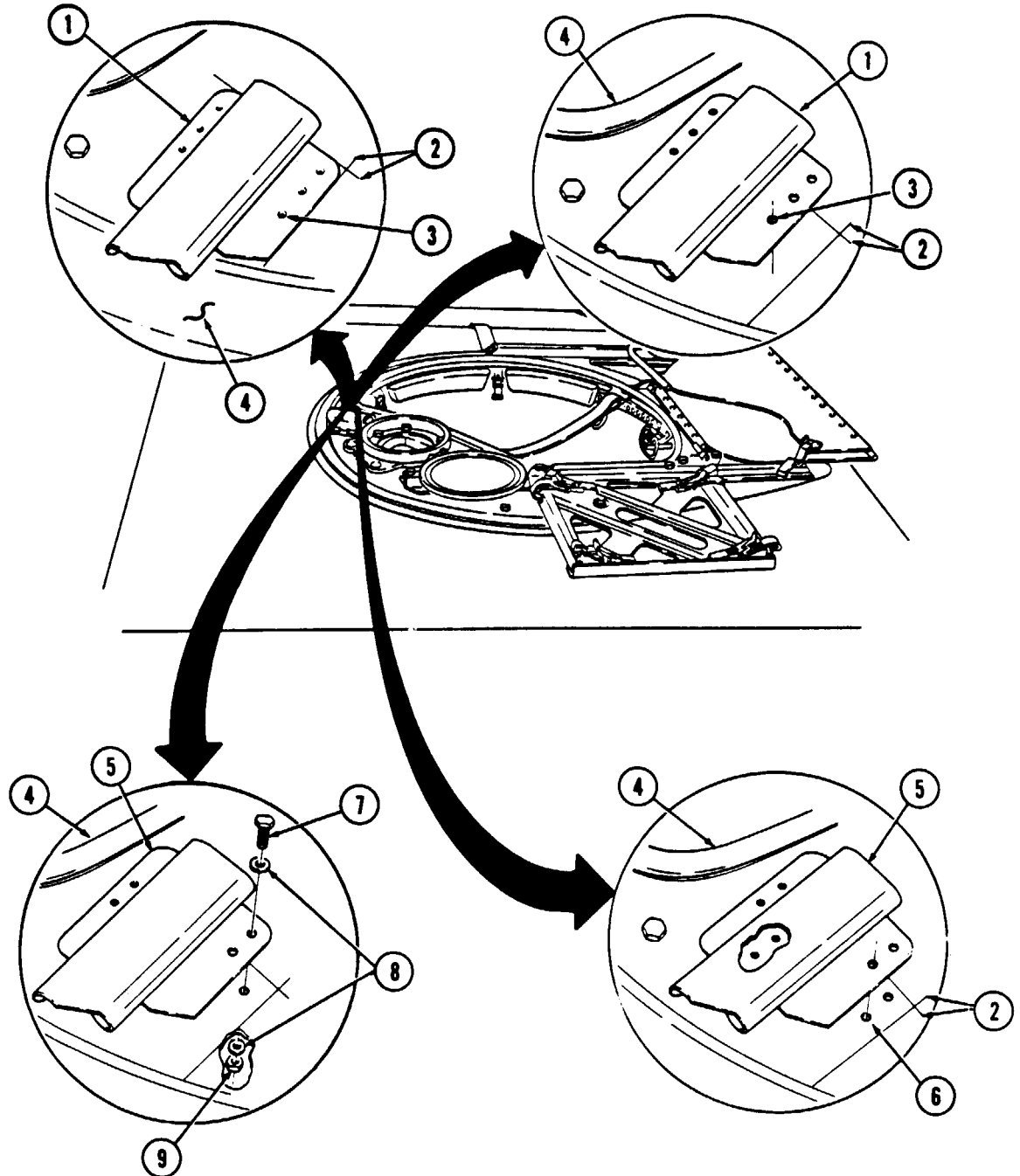

Figure D-95. Turret Handle Replacement.

Section II. ILLUSTRATED MANUFACTURING INSTRUCTIONS (Cont'd)

MATERIAL BLOCK		
STOCK SIZE	DESCRIPTION	SPECIFICATION
14 AWG N/A	WIRE, ELECTRICAL INSULATION SLEEVING	MIL-C-13486 MIL-I-23053/2

ITEM NO.	REQ'D	MATERIALS	
		DESCRIPTION	NSN/PART NUMBER
1	8	Insulation Sleeving: 2 in.	5970-01-815-1295
2	8	Electrical Wire: 48 in.	6145-00-152-6499
3	8	Wire Marker	46F5981
4	5	Tiedown Strap	5975-00-074-2072
5	1	Receptacle	5935-00-738-8328

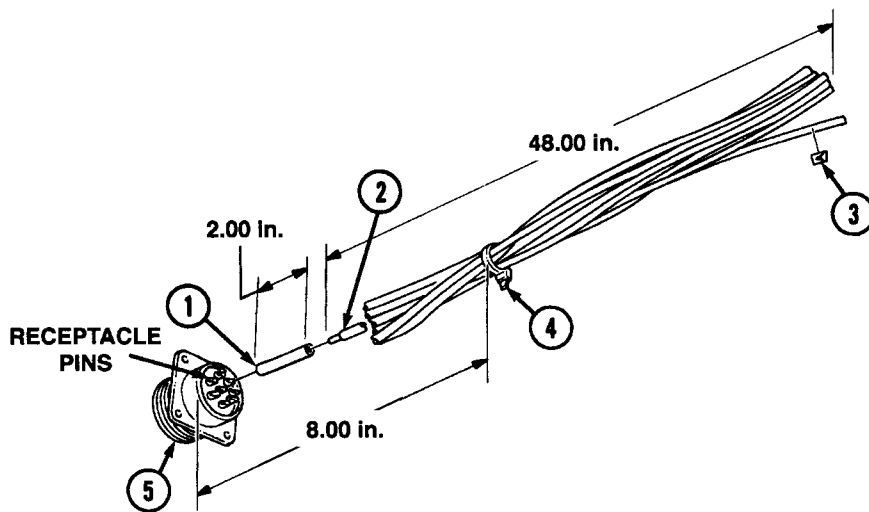

Figure D-96. Body Harness Receptacle Fabrication.

INSTRUCTIONS:

NOTE

When connecting electrical wire to connector pins on engine harness plug connector, use NSN 3439-00-133-1108 solder. (Refer to TB SIG-222 for soldering.)

1. Cut eight sections of wire (2) to length as shown.
2. Cut eight sections of insulation sleeving (1) as shown.
3. Position eight sections of insulation sleeving (1) on wires (2).
4. Connect eight sections of wire (2) to receptacle pins marked A, B, C, D, E, F, G, and H on receptacle (5). Place insulation sleeving (1) over wires (2) and receptacle pins and into position as shown.
5. Apply sealant NSN 8040-00-225-4918 to receptacle pins, wires, and sleeving.
6. Use wire markers (3) on eight sections of wire (2) to locate and mark wires. Secure eight sections of wire (2) with five tiedown straps (4).

Section II. ILLUSTRATED MANUFACTURING INSTRUCTIONS (Cont'd)

MATERIAL BLOCK		
STOCK SIZE	DESCRIPTION	SPECIFICATION
14 AWG	WIRE, ELECTRICAL	MIL-C-13486

ITEM NO.	REQ'D	MATERIALS	
		DESCRIPTION	NSN/PART NUMBER
1	1	Grommet	5365-00-772-2322
2	8	Electrical Wire: 48 in.	6145-00-152-6499
3	8	Wire Marker	46F5981
4	5	Tiedown Strap	5975-00-074-2072
5	1	Grommet Retaining Nut	5935-00-333-9414
6	1	Coupling Nut	5310-00-655-9860
7	1	Plug Shell Assembly	5935-00-686-2608

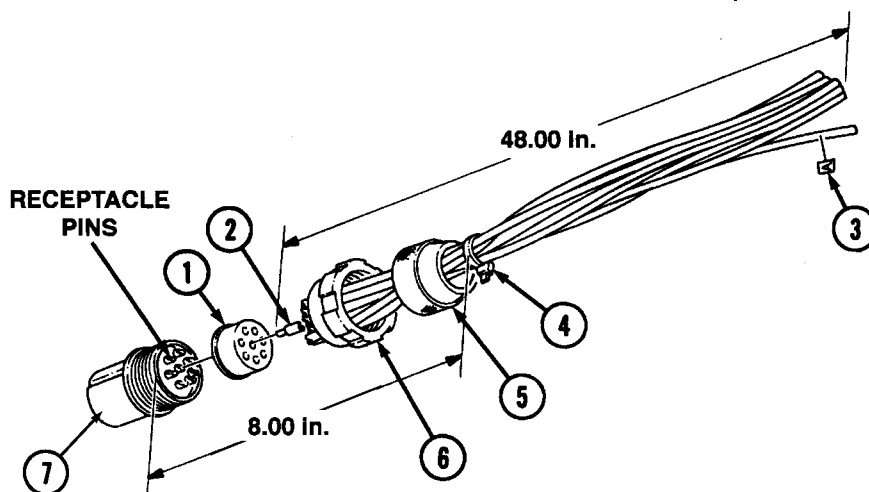

Figure D-97. Body Harness Connector Fabrication.

INSTRUCTIONS:

NOTE

When connecting electrical wires to connector pins on body harness connector, use NSN 3439-00-133-1108 solder. (Refer to TB SIG-222 for soldering.)

1. Cut eight sections of wire (2) to length as shown.
2. Place grommet retaining nut (5) over eight sections of wire (2).
3. Position eight sections of wire (2) in grommet (1).
4. Place coupling nut (6) over plug shell assembly (7).
5. Connect eight sections of wire (2) to receptacle pins marked A, B, C, D, E, F, G, and H on plug shell assembly (7).
6. Position grommet (1) in plug shell assembly (7) and secure with grommet retaining nut (5).
7. Use wire markers (3) on eight sections of wire (2) to locate and mark wires. Secure eight sections of wire (2) with five tiedown straps (4).

Section II. ILLUSTRATED MANUFACTURING INSTRUCTIONS (Cont'd)

MATERIAL BLOCK		
STOCK SIZE	DESCRIPTION	SPECIFICATION
14 AWG	WIRE, ELECTRICAL	MIL-C-13486
8 AWG	WIRE, ELECTRICAL	MIL-C-13486/1
N/A	INSULATION SLEEVING	MIL-I-23053/2

ITEM NO.	REQ'D	MATERIALS	
		DESCRIPTION	NSN/PART NUMBER
1	1	Plug Connector	5935-01-173-7654
2	6	Electrical Wire: 60 in.	6145-00-538-8222
3	9	Wire Marker	46F5981
4	6	Tiedown Strap	5975-00-074-2072
5	1	Coupling Nut	5310-00-655-9860
6	3	Electrical Wire: 60 in.	6145-00-152-6499
7	3	Insulation Sleeve: 3 in.	5970-00-812-2967

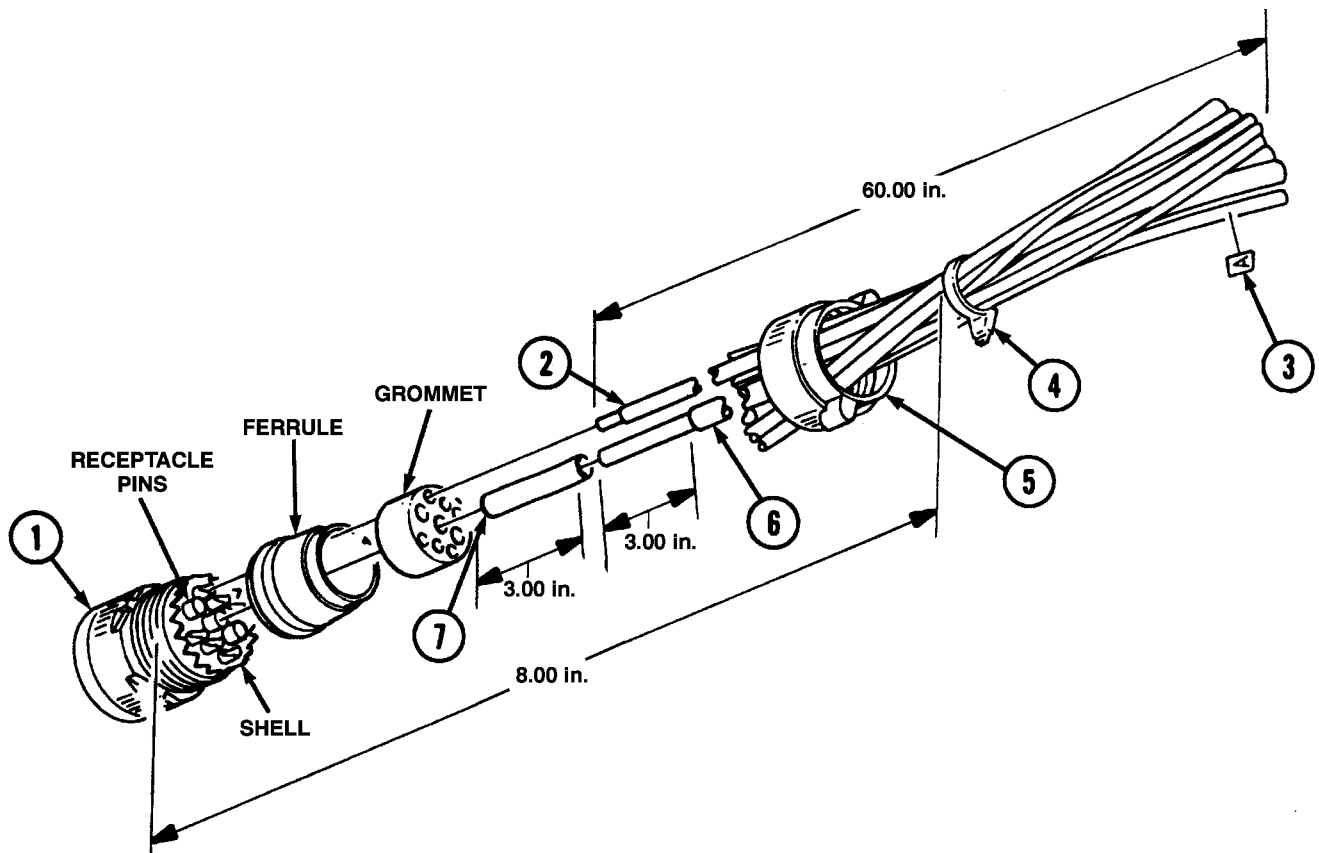

Figure D-98. Engine Harness Plug Connector Fabrication.

Section II. ILLUSTRATED MANUFACTURING INSTRUCTIONS (Cont'd)**INSTRUCTIONS:****NOTE**

When connecting electrical wire to connector pins on engine harness plug connector, use NSN 3439-00-133-1108 solder. (Refer to TB SIG-222 for soldering.)

1. Cut three sections of electrical wire (6) to length as shown.
2. Remove 3-in. (76.2 mm) section of electrical insulation from electrical wire (6).
3. Cut three sections of insulation sleeving (7) to length as shown.
4. Position three sections of insulation sleeving (7) over wires (6).
5. Using plug connector (1), disassemble shell, coupling nut (5), ferrule, and grommet.
6. Place coupling nut (5) and ferrule over three wires (6).
7. Place three wires (6) in holes marked D, E, and F in grommet.
8. Connect three wires (6) to receptacle pins marked D, E, and F on shell.
9. Cut six sections of electrical wire (2) to length as shown.
10. Place six wires (2) in coupling nut (5), ferrule, and holes marked A, B, C, G, H, and I on grommet.
11. Connect six wires (2) to receptacle pins marked A, B, C, G, H, and I on shell.
12. Position grommet and ferrule in shell and secure with coupling nut (5). Using three wires (6) with insulation, heat-shrink sleeving (7) in position.
13. Apply sealant NSN 8040-00-225-4918 to three wires (6) and insulation sleeving (7) on plug connector (1).
14. Using plug connector (1) and wire markers (3), locate and mark nine wires. Secure nine wires with six tiedown straps (4).

Section II. ILLUSTRATED MANUFACTURING INSTRUCTIONS (Cont'd)

MATERIAL BLOCK		
STOCK SIZE	DESCRIPTION	SPECIFICATION
14 AWG	WIRE, ELECTRICAL	MIL-C-13486
14 AWG	WIRE, ELECTRICAL	MIL-C-13486/1
N/A	INSULATION SLEEVING	MIL-I-23053/2
N/A	INSULATION SLEEVING	MIL-I-23053/5

ITEM NO.	REQ'D	MATERIALS	
		DESCRIPTION	NSN/PART NUMBER
1	3	Insulation Sleeving: 1-1/2 in. (38.1 mm)	5970-00-812-2967
2	3	Electrical Wire: 60 in. (1,524 mm)	6145-00-538-8222
3	9	Wire Marker	46F5981
4	6	Tiedown Strap	5975-00-074-2072
5	6	Electrical Wire: 60 in. (1,524 mm)	6145-00-152-6499
6	6	Insulation Sleeving: 1-1/2 in. (38.1 mm)	5970-00-815-1295
7	1	Receptacle Connector	5935-01-149-5163

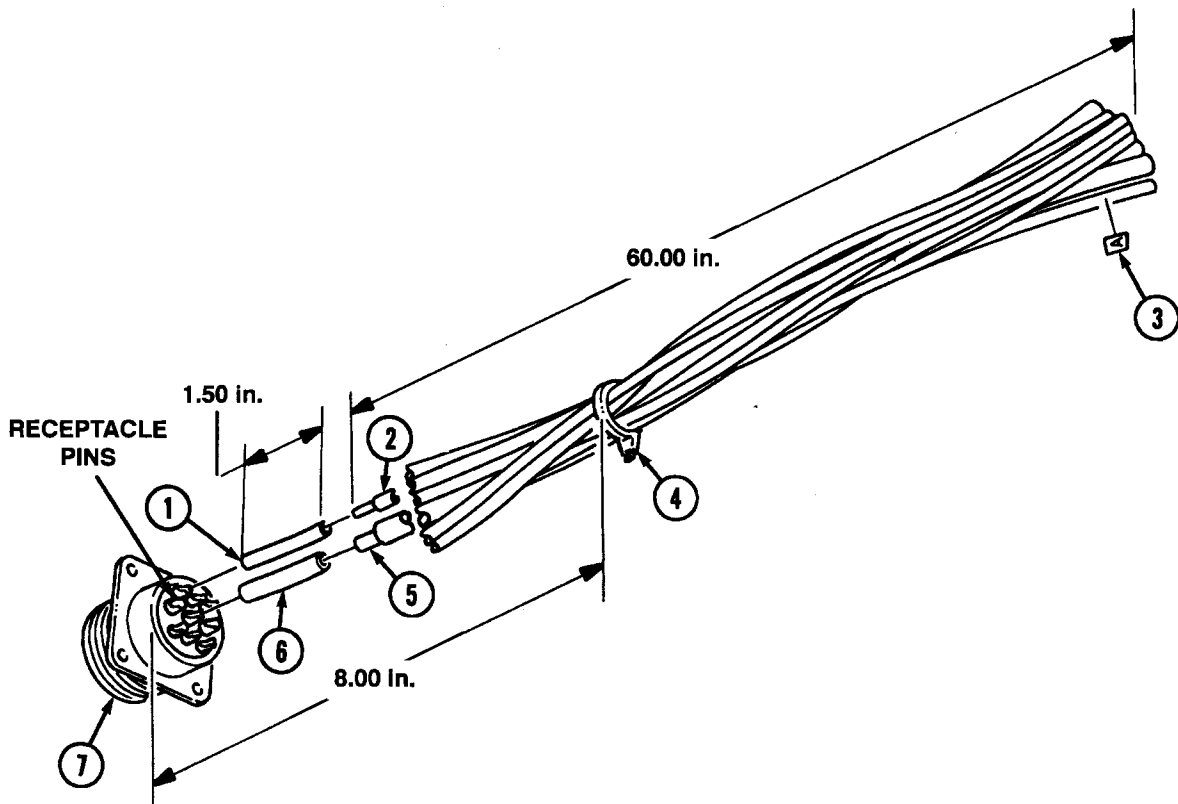

Figure D-99. Engine Harness Receptacle Fabrication.

Section II. ILLUSTRATED MANUFACTURING INSTRUCTIONS (Cont'd)**INSTRUCTIONS:****NOTE**

When connecting electrical wire to connector pins on engine harness receptacle, use NSN 3439-00-133-1108 solder. (Refer to TB SIG-222 for soldering.)

1. Cut three sections of electrical wire (2) to length as shown.
2. Cut three sections insulation sleeving (1) to length as shown.
3. Position three sections of insulation sleeving (1) on wires (2).
4. Connect three wires (2) to receptacle pins marked D, E, and F on receptacle connector (7). Place insulation sleeving (1) over wires (2) and receptacle pins and heat-shrink insulation sleeving (1) into position.
5. Apply sealant NSN 8040-00-225-4918 to three wires (2) and insulation sleeving (1) on receptacle connector (7).
6. Cut six sections of electrical wire (5) to length as shown.
7. Cut six sections of insulation sleeving (6) to length as shown.
8. Position six sections of insulation sleeving (6) on wires (5).
9. Connect six wires (5) to receptacle pins marked A, B, C, G, H, and I on receptacle connector (7). Place electrical insulating sleeving (6) over wires (5) and receptacle pins and heat-shrink insulation sleeving (6) into position.
10. Use wire markers (3) on nine sections of wire to locate and mark wires. Secure wires with six tiedown straps (4).

Section II. ILLUSTRATED MANUFACTURING INSTRUCTIONS (Cont'd)

ITEM NO.	REQ'D	MATERIALS	
		DESCRIPTION	NSN/PART NUMBER
4	1	Mini-box (bottom section)	5999-00-971-8848
7	6	Screw	5305-00-958-4353
8	6	Washer	5310-00-880-5976
9	6	Non-metallic Bumper	5340-01-219-6733
10	6	Nut	5310-00-934-9753

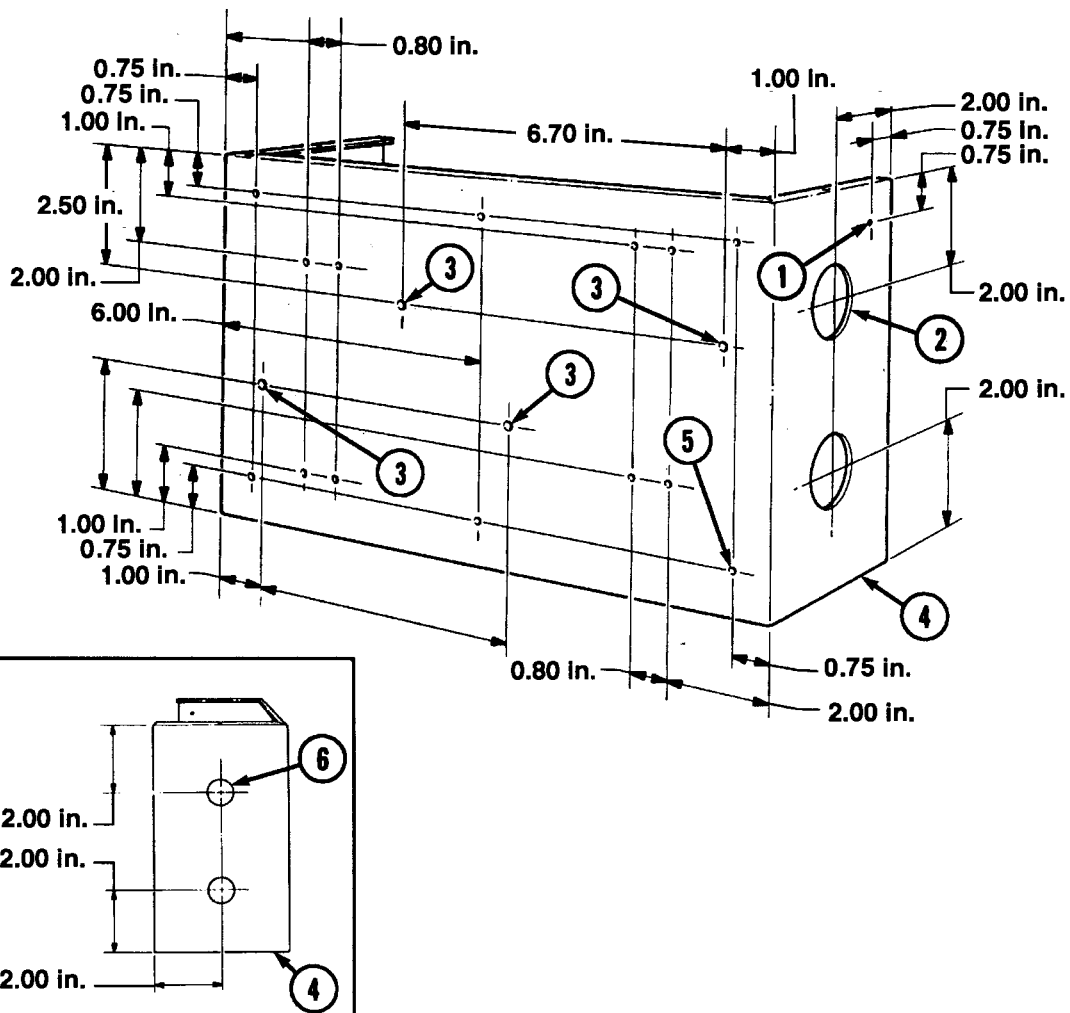

Figure D-100. Mini-box Bottom Section Drill Procedure.

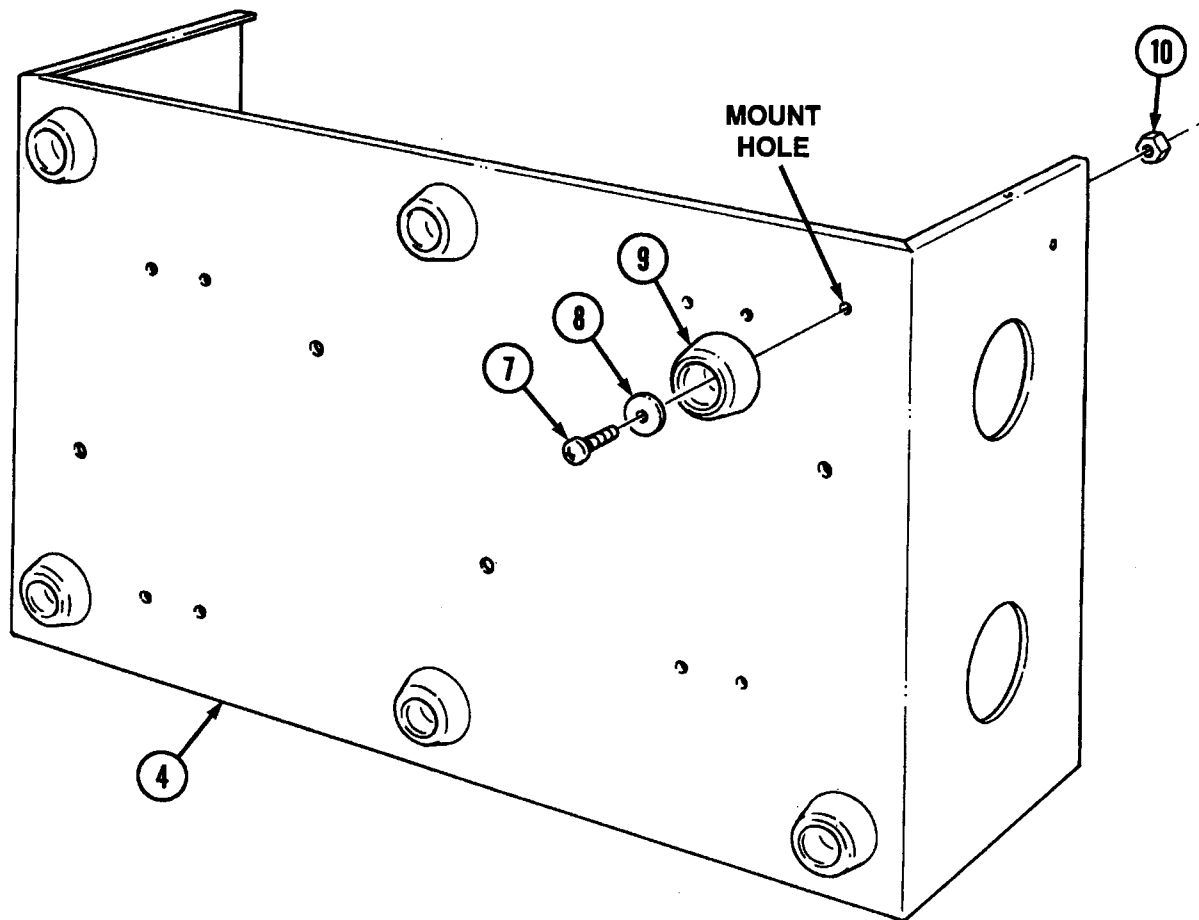

Figure D-100. Mini-box Bottom Section Drill Procedure (Cont'd).

INSTRUCTIONS:

1. Locate, mark, and drill 0.138-in. diameter hole (1) in mini-box bottom section (4) as shown.
2. Locate, mark, and drill two 1.250-in. diameter holes (2) in mini-box bottom section (4) as shown.
3. Locate, mark, and drill four 0.190-in. diameter holes (3) in mini-box bottom section (4) as shown.
4. Locate, mark, and drill fourteen 0.138-in. diameter holes (5) in mini-box bottom section (4) as shown.
5. Locate, mark, and drill two 0.750-in. diameter holes (6) in mini-box bottom section (4) as shown.
6. Install six non-metallic bumpers (9) on mount holes on mini-box bottom section (4) with washers (8), screws (7), and nuts (10) as shown.

Section II. ILLUSTRATED MANUFACTURING INSTRUCTIONS (Cont'd)

MATERIAL BLOCK		
STOCK SIZE	DESCRIPTION	SPECIFICATION
3 ft	CHANNEL	N/A

PRE-PUNCHED CHANNEL		
CHANNEL PART NUMBER	CUT LENGTH	MANUFACTURED FROM NSN
67	AS SHOWN	N/A

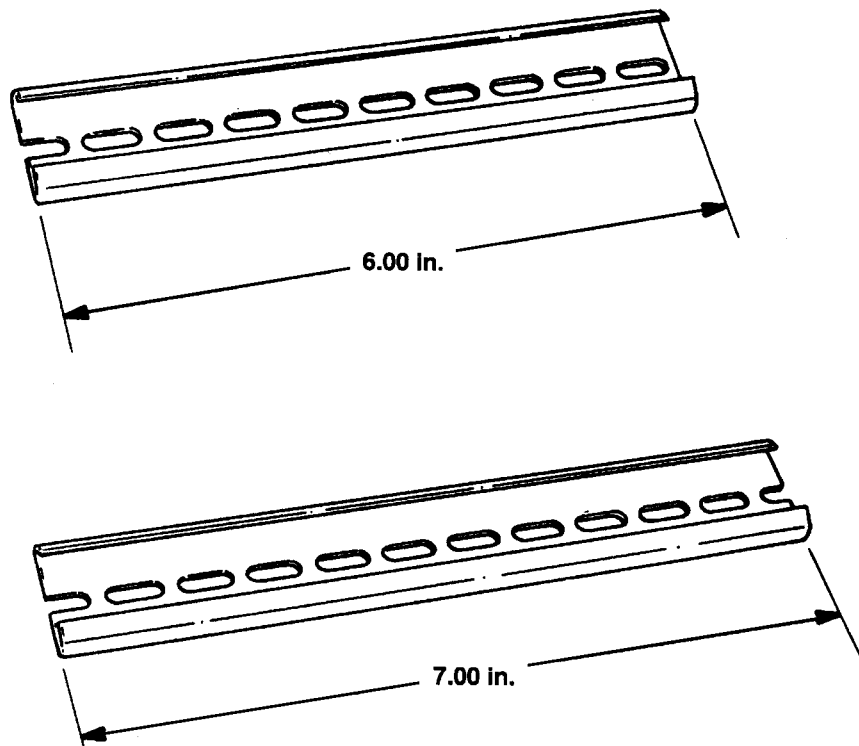

Figure D-101. Pre-punched Channel.

INSTRUCTIONS:

Cut two channels to length shown.

Section II. ILLUSTRATED MANUFACTURING INSTRUCTIONS (Cont'd)

ITEM NO.	REQ'D	MATERIALS	
		DESCRIPTION	PART NUMBER
1	1	Channel, Pre-punched: 7 in.	67
2	6	Terminal Block	0621
3	3	Terminal Block	0624
4	1	End Section	0630
5	2	Channel Clamp	68

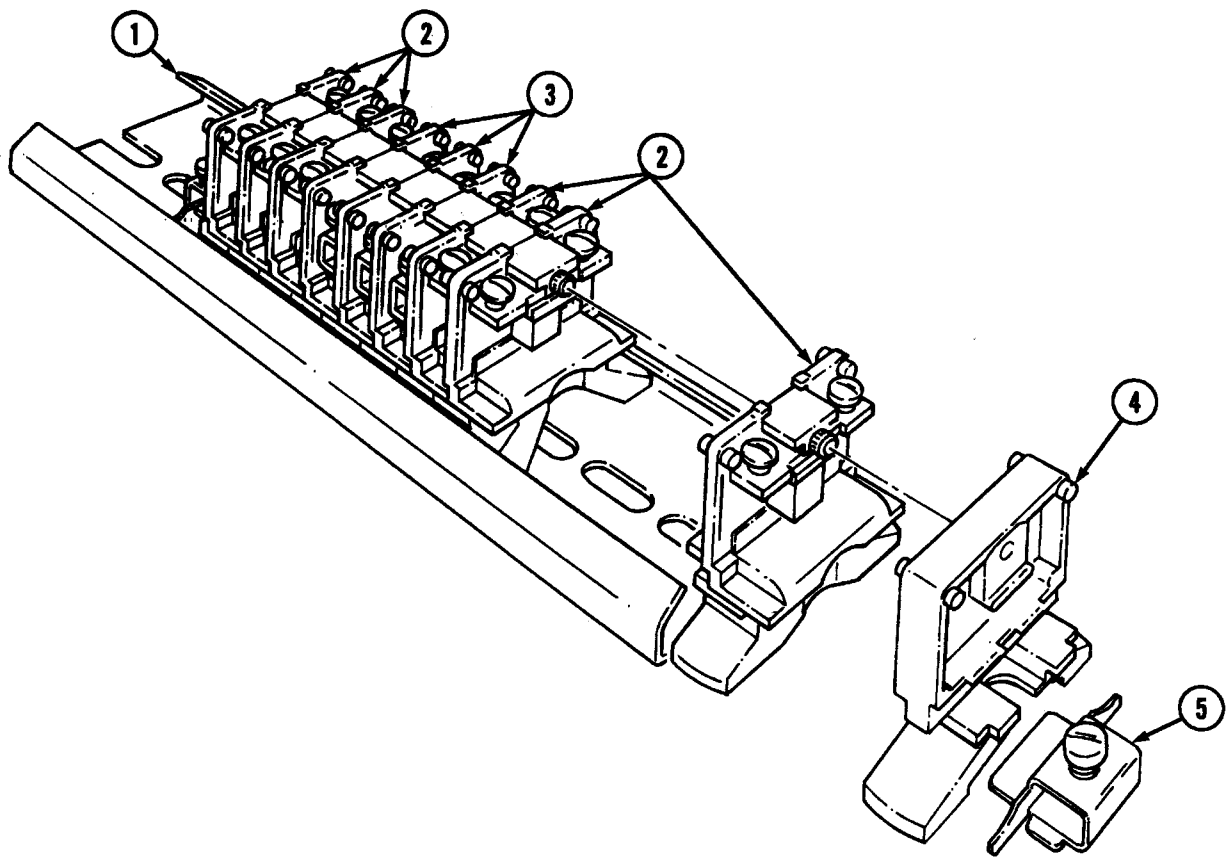

Figure D-102. Channel, 7.00-in. and Terminal Block Assembly.

INSTRUCTIONS:

Install three terminal blocks (2), terminal blocks (3), terminal blocks (2), and end section (4) on channel (1) with two channel clamps (5).

Section II. ILLUSTRATED MANUFACTURING INSTRUCTIONS (Cont'd)

ITEM NO.	REQ'D	MATERIALS	
		DESCRIPTION	PART NUMBER
1	1	Channel, Pre-punched: 6 in.	67
2	8	Terminal Block	0621
3	1	End Section	0630
4	2	Channel Clamp	68

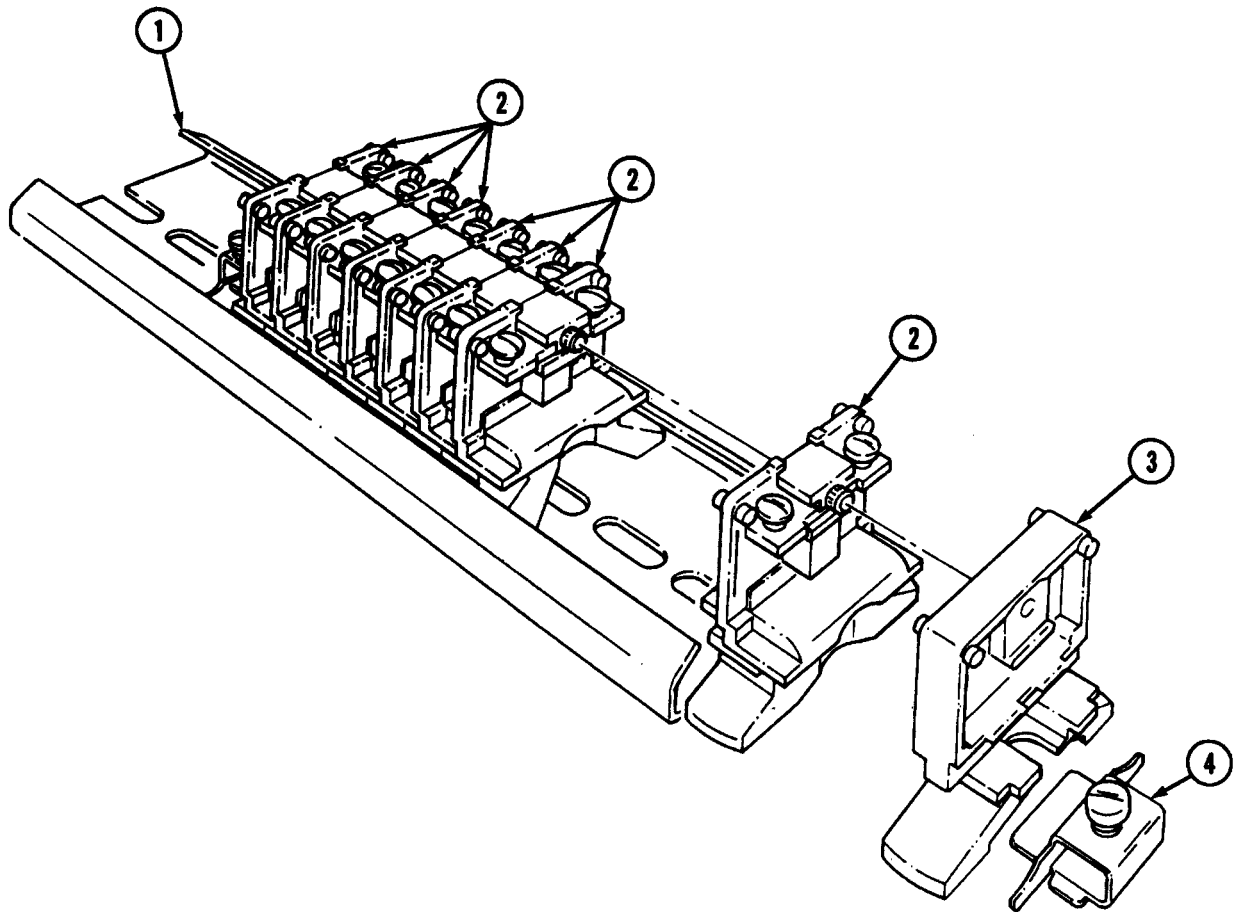

Figure D-103. Channel, 6.00-in. and Terminal Block Assembly.

INSTRUCTIONS:

Install eight terminal blocks (2) and end section (3) on channel (1) with two channel clamps (4).

Section II. ILLUSTRATED MANUFACTURING INSTRUCTIONS (Cont'd)

ITEM NO.	REQ'D	MATERIALS	
		DESCRIPTION	NSN/PART NUMBER
1	2	Grommet, Non-metallic	5325-00-270-8890
2	4	Cable Tie Holder	MB4A
3	8	Screw	5305-00-958-4353
4	4	Screw	5305-00-984-6210
5	1	Mini-box (bottom section)	5999-00-971-8848
6	2	Grommet, Non-metallic	5325-00-309-7164
7	1	Wire Marker	46F5981
8	4	Nut	5310-00-934-9758
9	4	Washer	5310-00-883-9384
10	8	Washer	5310-00-880-5976
11	8	Nut	5310-00-934-9753

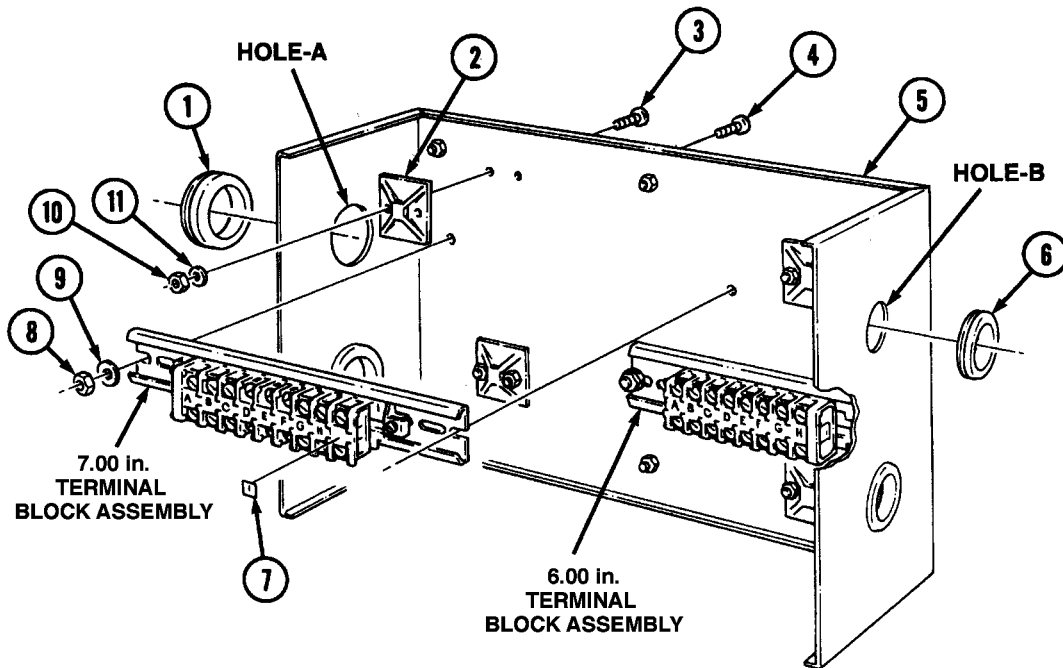

Figure D-104. Terminal Block Assemblies and Cable Tie Holder Installation.

INSTRUCTIONS:

1. Using wire marker (7) and 6-in. and 7-in. terminal block assemblies, locate and mark sections as shown.
2. Install 6-in. and 7-in. terminal block assemblies in mini-box bottom section (5) with four screws (4), washers (9), and nuts (8).
3. Install four cable tie holders (2) in mini-box bottom section (5) with eight screws (3), washers (10), and nuts (11).
4. Install two non-metallic grommets (1) in holes A on mini-box bottom section (5).
5. Install two non-metallic grommets (6) in holes B on mini-box bottom section (5).

Section II. ILLUSTRATED MANUFACTURING INSTRUCTIONS (Cont'd)

MATERIAL BLOCK		
STOCK SIZE	DESCRIPTION	SPECIFICATION
14 AWG	WIRE, ELECTRICAL	MIL-C-13486/1

ITEM NO.	REQ'D	MATERIALS	
		DESCRIPTION	NSN/PART NUMBER
1	16	Receptacle Pin	1-87756-6
2	14	Electrical Wire: 12 in.	6145-00-808-4849
3	14	Wire Marker	46F5981
4	11	Terminal Lug	5940-00-577-3807
5	1	Receptacle Plug	103308-8

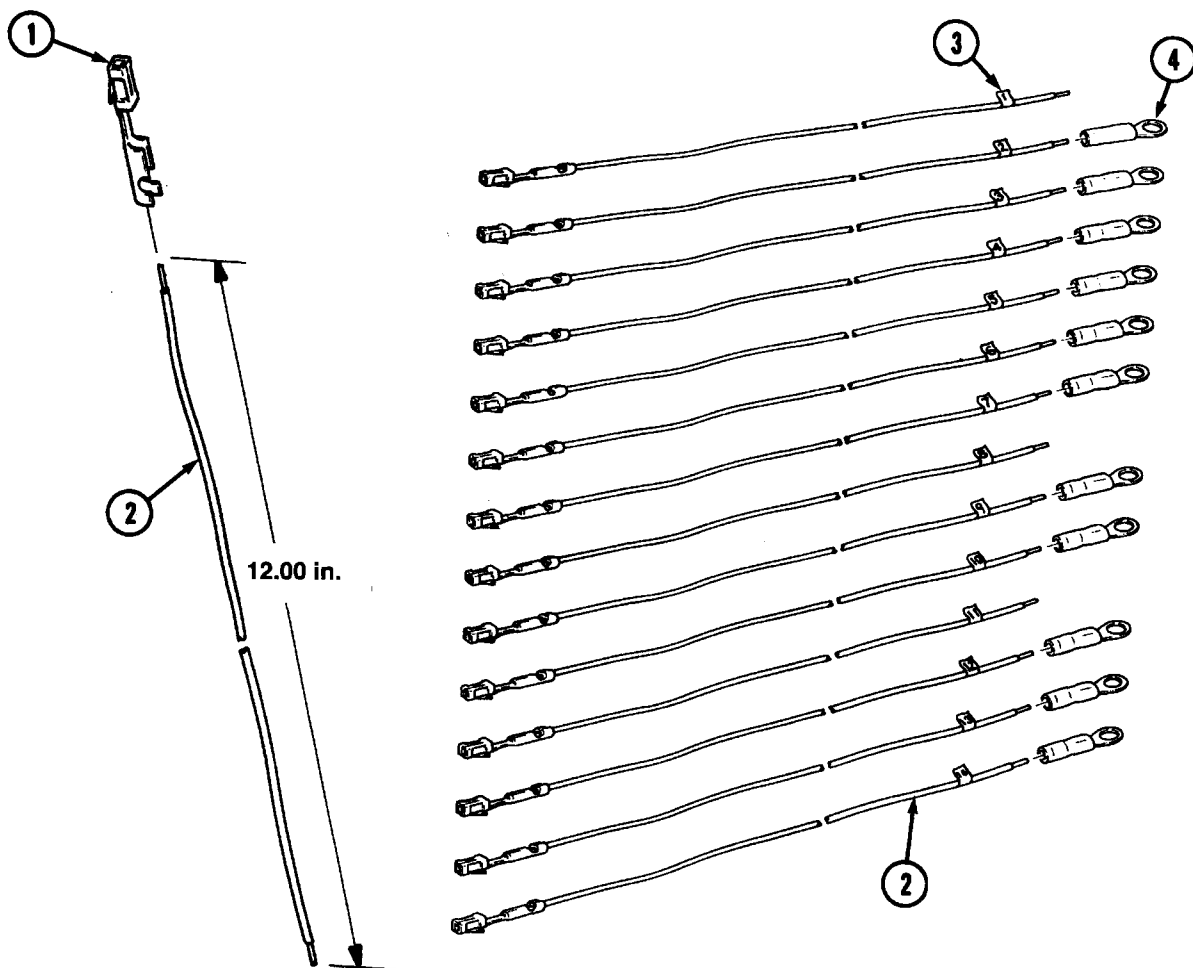

Figure D-105. Receptacle Plug and Pin Assemblies.

Section II. ILLUSTRATED MANUFACTURING INSTRUCTIONS (Cont'd)

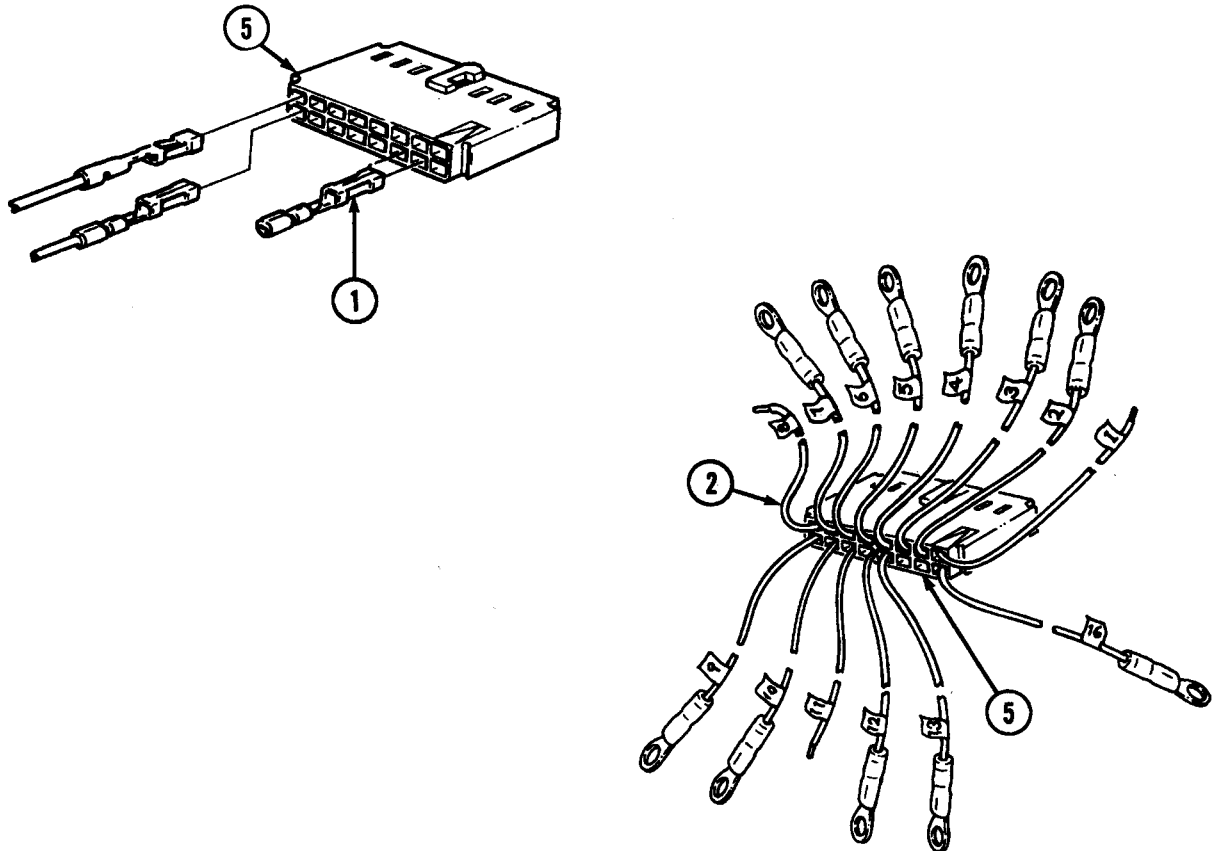

Figure D-105. Receptacle Plug and Pin Assemblies (Cont'd).

INSTRUCTIONS:

1. Cut fourteen sections of electrical wire (2) to length as shown.
2. Install fourteen receptacle pins (1) on wires (2) as shown.
3. Using fourteen wire markers, mark wires (2) with numbers 1 through 13 and 16 as shown.
4. Install eleven terminal lugs (4) on wires (2) marked 2, 3, 4, 5, 6, 7, 9, 10, 12, 13, and 16 as shown.
5. Install two receptacle pins (1) (without wires) in slotted positions marked 14 and 15 on receptacle plug (5).
6. Install fourteen receptacle pins (1) (with wires connected) in slotted positions marked 1, 2, 3, 4, 5, 6, 7, 8, 9, 10, 11, 12, 13, and 16 on receptacle plug (5).

Section II. ILLUSTRATED MANUFACTURING INSTRUCTIONS (Cont'd)

ITEM NO.	REQ'D	MATERIALS	
		DESCRIPTION	NSN
3	28	Terminal Lug	5940-00-283-5280

INSTRUCTIONS:

NOTE

- Ensure wire markers match letter identification for connector and receptacle harness assemblies.
- Trim excess wire to required length when installing wire and terminal lugs to terminal block assembly.

1. Route wires (5) from body harness receptacle (6) through grommet (7).
2. Install eight terminal lugs (3) on wires (5) from body harness receptacle (6).
3. Install wires (5) marked A, B, C, D, E, F, G, and H on body harness receptacle (6) to matching letters on terminal block assembly (4).
4. Route wires (10) from body harness connector (8) through grommet (9).
5. Install eight terminal lugs (3) on wires (10) from body harness connector (8).
6. Install wires (10) marked A, B, C, D, E, F, G, and H on body harness connector (8) to matching letters on terminal block assembly (4).
7. Route wires (13) on engine harness connector (14) through grommet (15).
8. Connect three wires (12) marked D, E, and F on engine harness connector (14) to matching letters on terminal block assembly (11). Do not tighten screws.
9. Install six terminal lugs (3) on wires (13) from engine harness connector (14)
10. Install wires (13) marked A, B, C, G, H, and I on engine harness connector (14) to matching letters on terminal block assembly (11).
11. Route wires (2) on engine harness receptacle (1) through grommet (16).
12. Connect three wires (12) marked D, E, and F on engine harness receptacle (1) to matching letters on terminal block assembly (11).
13. Install six terminal lugs (3) on wires (2) from engine harness receptacle (1).
14. Install wires (2) marked A, B, C, G, H, and I on engine harness receptacle (1) to matching letters on terminal block assembly (11).

Section II. ILLUSTRATED MANUFACTURING INSTRUCTIONS (Cont'd)

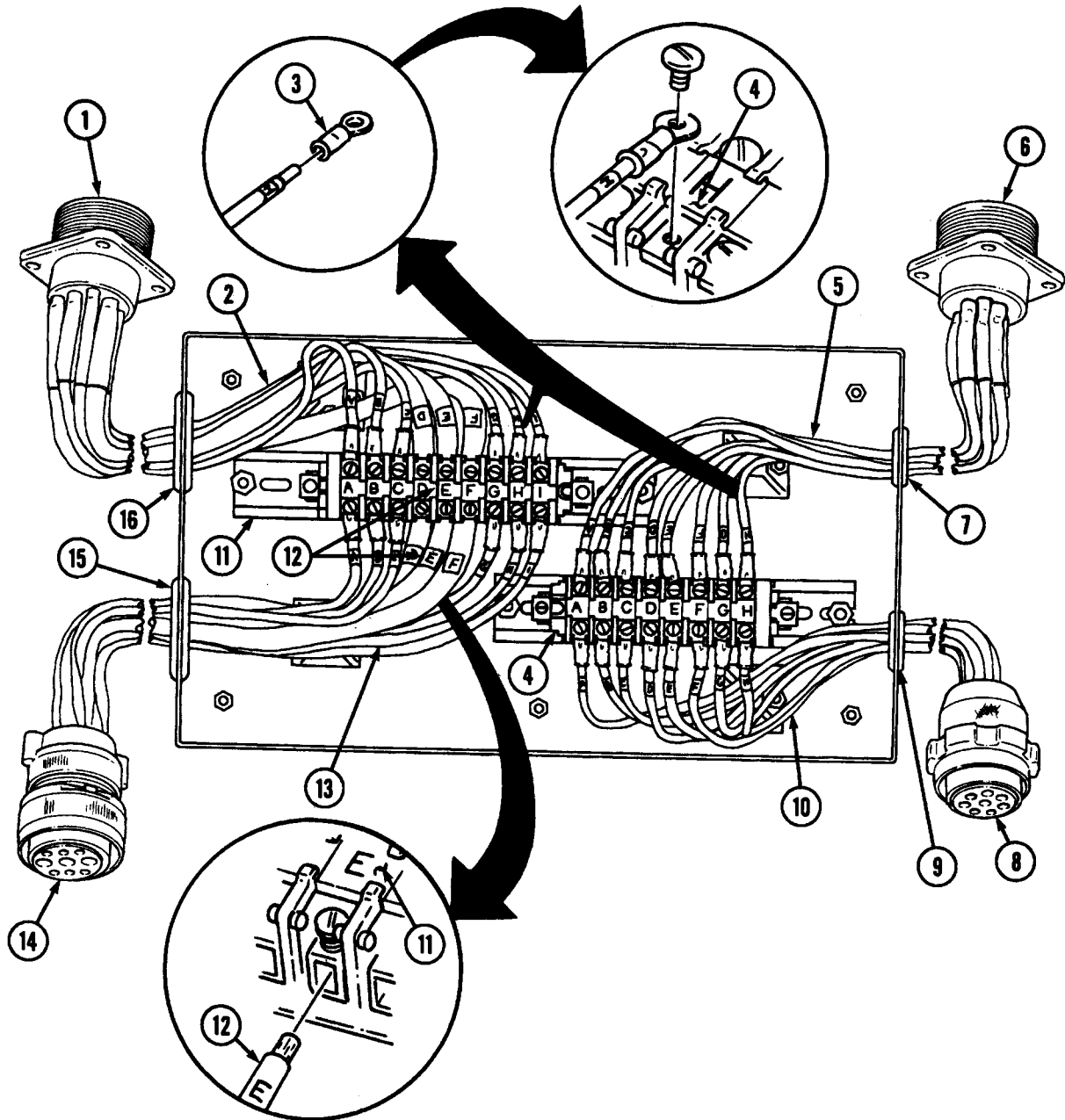

Figure D-106. Body, Engine Harness Connector, and Receptacle Installation.

Section II. ILLUSTRATED MANUFACTURING INSTRUCTIONS (Cont'd)

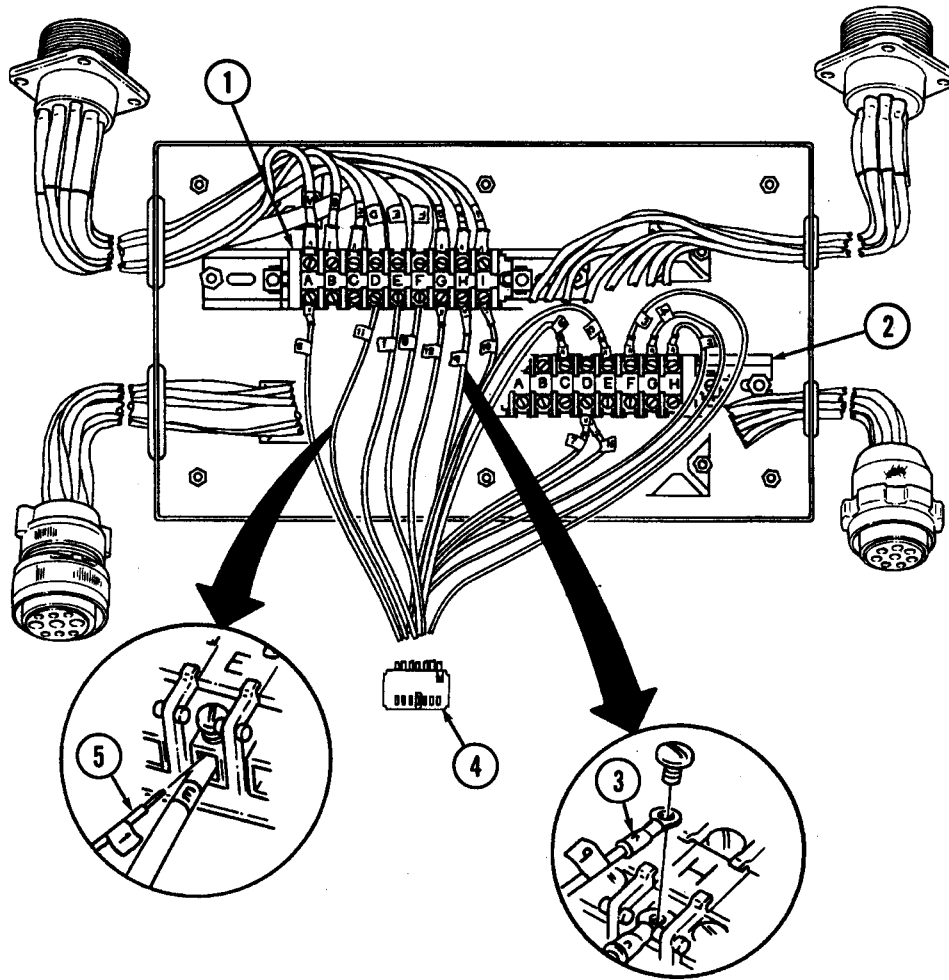

Figure D-107. Receptacle Plug Installation.

INSTRUCTIONS:

NOTE

- Ensure wire markers match letter identification for connector and receptacle harness assemblies.
- Trim excess wire to required length when installing wire and terminal lugs to terminal block assembly.

1. Connect wires (3) marked 2, 3, 4, 6, 7, and 16 on receptacle plug (4) to terminal strip (2) marked H, F, G, C, D, and B.
2. Connect wire (3) marked 13 on receptacle plug (4) to terminal strip (2) marked E.
3. Connect wires (5) marked 1, 8, 11 on receptacle plug (4) to terminal strip (1) marked E, F, D.
4. Connect wires (3) marked 5, 9, 10, and 12 on receptacle plug (4) to terminal strip (1) marked A, H, I, and G.

Section II. ILLUSTRATED MANUFACTURING INSTRUCTIONS (Cont'd)

ITEM NO.	REQ'D	MATERIALS	
		DESCRIPTION	NSN/PART NUMBER
3	4	Screw	5305-00-984-6210
4	2	Loop Clamp	5340-00-057-2904
5	2	Conduit Insulation: 48 in.	68240
6	AR	Tape	7510-00-802-8311
8	4	Washer	5310-00-883-9384
9	4	Nut	5310-00-934-9758
11	4	Tiedown Strap	5975-00-074-2072
12	2	Loop Clamp	5434-00-724-7038
13	2	Conduit Insulation: 54 in.	68243

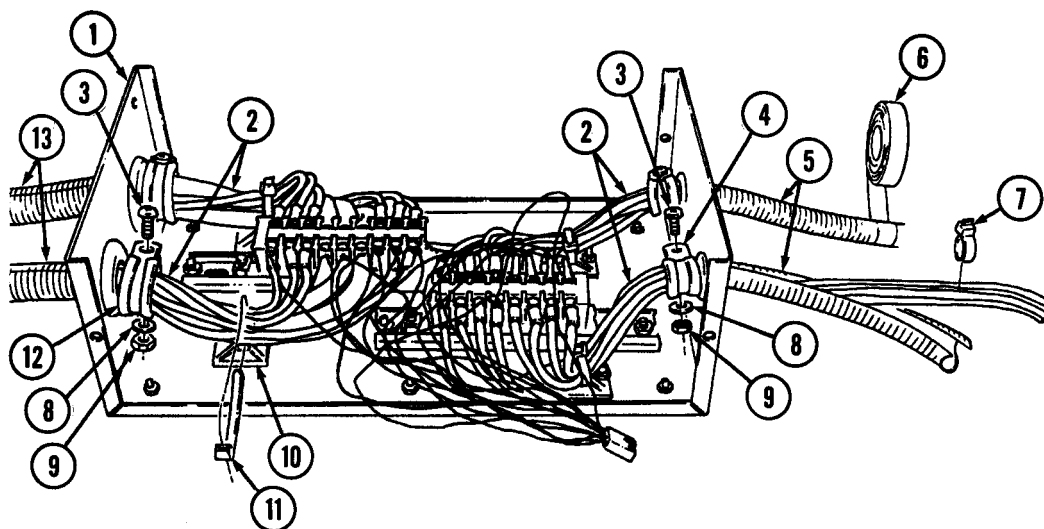

Figure D-108. Terminal Strip Installation.

INSTRUCTIONS:

1. Install four tiedown straps (11) in cable tie holders (10) and secure wires (2) to cable tie holders (10) with tiedown straps (11).
2. Install two loop clamps (4) on wires (2) of body harness connector and receptacle with screws (3), washers (8), and nuts (9).
3. Install two loop clamps (12) on wires (2) of engine harness connector and receptacle with screws (3), washers (8), and nuts (9).
4. Cut two 48-in. (1,219.2 mm) sections of conduit insulation (5).
5. Remove ten tiedown straps (7) from wires (2) of body harness connector and receptacle.
6. Position two sections of conduit insulation (5) over wires (2) of body harness connector and receptacle and secure with tape (6).
7. Cut two 54-in. (1,371.6 mm) sections of conduit insulation (13).
8. Remove twelve tiedown straps (7) from wires on engine harness connector and receptacle.
9. Position sections of conduit insulation (13) over wires (2) on engine harness connector and receptacle and secure with tape (6).

Section II. ILLUSTRATED MANUFACTURING INSTRUCTIONS (Cont'd)

MATERIAL BLOCK		
STOCK SIZE	DESCRIPTION	SPECIFICATION
14 AWG N/A	WIRE, ELECTRICAL INSULATION SLEEVING	MIL-C-13486/1 MIL-I-23053/5

ITEM NO.	REQ'D	MATERIALS	
		DESCRIPTION	NSN
1	5	Electrical Wire: 12 in.	6145-00-152-6499
2	5	Tip Jack	5935-00-683-7651
3	5	Insulation Sleeving: 1 in.	5970-00-815-1295

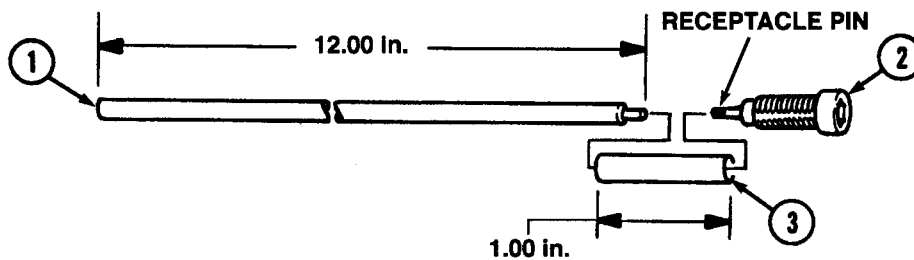

Figure D-109. Tip Jack Lead Assembly.

INSTRUCTIONS:

NOTE

When connecting electrical wire to receptacle pins on tip jacks, use NSN 3493-00-133-1108 solder. (Refer to TB SIG-222 for soldering.)

1. Cut wire (1) into five 12-in. sections as shown.
2. Cut insulation sleeving (3) into five 1-in. sections as shown.
3. Connect five wires (1) to receptacle pins on tip jacks (2).
4. Place insulation sleeving (3) over wires (1) and receptacle pins and heat-shrink insulation sleeving (3) into position.

Section II. ILLUSTRATED MANUFACTURING INSTRUCTIONS (Cont'd)

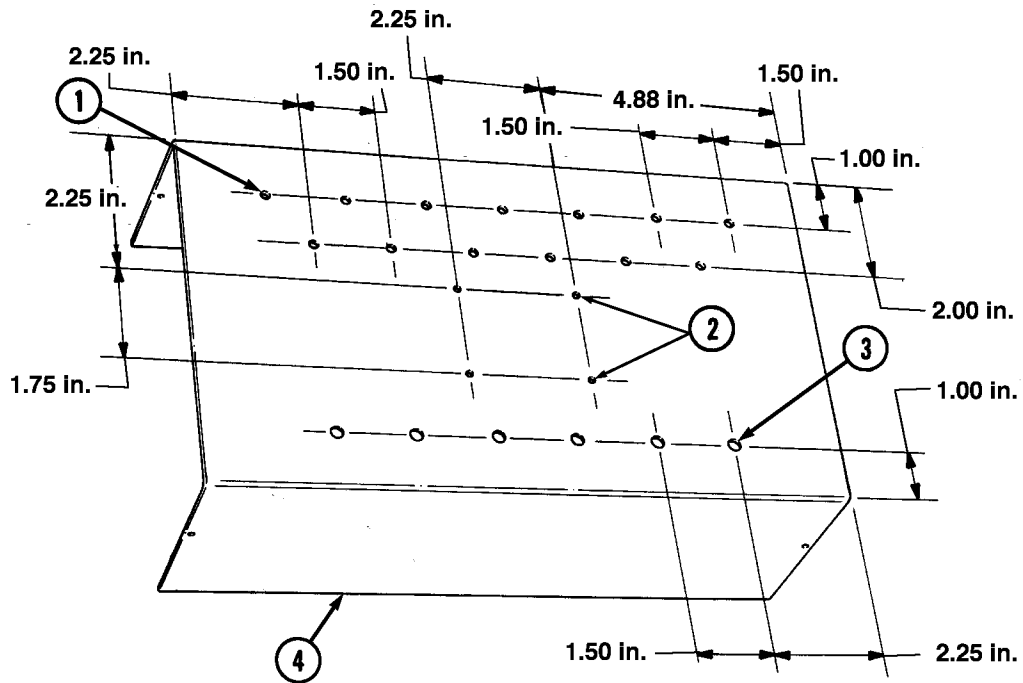

Figure D-110. Mini-box Top Section Drill Procedure.

INSTRUCTIONS:

1. Locate, mark, and drill thirteen 0.156-in. diameter holes (1) in mini-box top section (4).
2. Locate, mark, and drill six 0.205-in. diameter holes (3) in mini-box top section (4).
3. Locate, mark, and drill four 0.138-in. diameter holes (2) in mini-box top section (4).

Section II. ILLUSTRATED MANUFACTURING INSTRUCTIONS (Cont'd)

ITEM NO.	REQ'D	MATERIALS	
		DESCRIPTION	NSN
	1	Data Mark Set	7510-01-040-7110
	1	Data Mark Set	7510-01-158-1037
2	13	Led	5980-01-288-0188
3	1	Mini-Box (top section)	5999-00-971-8848
4	5	Tip Jack (assembled in figure D-109)	5935-00-683-7651
7	5	Terminal Lug	5940-00-283-5280
10	1	Tip Jack	5935-00-683-7651
13	25	Insulation Sleeve: 1 in.	5970-00-812-2974

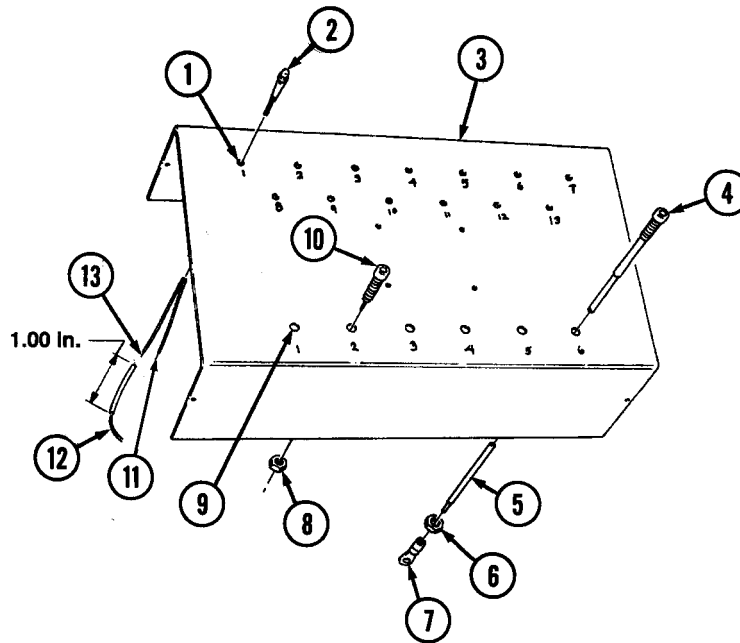

Figure D-110. Mini-box Top Section Drill Procedure (Cont'd).

INSTRUCTIONS (CONT'D):

4. Using data mark set, mark location of thirteen holes (1) on mini-box top section (3).
5. Using data mark set, mark location of six holes (9) on mini-box top section (3).
6. Install tip jack (10) and nut (8) in hole (9) marked 2 on mini-box top section (3).
7. Install five tip jacks (4) with wires (5) and nuts (6) in holes (9) marked 1, 3, 4, 5, and 6 on mini-box top section (3).
8. Install five terminal lugs (7) to wires (5) on tip jacks (4).
9. Install thirteen LEDs (2) in holes (1) marked 1 through 13 on mini-box top section (3).
10. Cut electrical insulation sleeving (13) into twenty-five sections as shown.
11. Place twelve sections of electrical insulation sleeving (13) over red (+) wires (11) marked 2, 3, 4, 5, 6, 7, 8, 9, 10, 11, 12, and 13 on LEDs (2).
12. Place thirteen sections of electrical insulation sleeving (13) over black (-) wires (12) marked 1, 2, 3, 4, 5, 6, 7, 8, 9, 10, 11, 12, and 13 on LEDs (2).

Section II. ILLUSTRATED MANUFACTURING INSTRUCTIONS (Cont'd)

MATERIAL BLOCK		
STOCK SIZE	DESCRIPTION	SPECIFICATION
N/A	WIRE, ELECTRICAL	MIL-W-16878/4
N/A	PUNCH BOARD	64P44EP

ITEM NO.	REQ'D	MATERIALS	
		DESCRIPTION	NSN/PART NUMBER
1	1	Punch Board: 2 x 3 in.	64P44EP
2	31	Electrical Wire: 5 in.	6145-00-808-4849

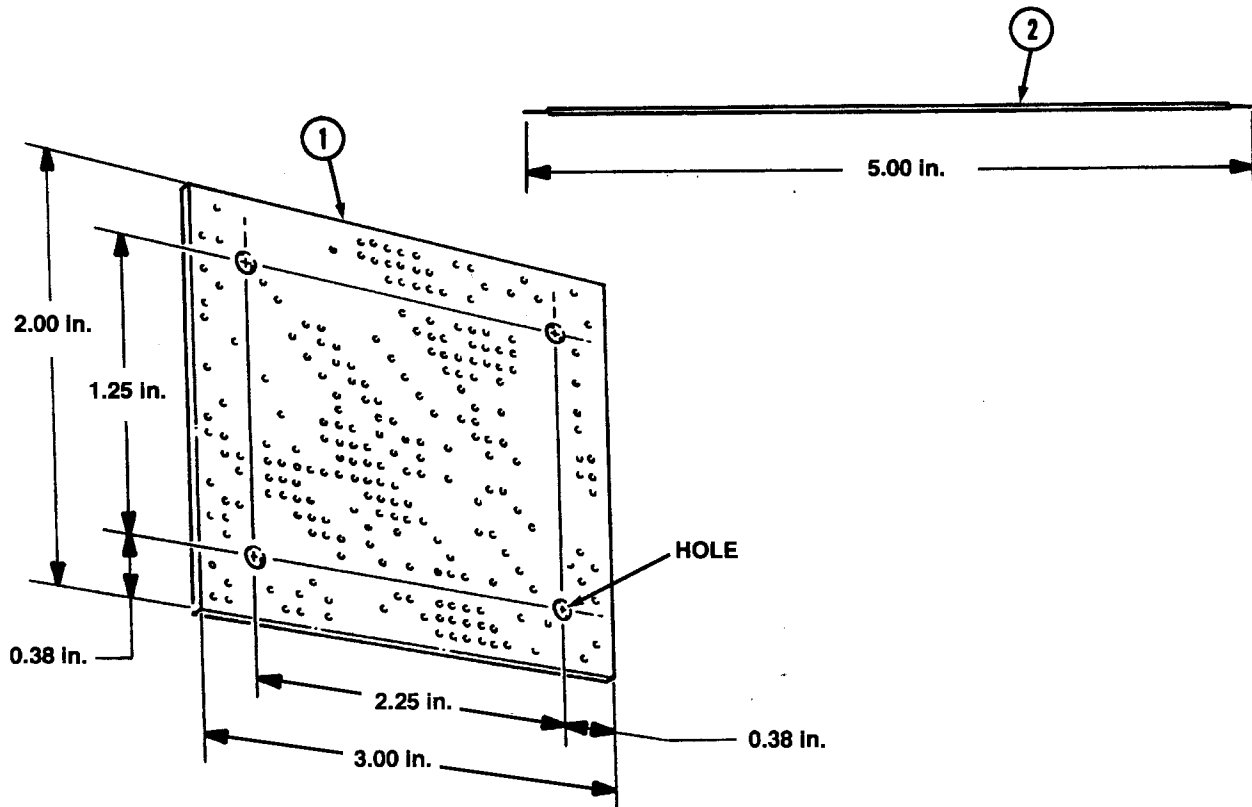

Figure D-111. Punch Board and Electrical Wire.

INSTRUCTIONS:

1. Cut punch board (1) to size as shown.
2. Locate, mark, and drill four 0.375-in. diameter holes in punch board (1) as shown.
3. Cut thirty-one 5-in. sections of electrical wire (2) as shown.

Section II. ILLUSTRATED MANUFACTURING INSTRUCTIONS (Cont'd)

ITEM NO.	REQ'D	MATERIALS	
		DESCRIPTION	NSN/PART NUMBER
1	1	Plug Connector	5935-01-230-9304
2	1	Punch Board (fabricated in figure D-99)	64P44EP
3	1	Isolated Resistor Network	13F170
4-6	3	Diode	ECG125
7	1	Bussed Resistor Network	13F171
31		Wire (cut in figure D-99)	

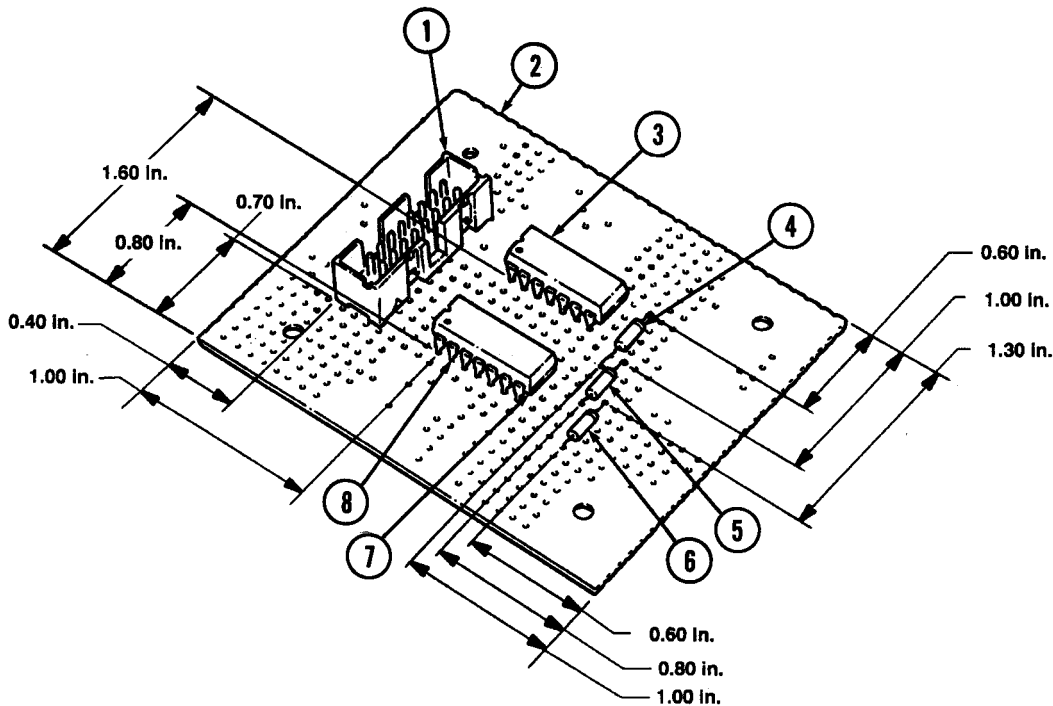

Figure D-112. Punch Board Assembly.

INSTRUCTIONS:

1. Install plug connector (1) on punch board (2).
2. Install fourteen wires to pins (8) marked 1, 2, 3, 4, 5, 6, 7, 8, 9, 10, 11, 12, 13, and 16 on plug connector (1).
3. Install insulated resistor network (3) on punch board (2).
4. Install six wires to pins (8) marked 1, 4, 7, 8, 11, and 14 on isolated resistor network (3).
5. Install bussed resistor network (7) on punch board (2).
6. Install eleven wires to pins (8) marked 1, 2, 3, 4, 5, 8, 9, 10, 11, 12, and 14 on bussed resistor network (7).
7. Install diodes (4), (5), and (6) on punch board (2).

Section II. ILLUSTRATED MANUFACTURING INSTRUCTIONS (Cont'd)

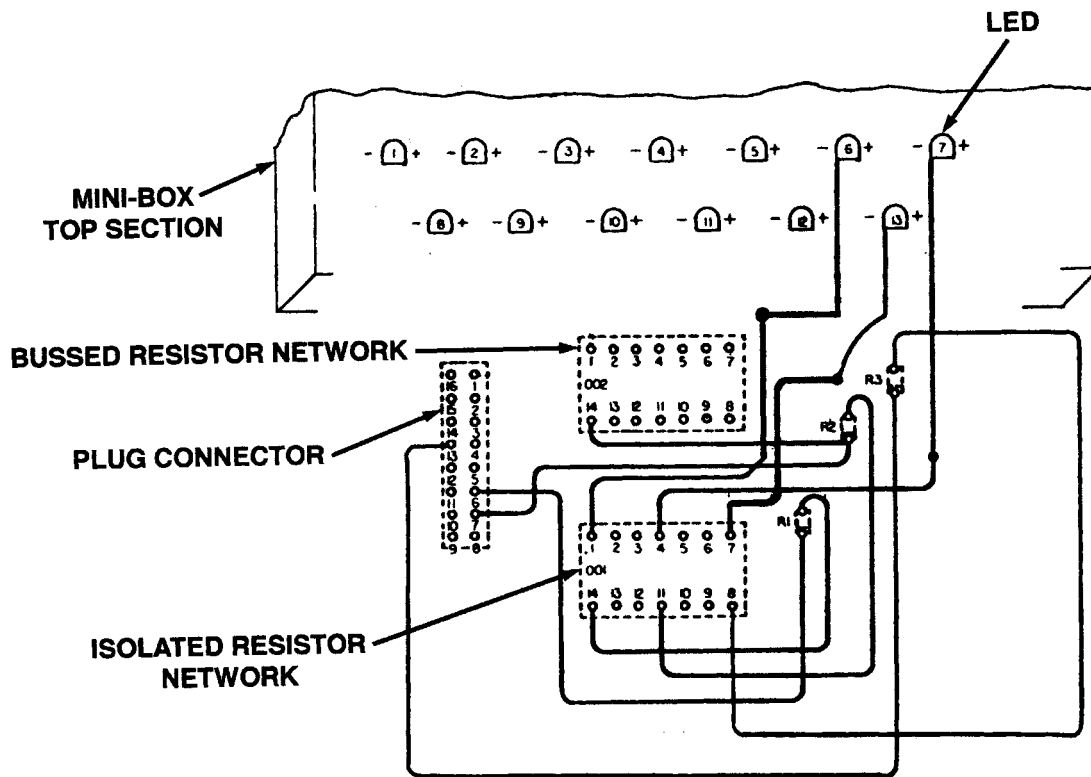

Figure D-113. Test Module Assembly.

INSTRUCTIONS:

1. Connect wire marked 6 on plug connector to banded end of diode R1.
2. Connect wire marked 14 on isolated resistor network to bandless end of diode R1.
3. Connect wire marked 7 on plug connector and wire marked 14 on bussed resistor network to banded end of diode R2.
4. Connect wire marked 13 on plug connector to bandless end of diode R3.
5. Connect wire marked 11 on isolated resistor network to bandless end of diode R2.
6. Connect wire marked 8 on isolated resistor network bandless end of diode R3.
7. Connect wire marked 1 on isolated resistor network to black (-) wire marked 6 on LED on mini-box top section.
8. Connect wire marked 4 on isolated resistor network to black (-) wire marked 7 on LED.
9. Connect wire marked 7 on isolated resistor network to black (-) wire marked 13 on LED.

Section II. ILLUSTRATED MANUFACTURING INSTRUCTIONS (Cont'd)

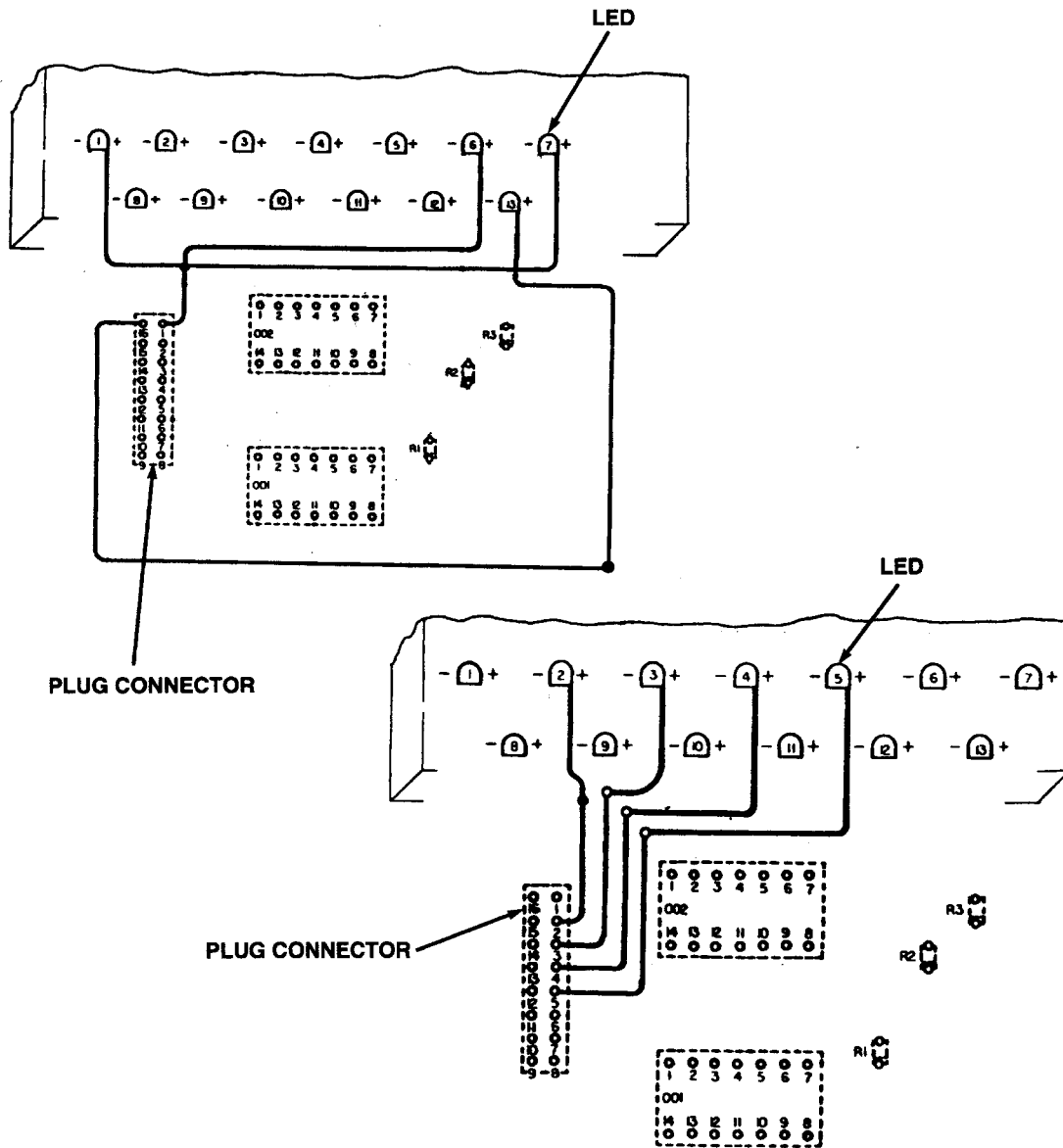

Figure D-113. Test Module Assembly (Cont'd).

INSTRUCTIONS (CONT'D):

10. Connect wire marked 16 on plug connector to red (+) wire marked 13 on LED.
11. Connect wire marked 1 on plug connector to three red (+) wires marked 1, 6, and 7 on LED.
12. Connect wire marked 2 on plug connector to red (+) wire marked 2 on LED.
13. Connect wire marked 3 on plug connector to red (+) wire marked 3 on LED.
14. Connect wire marked 4 on plug connector to red (+) wire marked 4 on LED.
15. Connect wire marked 5 on plug connector to red (+) wire marked 5 on LED.

Section II. ILLUSTRATED MANUFACTURING INSTRUCTIONS (Cont'd)

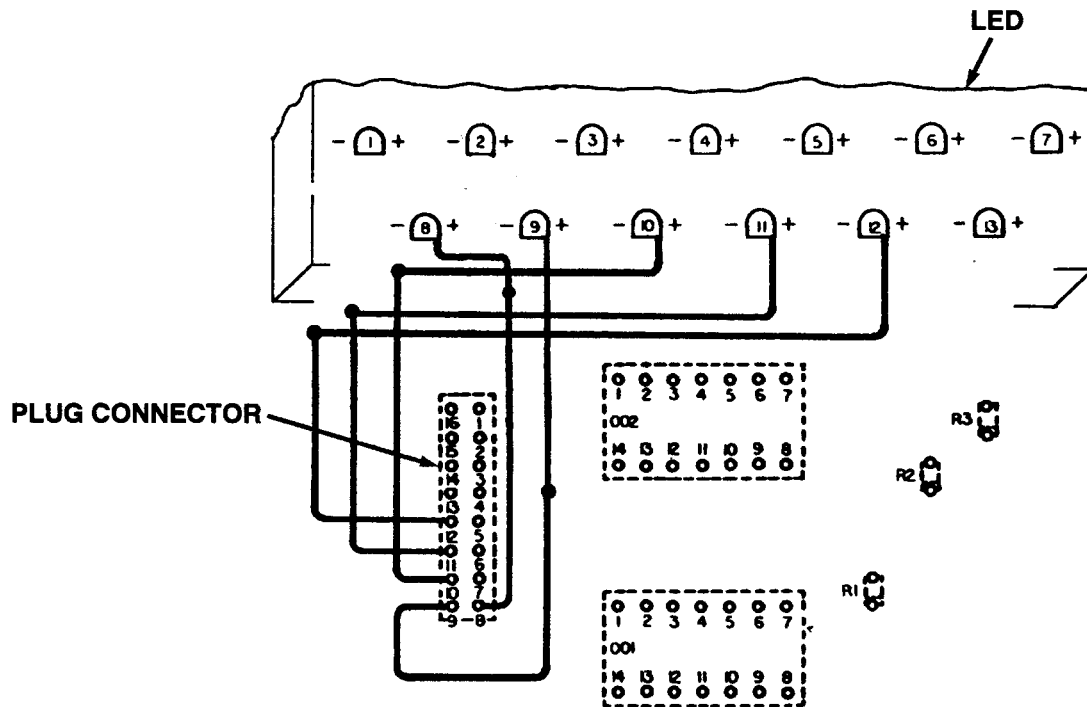

Figure D-113. Test Module Assembly (Cont'd).

INSTRUCTIONS (CONT'D):

16. Connect wire marked 8 on plug connector to red (+) wire marked 8 on LED.
17. Connect wire marked 9 on plug connector to red (+) wire marked 9 on LED.
18. Connect wire marked 10 on plug connector to red (+) wire marked 10 on LED.
19. Connect wire marked 11 on plug connector to red (+) wire marked 11 on LED.
20. Connect wire marked 12 on plug connector to red (+) wire marked 12 on LED.

Section II. ILLUSTRATED MANUFACTURING INSTRUCTIONS (Cont'd)

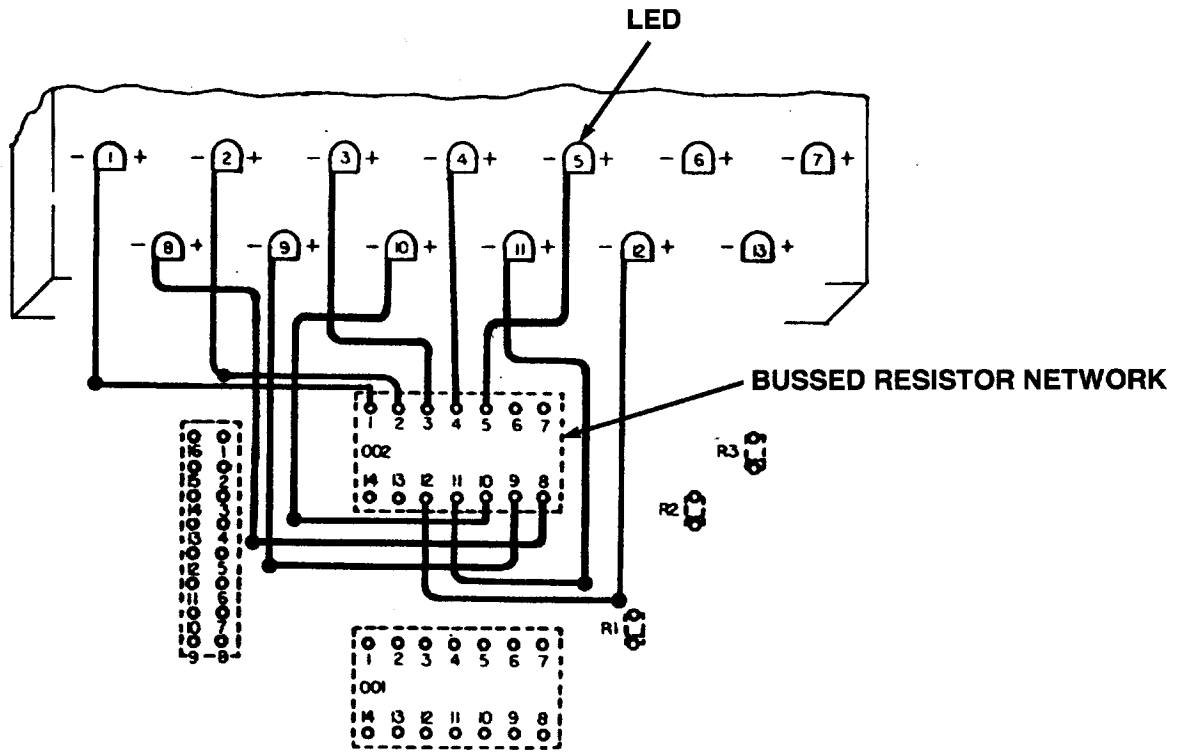

Figure D-113. Test Module Assembly (Cont'd).

INSTRUCTIONS (CONT'D):

21. Connect wire marked 1 on bussed resistor network to black (-) wire marked 1 on LED.
22. Connect wire marked 2 on bussed resistor network to black (-) wire marked 2 on LED.
23. Connect wire marked 3 on bussed resistor network to black (-) wire marked 3 on LED.
24. Connect wire marked 4 on bussed resistor network to black (-) wire marked 4 on LED.
25. Connect wire marked 5 on bussed resistor network to black (-) wire marked 5 on LED.
26. Connect wire marked 8 on bussed resistor network to black (-) wire marked 8 on LED.
27. Connect wire marked 9 on bussed resistor network to black (-) wire marked 9 on LED.
28. Connect wire marked 10 on bussed resistor network to black (-) wire marked 10 on LED.
29. Connect wire marked 11 on bussed resistor network to black (-) wire marked 11 on LED.
30. Connect wire marked 12 on bussed resistor network to black (-) wire marked 12 on LED.

Section II. ILLUSTRATED MANUFACTURING INSTRUCTIONS (Cont'd)

ITEM NO.	REQ'D	MATERIALS	
		DESCRIPTION	NSN/PART NUMBER
2	4	Spacer	313-1437-024
3	25	Insulation Sleeving (install in figure D-110)	5970-00-812-2974
4	4	Screw	5305-00-928-9021
8	4	Washer	5310-00-880-5976
9	4	Nut	5310-00-934-9753

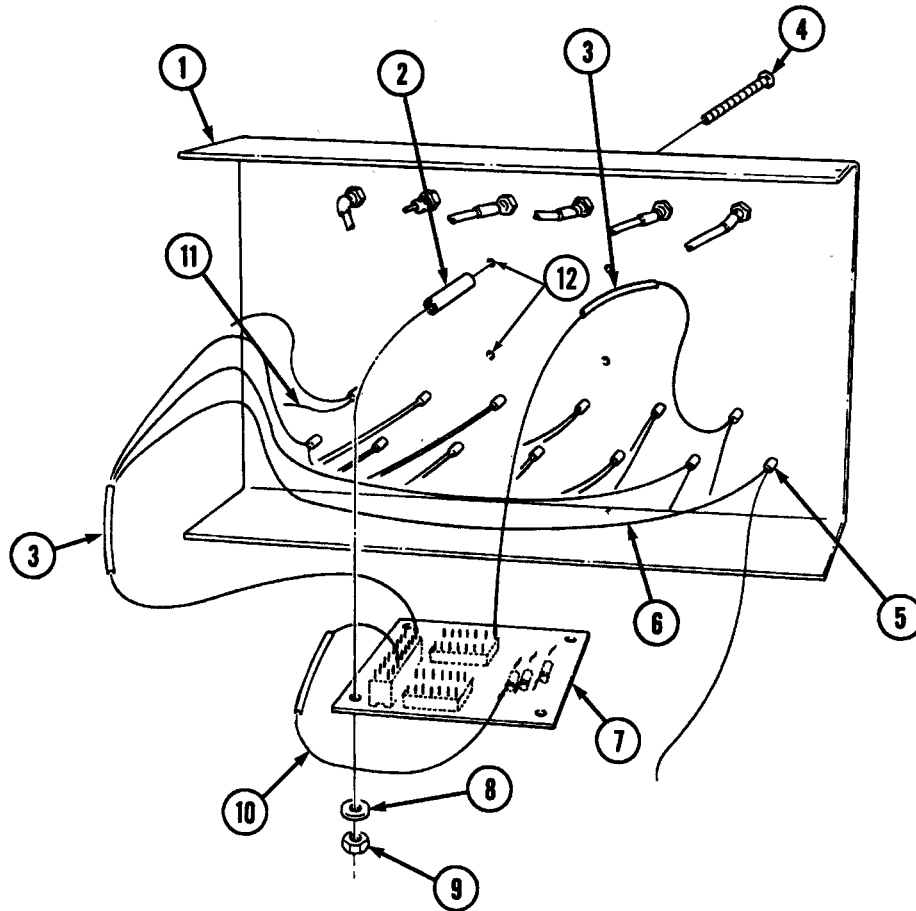

Figure D-113. Test Module Assembly (Cont'd).

INSTRUCTIONS (CONT'D):

31. Place electrical insulation sleeving (3) over wire (10) marked 1 on plug connector.
32. Place twenty-four sections of insulation sleeving (3) over connected wires (6) and (11) on LEDs (5) and heat-shrink into position.
33. Install four screws (4) in mount holes (12) on mini-box top section (1) and position four spacers (2) and punch board (7) on screws (4) and secure with four washers (8) and nuts (9).

Section II. ILLUSTRATED MANUFACTURING INSTRUCTIONS (Cont'd)

MATERIAL BLOCK		
STOCK SIZE	DESCRIPTION	SPECIFICATION
14 AWG	WIRE ELECTRICAL	MIL-C-13486/1

ITEM NO.	REQ'D	MATERIALS	
		DESCRIPTION	NSN
1	2	Terminal Lug	5940-00-577-3807
2	1	Electrical Wire: 12 in.	6145-00-808-4849
7	1	Screw	5305-00-984-6210
8	1	Nut	5310-00-934-9758
11	1	Washer	5310-00-883-9384

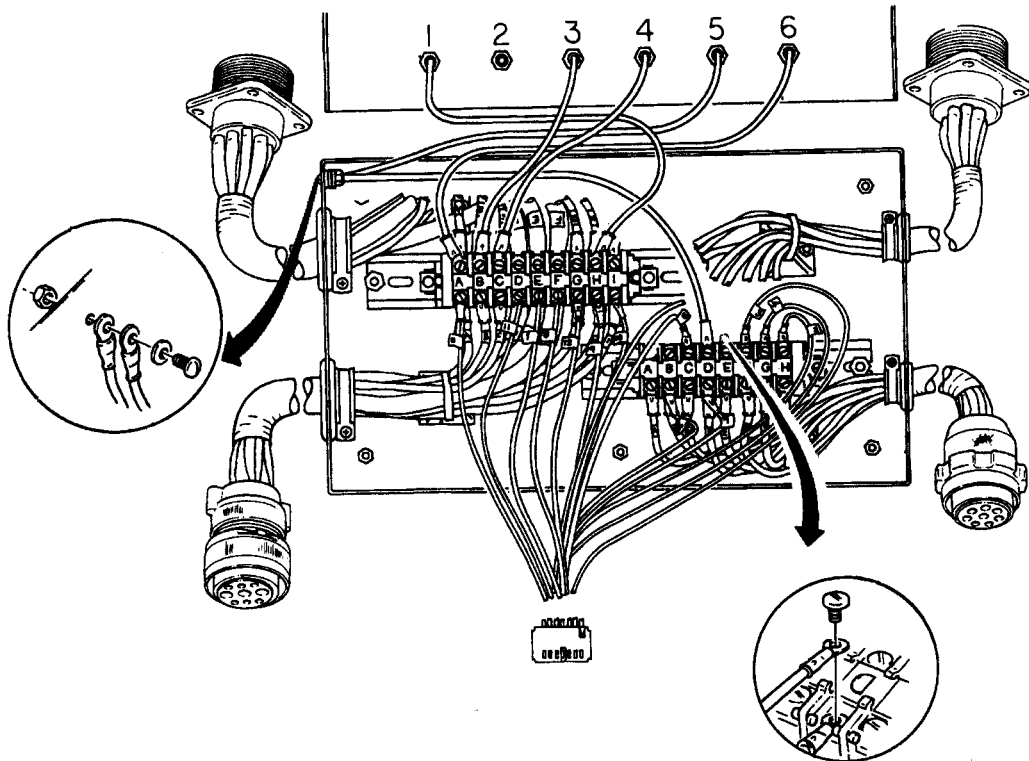
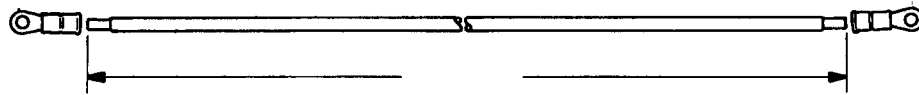

Figure D-113. Test Module Assembly (Cont'd).

Section II. ILLUSTRATED MANUFACTURING INSTRUCTIONS (Cont'd)

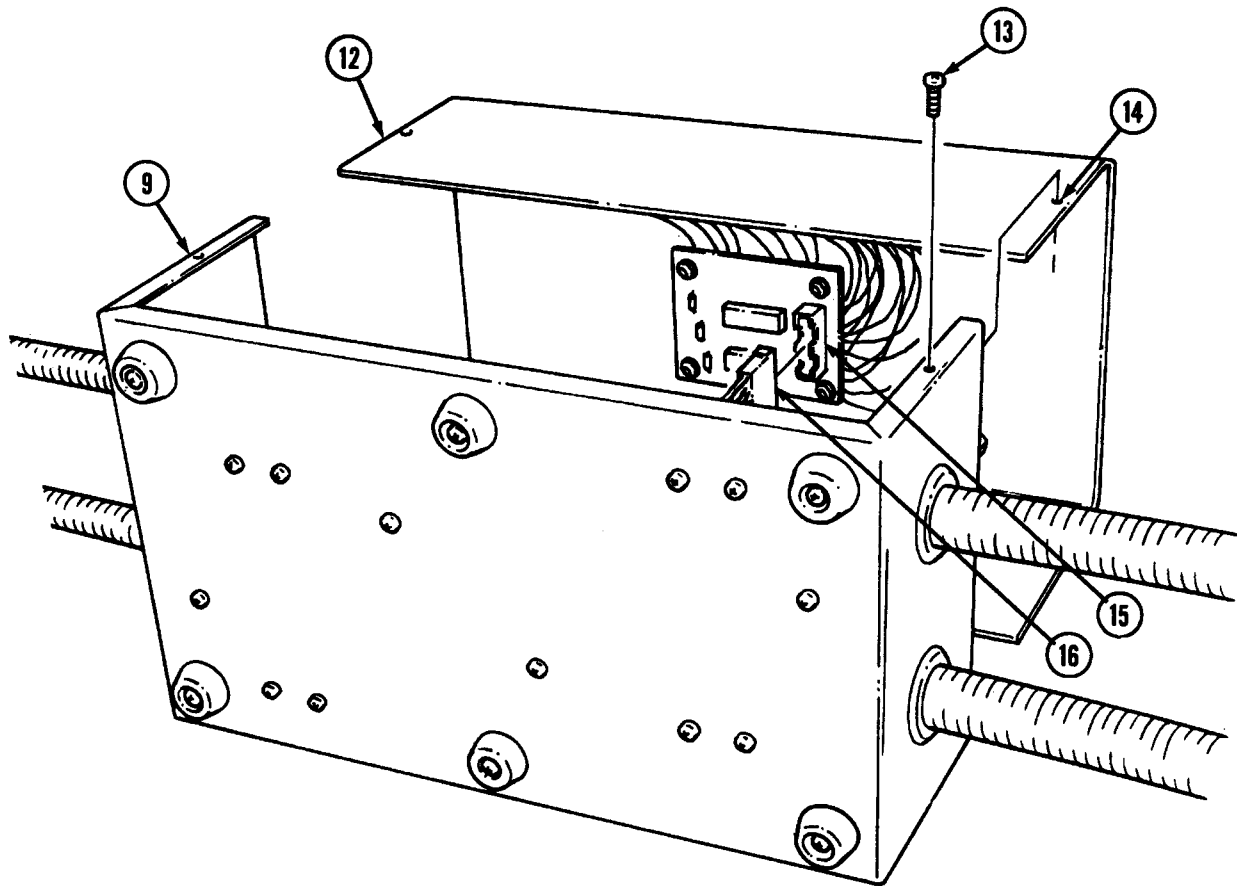

Figure D-113. Test Module Assembly (Cont'd).

INSTRUCTIONS (CONT'D):

34. Cut electrical wire (2) to length as shown.
35. Connect two terminal lugs (1) on wire (2).
36. Install wire (2) and tip jack lead (3) marked 5 on mount hole (10) on mini-box bottom section (9) with washer (11), screw (7), and nut (8).
37. Connect wire (2) to terminal strip (4) marked D with screw (5).
38. Connect tip jack lead (3) marked 1 to terminal strip (6) marked H with screw (5).
39. Connect tip jack lead (3) marked 3 to terminal strip (6) marked B with screw (5).
40. Connect tip jack lead (3) marked 4 to terminal strip (6) marked C with screw (5).
41. Connect tip jack lead (3) marked 6 to terminal strip (6) marked A with screw (5).
42. Using existing drive pin, punch out four screw mount holes (14) in mini-box top section (12).
43. Install plug (16) and connector (15) as shown.
44. Install mini-box top (12) on bottom section (9) with four existing screws (13).

Section II. ILLUSTRATED MANUFACTURING INSTRUCTIONS (Cont'd)

MATERIAL BLOCK		
STOCK SIZE	DESCRIPTION	SPECIFICATION
39.00 IN. MINIMUM	CLOTH, COATED PLASTIC, VINYL BOTH SIDES	11 TYPE AND 2 CLASS

GREEN RUBBER CANVAS		
PART NO.	CUT LENGTH (INCHES)	MANUFACTURED FROM NSN
8434398	2 at 3X12 4 at 4X15 2 at 36X6	8305-00-616-0022

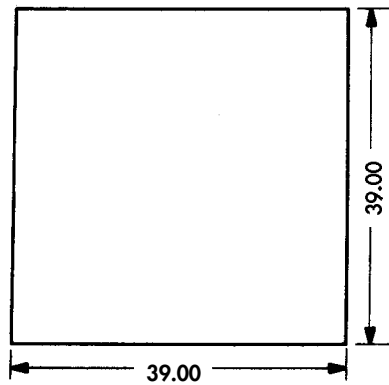
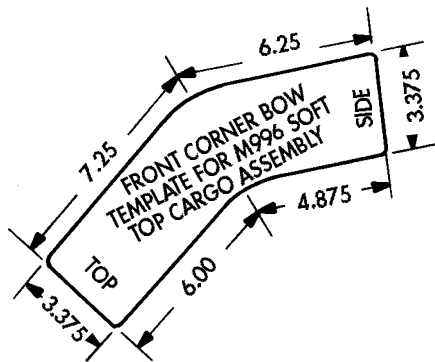

Figure D-114. Green Rubber Canvas Straps.

INSTRUCTIONS:

1. Cut canvas, NSN 8305-00-616-0022, into eight reinforcement straps for lengths shown.
2. Secure six grommets, NSN 5325-00-281-8643, and six stud turn buttons, NSN 5325-00-930-7607, to canvas straps using twelve clinch plate turn buttons, NSN 5325-00-371-8108.

Section II. ILLUSTRATED MANUFACTURING INSTRUCTIONS (Cont'd)

MATERIAL BLOCK		
STOCK SIZE	DESCRIPTION	SPECIFICATION
0.188 IN. THICK	STRIP, METAL	ASTM-A569

HEX WRENCH		
PART NO.	CUT LENGTH (INCHES)	MANUFACTURED FROM NSN
N/A	as shown	9515-00-814-7316

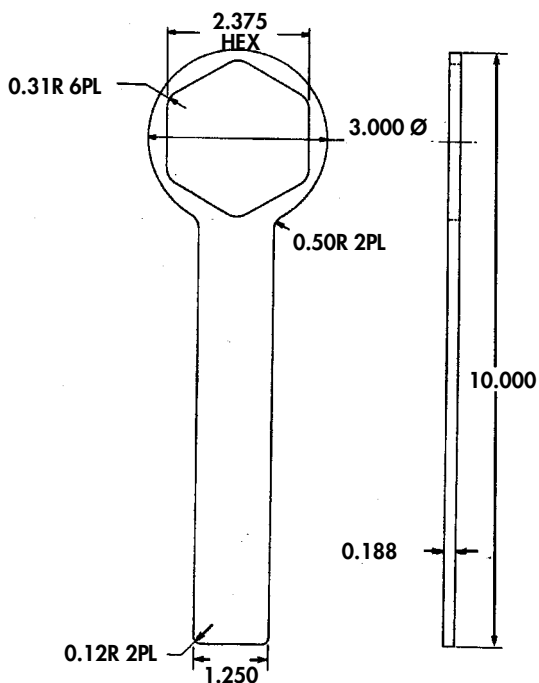

Figure D-115. Hex Wrench.

INSTRUCTIONS:

1. Cut piece of steel sheet metal to size as shown.
2. Remove all burrs and sharp edges.

Section II. ILLUSTRATED MANUFACTURING INSTRUCTIONS (Cont'd)

MATERIAL BLOCK		
STOCK SIZE	DESCRIPTION	SPECIFICATION
0.700 IN. THICK	ALUMINUM ALLOY	N/A

SHEET		
PART NO.	CUT LENGTH (INCHES)	MANUFACTURED FROM NSN
N/A	as shown	9530-00-226-0380

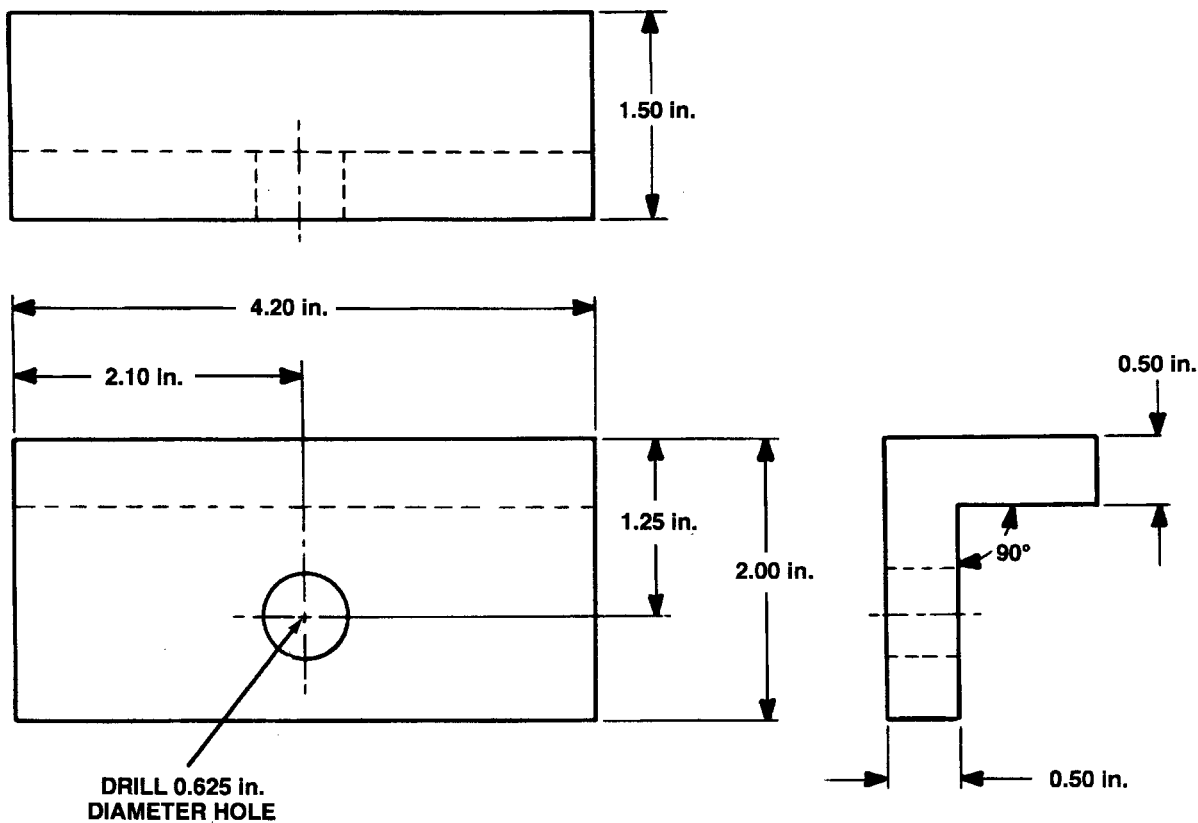

Figure D-117. Fixture Fabrication.

INSTRUCTIONS:

1. Fabricate fixture according to dimensions as shown.
2. Remove all burrs and sharp edges.

Section II. ILLUSTRATED MANUFACTURING INSTRUCTIONS (Cont'd)

MATERIAL BLOCK		
STOCK SIZE	DESCRIPTION	SPECIFICATION
N/A	BAR, METAL	ASTM A108

SHEET		
PART NO.	CUT LENGTH (INCHES)	MANUFACTURED FROM NSN
N/A	as shown	9510-00-229-4822

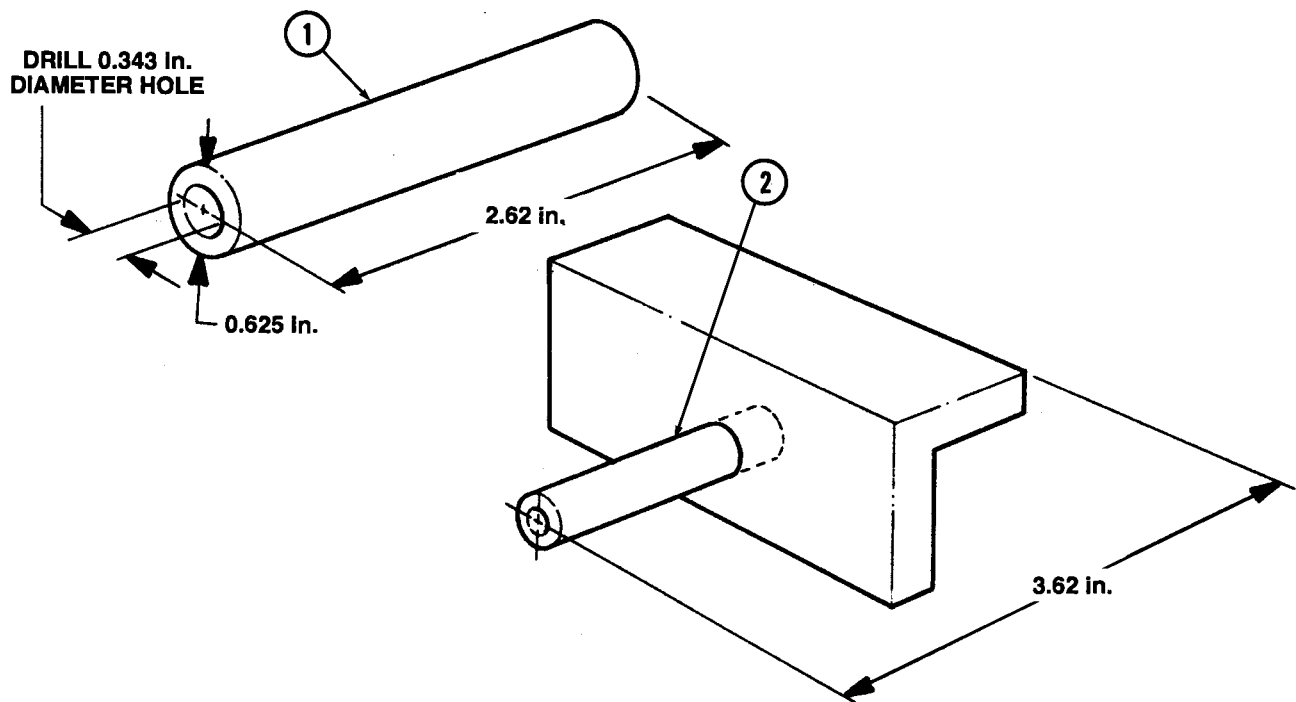

Figure D-118. Bushing Fabrication.

INSTRUCTIONS:

1. Using NSN 9510-00-229-4822 metal bar, fabricate bushing (1) as shown.
2. Remove all burrs and sharp edges.
3. Press bushing (1) into fixture hole (2) (fixture fabricated in figure D-117).

Section II. ILLUSTRATED MANUFACTURING INSTRUCTIONS (Cont'd)

MATERIAL BLOCK		
STOCK SIZE	DESCRIPTION	SPECIFICATION
0.375 IN. INSIDE DIAMETER 0.625 IN. OUTSIDE DIAMETER	HOSE, WIRE BRAIDED	N/A

ITEM NO.	REQ'D	MATERIALS	
		DESCRIPTION	NSN
	AR	Sealing Compound	8030-01-054-0740
1	1	Adapter, Straight Swivel	4730-00-547-0941
2	1	Adapter, Straight	4730-01-309-0949
3	2	Clamp, Hose	4730-00-024-3971
5	1	Adapter, Straight	4730-00-140-3770
6	1	Coupling, Pipe	4730-01-071-2859
7	1	Nipple, Pipe	4730-00-193-2709

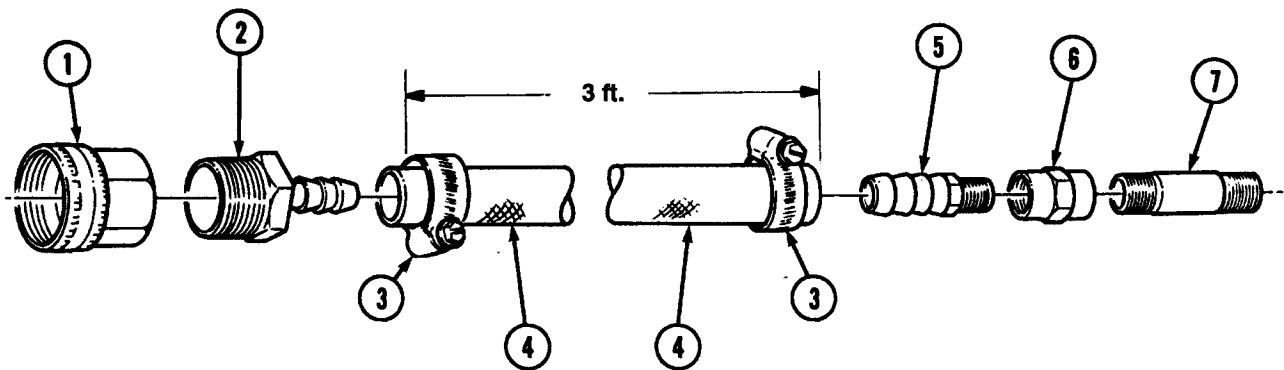

Figure D-119. Hose.

INSTRUCTIONS:

NOTE

Do not apply sealing compound to first two threads of straight adapter.

1. Connect clamp (3), straight adapter (2), and straight swivel adapter (1) to hose (4). Tighten clamp (3).
2. Connect clamp (3), straight adapter (5), pipe coupling (6), and pipe nipple (7) to hose (4). Tighten clamp (3).

Section II. ILLUSTRATED MANUFACTURING INSTRUCTIONS (Cont'd)

MATERIAL BLOCK		
STOCK SIZE	DESCRIPTION	SPECIFICATION
0.125 X 2.57 X 3.50 IN.	ALUMINUM FLAT SHEET	IAW ASTM B 209
0.125 X 0.75 X 24.0 IN.	ALUMINUM RECTANGLE	IAW ASTM B 211

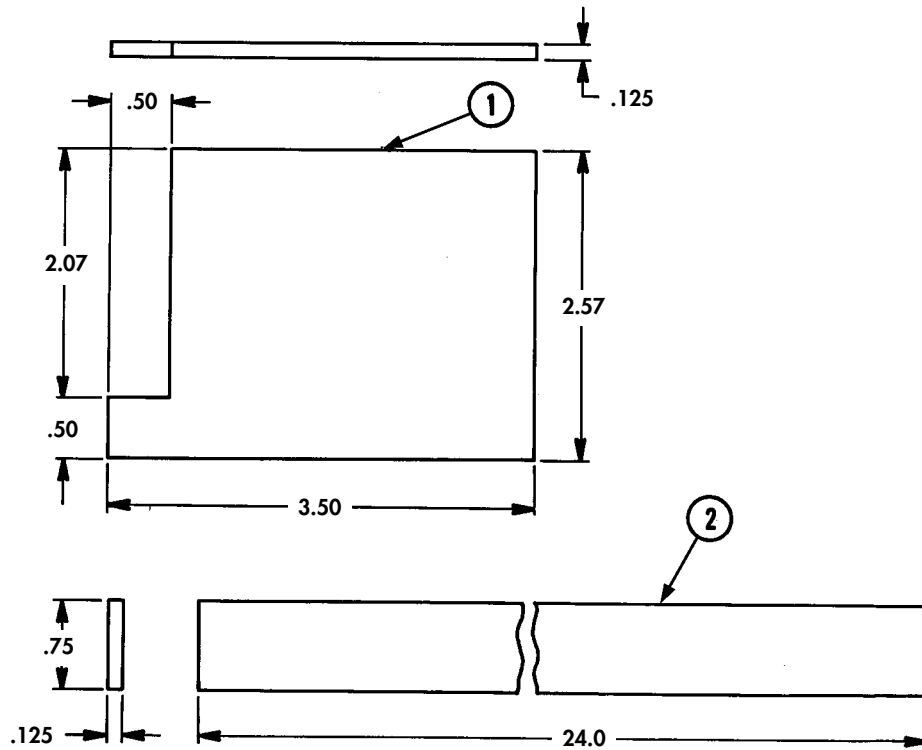

Figure D-120. Pulley Alignment Tool Fabrication.

INSTRUCTIONS:

NOTE

- Remove all burrs and sharp edges from aluminum sheet and rectangle.
- Pulley alignment tool can be assembled using nuts, bolts, rivets, or by welding.

1. Cut aluminum sheet (1) to size as shown.
2. Position aluminum rectangle (2) on top of aluminum sheet (1) as shown in figure D-130.

NOTE

Check all measurements before welding, riveting, or bolting pulley alignment tool together.

3. Assemble pulley alignment tool as shown in figure D-130.

Section II. ILLUSTRATED MANUFACTURING INSTRUCTIONS (Cont'd)

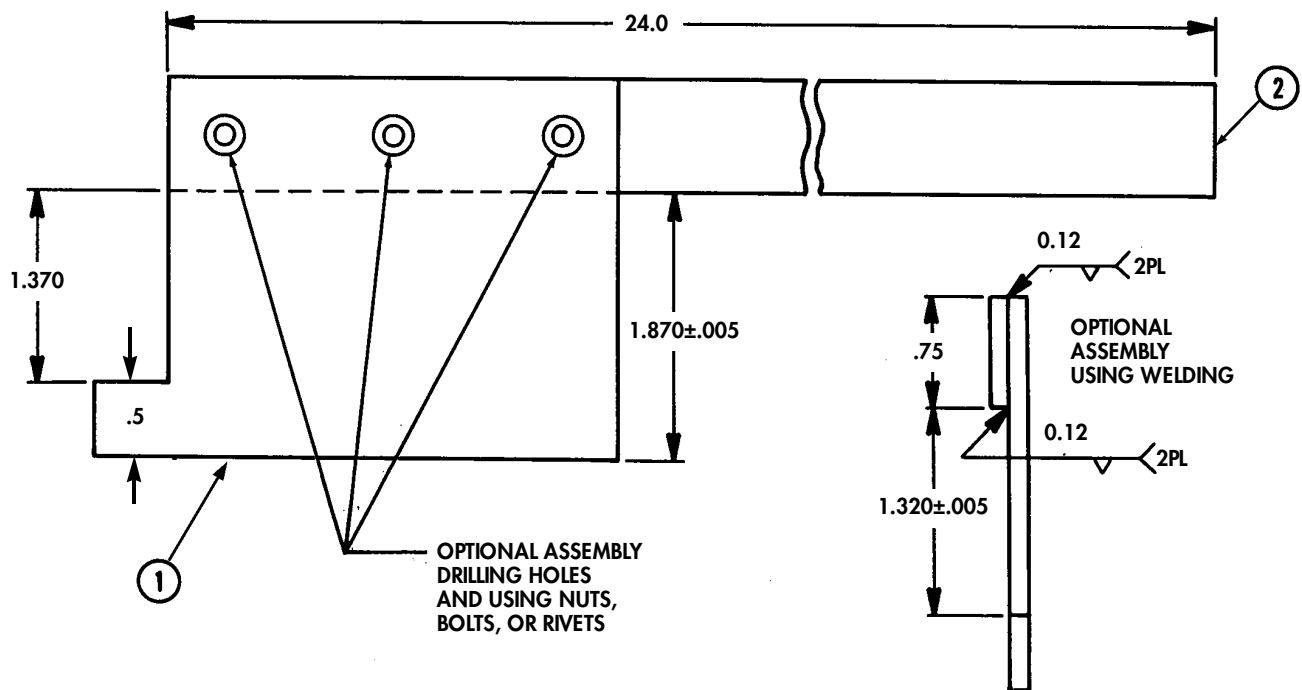

Figure D-120. Pulley Alignment Tool Fabrication (Cont'd).

MATERIAL BLOCK		
STOCK SIZE	DESCRIPTION	SPECIFICATION
18 AWG	WIRE, ELECTRICAL (WITH INSULATION)	MIL-C-13486

ITEM NO.	REQ'D	MATERIALS	
		DESCRIPTION	NSN/PART NUMBER
1	1	Terminal Lug	5940-00-113-8184
2	1	Terminal Lug	5940-00-504-4703
3	1	Electrical Wire: 9.7 in.	6145-00-570-0516

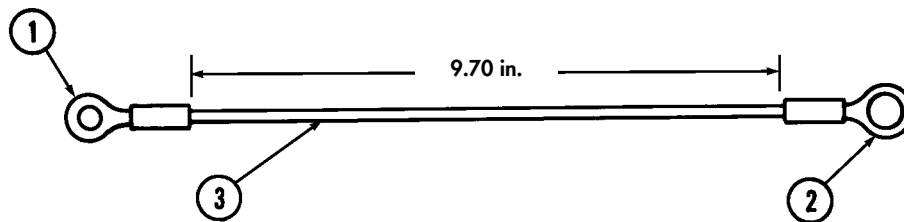

Figure D-121. Grounding Jumper Wire.

INSTRUCTIONS:

1. Cut a electrical wire (3) to length as shown.
2. Install terminal lugs (1) and (2) as shown.

APPENDIX E TORQUE LIMITS

E-1. GENERAL

This section provides general torque limits for screws used on the M998 series vehicles. Special torque limits are indicated in the maintenance procedures for applicable components. The general torque limits given in this appendix shall be used when specific torque limits are not indicated in the maintenance procedure. Unless otherwise specified, standard torque tolerance shall be $\pm 10\%$. These general torque limits cannot be applied to screws that retain rubber components. The rubber components will be damaged before the correct torque limit is reached. If a special torque limit is not given in the maintenance instructions, tighten the screw or nut until it touches the metal bracket, then tighten it one more turn.

E-2. TORQUE LIMITS

Table E-1 lists dry torque limits. Dry torque limits are used on screws that do not have lubricants applied to the threads. Table E-2 lists wet torque limits. Wet torque limits are used on screws that have high pressure lubricants applied to the threads.

E-3. HOW TO USE TORQUE TABLE

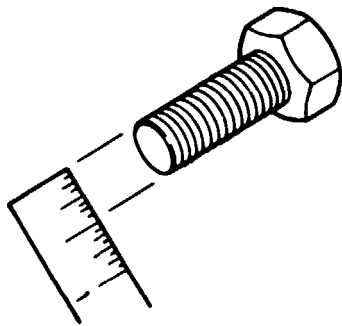

a. Measure the diameter of the screw you are installing.

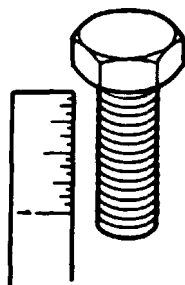

b. Count the number of threads per inch.

- c. Under the heading **SIZE**, look down the left-hand column until you find the diameter of the screw you are installing (there will usually be two lines beginning with the same size).
- d. In the second column under **SIZE**, find the number of threads per inch that matches the number of threads you counted in step b.

CAPSCREW HEAD MARKINGS

Manufacturer's marks may vary.
These are all SAE Grade 5
(3-line).



- e. To find the grade screw you are installing, match the markings on the head to the correct picture of **CAPSCREW HEAD MARKINGS** on the torque table.
- f. Look down the column under the picture you found in step e. until you find the torque limit (in lb-ft or NŹm) for the diameter and threads per inch of the screw you are installing.

Table E-1. Torque Limits for Dry Fasteners

CAPSCREW HEAD MARKINGS

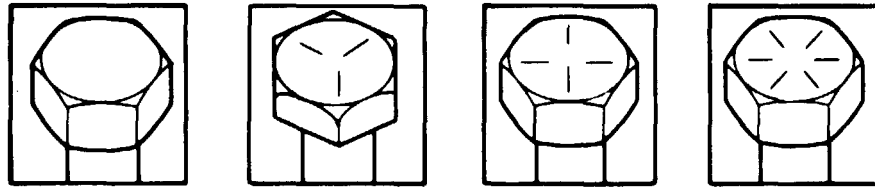

SIZE			TORQUE							
			SAE GRADE NO. 1 or 2		SAE GRADE NO. 5		SAE GRADE NO. 6 or 7		SAE GRADE NO. 8	
DIA. INCHES	THREADS PER INCH	MILLIMETERS	POUND FEET	NEWTON METERS	POUND FEET	NEWTON METERS	POUND FEET	NEWTON METERS	POUND FEET	NEWTON METERS
1/4	20	6.35	5	6.78	8	10.85	10	13.56	12	16.27
1/4	28	6.35	6	8.14	10	13.56	-	-	14	18.98
5/16	18	7.94	11	14.92	17	23.05	19	25.76	24	32.52
5/16	24	7.94	13	17.63	19	25.76	-	-	27	36.61
3/8	16	9.53	18	24.41	31	42.04	34	46.10	44	59.66
3/8	24	9.53	20	27.12	35	47.46	-	-	49	66.44
7/16	14	11.11	28	37.97	49	66.44	55	74.58	70	94.92
7/16	20	-	30	40.68	55	74.58	-	-	78	105.77
1/2	13	12.70	39	52.88	75	101.70	85	115.26	105	142.38
1/2	20	-	41	55.60	85	115.26	-	-	120	162.72
9/16	12	14.29	51	69.16	110	149.16	120	162.72	155	210.18
9/16	18	-	55	74.58	120	162.72	-	-	170	230.52
5/8	11	15.88	63	85.43	150	203.40	167	226.45	210	284.76
5/8	18	-	95	128.82	170	230.52	-	-	240	325.44
3/4	10	19.05	105	142.38	270	366.12	280	379.68	375	508.50
3/4	16	-	115	155.94	295	400.02	-	-	420	569.52
7/8	9	22.23	160	216.96	395	535.62	440	596.64	605	820.38
7/8	14	-	175	237.30	435	589.86	-	-	675	915.30
1	8	25.40	235	318.66	590	800.04	660	894.96	910	1233.96
1	14	-	250	339.00	660	894.96	-	-	990	1342.44
1-1/8	-	25.58	-	-	800- 880	1084.8- 1193.3	-	-	1280- 1440	1735.7- 1952.8
1-1/4	-	31.75	-	-	-	-	-	-	1820- 2000	2467.9- 2712.0
1-3/8	-	34.93	-	-	1460- 1680	1979.8 2278.1	-	-	2380- 2720	3227.3- 3688.3
1-1/2	-	38.10	-	-	1940- 2200	2630.6- 2983.2	-	-	3160- 3560	4285.0- 4827.4

Table E-2. Torque Limits for Wet Fasteners

CAPSCREW HEAD MARKINGS

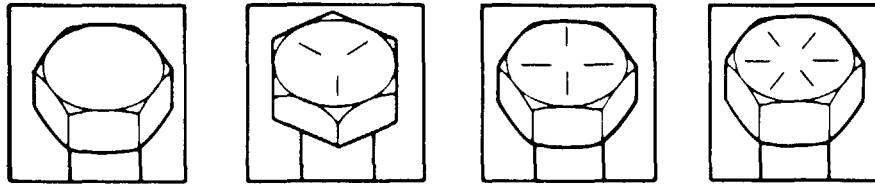

SIZE			TORQUE							
			SAE GRADE NO. 1 or 2		SAE GRADE NO. 5		SAE GRADE NO. 6 or 7		SAE GRADE NO. 8	
DIA. INCHES	THREADS PER INCH	MILLIMETERS	POUND FEET	NEWTON METERS	POUND FEET	NEWTON METERS	POUND FEET	NEWTON METERS	POUND FEET	NEWTON METERS
1/4	20	6.35	4.5	6.10	7.2	9.76	9.0	12.20	10.8	14.64
1/4	28	6.35	5.4	7.33	9.0	12.20	-	-	12.6	17.08
5/16	18	7.94	9.9	13.43	15.3	20.75	17.1	23.18	21.6	29.27
5/16	24	7.94	11.7	15.87	17.1	23.18	-	-	24.3	32.95
3/8	16	9.53	16.2	21.97	27.9	37.84	30.6	41.49	39.6	53.69
3/8	24	9.53	18.0	24.41	31.5	42.71	-	-	44.1	59.80
7/16	14	11.11	25.2	34.17	44.1	59.80	49.5	67.12	63.0	85.42
7/16	20	-	27.0	36.61	49.5	67.12	-	-	70.2	95.19
1/2	13	12.70	35.1	47.59	67.5	91.53	76.5	103.73	94.5	128.14
1/2	20	-	36.9	50.04	76.5	103.73	-	-	108.0	146.45
9/16	12	14.29	45.9	62.24	99.0	134.24	108.0	146.45	139.5	189.16
9/16	18	-	49.5	67.12	108.0	146.45	-	-	153.0	207.47
5/8	11	15.88	56.7	76.89	135.0	183.06	150.3	203.80	189.0	256.28
5/8	18	-	85.5	115.94	153.0	207.47	-	-	216.0	296.90
3/4	10	19.05	94.5	128.14	243.0	329.51	252.0	341.71	337.5	457.65
3/4	16	-	103.5	140.35	265.5	360.02	-	-	378.0	536.87
7/8	9	22.23	144.0	195.26	355.5	482.06	396.0	536.98	544.5	738.34
7/8	14	-	157.5	213.57	391.5	530.87	-	-	607.5	823.77
1	8	25.40	211.5	286.79	531.0	720.04	594.0	805.46	819.0	1110.56
1	14	-	225.0	305.10	594.0	805.46	-	-	891.0	1208.20
1-1/8	-	25.58	-	-	720.0- 792.0	976.32- 1073.97	-	-	1152.0- 1296.0	1562.13- 1757.52
1-1/4	-	31.75	-	-	-	-	-	-	1638- 1800	2221.11- 2440.80
1-3/8	-	34.93	-	-	1314.0- 1512.0	1781.82- 2050.29	-	-	2142.0- 2448.0	2904.57- 3319.47
1-1/2	-	38.10	-	-	1746.0- 1980.0	2367.54- 2684.88	-	-	2844.0- 3204.0	3856.5- 4344.66

APPENDIX E (Cont'd)

E-5. CONVERSION FORMULA

Corrected dial or scale readings are determined by the use of the following formula:

$$\text{Corrected reading} = \text{Required torque value} + \frac{\text{Length of torque wrench} + \text{Length of adapter}}{\text{Length of Torque Wrench}}$$

NOTE

The length of the torque wrench is measured from the center of the handle to the center of the drive. The length of the adapter is measured from the center of the drive to the center of the winch.

Example:

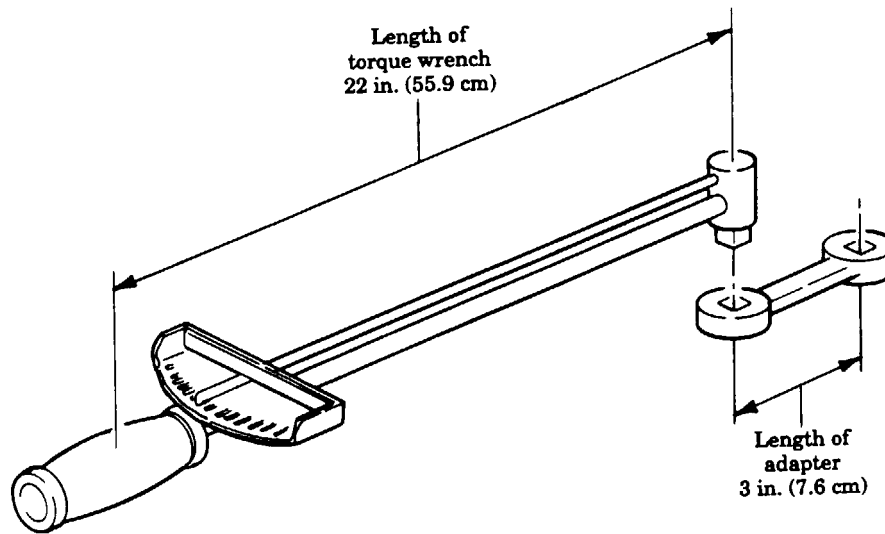

In this example, the torque wrench measures 22 in. (55.9 cm) and the adapter is 3 in. (7.6 cm). The required torque is 19 lb-ft (25.8 N·m).

$$\text{Corrected reading} = 19 \text{ lb-ft (25.8 N}\cdot\text{m)} + \frac{22 \text{ in. (55.9 cm)} + 3 \text{ in. (7.6 cm)}}{22 \text{ in. (55.9 cm)}}$$

$$\text{Corrected reading} = 19 \text{ lb-ft (25.8 N}\cdot\text{m)} + \frac{25 \text{ in. (63.5 cm)}}{22 \text{ in. (55.9 cm)}}$$

$$\text{Corrected reading} = 19 \text{ lb-ft (25.8 N}\cdot\text{m)} + 1.14$$

$$\text{Corrected reading} = 17 \text{ lb-ft (23.1 N}\cdot\text{m)}$$

APPENDIX F

WIRING DIAGRAMS AND SCHEMATIC

F-1. GENERAL

This appendix contains wiring diagrams of special vehicle equipment and an overall vehicle electrical system schematic you will need to maintain M998 series vehicles.

F-2. WIRING DIAGRAM AND SCHEMATIC INDEX

FIGURE NO.	TITLES	PAGE NO.
F-1	Winch Wiring Diagram	F-2
F-2	Arctic Winterization Kit Wiring Diagram	F-3
F-3	AN/GRC-160 Communications Kit Wiring Diagram	F-4
F-4	Slave Receptacle and TOW Harness Wiring Diagram	F-5
F-5	M1097, "A1", and "A2" Series Vehicles, Switch and Lamp Transfer Case Low Lock Indicator Wiring Diagram	F-6
F-6	M1097, "A1", and "A2" Series Vehicles, Auxiliary Power Supply Wiring Diagram	F-7
F-7	Siren and Warning Light Wiring Diagram	F-8
F-8	Glow Plug Control Functional Logic Diagram	F-9
F-9	Protective Control Box ("A2" Series Vehicles)	F-10
F-10	Buss Bar and 12 Volt Transmission Power ("A2" Series Vehicles)	F-11
FO-1	Electrical System Wiring Diagram	FP-1
FO-2	Electrical System Wiring Diagram (M996 and M996A1)	FP-3
FO-3	Electrical System Wiring Diagram (M997 and M997A1)	FP-7
FO-4	Electrical System Wiring Diagram (M1025A2, M1035A2, M1043A2, and M1045A2)	FP-11
FO-5	Electrical System Wiring Diagram (M1097A2)	FP-13
FO-6	Electrical System Wiring Diagram (M997A2)	FP-15

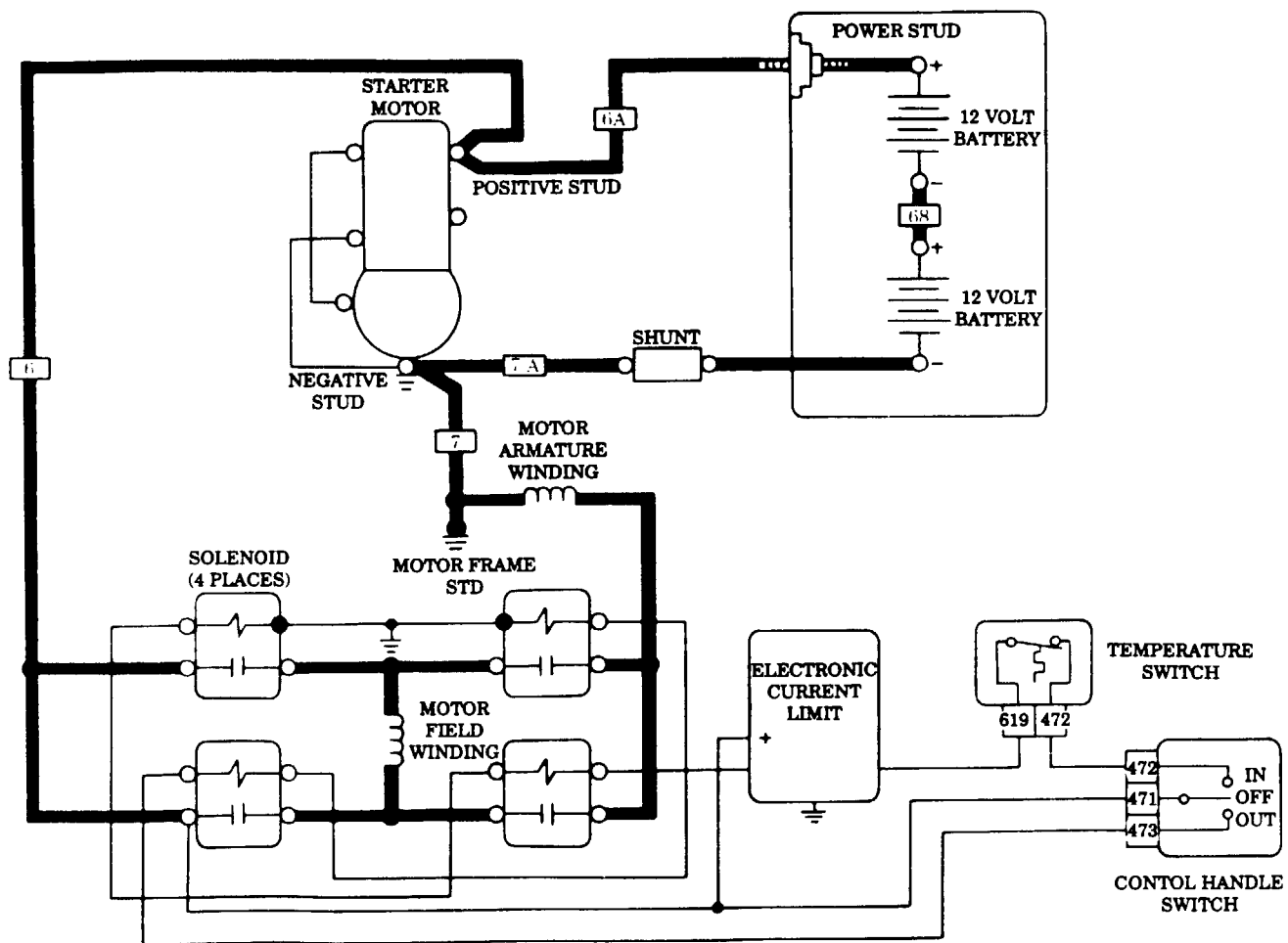

Figure 1. Winch Wiring Diagram.

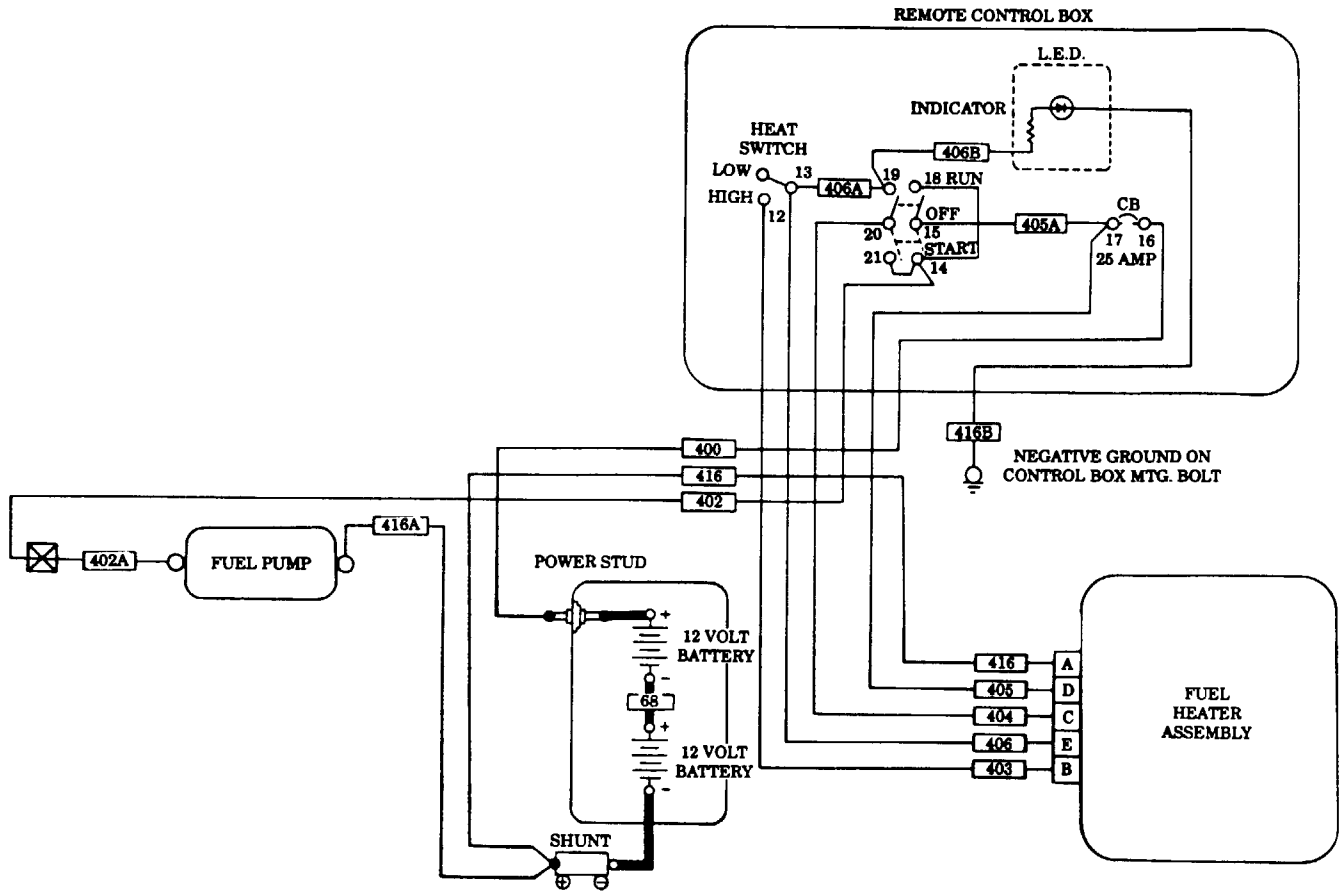

Figure 2. Arctic Winterization Kit Wiring Diagram.

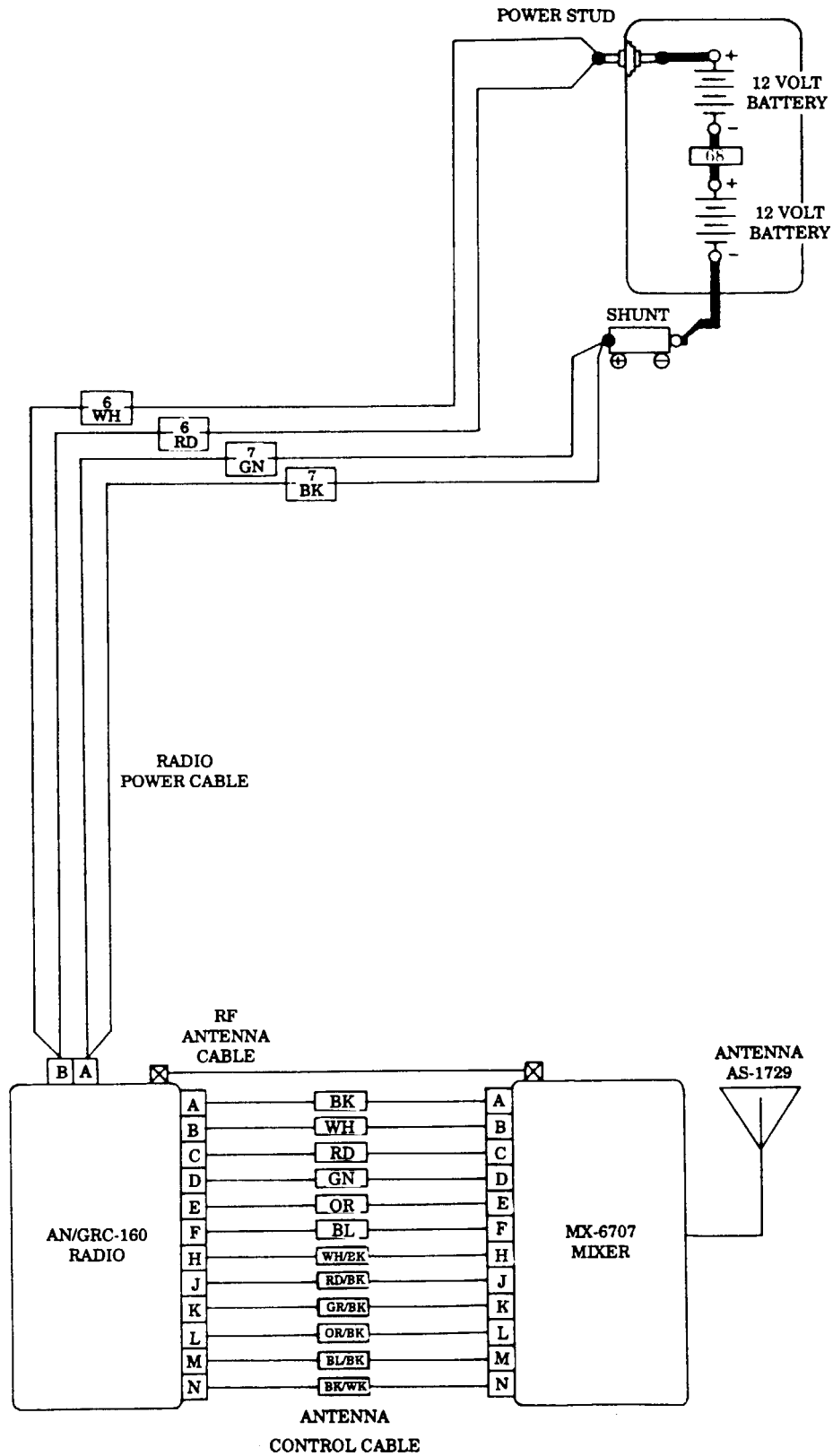

Figure 3. AN/GRC-160 Communications Kit Wiring Diagram.

The following applies to vehicles with serial number 100,000 and above and vehicles with kits 5705623 and 5705624 installed.

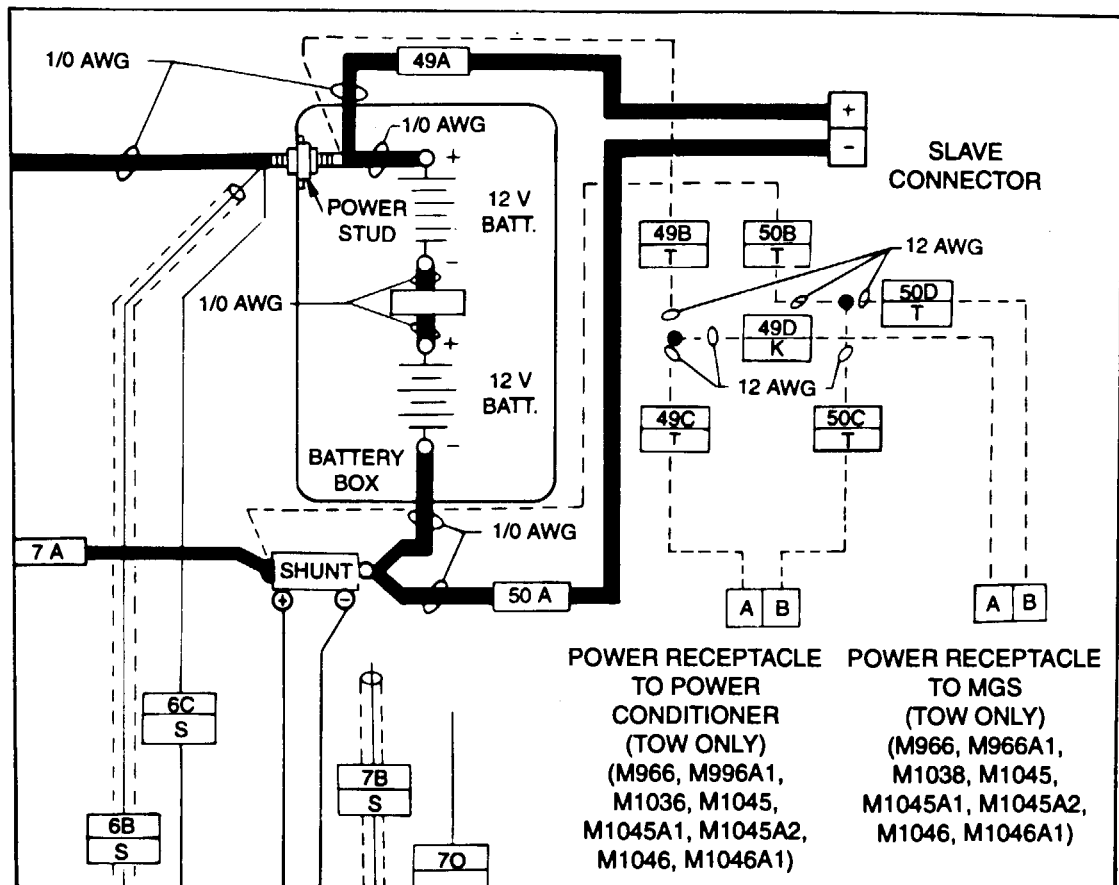

Figure 4. Slave Receptacle and TOW Harness Wiring Diagram.

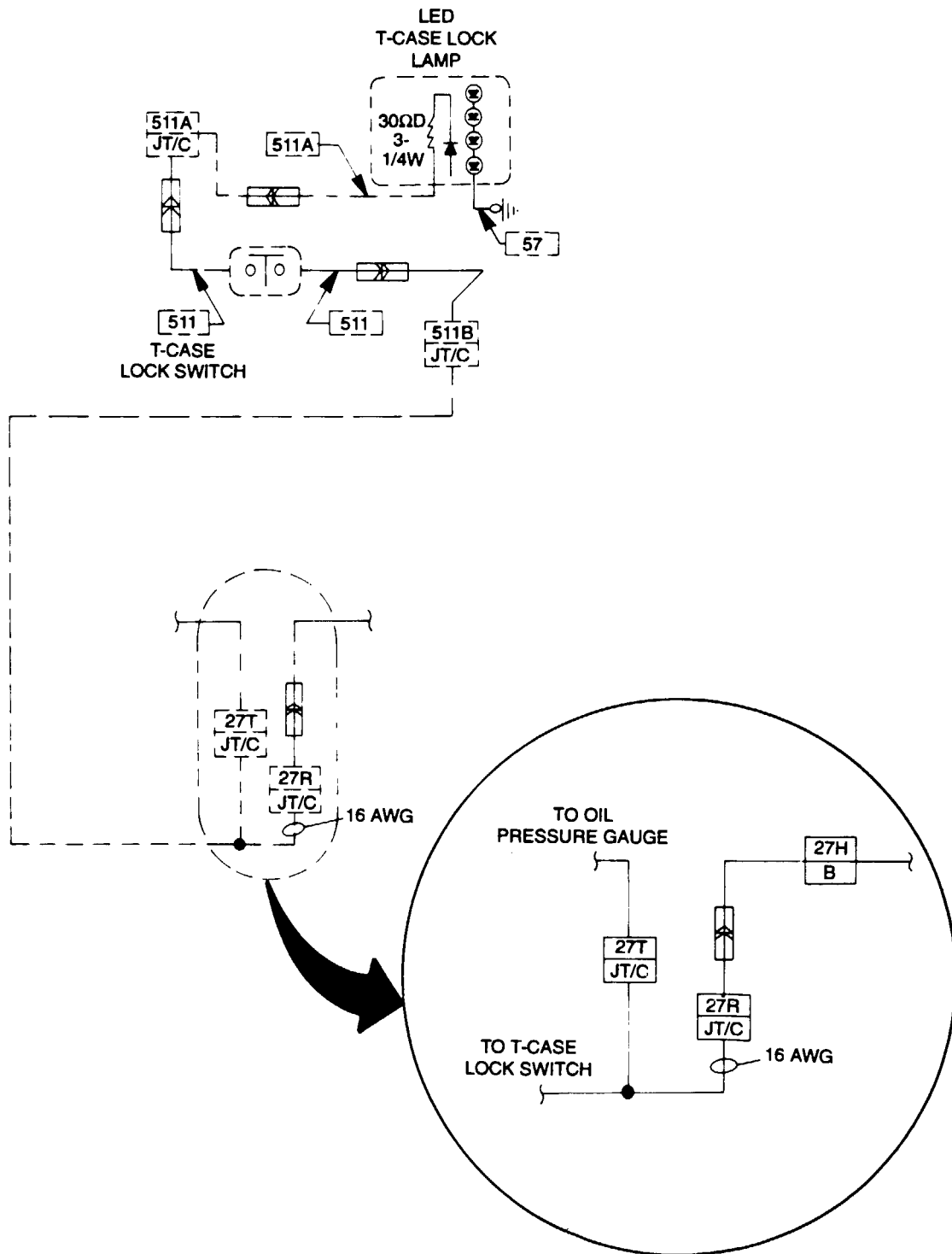

Figure F-5. M1097, "A1", and "A2" Series Vehicles, Switch and Lamp Transfer Case Low Lock Indicator Wiring Diagram.

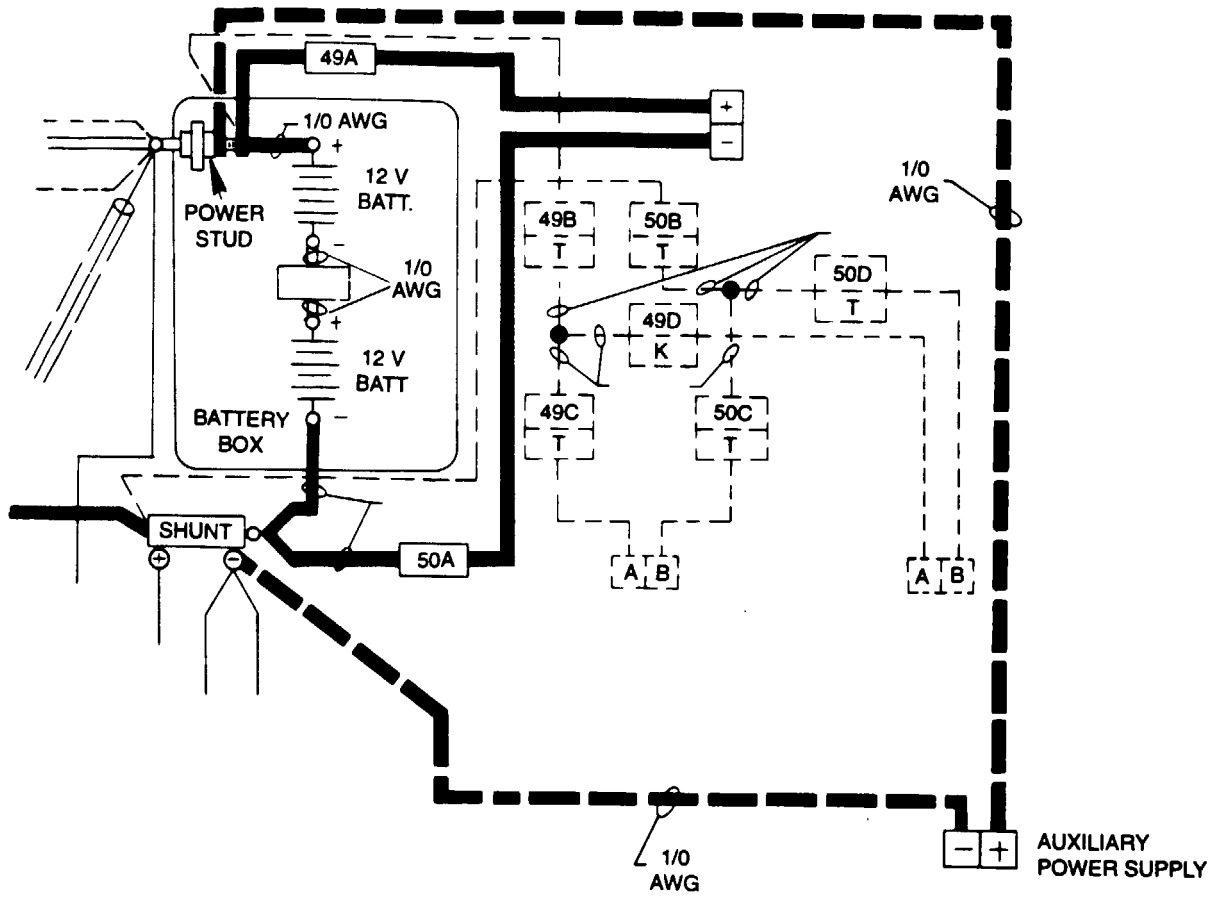

Figure F-6. M1097, "A1", and "A2" Series Vehicles, Auxiliary Power Supply Wiring Diagram.

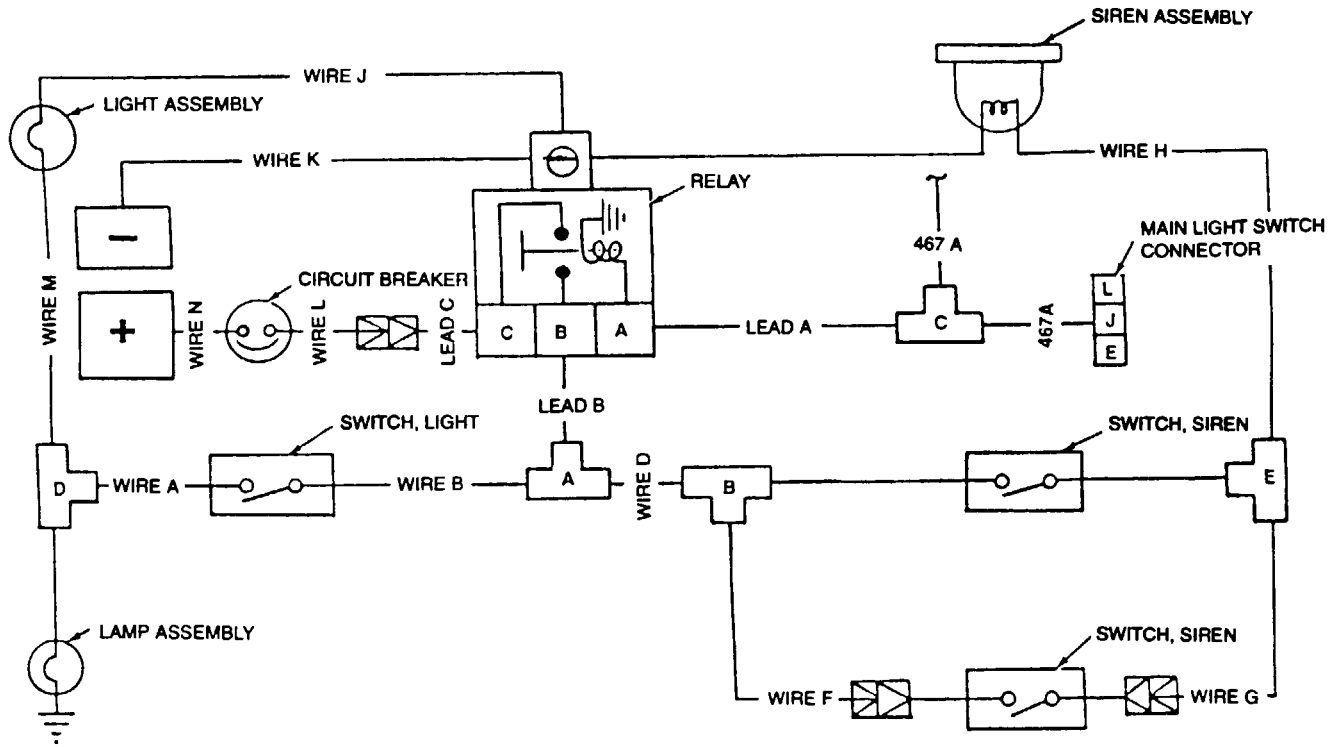

Figure F-7. Siren and Warning Light Wiring Diagram.

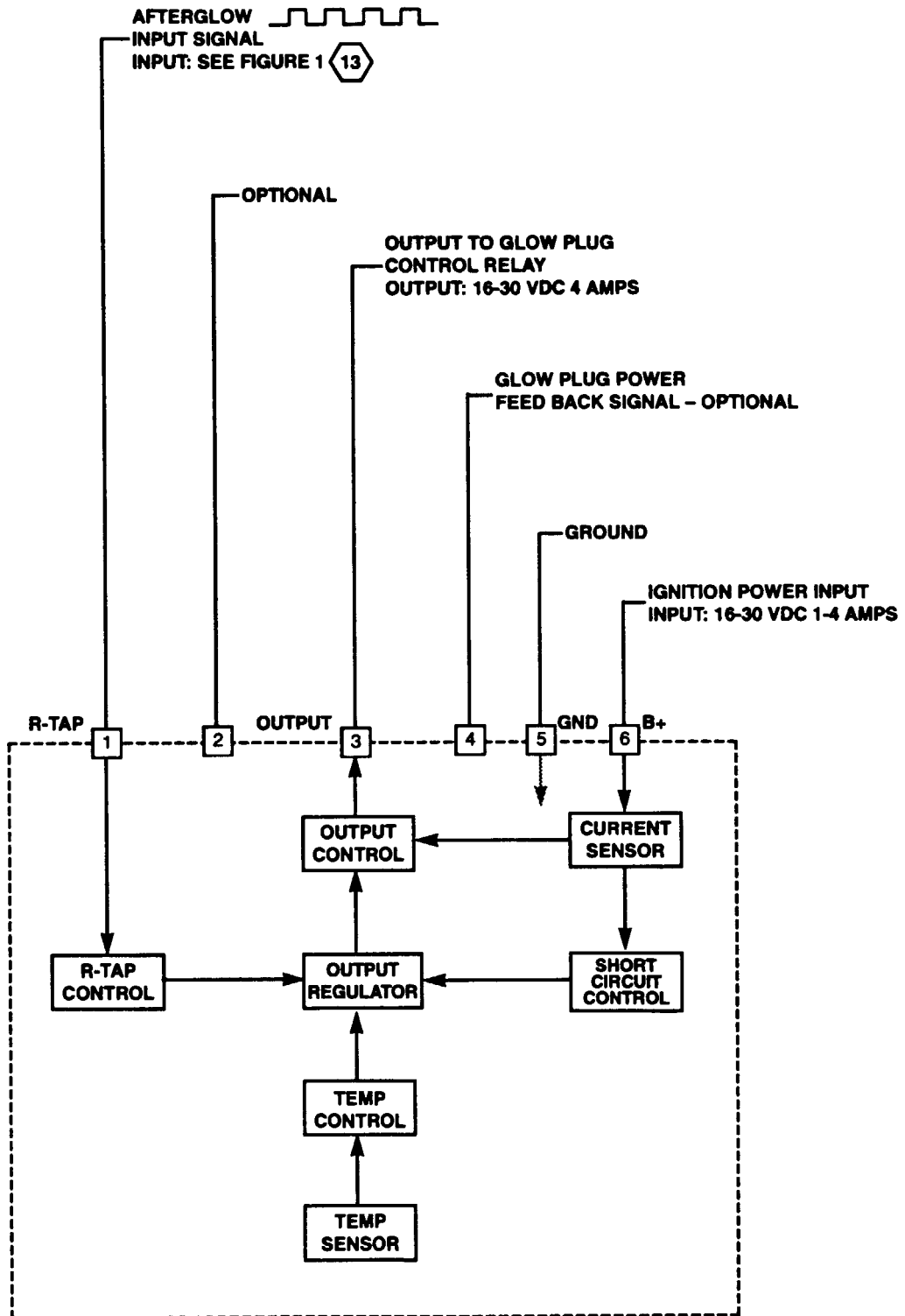

Figure F-8. Glow Plug Control Functional Logic Diagram.

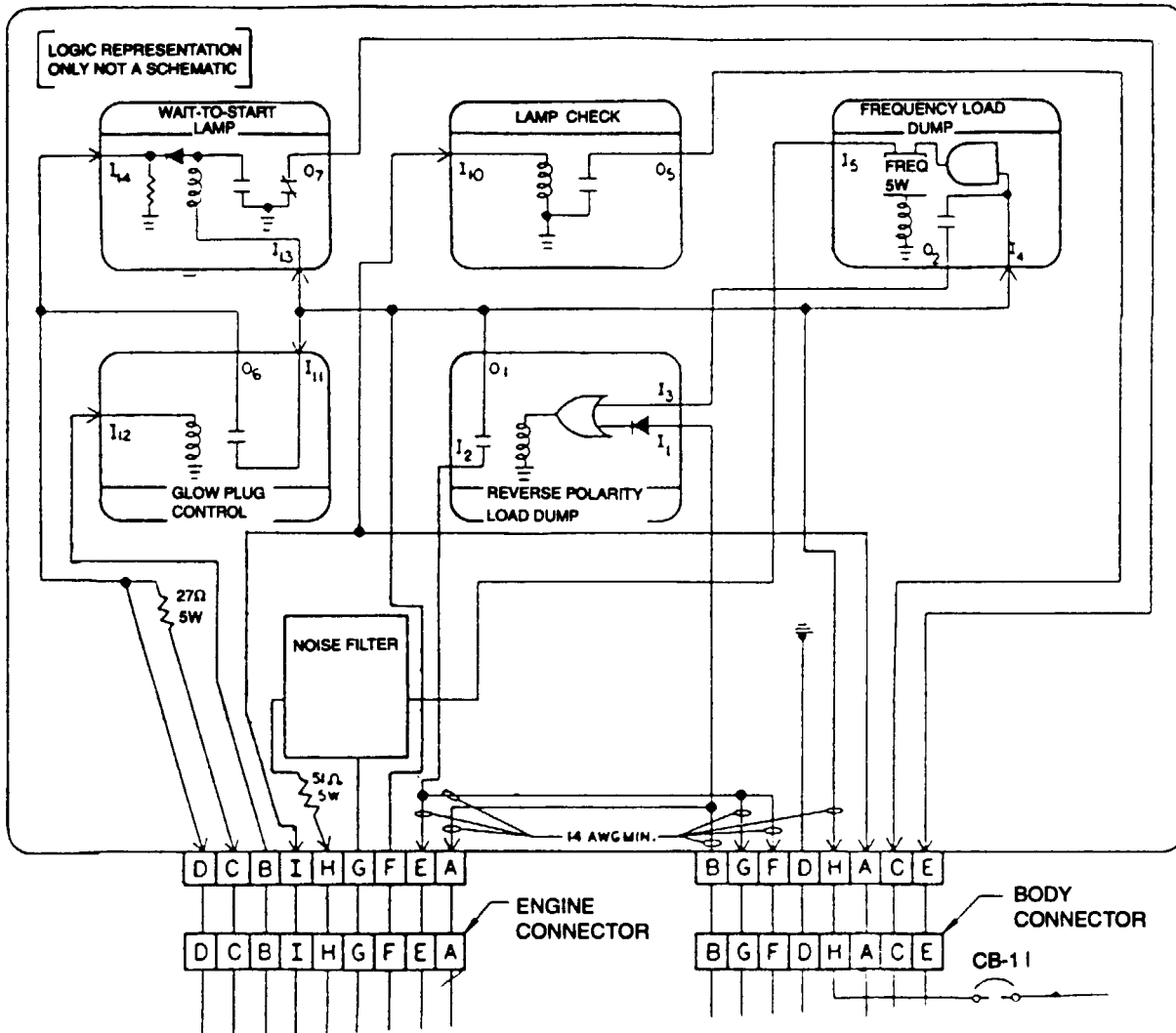

Figure F-9. Protective Control Box ("A2" Series Vehicles).

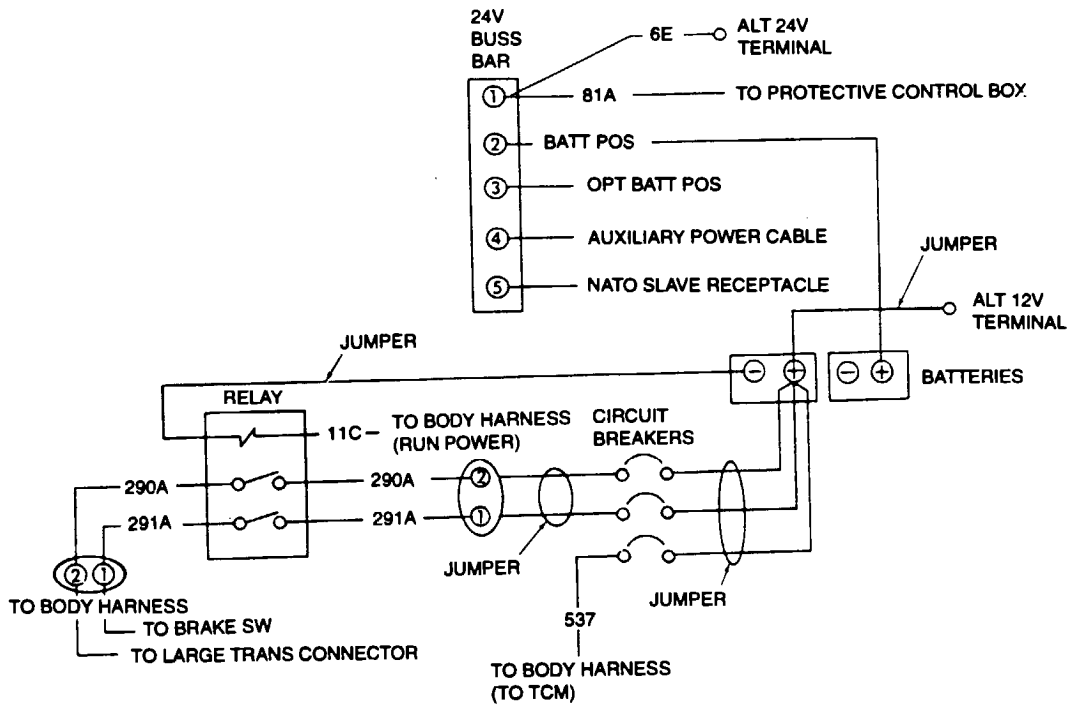

Figure F-10. Buss Bar & 12 Volt Transmission Power ("A2" Series Vehicles).

*Figure FO-1. Electrical System Wiring Diagram
(Located at Back of Manual).*

APPENDIX G

MANDATORY REPLACEMENT PARTS

Section I. INTRODUCTION

G-1. SCOPE

This appendix lists mandatory replacement parts you will need to maintain M998 series vehicles.

G-2. EXPLANATION OF COLUMNS

- a. **Column (1) - Item Number.** This number is assigned to each entry in the listing and is referenced in the “Initial Setup” of applicable tasks under the heading of “Materials/Parts”.
- b. **Column (2) - Nomenclature.** Name or identification of the part.
- c. **Column (3) - Part Number.** The manufacturer’s part number.
- d. **Column (4) - National Stock Number.** The national stock number of the part.

Section II. MANDATORY REPLACEMENT PARTS

(1) ITEM NO	(2) NOMENCLATURE	(3) PART NUMBER	(4) NATIONAL/NATO STOCK NUMBER
1	Access Cover Gasket	12338585	5330-01-194-0473
2	Balance Weights	5595966	6670-01-261-6844
3	Bearing, Sleeve	12L18F	3120-00-485-1017
4	Bolt	5597252	5306-01-264-3531
5	Bolt	12340845-3	5306-01-270-5448
6	Bolt	9423557	5306-01-360-1123
7	Boot Service Kit	287-0006 (fixed)	2530-01-191-8741
		5705606 (plunged)	2530-01-191-8740
		2880019 (fixed)	2530-01-394-6168
		M1097 and A1 series	
		57K2074 (plunged)	2530-01-394-3748
		2990054 A2 series (shaft, fixed L.H.)	2530-01-459-9493
		2990055 A2 series (shaft, fixed R.H.)	2530-01-459-9494
8	Button, Plug	12340258	5340-01-332-7599
9	Capscrew	160046	5305-00-068-0508
10	Clip	354-280308-00-0078	5325-01-197-3460
11	Cotter Pin	A-82-1	5315-00-839-2325
12	Cotter Pin	MS24665-283	5315-00-842-3044
13	Cotter Pin	MS24665-377	5315-00-285-7161
14	Cotter Pin	MS24665-355	5315-00-012-0123
15	Cotter Pin	PK379	5315-00-816-1794
16	Cotter Pin	MS24665-134	5315-00-839-5820
17	Cotter Pin	103384	5315-01-191-2611
18	Cotter Pin	MS24665-351	5315-00-839-5821
19	Cotter Pin	MS24665-319	5315-01-267-7570
20	Cotter Pin	MS24665-513	5315-00-239-8032
21	Cotter Pin	MS24665-423	5315-00-013-7228
22	Cotter Pin	MS24665-628	5315-00-846-0126
23	Cotter Pin	MS24665-298	5315-00-234-1861
24	Cotter Pin	MS24665-132	5315-00-839-2325
25	Cotter Pin	G121224	5315-01-206-7135

Section II. MANDATORY REPLACEMENT PARTS

(1) ITEM NO	(2) NOMENCLATURE	(3) PART NUMBER	(4) NATIONAL/NATO STOCK NUMBER
26	Cotter Pin	MS24665-208	5315-00-829-1480
27	Door Seal	R-451-N	5330-01-041-9721
28	Drive Screw	MS21318-47	5305-00-253-5626
29	Dust Cap	211121X	5340-01-188-1017
30	Fastener, Spring Tension	M36-0790-10	5325-01-257-0801
31	Filter Assembly	6437741	2940-01-121-6350
32	Filter Element Kit	A910044	4330-01-190-3579
33	Filter Element Kit	8684221	2520-01-398-4589
34	Filter, Particulate	197-54-692	4240-00-866-1825
35	Flat Washer	MS27183-20	5310-00-068-5285
36	Flat Washer	12447149	5310-01-465-9727
37	Flat Washer	12339052	5310-01-185-7214
38	Flat Washer	5582366	5310-01-189-8476
39	Flat Washer	5597347	5310-01-259-7554
40	Fuel Pump Gasket	1538769	5330-00-700-6868
40.1	Gasket	12341904	5330-01-298-8126
41	Gasket	12338382	5330-01-246-1822
42	Gasket	12338339	5330-01-200-0466
43	Gasket	12342104	5330-01-314-6781
44	Gasket	12342105	5330-01-315-1609
45	Gasket	7539072	5330-00-753-9072
46	Gasket	DC8226	5330-01-076-6172
47	Gasket	61-2028-01	5330-01-218-1196
48	Gasket	8655625	5330-01-148-7492
49	Gasket	12341487	5330-01-272-7471
50	Gasket	5574856	5330-01-194-0472
51	Gasket	10137488	5330-01-149-0874
52	Gasket	12356789	5330-01-319-7302
53	Gasket	5577933	5330-01-184-6500
54	Gasket	12551591	5330-01-434-8611
55	Gasket	C5136338	5330-01-309-4340
56	Gasket	MA128-21182	5330-01-037-0663
57	Gasket	12460095	5330-01-413-2118

Section II. MANDATORY REPLACEMENT PARTS (Cont'd)

(1) ITEM NO	(2) NOMENCLATURE	(3) PART NUMBER	(4) NATIONAL/NATO STOCK NUMBER
58	Gasket	8677743	5330-01-360-5271
59	Gasket	5741141	5330-01-211-1343
60	Gasket	5688049	5330-00-848-4439
61	Gasket, Oil Pan	OS34400	5330-01-310-6780
62	Gasket, Water Pump	10137492	5330-01-147-9808
62.1	Gasket, Water Pump	12553488	5330-01-476-3866
63	Grommet, Nonmetallic	12340526	5325-01-437-4175
64	Hex Nut	7063812	5310-00-126-3842
65	Key Washer	5584462	5310-01-213-4185
66	Kit, Universal Parts	5-213X	2520-01-189-2135
67	Lining, Friction	4026-38368-01	2930-01-189-8643
68	Lockbolt	5589067	5306-01-204-2139
69	Lockbolt	5597349	5306-01-276-1621
70	Locknut	MS51943-31	5310-00-061-4650
71	Locknut	9419471	5310-01-432-6727
72	Locknut	MS21044C3	5310-00-208-9255
73	Locknut	MS21245-L10	5310-00-449-2381
73.1	Locknut	MS21245-L12	5310-00-419-0876
74	Locknut	5593048	5310-01-252-0481
75	Locknut	83320	5815-01-186-6930
76	Locknut	5593035	5310-01-255-2695
77	Locknut	MS27183-10	5310-00-809-4058
78	Locknut	M45913/3-4FG8C	5310-00-935-9022
79	Locknut	MS51943-33	5310-00-814-0673
80	Locknut	12387349-43	5310-00-061-4651
81	Locknut	MS51943-39	5310-00-488-3889
82	Locknut	MS21245-8	5310-00-449-2376
83	Locknut	MS51967-6	5310-00-931-8167
84	Locknut	MS21044-N4	5310-00-877-5796
85	Locknut	12339728-3	5310-01-198-3487
86	Locknut	MS51943-34	5310-00-241-6658
87	Locknut	12339730	5310-01-254-4284

Section II. MANDATORY REPLACEMENT PARTS (Cont'd)

(1) ITEM NO	(2) NOMENCLATURE	(3) PART NUMBER	(4) NATIONAL/NATO STOCK NUMBER
88	Locknut	5584710	5310-01-203-3217
89	Locknut	MS51943-45	5310-00-409-3333
90	Locknut	5591514	5310-01-217-0715
91	Locknut	NAS1022-N08	5310-00-721-5447
92	Locknut	MS210-83-N08	5310-00-941-6019
93	Locknut	MS21045-7	5310-00-274-9364
93.1	Locknut	274209	5310-00-420-9713
94	Locknut	5590556	5310-01-208-5252
95	Locknut	454748	5310-01-038-9579
96	Locknut	131245	5310-00-013-1245
97	Locknut	9411893	5310-00-251-4503
98	Locknut	MS51967-12	5310-00-896-0903
99	Locknut	9442939	5310-01-149-4407
100	Locknut	8712289-4	5310-00-840-6222
101	Locknut	MS51968-15	5310-00-943-2141
102	Locknut	MS35649-205	5310-00-934-9764
103	Locknut	8712289-5	5310-00-044-3342
104	Locknut	MS51943-36	5310-00-814-0672
105	Locknut	9422299	5310-01-150-4003
106	Locknut	12339206	5310-01-439-1154
107	Locknut	AN365-1024A	5310-00-208-1918
108	Locknut	9411807	5310-01-461-8043
109	Locknut	MS21042L5	5310-00-807-1476
110	Locknut	MS21042L6	5310-00-807-1477
111	Locknut	MS21042L4	5310-00-807-1475
112	Locknut	190254	5320-01-219-7261
113	Locknut	5592958	5310-01-253-1615
114	Locknut	9416918	5310-01-012-8962
115	Locknut	12339501	5310-01-198-7585
116	Locknut	89325	5310-01-212-2215
117	Locknut	MS21044-N3	5310-00-877-5797
118	Locknut	454749	5310-00-164-1790

Section II. MANDATORY REPLACEMENT PARTS (Cont'd)

(1) ITEM NO	(2) NOMENCLATURE	(3) PART NUMBER	(4) NATIONAL/NATO STOCK NUMBER
119	Locknut	MS17829-4F	5310-00-483-8791
120	Locknut	192481	5310-01-058-3353
121	Locknut	190171	5310-00-774-9073
122	Locknut	2INE-040	5310-01-066-6759
123	Locknut	9419456	5310-01-318-5237
124	Locknut	272739	5310-01-317-8164
125	Locknut	190139	5310-00-088-0553
126	Locknut	M45913/1-4CG5C	5310-00-088-1251
127	Locknut	M45913/1-5CG5C	5310-00-984-3806
128	Locknut	MS51943-35	5310-00-935-9021
129	Locknut	11516075	5310-01-206-5479
130	Locknut, Assembled	271172	5310-01-152-0598
131	Locknut, Assembled	5593033	5310-01-252-2999
132	Lockpin	10392	5315-01-280-6185
133	Lockwasher	MS35338-46	5310-00-637-9541
134	Lockwasher	MS35338-45	5310-00-407-9566
135	Lockwasher	MS35338-44	5310-00-582-5965
136	Lockwasher	MS35338-42	5310-00-045-3299
137	Lockwasher	MS51415-9	5310-01-216-7390
138	Lockwasher	MS35338-43	5310-00-045-3296
139	Lockwasher	120217	5310-00-922-2017
140	Lockwasher	MS35336-53	5310-00-957-2677
141	Lockwasher	85031	5310-01-186-7066
142	Lockwasher	2434	5310-00-775-5139
143	Lockwasher	MS35338-41	5310-00-045-4007
144	Lockwasher	MS45904-60	5310-00-080-9786
145	Lockwasher	11500177	5310-01-185-7218
146	Lockwasher	MS35338-65	5310-00-011-5093
147	Lockwasher	MS35338-50	5310-00-820-6653
148	Lockwasher	MS35338-103	5310-00-184-8971
149	Lockwasher	2436162	5310-01-119-1024
150	Lockwasher	MS35338-67	5310-00-011-6121

Section II. MANDATORY REPLACEMENT PARTS (Cont'd)

(1) ITEM NO	(2) NOMENCLATURE	(3) PART NUMBER	(4) NATIONAL/NATO STOCK NUMBER
151	Lockwasher	MS35338-49	5310-00-167-0680
152	Lockwasher	9424258	5310-01-199-3440
153	Lockwasher	26351	5310-01-210-0819
154	Lockwasher	11503962	5310-01-444-3084
155	Lockwasher	MS35338-141	5310-00-984-7042
156	Lockwasher	1104018SS	5310-00-933-8119
157	Lockwasher	5593285	5310-01-250-7836
158	Lockwasher	MS35338-8	5310-00-261-7340
159	Lockwasher	202751	5310-00-274-8710
160	Lockwasher	12341800	5310-01-327-0387
161	Lockwasher	MS35333-47	5310-00-550-3714
162	Lockwasher	MS35333-44	5310-00-194-1483
163	Lockwasher	120380	5310-00-209-2946
164	Lockwasher	MS35338-27	5310-00-543-5101
165	Lockwasher	5596566	5310-01-253-8440
166	Lockwasher	210104-8S	5310-00-003-4094
167	Lockwasher	12338339	5330-01-200-0466
168	Lockwasher	MS35333-121	5310-00-905-5454
169	Lockwasher	MS35337-22	5310-00-596-7674
170	Lockwasher	123153	5310-01-185-4672
171	Lockwasher	MS35338-100	5310-00-261-8278
172	Lockwasher	120214	5310-00-012-0214
173	Lockwasher	MS122031	5310-00-285-7037
174	Lockwasher	2436161	5310-01-102-3270
175	Lockwasher	MS35333-40	5310-00-550-1130
176	Lockwasher	MS45904-68	5310-00-889-2528
177	Lockwasher	MS35338-63	5310-00-274-8715
178	Lockwasher	MS35338-48	5310-00-584-5272
179	Lockwasher	QR816	5310-00-007-1607
180	Lockwasher	MS51848-13	5310-01-016-9348
181	Lockwasher	AN8013-2	5310-00-167-0893
182	Lockwasher	202755	5310-01-270-2661

Section II. MANDATORY REPLACEMENT PARTS

(1) ITEM NO	(2) NOMENCLATURE	(3) PART NUMBER	(4) NATIONAL/NATO STOCK NUMBER
183	Lockwasher	MS35340-43	5310-00-721-7809
184	Lockwasher	36896	5310-01-162-9661
185	Lockwasher	N9459	5310-01-348-8393
186	Lockwasher	N9461	5310-01-348-8392
187	Lockwasher	N9015	5310-01-046-0186
188	Lockwasher	MS35338-47	5310-00-209-0965
189	Lockwasher	MS35335-33	5310-00-209-0786
190	Lockwasher	120384	5310-00-482-9493
191	Lockwasher	11500207	5310-01-206-7306
192	Lockwasher	5550554	5310-01-144-2779
193	Lockwasher	MS35333-43	5310-00-685-3228
194	Lockwasher	MS51415-7	5310-01-218-7137
195	Lockwasher	MS35338-27	5310-00-543-2705
196	Lubricant	D528235H-1	2640-01-419-6200
197	Manifold Seal Assembly	12338342	5330-01-189-9738
198	Mounting Plate Gasket	12560223	5330-01-472-8179
199	Nut, Plain-Assembled	272474	5310-01-204-1039
200	Nut, Plain-Assembled	511-120800-00	5310-01-995-4130
201	Nut, Plain-Assembled	271169	5310-00-124-9265
202	Nut, Plain-Assembled	271163	5310-01-069-5243
203	Nut, Plain-Assembled	31WLF3816	5310-00-355-5645
204	Nut, Plain-Assembled	G-00271166	5310-01-251-0760
205	Nut, Plain-Assembled	271184	5310-00-933-4310
206	Oil Filter	PH13	2940-00-082-6034
206.1	Oil Filter	PF1218	4330-01-398-8484
207	Oil Seal Retainer	14022683 (6.2L) 23502587 (6.5L)	5330-01-150-7744 5331-01-378-8572
208	O-Ring	5740436	5331-01-157-1884
209	O-Ring	274244	5331-00-935-9136
210	O-Ring	M83461/1-020	5331-01-107-4950
211	O-Ring	M83461/1-236	5331-01-183-0971
212	O-Ring	MS28775-110	5331-00-585-6663

Section II. MANDATORY REPLACEMENT PARTS

(1) ITEM NO	(2) NOMENCLATURE	(3) PART NUMBER	(4) NATIONAL/NATO STOCK NUMBER
213	O-Ring	12339002	5331-01-195-8889
214	O-Ring	5591345	5331-01-176-0923
215	O-Ring	12342933	5331-01-477-3657
216	O-Ring	12338998	5331-01-216-7392
217	O-Ring	12342633	5331-01-335-8878
218	O-Ring	2938-2	5331-00-580-6586
219	O-Ring	12342794	5331-01-346-3806
220	O-Ring	11639519-1	5331-00-463-0200
221	O-Ring	11639519-2	5331-00-462-0907
222	O-Ring	7700242	5331-01-770-0242
223	Packing, Preformed	7358626	5330-00-297-6329
224	Packing, Preformed	2-113N497-70	5330-01-184-6492
225	Platenut	MS51941-10	5310-01-025-6444
226	Push On Nut	12339313	5310-01-188-6861
227	Push On Nut	62229	5310-01-161-7308
228	Push On Nut	C183-012-4	5310-01-213-1333
229	Retainer, Packing	12342886	5330-01-381-1810
230	Retainer, Packing	8658110	5330-01-043-5572
231	Retaining Ring	MS16633-1050	5325-00-442-5845
232	Retaining Ring	MS16624-1062	5325-00-803-7305
233	Retaining Ring	5741098	5325-01-212-2403
234	Retaining Ring	012351	5325-01-135-4290
235	Retaining Ring	11505885	5325-01-196-5631
236	Rivet	BALM-6BP-14	5320-01-254-2283
237	Rivet, Blind	CR3213-6-2	5320-01-143-5075
238	Rivet, Blind	CR-213-4-2	5320-01-258-2576
239	Rivet, Blind	CR-3242-6-2	5320-01-033-8643
240	Rivet, Blind	NAS9301BNS-4-04	5320-01-143-5079
241	Rivet, Blind	5593050	5320-01-254-4251
242	Rivet, Blind	CR-3213-6-8	5320-01-086-1144
243	Rivet, Blind	AD42BS	5320-00-899-0981
244	Rivet, Blind	NAS9301BNS-6-04	5320-01-136-1782

Section II. MANDATORY REPLACEMENT PARTS

(1) ITEM NO	(2) NOMENCLATURE	(3) PART NUMBER	(4) NATIONAL/NATO STOCK NUMBER
245	Rivet, Blind	MSC66	5320-01-219-7261
246	Rivet, Blind	12339998-14	5310-01-198-1723
247	Rivet, Blind	CR213-4-3	5320-01-138-4239
248	Rivet, Blind	CR3243-6-3	5320-01-033-8638
249	Rivet, Blind	CR3242-6-4	5320-01-033-9126
250	Rivet, Blind	MGLP-B6-4	5320-01-271-6357
251	Rivet, Blind	12339355-2	5320-01-264-5978
252	Rivet, Blind	CR-213-4-5	5320-01-259-7423
253	Rivet, Blind	ADS43	5320-00-083-5009
254	Rivet, Blind	M24243/1-A404	5320-01-023-2529
255	Rivet, Blind	M24243/1-A408	5320-00-850-3282
256	Rivet, Blind	CR3243-6-5	5320-01-034-1884
257	Rivet, Blind	CR-213-6-3	5320-01-135-7319
258	Rivet, Blind	BAPKTR-64	5320-01-275-1998
259	Rivet, Blind	CR3213-6-7	5320-01-085-9995
260	Rivet, Blind	CR3213-6-5	5320-01-084-9235
261	Rivet, Blind	NAS9302BNS-6-05	5320-01-136-1787
262	Rivet, Blind	M24243/1-B604	5320-00-493-4101
263	Rivet, Blind	5982526	5310-01-198-1722
264	Rivet, Blind	M24243/1-A402	5320-01-019-5694
265	Rivet, Blind	AD45BS	5320-00-275-8344
266	Rivet, Blind	CR3243-6-4	5320-01-033-8637
267	Rivet, Solid	MS20426-AD6-9	5320-00-117-7289
268	Rivet, Solid	MS20470-AD6-10	5320-00-721-9062
269	Rivet, Solid	5575940	5320-01-271-1834
270	Rivet, Solid	MS20470-AD6-8	5320-00-117-6853
271	Rivet, Solid	5575936	5320-01-259-6155
272	Rivet, Solid	MS20426-AD6-7	5320-00-117-7287
273	Rivet, Solid	MS20426-AD10-16	5320-00-117-6910
274	Rivnut, Blind	ALS4-420-165	5310-01-411-3422
275	Rivnut, Blind	MS27130-CR31	5310-01-283-8482
276	Runflat Belt Repair Kit	J-39295	2530-01-338-3056

Section II. MANDATORY REPLACEMENT PARTS

(1) ITEM NO	(2) NOMENCLATURE	(3) PART NUMBER	(4) NATIONAL/NATO STOCK NUMBER
277	Runflat Belt Repair Kit	D-528240	4310-01-345-5723
278	Screw, Assembled Washer	5593006	5305-01-256-0406
279	Screw, Assembled Washer	5593313	5305-01-254-2459
280	Screw, Assembled Washer	10-35936-7	5305-00-543-4709
281	Screw, Assembled Washer	454542	5305-00-499-7694
282	Screw, Machine	MS35206-245	5305-00-984-6193
283	Screw, Tapping	12340792	5305-01-264-5874
284	Screw, Tapping	5592970	5305-01-255-2675
285	Seal	MT161A	5330-01-282-2213
286	Seal, Nonmetallic Round	12267802	5330-01-080-3253
287	Seal, Nonmetallic Round	5582936	5310-01-203-9187
288	Seal, Nonmetallic SP	12447172	5330-01-447-4762
289	Seal, Nonmetallic ST	12342343	5330-01-318-1998
290	Seal, Plain	2994-2106	5330-01-180-9099
291	Seal, Plain, Encased	CR535094-60	5330-01-203-6551
291.1	Seal Service Kit	7848522	5330-01-044-0703
292	Seal, Washer	4210973	5310-01-186-5237
293	Socket, Turnbutton Fastener	91-BS-78403-1E	5325-00-281-8642
294	Sound Dampener	12339029-1	2540-01-192-9716
295	Sound Dampener	12339029-2	2540-01-192-5948
296	Spacer, Plate	5584436	5365-01-201-4749
297	Spider, Universal Joint	CPL6N8	2520-00-352-2168
298	Spring Pin	MS16562-256	5315-00-753-3895
299	Spring Pin	NAS561C4-18	5315-00-559-7467
299.1	Spring	2-300.P5	5360-01-282-9316
300	Strip, Rubber	12342344	5330-01-318-9780
301	Strip, Rubber	12342345	5330-01-317-5393
302	Strip, Rubber	12342248	5330-01-317-5392
303	Stud, Turnbutton Fastener	XB78323-05001	5325-00-823-5999
304	Thermaseal, Heater	12275161	2540-01-123-1218
305	Tiedown Strap	MS3367-4-2	5975-00-903-2288
306	Tiedown Strap	MS3367-3-9	5975-00-451-5001

Section II. MANDATORY REPLACEMENT PARTS

(1) ITEM NO	(2) NOMENCLATURE	(3) PART NUMBER	(4) NATIONAL/NATO STOCK NUMBER
307	Tiedown Strap	MS3367-7	5975-01-205-5379
308	Tiedown Strap	MS3367-3-0	5975-00-985-6630
309	Tiedown Strap	MS3367-7-0	5975-01-034-5871
310	Tiedown Strap	MS3367-1-0	5975-00-984-6582
311	Tiedown Strap	MS3367-4-0	5975-00-903-2248
312	Tiedown Strap	MS3367-7-9	5975-00-570-9598
313	Tiedown Strap	MS3367-5-0	5975-00-133-8687
314	Tiedown Strap	MS3367-1-9	5975-00-074-2072
315	Tiedown Strap	MS3367-2-9	5975-00-156-3253
316	Turnbutton, Clinch Plate	BS78505	5325-00-371-8108
317	Washer, Spring Tension	4004616	5310-01-189-8485
318	Washer, Spring Tension	N9018	5310-01-032-4827
319	Washer, Spring Tension	12338124	5310-01-413-2049
320	Washer, Spring Tension	B0625-022-S	5310-01-203-3230
321	Woodruff Key	MS35756-8	5315-00-616-5526
322	Woodruff Key	MS35756-17	5315-00-012-4553

INDEX VOLUME III

A	Para	Page
AB-652/GR antenna:		
Installation	12-139b	12-213
Removal	12-139a	12-213
Accessory kits:		
Installation task summary	12-184	12-282
Air cleaner dust cap:		
Inspection	12-6b	12-8
Installation	12-6c	12-8
Removal	12-6a	12-8
Air cleaner extension elbow:		
Inspection	12-4b	12-6
Installation	12-4c	12-6
Removal	12-4a	12-5
Air cleaner to selector valve vent line:		
Installation	12-7b	12-9
Removal	12-7a	12-9
Air-conditioning duct louver:		
Installation	11-203b	11-308
Removal	11-203a	11-308
Air-conditioning/heat duct:		
Assembly	11-211c	11-320
Disassembly	11-211b	11-319
Installation	11-211d	11-320
Removal	11-211a	11-319
Air diverter:		
Installation	11-213b	11-323
Removal	11-213a	11-323
Air duct assembly:		
Installation	10-97b	10-165
Removal	10-97a	10-165
Air inlet/outlet grille:		
Installation	11-186b	11-270
Removal	11-186a	11-270
Air intake assembly, deep water fording kit:		
Installation	12-3b	12-4
Removal	12-3a	12-4
Air intake compartment panels:		
Installation	11-184b	11-268
Removal	11-184a	11-268
Air intake duct door:		
Installation	11-185b	11-269
Removal	11-185a	11-269
Air intake filter:		
Cleaning	11-205b	11-310
Inspection	11-205a	11-310
Airlift bracket to hood seal:		
Installation	10-65b	10-104
Removal	10-65a	10-104
Air line piping, NBC:		
Fabrication	11-166b	11-244
Installation	11-166c	11-244
Removal	11-166a	11-244
Alternator, 100 ampere (12340912):		
Installation	12-23b	12-30
Removal	12-23a	12-30

A (Cont'd)	Para	Page
Alternator, 100 ampere (12342944):		
Installation	12-24b	12-34
Removal	12-24a	12-32
Alternator and regulator, 100/200 ampere, dual voltage conversion:		
100 ampere dual voltage alternator and regulator installation	12-24.1b	12-34.2
200 ampere dual voltage alternator and regulator installation	12-24.1c	12-34.6
Part fabrication	12-24.1a	12-34.2
Alternator cable (12446821-2), 100 ampere:		
Installation	12-22.1b	12-28.2
Removal	12-22.1a	12-28.2
Alternator kit, 100 ampere:		
Maintenance task summary	12-20	12-23
Alternator regulator (R027096300):		
Installation	12-21b	12-26
Removal	12-21a	12-24
Ambulance body:		
Maintenance task summary	11-123	11-173
Ambulance compartment mat:		
Installation	11-153b	11-222
Removal	11-153a	11-222
Ambulance litter assembly, soft top:		
Assembly	11-124d	11-180
Disassembly	11-124b	11-178
Inspection	11-124c	11-178
Installation	11-124e	11-182
Removal	11-124a	11-176
Ambulance spreader bar repair:		
Assembly	11-215c	11-325
Disassembly	11-215b	11-325
Installation	11-215d	11-325
Removal	11-215a	11-325
Ambulatory patient seat:		
Installation	11-181b	11-264
Removal	11-181a	11-263
Ambulatory patient seat rear close out panel:		
Installation	11-182b	11-265
Removal	11-182a	11-265
Ammo box tray (40 mm and caliber .50):		
Installation	11-105b	11-147
Removal	11-105a	11-147
Ammo box tray (40 mm), double:		
Installation	11-106b	11-148
Removal	11-106a	11-148
Ammo box tray (40 mm), triple:		
Installation	11-107b	11-149
Removal	11-107a	11-149
Ammo box tray (caliber .50):		
Installation	11-104b	11-146
Removal	11-104a	11-146

INDEX (Cont'd)

A (Cont'd)	Para	Page	A (Cont'd)	Para	Page
Ammo box tray (caliber .50), double:			Antenna tower, rear radio rack:		
Installation	11-103b	11-145	Assembly	12-145c	12-228
Removal	11-103a	11-145	Disassembly	12-145b	12-228
Ammo container, mortar:			Installation	12-145d	12-228
Assembly	12-149c	12-238	Removal	12-145a	12-228
Disassembly	12-149b	12-237	Antiskid strip:		
Installation	12-149d	12-239	Installation	12-191b	12-316
Removal	12-149a	12-236	Removal	12-191a	12-316
Ammo divider (L119):			“A” pillar, former assembly:		
Installation	12-174b	12-267	Installation	10-98b	10-167
Removal	12-174a	12-267	Removal	10-98a	10-167
Ammo rack assembly, M16:			Appendix A:		
Installation	11-74b	11-106	References		A-1
Removal	11-74a	11-106	Appendix B:		
Ammo rack (L119):			Maintenance allocation chart		B-1
Assembly	12-181c	12-275	Appendix C:		
Disassembly	12-181b	12-275	Expendable/durable supplies and materials list		C-1
Installation	12-181d	12-276	Appendix D:		
Removal	12-181a	12-274	Illustrated list of manufactured items		D-1
Ammo tiedown strap (L119):			Appendix E:		
Installation	12-173b	12-266	Torque limits		E-1
Removal	12-173a	12-266	Appendix F:		
Antenna, AB-652/GR:			Wiring diagrams and schematic ...		F-1
Installation	12-139b	12-213	Appendix G:		
Removal	12-139a	12-213	Mandatory replacement parts		G-1
Antenna, AS 1729/VRC:			Arctic curtain angle assembly:		
Installation	12-137b	12-211	Installation	12-74b	12-107
Removal	12-137a	12-211	Removal	12-74a	12-107
Antenna blast shield:			Arctic curtain assembly:		
Installation	11-88b	11-130	Installation	12-73b	12-106
Removal	11-88a	11-130	Removal	12-73a	12-106
Antenna cables, rear:			Arctic curtain channel assembly (2-man crew):		
Installation	12-140b	12-217	Installation	12-76b	12-109
Removal	12-140a	12-214	Removal	12-76a	12-109
Antenna cables, rear radio rack to tower:			Arctic curtain channel assembly (4-man crew):		
Installation	12-146b	12-230	Inspection	12-77b	12-110
Removal	12-146a	12-230	Installation	12-77c	12-110
Antenna ground strap:			Removal	12-77a	12-110
Installation	12-136b	12-210	Arctic curtain fastener		
Removal	12-136a	12-209	tape hook:		
Antenna mount (M996, M996A1), radio:			Installation	12-78b	12-112
Installation	11-171b	11-253	Removal	12-78a	12-112
Removal	11-171a	11-253	Arctic defroster ducting:		
Antenna mount (M997, M997A1, M997A2), radio:			Installation	12-50b	12-74
Installation	11-172b	11-254	Removal	12-50a	12-73
Removal	11-172a	11-254	Arctic defroster nozzle, left:		
Antenna mounting bracket, rear:			Installation	12-51b	12-76
Installation	12-138b	12-212	Removal	12-51a	12-75
Removal	12-138a	12-212			
Antenna mounting bracket, troop/cargo winterization:					
Installation	12-125b	12-197			
Removal	12-125a	12-197			

INDEX (Cont'd)

A (Cont'd)	Para	Page	A (Cont'd)	Para	Page
Arctic defroster nozzle, right:			Arctic heater filter-to-		
Installation	12-52b	12-78	bulkhead fuel supply line:		
Removal	12-52a	12-78	Installation	12-34b	12-50
Arctic diverter box:			Removal	12-34a	12-50
Assembly	12-49c	12-72	Arctic heater filter-to-		
Disassembly	12-49b	12-72	heater fuel supply hose:		
Installation	12-49d	12-72	Installation	12-35b	12-52
Removal	12-49a	12-72	Removal	12-35a	12-52
Arctic diverter box cover:			Arctic heater front cowl		
Installation	12-55b	12-81	insulation:		
Removal	12-55a	12-81	Installation	12-46b	12-68
Arctic diverter ducting:			Removal	12-46a	12-68
Installation	12-56b	12-82	Arctic heater fuel filter assembly:		
Removal	12-56a	12-82	Installation	12-27b	12-40
Arctic foam insulation strip:			Removal	12-27a	12-40
Installation	12-79b	12-113	Arctic heater fuel pump:		
Removal	12-79a	12-113	Installation	12-26b	12-39
Arctic heater assembly:			Removal	12-26a	12-38
Installation	12-41b	12-60	Arctic heater fuel supply hose:		
Removal	12-41a	12-59	Installation	12-30b	12-44
Arctic heater battery box plugs:			Removal	12-30a	12-44
Installation	12-45b	12-67	Arctic heater fuel supply		
Removal	12-45a	12-67	line bulkhead coupling:		
Arctic heater bracket assembly:			Installation	12-33b	12-48
Installation	12-44b	12-66	Removal	12-33a	12-48
Removal	12-44a	12-66	Arctic heater fuel supply		
Arctic heater CDR valve			tube assembly:		
tube assembly:			Installation	12-28b	12-42
Installation	12-36b	12-54	Removal	12-28a	12-42
Removal	12-36a	12-53	Arctic heater hose:		
Arctic heater control box			Installation	12-54b	12-80
assembly maintenance:			Removal	12-54a	12-80
Assembly	12-43b	12-64	Arctic heater nozzle:		
Disassembly	12-43a	12-64	Installation	12-53b	12-79
Arctic heater control box			Removal	12-53a	12-79
assembly replacement:			Arctic heater oil pan shroud:		
Installation	12-42b	12-62	Installation	12-48.2b	12-70.4
Removal	12-42a	12-61	Removal	12-48.2a	12-70.4
Arctic heater control cable:			Arctic heater plenum assembly:		
Adjustment	12-42.1c	12-62.2	Installation	12-37b	12-55
Installation	12-42.1b	12-62.2	Removal	12-37a	12-55
Removal	12-42.1a	12-62.2	Arctic heater plenum cover:		
Arctic heater diverter box cover:			Installation	12-39b	12-57
Installation	12-47b	12-69	Removal	12-39a	12-57
Removal	12-47a	12-69	Arctic heater plenum hose:		
Arctic heater ducting:			Installation	12-38b	12-56
Installation	12-48.1b	12-70.2	Removal	12-38a	12-56
Removal	12-48.1a	12-70.2	Arctic heater pump-to-		
Arctic heater exhaust			bulkhead fuel supply line:		
diverter cable assembly:			Installation	12-32b	12-46
Adjustment	12-48c	12-70	Removal	12-32a	12-46
Installation	12-48b	12-70	Arctic heater pump-to-		
Removal	12-48a	12-70	hose fuel supply line:		
			Installation	12-31b	12-45
			Removal	12-31a	12-45

INDEX (Cont'd)

	Para	Page		Para	Page
A (Cont'd)			A (Cont'd)		
Arctic heater regulator:			AS 1729/VRC antenna:		
Installation	12-40b	12-58	Installation	12-137b	12-211
Removal	12-40a	12-58	Removal	12-137a	12-211
Arctic heater tank-to-hose fuel supply line:			Attendant seat:		
Installation	12-29b	12-43	Assembly	11-157c	11-232
Removal	12-29a	12-43	Disassembly	11-157b	11-232
Arctic top cover assembly:			Installation	11-157d	11-233
Installation	12-72b	12-105	Removal	11-157a	11-232
Removal	12-72a	12-105	Attendant seat guide rail:		
Arctic window:			Installation	11-158b	11-234
Installation	12-75b	12-108	Removal	11-158a	11-234
Removal	12-75a	12-108	Attendant seat stowage brackets:		
Arctic winterization crew top kits:			Installation	11-177b	11-259
Maintenance task summary	12-71	12-104	Removal	11-177a	11-259
Arctic winterization kit:			Auxiliary shelf:		
Maintenance task summary	12-25	12-36	Installation	12-131b	12-203
Armament cover and seal:			Removal	12-131a	12-203
Installation	11-62b	11-83			
Removal	11-62a	11-83	B		
Armament mount panel:			Backrest pad, weapon station:		
Installation	11-61b	11-82	Installation	11-54b	11-75
Removal	11-61a	11-82	Removal	11-54a	11-75
Armored grille, hood front:			Ballistic crew door:		
Installation	11-35b	11-54	Adjustment	11-2d	11-6
Removal	11-35a	11-54	Inspection	11-2c	11-6
Armored grille, hood top:			Installation	11-2b	11-5
Installation	11-34b	11-53	Removal	11-2a	11-5
Removal	11-34a	11-53	Ballistic crew door hinge:		
Armor plate, footwell:			Installation	11-3b	11-8
Installation	11-38b	11-57	Removal	11-3a	11-8
Removal	11-38a	11-57	Ballistic crew door latch:		
Armor plate, hood center:			Installation	11-11b	11-18
Installation	11-33b	11-52	Removal	11-11a	11-18
Removal	11-33a	11-52	Ballistic crew door latch tube:		
Armor plate, hood side:			Installation	11-12b	11-19
Installation	11-32b	11-51	Removal	11-12a	11-19
Removal	11-32a	11-51	Ballistic crew door seal:		
Armor plate, left cowl:			Installation	11-10b	11-17
Installation	11-37b	11-56	Removal	11-10a	11-17
Removal	11-37a	11-56	Ballistic crew door window assembly:		
Armor plate, left wheelhouse:			Assembly	11-7c	11-12
Installation	11-40b	11-60	Disassembly	11-7b	11-12
Removal	11-40a	11-60	Installation	11-7d	11-12
Armor plate, right cowl:			Removal	11-7a	11-12
Installation	11-36b	11-55	Ballistic crew door window protective shield:		
Removal	11-36a	11-55	Initial installation	11-8a	11-14
Armor plate, right wheelhouse:			Installation	11-8c	11-15
Installation	11-39b	11-58	Removal	11-8b	11-15
Removal	11-39a	11-58	Ballistic crew door window stop:		
Armor plate, tailgate:			Installation	11-9b	11-16
Installation	11-41b	11-61	Removal	11-9a	11-16
Removal	11-41a	11-61			

INDEX (Cont'd)

B (Cont'd)	Para	Page	B (Cont'd)	Para	Page
Base plate strap:			Blackout/dome light switch,		
Installation	12-150b	12-240	troop/cargo winterization:		
Removal	12-150a	12-240	Installation	12-106b	12-156
Battery box cover and companion seat:			Removal	12-106a	12-156
Installation	10-35b	10-62	Blackout/dome light wiring		
Removal	10-35a	10-62	harness, troop/cargo		
Battery box cover catch:			winterization:		
Installation	10-40b	10-68	Installation	12-105b	12-154
Removal	10-40a	10-68	Removal	12-105a	12-154
Battery box cover latch:			Blade and arm, windshield wiper:		
Installation	10-36b	10-63	Installation	10-70c	10-116
Removal	10-36a	10-63	Removal	10-70a	10-116
Battery box plugs, arctic heater:			Repair (optional)	10-70b	10-116
Installation	12-45b	12-67	Blower assembly:		
Removal	12-45a	12-67	Installation	11-212b	11-322
Battery bracket, front night sight:			Removal	11-212a	11-321
Installation	11-84b	11-126	Blower motor and housing:		
Removal	11-84a	11-126	Blower housing installation	11-198d	11-292
Battery bracket, rear night sight:			Blower housing removal	11-198c	11-292
Installation	11-85b	11-127	Blower motor installation	11-198f	11-294
Removal	11-85a	11-127	Blower motor removal	11-198e	11-294
Battery rack assembly,			Closing blower housing	11-198b	11-292
missile guidance set (MGS):			Opening blower housing	11-198a	11-292
Installation	11-77b	11-118	Blower motor resistor:		
Removal	11-77a	11-118	Installation	11-197b	11-291
Battery strap (L119), gun display unit:			Removal	11-197a	11-291
Installation	12-178b	12-271	Blower outlet deflector:		
Removal	12-178a	12-271	Installation	11-210b	11-318
Belt, compressor:			Removal	11-210a	11-318
Adjustment	11-202c	11-306	Body:		
Installation	11-202b	11-306	Maintenance task summary	10-1	10-1
Removal	11-202a	11-306	Body accessories:		
Bipod stowage tray:			Maintenance task summary	10-69	10-115
Assembly	12-152c	12-242	Body hinge mount:		
Disassembly	12-152b	12-242	Installation	10-64b	10-103
Installation	12-152d	12-242	Removal	10-64a	10-103
Removal	12-152a	12-242	Body repair:		
Blackout curtain, troop/cargo			General	10-66a	10-105
winterization:			Inspection	10-66b	10-106
Installation	12-104b	12-153	Rivet replacement	10-66c	10-106
Removal	12-104a	12-153	Boot, heater:		
Blackout/dome light assembly,			Installation	10-96b	10-165
troop/cargo winterization:			Removal	10-96a	10-165
Installation	12-108b	12-160	Boresight collimator or night		
Removal	12-108a	12-160	sight mounting spacers:		
Blackout/dome light door switch,			Installation	11-86b	11-128
troop/cargo winterization:			Removal	11-86a	11-128
Installation	12-107b	12-158	Bow and troop/cargo winterization		
Removal	12-107a	12-158	troop seat assembly:		
Blackout/dome light lamp,			Installation	12-121b	12-192
troop/cargo winterization:			Removal	12-121a	12-190
Installation	12-109b	12-161			
Removal	12-109a	12-161			

INDEX (Cont'd)

	Para	Page		Para	Page
B (Cont'd)			B (Cont'd)		
Bow pivot bracket, rear:			Bracket (L119), rear bumper brace:		
Installation	10-100b	10-169	Installation	12-165b	12-258
Removal	10-100a	10-169	Removal	12-165a	12-258
“B” pillar:			Bracket (L119), rear bumper		
Installation	10-67b	10-111	inner mounting:		
Removal	10-67a	10-111	Installation	12-169b	12-262
“B” pillar padding:			Removal	12-169a	12-262
Installation	11-30.1b	11-49	Bracket (L119), rear bumper		
Removal	11-30.1a	11-49	outer mounting:		
Brace (L119), rear bumper inner:			Installation	12-167b	12-260
Installation	12-168b	12-261	Removal	12-167a	12-260
Removal	12-168a	12-261	Bracket (L119), rear tiedown:		
Brace (L119), rear bumper outer:			Installation	12-172b	12-265
Installation	12-166b	12-259	Removal	12-172a	12-265
Removal	12-166a	12-259	Bracket, lower rifle mount:		
Bracket assembly, arctic heater:			Installation	11-94b	11-136
Installation	12-44b	12-66	Removal	11-94a	11-136
Removal	12-44a	12-66	Bracket (M16 A1 rifle/M203		
Bracket assembly, gasoline			grenade launcher), rifle		
cook stove:			mounting clamp:		
Installation	11-89b	11-131	Installation	11-93b	11-135
Removal	11-89a	11-131	Removal	11-93a	11-135
Bracket assembly, heater			Bracket, mirror mounting:		
mounting (M996, M996A1):			Installation	10-81b	10-132
Installation	11-208b	11-314	Removal	10-81a	10-132
Removal	11-208a	11-314	Bracket, mortar barrel stowage:		
Bracket, cargo shell door			Installation	12-159b	12-250
gas spring mounting:			Removal	12-159a	12-250
Installation	11-29b	11-47	Bracket, mounting, dual TSEC/KY57		
Removal	11-29a	11-47	and control switch bracket:		
Bracket, exhaust reinforcement:			Installation	12-134b	12-207
Installation	12-15b	12-18	Removal	12-134a	12-207
Removal	12-15a	12-18	Bracket, pioneer tool stowage		
Bracket, field glasses:			tray mounting:		
Installation	11-69b	11-99	Installation	10-51b	10-86
Removal	11-69a	11-99	Removal	10-51a	10-86
Bracket, fire extinguisher:			Bracket, rear antenna mounting:		
Installation	10-57b	10-93	Installation	12-138b	12-212
Removal	10-57a	10-93	Removal	12-138a	12-212
Bracket, front radio rack mounting:			Bracket, rear bow pivot:		
Installation	12-130b	12-202	Installation	10-100b	10-169
Removal	12-130a	12-202	Removal	10-100a	10-169
Bracket, handset:			Bracket, rifle mounting clamp:		
Installation	12-143b	12-224	Installation	11-92b	11-134
Removal	12-143a	12-224	Removal	11-92a	11-134
Bracket, headphone mounting:			Bracket, shelter carrier tailgate:		
Installation	12-142b	12-223	Installation	11-118b	11-165
Removal	12-142a	12-223	Removal	11-118a	11-165
Bracket, hood prop rod:			Bracket, shelter mounting:		
Assembly	10-4d	10-6	Installation	11-116b	11-163
Disassembly	10-4b	10-6	Removal	11-116a	11-163
Inspection	10-4c	10-6	Brackets, cargo bulkhead		
Installation	10-4e	10-7	mounting:		
Removal	10-4a	10-6	Installation	10-54b	10-89
			Removal	10-54a	10-89

INDEX (Cont'd)

B (Cont'd)	Para	Page	B (Cont'd)	Para	Page
Brackets, M11 decontamination:			Bulkhead door latch:		
Installation	10-68	10-112	Installation	11-156b	11-230
Brackets, NBC heater:			Removal	11-156a	11-228
Installation	11-165b	11-243	Bumper brace bracket (L119),		
Removal	11-165a	11-243	rear:		
Bracket, spineboard mounting:			Installation	12-165b	12-258
Installation	11-148b	11-216	Removal	12-165a	12-258
Removal	11-148a	11-216	Bumper inner brace (L119), rear:		
Brackets, tailgate chain:			Installation	12-168b	12-261
Installation	10-60b	10-96	Removal	12-168a	12-261
Removal	10-60a	10-96	Bumper inner mounting		
Bracket, stowage mount:			bracket (L119), rear:		
Installation	11-70b	11-100	Installation	12-169b	12-262
Removal	11-70a	11-100	Removal	12-169a	12-262
Bracket, tripod:			Bumper (L119), rear:		
Installation	11-102b	11-144	Installation	12-164b	12-257
Removal	11-102a	11-144	Removal	12-164a	12-257
Bracket, tripod head mounting:			Bumper lifting shackle (L119),		
Installation	11-79b	11-121	rear:		
Removal	11-79a	11-121	Installation	12-171b	12-264
Bracket, tripod leg mounting:			Removal	12-171a	12-264
Installation	11-78b	11-120	Bumper, litter handle:		
Removal	11-78a	11-120	Installation	11-147b	11-215
Bracket, upper litter rack latch:			Removal	11-147a	11-215
Installation	11-143b	11-211	Bumper outer brace (L119), rear:		
Removal	11-143a	11-211	Installation	12-166b	12-259
Bracket, upper litter rack			Removal	12-166a	12-259
striker support:			Bumper outer mounting		
Installation	11-141b	11-208	bracket (L119), rear:		
Removal	11-141a	11-208	Installation	12-167b	12-260
Bracket, upper litter rack			Removal	12-167a	12-260
support:			Bumper pad, weapon station:		
Installation	11-144b	11-212	Installation	11-48b	11-69
Removal	11-144a	11-212	Removal	11-48a	11-69
Bracket, vehicle power			Bumper, water can:		
conditioner (VPC) mounting:			Installation	11-76b	11-117
Installation	11-66b	11-91	Removal	11-76a	11-117
Removal	11-66a	11-91	Bumper, water can/M13 decon		
Bracket, windshield mounting:			can:		
Installation	12-5b	12-7	Installation	11-109b	11-151
Removal	12-5a	12-7	Removal	11-109a	11-151
Brushguard assembly replacement:			C		
Brushguard assembly			Cab enclosure panel:		
replacement	12-187a	12-310	Installation	11-122b	11-172
Lanyard replacement	12-187e	12-311	Removal	11-122a	11-172
Pivot brace replacement	12-187c	12-310	Cable, alternator, 100 ampere		
Quick release brace			(12446821-2):		
replacement	12-187d	12-310	Installation	12-22.1b	12-28.2
Tube assembly replacement	12-187b	12-310	Removal	12-22.1a	12-28.2
Bulkhead, cargo:					
Installation	10-53b	10-88			
Removal	10-53a	10-88			
Bulkhead door:					
Installation	11-155b	11-226			
Removal	11-155a	11-224			

INDEX (Cont'd)

C (Cont'd)	Para	Page	C (Cont'd)	Para	Page
Cable, arctic heater control:			Camouflage rack:		
Adjustment	12-42.1c	12-63.1	Assembly	12-183c	12-280
Installation	12-42.1b	12-63.1	Disassembly	12-183b	12-279
Removal	12-42.1a	12-63.1	Installation	12-183d	12-281
Cable, arctic heater exhaust			Removal	12-183a	12-278
diverter:			Cargo barrier channel:		
Adjustment	12-48c	12-70	Installation	12-190b	12-314
Installation	12-48b	12-70	Removal	12-190a	12-314
Removal	12-48a	12-70	Cargo barrier extension:		
Cable, cargo shell door			Assembly	10-55c	10-90
retention:			Disassembly	10-55b	10-90
Installation	11-20b	11-34	Installation	10-55d	10-90
Removal	11-20a	11-34	Removal	10-55a	10-90
Cable, heater control and			Cargo bulkhead:		
shutoff valve:			Installation	10-53b	10-88
Adjustment	10-90	10-150	Removal	10-53a	10-88
Cable, power, front radio:			Cargo bulkhead:		
Installation	12-141b	12-222	Installation	11-111b	11-153
Removal	12-141a	12-221	Removal	11-111a	11-153
Cable, rear radio rack power:			Cargo bulkhead mounting		
Installation	12-147b	12-234	brackets:		
Removal	12-147a	12-232	Installation	10-54b	10-89
Cable, rear steps retaining:			Removal	10-54a	10-89
Installation	11-136b	11-198	Cargo floor access cover (M1123):		
Removal	11-136a	11-198	Inspection	10-31.1b	10-56.2
Cables, duct door control:			Installation	10-31.1c	10-56.2
Cable adjustment	11-199g	11-300	Removal	10-31.1a	10-56.2
Evaporator intake cable			Cargo shell door:		
installation	11-199b	11-296	Adjustment	11-13c	11-24
Evaporator intake cable			Installation	11-13b	11-22
removal	11-199a	11-296	Removal	11-13a	11-20
Heater/air-conditioning			Cargo shell door dovetail assembly:		
outlet cable installation	11-199d	11-298	Adjustment	11-19c	11-32
Heater/air-conditioning			Installation	11-19b	11-32
outlet cable removal	11-199c	11-298	Removal	11-19a	11-32
Heater intake cable			Cargo shell door dovetail spring:		
installation	11-199f	11-298	Installation	11-28b	11-46
Heater intake cable			Removal	11-28a	11-46
removal	11-199e	11-298	Cargo shell door front striker:		
Cables, rear antenna:			Installation	11-25b	11-43
Installation	12-140b	12-217	Removal	11-25a	11-43
Removal	12-140a	12-214	Cargo shell door gas spring:		
Cable stowage cleat:			Assembly	11-21d	11-38
Installation	11-68b	11-98	Disassembly	11-21c	11-38
Removal	11-68a	11-98	Installation	11-21e	11-38
Cable, winch (6,000 lb and			Removal	11-21b	11-37
9,000 lb electric):			Rotating	11-21a	11-35
Installation	10-110b	10-190	Cargo shell door gas spring		
Removal	10-110a	10-190	mounting bracket:		
Cable, winch (10,500 lb hydraulic):			Installation	11-29b	11-47
Installation	10-110.1b	10-190.2	Removal	11-29a	11-47
Removal	10-110.1a	10-190.2			

INDEX (Cont'd)

C (Cont'd)	Para	Page	C (Cont'd)	Para	Page
Cargo shell door grab handle:			CDR valve tube assembly,		
Installation	11-15b	11-27	arctic heater:		
Removal	11-15a	11-27	Installation	12-36b	12-54
Cargo shell door handle latch:			Removal	12-36a	12-53
Installation	11-16b	11-28	CDR valve vent line:		
Removal	11-16a	11-28	Installation	12-10b	12-13
Cargo shell door latch:			Removal	12-10a	12-13
Adjusting	11-17c	11-29	Chain, shelter carrier tailgate:		
Installation	11-17b	11-29	Assembly	11-119c	11-166
Removal	11-17a	11-29	Disassembly	11-119b	11-166
Cargo shell door latch rod:			Installation	11-119d	11-166
Adjustment	11-18c	11-30	Removal	11-119a	11-166
Installation	11-18b	11-30	Channel assembly, arctic curtain		
Removal	11-18a	11-30	(2-man crew):		
Cargo shell door liner:			Installation	12-76b	12-109
Installation	11-30b	11-48	Removal	12-76a	12-109
Removal	11-30a	11-48	Circuit breaker, troop/cargo		
Cargo shell door rear striker:			winterization:		
Installation	11-26b	11-44	Installation	12-103b	12-152
Removal	11-26a	11-44	Removal	12-103a	12-152
Cargo shell door rear striker			Clamp, rifle mounting:		
mounting plate:			Installation	11-91b	11-133
Installation	11-27b	11-45	Removal	11-91a	11-133
Removal	11-27a	11-45	Cleaning staff stowage clip:		
Cargo shell door retention cable:			Installation	12-151b	12-241
Installation	11-20b	11-34	Removal	12-151a	12-241
Removal	11-20a	11-34	Cleat, cable stowage:		
Cargo shell door seal:			Installation	11-68b	11-98
Installation	11-24b	11-42	Removal	11-68a	11-98
Removal	11-24a	11-42	Clip, cleaning staff stowage:		
Cargo shell door seal protector:			Installation	12-151b	12-241
Installation	11-23b	11-41	Removal	12-151a	12-241
Removal	11-23a	11-41	Clip, Red Cross placard		
Cargo shell door strap:			retaining:		
Installation	11-22b	11-40	Installation	11-174b	11-256
Removal	11-22a	11-40	Removal	11-174a	11-256
Cargo shell door wire handle			Communications kits:		
lock:			Maintenance task summary	12-129	12-201
Installation	11-14b	11-26	Compressor belt:		
Removal	11-14a	11-26	Adjustment	11-202c	11-306
Cargo shell roof insulation			Installation	11-202b	11-306
panel:			Removal	11-202a	11-306
Installation	11-31b	11-50	Condenser cooling fan:		
Removal	11-31a	11-50	Installation	11-201b	11-304
Cargo tiedown:			Removal	11-201a	11-304
Installation	10-56b	10-92	Control box assembly		
Removal	10-56a	10-92	arctic heater maintenance:		
Catch, battery box cover			Assembly	12-43b	12-64
Installation	10-40b	10-68	Disassembly	12-43a	12-64
Removal	10-40a	10-68			

INDEX (Cont'd)

C (Cont'd)	Para	Page	C (Cont'd)	Para	Page
Control box assembly, arctic heater:			Cowl insulation panel, right inner:		
Installation	12-42b	12-62	Installation	10-30b	10-51
Removal	12-42a	12-61	Removal	10-30a	10-51
Control box, winch (6,000 lb and 9,000 lb electric):			Cowl insulation, right front:		
Installation	10-109b	10-188	Installation	10-27b	10-47
Removal	10-109a	10-188	Removal	10-27a	10-47
Coolant base, night sight:			“C” pillar:		
Installation	11-83b	11-125	Installation	10-99b	10-168
Removal	11-83a	11-125	Removal	10-99a	10-168
Cover and latch, medical stowage:			“C” pillar reinforcement brackets:		
Installation	11-179b	11-261	Installation	10-105	10-177
Removal	11-179a	11-261	Curtain angle assembly, arctic:		
Cover and seal, armament:			Installation	12-74b	12-107
Installation	11-62b	11-83	Removal	12-74a	12-107
Removal	11-62a	11-83	Curtain assembly, arctic:		
Cover assembly, arctic top:			Installation	12-73b	12-106
Installation	12-72b	12-105	Removal	12-73a	12-106
Removal	12-72a	12-105	Cushions, companion seat and seat back:		
Cover assembly, troop/cargo winterization top:			Installation	10-37b	10-64
Installation	12-119b	12-182	Removal	10-37a	10-64
Removal	12-119a	12-180	Cushions, driver's seat and seat back:		
Cover, cargo floor access:			Installation	10-33b	10-60
Inspection	10-31.1b	10-56.2	Removal	10-33a	10-60
Installation	10-31.1c	10-56.2	Cushions, passenger seat and seat back:		
Removal	10-31.1a	10-56.2	Installation	10-46b	10-74
Cover, engine access:			Removal	10-46a	10-74
Assembly	10-15c	10-24			
Disassembly	10-15b	10-22	D		
Installation	10-15d	10-26	Data plate, troop/cargo winterization:		
Removal	10-15a	10-22	Installation	12-128b	12-200
Cover, passenger seat and storage compartment:			Removal	12-128a	12-200
Installation	10-43b	10-71	Day sight stowage bracket:		
Removal	10-43a	10-71	Installation	11-81b	11-123
Cowl armor plate, left:			Removal	11-81a	11-123
Installation	11-37b	11-56	Deep water fording kit:		
Removal	11-37a	11-56	Maintenance task summary	12-1	12-1
Cowl armor plate, right:			Deep water fording kit air intake assembly:		
Installation	11-36b	11-55	Installation	12-3b	12-4
Removal	11-36a	11-55	Removal	12-3a	12-4
Cowl insulation, arctic heater front:			Deep water fording kit exhaust assembly:		
Installation	12-46b	12-68	Inspection	12-2b	12-2
Removal	12-46a	12-68	Installation	12-2c	12-3
Cowl insulation, left front:			Removal	12-2a	12-2
Installation	10-26b	10-46	Deep water fording sensor cup:		
Removal	10-26a	10-46	Installation	12-12b	12-15
Cowl insulation, left outer:			Removal	12-12a	12-15
Installation	10-25b	10-45	Deflector, blower outlet:		
Removal	10-25a	10-45	Installation	11-210b	11-318
Cowl insulation panel, left inner:			Removal	11-210a	11-318
Installation	10-31b	10-54			
Removal	10-31a	10-52			

INDEX (Cont'd)

D (Cont'd)	Para	Page	D (Cont'd)	Para	Page
Defrost control:			Door, ballistic crew:		
Installation	10-88b	10-146	Adjustment	11-2d	11-6
Removal	10-88a	10-146	Inspection	11-2c	11-6
Defroster ducting			Installation	11-2b	11-5
(All except M1097, M1123):			Removal	11-2a	11-5
Installation	10-93b	10-158	Door, bulkhead:		
Removal	10-93a	10-156	Installation	11-155b	11-226
Defroster ducting			Removal	11-155a	11-224
(M1097, M1123):			Door, cargo shell:		
Installation	10-96.1b	10-164.2	Adjustment	11-13c	11-24
Removal	10-96.1a	10-164.2	Installation	11-13b	11-22
Defroster nozzle, left:			Removal	11-13a	11-20
Installation	10-94b	10-160	Door cover, troop/cargo		
Removal	10-94a	10-160	winterization fixed:		
Defroster nozzle, right:			Installation	12-113b	12-166
Installation	10-95b	10-164	Removal	12-113a	12-166
Removal	10-95a	10-164	Door, exterior stowage:		
Diverter, air (M996, M996A1):			Installation	11-176b	11-258
Installation	11-213b	11-323	Removal	11-176a	11-258
Removal	11-213a	11-323	Door, fixed rear:		
Diverter assembly, troop/cargo			Installation	10-14b	10-21
winterization heater:			Removal	10-14a	10-21
Installation	12-96b	12-140	Door handle assembly:		
Removal	12-96a	12-140	Installation	10-13c	10-20
Diverter box (All except M998A2):			Removal	10-13a	10-18
Installation	10-92b	10-154	Repair	10-13b	10-18
Removal	10-92a	10-154	Door handles, rear:		
Diverter box, arctic:			Installation	11-127b	11-186
Assembly	12-49c	12-72	Removal	11-127a	11-186
Disassembly	12-49b	12-72	Door hinge, ballistic crew:		
Installation	12-49d	12-72	Installation	11-3b	11-8
Removal	12-49a	12-72	Removal	11-3a	11-8
Diverter box (M998A2):			Door hinge, rear:		
Installation	10-97.1b	10-166	Installation	11-126b	11-185
Removal	10-97.1a	10-166	Removal	11-126a	11-185
Diverter box cover:			Door hinge, soft top:		
Installation	10-96.3b	10-164.5	Installation	10-101b	10-170
Removal	10-96.3a	10-164.5	Removal	10-101a	10-170
Diverter ducting:			Door holder assembly, rear:		
Installation	10-96.4b	10-164.6	Installation	11-132b	11-192
Removal	10-96.4a	10-164.6	Removal	11-132a	11-192
Diverter box cover, arctic heater:			Door latch assembly		
Installation	12-47b	12-69	and guide, rear:		
Removal	12-47a	12-69	Installation	11-128b	11-187
Diverter manifold and housing:			Removal	11-128a	11-187
Installation	10-92.1b	10-154.2	Door latch, bulkhead:		
Removal	10-92.1a	10-154.2	Installation	11-156b	11-230
Door, air intake duct:			Removal	11-156a	11-228
Installation	11-185b	11-269	Door latch, NBC compartment:		
Removal	11-185a	11-269	Installation	11-163b	11-241
Door and frame assembly,			Removal	11-163a	11-241
troop/cargo winterization:			Door latch rod striker guides		
Installation	12-117b	12-174	and brackets, rear:		
Removal	12-117a	12-172	Bracket installation	11-131d	11-190
			Bracket removal	11-131c	11-190
			Striker guide adjustment	11-131e	11-190
			Striker guide installation	11-131b	11-190
			Striker guide removal	11-131a	11-190

INDEX (Cont'd)

D (Cont'd)	Para	Page	D (Cont'd)	Para	Page
Door liner, cargo shell:			Driver's seat and seat		
Installation	11-30b	11-48	back cushions:		
Removal	11-30a	11-48	Installation	10-33b	10-60
Door, litter stowage:			Removal	10-33a	10-60
Installation	11-159b	11-235	Driver's seat frame:		
Removal	11-159a	11-235	Installation	10-32b	10-58
Door (M996, M996A1), NBC:			Removal	10-32a	10-58
Installation	11-183b	11-266	Driver's seat retainer plate		
Removal	11-183a	11-266	assembly:		
Door (M997, M997A1, M997A2),			Installation	10-59b	10-95
NBC compartment:			Removal	10-59a	10-95
Installation	11-162b	11-240	Duct, air		
Removal	11-162a	11-240	Installation	10-97b	10-165
Door, rear:			Removal	10-97a	10-165
Adjustment	11-125c	11-184	Duct door, air intake:		
Installation	11-125b	11-183	Installation	11-185b	11-269
Removal	11-125a	11-183	Removal	11-185a	11-269
Door seal protector, rear:			Duct door control cables:		
Installation	11-129b	11-188	Cable adjustment	11-199g	11-300
Removal	11-129a	11-188	Evaporator intake cable		
Door seals, rear:			installation	11-199b	11-296
Installation	11-130b	11-189	Evaporator intake cable		
Removal	11-130a	11-189	removal	11-199a	11-296
Door, soft top:			Heater/air-conditioning		
Adjustment	10-102	10-172	outlet cable installation	11-199d	11-298
Door, stowage:			Heater/air-conditioning		
Installation	11-152b	11-221	outlet cable removal	11-199c	11-298
Removal	11-152a	11-221	Heater intake cable		
Door striker, soft top:			installation	11-199f	11-298
Installation	10-103b	10-174	Heater intake cable removal	11-199e	11-298
Removal	10-103a	10-174	Duct, heat/air-conditioning:		
Door, troop/cargo winterization:			Assembly	11-211c	11-320
Adjustment	12-116	12-170	Disassembly	11-211b	11-320
Door vent assembly, rear:			Installation	11-211d	11-319
Installation	11-178b	11-260	Removal	11-211a	11-319
Removal	11-178a	11-260	Ducting, defroster:		
Dovetail assembly, cargo shell door:			Installation	10-93b	10-158
Adjustment	11-19c	11-32	Removal	10-93a	10-156
Installation	11-19b	11-32	Ducting, heater:		
Removal	11-19a	11-32	Installation	10-91b	10-152
Dovetail spring, cargo shell door:			Removal	10-91a	10-152
Installation	11-28b	11-46	Dust cap, air cleaner:		
Removal	11-28a	11-46	Installation	12-6b	12-8
Drain tube, evaporator:			Removal	12-6a	12-8
Installation	11-200b	11-302			
Removal	11-200a	11-302	E		
Drip rail, rear:			Edge protector:		
Installation	11-170b	11-252	Installation	11-180b	11-262
Removal	11-170a	11-252	Removal	11-180a	11-262
Driver's seat assembly:			Elbow, air cleaner extension:		
Assembly	10-39b	10-66	Inspection	12-4b	12-6
Disassembly	10-39a	10-66	Installation	12-4c	12-6
Installation	10-38b	10-65	Removal	12-4a	12-5
Removal	10-38a	10-65			

INDEX (Cont'd)

E (Cont'd)	Para	Page	F	Para	Page
Elevation and depression stop assembly:			Fan, condenser cooling:		
Assembly	11-73b	11-104	Installation	11-201b	11-304
Disassembly	11-73a	11-104	Removal	11-201a	11-304
Enclosure assembly, troop/cargo			Field glasses bracket:		
winterization top:			Installation	11-69b	11-99
Installation	12-120b	12-188	Removal	11-69a	11-99
Removal	12-120a	12-186	Filter, air intake:		
End closure, troop/cargo			Cleaning	11-205b	11-310
winterization:			Inspection	11-205a	11-310
Installation	12-118b	12-178	Filter and bracket, NBC gas:		
Removal	12-118a	12-176	Installation	11-167b	11-247
Engine access cover:			Removal	11-167a	11-246
Assembly	10-15c	10-24	Filter assembly, and bracket, NBC precleaner, particulate:		
Disassembly	10-15b	10-22	Installation	11-168b	11-249
Installation	10-15d	10-26	Removal	11-168a	11-248
Removal	10-15a	10-22	Filter, heater fuel:		
Engine access cover flexible latch and holddown strike:			Installation	11-192b	11-278
Installation	10-16b	10-27	Removal	11-192a	11-278
Removal	10-16a	10-27	Fire extinguisher bracket:		
Engine left splash shield:			Installation	10-57b	10-93
Assembly	10-17c	10-30	Removal	10-57a	10-93
Disassembly	10-17b	10-28	Fire extinguisher support:		
Installation	10-17d	10-30	Installation	10-58b	10-94
Removal	10-17a	10-28	Removal	10-58a	10-94
Engine left splash shield access covers:			Fixed rear door:		
Installation	10-18b	10-32	Installation	10-14b	10-21
Removal	10-18a	10-32	Removal	10-14a	10-21
Engine right splash shield:			Floorboard, front:		
Assembly	10-20c	10-36	Installation	11-154b	11-223
Disassembly	10-20b	10-34	Removal	11-154a	11-223
Installation	10-20d	10-36	Floor bracket, troop/cargo		
Removal	10-20a	10-34	winterization:		
Equipment rack:			Installation	12-99b	12-143
Installation	12-156b	12-247	Removal	12-99a	12-143
Removal	12-156a	12-247	Floor cover, troop/cargo		
Evaporator drain tube:			winterization front and rear cargo:		
Installation	11-200b	11-302	Installation	12-110b	12-162
Removal	11-200a	11-302	Removal	12-110a	12-162
Exhaust assembly, deep water fording kit:			Floor cover, troop/cargo		
Inspection	12-2b	12-2	winterization side:		
Installation	12-2c	12-3	Installation	12-114b	12-167
Removal	12-2a	12-2	Removal	12-114a	12-167
Exhaust pipe, heater:			Floor drain hole plate:		
Installation	11-207b	11-313	Installation	12-188	12-312
Removal	11-207a	11-313	Floor heat duct louver:		
Exhaust pipe (M997, M997A1, M997A2), heater:			Installation	11-196b	11-290
Installation	11-189b	11-273	Removal	11-196a	11-290
Removal	11-189a	11-273	Floor insulation, rear seat:		
Exhaust reinforcement bracket:			Installation	10-29b	10-50
Installation	12-15b	12-18	Removal	10-29a	10-50
Removal	12-15a	12-18	Footman loop and strap:		
Expendable/durable supplies and materials list:			Installation	10-9b	10-14
Appendix C		C-1	Removal	10-9a	10-14

INDEX (Cont'd)

F (Cont'd)	Para	Page	F (Cont'd)	Para	Page
Footwell armor plate:			Fuel supply hose, arctic heater		
Installation	11-38b	11-57	filter-to-heater:		
Removal	11-38a	11-57	Installation	12-35b	12-52
Fording kit air intake			Removal	12-35a	12-52
assembly, deep water:			Fuel supply hose, arctic heater		
Installation	12-3b	12-4	pump-to-bulkhead:		
Removal	12-3a	12-4	Installation	12-32b	12-46
Former, "A" pillar assembly:			Removal	12-32a	12-46
Installation	10-98b	10-167	Fuel supply hose, troop/cargo		
Removal	10-98a	10-167	winterization heater		
Frame, driver's seat:			filter-to-bulkhead coupling:		
Installation	10-32b	10-58	Installation	12-91b	12-132
Removal	10-32a	10-58	Removal	12-91a	12-131
Fuel can mounting bracket,			Fuel supply hose, troop/cargo		
troop/cargo winterization:			winterization heater:		
Installation	12-124b	12-196	Installation	12-85b	12-123
Removal	12-124a	12-196	Removal	12-85a	12-123
Fuel can tray and hose:			Fuel supply hose, troop/cargo		
Installation	11-80b	11-122	winterization heater bulkhead:		
Removal	11-80a	11-122	Installation	12-88b	12-127
Fuel filler housing:			Removal	12-88a	12-127
Installation	10-2b	10-3	Fuel supply hose, troop/cargo		
Removal	10-2a	10-3	winterization heater filter-		
Fuel filter assembly, arctic heater:			to-heater:		
Installation	12-27b	12-40	Installation	12-92b	12-134
Removal	12-27a	12-40	Removal	12-92a	12-133
Fuel filter assembly, troop/cargo			Fuel supply line, arctic heater		
winterization heater:			filter-to-bulkhead:		
Installation	12-82b	12-120	Installation	12-34b	12-50
Removal	12-82a	12-119	Removal	12-34a	12-50
Fuel filter, heater:			Fuel supply line, arctic heater		
Installation	11-192b	11-278	pump-to-hose:		
Removal	11-192a	11-278	Installation	12-31b	12-45
Fuel lines replacement, heater:			Removal	12-31a	12-45
"B" beam fuel line	11-193d	11-282	Fuel supply line, arctic heater		
Bulkhead coupling	11-193f	11-282	tank-to-hose:		
Bulkhead fuel line	11-193g	11-284	Installation	12-29b	12-43
Cab fuel line	11-193b	11-280	Removal	12-29a	12-43
Filter fuel line	11-193e	11-282	Fuel supply line, bulkhead		
Heater fuel line	11-193a	11-280	coupling, arctic heater:		
Pump fuel line	11-193h	11-284	Installation	12-33b	12-48
Shutoff valve	11-193c	11-282	Removal	12-33a	12-48
Tank fuel line and supply tube ...	11-193i	11-284	Fuel supply line bulkhead		
Fuel pump, arctic heater:			coupling, troop/cargo		
Installation	12-26b	12-39	winterization heater:		
Removal	12-26a	12-38	Installation	12-90b	12-130
Fuel pump, heater:			Removal	12-90a	12-129
Installation	11-194b	11-286	Fuel supply line, troop/cargo		
Removal	11-194a	11-286	winterization heater bulkhead		
Fuel pump, troop/cargo			hose-to-bulkhead coupling:		
winterization heater:			Installation	12-89b	12-128
Installation	12-81b	12-118	Removal	12-89a	12-128
Removal	12-81a	12-116			
Fuel supply hose, arctic heater:					
Installation	12-30b	12-44			
Removal	12-30a	12-44			

INDEX (Cont'd)

F (Cont'd)	Para	Page	G (Cont'd)	Para	Page
Fuel supply line, troop/cargo winterization heater pump-to-bulkhead:			Lubrication	13-9	13-3
Installation	12-87b	12-126	Records and reports	13-10	13-3
Removal	12-87a	12-125	Repair, printing, and preservation	13-8	13-3
Fuel supply line, troop/cargo winterization heater pump-to-hose:			Scope	13-1	13-1
Installation	12-86b	12-124	Security	13-3	13-1
Removal	12-86a	12-124	Special packaging and shipping requirements	13-4	13-1
Fuel supply line, troop/cargo winterization heater tank-to-hose:			Grab handle, cargo shell door:		
Installation	12-84b	12-122	Installation	11-15b	11-27
Removal	12-84a	12-122	Removal	11-15a	11-27
Fuel supply tube assembly, arctic heater:			Grille, air inlet/outlet:		
Installation	12-28b	12-42	Installation	11-186b	11-270
Removal	12-28a	12-42	Removal	11-186a	11-270
Fuel supply tube assembly, troop/cargo winterization heater:			Grille and screen, hood:		
Installation	12-83b	12-121	Installation	10-12b	10-17
Removal	12-83a	12-121	Removal	10-12a	10-17
Fuel system bleeding, heater	11-195	11-288	Grille, hood top armored:		
Fuel tank vent stack tube:			Installation	11-34b	11-53
Installation	12-8b	12-10	Removal	11-34a	11-53
Removal	12-8a	12-10	Ground strap, antenna:		
G			Installation	12-136b	12-210
Gas filter and bracket, NBC:			Removal	12-136a	12-209
Installation	11-167b	11-247	Gun adapter plate assembly:		
Removal	11-167a	11-246	Installation	11-95b	11-137
Gasoline cook stove bracket assembly:			Removal	11-95a	11-137
Installation	11-89b	11-131	Gun display unit battery strap (L119):		
Removal	11-89a	11-131	Installation	12-178b	12-271
Gas spring, cargo shell door:			Removal	12-178a	12-271
Assembly	11-21d	11-38	Gun mount plate assembly, front:		
Disassembly	11-21c	11-38	Installation	11-96b	11-138
Installation	11-21e	11-38	Removal	11-96a	11-138
Removal	11-21b	11-37	Gun mount plate assembly, rear:		
Rotating	11-21a	11-35	Installation	11-97b	11-139
Gas spring mounting bracket, cargo shell door:			Removal	11-97a	11-139
Installation	11-29b	11-47	Gun mount support (caliber .50):		
Removal	11-29a	11-47	Installation	11-98b	11-140
General instructions, preparation for stowage and shipment:			Removal	11-98a	11-140
Administrative storage	13-2	13-1	Gun mount support (40 mm):		
Cleaning	13-6	13-2	Installation	11-99b	11-141
General storage and shipping information	13-5	13-2	Removal	11-99a	11-141
Inspections, stowage and inventory	13-7	13-2	Gunner's platform:		
			Installation	11-63b	11-84
			Removal	11-63a	11-84
			Gunner's platform assembly:		
			Assembly	11-64b	11-88
			Disassembly	11-64a	11-86
			Installation	11-65b	11-90
			Removal	11-65a	11-90
			Gunner's sling, hinge pivot bracket and:		
			Installation	11-52b	11-73
			Removal	11-52a	11-73
			Gunner's sling hook:		
			Installation	11-53b	11-74
			Removal	11-53a	11-74

INDEX (Cont'd)

H	Para	Page	H (Cont'd)	Para	Page
Hand guard, ready rack:			Heat deflector, troop/cargo		
Installation	12-155b	12-246	winterization:		
Removal	12-155a	12-246	Installation	12-94b	12-136
Handle assembly, door:			Removal	12-94a	12-136
Installation	10-13c	10-20	Heater air intake assembly,		
Removal	10-13a	10-18	troop/cargo winterization:		
Repair	10-13b	10-18	Installation	12-97b	12-141
Handle assembly, troop/cargo			Removal	12-97a	12-141
winterization:			Heater assembly:		
Installation	12-123b	12-195	Installation	10-87b	10-144
Removal	12-123a	12-195	Removal	10-87a	10-144
Handle, cargo shell door grab:			Heater assembly, arctic:		
Installation	11-15b	11-27	Installation	12-41b	12-60
Removal	11-15a	11-27	Removal	12-41a	12-59
Handle latch, cargo shell door:			Heater assembly, troop/cargo		
Installation	11-16b	11-28	winterization:		
Removal	11-16a	11-28	Installation	12-95b	12-138
Handles, rear door:			Removal	12-95a	12-137
Installation	11-127b	11-186	Heater base assembly,		
Removal	11-127a	11-186	troop/cargo winterization:		
Handset bracket:			Installation	12-98b	12-142
Installation	12-143b	12-224	Removal	12-98a	12-142
Removal	12-143a	12-224	Heater boot:		
Hatch handle, weapon station:			Installation	10-96b	10-164.1
Installation	11-43b	11-63	Removal	10-96a	10-164.1
Removal	11-43a	11-63	Heater brackets, NBC:		
Hatch hinge pin, weapon station:			Installation	11-165b	11-243
Installation	11-44b	11-64	Removal	11-165a	11-243
Removal	11-44a	11-64	Heater compartment panel		
Hatch hinge, weapon station:			(M996, M996A1):		
Installation	11-45b	11-66	Installation	11-204b	11-309
Removal	11-45a	11-65	Removal	11-204a	11-309
Hatch holddown striker,			Heater control:		
weapon station:			Installation	10-89b	10-148
Installation	11-46b	11-67	Removal	10-89a	10-148
Removal	11-46a	11-67	Heater control box and angle		
Hatch latch, weapon station:			bracket, troop/cargo		
Installation	11-50b	11-71	winterization:		
Removal	11-50a	11-71	Installation	12-100b	12-144
Hatch tube assembly, weapon			Removal	12-100a	12-144
station:			Heater control cable		
Installation	11-51b	11-72	and shutoff valve:		
Removal	11-51a	11-72	Adjustment	10-90	10-150
Hatch, weapon station:			Heater ducting:		
Installation	11-42b	11-62	Installation	10-91b	10-152
Removal	11-42a	11-62	Removal	10-91a	10-152
Headphone mounting bracket:			Heater exhaust pipe		
Installation	12-142b	12-223	(M996, M996A1):		
Removal	12-142a	12-223	Installation	11-207b	11-313
Heat/air-conditioning duct:			Removal	11-207a	11-313
Assembly	11-211c	11-320	Heater exhaust pipe		
Disassembly	11-211b	11-319	(M997, M997A1, M997A2):		
Installation	11-211d	11-320	Installation	11-189b	11-273
Removal	11-211a	11-319	Removal	11-189a	11-273

INDEX (Cont'd)

H (Cont'd)	Para	Page	H (Cont'd)	Para	Page
Heater fan motor resistor assembly:			Heater outlet/inlet piping:		
Installation	10-86b	10-142	Inspection	10-84b	10-138
Removal	10-86a	10-142	Installation	10-84c	10-138
Heater fan switch:			Removal	10-84a	10-138
Installation	10-85b	10-140	Heater shutoff valve:		
Removal	10-85a	10-140	Installation	10-83b	10-137
Heater fuel filter:			Removal	10-83a	10-137
Installation	11-192b	11-278	Heater wiring harness adapter, troop/cargo winterization:		
Removal	11-192a	11-278	Installation	12-102b	12-150
Heater, fuel lines replacement:			Removal	12-102a	12-150
"B" beam fuel line	11-193d	11-282	Heater wiring harness, troop/cargo winterization:		
Bulkhead coupling	11-193f	11-282	Installation	12-101b	12-148
Bulkhead fuel line	11-193g	11-284	Removal	12-101a	12-146
Cab fuel line	11-193b	11-280	Hinge, ballistic crew door:		
Filter fuel line	11-193e	11-282	Installation	11-3b	11-8
Heater fuel line	11-193a	11-280	Removal	11-3a	11-8
Pump fuel line	11-193h	11-284	Hinge, hood:		
Shutoff valve	11-193c	11-282	Alignment	10-5c	10-10
Tank fuel line and supply tube	11-193i	11-284	Installation	10-5b	10-8
Heater fuel pump:			Removal	10-5a	10-8
Installation	11-194b	11-286	Hinge pin, weapon station hatch:		
Removal	11-194a	11-286	Installation	11-44b	11-64
Heater fuel system bleeding	11-195	11-288	Removal	11-44a	11-64
Heater guard assembly, troop/cargo winterization:			Hinge pivot bracket and gunner's sling:		
Installation	12-93b	12-135	Installation	11-52b	11-73
Removal	12-93a	12-135	Removal	11-52a	11-73
Heater hose:			Hinge, rear door:		
Installation	10-96.2b	10-164.4	Installation	11-126b	11-185
Removal	10-96.2a	10-164.4	Removal	11-126a	11-185
Heater (M996, M996A1):			Hinge, rear steps:		
Installation	11-209b	11-316	Installation	11-133b	11-193
Removal	11-209a	11-316	Removal	11-133a	11-193
Heater (M997, M997A1, M997A2):			Hinge, soft top door:		
Installation	11-190b	11-274	Installation	10-101b	10-170
Removal	11-190a	11-274	Removal	10-101a	10-170
Heater mounting bracket assembly (M996, M996A1):			Hinge, tailgate upper		
Installation	11-208b	11-314	Installation	10-62b	10-100
Removal	11-208a	11-314	Removal	10-62a	10-100
Heater, NBC:			Hinge, weapon station hatch:		
Installation	11-164b	11-242	Installation	11-45b	11-66
Removal	11-164a	11-242	Removal	11-45a	11-65
Heater nozzle deflector:			Holddown strike, engine access cover flexible latch and:		
Installation	10-94.1b	10-163	Installation	10-16b	10-27
Removal	10-94.1a	10-163	Removal	10-16a	10-27
Heater outlet/blower fan hose (M996, M996A1):			Holder assembly, rear door:		
Installation	11-206b	11-312	Installation	11-132b	11-192
Removal	11-206a	11-312	Removal	11-132a	11-192
Heater outlet hose (M997, M997A1, M997A2):					
Installation	11-191b	11-276			
Removal	11-191a	11-276			

INDEX (Cont'd)

H (Cont'd)	Para	Page	H (Cont'd)	Para	Page
Hood and hinge:			Hose, heater outlet/blower fan (M996, M996A1):		
Alignment	10-5c	10-10	Installation	11-206b	11-312
Installation	10-5b	10-8	Removal	11-206a	11-312
Removal	10-5a	10-8	Hoses, windshield washer:		
Hood center armor plate:			Installation	10-76b	10-126
Installation	11-33b	11-52	Removal	10-76a	10-126
Removal	11-33a	11-52	Housing, fuel filter:		
Hood front armored grille:			Installation	10-2b	10-3
Installation	11-35b	11-54	Removal	10-2a	10-3
Removal	11-35a	11-54	Hydro-boost vent line:		
Hood grille and screen:			Installation	12-11b	12-14
Installation	10-12b	10-17	Removal	12-11a	12-14
Removal	10-12a	10-17	I		
Hood latch and bracket:			Illustrated list of manufactured items:		
Assembly	10-3c	10-4	Appendix D		D-1
Disassembly	10-3b	10-4	Inclinometer, weapon station:		
Installation	10-3d	10-4	Installation	11-60b	11-81
Removal	10-3a	10-4	Removal	11-60a	11-81
Hood prop rod and bracket:			Insulation, arctic heater front cowl:		
Assembly	10-4d	10-6	Installation	12-46b	12-68
Disassembly	10-4b	10-6	Removal	12-46a	12-68
Inspection	10-4c	10-6	Insulation, left front cowl:		
Installation	10-4e	10-7	Installation	10-26b	10-46
Removal	10-4a	10-6	Removal	10-26a	10-46
Hood screen, front:			Insulation, left outer cowl:		
Installation	10-11b	10-16	Installation	10-25b	10-45
Removal	10-11a	10-16	Removal	10-25a	10-45
Hood seal, outer:			Insulation, panel:		
Installation	10-6b	10-11	Installation	11-214b	11-324
Removal	10-6a	10-11	Removal	11-214a	11-324
Hood side armor plate:			Insulation panel, cargo shell roof:		
Installation	11-32b	11-51	Installation	11-31b	11-50
Removal	11-32a	11-51	Removal	11-31a	11-50
Hood stop, center:			Insulation panel, left inner cowl:		
Installation	10-8b	10-13	Installation	10-31b	10-54
Removal	10-8a	10-13	Removal	10-31a	10-52
Hood stop guide, center:			Insulation panel, right inner cowl:		
Installation	10-10b	10-15	Installation	10-30b	10-51
Removal	10-10a	10-15	Removal	10-30a	10-51
Hood stop, side:			Insulation, rear seat floor:		
Installation	10-7b	10-12	Installation	10-29b	10-50
Removal	10-7a	10-12	Removal	10-29a	10-50
Hood top armored grille:			Insulation, right front cowl:		
Installation	11-34b	11-53	Installation	10-27b	10-47
Removal	11-34a	11-53	Removal	10-27a	10-47
Hook, gunner's sling:			Insulation strip, arctic foam:		
Installation	11-53b	11-74	Installation	12-79b	12-113
Removal	11-53a	11-74	Removal	12-79a	12-113
Hook, IV bag:			Insulation, tunnel interior side:		
Installation	11-150b	11-219	Installation	10-28b	10-48
Removal	11-150a	11-219	Removal	10-28a	10-48
Hose, heater outlet (M997, M997A1, M997A2):			Intercom and brackets:		
Installation	11-191b	11-277	Installation	11-169b	11-251
Removal	11-191a	11-276	Removal	11-169a	11-250

INDEX (Cont'd)

	Para	Page		Para	Page
I (Cont'd)			L (Cont'd)		
IV bag hook:			Latch, NBC compartment door:		
Installation	11-150b	11-219	Installation	11-163b	11-241
Removal	11-150a	11-219	Removal	11-163a	11-241
IV bag strap:			Latch, passenger seat stowage compartment:		
Installation	11-149b	11-218	Installation	10-44b	10-72
Removal	11-149a	11-218	Removal	10-44a	10-72
J			Latch rod, cargo shell door:		
Jack retaining strap:			Adjustment	11-18c	11-30
Installation	10-9.1b	10-14.1	Installation	11-18b	11-30
Removal	10-9.1a	10-14.1	Removal	11-18a	11-30
Jack stowage bracket and cover, 3.5-ton:			Latch, upper litter rack:		
Installation	10-19b	10-33	Adjustment	11-142c	11-210
Removal	10-19a	10-33	Installation	11-142b	11-210
L			Removal	11-142a	11-210
Lamp, troop/cargo winterization blackout/dome light:			Launch tube stowage brackets:		
Installation	12-109b	12-161	Installation	11-87b	11-129
Removal	12-109a	12-161	Removal	11-87a	11-129
Latch and bracket, hood:			Lever, weapon station tray:		
Assembly	10-3c	10-4	Installation	11-49b	11-70
Disassembly	10-3b	10-4	Removal	11-49a	11-70
Installation	10-3d	10-4	Lifting shackle (L119), rear bumper:		
Removal	10-3a	10-4	Installation	12-171b	12-264
Latch assembly and guide, rear door:			Removal	12-171a	12-264
Installation	11-128b	11-187	Light assembly, troop/cargo winterization blackout/dome:		
Removal	11-128a	11-187	Installation:	12-108b	12-160
Latch assembly, rear steps:			Removal	12-108a	12-160
Adjustment	11-135c	11-196	Light housing, troop/cargo winterization rear composite:		
Installation	11-135b	11-196	Installation	12-127b	12-199
Removal	11-135a	11-196	Removal	12-127a	12-199
Latch, ballistic crew door:			Liner, cargo shell door:		
Installation	11-11b	11-18	Installation	11-30b	11-48
Removal	11-11a	11-18	Removal	11-30a	11-48
Latch, battery box cover:			Linkage, windshield wiper:		
Installation	10-36b	10-63	Installation	10-73b	10-122
Removal	10-36a	10-63	Removal	10-73a	10-122
Latch, bulkhead door:			Litter assembly, soft top ambulance:		
Installation	11-156b	11-230	Assembly	11-124d	11-180
Removal	11-156a	11-228	Disassembly	11-124b	11-178
Latch, cargo shell door:			Inspection	11-124c	11-178
Adjustment	11-17c	11-29	Installation	11-124e	11-182
Installation	11-17b	11-29	Removal	11-124a	11-176
Removal	11-17a	11-29	Litter handle bumper:		
Latch, cargo shell door handle:			Installation	11-147b	11-215
Installation	11-16b	11-28	Removal	11-147a	11-215
Removal	11-16a	11-28	Litter rack latch bracket, upper:		
Latch, engine access cover flexible holddown strike:			Installation	11-143b	11-211
Installation	10-16b	10-27	Removal	11-143a	11-211
Removal	10-16a	10-27	Litter rack latch, upper:		
			Adjustment	11-142c	11-210
			Installation	11-142b	11-210
			Removal	11-142a	11-210

INDEX (Cont'd)

L (Cont'd)	Para	Page	M	Para	Page
Litter rack strap and ring, upper:			M11 decontamination		
Installation	11-145b	11-212.1	brackets installation:		
Removal	11-145a	11-212.1	Installation	10-68	10-112
Litter rack striker support			M16 ammo rack assembly:		
bracket, upper:			Installation	11-74b	11-106
Installation	11-141b	11-208	Removal	11-74a	11-106
Removal	11-141a	11-208	Machine gun stop:		
Litter rack striker, upper:			Installation	11-100b	11-142
Installation	11-139b	11-206	Removal	11-100a	11-142
Removal	11-139a	11-206	Machine gun strap (L119), M60:		
Litter rack support bracket,			Installation	12-182b	12-277
upper:			Removal	12-182a	12-277
Installation	11-144b	11-212	Maintenance allocation chart:		
Removal	11-144a	11-212	Appendix B		B-1
Litter rack, upper:			Mandatory replacement parts:		
Installation	11-140b	11-207	Appendix G		G-1
Removal	11-140a	11-207	Mat, ambulance compartment:		
Litter rail extension:			Installation	11-153b	11-222
Assembly	11-161b	11-238	Removal	11-153a	11-222
Disassembly	11-161a	11-238	Medical stowage cover and latch:		
Litter skid pad:			Installation	11-179b	11-261
Installation	11-146b	11-214	Removal	11-179a	11-261
Removal	11-146a	11-214	Mirror:		
Litter skid tracks edge trim:			Installation	10-79b	10-130
Installation	11-145.1b	11-212.2	Removal	10-79a	10-130
Removal	11-145.1a	11-212.2	Mirror arm assembly:		
Litter stowage door:			Installation	10-80b	10-131
Installation	11-159b	11-235	Removal	10-80a	10-131
Removal	11-159a	11-235	Mirror mounting bracket:		
Litter stowage tray support			Installation	10-81b	10-132
and strap:			Removal	10-81a	10-132
Leg installation	11-160b	11-236	Mirror, rearview:		
Leg removal	11-160a	11-236	Assembly	10-82d	10-134
Straps installation	11-160d	11-236	Disassembly	10-82c	10-134
Straps removal	11-160c	11-236	Inspection	10-82b	10-133
Lock, ballistic crew door paddle:			Installation	10-82e	10-136
Installation	11-6b	11-11	Removal	10-82a	10-133
Removal	11-6a	11-11	Missile guidance set (MGS)		
Lock, cargo shell door wire			battery rack assembly:		
handle:			Installation	11-77b	11-118
Installation	11-14b	11-26	Removal	11-77a	11-118
Removal	11-14a	11-26	Missile rack, TOW:		
Lock, turret:			Assembly	11-75d	11-112
Installation	11-56b	11-77	Disassembly	11-75b	11-108
Removal	11-56a	11-77	Inspection	11-75c	11-110
Louver, air-conditioning duct:			Installation	11-75e	11-116
Installation	11-203b	11-308	Removal	11-75a	11-107
Removal	11-203a	11-308	Mortar ammo container:		
Louver, floor heat duct:			Assembly	12-149c	12-238
Installation	11-196b	11-290	Disassembly	12-149b	12-237
Removal	11-196a	11-290	Installation	12-149d	12-239
			Removal	12-149a	12-236

INDEX (Cont'd)

M (Cont'd)	Para	Page	N (Cont'd)	Para	Page
Mortar barrel stowage bracket:			NBC precleaner, particulate, filter assembly, and bracket:		
Installation	12-159b	12-250	Installation	11-168b	11-249
Removal	12-159a	12-250	Removal	11-168a	11-248
Mortar kit, 81 mm:			Net, stowage assembly:		
Maintenance task summary	12-148	12-235	Installation	11-173b	11-255
Motor and housing, blower:			Removal	11-173a	11-255
Blower housing installation	11-198d	11-292	Night sight battery bracket, front:		
Blower housing removal	11-198c	11-292	Installation	11-84b	11-126
Blower motor installation	11-198f	11-294	Removal	11-84a	11-126
Blower motor removal	11-198e	11-294	Night sight battery bracket, rear:		
Closing blower housing	11-198b	11-292	Installation	11-85b	11-127
Opening blower housing	11-198a	11-292	Removal	11-85a	11-127
Motor (SF5578716), windshield wiper:			Night sight coolant base:		
Installation	10-71b	10-118	Installation	11-83b	11-125
Removal	10-71a	10-118	Removal	11-83a	11-125
Motor (12342501), windshield wiper/switch:			Night sight mounting spacers or boresight collimator:		
Installation	10-72b	10-120	Installation	11-86b	11-128
Removal	10-72a	10-120	Removal	11-86a	11-128
Mount adapter, traversing unit:			Night sight retainer:		
Assembly	11-72b	11-103	Installation	11-101b	11-143
Disassembly	11-72a	11-103	Removal	11-101a	11-143
Mount, body hinge:			Night sight support:		
Installation	10-64b	10-103	Installation	11-82b	11-124
Removal	10-64a	10-103	Removal	11-82a	11-124
Mud flap installation	10-63	10-102	Nozzle, left defroster:		
			Installation	10-94b	10-162
N			Removal	10-94a	10-160
NBC air line piping:			Nozzle, right defroster:		
Fabrication	11-166b	11-244	Installation	10-95b	10-164
Installation	11-166c	11-244	Removal	10-95a	10-164
Removal	11-166a	11-244	Nozzle, windshield washer:		
NBC compartment door latch:			Installation	10-78b	10-129
Installation	11-163b	11-241	Removal	10-78a	10-129
Removal	11-163a	11-241			
NBC compartment door (M997, M997A1, M997A2):			P		
Installation	11-162b	11-240	Padding, "B" pillar:		
Removal	11-162a	11-240	Installation	11-30.1b	11-49
NBC door (M996, M996A1):			Removal	11-30.1a	11-49
Installation	11-183b	11-266	Paddle lock, ballistic crew door:		
Removal	11-183a	11-266	Installation	11-6b	11-11
NBC gas filter and bracket:			Removal	11-6a	11-11
Installation	11-167b	11-247	Pad, litter skid:		
Removal	11-167a	11-246	Installation	11-146b	11-214
NBC heater:			Removal	11-146a	11-214
Installation	11-164b	11-242	Pad, troop seat support:		
Removal	11-164a	11-242	Installation	12-158b	12-249
NBC heater brackets:			Removal	12-158a	12-249
Installation	11-165b	11-243	Panel, ambulatory patient seat rear closeout:		
Removal	11-165a	11-243	Installation	11-182b	11-265
			Removal	11-182a	11-265

INDEX (Cont'd)

	Para	Page		Para	Page
P (Cont'd)			P (Cont'd)		
Panel, cab enclosure:			Placard, Red Cross:		
Installation	11-122b	11-172	Installation	11-175b	11-257
Removal	11-122a	11-172	Removal	11-175a	11-257
Panel, front cover:			Plate assembly, front gun mount:		
Installation	11-187b	11-271	Installation	11-96b	11-138
Removal	11-187a	11-271	Removal	11-96a	11-138
Panel insulation:			Plate assembly, gun adapter:		
Installation	11-214b	11-324	Installation	11-95b	11-137
Removal	11-214a	11-324	Removal	11-95a	11-137
Panel (M996, M996A1), heater compartment:			Plate assembly, rear gun mount:		
Installation	11-204b	11-309	Installation	11-97b	11-139
Removal	11-204a	11-309	Removal	11-97a	11-139
Panel, rear cover:			Plate, ballistic crew door front striker:		
Installation	11-188b	11-272	Adjustment	11-5c	11-10
Removal	11-188a	11-272	Installation	11-5b	11-10
Panels, air intake compartment:			Removal	11-5a	11-10
Installation	11-184b	11-268	Plate, ballistic crew door rear striker:		
Removal	11-184a	11-268	Installation	11-4b	11-9
Pan, TOW Missile Guidance System:			Removal	11-4a	11-9
Installation	11-59b	11-80	Plate, cargo shell door rear striker mounting:		
Removal	11-59a	11-80	Installation	11-27b	11-45
Pedestal cover, TOW mount:			Removal	11-27a	11-45
Installation	11-58b	11-79	Plate, driver's seat retainer:		
Removal	11-58a	11-79	Installation	10-59b	10-95
Pedestal, stowage:			Removal	10-59a	10-95
Installation	11-71b	11-102	Platform assembly, gunner's:		
Removal	11-71a	11-102	Installation	11-65b	11-90
Pedestal, TOW mount:			Removal	11-65a	11-90
Installation	11-57b	11-78	Platform assembly maintenance, gunner's:		
Removal	11-57a	11-78	Assembly	11-64c	11-86
Pioneer tool stowage rack latch striker (L119):			Disassembly	11-64b	11-86
Installation	12-170b	12-263	Installation	11-64d	11-88
Removal	12-170a	12-263	Removal	11-64a	11-86
Pioneer tool stowage tray:			Platform, gunner's:		
Assembly	10-50b	10-84	Installation	11-63b	11-84
Disassembly	10-50a	10-84	Removal	11-63a	11-84
Pioneer tool stowage tray latch striker:			Plenum assembly, arctic heater:		
Installation	10-52b	10-87	Installation	12-37b	12-55
Removal	10-52a	10-87	Removal	12-37a	12-55
Pioneer tool stowage tray mounting bracket:			Plenum cover, arctic heater:		
Installation	10-51b	10-86	Installation	12-39b	12-57
Removal	10-51a	10-86	Removal	12-39a	12-57
Piping, heater outlet/inlet:			Plenum hose, arctic heater:		
Inspection	10-84b	10-138	Installation	12-38b	12-56
Installation	10-84c	10-138	Removal	12-38a	12-56
Removal	10-84a	10-138	Power cable, front radio rack:		
Pivot, windshield wiper arm:			Installation	12-141b	12-222
Installation	10-74b	10-123	Removal	12-141a	12-221
Removal	10-74a	10-123	Power steering vent line:		
			Installation	12-14b	12-17
			Removal	12-14a	12-17

INDEX (Cont'd)

P (Cont'd)	Para	Page	R (Cont'd)	Para	Page
Precleaner and particulate filter assembly and bracket, NBC:			Radio rack, front lower:		
Installation	11-168b	11-249	Installation	12-133b	12-206
Removal	11-168a	11-248	Removal	12-133a	12-206
Preparation for storage or shipment:			Radio rack, front upper mounting brackets:		
Administrative storage	13-2	13-1	Installation	12-131.1b	12-202.2
Cleaning	13-6	13-2	Removal	12-131.1a	12-202.2
General storage and shipping information	13-5	13-2	Radio rack mounting bracket, front:		
Inspections, stowage, and inventory	13-7	13-2	Installation	12-130b	12-202
Lubrication	13-9	13-3	Removal	12-130a	12-202
Records and reports	13-10	13-3	Radio rack, new configuration front bracket:		
Repair, painting, and preservation	13-8	13-3	Installation	12-132.1b	12-204.3
Scope	13-1	13-1	Vehicle preparation	12-132.1a	12-204.2
Security	13-3	13-1	Radio rack power cable, front:		
Special packaging and shipping requirements	13-4	13-1	Installation	12-141b	12-222
Prop rod and bracket, hood:			Removal	12-141a	12-221
Assembly	10-4d	10-6	Radio rack power cable, rear:		
Disassembly	10-4b	10-6	Installation	12-147b	12-234
Inspection	10-4c	10-6	Removal	12-147a	12-232
Installation	10-4e	10-7	Radio rack, rear:		
Removal	10-4a	10-6	Assembly	12-144c	12-226
Pump assembly, windshield washer reservoir:			Disassembly	12-144b	12-226
Installation	10-75b	10-124	Installation	12-144d	12-227
Removal	10-75a	10-124	Removal	12-144a	12-225
R			Radio rack to tower antenna cables, rear:		
Rack, equipment:			Installation	12-146b	12-230
Installation	12-156b	12-247	Removal	12-146a	12-230
Removal	12-156a	12-247	Rail, attendant seat guide:		
Rack, ready:			Installation	11-158b	11-234
Installation	12-153b	12-244	Removal	11-158a	11-234
Removal	12-153a	12-244	Rail extension, litter:		
Radio antenna mount (M996, M996A1):			Assembly	11-161b	11-238
Installation	11-171b	11-253	Disassembly	11-161a	11-238
Removal	11-1712a	11-253	Rail, rear drip:		
Radio antenna mount (M997, M997A1, M997A2):			Installation	11-170b	11-252
Installation	11-172b	11-254	Removal	11-170a	11-252
Removal	11-172a	11-254	Ready rack:		
Radio rack antenna tower, rear:			Installation	12-153b	12-244
Assembly	12-145c	12-228	Removal	12-153a	12-244
Disassembly	12-145b	12-228	Ready rack hand guard:		
Installation	12-145d	12-228	Installation	12-155b	12-246
Removal	12-145a	12-228	Removal	12-155a	12-246
Radio rack, front:			Ready rack strap:		
Installation	12-132b	12-204	Installation	12-154b	12-245
Removal	12-132a	12-204	Removal	12-154a	12-245
			Rear seat stowage compartment net brackets:		
			Installation	11-110b	11-152
			Removal	11-110a	11-152

INDEX (Cont'd)

	Para	Page		Para	Page
R (Cont'd)			R (Cont'd)		
Rear steps:			Retainer, night sight:		
Assembly	11-138c	11-202.2	Installation	11-101b	11-143
Disassembly	11-138b	11-202.2	Removal	11-101a	11-143
Installation	11-138d	11-204	Retaining cable, rear steps:		
Removal	11-138a	11-202	Installation	11-136b	11-198
Rear steps latch assembly:			Removal	11-136a	11-198
Adjustment	11-135c	11-196	Retention cable, cargo shell door:		
Installation	11-135b	11-196	Installation	11-20b	11-34
Removal	11-135a	11-196	Removal	11-20a	11-34
Rearview mirror:			Retractor, rear steps:		
Assembly	10-82d	10-134	Installation	11-137b	11-200
Disassembly	10-82c	10-134	Removal	11-137a	11-200
Inspection	10-82b	10-133	Rifle mount bracket, lower:		
Installation	10-82e	10-136	Installation	11-94b	11-136
Removal	10-82a	10-133	Removal	11-94a	11-136
Red Cross placard:			Rifle mounting clamp:		
Installation	11-175b	11-257	Installation	11-91b	11-133
Removal	11-175a	11-257	Removal	11-91a	11-133
Red Cross placard retaining clip:			Rifle mounting clamp bracket:		
Installation	11-174b	11-256	Installation	11-92b	11-134
Removal	11-174a	11-256	Removal	11-92a	11-134
References:			Rifle mounting clamp bracket (M16 A1 rifle/M203 grenade launcher):		
Appendix A		A-1	Installation	11-93b	11-135
Reflector, troop/cargo			Removal	11-93a	11-135
winterization rear:			Rifle support:		
Installation	12-126b	12-198	Installation	11-90b	11-132
Removal	12-126a	12-198	Removal	11-90a	11-132
Regulator, arctic heater:					
Installation	12-40b	12-58	S		
Removal	12-40a	12-58	Screen, front hood:		
Regulator, 100 ampere (R027096300):			Installation	10-11b	10-16
Installation	12-21b	12-26	Removal	10-11a	10-16
Removal	12-21a	12-24	Seal, airlift to hood:		
Regulator, 100 ampere (12342944, N3106):			Installation	10-65b	10-104
Installation	12-22b	12-28	Removal	10-65a	10-104
Removal	12-22a	12-28	Seal, ballistic crew door:		
Reinforcement bracket, exhaust:			Installation	11-10b	11-17
Installation	12-15b	12-18	Removal	11-10a	11-17
Removal	12-15a	12-18	Seal, cargo shell door:		
Reinforcement, shelter support:			Installation	11-24b	11-42
Installation	11-115b	11-162	Removal	11-24a	11-42
Removal	11-115a	11-162	Seal, outer hood:		
Reservoir and pump assembly, windshield washer:			Installation	10-6b	10-11
Installation	10-75b	10-124	Removal	10-6a	10-11
Removal	10-75a	10-124	Seal protector, cargo shell door:		
Resistor assembly, heater fan motor:			Installation	11-23b	11-41
Installation	10-86b	10-142	Removal	11-23a	11-41
Removal	10-86a	10-142	Seal protector, rear door:		
Resistor, blower motor:			Installation	11-129b	11-188
Installation	11-197b	11-291	Removal	11-129a	11-188
Removal	11-197a	11-291	Seals, rear door:		
			Installation	11-130b	11-189
			Removal	11-130a	11-189

INDEX (Cont'd)

S (Cont'd)	Para	Page	S (Cont'd)	Para	Page
Seal, weapon station tray:			Seatbelt brackets, three point:		
Installation	11-47b	11-68	(M996, M996A1, M997, M997A1, and M997A2):		
Removal	11-47a	11-68	Installation	10-49.1b	10-82.2
Seat, ambulatory patient:			Removal	10-49.1a	10-82.2
Installation	11-181b	11-264	Seatbelt maintenance, three point:		
Removal	11-181a	11-263	Front seatbelt bracket		
Seat assembly, companion:			inspection	10-48b	10-78
Assembly	10-42b	10-70	Front seatbelt installation	10-48c	10-78
Disassembly	10-42a	10-70	Front seatbelt removal	10-48a	10-76
Seat assembly, companion and battery box cover:			Rear seatbelt bracket		
Installation	10-41b	10-69	inspection	10-48e	10-80
Removal	10-41a	10-69	Rear seatbelt installation	10-48f	10-80
Seat assembly, driver's:			Rear seatbelt removal	10-48d	10-80
Assembly	10-39b	10-66	Seatbelt, three point (M996, M996A1, M997, M997A1, and M997A2):		
Disassembly	10-39a	10-66	Bracket inspection	10-48.1b	10-80.2
Installation	10-38b	10-65	Seatbelt installation	10-48.1c	10-80.2
Removal	10-38a	10-65	Seatbelt removal	10-48.1a	10-80.2
Seat, attendant:			Seat board, troop:		
Assembly	11-157c	11-232	Installation	12-19b	12-22
Disassembly	11-157b	11-232	Removal	12-19a	12-22
Installation	11-157d	11-233	Seat, companion and battery box cover:		
Removal	11-157a	11-232	Installation	10-35b	10-62
Seat back, companion:			Removal	10-35a	10-62
Installation	10-34b	10-61	Seat guide rail, attendant:		
Removal	10-34a	10-61	Installation	11-158b	11-234
Seat back cover, troop/cargo winterization:			Removal	11-158a	11-234
Installation	12-112b	12-165	Seat kit, troop:		
Removal	12-112a	12-165	Maintenance task summary	12-16	12-19
Seat back cushions, companion seat:			Seat kit, troop:		
Installation	10-37b	10-64	Installation	12-18b	12-20
Removal	10-37a	10-64	Removal	12-18a	12-20
Seat back cushions, passenger seat:			Seat rear close out panel, ambulatory patient:		
Installation	10-46b	10-74	Installation	11-182b	11-265
Removal	10-46a	10-74	Removal	11-182a	11-265
Seat back, passenger:			Seat stowage brackets, attendant:		
Installation	10-45b	10-73	Installation	11-177b	11-259
Removal	10-45a	10-73	Removal	11-177a	11-259
Seatbelt assembly:			Seat support:		
Installation	10-47b	10-75	Installation	12-17b	12-19
Removal	10-47a	10-75	Removal	12-17a	12-19
Seatbelt brackets, three point:			Seat support pad, troop:		
Front seatbelt bracket installation	10-49b	10-82	Installation	12-158b	12-249
Front seatbelt bracket removal	10-49a	10-82	Removal	12-158a	12-249
Rear seatbelt bracket installation	10-49d	10-82	Section chest strap (L119):		
Rear seatbelt bracket removal	10-49c	10-82	Installation	12-176b	12-269
			Removal	12-176a	12-269

INDEX (Cont'd)

S (Cont'd)	Para	Page	S (Cont'd)	Para	Page
Selector valve:			Passenger's side siren switch and driver's side siren switch installation	12-185g	12-288
Installation	12-9b	12-11	Siren and warning light switch and indicator installation	12-185e	12-286
Removal	12-9a	12-11	Siren assembly installation	12-185c	12-284
Sensor cup, deep water fording:			Siren battery wires installation	12-185i	12-292
Installation	12-12b	12-15	Siren electrical wires installation	12-185f	12-287
Removal	12-12a	12-15	Warning light assembly electrical wires installation	12-185h	12-290
Sensor cup vent line:			Warning light assembly installation	12-185b	12-283
Installation	12-13b	12-16	Skid strips, troop/cargo winterization cargo floor:		
Removal	12-13a	12-16	Installation	12-111b	12-164
Shelf, auxiliary:			Removal	12-111a	12-164
Installation	12-131b	12-203	Soft top door:		
Removal	12-131a	12-203	Adjustment	10-102	10-172
Shelter:			Soft top door handle:		
Installation	11-120b	11-168	Installation	10-102.1c	10-172.3
Removal	11-120a	11-168	Removal	10-102.1a	10-172.1
S250 shelter carrier body:			Repair	10-102.1b	10-172.2
Maintenance task summary	11-114	11-161	Soft top door hinge:		
Shelter carrier tailgate:			Installation	10-101b	10-170
Installation	11-117b	11-164	Removal	10-101a	10-170
Removal	11-117a	11-164	Soft top door striker:		
Shelter carrier tailgate bracket:			Installation	10-103b	10-174
Installation	11-118b	11-165	Removal	10-103a	10-174
Removal	11-118a	11-165	Soft top repair:		
Shelter carrier tailgate chain:			Inspection and cleaning	10-104a	10-175
Assembly	11-119c	11-166	Soft top canvas repair	10-104e	10-176.1
Disassembly	11-119b	11-166	Soft top material repair	10-104b	10-175
Installation	11-119d	11-166	Soft top window repair	10-104c	10-176
Removal	11-119a	11-166	Soft top window zipper repair	10-104d	10-176
Shelter mounting bracket:			Speaker stop:		
Installation	11-116b	11-163	Installation	12-135b	12-208
Removal	11-116a	11-163	Removal	12-135a	12-208
Shelter support assembly:			Spineboard mounting bracket:		
Installation	11-121b	11-170	Installation	11-148b	11-216
Removal	11-121a	11-170	Removal	11-148a	11-216
Shelter support reinforcement:			Splash shield, left, engine:		
Installation	11-115b	11-162	Assembly	10-17c	10-30
Removal	11-115a	11-162	Disassembly	10-17b	10-28
Shield, antenna blast:			Installation	10-17d	10-30
Installation	11-88b	11-130	Removal	10-17a	10-28
Removal	11-88a	11-130	Splash shield, right, engine:		
Shutoff valve, heater:			Assembly	10-20c	10-36
Installation	10-83b	10-137	Disassembly	10-20b	10-34
Removal	10-83a	10-137	Installation	10-20d	10-36
Sight box straps (L119):			Removal	10-20a	10-34
Installation	12-179b	12-272			
Removal	12-179a	12-272			
Siren and warning light installation:					
Circuit breaker and relay installation	12-185d	12-285			
Manufactured items	12-185a	12-282			

INDEX (Cont'd)

S (Cont'd)	Para	Page	S (Cont'd)	Para	Page
Spreader bar tiedown:			Repair, painting, and preservation	13-8	13-3
Installation	11-180.1b	11-262.1	Scope	13-1	13-1
Removal	11-180.1a	11-262.1	Security	13-3	13-1
Spring, cargo shell door dovetail:			Special packaging and shipping requirements	13-4	13-1
Installation	11-28b	11-46	Storage compartment cover, passenger seat:		
Removal	11-28a	11-46	Installation	10-43b	10-71
Spring, cargo shell door gas:			Removal	10-43a	10-71
Assembly	11-21d	11-38	Stowage box turnbutton:		
Disassembly	11-21c	11-38	Installation	11-151b	11-220
Installation	11-21e	11-38	Removal	11-151a	11-220
Removal	11-21b	11-37	Stowage bracket, day sight:		
Rotating	11-21a	11-35	Installation	11-81b	11-123
Step assembly, troop/cargo winterization rear:			Removal	11-81a	11-123
Installation	12-122b	12-194	Stowage brackets, attendant seat:		
Removal	12-122a	12-194	Installation	11-177b	11-259
Steps, rear:			Removal	11-177a	11-259
Assembly	11-138c	11-202.2	Stowage bracket, launch tube:		
Disassembly	11-138b	11-202.2	Installation	11-87b	11-129
Installation	11-138d	11-204	Removal	11-87a	11-129
Removal	11-138a	11-202	Stowage bracket, mortar barrel:		
Stop assembly, elevation and depression:			Installation	12-159b	12-250
Assembly	11-73b	11-104	Removal	12-159a	12-250
Disassembly	11-73a	11-104	Stowage clip, cleaning staff:		
Stop, ballistic crew door window:			Installation	12-151b	12-241
Installation	11-9b	11-16	Removal	12-151a	12-241
Removal	11-9a	11-16	Stowage compartment latch, passenger seat:		
Stop, center hood:			Installation	10-44b	10-72
Installation	10-8b	10-13	Removal	10-44a	10-72
Removal	10-8a	10-13	Stowage compartment net brackets, rear seat:		
Stop guide, center hood:			Installation	11-110b	11-152
Installation	10-10b	10-15	Removal	11-110a	11-152
Removal	10-10a	10-15	Stowage door:		
Stop, machine gun:			Installation	11-152b	11-221
Installation	11-100b	11-142	Removal	11-152a	11-221
Removal	11-100a	11-142	Stowage door, exterior:		
Stop, side hood:			Installation	11-176b	11-258
Installation	10-7b	10-12	Removal	11-176a	11-258
Removal	10-7a	10-12	Stowage mount bracket:		
Stop, speaker:			Installation	11-70b	11-100
Installation	12-135b	12-208	Removal	11-70a	11-100
Removal	12-135a	12-208	Stowage net assembly:		
Storage and/or shipment, preparation for:			Installation	11-173b	11-255
Administrative storage	13-2	13-1	Removal	11-173a	11-255
Cleaning	13-6	13-2	Stowage pedestal:		
General storage and shipping information	13-5	13-2	Installation	11-71b	11-102
Inspections, stowage, and inventory	13-7	13-2	Removal	11-71a	11-102
Lubrication	13-9	13-3			
Records and reports	13-10	13-3			

INDEX (Cont'd)

S (Cont'd)	Para	Page	S (Cont'd)	Para	Page
Stowage tray, bipod:			Striker plate, ballistic crew door,		
Assembly	12-152c	12-242	rear:		
Disassembly	12-152b	12-242	Installation	11-4b	11-9
Installation	12-152d	12-242	Removal	11-4a	11-9
Removal	12-152a	12-242	Striker, upper litter rack:		
Strap and ring, upper litter rack:			Installation	11-139b	11-206
Installation	11-145b	11-213	Removal	11-139a	11-206
Removal	11-145a	11-213	Striker, weapon station		
Strap, base plate:			hatch holddown:		
Installation	12-150b	12-240	Installation	11-46b	11-67
Removal	12-150a	12-240	Removal	11-46a	11-67
Strap, cargo shell door:			Sun visor:		
Installation	11-22b	11-40	Installation	10-77b	10-128
Removal	11-22a	11-40	Removal	10-77a	10-128
Strap, footman loop:			Support and strap, litter		
Installation	10-9b	10-14	storage tray:		
Removal	10-9a	10-14	Leg installation	11-160b	11-236
Strap, IV bag:			Leg removal	11-160a	11-236
Installation	11-149b	11-218	Straps installation	11-160d	11-236
Removal	11-149a	11-218	Straps removal	11-160c	11-236
Strap, jack retaining:			Support assembly, shelter:		
Installation	10-9.1b	10-14.1	Installation	11-121b	11-170
Removal	10-9.1a	10-14.1	Removal	11-121a	11-170
Strap, ready rack:			Support (caliber .50), gun		
Installation	12-154b	12-245	mount:		
Removal	12-154a	12-245	Installation	11-98b	11-140
Strap, tool chest:			Removal	11-98a	11-140
Installation	12-157b	12-248	Support, fire extinguisher:		
Removal	12-157a	12-248	Installation	10-58b	10-94
Striker and bracket, rear steps:			Removal	10-58a	10-94
Bracket adjustment	11-134e	11-194	Support (40 mm), gun mount:		
Bracket installation	11-134d	11-194	Installation	11-99b	11-141
Bracket removal	11-134c	11-194	Removal	11-99a	11-141
Striker installation	11-134b	11-194	Support, night sight:		
Striker removal	11-134a	11-194	Installation	11-82b	11-124
Striker, cargo shell door, front:			Removal	11-82a	11-124
Installation	11-25b	11-43	Support, rifle:		
Removal	11-25a	11-43	Installation	11-90b	11-132
Striker, cargo shell door, rear:			Removal	11-90a	11-132
Installation	11-26b	11-44	Support, seat:		
Removal	11-26a	11-44	Installation	12-17b	12-19
Striker guides and brackets,			Removal	12-17a	12-19
rear door latch rod:			Swingfire circuit breaker		
Bracket installation	11-131d	11-190	and harness lead:		
Bracket removal	11-131c	11-190	Installation	12-69b	12-102
Striker guide adjustment	11-131e	11-190	Removal	12-69a	12-102
Striker guide installation	11-131b	11-190	Swingfire heater brushguard		
Striker guide removal	11-131a	11-190	and shield assembly:		
Striker, pioneer tool stowage			Installation	12-59b	12-86
tray latch:			Removal	12-59a	12-86
Installation	10-52b	10-87	Swingfire heater exhaust		
Removal	10-52a	10-87	pipe assembly:		
Striker plate, ballistic crew door,			Installation	12-60b	12-87
front:			Removal	12-60a	12-87
Adjustment	11-5c	11-10	Swingfire heater harness		
Installation	11-5b	11-10	assembly:		
Removal	11-5a	11-10	Installation	12-68b	12-100
			Removal	12-68a	12-99

INDEX (Cont'd)

S (Cont'd)	Para	Page	T (Cont'd)	Para	Page
Swingfire heater hood guard:			Drill sizes for solid shank rivets (table 10-1)	10-66	10-107
Installation	12-62b	12-89	Minimum sheet gauge for 100° machine countersink (table 10-4)	10-66	10-108
Removal	12-62a	12-89	Rivet grip length determination (table 10-5)	10-66	10-109
Swingfire heater inlet hose and tee:			Tailgate:		
Installation	12-64b	12-92	Installation	10-61b	10-98
Removal	12-64a	12-92	Removal	10-61a	10-98
Swingfire heater pump assembly, bracket, and lower hose:			Tailgate armor plate:		
Installation	12-65b	12-94	Installation	11-41b	11-61
Removal	12-65a	12-93	Removal	11-41a	11-61
Swingfire heater radiator lower tube:			Tailgate bracket, shelter carrier:		
Installation	12-63b	12-90	Installation	11-118b	11-165
Removal	12-63a	12-90	Removal	11-118a	11-165
Swingfire heater U-clamps:			Tailgate chain and brackets:		
Installation	12-58b	12-85	Installation	10-60b	10-96
Removal	12-58a	12-85	Removal	10-60a	10-96
Swingfire heater water jacket:			Tailgate chain, shelter carrier:		
Installation	12-57b	12-84	Assembly	11-119c	11-166
Removal	12-57a	12-83	Disassembly	11-119b	11-166
Swingfire heater water jacket to pump and tee hoses:			Installation	11-119d	11-166
Installation	12-66b	12-96	Removal	11-119a	11-166
Removal	12-66a	12-95	Tailgate, shelter carrier:		
Swingfire heater windshield washer reservoir plate:			Installation	11-117b	11-164
Installation	12-61b	12-88	Removal	11-117a	11-164
Removal	12-61a	12-88	Tailgate upper hinge:		
Swingfire relay and harness assembly:			Installation	10-62b	10-100
Installation	12-67b	12-98	Removal	10-62a	10-100
Removal	12-67a	12-97	Tape hook, arctic curtain fastener:		
Swingfire windshield washer pump harness extension:			Installation	12-78b	12-112
Installation	12-70b	12-103	Removal	12-78a	12-112
Removal	12-70a	12-103	Telephone strap (L119):		
Switch, heater fan:			Installation	12-175b	12-268
Installation	10-85b	10-140	Removal	12-175a	12-268
Removal	10-85a	10-140	Three point seatbelt brackets:		
Switch, troop/cargo winterization blackout/dome light:			Front seatbelt bracket installation	10-49b	10-82
Installation	12-106b	12-156	Front seatbelt bracket removal	10-49a	10-82
Removal	12-106a	12-156	Rear seatbelt bracket installation	10-49d	10-82
Switch, troop/cargo winterization blackout/dome light door:			Rear seatbelt bracket removal	10-49c	10-82
Installation	12-107b	12-158	Three point seatbelt brackets (M996, M996A1, M997, M997A1, and M997A2):		
Removal	12-107a	12-158	Installation	10-49.1b	10-82.2
T			Removal	10-49.1a	10-82.2
Tables:			Three point seatbelt:		
Countersinking dimensions for 100° countersunk blind rivets (table 10-3)	10-66	10-108	Front seatbelt bracket inspection	10-48b	10-78
Drill sizes for blind rivets (table 10-2)	10-66	10-107	Front seatbelt installation	10-48c	10-78
			Front seatbelt removal	10-48a	10-76

INDEX (Cont'd)

T (Cont'd)	Para	Page	Para	Page
Rear seatbelt bracket inspection	10-48e	10-80	Tray and hose, fuel can:	
Rear seatbelt installation	10-48f	10-80	Installation	11-80b 11-122
Rear seatbelt removal	10-48d	10-80	Removal	11-80a 11-122
Three point seatbelt (M996, M996A1, M997, M997A1, and M997A2):			Tray (caliber .50), ammo box:	
Bracket inspection	10-48.1b	10-80.2	Installation	11-104b 11-146
Seatbelt installation	10-48.1c	10-80.2	Removal	11-104a 11-146
Seatbelt removal	10-48.1a	10-80.2	Tray (caliber .50), double ammo box:	
Tiedown bracket (L119), rear:			Installation	11-103b 11-145
Installation	12-172b	12-265	Removal	11-103a 11-145
Removal	12-172a	12-265	Tray (40 mm and .50 caliber), ammo box:	
Tiedown, cargo:			Installation	11-105b 11-147
Installation	10-56b	10-92	Removal	11-105a 11-147
Removal	10-56a	10-92	Tray (40 mm), double ammo box:	
Tiedown, spreader bar:			Installation	11-106b 11-148
Installation	11-180.1b	11-262.1	Removal	11-106a 11-148
Removal	11-180.1a	11-262.1	Tray (40 mm), triple ammo box:	
Tool chest strap:			Installation	11-107b 11-149
Installation	12-157b	12-248	Removal	11-107a 11-149
Removal	12-157a	12-248	Tray, pioneer tool stowage:	
Torque limits:			Assembly	10-50b 10-84
Appendix E		E-1	Disassembly	10-50a 10-84
TOW missile guidance system pan:			Tray, water can:	
Installation	11-59b	11-80	Installation	11-108b 11-150
Removal	11-59a	11-80	Removal	11-108a 11-150
TOW missile rack:			Tripod bracket:	
Assembly	11-75d	11-112	Installation	11-102b 11-144
Disassembly	11-75b	11-108	Removal	11-102a 11-144
Inspection	11-75c	11-110	Tripod head mounting bracket:	
Installation	11-75e	11-116	Installation	11-79b 11-121
Removal	11-75a	11-107	Removal	11-79a 11-121
TOW mount pedestal:			Tripod leg mounting bracket:	
Installation	11-57b	11-78	Installation	11-78b 11-120
Removal	11-57a	11-78	Removal	11-78a 11-120
TOW mount pedestal cover:			Tripod strap (L119):	
Installation	11-58b	11-79	Installation	12-177b 12-270
Removal	11-58a	11-79	Removal	12-177a 12-270
TOW wiring harness:			Troop/cargo winterization antenna mounting bracket:	
Installation	11-67b	11-94	Installation	12-125b 12-197
Removal	11-67a	11-92	Removal	12-125a 12-197
Traversing bar kit:			Troop/cargo winterization blackout curtain:	
Maintenance task summary	12-160	12-251	Installation	12-104b 12-153
Traversing bar kit:			Removal	12-104a 12-153
Installation	12-161b	12-252	Troop/cargo winterization blackout/dome light assembly:	
Removal	12-161a	12-252	Installation	12-108b 12-160
Traversing unit mount adapter:			Removal	12-108a 12-160
Assembly	11-72b	11-103	Troop/cargo winterization blackout/dome light door switch:	
Disassembly	11-72a	11-103	Installation	12-107b 12-158
Tray and bearing seals, weapon station:			Removal	12-107a 12-158
Adjustment	11-112c	11-156		
Installation	11-112b	11-155		
Removal	11-112a	11-154		

INDEX (Cont'd)

T (Cont'd)	Para	Page	T (Cont'd)	Para	Page
Troop/cargo winterization blackout/dome light lamp:			Troop/cargo winterization heat deflector:		
Installation	12-109b	12-161	Installation	12-94b	12-136
Removal	12-109a	12-161	Removal	12-94a	12-136
Troop/cargo winterization blackout/dome light switch:			Troop/cargo winterization heater air intake assembly:		
Installation	12-106b	12-156	Installation	12-97b	12-141
Removal	12-106a	12-156	Removal	12-97a	12-141
Troop/cargo winterization blackout/dome light wiring harness:			Troop/cargo winterization heater assembly:		
Installation	12-105b	12-154	Installation	12-95b	12-138
Removal	12-105a	12-154	Removal	12-95a	12-137
Troop/cargo winterization cargo floor skid strips:			Troop/cargo winterization heater base assembly:		
Installation	12-111b	12-164	Installation	12-98b	12-142
Removal	12-111a	12-164	Removal	12-98a	12-142
Troop/cargo winterization circuit breaker:			Troop/cargo winterization heater bulkhead fuel supply hose:		
Installation	12-103b	12-152	Installation	12-88b	12-127
Removal	12-103a	12-152	Removal	12-88a	12-127
Troop/cargo winterization data plate:			Troop/cargo winterization heater bulkhead hose-to-bulkhead coupling fuel supply line:		
Installation	12-128b	12-200	Installation	12-89b	12-128
Removal	12-128a	12-200	Removal	12-89a	12-128
Troop/cargo winterization door:			Troop/cargo winterization heater control box and angle bracket:		
Adjustment	12-116	12-170	Installation	12-100b	12-144
Troop/cargo winterization door and frame assembly:			Removal	12-100a	12-144
Installation	12-117b	12-174	Troop/cargo winterization heater diverter assembly:		
Removal	12-117a	12-172	Installation	12-96b	12-140
Troop/cargo winterization end closure:			Removal	12-96a	12-140
Installation	12-118b	12-178	Troop/cargo winterization heater filter-to-bulkhead coupling fuel supply hose:		
Removal	12-118a	12-176	Installation	12-91b	12-131
Troop/cargo winterization fixed door cover:			Removal	12-91a	12-131
Installation	12-113b	12-166	Troop/cargo winterization heater filter-to-heater fuel supply hose:		
Removal	12-113a	12-166	Installation	12-92b	12-134
Troop/cargo winterization floor bracket:			Removal	12-92a	12-133
Installation	12-99b	12-143	Troop/cargo winterization heater fuel filter assembly:		
Removal	12-99a	12-143	Installation	12-82b	12-120
Troop/cargo winterization front and rear cargo floor cover:			Removal	12-82a	12-119
Installation	12-110b	12-162	Troop/cargo winterization heater fuel pump:		
Removal	12-110a	12-162	Installation	12-81b	12-118
Troop/cargo winterization fuel can mounting bracket:			Removal	12-81a	12-116
Installation	12-124b	12-196			
Removal	12-124a	12-196			
Troop/cargo winterization handle assembly:					
Installation	12-123b	12-195			
Removal	12-123a	12-195			

INDEX (Cont'd)

T (Cont'd)	Para	Page	T (Cont'd)	Para	Page
Troop/cargo winterization heater fuel supply hose:			Troop/cargo winterization seat back cover:		
Installation	12-85b	12-123	Installation	12-112b	12-165
Removal	12-85a	12-123	Removal	12-112a	12-165
Troop/cargo winterization heater fuel supply line bulkhead coupling:			Troop/cargo winterization side floor cover:		
Installation	12-90b	12-130	Installation	12-114b	12-167
Removal	12-90a	12-129	Removal	12-114a	12-167
Troop/cargo winterization heater fuel supply tube assembly:			Troop/cargo winterization top cover assembly:		
Installation	12-83b	12-121	Installation	12-119b	12-182
Removal	12-83a	12-121	Removal	12-119a	12-180
Troop/cargo winterization heater guard assembly:			Troop/cargo winterization top enclosure assembly:		
Installation	12-93b	12-135	Installation	12-120b	12-188
Removal	12-93a	12-135	Removal	12-120a	12-186
Troop/cargo winterization heater pump-to-bulkhead fuel supply line:			Troop/cargo winterization troop seat assembly and bow:		
Installation	12-87b	12-126	Installation	12-121b	12-192
Removal	12-87a	12-125	Removal	12-121a	12-190
Troop/cargo winterization heater pump-to-hose fuel supply line:			Troop/cargo winterization wheelhousing covers:		
Installation	12-86b	12-124	Installation	12-115b	12-168
Removal	12-86a	12-124	Removal	12-115a	12-168
Troop/cargo winterization heater tank-to-hose fuel supply line:			Troop seat board:		
Installation	12-84b	12-122	Installation	12-19b	12-22
Removal	12-84a	12-122	Removal	12-19a	12-22
Troop/cargo winterization heater wiring harness:			Troop seat kit:		
Installation	12-101b	12-148	Maintenance task summary	12-16	12-19
Removal	12-101a	12-146	Troop seat kit:		
Troop/cargo winterization heater wiring harness adapter:			Installation	12-20b	12-20
Installation	12-102b	12-150	Removal	12-20a	12-20
Removal	12-102a	12-150	Troop seat support pad:		
Troop/cargo winterization kit:			Installation	12-158b	12-249
Maintenance task summary	12-80	12-114	Removal	12-158a	12-249
Troop/cargo winterization rear composite light housing:			TSEC/KY-57 mounting bracket and control switch bracket, dual:		
Installation	12-127b	12-199	Installation	12-134b	12-207
Removal	12-127a	12-199	Removal	12-134a	12-207
Troop/cargo winterization rear reflector:			Tube, ballistic crew door latch:		
Installation	12-126b	12-198	Installation	11-12b	11-19
Removal	12-126a	12-198	Removal	11-12a	11-19
Troop/cargo winterization rear step assembly:			Tube, evaporator drain:		
Installation	12-122b	12-194	Installation	11-200b	11-302
Removal	12-122a	12-194	Removal	11-200a	11-302
			Tube, fuel tank vent stack:		
			Installation	12-8b	12-10
			Removal	12-8a	12-10
			Tunnel interior side insulation:		
			Installation	10-28b	10-48
			Removal	10-28a	10-48
			Turnbutton, stowage box:		
			Installation	11-151b	11-220
			Removal	11-151a	11-220

INDEX (Cont'd)

	Para	Page		Para	Page
T (Cont'd)			V (Cont'd)		
Turret bearing:			Vent line, CDR valve:		
Adjustment	11-113d	11-1601	Installation	12-10b	12-13
Cleaning and inspection	11-113c	11-159	Removal	12-10a	12-13
Installation	11-113b	11-160	Vent line, hydro-boost:		
Removal	11-113a	11-158	Installation	12-11b	12-14
Turret cleaning:			Removal	12-11a	12-14
Cleaning	11-112.1b	11-1564	Vent line, power steering:		
Modification	11-112.1a	11-1562	Installation	12-14b	12-17
Turret handle:			Removal	12-14a	12-17
Installation	11-55b	11-76	Vent line, sensor cup:		
Removal	11-55a	11-76	Installation	12-13b	12-16
Turret lock:			Removal	12-13a	12-16
Installation	11-56b	11-77	Vent line, winch (6,000 and 9,000 lb electric):		
Removal	11-56a	11-77	Installation	10-111b	10-192
	U		Removal	10-111a	10-192
Underbody protection kit:			Vent, rear door:		
Front shield installation	12-186k	12-308	Installation	11-178b	11-260
Front shield removal	12-186b	12-297	Removal	11-178a	11-260
Front skid plate installation	12-186l	12-309	Vent stack tube, fuel tank:		
Front skid plate removal	12-186a	12-296	Installation	12-8b	12-10
Fuel tank shield installation	12-186g	12-302	Removal	12-8a	12-10
Fuel tank shield removal	12-186f	12-302			
Intermediate shield installation	12-186j	12-306	W		
Intermediate shield removal	12-186c	12-298	Water can bumper:		
Rear shield installation	12-186h	12-304	Installation	11-76b	11-117
Rear shield removal	12-186e	12-301	Removal	11-76a	11-117
Transfer case shield installation	12-186i	12-305	Water can/M13 decon can bumper:		
Transfer case shield removal	12-186d	12-300	Installation	11-109b	11-151
	V		Removal	11-109a	11-151
Valve, heater shutoff			Water can tray:		
Installation	10-83b	10-137	Installation	11-108b	11-150
Removal	10-83a	10-137	Removal	11-108a	11-150
Valve, selector:			Water/fuel can strap (L119):		
Installation	12-9b	12-11	Installation	12-180b	12-273
Removal	12-9a	12-11	Removal	12-180a	12-273
Vehicle power conditioner (VPC) mounting bracket:			Weapon carrier body:		
Installation	11-66b	11-91	Maintenance task summary	11-1	11-1
Removal	11-66a	11-91	Weapon station backrest pad:		
Vent line, air cleaner to selector valve:			Installation	11-54b	11-75
Installation	12-7b	12-9	Removal	11-54a	11-75
Removal	12-7a	12-9	Weapon station bumper pad:		
			Installation	11-48b	11-69
			Removal	11-48a	11-69
			Weapon station hatch:		
			Installation	11-42b	11-62
			Removal	11-42a	11-62
			Weapon station hatch handle:		
			Installation	11-43b	11-63
			Removal	11-43a	11-63
			Weapon station hatch hinge:		
			Installation	11-45b	11-66
			Removal	11-45a	11-65

INDEX (Cont'd)

	Para	Page		Para	Page
W (Cont'd)			W (Cont'd)		
Weapon station hatch hinge pin:			Winch (10,500 lb hydraulic)		
Installation	11-44b	11-64	and brackets:		
Removal	11-44a	11-64	Brackets installation	10-108.1c	10-186.4
Weapon station hatch			Brackets removal	10-108.1b	10-186.4
holddown striker:			Winch installation	10-108.1d	10-186.4
Installation	11-46b	11-67	Winch removal	10-108.1a	10-186.2
Removal	11-46a	11-67	Winch cable (6,000 lb and		
Weapon station hatch latch:			9,000 lb electric):		
Installation	11-50b	11-71	Installation	10-110b	10-190
Removal	11-50a	11-71	Removal	10-110a	10-190
Weapon station hatch tube			Winch (10,500 lb hydraulic), cable:		
assembly:			Installation	10-110.1b	10-190.2
Installation	11-51b	11-72	Removal	10-110.1a	10-190.2
Removal	11-51a	11-72	Winch (10,500 lb hydraulic),		
Weapon station inclinometer:			controller plug		
Installation	11-60b	11-81	Installation	10-114b	10-201
Removal	11-60a	11-81	Removal	10-114a	10-196
Weapon station tray			Winch (10,500 lb hydraulic), hose:		
and bearing seals:			Installation	10-113b	10-194
Adjustment	11-112c	11-156	Removal	10-113a	10-194
Installation	11-112b	11-155	Winch:		
Removal	11-112a	11-154	Maintenance task summary	10-106	10-179
Weapon station tray lever:			Winch (6,000 lb and 9,000 lb		
Installation	11-49b	11-70	electric) control box:		
Removal	11-49a	11-70	Installation	10-109b	10-188
Weapon station tray seal:			Removal	10-109a	10-188
Installation	11-47b	11-68	Winch (6,000 lb and 9,000 lb		
Removal	11-47a	11-68	electric) vent line:		
Weapon station turret handle:			Installation	10-111b	10-192
Installation	11-55b	11-76	Removal	10-111a	10-192
Removal	11-55a	11-76	Window, arctic:		
Weatherstrip, windshield glass:			Installation	12-75b	12-108
Installation	10-21b	10-38	Removal	12-75a	12-108
Removal	10-21a	10-38	Window assembly,		
Wheelhouse armor plate, left:			ballistic crew door:		
Installation	11-40b	11-60	Assembly	11-7c	11-12
Removal	11-40a	11-60	Disassembly	11-7b	11-12
Wheelhouse armor plate, right:			Installation	11-7d	11-12
Installation	11-39b	11-58	Removal	11-7a	11-12
Removal	11-39a	11-58	Window protective shield,		
Wheelhousing covers,			ballistic crew door:		
troop/cargo winterization:			Initial Installation	11-8a	11-14
Installation	12-115b	12-168	Installation	11-8c	11-15
Removal	12-115a	12-168	Removal	11-8b	11-14
Winch (6,000 lb electric):			Window, soft top door:		
Installation	10-107b	10-182	Repair	10-104	10-175
Removal	10-107a	10-180	Window stop, ballistic crew door:		
Winch (9,000 lb electric):			Installation	11-9b	11-16
Installation	10-108b	10-186	Removal	11-9a	11-16
Removal	10-108a	10-184	Windshield assembly:		
			Assembly	10-23c	10-42
			Disassembly	10-23b	10-42
			Installation	10-23d	10-42
			Removal	10-23a	10-42

INDEX

W (Cont'd)	Para	Page
Windshield ballistic glass:		
Installation	10-22b	10-40
Removal	10-22a	10-40
Windshield glass and weatherstrip:		
Installation	10-21b	10-38
Removal	10-21a	10-38
Windshield mounting bracket:		
Installation	12-5b	12-7
Removal	12-5a	12-7
Windshield retention bracket:		
Installation	10-24b	10-44
Removal	10-24a	10-44
Windshield washer hoses:		
Installation	10-76b	10-126
Removal	10-76a	10-126
Windshield washer nozzle:		
Installation	10-78b	10-129
Removal	10-78a	10-129
Windshield washer reservoir and pump assembly:		
Installation	10-75b	10-124
Removal	10-75a	10-124
Windshield wiper arm pivot:		
Installation	10-74b	10-123
Removal	10-74a	10-123
Windshield wiper blade and arm:		
Installation	10-70c	10-116
Removal	10-70a	10-116
Repair (optional)	10-70b	10-116
Windshield wiper linkage:		
Installation	10-73b	10-122
Removal	10-73a	10-122
Windshield wiper motor (SF 5578716):		
Installation	10-71b	10-118
Removal	10-71a	10-118
Windshield wiper switch/motor (12342501):		
Installation	10-72b	10-120
Removal	10-72a	10-120
Wire handle lock, cargo shell door:		
Installation	11-14b	11-26
Removal	11-14a	11-26
Wiring diagrams and schematic:		
Appendix F		F-1
Wiring harness (L119), trailer connector and:		
Installation	12-163b	12-256
Removal	12-163a	12-255
Wiring harness, TOW:		
Installation	11-67b	11-94
Removal	11-67a	11-92

By Order of the Secretary of the Army:

DENNIS J. REIMER
General, United States Army
Chief of Staff

Official:

Yvonne M. Harrison
YVONNE M. HARRISON
Administrative Assistant to the
Secretary of the Army
01702

By Order of the Secretary of the Air Force:

RONALD R. FOGLEMAN
General, United States Air Force
Chief of Staff

Official:

HENRY VICCELLIO, JR.
General, United States Air Force
Commander, Air Force Materiel Command

By Order of the Marine Corps:

D. R. BLOOMER
Colonel, USMC
Director, Program Support
Marine Corps Systems Command

DISTRIBUTION:

To be distributed in accordance with DA Form 12-38-E, block 0900, requirements for TM 9-2320-280-20-3.

RECOMMENDED CHANGES TO PUBLICATIONS AND BLANK FORMS For use of this form, see AR 25-30; the proponent agency is ODISC4.	Use Part II (reverse) for Repair Parts and Special Tools Lists (RPSTL) and Supply Catalogs/Supply Manuals (SC/SM).	DATE: 14 Dec 2001
---	--	-----------------------------

TO: (Forward to proponent of publication or form) (include ZIP code) AMSTA-LC-CI Tech Pubs, TACOM-RI 1 Rock Island Arsenal Rock Island, IL 61299-7630	FROM: (Activity and location) (include ZIP code) Co. B, 1st BN, 2nd Brigade Ft. Hood, TX 76445
---	--

PART I - ALL PUBLICATIONS (EXCEPT RPSTL AND SC/SM) AND BLANK FORMS

PUBLICATION/FORM NUMBER TM 9-2320-280-20-3	DATE 31 JAN 96	TITLE TECHNICAL MANUAL UNIT MAINTENACE
--	--------------------------	--

ITEM NO.	PAGE NO.	PARA-GRAPH	LINE NO.*	FIGURE NO.	TABLE NO.	RECOMMENDED CHANGES AND REASON (Provide exact wording of recommended changes, if possible).
1	10-107	10-66			10-1	Drill size for 5/32 rivet diameter should be #21.
2	12-60	12-41				We are using a cotter pin to install elbow on exhaust pipe elbow.

SAMPLE

**Reference to line numbers within the paragraph or subparagraph.*

TYPED NAME, GRADE, OR TITLE Pat Smith, ILT	TELEPHONE EXCHANGE/AUTOVON, PLUS EXTENSION AV272-4162	SIGNATURE <i>Pat Smith, ILT</i>
--	--	------------------------------------

TO: <i>(Forward direct to addressee listed in publication)</i> AMSTA-LC-CI Tech Pubs, TACOM-RI 1 Rock Island Arsenal Rock Island, IL 61299-7630	FROM: <i>(Activity and location)</i> <i>(include ZIP code)</i>	DATE:
--	--	--------------

PART II - REPAIR PARTS AND SPECIAL TOOLS LISTS AND SUPPLY CATALOGS/SUPPLY MANUALS

PUBLICATION/FORM NUMBER	DATE	TITLE
--------------------------------	-------------	--------------

PAGE NO.	COLM NO.	LINE NO.	NATIONAL STOCK NUMBER	REFERENCE NO.	FIGURE NO.	ITEM NO.	TOTAL NO. OF MAJOR ITEMS SUPPORTED	RECOMMENDED ACTION
<h1>SAMPLE</h1>								

PART III - REMARKS *(Any general remarks or recommendations, or suggestions for improvement of publications and blank forms. Additional blank sheets may be used if more space is needed.)*

--

TYPED NAME, GRADE, OR TITLE	TELEPHONE EXCHANGE/AUTOVON, PLUS EXTENSION	SIGNATURE
------------------------------------	---	------------------

RECOMMENDED CHANGES TO PUBLICATIONS AND BLANK FORMS For use of this form, see AR 25-30; the proponent agency is ODISC4.	Use Part II (reverse) for Repair Parts and Special Tools Lists (RPSTL) and Supply Catalogs/Supply Manuals (SC/SM).	DATE:
---	--	-------

TO: <i>(Forward to proponent of publication or form) (include ZIP code)</i> AMSTA-LC-CI Tech Pubs, TACOM-RI 1 Rock Island Arsenal Rock Island, IL 61299-7630	FROM: <i>(Activity and location) (include ZIP code)</i>
--	---

PART I - ALL PUBLICATIONS (EXCEPT RPSTL AND SC/SM) AND BLANK FORMS

PUBLICATION/FORM NUMBER TM 9-2320-280-20-3	DATE 31 JAN 96	TITLE TECHNICAL MANUAL UNIT MAINTENACE
--	--------------------------	--

ITEM NO.	PAGE NO.	PARA-GRAPH	LINE NO.*	FIGURE NO.	TABLE NO.	RECOMMENDED CHANGES AND REASON <i>(Provide exact wording of recommended changes, if possible).</i>

**Reference to line numbers within the paragraph or subparagraph.*

TYPED NAME, GRADE, OR TITLE	TELEPHONE EXCHANGE/AUTOVON, PLUS EXTENSION	SIGNATURE
-----------------------------	---	-----------

TO: (Forward direct to addressee listed in publication) AMSTA-LC-CI Tech Pubs, TACOM-RI 1 Rock Island Arsenal Rock Island, IL 61299-7630	FROM: (Activity and location) <i>(include ZIP code)</i>	DATE:
---	---	--------------

PART II - REPAIR PARTS AND SPECIAL TOOLS LISTS AND SUPPLY CATALOGS/SUPPLY MANUALS

PUBLICATION/FORM NUMBER				DATE	TITLE			
PAGE NO.	COLM NO.	LINE NO.	NATIONAL STOCK NUMBER	REFERENCE NO.	FIGURE NO.	ITEM NO.	TOTAL NO. OF MAJOR ITEMS SUPPORTED	RECOMMENDED ACTION

PART III - REMARKS *(Any general remarks or recommendations, or suggestions for improvement of publications and blank forms. Additional blank sheets may be used if more space is needed.)*

--

TYPED NAME, GRADE, OR TITLE	TELEPHONE EXCHANGE/AUTOVON, PLUS EXTENSION	SIGNATURE
-----------------------------	--	-----------

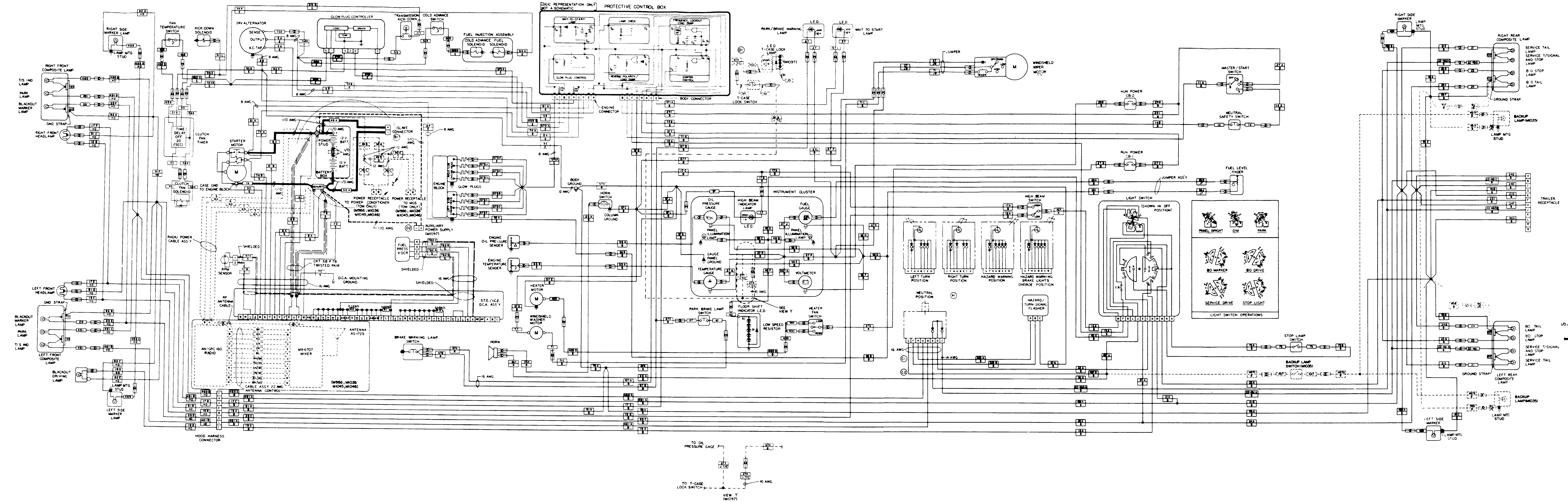

FO-1. Electrical System Wiring Diagram.

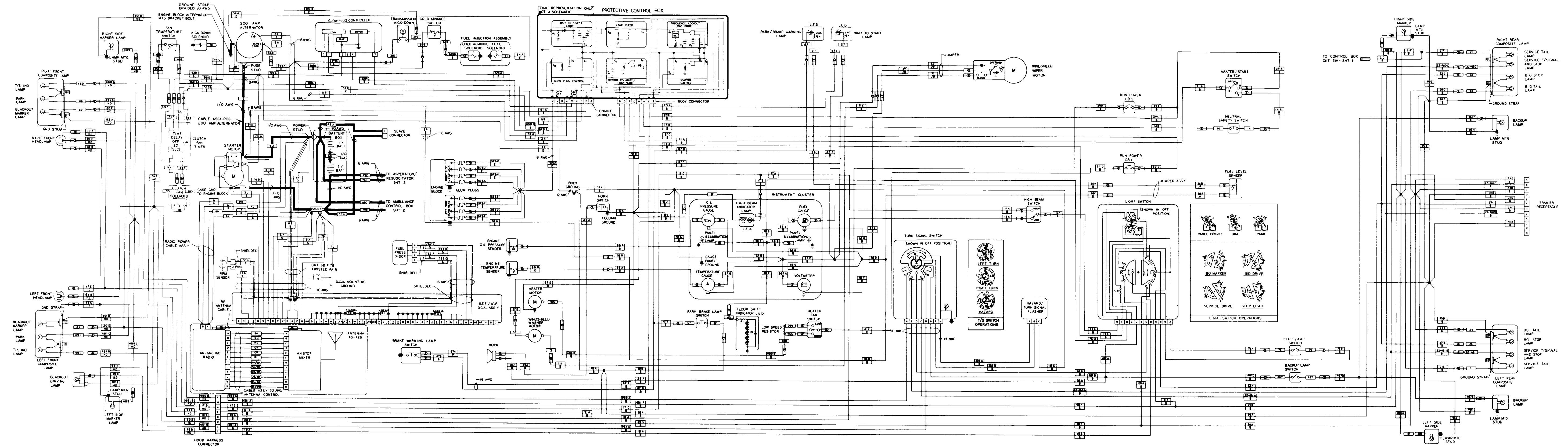

FO-2. Electrical System Wiring Diagram (M996 and M996A1).

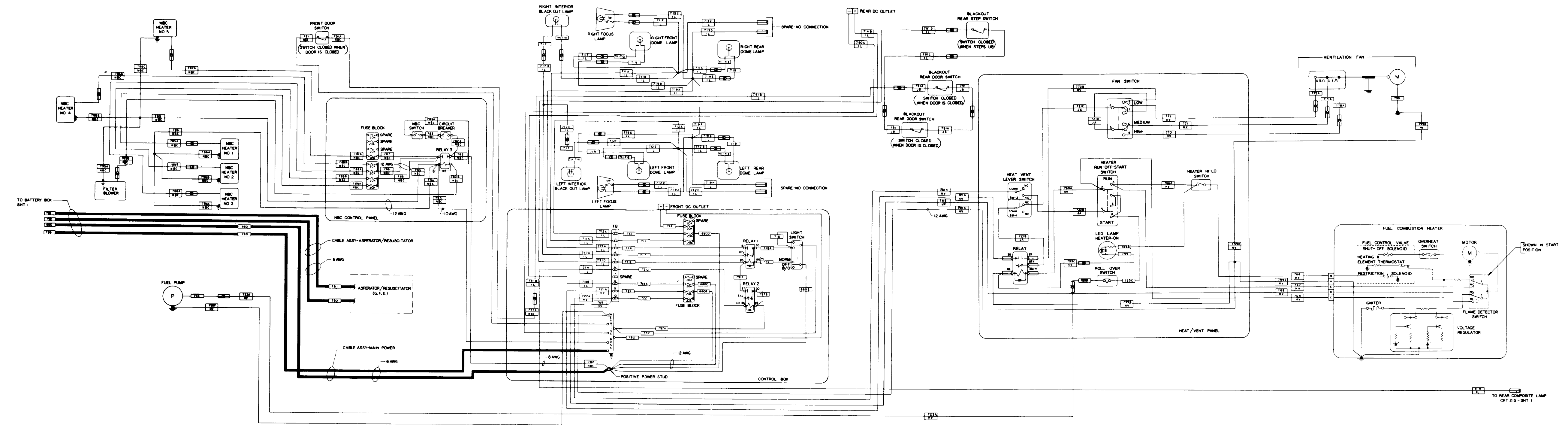

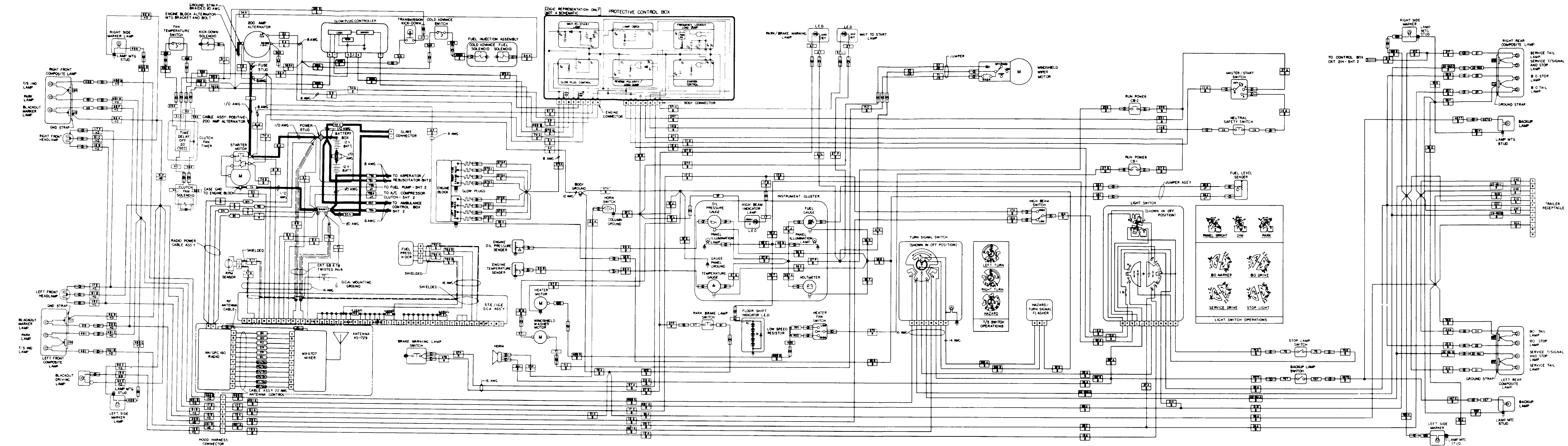

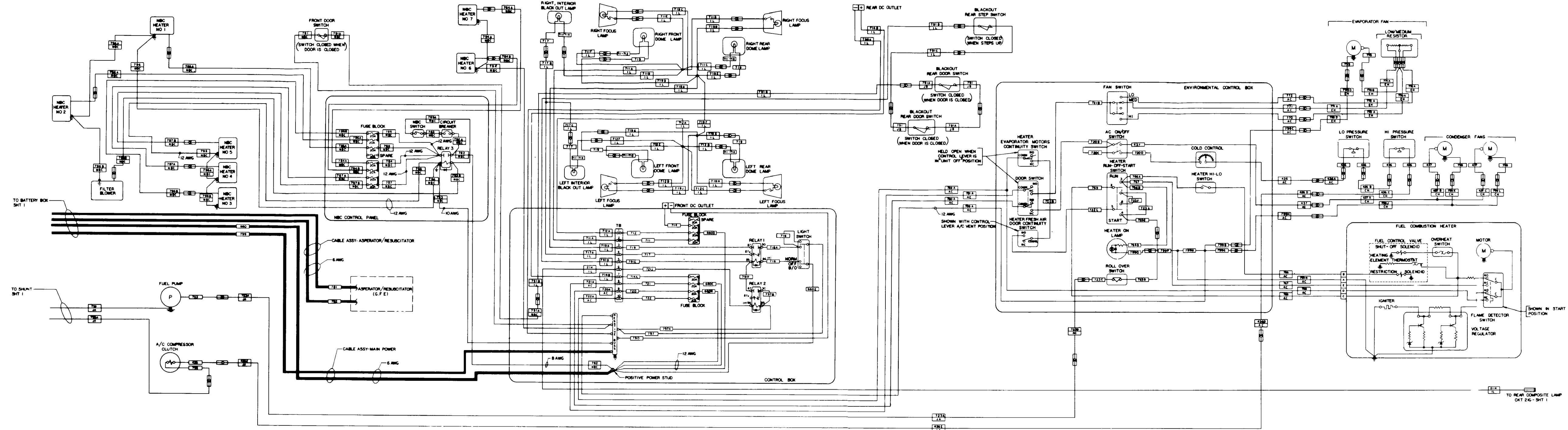

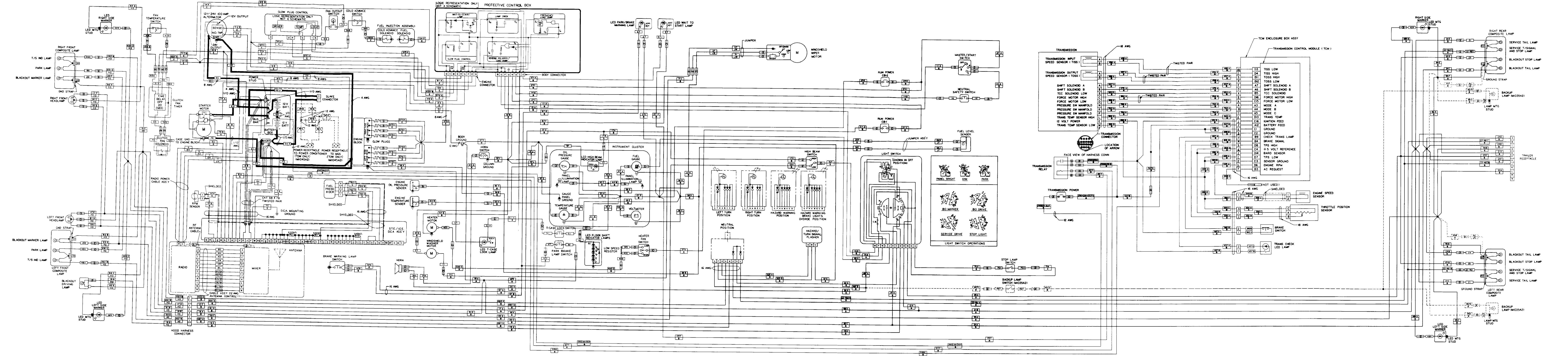

PO-4. Electrical System Wiring Diagram (M1025A2, M1035A2, M1043A2, M1045A2)

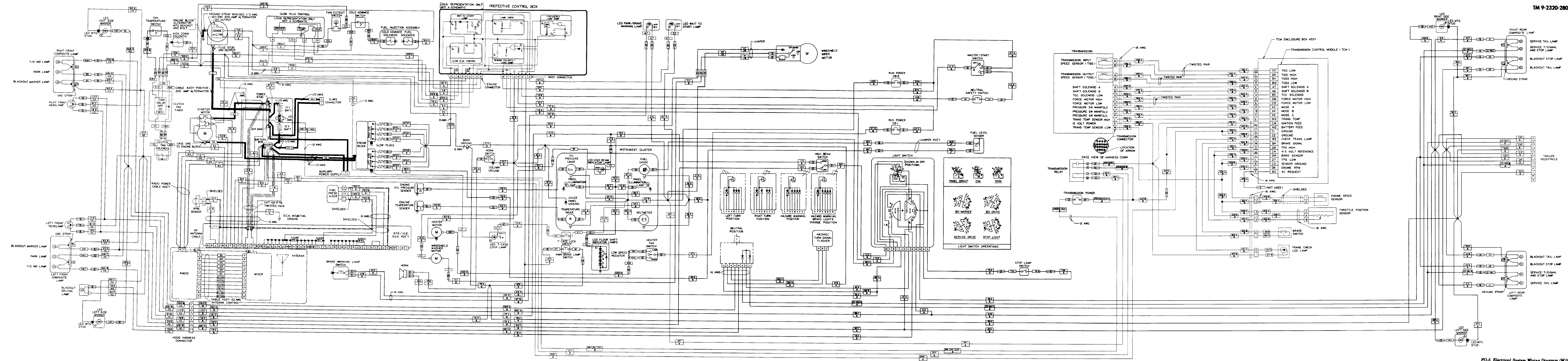

FO-5. Electrical System Wiring Diagram (M1097A2).

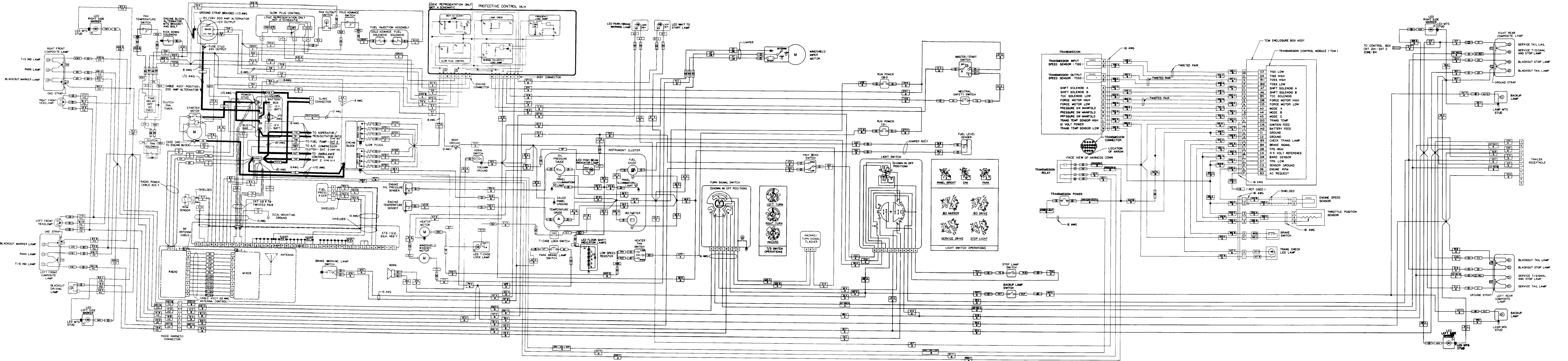

FO-6. Electrical System Wiring Diagram (M97A2).

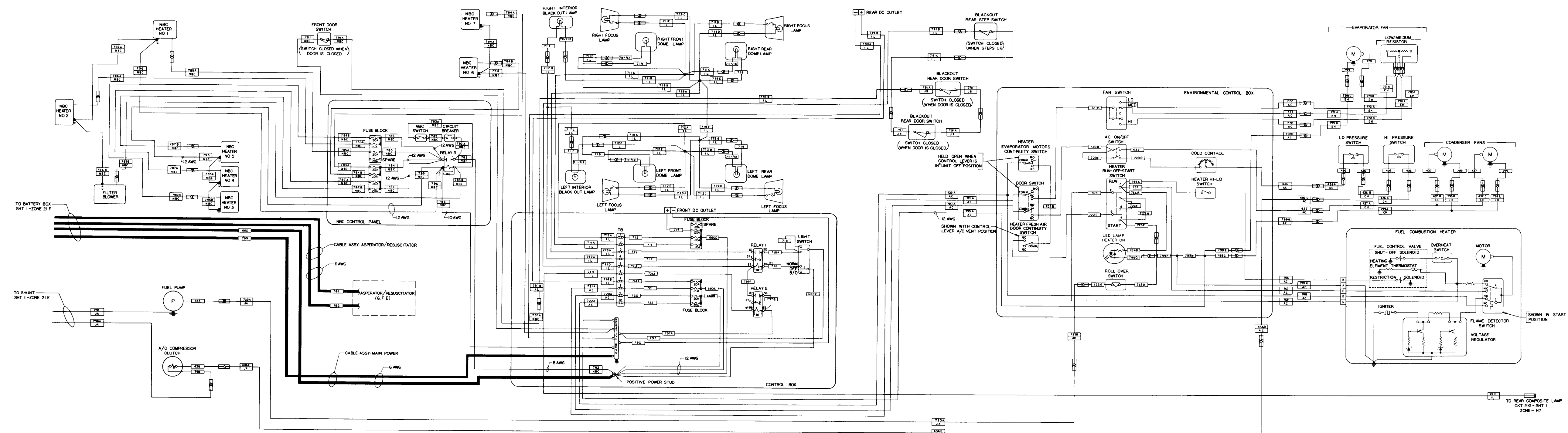

THE METRIC SYSTEM AND EQUIVALENTS

LINEAR MEASURE

- 1 Centimeter = 10 Millimeters = 0.01 Meters = 0.3937 Inches
- 1 Meter = 100 Centimeters = 1,000 Millimeters = 39.37 Inches
- 1 Kilometer = 1,000 Meters = 0.621 Miles

SQUARE MEASURE

- 1 Sq Centimeter = 100 Sq Millimeters = 0.155 Sq Inches
- 1 Sq Meter = 10,000 Sq Centimeters = 10.76 Sq Feet
- 1 Sq Kilometer = 1,000,000 Sq Meters = 0.386 Sq Miles

CUBIC MEASURE

- 1 Cu Centimeter = 1,000 Cu Millimeters = 0.06 Cu Inches
- 1 Cu Meter = 1,000,000 Cu Centimeters = 35.31 Cu Feet

LIQUID MEASURE

- 1 Milliliter = 0.001 Liters = 0.0338 Fluid Ounces
- 1 Liter = 1,000 Milliliters = 33.82 Fluid Ounces

TEMPERATURE

- Degrees Fahrenheit (F) = $^{\circ}\text{C} \cdot 9 \div 5 + 32$
- Degrees Celsius (C) = $\text{F}^{\circ} - 32 \cdot 5 \div 9$
- 212° Fahrenheit is equivalent to 100° Celsius
- 90° Fahrenheit is equivalent to 32.2° Celsius
- 32° Fahrenheit is equivalent to 0° Celsius

WEIGHTS

- 1 Gram = 0.001 Kilograms = 1,000 Milligrams = 0.035 Ounces
- 1 Kilogram = 1,000 Grams = 2.2 Lb
- 1 Metric Ton = 1,000 Kilograms = 1 Megagram = 1.1 Short Tons

APPROXIMATE CONVERSION FACTORS

TO CHANGE	TO	MULTIPLY BY
Inches	Millimeters	25.4
Inches	Centimeters	2.540
Feet	Meters	0.305
Yards	Meters	0.914
Miles	Kilometers	1.609
Square Inches	Square Centimeters	6.451
Square Feet	Square Meters	0.093
Square Yards	Square Meters	0.836
Square Miles	Square Kilometers	2.590
Acres	Square Hectometers	0.405
Cubic Feet	Cubic Meters	0.028
Cubic Yards	Cubic Meters	0.765
Fluid Ounces	Milliliters	29.573
Pints	Liters	0.473
Quarts	Liters	0.946
Gallons	Liters	3.785
Ounces	Grams	28.349
Pounds	Kilograms	0.4536
Short Tons	Metric Tons	0.907
Pound-Feet	Newton-Meters	1.356
Pounds Per Square Inch	Kilopascals	6.895
Miles Per Gallon	Kilometers Per Liter	0.425
Miles Per Hour	Kilometers Per Hour	1.609
TO CHANGE		
Millimeters	Inches	0.03937
Centimeters	Inches	0.3937
Meters	Feet	3.280
Meters	Yards	1.094
Kilometers	Miles	0.621
Square Centimeters	Square Inches	0.155
Square Meters	Square Feet	10.764
Square Meters	Square Yards	1.196
Square Kilometers	Square Miles	0.386
Square Hectometers	Acres	2.471
Cubic Meters	Cubic Feet	35.315
Cubic Meters	Cubic Yards	1.308
Milliliters	Fluid Ounces	0.034
Liters	Pints	2.113
Liters	Quarts	1.057
Liters	Gallons	0.264
Grams	Ounces	0.035
Kilograms	Pounds	2.2046
Metric Tons	Short Tons	1.102
Newton-Meters	Pound-Feet	0.738
Kilopascals	Pounds Per Square Inch	0.145
Kilometers Per Liter	Miles Per Gallon	2.354
Kilometers Per Hour	Miles Per Hour	0.621

