

**ROUTINE**

MWO effective date is 15 DEC 05 and completion date is 31 OCT 08

**MODIFICATION WORK ORDER**

---

**MODIFICATION OF  
M93 PALADIN MUZZLE VELOCITY SYSTEM  
(NSN 1290-01-412-5759)  
(EIC: 3TC)**

---

HEADQUARTERS, DEPARTMENT OF THE ARMY, WASHINGTON D.C.

15 December 2005

**REPORTING OF ERRORS AND RECOMMENDING IMPROVEMENTS**

You can help improve this publication. If you find any mistakes or if you know of a way to improve the procedures, please let us know. Submit your DA Form 2028 (Recommended Changes to Equipment Technical Publications), through the Internet, on the Army Electronic Product Support (AEPS) website. The Internet address is <http://aeeps.ria.army.mil>. If you need a password, scroll down and click on "ACCESS REQUEST FORM." The DA Form 2028 is located in the ONLINE FORMS PROCESSING section of the AEPS. Fill out the form and click on SUBMIT. Using this form on the AEPS will enable us to respond quicker to your comments and better manage the DA Form 2028 program. You may also mail, fax or E-mail your letter or DA Form 2028 direct to: AMSTA-LC-CI / TECH PUBS, TACOM-RI, 1 Rock Island Arsenal, Rock Island, IL 61299-7630. The email address is TACOM-TECH-PUBS@ria.army.mil. The fax number is DSN 793-0726 or Commercial (309) 782-0726.

**DISTRIBUTION STATEMENT A:** Approved for public release; distribution is unlimited.

1. **PURPOSE.** This MWO describes procedures to install a M93 (Upgraded) Muzzle Velocity System (MVS) Receiver-Transmitter (commonly referred to as Transceiver) in place of the original M93 Receiver-Transmitter.
2. **PRIORITY.** This modification is classified ROUTINE.
3. **END ITEMS OR SYSTEM TO BE MODIFIED.** See table 1.

Table 1. End Items or System to be Modified

NOMENCLATURE	NSN	Part Number	QTY	CAGEC	LIN
M93 (Paladin) MVS	1290-01-412-5759	12950995	650 ea	19200	R20826

4. **MODULES (COMPONENTS, ASSEMBLIES, SUBASSEMBLIES, BOARDS AND CARDS) TO BE REMOVED/INSTALLED.** See table 2.

**Table 2. Modules (Components, Assemblies, Subassemblies, Boards, and Cards) to be Removed/Installed**

	<b>NOMENCLATURE</b>	<b>NSN</b>	<b>Part Number</b>	<b>QTY</b>	<b>CAGEC</b>
<b>REMOVE</b>	Receiver-Transmitter	5895-01-417-7101	12927002	1	19200
	Mount, Resilient	5342-00-985-0248	12922110	4	19200
<b>INSTALL</b>	Receiver-Transmitter (Upgraded)	5895-01-503-8609	13002074	1	19200
	Mount, Resilient, Gen	5340-01-494-1557	70474-1	4	0LRN7

5. **PARTS TO BE MODIFIED.** Internal modification has been performed at the contractor/depot facility.

6. **APPLICATION.**

a. Time Compliance Schedule: MWO effective date is 15 December 2005 and completion date is 31 October 2008.

b. Maintenance Level. The lowest level of maintenance authorized to apply this MWO is Unit Maintenance.

c. Work Force and Man-Hour Requirements. Total man-hour for a single application of this MWO is 45 minutes.

7. **TECHNICAL PUBLICATIONS AFFECTED/CHANGED.** The following technical manual (TM) will be affected by this MWO.

TM 9-1290-365-24&P

8. **MWO KIT(S)/PART(S) AND THEIR DISPOSITION.**

a. Parts Needed to Apply this MWO. See table 3 for the list of parts to be installed.

**Table 3. Parts Needed to Apply this MWO**

<b>NOMENCLATURE</b>	<b>NSN</b>	<b>Part Number</b>	<b>QTY</b>	<b>CAGEC</b>
Transceiver (Upgraded)	5895-01-503-8609	13002074	1 ea	19200
Mount, Resilient Gen	5340-01-494-1557	70474-1	4 ea	0LRN7
<b>ATTACHING HARDWARE</b>				
Screws	5305-00-054-6669	MS51957-44	16 ea	96906
Lock washers	5310-00-933-8119	MS35338-137	16 ea	96906
Flat Washers	5310-00-880-5975	REW620C8L	16 ea	81349
Screw	5305-01-240-1796	438285-47	4 ea	70276
Lock Washer	5310-00-933-8121	MS35338-139	4 ea	80205

b. Contents of MWO Kit. Not Applicable

c. Bulk and Expendable Material. Not Applicable.

d. Parts Disposition. See table 4 for a list of parts removed during application of this MWO:

**Table 4. Parts Removed During Application of MWO**

NOMENCLATURE	NSN	Part Number	QTY	CAGEC
Transceiver	5895-01-417-7101	12979002	1 ea	19200
Mount, Resilient Gen	5342-00-985-0248	12922110	4 ea	19200
<b>ATTACHING HARDWARE</b>				
Screws	5305-00-054-6669	MS51957-44	16 ea	96906
Lock washers	5310-00-933-8119	MS35338-137	16 ea	96906
Flat Washers	5310-00-880-5975	REW620C8L	16 ea	81349
Screw	5305-01-240-1796	438285-47	4 ea	07690
Lock Washer	5310-00-933-8121	MS35338-139	4 ea	80205

(1) Transceiver instructions:

(a) Transceivers shall be turned-in through respective property book offices for appropriate record-keeping.

(b) Transceiver(s) shall be wrapped in a manner which will offer some protection during shipment; i.e., bubble wrap, foam inserts, standard Styrofoam packing, etc. If possible, utilize the box/container and packaging materials that the upgraded transceivers were shipped in.

(c) A DD1348 reflecting "M93 Transceiver, NSN 5895-01-417-7101, quantity, serial numbers, and turn-in unit with a POC should be included in each box/container being turned-in.

(d) M93 Transceivers to be upgraded should be shipped to DODAAC CMASD9, RIC CCA, citing contract number DAAE20-03-C-0044. In the clear address is as follows:

RSL Electronics, USA, Inc.  
 Borisch Manufacturing, Corp.  
 4511 East Paris, S. E.  
 Grand Rapids, MI 49512

(2) Resilient Mounts identified in table 4, upon replacement, should be disposed of locally.

(3) The attaching hardware for the Transceivers and Resilient Mounts, as identified in tables 3 and 4, are the same. If the upgraded transceiver is received without new attaching hardware, reuse the original attaching hardware. If new attaching hardware is included with the upgraded transceiver, the old attaching hardware should be disposed of locally.

**NOTE: New hardware was not considered part of the upgrade or engineering change proposal, however, after a few initial upgrades, the contractor is now including new attaching hardware with each upgraded transceiver.**

**9. SPECIAL TOOLS; TOOL KITS; JIGS; TEST, MEASUREMENT AND DIAGNOSTIC EQUIPMENT (TMDE); AND FIXTURES REQUIRED:**

Tools identified in table 5 by Part Number and NSN can be substituted with other tools that perform the same function. If these items are not readily available at the organizational level, the direct support shop should have them.

TABLE 5. Special Tools

TOOL	SIZE	PART NUMBER	NSN	QTY
TORQUE WRENCH	0-50 IN LBS, 1/4 IN DRIVE	TQSC4FUA	5120-01-131-4467	1 EA
TORQUE WRENCH	0-150 IN LBS, 3/8 IN DRIVE	TE12FUA	5120-01-355-1813	1 EA
BIT SCREWDRIVER	#2 CROSSTIP	FP22E2	5120-01-474-5085	2 EA
SCREWDRIVER	#2 CROSSTIP	SSDP216	5120-01-367-3814	1 EA
ELECTRIC SCREWDRIVER	1/4 IN DRIVE, 3.6 VDC	VP730T	5130-01-458-4495	1 EA
TORQUE WRENCH	30-150 FT LBS, 1/2 IN DRIVE	QC3R150	5120-01-496-6664	1 EA
SOCKET, SOCKET WRENCH	3/4 IN 12 POINT 3.25 IN LONG	GS241	5120-01-437-1810	1 EA
PLIERS, SLIP JOINT	CONNECTOR PLIERS	PWC52A	5120-01-380-9000	1 EA
BIT SCREWDRIVER	5mm HEX TIP	BNAE-5MM	5120-01-430-6877	2 EA
HOLDER, SCREWDRIVER BIT	1/4 IN HEX TO 1/4 IN HEX BIT	SDM11	5130-01-348-9534	1 EA
ADAPTER HEX OPENING TO SQUARE OPENING	1/4 IN SQUARE TO 1/4 IN HEX	TMBS8	5120-01-380-8979	1 EA
ADAPTER HEX OPENING TO SQUARE OPENING	1/4 IN HEX OPENING, 3/8 IN SQUARE DRIVE	FBS8	5120-01-380-8975	1 EA

**10. MODIFICATION PROCEDURES.**

**a. REQUIREMENT:** At least one M109A6 Paladin SP howitzer platform in operational condition, 10-20 standards, prior to installation and testing of all M93 (Upgraded) transceivers at each location. Perform initial AFCS BIT, with original transceiver installed. Data to be recorded for the old M93 and each new M93 on the MVS installation data sheet located at appendix A. Suspected M93 cable problems can be checked IAW Chapter 3, TM9-1290-365-24&P. Preferred installation would be done using a different howitzer for each M93.

**WARNING:** Remain at least 2 feet from radiating antennas of vehicle-mounted radios. Antennas can radiate harmful levels of radio frequency.

**b. INITIAL CHECK PRIOR TO REMOVAL:**

- (1) Turn vehicle **MASTER** switch (1) to **ON** position.
- (2) Power up AFCS with existing M93 installed and note all data and faults on the provided data sheet.
- (3) Power down AFCS.
- (4) Turn vehicle **MASTER** switch (1) to **OFF** position.

**c. PROCEDURES FOR REMOVAL:** The M93 Paladin Muzzle Velocity System must be removed from the howitzer in accordance with the following steps and figure 1:

- (1) Ensure that the vehicle **MASTER** switch (1) is in the **OFF** position.
- (2) Disconnect W92 power and data cable (5) from M93 radar antenna transceiver (2).
- (3) Remove antenna-mounting bracket (3) from howitzer mounting bracket (4) by unscrewing the hex head mounting bolt (fig. 3, item 1) securing the two brackets together.

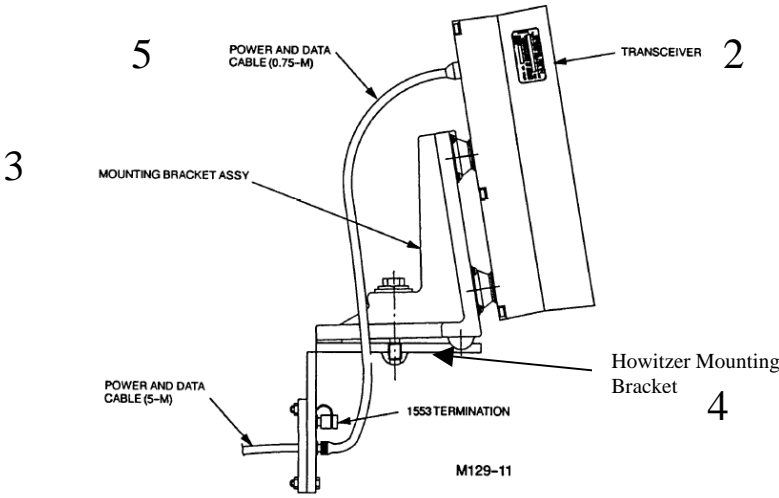
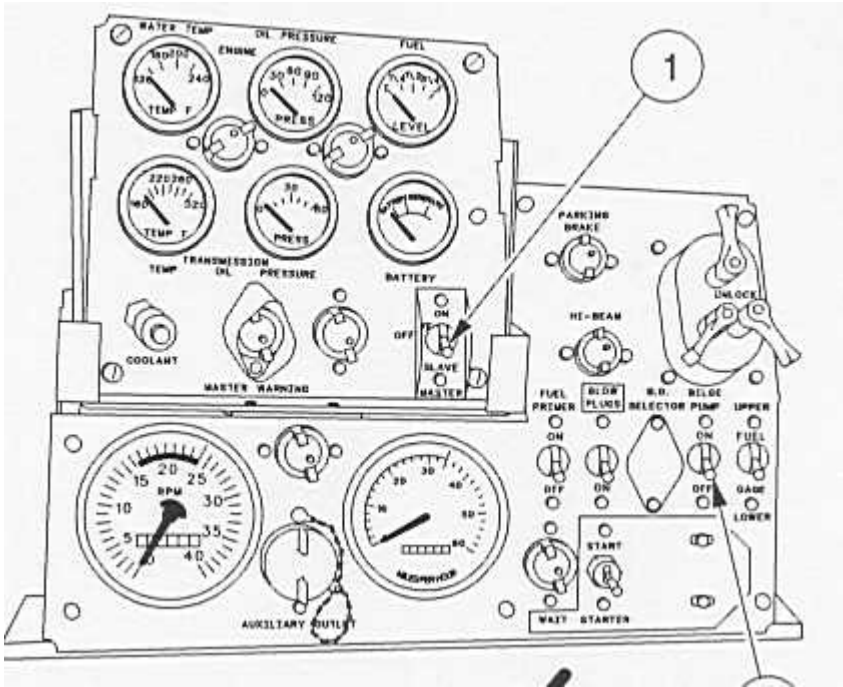
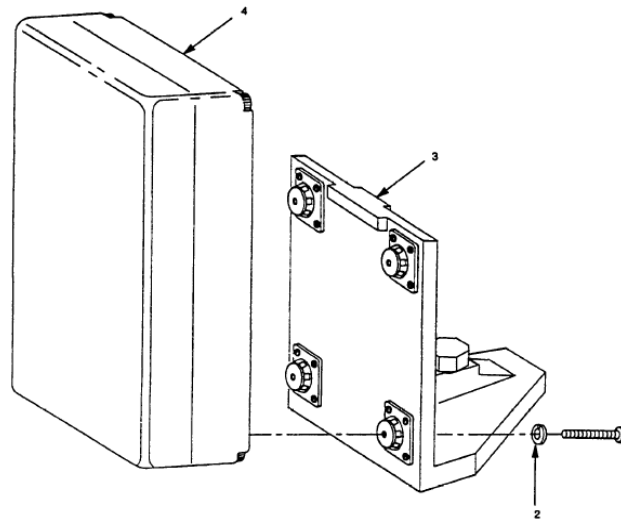

FIGURE 1

**d. DISASSEMBLY:**

(1) Transceiver from antenna-mounting bracket. Remove the following parts in accordance with the following steps and figure 2:

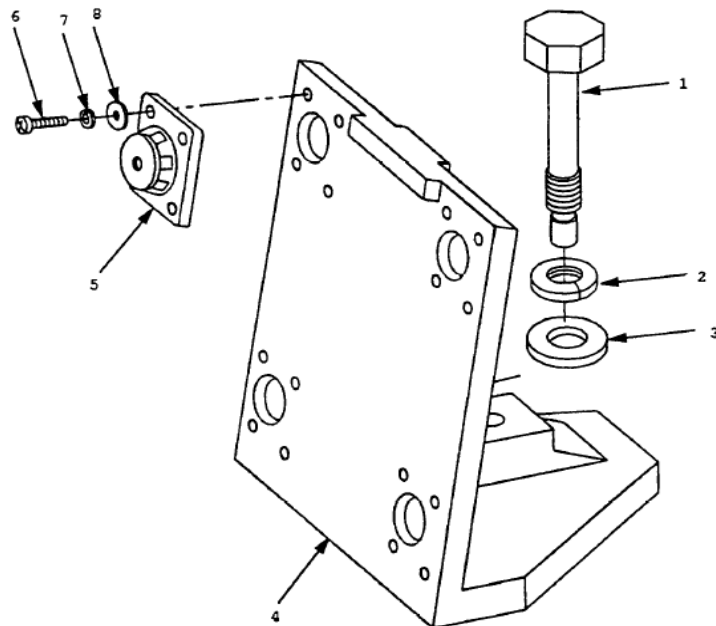

**Figure 2**

(a) Unscrew and remove four screws (1) and four lock washers (2) that secure transceiver (4) to bracket assembly (3). See paragraph 8d regarding disposition of hardware.

(b) Remove and set aside for disposition per paragraph 8d, the transceiver (4) from bracket assembly (3).

(2) Resilient mounts from antenna-mounting bracket. Remove the following parts in accordance with the following steps and figure 3:



**Figure 3**

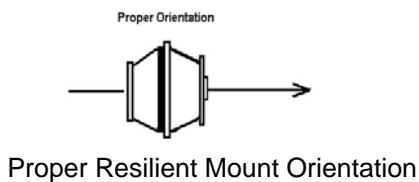

(a) Unscrew and remove 16 screws (6), 16 lock washers (7), and 16 flat washers (8) from four resilient mounts (5).

(b) Remove and set aside for disposition per paragraph 8d, four resilient mounts (5) from bracket (4).

**e. PROCEDURES FOR ASSEMBLY:**

(1) Resilient mounts to antenna-mounting bracket. Install the following parts in accordance with the following steps and figure 3:

(a) Install four new (blue) resilient mounts (5) in the place of the four removed during disassembly.

**NOTE: Blue resilient mounts must be installed with the hex nut visible from the backside of bracket.**

(b) Insert and tighten 16 new screws (6), 16 new lock washers (7) and 16 new flat washers (8).

(c) Using a cross-tip torque wrench (table 5), tighten the mounting screws to between 20 and 25 in-lb (1.66-2.08 ft-lb).

**NOTE: One antenna-mounting bracket off of one M109A6 howitzer will be used for all system check-outs at the time of hand-off or fielding of the upgraded M93 transceiver. When the upgraded transceiver is placed on a different howitzer, and an old transceiver is removed, that is when each antenna-mounting bracket will have the new resilient mounts installed.**

(2) Transceiver to antenna-mounting bracket. Install the following parts in accordance with the following steps and figure 2:

(a) Correctly position transceiver (4) on bracket (3).

(b) Install four new screws (1) and four new lock washers (2).

(c) Using a hex head torque wrench (table 5), tighten each mounting bolt to between 60 and 70 in-lb (5.00-5.83 ft-lb).

**WARNING: Remain at least 2 feet from radiating antennas of vehicle-mounted radios. Antennas can radiate harmful levels of radio frequency.**

**f. INSTALLATION:** Install the transceiver and mounting bracket to the howitzer in accordance with the following steps and figure 1.

(1) Ensure that the vehicle **MASTER** switch (1) is in the **OFF** position.

(2) Position antenna-mounting bracket (3) on howitzer bracket (4).

(3) Secure with hex head mounting bolt (1), lock washer (2) and flat washer (3) as noted in figure 3.

(4) Install mounting bracket with attached transceiver to the howitzer's bracket and torque main bolt to between 450 and 500 in-lb (37.5-41.67 ft-lb).

(5) Connect W92 power and data cable (Fig. 1, Item 5) to M93 (upgraded) transceiver (Fig. 1, item 2).

(6) Turn vehicle **MASTER** switch (1) to **ON** position.

(7) Power up AFCS with M93 (upgraded) transceiver installed; note any data and/or faults on the data sheet provided at appendix A.

**NOTE: If there is a BIT failure with an upgraded M93 receiver/transmitter, repeat installation using the same serial numbered M93 on a different M109A6 howitzer that has already had the MWO applied. If the same M93 (upgrade) fails on a second M109A6, return to contractor for analysis/repair.**

(8) Power down the AFCS and return the vehicle **MASTER** switch to the **OFF** position.

(9) Remove the upgraded M93 transceiver IAW paragraph 10c through 10d(1)(b). This transceiver is now ready to install on any M109A6 howitzer equipped with new resilient mounts.

(10) Using the same M109A6 and antenna-mounting bracket, repeat the steps in paragraphs 10e(2) through 10f(9) for each M93 (upgraded) receiver-transmitter.

**MWO 9-1290-365-20-1**

- 11. **CALIBRATION REQUIREMENTS.** Not applicable.
- 12. **WEIGHT AND BALANCE DATA.** Not applicable.
- 13. **QUALITY ASSURANCE REQUIREMENTS.** Not applicable.
- 14. **RECORDING AND REPORTING OF THE MODIFICATION.**

a. Reporting will be accomplished by electronic means. MWO application information can be input directly into the Modification Management Information System (MMIS) over the Internet. Entry into the MMIS system is password protected. New users can register on-line at <https://www.mmis.army.mil/mwo/>. Passwords are normally approved and issued within 48 hours.

b. Submission will be comprised of the fifteen (15) data elements listed in table 6, Elements 1, 2, 6, 7, 8, 10 and 12 are provided for this MWO. The person reporting the MWO data will acquire the remaining elements (3, 4, 5, 9, 11, 13, 14 and 15) and input all fifteen elements into the MMIS.

**Table 6. Data Elements**

DATA ELEMENT		INPUT DATA
1	Materiel Change Number (MCN)	1-03-05-0004
2	MWO Number	9-1290-365-20-1
3	Unit Identification Code (UIC) @ Battalion Level	
4	Unit Name	
5	Unit Location	
6	NSN of the End Item (Old)	1290-01-412-5759
7	NSN of the End Item (New)	1290-01-503-4395
8	Registration Number	N/A
9	Date of Application	
10	Man-Hours Required for Application	2.5
11	Applied By	
12	Software Version	N/A
13	Serial Number	
14	Your Email Address	
15	Comments	

c. If any of these data elements are not available, or if no record is found, one of the following will be entered for that element: N/A – Not Applicable  
N/R – No Record Found

d. The completed MVS data installation sheets (appendix A) shall be sent to the TACOM-ARDEC Quality Engineer, as follows:

Brian Lesko, Paladin Quality Engineer  
 AMSRD-AAR-QEW-A, QESA, ARDEC  
 Picatinny, NJ 07806-5000  
 DSN 880-6302  
 COMM (973) 724-6302  
 FAX (973) 724-3729



e. Marking Equipment. Not Applicable.

f. Identification Data.

	<u>Before Modification</u>	<u>After Modification</u>
Nomenclature	MVS	MVS
Model Number	M93	M93 (UPGRADED)
CAGEC/Part Number	(19200) 12950995	(19200) 13002073
NSN	1290-01-412-5759	1290-01-503-4395

15. **MATERIEL CHANGE (MC) NUMBER.** This MWO is authorized by MCN 1-03-05-0004.

APPENDIX A. MVS INSTALLATION DATA SHEET

SOFTWARE REVISION				
LOCATION			OK/DEGRADED/OUT/--	
DATE		Subsystem	With Old MVS Installed	With New MVS Installed
PAL #		DCU		
Serial #		COMMO		
Bumper #		NAV		
Unit ID		WPN		
AFCS21 ACU		PCU		
New MVS S/N		1553		
Old MVS S/N		PDIU		
ACU Hours		MVS		
Installed by				
Inspected by				

Submit the completed data sheet to the following POC and address:

Brian Lesko, Paladin Quality Engineer  
 AMSRD-AAR-QEW-A, QESA, ARDEC  
 Picatinny, NJ 07806-5000  
 DSN 880-6302  
 COM (973) 724-6302  
 FAX (973) 724-3729

By Order of the Secretary of the Army:

Official:

  
SANDRA R. RILEY  
*Administrative Assistant to the  
Secretary of the Army*  
0513707

PETER J. SCHOOMAKER  
*General, United States Army  
Chief of Staff*

DISTRIBUTION: To be distributed in accordance with the Initial Distribution Number (IDN) 372590, requirements for MWO 9-1290-365-20-1.

PIN: 082495-000