

ROUTINE

MWO effective date is 1 April 1992 and completion date is 30 September 1999.

MWO 9-2350-311-20-2

MODIFICATION WORK ORDER

HOWITZER, MEDIUM SELF-PROPELLED

155MM, M109A2 (2350-01-031-0586) (EIC: 3EZ)
155MM, M109A3 (2350-01-031-8851) (EIC: 3E2)
155MM, M109A4 (2350-01-277-5770) (EIC: 3E8)
155MM, M109A5 (2350-01-281-1719) (EIC: 3E7)

Headquarters, Department of the Army, Washington, DC

14 April 1992

REPORTING OF ERRORS AND RECOMMENDING IMPROVEMENTS

You can help improve this MWO. If you find any mistakes or if you know of a way to improve these procedures, please let us know. Write a letter or complete and mail a DA Form 2028, Recommended Changes to Publications and Blank Forms, to: Commander, U.S. Army Armament, Munitions and Chemical Command, ATTN: AMSMC-MAS, Rock Island, IL 61299-6000. A reply will be provided to you.

1. PURPOSE.

This modification is reducing the infrared detectability of the Elbow Telescope used on the M109 Series Howitzers by replacing M118A2 Elbow Telescopes with M118A3 Elbow Telescopes.

2. PRIORITY.

This modification is classified ROUTINE.

DISTRIBUTION STATEMENT A. Approved for public release; distribution is unlimited.

3. END ITEM(S) OR SYSTEM(S) TO BE MODIFIED.

See table 1 for listing of end item(s) or system(s) to be modified.

Table 1. End Item(s) or System(s) to be Modified.

Nomenclature	NSN	Part Number	FSCM	Type of Model No.	Serial No. Range
Howitzer, Self-Propelled Medium, 155MM,	2350-01-031-0586	12012100	19204	M109A2	A1
Howitzer, Self-Propelled Medium, 155MM	2350-01-031-8851	12012200	19204	M109A3	A1
Howitzer, Self-Propelled Medium, 155MM	2350-01-277-5770	9399100	19200	M109A4	A1
Howitzer, Self-Propelled Medium, 155MM	2350-01-281-1719	12910870	19200	M109A5	A1

4. MODULE(S) (COMPONENTS, ASSEMBLIES, SUBASSEMBLIES, BOARDS AND CARDS) TO BE MODIFIED.

Not applicable.

5. PARTS TO BE MODIFIED.

Not applicable.

6. APPLICATION.

a. Time compliance schedule. The effective date of this MWO is 1 April 1992 and its completion date is 30 September 1999.

b. Level of maintenance. Organizational.

c. Work force and man-hour requirements for application of the MWO to a single unit, end item, or system.

WORK FORCE SKILLS

MAN-HOURS

Self-propelled Field
Artillery Mechanic 45D

0.5 hrs

Total man-hours required for a single application of this MWO is 0.5 hours.

d. MWO to be applied prior to or concurrently with the application of this MWO.
Not applicable.

e. Additional information. Refer to TM 750-116, Purging and Charging of Fire Control Instruments.

7. TECHNICAL PUBLICATIONS AFFECTED/CHANGED.

- DMWR 9-1240-276 dated 6 DEC 83
- TM 9-2350-311-10 dated 27 JUN 86
- TM 9-2350-311-20-2 dated 30 JUN 86
- TM 9-2350-311-20P-2 dated 15 Nov 89
- TM 9-2350-311-34-2 dated 14 NOV 86
- TM 9-1240-401-34 dated 22 MAY 87
- TM 9-1240-401-34P dated 28 Jun 89

8. MWO KIT(S)/PART(S) AND THEIR DISPOSITION.

a. Kit(s)/part(s) needed to apply the MWO. See table 2.

Table 2. Kit/Parts Required.

NSN	Item Name and Part Number	FSCM	QTY	Figure and Item No.	
				Fig.	Item
1240-01-317-9241	Modification kit P/N N/A consisting of: Elbow Telescope, M118A3 9356014	19200	1	1	1

b. Kit packaging See table 3 for listing of kit packaging.

Table 3. Kit Packaging.

NSN	Weight	Dimensions	Cube	Security Classification
1240-01-317-9241	70 lb	3.69 x 1.85 x .92 FT	6.28 CU FT	UNCLASSIFIED

c. Contents of MWO kits. See table 2 for listing of kit/parts required. Illustration of kit is shown in figure 1.

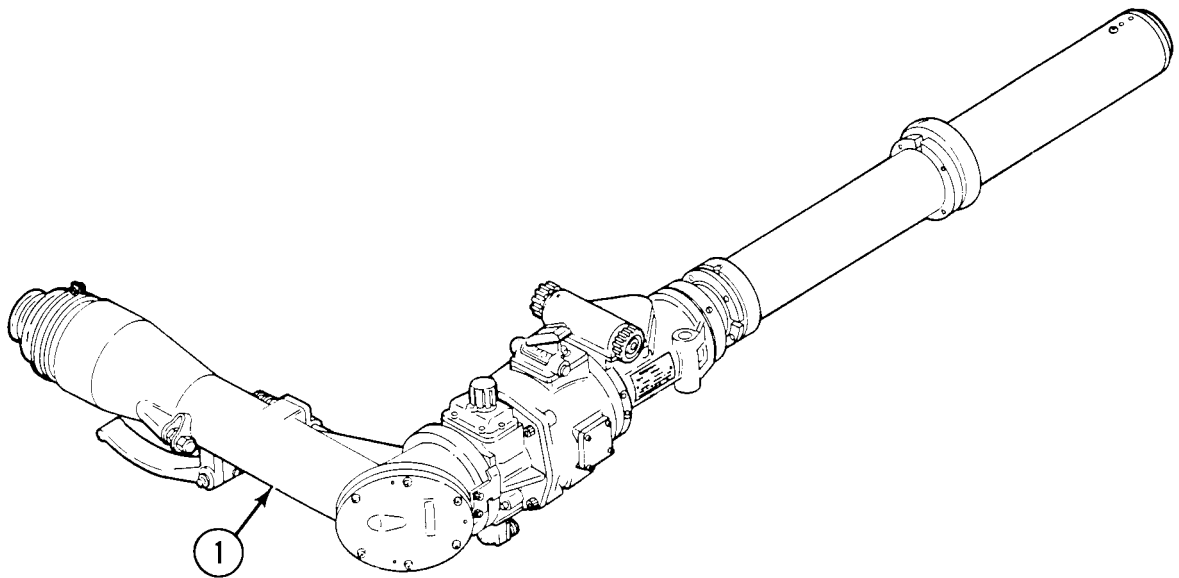

LEGEND:

- 1. M118A3 Elbow Telescope 9356014

Figure 1. Modification Kit.

d. Bulk and expendable material. Not applicable.

e. Part disposition. Parts no longer required are listed in table 4 and will be disposed of in accordance with Modification Work Order Fielding Plan (MWOFP).

Table 4. Parts Disposition.

Nomenclature	NSN	FSCM	Part Number	Q
Elbow Telescope, M118A2*	1240-01-092-2693	19200	11829207	1

* Dispose according to SMR code PAODD.

9. SPECIAL TOOLS; TOOL KITS; JIGS; TEST, MEASUREMENT, AND DIAGNOSTIC EQUIPMENT (TMDE); AND FIXTURES REQUIRED.

Not applicable.

10. MODIFICATION PROCEDURES.

WARNING

Elbow telescope weighs 55 pounds (24.9 kg). Gun tube must be approximately level or in stowed position when kingpin is removed to prevent injury to personnel and damage to M118A2 telescope.

- a. Refer to figure 2. Remove the M118A2 telescope as follows:
- (1) Disconnect electrical connector (1) on underside of telescope (2).
 - (2) Support telescope (2) to prevent it from sliding out of mount (3).
 - (3) Remove kingpin (4) by turning it counterclockwise.
 - (4) Slide telescope (2) out of mount (3).
- b. Refer to figure 2. Install the M118A3 telescope as follows:

WARNING

Elbow telescope weighs 55 pounds (24.9 kg). Failure to install and tighten kingpin may result in injury to personnel and damage to M118A3 telescope when gun tube is elevated.

CAUTION

When installing telescope, make sure electrical connector is not lying on top of mount.

NOTE

Before installing telescope, clean forward lens and eyepiece lens using lens paper.

- (1) Slide telescope (5) into mount (3). Support telescope.
- (2) Install kingpin (4) and tighten.
- (3) Connect electrical connector (1) from M146 mount (3) to underside of M118A3 telescope (5).

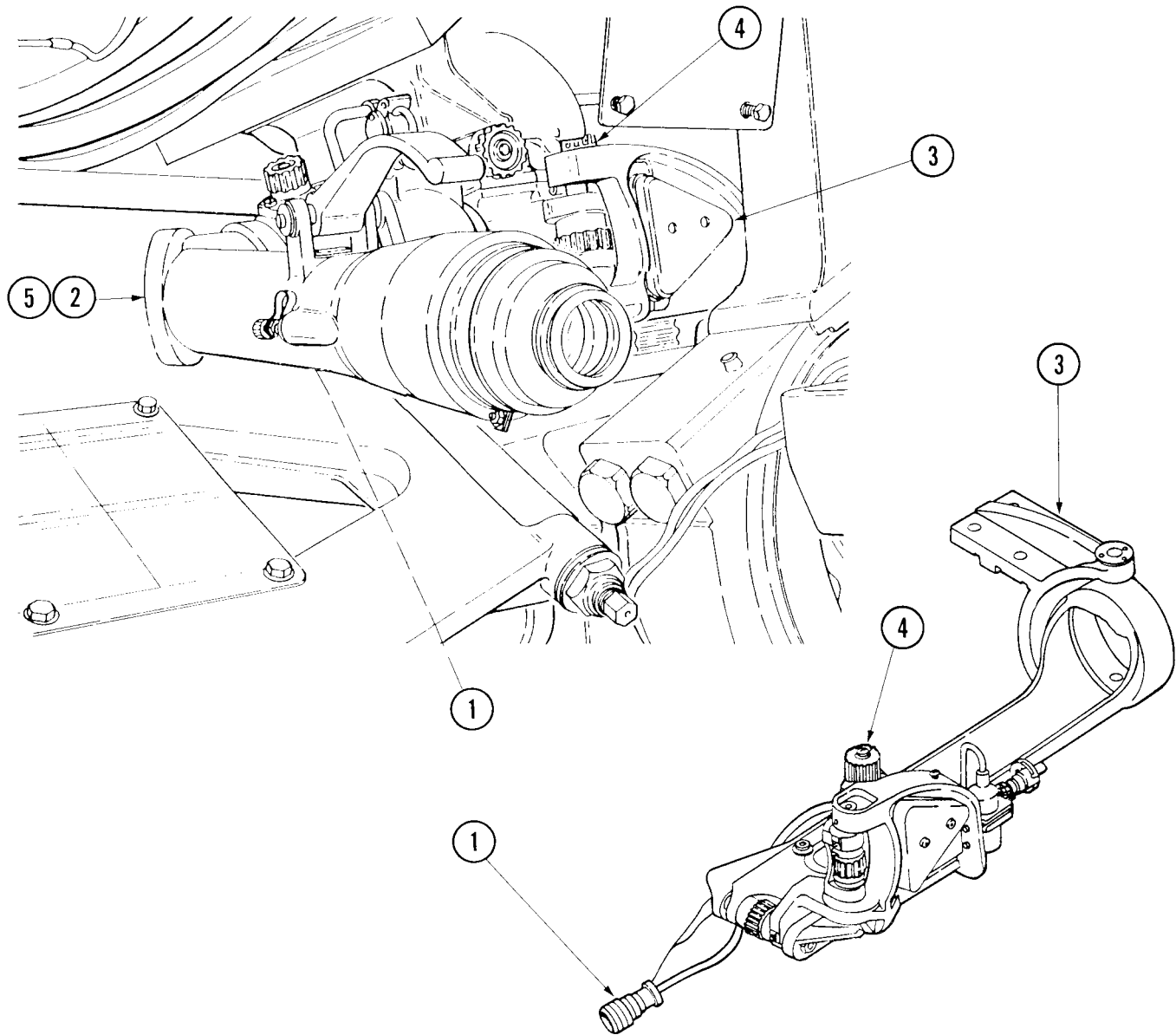

LEGEND:

- 1. Connector (Part of Cable Assembly 8616025) (Ref)
- 2. Elbow Telescope, M118A2 11829207 (Return to Depot)
- 3. M146 Telescope Mount 8616011 (Ref)
- 4. Kingpin 8616056 (Reuse)
- 5. Elbow Telescope, M118A3 9356014 (New)

Figure 2. Removal of Elbow Telescope M118A2 and installation of Elbow Telescope M118A3.

11. CALIBRATION REQUIREMENTS.
Not applicable.

12. WEIGHT AND BALANCE DATA.
Not applicable.

13. QUALITY ASSURANCE REQUIREMENTS.
Perform final inspection per TM 9-2350-311-10.

14. RECORDING AND REPORTING OF THE MODIFICATION.

a. Record and reports.

(1). Refer to DA Pamphlet 738-750, The Army Maintenance modification. Completion of DA Form 2407, Maintenance Request, or DA Form 5504 (if SAMS I and SAMS II are available) to report MWO application is mandatory. Refer to DA Pam 738-750 for instructions on how to request and report MWO applications.

(2). After completing the DA Form 2407 or DA Form 5504, forward the NMP copy (no. 2) to Commander, U.S. Army Armament, Munitions and Chemical Command, ATTN: AMSMC-MAE-M, Rock Island, IL 61299-6000. Mail control copy (no. 3) to Commander, U.S. Army Depot Systems Command, ATTN: AMSDS-SM-MV, Chambersburg, PA 17201-4170.

a. Marking equipment. Not applicable.

b. Identification data.

Nomenclature		FSCM and Part Number		NSN	
Before Modification	After Modification	Before Modification	After Modification	Before Modification	After Modification
Telescope, Elbow M118A2	Telescope, Elbow M118A3	19200 11829207	19200 9356014	1240-01- 092-2693	1240-01- 317-9241

15. PRODUCT IMPROVEMENT PROPOSAL (PIP) NUMBER.
This MWO is authorized by PIP number 1-84-05-7125.

16. MODIFICATION IDENTIFICATION.
Refer to figure 3. Identification of this MWO application is indicated by checking the identification plate on the Elbow Telescope to ensure it is the M118A3.

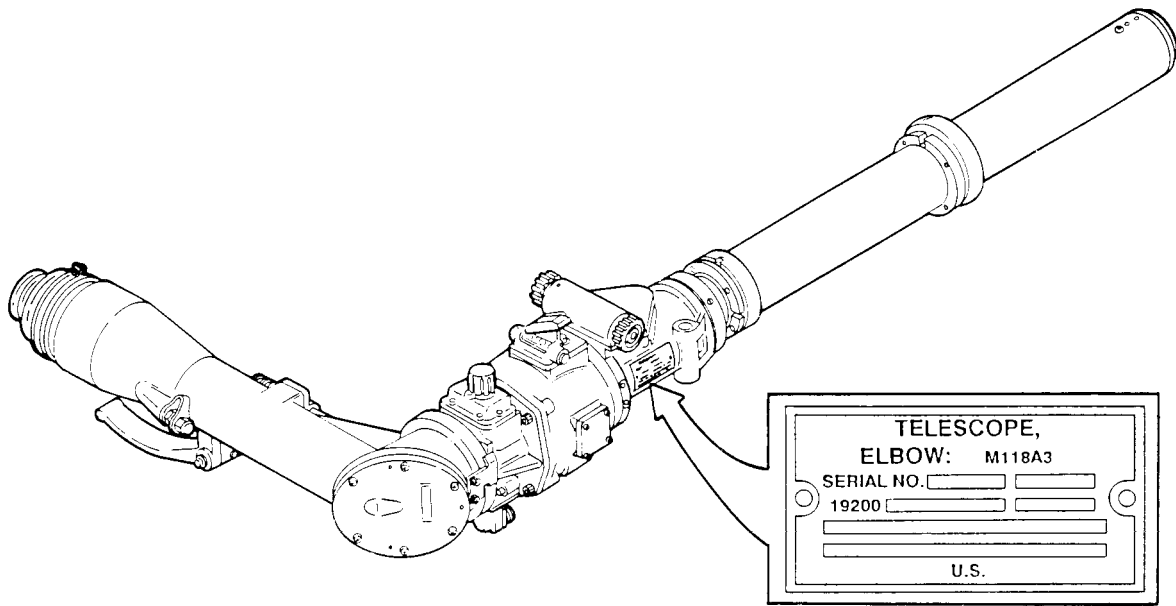
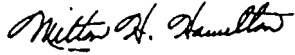

Figure 3. Modification Identification.

By Order of the Secretary of the Army:

GORDON R. SULLIVAN
General, United States Army
Chief of Staff

Official:



MILTON H. HAMILTON
Administrative Assistant to the
Secretary of the Army

00872

DISTRIBUTION:

To be distributed in accordance with DA Form 12-37-E, (Block 2078), Direct and General Support Maintenance requirements for MWO 9-2350-311-20-2.

RECOMMENDED CHANGES TO EQUIPMENT TECHNICAL PUBLICATIONS



THEN...JOT DOWN THE DOPE ABOUT IT ON THIS FORM. CAREFULLY TEAR IT OUT, FOLD IT AND DROP IT IN THE MAIL.

SOMETHING WRONG WITH PUBLICATION

FROM: (PRINT YOUR UNIT'S COMPLETE ADDRESS)

DATE SENT

PUBLICATION NUMBER

PUBLICATION DATE

PUBLICATION TITLE

BE EXACT PIN-POINT WHERE IT IS

PAGE NO.

PARA-GRAPH

FIGURE NO.

TABLE NO.

IN THIS SPACE, TELL WHAT IS WRONG AND WHAT SHOULD BE DONE ABOUT IT.

TEAR ALONG PERFORATED LINE

PRINTED NAME, GRADE OR TITLE AND TELEPHONE NUMBER

SIGN HERE

THE METRIC SYSTEM AND EQUIVALENTS

WEIGHT MEASURE

1 Centimeter = 10 Millimeters = 0.01 Meters = 0.3937 Inches
 1 Meter = 100 Centimeters = 1000 Millimeters = 39.37 Inches
 1 Kilometer = 1000 Meters = 0.621 Miles

WEIGHTS

1 Gram = 0.001 Kilograms = 1000 Milligrams = 0.035 Ounces
 1 Kilogram = 1000 Grams = 2.2 lb.
 1 Metric Ton = 1000 Kilograms = 1 Megagram = 1.1 Short Tons

LIQUID MEASURE

1 Milliliter = 0.001 Liters = 0.0338 Fluid Ounces
 1 Liter = 1000 Milliliters = 33.82 Fluid Ounces

SQUARE MEASURE

1 Sq. Centimeter = 100 Sq. Millimeters = 0.155 Sq. Inches
 1 Sq. Meter = 10,000 Sq. Centimeters = 10.76 Sq. Feet
 1 Sq. Kilometer = 1,000,000 Sq. Meters = 0.386 Sq. Miles

CUBIC MEASURE

1 Cu. Centimeter = 1000 Cu. Millimeters = 0.06 Cu. Inches
 1 Cu. Meter = 1,000,000 Cu. Centimeters = 35.31 Cu. Feet

TEMPERATURE

$5/9(^{\circ}\text{F} - 32) = ^{\circ}\text{C}$
 212° Fahrenheit is equivalent to 100° Celsius
 90° Fahrenheit is equivalent to 32.2° Celsius
 32° Fahrenheit is equivalent to 0° Celsius
 $9/5^{\circ}\text{C} + 32 = ^{\circ}\text{F}$

APPROXIMATE CONVERSION FACTORS

TO CHANGE	TO	MULTIPLY BY
Inches	Centimeters	2.540
Feet	Meters	0.305
Yards	Meters	0.914
Miles	Kilometers	1.609
Square Inches	Square Centimeters	6.451
Square Feet	Square Meters	0.093
Square Yards	Square Meters	0.836
Square Miles	Square Kilometers	2.590
Acres	Square Hectometers	0.405
Cubic Feet	Cubic Meters	0.028
Cubic Yards	Cubic Meters	0.765
Fluid Ounces	Milliliters	29.573
its	Liters	0.473
arts	Liters	0.946
allons	Liters	3.785
Ounces	Grams	28.349
Pounds	Kilograms	0.454
Short Tons	Metric Tons	0.907
Pound-Feet	Newton-Meters	1.356
Pounds per Square Inch	Kilopascals	6.895
Miles per Gallon	Kilometers per Liter	0.425
Miles per Hour	Kilometers per Hour	1.609

TO CHANGE	TO	MULTIPLY BY
Centimeters	Inches	0.394
Meters	Feet	3.280
Meters	Yards	1.094
Kilometers	Miles	0.621
Square Centimeters	Square Inches	0.155
Square Meters	Square Feet	10.764
Square Meters	Square Yards	1.196
Square Kilometers	Square Miles	0.386
Square Hectometers	Acres	2.471
Cubic Meters	Cubic Feet	35.315
Cubic Meters	Cubic Yards	1.308
Milliliters	Fluid Ounces	0.034
Liters	Pints	2.113
Liters	Quarts	1.057
ers	Gallons	0.264
ms	Ounces	0.035
ograms	Pounds	2.205
Metric Tons	Short Tons	1.102
Newton-Meters	Pounds-Feet	0.738
Kilopascals	Pounds per Square Inch	0.145
ometers per Liter	Miles per Gallon	2.354
ometers per Hour	Miles per Hour	0.621

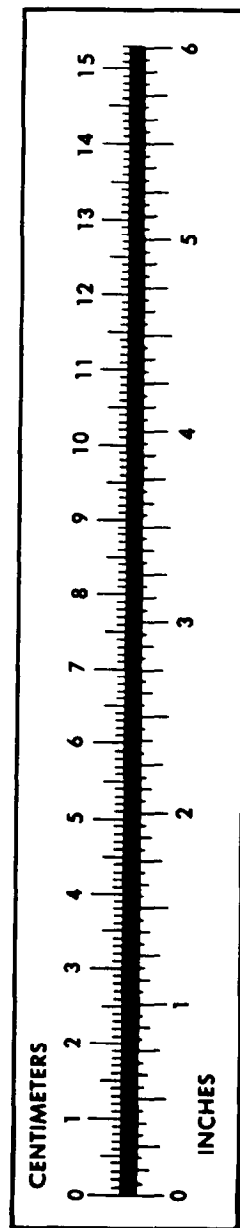

PIN: 069492-000