

**UNIT MAINTENANCE MANUAL FOR
HULL, POWERPLANT, DRIVE
CONTROLS, TRACKS, SUSPENSION,
AND ASSOCIATED COMPONENTS**

**HOWITZER, MEDIUM,
SELF-PROPELLED, 155 MM,
M109A2 (EIC:3EZ)**

**(NSN 2350-01-031-0586)
AND**

**HOWITZER, MEDIUM,
SELF-PROPELLED, 155 MM,
M109A3 (EIC:3E2)**

**(NSN 2350-01-031-8851)
AND**

**HOWITZER, MEDIUM,
SELF-PROPELLED, 155 MM,
M109A4 (EIC:3E8)**

**(NSN 2350-01-277-5770)
AND**

**HOWITZER, MEDIUM,
SELF-PROPELLED, 155MM,
M109A5 (EIC:3E7)**

(NSN 2350-01-281-1719)

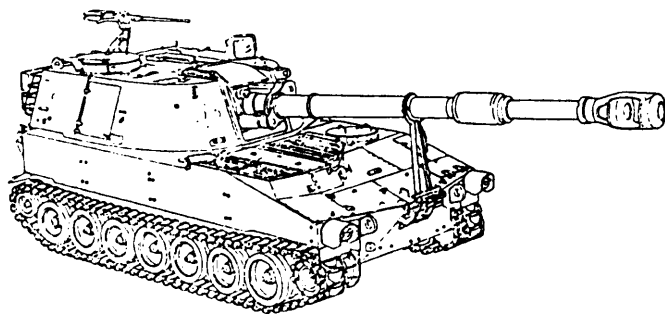

INTRODUCTION	1-1
GENERAL HULL MAINTENANCE	2-1
TROUBLESHOOTING	3-1
POWERPLANT	4-1
ENGINE COMPONENTS	5-1
FUEL, AIR INTAKE, AND EXHAUST SYSTEMS	6-1
COOLING SYSTEM	7-1
ELECTRICAL SYSTEMS	8-1
TRANSMISSION, TRANSFER, AND DRIVE CONTROL ASSEMBLIES	9-1
TRACKS, SUSPENSION SYSTEM, FINAL DRIVES, AND UNIVERSAL JOINTS	10-1
HULL-RELATED COMPONENTS	11-1
NUCLEAR, BIOLOGICAL, AND CHEMICAL (NBC) PROTECTION EQUIPMENT	12-1
HULL STOWAGE	13-1
ENGINE AND BATTERY WINTERIZATION KIT	14-1
REFERENCES	A-1
MAINTENANCE ALLOCATION CHART (MAC)	B-1
REPAIR PARTS AND SPECIAL TOOLS LIST	C-1
EXPENDABLE AND DURABLE ITEMS LIST	D-1
ILLUSTRATED LIST OF MANUFACTURED ITEMS	E-1
TORQUE LIMITS	F-1
MANDATORY REPLACEMENT PARTS	G-1
TOOL IDENTIFICATION LIST	H-1
STE/ICE-R	I-1

This manual supersedes TM 9-2350-311 -20-1 dated 4 November 1986.
Approved for public release; distribution is unlimited.

W A R N I N G

**RADIOACTIVE MATERIAL(S) TRITIUM (HYDROGEN-3) GAS**

Handle with care. In the event the radioluminous source is broken, cracked, or there is no illumination, immediately wrap device in plastic bag (item 10, Appx D) and notify the local Radiation Protection Officer (RPO). Contact the base safety office for the name and telephone number of your local RPO:

LOCAL RPO:

TELEPHONE:

**SAFETY PROCEDURES FOR NUCLEAR REGULATORY COMMISSION
(NRC) TRITIUM FIRE CONTROL DEVICES**

1. Purpose: To implement mandatory license requirements for use and maintenance of tritium radioluminous fire control devices used on howitzers, mortars, tanks, and rifles.
2. Scope: This procedure is applicable to all personnel working with tritium devices, including unit, direct support, general support maintenance, and operator's levels.
3. Radiological hazard: The beta radiation emitted by tritium presents no external radiation hazard. However, if taken internally, it can damage soft tissue. If a capsule is broken, the tritium gas will dissipate into the surrounding air and surfaces near the vicinity of the break may become contaminated. Tritium can be taken into the body by inhalation, ingestion, or percutaneous (skin) absorption/injection.
4. Safety precautions:
 - a. Check for illumination prior to use or service in low light or darkroom. If not illuminated, do not repair. Wrap the entire device in plastic bag (item 10, Appx D) and notify the local RPO.
 - b. No eating, drinking, or smoking will be allowed in tritium device work areas.
5. Emergency procedures: If a tritium source breaks, inform other personnel to vacate the area or move upwind. If skin contact is made with any area contaminated with tritium, wash immediately with nonabrasive soap and water. Report the incident to the local RPO. Actions below will be taken under supervision or direction of the local RPO.
 - a. Personnel handling the device should wear rubber or latex gloves (item 23, Appx D). Device must be immediately double wrapped in plastic, sealed, packaged, and evacuated to depot. Outside package must be identified as 'Broken Tritium Device - Do Not Open'. Dispose of used gloves as radioactive waste, per instructions from local RPO and wash hands well.
 - b. Personnel who may have handled the broken tritium should report to health clinic for tritium bioassay. Optimum bioassay sample is at least 4 hours after exposure.
 - c. Broken tritium sources indoors may result in tritium contamination in the area, such as work bench or table. The area must be cordoned off, restricted until wipe tests indicate no contamination.

6. Further information:

a. Requirements for safe handling and maintenance are located in TM 9-254, General Maintenance Procedures for Fire Control Materiel.

b. If assistance is needed, contact your local or major command (MACOM) safety office(s) for information on safe handling, shipping, storage, maintenance, or disposal of radioactive devices.

c. The AMCCOM RPO/licensee maybe contacted by calling: DSN 793-2965/2969/2995, Commercial (309) 782-2965/2969/2995. After duty hours contact the Staff Duty Office through the operator at DSN 793-6001, Commercial (309) 782-6001. The following rules and regulations are available from HQ, AMCCOM, AITN: AMSMC-SFS. Rock Island, IL 61299-6000. Copies may be requested, or further information obtained by contacting the AMCCOM Radiation Protection Officer (RPO).

(1) 10 CFR Part 19-Notices, Instructions, and Reports to Workers

(2) 10 CFR Part 20-Standards for Protection Against Radiation

(3) NRC License, License Conditions, and License Application

WARNING

CARBON MONOXIDE HAZARD

Carbon monoxide is a colorless, odorless, deadly poisonous gas, which, when breathed, deprives the body of oxygen and causes suffocation. Exposure to carbon monoxide can produce headache, dizziness, loss of muscular control, drowsiness, and coma. Permanent brain damage or death can result from severe exposure.

Carbon monoxide occurs in the exhaust of fuel-burning heaters and internal-combustion engines and becomes dangerously concentrated under conditions of inadequate ventilation. The following precautions must be observed to ensure the safety of personnel whenever the personnel heater or main or auxiliary engine of any vehicle is operated for maintenance purposes or tactical use:

1. Do not operate heater or engine of vehicle in an enclosed area unless it is adequately ventilated.
2. Do not idle engine for long periods without maintaining adequate ventilation in personnel compartments.
3. Do not drive any vehicle with inspection plates, cover plates, or engine compartment doors removed unless necessary for maintenance purposes.
4. Be alert at all times during vehicle operation for exhaust odors and exposure symptoms. If either are present, immediately ventilate personnel compartments. If symptoms persist, remove affected personnel from vehicle and treat as follows: Expose to fresh air keep warm; do not permit physical exercise; if necessary, administer artificial respiration. For detailed first aid instructions, consult FM 21-11, First Aid for Soldiers.

THE BEST DEFENSE AGAINST CARBON MONOXIDE POISONING IS ADEQUATE VENTILATION.

WARNING

PAINT HAZARD

Chemical Agent Resistant Coating (CARC) paint contains isocyanate, a constituent that can cause respiratory effects during and after the application of the material. During the application of CARC paint, coughing, shortness of breath, pain on respiration, increased sputum, and chest tightness may occur. CARC paint also produces itching and reddening of the skin, a burning sensation of the throat and nose, and watering of the eyes. An allergic reaction may occur after initial exposure (ranging from a few days to a few months later) producing asthmatic symptoms including coughing, wheezing, tightness in the chest, or shortness of breath. The following precautions must be observed to ensure the safety of personnel when CARC paint is applied:

- For spray/brush/roller painting in confined spaces, an air line respirator is required, unless an air sampling shows exposure to be below standards. If the air sampling is below standards, either the chemical cartridge or air line respirators are required.
- Spot painters applying CARC paint by brush or roller must wear clothing and gloves affording full coverage. Personnel using touchup spray kits should wear an air line respirator and protective clothing.
- Do not use water, alcohol, or amine-based solvents to thin or remove CARC paint. Use of these solvents with CARC paint can produce chemical reactions resulting in nausea, disease, burns, or severe illness.
- Do not use paint solvents to remove paint/coating from your skin.
- Mix paint/coating in a well-ventilated mixing room or spraying area away from open flames. Personnel mixing paint/coating should wear eye protection.
- Use paint/coating with adequate ventilation.
- Personnel grinding or sanding on painted equipment should use high-efficiency, air-purifying respirators.
- Do not weld, cut, or apply any form of heat to CARC-coated metal until the paint has been removed from a 4-in. (10.2-cm) area surrounding the rework site. Substances may be released that cause skin or respiratory irritation if this is not done. Sand or grind the paint down to the base metal in the surrounding area and also remove any paint from the other side of the metal.
- When sanding any paint, use the wet sanding method. Older paints may contain lead, chromates, or other toxic material. Using wet or dry sandpaper, wet down the area before starting. Keep the sandpaper wet as you sand to keep down paint dust (FM 21-11).

WARNING

MINERAL SPIRITS AND PAINT THINNER HAZARD

Do not use mineral spirits or paint thinner to clean the Howitzer. Mineral spirits and paint thinners are highly toxic and combustible. Prolonged breathing can cause dizziness, nausea, and even death (FM 21-11).

WARNING

DRY-CLEANING SOLVENT HAZARD

Dry-cleaning solvent (P-D-880) is toxic and flammable. Wear protective goggles and gloves and use only in a well-ventilated area. Avoid contact with skin, eyes, and clothes, and don't breathe vapors. Do not use near open flame or excessive heat. The flashpoint for type #1 is 100°F (38°C), and for type #2 is 138°F (59°C). If you become dizzy while using dry-cleaning solvent, get fresh air immediately and seek medical aid. If contact with eyes is made, wash your eyes with water and seek medical aid immediately (FM 21-1 1).

WARNING

ADHESIVE HAZARD

Adhesives are toxic and flammable. Apply adhesives only in a well-ventilated area. Avoid contact with skin, eyes, and clothes, and don't breathe vapors. Do not use near heat, sparks, or open flame. Read and follow all warnings and instructions on labels of adhesives. If contact with skin or eyes is made, wash area with water and seek medical aid immediately (FM 21-1 1).

WARNING

FIRE HAZARD

Diesel fuel and combustible materials are used in operation and maintenance of this equipment. Do not smoke or allow open flames or sparks in areas where diesel fuel and combustible materials are used or stored. Death or severe injury may result if personnel fail to observe this precaution. If you are burned, seek medical aid immediately (FM 21-1 1).

FIRE HAZARD

Do not place flammables or explosives on or near the personnel heater (FM 21-1 1).

WARNING

COMPRESSED AIR HAZARD

Compressed air used for cleaning purposes must not exceed 30 psi (207 kPa). Use only with effective chip guarding and personal protective equipment (goggles/shield, gloves, etc) (FM 21-11).

WARNING

ELECTRICAL HAZARD

Be certain MASTER switch is off when working on hull electrical system to prevent injury due to electrical shock (FM 21-1 1).

WARNING

BURN HAZARD

Batteries contain sulfuric acid that can cause severe burns. Avoid contact with skin, eyes, or clothing, and remove all metal or jewelry. If battery electrolyte is spilled, stop its burning effects immediately (FM 21-11).

WARNING

FLAMMABLE

Battery gases can explode. Do not smoke, have an open flame, or create sparks around a battery, especially if the caps are off. Severe injury may result if you fail to heed this warning. Seek medical aid immediately should explosion occur (FM 21-1 1).

WARNING

NOISE HAZARD

Excessive noise levels are present any time the equipment is operating. Wear hearing protection while operating or working around equipment while it is running. Failure to do so could result in damage to your hearing. Seek medical aid should you suspect a hearing problem (FM 21-1 1).

WARNING

HAZARDOUS WASTE

When servicing this vehicle, performing maintenance, or disposing of materials such as engine coolant, transmission fluid, lubricants, battery acids or batteries, and CARC paint, consult your unit/local regulatory guidance. If further information is needed, please contact the U.S. Army Environmental Hotline at 1-800-872-3845.

WARNING

ROTATION HAZARD

Protective fan screens must be installed prior to performing maintenance in the engine compartment when the engine is running or in ground hop mode. Contact with rotating fan can cause injury (FM 21-11).

WARNING

FALLING EQUIPMENT HAZARD

Never crawl under equipment when performing maintenance unless the equipment is securely blocked. Keep clear of the equipment when it is being raised or lowered. Do not allow heavy components to swing while suspended by a lifting device. Exercise extreme caution when working near a cable or under tension. In case of injury, seek medical aid immediately (FM 21-11).

WARNING

FALLING EQUIPMENT/ROLLING VEHICLE HAZARD

Unless otherwise specified, perform all maintenance procedures with all equipment lowered to the ground, transmission in neutral, parking/emergency brake applied, and engine stopped to prevent possible injury due to falling equipment or rolling vehicle (FM 21-11).

WARNING

PARKING HAZARD

Do not park vehicles head-to-head. Injury to personnel or damage to the vehicles could occur if one vehicle jumps (FM 21-1 1).

WARNING

STEAM UNDER PRESSURE

Remove radiator cap slowly to relieve pressure before completely removing it when the engine is hot. Failure to follow this procedure could cause severe injury. If you are scalded by steam, seek medical aid immediately (FM 21-11).

WARNING

NUCLEAR, BIOLOGICAL, AND CHEMICAL (NBC) HAZARD

If NBC exposure is suspected, all air filter media must be handled by personnel wearing full NBC-protective equipment (FM 21-1 1).

WARNING

EXPLOSION HAZARD

Cylinders must not be dropped, struck, or subjected to any temperature above 1400F (60°C). This could result in an explosion and injury to personnel (FM 21-1 1).

UNIT MAINTENANCE MANUAL
FOR HULL,POWERPLANT, DRIVE CONTROLS,
TRACKS, SUSPENSION, AND ASSOCIATED COMPONENTS

HOWITZER,MEDIUM,
SELF-PROPELLED, 155MM, M109A2(EIC: 3EZ)
(NSN 2350-01-031 -0586)

AND

HOWITZER, MEDIUM,
SELF-PROPELLED, 155 MM, M109A3 (EIC: 3E2)
(NSN 2350-01-031 -8851)

AND

HOWITZER, MEDIUM,
SELF-PROPELLED, 155 MM, M109A4 (EIC: 3E8)
(NSN 2350-01 -277-5770)

AND

HOWITZER, MEDIUM,
SELF-PROPELLED, 155 MM, M109A5 (EIC: 3E7)
(NSN 2350-01-281 -1719)

REPORTING ERRORS AND RECOMMENDING IMPROVEMENTS

You can help improve this manual. If you find any mistakes or if you know of a way to improve the procedures, please let us know. Mail your letter, DA Form 2028 (Recommended Changes to Publications and Blank Forms), or DA Form 2028-2 located in the back of this manual direct to Commander, U.S. Army Tank–automotive and Armaments Command, ATTN: AMSTA-MMAA, Warren, MI 48397-5000. A reply will be furnished to you.

You may also provide DA Form 2028-2 information to TACOM via datafax or e-mail:

- TACOM'S fax number is DSN 786-6323
- TACOM'S e-mail address is amsta-mmaa@cc.tacom. army.mil

This manual supersedes TM 9-2350-311 -20-1 dated 4 November 1986.

Approved for public release; distribution is unlimited.

TABLE OF CONTENTS

CONTENTS		PAGE
CHAPTER 1— INTRODUCTION		1-1
Section	GENERAL INFORMATION	1-5
Section II	EQUIPMENT DESCRIPTION AND DATA	1-9
Section III	PRINCIPLES OF OPERATION	1-17

<u>CONTENTS</u>	<u>PAGE</u>
<u>CHAPTER 2—GENERAL HULL MAINTENANCE.</u>	<u>2-1</u>
Section I REPAIR PARTS, SPECIAL TOOLS, TMDE, AND SUPPORT EQUIPMENT.	2-2
Section II SERVICE UPON RECEIPT	2-2
Section III Operational CHECKS	2-8
Section IV PREVENTIVE MAINTENANCE CHECKS AND SERVICES (PMCS).	2-20
Section V MAINTENANCE PROCEDURES	2-46
<u>CHAPTER 3—TROUBLESHOOTING.</u>	<u>3-1</u>
<u>CHAPTER 4—POWERPLANT.</u>	<u>4-11</u>
<u>CHAPTER 5 — ENGINE COMPONENTS</u>	<u>5-11</u>
<u>CHAPTER 6—FUEL, AIR INTAKE, AND EXHAUST SYSTEMS</u>	<u>6-1</u>
Section I FUEL SYSTEM	6-2
Section II AIR INTAKE SYSTEM	6-30
Section III EXHAUST SYSTEM	6-39
Section IV FUEL TANK HEATSHIELD	6-44
<u>CHAPTER 7—COOLING SYSTEM</u>	<u>7-1</u>
<u>CHAPTER 8—ELECTRICAL SYSTEMS</u>	<u>8-11</u>
Section I POWERPLANT ELECTRICAL SYSTEMS	8-4
Section II HULL ELECTRICAL SYSTEMS	8-34
Section III POWERPLANT AND HULL WIRING HARNESSSES	8-100
Section IV POWERPLANT AND HULL ELECTRICAL LEADS	8-166
<u>CHAPTER 9— TRANSMISSION, TRANSFER, AND DRIVE CONTROL ASSEMBLIES</u>	<u>9-1</u>
Section I TRANSMISSION AND TRANSFER ASSEMBLIES	9-2
Section II DRIVE CONTROL ASSEMBLIES	9-14
<u>CHAPTER 10 —TRACKS, SUSPENSION SYTEM, FINAL DRIVES, AND UNIVERSAL JOINTS</u>	<u>10-1</u>
Section I TRACKS	10-2
Section II SUSPENSION SYSTEM	10-21
Section III FINAL DRIVES AND UNIVERSAL JOINTS	10-51
<u>CHAPTER 11 —HULL-RELATED COMPONENTS</u>	<u>11-1</u>
Section I DRIVER’S AND CANNONEER’S SEAT ASSEMBLIES	11-2
Section II HATCHES, LATCHES, LOCKS, AND COVER PLATES	11-18
Section III TRAVEL LOCK, SPADE, FENDERS, AND TOWING PINTLE	11-44
Section IV BILGE PUMP, PERSONNEL HEATER, PERSONNEL AIR VENTILATION SYSTEM, AND FIXED FIRE EXTINGUISHER SYSTEM	11-62

CONTENTS	PAGE
CHAPTER 1 2 — NUCLEAR, BIOLOGICAL, AND CHEMICAL (NBC) PROTECTION EQUIPMENT	12-1
CHAPTER 13— HULL STOWAGE	13-1
CHAPTER 1 4 — ENGINE AND BATTERY WINTERIZATION KIT	14-1
Appendix A—References	A-1
APPENDIX B—MAINTENANCE ALLOCATION CHART(MAC)	B-1
Section I INTRODUCTION	B-2
Section II MAC	B-6
Section III TOOL AND TEST EQUIPMENT REQUIREMENTS	B-24
APPENDIX C—REPAIR PARTS AND SPECIAL TOOLS LIST	C-1
APPENDIX D—EXPENENDABLE AND DURABLE ITEMS List	D-1
Section I INTRODUCTION	D-2
Section II EXPENDABLE AND DURABLE ITEMS LIST	D-3
APPENDIX E—ILLUSTRATED LIST OF MANUFACTURED Items	E-1
APPENDIX F—TORQUE LIMITS.	F-1
APPENDIX G— MANDATORY REPLACEMENT PARTS	G-1
APPENDIX H—TOOL IDENTIFICATION LIST	H-1
APPENDIX I— SIMPLIFIED TEST EQUIPMENT FOR INTERNAL COMBUSTION ENGINES-REPROGRAMMABLE (STE/WICE-R)	1-1
Section I INTRODUCTION	1-2
Section II ENGINE TESTING	1-2
Section III BATTERY TESTING	1-63
INDEX	INDEX-1
FOLDOUTS—HULL ELECTRICAL SCHEMATICS (1 Thru 8)	FP-1

HOW TO USE THIS MANUAL

GENERAL

This manual contains unit maintenance instructions for the M109A2/M109A3/M109A4/M109A5 Howitzers' hull and hull-related components.

The front matter in this manual consists of a cover index, general warnings, and a table of contents.

This manual is divided into 14 chapters and 9 appendixes. Each chapter and appendix starts on a right-hand page with the page number of 1. Pages are numbered after the chapter number or appendix letter. For example, 1-14 means Chapter 1, page 14, and A-2 means Appendix A, page 2.

At the end of this manual are an alphabetical index, eight schematics, DA Form 2028-2, and a metric conversion chart.

a. Front Matter

The front cover has an index for the major divisions in this manual. The first page of the associated major division has a black edge that lines up with the applicable cover boxed-in area.

There are general warnings that start on the first right-hand page immediately after the cover that should be read before performing any maintenance on the howitzer.

The table of contents has the page where each chapter, section, appendix, and paragraph starts.

b. Chapters

Chapter 1 provides general information, equipment description, and principles of operation of the howitzer.

Chapter 2 provides general unit maintenance instructions for the hull including Preventive Maintenance Checks and Services (PMCS).

Chapter 3 covers troubleshooting the howitzer.

Chapter 4 provides unit maintenance instructions for removing the powerplant.

Chapter 5 provides unit maintenance instructions for the engine.

Chapter 6 provides unit maintenance instructions for the fuel, air intake, and exhaust systems.

Chapter 7 provides unit maintenance instructions for the engine cooling system.

Chapter 8 provides unit maintenance instructions for the hull electrical systems.

Chapter 9 provides unit maintenance instructions for the transmission, transfer, and drive control assemblies.

Chapter 10 provides unit maintenance instructions for the tracks, suspension system, final drives, and universal joints.

Chapter 11 provides unit maintenance instructions for hull-related components.

Chapter 12 provides unit maintenance instructions for the Nuclear, Biological, and Chemical (NBC) protection equipment.

Chapter 13 provides unit maintenance instructions for hull stowage equipment. The location for stowage of Basic Issue Items (BII) is also included in this chapter.

Chapter 14 provides unit maintenance instructions for the engine and battery winterization kit.

c. Appendixes

Appendix A provides titles of documents and publications referenced in this manual.

Appendix B provides the Maintenance Allocation Chart (MAC) and special tools list.

Appendix C provides a repair parts and special tools list reference.

Appendix D provides a list of the expendable and durable items necessary to perform the unit maintenance procedures.

Appendix E provides an illustrated list of manufactured items.

Appendix F provides wet torque limits for screws and fastener information.

Appendix G provides a list of the mandatory replacement parts necessary to perform the unit maintenance procedures.

Appendix H provides a tool identification list of common tools necessary to perform the unit maintenance procedures.

Appendix I provides a general overview of Simplified Test Equipment for Internal Combustion Engines — Reprogrammable (STE/ICE-R) equipment and operations.

d. Alphabetical Index

The alphabetical index is located after the last appendix and provides an alphabetical listing of information contained in this manual.

e. Schematics

There are eight electrical schematics in the form of foldouts located at the end of this manual.

f. DA Form 2028-2

DA Form 2028-2 is used to report errors and to recommend improvements for the tasks in this manual.

g. Metric Conversion Chart

The metric conversion chart converts English measurements to metric equivalents. Measurements in this manual are provided in both English and metric units.

WARNINGS, CAUTIONS, AND NOTES

Warnings, cautions, and notes are provided throughout this manual:

A warning is provided where injury may occur to personnel on or near the howitzer.

A caution is provided where equipment may be damaged, but no injuries to personnel should result.

A note provides information, but no personnel injury or equipment damage should result.

INITIAL SETUPS

Before starting a task, you must obtain all the tools, supplies, and personnel listed in the initial setup. Be sure to read the task before performing the maintenance. If any other tasks are referenced, you must go to the initial setup page for each of those tasks to find out what tools, supplies, and personnel will be needed.

LOCATIONAL TERMS

The terms “front,” “rear,” “left,” and “right” are used to indicate where items are located on the howitzer. These locations are from the viewpoint of standing behind the howitzer and facing it.

REFERENCING

In this manual, internal referencing is done by chapter, appendix, paragraph, section, or task. For example, (para 8-15) refers you to Chapter 8, paragraph 15.

Referencing outside this manual is done by the military document or publication number. For example, (TM 9-2350-311-10) refers you to that manual.

LOCATING INFORMATION

This manual provides five ways to locate information quickly:

The cover index lists most frequently used major divisions by name and starting page number.

The table of contents.

The chapter and appendixes indexes list data and information covered within those chapters.

The malfunction index (Chapter 3) provides a quick guide to troubleshooting malfunctions.

The alphabetical index provides an alphabetical listing of information contained in this manual.

CHAPTER 1 INTRODUCTION

GENERAL

This chapter provides information to familiarize the mechanic with the M109A2/M109A3/M109A4/M109A5 Medium, Self-Propelled Howitzers' hull, powerplant, drive controls, tracks, suspension, and other hull-related components. The familiarization is provided through a physical description of major components that the mechanic at unit level is required to inspect, service, replace, or repair.

<u>CONTENTS</u>	<u>PAGE</u>
Section I GENERAL INFORMATION	1-5
1-1 SCOPE	1-5
1-2 MAINTENANCE FORMS, RECORDS, AND REPORTS	1-5
1-3 DESTRUCTION OF ARMY MATERIEL TO PREVENT ENEMY USE	1-5
1-4 PREPARATION FOR SHIPMENT AND STORAGE.	1-6
1-5 QUALITY ASSURANCE (QA)	1-6
1-6 OFFICIAL NOMENCLATURE, NAMES, AND DESIGNATIONS	1-6
1-7 REPORTING EQUIPMENT IMPROVEMENT RECOMMENDATIONS (EIRs)	1-7
1-8 WARRANTY INFORMATION	1-7
1-9 SAFETY, CARE, AND HANDLING	1-7
1-10 CORROSION PREVENTION AND CONTROL (CPC)	1-8
1-11 NUCLEAR HARDNESS	1-9
1-12 SECURITY MEASURES FOR ELECTRONIC DATA	1-9
Section II EQUIPMENT DESCRIPTION AND DATA	1-9
1-13 CAPABILITIES AND FEATURES	1-9
1-14 LOCATION OF MAJOR COMPONENTS	1-10
1-15 DIFFERENCES BETWEEN MODELS.	1-14
1-16 EQUIPMENT DATA	1-15
Section III PRINCIPLES OF OPERATION	1-17
1-17 EQUIPMENT OPERATION AND DESCRIPTION.	1-18

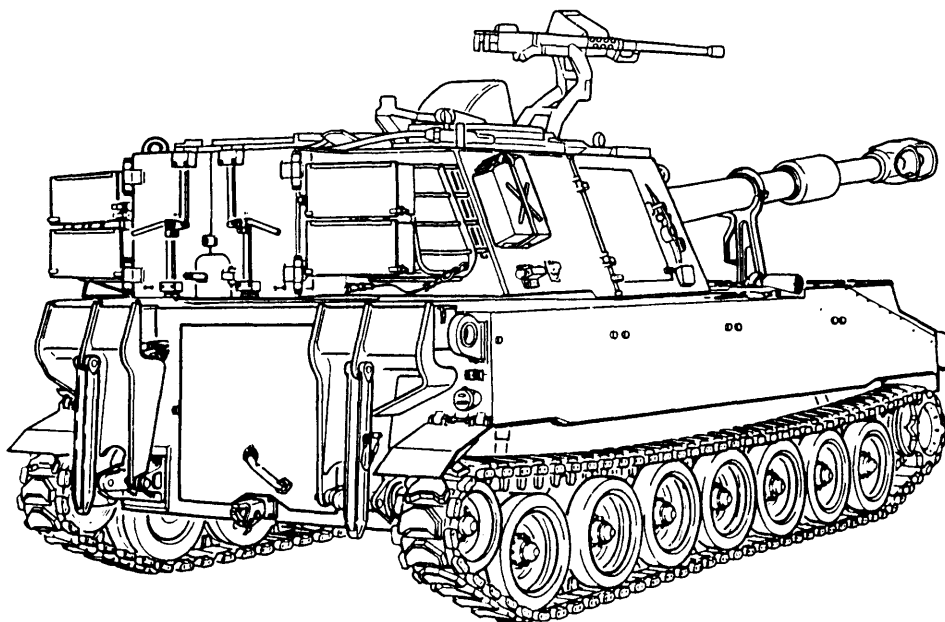
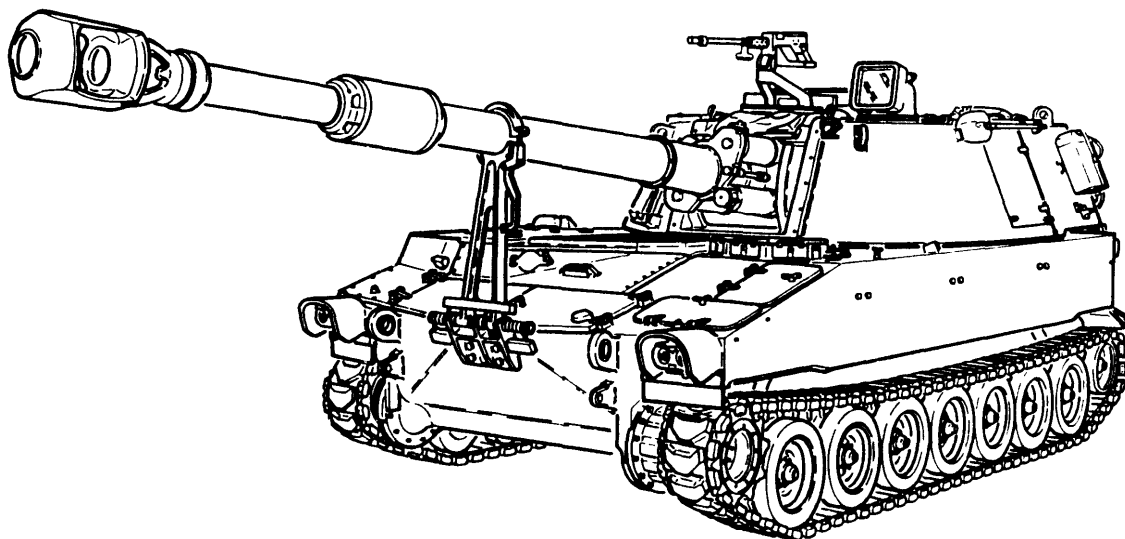

M109A2

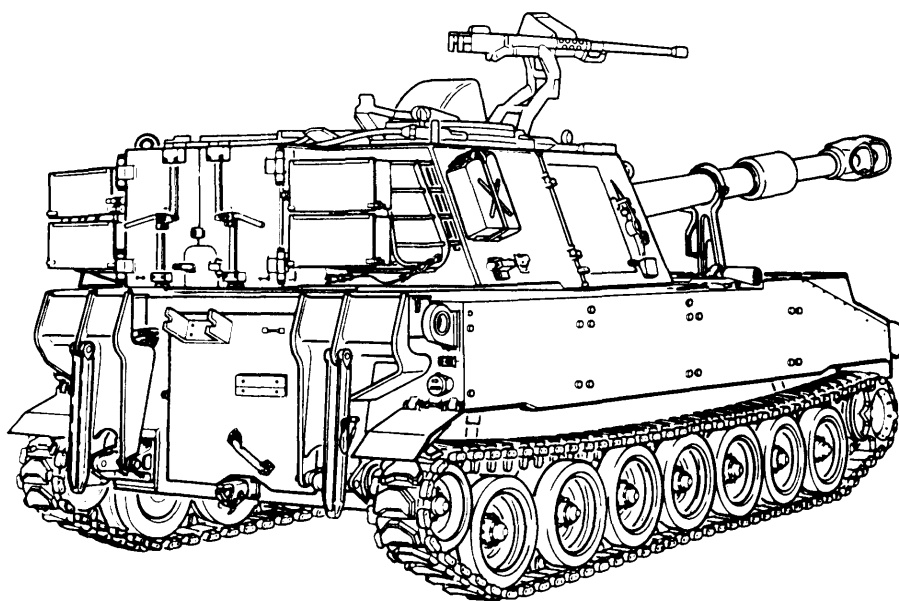
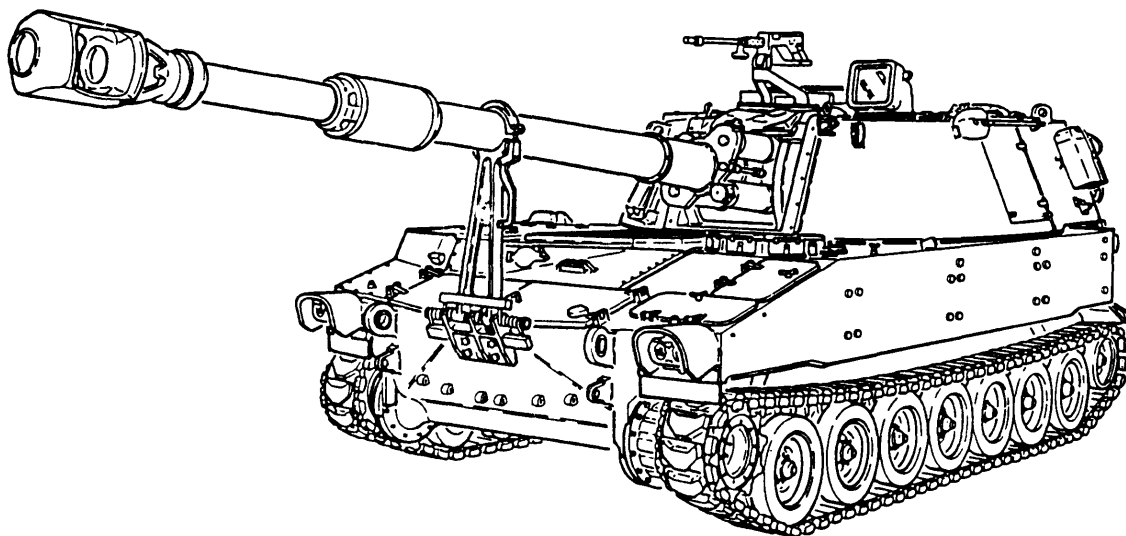

M109A3

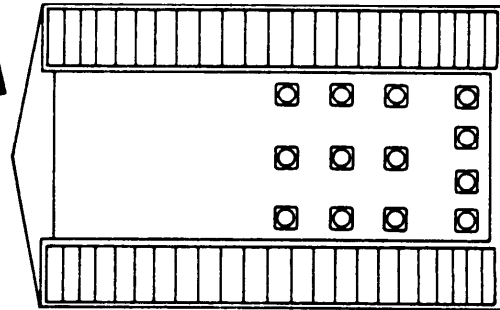
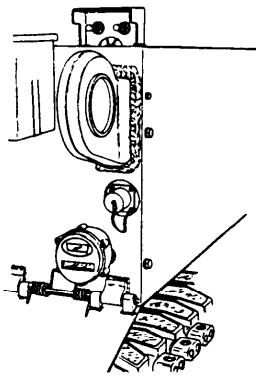
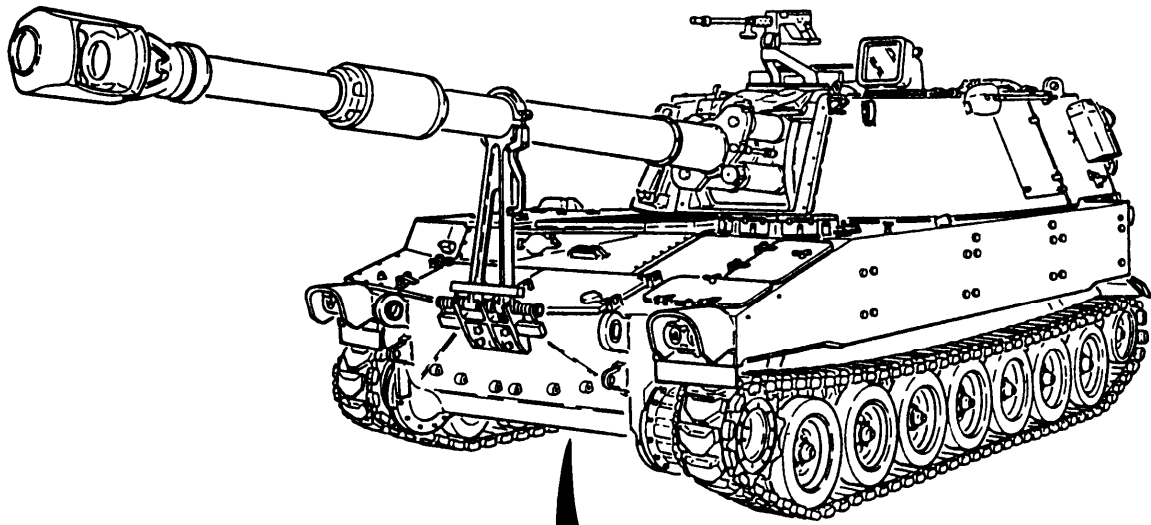

BOTTOM VIEW

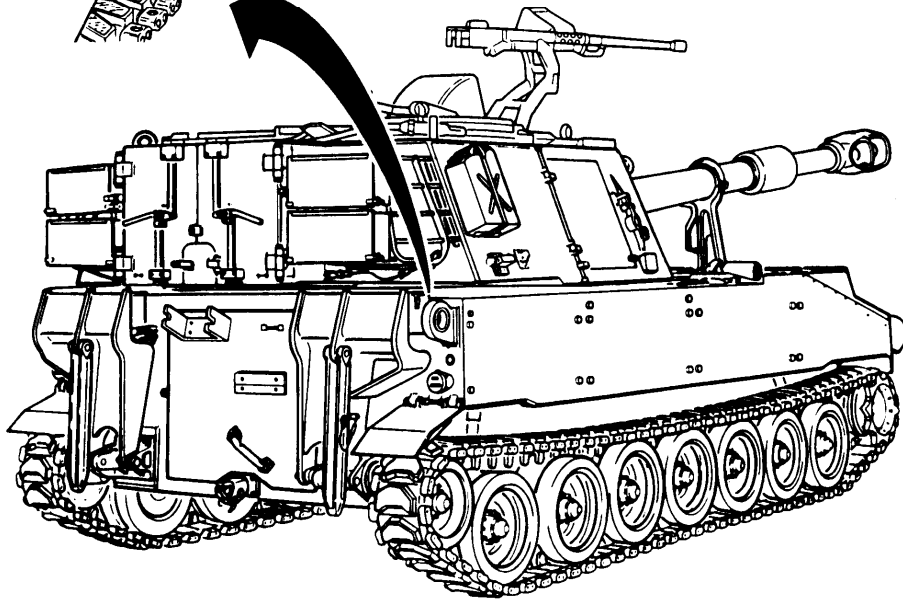

M109A4/M109A5

SECTION 1. GENERAL INFORMATION

1-1 SCOPE

This maintenance manual contains instructions for unit-level maintenance of M109A2/M109A3/M109A4/M109A5 Howitzers' hull, powerplant, drive controls, tracks, suspension, and other hull-related components.

When the nature of the repair, modification, or adjustment is beyond the scope of facilities of unit maintenance, the supporting unit should be informed so trained personnel with the correct tools and equipment may be provided, or other instructions issued.

Replacement or adjustment of parts or major assemblies that are normally support maintenance operations maybe done at unit maintenance in an emergency if permission is obtained from the responsible commander. A replacement part or assembly, a tool needed for work, and any special instructions should be obtained from the supporting maintenance unit.

1-2 MAINTENANCE FORMS, RECORDS, AND REPORTS

Department of the Army forms and procedures used for equipment maintenance will be those prescribed by (as applicable) DA PAM 738-750, The Army Maintenance Management System (TAMMS); DA PAM 738-751, Functional Users Manual for The Army Maintenance Management System — Aviation (TAMMS-A); or AR700-138, Army Logistics Readiness and Sustainability.

Accidents involving injury to personnel or damage to materiel will be reported on DA Form 285, US Army Accident Investigation Report, in accordance with AR 385-40. Explosive ammunition malfunctions will be reported in accordance with AR 75-1.

1-3 DESTRUCTION OF ARMY MATERIEL TO PREVENT ENEMY USE

Destruction of the vehicle, armament, and equipment, when subject to capture or abandonment in a combat zone, will be undertaken by the using army only when the unit commander decides such action is necessary in accordance with orders of, or policy established by, the Army commander.

Read TM 750-244-6, Procedures for Destruction of Tank-Automotive Equipment to Prevent Enemy Use, for information on destruction of all mechanical equipment. In general, destruction of essential components, followed by burning, will usually be sufficient to render the vehicle, armament, and equipment useless. Time is usually critical.

Materiel must be damaged so that it cannot be restored to usable condition by either repair or cannibalization. If a lack of time or personnel prevents destruction of all parts, give priority to destruction of parts hardest to replace. It is important that the same parts be destroyed on all vehicles to prevent construction of one complete vehicle from several damaged ones.

All items of sighting and fire control instruments and equipment, especially telescopes, gunner's quadrants, and binoculars, are costly and difficult to replace. They should be conserved whenever possible. If you cannot carry them with you, destroy them by smashing with your sledgehammer, pick, or mattock. Throw the pieces in all directions.

1-3 DESTRUCTION OF ARMY MATERIEL TO PREVENT ENEMY USE — CONTINUED

When time is short, a method of destroying the equipment with materials at hand is as follows:

- Retrieve or smash the sighting and fire control equipment.
- Load the cannon with a projectile and a full powder charge. Attach a 50-ft (15.24-m) or longer lanyard to the firing mechanism. Disconnect all recoil cylinders and fire the weapon.
- Take a sledgehammer and bend the end of the recoil system rods.

A second method is to close the breechblock, elevate the tube, and toss several thermite grenades down the tube. Elevate the tube so that the grenades will fall against the breechblock. This will melt the breech and the powder chamber, causing them to fuse together.

1-4 PREPARATION FOR SHIPMENT AND STORAGE

Basic requirements for administrative storage are covered in TM 9-2350-311-20-2.

1-5 QUALITY ASSURANCE (QA)

Not applicable.

1-6 OFFICIAL NOMENCLATURE, NAMES, AND DESIGNATIONS

Nomenclature in this manual was chosen in accordance with the terms used for provisioning as they appear in the Repair Parts and Special Tools List (RPSTL) and Maintenance Allocation Chart (MAC) for unit maintenance. A few tools and hull components are, however, referred to by names more common than those in the RPSTL. In many cases the more common name is a shorter name for the same component.

OFFICIAL PROVISIONING NOMENCLATURE

Ammunition rack
Cable assembly
Gage rod
Intercommunications power harness
Intercommunications system
155mm, medium, self-propelled howitzer
Safety wire or nonelectrical wire
Socket head screw key

MORE COMMON NAME

Ammo rack
Wiring harness
Dipstick
Intercom wiring harness
Intercom system
Howitzer
Lockwire
Hex key

1-7 REPORTING EQUIPMENT IMPROVEMENT RECOMMENDATIONS (EIRs)

If your M1 09A2/M109A3/M109A4/M1 09A5 Howitzer needs improvement, let us know. Send us an EIR. You, the user, are the only one who can tell us what you don't like about your equipment. Let us know why you don't like the design or performance. Put it on an SF 368, Product Quality Deficiency Report. Mail it to the address specified in DA PAM 738-750.

NOTE

When equipment failure occurs but is not caused by normal wear, poor operation, or accidental damage, an EIR must be submitted.

TABLE 1-1 AUTHORIZED EQUIPMENT CONFIGURATION CHANGES

CHANGE DOCUMENT	PART OR MODEL NO. TO BE MODIFIED	DESCRIPTION
M109A2/M109A3/M109A4/ M109A5 Howitzer (Fuel Pump EIR Digest Article)	M109A2/M109A3/M109A4/ M109A5	Eliminates electrically driven fuel pump, modifies fuel pump circuit and air cleaner blower motor circuit

1-8 WARRANTY INFORMATION

The M1 09 Howitzer series is no longer warranted.

1-9 SAFETY, CARE, AND HANDLING

WARNING

Nuclear, Biological, and Chemical (NBC) agents can kill you. If NBC exposure is suspected, all air filter media must be handled by personnel wearing full NBC-protective equipment (FM 21-1 1).

1-9 SAFETY, CARE, AND HANDLING — CONTINUED



WARNING

M140 alinement device and Al Al collimator are illuminated by sealed, radioactive sources of tritium gas (H_3). As long as these sources remain sealed, they do not emit any harmful radiation. There is no limit on handling time. Radioactively illuminated collimators are indicated by the radioactive sign shown above. If the seal is broken, see below.

- a. Refer to warning page inside front cover of manual.
- b. Prior to purging or charging, make the following checks:
 - (1) Lift cover assembly and check for cracks or loss of illumination.
 - (2) Look through objective end of collimator and check for broken/cracked reticle and loss of illumination. If reticle is intact, no cracks are observed, and collimator is illuminated, proceed with maintenance actions.
 - (3) If cracks are observed, but collimator is still illuminated, remove collimator scope and notify the local Radiation Protection Officer (RPO). Seal collimator scope in a double plastic bag (item 10, Appx D) and return it to depot for disposal.
 - (4) If no illumination is observed, remove collimator scope and check for illumination in a dark room. If a slight glow/haze appears, follow procedure in paragraph (3) above. If illumination still is not detected, notify local RPO. Return collimator scope to depot as follows for disposal.
 - (a) Seal collimator scope in a double plastic bag (item 10, Appx D) and place in a strong, tight container (such as a fiberboard box) (item 11, Appx D) with all seams secured using tape (item 60, Appx D) (masking tape is not authorized).
 - (b) Label the container CAUTION – BROKEN H_3 SOURCE. DO NOT OPEN.

1-10 CORROSION PREVENTION AND CONTROL (CPC)

CPC of Army materiel is a continuing concern. It is important that any corrosion problems with this item be reported so that the problem can be corrected and improvements can be made to prevent the problem in future items. While corrosion is typically associated with rusting of metals, it can also include deterioration of other materials, such as rubber and plastic. Unusual cracking, softening, swelling, or breaking of these materials may be a corrosion problem. If a corrosion problem is identified, it can be reported using SF 368. Use of keywords such as "corrosion," "rust," "deterioration," or "cracking" will ensure that the information is identified as a CPC problem. The form should be submitted to the address specified in DA PAM 738-750.

1-11 NUCLEAR HARDNESS

Not applicable.

1-12 SECURITY MEASURES FOR ELECTRONIC DATA

Not applicable.

SECTION II. EQUIPMENT DESCRIPTION AND DATA

1-13 CAPABILITIES AND FEATURES

NOTE

Refer to TM 9-2350-311-10 for further equipment description and data.

1-13.1 Electrical System

M109A2/M109A3/M109A4/M109A5 Howitzers' electrical power is provided through a 24-Vdc (nominal) generating system consisting of the following components (Chap 8):

- a. Four 12-Vdc (nominal) batteries connected in series/parallel that provide 24 Vdc (nominal) to the master relay.
- b. M109A2/M109A3 Howitzers have 3-phase, 100-amp alternator that maintains 24-Vdc (nominal) electrical power through the voltage rectifier, voltage regulator, and to the master relay for systems operation. M109A4/M109A5 Howitzers have a 3-phase, 180-amp alternator.
- c. Master relay that delivers electrical power to electrically operated systems/equipment in M109A2/M109A3/M109A4/M109A5 Howitzers (hull and cab) by turning on the MASTER switch. The MASTER switch, located on the driver's portable instrument panel, actuates the vehicles' electrical system. With the powerplant off (engine not running), activation of the MASTER switch provides delivery of electrical power direct through the alternator, voltage rectifier, voltage regulator, and master relay circuit.

1-13.2 Powerplant (Engine and Transmission)

The powerplant (engine and transmission) provides the mobility for M109A2/M109A3/M109A4/M109A5 Howitzers. The powerplant consists of the following subsystems:

- a. Two engines are available:
 - Detroit Diesel 8V71T, model 7083-7396, diesel, liquid-cooled, V-8 engine, which generates 405 horsepower at 2300 rpm.
 - Detroit Diesel 8V71T, model 7083-7391, diesel, liquid-cooled, V-8 engine, which generates 440 horsepower at 2300 rpm.

1-13 CAPABILITIES AND FEATURES — CONTINUED

1-13.2 Powerplant (Engine and Transmission) — Continued

b. Two transmissions are used:

- Allison XTG-411 -2A transmission (with engine model 7083-7396) with drive controls and final drive assemblies.
- Allison XTG-411 -4A transmission (with engine model 7083-7391) with drive controls and final drive assemblies.

Drive control linkages to the transmission are steer control, shift control, and braking. Final drive assemblies are the interface between the transmission and drive sprockets.

1-13.3 Suspension

independent, torsion-bar mounted, dual-sided road wheels (seven per side), which support and guide the vehicle track.

1-13.4 Air Cleaner Assembly

Provides filtered air to the engine air intake system.

1-14 LOCATION OF MAJOR COMPONENTS

1-14.1 Location of Major Components

NOTE

The primary fuel filter on some M109s is located inside the engine compartment access door.

LEGEND

1 External power receptacle (M109A4/M109A5)	16 Bilge pump relay
2 Combat override switch (M109A4/M109A5)	17 Secondary fuel filter
3 Accessory control box	18 Oil filters (engine)
4 Cannoneer no. 2 heater (M109A4/M109A5)	19 Primary fuel filter
5 Turbocharger	20 Transmission
6 Driver's seat	21 Coolant surge tank
7 Driver's and portable instrument panels	22 Fuel tanks and pumps
8 Drive control	23 Bilge pump
9 Driver's heater (M109A4/M109A5)	24 Engine
10 Batteries (4)	25 Radiator
11 Air purifier (M1 09A4/M109A5)	26 Alternator
12 Rectifier	27 Fan assembly
13 Master relay	28 Air cleaner
14 Voltage regulator	29 Personnel heater
15 Starter relay	30 Fixed fire extinguisher

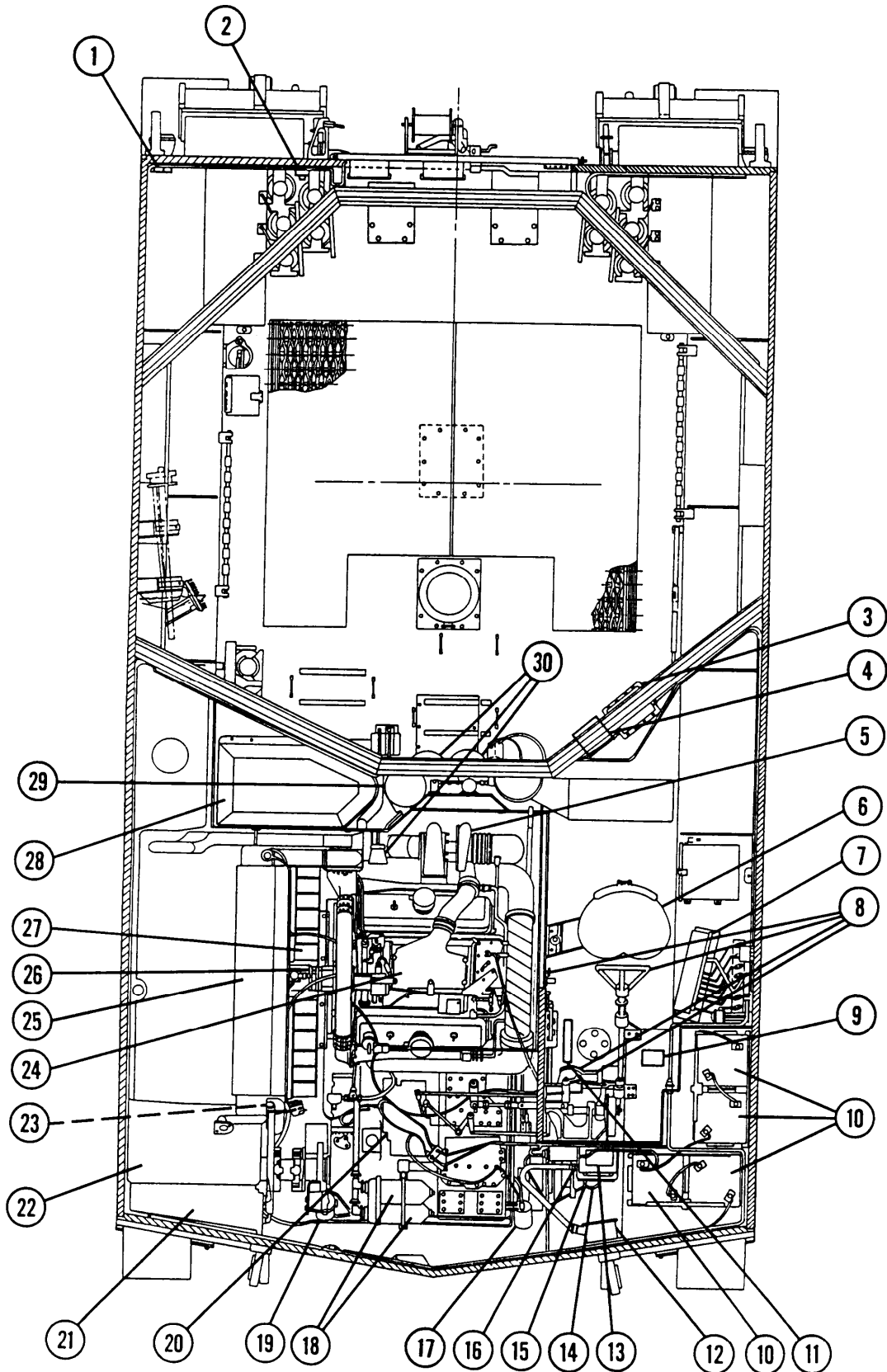

1-14 LOCATION OF MAJOR COMPONENTS — CONTINUED

1.14.2 Stencil Locations for Basic Issue Items

LEGEND

- | | |
|--------------------------------|------------------------------|
| 1 Powder cans | 8 Portable fire extinguisher |
| 2 Fuses | 9 Canteen |
| 3 Projectile stowage | 10 Rations (exterior) |
| 4 M14 aiming light | 11 Telephone |
| 5 Bucket | 12 Rifles |
| 6 M712 (or powder can stowage) | 13 Spare periscope (M45) |
| 7 Projectile spacer | 14 Flashlight |

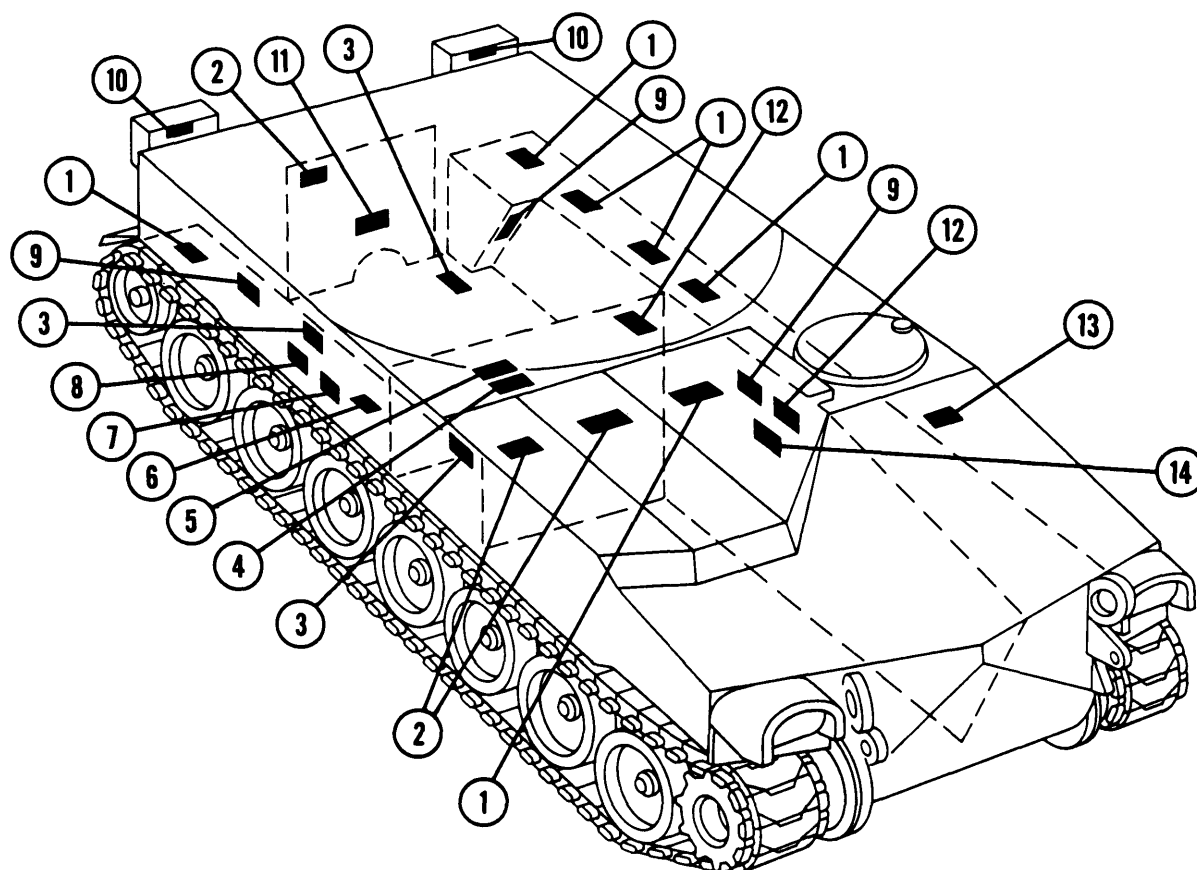

1-14.3 Serial Number Locations

NOTE

- The M109A2, M109A3, M109A4, and M109A5 Howitzers have similar data plates.
- If nameplates are missing or damaged, notify support maintenance.
- Engine serial number and model are stamped on the right upper front corner of the cylinder block.

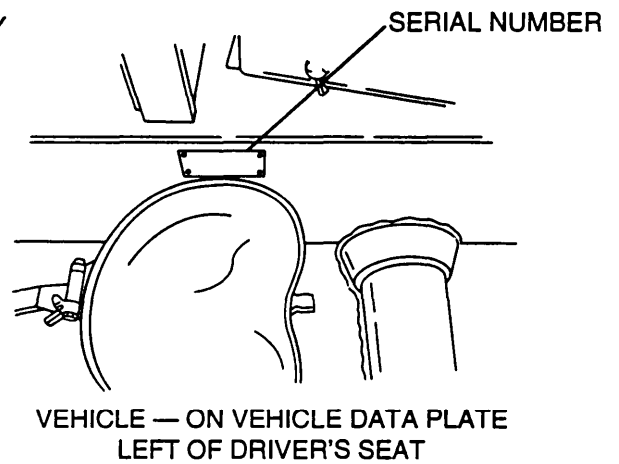
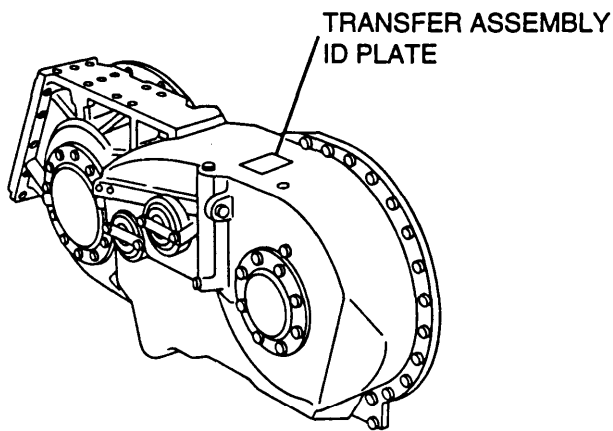
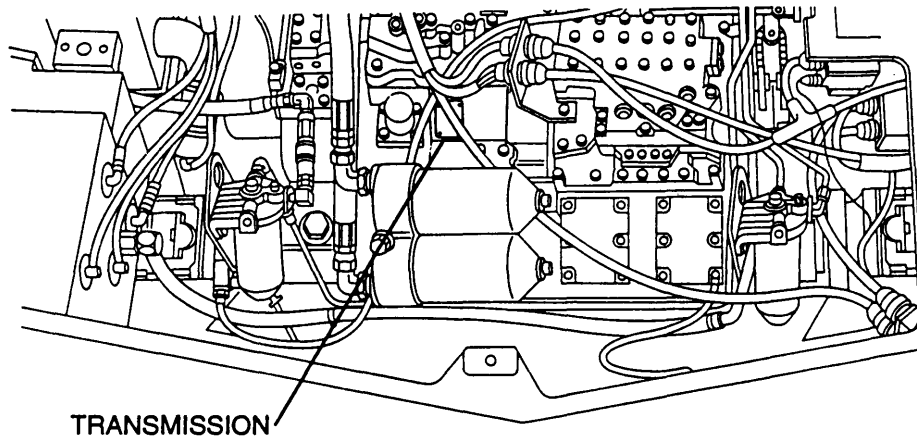

HOWITZER, MEDIUM, SELF-PROPELLED: 155MM, M109A2 CREW 6 MEN U.S. ARMY SERIAL NO. ██████████	
MFD BY: ██████████ OPERATOR'S MANUAL: TM9-2350-311-10 MAINT. MANUALS: LOG-2350-311-12, TM9-2350-311-20-1, -20-2, -20P-2, -24P-1, -34-1, -34-2, -34P-2	
MAX VEHICLE SPEEDS LOW: 6 MPH HIGH: 35 MPH REVERSE: 7 MPH	
OVERALL LENGTH: 357 OVERALL WIDTH: 124 OVERALL HEIGHT: 129	LOWEST OPERABLE HEIGHT: 114 SHIPPING VOLUME: 2573 FT ³ FIGHTING WEIGHT: 27.5 TONS
██████████ NATIONAL STOCK NO.: 2350-01-031-0586 ██████████	

1-15 DIFFERENCES BETWEEN MODELS

Differences between models exist (1) when comparing the M109A2 and M109A3 Howitzers; (2) when comparing one M109A3 to another M109A3 Howitzer and (3) when comparing the M109A2/M109A3 and M109A4/M109A5 Howitzers.

1-15.1 Hull Rear Doors

The hull rear doors differ among the howitzers. Earlier versions have double doors and later versions have single doors. All M109A2 Howitzers have single doors (para 11 -12).

1-15.2 Personnel Heater Exhaust Deflector

There is no personnel heater exhaust deflector on earlier howitzers. All later howitzers and all M109A2 Howitzers have the personnel heater exhaust deflectors mounted on the exhaust grille.

1-15.3 NATO Slave Start Receptacle

At present, not all of the M109 Howitzers have NATO slave start receptacles. Also, the slave start receptacle location differs between the M109A2/M109A3 and M109A4/M109A5 Howitzers. The M109A2/M109A3 NATO slave start receptacle is located in the battery compartment. The M109A4/M109A5 NATO slave start receptacle is located in the driver's compartment (para 8-38).

1-15.4 Primary Fuel Filters

The primary fuel filters are located in different areas of the engine compartment. Some earlier howitzers' primary fuel filters are positioned near the engine vibration damper and the engine oil pan. The later howitzers' primary fuel filters are positioned near the oil filters attached to the transmission (vehicle front) (para 6-6).

1-15.5 Travel Locks

There are some travel lock differences involving the spring anchors. Differences are minor and are shown in paragraph 11-14.

1-15.6 Ventilated Face Piece System (VFPS)

M109A4/M109A5 Howitzer hulls have a VFPS consisting of two air heaters, an air purifier, and required hoses.

1-15.7 Telephone Terminals

The location of vehicle telephone terminals differ on M109A2/M109A3 and M109A4/M109A5 Howitzers. The M109A2/M109A3 terminals are located on the hull rear bulkhead. M109A4/M109A5 terminals are located on the hull rear roof (exterior).

1-15.8 External Power Receptacle

M109A4/M109A5 Howitzers have external power receptacles located on the rear hull bulkhead.

1-15.9 Alternator and Charging System

M109A2/M109A3 Howitzers have 100-amp alternators/rectifiers. M109A4/M109A5 Howitzers have 180-amp alternators/rectifiers. The location for both configurations is the same.

1-15.10 Crew Compartment Subfloor Drains

M109A4/M109A5 Howitzers have 13 subfloor drains installed.

1-16 EQUIPMENT DATA

1-16.1 General

Crew	6
Weight (combat loaded)	55,000 lb (24,948 kg)
Weight (less crew, fuel, and stowage)	52,000 lb (23,587 kg)
Length (M109A2/M109A3/M109A4) (with armament)	359.375 in. (9.13 m)
Length (M109A5) (with armament)	361 in. (9.17 m)
Length (without armament)	243.75 in. (6.19 m)
Width	124 in. (3.15 m)
Height	120.43 in. (3.06 m)
Lowest operable height	109.93 in. (2.79 m)
Ground clearance	18 in. (45.7 cm)
Shipping volume	2250 cu ft (63.72 cu m)
Bridge classification	26 tons (23,587 kg)

1-16.2 Performance

High speed (max)	35 mph (56 km/h) (governed)
Low speed (max)	6 mph (10 km/h)
Reverse speed (max)	7 mph (11 km/h)
Max grade	60%
Max trench	72 in. (1.83 m)
Max vertical wall	21 in. (53.3 cm)
Turn radius (min)	1 vehicle length
Cruising range	217 miles (349 km)
Fuel capacity	135 gal (511 L)

1-16.3 Engine

Type/model	Detroit Diesel 8V71T, model 7083-7396 or 7083-7391, liquid-cooled
Manufacturer	Detroit Diesel Corp (Division of GMC)
Horsepower (gross) at 2300 rpm	405 (engine model 7083-7396), 440 (engine model 7083-7391)
Horsepower (net)	345 at 2300 rpm
Displacement	568 cu in. (9308 cc)
Bore	4.25 in. (10.8 cm)
Stroke	5.0 in. (12.7 cm)
Compression ratio	17:1
Torque (max gross)	980 lb-ft (1329 N•m) at 1700 rpm
Torque (max net)	895 lb-ft (1213 N•m) at 1600 rpm
Ignition	Compression

1-16 EQUIPMENT DATA — CONTINUED

1-16.3 Engine — Continued

NOTE

Under emergency conditions and in military operations involving jet transportation, JP-5 aircraft turbine engine fuel may be used instead of VV-F-800.

Fuel oil	Diesel: 40 cetane, VV-F-800
Regular grade (DF-2) (NATO F-54) temperature range	20 to 115°F (-7 to 46°C)
Winter grade (DF-1) temperature range	-20 to 20°F (-29 to 7°C)
Arctic grade (DF-A) temperature range	-65 to -25°F (-54 to -32°C)
Fuel acceptance (safe max)	50 gpm (3.2 L/s)
Lubrication oil system capacity (refill)	28 qt (26.5 L) (approx)
Lubrication oil system capacity (dry)	38 qt (36.0 L) (approx)
Cooling system capacity (refill)	56 qt (53 L)
Cooling system capacity (dry)	88 qt (83 L)

1-16.4 Transmission

Model	XTG-411-2A or XTG-411-4A
Manufacturer	Allison Transmission (Division of GMC)
Usable ranges:	

	XTG-411-2A	XTG-411-4A
First (1) (low range)	5.69:1	4.69:1
Second (2) (low intermediate)	3.17:1	3.17:1
Third (3) (intermediate)	1.58:1	1.58:1
Fourth (4) (high range)	0.79:1	0.79:1
Low reverse (R-1)	5.60:1	5.60:1
High reverse (R-2)	3.79:1	3.79:1
Steer	1.475:1	1.475:1
Steer control — first and second	Clutch brake	Clutch brake
Steer control — third and fourth	Geared	Geared
Brakes	Mechanical — applied	Mechanical — applied
Oil capacity (refill)	56 qt (53 L)	48 qt (45.5 L)
Oil capacity (dry)	84 qt (79 L)	84 qt (79 L)

1-16.5 Electrical System

Voltage (nominal)	24 Vdc
Batteries (12 Vdc each, series-parallel connected)	4
Type	6TN
Alternator (M109A2/M109A3)	
Manufacturer	Leece-Neville
Model	A001-5504AA
Type	3-phase
Amperage	100
Alternator (M109A4/M109A5)	
Manufacturer	Leece-Neville
Model	A001-5520AB

Type 3-phase
 Amperage 180

1-16.6 Communications

Intercommunications set AN/VIC-1
 Outlets 5
 External extension C-988/U

1-16.7 Suspension

Type Independent torsion bar
 Road wheels 14 sets
 Size 24 in. (61.0 cm)
 Loadings:
 1, 2, and 7 positions 4000 lb (1814 kg) (approx)
 Intermediate positions 2600 lb (1179 kg) (approx)

1-16.8 Track

Adjustment at idler wheel Track adjuster
 Shoes per track 79
 Pitch 6 in. (15.2 cm)
 Width 15 in. (38.1 cm)

1-16.9 Final Drives and Sprockets

Type Spur gear
 Ratio 4.36:1
 Sprocket pitch diameter 19.5 in. (49.5 cm)
 Teeth per sprocket 10

1-16.10 Fire Extinguisher

Fixed — 10-lb (4.5-kg) bottles 2
 Portable — 5-lb (2.3-kg) bottle 1

SECTION III. PRINCIPLES OF OPERATION

The purpose of this section is to familiarize the mechanic with the basic operating characteristics of the M109A2/ M109A3/M109A4/M109A5 hull-related systems and components. A basic, physical description of the systems/ components and an operational flow diagram is provided. Use the general index below to pinpoint a particular system.

1-17 EQUIPMENT OPERATION AND DESCRIPTION

1-17.1 Drivetrain

The drivetrain flow diagram illustrates the transfer of power generated by the powerplant to the tracks.

- a. Powerplant (1) — consists of engine (2), transfer assembly (3), and transmission (4) that can be removed from the vehicle as a complete unit. The powerplant may be operated when removed from the vehicle with a minimum of special equipment (para 4-5).
- b. Engine (2) — is a Detroit Diesel, liquid-cooled, two-stroke-cycle, diesel-type, model 8V71T equipped with exhaust-driven turbocharger. The engine develops 405 horsepower (engine model 7083-7396) or 440 horsepower (engine model 7083-7391) at 2300 rpm and delivers power to the transfer assembly (3).
- c. Transfer assembly (3) — receives power from the engine (2) and transfers that power to the transmission (4).
- d. Transmission (4) — oil cooled and mechanically and hydraulically operated. It receives power from the engine through a geared power transfer assembly (3). The transmission has seven gears — four forward, one neutral, and two reverse — and delivers power to the left and right drive sprockets through the output shaft, universal joints (5), and final drives (6). It also functions as the steering and braking mechanism for the M109A2/M109A3/M109A4/M109A5 Howitzers.
- e. Universal joints (5) — receive the transmission power output and transfer the output to the final drives (6).
- f. Final drives (6) — reduce the power output they receive from the universal joints through a series of gear reductions.
- g. Sprockets and hubs (7) — bolted to the final drive, the sprocket and hub transfers the power output received from the final drives and distributes it to the track (8).
- h. Track (8) — the rotation of the track provides mobility to M109A2/M109A3/M109A4/M109A5 Howitzers. The track consists of track shoes connected together by end connectors. Each track shoe has a centerguide that runs through the road wheel and idler wheel to prevent “throwing” a full track.

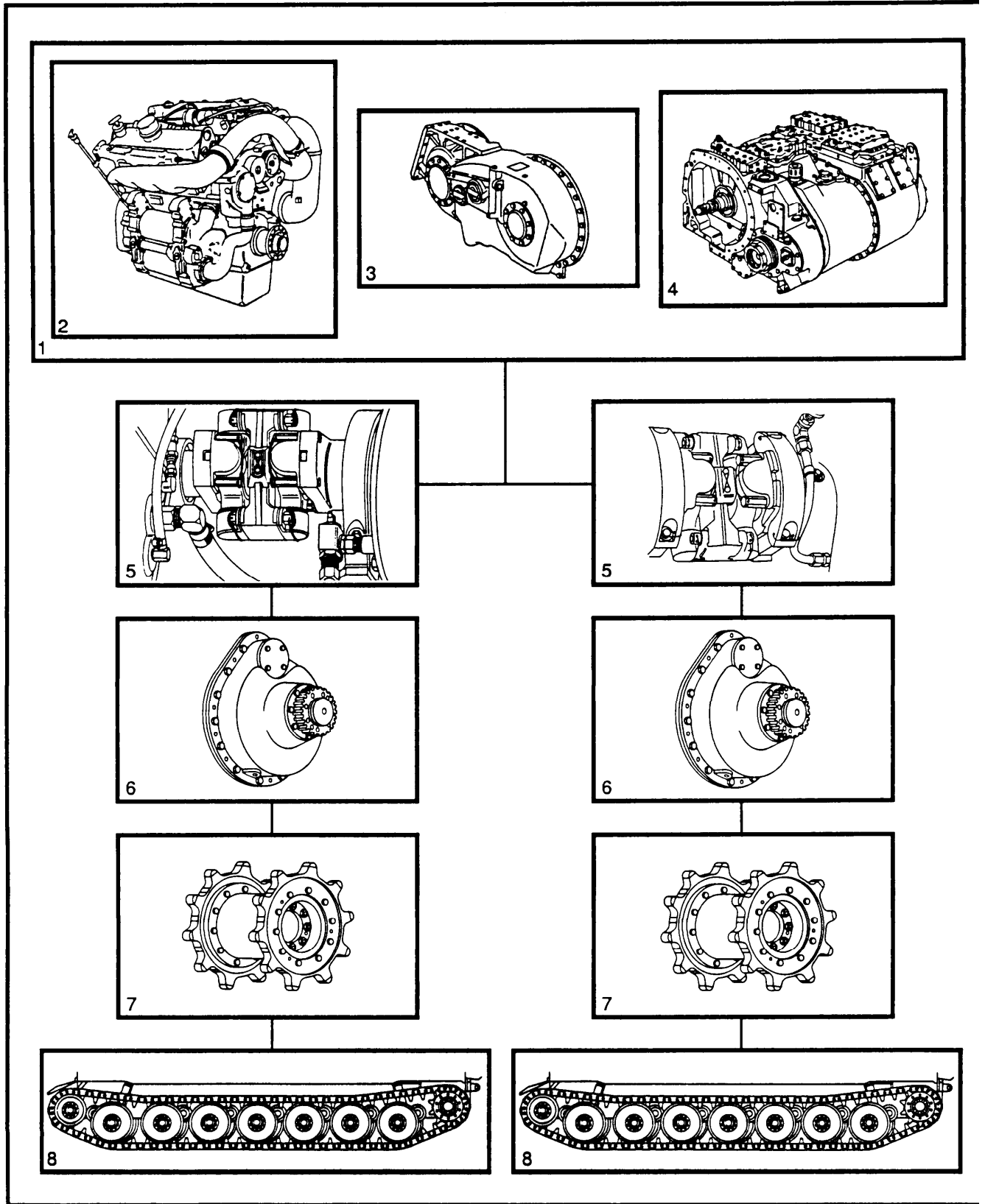

1-17 EQUIPMENT OPERATION AND DESCRIPTION — CONTINUED

1-17.2 Fuel System

The fuel system flow diagram shows the interaction between the electrical system and fuel system to determine the flow of fuel.

- a. Upper fuel tank (1) — provides additional fuel to the lower fuel tank (2). Filling of both fuel tanks takes place through the filler neck of the upper fuel tank.
- b. Lower fuel tank (2) — provides for fuel storage and for the return of unused fuel from the fuel return system (9).
- c. Electric fuel pumps (3) — activated by the MASTER switch on the instrument panel (M109A2/M109A3) or by an oil pressure switch (M109A4/M109A5), these pumps distribute fuel from the lower fuel tank (2) to the fuel distribution center (4).

When engine is not operating, the electric fuel pumps, activated by the fuel prime switch on the instrument panel, pumps fuel from the primary fuel filter (5) to the secondary fuel filter (7).

- d. Fuel distribution center (4) — distributes fuel to the primary fuel filter (5).
- e. Primary fuel filter (5) — first filter from the fuel tank.
- f. Secondary fuel filter (6) — filters fuel a second time for additional impurities.
- g. Engine-driven fuel pump (7) — boosts fuel pressure and delivers fuel to engine (8).
- h. Engine (8) — burns fuel.
- i. Fuel return system (9) — distributes excess fuel back to either the lower fuel tank (2) or the flame heater system.

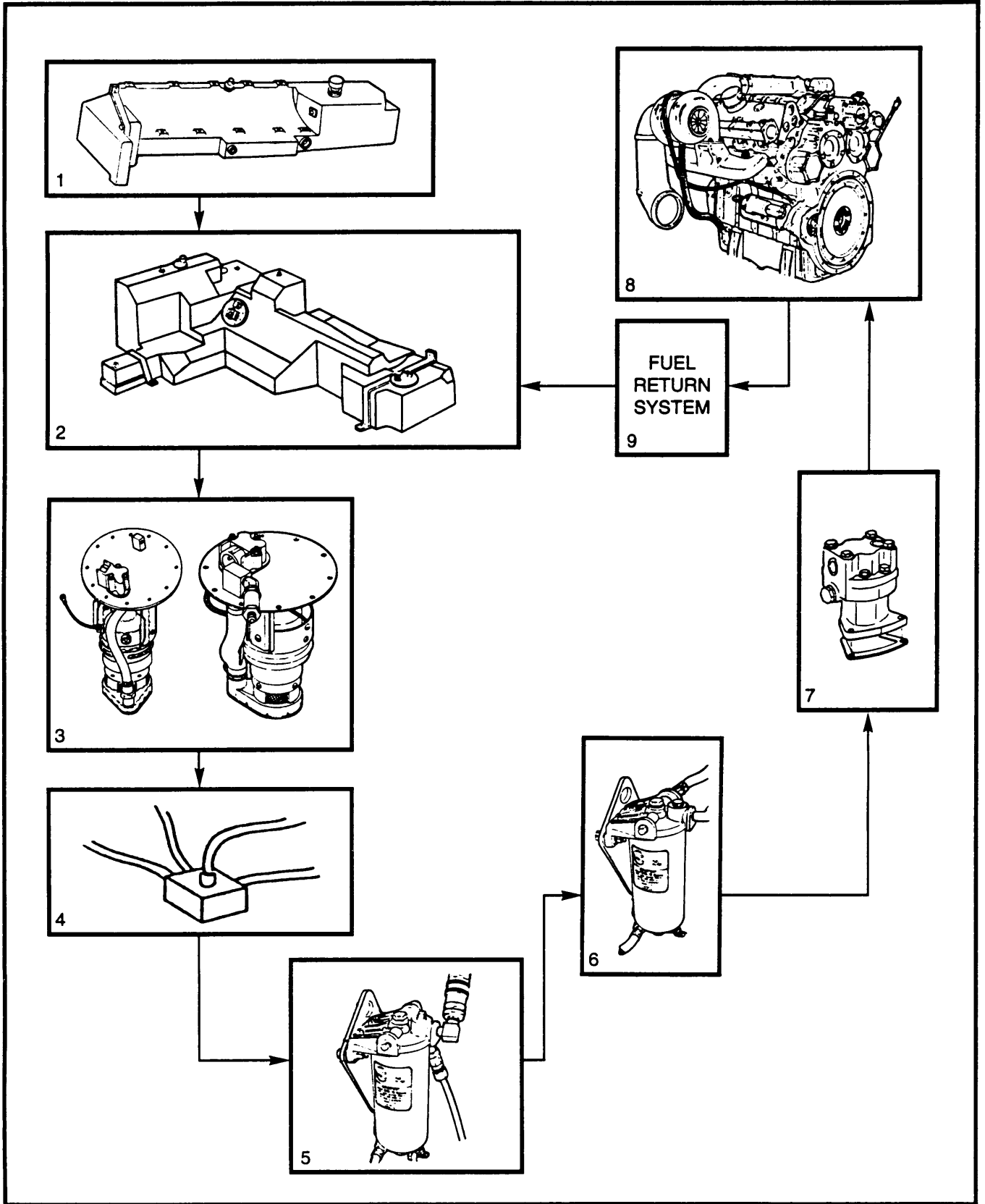

1-17 EQUIPMENT OPERATION AND DESCRIPTION — CONTINUED

1-17.3 Flame Heater System (Engine Model 7083-7396)

- a. Flame heater solenoid valve (1) — receives fuel from the fuel return system (2) and delivers this fuel to the flame heater box (3).
- b. Air motor and pump (4) — pumps air to the flame heater box (3).
- c. Flame heater igniter (5) — provides electrical ignition of atomized fuel in the flame heater box (3).

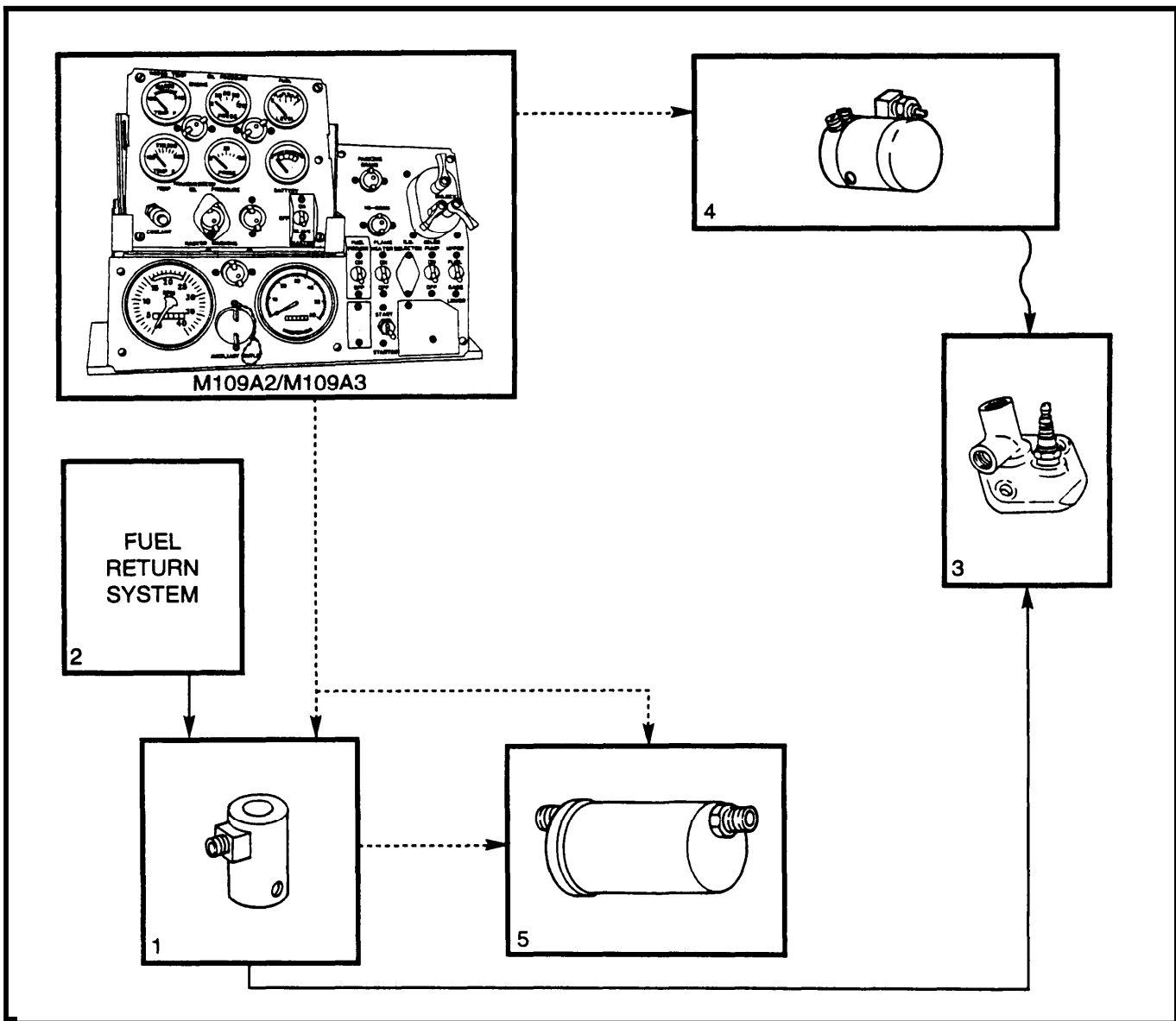

1-17.4 Glow Plug System (Engine Model 7083-7391)

- a. GLOW PLUGS switch (1) and wait light (2) — GLOW PLUGS switch activates controller and GLOW PLUGS wait light.
- b. Controller (3) and glow plugs (4) — The controller powers glow plugs and GLOW PLUGS wait light (2). When activated, the light comes on for 35 seconds while glow plugs reach sufficient temperature. The light then flashes to indicate that the engine (5) can be started. After the engine is started, the light and glow plugs stay 01 for an additional 60 seconds.
- c. Engine (5) — contains controller and eight glow plugs.

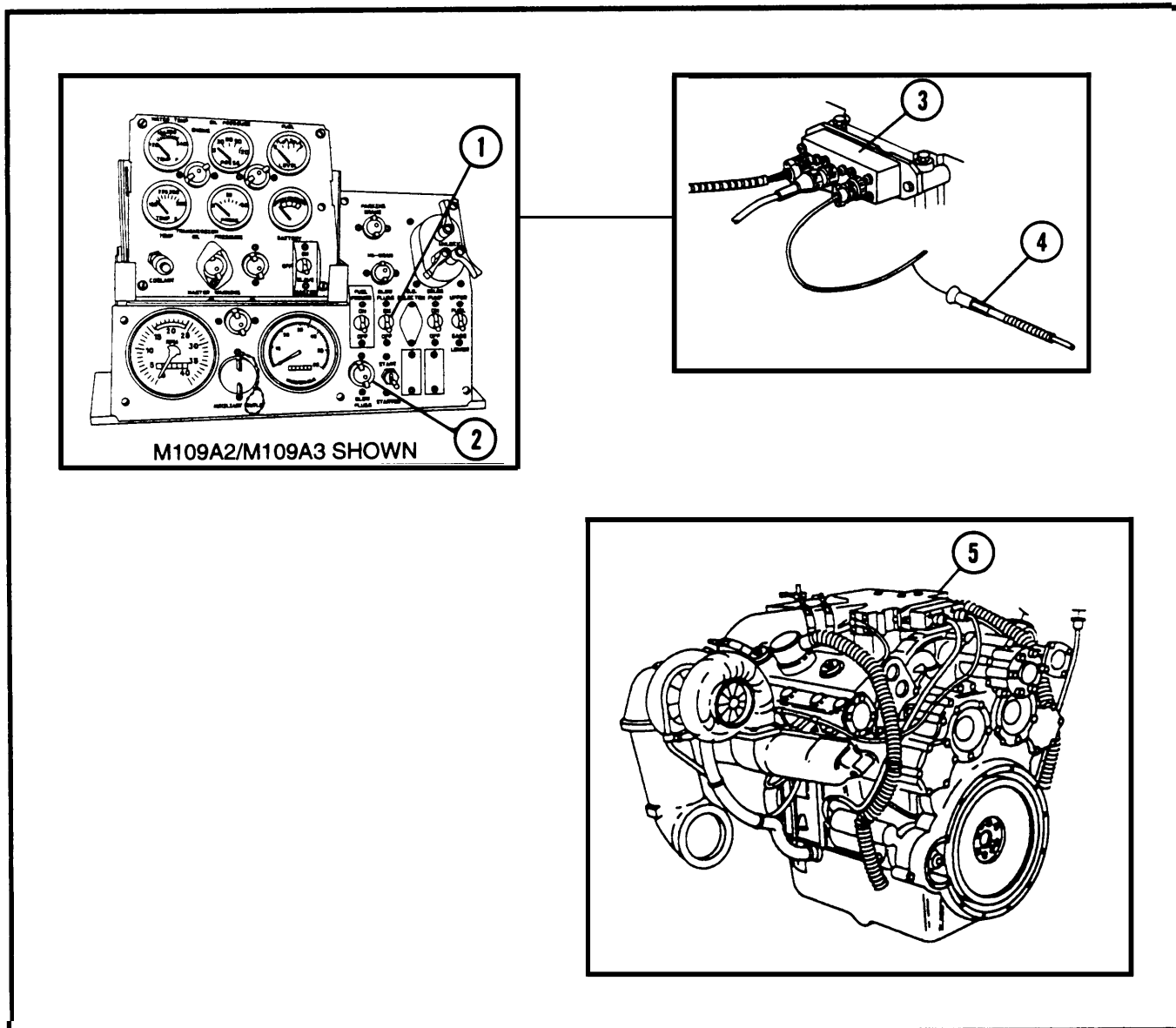

1-17 EQUIPMENT OPERATION AND DESCRIPTION — CONTINUED

1-17.5 Cooling System

- a. Radiator (1) — cools the coolant flowing through it.
- b. Surge tank (2) — allows for overflow from the radiator (1) in this closed cooling system. The capacity of the surge tank and the radiator is 22 gal (83 L).
- c. Engine-driven coolant pump (3) — pulls coolant from the radiator (1) and distributes it to the engine and transmission oil coolers (4) and back to the radiator or surge tank (2).
- d. Engine and transmission oil coolers (4) — cools the oil within the engine and transmission by surrounding the oil cooler tubes with coolant.
- e. Inlet thermostat (5) — directs the flow of the coolant from the engine to different areas of the cooling system. If the engine is running hot enough to open the inlet thermostat, the coolant flow will be directed to the radiator (1) so it can be cooled. If the engine is running cool enough, the inlet thermostat will direct flow to the bypass thermostat (6) or surge tank (2).
- f. Bypass thermostat (6) — allows inflow from the inlet thermostat (5) and cooling crossover tube and directs it back to the engine-driven coolant pump (3) and to the oil coolers (4).
- g. Air intake grille (7) — allows air to be pulled into the engine compartment by the radiator fan assembly (8).
- h. Radiator fan assembly (8) — pulls in air through the air intake grille (7) across the engine and pushes the air through the radiator (1) 'honeycomb.' The air is then discharged through the exhaust grille (9).
- i. Exhaust grille (9) — allows air pushed and pulled by the fan assembly (8) through the radiator (1) and back out of the engine compartment.

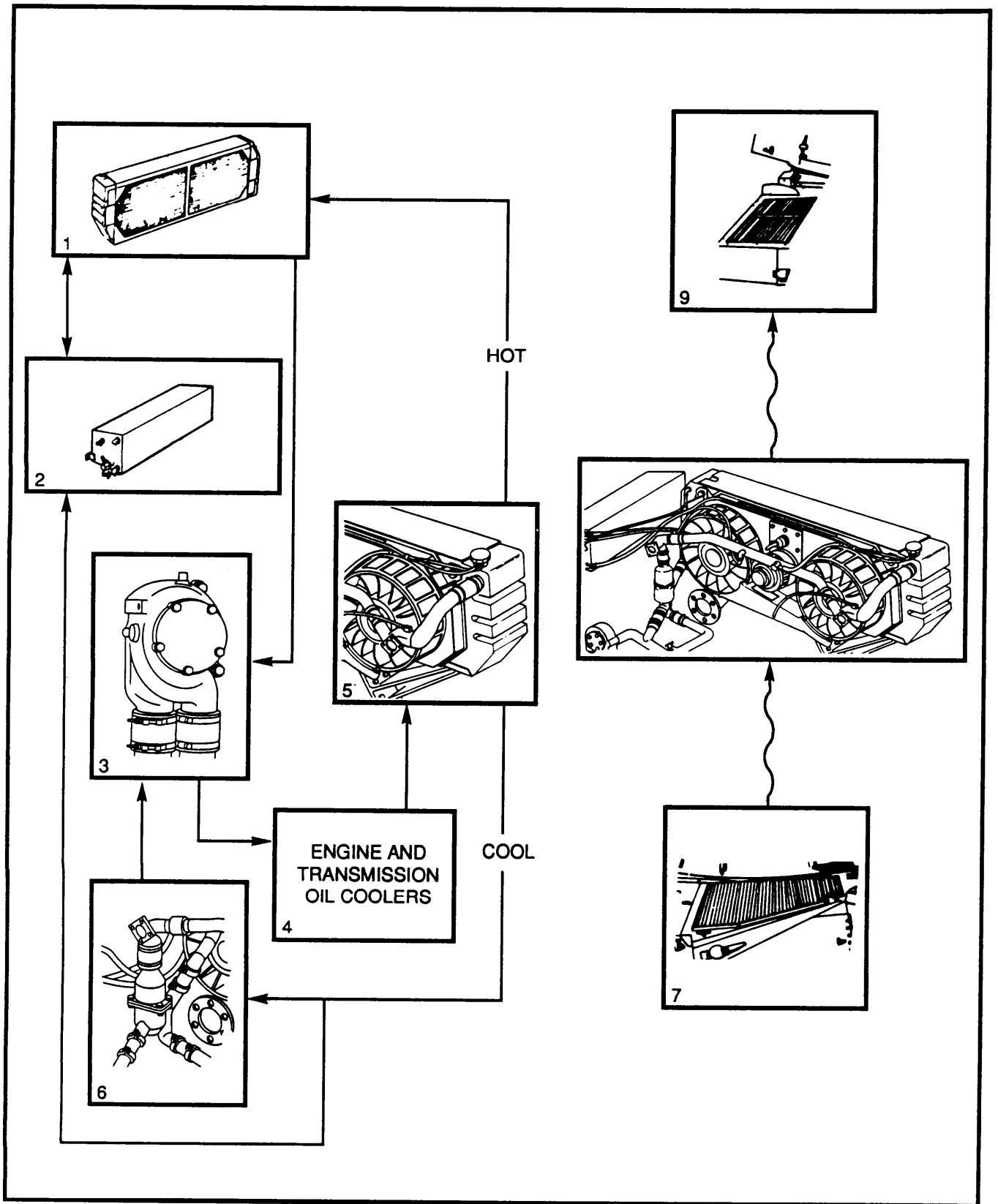

1-17 EQUIPMENT OPERATION AND DESCRIPTION — CONTINUED

1-17.6 Electrical System

The M109A2/M109A3/M109A4/M109A5 Howitzers' electrical system consists of:

- a. Batteries (1) — four 12-V connected in series and parallel to deliver 24 Vdc (nominal) to the master relay (2).
- b. Master relay (2) — delivers electrical power (24 Vdc [nominal]) to operating systems when the MASTER switch (3) is on. The master relay delivers power directly to the slip ring contact board (TM 9-2350-311-20-2), engine starter (4), slave start receptacle (5) (M109A3 shown), circuit breaker board (6) (M109A2/M109A3 shown), and cab (slip ring segment board) (TM 9-2350-311-20-2).
- c. MASTER switch (3) — when activated, draws 24 Vdc (nominal) from the battery through the master relay (2) to operate the M109A2/M109A3/M109A4/M109A5 Howitzers' electrical systems. With the MASTER switch ON, systems can be operated without running the engine.
- d. Alternator (7) — engine driven and delivers 24 Vac (nominal) to the rectifier (8).
- e. Rectifier (8) — full-wave, bridge rectifier converts the generator ac voltage to dc voltage which is in turn delivered to the voltage regulator (9).
- f. Voltage regulator (9) — controls the delivery of 24 Vdc (nominal) to the vehicle operating systems through the master relay (2) and also acts as a recharger for the batteries when the engine is operating.
- g. External power receptacle (10) — provides vehicle auxiliary power from an external source.

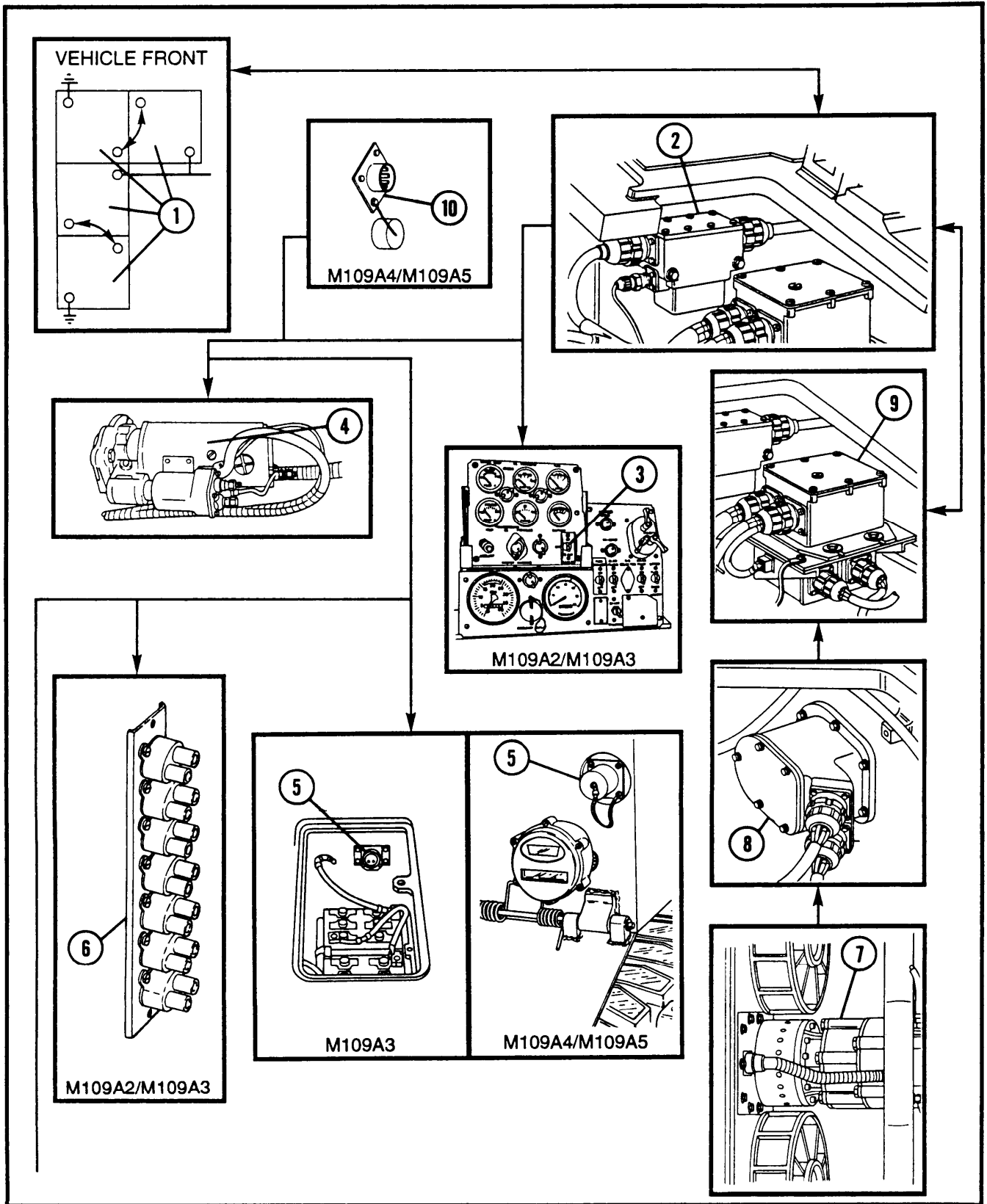

1-17 EQUIPMENT OPERATION AND DESCRIPTION — CONTINUED

1-17.7 Instrument Panels

The M109A2/M109A3/M109A4/M109A5 Howitzers have two instrument panels.

1-17.7.1 The portable instrument panel (1) consists of the following:

- a. MASTER switch (2) — activates the vehicle electrical system.
- b. MASTER WARNING light (3) — indicates critical engine operating conditions for transmission oil low pressure, transmission oil high temperature, engine coolant high temperature, and engine oil low temperature.
- c. WATER TEMP gage (4) — indicates engine water temperature.
- d. ENGINE OIL PRESSURE gage (5) — indicates engine oil pressure.
- e. FUEL gage (6) — indicates fuel level.
- f. TRANSMISSION OIL TEMP gage (7) — indicates transmission oil temperature.
- g. TRANSMISSION OIL PRESSURE gage (8) — indicates transmission oil pressure.
- h. BATTERY gage (9) — indicates battery condition.
- i. COOLANT warning indicator lamp (10) — indicates low coolant.

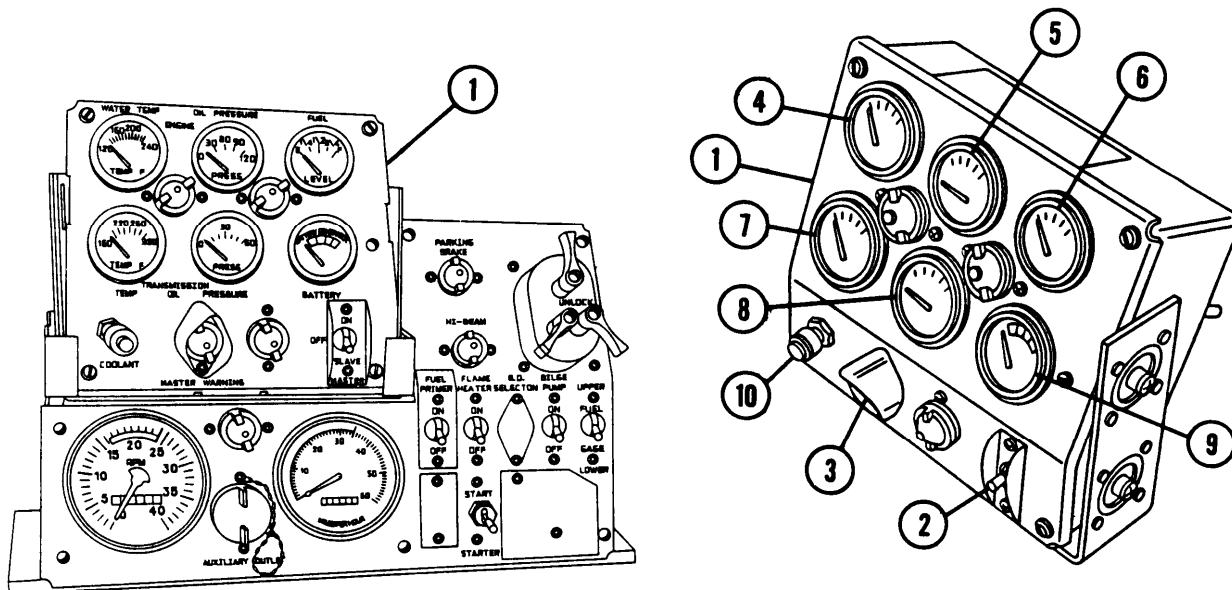

M109A2/M109A3
(ENGINE MODEL 7083-7396) SHOWN

1-17.7.2 The driver's instrument panel (11) contains:

- a. FUEL PRIME control switch (12) — activates the fuel pump.
- b. FLAME HEATER control switch (13) (on vehicles with engine model 7083-7396) — activates the flame heater.
- c. Driving light control switches (14) — activate the driving lights.
- d. BILGE PUMP control switch (15) — activates the bilge pump.
- e. FUEL GAGE control switch (16) — activates the upper and lower fuel tank transmitters for FUEL gage readings.
- f. STARTER control switch (17) — activates the starter motor.
- g. NBC power switch (M109A4/M109A5) (18) — powers the NBC system.
- h. Tachometer (19) — indicates engine rpm and vehicle operating hours.
- i. Speedometer (20) — indicates vehicle speed and mileage.
- j. GLOW PLUGS switch (21) (on vehicles with engine model 7083-7391) — activates glow plug controller.
- k. GLOW PLUGS light (22) (on vehicles with engine model 7083-7391) — indicates glow plugs have reached sufficient temperature for engine to start.

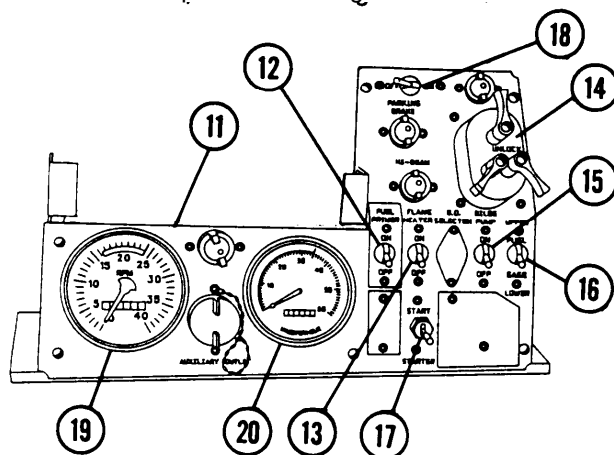

M109A4/M109A5
(ENGINE MODEL 7083-7396) SHOWN

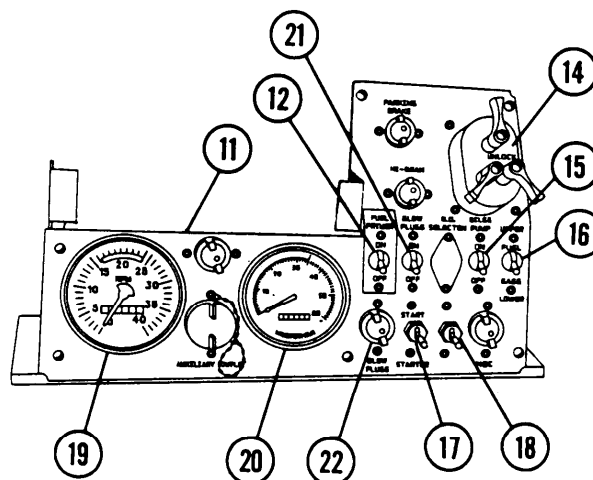

M109A4/M109A5
(ENGINE MODEL 7083-7391) SHOWN

1-17 EQUIPMENT OPERATION AND DESCRIPTION — CONTINUED

1-17.8 Drive Controls

- a. Parking brake (1) — when set, moves brake apply lever to provide internal braking for right and left transmission drive assemblies (2).
- b. Brake pedal (3) — when depressed, provides internal braking for right and left transmission drive assemblies (2).
- c. Steering (4) — applies brakes to track on the inside of the turn. (Left turn — brake is applied to left drive output; right turn — brake is applied to right drive output.)
- d. Fuel shutoff (5) — when the fuel shutoff handle has been pulled out, it cuts the fuel supply and shuts down the engine (6).
- e. Accelerator pedal (7) — when depressed, accelerates the engine so the engine operates with greater rpm. When the accelerator pedal is released, engine rpm will return to idle speed.
- f. Hand throttle control (8) — is another method of controlling the speed (rpm) of the engine (6). (Push forward — engine speed increases; pull back — engine speed decreases.)
- g. Engine throttle control rod (9) — is the throttle linkage from the hand throttle control (8) and the accelerator pedal (7).
- h. Transmission shift control (10) — selects the speed range and the direction of the power output of the transmission (2).

NOTE

The transmission throttle valve control rod (11) does not govern the speed of the vehicle or the transmission rpm. Speed and rpm are determined by engine rpm and the shift control (10) position.

- i. Transmission throttle valve control rod (11) — is interconnected with the engine throttle control rod (9) and the transmission shift control (10). With the engine operating and the shift control in the neutral position, the transmission throttle valve is locked out. When the shift control is in one of the drive gears (or reverse), the transmission throttle valve is locked in allowing transfer of power from the transfer assembly (12) into the transmission and to the drive assembly.

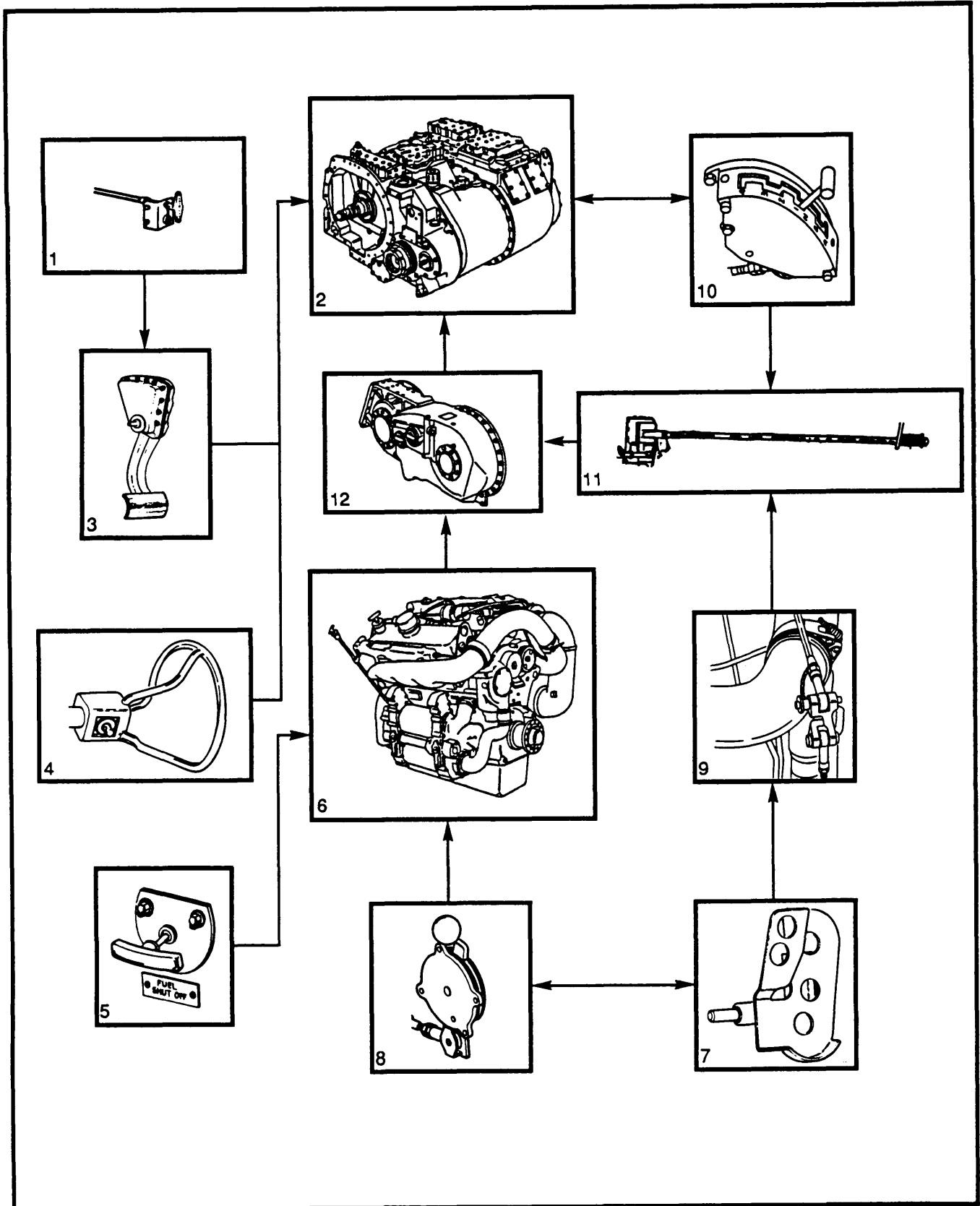

1-17 EQUIPMENT OPERATION AND DESCRIPTION — CONTINUED

1-17.9 Suspension System

- a. Torsion bar anchors (1) — secure the ends of the torsion bars (2). One anchor secures two torsion bars, one from the right and one from the left.
- b. Torsion bars (2) — secured at the anchor (1) and connected to the road wheel arm (3), the torsion bar acts like a spring for the road wheel and track.
- c. Road wheel arm (3) — connected to the torsion bar (2), the road wheel arm provides a pivot point between the torsion bar and the road wheel (4).
- d. Road wheels (4) — are suspended from the hull of the howitzer by road wheel arms (3). There are seven road wheels per side located between the sprocket and idler wheel. The road wheels have two wheel halves separated by a valley to allow track centerguides to pass between the halves.
- e. Shock absorbers (5) — handle differences in the terrain over which the vehicle operates. They are located in the front and back of the vehicle (road wheels 1 and 7).
- f. Bump stops (6) — keep shock absorbers (5) from moving beyond their limits.
- g. Idler arm assembly (7) and track adjuster (8) — the idler arm assembly consists of an idler arm with an idler wheel attached, all rotating within the idler arm housing. The angle of the idler arm and wheel is determined by the length of the track adjuster. The track tension may be increased or decreased by adding or removing GAA grease to or from the track adjuster.

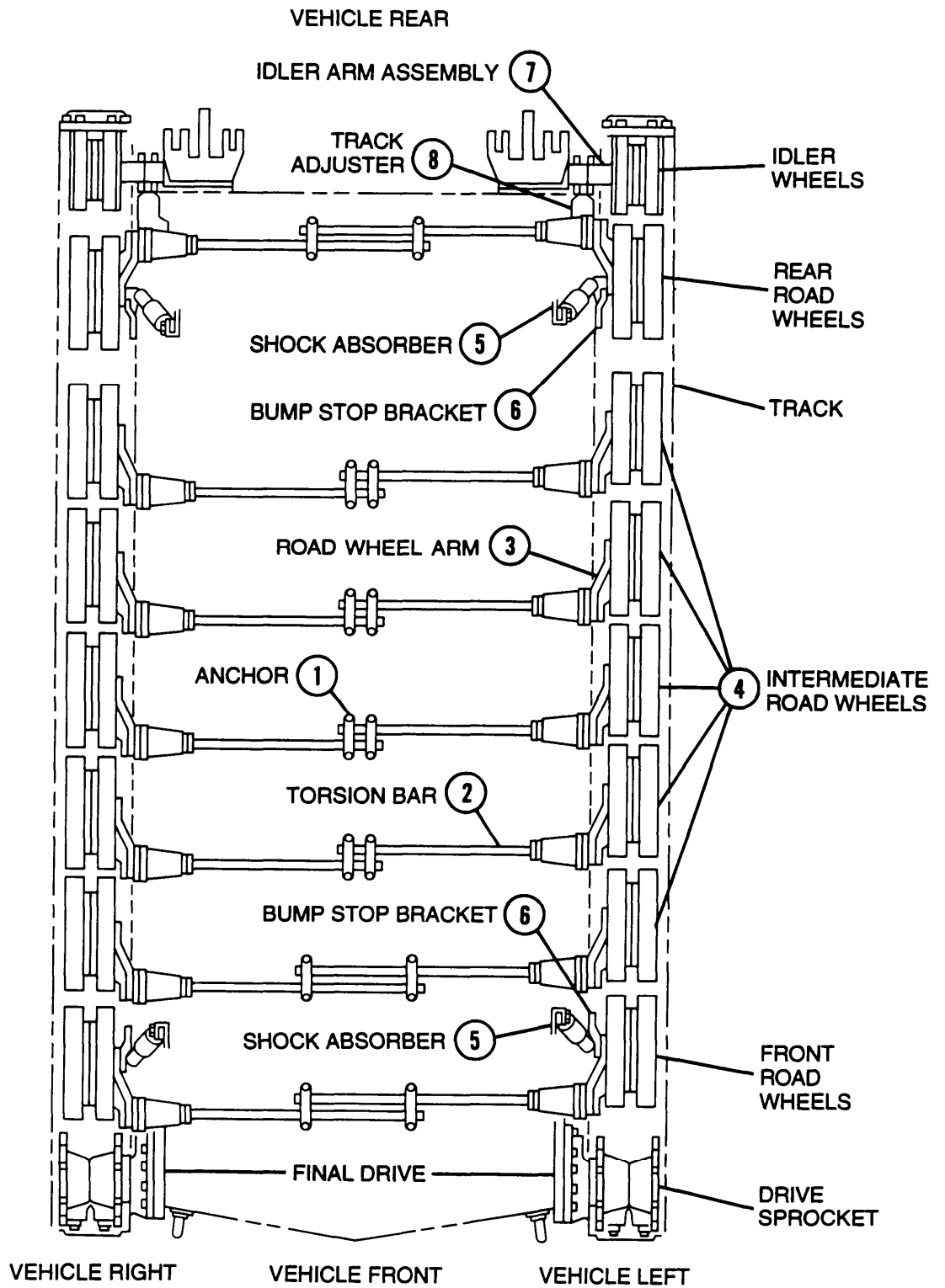

CHAPTER 2 GENERAL HULL MAINTENANCE

GENERAL

This chapter provides information and instructions needed to keep hull equipment and components in good repair. These instructions provide a step-by-step, and item-by-item, illustrated text describing equipment, component service, and maintenance.

The maintenance functions described in this chapter are limited to those functions authorized by the MAC for unit maintenance level activities. If maintenance is needed on any hull equipment or components that are not discussed in this chapter, notify support maintenance for assistance.

<u>CONTENTS</u>	<u>PAGE</u>
Section 1 REPAIR PARTS, SPECIAL TOOLS, TMDE, AND SUPPORT EQUIPMENT.	2-2
2-1 GENERAL	2-2
2-2 COMMON TOOLS AND EQUIPMENT.	2-2
2-3 SPECIAL TOOLS, TMDE, AND SUPPORT EQUIPMENT.	2-2
2-4 REPAIR PARTS	2-2
Section II SERVICE UPON RECEIPT	2-2
2-5 GENERAL INFORMATION	2-2
2-6 INITIAL PROCEDURES	2-3
2-7 DECALS, LABELS, AND INSTRUCTION SIGNS	2-4
2-8 PRE-OPERATIONAL PROCEDURES.	2-5
2-9 OPERATIONAL PROCEDURES	2-7
2-10 EQUIPMENT FAULTS	2-8
Section II OPERATIONAL CHECKS	2-8
2-11 GENERAL	2-8
2-12 PERFORMING ELECTRICAL TESTS AND EQUIPMENT CHECKS	2-8
2-13 WIRING HARNESS AND CABLE REPAIRS	2-11
Section IV PREVENTIVE MAINTENANCE CHECKS AND SERVICES (PMCS)	2-20
2-14 GENERAL	2-20
2-15 PROCEDURES FOR SEMIANNUAL/ANNUAL SERVICES	2-21
Section V MAINTENANCE PROCEDURES.	2-46
2-16 PRE-STARTING INSTRUCTIONS.	2-46
2-17 STARTING INSTRUCTIONS	2-49
2-18 PAINTING INSTRUCTIONS	2-50

SECTION 1. REPAIR PARTS, SPECIAL TOOLS, TMDE, AND SUPPORT EQUIPMENT

2-1 GENERAL

Tools, equipment, and repair parts will be issued to unit maintenance personnel for maintenance. The tools and equipment issued should only be used for tasks in this manual. When not in use, these tools should be properly stored in the tool chests and rolls provided.

2-2 COMMON TOOLS AND EQUIPMENT

For authorized common tools and equipment, refer to the Modified Table of Organization and Equipment (MTOE) CTA 50-970 or CTA 8-100, as applicable to your unit.

2-3 SPECIAL TOOLS, TMDE, AND SUPPORT EQUIPMENT

Certain tools and equipment, especially designed for unit maintenance, repair, and general use, are listed in Appendix B for information only. This list is not to be used for requisitioning parts.

2-4 REPAIR PARTS

Repair parts are listed and illustrated in the Repair Parts and Special Tools List (RPSTL) covering unit and support maintenance (TM 9-2350-311-24P-1).

Gaskets, packings, bushings, preformed packings, seals, lockwashers, locknuts, self-locking fasteners (screws, nuts, etc), cotter pins, and spring pins must be replaced if removed.

Springs must be replaced if broken, kinked, cracked, or do not conform to standards specified in the repair data.

SECTION II. SERVICE UPON RECEIPT

2-5 GENERAL INFORMATION

This section covers the procedures for servicing M109A2/M109A3/M109A4/M109A5 vehicles upon receipt. A run-in of at least 5 miles (8 km) will be performed on all new or reconditioned vehicles, and of a sufficient number of miles on used vehicles, to check their operation completely. This section may provide material that is duplicated in TM 9-2350-311 -20-2 (M109A2/M109A3/M109A4/M109A5 cab). This duplication is limited only to the activities that require crew and unit mechanics' joint efforts.

2-6 INITIAL PROCEDURES

If the vehicle has been shipped by rail, unblock and unload the equipment according to TM 9-2350-311-20-2. Observe existing regulations.

2-6.1 Checking Unpacked Equipment

- a. Inspect the equipment for damage incurred during shipment. If the equipment has been damaged, report the damage on SF 364, Packing Improvement Report.
- b. Check the equipment against the packing slip to see if the shipment is complete. Report all discrepancies in accordance with the instructions in DA PAM 738-750.
- c. Check whether the equipment has been modified. Reference shall be made to Table 1-1, Authorized Equipment Configuration Changes.

2-6.2 Processing Unpacked Equipment

- a. Install fire control and sighting equipment as is. No cleaning is required.
- b. Clean all other tools and equipment.
- c. Store all Basic Issue Items (BII) in their respective vehicle storage facility as indicated in paragraph 1-14 and TM 9-2350-311-10.

WARNING

Do not use mineral spirits or paint thinner to clean the howitzer. Mineral spirits and paint thinners are highly toxic and combustible. Prolonged breathing can cause dizziness, nausea, and even death.

- d. Clean the vehicle as follows:

WARNING

Dry-cleaning solvent (P-D-680) is toxic and flammable. Wear protective goggles and gloves and use only in a well-ventilated area. Avoid contact with skin, eyes, and clothes, and don't breathe vapors. Do not use near open flame or excessive heat. The flashpoint for type #1 is 100°F (38°C), and for type #2 is 138°F (59°C). If you become dizzy while using dry-cleaning solvent, get fresh air immediately and get medical aid. If contact with eyes is made, wash your eyes with water and get medical aid immediately.

Remove any rust-preventive compound from exterior surfaces with dry-cleaning solvent (item 33, Appx D). Whenever possible, the vehicle crew will help in the cleaning.

Armament parts are coated with rust-preventive compound when received from storage. Clean these parts thoroughly with rags or a brush saturated with dycleaning solvent. After complete removal of the rust-preventive compound, lubricate as specified in TM 9-2350-311-10 and TM 9-2350-311-20-2. Component parts of each item should be cleaned separately where possible. Some component parts are interchangeable; however, the parts originally assembled work best together.

2-6 INITIAL PROCEDURES — CONTINUED

2-6.3 Assembly of Equipment

The M109A2/M109A3/M109A4/M109A5 hull equipment and systems are shipped as assembled units. Assembly is not required. However, assembly of hull components is discussed in detail in Chapters 4 thru 12 of this manual. These chapters provide detailed information on removal, disassembly, assembly, and installation of equipment for maintenance purposes.

2-6.4 Equipment Installation Instructions

Installation instructions for the M109A2/M109A3/M109A4/M109A5 hull require installation of on-board vehicle equipment, equipment racks, and stowage of equipment in the hull as shown in Chapter 13. Installation of other components removed for maintenance purposes is discussed in detail in Chapters 4 thru 12 of this manual.

Follow all precautions on DD Form 1397, Processing and Reprocessing Record for Shipment, Storage, and Issue of Vehicles and Spare Engines. One tag will be with the Records Book and one in an envelope attached to a headlamp.

2-7 DECALS, LABELS, AND INSTRUCTION SIGNS

2-7.1 Removal

NOTE

- Replace only decals, labels, and instruction signs that are damaged, illegible, or missing.
- All decals, labels, and instruction signs are removed and installed using the same procedure.

Scrape label (1) from mounting surface (2). Discard label.

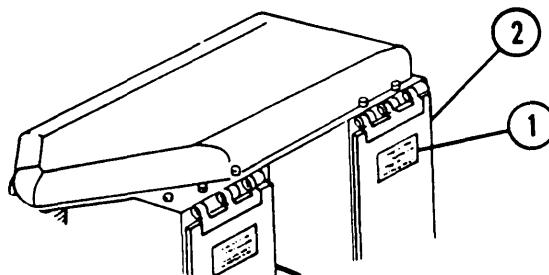

2-7.2 Installation

WARNING

Dry-cleaning solvent (P-D-680) is toxic and flammable. Wear protective goggles and gloves and use only in a well-ventilated area. Avoid contact with skin, eyes, and clothes, and don't breathe vapors. Do not use near open flame or excessive heat. The flashpoint for type #1 is 100°F (38°C), and for type #2 is 138°F (59°C). If you become dizzy while using dry-cleaning solvent, get fresh air immediately and get medical aid. If contact with eyes is made, wash your eyes with water and get medical aid immediately.

- a. Clean mounting surface (2) with dry-cleaning solvent (item 22, Appx D).
- b. Remove paper backing from new label (1) and position in place on mounting surface (2).
- c. Press label (1) firmly to remove air bubbles.

2-8 PRE-OPERATIONAL PROCEDURES

Inspect all wires/hydraulic lines/connectors, electrical connectors, welds, bolts, and seals.

2-8.1 Installation of Batteries

WARNING

- Battery gases can explode. Do not smoke or allow sparks or open flames near batteries. Wear safety glasses or goggles when checking batteries. Failure to follow this procedure could cause serious injury or death.
- When working on batteries, wear eye protection and remove all jewelry, dog tags, and metal items to avoid electrical shocks and burns.
- Sulfuric acid contained in batteries can cause serious burns. If battery corrosion or electrolyte makes contact, take immediate action to stop the burning effects.

CAUTION

Ground straps must be disconnected before removal of battery cables or leads and connected after installation of cables to avoid possibility of arcing and damage to materiel.

2-8 PRE-OPERATIONAL PROCEDURES — CONTINUED

2-8.1 Installation of Batteries — Continued

Install and service the batteries (TM 9-2350-311-10 and TM 9-61 40-200-14) as follows:

- a. Remove ground cables first when disconnecting batteries and install ground cables last when connecting batteries. When replacing batteries, connect them as shown in the battery hookup diagram.

NOTE

If batteries are new and empty, notify support maintenance to add electrolyte.

Remove six filler caps (1) from each battery. Fill each battery with distilled water so that electrolyte level is above the top of battery plates. Replace filler caps.

- b. For M109A2/M109A3 Howitzers, install two battery cables (2). Install cable 81 on two positive terminals (3). Install two ground cables from terminals (4) to hull.
- c. For M109A4/M109A5 Howitzers, install two battery cables (2). Install cables 81, 2A, 2B, 6, and 49 onto two positive terminals (3). Install cables 5 and 50 onto negative terminals (4). Install two ground cables from terminals (5) to hull.

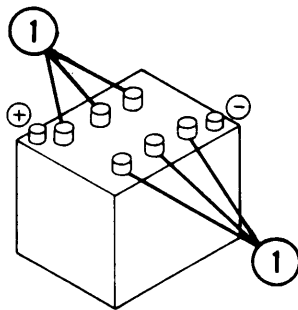
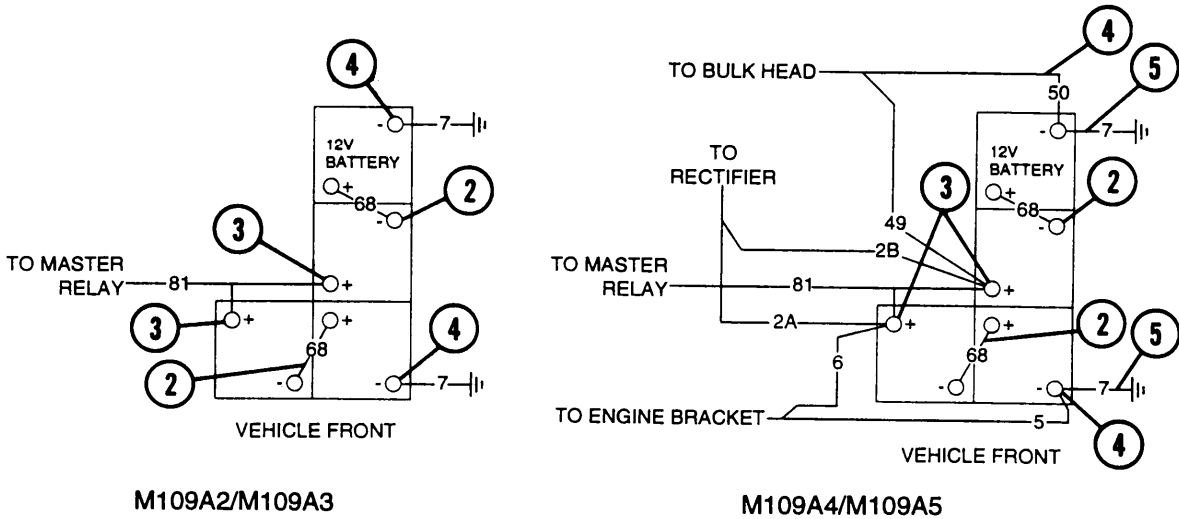

2-8.2 Checking Vehicle Systems

Check for the following:

- a. Engine coolant: Check level and specific gravity (TM 9-2350-311-10).
- b. Engine oil: Check level (TM 9-2350-311-10).
- c. Fuel: Fuel vehicle (TM 9-2350-311-10).
- d. Transmission oil: Check level (TM 9-2350-311-10).
- e. Fire extinguisher cylinders: Check valve antipilferage seal (item 9, Table 2-1).

2-9 OPERATIONAL PROCEDURES

Before starting vehicle, check TM 9-2350-311-10 for proper starting instructions.

2-9.1 Initial Starting and Break-In

NOTE

- Engine contains preservative oil upon receipt. Preservative engine oils PE-1 and PE-2 are identical to engine oils OE-10 and OE-30, except that they contain a preservative additive. PE-1 and PE-2 will be used in the same manner as the regularly used engine oils OE-10 or OE-30. PE-1 or PE-2 will also be used in the transmission until the first scheduled 2000-mile (3219-km) or semiannual oil change. Refer to TM 9-2350-311-10 and paragraph 2-15 for correct lubrication instructions.
 - Due to internal processing, engine may be hard to start, and may smoke and run rough. Let it run for 5 minutes and see if it improves. Perform troubleshooting procedure if engine fails to develop full power after 5 minutes.
- a. Start and run engine until preservative oil is out of combustion chambers and engine is operating smoothly. Check for fuel and oil leaks immediately.
 - b. Perform complete annual service (para 2-15).

2-9.2 Operations Test

Test vehicle systems for proper operation (TM 9-2350-311-10).

2-9.3 Road Test

Road test vehicle to check and qualify all operational systems (TM 9-2350-311-10).

2-10 EQUIPMENT FAULTS

Equipment faults disclosed during preliminary inspection and servicing or during break-in period will be corrected by the using unit or support maintenance.

Serious equipment faults which appear to involve unsatisfactory design or material will be reported on SF Form 368, Quality Deficiency Report (Category II), as prescribed in DA PAM 738-750.

SECTION III. OPERATIONAL CHECKS

2-11 GENERAL

This section identifies operational check procedures and instructions for test and repair. Authorized crew and unit maintenance are listed in Appendix B.

See the Table of Contents of each chapter for appropriate page references.

2-12 PERFORMING ELECTRICAL TESTS AND EQUIPMENT CHECKS

Perform electrical tests and equipment checks on the M109A2/M109A3/M109A4/M109A5 vehicles with Simplified Test Equipment for Internal Combustion Engines — Reprogrammable (STE/ICE-R) and multimeters.

2-12.1 STE/ICE-R

STE/ICE-R is a portable diagnostic set that can measure standard voltage, current, resistance, pressure, and speed of measurements of the M109A2/M109A3/M109A4/M109A5 engine system. Equipment set up and testing procedures are covered in Appendix I and TM 9-4910-571-12&P.

2-12.2 Multimeters

All electrical checks and tests on the M109A2/M109A3/M109A4/M109A5 Howitzer can be performed with a multimeter. This section shows how to use the multimeter to find the cause of electrical problems in the M109A2/M109A3/M109A4/M109A5 systems, and how to repair or replace electrical wiring and connectors in these systems. For troubleshooting the charging system, refer to DA PAM 750-33.

NOTE

Refer to instructions supplied with multimeter for proper operation and any necessary adjustments.

2-12.3 Using the Ohms Scale

The ohms (Ω) scale is used to test for continuity, shorts, and resistance.

Proper operation of electrical components depends upon proper grounding. In all troubleshooting procedures of components that depend on screws or physical contact for their electrical ground (lamp sockets, transmitters, batteries, etc), use a jumper wire from the device to the hull to check grounding.

2-12.4 Testing for Short Circuits

A short circuit occurs when two circuits (electrical leads/wires) that should not be connected make contact with each other. A short also occurs when a circuit that should not touch ground makes contact with ground. To check for shorts, do the following steps:

- a. Set up multimeter.

CAUTION

Failure to do the following steps can damage the multimeter.

- b. Disconnect circuit being tested from power source. To be safe, disconnect battery ground strap.
- c. Connect one probe to one circuit and other probe to other circuit or ground (if checking for a short to ground).
The example shows a check to see if wire A is shorted to wire B in wiring harness.
- d. Observe multimeter reading.
 - If multimeter indicates zero (0) Ω impedance, circuits are shorted.
 - If multimeter indicates infinite (∞) Ω impedance, circuits are not shorted.
 - If multimeter reading jumps or changes, circuits are intermittently short circuited.

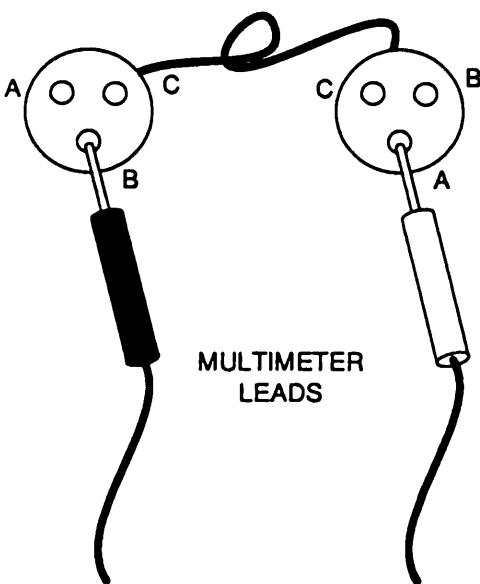

2-12 PERFORMING ELECTRICAL TESTS AND EQUIPMENT CHECKS — CONTINUED

2-12.5 Measuring Continuity

- a. Set up multimeter.

CAUTION

Failure to do the following steps can damage the multimeter.

- b. Disconnect circuit being tested from power source. To be safe, disconnect battery ground strap.
- c. If test calls for an ohms range different than RX1 or X1, set selector switch to that range (like RX10 or X10).
- d. Connect probes across circuit or item to be measured. The example shows measuring the resistance of one wire in a three-wire cable.
- e. Read multimeter.

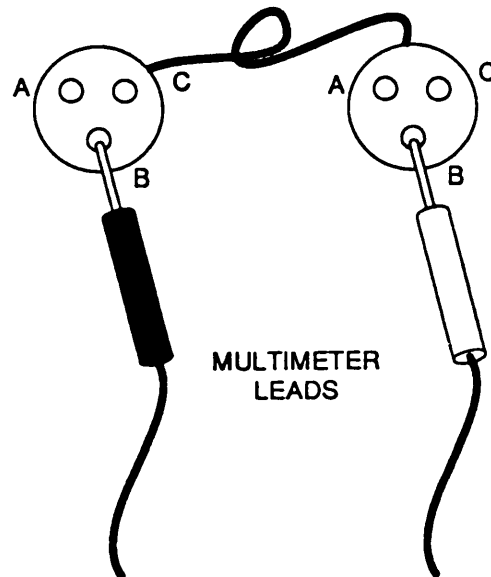

2-12.6 Measuring Dc Voltage

- a. Set up multimeter.

CAUTION

If you are unsure of the voltage to be measured on the vehicle, always start on the highest range. This will protect the meter from damage.

- b. Connect red probe to positive (+) side of circuit and black probe to negative (-) side. The example shows 24 Vdc being measured across the batteries.
- c. If multimeter indicates negative voltage, check to ensure that probes are connected as described in step b above.

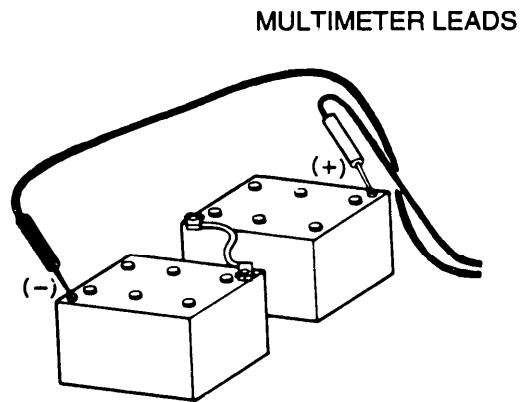

2-13 WIRING HARNESS AND CABLE REPAIRS

Step-by-step procedures for the disassembly and assembly of typical receptacles, plugs, and cable connectors used on the M109A2/M109A3/M109A4/M109A5 are shown here.

For any electrical repairs use Electric Tool Kit (item 63, Appx H).

For detailed instructions on soldering and solder, see TB SIG 222.

2-13.1 Cable Wires, Identifiers, Receptacles, and Plugs

CAUTION

To avoid damaging wires, use resin core solder only.

2-13 WIRING HARNESS AND CABLE REPAIRS — CONTINUED

2-13.1 Cable Wires, Identifiers, Receptacles, and Plugs — Continued

NOTE

When removing more than one wire from a multiple wire receptacle, tag wires for later identification (ID).

- a. Cable identifiers (1) are aluminum tags attached to cables. These tags are embossed with the cable ID number. The ID number is the same number as shown on the system's wiring diagram.
- b. Wire identifiers (2) are embossed with the individual wire number. The wire number is the same as shown on the systems wiring diagram.

NOTE

if cables or wires are replaced, remove tags from old wire and place them on new wires.

- c. All pins (male connectors) and sockets (female connectors) in receptacles and plugs are identified by alphabetic code. Coded ID starts at the connector key (3) or groove (4) and for:
 - Male connectors identifying letters run clockwise.
 - Female connectors identifying letters run counterclockwise.

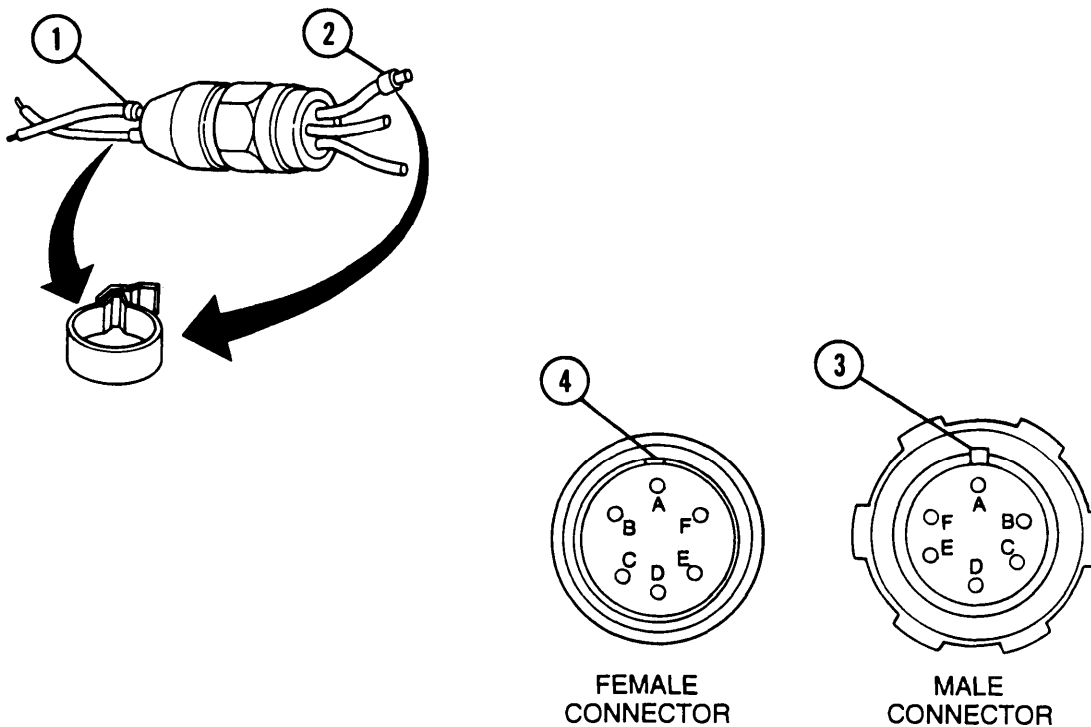

2-13.2 Typical Female-Type Panel Mounting Receptacle

2-13.2.1 Disassembly

- a. Drive socket contact out through rear of insert with pin extractor.
- b. Unsolder cable leads from solder wells on socket contacts.
- c. Slide insert out through rear of shell.

2-13.2.2 Assembly

- a. Strip cable insulation equal to depth of solder wells of socket contacts.
- b. Insert cable leads into solder wells of socket contacts and solder using resin core solder.
- c. Push insert into shell from rear until seated. Groove in insert must be aligned with guide in shell to ensure proper fit.
- d. Push socket contacts into insert from rear until seated.

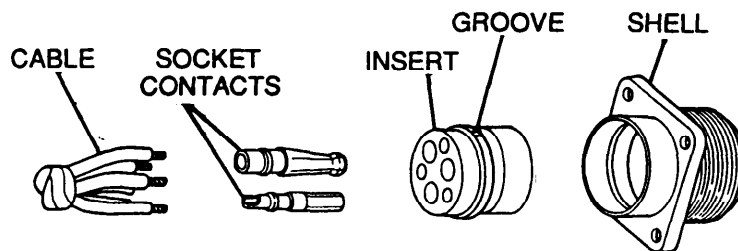

2-13.3 Typical Male-Type Panel Mounting Receptacle

2-13.3.1 Disassembly

- a. Drive pin contacts out through rear of insert with pin extractor.
- b. Unsolder cable leads from solder wells on pin contacts.
- c. Slide insert out through rear of shell.
- d. Push pin contacts into insert from rear until seated.

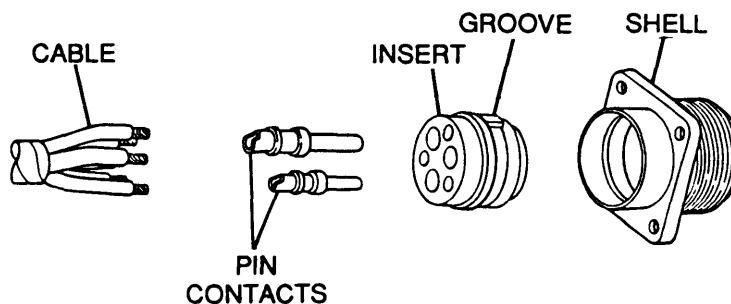

2-13 WIRING HARNESS AND CABLE REPAIRS — CONTINUED

2-13.3 Typical Male-Type Panel Mounting Receptacle — Continued

2-13.3.2 Assembly

- a. Strip cable insulation equal to depth of solder wells of pin contacts.
- b. Insert cable leads into solder wells of pin contacts and solder using resin core solder.
- c. Push insert into shell from rear until seated. Groove in insert must be aligned with guide in shell to ensure proper fit.
- d. Push pin contacts into insert from rear until seated.

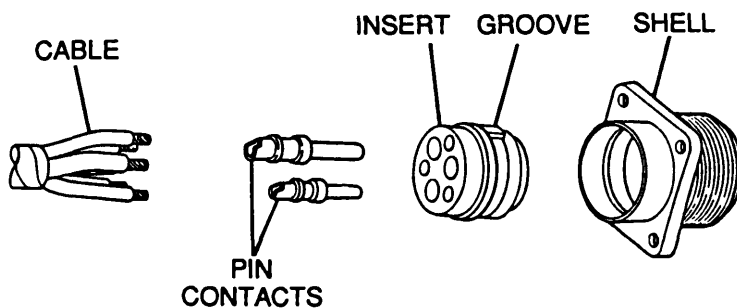

2-13.4 Typical Female-Type Panel Mounting Receptacle with Ridged Locking Nut

2-13.4.1 Disassembly

- a. Unscrew nut from shell assembly and slide back on cable.
- b. Slide grommet back on cable leads.
- c. Drive socket contacts out through front of insert with pin extractors.
- d. Unsolder leads from socket contacts.
- e. Push insert out through rear of shell.

2-13.4.2 Assembly

- a. Strip cable insulation equal to depth of solder wells of socket contacts.
- b. Slide nut over cable.
- c. Slide grommet over cable leads.
- d. Insert cable leads into solder wells of socket contacts and solder using resin core solder.

- e. Push insert into shell from rear until seated. Groove in insert must be aligned with guide in shell to ensure proper fit.
- f. Push socket contacts into insert from rear until seated.
- g. Push grommet down cable leads and over solder wells of socket contacts.
- h. Screw nut onto shell assembly.

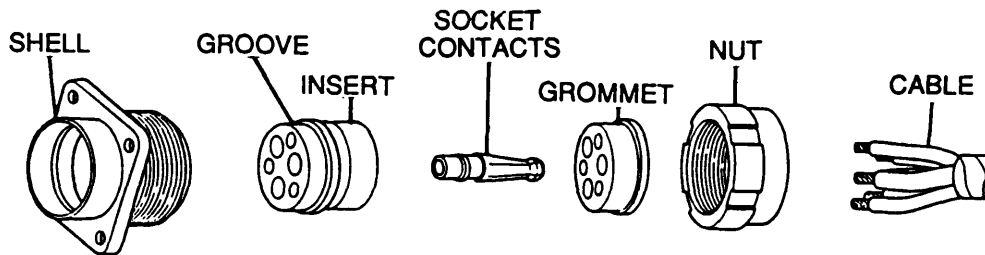

2-13.5 Typical Male-Type Panel Mounting Receptacle with Ridged Locking Nut

2-13.5.1 Disassembly

- a. Unscrew nut from shell assembly and slide back on cable.
- b. Push grommet back on cable leads.
- c. Drive pin contacts out through rear of insert with pin extractor.
- d. Push insert out through rear of shell.
- e. Unsolder leads from pin contacts.

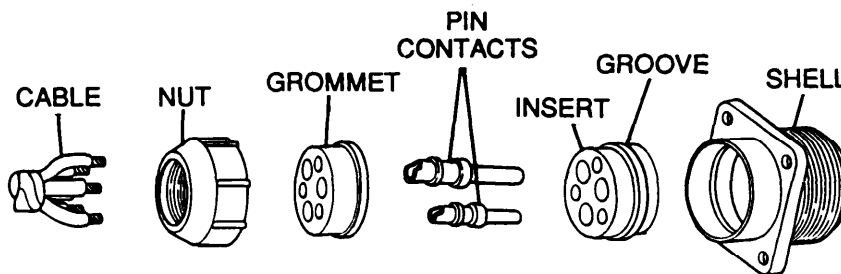

2-13 WIRING HARNESS AND CABLE REPAIRS — CONTINUED

2-13.5 Typical Male-Type Panel Mounting Receptacle with Ridged Locking Nut — Continued

2-13.5.2 Assembly

- a. Strip cable insulation equal to depth of solder wells of pin contacts.
- b. Slide nut onto cable.
- c. Slide grommet over cable leads.
- d. Insert cable leads into solder wells of pin contacts and solder using resin core solder.
- e. Push insert into shell from rear until seated. Groove in insert must be aligned with guide in shell to ensure proper fit.
- f. Push pin contacts into insert from rear until seated.
- g. Push grommet down cable leads and over solder wells of pin contacts.
- h. Screw nut onto shell assembly.

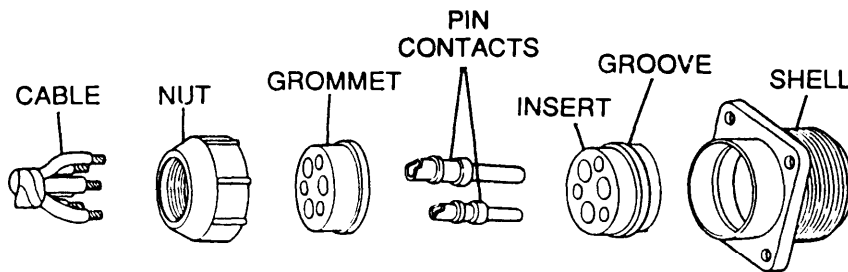

2-13.6 Typical Female-Type Plug with Ridged Locking Nut

2-13.6.1 Disassembly

- a. Unscrew nut from shell assembly and slide back on cable.
- b. Slide grommet back on cable leads.
- c. Slide coupling nut off shell.
- d. Drive socket contacts out through rear of insert with pin extractor.
- e. Push insert out through rear of shell.
- f. Unsolder leads from socket contact.

2-13.6.2 Assembly

- a. Strip cable insulation equal to depth of solder wells of socket contacts.
- b. Slide nut over cable leads.
- c. Slide grommet over cable leads.
- d. Insert cable leads into solder wells of socket contacts and solder using resin core solder.
- e. Push insert into shell from rear until seated. Groove in insert must be aligned with guide in shell to ensure proper fit.
- f. Push socket contacts into insert rear until seated.
- g. Slide coupling nut onto shell assembly.
- h. Push grommet down cable leads and over solder wells of socket contacts.
- i. Screw nut onto shell assembly.

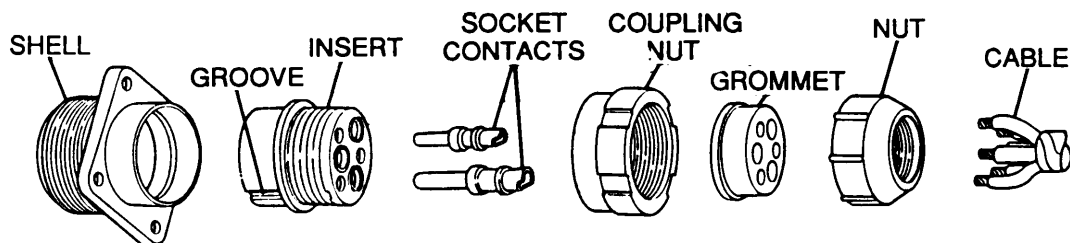

2-13.7 Typical Male-Type Plug with Ridged Locking Nut

2-13.7.1 Disassembly

- a. Unscrew nut from shell assembly and slide back on cable.
- b. Slide grommet back on cable leads.
- c. Slide coupling nut off shell assembly.
- d. Drive pin contacts out through rear insert with pin extractor.
- e. Push insert out through rear of shell.
- f. Unsolder cable leads from pin contacts.

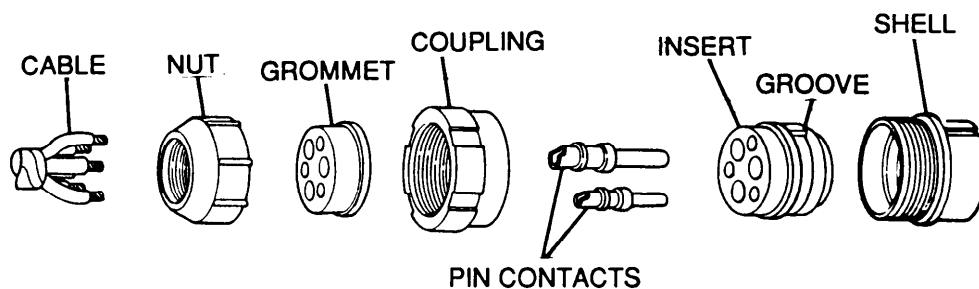

2-13 WIRING HARNESS AND CABLE REPAIRS — CONTINUED

2-13.7 Typical Male-Type Plug with Ridged Locking Nut — Continued

2-13.7.2 Assembly

- a. Strip cable of insulation equal to depth of solder wells of pin contact.
- b. Slide nut over cable.
- c. Slide grommet over cable leads.
- d. Insert cable leads into solder wells of pin contacts and solder using resin core solder.
- e. Push insert into shell from rear until seated. Groove in insert must be aligned with guide in shell to ensure proper fit.
- f. Push pin contacts into insert from rear until seated.
- g. Slide coupling nut onto shell assembly.
- h. Push grommet down cable leads and over solder wells of pin contacts.
- i. Screw nut onto shell assembly.

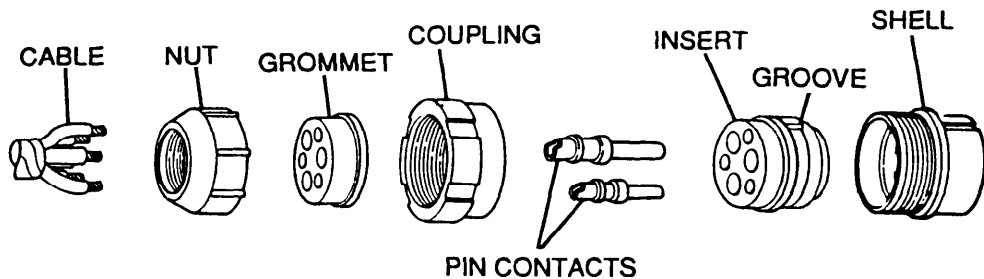

2-13.8 Cable Terminals and Connectors: Replacement Terminal-Type Cable Connector

- a. Strip cable insulation equal to depth of terminal well.
- b. Slide insulator over cable.
- c. Insert cable into terminal well and crimp.
- d. Slide insulator over crimped end of terminal.

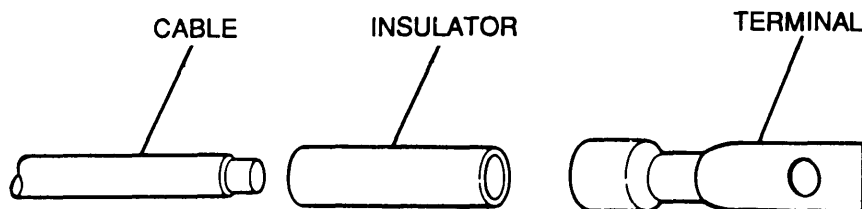

2-13.9 Female Cable Connector (with Washer)

- a. Strip cable insulation approximately 0.125 in. (3.2 mm).
- b. Slide shell and washer over cable.
- c. Place cable in cylinder end of terminal and crimp.
- d. Slide shell and washer over terminal.

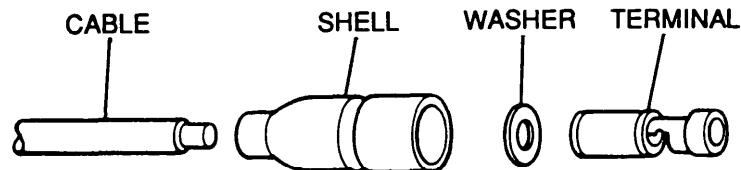
**2-13.10 Male Cable Connector (with Washer)**

- a. Strip cable insulation equal to depth of terminal well.
- b. Slide shell over cable.
- c. Insert cable into terminal well and crimp.
- d. Place C-washer over cable at crimped junction and slide shell over C-washer and terminal.

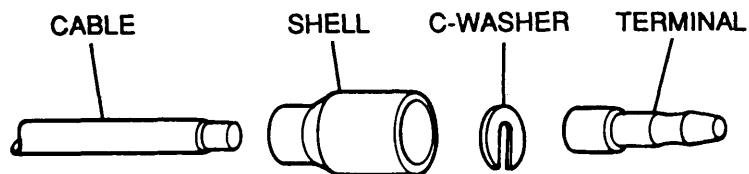
**2-13.11 Female Cable Connector (with Sleeve)**

- a. Strip cable insulation approximately 0.125 in. (3.2 mm).
- b. Slide shell and sleeve over cable.
- c. Place cable in cylinder end of terminal and crimp.
- d. Slide shell and sleeve over terminal.

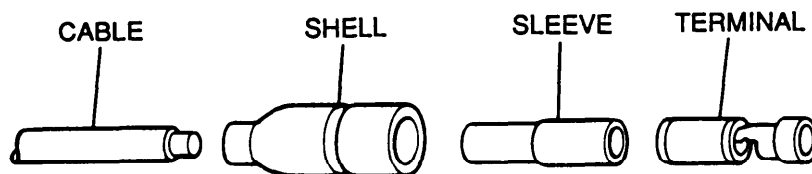

SECTION IV. PREVENTIVE MAINTENANCE CHECKS AND SERVICES (PMCS)

2-14 GENERAL

This section contains unit PMCS. Preventive maintenance is the step-by-step care, inspection, and service of equipment to maintain it in good condition and to find problems before extensive and time-consuming repairs or replacements are needed. Refer to DA PAM 738-750 for instructions on use of forms for PMCS.

2-14.1 Intervals

The PMCS listed in Table 2-1 are to be performed at organizational level at intervals determined by whichever comes first: (a) semiannually, 1500 miles (2539 km), or 150 hours; (b) annually, 3000 miles (4828 km), or 300 hours.

PMCS items and intervals have been determined by using Reliability Centered Maintenance (RCM) logic and are to be scheduled on DD Form 314 in accordance with DA PAM 738-750.

After operation in water, mud, and loose sand, the vehicle should be cleaned as soon as possible. Lubricate without waiting for the next scheduled service.

2-14.2 Lubrication

Paragraph 2-15 has detailed lubrication steps and instructions covering locations, intervals, and lubricants for M109A2/M109A3/M109A4/M109A5 Howitzers. The crew will assist the unit maintenance personnel in lubricating the vehicle.

2-14.3 Procedures

2-14.3.1 Routine applications — TM 9-2350-311-10 contains maintenance instructions that the unit mechanic must use to perform his duties.

2-14.3.2 Crew participation — The crew will accompany the vehicle and help the unit mechanics perform unit services.

CAUTION

Do not direct a stream of water or steam against the opening between the hull and cab (cab race ring), grilles exhaust deflectors, fire control, or armament openings.

2-14.3.3 Vehicle cleanliness — The crew should bring a clean vehicle to a scheduled PMCS. It should be dry and not caked with mud. Washing the vehicle should not be done just before an inspection. Some defects, such as loose parts and oil leaks, may not be noticed immediately after washing.

2-14.4 Services

Unit services are defined by, and limited to, the following general procedures. Approval to perform higher category services must be given by the supporting maintenance unit.

2-14.4.1 Adjustment — Make all needed adjustments using instructions in this manual and technical bulletins.

2-14.4.2 Cleaning — Clean the vehicle to remove old lubricant, dirt, and other foreign matter. Special cleaning instructions are given as needed.

2-14.4.3 Special lubrication — Special lubrication applies either to lubrication operations that do not appear in TM 9-2350-311-10, TM 9-2350-311-20-2, or paragraph 2-15 or to items that do appear, but that should be done with the annual services.

2-14.4.4 Service — Servicing covers operations such as adding battery water, draining and refilling units with oil, and changing or cleaning the oil filters, fuel filters, and air cleaners.

2-14.4.5 Tightening — All tightening operations should be done according to specified torque readings where noted in this manual. When torque isn't specified, care should be taken not to strip or distort threads by overtightening. Use a torque wrench where specified. Tightening includes the correct installing of lockwasher, nut, lockwire, or cotter pin needed to secure the tightened nut or bolt in place. See Appendix F for torque requirements.

2-14.4.6 Repair — Restore an item to a serviceable condition. This includes, but is not limited to, inspection, cleaning, preserving, adjusting, replacing, welding, riveting, and strengthening.

2-15 PROCEDURES FOR SEMIANNUAL/ANNUAL SERVICES

DA Form 2404, Equipment Inspection and Maintenance Worksheet, is used by the mechanic to record periodic maintenance services performed and faults corrected. The item number on the DA Form 2404 must correspond to the item number of the preventive maintenance check.

Specified items to be checked semiannually and annually are found in Table 2-1. Before you begin to check specific items, remember to check things common in all areas as shown in the following illustrations.

NOTE

Perform unit maintenance level repair or replacement as authorized. Report faulty equipment which is beyond unit maintenance level as prescribed in DA PAM 738-750.

2-15.1 Electrical Wires and Connectors

Electrical wiring should be checked for cracks due to aging and for exposed wires that cause electrical shorts. Repair with electrical tape or replace. Check connectors and tighten if loose (complete hull wiring diagram, wiring harness schematics, and details are in Chapter 8 and the foldout pages of this manual). If connector pins are corroded, spray pins with cleaning lubricant (item 13, Appx D).

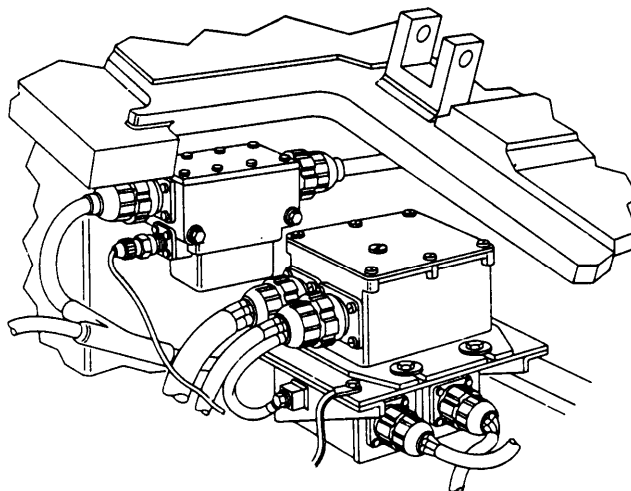

2-15 PROCEDURES FOR SEMIANNUAL/ANNUAL SERVICES — CONTINUED

2-15.2 Welds

Many items are attached to the hull with welds. Check for damaged welds by looking for chipped paint or oxidation. Make repairs if authorized.

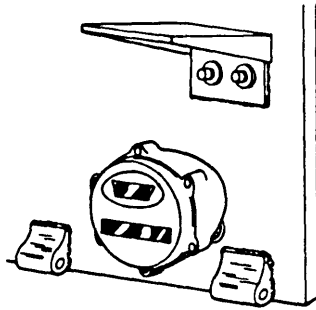

2-15.3 Seals

Check for leaks around seals. Check gasket material. Check door and hatch seals. Check for deterioration, cracks, and tears.

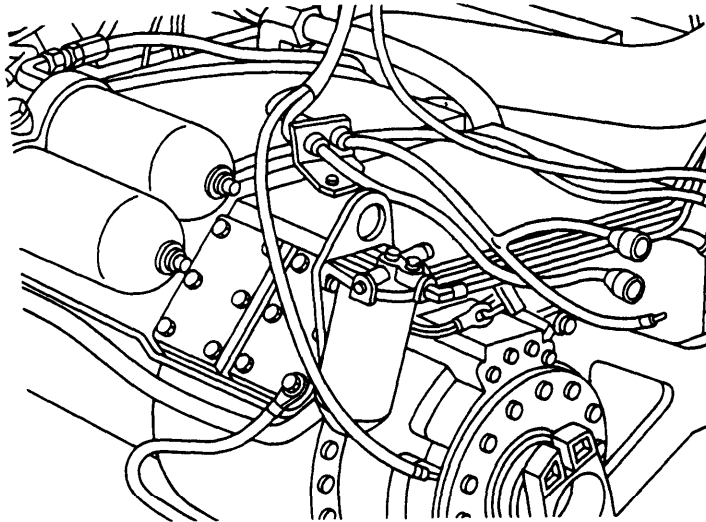

2-15.4 Bolts

Check for loose bolts. A loose bolt can be difficult to spot without actually applying a wrench. You can often tell by loose or chipped paint around the bolt head and bare metal or oxidation present at the base of the bolt head.

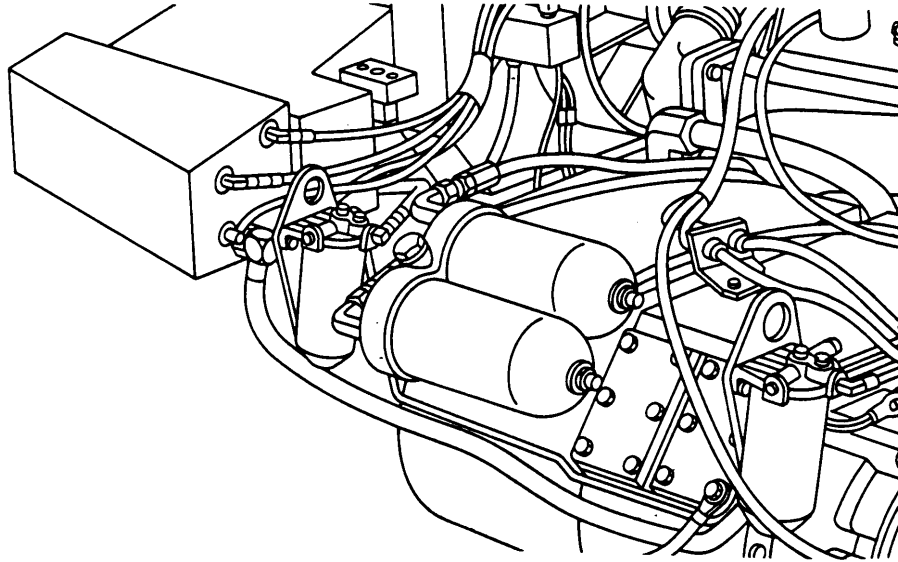

2-15.5 Hoses and Fluid Lines

Check all hoses and lines for signs of wear (deterioration or cracks), leaks, loose clamps, and loose fittings. A stain around a fitting is a sign of a leak. Tighten, repair, or replace hoses and fittings as necessary.

2-15.6 Classification of Fluid Leaks

The following definitions concern types/classes of fluid leakage. Each mechanic must be familiar with these definitions in order to determine whether or not the vehicle is mission capable.

CAUTION

Equipment operation is allowable with minor leakage (class I or II). Consideration must be given to the fluid capacity in the item or system being checked or inspected. When in doubt notify your supervisor. When operating with class I or class II leaks, continue to check fluid levels as required in your PMCS. Class III leaks should be reported to unit maintenance supervisor.

Class I — Seepage of fluid (indicated by wetness or discoloration) not great enough to form drops.

Class II — Leakage of fluid great enough to form drops, but not enough to cause drops to drip from item being checked or inspected.

Class III — Leakage of fluid great enough to form drops that fall from the item being checked or inspected.

2-15 PROCEDURES FOR SEMIANNUAL/ANNUAL SERVICES — CONTINUED

2-15.7 Introduction to PMCS Table

2-15.7.1 General

Table 2-1 (PMCS) has been provided so you can keep your equipment in good operating condition and ready for its primary mission.

2-15.7.2 Warnings and Cautions

Always observe the warnings and cautions appearing in your PMCS table. Warnings and cautions appear before applicable procedures. You must observe these warnings and cautions to prevent serious injury to yourself and to others or to prevent your equipment from being damaged.

2-15.7.3 Explanation of Table Entries

- a. ITEM NO. column — Numbers in this column are for reference. When completing DA Form 2404, Equipment Inspection and Maintenance Worksheet, include the item number for the check/service indicating a fault. Item numbers also appear in the order that you must do checks and services for the intervals listed.
- b. INTERVAL column — This column tells you when to do a certain check or service. Semiannual procedures must be done every 6 months, 1500 miles (2414 km), or 150 hours of vehicle operation. Annual procedures must be done every 12 months, 3000 miles (4828 km), or 300 hours of vehicle operation.
- c. ITEM TO BE INSPECTED column — This column provides the item to be checked or serviced.
- d. PROCEDURE column — This column gives the procedure you must perform to check or service the item listed in the ITEM TO BE INSPECTED column to know if the equipment is ready or available for its intended mission or operation. You must do the procedure at the time stated in the INTERVAL column.
- e. NOT FULLY MISSION CAPABLE IF: column — Information in this column tells you what faults will keep your equipment from performing its primary mission. If you make inspection procedures that show faults listed-in this column, do not operate the equipment. Follow standard operating procedures for maintaining the equipment or reporting equipment failure.

2-15.7.4 Other Table Entries

Be sure to observe all special information and notes that appear in your table.

2-15.8 PMCS

INITIAL SETUP

Tools

- General mechanics tool kit (item 64, Appx H)
- Air compressor (item 13, Appx H)
- Gage and case assemblies (item 22, Appx H) (A)
- Radiator cleaning tool (item 12, Appx H)
- Socket set (item 56, Appx H)
- Torque multiplier (item 37, Appx H)
- Torque wrench (item 71, Appx H)
- Torque wrench (item 72, Appx H)

- Gasket (item 143, Appx G) (S)
- Gasket (item 188, Appx G) (S/A)
- Gasket (item 200, Appx G) (S/A)
- Gaskets (2) (item 175, Appx G) (S/A)
- Gaskets (2) (item 190, Appx G) (S)
- Gasket sets (2) (item 195, Appx G) (S)
- Grease (item 31, Appx D)
- Lockwire (item 113, Appx G) (S)
- Lubricating oil (item 36, Appx D)
- Lubricating oil (item 40, Appx D) (A)
- Lubricating oil (item 47, Appx D) (A)
- Preformed packing (item 198, Appx G) (S)
- Preformed packing (item 199, Appx G) (S/A)
- Preformed packings (2) (item 183, Appx G) (S/A)
- Strainer element (item 201, Appx G) (S/A)
- Strainer elements (2) (item 176, Appx G) (S/A)
- Transmission parts kit (item 191, Appx G) (S)

Materials/Parts

- Antipilferage seal (item 225, Appx G) (S)
- Cotter pins (item 104, Appx G) (A)
- Detergent (item 20, Appx D) (A)
- Distilled water (item 66, Appx D) (S)
- Dry-cleaning solvent (item 21, Appx D) (A)
- Filter element (item 6, Appx G) (S/A)
- Filter element (item 115, Appx G) (S/A)
- Filter element (item 189, Appx G) (S/A)
- Filter elements (2) (item 106, Appx G) (S)
- Gasket (item 142, Appx G) (S)

References

- TB 750-651 (A)
- TM 9-2530-200-24 (A)
- TM 9-2350-311-10 (S/A)

TABLE 2-1 UNIT PMCS FOR M109A2/M109A3/M109A4/M109A5 HOWITZERS

ITEM NO.	INTERVAL	ITEM TO BE INSPECTED	PROCEDURE	NOT FULLY MISSION CAPABLE IF:
1	Semiannual	Road Test Before Service	<p style="text-align: center;">NOTE</p> <p>Ensure that operator has performed entire PMCS in TM 9-2350-311 -10.</p> <p>Have operator perform a road test at least 5 miles (8 km) within a designated route.</p> <p style="text-align: center;">NOTE</p> <p>When conditions prevent a road test, perform engine testing, STE/ICE-R test, 10, 13, 14, 50, 67,72,73,74, and 75 (Appx I, Sect II).</p> <p>Check instruments, gages, and warning light for normal indications as outlined in TM 9-2350-311-10, before the road test.</p>	Engine, transmission, coolant temperature, or pressure gages do not operate.

2-15 PROCEDURES FOR SEMIANNUAL/ANNUAL SERVICES — CONTINUED

TABLE 2-1 UNIT PMCS FOR M109A2/M109A3/M109A4/M109A5 HOWITZERS — CONTINUED

ITEM NO.	INTERVAL	ITEM TO BE INSPECTED	PROCEDURE	NOT FULLY MISSION CAPABLE IF:
2	Semiannual	Starter	While starting engine, listen for unusual noises and difficult cranking at starter.	Any unusual noise or difficult cranking.
3	Semiannual	Engine	Listen for unusual noises, hesitations, and varying idle speed.	Any unusual noises, hesitation, or varying idle speed.
4	Semiannual	Steering Control	Move steering wheel through its entire range and observe if steering response is satisfactory. With vehicle operating at 15 to 20 mph (24 to 32 km/h) and steering wheel centered, observe if steering wheel wanders or pulls to one side.	Linkage bent, broken, or out of adjustment.
5	Semiannual	Brakes	Accelerate vehicle to 15 mph (24 km/h). Release accelerator pedal, and apply brakes. Vehicle should stop without pulling to one side. With vehicle stopped on an incline, and with transmission in neutral, depress brake pedal and apply parking brakes. Brakes should lock securely and hold vehicle in place. Adjust brakes, if required (para 9-10).	Brake pedal goes to floor and will not stop vehicle
6	Semiannual	Fuel System	<p>a. Change fuel filter elements (1) (primary and secondary), personnel heater fuel filter element, and coolant heater fuel filter element (2) (para 6-6, 6-7, 11-21, and 14-6), personnel heater fuel pump strainer element (3) and coolant heater fuel pump filter element (para 11-23 and 14-5).</p> <p>b. Check all fuel lines and fittings (4) for serviceability and evidence of leaks.</p>	<p>a. Cracked or broken fitting and fuel lines. Any bent fuel line that would restrict or stop fuel flow.</p> <p>b. Any class III leaks.</p>

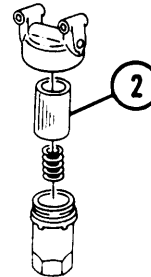
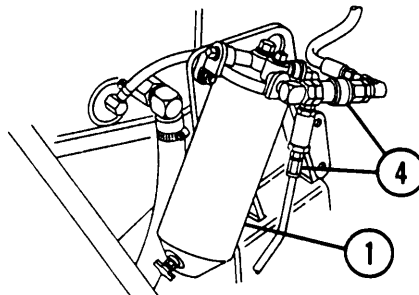
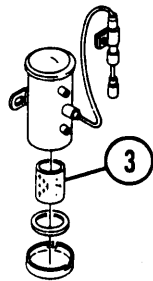

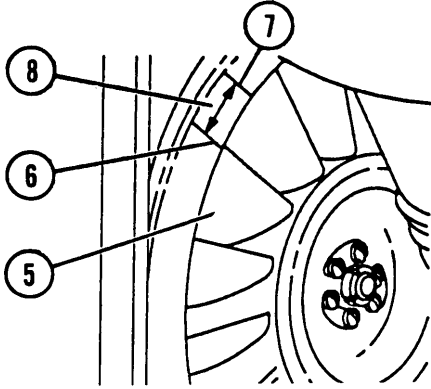
ITEM NO.	INTERVAL	ITEM TO BE INSPECTED	PROCEDURE	NOT FULLY MISSION CAPABLE IF:
7	Semiannual	Engine Fan Drive System	<p>Perform backlash test as follows:</p> <ol style="list-style-type: none"> a. Disconnect both battery ground cables. b. Open air intake grille. c. Mark any accessible blade (5). d. While holding the opposite fan impeller, rotate marked blade as far left as possible. Mark (6) fan housing directly above blade mark. e. While holding opposite fan impeller, rotate marked blade as far right as possible. Mark (7) fan housing directly above the blade mark. f. Measure distance (8) between marks. If distance is over 1 in. (2.5 cm), backlash is excessive. Notify support maintenance. g. Inspect fan for cracked and loose rubber boot and loose retaining ring on boot covering the drive shaft U-joints.  <p>The diagram shows a cross-section of the fan assembly. Point 5 is on a fan blade, point 6 is on the fan housing directly above it, point 7 is on the fan housing directly above the opposite blade, and point 8 is the distance between points 6 and 7.</p>	<ol style="list-style-type: none"> f. Backlash is over 1 in. (2.5 cm). g. Cracked rubber boot or loose retaining ring on covers for drive shaft U-joint.
8	Semiannual	Fan Gear Case	<p style="text-align: center;"><u>WARNING</u></p> <p>Dry-cleaning solvent (P-D-680) is toxic and flammable. Wear protective goggles and gloves and use only in a well ventilated area. Avoid contact with skin, eyes, and clothes, and don't breath vapors. Do not use near open flame or excessive heat. The flashpoint for type #1 is 100°F (38°C) and for type #2 is 138°F (59°C). If you become dizzy while using dry-cleaning solvent, get fresh air immediately and get medical aid. If contact with eyes is made, wash your eyes with water and get medical aid immediately.</p>	

2-15 PROCEDURES FOR SEMIANNUAL/ANNUAL SERVICES — CONTINUED

TABLE 2-1 UNIT PMCS FOR M109AZM109A3/M109A4/M109A5 HOWITZERS — CONTINUED

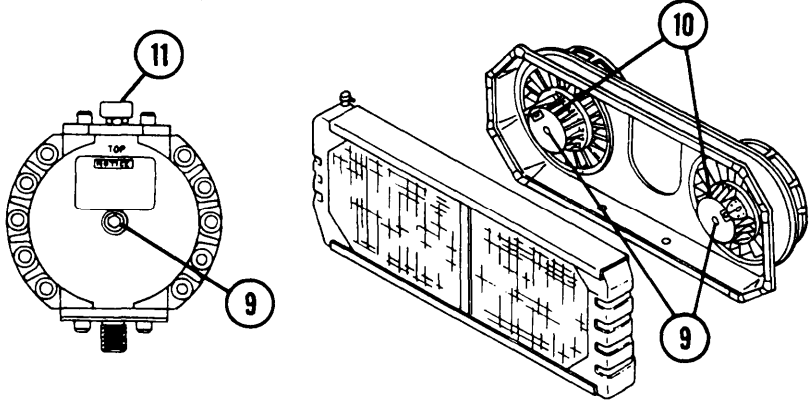
ITEM NO.	INTERVAL	ITEM TO BE INSPECTED	PROCEDURE	NOT FULLY MISSION CAPABLE IF:
8	Semiannual	Fan Gear Case — Continued	<p>Remove from shroud (para 7-6 and 7-7). Clean area around plugs (9) on fan gearbox housings (10) with dry cleaning solvent. Remove plug. Check that oil level is up to bottom of plug hole. If not, remove breather (11) and add 0-156 unit oil level reaches bottom of hole. Clean and install plug. Clean breather with dry cleaning solvent before installing.</p> 	
9	Semiannual	Fire Extinguisher System	<p style="text-align: center;">WARNING</p> <p>Cylinders must not be dropped, struck or subject to any temperature above 140°F (60°C). An explosion may result causing severe injury or death.</p> <p>a. Remove and weigh cylinders. Cylinders are to be recharged to “FULL” weight stamped on cylinder if difference between the “FULL” and “CURRENT” (after weighing) weight exceeds 1 lb (0.45 kg).</p> <p>b. Before replacing cylinder, operate the discharge handles (12) to ensure cables do not bind. Replace antipilferage seal (13) and wire (14) on control valve (15). Driver’s and outside handles require antipilferage seal and wire (para 11-25).</p> <p>c. Check distribution lines for loose fittings, loose mounting, and cracks.</p>	<p>a. Any cylinders require recharging.</p> <p>b. Any binding or unserviceable cables and discharge handles.</p> <p>c. Distribution lines loose, cracked, or not mounted tightly.</p>

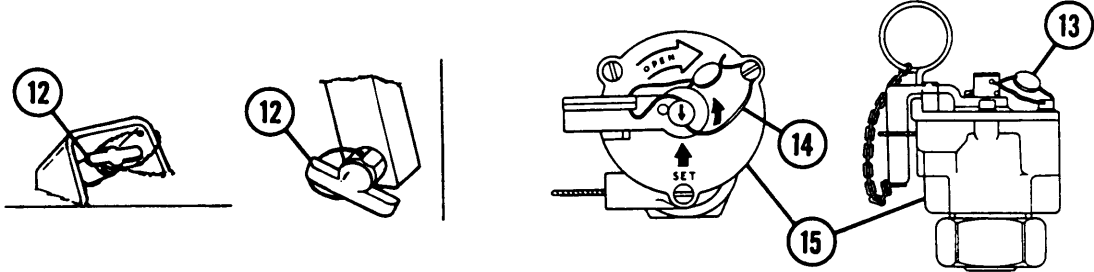
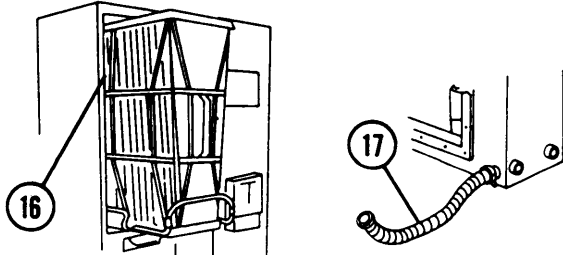
ITEM NO.	INTERVAL	ITEM TO BE INSPECTED	PROCEDURE	NOT FULLY MISSION CAPABLE IF:
10	Semiannual	Air Cleaner Fitter	 <p>d. Inspect fire extinguisher cylinder data plates to ensure that a hydrostatic test has been performed within past 5 years. Faulty extinguishers or those past test time limit (5 years) shall be declared unserviceable and replaced.</p> <p style="text-align: center;">WARNING</p> <p>If NBC exposure is suspected, all air filter media will be handled by personnel wearing full NBC protective equipment.</p> <p>Check for worn or missing gaskets (16) and hoses (17). Check blower motors for operation. Troubleshoot if necessary (para 3-3). Clean as follows:</p> <p style="text-align: center;">WARNING</p> <p>Compressed air used for cleaning purposes will not exceed 30 psi (207 kPa). Use only with effective chip guarding and personal protective equipment (goggles/shield, gloves, etc).</p> <p>a. Shakeout dust. Using compressed air, clean the filter on the inside and blow dust outward away from filter.</p> <p>b. Replace filter elements which have holes or ruptures.</p> 	<p>d. Any cylinder is faulty or past the test time limit.</p> <p>Seals tom or missing. Air filter element clogged or wet. Rubber hose cracked or tom. Air cleaner doors do not close property.</p>

2-15 PROCEDURES FOR SEMIANNUAL/ANNUAL SERVICES — CONTINUED

TABLE 2-1 UNIT PMCS FOR M109A2/M109A3/M109A4/M109A5 HOWITZERS — CONTINUED

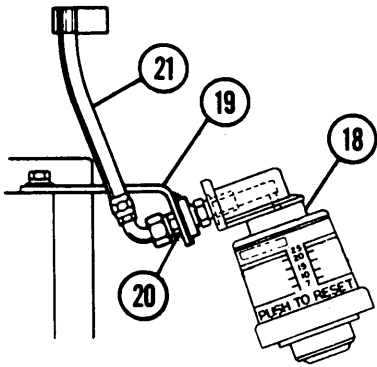
ITEM NO.	INTERVAL	ITEM TO BE INSPECTED	PROCEDURE	NOT FULLY MISSION CAPABLE IF:
11	Semiannual	Air Cleaner Indicator	<p>a. Check indicator casing (18) for damage and corrosion.</p> <p>b. Check that bracket (19) is secure.</p> <p>c. Check nut (20) for tightness.</p> <p>d. Check hose (21) for leaks.</p>  <p>The diagram shows a mechanical assembly. Callout 18 points to a rectangular indicator casing with a gauge and a 'PUSH TO RESET' button. Callout 19 points to a bracket that secures the casing. Callout 20 points to a nut on a bolt that connects the bracket to a vertical post. Callout 21 points to a curved hose attached to the bracket.</p>	
12	Semiannual	Battery	<p>WARNING</p> <p>Battery gasses can explode. Do not smoke, have open flame, or create sparks around battery. Severe injury may result due to explosion.</p> <p>a. Check and record specific gravity of each cell (para 8-28).</p> <p>Specific gravity ranges: Tropical electrolyte — 1.180 to 1.225 Temperate electrolyte — 1.225 to 1.280</p> <p>b. Check electrolyte level; if low, add distilled water. Check battery cables for frays, missing, or broken. Clean top of batteries and coat terminals lightly with grease (para 8-28).</p>	<p>3. Specific gravity is not within set standards.</p> <p>3. One or more batteries Unserviceable. Cables frayed, missing or broken.</p>

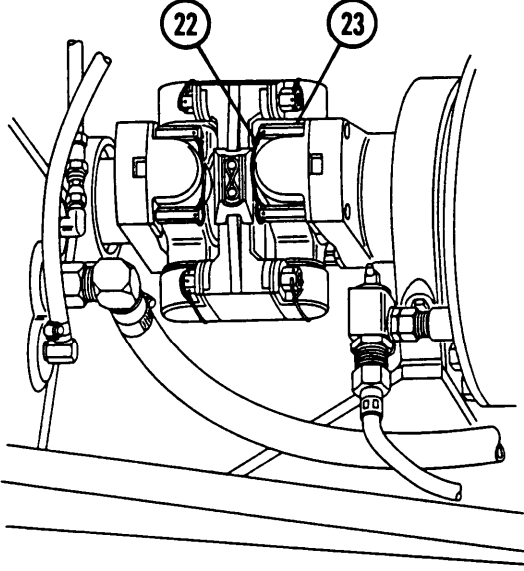
ITEM NO.	INTERVAL	ITEM TO BE INSPECTED	PROCEDURE	NOT FULLY MISSION CAPABLE IF:
13	Semiannual	Final Drive and Universal Joints	<p>a. Check for missing or broken lockwires (22). Torque mounting screws (23) to 90 lb-ft (122 N·m).</p> <p>b. Remove end cover. Inspect bearing retainer nut.</p> 	<p>a. Any loose, missing, or broken retaining bolts or cotter pins. Lockwire broken or missing.</p> <p>b. Any visual signs of a loose nut or sheared cotter pin, final drive will be removed and replaced.</p>
14	Semiannual	Road Test	Check the performance of items that were adjusted, repaired, or replaced as a result of the road test.	
15	Annual	Bump Stop Brackets	Check bump stop brackets (24) with a wrench for looseness, if loose, torque bump stop mounting bracket bolts (25) to 300-350 lb-ft (407-475 N·m).	

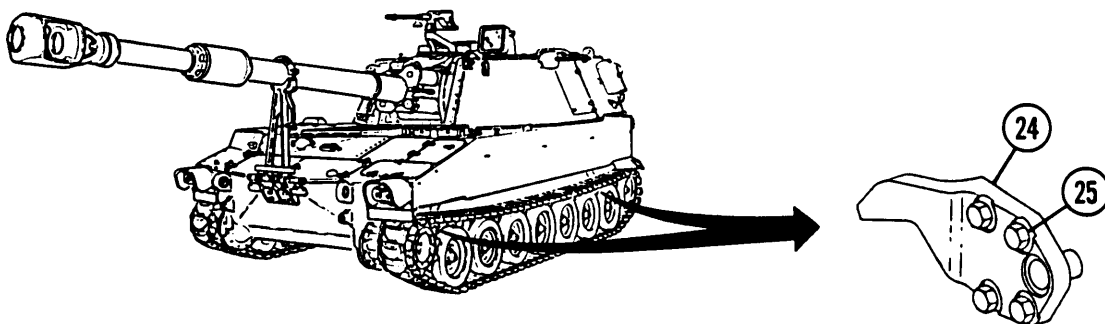

2-15 PROCEDURES FOR SEMIANNUAL/ANNUAL SERVICES — CONTINUED

TABLE 2-1 UNIT PMCS FOR M109A2/M109A3/M109A4/M109A5 HOWITZERS — CONTINUED

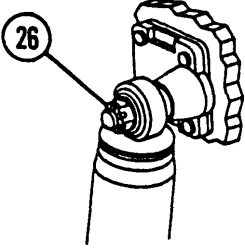
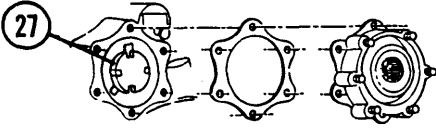
ITEM NO.	INTERVAL	ITEM TO BE INSPECTED	PROCEDURE	NOT FULLY MISSION CAPABLE IF:
16	Annual	Shock Absorbers	<p>Check all shock mount nuts (26) for missing cotter pins and looseness. If shock absorber mounting retaining nuts are loose, torque to 100-140 lb-ft (136-190 N·m).</p> 	Any missing or broken cotter pins. Any class III leaks. Any missing or broken shock mount bolts.
17	Annual	Alternator Drive Coupling	<p>Check alternator drive coupling (27) by turning alternator fan, it should not move more than 0.125 in. (3.2 mm). If it moves more than 0.125 in. (3.2 mm), remove and inspect alternator drive coupling (para 8-2). Replace if drive coupling is cracked or broken.</p> 	More than 0.125-in. (3.2-mm) play in coupling gear drive, bolts missing from drive coupling, or cracked or broken housing.
18	Annual	Starter	<p style="text-align: center;">NOTE</p> <ul style="list-style-type: none"> • Remove powerplant from the vehicle and perform a walk-around of the powerplant (para 4-5). • Check that all starter bolts and mounting hardware are properly secured. <p>a. Check for missing or loose mounting hardware, if loose, torque to 95–105 lb-ft (129-142 N·m).</p> <p>b. Check wiring harness and cables for frays, breaks, or looseness.</p>	<p>a. Any loose or missing bolts.</p> <p>b. Any loose or frayed wires.</p>

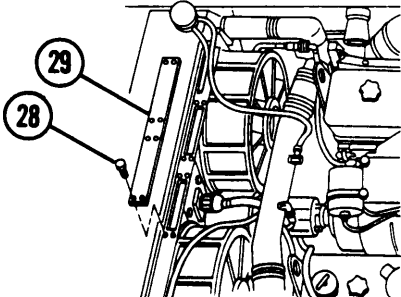
ITEM NO.	INTERVAL	ITEM TO BE INSPECTED	PROCEDURE	NOT FULLY MISSION CAPABLE IF:
19	Annual	Cooling System, Radiator Hoses, and Pumps	<p style="text-align: center;">WARNING</p> <p>Do not remove a radiator cap from a warm engine. Steam and hot gases can burn severely.</p> <ol style="list-style-type: none"> a. Check for cracked, weak or broken hoses. b. Check coolant system for leakage. c. Check coolant level. d. Remove shroud cover and inspect drive shafts for excessive wear and loose rubber-boots. e. Radiator should be cleaned with a radiator cleaning tool (item 12, Appx H) and a cleaning agent which removes deposits of sand, oil, clay and other debris from radiator cooling fins. <div style="text-align: center;"> <p>RADIATOR CLEANING TOOL</p>  </div> <p style="text-align: center;">NOTE</p> <p>Cleaning agent can be a solution of one part detergent to five parts water, or nontoxic, nonflammable solvent and water. The cleaning agent may be mixed one part detergent to five parts water.</p> <p>Clean radiator as follows:</p> <ol style="list-style-type: none"> (1) Remove eight screws (28) and shroud cover (29). <div style="text-align: center;">  </div>	Any weak, cracked, or broken hoses or any coolant leak. Drive shaft boots torn or loose.

2-15 PROCEDURES FOR SEMIANNUAL/ANNUAL SERVICES — CONTINUED

TABLE 2-1 UNIT PMCS FOR M109A2/M109A3/M109A4/M109A5 HOWITZERS — CONTINUED

ITEM NO.	INTERVAL	ITEM TO BE INSPECTED	PROCEDURE	NOT FULLY MISSION CAPABLE IF:
19	Annual	Cooling System, Radiator Hoses, and Pumps — Continued	<p>(2) Open hull drains.</p> <p>(3) Cover all exposed openings of engine.</p> <p style="text-align: center;">WARNING</p> <p>Compressed air used for cleaning purposes will not exceed 30 psi (207 kPa). Use only with effective chip guarding and personal protective equipment (goggles/shield, gloves, etc).</p> <p>(4) Connect tool to air supply and insert liquid supply hose into container of cleaning solution.</p> <p>(5) Insert tool through shroud cover opening and wet front and back of radiator with cleaning solution. Soak for approximately 10 minutes.</p> <p>(6) Remove heavy deposits from face of radiator by brushing with medium stiff brush that will not damage radiator fins.</p> <p>(7) Blast radiator with air/solution mixture, holding head of tool approximately 0.5 in. (13 mm) from face of radiator. Alternate from back to front until cleaning solution flows smoothly through radiator.</p> <p>(8) Drain container and fill with clean water. Flush engine parts and radiator completely. Remove liquid supply hose from container and use air to complete operation.</p> <p>(9) Uncover engine openings and install radiator shroud cover with eight screws. Close hull drains.</p>	
20	Annual	Coolant	Test radiator coolant for proper protection (TB 750-651).	Does not pass alkalinity test in TB 750-651. Not protected to -20°F (-30°C).

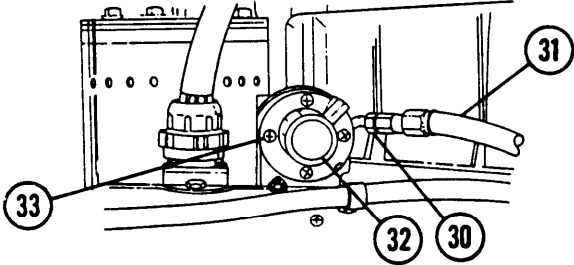
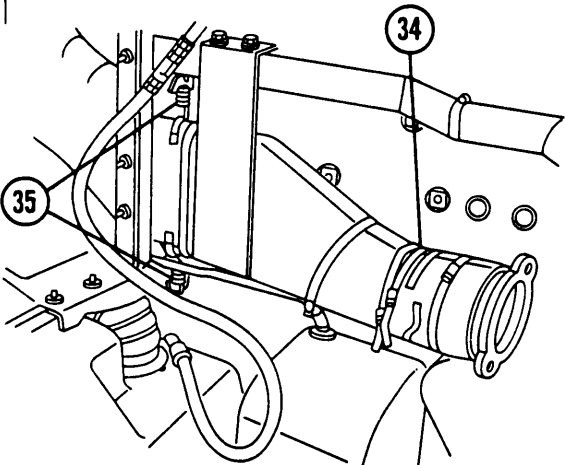
ITEM NO.	INTERVAL	ITEM TO BE INSPECTED	PROCEDURE	NOT FULLY MISSION CAPABLE IF:
21	Annual	Cooling System Pressure Relief Valve	<p>Remove and clean pressure relief valve as follows:</p> <ol style="list-style-type: none"> Unscrew nut (30) and remove hose (31) from lower end of relief valve (32). Remove four screws (33). Lift off relief valve (32). Wipe off accumulation of rust. Depress spring to ensure it is not broken. Install pressure relief valve (32) (para 7-5). 	Any screws missing, coolant leaks, or any missing or broken valve parts.
22	Annual	Exhaust Ducts	<p>Check and replace all damaged components. Check all clamps (34) and mounting bolts (35).</p> 	Any damaged component, loose clamps, or exhaust leaks.
23	Semiannual	Fuel Tank and Heat Shield	<p>Inspect the upper fuel tank and lower tank heat shield for damage. Check condition and tightness of all seals and fasteners (para 6-20).</p>	Any Class III leaks. Upper heat shield missing. Seal cracked or loose fasteners.

2-15 PROCEDURES FOR SEMIANNUAL/ANNUAL SERVICES — CONTINUED

TABLE 2-1 UNIT PMCS FOR M109A2/M109A3/M109A4/M109A5 HOWITZERS — CONTINUED

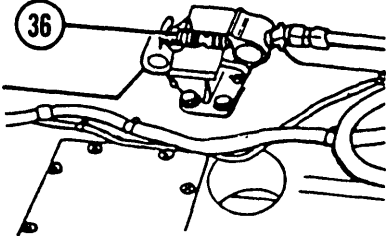
ITEM NO.	INTERVAL	ITEM TO BE INSPECTED	PROCEDURE	NOT FULLY MISSION CAPABLE IF:
24	Annual	Engine Mounting Base	Lubricate engine rear jaw mount screw (36) with GMD (item 47, Appx D).  NOTE Reinstall powerplant (para 4-5).	Rear mount mounting base screw or jaw broken.
25	Annual	Road Wheels and Idler Wheels	Check for cracks in wheel (37). Tighten nuts (36) to 160-200 lb-ft (217-271 N·m). Measure road wheel wear as follows: a. Pull out threaded rod and place gage (item 22, Appx H) over road wheel as shown, backing off knurled knob as required. b. When gaging balls are in contact with wear ring and inside of wheel disk, slowly turn knurled knob clockwise until it just contacts rod housing. Do not tighten knob, since this will pull inner gage ball away from wheel disk (39). c. Pull rod back, without disturbing knob, until gage can be removed from wheel.	Missing, bent, elongated, or cracked road wheel or idler wheel mounting holes.

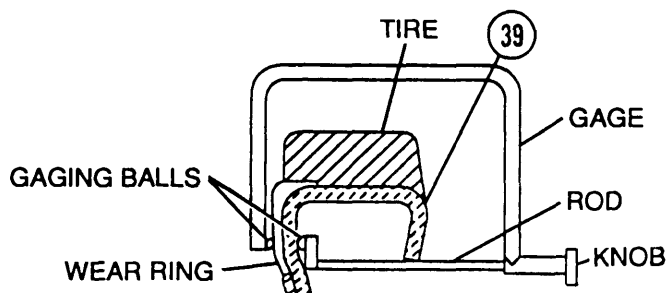
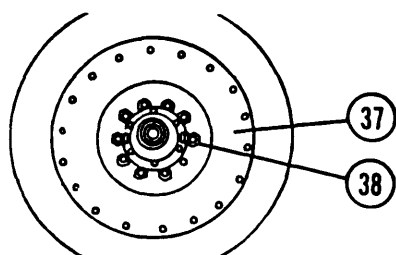

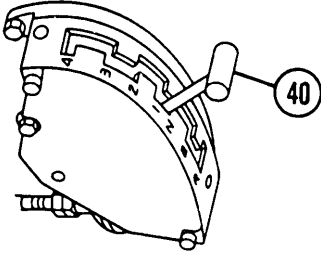
ITEM NO.	INTERVAL	ITEM TO BE INSPECTED	PROCEDURE	NOT FULLY MISSION CAPABLE IF:
26	Annual	Transmission Shifter Control Lever	<p>d. Push rod until knob contacts housing. Measure dimension between gaging balls.</p> <p>e. If dimension between balls is 0.436 in. (11 mm) or less, road wheel should be replaced.</p> <p>Move transmission shift control lever (40) to all positions. Shift control lever should not bind. If binding occurs, adjust as prescribed in paragraph 9-9.</p> 	<p>Dimension between gaging balls is less than 0.436 in. (11 mm) (TM 9-2530-200-24).</p> <p>Transmission shifter control out of adjustment, excessive looseness, or binding.</p>
27	Annual	Neutral Safety Switch	<p style="text-align: center;">WARNING</p> <p>Clear personnel and equipment from near vehicle.</p> <p>a. Apply brakes.</p> <p>b. Place transmission gear lever in gear.</p> <p>c. Hold fuel shutoff control.</p> <p>d. Attempt to crank engine. If starter engages, stop immediately and follow system troubleshooting procedures in paragraph 3-3.</p>	<p>Starter engages in any gear but neutral.</p>
28	Annual	Starter Protection Relay	<p>Do starter protection relay procedures as follows:</p> <p>a. Pull fuel shutoff to prevent engine from starting during procedure (TM 9-2350-311-10).</p> <p>b. Engage starter (TM 9-2350-311-10). Note amount of time that starter cranks and when it stops.</p>	

2-15 PROCEDURES FOR SEMIANNUAL/ANNUAL SERVICES — CONTINUED

TABLE 2-1 UNIT PMCS FOR M109A2/M109A3/M109A4/M109A5 HOWITZERS — CONTINUED

ITEM NO.	INTERVAL	ITEM TO BE INSPECTED	PROCEDURE	NOT FULLY MISSION CAPABLE IF:
28	Annual	Starter Protection Relay — Continued	<p style="text-align: center;">NOTE</p> <p>During normal operation when starter is cranking, starter protection device should automatically cut starter off after cranking for the following period of time:</p> <p style="padding-left: 40px;">25 to 35 seconds at 50°F (10°C) or above.</p> <p style="padding-left: 40px;">55 to 65 seconds at 0 to 50°F (-18 to 10°C).</p> <p style="padding-left: 40px;">100 to 140 seconds at 0 to -50°F (-18 to -45°C).</p> <p>Starter protection device should reset in 105 to 140 seconds. If starter does not shut off as indicated or device will not reset, replace device.</p> <p>c. If starter cranks for only 1 to 2 seconds, troubleshoot batteries for low power (para 3-3).</p> <p>d. If starter cranks longer than listed times, troubleshoot starter protection circuit (para 3-3).</p> <p>e. If starter cranks for listed times, wait 1 minute and try to engage again. If starter operates, troubleshoot starter protection circuit (para 3-3).</p> <p style="text-align: center;">CAUTION</p> <p>Combat override switch should be used only in an emergency or when tested as in this step. Excessive use may cause damage to starter.</p> <p style="text-align: center;">NOTE</p> <p>Combat override switch is found only on M109A4/M109A5 Howitzers.</p>	

ITEM NO.	INTERVAL	ITEM TO BE INSPECTED	PROCEDURE	NOT FULLY MISSION CAPABLE IF:
29	Annual	Transmission Gearcase	<p>f. Place combat override switch on (TM 9-2350-311-10) and engage starter for 5 seconds or less. If starter does not operate, troubleshoot starter protection circuit (para 3-3).</p> <p>g. Release combat override switch to off. Release fuel shutoff handle and attempt to start engine. If starter engages before 2.0 to 2.8 minutes have elapsed since step b, troubleshoot starter protection circuit (para 3-3).</p> <p style="text-align: center;"><u>W A R N I N G</u></p> <ul style="list-style-type: none"> • Oil is hazardous waste and must be disposed of in accordance with local procedures or direction of local Hazardous Waste Management office. • Dry-cleaning solvent (P-D-680) is toxic and flammable. Wear protective goggles and gloves and use only in a well ventilated area. Avoid contact with skin, eyes, and clothes, and don't breath vapors. Do not use near open flame or excessive heat. The flashpoint for type #1 is 100°F (38°C) and for type #2 is 138°F (59°C). If you become dizzy while using dry-cleaning solvent, get fresh air immediately and get medical aid. If contact with eyes is made, wash your eyes with water and get medical aid immediately. <p style="text-align: center;"><u>C A U T I O N</u></p> <p>Transmission holds approximately 48 or 56 qt (45 or 53 L) of oil. Before draining, provide enough container capacity to hold oil being drained.</p> <p style="text-align: center;"><u>N O T E</u></p> <p>Only drain if directed by Army Oil Analysis Program (AOAP), this would be done while powerplant is removed.</p>	

2-15 PROCEDURES FOR SEMIANNUAL/ANNUAL SERVICES — CONTINUED

TABLE 2-1 UNIT PMCS FOR M109A2/M109A3/M109A4/M109A5 HOWITZERS — CONTINUED

ITEM NO.	INTERVAL	ITEM TO BE INSPECTED	PROCEDURE	NOT FULLY MISSION CAPABLE IF:
29	Annual	Transmission Gearcase — Continued	<p>Drain transmission (only after operation). Place vehicle on level ground, remove drain plug. After draining, clean and reinstall plug and cover. Refill transmission (approximately 48 or 56 qt [45 to 53 L]) with OE/HDO (item 49, Appx D) to within OPERATION RANGE on dipstick. For extreme cold operation with OEA (item 47, Appx D) this is a semiannual check. Remove cover and filter element. Inspect and clean with dry-cleaning solvent (item 21, Appx D), dry and reinstall.</p>	<p>Oil is milky, any Class III leak or AOAP requests oil change.</p>
30	Annual	Engine Crankcase	<p style="text-align: center;">WARNING</p> <ul style="list-style-type: none"> • Oil is hazardous waste and must be disposed of in accordance with local procedures or direction of local Hazardous Waste Management office. • Dry-cleaning solvent (P-D-680) is toxic and flammable. Wear protective goggles and gloves and use only in a well ventilated area. Avoid contact with skin, eyes, and clothes, and don't breath vapors. Do not use near open flame or excessive heat. The flashpoint for type #1 is 100°F (38°C) and for type #2 is 138°F (59°C). If you become dizzy while using dry-cleaning solvent, get fresh air immediately and get medical aid. If contact with eyes is made, wash your eyes with water and get medical aid immediately. <p style="text-align: center;">CAUTION</p> <p>Engine holds approximately 38 qt (36 L) of oil. Before draining, provide enough container capacity to hold oil being drained.</p> <p style="text-align: center;">NOTE</p> <p>Only drain if directed by Army Oil Analysis Program (AOAP), this would be done while powetplant is removed.</p>	

ITEM NO.	INTERVAL	ITEM TO BE INSPECTED	PROCEDURE	NOT FULLY MISSION CAPABLE IF:
			<p>Drain engine crankcase (only after operation). Coordinate any required seasonal change of oil weight with this service, if possible. Place vehicle on level ground, remove cover on bottom of hull and remove oil drain plug. After draining, clean and reinstall plug and cover. Refill crankcase (approximately 27 to 38 qt [26 to 36 L] dry) with OE/HDO (item 49, Appx D) to ADD mark on dipstick. For extreme cold operation with OEA (item 47, Appx D) this is a semiannual check. Drain oil filter and remove elements, clean shell parts with dry-cleaning solvent (item 21, Appx D). Dry, inspect, and reinstall with new elements.</p>	<p>Oil is milky, any Class III leak, or AOAP requests oil change.</p>
31	Annual	Engine	<p>Perform STE/ICE-R PMCS testing. Perform STE/ICE-R 10, 13, 14,50,67, 72,73,74, and 75 (Appendix i).</p>	
32	Annual	Decals, Instruction Plates, Stencil Markings, and Paint	<p>Replace decals and instruction plates and restencil markings that are not legible. Clean and paint bare or worn spots (para 2-7 and 2-18).</p>	
33	Annual	Final Road Test	<p>a. Check performance of items that were adjusted, repaired, or replaced as a result of road test.</p> <p>b. Move steering wheel through its entire range and observe if steering response is satisfactory. With vehicle operating at 15 to 20 mph and steering wheel centered, observe if wheel wanders or pulls to one side.</p> <p>c. Accelerate vehicle to 15 mph (24 km/h). Release accelerator pedal and apply brakes. Vehicle should stop without pulling to one side. With vehicle stopped on an incline, and with transmission in neutral (N), depress brake pedal and apply parking brakes. Brakes should lock securely and hold vehicle in place. Adjust brakes if required (para 9-10).</p>	

2-15 PROCEDURES FOR SEMIANNUAL/ANNUAL SERVICES — CONTINUED

TABLE 2-1 UNIT PMCS FOR M109A2/M109A3/M109A4/M109A5 HOWITZERS — CONTINUED

ITEM NO.	INTERVAL	ITEM TO BE INSPECTED	PROCEDURE	NOT FULLY MISSION CAPABLE IF:
34	Annual	Engine Governed Speed and Performance	Test engine for acceleration and power in each gear. While testing in first gear, accelerate with wide open throttle from low speed to top speed. Governed speed under load should not exceed 2300 rpm. Maximum speeds are as follows: 1 st 6 mph 10 km/h 2nd 9 mph 14 km/h 3rd 24 mph 39 km/h 4th 35 mph 56 km/h R1 5 mph 8 km/h R2 7 mph 11 km/h	If governed speed under load exceeds 2300 rpm.
35	Annual	Leakage from Powerplant or Cab Hydraulic Systems	Inspect all areas inside and outside of vehicle for fuel or oil leaks.	Any fuel or class III leaks.

2-15.9 PMCS Parts List

The following parts are required when performing semiannual, annual, or on-condition PMCS. The semiannual/annual parts list contains the mandatory replacement parts for one semiannual PMCS or one annual PMCS. The on-condition parts list contains replacement parts that are required when engine and transmission oil changes are directed by the AOAP Laboratory. If AOAP Laboratory support is not available, change oil and filter elements/gaskets every 1500 miles (2414 km) or 150 hours.

SEMIANNUAL (1 500 MILES [2414KM] OR 150 HOURS)/
ANNUAL (3000 MILES [4828 KM] OR 300 HOURS) PARTS LIST

ITEM NO.	PART NUMBER	NSN	NOMENCLATURE	QTY
1	5575032	2940-00-745-7730	Filter element	1
2	CW226MP	2910-00-287-1912	Filter element	1
3	5574161	5330-00-846-9841	Gasket	1
4	10861673	2910-00-893-6402	Strainer element	1
5	7413738	5330-00-265-1089	Packing, preformed	1
6	7413775	5330-00-893-6402	Strainer element	1
7	7413774	5330-00-741-3774	Gasket	1

ITEM NO.	PART NUMBER	NSN	NOMENCLATURE	QTY
8	8720150	5340-00-835-9815	Seal, antipilferage	3
9	479729	4730-00-893-6402	Strainer element	2
10	479136	5330-00-736-9322	Gasket	2

SEMIANNUAL (1 500 MILES [2414 KM] OR 150 HOURS) PARTS LIST

ITEM NO.	PART NUMBER	NSN	NOMENCLATURE	QTY
1	5187310	5330-00-604-8094	Packing, preformed	2
2	MS35802-3	2940-00-580-6283	Filter element	2
3	6473298	5330-00-833-0870	Gasket set	2
4	5575086	5330-00-736-3508	Gasket	2
5	7374386	5330-00-599-2180	Packing, preformed	1
6	5703114	2940-00-740-3158	Parts kit, transmission	1

2-15.10 Lubrication

Table 2-2 contains detailed lubrication instructions covering locations, intervals, and lubricants for M109A2/M109A3/M109A4/M109A5 Howitzers. The crew will assist unit maintenance personnel in lubricating the vehicle.

2-15 PROCEDURES FOR SEMIANNUAL/ANNUAL SERVICES — CONTINUED

2-15.10 Lubrication — Continued

TABLE 2-2 LUBRICATION

LUBRICANT/COMPONENT	CAPACITIES	ABOVE +5°F (-15°C)	+5 to -65°F (-15 to -54°C)	LUBRICANT FOR EXPECTED TEMPERATURE			INTERVALS
				ABOVE +15°F (-9°C)	+40 to -15°F (+4 to -26°C)	+40 to -65°F (+4 to -54°C)	
OE/HDO (MIL-L-2104) Lubricating Oil, ICE, Tactical (items 37 thru 40, Appx D) OEA (MIL-L-46167) Lubricating Oil, ICE, Arctic (items 47 and 48, Appx D) Engine <u>Engine</u> <u>Final Drive</u>	27 qt (26 L) As required	OE/HDO-15/ 40 See note 3	OEA	OE/HDO-15/ 40 or OE/HDO-30 (0-238) See note 3	OE/HDO-15/ 40 or OE/HDO-10 (0-237) See notes 1 & 3	OEA (0-183)	S/A
<u>Transmission</u>	48 qt (45 L)	OE/HDO-15/ 40 See note 3	OEA	OE/HDO-15/ 40 or OE/HDO-10 (0-237) See notes 1 & 3	OE/HDO-15/ 40 or OE/HDO-10 (0-237) See notes 1 & 3	OEA (0-183)	S/A
GO (MIL-L-2105) Lubricating Oil, Gear, Multipurpose (items 41 thru 44, Appx D) <u>Traversing Mechanism</u>	4 qt (4 L)			GO-80/90 (O- 226) See note 2	GO-80/90 (O- 226) See note 2	GO-75 (0-186)	S/A
GAA (MIL-L-10924) Grease, Automotive and Artillery (item 25 thru 27, Appx D) <u>Suspension & Road Wheels</u> GMD (MIL-G-21164) Grease, Molybdenum Disulfide (items 31 thru 33, Appx D) GGP (MIL-G-23549) Grease, General Purpose (items 28 thru 30, Appx D) <u>Mount Cradle Bearing and Torque Key</u>	As required As required			GMD	GGP	GAA (G-403)	S/A
<u>Muzzle Brake Evacuator</u>	As required				GMD (353)		S/A

For arctic operation, refer to FM 9-207

LUBRICANT/COMPONENT	CAPACITIES	ABOVE +5°F (-15°C)	+5 to -65°F (-15 to -54°C)	LUBRICANT FOR EXPECTED TEMPERATURE			INTER- VALS
				ABOVE +15°F (-9°C)	+40 to -15°F (+4 to -26°C)	+40 to -65°F (+4 to -54°C)	
<u>Engine Mount Screw</u> LOMD NATO S-1735 (item 46, Appx D) Lubricating Oil Molybdenum Disulfide	As required	Lubricating oil, molybdenum disulfide (all temperatures) LOMD (item 46, Appx D)					S/A
<u>0-156 (MIL-L-23699)</u> Lubricating Oil, Aircraft Turbine Engine (item 36, Appx D)							S/A
<u>Fan Gear Case (Oil)</u>	As required				0-156 All temperatures		
<u>OHT (MIL-H-46170)</u> Hydraulic Fluid, Petroleum Base for Preservation and Operation (items 34 and 35, Appx D)							S/A
<u>Hydraulic Power Pack & Equilibrator</u>	48 qt (45L)			OHT	OHT	OHT	
<u>Recuperator</u>	0.7/0.4 qt (0.7/0.4 L)						
<u>Gun Mount & Replenisher</u>	30 qt (28 L)						

For arctic operation, refer to FM 9-207

Table 2-2 notes:

- 1 If OEA lubricant is required to meet the low expected temperature range, OEA lubricant is to be used in lieu of OE/HDO-10 lubricant for all expected temperature ranges where OE/HDO-10 is specified in the KEY.
- 2 Grade 85W-140 (60-85/140) may be used when expected temperatures are above +10°F (-12°C). The NATO Code for 60-85/1 40 is 0-220.
- 3 Multigrade oil (15W-40) does not automatically replace single weight oils. Use 15W-40 oil to avoid seasonal oil changes if your operational conditions match the table.

SECTION V. MAINTENANCE PROCEDURES

2-16 PRE-STARTING INSTRUCTIONS

WARNING

Battery gases can explode. Do not smoke, have open flame, or create sparks around a battery. Severe injury may result due to explosion.

- a. Check batteries for damage. Replace damaged batteries (para 2-8).
- b. Check electrolyte level in batteries. Replenish as required (TM 9-2350-311-10).

WARNING

- Do not park vehicles head-to-head. Personnel injury or damage to vehicles could occur if one vehicle jumps.
- Ž Do not allow vehicles to touch and leave enough space between vehicles to permit working room for technician. Shorted circuits could allow electricity to flow through vehicles causing injury to personnel and damage to equipment.

- c. Park vehicles in a side-by-side position or park live vehicle in front of and at right angles to dead vehicle.

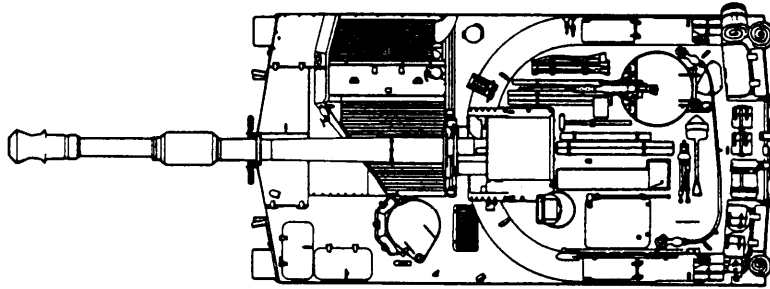

SAFE POSITION

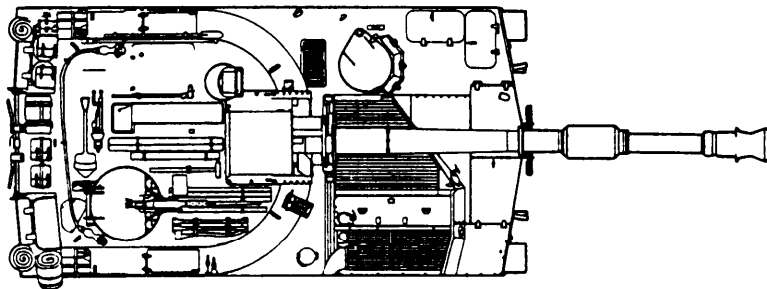

- d. Place both vehicles' shift levers (1) in N (neutral) position.
- e. Set parking brakes (2) on both vehicles.

CAUTION

Ensure all electrical equipment and all switches are off to prevent damage to electrical system.

- f. Place MASTER switch (3) in OFF position.
- g. Place all electrical switches in OFF position in driver's (4) and portable (5) instrument panels.

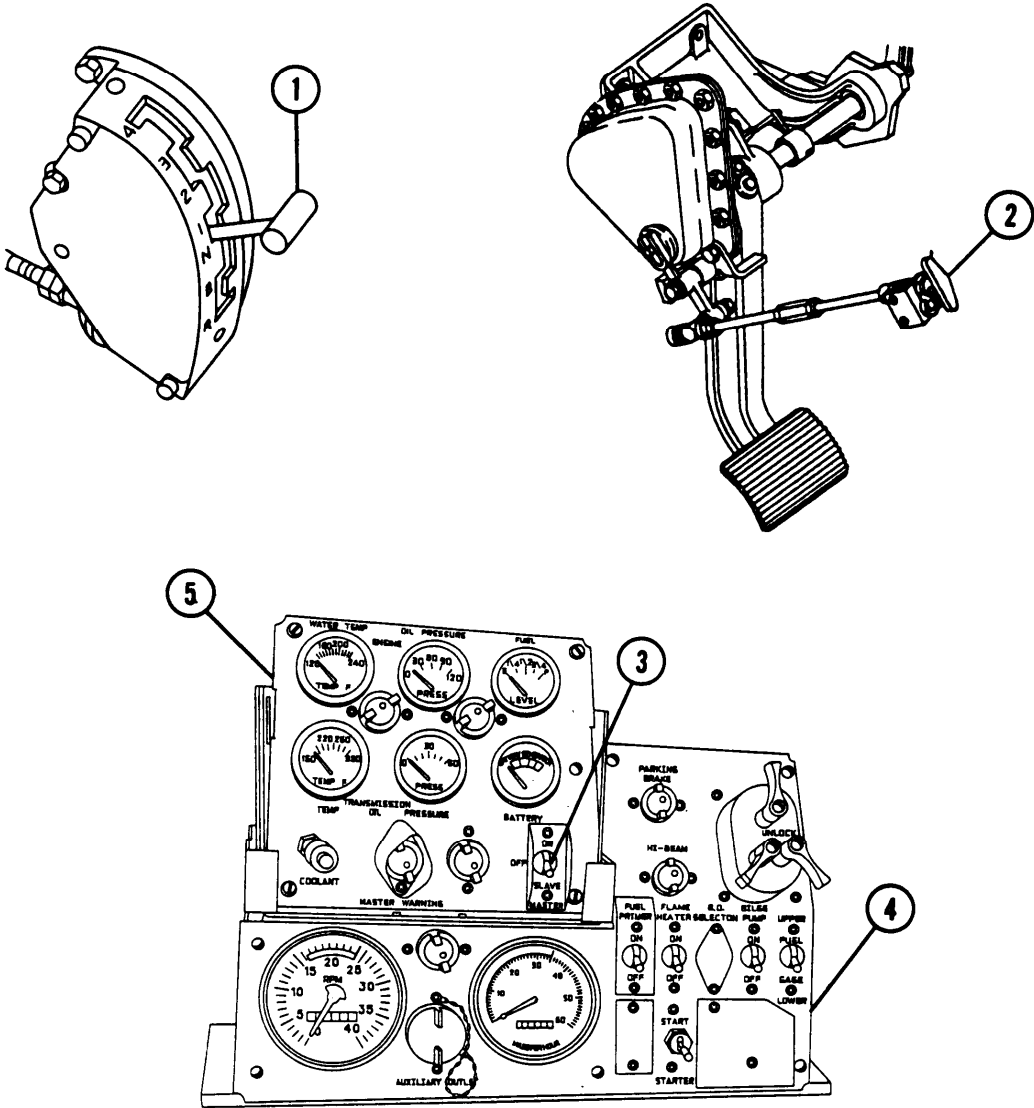

M109A2/M109A3 (ENGINE MODEL 7083-7396) SHOWN

2-16 PRE-STARTING INSTRUCTIONS — CONTINUED

NOTE

- Location of slave start receptacle differs in M109A2/M109A3 and M109A4/M109A5 Howitzers (para 8-38).
- NATO slave start cables (6) are used on M109A4/M109A5 and some M109A2 Howitzers.

h. Attach slave start cable (6 or 7) securely to slave start receptacle (8) in both vehicles.

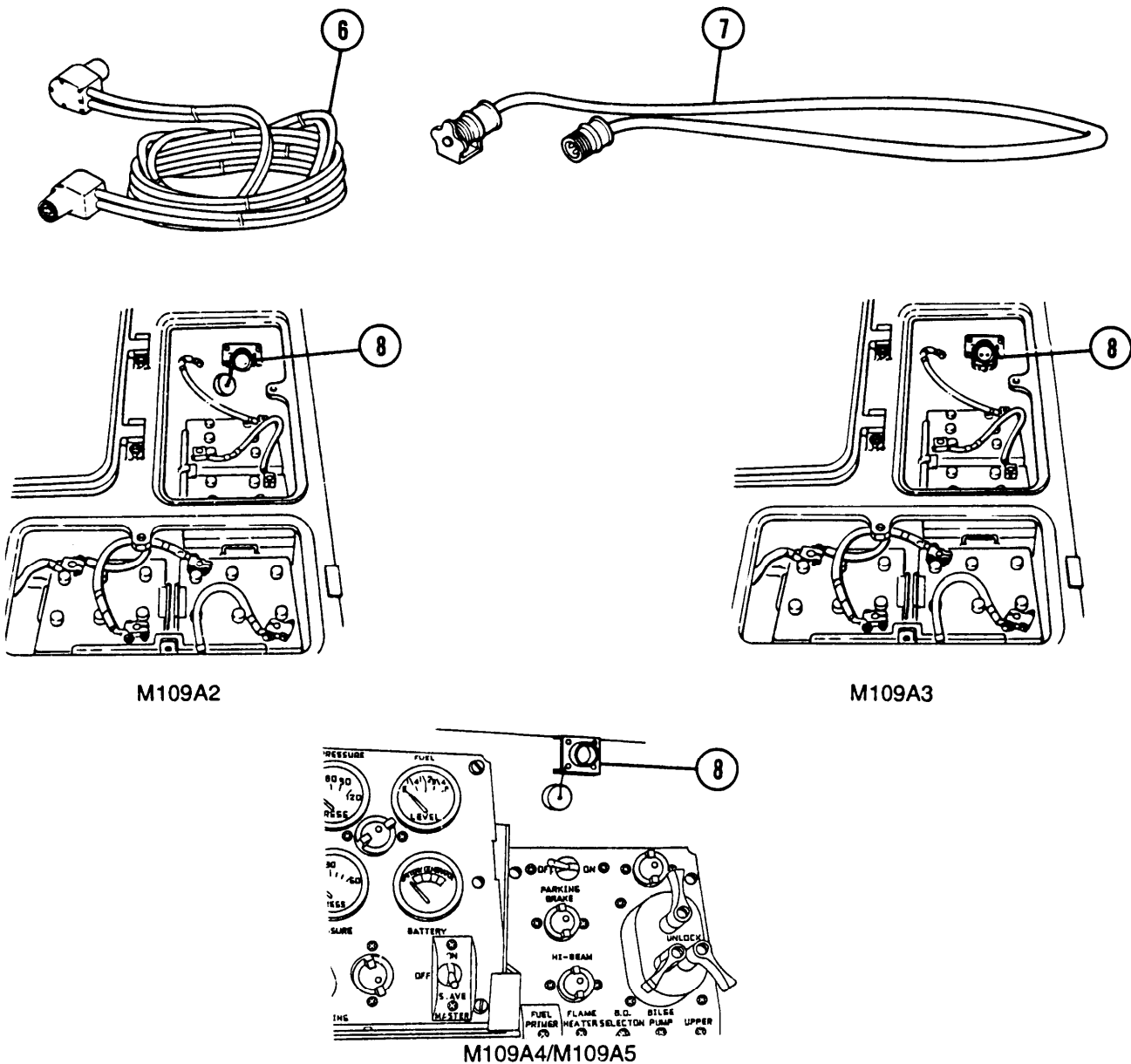

2-17 STARTING INSTRUCTIONS

WARNING

Ensure MASTER switches are OFF on both vehicles after vehicles are fully charged.

- a. For M109A2/M109A3 vehicles only, place MASTER switch to SLAVE position on dead vehicle. Leave switch OFF for M109A4/M109A5.
- b. Place MASTER switch to ON in live vehicle and run engine at 1000 to 1200 rpm.
- c. Allow batteries in dead vehicle to charge for 5 minutes before trying to start vehicle.
- d. Idle engine of live vehicle and turn MASTER switch OFF.
- e. Start up dead vehicle (TM 9-2350-311-10).
- f. After engine is running smoothly, turn MASTER switch OFF.

2-18 PAINTING INSTRUCTIONS

W A R N I N G

Chemical Agent Resistant Coating (CARC) paint contains isocyanate, a constituent that can cause respiratory effects during and after the application of the material. During the application of CARC paint, coughing, shortness of breath, pain on respiration, increased sputum, and chest tightness may occur. CARC paint also produces itching and reddening of the skin, a burning sensation of the throat and nose, and watering of the eyes. An allergic reaction may occur after initial exposure (ranging from a few days to a few months later) producing asthmatic symptoms including coughing, wheezing, tightness in the chest, or shortness of breath. The following precautions must be observed to insure the safety of personnel when CARC paint is applied:

- For spray/brush/roller painting in confined spaces, an air line respirator is required, unless an air sampling shows exposure to be below standards. If the air sampling is below standards, either chemical cartridge or air line respirators are required.
- Spot painters applying CARC paint by brush or roller must wear clothing and gloves affording full coverage. Personnel using touchup spray kits should wear an air line respirator and protective clothing.
- Do not use water, alcohol, or amine-based solvents to thin or remove CARC paint. Use of these solvents with CARC paint can produce chemical reactions resulting in nausea, disease, burns, or severe illness to personnel.
- Do not use paint solvents to remove paint/coating from your skin.
- Mix paint/coating in a well ventilated mixing room or spraying area away from open flames. Personnel mixing paint/coating should wear eye protection.
- Use paint/coating with adequate ventilation.
- Personnel grinding or sanding on painted equipment should use high-efficiency, air-purifying respirators.
- Do not weld, cut, or apply any form of heat to CARC-coated metal until the paint has been removed from a 4-in. (10.2-cm) area surrounding the rework site. Substances may be released that cause skin or respiratory irritation if this is not done. Sand or grind the paint down to the base metal in the surrounding area and also remove any paint from the other side of the metal.
- When sanding any paint, use the wet sanding method. Older paints may contain lead, chromates, or other toxic material. Using wet or dry sandpaper, wet down the area before starting. Keep the sandpaper wet as you sand to keep down paint dust.

NOTE

Ž Painting at unit maintenance level using a brush or roller is limited to spot painting. Spot painting includes restoration of painted surfaces after repair.

Ž Spot painting of CARC-painted equipment will be with CARC paint only.

Ž Scratches, chips, or marring of the paint surface observed during PMCS will be repaired at unit maintenance level to prevent corrosion damage.

Ž CARC paint can be applied over old CARC paint as long as the old paint is clean and sound.

2-18.1 Instructions for Painting

- a. Clean off all rust, corrosion, oil, grease, moisture, dirt, and loose or blistered paint.
- b. Remove all loose paint by light sandblasting or with an orbital sander.
- c. If old paint is sound, sanding to bare metal and application of primer are not required, but edges still must be feathered.
- d. Prepare ferrous metal (steel and iron) or aluminum surfaces by washing with liquid detergent (item 20, Appx D) and water. Rinse with fresh water and let area dry.
- e. Thin CARC paint with polyurethane coating thinner (item 64 or 65, Appx D).
- f. Repaint all surfaces on which paint has deteriorated or become damaged.
- g. Do not paint electrical wiring harnesses or leads.
- h. Prime hull interior (including engine compartment) and hull exterior with CARC primer (item 52 or 55, Appx D).
- i. Coat inside of battery box with bituminous coating compound (item 15, Appx D).
- j. Paint hull interior (including engine compartment) with CARC, white, semigloss enamel no. 17925 (item 16, Appx D).
- k. Paint walkways on hull exterior with CARC olive drab (item 14, Appx D).

2-18.2 Publications for Painting

- a. TM 43-0139, Preparation of the Materiel for Painting, Methods of Painting, and Materials to be Used.
- b. TB 43-0209, Instructions on Color and Marking of Military Vehicles.
- c. FM 5-20, Instructions for Camouflage Painting.

2-18 PAINTING INSTRUCTIONS — CONTINUED

2-18.3 Nonskid Areas

Nonskid coating system conforming to DOD-C-24667, type IA, composition G, grade B, class 1 (item 17, Appx D) will be used to coat areas where personnel walk, such as front deck plates and crew compartment interiors. This material is resistant to oils and hydraulic fluids. Areas to be coated are shown below.

NOTE

- Crew compartment floor will be coated with nonskid coating system as specified above.
- Shaded areas will be coated with nonskid coating system as specified above.

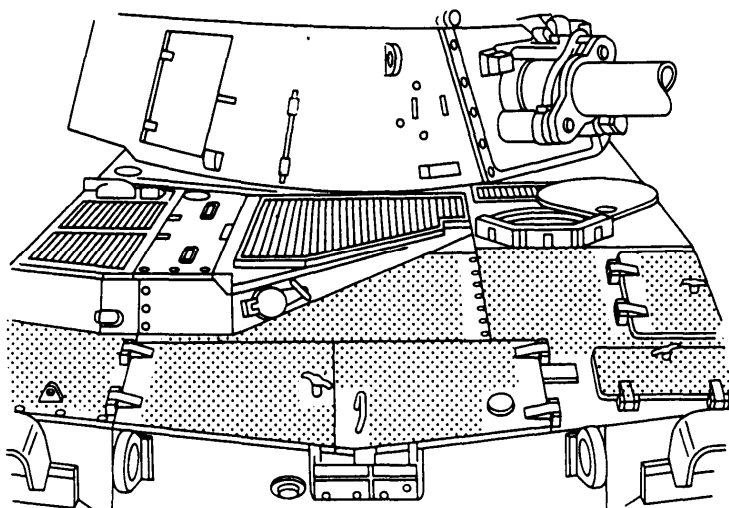

HULL FRONT ACCESS DOORS AND GRILLES

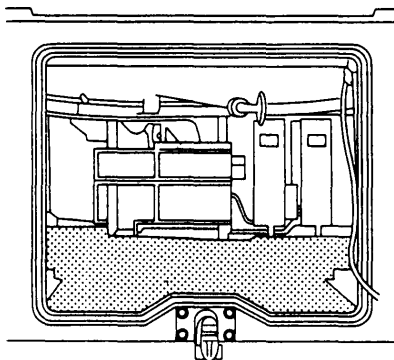

CREW COMPARTMENT

CHAPTER 3 TROUBLESHOOTING

GENERAL

This chapter provides instructions for troubleshooting.

<u>CONTENTS</u>		PAGE
3-1	GENERAL TROUBLESHOOTING INSTRUCTIONS	3-2
3-2	QUICK GUIDE TO TROUBLESHOOTING.....	3-3
3-3	TROUBLESHOOTING CHART.....	3-11

3-1 GENERAL TROUBLESHOOTING INSTRUCTIONS

a. General

This chapter contains a Quick Guide to Troubleshooting index and a Troubleshooting Chart. The Quick Guide to Troubleshooting is the master reference table for locating troubleshooting information. The Quick Guide to Troubleshooting index contains a list of various malfunctions which may occur during operation or inspection of the M109A2/M109A3/M109A4/M109A5 Howitzers and provides a reference to the troubleshooting information in the troubleshooting chart or a solution. The troubleshooting chart provides step-by-step instructions for isolating and correcting malfunctions.

WARNING

Protective radiator fan screens must be installed prior to troubleshooting in the engine compartment when the engine is running or when the engine is in ground hop mode. Contact with a rotating fan can cause severe injury (para 4-5).

b. STE/ICE-R Troubleshooting

When a malfunction is recognized on the engine systems of the M109A2/M109A3/M109A4/M109A5 Howitzers, the Quick Guide to Troubleshooting may reference an Appendix I NO-GO CHAIN. This means there is a STE-ICE-R method for analyzing the malfunction. The STE/ICE-R method will be the primary troubleshooting procedure when referenced; the backup procedure should be used only when STE/ICE-R is unavailable.

c. Electrical Troubleshooting

Electrical troubleshooting in this chapter includes schematic diagrams and pictorial diagrams to give insight to the harnesses involved.

When troubleshooting any electrical system or component, exercise care to prevent electrical shock.

WARNING

Ensure MASTER switch is OFF between every step unless otherwise directed throughout troubleshooting of the electrical system or electrical components. Remove all jewelry and metal objects when working on electrical systems to prevent injury due to electrical shock.

The multimeter is used throughout electrical troubleshooting. For a quick reference to multimeter operation, see para 2-12. STE/ICE-R can also perform as a multimeter and instruction on its use is in TM 9-4910-571-12&P.

3-2 QUICK GUIDE TO TROUBLESHOOTING

To use the Quick Guide to Troubleshooting and the Troubleshooting Chart, follow the instructions below. If any problem is not listed or cannot be corrected through troubleshooting, notify support maintenance.

- a. Determine the symptom.
- b. Locate the symptom in the Quick Guide to Troubleshooting.
- c. Locate the Troubleshooting Chart for your symptom.
- d. Turn to the chart identified in the Quick Guide to Troubleshooting.
- e. Study the function description, pictorial view, and/or schematic located at the beginning of each troubleshooting section.
- f. Perform the corrective action as required by troubleshooting procedure.
- g. Verify that the corrective action eliminated the symptom.

3-2 QUICK GUIDE TO TROUBLESHOOTING — CONTINUED

ITEM	SYMPTOM	PRIMARY	ALTERNATE
TRACKS AND SUSPENSION — CONTINUED	VEHICLE PULLS TO ONE SIDE WITH STEERING WHEEL IN CENTER POSITION	Para 3-3g(2)	None

3-3 TROUBLESHOOTING CHART — CONTINUED

g. TRACKS AND SUSPENSION — CONTINUED (2) VEHICLE PULLS TO ONE SIDE WITH STEERING WHEEL IN CENTER POSITION

INITIAL SETUP

Tools

General mechanic's tool kit (item 64, Appx H)
 STEACE-R test set (item 61, Appx H)

Equipment Conditions

Transmission access doors open (TM 9-2350-311-10)

References

TM 9-2350-311-10

NOTE

Crown on road causes vehicle to pull away from center of road. Road test vehicles on flat surface.

3-2 QUICK GUIDE TO TROUBLESHOOTING — CONTINUED

ITEM	SYMPTOM	PRIMARY	ALTERNATE
BATTERY	ENGINE CRANKS SLOWLY	Para I-5, NG 30	Para 3-3a
MASTER RELAY	MASTER SWITCH INDICATOR LIGHT IS LIT	Para 3-3b(1)	None
	MASTER SWITCH INDICATOR LIGHT FAILS TO OPERATE; MASTER SWITCH IS ON	Para 3-3b(2)	None
STARTER	ENGINE DOES NOT CRANK; ALL ELECTRICAL ACCESSORIES OPERATE	Para I-5, NG 20 and/or NG 60	Para 3-3c, M109A2/M109A3 Para 3-3d(1), M109A4/M109A5
	COMBAT OVERRIDE SWITCH WILL NOT OVERRIDE	Para 3-3d(2)	None
	ENGINE CRANKS FOR SHORT TIME ONLY; BATTERY POWER LEVEL IS CORRECT	Para 3-3d(3)	None
ENGINE	ENGINE CRANKS BUT FAILS TO START	Para 3-3e(1)	None
	ENGINE IDLES OVER 650. RPM	Adjust hand throttle control rod and accelerator pedal (para 9-15 and 9-16)	
	ENGINE DOES NOT ACCELERATE PROPERLY OR DOES NOT DEVELOP FULL POWER	Para 3-3e(2)	None
	ENGINE DOES NOT MAINTAIN STEADY RPM	Para 3-3e(3)	None
	ENGINE USES EXCESSIVE OIL	Check oil lines, oil filters, and engine cover for excessive leaks	
	ENGINE USES EXCESSIVE FUEL	Para 3-3e(4)	None
	WHITE EXHAUST SMOKE IS PRESENT	Para 3-3e(5)	None

ITEM	SYMPTOM	PRIMARY	ALTERNATE
	EXHAUST FUMES PRESENT IN CREW COMPARTMENT	Para 3-3e(6)	None
	ENGINE HAS LOW OR NO OIL PRESSURE	Para I-5, G 5	Para 3-3e (7)
	ENGINE OVERHEATS	Para 3-3e(8)	None
TRANSMISSION AND DRIVING CONTROLS	HAND THROTTLE CONTROL DOES NOT MAINTAIN CONSTANT SPEED	Check for loose mounting bolts on hand throttle control rod and accelerator shaft (para 9-15 and 9-16)	None
	ENGINE DOES NOT CHANGE RPM WHEN ACCELERATED	Adjust accelerator pedal and hand throttle control rod (para 9-15 and 9-16)	None
	VEHICLE CREEPS FORWARD IN NEUTRAL	Adjust transmission shift control linkage (para 9-9)	None
	TRANSMISSION OVERHEATS; TRANSMISSION OIL TEMP GAGE READS OVER 270°F (132°C), MASTER WARNING LIGHT IS LIT	Para 3-3f(1)	None
	VEHICLE DRIVES, BUT NOT IN SELECTED RANGE; SHIFT LEVER IS IN THIRD GEAR, TRANSMISSION IS IN FIRST GEAR	Adjust transmission shift control linkage (para 9-9)	None
	VEHICLE DOES NOT DRIVE; TRANSMISSION DOES NOT OPERATE IN ANY SHIFT POSITION	Para 3-3f(2)	None
	SHIFT CONTROL DOES NOT MOVE TO SELECTED RANGE	Adjust transmission shift control linkage (para 9-9)	None
	VEHICLE DOES NOT STEER IN EITHER DIRECTION IN ANY RANGE	Para 3-3f(3)	None
	VEHICLE STEERS WELL IN ONE DIRECTION ONLY	Para 3-3f(4)	None
TRACKS AND SUSPENSION	VEHICLE BRAKES POORLY; VEHICLE DOES NOT STOP CORRECTLY WHEN BRAKE IS APPLIED	Para 3-3g(1)	None

3-2 QUICK GUIDE TO TROUBLESHOOTING — CONTINUED

ITEM	SYMPTOM	PRIMARY	ALTERNATE
TRACKS AND SUSPENSION — CONTINUED	VEHICLE PULLS TO ONE SIDE WITH STEERING WHEEL IN CENTER POSITION	Para 3-3g(2)	None
	VEHICLE THROWS TRACK(S)	Para 3-3g(3)	None
	VEHICLE SAGS TO ONE SIDE	Check for correct installation of torsion bars (para 10-13)	None
	VEHICLE RIDE IS ROUGH OR SUSPENSION SYSTEM IS NOISY DURING OPERATION	Para 3-3g(4)	None
FINAL DRIVE ASSEMBLY	EXCESSIVE OIL LEAKAGE AROUND FINAL DRIVE	Inspect final drive assembly (para 10-22)	None
FLAME HEATER (ENGINE MODEL 7083-7396)	FLAME HEATER DOES NOT OPERATE	Para 3-3h	None
GLOW PLUGS (ENGINE MODEL 7083-7391)	GLOW PLUG WAIT LIGHT FAILS TO OPERATE; GLOW PLUG SYSTEM OPERATES USING MANUAL OVERRIDE	Para 3-3i(1)	None
	GLOW PLUG SYSTEM FAILS TO OPERATE AT LOW AMBIENT TEMPERATURE; GLOW PLUG WAIT LIGHT OPERATES	Para 3-3i(2)	None
ENGINE MASTER WARNING LIGHT (STEERING SHAFT)	MASTER WARNING LIGHT (STEERING SHAFT) FAILS TO OPERATE; OTHER MASTER WARNING LIGHT(S) OPERATE PROPERLY	Para 3-3j(1)	None
	MASTER WARNING LIGHT (STEERING SHAFT) FAILS TO OPERATE DURING PRESS-TO-TEST; OTHER MASTER WARNING LIGHTS OPERATE PROPERLY	Para 3-3j(2)	None
ENGINE WARNING LIGHT (PORTABLE INSTRUMENT PANEL)	MASTER WARNING LIGHT FAILS TO OPERATE WITH MASTER SWITCH ON AND ENGINE OFF	Para 3-3k(1)	None
	MASTER WARNING LIGHT IS LIT; EVERYTHING ELSE APPEARS NORMAL	Para 3-3k(2)	None

ITEM	SYMPTOM	PRIMARY	ALTERNATE
AIR CLEANER BLOWER MOTORS	BLOWER MOTORS FAIL TO OPERATE WHEN VEHICLE IS IN DRIVE	Para 3-31(1)	None
	ONE BLOWER MOTOR FAILS TO OPERATE	Para 3-31(2)	None
	BLOWER MOTORS FAIL TO STOP WHEN VEHICLE IS PLACED IN NEUTRAL	Para 3-31(3)	None
ALTERNATOR	ALTERNATOR FAILS TO CHARGE BATTERIES; GAGE INDICATION: NOT CHARGING, UNSTEADY OR INACCURATE READING	Para 3-3m M109A2/M109A3 Para 3-3n M109A4/M109A5	None
GAGES	ENGINE WATER TEMP INDICATOR NEEDLE FAILS TO MOVE OR IS UNSTEADY; ALL OTHER GAGES OPERATE PROPERLY	Para 3-30(1)	None
	ENGINE LOW LEVEL COOLANT LIGHT FAILS TO LIGHT WHEN PRESSED-TO-TEST; ALL OTHER LIGHTS OPERATE	Para 3-30(2)	None
	ENGINE LOW LEVEL COOLANT LIGHT FAILS TO LIGHT WHEN ENGINE COOLANT LEVEL IS LOW, OPERATES WHEN PRESSED-TO-TEST	Para 3-30(3)	None
	TRANSMISSION OIL TEMP INDICATOR NEEDLE FAILS TO MOVE OR IS UNSTEADY; ALL OTHER GAGES OPERATE PROPERLY	Para 3-3p	None
	TRANSMISSION OIL PRESSURE INDICATOR NEEDLE FAILS TO MOVE OR IS UNSTEADY; ALL OTHER GAGES OPERATE PROPERLY	Para 3-3q	None
	ENGINE OIL PRESSURE INDICATOR FAILS TO OPERATE WITH ENGINE RUNNING; ALL OTHER INSTRUMENTS OPERATE	Para 3-3r	None
	FUEL LEVEL INDICATOR NEEDLE FAILS TO MOVE OR IS UNSTEADY; ALL OTHER GAGES OPERATE PROPERLY	Para 3-3s(1)	None

3-2 WICK GUIDE TO TROUBLESHOOTING — CONTINUED

ITEM	SYMPTOM	PRIMARY	ALTERNATE
GAGES — CONTINUED	FUEL LEVEL INDICATOR (GAGE) SHOWS LEVEL FOR UPPER FUEL TANK, BUT NOT FOR LOWER FUEL TANK	Para 3-3s(2)	None
	FUEL LEVEL INDICATOR (GAGE) SHOWS LEVEL FOR LOWER FUEL TANK, BUT NOT FOR UPPER FUEL TANK	Para 3-3s(3)	None
DOME LIGHTS	DOME LIGHT FAILS TO OPERATE; ALL OTHER LIGHTS OPERATE	Para 3-3t	None
SERVICE HEADLIGHTS, TAILLIGHTS, AND STOP LIGHTS	HEADLIGHTS FAIL TO OPERATE; ALL OTHER LIGHTS OPERATE	Para 3-3u(1)	None
	HEADLIGHTS OPERATE ON ONE BEAM ONLY	Para 3-3u(2)	None
	RIGHT OR LEFT HEADLIGHT FAILS TO OPERATE; ALL OTHER LIGHTS OPERATE	Para 3-3u(3)	None
	TAILLIGHT FAILS TO OPERATE; ALL OTHER LIGHTS OPERATE	Para 3-3u(4)	None
	STOP LIGHT FAILS TO OPERATE; ALL OTHER LIGHTS OPERATE	Para 3-3u(5)	None
B.O. MARKERS AND 6.O. DRIVE LIGHTS	FRONT B.O. MARKER LIGHTS FAIL TO OPERATE; ALL OTHER LIGHTS OPERATE	Para 3-3v(1)	None
	REAR B.O. MARKER LIGHTS FAIL TO OPERATE; ALL OTHER LIGHTS OPERATE	Para 3-3v(2)	None
	B.O. DRIVE LIGHT FAILS TO OPERATE; ALL OTHER LIGHTS OPERATE	Para 3-3v(3)	None
	ALL B.O. MARKER LIGHTS FAIL TO OPERATE; ALL OTHER LIGHTS OPERATE	Para 3-3v(4)	None

ITEM	SYMPTOM	PRIMARY	ALTERNATE
SERVICE B.O. INFRARED HEADLIGHTS AND B.O. STOP LIGHTS	B.O. STOP LIGHT FAILS TO OPERATE; ALL OTHER LIGHTS OPERATE	Para 3-3w	None
INSTRUMENT PANEL/ PORTABLE INSTRUMENT PANEL LIGHTS	ONE OR MORE INSTRUMENT PANEL LIGHTS FAIL TO OPERATE	Para 3-3x(1)	None
	ALL INSTRUMENT PANEL LIGHTS FAIL TO OPERATE	Para 3-3x(2)	None
HI-BEAM INDICATOR LIGHT	HI-BEAM INDICATOR LIGHT FAILS TO OPERATE; ALL OTHER LIGHTS OPERATE	Para 3-3y	None
PERSONNEL HEATER	PERSONNEL HEATER FAILS TO OPERATE	Para 3-32(1)	None
	PERSONNEL HEATER WILL NOT STOP WHEN SWITCH IS TURNED OFF	Notify support maintenance	None
	PERSONNEL HEATER INDICATOR LIGHT FAILS TO OPERATE; PERSONNEL HEATER OPERATES	Para 3-3z(2)	None
PERSONNEL VENTILATION BLOWER	PERSONNEL VENTILATION BLOWER FAILS TO OPERATE	Para 3-3aa	None
BILGE PUMP	BILGE PUMP FAILS TO OPERATE	Para 3-3ab	None
WINTERIZATION KIT	COOLANT HEATER FAILS TO OPERATE	Para 3-3ac(1)	None
	COOLANT HEATER MOTOR OVERHEATS	Para 3-3ac(2)	None
PARKING BRAKE WARNING LIGHT	PARKING BRAKE WARNING LIGHT FAILS TO OPERATE	Para 3-3ad	None
ELECTRIC FUEL PUMP	ENGINE MISSES WHEN LOW ON FUEL; ONE OR BOTH FUEL PUMPS FAIL TO OPERATE	Para 3-3ae	None

3-2 QUICK GUIDE TO TROUBLESHOOTING — CONTINUED

ITEM	SYMPTOM	PRIMARY	ALTERNATE
VENTILATED FACEPIECE SYSTEM (M109A4/ M109A5)	NBC INDICATOR LIGHT FAILS TO OPERATE; NBC HEATERS AND PURIFIER OPERATE	Para 3-3af(1)	None
	AIR PURIFIER FAILS TO OPERATE; HEATERS OPERATE PROPERLY	Para 3-3af(2)	None
	DRIVER'S NBC HEATER FAILS TO OPERATE; PURIFIER AND CANNONEER NO. 2 NBC HEATER OPERATE PROPERLY	Para 3-3af(3)	None
	CANNONEER NO. 2 HEATER FAILS TO OPERATE; PURIFIER AND DRIVER'S NBC HEATER OPERATE PROPERLY	Para 3-3af(4)	None
	AIR PURIFIER, DRIVER'S AND CANNONEER NO. 2 NBC HEATERS FAIL TO OPERATE	Para 3-3af(5)	None
SLAVE START RECEPTACLE (M109A21 M109A3)	NO POWER TO VEHICLE FROM SLAVE START RECEPTACLE; SLAVED VEHICLE HAD POWER WHEN OPERATING.	Para 3-3ag	None
SLAVE START POWER RECEPTACLE (M109A4/ M109A5)	NO POWER TO VEHICLE FROM SLAVE START RECEPTACLE; SLAVED VEHICLE HAD POWER WHEN OPERATING	Para 3-3ah(1)	None
	EXTERNAL POWER RECEPTACLE FAILS TO OPERATE	Para 3-3ah(2)	None

3-3 TROUBLESHOOTING CHART

a. BATTERY CIRCUIT

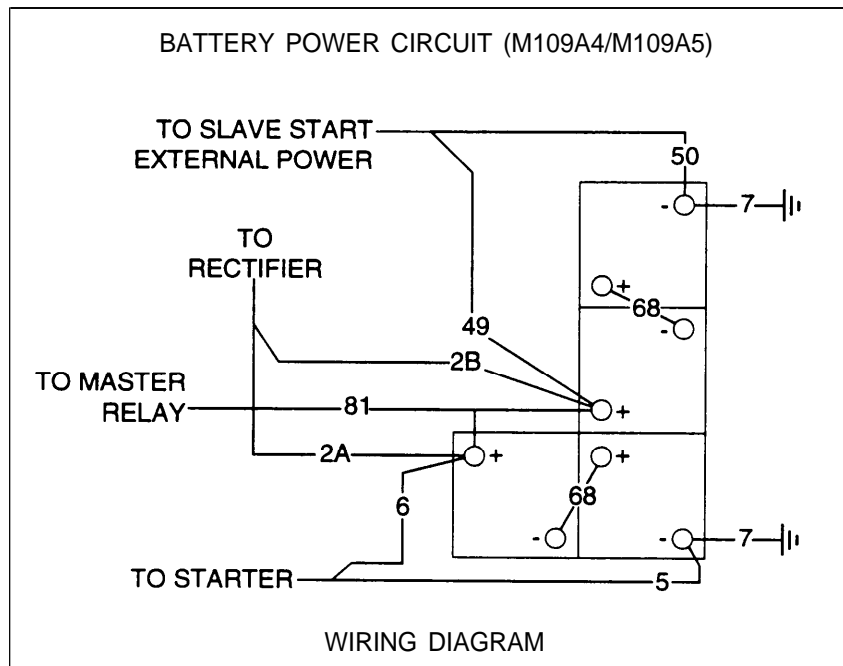
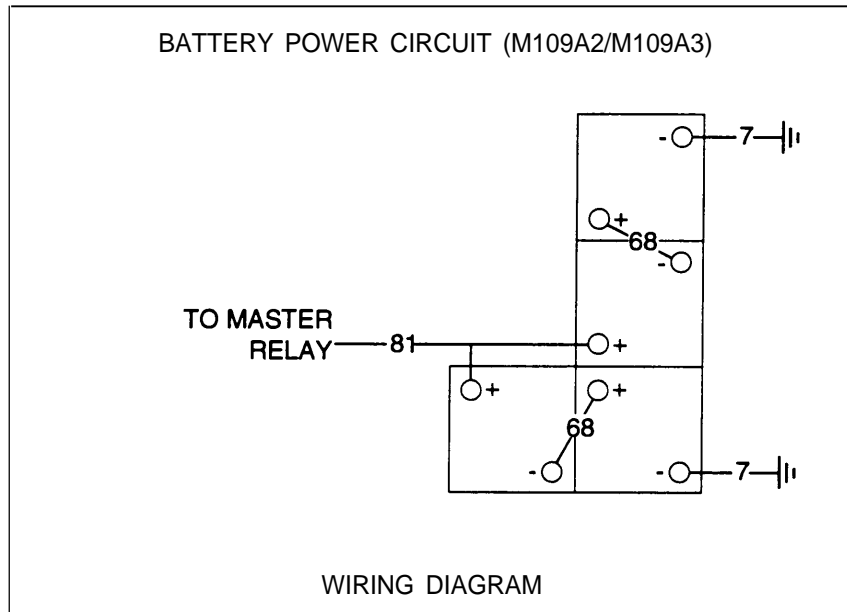

3-3 TROUBLESHOOTING CHART—CONTINUED

a. BATTERY CIRCUIT — CONTINUED

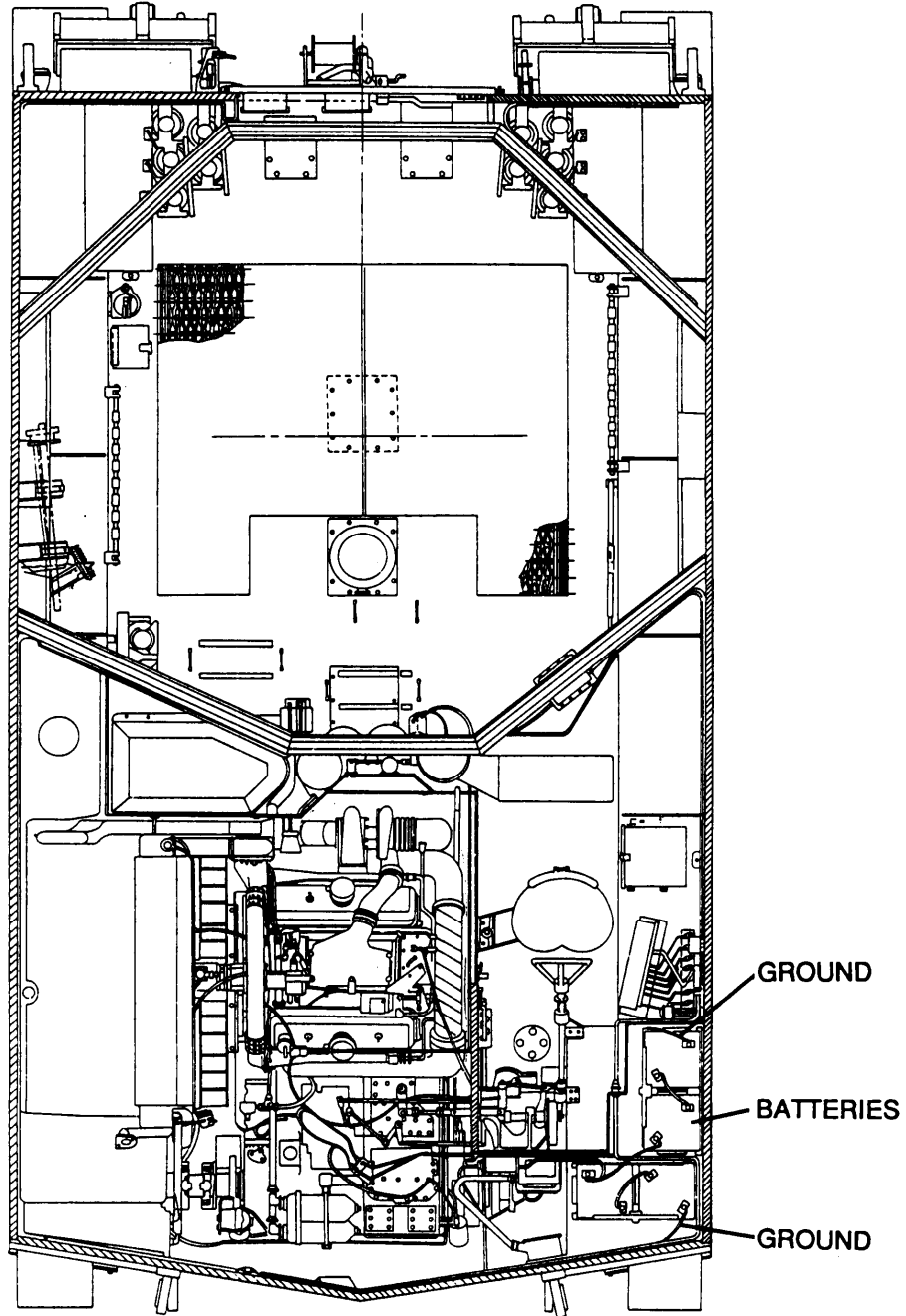

PICTORIAL VIEW

ENGINE CRANKS SLOWLY

INITIAL SETUPTools

General mechanic's tool kit (item 64, Appx H)
STE/ICE-R test set (item 61, Appx H)

Equipment Conditions

Engine access door open (TM 9-2350-311-10)
Fuel shutoff shut off (TM 9-2350-311-10)

WARNING

The MASTER switch must be turned OFF before repairing or replacing batteries, battery cables, or starter motor.

NOTE

When using multimeter, refer to multimeter operating instructions for setup.

A

1. Turn MASTER switch ON.
2. Place red multimeter lead on positive post and black lead to ground.
3. Crank engine and check for voltage.
4. If voltage is below 18 Vdc while cranking, clean, tighten, repair, or replace necessary cables (para 8-28). Crank engine and check voltage.
5. Turn MASTER switch OFF.

Is voltage 18 Vdc or above?

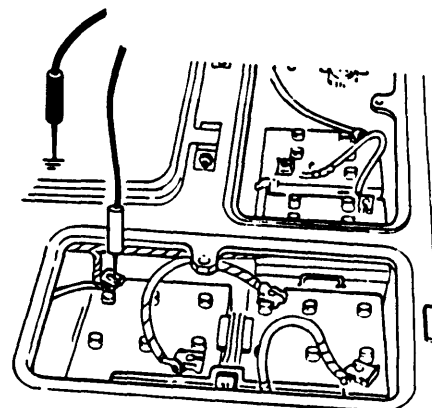

CONTINUED ON NEXT PAGE

3-3 TROUBLESHOOTING CHART — CONTINUED

a. BATTERY CIRCUIT — CONTINUED

ENGINE CRANKS SLOWLY — CONTINUED

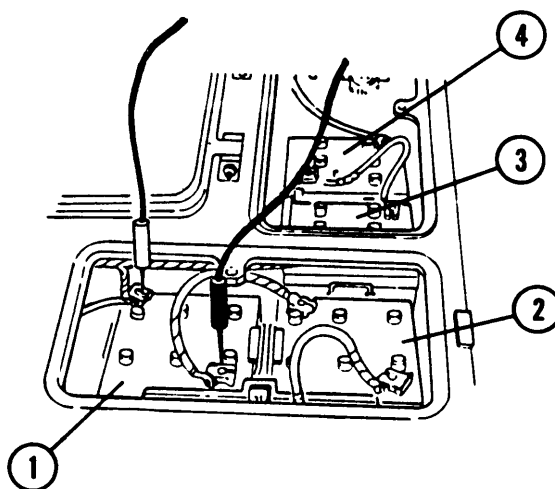
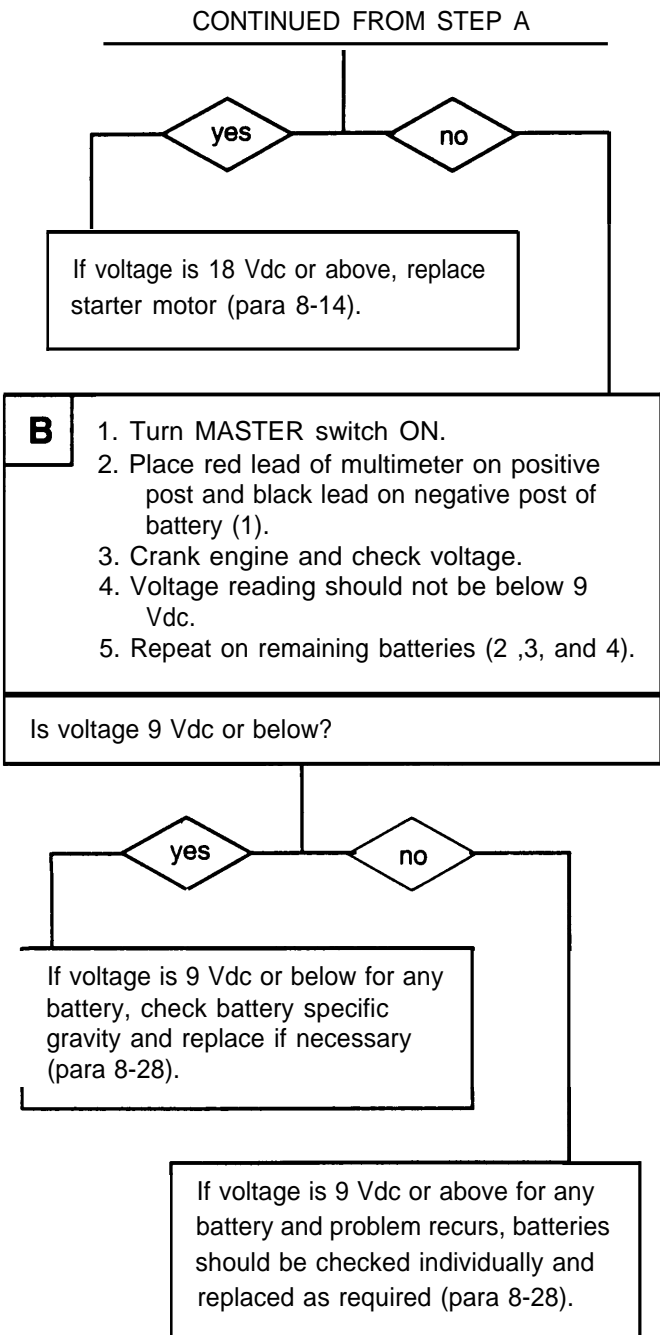

END OF TASK

b. MASTER RELAY CIRCUIT

Although the master relay circuit differs slightly between M109A2/M109A3 and M109A4/M109A5 Howitzers, the following procedure applies to all vehicles.

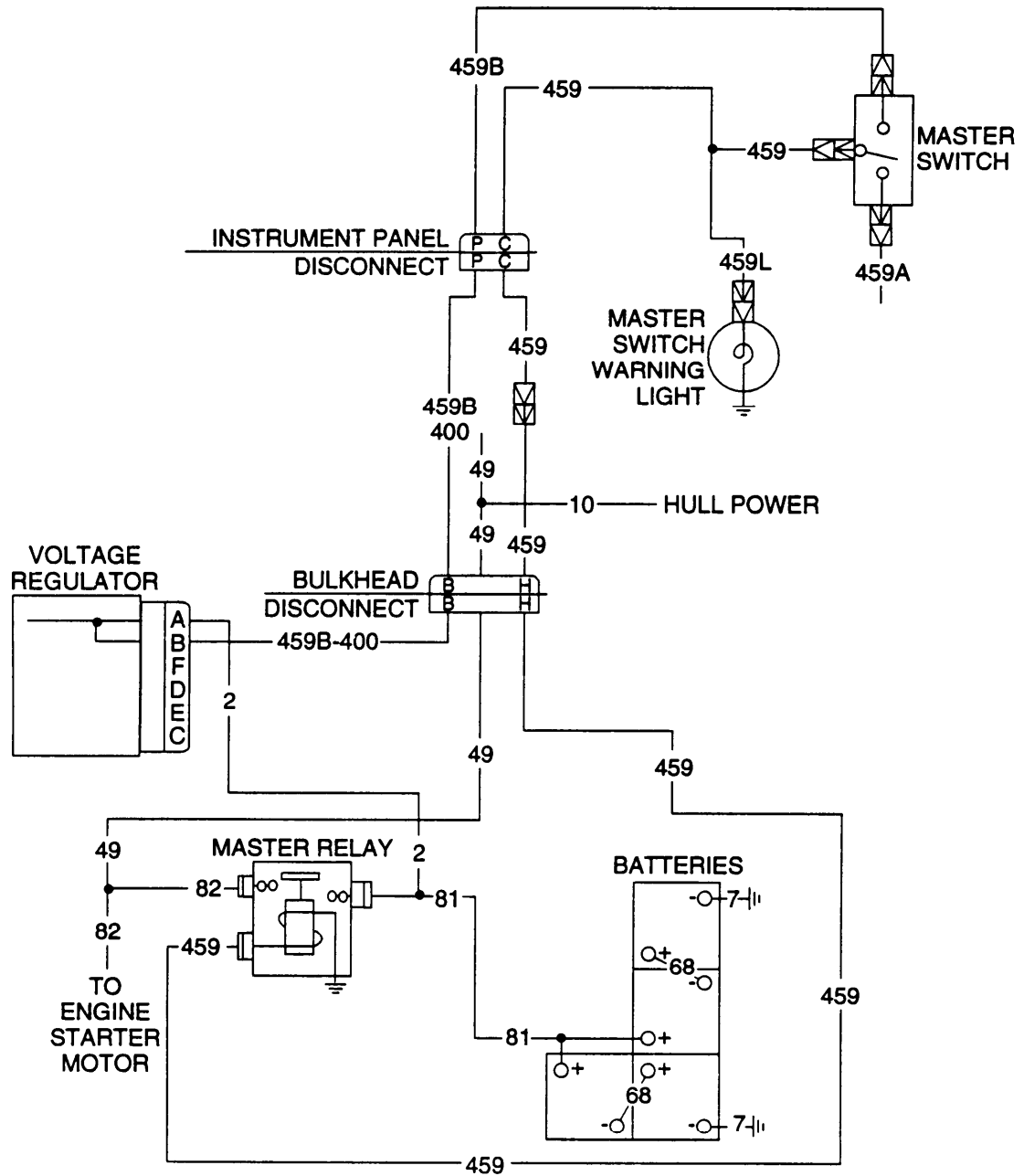

3-3 TROUBLESHOOTING CHART — CONTINUED

b. MASTER RELAY CIRCUIT-CONTINUED

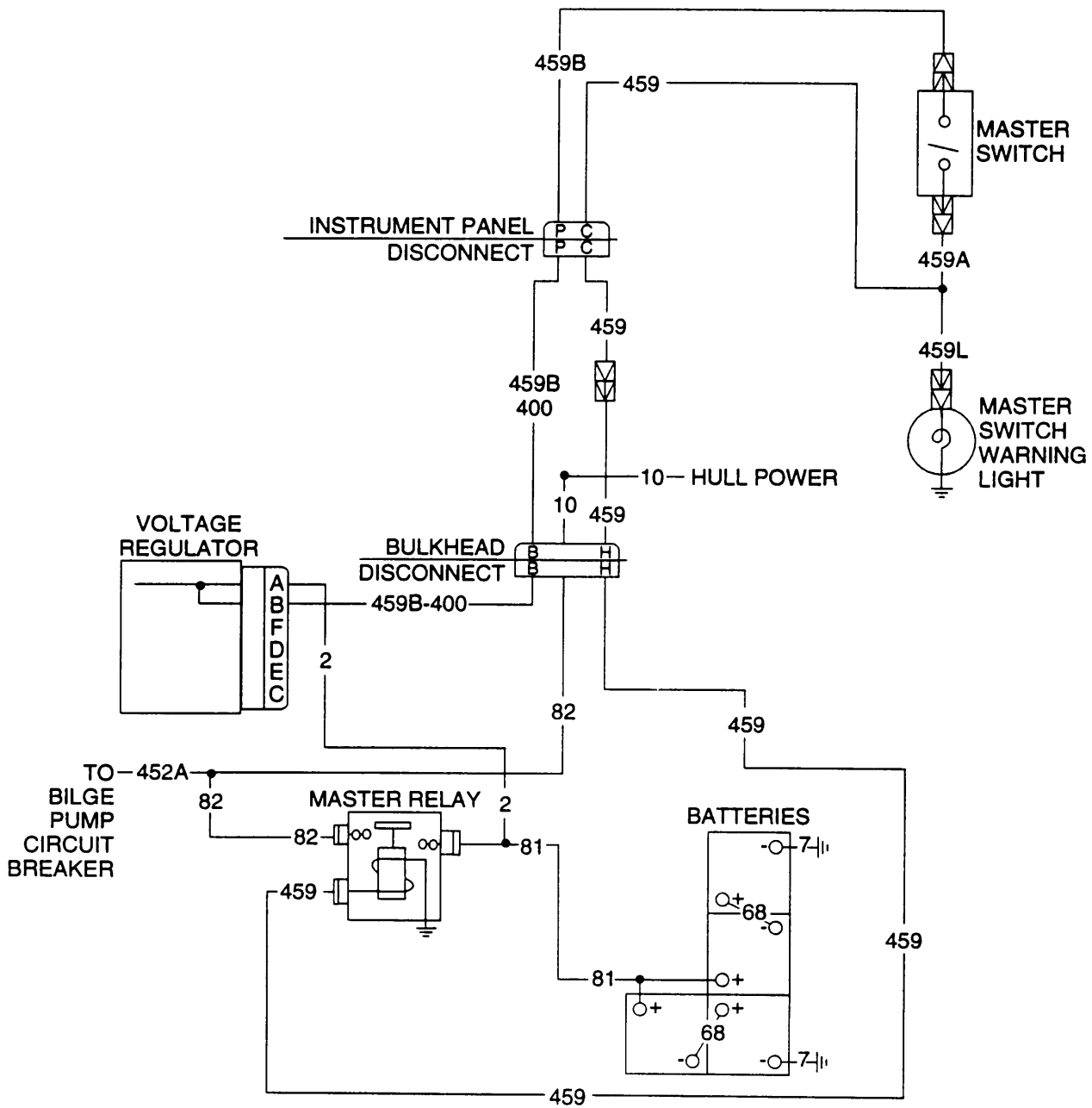

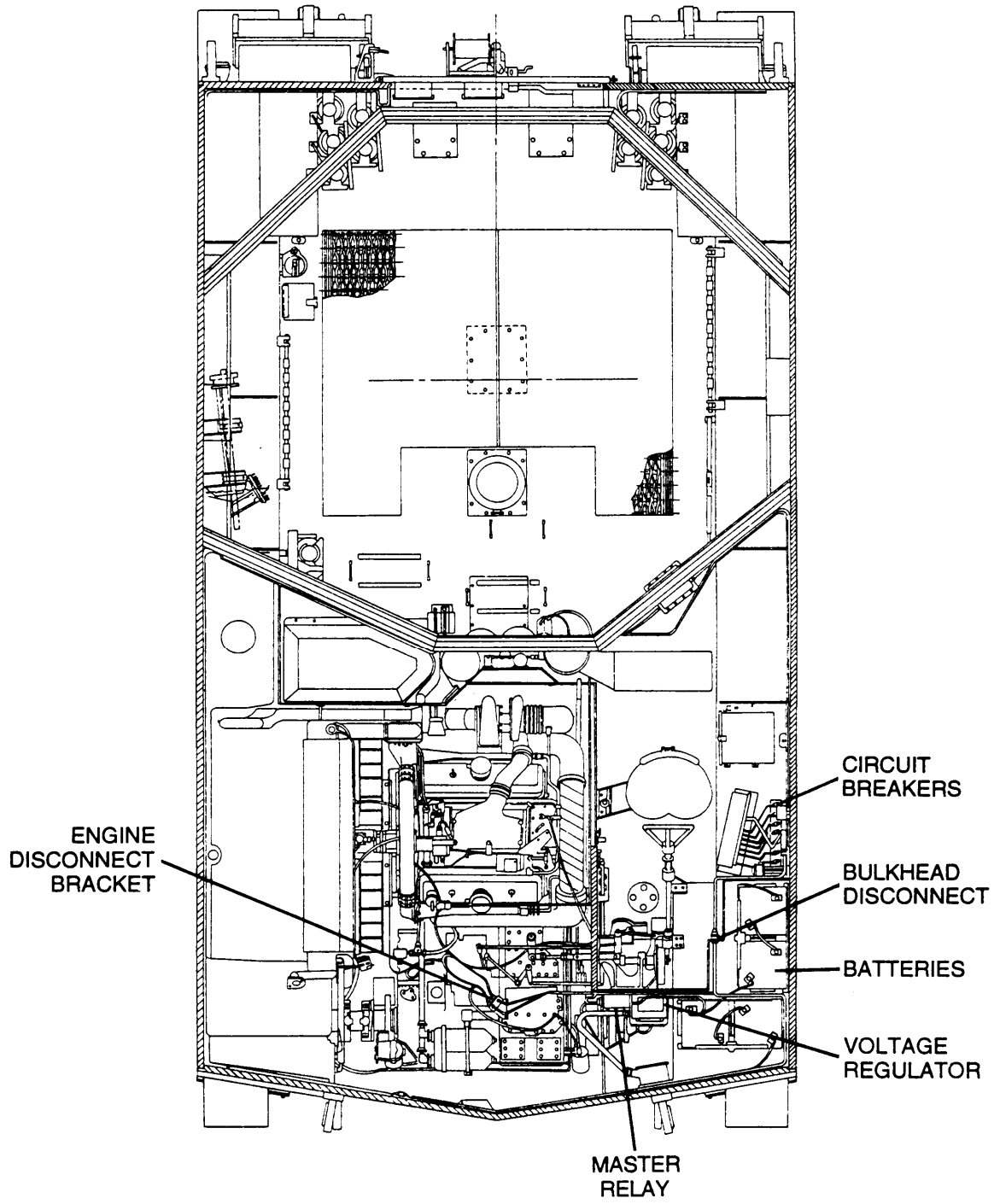

PICTORIAL VIEW

3-3 TROUBLESHOOTING CHART — CONTINUED

b. MASTER RELAY CIRCUIT — CONTINUED

(1) MASTER SWITCH INDICATOR LIGHT IS LIT

INITIAL SETUP

Tools

- General mechanic's tool kit (item 64, Appx H)
- Multimeter (item 36, Appx H)
- TA-1 probe kit (item 43, Appx H)

Equipment Conditions

Engine access doors open (TM 9-2350-311-10)

A

1. Disconnect lead 459 from master relay.
2. Place red lead of multimeter in lead 459 and black lead to ground.
3. Turn MASTER switch ON, and check for voltage.
4. Turn MASTER switch OFF.

Is voltage present?

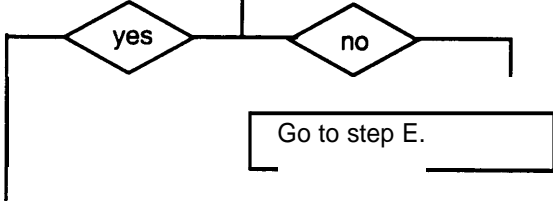

B

1. Reconnect lead 459 to master relay.
2. Disconnect lead 81 from master relay.
3. Place red lead of multimeter in lead 81 and black lead to ground.
4. Turn MASTER switch ON, and check for voltage.
5. Turn MASTER switch OFF.

Is voltage present?

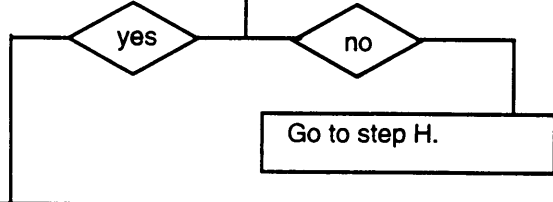

CONTINUED ON NEXT PAGE

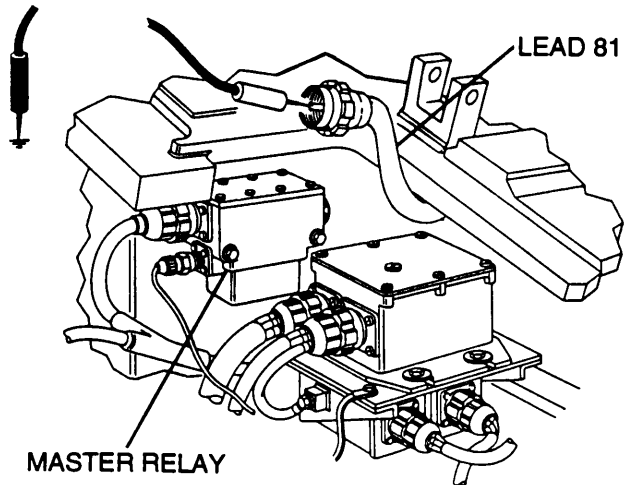
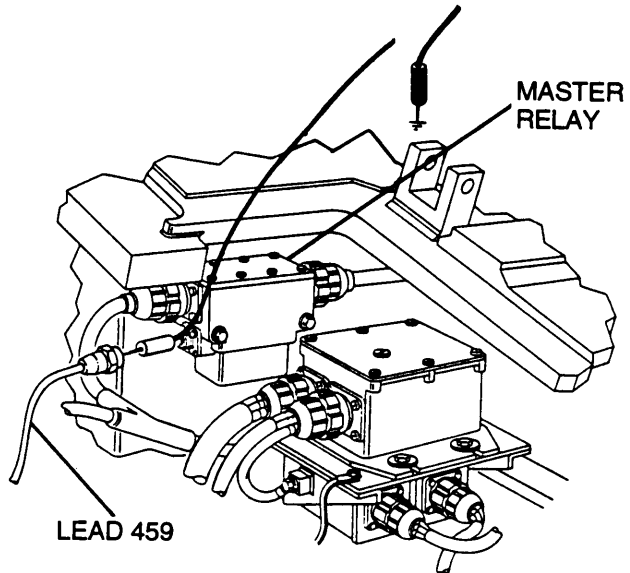

CONTINUED FROM STEP B

- C**
1. Reconnect lead 81 to master relay.
 2. Disconnect lead 82 from master relay.
 3. Place red lead of multimeter in master relay and black lead to ground.
 4. Turn MASTER switch ON, and check for voltage.
 5. Turn MASTER switch OFF.

Is voltage present?

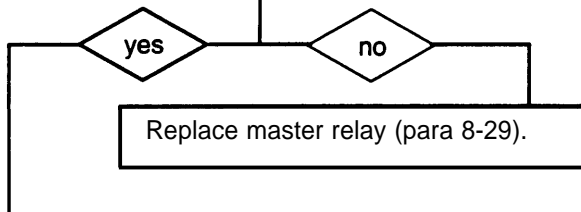

- D**
1. Reconnect lead 82 to master relay.
 2. Disconnect engine bracket-to-drivets bulkhead lead assembly (lead 82, M109A4/M109A5; lead 49, M109A2/M109A3) from driver's bulkhead.
 3. Place red lead of multimeter on pin of lead 82 (lead 49, M109A2/M109A3) and black lead to ground.
 4. Turn MASTER switch ON, and check for voltage.
 5. Turn MASTER switch OFF.

Is voltage present?

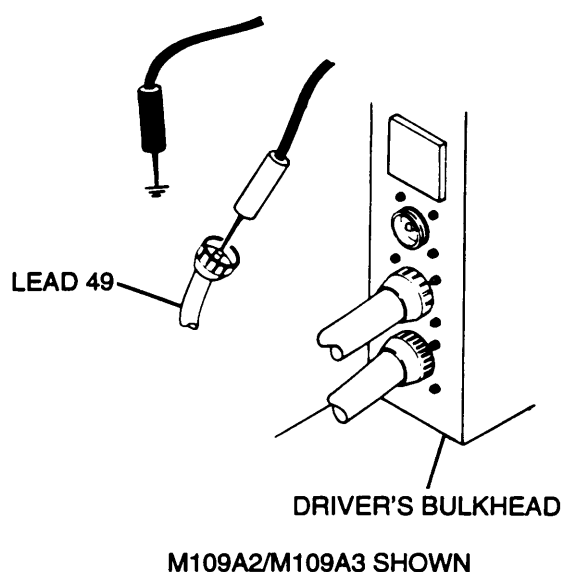
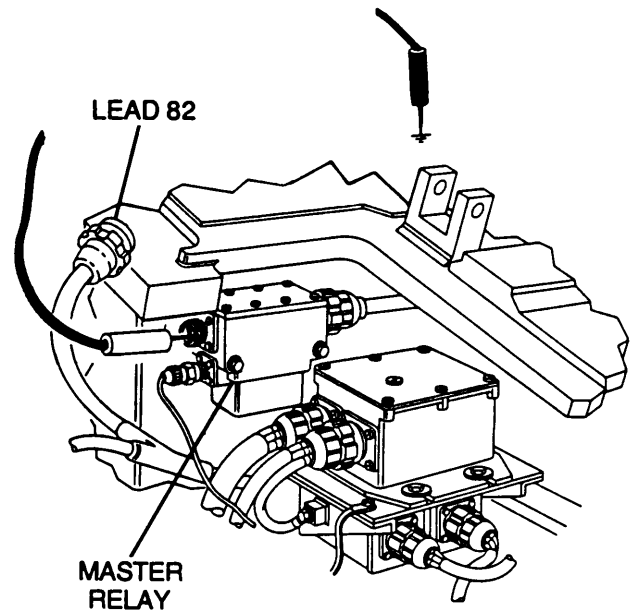
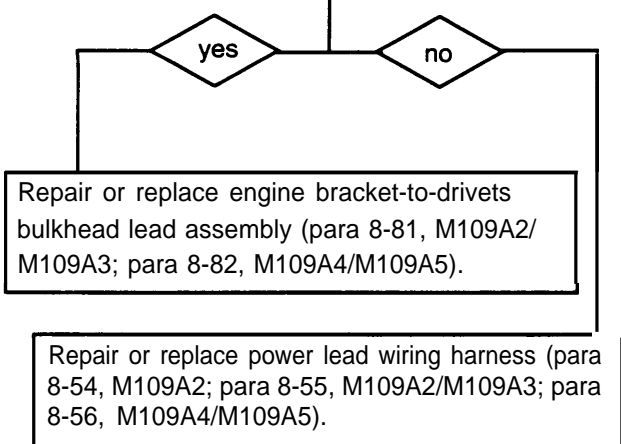

3-3 TROUBLESHOOTING CHART — CONTINUED

b. MASTER RELAY CIRCUIT — CONTINUED

(1) MASTER SWITCH INDICATOR LIGHT IS LIT — CONTINUED

CONTINUED FROM STEP A

- E**
1. Reconnect lead 459 to master relay.
 2. Disconnect bulkhead-to-headlights/bilge pump wiring harness from driver's bulkhead.
 3. Place red lead of multimeter on pin H (lead 459) and black lead to ground.
 4. Turn MASTER switch ON, and check for voltage.
 5. Turn MASTER switch OFF.

Is voltage present?

yes

no

Repair or replace lead 459 of bulkhead-to-headlights/bilge pump wiring harness (para 8-47).

- F**
1. Reconnect bulkhead-to-headlights/bilge pump wiring harness to driver's bulkhead.
 2. Disconnect lead 459 from bulkhead-to-portable instrument panel wiring harness connector.
 3. Place red lead of multimeter in lead 459 and black lead to ground.
 4. Reconnect battery ground leads.
 5. Turn MASTER switch ON, and check for voltage.
 6. Turn MASTER switch OFF.

Is voltage present?

yes

no

Repair or replace lead 459 of bulkhead-to-driver's instrument panel wiring harness (para 8-50).

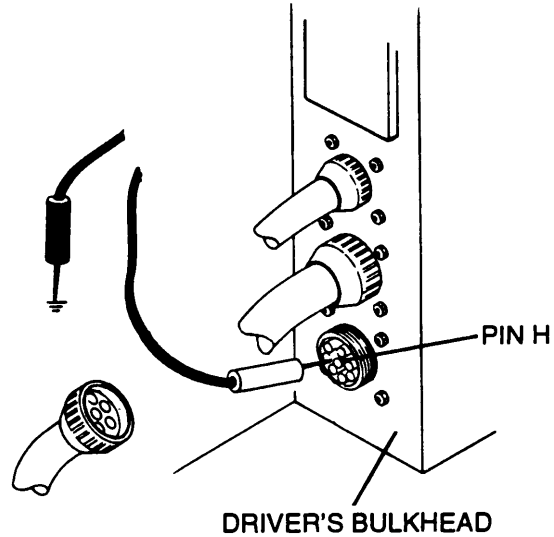

M109A2/M109A3 SHOWN

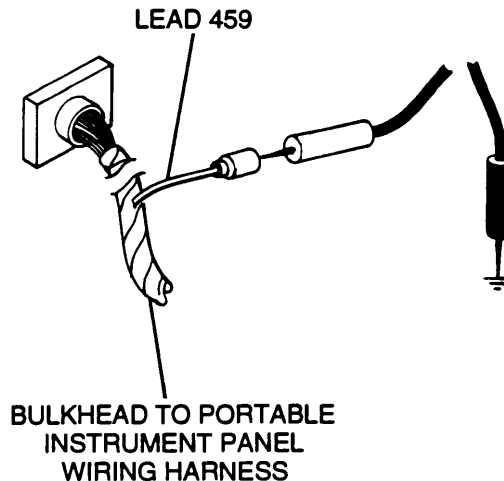

CONTINUED ON NEXT PAGE

CONTINUED FROM STEP F

- G**
1. Reconnect lead 459 to bulkhead-to-portable instrument panel wiring harness connector.
 2. Disconnect portable instrument panel wiring harness from instrument panel disconnect.
 3. Place a jumper wire from socket P (lead 459 B/400) to pin P (lead 459 B).
 4. Place red lead of multimeter on pin C (lead 459) and black lead to ground.
 5. Turn MASTER switch ON, and check for voltage.
 6. Turn MASTER switch OFF.
- Is voltage present?

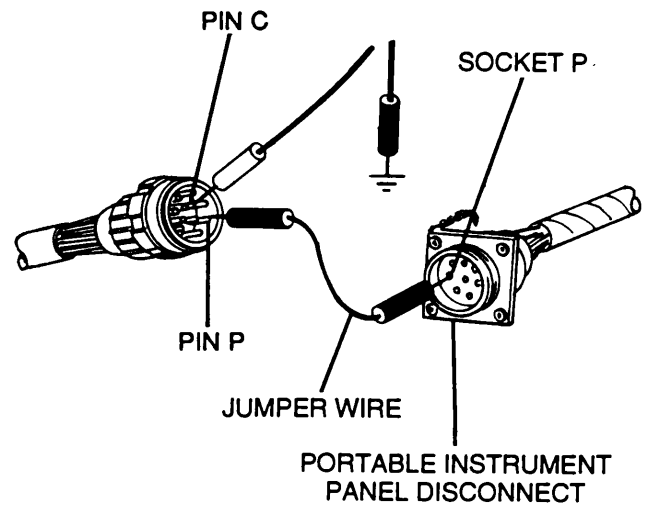
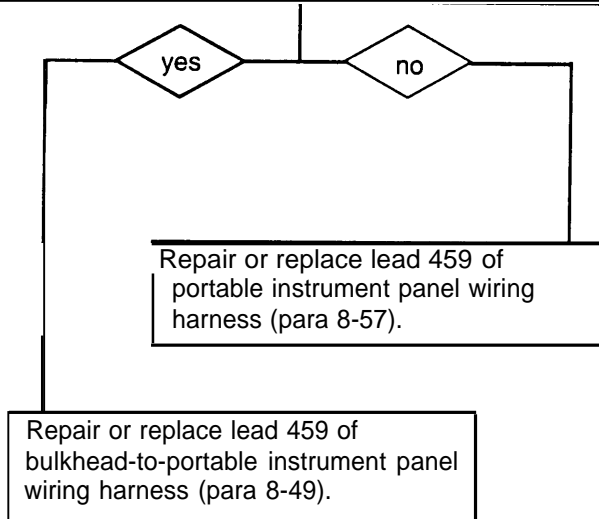

3-3 TROUBLESHOOTING CHART — CONTINUED

b. MASTER RELAY CIRCUIT — CONTINUED

(1) MASTER SWITCH INDICATOR LIGHT IS LIT – CONTINUED

CONTINUED FROM STEP B

H	<ol style="list-style-type: none">1. Reconnect lead 81 to master relay.2. Place red lead of multimeter on positive battery post and black lead to ground.3. Check for voltage.4. If voltage is below 18 Vdc, clean, tighten, repair, or replace necessary cables.5. Check for voltage.
Is voltage above 18 Vdc?	

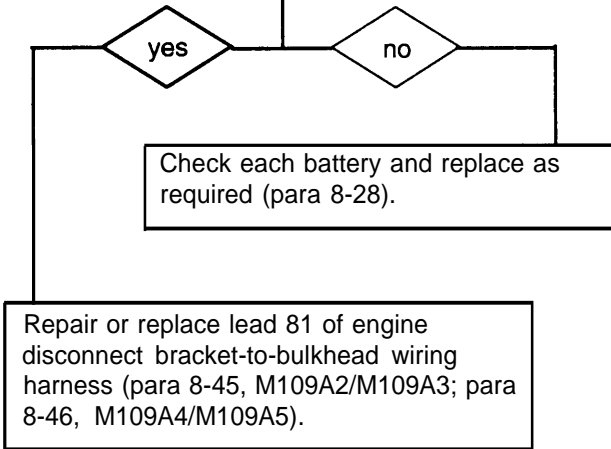
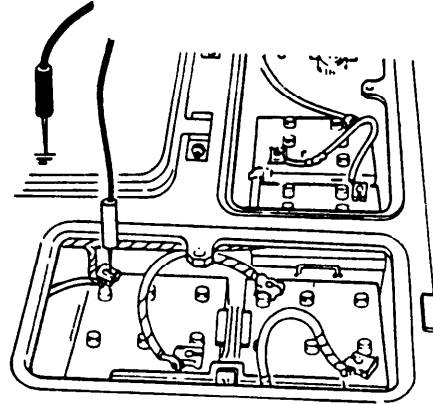

END OF TASK

(2) MASTER SWITCH INDICATOR LIGHT FAILS TO OPERATE; MASTER SWITCH IS ON

INITIAL SETUP

Tools

General mechanic's tool kit (item 64, Appx H)
 Multimeter (item 36, Appx H)
 TA-1 probe kit (item 43, Appx H)

Equipment Conditions

Engine access doors open (TM 9-2350-311-10)

- A**
1. Remove MASTER switch indicator light from socket.
 2. Place red lead of multimeter in socket and black lead to ground.
 3. Turn MASTER switch ON, and check for voltage.
 4. Turn MASTER switch OFF.
- Is voltage present?

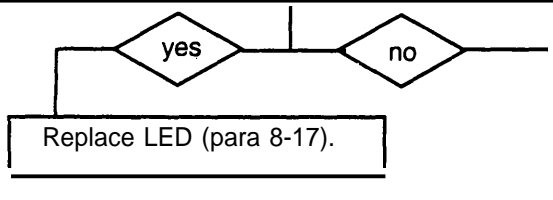

- B**
1. Disconnect lead 459L from MASTER switch indicator light.
 2. Place red lead of multimeter in lead 459L and black lead to ground.
 3. Turn MASTER switch ON, and check for voltage.
 4. Turn MASTER switch OFF.
- Is voltage present?

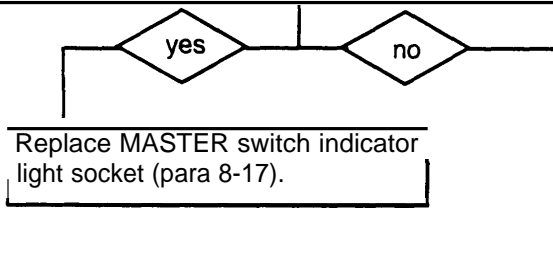

CONTINUED ON NEXT PAGE

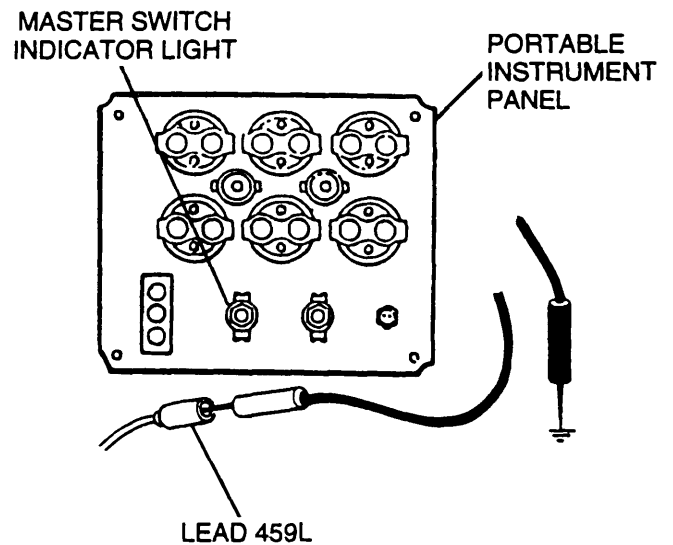
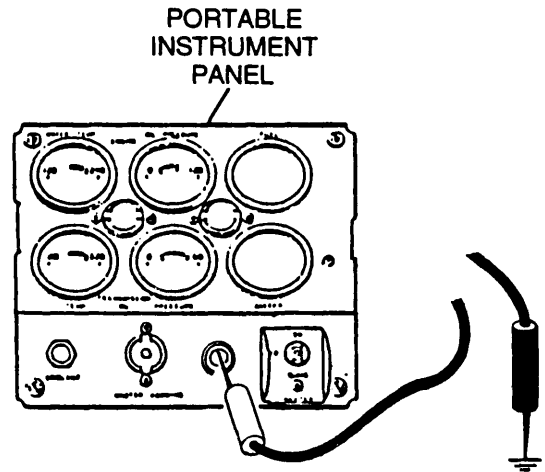

3-3 TROUBLESHOOTING CHART — CONTINUED

b. MASTER RELAY CIRCUIT — CONTINUED

(2) MASTER SWITCH INDICATOR LIGHT FAILS TO OPERATE; MASTER SWITCH IS ON — CONTINUED

CONTINUED FROM STEP B

C

1. Reconnect lead 459L to MASTER switch indicator light.
2. Disconnect lead 459 from MASTER switch.
3. Place red lead of multimeter in MASTER switch and black lead to ground.
4. Turn MASTER switch ON and check for voltage.
5. Turn MASTER switch OFF.

Is voltage present?

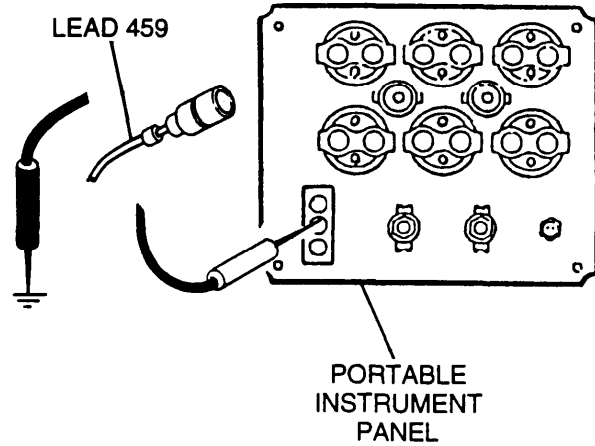

yes

no

Replace or repair lead 459 of portable instrument panel wiring harness (para 8-57).

D

1. Reconnect lead 459 to MASTER switch.
2. Disconnect lead 459B from MASTER switch.
3. Place red lead of multimeter in lead 459B and black lead to ground.
4. Turn MASTER switch ON and check for voltage.
5. Turn MASTER switch OFF.

Is voltage present?

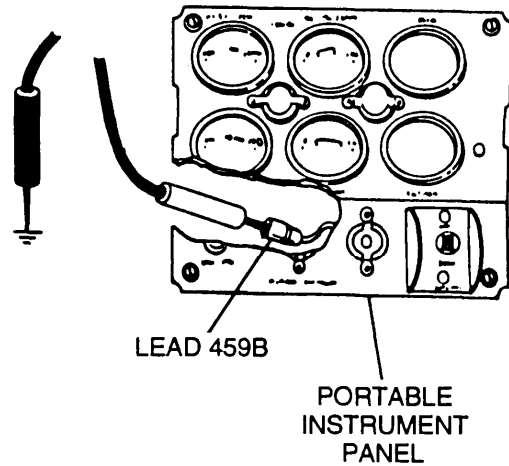

yes

no

Replace MASTER switch (para 8-17).

CONTINUED ON NEXT PAGE

CONTINUED FROM STEP D

- E**
1. Reconnect lead 4596 to MASTER switch.
 2. Disconnect engine disconnect bracket-to-bulkhead wiring harness from voltage regulator.
 3. Place red lead of multimeter in socket A (lead 2) and black lead to ground.
 4. Turn MASTER switch ON and check for voltage.
 5. Turn MASTER switch OFF.
- Is voltage present?

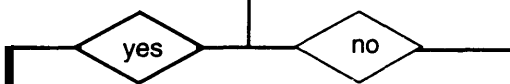

Replace or repair lead 2 of engine disconnect bracket-to-bulkhead wiring harness (para 8-45, M109A2/M109A3; para 8-46, M109A4/M109A5).

- F**
1. Place a jumper wire from socket A to pin A.
 2. Place red lead of multimeter on pin B (lead 459B/400) and black lead to ground.
 3. Turn MASTER switch ON and check for voltage.
 4. Turn MASTER switch OFF.
- Is voltage above 18 Vdc?

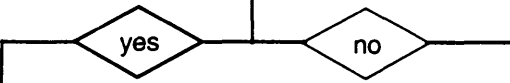

Replace voltage regulator (para 8-3).

CONTINUED ON NEXT PAGE

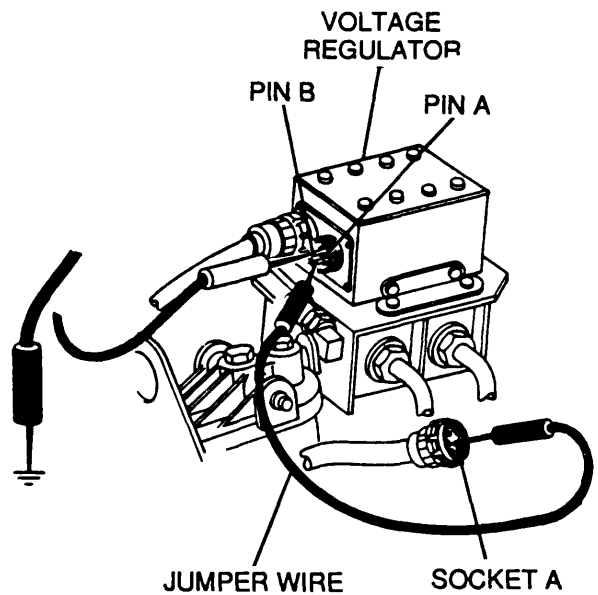
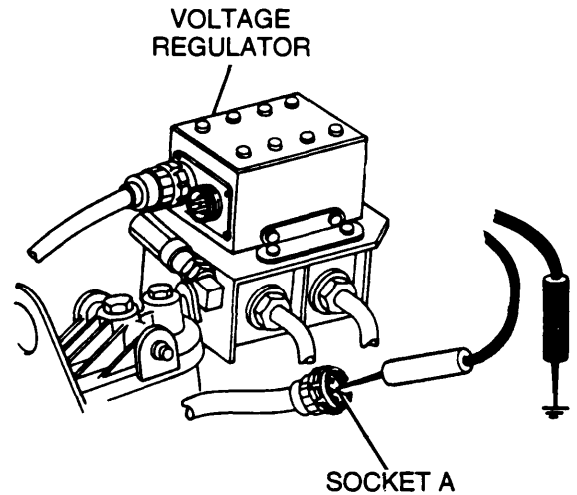

3-3 TROUBLESHOOTING CHART — CONTINUED

b. MASTER RELAY CIRCUIT — CONTINUED

(2) MASTER SWITCH INDICATOR LIGHT FAILS TO OPERATE; MASTER SWITCH IS ON — CONTINUED

CONTINUED FROM STEP F

G	<ol style="list-style-type: none"> 1. Reconnect connector to voltage regulator. 2. Disconnect engine disconnect bracket-to-bulkhead wiring harness from driver's bulkhead. 3. Place red lead of multimeter in socket B (lead 400/459B) and black lead to ground. 4. Turn MASTER switch ON and check for voltage. 5. Turn MASTER switch OFF.
Is voltage present?	

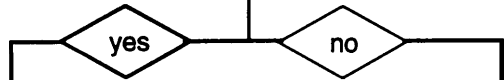

Replace or repair lead 400/459B of engine disconnect bracket-to-bulkhead wiring harness (para 8-45, M109A2/M109A3; para 8-48, M109A4/M109A5).

CONTINUED ON NEXT PAGE

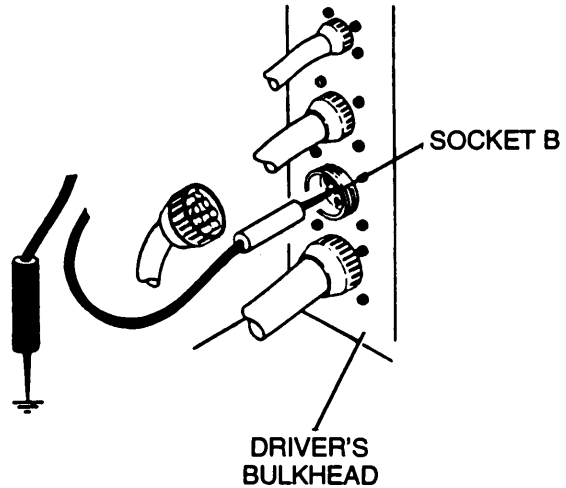

M109A4/M109A5 SHOWN

CONTINUED FROM STEP G

H

1. Reconnect connector to driver's bulkhead.
2. Disconnect portable instrument panel wiring harness from portable instrument panel disconnect.
3. Place red lead of multimeter in socket P (lead 459B) and black lead to ground.
4. Turn MASTER switch ON and check for voltage.
5. Turn MASTER switch OFF.

Is voltage above 18 Vdc?

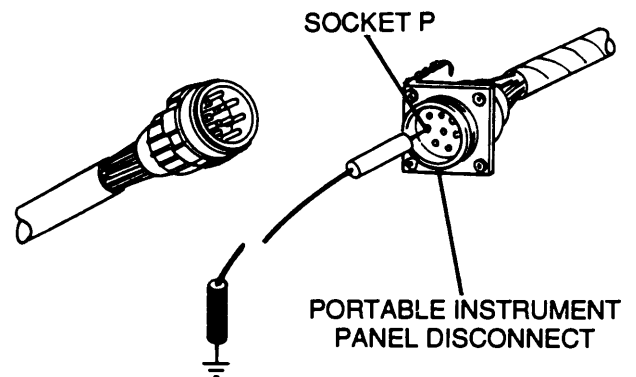
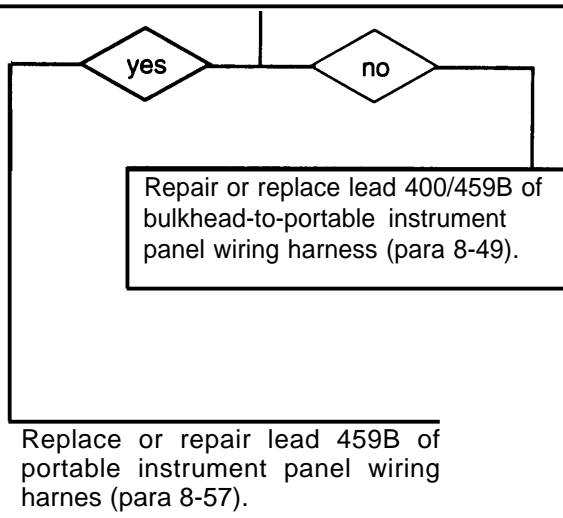

END OF TASK

3-3 TROUBLESHOOTING CHART — CONTINUED

c. STARTER MOTOR CIRCUIT (M109A2/M109A3)

NOTE

Ensure shift lever is in neutral position before troubleshooting this circuit.

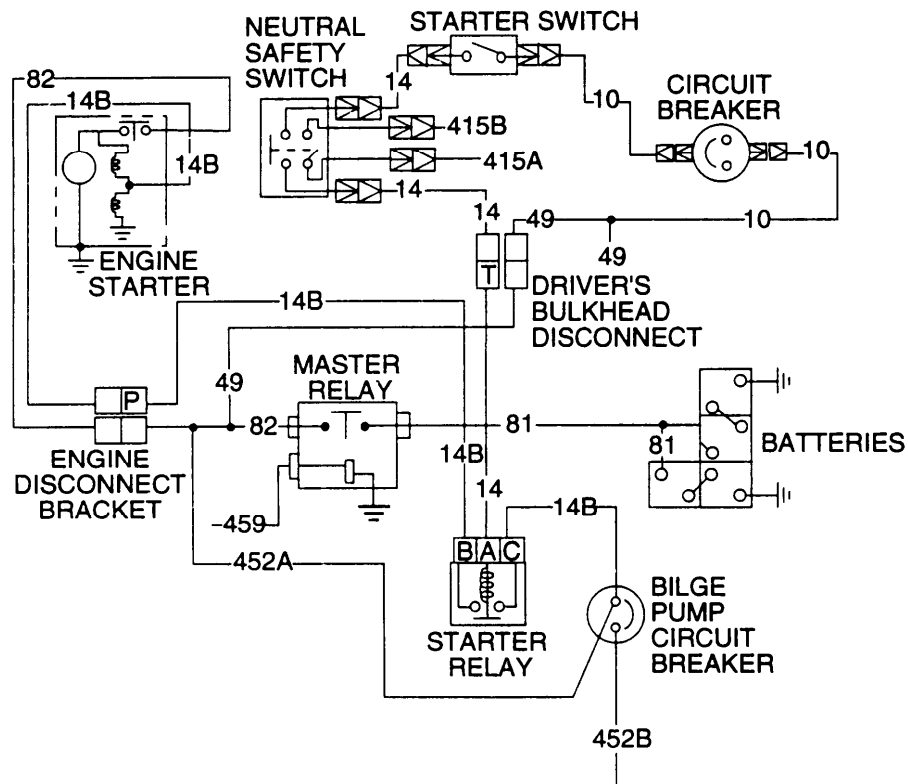

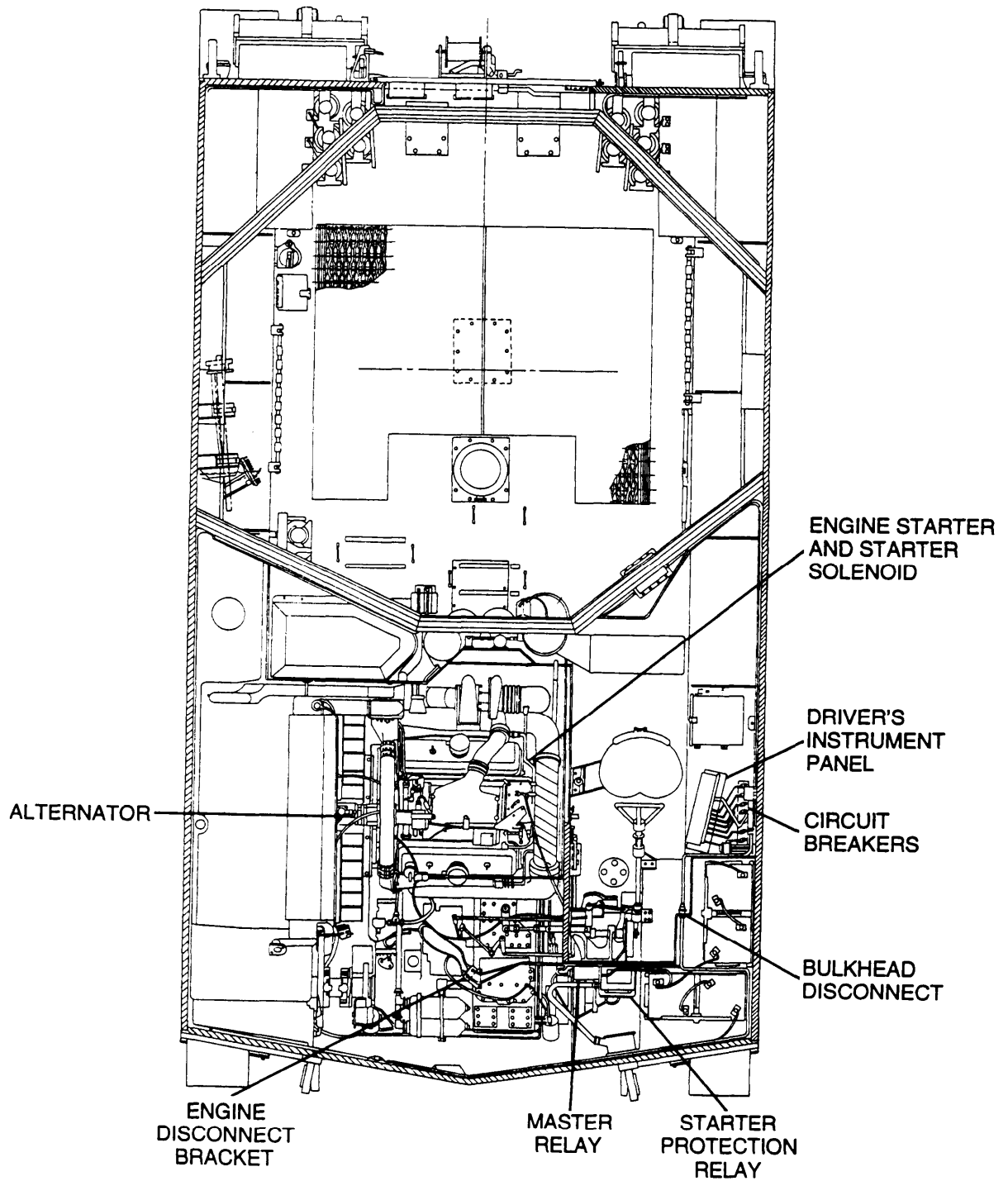

PICTORIAL VIEW

3-3 TROUBLESHOOTING CHART — CONTINUED

c. STARTER MOTOR CIRCUIT (M109A2/M109A3) — ENGINE DOES NOT CRANK; ALL ELECTRICAL ACCESSORIES OPERATE

INITIAL SETUP

Applicable Configurations
M109A2/M109A3

Personnel Required
Two

Tools
General mechanic's tool kit (item 64, Appx H)
Multimeter (item 36, Appx H)
TA-1 probe kit (item 43, Appx H)
(Long test leads may be needed for some tests;
16 AWG wire may be used as an extension.)

Equipment Conditions
Transmission left access door open (TM 9-2350-311-10)
Battery access doors open (TM 9-2350-311-10)
Portable instrument panel cover removed (para 8-17)

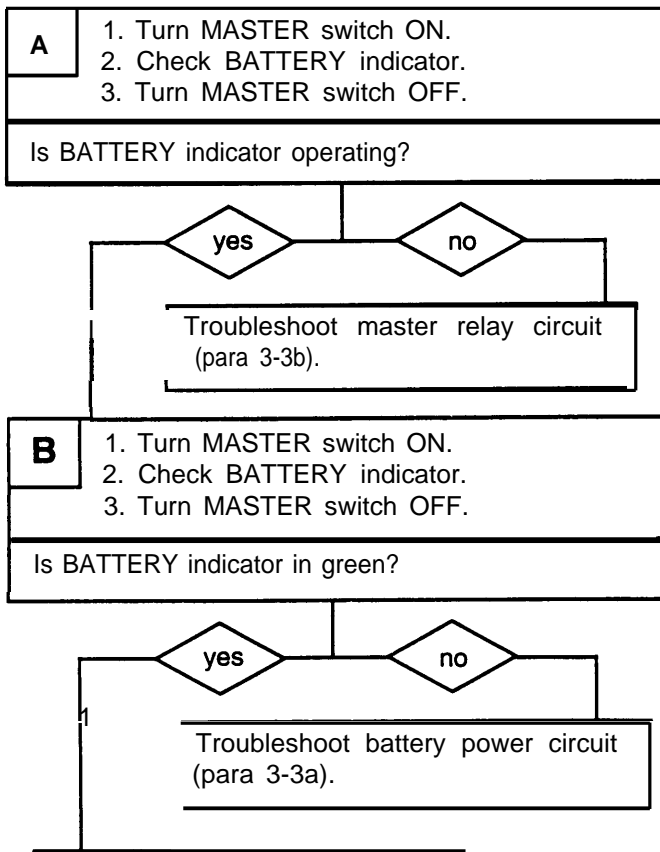

CONTINUED ON NEXT PAGE

CONTINUED FROM STEP B

C

1. Disconnect lead 82 of engine bracket-to-driver's bulkhead lead assembly from engine disconnect bracket.
2. Place red lead of multimeter in lead 82 and black lead to ground.
3. Turn MASTER switch ON, and check for voltage.
4. Turn MASTER switch OFF.

Is voltage present?

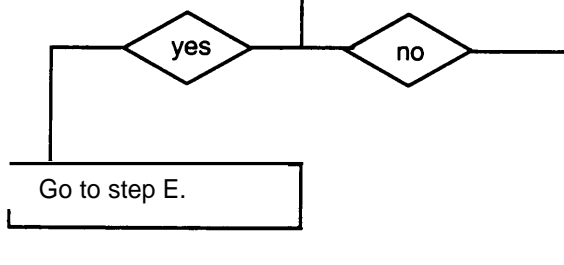

D

1. Reconnect lead 82 to engine disconnect bracket.
2. Disconnect lead 82 from master relay.
3. Place red lead of multimeter in master relay and black lead to ground.
4. Turn MASTER switch ON, and check for voltage.
5. Turn MASTER switch OFF.

Is voltage present?

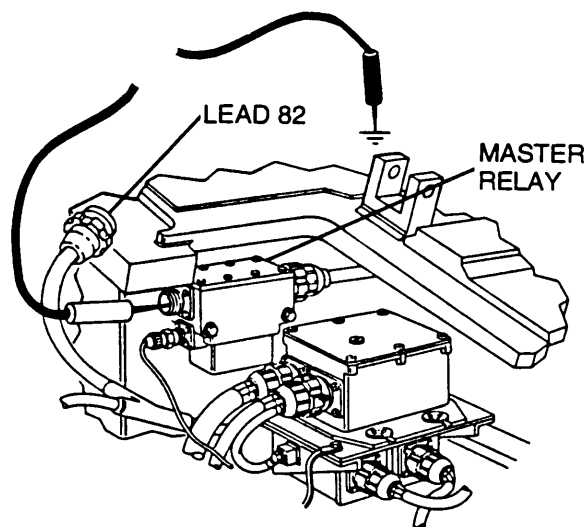
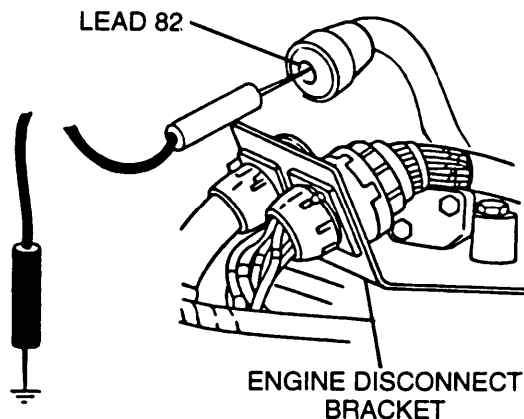
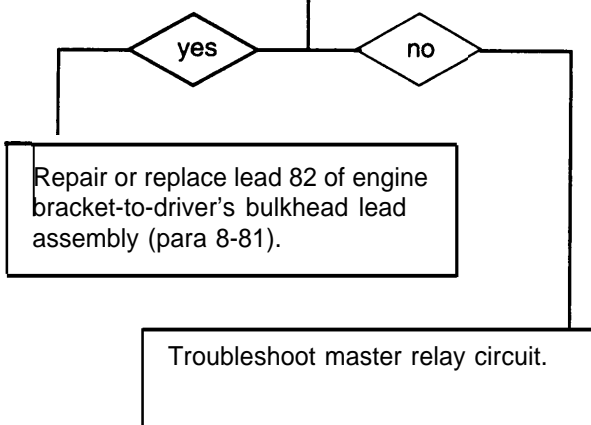

3-3 TROUBLESHOOTING CHART — CONTINUED

C. STARTER MOTOR CIRCUIT (M109A2/M109A3) — ENGINE DOES NOT CRANK; ALL ELECTRICAL ACCESSORIES OPERATE — CONTINUED

CONTINUED FROM STEP C

- E**
1. Reconnect lead 82 to engine disconnect bracket.
 2. Disconnect engine disconnect bracket-to-driver's bulkhead wiring harness from engine disconnect bracket.
 3. Place red lead of multimeter in socket P (lead 14B) and black lead to ground.
 4. Turn MASTER switch ON, push STARTER switch and check for voltage.
 5. Turn MASTER switch OFF.
- Is voltage present?

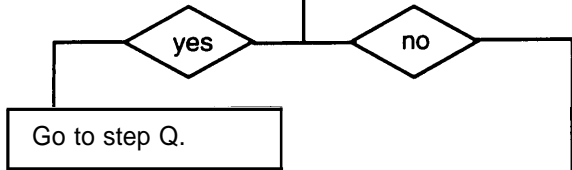
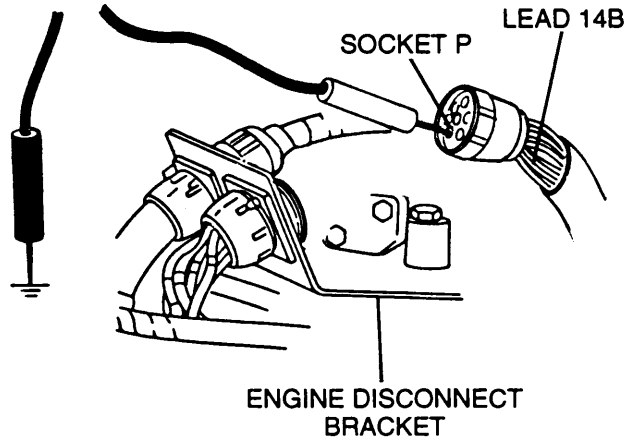

- F**
1. Reconnect connector to engine disconnect bracket.
 2. Disconnect engine disconnect bracket-to-driver's bulkhead wiring harness from starter switch relay.
 3. Place a jumper wire from socket C to socket B (lead 14B).
 4. Turn MASTER switch ON and push STARTER switch.
 5. Turn MASTER switch OFF.
- Does engine crank?

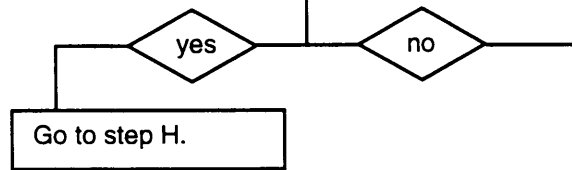
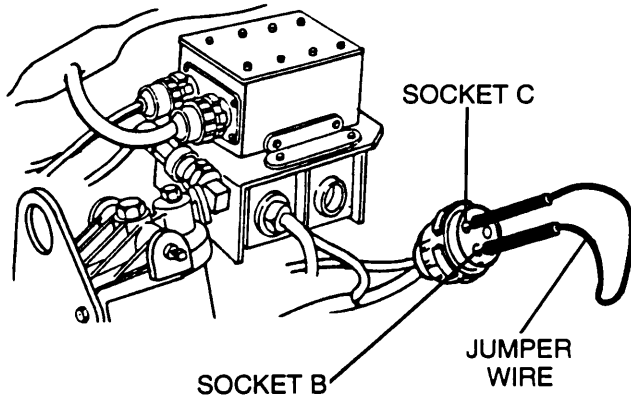

CONTINUED ON NEXT PAGE

CONTINUED FROM STEP F

- G**
1. Reconnect connector to starter relay.
 2. Place red lead of multimeter on leads 452A/14B at input terminal of bilge pump circuit breaker and black lead to ground.
 3. Turn MASTER switch ON, and check for voltage.
 4. Turn MASTER switch OFF.
- Is voltage present?

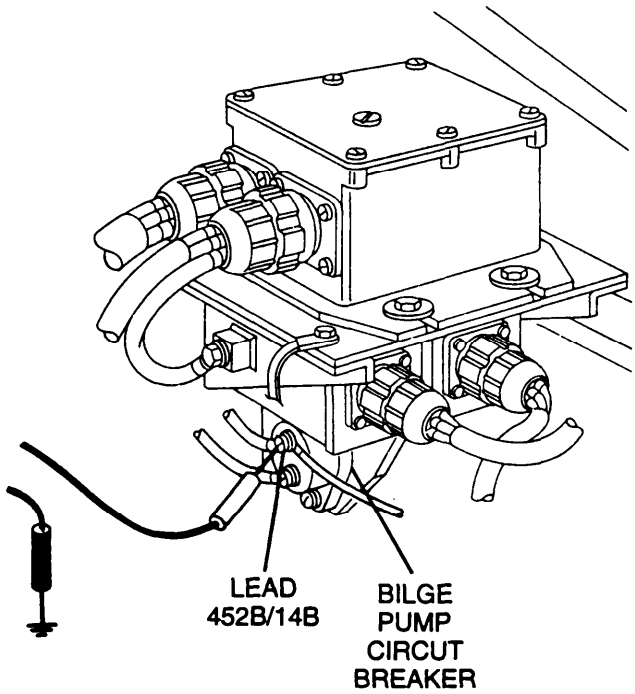
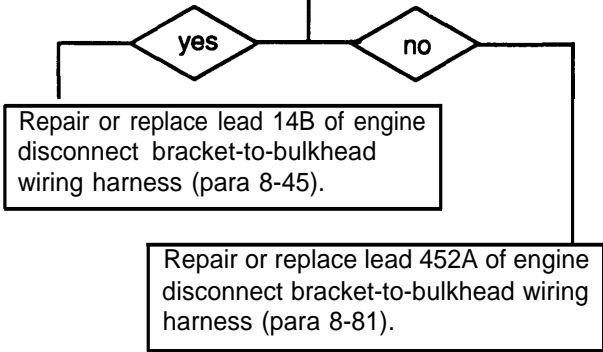

CONTINUED FROM STEP F

- H**
1. Place red lead of multimeter in socket A (lead 14) and black lead to ground.
 2. Turn MASTER switch ON, push STARTER switch and check for voltage.
 3. Turn MASTER switch OFF.
- Is voltage present?

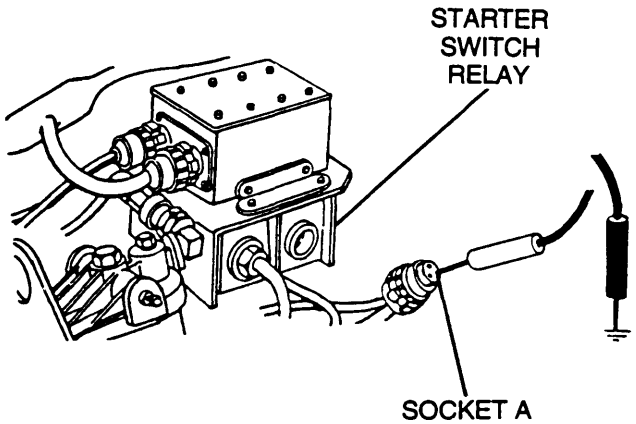
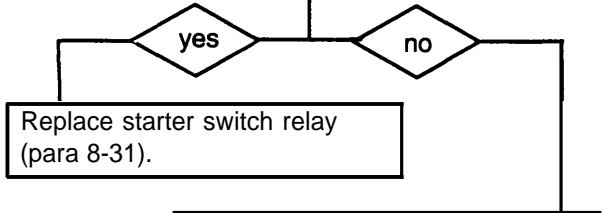

CONTINUED ON NEXT PAGE

3-3 TROUBLESHOOTING CHART — CONTINUED

C. STARTER MOTOR CIRCUIT (M109A2/M109A3) — ENGINE DOES NOT CRANK; ALL ELECTRICAL ACCESSORIES OPERATE — CONTINUED

CONTINUED FROM STEP H

- I**
1. Reconnect connector to starter switch relay.
 2. Disconnect lead 14 from output side of neutral safety switch.
 3. Place red lead of multimeter in lead 14 and black lead to ground.
 4. Turn MASTER switch ON, push STARTER switch, and check for voltage.
 5. Turn MASTER switch OFF.
- Is voltage present?

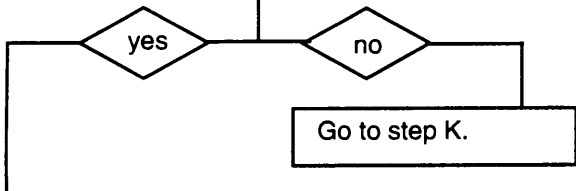
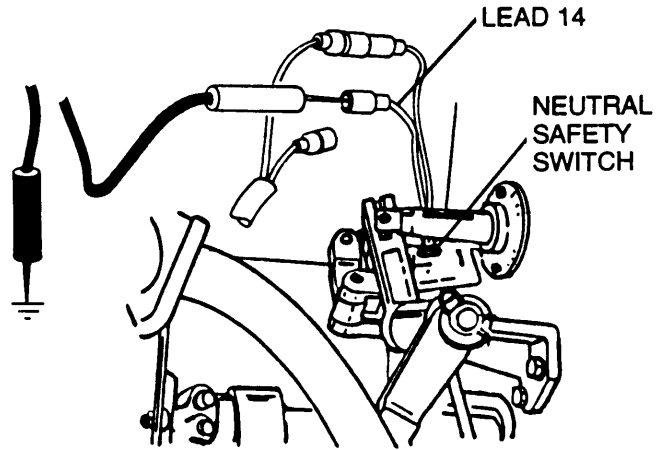

- J**
1. Reconnect lead 14 to output side of neutral safety switch.
 2. Disconnect engine disconnect-to-bulkhead harness from driver's bulkhead.
 3. Place a jumper wire from pin B to socket B (lead 4596).
 4. Place red lead of multimeter on pin T (lead 14) and black lead to ground.
 5. Turn MASTER switch ON, push STARTER switch and check for voltage.
 6. Turn MASTER switch OFF.
- Is voltage present?

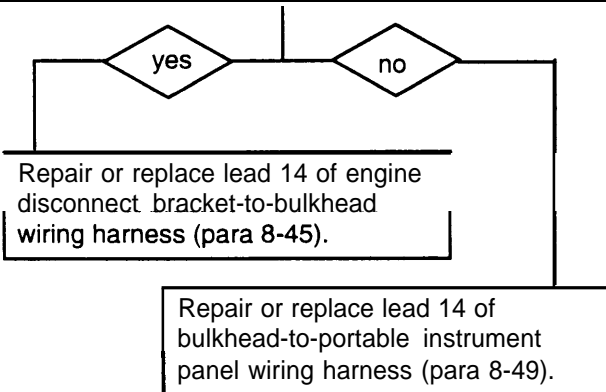
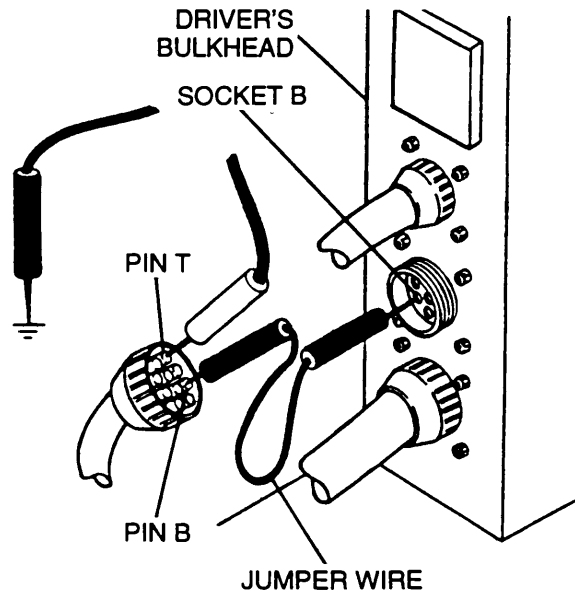

CONTINUED FROM STEP I

- K**
1. Reconnect lead 14 to output side of neutral safety switch.
 2. Disconnect lead 14 from input side of neutral safety switch.
 3. Place red lead of multimeter in lead 14 and black lead to ground.
 4. Turn MASTER switch ON, push STARTER switch, and check for voltage.
 5. Turn MASTER switch OFF.

Is voltage present?

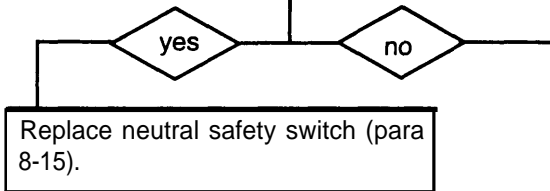

- L**
1. Reconnect lead 14 to input side of neutral safety switch.
 2. Disconnect lead 14 from output side of STARTER switch.
 3. Place red lead of multimeter in STARTER switch and black lead to ground.
 4. Turn MASTER switch ON, push STARTER switch and check for voltage.
 5. Turn MASTER switch OFF.

Is voltage present?

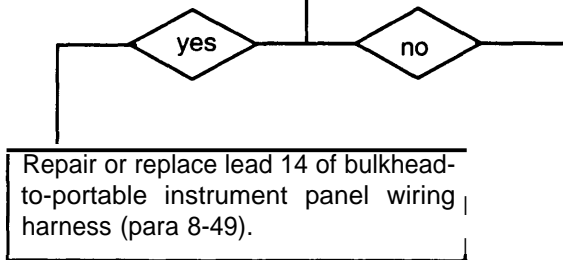

CONTINUED ON NEXT PAGE

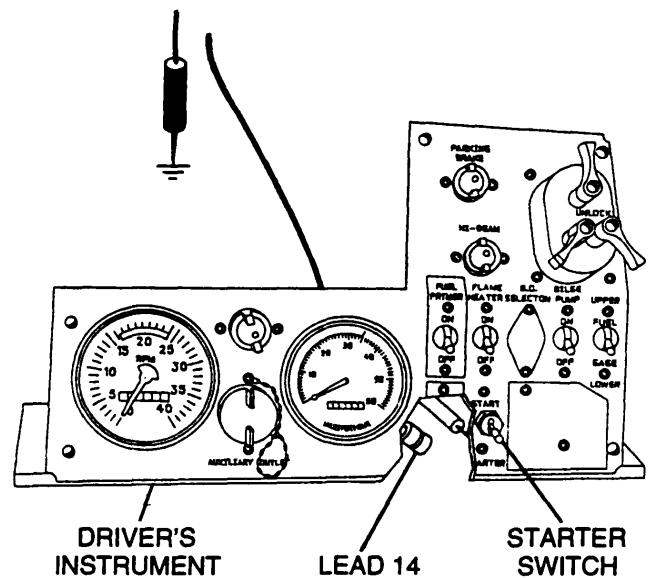
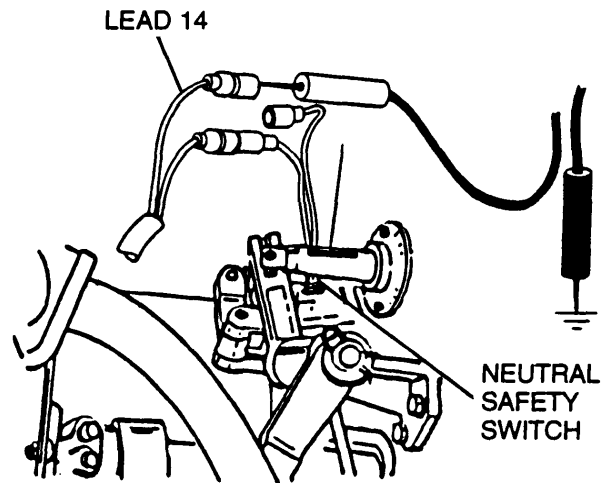

3-3 TROUBLESHOOTING CHART — CONTINUED

c. STARTER MOTOR CIRCUIT (M109A2/M109A3) — ENGINE DOES NOT CRANK; ALL ELECTRICAL ACCESSORIES OPERATE — CONTINUED

CONTINUED FROM STEP L

- M**
1. Reconnect lead 14 to output side of STARTER switch.
 2. Disconnect lead 10 from input side of STARTER switch.
 3. Place red lead of multimeter in lead 10 and black lead to ground.
 4. Turn MASTER switch ON and check for voltage.
 5. Turn MASTER switch OFF.

Is voltage present?

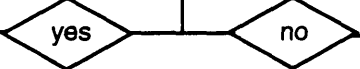

Replace STARTER switch (para 8-17).

- N**
1. Reconnect lead 10 to input side of STARTER switch.
 2. Disconnect lead 10 of driver's instrument panel wiring harness from output side of circuit breaker.
 3. Place red lead of multimeter in output side of circuit breaker and black lead to ground.
 4. Turn MASTER switch ON and check for voltage.
 5. Turn MASTER switch OFF.

Is voltage present?

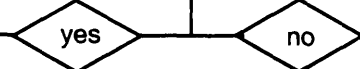

Repair or replace lead 10 of driver's instrument panel wiring harness (para 8-51).

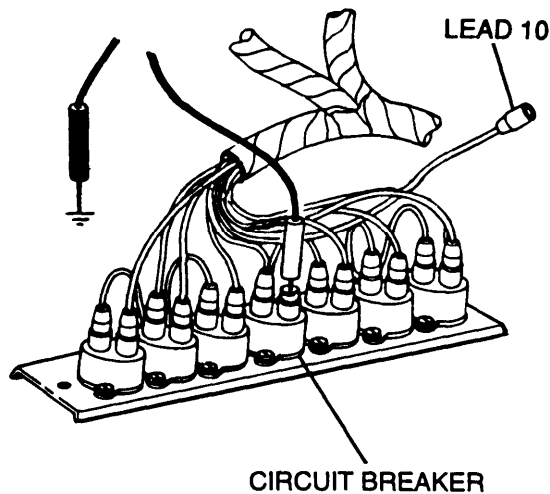
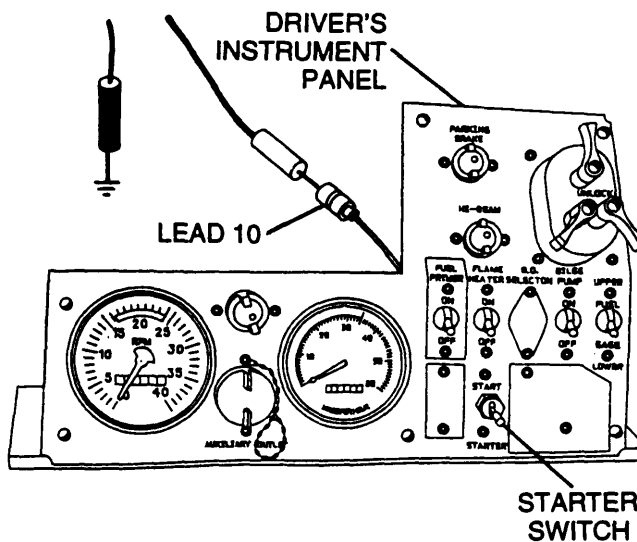

CONTINUED ON NEXT PAGE

CONTINUED FROM STEP N

- O**
1. Reconnect lead 10 to output side of circuit breaker.
 2. Disconnect lead 10 of power lead wiring harness from input side of circuit breaker.
 3. Place red lead of multimeter in lead 10 and black lead to ground.
 4. Turn MASTER switch ON and check for voltage.
 5. Turn MASTER switch OFF.

Is voltage present?

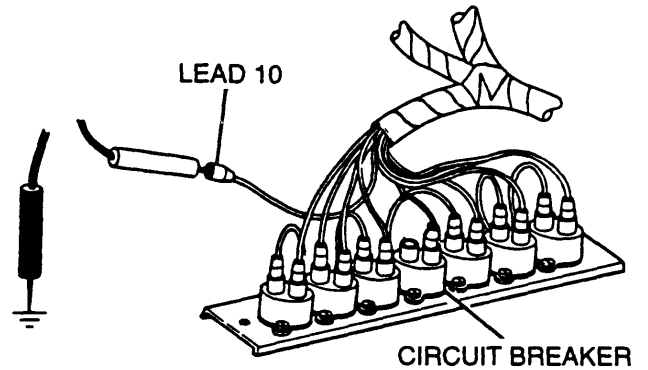
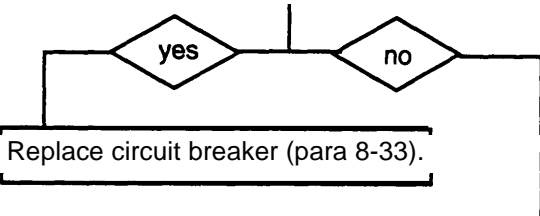

- P**
1. Reconnect lead 10 to input side of circuit breaker.
 2. Disconnect lead 49 of engine bracket-to-driver's bulkhead lead assembly from driver's bulkhead.
 3. Place red lead of multimeter in lead 49 and black lead to ground.
 4. Turn MASTER switch ON and check for voltage.
 5. Turn MASTER switch OFF.

Is voltage present?

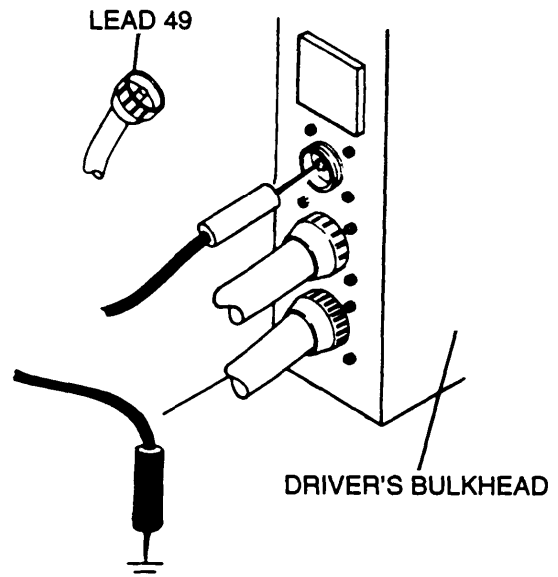
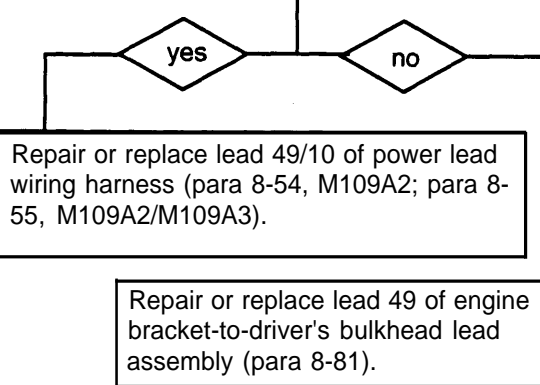

3-3 TROUBLESHOOTING CHART — CONTINUED

C. STARTER MOTOR CIRCUIT (M109A2/M109A3) — ENGINE DOES NOT CRANK; ALL ELECTRICAL ACCESSORIES OPERATE — CONTINUED

CONTINUED FROM STEP E

Q

1. Reconnect connector to engine disconnect bracket.
2. Remove powerplant from vehicle (para 4-3).
3. Connect special equipment for operation of equipment outside of vehicle (para 4-3).
4. Place red lead of multimeter on lead 14B at starter solenoid and black lead to ground.
5. Place shift lever in neutral.
6. Turn MASTER switch ON, push STARTER switch, and check for voltage.
7. Turn MASTER switch OFF.

Is voltage present?

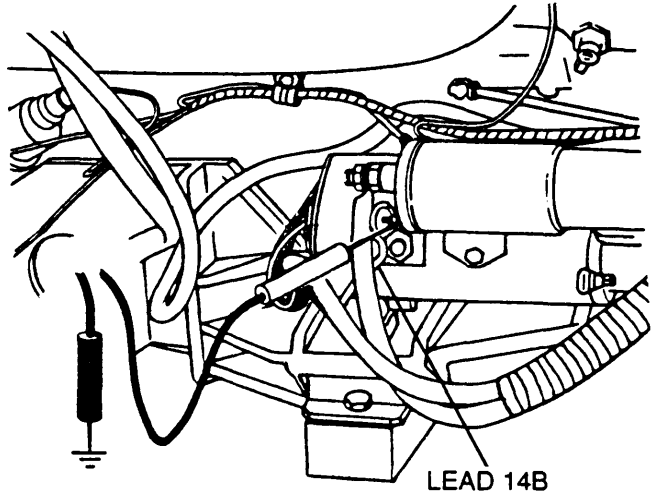

yes

no

Repair or replace lead 14B of powerplant wiring harness (para 8-43).

R

1. Place red lead of multimeter on lead 82 at starter solenoid and black lead to gerund.
2. Turn MASTER switch ON and check for voltage.
3. Turn MASTER switch OFF.

Is voltage present?

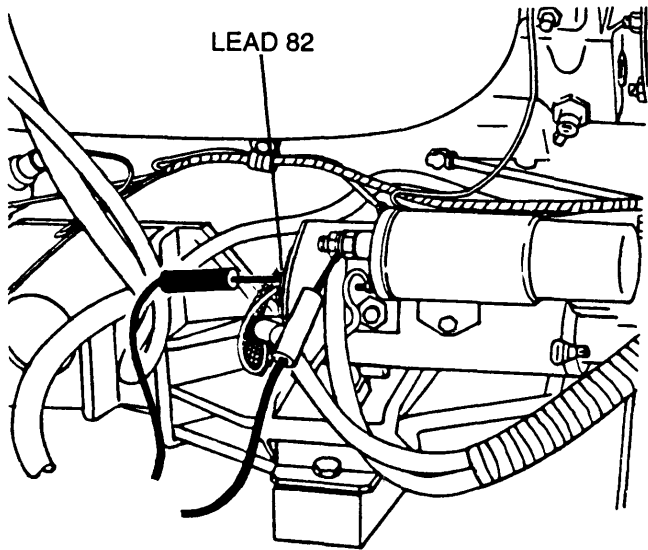

yes

no

Replace starter motor (para 8-14).

Repair or replace lead 82 of powerplant wiring harness (para 8-43).

END OF TASK

d. STARTER MOTOR CIRCUIT (M109A4/M109A5)

NOTE

Ensure shift lever is in neutral position before troubleshooting this circuit.

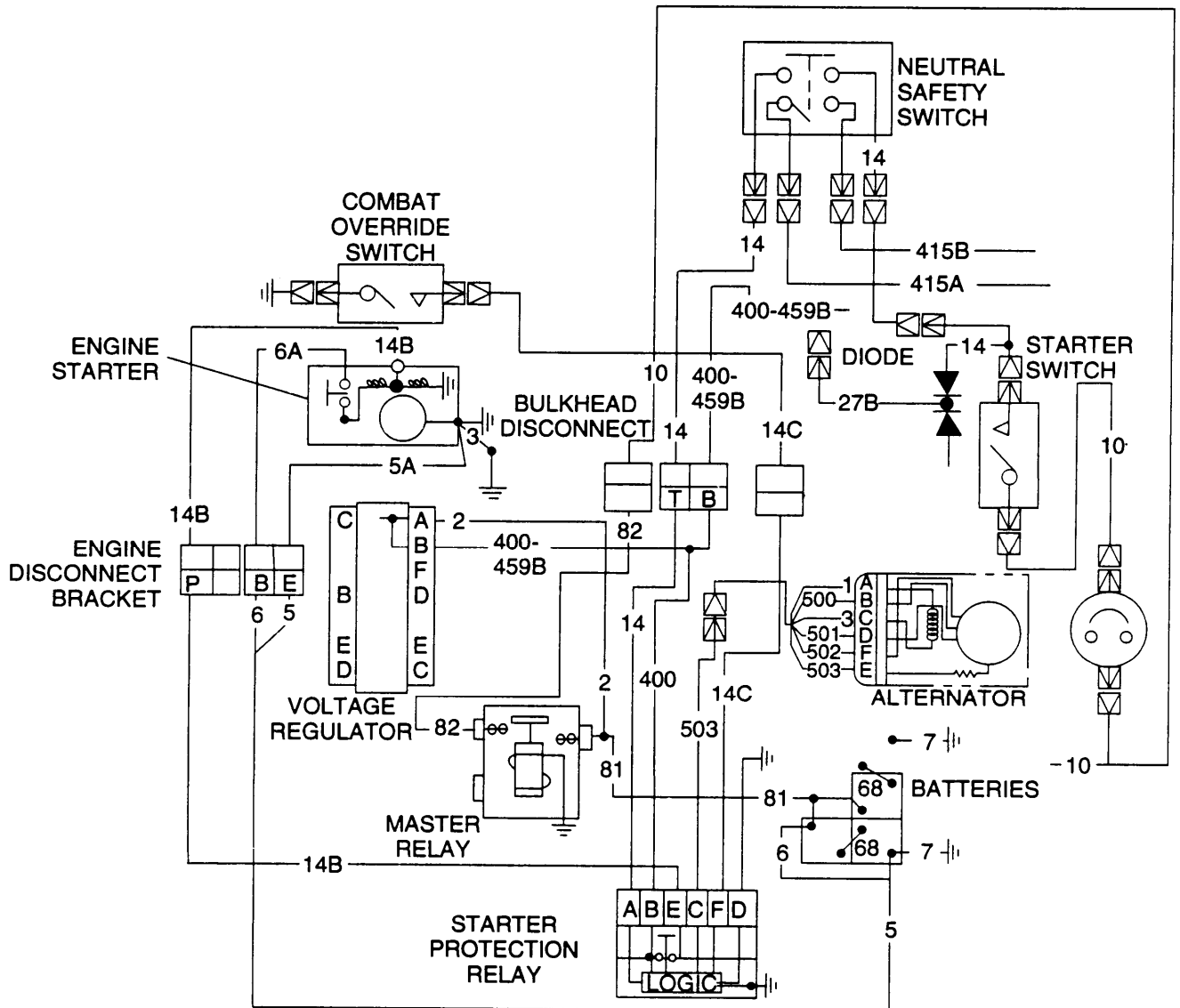

3-3 TROUBLESHOOTING CHART — CONTINUED

d. STARTER MOTOR CIRCUIT (M109A4/M109A5) —
CONTINUED

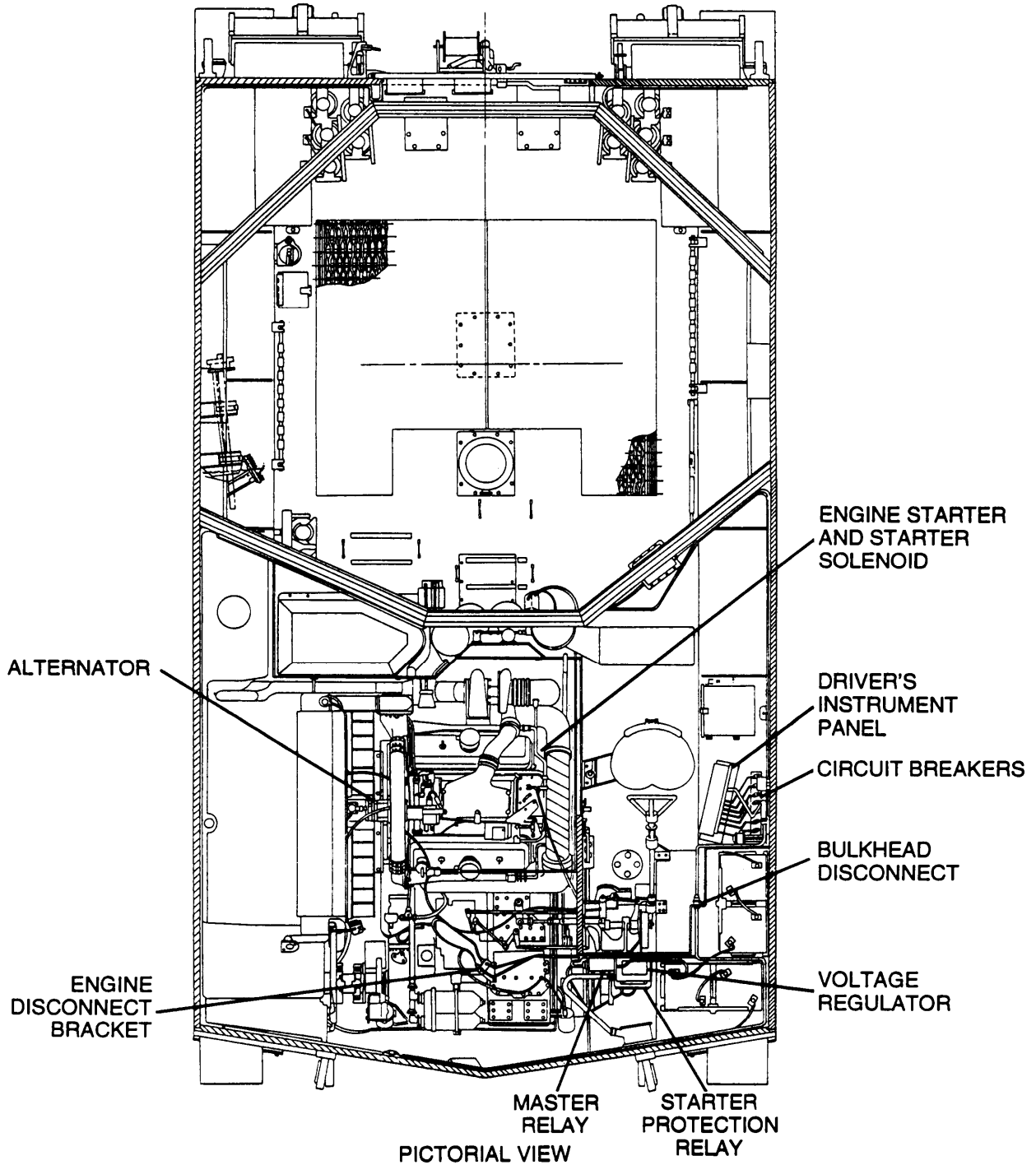

(1) ENGINE DOES NOT CRANK; ALL ELECTRICAL ACCESSORIES OPERATE

INITIAL SETUP

Applicable Configurations
M109A4/M109A5

Personnel Required
Two

Tools

General mechanic's tool kit (item 64, Appx H)
Multimeter (item 36, Appx H)
TA-1 probe kit (item 43, Appx H)
(Long test leads may be needed for some tests;
16 AWG wire may be used as an extension.)

Equipment Conditions

Transmission left access door open (TM 9-2350-311-10)
Battery access doors open (TM 9-2350-311-10)
Portable instrument panel cover removed (para 8-17)

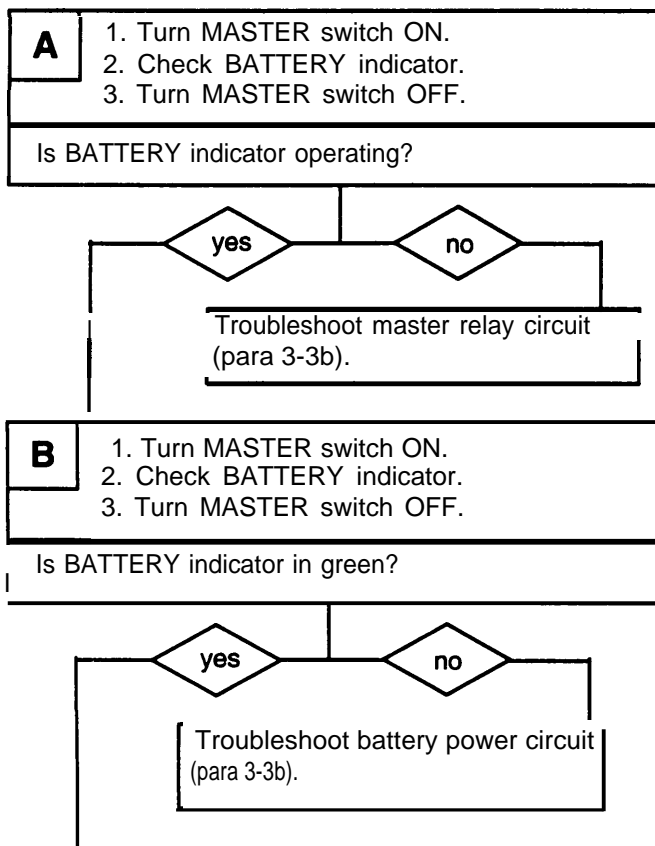

CONTINUED ON NEXT PAGE

3-3 TROUBLESHOOTING CHART — CONTINUED

d. STARTER MOTOR CIRCUIT (M109A4/M109A5) — (1) ENGINE DOES NOT CRANK; ALL ELECTRICAL ACCESSORIES OPERATE — CONTINUED

CONTINUED FROM STEP B

- C**
1. Disconnect engine disconnect bracket-to-batteries lead assembly from engine disconnect bracket.
 2. Place red lead of multimeter in socket B (lead 6) and black lead to ground.
 3. Turn MASTER switch ON and check for voltage.
 4. Turn MASTER switch OFF.

Is voltage present?

yes

no

Repair or replace lead 6 of engine disconnect bracket-to-batteries lead assembly (para 8-87).

- D**
1. Place red lead of multimeter in socket E (lead 5) and black lead to ground.
 2. Check for continuity.

Is continuity present?

yes

no

Repair or replace lead 5 of engine disconnect bracket-to-batteries lead assembly (para 8-87).

CONTINUED ON NEXT PAGE

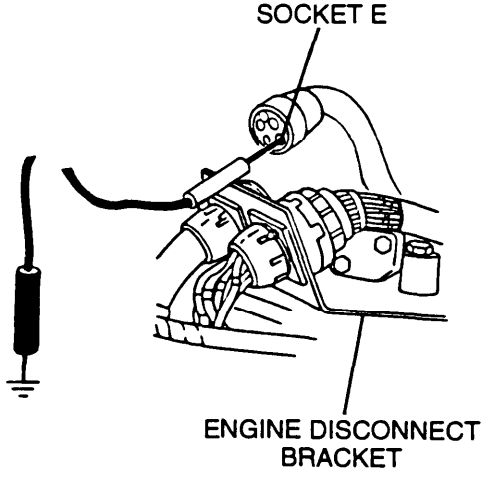
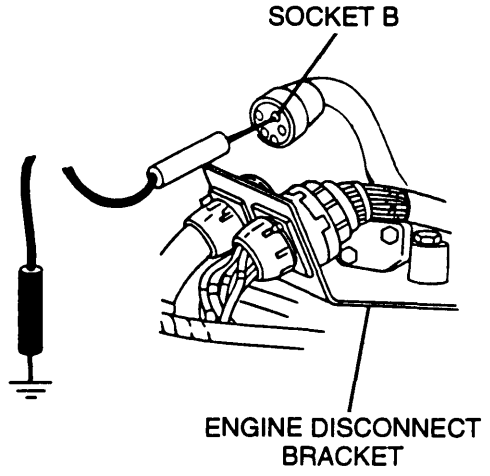

CONTINUED FROM STEP D

- E**
1. Reconnect engine disconnect bracket-to-batteries lead assembly to engine disconnect bracket.
 2. Disconnect driver's bulkhead-to-master relay wiring harness from engine disconnect.
 3. Place red lead of multimeter in socket P (lead 14B) and black lead to ground.
 4. Turn MASTER switch ON, push STARTER switch, and check for voltage.
 5. Turn MASTER switch OFF.
- Is voltage present?

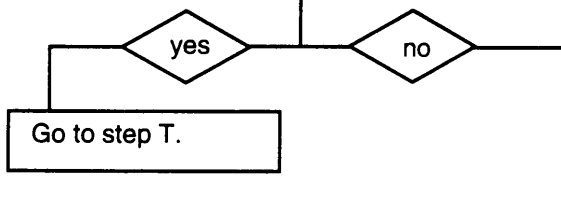

- F**
1. Reconnect connector to engine disconnect bracket.
 2. Disconnect driver's bulkhead-to-master relay wiring harness from starter protection relay.
 3. Place a jumper wire from socket B (lead 400) to socket E (lead 14B).
 4. Turn MASTER switch ON and push STARTER switch.
 5. Turn MASTER switch OFF.
- Does engine crank?

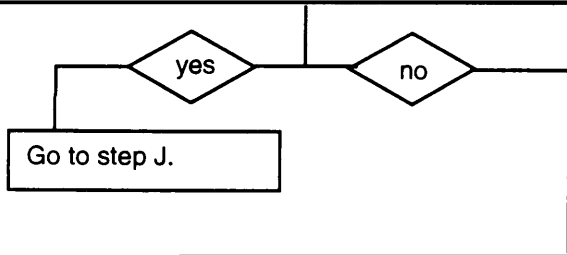

CONTINUED ON NEXT PAGE

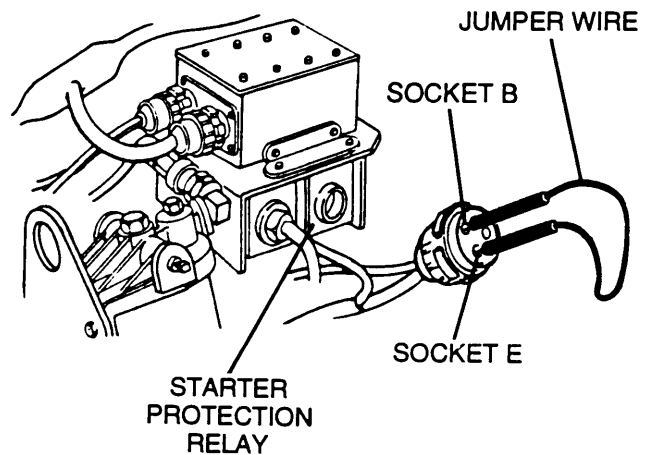
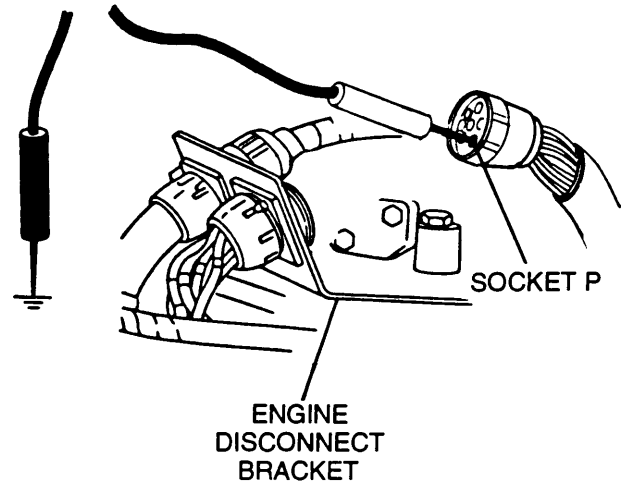

3-3 TROUBLESHOOTING CHART — CONTINUED

d. STARTER MOTOR CIRCUIT (M109A4/M109A5) — (1) ENGINE DOES NOT CRANK; ALL ELECTRICAL ACCESSORIES OPERATE — CONTINUED

CONTINUED FROM STEP F

G

1. Place red lead of multimeter in socket B (lead 400-4595) and black lead to ground.
2. Turn MASTER switch ON and check for voltage.
3. Turn MASTER switch OFF.

Is voltage present?

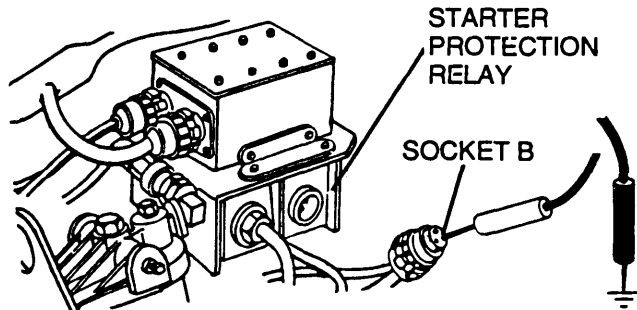

yes

no

Repair or replace lead 14B of driver's bulkhead-to-master relay wiring harness (para 8-46).

H

1. Reconnect connector to starter protection relay.
2. Disconnect driver's bulkhead-to-master relay wiring harness from voltage regulator.
3. Place a jumper wire from pin A (lead 2) to socket A (lead 2).
4. Place red lead of multimeter on pin B (lead 400-459B) and black lead to ground.
5. Turn MASTER switch ON and check for voltage.
6. Turn MASTER switch OFF.

Is voltage present?

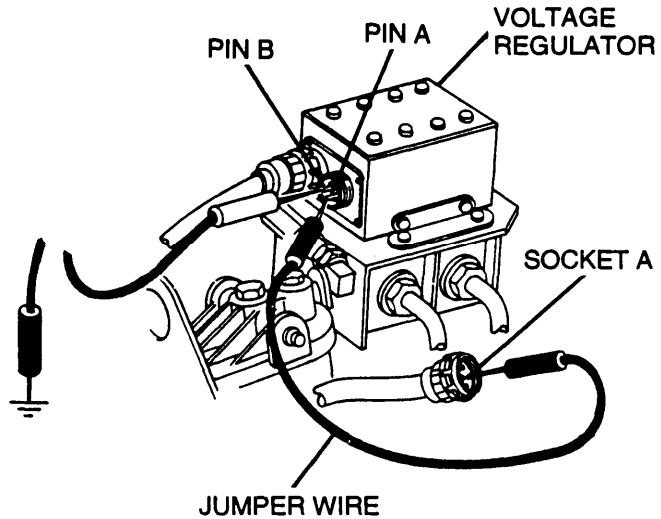

yes

no

Repair or replace lead 400-459B of driver's bulkhead-to-master relay wiring harness (para 8-46).

CONTINUED ON NEXT PAGE

CONTINUED FROM STEP H

- I**
1. Place red lead of multimeter in socket A (lead 2) and black lead to ground.
 2. Turn MASTER switch ON and check for voltage.
 3. Turn MASTER switch OFF.

Is voltage present?

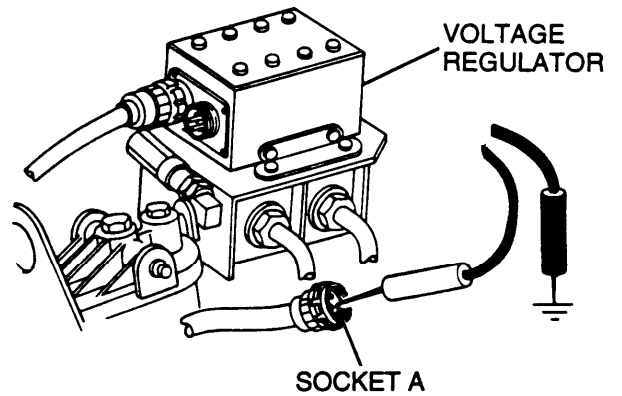
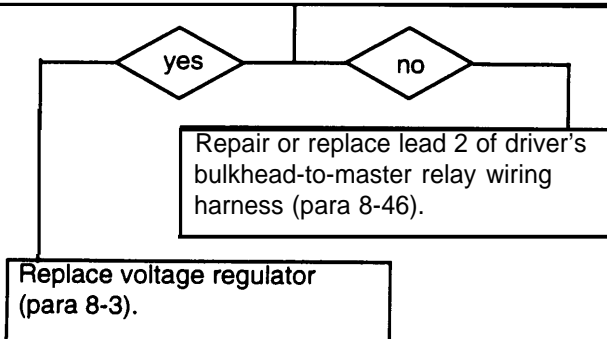

CONTINUED FROM STEP F

- J**
1. Place red lead of multimeter in socket A (lead 14) and black lead to ground.
 2. Turn MASTER switch ON, push STARTER switch, and check for voltage.
 3. Turn MASTER switch OFF.

Is voltage present?

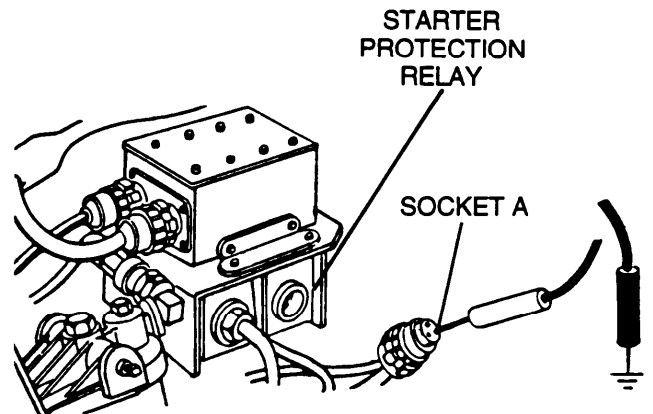
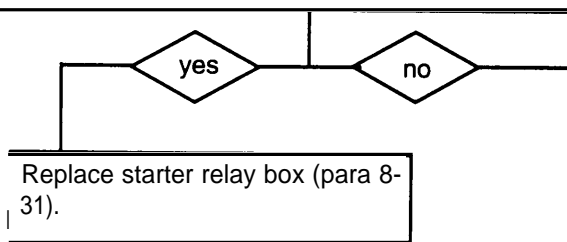

CONTINUED ON NEXT PAGE

3-3 TROUBLESHOOTING CHART — CONTINUED

d. STARTER MOTOR CIRCUIT (M109A4/M109A5)—
CONTINUED

(1) ENGINE DOES NOT CRANK; ALL ELECTRICAL
ACCESSORIES OPERATE — CONTINUED

CONTINUED FROM STEP J

K

1. Reconnect connector to voltage regulator.
2. Disconnect lead 14 from output side of neutral safety switch.
3. Place red lead of multimeter on lead 14 and black lead to ground.
4. Turn MASTER switch ON, push STARTER switch, and check for voltage.
5. Turn MASTER switch OFF.

Is voltage present?

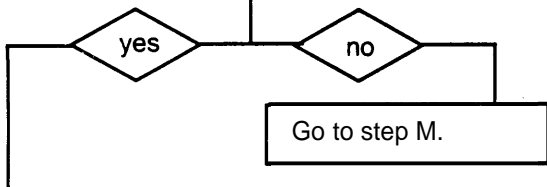

L

1. Reconnect lead 14 to output side of neutral safety switch.
2. Disconnect driver's bulkhead-to-master relay wiring harness from driver's bulkhead.
3. Place a jumper wire from socket B to pin B (lead 400-459B).
4. Place red lead of multimeter in socket T (lead 14) and black lead to ground.
5. Turn MASTER switch ON, push STARTER switch, and check for voltage.
6. Turn MASTER switch OFF.

Is voltage present?

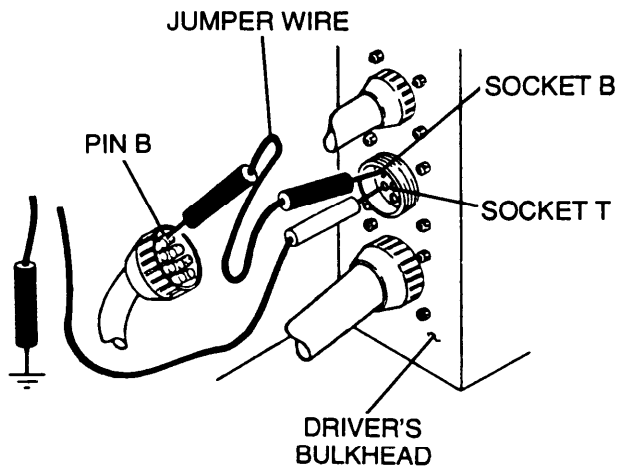
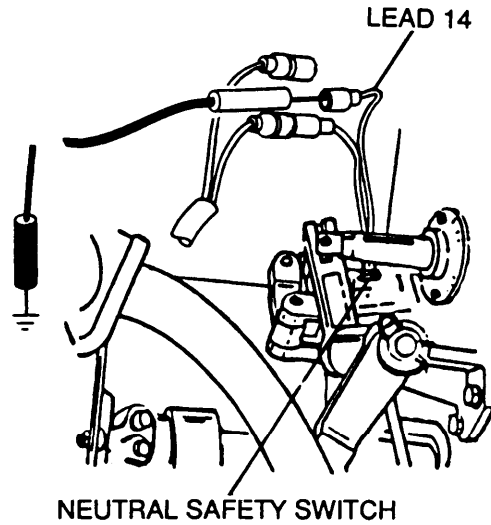
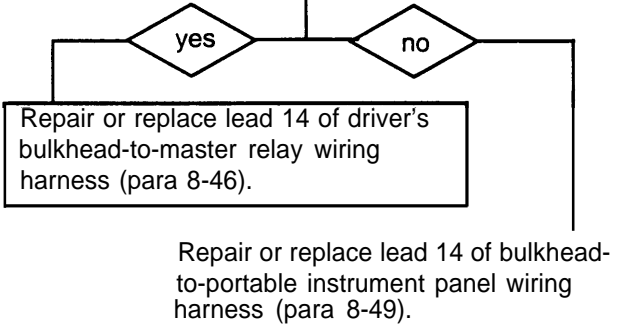

CONTINUED FROM STEP K

- M**
1. Reconnect lead 14 to output side of neutral safety switch.
 2. Disconnect lead 14 from input side of neutral safety switch.
 3. Place red lead of multimeter in lead 14 and black lead to ground.
 4. Turn MASTER switch ON, push STARTER switch, and check for voltage.
 5. Turn MASTER switch OFF.

Is voltage present?

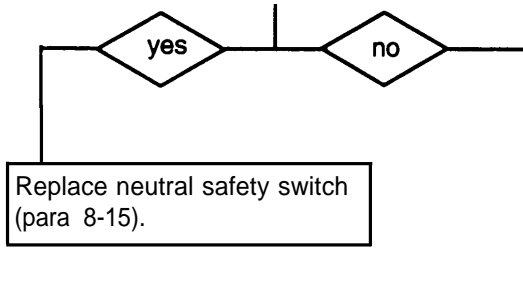

- N**
1. Reconnect lead 14 to input side of neutral safety switch.
 2. Disconnect lead 14 from output side of STARTER switch.
 3. Place red lead of multimeter in output side of STARTER switch and black lead to ground.
 4. Turn MASTER switch ON, push STARTER switch and check for voltage.
 5. Turn MASTER switch OFF.

Is voltage present?

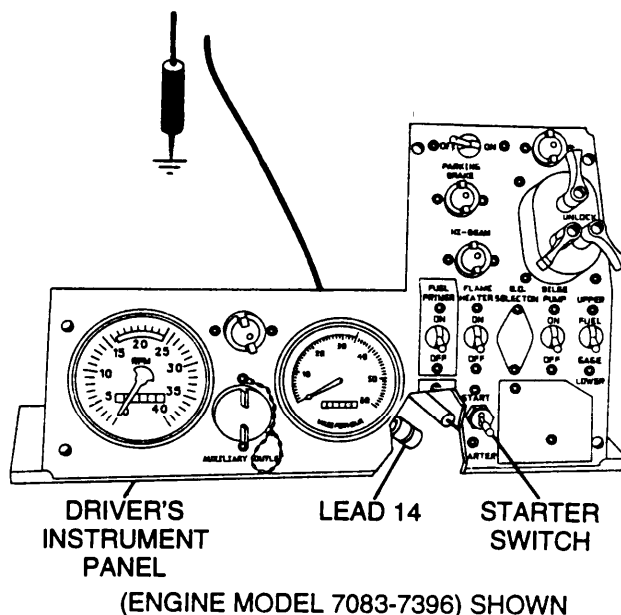
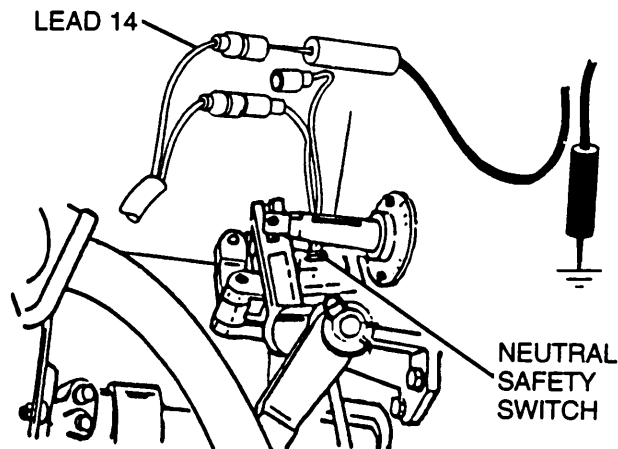
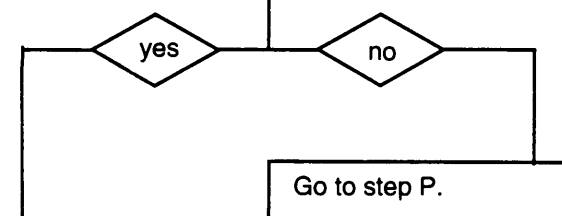

CONTINUED ON NEXT PAGE

3-3 TROUBLESHOOTING CHART — CONTINUED

d. STARTER MOTOR CIRCUIT (M109A4/M109A5) — (1) ENGINE DOES NOT CRANK; ALL ELECTRICAL ACCESSORIES OPERATE — CONTINUED

CONTINUED FROM STEP N

O	<ol style="list-style-type: none"> 1. Reconnect lead 14 to output side of STARTER switch. 2. Disconnect lead 14 at connector between STARTER switch and neutral safety switch. 3. Place red lead of multimeter on lead 14 and black lead to ground. 4. Turn MASTER switch ON, push STARTER switch, and check for voltage. 5. Turn MASTER switch OFF.
Is voltage present?	

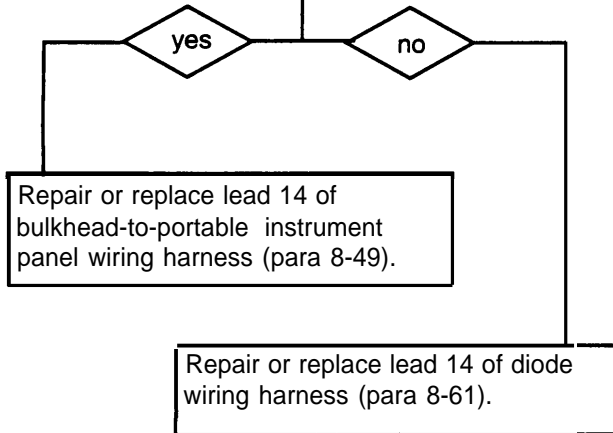
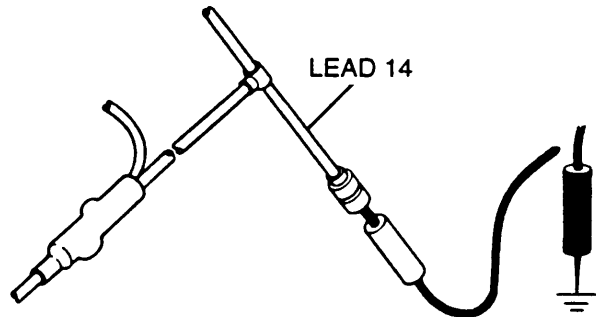

CONTINUED FROM STEP N

- P**
1. Reconnect lead 14 to output side of STARTER switch.
 2. Disconnect lead 10 from input side of STARTER switch.
 3. Place red lead of multimeter in lead 10 and black lead to ground.
 4. Turn MASTER switch ON and check for voltage.
 5. Turn MASTER switch OFF.

Is voltage present?

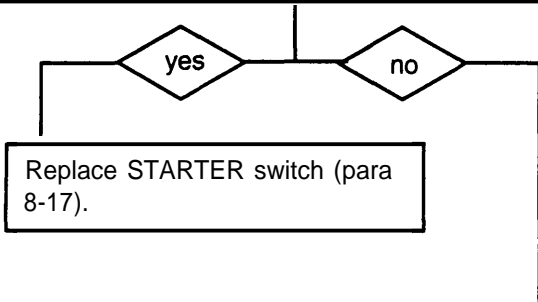

- Q**
1. Reconnect lead 10 to input side of STARTER switch.
 2. Disconnect lead 10 from output side of circuit breaker.
 3. Place red lead of multimeter in output side of circuit breaker and black lead to ground.
 4. Turn MASTER switch ON and check for voltage.
 5. Turn MASTER switch OFF.

Is voltage present?

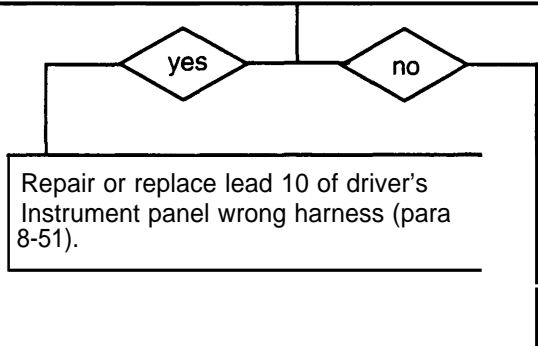

CONTINUED ON NEXT PAGE

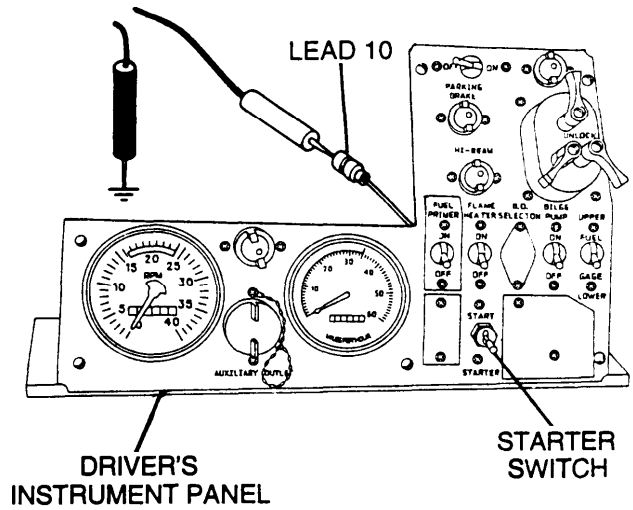

DRIVER'S INSTRUMENT PANEL

STARTER SWITCH

(ENGINE MODEL 7083-7396 SHOWN)

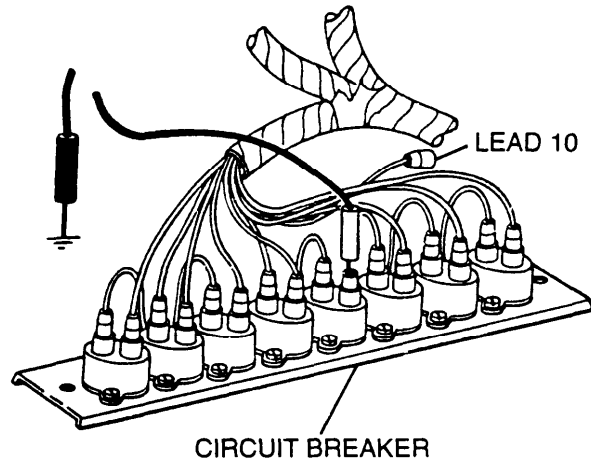

CIRCUIT BREAKER

3-3 TROUBLESHOOTING CHART — CONTINUED

d. STARTER MOTOR CIRCUIT (M109A4/M109A5) — (1) ENGINE DOES NOT CRANK; ALL ELECTRICAL ACCESSORIES OPERATE — CONTINUED

CONTINUED FROM STEP Q

R

1. Reconnect lead 10 to output side of circuit breaker.
2. Disconnect lead 10 from input side of circuit breaker.
3. Place red lead of multimeter in lead 10 and black lead to ground.
4. Turn MASTER switch ON and check for voltage.
5. Turn MASTER switch OFF.

Is voltage present?

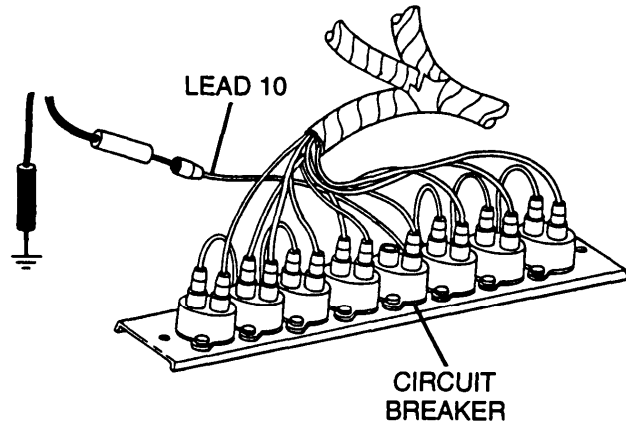

yes

no

Replace circuit breaker (para 8-34).

S

1. Reconnect lead 10 to input side of circuit breaker.
2. Disconnect master relay-to-driver's bulkhead lead assembly from driver's bulkhead.
3. Place red lead of multimeter in lead 82 and black lead to ground.
4. Turn MASTER switch ON and check for voltage.
5. Turn MASTER switch OFF.

Is voltage present?

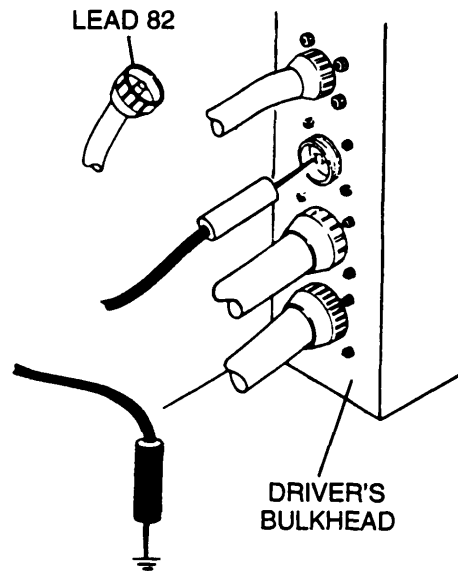

yes

no

Repair or replace lead 10 of power lead wiring harness (para 8-56).

Repair or replace lead 82 of master relay-to-driver's bulkhead lead assembly (para 8-82).

CONTINUED FROM STEP E

T	<ol style="list-style-type: none"> 1. Remove powerplant (para 4-5). 2. Connect special equipment for operation of powerplant out of vehicle (para 4-5). 3. Place red lead of multimeter on lead 14B at starter solenoid and black lead to ground. 4. Turn MASTER switch ON, push STARTER switch, and check for voltage. 5. Turn MASTER switch OFF.
Is voltage present?	

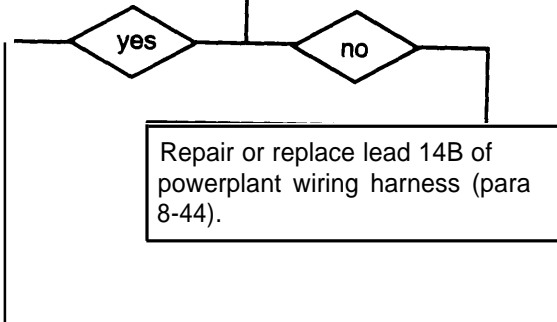

U	<ol style="list-style-type: none"> 1. Place red lead of multimeter on lead 6A at starter solenoid and black lead on ground (lead 5A). 2. Turn MASTER switch ON and check for voltage. 3. Turn MASTER switch OFF.
Is voltage present?	

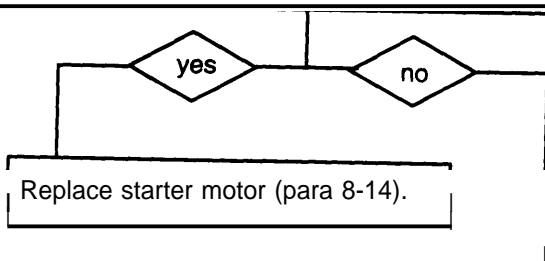

Repair or replace leads 5A and 6A of starter-to-engine electrical disconnect (para 8-84).

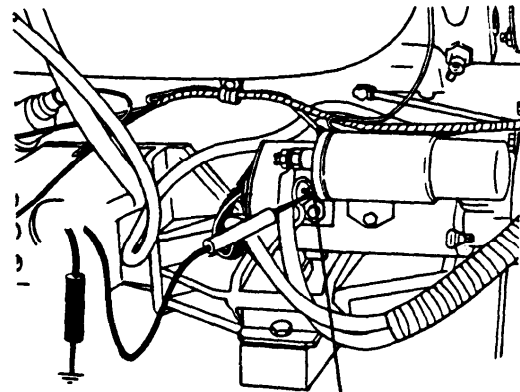

LEAD 14B

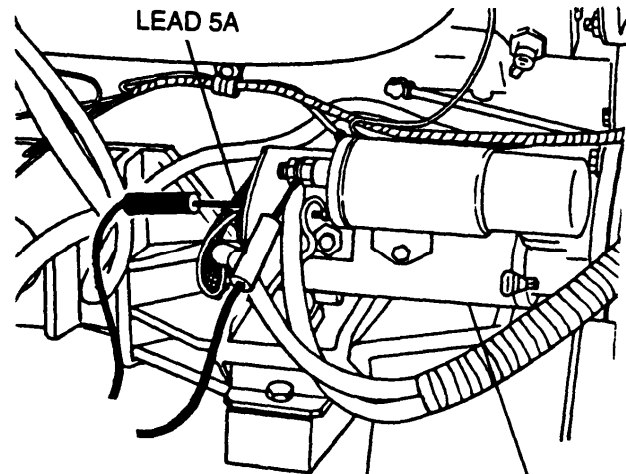

LEAD 6A

STARTER SOLENOID

END OF TASK

3-3 TROUBLESHOOTING CHART — CONTINUED

d. STARTER MOTOR CIRCUIT (M109A4/M109A5)— (2) COMBAT OVERRIDE SWITCH WILL NOT OVERRIDE
CONTINUED

INITIAL SETUP

Applicable Configurations

M109A4/M109A5

Personnel Required

Two

Tools

General mechanic's tool kit (item 64, Appx H)
Multimeter (item 36, Appx H)
TA-1 probe kit (item 43, Appx H)
(Long test leads may be needed for some tests;
16 AWG wire may be used as an extension.)

Equipment Conditions

Transmission left access door open (TM 9-2350-311-10)
Battery access doors open (TM 9-2350-311-10)
Portable instrument panel cover removed (para 8-17)

- A**
1. With MASTER switch ON and fuel shutoff handle pulled out, crank starter until it automatically shuts off.
 2. Disconnect leads 14C and GND from combat override switch.
 3. Place a jumper wire from lead 14C to lead GND wire.
 4. Turn MASTER switch ON and push STARTER switch.
 5. Turn MASTER switch OFF.

Does engine crank?

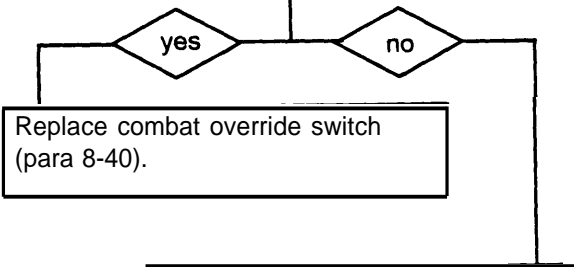

CONTINUED ON NEXT PAGE

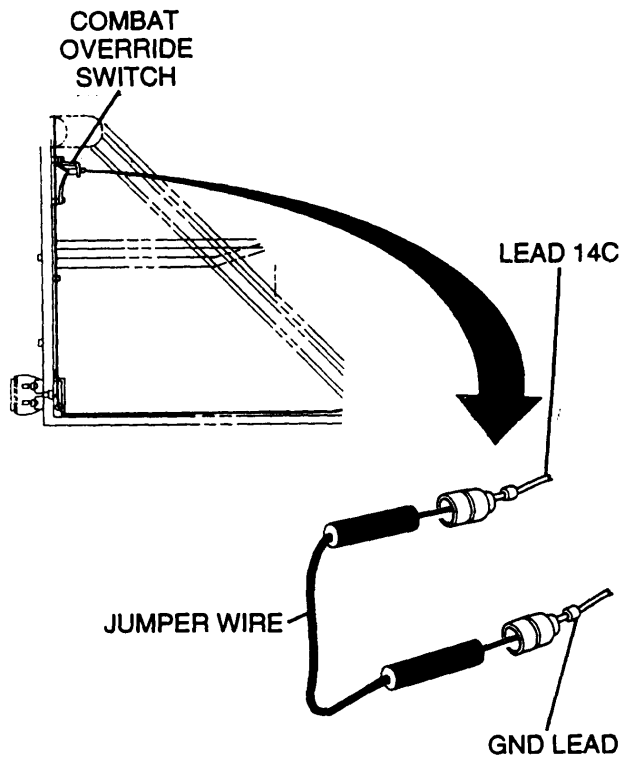

CONTINUED FROM STEP A

- B**
1. Place red lead of multimeter in GND lead connector of override switch and black lead to ground.
 2. Check for continuity.

Is continuity present?

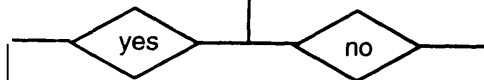

Replace combat override switch ground lead (para 8-89).

- C**
1. With MASTER switch ON and fuel shutoff handle pulled out, crank starter until it automatically shuts off.
 2. Turn MASTER switch OFF.
 3. Disconnect bulkhead-to-override switch lead assembly from driver's bulkhead.
 4. Place a jumper wire on lead 14C and other end to ground.
 5. Turn MASTER switch ON, push STARTER switch and check for voltage.
 6. Turn MASTER switch OFF.

Is voltage present?

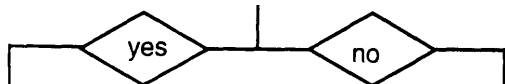

Repair or replace lead 14C of bulkhead-to-override switch lead assembly (para 8-88).

CONTINUED ON NEXT PAGE

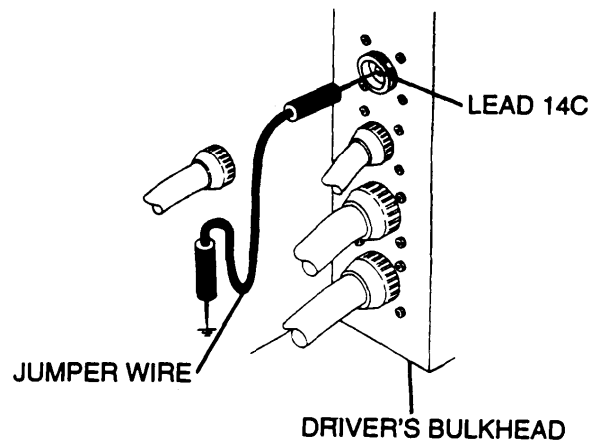
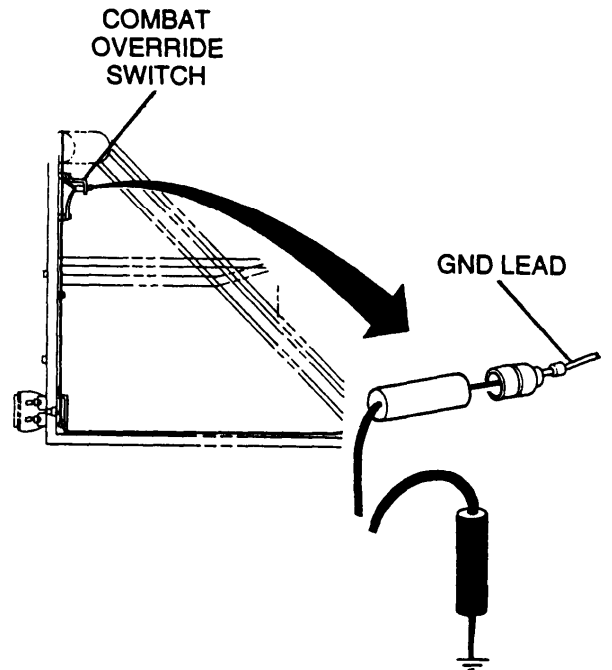

3-3 TROUBLESHOOTING CHART — CONTINUED

d. STARTER MOTOR CIRCUIT (M109A4/M109A5) — (2) COMBAT OVERRIDE SWITCH WILL NOT OVERRIDE — CONTINUED

CONTINUED FROM STEP C

D	<ol style="list-style-type: none"> 1. Disconnect driver's bulkhead-to-master relay wiring harness from starter protection relay. 2. Place red lead of multimeter in socket F (lead 14C) and black lead in lead 14C at bulkhead. 3. Check for continuity.
Is continuity present?	

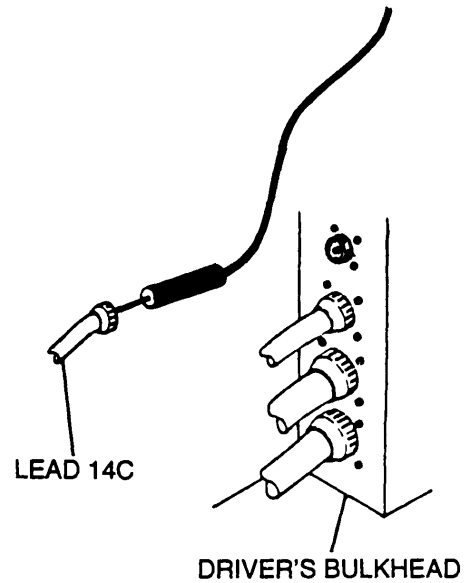
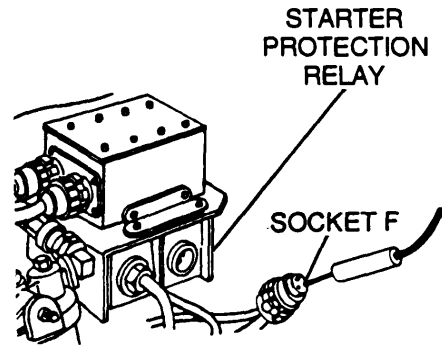
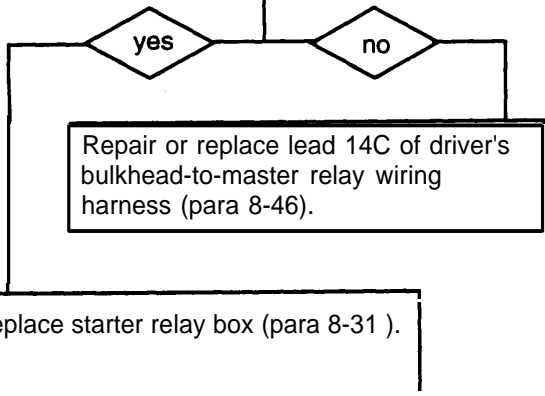

END OF TASK

(3) ENGINE CRANKS FOR SHORT TIME ONLY;
BATTERY POWER LEVEL IS CORRECT

INITIAL SETUP

Applicable Configurations
M109A4/M109A5

Personnel Required
Two

Tools

General mechanic's tool kit (item 64, Appx H)
Multimeter (item 36, Appx H)
TA-1 probe kit (item 43, Appx H)
(Long test leads may be needed for some tests;
16 AWG wire maybe used as an extension.)

Equipment Conditions

Transmission left access door open (TM 9-2350-311-1 0)
Battery access doors open (TM 9-2350-31 1-10)
Portable instrument panel cover removed (para 8-17)

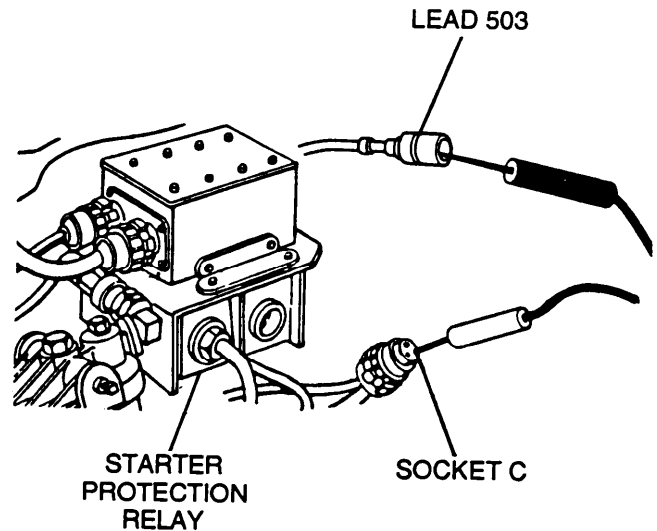
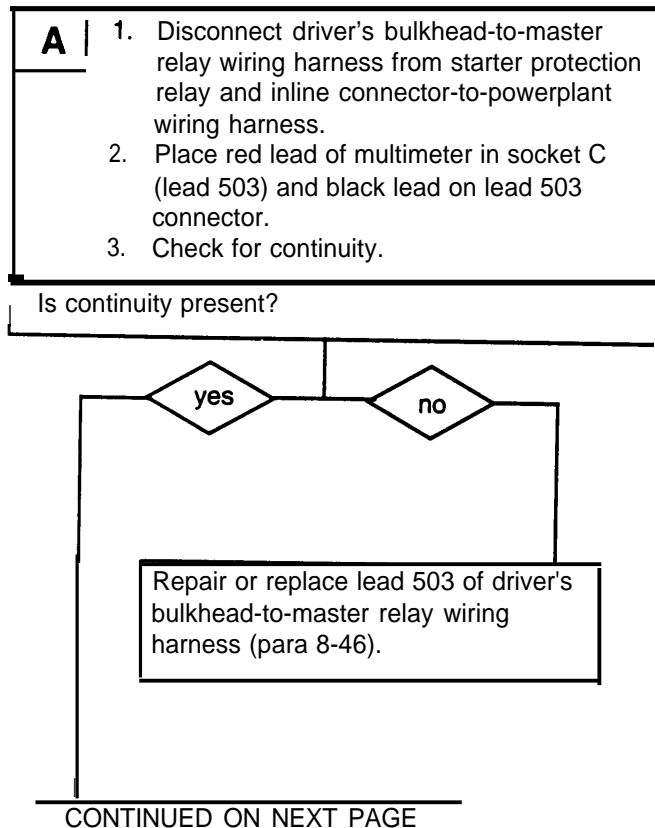

3-3 TROUBLESHOOTING CHART — CONTINUED

d. STARTER MOTOR CIRCUIT (M109A4/M109A5) — (3) ENGINE CRANKS FOR SHORT TIME ONLY;
CONTINUED BATTERY POWER LEVEL IS CORRECT — CONTINUED

CONTINUED FROM STEP A

	<p>Reconnect driver's bulkhead-to-master relay wiring harness to starter protection relay.</p> <ol style="list-style-type: none"> 2. With powerplant wiring harness still disconnected from inline connector, disconnect wiring harness from alternator. 3. Place red lead of multimeter in socket E (lead 503) at alternator and black lead in lead 503 connector. 4. Check for continuity.
<p>Is continuity present?</p>	

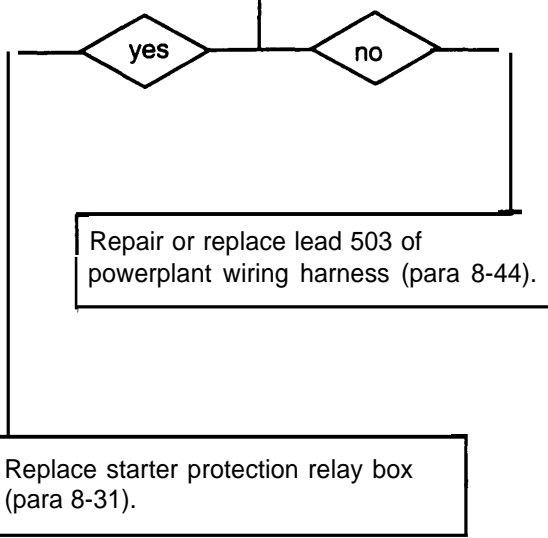
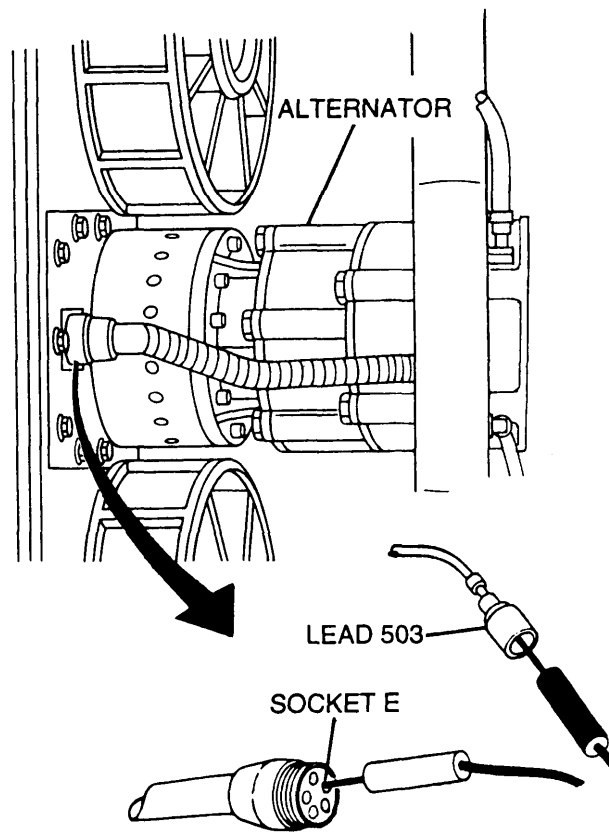

END OF TASK

e. ENGINE

The engine is an internal combustion, liquid-cooled, diesel engine with an exhaust-driven turbocharger. The engine is the main component of the vehicle drivetrain and has many components and associated wiring. The relationship of the engine and these components is shown below in the pictorial diagram.

The engine is started by turning on the MASTER switch which supplies voltage from the batteries through the MASTER relay. When the START button is pushed, voltage is supplied to the starter which cranks and starts the engine. Once started, the engine can develop up to 405 horsepower at 2350 rpm and deliver this power to the transfer assembly. The transfer assembly then sends this power to the transmission.

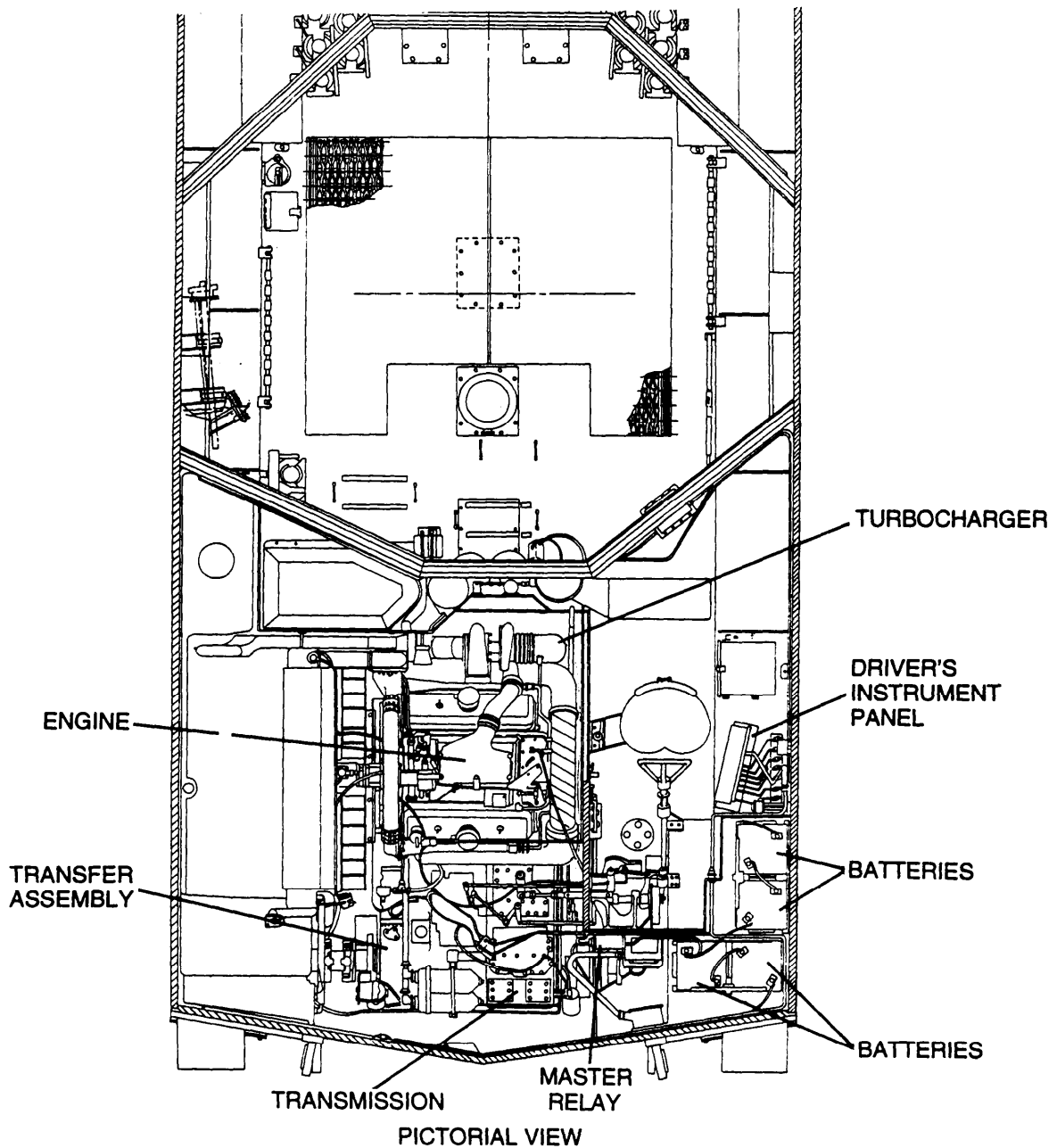

3-3 TROUBLESHOOTING CHART — CONTINUED

e. ENGINE—CONTINUED

(1) ENGINE CRANKS BUT FAILS TO START

INITIAL SETUP

Tools

General mechanic's tool kit (item 64, Appx H)
 TA-1 probe kit (item 43, Appx H)

Personnel Required

Two

References

TM 9-4910-571-12&P

Equipment Conditions

Engine compartment access door open
 (TM 9-2350-31 1-10)
 Transmission access doors open (TM 9-2350-311-10)

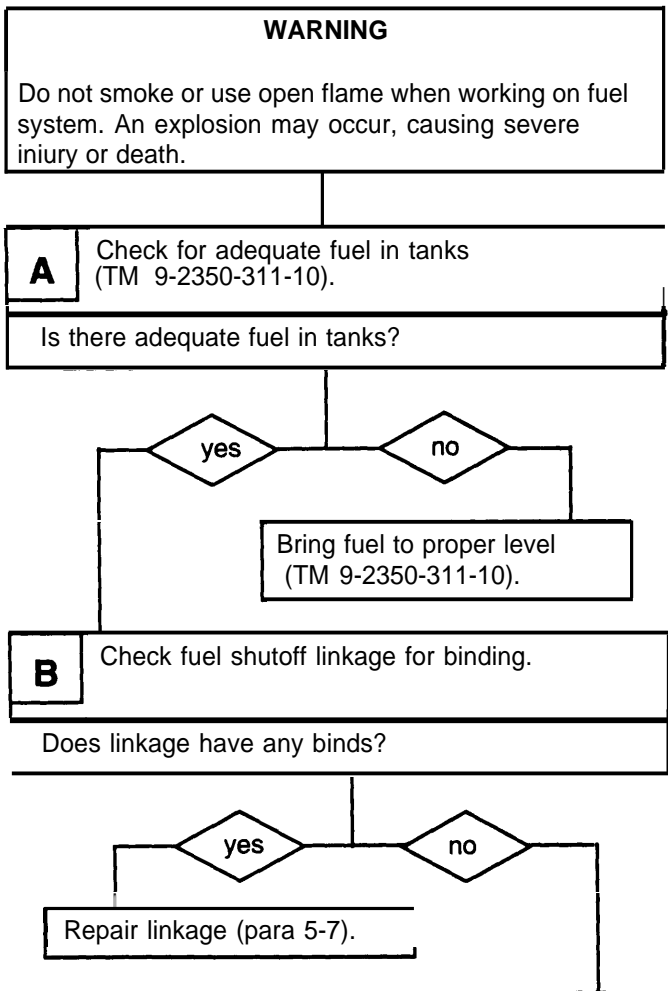

CONTINUED ON NEXT PAGE

CONTINUED FROM STEP B

WARNING

Fuel is hazardous waste and must be disposed of in accordance with local procedures or direction of the local Hazardous Waste Management office.

- C**
1. Open drain valve on bottom of primary fuel filter (TM 9-2350-31 1-10).
 2. Check for fuel.

Is fuel present in primary fuel filter?

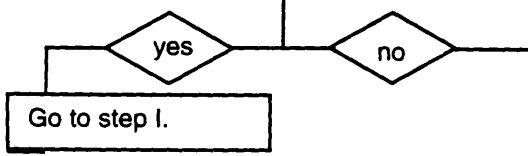

- D**
- Check primary fuel filter for contamination (TM 9-2350-311-10).

Is primary fuel filter free of contamination?

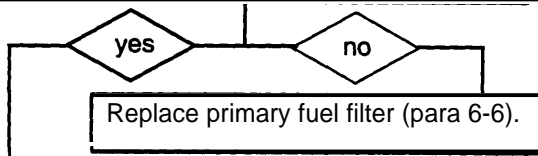

- E**
1. Open drain valve on bottom of secondary fuel filter (TM 9-2350-311-10).
 2. Check for fuel.

Is fuel present in secondary fuel filter?

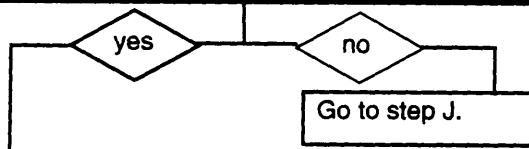

- F**
- Check secondary fuel filter for contamination (TM 9-2350-311 -10).

Is secondary fuel filter free of contamination?

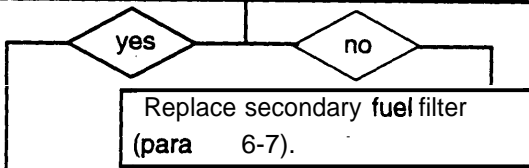

CONTINUED ON NEXT PAGE

3-3 TROUBLESHOOTING CHART — CONTINUED

e. ENGINE—CONTINUED

(1) ENGINE CRANKS BUT FAILS TO START — CONTINUED

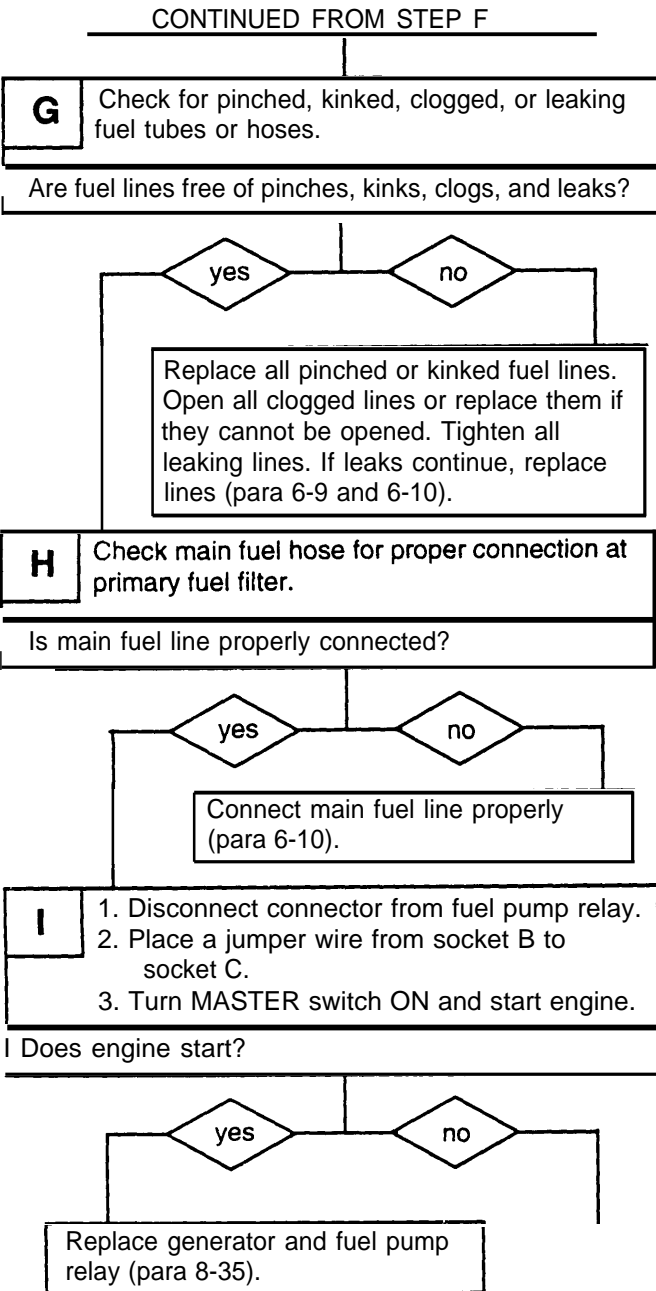

CONTINUED ON NEXT PAGE

CONTINUED FROM STEP I

J 1. Reconnect connector to fuel pump relay.
2. Hold down fuel prime switch for 45 seconds.
3. Check secondary filter for fuel (TM 9-2350-311-10).

Is secondary filter full of fuel?

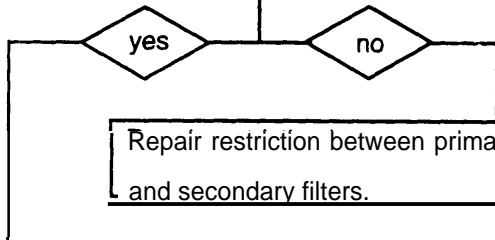

Repair restriction between primary and secondary filters.

K Crank engine to start (TM 9-2350-311-10).

Does engine start?

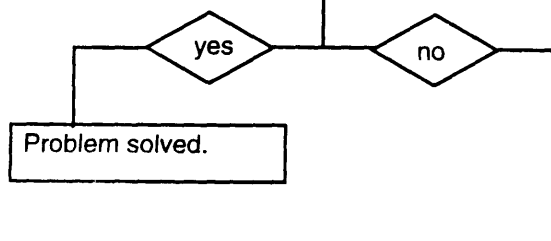

Problem solved.

L Check the engine air cleaner system for clogs or restrictions (TM 9-2350-311-10).

Is the system clogged or restricted?

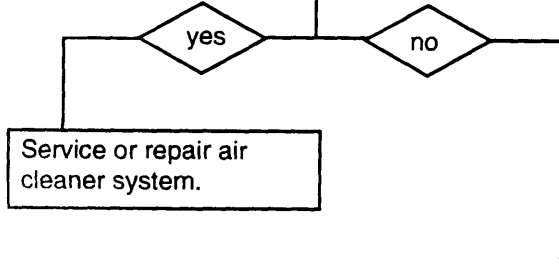

Service or repair air cleaner system.

Perform STE/ICE-R tests 24, 14, and 10 for fuel and air systems, compression unbalance, and cranking rpm (TM 9-4910-571-12&P).

END OF TASK

3-3 TROUBLESHOOTING CHART — CONTINUED

e. ENGINE — CONTINUED

(2) ENGINE DOES NOT ACCELERATE PROPERLY OR DOES NOT DEVELOP FULL POWER

INITIAL SETUP

Tools

General mechanic's tool kit (item 64, Appx H)
Gage (item 23, Appx H)

Equipment Conditions

Engine compartment access doors open
(TM 9-2350-311 -10)

References

TM 9-2350-311-10

WARNING

Do not smoke or use open flame when working on fuel system. An explosion may occur, causing severe injury or death.

A Check hand throttle control rod and accelerator pedal adjustment (para 9-15 and 9-16).

Are hand throttle control rod and accelerator pedal properly adjusted?

yes

no

Adjust hand throttle control rod and/or accelerator pedal linkage (para 9-15 and 9-16).

CONTINUED ON NEXT PAGE

CONTINUED FROM STEP A

B

1. Remove fuel pressure transducer at secondary fuel filter (para 6-7).
2. Install appropriate pressure gage (para 6-7).
3. Start engine and run at idle (TM 9-2350-31 1-10). Pressure should be 40 to 70 psi (276 to 483 kPa) at 1500 to 2300 rpm.

Is fuel pressure below 40 psi (276 kPa)?

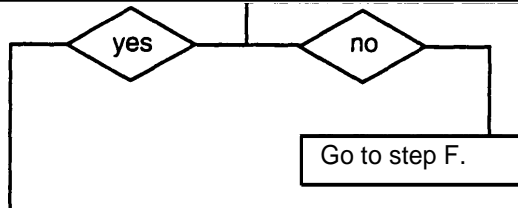

C

1. Install fuel pressure transducer at secondary fuel filter (para 6-7).
2. Place a 100 psi (690 kPa) gage with a tee fitting in the primary fuel filter inlet.
3. Disconnect connector from the fuel pump relay.
4. Place a jumper wire from socket A to socket C.
5. Turn MASTER switch ON and check gage.

Is fuel pressure at least 4 psi (28 kPa)?

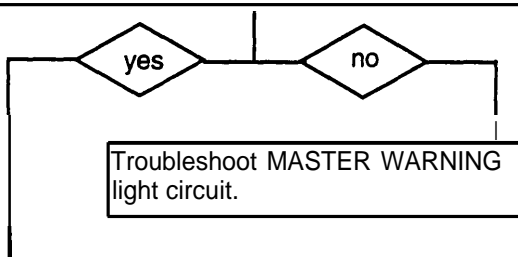

D Check fuel lines to secondary fuel filter for restrictions and/or leaks.

Are fuel lines free of leaks and/or restrictions?

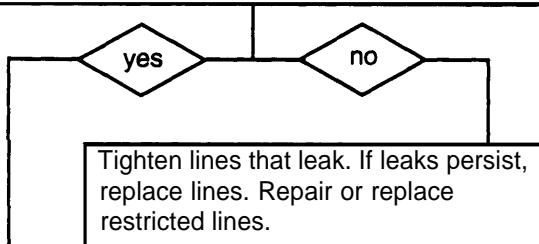

CONTINUED ON NEXT PAGE

3-3 TROUBLESHOOTING CHART — CONTINUED

e. ENGINE—CONTINUED

(2) ENGINE DOES NOT ACCELERATE PROPERLY OR DOES NOT DEVELOP FULL POWER — CONTINUED

CONTINUED FROM STEP D

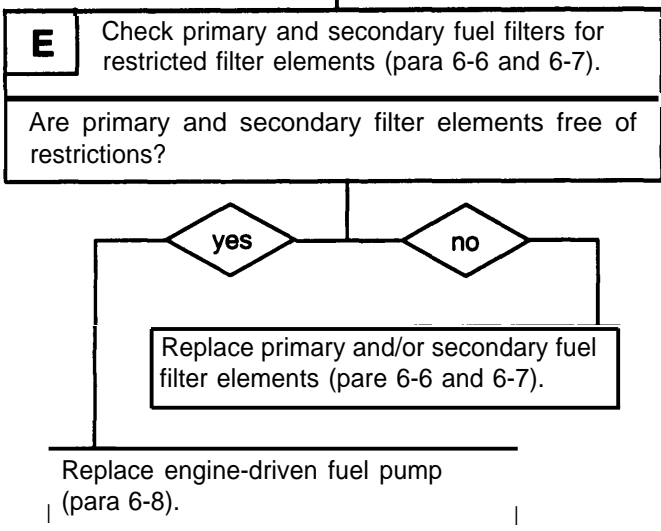

CONTINUED FROM STEP B

- F**
1. Install fuel pressure transducer at secondary fuel filter (para 6-7).
 2. Ensure brakes are properly adjusted (not adjusted to tight) (para 9-12).

Are brakes properly adjusted?

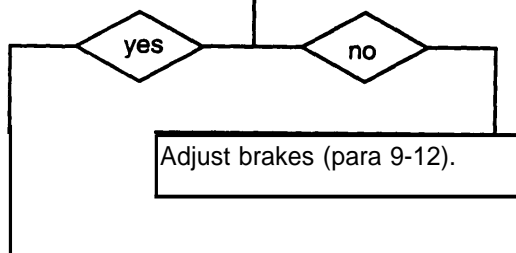

- G**
- Perform fuel flow test (para 6-11).

Is fuel flow at least 0.5 gal (1.9 L) per minute?

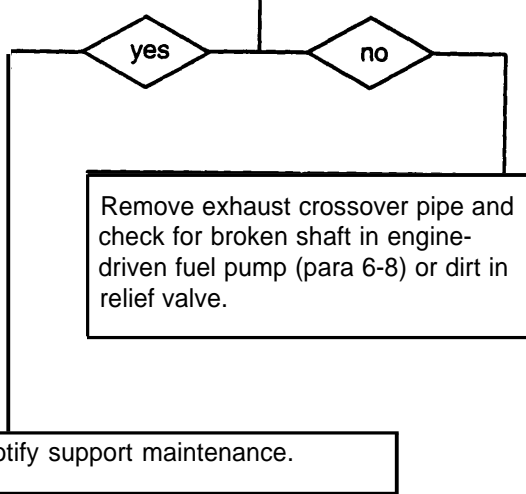

END OF TASK

3-3 TROUBLESHOOTING CHART — CONTINUED

e. ENGINE — CONTINUED

(3) ENGINE DOES NOT MAINTAIN STEADY RPM

INITIAL SETUP

Tools

General mechanic's tool kit (item 64, Appx H)

Equipment Conditions

Engine compartment access door open
(TM 9-2350-311-10)

References

TM 9-2350-311-10

WARNING

Do not smoke or use open flame when working on fuel system. An explosion may occur, causing severe injury or death.

A

Ensure that the engine coolant is at operating temperature (170°F) (77°C)
(TM 9-2350-311-10).

Is engine coolant at operating temperature?

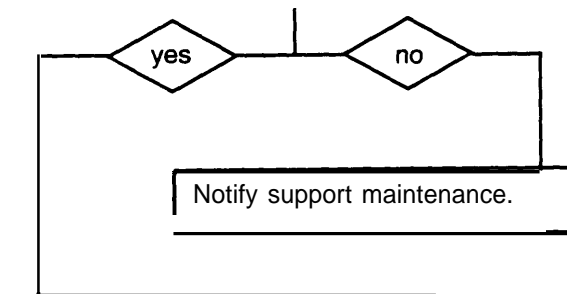

CONTINUED ON NEXT PAGE

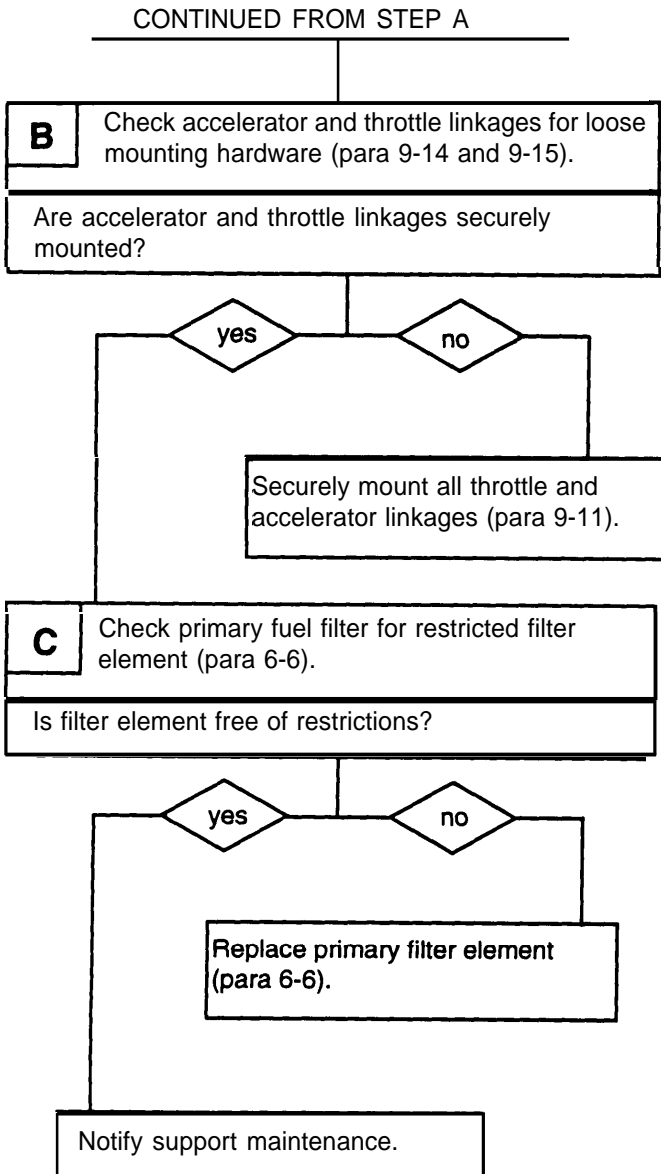

END OF TASK

3-3 TROUBLESHOOTING CHART — CONTINUED

e. ENGINE—CONTINUED

(4) ENGINE USES EXCESSIVE FUEL

INITIAL SETUP

Tools

General mechanic's tool kit (item 64, Appx H)

References

TM 9-2350-311-10

Equipment Conditions

Engine compartment access door open
(TM 9-2350-311-10)

Transmission access doors open (TM 9-2350-311-10)

WARNING

Do not smoke or use open flame when working on fuel system. An explosion may occur, causing severe injury or death.

A

Start engine and check exhaust output
(TM 9-2350-311-10).

Is exhaust black or grey?

yes

no

Notify support maintenance.

CONTINUED ON NEXT PAGE

CONTINUED FROM STEP A

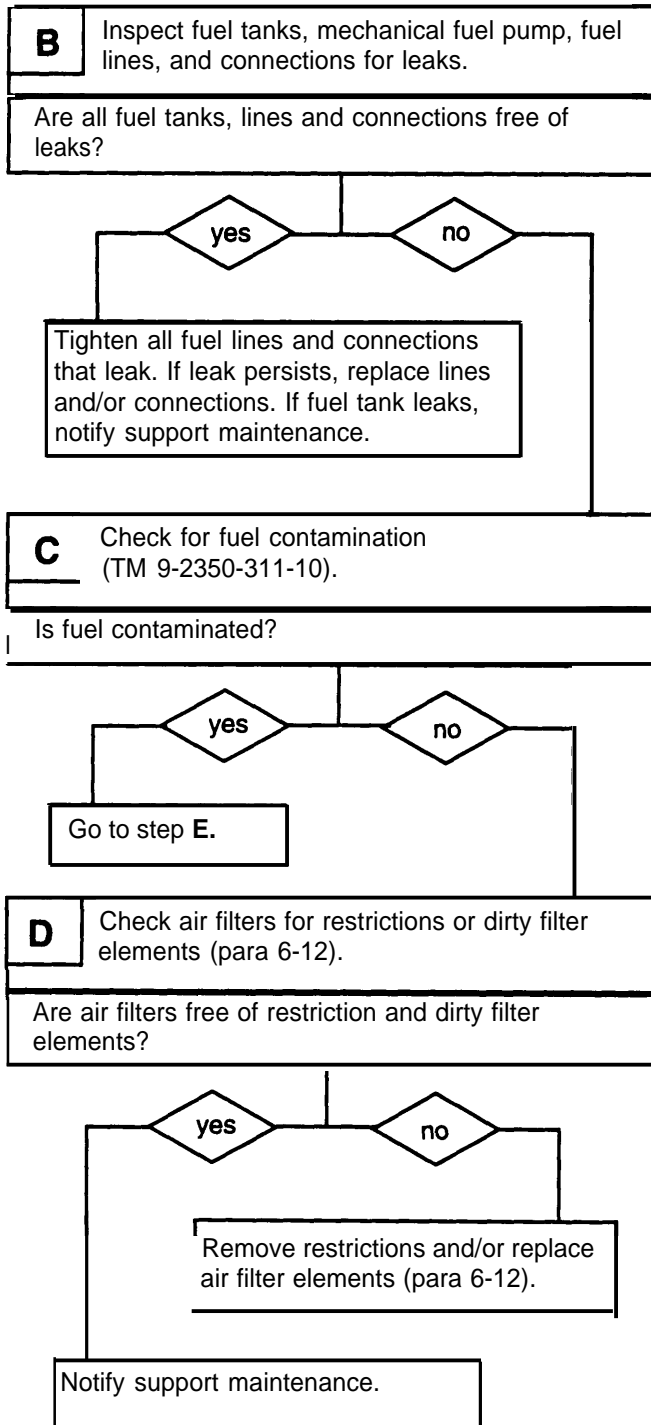

END OF TASK

3-3 TROUBLESHOOTING CHART — CONTINUED

e. ENGINE — CONTINUED

(4) ENGINE USES EXCESSIVE FUEL — CONTINUED

CONTINUED FROM STEP C

E	1. Remove engine-driven fuel pump (para 6-8). 2. Check housing and shaft seal for cracks and leaks.
Is the fuel pump serviceable?	

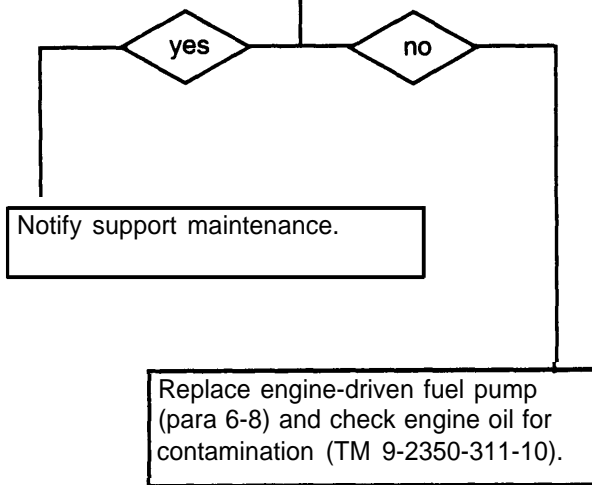

END OF TASK

(5) WHITE EXHAUST SMOKE IS PRESENT

INITIAL SETUP

Tools

General mechanic's tool kit (item 64, Appx H)

Equipment Condition

Transmission access doors open (TM 9-2350-311-10)

References

TM 9-2350-311-10

WARNING

- Do not smoke or use open flame when working on fuel system. An explosion may occur, causing severe injury or death.
- Fuel is hazardous waste and must be disposed in accordance with local procedures or direction of the local Hazardous Waste Management Office.

A

Check primary and secondary fuel filters for contaminated fuel and dirty filter elements (para 6-6 and 6-7).

Are fuel and filter elements clean?

yes

no

Drain fuel filter and change primary and secondary fuel filter elements (para 6-6 and 6-7).

CONTINUED ON NEXT PAGE

3-3 TROUBLESHOOTING CHART — CONTINUED

e. ENGINE—CONTINUED

(5) WHITE EXHAUST SMOKE IS PRESENT –
CONTINUED

CONTINUED FROM STEP A

WARNING

Ensure engine is cool before removing radiator cap.
Hot coolant can cause severe burns.

B Check radiator for low coolant level. If low,
check engine oil for contamination
(TM 9-2350-311-10).

Is radiator coolant level low and oil contaminated?

yes

no

Notify support maintenance.

If smoke persists, notify support
maintenance.

END OF TASK

(6) EXHAUST FUMES PRESENT IN CREW COMPARTMENT

INITIAL SETUP

Tools

General mechanic's tool kit (item 64, Appx H)

Equipment Conditions

Air intake grille open (TM 9-2350-311-10)

References

TM 9-2350-311-10

WARNING

Ensure engine and exhaust systems are cool enough to permit handling. Failure to do so may cause serious burns to personnel.

A

Check exhaust system pipe and connections for leaks.

Are there any leaks in exhaust outlet pipe and connections?

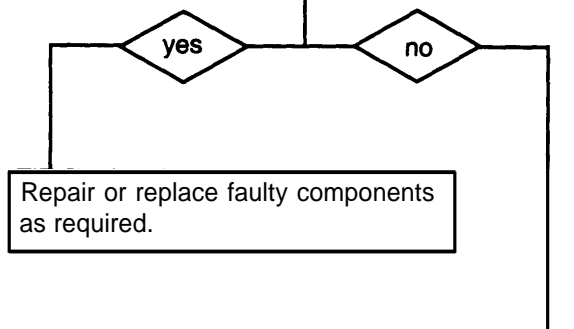

CONTINUED ON NEXT PAGE

3-3 TROUBLESHOOTING CHART — CONTINUED

e. ENGINE—CONTINUED

(6) EXHAUST FUMES PRESENT IN CREW COMPARTMENT — CONTINUED

CONTINUED FROM STEP A

WARNING
When installing engine compartment access cover, ensure that all screws are secured.

B Remove engine compartment access cover and inspect seal (para 11-5).
Is access cover seal serviceable?

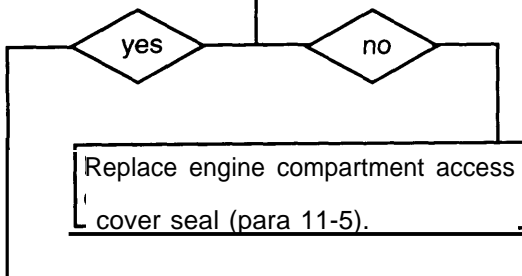

Replace engine compartment access cover seal (para 11-5).

C Inspect all exhaust pipes and clamps for damage or looseness (para 6-15 and 6-16).
Are all exhaust pipes and clamps tight and serviceable.

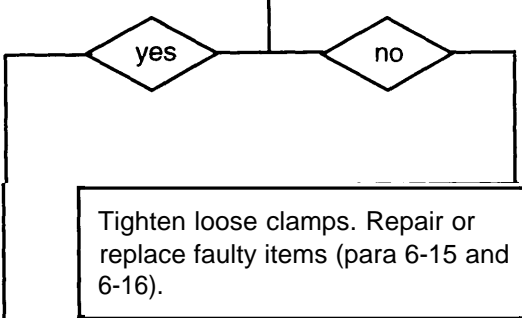

Tighten loose clamps. Repair or replace faulty items (para 6-15 and 6-16).

CONTINUED ON NEXT PAGE

CONTINUED FROM STEP C

WARNING
Ensure exhaust system is cool enough to permit handling. Failure to do so may cause serious burns to personnel.

D 1. Operate personnel heater (TM 9-2350-311-10).
2. Check personnel heater for faulty exhaust components (para 11-22).
Are personnel heater exhaust components in good condition?

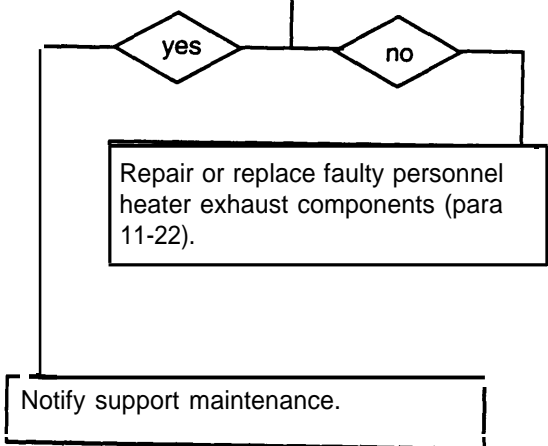

END OF TASK

3-3 TROUBLESHOOTING CHART — CONTINUED

e. ENGINE—CONTINUED

(7) ENGINE HAS LOW OR NO OIL PRESSURE

INITIAL SETUP

Tools

General mechanic's tool kit (item 64, Appx H)
Gage (item 23, Appx H)

Equipment Conditions

Transmission access doors open (TM 9-2350-311-10)
Air intake grille open (TM 9-2350-311-10)

References

TM 9-2350-311-10

CAUTION

If engine indicates low oil pressure (MASTER warning light on) or no oil pressure, shut engine off immediately. Failure to do so may result in serious damage to engine.

A Check engine oil level. Level should be between add and full marks (TM 9-2350-311-10).

Is engine oil at proper level?

yes

no

Bring oil to proper level with proper grade of oil (para 2-15).

B Check oil lines, oil filter housing and engine cover for oil leaks (para 5-4).

Is engine oil system free of leaks?

yes

no

Repair or replace faulty components (para 5-4). If leak cannot be corrected, notify support maintenance.

CONTINUED ON NEXT PAGE

CONTINUED FROM STEP B

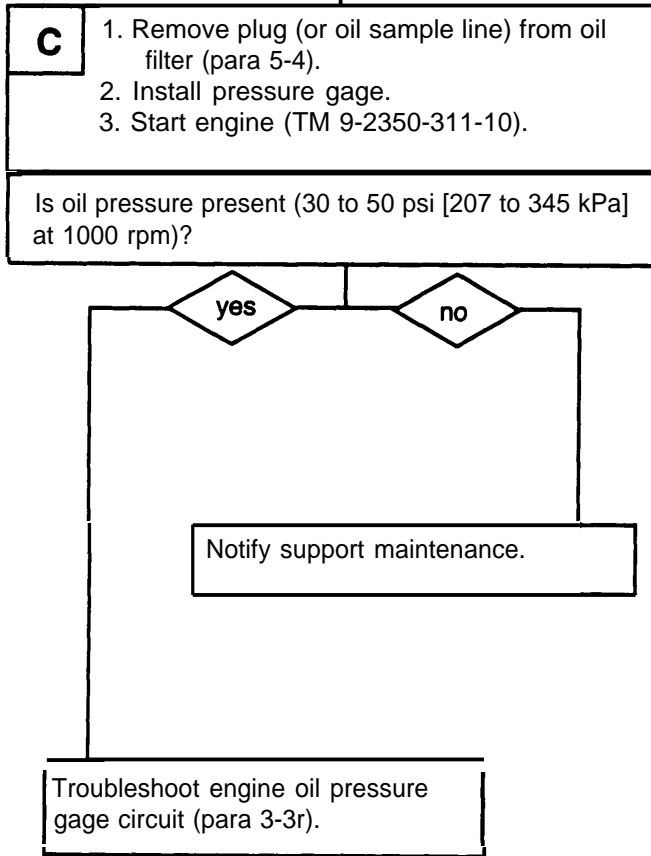

END OF TASK

3-3 TROUBLESHOOTING CHART — CONTINUED

e. ENGINE — CONTINUED

(8) ENGINE OVERHEATS

I INITIAL SETUP I

Tools

General mechanic's tool kit (item 64, Appx H)
Multimeter (item 36, Appx H)
TA-1 probe kit (item 43, Appx H)

Equipment Conditions

Engine compartment access door open
(TM 9-2350-311-10)
Transmission access doors open (TM 9-2350-311-10)

References

TM 9-2350-311-10

WARNING

When engine is hot, remove radiator cap slowly to relieve pressure. Failure to follow this procedure may result in severe injury.

WARNING

To avoid burns, ensure engine and coolant have cooled before removing components. Failure to comply may result in severe injury.

WARNING

A protective fan screen must be installed prior to doing maintenance in the engine compartment while the engine is running or is in ground hop mode. Contact with rotating fan can cause severe injury.

A

Check coolant in radiator for proper level (TM 9-2350-311-10).

Is coolant at proper level?

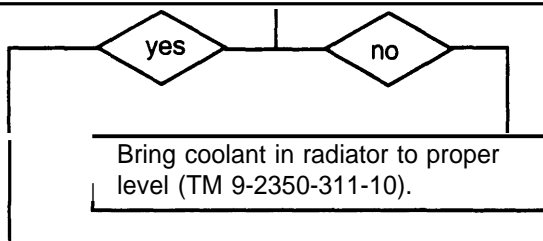

CONTINUED ON NEXT PAGE

CONTINUED FROM STEP A

B Check engine oil level. Level should be between add and full marks (TM 9-2350-311-10).

Is engine oil at proper level?

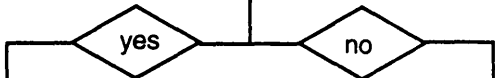

Bring engine oil to proper level with proper grade of oil (para 2-15).

C Troubleshoot engine coolant temperature indicator circuit.

Is engine coolant temperature indicator circuit operating properly?

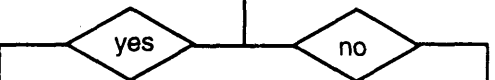

Repair or replace engine coolant temperature indicator circuit components as required.

D 1. Remove radiator cap and start engine (TM 9-2350-311-10).
2. Check radiator for contaminated coolant or restricted water tubes (TM 9-2350-311-10).

Are there restrictions in the radiator or is coolant contaminated?

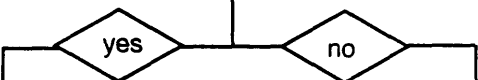

Clean and flush cooling system (para 7-6, M109A2/M109A4/M109A5; 7-7, M109A3).

CONTINUED ON NEXT PAGE

3-3 TROUBLESHOOTING CHART — CONTINUED

e. ENGINE—CONTINUED

(8) ENGINE OVERHEATS – CONTINUED

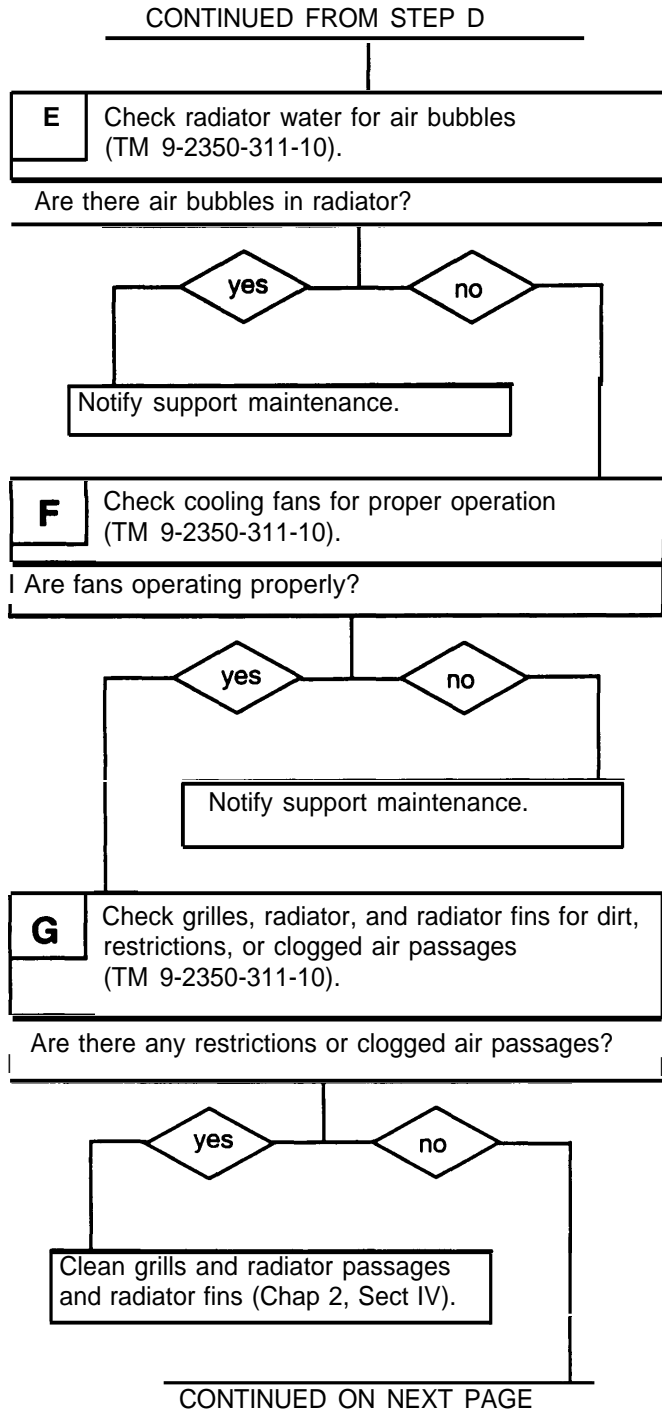

CONTINUED FROM STEP G

H Check for restricted or collapsed coolant hoses and tubes (para 7-3 and 7-4).

Are there restrictions or collapsed hoses and tubes?

yes

no

Repair or replace hoses and tubes (para 7-3 and 7-4).

- I**
1. Remove inlet and bypass thermostats (para 7-8 and 7-9).
 2. Reassemble thermostat housing without thermostats.
 3. Start engine and check if engine still overheats (TM 9-2350-311-10).

Does engine overheat?

yes

no

Replace inlet and bypass thermostats (para 7-8 and 7-9).

Replace pressure relief valve (para 7-5).
If overheating persists, notify support maintenance.

END OF TASK

3-3 TROUBLESHOOTING CHART — CONTINUED

f. TRANSMISSION AND DRIVING CONTROLS

The transmission is mechanically and hydraulically operated and is oil cooled. Power to operate the transmission is delivered by the engine through the transfer assembly. See diagram below.

The transmission has 7 gears: 4 forward, 1 neutral, and 2 reverse. Once power is provided to the transmission, it delivers this power to the left and right drive sprockets through an output shaft, universal joints, and the final drive assemblies. The final drive assemblies reduce the transmission power and provides this reduced power to the sprockets and hubs.

The transmission also serves as the steering and braking mechanism for the vehicle.

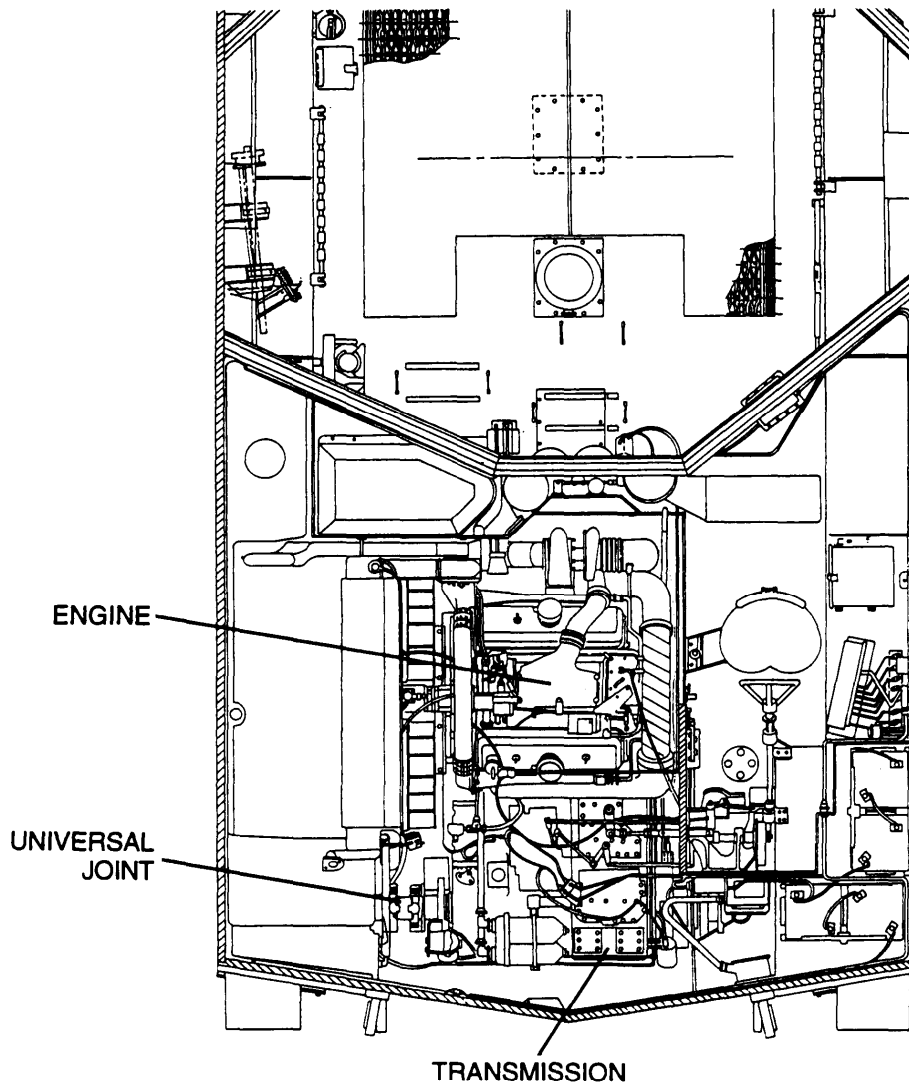

PICTORIAL VIEW

(1) TRANSMISSION OVERHEATS; TRANSMISSION OIL TEMPERATURE GAGE READS OVER 270°F (132°C), MASTER WARNING LIGHT IS LIT

INITIAL SETUP

Tools

General mechanic's tool kit (item 64, Appx H)
Gage (item 23, Appx H)

Equipment Conditions

Transmission access doors open (TM 9-2350-311-10)

References

TM 9-2350-311-10

WARNING

Vehicle has no brakes when final drives are disconnected. Failure to securely block vehicle could injure personnel or damage vehicle or equipment if vehicle rolls out of control.

WARNING

Transmission contains hot oil under high pressure. Stop engine before removing or installing pipe plugs and gage adapters in pressure test points. Install pipe plug as soon as gage adapter is removed. Remove only pipe plug at test point. Failure to comply with these precautions may result in personnel injury or equipment damage.

A

Check transmission oil level (TM 9-2350-311-10).

Is transmission oil at proper level?

CONTINUED ON NEXT PAGE

3-3 TROUBLESHOOTING CHART — CONTINUED

f. TRANSMISSION AND DRIVING CONTROLS — CONTINUED

(1) TRANSMISSION OVERHEATS; TRANSMISSION OIL TEMPERATURE GAGE READS OVER 270°F (132°C), MASTER WARNING LIGHT IS LIT — CONTINUED

CONTINUED FROM STEP A

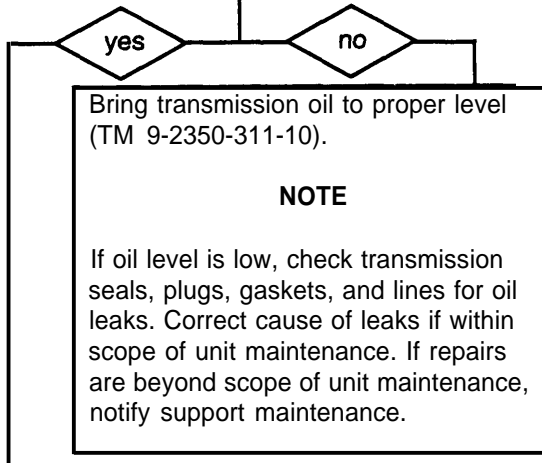

B Check transmission oil cooler lines for leaks or restrictions (para 9-4).

Are transmission oil cooler lines free of leaks and restrictions?

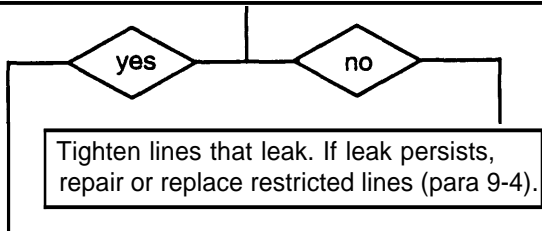

C Troubleshoot transmission oil temperature indicator circuit (para 3-3p).

Is transmission oil temperature indicator circuit operating properly?

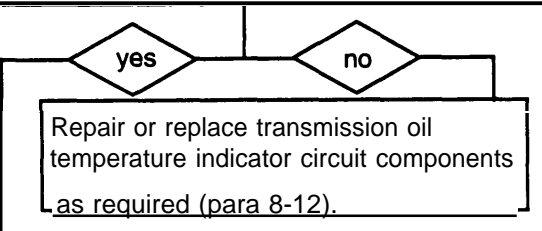

CONTINUED ON NEXT PAGE

CONTINUED FROM STEP D

D Check transmission oil filter for cleanliness and proper installation (para 9-5).

Is transmission oil filter clean and properly installed?

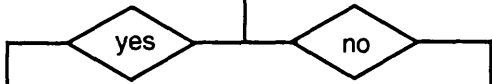

Replace transmission oil filter element (para 9-5).

NOTE

To test transmission oil pressures, use a 400 psi (2758 kPa) gage or do STE/ICE-R test 50 using the blue striped transducer.

E Start engine (TM 9-2350-311-10) and hold speed at 1000 to 1500 rpm and check the transmission oil pressure.

Is transmission oil pressure below specifications?

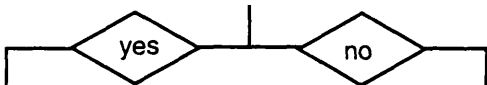

If transmission still overheats notify support maintenance.

F Check the brake linkage and internal brake clearance for correct adjustment (para 9-10 and 9-12).

Are brakes correctly adjusted?

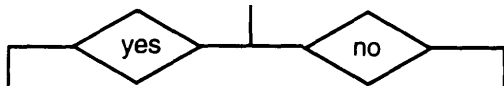

Adjust brakes (para 9-12).

Notify support maintenance.

END OF TASK

3-3 TROUBLESHOOTING CHART — CONTINUED

- f. TRANSMISSION AND DRIVING CONTROLS — CONTINUED (2) VEHICLE DOES NOT DRIVE; TRANSMISSION DOES NOT OPERATE IN ANY SHIFT POSITION
-

INITIAL SETUP

Tools

General mechanic's tool kit (item 64, Appx H)
Gage (item 23, Appx H)

Equipment Conditions

Engine compartment access door open
(TM 9-2350-311-10)

References

TM 9-2350-311-10

WARNING

Vehicle has no brakes when final drives are disconnected. Failure to securely block vehicle could injure personnel or damage vehicle equipment if vehicle rolls out of control.

WARNING

Transmission contains hot oil under high pressure. Stop engine before removing or installing pipe plugs and gage adapters in pressure test points. Install pipe plug as soon as gage adapter is removed. Remove only pipe plug at test point. Failure to comply with these precautions may result in personnel injury or equipment damage.

A

Check transmission oil level
(TM 9-2350-311-10).

Is transmission oil at proper level?

CONTINUED ON NEXT PAGE

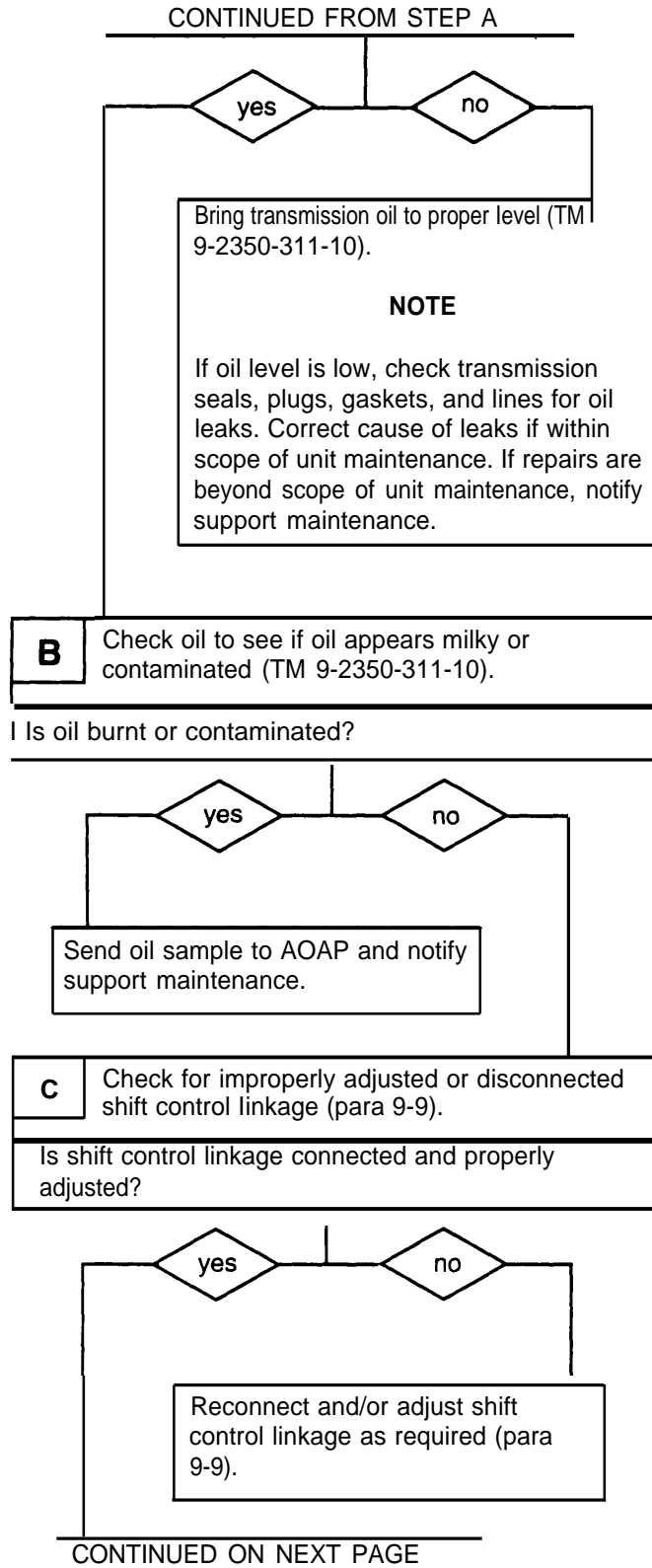

3-3 TROUBLESHOOTING CHART — CONTINUED

f. TRANSMISSION AND DRIVING CONTROLS —
CONTINUED

(2) VEHICLE DOES NOT DRIVE; TRANSMISSION
DOES NOT OPERATE IN ANY SHIFT POSITION —
CONTINUED

CONTINUED FROM STEP C

D Check brake linkage (para 9-10) and transmission internal brake (para 9-12) adjustment.

Is brake linkage and transmission internal brake properly adjusted?

yes

no

Adjust brake linkage (para 9-10) and/or transmission internal brake (para 9-12).

E Remove final drive quick-disconnects and check for broken universal joints (para 10-23).

Are universal joints unbroken and in good condition?

yes

no

Replace universal joints (para 10-23).

CONTINUED ON NEXT PAGE

CONTINUED FROM STEP E

F	<ol style="list-style-type: none"> 1. Reconnect final drive quick-disconnects. 2. Start engine (TM 9-2350-311-10) and hold 1000 to 1500 rpm. 3. Using a 400 psi (2758 kPa) gage or STE/ICE-R test 50 with blue striped transducer, check transmission oil pressure (para 9-2) at the following points: <ol style="list-style-type: none"> a. main — test point 3 b. range clutch — test points 4,5, and 6 c. transmission lubrication — test points 11 and 20 d. gear steer clutch — test points 10 and 18 e. output clutch — test points 13 and 21. 4. Record the results.
<p>Is transmission oil pressure below specifications?</p>	

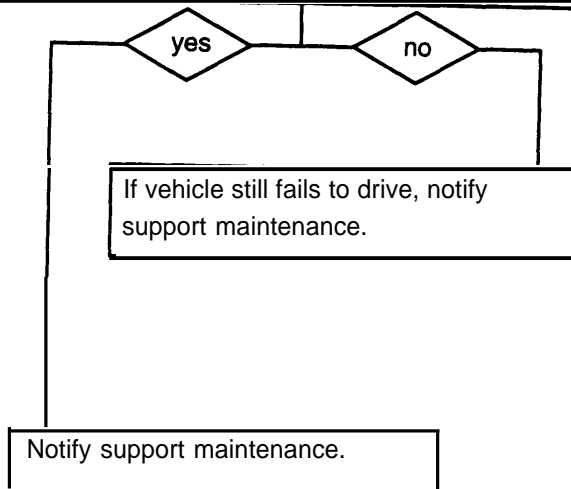

END OF TASK

3-3 TROUBLESHOOTING CHART — CONTINUED

f. TRANSMISSION AND DRIVING CONTROLS — CONTINUED (3) VEHICLE DOES NOT STEER IN EITHER DIRECTION IN ANY RANGE

INITIAL SETUP

Tools

General mechanic's tool kit (item 64, Appx H)
STE/ICE-R test set (item 61, Appx H)

Equipment Conditions

Engine compartment access door open
(TM 9-2350-311-10)

References

TM 9-2350-311-10

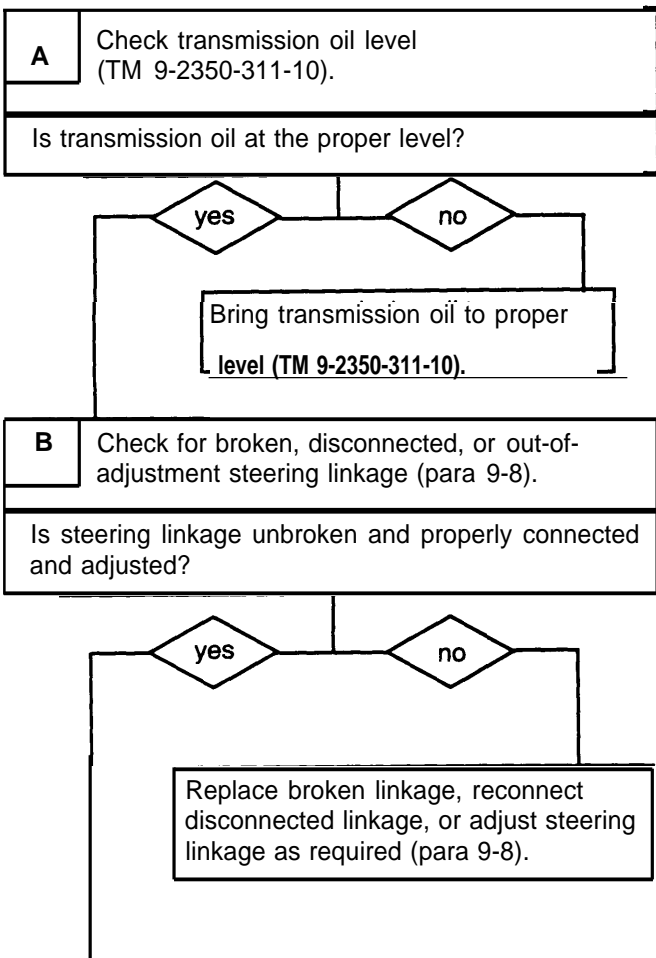

CONTINUED ON NEXT PAGE

CONTINUED FROM STEP B

C	<p>1. Do STE/ICE-R test 50 using blue striped transducer at the following points:</p> <ul style="list-style-type: none">a. gear steer pressure applied — — 16, right —15.b. output clutch — left— 21, right — 13.c. gear steer clutches — left — 18, right — 10. <p>2. Record results.</p>
<p>Are any pressures below specifications?</p>	

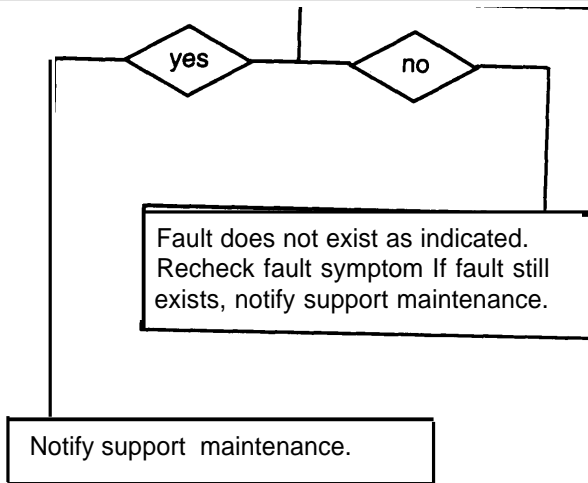

END OF TASK

3-3 TROUBLESHOOTING CHART — CONTINUED

f. TRANSMISSION AND DRIVING CONTROLS — (4) VEHICLE STEERS WELL IN ONE DIRECTION ONLY
CONTINUED

INITIAL SETUP

Tools

General mechanic's tool kit (item 64, Appx H)
STE/ICE-R test set (item 61, Appx H)

Equipment Conditions

Transmission access doors open (TM 9-2350-311-10)

WARNING
Vehicle has no brakes when final drives are disconnected. Failure to securely block vehicle could injure personnel or damage vehicle equipment if vehicle rolls out of control.

WARNING
Transmission contains hot oil under high pressure. Stop engine before removing or installing pipe plugs and gage adapters in pressure test points. Install pipe plug as soon as gage adapter is removed. Remove only pipe plug at test point. Failure to comply with these precautions may result in personnel injury or equipment damage.

A Check steering control linkage adjustment (para 9-8).

Is steering control linkage properly adjusted?

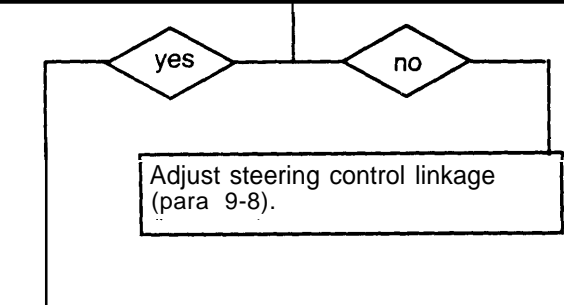

CONTINUED ON NEXT PAGE

CONTINUED FROM STEP A

B Check brake linkage (para 9-10) and transmission internal brake (para 9-12) for correct adjustment.

Is brake linkage and transmission internal brake adjusted properly?

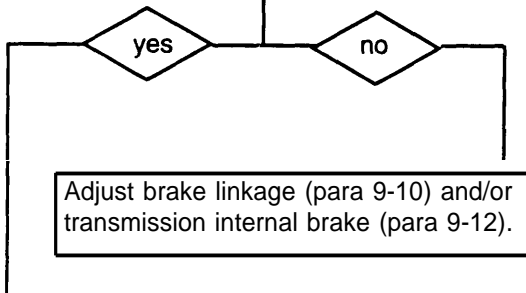

C

1. Do STE/ICE-R test 50 using blue striped transducer at the following points:
 - a. first gear, second gear, and reverse
1 — brake pressure: left 16, right 15.
gear steer: left 18, right 10.
brake coolant: left 17, right 14.
 - b. third gear, fourth gear, and reverse
2 — output clutch: left 21, right 13.
gear steer: left 18, right 10.
steer gear coolant: left 19, right 12.
2. Record results.

Is transmission oil pressure below specifications?

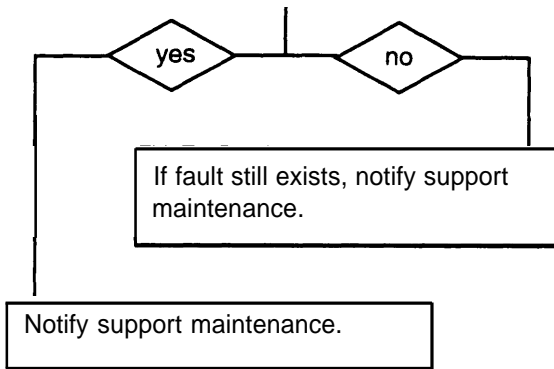

END OF TASK

3-3 TROUBLESHOOTING CHART — CONTINUED

g. TRACKS AND SUSPENSION

The track and suspension system consists of the vehicle tracks, final drives, sprocket wheel, universal joints, road wheels, idler wheels, idler hubs, shocks, and torsion bars. The relationship of these components is shown in the diagram below.

When the track receives power from the transmission through the universal joint, final drives, and sprockets, the track begins to revolve around road wheels, over the idler wheels and back to the sprockets. This propels the vehicle forward and backward, depending on selected transmission gear.

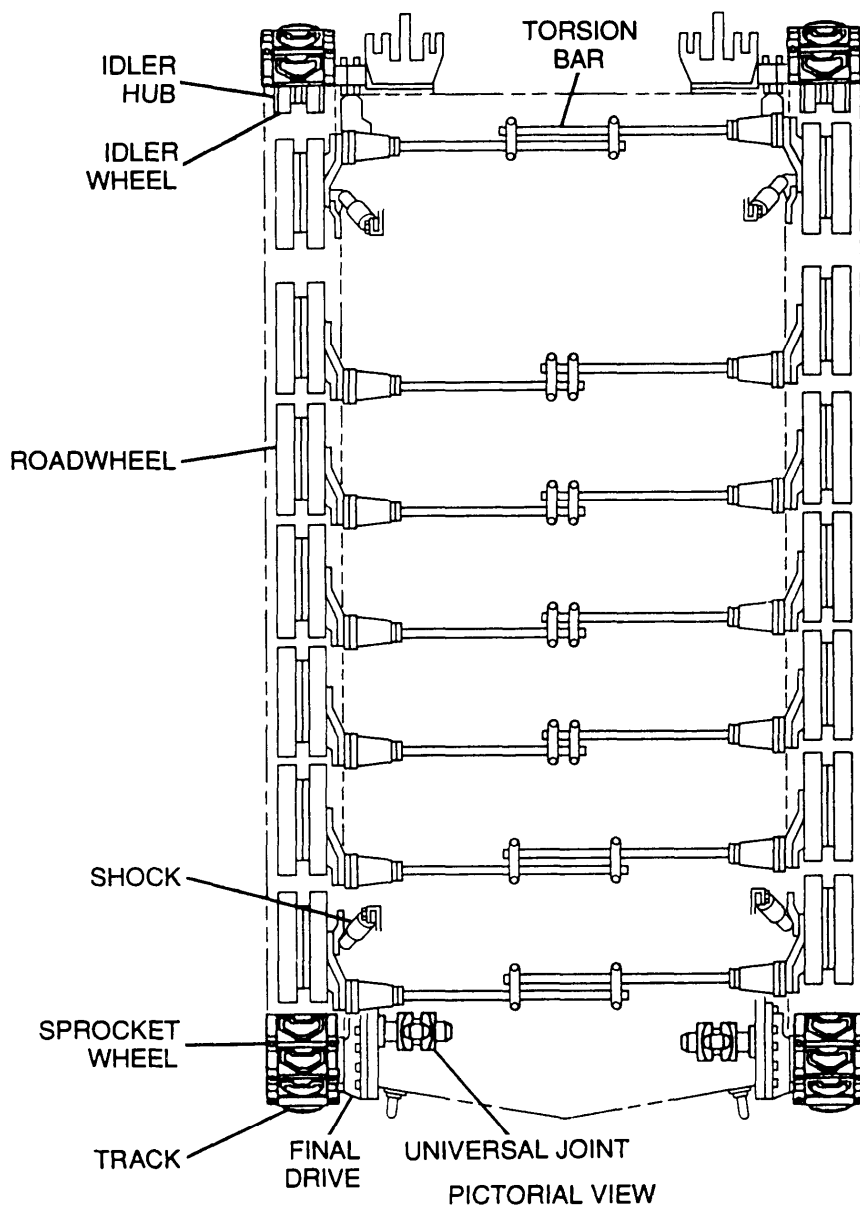

(1) VEHICLE BRAKES POORLY; VEHICLE DOES NOT STOP CORRECTLY WHEN BRAKE IS APPLIED

INITIAL SETUP

Tools

General mechanic's tool kit (item 64, Appx H)

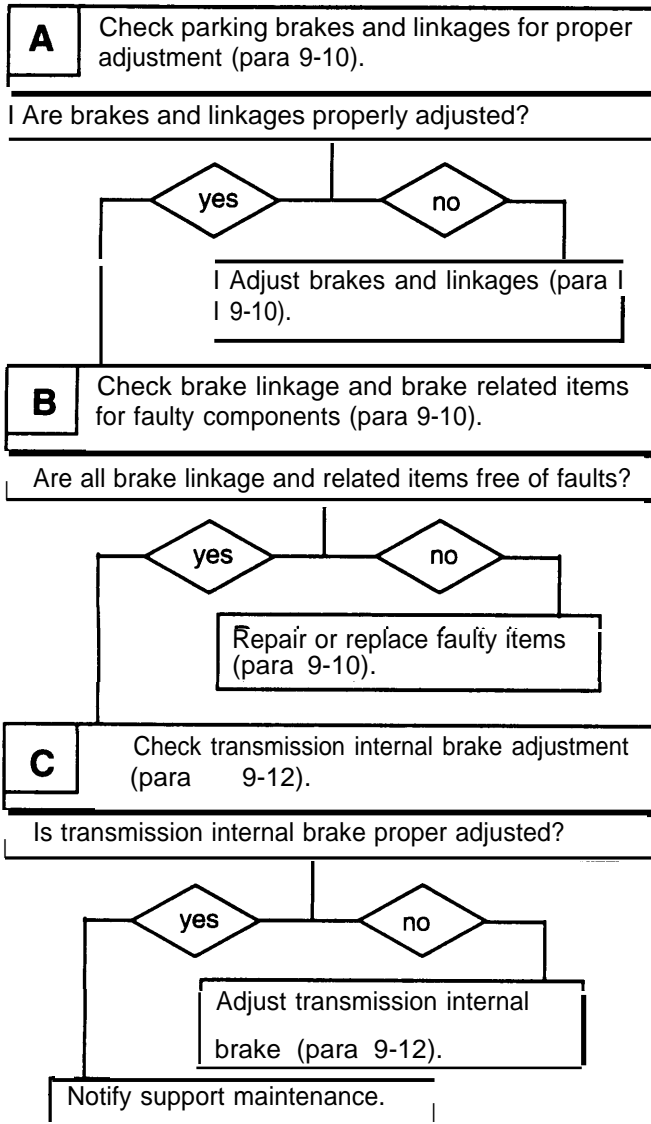

END OF TASK

3-3 TROUBLESHOOTING CHART — CONTINUED

g. TRACKS AND SUSPENSION — CONTINUED

(2) VEHICLE PULLS TO ONE SIDE WITH STEERING WHEEL IN CENTER POSITION

INITIAL SETUP

<p>Tools General mechanic's tool kit (item 64, Appx H) STE/ICE-R test set (item 61, Appx H)</p> <p>References TM 9-2350-311-10</p>	<p>Equipment Conditions Transmission access doors open (TM 9-2350-311-10)</p>
---	---

NOTE

Crown on road causes vehicle to pull away from center of road. Road test vehicles on flat surface.

A Check for disconnected or improperly adjusted steering control linkage (para 9-8).

Is steering control linkage properly connected and adjusted?

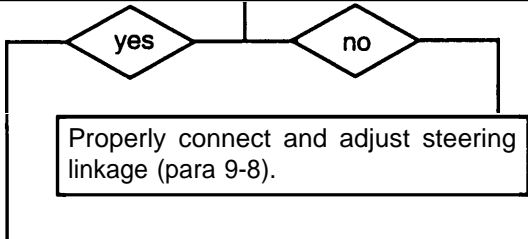

B Check brake pedal and linkages for proper adjustment (para 9-10).

Are brakes and linkages properly adjusted?

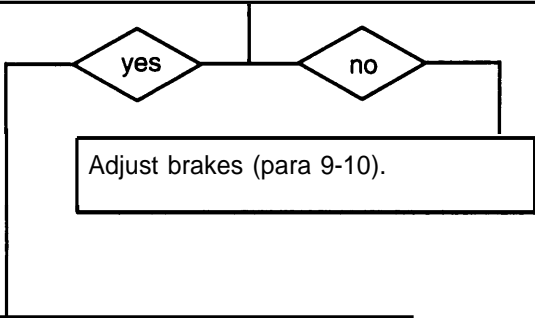

CONTINUED ON NEXT PAGE

CONTINUED FROM STEP B

C Check tracks for proper adjustment (para 10-8).
Are tracks properly adjusted?

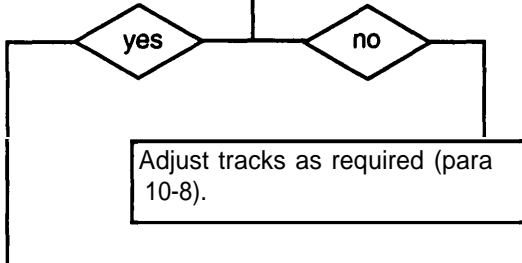

D Check suspension system for broken, damaged, and binding suspension components.
Are suspension components in good condition?

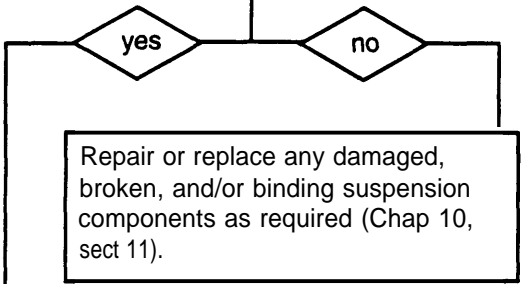

E Check final drive sprockets for even wear of all sprockets (TM 9-2350-311-10).
Are all sprockets worn the same?

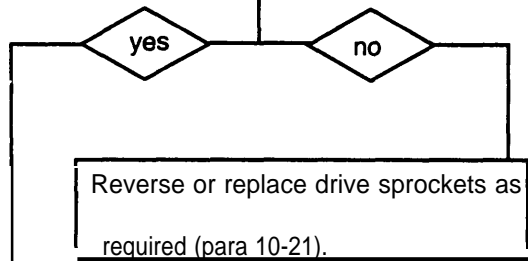

CONTINUED ON NEXT PAGE

3-3 TROUBLESHOOTING CHART — CONTINUED

g. TRACKS AND SUSPENSION — CONTINUED

(2) VEHICLE PULLS TO ONE SIDE WITH STEERING WHEEL IN CENTER POSITION — CONTINUED

CONTINUED FROM STEP E

F	<ol style="list-style-type: none">1. Remove universal joints (para 10-23).2. Start engine (TM 9-2350-311-10) and maintain 1000 to 1500 rpm.3. Do STE/ICE-R test 50 using blue striped transducer.4. Use the following test points:<ol style="list-style-type: none">a. gear steer apply pressure — left 16, right 15.b. output clutch apply pressure — left 21, right 13.5. Record results.
Are any pressures below specifications?	

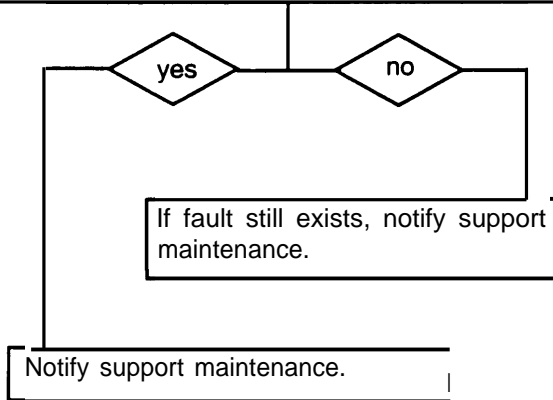

END OF TASK

(3) VEHICLE THROWS TRACK(S)

I INITIAL SETUP I

Tools

General mechanic's tool kit (item 64, Appx H)

References

TM 9-2350-311-10

NOTE
Improper driving or operation of vehicle (high speed turns) causes the vehicle to throw tracks.

A Check for loose, worn, or damaged tracks (TM 9-2350-311-10).

Are tracks tight and in good condition?

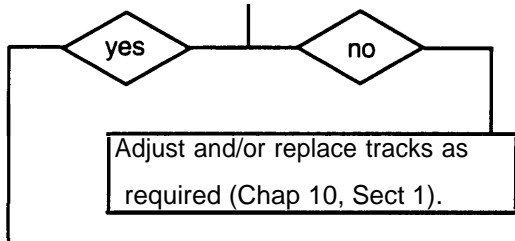

B Check drive sprockets for excessive wear (TM 9-2350-311-10).

Are drive sprockets free of excessive wear?

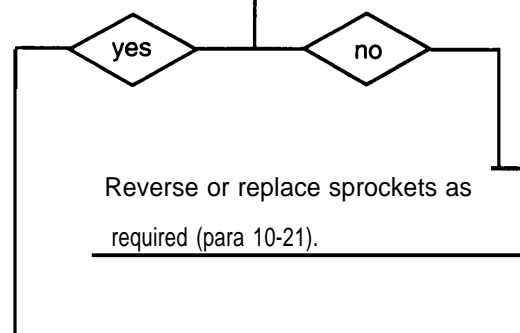

CONTINUED ON NEXT PAGE

3-3 TROUBLESHOOTING CHART -- CONTINUED

g. TRACKS AND SUSPENSION — CONTINUED

(3) VEHICLE THROWS TRACK(S) – CONTINUED

CONTINUED FROM STEP B

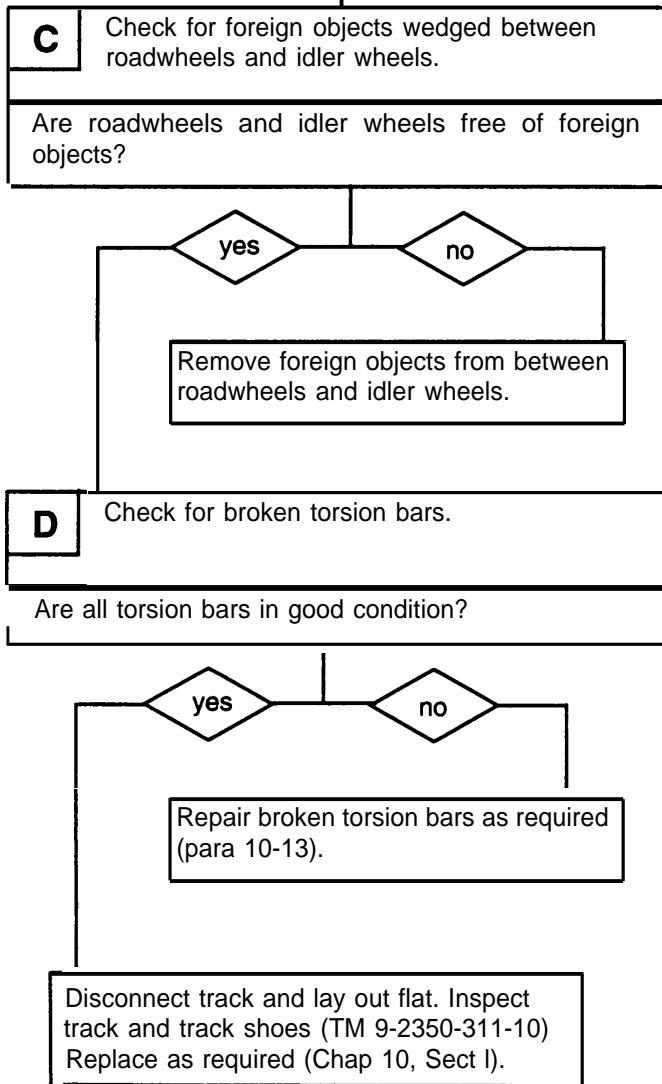

END OF TASK

(4) VEHICLE RIDE IS ROUGH OR SUSPENSION SYSTEM IS NOISY DURING OPERATION

INITIAL SETUP

Tools

General mechanic's tool kit (item 64, Appx H)

References

TM 9-2350-311-10

WARNING

Use caution when feeling shock absorbers. They can get hot enough to cause severe burns.

NOTE

A defective shock absorber will be colder than the other shock absorbers.

A

1. Immediately after road test, using back of your hand feel for presence of heat from shock absorbers. Heat indicates shock absorbers are functioning properly.
2. Check shock absorbers for oil leaks (TM 9-2350-311-10).
3. Check shock absorbers for proper mounting (para 10-19).

Are shock absorbers properly mounted, free of oil leaks and are all shock absorbers approximately the same temperature?

yes

no

Tighten loose and replace faulty shock absorbers as required (para 10-19).

CONTINUED ON NEXT PAGE

3-3 TROUBLESHOOTING CHART — CONTINUED

g. TRACKS AND SUSPENSION — CONTINUED

(4) VEHICLE RIDE IS ROUGH OR SUSPENSION SYSTEM IS NOISY DURING OPERATION — CONTINUED

CONTINUED FROM STEP A

NOTE

Roadwheels which are hot to the touch indicate a bearing problem.

B

Immediately after road test, check roadwheel hubs with the back of your hand for excessive heat.

Are roadwheel hubs at normal operation temperature?

yes

no

Replace defective roadwheel components as required (para 10-10,

C

Check final drive sprockets for excessive wear (para 10-21).

Are final drive sprockets free of excessive wear?

yes

no

Reverse or replace final drive sprockets as required (para 10-21).

CONTINUED ON NEXT PAGE

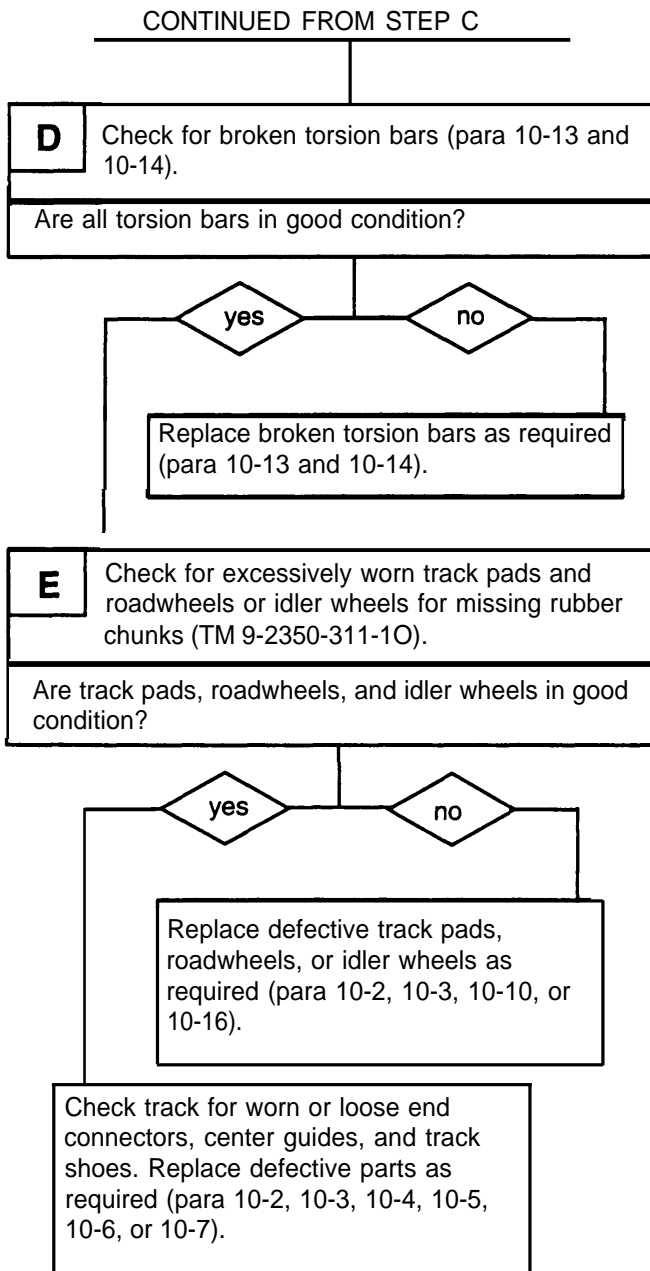

END OF TASK

3-3 TROUBLESHOOTING CHART — CONTINUED

h. FLAME HEATER CIRCUIT (ENGINE MODEL 7083-7396)

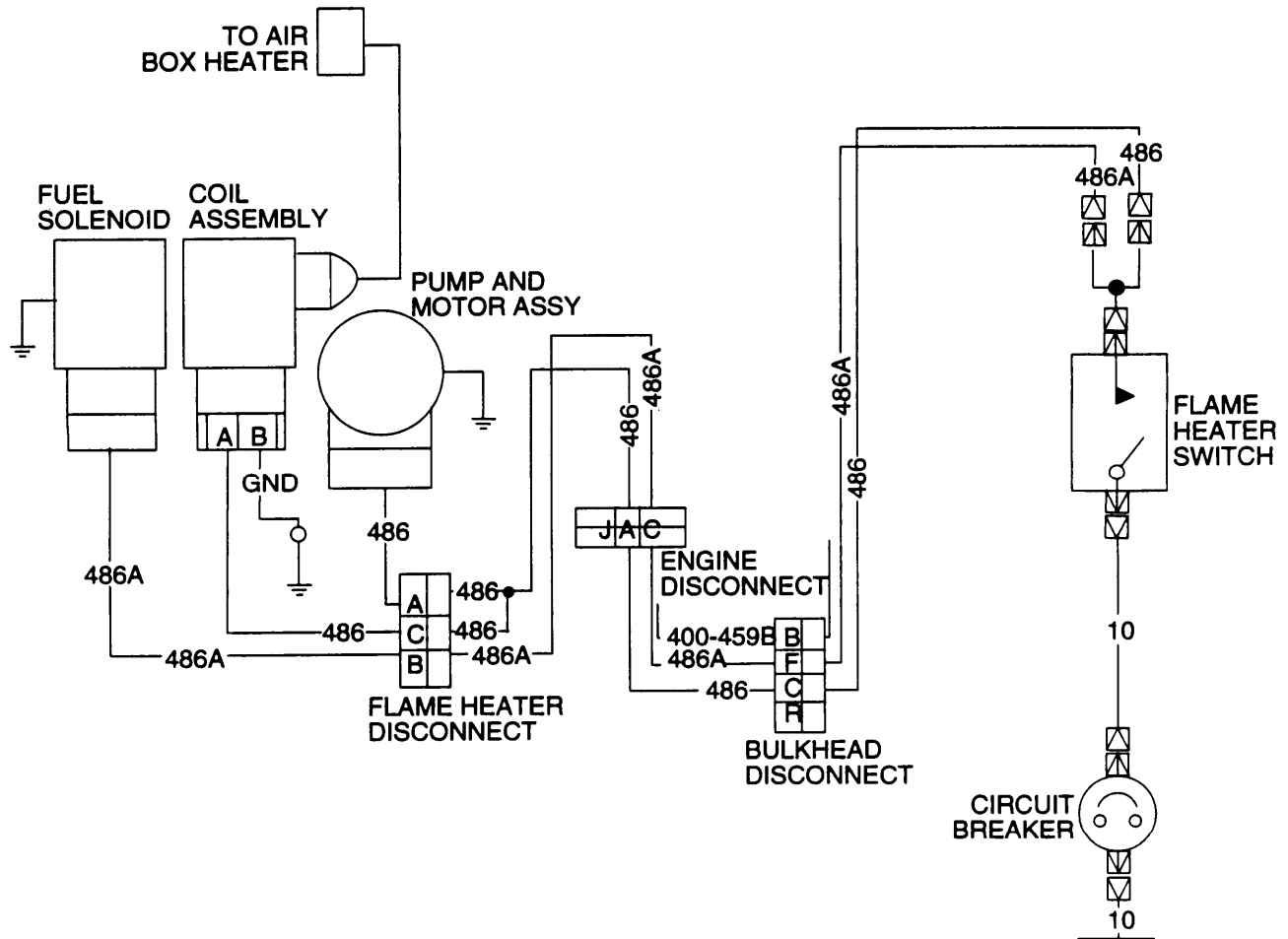

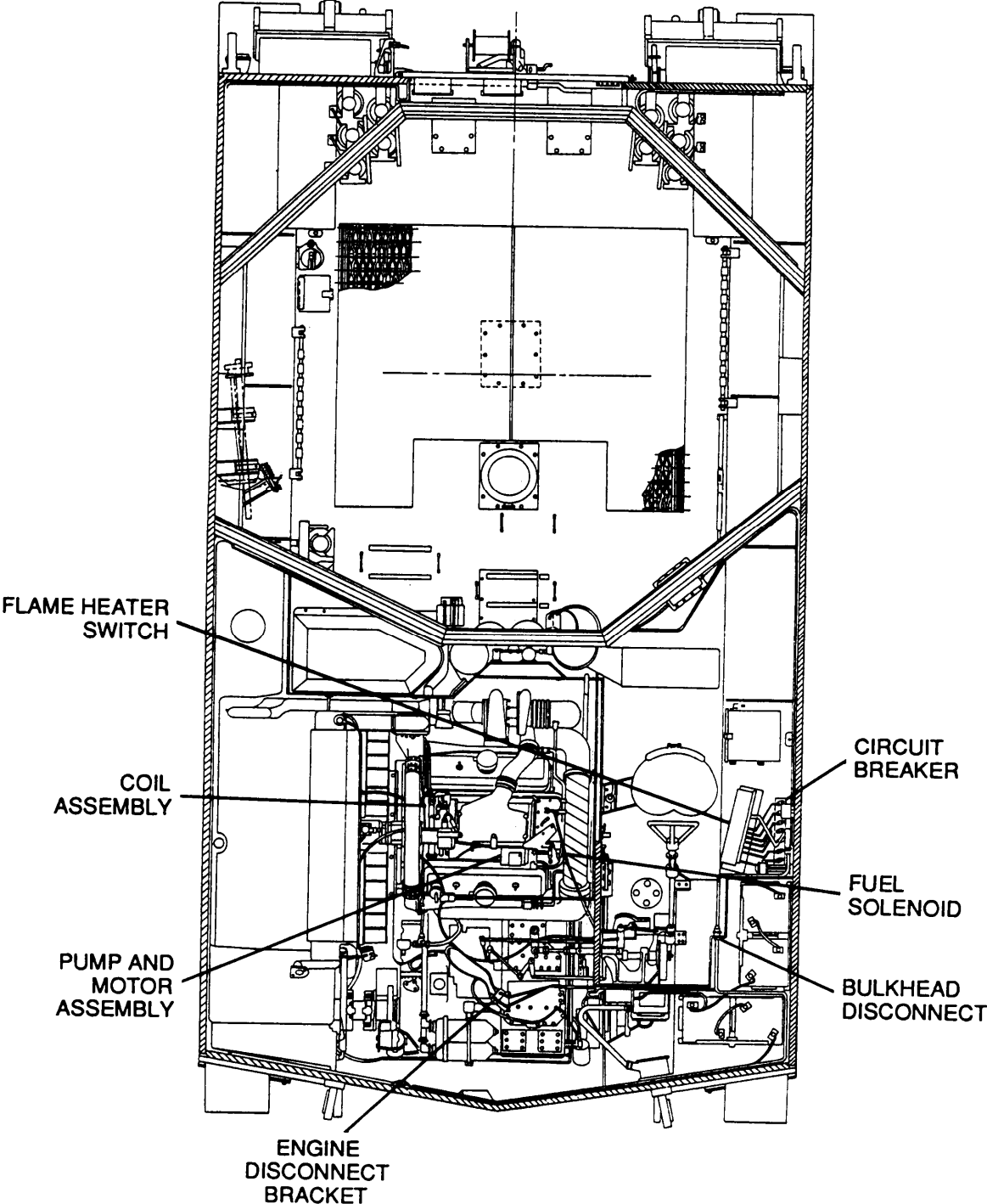

PICTORIAL VIEW

3-3 TROUBLESHOOTING CHART — CONTINUED

h. FLAME HEATER CIRCUIT (ENGINE MODEL 7083-7396) — CONTINUED

FLAME HEATER DOES NOT OPERATE

INITIAL SETUP

Tools

General mechanic's tool kit (item 64, Appx H)
 Multimeters (item 36, Appx H)
 TA-1 probe kit (item 43, Appx H)
 (Long test leads may be needed for some tests;
 16 AWG wire may be used as an extension.)

Personnel Required

Two

Equipment Conditions

Transmission left access door open (TM 9-2350-311-10)
 Air intake grille open (TM 9-2350-311-10)

WARNING

- If flammable vapors are present, do not perform step A. Performance of step A could cause fire or explosion.
- Do not touch coil assembly or air box heater while performing step A. High voltage is present and personal injury may result.
- Fuel is hazardous waste and must be disposed of in accordance with local procedures or direction of the local Hazardous Waste Management office.

NOTE

Use a container to catch any fuel that may flow out of the input and/or output hoses during the following steps.

- A**
1. Disconnect air box heater fuel input hose.
 2. Remove air box heater with coil assembly to air box heater lead attached (para 5-8).
 3. Place a jumper wire from air box heater to ground.
 4. Turn MASTER and FLAME HEATER switches ON.
 5. Check for electric arc between electrode and wire in air box heater. Arc should be steady with a crackling sound.
 6. Turn MASTER and FLAME HEATER switches OFF.

Note results.

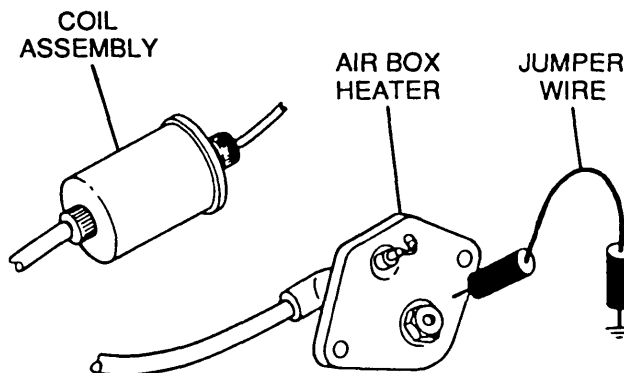

CONTINUED ON NEXT PAGE

CONTINUED FROM STEP A

B

1. Reconnect air box heater fuel input hose and install air box heater (para 5-8).
2. Turn MASTER and FLAME HEATER switches ON.
3. Listen for a clicking sound from the fuel solenoid or touch the fuel solenoid to confirm that it is opening and closing.
4. Turn MASTER and FLAME HEATER switches OFF.

Note results.

C

1. Disconnect air output hose at the pump and motor assembly.
2. Turn MASTER and FLAME HEATER switches ON.
3. Check for airflow.
4. Turn MASTER and FLAME HEATER switches OFF.

Note results.

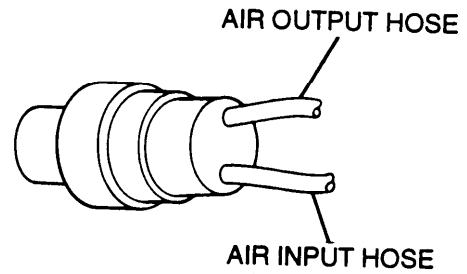
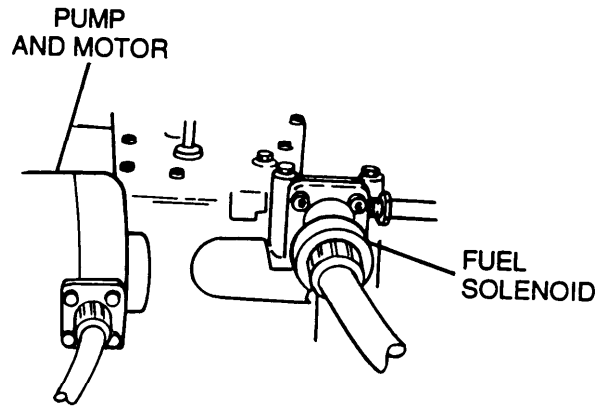

CONTINUED ON NEXT PAGE

3-3 TROUBLESHOOTING CHART — CONTINUED

h. FLAME HEATER CIRCUIT (ENGINE MODEL 7083-7396) — CONTINUED

FLAME HEATER DOES NOT OPERATE — CONTINUED

CONTINUED FROM STEP C

- D**
1. Reconnect hose to pump and motor assembly.
 2. If air box heater, fuel solenoid, and pump and motor assembly all failed to operate, go to step Q.
 3. If air box heater and pump and motor assembly both failed to operate, go to step L.
 4. If only air box heater failed to operate, go to step E.
 5. If only pump and motor assembly failed to operate, go to step G.
 6. If only fuel solenoid failed to operate, go to step L.

- E**
1. Disconnect lead 486 from flame heater ignition coil assembly.
 2. Place red lead of multimeters on pin A (lead 486) and black lead to ground.
 3. Turn MASTER switch ON and check for voltage.
 4. Turn MASTER switch OFF.
- Is voltage present?

yes

no

Replace flame heater ignition coil assembly (para 5-10).

CONTINUED ON NEXT PAGE

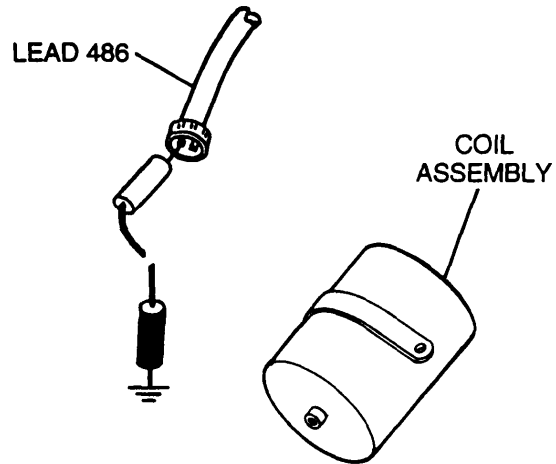

CONTINUED FROM STEP E

F	<ol style="list-style-type: none"> 1. Reconnect lead 486 to the flame heater ignition coil assembly. 2. Disconnect powerplant wiring harness from flame heater disconnect. 3. Place red lead of multimeters in socket C (lead 486) and black lead to ground. 4. Turn MASTER and FLAME HEATER switches ON and check for voltage. 5. Turn MASTER and FLAME HEATER switches OFF.
Is voltage present?	

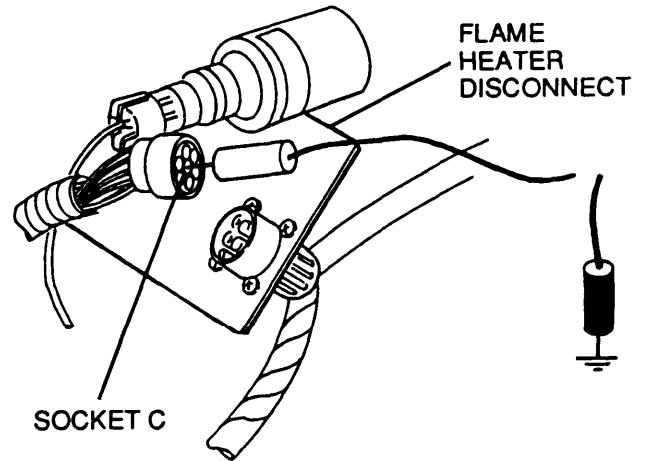
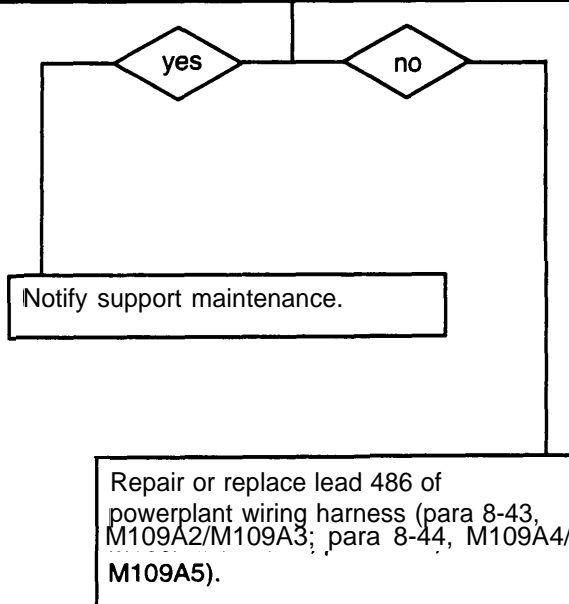

3-3 TROUBLESHOOTING CHART — CONTINUED

h. FLAME HEATER CIRCUIT (ENGINE MODEL 7083-7396) — CONTINUED

FLAME HEATER DOES NOT OPERATE — CONTINUED

CONTINUED FROM STEP D

- G**
1. Disconnect lead 486 from pump and motor assembly.
 2. Place red lead of multimeters in lead 486 and black lead to ground.
 3. Turn MASTER and FLAME HEATER switches ON and check for voltage.
 4. Turn MASTER and FLAME HEATER switches OFF.

Is voltage present?

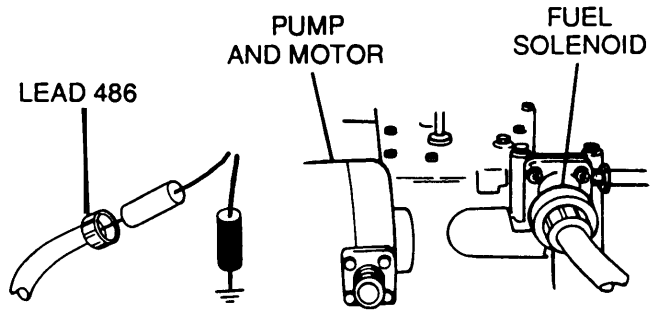
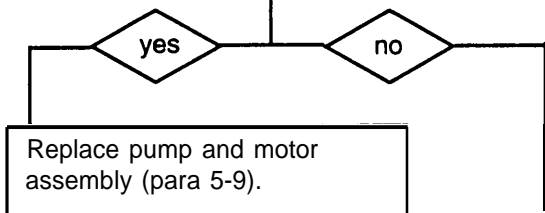

- H**
1. Reconnect lead 486 to pump and motor assembly.
 2. Disconnect powerplant wiring harness from flame heater disconnect.
 3. Place red lead of multimeters in socket A (lead 486) and black lead to ground.
 4. Turn MASTER and FLAME HEATER switches ON and check for voltage.
 5. Turn MASTER and FLAME HEATER switches OFF.

Is voltage present?

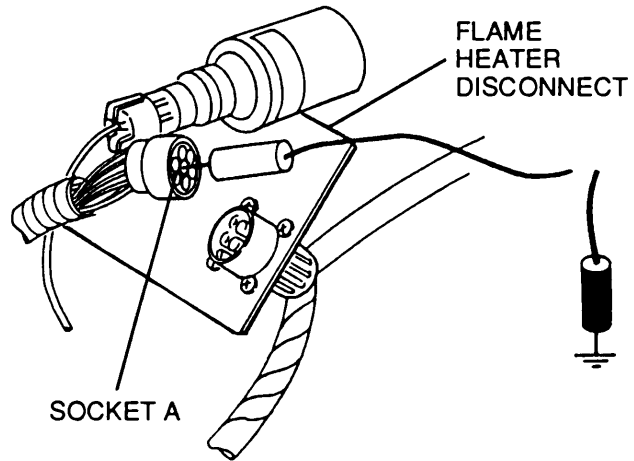
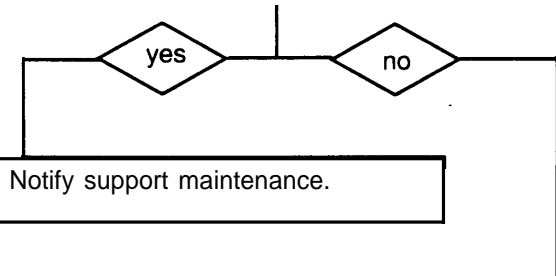

CONTINUED ON NEXT PAGE

CONTINUED FROM STEP H

- I**
1. Reconnect powerplant wiring harness to flame heater disconnect.
 2. Disconnect FLAME HEATER switch lead (lead 486) from bulkhead-to-portable instrument panel wiring harness.
 3. Place red lead of multimeters on lead 486 and black lead to ground.
 4. Turn MASTER and FLAME HEATER switches ON and check for voltage.
 5. Turn MASTER and FLAME HEATER switches OFF.
- Is voltage present?

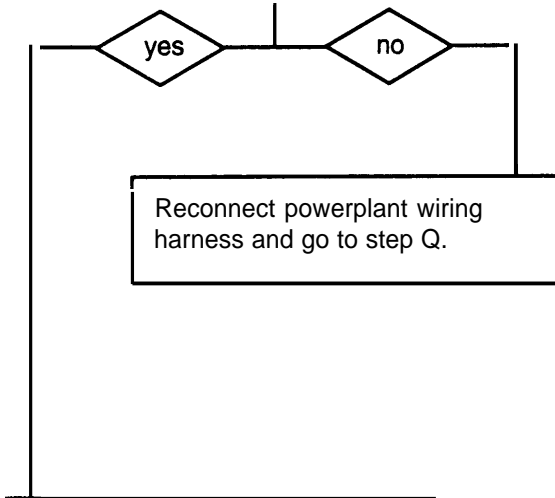

CONTINUED ON NEXT PAGE

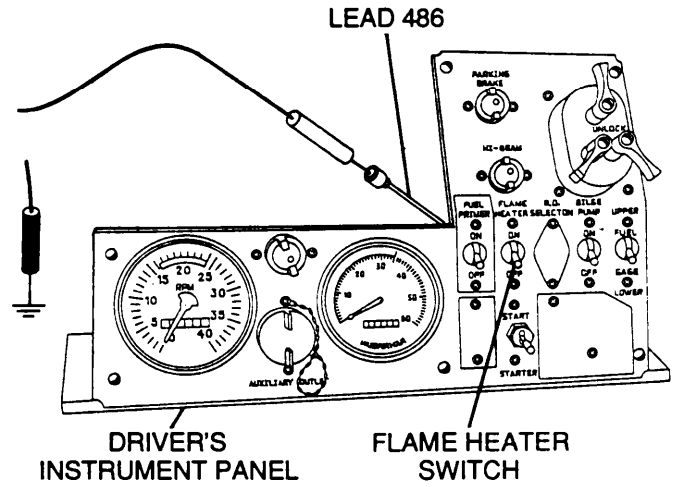

M109A2/M109A3 SHOWN

3-3 TROUBLESHOOTING CHART — CONTINUED

h. FLAME HEATER CIRCUIT (ENGINE MODEL 7083-7396) — CONTINUED

FLAME HEATER DOES NOT OPERATE — CONTINUED

CONTINUED FROM STEP I

J

1. Reconnect FLAME HEATER switch lead to bulkhead-to-portable instrument panel wiring harness.
2. Disconnect battery ground leads.
3. Disconnect bulkhead-to-portable instrument panel wiring harness from driver's bulkhead.
4. Place a jumper wire from pin B to socket B (lead 400-459B).
5. Place red lead of multimeters on pin C (lead 486) and black lead to ground.
6. Reconnect battery ground leads.
7. Turn MASTER and FLAME HEATER switches ON and check for voltage.
8. Turn MASTER and FLAME HEATER switches OFF.

Is voltage present?

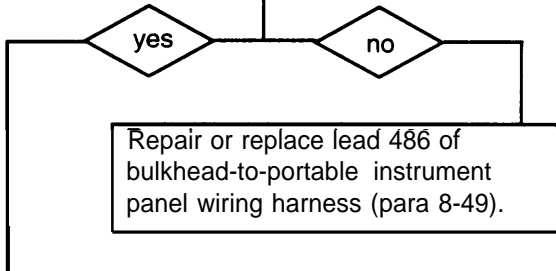
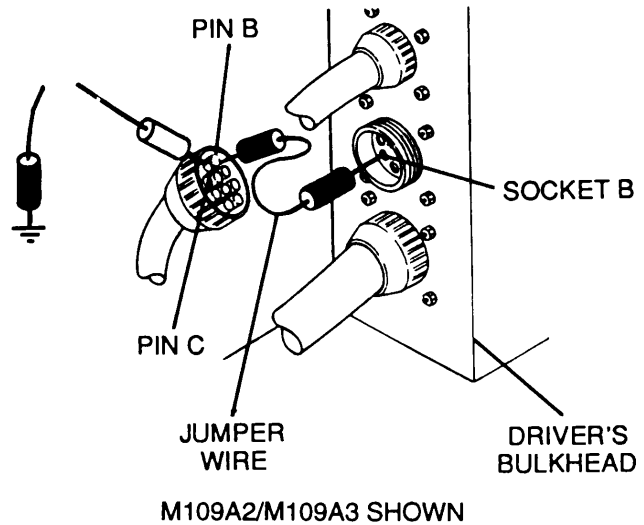

K

1. Reconnect bulkhead-to-portable instrument panel wiring harness to driver's bulkhead.
2. Disconnect engine disconnect to bulkhead wiring harness from engine disconnect bracket.
3. Place red lead of multimeters in socket A (lead 486) and black lead to ground.
4. Turn MASTER and FLAME HEATER switches ON and check for voltage.
5. Turn MASTER and FLAME HEATER switches OFF.

Is voltage present?

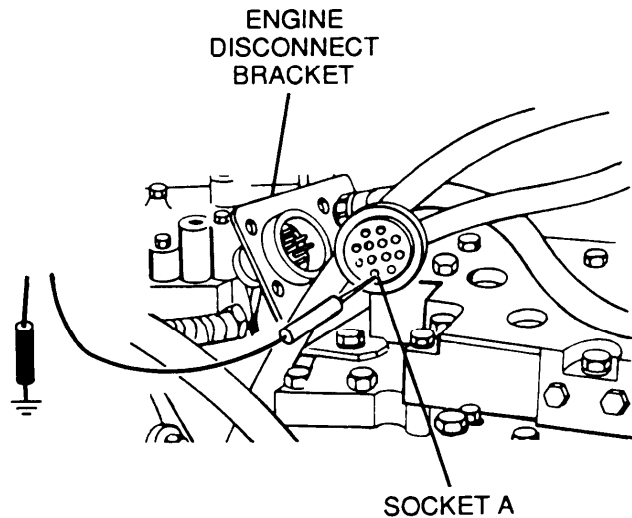

CONTINUED ON NEXT PAGE

CONTINUED FROM STEP K

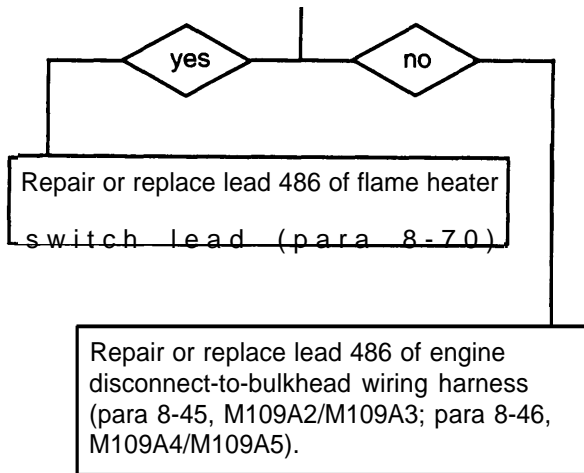

CONTINUED FROM STEP D

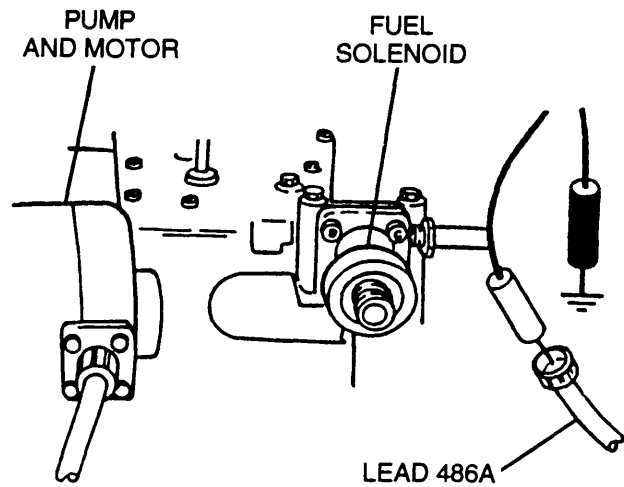
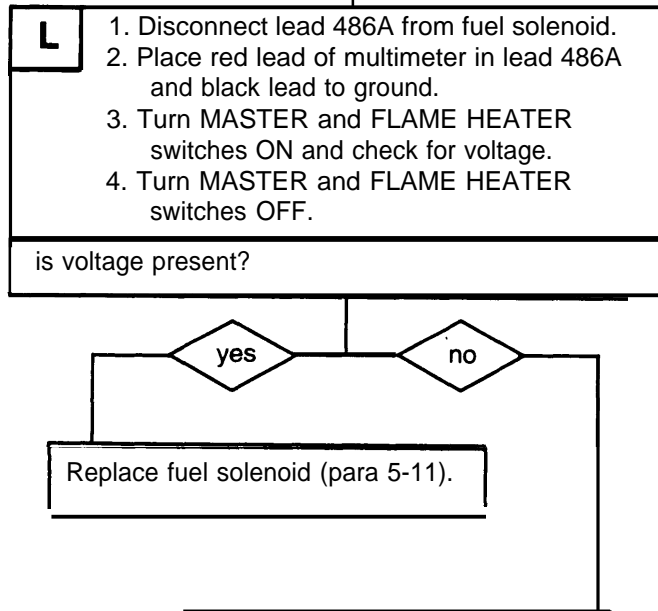

CONTINUED ON NEXT PAGE

3-3 TROUBLESHOOTING CHART — CONTINUED

h. FLAME HEATER CIRCUIT (ENGINE MODEL 7083-7396) — CONTINUED

FLAME HEATER DOES NOT OPERATE — CONTINUED

CONTINUED FROM STEP L

- M**
1. Reconnect lead 486A to fuel solenoid.
 2. Disconnect powerplant wiring harness from flame heater disconnect.
 3. Place red lead of multimeter in socket B (lead 486A) and black lead to ground.
 4. Turn MASTER and FLAME HEATER switches ON and check for voltage.
 5. Turn MASTER and FLAME HEATER switches OFF.

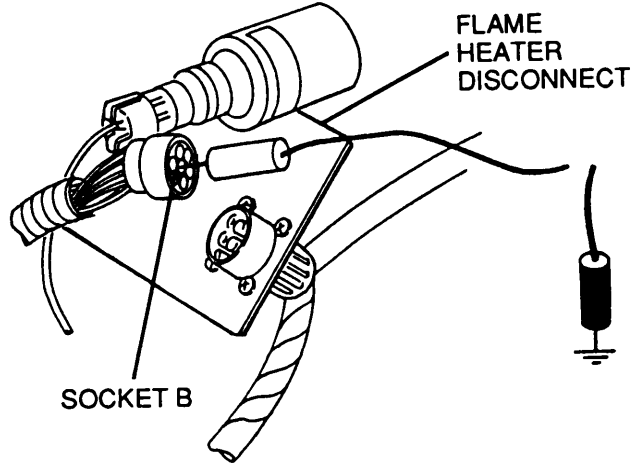

Is voltage present?

yes

no

Notify support maintenance.

- N**
1. Reconnect powerplant wiring harness to flame heater disconnect.
 2. Disconnect lead 486A from FLAME HEATER switch output.
 3. Place red lead of multimeter in FLAME HEATER switch output and black lead to ground.
 4. Turn MASTER and FLAME HEATER switches ON and check for voltage.
 5. Turn MASTER and FLAME HEATER switches OFF.

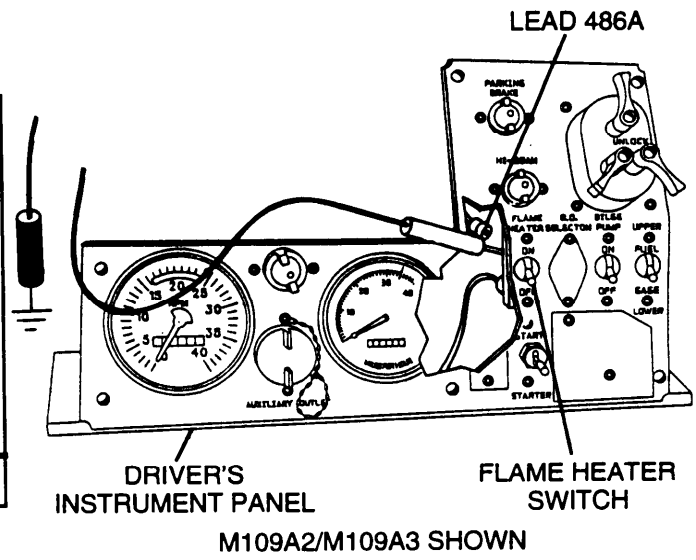

Is voltage present?

yes

no

Go to step R

CONTINUED ON NEXT PAGE

CONTINUED FROM STEP N

- | | |
|----------|--|
| O | <ol style="list-style-type: none"> 1. Reconnect lead 486A to FLAME HEATER switch output. 2. Disconnect bulkhead-to-portable instrument panel wiring harness from driver's bulkhead. 3. Place a jumper wire from pin B to socket B (lead 400-459B). 4. Place red lead of multimeter on pin F (lead 486A) and black lead to ground. 5. Turn MASTER and FLAME HEATER switches ON and check for voltage. 6. Turn MASTER and FLAME HEATER switches OFF. |
|----------|--|

Is voltage present?

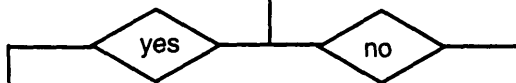

<p>Repair or replace lead 486A of bulkhead-to-portable instrument panel wiring harness (para 8-49).</p>

CONTINUED ON NEXT PAGE

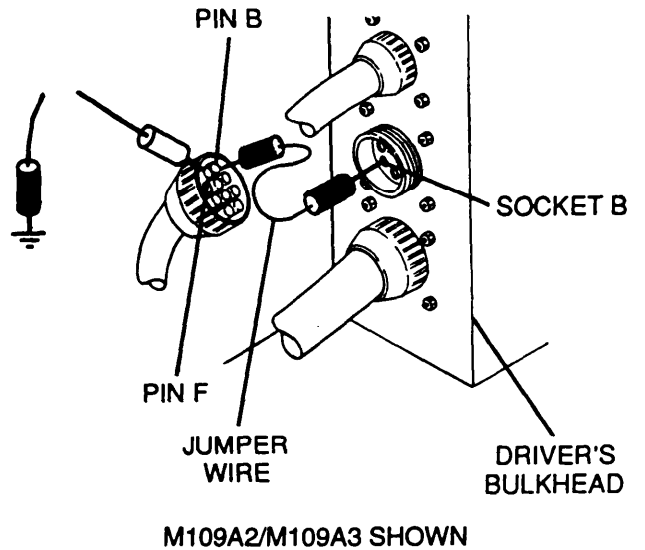

3-3 TROUBLESHOOTING CHART — CONTINUED

h. FLAME HEATER CIRCUIT (ENGINE MODEL 7083-7396) — CONTINUED

FLAME HEATER DOES NOT OPERATE — CONTINUED

CONTINUED FROM STEP N

P	<ol style="list-style-type: none"> 1. Reconnect bulkhead-to-portable instrument panel wiring harness to driver's bulkhead. 2. Disconnect engine disconnect-to-bulkhead wiring harness from engine disconnect bracket. 3. Place red lead of multimeter in socket C (lead 486A) and black lead to ground. 4. Turn MASTER and FLAME HEATER switches ON and check for voltage. 5. Turn MASTER and FLAME HEATER switches OFF.
Is voltage present?	

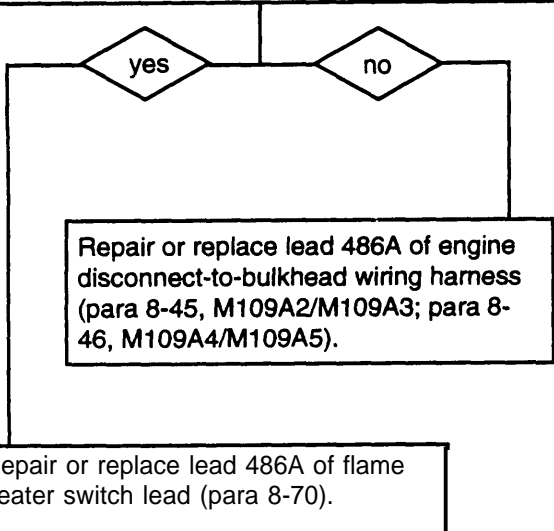
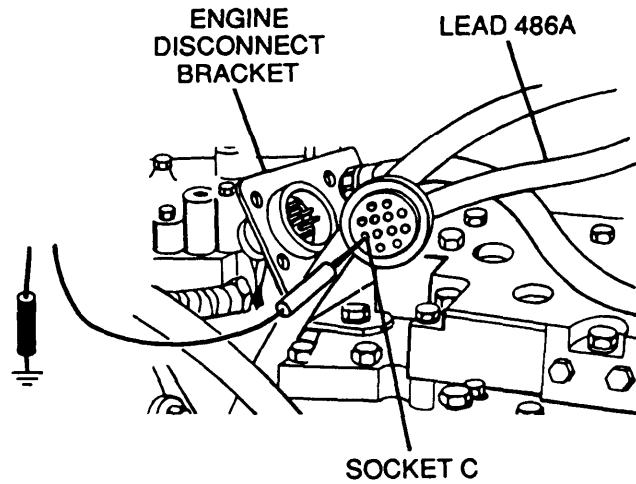

CONTINUED FROM STEP D AND I

- Q**
1. Disconnect lead 486A of flame heater switch lead from FLAME HEATER switch output.
 2. Place red lead of multimeter in FLAME HEATER switch output and black lead to ground.
 3. Turn MASTER and FLAME HEATER switches ON and check for voltage.
 4. Turn MASTER and FLAME HEATER switches OFF.

Is voltage present?

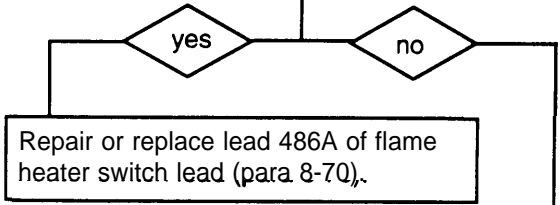

- R**
1. Reconnect lead 486A to FLAME HEATER switch output.
 2. Disconnect lead 10 from FLAME HEATER switch input.
 3. Place red lead of multimeter in lead 10 and black lead to ground.
 4. Turn MASTER switch ON and check for voltage.
 5. Turn MASTER switch OFF.

Is voltage present?

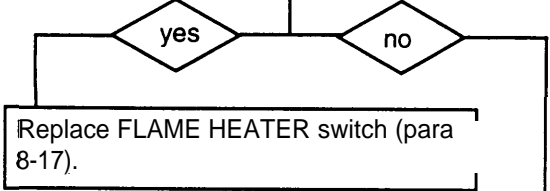

CONTINUED ON NEXT PAGE

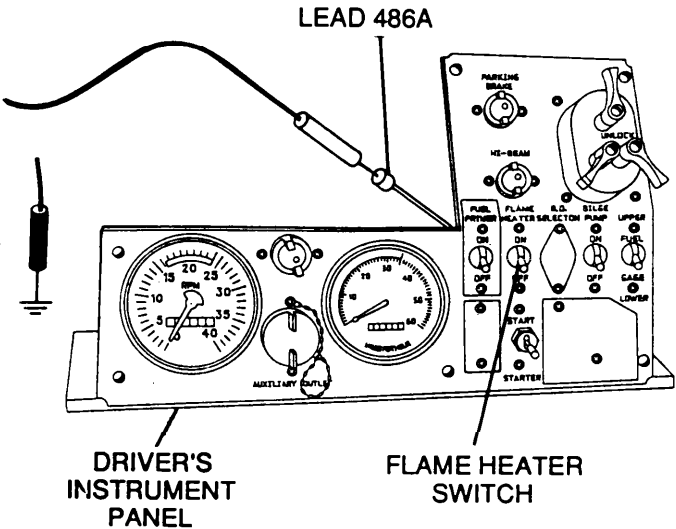

M109A2/M109A3 SHOWN

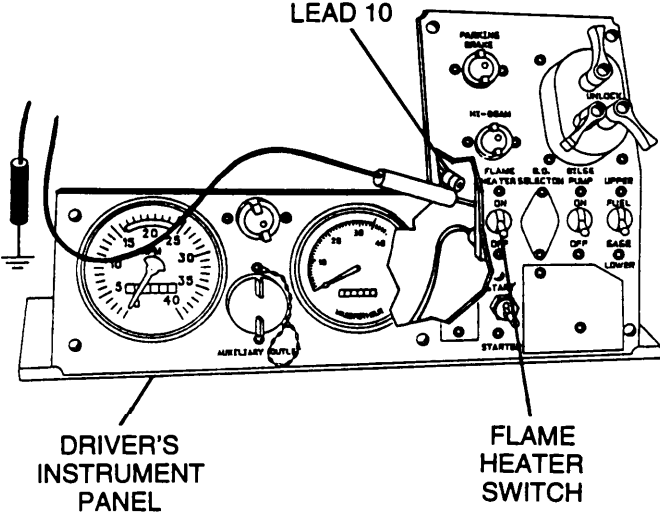

M109A2/M109A3 SHOWN

3-3 TROUBLESHOOTING CHART — CONTINUED

h. FLAME HEATER CIRCUIT (ENGINE MODEL 7083-7396) — CONTINUED

FLAME HEATER DOES NOT OPERATE — CONTINUED

CONTINUED FROM STEP R

- S**
1. Reconnect lead 10 to FLAME HEATER switch input.
 2. Disconnect lead 10 from circuit breaker output.
 3. Place red lead of multimeter in circuit breaker output and black lead to ground.
 4. Turn MASTER switch ON and check for voltage.
 5. Turn MASTER switch OFF.

Is voltage present?

yes

no

Repair or replace lead 10 of driver's instrument panel wiring harness (para 8-51).

- T**
1. Reconnect lead 10 to circuit breaker output.
 2. Disconnect lead 10 from circuit breaker input.
 3. Place red lead of multimeter in lead 10 and black lead to ground.
 4. Turn MASTER switch ON and check for voltage.
 5. Turn MASTER switch OFF.

Is voltage present?

yes

no

Replace circuit breaker (para 8-33, M109A2/M109A3; para 8-34, M109A4/M109A5).

Troubleshoot master relay circuit (para 3-3b).

END OF TASK

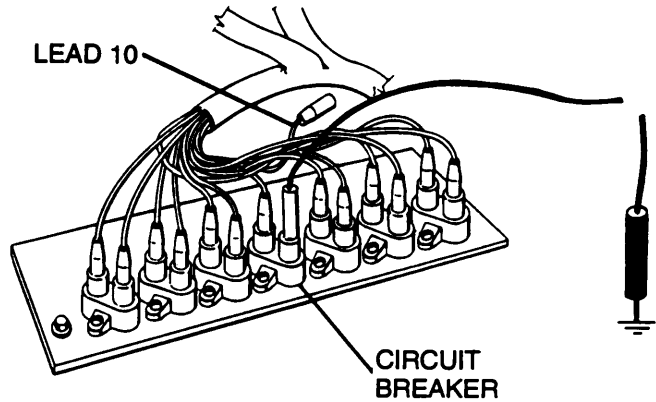

M109A2/M109A3 SHOWN

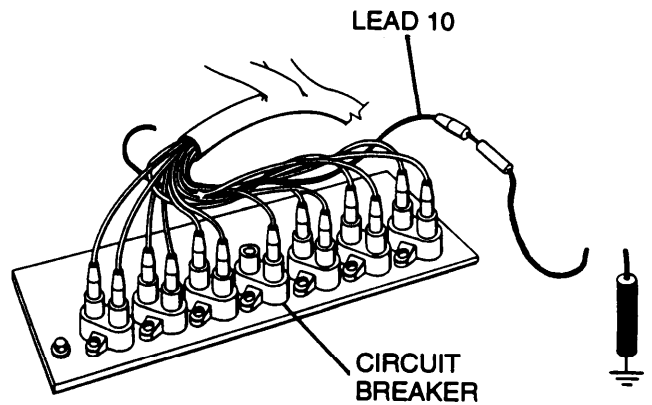

M109A2/M109A3 SHOWN

i. GLOW PLUGS CIRCUIT (ENGINE MODEL 7083-7391)

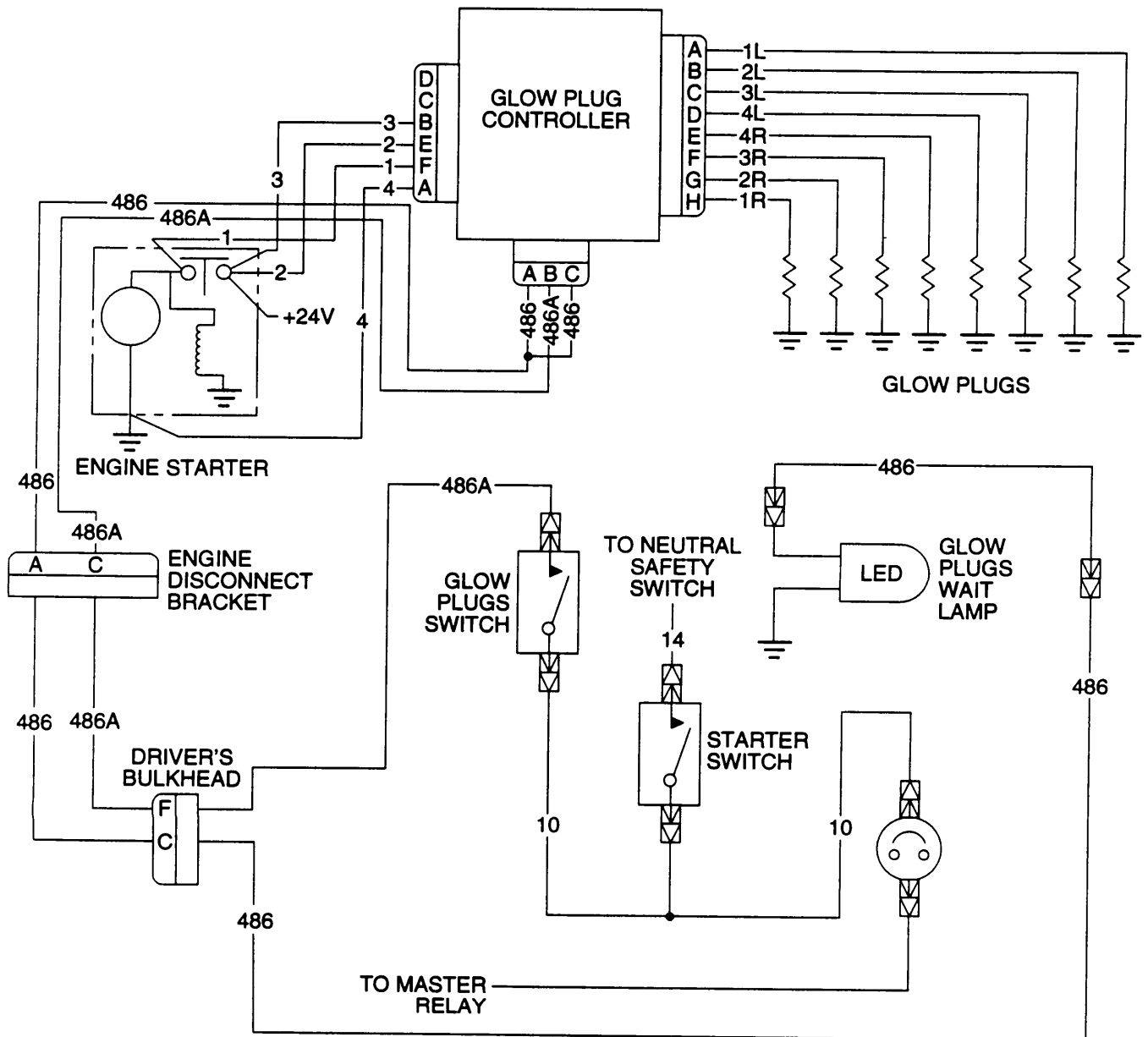

3-3 TROUBLESHOOTING CHART — CONTINUED

- i. GLOW PLUGS CIRCUIT (ENGINE MODEL 7083-7391) — CONTINUED

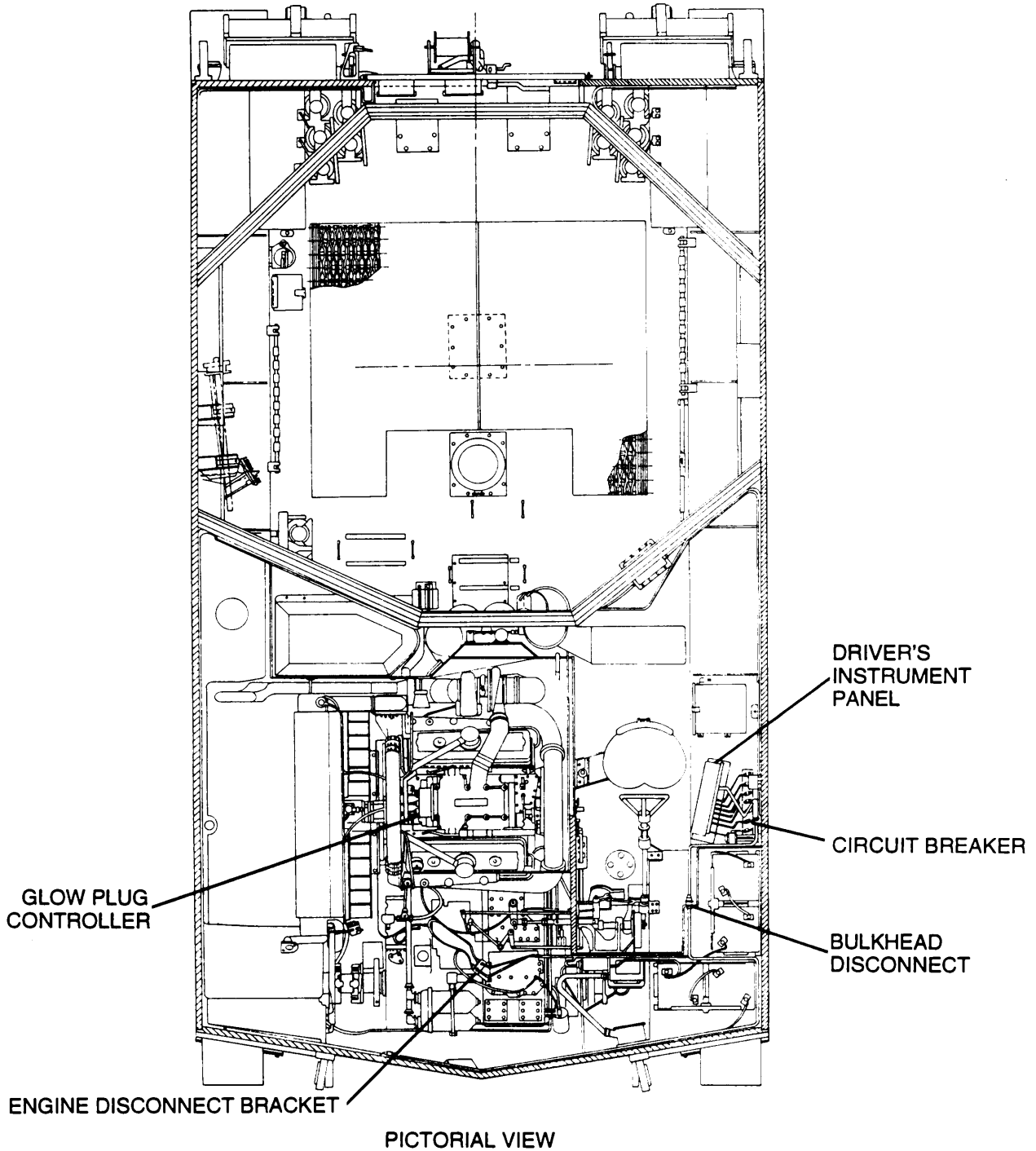

(1) GLOW PLUG WAIT LIGHT FAILS TO OPERATE;
GLOW PLUG SYSTEM OPERATES USING MANUAL
OVERRIDE

INITIAL SETUP

Tools

General mechanic's tool kit (item 64, Appx H)
Multimeters (item 36, Appx H)
TA-1 probe kit (item 43, Appx H)
(Long test leads may be needed for some tests;
16 AWG wire may be used as an extension.)

Personnel Required

Two

Equipment Conditions

Transmission access door open (TM 9-2350-311-10)
Air intake grille open (TM 9-2350-311-10)

- A**
1. Remove inoperative LED (para 8-17).
 2. Place red lead of multimeters in center contact of socket and black lead to ground.
 3. Turn MASTER and GLOW PLUGS switches ON and check for voltage.
 4. Turn MASTER and GLOW PLUGS switches OFF.

Is voltage present?

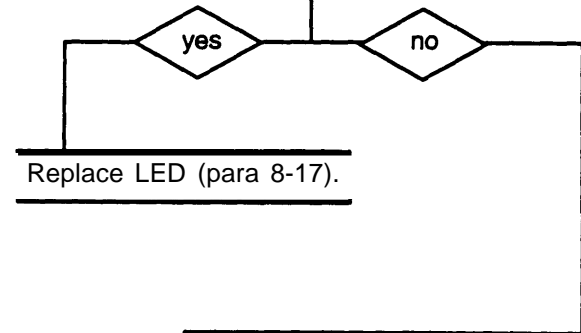

CONTINUED ON NEXT PAGE

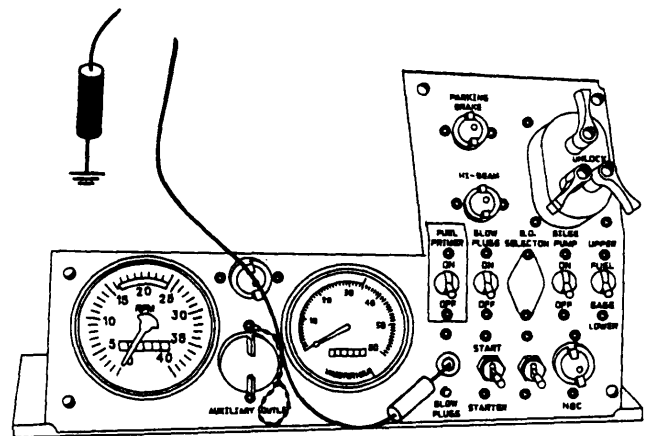

DRIVER'S
INSTRUMENT
PANEL

M109A4/M109A5 SHOWN

3-3 TROUBLESHOOTING CHART — CONTINUED

i. GLOW PLUGS CIRCUIT (ENGINE MODEL 7083-7391) — CONTINUED

(1) GLOW PLUG WAIT LIGHT FAILS TO OPERATE; GLOW PLUG SYSTEM OPERATES USING MANUAL OVERRIDE — CONTINUED

CONTINUED FROM STEP A

- B**
1. Install inoperative LED (para 8-17).
 2. Disconnect lead 486 from GLOW PLUGS indicator light.
 3. Place red lead of multimeters on lead 486 and black lead to ground.
 4. Turn MASTER and GLOW PLUGS switches ON and check for voltage.
 5. Turn MASTER and GLOW PLUGS switches OFF.

Is voltage present?

yes

no

Replace GLOW PLUGS indicator light (para 8-17).

C

1. Reconnect lead 486 to GLOW PLUG indicator light.
2. Disconnect lead 486A from GLOW PLUGS switch.
3. Place red lead of multimeter on GLOW PLUGS switch and black lead to ground.
4. Turn MASTER and GLOW PLUGS switches ON and check for voltage.
5. Turn MASTER and GLOW PLUGS switches OFF.

Is voltage present?

yes

no

Go to step D.

Go to step E.

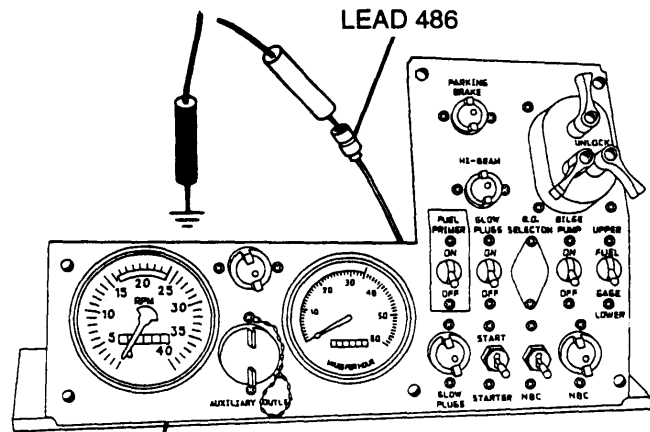

DRIVER'S INSTRUMENT PANEL

M109A4/M109A5 SHOWN

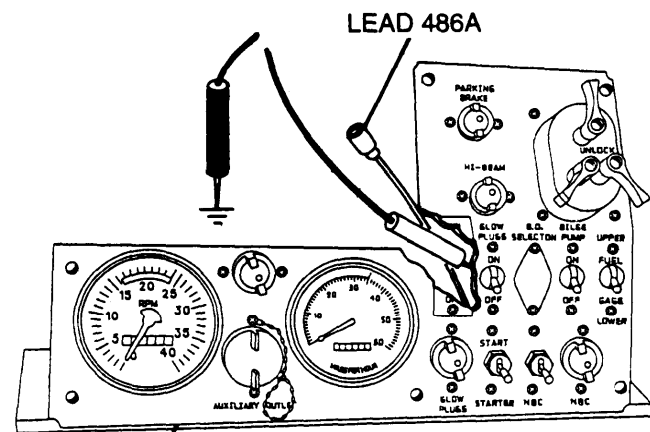

DRIVER'S INSTRUMENT PANEL

M109A4/M109A5 SHOWN

CONTINUED FROM STEP C

- D**
1. Reconnect lead 486A to GLOW PLUGS switch.
 2. Disconnect powerplant wiring harness from glow plug controller.
 3. Place red lead of multimeter in socket B (lead 486A) and black lead to ground.
 4. Turn MASTER and GLOW PLUGS switches ON and check for voltage.
 5. Turn MASTER and GLOW PLUGS switches OFF.

Is voltage present?

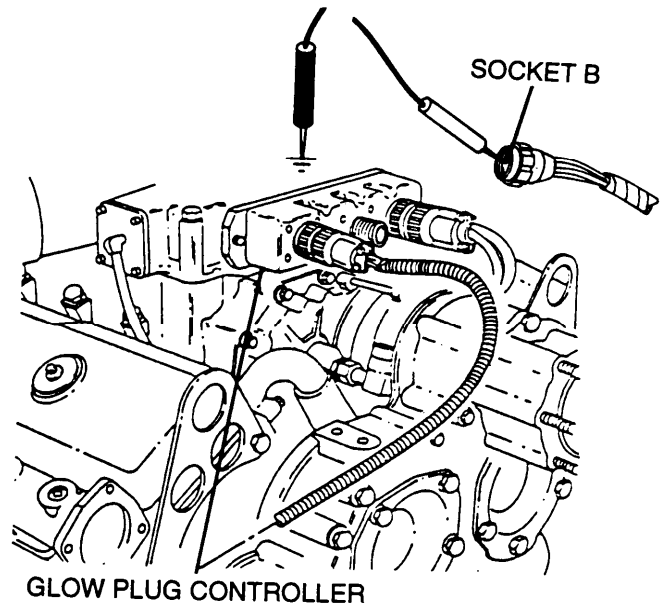
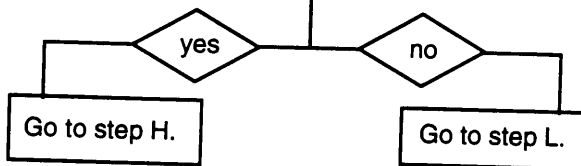

GLOW PLUG CONTROLLER

CONTINUED FROM STEP C

- E**
1. Reconnect lead 486A to GLOW PLUGS switch.
 2. Disconnect lead 10 from GLOW PLUGS switch.
 3. Place red lead of multimeter in lead 10 and black lead to ground.
 4. Turn MASTER switch ON and check for voltage.
 5. Turn MASTER switch OFF.

Is voltage present?

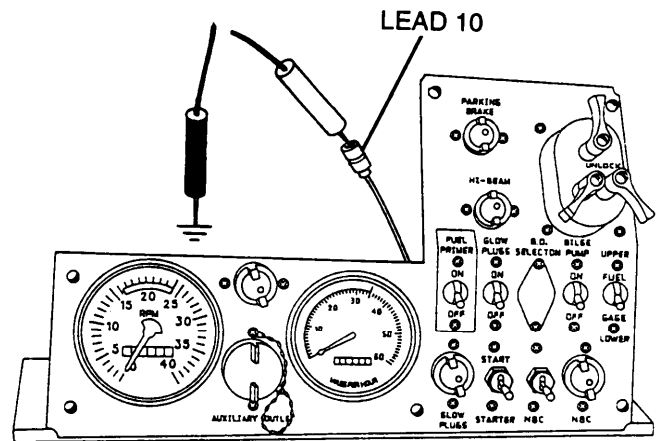
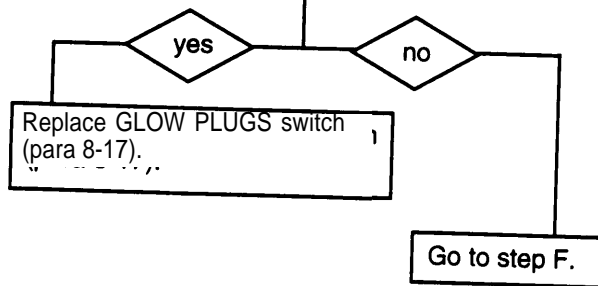

DRIVER'S INSTRUMENT PANEL

M109A4/M109A5 SHOWN

3-3 TROUBLESHOOTING CHART — CONTINUED

- i. GLOW PLUGS CIRCUIT (ENGINE MODEL 7083-7391) — CONTINUED (1) GLOW PLUG WAIT LIGHT FAILS TO OPERATE; GLOW PLUG SYSTEM OPERATES USING MANUAL OVERRIDE — CONTINUED

CONTINUED FROM STEP E

F

1. Reconnect lead 10 to GLOW PLUGS switch.
2. Disconnect lead 10 of driver's instrument panel wiring harness from output side from circuit breaker output.
3. Place red lead of multimeter in output side of circuit breaker output and black lead to ground.
4. Turn MASTER switch ON and check for voltage.
5. Turn MASTER switch OFF.

Is voltage present?

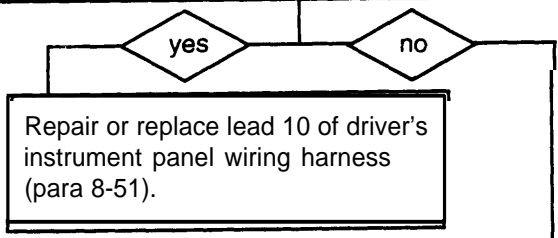

G

1. Reconnect lead 10 to output side of circuit breaker.
2. Disconnect lead 10 of power lead wiring harness from input side of circuit breaker.
3. Place red lead of multimeter in lead 10 and black lead to ground.
4. Turn MASTER switch ON and check for voltage.
5. Turn MASTER switch OFF.

Is voltage present?

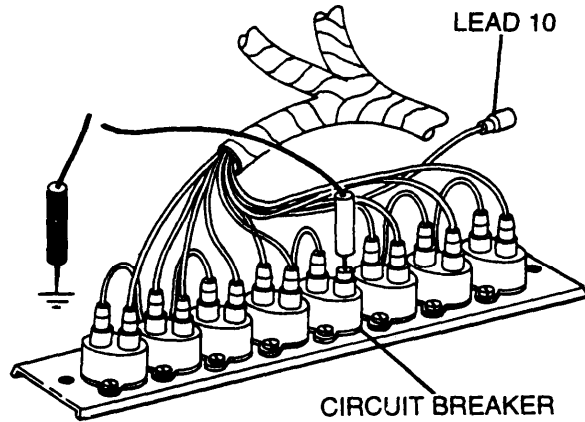
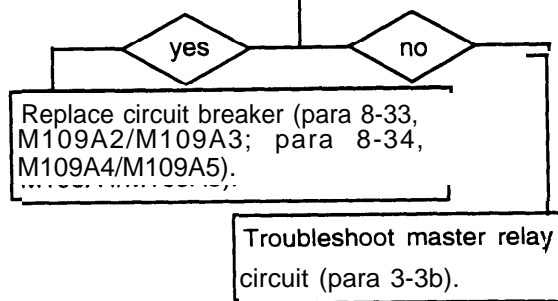

M109A4/M109A5 SHOWN

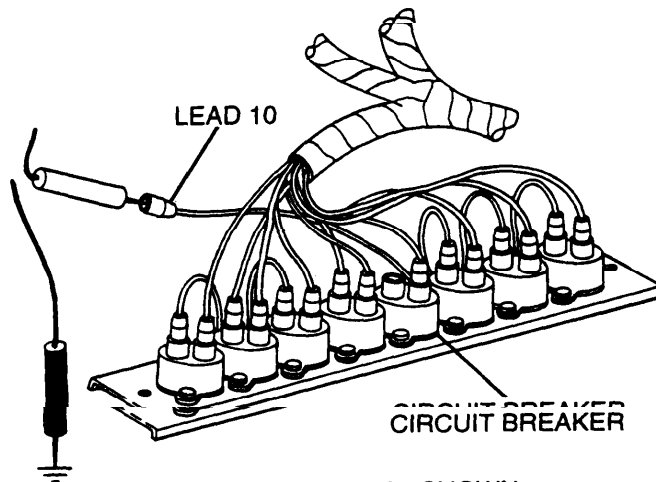

M109A4/M109A5 SHOWN

CONTINUED FROM STEP D

H

1. Place a jumper wire from socket B to pin B (lead 486A).
2. Place red lead of multimeter on pin A (lead 486) and black lead to ground.
3. Turn MASTER and GLOW PLUGS switches ON and check for voltage.
4. Turn MASTER and GLOW PLUGS switches OFF.
5. Place red lead of multimeter on pin C (lead 486) and black lead to ground.
6. Turn MASTER and GLOW PLUGS switches ON and check for voltage.
7. Turn MASTER and GLOW PLUGS switches OFF.

Is voltage present in both locations?

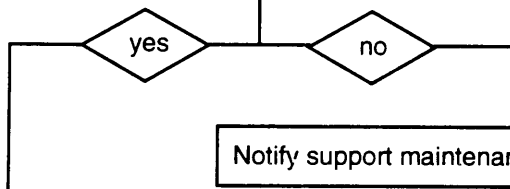
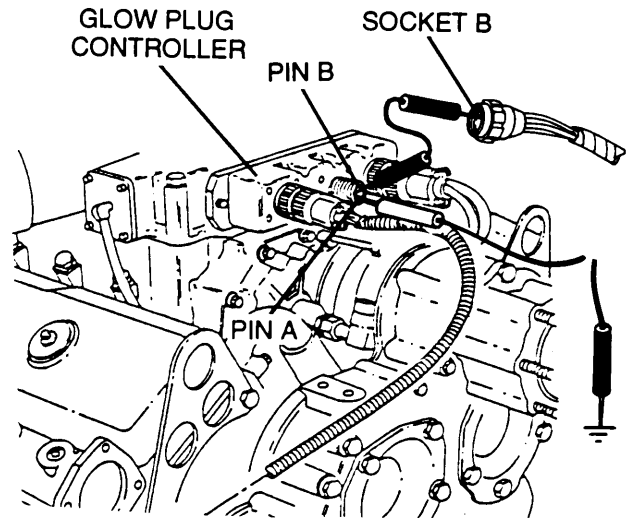

I

1. Reconnect powerplant wiring harness to glow plug controller.
2. Disconnect engine disconnect-to-bulkhead wiring harness from engine disconnect.
3. Place red lead of multimeter on pin A (lead 486) and black lead to ground.
4. Turn MASTER and GLOW PLUGS switches ON and check for voltage.
5. Turn MASTER and GLOW PLUGS switches OFF.

Is voltage present?

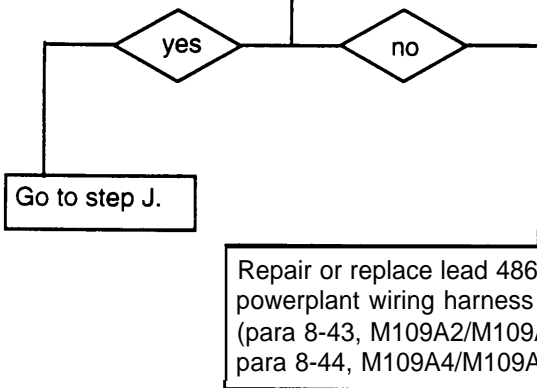
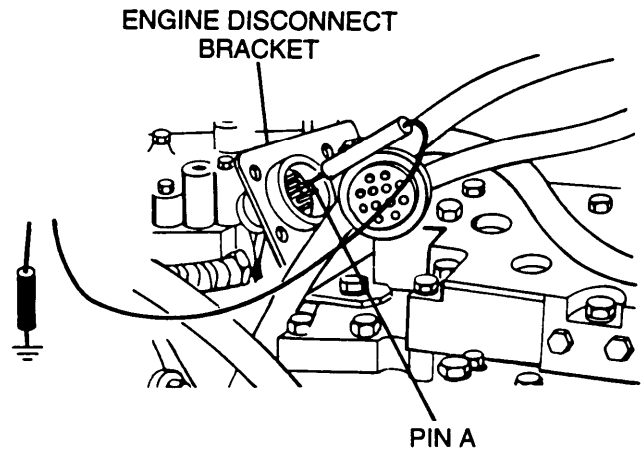

3-3 TROUBLESHOOTING CHART — CONTINUED

- i. GLOW PLUGS CIRCUIT (ENGINE MODEL 7083-7391) — CONTINUED (1) GLOW PLUG WAIT LIGHT FAILS TO OPERATE; GLOW PLUG SYSTEM OPERATES USING MANUAL OVERRIDE — CONTINUED

CONTINUED FROM STEP I

- J**
1. Reconnect engine disconnect-to-bulkhead wiring harness to engine disconnect.
 2. Disconnect bulkhead-to-portable instrument panel wiring harness from driver's bulkhead.
 3. Place a jumper wire from pin B to socket B (lead 400-459B) and black lead to ground.
 4. Place red lead of multimeter in socket C (lead 486) and black lead to ground.
 5. Turn MASTER and GLOW PLUGS switches ON and check for voltage.
 6. Turn MASTER and GLOW PLUGS switches OFF.

Is voltage present?

yes

no

Repair or replace lead 486 of engine disconnect-to-bulkhead wiring harness (para 8-45, M109A2/M109A3; para 8-46, M109A4/M109A5).

K

1. Reconnect bulkhead-to-portable instrument panel wiring harness to driver's bulkhead.
2. Disconnect glow plug wait light lead from lead 486 of bulkhead-to-portable instrument panel wiring harness.
3. Place red lead of multimeter in lead 486 and black lead to ground.
4. Turn MASTER and GLOW PLUGS switches ON and check for voltage.
5. Turn MASTER and GLOW PLUGS switches OFF.

Is voltage present?

yes

no

Replace glow plug wait light lead (para 8-77).

Repair or replace lead 486 of bulkhead-to-portable instrument panel wiring harness (para 8-49).

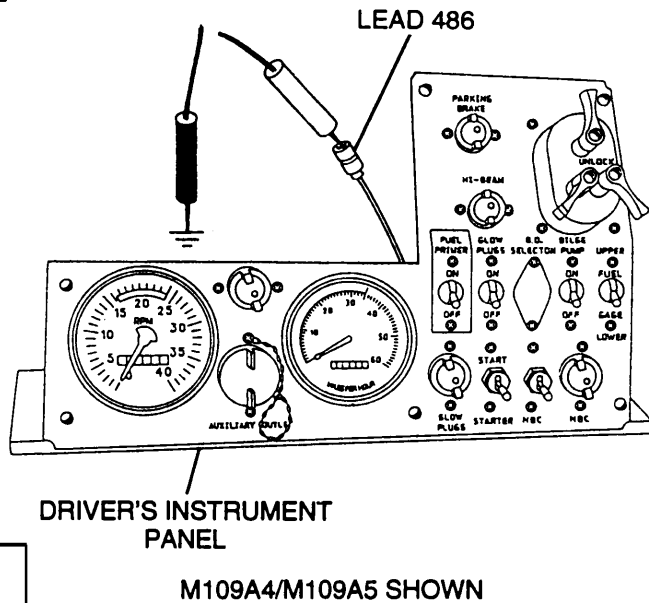
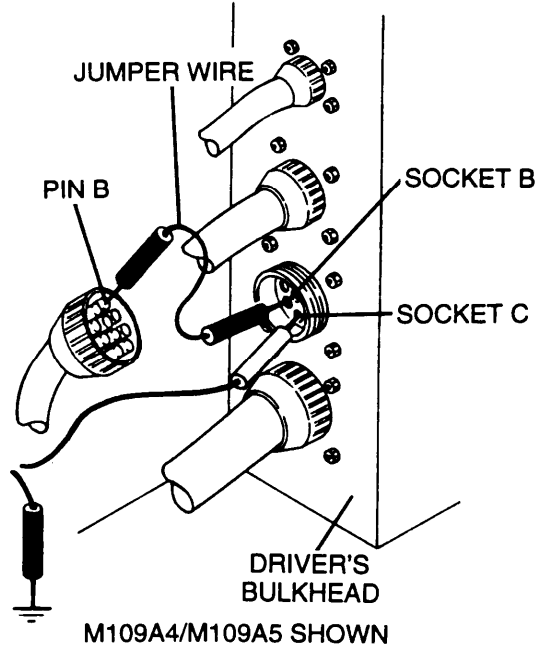

CONTINUED FROM STEP D

L

1. Reconnect powerplant wiring harness to glow plug controller.
2. Disconnect engine disconnect-to-bulkhead wiring harness from engine disconnect.
3. Place red lead of multimeter in socket C (lead 486A) and black lead to ground.
4. Turn MASTER and GLOW PLUGS switches ON and check for voltage.
5. Turn MASTER and GLOW PLUGS switches OFF.

Is voltage present?

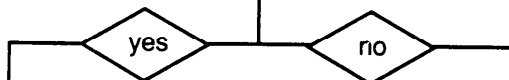
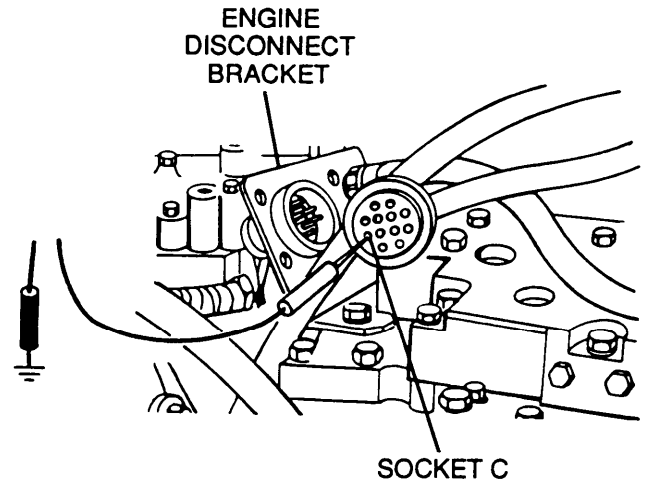

Repair or replace lead 486A of powerplant wiring harness (para 8-43, M109A2/M109A3; para 8-44, M109A4/M109A5).

M

1. Reconnect engine disconnect-to-bulkhead wiring harness to engine disconnect.
2. Disconnect bulkhead-to-portable instrument panel wiring harness from driver's bulkhead.
3. Place jumper wire from pin B to socket B (lead 400-459B) and black lead to ground.
4. Place red lead of multimeter on pin F (lead 486A) and black lead to ground.
5. Turn MASTER and GLOW PLUGS switches ON and check for voltage.
6. Turn MASTER and GLOW PLUGS switches OFF.

Is voltage present?

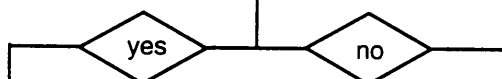
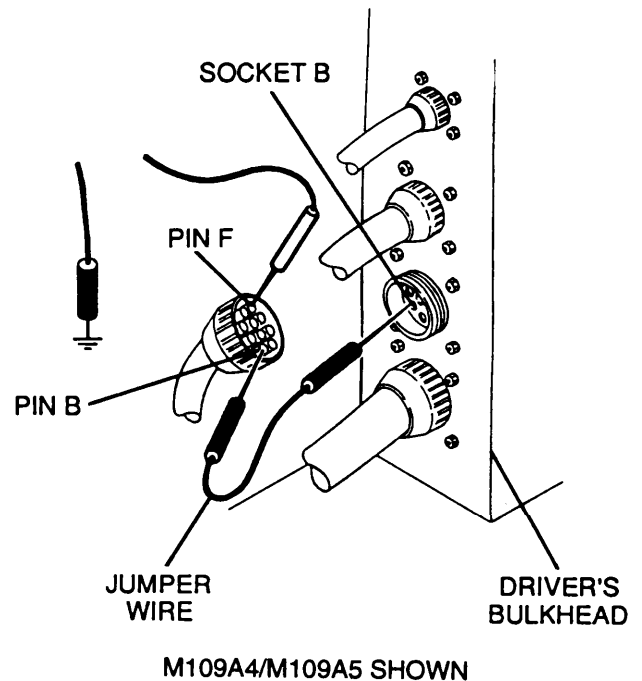

Repair or replace lead 486A of engine disconnect-to-bulkhead wiring harness (para 8-45, M109A2/M109A3; para 8-46, M109A4/M109A5).

Repair or replace lead 486A of bulkhead wiring harness (para 8-45, M109A2/M109A3; 8-46, M109A4/M109A5)

END OF TASK

3-3 TROUBLESHOOTING CHART — CONTINUED

- i. GLOW PLUGS CIRCUIT (ENGINE MODEL 7083-7391) — CONTINUED (2) GLOW PLUG SYSTEM FAILS TO OPERATE AT LOW AMBIENT TEMPERATURE; GLOW PLUG WAIT LIGHT OPERATES

INITIAL SETUP

<p>Tools General mechanic's tool kit (item 64, Appx H) Multimeters (item 36, Appx H) TA-1 probe kit (item 43, Appx H) (Long test leads may be needed for some tests; 16 AWG wire may be used as an extension.)</p>	<p>Personnel Required Two</p> <p>Equipment Conditions Transmission access door open (TM 9-2350-311-10) Air intake grille open (TM 9-2350-311-10)</p>
--	---

- A**
1. Disconnect glow plug controller-to-starter wiring harness from glow plug controller.
 2. Place red lead of multimeter in socket B (lead 3) and black lead to ground.
 3. Turn MASTER switch ON and check for voltage.
 4. Place red lead of multimeter in socket E (lead 2) and black lead to ground.
 5. Check for voltage.
 6. Place red lead of multimeter in socket F (lead 1) and black lead to ground.
 7. Check for voltage.
 8. Turn MASTER switch OFF.

Is voltage present in all locations?

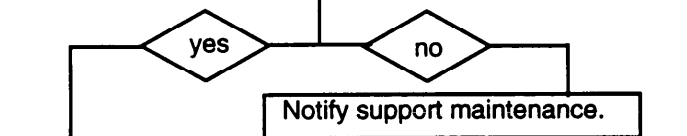

- B**
1. Reconnect glow plug controller-to-starter wiring harness to glow plug controller.
 2. Disconnect glow plug wiring harness from glow plug controller.
 3. Place red lead of multimeter in pin A (lead 1L) and black lead to ground.
 4. Turn MASTER and GLOW PLUGS switches ON and check for voltage.
 5. Repeat steps 3 and 4 for pins B thru H (leads 2L, 3L, 4L, 4R, 3R, 2R, and 1R).
 6. Turn MASTER and GLOW PLUGS switches OFF.

Is voltage present in all locations?

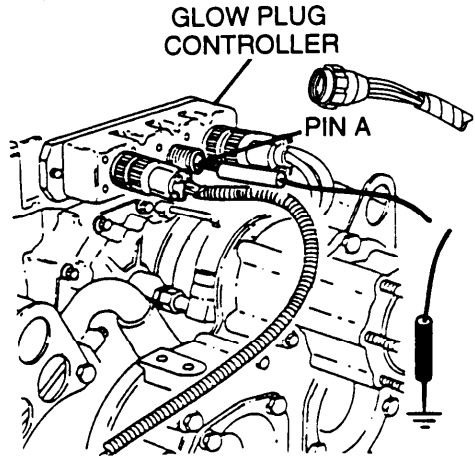
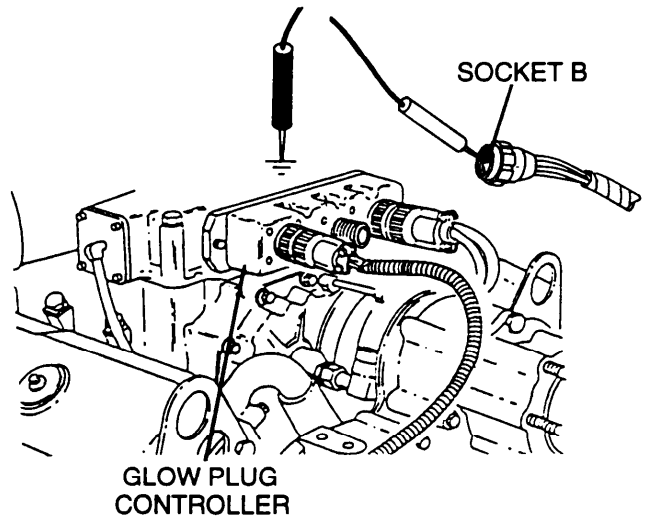
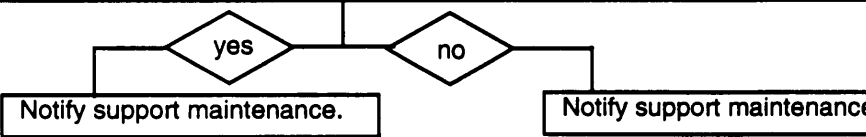

j. MASTER WARNING LIGHT (STEERING SHAFT)
CIRCUIT

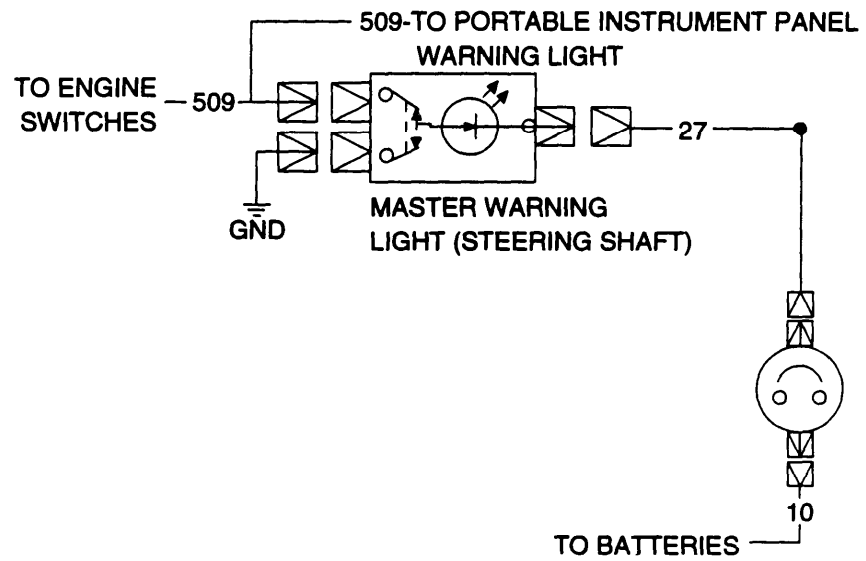

3-3 TROUBLESHOOTING CHART — CONTINUED

- i. MASTER WARNING LIGHT (STEERING SHAFT)
CIRCUIT — CONTINUED
-

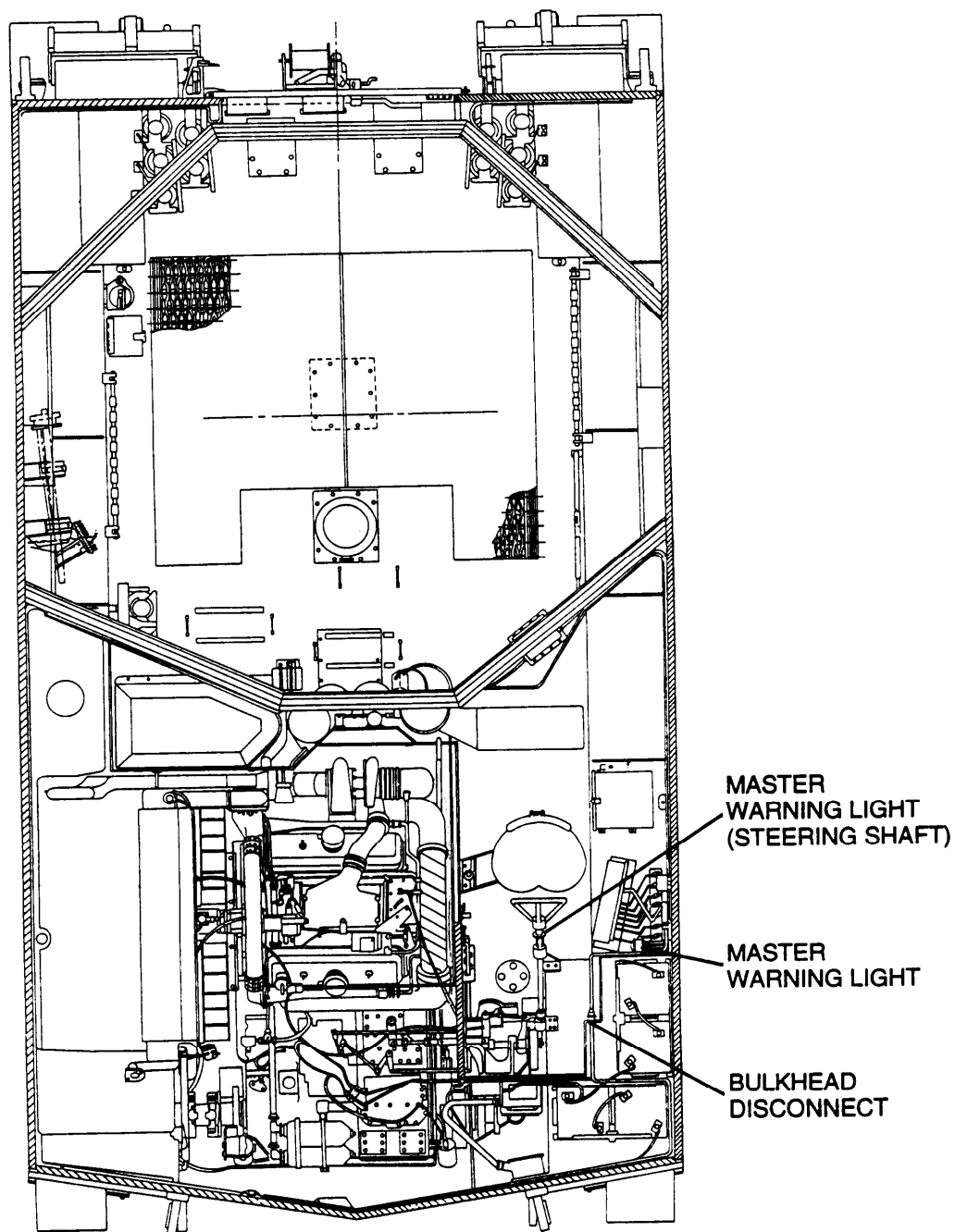

PICTORIAL VIEW

(1) MASTER WARNING LIGHT (STEERING SHAFT)
FAILS TO OPERATE; OTHER MASTER WARNING
LIGHT(S) OPERATE PROPERLY

INITIAL SETUP

Tools

- General mechanic's tool kit (item 64, Appx H)
- Multimeters (item 36, Appx H)
- TA-1 probe kit (item 43, Appx H)
(Long test leads may be needed for some tests;
16 AWG wire may be used as an extension.)

A

1. Disconnect lead 27 from master warning light (steering shaft).
2. Place red lead of multimeter in lead 27 and black lead to ground.
3. Turn MASTER switch ON and check for voltage.
4. Turn MASTER switch OFF.

Is voltage present?

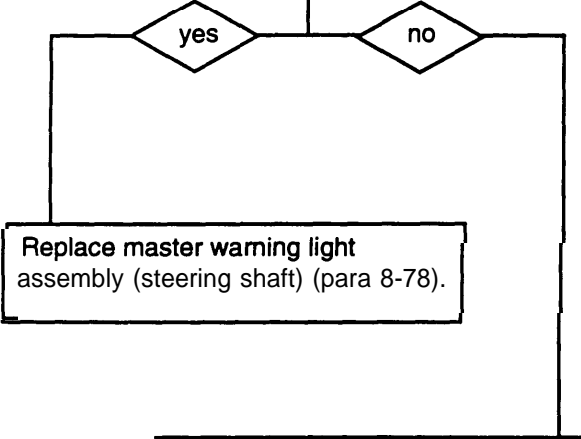
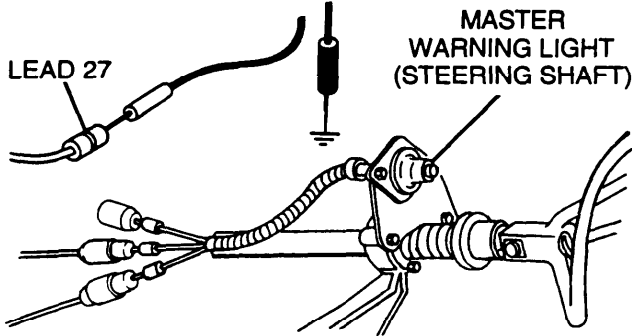

CONTINUED ON NEXT PAGE

3-3 TROUBLESHOOTING CHART — CONTINUED

- j. MASTER WARNING LIGHT (STEERING SHAFT) (1) MASTER WARNING LIGHT (STEERING SHAFT CIRCUIT — CONTINUED
 FAILS TO OPERATE; OTHER MASTER WARNING LIGHT(S) OPERATE PROPERLY — CONTINUED

CONTINUED FROM STEP A

- B**
1. Reconnect lead 27 to master warning light (steering shaft).
 2. Disconnect lead 27 from circuit breaker output.
 3. Place red lead of multimeter in circuit breaker output and black lead to ground.
 4. Turn MASTER switch ON and check for voltage.
 5. Turn MASTER switch OFF.
- Is voltage present?

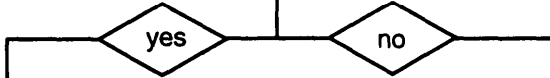

Repair or replace lead 27 of bulkhead-to-portable instrument panel wiring harness (para 8-49).

- C**
1. Reconnect lead 27 to circuit breaker output.
 2. Disconnect lead 10 from circuit breaker input.
 3. Place red lead of multimeter in lead 10 and black lead to ground.
 4. Turn MASTER switch ON and check for voltage.
 5. Turn MASTER switch OFF.
- Is voltage present?



Replace circuit breaker (para 8-33, M109A2/M109A3; para 8-34, M109A4/M109A5).

Troubleshoot master relay circuit (para 3-3b).

END OF TASK

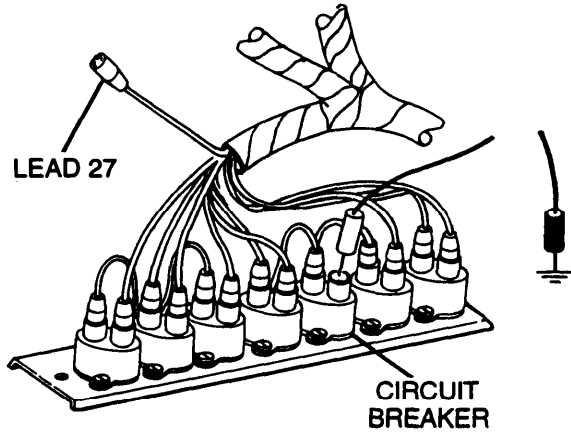

M109A2/M109A3 SHOWN

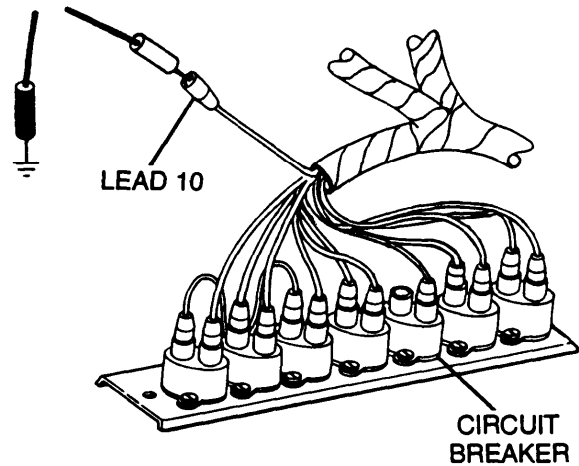

M109A2/M109A3 SHOWN

(2) MASTER WARNING LIGHT (STEERING SHAFT FAILS TO OPERATE DURING PRESS-TO-TEST; OTHER MASTER WARNING LIGHTS OPERATE PROPERLY

INITIAL SETUP

Tools

General mechanic's tool kit (item 64, Appx H)
 Multimeters (item 36, Appx H)
 TA-1 probe kit (item 43, Appx H)
 (Long test leads may be needed for some tests;
 16 AWG wire may be used as an extension.)

- A**
1. Disconnect lead GND from master warning light (steering shaft).
 2. Place red lead of multimeter on lead GND and black lead to ground.
 3. Check for continuity.
- Is continuity present?

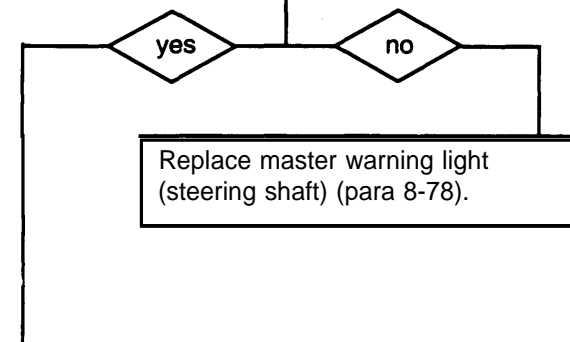

CONTINUED ON NEXT PAGE

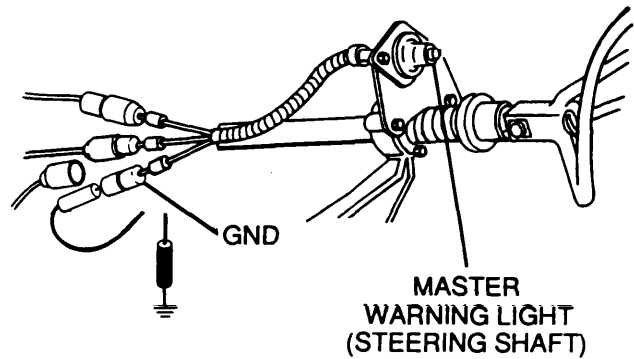

3-3 TROUBLESHOOTING CHART — CONTINUED

- j. MASTER WARNING LIGHT (STEERING SHAFT) (2) MASTER WARNING LIGHT (STEERING SHAFT) CIRCUIT—CONTINUED FAILS TO OPERATE DURING PRESS-TO-TEST; OTHER MASTER WARNING LIGHTS OPERATE PROPERLY — CONTINUED

CONTINUED FROM STEP A

- B**
1. Reconnect lead GND to master warning light (steering shaft).
 2. Disconnect lead 27 from master warning light (steering shaft).
 3. Place red lead of multimeter in lead 27 and black lead to ground.
 4. Turn MASTER switch ON and check for voltage.
 5. Turn MASTER switch OFF.

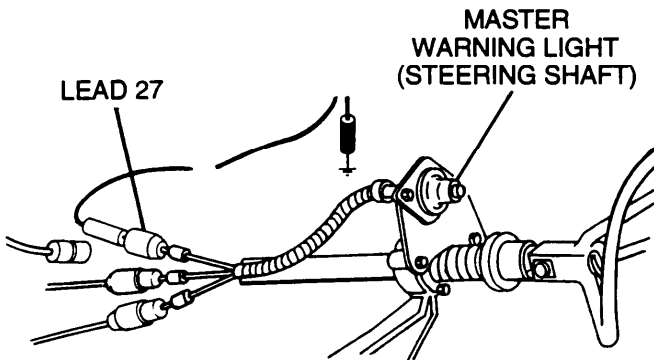

Is voltage present?



Repair or replace lead 27 of bulkhead-to-portable instrument panel wiring harness (para 8-49).

Replace master warning light (steering shaft) (para 8-78).

END OF TASK

k. MASTER WARNING LIGHT (PORTABLE INSTRUMENT PANEL) CIRCUIT

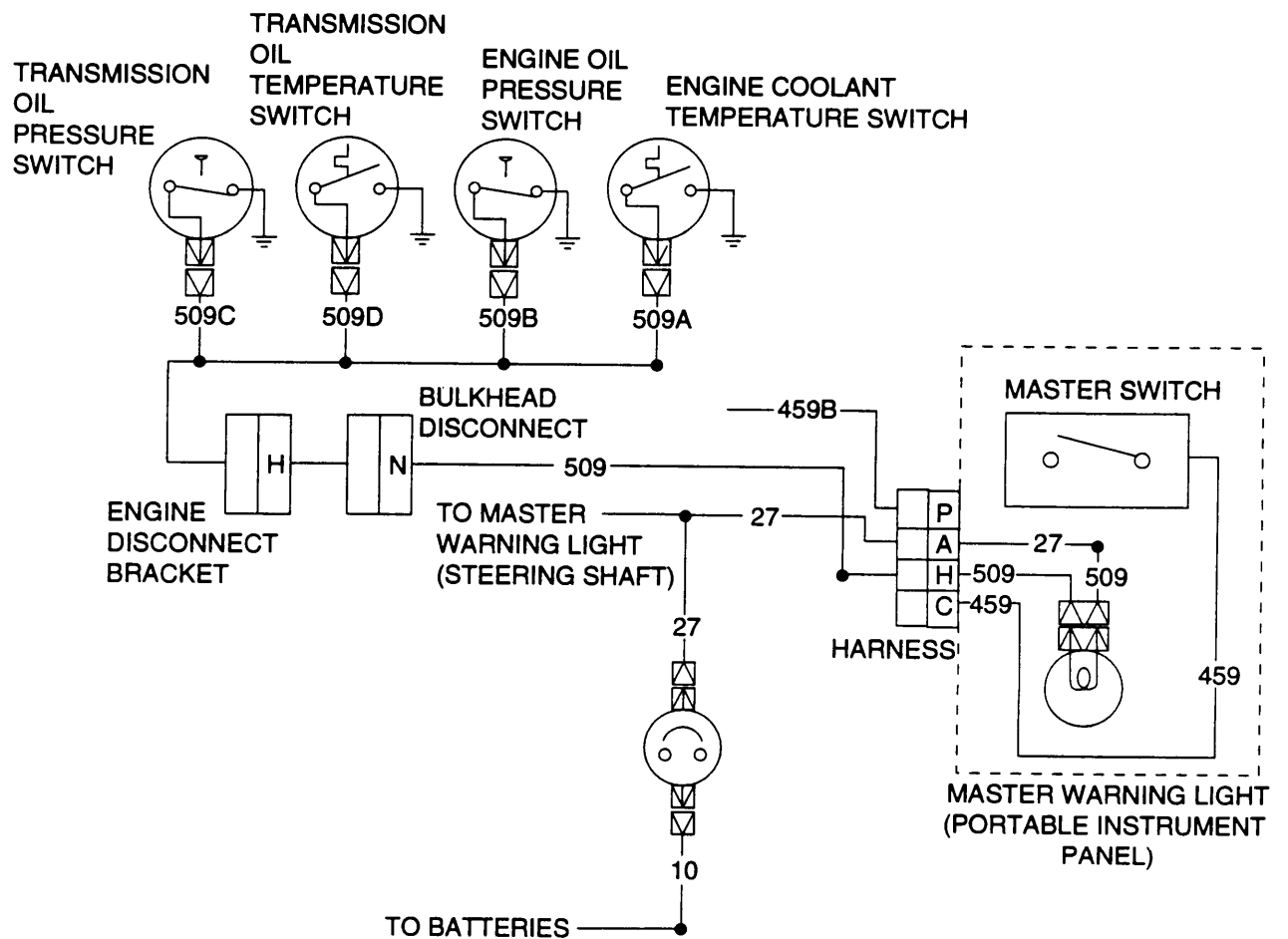

3-3 TROUBLESHOOTING CHART — CONTINUED

k. MASTER WARNING LIGHT (PORTABLE INSTRUMENT PANEL) CIRCUIT — CONTINUED

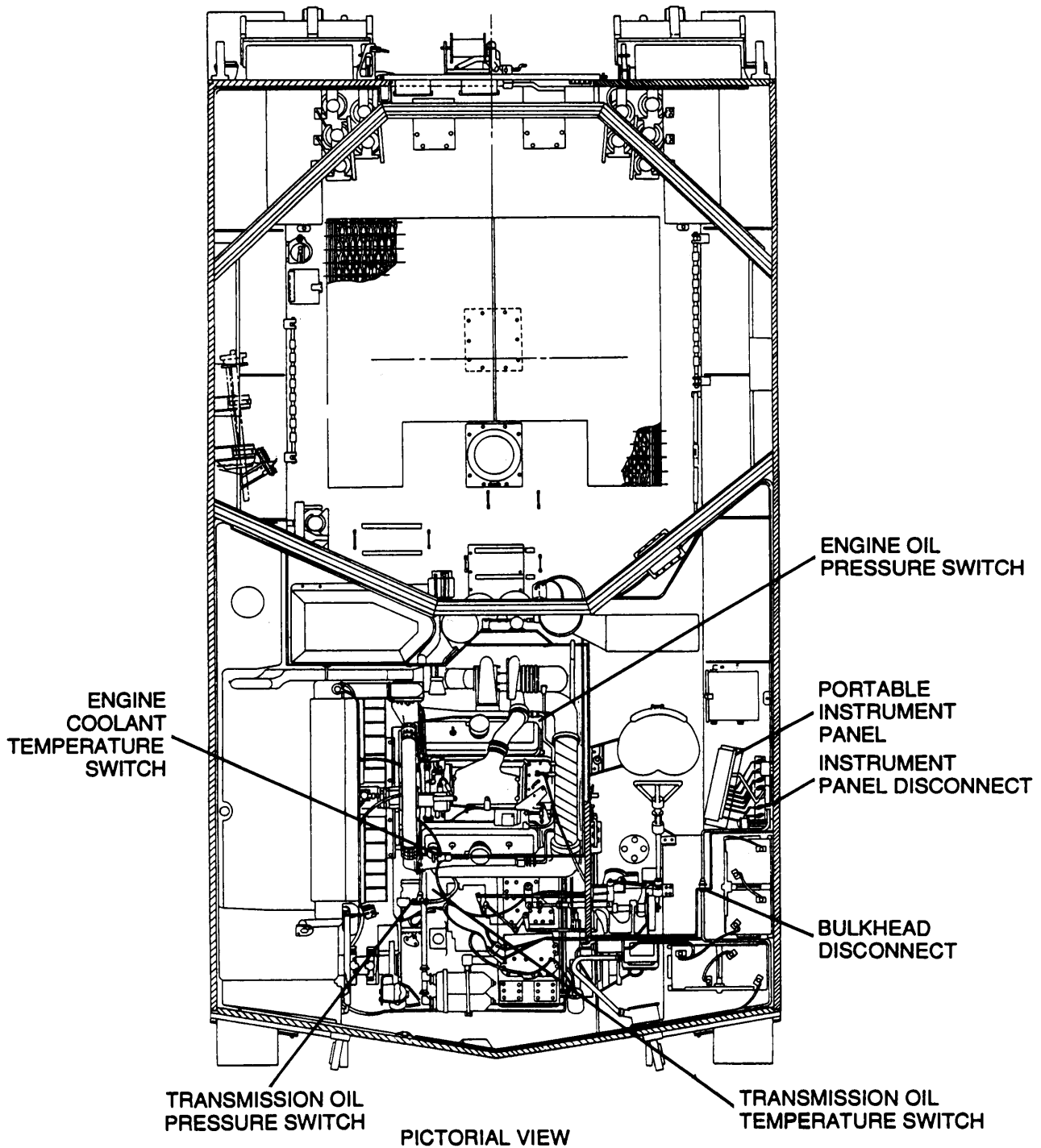

(1) MASTER WARNING LIGHT FAILS TO OPERATE WITH MASTER SWITCH ON AND ENGINE OFF

INITIAL SETUP

Tools

General mechanic's tool kit (item 64, Appx H)
 Multimeters (item 36, Appx H)
 TA-1 probe kit (item 43, Appx H)
 (Long test leads may be needed for some tests;
 16 AWG wire may be used as an extension.)

Personnel Required

Two

Equipment Conditions

Transmission access doors open (TM 9-2350-311-10)
 Engine access grille open (TM 9-2350-311-10)

- A**
1. Remove LED from MASTER WARNING light.
 2. Place red lead of multimeter in center contact and black lead to ground.
 3. Turn MASTER switch ON and check for voltage.
 4. Turn MASTER switch OFF.

Is voltage present?

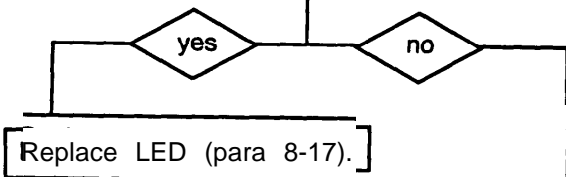

- B**
1. Disconnect connector from MASTER WARNING light.
 2. Place red lead of multimeter in lead 27/509 and black lead to ground.
 3. Turn MASTER switch ON and check for voltage.
 4. Turn MASTER switch OFF.

Is voltage present?

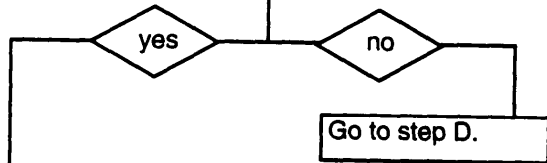

CONTINUED ON NEXT PAGE

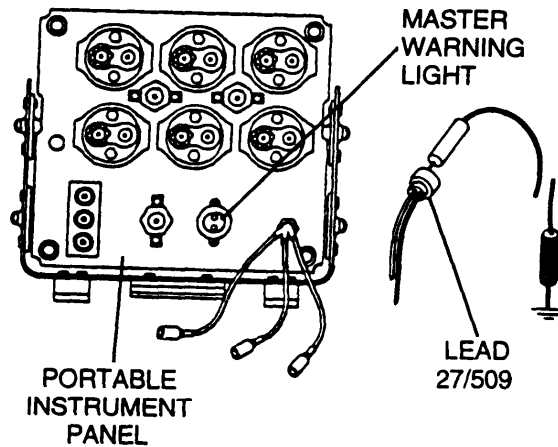
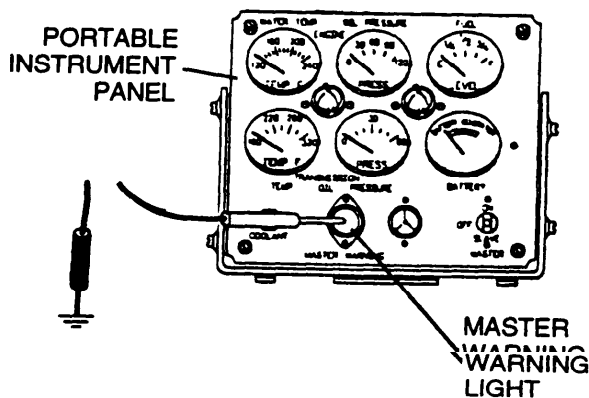

3-3 TROUBLESHOOTING CHART — CONTINUED

k. MASTER WARNING LIGHT (PORTABLE INSTRUMENT PANEL) CIRCUIT — CONTINUED

(1) MASTER WARNING LIGHT FAILS TO OPERATE WITH MASTER SWITCH ON AND ENGINE OFF — CONTINUED

CONTINUED FROM STEP B

C 1. Place red lead of multimeter in lead 509 and black lead to ground.
2. Check for continuity.

Is continuity present?

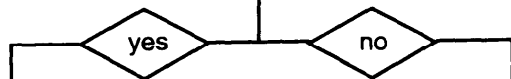

Replace MASTER WARNING light (para 8-17).

D 1. Reconnect connector to MASTER WARNING light.
2. Disconnect portable instrument panel wiring harness from portable instrument panel disconnect.
3. Place jumper wires from socket C to pin C (lead 459) and socket P to pin P (lead 459B).
4. Place red lead of multimeter in socket A (lead 27) and black lead to ground.
5. Turn MASTER switch ON and check for voltage.
6. Turn MASTER switch OFF.

Is voltage present?

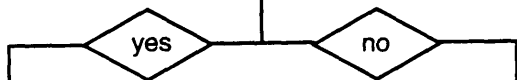

Repair or replace lead 27/509 of portable instrument panel wiring harness (para 8-57).

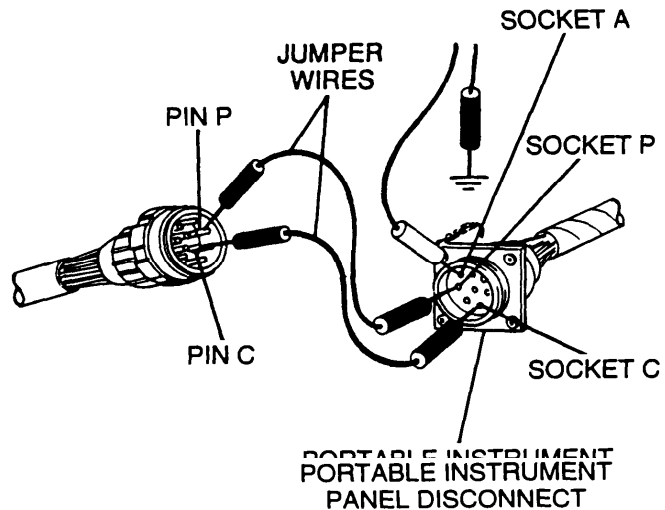
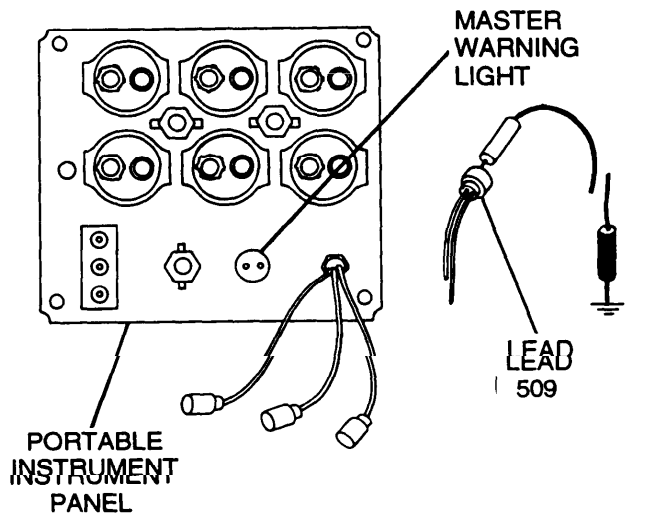

CONTINUED ON NEXT PAGE

CONTINUED FROM STEP D

- E**
1. Reconnect portable instrument panel wiring harness to portable instrument panel disconnect.
 2. Disconnect lead 27 from circuit breaker output.
 3. Place red lead of multimeter in circuit breaker output and black lead to ground.
 4. Turn MASTER switch ON and check for voltage.
 5. Turn MASTER switch OFF.

Is voltage present?

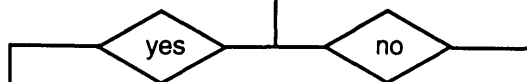

Repair or replace lead 27 of portable instrument panel wiring harness (para 8-57).

- F**
1. Reconnect lead 27 to circuit breaker output.
 2. Disconnect lead 10 from circuit breaker input.
 3. Place red lead of multimeter in lead 10 and black lead to ground.
 4. Turn MASTER switch ON and check for voltage.
 5. Turn MASTER switch OFF.

Is voltage present?

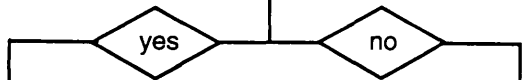

Troubleshoot master relay circuit (para 3-3b).

Replace circuit breaker (para 8-33, M109A2/M109A3; 8-34, M109A4/M109A5).

END OF TASK

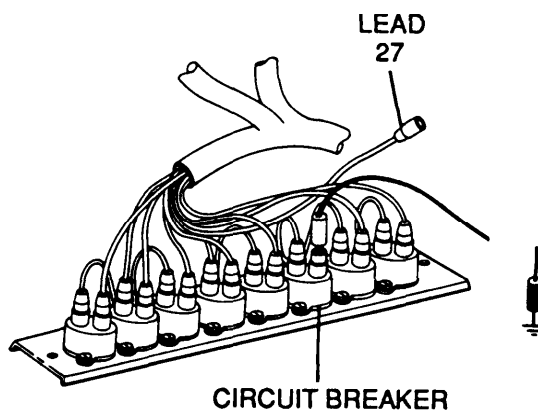

CIRCUIT BREAKER

M109A4/M109A5 SHOWN

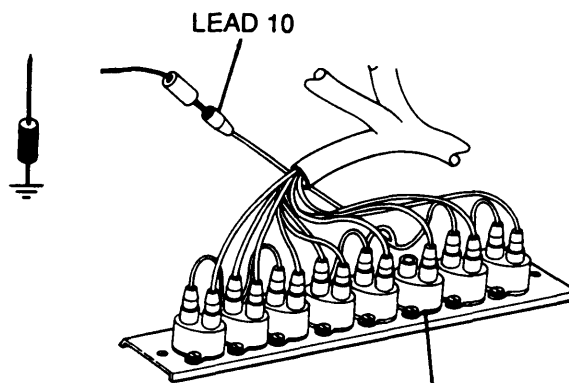

CIRCUIT BREAKER

M109A4/M109A5 SHOWN

3-3 TROUBLESHOOTING CHART — CONTINUED

k. MASTER WARNING LIGHT (PORTABLE INSTRUMENT PANEL) CIRCUIT — CONTINUED

(2) MASTER WARNING LIGHT IS LIT; EVERYTHING ELSE APPEARS NORMAL

INITIAL SETUP

Tools

General mechanic's tool kit (item 64, Appx H)
 Multimeters (item 36, Appx H)
 TA-1 probe kit (item 43, Appx H)
 (Long test leads may be needed for some tests;
 16 AWG wire may be used as an extension.)

Personnel Required

Two

Equipment Conditions

Transmission access doors open (TM 9-2350-311-10)
 Engine compartment access panel open
 (TM 9-2350-311-10)

- A**
1. Turn MASTER switch ON, start engine and disconnect lead 509C from transmission oil pressure switch.
 2. Check MASTER WARNING light.
 3. Turn engine and MASTER switch OFF.

Is MASTER WARNING light lit?

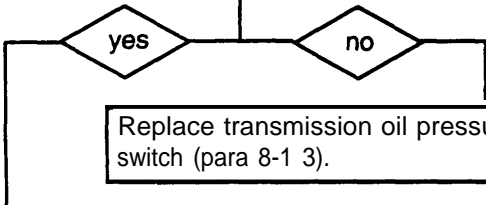

- B**
1. Reconnect lead 509C to transmission oil pressure switch.
 2. Turn MASTER switch ON, start engine and disconnect lead 509D from transmission high oil temperature switch.
 3. Check MASTER WARNING light.
 4. Turn engine and MASTER switch OFF.

Is MASTER WARNING light lit?

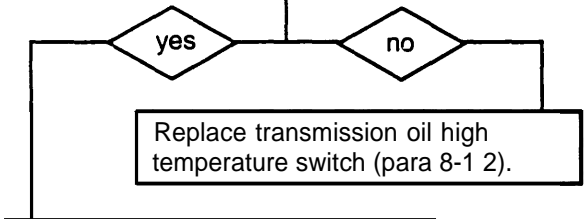

CONTINUED ON NEXT PAGE

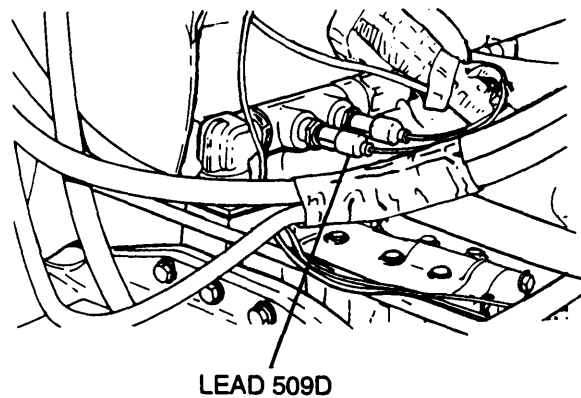
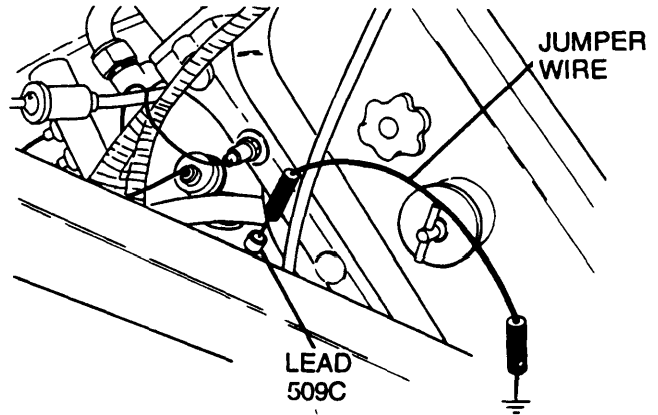

CONTINUED FROM STEP B

- C**
- 1. Reconnect lead 509D to transmission oil high temperature switch.
 - 2. Turn MASTER switch ON, start engine, and disconnect lead 509B from engine oil low pressure switch.
 - 3. Check MASTER WARNING light.
 - 4. Turn engine and MASTER switch OFF.
- Is MASTER WARNING light lit?

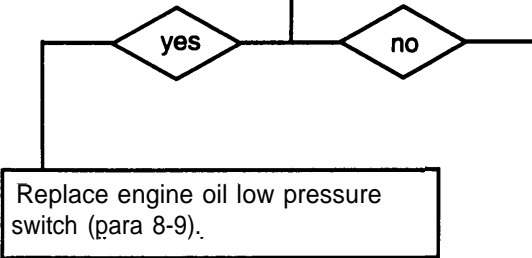

- D**
- 1. Reconnect lead 509B to engine oil low pressure switch.
 - 2. Turn MASTER switch ON, start engine, and disconnect lead 509A from engine coolant high temperature switch.
 - 3. Check MASTER WARNING light.
 - 4. Turn engine and MASTER switch OFF.
- Is MASTER WARNING light lit?

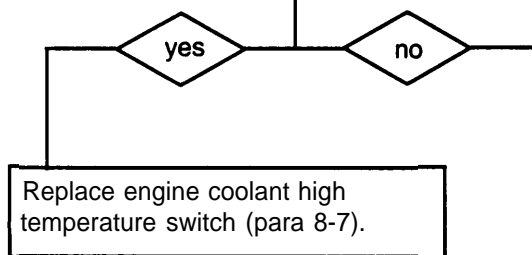

CONTINUED ON NEXT PAGE

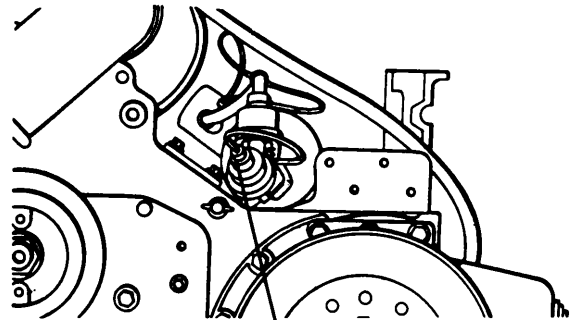

LEAD 509B

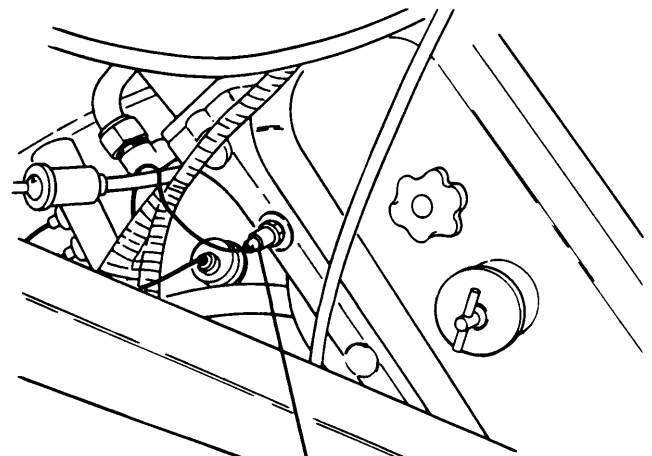

LEAD 509A

3-3 TROUBLESHOOTING CHART — CONTINUED

k. MASTER WARNING LIGHT (PORTABLE INSTRUMENT PANEL) CIRCUIT — CONTINUED

(2) MASTER WARNING LIGHT IS LIT; EVERYTHING ELSE APPEARS NORMAL — CONTINUED

CONTINUED FROM STEP D

- | | |
|-------------------------------------|--|
| E | <ol style="list-style-type: none"> 1. Reconnect lead 509A to engine coolant high temperature switch. 2. Disconnect engine disconnect bracket-to-bulkhead wiring harness from driver's bulkhead. 3. Place a jumper wire from pin B to socket B (lead 400-459B). 4. Turn MASTER switch ON and start engine. 5. Check MASTER WARNING light. 6. Turn engine and MASTER switch OFF. |
| <p>Is MASTER WARNING light lit?</p> | |

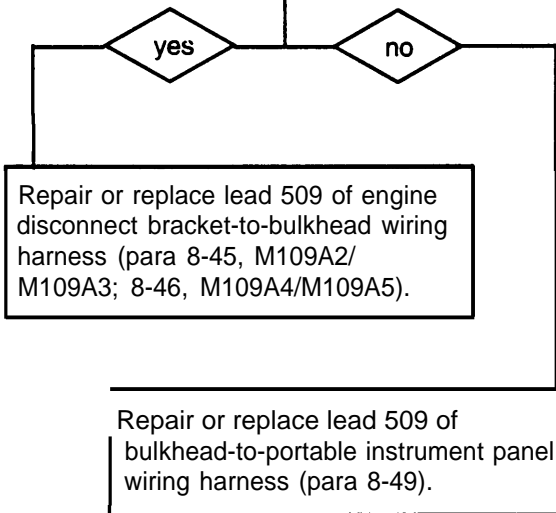
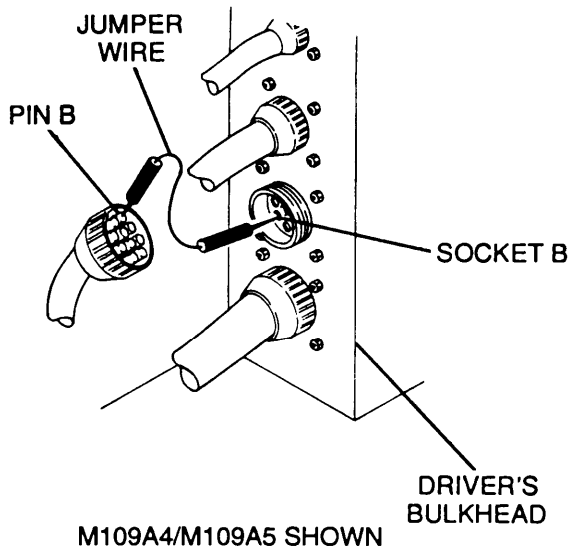

END OF TASK

AIR CLEANER BLOWER MOTOR CIRCUIT

NOTE

Although air cleaner blower motor circuit differs slightly between M109A2, M109A3, M109A4, and M109A5 Howitzers, the following troubleshooting procedure applies to all vehicles.

The air cleaner blower motor system consists of the blower motor, the air cleaner blower motor relay, air cleaner generator system relay switch, neutral safety switch, circuit breakers, and associated wiring. The relationship of these components is shown in the diagram below.

When the MASTER switch is turned ON, 24 Vdc is supplied to the air cleaner blower motors, MASTER relay, and circuit breakers. The 24 Vdc from the circuit breaker goes to the air cleaner blower motors. This allows the air cleaner blower motor to be energized.

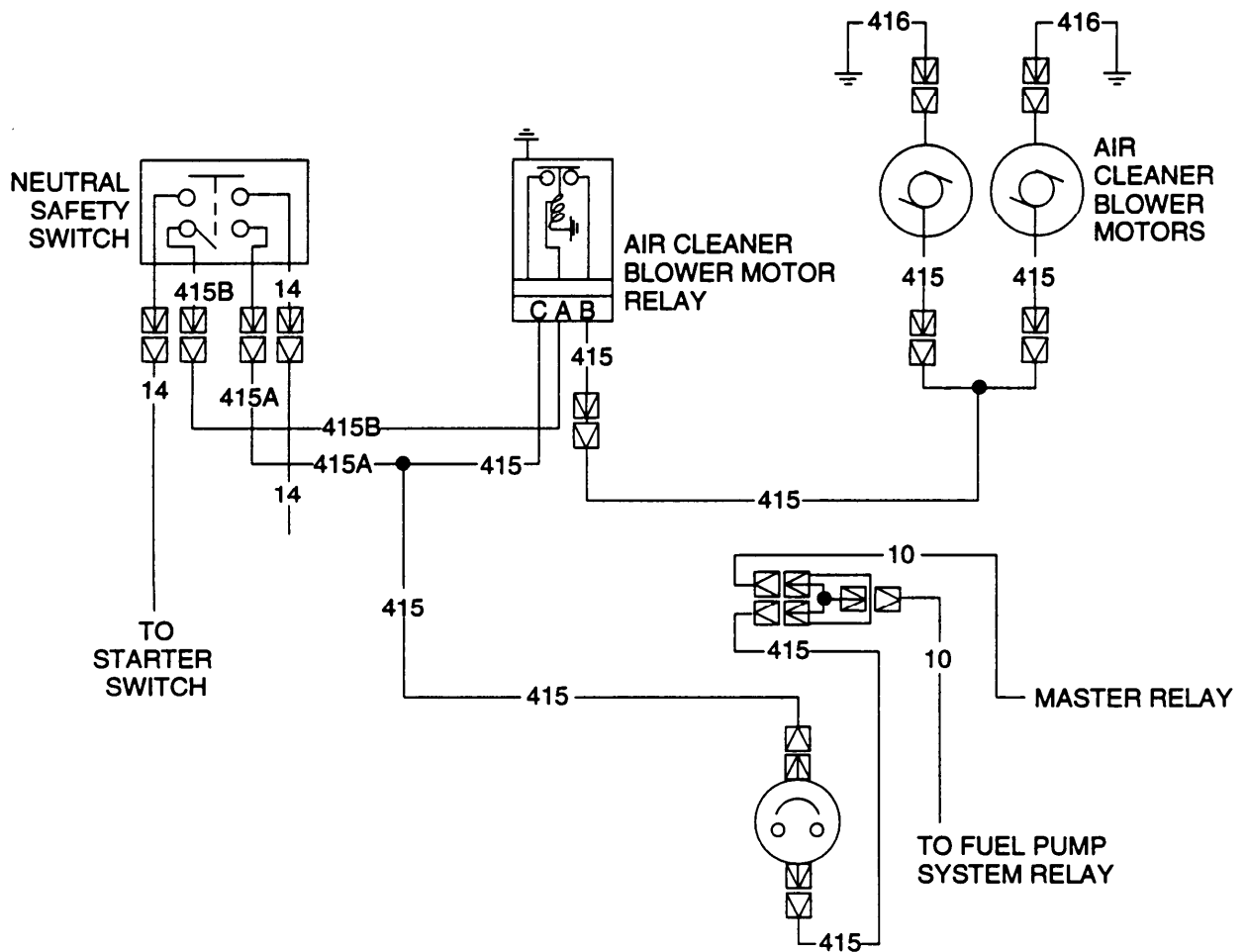

M109A2/M109A4/M109A5

3-3 TROUBLESHOOTING CHART — CONTINUED

AIR CLEANER BLOWER MOTOR CIRCUIT —
CONTINUED

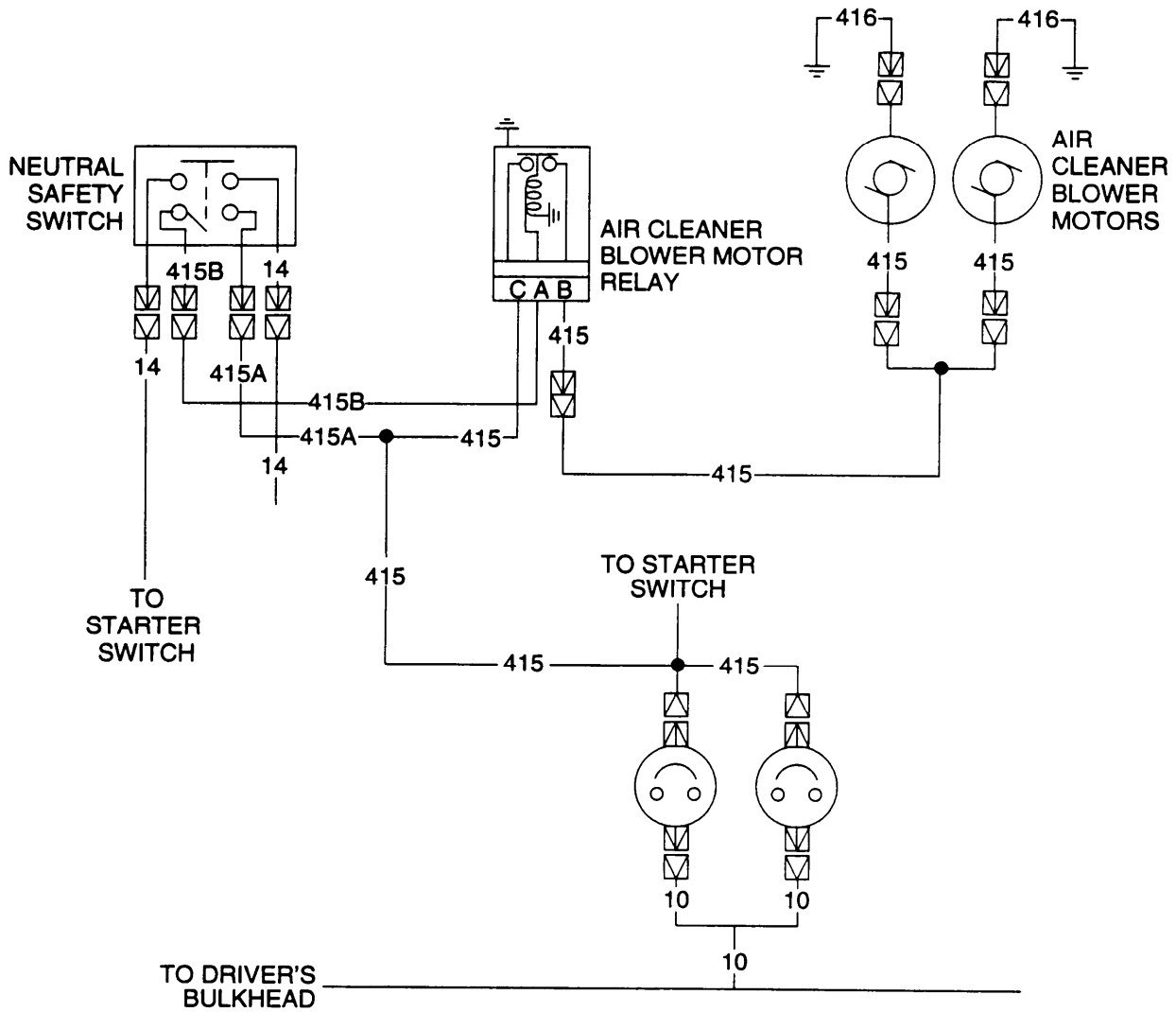

M109A3

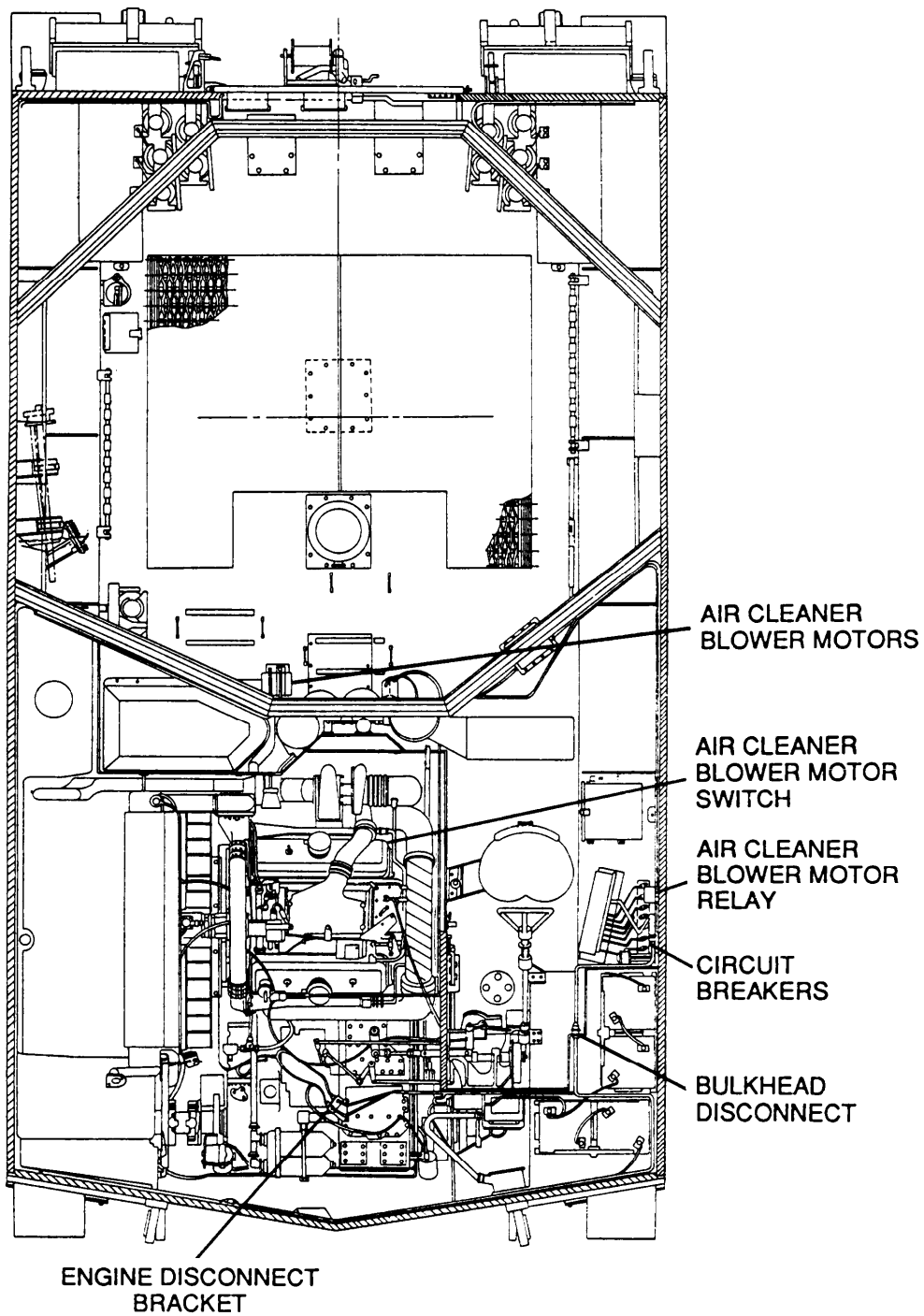

PICTORIAL VIEW

3-3 TROUBLESHOOTING CHART — CONTINUED

- I. AIR CLEANER BLOWER MOTOR CIRCUIT — CONTINUED (1) BLOWER MOTORS FAIL TO OPERATE WHEN VEHICLE IS IN DRIVE

INITIAL SETUP

Tools

General mechanic's tool kit (item 64, Appx H)
 Multimeters (item 36, Appx H)
 TA-1 probe kit (item 43, Appx H)
 (Long test leads may be needed for some tests;
 16 AWG wire may be used as an extension.)

Personnel Required

Two

Equipment Conditions

Engine compartment access cover removed (para 11-5)
 Transmission left access door open (TM 9-2350-311-10)
 Air intake grille open (TM 9-2350-311-10)

NOTE

Vehicle must be in gear in order for fans to operate. All steps require this condition unless otherwise specified.

- A**
1. Disconnect lead 415 from each blower motor.
 2. Place red lead of multimeter in lead 415 and black lead to ground.
 3. Turn MASTER switch ON, run engine at 1000 rpm, and check for voltage.
 4. Turn MASTER switch and engine OFF.

Is voltage present?

yes

no

Replace air cleaner blower motors
 (para 8-36).

CONTINUED ON NEXT PAGE

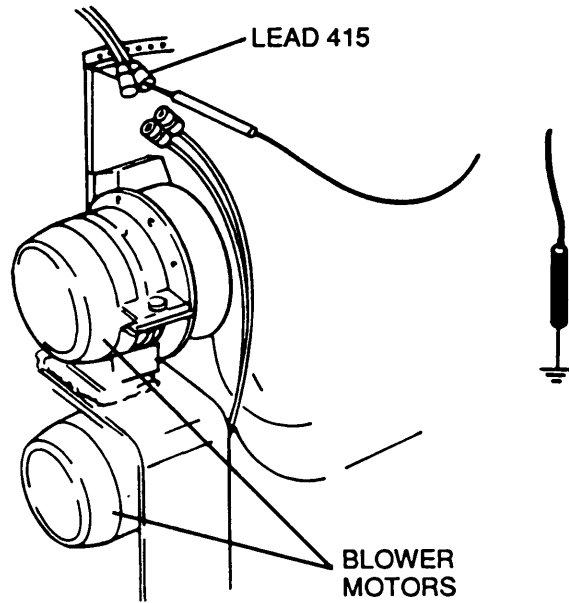

CONTINUED FROM STEP A

- B**
1. Reconnect lead 415 to each blower motor.
 2. Disconnect lead 415 of accessory control box wiring harness from air cleaner blower lead assembly connector.
 3. Place red lead of multimeter on lead 415 (from blower relay) and black lead to ground.
 4. Turn MASTER switch ON and check for voltage.
 5. Turn MASTER switch OFF.

Is voltage present?



Repair or replace lead 415 of accessory control box wiring harness (para 8-52).

- C**
1. Reconnect lead 415 to air cleaner blower lead assembly.
 2. Disconnect air cleaner blower lead assembly from air cleaner blower relay.
 3. Place red lead of multimeter in socket A (lead 415B) and black lead to ground.
 4. Turn MASTER switch ON and check for voltage.
 5. Turn MASTER switch OFF.

Is voltage present?

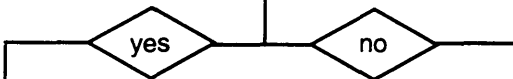

Go to step F.

CONTINUED ON NEXT PAGE

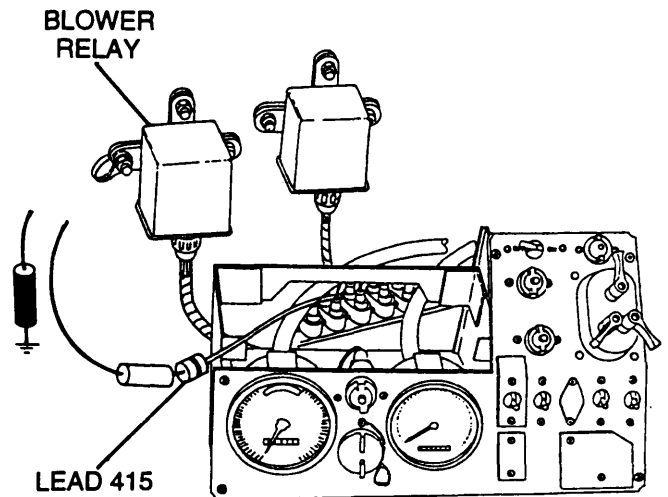

M109A4/M109A5
(ENGINE MODEL 7983-7396) SHOWN

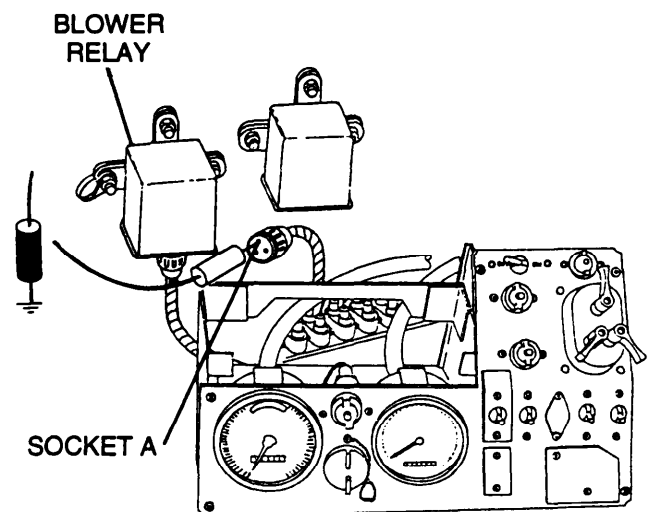

M109A4/M109A5
(ENGINE MODEL 7083-7396) SHOWN

3-3 TROUBLESHOOTING CHART — CONTINUED

I. AIR CLEANER BLOWER MOTOR CIRCUIT — CONTINUED

(1) BLOWER MOTORS FAIL TO OPERATE WHEN VEHICLE IS IN DRIVE — CONTINUED

CONTINUED FROM STEP C

D

1. Place red lead of multimeter in socket C (lead 415) and black lead to ground.
2. Turn MASTER switch ON and check for voltage.
3. Turn MASTER switch OFF.

Is voltage present?

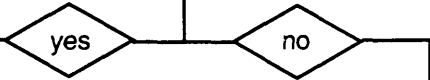

Reconnect air cleaner blower lead assembly and go to step G.

E

1. Place a jumper wire from socket B to socket C (lead 415).
2. Turn MASTER switch ON and check air cleaner blower motors for operation.
3. Turn MASTER switch OFF.

Do air cleaner blower motors operate?

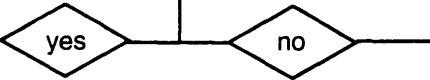

Repair or replace lead 415 of air cleaner blower lead assembly (para 8-72).

Replace air cleaner blower relay (para 8-36).

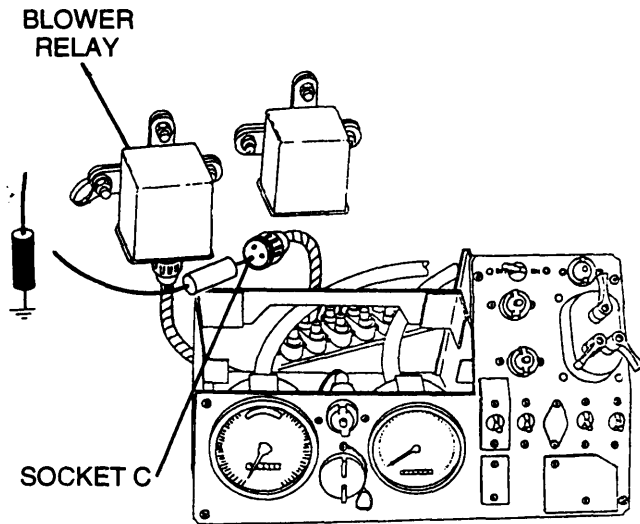

M109A4/M109A5
(ENGINE MODEL 7083-7396) SHOWN

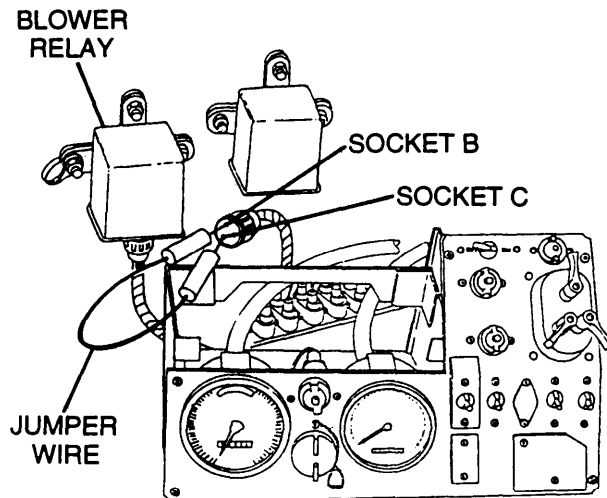

M109A4/M109A5
(ENGINE MODEL 7083-7396) SHOWN

CONTINUED FROM STEP C

F

1. Reconnect air cleaner blower lead assembly to air cleaner blower relay.
2. Disconnect lead 415A from neutral safety switch.
3. Place red lead of multimeter in lead 415A and black lead to ground.
4. Turn MASTER switch ON and check for voltage.
5. Turn MASTER switch OFF.

Is voltage present?

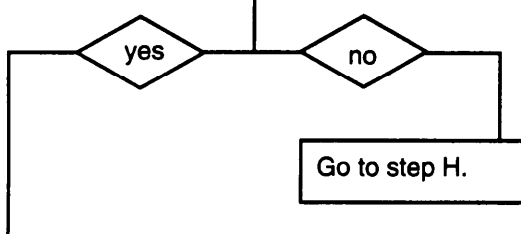

G

1. Reconnect lead 415A to neutral safety switch.
2. Disconnect lead 415B from neutral safety switch.
3. Place red lead of multimeter in lead 415B and black lead to ground.
4. Turn MASTER switch ON and check for voltage.
5. Turn MASTER switch OFF.

Is voltage present?

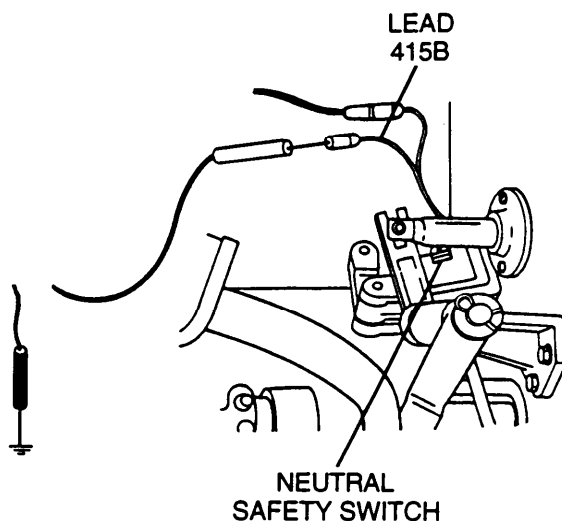
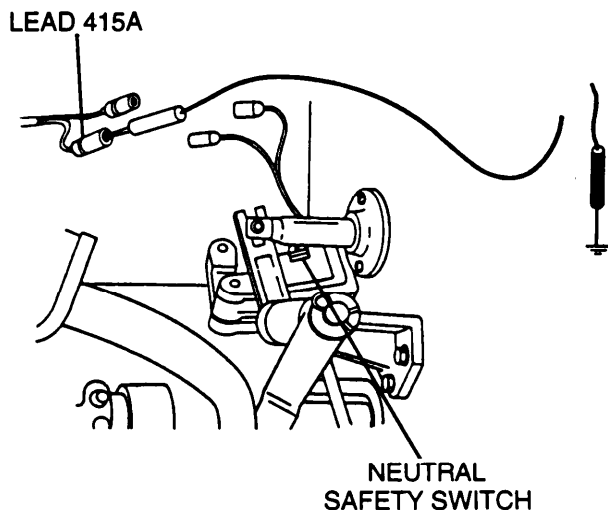
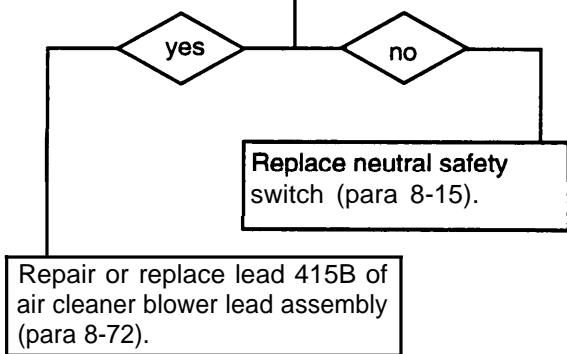

3-3 TROUBLESHOOTING CHART — CONTINUED

I. AIR CLEANER BLOWER MOTOR CIRCUIT — CONTINUED

(1) BLOWER MOTORS FAIL TO OPERATE WHEN VEHICLE IS IN DRIVE — CONTINUED

CONTINUED FROM STEP F

- H**
1. Reconnect lead 415A to neutral safety switch.
 2. Disconnect lead 415 from circuit breaker output.
 3. Place red lead of multimeter in circuit breaker output and black lead to ground.
 4. Turn MASTER switch ON and check for voltage.
 5. Turn MASTER switch OFF.

Is voltage present?

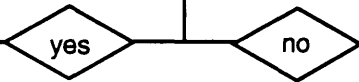

Repair or replace lead 415/415A of air cleaner blower lead assembly (para 8-72).

- I**
1. Reconnect lead 415 to circuit breaker output.
 2. Disconnect lead 415 from circuit breaker input.
 3. Place red lead of multimeter in lead 415 and black lead to ground.
 4. Turn MASTER switch ON and check for voltage.
 5. Turn MASTER switch OFF.

Is voltage present?

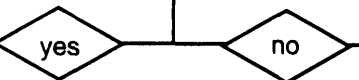

Replace circuit breaker (para 8-34).

CONTINUED ON NEXT PAGE

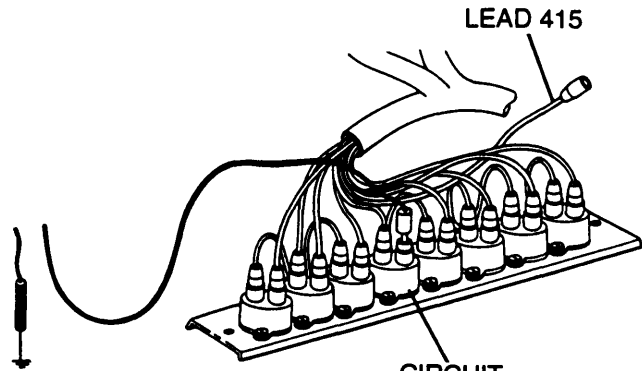

M109A4/M109A5 SHOWN

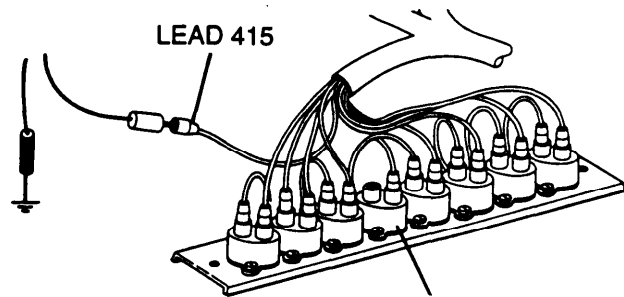

M109A4/M109A5 SHOWN

CONTINUED FROM STEP I

- J**
1. Reconnect lead 415 to circuit breaker input.
 2. Disconnect lead 415 from "Y" connector near circuit breaker.
 3. Place red lead of multimeter on "Y" connector and black lead to ground.
 4. Turn MASTER switch ON and check for voltage.
 5. Turn MASTER switch OFF.
- Is voltage present?

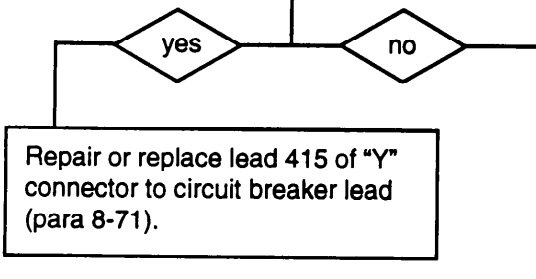

- K**
1. Reconnect lead 415 to "Y" connector.
 2. Disconnect lead 10 of power lead from "Y" connector.
 3. Place red lead of multimeter in lead 10 and black lead to ground.
 4. Turn MASTER switch ON and check for voltage.
 5. Turn MASTER switch OFF.
- Is voltage present?

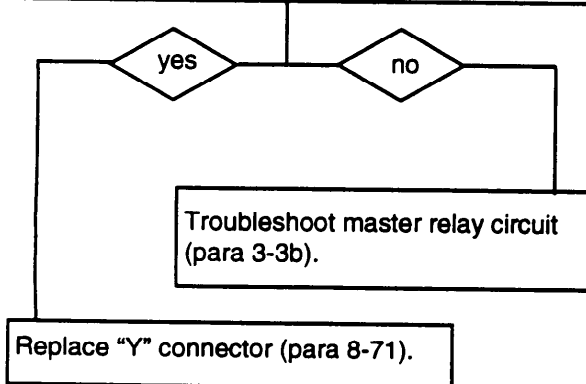

END OF TASK

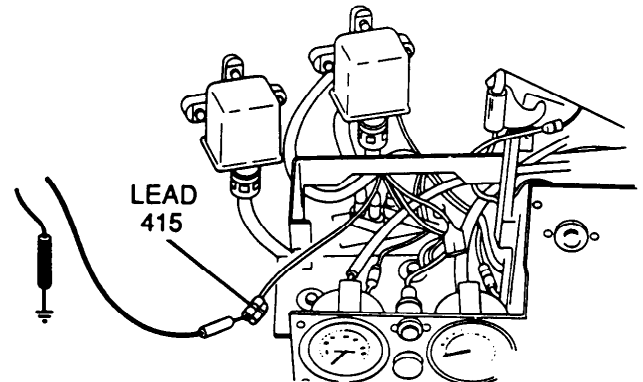

M109A4/M109A5 SHOWN

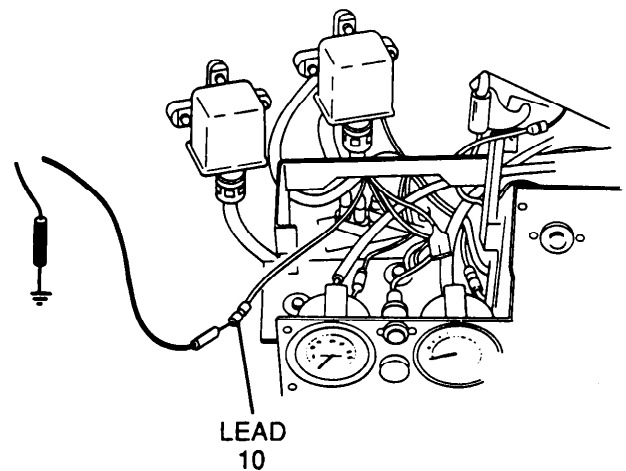

3-3 TROUBLESHOOTING CHART — CONTINUED

1. AIR CLEANER BLOWER MOTOR CIRCUIT — (2) ONE BLOWER MOTOR FAILS TO OPERATE CONTINUED

INITIAL SETUP

Tools

General mechanic's tool kit (item 64, Appx H)
 Multimeters (item 36, Appx H)
 TA-1 probe kit (item 43, Appx H)

Equipment Conditions

Engine compartment access cover removed (para 11-5)
 Transmission left access door open (TM 9-2350-311-10)
 Air intake grille open (TM 9-2350-311-10)

Personnel Required

Two

NOTE

Vehicle must be in neutral for the following step.

A

1. Disconnect lead 415 from disabled blower motor.
2. Place red lead of multimeters in lead 415 and black lead to ground.
3. Turn MASTER switch ON and check for voltage.
4. Turn MASTER switch OFF.

Is voltage present?

yes

no

Replace air cleaner blower motor (para 8-36).

Repair or replace lead 415 of accessory control box to heater/blower wiring harness (para 8-52).

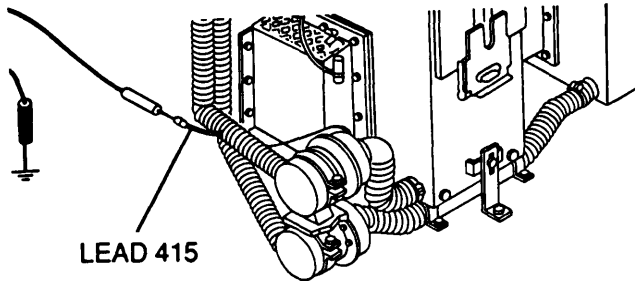

END OF TASK

(3) BLOWER MOTORS FAIL TO STOP WHEN VEHICLE IS PLACED IN NEUTRAL

INITIAL SETUP

Tools

General mechanic's tool kit (item 64, Appx H)
 Multimeters (item 36, Appx H)
 TA-1 probe kit (item 43, Appx H)

Equipment Condition

Engine compartment access cover removed (para 11-5)
 Transmission left access door open (TM 9-2350-311-10)
 Air intake grille open (TM 9-2350-311-10)

Personnel Required

Two

NOTE

Vehicle must be in neutral for the following step.

- A**
1. Disconnect lead 415B from neutral safety switch.
 2. Turn MASTER switch ON and check air cleaner blower motors for operation.
 3. Turn MASTER switch OFF.

Do air cleaner blower motors stop?

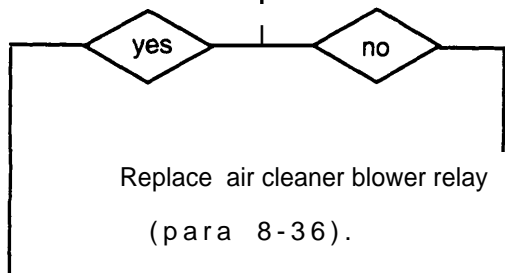

Replace neutral safety switch (para 8-15).

END OF TASK

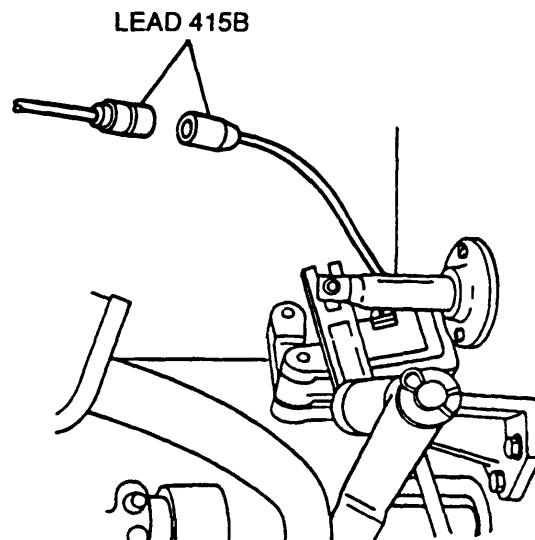

3-3 TROUBLESHOOTING CHART — CONTINUED

m. ALTERNATOR CIRCUIT (M109A2/M109A3)

The alternator circuit consists of the alternator, voltage regulator, rectifier, master relay, vehicle batteries, circuit breaker, portable instrument panel, battery indicator gage, and air cleaner blower relay.

When the MASTER switch is turned ON, 24 Vdc is supplied through the circuit breaker to the master relay. Voltage is also supplied to the voltage regulator through the air cleaner blower relay. When the engine is cranked and oil pressure reaches 4 to 8 psi (28 to 55 kPa), the air cleaner blower relay and the master relay close. This closes a circuit in the voltage regulator and the generator begins operating and supplying voltage to charge the batteries and operate all electrical components on the vehicle.

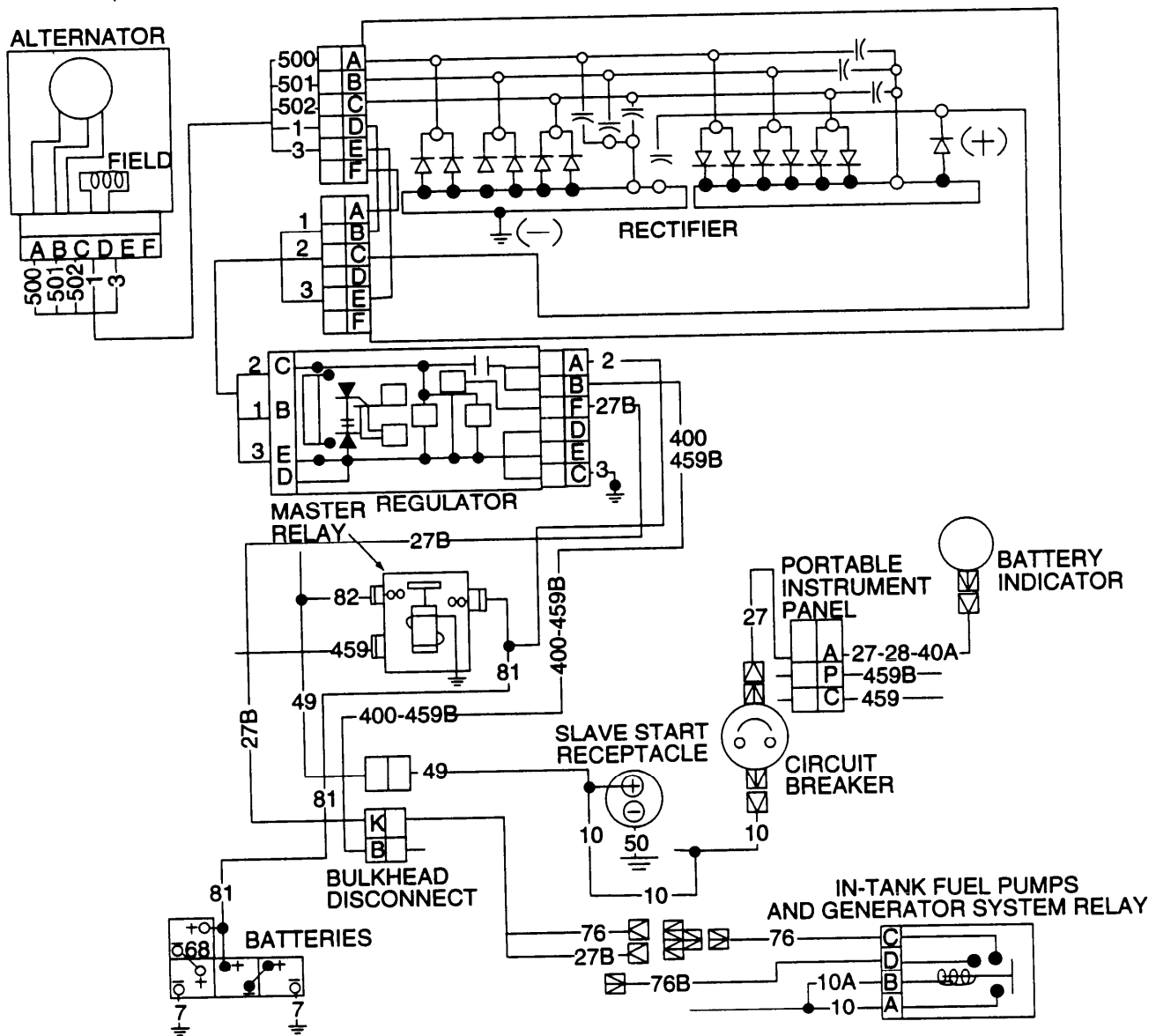

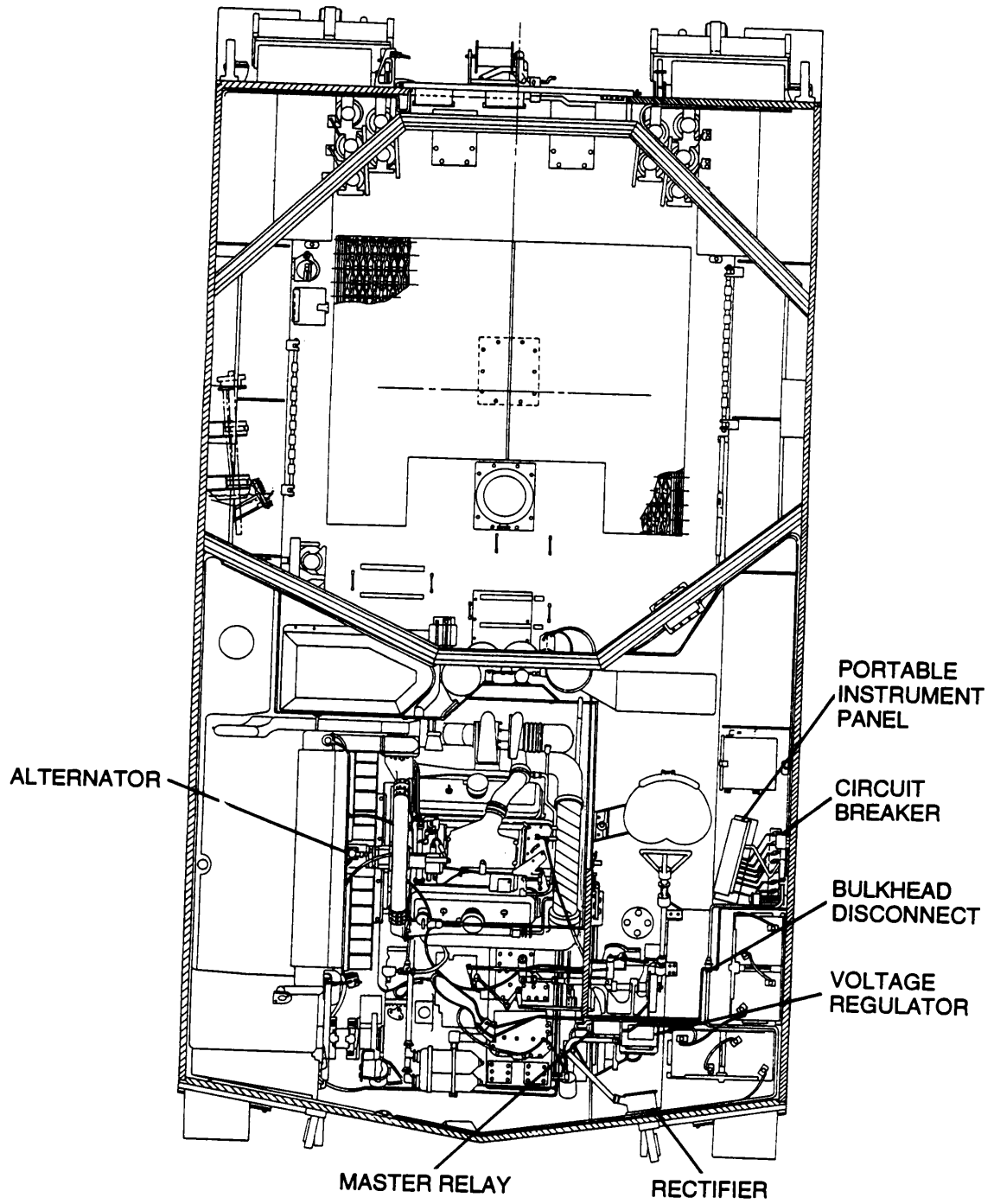

PICTORIAL VIEW

3-3 TROUBLESHOOTING CHART — CONTINUED

m. ALTERNATOR CIRCUIT (M109A2/M109A3) —
CONTINUED

ALTERNATOR FAILS TO CHARGE BATTERIES; GAGE
INDICATION: NOT CHARGING, UNSTEADY OR
INACCURATE READING

INITIAL SETUP

Applicable Configurations

M109A2/M109A3

References

TM 9-2350-311-10

TM 9-6140-200-14

Tools

General mechanic's tool kit (item 64, Appx H)

Multimeters (item 36, Appx H)

TA-1 probe kit (item 43, Appx H)

(Long test leads may be needed for some tests;
16 AWG wire may be used as an extension.)

Equipment Conditions

Engine compartment access cover removed (para 11-5)

Engine access door open (TM 9-2350-311-10)

Transmission access doors open (TM 9-2350-311-1 0)

CAUTION

Extremely low battery electrolyte levels will cause a low voltage indication on BATTERY indicator on portable instrument panel. Regulators can be damaged by attempts to adjust rheostat beyond its stops when the only problem is dry batteries.

NOTE

Vehicle idle speed must be 750 rpm in order for alternator to charge properly. Check idle speed before troubleshooting (TM 9-2350-311-10).

A

1. Run engine at 1000 rpm.
2. Place red lead of multimeters on battery positive terminal and black lead to ground.
3. Check for voltage.
4. Turn engine off.

Is voltage 27.5 Vdc or higher?

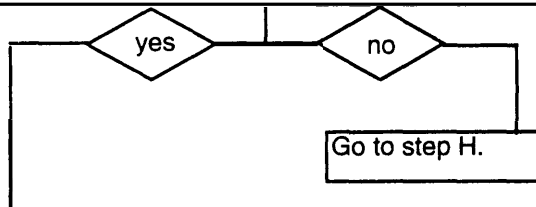

CONTINUED ON NEXT PAGE

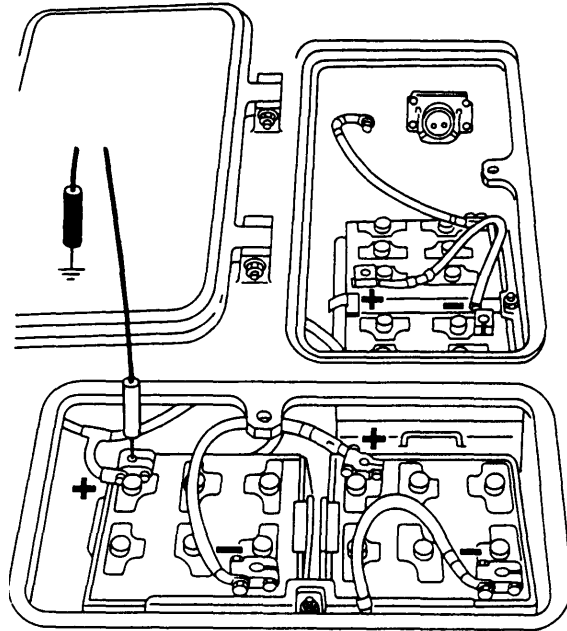

CONTINUED FROM STEP A

B	<ol style="list-style-type: none"> 1. Disconnect lead 40A from BATTERY indicator. 2. Place red lead of multimeter in lead 40A and black lead to ground. 3. Turn MASTER switch ON and check for voltage. 4. Turn MASTER switch OFF.
Is voltage present?	

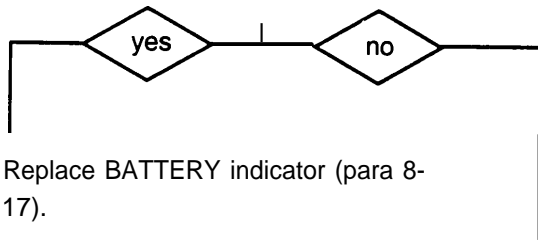
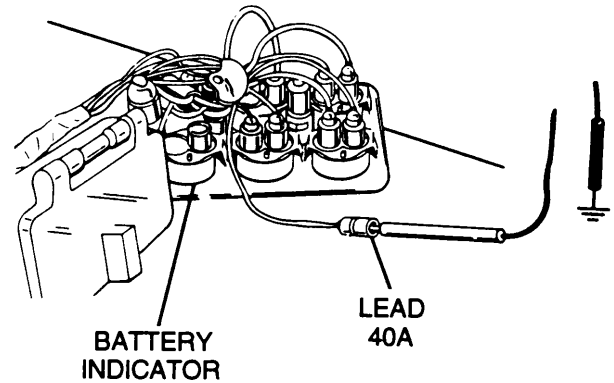

C	<ol style="list-style-type: none"> 1. Reconnect lead 40A to BATTERY indicator. 2. Disconnect lead 27 from circuit breaker output. 3. Place red lead of multimeter in circuit breaker output and black lead to ground. 4. Turn MASTER switch ON and check for voltage. 5. Turn MASTER switch OFF.
Is voltage present?	

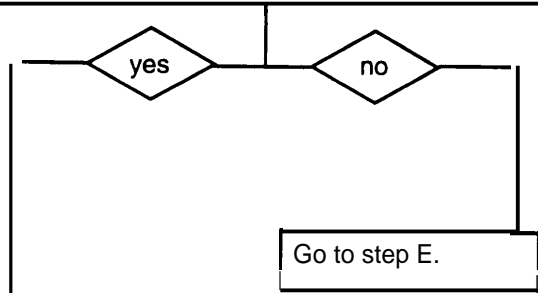
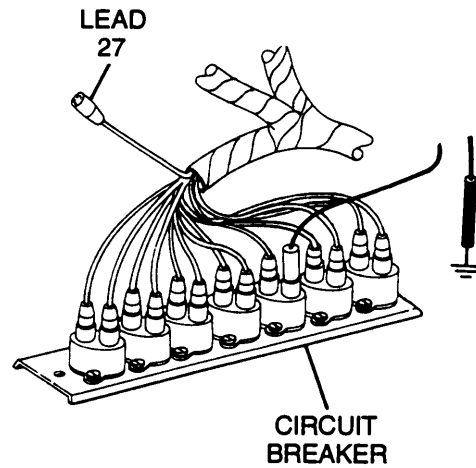

CONTINUED ON NEXT PAGE

3-3 TROUBLESHOOTING CHART — CONTINUED

m. ALTERNATOR CIRCUIT (M109A2/M109A3) — CONTINUED

ALTERNATOR FAILS TO CHARGE BATTERIES; GAGE INDICATION: NOT CHARGING, UNSTEADY OR INACCURATE READING — CONTINUED

CONTINUED FROM STEP C

D	<ol style="list-style-type: none"> 1. Reconnect lead 27 to circuit breaker output. 2. Disconnect battery ground leads. 3. Disconnect portable instrument panel wiring harness from portable instrument panel disconnect. 4. Place a jumper wire from socket C (lead 459) to socket P (lead 459B). 5. Place red lead of multimeters in socket A (lead 27) and black lead to ground. 6. Reconnect battery ground leads. 7. Turn MASTER switch ON and check for voltage. 8. Turn MASTER switch OFF.
Is voltage present?	

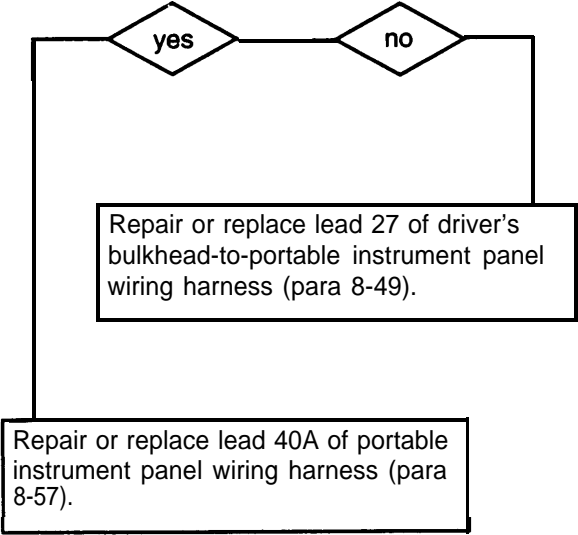
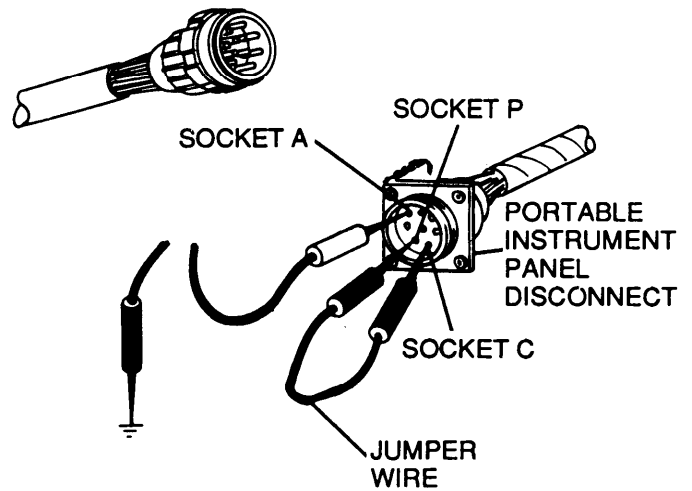

CONTINUED FROM STEP C

E

1. Reconnect lead 27 to circuit breaker output.
2. Disconnect lead 10 from circuit breaker input.
3. Place red lead of multimeters in lead 10 and black lead to ground.
4. Turn MASTER switch ON and check for voltage.
5. Turn MASTER switch OFF.

Is voltage present?

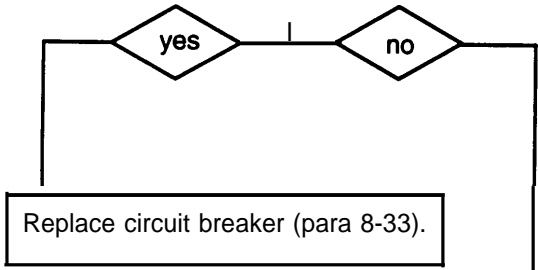

F

1. Reconnect lead 10 to circuit breaker input.
2. Disconnect lead 82 of engine disconnect bracket-to-driver's bulkhead lead assembly from master relay.
3. Place red lead of multimeters in master relay and black lead to ground.
4. Turn MASTER switch ON and check for voltage.
5. Turn MASTER switch OFF.

Is voltage present?

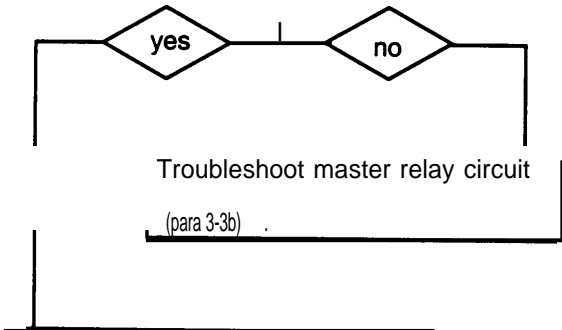

CONTINUED ON NEXT PAGE

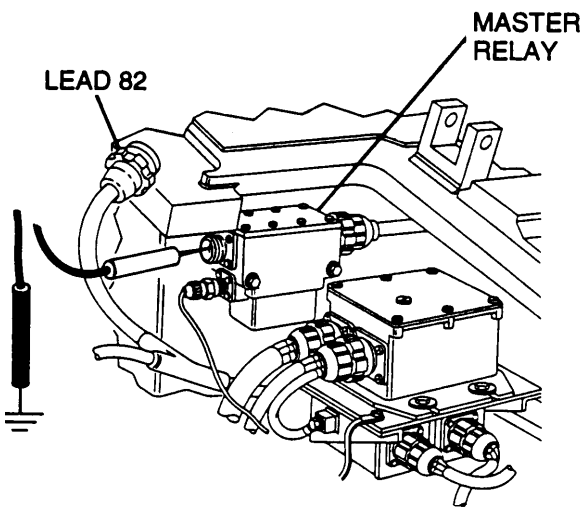
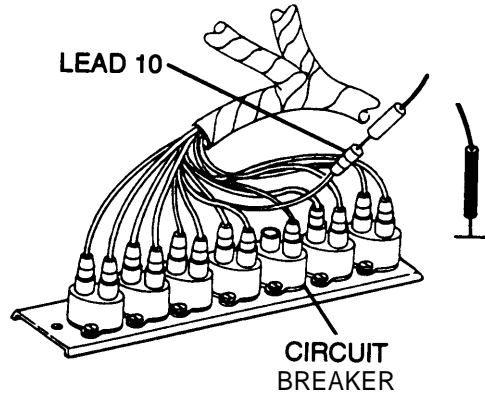

3-3 TROUBLESHOOTING CHART — CONTINUED

m. ALTERNATOR CIRCUIT (M109A2/M109A3) —
CONTINUED

ALTERNATOR FAILS TO CHARGE BATTERIES; GAGE
INDICATION: NOT CHARGING, UNSTEADY OR
INACCURATE READING — CONTINUED

CONTINUED FROM STEP F

G

1. Reconnect lead 82 of engine disconnect bracket-to-driver's bulkhead lead assembly to master relay.
2. Disconnect engine disconnect bracket-to-driver's bulkhead lead assembly from driver's bulkhead.
3. Place red lead of multimeters in lead 49 and black lead to ground.
4. Turn MASTER switch ON and check for voltage.
5. Turn MASTER switch OFF.

Is voltage present?

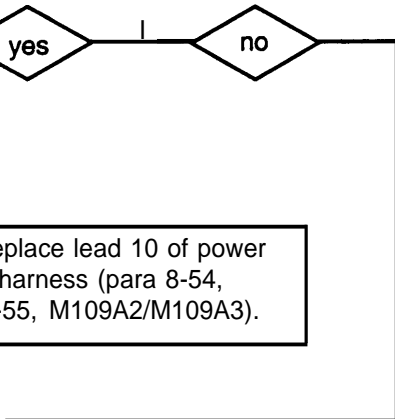

Repair or replace lead 10 of power lead wiring harness (para 8-54, M109A2; 8-55, M109A2/M109A3).

Repair or replace lead 82 of engine disconnect bracket-to-driver's bulkhead lead assembly (para 8-45).

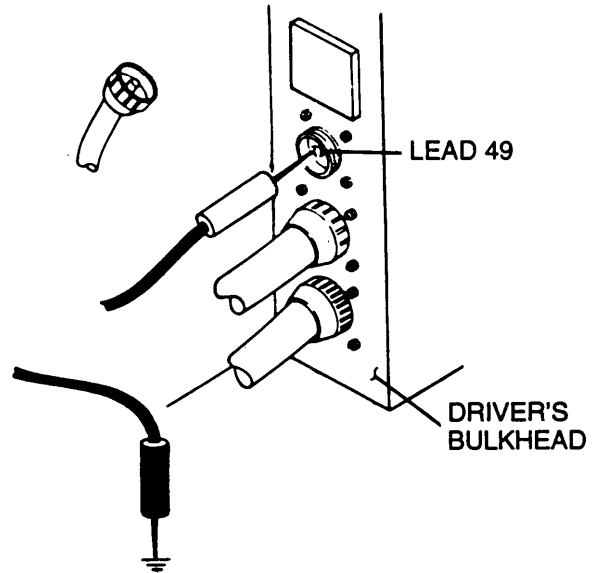

CONTINUED FROM STEP A

NOTE

For steps H, I, J, and K, use heavy jumper wires with alligator clips.

H

1. Disconnect powerplant wiring harness from alternator.
2. Place jumper wires from pin E (lead 3) of alternator to battery negative terminal and pin D (lead 1) of alternator to positive terminal of same battery to apply 12 Vdc to alternator field.
3. Turn MASTER switch ON and run vehicle engine at idle speed (750 rpm).
4. Set multimeters on ac scale, and place red lead of multimeters on pin A (lead 500) and black lead on pin B (lead 501).
5. Check for voltage.
6. Place red lead of multimeters on pin C (lead 502) and black lead on pin A (lead 500).
7. Check for voltage.
8. Turn MASTER switch and engine OFF.

Is voltage above 27.5 Vdc?

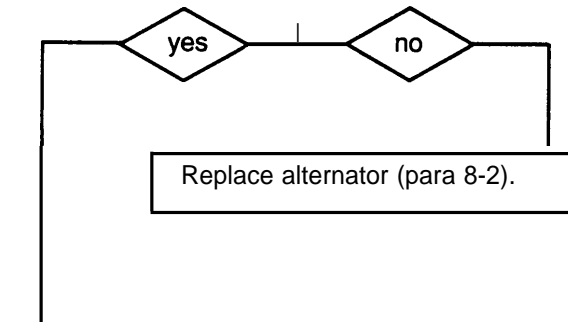

CONTINUED ON NEXT PAGE

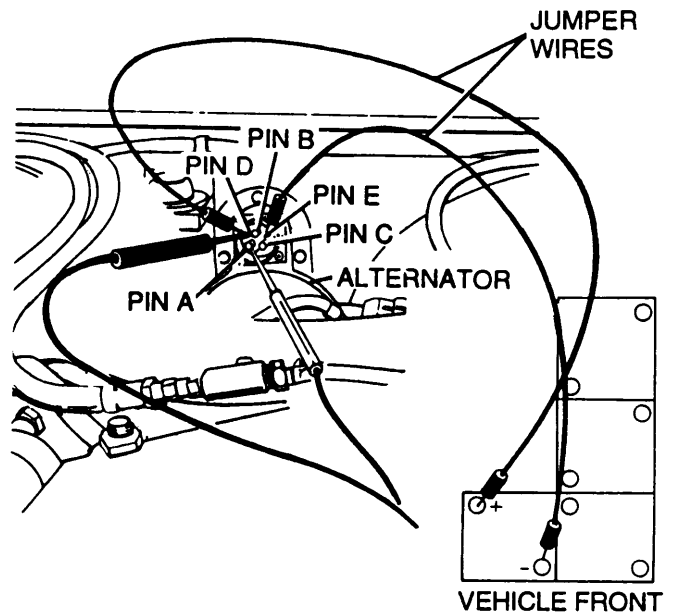

3-3 TROUBLESHOOTING CHART — CONTINUED

m. ALTERNATOR CIRCUIT (M109A2/M109A3) — CONTINUED

ALTERNATOR FAILS TO CHARGE BATTERIES; GAGE INDICATION: NOT CHARGING, UNSTEADY OR INACCURATE READING — CONTINUED

CONTINUED FROM STEP H

- | | |
|-----------------------------------|--|
| I | <ol style="list-style-type: none"> 1. Reconnect powerplant wiring harness to alternator. 2. Disconnect powerplant wiring harness from rectifier. 3. Place jumper wires from pin E (lead 3) to battery negative terminal and pin D (lead 1) to the positive terminal of the same battery to apply 12 Vdc to the alternator field. 4. Turn MASTER switch ON and run vehicle engine at idle speed (750 rpm). 5. Set multimeters on ac scale, and place red lead of multimeter on pin A (lead 500) and black lead on pin B (lead 501). 6. Check for voltage. 7. Place red lead of multimeters on pin C (lead 502) and black lead on pin A (lead 500). 8. Check for voltage. 9. Turn MASTER switch and engine OFF. |
| <p>Is voltage above 27.5 Vat?</p> | |

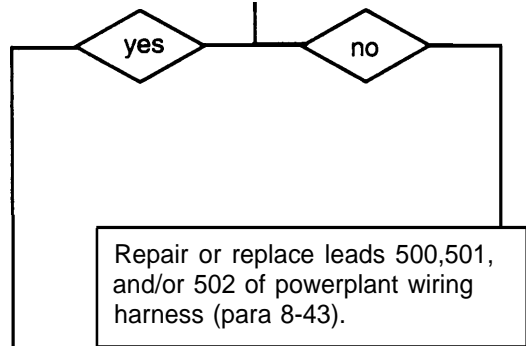
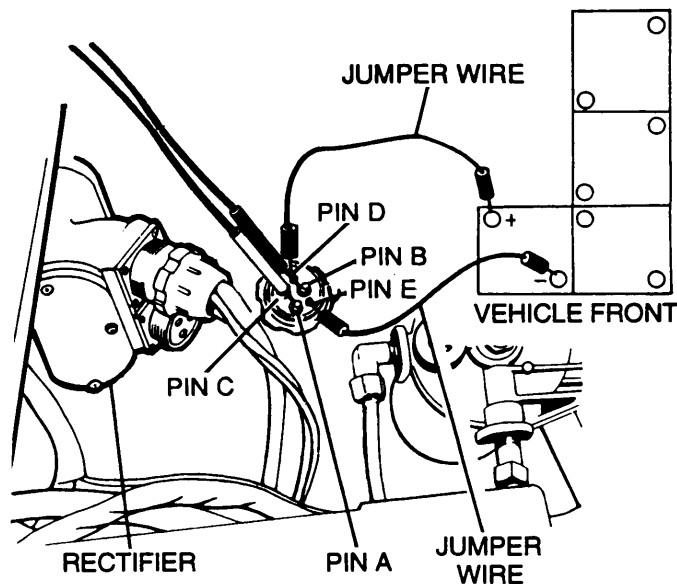

CONTINUED ON NEXT PAGE

CONTINUED FROM STEP I

- J**
1. Reconnect powerplant wiring harness to rectifier.
 2. Disconnect rectifier-to-voltage regulator wiring harness from rectifier.
 3. Place jumper wires from pin E (lead 3) to a battery negative terminal and pin B (lead 1) to positive terminal of same battery.
 4. Turn MASTER switch ON and run vehicle engine at idle speed (750 rpm).
 5. Set multimeter on dc scale and place red lead of multimeter on pin C (lead 2) and black lead to ground.
 6. Check for voltage.
 7. Turn MASTER switch and engine OFF.
- Is voltage above 27.5 Vdc?

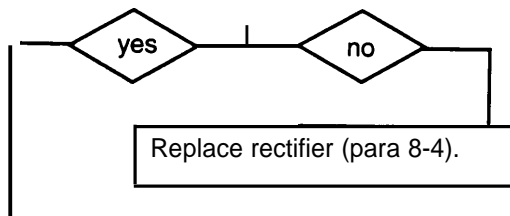

- K**
1. Reconnect rectifier-to-voltage regulator wiring harness to the rectifier.
 2. Disconnect rectifier to voltage regulator wiring harness from voltage regulator.
 3. Place jumper wires from pin E (lead 3) to a battery negative terminal and pin B (lead 1) to positive terminal of same battery.
 4. Turn MASTER switch ON and run vehicle engine at idle speed (750 rpm).
 5. Set multimeter on dc scale and place red lead of multimeter on pin C (lead 2) and black lead to ground.
 6. Check for voltage.
 7. Turn MASTER switch and engine OFF.
- Is voltage above 27.5 Vdc?

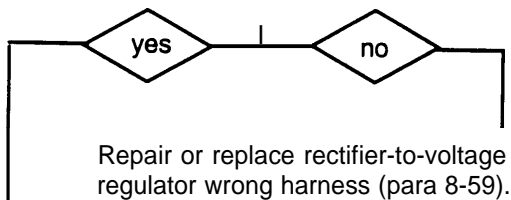

CONTINUED ON NEXT PAGE

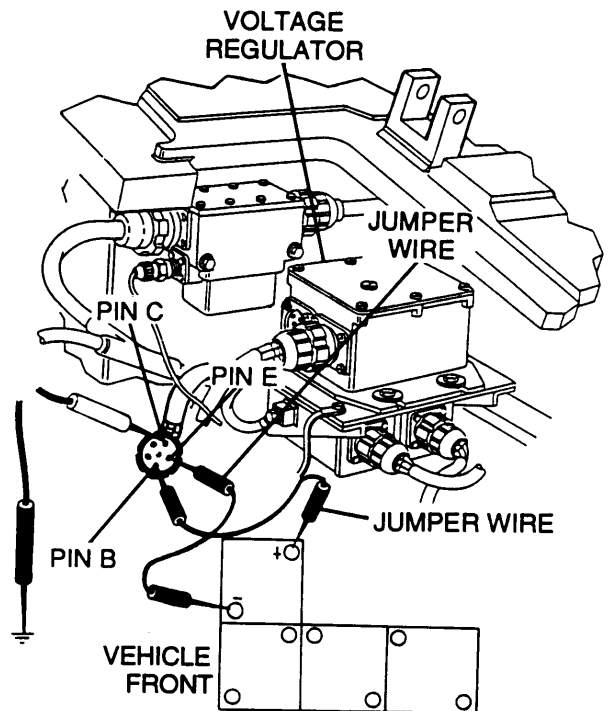
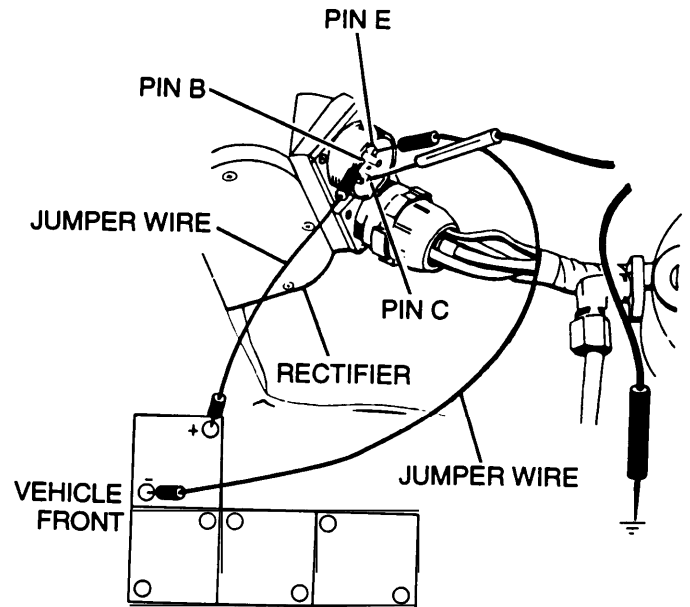

3-3 TROUBLESHOOTING CHART — CONTINUED

m. ALTERNATOR CIRCUIT (M109A2/M109A3)—
CONTINUED

ALTERNATOR FAILS TO CHARGE BATTERIES; GAGE
INDICATION: NOT CHARGING, UNSTEADY OR
INACCURATE READING — CONTINUED

CONTINUED FROM STEP K

NOTE

- Batteries can be totally discharged within 4 to 6 hours if air cleaner blower motor system is malfunctioning or if blower motors operate full time. Troubleshooting step L provides a basic test of blower motor circuit by testing blower motor relay output voltage to voltage regulator (lead 27B).
- If blower motor relay output is 24 Vdc or greater (battery power) with voltage regulator disconnected from circuit, voltage regulator is malfunctioning/inoperative and will not charge battery.
- If voltage is less than 24 Vdc (battery power), blower motor circuit is malfunctioning and discharging battery.

L

1. Reconnect rectifier to voltage regulator wiring harness to voltage regulator.
2. Disconnect battery ground leads.
3. Disconnect engine disconnect bracket-to-bulkhead wiring harness from voltage regulator.
4. Place jumper wires from socket A (lead 2) to socket B (lead 400-459B), from pin C (lead 3) to battery negative terminal, and from pin F (lead 27B) to positive terminal of same battery to apply 12 Vdc to alternator field.
5. Reconnect battery ground leads.
6. Turn MASTER switch ON and run vehicle engine at 1000 rpm (oil pressure at 12 psi [83 kPa]).
7. Place red lead of multimeters in socket F (lead 27B) and black lead to ground.
8. Check for voltage.

Is voltage above 27.5 Vdc?

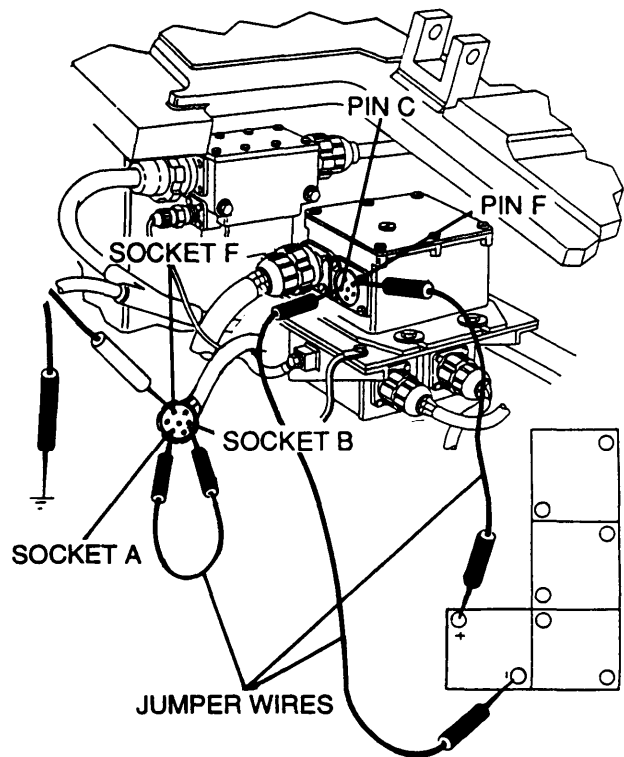

CONTINUED ON NEXT PAGE

CONTINUED FROM STEP L

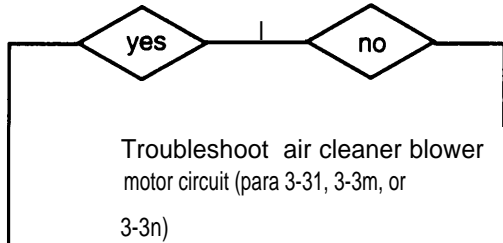

NOTE

Perform step M only if vehicle is equipped with an adjustable regulator. If not, replace regulator (para 8-3).

- M** Do not check or adjust voltage regulator except as follows:
1. Make sure batteries are fully charged while checking and/or adjusting regulator (TM 9-2350-311 -10).
 2. Connect red lead of multimeters to positive battery cable terminal and black lead to negative battery cable terminal.
 3. Start engine and run at approximately 1000 rpm. Run engine as required to bring engine compartment, regulator, and batteries to normal operating temperature.
 4. During above warm-up period, increase engine speed to approximately 2500 rpm and then return to idle speed (750 rpm) while observing multimeters. Voltage reading should not vary more than ± 0.1 volt during above check. This also provides a check on tightness of wiring connection. Turn headlights on and off several times. Multimeters needle may vary slightly, but should return to its original voltage quickly.
 5. Turn off all major vehicle electrical components and turn on vehicle headlights.
 6. Open transmission left access door and remove square head pipe plug from end of voltage regulator (between and above harness connectors).

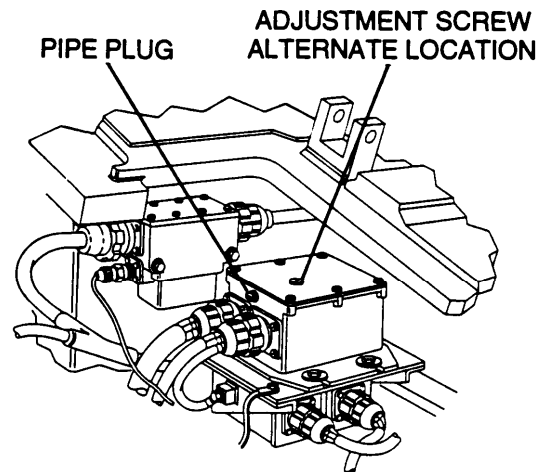

CONTINUED ON NEXT PAGE

3-3 TROUBLESHOOTING CHART — CONTINUED

m. ALTERNATOR CIRCUIT (M109A2/M109A3) —
CONTINUED

ALTERNATOR FAILS TO CHARGE BATTERIES; GAGE
INDICATION: NOT CHARGING, UNSTEADY OR
INACCURATE READING — CONTINUED

CONTINUED FROM STEP M

CAUTION

Rheostat turns easily. Do not force beyond the stops or damage to regulator may occur.

M

7. With engine running at 1000 rpm, use a screwdriver to adjust rheostat to obtain a voltage reading of 27.5 to 28.5 Vdc. Turn screwdriver counterclockwise to reduce voltage. Slowly turn screwdriver to bring regulated voltage up to 27.5 to 28.5 Vdc.
8. Replace pipe plug in end of voltage regulator.
9. Turn off vehicle headlights.
10. Repeat step 4. If this check is satisfactory, shut off engine and remove multimeters.
11. If voltage regulator cannot be adjusted, replace regulator (para 8-3).
12. If electrical (battery) problems continue after regulator has been properly checked and/or adjusted, check service, maintenance, and usage of battery (TM 9-6140-200-1 4).

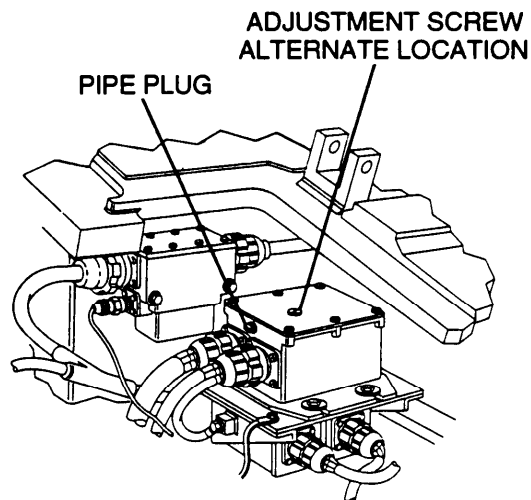

END OF TASK

n. ALTERNATOR CIRCUIT (M109A4/M109A5)

The alternator circuit consists of the alternator, voltage regulator, rectifier, master relay, vehicle batteries, circuit breaker, portable instrument panel, battery indicator gage, and air cleaner blower relay.

When the MASTER switch is turned ON, 24 Vdc is supplied through the circuit breaker to the master relay. Voltage is also supplied to the voltage regulator through the air cleaner blower relay. When the engine is cranked and oil pressure reaches 4 to 8 psi (28 to 55 kPa), the air cleaner blower relay and the master relay close. This closes a circuit in the voltage regulator and the generator begins operating and supplying voltage to charge the batteries and operate all electrical components on the vehicle.

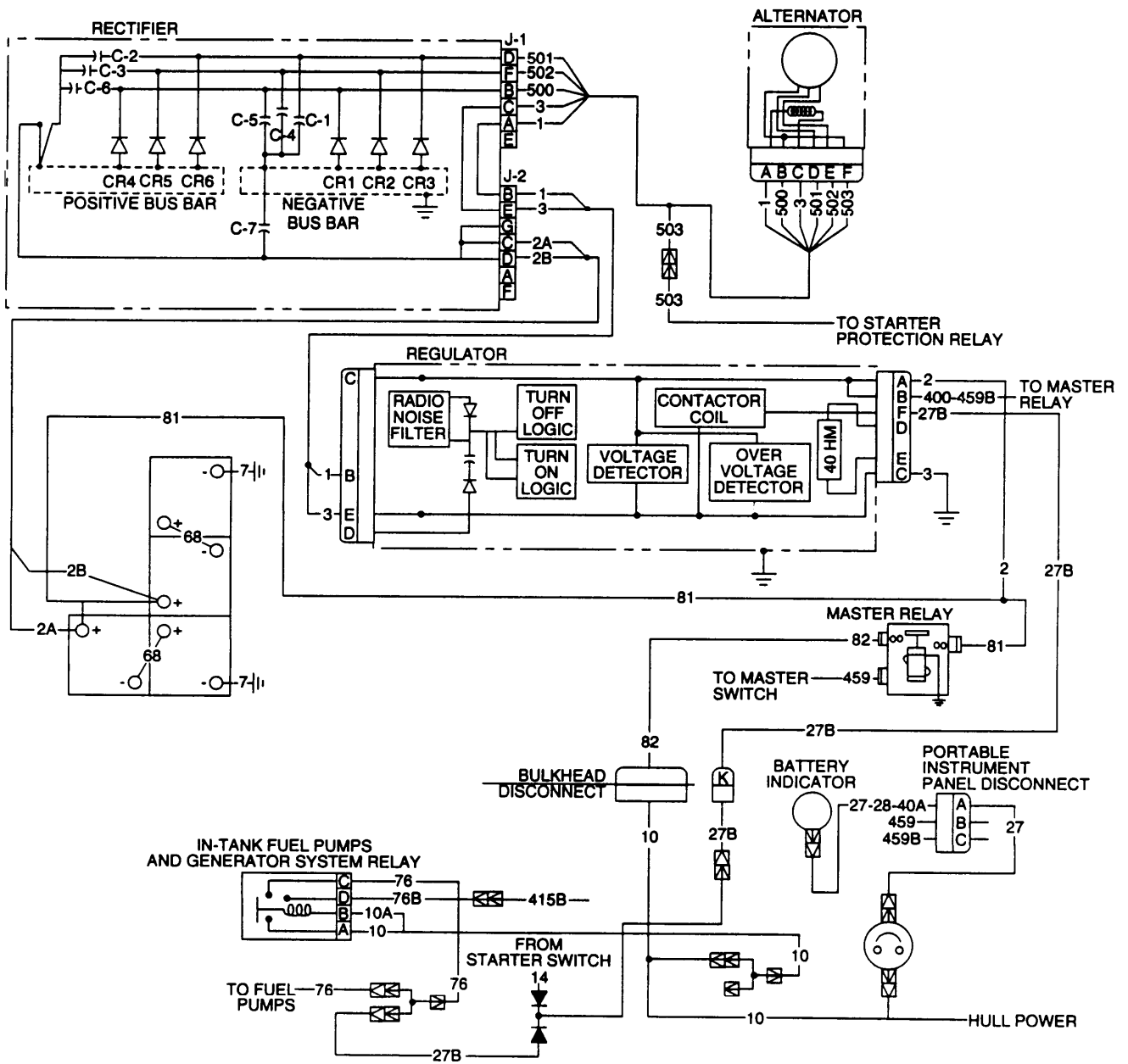

3-3 TROUBLESHOOTING CHART — CONTINUED

n. ALTERNATOR CIRCUIT (M109A4/M109A5)—
CONTINUED

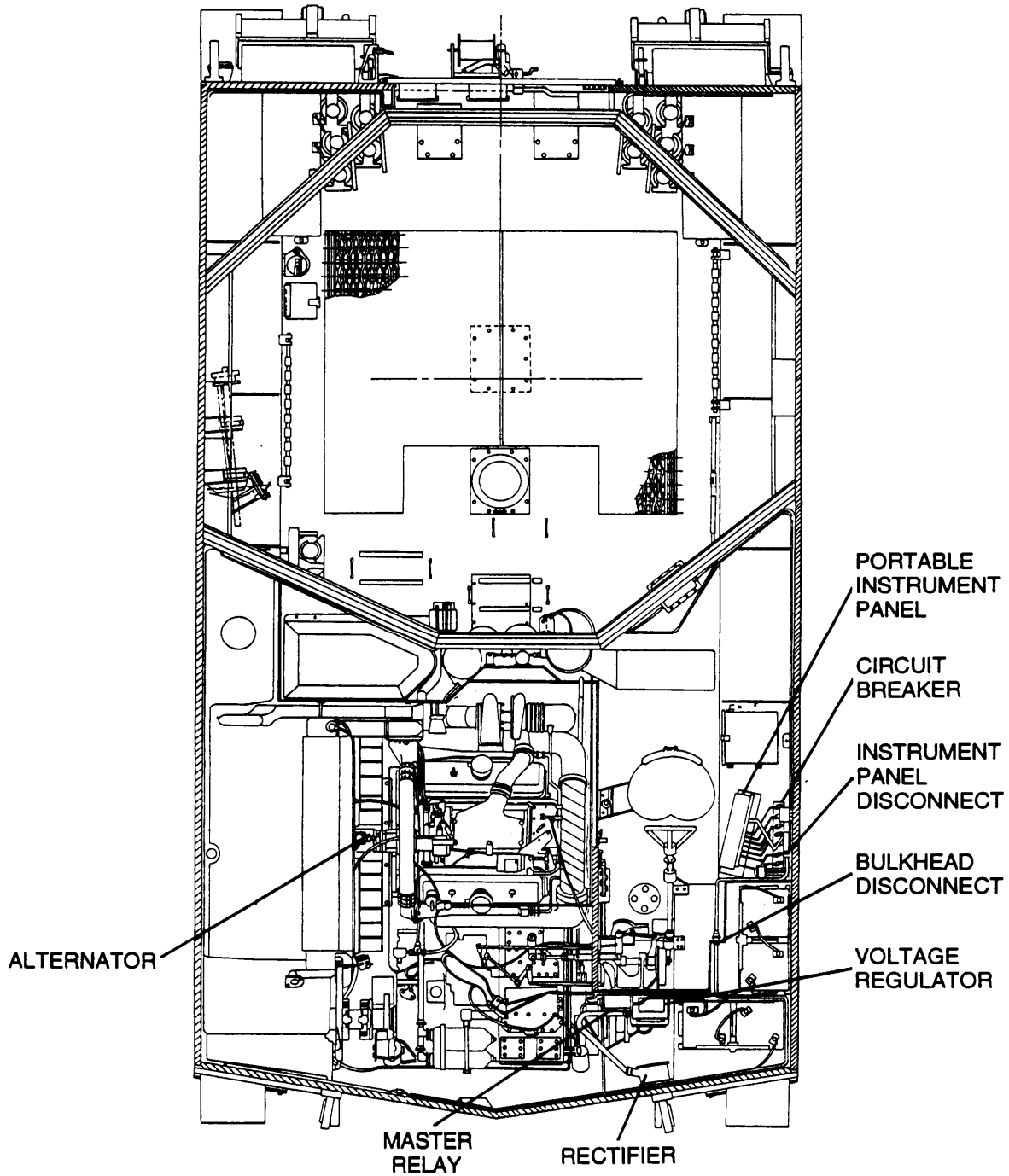

PICTORIAL VIEW

ALTERNATOR FAILS TO CHARGE BATTERIES; GAGE INDICATION: NOT CHARGING, UNSTEADY OR INACCURATE READING

INITIAL SETUP

Applicable Configurations
M109A4/M109A5

References
TM 9-2350-311-10
TM 9-6140-200-14

Tools

General mechanic's tool kit (item 64, Appx H)
Multimeter (item 36, Appx H)
TA-1 probe kit (item 43, Appx H)
(Long test leads may be needed for some tests;
16 AWG wire may be used as an extension.)

Equipment Conditions

Engine compartment access cover removed (para 11 -5)
Engine access door open (TM 9-2350-311-10)
Transmission access doors open (TM 9-2350-311-10)

CAUTION

Extremely low battery electrolyte levels will cause a low voltage indication on BATTERY indicator on portable instrument panel. Regulators can be damaged by attempts to adjust rheostat beyond its stops when the only problem is dry batteries.

NOTE

Vehicle idle speed must be 750 rpm in order for alternator to charge properly. Check idle speed before troubleshooting (TM 9-2350-311-10).

- A**
1. Run engine at 1000 rpm.
 2. Place red lead of multimeter on battery positive terminal and black lead to ground.
 3. Check for voltage.
 4. Turn engine off.

Is voltage 27.5 Vdc or higher?

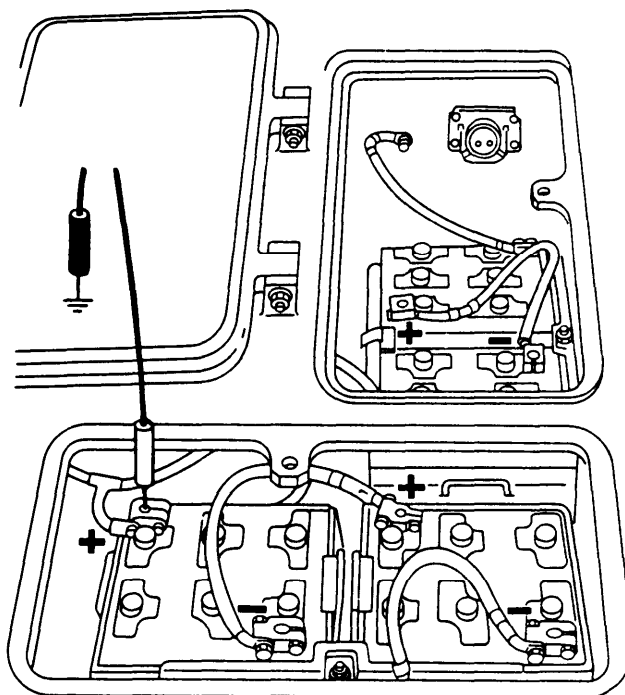
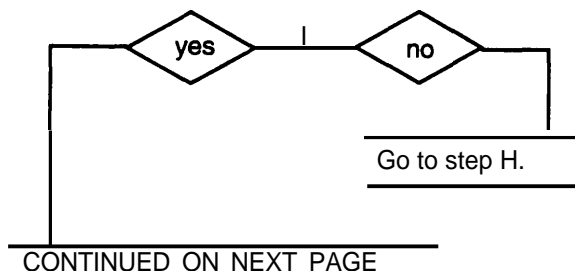

3-3 TROUBLESHOOTING CHART — CONTINUED

n. ALTERNATOR CIRCUIT (M109A4/M109A5) — CONTINUED

ALTERNATOR FAILS TO CHARGE BATTERIES; GAGE INDICATION: NOT CHARGING, UNSTEADY OR INACCURATE READING — CONTINUED

CONTINUED FROM STEP A

B

1. Disconnect lead 40A from BATTERY indicator.
2. Place red lead of multimeter in lead 40A and black lead to ground.
3. Turn MASTER switch ON and check for voltage.
4. Turn MASTER switch OFF.

Is voltage present?

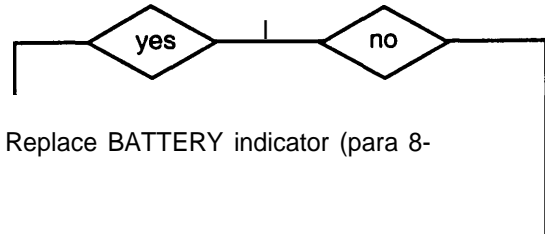
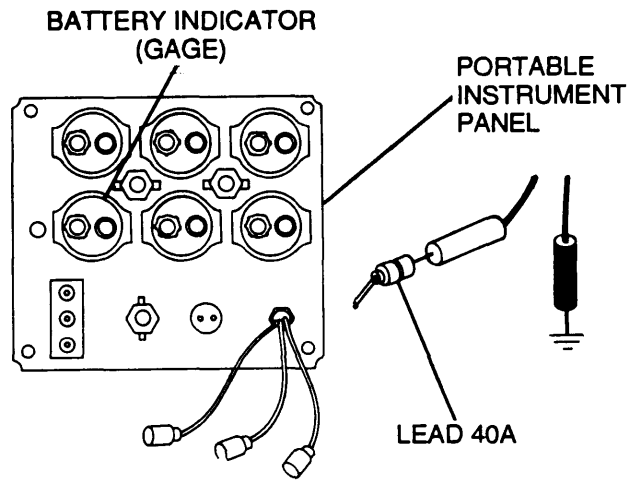

C

1. Reconnect lead 40A to BATTERY indicator.
2. Disconnect lead 27 from circuit breaker output.
4. Place red lead of multimeter in circuit breaker output and black lead to ground.
5. Turn MASTER switch ON and check for voltage.
6. Turn MASTER switch OFF.

Is voltage present?

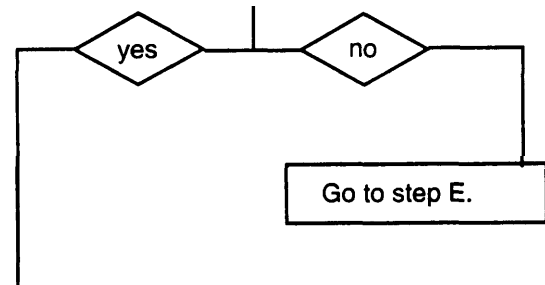
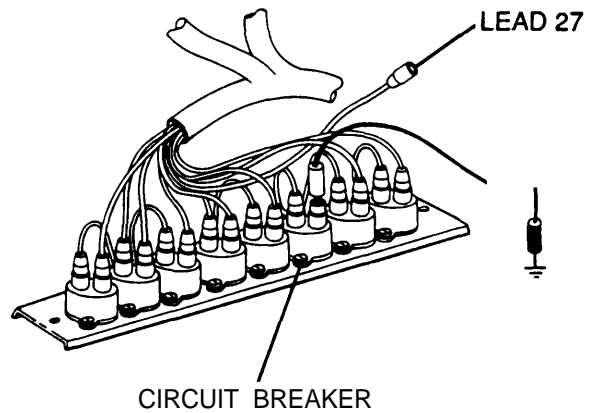

CONTINUED ON NEXT PAGE

CONTINUED FROM STEP C

- D**
1. Reconnect lead 27 to circuit breaker output.
 2. Disconnect battery ground leads.
 3. Disconnect portable instrument panel wiring harness from portable instrument panel disconnect.
 4. Place a jumper wire from socket C (lead 459) to socket P (lead 459B).
 5. Place red lead of multimeter in socket A (lead 27) and black lead to ground.
 6. Reconnect battery ground leads.
 7. Turn MASTER switch ON and check for voltage.
 8. Turn MASTER switch OFF.
- Is voltage present?

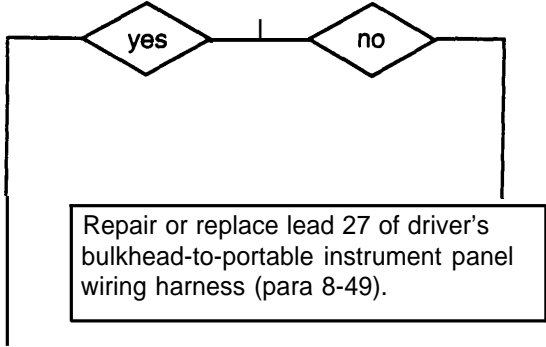

Repair or replace lead 40A of portable instrument panel wiring harness (para 8-57).

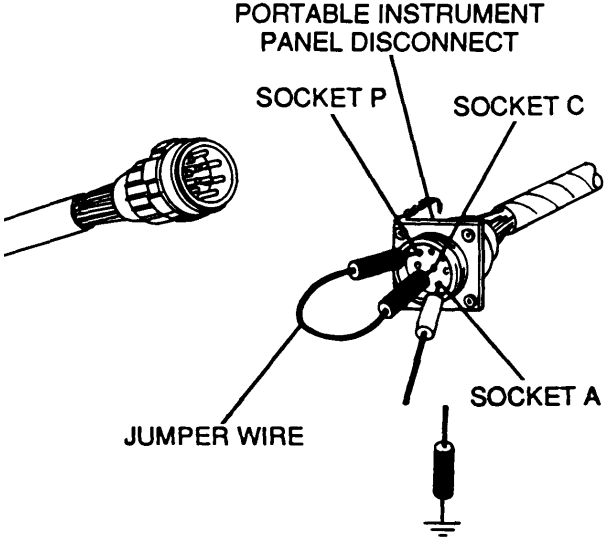

3-3 TROUBLESHOOTING CHART — CONTINUED

n. ALTERNATOR CIRCUIT (M109A4/M109A5) — CONTINUED

ALTERNATOR FAILS TO CHARGE BATTERIES; GAGE INDICATION: NOT CHARGING, UNSTEADY OR INACCURATE READING — CONTINUED

CONTINUED FROM STEP C

- | | |
|----------|---|
| E | <ol style="list-style-type: none"> 1. Reconnect lead 27 to circuit breaker output. 2. Disconnect lead 10 from circuit breaker input. 3. Place red lead of multimeter in lead 10 and black lead to ground. 4. Turn MASTER switch ON and check for voltage. 5. Turn MASTER switch OFF. |
|----------|---|

Is voltage present?

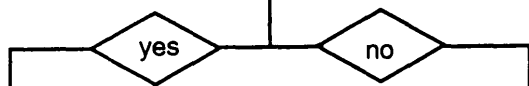

Replace circuit breaker (para 8-34).

- | | |
|----------|---|
| F | <ol style="list-style-type: none"> 1. Reconnect lead 10 to circuit breaker input. 2. Disconnect lead 82 of master relay-to-driver's bulkhead lead assembly from master relay. 3. Place red lead of multimeter in master relay and black lead to ground. 4. Turn MASTER switch ON and check for voltage. 5. Turn MASTER switch OFF. |
|----------|---|

Is voltage present?

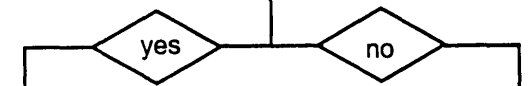

Troubleshoot master relay circuit (para 3-3b).

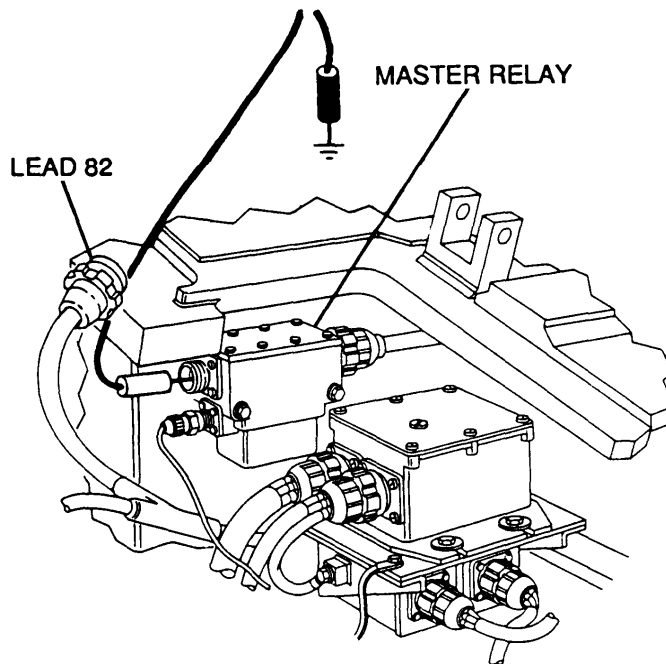
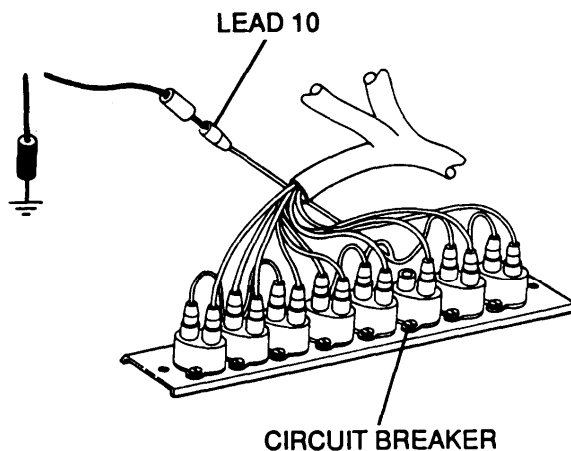

CONTINUED ON NEXT PAGE

CONTINUED FROM STEP F

G	<ol style="list-style-type: none"> 1. Reconnect lead 82 of master relay-to-driver's bulkhead lead assembly to master relay. 2. Disconnect master relay-to-driver's bulkhead lead assembly from driver's bulkhead. 3. Place red lead of multimeter in lead 82 and black lead to ground. 4. Turn MASTER switch ON, and check for voltage.
<p>Is voltage present?</p>	

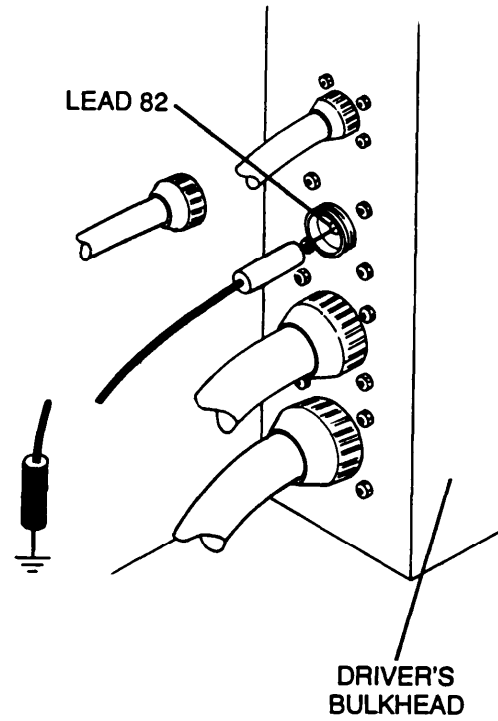
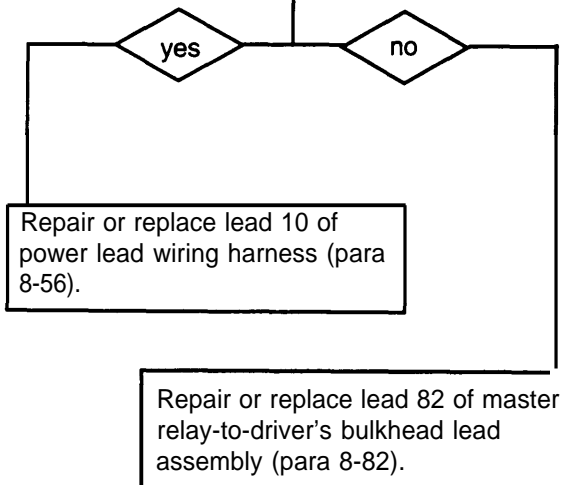

3-3 TROUBLESHOOTING CHART — CONTINUED

n. ALTERNATOR CIRCUIT (M109A4/M109A5) — CONTINUED

ALTERNATOR FAILS TO CHARGE BATTERIES; GAGE INDICATION: NOT CHARGING, UNSTEADY OR INACCURATE READING — CONTINUED

CONTINUED FROM STEP A

NOTE

For steps H, I, J, and K use heavy jumper wires with alligator clips.

H

1. Disconnect powerplant wiring harness from alternator.
2. Place jumper wires from pin C (lead 3) of alternator to battery negative terminal and pin A (lead 1) of alternator to positive terminal of same battery to apply 12 Vdc to alternator field.
3. Place a jumper wire from pin E to socket E (lead 503).
4. Turn MASTER switch ON and run vehicle engine at 1000 rpm.
5. Set multimeter on ac scale, and place red lead of multimeter on pin B (lead 500) and black lead on pin D (lead 501).
6. Check for voltage.
7. Place red lead of multimeter on pin F (lead 502) and black lead on pin B (lead 500).
8. Check for voltage.
9. Turn MASTER switch and engine OFF.

Is voltage above 27.5 Vat?

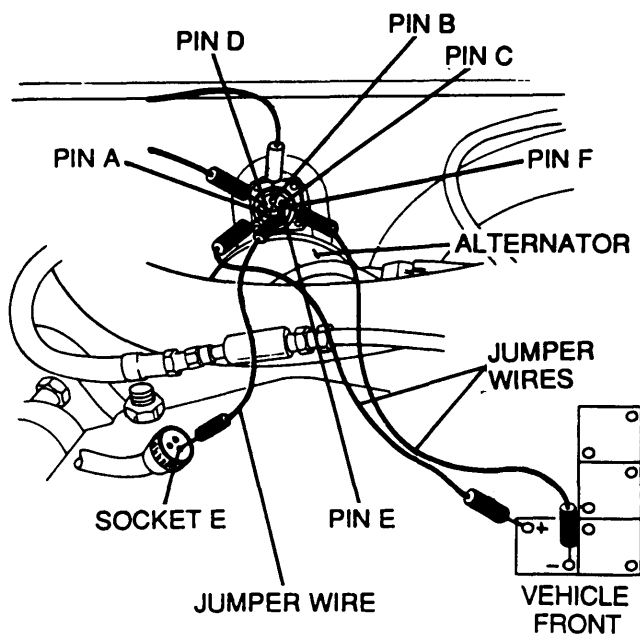

yes

no

Replace alternator (para 8-2).

CONTINUED ON NEXT PAGE

CONTINUED FROM STEP H

- | | |
|-----------------------------------|--|
| I | <ol style="list-style-type: none"> 1. Reconnect powerplant wiring harness to alternator. 2. Disconnect powerplant wiring harness from rectifier. 3. Place jumper wires from pin C (lead 3) to battery negative terminal and pin A (lead 1) to positive terminal of same battery to apply 12 Vdc to alternator field. 4. Turn MASTER switch ON and run vehicle engine at 1000 rpm. 5. Set multimeter on ac scale, and place red lead of multimeter on pin B (lead 500) and black lead on pin D (lead 501). 6. Check for voltage. 7. Place red lead of multimeter on pin F (lead 502) and black lead on pin B (lead 500). 8. Check for voltage. 9. Turn MASTER switch and engine OFF. |
| <p>Is voltage above 27.5 Vac?</p> | |

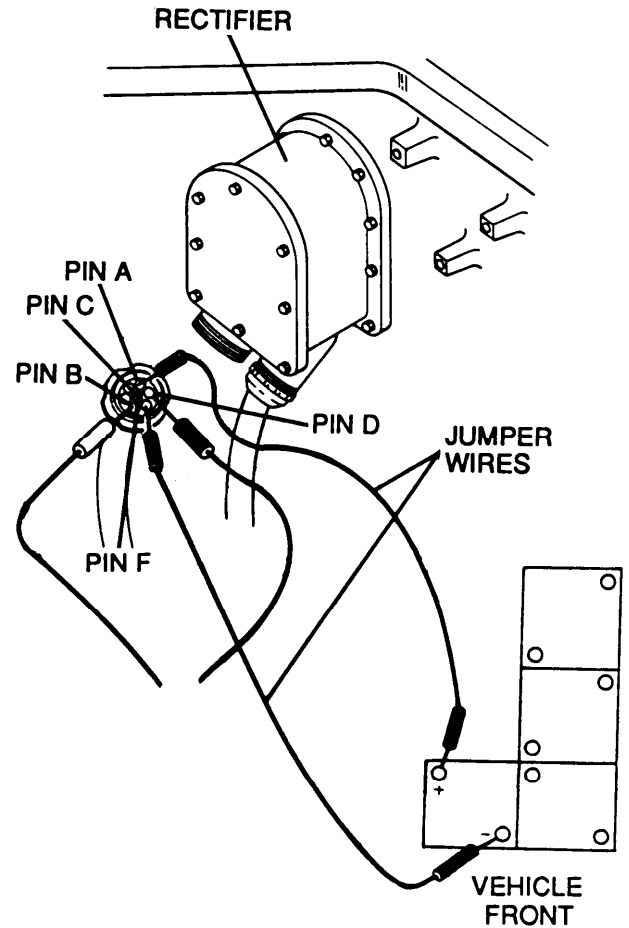
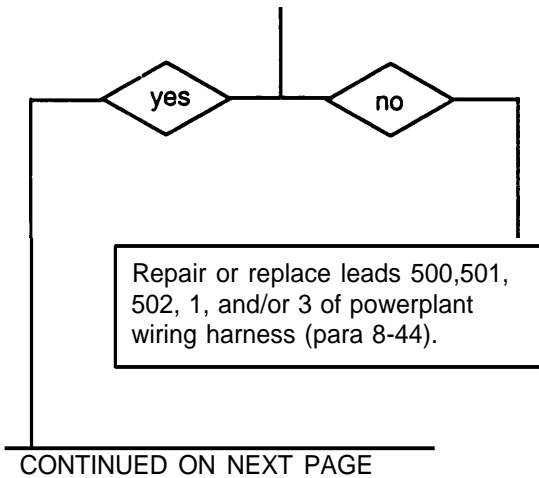

3-3 TROUBLESHOOTING CHART — CONTINUED

n. ALTERNATOR CIRCUIT (M109A4/M109A5) — CONTINUED

ALTERNATOR FAILS TO CHARGE BATTERIES; GAGE INDICATION: NOT CHARGING, UNSTEADY OR INACCURATE READING — CONTINUED

CONTINUED FROM STEP I

J	<ol style="list-style-type: none"> 1. Reconnect powerplant wiring harness to rectifier. 2. Disconnect rectifier-to-voltage regulator wiring harness from rectifier. 3. Place jumper wires from pin E (lead 3) to a battery negative terminal and pin B (lead 1) to positive terminal of same battery to apply 12 Vdc to alternator field. 4. Turn MASTER switch ON and run vehicle engine at 1000 rpm. 5. Set multimeter on dc scale and place red lead of multimeter on pin C (lead 2A) and black lead to ground. 6. Check for voltage. 7. Turn MASTER switch and engine OFF.
<p>Is voltage above 27.5 Vdc?</p>	

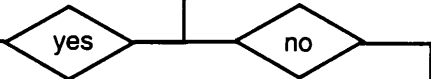
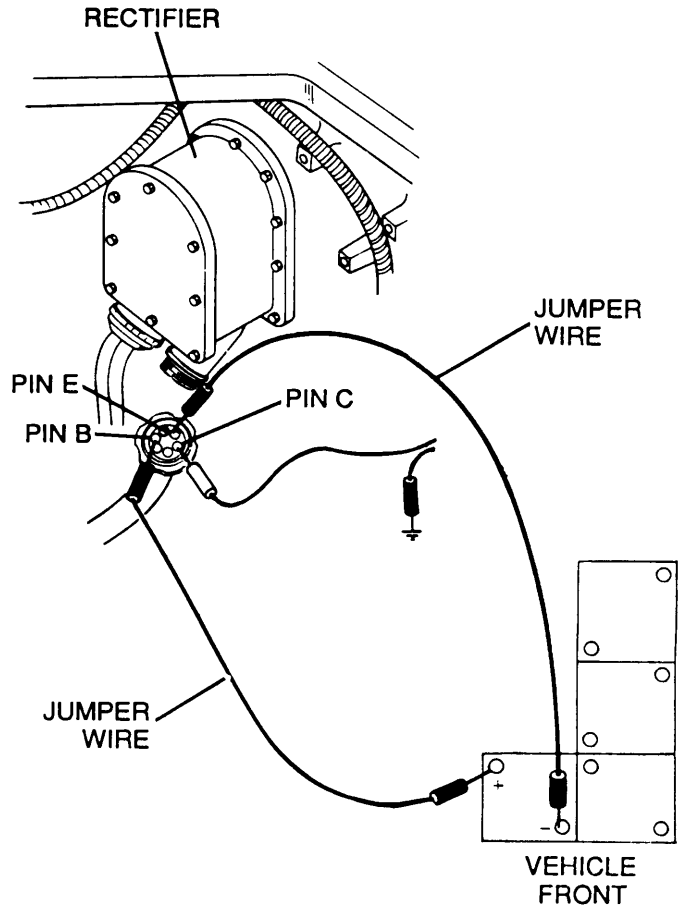

Replace rectifier (para 8-5)

CONTINUED ON NEXT PAGE

CONTINUED FROM STEP J

K	<ol style="list-style-type: none"> 1. Reconnect rectifier-to-voltage regulator wiring harness to rectifier, 2. Disconnect battery ground leads. 3. Disconnect rectifier-to-voltage regulator wiring harness from voltage regulator. 4. Place jumper wires from pin E (lead 3) to a battery negative terminal and pin B (lead 1) to the positive terminal of same battery. 5. Disconnect lead 2A from battery positive terminal. 6. Reconnect battery ground leads. 7. Turn MASTER switch ON and run vehicle engine at idle speed (750 rpm). 8. Set multimeter on dc scale and place red lead of multimeter on lead 2A and black lead to ground. 9. Check for voltage. 10. Turn MASTER switch and engine OFF.
<p>Is voltage above 27.5 Vdc?</p>	

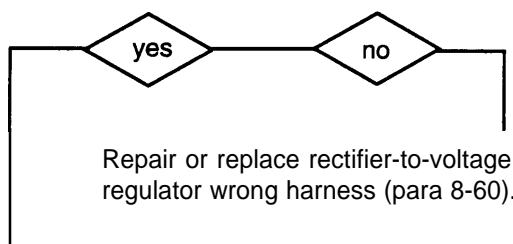

NOTE
<ul style="list-style-type: none"> • Batteries can be totally discharged within 4 to 6 hours if air cleaner blower motor system is malfunctioning or if blower motors operate full time. Troubleshooting step L provides a basic test of blower motor circuit by testing blower motor relay output voltage to voltage regulator (lead 27 B). • If blower motor relay output is 24 Vdc or greater (battery power) with voltage regulator disconnected from circuit, voltage regulator is malfunctioning/inoperative and will not charge battery. • If voltage is less than 24 Vdc (battery power), blower motor circuit is malfunctioning and discharging battery.

CONTINUED ON NEXT PAGE

3-3 TROUBLESHOOTING CHART — CONTINUED

n. ALTERNATOR CIRCUIT (M109A4/M109A5) — CONTINUED

ALTERNATOR FAILS TO CHARGE BATTERIES; GAGE INDICATION: NOT CHARGING, UNSTEADY OR INACCURATE READING — CONTINUED

CONTINUED FROM STEP K

L

1. Reconnect rectifier to voltage regulator wiring harness to voltage regulator.
2. Disconnect battery ground leads.
3. Disconnect engine disconnect bracket-to-bulkhead wiring harness from voltage regulator.
4. Place jumper wires from socket A (lead 2) to socket B (lead 400-459B) and from pin C (lead 3) to battery negative terminal and pin F (lead 27B) to the positive terminal of the same battery to apply 12 Vdc to alternator field.
5. Reconnect battery ground leads.
6. Turn MASTER switch ON and run vehicle engine at 1000 rpm (oil pressure at 12 psi [83 kPa]).
7. Place red lead of multimeter in socket F (lead 276) and black lead to ground.
8. Check for voltage.

Is voltage above 27.5 Vdc?

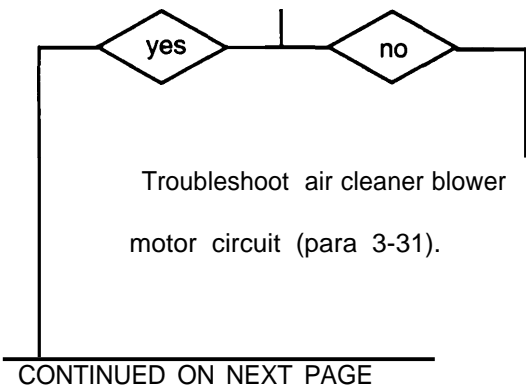
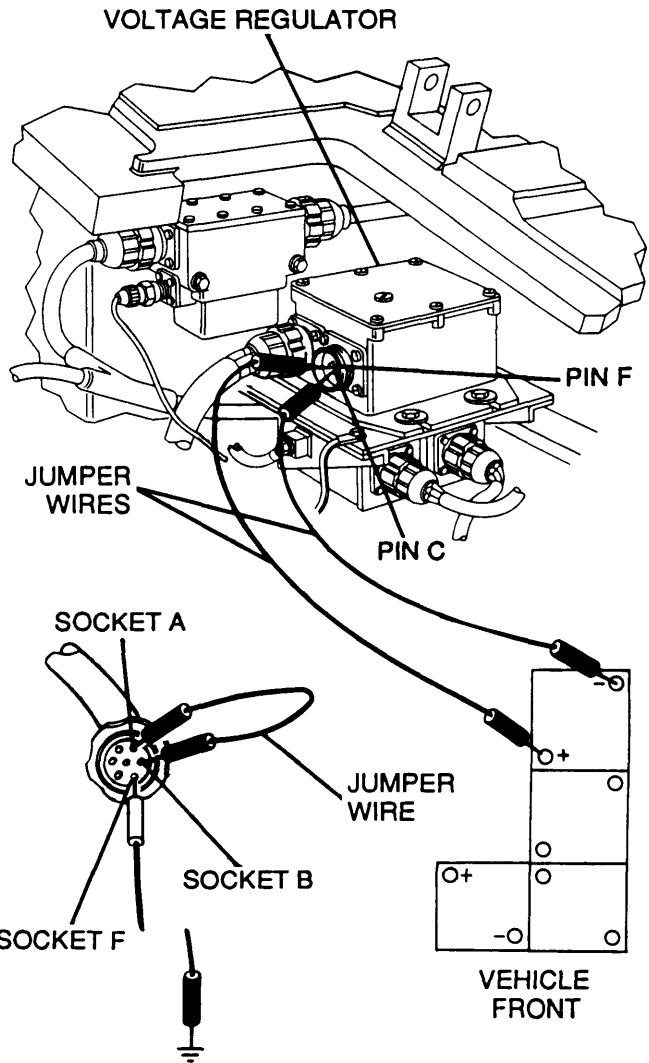

CONTINUED FROM STEP M

NOTE

Perform step M ONLY if vehicle is equipped with adjustable regulator. If not, replace voltage regulator (para 8-3).

M

Do not check or adjust voltage regulator except as follows:

1. Make sure batteries are fully charged while checking and/or adjusting regulator (TM 9-2350-311 -10).
2. Connect red lead of multimeter to positive battery cable terminal and black lead to negative battery cable terminal.
3. Start engine and run at approximately 1000 rpm. Run engine as required to bring engine compartment, regulator, and batteries to normal operating temperature.
4. During above warm-up period, increase engine speed to approximately 2500 rpm and then return to idle speed (750 rpm) while observing multimeter. Voltage reading should not vary more than ± 0.1 volt during above check. This also provides a check on tightness of wiring connection. Turn headlights on and off several times. Multimeter needle may vary slightly, but should return to its original voltage quickly.
5. Turn off all major vehicle electrical components and turn on vehicle headlights.
6. Open transmission left access door and remove square head pipe plug from end of voltage regulator (between and above harness connectors).

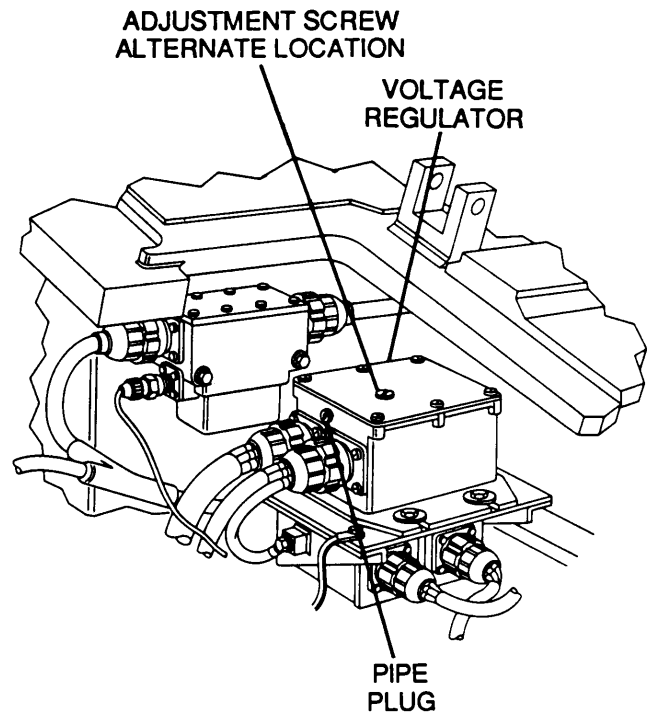

CONTINUED ON NEXT PAGE

3-3 TROUBLESHOOTING CHART — CONTINUED

n. ALTERNATOR CIRCUIT (M109A4/M109A5) —
CONTINUED

ALTERNATOR FAILS TO CHARGE BATTERIES; GAGE
INDICATION: NOT CHARGING, UNSTEADY OR
INACCURATE READING — CONTINUED

CONTINUED FROM STEP M

CAUTION

Rheostat turns easily. Do not force beyond the stops or damage to regulator may occur.

M

7. With engine running at 1000 rpm, use a screwdriver to adjust rheostat to obtain a voltage reading of 27.5 to 28.5 Vdc. Turn screwdriver counterclockwise to reduce voltage. Slowly turn screwdriver to bring regulated voltage up to 27.5 to 28.5 Vdc.
8. Replace pipe plug in end of voltage regulator.
9. Turn off vehicle headlights.
10. Repeat step 4. If this check is satisfactory, shut off engine and remove multimeter.
11. If voltage regulator cannot be adjusted, replace voltage regulator (para 8-3).
12. If electrical (battery) problems continue after the regulator has been properly checked and/or adjusted, check service, maintenance, and/or usage of battery (TM 9-6140-200-14).

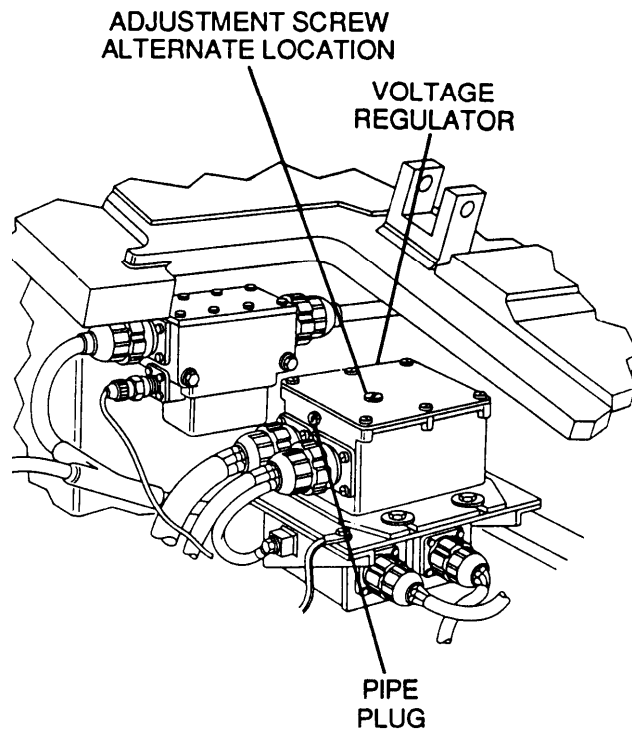

END OF TASK

0. ENGINE WATER TEMP INDICATOR CIRCUIT

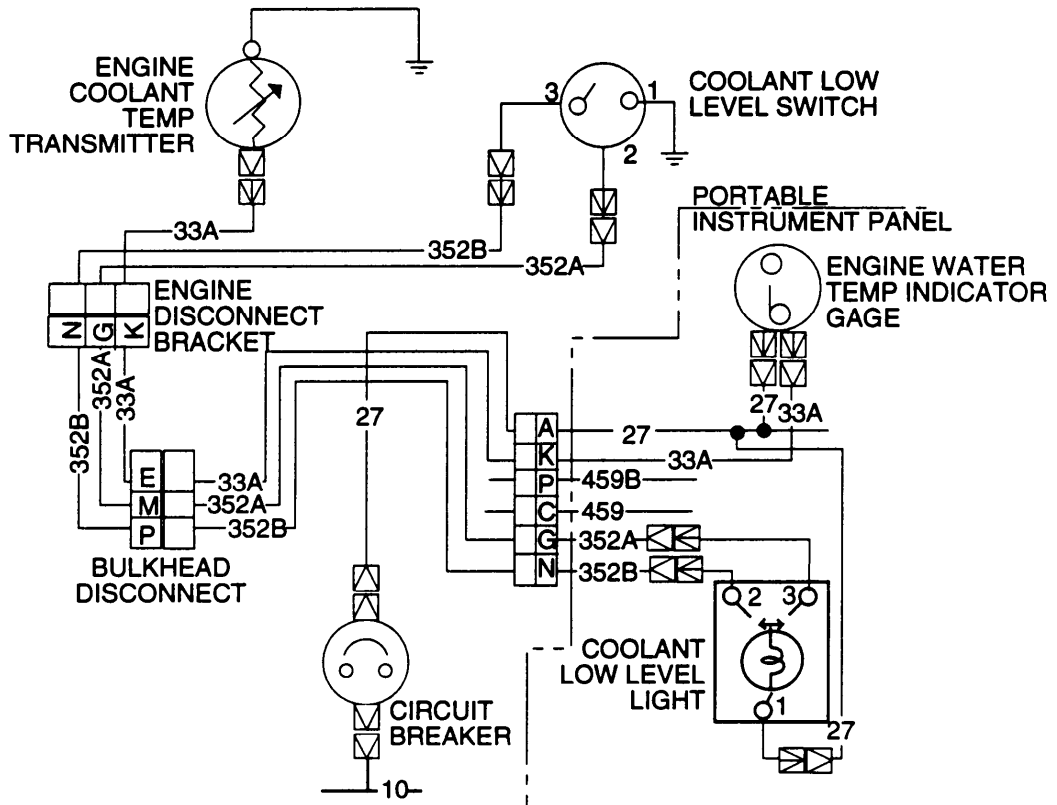

M109A2/M109A3

3-3 TROUBLESHOOTING CHART — CONTINUED

**o. ENGINE WATER TEMP INDICATOR CIRCUIT —
CONTINUED**

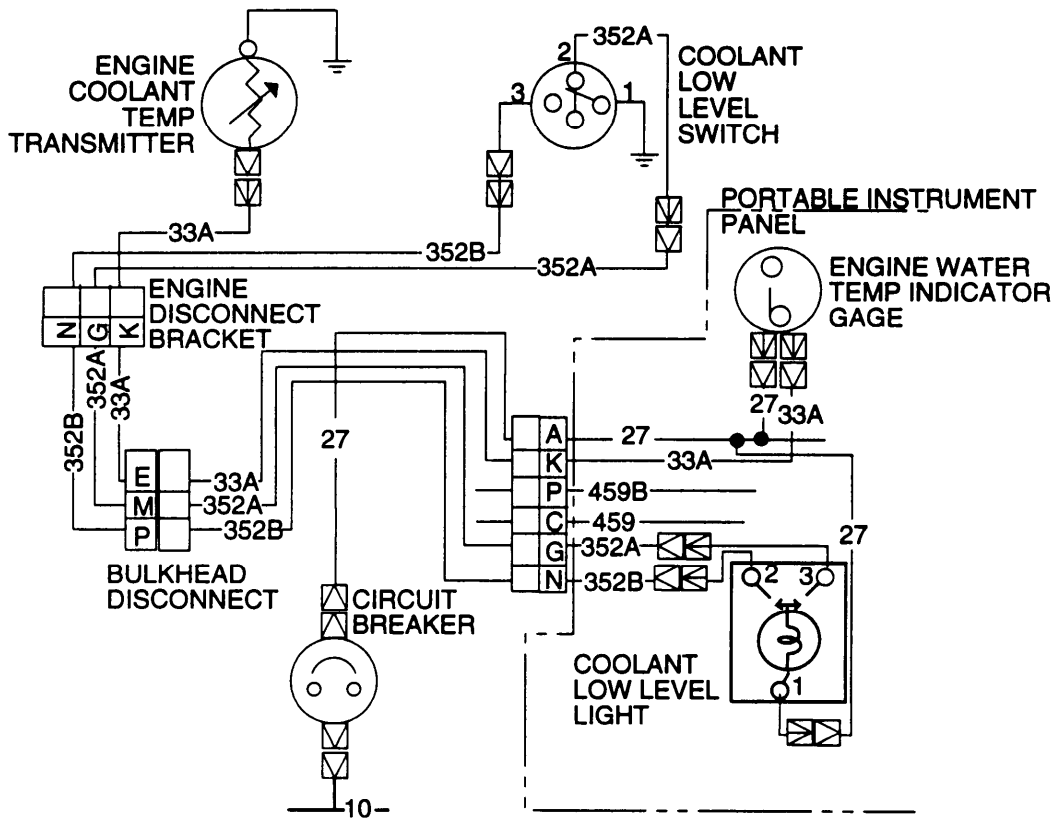

M109A4/M109A5

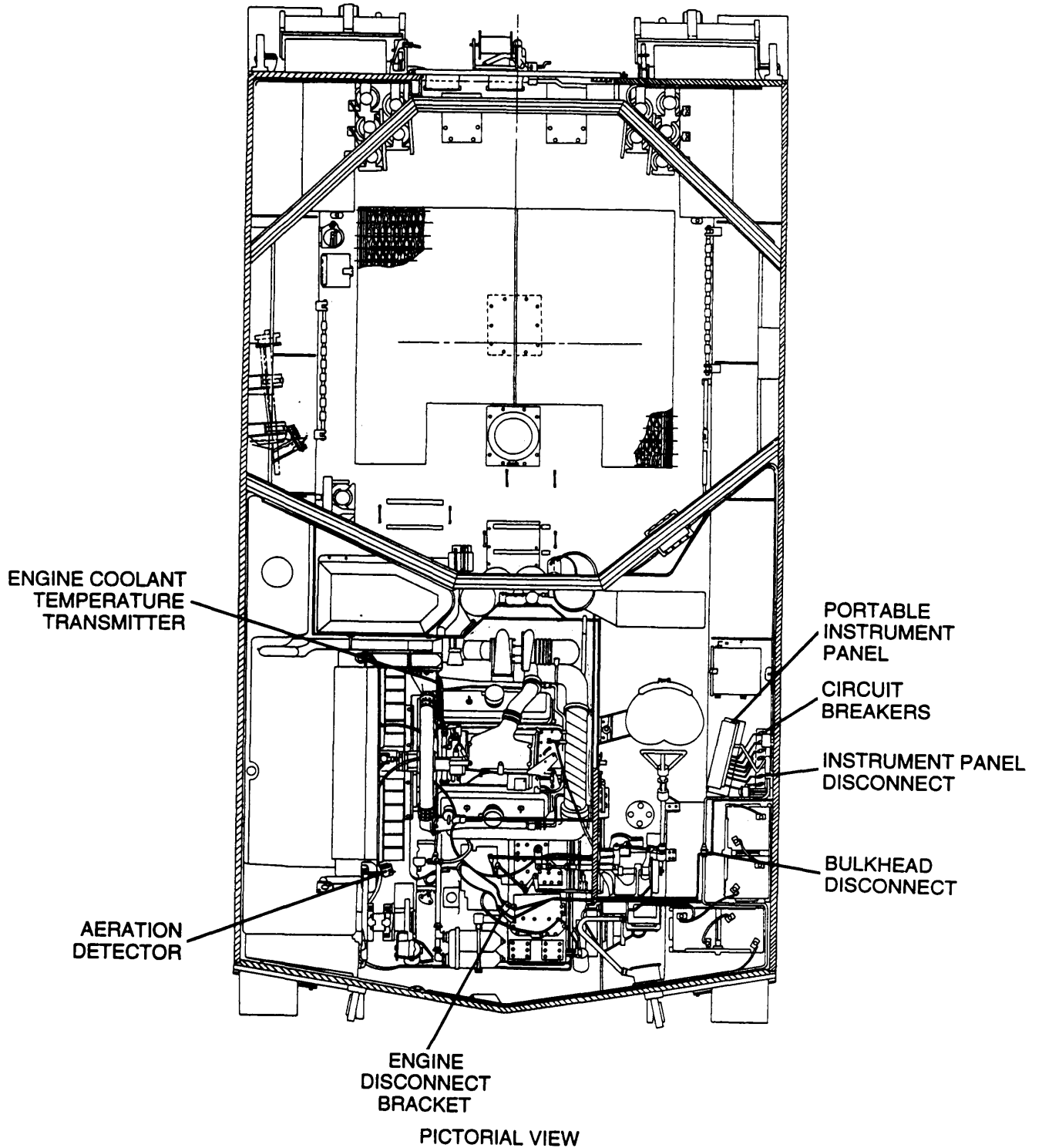

3-3 TROUBLESHOOTING CHART — CONTINUED

- o. ENGINE WATER TEMP INDICATOR CIRCUIT — CONTINUED (1) ENGINE WATER TEMP INDICATOR NEEDLE FAILS TO MOVE OR IS UNSTEADY; ALL OTHER GAGES OPERATE PROPERLY

INITIAL SETUP

<p><u>Tools</u> General mechanic's tool kit (item 64, Appx H) Multimeter (item 36, APPX H) TA-1 probe kit (item 43, APPX H) (Long test leads may be needed for some tests; 16 AWG wire maybe used as an extension.)</p>	<p><u>Personnel Required</u> Two</p> <p><u>Equipment Conditions</u> Engine access door open (TM 9-2350-311-10) Transmission access doors open (TM 9-2350-311-10) Portable instrument panel cover removed (para 8-17)</p>
---	--

A

1. Disconnect lead 33A from engine coolant temperature transmitter.
2. Turn MASTER switch ON and check ENGINE WATER TEMP gage for a reading.
3. If ENGINE WATER TEMP gage shows a minimum reading, place a jumper wire from lead 33A to ground.
4. Check ENGINE WATER TEMP gage for reading.
5. Turn MASTER switch OFF.

Does ENGINE WATER TEMP gage show minimum when not grounded, and maximum when grounded?

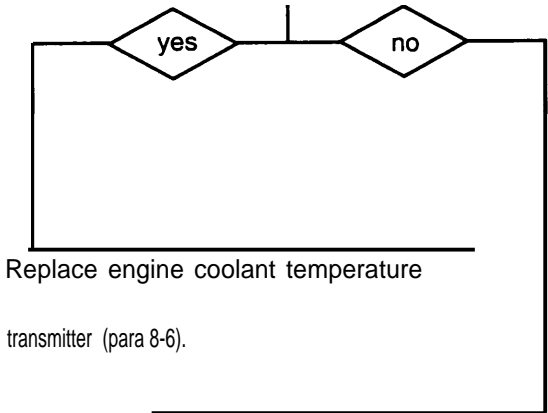
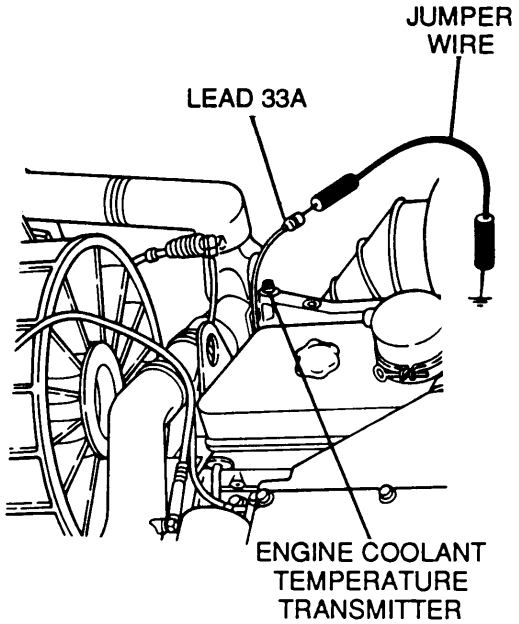

CONTINUED FROM STEP A

B

1. Reconnect lead 33A to engine coolant temperature transmitter.
2. Disconnect lead 33A from ENGINE WATER TEMP gage.
3. Turn MASTER switch ON and ENGINE WATER TEMP gage check for reading.
4. If ENGINE WATER TEMP gage shows a minimum reading, use a jumper wire to ground gage.
5. Check gage for reading.
6. Turn MASTER switch OFF.

Does ENGINE WATER TEMP gage show minimum when not grounded, and maximum when grounded?

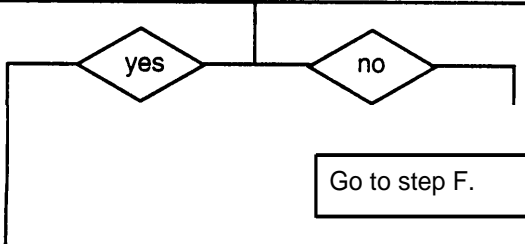

c

1. Reconnect lead 33A to ENGINE WATER TEMP gage.
2. Disconnect battery ground leads.
3. Disconnect bulkhead-to-portable instrument panel wiring harness from portable instrument panel bracket.
4. Place jumper wires from pin A to socket A (lead 27), from socket P (lead 459B) to socket C (lead 459).
5. Reconnect battery ground leads.
6. Turn MASTER switch ON and check ENGINE WATER TEMP gage for reading.
7. If gage shows a minimum reading, place a jumper wire from pin K (lead 33A) to ground.
8. Check gage for reading.
9. Turn MASTER switch OFF.

Does ENGINE WATER TEMP gage show minimum when not grounded, and maximum when grounded?

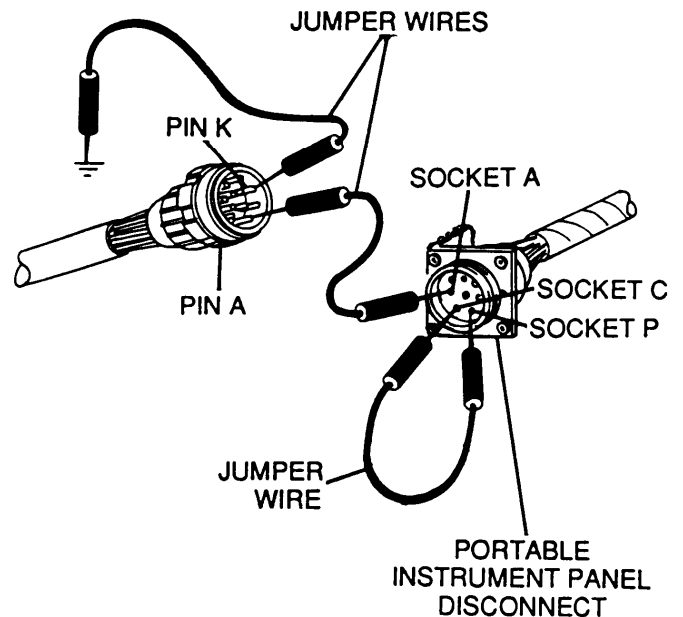
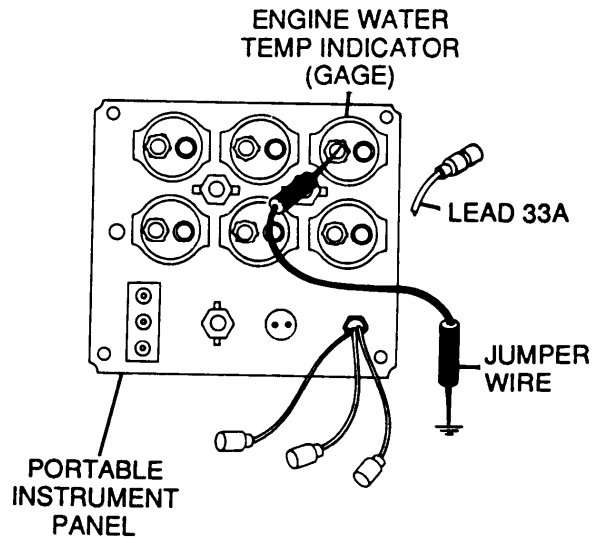
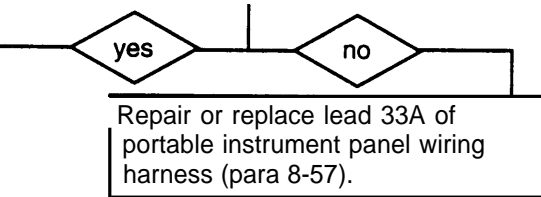

CONTINUED ON NEXT PAGE

3-3 TROUBLESHOOTING CHART — CONTINUED

o. ENGINE WATER TEMP INDICATOR CIRCUIT — CONTINUED

(1) ENGINE WATER TEMP INDICATOR NEEDLE FAILS TO MOVE OR IS UNSTEADY; ALL OTHER GAGES OPERATE PROPERLY — CONTINUED

CONTINUED FROM STEP C

D

1. Reconnect portable instrument panel wiring harness to portable instrument panel disconnect.
2. Disconnect battery ground leads.
3. Disconnect bulkhead-to-portable instrument panel wiring harness from driver's bulkhead.
4. Place a jumper wire from pin B to socket B (lead 400-459B).
5. Reconnect battery ground leads.
6. Turn MASTER switch ON and check ENGINE WATER TEMP gage for reading.
7. If gage shows a minimum reading, place a jumper wire from pin E (lead 33A) to ground.
8. Check gage for reading.
9. Turn MASTER switch OFF.

Does ENGINE WATER TEMP gage show minimum when not grounded, and maximum when grounded?

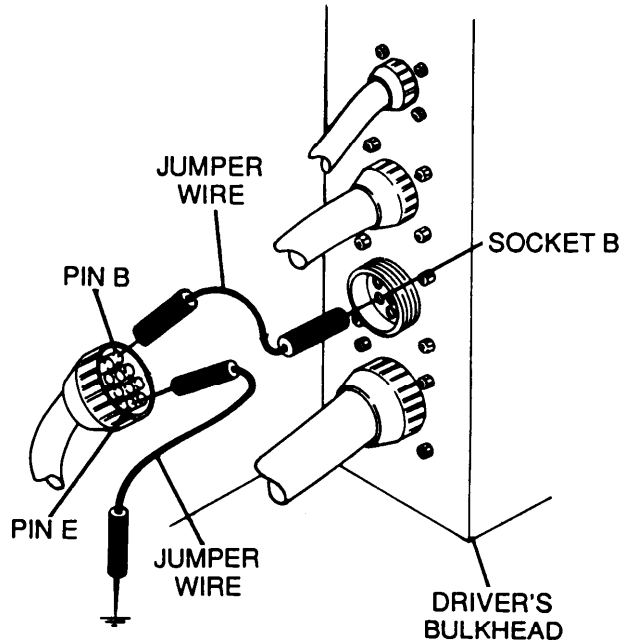

M109A4/M109A5 SHOWN

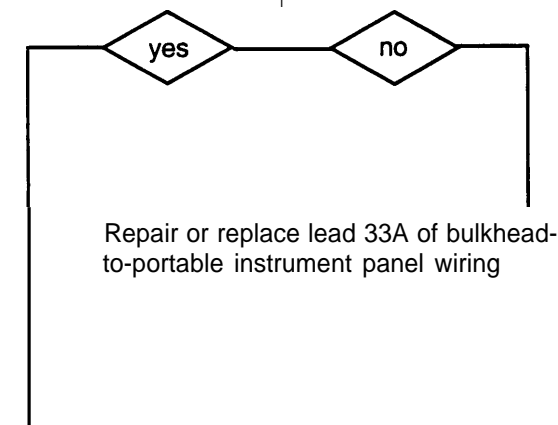

CONTINUED ON NEXT PAGE

CONTINUED FROM STEP D

- | | |
|----------|--|
| E | <ol style="list-style-type: none"> 1. Reconnect bulkhead-to-portable instrument panel wiring harness to driver's bulkhead. 2. Disconnect engine disconnect bracket-to-bulkhead wiring harness from engine disconnect bracket. 3. Turn MASTER switch ON and check ENGINE WATER TEMP gage for reading. 4. If gage shows a minimum reading, place a jumper wire from socket K (lead 33A) to ground. 5. Check gage for reading. 6. Turn MASTER switch OFF. |
|----------|--|

Does ENGINE WATER TEMP gage show minimum when not grounded, and maximum when grounded?

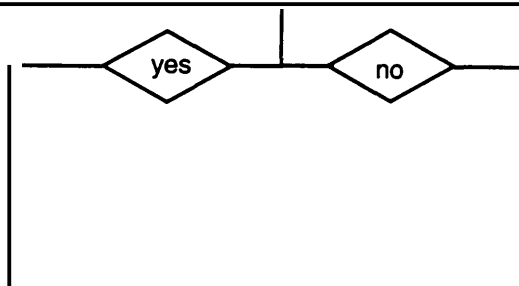

Repair or replace lead 33A of engine disconnect bracket-to-bulkhead wiring harness (para 8-45, M109A2/M109A3; 8-46, M109A4/M109A5).

Repair or replace lead 33A of powerplant wiring harness (para 8-43, M109A2/M109A3; 8-44, M109A4/M109A5).

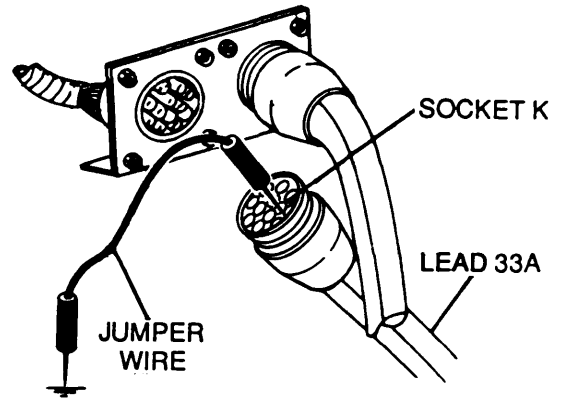

M109A4/M109A5 SHOWN

3-3 TROUBLESHOOTING CHART — CONTINUED

o. ENGINE WATER TEMP INDICATOR CIRCUIT — CONTINUED (1) ENGINE WATER TEMP INDICATOR NEEDLE FAILS TO MOVE OR IS UNSTEADY; ALL OTHER GAGES OPERATE PROPERLY — CONTINUED

CONTINUED FROM STEP B

F

1. Reconnect lead 33A to ENGINE WATER TEMP gage.
2. Disconnect lead 27 from ENGINE WATER TEMP gage.
3. Place red lead of multimeter in lead 27 and black lead to ground.
4. Turn MASTER switch ON and check for voltage.
5. Turn MASTER switch OFF.

Is voltage present?

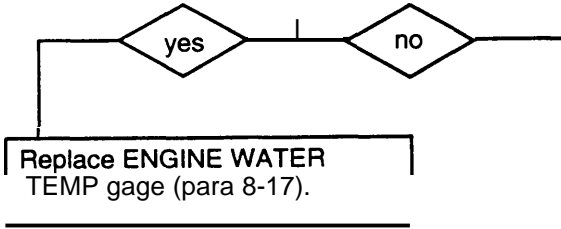
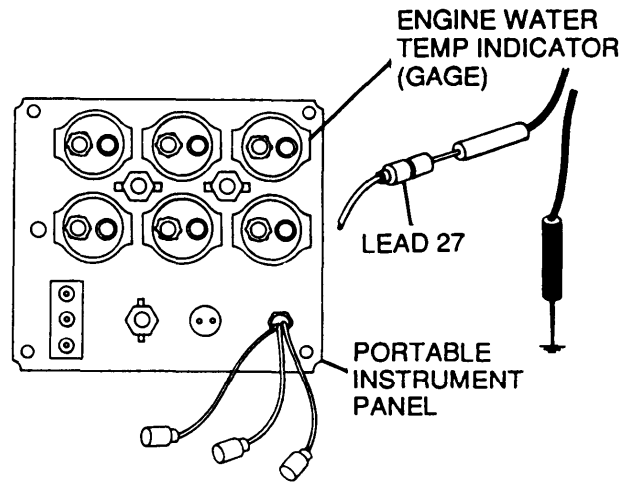

G

1. Reconnect lead 27 to ENGINE WATER TEMP gage.
2. Disconnect lead 27 from circuit breaker output.
3. Place red lead of multimeter in circuit breaker and black lead to ground.
4. Turn MASTER switch ON and check for voltage.
5. Turn MASTER switch OFF.

Is voltage present?

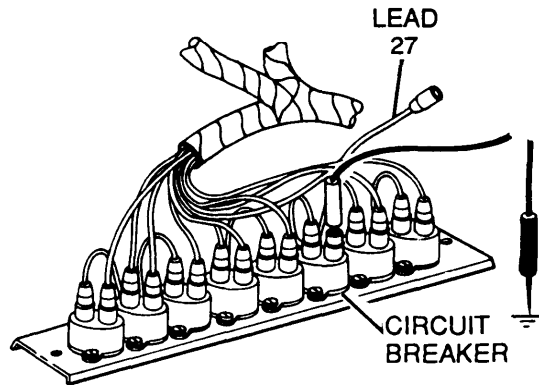

M109A4/M109A5 SHOWN

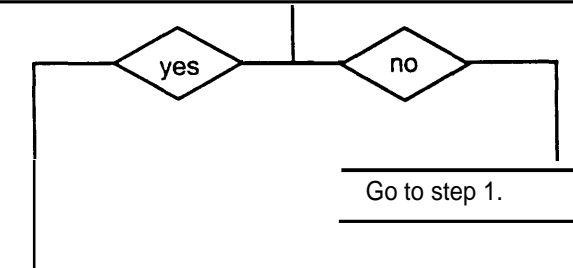

CONTINUED ON NEXT PAGE

CONTINUED FROM STEP G

- H**
1. Reconnect lead 27 to circuit breaker output.
 2. Disconnect bulkhead-to-portable instrument panel wiring harness from portable instrument panel bracket.
 3. Place a jumper wire from socket P (lead 459B) to socket C (lead 459).
 4. Place red lead of multimeter in socket A (lead 27) and black lead to ground.
 5. Turn MASTER switch ON and check for voltage.
 6. Turn MASTER switch OFF.

Is voltage present?

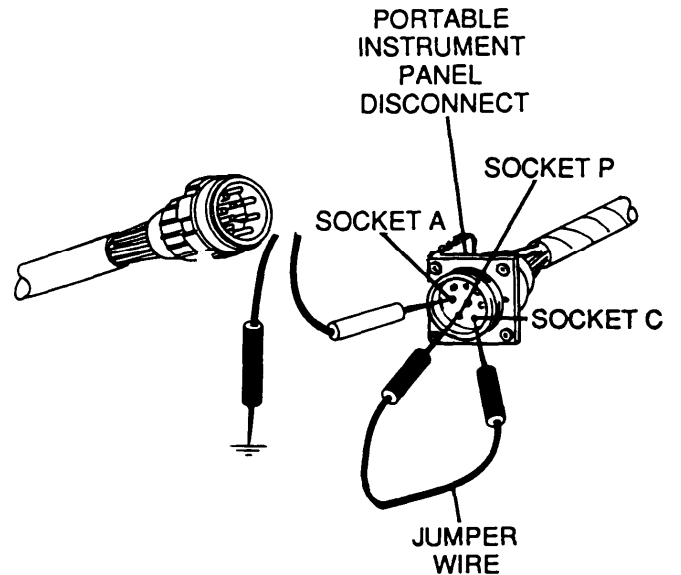
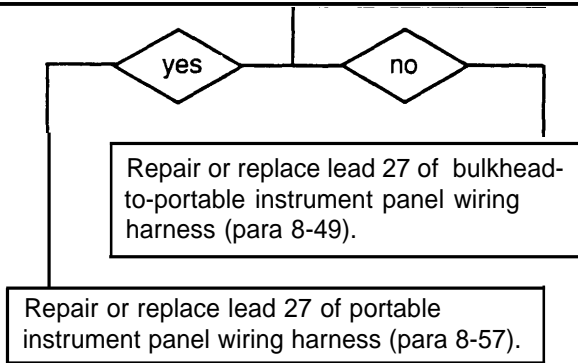

CONTINUED FROM STEP G

- I**
1. Reconnect lead 27 to circuit breaker output.
 2. Disconnect lead 10 from circuit breaker input.
 3. Place red lead of multimeter in lead 10 and black lead to ground.
 4. Turn MASTER switch ON and check for voltage.
 5. Turn MASTER switch OFF.

Is voltage present?

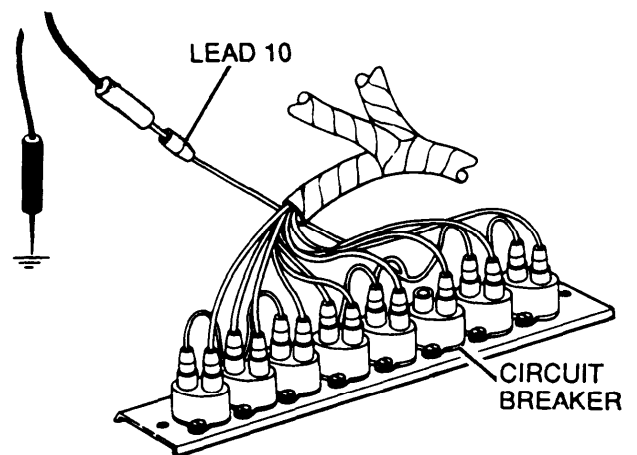
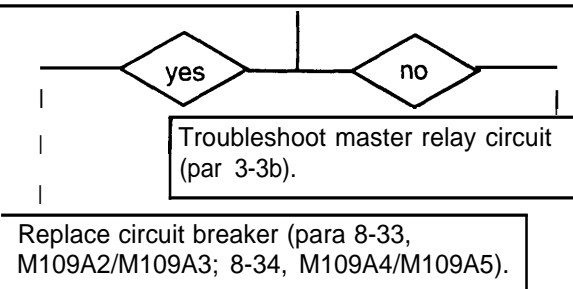

M109A4/M109A5 SHOWN

END OF TASK

3-3 TROUBLESHOOTING CHART — CONTINUED

- o. ENGINE WATER TEMP INDICATOR CIRCUIT — CONTINUED (2) ENGINE LOW LEVEL COOLANT LIGHT FAILS TO LIGHT WHEN PRESSED-TO-TEST; ALL OTHER LIGHTS OPERATE

INITIAL SETUP

Tools

General mechanic's tool kit (item 64, APPX H)
 Multimeter (item 36, Appx H)
 TA-1 probe kit (item 43, Appx H)
 (Long test leads may be needed for some tests; 16 AWG wire maybe used as an extension.)

Personnel Required

Two

Equipment Conditions

Engine access door open (TM 9-2350-311-10)
 Transmission access covers open (TM 9-2350-311-1 0)
 Portable instrument panel cover removed (para 8-17)

A

1. Disconnect lead 352A from COOLANT indicator light.
2. Place a jumper wire from lead 352A to ground.
3. Turn MASTER switch ON and press COOLANT indicator light.
4. Turn MASTER switch OFF.

Does COOLANT indicator light operate?

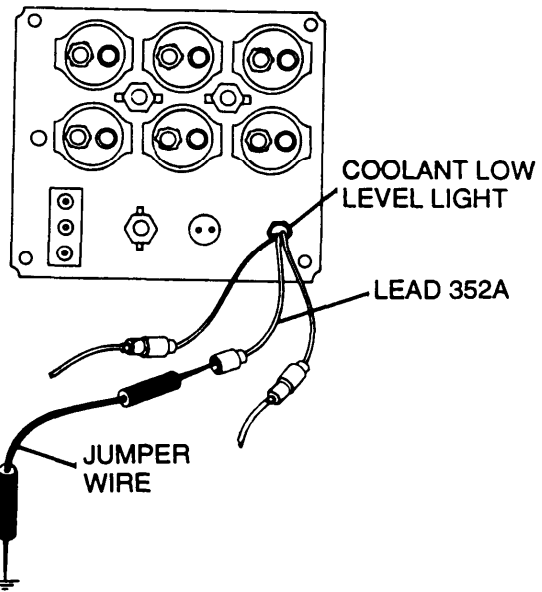
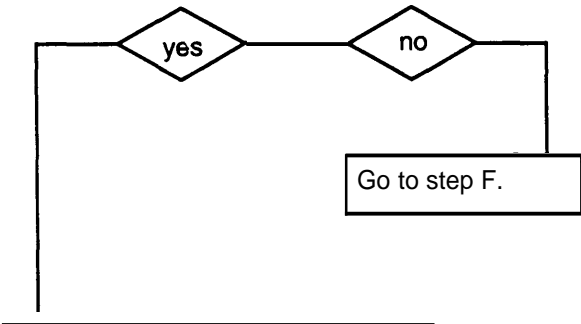

CONTINUED FROM STEP A

- B**
1. Reconnect lead 352A to COOLANT indicator light.
 2. Disconnect battery ground leads.
 3. Disconnect portable instrument panel wiring harness from portable instrument panel bracket.
 4. Place jumper wires from pin A to socket A (lead 27), from socket P (lead 4596) to socket C (459), and from pin G (lead 352A) to ground.
 5. Reconnect battery ground leads.
 6. Turn MASTER switch ON and press COOLANT indicator light.
 7. Turn MASTER switch OFF.
- Does COOLANT indicator light operate?

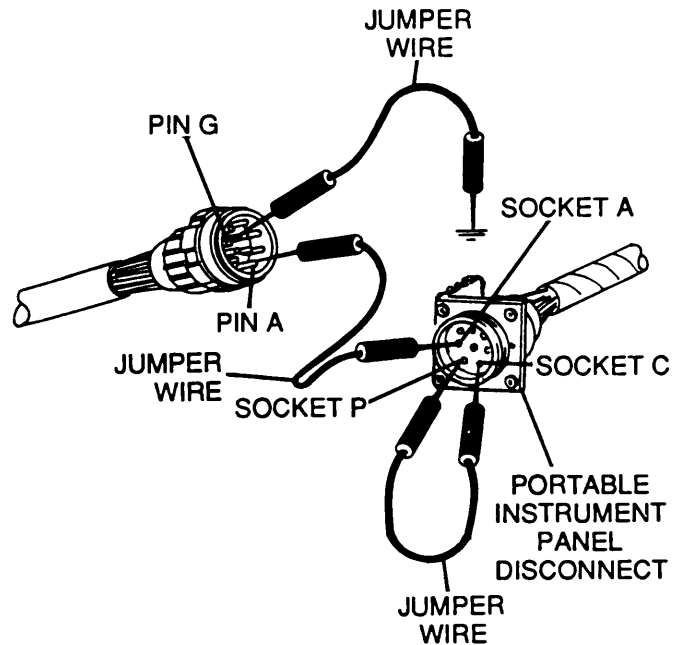
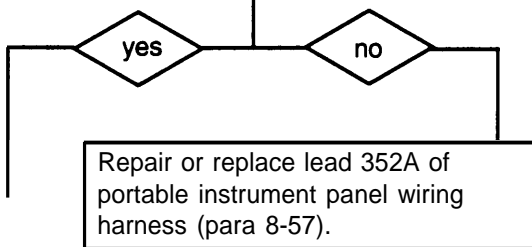

- C**
1. Reconnect portable instrument panel wiring harness to portable instrument panel disconnect.
 2. Disconnect battery ground leads.
 3. Disconnect bulkhead-to-portable instrument panel wiring harness from driver's bulkhead.
 4. Place jumper wires from pin B to socket B (lead 400-459B) and from pin M (lead 352A) to ground.
 5. Reconnect battery ground leads.
 6. Turn MASTER switch ON and press COOLANT indicator light.
 7. Turn MASTER switch OFF.
- Does **COOLANT** indicator light operate?

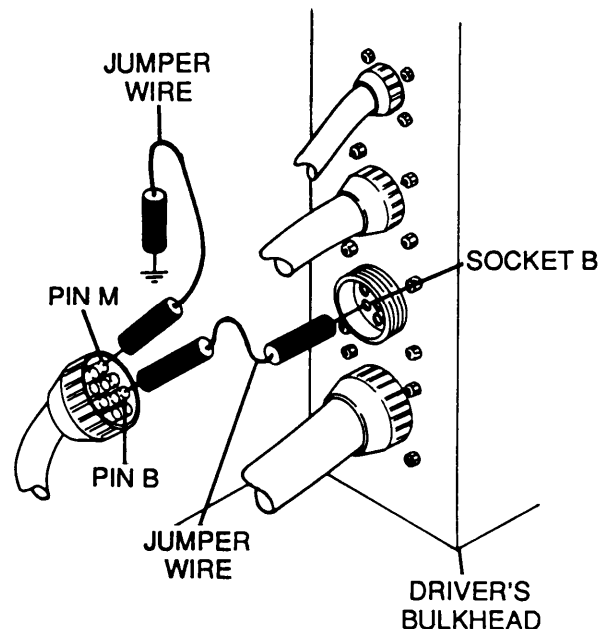
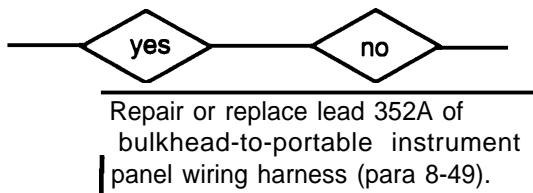

M109A4/M109A5 SHOWN

CONTINUED ON NEXT PAGE

3-3 TROUBLESHOOTING CHART — CONTINUED

- o. ENGINE WATER TEMP INDICATOR CIRCUIT — CONTINUED (2) ENGINE LOW LEVEL COOLANT LIGHT FAILS TO LIGHT WHEN PRESSED-TO-TEST; ALL OTHER LIGHTS OPERATE — CONTINUED

CONTINUED FROM STEP C

D	<ol style="list-style-type: none"> 1. Reconnect bulkhead-to-portable instrument panel wiring harness to driver's bulkhead. 2. Disconnect engine disconnect bracket-to-bulkhead wiring harness at engine disconnect bracket. 3. Place a jumper wire from socket G (lead 352A) to ground. 4. Turn MASTER switch ON and press COOLANT indicator light. 5. Turn MASTER switch OFF.
Does COOLANT indicator light operate?	

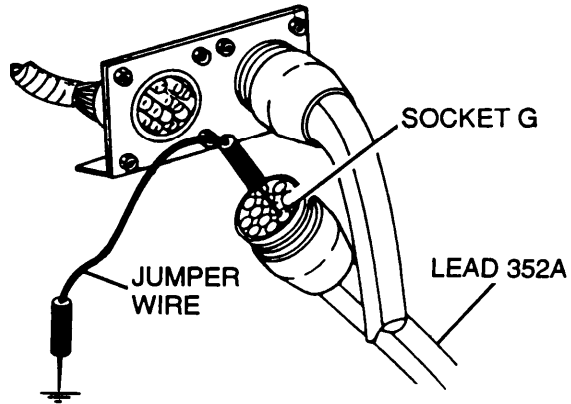

M109A4/M109A5 SHOWN

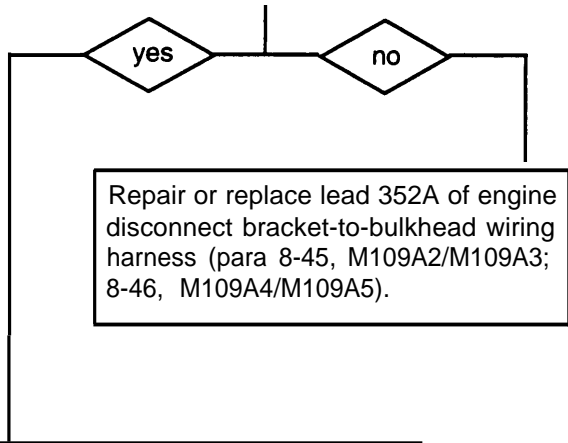

CONTINUED ON NEXT PAGE

CONTINUED FROM STEP D

- E**
1. Reconnect bulkhead-to-engine disconnect bracket wiring harness to engine disconnect bracket.
 2. Disconnect lead 352A from aeration detector.
 3. Place jumper wire from lead 352A to ground.
 4. Turn MASTER switch ON and press COOLANT indicator light.
 5. Turn MASTER switch OFF.
- Does COOLANT indicator light operate?

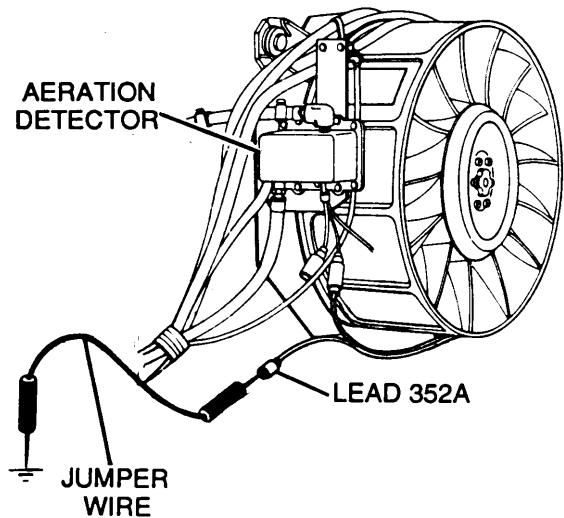
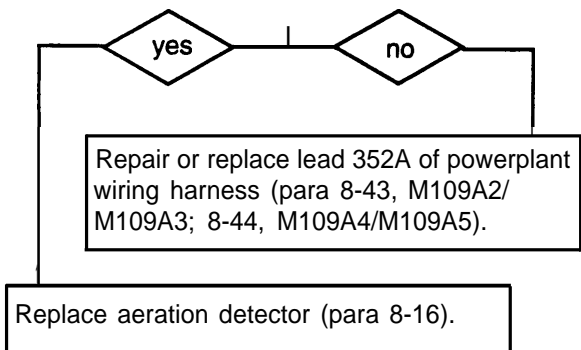

CONTINUED FROM STEP A

- F**
1. Reconnect lead 352A to COOLANT indicator light.
 2. Disconnect lead 27 from COOLANT indicator light.
 3. Place red lead of multimeter in lead 27 and black lead to ground.
 4. Turn MASTER switch ON and check for voltage.
 5. Turn MASTER switch OFF.
- Is voltage present?

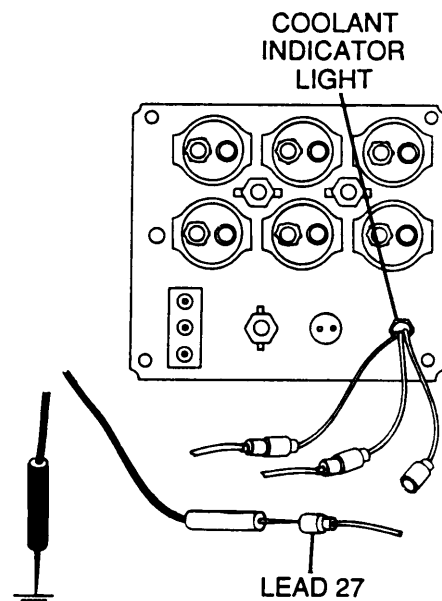
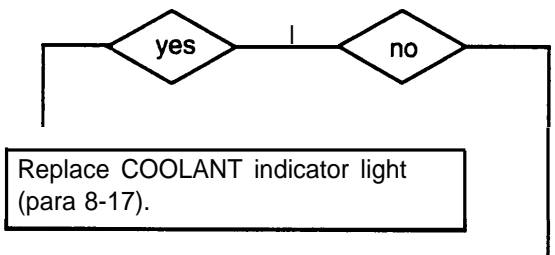

CONTINUED ON NEXT PAGE

3-3 TROUBLESHOOTING CHART — CONTINUED

o. ENGINE WATER TEMP INDICATOR CIRCUIT — CONTINUED

(2) ENGINE LOW LEVEL COOLANT LIGHT FAILS TO LIGHT WHEN PRESSED-TO-TEST; ALL OTHER LIGHTS OPERATE

CONTINUED FROM STEP F

G

1. Reconnect lead 27 to COOLANT indicator light.
2. Disconnect lead 27 from circuit breaker output.
3. Place red lead of multimeter in circuit breaker output and black lead to ground.
4. Turn MASTER switch ON and check for voltage.
5. Turn MASTER switch OFF.

Is voltage present?

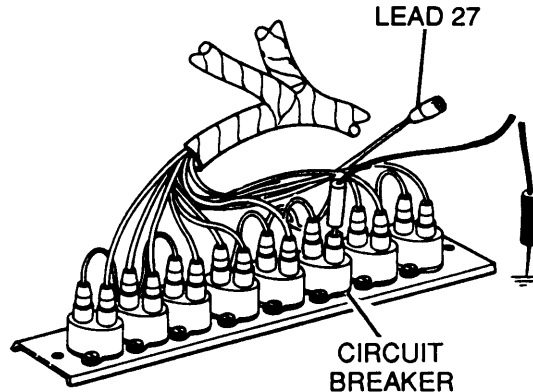

M109A4/M109A5 SHOWN

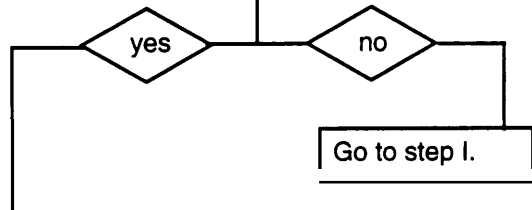

H

1. Reconnect lead 27 to circuit breaker output.
2. Disconnect portable instrument panel wiring harness from portable instrument panel bracket.
3. Place a jumper wire from socket P (lead 4596) to socket C (lead 459).
4. Place red lead of multimeter in socket A (lead 27).
5. Turn MASTER switch ON and check for voltage.
6. Turn MASTER switch OFF.

Is voltage present?

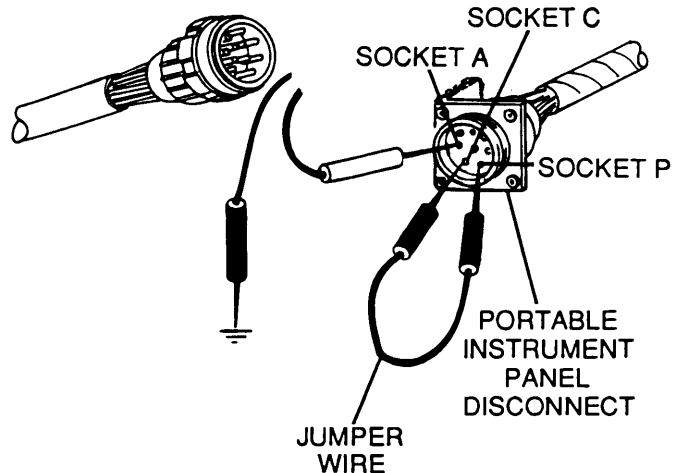

CONTINUED ON NEXT PAGE

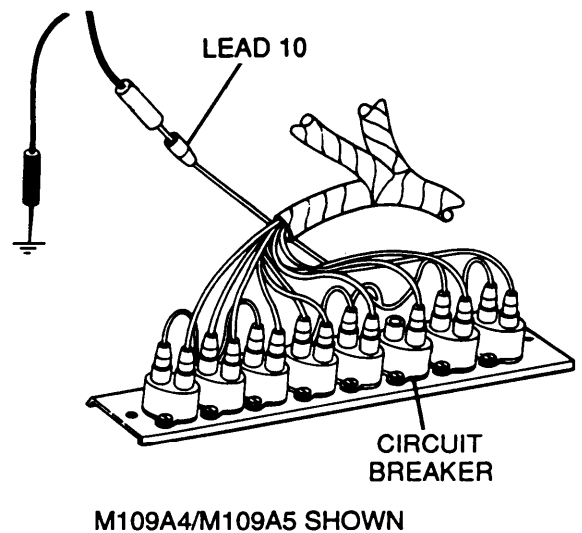
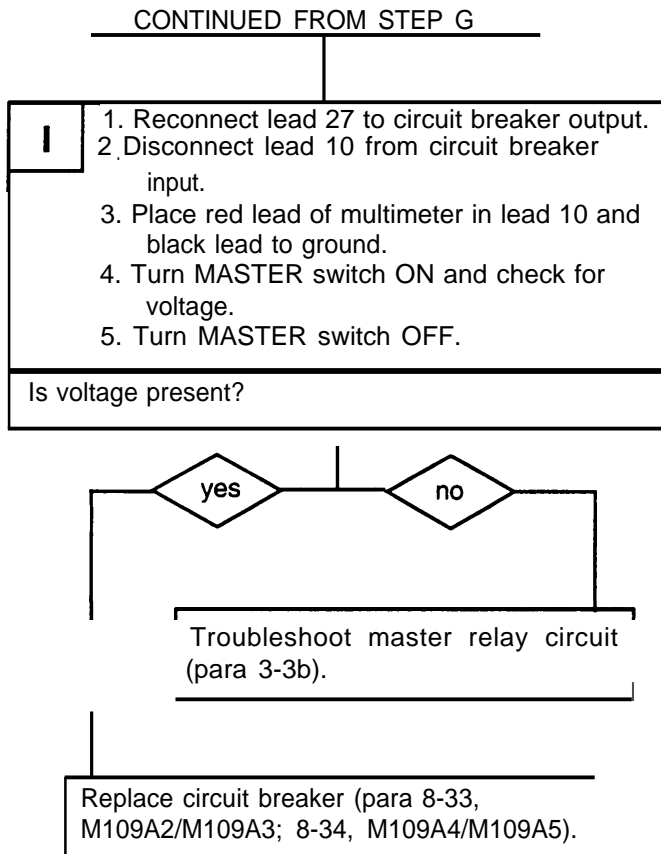
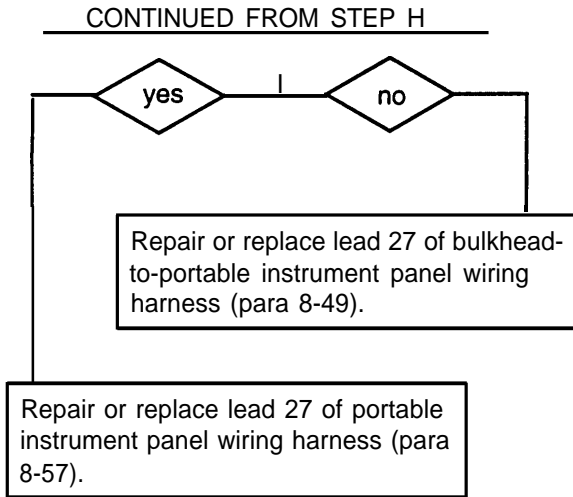

END OF TASK

3-3 TROUBLESHOOTING CHART — CONTINUED

- o. ENGINE WATER TEMP INDICATOR CIRCUIT — CONTINUED (3) ENGINE LOW LEVEL COOLANT LIGHT FAILS TO LIGHT WHEN ENGINE COOLANT LEVEL IS LOW; OPERATES WHEN PRESSED-TO-TEST

INITIAL SETUP

Tools

General mechanic's tool kit (item 64, Appx H)
 Multimeter (item 36, Appx H)
 TA-1 probe kit (item 43, Appx H)
 (Long test leads may be needed for some tests;
 16 AWG wire may be used as an extension.)

Personnel Requires

Two

Equipment Conditions

Engine access door open (TM 9-2350-311-10)
 Transmission access doors open (TM 9-2350-311-10)
 Portable instrument panel cover removed (para 8-17)

A	<ol style="list-style-type: none"> 1. Disconnect lead 352B from COOLANT indicator light. 2. Place a jumper wire from lead 352B to ground. 3. Turn MASTER switch ON and press COOLANT indicator light. 4. Turn MASTER switch OFF.
Does COOLANT indicator light operate?	

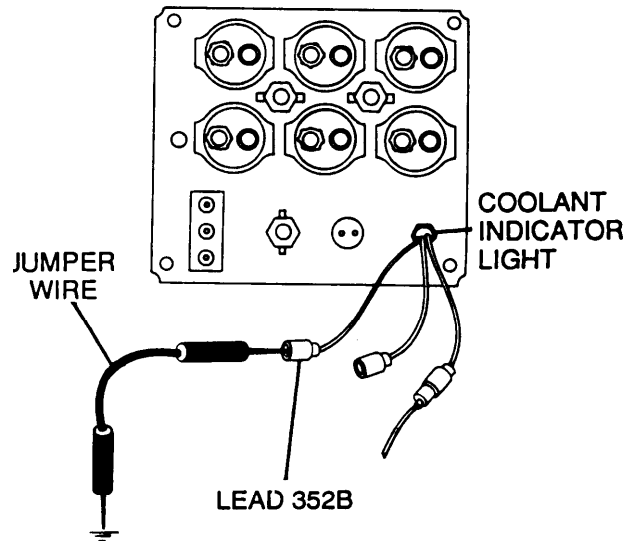
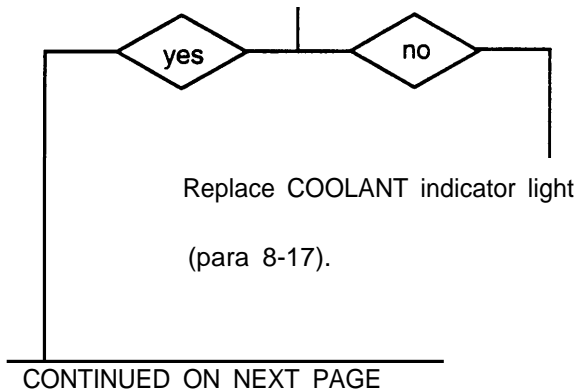

CONTINUED FROM STEP A

B

1. Reconnect lead 3526 to COOLANT indicator light.
2. Disconnect portable instrument panel wiring harness from portable instrument panel disconnect.
3. Place jumper wires from pin A to socket A (lead 27), and from socket P (lead 459B) to socket C (lead 459).
4. Place a jumper wire from pin N (lead 352B) to ground.
5. Turn MASTER switch ON and press COOLANT indicator light.
6. Turn MASTER switch OFF.

Does COOLANT indicator light operate?

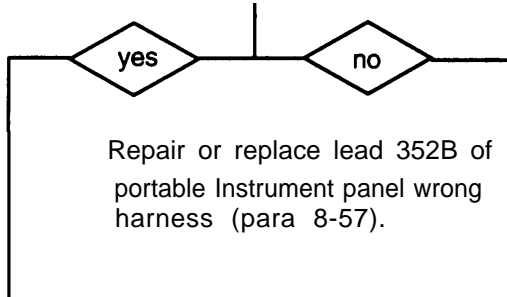
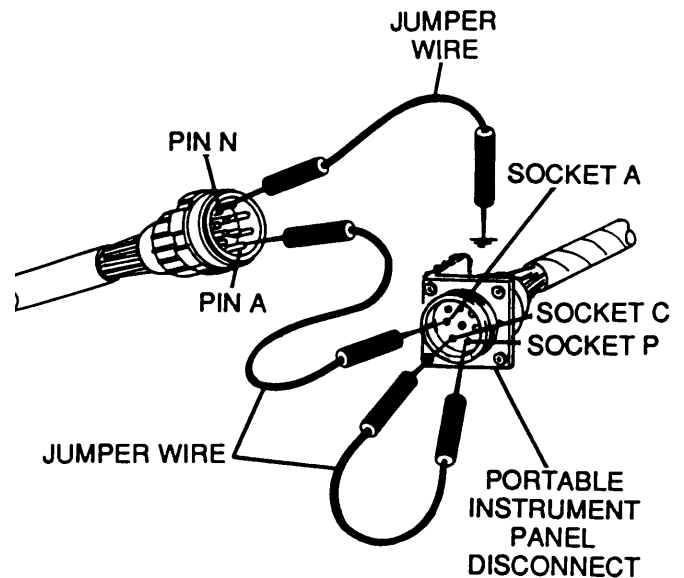

C

1. Reconnect portable instrument panel wiring harness to portable instrument panel disconnect.
2. Disconnect battery ground leads.
3. Disconnect bulkhead-to-portable instrument panel wiring harness from driver's bulkhead.
4. Place jumper wires from pin B to socket B (lead 400-459B), and from pin P (lead 352B) to ground.
5. Reconnect battery ground leads.
6. Turn MASTER switch on and press COOLANT indicator light.
7. Turn MASTER switch OFF.

Does COOLANT indicator light operate?

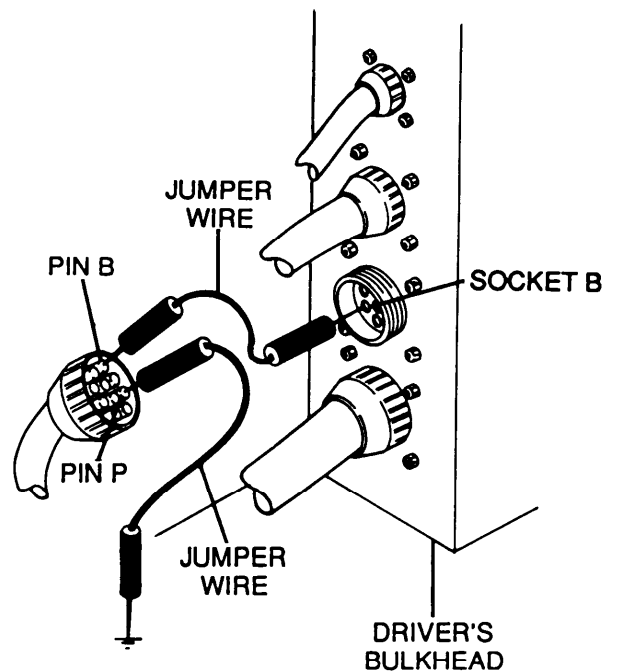

M109A4/M109A5 SHOWN

CONTINUED ON NEXT PAGE

3-3 TROUBLESHOOTING CHART — CONTINUED

- o. ENGINE WATER TEMP INDICATOR CIRCUIT — CONTINUED
- (3) ENGINE LOW LEVEL COOLANT LIGHT FAILS TO LIGHT WHEN ENGINE COOLANT LEVEL IS LOW; OPERATES WHEN PRESSED-TO-TEST — CONTINUED

CONTINUED FROM STEP C

D	<ol style="list-style-type: none"> 1. Reconnect bulkhead-to-portable instrument panel wiring harness to driver's bulkhead. 2. Disconnect bulkhead-to-engine bracket wiring harness from engine disconnect bracket. 3. Place a jumper wire from socket N (lead 3526) to ground. 4. Turn MASTER switch ON and press COOLANT indicator light. 5. Turn MASTER switch OFF.
Does COOLANT indicator light operate?	

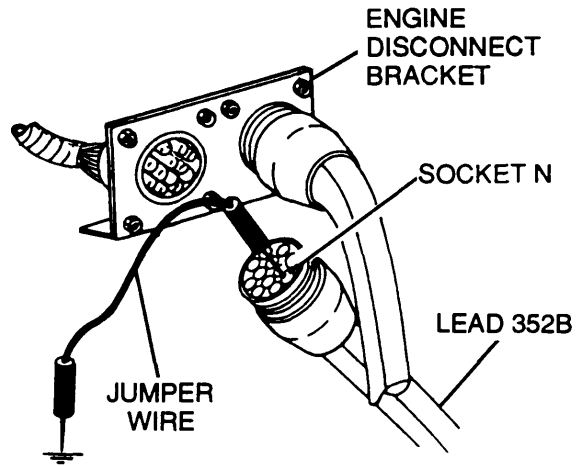

M109A4/M109A5 SHOWN

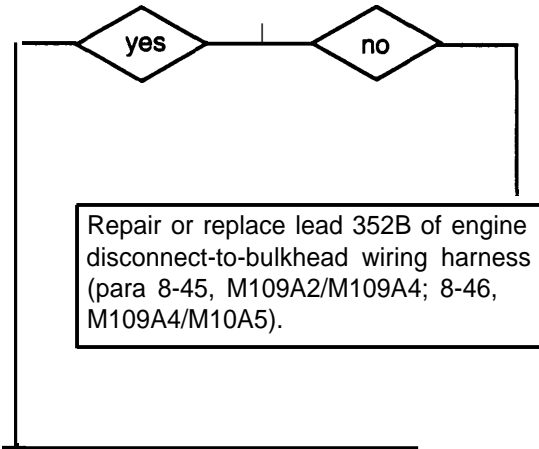

CONTINUED ON NEXT PAGE

CONTINUED FROM STEP D

- | | |
|--|--|
| E | <ol style="list-style-type: none"> 1. Reconnect bulkhead-to-engine bracket wiring harness to engine disconnect bracket. 2. Disconnect lead 352B from aeration detector. 3. Place a jumper wire from lead 352B to ground. 4. Turn MASTER switch ON and press COOLANT indicator light. 5. Turn MASTER switch OFF. |
| <p>Does COOLANT indicator light operate?</p> | |

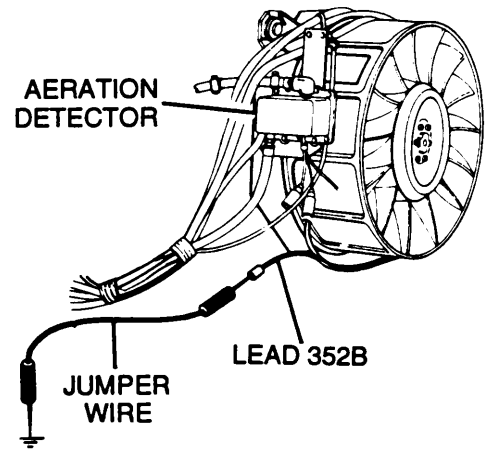
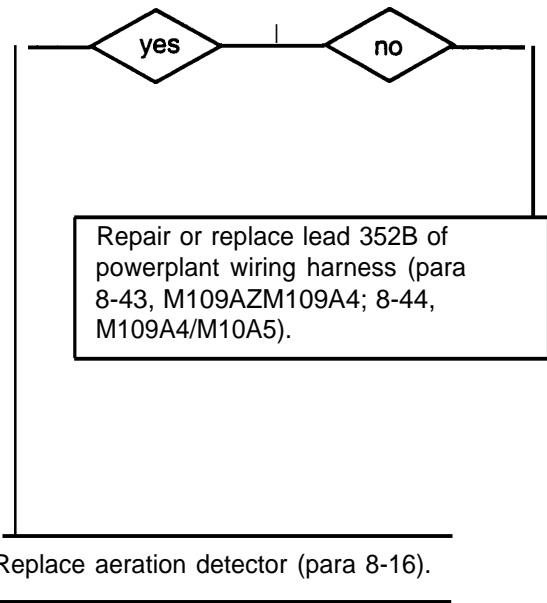

END OF TASK

3-3 TROUBLESHOOTING CHART — CONTINUED

p. TRANSMISSION OIL TEMPERATURE INDICATOR
CIRCUIT

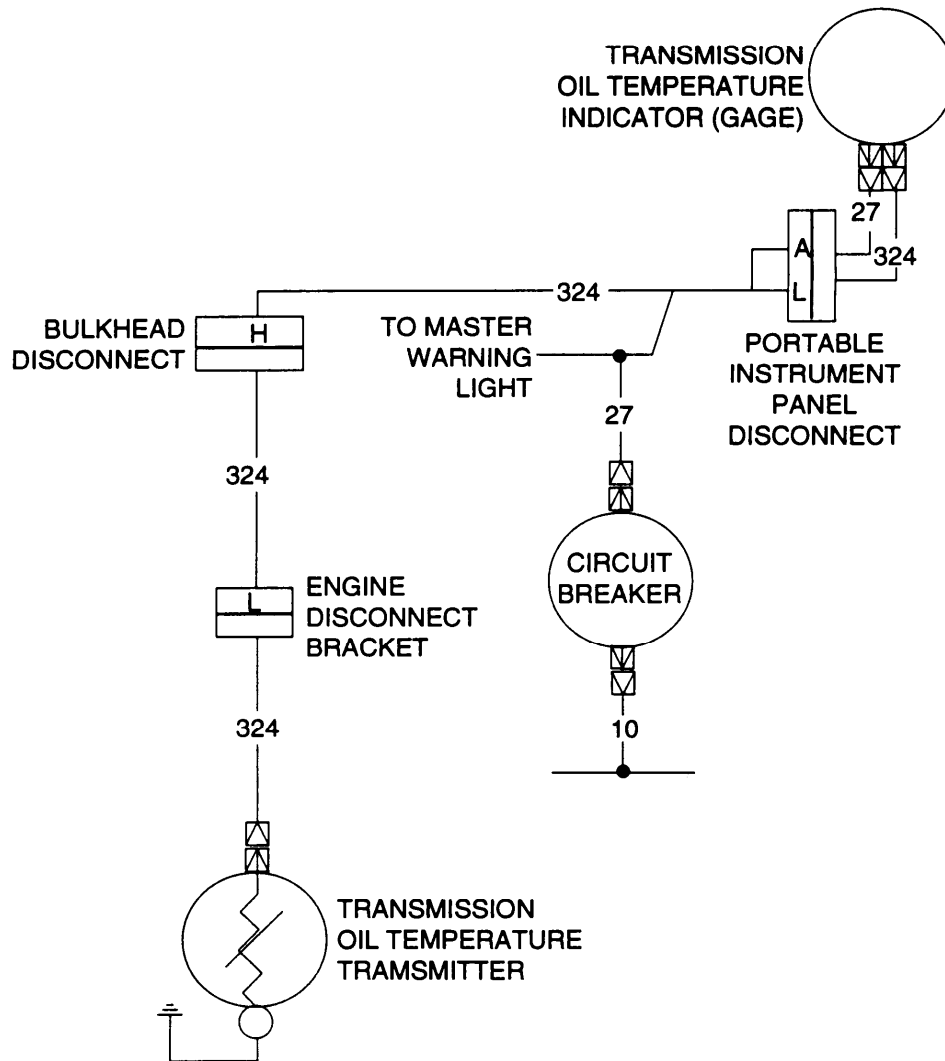

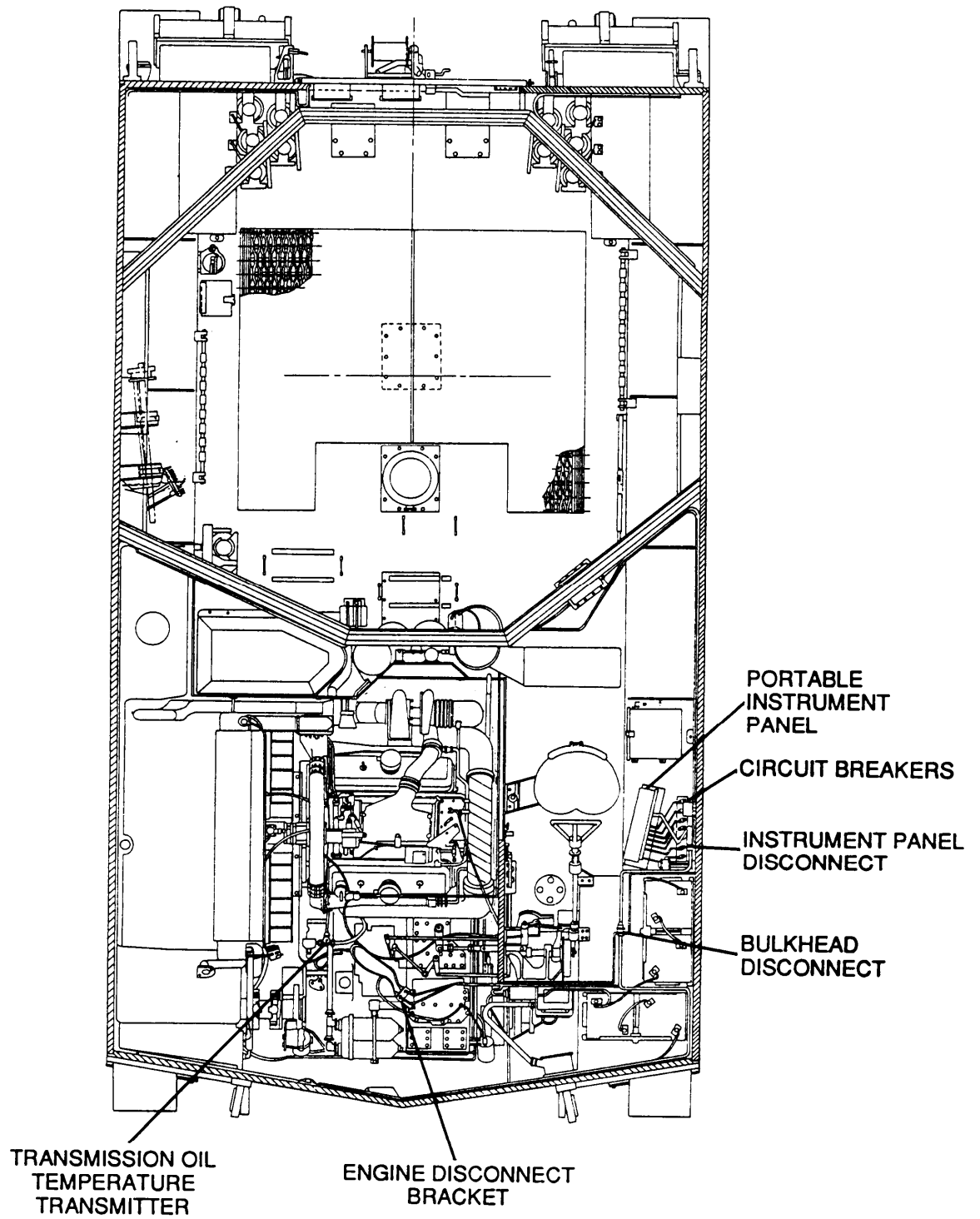

PICTORIAL VIEW

3-3 TROUBLESHOOTING CHART — CONTINUED

p. TRANSMISSION OIL TEMPERATURE INDICATOR CIRCUIT — CONTINUED
 TRANSMISSION OIL TEMP INDICATOR NEEDLE FAILS TO MOVE OR IS UNSTEADY; ALL OTHER GAGES OPERATE PROPERLY

INITIAL SETUP

Tools

General mechanic's tool kit (item 64, Appx H)
 Multimeters (item 36, Appx H)
 TA-1 probe kit (item 43, Appx H)
 (Long test leads may be needed for some tests;
 16 AWG wire maybe used as an extension.)

Personnel Required

Two

Equipment Conditions

Engine access door open (TM 9-2350-311-10)
 Transmission access doors open (TM 9-2350-311-10)
 Portable instrument panel cover removed (para 8-1 7)

A

1. Disconnect lead 324 from transmission oil temperature transmitter.
2. Turn MASTER switch ON and check TRANSMISSION OIL TEMP gage for a reading.
3. If ENGINE WATER TEMP gage shows a maximum reading, place a jumper wire from lead 324 to ground.
4. Check TRANSMISSION OIL TEMP gage for reading.
5. Turn MASTER switch OFF.

Does TRANSMISSION OIL TEMP gage show minimum when grounded and maximum when not grounded?

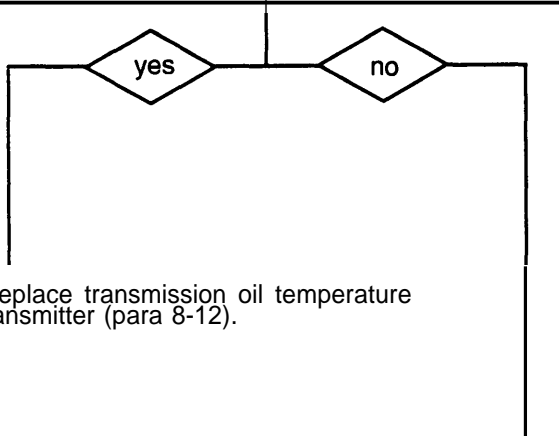
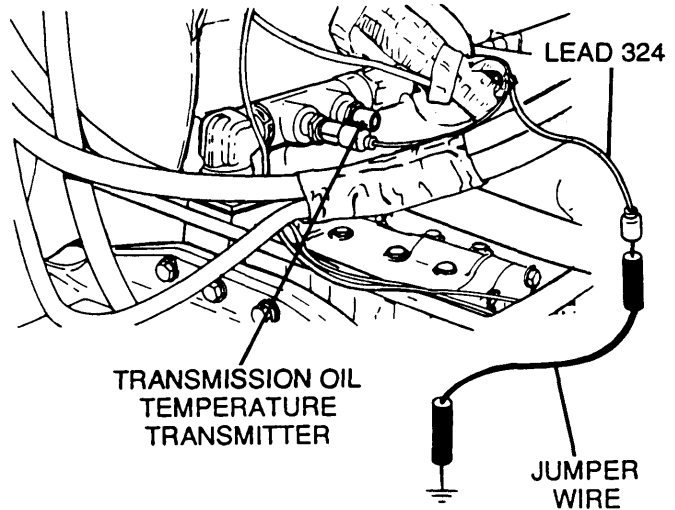

CONTINUED ON NEXT PAGE

CONTINUED FROM STEP A

B	<ol style="list-style-type: none"> 1. Reconnect lead 324 to transmission oil temperature transmitter. 2. Disconnect lead 324 from TRANSMISSION OIL TEMP gage. 3. Turn MASTER switch ON and check TRANSMISSION OIL TEMP gage for a reading. 4. If TRANSMISSION OIL TEMP gage shows a maximum reading, use a jumper wire to ground gage. 5. Check gage for reading. 6. Turn MASTER switch OFF. <p>Does TRANSMISSION OIL TEMP gage show minimum when grounded, and maximum when not grounded?</p>
----------	--

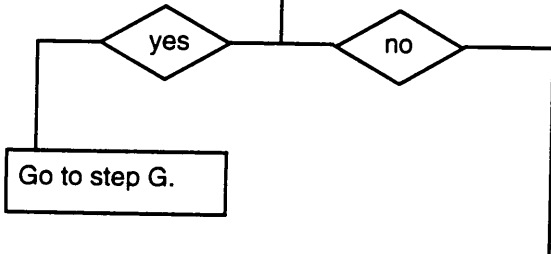

c	<ol style="list-style-type: none"> 1. Reconnect lead 324 to TRANSMISSION OIL TEMP gage. 2. Disconnect lead 27 from TRANSMISSION OIL TEMP gage. 3. Place red lead of multimeters in lead 27 and black lead to ground. 4. Turn MASTER switch ON and check for voltage. 5. Turn MASTER switch OFF. <p>Is voltage present?</p>
----------	---

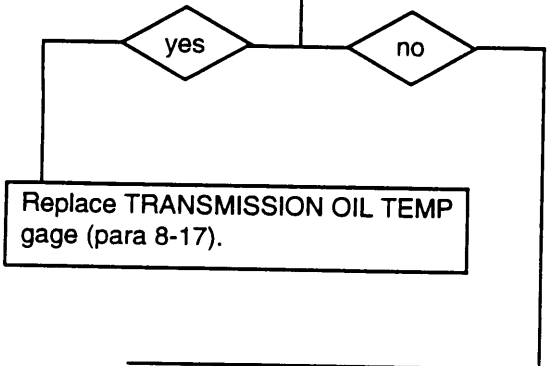

CONTINUED ON NEXT PAGE

3-3 TROUBLESHOOTING CHART — CONTINUED

p, TRANSMISSION OIL TEMPERATURE INDICATOR CIRCUIT — CONTINUED
 TRANSMISSION OIL TEMP INDICATOR NEEDLE FAILS TO MOVE OR IS UNSTEADY; ALL OTHER GAGES OPERATE PROPERLY — CONTINUED

CONTINUED FROM STEP C

D	<ol style="list-style-type: none"> 1. Reconnect lead 27 to TRANSMISSION OIL TEMP gage. 2. Disconnect battery ground leads. 3. Disconnect portable instrument panel wiring harness from portable instrument panel disconnect. 4. Place a jumper wire from socket P (lead 459B) to socket C (lead 459). 5. Place red lead of multimeters in socket A (lead 27) and black lead to ground. 6. Reconnect battery ground leads. 7. Turn MASTER switch ON and check for voltage. 8. Turn MASTER switch OFF.
Is voltage present?	

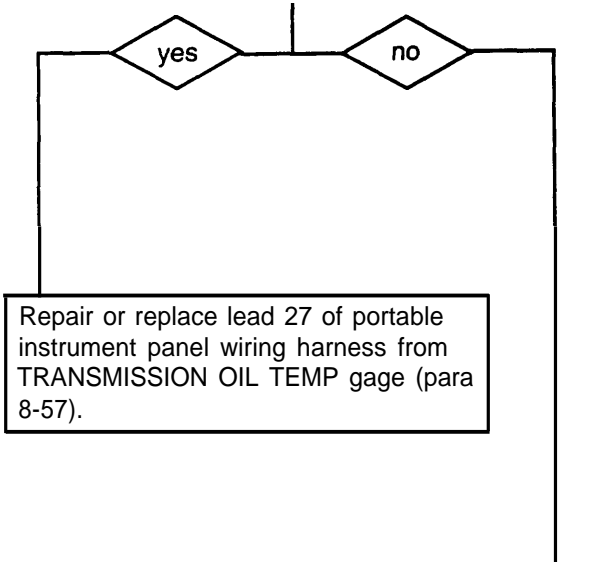
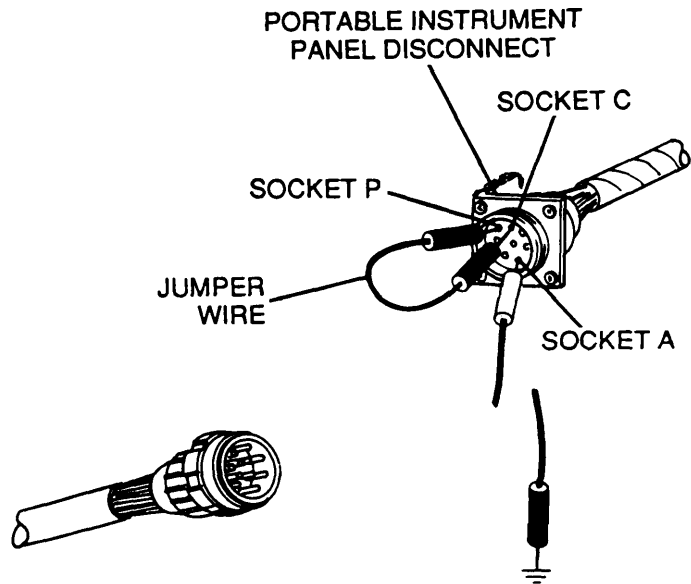

CONTINUED ON NEXT PAGE

CONTINUED FROM STEP D

E

1. Reconnect portable instrument panel wiring harness to portable instrument panel bracket.
2. Disconnect lead 27 from circuit breaker output.
3. Place red lead of multimeters in circuit breaker output and black lead to ground.
4. Turn MASTER switch ON and check for voltage.
5. Turn MASTER switch OFF.

is voltage present?

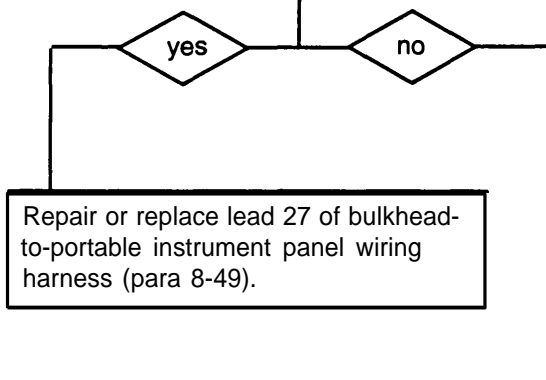

F

1. Reconnect lead 27 to circuit breaker output.
2. Disconnect lead 10 from circuit breaker input.
3. Place red lead of multimeters in lead 10 and black lead to ground.
4. Turn MASTER switch ON and check for voltage.
5. Turn MASTER switch OFF.

Is voltage present?

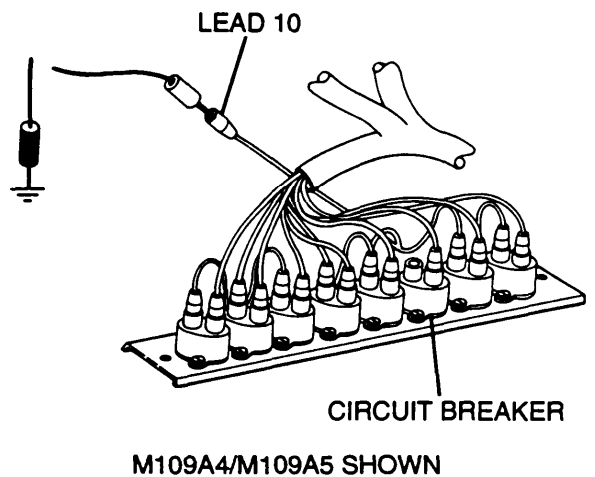
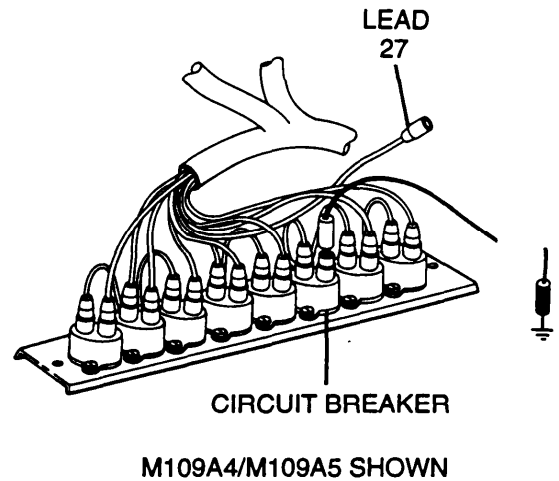
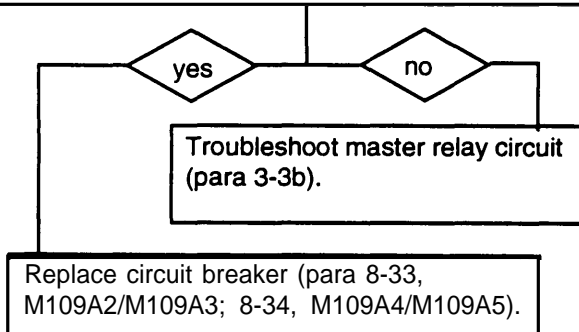

3-3 TROUBLESHOOTING CHART — CONTINUED

p. TRANSMISSION OIL TEMPERATURE INDICATOR CIRCUIT — CONTINUED
 TRANSMISSION OIL TEMP INDICATOR NEEDLE FAILS TO MOVE OR IS UNSTEADY; ALL OTHER GAGES OPERATE PROPERLY — CONTINUED

CONTINUED FROM STEP B

G	<ol style="list-style-type: none"> 1. Reconnect lead 324 to TRANSMISSION OIL TEMP gage. 2. Disconnect battery ground leads. 3. Disconnect portable instrument panel wiring harness from portable instrument panel disconnect. 4. Place jumper wires from pin A to socket A (lead 27), from socket P (lead 459B) to socket C (lead 459). 5. Reconnect battery ground leads. 6. Turn MASTER switch ON and check TRANSMISSION OIL TEMP gage for reading. 7. If TRANSMISSION OIL TEMP gage shows a maximum reading, place a jumper wire from pin L (lead 324) to ground. 8. Check gage for reading. 9. Turn MASTER switch OFF.
<p>Does TRANSMISSION OIL TEMP gage show minimum when grounded, and maximum when not grounded?</p>	

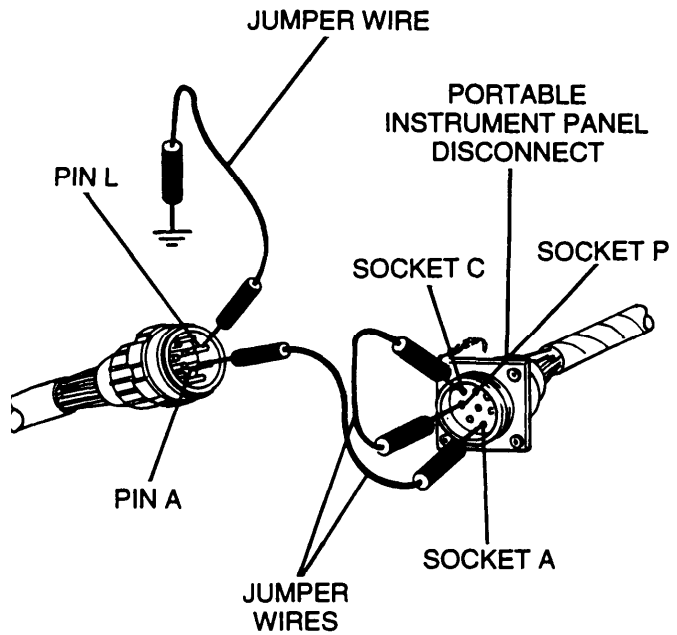

Repair or replace lead 324 of portable instrument panel wiring harness (para 8-57).

CONTINUED ON NEXT PAGE

CONTINUED FROM STEP G

H	<ol style="list-style-type: none"> 1. Reconnect portable instrument panel wiring harness to portable instrument panel disconnect. 2. Disconnect battery ground leads. 3. Disconnect bulkhead-to-headlights/bilge pump wiring harness from drivers bulkhead. 4. Place a jumper wire from pin B to socket B (lead 400-459B). 5. Reconnect battery ground leads. 6. Turn MASTER switch ON and check TRANSMISSION OIL TEMP gage for a reading. 7. If TRANSMISSION OIL TEMP gage shows a maximum reading, place a jumper wire from socket H (lead 324) to ground. 8. Turn MASTER switch OFF.
<p>Does TRANSMISSION OIL TEMP gage show minimum when grounded, and maximum when not grounded?</p>	

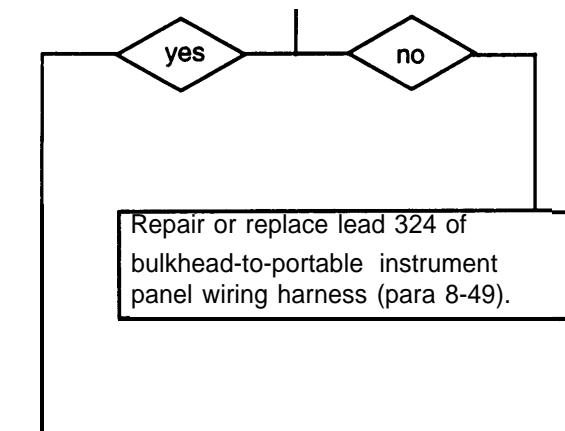

CONTINUED ON NEXT PAGE

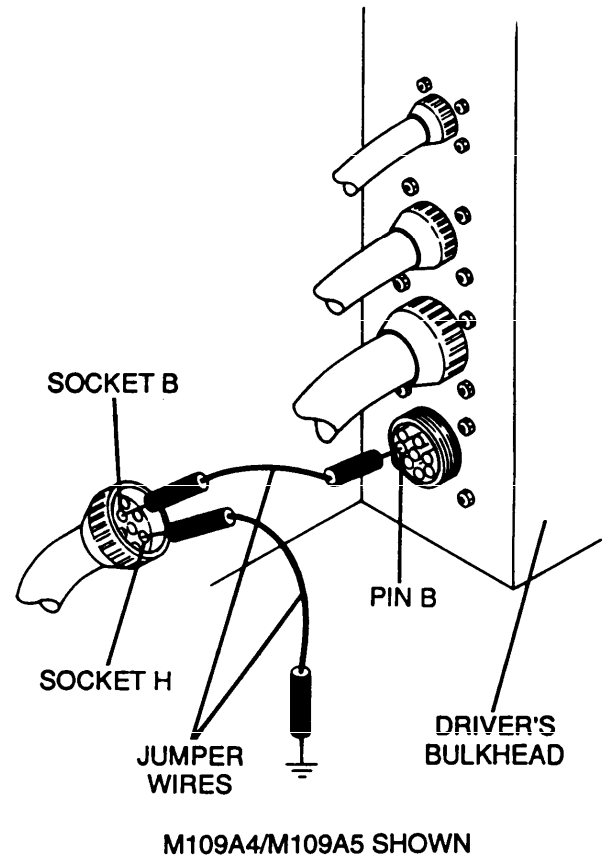

3-3 TROUBLESHOOTING CHART — CONTINUED

p. TRANSMISSION OIL TEMPERATURE INDICATOR CIRCUIT — CONTINUED
 TRANSMISSION OIL TEMP INDICATOR NEEDLE FAILS TO MOVE OR IS UNSTEADY; ALL OTHER GAGES OPERATE PROPERLY — CONTINUED

CONTINUED FROM STEP H

I	<ol style="list-style-type: none"> 1. Reconnect bulkhead-to-headlights/bilge pump wiring harness to driver's bulkhead. 2. Disconnect engine disconnect bracket-to-bulkhead wiring harness from engine disconnect bracket. 3. Turn MASTER switch ON and check TRANSMISSION OIL TEMP gage for a reading. 4. If TRANSMISSION OIL TEMP gage shows a maximum reading, place a jumper wire from socket L (lead 324) to ground. 5. Check gage for reading. 6. Turn MASTER switch OFF.
<p>Does TRANSMISSION OIL TEMP gage show minimum when grounded, and maximum when not grounded?</p>	

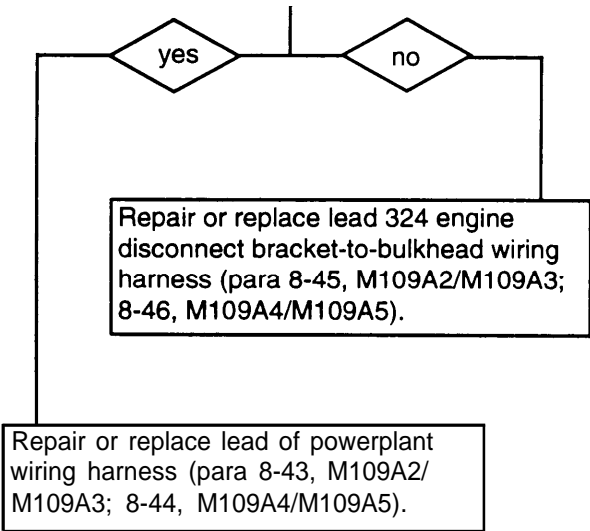
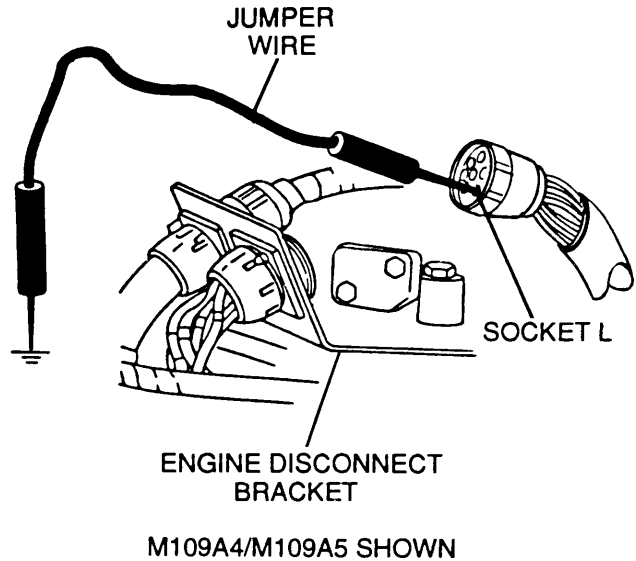

END OF TASK

q. TRANSMISSION OIL PRESSURE INDICATOR
CIRCUIT

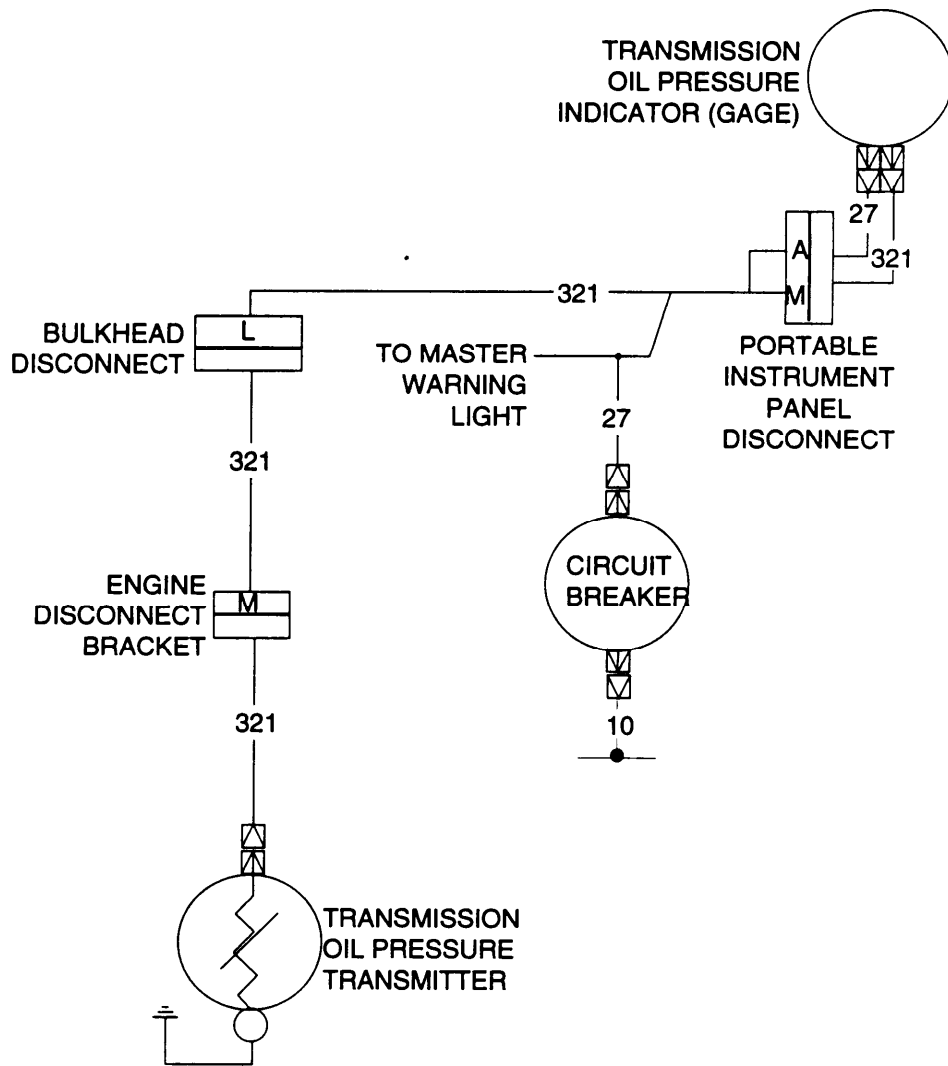

3-3 TROUBLESHOOTING CHART — CONTINUED

q. TRANSMISSION OIL PRESSURE INDICATOR
CIRCUIT — CONTINUED

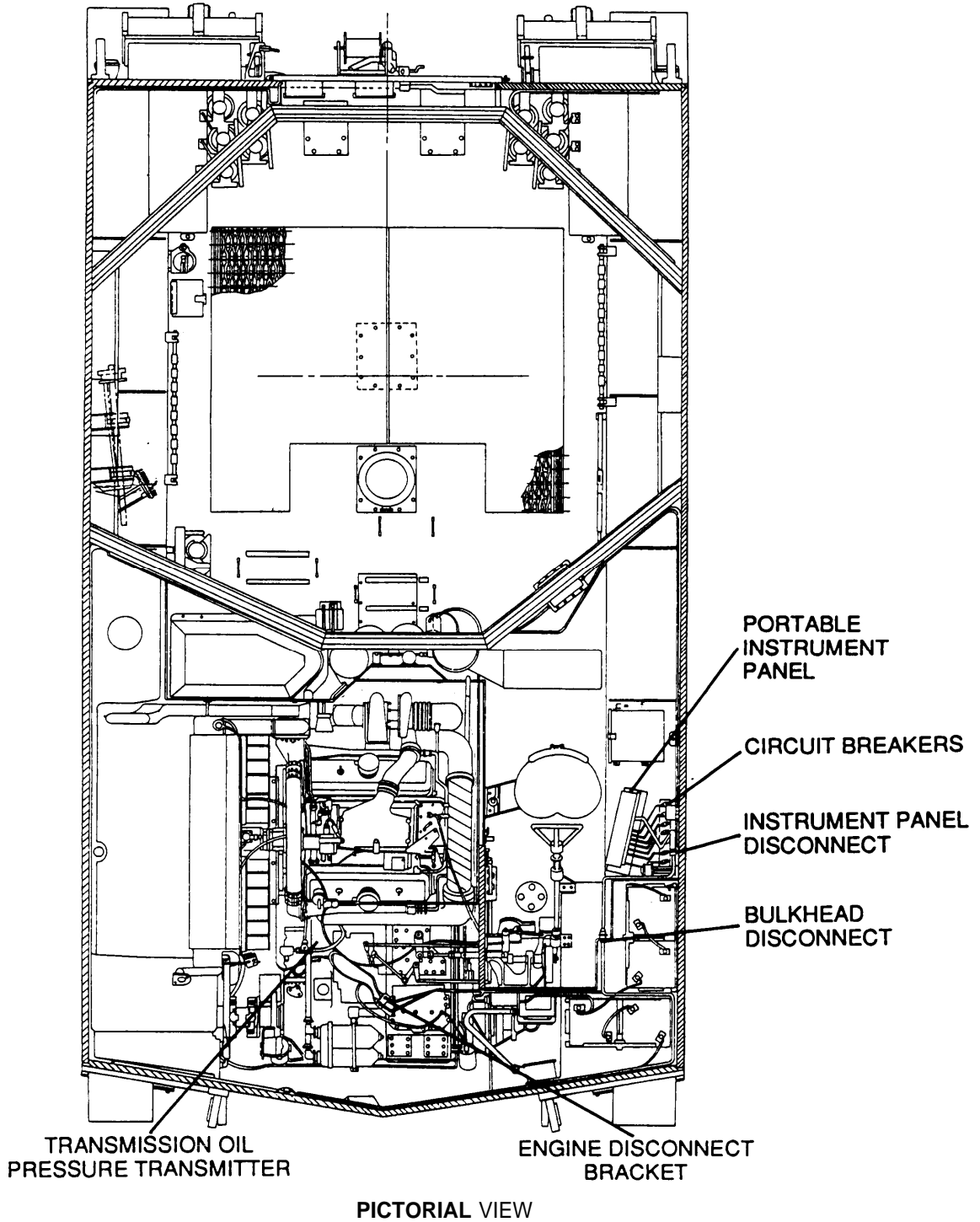

TRANSMISSION OIL PRESSURE INDICATOR NEEDLE FAILS TO MOVE OR IS UNSTEADY; ALL OTHER GAGES OPERATE PROPERLY

INITIAL SETUP

Tools

General mechanic's tool kit (item 64, Appx H)
 Multimeters (item 36, Appx H)
 TA-1 probe kit (item 43, Appx H)
 (Long test leads may be needed for some tests;
 16 AWG wire may be used as an extension.)

Personnel Required

Two

Equipment Conditions

Engine access door open (TM 9-2350-31 1-10)
 Transmission access doors open (TM 9-2350-311-10)
 Portable instrument panel cover removed (para 8-17')

- A**
1. Disconnect lead 321 from transmission oil pressure transmitter.
 2. Turn MASTER switch ON and check TRANSMISSION OIL PRESSURE gage for a reading.
 3. If TRANSMISSION OIL PRESSURE gage shows a maximum reading, place a jumper wire from lead 321 to ground.
 4. Check TRANSMISSION OIL PRESSURE gage for reading.
 5. Turn MASTER switch OFF.
- Does TRANSMISSION OIL PRESSURE gage show minimum when grounded and maximum when not grounded?

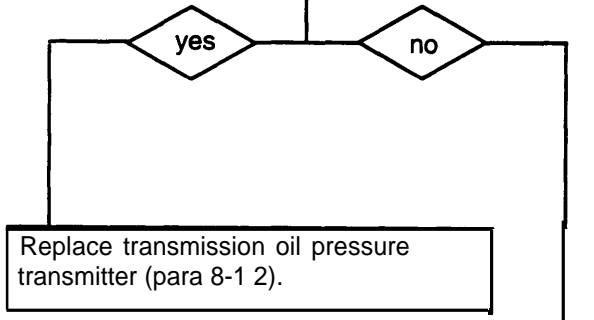
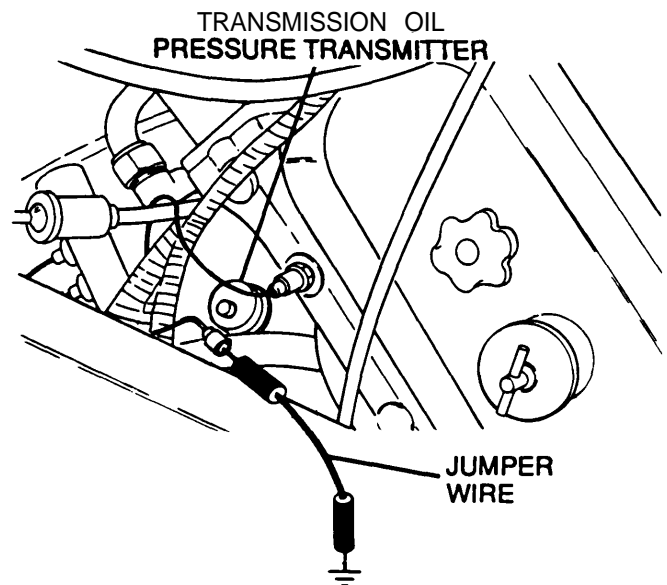

CONTINUED ON NEXT PAGE

3-3 TROUBLESHOOTING CHART — CONTINUED

q. TRANSMISSION OIL PRESSURE INDICATOR CIRCUIT — CONTINUED

TRANSMISSION OIL PRESSURE INDICATOR NEEDLE FAILS TO MOVE OR IS UNSTEADY; ALL OTHER GAGES OPERATE PROPERLY — CONTINUED

CONTINUED FROM STEP A

B

1. Reconnect lead 321 to transmission oil pressure transmitter.
2. Disconnect lead 321 from TRANSMISSION OIL PRESSURE gage.
3. Turn MASTER switch ON and check TRANSMISSION OIL PRESSURE gage for a reading.
4. If TRANSMISSION OIL PRESSURE gage shows a maximum reading, use a jumper wire to ground gage.
5. Check gage for reading.
6. Turn MASTER switch OFF.

Does TRANSMISSION OIL PRESSURE gage show minimum when grounded and maximum when not grounded?

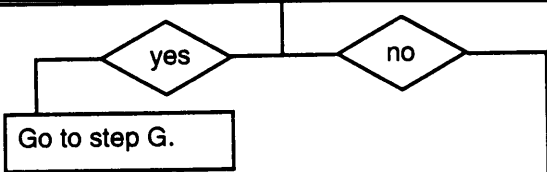
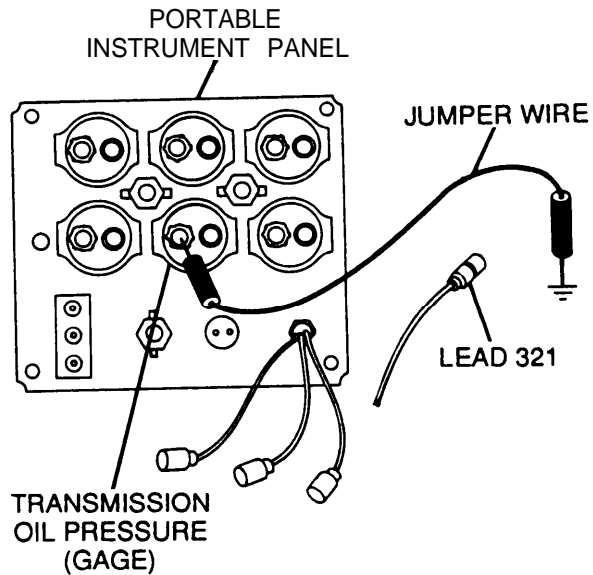

C

1. Reconnect lead 321 to TRANSMISSION OIL PRESSURE gage.
2. Disconnect lead 27 from TRANSMISSION OIL PRESURE gage.
3. Place red lead of multimeters in lead 27 and black lead to ground.
4. Turn MASTER switch ON and check for voltage.
5. Turn MASTER switch OFF.

Is voltage present?

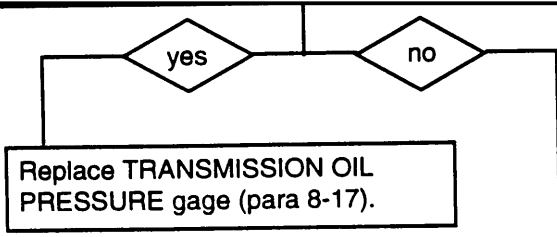

CONTINUED ON NEXT PAGE

CONTINUED FROM STEP C

- D**
1. Reconnect lead 27 to TRANSMISSION OIL PRESSURE gage,
 2. Disconnect battery ground leads.
 3. Disconnect portable instrument panel wiring harness from portable instrument panel disconnect.
 4. Place a jumper wire from socket P (lead 459B) to socket C (lead 459).
 5. Place red lead of multimeters in socket A (lead 27) and black lead to ground.
 6. Reconnect battery ground leads.
 7. Turn MASTER switch ON and check for voltage.
 8. Turn MASTER switch OFF.
- Is voltage present?

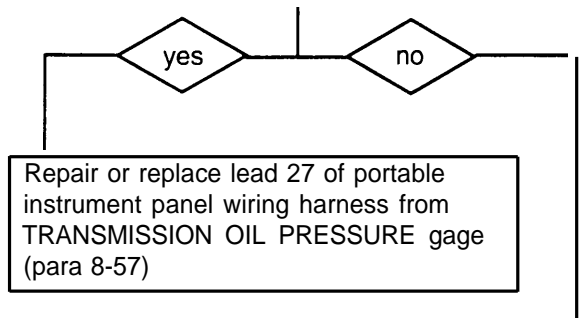

- E**
1. Reconnect portable instrument panel wiring harness to portable instrument panel bracket.
 2. Disconnect lead 27 from circuit breaker output.
 3. Place red lead of multimeters in circuit breaker output and black lead to ground.
 4. Turn MASTER switch ON and check for voltage.
 5. Turn MASTER switch OFF.
- Is voltage present?

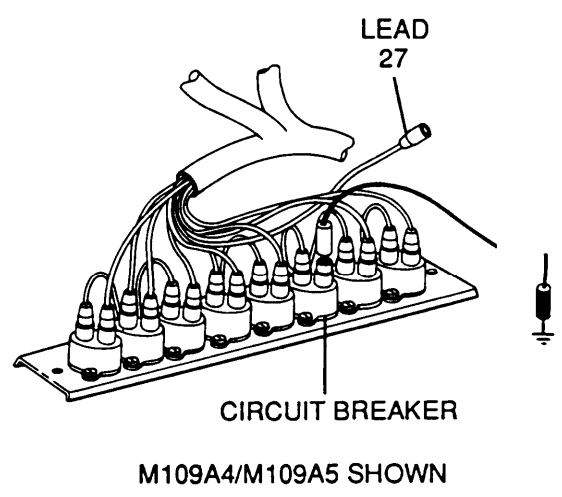
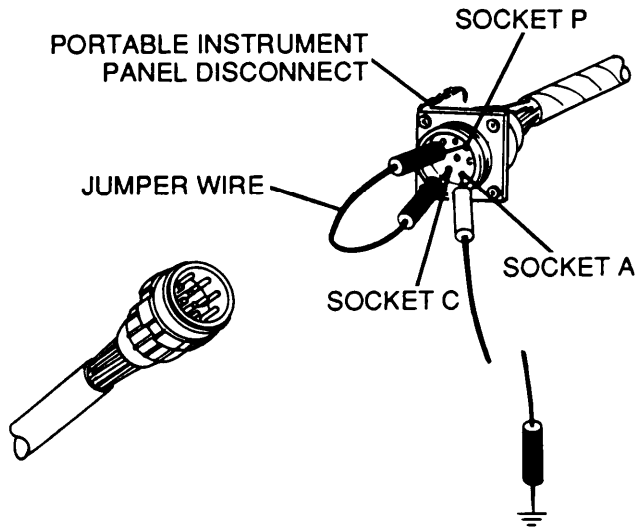
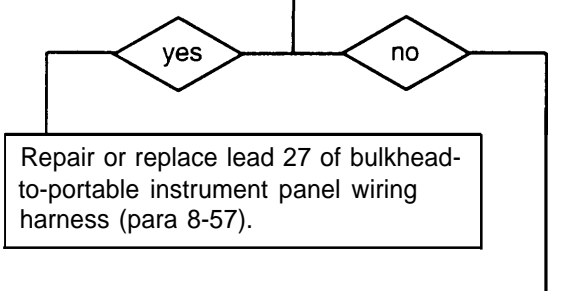

CONTINUED ON NEXT PAGE

3-3 TROUBLESHOOTING CHART — CONTINUED

q. TRANSMISSION OIL PRESSURE INDICATOR
CIRCUIT — CONTINUED

TRANSMISSION OIL PRESSURE INDICATOR NEEDLE
FAILS TO MOVE OR IS UNSTEADY; ALL OTHER GAGES
OPERATE PROPERLY — CONTINUED

CONTINUED FROM STEP D

F	<ol style="list-style-type: none"> 1. Reconnect lead 27 to circuit breaker output. 2. Disconnect lead 10 from circuit breaker input. 3. Place red lead of multimeters in lead 10 and black lead to ground. 4. Turn MASTER switch ON and check for voltage. 5. Turn MASTER switch OFF.
Is voltage present?	

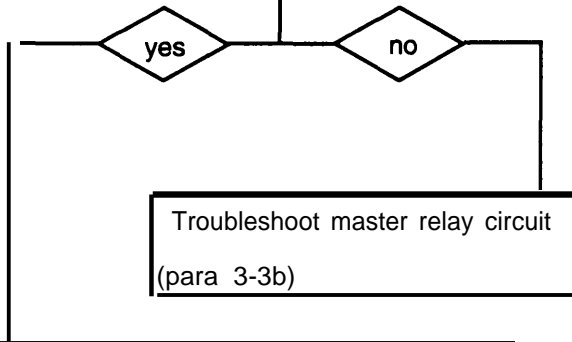

Replace circuit breaker (para 8-33,
M109A2/M109A3; 8-34, M109A4/M109A5).

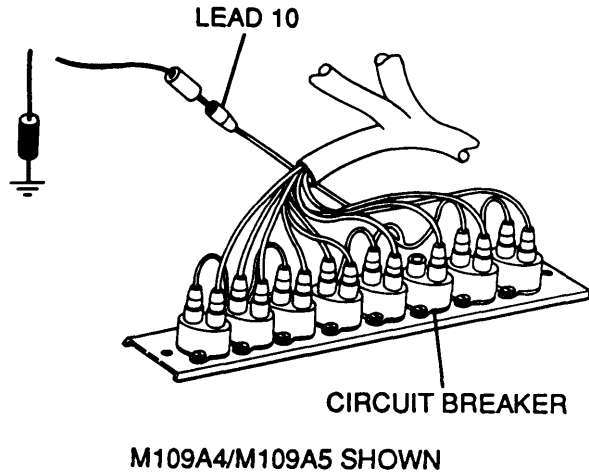

CONTINUED FROM STEP B

G	<ol style="list-style-type: none"> 1. Reconnect lead 321 to TRANSMISSION OIL PRESSURE gage. 2. Disconnect battery ground leads. 3. Disconnect portable instrument panel wiring harness from portable instrument panel disconnect. 4. Place jumper wires from pin A to socket A (lead 27) and from socket P (lead 459B) to socket C (lead 459). 5. Reconnect battery ground leads. 6. Turn MASTER switch ON and check TRANSMISSION OIL PRESSURE gage for a reading. 7. If TRANSMISSION OIL PRESSURE gage shows a maximum reading, place a jumper wire from pin M (lead 321) to ground. 8. Check gage for reading. 9. Turn MASTER switch OFF.
<p>Does TRANSMISSION OIL PRESSURE gage show minimum when grounded and maximum when not grounded?</p>	

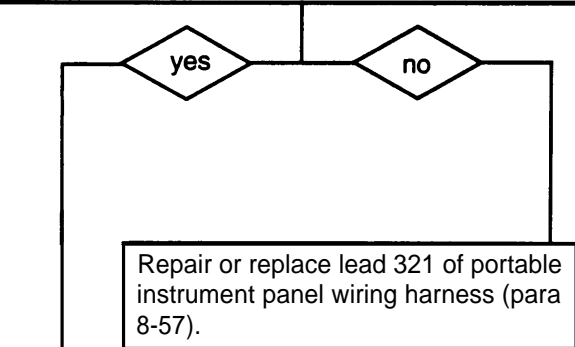
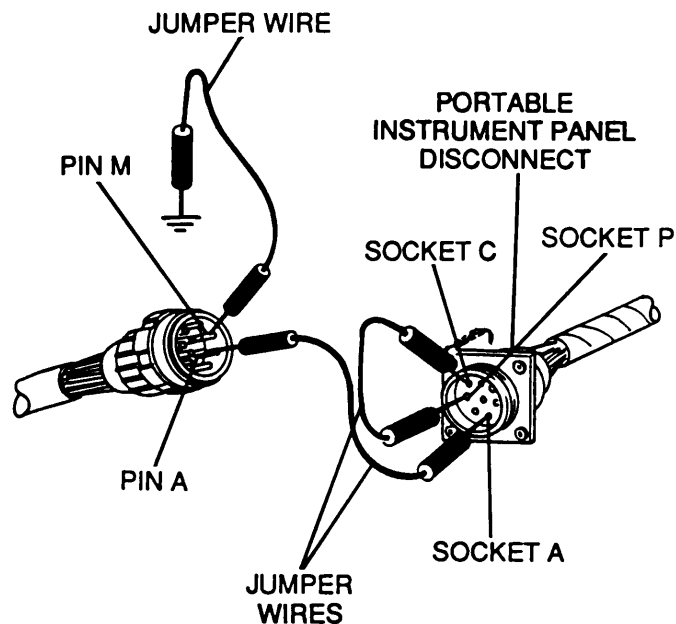

CONTINUED ON NEXT PAGE

3-3 TROUBLESHOOTING CHART — CONTINUED

q. TRANSMISSION OIL PRESSURE INDICATOR CIRCUIT — CONTINUED

TRANSMISSION OIL PRESSURE INDICATOR NEEDLE FAILS TO MOVE OR IS UNSTEADY; ALL OTHER GAGES OPERATE PROPERLY — CONTINUED

CONTINUED FROM STEP G

H	<ol style="list-style-type: none"> 1. Reconnect portable instrument panel wiring harness to portable instrument panel disconnect. 2. Disconnect battery ground leads. 3. Disconnect bulkhead-to-headlights/bilge pump wiring harness from driver's bulkhead. 4. Place a jumper wire from pin B to socket B (lead 400-459B). 5. Reconnect battery ground leads. 6. Turn MASTER switch ON and check TRANSMISSION OIL PRESSURE gage for a reading. 7. If TRANSMISSION OIL PRESSURE gage shows a maximum reading, place a jumper wire from socket L (lead 321) to ground. 8. Turn MASTER switch OFF.
<p>Does TRANSMISSION OIL TEMP gage show minimum when grounded and maximum when not grounded?</p>	

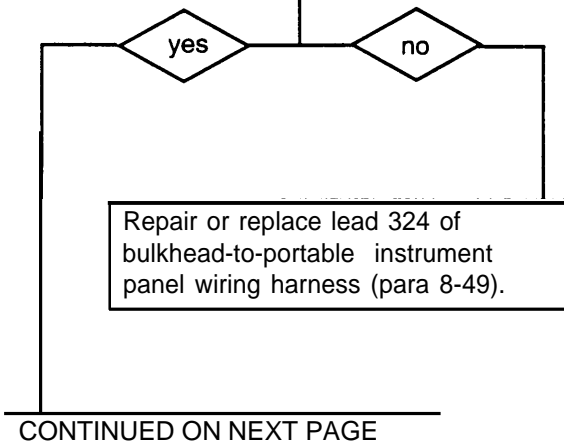
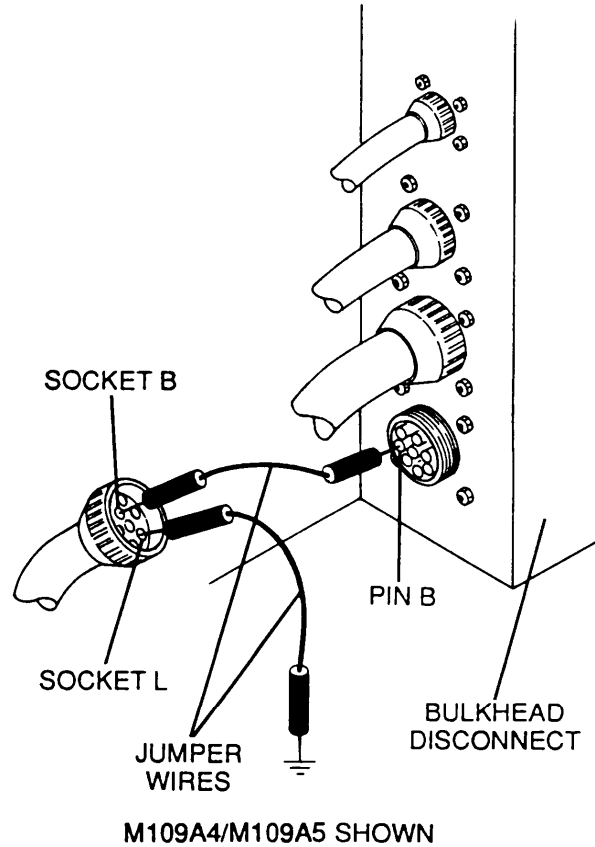

CONTINUED FROM STEP H

- | | |
|---|---|
| I | <ol style="list-style-type: none"> 1. Reconnect bulkhead-to-headlights/bilge pump wiring harness from drivers bulkhead. 2. Disconnect engine disconnect bracket-to-bulkhead wiring harness from engine disconnect bracket. 3. Turn MASTER switch ON and check TRANSMISSION OIL PRESSURE gage for a reading. 4. If TRANSMISSION OIL PRESURE gage shows a maximum reading place a jumper wire from socket M (lead 321) to ground. 5. Check gage for reading. 6. Turn MASTER switch OFF. |
|---|---|

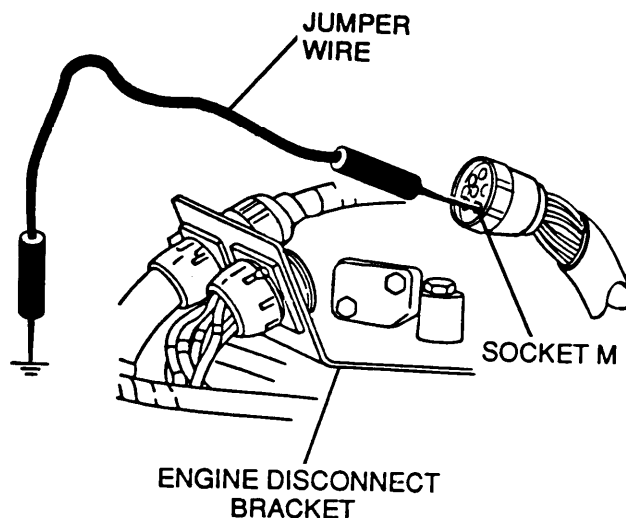

<p>Does TRANSMISSION OIL PRESSURE gage show minimum when grounded and maximum when not grounded?</p>
--

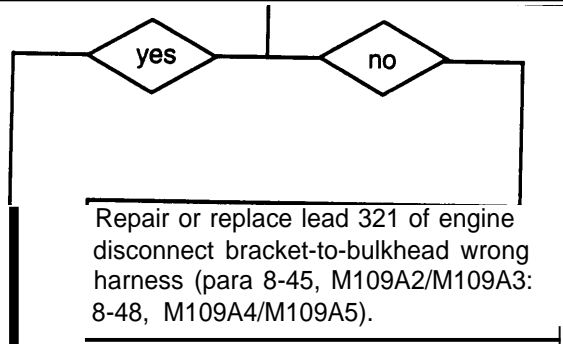

<p>Repair or replace lead 321 of powerplant wiring harness (para 8-43, M109A2/M109A3; 8-44, M109A4/M109A5).</p>

END OF TASK

3-3 TROUBLESHOOTING CHART — CONTINUED

r. ENGINE OIL PRESSURE GAGE CIRCUIT

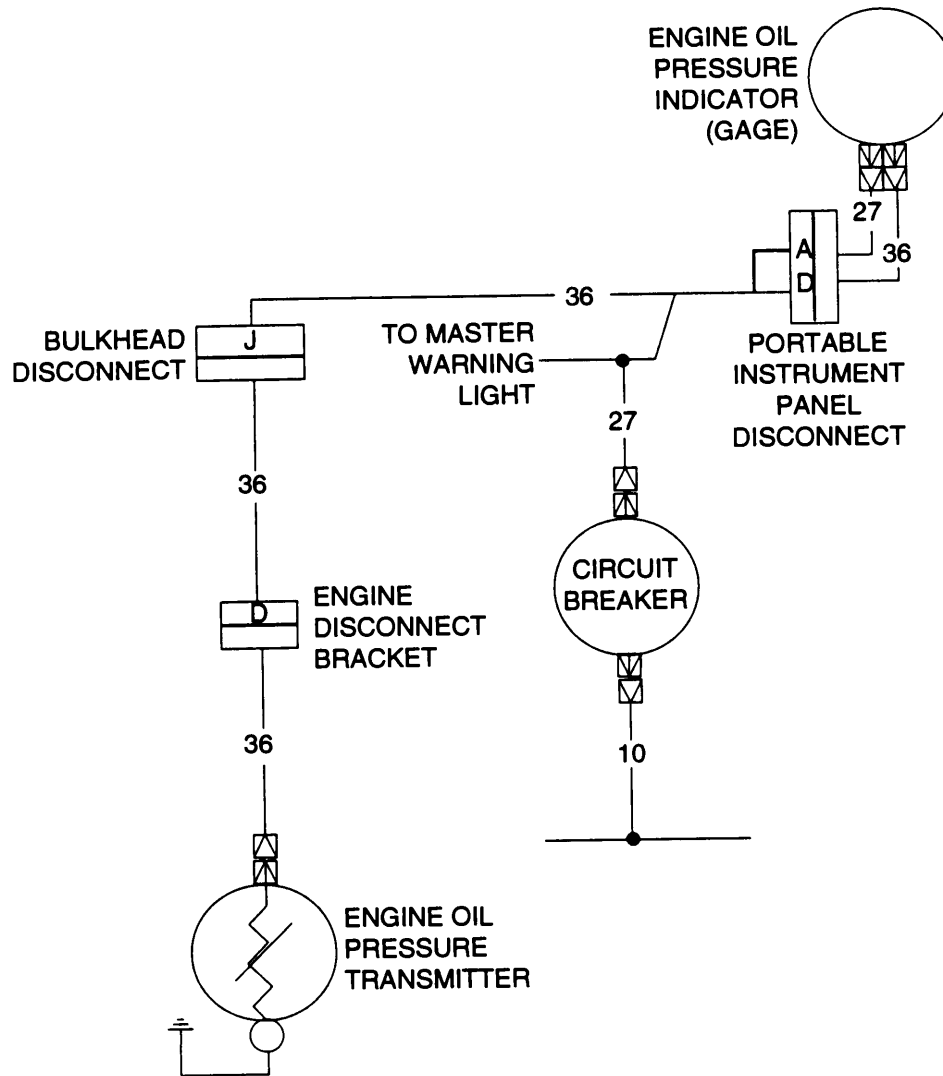

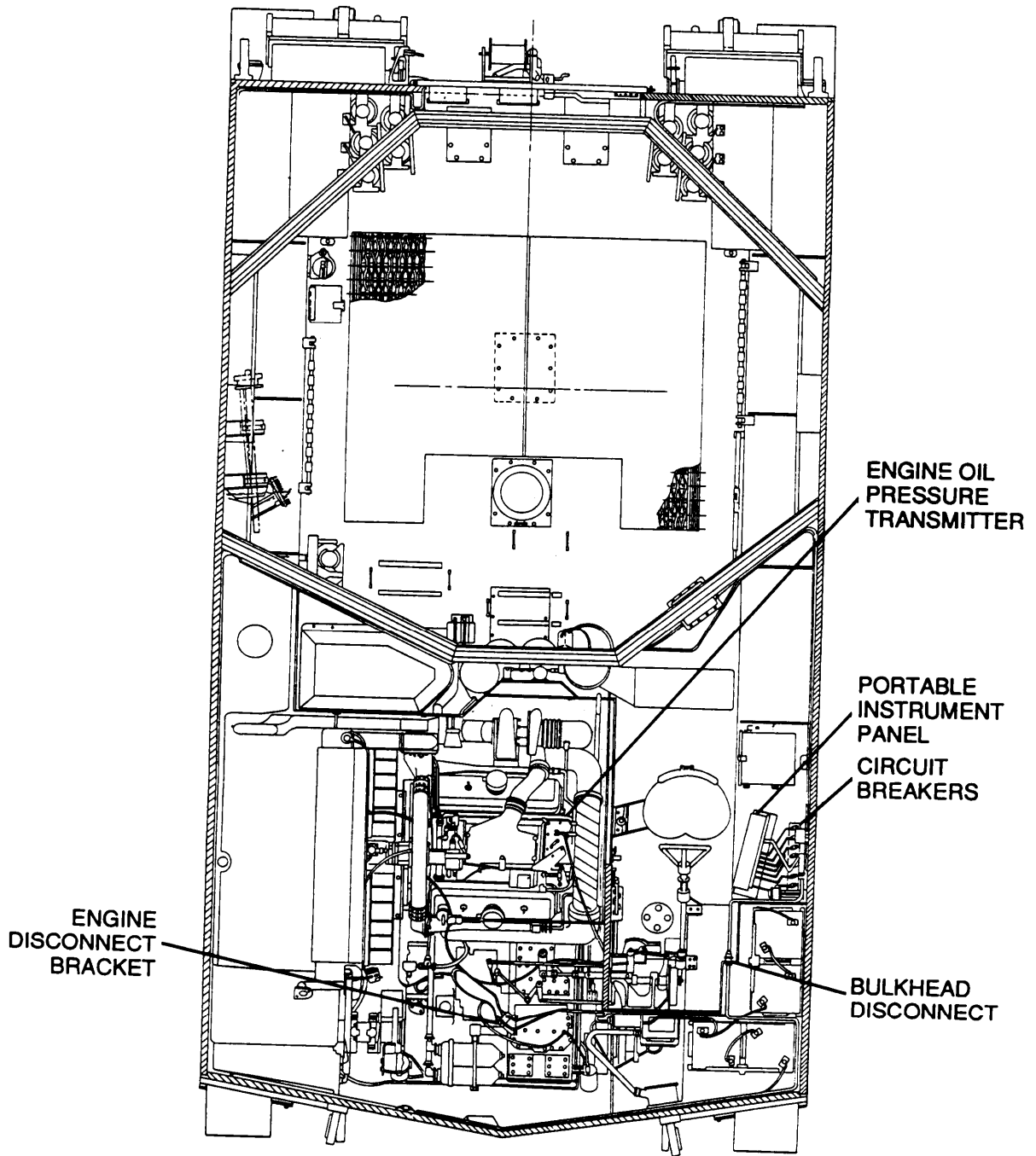

PICTORIAL VIEW

3-3 TROUBLESHOOTING CHART — CONTINUED

r. ENGINE OIL PRESSURE GAGE CIRCUIT — CONTINUED

ENGINE OIL PRESSURE INDICATOR FAILS TO OPERATE WITH ENGINE RUNNING; ALL OTHER INSTRUMENTS OPERATE

INITIAL SETUP

Tools

General mechanic's tool kit (item 64, Appx H)
 Multimeters (item 36, Appx H)
 TA-1 probe kit (item 43, Appx H)
 (Long test leads may be needed for some tests;
 16 AWG wire may be used as an extension.)

Equipment Conditions

Engine access door open (TM 9-2350-311-10)
 Transmission access doors open (TM 9-2350-311-10)
 Portable instrument panel cover removed (para 8-17)
 Engine compartment access cover removed (para 11-5)

Personnel Required

Two

A	<ol style="list-style-type: none"> 1. Disconnect lead 36 from engine 011 pressure transmitter. 2. Turn MASTER switch ON and check ENGINE OIL PRESSURE gage for a reading. 3. If ENGINE OIL PRESSURE gage shows a maximum reading, place a jumper wire from lead 36 to ground. 4. Check gage for reading. 5. Turn MASTER switch OFF.
Does ENGINE OIL PRESSURE gage read minimum when grounded and maximum when not grounded?	

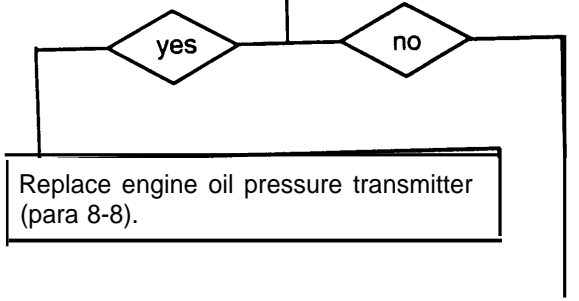
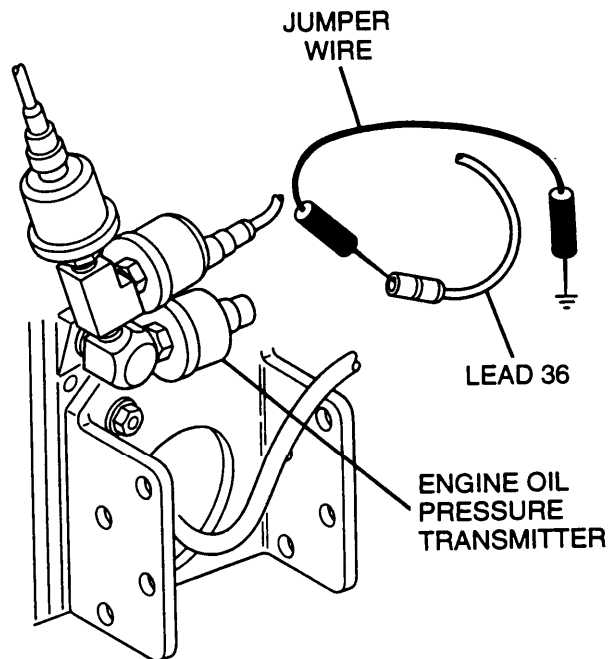

CONTINUED ON NEXT PAGE

CONTINUED FROM STEP A

- B**
1. Reconnect lead 36 to engine oil pressure transmitter.
 2. Disconnect lead 36 from ENGINE OIL PRESSURE gage.
 3. Turn MASTER switch ON and check ENGINE OIL PRESSURE gage for a reading.
 4. If ENGINE OIL PRESURE gage shows a maximum reading, use a jumper wire to ground gage.
 5. Check gage for reading.
 6. Turn MASTER switch OFF.

Does ENGINE OIL PRESSURE gage show minimum when grounded and maximum when not grounded?

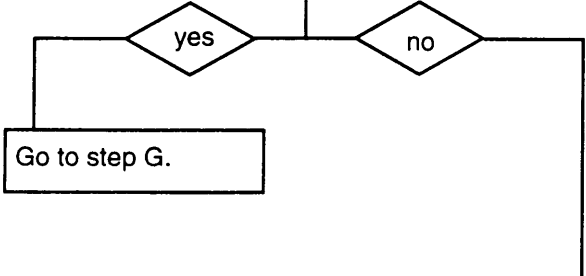

- C.**
1. Reconnect lead 36 to ENGINE OIL PRESSURE gage.
 2. Disconnect lead 27 from ENGINE OIL PRESSURE gage.
 3. Place red lead of multimeters in lead 27 and black lead to ground.
 4. Turn MASTER switch ON and check for voltage.
 5. Turn MASTER switch OFF.

Is voltage present?

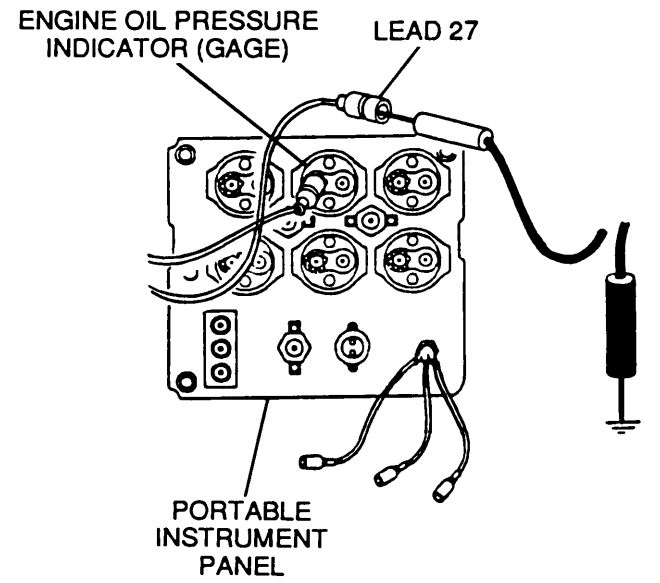
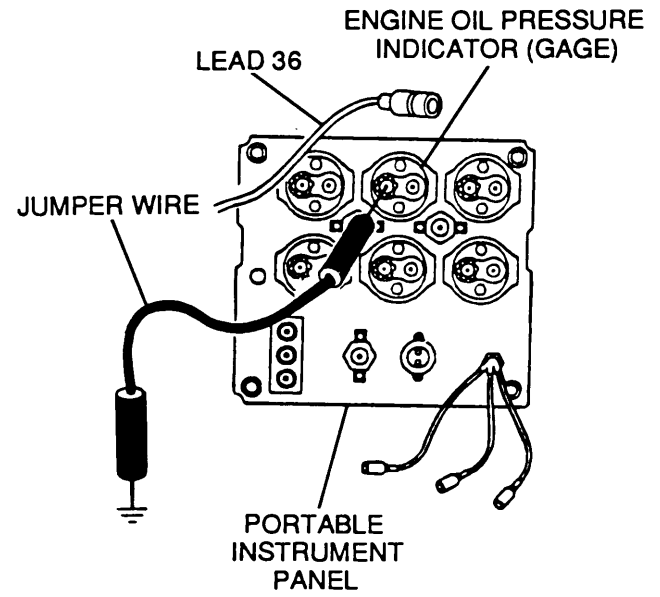
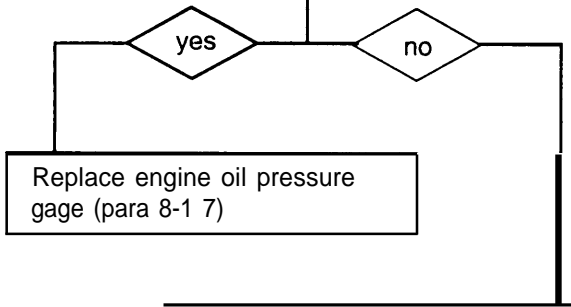

CONTINUED ON NEXT PAGE

3-3 TROUBLESHOOTING CHART — CONTINUED

r. ENGINE OIL PRESSURE GAGE CIRCUIT — CONTINUED

ENGINE OIL PRESSURE INDICATOR FAILS TO OPERATE WITH ENGINE RUNNING; ALL OTHER INSTRUMENTS OPERATE — CONTINUED

CONTINUED FROM STEP C

D	<ol style="list-style-type: none"> 1. Reconnect lead 27 to ENGINE OIL PRESSURE gage. 2. Disconnect battery ground leads. 3. Disconnect portable instrument panel wiring harness from portable instrument panel disconnect. 4. Place a jumper wire from socket P (lead 459B) to socket C (lead 459). 5. Place red lead of multimeters in socket A (lead 27) and black lead to ground. 6. Reconnect battery ground leads. 7. Turn MASTER switch ON and check for voltage. 8. Turn MASTER switch OFF.
Is voltage present?	

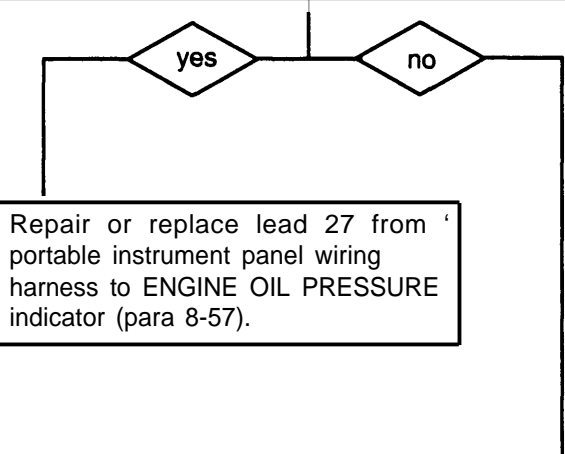
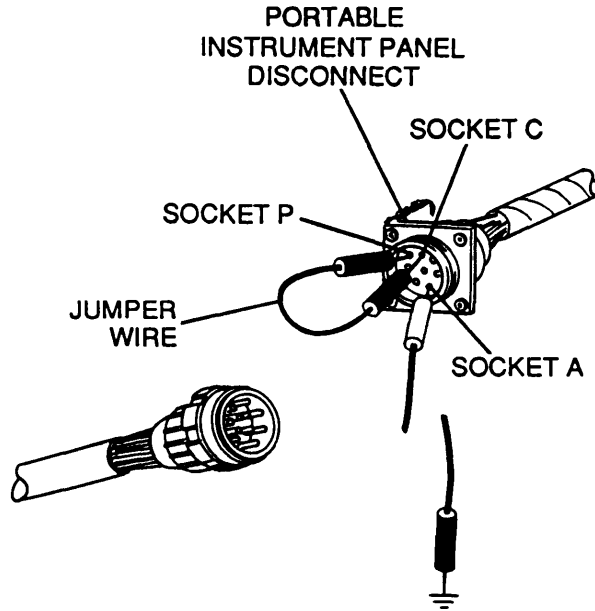

CONTINUED ON NEXT PAGE

CONTINUED FROM STEP D

E

1. Reconnect portable instrument panel wiring harness to portable instrument panel disconnect.
2. Disconnect lead 27 of bulkhead-to-portable instrument panel harness from circuit breaker output.
3. Place red lead of multimeters in circuit breaker output and black lead to ground.
4. Turn MASTER switch ON and check for voltage.
5. Turn MASTER switch OFF.

Is voltage present?

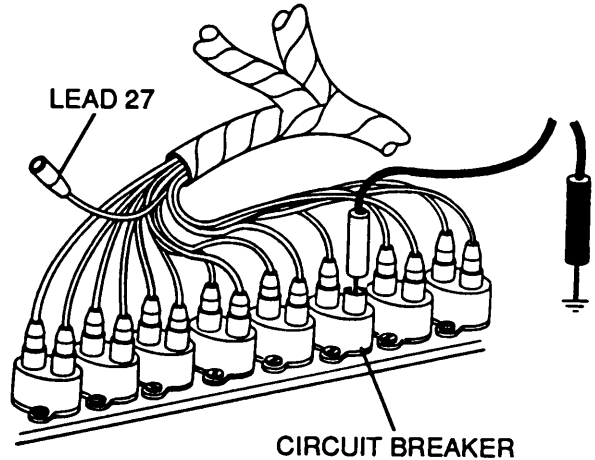

M109A4/M109A5 SHOWN

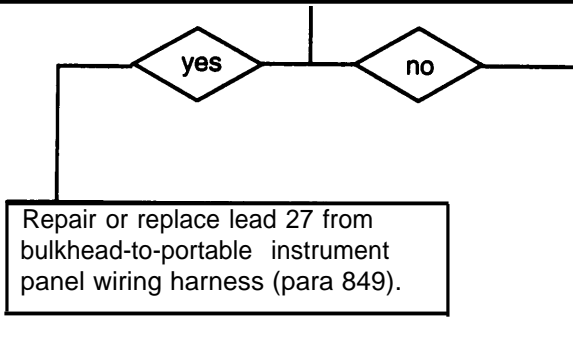

F

1. Reconnect lead 27 to circuit breaker output.
2. Disconnect lead 10 from circuit breaker" input.
3. Place red lead of multimeters in lead 10 and black lead to ground.
4. Turn MASTER switch ON and check for voltage.
5. Turn MASTER switch OFF.

Is voltage present?

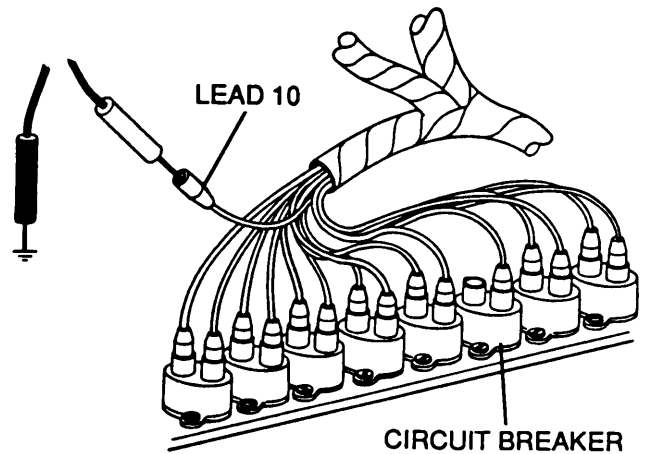

M109A4/M109A5 SHOWN

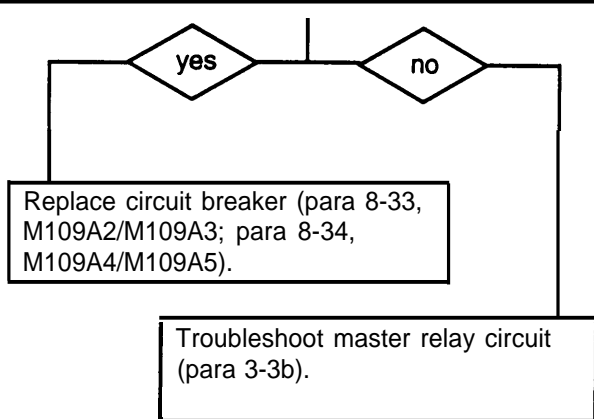

3-3 TROUBLESHOOTING CHART — CONTINUED

r. ENGINE OIL PRESSURE GAGE CIRCUIT — CONTINUED

ENGINE OIL PRESSURE INDICATOR FAILS TO OPERATE WITH ENGINE RUNNING; ALL OTHER INSTRUMENTS OPERATE — CONTINUED

CONTINUED FROM STEP B

G	<ol style="list-style-type: none"> 1. Reconnect lead 36 to ENGINE OIL PRESSURE gage. 2. Disconnect battery ground leads. 3. Disconnect bulkhead-to-portable instrument panel harness from portable instrument panel disconnect. 4. Place jumper wires from socket P (lead 459B) to socket C (lead 459) and from pin A to socket A (lead 27). 5. Reconnect battery ground leads. 6. Turn MASTER switch ON and check ENGINE OIL PRESSURE gage for reading. 7. If ENGINE OIL PRESSURE gage shows a maximum reading, place a jumper wire from pin D (lead 36) to ground. 8. Check gage for reading. 9. Turn MASTER switch OFF.
<p>Does ENGINE OIL PRESSURE gage show minimum when grounded and maximum when not grounded?</p>	

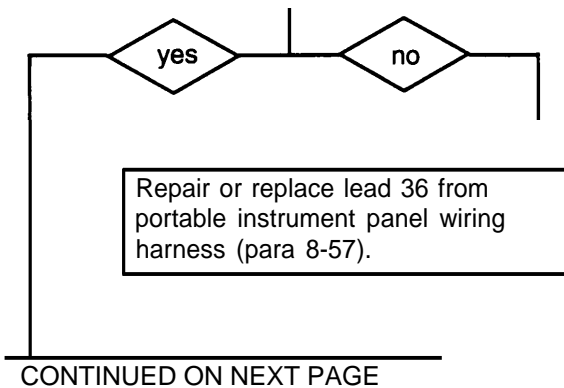
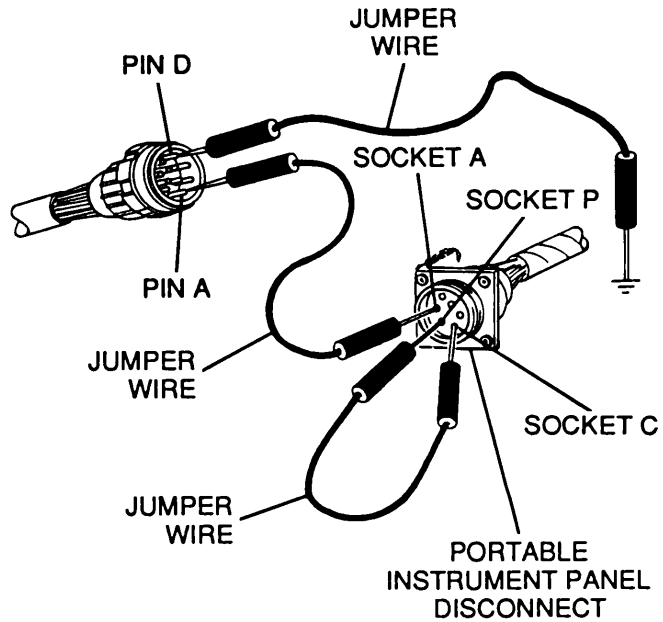

CONTINUED FROM STEP G

H	<ol style="list-style-type: none"> 1. Reconnect portable instrument panel wiring harness from portable instrument panel disconnect. 2. Disconnect battery ground leads. 3. Disconnect engine disconnect-to-bulkhead wiring harness from driver's bulkhead. 4. Place a jumper wire from pin B to socket B (lead 459B). 5. Reconnect battery ground leads. 6. Turn MASTER switch ON and check ENGINE OIL PRESSURE gage for a reading. 7. if ENGINE OIL PRESSURE gage shows a maximum reading, place a jumper wire from pin J (lead 36) to ground. 8. Check gage for reading. 9. Turn MASTER switch OFF.
<p>Does ENGINE OIL PRESSURE gage show minimum when grounded and maximum when not grounded?</p>	

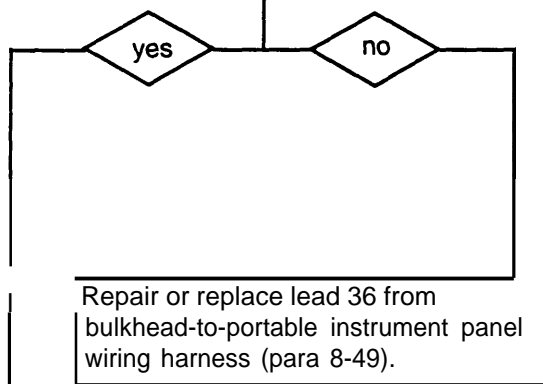
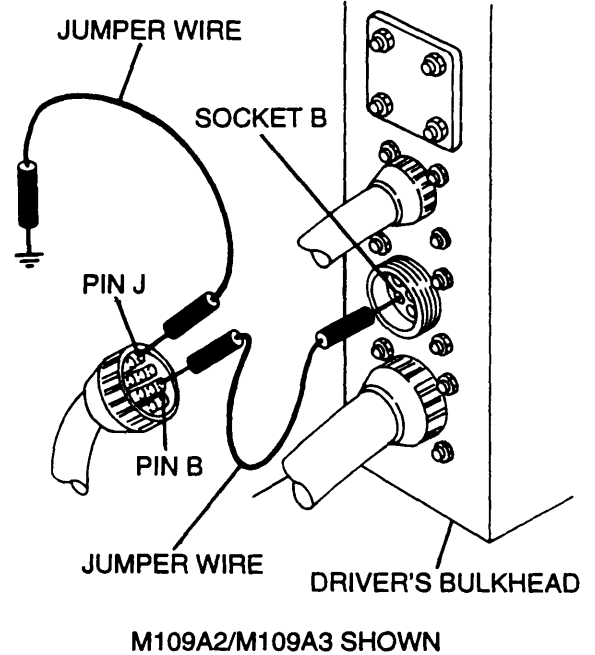

CONTINUED ON NEXT PAGE

3-3 TROUBLESHOOTING CHART — CONTINUED

r. ENGINE OIL PRESSURE GAGE CIRCUIT — CONTINUED

ENGINE OIL PRESSURE INDICATOR FAILS TO OPERATE WITH ENGINE RUNNING; ALL OTHER INSTRUMENTS OPERATE — CONTINUED

CONTINUED FROM STEP H

- T**
- 1 Reconnect engine disconnect-to-bulkhead wiring harness to drivers bulkhead.
 2. Disconnect engine disconnect-to-bulkhead wiring harness from engine disconnect.
 3. Turn MASTER switch ON and check ENGINE OIL PRESSURE gage for a reading.
 4. If ENGINE OIL PRESSURE gage shows a maximum reading, place a jumper wire from socket D (lead 36) to ground.
 5. Check gage for reading.
 6. Turn MASTER switch OFF.

Does ENGINE OIL PRESSURE gage show minimum when grounded and maximum when not grounded?

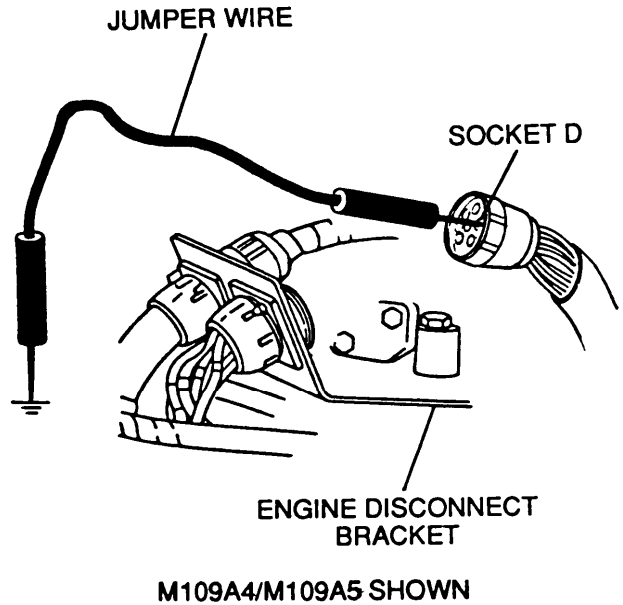
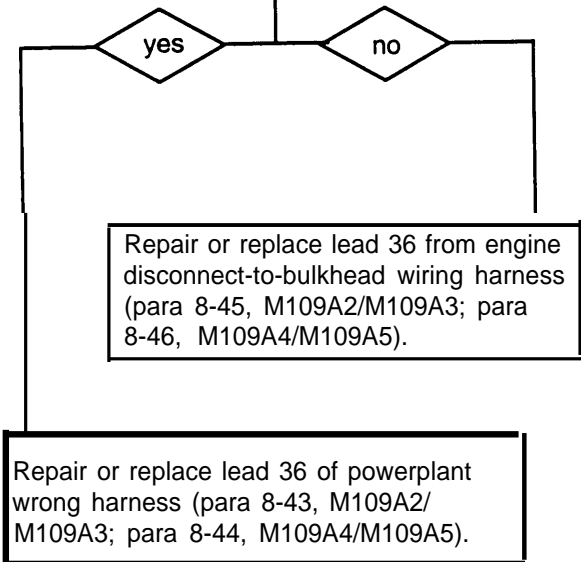

END OF TASK

s. FUEL LEVEL INDICATOR CIRCUIT

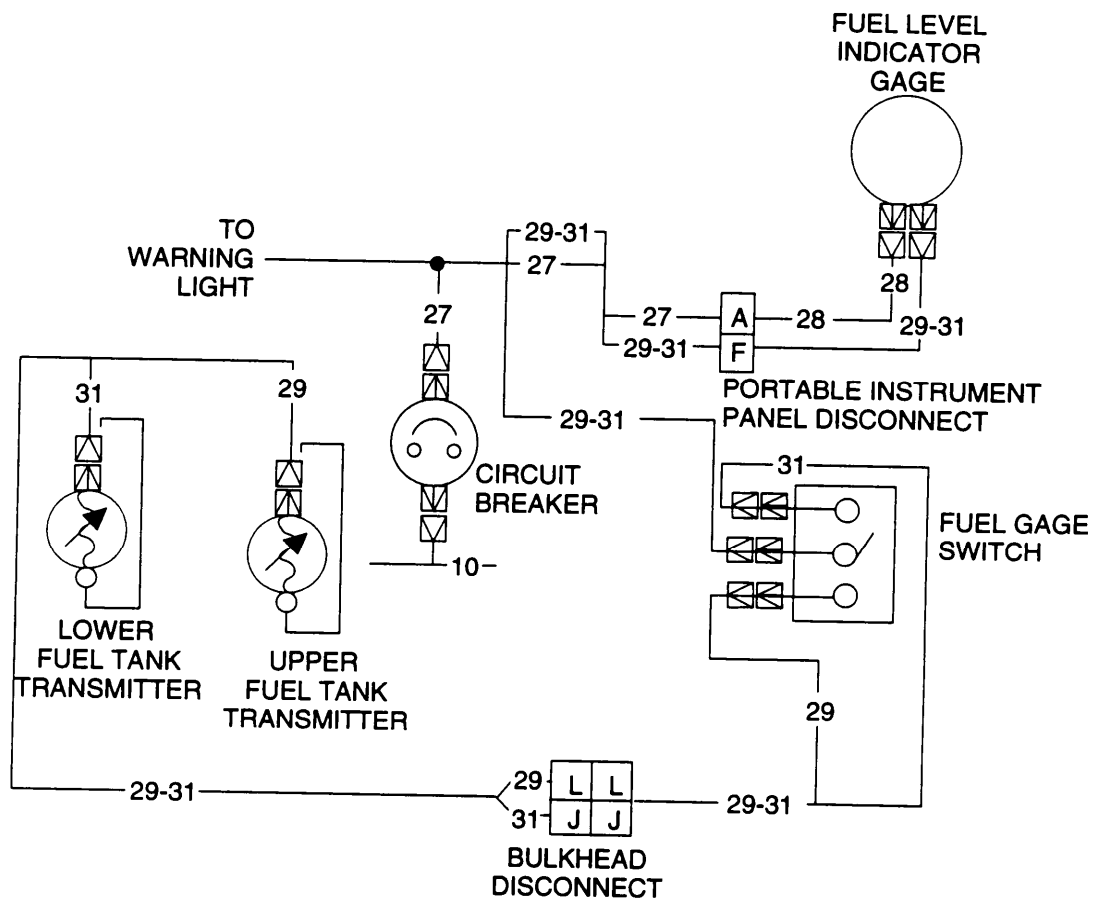

3-3 TROUBLESHOOTING CHART — CONTINUED

s. FUEL LEVEL INDICATOR CIRCUIT —
CONTINUED

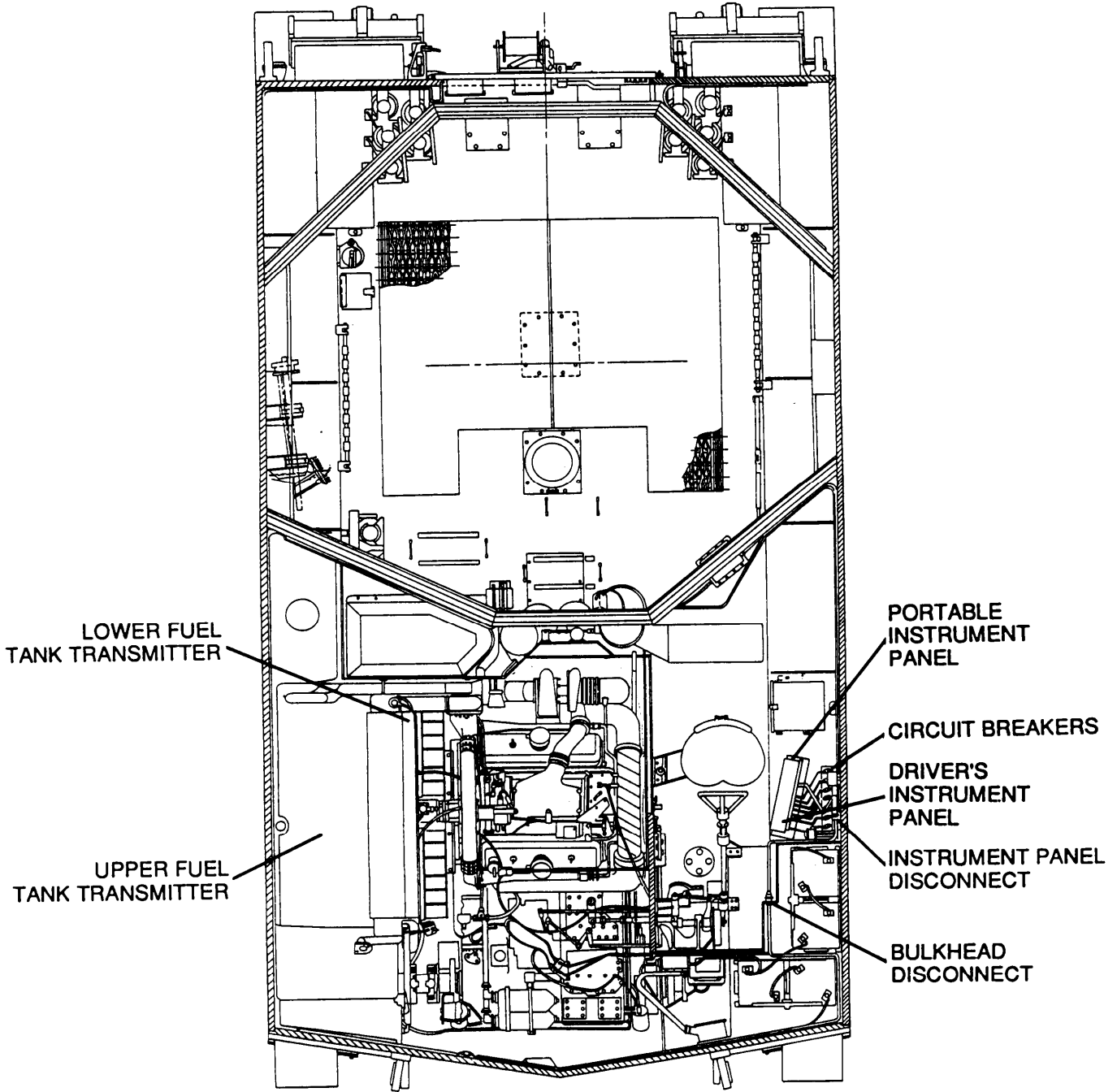

PICTORIAL VIEW

(1) FUEL LEVEL INDICATOR NEEDLE FAILS TO MOVE OR IS UNSTEADY; ALL OTHER GAGES OPERATE PROPERLY

INITIAL SETUP

Tools

General mechanic's tool kit (item 64, Appx H)
 Multimeters (item 36, APPX H)
 TA-1 probe kit (item 43, Appx H)
 (Long test leads may be needed for some tests;
 16 AWG wire maybe used as an extension.)

Equipment Conditions

Engine access door open (TM 9-2350-311-10)
 Transmission access doors open (TM 9-2350-311-10)
 Portable instrument panel cover removed (para 8-17)
 Driver's instrument panel cover removed (para 8-17)
 Fuel tanks full (TM 9-2350-311-1 O)

- | | |
|--|---|
| A | <ol style="list-style-type: none"> 1. Disconnect lead 29-31 from FUEL LEVEL gage. 2. Turn MASTER switch ON and check FUEL LEVEL gage for a reading. 3. If FUEL LEVEL gage shows a maximum reading, use a jumper wire to ground FUEL LEVEL gage. 4. Check FUEL LEVEL gage for a reading. 5. Turn MASTER switch OFF. |
| Does FUEL LEVEL gage show minimum when grounded and maximum when not grounded? | |

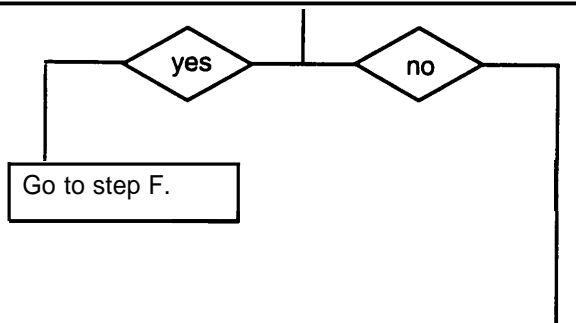

CONTINUED ON NEXT PAGE

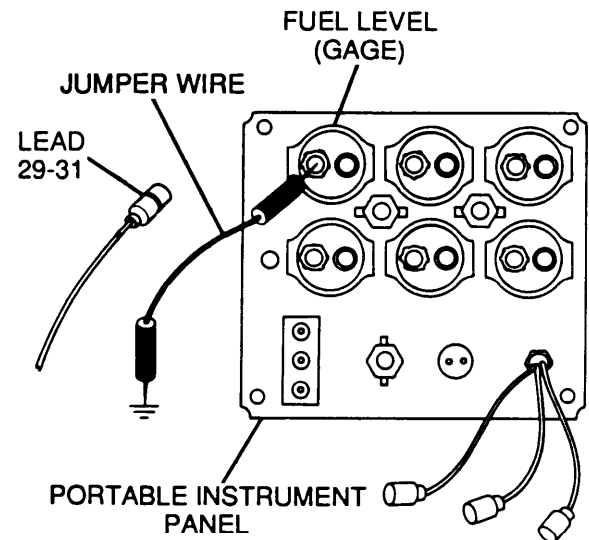

3-3 TROUBLESHOOTING CHART — CONTINUED

s. FUEL LEVEL INDICATOR CIRCUIT — CONTINUED

(1) FUEL LEVEL INDICATOR NEEDLE FAILS TO MOVE OR IS UNSTEADY; ALL OTHER GAGES OPERATE PROPERLY—CONTINUED

CONTINUED FROM STEPA

B

1. Reconnect lead 29-31 to FUEL LEVEL gage.
2. Disconnect lead 28 from FUEL LEVEL gage.
3. Place red lead of multimeters in lead 28 and black lead to ground.
4. Turn MASTER switch ON and check for voltage.
5. Turn MASTER switch OFF.

Is voltage present?

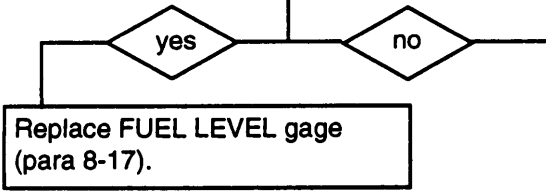

C

1. Reconnect lead 28 to FUEL LEVEL gage.
2. Disconnect battery ground leads.
3. Disconnect portable instrument panel wiring harness from portable instrument disconnect.
4. Place a jumper wire from socket P (lead 459B) to socket C (lead 459).
5. Place red lead of multimeters in socket A (lead 28) and black lead to ground.
6. Turn MASTER switch ON and check for voltage.
7. Turn MASTER switch OFF.

Is voltage present?

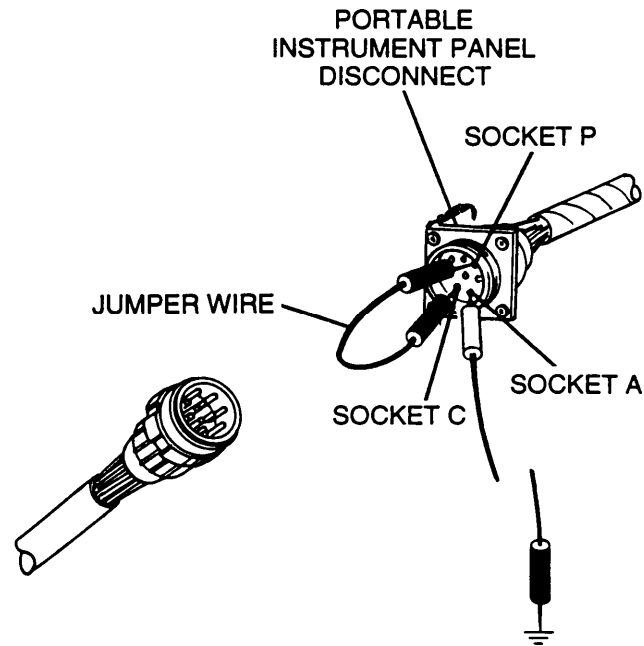
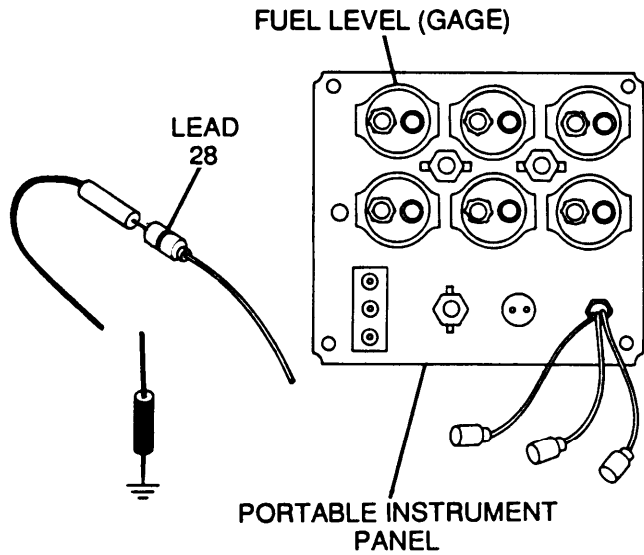
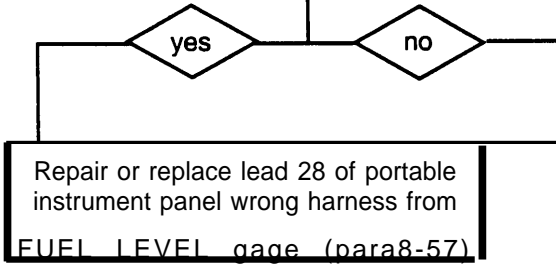

CONTINUED ON NEXT PAGE

CONTINUED FROM STEP C

- D**
1. Reconnect portable instrument panel wiring harness to portable instrument panel disconnect.
 2. Disconnect lead 27 from circuit breaker output.
 3. Place red lead of multimeters in circuit breaker output and black lead to ground.
 4. Turn MASTER switch ON and check for voltage.
 5. Turn MASTER switch OFF.

Is voltage present?

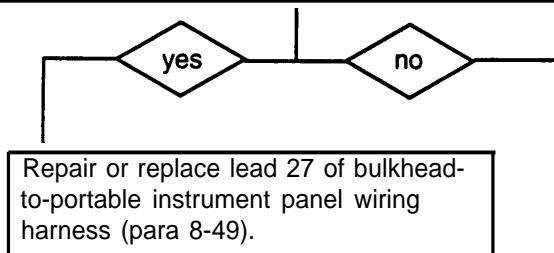

- E**
1. Reconnect lead 27 to circuit breaker output.
 2. Disconnect lead 10 from circuit breaker input.
 3. Place red lead of multimeters in lead 10 and black lead to ground.
 4. Turn MASTER switch ON and check for voltage.
 5. Turn MASTER switch OFF.

Is voltage present?

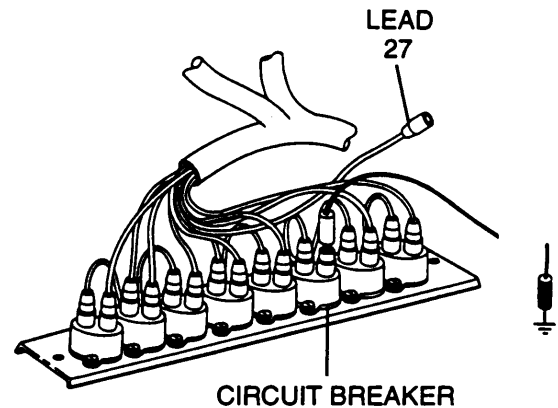
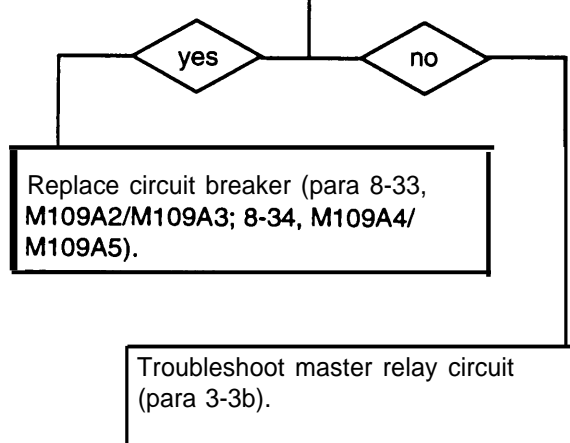

CIRCUIT BREAKER

M109A4/M109A5 SHOWN

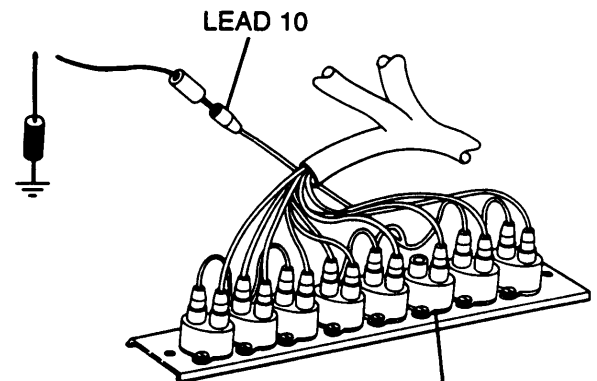

CIRCUIT BREAKER

M109A4/M109A5 SHOWN

3-3 TROUBLESHOOTING CHART — CONTINUED

s. FUEL LEVEL INDICATOR CIRCUIT — CONTINUED

(1) FUEL LEVEL INDICATOR NEEDLE FAILS TO MOVE OR IS UNSTEADY; ALL OTHER GAGES OPERATE PROPERLY — CONTINUED

CONTINUED FROM STEP A

- F**
1. Reconnect lead 29-31 to FUEL LEVEL gage.
 2. Disconnect lead 29-31 from FUEL GAGE switch.
 3. Place red lead of multimeters in lead 29-31 and black lead to ground.
 4. Turn MASTER switch ON and check for voltage.
 5. Turn MASTER switch OFF.

Is voltage present?

yes

no

Replace FUEL GAGE switch (para 8-1 7).

Repair or replace lead 29-31 of bulkhead-to-portable instrument panel wiring harness (para 8-49).

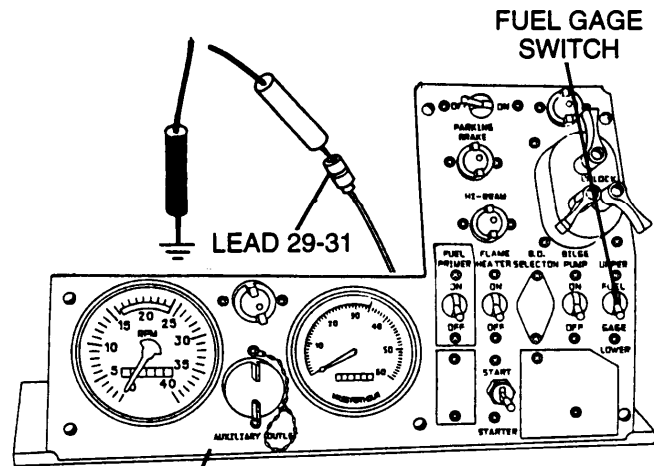

DRIVER'S INSTRUMENT PANEL

M109A4/M109A5 (ENGINE MODEL 7083-7396) SHOWN

END OF TASK

(2) FUEL LEVEL INDICATOR (GAGE) SHOWS LEVEL FOR UPPER FUEL TANK, BUT NOT FOR LOWER FUEL TANK

INITIAL SETUP

Tools

General mechanic's tool kit (item 64, Appx H)
 Multimeters (item 36, Appx H)
 TA-1 probe kit (item 43, Appx H)
 (Long test leads may be needed for some tests;
 16 AWG wire maybe used as an extension.)

Equipment Condition

Engine access door. open (TM 9-2350-311-1 O)
 Transmission access doors open (TM 9-2350-311-1 O)
 Portable instrument panel cover removed (para 8-1 7)
 Driver's instrument panel cover removed (para 8-1 7)
 Fuel tanks full (TM 9-2350-311-10)

- A**
1. Place FUEL GAGE switch in UPPER position.
 2. Disconnect lead 29 from upper fuel tank transmitter.
 3. Turn MASTER switch ON and check FUEL LEVEL gage for a reading.
 4. If FUEL LEVEL gage shows a maximum reading, place a jumper wire from lead 29 to ground.
 5. Check gage for reading.
 6. Turn MASTER switch OFF.

Does FUEL LEVEL gage show minimum when grounded and maximum when not grounded?

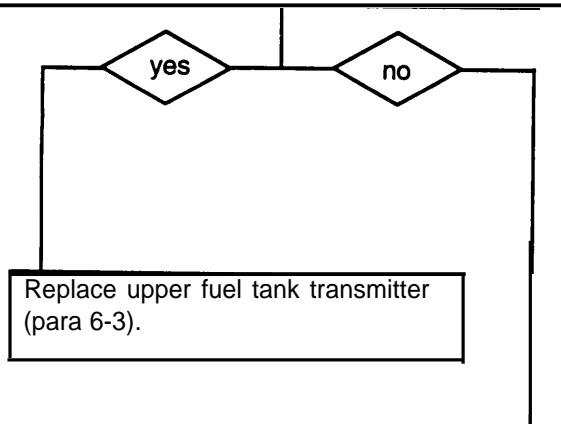

CONTINUED ON NEXT PAGE

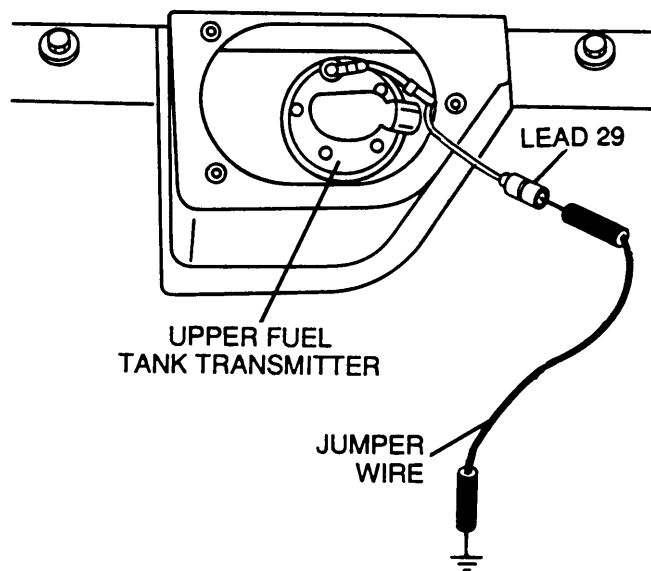

3-3 TROUBLESHOOTING CHART — CONTINUED

s. FUEL LEVEL INDICATOR CIRCUIT —
CONTINUED

(2) FUEL LEVEL INDICATOR (GAGE) SHOWS LEVEL
FOR UPPER FUEL TANK, BUT NOT FOR LOWER
FUEL TANK — CONTINUED

CONTINUED FROM STEP A

B	<ol style="list-style-type: none"> 1. Reconnect lead 29 to upper fuel tank transmitter. 2. Place FUEL GAGE switch in UPPER position. 3. Disconnect lead 29 from FUEL GAGE switch. 4. Place red lead of multimeters in FUEL GAGE switch and black lead to ground. 5. Turn MASTER switch ON and check for voltage. 6. Turn MASTER switch OFF.
Is voltage present?	

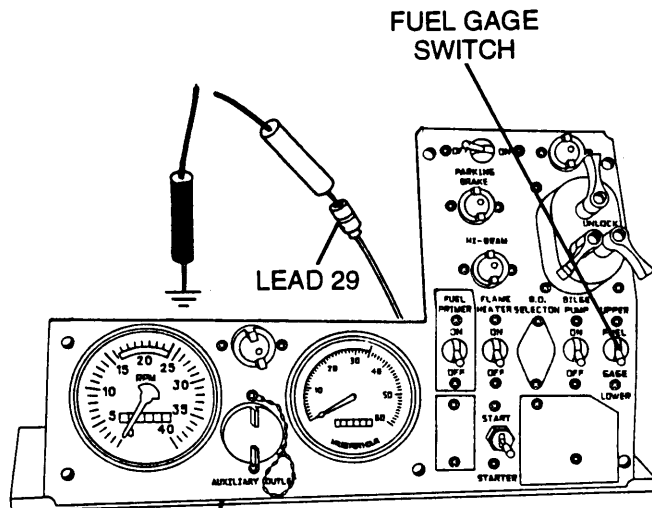
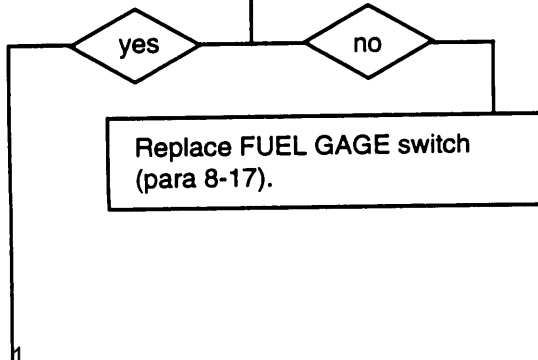

DRIVER'S INSTRUMENT PANEL

M109A4/M109A5
(ENGINE MODEL 7083-7396) SHOWN

CONTINUED ON NEXT PAGE

CONTINUED FROM STEP A

- C**
1. Reconnect lead 29 to upper FUEL GAGE switch.
 2. Place FUEL GAGE switch in UPPER position.
 3. Disconnect bulkhead-to-driver's instrument panel wiring harness from driver's bulkhead.
 4. Place a jumper wire from pin H to socket H (lead 459).
 5. Turn MASTER switch ON and check FUEL LEVEL gage for a reading.
 6. If FUEL LEVEL gage shows a maximum reading, place a jumper wire from socket L (lead 29) to ground.
 7. Check gage for a reading.
 8. Turn MASTER switch OFF.
- Does FUEL LEVEL gage show minimum when grounded and maximum when not grounded?

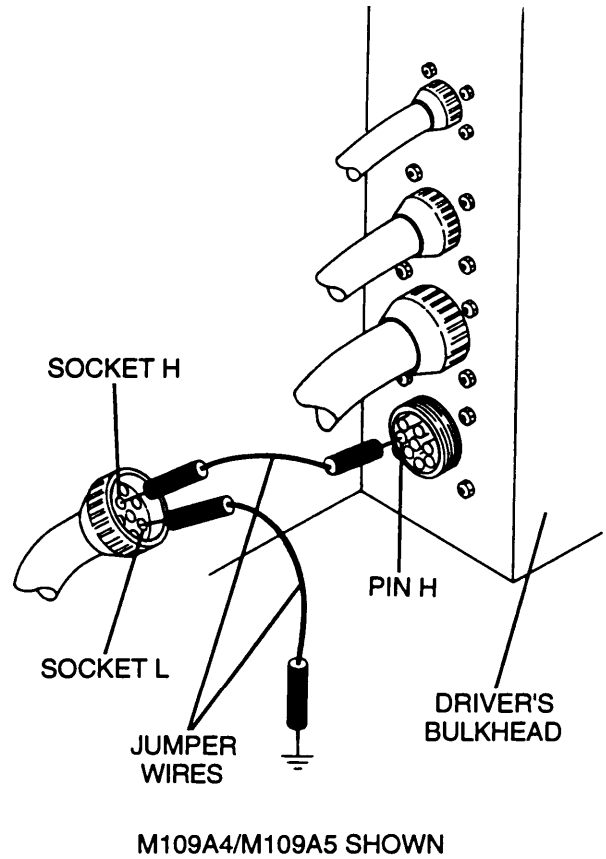
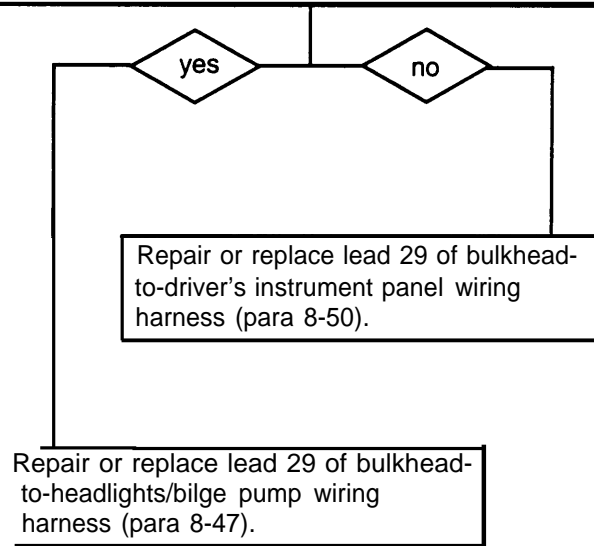

END OF TASK

3-3 TROUBLESHOOTING CHART — CONTINUED

s. FUEL LEVEL INDICATOR CIRCUIT —
CONTINUED

(3) FUEL LEVEL INDICATOR (GAGE) SHOWS LEVEL
FOR LOWER FUEL TANK, BUT NOT FOR UPPER
FUEL TANK

Tools

General mechanic's tool kit (item 64, Appx H)
Multimeter (item 36, Appx H)
TA-1 probe kit (item 43, Appx H)
(Long test leads may be needed for some tests;
16 AWG wire maybe used as an extension.)

Equipment Conditions

Engine access door open (TM 9-2350-311-10)
Transmission access doors open (TM 9-2350-311-10)
Portable instrument panel cover removed (para 8-17)
Drivers instrument panel cover removed (para 8-17)
Fuel tanks full (TM 9-2350-311-10)

A

1. Place FUEL GAGE switch in LOWER position.
2. Disconnect lead 31 from lower fuel tank transmitter.
3. Turn MASTER switch ON and check FUEL LEVEL gage for a reading.
4. If FUEL LEVEL gage shows a maximum reading, place a jumper wire from lead 31 to ground.
5. Check gage for reading.
6. Turn MASTER switch OFF.

Does FUEL LEVEL gage show minimum when grounded and maximum when not grounded?

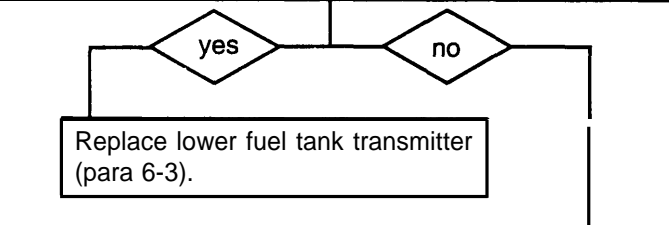

B

1. Reconnect lead 31 to lower fuel tank transmitter.
2. Place FUEL GAGE switch in LOWER position.
3. Disconnect lead 31 from FUEL GAGE switch.
4. Place red lead of multimeter in FUEL GAGE switch and black lead to ground.
5. Turn MASTER switch ON and check for voltage.
6. Turn MASTER switch OFF.

Is voltage present?

CONTINUED ON NEXT PAGE

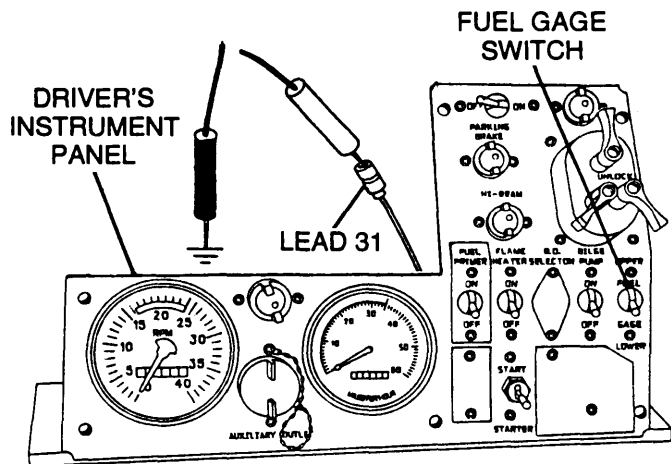
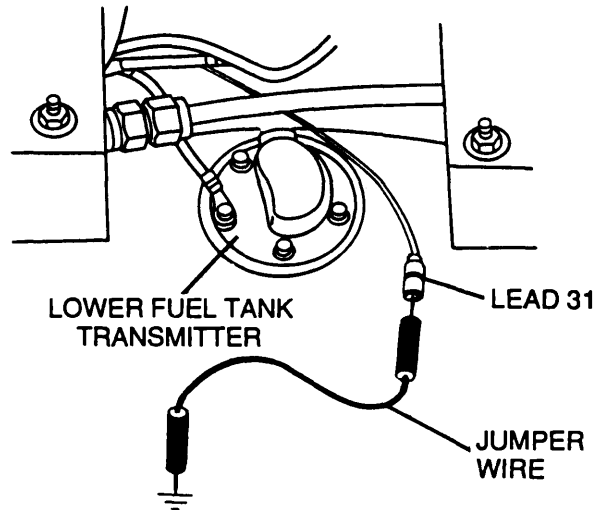

M109A4/M109A5 (ENGINE MODEL 7083-7396) SHOWN

CONTINUED FROM STEP B

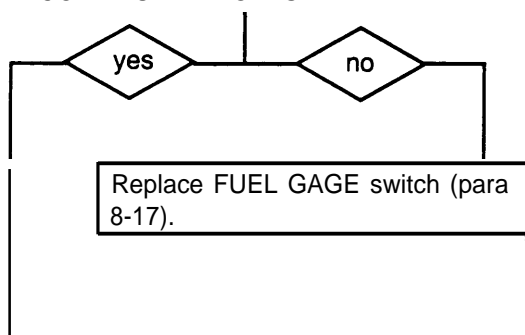

c

1. Reconnect lead 31 to lower FUEL GAGE switch.
2. Place FUEL GAGE switch in LOWER position.
3. Disconnect bulkhead-to-driver's instrument panel wiring harness from driver's bulkhead,
4. Place a jumper wire from pin H to socket H (lead 459).
5. Turn MASTER switch ON and check FUEL LEVEL gage for a reading.
6. If FUEL LEVEL gage shows a maximum reading, place a jumper wire from socket J (lead 31) to ground.
7. Check gage for a reading.
8. Turn MASTER switch OFF.

Does FUEL LEVEL gage show minimum when grounded and maximum when not grounded?

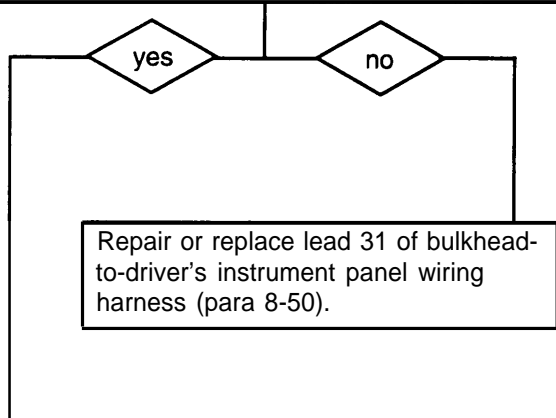

Repair or replace lead 31 of bulkhead-to-headlights/bilge pump wiring harness (para 8-47)

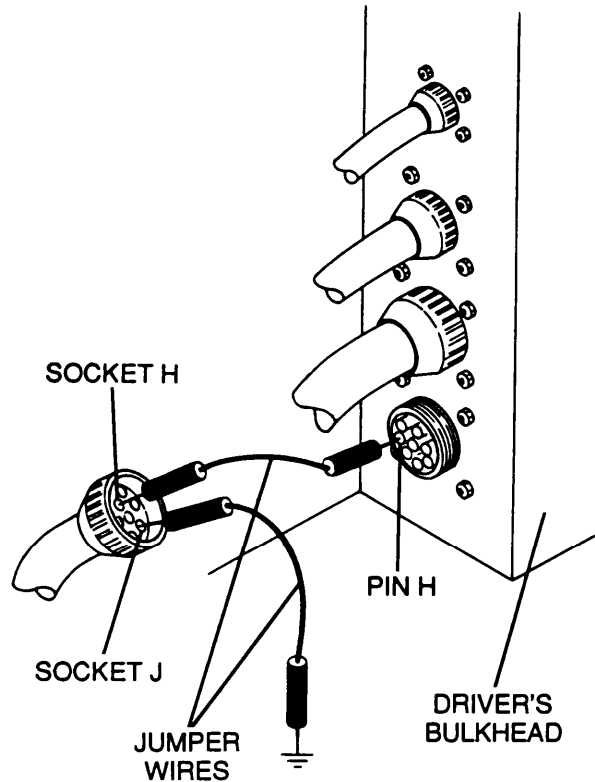

M109A4/M109A5 SHOWN

END OF TASK

3-3 TROUBLESHOOTING CHART — CONTINUED

t. DOME LIGHT CIRCUIT

NOTE

Although the dome light circuit differs slightly between M109A2, M109A3, M109A4, and M109A5 Howitzers, the following troubleshooting procedure applies to all vehicles.

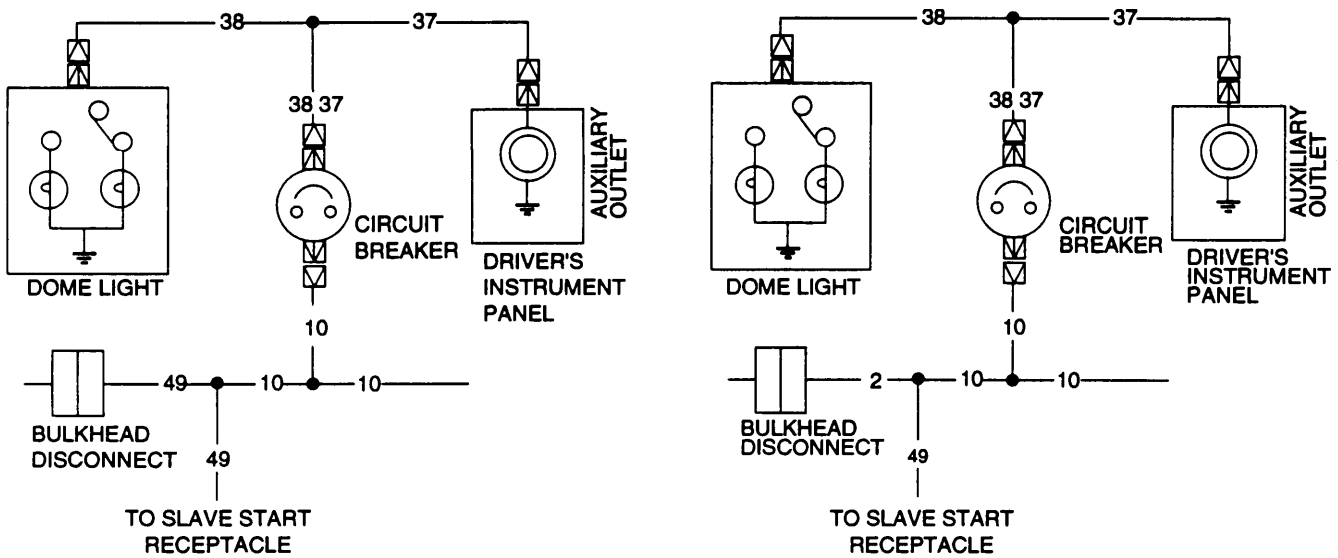

M109A2

M109A3

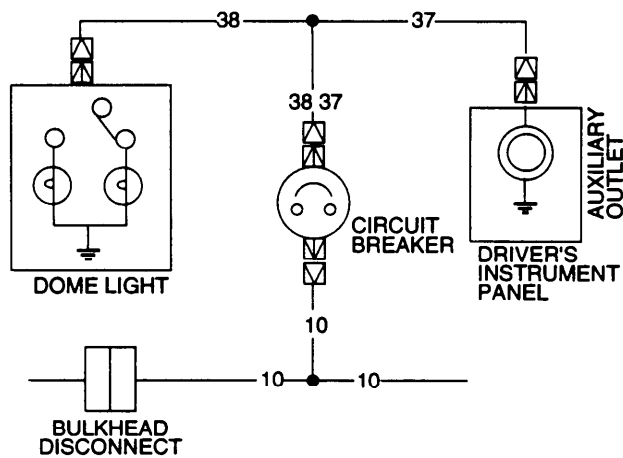

M109A4/M109A5

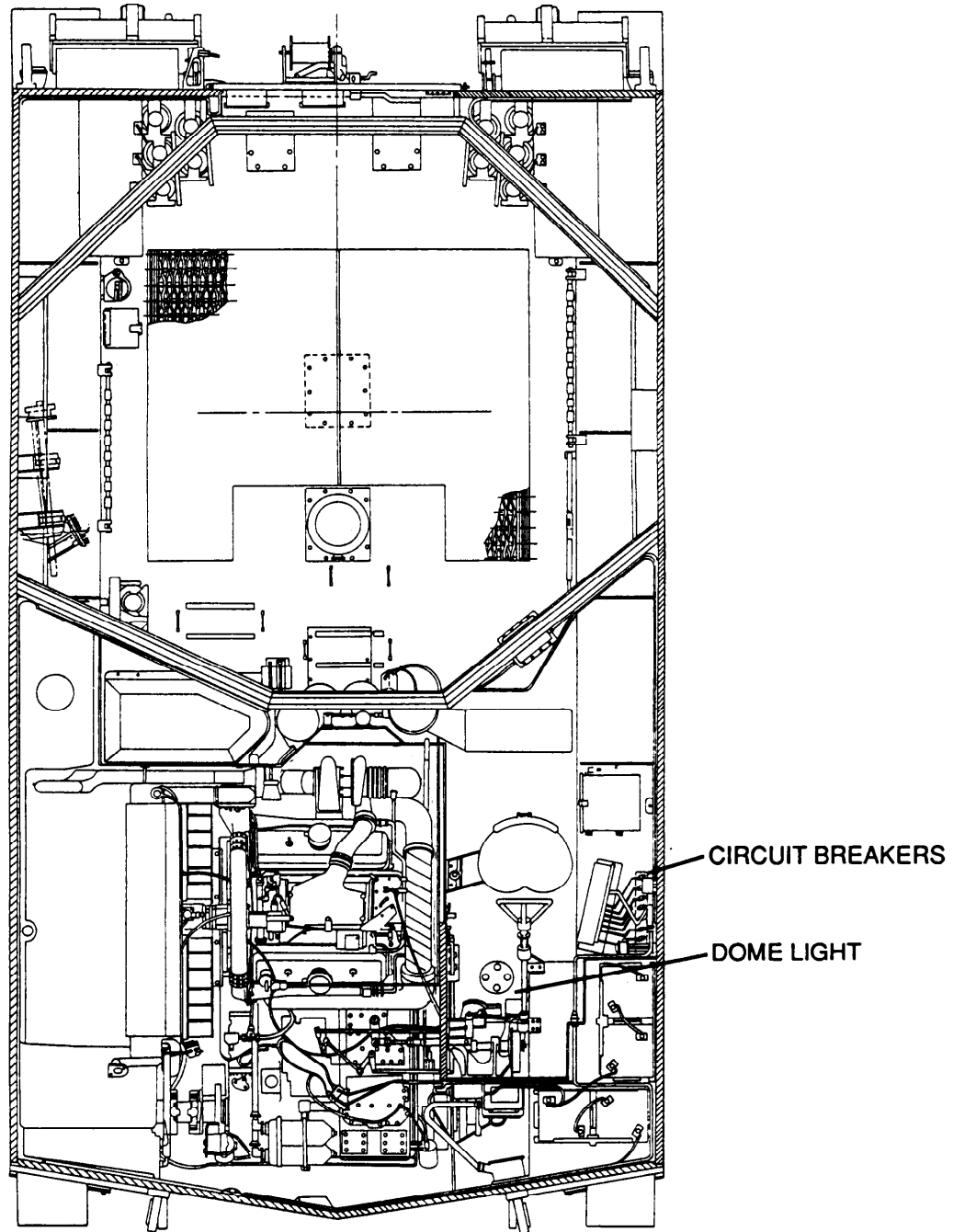

PICTORIAL VIEW

3-3 TROUBLESHOOTING CHART — CONTINUED

t. DOME LIGHT CIRCUIT— CONTINUED

DOME LIGHT FAILS TO OPERATE; ALL OTHER LIGHTS OPERATE

INITIAL SETUP

Tools

- General mechanic's tool kit (item 64, Appx H)
- Multimeters (item 36, Appx H)
- TA-1 probe kit (item 43, Appx H)

NOTE

Move dome light switch to both positions. If dome light comes on in one position only, go to step F.

- A**
1. Disconnect lead 38 from dome light.
 2. Place red lead of multimeters in lead 38 and black lead to ground.
 3. Turn MASTER switch ON and check for voltage.
 4. Turn MASTER switch OFF.
- Is voltage present?

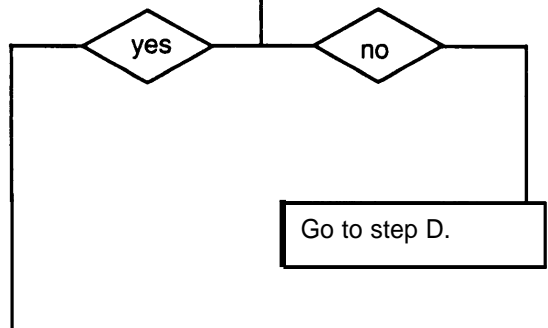
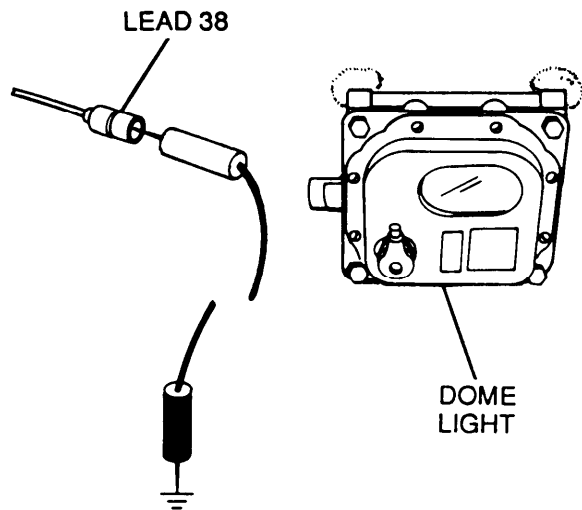

CONTINUED ON NEXT PAGE

CONTINUED FROM STEP A

NOTE

In the following step, if B.O. light is out, place red lead of multimeters on switch terminal (1). If white light is out, place red lead of multimeters on switch terminal (2).

B

1. Reconnect lead 38 to dome light.
2. Remove cover from dome light (para 8-27).
3. Place red lead of multimeters on output terminal (1 or 2) of dome light switch and black lead to ground.
4. Turn MASTER and dome light switches ON and check for voltage.
5. Turn dome light and MASTER switches OFF.

Is voltage present?

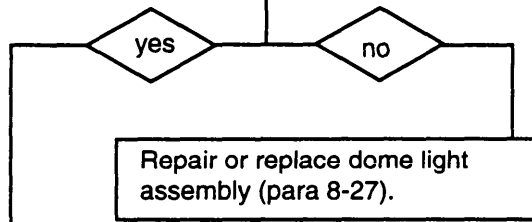

C

1. Remove lamp from lamp assembly.
2. Place red lead of multimeters on contact in center of socket and black lead to ground.
3. Turn MASTER and dome light switches ON and check for voltage.
4. Turn dome light and MASTER switches OFF.

Is voltage present?

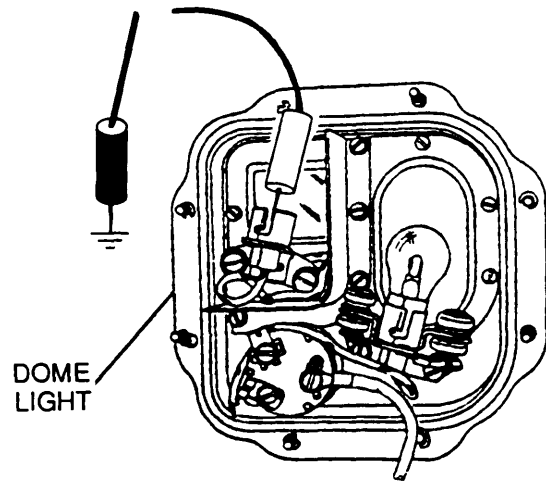
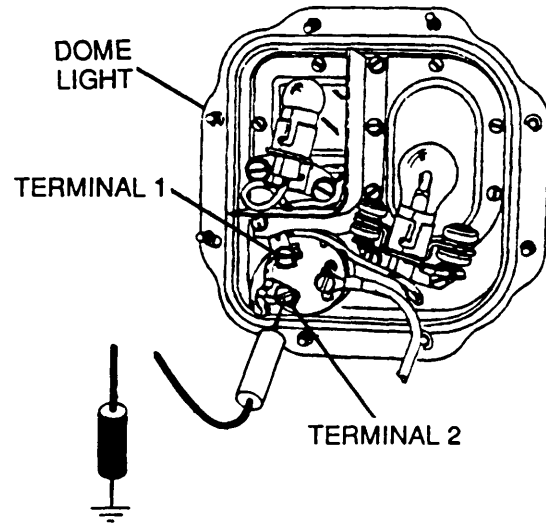
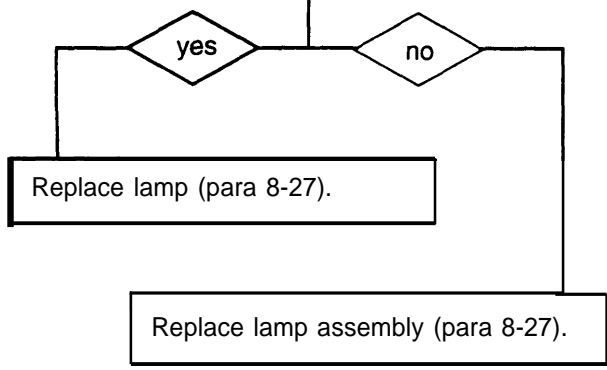

3-3 TROUBLESHOOTING CHART — CONTINUED

t. DOME LIGHT CIRCUIT — CONTINUED

DOME LIGHT FAILS TO OPERATE; ALL OTHER LIGHTS OPERATE — CONTINUED

CONTINUED FROM STEP A

- D**
1. Reconnect lead 38 to dome light.
 2. Disconnect lead 37-38 from circuit breaker output.
 3. Place red lead of multimeters in circuit breaker output and black lead to ground.
 4. Turn MASTER switch ON and check for voltage.
 5. Turn MASTER switch OFF.

Is voltage present?

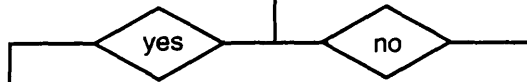

Repair or replace lead 37-38 of bulkhead-to-driver's instrument panel wiring harness (para 8-50).

- E**
1. Reconnect lead 37-38 from circuit breaker output.
 2. Disconnect lead 10 from circuit breaker input.
 3. Place red lead of multimeters in lead 10 and black lead to ground.
 4. Turn MASTER switch ON and check for voltage.
 5. Turn MASTER switch OFF.

Is voltage present?

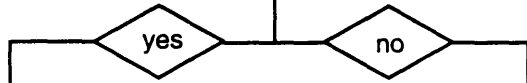

Replace circuit breaker (para 8-33, M109A2/M109A3; 8-34, M109A4/M109A5).

Repair or replace lead 10 of power lead wiring harness (para 8-55, M109A2/M109A3; 8-56, M109A4/M109A5).

END OF TASK

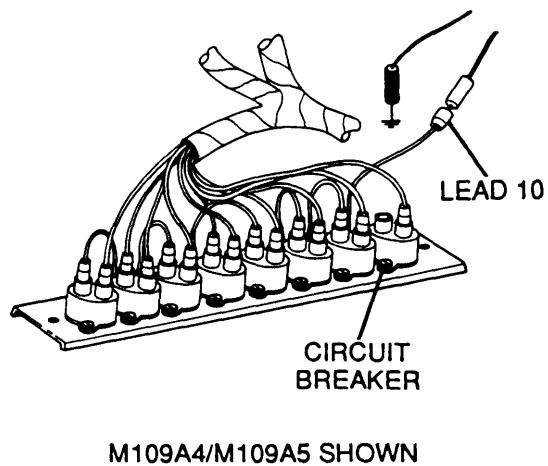
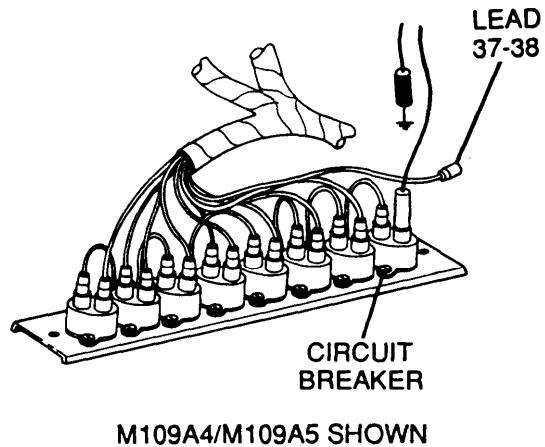

u. SERVICE HEADLIGHTS, TAILLIGHT, AND STOP LIGHT CIRCUIT

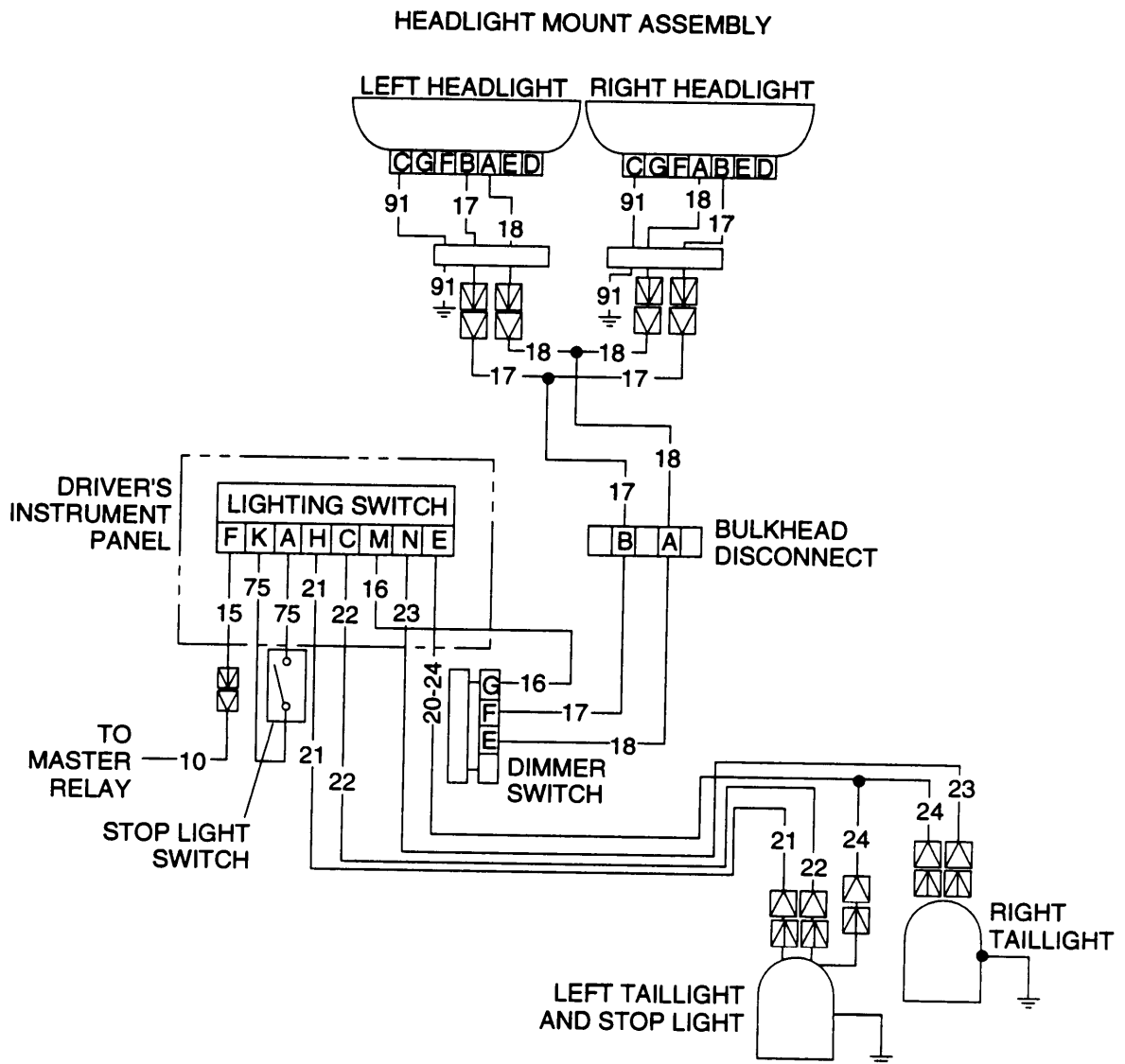

3-3 TROUBLESHOOTING CHART — CONTINUED

II. SERVICE HEADLIGHTS, TAILLIGHT, AND STOP LIGHT CIRCUIT — CONTINUED

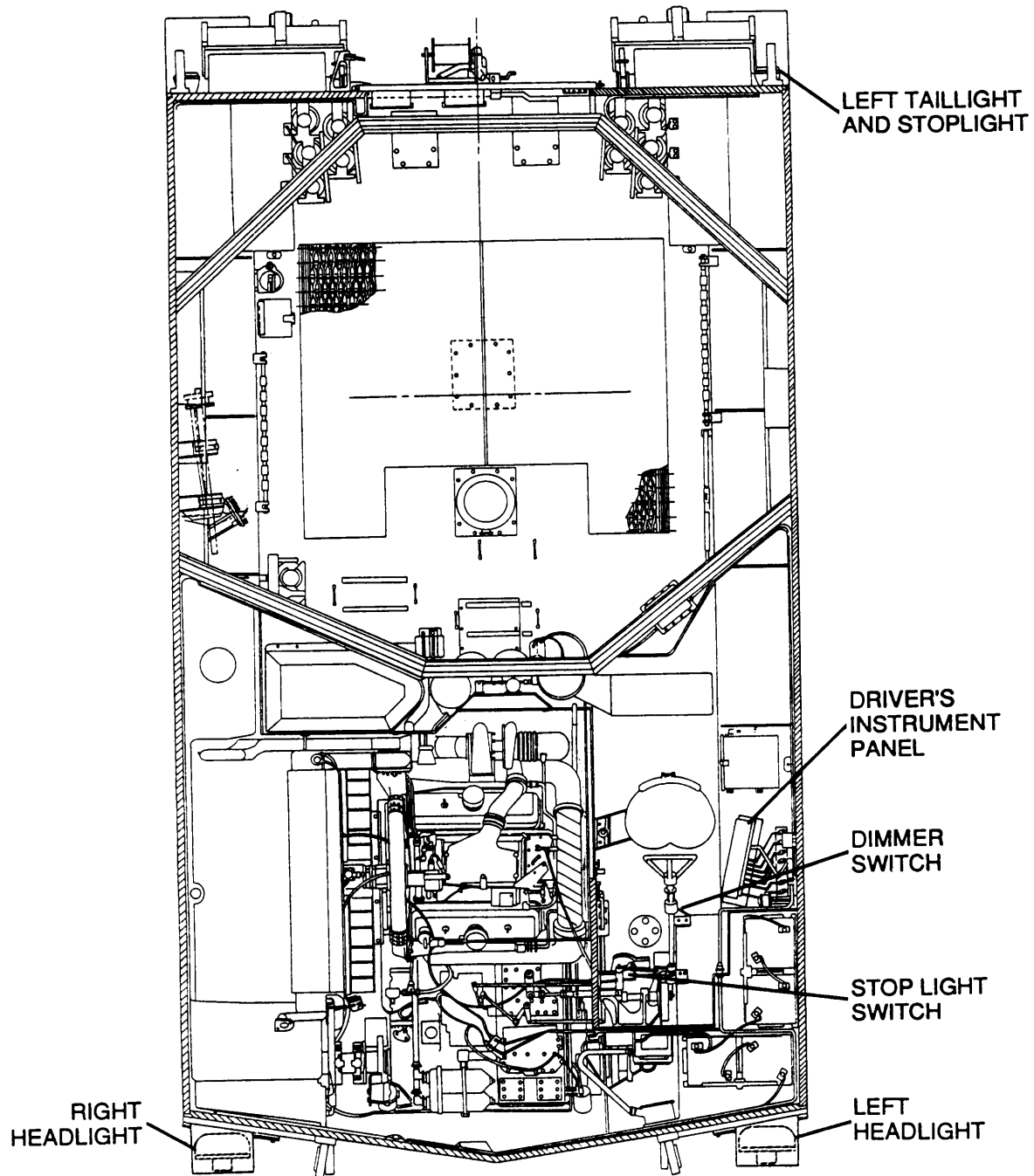

PICTORIAL VIEW

(1) HEADLIGHTS FAIL TO OPERATE; ALL OTHER LIGHTS OPERATE

INITIAL SETUP

Tools

General mechanic's tool kit (item 64, Appx H)
 Multimeters (item 36, Appx H)
 TA-1 probe kit (item 43, Appx H)
 (Long test leads may be needed for some tests;
 16 AWG wire may be used as an extension.)

Personnel Required

Two

Equipment Condition

Engine access door open (TM 9-2350-311-1 O)
 Transmission access doors open (TM 9-2350-311-1 O)
 Driver's instrument panel released (para 8-1 7)

- A**
1. Disconnect bulkhead-to-drivers instrument panel wiring harness from main light switch.
 2. Place red lead of multimeters in socket F (lead 15) and black lead to ground.
 3. Turn MASTER switch ON and check for voltage.
 4. Turn MASTER switch OFF.

Is voltage is present?

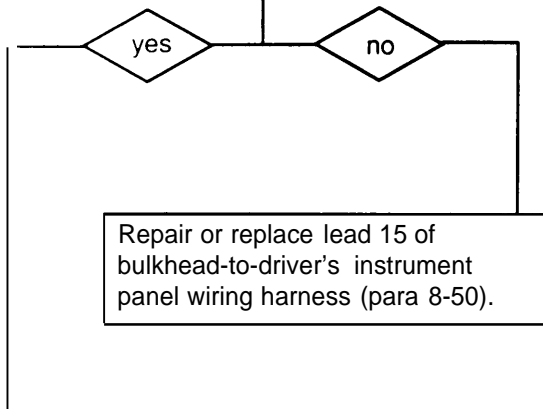

CONTINUED ON NEXT PAGE

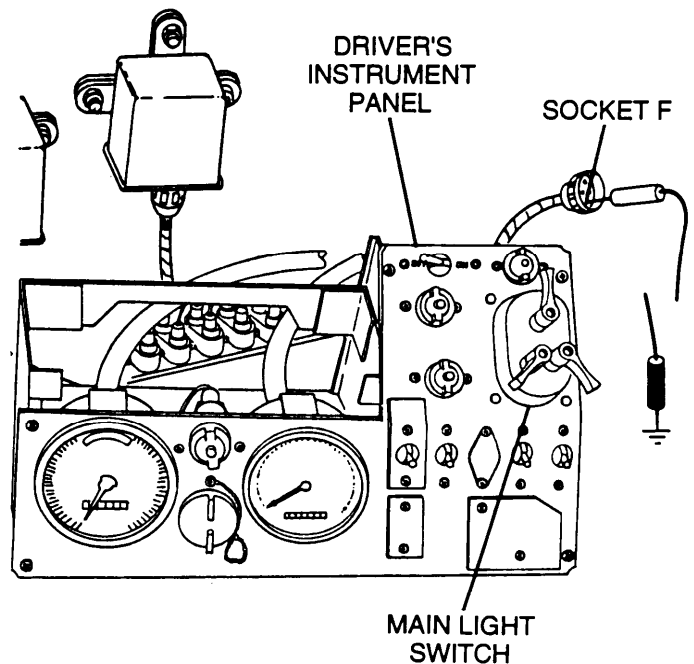

M109A4/M109A5 (ENGINE MODEL 7083-7396) SHOWN

3-3 TROUBLESHOOTING CHART — CONTINUED

u. SERVICE HEADLIGHTS, TAILLIGHT, AND STOP (1) HEADLIGHTS FAIL TO OPERATE; ALL OTHER LIGHT CIRCUIT — CONTINUED
 LIGHTS OPERATE — CONTINUED

CONTINUED FROM STEP A

- B**
1. Place a jumper wire from socket F (lead 15) to socket M (lead 16).
 2. Turn MASTER switch ON and check headlights for operation.
 3. Turn MASTER switch OFF.
- Do headlights operate?

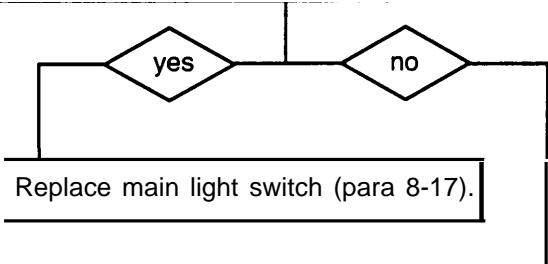

- C**
1. Leave jumper wire from socket F (lead 15) to socket M (lead 16).
 2. Disconnect bulkhead-to-driver's instrument panel wiring harness from dimmer switch.
 3. Place red lead of multimeter in socket G (lead 16) and black lead to ground.
 4. Turn MASTER switch ON and check for voltage.
 5. Turn MASTER switch OFF.
- Is voltage present?

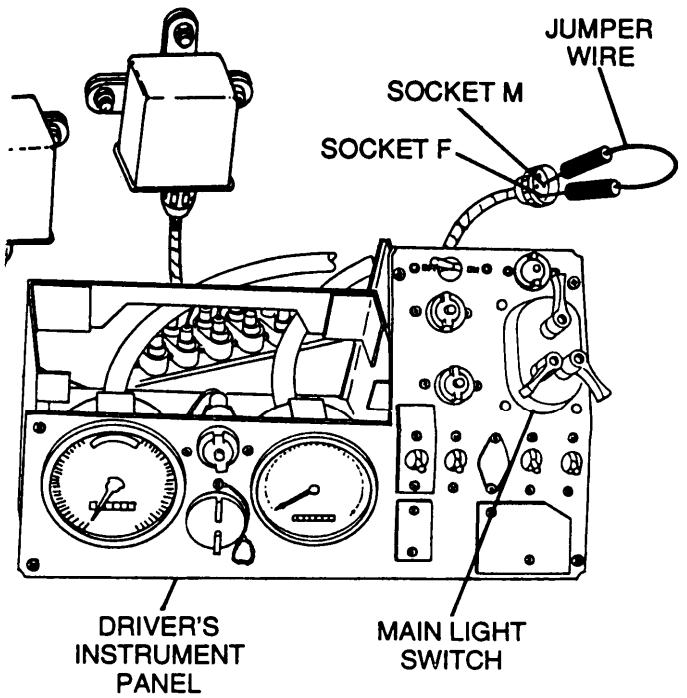
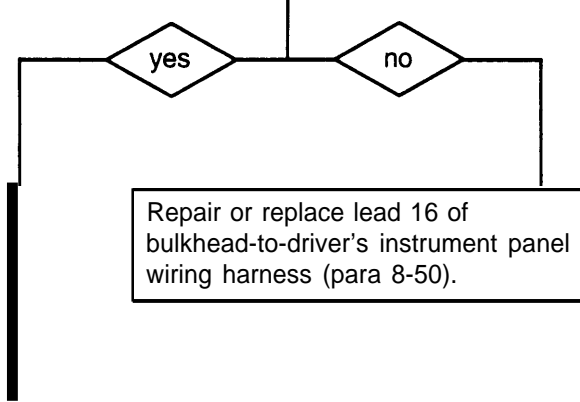

M109A4/M109A5 (ENGINE MODEL 7083-7396) SHOWN

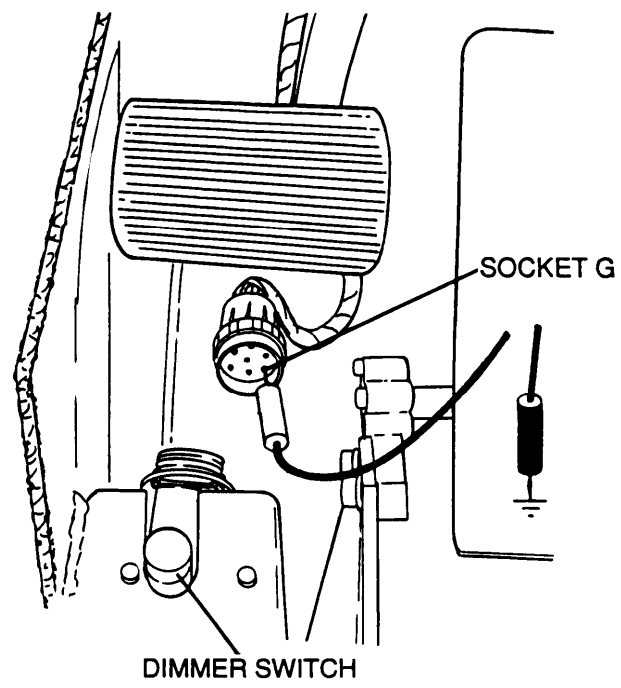

CONTINUED ON NEXT PAGE

CONTINUED FROM STEP C

- D**
1. Reconnect bulkhead-to-driver's instrument panel wiring harness to main light switch.
 2. Place a jumper wire from socket G (lead 16) and socket E (lead 18) of dimmer switch connector.
 3. Turn MASTER switch ON and check headlights for operation.
 4. Turn MASTER switch OFF.

Do headlights operate?

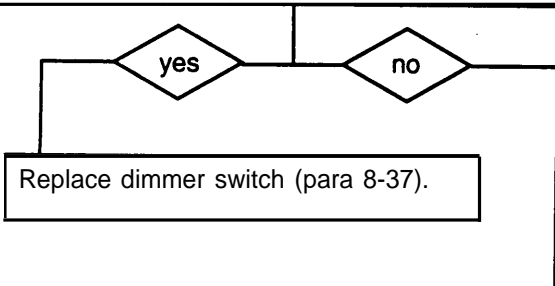

- E**
1. Reconnect bulkhead-to-driver's instrument Panel wiring harness to dimmer switch.
 2. Remove headlight assembly (para 8-21).
 3. Place red lead of multimeters in socket B (lead 17) and black lead to ground.
 4. Turn MASTER switch ON and check for voltage.
 5. Place red lead of multimeters in socket A (lead 18) and black lead to ground.
 6. Check for voltage.
 7. Turn MASTER switch OFF.

Is voltage present in both locations?

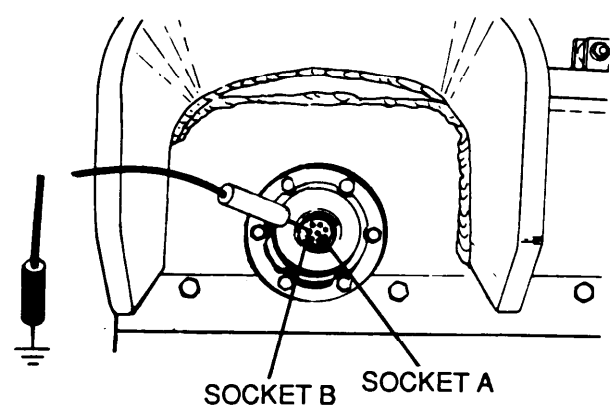
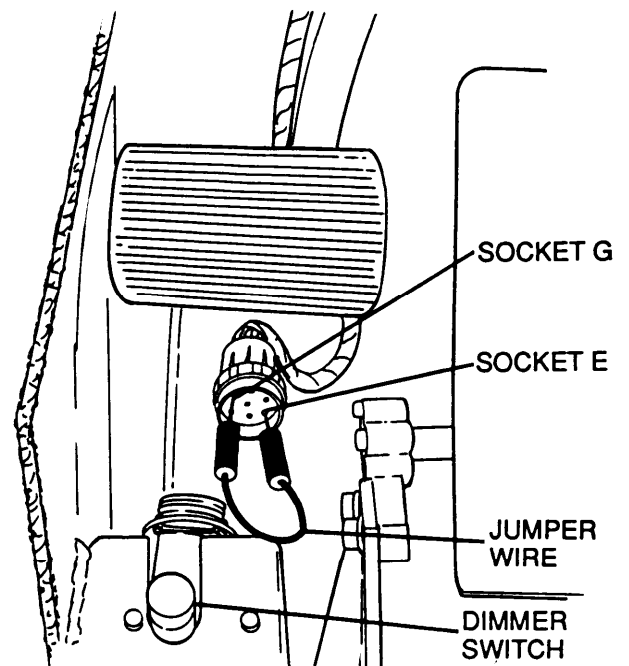
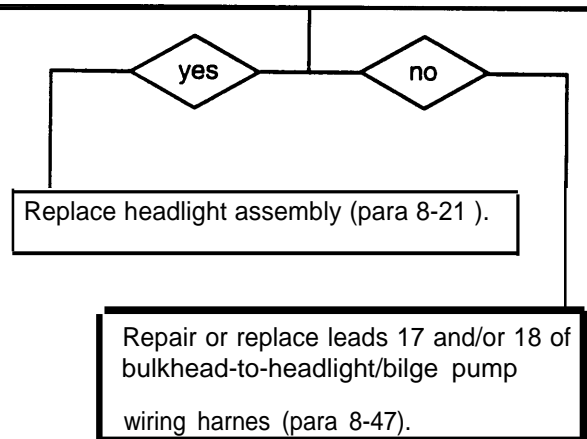

END OF TASK

3-3 TROUBLESHOOTING CHART — CONTINUED

u. SERVICE HEADLIGHTS, TAILLIGHT, AND STOP (2) HEADLIGHTS OPERATE ON ONE BEAM ONLY LIGHT CIRCUIT — CONTINUED

INITIAL SETUP

<p><u>Tools</u> General mechanic's tool kit (item 64, Appx H) Multimeters (item 36, Appx H) TA-1 probe kit (item 43, Appx H) (Long test leads may be needed for some tests; 16 AWG wire may be used as an extension.)</p>	<p><u>Personel Required</u> Two</p> <p><u>Equipment Condition</u> Engine access door open (TM 9-2350-311-1 O) Transmission access doors open (TM 9-2350-311-1 O)</p>
--	---

NOTE

Both headlight assemblies have identical wiring. The following procedures apply to both right and left headlight assemblies.

- A**
1. Remove inoperative headlight assembly (para 8-21).
 2. If low beam is inoperative, place red lead of multimeters in socket A (lead 18) and black lead to ground.
 3. Turn MASTER switch ON, place dimmer switch in the low beam position, and check for voltage.
 4. If high beam is inoperative, place red lead of multimeters in socket B (lead 17) and black lead to ground.
 5. Turn MASTER switch ON, place dimmer switch in the high beam position, and check for voltage.
 6. Turn MASTER switch OFF.

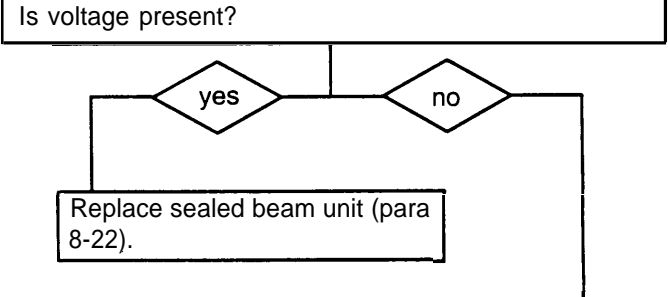
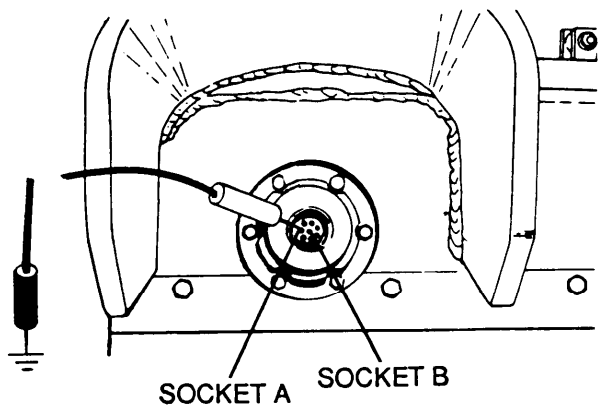

CONTINUED ON NEXT PAGE

CONTINUED FROM STEP A

- B**
1. Install inoperative headlight assembly (para 8-21).
 2. Disconnect bulkhead-to-driver's instrument panel wiring harness from dimmer switch.
 3. If low beam is inoperative, place red lead of multimeters on pin E (lead 18) and black lead on pin G (lead 16).
 4. Place dimmer switch in low beam position and check for continuity.
 5. If high beam is inoperative, place red lead of multimeters on pin F (lead 17) and black lead on pin H (lead 16).
 6. Place dimmer switch in high beam position and check for continuity.
- Is continuity present?

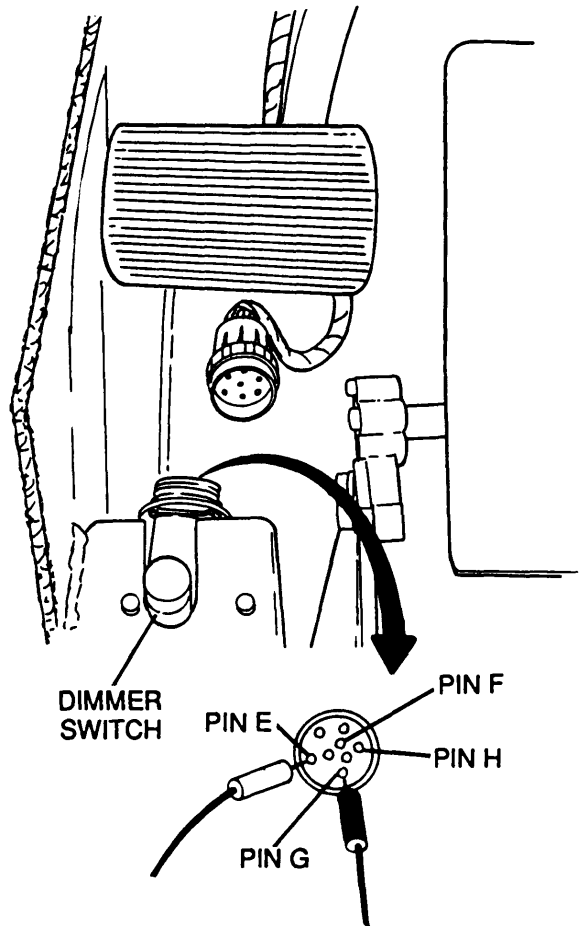
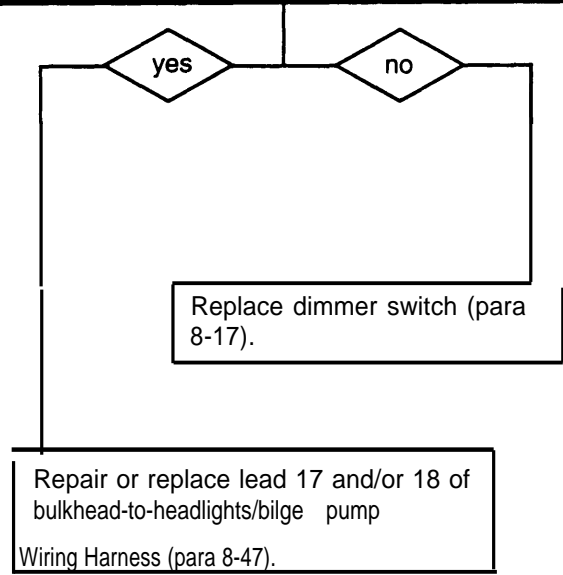

END OF TASK

3-3 TROUBLESHOOTING CHART — CONTINUED

u. SERVICE HEADLIGHTS, TAILLIGHT, AND STOP (3) RIGHT OR LEFT HEADLIGHT FAILS TO OPERATE;
LIGHT CIRCUIT — CONTINUED ALL OTHER LIGHTS OPERATE

INITIAL SETUP

Tools

General mechanic's tool kit (item 64, Appx H)
Multimeters (item 36, Appx H)
TA-1 probe kit (item 43, Appx H)
(Long test leads may be needed for some tests;
16 AWG wire may be used as an extension.)

Personnel Required

Two

Equipment Conditions

Engine access door open (TM 9-2350-311-10)
Transmission access doors open (TM 9-2350-311-10)

NOTE

Both headlight assemblies have identical wiring. The following procedures apply to both left and right headlight assemblies.

- A**
1. Disconnect bulkhead-to-driver's instrument panel wiring harness from dimmer switch.
 2. Place a jumper wire from socket G (lead 16) to socket E (lead 18).
 3. Turn MASTER switch ON and place main light switch in SER. DRIVE position.
 4. Check headlight for operation.
 5. Turn MASTER switch OFF.

Does headlight operate?

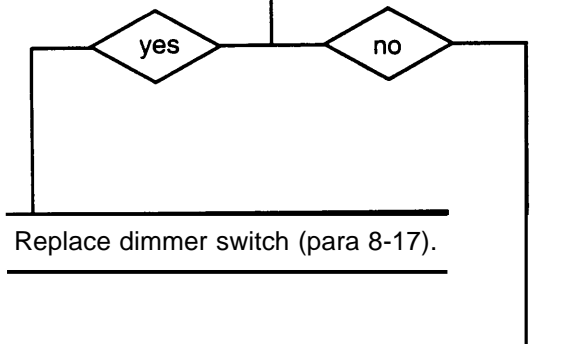

CONTINUED ON NEXT PAGE

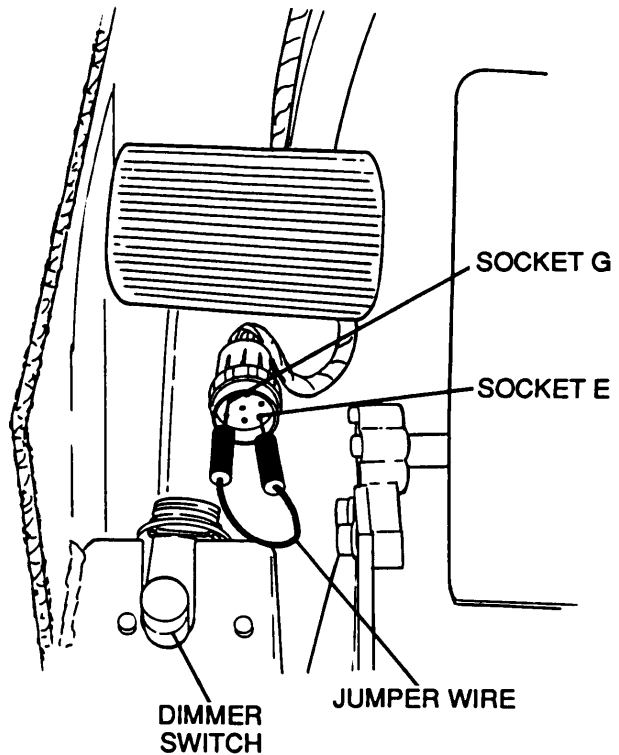

CONTINUED FROM STEP A

B	<ol style="list-style-type: none"> 1. Reconnect bulkhead-to-driver's instrument panel wiring harness to dimmer switch. 2. Remove inoperative headlight assembly (para 8-21). 3. If low beam is inoperative, place red lead of multimeters in socket A (lead 18) and black lead to ground. 4. Turn MASTER switch ON, place dimmer switch in the low beam position, and check for voltage. 5. If high beam is inoperative, place red lead of multimeters in socket B (lead 17) and black lead to ground. 6. Turn MASTER switch ON, place dimmer switch in the high beam position and check for voltage. 7. Turn MASTER switch OFF.
<p>Is voltage present?</p>	

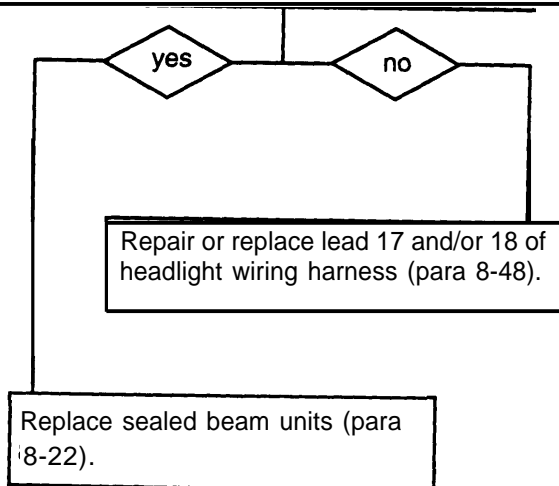
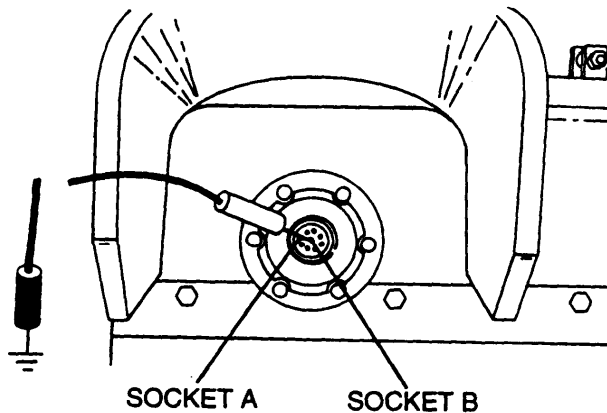

END OF TASK

3-3 TROUBLESHOOTING CHART — CONTINUED

u. SERVICE HEADLIGHTS, TAILLIGHT, AND STOP (4) TAILLIGHT FAILS TO OPERATE; ALL OTHER LIGHTS OPERATE
LIGHT CIRCUIT — CONTINUED

INITIAL SETUP

Tools

General mechanic's tool kit (item 64, Appx H)
Multimeter (item 36, Appx H)
TA-1 probe kit (item 43, Appx H)

Equipment Condition:

Driver's instrument panel released (para 8-17)
Taillight cover removed (para 8-25)

A

1. Remove taillight bulb (para 8-25).
2. Place red lead of multimeters in center contact and black lead to ground.
3. Turn MASTER switch ON, place main light switch to SER. DRIVE position, and check for voltage.
4. Turn MASTER switch OFF.

Is voltage present?

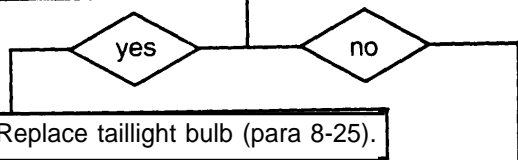

B

1. Install taillight bulb in socket (para 8-25).
2. Disconnect bulkhead-to-driver's instrument panel wiring harness from main light switch.
3. Place a jumper wire from socket F (lead 15) to socket H (lead 21).
4. Turn MASTER switch ON and check taillight for operation.
5. Turn MASTER switch OFF.

Does taillight operate?

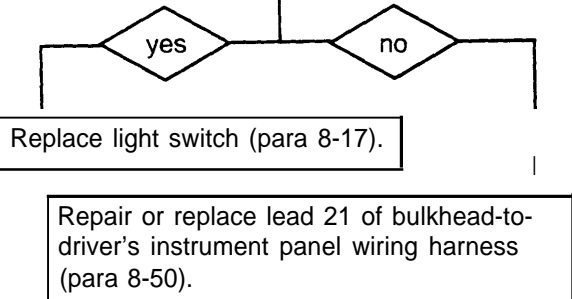

END OF TASK

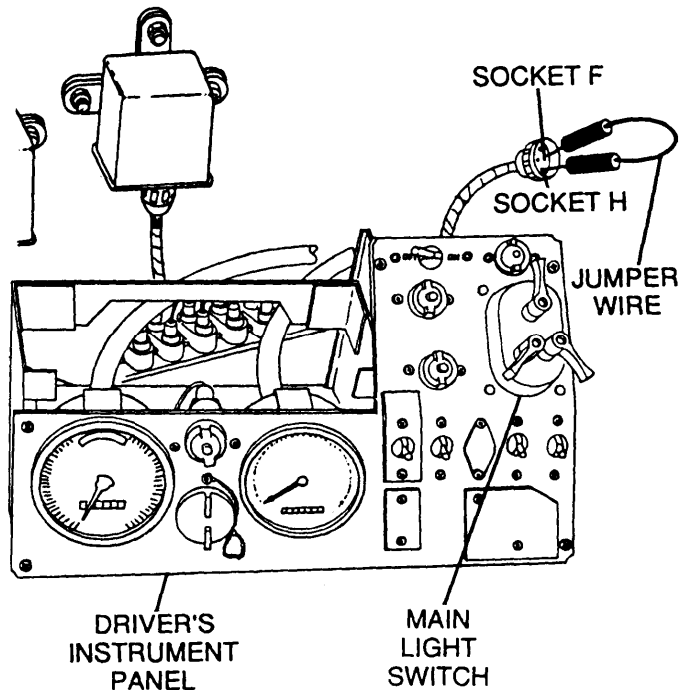
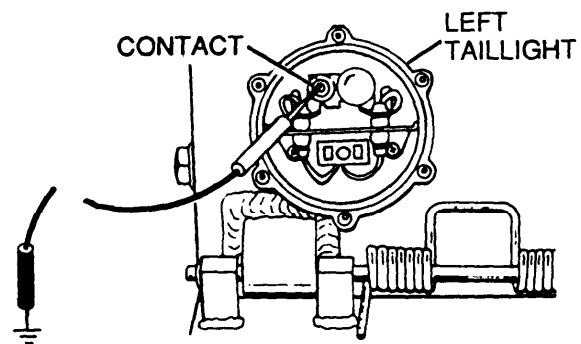

M109A4/M109A5 (ENGINE MODEL 7083-7396) SHOWN

(5) STOP LIGHT FAILS TO OPERATE; ALL OTHER LIGHTS OPERATE

Tools

General mechanic's tool kit (item 64, Appx H)
 Multimeters (item 36, Appx H)
 TA-1 probe kit (item 43, Appx H)

Equipment Conditions

Driver's instrument panel released (para 8-17)
 Taillight cover removed (para 8-25)

- A**
1. Remove stop light bulb (para 8-25).
 2. Place red lead of multimeters in center contact and black lead to ground.
 3. Turn MASTER switch ON, place main light switch to SER. DRIVE position, and check for voltage.
 4. Turn MASTER switch OFF.
- Is voltage present?

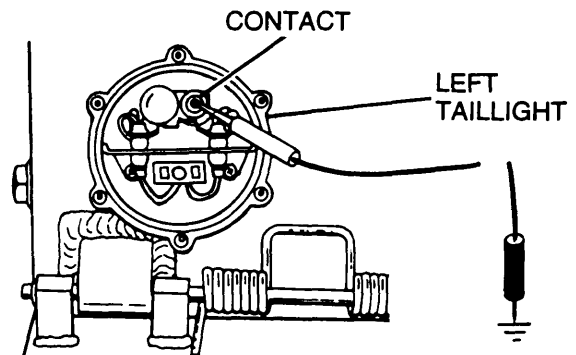
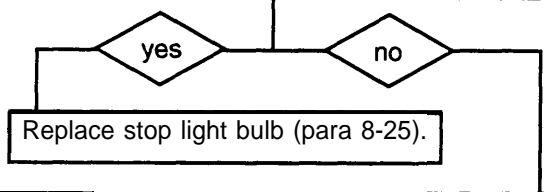

- B**
1. Install stop light bulb in socket (para 8-25).
 2. Disconnect two leads 75 from stop light switch.
 3. Place red lead of multimeters in first lead 75 and black lead to ground.
 4. Turn MASTER switch ON and check for voltage.
 5. Place red lead of multimeters in second lead 75 and black lead to ground.
 6. Check for voltage.
 7. Turn MASTER switch OFF.
- Is voltage present?

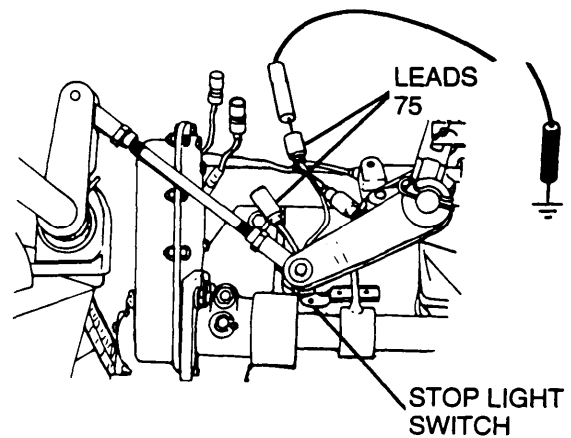
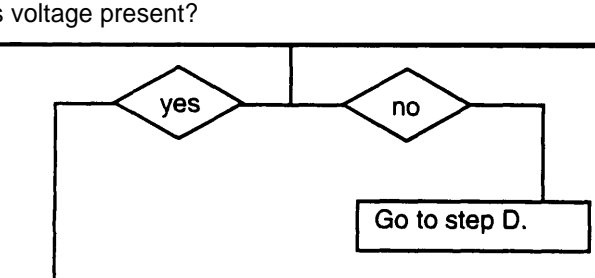

CONTINUED ON NEXT PAGE

3-3 TROUBLESHOOTING CHART — CONTINUED

u. SERVICE HEADLIGHTS, TAILLIGHT, AND STOP LIGHT CIRCUIT — CONTINUED

(5) STOP LIGHT FAILS TO OPERATE; ALL OTHER LIGHTS OPERATE — CONTINUED

CONTINUED FROM STEP B

- C**
1. Place a jumper wire from lead 75 to lead 75 at stop light switch.
 2. Turn MASTER switch ON and check stop light for operation.
 3. Turn MASTER switch OFF.

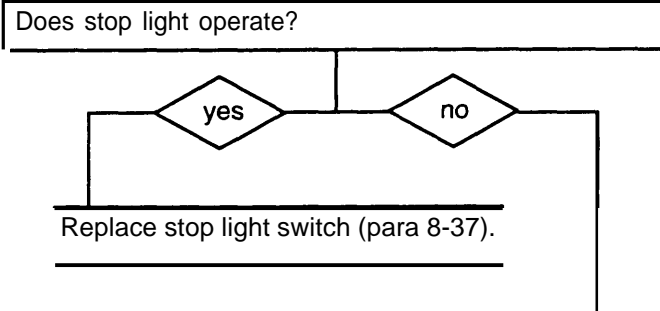

- D**
1. Reconnect both leads 75 to stop light switch
 2. Disconnect bulkhead-to-driver's instrument panel wiring harness from main light switch.
 3. Place a jumper wire from socket F (lead 15) to socket K (lead 75).
 4. Place red lead of multimeters in socket A (lead 75) and black lead to ground.
 5. Turn MASTER switch ON, press brake pedal, and check for voltage.
 6. Turn MASTER switch OFF.

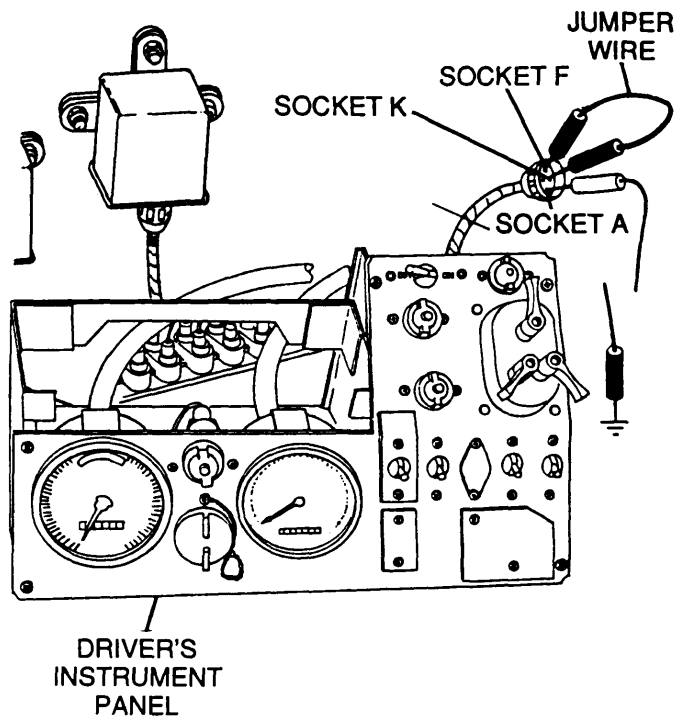
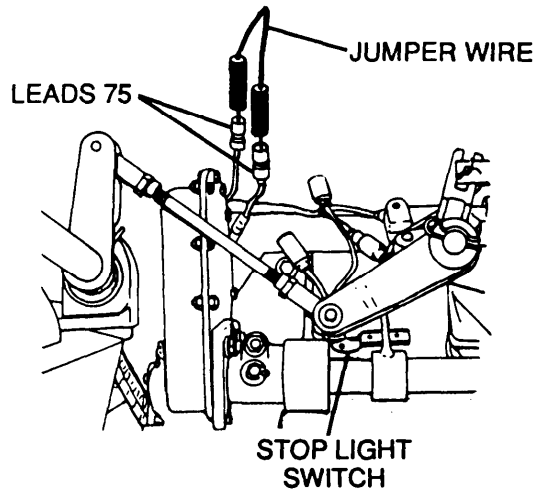
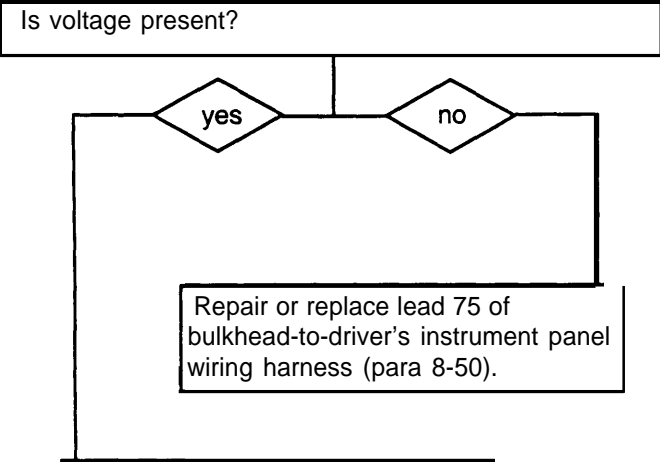

M109A4/M109A5 (ENGINE MODEL 7083-7396) SHOWN

CONTINUED ON NEXT PAGE

CONTINUED FROM STEP D

- E**
1. Place jumper wires from socket F (lead 15) to socket K (lead 75) and from socket A (lead 75) to socket C (lead 22).
 2. Turn MASTER switch ON, apply brake pedal, and check stop light for operation.
 3. Turn MASTER switch OFF.

Does stop light operate?

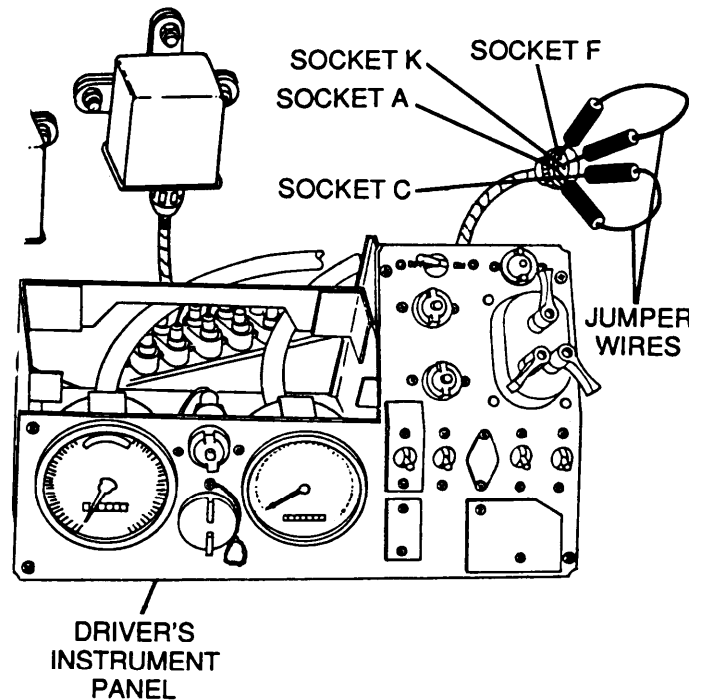
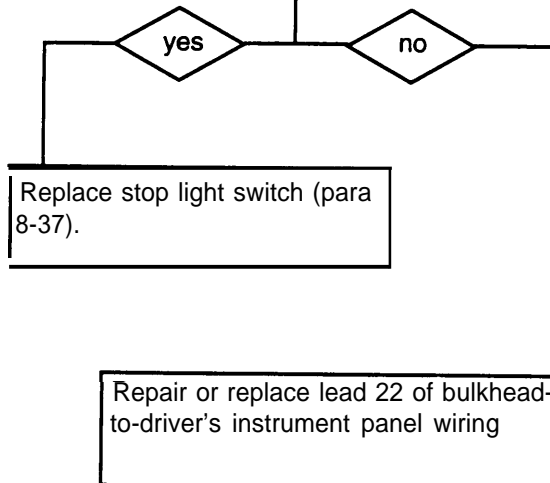

M109A4/M109A5 (ENGINE MODEL 7083-7396) SHOWN

END OF TASK

3-3 TROUBLESHOOTING CHART — CONTINUED

v. B.O. MARKERS AND B.O. DRIVE LIGHTS
CIRCUIT

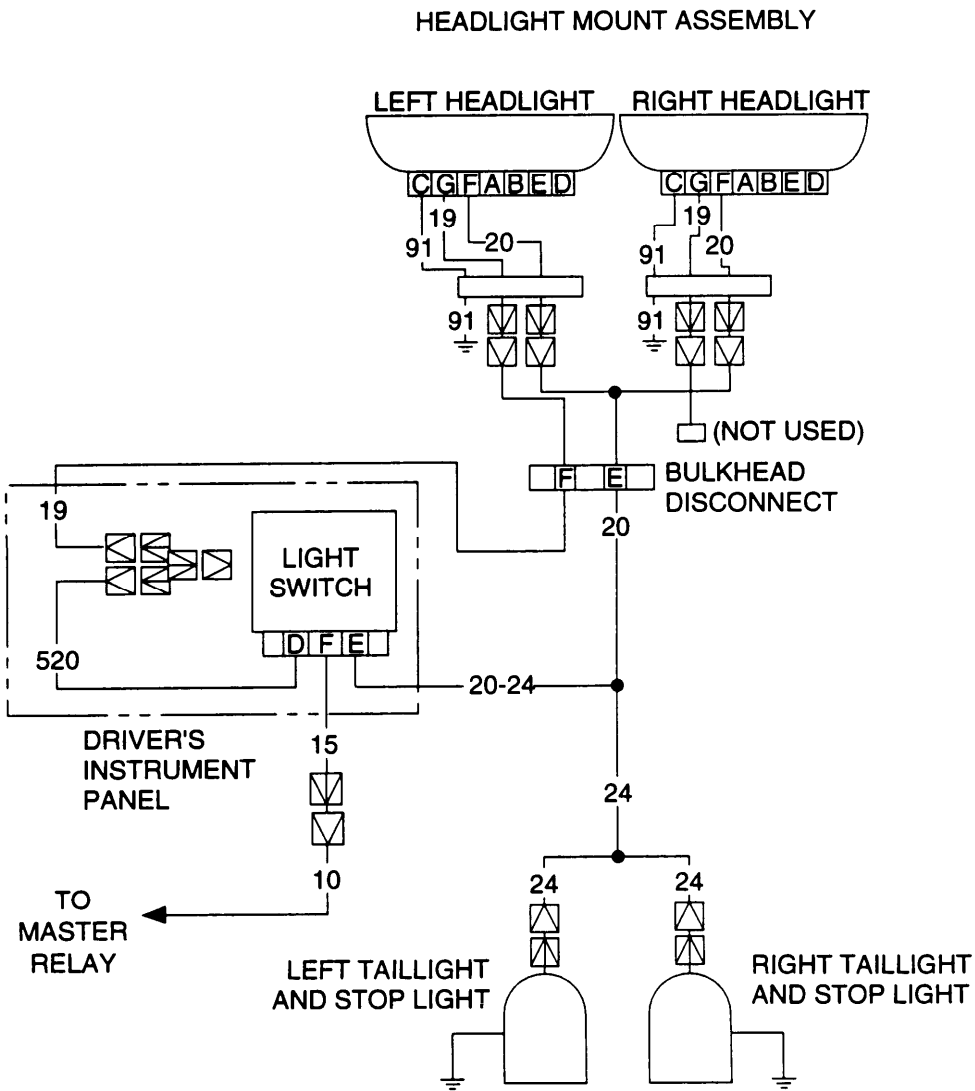

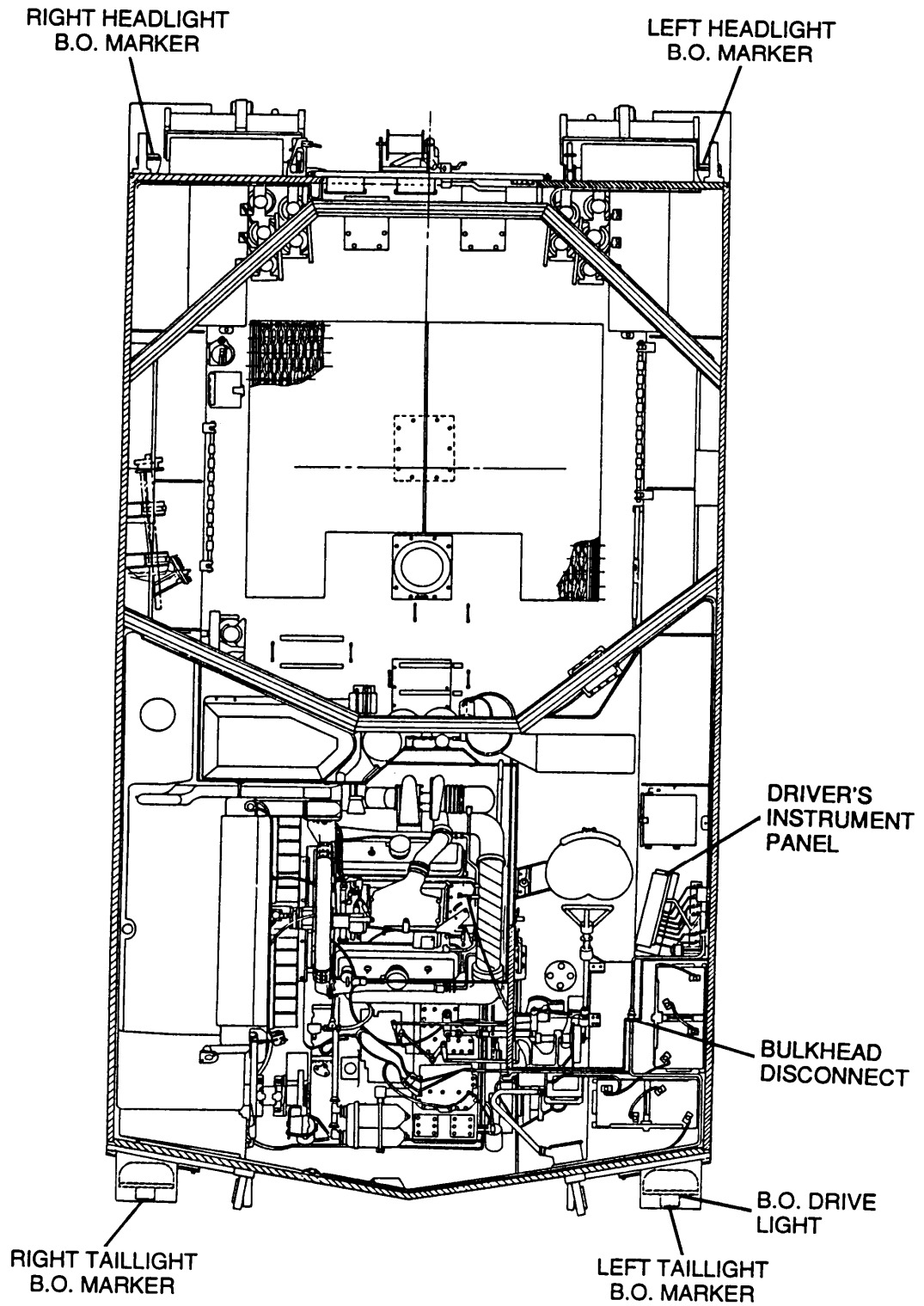

PICTORIAL VIEW

3-3 TROUBLESHOOTING CHART — CONTINUED

v. B.O. MARKERS AND B.O. DRIVE LIGHTS CIRCUIT — CONTINUED

(1) FRONT B.O. MARKER LIGHTS FAIL TO OPERATE; ALL OTHER LIGHTS OPERATE

INITIAL SETUP

Tools

General mechanic's tool kit (item 64, Appx H)
 Multimeters (item 36, Appx H)
 TA-1 Probe kit (item 43, Appx H)

Equipment Conditions

Driver's instrument panel released (para 8-17)

- A**
1. Disconnect bulkhead-to-driver's instrument panel wiring harness from main light switch.
 2. Place a jumper wire from socket F (lead 15) to socket E (lead 20/24).
 3. Turn MASTER switch ON, place main light switch to B.O. MARKER position, and check front B.O. marker lights for operation.
 4. Turn MASTER and main light switches OFF.

Do front B.O. marker lights operate?

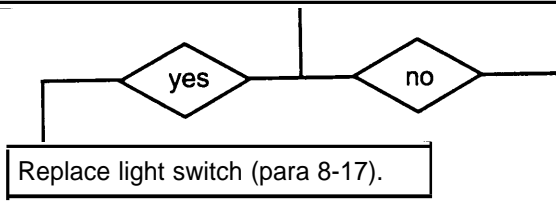

- B**
1. Reconnect bulkhead-to-drive's instrument panel wiring harness to light switch.
 2. Remove inoperative B.O. marker assembly (para 8-22).
 3. Place red lead of multimeters in center contact of socket and black lead to ground.
 4. Turn MASTER switch ON, place main light switch to B.O. MARKER position, and check for voltage.
 5. Turn MASTER and light switches OFF.

Is voltage present?

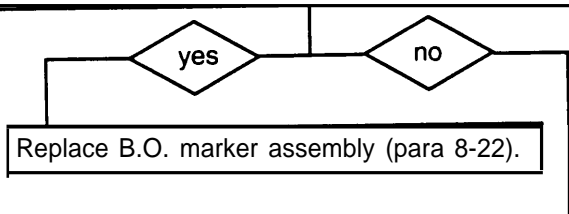

CONTINUED ON NEXT PAGE

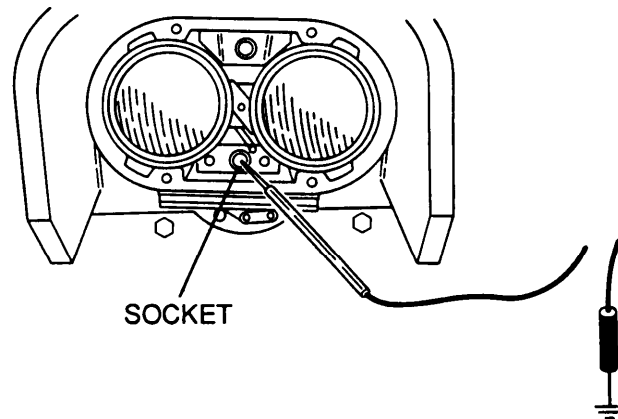
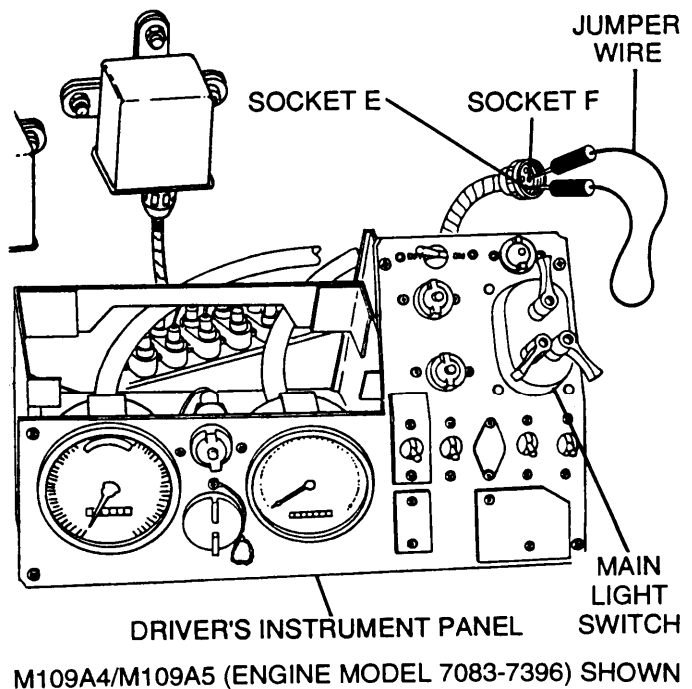

CONTINUED FROM STEP B

- C**
1. Install B.O. marker assembly (para 8-22).
 2. Remove headlight assembly (para 8-23).
 3. Place red lead of multimeters in socket F (lead 20) and black lead to ground.
 4. Turn MASTER switch ON, place main light switch in B.O. MARKER position, and check for voltage.
 5. Turn MASTER and light switches OFF.
- Is voltage present?

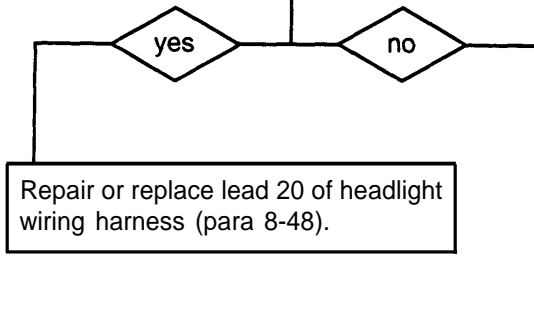
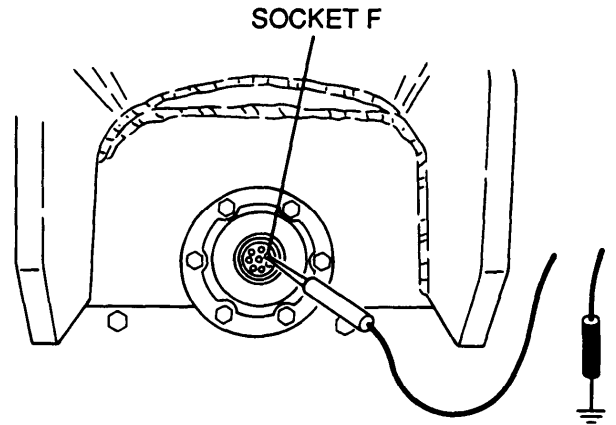

- D**
1. Install headlight assembly (para 8-23)
 2. Disconnect lead 20 of bulkhead-to-headlights/bilge pump wiring harness from headlight resilient mount wiring harness.
 3. Place red lead of multimeters in lead 20 and black lead to ground.
 4. Turn MASTER switch ON, place main light switch to B.O. MARKER position, and check for voltage.
 5. Turn MASTER and main light switches OFF.
- Is voltage present?

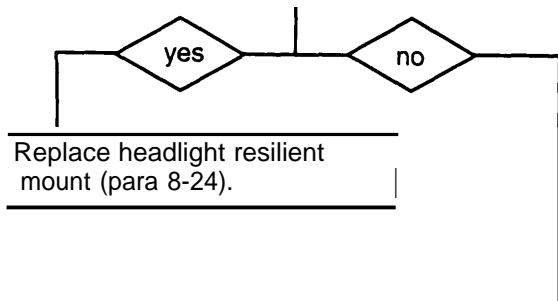
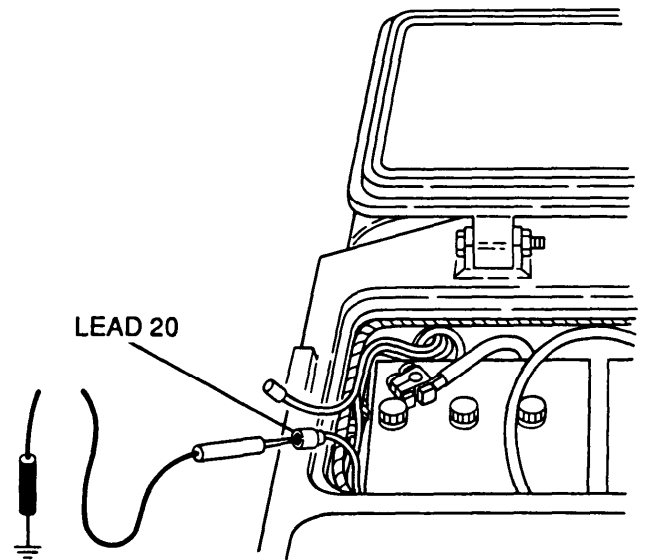

CONTINUED ON NEXT PAGE

3-3 TROUBLESHOOTING CHART — CONTINUED

v. B.O. MARKERS AND B.O. DRIVE LIGHTS
CIRCUIT — CONTINUED

(1) FRONT B.O. MARKER LIGHTS FAIL TO
OPERATE; ALL OTHER LIGHTS OPERATE —
CONTINUED

CONTINUED FROM STEP D

E	<ol style="list-style-type: none"> 1. Reconnect lead 20 of bulkhead-to-headlights/bilge pump wiring harness to headlight resilient mount wiring harness. 2. Disconnect bulkhead-to-driver's instrument panel wiring harness from driver's bulkhead. 3. Place a jumper wire from pin H to socket H (lead 459). 4. Place red lead of multimeters in socket E (lead 20) and black lead to ground. 5. Turn MASTER switch ON, place main light switch to B.O. MARKER position, and check for voltage. 6. Turn MASTER and main light switches OFF.
Is voltage present?	

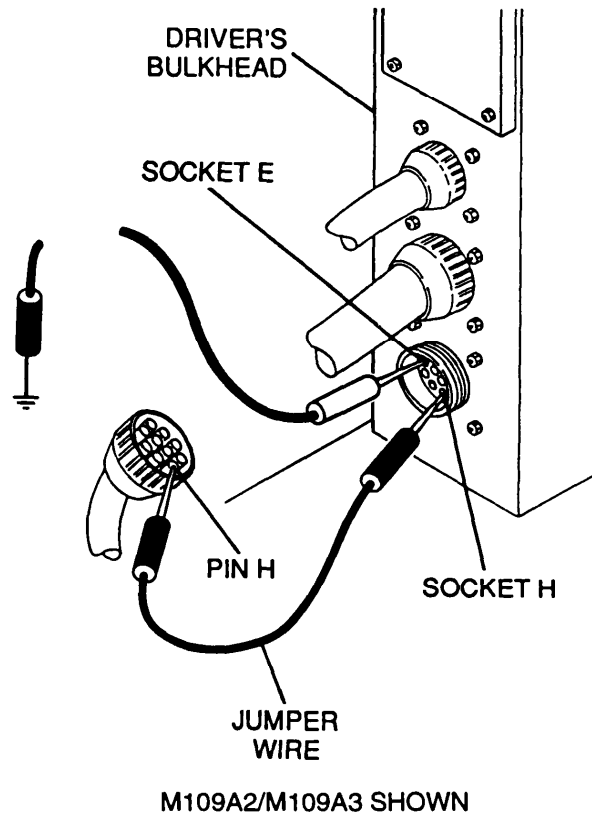
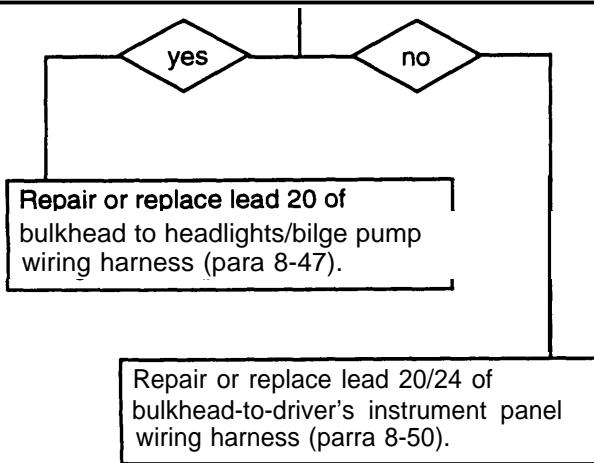

END OF TASK

(2) REAR B.O. MARKER LIGHTS FAIL TO OPERATE;
ALL OTHER LIGHTS OPERATE

INITIAL SETUP

Tools

General mechanic's tool kit (item 64, Appx H)
Multimeters (item 36, Appx H)
TA-1 probe kit (item 43, Appx H)

Equipment Conditions

Driver's instrument panel released (para 8-1 7)

- A**
1. Disconnect bulkhead-to-driver's instrument panel wiring harness from main light switch.
 2. Place a jumper wire from socket F (lead 15) to socket E (lead 20/24).
 3. Turn MASTER switch ON, apply brake pedal, and check rear B.O. marker lights for operation.
 4. Turn MASTER switch OFF.

Do rear blackout marker lights operate?

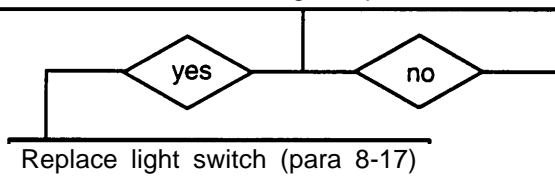

- B**
1. Reconnect bulkhead-to-driver's instrument panel wiring harness to light switch.
 2. Remove inoperative B.O. marker assembly (para 8-25).
 3. Place red lead of multimeters in center contact of socket and black lead to ground.
 4. Turn MASTER switch ON, place main light switch to B.O. MARKER position, and check for voltage.
 5. Turn MASTER and main light switches OFF.

Is voltage present?

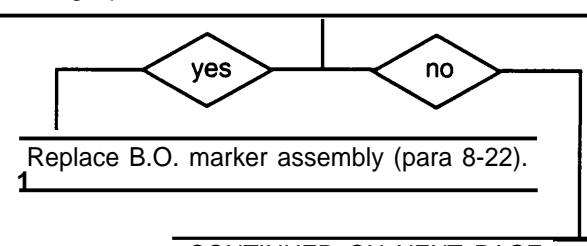

CONTINUED ON NEXT PAGE

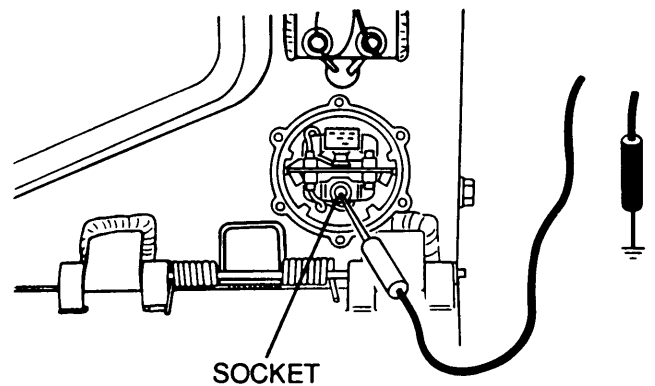
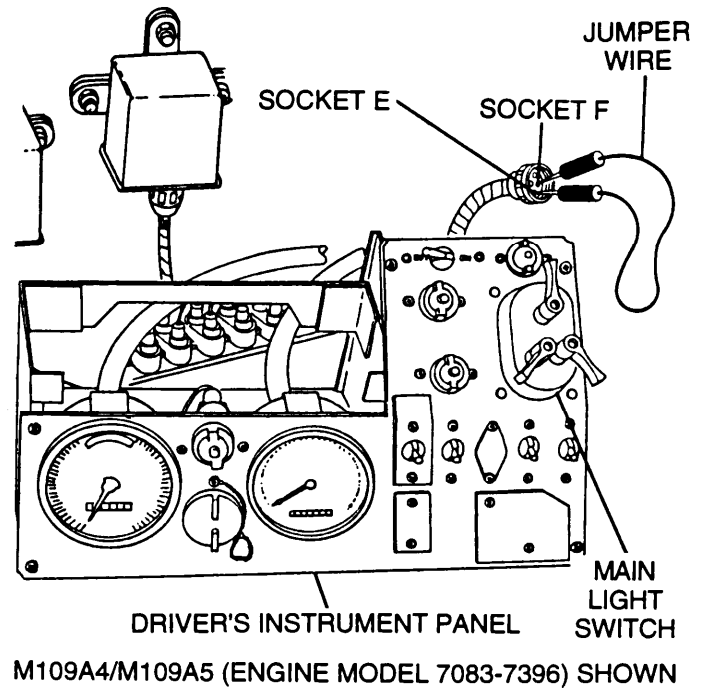

3-3 TROUBLESHOOTING CHART — CONTINUED

v. B.O. MARKERS AND B.O. DRIVE LIGHTS
CIRCUIT — CONTINUED

(2) REAR B.O. MARKER LIGHTS FAIL TO OPERATE;
ALL OTHER LIGHTS OPERATE — CONTINUED

CONTINUED FROM STEP B

C	<ol style="list-style-type: none"> 1. Install B.O. marker assembly (para 8-25) 2. Disconnect lead 24 of bulkhead-to-driver's instrument panel wiring harness from taillight lead assembly. 3. Place red lead of multimeters in lead 24 and black lead to ground. 4. Turn MASTER switch ON, place main light switch to B.O. MARKER position, and check for voltage. 5. Turn MASTER and main light switches OFF.
Is voltage present?	

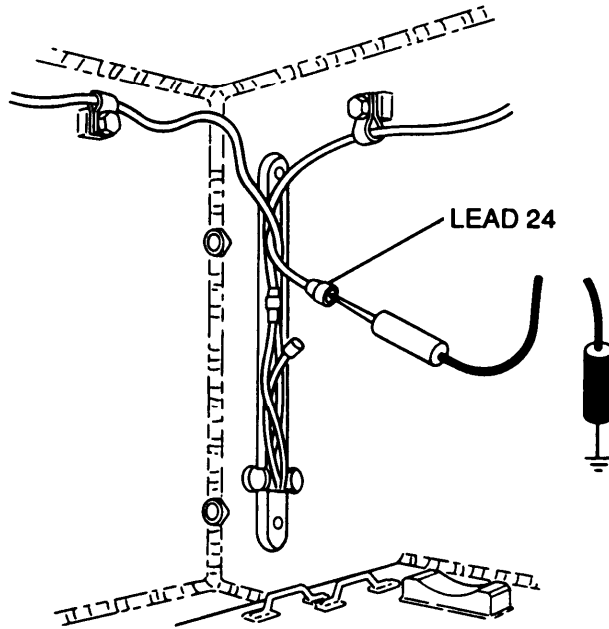
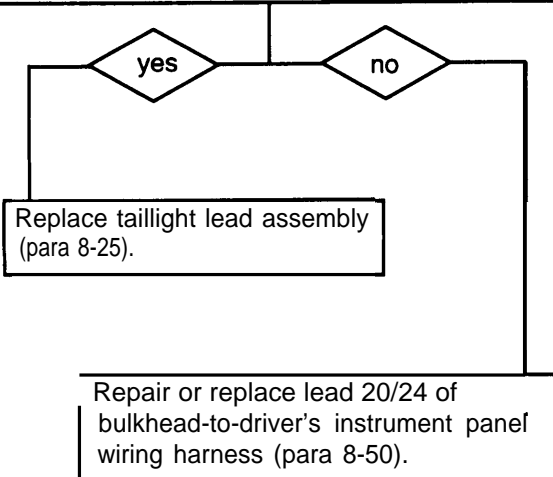

END OF TASK

(3) B.O. DRIVE LIGHT FAILS TO OPERATE; ALL OTHER LIGHTS OPERATE

INITIAL SETUP

Tools

General mechanic's tool kit (item 64, Appx H)
 Multimeters (item 36, Appx H)
 TA-1 probe kit (item 43, Appx H)

Equipment Conditions

Driver's instrument panel released (para 8-1 7)

CAUTION

B.O. drive light must be kept free of foreign material such as dirt, oil, grease, and fingerprints. Failure to do so will cause damage to halogen bulb.

- A**
1. Disconnect bulkhead-to-driver's instrument panel wiring harness from main light switch.
 2. Place a jumper wire from socket F (lead 15) to socket D (lead 19/520).
 3. Turn MASTER switch ON, place main light switch to B.O. DRIVE position, and check B.O. drive light for operation.
 4. Turn MASTER and main light switches OFF.

Does B.O. drive light operate?

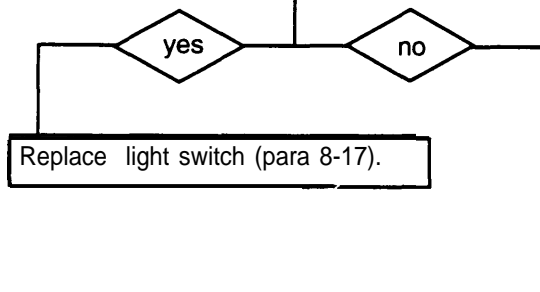

CONTINUED ON NEXT PAGE

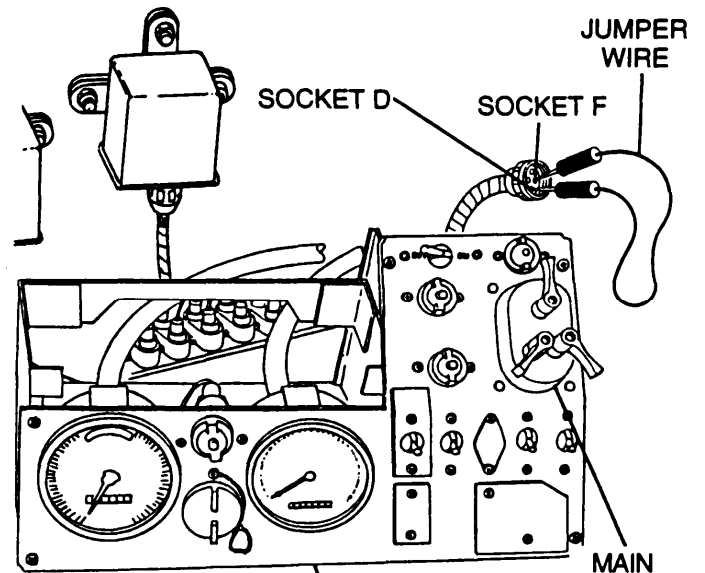

DRIVER'S INSTRUMENT PANEL
 M109A4/M109A5 (ENGINE MODEL 7083-7396) SHOWN

3-3 TROUBLESHOOTING CHART — CONTINUED

v. B.O. MARKERS AND B.O. DRIVE LIGHTS
CIRCUIT — CONTINUED

(3) B.O. DRIVE LIGHT FAILS TO OPERATE; ALL
OTHER LIGHTS OPERATE — CONTINUED

CONTINUED FROM STEP A

B

1. Reconnect bulkhead-to-driver's instrument panel wiring harness to main light switch.
2. Remove reflector and B.O. drive light bulb (para 8-22).
3. Place red lead of multimeters in center contact and black lead to ground.
4. Turn MASTER switch ON, place main light switch to B.O. DRIVE position, and check for voltage.
5. Turn MASTER and main light switches OFF.

Is voltage present?

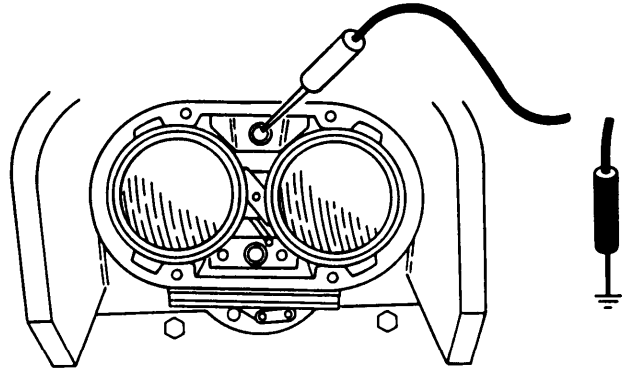

yes

no

Replace B.O. drive light bulb (para 8-22).

C

1. Install reflector and B.O. drive light bulb (para 8-22).
2. Remove headlight assembly (para 8-23).
3. Place red lead of multimeters in socket G (lead 19) and black lead to ground.
4. Turn MASTER switch ON, place main light switch to B.O. DRIVE position, and check for voltage.
5. Turn MASTER and main light switches OFF.

Is voltage present?

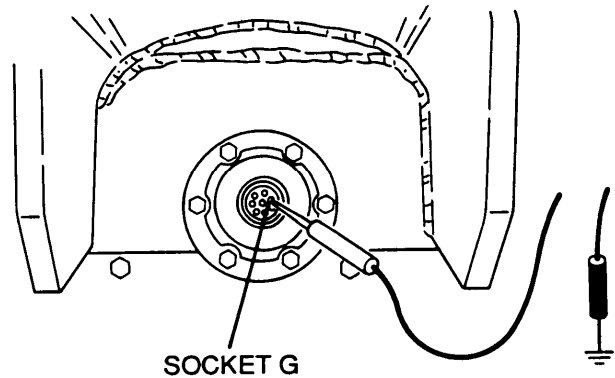

yes

no

Replace lead 19 of headlight wiring harness (para 8-48).

CONTINUED ON NEXT PAGE

CONTINUED FROM STEP C

- D**
1. Install headlight assembly (para 8-23).
 2. Disconnect lead 19 of bulkhead-to-headlights/bilge pump wiring harness from headlight resilient mount wiring harness.
 3. Place red lead of multimeters in lead 19 and black lead to ground.
 4. Turn MASTER switch ON, place main light switch to B.O. DRIVE position, and check for voltage.
 5. Turn MASTER and main light switches OFF.
- Is voltage present?

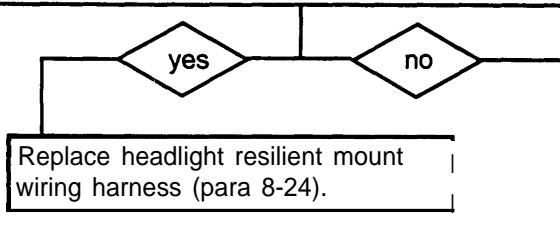

- E**
1. Reconnect lead 19 of bulkhead-to-headlights/bilge pump wiring harness to headlight resilient mount wiring harness.
 2. Disconnect bulkhead-to-driver's instrument panel wiring harness from driver's bulkhead.
 3. Place a jumper wire from pin H to socket H (lead 459).
 4. Place red lead of multimeters in socket F (lead 19) and black lead to ground.
 5. Turn MASTER switch ON, place main light switch to B.O. DRIVE position, and check for voltage.
 6. Turn MASTER and main light switches OFF.
- Is voltage present?

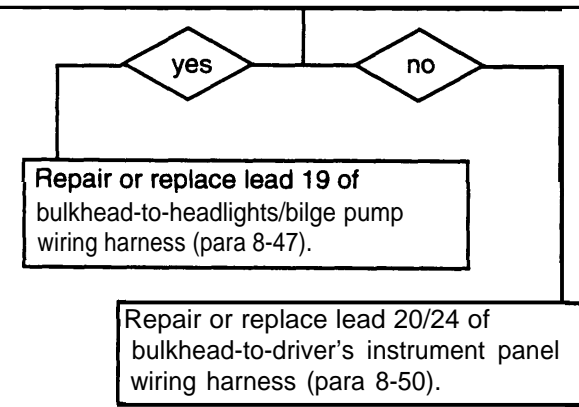

END OF TASK

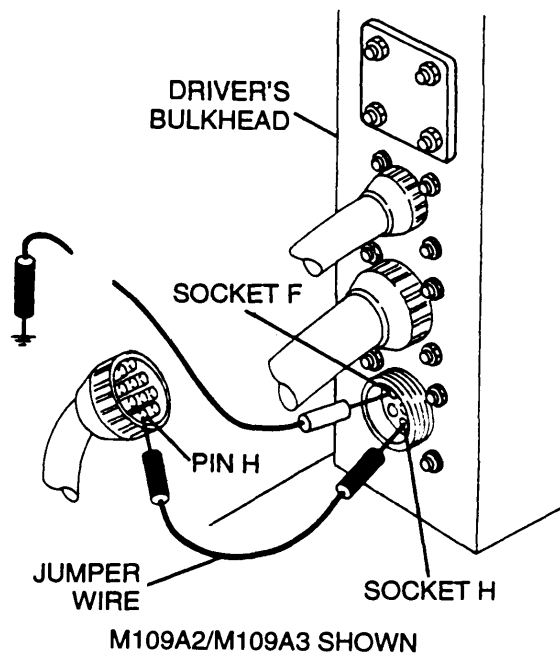
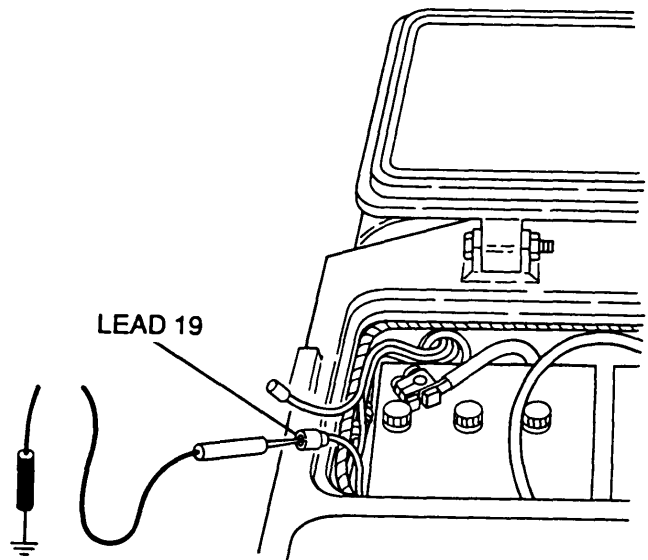

3-3 TROUBLESHOOTING CHART — CONTINUED

v. B.O. MARKERS AND B.O. DRIVE LIGHTS
CIRCUIT — CONTINUED

(4) ALL B.O. MARKER LIGHTS FAIL TO OPERATE; ALL
OTHER LIGHTS OPERATE

INITIAL SETUP

Tools

General mechanic's tool kit (item 64, Appx H)
Multimeters (item 36, Appx H)
TA-1 probe kit (item 43, Appx H)

Equipment Conditions

Driver's instrument panel released (para 8-17)

- A**
1. Disconnect bulkhead-to-driver's instrument panel wiring harness from main light switch.
 2. Place a jumper wire from socket F (lead 15) to socket E (lead 20/24).
 3. Turn MASTER switch ON, apply brake pedal, and check B.O. marker lights for operation.
 4. Turn MASTER switch OFF.
- Do B.O. marker lights operate?

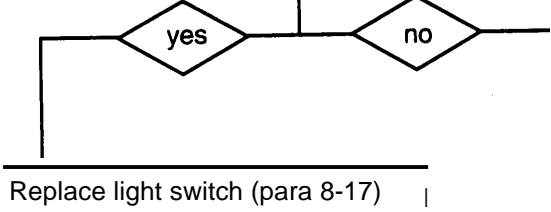
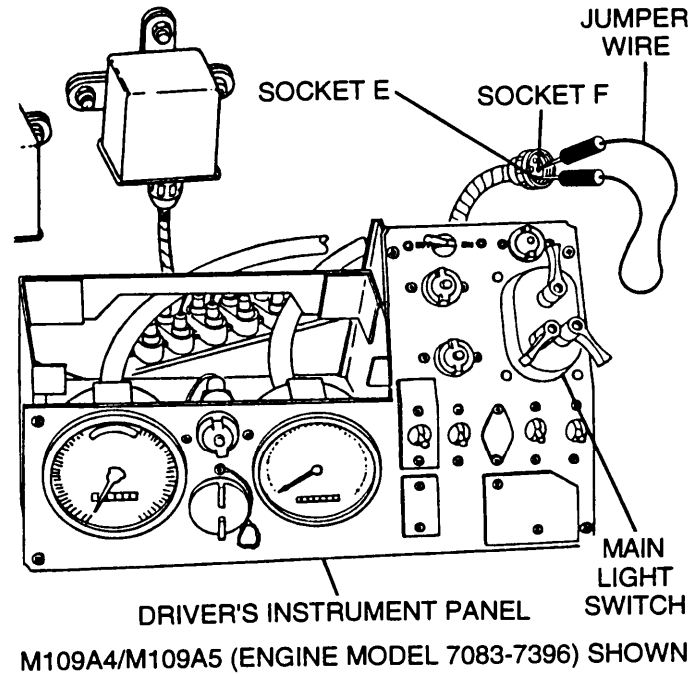

Repair or replace lead 19 and/or 20/24 of bulkhead-to-driver's instrument panel wiring harness (para 8-50).

END OF TASK

w. B.O. STOP LIGHT CIRCUIT

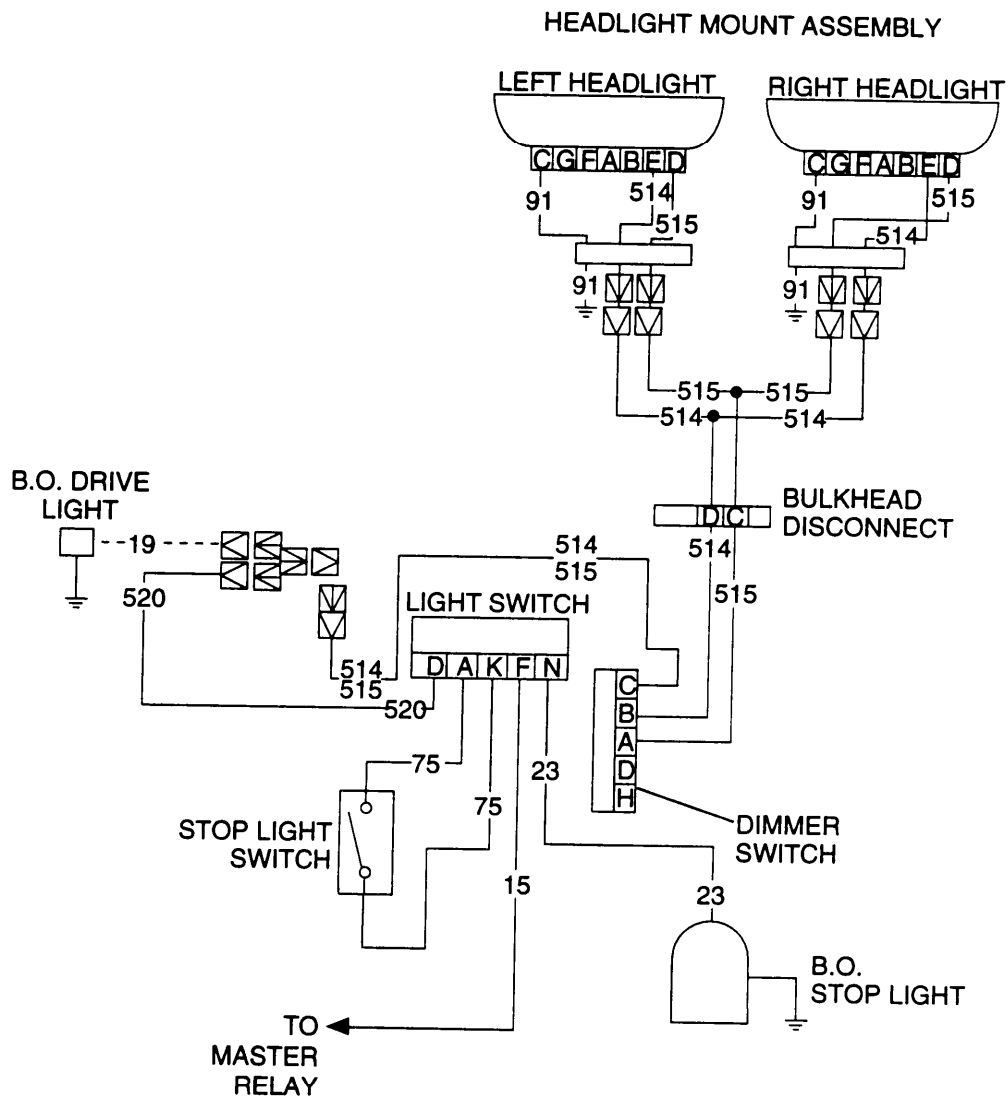

3-3 TROUBLESHOOTING CHART — CONTINUED

w. B.O. STOP LIGHT CIRCUIT — CONTINUED

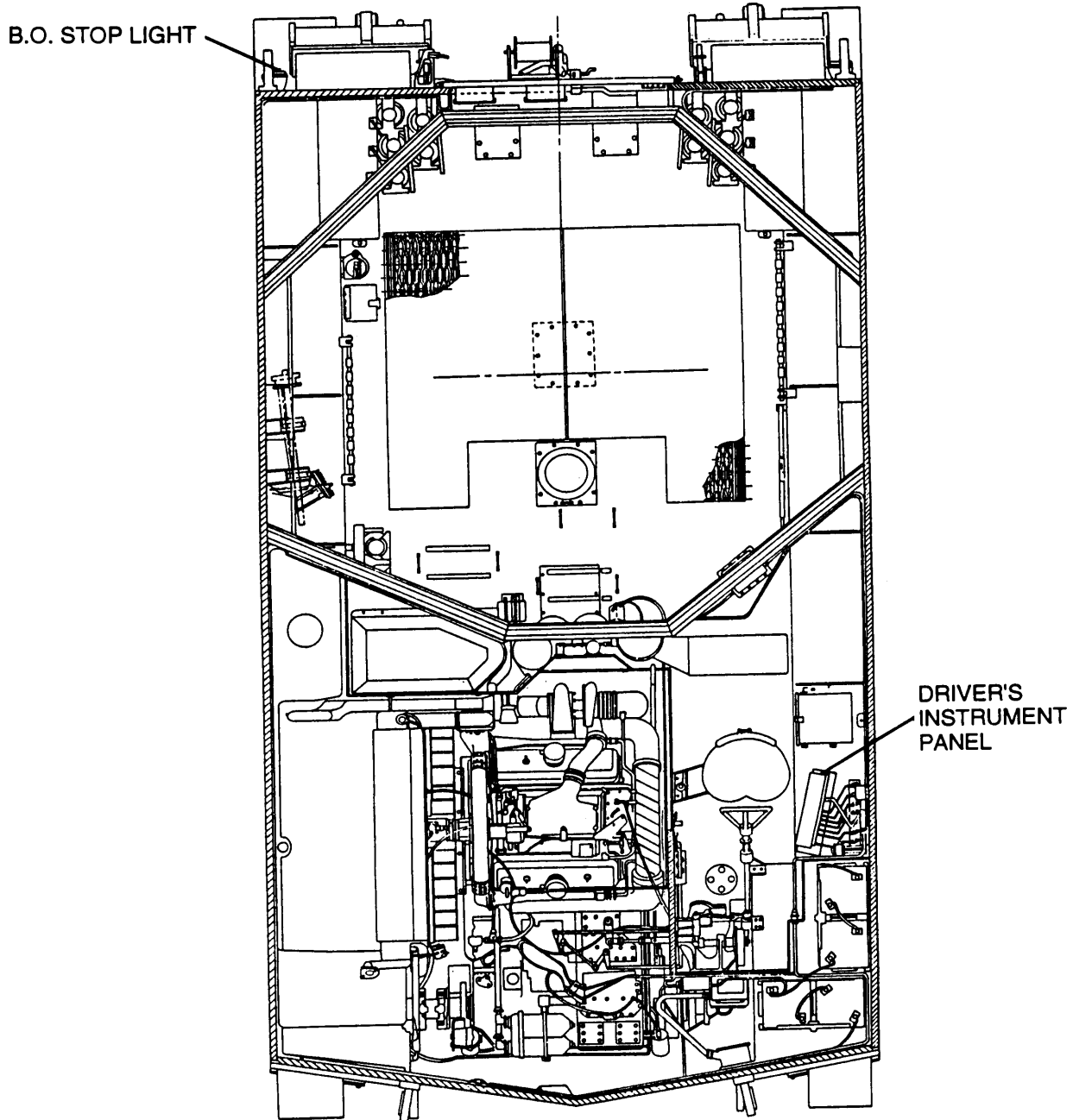

PICTORIAL VIEW

B.O. STOP LIGHT FAILS TO OPERATE; ALL OTHER LIGHTS OPERATE

INITIAL SETUP

Tools

General mechanic's tool kit (item 64, Appx H)
 Multimeters (item 36, Appx H)
 TA-1 probe kit (item 43, Appx H)

Equipment Conditions

Driver's instrument panel released (para 8-1 7)

NOTE

Before performing these steps, ensure that service stop light is operational.

A

1. Remove inoperative B.O. stop light assembly (para 8-25).
2. Place red lead of multimeters in center contact of socket and black lead to ground.
3. Turn MASTER switch ON, light switch to B.O. DRIVE position, apply parking brake and check for voltage.
4. Turn MASTER and light switches OFF.

Is voltage present?

yes

no

Replace B.O. stop light assembly (para 8-25).

CONTINUED ON NEXT PAGE

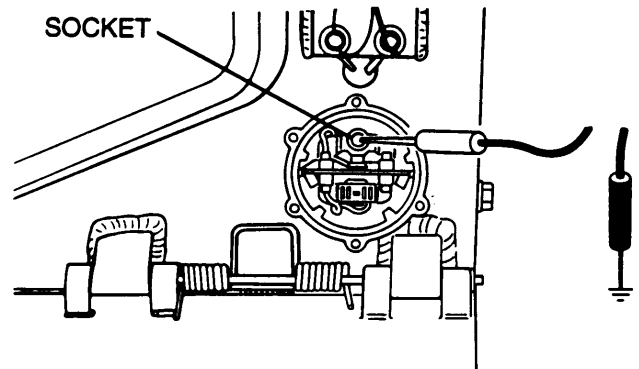

3-3 TROUBLESHOOTING CHART — CONTINUED

w. STOP LIGHT CIRCUIT — CONTINUED

B.O. STOP LIGHT FAILS TO OPERATE; ALL OTHER LIGHTS OPERATE — CONTINUED

CONTINUED FROM STEP A

- B**
1. Install inoperative B.O. stop light assembly (para 8-25).
 2. Disconnect lead 23 of bulkhead-to-driver's instrument panel wiring harness from taillight lead assembly.
 3. Place red lead of multimeters in lead 23 and black lead to ground.
 4. Turn MASTER switch ON, place main light switch to B.O. DRIVE position, apply parking brake, and check for voltage.
 5. Turn MASTER and main light switches OFF.

Is voltage present?

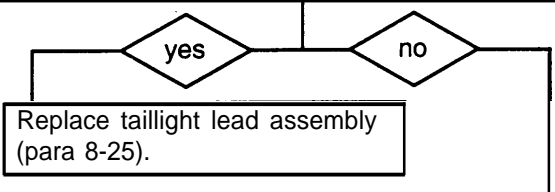

- C**
1. Reconnect lead 23 of bulkhead-to-driver's instrument panel wiring harness to taillight assembly.
 2. Disconnect bulkhead-to-driver's instrument panel wiring harness from main light switch.
 3. Place a jumper wire from socket F (lead 15) to socket N (lead 23).
 4. Turn MASTER switch ON, place main light switch to B.O. DRIVE position, apply parking brake, and check B.O. stop light for operation.
 5. Turn MASTER and main light switches OFF.

Does B.O. stop light operate?

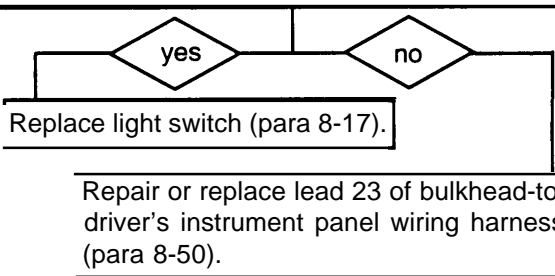

END OF TASK

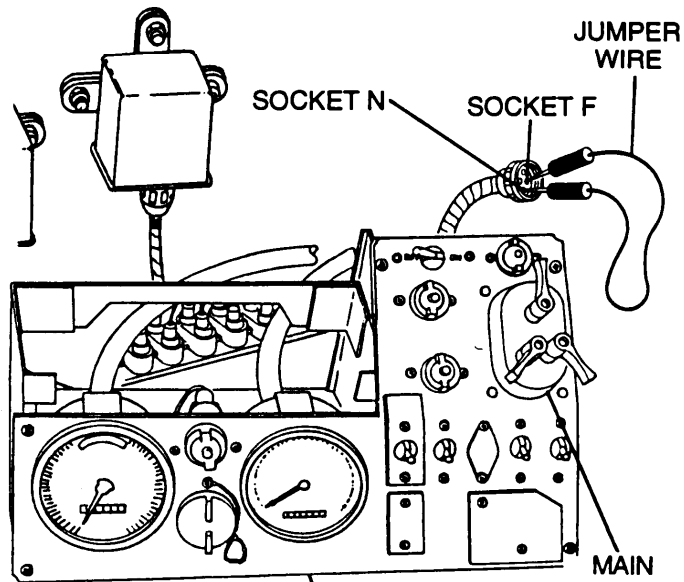
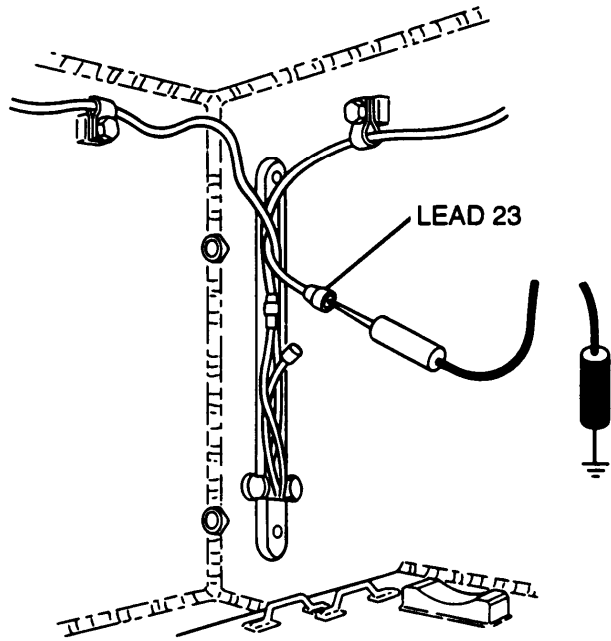

DRIVER'S INSTRUMENT PANEL

MAIN LIGHT SWITCH

M109A4/M109A5 (ENGINE MODEL 7083-7396) SHOWN

x. INSTRUMENT PANEL/PORTABLE INSTRUMENT
PANEL LIGHT CIRCUIT

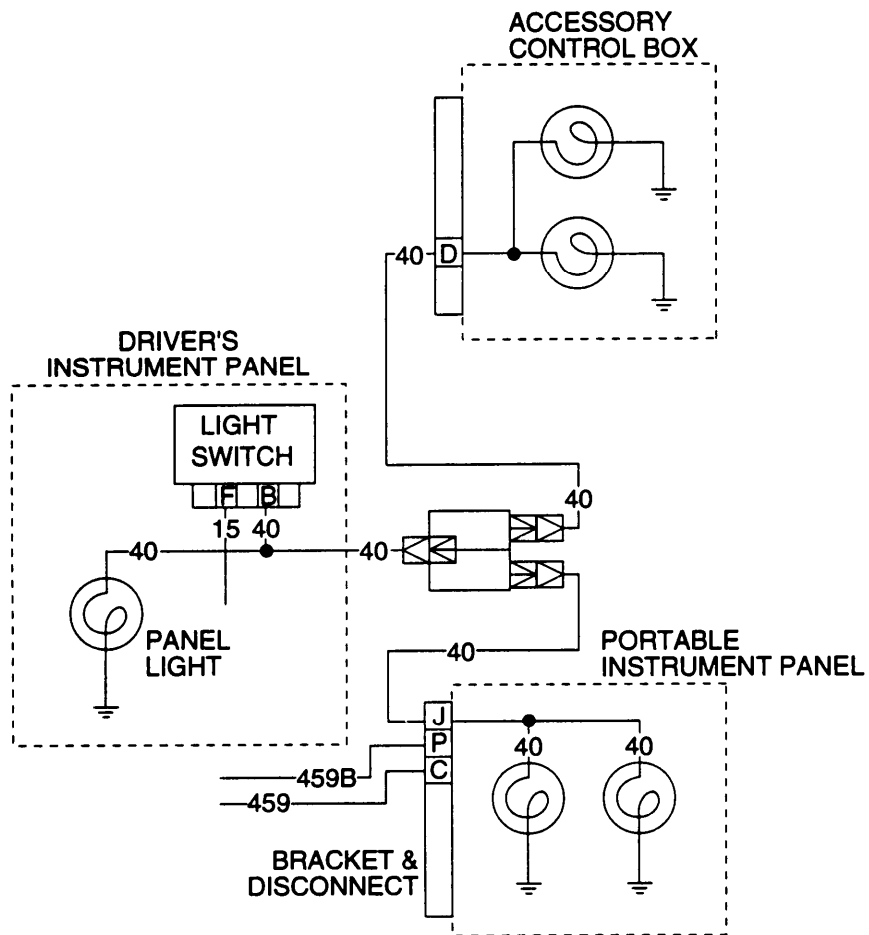

3-3 TROUBLESHOOTING CHART — CONTINUED

x. INSTRUMENT PANEL/PORTABLE INSTRUMENT
PANEL LIGHT CIRCUIT — CONTINUED

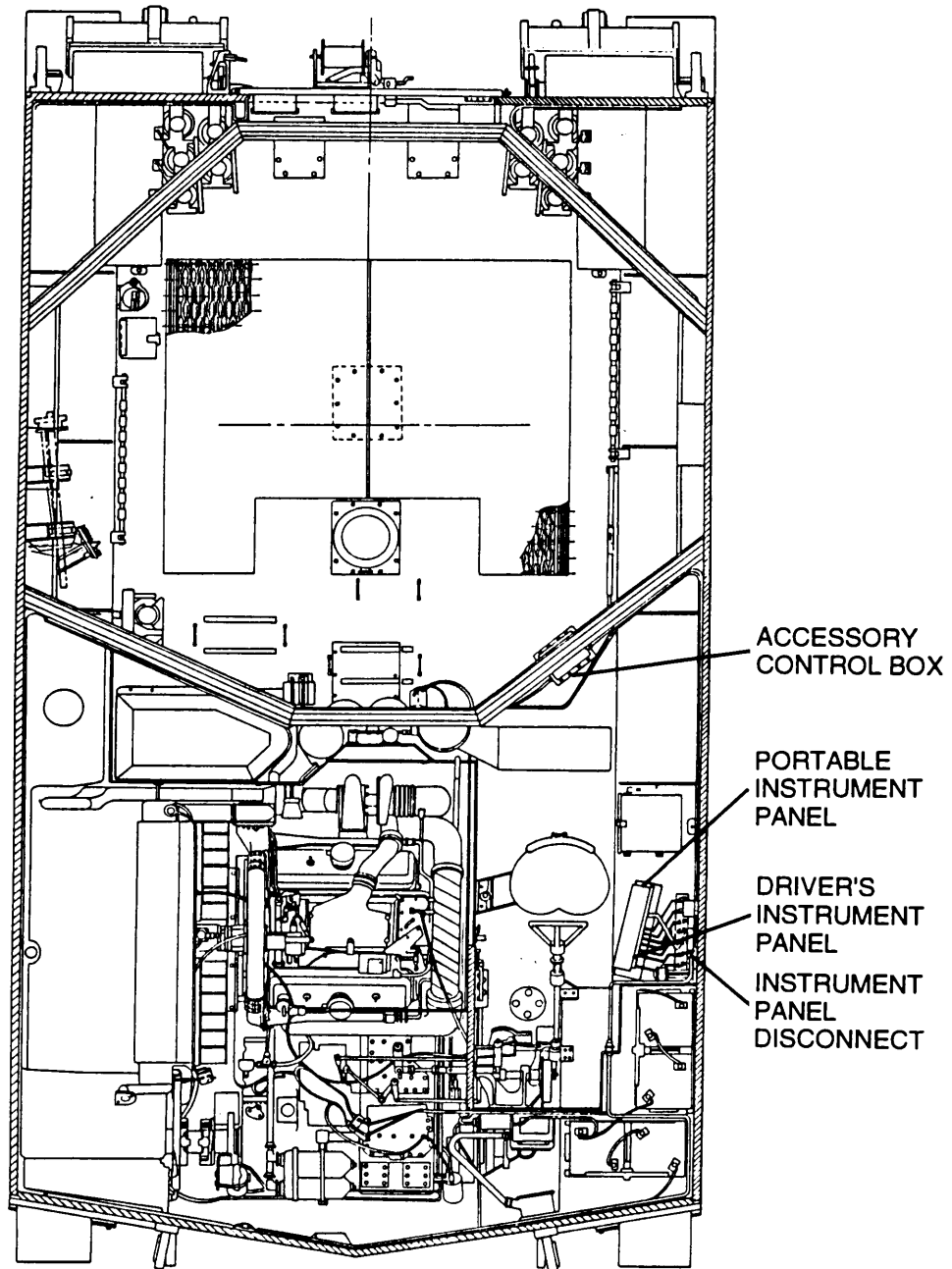

PICTORIAL VIEW

(1) ONE OR MORE INSTRUMENT PANEL LIGHTS FAIL TO OPERATE

INITIAL SETUP

Tools

General mechanic's tool kit (item 64, Appx H)
 Multimeters (item 36, Appx H)
 TA-1 probe kit (item 43, Appx H)

Equipment Conditions

Portable instrument panel cover removed (para 8-17)
 Driver's instrument panel released (para 8-17)

NOTE

Before troubleshooting instrument panel lights, be sure that service drive lights are operational. The following procedure applies to both portable and driver's instrument panels and accessory control box lights.

A

1. Remove inoperative panel light bulb (para 8-17).
2. Place red lead of multimeters in center contact of socket and black lead to ground.
3. Turn MASTER switch ON, instrument panel light switch on, and check for voltage.
4. Turn MASTER and instrument panel light switches OFF.

Is voltage present?

yes

no

Replace panel light bulb (para 8-1 7).

For portable instrument panel, go to step B.
 For driver's instrument panel, go to step F.
 For accessory control box, go to step D.

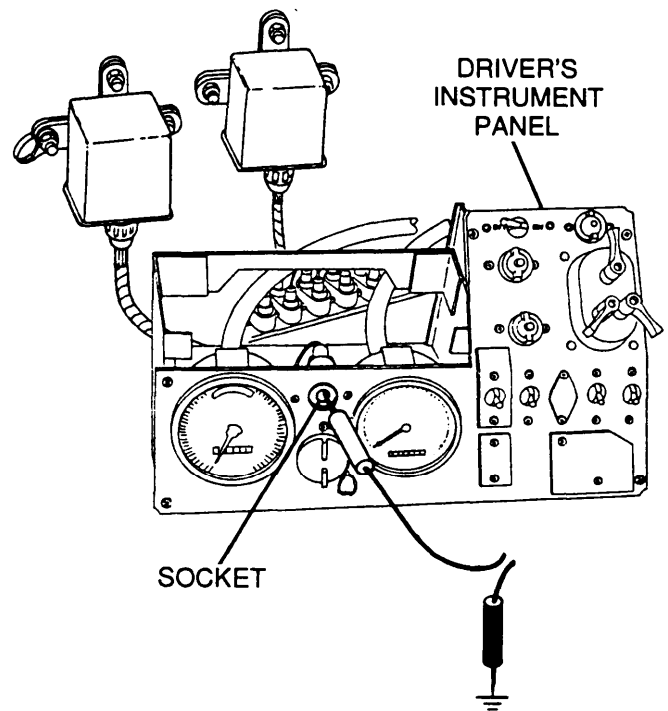

M109A4/M109A5
 (ENGINE MODEL 7083-7396) SHOWN

3-3 TROUBLESHOOTING CHART — CONTINUED

x. INSTRUMENT PANEL/PORTABLE INSTRUMENT PANEL LIGHT CIRCUIT — CONTINUED

(1) ONE OR MORE INSTRUMENT PANEL LIGHTS FAIL TO OPERATE — CONTINUED

CONTINUED FROM STEP A

B

1. Install inoperative panel light bulb (para 8-17).
2. Disconnect battery ground leads.
3. Disconnect portable instrument panel wiring harness from portable instrument panel disconnect.
4. Place a jumper wire from socket C to pin C (lead 459) and from socket P to pin P (lead 459B).
5. Place red lead of multimeters on pin J (lead 40) and black lead to ground.
6. Reconnect battery ground leads.
7. Turn MASTER and instrument panel light switches ON and check for voltage.
8. Turn MASTER and instrument panel light switches OFF.

Is voltage present?

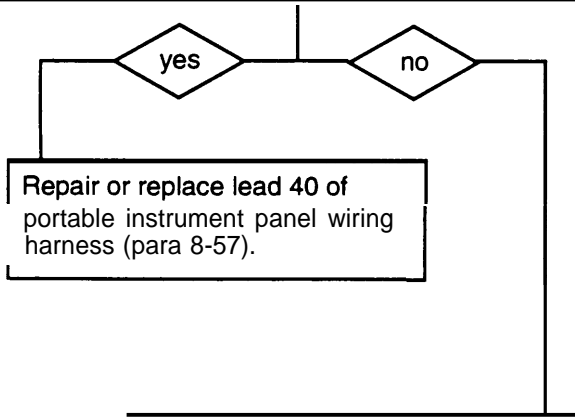
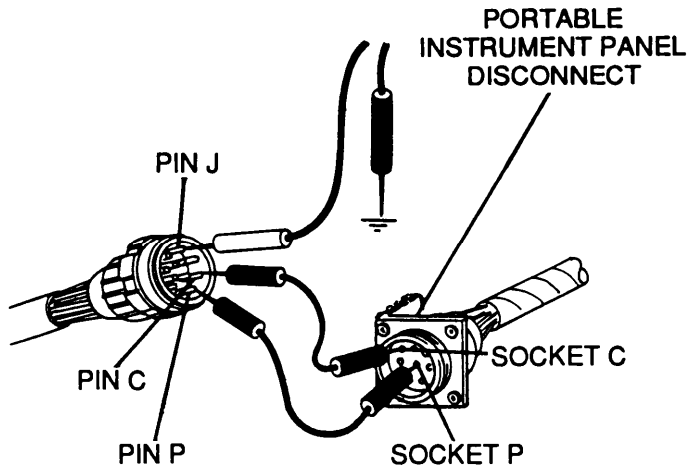

CONTINUED ON NEXT PAGE

CONTINUED FROM STEP B

- C**
1. Reconnect portable instrument panel wiring harness to portable instrument panel disconnect.
 2. Disconnect lead 40 of bulkhead-to-portable instrument panel wiring harness from "Y" connector.
 3. Place red lead of multimeters on "Y" connector and black lead to ground.
 4. Turn MASTER switch ON, instrument panel light switch on, and check for voltage.
 5. Turn MASTER and instrument panel light switches OFF.

Is voltage present?

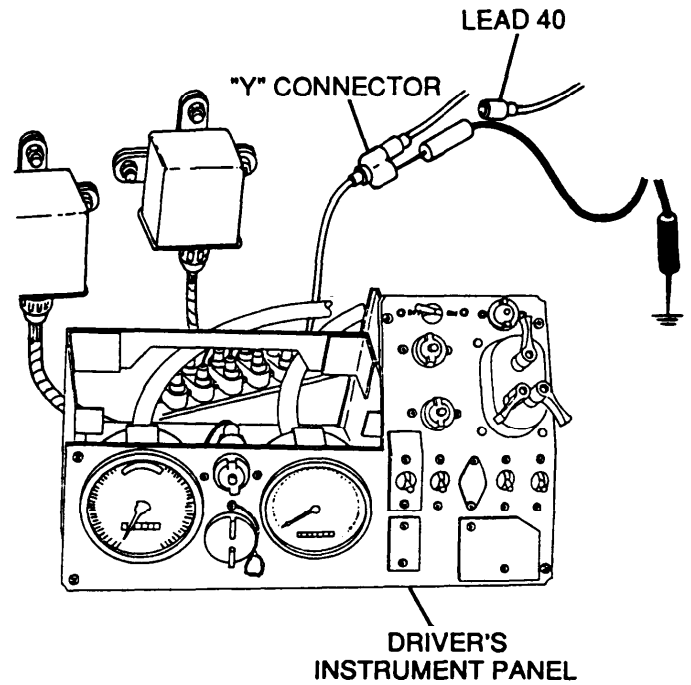
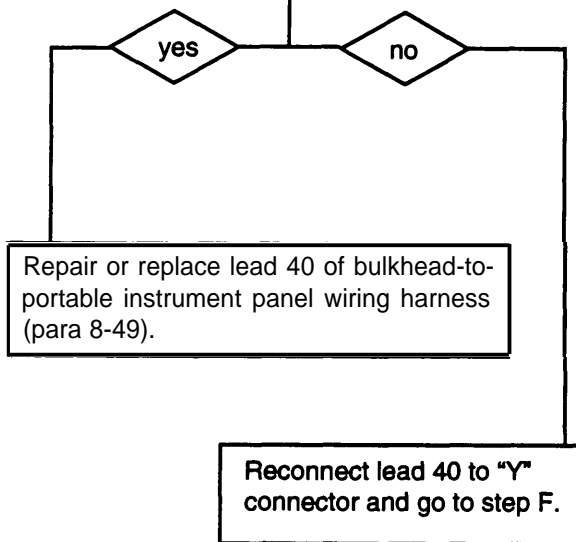

3-3 TROUBLESHOOTING CHART — CONTINUED

- x. INSTRUMENT PANEL/PORTABLE INSTRUMENT PANEL LIGHT CIRCUIT — CONTINUED (1) ONE OR MORE INSTRUMENT PANEL LIGHTS FAIL TO OPERATE — CONTINUED

CONTINUED FROM STEP A

- D**
1. Install inoperative panel light bulb (para 8-17).
 2. Disconnect accessory control box-to-heater/blower wiring harness from accessory control panel.
 3. Place red lead of multimeters in socket D (lead 40) and black lead to ground.
 4. Turn MASTER and instrument panel light switches ON and check for voltage.
 5. Turn MASTER and instrument panel light switches OFF.

Is voltage present?

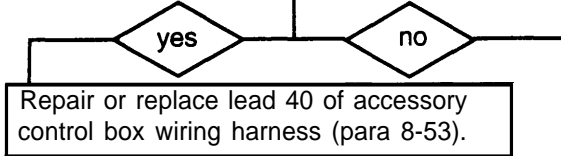

- E**
1. Reconnect accessory control box-to-heater blower wiring harness from accessory control panel.
 2. Disconnect lead 40 of accessory control box to heater/blower wiring harness from "Y" connector.
 3. Place red lead of multimeters on "Y" connector and black lead to ground.
 4. Turn MASTER switch ON, instrument panel light switch on, and check for voltage.
 5. Turn MASTER and instrument panel light switches OFF.

Is voltage present?

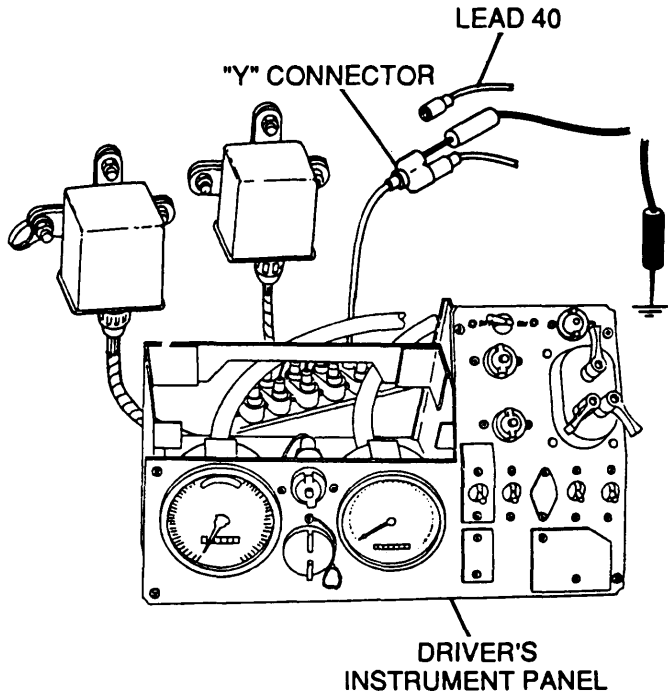
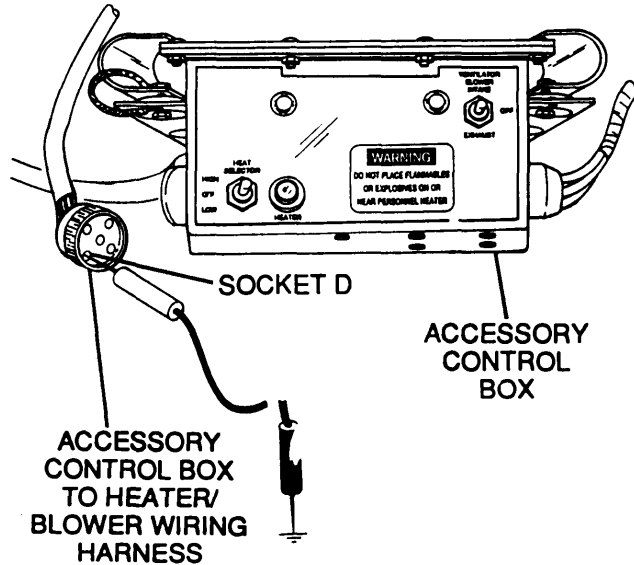
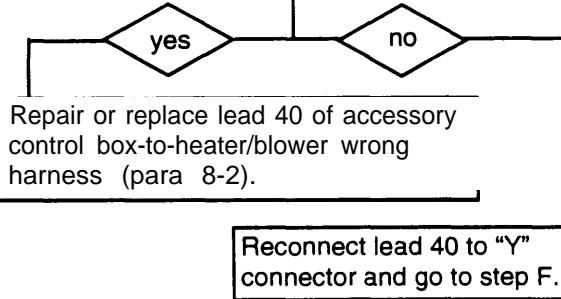

M109A4/M109A5
(ENGINE MODEL 7083-7396) SHOWN

CONTINUED FROM STEP A

- F**
1. Install inoperative panel light bulb (para 8-17).
 2. Disconnect bulkhead-to-driver's instrument panel wiring harness from main light switch.
 3. Place a jumper wire from socket F (lead 15) to socket B (lead 40).
 4. Turn MASTER and instrument panel light switches ON and check all instrument panel lights for operation.
 5. Turn MASTER and instrument panel light switches OFF.

Do all panel lights operate?

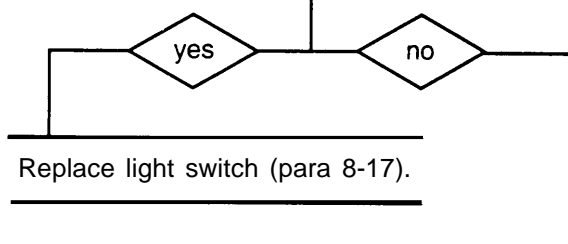

- G**
1. Reconnect bulkhead-to-driver's instrument panel wiring harness to light switch.
 2. Disconnect lead 40 of bulkhead-to-driver's instrument panel wiring harness from "Y" connector.
 3. Place red lead of multimeters in lead 40 and black lead to ground.
 4. Turn MASTER and instrument panel light switches ON and check for voltage.
 5. Turn MASTER and instrument panel light switches OFF.

Is voltage present?

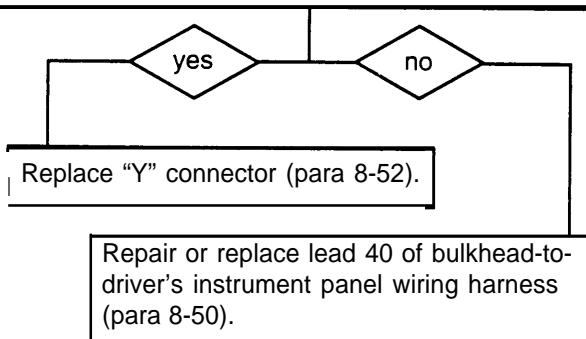

END OF TASK

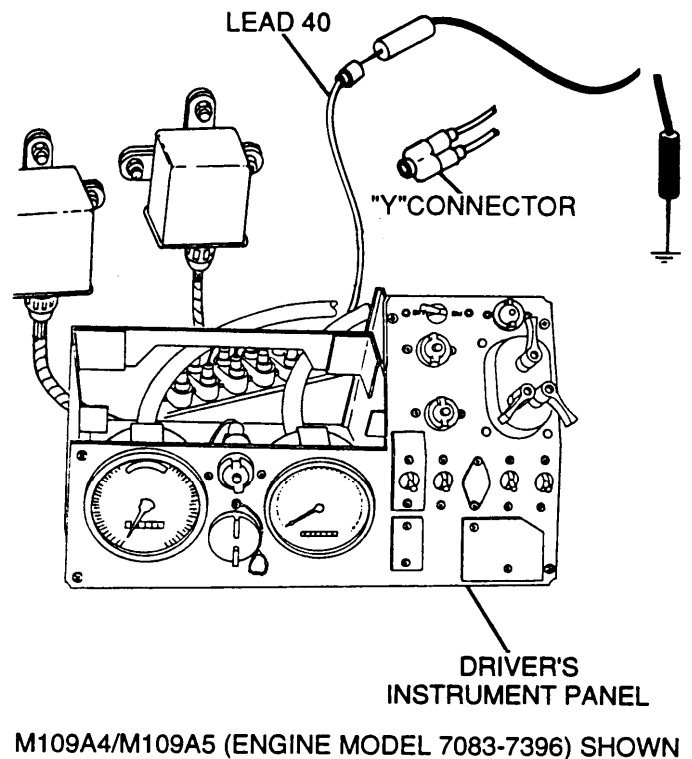
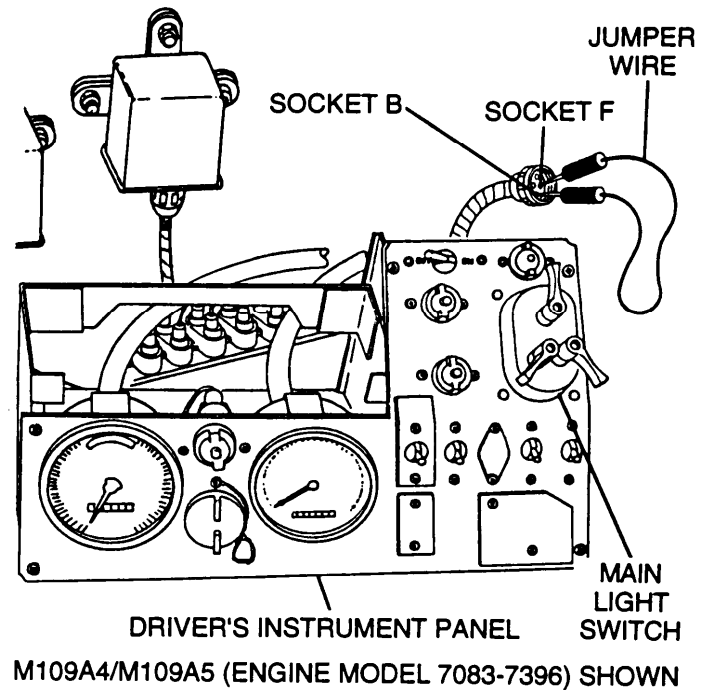

3-3 TROUBLESHOOTING CHART — CONTINUED

- x. INSTRUMENT PANEL/PORTABLE INSTRUMENT PANEL LIGHT CIRCUIT — CONTINUED (2) ALL INSTRUMENT PANEL LIGHTS FAIL TO OPERATE

INITIAL SETUP

Tools

General mechanic's tool kit (item 64, Appx H)
 Multimeters (item 36, Appx H)
 TA-1 probe-kit (item 43, Appx H)

Equipment Conditions

Portable instrument panel cover removed (para 8-17)
 Driver's instrument panel released (para 8-17)

- A**
1. Disconnect bulkhead-to-driver's instrument panel wiring harness from light switch.
 3. Place a jumper wire from socket F (lead 15) to socket B (lead 40).
 4. Turn MASTER and instrument panel light switches ON and check all instrument panel lights for operation.
 5. Turn MASTER and instrument panel light switches OFF.

Do all panel lights operate?

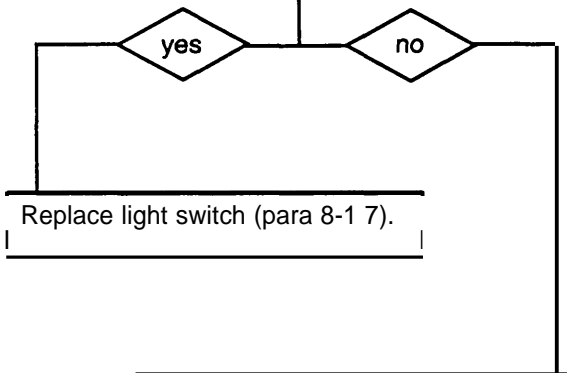

CONTINUED ON NEXT PAGE

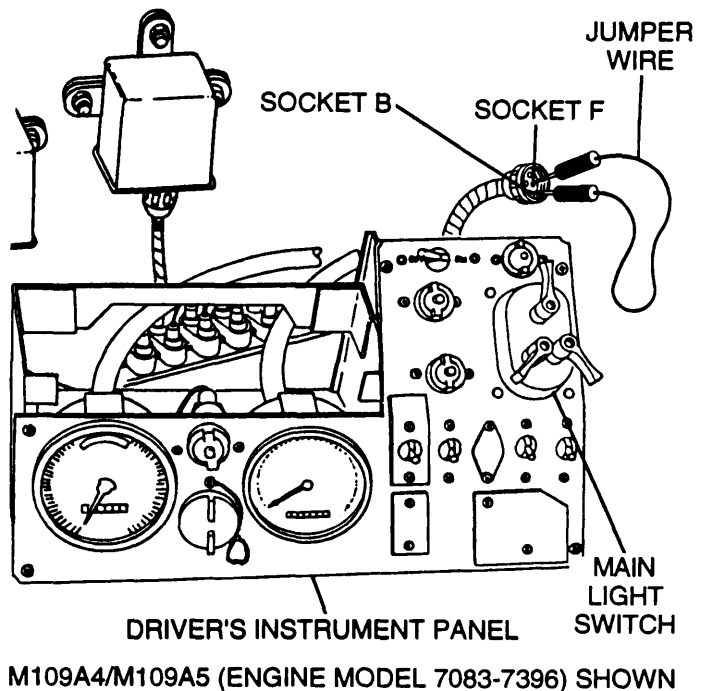

CONTINUED FROM STEP A

B

1. Reconnect bulkhead-to-driver's instrument panel wiring harness to light switch.
2. Disconnect lead 40 of bulkhead-to-driver's instrument panel wiring harness from "Y" connector.
3. Place red lead of multimeters in lead 40 and black lead to ground.
4. Turn MASTER and instrument panel light switches ON and check for voltage.
5. Turn MASTER and instrument panel light switches OFF.

Is voltage present?

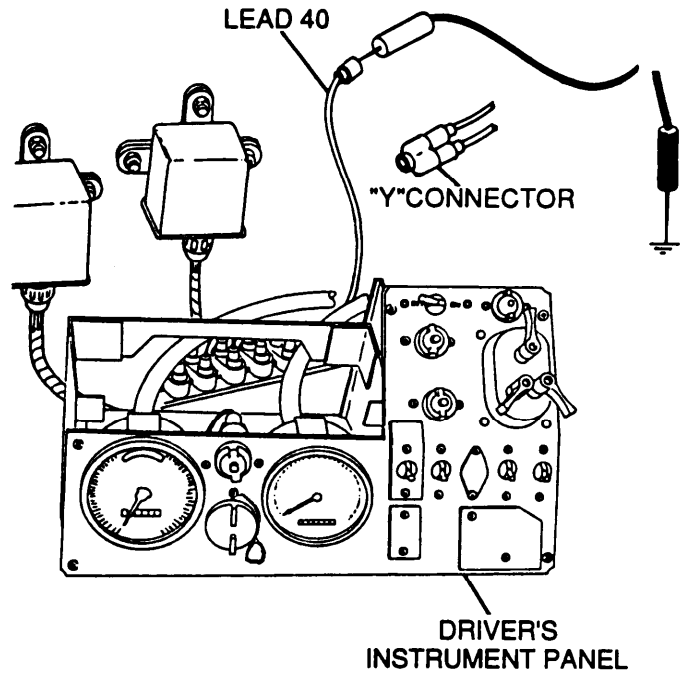
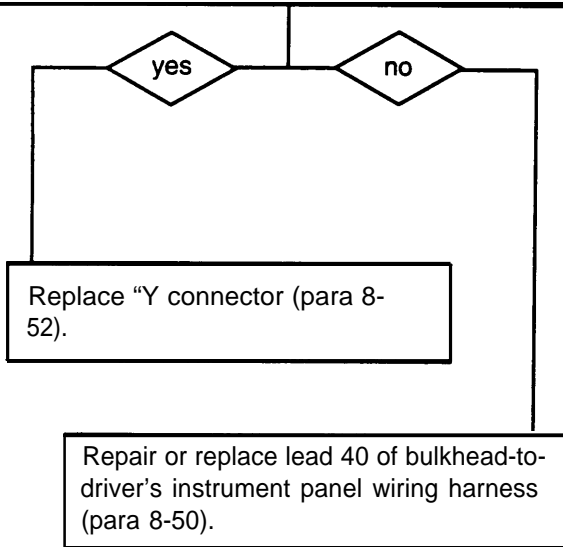

M109A4/M109A5 (ENGINE MODEL 7083-7396) SHOWN

END OF TASK

3-3 TROUBLESHOOTING CHART — CONTINUED

y. HI-BEAM INDICATOR LIGHT CIRCUIT

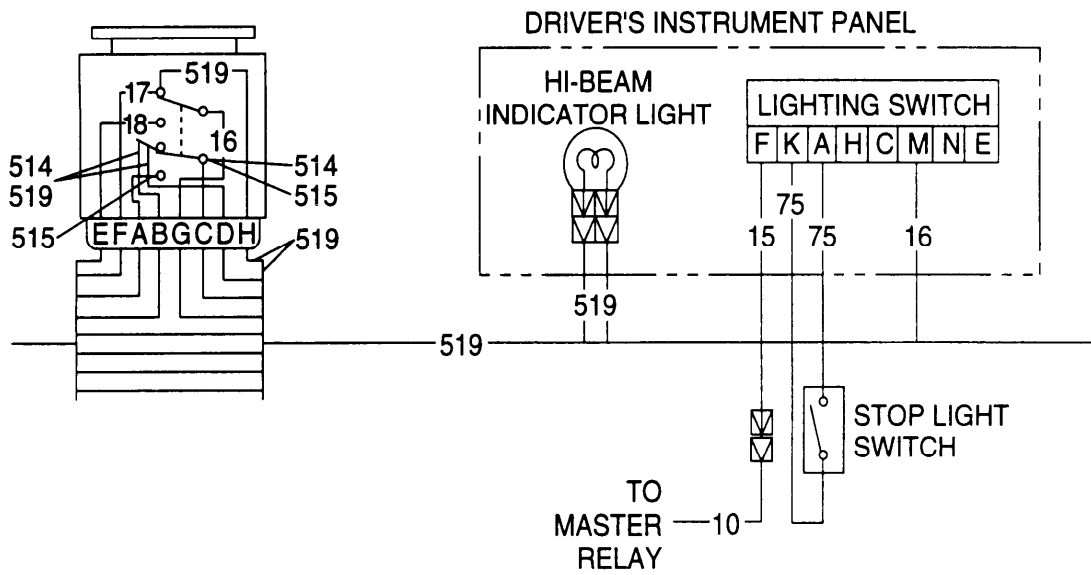

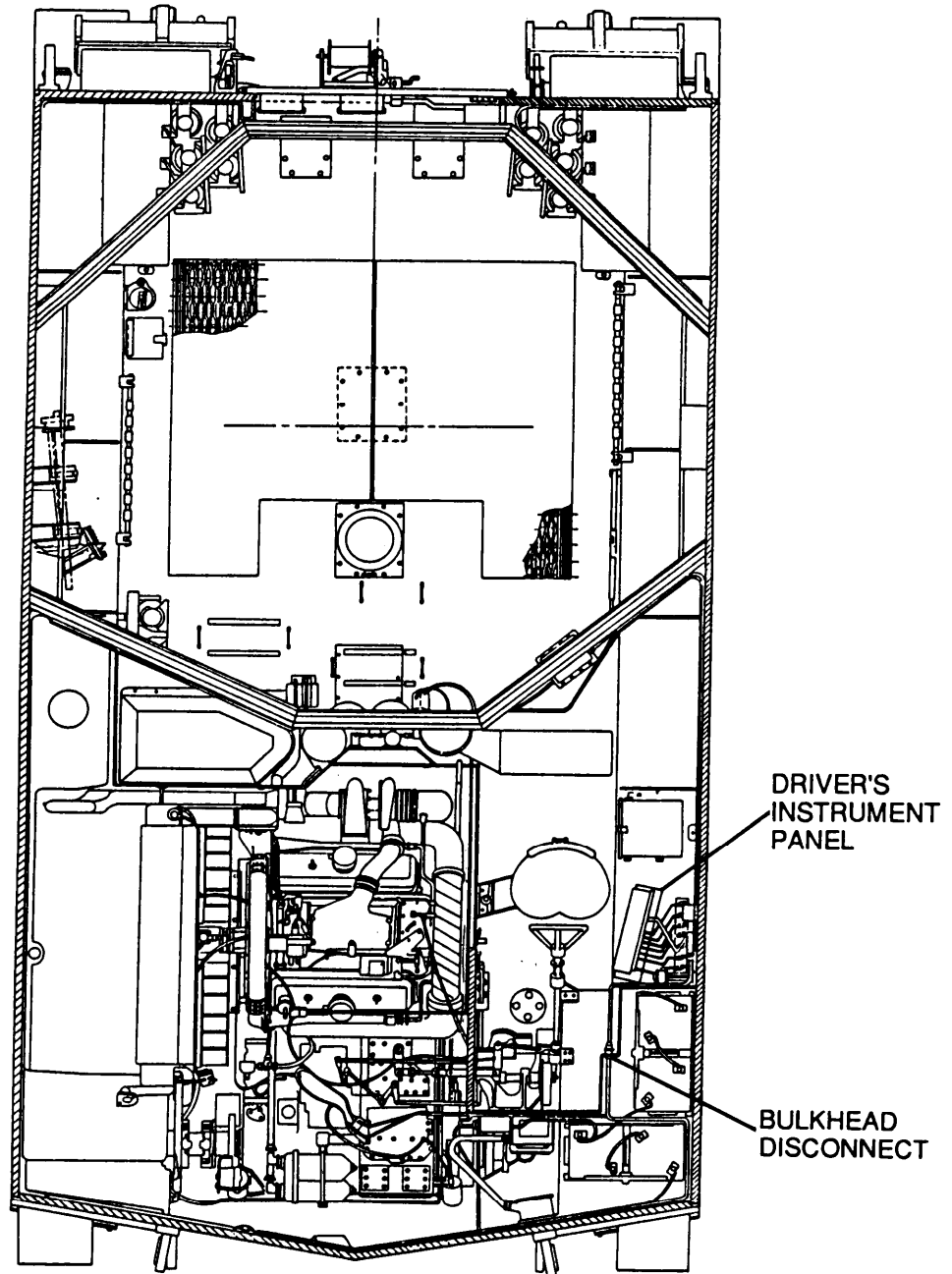

PICTORIAL VIEW

3-3 TROUBLESHOOTING CHART — CONTINUED

y. HI-BEAM INDICATOR LIGHT CIRCUIT —
CONTINUED

HI-BEAM INDICATOR LIGHT FAILS TO OPERATE; ALL
OTHER LIGHTS OPERATE

INITIAL SETUP

Tools

General mechanic's tool kit (item 64, Appx H)
Multimeter (item 36, Appx H)
TA-1 probe kit (item 43, Appx H)

Equipment Conditions

Driver's instrument panel released (para 8-17)

A

1. Remove inoperative HI-BEAM indicator light bulb (para 8-17).
2. Place red lead of multimeters in center contact of socket and black lead to ground.
3. Turn MASTER switch ON, place main light switch in SER. DRIVE position, and check for voltage.
4. Turn MASTER and main light switches OFF.

Is voltage present?

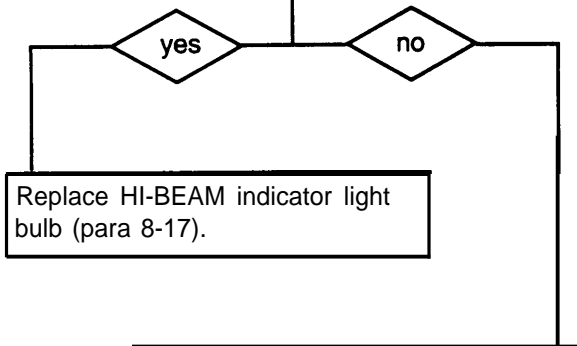

CONTINUED ON NEXT PAGE

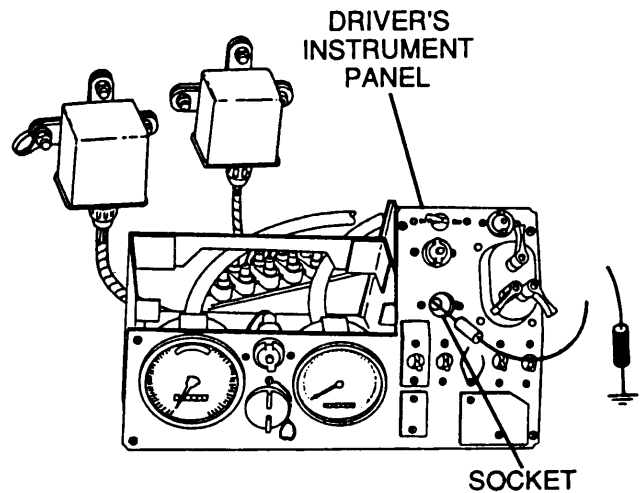

M109A4/M109A5
(ENGINE MODEL 7083-7396) SHOWN

CONTINUED FROM STEP A

- B**
1. Install inoperative HI-BEAM indicator light bulb (para 8-17).
 2. Disconnect two leads 519 of bulkhead-to-driver's instrument panel wiring harness from HI-BEAM indicator light.
 3. Place red lead of multimeters in one lead 519 and black lead to ground.
 4. Turn MASTER switch ON, main light switch to SER. DRIVE, depress dimmer switch, and check for voltage.
 5. Place red lead of multimeters in other lead 519 and black lead to ground.
 6. Turn MASTER switch ON, main light switch to SER. DRIVE, depress dimmer switch, and check for voltage.
 7. Turn MASTER and main light switches OFF.
- Is voltage present?

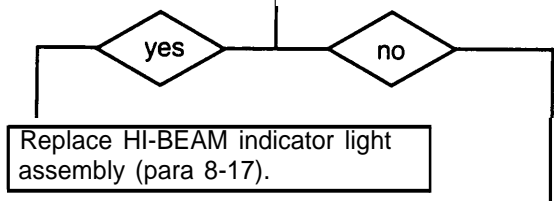

- C**
1. Reconnect two leads 519 of bulkhead-to-driver's instrument panel wiring harness leads to HI-BEAM indicator light.
 2. Disconnect bulkhead-to-driver's instrument panel wiring harness from dimmer switch.
 3. Place red lead of multimeters on pin C (lead 514/51 5) and black lead on pin D (lead 51 9).
 4. Depress dimmer switch and check for continuity.
 5. Place red lead of multimeter on pin G (lead 16) and black lead on pin H (lead 519);
 6. Depress dimmer switch and check for continuity.
- Is continuity present?

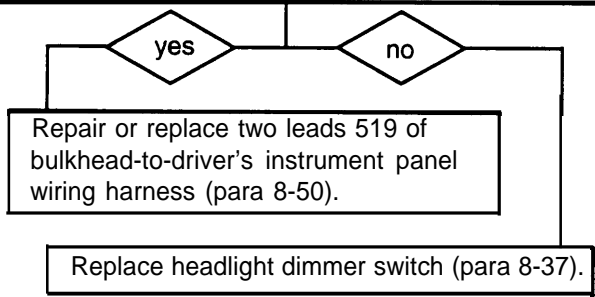

END OF TASK

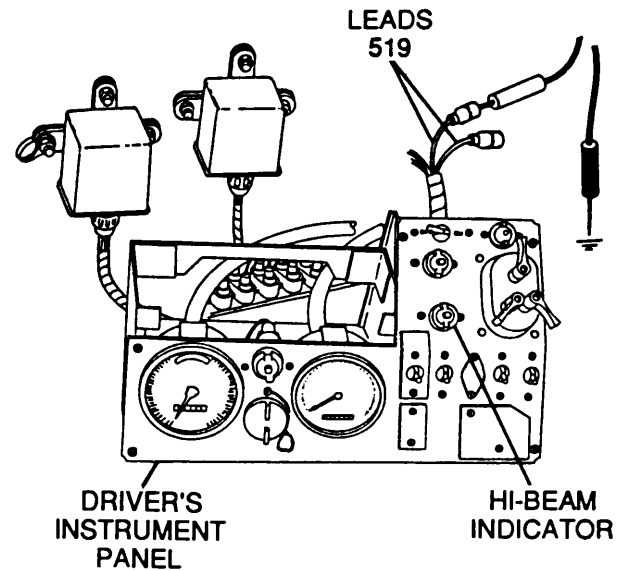

M109A4/M109A5 (ENGINE MODEL 7083-7396) SHOWN

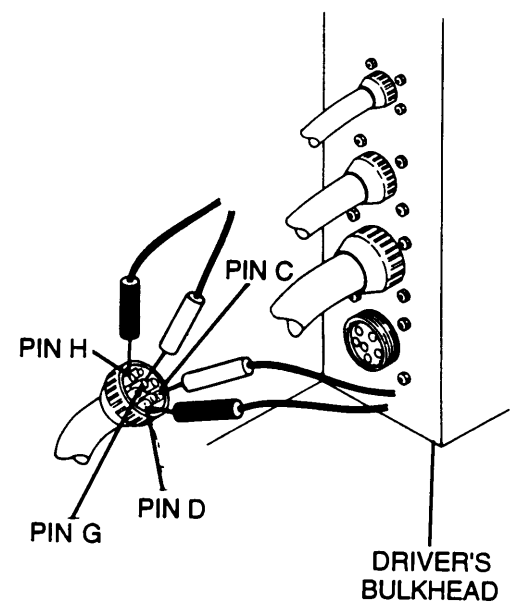

M109A4/M109A5 SHOWN

3-3 TROUBLESHOOTING CHART — CONTINUED

z. PERSONNEL HEATER CIRCUIT

The personnel heater system consists of the personnel heater, accessory control box, and heater fuel pump. The diagram below shows the relationship of these components.

When the MASTER switch is turned ON, 24 Vdc is supplied to the accessory control panel. When the HEAT SELECTOR SWITCH is turned to LOW, voltage is supplied to the heater fuel pump and personnel heater. After approximately 3 minutes, the heater indicator light will illuminate to indicate the personnel heater is operating properly.

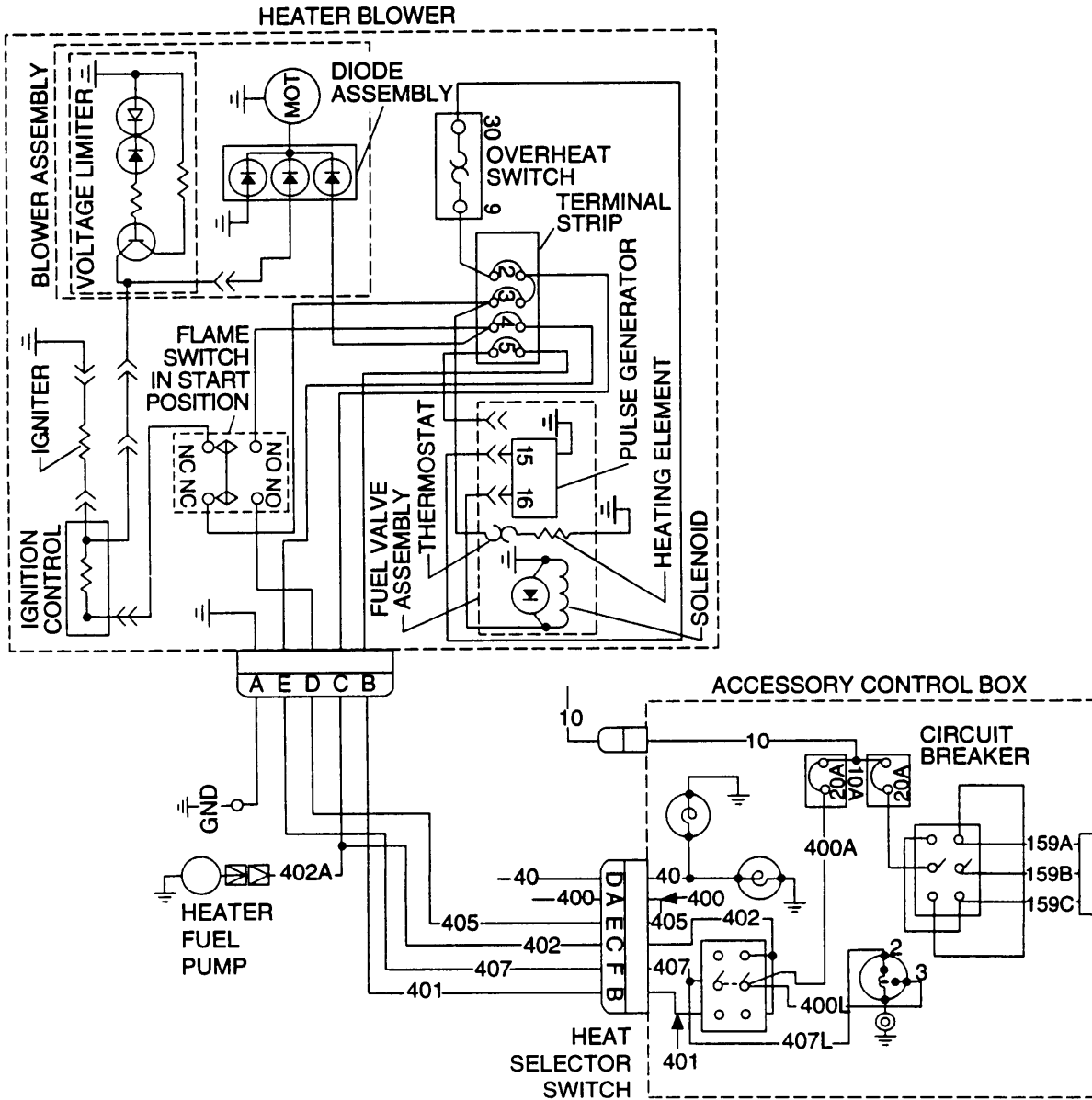

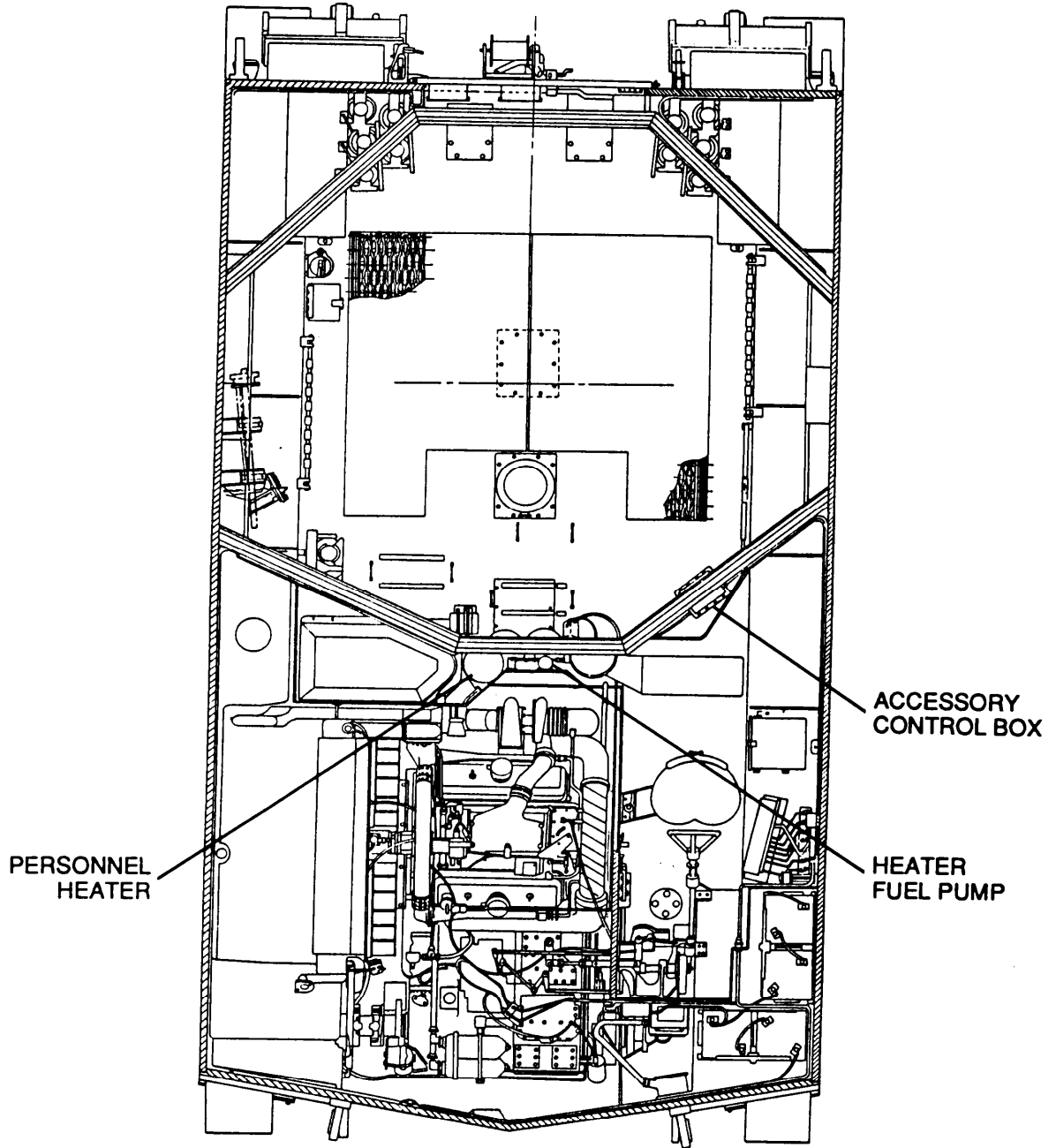

PICTORIAL VIEW

3-3 TROUBLESHOOTING CHART — CONTINUED

z. PERSONNEL HEATER CIRCUIT — CONTINUED (1) PERSONNEL HEATER FAILS TO OPERATE

INITIAL SETUP

Tools

General mechanic's tool kit (item 64, Appx H)
 Multimeters (item 36, Appx H)
 TA-1 probe kit (item 43, Appx H)

Personnel Required

Two

NOTE
 Although personnel heater circuit differs slightly between M109A2, M109A3, M109A4, and M109A5 Howitzers, the following troubleshooting procedure applies to all vehicles.

- A**
1. Disconnect battery ground leads.
 2. Disconnect accessory control box-to-heater/blower wiring harness from personnel heater.
 3. Place red lead of multimeters in socket C (lead 402) and black lead to ground.
 4. Reconnect battery ground leads.
 5. Turn MASTER switch ON, HEAT SELECTOR switch to LOW and check for voltage.
 6. Turn MASTER and HEAT SELECTOR switches OFF.

Is voltage present?

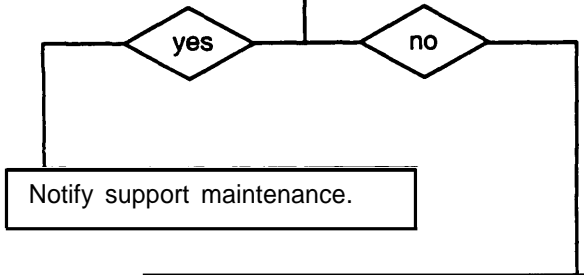
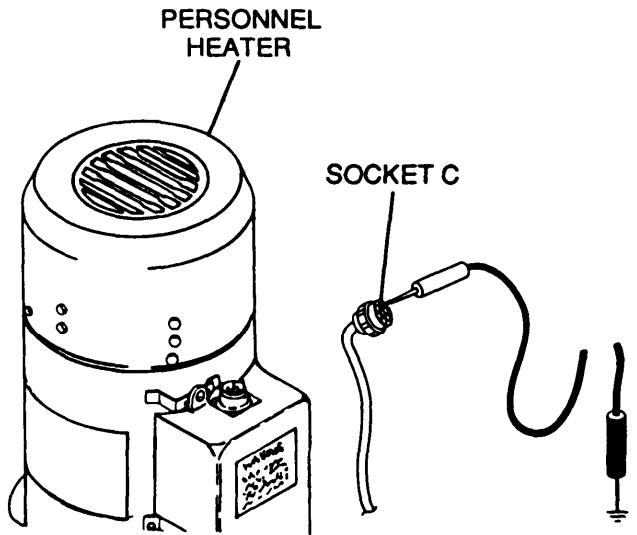

CONTINUED ON NEXT PAGE

CONTINUED FROM STEP A

- B**
1. Reconnect accessory control box-to-heater/blower wiring harness to personnel heater.
 2. Disconnect battery ground leads.
 3. Disconnect accessory control box-to-heater/blower wiring harness from accessory control box.
 4. Place a jumper wire from pin A to socket A (lead 400).
 5. Place red lead of multimeters in socket E (lead 405) and black lead to ground.
 6. Reconnect battery ground leads.
 7. Turn MASTER switch ON, HEAT SELECTOR switch to LOW and check for voltage.
 8. Turn MASTER and HEAT SELECTOR switches OFF.

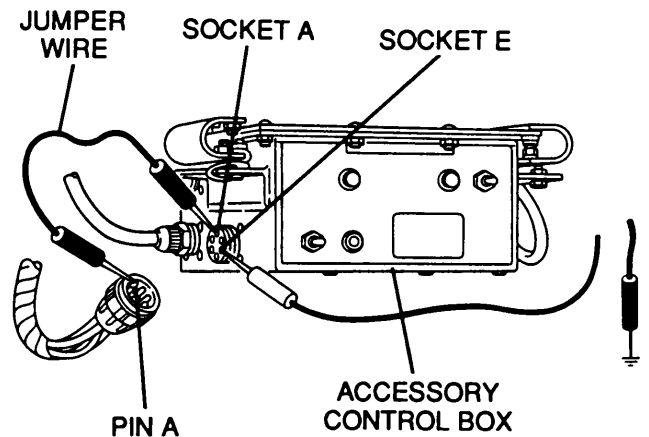

is voltage present?

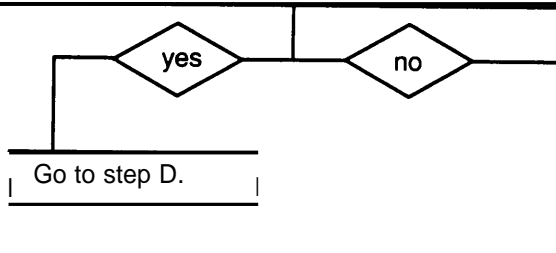

- C**
1. Disconnect battery ground leads.
 2. Place red lead of multimeters on pin A (lead 400) and black lead to ground.
 3. Reconnect battery ground leads.
 4. Turn MASTER switch ON and check for voltage.
 5. Turn MASTER switch OFF.

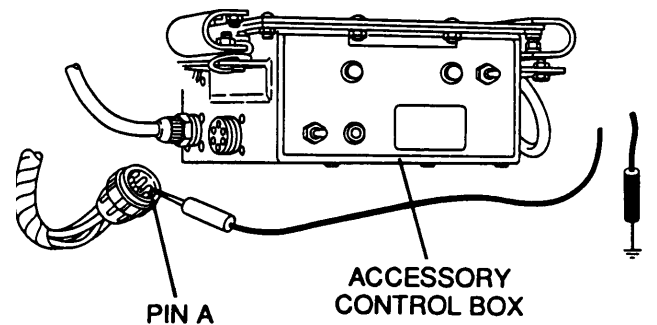

Is voltage present?

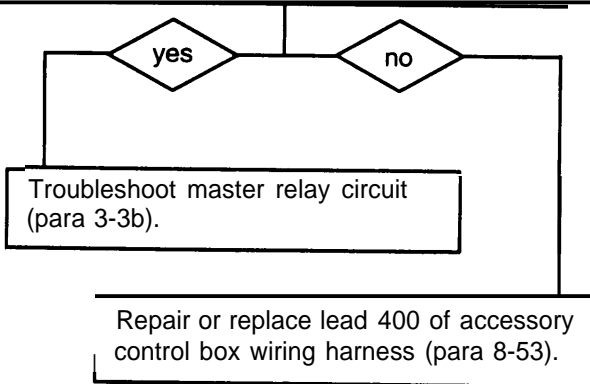

3-3 TROUBLESHOOTING CHART — CONTINUED

z. PERSONNEL HEATER CIRCUIT — CONTINUED (1) PERSONNEL HEATER FAILS TO OPERATE — CONTINUED

CONTINUED FROM STEP B

D

1. Disconnect battery ground leads.
2. Place a jumper wire from pin A to socket A (lead 400).
3. Place red lead of multimeters in socket C (lead 402) and black lead to ground.
4. Turn MASTER switch ON, HEAT SELECTOR switch to LOW and check for voltage.
5. Turn MASTER and HEAT SELECTOR switches OFF.

Is voltage present?

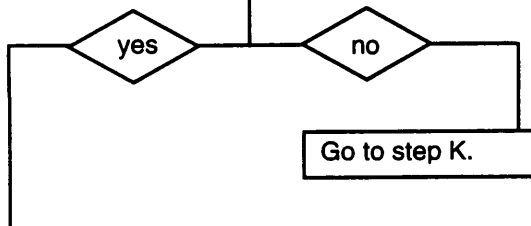
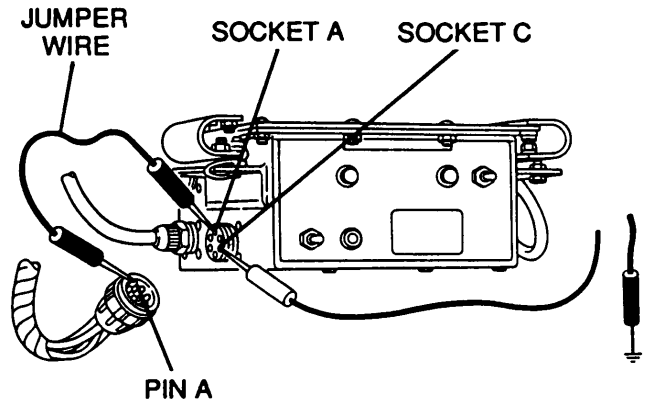

E

1. Reconnect accessory control box-to-heater/blower wiring harness to accessory control box.
2. Disconnect lead 10 of power lead wiring harness from accessory control box.
3. Place red lead of multimeters in lead 10 and black lead to ground.
4. Turn MASTER switch ON and check for voltage.
5. Turn MASTER switch OFF.

Is voltage present?

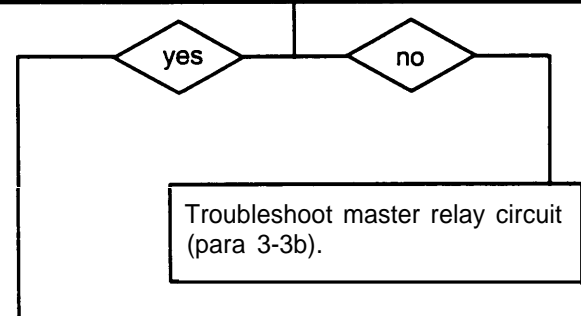
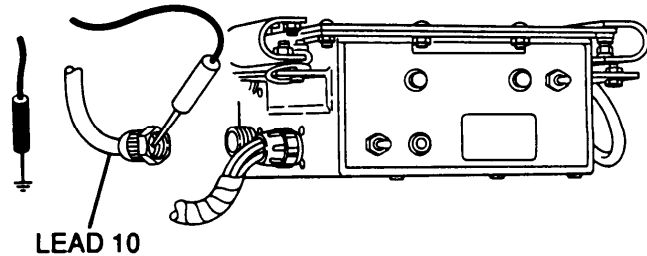

CONTINUED ON NEXT PAGE

CONTINUED FROM STEP E

- F**
1. Reconnect lead 10 of power lead assembly to accessory control box.
 2. Remove accessory control box cover (para 8-20).
 3. Disconnect lead 10A from circuit breaker input.
 4. Place red lead of multimeters in lead 10A and black lead to ground.
 5. Turn MASTER switch ON and check for voltage.
 6. Turn MASTER switch OFF.
- Is voltage present?

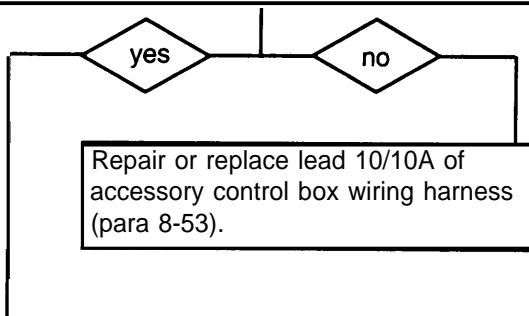

- G**
1. Reconnect lead 10A to circuit breaker input.
 2. Disconnect lead 400A from circuit breaker output.
 3. Place red lead of multimeters in circuit breaker output and black lead to ground.
 4. Turn MASTER switch ON and check for voltage.
 5. Turn MASTER switch OFF.
- Is voltage present?

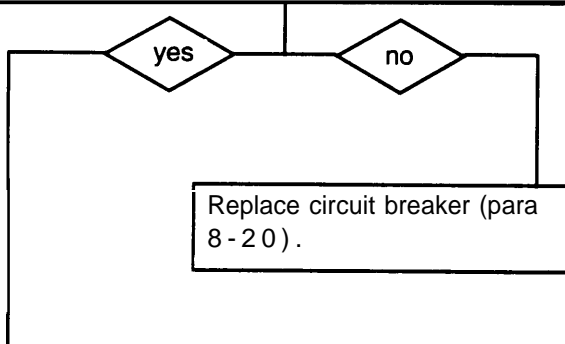

CONTINUED ON NEXT PAGE

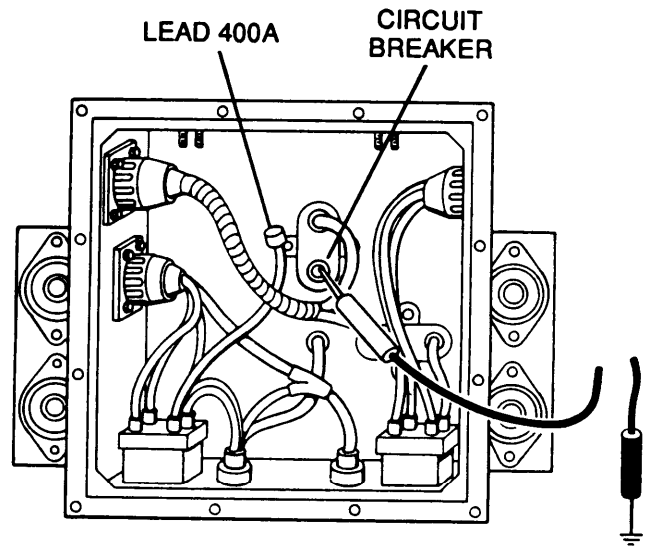
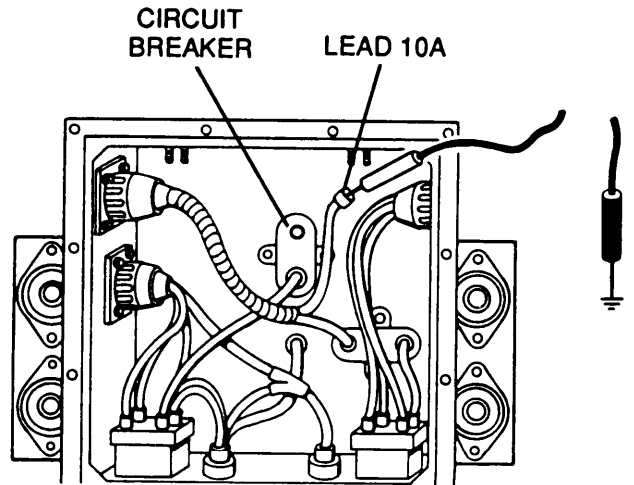

3-3 TROUBLESHOOTING CHART — CONTINUED

z. PERSONNEL HEATER CIRCUIT — CONTINUED (1) PERSONNEL HEATER FAILS TO OPERATE — CONTINUED

CONTINUED FROM STEP G

- H**
1. Reconnect lead 400A to circuit breaker output.
 2. Disconnect lead 400A from HEAT SELECTOR switch.
 3. Place red lead of multimeter in lead 400A and black lead to ground.
 4. Turn MASTER switch ON and check for voltage.
 5. Turn MASTER switch OFF.

Is voltage present?

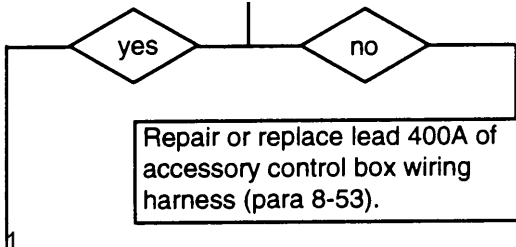

- I**
1. Reconnect lead 400A to HEAT SELECTOR switch.
 2. Disconnect both leads 402 from HEAT SELECTOR switch terminals.
 3. Place red lead of multimeter on HIGH terminal and black lead to ground.
 4. Turn MASTER switch ON, HEAT SELECTOR switch to HIGH and check for voltage.
 5. Place red lead of multimeter on LOW terminal and black lead to ground.
 6. Turn MASTER switch ON, HEAT SELECTOR switch to HIGH and check for voltage.
 7. Turn MASTER and HEAT SELECTOR switches OFF.

Is voltage present in both positions?

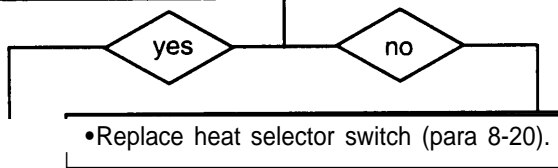

CONTINUED ON NEXT PAGE

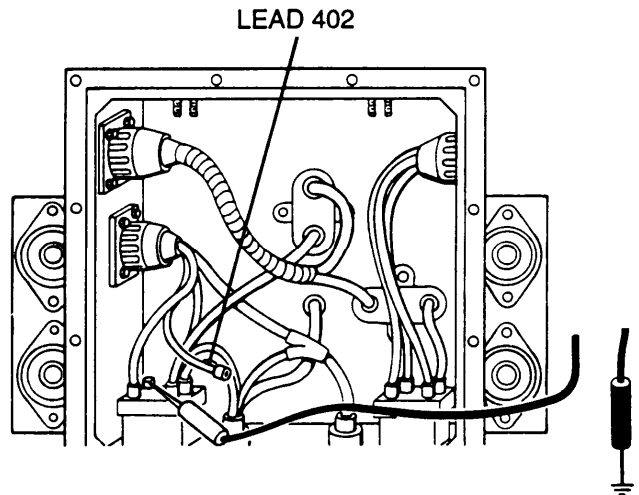
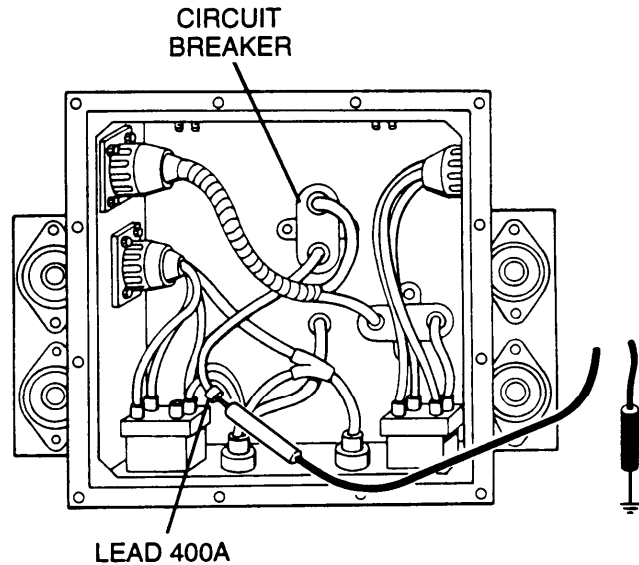

CONTINUED FROM STEP I

J	<ol style="list-style-type: none"> 1. Repair or replace both leads 402 of accessory control box wiring harness (para 8-53). 2. Reassemble and install accessory control box (para 8-20). 3. Turn MASTER switch ON, HEAT SELECTOR switch to LOW and check personnel heater for operation. 4. Turn MASTER and HEAT SELECTOR switches OFF.
<p>If personnel heater still does not operate, replace personnel heater (para 11-20).</p>	

CONTINUED FROM STEP D

K	<ol style="list-style-type: none"> 1. Reconnect accessory control box to heater/blower wiring harness to accessory control box. 2. Disconnect lead 402A from personnel heater fuel pump. 3. Place red lead of multimeters in lead 402A and black lead to ground. 4. Turn MASTER switch ON, HEAT SELECTOR switch to LOW and check for voltage. 5. Turn MASTER and HEAT SELECTOR switches OFF.
<p>Is voltage present?</p>	

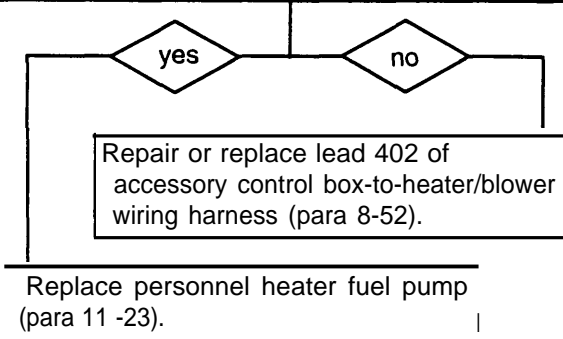

NOTE
<p>If personnel heater still does not operate, replace personnel heater (para 11-20).</p>

END OF TASK

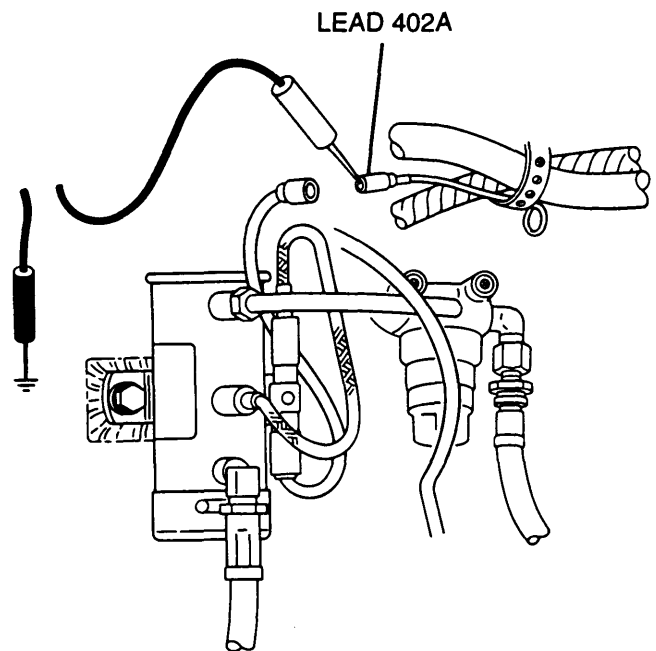

3-3 TROUBLESHOOTING CHART — CONTINUED

- z. PERSONNEL HEATER CIRCUIT — CONTINUED (2) PERSONNEL HEATER INDICATOR LIGHT FAILS TO OPERATE; PERSONNEL HEATER OPERATES

INITIAL SETUP

Tools

General mechanic's tool kit (item 64, Appx H)
 Multimeters (item 36, Appx H)
 TA-1 probe kit (item 43, Appx H)

- A**
1. Remove personnel HEATER indicator lamp.
 2. Place red lead of multimeters in center contact and black lead to ground.
 3. Turn MASTER switch ON, HEAT SELECTOR switch to LOW and check for voltage.
 4. Turn MASTER and HEAT SELECTOR switches OFF.

Is voltage present?

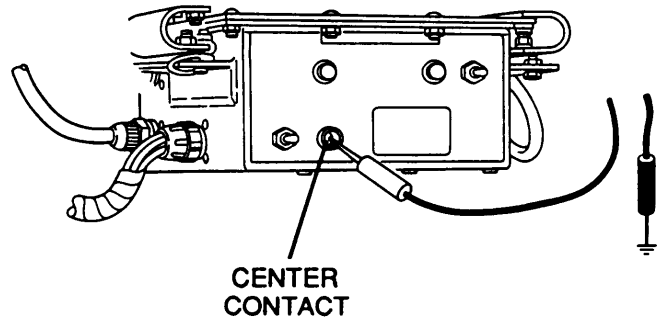
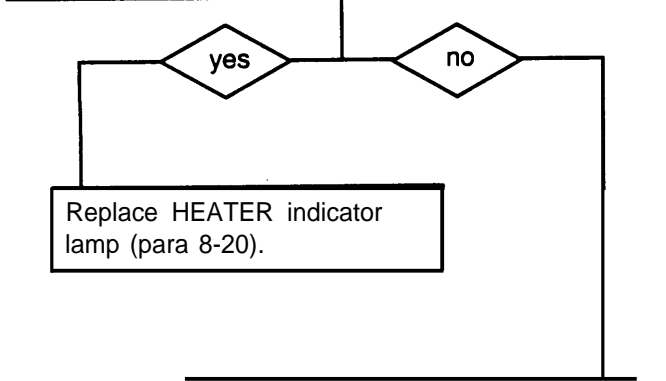

CONTINUED ON NEXT PAGE

CONTINUED FROM STEP A

B

1. Install HEATER indicator lamp.
2. Remove accessory control box cover (para 8-20).
3. Disconnect lead 400L from HEATER indicator lamp assembly.
4. Place red lead of multimeters on lead 407L and black lead to ground.
5. Turn MASTER switch ON, HEAT SELECTOR switch to LOW, and check for voltage.
6. Place red lead of multimeters on lead 400L and black lead to ground.
7. Turn MASTER switch ON, HEAT SELECTOR switch to LOW and check for voltage.
8. Turn MASTER and HEAT SELECTOR switches OFF.

Is voltage present?

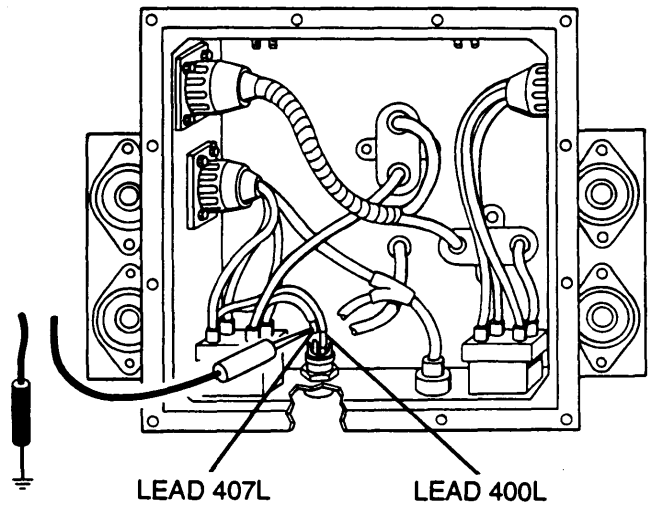
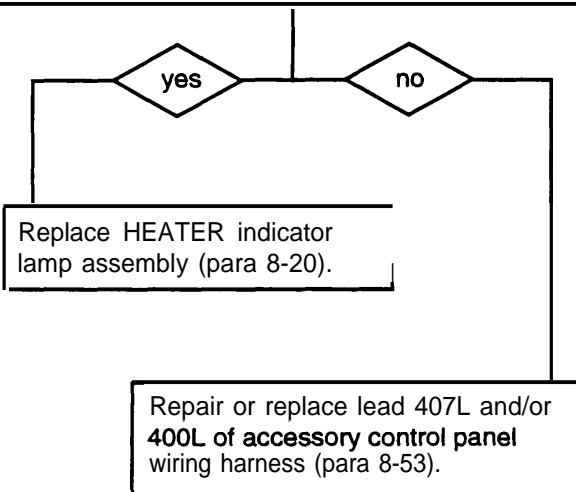

END OF TASK

3-3 TROUBLESHOOTING CHART — CONTINUED

aa. PERSONNEL VENTILATION BLOWER CIRCUIT

The personnel ventilation blower system consists of the personnel ventilation blower and the accessory control box. The diagram below shows the relationship of these components.

When the MASTER switch is turned ON, 24 Vdc is supplied from the batteries through the master relay to the accessory control panel. When the ventilation blower switch is set to EXHAUST, voltage is applied to energize the personnel ventilation blower in either a forward or reverse direction.

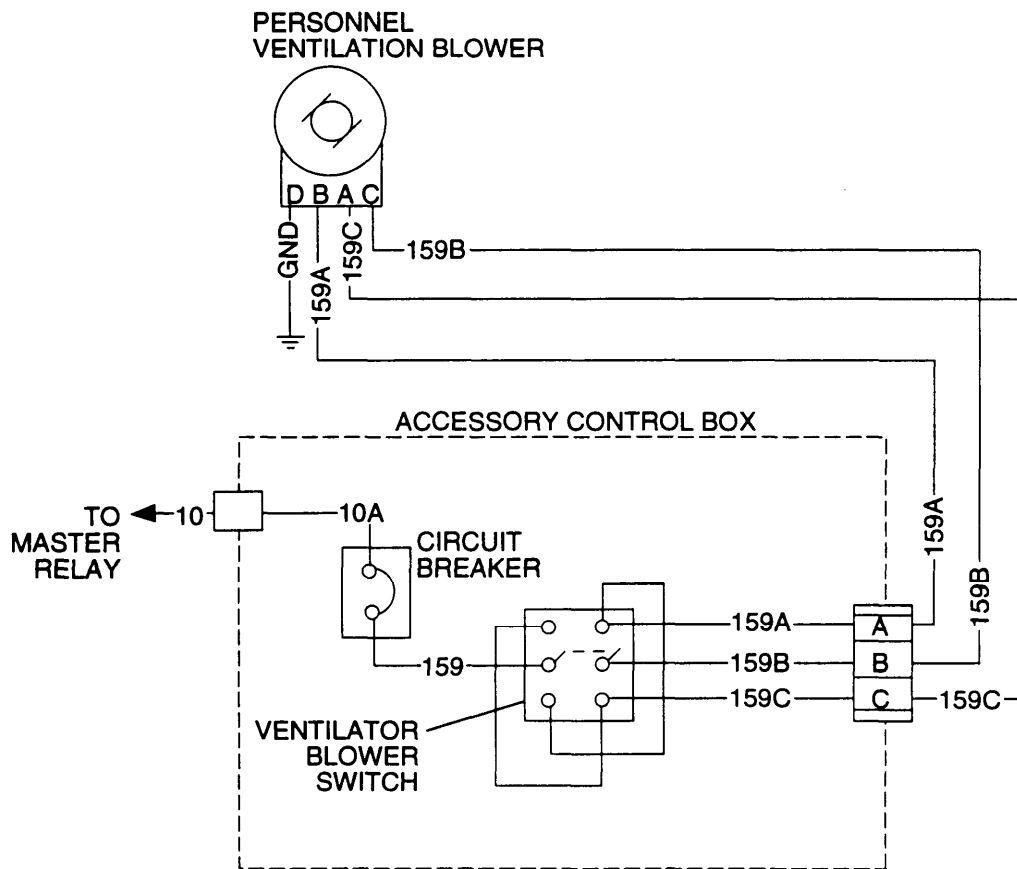

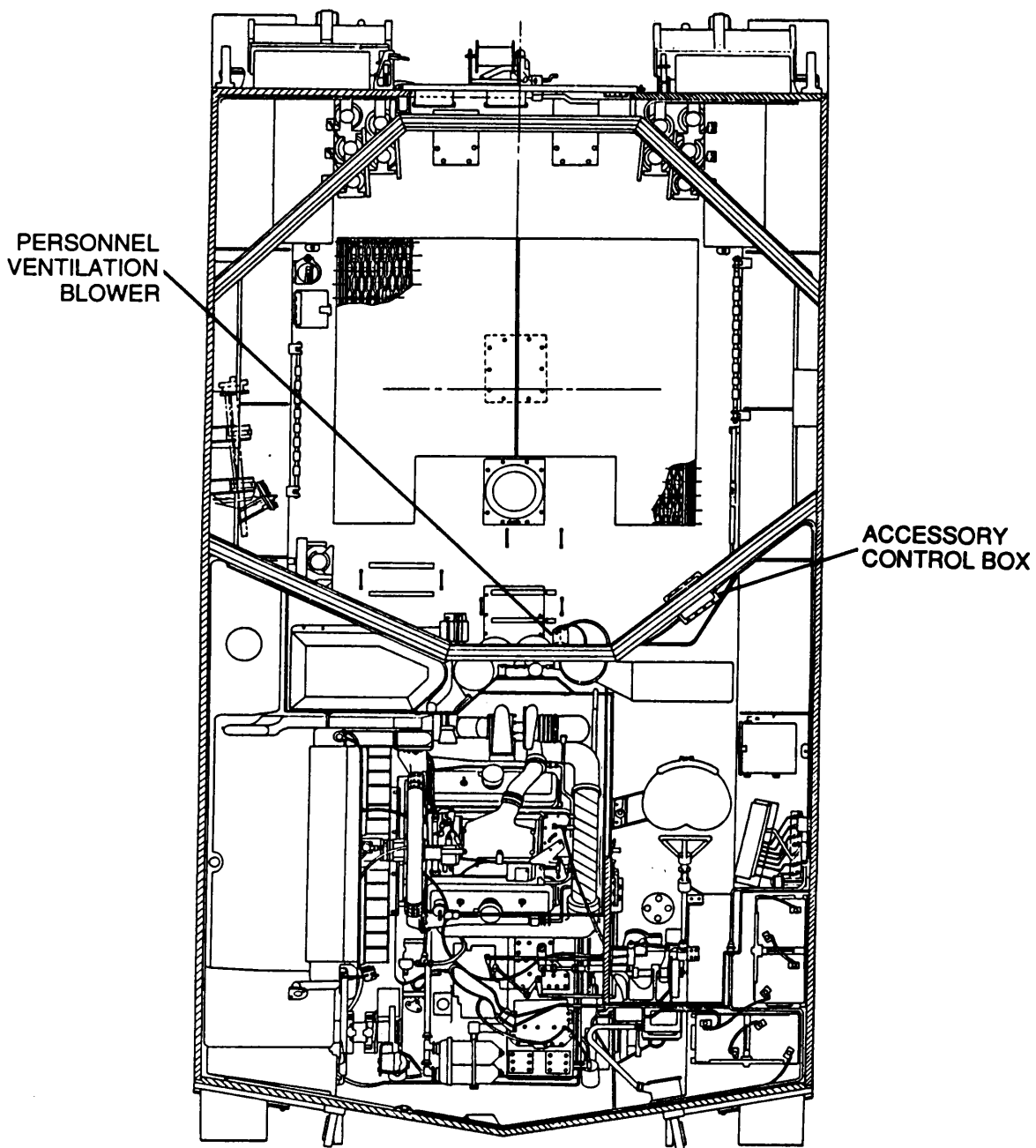

PICTORIAL VIEW

3-3 TROUBLESHOOTING CHART — CONTINUED

aa. PERSONNEL VENTILATION BLOWER CIRCUIT — PERSONNEL VENTILATION BLOWER FAILS TO OPERATE
CONTINUED

INITIAL SETUP

Tools

General mechanic's tool kit (item 64, Appx H)

Multimeters (item 36, Appx H)

TA-1 probe kit (item 43, Appx H)

- A**
1. Disconnect accessory control box-to-heater/blower wiring harness from personnel ventilation blower.
 2. Place a jumper wire from socket B (lead 159A) to ground.
 3. Place red lead of multimeters in socket A (lead 159C) and black lead to ground.
 4. Turn MASTER switch ON, VENTILATOR BLOWER switch in EXHAUST position and check for voltage.
 5. Place VENTILATOR BLOWER switch in INTAKE position and check for voltage.
 6. Turn MASTER and VENTILATOR BLOWER INTAKE switches OFF.
- Is voltage present in one position?

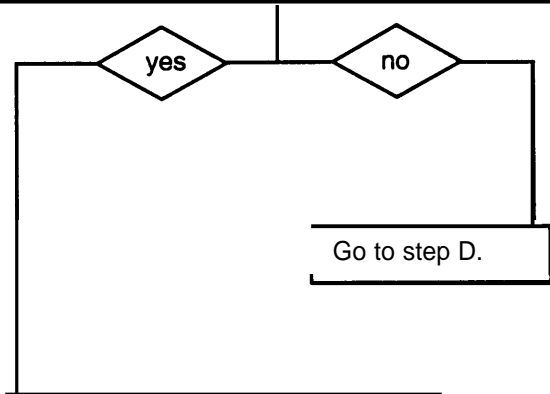
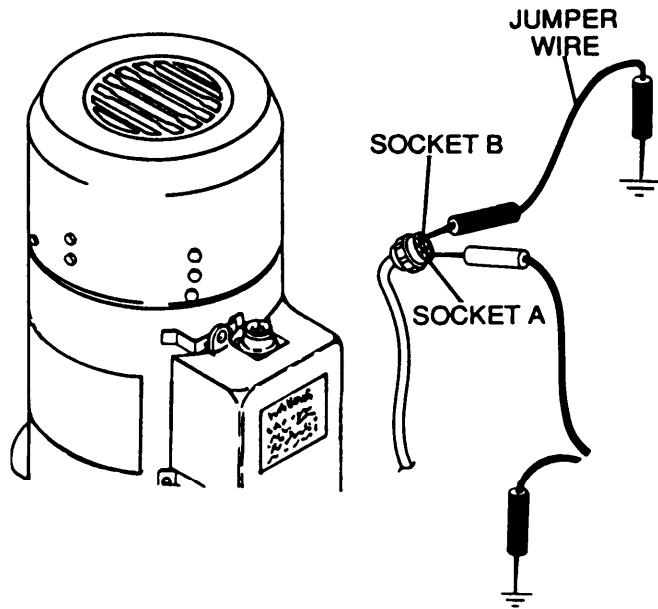

CONTINUED ON NEXT PAGE

CONTINUED FROM STEP A

B

1. With connections and VENTILATOR BLOWER switch in the position where voltage was present in step A, move black lead of multimeters to socket C (lead 159B).
2. Turn MASTER switch ON and check for voltage.
3. Turn MASTER switch OFF.

Is voltage present?

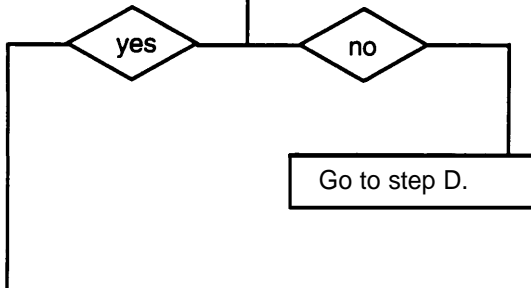

C

1. With multimeters disconnected and socket B (lead 159A) grounded, place VENTILATOR BLOWER switch in opposite position of where voltage was obtained in steps A and B.
2. Place red lead of multimeters in socket C (lead 159B) and black lead in socket A (lead 159C).
3. Turn MASTER switch ON and check for voltage.
4. Turn MASTER switch OFF.

Is voltage present?

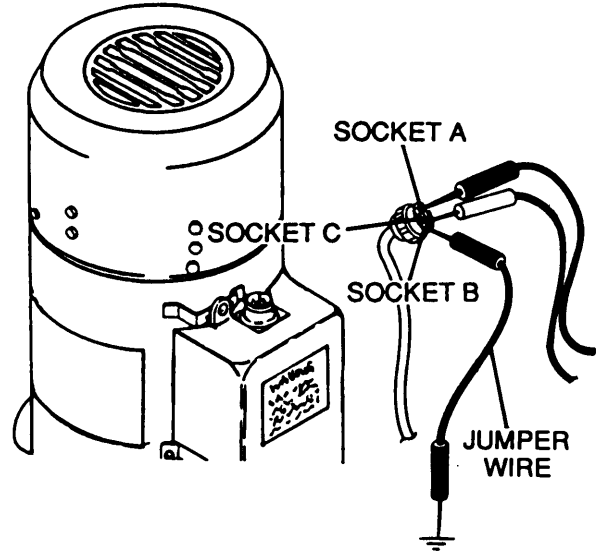
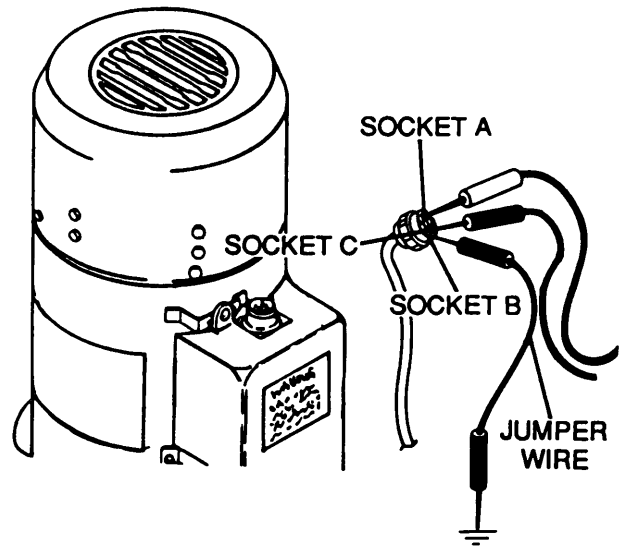
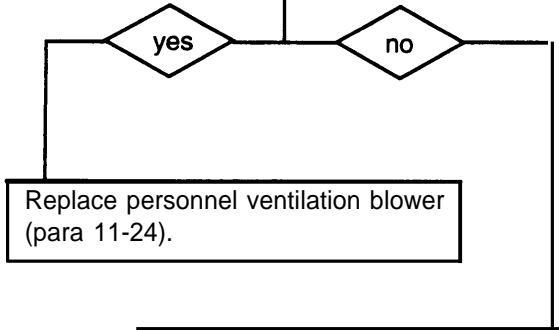

CONTINUED ON NEXT PAGE

3-3 TROUBLESHOOTING CHART — CONTINUED

aa. PERSONNEL VENTILATION BLOWER CIRCUIT — PERSONNEL VENTILATION BLOWER FAILS TO OPERATE — CONTINUED

CONTINUED FROM STEP C

D

1. Reconnect accessory control box-to-heater/blower wiring harness to ventilation blower.
2. Disconnect accessory control box-to-heater/blower wiring harness from accessory control box.
3. Place a jumper wire from socket B (lead 159B) to ground.
4. Place red lead of multimeters in socket A (lead 159A) and black lead to ground.
5. Turn MASTER switch ON, VENTILATOR BLOWER switch in EXHAUST position and check for voltage.
6. Place VENTILATOR BLOWER switch in INTAKE position and check for voltage.
7. Turn MASTER and VENTILATOR BLOWER switches OFF.

Is voltage present?

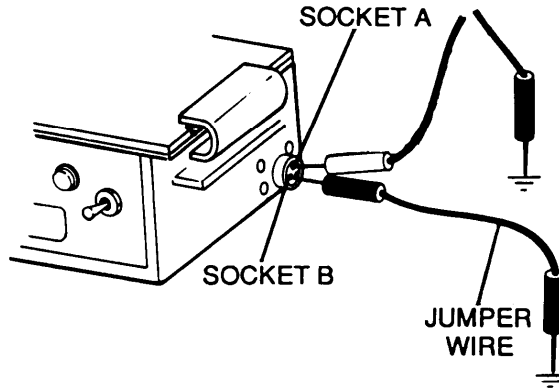

yes no

Go to step G.

E

1. With connections and VENTILATOR BLOWER switch in positions where voltage was obtained in step D, move black lead of multimeters to socket C (lead 159C).
2. Turn MASTER switch ON and check for voltage.
3. Turn MASTER switch OFF.

Is voltage present?

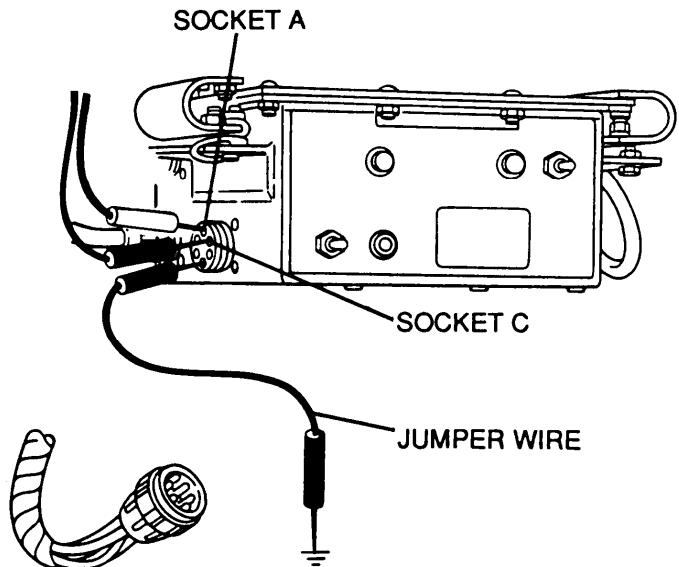

yes no

Go to step H.

CONTINUED ON NEXT PAGE

CONTINUED FROM STEP E

- F**
1. With multimeters disconnected and socket B (lead 159A) grounded, place VENTILATOR BLOWER switch in opposite position of where voltage was obtained in steps D and E.
 2. Place red lead of multimeters in socket C (lead 159B) and black lead in socket A (lead 159C).
 3. Turn MASTER switch ON and check for voltage.
 4. Turn MASTER switch OFF.

Is voltage present?

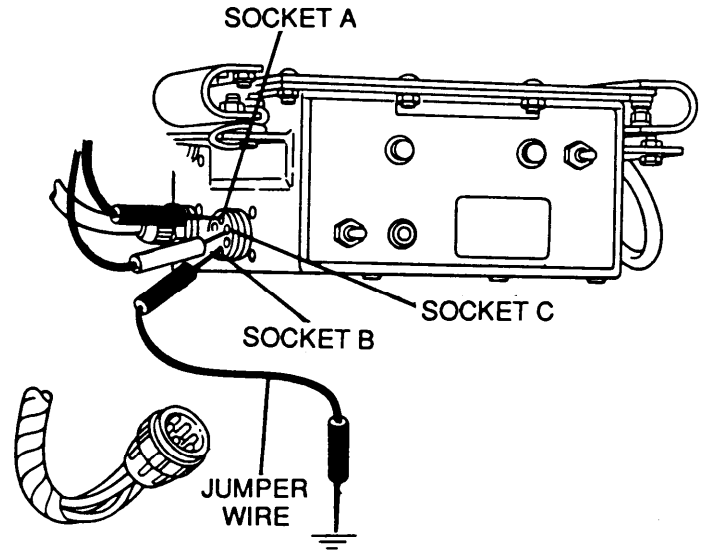
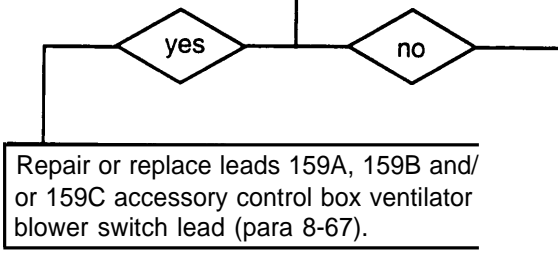

CONTINUED FROM STEP E

- G**
1. Reconnect accessory control box-to-heater/blower wiring harness to accessory control box.
 2. Disconnect lead 10 from accessory control box.
 3. Place red lead of multimeter in lead 10 and black lead to ground.
 4. Turn MASTER switch ON and check for voltage.
 5. Turn MASTER switch OFF.

Is voltage present?

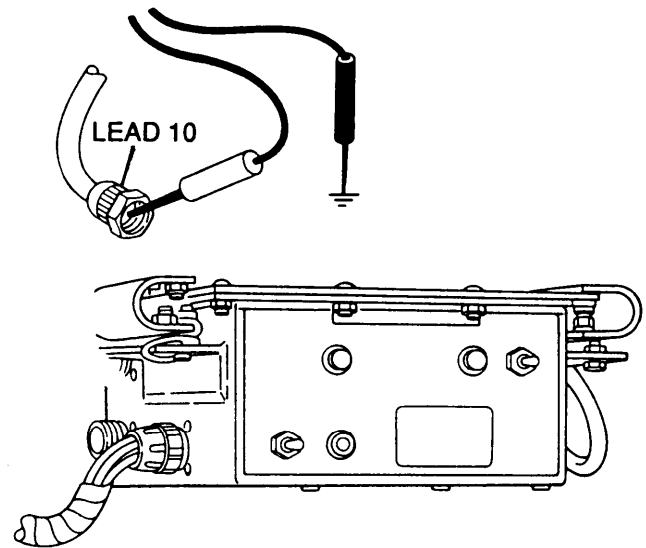
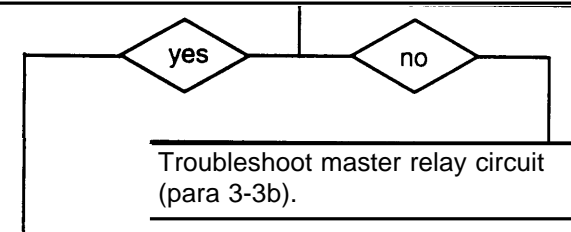

CONTINUED ON NEXT PAGE

3-3 TROUBLESHOOTING CHART — CONTINUED

aa. PERSONNEL VENTILATION BLOWER CIRCUIT — PERSONNEL VENTILATION BLOWER FAILS TO OPERATE — CONTINUED

CONTINUED FROM STEP G

- H**
1. Reconnect lead 10 to accessory control box.
 2. Remove accessory control box cover (para 8-20).
 2. Disconnect lead 10A from circuit breaker input.
 3. Place red lead of multimeters in lead 10 and black lead to ground.
 4. Turn MASTER switch ON and check for voltage.
 5. Turn MASTER switch OFF.

Is voltage Present?

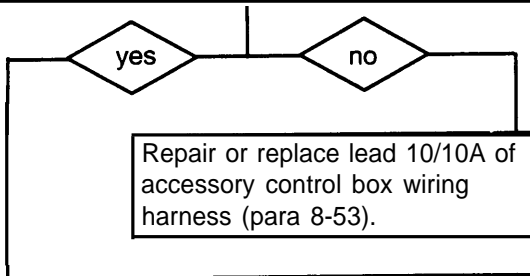

- I**
1. Reconnect lead 10A to circuit breaker input.
 2. Disconnect lead 159 from circuit breaker output.
 3. Place red lead of multimeters in circuit breaker output and black lead to ground.
 4. Turn MASTER switch ON and check for voltage.
 5. Turn MASTER switch OFF.

Is voltage present?

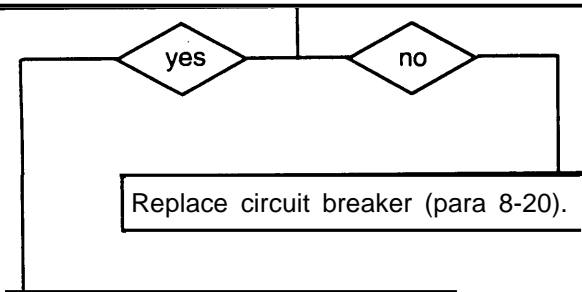

CONTINUED ON NEXT PAGE

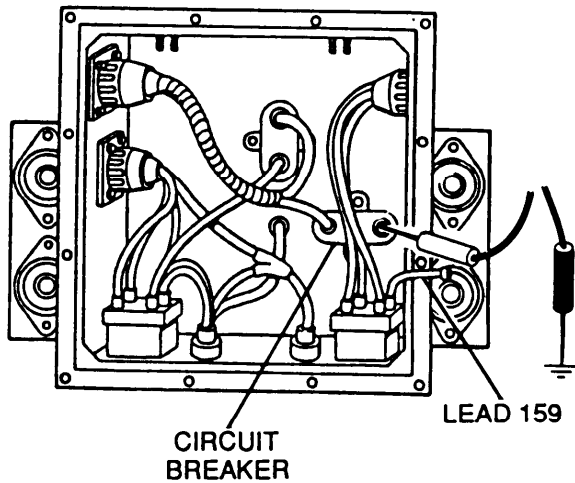
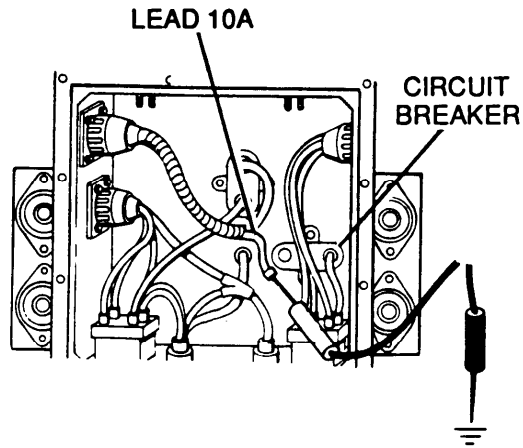

CONTINUED FROM STEP I

- | | |
|---------------------|---|
| J | <ol style="list-style-type: none"> 1. Reconnect lead 159 to circuit breaker output. 2. Disconnect lead 159 from VENTILATOR BLOWER switch. 3. Place red lead of multimeter in lead 159 and black lead to ground. 4. Turn MASTER switch ON and check for voltage. 5. Turn MASTER switch OFF. |
| Is voltage present? | |

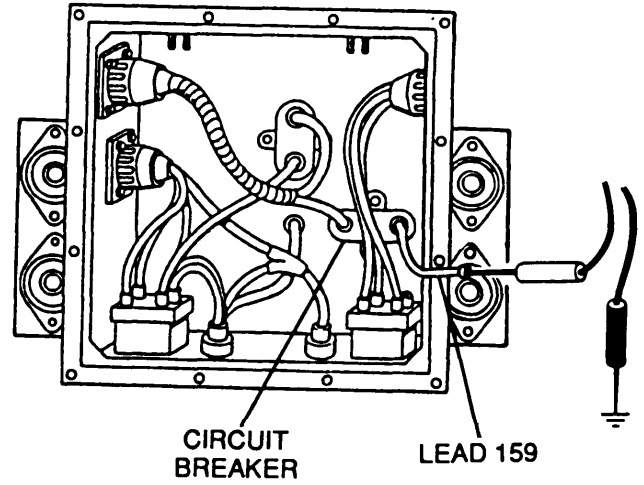
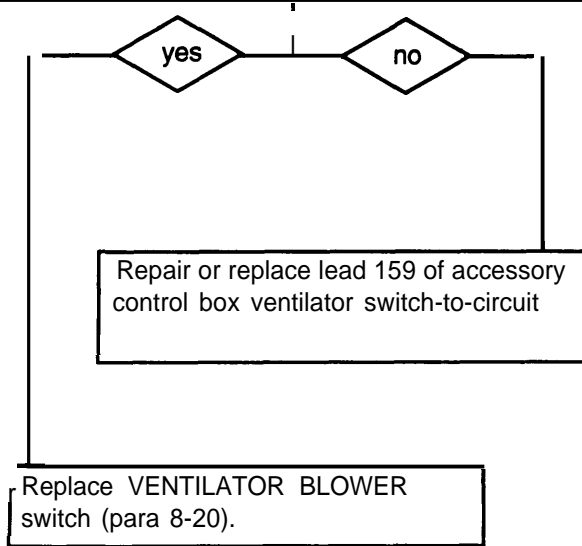

END OF TASK

3-3 TROUBLESHOOTING CHART — CONTINUED

ab. BILGE PUMP CIRCUIT

The bilge pump is used to evacuate water from the engine compartment, usually after fording. The bilge pump is not to be run for more than 1 minute in a dry compartment or 15 minutes in a wet compartment unless the engine is running.

The bilge pump system consists of the bilge pump, bilge pump relay, bilge pump circuit breaker, and related electrical wiring.

To operate the bilge pump, the MASTER switch must be ON. By turning the MASTER switch ON, power from the batteries travels through the MASTER relay to the circuit breaker. From the circuit breaker the power travels to the BILGE PUMP switch. Once the BILGE PUMP switch is turned ON, the power travels through the bilge pump circuit breaker to the bilge pump relay. The bilge pump relay sends the power to the bilge pump and the bilge pump is energized.

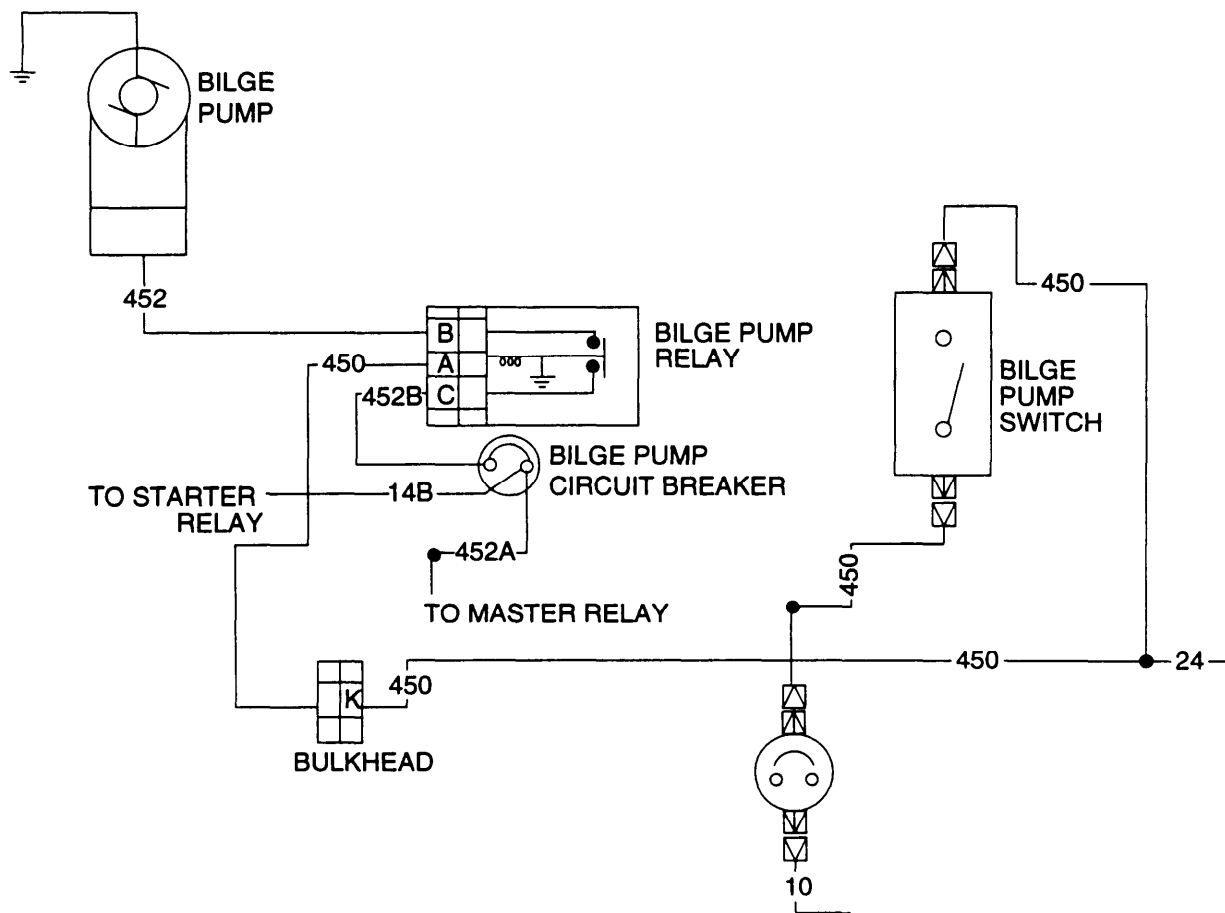

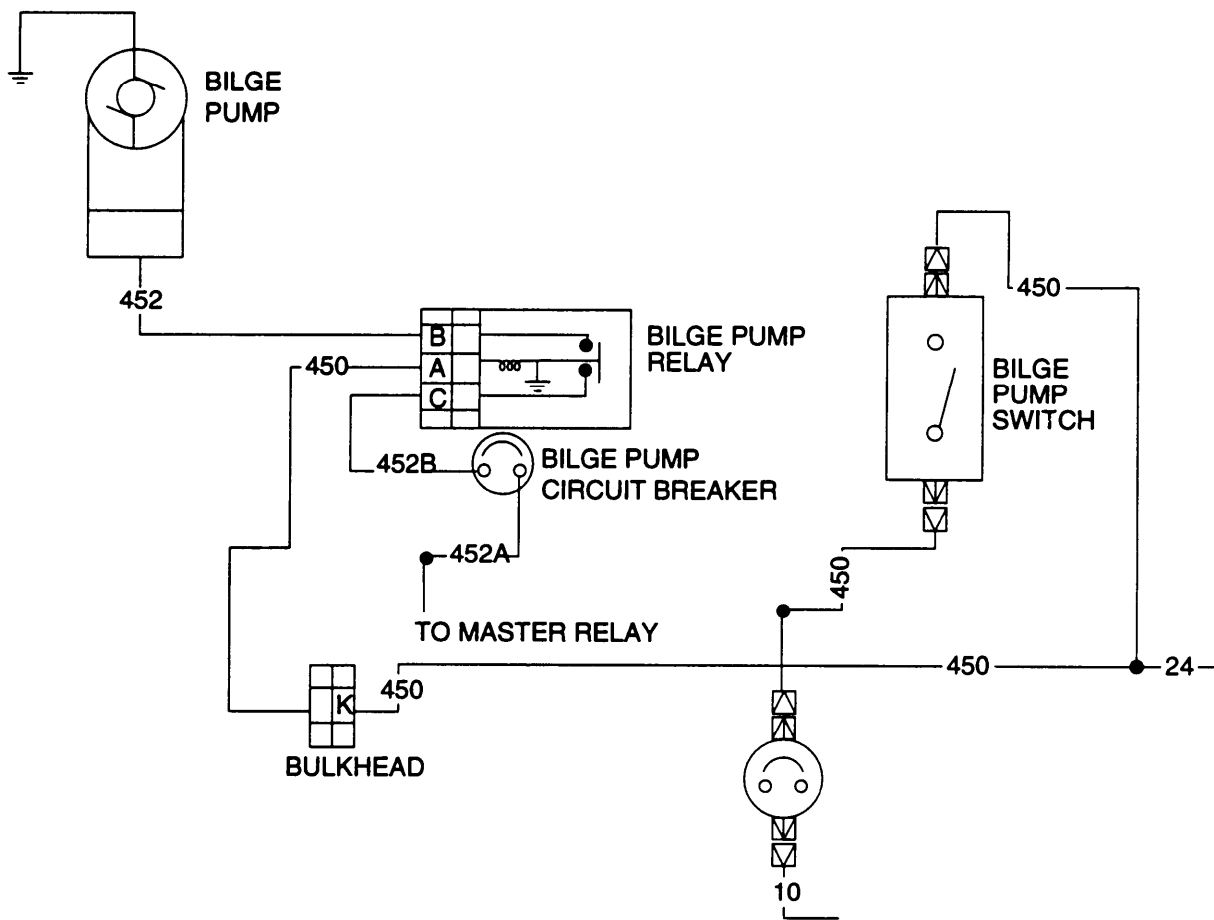

3-3 TROUBLESHOOTING CHART — CONTINUED

ab. BILGE PUMP CIRCUIT — CONTINUED

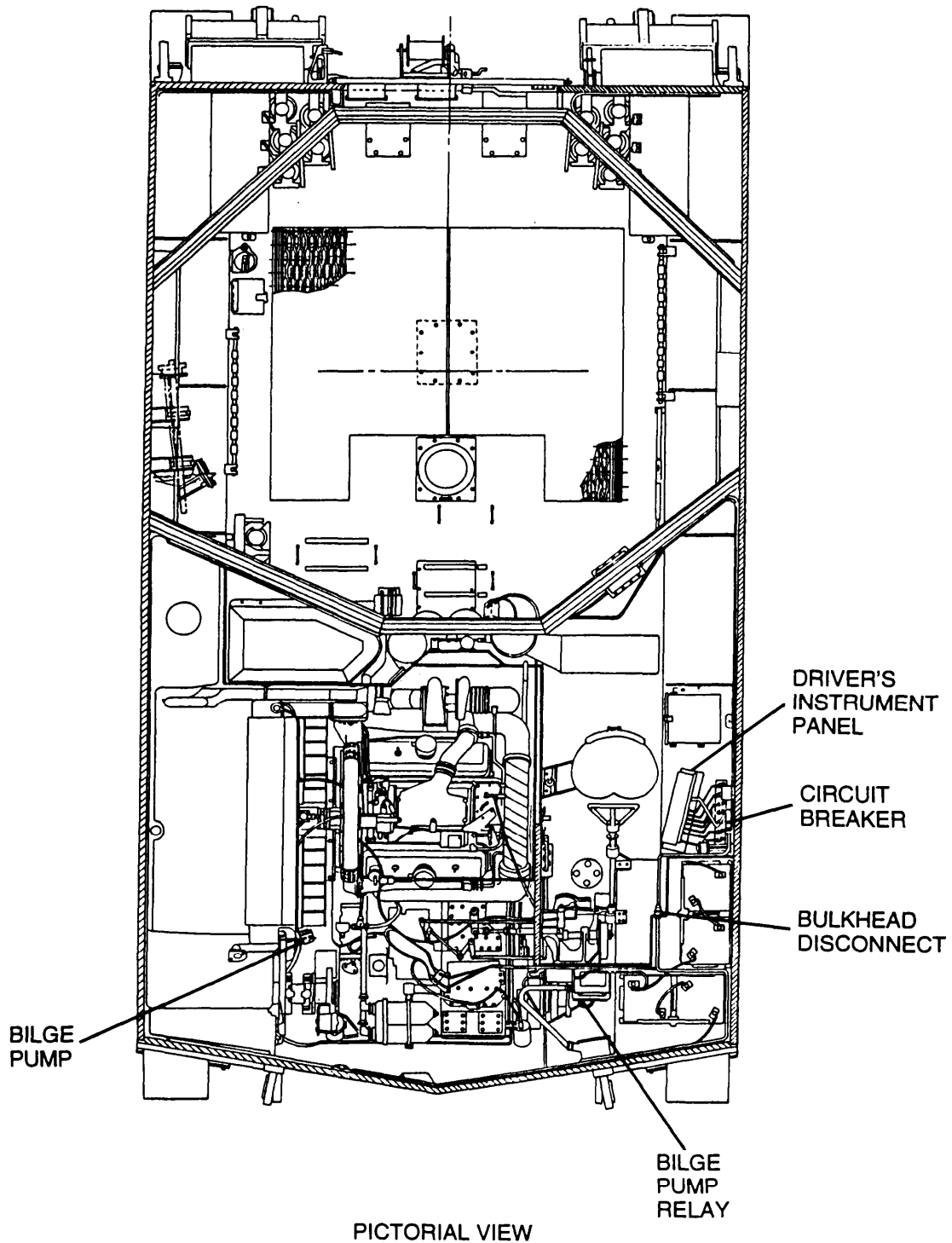

BILGE PUMP FAILS TO OPERATE

INITIAL SETUP

Tools
General mechanic's tool kit (item 64, Appx H)
Multimeter (item 36, Appx H)
TA-1 probe kit (item 43, Appx H)

Personnel required
Two

Equipment Conditions
Powerplant removed and special equipment installed (para 4-5)

- A**
1. Disconnect lead 452 from bilge pump.
 2. Place red lead of multimeter in lead 452 and black lead to ground.
 3. Turn MASTER switch ON and check for voltage.
 4. Turn MASTER switch OFF.
- Is voltage present?

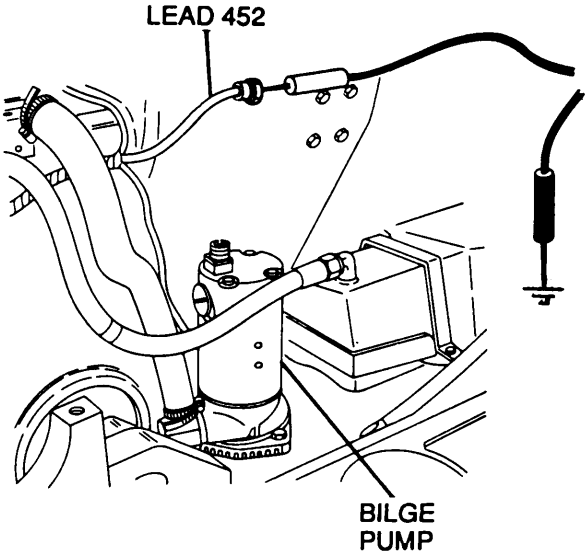
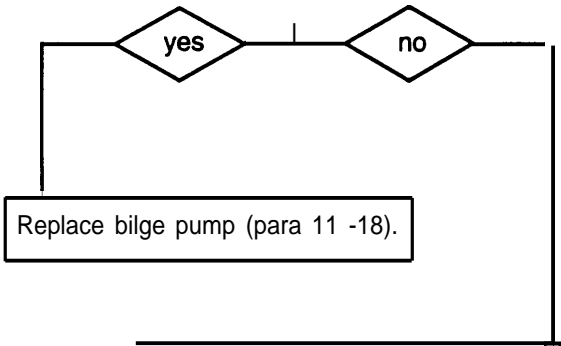

3-3 TROUBLESHOOTING CHART — CONTINUED

ab. BILGE PUMP CIRCUIT — CONTINUED

BILGE PUMP FAILS TO OPERATE — CONTINUED

CONTINUED FROM STEP A

- B**
1. Reconnect lead 452 to bilge pump.
 2. Disconnect engine disconnect bracket-to-bulkhead wiring harness from bilge pump relay.
 3. Place red lead of multimeter in socket C (lead 452B) and black lead to ground.
 4. Turn MASTER switch ON and check for voltage.
 5. Turn MASTER switch OFF.
- Is voltage present?

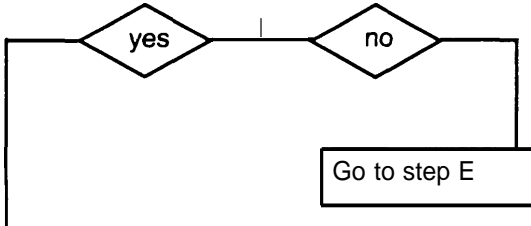
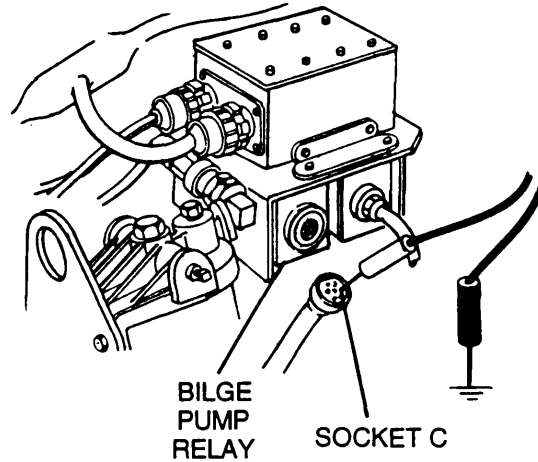

- C**
1. Place a jumper wire from socket C (lead 452B) to socket B (lead 452).
 2. Turn MASTER and BILGE PUMP switches ON and check bilge pump for operation.
 3. Turn MASTER and BILGE PUMP switches OFF.
- Does bilge pump operate?

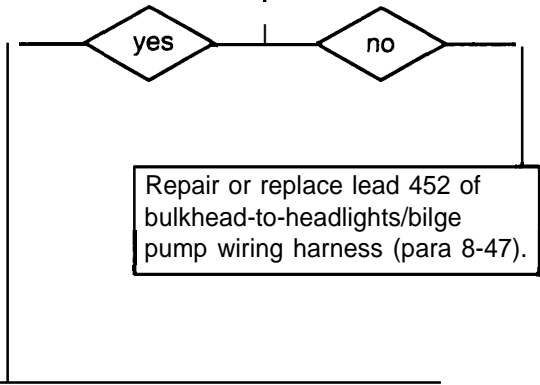
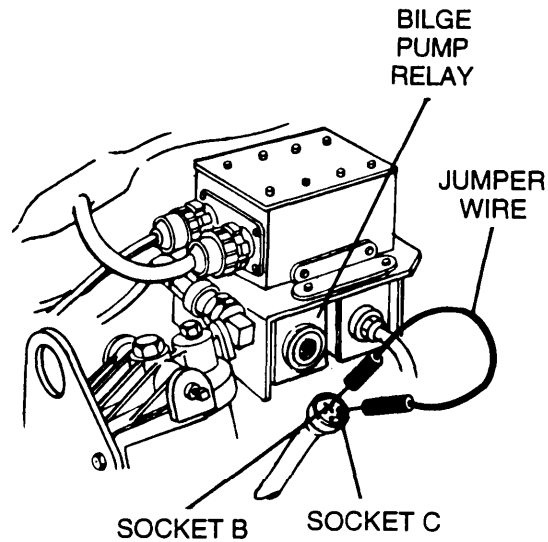

CONTINUED ON NEXT PAGE

CONTINUED FROM STEP C

- D**
1. Place red lead of multimeter in socket A (lead 450) and black lead to ground.
 2. Turn MASTER and BILGE PUMP switches ON and check for voltage.
 3. Turn MASTER and BILGE PUMP switches OFF.

Is voltage present?

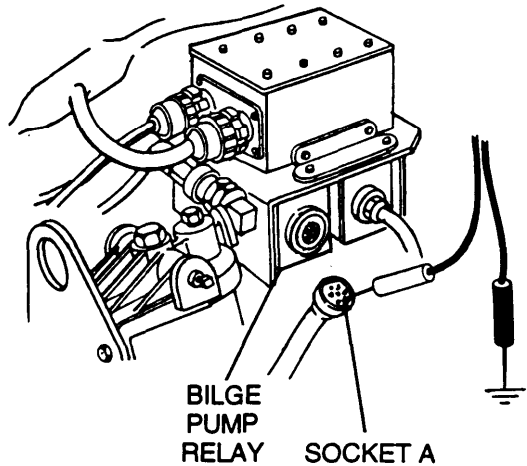
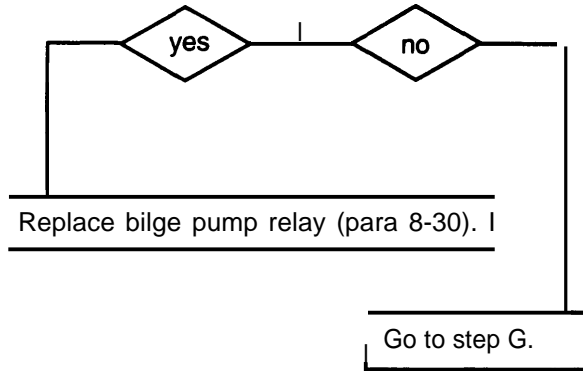

CONTINUED FROM STEP B

- E**
1. Reconnect engine disconnect bracket-to-bulkhead wiring harness to bilge pump relay.
 2. Disconnect lead 452B from bilge pump circuit breaker output.
 3. Place red lead of multimeter on circuit breaker output and black lead to ground.
 4. Turn MASTER switch ON and check for voltage.
 5. Turn MASTER switch OFF.

Is voltage present?

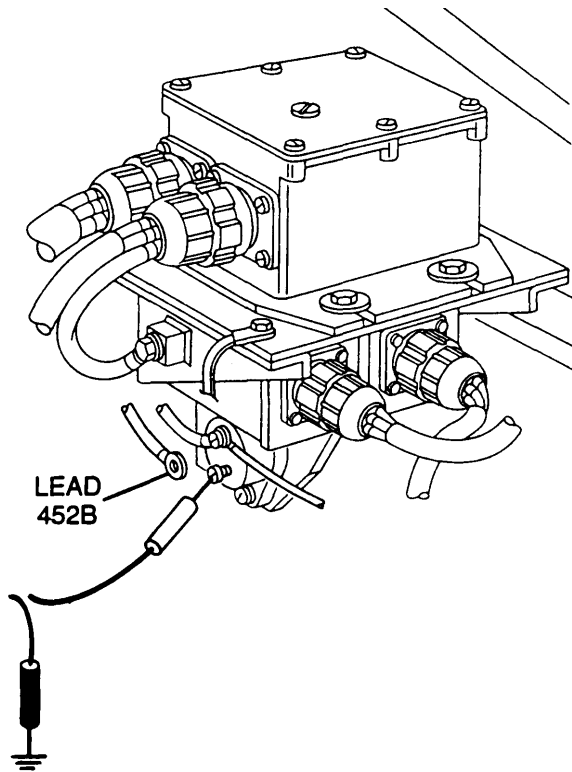
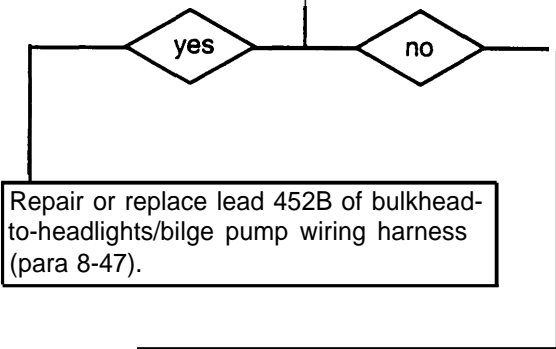

CONTINUED ON NEXT PAGE

3-3 TROUBLESHOOTING CHART — CONTINUED

ab. BILGE PUMP CIRCUIT — CONTINUED

BILGE PUMP FAILS TO OPERATE — CONTINUED

CONTINUED FROM STEP E

- F**
1. Reconnect lead 452B to bilge pump circuit breaker output.
 2. Disconnect lead 452A from bilge pump circuit breaker input.
 3. Place red lead of multimeter in lead 452A and black lead to ground.
 4. Turn MASTER switch ON and check for voltage.
 5. Turn MASTER switch OFF.

Is voltage present?

yes

no

Repair or replace lead 452A of engine disconnect bracket-to-driver's bulkhead lead assembly (para 8-81, M109A2/M109A3; 8-82, M109A4/M109A5).

Replace circuit breaker (para 8-20).

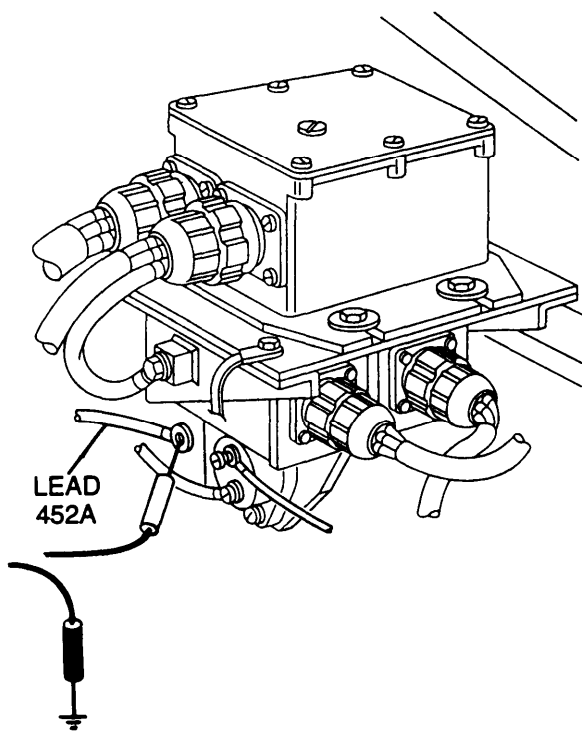

CONTINUED FROM STEP D

- G**
1. Reconnect engine disconnect bracket-to-bulkhead wiring harness to bilge pump relay.
 2. Disconnect lead 450 from BILGE PUMP switch output.
 3. Place red lead of multimeter in BILGE PUMP switch output and black lead to ground.
 4. Turn MASTER and BILGE PUMP switches ON.
 5. Turn MASTER and BILGE PUMP switches OFF.
- Is voltage present?

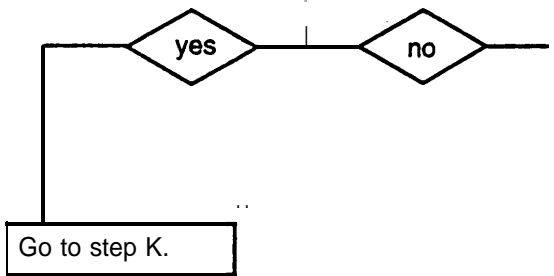

- H**
1. Reconnect lead 450 to BILGE PUMP switch output.
 2. Disconnect lead 450 to BILGE PUMP switch input.
 3. Place red lead of multimeter in lead 450 and black lead to ground.
 4. Turn MASTER switch ON and check for voltage.
 5. Turn MASTER switch OFF.
- Is voltage present?

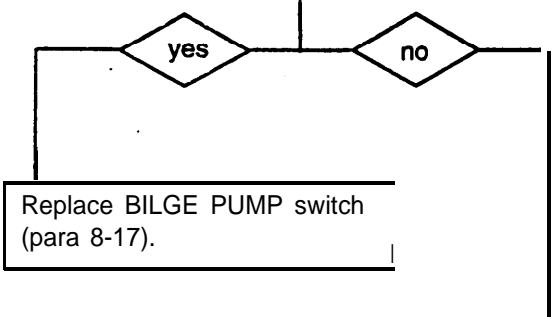

CONTINUED ON NEXT PAGE

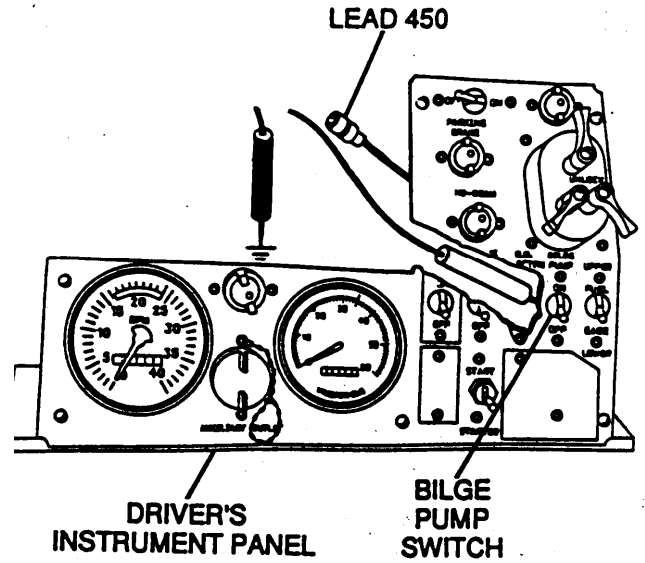

M109A4/M109A5
(ENGINE MODEL 7083-7396) SHOWN

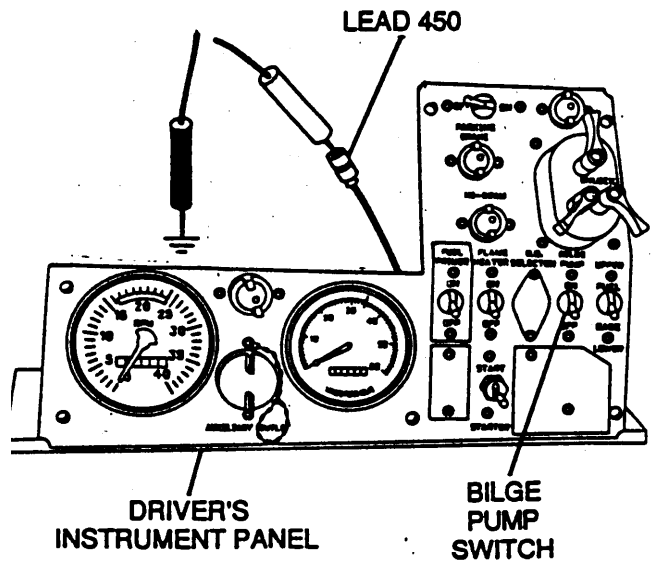

M109A4/M109A5
(ENGINE MODEL 7063-7396) SHOWN

3-3 TROUBLESHOOTING CHART — CONTINUED

ab. BILGE PUMP CIRCUIT — CONTINUED

BILGE PUMP FAILS TO OPERATE — CONTINUED

CONTINUED FROM STEP H

I

1. Reconnect lead 450 to BILGE PUMP switch input.
2. Disconnect lead 450 from circuit breaker output.
3. Place red lead of multimeter in circuit breaker output and black lead to ground.
4. Turn MASTER switch ON and check for voltage.
5. Turn MASTER switch OFF.

Is voltage present?

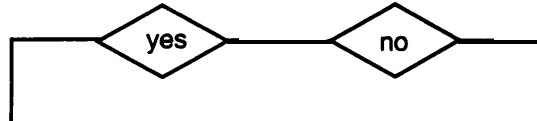

Repair or replace lead 450 of driver's instrument panel wiring harness (para

J

1. Reconnect lead 450 to circuit breaker output.
2. Disconnect lead 10 from circuit breaker input.
3. Place red lead of multimeter in lead 10 and black lead to ground.
4. Turn MASTER switch ON and check for voltage.
5. Turn MASTER switch OFF.

Is voltage present?

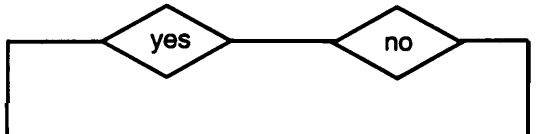

Replace circuit breaker (para 8-33, M109A2/M109A3; 8-34, M109A4/M109A5).

Troubleshoot master relay circuit (para 3-3b).

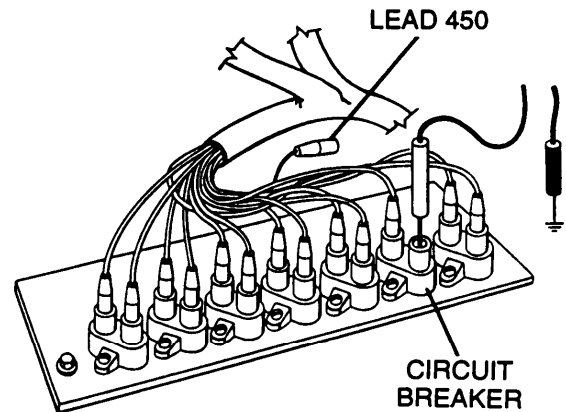

M109A2/M109A3 SHOWN

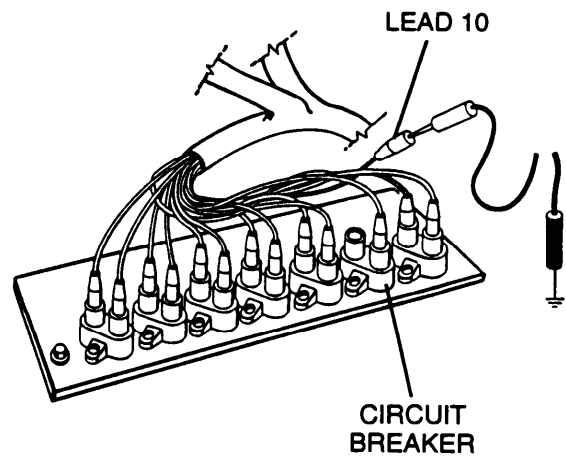

M109A2/M109A3 SHOWN

CONTINUED FROM STEP G

- | | |
|---------------------|--|
| K | <ol style="list-style-type: none"> 1. Reconnect lead 450 to BILGE PUMP switch output. 2. Disconnect bulkhead-to-driver's instrument panel wiring harness from driver's bulkhead. 3. Place a jumper wire from pin H to socket H (lead 459). 4. Place red lead of multimeter in socket K (lead 450) and black lead to ground. 5. Turn MASTER and BILGE PUMP switches ON and check for voltage. 6. Turn MASTER and BILGE PUMP switches OFF. |
| Is voltage present? | |

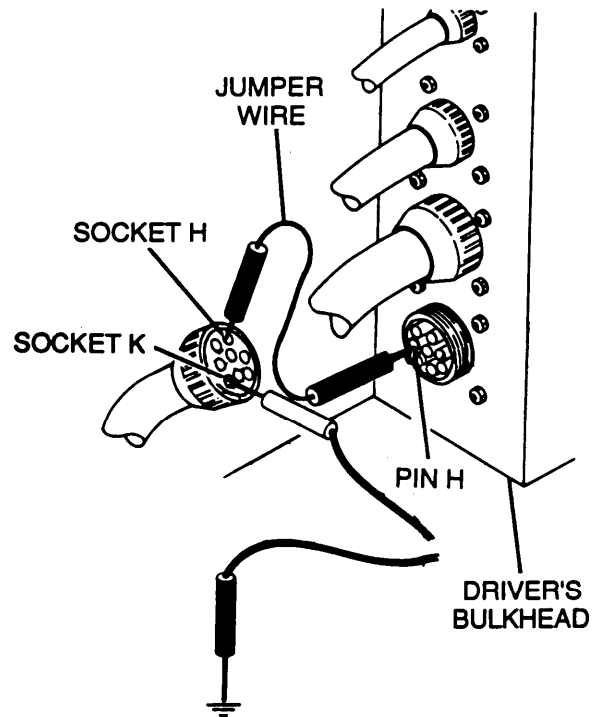
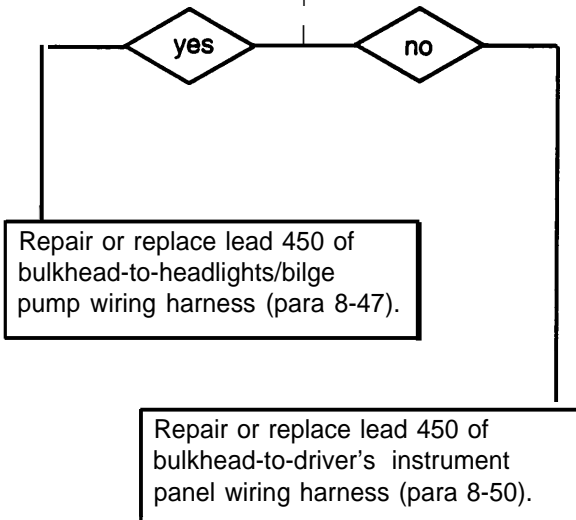

M109A4/M109A5 SHOWN

END OF TASK

3-3 TROUBLESHOOTING CHART — CONTINUED

ac. WINTERIZATION KIT CIRCUIT

The winterization kit consists of a coolant heater (blower motor, flame detector switch, overheat thermostat, restriction thermostat, resistor igniter, fuel control valve, shutoff solenoid, and restriction solenoid), coolant pump, fuel pump, and control box. The diagram below shows the relationship of these components.

The winterization kit works whether the MASTER switch is ON or OFF. Placing the START/OFF/RUN switch in START position energizes the coolant heater and causes the indicator on the control box to illuminate. Placing the START/OFF/RUN switch in the RUN position energizes the coolant pump and blower motor, causing the coolant to be circulated through the engine and battery compartment.

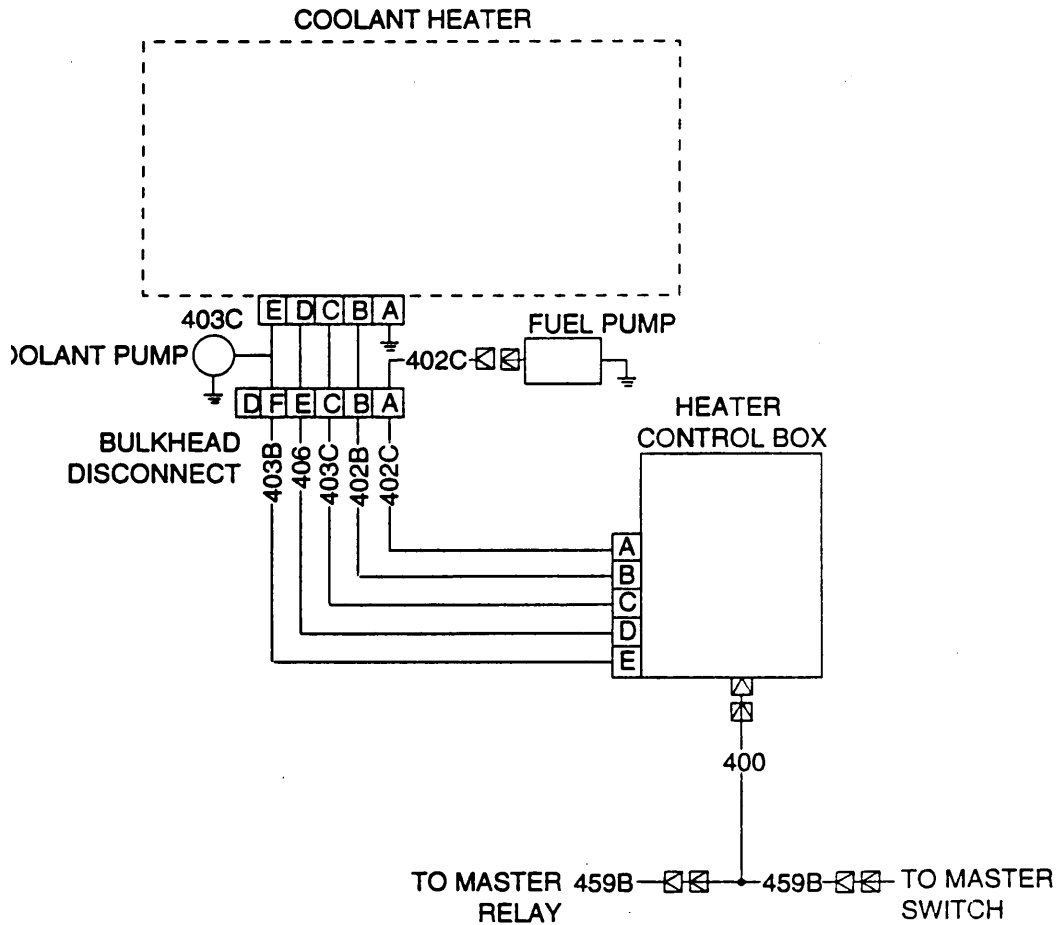

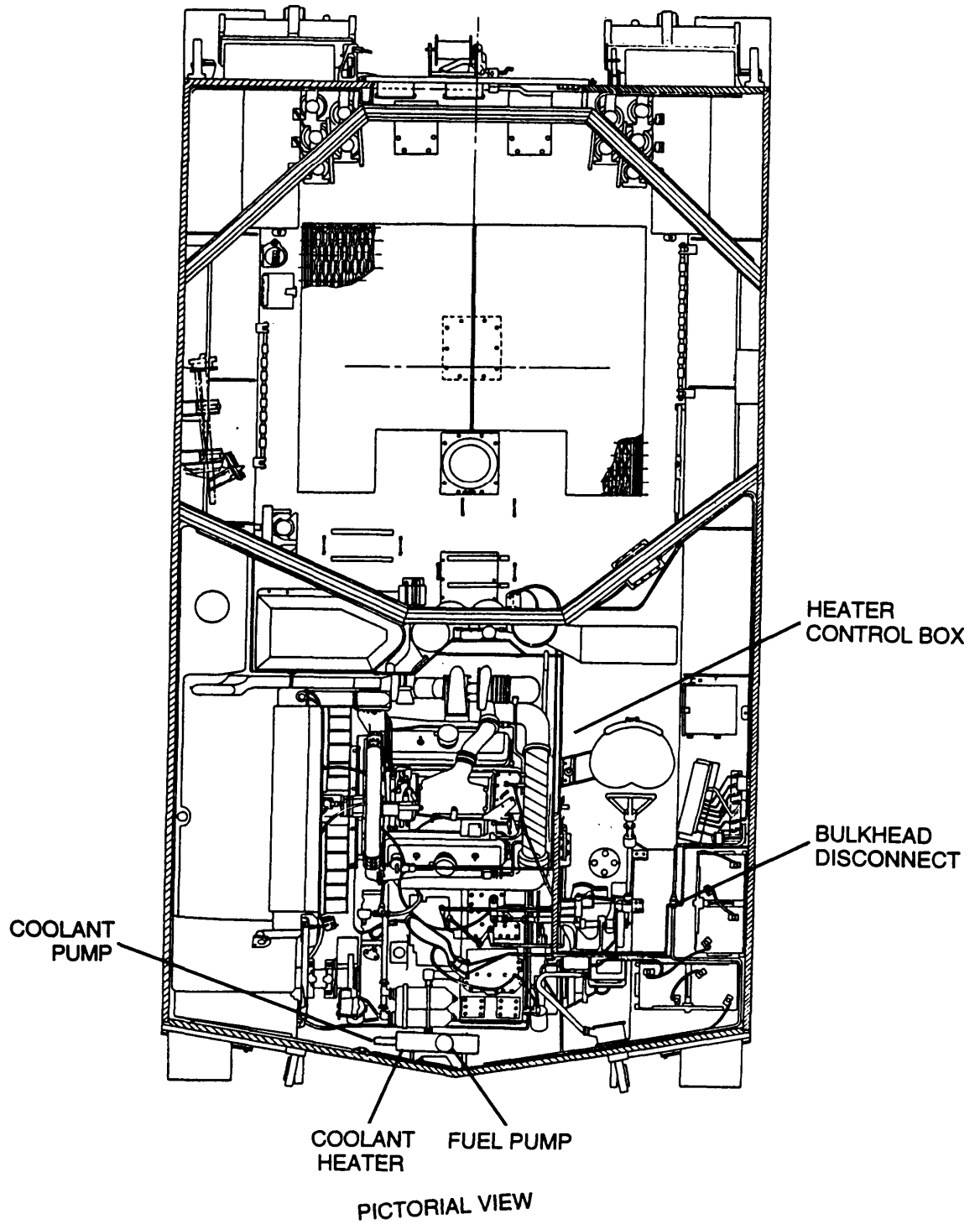

3-3 TROUBLESHOOTING CHART — CONTINUED

ac. WINTERIZATION KIT CIRCUIT — CONTINUED

(1) COOLANT HEATER FAILS TO OPERATE

INITIAL SETUP

Tools

General mechanic's tool kit (item 64, Appx H)
Multimeter (item 36, Appx H)
TA-1 probe kit (item 43, Appx H)

Equipment Conditions

Engine access door open (TM 9-2350-311-1 O)
Transmission access doors open (TM 9-2350-311-1 O)
Battery access doors open (TM 9-2350-31 1-10)

- A**
1. Disconnect battery ground leads.
 2. Disconnect bulkhead-to-coolant heater control box wiring harness from coolant heater.
 3. Place red lead of multimeter on pin C (lead 430C) and black lead to ground.
 4. Reconnect battery ground leads.
 5. Turn MASTER switch ON and heater control switch to start.
 6. Check for voltage.
 7. Turn MASTER and heater control switches OFF.

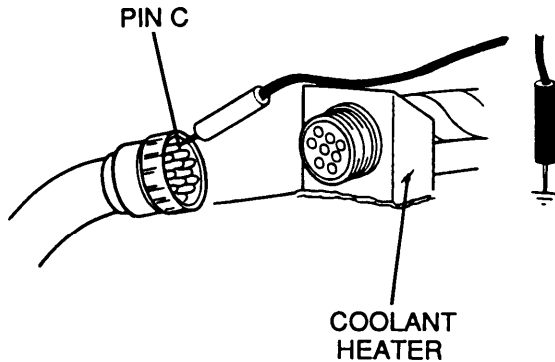

Is voltage present?

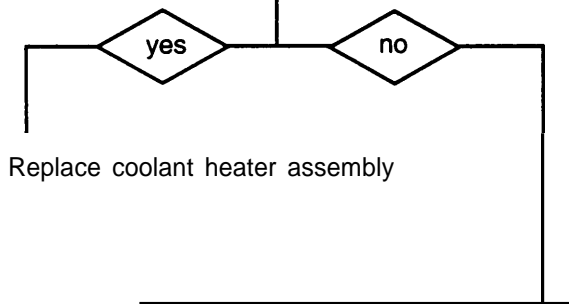

CONTINUED ON NEXT PAGE

CONTINUED FROM STEP A

B

1. Reconnect bulkhead-to-coolant heater control box wiring harness to coolant heater.
2. Disconnect battery ground leads.
3. Disconnect lead 400 from heater control box.
4. Place red lead of multimeter in lead 400 and black lead to ground.
5. Reconnect battery ground leads.
6. Turn MASTER switch ON and check for voltage.
7. Turn MASTER switch OFF.

Is voltage present?

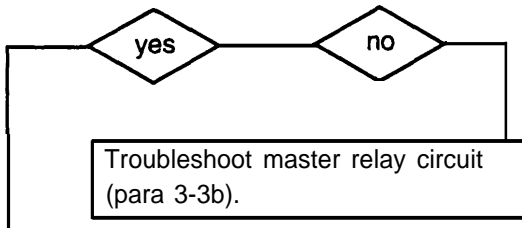
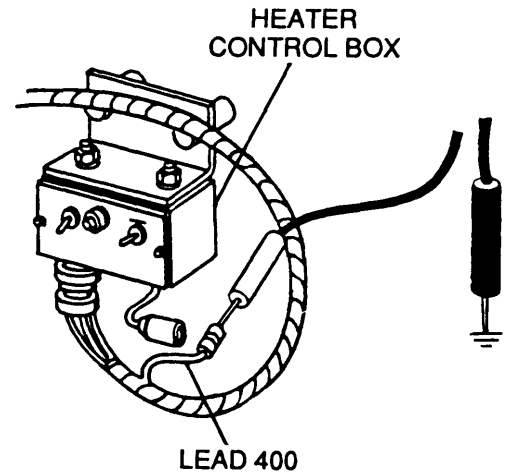

C

1. Reconnect lead 400 to heater control box.
2. Disconnect battery ground leads.
3. Disconnect bulkhead-to-coolant heater control box wiring harness from heater control box.
4. Place red lead of multimeter on pin C (lead 430C) and black lead to ground.
5. Reconnect battery ground leads.
6. Turn MASTER switch ON, heater control switch to start, and check for voltage.
7. Turn MASTER and heater control switches OFF.

Is voltage present?

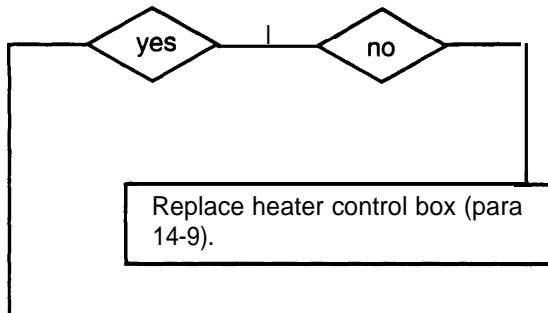
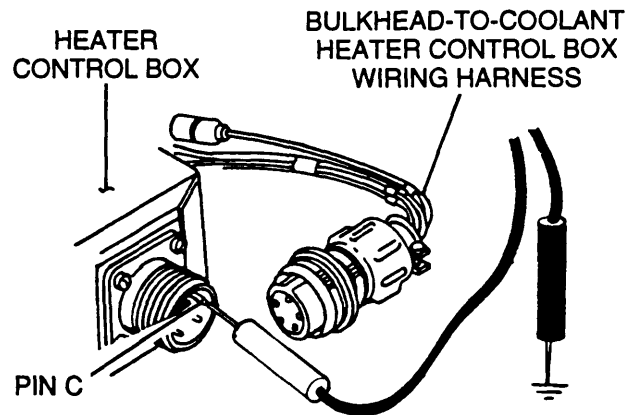

CONTINUED ON NEXT PAGE

3-3 TROUBLESHOOTING CHART — CONTINUED

ac. WINTERIZATION KIT CIRCUIT — CONTINUED

(1) COOLANT HEATER FAILS TO OPERATE – CONTINUED

CONTINUED FROM STEP C

D	<ol style="list-style-type: none"> 1. Reconnect bulkhead-to-coolant heater control box wiring harness to heater control box. 2. Disconnect battery ground leads. 3. Disconnect bulkhead-to-coolant heater control box wiring harness from driver's bulkhead. 4. Place red lead of multimeter in socket C (lead 403C) and black lead to ground. 5. Reconnect battery ground leads. 6. Turn MASTER switch ON, heater control switch to start, and check for voltage. 7. Turn MASTER and heater control switches OFF.
Is voltage present?	

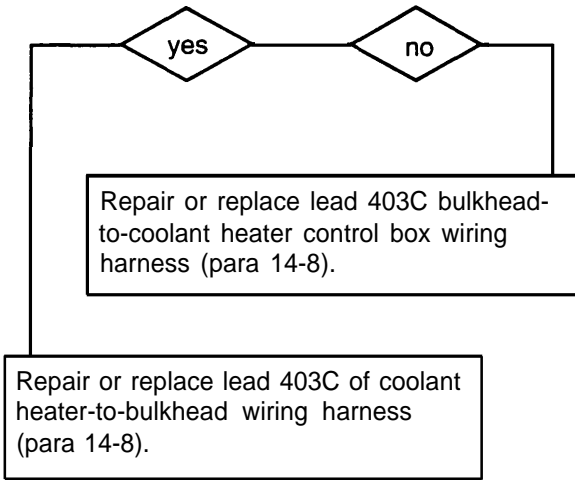
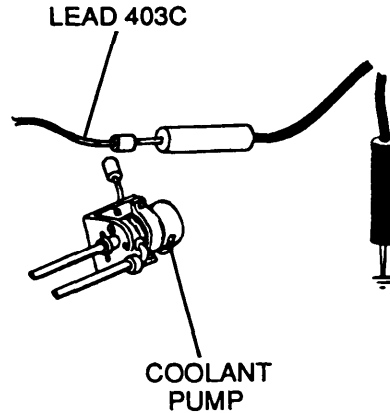

END OF TASK

(2) COOLANT HEATER MOTOR OVERHEATS

INITIAL SETUP I

Tools

General mechanic's tool kit (item 64, Appx H)
 Multimeter (item 36, Appx H)
 TA-1 probe kit (item 43, Appx H)

Equipment Condition

Engine access door open (TM 9-2350-311-10)
 Transmission access doors open (TM 9-2350-311-1 0)
 Battery access doors open (TM 9-2350-31 1-10)

- A**
1. Disconnect battery ground leads.
 2. Disconnect lead 403C from coolant pump.
 3. Place red lead of multimeter on lead 403C and black lead to ground.
 4. Reconnect battery ground leads.
 5. Turn MASTER switch ON and check for voltage.
 6. Turn MASTER switch OFF.

Is voltage present?

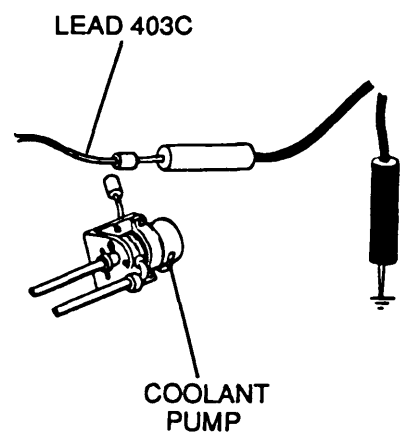
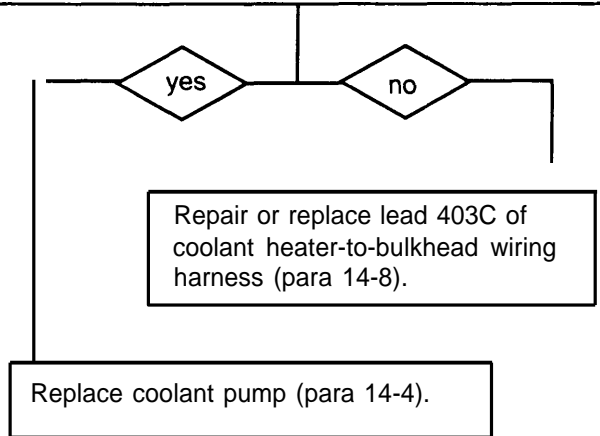

END OF TASK

3-3 TROUBLESHOOTING CHART — CONTINUED

ad. PARKING BRAKE WARNING LIGHT CIRCUIT

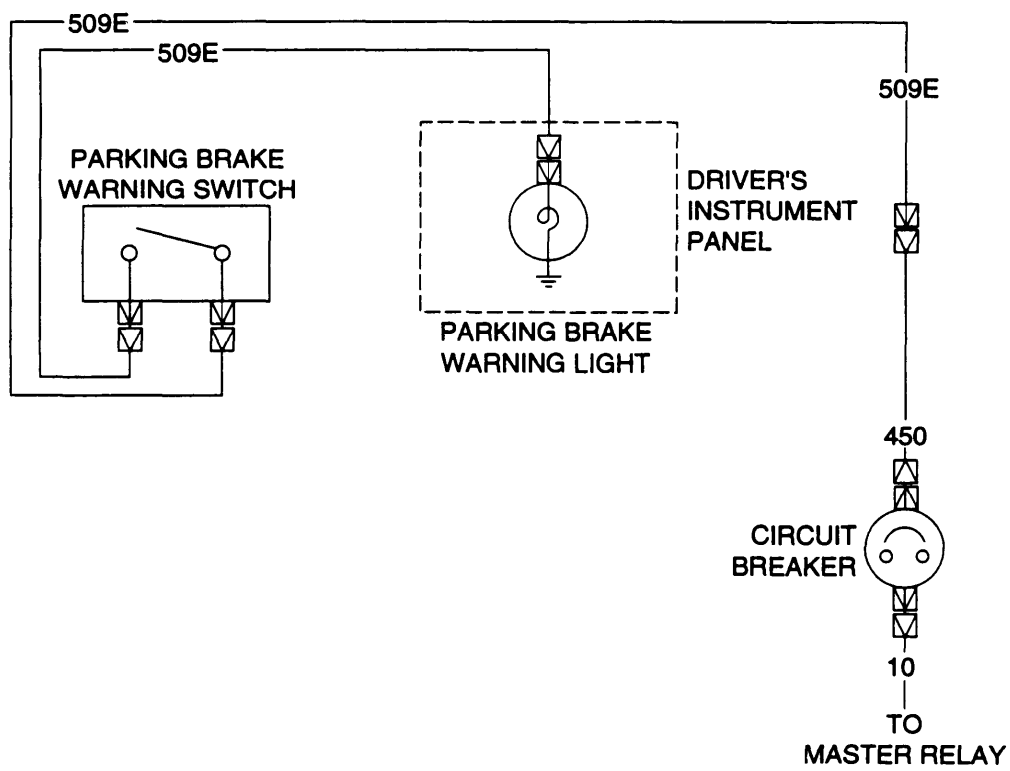

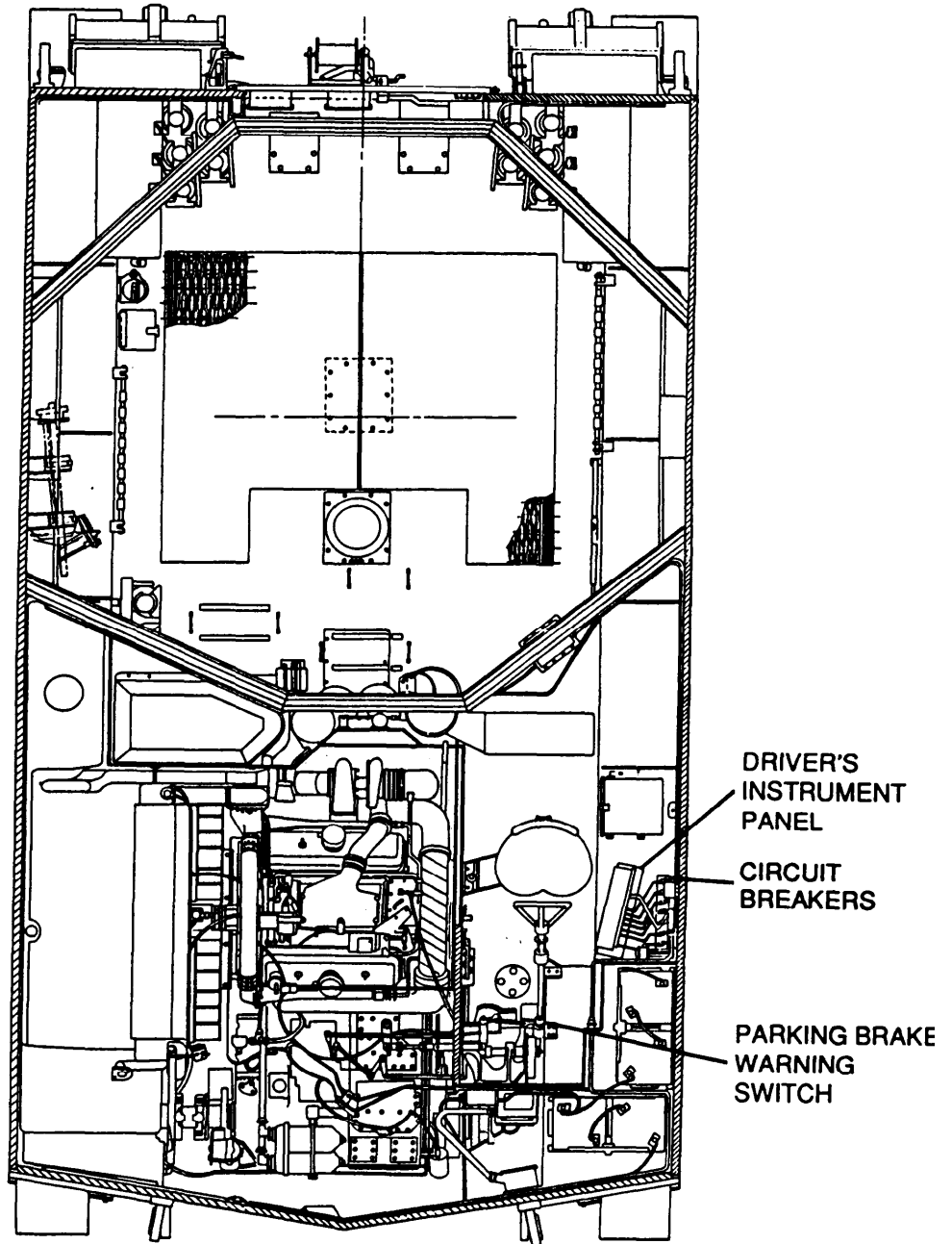

PICTORIAL VIEW

3-3 TROUBLESHOOTING CHART — CONTINUED

ad. PARKING BRAKE WARNING LIGHT CIRCUIT — PARKING BRAKE WARNING LIGHT FAILS TO OPERATE
CONTINUED

INITIAL SETUP

Tools

General mechanic's tool kit (item 64, Appx H)
Multimeter (item 36, Appx H)
TA-1 probe kit (item 43, Appx H)

Equipment Conditions

Engine compartment access door open
(TM9-2350-311-10)
Transmission access doors open (TM 9-2350-311-10)
Driver's instrument panel released (para 8-17)

Personnel Required

Two

- A**
1. Remove LED from PARKING BRAKE warning light (para 8-17).
 2. Place red lead of multimeter in center contact and black lead to ground.
 3. Turn MASTER switch ON, apply brake pedal, and check for voltage.
 4. Turn MASTER switch OFF.

Is voltage present?

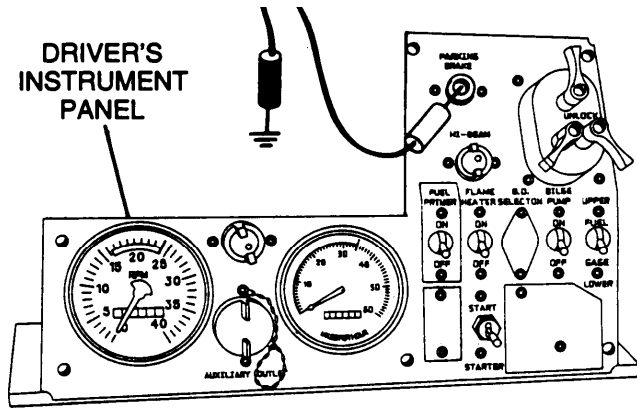
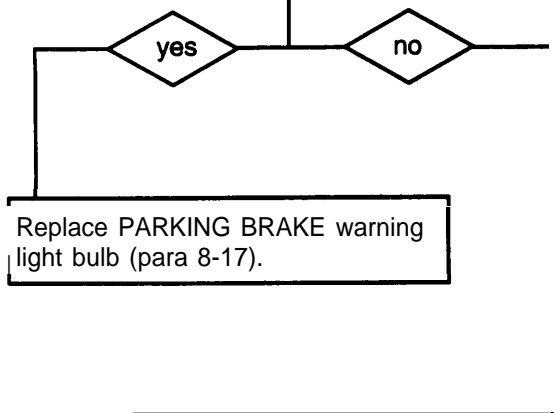

**M109A2/M109A3
(ENGINE MODEL 7083-7396) SHOWN**

CONTINUED FROM STEP A

- B**
1. Install LED in PARKING BRAKE warning light (para 8-17).
 2. Disconnect lead 509E from PARKING BRAKE warning light.
 3. Place red lead of multimeter in lead 509E and black lead to ground.
 4. Turn MASTER switch ON, apply brake pedal, and check for voltage.
 5. Turn MASTER switch OFF.

Is voltage present?

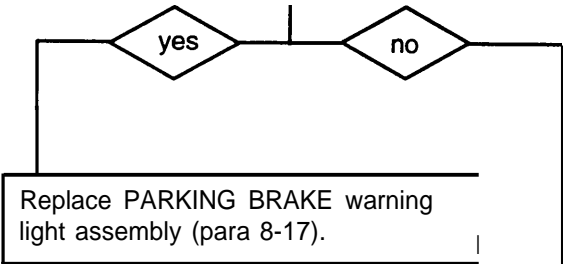

- C**
1. Reconnect lead 509E to PARKING BRAKE warning light.
 2. Disconnect both leads 509E from parking brake warning switch.
 3. Use a jumper-wire to connect both leads 509E.
 4. Turn MASTER switch ON and check PARKING BRAKE warning light for operation.
 5. Turn MASTER switch OFF.

Does PARKING BRAKE warning light operate?

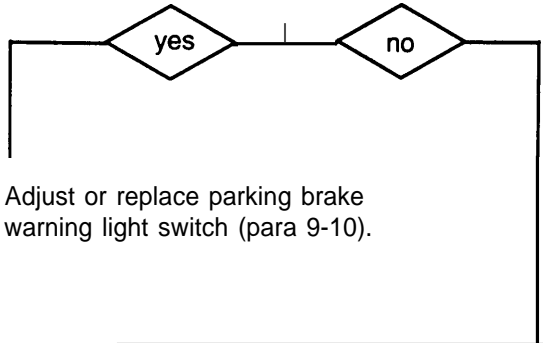

CONTINUED ON NEXT PAGE

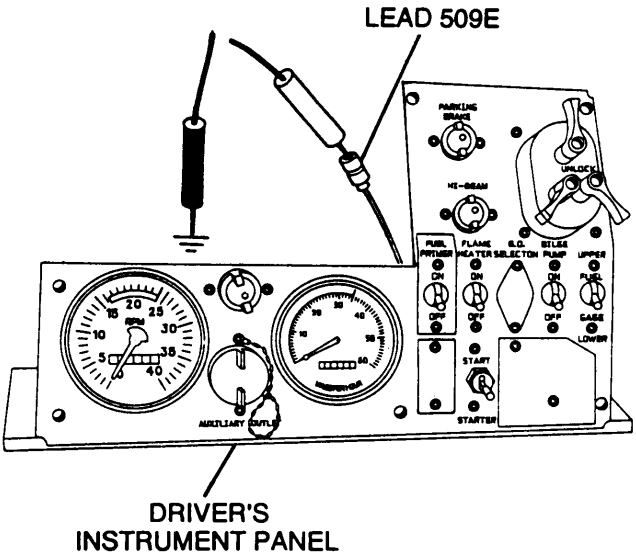

M109A2/M109A3 (ENGINE MODEL 7083-7396) SHOWN

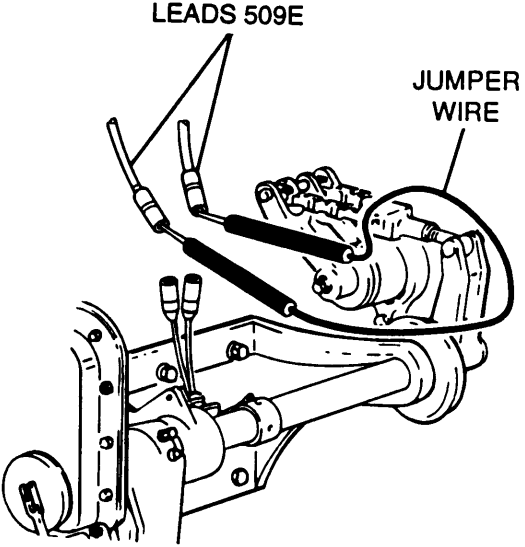

3-3 TROUBLESHOOTING CHART — CONTINUED

ad. PARKING BRAKE WARNING LIGHT CIRCUIT — CONTINUED

PARKING BRAKE WARNING LIGHT FAILS TO OPERATE — CONTINUED

CONTINUED FROM STEP C

- D**
1. Reconnect lead 509E to PARKING BRAKE warning light.
 2. Disconnect lead 10 from circuit breaker input.
 3. Place red lead of multimeter in lead 10 and black lead to ground.
 4. Turn MASTER switch ON and check for voltage.
 5. Turn MASTER switch OFF.

Is voltage present?

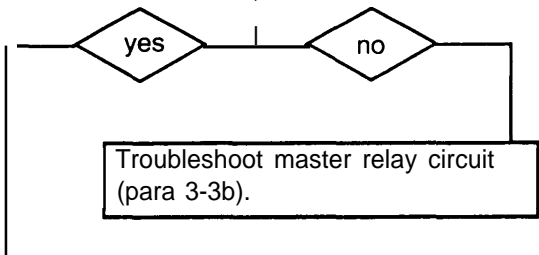

- E**
1. Reconnect lead 10 from circuit breaker input.
 2. Disconnect lead 450 from circuit breaker output.
 3. Place red lead of multimeter in circuit breaker output and black lead to ground.
 4. Turn MASTER switch ON and check for voltage.
 5. Turn MASTER switch OFF.

Is voltage present?

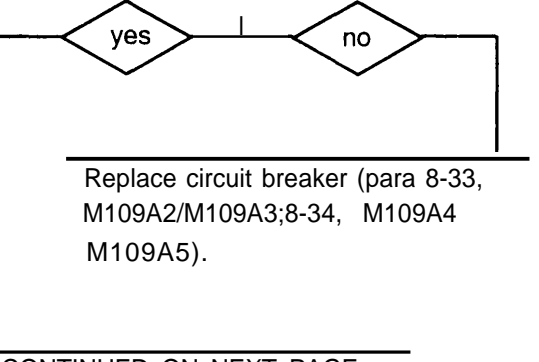

CONTINUED ON NEXT PAGE

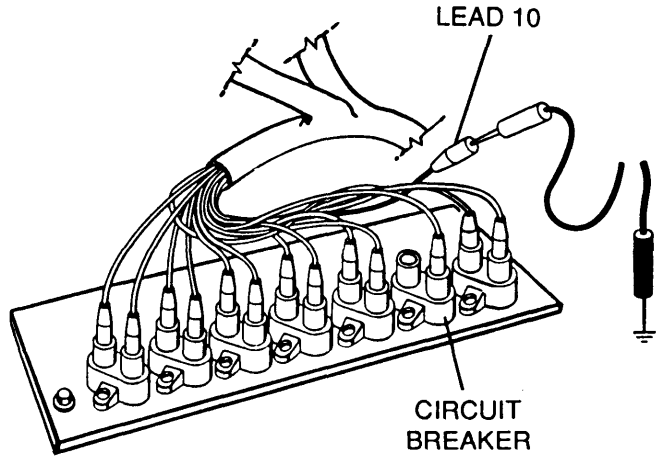

M109A2/M109A3 SHOWN

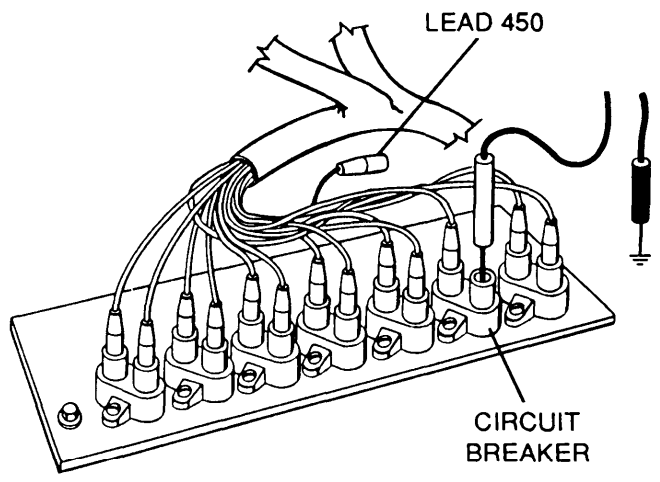

M109A2/M109A3 SHOWN

CONTINUED FROM STEP E

- F**
1. Reconnect lead 450 to circuit breaker output.
 2. Disconnect lead 450 of driver's instrument panel wiring harness from connector near circuit breaker.
 3. Place red lead of multimeter in lead 450 and black lead to ground.
 4. Turn MASTER switch ON and check for voltage.
 5. Turn MASTER switch OFF.

is voltage present?

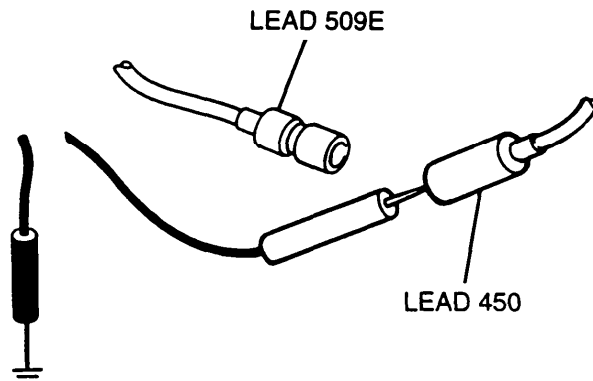
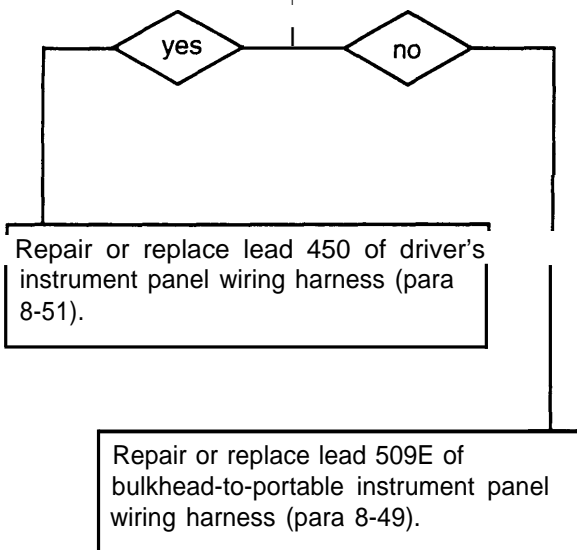

END OF TASK

3-3 TROUBLESHOOTING CHART — CONTINUED

ae. ELECTRIC FUEL PUMP CIRCUIT

The electric fuel pump system consists of in-tank fuel pumps, in-tank fuel pump and generator relay, left and right fuel pump assembly, oil pressure switch, and related wiring.

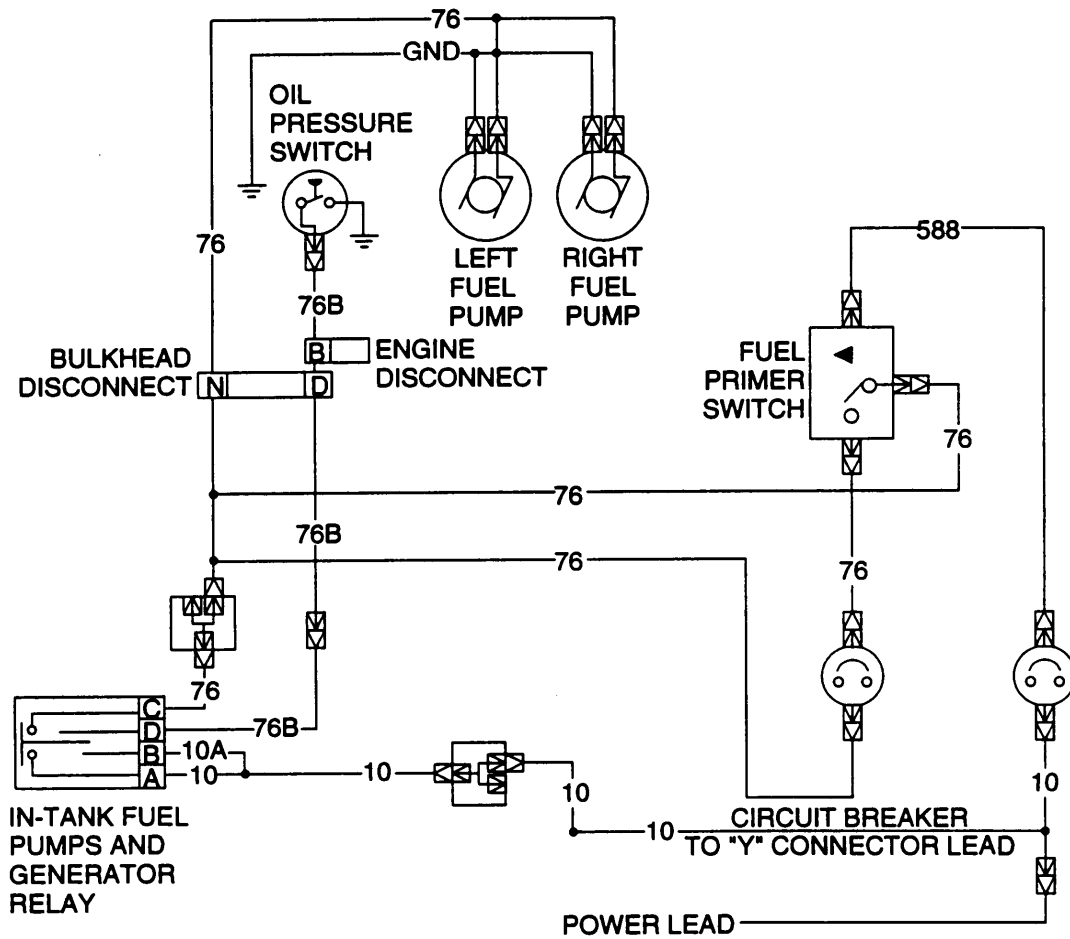

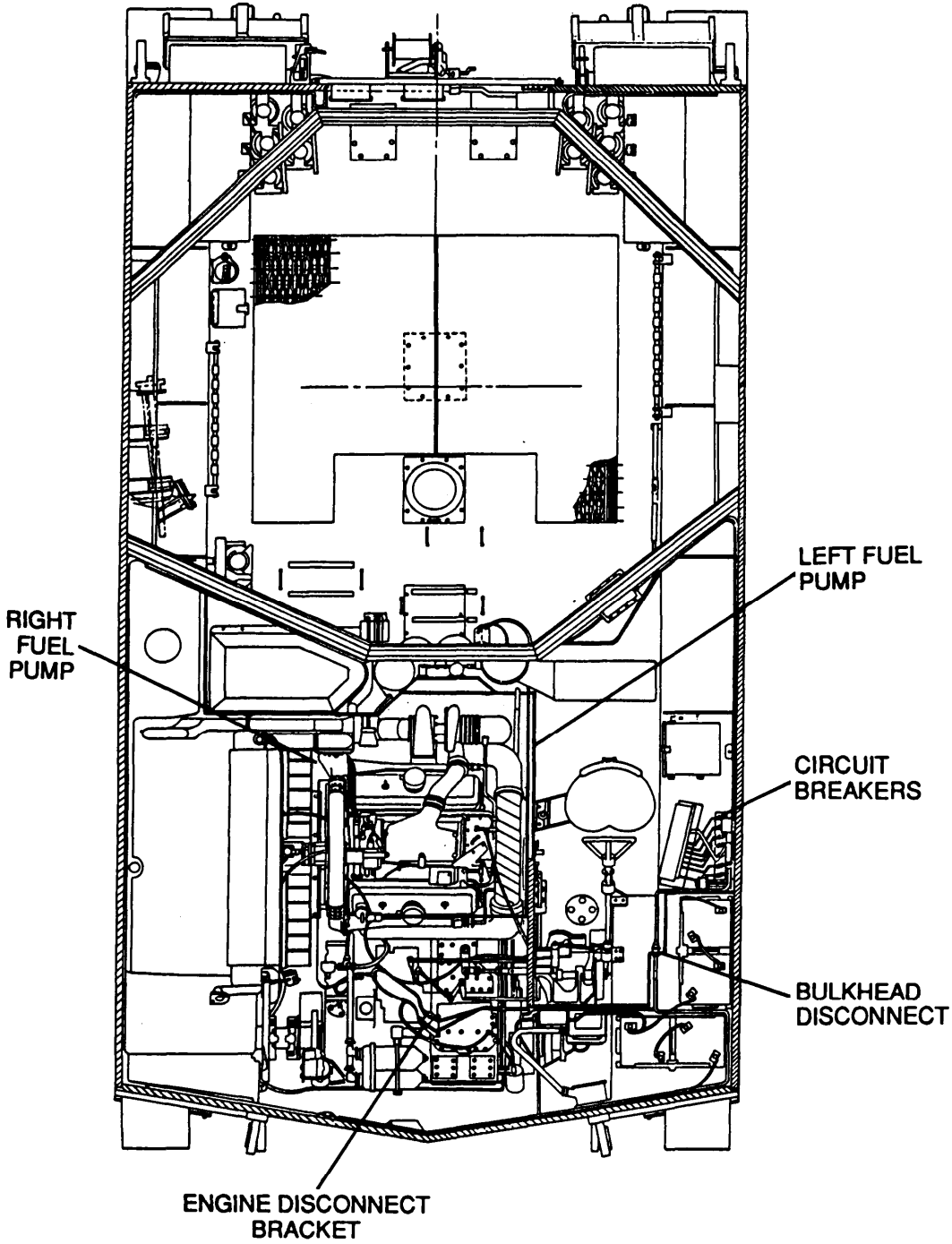

PICTORIAL VIEW

3-3 TROUBLESHOOTING CHART — CONTINUED

ae. ELECTRIC FUEL PUMP CIRCUIT — CONTINUED ENGINE MISSES WHEN LOW ON FUEL; ONE OR BOTH FUEL PUMPS FAIL TO OPERATE

INITIAL SETUP

Tools

General mechanic's tool kit (item 64, Appx H)
Multimeter (item 36, Appx H)

Hose (item 29, Appx H)
(Long test leads may be needed for some tests;
16 AWG wire maybe used as an extension.)

Personnel Required

Two

Equipment Conditions

Engine access doors open (TM 9-2350-311-10)
Powerplant removed (para 4-5)

WARNING

Do not use open flame or smoke when working on fuel system. An explosion may occur, causing severe injury or death.

NOTE

Left fuel pump can be tested from driver's access panel. Powerplant must be removed to test right fuel pump.

- A**
1. Disconnect lead 76B from relay oil pressure switch.
 2. Place red lead of multimeter in lead 76B and black lead to ground.
 3. Turn MASTER switch ON and check for voltage.
 4. Turn MASTER switch OFF.

Is voltage present?

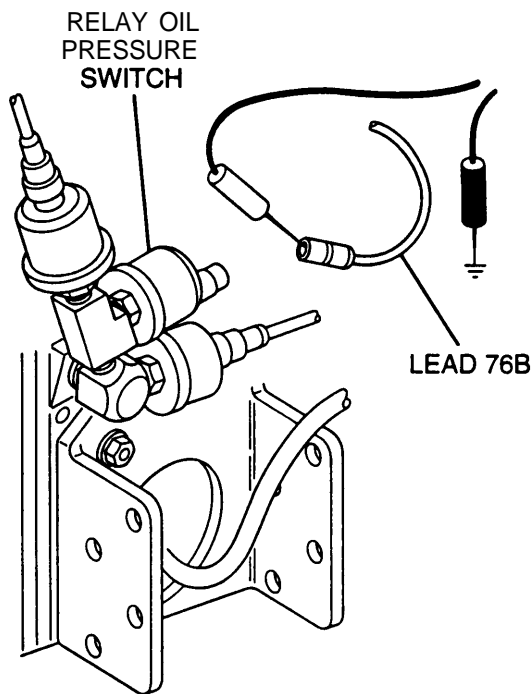
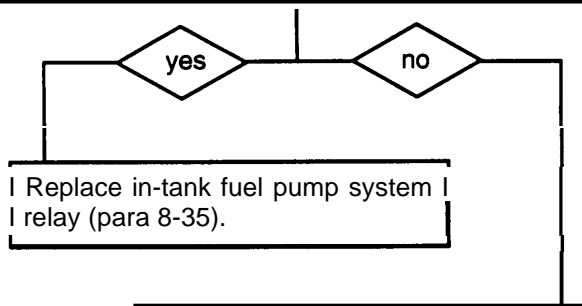

CONTINUED FROM STEP A

B

1. Reconnect lead 76B to relay oil pressure switch.
2. Disconnect in-tank fuel pump lead assembly from relay and lead 76B from bulkhead-to-portable instrument panel wiring harness.
3. Place a jumper wire from socket B (lead 10) to socket D (lead 76B).
4. Place red lead of multimeter in lead 76B and black lead to ground.
5. Turn MASTER switch ON and check for voltage.
6. Turn MASTER switch OFF.

Is voltage present?

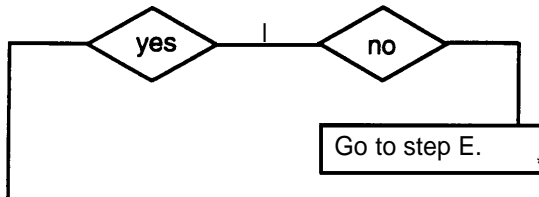

C

1. Disconnect battery ground leads.
2. Disconnect bulkhead-to-portable instrument panel wiring harness from driver's bulkhead.
3. With jumper wire in place from step B, place a jumper wire from pin B to socket B (lead 400-459B).
4. Place red lead of multimeter on pin D (lead 76B) and black lead to ground.
5. Reconnect battery ground leads.
6. Turn MASTER switch ON and check for voltage.
7. Turn MASTER switch OFF.

Is voltage present?

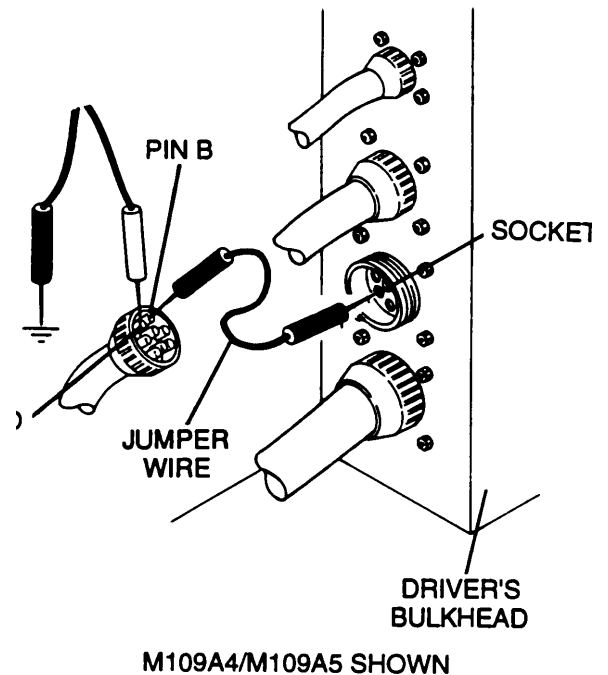
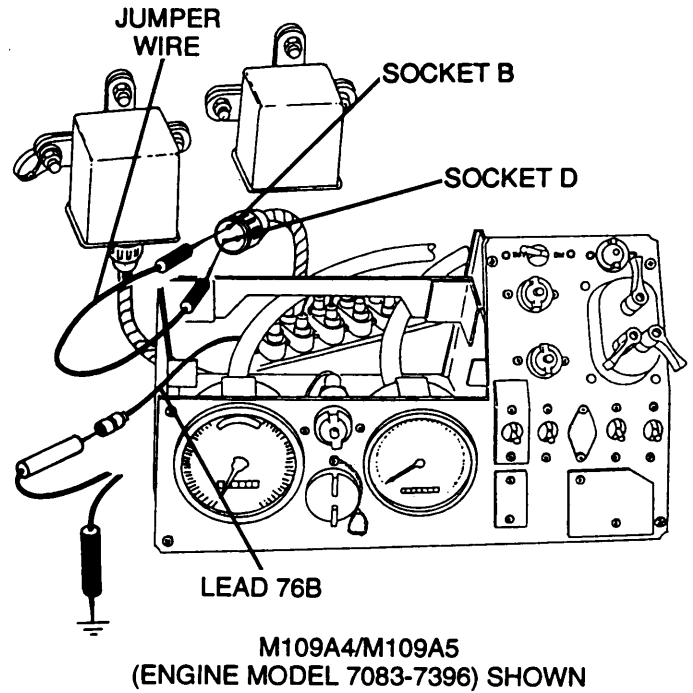
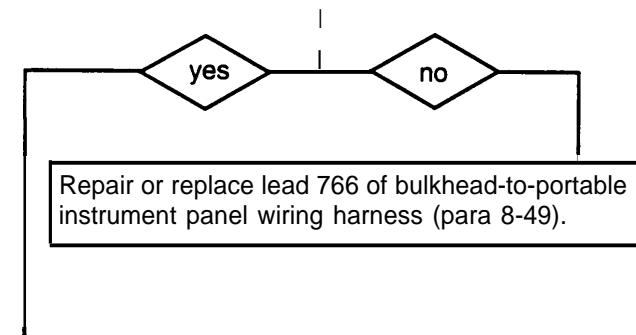

CONTINUED ON NEXT PAGE

3-3 TROUBLESHOOTING CHART — CONTINUED

ae. ELECTRIC FUEL PUMP CIRCUIT — CONTINUED ENGINE MISSES WHEN LOW ON FUEL; ONE OR BOTH FUEL PUMPS FAIL TO OPERATE — CONTINUED

CONTINUED FROM STEP C

D	<ol style="list-style-type: none"> 1. Reconnect bulkhead-to-portable instrument panel wiring harness to driver's bulkhead. 2. Disconnect battery ground leads. 3. Disconnect driver's bulkhead-to-master relay wiring harness from engine disconnect bracket. 4. Place red lead of multimeter in socket B (lead 76B) and black lead to ground. 5. Reconnect battery ground leads. 6. Turn MASTER switch ON and check for voltage. 7. Turn MASTER switch OFF.
Is voltage present?	

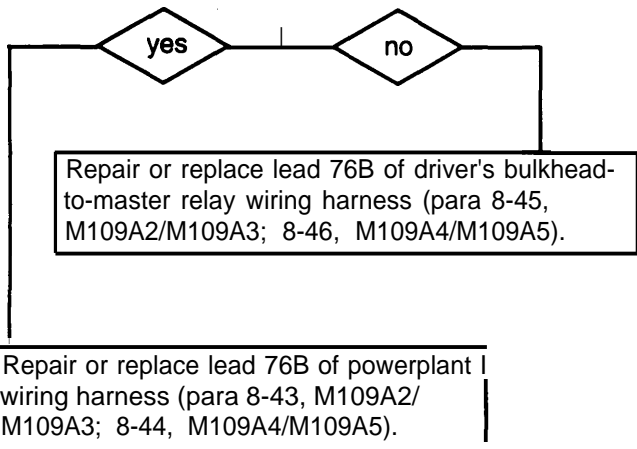
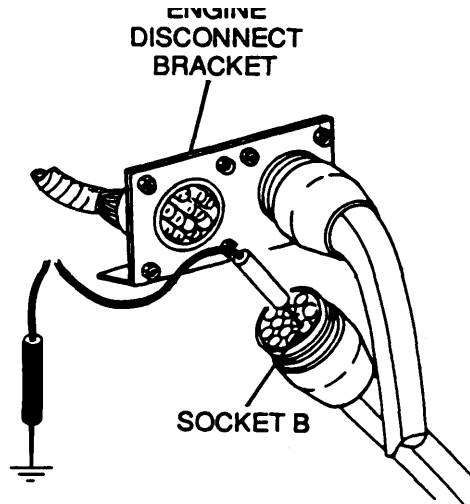

CONTINUED FROM STEP B

- E**
1. Reconnect lead 76B to bulkhead-to-portable instrument panel wiring harness.
 2. Leave in-tank fuel pump lead assembly disconnected from relay.
 3. Place red lead of multimeter in socket A (lead 10) and black lead to ground.
 4. Turn MASTER switch ON and check for voltage.
 5. Place red lead of multimeter in socket B (lead 10) and black lead to ground.
 6. Turn MASTER switch ON and check for voltage.
 7. Turn MASTER switch OFF.
- Is voltage present at both sockets?

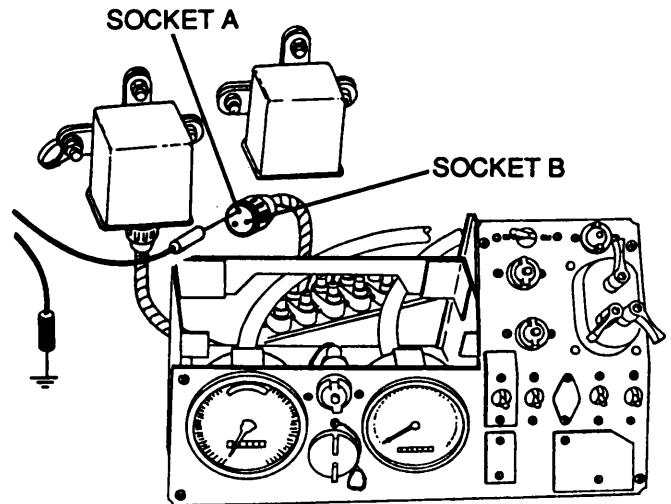
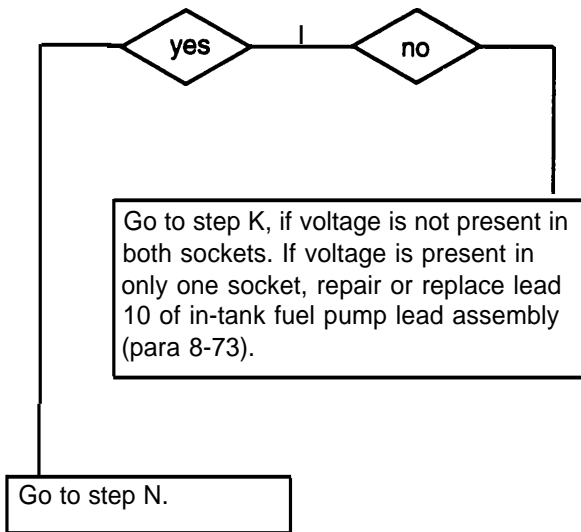

M109A4/M109A5
(ENGINE MODEL 7083-7396) SHOWN

3-3 TROUBLESHOOTING CHART — CONTINUED

ae. ELECTRIC FUEL PUMP CIRCUIT — CONTINUED ENGINE MISSES WHEN LOW ON FUEL; ONE OR BOTH FUEL PUMPS FAIL TO OPERATE — CONTINUED

CONTINUED FROM STEP E

F

1. Leave in-tank fuel pump lead assembly disconnected from relay.
2. Disconnect lead 76 of in-tank fuel pump lead assembly from "Y" connector.
3. Place a jumper wire from socket A (lead 10) to socket C (lead 76).
4. Place red lead of multimeter in lead 76 and black lead to ground.
5. Turn MASTER switch ON and check for voltage.
6. Turn MASTER switch OFF.

Is voltage present?

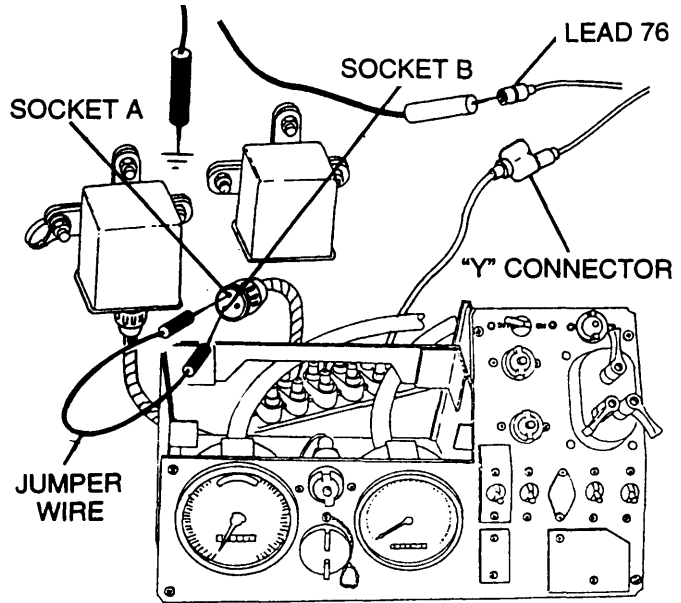

M109A4/M109A5
(ENGINE MODEL 7083-7396) SHOWN

yes

no

Repair or replace lead 76 of in-tank fuel pump lead assembly (para 8-73).

G

1. Reconnect lead 76 of in-tank fuel pump lead assembly to "Y" connector.
2. Disconnect lead 76 of circuit breaker lead assembly from "Y" connector.
3. Place red lead of multimeter in "Y" connector and black lead to ground.
4. Turn MASTER switch ON and check for voltage.
5. Turn MASTER switch OFF.

Is voltage present?

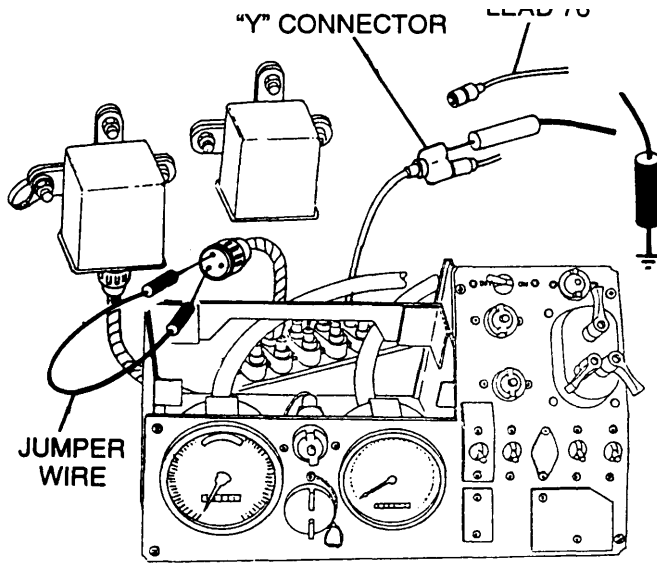

M109A4/M109A5
(ENGINE MODEL 7083-7396) SHOWN

yes

no

Replace "Y" connector (para 8-54).

CONTINUED ON NEXT PAGE

CONTINUED FROM STEP G

- H**
1. Reconnect lead 76 of fuel pump circuit breaker lead assembly to "Y" connector.
 2. Disconnect lead 76 from circuit breaker input.
 3. Place red lead of multimeter in lead 76 and black lead to ground.
 4. Turn MASTER switch ON and check for voltage.
 5. Turn MASTER switch OFF.

Is voltage present?

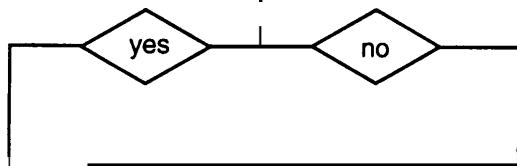

Repair or replace lead 76 of fuel pump circuit breaker lead assembly (para 8-74).

- I**
1. Reconnect lead 76 of fuel pump circuit breaker lead assembly to circuit breaker input.
 2. Disconnect lead 76 of fuel pump circuit breaker lead assembly from circuit breaker output.
 3. Place red lead of multimeter on circuit breaker output and black lead to ground.
 4. Turn MASTER switch ON and check for voltage.
 5. Turn MASTER switch OFF.

Is voltage present?

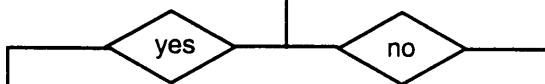

Replace circuit breaker (para 8-33, M109A2/M109A3; 8-34, M109A4/M109A5).

CONTINUED ON NEXT PAGE

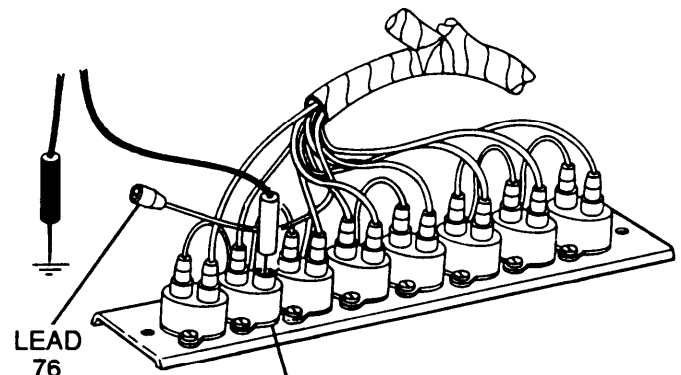

CIRCUIT BREAKER

M109A4/M109A5 SHOWN

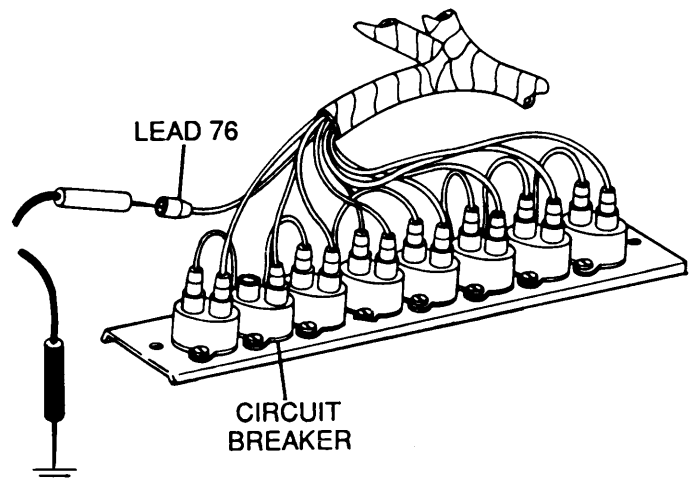

CIRCUIT BREAKER

M109A4/M109A5 SHOWN

3-3 TROUBLESHOOTING CHART — CONTINUED

ae. ELECTRIC FUEL PUMP CIRCUIT — CONTINUED ENGINE MISSES WHEN LOW ON FUEL; ONE OR BOTH FUEL PUMPS FAIL TO OPERATE — CONTINUED

CONTINUED FROM STEP I

J

1. Reconnect lead 76 of fuel pump switch-to-circuit breaker lead assembly to circuit breaker output and disconnect from FUEL PRIMER switch.
2. Place red lead of multimeter in lead 76 and black lead to ground.
3. Turn MASTER switch ON and check for voltage.
4. Turn MASTER switch OFF.

Is voltage present?

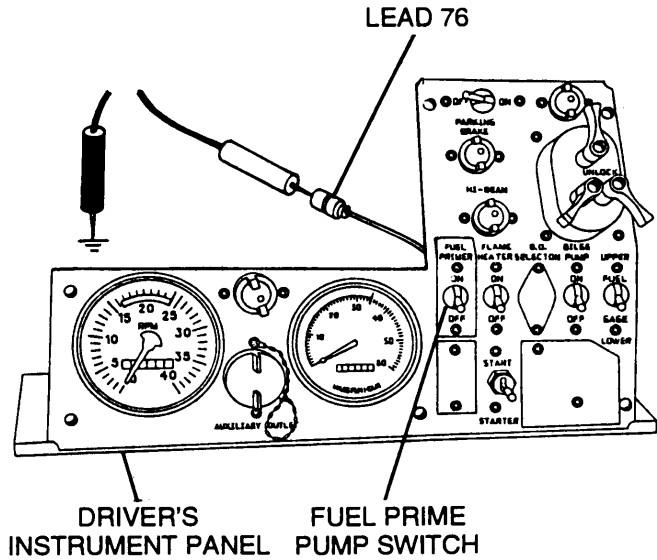
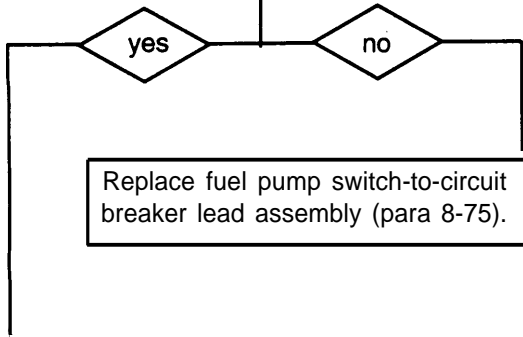

M109A4/M109A5 (ENGINE MODEL 7083-7396) SHOWN

CONTINUED ON NEXT PAGE

CONTINUED FROM STEP J

- K**
1. Reconnect lead 76 of fuel pump switch-to-circuit breaker lead assembly to FUEL PRIMER switch.
 2. Disconnect lead 588 of driver's instrument panel wiring harness from FUEL PRIMER switch.
 3. Place red lead of multimeter in lead 588 and black lead to ground.
 4. Turn MASTER switch ON and check for voltage.
 5. Turn MASTER switch OFF.

Is voltage present?

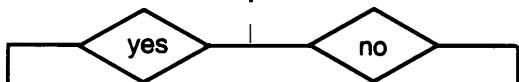

Go to step U.

CONTINUED ON NEXT PAGE

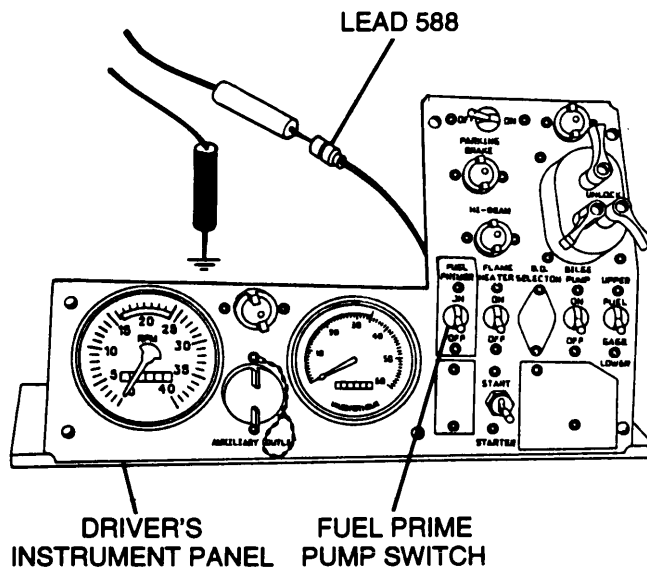

M109A4/M109A5
(ENGINE MODEL 7083-7396) SHOWN

3-3 TROUBLESHOOTING CHART — CONTINUED

ae. ELECTRIC FUEL PUMP CIRCUIT — CONTINUED ENGINE MISSES WHEN LOW ON FUEL; ONE OR BOTH FUEL PUMPS FAIL TO OPERATE — CONTINUED

CONTINUED FROM STEP K

- | | |
|---------------------|--|
| L | <ol style="list-style-type: none"> 1. Reconnect lead 588 of driver's instrument panel wiring harness to FUEL PRIMER switch. 2. Disconnect lead 76 of bulkhead-to-driver's instrument panel wiring harness from FUEL PRIMER switch. 3. Place red lead of multimeter on FUEL PRIMER switch and black lead to ground. 4. Turn MASTER and FUEL PRIMER switches ON and check for voltage. 5. Turn MASTER and FUEL PRIMER switches OFF. |
| Is voltage present? | |

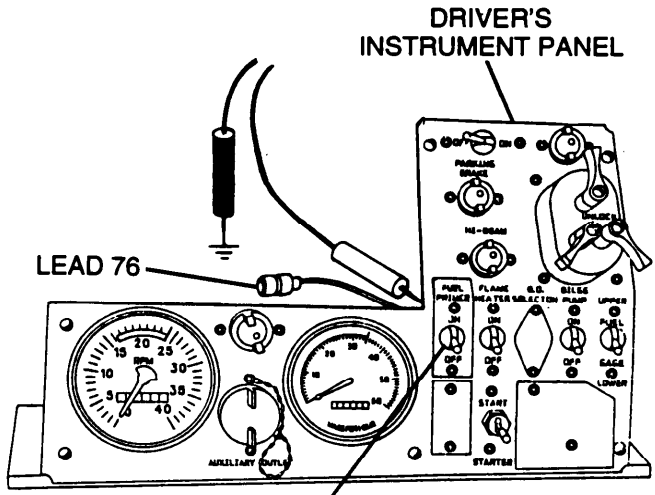
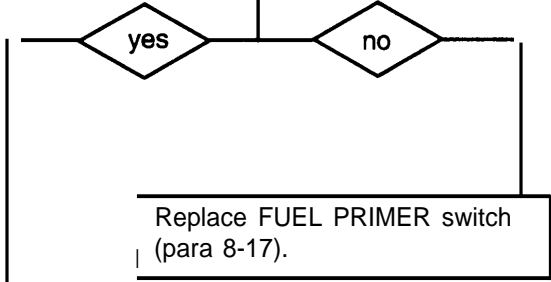

M109A4/M109A5 (ENGINE MODEL 7083-7396) SHOWN

CONTINUED ON NEXT PAGE

CONTINUED FROM STEP L

- M**
1. Reconnect lead 76 of bulkhead-to-driver's instrument panel wiring harness to FUEL PRIMER switch.
 2. Disconnect bulkhead-to-driver's instrument panel wiring harness from driver's bulkhead.
 3. Place a jumper wire from socket H to pin H (lead 459).
 4. Place red lead of multimeter on pin N (lead 76) and black lead to ground.
 5. Turn MASTER switch ON and check for voltage.
 6. Turn MASTER switch OFF.

Is voltage present?

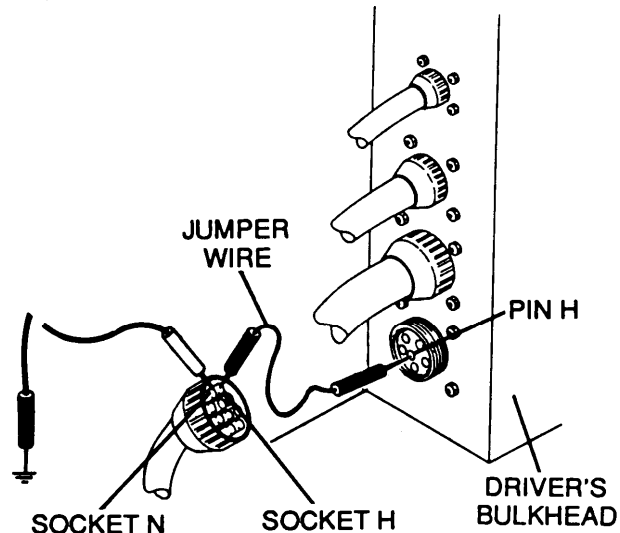
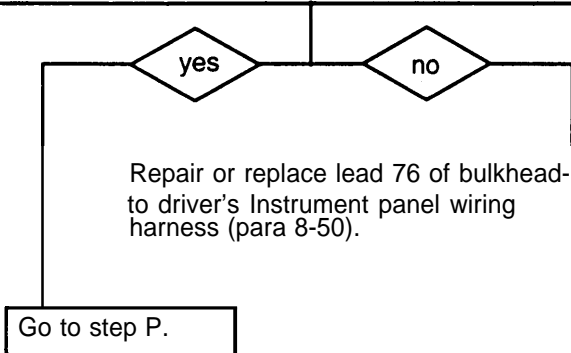

M109A4/M109A5 SHOWN

CONTINUED FROM STEP E

- N**
1. Reconnect in-tank fuel pump lead assembly to relay.
 2. Disconnect lead 10 of in-tank fuel pump lead assembly from "Y" connector.
 3. Place red lead of multimeter on "Y" connector and black lead to ground.
 4. Turn MASTER switch ON and check for voltage.
 5. Turn MASTER switch OFF.

Is voltage present?

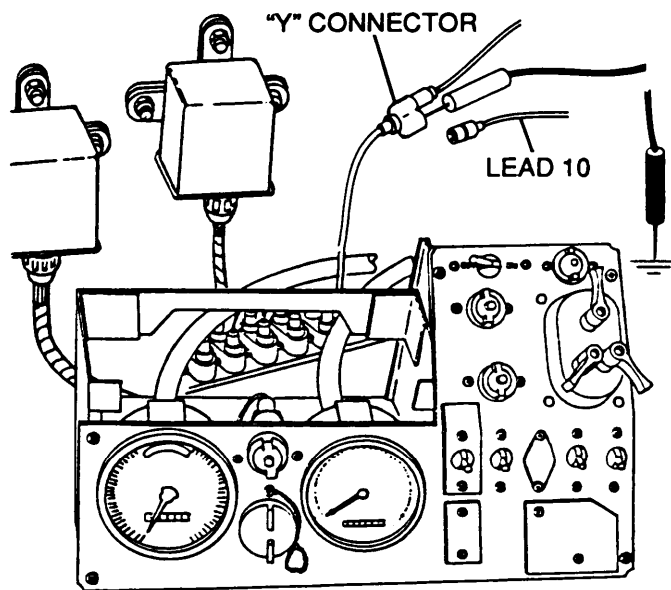
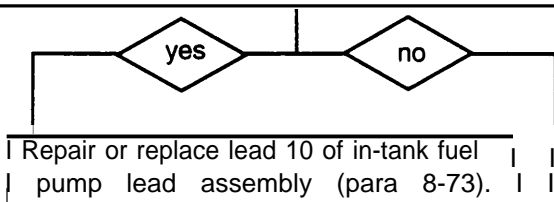

DRIVER'S INSTRUMENT PANEL

M109A4/M109A5
ENGINE MODEL 7083-7396 SHOWN

CONTINUED ON NEXT PAGE

3-3 TROUBLESHOOTING CHART — CONTINUED

ae. ELECTRIC FUEL PUMP CIRCUIT — CONTINUED ENGINE MISSES WHEN LOW ON FUEL; ONE OR BOTH FUEL PUMPS FAIL TO OPERATE — CONTINUED

CONTINUED FROM STEP N

- | | |
|----------|--|
| O | <ol style="list-style-type: none"> 1. Reconnect lead 10 of in-tank fuel pump lead assembly to "Y" connector. 2. Disconnect lead 10 of power lead assembly from "Y" connector. 3. Place red lead of multimeter in lead 10 and black lead to ground. 4. Turn MASTER switch ON and check for voltage. 5. Turn MASTER switch OFF. |
|----------|--|

Is voltage present?

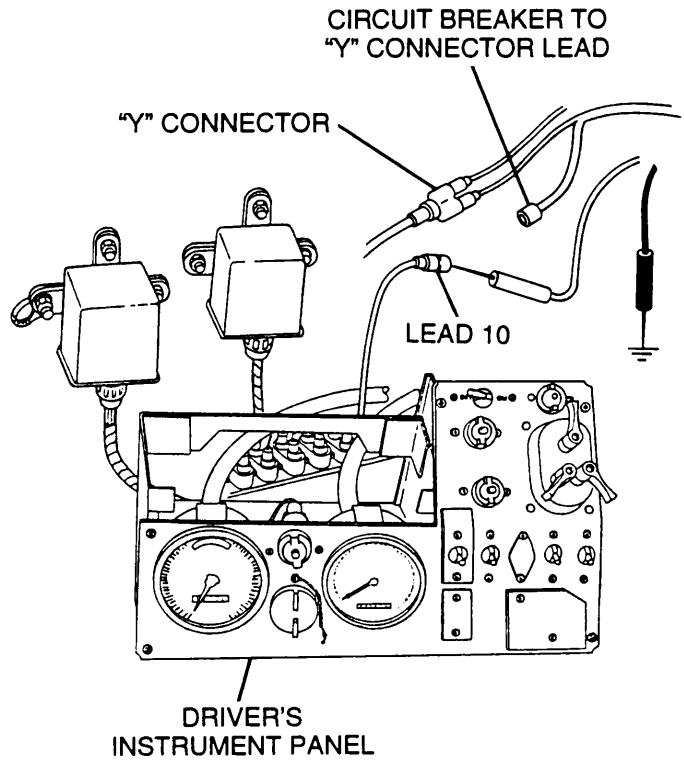
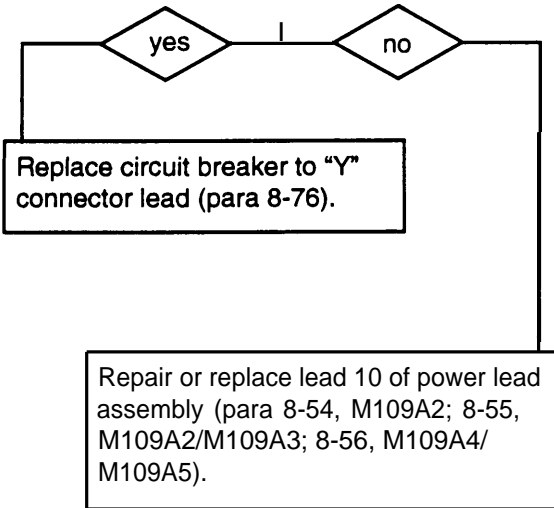

M109A4/M109A5
(ENGINE MODEL 7083-7396) SHOWN

CONTINUED FROM STEP M

- P**
1. Reconnect bulkhead-to-driver's instrument panel wiring harness to driver's bulkhead.
 2. Disconnect lead 76B from engine oil pressure switch.
 3. Place red lead of multimeter in relay oil pressure switch and black lead to ground.
 4. Turn MASTER switch ON, start engine, and run at 1000 rpm.
 5. Check for continuity.
 6. Turn MASTER switch and engine OFF.

Is continuity present?

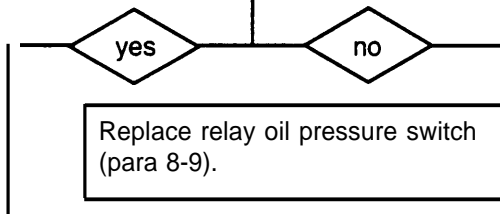

WARNING

Fuel is hazardous waste and must be disposed of in accordance with local procedures or direction of local Hazardous Waste Management office.

NOTE

Step Q must be performed before proceeding. Fuel line arrangement will remain the same for steps R and S.

- Q**
1. Disconnect quick disconnect at primary fuel
 2. Remove male portion of quick disconnect and elbow from fuel filter.
 3. Install male portion of quick disconnect and elbow on hose.
 4. Connect assembled hose to fuel line and place other end in five gallon container to catch flowing fuel.

CONTINUED ON NEXT PAGE

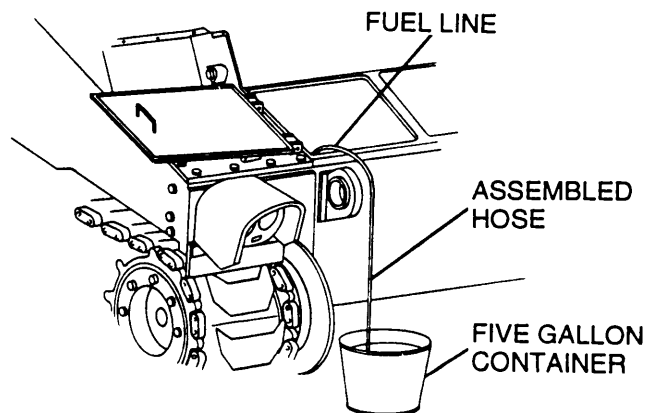
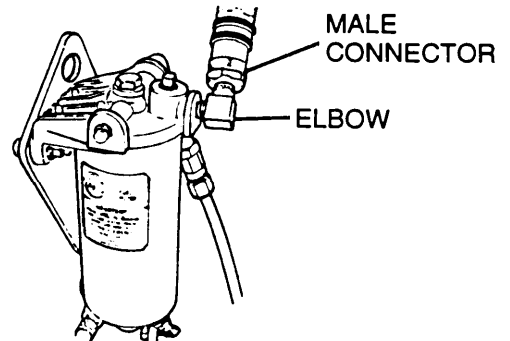
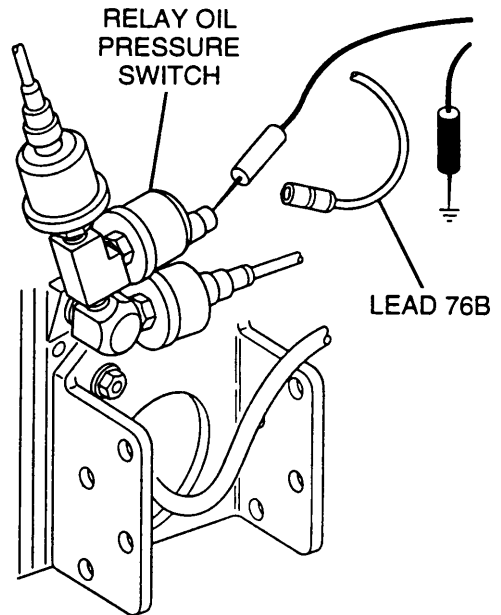

3-3 TROUBLESHOOTING CHART — CONTINUED

ae. ELECTRIC FUEL PUMP CIRCUIT — CONTINUED ENGINE MISSES WHEN LOW ON FUEL; ONE OR BOTH FUEL PUMPS FAIL TO OPERATE — CONTINUED

CONTINUED FROM STEP Q

- R**
1. With lead 76B still disconnected from engine oil pressure switch, disconnect lead 76 from left fuel pump.
 2. Place jumper wire from lead 76B to ground.
 3. Turn MASTER switch ON and check for fuel flow.
 4. Turn MASTER switch OFF.
- Is there fuel flow?

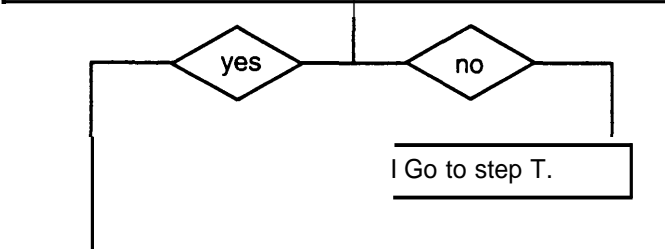
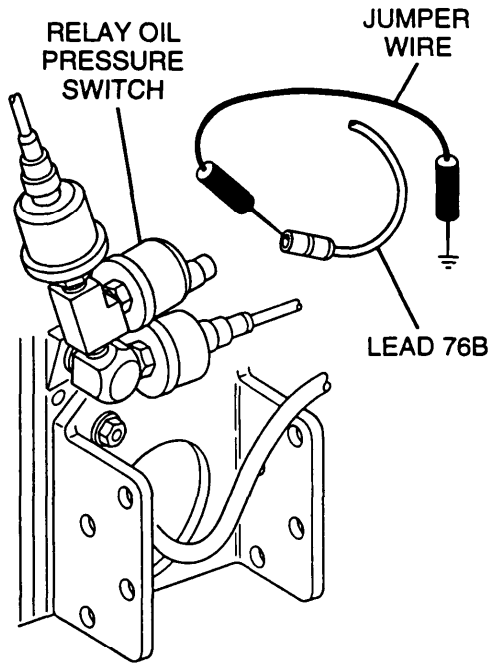

- S**
1. Reconnect lead 76B to engine oil pressure switch.
 2. With lead 76 disconnected from left fuel pump, disconnect lead GND from fuel pump.
 3. Using jumper wires, connect lead GND to bulkhead and lead 76 to positive battery terminal.
 4. Turn MASTER switch ON and check for fuel flow.
 5. Turn MASTER switch OFF.
- Is there fuel flow?

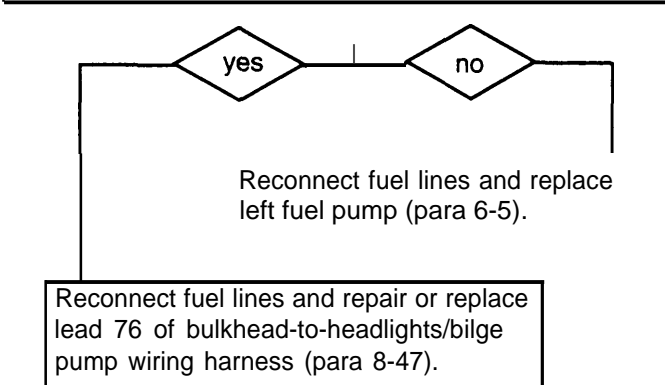
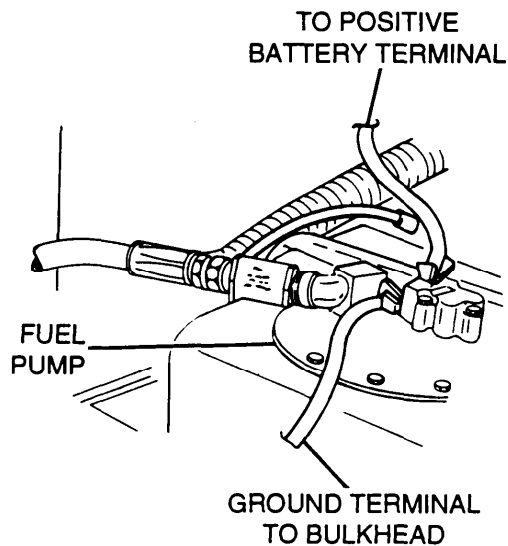

CONTINUED FROM STEP R

- | | |
|----------------------------|---|
| T | <ol style="list-style-type: none"> 1. Reconnect lead 76B to engine oil pressure switch and lead 76 to left fuel pump. 2. Remove powerplant and install special equipment (para 4-3). 3. Disconnect leads 76 and GND from right fuel pump. 4. Disconnect engine disconnect bracket-to-bulkhead wiring harness from engine disconnect bracket. 5. Place a jumper wire from socket B (lead 76B) to ground. 6. Place red lead of multimeter in lead 76 and and black lead in lead GND. 7. Turn MASTER switch ON and check for voltage. 8. Turn MASTER switch OFF. |
| <p>Is voltage present?</p> | |

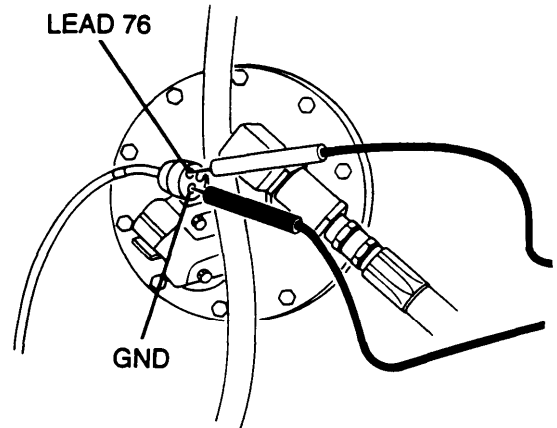
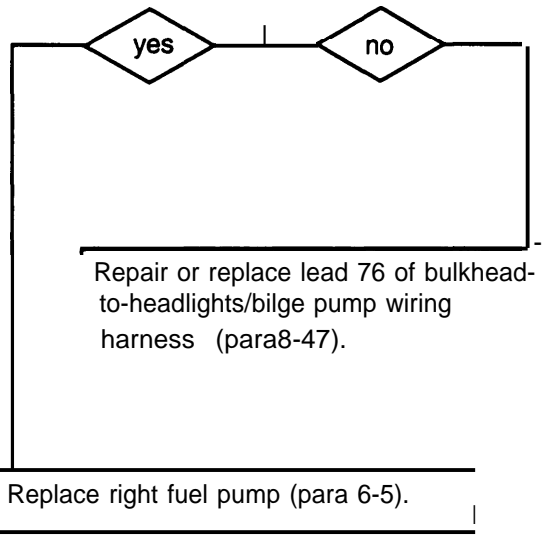
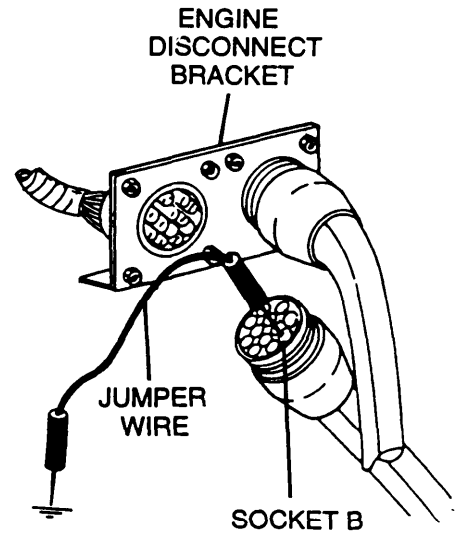

3-3 TROUBLESHOOTING CHART — CONTINUED

ae. ELECTRIC FUEL PUMP CIRCUIT — CONTINUED ENGINE MISSES WHEN LOW ON FUEL; ONE OR BOTH FUEL PUMPS FAIL TO OPERATE — CONTINUED

CONTINUED FROM STEP K

U

1. Reconnect lead 588 to driver's instrument panel wiring harness to FUEL PRIMER switch.
2. Disconnect lead 588 of driver's instrument panel wiring harness from circuit breaker output.
3. Place red lead of multimeter on circuit breaker output and black lead to ground.
4. Turn MASTER switch ON and check for voltage.
5. Turn MASTER switch OFF.

Is voltage present?

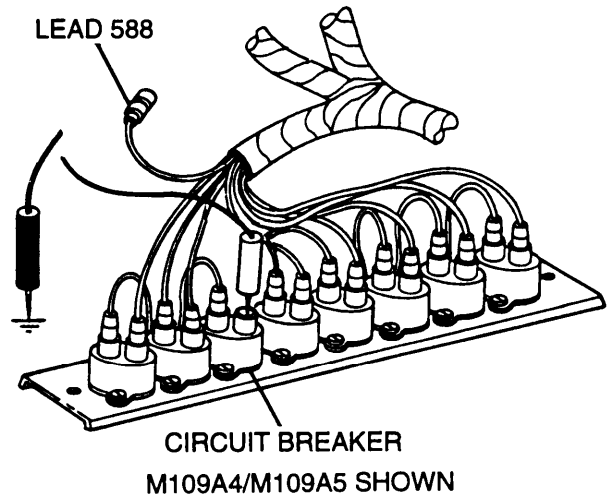

yes

no

Repair or replace lead 588 of driver's instrument panel wiring harness (para 8-51).

V

1. Reconnect lead 588 of driver's instrument panel wiring harness to circuit breaker.
2. Disconnect lead 10 of circuit breaker-to-"Y" connector lead from circuit breaker input.
3. Place red lead of multimeter in lead 10 and black lead to ground.
4. Turn MASTER switch ON and check for voltage.
5. Turn MASTER switch OFF.

Is voltage present?

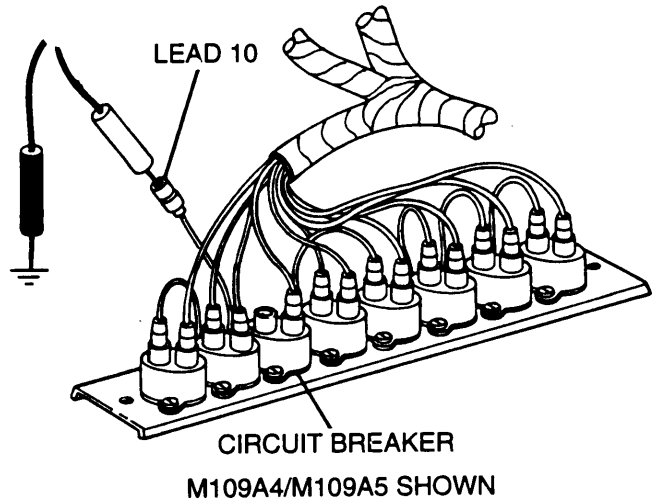

yes

no

Replace circuit breaker (para 8-33, M109A2/M109A3; 8-34, M109A4/M109A5).

CONTINUED ON NEXT PAGE

CONTINUED FROM STEP V

- W**
1. Reconnect lead 10 of circuit breaker-to-"Y" connector lead to circuit breaker input and disconnect from power lead assembly.
 2. Place red lead of multimeter in lead 10 and black lead to ground.
 3. Turn MASTER switch ON and check for voltage.
 4. Turn MASTER switch OFF.
- Is voltage present?

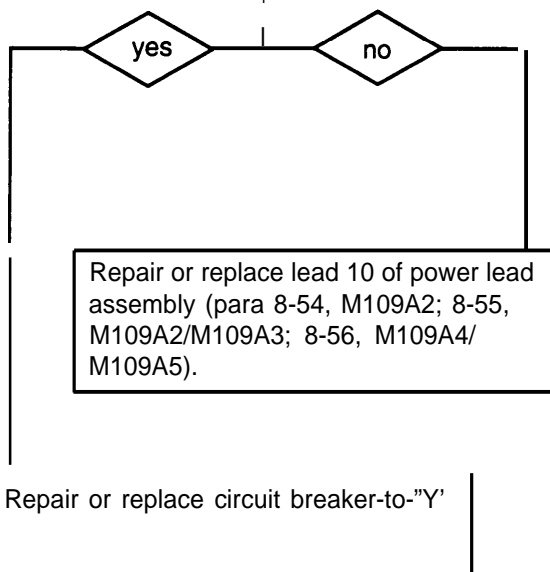
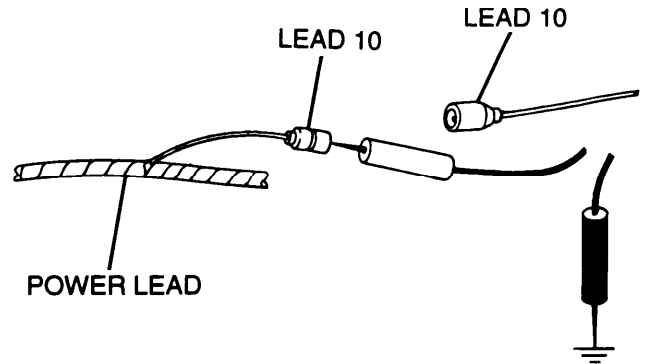

END OF TASK

3-3 TROUBLESHOOTING CHART — CONTINUED

af. VENTILATED FACE PIECE SYSTEM CIRCUIT

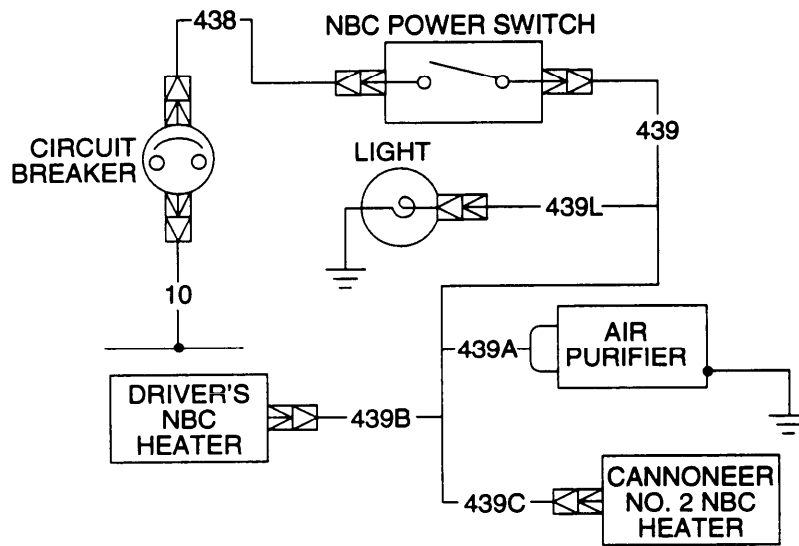

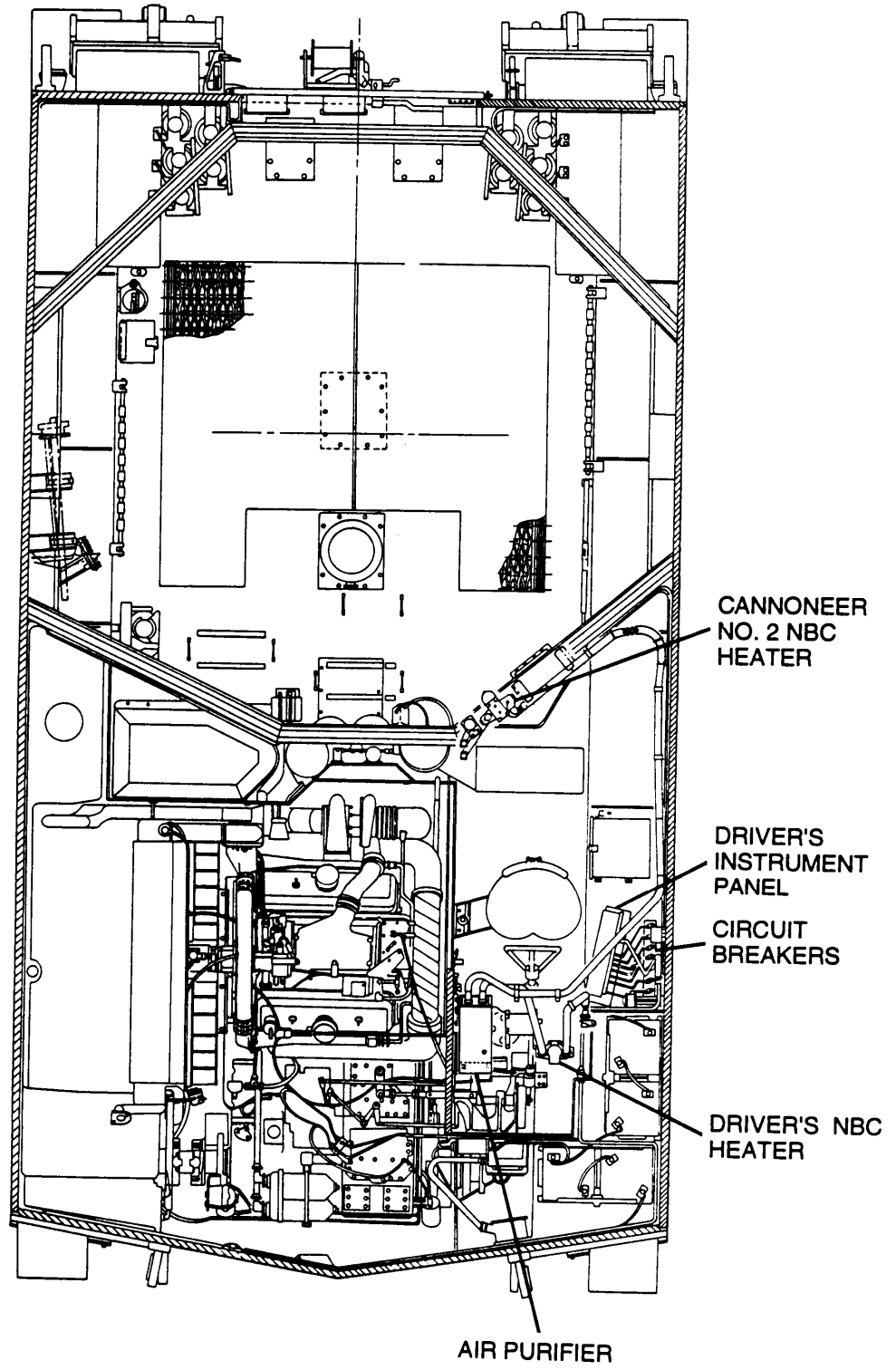

PICTORIAL VIEW

3-3 TROUBLESHOOTING CHART — CONTINUED

af. VENTILATED FACE PIECE SYSTEM CIRCUIT — (1) NBC INDICATOR LIGHT FAILS TO OPERATE; NBC HEATERS AND PURIFIER OPERATE

I INITIAL SETUP I

Tools
General mechanic's tool kit (item 64, Appx H)
Multimeter (item 36, Appx H)
TA-1 probe kit (item 43, Appx H)

A	<ol style="list-style-type: none">1. Remove LED from NBC indicator light assembly.2. Place red lead of multimeter in center socket and black lead to ground.3. Turn MASTER and NBC switches ON and check for voltage.4. Turn MASTER and NBC switches OFF.
Is voltage present?	

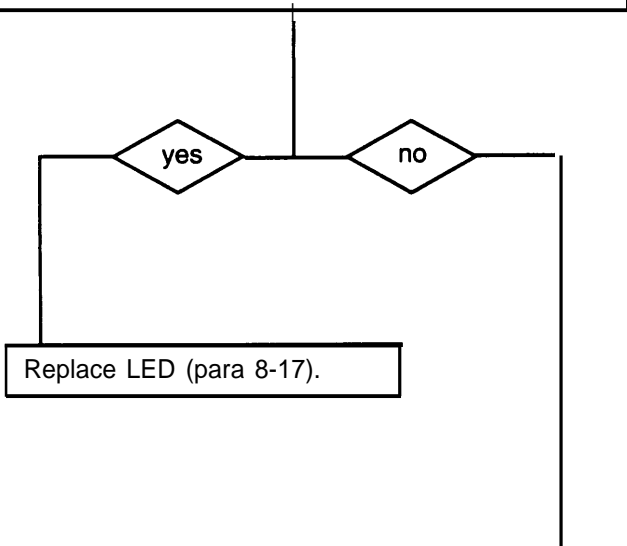

CONTINUED ON NEXT PAGE

CONTINUED FROM STEP A

- B**
1. Install LED in NBC indicator light assembly.
 2. Disconnect lead 439L from NBC indicator light assembly.
 4. Place red lead of multimeter in lead 439L and black lead to ground.
 5. Turn MASTER switch ON and check for voltage.
 6. Turn MASTER switch OFF.
- Is voltage present?

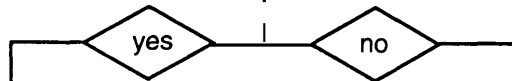

Replace NBC indicator light assembly (para 8-17).

Repair or replace lead 439L of ventilated face piece system power harness (para 8-62).

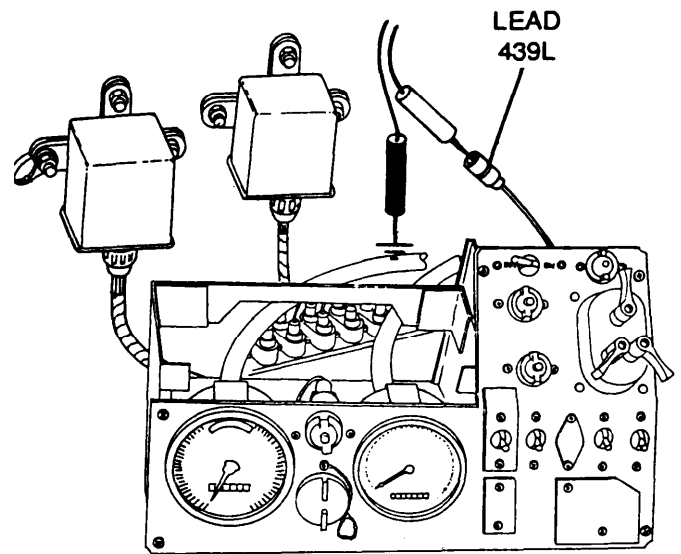

DRIVER'S INSTRUMENT PANEL

M109A4/M109A5
(ENGINE MODEL 7083-7396) SHOWN

END OF TASK

3-3 TROUBLESHOOTING CHART — CONTINUED

af. VENTILATED FACE PIECE SYSTEM CIRCUIT — (2) AIR PURIFIER FAILS TO OPERATE; HEATERS CONTINUED OPERATE PROPERLY

INITIAL SETUP

Tools

General mechanic's tool kit (item 64, Appx H)

Multimeter (item 36, Appx H)

TA-1 probe kit (item 43, Appx H)

- A**
1. Disconnect lead 439A from air purifier.
 2. Place red lead of multimeter in lead 439A and black lead to ground.
 3. Turn MASTER and NBC switches ON and check for voltage.
 4. Turn MASTER and NBC switches OFF.
- Is voltage present?

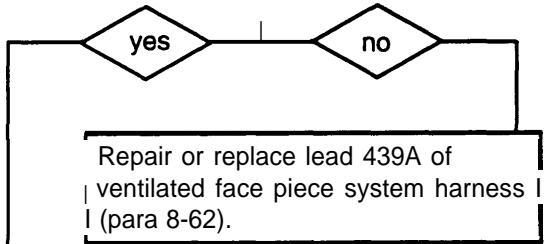

- B**
1. Reconnect lead 439A to air purifier.
 2. Disconnect ground lead from air purifier.
 3. Place red lead of multimeter on ground lead and black lead to ground.
 4. Check for continuity.
- Is continuity present?

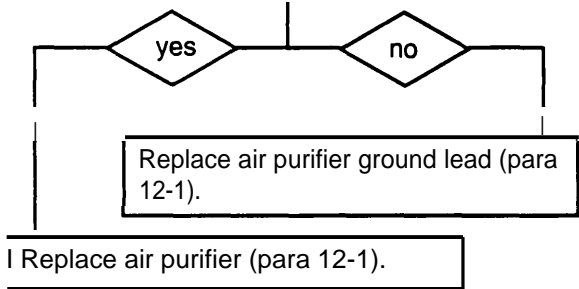

END OF TASK

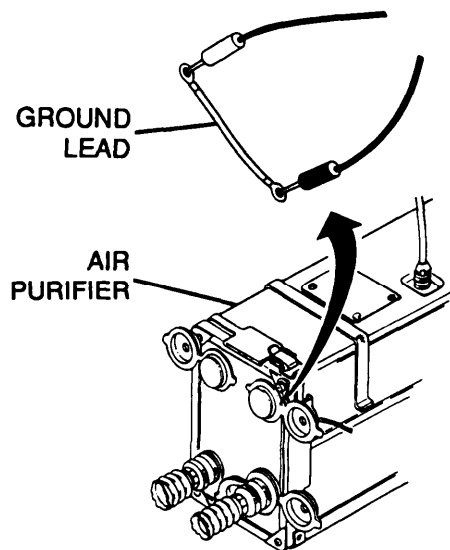
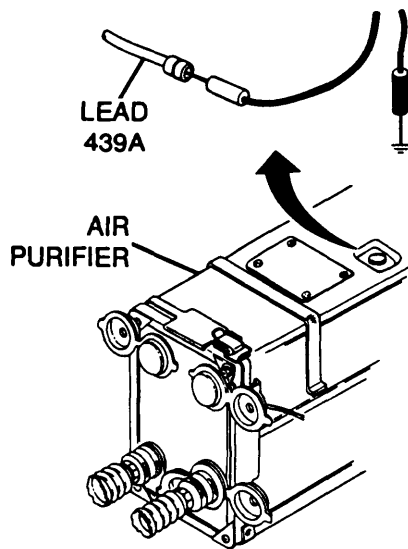

(3) DRIVER'S NBC HEATER FAILS TO OPERATE;
PURIFIER AND CANNONEER NO. 2 NBC HEATER
OPERATE PROPERLY

INITIAL SETUP

Tools

General mechanic's tool kit (item 64, Appx H)

Multimeter (item 36, Appx H)

TA-1 probe kit (item 43, Appx H)

- A**
1. Disconnect lead 4396 from driver's NBC heater.
 2. Place red lead of multimeter in lead 4396 and black lead to ground.
 - 3 Turn MASTER and NBC switches ON and check for voltage.
 4. Turn MASTER-and NBC switches OFF.

Is voltage present?

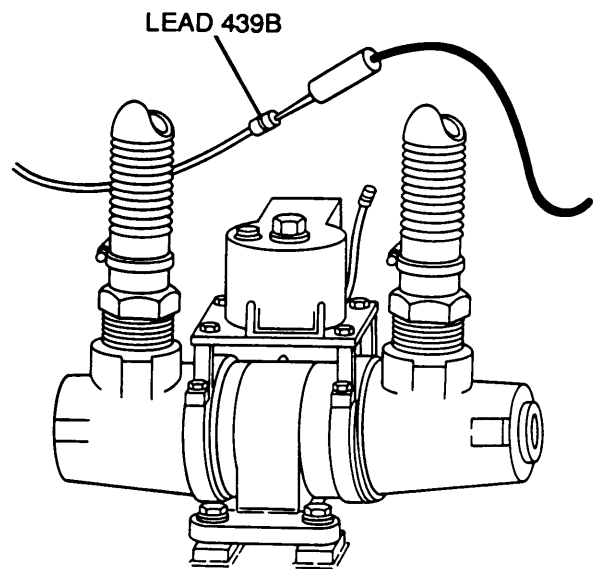
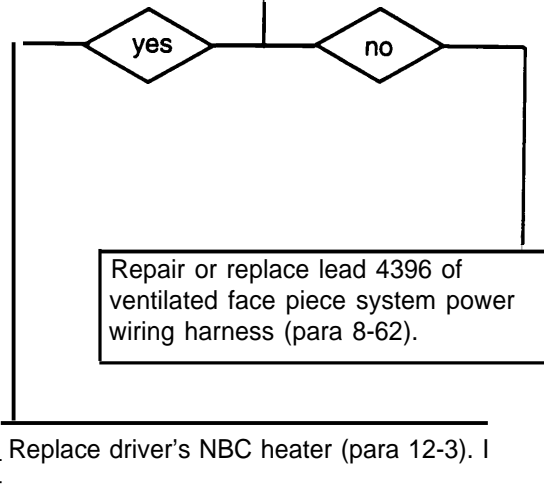

END OF TASK

3-3 TROUBLESHOOTING CHART — CONTINUED

af. VENTILATED FACE PIECE SYSTEM CIRCUIT — CONTINUED (4) CANNONEER NO. 2 NBC HEATER FAILS TO OPERATE; PURIFIER AND DRIVER'S NBC HEATER OPERATE PROPERLY

INITIAL SETUP

Tools

- General mechanic's tool kit (item 64, Appx H)
- Multimeter (item 36, Appx H)
- TA-1 probe kit (item 43, Appx H)

A	<ol style="list-style-type: none"> 1. Disconnect lead 439C from cannoneer no. 2 NBC heater. 2. Place red lead of multimeter in lead 439C and black lead to ground. 3 Turn MASTER and NBC switches ON and check for voltage. 4. Turn MASTER and NBC switches OFF.
Is voltage present?	

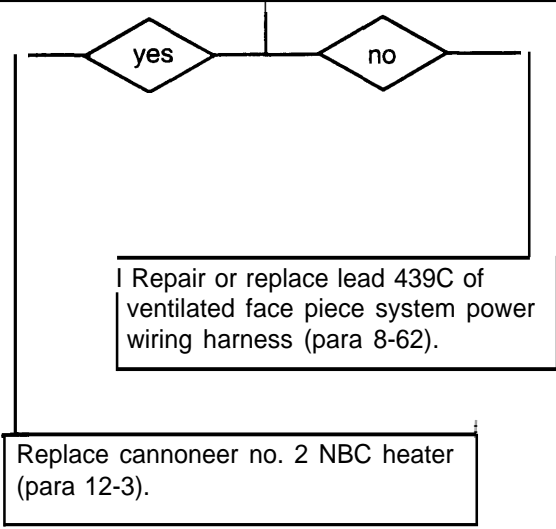
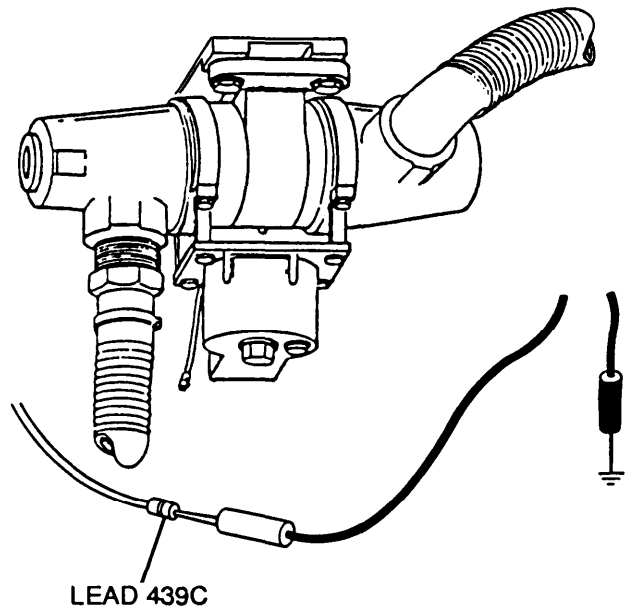

END OF TASK

(5) AIR PURIFIER, DRIVER'S AND CANNONEER NO. 2
NBC HEATERS FAIL TO OPERATE

INITIAL SETUP

Tools

General mechanic's tool kit (item 64, Appx H)

Multimeter (item 36, Appx H)

TA-1 probe kit (item 43, Appx H)

- A**
1. Disconnect lead 439 from NBC switch.
 2. Place red lead of multimeter on NBC switch and black lead to ground.
 3. Turn MASTER and NBC switches ON and check for voltage.
 4. Turn MASTER and NBC switches OFF.
- Is voltage present?

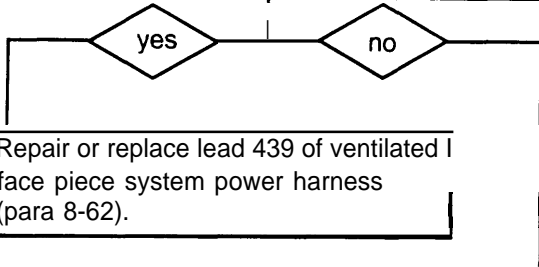

- B**
1. Reconnect lead 439 to NBC switch.
 2. Disconnect lead 438 from NBC switch.
 3. Place red lead of multimeter in lead 438 and black lead to ground.
 4. Turn MASTER switch ON and check for voltage.
 5. Turn MASTER switch OFF.
- Is voltage present?

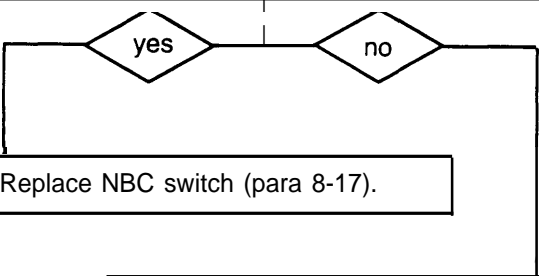

CONTINUED ON NEXT PAGE

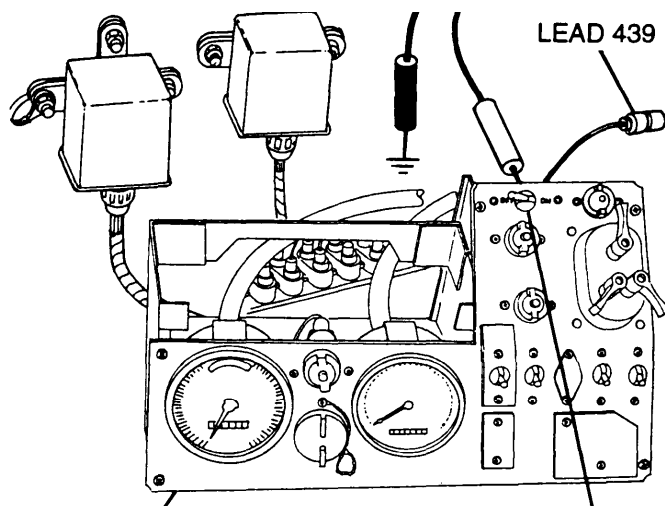

DRIVER'S INSTRUMENT PANEL NBC SWITCH
M109A4/M109A5 (ENGINE MODEL 7083-7396) SHOWN

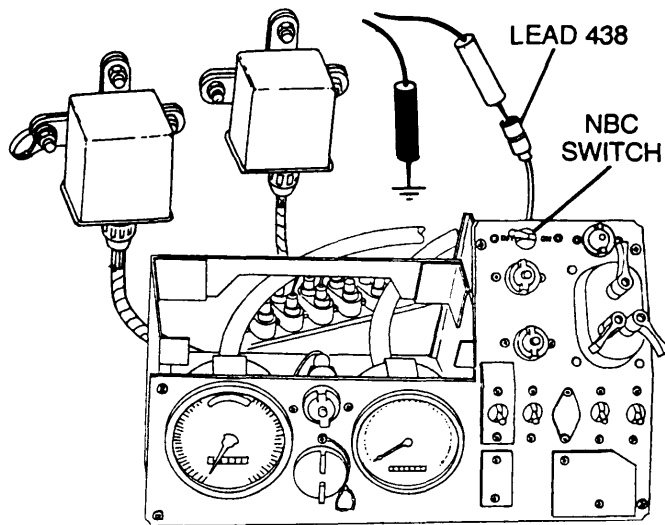

M109A4/M109A5 (ENGINE MODEL 7083-7396) SHOWN

3-3 TROUBLESHOOTING CHART — CONTINUED

af. VENTILATED FACE PIECE SYSTEM CIRCUIT — (5) AIR PURIFIER, DRIVER'S AND CANNONEER NO. 2
CONTINUED NBC HEATERS FAIL TO OPERATE — CONTINUED

CONTINUED FROM STEP B

C

1. Reconnect lead 438 to NBC switch.
2. Disconnect lead 438 from circuit breaker output.
3. Place red lead of multimeter on circuit breaker output and black lead to ground.
4. Turn MASTER switch ON and check for voltage.
5. Turn MASTER switch OFF.

Is voltage present?

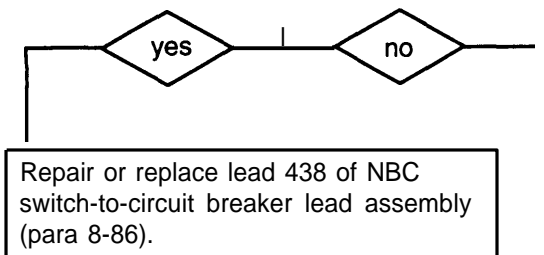
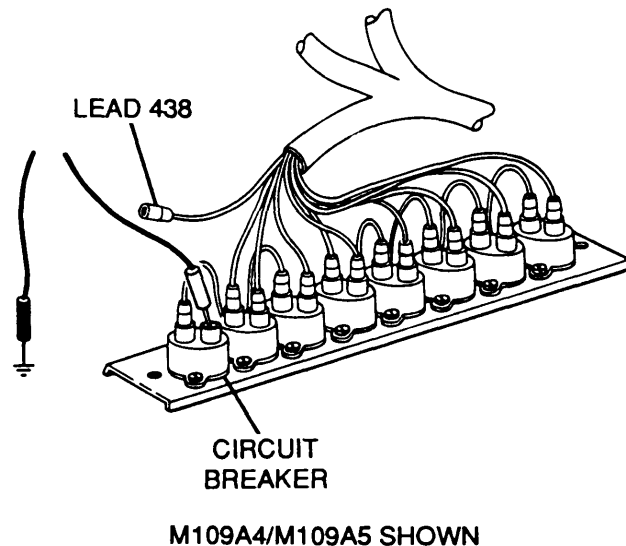

D

1. Reconnect lead 438 to circuit breaker output.
2. Disconnect lead 10 from circuit breaker input.
3. Place red lead of multimeter in lead 10 and black lead to ground.
4. Turn MASTER switch ON and check for voltage.
5. Turn MASTER switch OFF.

Is voltage present?

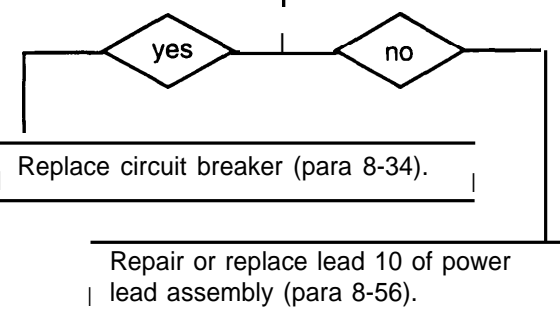
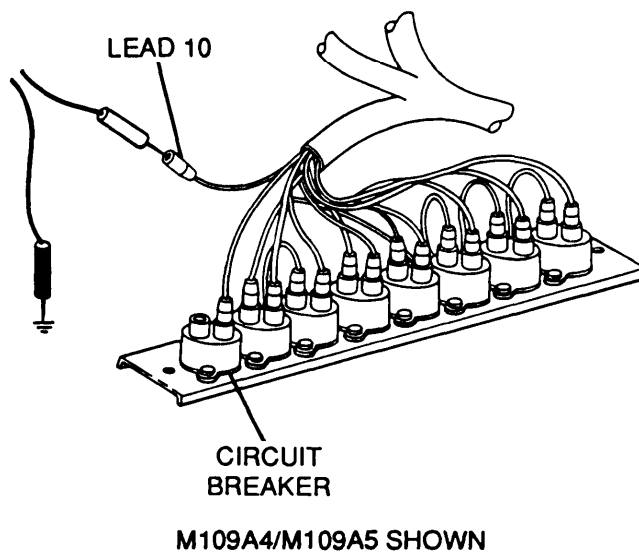

END OF TASK

ag. SLAVE START RECEPTACLE CIRCUIT (M109A2/
M109A3)

The slave start receptacle is located in the battery compartment. When a slave start cable is connected between the slave start receptacles of two vehicles, one vehicle can power the other vehicle's electrical system. With the MASTER switch set to ON in the first vehicle and the MASTER switch set to SLAVE in the second vehicle, 24 Vdc is supplied to the second vehicle's master relay. This energizes the master relay circuit which supplies voltage throughout the vehicle's electrical system.

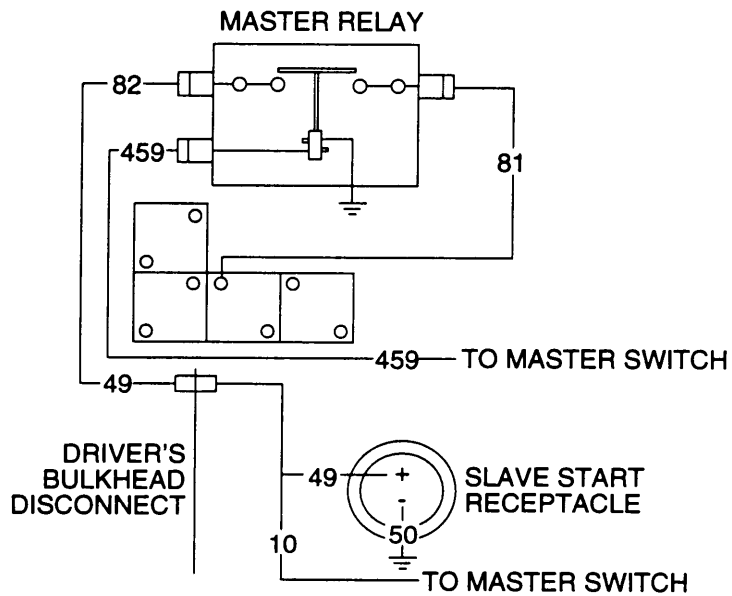

3-3 TROUBLESHOOTING CHART — CONTINUED

ag. SLAVE START RECEPTACLE CIRCUIT (M109A2/
M109A3) — CONTINUED

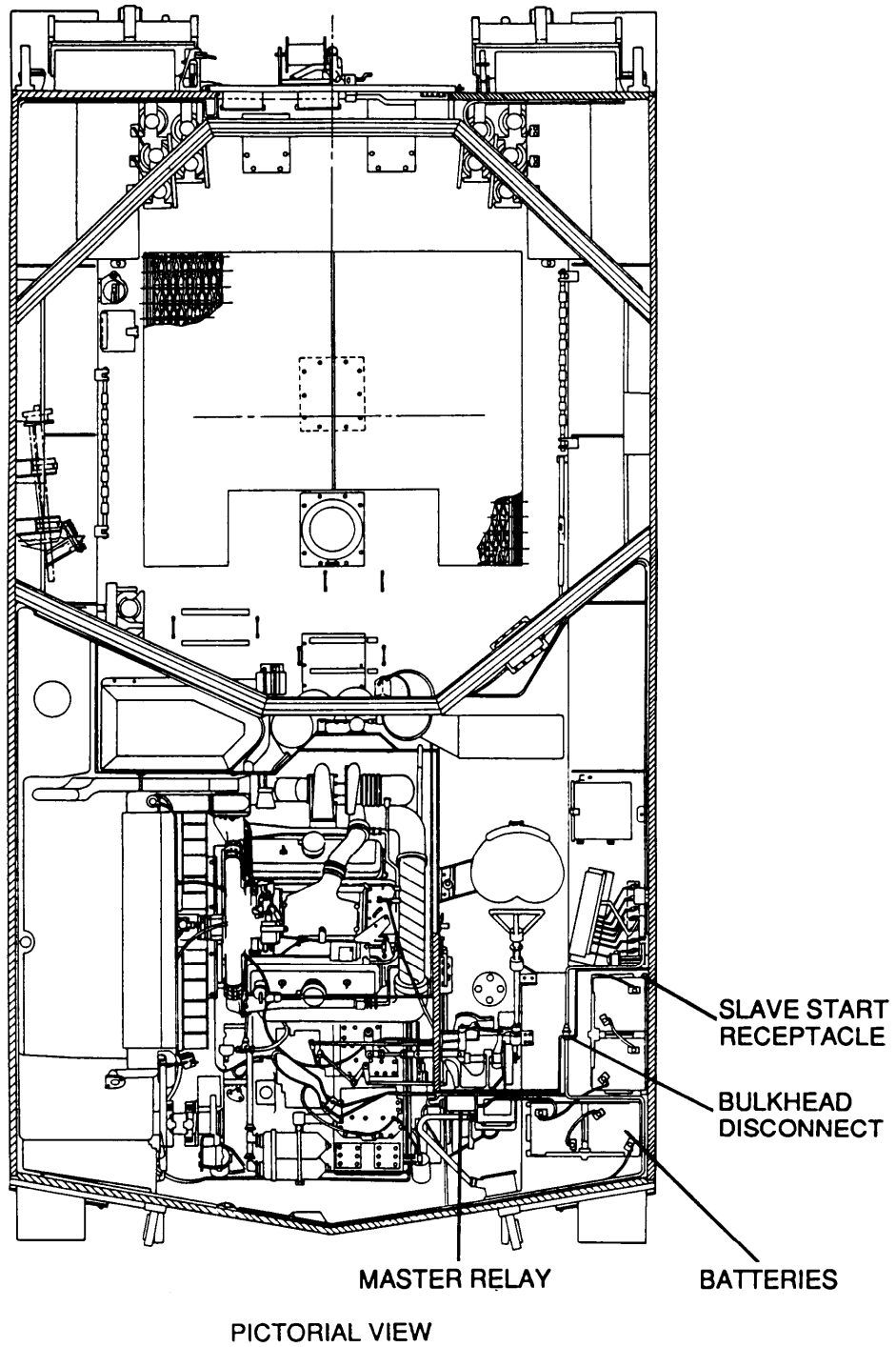

NO POWER TO VEHICLE FROM SLAVE START RECEPTACLE; SLAVED VEHICLE HAD POWER WHEN OPERATING

INITIAL SETUP

Applicable Configurations
M109A2/M109A3

Equipment Conditions
Batteries disconnected (para 8-28)

Tools
General mechanic's tool kit (item 64, Appx H)
Multimeter (item 36, Appx H)
TA-1 probe kit (item 43, Appx H)

A

1. Disconnect slave start cable from vehicle being slaved.
2. Place red lead of multimeter on slave start cable center contact and black lead to outer contact.
3. Check for voltage.

Is voltage present?

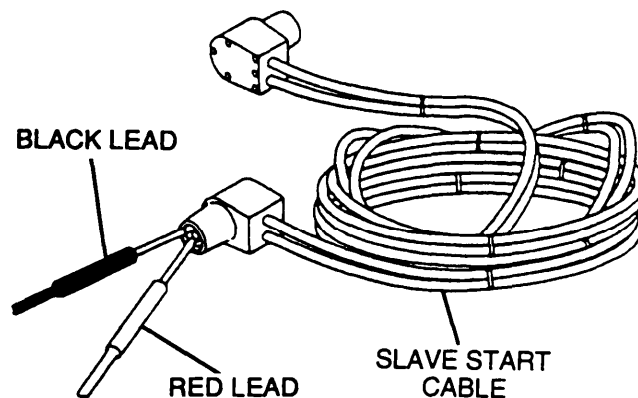
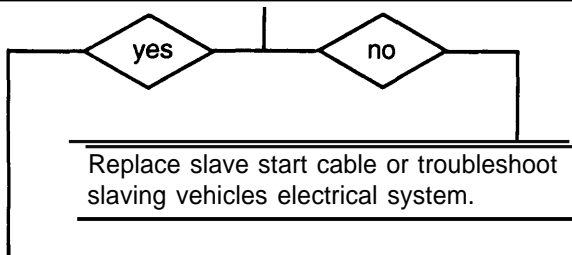

B

1. Reconnect slave start cable to vehicle to be slaved. Slave start cable must be fully seated in slave start receptacle.
2. Place red lead of multimeter on slave start receptacle positive terminal (lead 49) and black lead on negative terminal (lead 50).
3. Check for voltage.

Is voltage present?

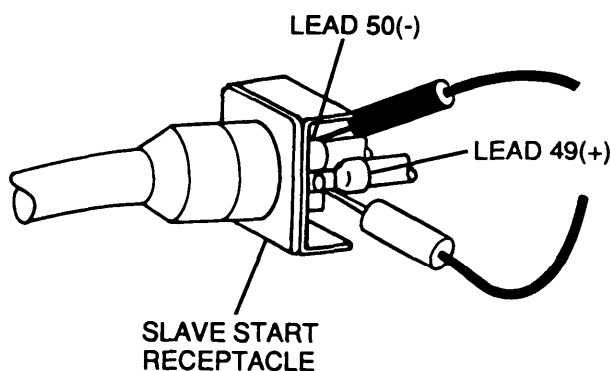
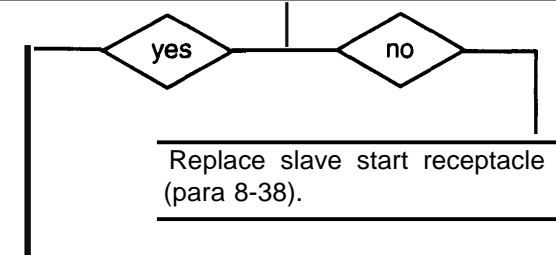

CONTINUED ON NEXT PAGE

3-3 TROUBLESHOOTING CHART — CONTINUED

ag. SLAVE START RECEPTACLE CIRCUIT (M109A2/NO POWER TO VEHICLE FROM SLAVE START RECEPTACLE; SLAVED VEHICLE HAD POWER WHEN OPERATING — CONTINUED

CONTINUED FROM STEP B

- C**
1. Disconnect lead 50 from slave start receptacle.
 2. Place red lead of multimeter on lead 50 and black lead to ground.
 3. Check for continuity.

Is continuity present?

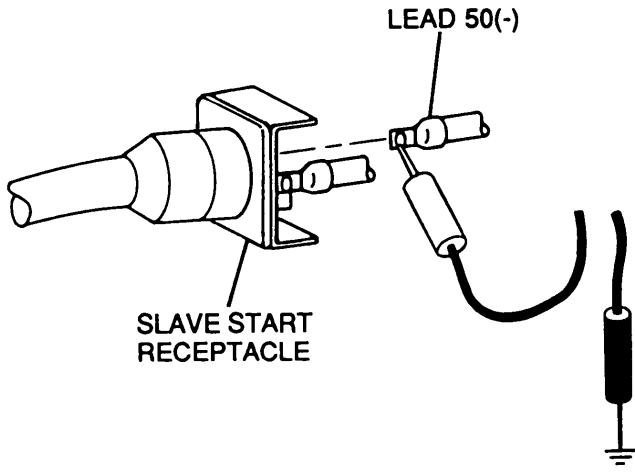
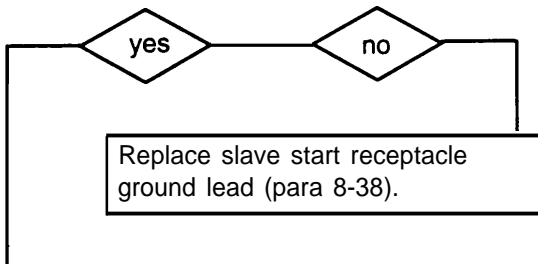

- D**
1. Disconnect slave start cable from slave start receptacle of vehicle being slaved.
 2. Reconnect lead 50 to slave start receptacle.
 3. Disconnect lead 81 from master relay.
 4. Reconnect slave start cable to vehicle being slaved.
 5. Place red lead of multimeter on master relay terminal and black lead to ground.
 6. Turn MASTER switch to SLAVE and check for voltage.
 7. Turn MASTER switch OFF.

Is voltage present?

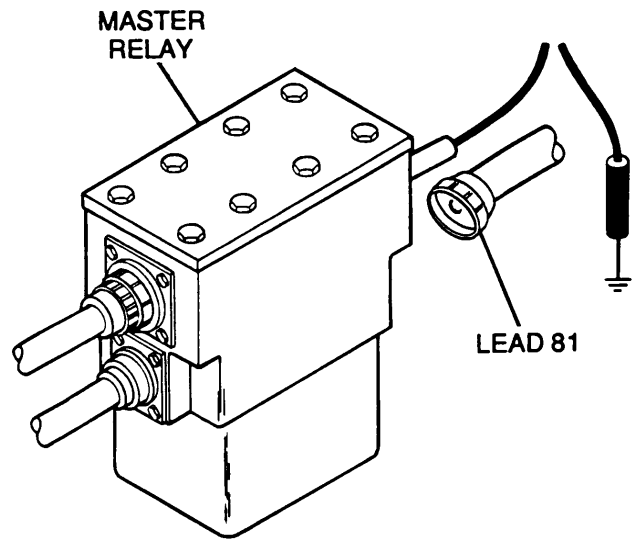
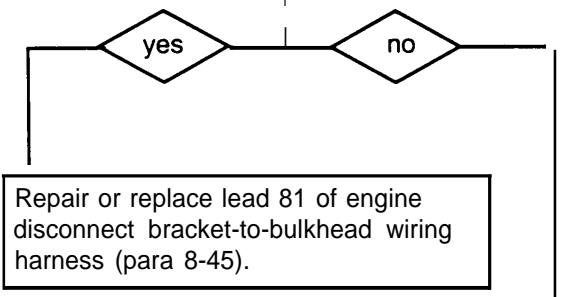

CONTINUED ON NEXT PAGE

CONTINUED FROM STEP D

- | | |
|---------------------|--|
| E | <ol style="list-style-type: none"> 1. Reconnect lead 81 to master relay. 2. Disconnect power lead from driver's bulkhead. 3. Place red lead of multimeter in lead 49 and black lead to ground. 4. Turn MASTER switch to SLAVE and check for voltage. 5. Turn MASTER switch OFF. |
| Is voltage present? | |

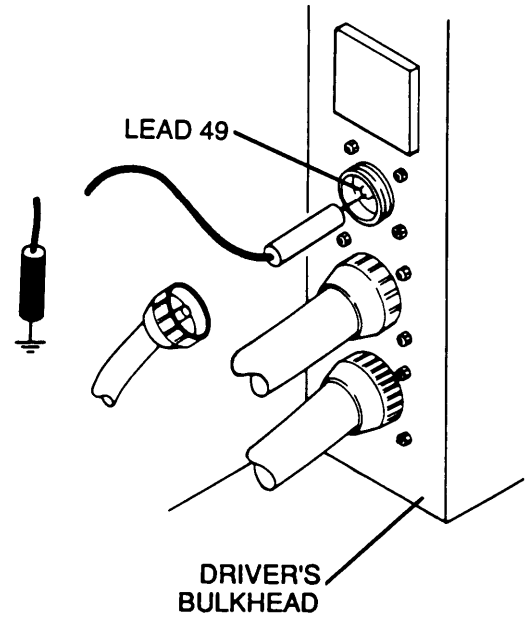
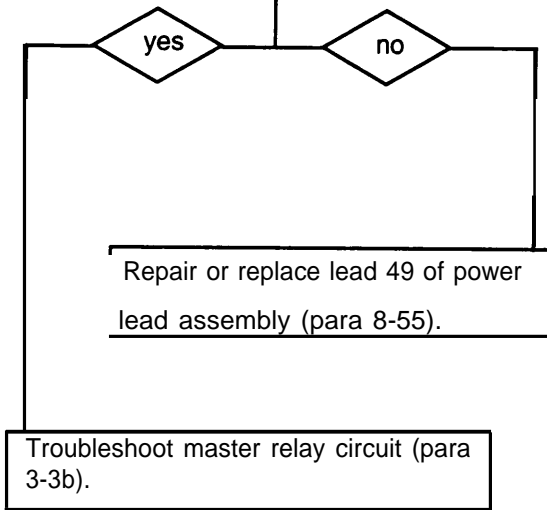

END OF TASK

3-3 TROUBLESHOOTING CHART — CONTINUED

ah. SLAVE START/EXTERNAL POWER
RECEPTACLE CIRCUIT (M109A4/M109A5)

The slave start receptacle is located in the driver's compartment. The external power receptacle is located on the rear hull bulkhead. When a slave start cable is connected between the slave start receptacles of two vehicles, one vehicle can power the other vehicle's electrical system. With the MASTER switch set to ON in the first vehicle and the MASTER switch set to SLAVE in the second vehicle, 24 Vdc is supplied to the second vehicle's master relay. This energizes the master relay circuit which supplies voltage throughout the vehicle's electrical system.

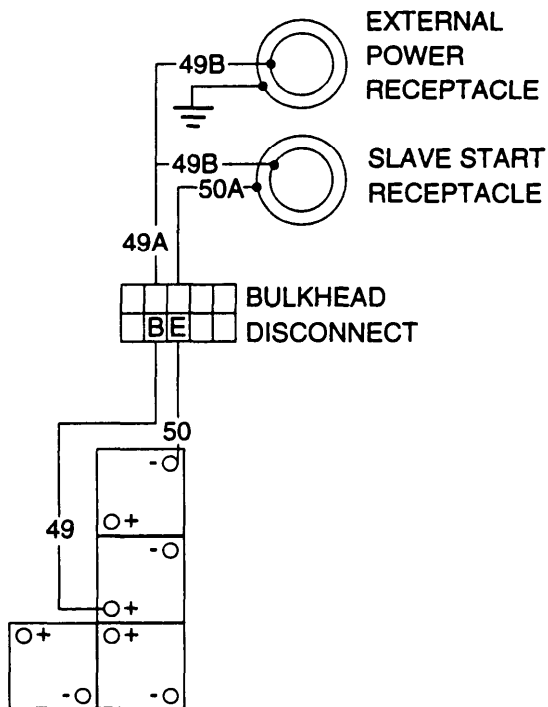

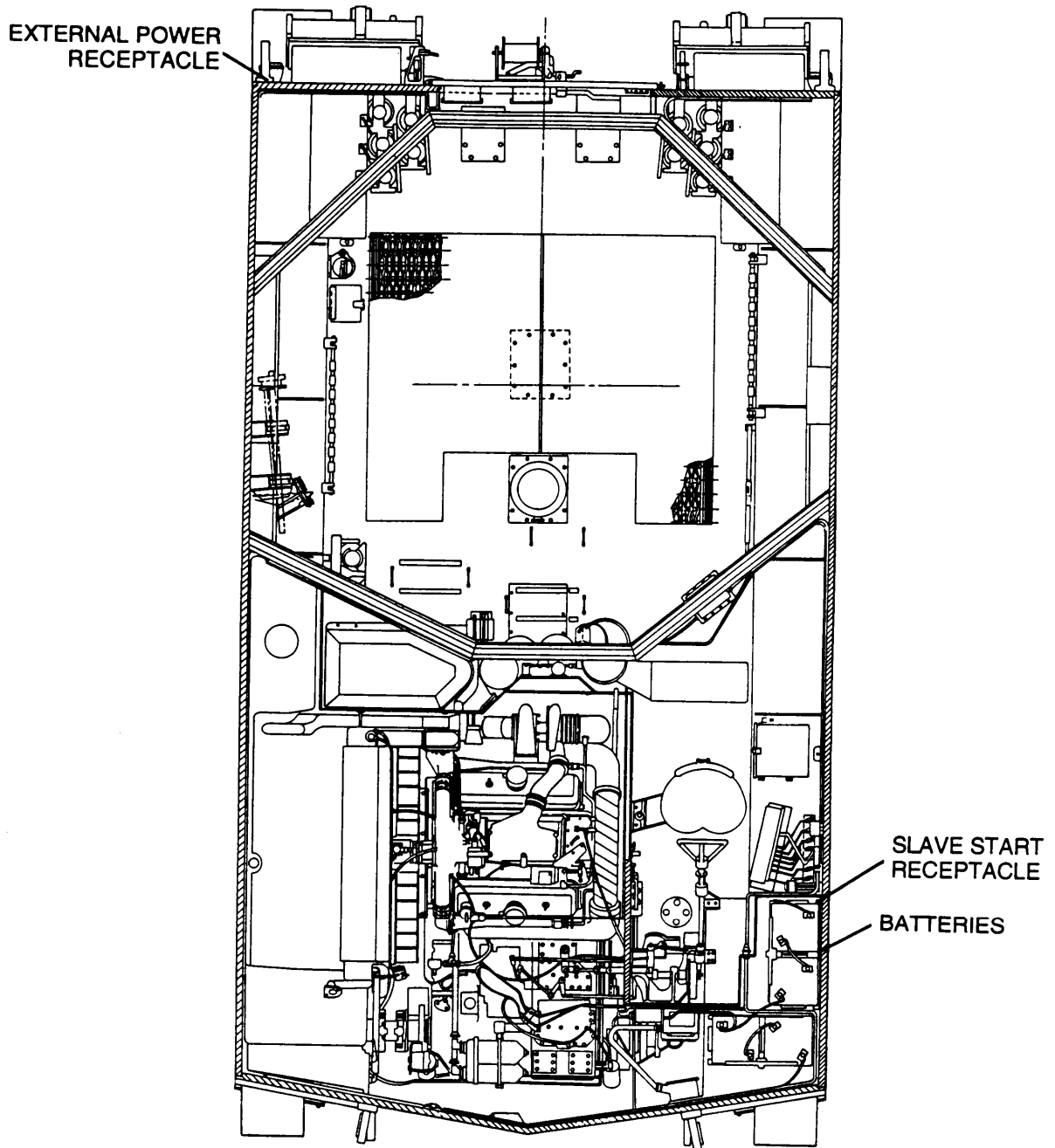

PICTORIAL VIEW

3-3 TROUBLESHOOTING CHART — CONTINUED

ah. SLAVE START/EXTERNAL POWER RECEPTACLE CIRCUIT (M109A4/M109A5) — CONTINUED

(1) NO POWER TO VEHICLE FROM SLAVE START RECEPTACLE; SLAVED VEHICLE HAD POWER WHEN OPERATING

INITIAL SETUP

Applicable Configurations
M109A4/M109A5

Multimeter (item 36, Appx H)
TA-1 probe kit (item 43, Appx H)

Tools
General mechanic's tool kit (item 64, Appx H)

Equipment Conditions
Batteries disconnected (para 8-28)

A

1. Disconnect slave start cable from vehicle being slaved.
2. Place red lead of multimeter on slave start cable center contact and black lead to outer contact.
3. Check for voltage.

Is voltage present?

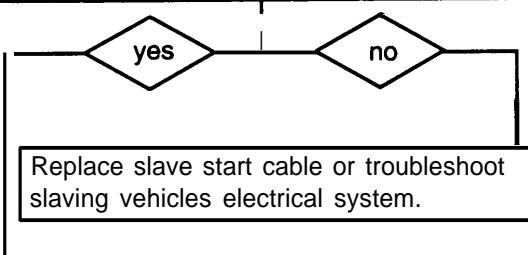
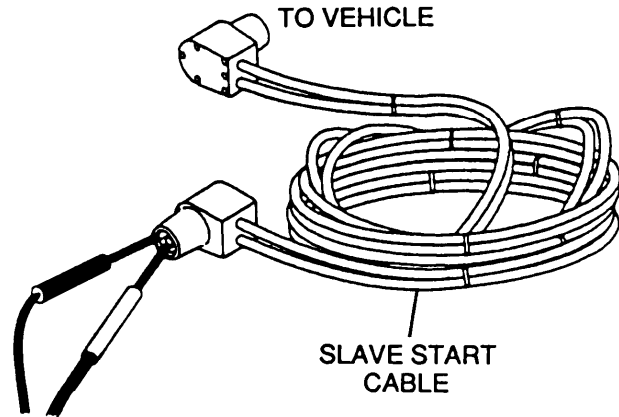

B

1. Reconnect slave start cable to vehicle to be slaved. Slave start cable must be fully seated in slave start receptacle.
2. Place red lead of multimeter on slave start receptacle positive terminal (lead 49A) and black lead on negative terminal (lead 50A).
3. Check for voltage.

Is voltage present?

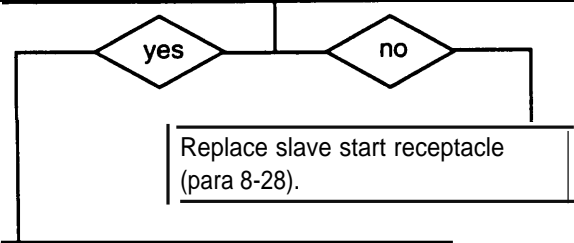
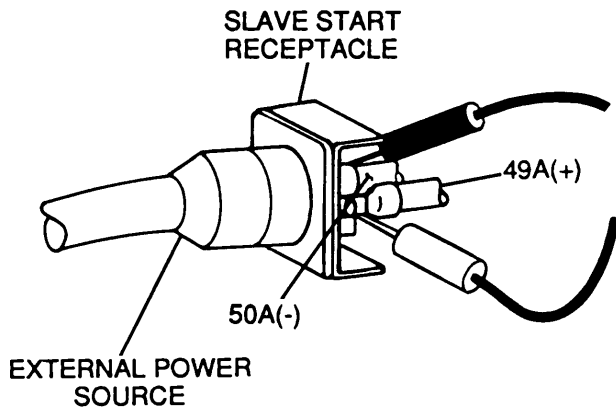

CONTINUED ON NEXT PAGE

CONTINUED FROM STEP B

- C**
1. Disconnect lead 50A from slave start receptacle.
 2. Place red lead of multimeter on lead 50A and black lead to ground.
 3. Check for continuity.

Is continuity present?

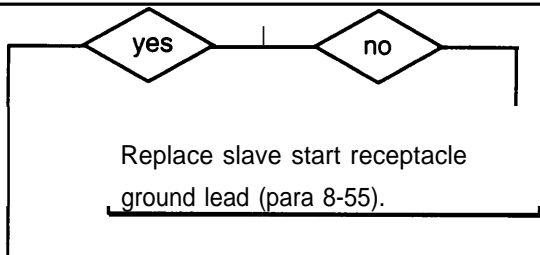

- D**
1. Disconnect slave start cable from slave start receptacle of vehicle being slaved.
 2. Reconnect lead 50A to slave start receptacle.
 3. Disconnect NATO slave start-to-external power wiring harness from driver's bulkhead.
 4. Reconnect slave start cable to vehicle being slaved.
 5. Place red lead of multimeter on pin B (lead 49A) and black lead on pin E (lead 50A).
 6. Turn MASTER switch to SLAVE and check for voltage.
 7. Turn MASTER switch OFF.

Is voltage present?

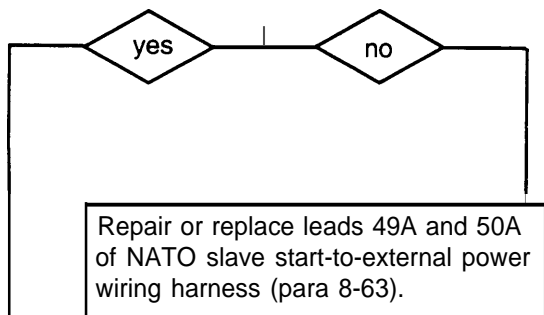

CONTINUED ON NEXT PAGE

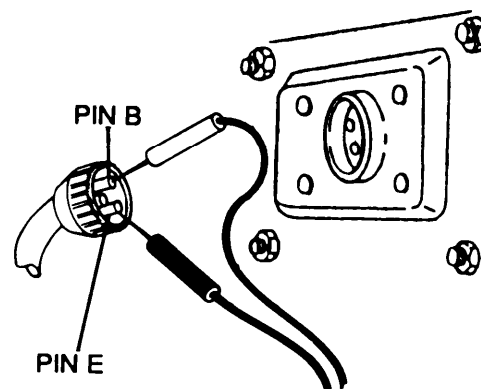
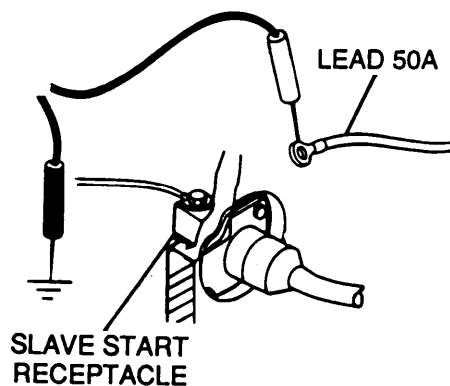

3-3 TROUBLESHOOTING CHART — CONTINUED

ah. SLAVE START/EXTERNAL POWER RECEPTACLE CIRCUIT (M109A4/M109A5) — CONTINUED

(1) NO POWER TO VEHICLE FROM SLAVE START RECEPTACLE; SLAVED VEHICLE HAD POWER WHEN OPERATING — CONTINUED

CONTINUED FROM STEP D

E	<ol style="list-style-type: none"> 1. Reconnect NATO slave start-to-external power wiring harness to driver's bulkhead. 2. Disconnect leads 49 and 50 from batteries. 3. Place red lead of multimeter on lead 49 and black lead on lead 50. 4. Turn MASTER switch to SLAVE and check for voltage. 5. Turn MASTER switch OFF.
<p>Is voltage present?</p>	

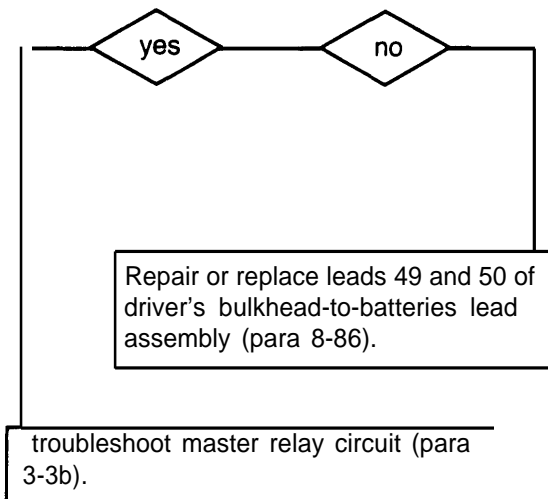
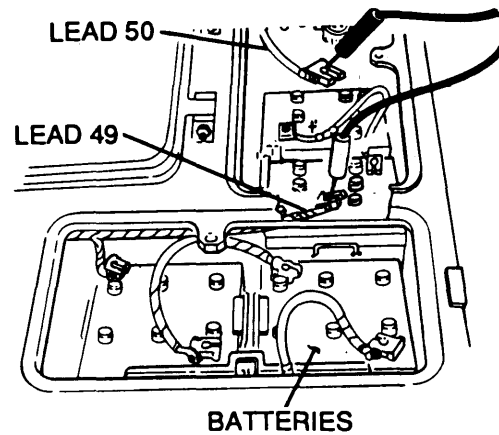

END OF TASK

(2) EXTERNAL POWER RECEPTACLE FAILS TO OPERATE

INITIAL SETUP

Applicable Configurations
M109A4/M109A5

Equipment Conditions
Batteries disconnected (para 8-28)

Tools

General mechanic's tool kit (item 64, Appx H)
Multimeter (item 36, Appx H)
TA-1 probe kit (item 43, Appx H)

A	<ol style="list-style-type: none"> 1. Remove external power receptacle guard (para 8-39). 2. Disconnect leads 496 and GND from external power receptacle. 3. Using an external power source, apply 24Vdc to the external power receptacle. 4. Place red lead of multimeter on external power receptacle positive terminal (lead 496) and black lead on negative terminal (lead GND). 5. Check for voltage.
Is voltage present?	

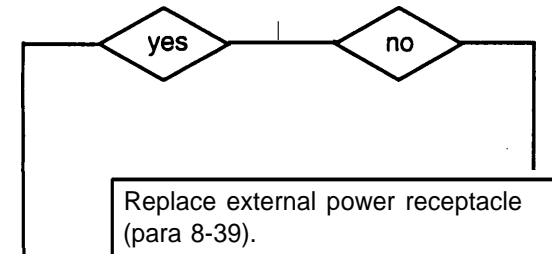
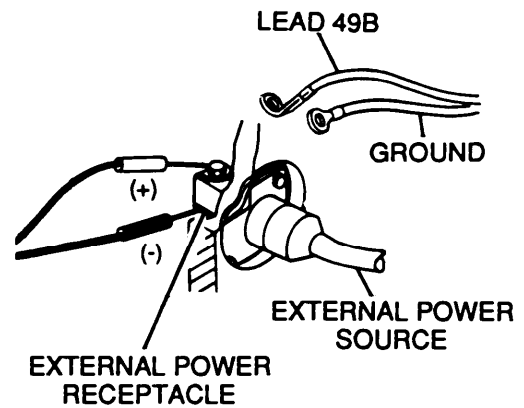

CONTINUED ON NEXT PAGE

3-3 TROUBLESHOOTING CHART — CONTINUED

ah. SLAVE START/EXTERNAL POWER RECEPTACLE CIRCUIT (M1 09A4/M109A5) — CONTINUED

(2) EXTERNAL POWER RECEPTACLE FAILS TO OPERATE — CONTINUED

CONTINUED FROM STEP A

B	<ol style="list-style-type: none"> 1. Remove external power source from external power receptacle. 2. Reconnect leads 49B and GND to external power receptacle. 3. Disconnect NATO slave start-to-external power wiring harness from driver's bulkhead. 4. Reapply external power source. 5. Place red lead of multimeter on pin B (lead 49A) and black lead to ground. 6. Turn MASTER switch to SLAVE and check for voltage. 7. Turn MASTER switch OFF.
Is voltage present?	

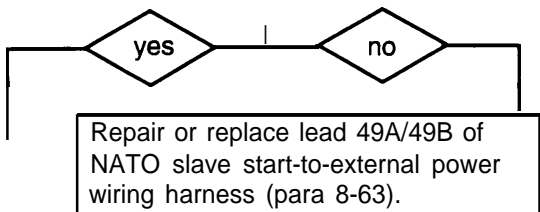
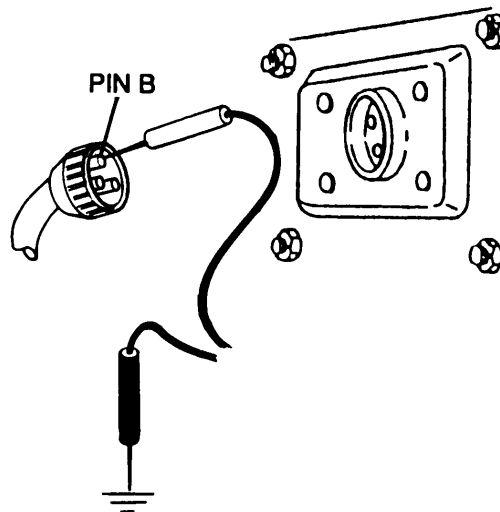

E	<ol style="list-style-type: none"> 1. Reconnect NATO slave start-to-external power wiring harness to driver's bulkhead. 2. Disconnect lead 49 from batteries. 3. Place red lead of multimeter on lead 49 and black lead to ground. 4. Turn MASTER switch to SLAVE and check for voltage. 5. Turn MASTER switch OFF.
Is voltage present?	

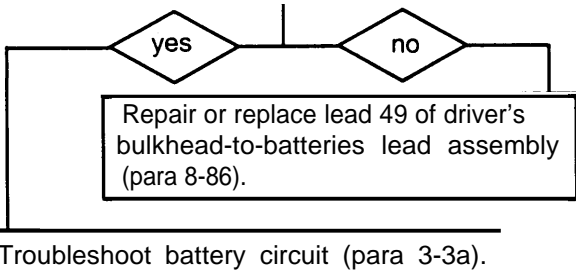
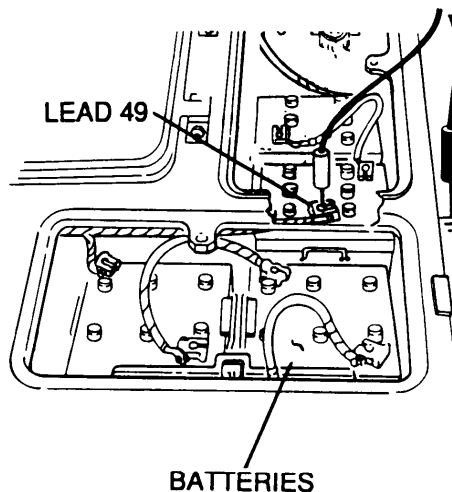

END OF TASK

CHAPTER 4 POWERPLANT

GENERAL

This chapter provides instructions for removal and installation of the powerplant consisting of the engine, transfer case and transmission assemblies, and related accessories. Procedures for operating the powerplant outside the vehicle are also provided.

The powerplant shall be given periodic checks to find possible fire hazards. Inspections for foreign matter shall be performed on the powerplant cooling accessories, air shrouding, wiring, and powerplant hull compartment during each maintenance service.

Whenever the powerplant is removed for maintenance, the powerplant and engine compartment should be given a general cleaning and inspection of wiring, hoses, and piping.

<u>CONTENTS</u>	<u>PAGE</u>
4-1 LOCATION OF POWERPLANT COMPONENTS (ENGINE MODEL 7083-7396)	4-2
4-2 LOCATION OF POWERPLANT DISCONNECTS (ENGINE MODEL 7083-7396)	4-4
4-3 LOCATION OF POWERPLANT COMPONENTS (ENGINE MODEL 7083-7391)	4-6
4-4 LOCATION OF POWERPLANT DISCONNECTS (ENGINE MODEL 7083-7391)	4-8
4-5 POWERPLANT	4-10

4-1 LOCATION OF POWERPLANT COMPONENTS (ENGINE MODEL 7083-7396)

NOTE

Location of surge tank pressure relief valve differs in M109A2/M109A3 and M109A4/M109A5 Howitzers (para 7-5).

LEGEND

- | | |
|---|--|
| 1 Transmission lifting eye | 26 Radiator filler |
| 2 Engine oil filter-to-oil cooler hose | 27 Radiator cooling fans |
| 3 Engine oil cooler-to-filter hose | 28 Fuel return line quick disconnect |
| 4 Flame heater igniter | 29 Inlet thermostat housing |
| 5 Coolant pump | 30 Engine lifting eye |
| 6 Engine viscous vibration damper | 31 Engine coolant temperature transmitter |
| 7 Oil pan | 32 Engine exhaust outlet duct |
| 8 Tachometer driveshaft | 33 Engine blower inlet housing |
| 9 Speedometer driveshaft | 34 Turbocharger |
| 10 Engine coolant inlet tube | 35 Engine turbocharger inlet duct |
| 11 Engine and transmission support | 36 Engine governor |
| 12 Brake apply lever — right | 37 Engine governor throttle control rod |
| 13 Brake apply lever — left | 38 Exhaust crossover tube |
| 14 Universal joint flange adapter | 39 Air box heater fuel pump solenoid valve |
| 15 Transmission | 40 Air box heater motor and pump assembly |
| 16 Transmission throttle valve rod | 41 Right engine exhaust manifold |
| 17 Transmission steer control rod | 42 Engine oil filler cap |
| 18 Transmission shift control rod | 43 Transfer breather tube |
| 19 Secondary fuel filter | 44 Bypass thermostat housing |
| 20 Alternator-to-rectifier wiring harness | 45 Aeration detector |
| 21 Transmission inspection cover (brake adjustment) | 46 Radiator cooling fan shroud |
| 22 Surge tank-to-coolant pump hose | 47 Radiator-to-surge tank hose |
| 23 Engine oil filters | 48 Crossover tube-to-surge tank hose |
| 24 Primary fuel filter | 49 Surge tank pressure relief valve |
| 25 Coolant surge tank | 50 Crossover tube |
| | 51 Radiator |

POWERPLANT
(LEFT FRONT VIEW)

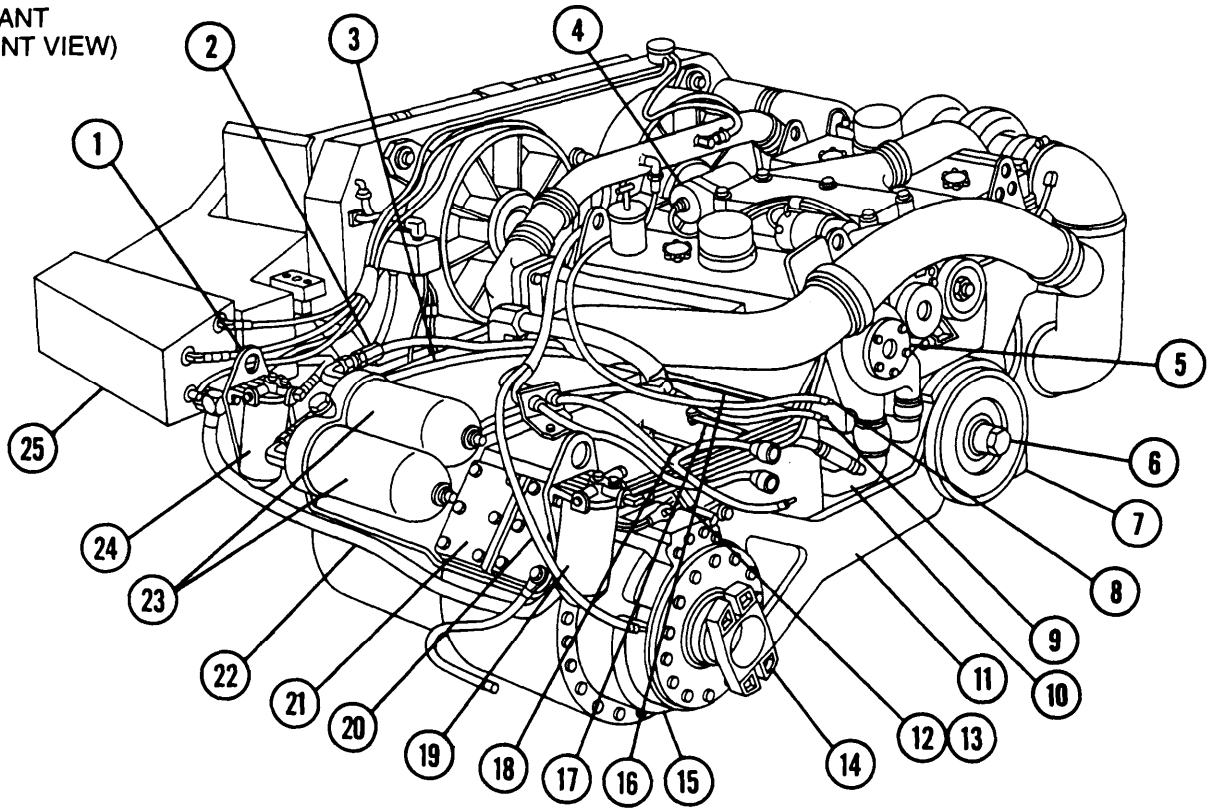

(TOP VIEW)

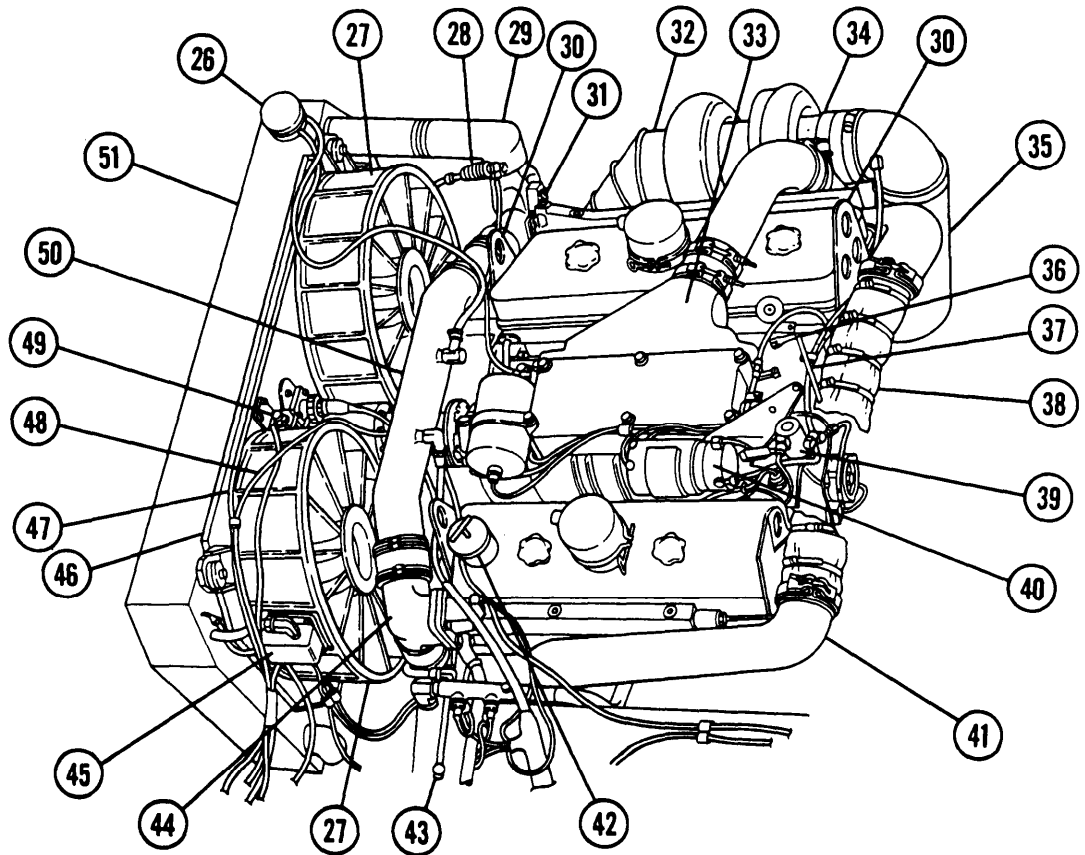

4-2 LOCATION OF POWERPLANT DISCONNECTS (ENGINE MODEL 7083-7396)

The following legend and illustrations are for reference only. For removal and installation of the powerplant, see paragraph 4-5.

NOTE

M109A4/M109A5 powerplant ground cable is located at starter. For information on disconnect points of winterization kit, see Chapter 14.

LEGEND

- | | |
|--|---|
| 1 Engine-to-lower fuel tank return hose and clamp | 19 Powerplant ground cable (M109A2/M109A3) |
| 2 Engine exhaust pipe flanges | 20 Alternator-to-rectifier harness (at rectifier) |
| 3 Fixed fire extinguisher nozzle | 21 Coolant pump-to-surge tank hose clamps |
| 4 Air cleaner duct hose at turbocharger inlet | 22 Primary fuel filter input hose |
| 5 Governor fuel shutoff lever, pulley, and cable | 23 Speedometer right angle rod |
| 6 Throttle governor control rod | 24 Coolant surge tank, retainer, and pad |
| 7 Throttle governor control rod (linkage) | 25 Separation of starter cable and generator-to-rectifier harness |
| 8 Steer control rod | 26 Air cleaner duct hose |
| 9 Throttle control tube | 27 Engine compartment access cover |
| 10 Accelerator and throttle control bracket | 28 Engine mount release shaft |
| 11 Tachometer flexible driveshaft | 29 Throttle valve control rod linkage |
| 12 Speedometer flexible driveshaft | 30 Brake control sprocket and shaft |
| 13 Shift control rod | 31 Master relay and voltage regulator |
| 14 Master relay and voltage regulator disconnects | 32 Transmission support caps |
| 15 Final drive universal joints | 33 Powerplant ground cable terminal (M109A2/M109A3) |
| 16 Transmission trunnion caps | 34 Bilge pump hose and tube (para 11-18) |
| 17 Brake control sprocket, shaft, and pin | |
| 18 Engine starter cable and master circuit harness | |

**POWERPLANT
DISCONNECT
POINTS
(POWERPLANT
OUT OF
VEHICLE)**

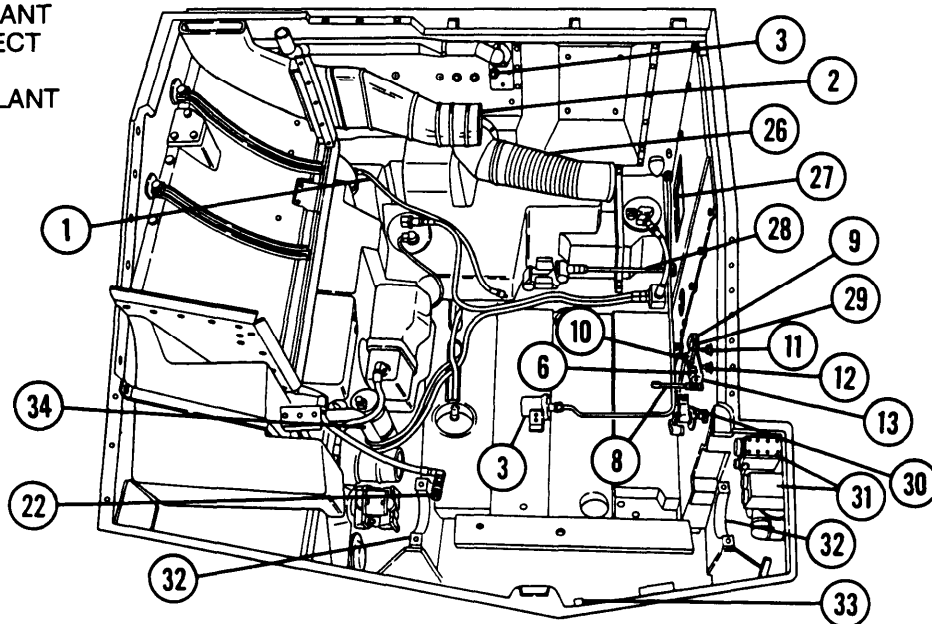

POWERPLANT DISCONNECT POINTS IN HULL
(POWERPLANT IN VEHICLE)

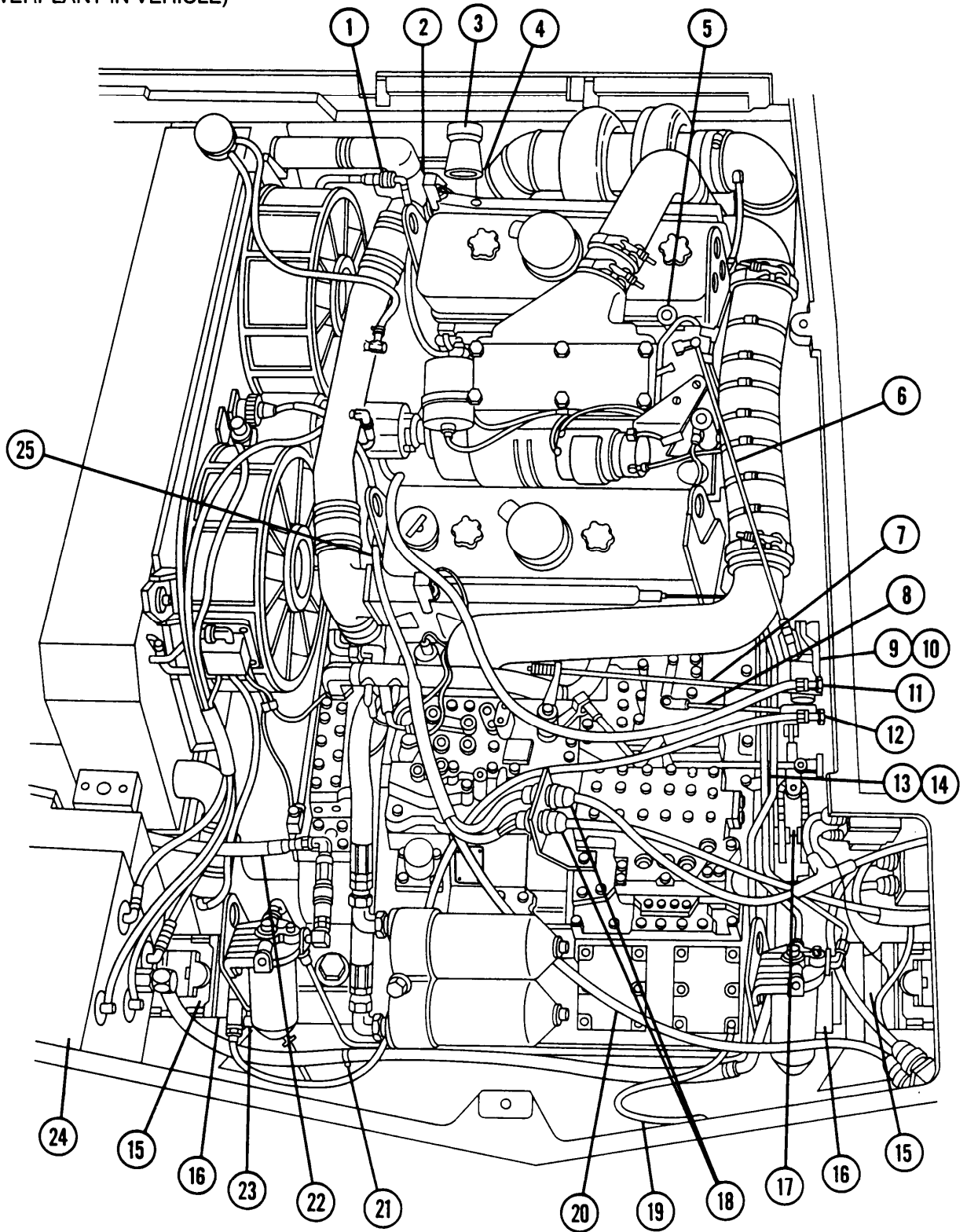

4-3 LOCATION OF POWERPLANT COMPONENTS (ENGINE MODEL 7083-7391)

NOTE

Location of surge tank pressure relief valve differs in M109A2/M109A3 and M109A4/M109A5 Howitzers (para 7-5).

LEGEND

- | | |
|---|---|
| 1 Transmission lifting eye | 25 Radiator filler |
| 2 Engine oil filter-to-oil cooler hose | 26 Radiator cooling fans |
| 3 Engine oil cooler-to-filter hose | 27 Fuel return line quick disconnect |
| 4 Coolant pump | 28 Inlet thermostat housing |
| 5 Engine viscous vibration damper | 29 Engine lifting eye |
| 6 Oil pan | 30 Engine coolant temperature transmitter |
| 7 Tachometer driveshaft | 31 Engine exhaust outlet duct |
| 8 Speedometer driveshaft | 32 Engine blower inlet housing |
| 9 Engine coolant inlet tube | 33 Turbocharger |
| 10 Engine and transmission support | 34 Engine turbocharger inlet duct |
| 11 Brake apply lever — right | 35 Engine governor |
| 12 Brake apply lever — left | 36 Engine governor throttle control rod |
| 13 Universal joint flange adapter | 37 Exhaust crossover tube |
| 14 Transmission | 38 Right engine exhaust manifold |
| 15 Transmission throttle valve rod | 39 Glow plug controller |
| 16 Transmission steer control rod | 40 Engine oil filler cap |
| 17 Transmission shift control rod | 41 Transfer breather tube |
| 18 Secondary fuel filter | 42 Bypass thermostat housing |
| 19 Alternator-to-rectifier wiring harness | 43 Aeration detector |
| 20 Transmission inspection cover (brake adjustment) | 44 Radiator cooling fan shroud |
| 21 Surge tank-to-coolant pump hose | 45 Radiator-to-surge tank hose |
| 22 Engine oil filters | 46 Crossover tube-to-surge tank hose |
| 23 Primary fuel filter | 47 Surge tank pressure relief valve |
| 24 Coolant surge tank | 48 Crossover tube |
| | 49 Radiator |

POWERPLANT
(LEFT FRONT VIEW)

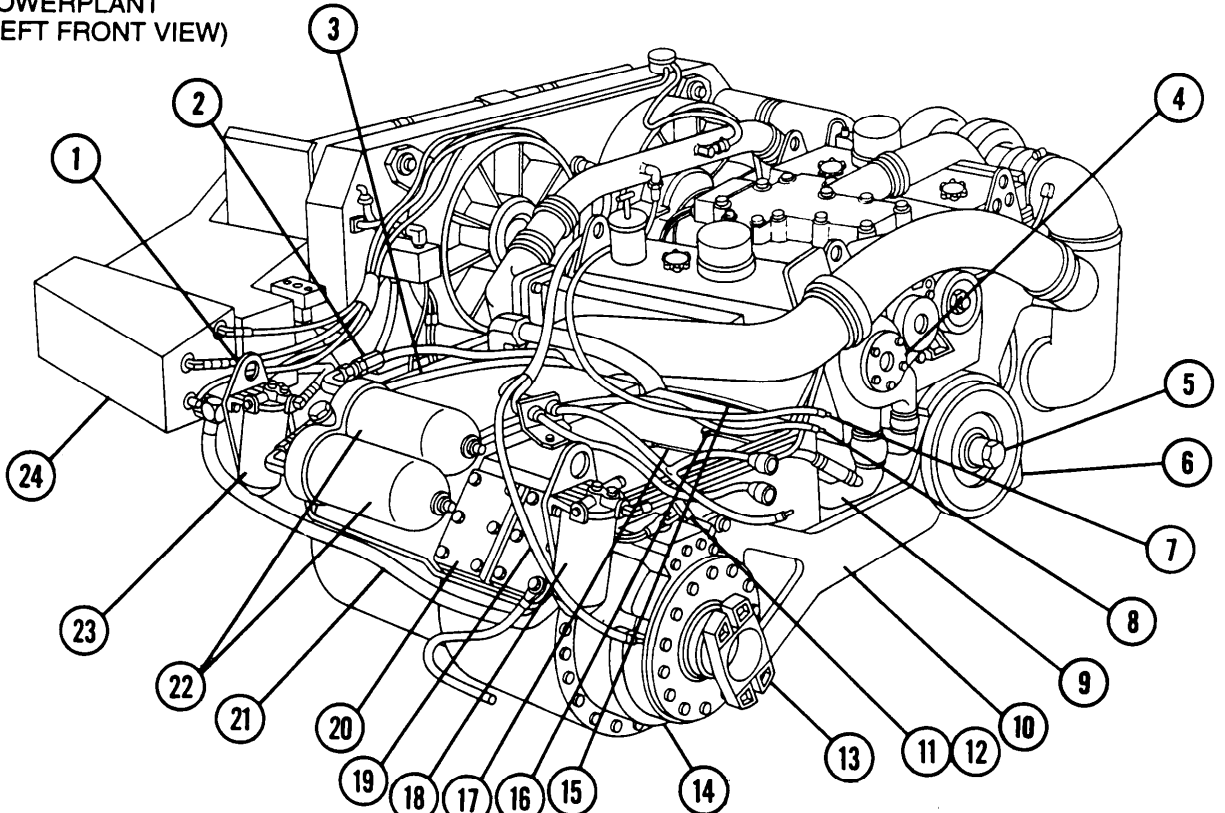

(TOP VIEW)

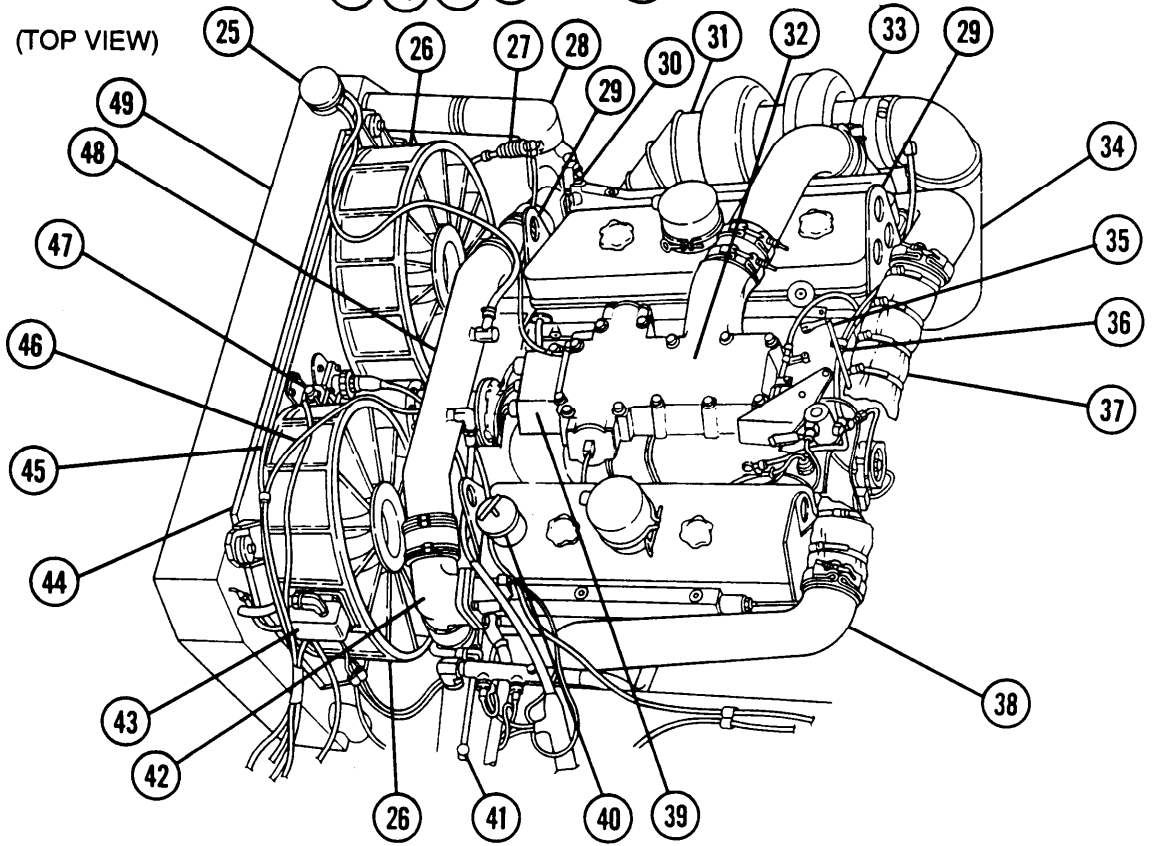

4-4 LOCATION OF POWERPLANT DISCONNECTS (ENGINE MODEL 7083-7391)

The following legend and illustrations are for reference only. For removal and installation of the powerplant, see paragraph 4-5.

NOTE

M109A4/M109A5 powerplant ground cable is located at starter. For information on disconnect points of winterization kit, see Chapter 14.

LEGEND

- | | | | |
|----|---|----|--|
| 1 | Engine-to-lower fuel tank return hose and clamp | 19 | Powerplant ground cable (M109A2/M109A3) |
| 2 | Engine exhaust pipe flanges | 20 | Alternator-to-rectifier harness (at rectifier) |
| 3 | Fixed fire extinguisher nozzle | 21 | Coolant pump-to-surge tank hose clamps |
| 4 | Air cleaner duct hose at turbocharger inlet | 22 | Primary fuel filter input hose |
| 5 | Governor fuel shutoff lever, pulley, and cable | 23 | Speedometer right angle rod |
| 6 | Throttle governor control rod | 24 | Coolant surge tank, retainer, and pad |
| 7 | Throttle governor control rod (linkage) | 25 | Separation of starter cable and generator-to-rectifier harness |
| 8 | Steer control rod | 26 | Air cleaner duct hose |
| 9 | Throttle control tube | 27 | Engine compartment access cover |
| 10 | Accelerator and throttle control bracket | 28 | Engine mount release shaft |
| 11 | Tachometer flexible driveshaft | 29 | Throttle valve control rod linkage |
| 12 | Speedometer flexible driveshaft | 30 | Brake control sprocket and shaft |
| 13 | Shift control rod | 31 | Master relay and voltage regulator |
| 14 | Master relay and voltage regulator disconnects | 32 | Transmission support caps |
| 15 | Final drive universal joints | 33 | Powerplant ground cable terminal (M109A2/M109A3) |
| 16 | Transmission trunnion caps | 34 | Bilge pump hose and tube (para 11-1 8) |
| 17 | Brake control sprocket, shaft, and pin | | |
| 18 | Engine starter cable and master circuit harness | | |

POWERPLANT DISCONNECT POINTS IN HULL
(POWERPLANT IN VEHICLE)

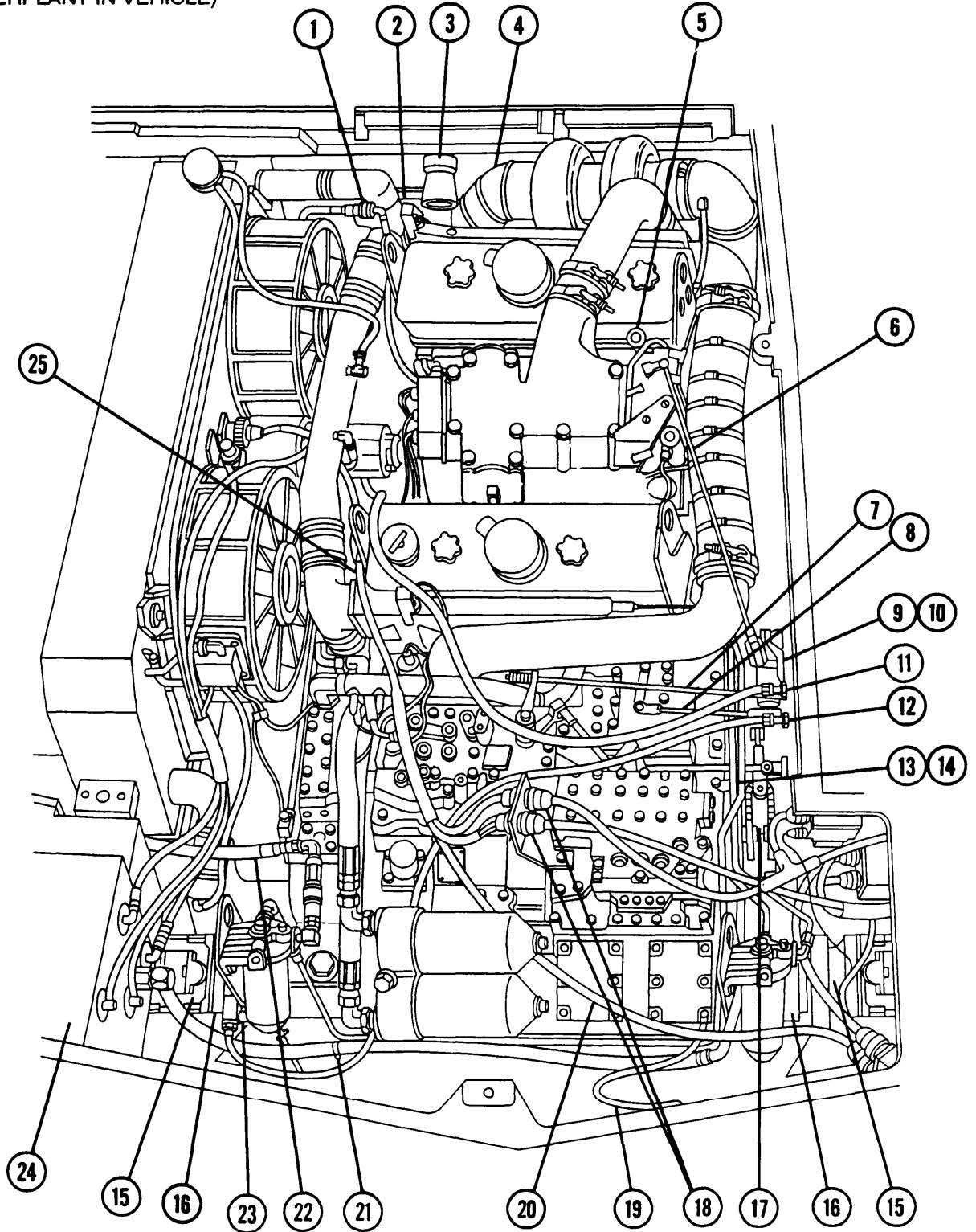

4-5 POWERPLANT

This task covers:	a. Removal	b. Inspection
	c. Special Equipment Hookup	d. Test Run
	e. Special Equipment Removal	f. Installation

INITIAL SETUP

Tools

General mechanic's tool kit (item 64, Appx H)
 Adapters (2) (item 4, Appx H)
 Box wrench (item 67, Appx H)
 Ground cable (M109A2/M109A3) (item 7, Appx H)
 Hose assemblies (2) (item 30, Appx H)
 Lifting sling (item 59, Appx H)
 Power cable (rectifier-to-alternator) (M109A2/M109A3) (item 8, Appx H)
 Power cable (rectifier-to-alternator) (M109A4/M109A5) (item 9, Appx H)
 Power cable (starter and master warning circuit) (item 11, Appx H)
 Power cable (starter circuit) (M109A4/M109A5) (item 10, Appx H)
 Protective fan screens (2) (item 53, Appx H)
 Quick disconnects (2) (item 14, Appx H)
 Safety screen (item 54, Appx H)
 Socket wrench set (item 56, Appx H)
 Starter electrical lead (M109A2/M109A3) (item 34, Appx H)
 Torque multiplier (item 37, Appx H)
 Torque wrench (item 71, Appx H)
 Torque wrench (item 72, Appx H)

Materials/Parts

Antiseize compound (item 9, Appx D)
 Cotter pins (2) (item 38, Appx G)
 Cotter pins (2) (item 40, Appx G)

LockWashers (2) (item 74, Appx G)
 LockWashers (2) (item 88, Appx G)
 LockWashers (12) (item 89, Appx G)
 LockWashers (3) (item 90, Appx G)
 LockWashers (2) (item 91, Appx G)
 LockWashers (3) (item 96, Appx G)
 LockWashers (2) (item 100, Appx G)
 LockWires (2) (item 25, Appx G)
 Packing (item 151, Appx G)
 Wood blocks (item 3, Appx E)

Personnel Required
 Three

References
 TM 9-2350-311-10
 TM 9-4910-571-1 2&P

Equipment Conditions
 Battery ground straps disconnected (para 8-28)
 Gun tube traversed to right angles with hull (TM 9-2350-311 -10)
 Howitzer moved to level surface (TM 9-2350-311-10)
 Howitzer secured, tracks blocked (TM 9-2350 -311-10)
 MASTER switch OFF (TM 9-2350-311-10)
 Parking brake released (TM 9-2350-311-10)
 Steering wheel moved to right (TM 9-2350-311-10)
 Throttle moved to idle position (TM 9-2350-311-10)
 Transmission placed in R2 (TM 9-2350-311-10)

a. Removal

CAUTION

Track must be blocked so that vehicle will not roll out of control. When powerplant is disconnected, vehicle is without brakes.

NOTE

- PowerPlant disconnect points are illustrated in paragraphs 4-2 and 4-4. Refer to paragraphs 4-2 and 4-4 during removal of powerplant.
- Equipment used to remove powerplant unit must have a lifting capacity of at least 7500 lb (3402 kg), a reach of at least 9 ft (2.7 m), and a lift of at least 10 ft (3.0 m). Lifting equipment should be movable, or provisions must be made to move vehicle as powerplant is removed.
- An area 8 ft x 10 ft (2.4 m x 3.0 m) must be provided near track for powerplant after removal.
- A fabricated stand of wood blocks 6 in. x 6 in. x 18 in. (15.2 cm x 15.2 cm x 45.7 cm) must be provided to hold powerplant after removal.

1 Open air intake grille(1) and secure to machinegun pintle mount (2) with rope or strap (3).

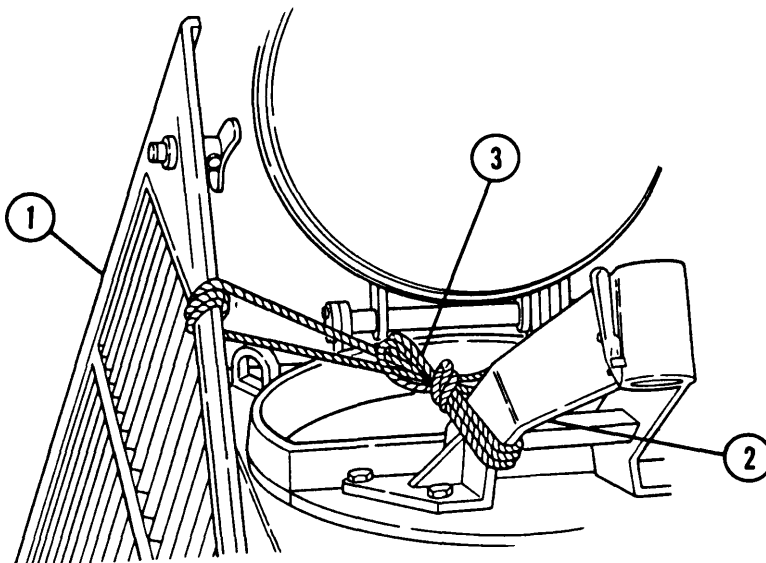

4-5 POWERPLANT — CONTINUED

a. Removal — continued

2 Remove screw (4), flat washer (5), support arm pin (6), and air intake grille hold-open support arm (7).

3 Remove four screws (8), engine exhaust deflector (9), and packing (10). Discard packing.

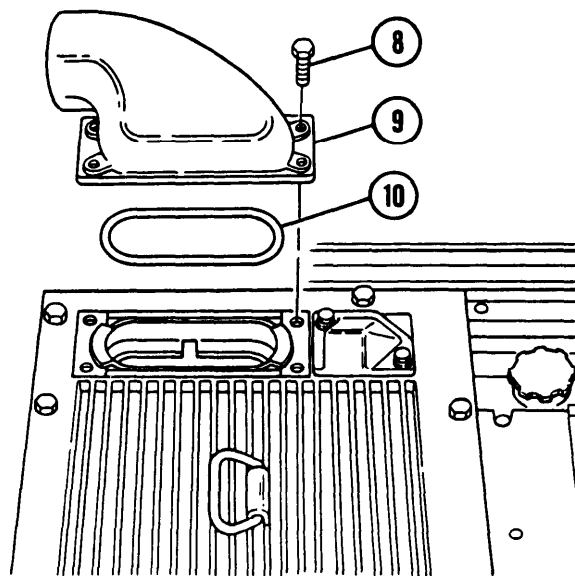
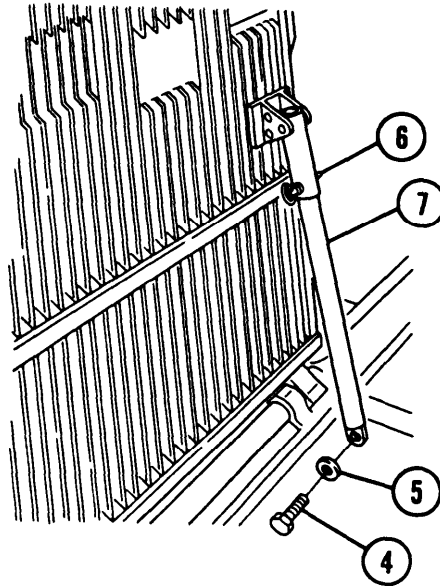

WARNING

Keep clear of equipment when it is being raised or lowered. To prevent injury, do not allow grilles or access doors to swing while suspended by lifting device.

NOTE

Each grille has different length screws. Keep screws with grille after removal.

4 Remove 14 screws(11) and engine exhaust grille (12).

5 Remove six screws (13), six washers (14), and radiator fan access door (15).

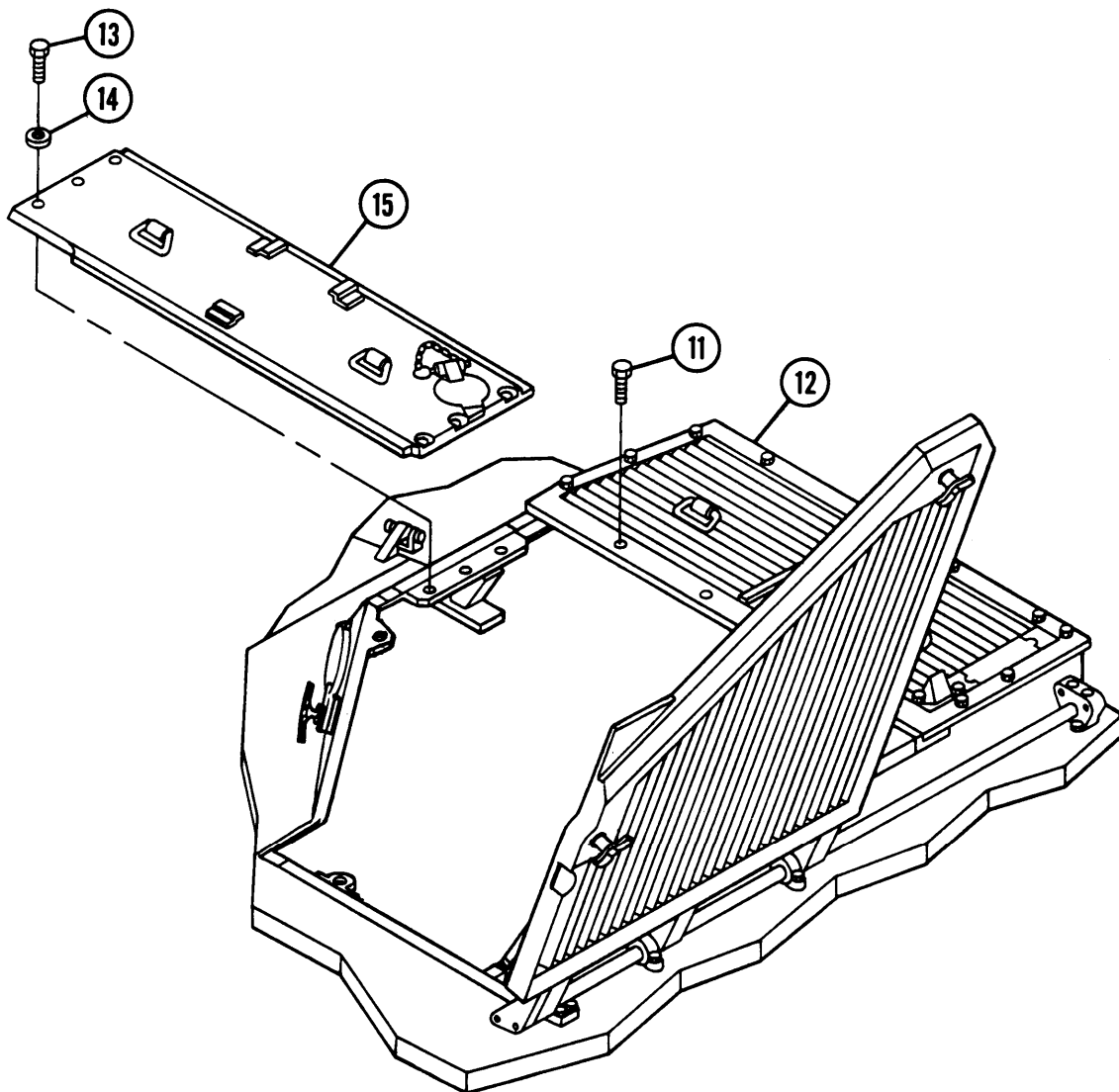

4-5 POWERPLANT — CONTINUED

a. Removal — Continued

6 Open right and left transmission access doors(16 and 17).

7 Remove two nuts (18), two washers (19), two screws (20), and transmission door support (21).

WARNING

Center front slope plate assembly is heavy. Do not allow center front slope plate to swing while suspended by hoist and sling. Use caution when working near a sling under tension to prevent severe injury.

CAUTION

Support center front slope plate during removal to prevent equipment damage.

NOTE

Use engine oil level access hole to remove center front slope plate.

8 Remove seven screws (22), seven washers (23), three screws (24), three washers (25), and center front slope plate assembly (26). If center front slope plate assembly is damaged, notify depot maintenance.

WARNING

Transmission access doors are heavy. If hoisting sling is not available, two personnel are required to lift and move doors.

9 Attach hoist and sling (27) to right transmission access door (16), supporting door at 45° angle. Remove two nuts (28), two washers (29), and two screws (30). Remove left transmission access door (17) using same procedure.

10 Remove two screws (31), two washers (32), two screws (33), four washers (34), two lockwashers (35), two nuts (36), and grille support assembly (37). Discard lockwashers.

11 Loosen hose clamp (38). Pull bilge pump hose (39) away from connector tube (40).

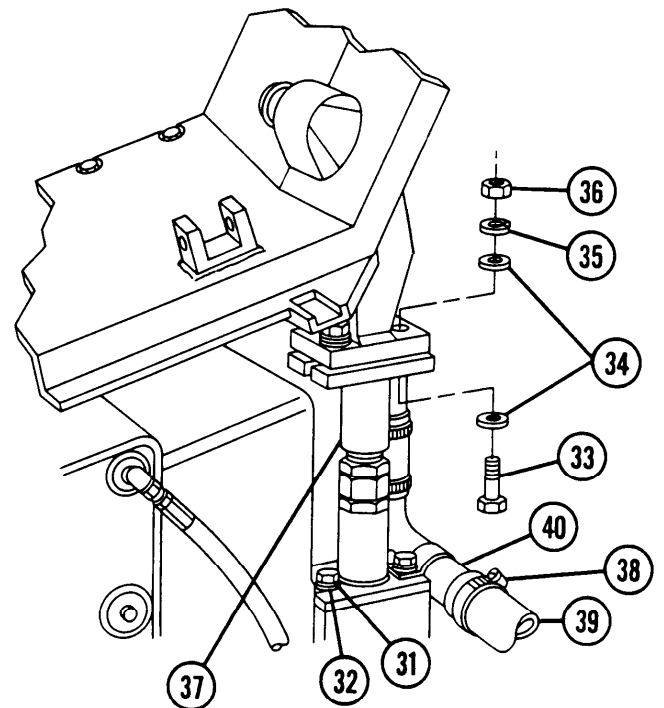
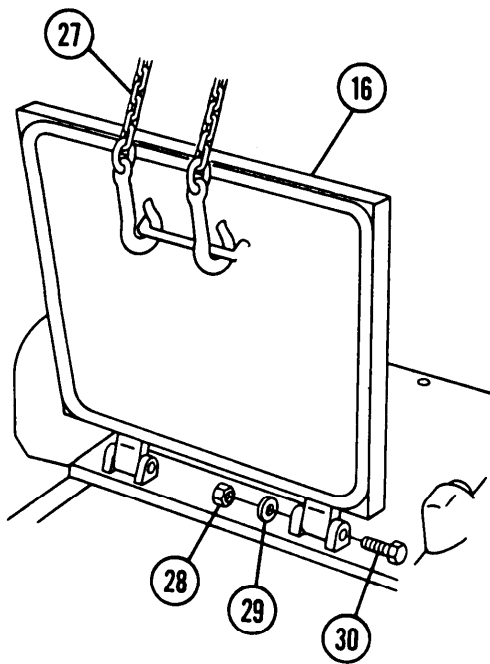
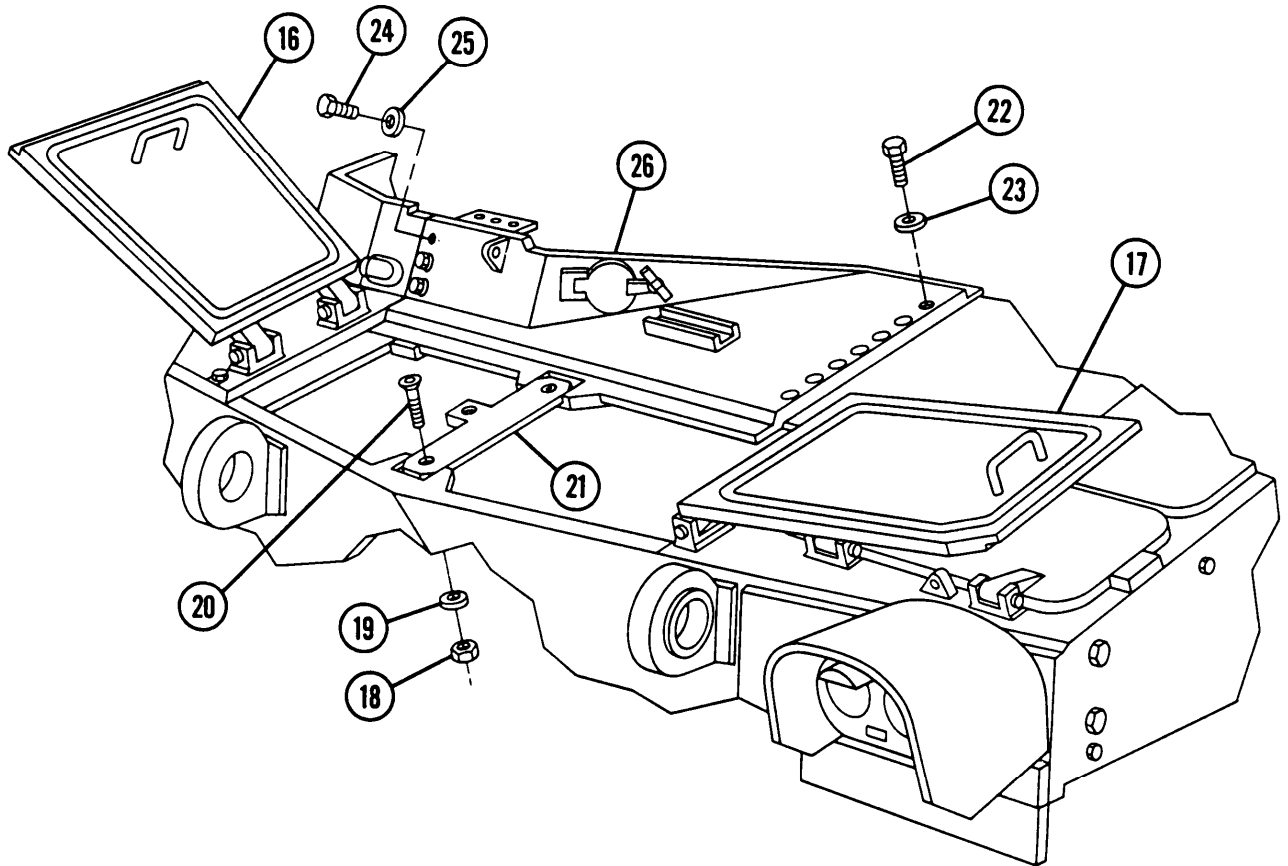

4-5 POWERPLANT — CONTINUED

a. Removal — Continued

- 12 Remove seven screws (41), seven washers (42), six socket head screws (43), and right front grille assembly (44).
- 13 Remove two screws (45) and air intake grille handle bracket (46).

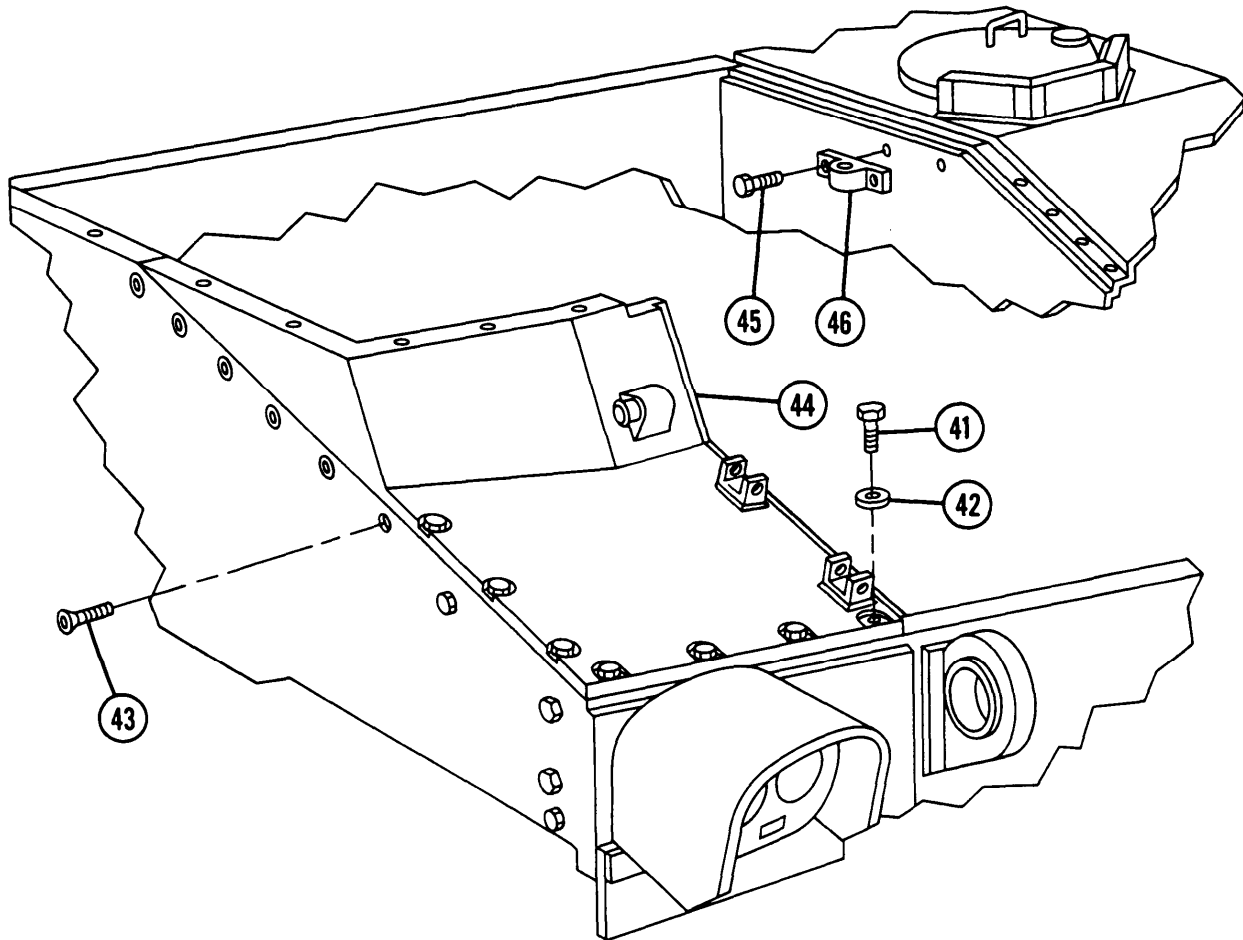

- 14 Disconnect fuel return hose (47) at quick disconnect assembly (48).

NOTE

Position of rubber-coated clamp is same for both M109A2 and M109A3 Howitzers.

- 15 Remove screw (49) and washer (50) from rubber-coated clamp (51).
- 16 Unscrew swivel nut (52) and remove fixed fire extinguisher nozzle (53).
- 17 Remove two cotter pins (54), two castle nuts (55), two springs (56), and two screws (57) and disconnect engine exhaust pipe flanges (58). Discard cotter pins.
- 18 Loosen clamp (59).
- 19 Remove engine exhaust pipe (60) and place on top of engine (61).

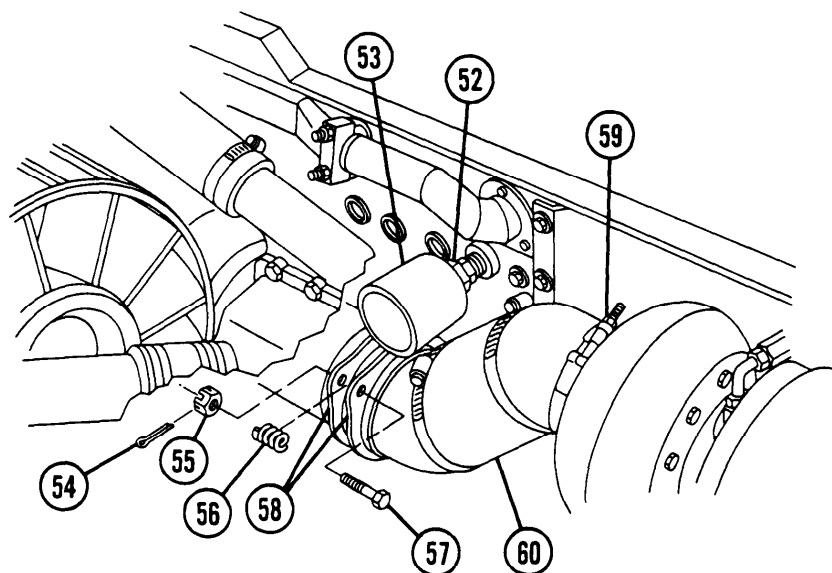
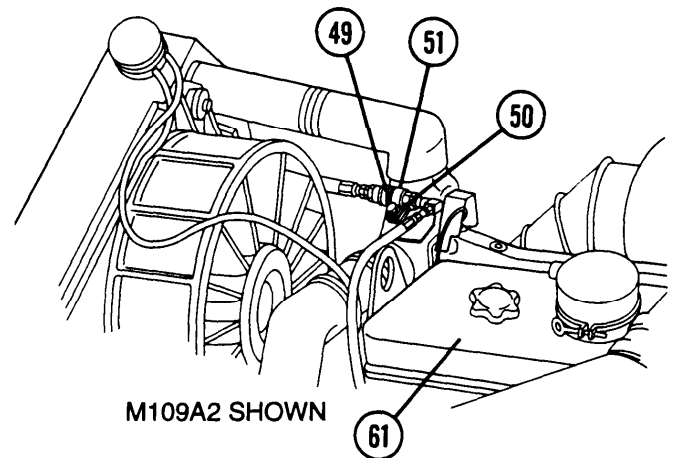
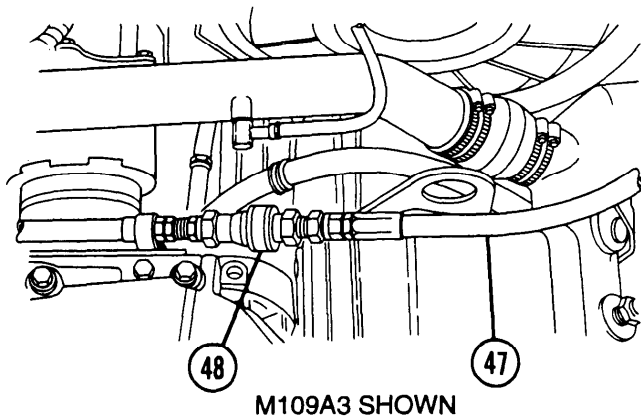

4-5 POWERPLANT — CONTINUED

a. Removal — Continued

- 20 Pull out quick-release pin (62), remove two screws (63) from bracket and pulley (64), and disconnect governor fuel shutoff cable (65). Lay cable on hull.
- 21 Loosen two clamps (66) and pull hose (67) away from engine compartment access cover (68).
- 22 Remove 12 screws (69), 12 lockwashers (70), and access cover (68). Discard lockwashers.
- 23 Turn engine mount release shaft (71) counterclockwise to loosen engine mount.

NOTE

Position of primary fuel filter differs in M109A2 and M109A3 Howitzers (para 1-15).

- 24 Disconnect primary fuel filter input hose (72) quick disconnect (73).

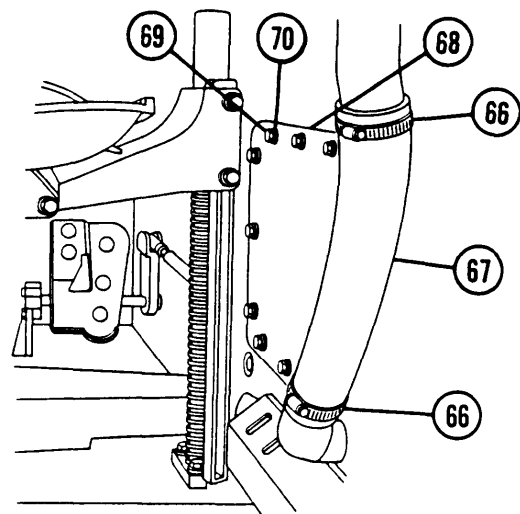
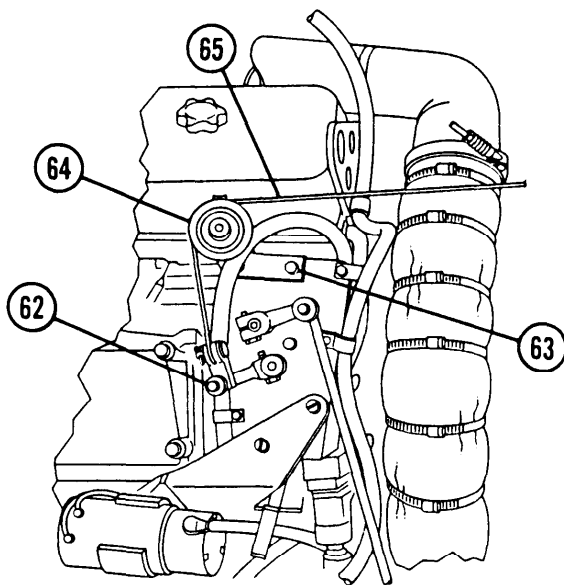

DRIVER'S COMPARTMENT

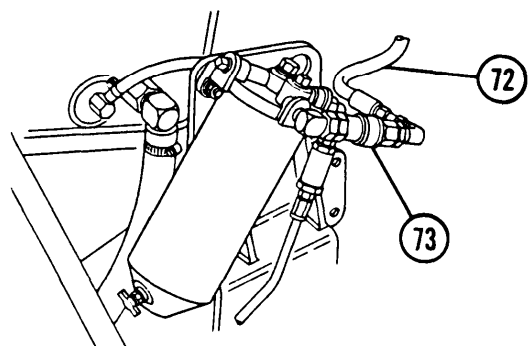
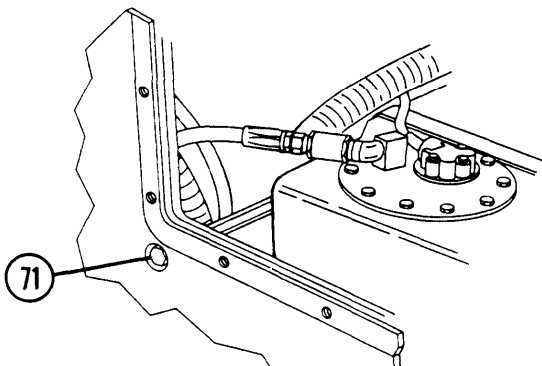

25 Loosen nut (74) and remove clamp (75). Disconnect air cleaner duct (76).

26 Disconnect alternator-to-rectifier wiring harness (77) and rectifier-to-voltage regulator lead (78).

NOTE

- Turn universal joint on left side of vehicle straight up and down.
- If adapter screws are inaccessible, remove blocking from vehicle tracks and push or tow vehicle until universal joints rotate enough to gain access to adapter screws.

27 Remove lockwire (79) and four screws (80). Push apart right final drive universal joint (81) from flange (82) on transmission (83). Repeat this procedure for left final drive universal joint. Discard lockwire.

28 Unscrew nut (84) and remove speedometer right angle drive (85).

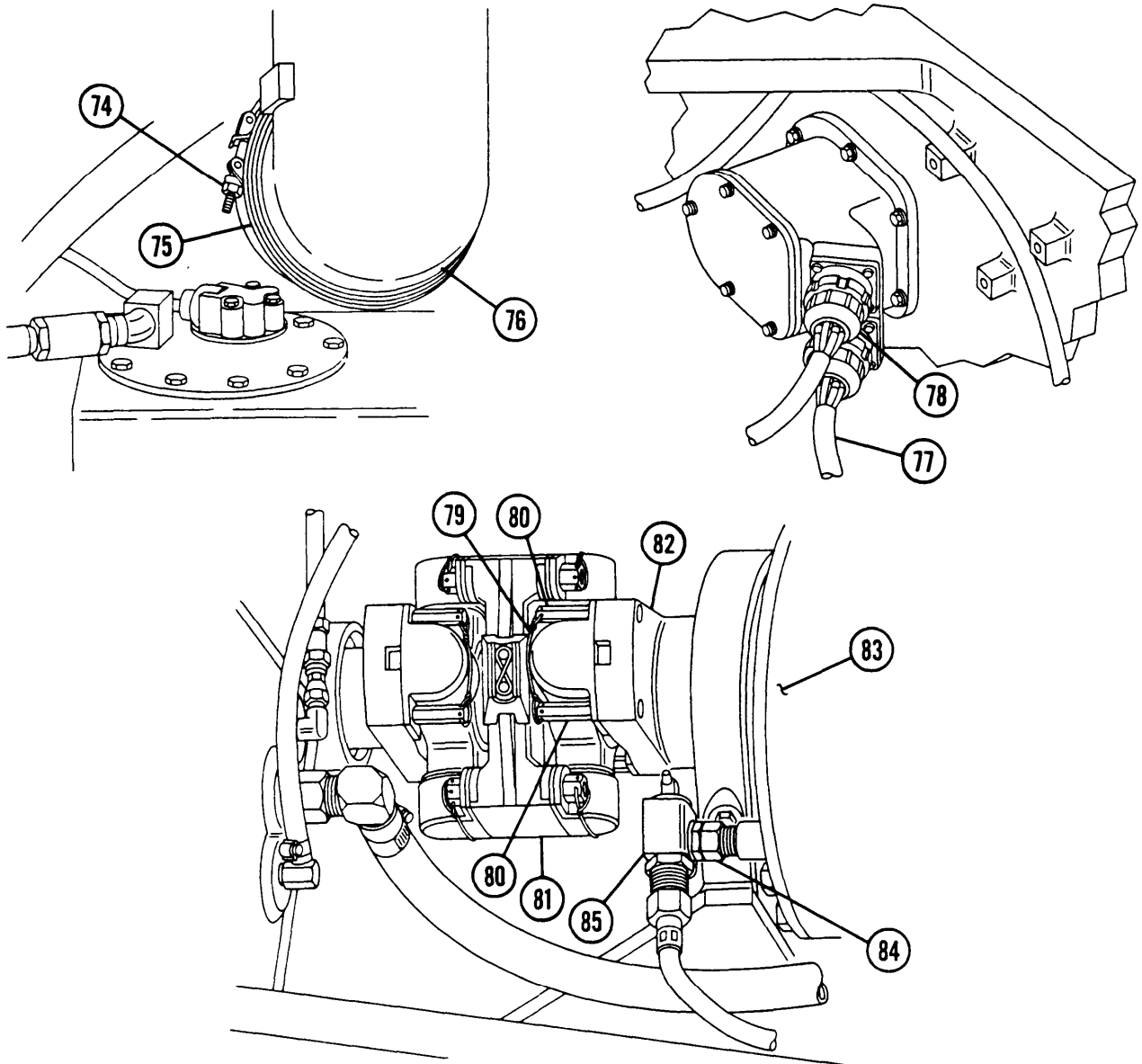

4-5 POWERPLANT — CONTINUED

a. Removal — Continued

- 29 Disconnect four electrical connectors (86) at master relay (87) and voltage regulator (88).

NOTE

Step 30 applies only to M109A2/M109A3 Howitzers.

- 30 Remove screw (89) and two lockwashers (90) and disconnect powerplant ground cable (91). Install lockwashers and screw.
- 31 Move throttle control to full open position, pull out quick-release pin (92), and release throttle governor control rod (93).
- 32 Tag tachometer and speedometer flexible driveshafts (94 and 95). Unscrew two nuts (96) and disconnect driveshafts.
- 33 Unscrew nut (97) and disconnect throttle valve control rod (98).
- 34 Pull out two quick-release pins (99) and disconnect steer control rod (100). Remove rod with boot (101) through engine compartment.

CAUTION

After disconnecting shift control rod, ensure rod is in driver's compartment wall to prevent damage when powerplant is hoisted or reinstalled,

- 35 Pull out quick-release pin (102) and disconnect shift control rod (103). Move rod into hull to prevent damage. Place shift control in R2 position.

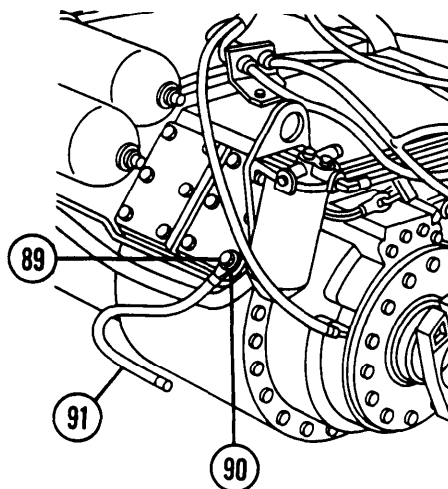
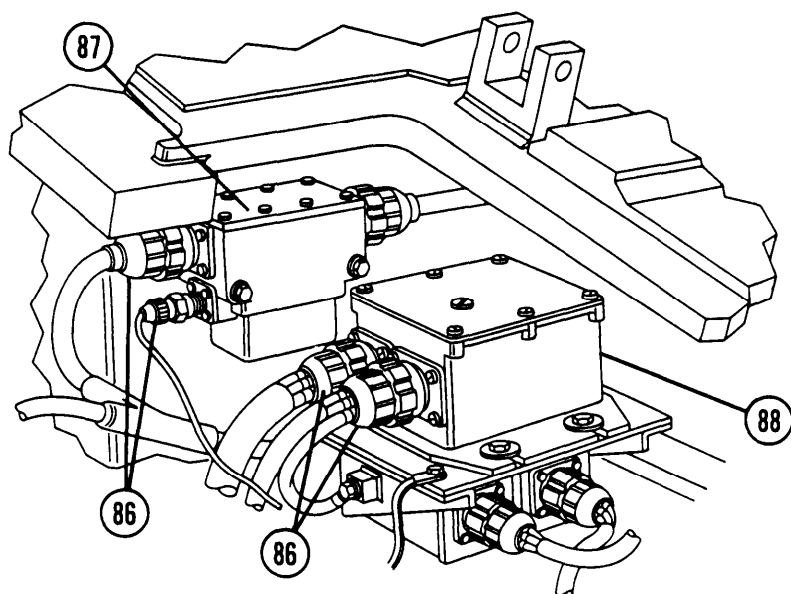

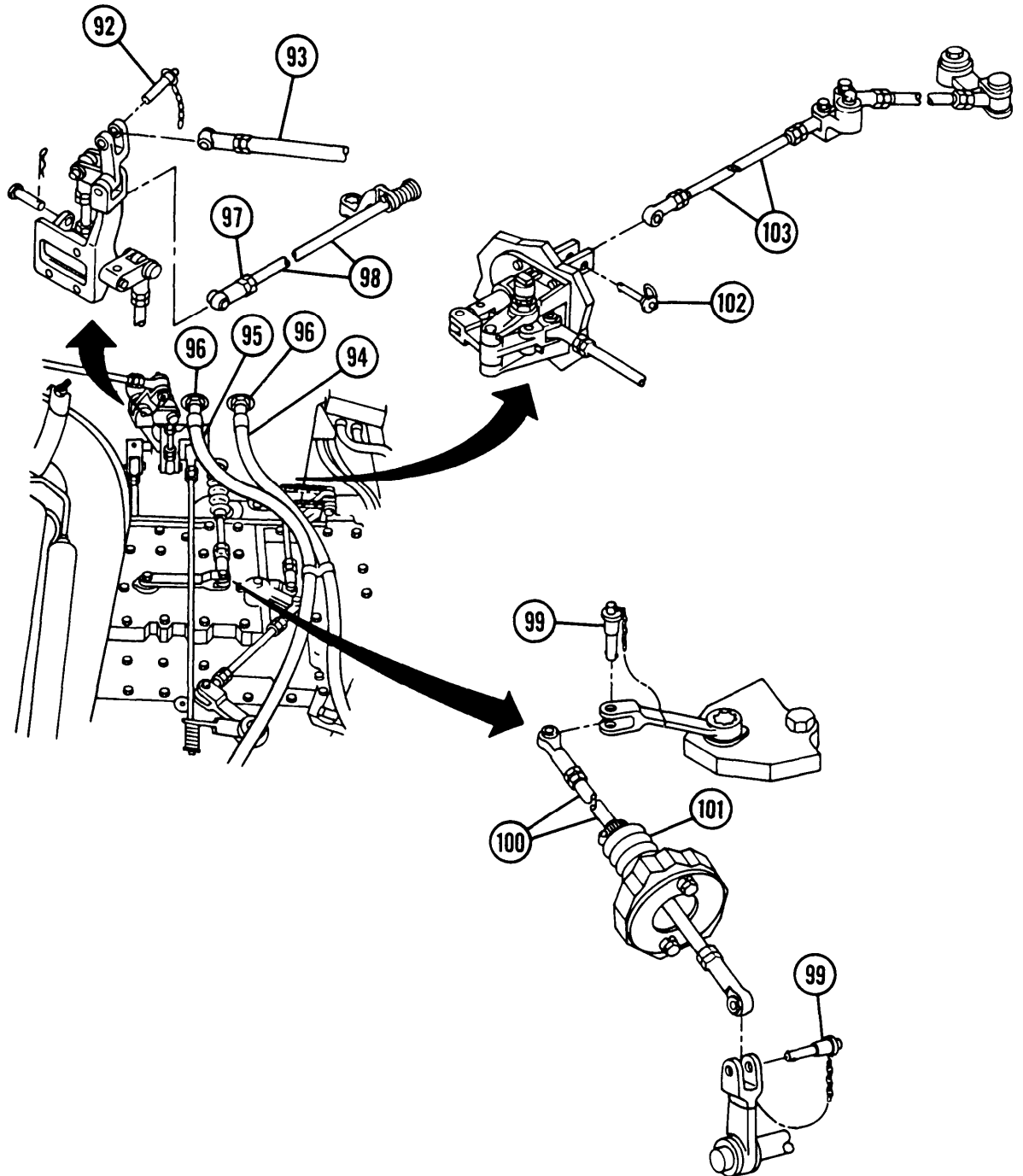

- 40 Disconnect starter cable (117) and master circuit harness (118).
- 41 Disconnect fuel filter-to-fuel pump tube (119).
- 42 Remove three bolts (120), three lockwashers(121), and bracket (122) with primary fuel filter (123) from transmission.

NOTE

- Mark transmission trunnion caps (124) and shims (125) with location (left front or right front) at removal.
- Retain shims (125) if present.
- If trunnion caps (124) are damaged, notify support maintenance.

- 43 Remove left trunnion cap (124) from transmission support assembly (126) by removing two bolts(127 and 128), two flat washers (129), and shims (125) if present. Repeat for right support assembly.
- 44 Install bracket (122) with primary fuel filter (123), three lockwashers (121), and three bolts (120). Connect fuel filter-to-fuel pump tube (119).

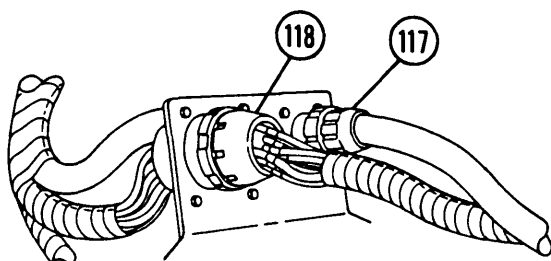

TRANSMISSION—TOP CENTER
M109A2/M109A3

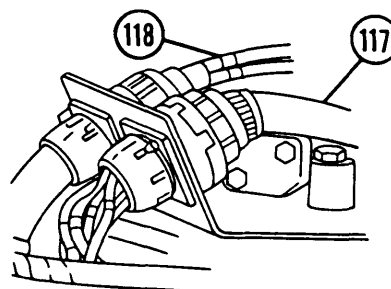

M109A4/M109A5

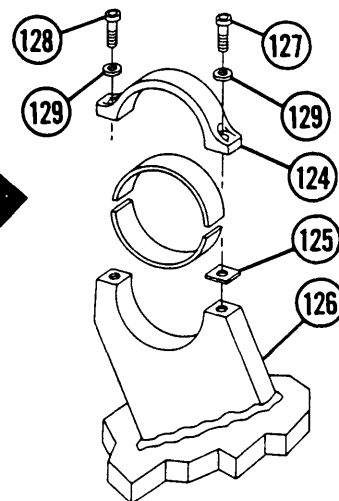
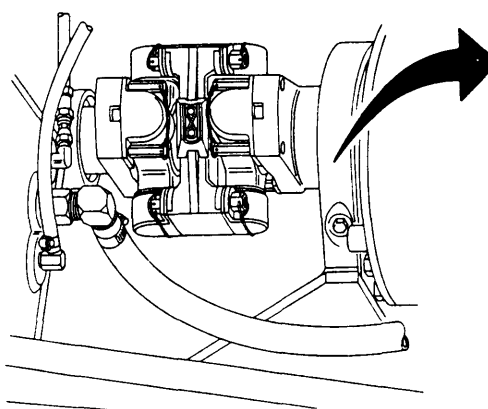
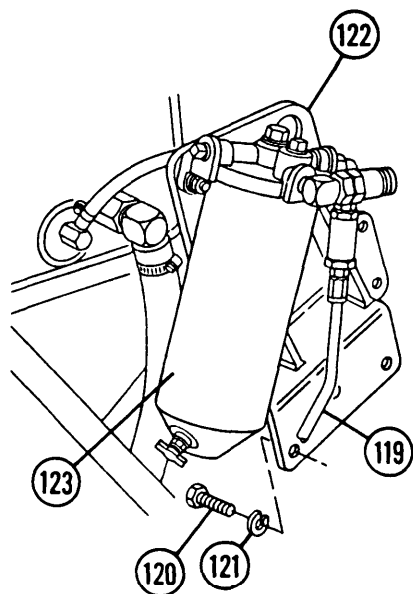

POWERPLANT SHOWN
REMOVED FOR CLARITY

4-5 POWERPLANT — CONTINUED

a. Removal — Continued

45 Remove two screws (1 30), two washers(131), and retainer pad (132).

46 Remove two screws (133), two nuts (134), and two lockwashers (135) on coolant pump-to-surge tank hose (136). Discard lockwashers.

47 Remove coolant surge tank (1 37) and place on top of transmission (83).

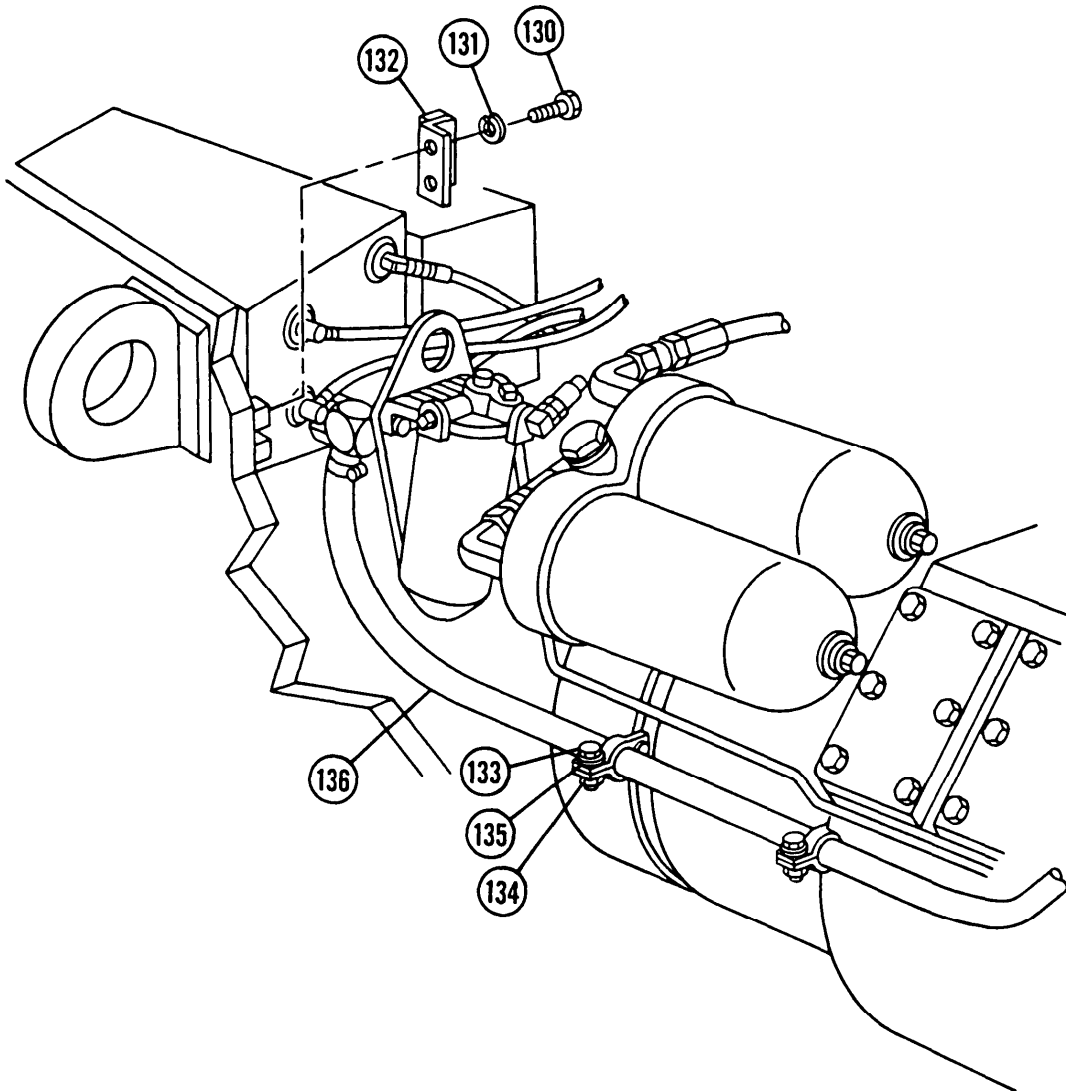

WARNING

Perform visual inspection and check load test date on lifting sling. Never crawl under equipment when performing maintenance unless equipment is securely blocked. Keep clear of equipment when it is being raised or lowered. Do not allow heavy components to swing while suspended by lifting device. Exercise extreme caution when working near a cable or chain under tension. Failure to do so could cause severe injury or death.

CAUTION

Use extreme care when removing and installing powerplant to avoid damaging fuel tanks and radiator.

48 Attach lifting sling to power plant (138) at four lifting eyes (139).

49 Lift powerplant (138) out of hull slowly, After lifting powerplant several inches, shift it toward front of vehicle for clearance. Watch all sides of powerplant to ensure clearance during removal.

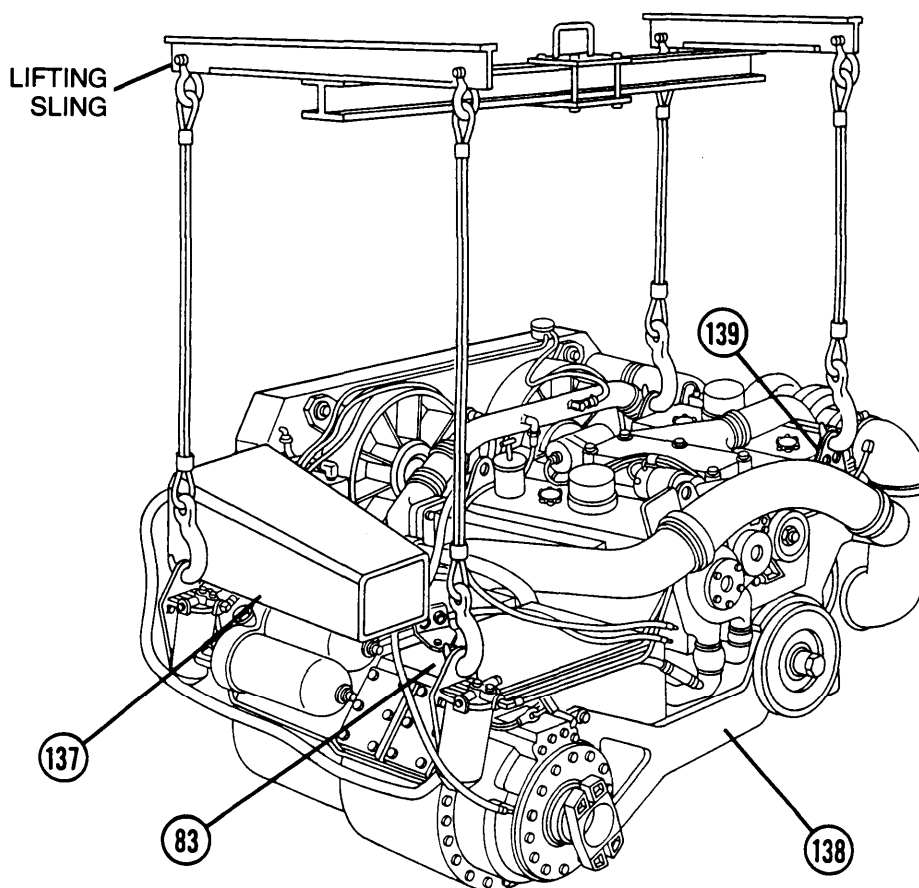

4-5 POWERPLANT — CONTINUED

a. Removal — Continued

CAUTION

Provide clearance for engine oil drain plug.

50 Place powerplant (138) on wood blocks (140).

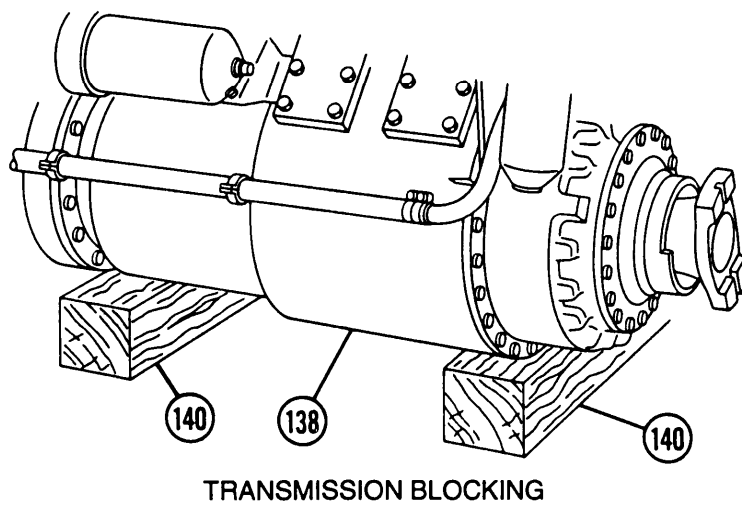
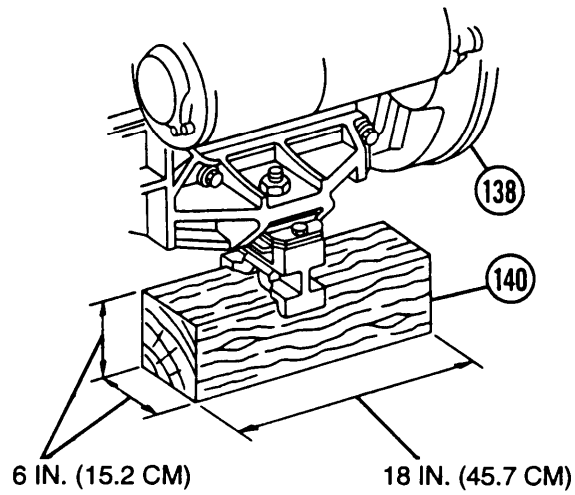

b. Inspection

Powerplant should be given a general inspection in the following areas whenever the powerplant is removed from vehicle.

NOTE

Replace or repair any defective or damaged item or component as required, if replacement or repair is beyond scope of unit maintenance, notify support maintenance.

- 1 Check gaskets (141), seals (142), and covers (143) for seepage of fuel and oil.
- 2 Check for damaged, distorted, or broken hose, tube, and line connectors (nuts, adapters, reduction fittings, and couplers) (144).
- 3 Check fuel hoses, tubes (145), and connectors (144) for cracks, leaks, and seepage of fuel (para 6-10).

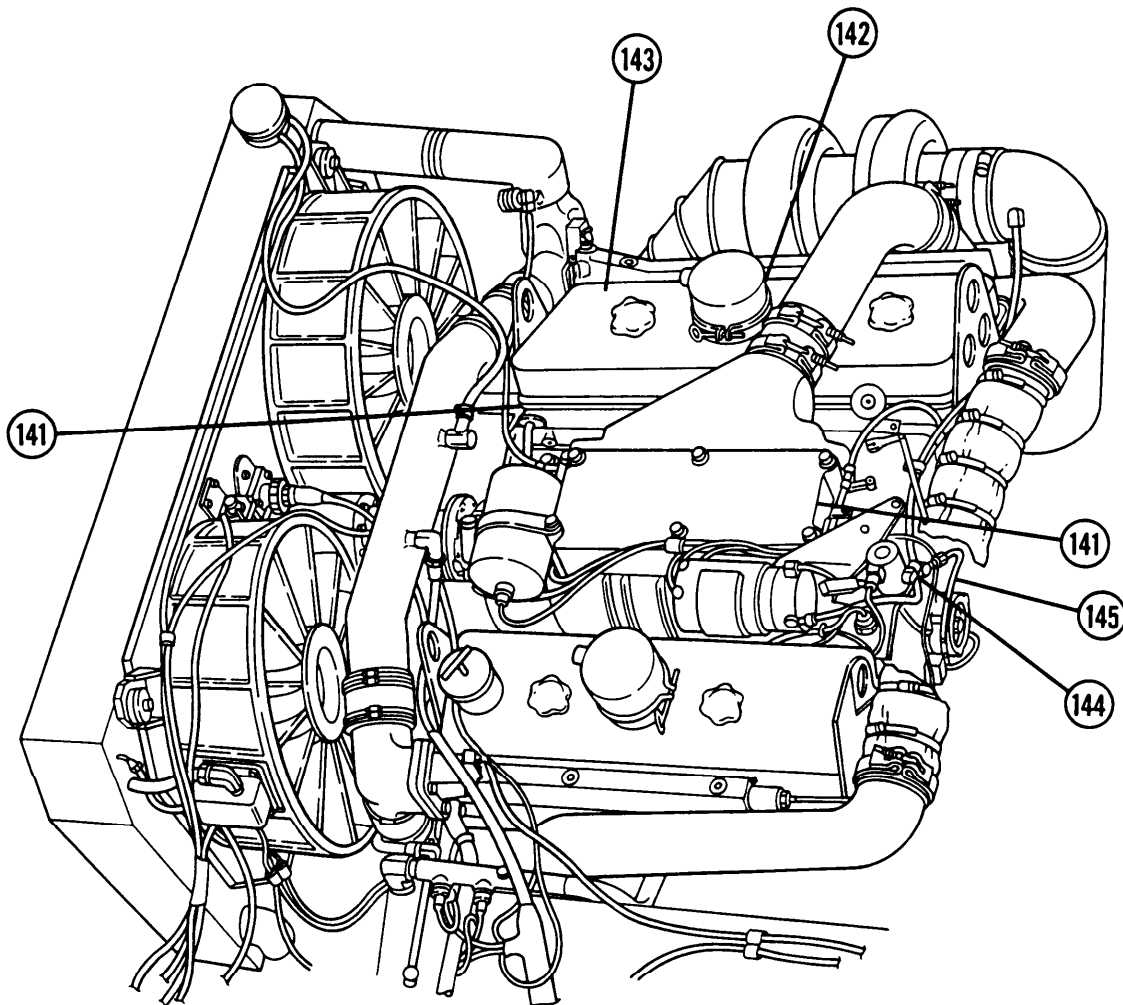

4-5 POWERPLANT — CONTINUED

b. Inspection — Continued

- 4 Check oil hoses, tubes (146), and connectors (144) for cracks, leaks, and seepage of oil (para 5-3 and 9-4).
- 5 Check for stripped or damaged threads on connectors (147), retaining bolts, nuts, and studs. Repair threads or replace components/items as appropriate.
- 6 Check electrical wires, leads, and connectors (148) for cracked insulation, oil, and grease on cables and connectors (para 8-41 or 8-42).
- 7 Check for broken screws and bolts. Replace broken screws or bolts.
- 8 Check for damaged, burred, pitted, or gummed-up seals, gaskets, and preformed packing seats. Clean, remove burrs, and replace components as required.
- 9 Check hull engine compartment floor for pools of oil, fuel, and coolant.
- 10 Check radiator (1 49) for coolant level. Check coolant for serviceability (para 2-15).
- 11 Check coolant hoses (150) and tubes for cracks, deterioration, and signs of coolant seepage (para 7-1 and 7-2).
- 12 Check oil filters (151) and fuel filters (123 and 152) for collection of sediment on filter elements (para 5-4, 6-6, and 6-7).

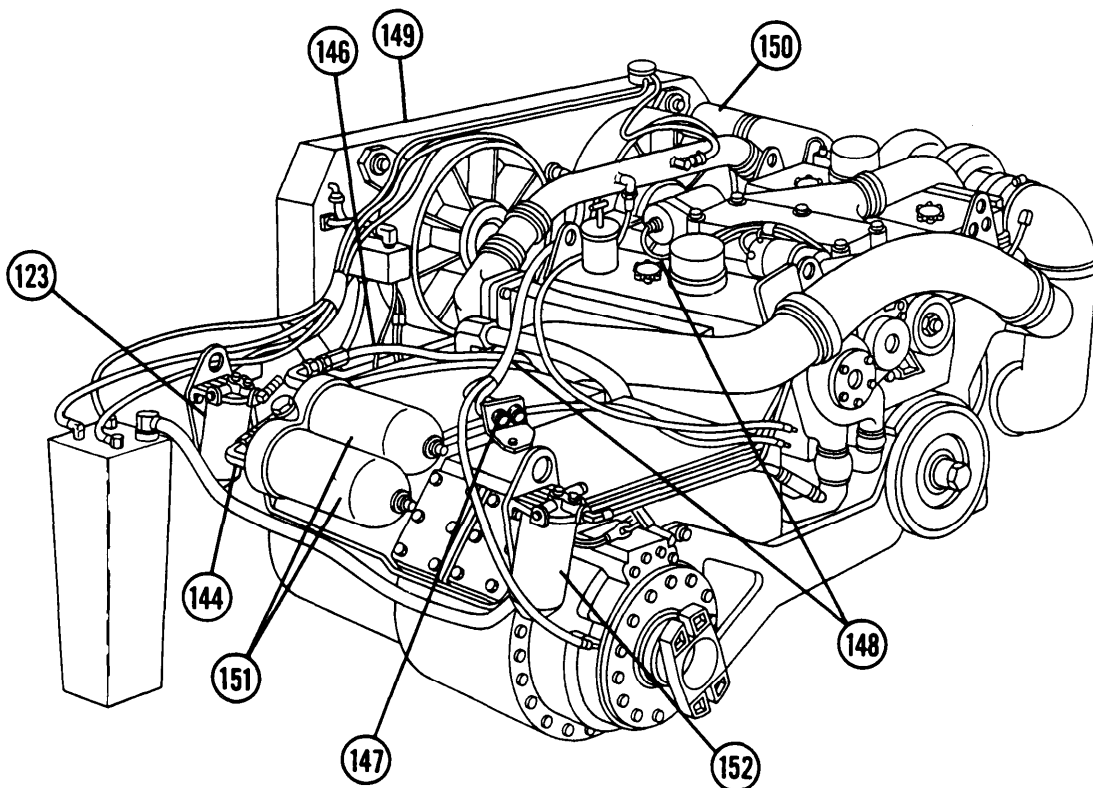

Operating the powerplant out of the vehicle lets maintenance personnel inspect the control and drive components of the powerplant by hand-operating control linkages on the transmission. Components can be checked for proper functioning and performance with the powerplant outside the vehicle without harm to the unit.

c. Special Equipment Hookup

- 1 Install two protective screens on radiator fans (153) with two thumbscrews and two nuts.
- 2 Install safety screen on air cleaner duct (76) with fine screen side facing out and install clamp (75).
- 3 Install engine exhaust pipe (60) on exhaust outlet (154) with clamp (59).
- 4 Position coolant surge tank (137) to one side, being careful not to bend hoses.

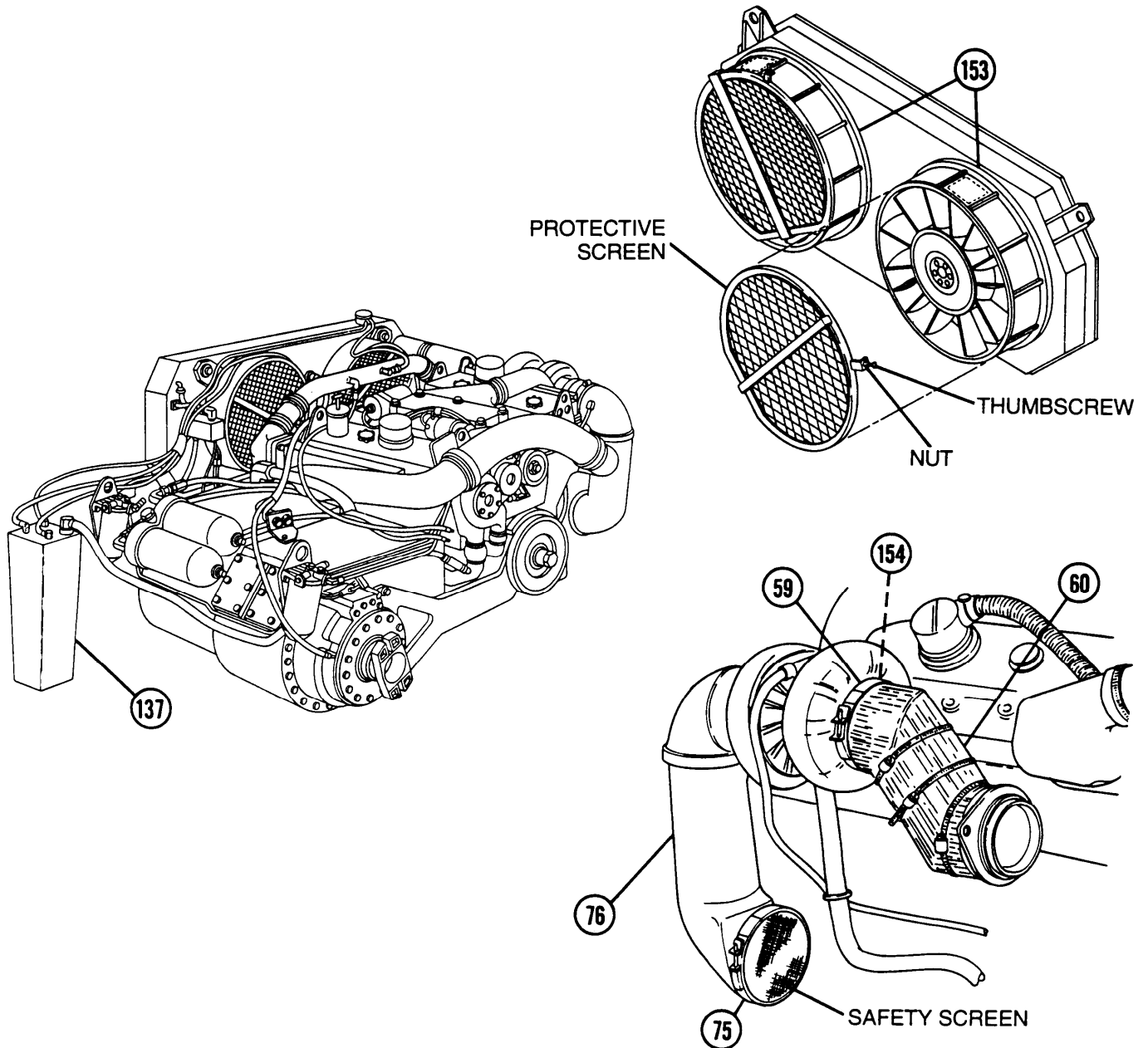

4-5 POWERPLANT — CONTINUED

c. Special Equipment Hookup — Continued

5 Connect adapter and hose assembly (155) to quick disconnect assembly (48) on engine-to-lower fuel tank return hose (156).

6 Connect quick disconnect and hose assembly (157) to primary fuel filter (123).

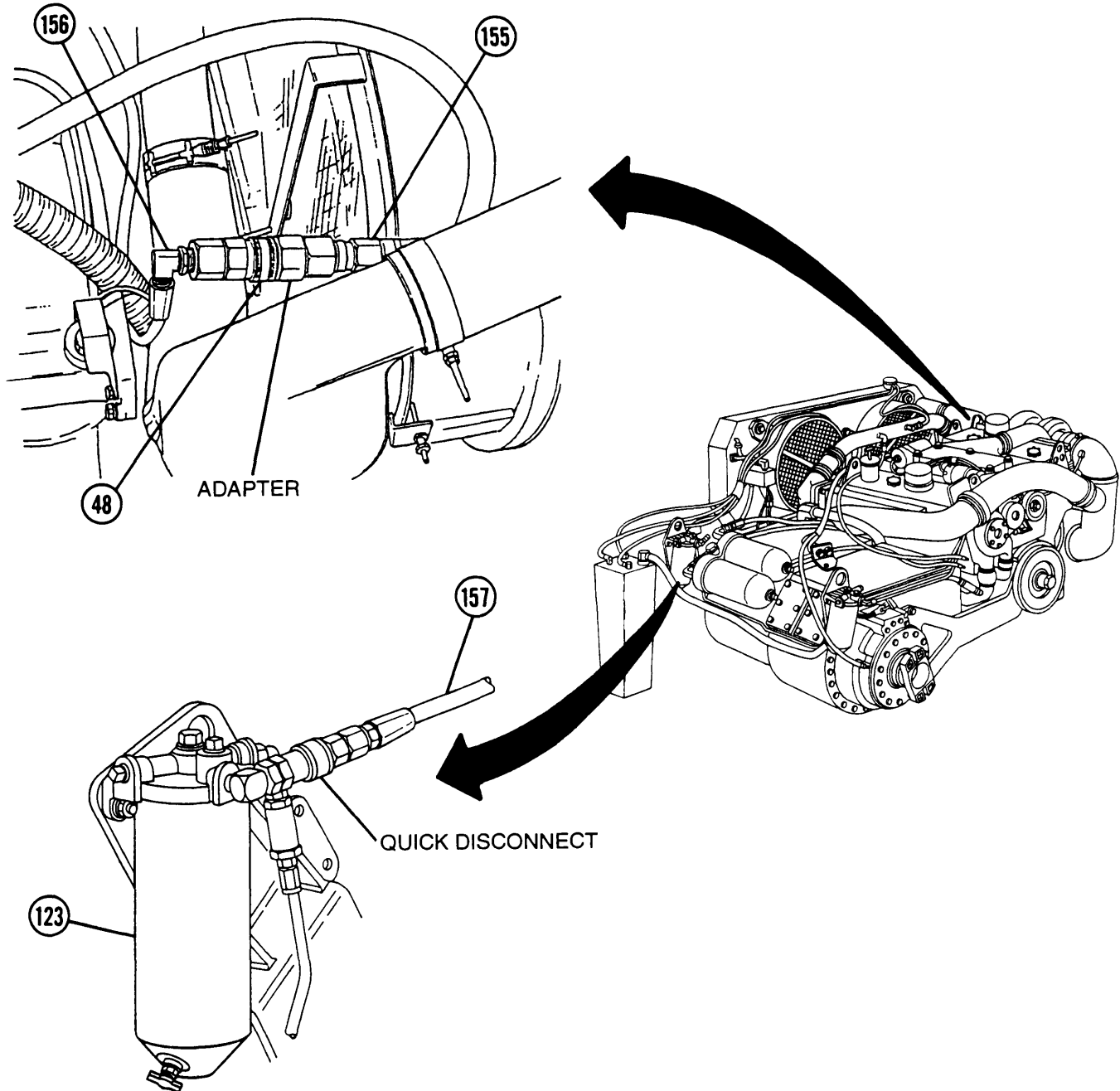

7 Connect quick disconnect and hose assembly (155) to fuel return hose (47).

8 Connect adapter and hose assembly (157) to quick disconnect (73) on primary fuel filter input hose (72).

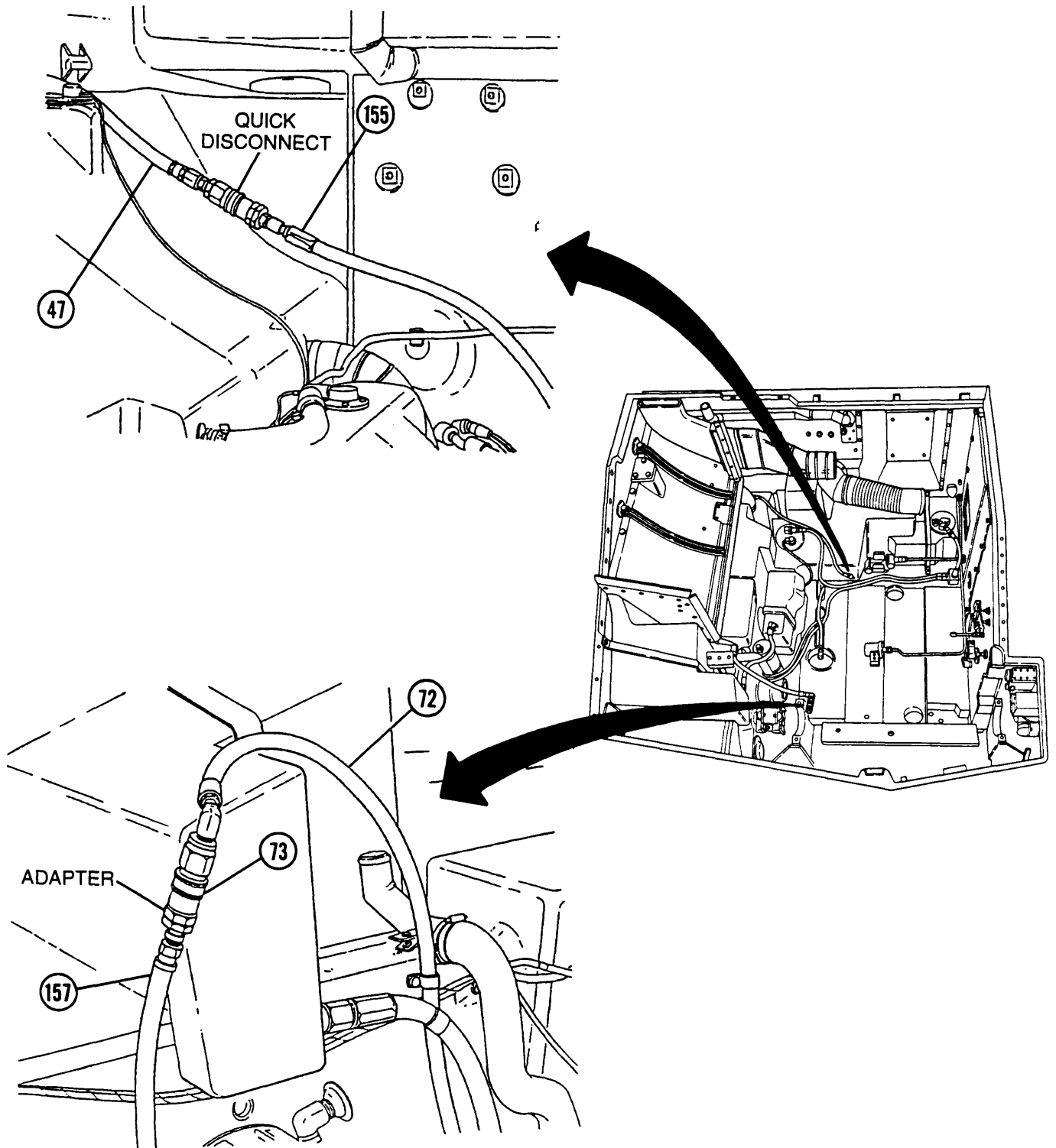

4-5 POWERPLANT — CONTINUED

c. Special Equipment Hookup — Continued

- 9 Connect two electrical connectors (86) to master relay (87).
- 10 Connect two electrical connectors (86) to voltage regulator (88).
- 11 Connect rectifier-to-voltage regulator lead 11593806 (M109A2/M109A3) or 12268303 (M109A4/M109A5) connector (78) to rectifier (1 58).
- 12 Connect power cable (rectifier-to-alternator) (item 8, Appx H) (M109A2/M109A3) or (item 9, Appx H) (M109A4/M109A5) (159) to rectifier (1 58).

NOTE

Step 13 applies to M109A4/M109A5 Howitzers.

- 13 Connect starter protection relay electrical lead 503 (160) to power cable (rectifier-to-alternator) (item 9, Appx H) (159).
- 14 Connect power cable (starter circuit) (item 34, Appx H) (M109A2/M109A3) or (item 10, Appx H) (M109A4/M109A5) (161) to starter cable 11593782 (M109A2/M109A3) or 12353401 (M109A4/M109A5) connector (117).
- 15 Connect power cable (starter and master warning circuit) (item 11, Appx H) (162) to master circuit wiring harness 12268100 (M109A2/M109A3) or 12268418 (M109A4/M109A5) connector (118).

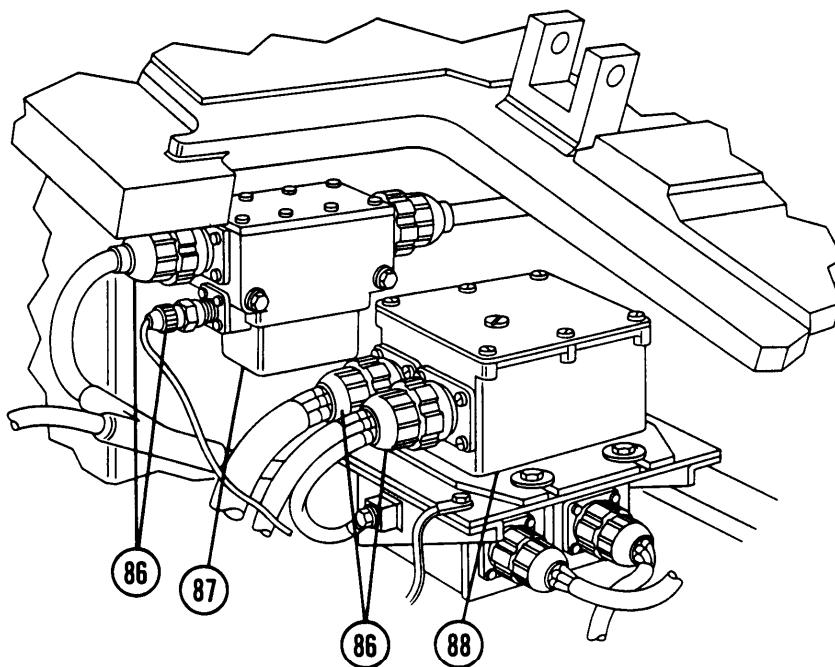

- 16 Connect power cable (rectifier-to-alternator) (item 8, Appx H) (M109A2/M109A3) or (item 9, Appx H) (M109A4/M109A5) (159) to alternator-to-rectifier wiring harness 12268102 (M109A2/M109A3) or 12268308 (M109A4/M109A5) (77).

NOTE

Step 17 applies to M109A4/M109A5 Howitzers.

- 17 Connect starter protection electrical lead 503(159) to electrical lead 503(163).

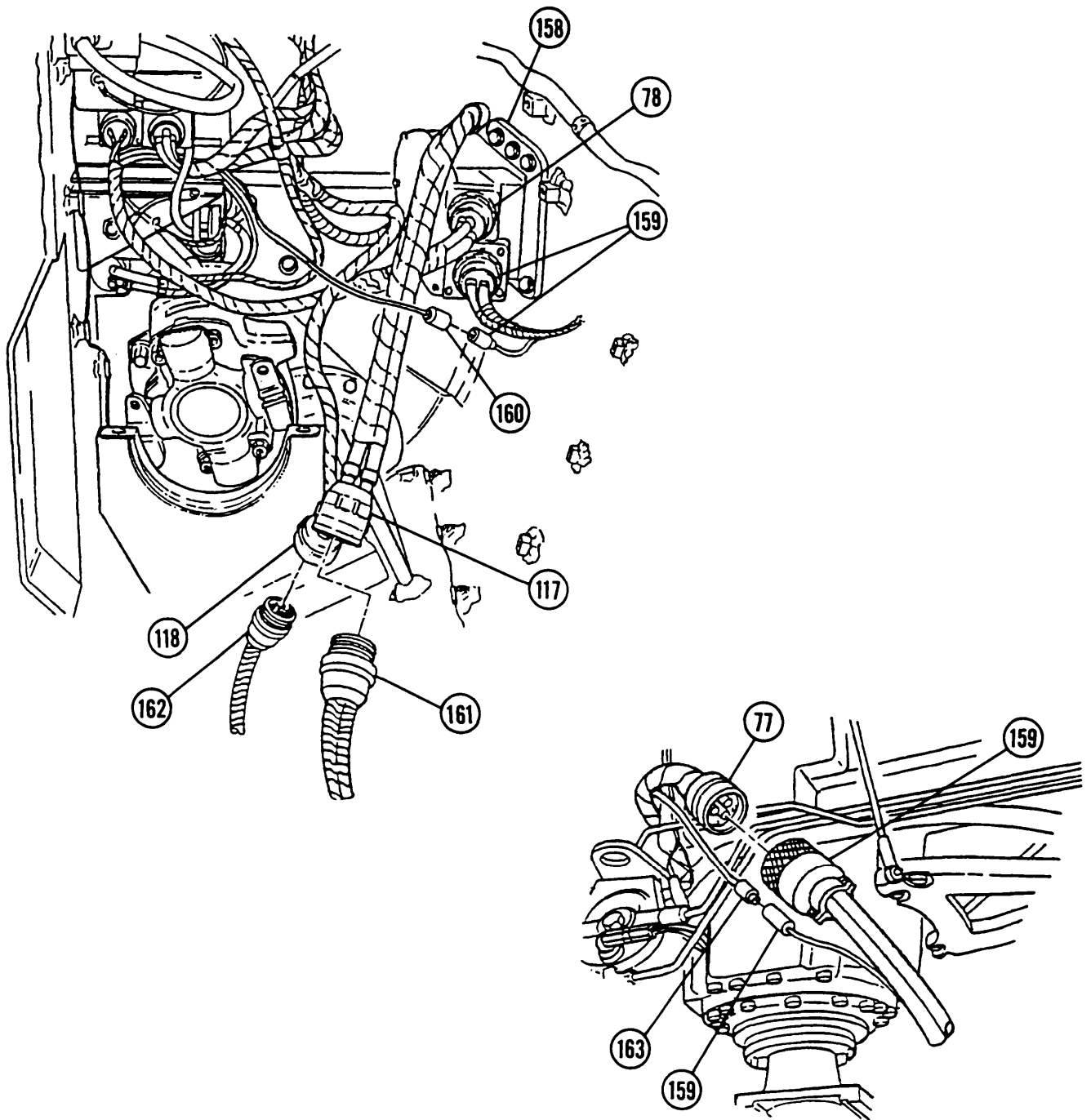

4-5 POWERPLANT — CONTINUED

c. Special Equipment Hookup — Continued

18 Connect power cable (item 34, Appx H) (M109A2/M109A3) or (item 10, Appx H) (M109A4/M109A5) (161) to right terminal of engine disconnect bracket (164).

19 Connect power cable (starter and master warning circuit) (item 11, Appx H) (162) to left terminal of engine disconnect bracket (164).

20 Connect ground cable (item 7, Appx H) (165) to transmission with two lockwashers (90) and screw (89).

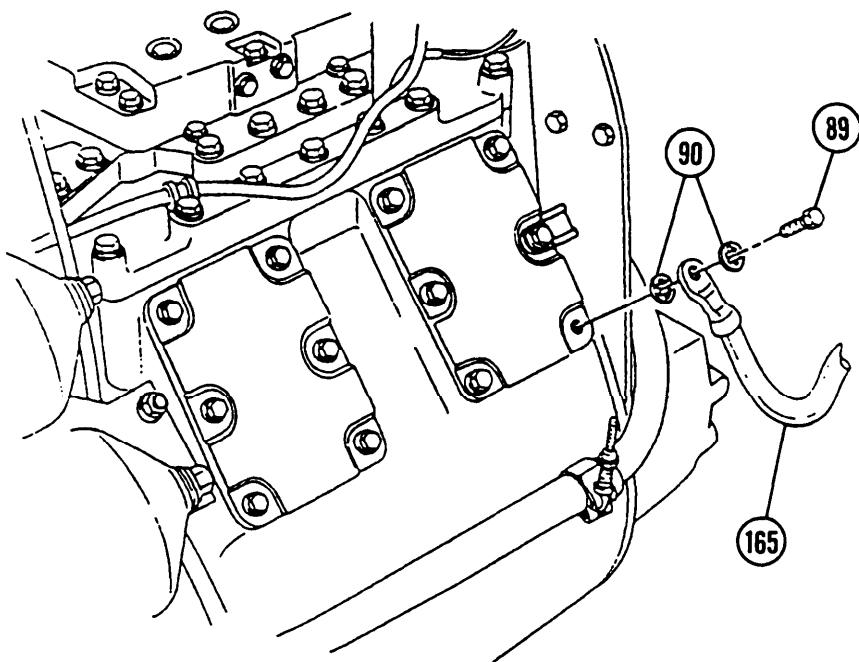
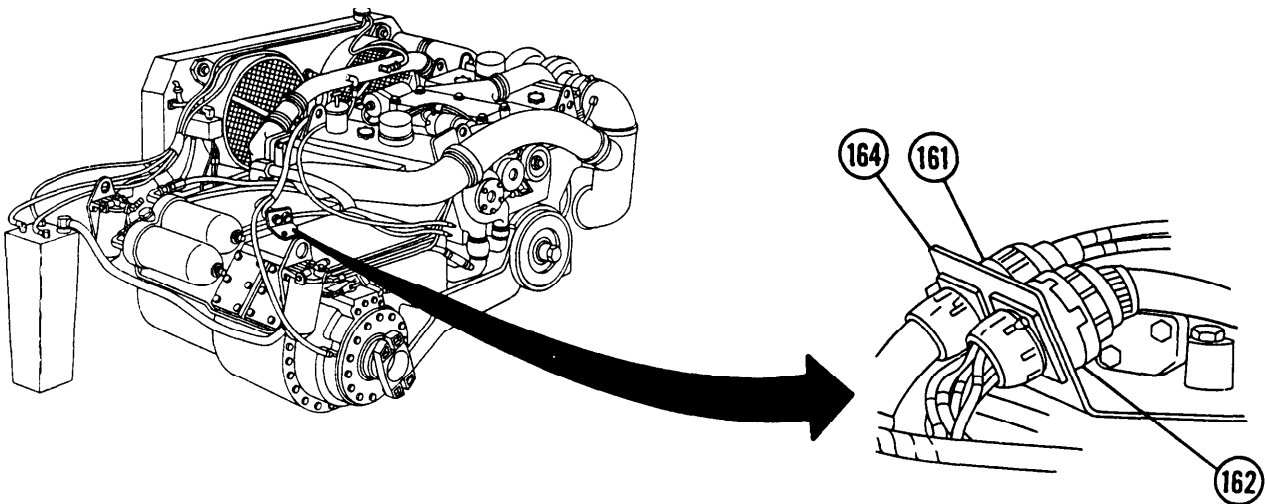

- 21 Remove screw (166), two lockwashers (167), and powerplant ground cable (91) from vehicle hull.
- 22 Connect opposite end of ground cable (item 7, Appx H) (165) to vehicle hull with screw (166) and two lockwashers (167).
- 23 Connect battery ground cables (para 8-28).

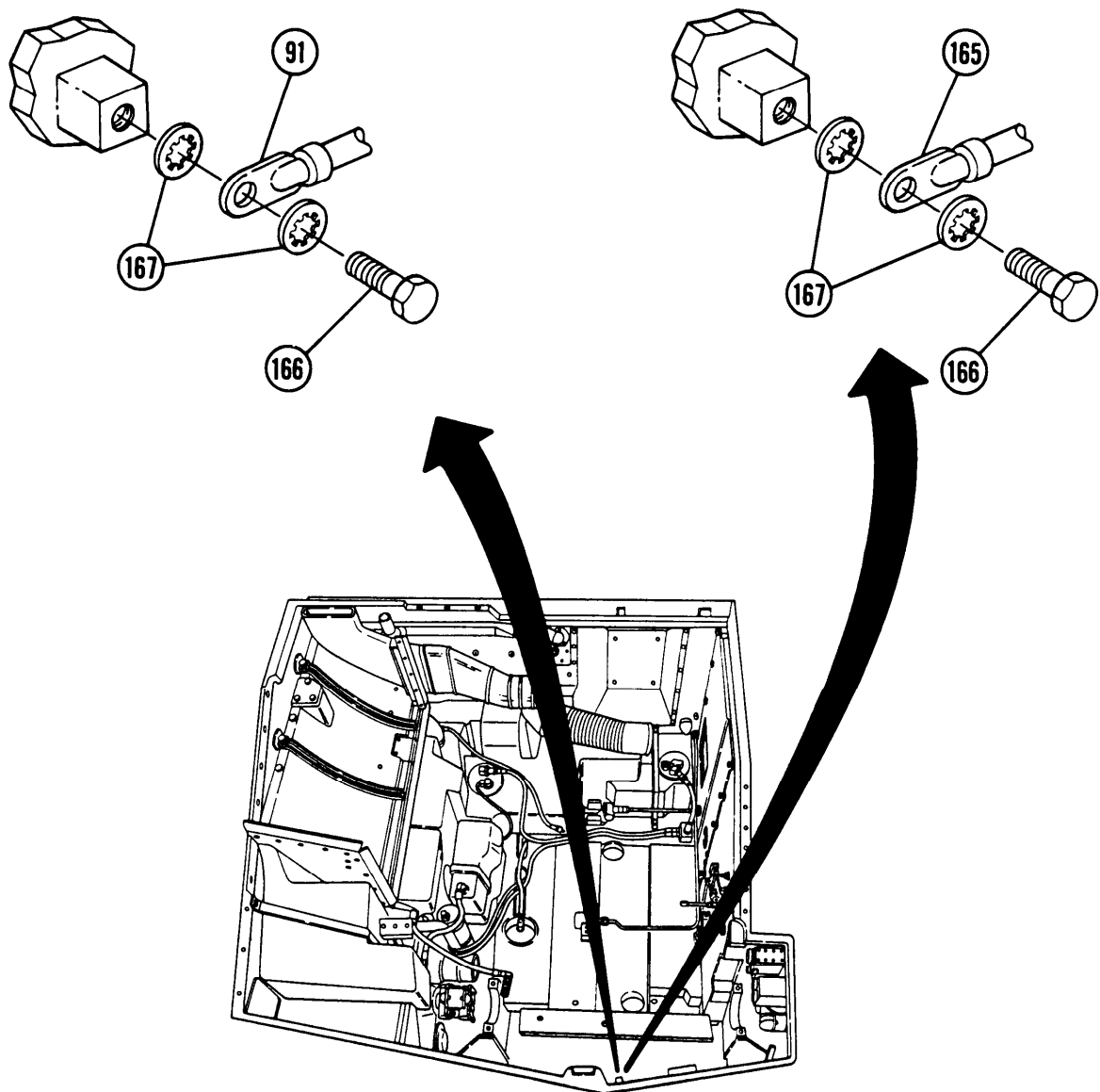

4-5 POWERPLANT — CONTINUED

c. Special Equipment Hookup — Continued

- 24 Connect STE/ICE-RW-5 power cable (168) to STE/ICE-R vehicle test meter (VTM) (169) and to vehicle batteries (170) using TK mode.
- 25 Connect tachometer drive adapter (171) to pulse tachometer (1 72) and tachometer flexible driveshaft (94).
- 26 Connect W-4 cable (173) to pulse tachometer (1 72) and VTM (169).

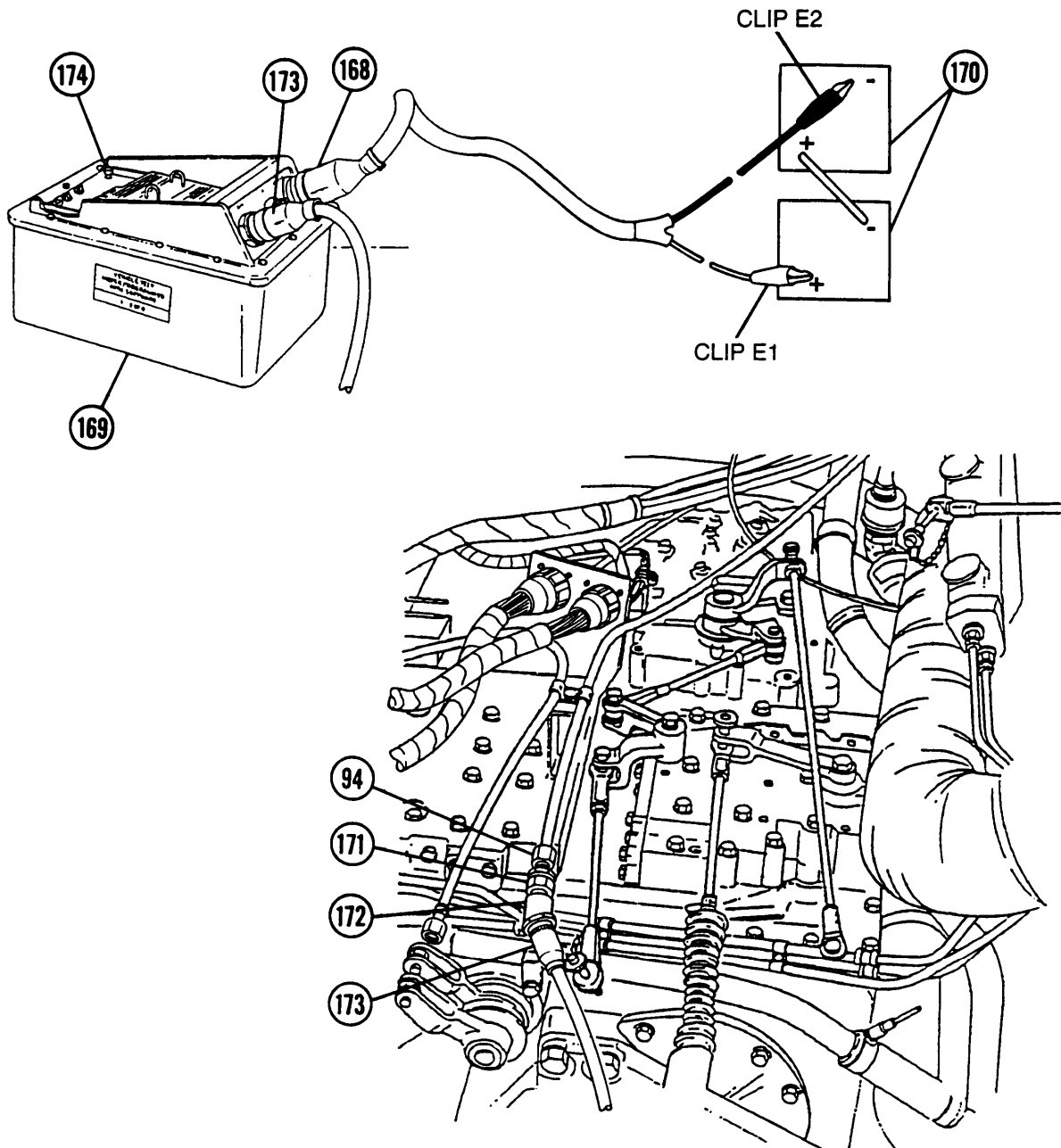

d. Test Run

WARNING

- Carbon monoxide is a colorless, odorless, deadly poisonous gas which, when breathed, deprives the body of oxygen and causes suffocation. Exposure to carbon monoxide produces headache, dizziness, loss of muscular control, drowsiness, and coma. Permanent brain damage or death can result from severe exposure.
- Do not operate powerplant outside of vehicle without adequate ventilation. Buildup of exhaust gases can cause carbon monoxide poisoning.
- Keep tools, power cables, hose assemblies, clothing, and body parts clear of moving parts on the powerplant. Failure to follow this warning can result in severe injury or death to personnel.
- Do not touch coolant hoses, exhaust manifolds, or turbocharger. These components are very hot during immediately after engine operation. Failure to follow this warning can result in severe injury to personnel.
- Wear hearing protection while operating powerplant outside of vehicle. High noise levels can cause permanent hearing damage.
- Do not touch power cable assembly connectors while powerplant is operating or while MASTER switch is set to ON. Failure to follow this warning can result in electrical shock to personnel.

CAUTION

- Do not allow powerplant to exceed 2350 rpm. Damage to engine can result.
- Ensure engine coolant and lubricant levels are replenished before operating powerplant outside of vehicle. Failure to do this can result in damage to powerplant.
- When operating the powerplant while mounted on blocks, be careful to keep powerplant from vibrating off blocks. Damage to powerplant may result.

1 Push VTM power switch (174) ON.

2 Perform STE/ICE-R confidence test (TM 9-4910-571-12&P).

4-5 POWERPLANT — CONTINUED

d. Test Run — Continued

WARNING

Ensure transmission is in neutral position or injury to personnel could occur.

- 3 From inside driver's compartment, place transmission in N (neutral) position.
- 4 Pull transmission shift linkage (175) forward all the way. Push transmission shift linkage back two clicks to shift into neutral.
- 5 Turn MASTER switch (176) ON.
- 6 Hold FUEL PRIME switch (177) to ON for 1 minute, then release.
- 7 Push and hold engine STARTER switch (178) to START until powerplant starts.

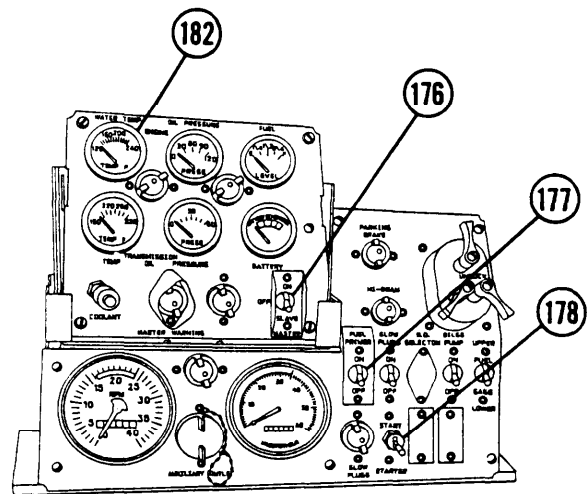
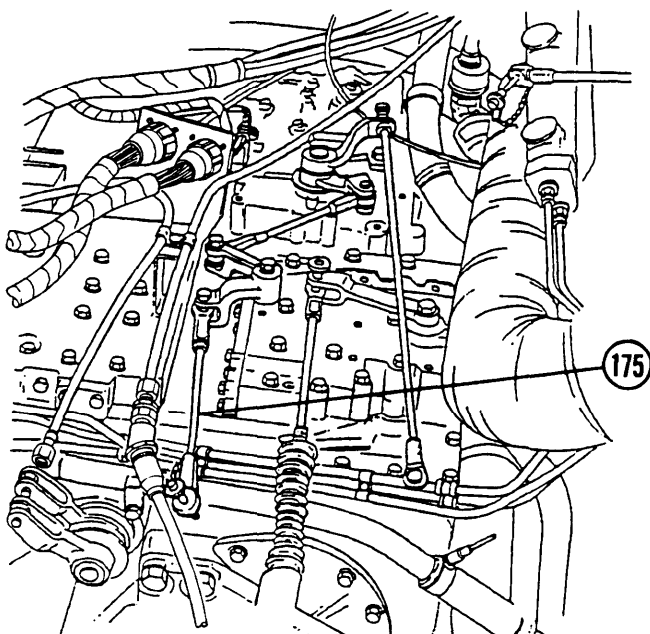

M109A2/M109A3 (ENGINE MODEL 7083-7391) SHOWN

- 8 Dial 10 into TEST SELECT (179) on VTM (169) and press and release TEST button (180). VTM should now display engine rpm. Idle speed should be between 550 and 600 rpm.
- 9 Idle powerplant between 550 and 600 rpm for about 2 minutes.
- 10 Push throttle control lever (181) until engine speed increases to 1000 rpm.
- 11 Continue to operate powerplant at 1000 rpm until ENGINE WATER TEMP gage (182) registers at least 185°F (85°C).

CAUTION

Failure to idle engine before shutting engine down can result in damage to turbocharger.

- 12 After powerplant has reached normal operating temperature, release throttle control lever(181), and allow engine to idle at 550 to 600 rpm.
- 13 Perform any additional STE/ICE-R test as required.
- 14 Check engine for leaks, excessive smoke, strange noises, and/or vibrations. If any of these problems persist, notify support maintenance.

WARNING

Keep hands and clothing clear of moving parts when operating shutoff lever. Failure to follow this warning can result in severe injury or death to personnel.

- 15 To shut off powerplant, pull and hold shutoff lever (183) until powerplant stops, then release lever.
- 16 Turn MASTER switch (176) OFF.
- 17 Pull VTM power switch (174) to OFF.

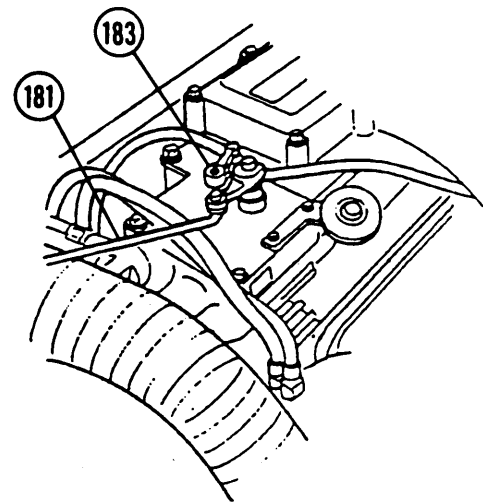
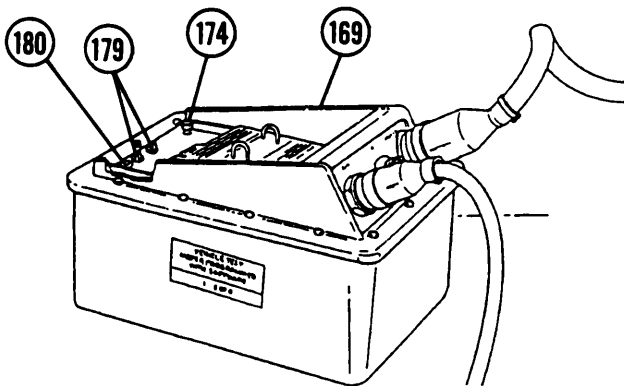

4-5 POWERPLANT — CONTINUED

e. Special Equipment Removal

- 1 Disconnect STE/ICE-R W-5 power cable (168) from STE/ICE-R VTM (169) and vehicle batteries (170).
- 2 Remove W-4 cable (173) from pulse tachometer (1 72) and VTM (169).
- 3 Remove tachometer drive adapter(171) from pulse tachometer (1 72) and tachometer flexible driveshaft (94).

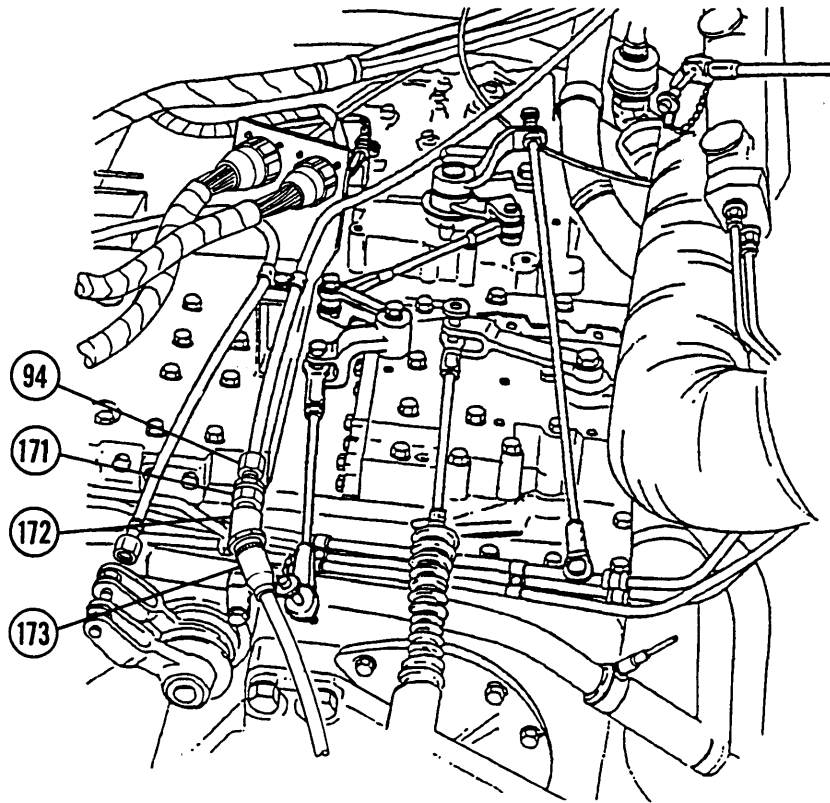
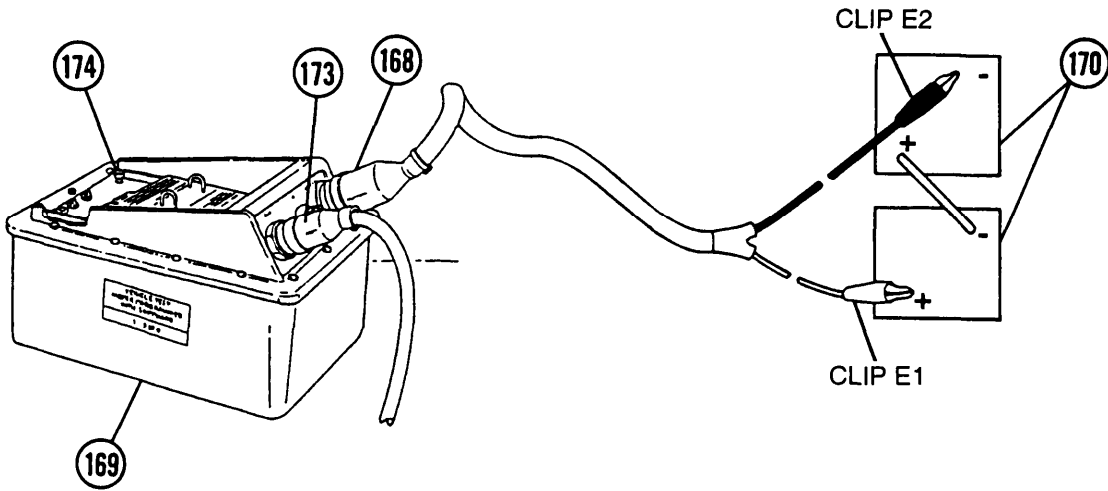

WARNING

- Ensure MASTER switch is OFF before disconnecting electrical connectors of power cable assemblies. Failure to follow this warning can result in injury to personnel.
- Allow powerplant to cool off before removing special equipment. Hot components can cause severe burns.

4 Disconnect battery ground cables (para 8-28).

5 Remove screw (166), two lockwashers (167), and ground cable assembly (item 7, Appx H) (165) from vehicle hull. Discard lockwashers.

6 Remove screw (89), two lockwashers (90), and ground cable (item 7, Appx H) (165) from transmission. Install lockwashers and screw.

7 Install powerplant ground cable (91), two new lockwashers (167), and screw (166) on vehicle hull.

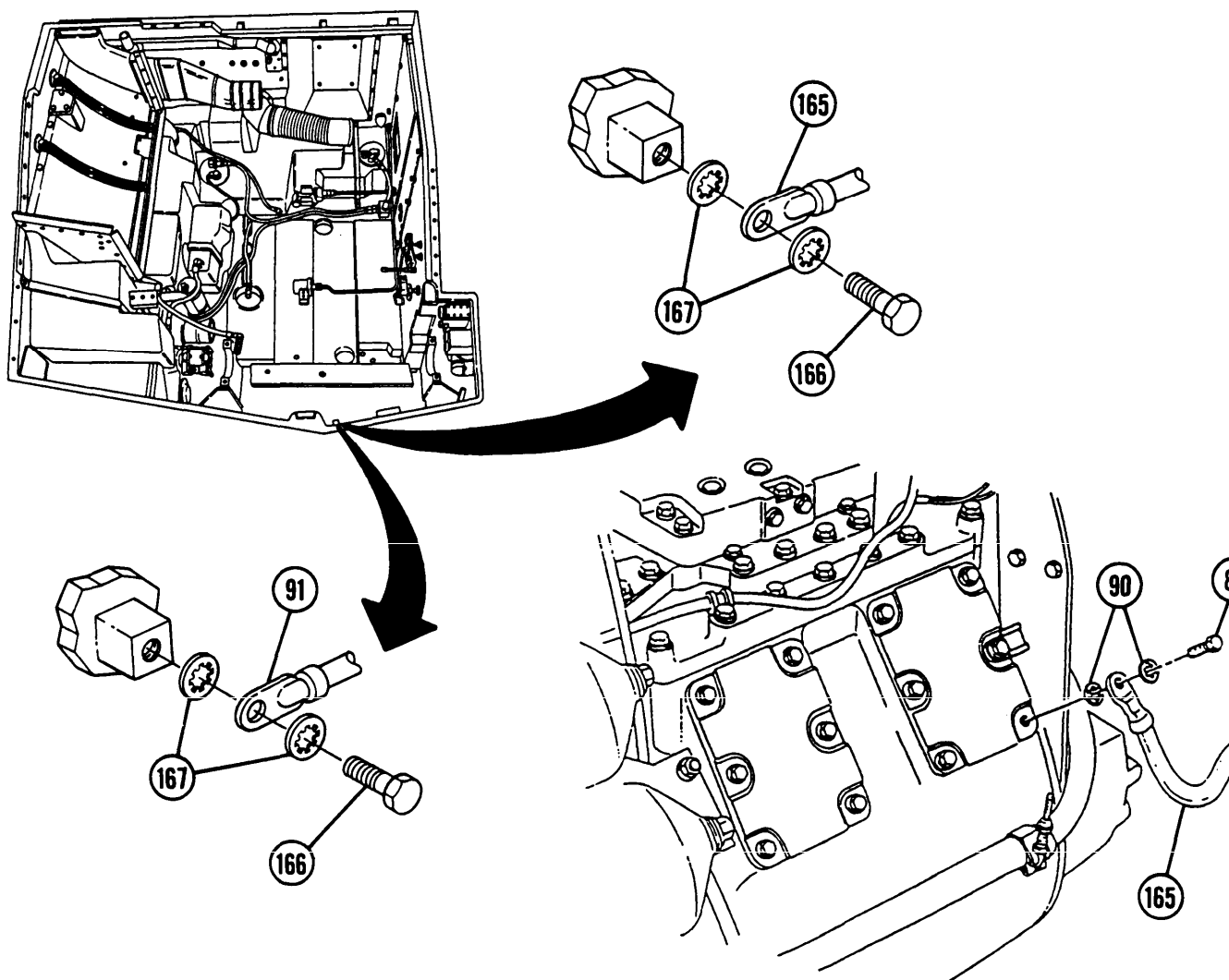

495 POWERPLANT — CONTINUED

e. Special Equipment Removal — Continued

- 8 Disconnect power cable (starter and master warning circuit) (item 11, Appx H) (162) from left terminal of engine disconnect bracket (164).
- 9 Disconnect power cable (starter circuit) (item 10, Appx H) (M109AZM109A3) or (item 34, Appx H) (M109A4/M109A5) (161) from right terminal of engine disconnect bracket (164).

NOTE

Step 10 applies to M109A4/M109A5 Howitzers.

- 10 Disconnect starter protection electrical lead 503 (159) from electrical lead 503 (163).
- 11 Disconnect power cable (rectifier-to-alternator) (item 8, Appx H) (M109A2/M109A3) or (item 9, Appx H) (M109A4/M109A5) (159) from alternator-to-rectifier wiring harness 12268102 (M109A2/M109A3) or 12268308 (M109A4/M109A5) connector (77).
- 12 Disconnect power cable (rectifier-to-alternator) (item 8, Appx H) (M109A2/M109A3) or (item 9, Appx H) (M109A4/M109A5) (159) from rectifier (158).

NOTE

Step 13 applies to M109A4/M109A5 Howitzers.

- 13 Disconnect starter protection relay electrical lead 503 (160) from power cable (rectifier-to-alternator) (item 8, Appx H) (M109A2/M109A3) or (item 9, Appx H) (M109A4/M109A5) (159).

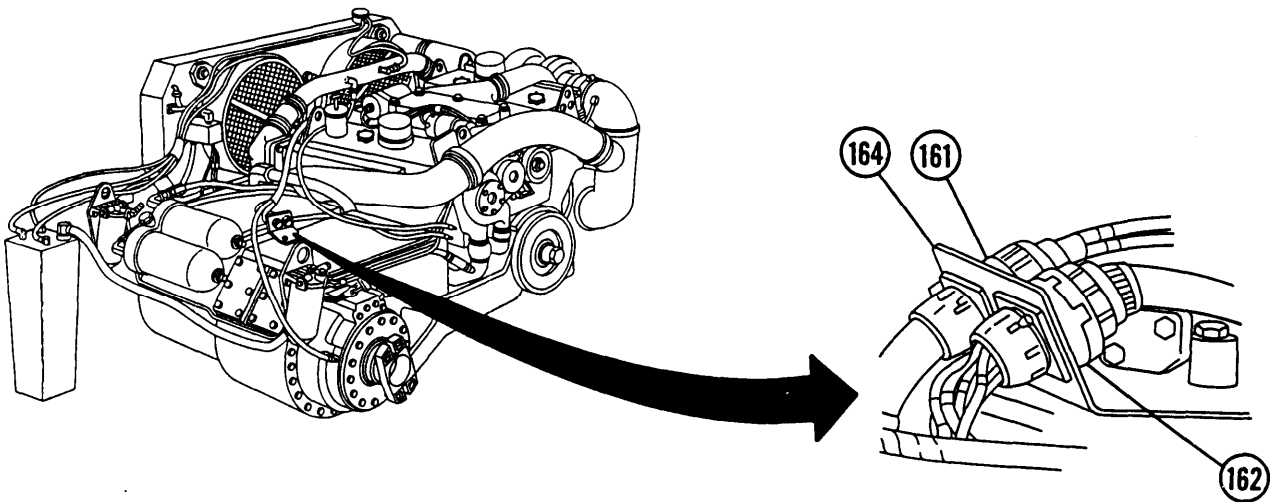

- 14 Disconnect power cable (starter and master warning circuit) (item 11, Appx H) (162) from master circuit wiring harness 12268100 (M109A2/M109A3) or 12268418 (M109A4/M109A5) connector (118).
- 15 Disconnect power cable (starter circuit) (item 34, Appx H) (M109A2/M109A3) or (item 10, Appx H) (M109A4/M109A5) (161) from starter cable 11593782 (M109A2/M109A3) or 12353401 (M109A4/M109A5) connector (117).
- 16 Disconnect rectifier-to-voltage regulator lead 11593806 (M109A2/M109A3) or 12268303 (M109A4/M109A5) (78) from rectifier (158).

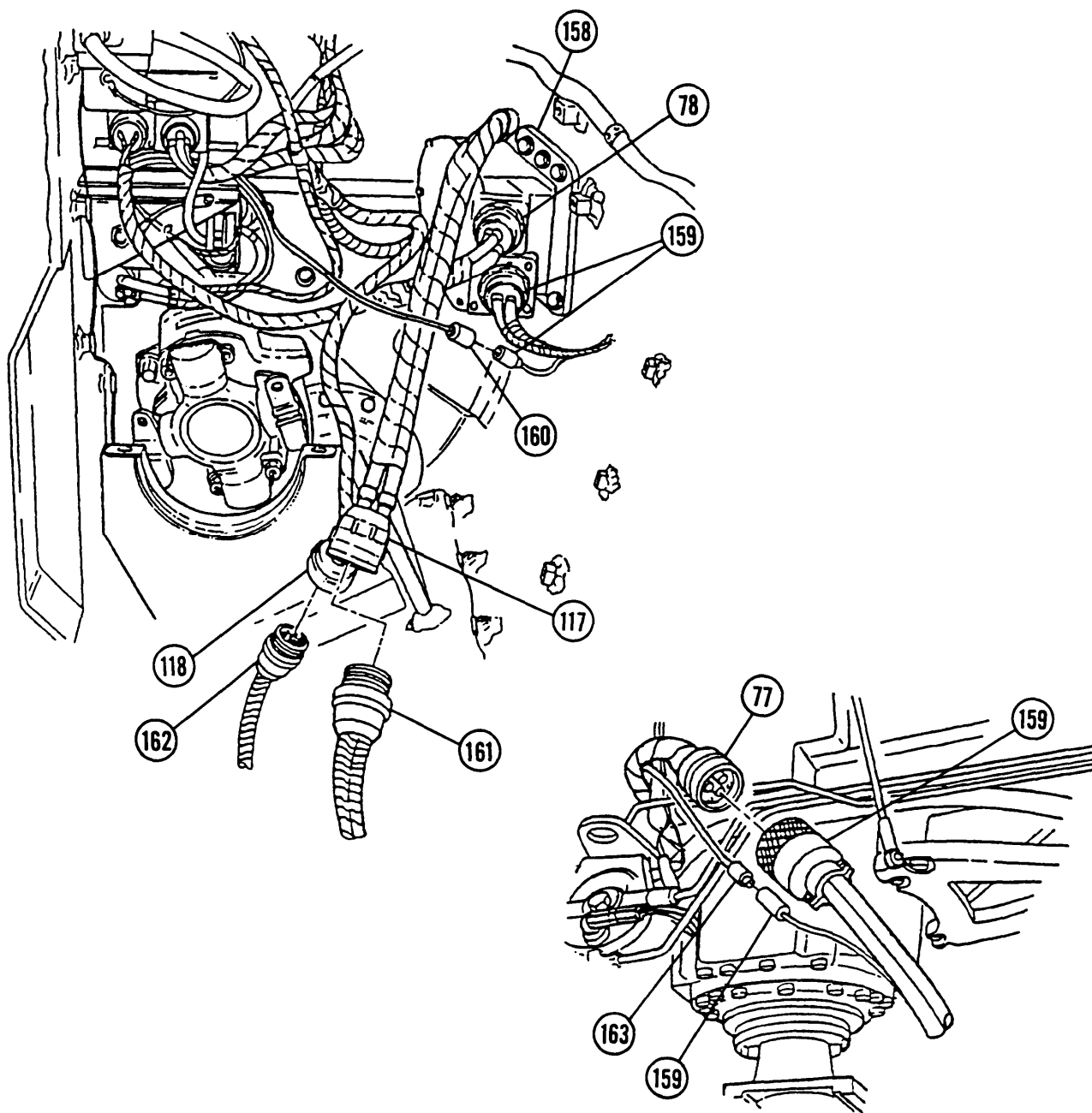

4-5 POWERPLANT — CONTINUED

e. Special Equipment Removal — Continued

- 17 Disconnect two electrical connectors (86) from voltage regulator (88).
- 18 Disconnect two electrical connectors (86) from master relay (87).
19. Disconnect hose assembly (157) and adapter from quick disconnect (73) on primary fuel filter input hose (72).
- 20 Disconnect quick disconnect and hose assembly (155) from fuel return hose (47).

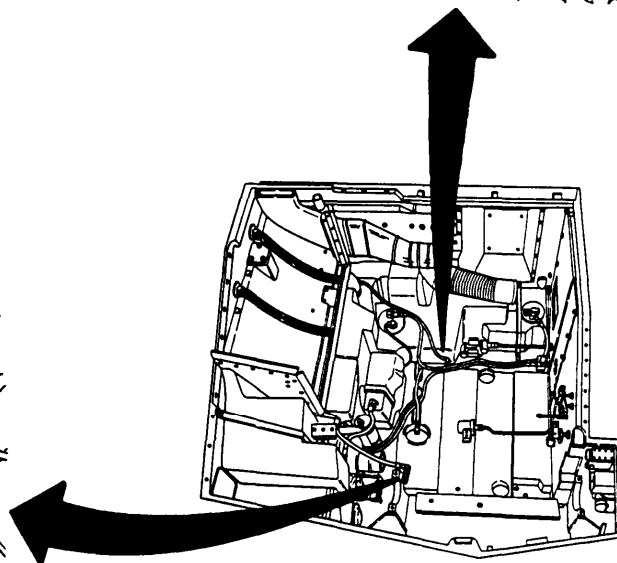
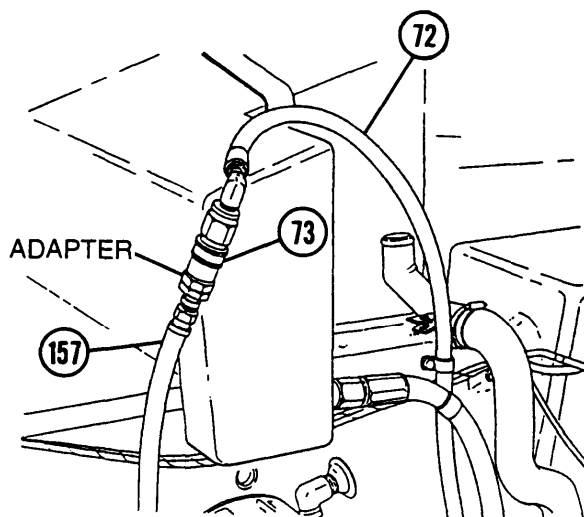
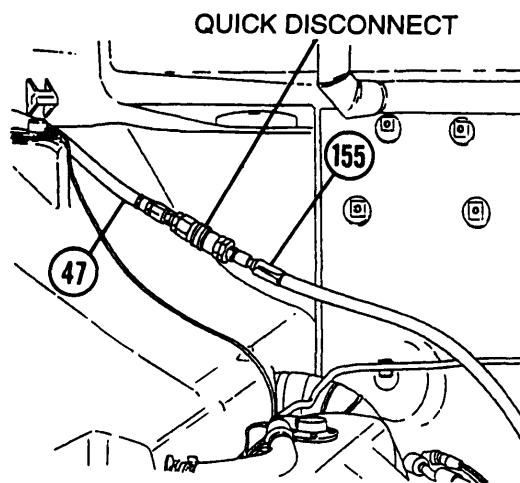
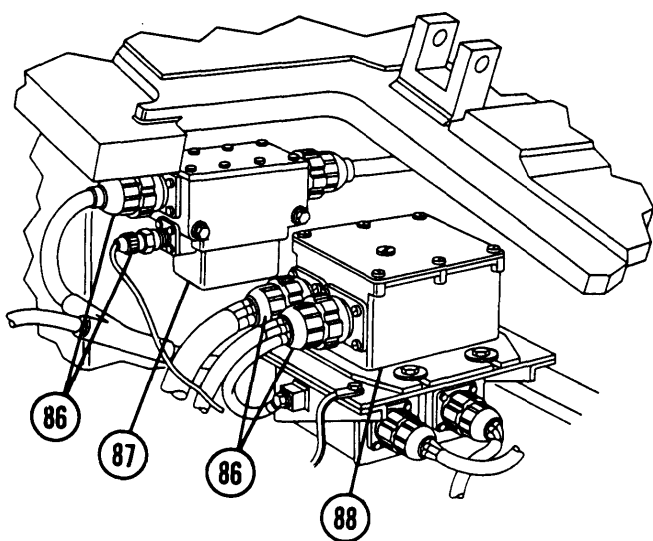

- 21 Disconnect quick disconnect and hose assembly (157) from primary fuel filter (123).
- 22 Disconnect adapter and hose assembly (155) from quick disconnect assembly (48) on engine-to-lower fuel tank return hose (156).

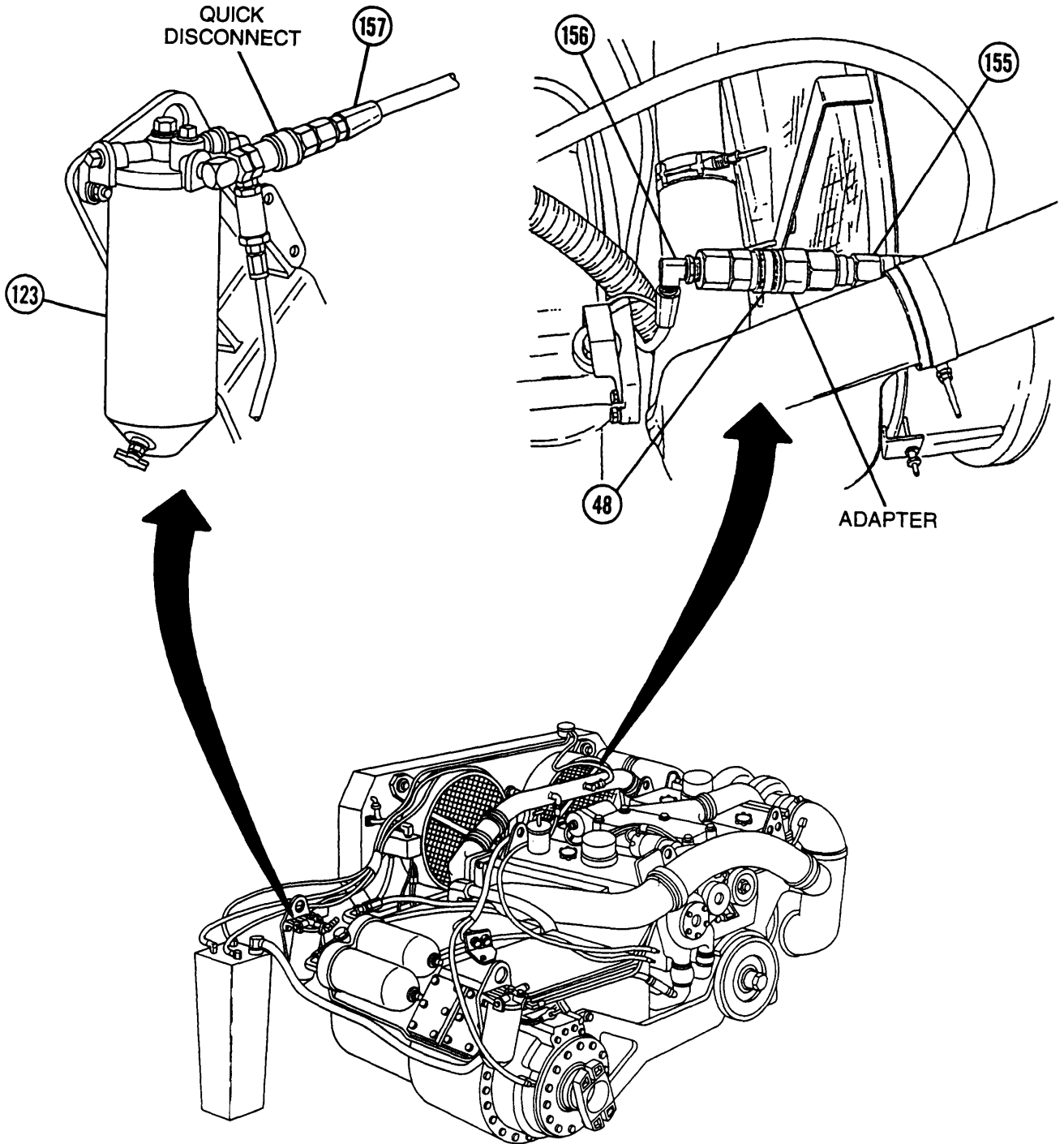

4-5 POWERPLANT - CONTINUED

e. Special Equipment Removal -Continued

- 23 Position surge tank (137) on powerplant.
- 24 Remove clamp (59) and engine exhaust pipe (60) from exhaust outlet (154).
- 25 Remove clamp (75) and safety screen from air cleaner duct (76).
- 26 Loosen two thumbscrews and two nuts and remove two protective screens from radiator fans (153).

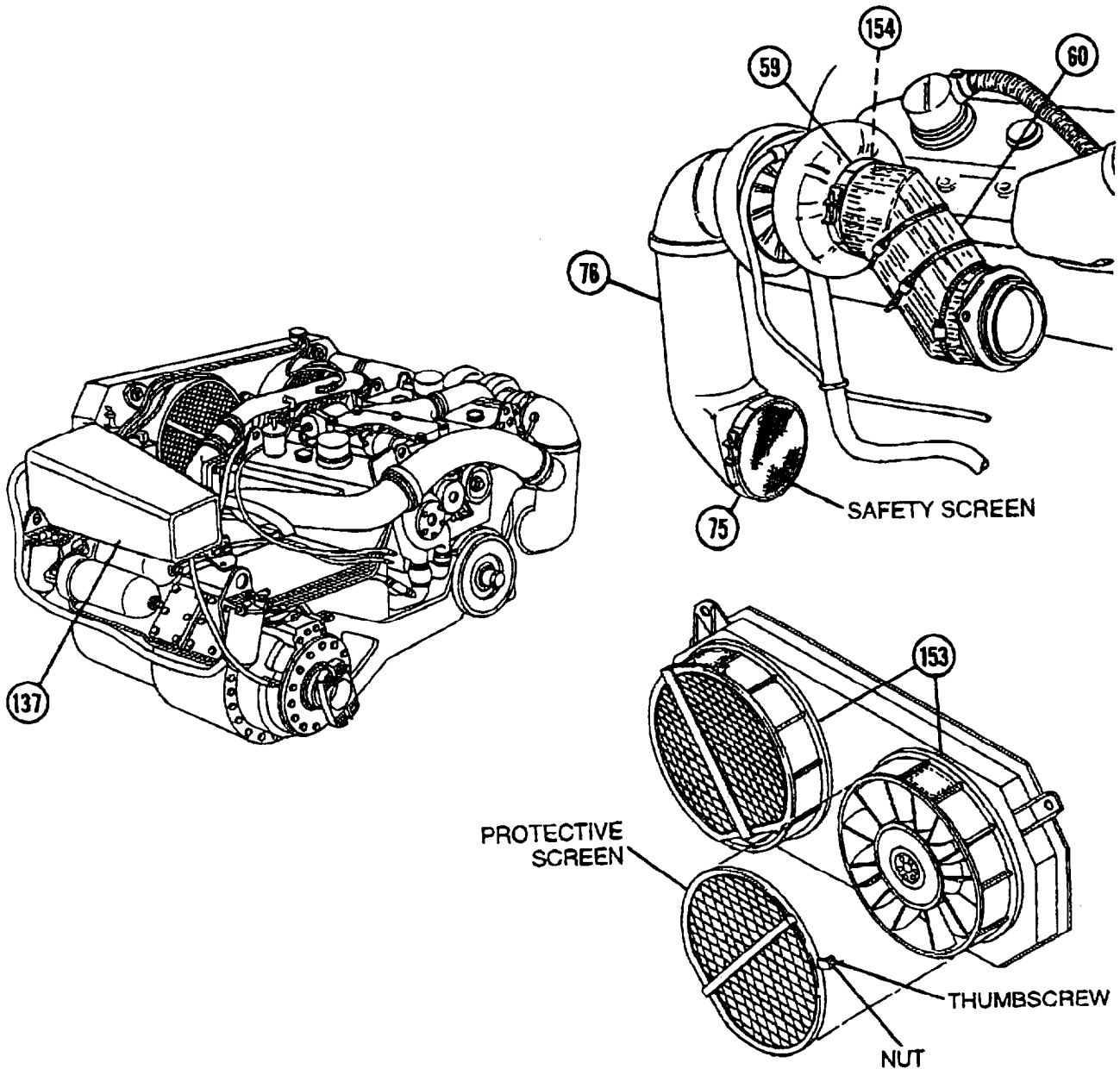

f. Installation**NOTE**

Be sure to lubricate and exercise engine mounting bracket before installing powerplant (para 2-15).

- 1 Position engine exhaust pipe (58) and engine-to-lower fuel tank return hose (47) against powerplant compartment wall.

CAUTION

Failure to secure accelerator and throttle linkage to engine compartment wall may damage linkage.

- 2 Fasten throttle valve control rod linkage (113) to compartment wall.

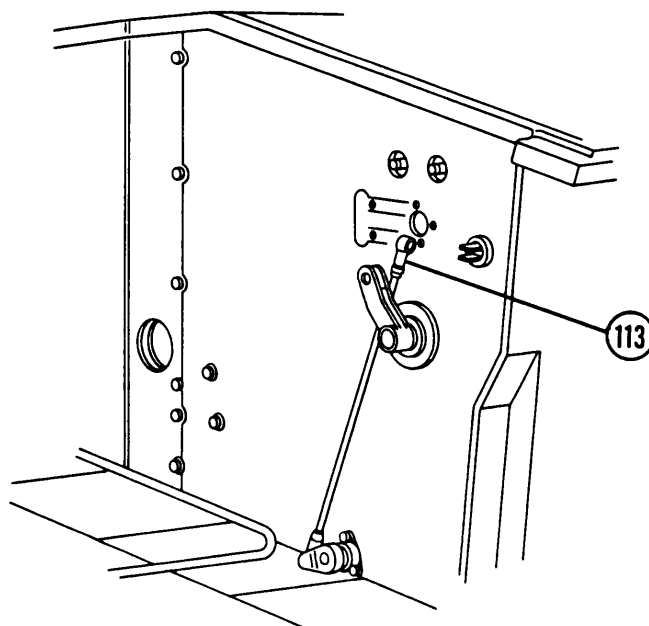
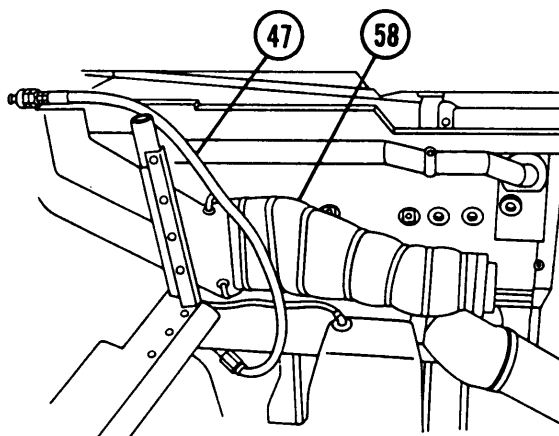

4-5 POWERPLANT — CONTINUED

f. Installation — Continued

- 3 Place coolant surge tank (1 37) on top of powerplant (138).
- 4 “ Position lifting equipment for powerplant (138) installation.
- 5 Attach lifting sling to powerplant (138) at four lifting eyes (139).

CAUTION

Watch all sides of powerplant, making sure it clears hull. Have one person observe from driver's compartment through engine compartment access to ensure air intake duct isn't forced into fuel tank, damaging it.

- 6 Lift and set powerplant(138) in vehicle hull.
- 7 Remove lifting sling from powerplant (138).

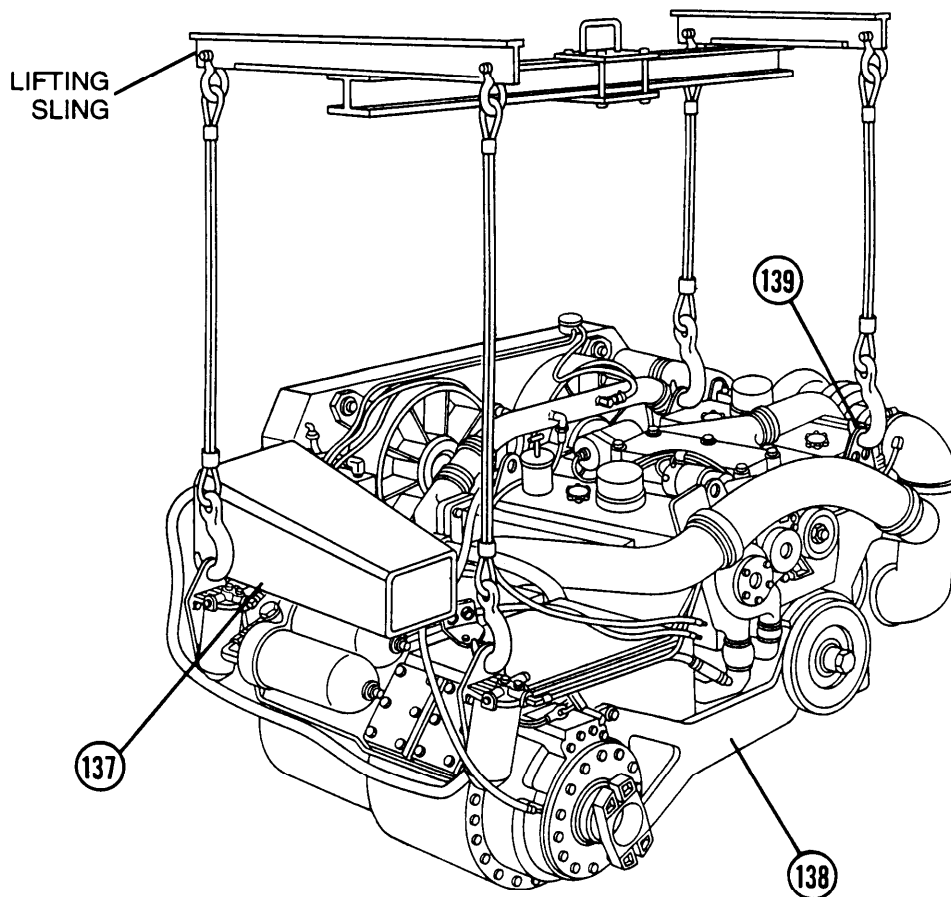

- 8 Install surge tank (137), retainer pad (132), two washers (131), and two screws (130).
- 9 Install two screws (133), two newlockwashers(135), and two nuts (134) on coolant pump-to-surge tank hose (136).
- 10 Disconnect fuel filter-to-fuel pump tube (1 19) and remove three bolts (120), three lockwashers (121), and bracket (122) with primary fuel filter (1 23). Discard lockwashers.

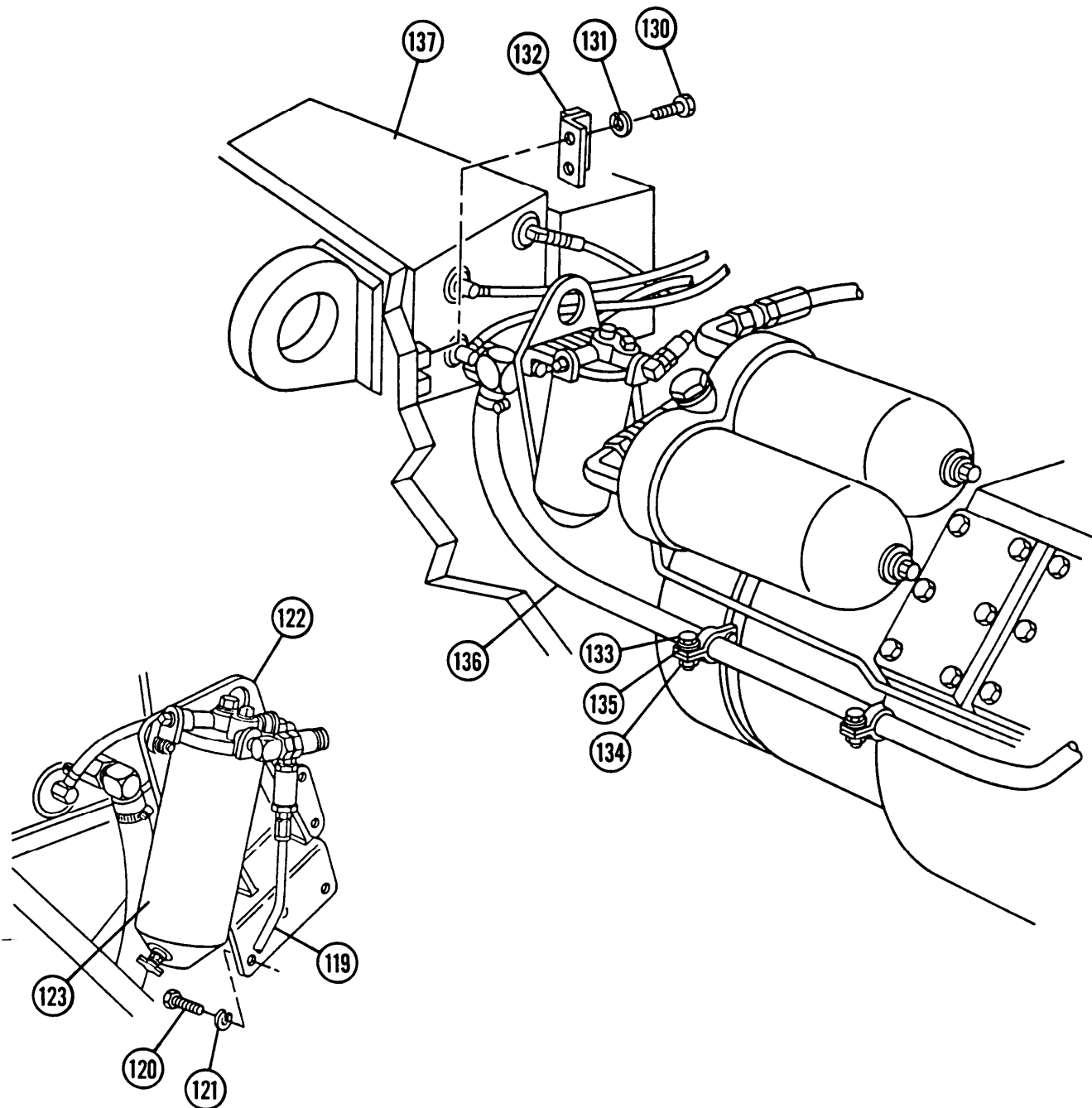

4-5 POWERPLANT — CONTINUED

f. Installation — Continued

NOTE

- Ensure trunnion cap shims are installed at original location from which they were removed.
- Ensure transmission trunnion caps are installed in proper location as marked on caps (left front and right front) with mark facing toward front of vehicle.
- Primary fuel pump bracket (lifting eye) must be disconnected and removed to install and properly torque right front trunnion cap screws.

- 11 Aline transmission inserts (157) in transmission support assembly (126) and transmission trunnion cap (124).
- 12 Install shims (125) if removed, left trunnion cap (124), two flat washers (129), and two bolts(127 and 128). Do not tighten bolts. Repeat for right support assembly and shim if present.
- 13 Measure clearance between each trunnion cap (124) and support (126) at forward and rear edges. Clearance should equal 0.005 to 0.007 in. (0.13 to 0.18 mm).

NOTE

If clearance is less than 0.005 in. (0.13 mm), notify support maintenance. If clearance is greater than 0.007 in. (0.18 mm), use shims (125) as required to reduce gap.

- 14 Torque rear bolt (128) to 85-90 lb-ft (115-122 N•m).
- 15 Torque forward bolt (127) to 85-90 lb-ft(115-122 N•m).

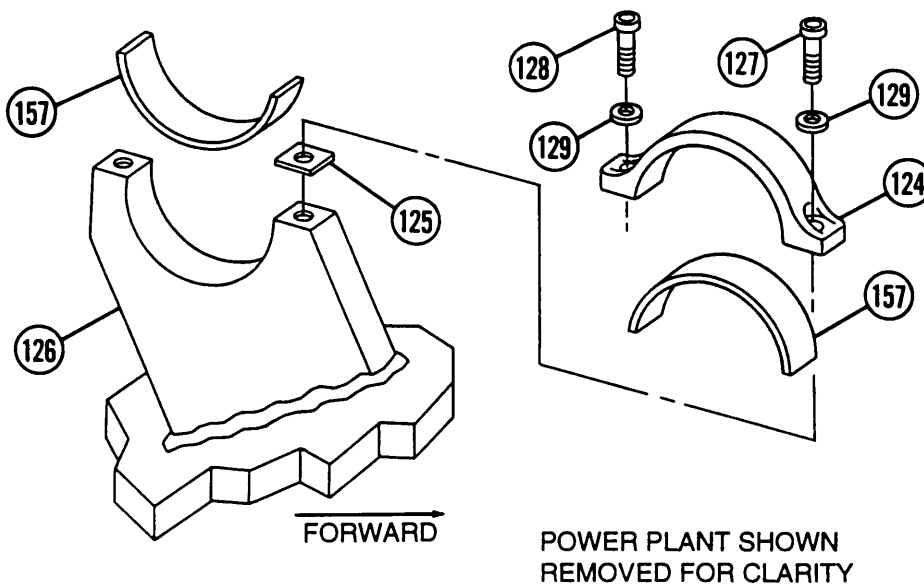

- 16 Install bracket (122) with primary fuel filter (123), three new lockwashers (121), and three bolts (120). Connect fuel filter-to-fuel pump tube (119).
- 17 Connect starter cable (117) and master circuit wiring harness (118).
- 18 Install accelerator and throttle control bracket (116), three screws (114), and three new lockwashers (115).
- 19 Connect throttle control tube (113) and install retainer pin (111), washer (112), and new cotter pin (110).
- 20 Connect brake control sprocket and shaft (106) and install retainer pin (105) and new cotter pin (104).
- 21 Secure brake arm (109) with washer (108) and screw (107).

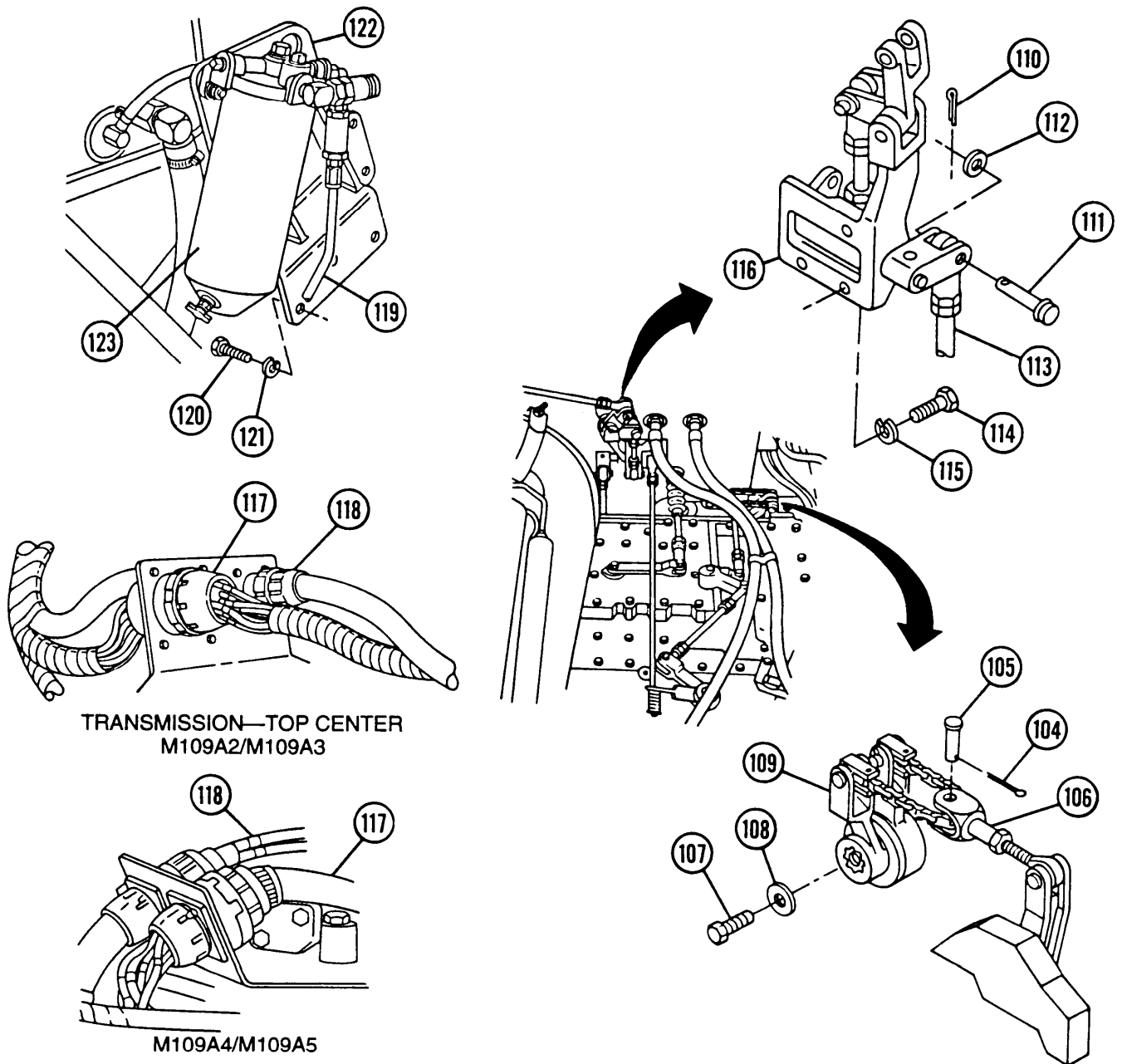

4-5 POWERPLANT — CONTINUED

f. Installation — Continued

- 22 Place shift control in R2 position. Connect shift control rod (103) and install quick-release pin (102).
- 23 Move steering wheel to right. Insert steer control rod (100) with boot (101) through bulkhead from engine compartment and install two quick-release pins (99).
- 24 Move throttle control to full open position. Connect throttle valve control rod (98) and tighten nut (97).
- 25 Connect tachometer and speedometer flexible drive shafts (94 and 95) and tighten two nuts (96).
- 26 Connect throttle governor control rod (93) and install quick-release pin (92).

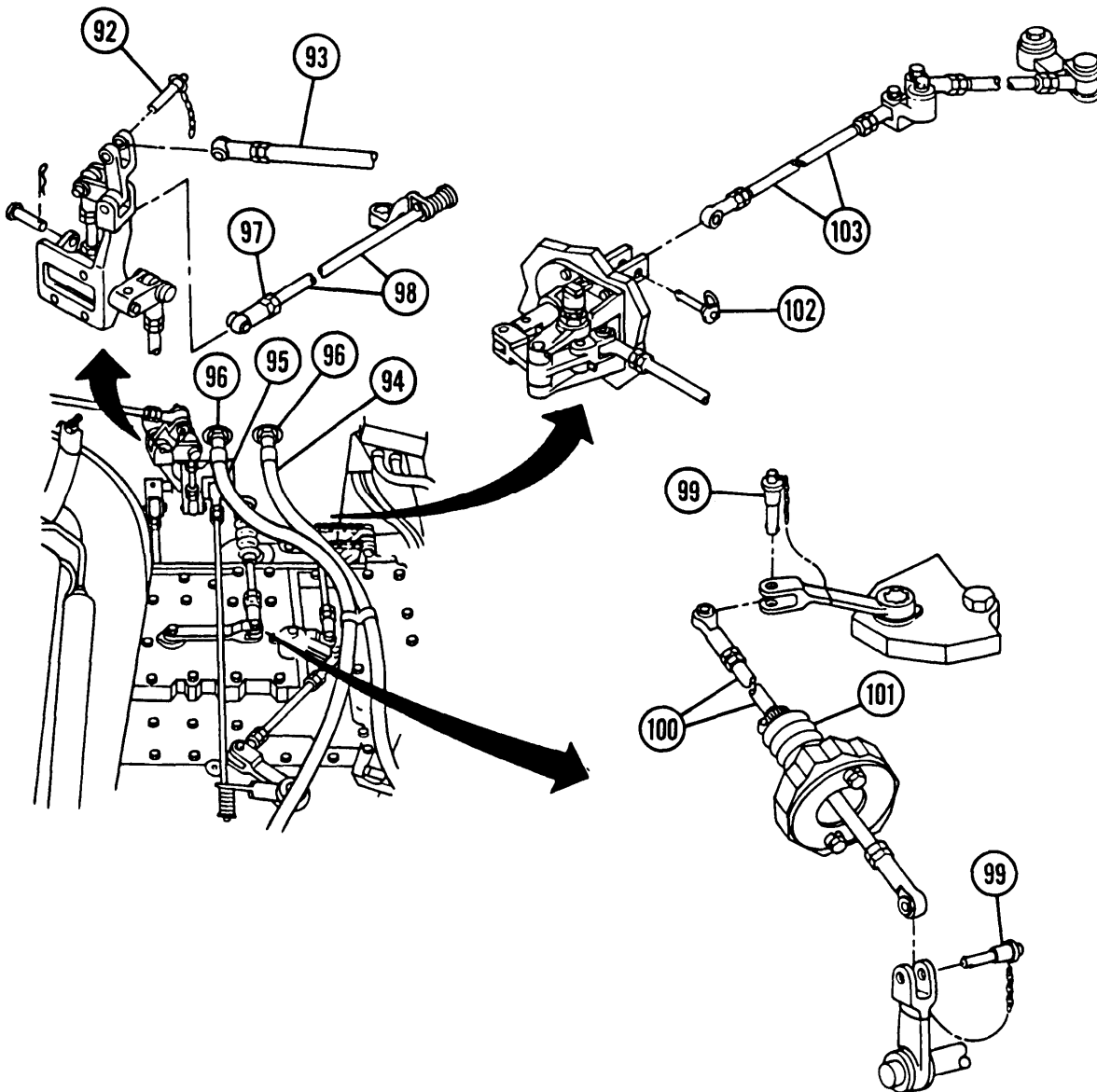

NOTE

Step 27 applies to M109A2/M109A3 Howitzers.

- 27 Remove screw (89) and two lockwashers (90). Discard lockwashers. Connect powerplant ground cable (91) and install two new lockwashers and screw.
- 28 Connect four electrical connectors (86) at master relay (87) and regulator (88).
- 29 Install speedometer right angle drive (85) and tighten nut (84).

NOTE

- Turn universal joint on left side of vehicle straight up and down.
 - If adapter screws (80) are inaccessible, remove blocking from vehicle tracks and push or tow vehicle until universal joints rotate enough to gain access to adapter screws.
- 30 Position flange (82) against right final drive universal joint (81) and install four screws (80). Place new lockwire (79) through four screws to prevent screws from turning. Repeat this procedure for left final drive universal joint.

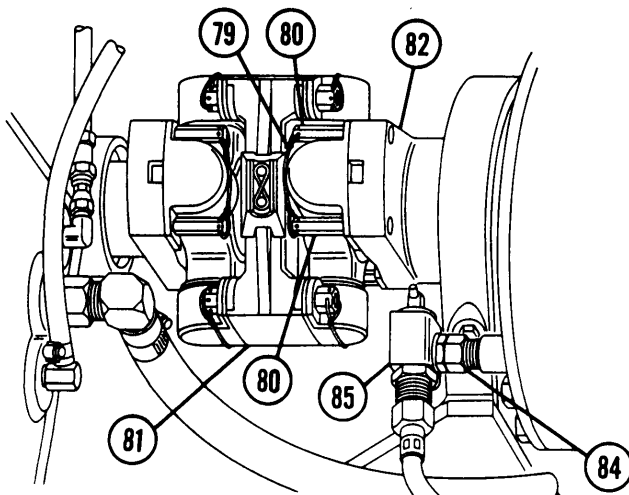
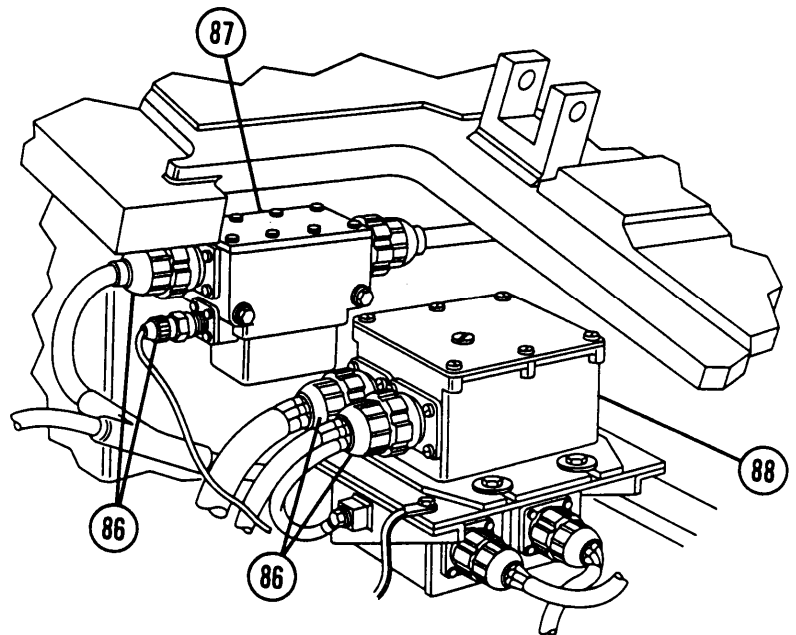
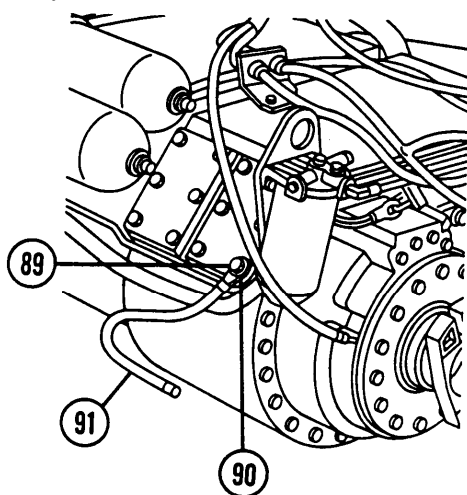

4-5 POWERPLANT — CONTINUED

f. Installation — Continued

- 31 Connect alternator-to-rectifier wiring harness (77) and rectifier-to-voltage regulator lead (78).
- 32 Connect air cleaner duct (76). Install clamp (75) and tighten nut (74).

NOTE

Position of primary fuel filter differs in M109A2 and M109A3 Howitzers (para 1-15).

- 33 Connect primary fuel filter input hose (72) quick disconnect (73).
- 34 Install engine compartment access cover (68), 12 screws (69), and 12 new lockwashers (70). Connect hose (67) and tighten two clamps (66).
- 35 Turn engine mount release shaft (71) clockwise to tighten. Torque shaft to 175-190 lb-ft (237–258 Nžm).

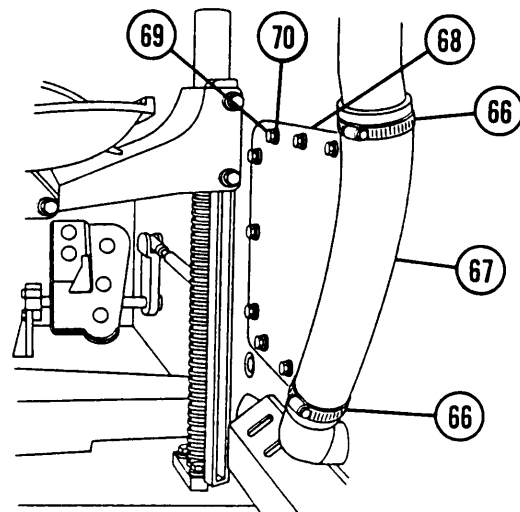
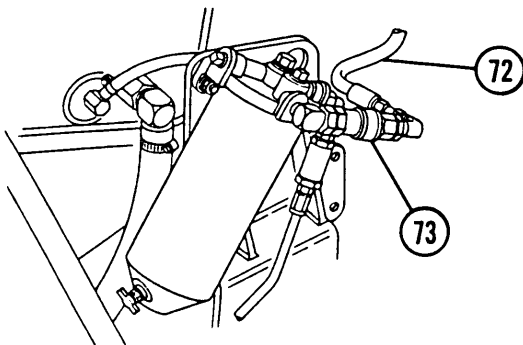
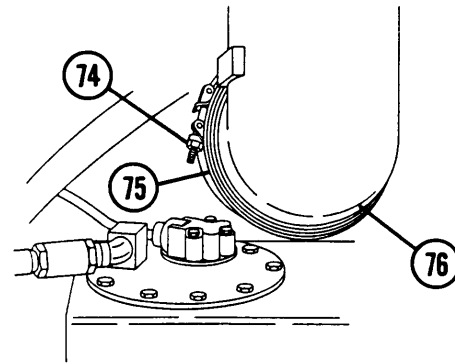
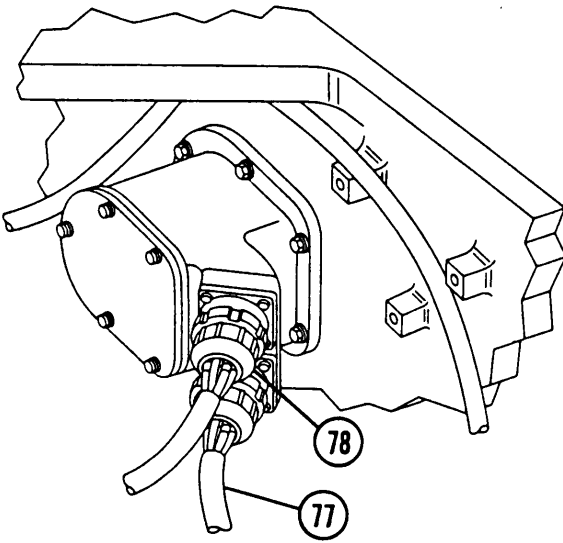

DRIVER'S COMPARTMENT

- 36 Connect governor fuel shutoff cable (65) and install quick-release pin (62) in clevis (160). Install bracket and pulley (64) with two screws (63).
- 37 Install engine exhaust pipe (60) and tighten clamp (59).
- 38 Connect engine exhaust flanges (58) and install two screws (57), two springs (56), two castle nuts (55), and two new cotter pins (54).
- 39 Install fixed fire extinguisher nozzle (53) and tighten swivel nut (52).

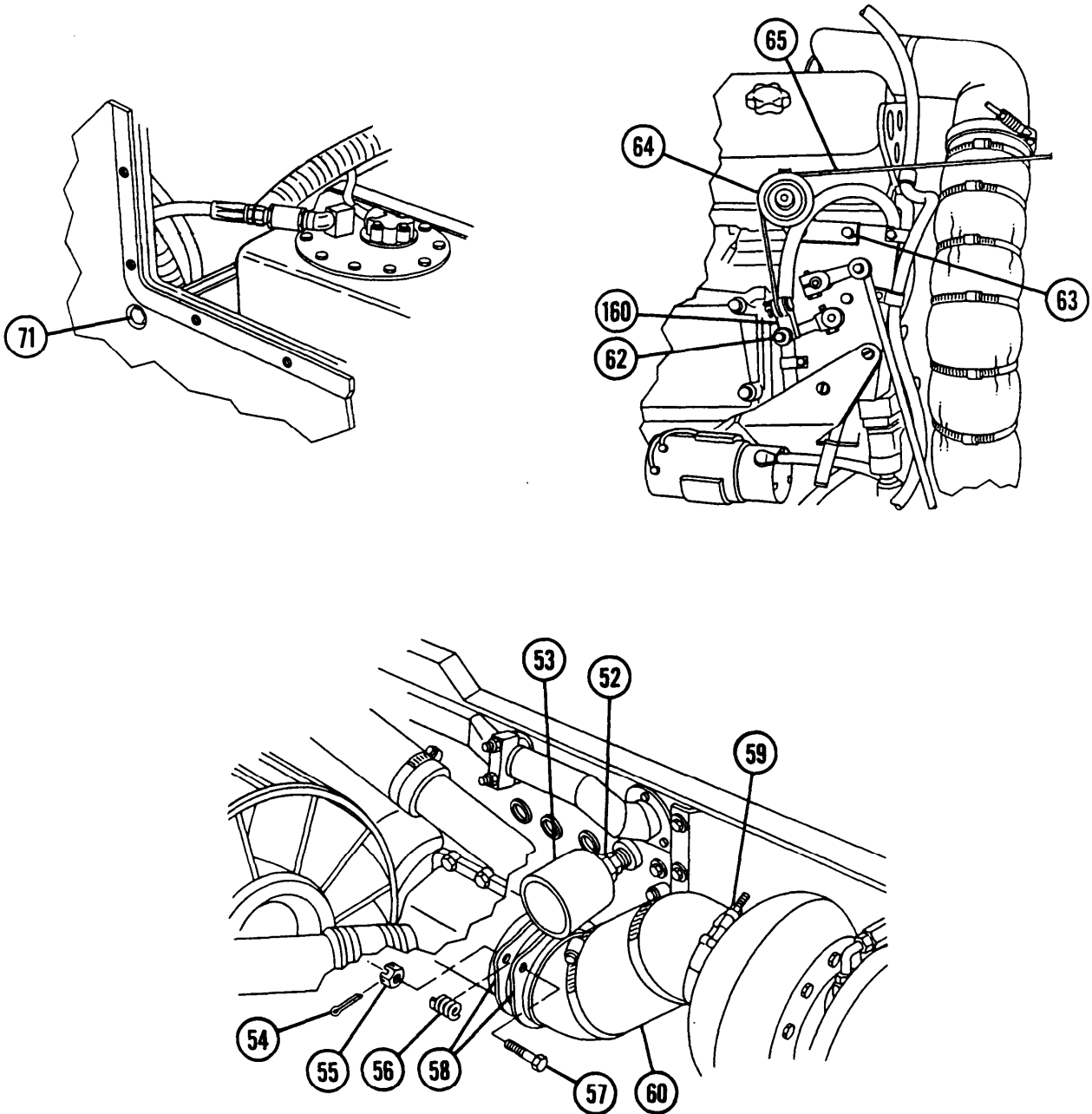

4-5 POWERPLANT — CONTINUED

f. Installation — Continued

NOTE

Position of rubber-coated clamp is same for both M109A2 and M109A3 Howitzers.

40 Connect engine-to-lower fuel tank return hose (47) at quick disconnect assembly (48).

41 Install washer (50) and screw (49) at rubber-coated clamp (51).

WARNING

Protective fan screens must be installed prior to doing maintenance in engine compartment when engine is running or when engine is in ground hop mode. Contact with rotating fan can cause injury.

42 Install two protective fan screens on radiator fans (153) with thumbscrews and nuts.

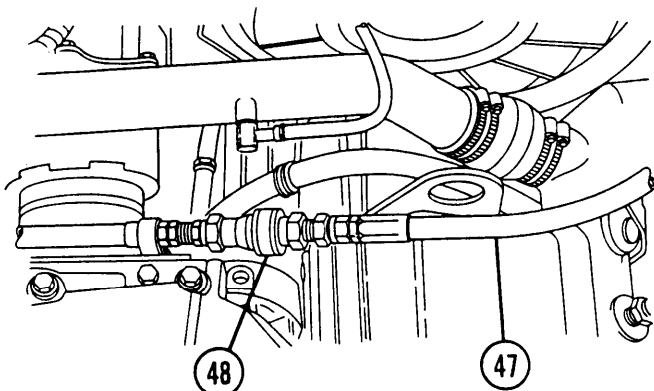

M109A3 SHOWN

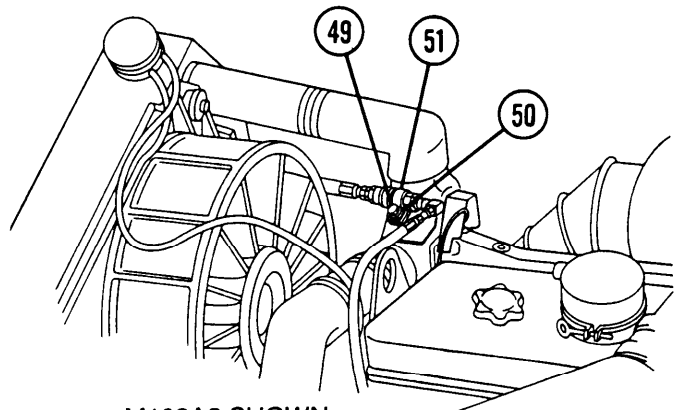

M109A2 SHOWN

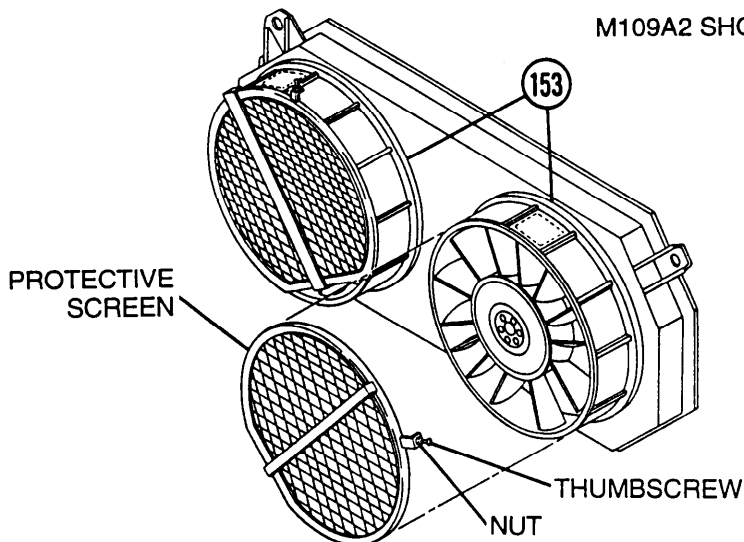

WARNING

Excessive noise levels are present any time equipment is operating. Wear hearing protection while equipment is running. Failure to do so could result in damage to your hearing.

CAUTION

- Ensure coolant and engine lubricant are replenished before starting engine (TM 9-2350-311-10 and para 2-1 5).
- While performing test run, check coolant and oil temperatures. Coolant temperature should not exceed 180°F (82°C). Oil temperature should not exceed 259°F (126°C). If either condition exists, run engine at 1000 to 1200 rpm for 2 minutes before shutdown.

43 Connect both battery ground straps (para 8-28). Place MASTER switch in ON position. Start engine and operate at 1200 'to 1400 rpm until engine coolant temperature is 169°F (76°C) and transmission oil temperature is 160°F (71 'C). Allow engine to return to normal idle speed (650 to 750 rpm).

44 Check engine operation. If engine is not operating properly, perform STE/ACE-R PMCS testing (Appx I).

45 Check for leaks, excess smoke, and strange noises. If any problems persist, notify support maintenance.

46 Remove two locknuts, two screws, and two protective screens from cooling fans (1 53).

47 Install air intake grille handle bracket (46) and two screws (45).

48 Install right front grille assembly (44), six socket head screws (43), seven washers (42), and seven screws (41).

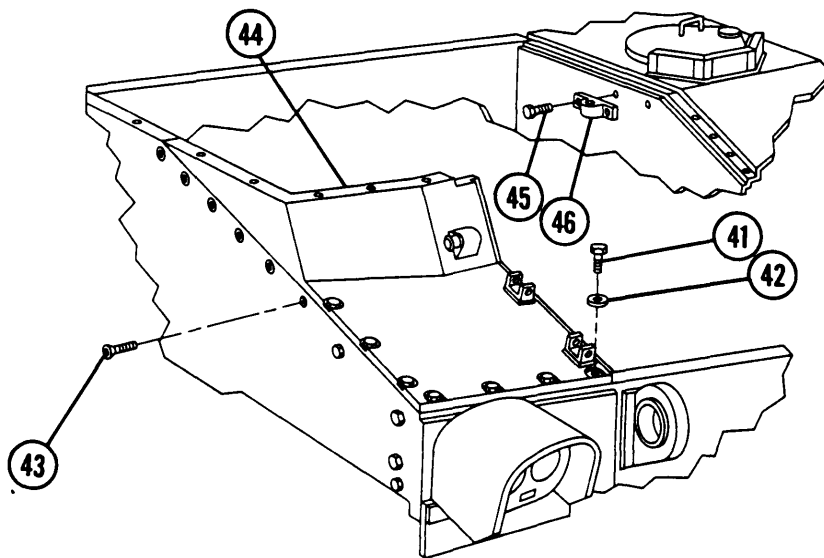

4-5 POWERPLANT — CONTINUED

f. Installation — Continued

- 49 Connect bilge pump hose (39) to connector tube (40). Tighten hose clamp (38).
- 50 Install grille support assembly (37), two washers (32), four washers (34), two screws (31), two screws (33), two new lockwashers (35), and two nuts (36).

WARNING

Center front slope plate assembly is heavy. Do not allow center front slope plate to swing while suspended by hoist and sling. Use caution when working near a sling under tension to prevent severe injury.

CAUTION

Support center front slope plate during installation to prevent equipment damage.

- 51 Install center front slope plate assembly (26), seven washers (23), seven screws (22), three washers (25), and three screws (24).
- 52 Install transmission door support (21), two screws (20), two washers (19), and two nuts (18).

WARNING

Transmission access doors are heavy. If hoisting sling is not available, two personnel are required to lift and move doors.

- 53 Install right transmission access door (16), two screws (30), two washers (29), and two nuts (28). Repeat procedure for left transmission access door (17). Close transmission access doors.
- 54 Install radiator fan access door (15), six washers (14), and six screws (13).

WARNING

Keep clear of equipment when it is being raised or lowered. To prevent injury, do not allow grilles or access doors to swing while suspended by lifting device.

- 55 Install engine exhaust grille (12) and 14 screws (11).

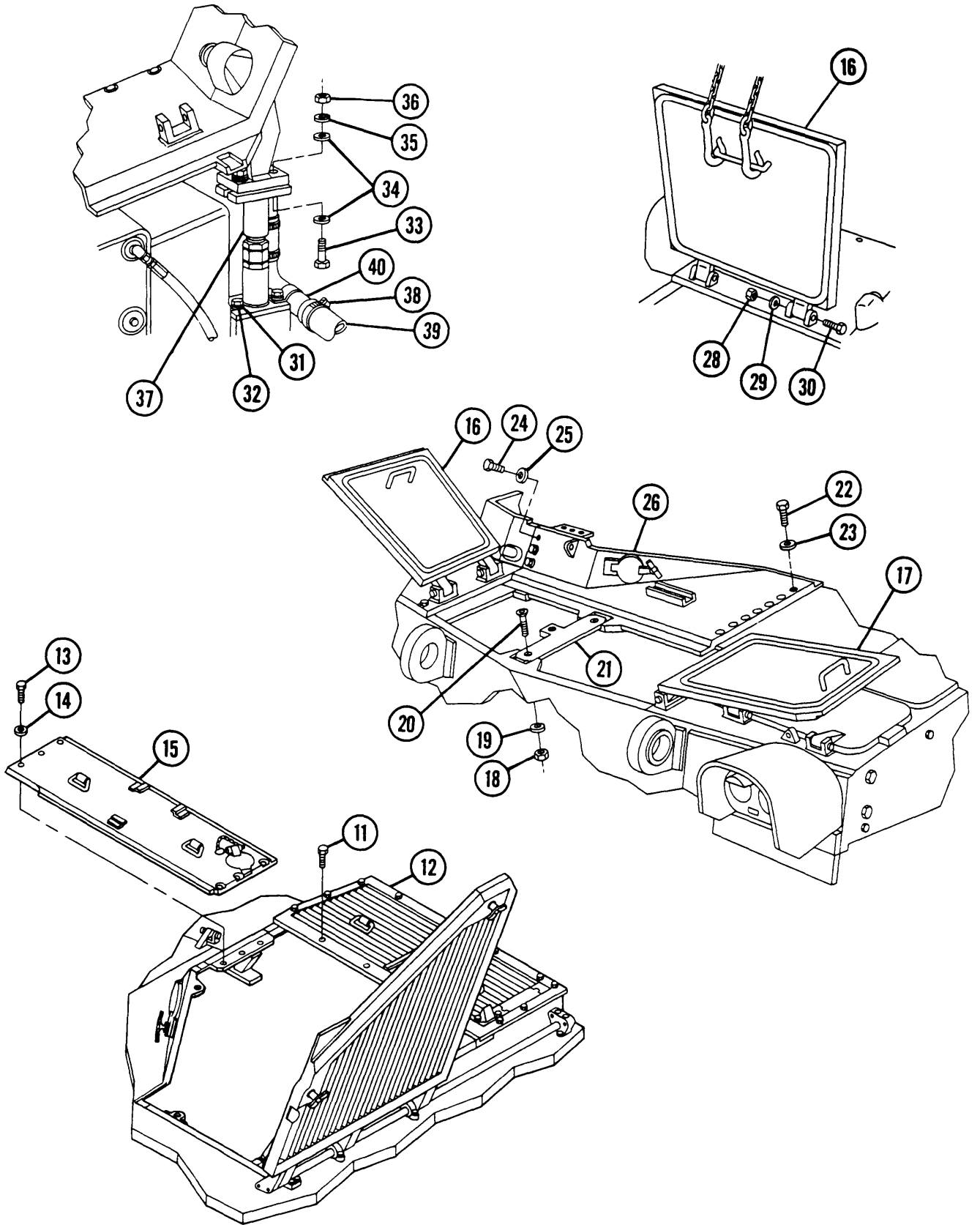

4-5 POWERPLANT — CONTINUED

f. Installation — Continued

- 56 Install new packing (10) in exhaust deflector seat.
- 57 Apply antiseize compound to four screws (8) and install engine exhaust deflector (9) and four screws.
- 58 Insert air intake grille hold-open support arm (7) into upper sleeve (161). Install flat washer (5), screw (4), and support arm pin (6).
- 59 Remove rope or strap (3) secured to machinegun pintle mount (2) and close air intake grille (1).

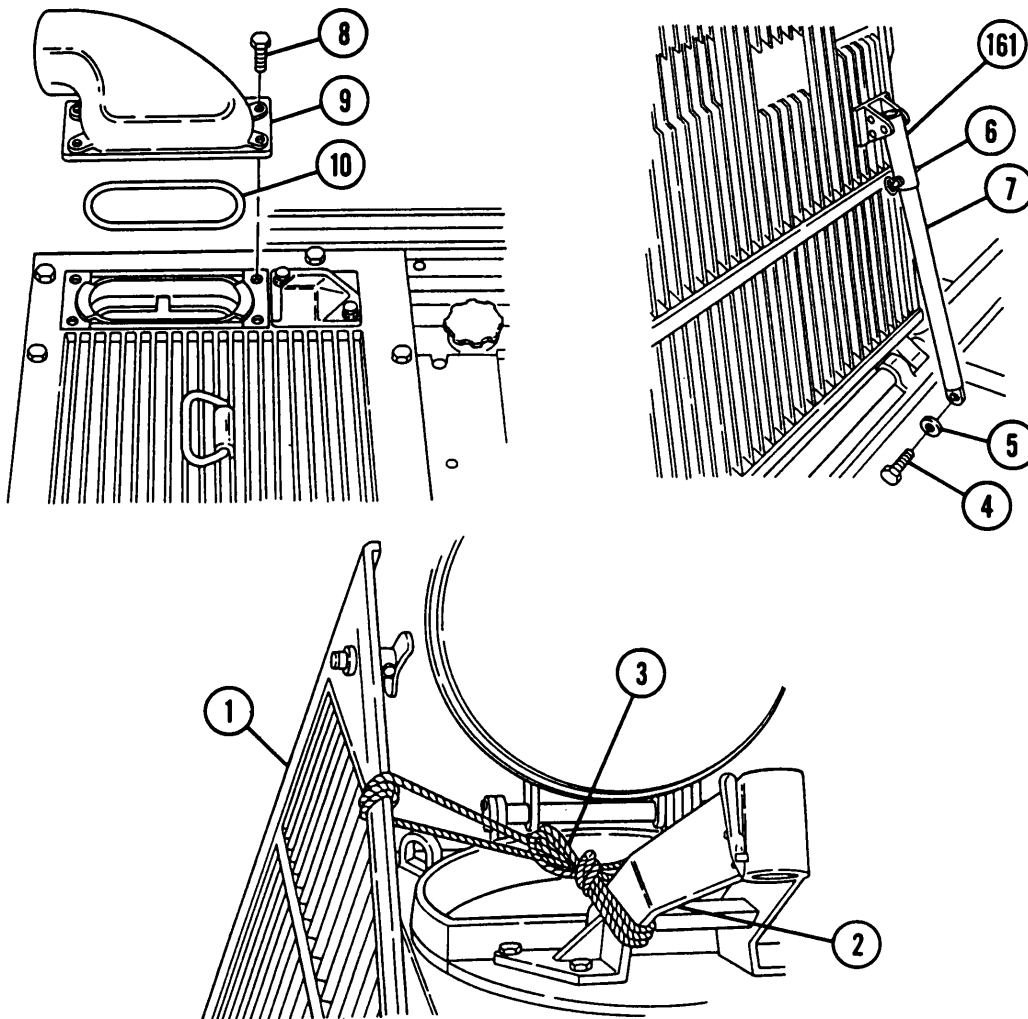

NOTE

FOLLOW-ON MAINTENANCE:

- Install travel lock (para 11-14)
- Install battery ground straps (para 8-28)
- Unblock tracks (TM 9-2350-311-10)

CHAPTER 5 ENGINE COMPONENTS

GENERAL

This chapter provides instructions for maintenance functions and procedures for various engine components, including instructions for removal, disassembly, assembly, installation, and inspection.

<u>CONTENTS</u>	<u>PAGE</u>
5-1 LUBRICATION	5-2
5-2 ENGINE INSPECTION	5-2
5-3 OIL COOLER HOSES	5-5
5-4 OIL FILTER ASSEMBLY AND ENGINE OIL SAMPLING COMPONENTS	5-7
5-5 ENGINE MOUNT BASE ASSEMBLY	5-10
5-6 SHOCK MOUNT AND BRACKET	5-12
5-7 FUEL SHUTOFF ASSEMBLY	5-14
5-8 AIR BOX HEATER (ENGINE MODEL 7083-7396)	5-15
5-9 AIR PUMP (ENGINE MODEL 7083-7396)	5-16
5-10 IGNITION COIL (ENGINE MODEL 7083-7396)	5-19
5-11 SOLENOID VALVE AND BRACKET (ENGINE MODEL 7083-7396)	5-21
5-12 ENGINE VALVE FILLER CAP	5-23
5-13 VALVE COVER BREATHER HOSE	5-25
5-14 OIL LEVEL ROD	5-26
5-15 ENGINE AIR INLET HOUSING HOSE	5-27
5-16 TURBOCHARGER LINES	5-29
5-17 ENGINE RIGHT EXHAUST MANIFOLD AND CROSSOVER TUBE	5-31

5-1 LUBRICATION

Engine lubrication requirements and procedures are defined in TM **9-2350-311-10** and paragraph 2-15.

5-2 ENGINE INSPECTION

This task covers: Inspection

INITIAL SETUP

Tools

General mechanic's tool kit (item 64, Appx H))

References

TM 9-2350-311-10

Materials/Parts

Antifreeze test kit (item 63, Appx D)

Equipment Conditions

Air intake grille open (para 11-8)

Engine compartment access cover removed (para 11-5)

Transmission access doors open (para 11-7)

Inspection

- 1 Check gaskets (1), seals (2), and covers (3) for seepage of fuel and oil.
- 2 Check for damaged, distorted, or broken hose, tube, and line connectors (nuts, adapters, reduction fittings, and couplers) (4).
- 3 Check fuel hoses, tubes (5), and connectors (4) for cracks, leaks, and seepage of fuel (para 6-9).
- 4 Check oil hoses, tubes (6), and connectors (4) for cracks, leaks, and seepage of oil (para 5-3 and 9-4).
- 5 Check for stripped or damaged threads on electrical connectors (7), retaining bolts, nuts, and studs. Repair threads or replace components/items as appropriate.
- 6 Check electrical wires, leads, and connectors (8) for cracked insulation, oil, and grease on cables/connectors (para 8-37).
- 7 Check for broken screws and bolts. If broken, drill and remove with screw extractor. Replace broken screws and bolts.
- 8 Check for damaged, burred, pitted, or gummed-up seal, gasket, and preformed packing seats. Clean, remove burrs, and replace components as required. If damaged beyond repair, or if scope of task is beyond unit maintenance capability, notify support maintenance.
- 9 Check hull engine compartment floor for pools of oil/fuel and coolant.

WARNING

Ensure engine is cool before removing radiator cap. Hot coolant can cause severe burns.

10 Check radiator (9) for coolant level. Check coolant for serviceability by following PMCS procedure (para 2-15) or use test strips.

11 Check coolant hoses (10) for cracks, deterioration, and signs of coolant seepage (para 7-1 and 7-2).

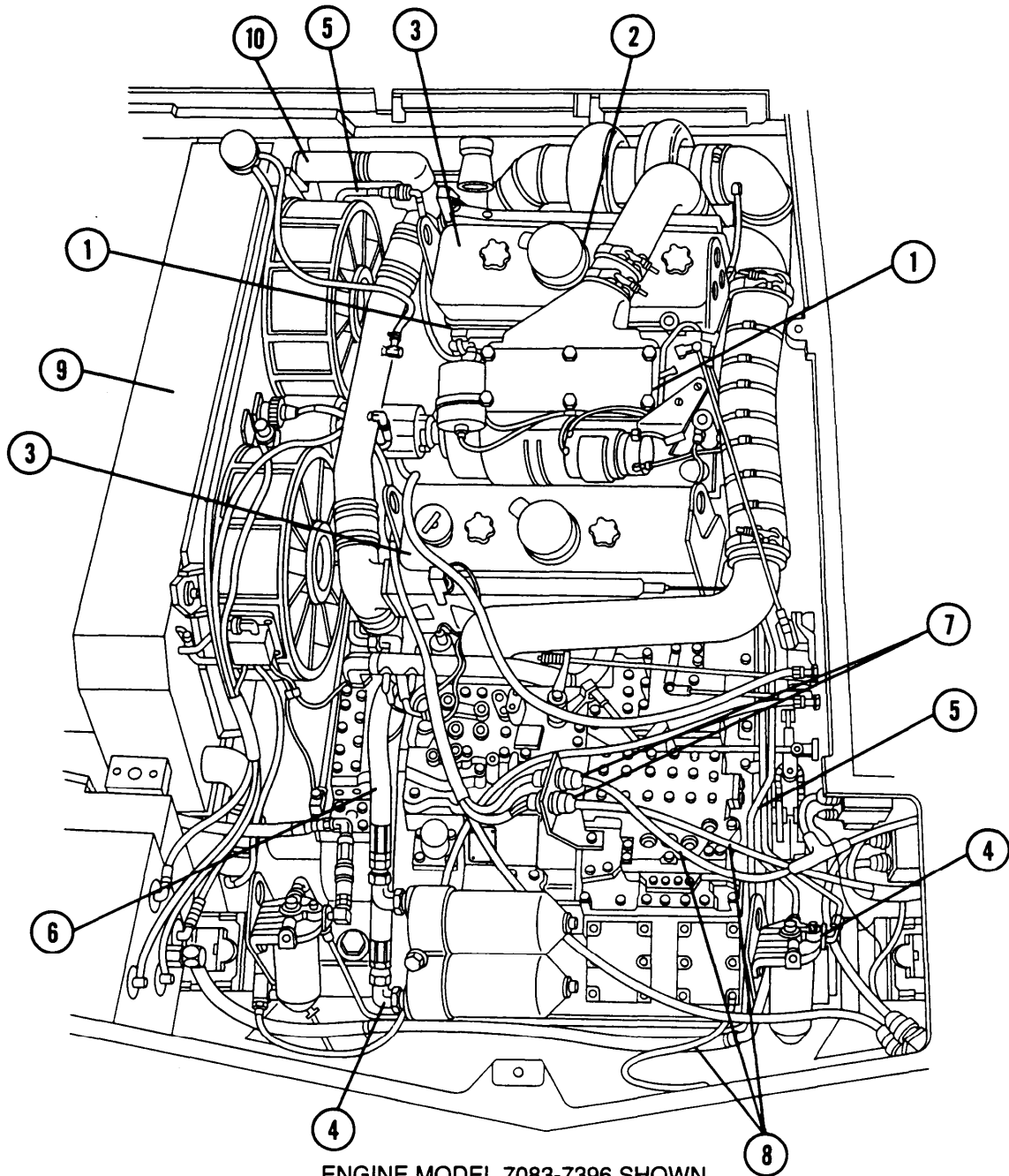

5-2 ENGINE INSPECTION — CONTINUED

Inspection — Continued

- 12 Check oil filters (11) and fuel filters(12) for collection of sediment on filter elements (para 5-4,6-6, and 6-7).
- 13 Start engine and check instrument panel indicators (TM 9-2350-311-10).

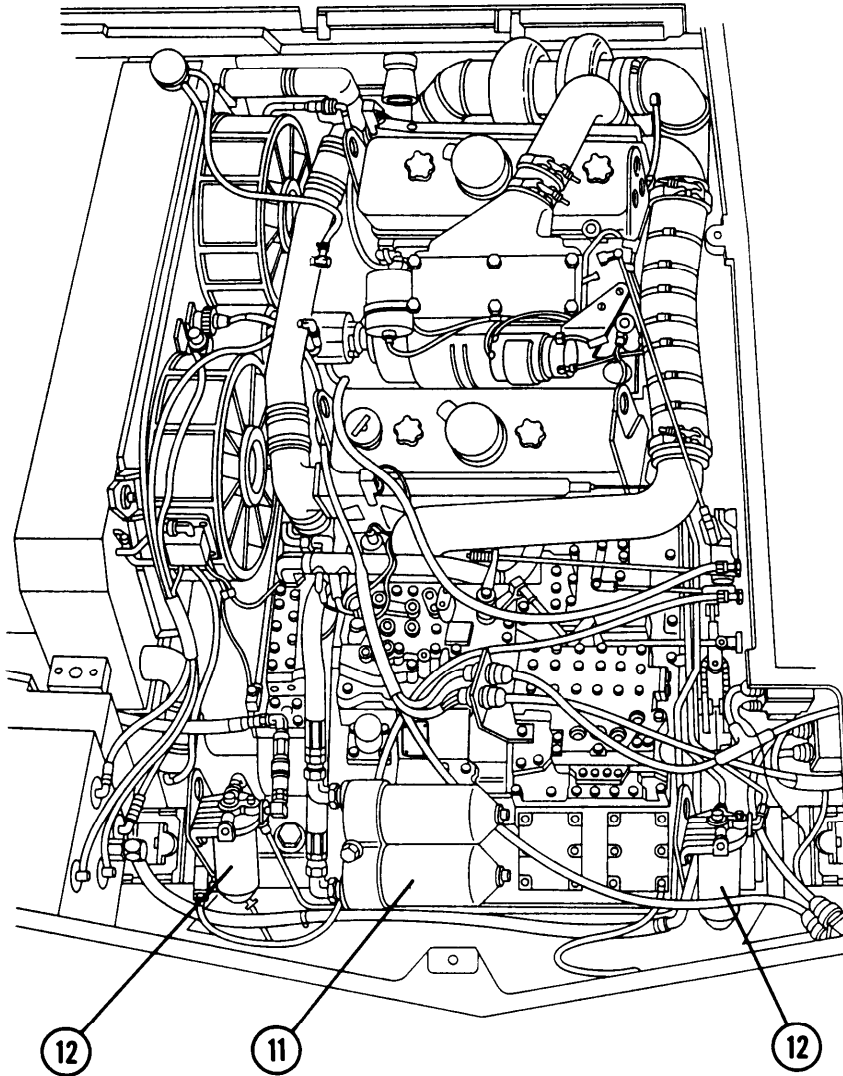

ENGINE MODEL 7083-7396 SHOWN

NOTE

- FOLLOW-ON MAINTENANCE:
- Install engine compartment access door (para 11-5)
 - Close air intake grille (para 11-8)
 - Close transmission access doors (para 11-7)

5-3 OIL COOLER HOSES

This task covers: a. Removal b. Installation

INITIAL SETUP

Tools

General mechanic's tool kit (item 64, Appx H)

Adjustable wrench (item 66, Appx H)

Suitable container

Preformed packings (2) (item 61, Appx G)

Strap (M109A4/M109A5) (item 137, Appx G)

References

TM 9-2350-311-10

Materials/Parts

Lockwashers (8) (item 97, Appx G)

a. Removal

WARNING

- Ensure exhaust is cool before removing hoses to prevent burns or injury.
- Oil is hazardous waste and must be disposed of in accordance with local procedures or direction of the local Hazardous Waste Management office.

1 Remove two drain plugs (1) from oil filters (2), draining oil from filters into suitable container.

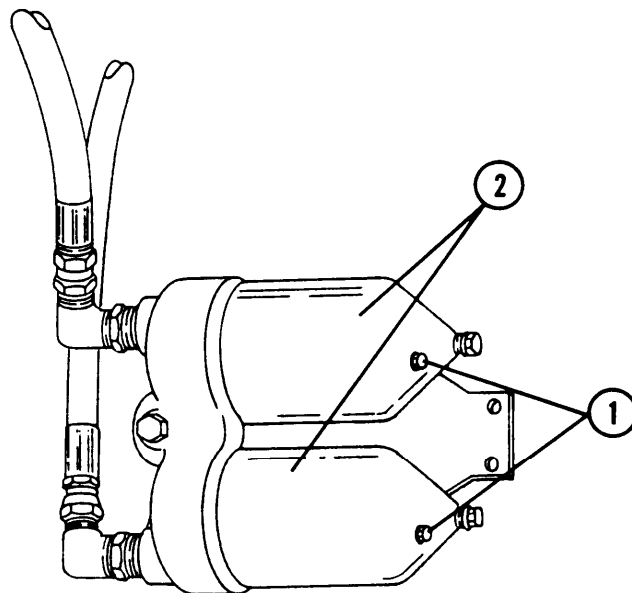

5-3 OIL COOLER HOSES — CONTINUED

a. Removal — Continued

- 2 Remove strap (3) from hoses (4 and 5) (M109A4/M109A5). Discard strap.
- 3 Loosen two nuts (6) to disconnect hoses (4 and 5).
- 4 Remove four screws (7) and four lockwashers (8). Discard lockwashers.
- 5 Remove split flange (9), preformed packing (10), and hose (4) from front of engine oil cooler. Discard preformed packing.
- 6 Remove four screws (11) and four lockwashers (12). Discard lockwashers.
- 7 Remove split flange (13), preformed packing (14), and hose (5) from rear of engine oil cooler. Discard preformed packing.

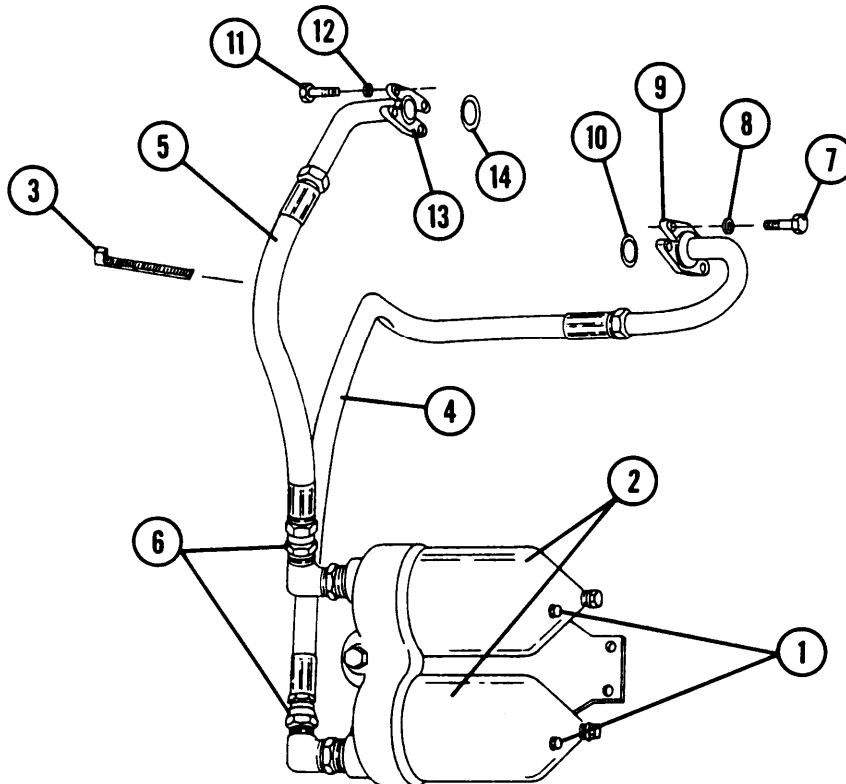

b. Installation

- 1 Install new preformed packing (14), split flange (13), and hose (5) on rear of engine oil cooler.
- 2 Install four new lockwashers(12) and four screws (11).
- 3 Install new preformed packing (10), split flange (9), and hose (4) on front of engine oil cooler.
- 4 Install four new lockwashers (8) and four screws (7).
- 5 Connect hoses (4 and 5) by tightening two nuts (6).
- 6 Install new strap (3) on hoses (4 and 5) (M109A4/M109A5).
- 7 Install two drain plugs(1) into oil filters (2).
- 8 Check engine oil level (TM 9-2350-311-10).

5-4 OIL FILTER ASSEMBLY AND ENGINE OIL SAMPLING COMPONENTS

This task covers: a. Removal b. Installation

INITIAL SETUP

Tools

General mechanic's tool kit (item 64, Appx H)
 Suitable container
 Torque wrench (item 72, Appx H)

Filter elements (2) (item 106, Appx G)
 Preformed packings (2) (item 183, Appx G)

References
 TM 9-2350-311-10

Materials/Parts

Gaskets (2) (item 187, Appx G)
 Gasket sets (2) (item 194, Appx G)

Equipment Conditions
 Transmission access doors open (para 11-7)

5-4 OIL FILTER ASSEMBLY AND ENGINE OIL SAMPLING COMPONENTS — CONTINUED

a. Removal

WARNING

Oil is hazardous waste and must be disposed of in accordance with local procedures or direction of the local Hazardous Waste Management office.

- 1 Remove two drain plugs (1) and drain oil from filter shells (2) into suitable container.
- 2 Unscrew two center studs (3) and remove two filter shells (2) with two filter assemblies (4).
- 3 Remove nut (5) and gasket (6) from adapter (7). Discard gasket.

NOTE

Illustration shown is the M109A2 vehicle. The procedure is identical for the M109A3 and M109A4 Howitzers.

- 4 Remove from each filter shell (2): center stud (3), gasket (8), filter element (9), packing retainer (1 O), ring spacer (11), preformed packing (12), and spring (13). Discard gaskets, filter elements, and preformed packings.
- 5 Remove pipe plug (14), plug (15), and gasket (1 6). Discard gasket.
- 6 Loosen two nuts (17) and disconnect hoses(18 and 19).
- 7 Remove engine oil sampling hose clamp (20), sampling hose (21), and two elbows (22).
- 8 Loosen sampling valve locknut (23) on mounting bracket (24) marked 'ENGINE" and remove valve assembly (25).
- 9 Remove four screws (26) and adapter (7).

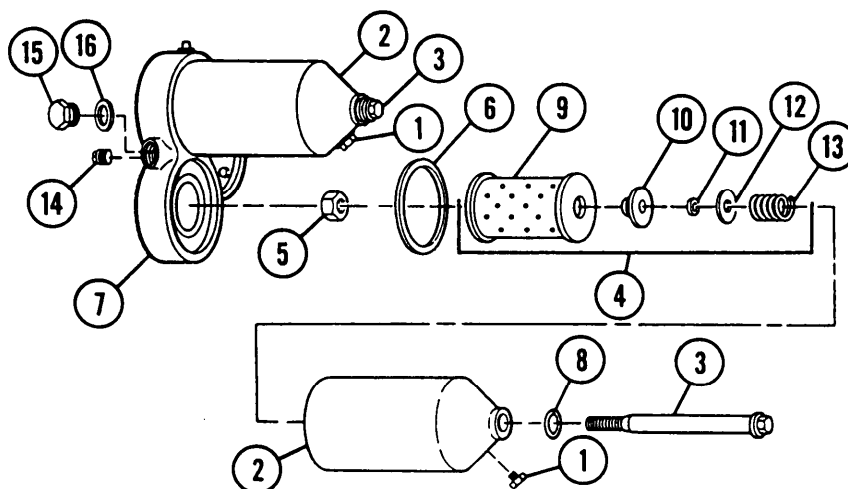

b. Installation

- 1 Install adapter (7) and four screws (26).
- 2 Install valve assembly (25) on mounting bracket (24) marked “ENGINE” and tighten sampling valve locknut (23).
- 3 Install two elbows (22), sampling hose (21), and engine oil sampling hose clamp (20).
- 4 Connect hoses (18 and 19) and tighten two nuts (17).
- 5 Install new gasket (16), plug (15), and pipe plug (14).

NOTE

Steps 6 thru 11 apply to each oil filter assembly.

- 6 **Install** new gasket (8) and center stud (3) on shell (2).
- 7 install spring (13), new preformed packing (12), ring spacer (11), and packing retainer (10) on center stud (3) in shell (2).
- 8 Install new filter element (9) on center stud (3) in shell (2).
- 9 Install nut (5) on center stud (3) and new gasket (6) on adapter (7).
- 10 install filter assembly (4) with filter shell (2) on adapter (7).
- 11 install drain plug (1).
- 12 Torque center stud (3) to 50-60 lb-ft (68-81 N•m).
- 13 Check oil level (TM 9-2350-31 1-10).

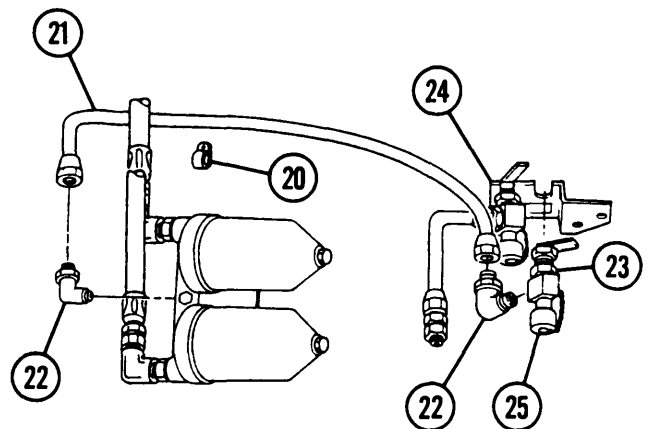
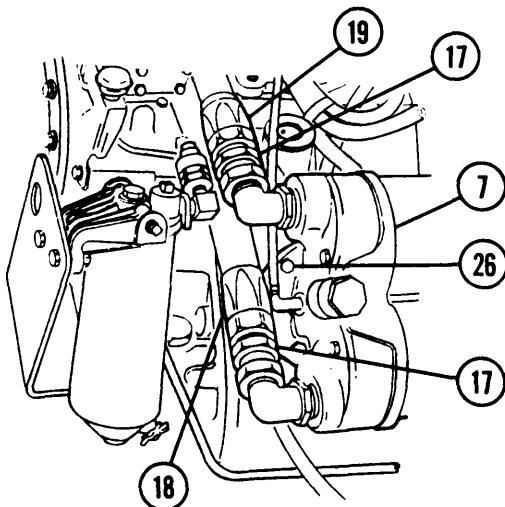

NOTE

FOLLOW-ON MAINTENANCE: Close transmission access doors (para 11-7)

5-5 ENGINE MOUNT BASE ASSEMBLY

This task covers: a. Removal b. Disassembly
 c. Assembly d. Installation

INITIAL SETUP

Tools

General mechanic's tool kit (item 64, Appx H)
Socket wrench (item 56, Appx H)

Materials/Parts

Cotter pins (4) (item 46, Appx G)
Cotter pins (2) (item 51, Appx G)

Equipment Conditions

Powerplant removed (para 4-5)

a. Removal

Remove four screws (1) and mount base assembly (2) using socket wrench.

b. Disassembly

- 1 Remove two cotter pins (3). Discard cotter pins.
- 2 Separate mount handle (4) and universal joint (5) and remove from mount base assembly (2).
- 3 Remove four cotter pins (6) and two jaw pins (7). Discard cotter pins.
- 4 Remove jaw assembly (8) from mount base (9).
- 5 Turn jaw (10) counterclockwise to remove from bolt (11).

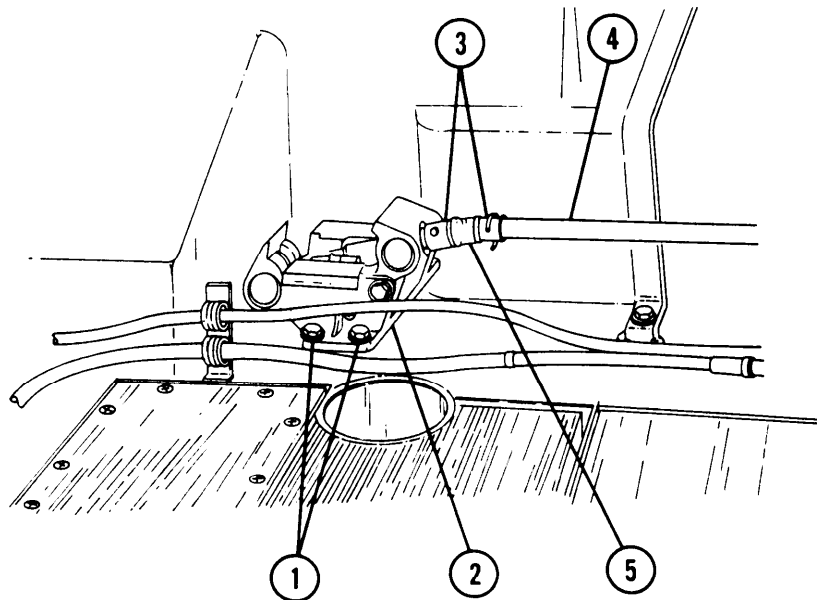

- 6 Turn jaw(12) clockwise to remove from bolt(11) .
- 7 Slide jaw nuts(13 and 14) out of jaws (10 and 12).
- 8 Inspect mount base (9), two jaws (10 and 12), and jaw nuts (13 and 14) for cracks.
- 9 Inspect bolt (11) and jaw nuts(13 and 14) for damaged threads.

c. Assembly

- 1 Slide jaw nuts(13 and 14) into jaws (10 and 12).
- 2 Turn jaw(12) counterclockwise to install on bolt (11).
- 3 Turn jaw (10) clockwise to install on bolt (11).
- 4 Ensure jaws (10 and 12) have been evenly spaced on bolt (11).
- 5 Ensure hex head on bolt (11) is installed on high side of mount base (9).
- 6 Install jaw assembly (8) on mount base (9).
- 7 Install two jaw pins (7) and four new cotter pins (6).
- 8 Install universal joint (5) and mount handle (4) on mount base assembly (2) with two new cotter pins (3).

d. Installation

Install mount base assembly (2) and four screws (1) using socket wrench.

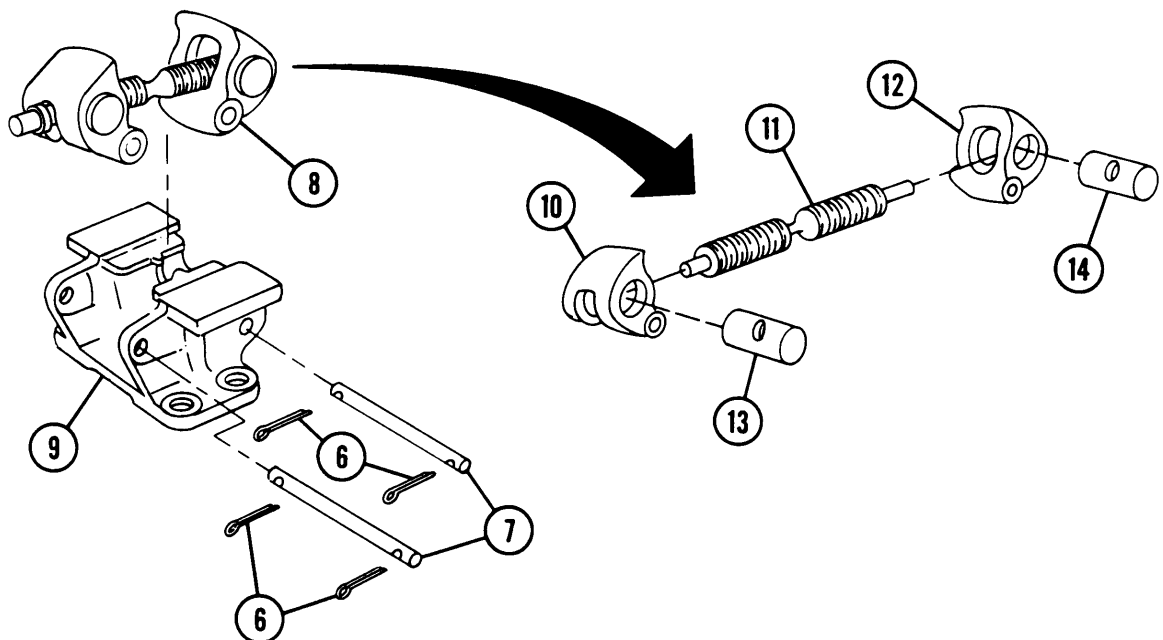

NOTE

FOLLOW-ON MAINTENANCE: Install powerplant (para 4-5)

5-6 SHOCK MOUNT AND BRACKET

This task covers: a. Removal b. Installation

INITIAL SETUP

Tools

General mechanic's tool kit (item 64, Appx H)
Socket wrench set (item 56, Appx H)
Torque wrench (item 72, Appx H)

Equipment Conditions

Powerplant removed (para 4-5)

WARNING

Support powerplant before removing mount to avoid injury to personnel and damage to powerplant.

a. Removal

NOTE

Shock mount and bracket are located on lower rear of engine.

- 1 Remove nut (1) and engine mount group (2).
- 2 Remove two screws (3) and two washers (4).
- 3 Separate two engine shock mount plates (5), spacer (6), and screw (7) from mount (8).
- 4 Remove eight screws (9), eight flat washers (1 O), eight nuts(11), and two support plates (1 2).
- 5 Remove three screws(13) and three washers (14).
- 6 Remove eight screws (1 5), eight washers (1 6), and bracket(17) from engine. Inspect mount (8) and bracket for cracks.

b. Installation

- 1 Install bracket (17) on engine with eight washers(16) and eight screws (1 5). Torque screws to 60-65 ft-lb (81–88 N•m).
- 2 Install three washers (14) and three screws (1 3).
- 3 Install two support plates(12) with eight flat washers (1 O), eight screws (9), and eight nuts (11).
- 4 Install mount (8), screw (7), plate (5), spacer (6), and plate (5).
- 5 Install two washers (4) and two screws (3).

6 Install engine mount group (2) and nut (1).

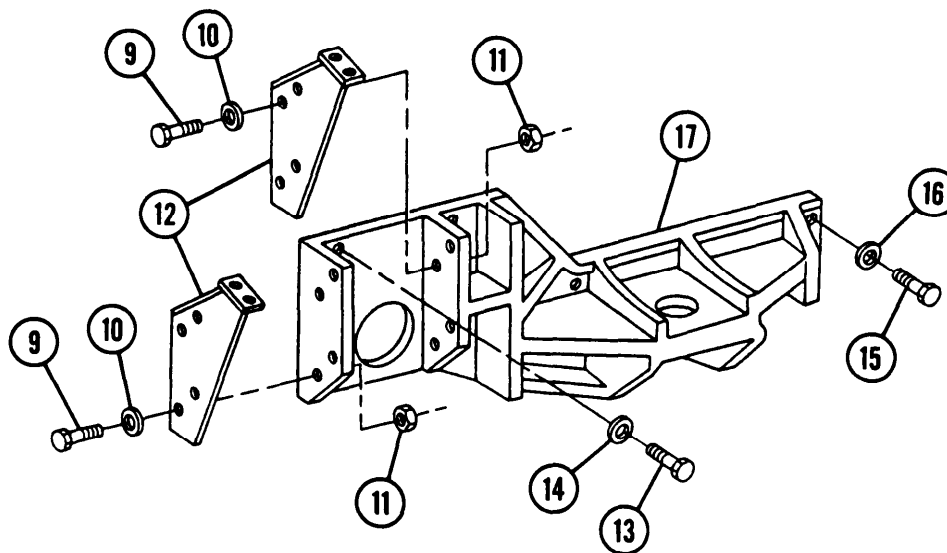
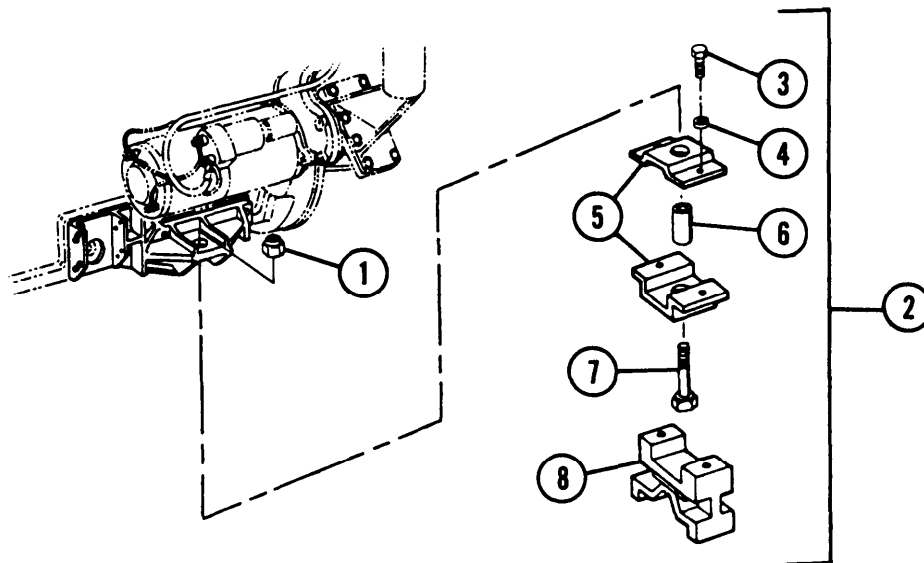

NOTE

FOLLOW-ON MAINTENANCE: Install powerplant (para 4-5)

5-7 FUEL SHUTOFF ASSEMBLY

This task covers: a. Removal b. Installation

INITIAL SETUP

Tools

General mechanic's tool kit (item 64, Appx H)

Materials/Parts

Cotter pin (item 37, Appx G)

Lockwashers (3) (item 95, Appx G)

a. Removal

- 1 Remove quick-release pin (1).
- 2 Remove cotter pin (2), clevis pin (3), and clevis lever (4). Discard cotter pin.
- 3 Remove three screws (5) and three lockwashers (6) at fuel shutoff control assembly (7), located in driver's compartment. Discard lockwashers.
- 4 Remove two screws (8) and pulley bracket (9).

b. Installation

- 1 Inspect cable for deterioration and inspect pulley for wear and cracks.
- 2 Install pulley bracket (9) with two screws (8).
- 3 Install fuel shutoff control assembly (7) in driver's compartment with three new lockwashers (6) and three screws (5).
- 4 Install clevis lever (4), clevis pin (3), new cotter pin (2), and quick-release pin (1).

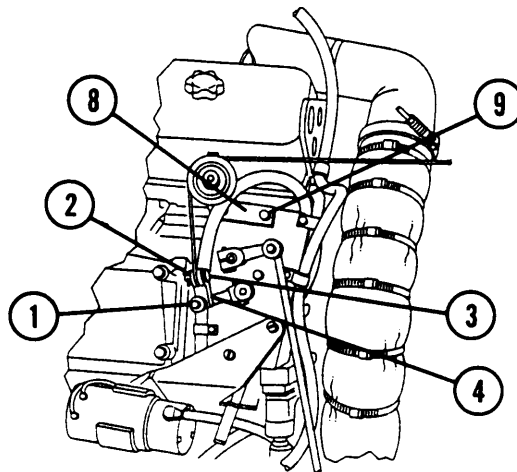
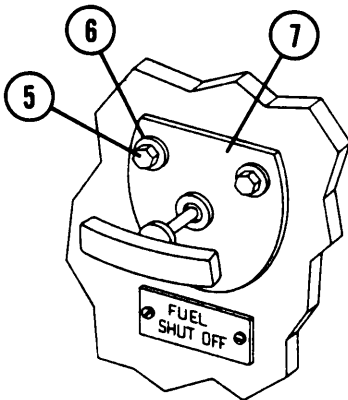

5-8 AIR BOX HEATER (ENGINE MODEL 7083-7396)

This task covers: a. Removal/Disassembly b. Assembly/Installation

INITIAL SETUP

Tools

General mechanic's tool kit (item 64, Appx H)

Materials/Parts

Gasket (item 181, Appx G)

Lockwashers (2) (item 88, Appx G)

a Removal/Disassembly

WARNING

Do not smoke or use open flame when working on fuel systems. An explosion may occur, causing severe injury or death.

NOTE

For ease of removal of air box heater, engine fuel pump maybe removed first (para 6-8).

- 1 Disconnect air box heater-to-solenoid tube assembly(1) at air box heater (2).
- 2 Disconnect coil assembly-to-air box heater lead assembly (3) at heater (2).
- 3 Disconnect pump and motor-to-air box heater hose assembly (4) at heater (2).
- 4 Remove two bolts (5) and two lockwashers (6). Discard lockwashers.
- 5 Remove heater (2) and gasket (7). Discard gasket.
- 6 Remove fuel igniter (8) and fuel injection nozzle (9).

5-8 AIR BOX HEATER (ENGINE MODEL 7083-7396) — CONTINUED

b. Assembly/Installation

- 1 Install fuel injection nozzle (9) and fuel igniter (8).
- 2 Install new gasket (7) and air box heater (2) with two new lockwashers (6) and two bolts (5).
- 3 Connect pump and motor-to-air box heater hose assembly (4) to heater (2).
- 4 Connect coil assembly-to-air box heater lead assembly (3) to heater (2).
- 5 Connect air box heater-to-solenoid tube assembly (1) to heater (2).

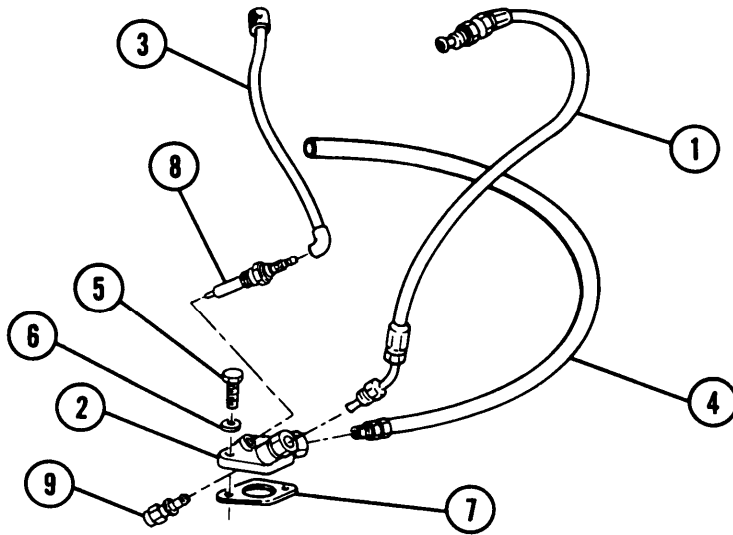

5-9 AIR PUMP (ENGINE MODEL 7083-7396)

This task covers: a. Removal b. Installation

INITIAL SETUP

Tools

General mechanic's tool kit (item 64, Appx H)
Torque wrench (item 72, Appx H)

Equipment Conditions

Batteries disconnected (para 8-28)

Materials/Parts

Lockwasher (item 89, Appx G)

a. Removal

- 1 Disconnect hose (1) from check valve (2).
- 2 Disconnect hose (3) from elbow (4) on air pump (5).
- 3 Remove screw (6) and clamp (7) from governor cover (8).
- 4 Remove elbow or adapter (9) from hose (3).
- 5 Remove two nuts (10 and 11) from two wiring harness leads(12 and 13) on air pump (5). Disconnect two leads from air pump.
- 6 Remove bolt (14), lockwasher (1 5), washer (1 6), air pump clamp (1 7), cushion (18), and air pump (5). Discard lockwasher.
- 7 Remove hose (19) and check valve (2) from adapter (20) on air pump (5).

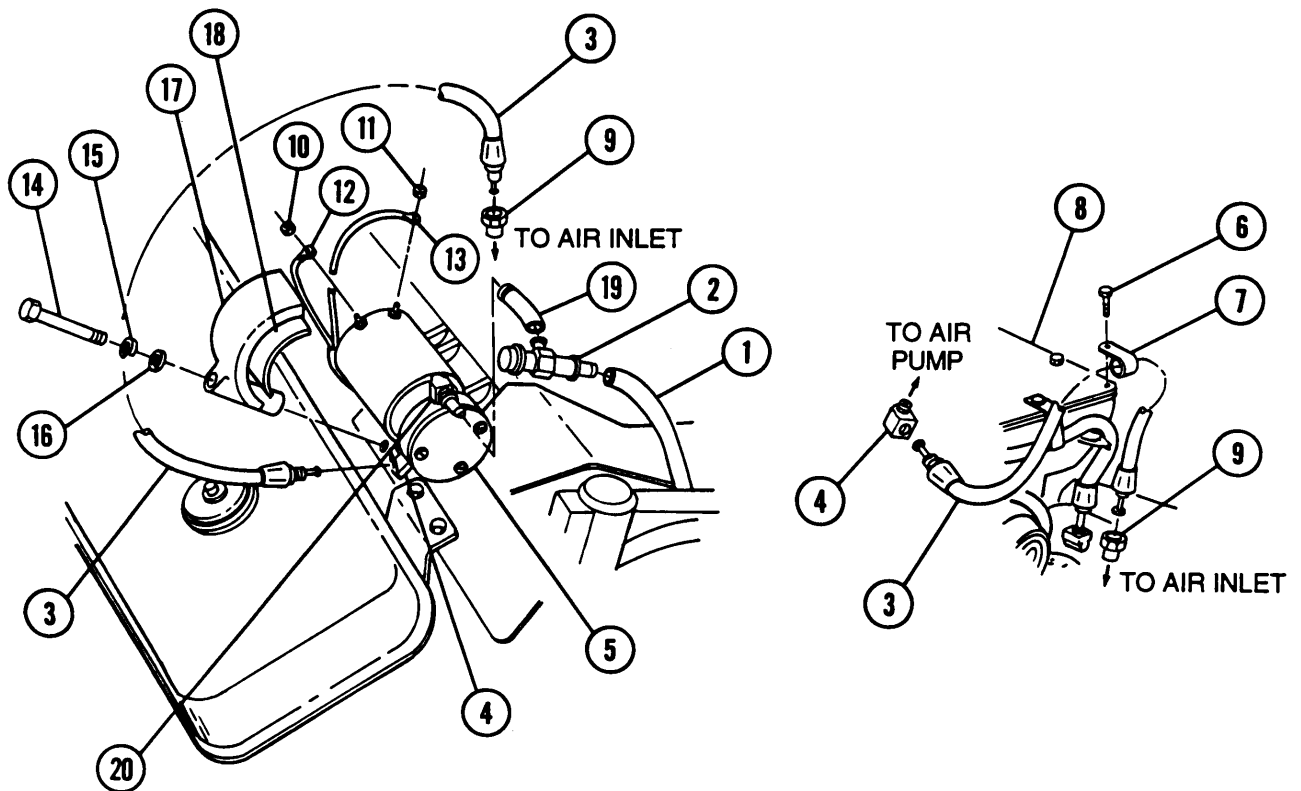

5-9 AIR PUMP (ENGINE MODEL 7083-7396) — CONTINUED

b. Installation

- 1 Install hose (19) to adapter (20) on air pump (5).
- 2 Position air pump (5), cushion (18), and air pump clamp (17) on bracket (21) and install washer (16), new lockwasher (15), and screw (14). Torque screw to 35-39 lb-ft (47-53 N•m).
- 3 Install check valve (2) on hose (19).
- 4 Install hose (3) on elbow (4) on air pump (5).
- 5 Install adapter (9) on hose (3).
- 6 Secure clamp (7) to governor cover (8) with screw (6).
- 7 Install two wiring harness leads (12 and 13) and secure with two nuts (10 and 11).
- 8 Install hose (1) on check valve (2).

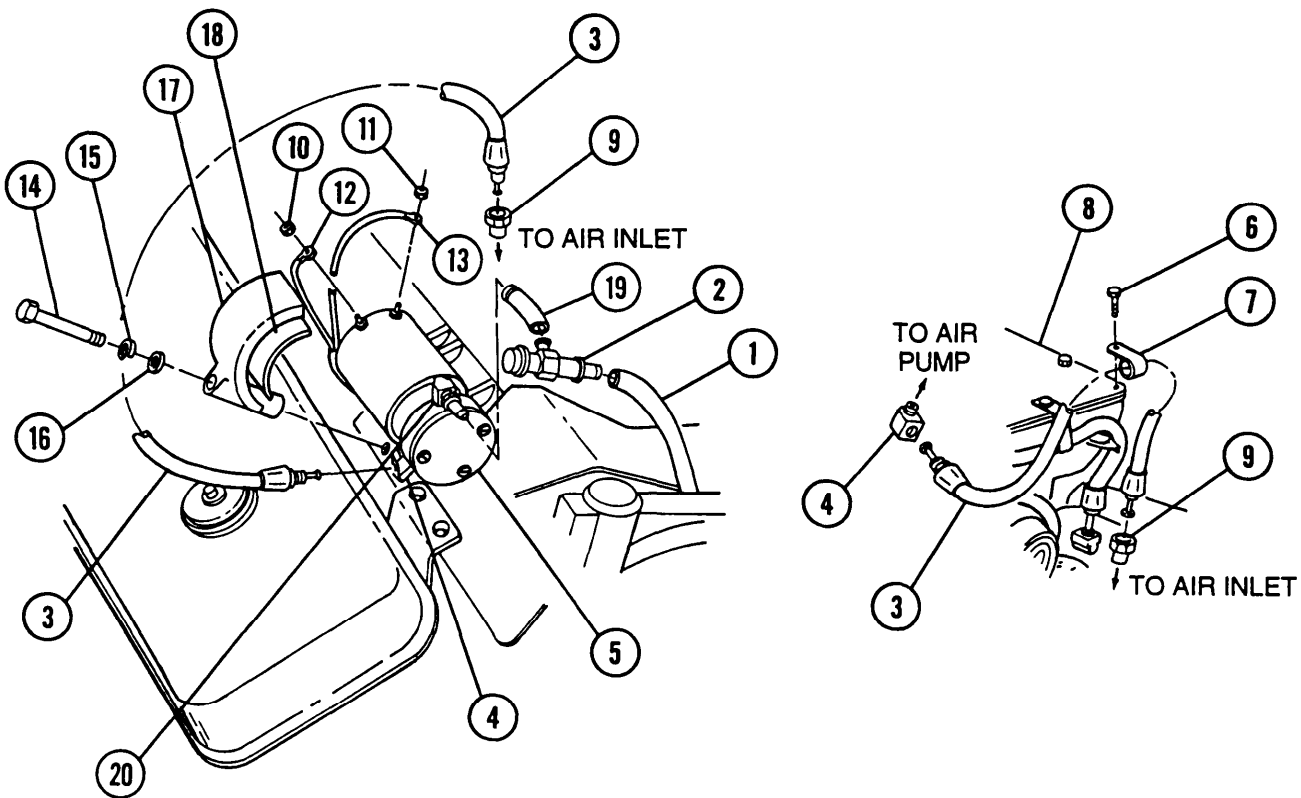

NOTE

FOLLOW-ON MAINTENANCE: Connect batteries (para 8-28)

5-10 IGNITION COIL (ENGINE MODEL 7083-7396)

This task covers: a. Removal b. Installation

INITIAL SETUP

Tools

General mechanic's tool kit (item 64, Appx H)
Torque wrench (item 72, Appx H)

Equipment Conditions

Batteries disconnected (para 8-28)

Materials/Parts

Lockwashers (2) (item 89, Appx G)

a. Removal

- 1 Disconnect electrical lead(1) from ignition coil (2).
- 2 Disconnect wiring harness (3) from ignition coil (2).
- 3 Remove screw (4), lockwasher (5), and washer (6). Remove bracket (7) and coil (2) as an assembly. Discard lockwasher.
- 4 Remove nut (8), lockwasher (9), screw (10), and coil (2) from bracket (7). Discard lockwasher.

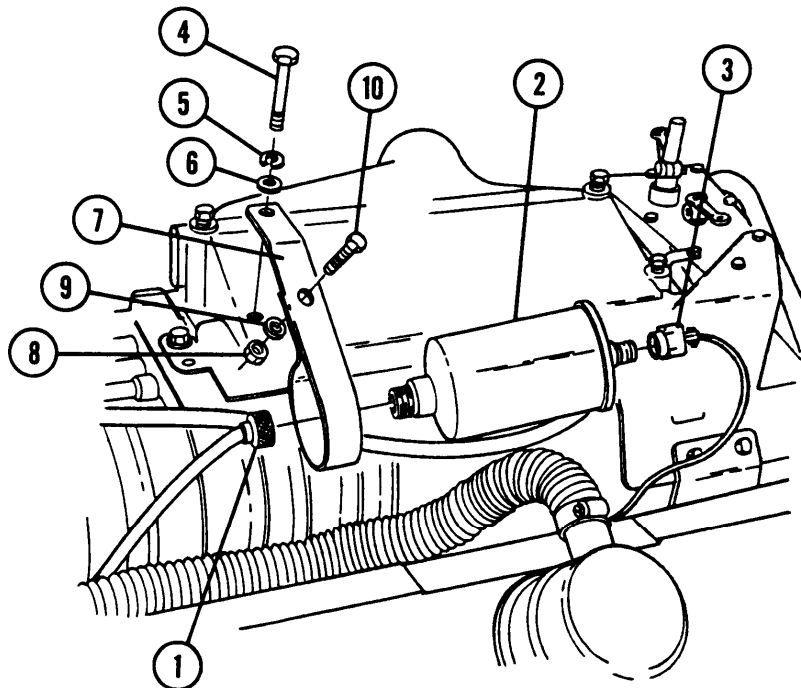

5-10 IGNITION COIL (ENGINE MODEL 7083-7396) — CONTINUED

b. Installation

- 1 Insert ignition coil (2) into bracket (7) and secure with new lockwasher (9), screw (10), and nut (8). Torque nut to 7-9lb-ft(10-12 N•m).
- 2 Position ignition coil (2) and bracket (7) on air inlet housing (11) and secure with washer (6), new lockwasher (5), and screw (4). Torque screw to 16-20 lb-ft (22-27 N•m).
- 3 Connect electrical lead (1) to ignition coil (2).
- 4 Connect wiring harness (3) to ignition coil (2).

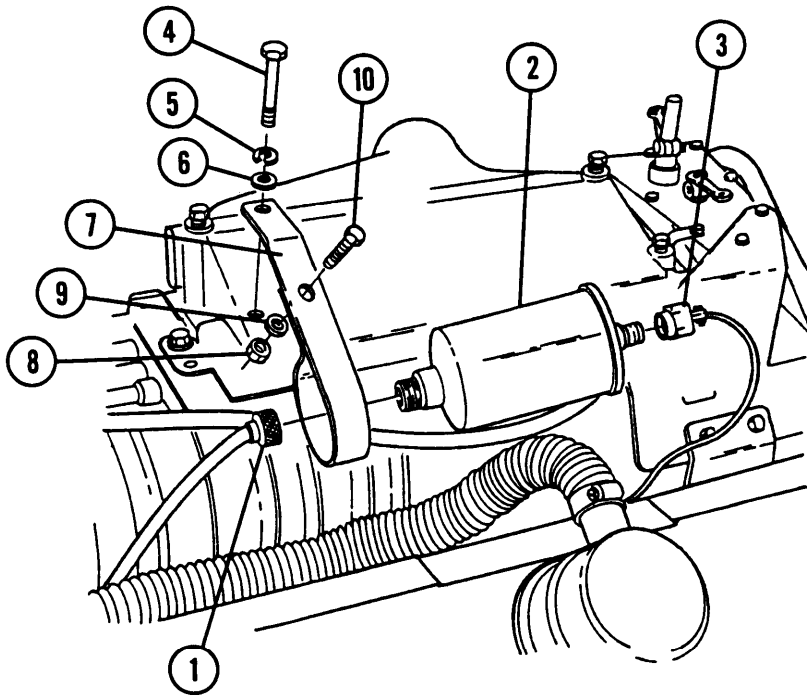

NOTE

FOLLOW-ON MAINTENANCE: Connect batteries (para 8-28)

5-11 SOLENOID VALVE AND BRACKET (ENGINE MODEL 7083-7396)

This task covers: a. Removal b. Installation

INITIAL SETUP

Tools

General mechanic's tool kit (item 64, Appx H)
Torque wrench (item 72, Appx H)

Materials/Parts

Lockwashers (2) (item 86, Appx G)
Lockwashers (4) (item 89, Appx G)

Equipment Conditions

Air box heater removed (para 5-8)
Air pump removed (para 5-9)
Ignition coil removed (para 5-10)
Batteries disconnected (para 8-28)

a. Removal

- 1 Disconnect fuel hoses (1 and 2) from connector (3) and elbow (4) on solenoid valve (5).
- 2 Remove screw (6) and clamp (7) from governor cover (8). Reinstall screw.
- 3 Remove hose(1) from connector (9) on left cylinder head (10).
- 4 Remove connector (9) and tee (11).

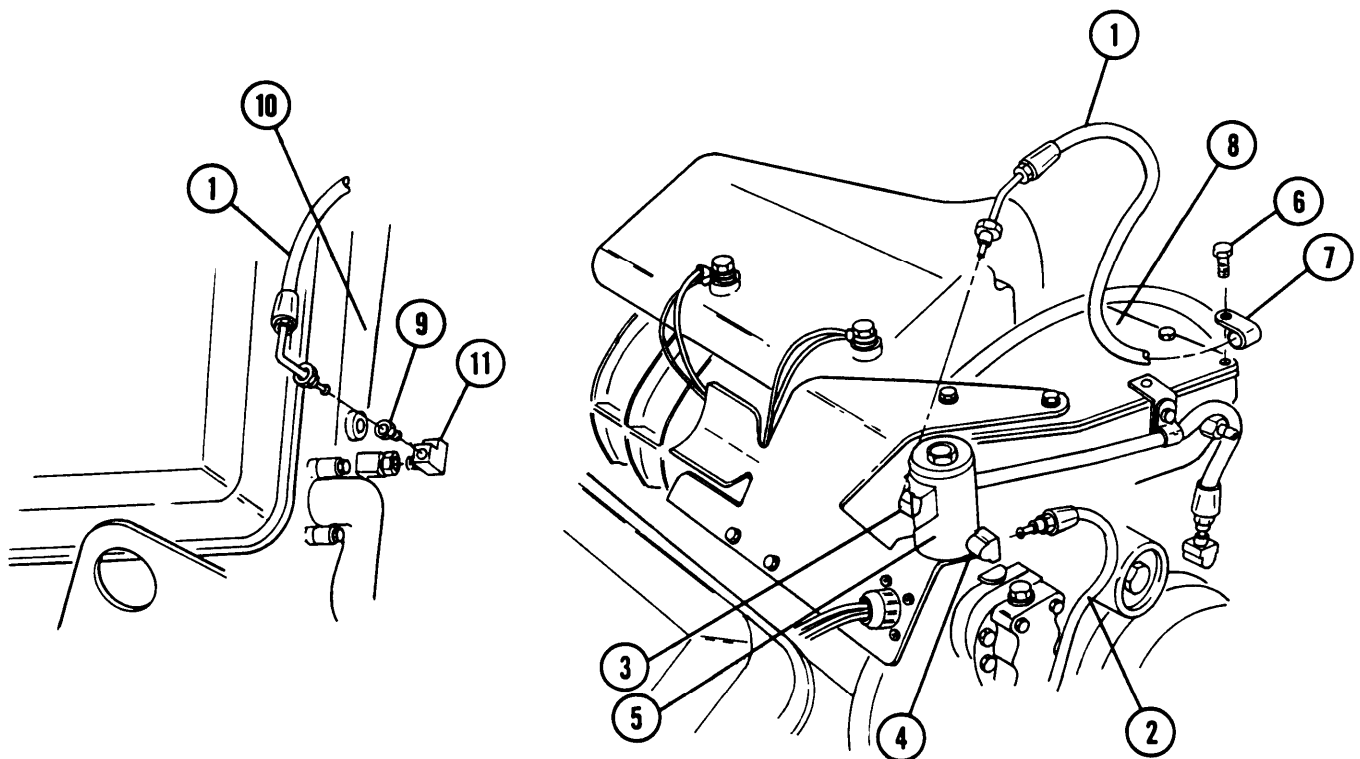

5-11 SOLENOID VALVE AND BRACKET — CONTINUED

Removal — Continued

- 5 Remove two screws (12), two lockwashers (13), and two washers (14) and disconnect four wiring harness leads (15 and 16). Discard lockwashers.
- 6 Remove two screws (17) and two lockwashers (18). Discard lockwashers.
- 7 Disconnect electrical lead (19).
- 8 Remove two screws (20), four flat washers (21), and bracket assembly (22) with solenoid valve (5) and electrical lead (23).
- 9 Remove two screws (24), two lockwashers (25), and solenoid valve (5). Discard lockwashers.
- 10 Remove four screws (26), four nuts (27), and electrical lead (23).

b. Installation

- 1 Install electrical lead (23) with four nuts (27) and four screws (26).
- 2 Secure wiring harness leads (15 and 16) to air inlet housing (28) with two washers (14), two new lockwashers (13), and two screws (12). Torque screws to 16-20 lb-ft (22-27 N•m).
- 3 Install solenoid valve (5), two new lockwashers (25), and two screws (24).
- 4 Install hose (1) to connector (3) on solenoid valve (5).
- 5 Position solenoid valve (5) with bracket assembly (22) on governor cover (8) inside bracket (29). Loosely secure solenoid valve and bracket assembly with four washers (21) and two screws (20). Do not tighten screws.
- 6 Install two new lockwashers(18) and two screws (17), securing solenoid valve (5) and bracket assembly (22) to support bracket (29). Torque screws to 30-35 lb-ft (41-47 NŻm).
- 7 Tighten two screws (20).
- 8 Connect electrical lead (19).
- 9 Install tee (11) into left cylinder head (1 O).
- 10 Install connector (9) to tee(11).

NOTE

Engine model 7083-7396 does not use clamp (1) on hose (2).

- 11 Install hose (2) into connector (9).
- 12 Install clamp (1) on hose (2) and secure to governor cover (8) with screw (7).

13 Install hose (4) on elbow (5).

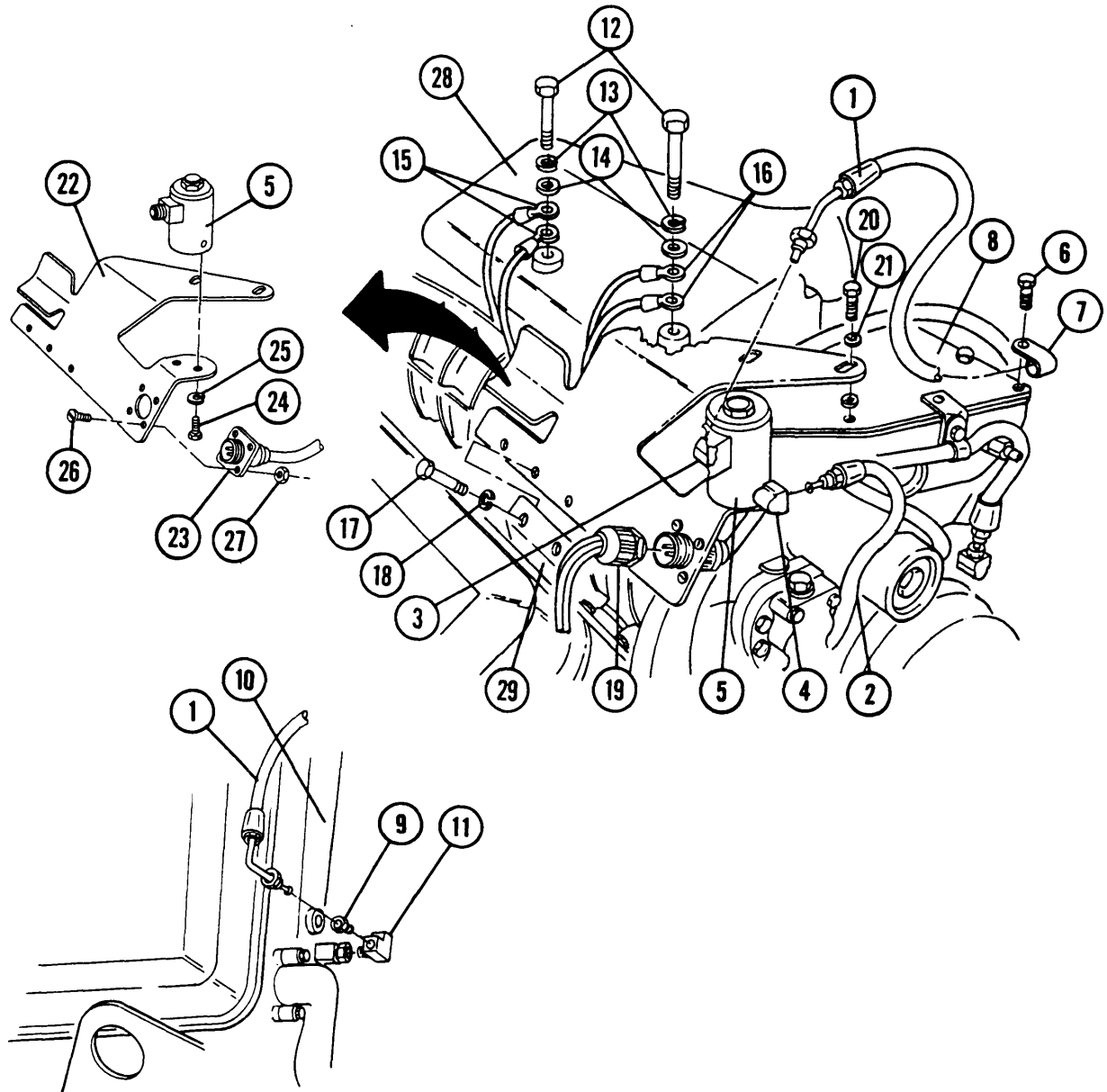

NOTE

FOLLOW-ON MAINTENANCE:

- Install ignition coil (para 5-10)
- Install air pump (para 5-9)
- Install air box heater (para 5-8)
- Connect batteries (para 8-28)

5-12 ENGINE VALVE FILLER CAP

This task covers: a. Removal b. Installation

INITIAL SETUP

Tools

General mechanic's tool kit (item 64, Appx H)

a. Removal

1 Unscrew engine valve filler cap(1) and pull cap from engine valve cover (2).

2 Detach engine filler cap (1) from cap chain (3) and secure cap chain.

b. Installation

1 Attach engine valve filler cap (1) on cap chain (3).

2 Insert engine valve filler cap(1) with cap chain (3) into engine valve cover (2).

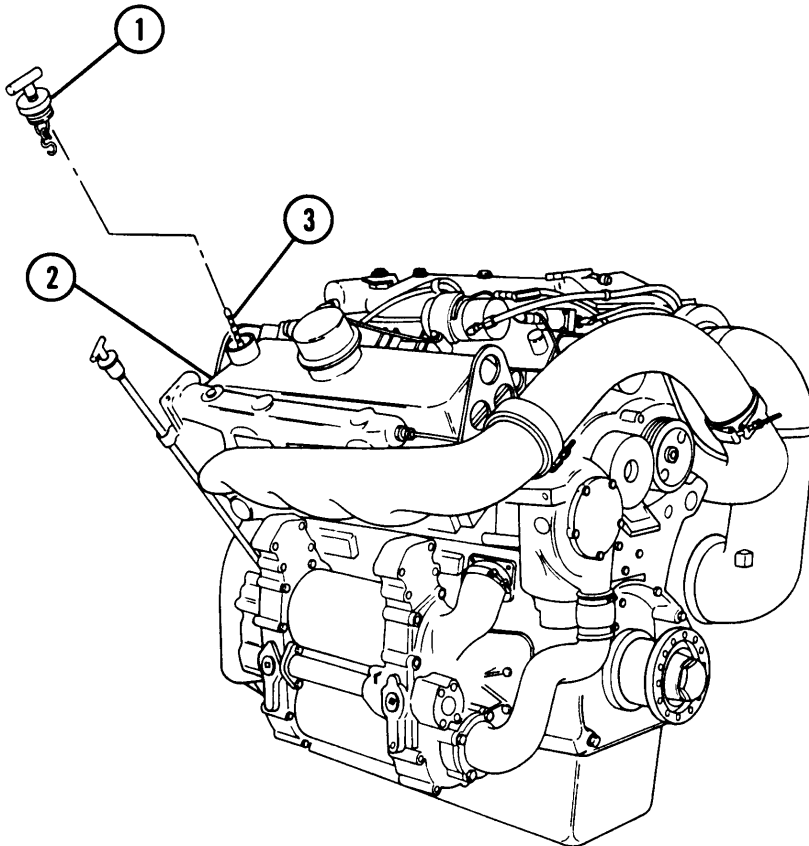

ENGINE SHOWN REMOVED FOR CLARITY

5-13 VALVE COVER BREATHER HOSE

This task covers: a. Removal b. installation

INITIAL SETUP

Tools

General mechanic's tool kit (item 64, Appx H)

a. Removal

- 1 Remove four clamps (1) and two breather hoses (2).

b. Installation

- 1 Install two breather hoses (2) and four clamps (1).

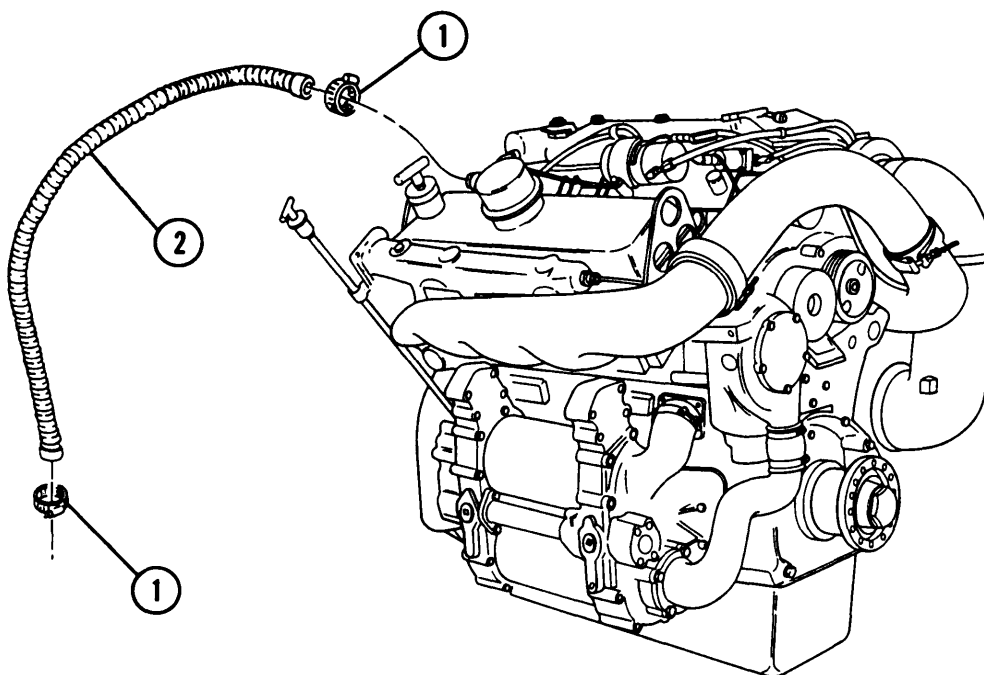

ENGINE SHOWN REMOVED FOR CLARITY

5-14 OIL LEVEL ROD

This task covers: a. Removal b. Installation

INITIAL SETUP

Tools
General mechanic's tool kit (item 64, Appx H)

Equipment Conditions
Powerplant removed (para 4-5)

a. Removal

1 Remove nut(1), clamp (2), oil level rod (3), rod tube (4), and adapter (5).

b. Installation

1 Install adapter (5), rod tube (4), oil level rod (3), clamp (2), and nut (1).

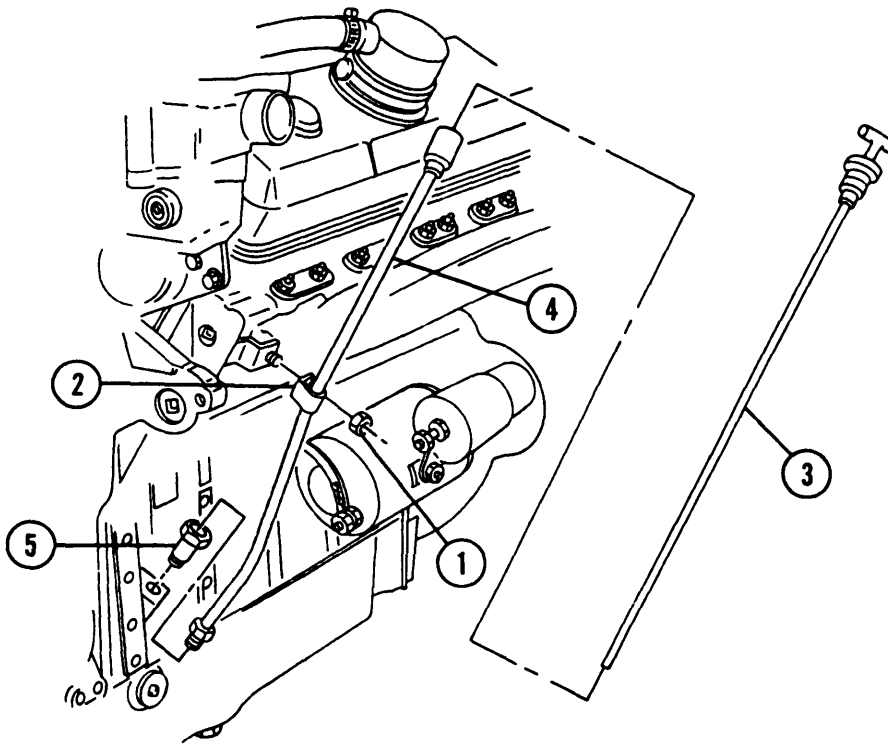

NOTE

FOLLOW-ON MAINTENANCE: Install powerplant (para 4-5)

5-15 ENGINE AIR INLET HOUSING HOSE

This task covers: a. Removal b. Installation

INITIAL SETUP

Tools

General mechanic's tool kit (item 64, Appx H)

a. Removal

WARNING

Ensure engine is cool before removing inlet housing hose to prevent burns or injury.

- 1 Loosen four clamps(1) and remove tube (2).
- 2 Remove clamp (1), hose (3), and clamp (1) from air inlet housing (4).
- 3 Remove clamp(1), hose (3), and clamp(1) from turbocharger (5).

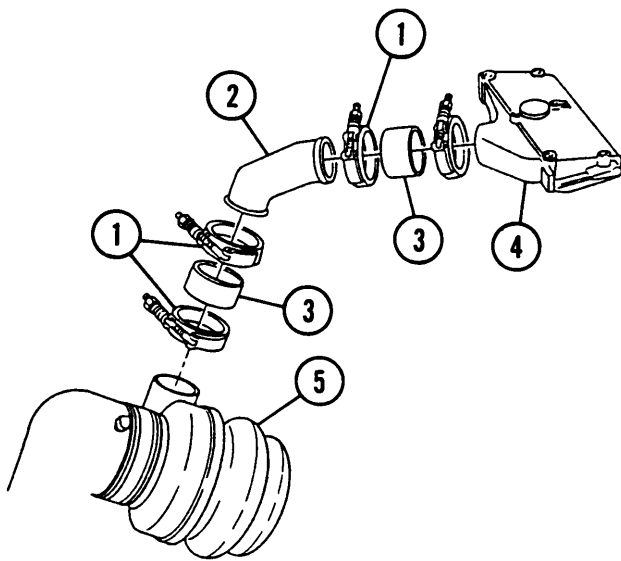

ENGINE MODEL 7083-7396 SHOWN

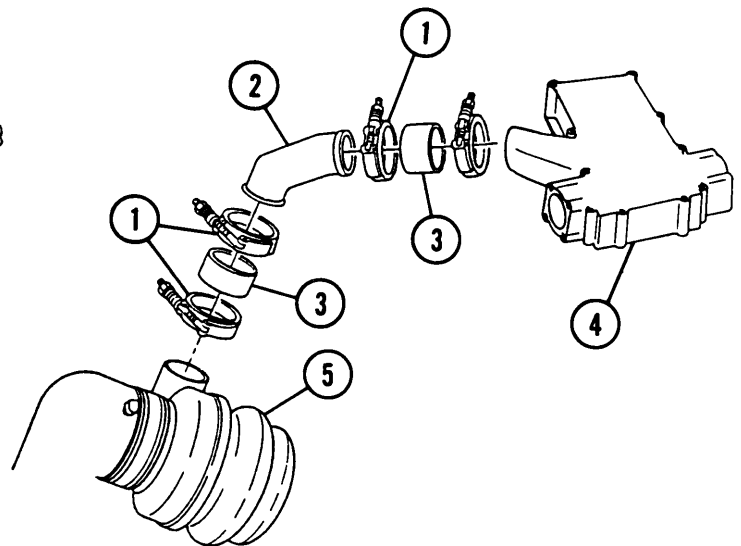

ENGINE MODEL 7083-7391 SHOWN

5-15 ENGINE AIR INLET HOUSING HOSE — CONTINUED

b. Installation

WARNING

Ensure engine is cool before installing inlet housing hose to prevent burns or injury.

- 1 Install clamp (1), hose (3), and clamp (1) on turbocharger (5). Do not tighten clamps.
- 2 Install clamp (1), hose (3), and clamp (1) on air inlet housing (4). Do not tighten clamps.
- 3 Install tube (2) and tighten four clamps (1).

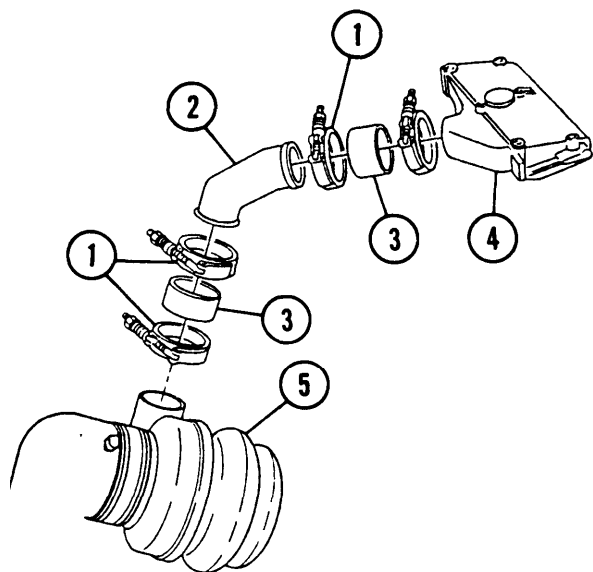

ENGINE MODEL 7083-7396 SHOWN

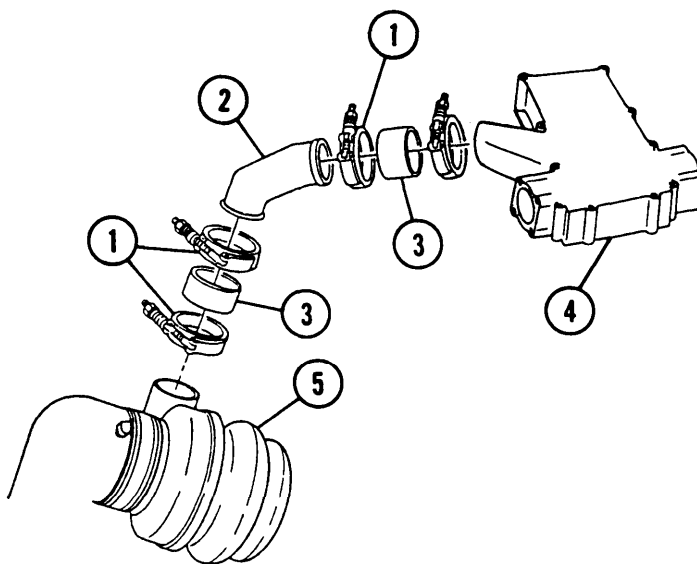

ENGINE MODEL 7083-7391 SHOWN

5-16 TURBOCHARGER LINES

This task covers: a. Removal b. Installation

INITIAL SETUP

Tools

General mechanic's tool kit (item 64, Appx H)

Equipment Condition

Powerplant removed (para 4-5)

Materials/Parts

LockWasher (item 88, Appx G)

a. Removal

WARNING

Ensure engine is cool before removing or installing turbocharger lines to prevent burns or injury .

- 1 Remove nut (1), lockwasher (2), washer (3), and screw (4). Discard lockwasher.
- 2 Remove screw (5) and oil supply line (6) from turbocharger (7) and elbow (8).
- 3 Remove two clamps (9) and oil return line (10).

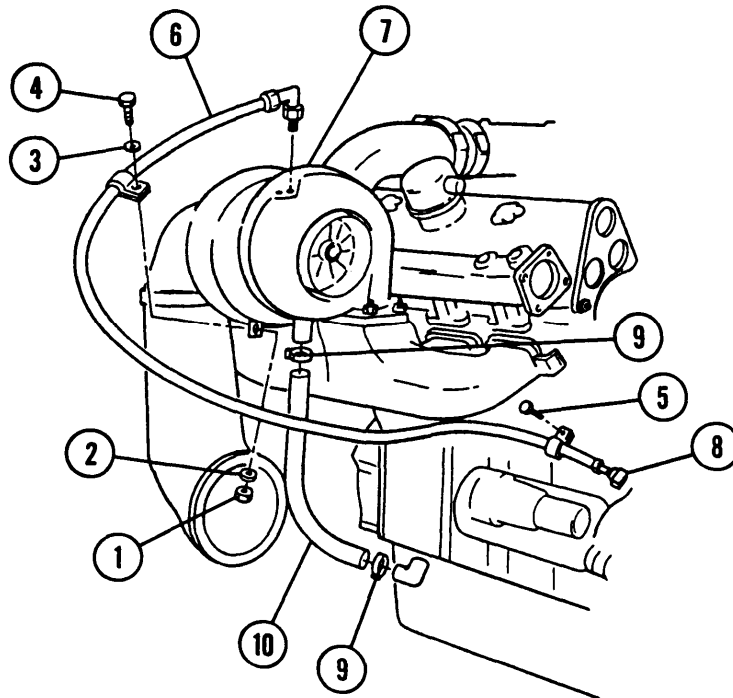

5-16 TURBOCHARGER LINES — CONTINUED

b. Installation

WARNING

Ensure engine is cool before removing or installing turbocharger lines to prevent burns or injury.

- 1 Install oil return line (10) and two clamps (9).
- 2 Install oil supply line (6) on turbocharger (7) and elbow (8).
- 3 Install washer (3), screw (4), new lockwasher (2), and nut (1).
- 4 Install screw (5).

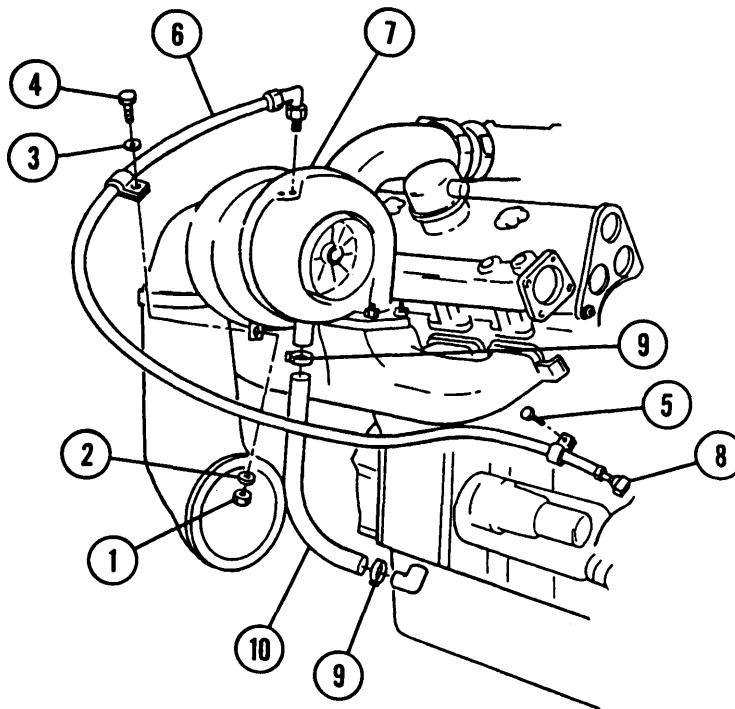

NOTE

FOLLOW-ON MAINTENANCE: Install powerplant (para 4-5)

5-17 ENGINE RIGHT EXHAUST MANIFOLD AND CROSSOVER TUBE

This task covers: a. Removal b. Installation

INITIAL SETUP

Tools

General mechanic's tool kit (item 64, Appx H)
Torque wrench (item 72, Appx H)

Equipment Conditions

Air inlet manifold removed (para 5-15)
Turbocharger oil return line removed (para 5-16)
Turbocharger oil supply line removed (para 5-16)

Materials/Parts

Gasket (engine model 7083-7391) (item 179, Appx G)
Gasket (engine model 7083-7396) (item 170, Appx G)
Locking nuts (5) (item 172, Appx G)

NOTE

For removal and installation of engine left exhaust manifold, notify support maintenance.

a. Removal

WARNING

- Ensure engine and exhaust systems are cool enough to permit handling in order to prevent burns or injury.
- Engine exhaust manifold may slip or fall during removal. Assistance is required to prevent injury to personnel.

5-17 ENGINE RIGHT EXHAUST MANIFOLD AND CROSSOVER TUBE — CONTINUED

a. Removal — Continued

- 1 Remove two nuts (1) from two clamps (2) securing exhaust crossover tube (3) to right exhaust manifold (4) and left exhaust manifold (5). Slide clamps onto manifolds.
- 2 Loosen five locking nuts (6), securing right exhaust manifold (4) to side of cylinder head.
3. Remove exhaust crossover tube (3) from exhaust manifolds (4 and 5). Slide right exhaust manifold (4) upward and off cylinder head. Remove clamp (2) from manifold.

NOTE

Engine model 7083-7391 has five beveled washers and no end retainers.

- 4 Remove five locking nuts (6), three beveled washers (7), and two end retainers (8) from studs (9) on right cylinder head. Discard locking nuts.
- 5 Remove exhaust manifold gasket (10). Discard gasket.

b. Installation

WARNING

- Ensure engine and exhaust systems are cool enough to permit handling in order to prevent burns or injury.
- Engine exhaust manifold may slip or fall during installation. Assistance is required to prevent injury to personnel.

NOTE

Engine model 7083-7391 has an unidirectional exhaust manifold gasket that must be installed with the mark "TOP" facing outward and at the top.

- 1 Position new gasket (10) over exhaust manifold studs (9) on right cylinder head.

NOTE

- Position beveled washers with crown facing nut.
- Engine model 7083-7391 has five beveled washers and no end retainers.

- 2 Install three beveled washers (7), two end retainers (8), and five new locking nuts (6) on right exhaust manifold studs (9).

CAUTION

Use care when sliding exhaust manifold down past exhaust gasket so not to bend or damage gasket or exhaust leaks will result.

N O T E

- Do not tighten or torque exhaust manifold nuts until crossover tube has been installed.
- Ensure locating pads on exhaust manifold rest on cylinder block locating pads.

- 3 Install right exhaust manifold (4) onto cylinder head by sliding downward between gasket and retainers.
- 4 Position two clamps (2) on exhaust crossover tube (3). Install exhaust crossover tube between exhaust manifolds (4 and 5).
- 5 Secure crossover tube (3) to exhaust manifolds (4 and 5) with two clamps (2) and two nuts(1).
- 6 For engine model 7083-7396, torque five locking nuts (6), securing right exhaust manifold (4) to cylinder head to 30-35 lb-ft (41-47 Nom), starting from center and working outward alternately toward either end. For engine model 7083-7391, torque five locking nuts to 43-48 lb-ft (59-67 Nom).

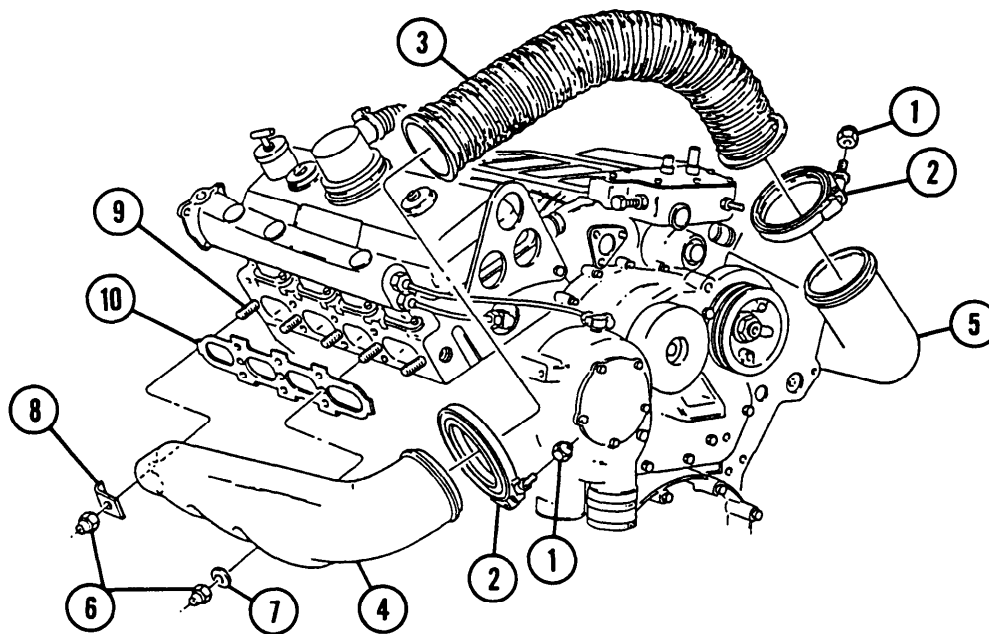

ENGINE MODEL 7083-7391 SHOWN

NOTE

- FOLLOW-ON MAINTENANCE:
- Install air inlet manifold (para 5-15)
 - Install turbocharger oil return line (para 5-16)
 - Install turbocharger oil supply line (para 5-16)

CHAPTER 6
FUEL, AIR INTAKE, AND EXHAUST SYSTEMS

GENERAL

This chapter provides instructions for removal, disassembly, assembly, installation, and servicing fuel, air intake, and exhaust systems.

<u>CONTENTS</u>	<u>PAGE</u>
Section I FUEL SYSTEM	6-2
6-1 HOSES, TUBES, AND Flutings	6-2
6-2 FUEL TANK FILLER ASSEMBLY (CAP, SEAL, AND FILLER)	6-4
6-3 FUEL TANK LEVEL TRANSMITTERS (UPPER AND LOWER)	6-6
6-4 FUEL CHECK VALVES	6-10
6-5 ELECTRIC FUEL PUMPS	6-12
6-6 PRIMARY FUEL FILTER	6-14
6-7 SECONDARY FUEL FILTER	6-17
6-8 ENGINE-DRIVEN FUEL PUMP.....	6-20
6-9 POWERPLANT FUEL HOSES,TUBES,AND FITTINGS	6-23
6-10 ENGINE FUEL LINES.	6-26
6-11 FUEL FLOW TEST	6-28
Section II AIR INTAKE SYSTEM.....,	6-30
6-12 AIR CLEANER	6-30
6-13 AIR CLEANER FILTER	6-34
6-14 DUCTS AND HOSES	6-36
Section III EXHAUST SYSTEM	6-39
6-15 EXHAUST CROSSOVER TUBE....	6-39
6-16 EXHAUST DUCT, BUFFER PLATE, AND PIPE INSULATION	6-41
Section IV FUEL TANK HEATSHIELD	6-44
6-17 FUEL TANK HEATSHIELD,	6-44

SECTION 1. FUEL SYSTEM

6-1 HOSES, TUBES, AND FITTINGS

This task covers: Removal/installation

INITIAL SETUP

Tools

General mechanic's tool kit (item 64, APPX H)

Materials/Parts

Gasket (item 120, Appx G)

Lockwashers (10) (item 95, Appx G)

Lockwashers (4) (item 192, Appx G)

Silicone compound (item 19, APPX D)

Equipment Conditions

Powerplant removed (para 4-5)

Fuel tanks drained (TM 9-2350-311-1 O)
(de-fueling tanker may be required)

Removal/Installation

WARNING

Do not use open flame or smoke when working on the fuel system. An explosion may occur, causing severe injury or death.

For removal/installation, follow illustration and legend as a guide. During installation, use silicone compound on pipe threads (only). Secure loop clamp (14) using existing screw on thermostat housing.

LEGEND

- | | |
|---|------------------------------------|
| 1 Upper fuel tank | 18 Adapter |
| 2 Upper tank fuel level transmitter | 19 Coupler (male) |
| 3 Fuel filler cap gasket* | 20 Coupler (female) |
| 4 Fuel tank filler neck and cap | 21 Adapter |
| 5 Adapter | 22 Lower fuel tank return hose |
| 6 Tee | 23 Elbow |
| 7 Adapter | 24 Fuel pump |
| 8 Lower fuel tank breather hose | 25 Elbow (2) |
| 9 Hose clamp | 26 Fuel pump |
| 10 Upper-to-lower drain tank main drain | 27 Lower fuel tank |
| 11 Hose flange | 28 Elbow |
| 12 Coupling clamp | 29 Fuel pump discharge check valve |
| 13 Elbow | 30 Fuel tank pump hose |
| 14 Loop clamp (10) | 31 Nipple (2) |
| 15 Engine-to-lower fuel tank hose
(engine model 7083-7396) | 32 Personnel heater hose |
| 16 Engine-to-lower fuel tank hose
(engine model 7083-7391) | 33 Screw (1 O) |
| 17 Elbow | 34 LockWasher (1 O)* |
| | 35 Screw (4) |
| | 36 LockWasher (4)* |

- | | |
|---------------------------------------|---|
| 37 Fuel distribution terminal fitting | 47 Terminal fitting to primary fuel filter hose |
| 38 Nipple (3) | 48 Coupler assembly |
| 39 Elbow | 49 Elbow |
| 40 Fuel tank drain hose | 50 Lower tank fuel level transmitter |
| 41 Nut | 51 Nut (2) |
| 42 Washer | 52 Upper-to-lower fuel tank breather hose |
| 43 Elbow | 53 Adapter |
| 44 Plug | 54 Upper-to-lower fuel tank drain hose |
| 45 Fuel tank pump hose | 55 Nipple |

I Discard item, install new.

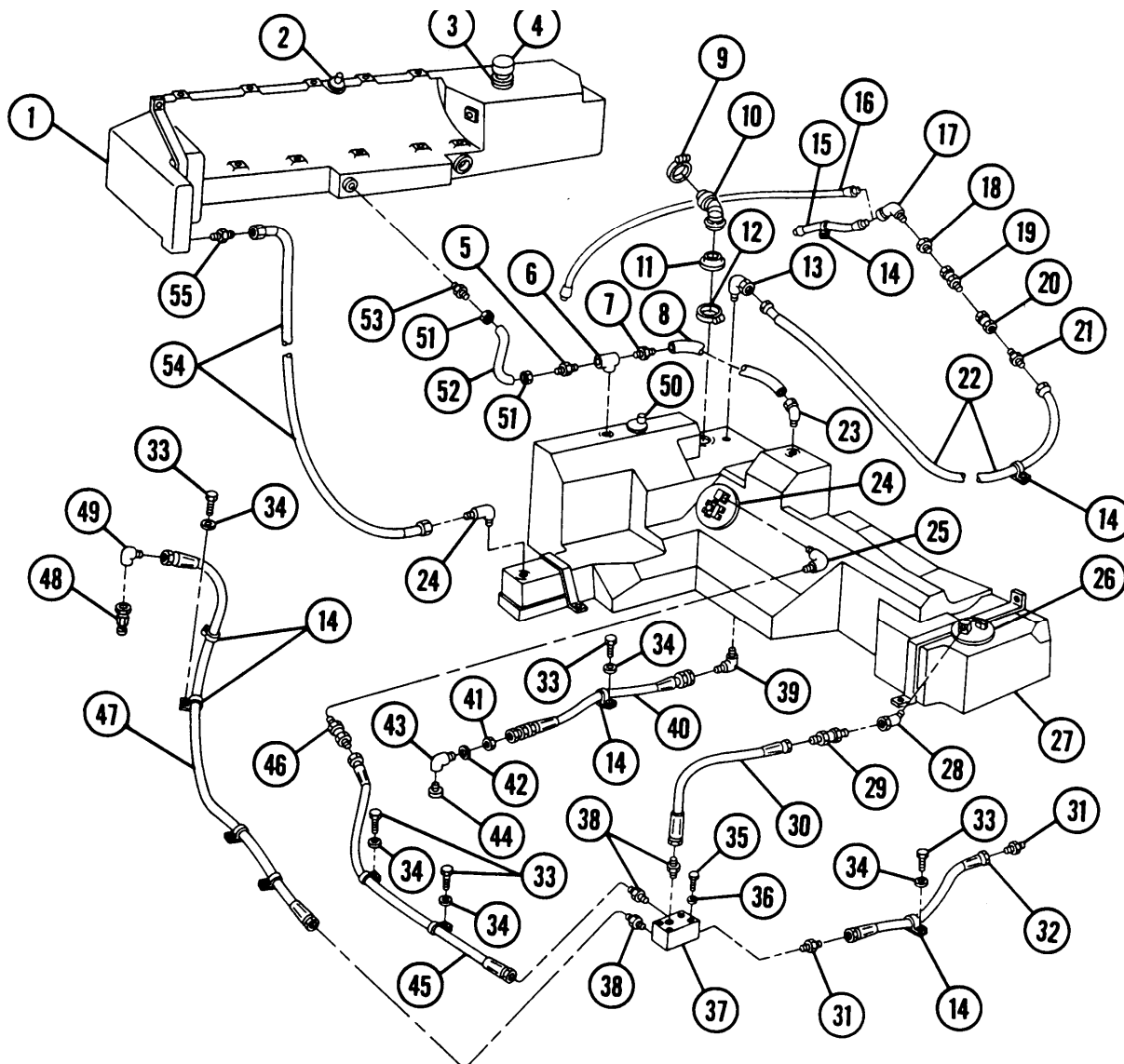

NOTE

FOLLOW-ON MAINTENANCE: Install powerplant (para 4-5)
 Fill fuel tanks (TM 9-2350-31 1-10)

WARNING

Dry-cleaning solvent (P-D-680) is toxic and flammable. Wear protective goggles and gloves and use only in a well ventilated area. Avoid contact with skin, eyes, and clothes, and don't breath vapors. Do not use near open flame or excessive heat. The flashpoint for type #1 is 100°F (38° C), and for type #2 is 138° F (59° C). If you become dizzy while using dry-cleaning solvent, get fresh air immediately and seek medical aid. If contact with eyes is made, wash your eyes with water and seek medical aid immediately.

- 6 Remove fuel filter screen (15). Clean screen with dry-cleaning solvent. Discard screen if torn.
- 7 Remove six screws (16), six flat washers (17), and six lockwashers (18). Discard lockwashers.
- 8 Remove filler neck (19), gasket (20), spacer (21), and gasket (22). Discard gaskets.

b. Installation**WARNING**

Do not smoke or use open flame when working on fuel system. An explosion may occur, causing severe injury or death.

- 1 Install new gasket (22), spacer (21), new gasket (20), and filler neck (19).
- 2 Install six new lockwashers (18), six flat washers (17), and six screws (1 6).
- 3 Install fuel filter screen (15).
- 4 Install bottom washer (14), inner seal (13), outer seal (12), top washer (11), and eight screws (1 O).
- 5 Install new filler cap gasket (8) over locking tab (9).
- 6 Clip filler cap chain (6) to filler tube (7).
- 7 Install filler cap (5).
- 8 Install cover (4), straight pin (3), new cotter pin (2), and locking pin (1).

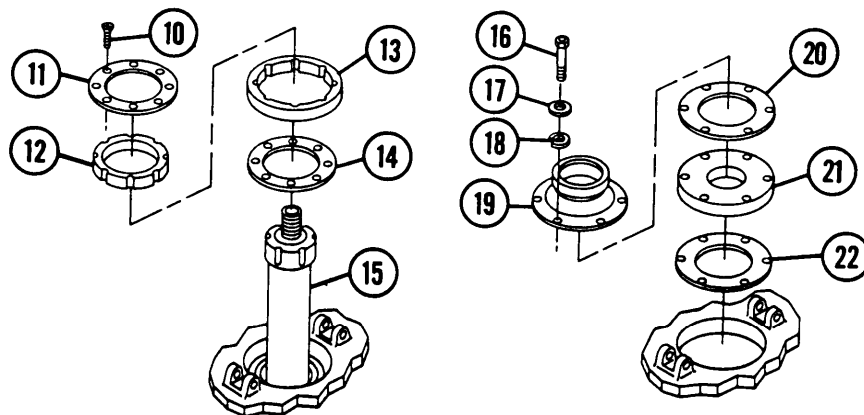

WARNING

Fuel is a hazardous waste and must be disposed of in accordance with local procedures or direction of the local Hazardous Waste Management office.

NOTE

Fuel tank must be drained to remove lower fuel tank level transmitter.

5 Remove six nuts (10), six washers(11), one screw (1 2), one flat washer (1 3), and bar (14).

6 Remove two nuts (15), two flat washers (1 6), and plate (1 7).

7 Remove electrical connector (1 8).

8 Remove five screws (1 9), five washers (20), and ground lead (21).

9 Remove transmitter (22) and gasket (23). Discard gasket.

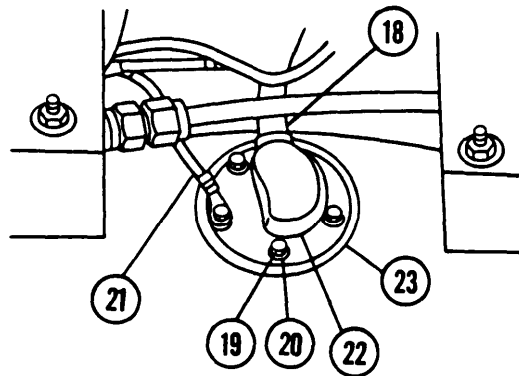
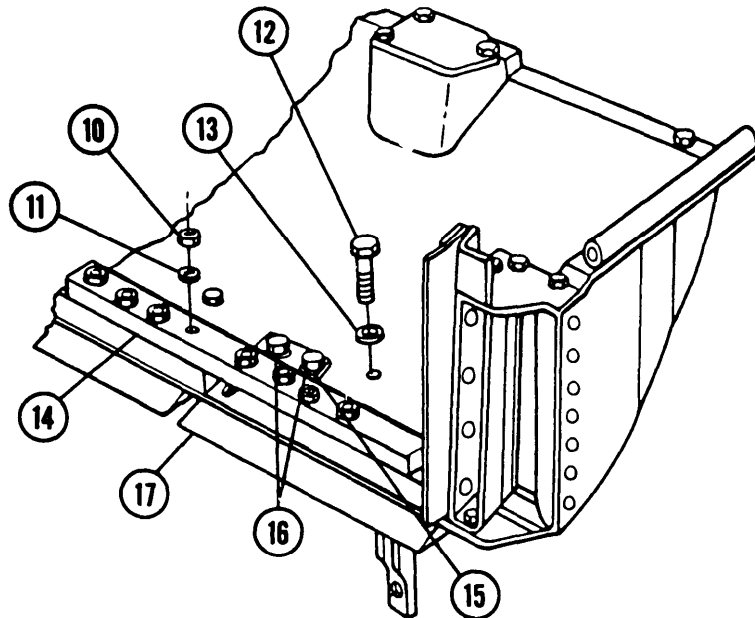

6-3 FUEL TANK LEVEL TRANSMITTERS (UPPER AND LOWER) — CONTINUED

b. Installation

WARNING

Do not smoke or use open flame when working on fuel system. An explosion may occur, causing severe injury or death.

- 1 Install new gasket (23) and transmitter (22).
- 2 Install ground lead (21), five washers (20), and five screws (19).
- 3 Install electrical connector (1 8).
- 4 Install plate (1 7), two flat washers (1 6), and two nuts (1 5).
- 5 Install bar (1 4), flat washer (1 3), screw (1 2), six washers (11), and six nuts (1 O).

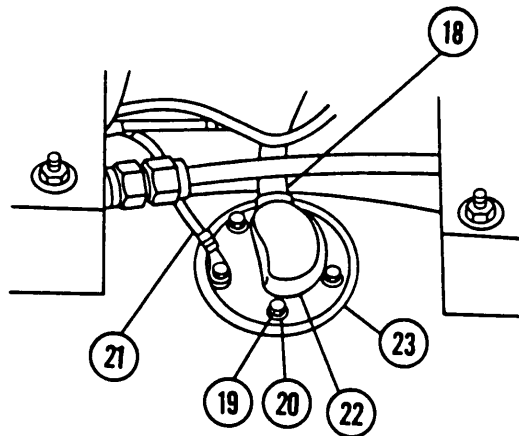

- 6 Install new gasket (9) and transmitter (8).
- 7 Install ground lead (7), five washers (6), and five screws (5).
- 8 Connect electrical connector (4).
- 9 Install cover (3), three new lockwashers (2), and three screws(1).

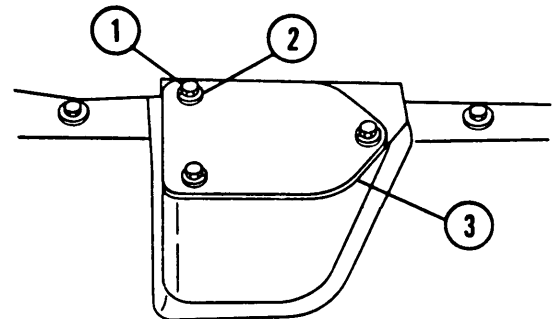
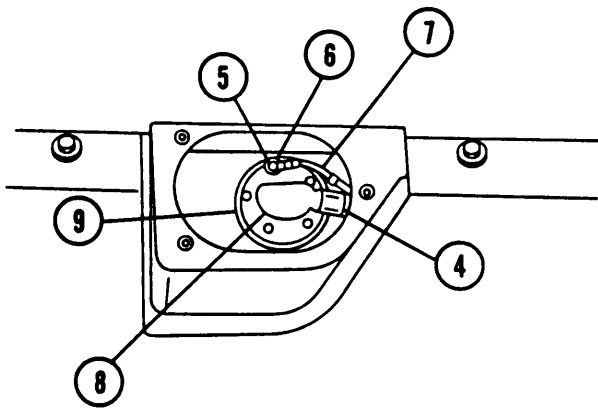
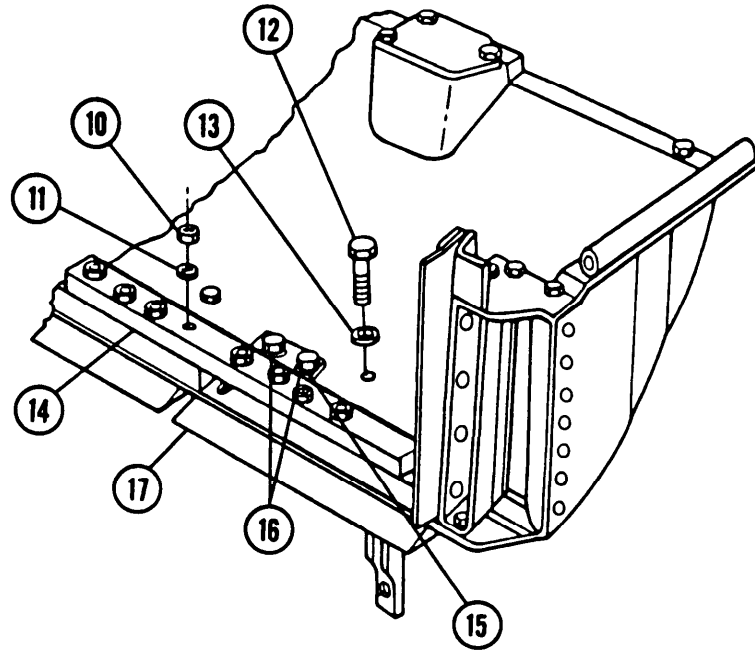

NOTE

FOLLOW-ON MAINTENANCE:

- Install exhaust deflector (para 4-5)
- Install exhaust grille (para 4-5)
- Fill fuel tank if drained (TM 9-2350-311-1 O)

4 Connect fuel hose(1) to right check valve (2).

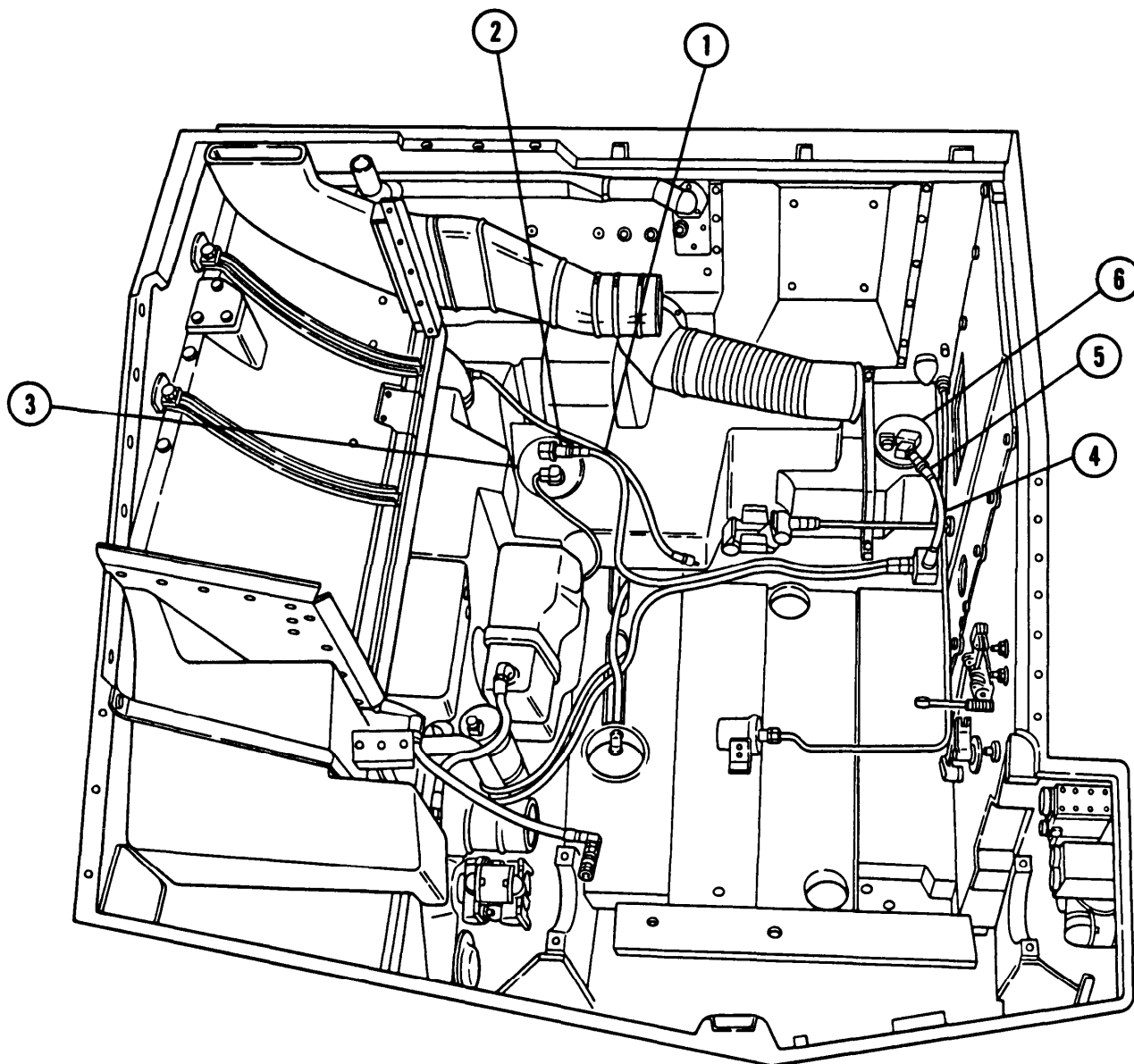

NOTE

FOLLOW-ON MAINTENANCE:

- Install powerplant if removed (para 4-5)
- Install engine compartment access cover if removed (para 11-5)
- Fill fuel tanks (TM 9-2350-311-1 O)

6-5 ELECTRIC FUEL PUMPS

This task covers:

a. Removal

b. Installation

INITIAL SETUP

Tools

General mechanic's tool kit (item 64, Appx H)

Material/Parts

Gaskets (2) (item 136, Appx G)

Equipment Conditions

Engine compartment access cover removed for removal of left electric fuel pump (para 11-5)

Powerplant removed for removal of right electric fuel pump (para 4-5)

Fuel tanks drained (TM 9-2350-311-1 O)
(de-fueling tanker may be required)

a. Removal

WARNING

Do not smoke or use open flame when working on fuel system. An explosion may occur, causing severe injury or death.

NOTE

- Both left and right electric fuel pump assemblies are removed and installed using the same procedures.
- Left electric fuel pump maybe accessed through the engine compartment access cover.
- Right electric fuel pump maybe accessed after powerplant is removed.

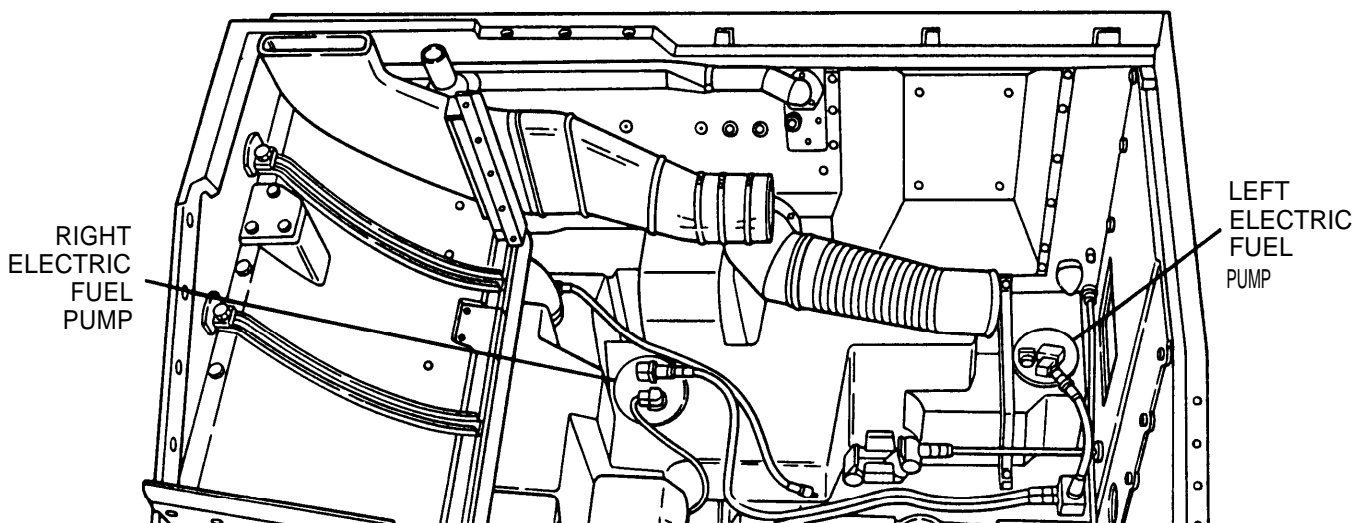

- 1 Disconnect electrical connector(1).
- 2 Remove fuel hose (2) and check valve (3).
- 3 Remove 10 screws (4), electric fuel pump assembly (5), and gasket (6). Discard gasket.

b. Installation

WARNING

Do not smoke or use open flame when working on fuel system. An explosion may occur, causing severe injury or death.

NOTE

Steps 1 thru 3 apply to the left electric fuel pump assembly.

- 1 Install new gasket (6), electric fuel pump assembly (5), and 10 screws (4).
- 2 Install check valve (3) and fuel hose (2).
- 3 Install electrical connector(1).

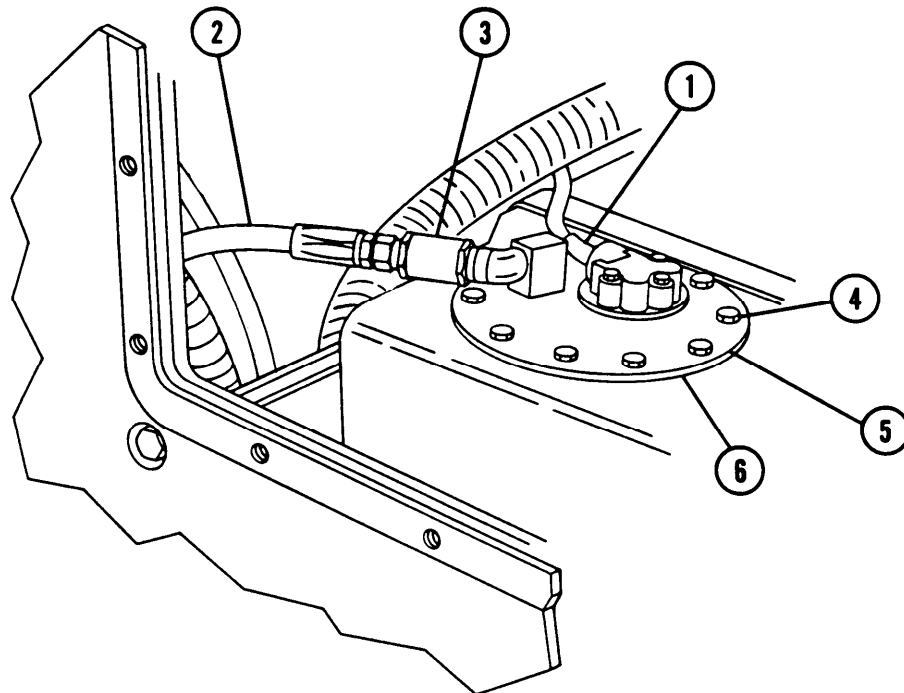

NOTE

FOLLOW-ON MAINTENANCE:

- Install powerplant if removed (para 4-5)
- Install engine compartment access cover if removed (para 11-5)
- Fill fuel tanks (TM 9-2350-311-1 O)

- 7 Remove plug (12).
- 8 Remove two nuts (13), two lockwashers (14), two flat washers (15), two screws(16) and filter cover (17). Discard lockwashers.
- 9 Remove two screws (18), two lockwashers (19), and bracket (20). Discard lockwashers.

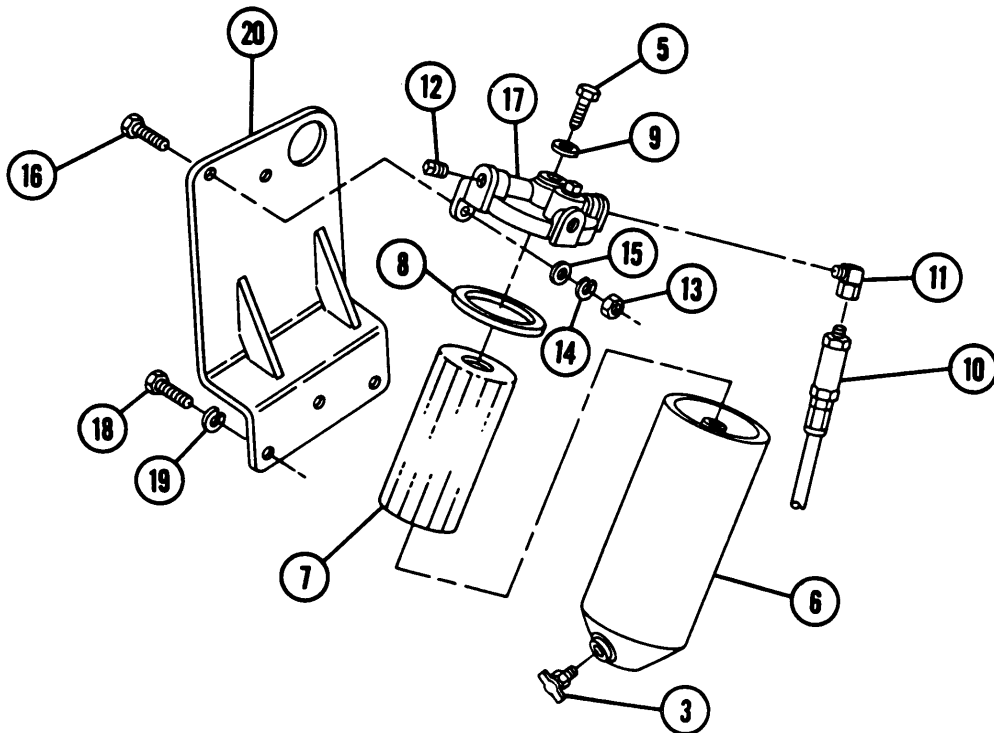
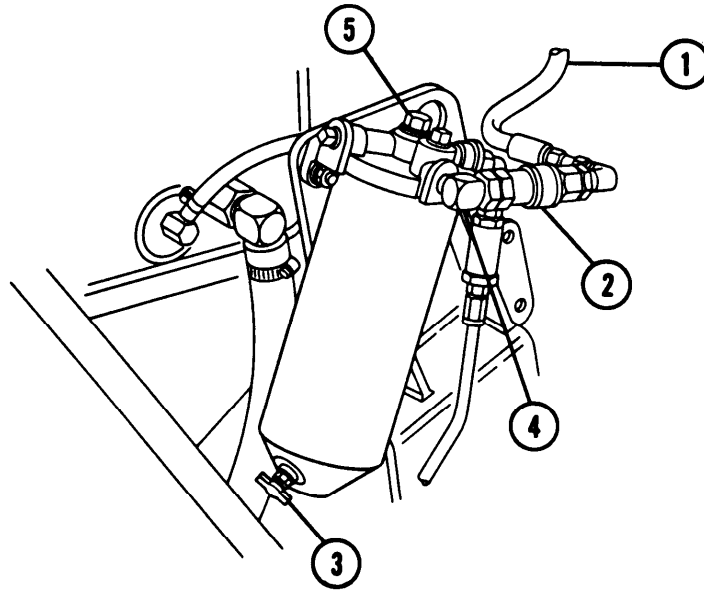

6-6 PRIMARY FUEL FILTER — CONTINUED

b. Installation/Assembly

WARNING

Do not smoke or use open flame when working on fuel system. An explosion may occur, causing severe injury or death.

- 1 Install bracket (20), two newlockwashers(19), and two screws (18).
- 2 Install filter cover (17), two screws (16), two flat washers (15), two newlockwashers(14), and two nuts (13).
- 3 Install plug (12).
- 4 Install elbow (11) and connect primary filter-to-air box heater hose (10) to elbow.
- 5 install draincock (3) to filter shell (6).
- 6 Install new gasket (8), new filter element (7), filter shell (6), new washer (9), and cover screw (5) on filter cover (17).
- 7 Install elbow (4) and connect primary fuel filter input hose(1) at quick disconnect (2).

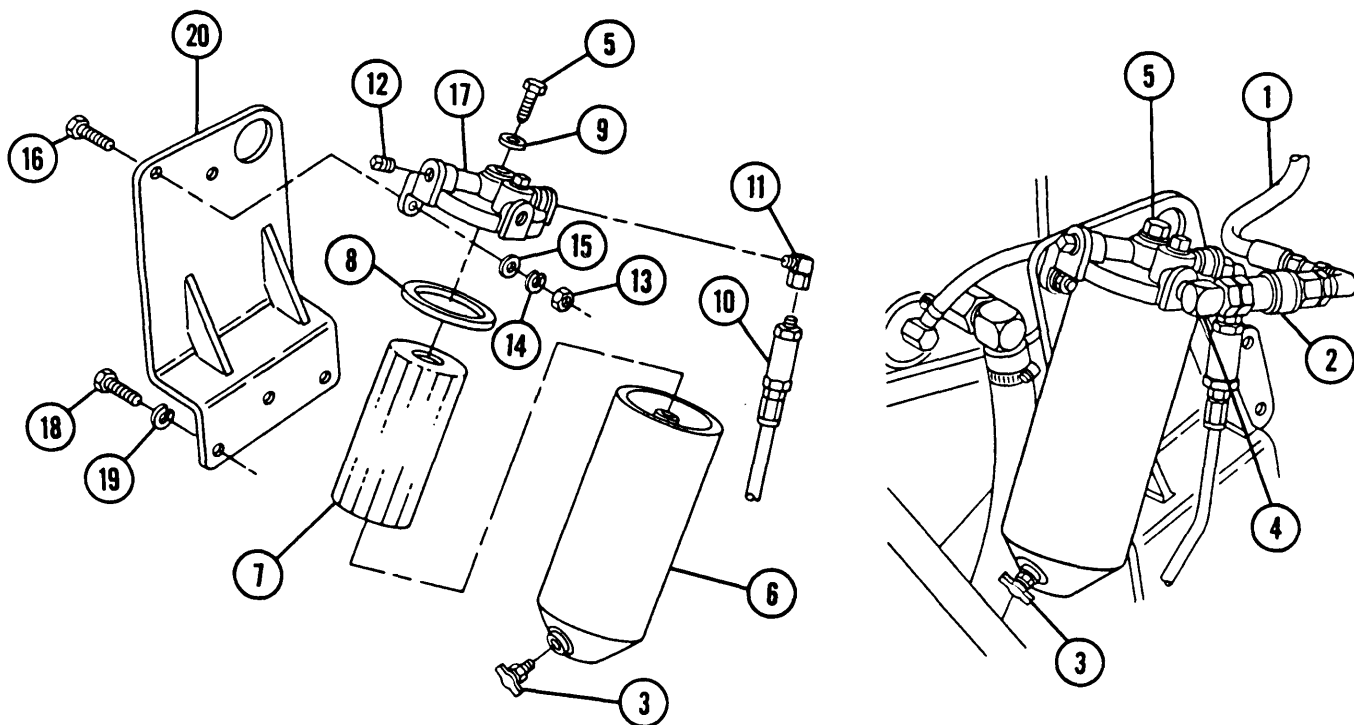

NOTE

FOLLOW-ON MAINTENANCE: Close right transmission access door (para 11-7)

6-7 SECONDARY FUEL FILTER

This task covers: a. Removal/Disassembly b. Assembly/installation

INITIAL SETUP

Tools

General mechanic's tool kit (item 64, Appx H)
 Suitable container

Gasket (item 188, Appx G)
 LockWashers (2) (item 89, Appx G)
 LockWashers (2) (item 100, Appx G)
 Tape (item 98, Appx D)

Materials/Parts

Filter element (item 6, Appx G)
 Gasket (item 171, Appx G)

Equipment Conditions
 Left transmission access door opened (para 11-7)

a. Removal/Disassembly

- Do not smoke or use open flame when working on fuel system. An explosion may occur, causing severe injury or death.
- Fuel is a hazardous waste and must be disposed of in accordance with local procedures or direction of the local Hazardous Waste Management office.

NOTE

Secondary fuel filter does not need to be removed from vehicle to remove filter element.

- 1 Open draincock (1) and drain fuel into suitable container.
- 2 Remove cover screw (2) and gasket (3). Discard gasket.

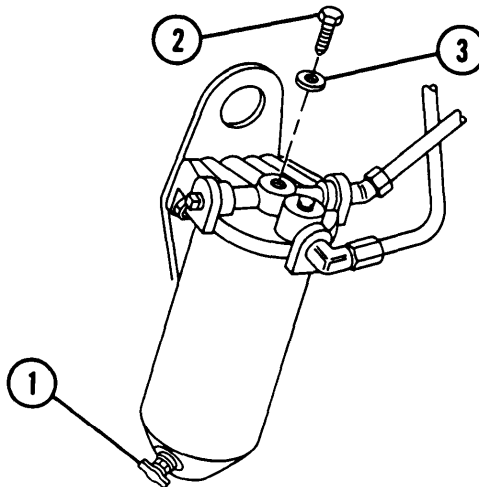

6-7 SECONDARY FUEL FILTER — CONTINUED

a. Removal/Disassembly — Continued

- 3 Remove filter shell (4), filter element (5), gasket (6), retainer (7), seat (8), seal (9), seat (10), and spring(11). Discard filter element and gasket.

NOTE

Continue removal process only if complete removal of secondary fuel filter assembly is necessary.

- 4 Remove draincock (1).
- 5 Disconnect secondary fuel filter to cylinder head tube (12).
- 6 Disconnect engine-driven fuel pump-to-secondary fuel filter tube (13).
- 7 Remove two nuts (14), two lockwashers (15), two flat washers (1 6), two screws (17), and filter cover (18). Discard lockwashers.
- 8 Remove two screws (19), two lockwashers (20), and bracket (21). Discard lockwashers.
- 9 Remove two plugs (22) from filter cover (18).

b .Assembly/Installation

WARNING

Do not smoke or use open flame when working on fuel system. An explosion may occur, causing severe injury or death.

- 1 Install bracket (21), two new lockwashers (20), and two screws (19).
- 2 Install filter cover (18), two flat washers (1 6), two new lockwashers (15), two screws (17), and two nuts (14).
- 3 Apply tape to threads of plugs (22). Install plugs in filter cover (18).
- 4 Connect engine-driven fuel pump-to-secondary fuel filter tube (13).
- 5 Connect secondary fuel filter-to-cylinder head tube (12).

6 Install draincock (1) on filter shell (4).

7 Install spring(11), seat (1 O), seal (9), seat (8), retainer (7), new gasket (6), new filter element (5), and filter shell (4) on filter cover (1 8).

8 Install new gasket (3) and cover screw (2).

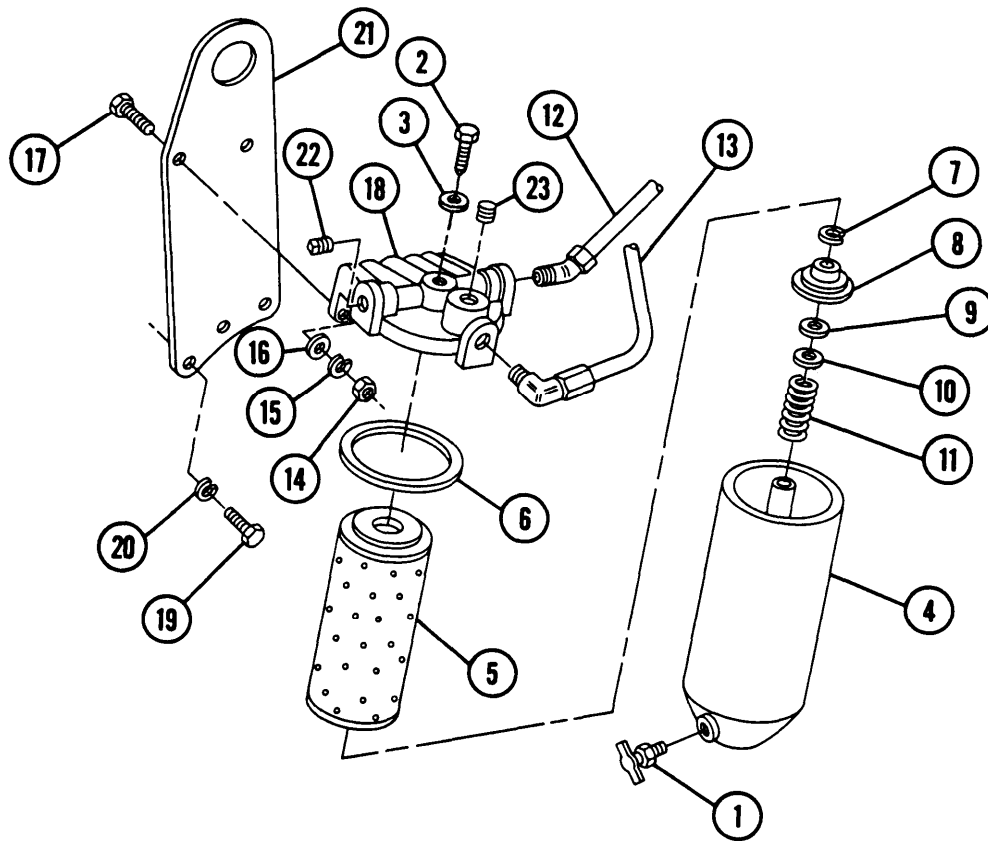

NOTE

FOLLOW-ON MAINTENANCE: Close left transmission access door (para 11-7)

6-8 ENGINE-DRIVEN FUEL PUMP

This task covers: a. Shaft Check b. Removal c. Installation

INITIAL SETUP

Tools

General mechanic's tool kit (item 64, Appx H)

Materials/Parts

Gasket (item 182, Appx G)

Equipment Condition

Air intake grille opened and secured (para 11 -8)

Exhaust crossover tube removed (para 6-15)

Exhaust grille removed (para 4-5)

Radiator fan access door removed (para 4-5)

Front slope plate removed (para 4-5)

a. Shaft Check

WARNING

Do not smoke or use open flame when working on fuel system. An explosion may occur, causing severe injury or death.

Check for broken shaft by removing top pump body drain plug (1). Insert small wire (approximate length and size of a straightened paper clip) in pump body hole (2). Rotate shaft by cranking engine momentarily. If vibration is felt, shaft is good. If no vibration is felt, replace pump.

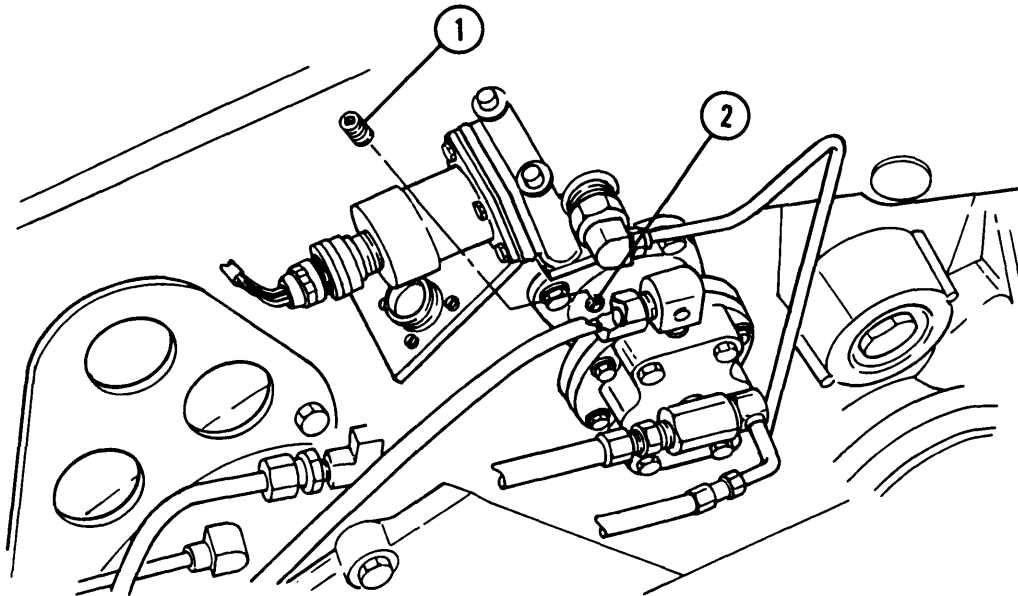

b. Removal

WARNING

Do not smoke or use open flame when working on fuel system. An explosion may occur, causing severe injury or death.

- 1 Disconnect primary fuel filter-to-engine-driven fuel pump tube (3) and remove tee (4).
- 2 Disconnect engine-driven fuel pump-to-electric fuel pump hose (5).
- 3 Disconnect engine-driven fuel pump-to-secondary fuel filter tube (6) and remove elbow (7).
- 4 Remove three screws (8) and three washers (9).
- 5 Remove fuel pump (10), gasket(11), and fork coupling (12). Discard gasket.

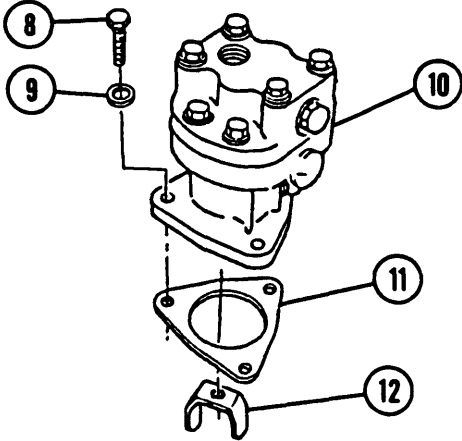
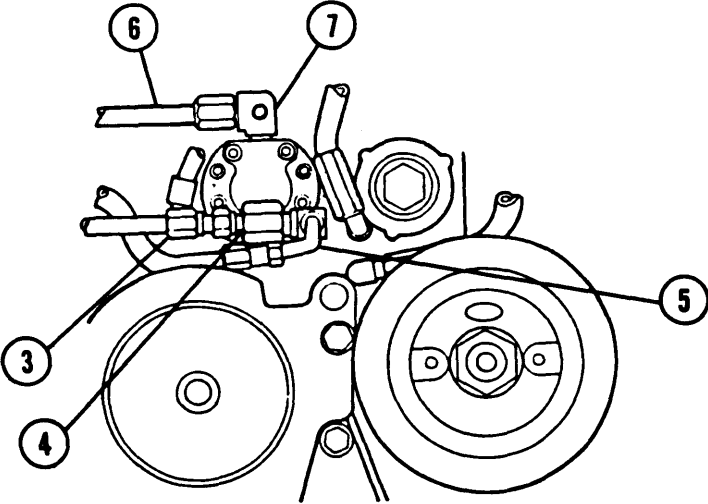

6-8 ENGINE-DRIVEN FUEL PUMP — CONTINUED

c. Installation

WARNING

Do not smoke or use open flame when working on fuel system. An explosion may occur, causing severe injury or death.

- 1 Install fork coupling (12), new gasket(11), and fuel pump (10).
- 2 Install three washers (9) and three screws (8).
- 3 Install elbow (7) and connect engine-driven fuel pump-to-secondary fuel filter tube (6).
- 4 Connect engine-driven fuel pump-to-electric fuel pump hose (5).
- 5 Install tee (4) and connect primary fuel filter-to-engine-driven fuel pump tube (3).

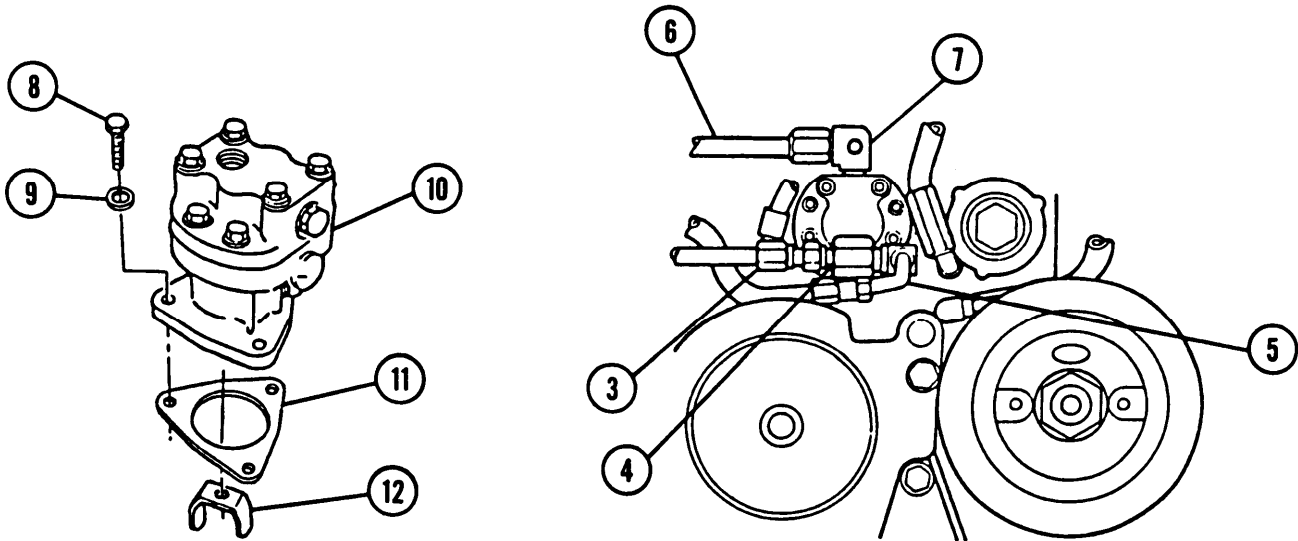

NOTE

FOLLOW-ON MAINTENANCE:

- Install exhaust crossover tube (para 6-15)
- Install front slope plate (para 4-5)
- Install exhaust grille (para 4-5)
- Install radiator fan access door (para 4-5)
- Close air intake grille (para 11-8)

6-9 POWERPLANT FUEL HOSES, TUBES, AND FITTINGS

This task covers: Removal/installation

INITIAL SETUP

Tools

General mechanic's tool kit (item 84, Appx H)

Materials/Parts

Lockwasher (item 84, Appx G)

Preformed packings (4) (item 5, APPX G)

Removal/Installation

WARNING

Do not smoke or use open flame when working on fuel system. An explosion may occur, causing severe injury or death.

NOTE

Restrict removal to only those hoses and tubes that must be replaced. Use the following legend and fuel system diagram for reference only.

6-9 POWERPLANT FUEL HOSES, TUBES, AND FITTINGS — CONTINUED

Removal/installation — Continued

For removal/installation, follow illustration and legend as a guide.

LEGEND

1	Secondary fuel filter-to-engine cylinder heads tube assembly	13	Nut
2	Engine hose connector tube assembly	14	Secondary fuel filter
3	Elbow (2)	15	Pipe plug
4	Engine-driven fuel pump	16	Elbow
5	Engine-driven fuel pump-to-secondary filter tube assembly	17	Tube attaching strap
6	Tube attaching strap assembly (6)	18	Screw
7	Primary fuel filter to engine-driven fuel pump tube	19	Preformed packing*
8	Tube clamp assembly (2)	20	Nut
9	Elbow	21	Sleeve
10	Tube attaching strap assembly	22	Tube nipple
11	Elbow	23	Check valve
12	LockWasher	24	Adapter
		25	Fuel tank-to-primary fuel filter hose connector
		26	Primary fuel filter
		27	Elbow

* Discard item, install new.

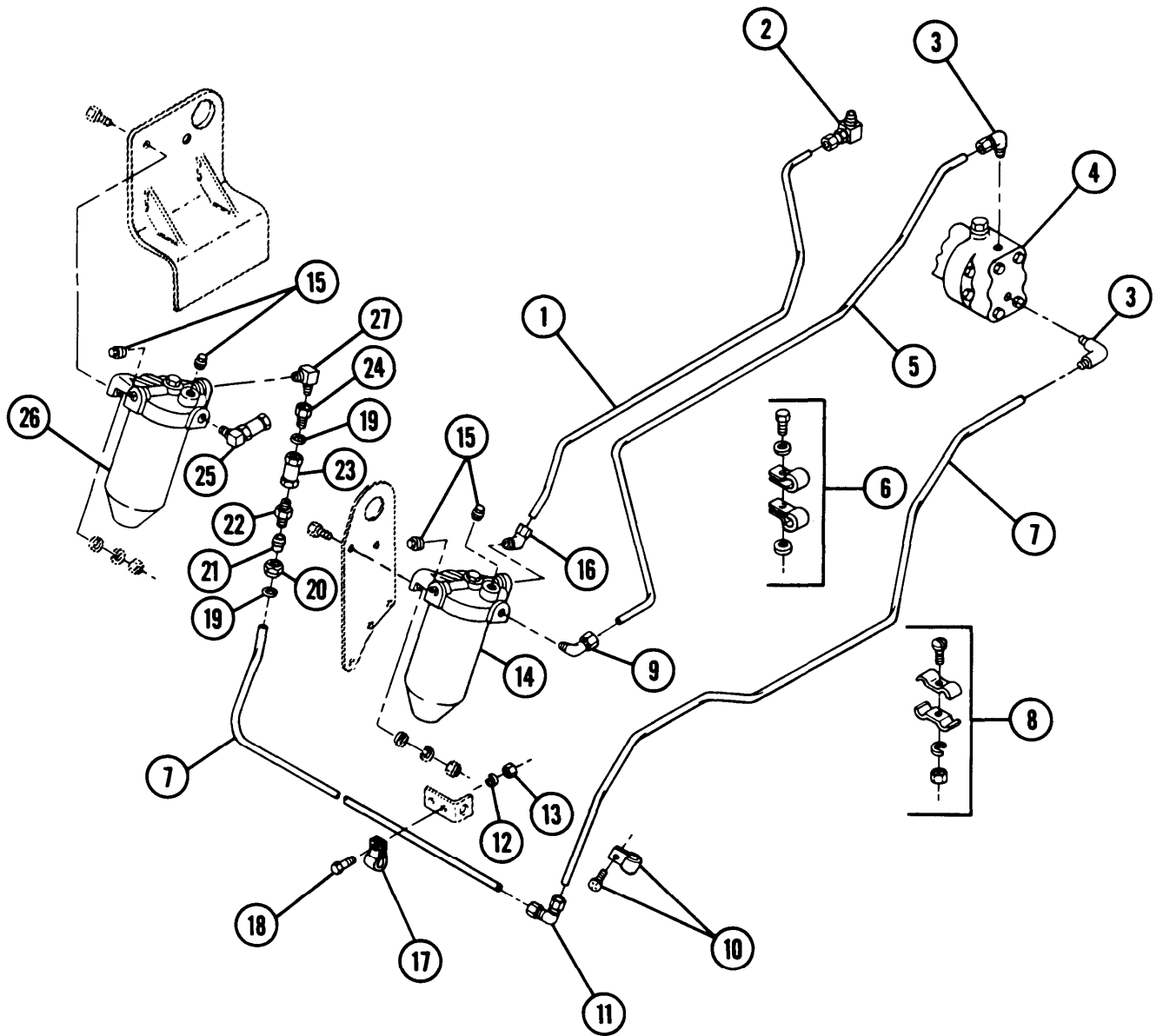

6-10 ENGINE FUEL LINES

This task covers: a. Removal b. Installation

INITIAL SETUP

Tools

General mechanic's tool kit (item 64, Appx H)

Equipment Condition

Powerplant removed (para 4-5)

Exhaust crossover tube removed (para 6-15)

a. Removal

WARNING

- Do not smoke or use open flame when working on fuel system. An explosion may occur causing severe injury or death.
- Ensure engine is cool before removing fuel lines to prevent burns or injury.

1 Remove four screws(1), four washers (2), and four clamps (3).

2 Remove fuel line (4), two elbows (5), and bushing (6).

3 Remove fuel line (7) and two elbows (8 and 9).

4 Remove fuel line (10), restrictor(11), and elbow (12).

b. Installation

WARNING

Do not smoke or use open flame when working on fuel system. An explosion may occur causing severe injury or burns.

Ensure engine is cool before installing fuel lines to prevent burns or injury.

1 Install restrictor(11), elbow (12), and fuel line (10).

2 Install two elbows (8 and 9) and fuel line (7).

3 Install bushing (6), two elbows (5), and fuel line (4).

4 Install four clamps (3), four washers (2), and four screws (1).

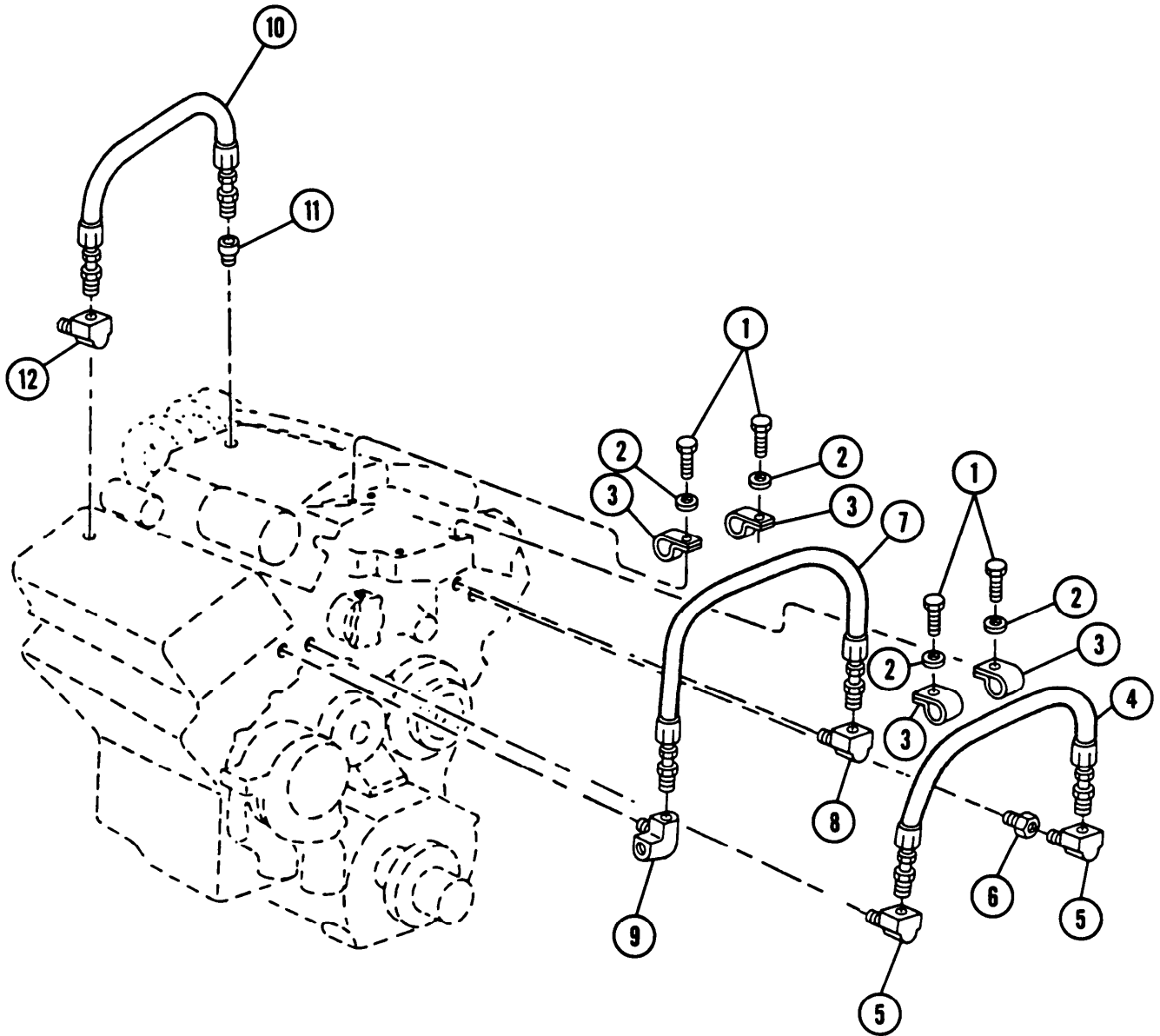

NOTE

FOLLOW-ON MAINTENANCE:

Install powerplant (para 4-5)
 Install exhaust crossover tube (para 6-15)

6-11 FUEL FLOW TEST

This task covers: Test

INITIAL SETUP

<u>Tools</u>	<u>References</u>
General mechanic's tool kit (item 64, Appx H)	TM 9-2350-311-10
Watch (timer)	
Suitable container	<u>Equipment Condition</u>
	Air intake grille opened and secured (para 11-8)

Test

WARNING

Do not smoke or use open flame when working on fuel system. An explosion may occur, causing severe injury or death.

- 1 Check quick disconnect (1) to ensure main fuel hose (2) is fully seated.
- 2 Install new fuel filter elements (para 6-6 and 6-7).

- 3 Start engine and warmup to 170°F (77°C) (TM9-2350-311-10).
- 4 Disconnect fuel return hose (3) from female half of quick disconnect (4).

CAUTION

Ensure valve in quick disconnect is pushed all the way in during the test.

- 5 Place female half of quick disconnect (4) in suitable container to catch fuel.
- 6 Set engine at 1200 rpm.

WARNING

Fuel is a hazardous waste and must be disposed of in accordance with local procedures or direction of the local Hazardous Waste Management office.

- 7 Depress valve of female half of quick disconnect (4) for 1 minute. Measure the fuel container(5). If fuel flow is less than 0.5 gal (1.9 L) per minute, check for broken shaft in fuel pump or dirt in relief valve (para 6-8).
- 8 Reconnect fuel return hose (3) at female half of quick disconnect (4).

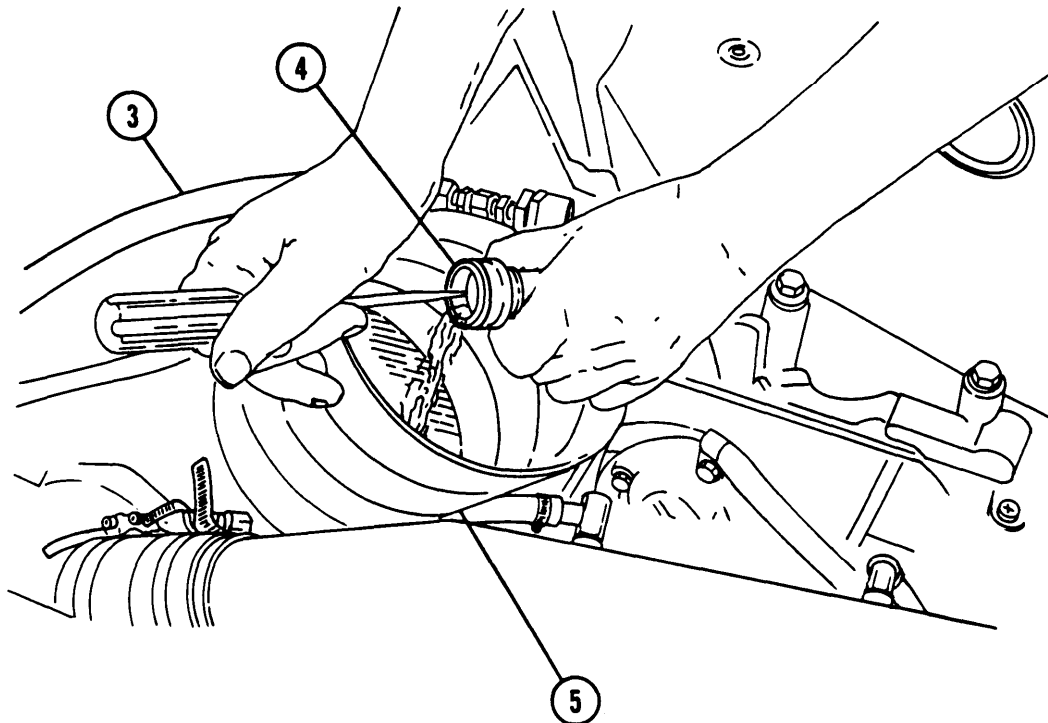

NOTE

FOLLOW-ON MAINTENANCE: Close air intake grille (para 11-8)

SECTION II. AIR INTAKE SYSTEM

6-12 AIR CLEANER

This task covers:

a. Removal	b. Disassembly
c. Assembly	d. Installation

INITIAL SETUP

Tools

General mechanic's tool kit (item 64, Appx H)

Gaskets (2) (item 143, Appx G)

LockWashers (20) (item 88, Appx G)

LockWashers (8) (item 96, Appx G)

Materials/Parts

Adhesive (item 1 or 3, Appx D)

Gaskets (2) (item 123, Appx G)

Gaskets (2) (item 124, Appx G)

Gaskets (2) (item 142, Appx G)

Equipment Condition

Air inlet ducts and hoses removed (para 6-14)

Fuze packs removed from in front of left air cleaner box
(TM 9-2350-31 1-10)

a. Removal

WARNING

If Nuclear, Biological, Chemical (NBC) exposure is suspected, all air filter media must be handled by personnel wearing full NBC-protective equipment (FM 21-1 1).

1 Replace decals (1) if illegible, damaged, or missing (para 2-7).

2 Remove filter packs (para 6-14).

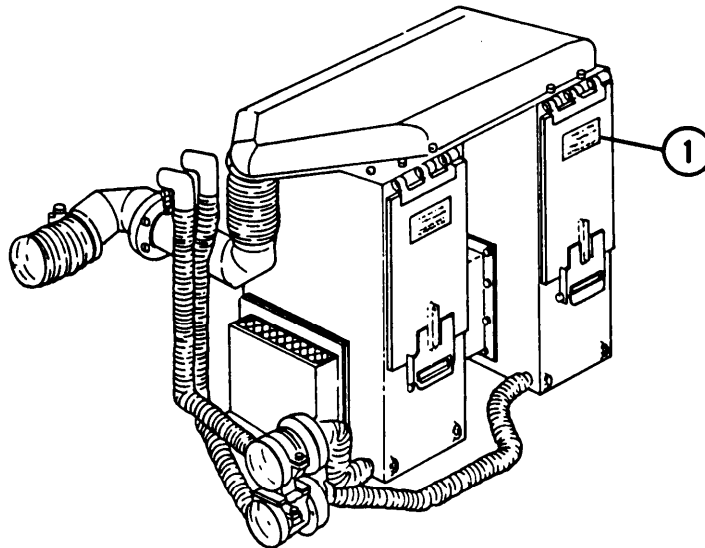

CAUTION

Place 2 x 4 supports under air cleaner boxes before proceeding.

- 3 Remove eight screws (2), eight lockwashers (3), and eight flat washers (4). Discard lockwashers.

CAUTION

Support air cleaner duct (5) while removing left and right air cleaner boxes (6 and 7).

- 4 Remove 2 x 4 supports and lower boxes (6 and 7) to hull deck.
- 5 Loosen nut (8) and disconnect hose (9). Remove adapter (10).
- 6 Remove 28 nuts(11) and 28 flat washers (12).
- 7 Lift air cleaner duct (5) clear of lugs (13). Air cleaner duct must be removed to permit removal of boxes (6 and 7).
- 8 Remove plug (14) from air cleaner duct (5).
- 9 Remove boxes (6 and 7).

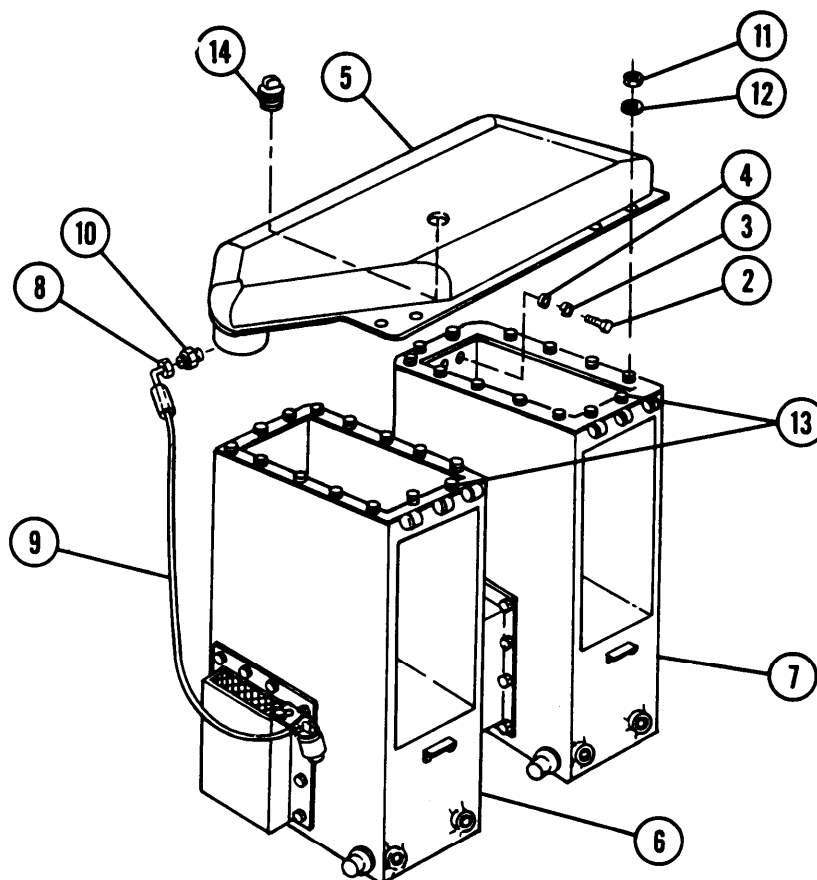

6-12 AIR CLEANER — CONTINUED

b. Disassembly

- 1 Remove two gaskets (15). Discard gaskets.
- 2 Loosen nut (16) and remove hose (9).
- 3 Remove two screws (17), two washers (18), two nuts (19), and indicator (20).
- 4 Remove two screws (21), two washers (22), and bracket (23).
- 5 Remove 20 screws (24), 20 lockwashers (25), 20 flat washers (26), 2 box assemblies (27 and 28), and 2 gaskets (29). Discard lockwashers and gaskets.
- 6 Remove two gaskets (30) from boxes (6 and 7) and two gaskets (31) from doors (32). Discard gaskets.

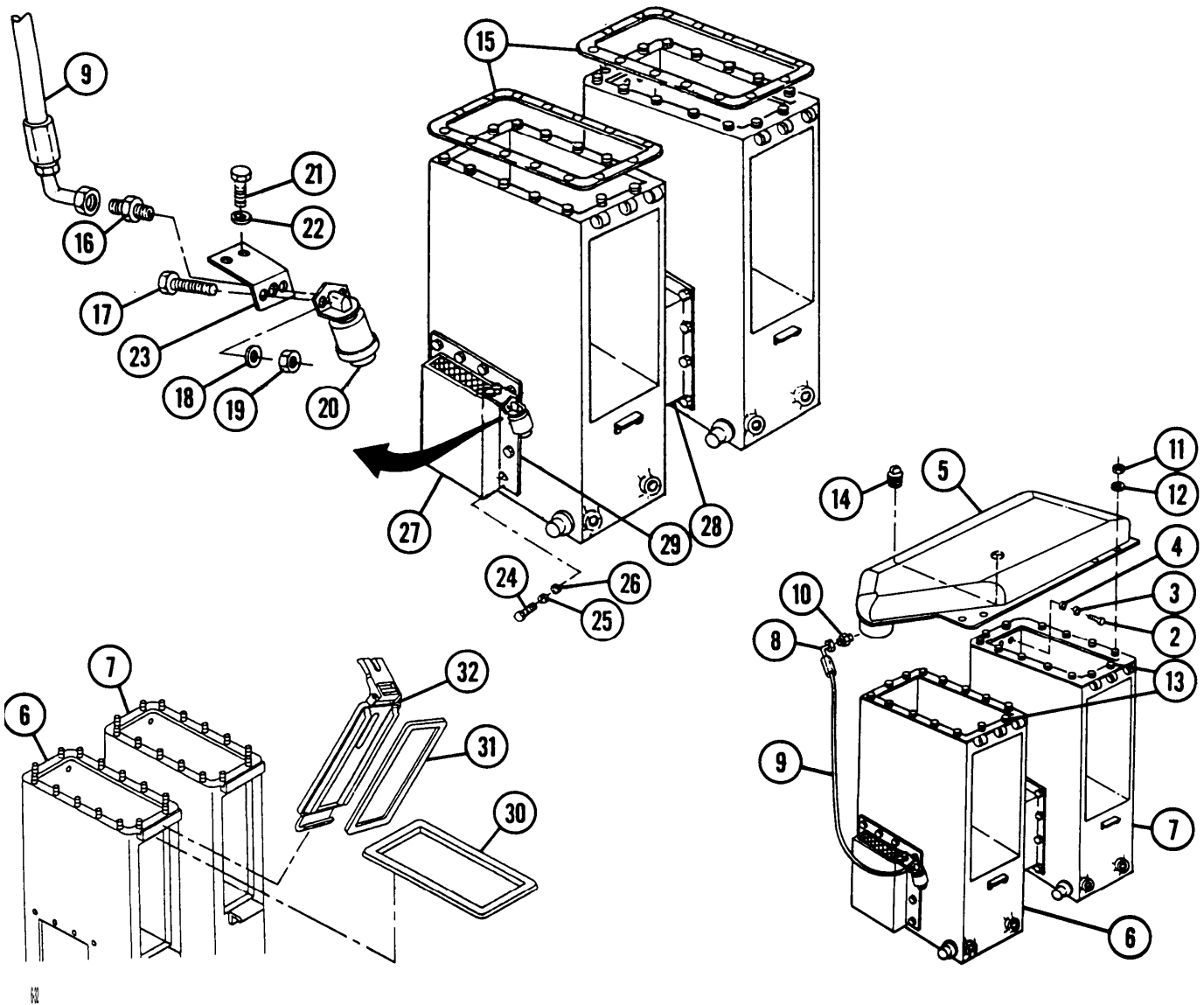

c. Assembly**WARNING**

Adhesives are toxic and flammable. Apply adhesives only in a well-ventilated area. Avoid contact with skin, eyes, and clothes, and don't breath vapors. Do not use near heat, sparks, or open flame. Read and follow all warnings and instructions on labels of adhesives. If contact with skin or eyes is made, wash area with water and seek medical aid immediately.

- 1 Apply adhesive to recess of air cleaner boxes (6 and 7) and doors (32).
- 2 Install two new gaskets (30) and two new gaskets (31).
- 3 Install 2 new gaskets (29),2 box assemblies (27 and 28),20 flat washers (26),20 new lockwashers (25), and 20 screws (24).
- 4 Install bracket (23), two washers (22), and two screws (21).
- 5 Install indicator (20), two washers (18), two screws (17), and two nuts (19).
- 6 Connect hose (9) and tighten nut (16).
- 7 Install two new gaskets (15).

d. Installation**WARNING**

If NBC exposure is suspected, all air filter media must be handled by personnel wearing full NBC-protective equipment (FM 21-11).

- 1 Position left and right air cleaner boxes (6 and 7) so air cleaner duct (5) can be installed.
- 2 Install plug (14) in air cleaner duct (5).
- 3 Place air cleaner duct (5) over lugs (13) and install 28 flat washers(12) and 28 nuts (11).
- 4 Install adapter (10). Install hose (9) and tighten nut (8).

NOTE

Placing 2 x 4 supports under air cleaner boxes may help position assembly for installation.

- 5 Position boxes (6 and 7) on hull wall to install and secure using eight flat washers (4), eight new lockwashers (3), and eight screws (2).
- 6 Remove 2 x 4 supports if used.
- 7 Install filter packs (para 6-1 3).

6-12 AIR CLEANER — CONTINUED

NOTE

FOLLOW-ON MAINTENANCE: Install air inlet ducts and hoses (para 6-14)
 Install fuze packs if removed (TM 9-2350-311-1 O)

6-13 AIR CLEANER FILTER

This task covers: a. Removal b. Installation

INITIAL SETUP

Equipment Conditions

Ammo pack removed from brackets if present
(TM 9-2350-311 -10)

M63 rack removed if present (TM 9-2350-311-1 O)
155mm projectiles removed (TM 9-2350-311-1 O)
Ammunition rack removed (para 13-2)

a. Removal

WARNING

If NBC exposure is suspected, all air filter media must be handled by personnel wearing full NBC-protective equipment (FM 21-1 1).

- 1 Pull down on locking latch (1), open door (2) slightly, and lift off hinge (3) and door.
- 2 Pull downward on filter pack locking lever (4) to release filter pack (5).
- 3 Pull on filter pack removal handle (6) to remove filter pack (5) from air cleaner boxes (7).

b. Installation

If NBC exposure is suspected, all air filter media must be handled by personnel wearing full NBC-protective equipment (FM 21-11).

- 1 Install filter pack (5) into air cleaner box (7).
- 2 Push filter pack locking lever (4) up to lock filter pack (5) in place.
- 3 Install door (2) on hinge (3), close door (2), and push upon locking latch (1) to secure door.

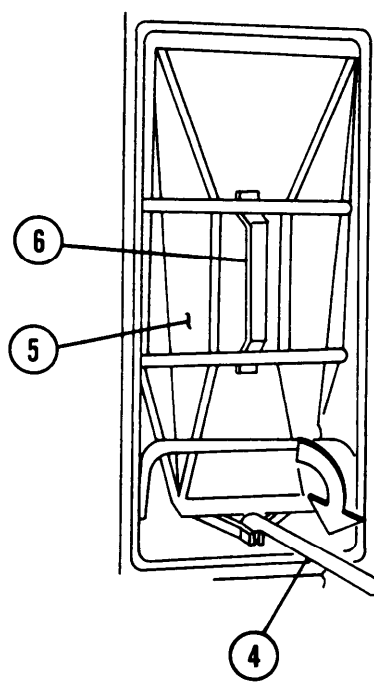
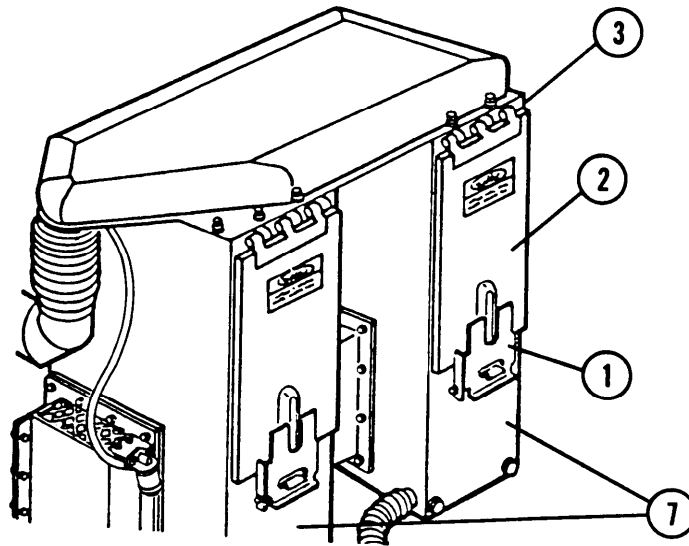

NOTE

FOLLOW-ON MAINTENANCE:

- Install ammunition rack (para 13-2)
- Install 155mm projectiles (TM 9-2350-311-1 O)
- Install M63 rack if removed (TM 9-2350 -311-1 O)
- Install ammo pack if removed (TM 9-2350-311-1 O)

6-14 DUCTS AND HOSES

This task covers: a. Removal

b. Installation

INITIAL SETUP

Tools

General mechanic's tool kit (item 64, Appx H)

Materials/Parts

Gasket (item 126, Appx G)

LockWashers (6) (item 95, Appx G)

LockWashers (2) (item 96, Appx G)

a. Removal

WARNING

If NBC exposure is suspected, all air filter media must be handled by personnel wearing full NBC-protective equipment (FM 21-1 1).

- 1 Remove two screws (1), two lockwashers (2), and two mounting clamps (3). Discard lockwashers.
- 2 Loosen four hose clamps (4).
- 3 Remove two air cleaner-to-duct exhaust hoses (5).

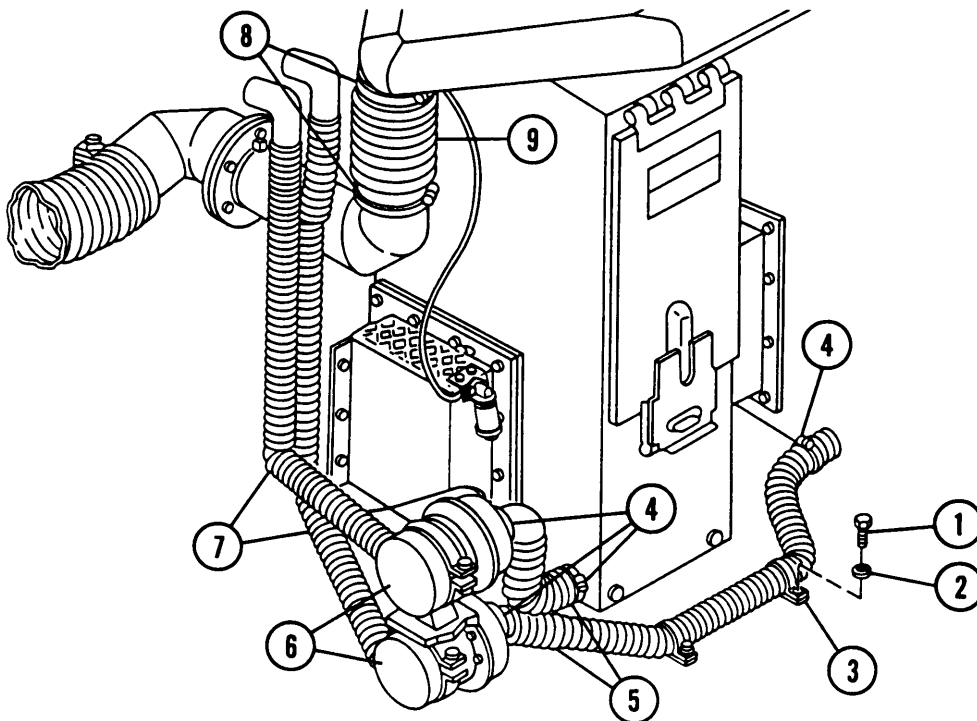

- 4 Remove blower motors (6) (para 8-35).
- 5 Remove two duct exhaust-to-elbow hoses (7).
- 6 Loosen two hose clamps (8).
- 7 Remove air cleaner duct-to-elbow duct hose (9).

NOTE

Powerplant must be removed to remove air intake duct, elbow duct, and flange assembly (para 4-5).

- 8 Remove hose clamp (10) and turbocharger air intake duct hose(11).
- 9 Remove six screws (12), six lockwashers (13), and six flat washers (14) at powerplant compartment bulkhead and separate elbow duct flange assembly (15). Discard lockwashers.
- 10 Remove elbow duct(16) and gasket (17). Discard gasket.
- 11 Remove elbow duct (18) by pulling through bulkhead into powerplant compartment.
- 12 Remove indicator hose (19).

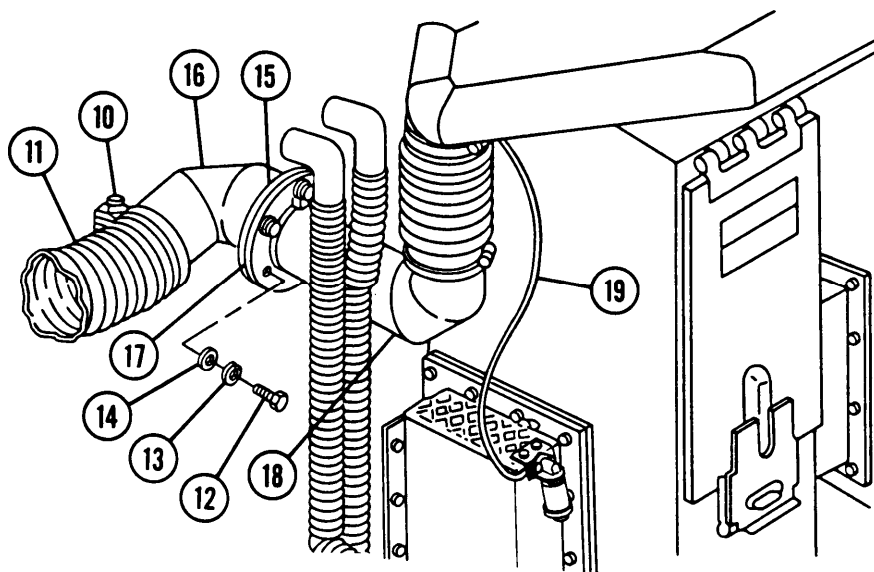

6-14 DUCTS AND HOSES — CONTINUED

b. Installation

WARNING

If NBC exposure is suspected, all air filter media must be handled by personnel wearing full NBC-protective equipment (FM 21-1 1).

- 1 Install indicator hose (19).
- 2 Install elbow duct (18) through powerplant compartment bulkhead.
- 3 Install new gasket (17) and elbow duct (16).
- 4 Connect elbow duct flange assembly (15) and install six flat washers (14), six new lockwashers(13) and six screws (12).
- 5 Install turbocharger air intake duct hose (11) and hose clamp (1 O).
- 6 Install air cleaner duct-to-elbow duct hose (9) and tighten two hose clamps (8).
- 7 Install two duct exhaust to elbow hoses (7).
- 8 Install blower motors (6) (para 8-35).
- 9 Install two air cleaner-to-duct exhaust hoses (5).
- 10 Tighten four hose clamps (4).
- 11 Install two mounting clamps (3), two new lockwasher (2), and two screws (1).

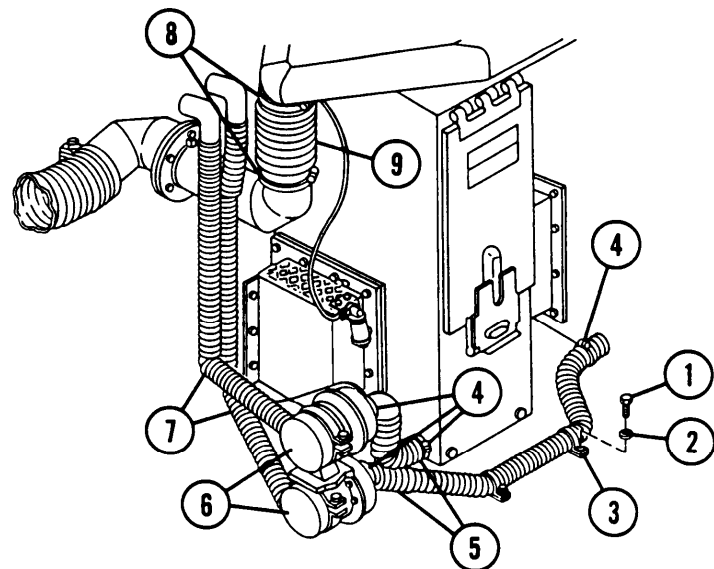
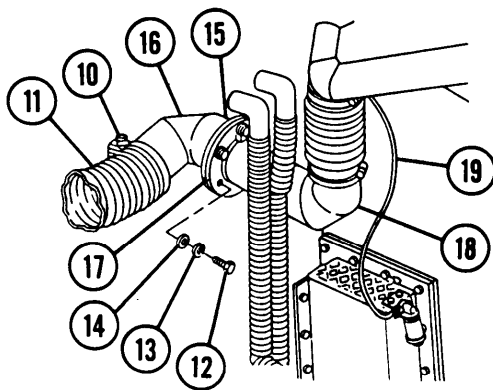

SECTION III. EXHAUST SYSTEM

6-15 EXHAUST CROSSOVER TUBE

This task covers: a. Removal b. Installation

INITIAL SETUP
Tools

General mechanic's tool kit (item 64, Appx H)

Equipment Conditions

Air intake grille opened and secured (para 11 -8)

Left side transmission access door opened (para 11 -7)

a. Removal
WARNING

Ensure engine and exhaust systems are cool enough to permit handling in order to prevent burns.

- 1 Disconnect throttle governor(1) at lever (2) (para 9-1 1).
- 2 Remove two nuts (3) and two clamps (4) at ends of pipes (5).
- 3 Remove exhaust crossover tube (6).

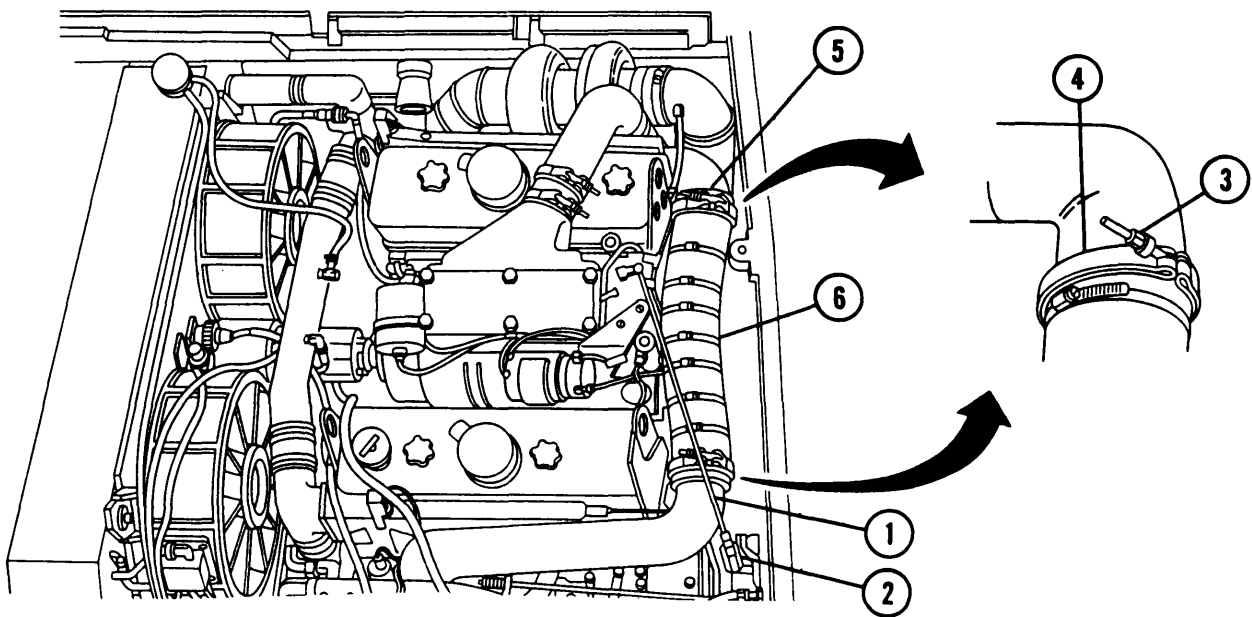

6-15 EXHAUST CROSSOVER TUBE — CONTINUED

b. Installation

WARNING

Ensure engine and exhaust systems are cool enough to permit handling in order to prevent burns.

- 1 Install exhaust crossover tube (6).
- 2 Install two clamps (4) with two nuts (3) on ends of pipes (5).
- 3 Connect throttle governor (1) at lever (2) (para 9-11).

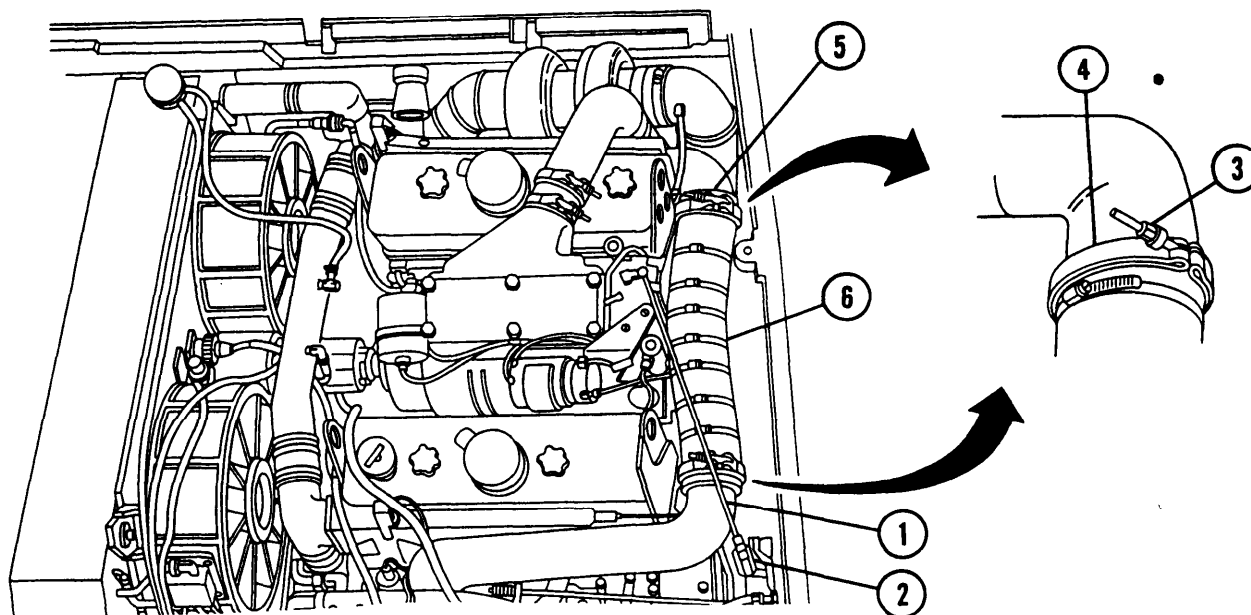
**NOTE****FOLLOW-ON MAINTENANCE:**

Close air intake grille (para 11-8)
Install left transmission access door (para 11 -7)

6-16 EXHAUST DUCT, BUFFER PLATE, AND PIPE INSULATION — CONTINUED

a. Removal — Continued

- 4 Remove two screws (6), two washers (7), two springs (8), and hanger (9).

NOTE

Three large clamps (10 and 11) are formed by assembling two smaller clamps. It is only necessary to loosen them at one spot for removal.

- 5 Loosen two large clamps (10) and remove insulation covers (12 and 13).
- 6 Loosen one large clamp (11), four clamps (16), and muffler insulation covers (14 and 15).
- 7 Remove three clamps (17) and exhaust pipe insulation covers (18 and 19) from exhaust pipe (20).

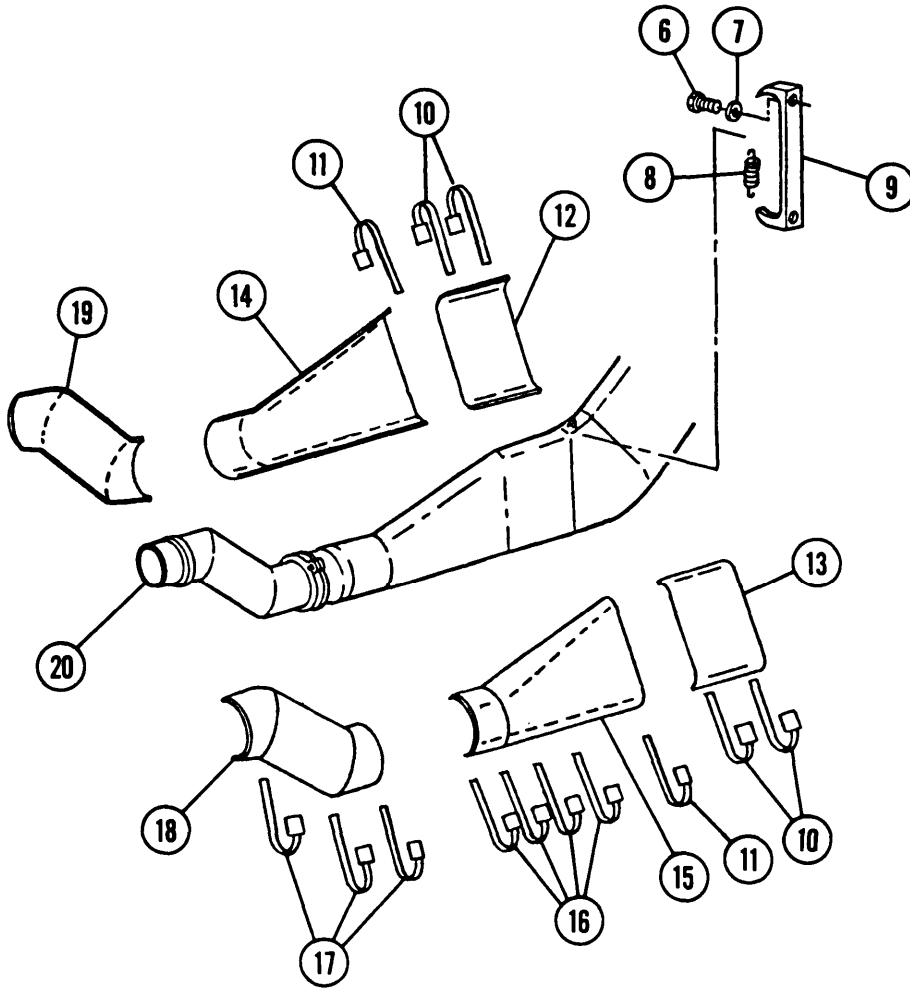

b. Installation**WARNING**

Ensure engine and exhaust systems are cool enough to permit handling in order to prevent burns.

- 1 Install exhaust pipe insulation covers(18 and 19) with three clamps (17) on exhaust pipe (20). Torque three clamps to 15-25 lb-in. (1.7-2.8 N*m).
- 2 Install muffler insulation covers(14 and 15) with four clamps(16) and one large clamp(11). Torque five clamps (16 and 11) to 15-25 lb-in. (1.7-2.8 N*m).
- 3 Install insulation covers(12 and 13) with two large clamps (10). Torque two clamps (10) to 15-25 lb-in. (1.7-2.8 N*m).
- 4 Install hangar (9), two springs (8), two washers (7), and two screws (6).
- 5 Install exhaust duct (5).
- 6 Connect two springs (4).

NOTE

Step 7 applies only to some M109A3 Howitzers.

- 7 Install buffer plate (3), two new lockwashers (2), and two screws(1).

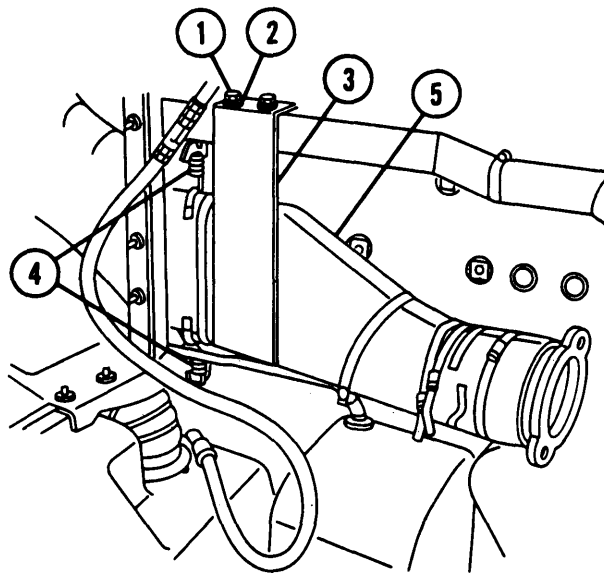
**NOTE**

FOLLOW-ON MAINTENANCE: Install powerplant (para 4-5)

SECTION IV. FUEL TANK HEAT SHIELD

6-17 FUEL TANK HEAT SHIELD

This task covers:

a. Removal	b. Disassembly
c. Assembly	d. Installation

INITIAL SETUP

Tools

General mechanic's tool kit (item 64, APPX H)

Personnel Required

Two

Materials/Parts

Rivets (9) (item 2, Appx G)

Rivets (5) (item 34, Appx G)

Sealing compound (item 19, Appx D)

Equipment Condition

Buffer plate and exhaust duct removed (para 6-16)

a. Removal

CAUTION

Ensure fuel tanks are not damaged while removing fuel tank heat shield pad.

- 1 Remove fuel tank heat shield pads (1).
- 2 Loosen two screws (2), two nuts (3), and two angle brackets (4).
- 3 Remove 10 screws (5) and 10 flat washers (6).
- 4 Remove two screws (7) and two flat washers (8).
- 5 Remove screw (9) and flat washer (10).
- 6 Remove fuel tank heat shield (11) from vehicle.

b. Disassembly

- 1 Remove two nuts (12), two flat washers (13), and two supports (14 and 15).
- 2 Remove two screws (16), two flat washers (17), and two stiffeners (18).
- 3 Remove two screws (19), four washers (20), two nuts (21), and support (22).
- 4 Remove 14 nuts (23), bar (24), 2 stiffeners (25), 3 seal segments (26), and 3 retainer segments (27).

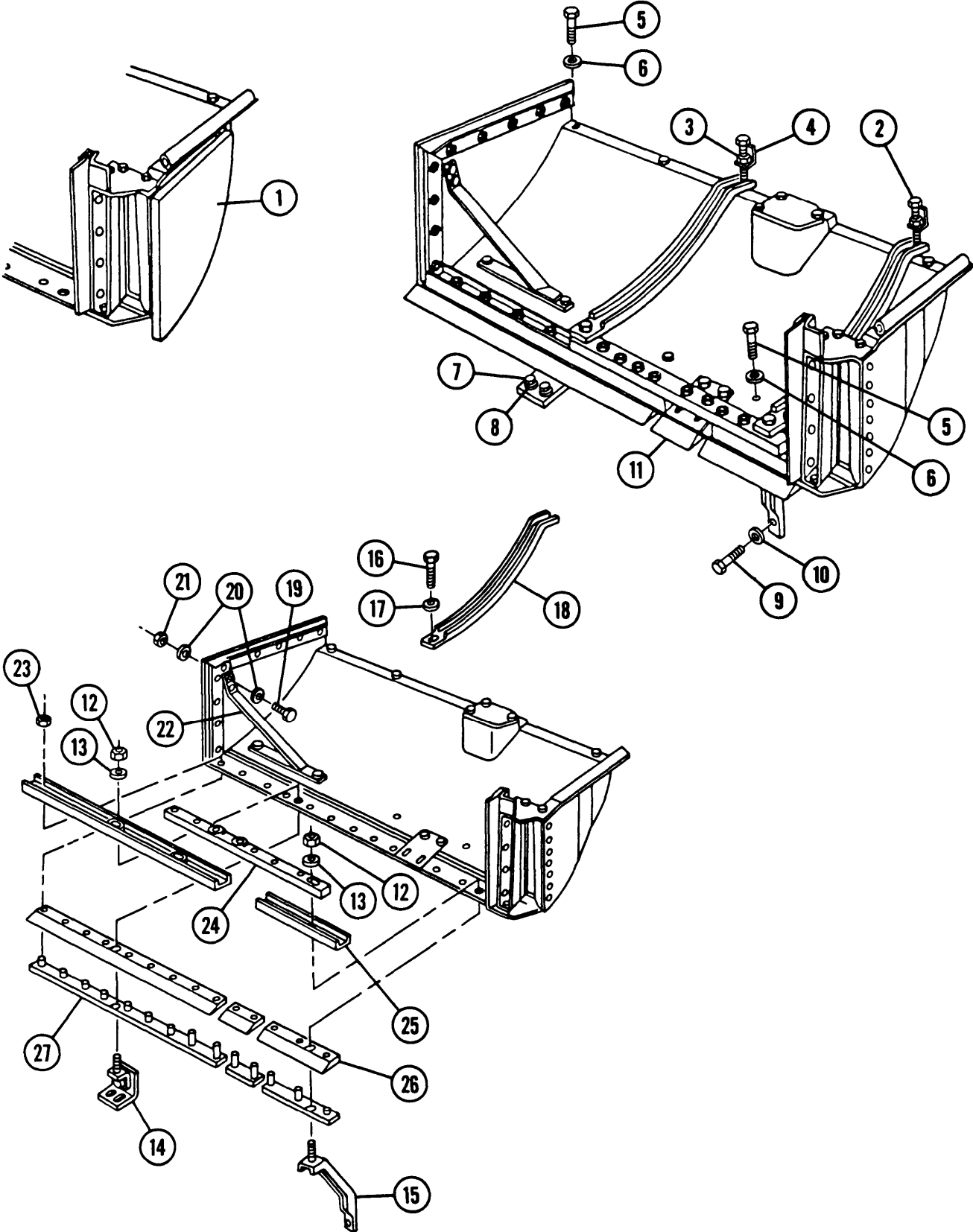

6-17 FUEL TANK HEAT SHIELD — CONTINUED

b. Disassembly — Continued

5 Remove three screws (28), three washers (29), and cover (30).

6 Remove two nuts (31), two washers (32), and cover (33).

7 Remove retainer (34) and insulation (35).

8 Remove five nuts (36), five washers (37), seal (38), and plate (39).

9 Remove four nuts (40), four washers (41), seal (42), and plate (43).

10 Remove four screws (44), four washers (45), four nuts (46), and assembled plate (47), seal (48), and retainer (49).

11 Remove five nuts (50) and five washers (51) to separate plate (47), seal (48), and retainer (49).

NOTE

Rivets are removed by drilling out.

12 Remove five rivets (52), plate (53), and seal (54). Discard rivets.

13 Remove seven rivets (55), seven flat washers (56), and two seals (57). Discard rivets.

14 Remove two rivets (58), two flat washers (59), and two seals (60). Discard rivets.

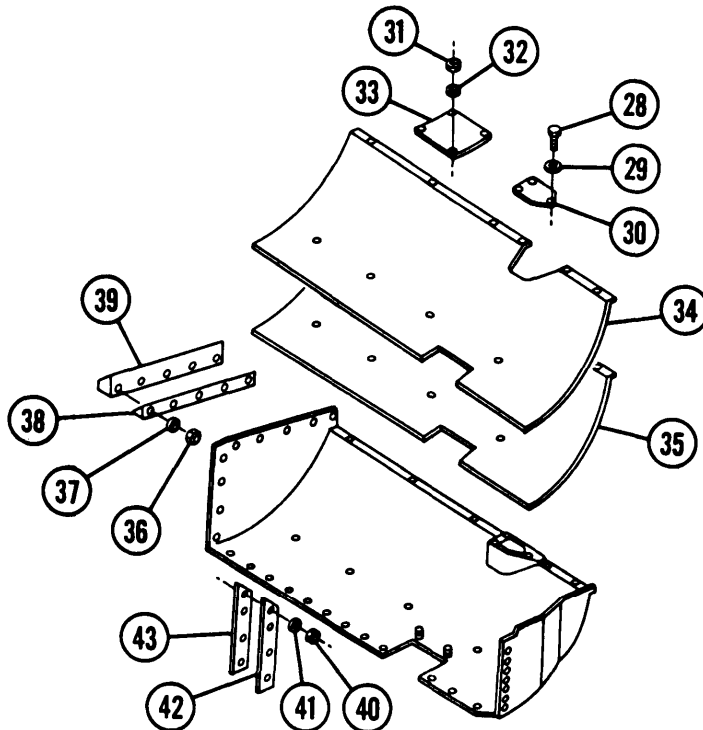

c. Assembly

- 1 Install two seals (6), two flat washers (59), and two new rivets (58).
- 2 Install two seals (57), seven flat washers (56), and seven new rivets (55).
- 3 Install seal (54), plate (53), and five new rivets (52).
- 4 Assemble retainer (49), seal (48), plate (47), five washers (51), and five nuts (50).
- 5 Install assembled retainer (49), seal (48), and plate (47), four washers (45), four nuts (46), and four screws (44).
- 6 Install plate (42), seal (43), four washers (41) and four nuts (40).
- 7 install plate (39), seal (38), five washers (37), and five nuts (36).
- 8 Install insulation (35) and retainer (34).
- 9 Install cover (33), two washers (32), and two nuts (31).
- 10 install cover (30), three washers (29), and three screws (28).

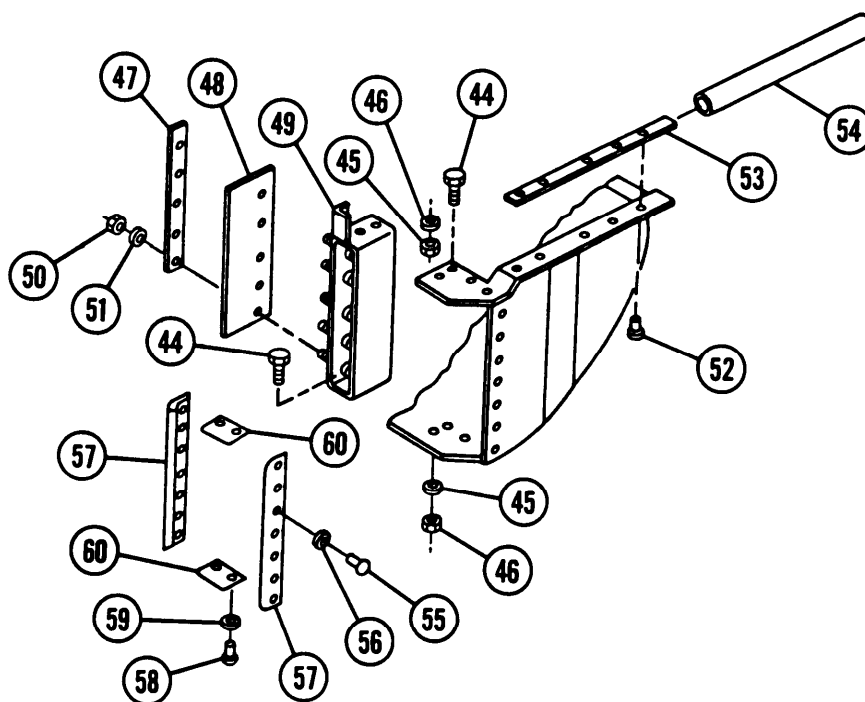

6-17 FUEL TANK HEAT SHIELD — CONTINUED

d. Assembly — Continued

- 11 Install 3 retainer segments (27), 3 seal segments (26), 2 stiffeners (25), bar (24), and 14 nuts (23).
- 12 Install support (22), two nuts (21), four washers (20), and two screws (19).
- 13 Install two stiffeners (18), two flat washers (17), and two screws (16).
- 14 Install two supports (14 and 15), two flat washers (13), and two nuts (12).

d. Installation

- 1 Install tank heat shield (11) back onto vehicle.
- 2 Install flat washers (10) and screw (9).
- 3 Install two flat washers (7) and two screws (8).

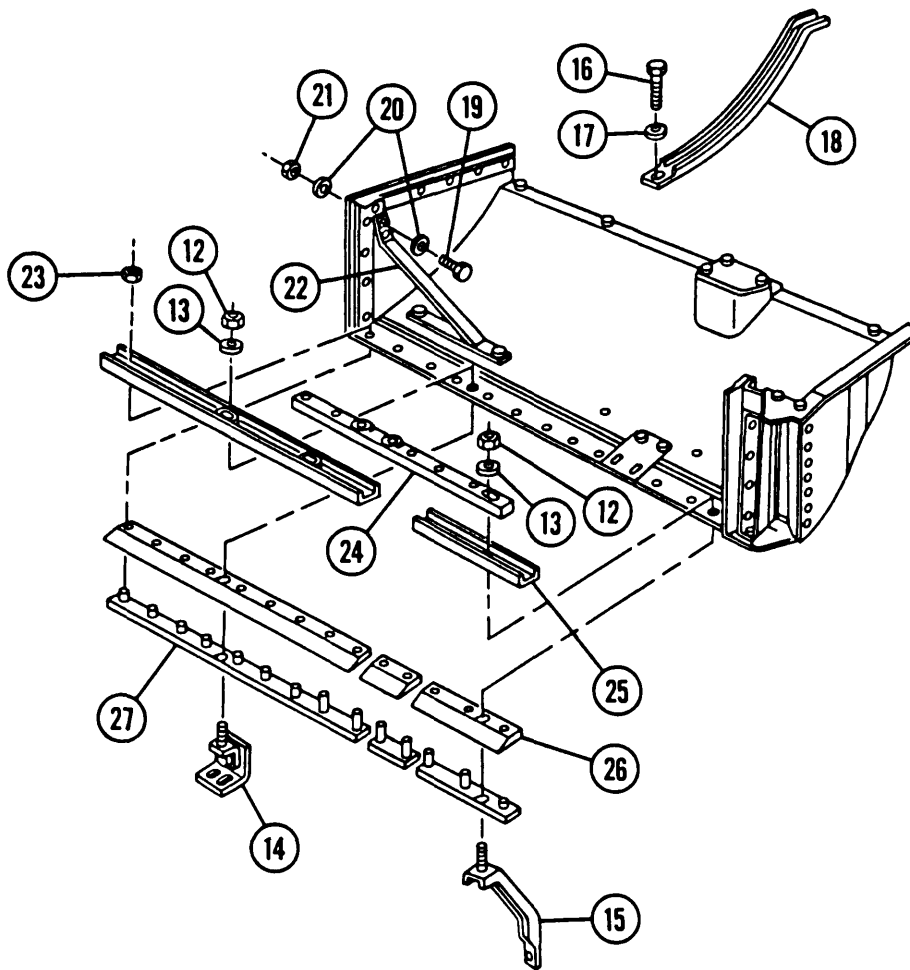

4 Install 10 flat washers (6) and 10 screws (5). Apply sealing compound.

5 Install two angle brackets (4), two nuts (3) and two screws (2). Tighten two nuts.

6 Install fuel tank heat shield pad (1).

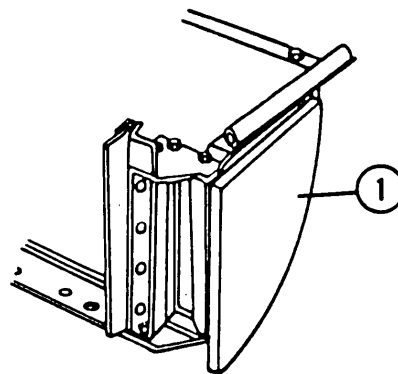
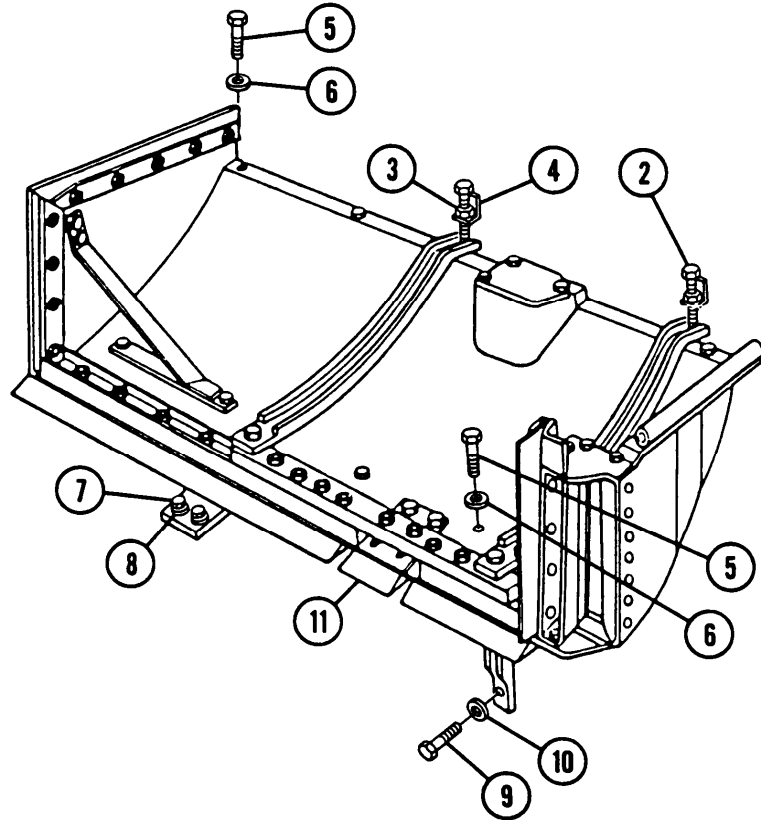

NOTE

FOLLOW-ON MAINTENANCE: Install bufferplate and exhaust duct (para 6-1 6)

CHAPTER 7 COOLING SYSTEM

GENERAL

This chapter provides instructions for maintenance, removal, installation, and cleaning of engine cooling system components.

<u>CONTENTS</u>	<u>PAGE</u>
7-1 ENGINE COOLING SYSTEM (M109A2/M109A4/M109A5) (PICTORIAL)	7-2
7-2 ENGINE COOLING SYSTEM (M109A3) (PICTORIAL)	7-4
7-3 MAIN ENGINE COOLANT TUBES	7-6
7-4 LOWER ENGINE COOLANT TUBES... ..	7-8
7-5 SURGE TANK AND PRESSURE RELIEF VALVE	7-10
7-6 RADIATOR AND SHROUD (M109A2/M109A4/M109A5)	7-13
7-7 RADIATOR AND SHROUD (M109A3)	7-22
7-8 INLET THERMOSTATS AND HOUSING ASSEMBLY	7-32
7-9 BYPASS THERMOSTAT AND HOUSING ASSEMBLY	7-36

7-1 ENGINE COOLING SYSTEM (M109A2/M109A4/M109A5) (PICTORIAL)

LEGEND

- | | | | |
|----|---|----|--|
| 1 | Surge tank | 15 | Engine coolant drain valve |
| 2 | Connector hose (8) | 16 | Bypass thermostat housing assembly-to-engine coolant main tube assembly tube |
| 3 | Radiator | 17 | Engine coolant pump |
| 4 | Engine coolant crossover tube-to-surge tank hose | 18 | Engine coolant pump-to-oil cooler tube |
| 5 | Engine coolant crossover tube | 19 | Surge tank-to-engine coolant pump tube/hose assembly |
| 6 | Engine coolant crossover tube-to-radiator vent hose | 20 | Radiator-to-surge tank hose |
| 7 | Radiator vent-to-surge tank hose | 21 | Surge tank-to-pressure relief valve hose |
| 8 | Radiator filler cap | 22 | Aeration detector |
| 9 | Inlet thermostat housing-to-radiator inlet hose | 23 | Pressure relief valve assembly |
| 10 | Inlet thermostat housing | 24 | Aeration detector-to-engine coolant main tube assembly hose |
| 11 | Engine coolant manifold connector housing | 25 | Radiator-to-aeration detector hose |
| 12 | Engine coolant manifold | 26 | Fan warning decal (4) |
| 13 | Engine coolant main tube assembly | | |
| 14 | Bypass thermostat housing assembly | | |

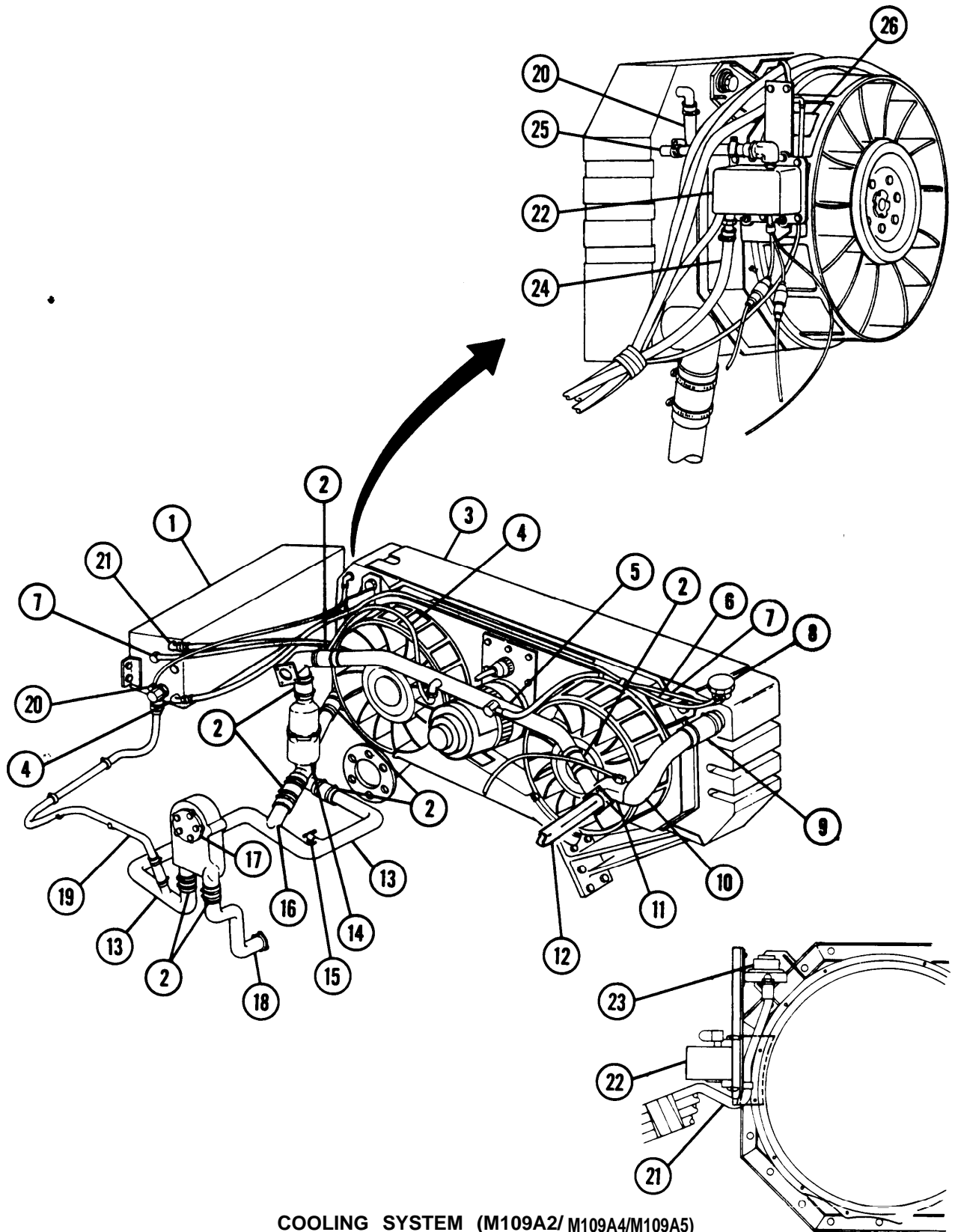

COOLING SYSTEM (M109A2/ M109A4/M109A5)

7-2 ENGINE COOLING SYSTEM (M109A3) (PICTORIAL)

LEGEND

- | | | | |
|----|--|----|---|
| 1 | Surge tank drain cock | 22 | Engine coolant drain valve |
| 2 | Surge tank-to-pressure relief valve hose | 23 | Engine coolant main tube |
| 3 | Radiator-to-surge tank hose | 24 | Engine coolant pump |
| 4 | Surge tank | 25 | Engine coolant pump-to-oil cooler tube |
| 5 | Engine coolant manifold connector housing | 26 | Engine coolant pump connector hose |
| 6 | Engine coolant manifold connector housing-to-engine coolant crossover tube hose | 27 | Surge tank tube-to-engine coolant main tube inlet hose |
| 7 | Radiator | 28 | Surge tank tube |
| 8 | Radiator fan | 29 | Surge tank hose |
| 9 | Surge tank pressure relief valve with block, gasket, and adapter (earlier version) | 30 | Bypass thermostat lower housing-to-engine coolant main tube inlet hose |
| 10 | Engine coolant crossover tube | 31 | Bypass thermostat lower housing |
| 11 | Engine coolant manifold connector housing-to-engine coolant crossover tube hose | 32 | Bypass thermostat upper housing |
| 12 | Radiator filler cap | 33 | Engine coolant manifold connector housing-to-bypass thermostat housing hose |
| 13 | Inlet thermostat housing-to-radiator inlet hose | 34 | Bypass thermostat housing-to-surge tank hose |
| 14 | Inlet thermostat housing | 35 | Engine coolant lower tube |
| 15 | Engine coolant manifold connector housing | 36 | Radiator outlet-to-engine coolant lower tube |
| 16 | Engine coolant manifold | 37 | Aeration detector-to-engine coolant lower tube |
| 17 | Engine coolant crossover tube-to-radiator vent hose | 38 | Aeration detector |
| 18 | Crossover tube-to-surge tank hose | 39 | Radiator-to-aeration detector hose |
| 19 | Radiator outlet-to-engine coolant lower tube hose | 40 | Surge tank-to-radiator hose |
| 20 | Engine coolant lower tube | 41 | Surge tank pressure relief valve (later version) |
| 21 | Engine coolant lower tube-to-engine coolant main tube hose | | |

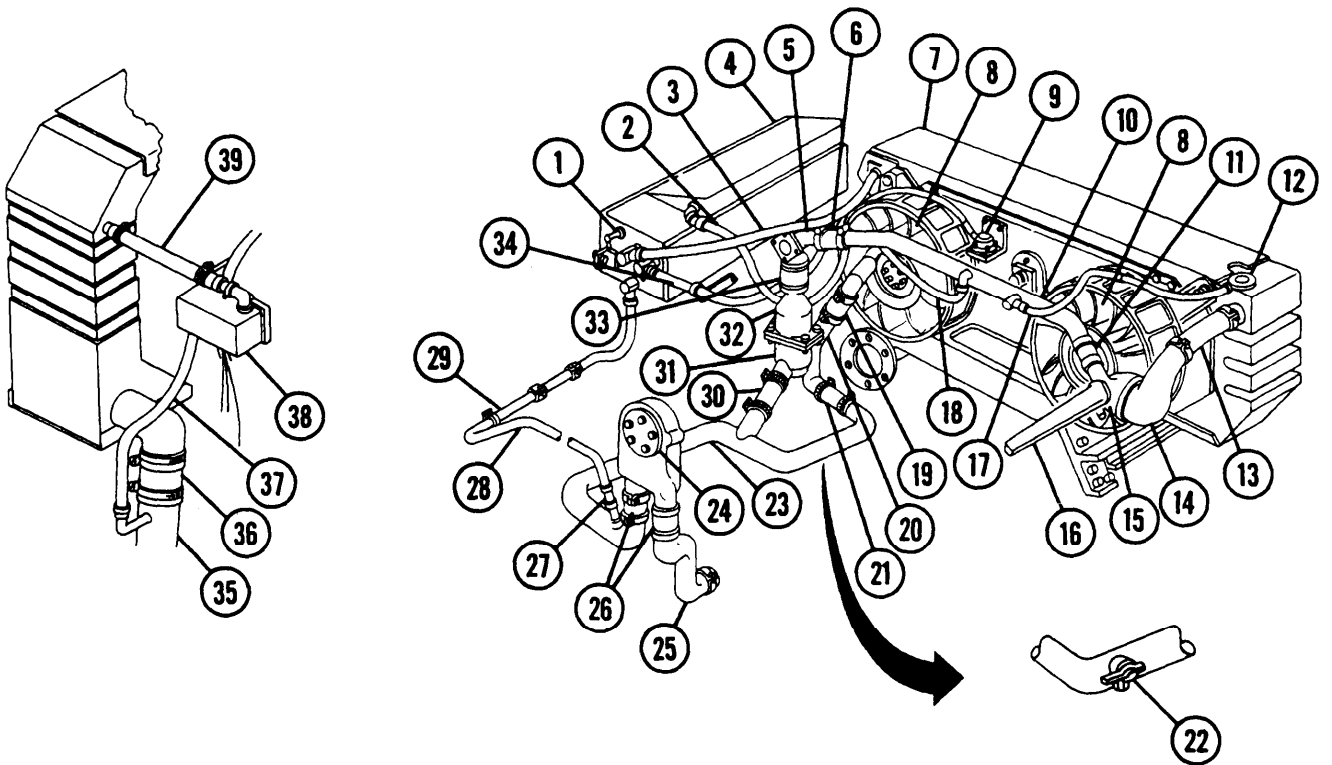

ENGINE COOLING SYSTEM (M109A3, EARLIER VERSION)

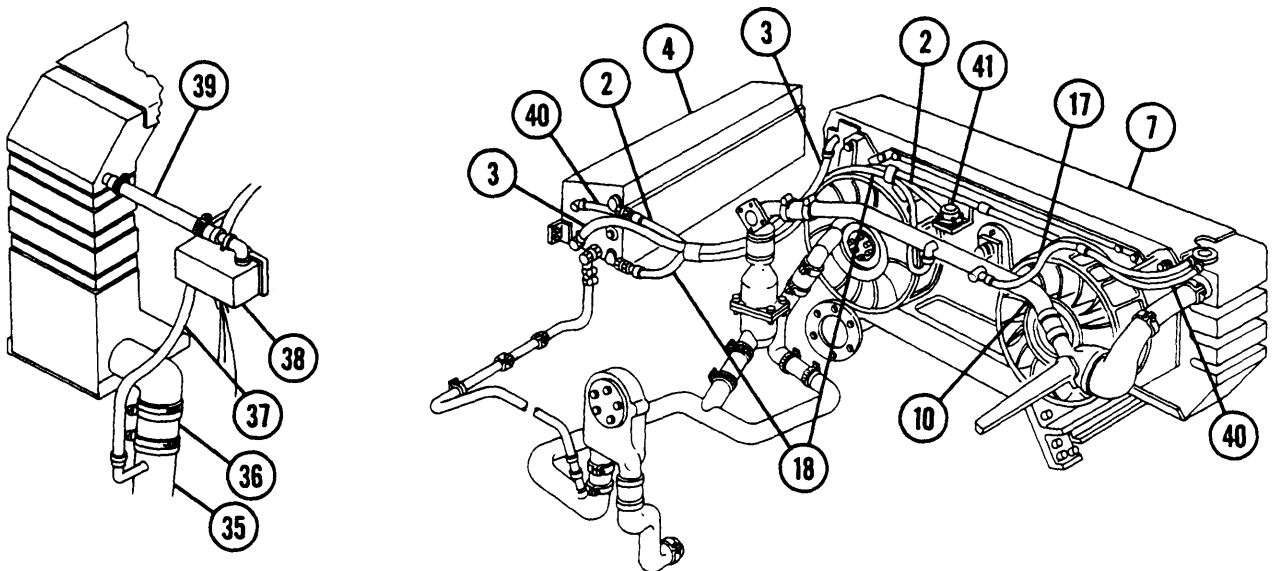

ENGINE COOLING SYSTEM (M109A3, LATER VERSION)

NOTE

- Hoses must cover unpainted areas of tubes and fittings or be positioned evenly between red bands on tubes and housings.
- Engine must be warmed up and then run for a minimum period of 5 minutes (para 4-5). Shut engine down before all hose clamps are retightened (para 4-5).

- 1 Apply adhesive at connections (1, 5, and 7) between hoses and mating tubes or castings.
- 2 Install main coolant tube (13) on tube connections (1,5,7, and 12).
- 3 Secure, but do not tighten, clamp (12), nut (11), new lockwasher (10), and screw (9) on main coolant tube (13).
- 4 Secure, but do not tighten, clamp (7) on radiator lower tube assembly (8).
- 5 Secure, but do not tighten, two clamps (5) on lower end of bypass thermostat lower housing-to-engine coolant main tube inlet hose (6).
- 6 Apply adhesive at connection (3) between hose and mating tube. Install surge tank tube-to-engine coolant main tube inlet hose (4) and secure, but do not tighten, clamp (3).
- 7 Secure, but do not tighten, clamp (1) on main inlet hose (2).
- 8 Refill coolant system (TM 9-2350-31 1-10).
- 9 Start engine and allow engine to run at least 5 minutes. Shut off engine (para 4-5).
- 10 Torque clamps (1, 5, 7, and 12) to 4&60 lb-in. (4.5-6.8 N-m). Torque clamp (3) to 20-40 lb-in. (2.3-4.5 N-m).

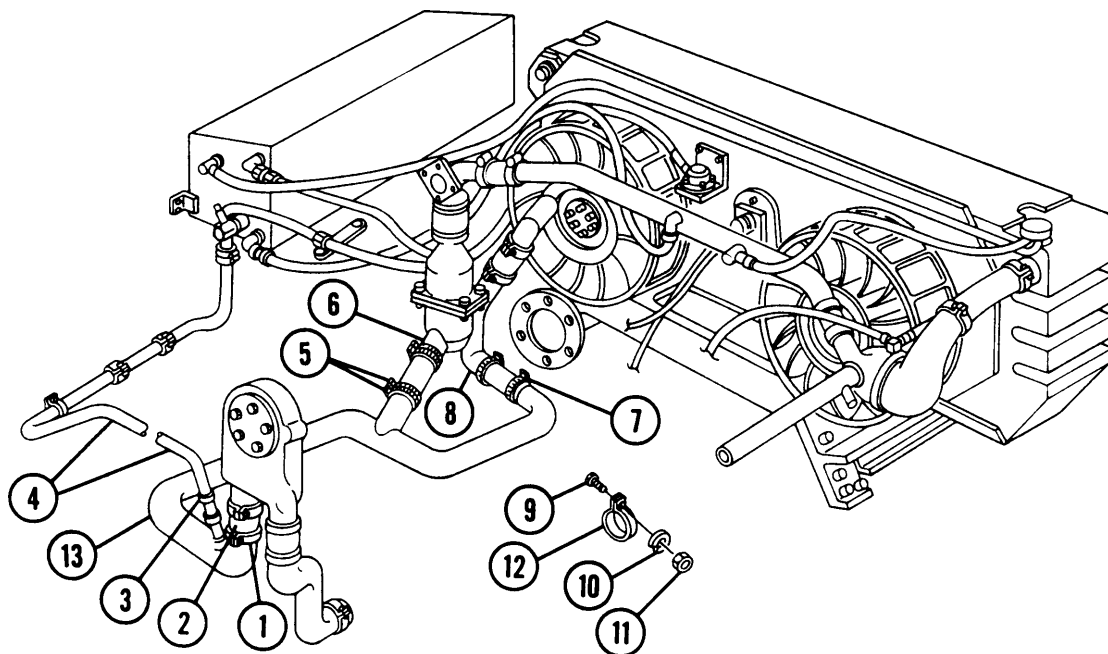
**NOTE**

FOLLOW-ON MAINTANENCE: Install powerplant (para 4-5)

NOTE

- Hoses must cover unpainted areas of tubes and fittings or be positioned evenly between red bands on tubes and housings.
- Before tightening hose clamps, engine must be warmed up and then run for a minimum of 5 minutes (para 4-5).

- 1 Apply adhesive between hoses and mating tubes.
- 2 Install engine coolant lower tube (7).
- 3 Secure two clamps (5) on radiator outlet-to-engine coolant lower tube hose (6).
- 4 Connect aeration detector hose (4) and secure with clamp (3).
- 5 Secure two clamps (1) on engine coolant lower tube-to-engine coolant main hose (2).
- 6 Refill coolant system (TM 9-2350-311-10).
- 7 Install special equipment to run powerplant outside of vehicle (para 4-5).
- 8 Start engine and allow engine to run at least 5 minutes. Shut off engine (para 4-5).
- 9 Torque five clamps (1, 3, and 5) to 40-60 lb-in. (4.5-6.8 N-m).

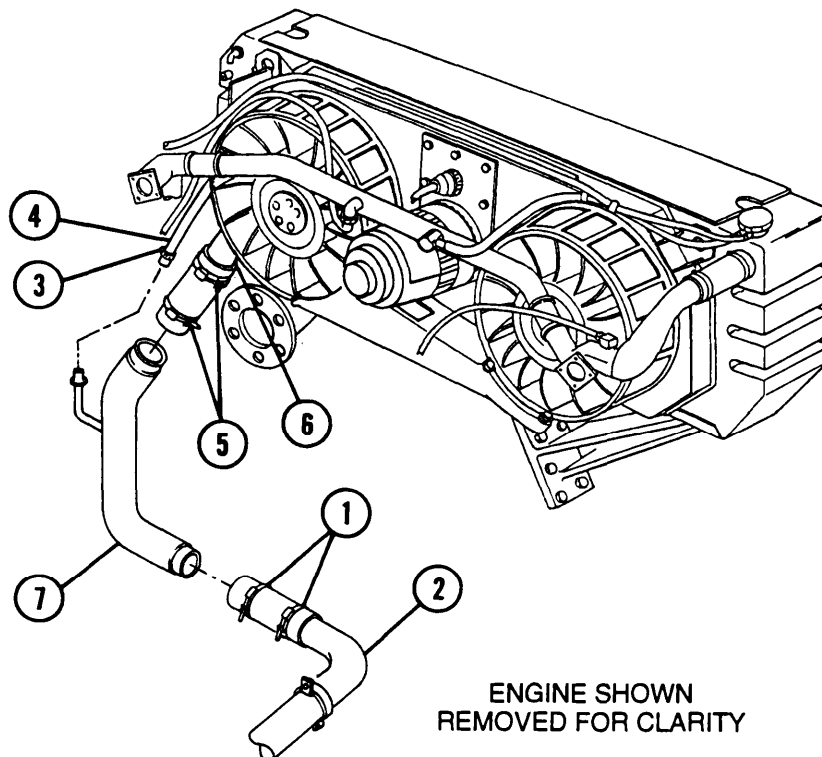
**NOTE**

FOLLOW-ON MAINTENANCE: Install powerplant (para 4-5)

b. Installation

WARNING

- Ensure engine and coolant system are cool enough to permit safe handling in order to prevent burns.
- Adhesives are toxic and flammable. Apply adhesives only in a well-ventilated area. Avoid contact with skin, eyes, and clothes, and don't breath vapors. Do not use near heat, sparks, or open flame. Read and follow all warnings and instructions on labels of adhesives. If contact with skin or eyes is made, wash area with water and seek medical aid immediately.

NOTE

Use adhesive at hose, tube, and casting interface when installing surge tank.

- 1 Install new gasket (21), relief valve (20), and four screws (19) onto block (22).
- 2 Install elbow (18) and hose (17) and screw on nut (16) at lower end of relief valve (20).
- 3 Place surge tank (15) back into position.

NOTE

Hoses must cover unpainted areas of tubes and fittings or be positioned evenly between red bands on tubes and housings.

- 4 Connect five hoses (10, 11, 12, 13, and 14) to surge tank (15).

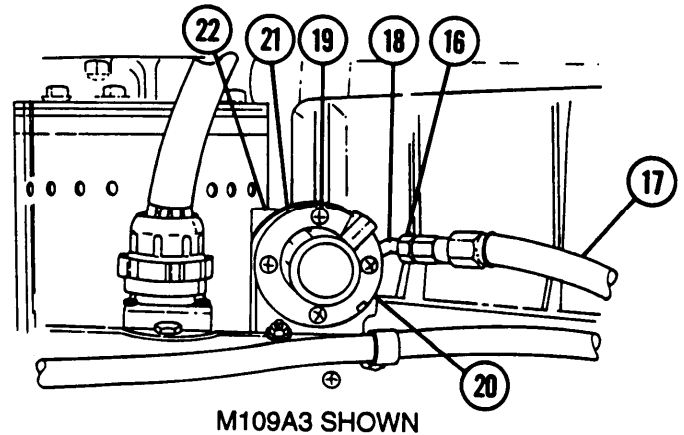
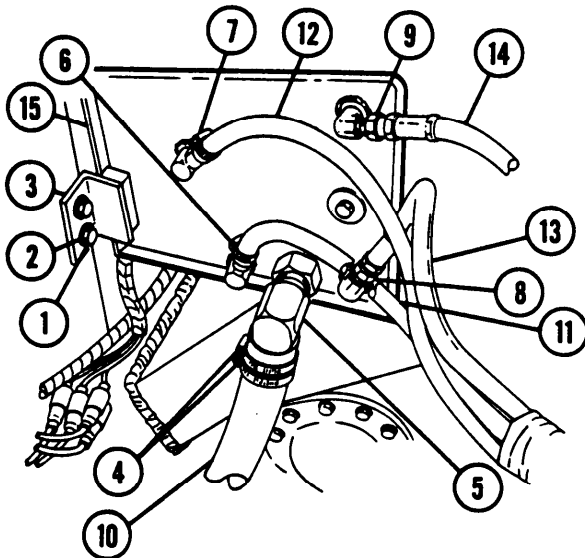

7-5 SURGE TANK AND PRESSURE RELIEF VALVE — CONTINUED

b. Installation — Continued

5 Screw two nuts (8 and 9) back on.

NOTE

- Engine must first be warmed up and then run for a minimum period of 5 minutes. Shut engine down before all hose clamps are retightened (para 4-5).
- Torque all hose clamps as follows:
 - 0.5 to 1 in. (12.7 to 25.4 mm) od hose: 15-25 lb-in. (1.7-2.8 N·m)
 - 1 to 2 in. (25.4 to 50.8 mm) od hose: 20-40 lb-in. (2.345 N·m)
 - Above 2 in. (50.8 mm) od hose: 40-60 lb-in. (4.5-6.8 N·m)

6 Tighten two clamps (6 and 7).

7 Tighten two clamps (4) at elbow (5).

8 Install retainer (3), two washers (2), and two screws (1).

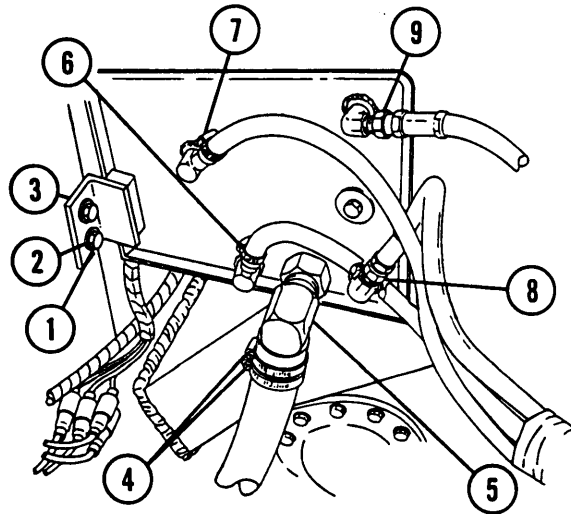

NOTE

FOLLOW-ON MAINTENANCE:

- Fill coolant system (TM 9-2350-311-1 0)
- Install engine exhaust deflector (para 4-5)
- Install engine exhaust grille (para 4-5)
- Install grille support plate (para 4-5)
- Install radiator fan access door (para 4-5)
- Install right front grille assembly (para 4-5)
- Install right transmission door (para 11-7)
- Close air intake grille (para 11 -8)

7-6 RADIATOR AND SHROUD (M109A2/M109A4/M109A5) — CONTINUED

a. Removal — Continued

- 2 Remove two screws (4), two lockwashers (5), two flat washers (6), and two resilient mounts (7). Discard lockwashers.
- 3 Loosen two clamps (8) from radiator outlet tube (9) and disconnect radiator outlet tube from radiator (10).
- 4 Loosen two vent hose clamps (11) and remove two radiator vent hoses (12).
- 5 Loosen two inlet hose clamps (13) and disconnect radiator inlet tube (14) from radiator.

WARNING

Radiator weighs 88 lb (39.9 kg). Two personnel are required during removal and installation.

- 6 Lift radiator (10) up and away from shroud (15).
- 7 Remove alternator (para 8-1).
- 8 Disconnect two electrical connectors (16) and ground lead (17).
- 9 Loosen clamp (18) and remove aeration detector-to-engine coolant main tube assembly hose (19).
- 10 Remove nut (20), lockwasher (21), screw (22), washer (23), and clamp (24). Discard lockwasher.
- 11 Loosen fitting (25) and disconnect surge tank-to-pressure relief valve hose (26).
- 12 Remove two screws (27), two lockwashers (28), two washers (29), and bracket (30) with aeration detector (31) and relief valve (32) installed. Discard lockwashers.
- 13 Remove eight screws (33), eight flat washers (34), and eight lockwashers (35) from bracket (36). Discard lockwashers.
- 14 Remove three screws (37), three flat washers (38), three lockwashers (39), and three clamps (40), releasing radiator vent hoses (12).
- 15 Depress fan universals (41), lift shroud (15) up to permit removal of universals, then remove shroud with fans (42) attached.

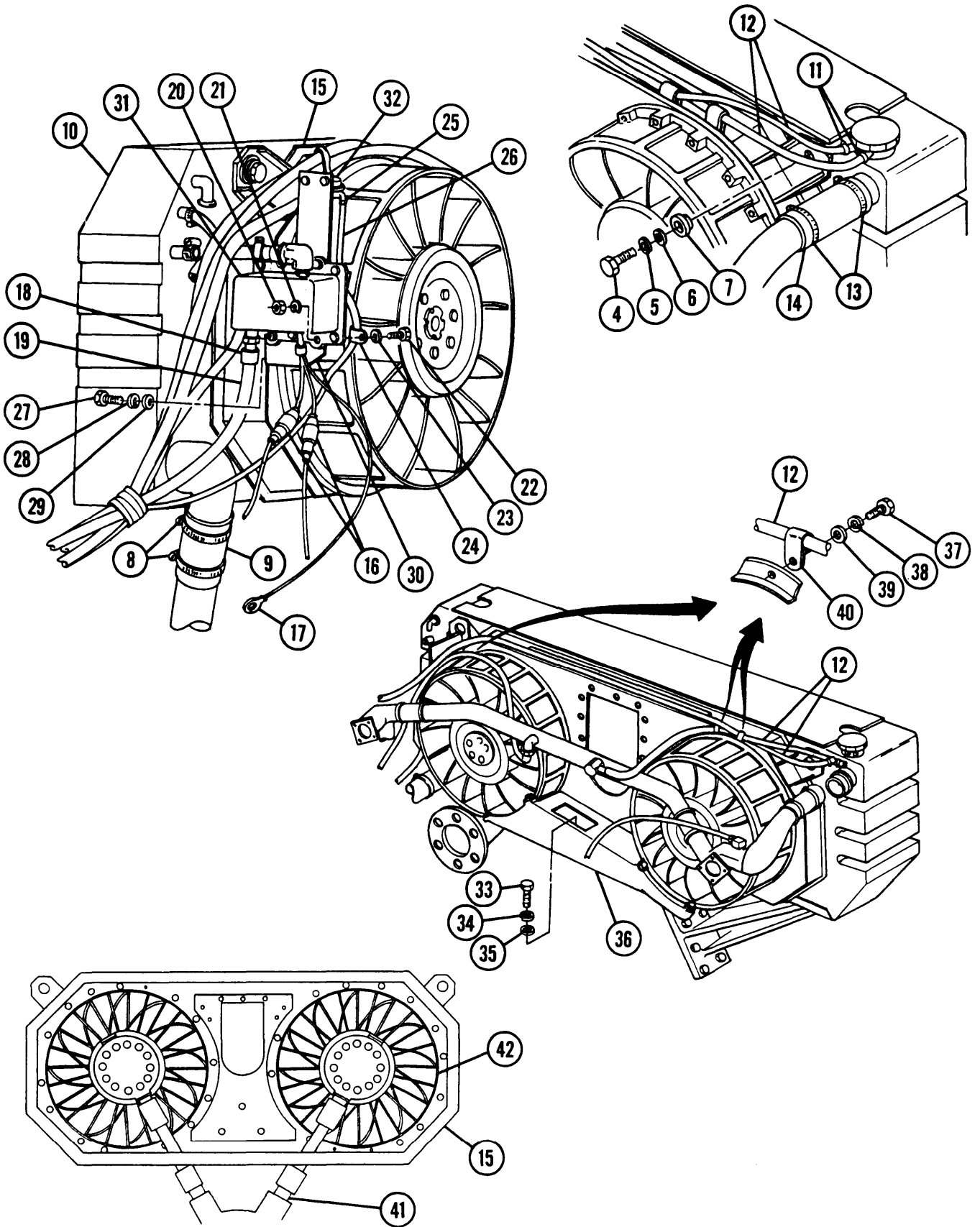

7-6 RADIATOR AND SHROUD (M109A2/M109A4/M109A5) — CONTINUED

a. Removal — Continued

- 16 Remove four screws (43), four lockwashers (44), four flat washers (45), and two brackets (46). Discard lockwashers.
- 17 Remove two bushings (47).
- 18 Remove eight screws (48) and cover (49).
- 19 Remove 36 retainers (50) and 4 seals (51 and 52).
- 20 Remove nine screws (53), nine lockwashers (54), nine washers (55), and rear radiator mount (56). Discard lockwashers.
- 21 Remove eight screws (57), eight lockwashers (58), eight washers (59), and front radiator mount (60). Discard lockwashers.
- 22 Remove radiator cap (61) and gasket (62). Discard gasket.

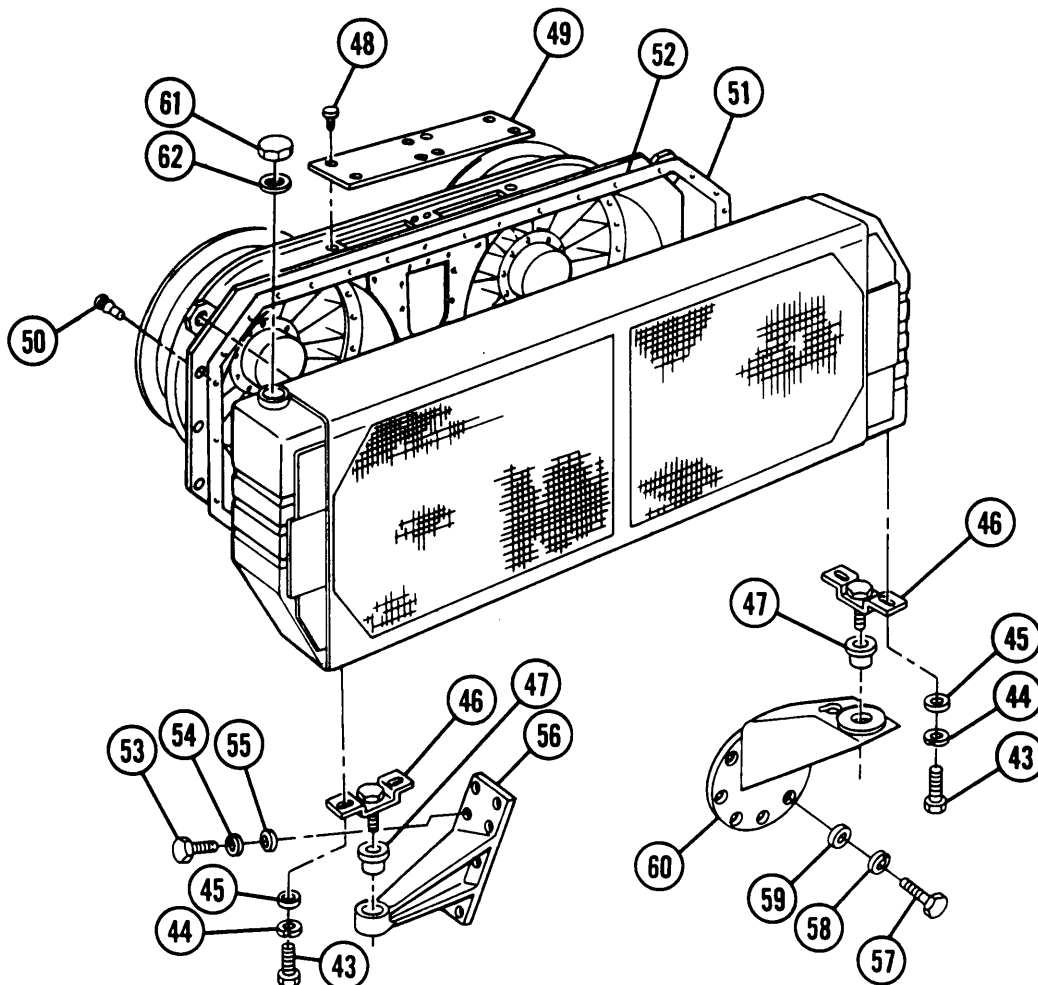

b. Installation**WARNING**

Ensure engine and coolant system are cool enough to permit safe handling in order to prevent burns.

- 1 Inspect oil level in fans (para 2-15.10).
- 2 Install front radiator mount (60), eight washers (59), eight new lockwashers (58), and eight screws (57).
- 3 Install rear radiator mount (56), nine washers (55), nine new lockwashers (54), and nine screws (53).
- 4 Install two bushings (47).
- 5 Install four seals (52 and 51).
- 6 Tape seals (51 and 52) with four complete wraparound with 0.5 in. (12.7 mm) overlap at eight seal joints.
- 7 Install 36 retainers (50), securing seals (51 and 52) to shroud (15).
- 8 Install cover (49) and eight screws (48).
- 9 Install two brackets (46), four flat washers (45), four new lockwashers (44), and four screws (43).
- 10 Install fan universals (41) and shroud (15) with fans (42) attached.

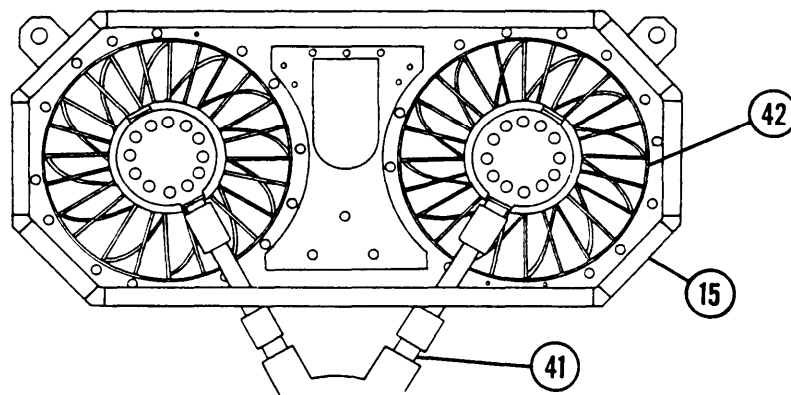

7-6 RADIATOR AND SHROUD (M109A2/M109A4/M109A5) — CONTINUED

b. Installation — Continued

- 11 Install eight new lockwashers (35), eight flat washers (34), and eight screws (33) on bracket (36).
- 12 Install bracket (30) with aeration detector (31) and relief valve (32) attached, two washers (29), two new lockwashers (28), and two screws (27).
- 13 Connect surge tank-to-pressure relief valve hose (26) and tighten fitting (25).
- 14 Install clamp (24), washer (23), screw (22), new lockwasher (21), and nut (20).
- 15 Install aeration detector-to-engine coolant main tube assembly hose (19) and tighten clamp (18).
- 16 Connect two electrical connectors (16) and ground lead (17).
- 17 Install alternator (para 8-2).

WARNING

- Radiator weighs 88 lb (39.9 kg). Two personnel are required during removal and installation.
 - Adhesives are toxic and flammable. Apply adhesives only in a well-ventilated area. Avoid contact with skin, eyes, and clothes, and don't breath vapors. Do not use near heat, sparks, or open flame. Read and follow all warnings and instructions on labels of adhesives. If contact with skin or eyes is made, wash area with water and seek medical aid immediately.
- 18 Apply adhesive (item 4, Appx D) on radiator inlet tube (14). Install radiator (10) and radiator inlet tube and tighten two inlet hose clamps (13).
 - 19 Apply adhesive (item 4, Appx D) to mating surface of radiator vent hoses (12). Install radiator vent hoses and tighten two clamps (11).
 - 20 Apply adhesive (item 4, Appx D) to mating surface of radiator outlet tube (9). Connect radiator outlet tube and tighten two clamps (8).
 - 21 Install two resilient mounts (7), two flat washers (6), two new lockwashers (5), and two screws (4).
 - 22 Apply adhesive (item 4, Appx D) to mating surfaces of surge tank-to-radiator hose (2) and radiator-to-aeration detector hose (3). Install hoses and tighten two clamps (1).
 - 23 Install three clamps (40), three lockwashers (39), three flat washers (38), and three screws (37), securing radiator vent hoses (12).
 - 24 Refill radiator with coolant (TM 9-2350-311-10).
 - 25 Apply adhesive (item 3, Appx D) to new gasket (62) and install gasket to cap (61).

26 Install cap (61) with new gasket (62) on radiator (14).

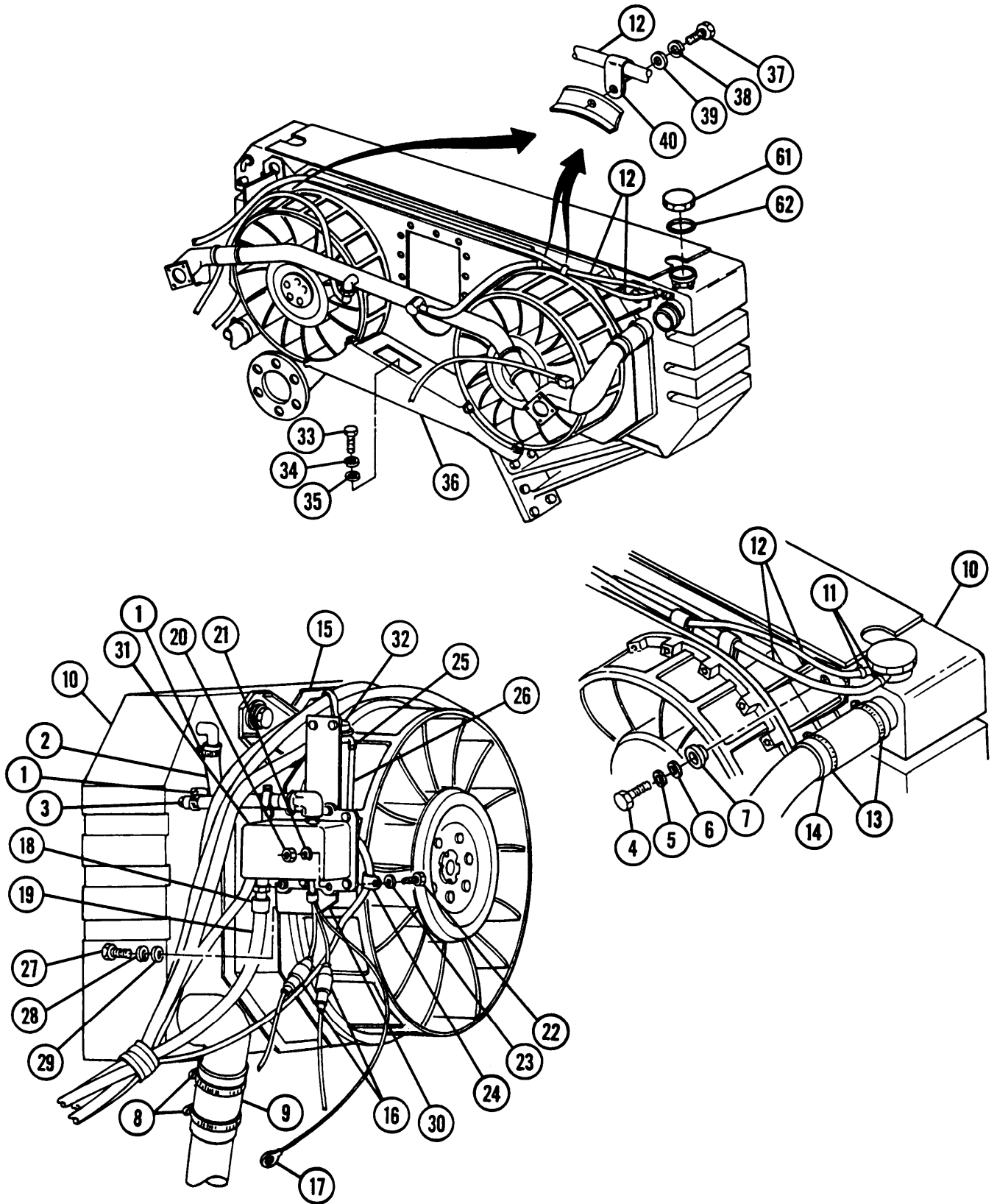

7-6 RADIATOR AND SHROUD (M109A2/M109A4/M109A5) — CONTINUED

c. Cleaning

WARNING

Ensure engine and coolant system are cool enough to permit handling in order to prevent burns.

- 1 Remove eight screws (48) and radiator shroud cover (49).
- 2 Open hull drains (TM 9-2350-311-10).
- 3 Cover all exposed openings of engine.

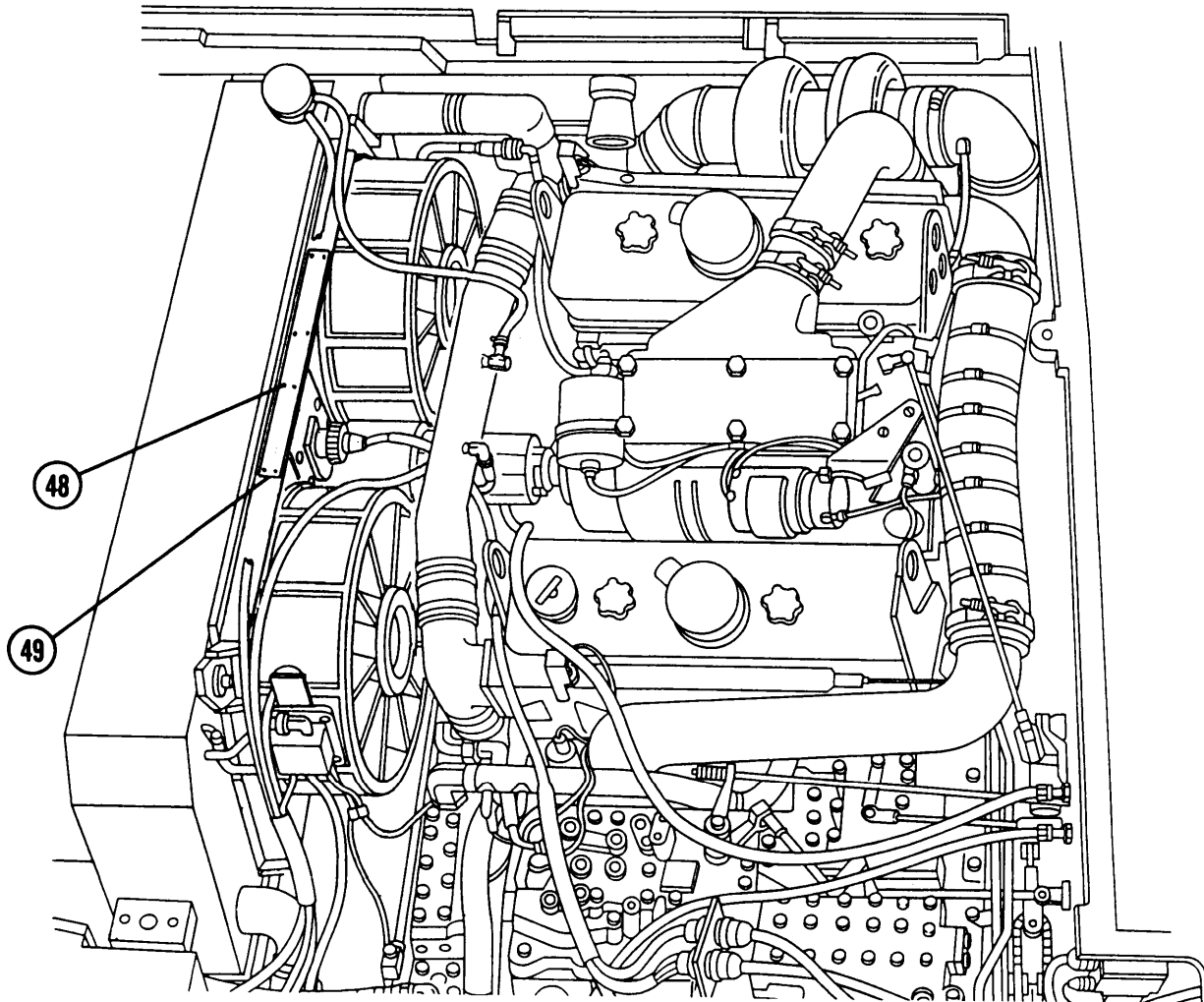

NOTE

The radiator cleaning tool is designed to remove deposits of sand, oil, clay, and other debris from the radiator cooling fins while installed in the vehicle. The cleaning agent may be a water solution of one part detergent to five parts water, or nontoxic, nonflammable solvent and water. A solution of detergent and water is recommended.

- 4 Connect radiator cleaning tool to air supply and insert hose in container of solution.
- 5 Insert cleaning tool through shroud cover opening (63). Saturate front and back of radiator with solution. Soak for approximately 10 minutes.
- 6 Remove heavy deposits from face of radiator by brushing with medium stiff brush that will not damage fins.
- 7 Blast radiator exterior with air/liquid mixture, holding head of tool approximately 0.5 in. (12.7 mm) from face of radiator. Alternate from back to front until good flow of liquid over radiator fins is observed over entire area.
- 8 Wash engine parts and exterior of radiator with clean water. Remove hose from container and use air to complete task.
- 9 Uncover engine openings. Install radiator shroud cover (49) with eight screws (48). Close hull drains.

NOTE

If overheating still occurs, notify support maintenance.

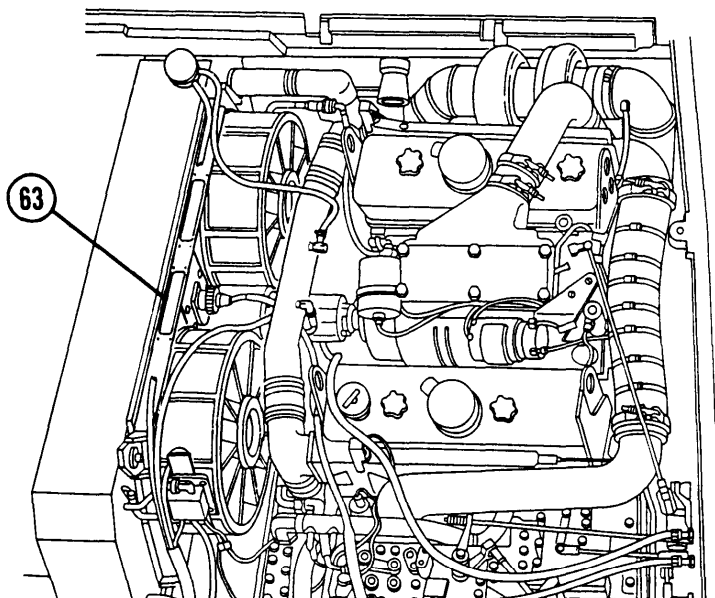
**NOTE****FOLLOW-ON MAINTENANCE:**

- Install engine exhaust grille (para 4-5)
- Install exhaust deflector (para 4-5)
- Install radiator fan access door (para 4-5)
- Install right front grille assembly (para 4-5)
- Install right transmission access door (para 11-7)
- Close air intake grille (para 11-8)

7-7 RADIATOR AND SHROUD (M109A3)

This task covers: a. Removal b. Installation c. Cleaning

INITIAL SETUP

Applicable Configurations

M109A3

Personnel Required

Two

Tools

General mechanic's tool kit (item 64, Appx H)
Radiator cleaning tool (item 12, Appx H)

References

TM 9-2350-311-10

Materials/Parts

Adhesive (item 3, Appx D)
Adhesive (item 5, Appx D)
Detergent (item 20, Appx D)
Gasket (item 160, Appx G)
Lockwashers (2) (item 95, Appx G)
Lockwashers (29) (item 96, Appx G)
Lockwashers (2) (item 98, Appx G)
Sealing compound (item 57, Appx D)
Tape (item 61, Appx D)

Equipment Conditions

Air intake grille opened (para 11-8)
Coolant system drained (TM 9-2350-311-10)
Engine exhaust grille removed (para 4-5)
Exhaust deflector removed (para 4-5)
Radiator fan access door removed (para 4-5)
Right front grille assembly removed (para 4-5)
Right transmission access door removed (para 11-7)

a. Removal

I WARNING I

Ensure engine and coolant system are cool enough to permit safe handling in order to prevent burns.

NOTE

If fan decals are illegible, damaged, or missing, see paragraph 2-7.

- 1 Loosen two clamps (1) and remove surge tank-to-radiator hose (2) and radiator-to-aeration detector hose (3).
- 2 Remove two screws (4), two lockwashers (5), two flat washers (6), and two resilient mounts (7). Discard lockwashers.
- 3 Loosen two clamps (8) from radiator outlet tube (9).
- 4 Loosen two vent hose clamps (10) and remove two radiator vent hoses (11).
- 5 Loosen two inlet hose clamps (12) and pull radiator inlet tube (13).

WARNING

Radiator weighs 88 lb (39.9 kg). Two personnel are required during removal.

6 Lift radiator (14) up and away from shroud (15).

7 Remove alternator (para 8-2).

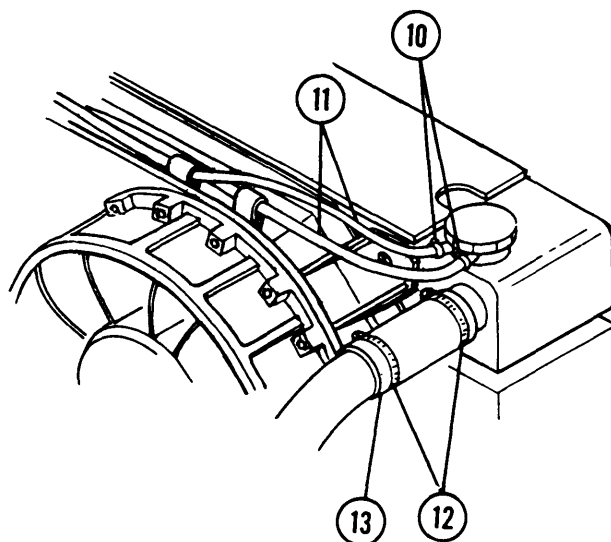
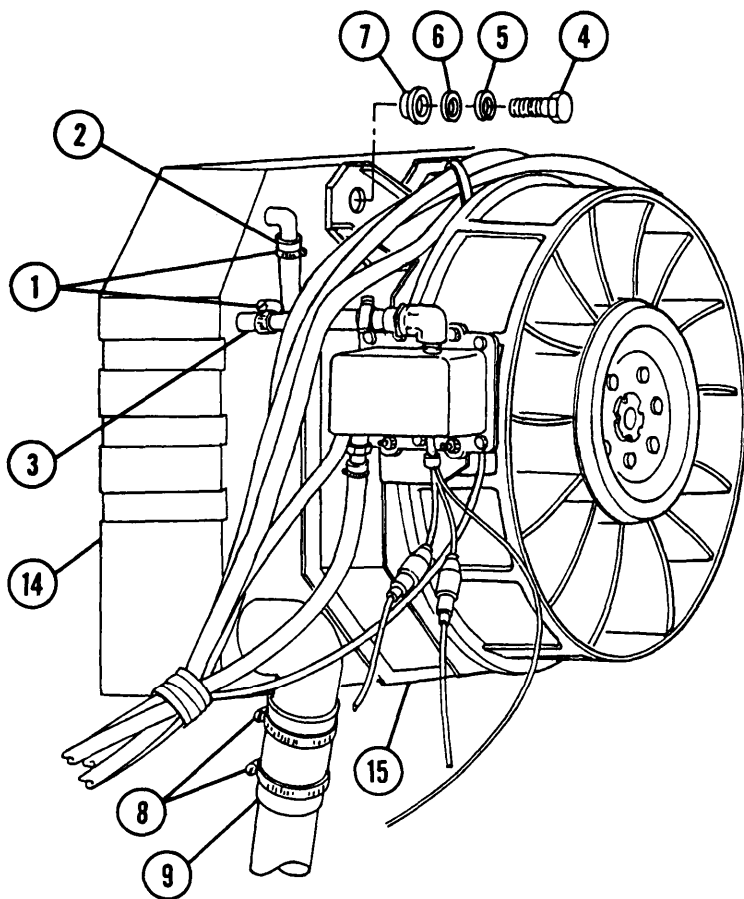

7-7 RADIATOR AND SHROUD (M109A3) — CONTINUED

a. Removal — Continued

- 8 Disconnect two electrical connectors (16) and ground lead (17).
- 9 Loosen clamp (18) and remove aeration detector-to-engine coolant main tube assembly hose (19).
- 10 Remove two screws (20), two lockwashers (21), two washers (22), and aeration detector bracket (23) with detector (24). Discard lockwashers.
- 11 Loosen clamp (25) and remove surge tank-to-pressure relief valve hose (26).
- 12 Remove eight screws (27), eight lockwashers (28), and eight flat washers (29) from bracket (30). Discard lockwashers.
- 13 Remove three screws (31), three lockwashers (32), three flat washers (33), and three clamps (34), releasing radiator vent hoses (11). Discard lockwashers.
- 14 Depress fan universals (35), lift shroud (15) up to permit removal of universals, then remove shroud with fans (36) attached.

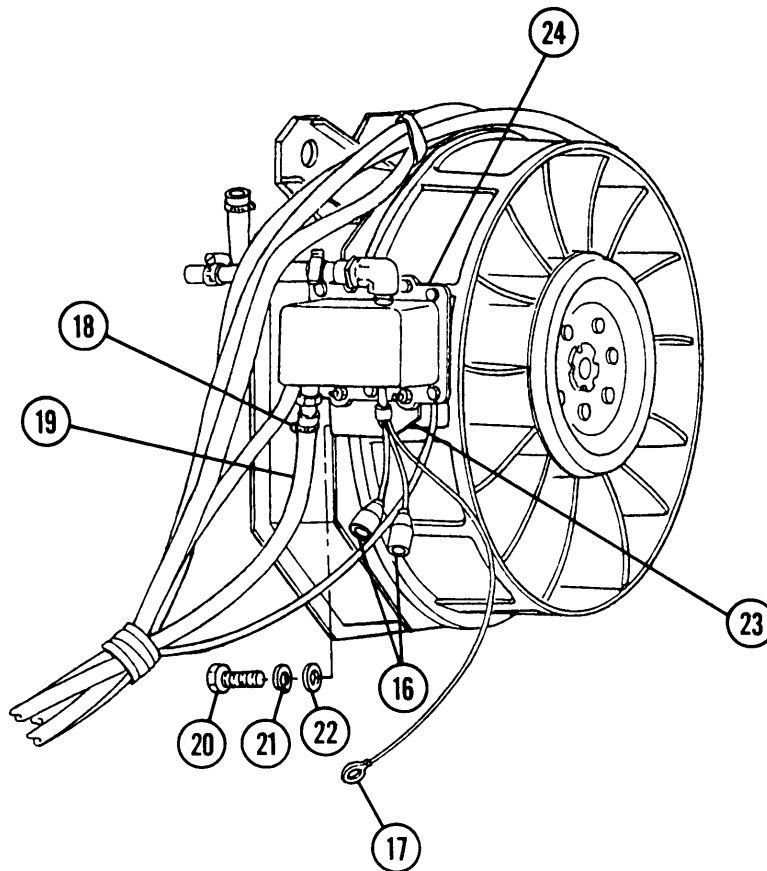

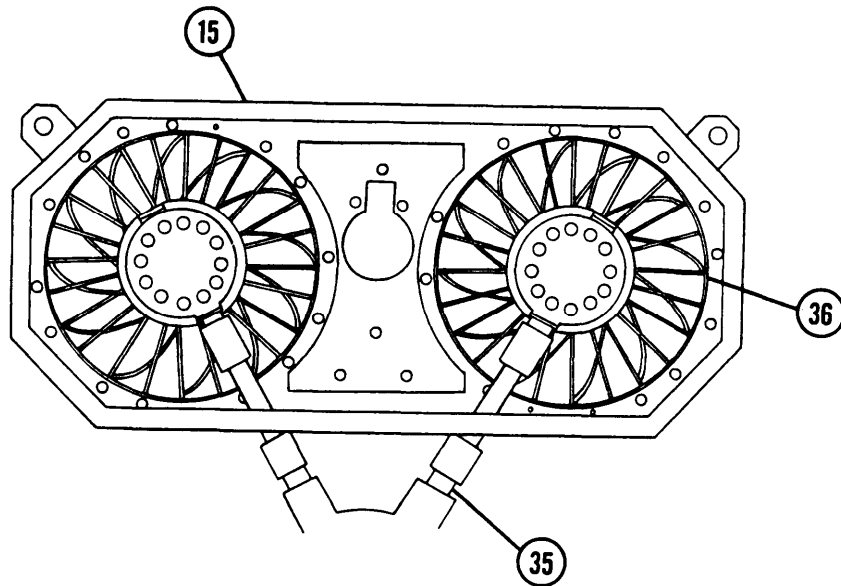
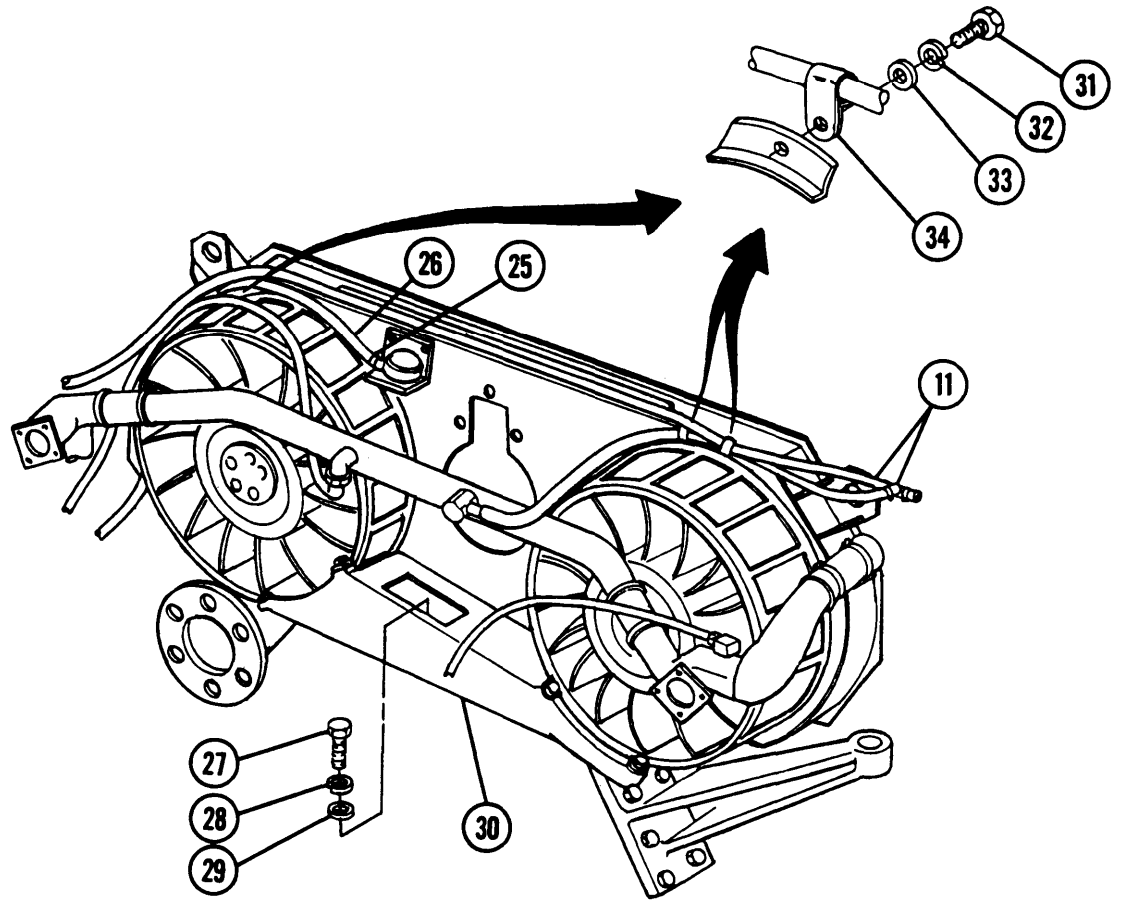

7-7 RADIATOR AND SHROUD (M109A3) — CONTINUED

a. Removal — Continued

- 15 Remove four screws (37), four lockwashers (38), four flat washers (39), and two brackets (40). Discard lockwashers.
- 16 Remove two bushings (41).
- 17 Remove eight screws (42) and cover (43).
- 18 Remove 36 retainers (44) and 4 seals (45 and 46).
- 19 Remove nine screws (47), nine lockwashers (48), nine washers (49), and rear radiator mount (50). Discard lockwashers.
- 20 Remove eight screws (51), eight lockwashers (52), eight washers (53), and front radiator mount (54). Discard lockwashers.
- 21 Remove radiator cap (55) and gasket (56). Discard gasket.

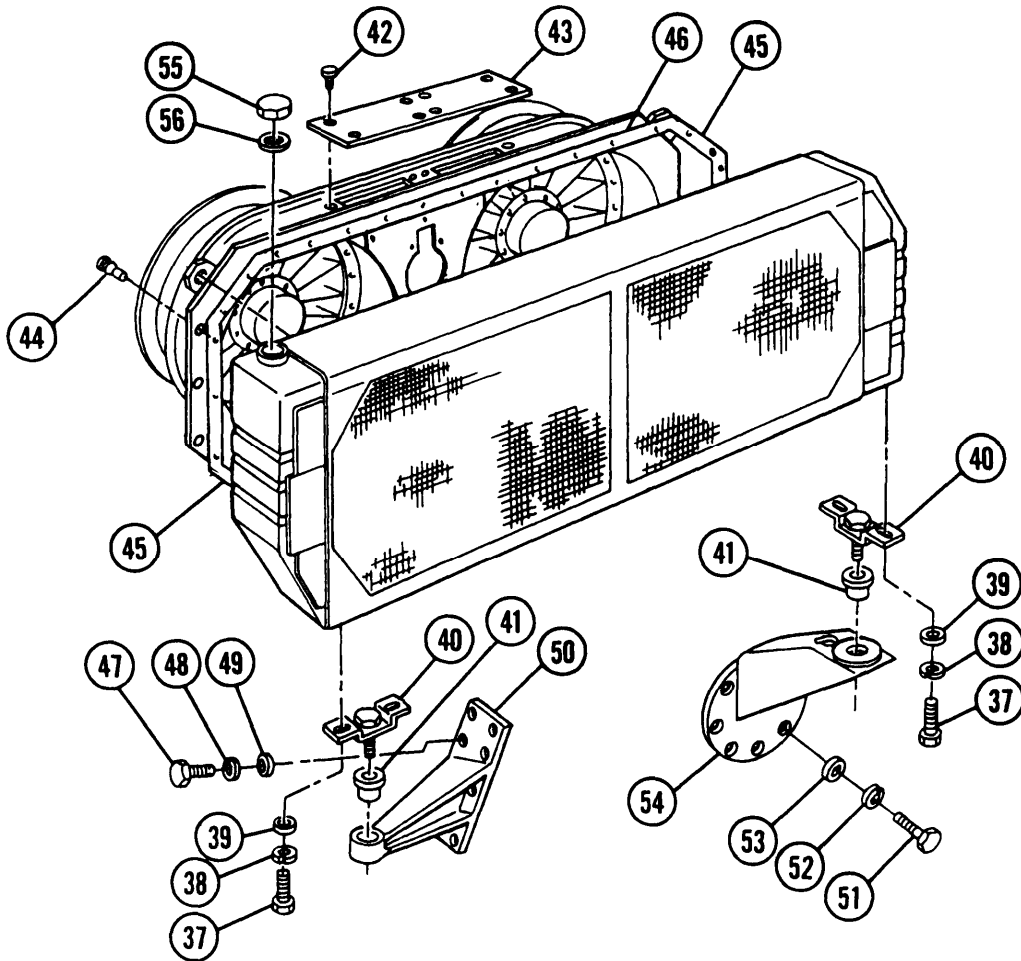

b. Installation**WARNING**

Ensure engine and coolant system are cool enough to permit handling in order to prevent burns.

- 1 Inspect oil level in fans (para 2-15.10).
- 2 Install front radiator mount (54), eight washers (53), eight new lockwashers (52), and eight screws (51).
- 3 Install rear radiator mount (50), nine washers (49), nine new lockwashers (48), and nine screws (47).
- 4 Install two bushings (41).
- 5 Install four seals (46 and 45).
- 6 Tape seals (45 and 46) with four complete wraparound with 0.5 in. (12.7 mm) overlap at eight seal joints.
- 7 Install 36 retainers (44), securing seals (45 and 46) to shroud (15).
- 8 Install cover (43) and eight screws (42).
- 9 Install two brackets (40), four flat washers (39), four new lockwashers (38), and four screws (37).
- 10 Install fan universals (35) and shroud (15) with fans (36) attached.

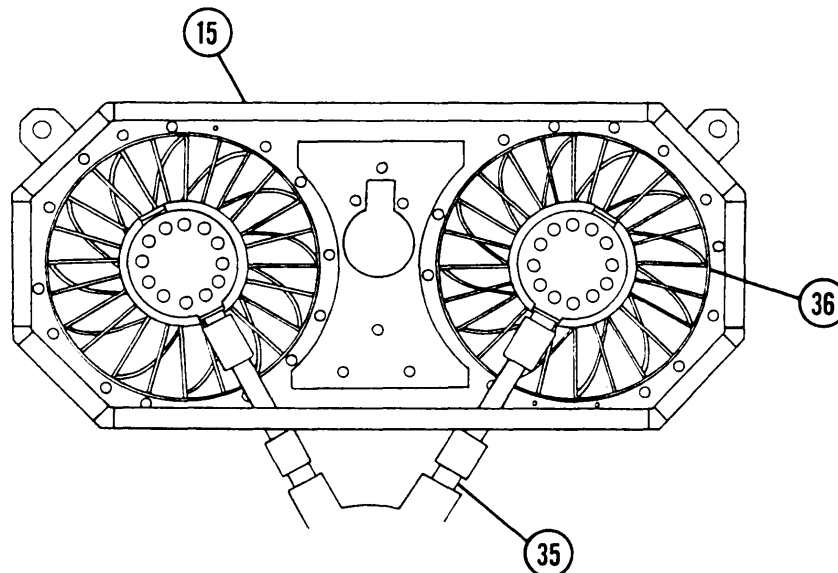

7-7 RADIATOR AND SHROUD (M109A3) — CONTINUED

b. Installation — Continued

- 11 Install bracket (30), eight flat washers (29), eight new lockwashers (28), and eight screws (27).
- 12 Install surge tank-to-pressure relief valve hose (26) and tighten clamp (25).
- 13 Install aeration detector bracket (23) with detector (24), two washers (22), two new lockwashers (21), and two screws (20).
- 14 Install aeration detector-to-engine coolant main tube assembly hose (19) and tighten clamp (18).
- 15 Install two electrical connectors (16) and ground (17).
- 16 Install alternator (para 8-2).

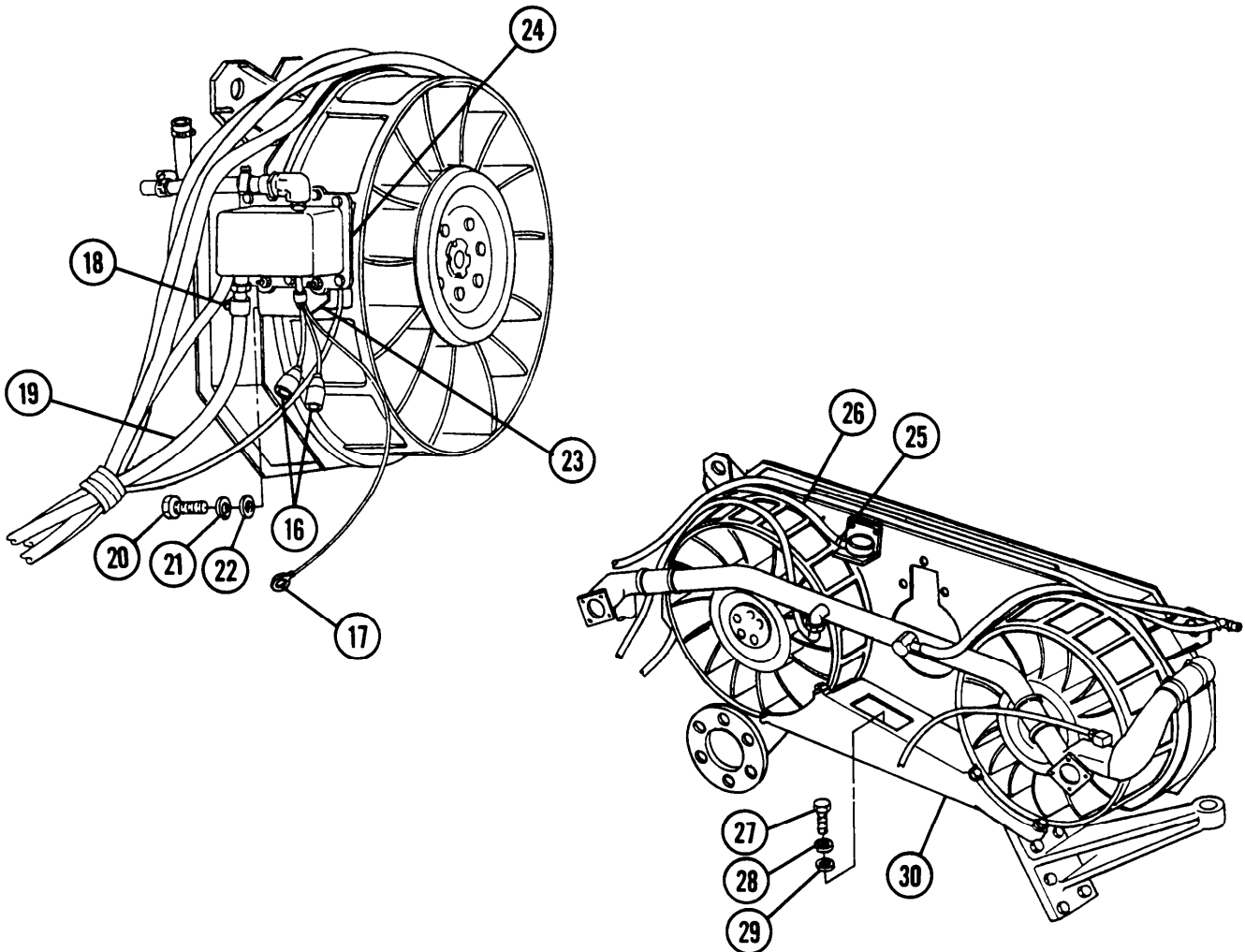

WARNING

- Radiator weighs 88 lb (39.9 kg). Two personnel are required during removal and installation.
- Adhesives are toxic and flammable. Apply adhesives only in a well-ventilated area. Avoid contact with skin, eyes, and clothes, and don't breath vapors. Do not use near heat, sparks, or open flame. Read and follow all warnings and instructions on labels of adhesives. If contact with skin or eyes is made, wash area with water and seek medical aid immediately.

- 17 Apply adhesive (item 3, Appx D) on radiator inlet tube (13). Install radiator (14) and radiator inlet tube and tighten two inlet hose clamps (12).
- 18 Apply adhesive (item 3, Appx D) to mating surface of two radiator vent hoses (11). Install vent hoses and tighten two clamps (10).
- 19 Apply adhesive (item 3, Appx D) to mating surface of radiator outlet tube (9). Connect radiator outlet tube (9) and tighten two clamps (8).
- 20 Install two resilient mounts (7), two flat washers (6), two new lockwashers (5), and two screws (4).
- 21 Apply adhesive (item 3, Appx D) to mating surfaces of surge tank-to-radiator hose (2) and radiator-to-aeration detector hose (3). Install two hoses and tighten two clamps (1).
- 22 Install three clamps (34), three flat washers (33), three new lockwashers (32), and three screws (31), securing radiator vent hoses (11).
- 23 Refill radiator with coolant (TM 9-2350-311-10).
- 24 Apply adhesive (item 5, Appx D) to new gasket (56) and install gasket on radiator cap (55).
- 25 Install cap (55) with new gasket (56) on radiator (14).

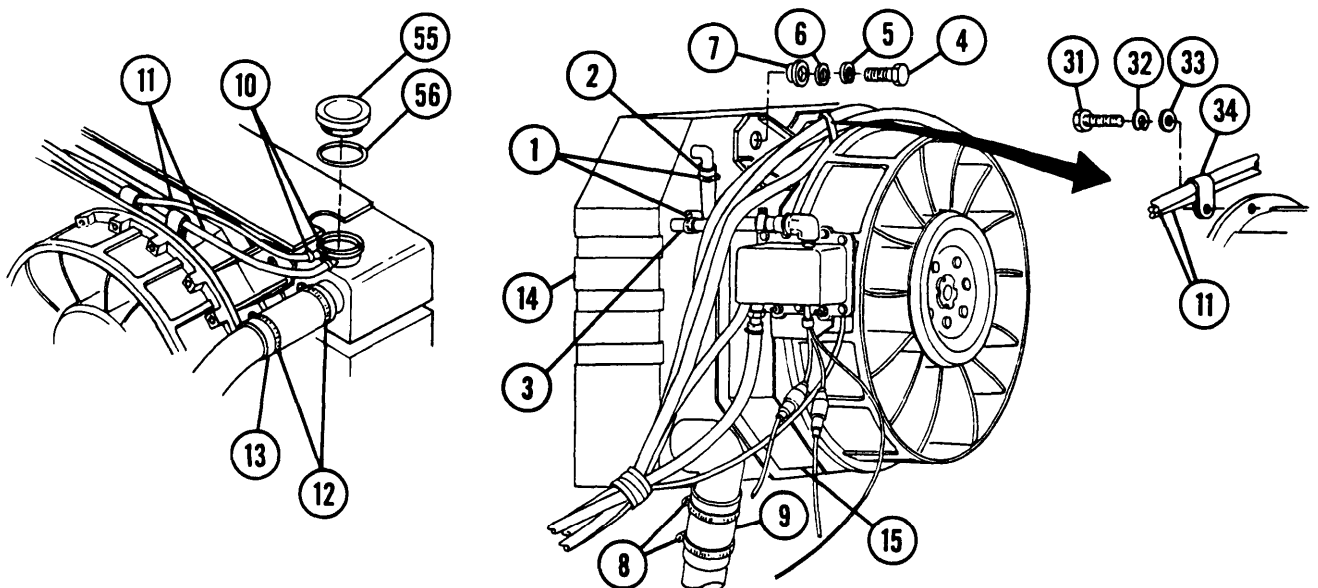

7-7 RADIATOR AND SHROUD (M109A3) — CONTINUED

c. Cleaning

WARNING

Ensure engine and coolant system are cool enough to permit handling in order to prevent burns.

- 1 Remove eight screws (42) and radiator shroud cover (43).
- 2 Open hull drains (TM 9-2350-311-10).
- 3 Cover all exposed openings of engine.

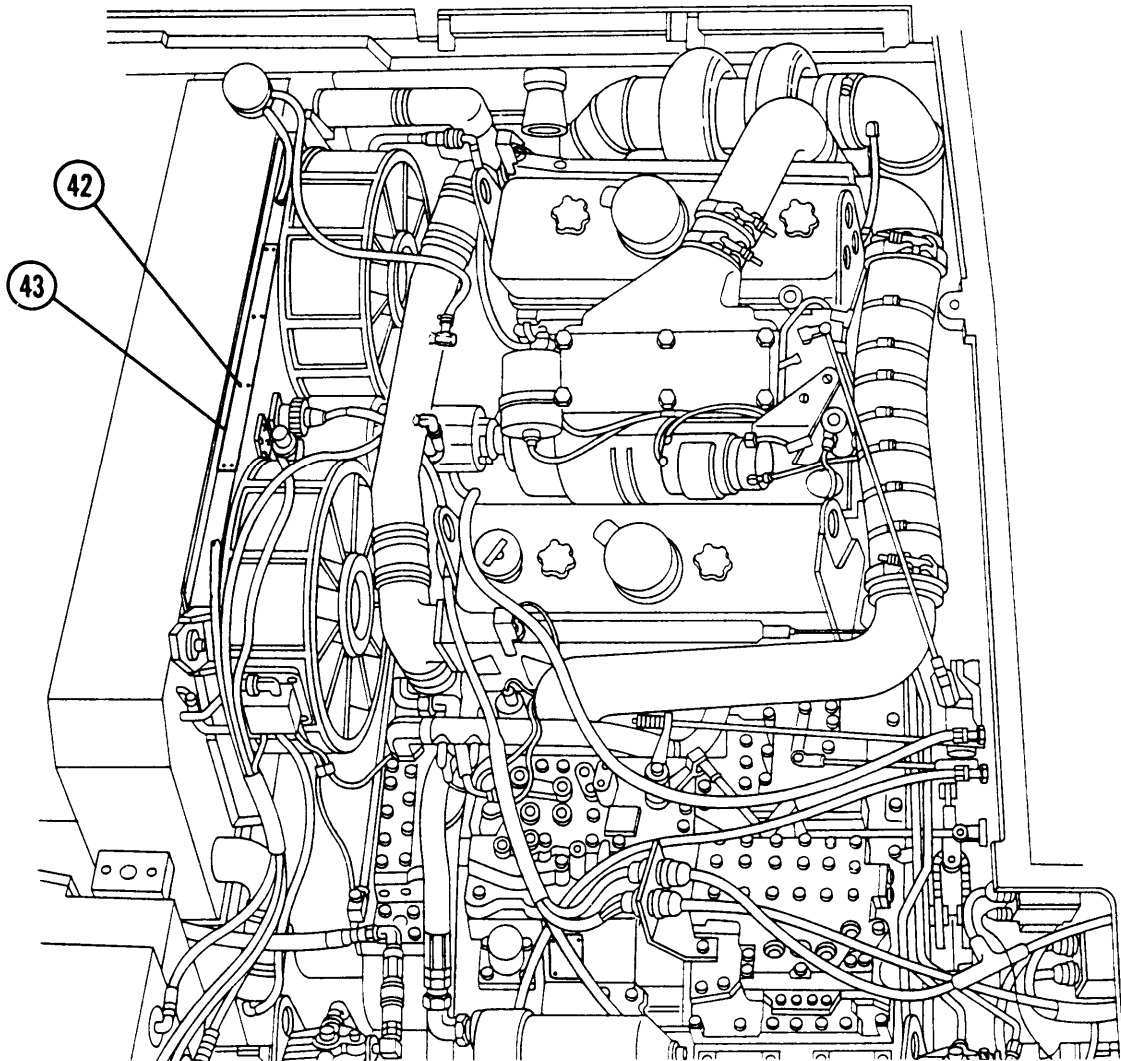

NOTE

The radiator cleaning tool is designed to remove deposits of sand, oil, clay, and other debris from the radiator cooling fins while installed in the vehicle. The cleaning agent may be a water solution of one part detergent to five parts water, or nontoxic, nonflammable solvent and water. A solution of detergent and water is recommended.

- 4 Connect radiator cleaning tool to air supply and insert hose in container of solution.
- 5 Insert cleaning tool through shroud cover opening (57). Saturate front and back of radiator with solution. Soak for approximately 10 minutes.
- 6 Remove heavy deposits from face of radiator by brushing with medium stiff brush that will not damage fins.
- 7 Blast radiator exterior with air/liquid mixture, holding head of tool approximately 0.5 in. (12.7 mm) from face of radiator. Alternate from back to front until good flow of liquid over radiator fins is observed over entire area.
- 8 Wash engine parts and exterior of radiator with clean water. Remove hose from container and use air to complete task.
- 9 Uncover engine openings. Install radiator shroud cover (43) with eight screws (42). Close hull drains.

NOTE

If overheating still occurs, notify support maintenance.

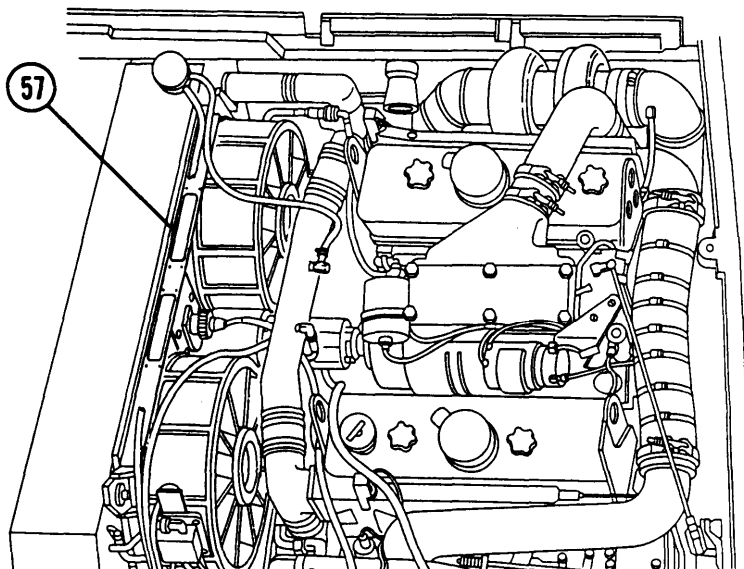
**NOTE****FOLLOW-ON MAINTENANCE:**

- Install engine exhaust grille (para 4-5)
- Install exhaust deflector (para 4-5)
- Install radiator fan access door (para 4-5)
- Install right front grille assembly (para 4-5)
- Install right transmission access door (para 11-7)
- Close air intake grille (para 11 -8)

7-8 INLET THERMOSTATS AND HOUSING ASSEMBLY

This task covers: a. Removal b. Installation

INITIAL SETUP

Tools

General mechanic's tool kit (item 64, Appx H)
Handle (item 27, Appx H)
Installer (item 31, Appx H)
Socket adapter (item 2, Appx H)
Socket set (item 55, Appx H)
Torque wrench (item 73, Appx H)

Gasket (item 129, Appx G)
Gasket (item 131, Appx G)
Lockwashers (10) (item 88, Appx G)
Sealing compound (item 57, Appx D)
Seals (2) (item 132, Appx G)

Equipment Conditions

Coolant system drained (TM 9-2350-311-10)

Materials/Parts

Adhesive (item 3, Appx D)

a. Removal

WARNING

Ensure engine and coolant system are cool enough to permit safe handling in order to prevent burns.

- 1 Loosen two clamps (1).
- 2 Remove housing-to-radiator tube (2).
- 3 Remove six screws (3), six lockwashers (4), and six washers (5). Discard lockwashers.
- 4 Remove inlet housing (6) and gasket (7). Discard gasket.
- 5 Remove two thermostats (8) and two seals (9) by pulling outward. Discard seals.
- 6 Remove three screws (10) and three lockwashers (11) at engine coolant manifold (12). Remove protective cover (13) if present. Discard lockwashers.
- 7 Remove nut (14), lockwasher (15), and stud (16). Discard lockwasher.
- 8 Loosen two clamps (17).
- 9 Remove manifold connector (18) and gasket (19). Discard gasket.

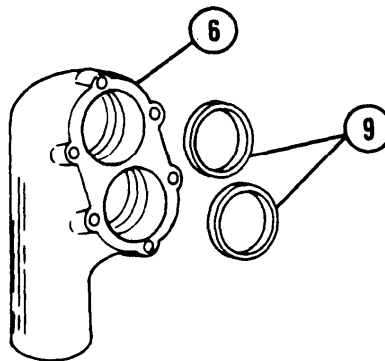
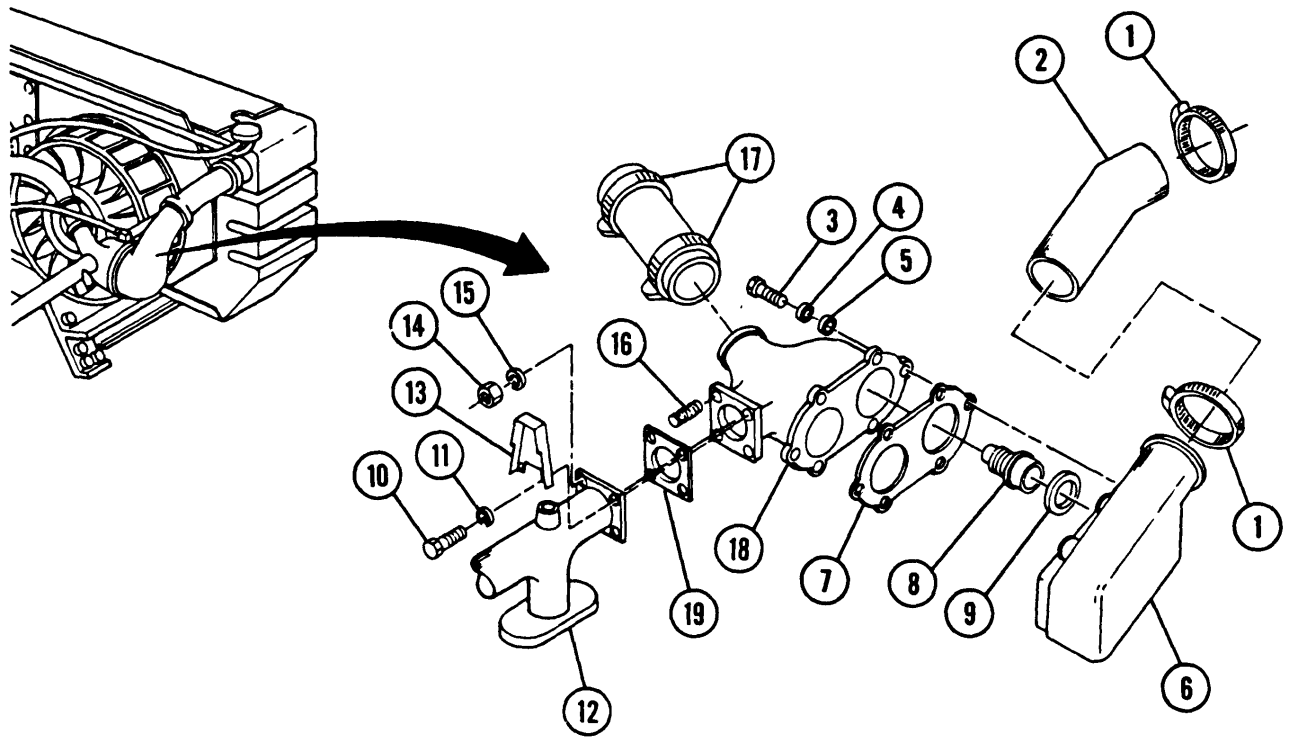

7-8 INLET THERMOSTATS AND HOUSING ASSEMBLY — CONTINUED

b. Installation

WARNING

- Ensure engine and coolant system are cool enough to permit safe handling in order to prevent burns.
- Adhesives are toxic and flammable. Apply adhesives only in a well-ventilated area. Avoid contact with skin, eyes, and clothes, and don't breath vapors. Do not use near heat, sparks, or open flame. Read and follow all warnings and instructions on labels of adhesives. If contact with skin or eyes is made, wash area with water and seek medical aid immediately.

- 1 Apply adhesive to mating surface of manifold coolant connector (18) and crossover tube (20).
- 2 Install new gasket (19) and manifold coolant connector (18). Tighten two clamps (17).
- 3 Apply sealing compound to stud (16) and install in manifold connector (18). Install new lockwasher (15) and nut (14).
- 4 Install protective cover (13), three new lockwashers (11), and three screws (10) on engine coolant manifold (12).
- 5 Install two new seals (9) into inlet housing (6) with leather facing outward using installer and handle.
- 6 Install two thermostats (8).
- 7 Install new gasket (7) and inlet housing (6) on manifold coolant connector (1 8).
- 8 Install six washers (5), six new lockwashers (4), and six screws (3).
- 9 Apply adhesive to mating surface of housing-to-radiator tube (2). Install tube.
- 10 Tighten two clamps (1).

NOTE

Engine must first be warmed up and then run for a minimum period of 5 minutes. Shut engine down before all hose clamps are retightened (para 4-5).

- 11 Torque two clamps (1) to 40-60 lb-in. (4.5-6.8 N-m).

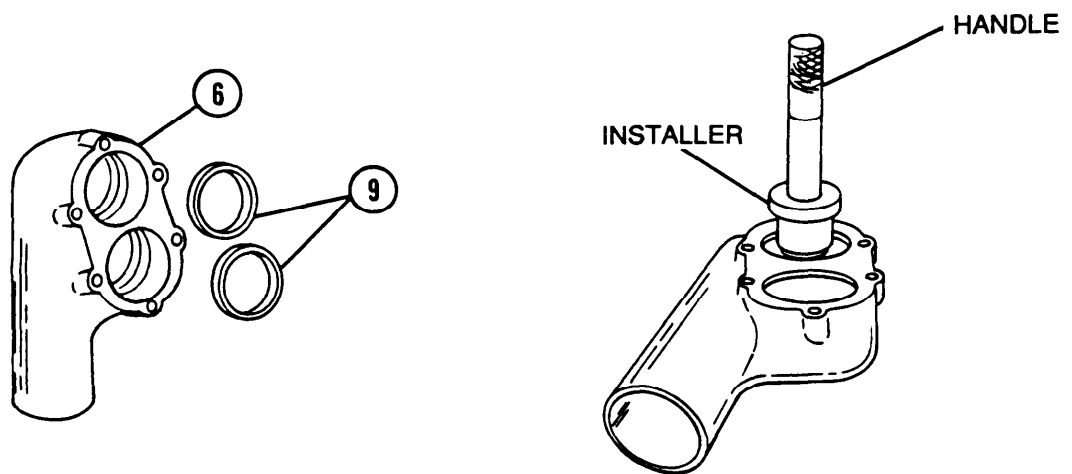
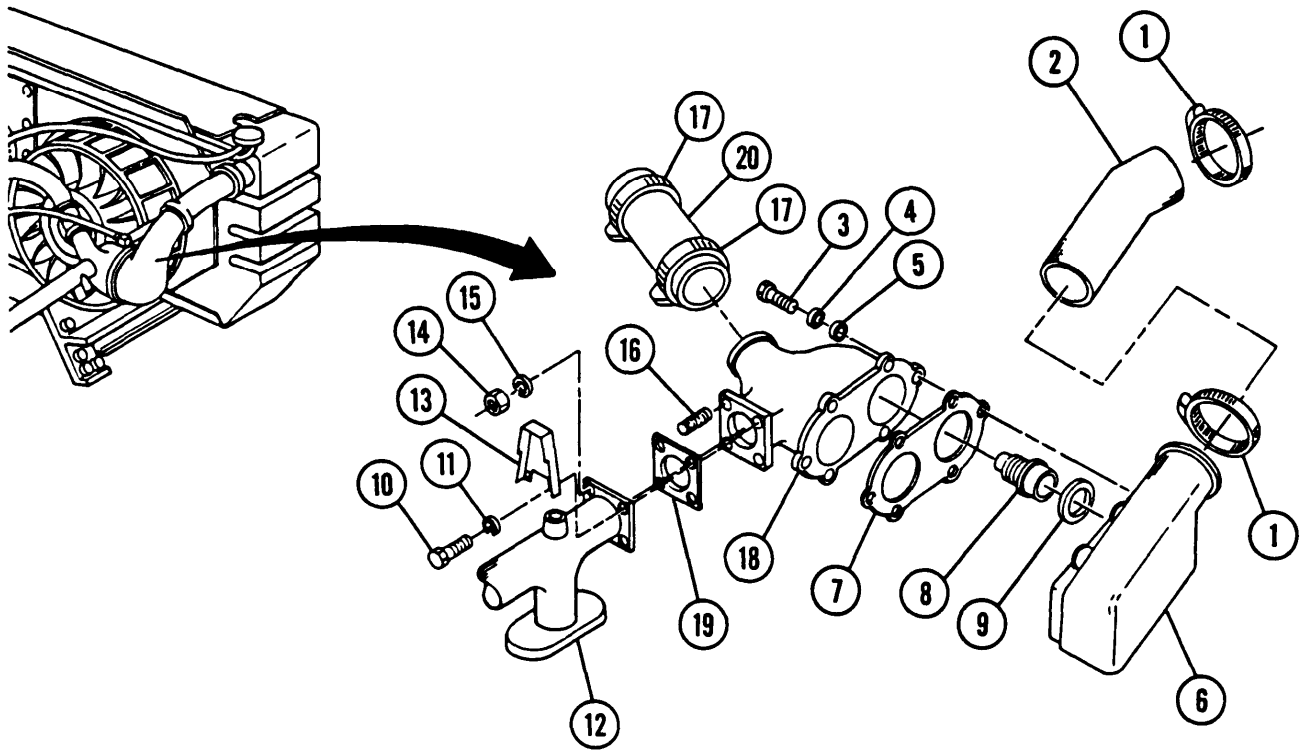

NOTE

FOLLOW-ON MAINTENANCE: Fill coolant system (TM 9-2350-311-10)

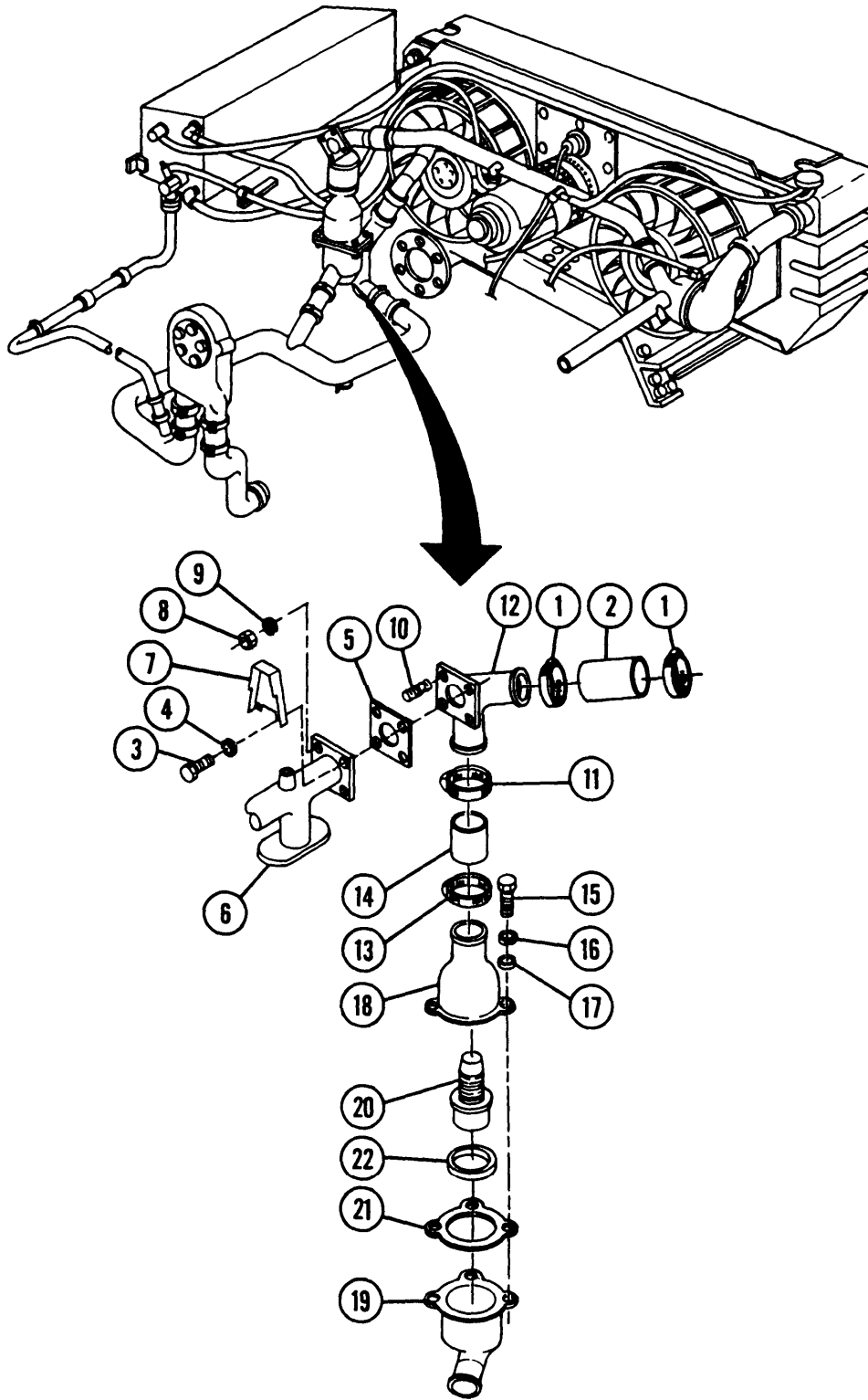

7-9 BYPASS THERMOSTAT AND HOUSING ASSEMBLY — CONTINUED

b. Installation

|| WARNING ||

Ensure engine and coolant system are cool enough to permit safe handling in order to prevent burns.

- 1 Install new seal (22) in lower housing (19) using installer and handle.
- 2 Install new gasket (21) and new thermostat (20) in lower housing (19).
- 3 Install upper housing (18), three flat washers (17), three new lockwashers (16), and three screws (15).
- 4 Apply adhesive on mating surfaces of coolant hose (14) and upper housing (18). Install hose and housing.
- 5 Tighten lower clamp (13).

WARNING

Adhesives are toxic and flammable. Apply adhesives only in a well-ventilated area. Avoid contact with skin, eyes, and clothes, and don't breath vapors. Do not use near heat, sparks, or open flame. Read and follow all warnings and instructions on labels of adhesives. If contact with skin or eyes is made, wash area with water and seek medical aid immediately.

- 6 Apply adhesive on mating surfaces of coolant hose (14) and manifold connector (12).
- 7 Tighten upper clamp (11).
- 8 Apply sealing compound to stud (10). Install stud, new lockwasher (9), and nut (8).
- 9 Install protective cover (7), new gasket (5), three new lockwashers (4), and three screws (3).
- 10 Apply adhesive to mating surfaces of crossover tube connector (2).
- 11 Install crossover tube connector (2) and tighten two clamps (1).

NOTE

Engine must first be warmed up and then run for a minimum period of 5 minutes. Shut engine down before all hose clamps are retightened (para 4-5).

- 12 Torque clamps (13, 11, and 1) to 40-60 lb-in. (4.5-6.8 N-m).

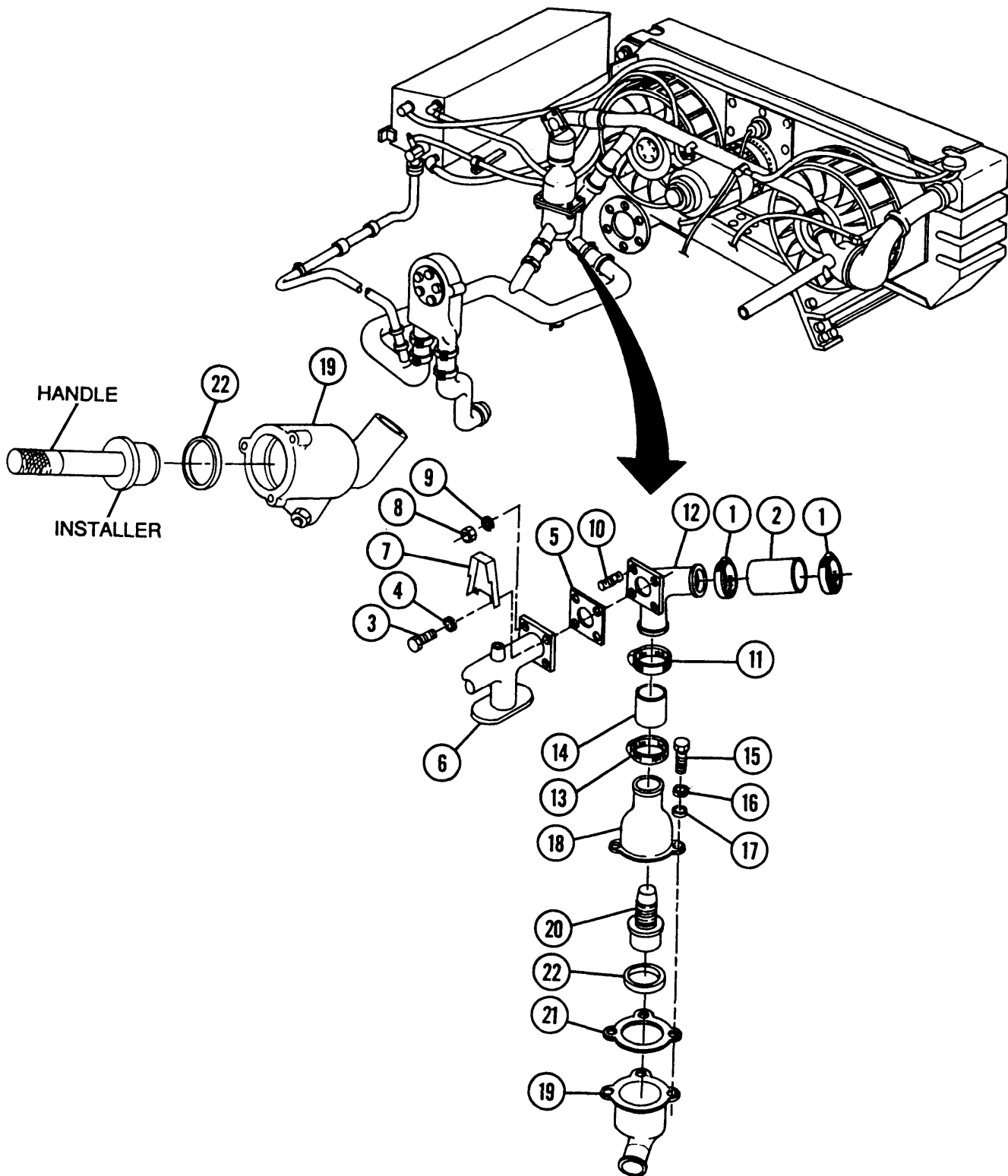

NOTE

FOLLOW-ON MAINTENANCE: Fill coolant system (TM 9-2350-311-10)

CHAPTER 8 ELECTRICAL SYSTEMS

GENERAL

This chapter provides instructions for removal and installation of the powerplant and hull electrical systems and components. Procedures are also included for disassembly, assembly, checks, and adjustments of electrical components, as authorized by the Maintenance Allocation Chart (MAC) for unit level maintenance.

<u>CONTENTS</u>	<u>PAGE</u>
Section I	POWERPLANT ELECTRICAL SYSTEMS 8-4
8-1	POWERPLANT ELECTRICAL SYSTEM DIAGRAMS 8-4
8-2	ALTERNATOR 8-6
8-3	VOLTAGE REGULATOR 8-10
8-4	RECTIFIER (M109A2/M109A3) 8-11
8-5	RECTIFIER (M109A4/M109A5)... 8-13
8-6	ENGINE COOLANT TEMPERATURE TRANSMITTER AND PROTECTIVE COVER 8-15
8-7	ENGINE COOLANT HIGH TEMPERATURE SWITCH AND PROTECTIVE COVER 8-17
8-8	ENGINE OIL PRESSURE TRANSMITTER 8-19
8-9	ENGINE OIL LOW PRESSURE SWITCH. 8-21
8-10	AIR CLEANER BLOWER MOTOR SWITCH 8-23
8-11	TRANSMISSION OIL TEMPERATURE Transmitter AND TRANSMISSION OIL HIGH TEMPERATURE SWITCH PROTECTIVE COVER (M109A4/M109A5). 8-24
8-12	TRANSMISSION OIL TEMPERATURE TRANSMITTER AND TRANSMISSION OIL HIGH TEMPERATURE SWITCH 8-25
8-13	TRANSMISSION OIL PRESSURE TRANSMITTER AND TRANSMISSION OIL LOW PRESSURE SWITCH 8-27
8-14	STARTER MOTOR 8-29
8-15	NEUTRAL SAFETY SWITCH 8-30
8-16	AERATION DETECTOR..... 8-32
Section II	HULL ELECTRICAL SYSTEMS 8-34
8-17	PORTABLE AND DRIVER'S INSTRUMENT PANELS. 8-34
8-18	DRIVER'S INSTRUMENT PANEL SUPPORT ASSEMBLY 8-48
8-19	PORTABLE INSTRUMENT PANEL COVER AND BRACKET ASSEMBLIES 8-49
8-20	ACCESSORY CONTROL BOX... 8-51
8-21	HEADLIGHTS 8-57
8-22	HEADLIGHT SEALED-BEAM AND INCANDESCENT LAMPS 8-59
8-23	HEADLIGHT ASSEMBLY GROUP. 8-61
8-24	HEADLIGHT MOUNT, 8-64
8-25	SERVICE AND B.O. TAILLIGHTS, STOP LIGHTS, AND LAMPS 8-66
8-26	TELEPHONE TERMINAL 8-70
8-27	DOME LIGHT 8-71
8-28	BATTERIES 8-76
8-29	MASTER RELAY BOX 8-80
8-30	BILGE PUMP RELAY 8-81
8-31	STARTER RELAY BOX 8-83
8-32	BILGE PUMP CIRCUIT BREAKER. 8-84
8-33	CIRCUIT BREAKERS (M109A2/M109A3) 8-86
8-34	CIRCUIT BREAKERS (M109A4/M109A5) 8-88
8-35	IN-TANK FUEL PUMPS AND GENERATOR SYSTEM RELAY. , 8-90
8-36	AIR CLEANER BLOWER RELAY AND AIR CLEANER BLOWER MOTORS 8-91

<u>CONTENTS</u>		<u>PAGE</u>
8-37	HEADLIGHT DIMMER AND STOP LIGHT SWITCHES	8-93
8-38	SLAVE START RECEPTACLE	8-95
8-39	EXTERNAL POWER RECEPTACLE (M109A4/M109A5).	8-96
8-40	COMBAT OVERRIDE SWITCH ASSEMBLY (M109A4/M109A5).	8-98
Section III	POWERPLANT AND HULL WIRING HARNESES.	8-100
8-41	CIRCUIT ID AND ILLUSTRATION OF ELECTRICAL WIRING HARNESES (M109A2/M109A3) ..	8-100
8-42	CIRCUIT ID AND ILLUSTRATION OF ELECTRICAL WIRING HARNESES (M109A4/M109A5) ..	8-102
8-43	POWERPLANT WIRING HARNESS (M109A/M109A3)	8-104
8-44	POWERPLANT WIRING HARNESS (M109A4/M109A5)	8-108
8-45	ENGINE DISCONNECT BRACKET-TO-BULKHEAD WIRING HARNESS (M109A/M109A3)	8-114
8-46	DRIVER'S BULKHEAD-TO-MASTER RELAY WIRING HARNESS (M109A4/M109A5)	8-116
8-47	BULKHEAD-TO-HEADLIGHT/BILGE PUMP WIRING HARNESS	8-118
8-48	HEADLIGHT WIRING HARNESS	8-121
8-49	BULKHEAD-TO-PORTABLE INSTRUMENT PANEL WIRING HARNESS.	8-122
8-50	BULKHEAD-TO-DRIVER'S INSTRUMENT PANEL WIRING HARNESS	8-125
8-51	DRIVER'S INSTRUMENT PANEL WIRING HARNESS	8-128
8-52	ACCESSORY CONTROL BOX-TO-HEATER/BLOWER WIRING HARNESS	8-132
8-53	ACCESSORY CONTROL BOX WIRING HARNESS	8-136
8-54	POWER LEAD WIRING HARNESS (M109A2).	8-137
8-55	POWER LEAD (M109A2/M109A3)	8-139
8-56	POWER LEAD (M109A4/M109A5)	8-141
8-57	PORTABLE INSTRUMENT PANEL WIRING HARNESS	8-143
8-58	INTERCOM/TELEPHONE WIRING HARNESS AND SLIP RING TELEPHONE FEED WIRING HARNESS	8-148
8-59	RECTIFIER-TO-VOLTAGE REGULATOR WIRING HARNESS (M109A2/M109A3)	8-154
8-60	RECTIFIER-TO-VOLTAGE REGULATOR WIRING HARNESS (M109A4/M109A5)	8-156
8-61	DIODE WIRING HARNESS (M109A4/M109A5).	8-158
8-62	VENTILATED FACE PIECE SYSTEM POWER WIRING HARNESS (M109A4/M109A5)	8-160
8-63	NATO SLAVE START-TO-EXTERNAL POWER WIRING HARNESS (M109A4/M109A5)	8-163
Section IV	POWERPLANT AND HULL ELECTRICAL LEADS.	8-166
8-64	ACCESSORY CONTROL BOX INDICATOR LIGHT GROUND LEAD.	8-166
8-65	ACCESSORY CONTROL BOX HEAT SELECTOR SWITCH-TO-CIRCUIT BREAKER LEAD	8-168
8-66	ACCESSORY CONTROL BOX VENTILATOR BLOWER SWITCH-TO-CIRCUIT BREAKER LEAD	8-169
8-67	ACCESSORY CONTRL BOX VENTILATOR BLOWER SWITCH LEAD	8-171
8-68	ACCESSORY CONTROL BOX POWER LEAD	8-173
8-69	LOW COOLANT INDICATOR LIGHT ASSEMBLY.	8-175
8-70	FLAME HEATER SWITCH LEAD	8-177
8-71	CIRCUIT BREAKER TO "Y" CONNECTOR LEAD	8-178
8-72	AIR CLEANER BLOWER LEAD ASSEMBLY.	8-180
8-73	IN-TANK FUEL PUMP LEAD ASSEMBLY	8-182
8-74	FUEL PUMP CIRCUIT BREAKER LEAD ASSEMBLY	8-184
8-75	FUEL PUMP SWITCH-TO-CIRCUIT BREAKER LEAD ASSEMBLY	8-185
8-76	CIRCUIT BREAKER-TO-"Y" CONNECTOR LEAD.	8-186
8-77	GLOW PLUG WAIT LIGHT-TO-BULKHEAD TO PORTABLE INSTRUMENT PANEL WIRING HARNESS LEAD	8-188
8-78	MASTER WARNING LIGHT ASSEMBLY (STEERING SHAFT).	8-189
8-79	PARKING BRAKE LIGHT SWITCH ASSEMBLY	8-191
8-80	BATTERY TERMINAL CONNECTOR AND GROUND CABLES	8-193
8-81	ENGINE BRACKET-TO-DRIVER'S BULKHEAD LEAD ASSEMBLY (M109A/M109A3)	8-194
8-82	MASTER RELAY-TO-DRIVER'S BULKHEAD LEAD ASSEMBLY (M109A4/M109A5)	8-196
8-83	ENGINE ELECTRICAL GROUND LEAD (M109A4/M109A5).	8-198
8-84	STARTER-TO-ENGINE ELECTRICAL DISCONNECT (M109A4/M109A5)	8-199

CONTENTS

PAGE

8-85	NBC SWITCH-TO-CIRCUIT BREAKER LEAD ASSEMBLY (M109A4/M109A5)	8-202
8-86	DRIVER'S BULKHEAD-TO-BATTERIES LEAD ASSEMBLY (M109A4/M109A5)	8-204
8-87	ENGINE DISCONNECT BRACKET-TO-BATTERIES LEAD ASSEMBLY (M109A4/M109A5)	8-206
8-88	BULKHEAD-TO-OVERRIDE SWITCH LEAD ASSEMBLY (M109A4/M109A5)	8-208
8-89	COMBAT OVERRIDE SWITCH GROUND LEAD (M109A4/M109A5)	8-210

WIRING HARNESS NO.	NOMENCLATURE	PARAGRAPH NO.	WIRING HARNESS NO.	NOMENCLATURE	PARAGRAPH NO.
MS35915-10	ENGINE ELECTRICAL GROUND LEAD	8-83	12268100	ENGINE DISCONNECT BRACKET-TO-	
10897989	SLIP RING TELEPHONE FEED WIRING HARNESS	8-58	12268102	BULK HEAD WIRING HARNESS	8-45
10897993	GROUND CABLES	8-80	12268104	POWERPLANT WIRING HARNESS	8-43
10921380	BULKHEAD-TO-HEADLIGHTS/BILGE PUMP WIRING HARNESS	8-47	12268224	DRIVER'S INSTRUMENT PANEL WIRING HARNESS	8-51
10922337	MASTER WARNING LIGHT ASSEMBLY	8-78	12268303	FLAME HEATER SWITCH LEAD	8-70
10925417	ACCESSORY CONTROL BOX WIRING HARNESS	8-53	12268304	RECTIFIER-TO-VOLTAGE REGULATOR WIRING HARNESS	8-60
10925418	ACCESSORY CONTROL BOX POWER LEAD	8-68	12268308	POWER LEAD	8-56
10925419	ACCESSORY CONTROL BOX INDICATOR LIGHT GROUND LEAD	8-64	12268348	POWERPLANT WIRING HARNESS	8-44
10925421	ACCESSORY CONTROL BOX VENTILATOR BLOWER SWITCH LEAD	8-67	12268417	CIRCUIT BREAKER-TO-"Y"	
10925829	ACCESSORY CONTROL BOX-TO- HEATER/BLOWER WIRING HARNESS	8-52	12268418	CONNECTOR LEAD	8-76
10930337-1	ACCESSORY CONTROL BOX HEAT SELECTOR SWITCH-TO-CIRCUIT BREAKER LEAD	8-65	12268419	DIODE WIRING HARNESS	8-61
10930337-2	ACCESSORY CONTROL BOX VENTILATOR BLOWER SWITCH-TO- CIRCUIT BREAKER LEAD	8-66	12352790	DRIVER'S BULKHEAD-TO-MASTER RELAY WIRING HARNESS	8-46
10930467	PARKING BRAKE LIGHT SWITCH ASSEMBLY	8-79	12353072	BULKHEAD-TO-OVERRIDE SWITCH LEAD ASSEMBLY	8-88
10942317	INTERCOM/TELEPHONE WIRING HARNESS	8-58	12353074	NBC SWITCH-TO-CIRCUIT BREAKER LEAD ASSEMBLY	6-85
11593782	ENGINE BRACKET-TO-DRIVER'S BULKHEAD LEAD ASSEMBLY	8-81	12353072	STARTER-TO-ENGINE ELECTRICAL DISCONNECT	8-84
11593784	POWER LEAD WIRING HARNESS	8-54	12353259	COMBAT OVERRIDE SWITCH GROUND LEAD	8-90
11593806	RECTIFIER-TO-VOLTAGE REGULATOR WIRING HARNESS	8-59	12353400	AIR CLEANER BLOWER LEAD ASSEMBLY	8-72
11594268	BULKHEAD-TO-DRIVER'S INSTRUMENT PANEL WIRING HARNESS	8-50	12353401	NATO SLAVE START-TO-EXTERNAL POWER WIRING HARNESS	8-63
1162358-2	FUEL PUMP SWITCH TO CIRCUIT BREAKER LEAD ASSEMBLY	8-75	12353401	ENGINE DISCONNECT BRACKET-TO- BATTERIES LEAD ASSEMBLY	8-87
11682358-1	FUEL PUMP CIRCUIT BREAKER LEAD ASSEMBLY	8-74	12353402	DRIVER'S BULKHEAD-TO-BATTERIES LEAD ASSEMBLY	8-86
12260266	POWER LEAD	8-55	12353403	MASTER RELAY-TO-DRIVER'S BULKHEAD LEAD ASSEMBLY	8-82
12260287	BULKHEAD-TO-PORTABLE INSTRUMENT PANEL WIRING HARNESS	8-49	12353646	IN-TANK FUEL PUMP LEAD ASSEMBLY	8-73
12260297	LOW COOLANT INDICATOR LIGHT ASSEMBLY	8-69	12353647	CIRCUIT BREAKER TO "Y" CONNECTOR LEAD	8-71
12260298	PORTABLE INSTRUMENT PANEL WIRING HARNESS	8-57	12353794	VENTILATED FACE PIECE SYSTEM POWER WIRING HARNESS	8-62
			12389711	GLOW PLUG WAIT LIGHT-TO- BULKHEAD TO PORTABLE INSTRUMENT PANEL WIRING HARNESS	8-77
			8744300	HEADLIGHT WIRING HARNESS	8-48

SECTION 1. POWERPLANT ELECTRICAL SYSTEMS

8-1 POWERPLANT ELECTRICAL SYSTEM DIAGRAMS

NOTE

M109A2/M109A3 powerplant electrical system is pictured here. For M109A4/M109A5 powerplant electrical system, see paragraph 8-44.

Connector No.	Electrical Lead To:	Wire No.	Connector No.	Electrical Lead To:	Wire No.
1	Aeration detector	352A	11	Air cleaner blower motor switch	415
2	Aeration detector	3526	12	Engine oil pressure transmitter	36
3	Transmission oil temperature transmitter	324	13	Starter motor solenoid from master relay	82
4	Transmission oil high temperature switch	509D	14	Flame heater ignition coil	486
5	Transmission oil low pressure switch	509C	15	Flame heater air pump	486
6	Transmission oil pressure transmitter	321	16	Flame heater solenoid	486A
7	Engine coolant high temperature	509A	17	Fuel prime pump	588
8	Engine coolant temperature transmitter	33A	18	Master circuit harness	12268102
9	Starter motor solenoid from starter relay	146	19	Starter cable connector	82
10	Engine oil low pressure switch	5096			

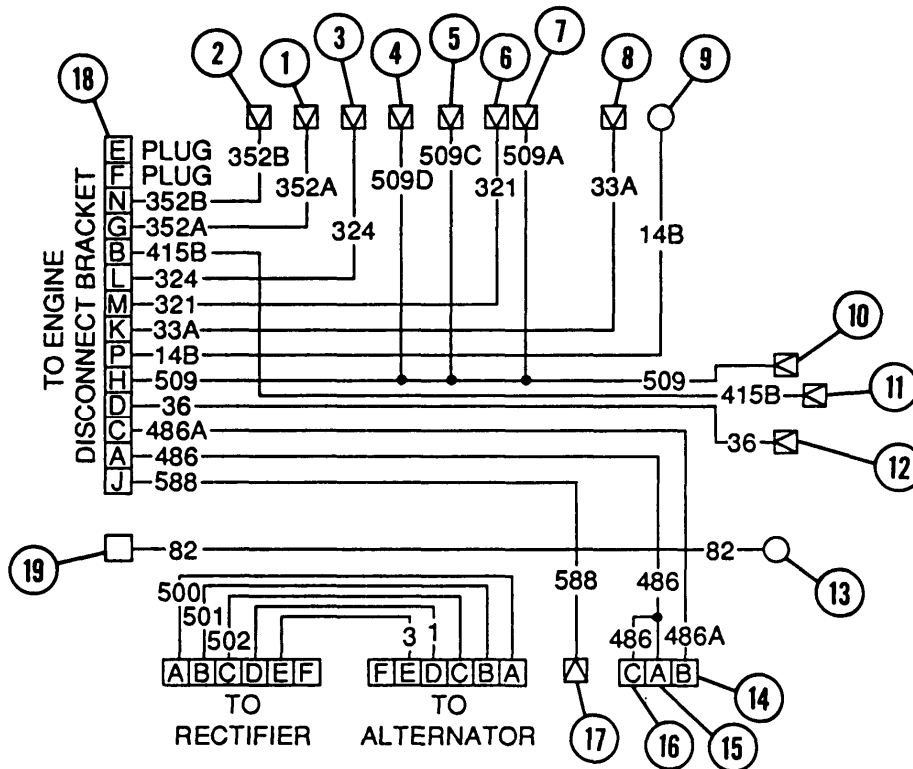

WIRING DIAGRAM

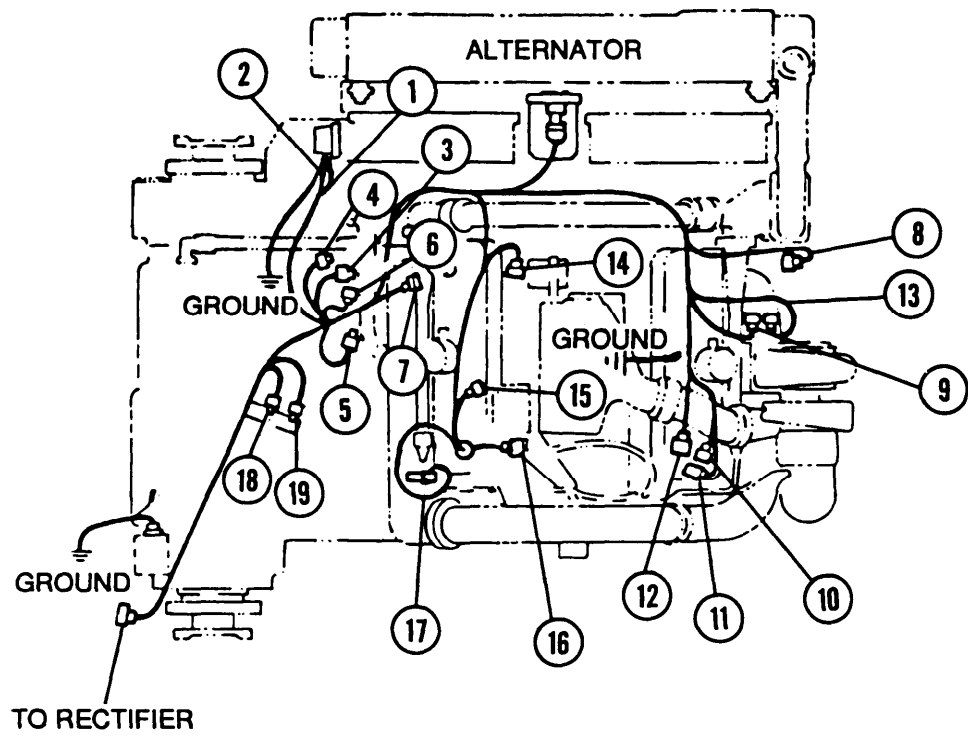

8-2 ALTERNATOR

This task covers: a. Removal b. Installation

INITIAL SETUP

Tools

General mechanic's tool kit (item 64, Appx H)
Pinch bar (item 39, Appx H)

Personnel Required

Two

Materials/Parts

Gasket (item 178, Appx G)
Lockwashers(19) (item 89, Appx G)
Lockwashers (3) (item 96, Appx G)
Lockwashers (2) (item 98, Appx G)

Equipment Condition

Air intake grille opened (para 4-5)
Batteries disconnected (para 8-28)
Engine exhaust grille removed (para 4-5)
Radiator fan access door removed (para 4-5)

a. Removal

- 1 Remove seven screws (1), seven lockwashers (2), and cover (3). Discard lockwashers.
- 2 Disconnect alternator-to-rectifier wiring harness (4) at alternator (5).
- 3 Remove six mounting nuts (6) and six lockwashers (7). Discard lockwashers.
- 4 Remove two screws (8), two lockwashers (9), and two flat washers (10). Discard lockwashers.
- 5 Remove three screws (11), three lockwashers (12), three flat washers (13), and three clamps (14), releasing radiator vent hoses (15). Discard lockwashers.
- 6 Loosen inlet hose clamp (16), but do not remove clamp from inlet hose (17).
- 7 Loosen clamp (18) at radiator-to-aeration detector hose (19), but do not remove clamp from radiator-to-aeration detector hose.

CAUTION

Ž Care must be taken when pushing radiator away from cooling fans to protect radiator fins from damage.

- Care must be taken that inlet hose and radiator-to-aeration detector hose do not disconnect from radiator.

- 8 Carefully push the radiator (20) away from the cooling fans (21) using a pinch bar. Be careful not to damage equipment or disconnect inlet hose (17) or radiator-to-aeration detector hose (19).

WARNING

Alternator weighs 47 lb (21.4 kg). Use care and grip firmly when removing to avoid serious injury.

- 9 With radiator (20) separated from cooling fans (21), carefully remove alternator (5) and grommet (22).

NOTE

Steps 10 thru 12 must be performed each time alternator is removed.

- 10 Remove six bolts (23) and six lockwashers (24). Discard lockwashers.
- 11 Separate accessory drive housing (25) from flywheel housing (26) and remove gasket (27) and drive coupling (28). Discard gasket.
- 12 Discard drive coupling (28) if cracked or broken, or shows sign of disintegration.

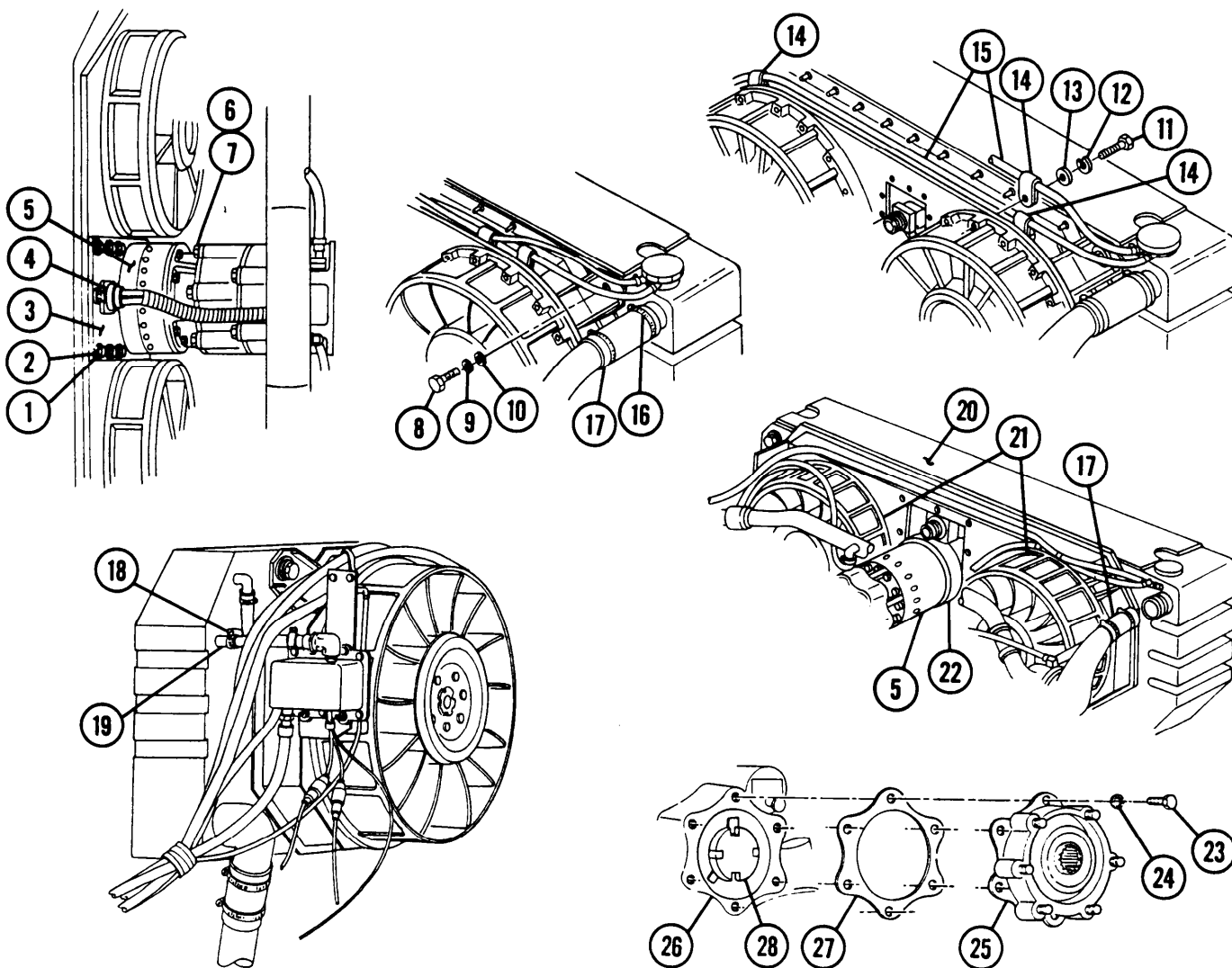

8-2 ALTERNATOR — CONTINUED

b. Installation

- 1 Install drive coupling (28), new gasket (27), and accessory drive housing (25) onto flywheel housing (26).
- 2 Install six new lockwashers (24) and six bolts (23).

CAUTION

Ž Care must be taken when pushing radiator away from cooling fans to protect radiator fins from damage.

- Care must be taken that inlet hose and radiator-to-aeration detector hose do not disconnect from radiator.

- 3 Carefully push radiator (20) away from cooling fans (21) using a pinch bar. Be careful not to damage equipment or disconnect inlet hose (17) or radiator-to-aeration detector hose (19).

WARNING

Alternator weighs 47 lb (21.4 kg). Use care and grip firmly when installing to avoid serious injury.

- 4 With radiator (20) separated from cooling fans (21), carefully install grommet (22) and alternator (5).
- 5 Install six new lockwashers (7) and six mounting nuts (6).
- 6 Remove pinch bar, returning radiator (20) to original position.
- 7 Tighten clamp (18) at radiator-to-aeration detector hose (19).
- 8 Tighten inlet hose clamp (16).
- 9 Secure radiator vent hoses (15) by installing three clamps (14), three flat washers (13), three new lockwashers (12), and three screws (11).
- 10 Install two flat washers (10), two new lockwashers (9), and two screws (8).
- 11 Connect alternator-to-rectifier wiring harness (4) at alternator (5).
- 12 Install cover (3), seven new lockwashers (2), and seven screws (1).

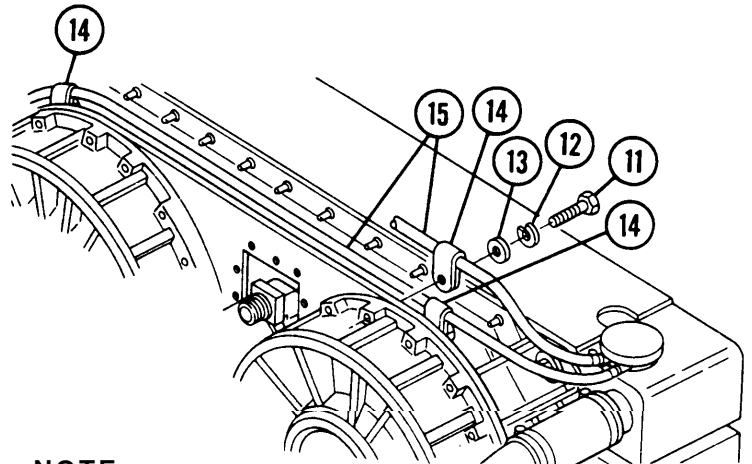
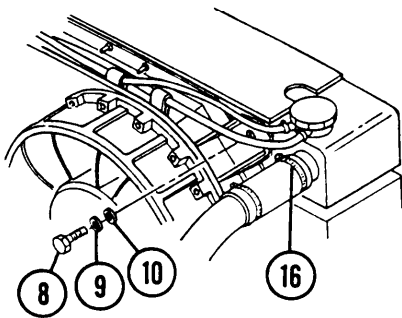
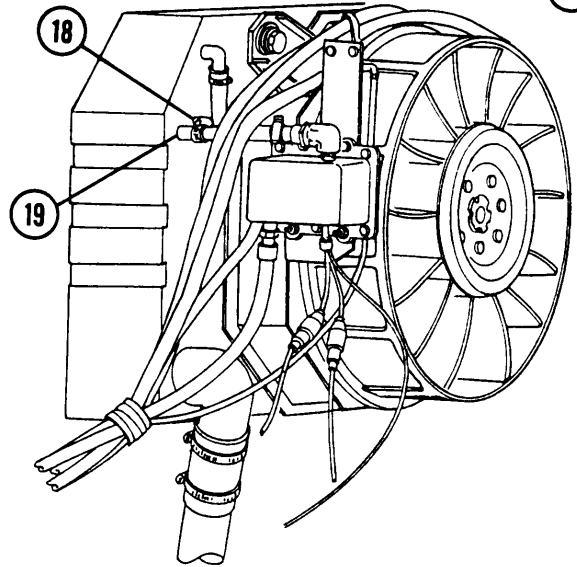
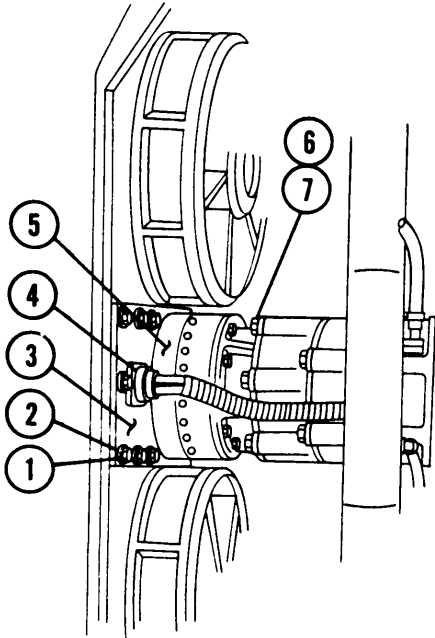
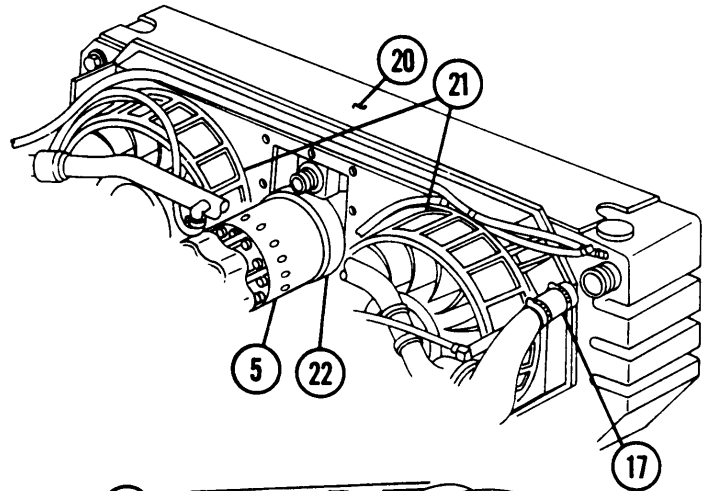
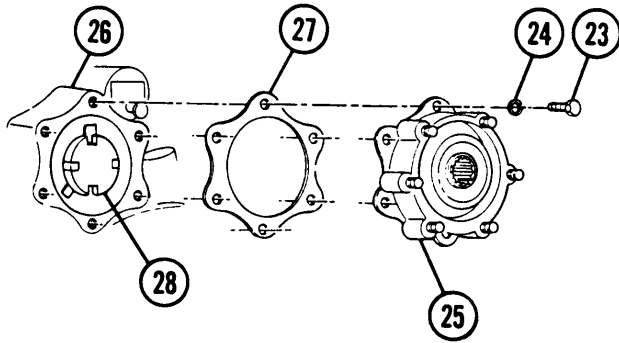

NOTE

FOLLOW-ON MAINTENANCE:

- Install radiator fan access door (para 4-5)
- Install engine exhaust grille (para 4-5)
- Connect batteries (para 8-28)
- Close air intake grille (para 4-5)

8-3 VOLTAGE REGULATOR

This task covers: a. Removal b. Installation

INITIAL SETUP

Tools

General mechanic's tool kit (item 64, Appx H)

Equipment Conditions

Batteries disconnected (para 8-28)

Materials/Parts

Lockwashers (4) (item 94, Appx G)

Lockwashers (4) (item 95, Appx G)

a. Removal

- 1 Disconnect wiring harness connectors (1 and 2) at voltage regulator (3).
- 2 Remove four screws (4), four flat washers (5), four lockwashers (6), and four nuts (7). Discard lockwashers.
- 3 Slide mount (8) forward far enough to gain access to voltage regulator mounting screws (9).
- 4 Remove four screws (9), four flat washers (10), four lockwashers (11), and four nuts (12). Discard lockwashers.

NOTE

Step 5 applies to M109A4/M109A5 Howitzers.

- 5 Remove strap (13).
- 6 Remove voltage regulator (3).

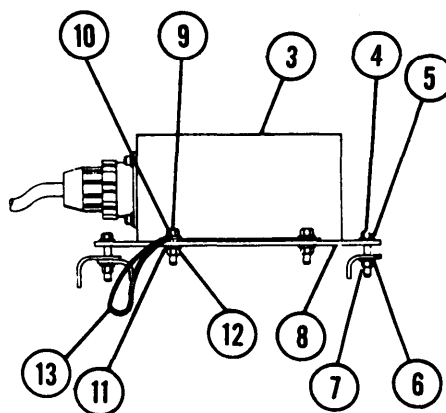
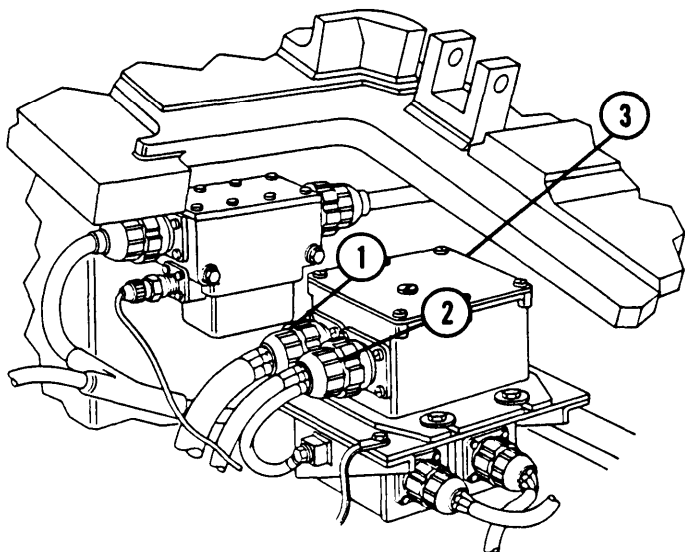

8-4 RECTIFIER (M109A2/M109A3) — CONTINUED

a. Removal

- 1 Disconnect two wiring harness connectors (1 and 2) at rectifier (3).
- 2 Remove four screws (4) and four flat washers (5).
- 3 Remove two brass screws (6) and two lockwashers (7). Discard lockwashers.
- 4 Remove rectifier (3).
- 5 Remove preformed packing (8) from rectifier (3) base. Scrape base groove clean. Discard preformed packing.

b. Installation

- 1 Remove paint from rectifier (3) mounting base and from mating surface of hull, if required. Ensure surfaces are clean.
- 2 Coat mounting base of rectifier (3) and mating surface of hull with silicone compound.
- 3 Install new preformed packing (8) in rectifier (3) base groove. Use silicone compound to hold packing.
- 4 Install rectifier (3), two new lockwashers (7), and two brass screws (6). Torque screws at 16 lb-ft (22 N·m).
- 5 Install four flat washers (5) and four screws (4). Torque screws to 30 lb-ft (41 N·m).
- 6 Connect two wiring harnesses (1 and 2) at rectifier (3).

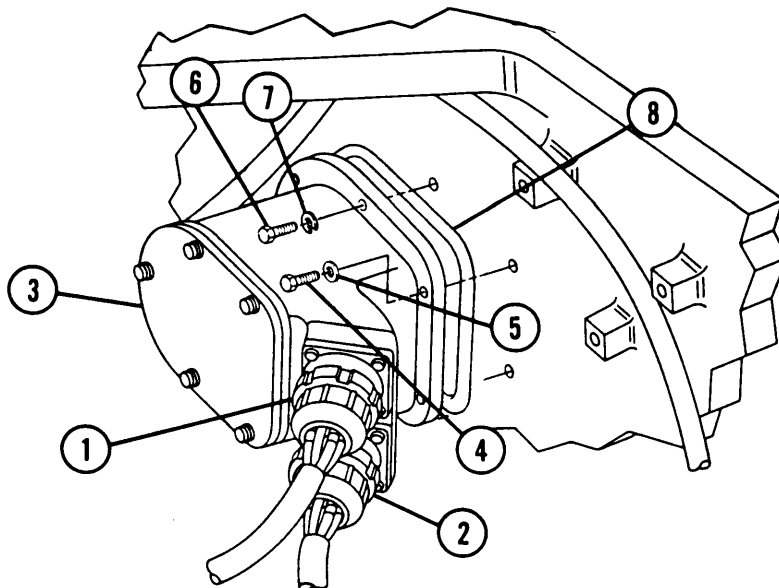

NOTE

FOLLOW-ON MAINTENANCE: Connect batteries (para 8-28)

8-5 RECTIFIER (M109A4/M109A5) — CONTINUED

b. Installation

- 1 Remove paint from rectifier (3) mounting base and from mating surface of hull, if required. Ensure surfaces are clean.
- 2 Coat mounting base of rectifier (3) and mating surface of hull with silicone heat sink compound.
- 3 Install new preformed packing (8) in rectifier (3) base groove.
- 4 Install rectifier (3), two new lockwashers (7), and two brass screws (6).
- 5 Install six flat washers (5) and six screws (4).
- 6 Connect two wiring harnesses (1 and 2) at rectifier (3).

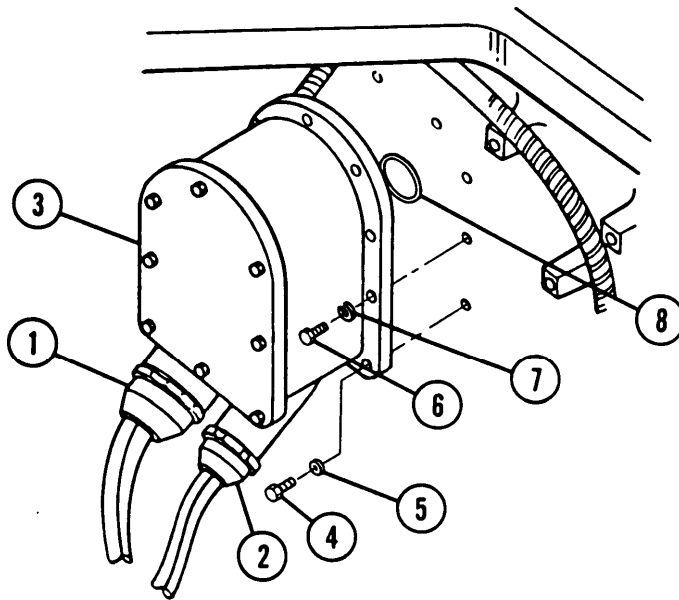

NOTE

FOLLOW-ON MAINTENANCE: Connect batteries (para 8-28)

8-6 ENGINE COOLANT TEMPERATURE TRANSMITTER AND PROTECTIVE COVER

This task covers: a. Removal b. Installation

INITIAL SETUP

Tools
General mechanic's tool kit (item 64, Appx H)

Equipment Conditions
Air intake grille opened (para 11-8)

Materials/Parts

Lockwashers (3) (item 88, Appx G)

a. Removal

WARNING

- Ensure engine and coolant system are cool enough to permit safe handling in order to prevent burns. Hot coolant will cause severe burns.
- Ensure MASTER switch is OFF when working on electrical system to avoid electrical shock and burns.

NOTE

Protective cover does not have to be removed for removal of engine coolant temperature transmitter.

1 Remove nut (1), lockwasher (2), clamp (3), and screw (4). Discard lockwasher.

2 Remove two screws (5) and two lockwashers (6) and lift protective cover (7) off. Discard lockwashers.

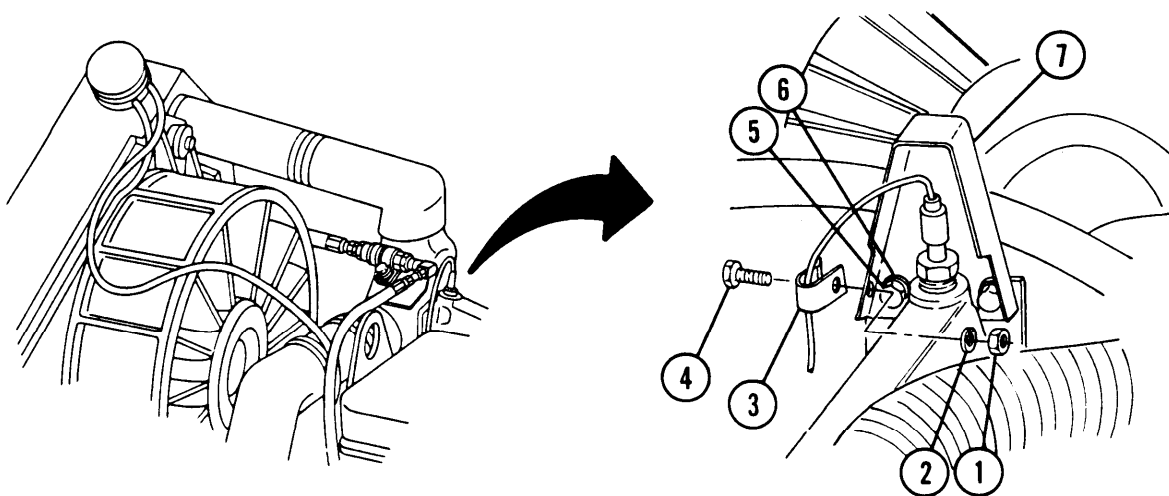

**8-6 ENGINE COOLANT TEMPERATURE TRANSMITTER AND PROTECTIVE COVER —
CONTINUED**

a. Removal—Continued

- 3 Disconnect electrical connector (8) of wire 33A.

WARNING

Coolant is hazardous waste and must be disposed of in accordance with local procedures or direction of the local Hazardous Waste Management office.

NOTE

Coolant will drain through opening when transmitter is removed. Install replacement transmitter immediately.

- 4 Unscrew engine coolant temperature transmitter (9) and remove.

b. Installation

WARNING

Ž Ensure engine and coolant system are cool enough to permit safe handling in order to prevent burns. Hot coolant will cause severe burns.

- Ensure MASTER switch is OFF when working on electrical system to avoid electrical shock and burns.

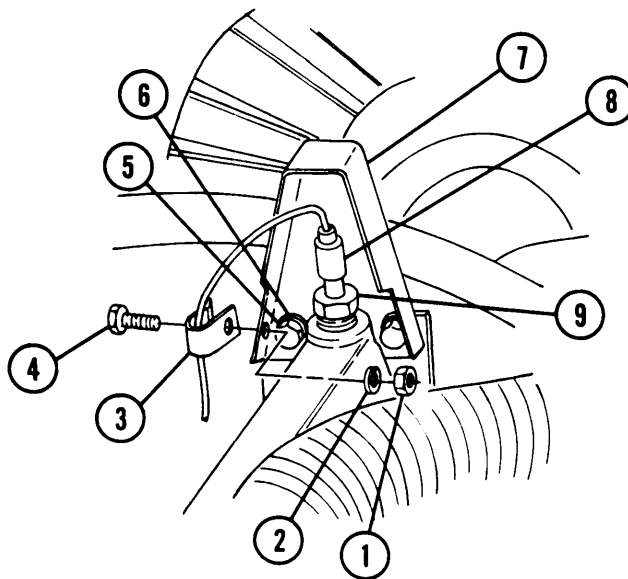

- 1 Install engine coolant temperature transmitter (9).
- 2 Connect electrical connector (8) of wire 33A.
- 3 Install protective cover (7), two new lockwashers (6), and two screws (5).
- 4 Install clamp (3), screw (4), new lockwasher (2), and nut (1).

NOTE

FOLLOW-ON MAINTENANCE: Close air intake grille (para 11-8)

8-7 ENGINE COOLANT HIGH TEMPERATURE SWITCH AND PROTECTIVE COVER

This task covers: a. Removal b. Installation

INITIAL SETUP**Tools**

General mechanic's tool kit (item 64, Appx H)

Equipment Conditions

Air intake grille opened (para 11-8)

Materials/Parts

Lockwashers (3) (item 88, Appx G)

a. Removal**WARNING**

- Ensure engine and coolant system are cool enough to permit safe handling to prevent burns. Hot coolant will cause severe burns.
- Ensure MASTER switch is OFF when working on electrical system to avoid electrical shock and burns.

- 1 Remove nut (1), lockwasher (2), clamp (3), and screw (4). Discard lockwasher.

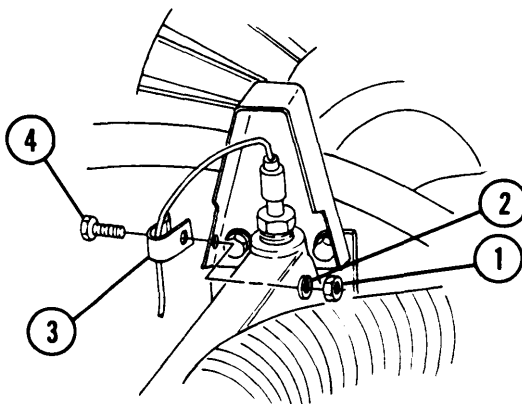

**8-7 ENGINE COOLANT HIGH TEMPERATURE SWITCH AND PROTECTIVE COVER —
CONTINUED**

a. Removal — Continued

- 2 Remove two screws (5) and two lockwashers (6) and lift protective cover (7) off. Discard lockwashers.
- 3 Disconnect electrical connector (8) of wire 509A.

WARNING

Coolant is hazardous waste and must be disposed of in accordance with local procedures or direction of the local Hazardous Waste Management office.

NOTE

Coolant will drain through opening when transmitter is removed. Install replacement transmitter immediately.

- 4 Unscrew and remove engine coolant temperature switch (9).

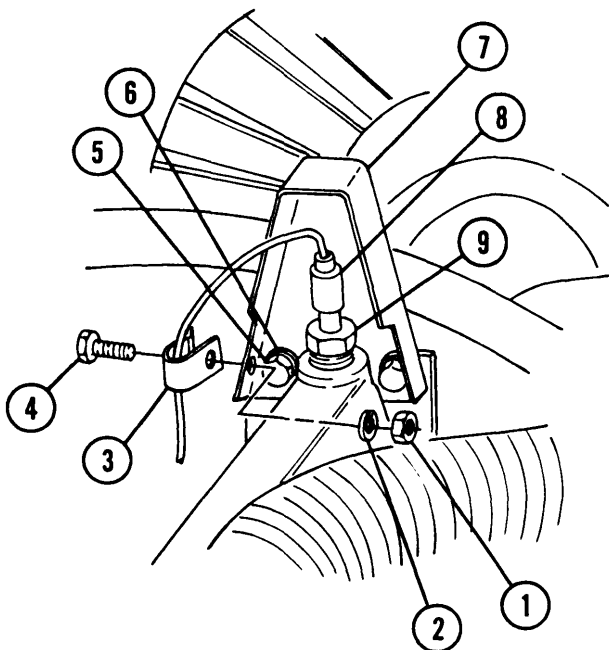

b. Installation**WARNING**

- Ensure engine and coolant system are cool enough to permit safe handling to prevent burns. Hot coolant will cause severe burns.
- Ensure MASTER switch is OFF when working on electrical system to avoid electrical shock and burns.

- 1 Install engine coolant temperature switch (9).
- 2 Install electrical connector (8) of wire 509A.
- 3 Install protective cover (7), two new lockwashers (6), and two **screws** (5).
- 4 Install clamp (3), new lockwasher (2), screw (4), and nut (1).

NOTE

FOLLOW-ON MAINTENANCE: Close air intake grille (para 11-8)

8-8 ENGINE OIL PRESSURE TRANSMITTER

This task covers: a. Removal b. Installation

INITIAL SETUP**Tools**

General mechanic's tool kit (item 64, Appx H)

Equipment Conditions

Engine compartment access cover removed (para 11-5)

a. Removal**WARNING**

Ensure MASTER switch is OFF when working on electrical system to avoid electrical shock and burns.

8-8 ENGINE OIL PRESSURE TRANSMITTER — CONTINUED

a. Removal — Continued

- 1 Disconnect electrical connector (1) of wire 36.
- 2 Unscrew and remove engine oil pressure transmitter (2) from elbow (3).

b. Installation

WARNING

Ensure MASTER switch is OFF when working on electrical system to avoid electrical shock and burns.

- 1 Install engine oil pressure transmitter (2) to elbow (3).
- 2 Install electrical connector (1) of wire 36.

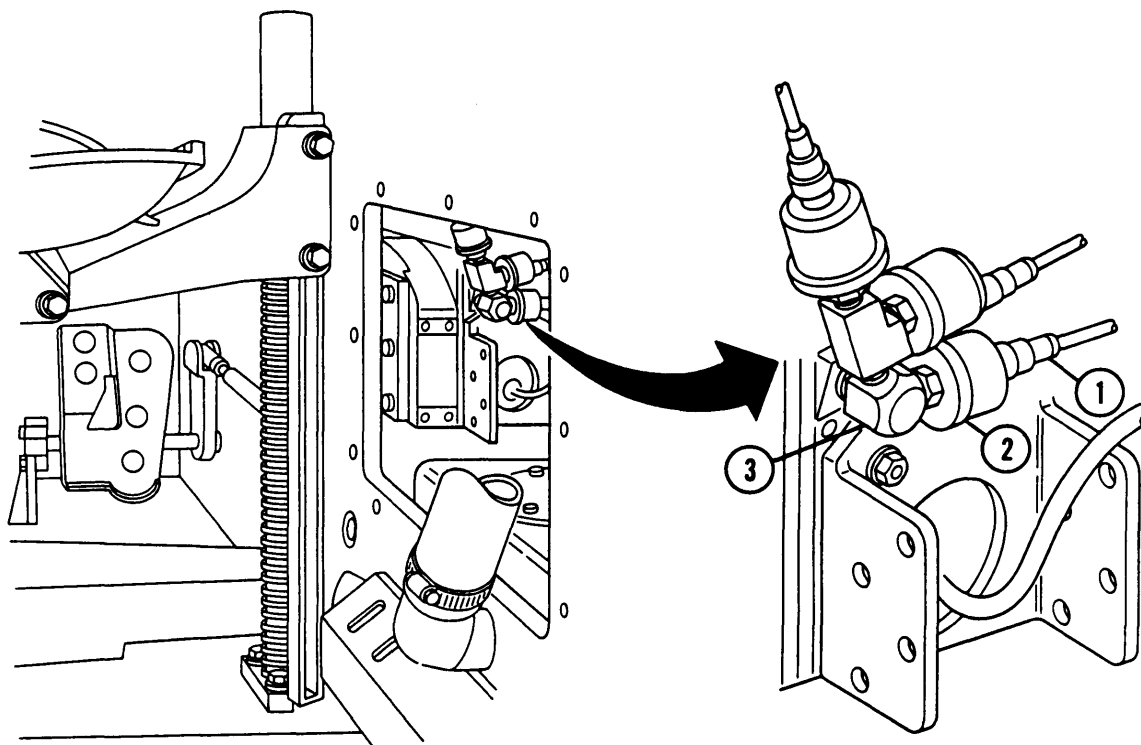

DRIVER'S COMPARTMENT

NOTE

FOLLOW-ON MAINTENANCE: Install engine compartment access cover (para 11-5)

8-9 ENGINE OIL LOW PRESSURE SWITCH

This task covers: a. Removal b. Installation

INITIAL SETUP**Tools**

General mechanic's tool kit (item 64, Appx H)

Equipment Conditions

Engine compartment access cover **removed** (para 11-5)

a. Removal**WARNING**

Ensure MASTER switch is OFF when working on electrical system to avoid electrical shock and burns.

- 1 Disconnect electrical connector (1) of wire 509B.
- 2 Unscrew and remove engine oil low pressure switch (2) from tee (3).

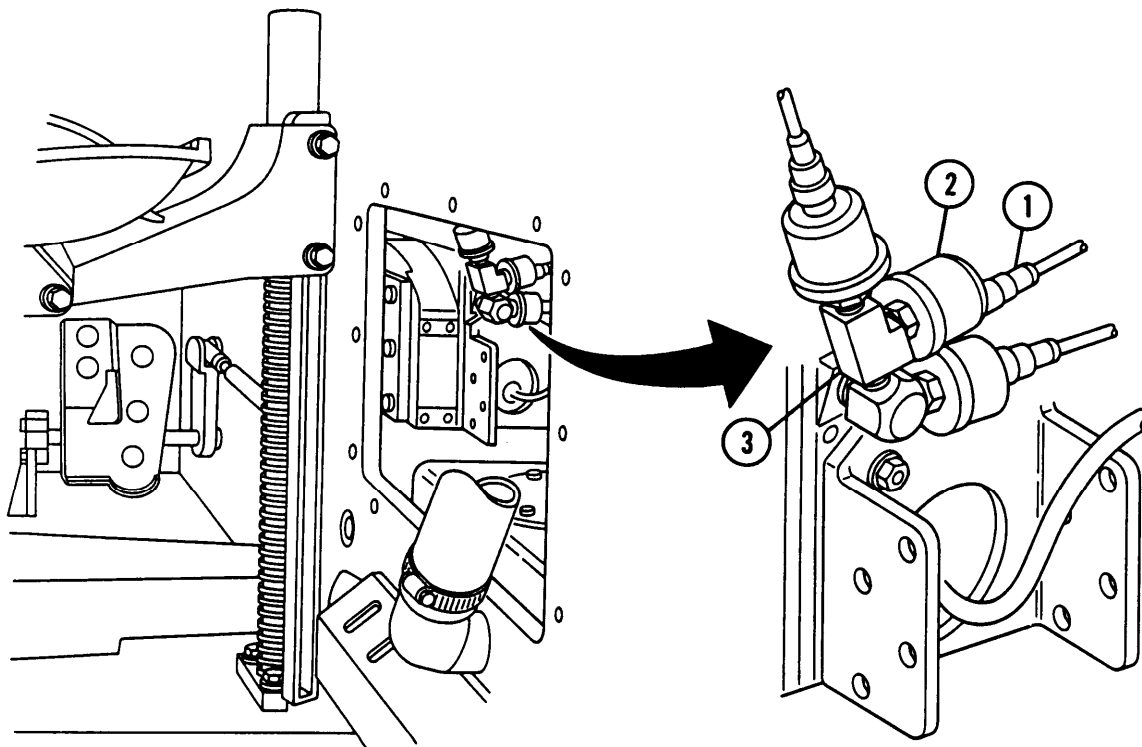

DRIVER'S COMPARTMENT

8-9 ENGINE OIL LOW PRESSURE SWITCH — CONTINUED

b. Installation

WARNING

Ensure MASTER switch is OFF when working on electrical system to avoid electrical shock and burns.

- 1 Install engine oil low pressure switch (2) to tee (3).
- 2 Install electrical connector (1) of wire 5096.

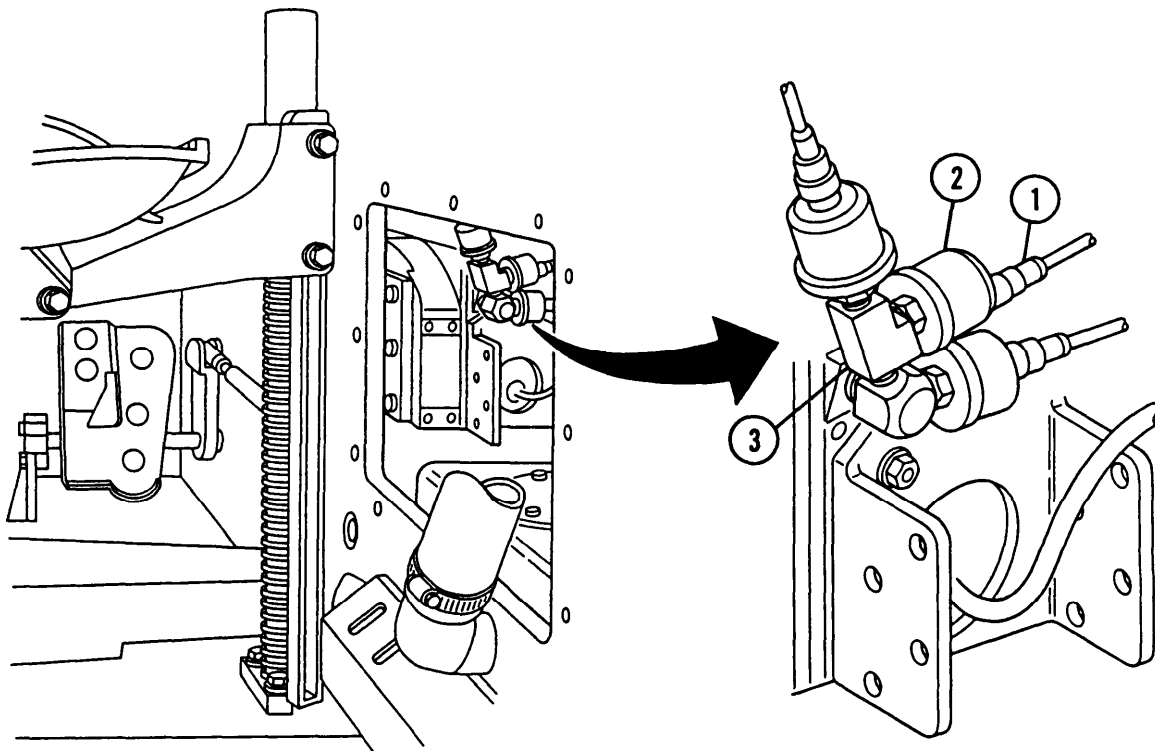

DRIVER'S COMPARTMENT

NOTE

FOLLOW-ON MAINTENANCE: Install engine compartment access cover (para 11-5)

8-10 AIR CLEANER BLOWER MOTOR SWITCH

This task covers: a. Removal b. Installation

INITIAL SETUP

Tools

General mechanic's tool kit (item 64, Appx H)

Equipment Conditions

Batteries disconnected (para 8-28)

Engine compartment access cover removed (para 11-5)

a. Removal

- 1 Disconnect electrical connector (1) of wire 415B.
- 2 Unscrew and remove air cleaner blower motor switch (2) from tee (3).

b. Installation

- 1 Install air cleaner blower motor switch (2) to tee (3).
- 2 Install electrical connector (1) of wire 415B.

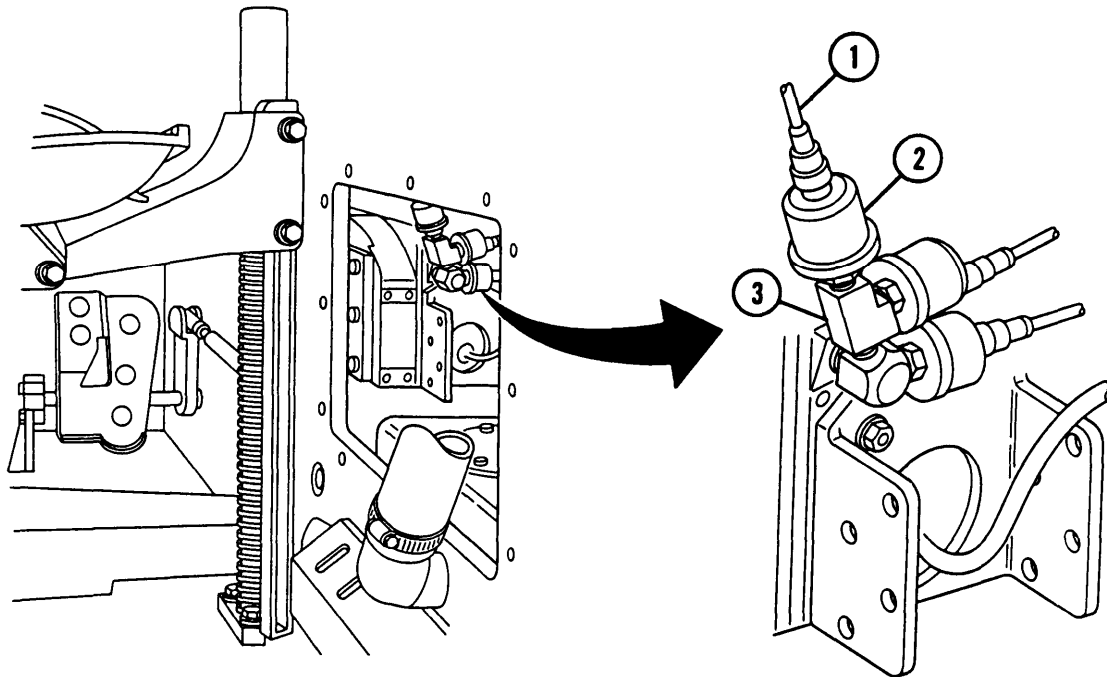

DRIVER'S COMPARTMENT

NOTE

FOLLOW-ON MAINTENANCE:

- Connect batteries (para 8-28)
- Install engine compartment access cover (para 11-5)

8-11 TRANSMISSION OIL TEMPERATURE TRANSMITTER AND TRANSMISSION OIL HIGH TEMPERATURE SWITCH PROTECTIVE COVER (M109A4/M109A5)

This task covers: a. Removal/Disassembly b. Assembly/installation

INITIAL SETUP

Applicable Configurations

M109A4/M109A5

Tools

General mechanic's tool kit (item 64, Appx H)

Materials/Parts

Lockwashers (2) (item 87, Appx G)

Lockwashers (2) (item 192, Appx G)

Equipment Conditions

Right transmission access door opened (para 11-7)

Transmission oil temperature transmitter and transmission oil high temperature switch removed (para 8-12)

a. Removal/Disassembly

WARNING

Ensure MASTER switch is OFF when working on electrical system to avoid electrical shock and burns.

1 Remove two screws (1), two Lockwashers (2), and protective cover (3). Discard Lockwashers.

2 Remove two nuts (4), two Lockwashers (5), four flat washers (6), two screws (7), and support leg (8). Discard Lockwashers.

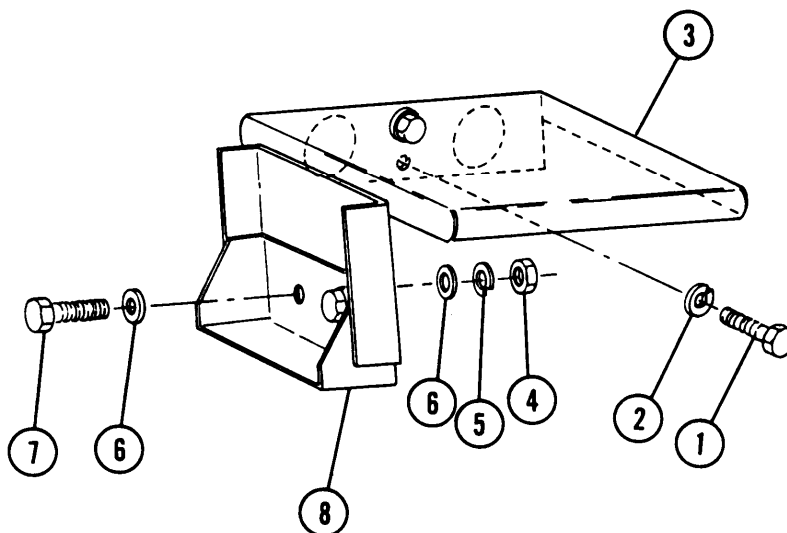

b. Assembly/installation

WARNING

Ensure MASTER switch is OFF when working on electrical system to avoid electrical shock and burns.

- 1 Install support leg (8), four flat **washers** (6), two new **lockwashers** (5), two screws (7), and two nuts (4) to protective cover (3).
- 2 Install protective cover (3), two new lockwashers (2), and two screws (1).
- 3 Loosen two nuts (4) and adjust support leg (8) to fit against transmission. Tighten two nuts.

NOTE

FOLLOW-ON MAINTENANCE: Install transmission oil temperature transmitter and transmission oil high temperature switch (para 8-12)
 Close right transmission access door (para 11-7)

8-12 TRANSMISSION OIL TEMPERATURE TRANSMITTER AND TRANSMISSION OIL HIGH TEMPERATURE SWITCH

This task covers: a. Removal b. Installation

INITIAL SETUP

Tools

General mechanic's tool kit (item 64, Appx H)

Equipment Conditions

Right transmission access door opened (para 11-7)

a. Removal

WARNING

Ensure MASTER switch is OFF when working on electrical system to avoid electrical shock and burns.

8-12 TRANSMISSION OIL TEMPERATURE TRANSMITTER AND TRANSMISSION OIL HIGH TEMPERATURE SWITCH — CONTINUED

a. Removal — Continued

- 1 Disconnect electrical connector (1) of wire 324.
- 2 Unscrew and remove transmission oil temperature transmitter (2).
- 3 Disconnect electrical connector (3) of wire 509D.
- 4 Unscrew and remove high temperature switch (4).

b. Installation

WARNING

Ensure MASTER switch is OFF when working on electrical system to avoid electrical shock and burns.

- 1 Install transmission oil high temperature switch (4).
- 2 Install electrical connector (3) of wire 509D.
- 3 Install transmission oil temperature transmitter (2).
- 4 Install electrical connector (1) of wire 324.

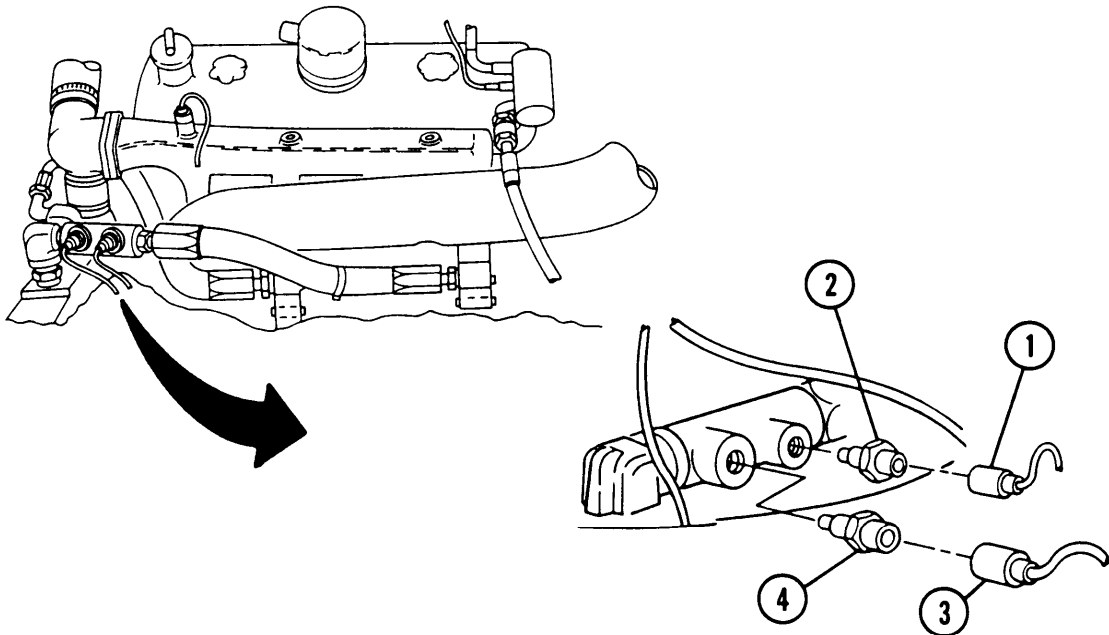

NOTE

FOLLOW-ON MAINTENANCE: Close right transmission access door (para 11-7)

8-13 TRANSMISSION OIL PRESSURE TRANSMITTER AND TRANSMISSION OIL LOW PRESSURE SWITCH — CONTINUED

b. Installation

WARNING

Ensure MASTER switch is OFF when working on electrical system to avoid electrical shock and burns.

- 1 Install transmission low oil pressure switch (4).
- 2 Install electrical connector (3) of wire 509C.
- 3 Install transmission oil pressure transmitter (2).
- 4 Install electrical connector (1) of wire 321.

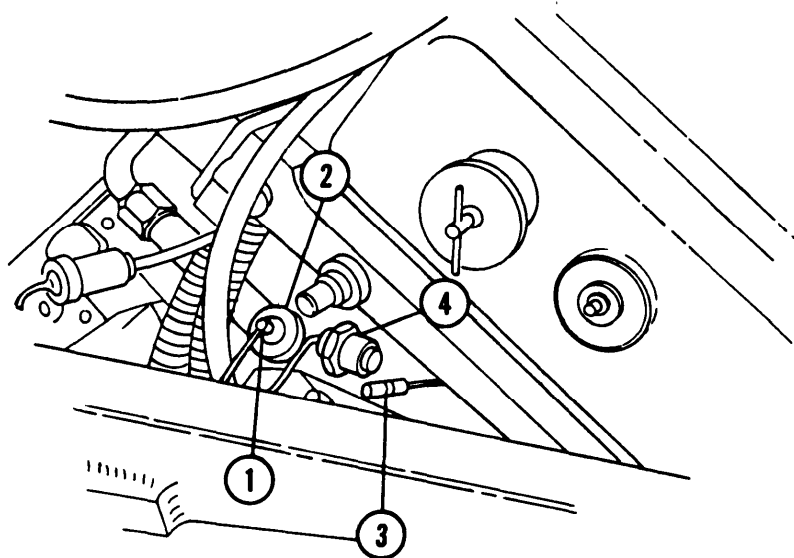

NOTE

FOLLOW-ON MAINTENANCE: Close right transmission access door (para 11-7)

8-14 STARTER MOTOR

This task covers: a. Removal b. Installation

INITIAL SETUP

Tools

General mechanic's tool kit (item 64, Appx H)
Torque wrench (item 72, Appx H)

Personnel Required

Two

Materials/Parts

Gasket (item 180, Appx G)
Lockwashers (3) (item 92, Appx G)

Equipment Conditions

Powerplant removed (para 4-5)

a. Removal

WARNING

Starter weighs 80 lb (36.3 kg). Use care during removal to avoid serious injury.

- 1 Remove nut (1) and ground lead (2) at starter motor (3). On M109A4/M109A5 Howitzers, disconnect ground lead 5A (4).
- 2 Remove nut (5), flat washer (6), and starter cable (wire 82 on M109A2/M109A3, wire 6A on M109A4/M109A5) (7) at starter solenoid (8).
- 3 Remove nut (9), flat washer (10), and solenoid lead (11) at solenoid (8).
- 4 Remove three screws (12) and three lockwashers (13). Discard lockwashers.
- 5 Remove starter motor (3) and mounting gasket (14). Discard gasket.

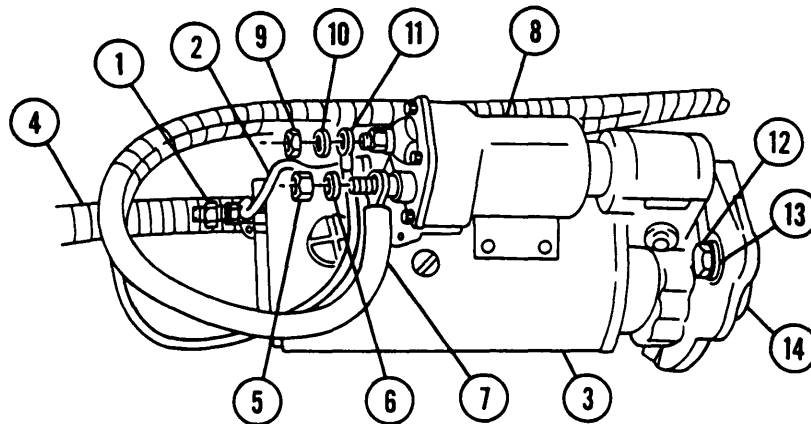

8-14 STARTER MOTOR — CONTINUED

b. Installation

WARNING

Starter weighs 80 lb (36.3 kg). Use care during installation to avoid serious injury.

- 1 Install new mounting gasket (14) and starter motor (3).
- 2 Install three new lockwashers (13) and three screws (12). Torque three screws to 95-105 lb-ft (129-142 N·m).
- 3 Install solenoid lead (11) at solenoid (8), flat washer (10), and nut (9).
- 4 Install starter cable (wire 82 on M109A2/M109A3 Howitzers, wire 6A on M109A4/M19A5 Howitzers) (7), flat washer (6), and nut (5).
- 5 Install ground lead (2) and nut (1) at starter (3). On M109A4/M109A5 Howitzers, connect ground lead 5A (4).
- 6 Test-run powerplant while removed from vehicle (para 4-3).

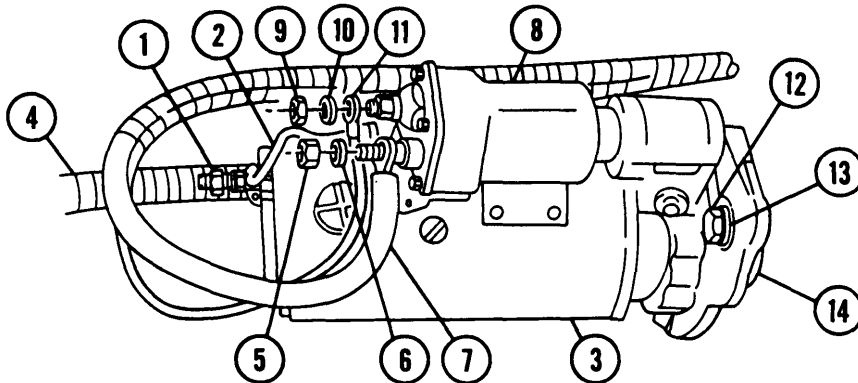

NOTE

FOLLOW-ON MAINTENANCE: Install powerplant (para 4-5)

8-15 NEUTRAL SAFETY SWITCH

This task covers: a. Removal b. Installation

INITIAL SETUP

Tools

General mechanic's tool kit (item 64, Appx H)

NOTE

Proceed only as required.

a. Removal**WARNING**

Ensure MASTER switch is OFF when working on electrical system to avoid electrical shock and burns.

- 1 Disconnect four electrical connectors (1).
- 2 Unscrew neutral safety switch (2) counterclockwise to remove from adapter (3). Remove pin (4) along with switch.

b. Installation**WARNING**

Ensure MASTER switch is OFF when working on electrical system to avoid electrical shock and burns.

- 1 Install pin (4) in adapter (3). Screw neutral safety switch (2) clockwise to install into adapter.
- 2 Install four electrical connectors (1).

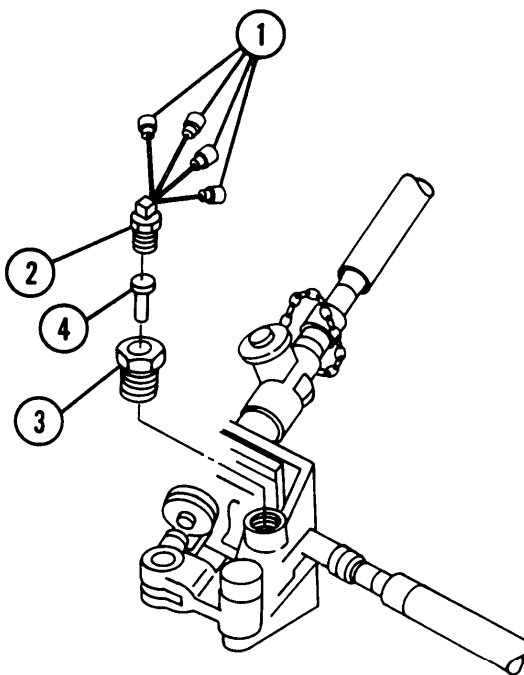

8-16 AERATION DETECTOR

This task covers: a. Removal b. Installation

INITIAL SETUP

Tools

General mechanic's tool kit (item 64, Appx H)

Equipment Conditions

Radiator drained (TM 9-2350-311-10)

Materials/Parts

Lockwashers (4) (item 87, Appx G)
Silicone compound (item 18, Appx D)

a. Removal

WARNING

Ensure engine and coolant system are cool enough to permit handling to prevent burns. Hot coolant will cause severe burns.

- 1 Disconnect two electrical connectors (1) of wires 352A and 352B.
- 2 Remove screw (2), flat washer (3), and ground wire (4).
- 3 Loosen two hose clamps (5).
- 4 Remove two hoses (6), elbow (7), and two adapters (8).
- 5 Remove four screws (9), four lockwashers (10), four flat washers (11), and four nuts (12). Discard lockwashers.
- 6 Remove aeration detector (13).

b. Installation

WARNING

Ensure engine and coolant system are cool enough to permit handling to prevent burns. Hot coolant will cause severe burns.

- 1 Install two adapters (8) and elbow (7).
- 2 Install aeration detector (13).
- 3 Install four new lockwashers (10), four flat washers (11), four screws (9), and four nuts (12).

4 Install two hoses (6) and tighten two hose clamps (5).

5 Install ground wire (4), flat washer (3), and screw (2).

6 Install two electrical connectors (1) of wires 352A and 352B.

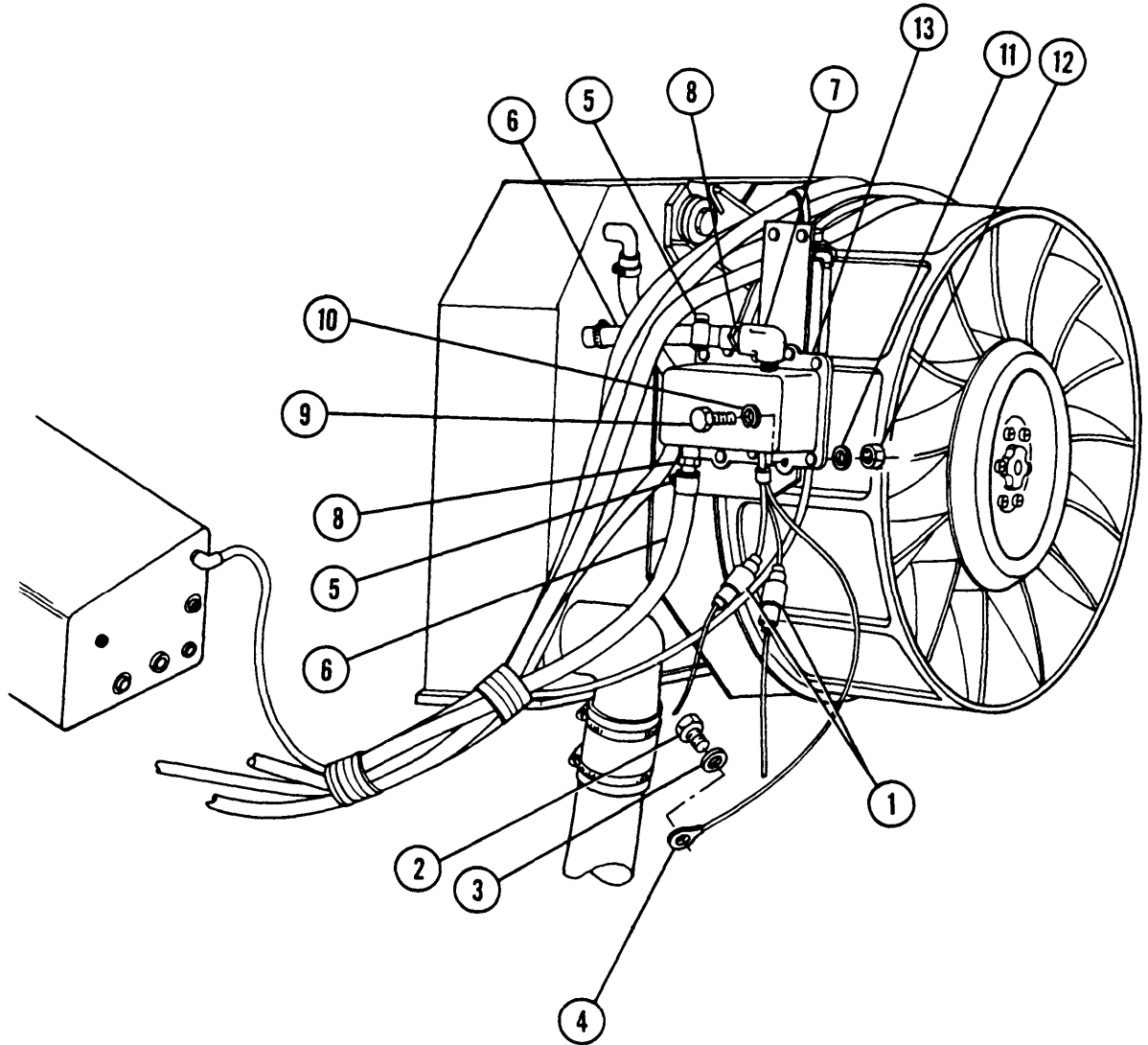

NOTE

FOLLOW-ON MAINTENANCE: Fill radiator (TM 9-2350-311-10)

- 5 Disconnect 17 instrument panel connectors (7) and light switch connector (8).
- 6 Disconnect 16 instrument panel connectors (9) and light switch connector (10).
- 7 For M109A4/M109A5 Howitzers, disconnect additional three connectors (11).
- 8 Remove driver's instrument panel (3) from mounting support (12).
- 9 Remove four screws (13), four washers (14), and ground strap (15).
- 10 Remove mounting support (12).

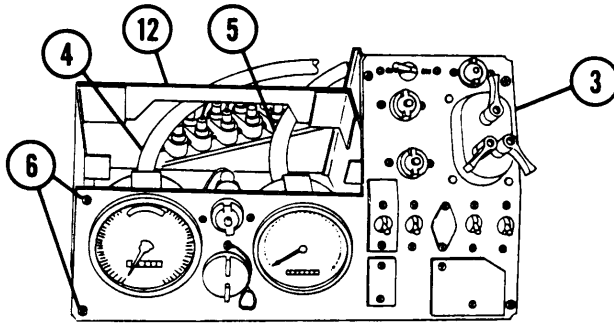

M109A4/M109A5
(ENGINE MODEL 7083-7396) SHOWN

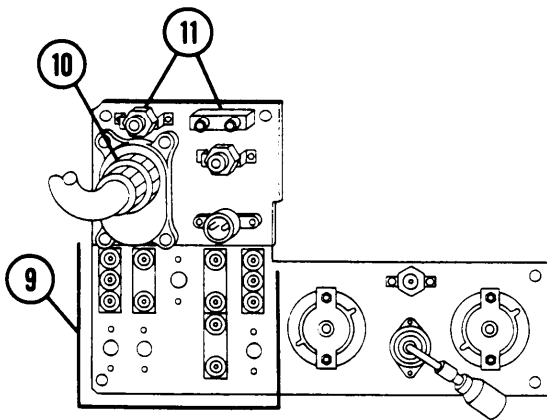
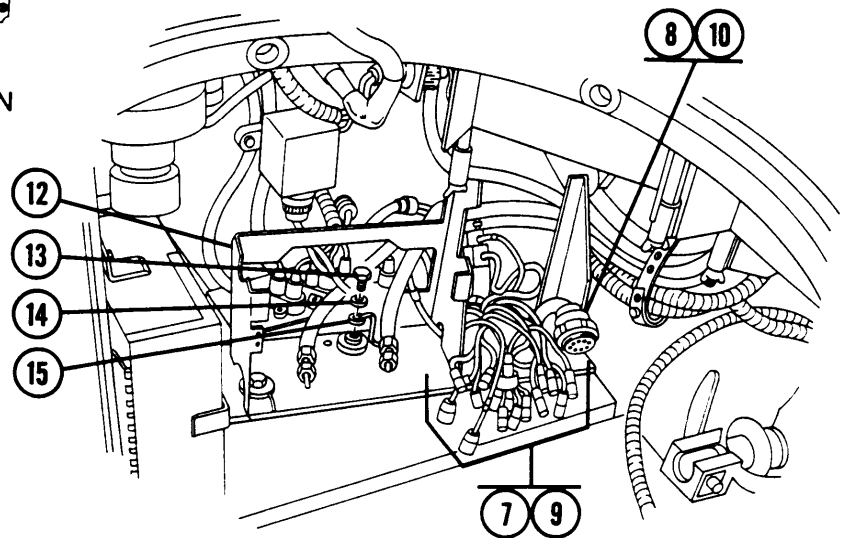

M109A4/M109A5
(ENGINE MODEL 7083-7396) SHOWN

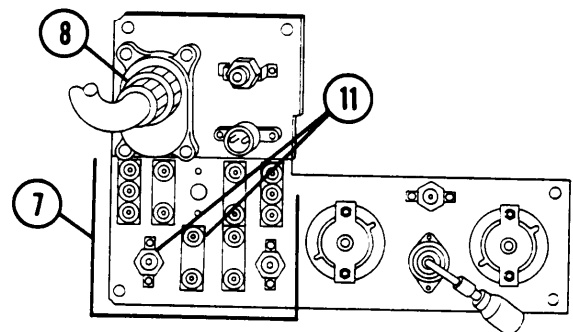

M109A4/M109A5
(ENGINE MODEL 7083-7391) SHOWN

8-17 PORTABLE AND DRIVER'S INSTRUMENT PANELS — CONTINUED

b. Disassembly/Repair

- 1 Remove four crosspoint screws (16) to separate portable instrument panel (2) from bracket assembly (17).
- 2 Disconnect four stud fasteners (18) by pushing in and turning counterclockwise.
- 3 Pull panel (19) away from portable instrument panel cover (20).
- 4 Slide grommet (21) back on wiring harness (1) to allow for slack to enable disassembly of panel (19). Remove grommet.
- 5 Disconnect all electrical connectors (22) from back of panel (19).
- 6 Remove wiring harness (1) from portable instrument panel cover (20).

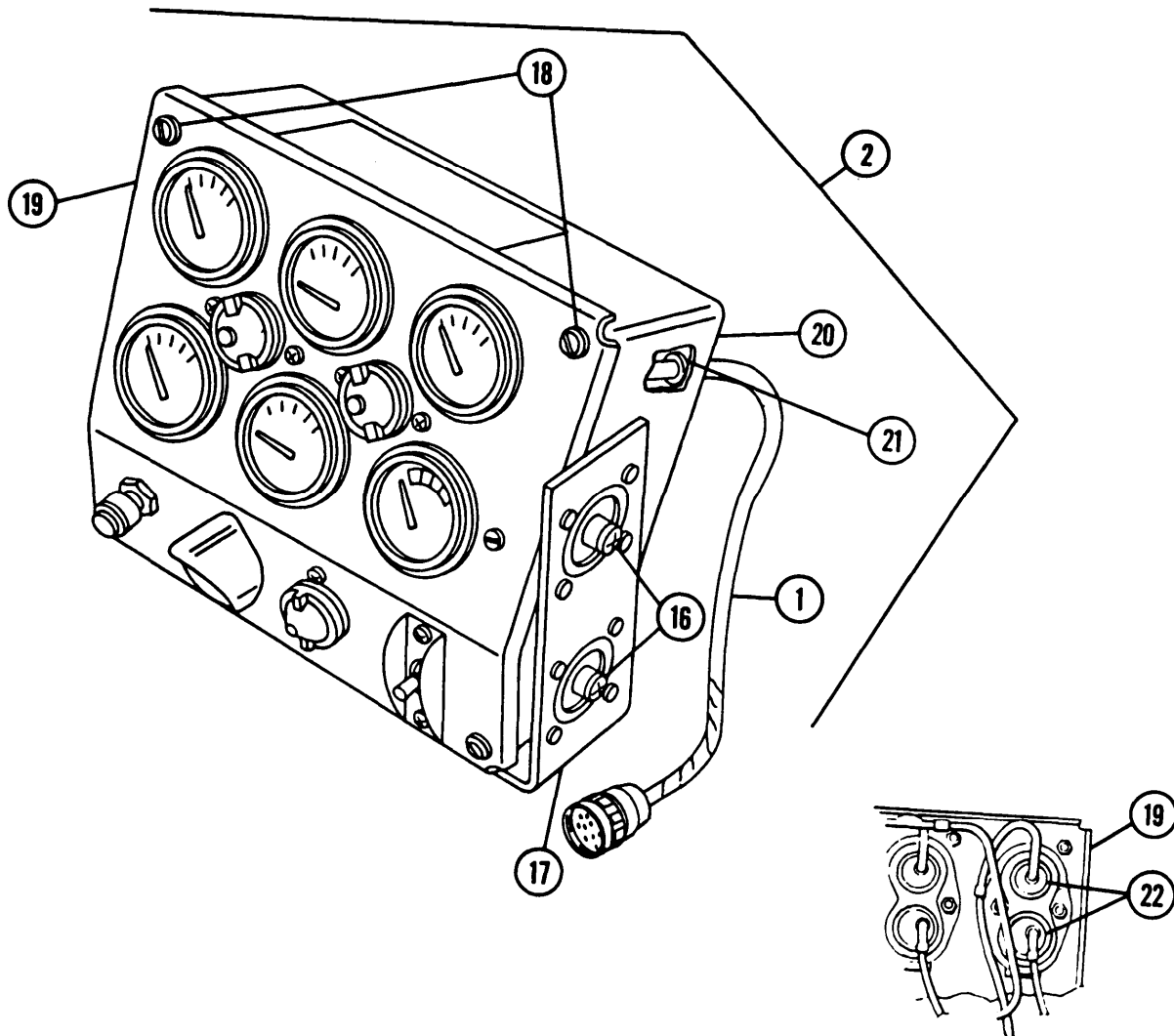

- 7 Unscrew and remove two lamp assemblies (lens, packing, lamp, and gasket) (23) from front of panel (19).
- 8 Unscrew and remove two LED assemblies (lens, LED, and gasket) (24) from front of panel (19).
- 9 Remove two screws (25), two flat washers (26), two lockwashers (27), switch guard (28), ID plate (29), and MASTER switch (30). Discard lockwashers.
- 10 Remove eight screws (31) and eight washers (32). Remove four light brackets (33) and shield light assembly (34).
- 11 Remove 12 nuts (35), 12 lockwashers (36), 6 brackets (37), and 6 indicators (38). Discard lockwashers.
- 12 Remove hex nut (39) and low coolant indicator light assembly (40).

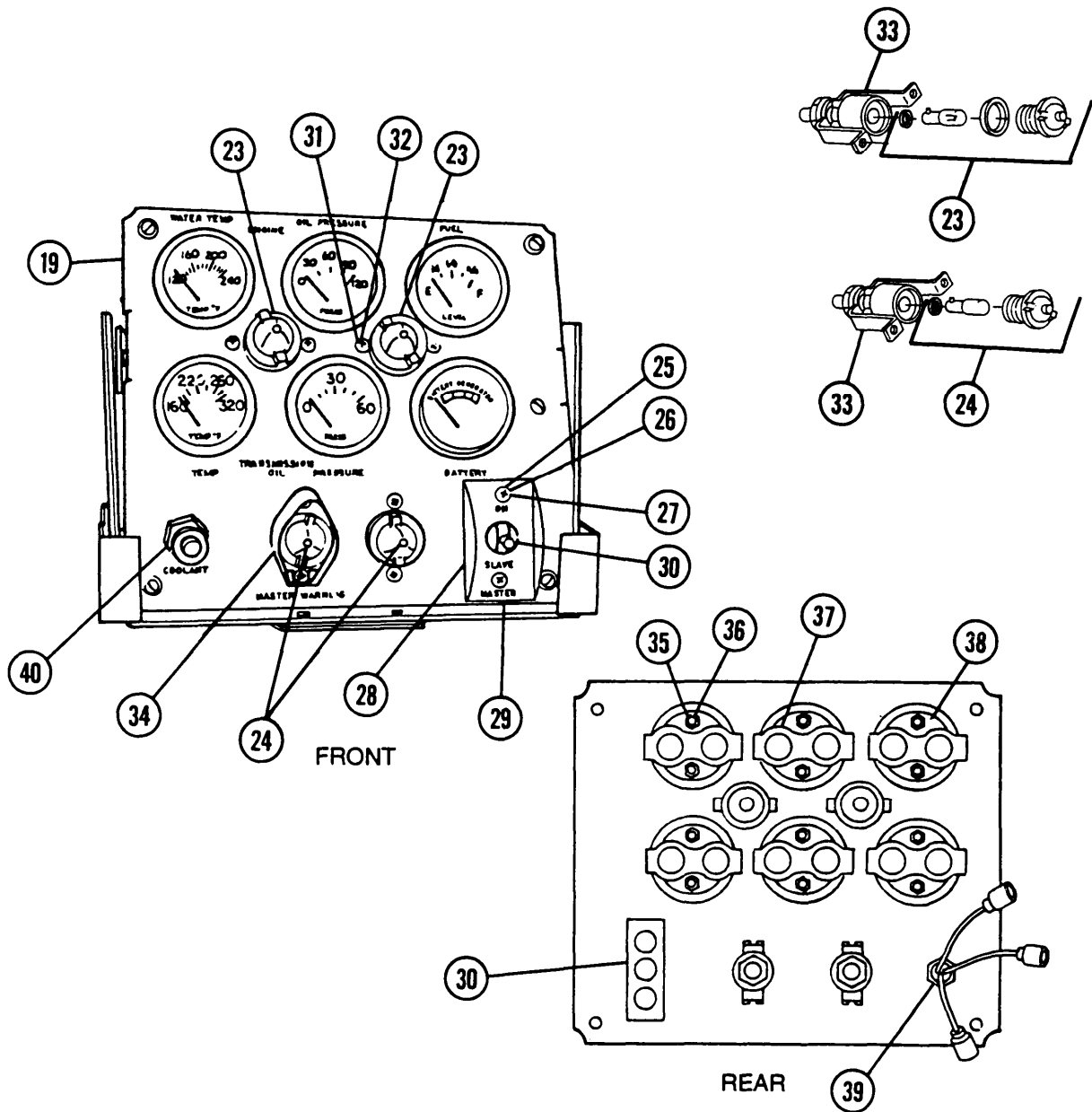

8-17 PORTABLE AND DRIVER'S INSTRUMENT PANELS — CONTINUED

b. Disassembly/Repair — Continued

- 13 Unscrew and remove lamp assembly (lens, packing, lamp, and gasket) (41) from driver's instrument panel (3).
- 14 For M109A4/M109A5 Howitzers, unscrew and remove lamp assembly (lens, packing, lamp, and gasket) (42) from panel (3).
- 15 Unscrew and remove two LED assemblies (lens, LED, and gasket) (43).
- 16 Unscrew and remove three LED assemblies (lens, LED, and gasket) (44).
- 17 Remove eight screws (45), eight washers (46), three light brackets (47), and cover (48).
- 18 Remove eight screws (49), eight washers (50), and four light brackets (51).
- 19 For M109A4/M109A5 Howitzers, remove two screws (52), two washers (53), and light bracket (54).
- 20 Remove 10 screws (55), 10 flat washers (56), and 5 switch assemblies (57).
- 21 For M109A4/M109A5 Howitzers, remove two screws (58), two flat washers (59), and switch assembly (60).

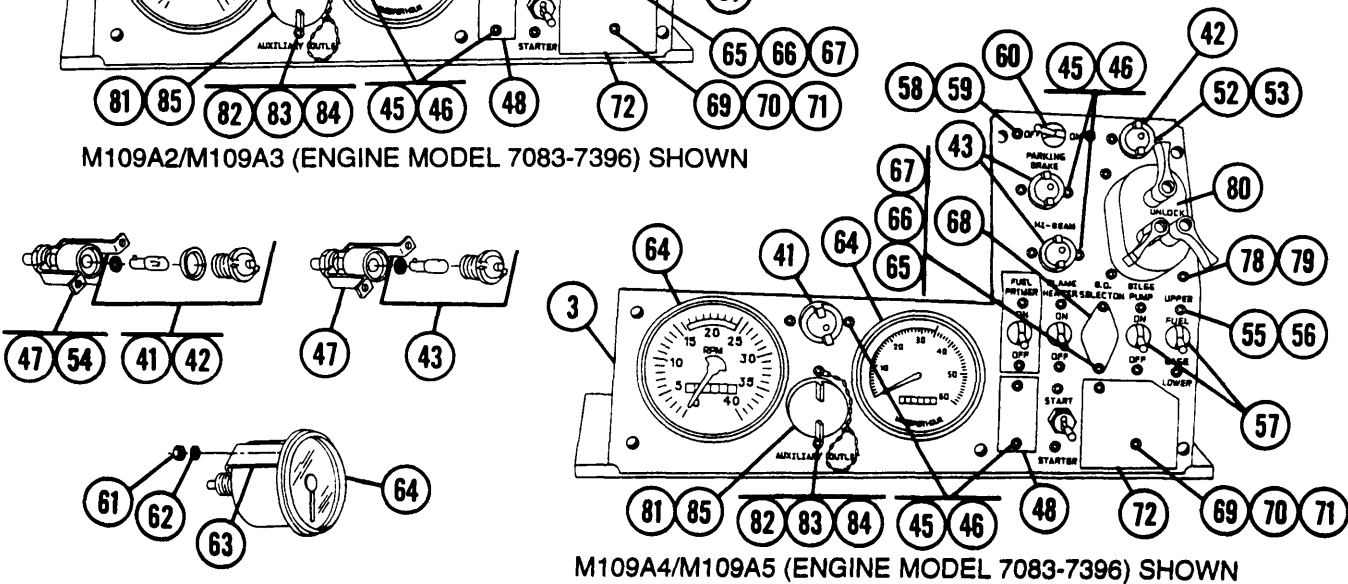
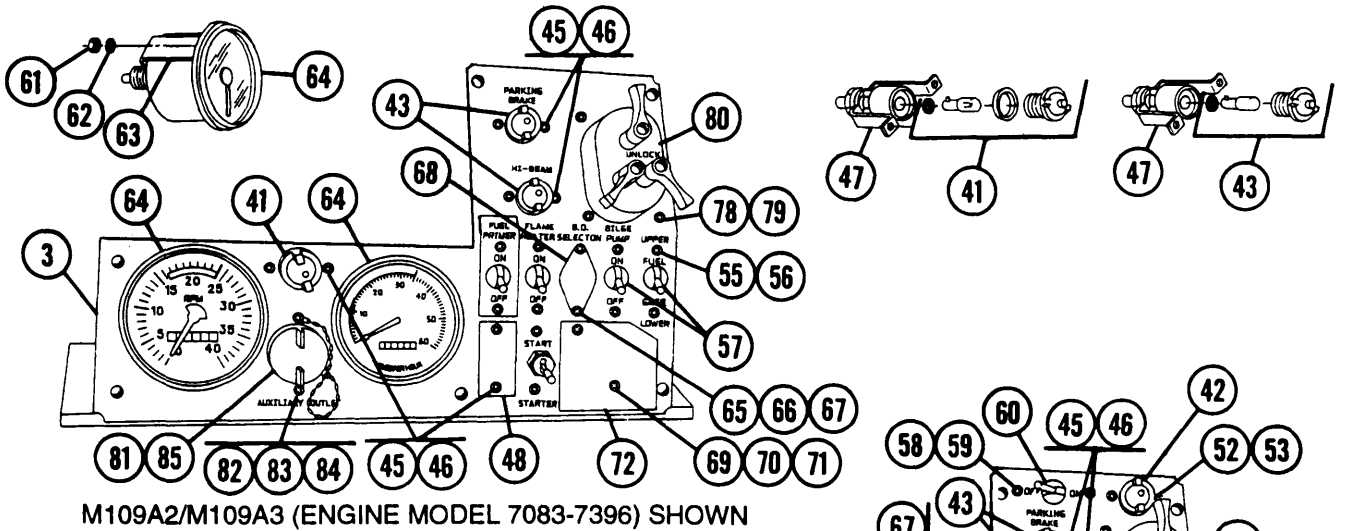

- 22 Remove four nuts (61), four washers (62), two brackets (63), and two indicators (64).
- 23 Remove two screws (65), two lockwashers (66), two nuts (67), and plate (68). Discard lockwashers.
- 24 Remove two screws (69), two lockwashers (70), two nuts (71), and plate (72). Discard lockwashers.
- 25 Remove four screws (73), four lockwashers (74), four nuts (75), and two plates (76 and 77). Discard lockwashers.
- 26 Remove four screws (78), four lockwashers (79), and light switch (80). Discard lockwashers.
- 27 Remove cover (81), two screws (82), two flat washers (83), two lockwashers (84), and auxiliary outlet (85). Discard lockwashers

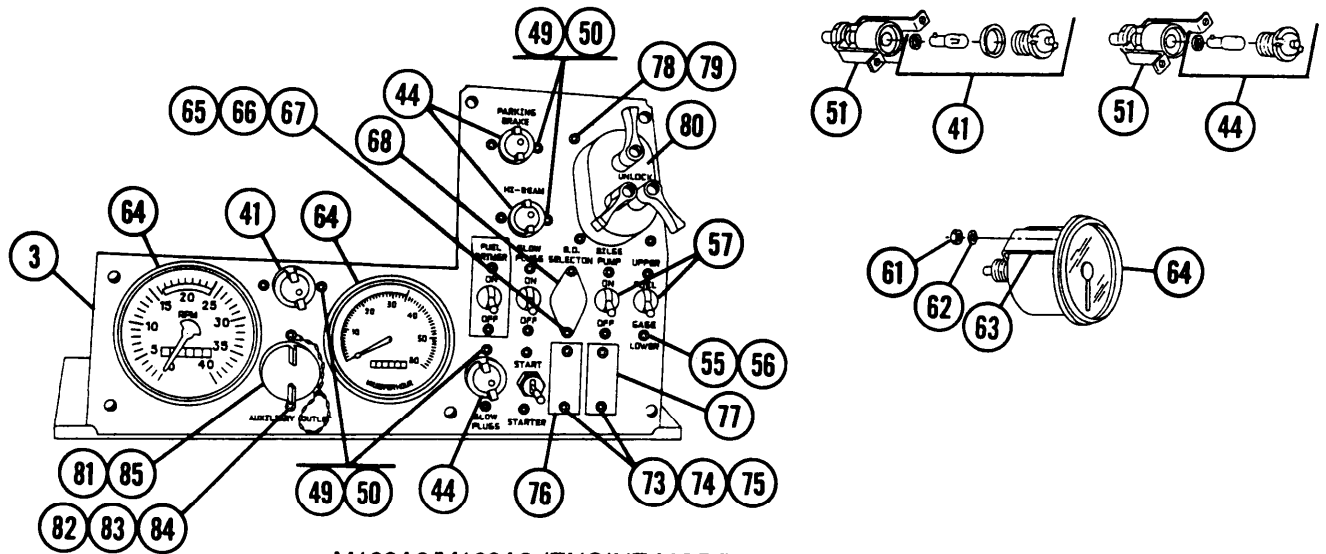

M109A2/M109A3 (ENGINE MODEL 7083-7391) SHOWN

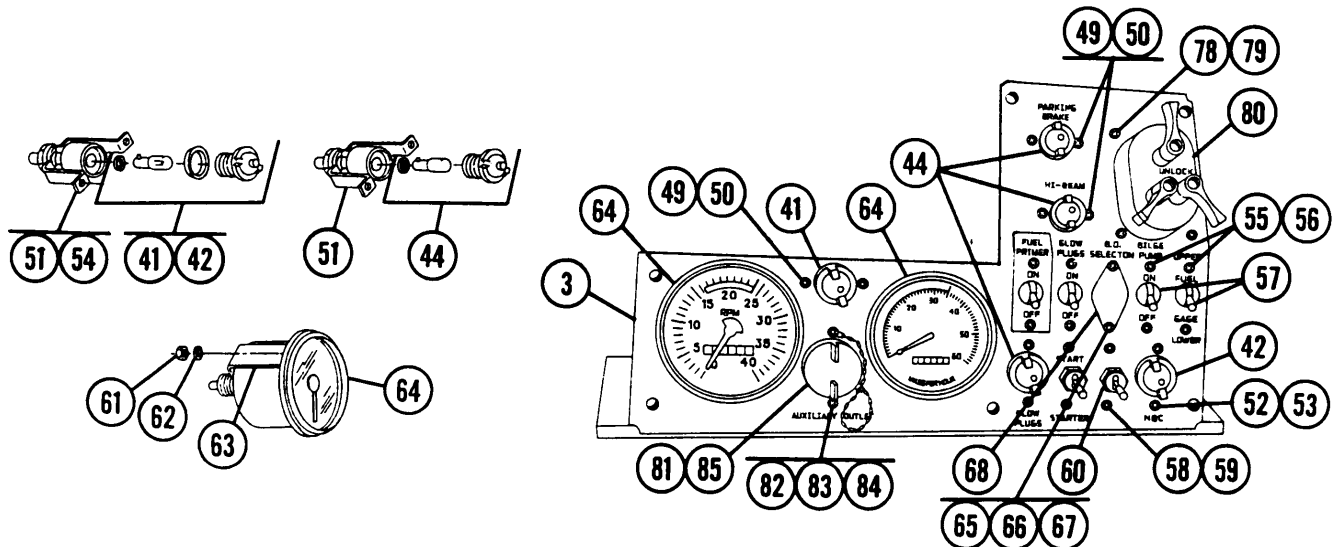

M109A4/M109A5 (ENGINE MODEL 7083-7391) SHOWN

8-17 PORTABLE AND DRIVER'S INSTRUMENT PANELS — CONTINUED

c. Assembly — Continued

- 1 Apply light coating of silicone compound to lamp sockets of driver's instrument panel (3).
- 2 Install auxiliary outlet (85), two new lockwashers (84), two flat washers (83), two screws (82), and cover (81).
- 3 Install light switch (80), four new lockwashers (79), and four screws (78).
- 4 install plate (72), two nuts (71), two new lockwashers (70), and two screws (69).
- 5 Install two plates (76 and 77), four nuts (75), four new lockwashers (74), and four screws (73).
- 6 Install plate (68), two nuts (67), two new lockwashers (66), and two screws (65).
- 7 Install two indicators (64), two brackets (63), four washers (62), and four nuts (61).

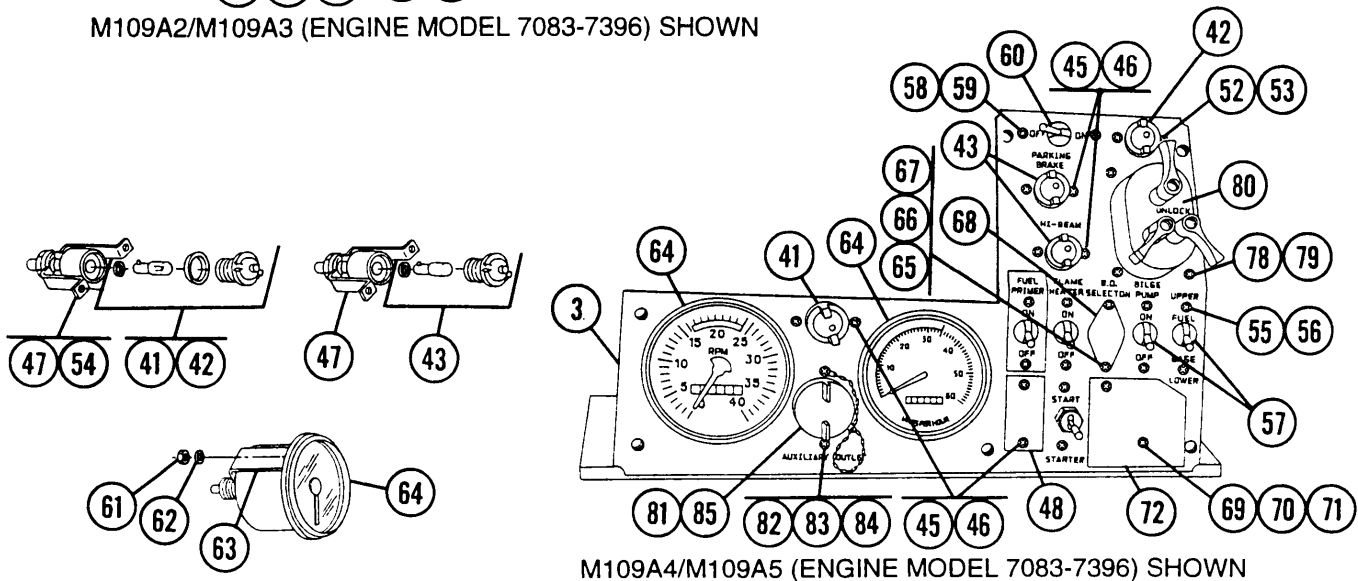
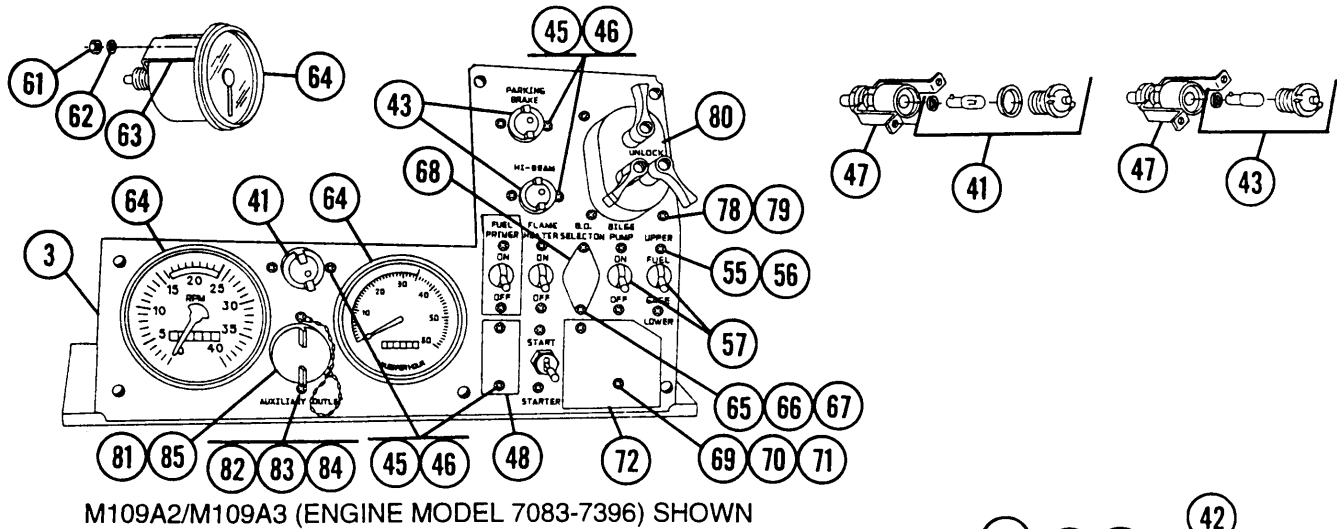

- 8 For M109A4/M109A5 Howitzers, install switch assembly (60), two flat washers (59), and two screws (51).
- 9 Install 5 switch assemblies (57), 10 flat washers (56), and 10 screws (55).
- 10 For M109A4/M109A5 Howitzers, install light bracket (54), two washers (53), and two screws (52).
- 11 Install four light brackets (51), eight washers (50), and eight screws (49).
- 12 Install three light brackets (47), cover (48), eight washers (46), and eight screws (45).
- 13 Install three LED assemblies (gasket, LED, and lens) (44).
- 14 Install two LED assemblies (gasket, LED, and lens) (43).
- 15 For M109A4/M109A5 Howitzers, install lamp assembly (gasket, lamp, packing, and lens) (42).
- 16 Install lamp assembly (gasket, lamp, packing, and lens) (41).

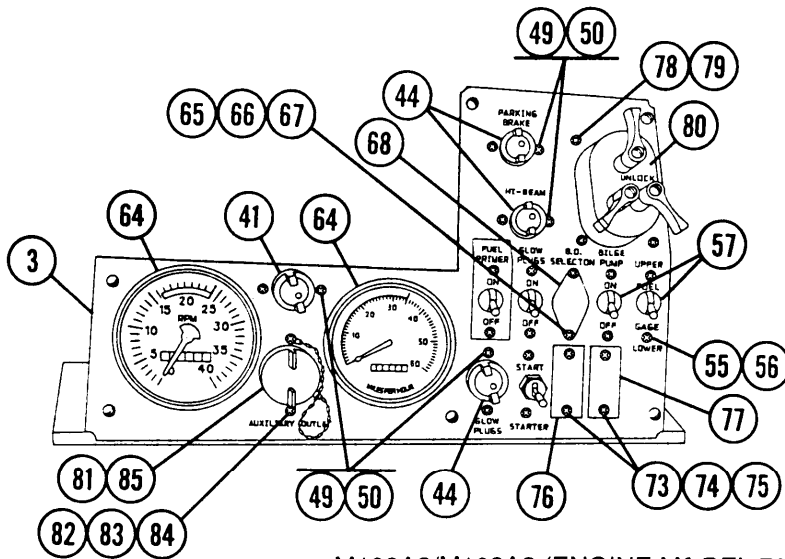

M109A2/M109A3 (ENGINE MODEL 7083-7391) SHOWN

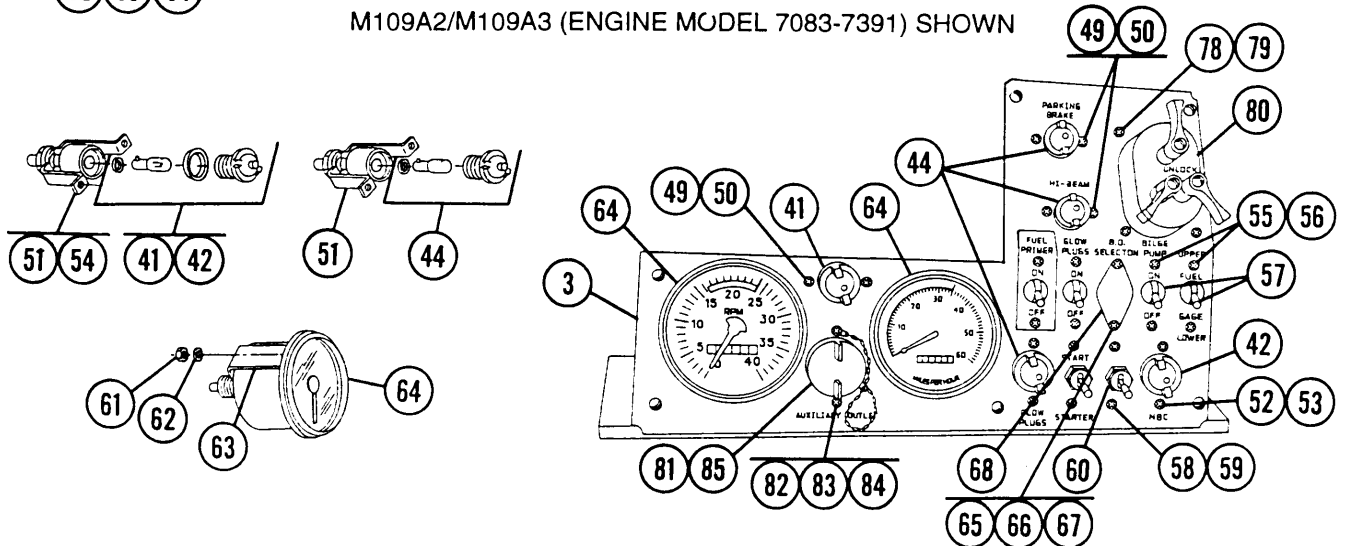
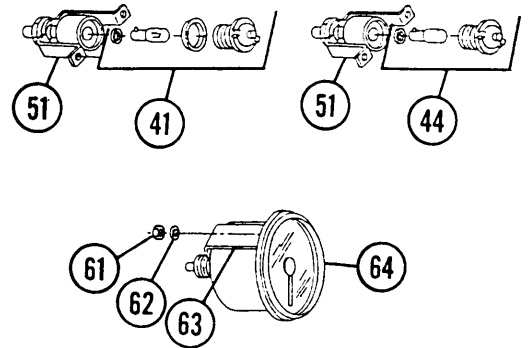

M109A4/M109A5 (ENGINE MODEL 7083-7391) SHOWN

8-17 PORTABLE AND DRIVER'S INSTRUMENT PANELS — CONTINUED

c. Assembly — Continued

- 17 Apply a light coating of silicone compound to lamp sockets of panel (19).
- 18 Install coolant indicator light assembly (40) and hex nut (39).
- 19 Install 6 indicators (38), 6 brackets (37), 12 new lockwashers (36), and 12 nuts (35).
- 20 Install shield light assembly (34), four light brackets (33), eight washers (32), and eight screws (31).
- 21 Install MASTER switch (30), switch guard (28), ID plate (29), two new lockwashers (27), two flat washers (26), and two screws (25).
- 22 Screw two lamp assemblies (gasket, lamp, packing, and lens) (23) into front of panel (19).
- 23 Screw two LED assemblies (gasket, LED, and lens) (24) into front of panel (19).

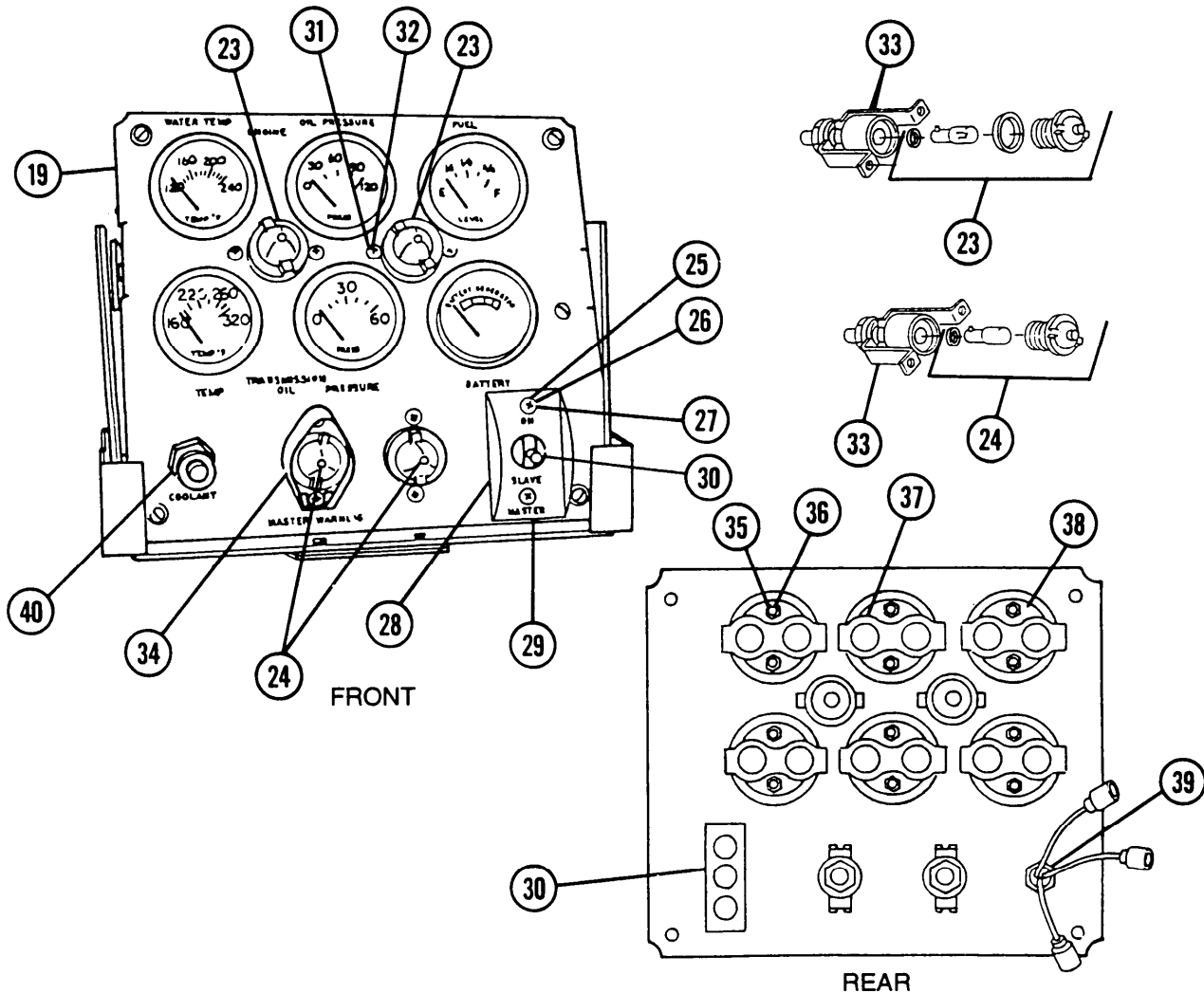

- 24 Install wiring harness (1) onto portable instrument panel cover (20).
- 25 Connect all electrical connectors (22) to back of panel (19).
- 26 Install grommet (21) and remove slack from wiring harness (1).
- 27 Position panel (19) onto panel cover (20) and connect four stud fasteners (18).
- 28 Position portable instrument panel (2) inside bracket assembly (17) and secure with four crosspoint screws (16).

d. Installation

- 1 Install mounting support (12).
- 2 Install ground strap (15), four washers (14), and four screws (13),
- 3 Position driver's instrument panel (3) into mounting support (12).

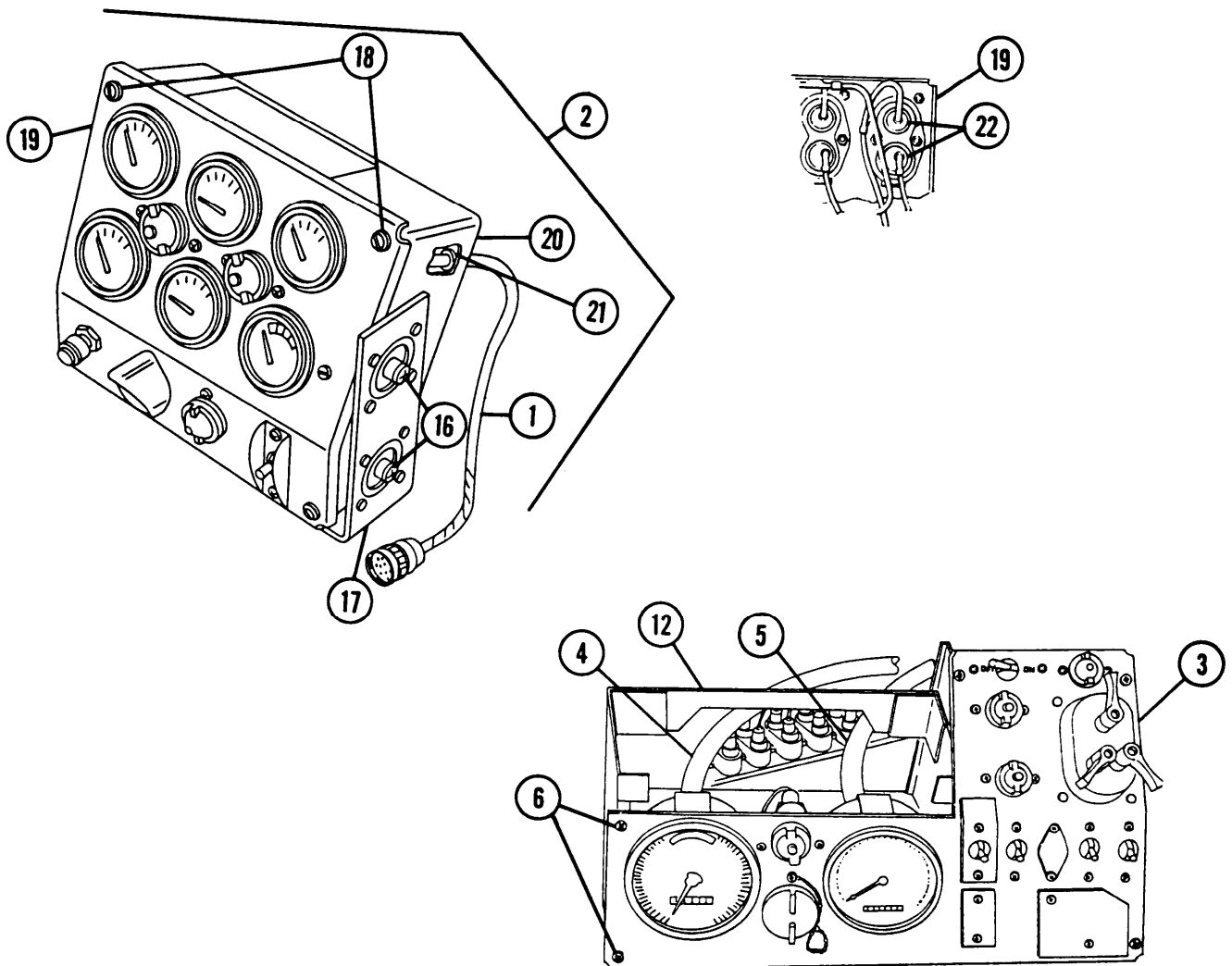

M109A4/M109A5
(ENGINE MODEL 7083-7396) SHOWN

8-17 PORTABLE AND DRIVER'S INSTRUMENT PANELS — CONTINUED

d. Installation — Continued

- 4 For M109A4/M109A5 Howitzers, connect three connectors (11) at back of panel (3) (see below).
- 5 Connect 17 instrument panel connectors (7) and light switch connector (8) at back of panel (3) (see below).
- 6 Connect 16 instrument panel connectors (9) and light switch connector (10) at back of panel (3).
- 7 Connect panel (3) with six stud fasteners (6) by pushing in and turning clockwise.

NOTE

Be certain not to switch cables.

- 8 Install flexible tachometer cable (4) and flexible speedometer cable (5).
- 9 Position portable instrument panel (2) into driver's instrument panel (3) bracket.
- 10 Connect wiring harness (1) connector.

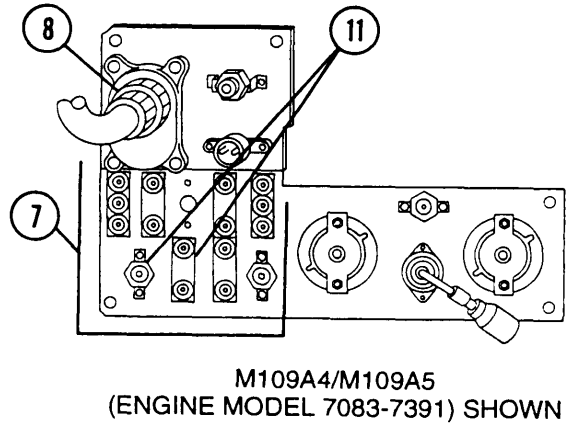
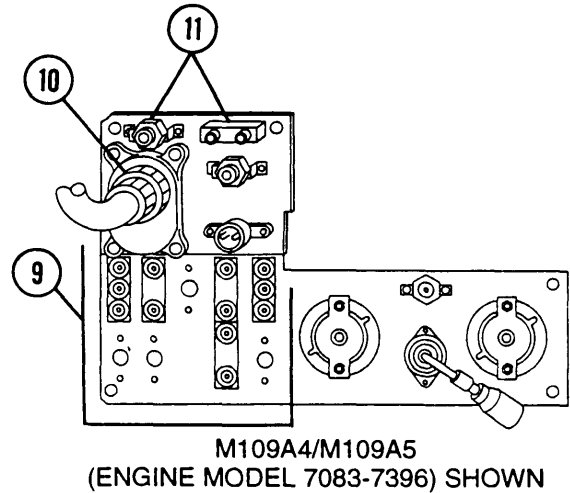
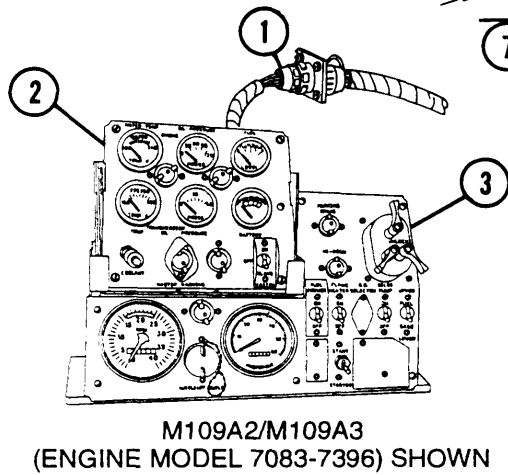
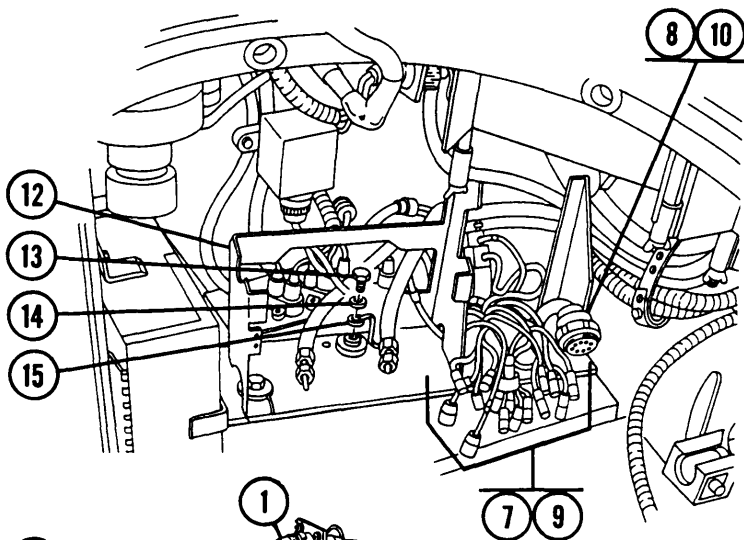

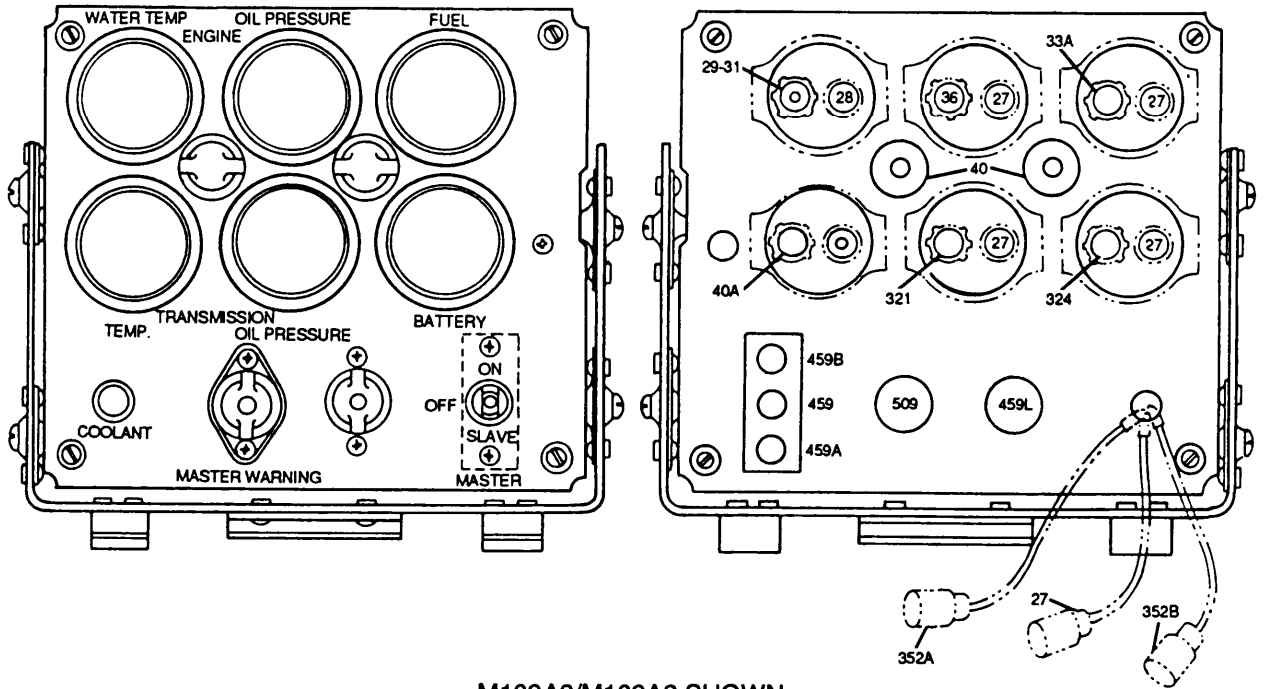

M109A2/M109A3 SHOWN

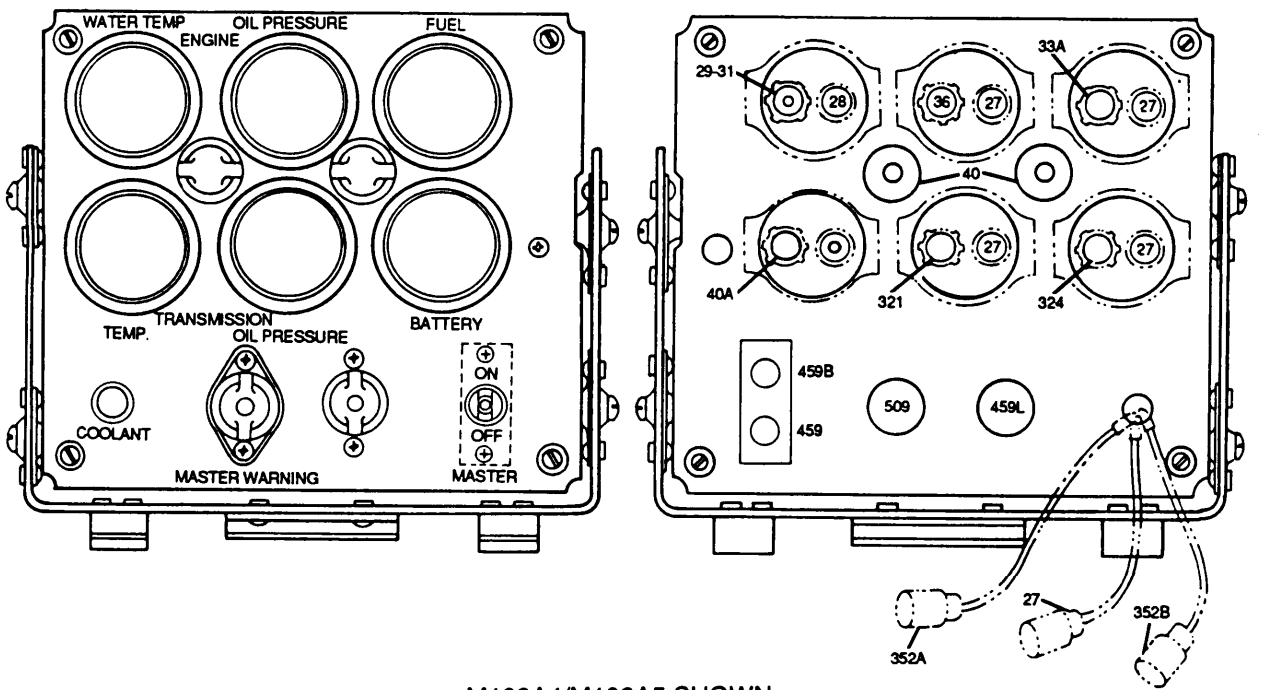

M109A4/M109A5 SHOWN

8-17 PORTABLE AND DRIVER'S INSTRUMENT PANELS — CONTINUED

d. Installation — Continued

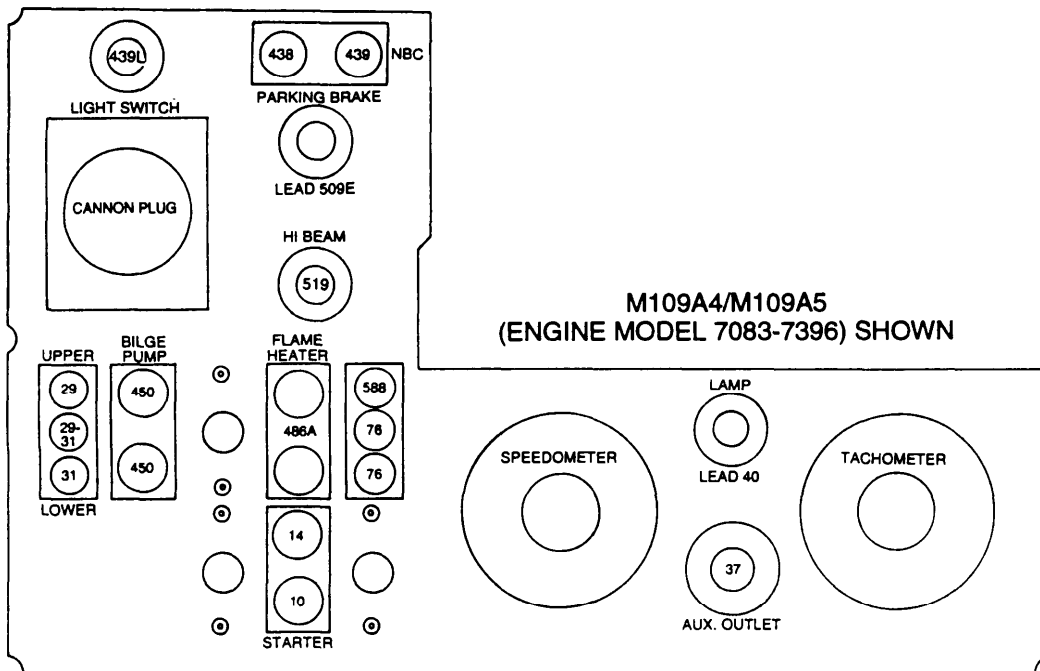
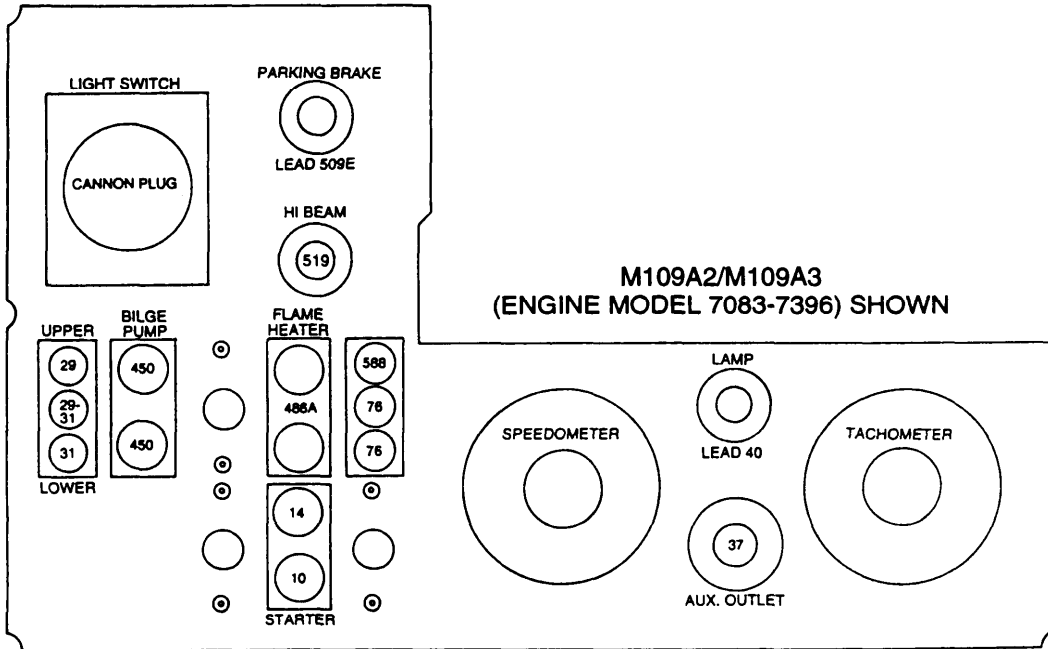

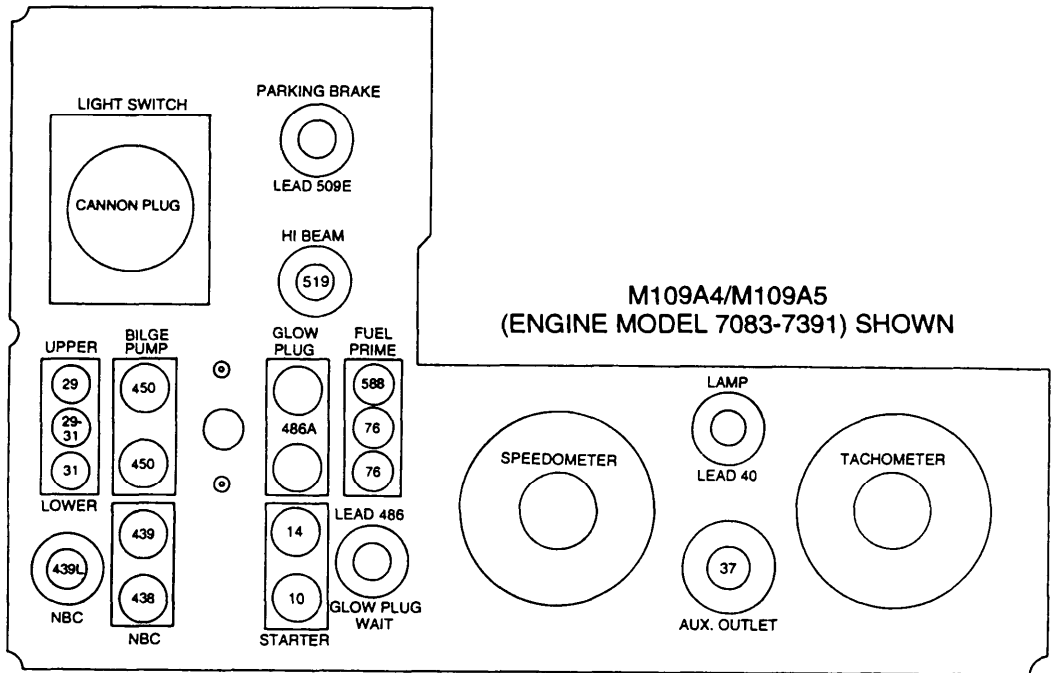
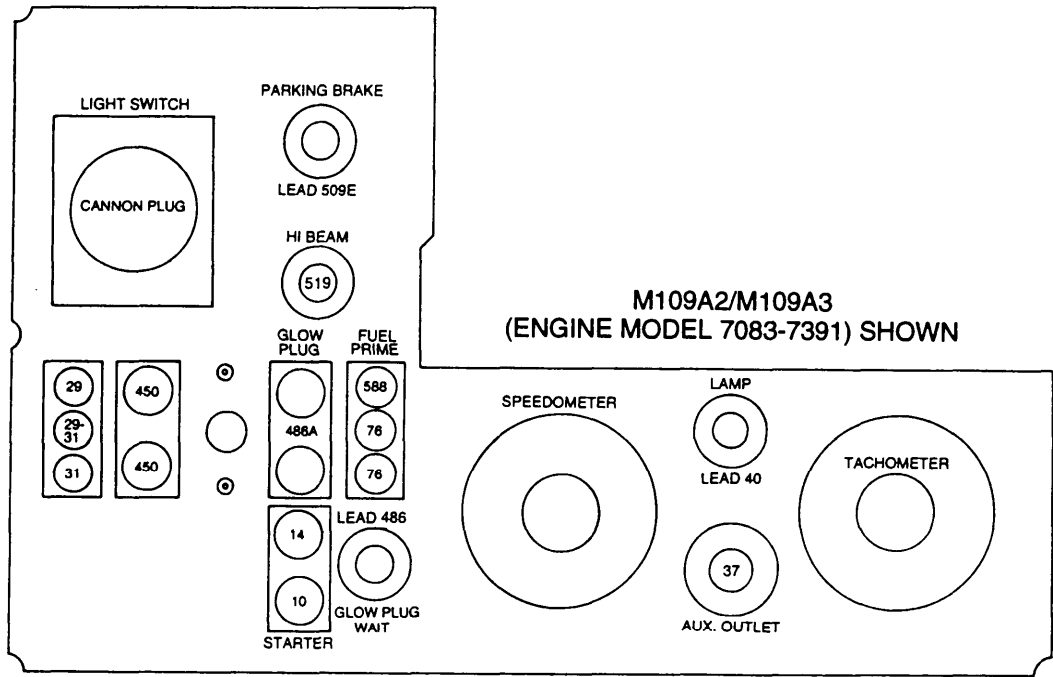

NOTE

FOLLOW-ON MAINTENANCE: Connect batteries (para 8-28)

8-18 DRIVER'S INSTRUMENT PANEL SUPPORT ASSEMBLY

This task covers: a. Disassembly b. Assembly

INITIAL SETUP

Tools

General mechanic's tool kit (item 64, Appx H)
 Rivet gun (item 25, Appx H)
 Wire brush (item 6, Appx H)

Rivets (12) (item 18, Appx G)
 Rivets (8) (item 21, Appx G)

Equipment Conditions

Driver's instrument panel removed (para 8-17)

Materials/Parts

Adhesive (item 6, Appx D)

a. Disassembly

- 1 Remove 12 rivets (1) and 6 turnlock receptacles (2). Discard rivets.
- 2 Remove eight rivets (3), four resilient mounts (4), and ground lead (5). Discard rivets.
- 3 Remove four cushions (6) from driver's instrument support assembly (7).

b. Assembly

- 1 Apply adhesive to four cushions (6) and install on driver's instrument panel support assembly (7).
- 2 Install four resilient mounts (4) and ground lead (5) with eight new rivets (3).
- 3 Install 6 turnlock receptacles (2) with 12 new rivets (1).

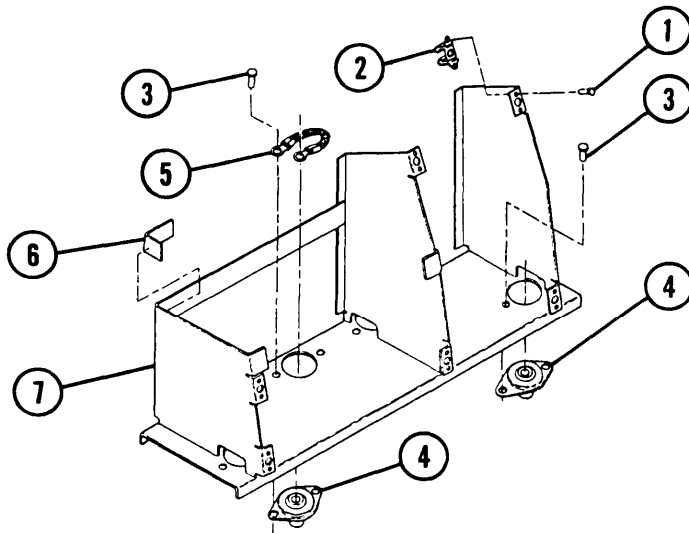

NOTE

FOLLOW-ON MAINTENANCE: Install driver's instrument panel (para 8-17)

8-19 PORTABLE INSTRUMENT PANEL COVER AND BRACKET ASSEMBLIES

This task covers: a. Disassembly b. Assembly

INITIAL SETUP
Tools

General mechanic's tool kit (item 64, Appx H)
Rivet gun (item 25, Appx H)

Rivets (4) (item 22, Appx G)
Rivets (2) (item 23, Appx G)

Materials/Parts

Rivets (24) (item 19, Appx G)
Rivets (8) (item 20, Appx G)

Equipment Conditions

Portable drivets instrument panel removed from cover and bracket (para 8-17)

a. Disassembly

- 1 Remove four rivets (1) and two retaining straps (2) from bracket (3). Discard rivets.
- 2 Remove two rivets (4) and latch (5) from bracket (3). Discard rivets.
- 3 Remove eight rivets (6) and four resilient mounts (7) from bracket (3). Discard rivets.
- 4 Remove 24 rivets (8), 4 turnlock mounts (9), and 4 nuts (10) from cover (11). Discard rivets.

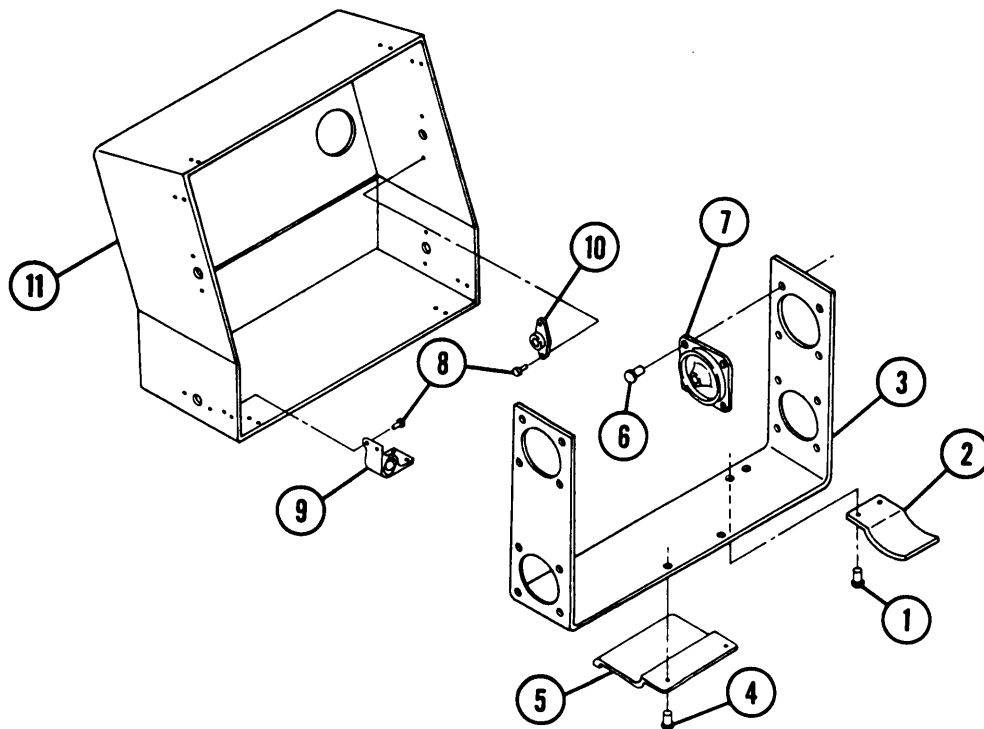

**8-19 PORTABLE INSTRUMENT PANEL COVER AND BRACKET ASSEMBLIES —
CONTINUED**

b. Assembly

- 1 Install 24 new rivets (8), 4 nuts (10), and 4 turnlock mounts (9) on cover (11).
- 2 Install four resilient mounts (7) with eight new rivets (6) on bracket (3).
- 3 Install cover (11) inside bracket (3).
- 4 Install two retaining straps (2) and four new rivets (1) securing cover (11) to bracket (3).
- 5 Install latch (5) with two new rivets (4) to bracket (3).

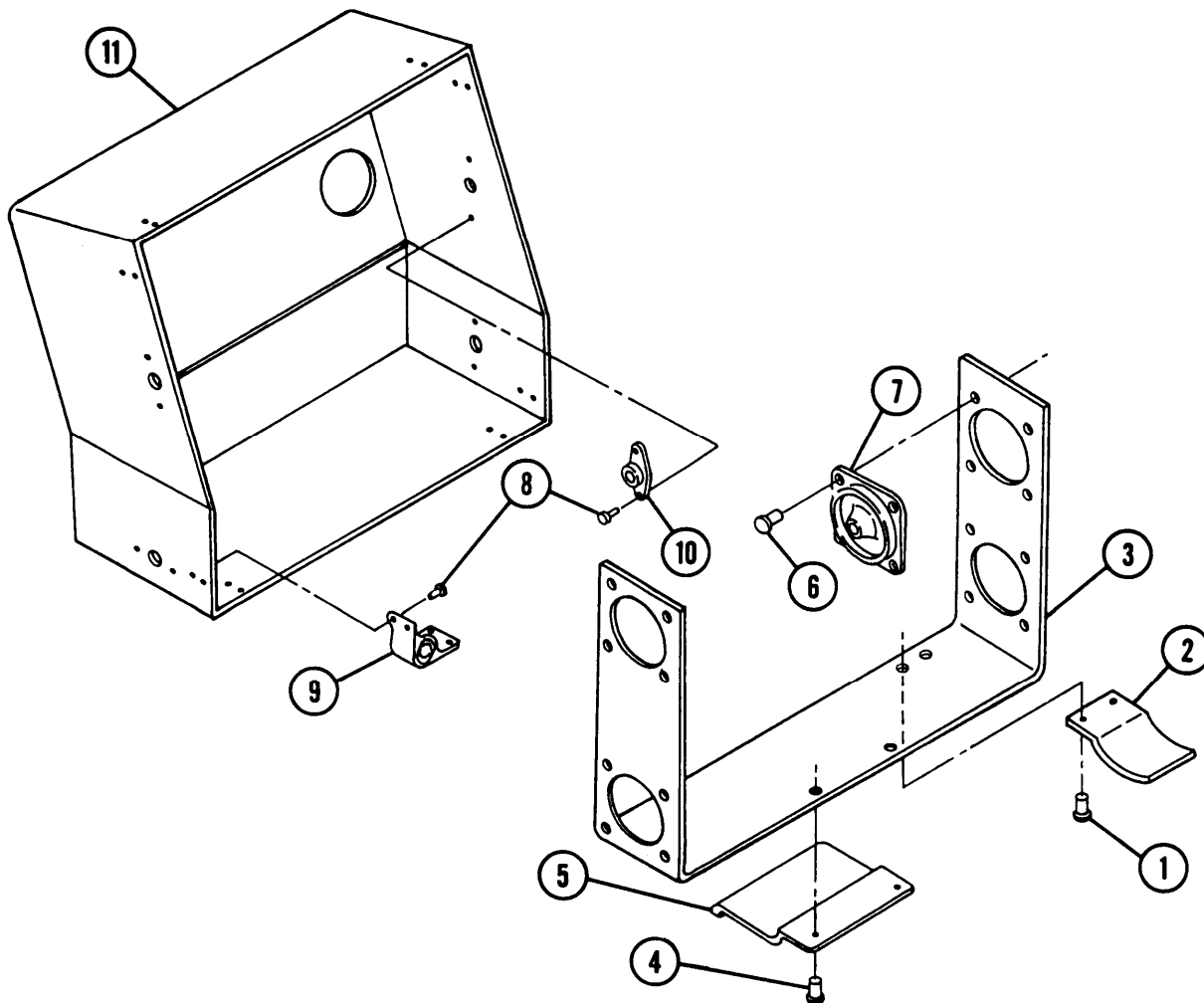

NOTE

FOLLOW-ON MAINTENANCE: Install portable instrument panel to cover and bracket (para 8-17)

8-20 ACCESSORY CONTROL BOX

- This task covers:
- | | |
|-------------|-----------------------|
| a. Removal | b. Disassembly/Repair |
| c. Assembly | d. Installation |

INITIAL SETUP

Tools

- General mechanic's tool kit (item 64, Appx H)
- Rivet gun (item 25, APPX H)
- Soldering gun (item 26, APPX H)

- Lockwashers (12) (item 94, Appx G)
- Rivet (item 20, Appx G)
- Rosin core solder (item 58, Appx D)
- Silicone compound (item 33, Appx D)

Materials/Parts

- Gasket (item 150, Appx G)
- Lockwasher (item 72, Appx G)
- Lockwashers (12) (item 86, APPX G)
- Lockwashers (3) (item 87, Appx G)
- Lockwashers (4) (item 93, Appx G)

Personnel Required

Two

Equipment Conditions

Batteries disconnected (para 8-28)

a. Removal

- 1 Disconnect three electrical connectors (1).
- 2 Remove four screws (2), four flat washers (3), four lockwashers (4), and four nuts (5) while supporting accessory control box (6). Discard lockwashers.
- 3 Remove four screws (7), four washers (8), and two mounting brackets (9).

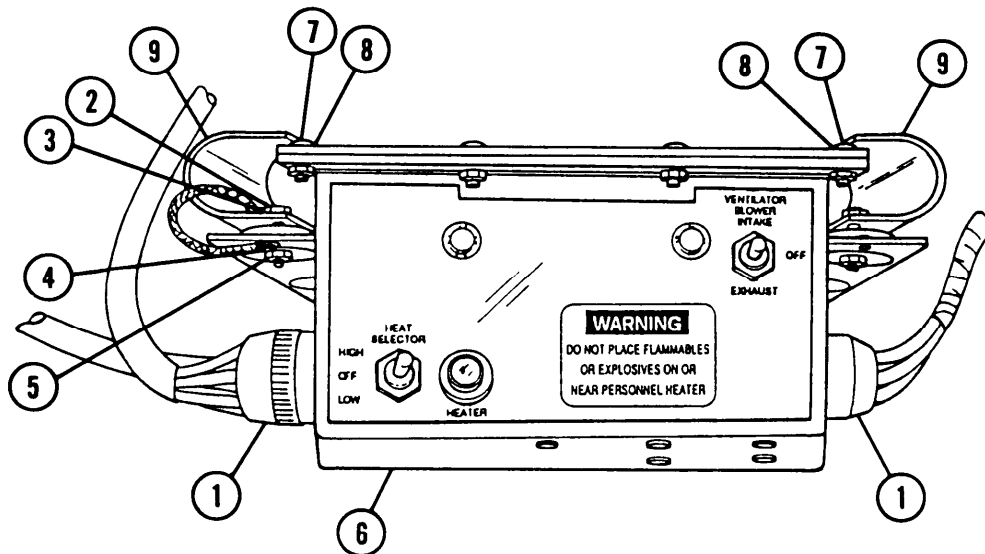

8-20 ACCESSORY CONTROL BOX — CONTINUED

b. Disassembly/Repair

NOTE

Some accessory control boxes may have additional wiring for the flotation blower. This wiring is no longer used.

- 1 Remove 12 nuts (10), 12 lockwashers (11), 12 flat washers (12), and 12 screws (13). Lift off cover (14) and gasket (15). Discard lockwashers and gasket.

NOTE

Follow step 2 only if ground lead is damaged.

- 2 Drill out rivet (16) to remove ground lead (17). Discard rivet.

NOTE

For accessory control box wiring diagram (ID/schematic), refer to personnel heater and personnel ventilation blower troubleshooting procedures (para 3-3).

- 3 Disconnect four electrical connectors (18) at circuit breakers (19).
- 4 Remove four screws (20), four flat washers (21), four lockwashers (22), and four nuts (23). Remove two circuit breakers (19). Discard lockwashers.
- 5 Remove screw (24), two flat washers (25), and nut (26).

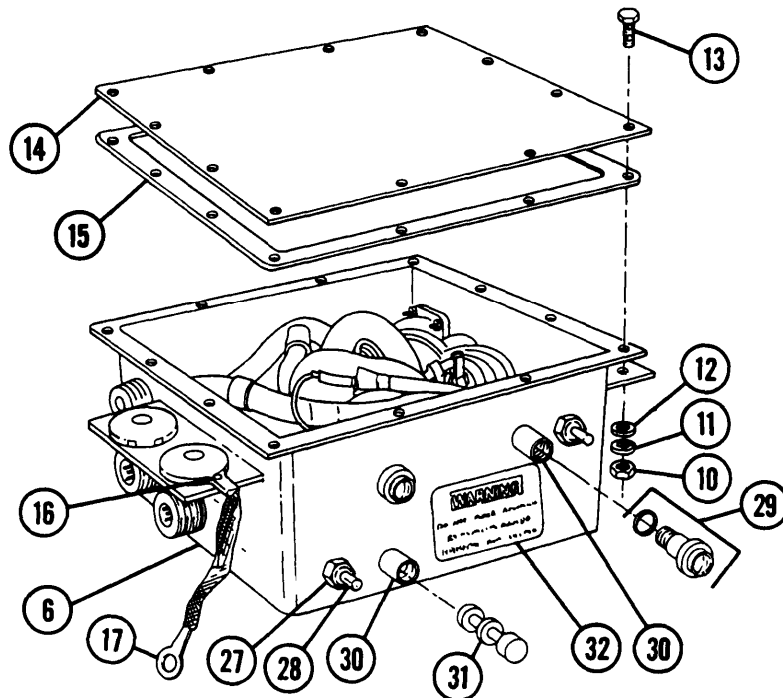

6 Unscrew two hex nuts (27) and pull two switches (28) into accessory control box (6).

7 Unscrew and remove two lamp assemblies (panel light LEDs and gaskets) (29). Pull light bracket (30) into accessory control box (6).

NOTE

To remove electrical connectors to lamp assemblies and/or switches, unsolder points of connection.

8 Remove indicator light lamp assembly (indicator lamp cap, LED, gasket, and hex nut) (31). Pull indicator light bracket (30) into accessory control box (6).

9 Remove WARNING decal (32) if damaged or illegible (para 2-7).

10 Remove eight screws (33), eight flat washers (34), eight lockwashers (35), and eight nuts (36). Remove two electrical connectors (37). Discard lockwashers.

11 Remove four screws (38), four flat washers (39), four lockwashers (40), and four nuts (41). Remove electrical connector (42). Discard lockwashers.

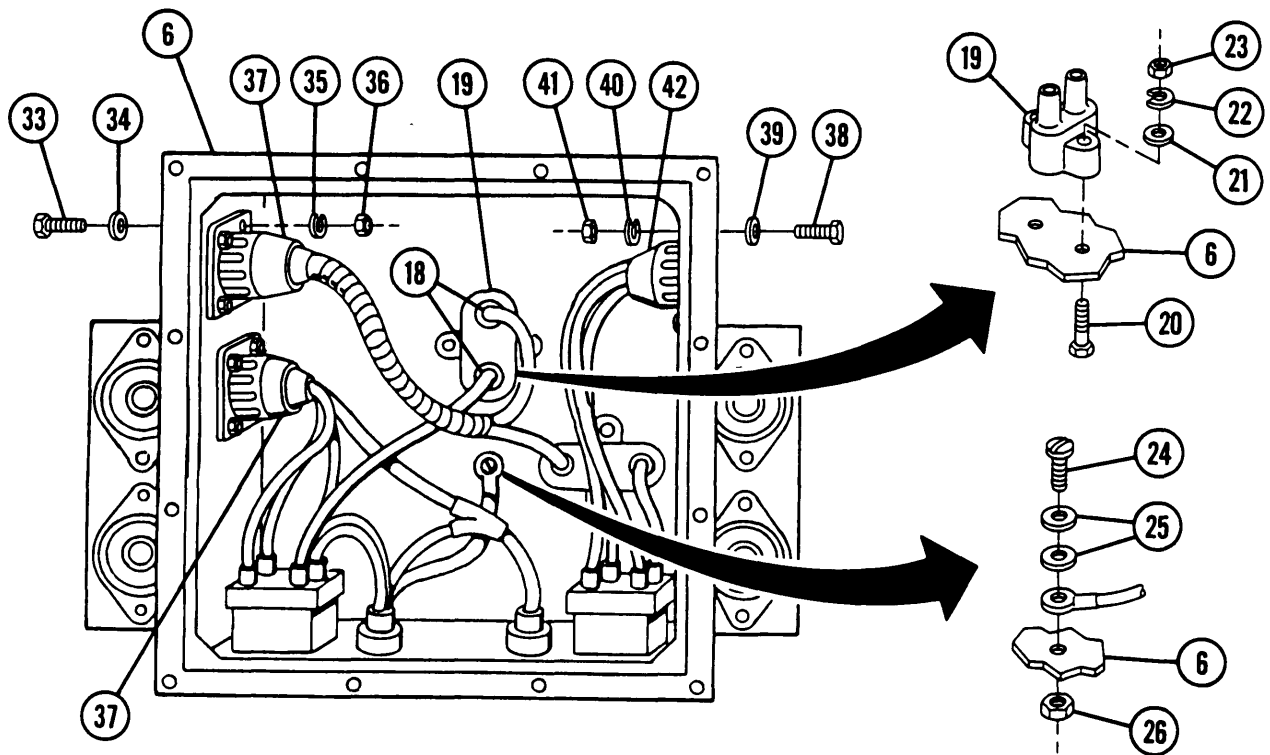

8-20 ACCESSORY CONTROL BOX — CONTINUED

c. Assembly

CAUTION

To avoid damaging wiring, use only rosin core solder to connect wires to terminal.

- 1 Install electrical connector (42), four flat washers (39), four new lockwashers (40), four screws (38), and four nuts (41).
- 2 Install two electrical connectors (37), eight flat washers (34), eight new lockwashers (35), eight screws (33), and eight nuts (36).
- 3 Push indicator light bracket (30) into accessory control box (6).
- 4 Apply light coating of silicone compound to three bulb sockets.
- 5 Install indicator light lamp assembly (gasket, indicator LED, hex nut, and cap) (31).
- 6 Push light bracket (30) into accessory control box (6).
- 7 Install two lamp assemblies (gaskets and panel light LEDs) (29).
- 8 Push two switches (28) into accessory control box (6) and screw in two hex nuts (27).
- 9 Replace WARNING decal (32) if removed (para 2-7).

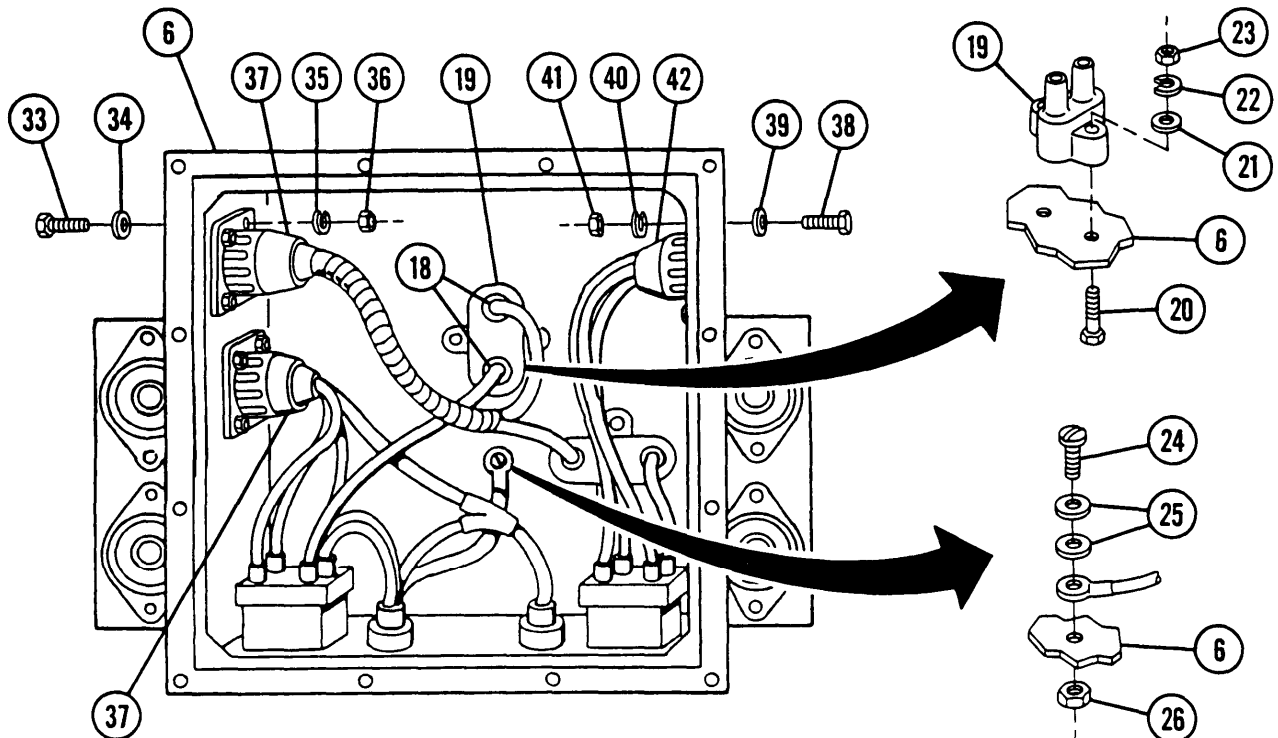

10 Install two flat washers (25), screw (24), and nut (26).

11 Install two circuit breakers (19), four flat washers (21), four new lockwashers (22), four screws (20), and four nuts (23).

12 Connect four electrical connectors (18) at circuit breakers (19).

NOTE

Follow step 13 to install ground lead, if necessary.

13 Install ground lead (17) with new rivet (16).

14 Install new gasket (15) and cover (14).

15 Install 12 flat washers (12), 12 new lockwashers (11), 12 screws (13), and 12 nuts (10).

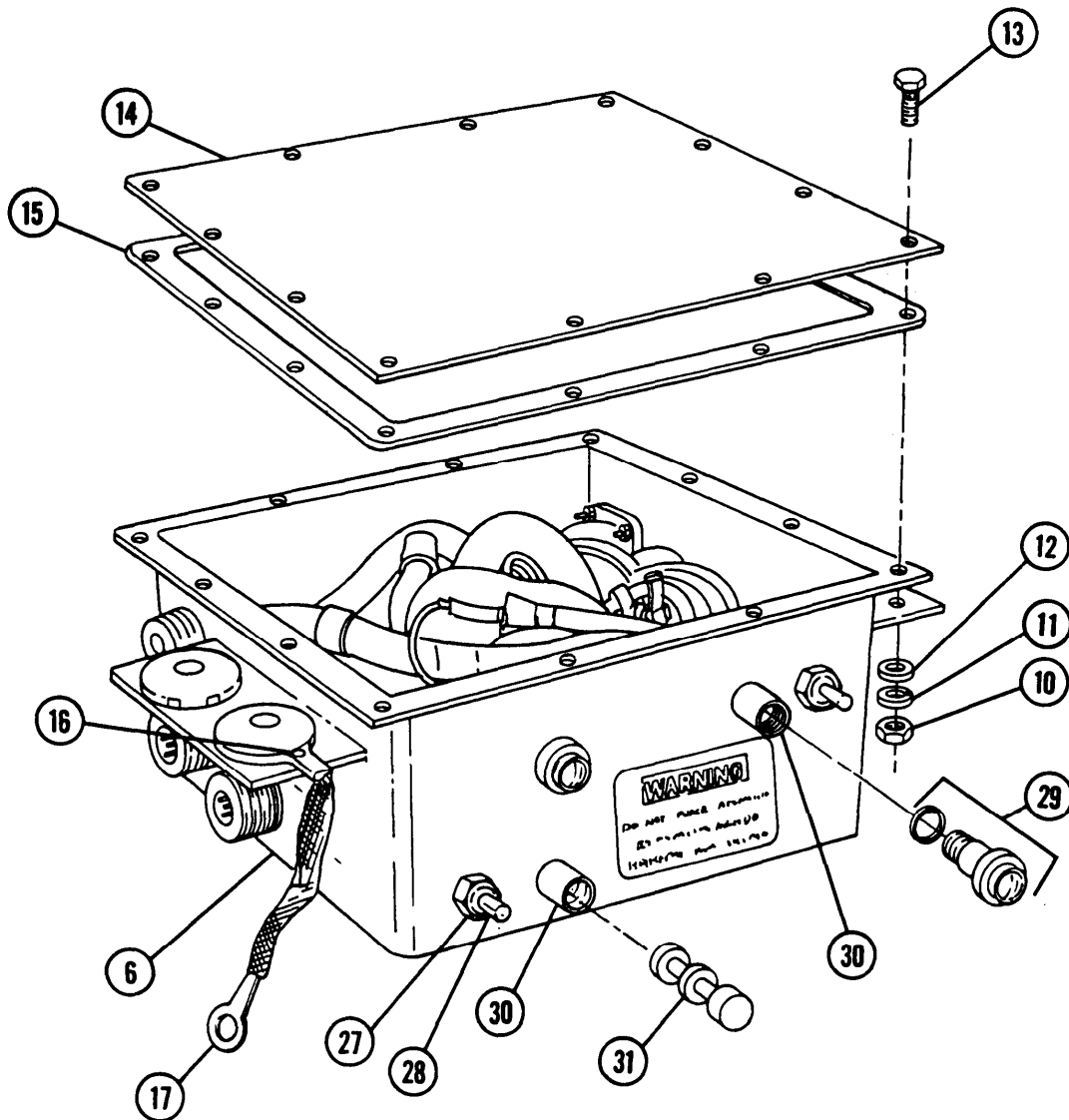

8-20 ACCESSORY CONTROL BOX — CONTINUED

d. Installation

- 1 Install two mounting **brackets** (9), four washers (8), and four screws (7).
- 2 Position accessory control box (6) on two mounting brackets (9) and install and tighten four nuts (5), four new lockwashers (4), four flat washers (3), and four screws (2).
- 3 Connect three electrical connectors (1).

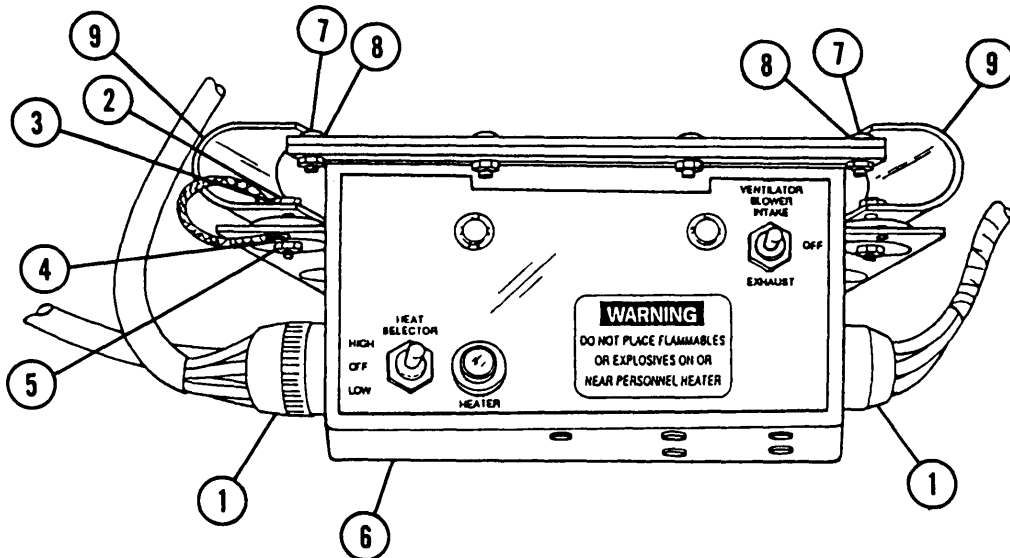

NOTE

FOLLOW-ON MAINTENANCE: Connect batteries (para 8-28)

8-21 HEADLIGHTS

This task covers: a. Alinement b. Removal
 c. Installation d. Adjustment

INITIAL SETUP

Tools

General mechanic's tool kit (item 64, Appx H)

Materials/Parts

Silicone compound (item 18, Appx D)

a. Alinement

NOTE

Alinement of lights should be performed in shaded or dimly-lit area.

- 1 Park vehicle on level ground or pavement 25 ft (7.62 m) from a wall.
- 2 Draw line (1) perpendicular to wall or screen, passing through center of vehicle.
- 3 Measure distance from center of sealed lamp unit (service side, clear) to ground. Duplicate this measurement on wall, drawing horizontal centerline (2) of lamp unit.
- 4 Draw a line (3) parallel to and 27.25 in. (69.2 cm) below centerline (2).
- 5 Draw a line (4) parallel to and 53 in. (1.35 m) left of centerline (1) of vehicle.
- 6 Draw a line (5) parallel to and 58 in. (1.47 m) right of centerline (1) of vehicle.
- 7 Turn on lights to low beam. Center of left beam's highest light intensity should be where lines (3 and 4) cross. Center of right beam's highest light intensity should be where lines (3 and 5) cross. Adjust if necessary (see below).

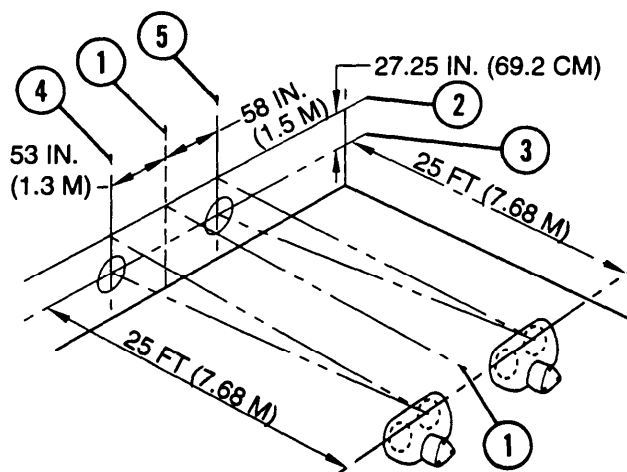

8-21 HEADLIGHTS — CONTINUED

b. Removal

- 1 Pull T-handle locking device (6) upward.
- 2 Remove retaining clamp (7).

CAUTION

Do not twist headlight assembly during removal. Damage to connectors may result.

- 3 Pull headlight assembly (8) straight out.

c. Installation

- 1 Apply silicone compound to electrical connectors.

CAUTION

Do not twist headlight assembly during installation. Damage to connectors may result.

- 2 Install headlight assembly (8).
- 3 Install retaining clamp (7).
- 4 Pull T-handle locking device (6) downward.

d. Adjustment

- 1 Remove headlight assembly (8) (see above).
- 2 Loosen two nuts (9) and two nuts (10).
- 3 Install headlight assembly (8) (see above).
- 4 Manually adjust headlight assembly (8) to alignment marks (see above).
- 5 Tighten two nuts (10).
- 6 Remove headlight assembly (8) (see above).
- 7 Tighten two nuts (9).
- 8 Install headlight assembly (8) (see above).

8-22 HEADLIGHT SEALED-BEAM AND INCANDESCENT LAMPS

This task covers: a. Removal b. Installation

INITIAL SETUP**Tools**

General mechanic's tool kit (item 64, Appx H)

Materials/Parts

Antiseize compound (item 8, Appx D)

Grease (item 24, Appx D)

Lockwashers (4) (item 54, Appx G)

Silicone compound (item 18, Appx D)

8-22 HEADLIGHT SEALED-BEAM AND INCANDESCENT LAMPS — CONTINUED

a. Removal

- 1 Remove four screws (1), four lockwashers (2), and cover group (3) from headlight mount (4). Discard lockwashers.
- 2 Pull two sealed-beam units (5) out of recess.
- 3 Disconnect two electrical connectors (6) from sealed-beam units (5).
- 4 Snap open marker assembly (7) cover (8). Using screwdriver, push in and turn assembly hose base. Remove marker assembly from socket.
- 5 Remove B.O. drive reflector (9) from left headlight or reflector (10) from right headlight.

CAUTION

Left headlight has a halogen B.O. lamp. Halogen 6.0. lamp must be kept free of dirt, oil, grease, fingerprints, etc. Failure to do so can result in damage to bulb.

- 6 Push in, turn counterclockwise, and remove halogen B.O. lamp (11) from left headlight or lamp (12) from right headlight.

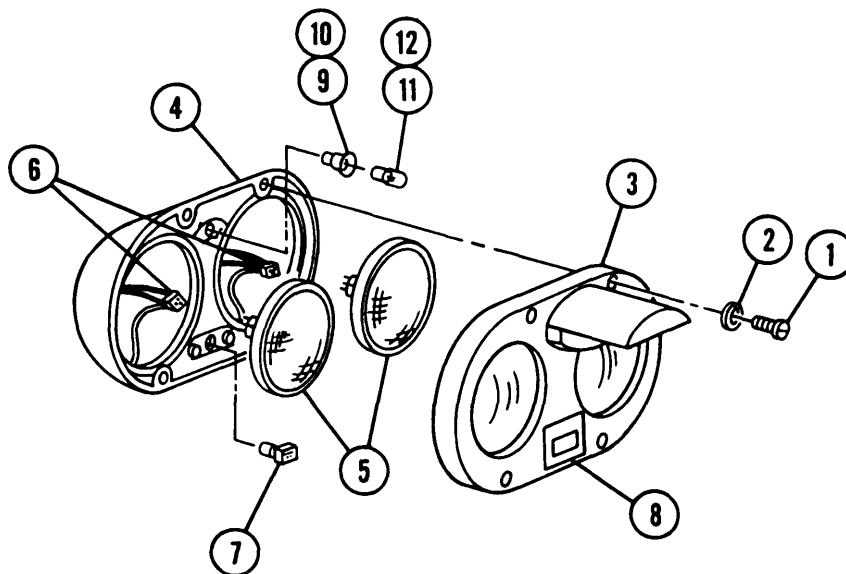

b. Installation

- 1 Apply light coating of silicone compound to lamp sockets.

CAUTION

Left headlight has a halogen B.O. lamp. Halogen B.O. lamp must be kept free of dirt, oil, grease, fingerprints, etc. Failure to do so can result in damage to bulb.

- 2 Install halogen B.O. lamp (11) in left headlight or lamp (12) in right headlight.
- 3 Install B.O. drive reflector (9) in left headlight or reflector (10) in right headlight.
- 4 Install marker assembly (7) and secure by turning base with screwdriver and closing marker assembly cover (8).
- 5 Connect two electrical connectors (6) to sealed-beam units (5).
- 6 Install two sealed-beam units (5) in recess.
- 7 Apply light coating of grease to cover group (3) contact surfaces.
- 8 Apply antiseize compound to threads of screws (1).
- 9 Install cover group (3) to headlight mount (4) with four new lockwashers (2) and four screws (1).

8-23 HEADLIGHT ASSEMBLY GROUP

This task covers: a. Disassembly/Repair b. Assembly

INITIAL SETUP

Tools

General mechanic's tool kit (item 64, Appx H)

Materials/Parts

Adhesive (item 4, Appx D)

Antiseize compound (item 8, Appx D)

Gasket (item 211, Appx G)

Gasket (item 212, Appx G)

Gasket (item 215, Appx G)

Gaskets (2) (item 210, Appx G)

Gaskets (2) (item 213, Appx G)

Gaskets (2) (item 214, Appx G)

Gaskets (2) (item 169, Appx G)

Grease (item 24, Appx D)

Lockwashers (2) (item 68, Appx G)

Lockwashers (11) (item 69, Appx G)

Sealing compound (item 57, Appx D)

8-23 HEADLIGHT ASSEMBLY GROUP — CONTINUED

a. Disassembly/Repair

- 1 Remove four screws (1), four washers (2), and cover group (3) at headlight mount (4).
- 2 Remove gasket (5), six screws (6), six lockwashers (7), two gaskets (8), B.O. lens (9), service headlight lens (10), two gaskets (11), two screws (12), two lockwashers (13), retainer (14), gasket (15), filter (16), lens (17), and gasket (18). Discard gaskets and lockwashers.
- 3 Remove three screws (19), three lockwashers (20), gasket (21), and B.O. drive light shield group (22). Discard lockwashers and gasket.
- 4 Remove two screws (23), two lockwashers (24), retainer (25), two gaskets (26), B.O. filter (27), lens (28), and gasket (29) from shield (30). Discard lockwashers and gaskets.

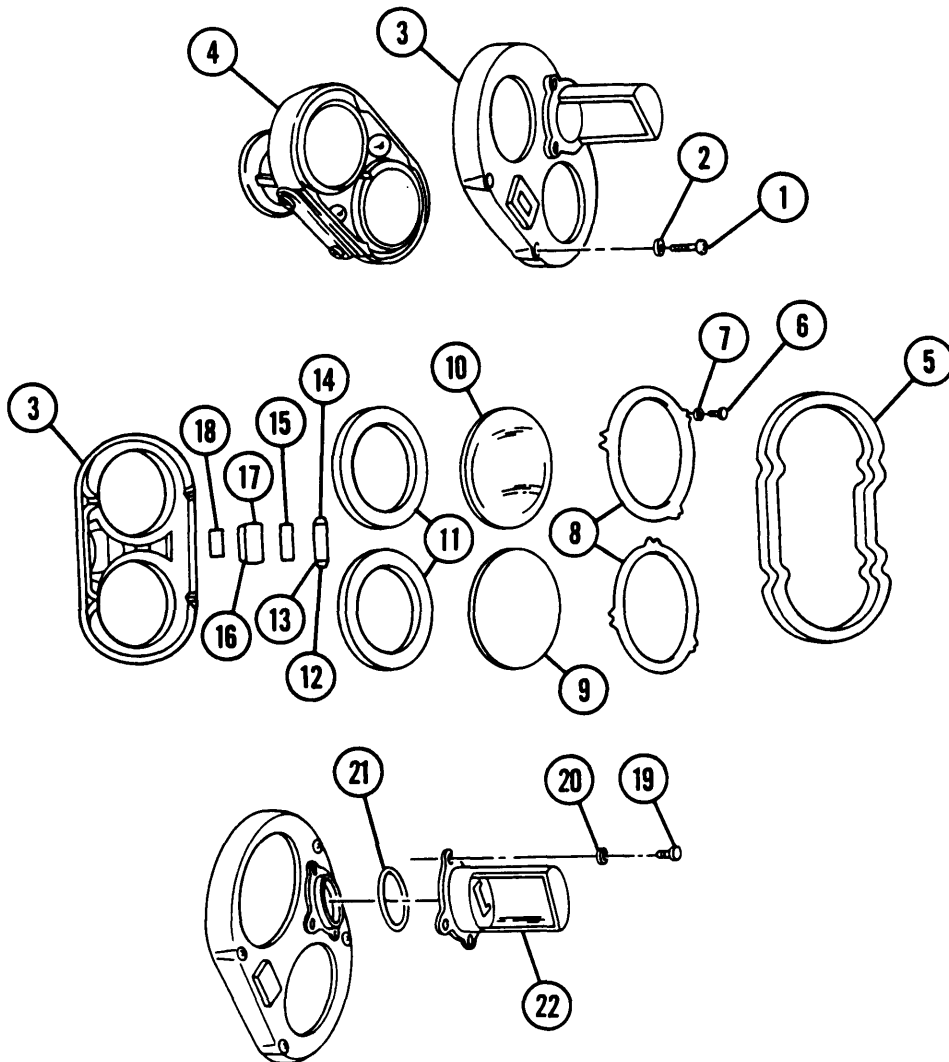

b. Assembly**WARNING**

Adhesives are toxic and flammable. Apply adhesives only in a well-ventilated area. Avoid contact with skin, eyes, and clothes, and don't breath vapors. Do not use near heat, sparks, or open flame. Read and follow all warnings and instructions on labels of adhesives. If contact with skin or eyes is made, wash area with water and seek medical aid immediately.

NOTE

Caution should be used when installing the following components to prevent light leakage from around filter.

- 1 Apply new gasket (29) to shield (30) with sealing compound.
- 2 Install these components in shield (30) after gasket (29) has been positioned: lens (28), two new gaskets (26), 6.0. filter (27), retainer (25), two new lockwashers (24), and two screws (23).
- 3 Cement new gasket (21) to B.O. drive light shield group (22) with adhesive. Apply light coating of grease to contact surfaces.
- 4 Apply antiseize compound to threads of screws (19). Install shield (22), three new lockwashers (20), and three screws to cover (3).
- 5 Cement new gasket (5) to cover (3) with adhesive.
- 6 Apply sealing compound to new gasket (18) and install to cover (3).
- 7 Apply antiseize compound to threads of screws (6). Install following components in cover group (3): lens (17), filter (16), new gasket (15), retainer (14), two new lockwashers (1 3), two screws (1 2), two new gaskets (11), service headlight lens (10), blackout lens (9), two new gaskets (8), six new lockwashers (7), and six screws.
- 8 Apply light coating of grease to cover group (3) contact surfaces. Apply antiseize compound to threads of screws (1).
- 9 Install cover group (3), four washers (2), and four screws (1) to headlight mount (4).

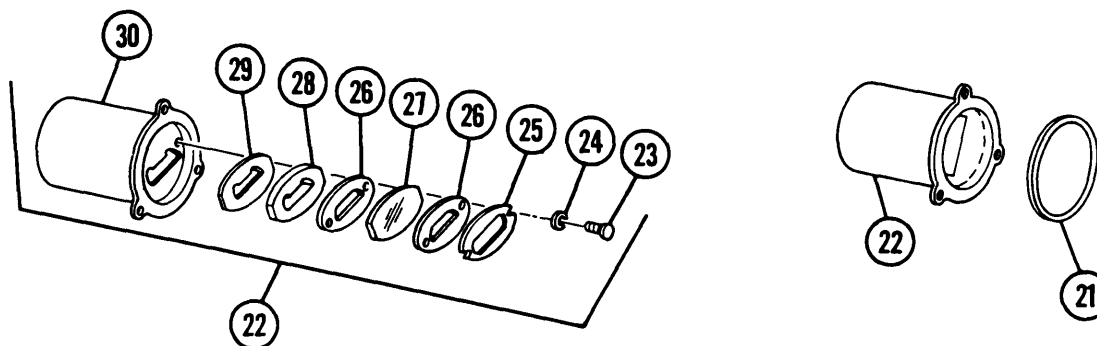

8-24 HEADLIGHT MOUNT

This task covers: a. Disassembly/Repair b. Assembly

INITIAL SETUP

Tools

General mechanic's tool kit (item 64, APPX H)

Gasket (item 150, Appx G)

LockWashers (4) (item 96, Appx G)

Silicone compound (item 18, Appx D)

Materials/Parts

Antiseize compound (item 8, APPX D)

Equipment Conditions

Headlight sockets removed (para 8-22)

Gasket (item 139, Appx G)

Gasket (item 149, Appx G)

a. Disassembly/Repair

WARNING

Ensure MASTER switch is OFF when working on headlight mount to avoid electrical shock and burns.

- 1 Remove headlight wiring harness (1) from headlight body (2).
- 2 Remove four nuts (3), four lockwashers (4), and four flat washers (5). Discard lockwashers.
- 3 Remove mounting bracket (6) and gasket (7). Discard gasket.
- 4 Remove three screws (8), plate (9), four screws (10), and gasket (11). Discard gasket.
- 5 Disconnect wiring harness terminals (12) at bulkhead-to-headlights bilge pump wiring harness (para 8-47).
- 6 Remove six screws (13).
- 7 Remove hull mount assembly (14) from hull.
- 8 Separate retainer (15), mount assembly (16), and gasket (17). Discard gasket.
- 9 Remove guide pin (18).

b. Assembly

WARNING

Ensure MASTER switch is OFF when working on headlight mount to avoid electrical shock and burns.

- 1 Install guide pin (18).
- 2 Assemble new gasket (17), mount assembly (16), and retainer (15).
- 3 Install hull mount assembly (14).
- 4 Install six screws (13).
- 5 Apply light coating of silicone compound to wiring harness terminals (12) and connect terminals at bulkhead-to-headlights/bilge pump wiring harness (para 8-47).
- 6 Apply antiseize compound to threads of screws (10).
- 7 Install new gasket (11), plate (9), three screws (8), and four screws (10) to headlight body (2).
- 8 Install new gasket (7), mounting bracket (6), four flat washers (5), four new lockwashers (4), four screws (10), and four nuts (3).
- 9 Install headlight wiring harness (1) to headlight body (2).

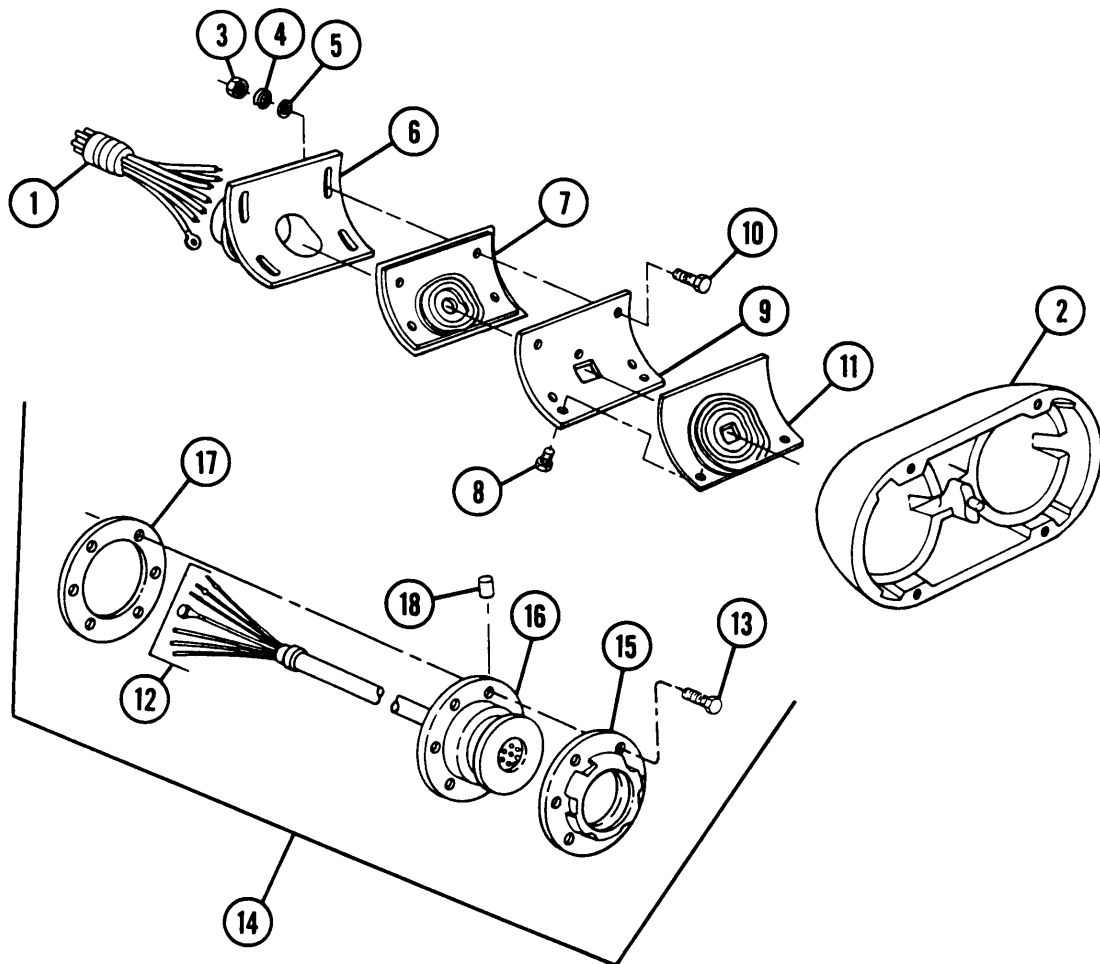

NOTE

FOLLOW-ON MAINTENANCE: Install headlight sockets (para 8-22)

8-25 SERVICE AND BLACKOUT TAILLIGHTS, STOP LIGHTS, AND LAMPS

This task covers: a. Removal b. Installation

INITIAL SETUP

Tools

General mechanic's tool kit (item 64, Appx H)

Materials/ Parts

Antiseize compound (item 8, Appx D)
 Lockwashers (4) (item 96, Appx G)
 Preformed packing (item 197, Appx G)
 Silicone compound (item 18, Appx D)

a. Removal

WARNING

Ensure MASTER switch is OFF when working on light to avoid electrical shock and burns.

NOTE

- Steps 1 thru 8 are for removal of service taillight; steps 9 thru 16 are for removal of B.O. taillights.
- Taillight does not need to be removed from vehicle to replace LEDs.

- 1 Remove two screws (1), cover plate (2), and two spacers (3) from inside hull.
- 2 Disconnect three electrical connectors (4).
- 3 Remove two screws (5), two lockwashers (6), and two flat washers (7) from inside hull. Discard lockwashers.
- 4 Remove taillight assembly (8), grommet (9), and electrical leads (10) from outside hull.

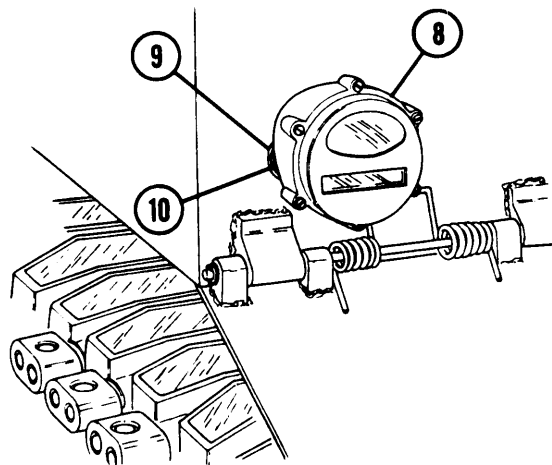
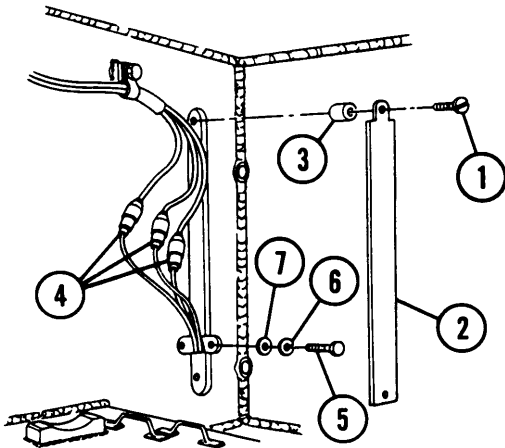

- 5 Unscrew six screws with retaining rings (11).
- 6 Separate door (12) with grommet (13) from taillight body (14).
- 7 Push in, turn counterclockwise, and remove two LEDs (15).
- 8 Using a screwdriver inserted into the marker assembly (16) center slot, push in and turn marker assembly base counterclockwise, and remove from socket.
- 9 Remove two screws (17), cover plate (18), and two spacers (19).
- 10 Disconnect two electrical connectors (20).
- 11 Remove two screws (21), two lockwashers (22), and two flat washers (23). Discard lockwashers.
- 12 Remove B.O. taillight assembly (24), grommet (25), and electrical leads (26).
- 13 Loosen six screws with retaining rings (27).
- 14 Remove door (28) with preformed packing (29). Discard preformed packing.
- 15 Open stop lamp assembly (30) housing cover. Insert screwdriver into center slot, push in, and turn base counterclockwise, and remove stop lamp from socket.
- 16 Insert screwdriver in marker assembly (31) center slot. Push in and turn counterclockwise, and remove marker assembly.

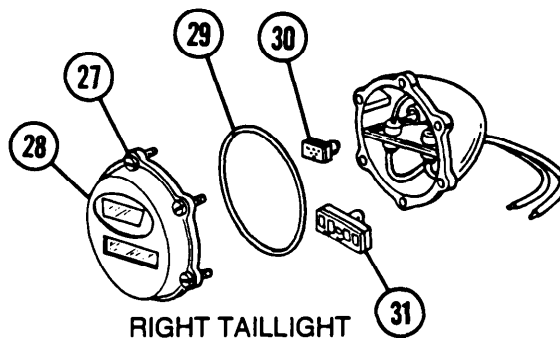
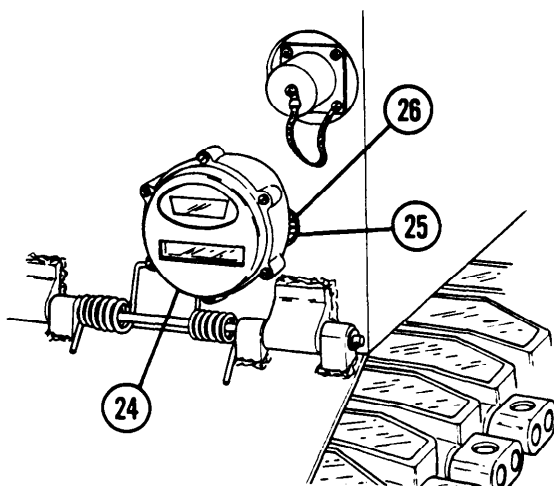
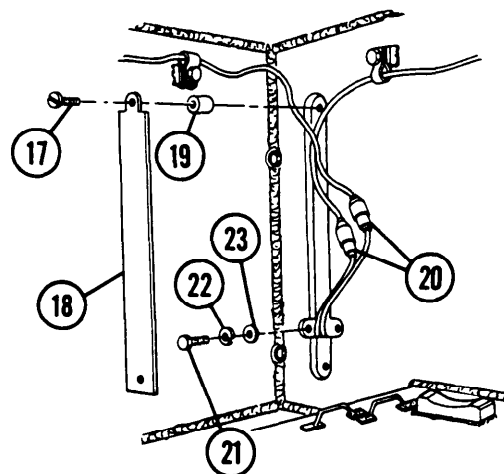
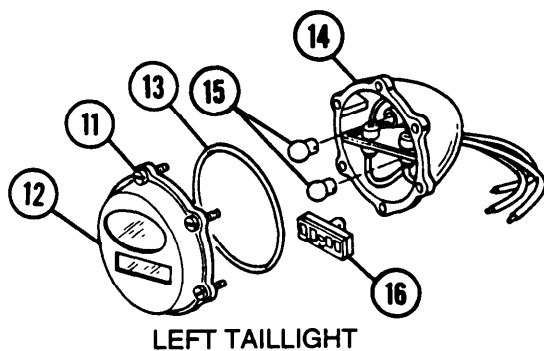

8-25 SERVICE AND BLACKOUT TAILLIGHTS, STOP LIGHTS, AND LAMPS — CONTINUED

b. Installation

WARNING

Ensure MASTER switch is OFF when working on light to avoid electrical shock and burns.

- 1 Lightly apply silicone compound to lamp sockets.
- 2 Install marker assembly (31). Insert screwdriver in marker assembly center slot, push in, and turn clockwise.
- 3 Install stop lamp assembly (30) with housing cover open. Insert screwdriver into center slot and turn base clockwise.
- 4 Install new preformed packing (29) and door (28).
- 5 Apply antiseize compound to threads of six screws with retaining rings (27).
- 6 Tighten six screws with retaining rings (27).
- 7 Install electrical leads (26), grommet (25), and taillight assembly (24).
- 8 Install two flat washers (23), two new lockwashers (22), and two screws (21).

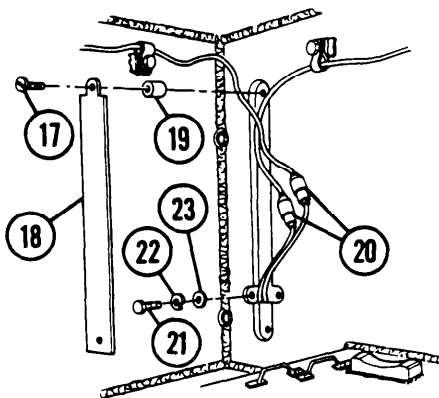
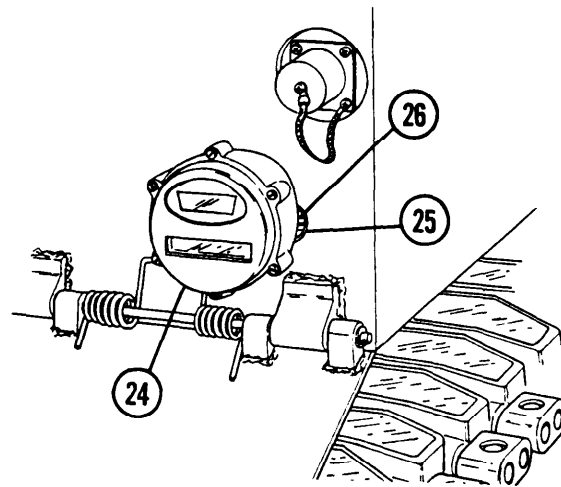
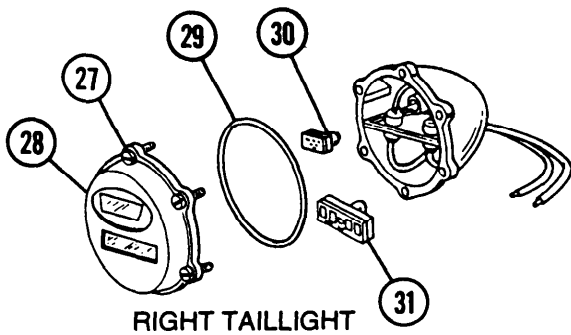

9 Connect two electrical connectors (20).

10 Install two spacers (19), cover plate (1 8), and two screws (1 7).

11 Install marker assembly (16) in taillight body (14). With screwdriver inserted in center slot, push in and turn marker assembly base clockwise.

12 Install two LEDs (15) by pushing in and turning clockwise.

13 Install grommet (13) and door (12) on taillight body (14). Tighten six screws with retaining rings (11).

14 Install electrical leads (10), grommet (9), and taillight assembly (8).

15 Install two flat washers (7), two new lockwashers (6), and two screws (5) inside hull.

16 Connect three electrical connectors (4).

17 Install two spacers (3), cover plate (2), and two screws (1) inside hull.

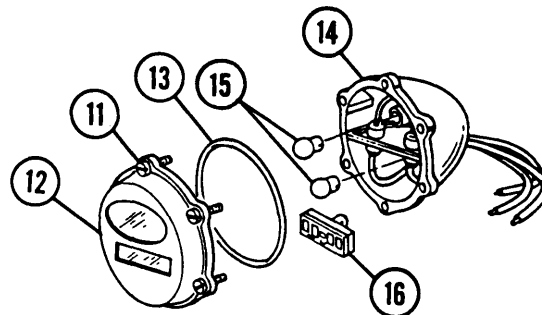

LEFT TAILLIGHT

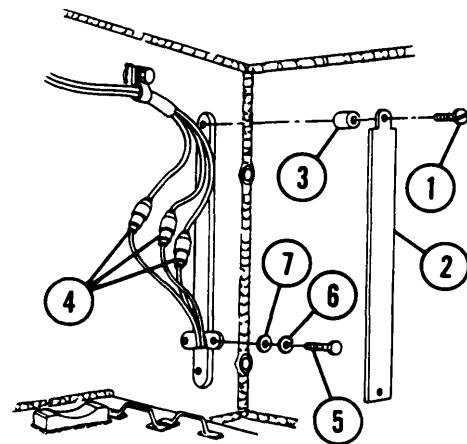
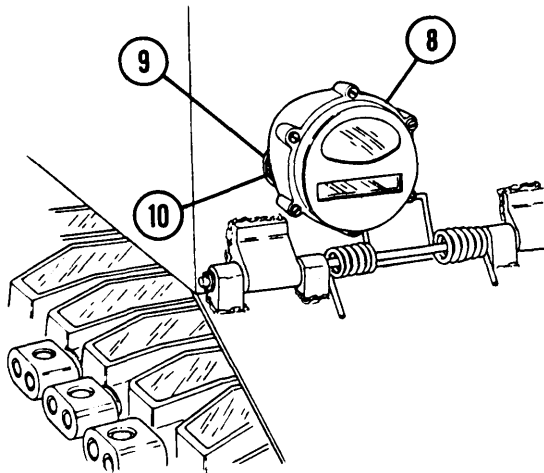

8-26 TELEPHONE TERMINAL

This task covers: a. Removal b. Installation

INITIAL SETUP

Tools
General mechanic's tool kit (item 64, Appx H)

Materials/Parts
Nonmetallic washers (2) (item 216, Appx G)

a. Removal

WARNING

Ensure MASTER switch is OFF when working on telephone terminal to avoid electrical shock and burns.

NOTE

Position of telephone terminals is different on M109A2/M109A3 and M109A4/M109A5 Howitzers.

- 1 Remove two nuts (1).
- 2 Remove two cables (2), two flat washers (3), and two flat washers (4).
- 3 Remove telephone terminal (5), two flat washers (6), two flat washers (7), and two nonmetallic washers (8) from bracket (9). Discard nonmetallic washers.

b. Installation

WARNING

Ensure MASTER switch is OFF when working on telephone terminal to avoid electrical shock and burns.

NOTE

Position of telephone terminals is different on M109A2/M109A3 and M109A4/M109A5 Howitzers.

- 1 Install two new nonmetallic washers (8), two flat washers (7), two flat washers (6), and telephone terminal (5).
- 2 Install two flat washers (4), two flat washers (3), and two cables (2).
- 3 Install two nuts (1).

8-27 DOME LIGHT

- | | | |
|-------------------|-------------|-----------------------|
| This task covers: | a. Removal | b. Disassembly/Repair |
| | c. Assembly | d. Installation |

INITIAL SETUP

Tools

General mechanic's tool kit (item 64, Appx H)

Lockwasher (item 71, Appx G)

Lockwashers (4) (item 95, Appx G)

Materials/Parts

Gasket (item 206, Appx G)

Gasket (item 207, Appx G)

Gasket (item 208, Appx G)

References

TB 9-2300-421-20

TM 9-2350-311-24P&1

a. Removal

WARNING

Ensure MASTER switch is OFF when working on hull electrical systems to avoid electrical shock and burns.

8-27 DOME LIGHT — CONTINUED

a. Removal — Continued

NOTE

Red lens on dome light must be replaced with blue lens per TB 9-2300-421-20,21 Jun 82 (TM 9-2350-311-24P-1).

- 1 Disconnect electrical lead (1).
- 2 Remove four screws (2), four lockwashers (3), and dome light (4). On M109A4/M109A5 Howitzers, ground lead (5) will be disconnected. Discard lockwashers.

b. Disassembly/Repair

- 1 Remove screw (6), lockwasher (7), switch knob (8), nut (9), and flat washer (10). Discard lockwasher.
- 2 Loosen eight screws with retaining rings (11).
- 3 Separate dome light door assembly (12) from light body (13).
- 4 Remove screw (14) and lockwasher (15). Disconnect electrical lead (16) at switch (17). Remove door assembly (12) from body (13).

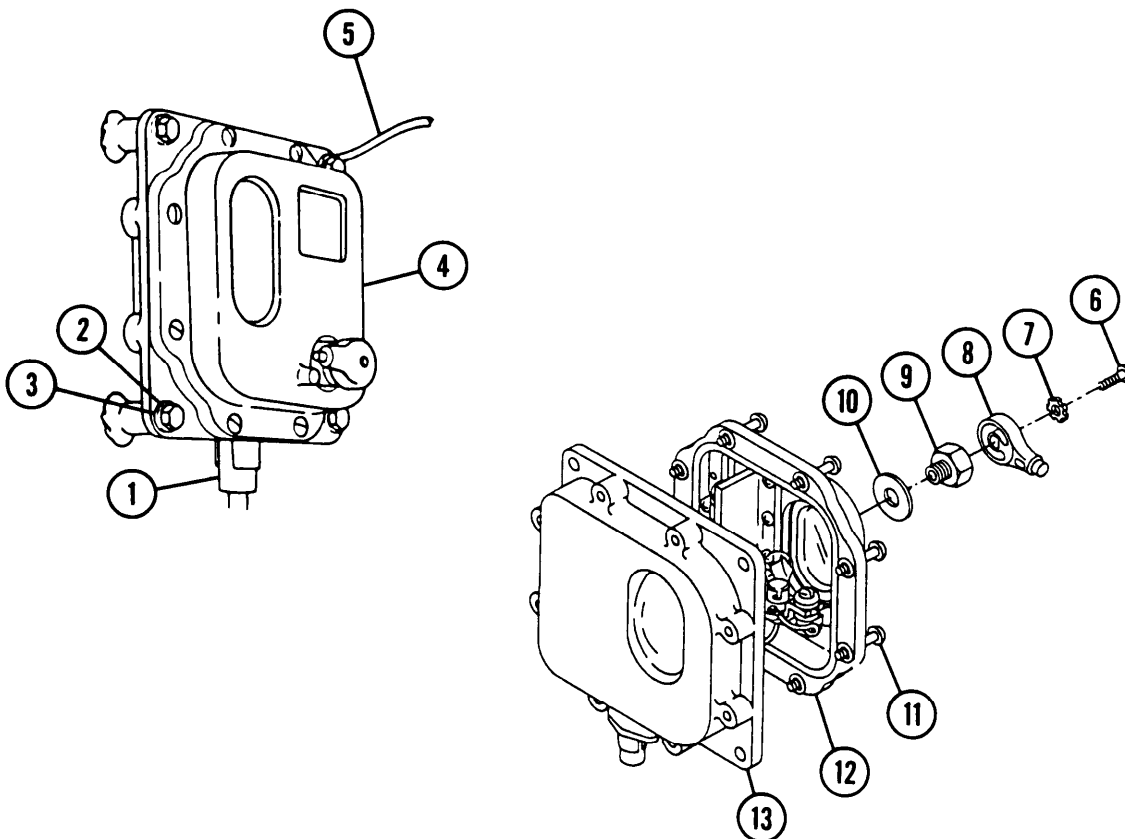

- 5 Remove two screws (18), two lockwashers (19), and two electrical leads (20) at switch (17). Remove switch.
- 6 Remove two screws (21), two lockwashers (22), two screws (23), two flat washers (24), lamp assembly (25), and lamp assembly (26).
- 7 Remove four screws (27), four lockwashers (28), and partitions (29).
- 8 Remove seven screws (30), plate (31), lens (32), gasket (33), lens (34), gasket (35), and gasket (36) from door assembly (12). Discard gaskets.
- 9 Remove two crosspoint screws (37), connector assembly (38), and grommet (39) from dome light body (13).

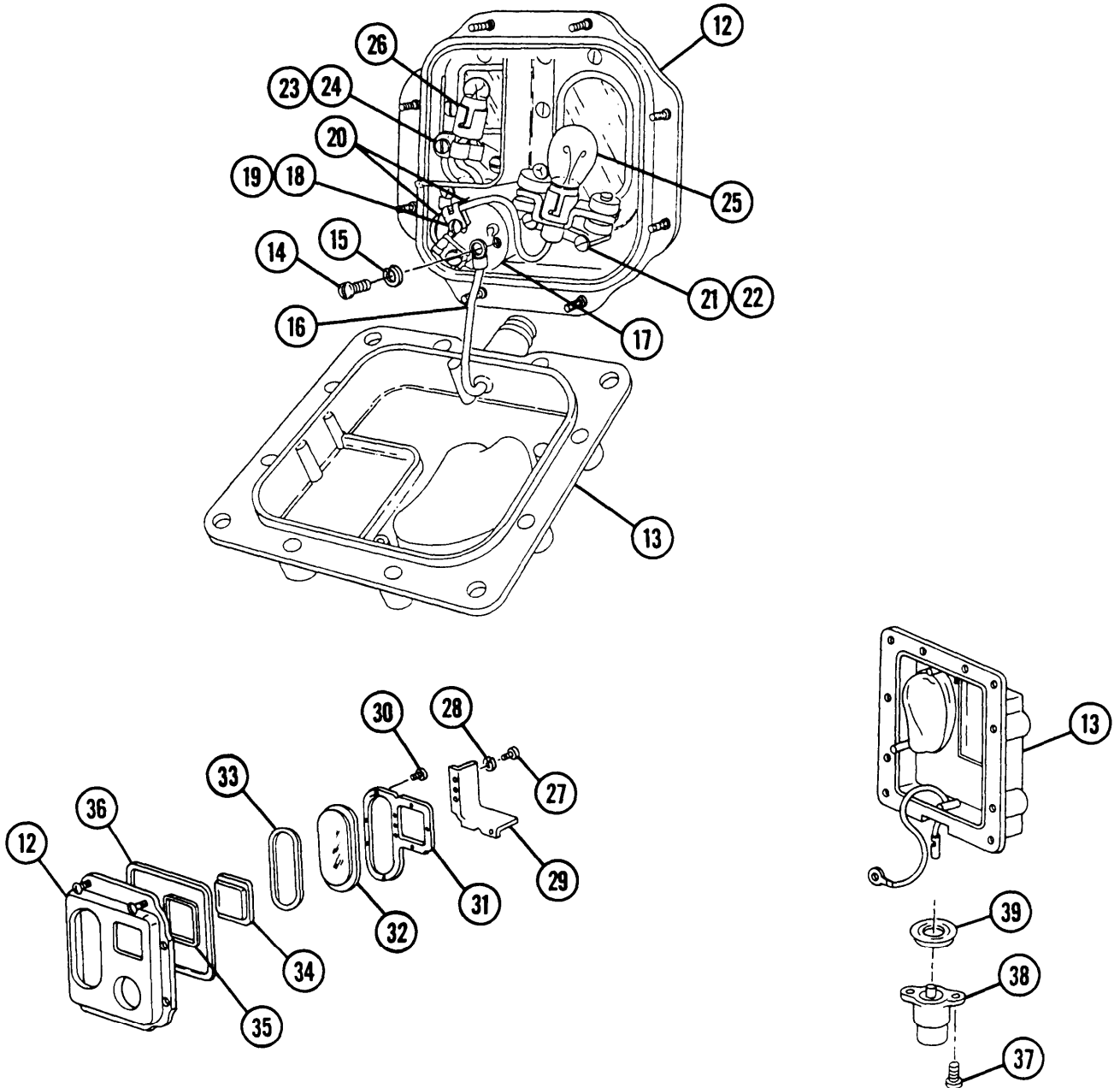

8-27 DOME LIGHT — CONTINUED

c. Assembly

- 1 Install grommet (39), connector assembly (38), and two screws (37) to dome light body (1 3).
- 2 Install new gasket (36) on door assembly (12).

NOTE

Red lens on dome light must be replaced with blue lens per TB 9-2300-421-20,21 Jun 82 (TM 9-2350-311-24P-1).

- 3 Install new gasket (35) and lens (34).
- 4 Install new gasket (33), lens (32), plate (31), and seven screws (30).
- 5 Install partition (29), four lockwashers (28), and four screws (27).

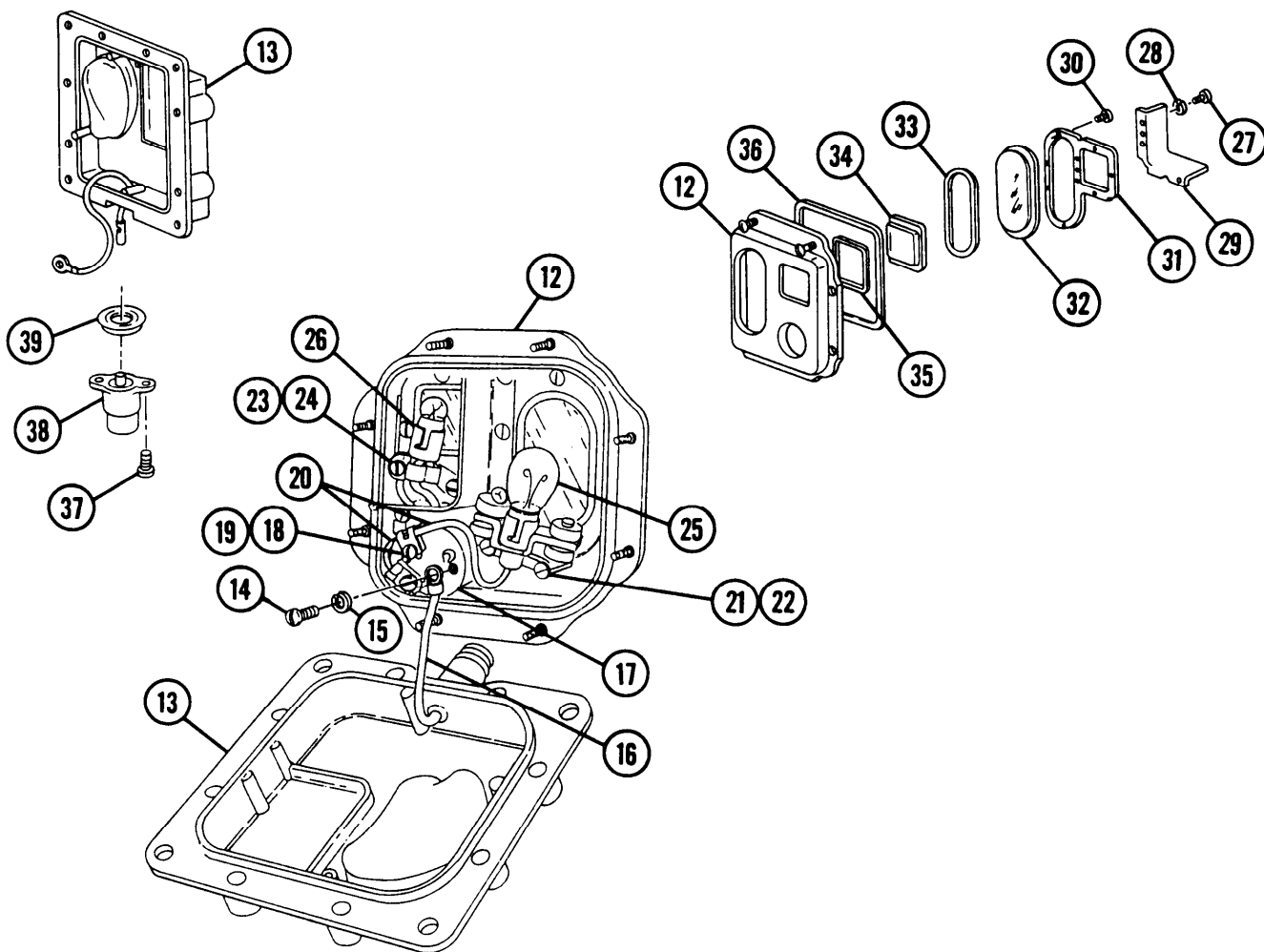

- 6 Install two lamp assemblies (25 and 26), two flat washers (24), two screws (23), two lockwashers (22), and two screws (21).
- 7 Install switch (17), two electrical leads (20), two lockwashers (19), and two screws (18).
- 8 Install electrical lead (16), lockwasher (15), and screw (14) on switch (17).
- 9 Install dome light door assembly (12) on light body (13).
- 10 Tighten eight screws with retaining rings (11).
- 11 Install flat washer (10), nut (9), switch knob (8), new lockwasher (7), and screw (6).

d. Installation

WARNING

Ensure MASTER switch is OFF when working on hull electrical systems to avoid electrical shock and burns.

- 1 Install dome light (4) with four new lockwashers (3) and four screws (2). On M109A4/M109A5 Howitzers, connect ground lead (5) under screw.
- 2 Connect electrical lead (1).

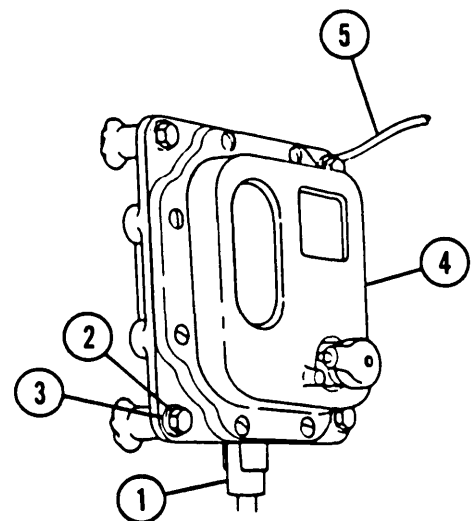
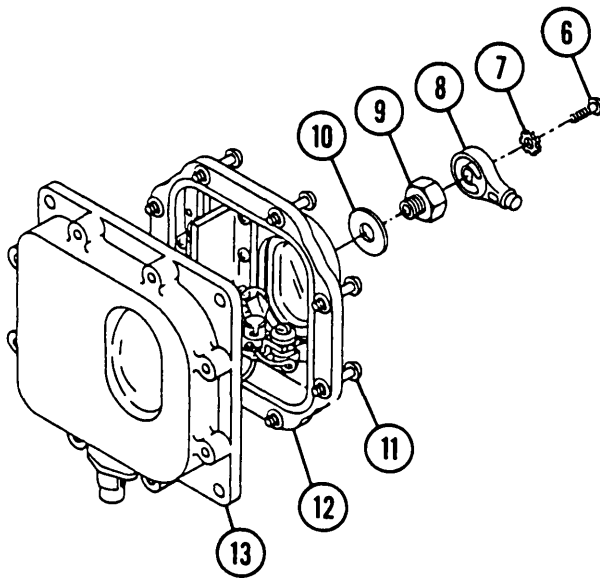

8-28 BATTERIES

This task covers:

- a. Battery Specific Gravity Check
- b. Removal
- c. Installation

INITIAL SETUP

Tools
General mechanic's tool kit (item 64, Appx H)
Duo-tester (item 18, Appx H)

Lockwashers (2) (item 87, Appx G)
Lockwashers (8) (item 96, Appx G)

Materials/Parts
Distilled water (item 66, Appx D)
Lockwashers (4) (item 77, Appx G)

References

TM 9-6140-200-14

Equipment Conditions

Battery compartment access doors open (para 11-6)

a. Battery Specific Gravity Checks

WARNING

- Battery gases can explode. Do not smoke or allow sparks or open flames near batteries. Wear safety glasses or goggles when checking batteries. Failure to follow this procedure could cause serious injury or death.
- When working on batteries, wear eye protection and remove all jewelry, dog tags, and metal items to avoid electrical shock and burns.
- Sulfuric acid contained in batteries can cause serious burns. If battery corrosion or electrolyte makes contact, take immediate action to stop the burning effects.

CAUTION

When removing batteries, always disconnect ground cables first to prevent damage to batteries.

1 Remove battery caps (1) from all cells.

NOTE

- Repeat steps 2 thru 5 for each cell.
- Periodically calibrate the duo-tester with distilled water.

2 Swing plastic cover (2) back on duo-check coolant and battery tester. Clean measuring surface (3) and bottom cover (4) with clean, soft cloth. Close cover.

- 3 Use black dipstick (5) to obtain a small sample of battery acid.
- 4 Place a few drops of acid onto measuring surface (3) through opening in cover plate.
- 5 Point instrument toward any light source (headlight) and look into eyepiece (6). The battery charge is at a point on the left part of the scale where the dividing line between light and dark (shadow) crosses the scale.

NOTE

A little experience will enable you to quickly obtain the best contrast between light and dark portions of the field of view. Tilt the instrument toward the light source until the best results are obtained. If the edge of the shadow is not sharp, the measuring surface was not sufficiently cleaned or dried.

b. Removal

WARNING

- Battery gases can explode. Do not smoke or allow sparks or open flames near batteries. Wear safety glasses or goggles when checking batteries. Failure to follow this procedure could cause serious injury or death.
- When working on batteries, wear eye protection and remove all jewelry, dog tags, and metal items to avoid electrical shock and burns.

CAUTION

When removing batteries, always disconnect ground leads first to prevent damage to batteries.

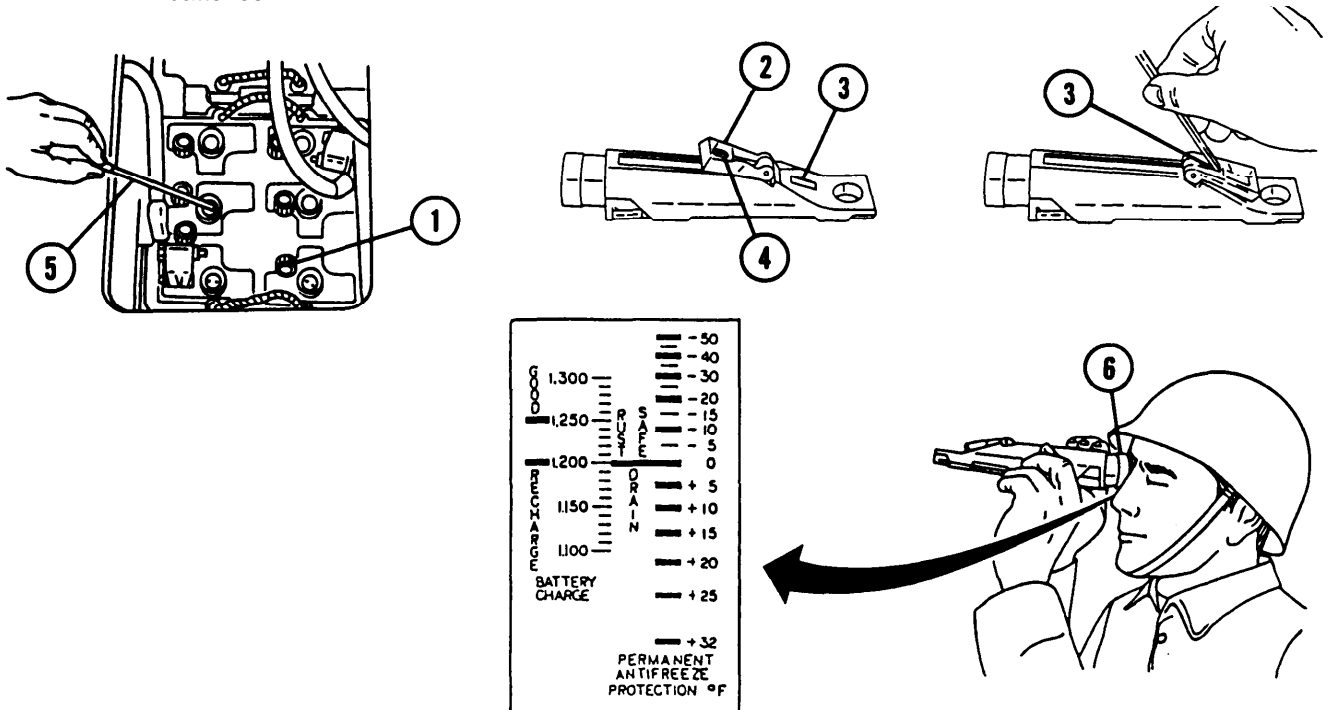

8-28 BATTERIES — CONTINUED

b. Removal — Continued

- 1 Remove two screws (7) and four lockwashers (8) from ground cables (9) (TM 9-6140-200-14). Discard lockwashers.
- 2 Loosen two screws (10).
- 3 Remove two ground cable lugs (11) and ground cables (9) from batteries (12).
- 4 Loosen six nuts (13).
- 5 Remove four cables with lugs attached (14) from batteries (12).
- 6 Remove two nuts (15), two lockwashers (16), and two holddown brackets (17). Discard lockwashers.
- 7 Lift batteries (12) out of battery compartment (1 8).
- 8 Remove eight screws (19), eight lockwashers (20), and two battery trays (21) from battery compartment (18). Discard lockwashers.

c. Installation

WARNING

- Battery gases can explode. Do not smoke or allow sparks or open flames near batteries. Wear safety glasses or goggles when checking batteries. Failure to follow this procedure could cause serious injury or death.
- When working on batteries, wear eye protection and remove all jewelry, dog tags, and metal items to avoid electrical shock and burns.

CAUTION

When installing batteries, always connect ground leads last to prevent damage to batteries.

- 1 Install two battery trays (21), eight new lockwashers (20), and eight screws (19) inside battery compartment (18).
- 2 Place batteries (12) in battery compartment (18).
- 3 Install two holddown brackets (17), two new lockwashers (16), and two nuts (1 5).
- 4 Install four cables with lugs attached (14).
- 5 Tighten six nuts (13).

6 install two ground cables (9) and two ground cable lugs (11).

7 Tighten two screws (10).

8 Install four new lockwashers (8), two ground cables (9), and two screws (7) to batte~compartment (18).

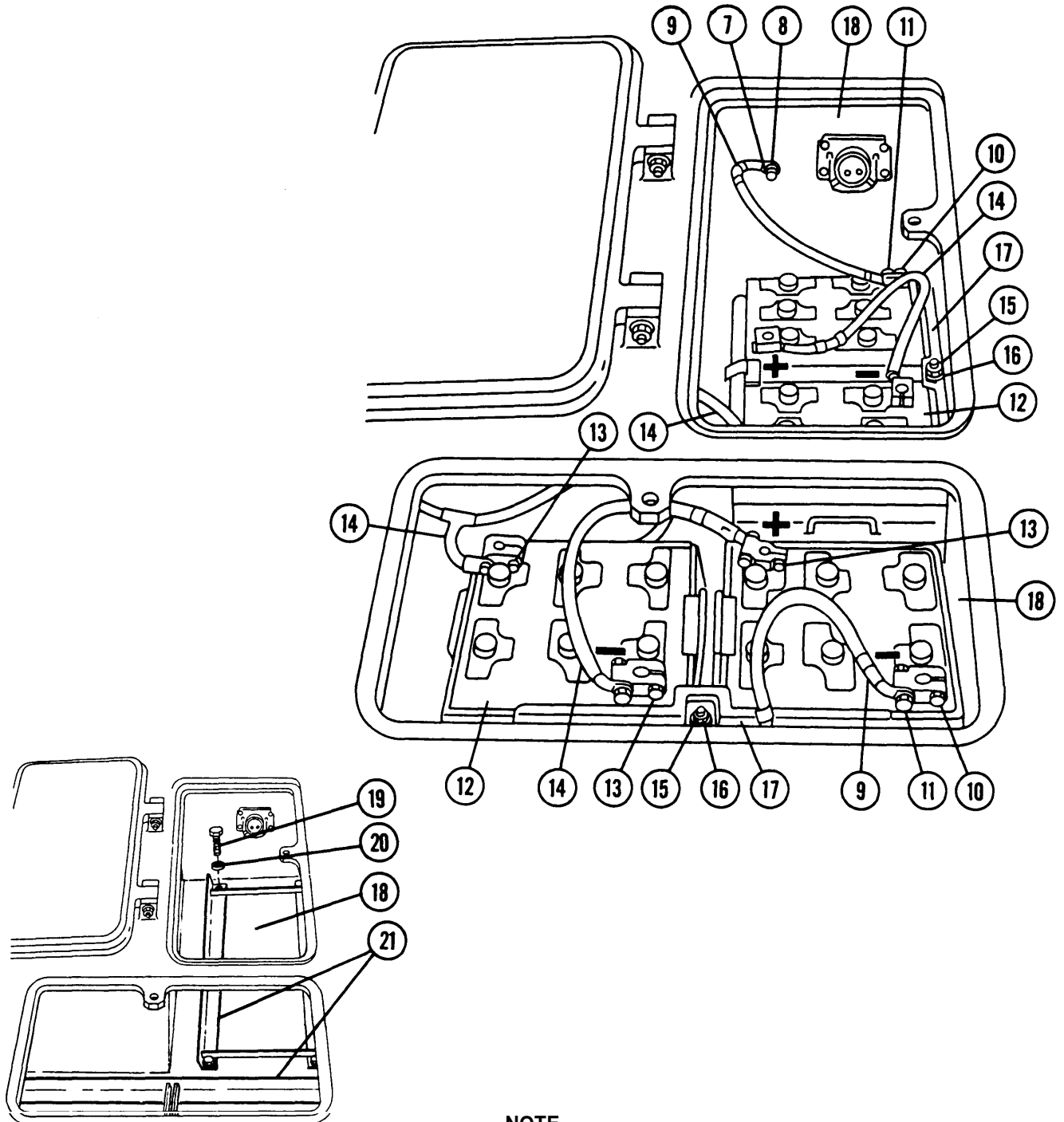

NOTE

FOLLOW-ON MAINTENANCE:

Close battery compartment access doors (para 11-6)

8-29 MASTER RELAY BOX

This task covers: a. Removal b. Installation

INITIAL SETUP

<u>Tools</u>	<u>Equipment Condition</u>
General mechanic's tool kit (item 64, Appx H)	Batteries ground cables disconnected (para 8-28)

a. Removal

- 1 Disconnect starter cable connector (1), master switch cable connector (2), and battery cable connector (3) at master relay box (4).
- 2 Remove two screws (5) and two washers (6).
- 3 Remove master relay box (4).

b. Installation

- 1 Install master relay box (4), two washers (6), and two screws (5).
- 2 Install battery cable connector (3), master switch cable connector (2), and starter cable connector (1).

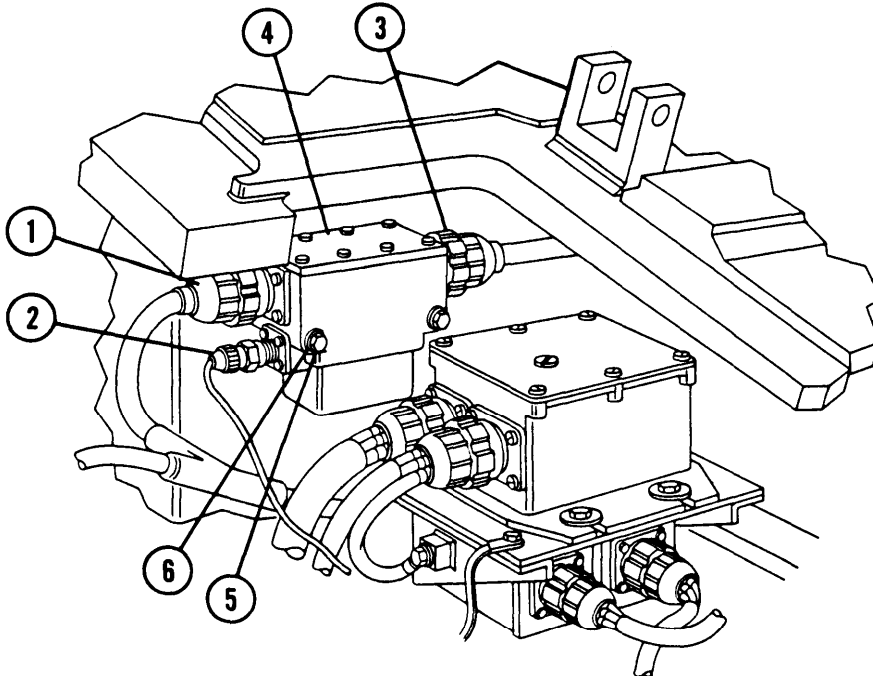

NOTE

FOLLOW-ON MAINTENANCE: Connect battery ground cables (para 8-28)

8-30 BILGE PUMP RELAY — CONTINUED

b. Installation

WARNING

Ensure MASTER switch is OFF when working on bilge pump relay to avoid electrical shock and burns.

- 1 Remove two nuts (2), two lockwashers (3), two screws (6), four external-tooth lockwashers (4), and two flat washers (5). Secure starter relay (8). Discard lockwashers and external-tooth lockwashers.
- 2 Install bilge pump relay (7), two flat washers (5), four new external-tooth lockwashers (4), two screws (5), two new lockwashers (3), and two nuts (2).
- 3 Connect electrical connector (1).

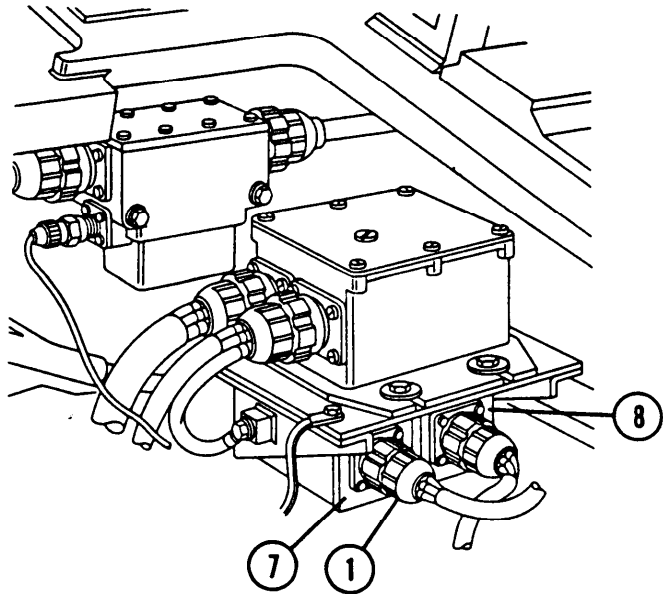
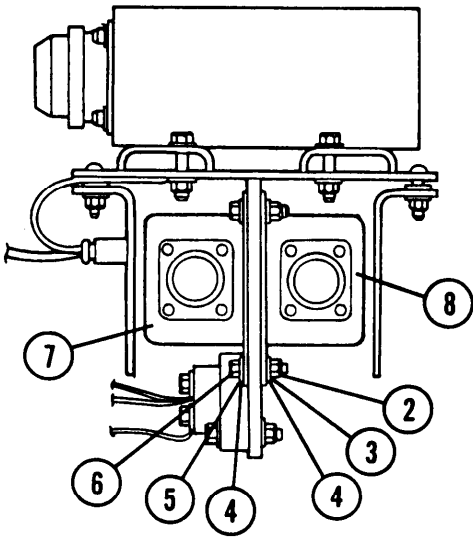

8-31 STARTER RELAY BOX — CONTINUED

b. Installation

WARNING

Ensure MASTER switch is OFF when working on starter switch relay boxes to avoid electrical shocks and burns.

- 1 Remove two nuts (2), two lockwashers (3), two screws (6), four external-tooth lockwashers (4), and two flat washers (5). Secure bilge pump relay (8). Discard lockwashers and external-tooth lockwashers.
- 2 Install starter relay box or starter protection relay box (7), two new lockwashers (3), four new external-tooth lockwashers (4), two flat washers (5), two screws (6), and two nuts (2).
- 3 Connect electrical connector (1).

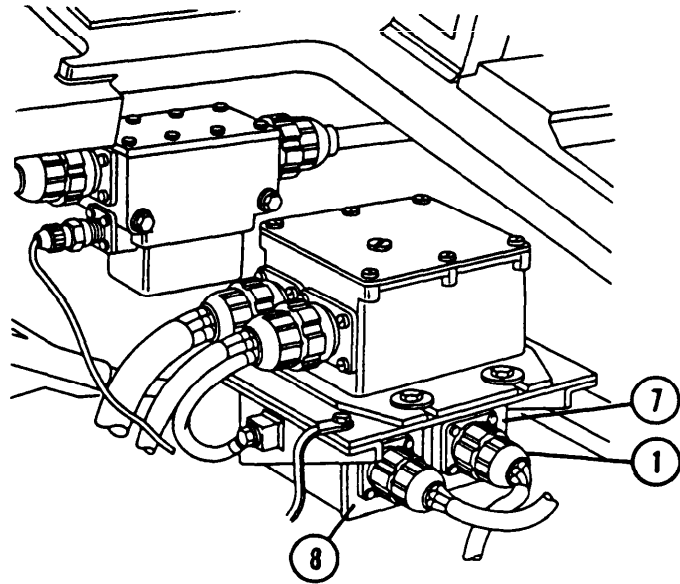
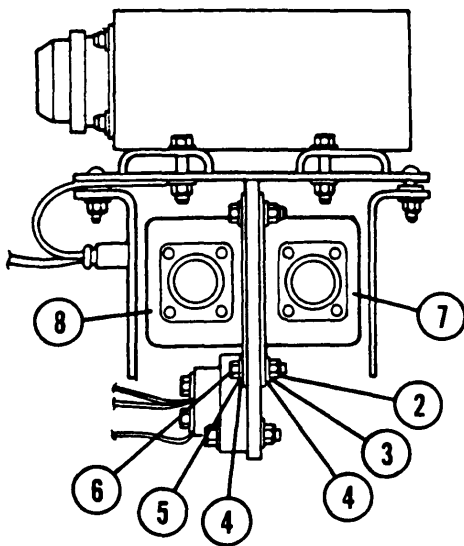

8-32 BILGE PUMP CIRCUIT BREAKER

This task covers: a. Removal b. Installation

INITIAL SETUP

Tools

General mechanic's tool kit (item 64, Appx H)

Materials/Parts

Lockwashers (2) (item 86, Appx G)

a. Removal**WARNING**

Ensure MASTER switch is OFF when working on bilge pump circuit breaker to avoid electrical shock and burns.

- 1 Remove two screws (1) and two washers (2).
- 2 Remove three electrical leads (3) from circuit breaker (4).
- 3 Remove two screws (5), two flat washers (6), two lockwashers (7), and two nuts (8). Discard lockwashers.
- 4 Remove circuit breaker (4).

b. Installation**WARNING**

Ensure MASTER switch is OFF when working on bilge pump circuit breaker to avoid electrical shock and burns.

- 1 Install circuit breaker (4).
- 2 Install two new lockwashers (7), two flat washers (6), two screws (5), and two nuts (8).
- 3 Install three electrical leads (3) on circuit breaker (4), two washers (2), and two screws (1).

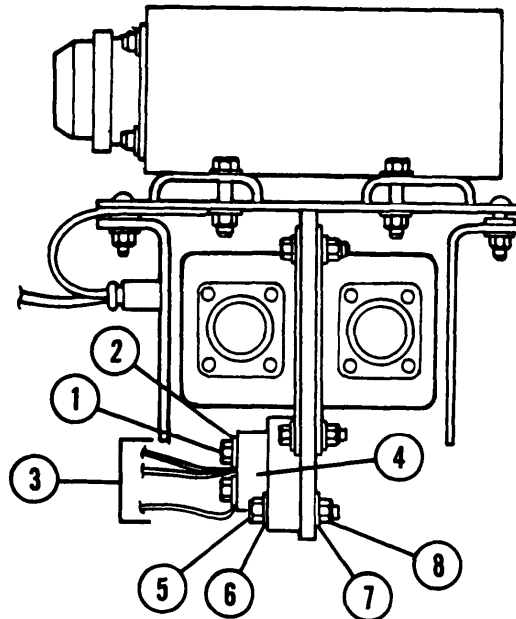

8-33 CIRCUIT BREAKERS (M109A2/M109A3)

This task covers: a. Removal b. Installation

INITIAL SETUP

Applicable Conditions
M109A2/M109A3

Material/Parts
Lockwashers (14) (item 85, Appx G)
Lockwashers (2) (item 95, Appx G)

Tools
General mechanic's tool kit (item 64, Appx H)

Equipment Condition
Portable and driver's instrument panels removed
(para 8-17)

a. Removal

WARNING

Ensure MASTER switch is OFF when working on hull electrical systems to avoid electrical shock and burns.

NOTE

Wiring of circuit breakers differs between M109A2/M109A3 Howitzers.

- 1 Identify and tag 14 electrical leads (1).
- 2 Remove two screws (2), two flat washers (3), and two lockwashers (4). Discard lockwashers.
- 3 Remove circuit breaker panel (5).
- 4 To remove individual circuits, first identify problem circuit. Refer to wiring diagrams in Section III, this chapter and Appendix 1.
- 5 Disconnect identified 14 electrical leads(1) at circuit breaker (6).
- 6 Remove two screws (7), two flat washers (8), two lockwashers (9), and two nuts (10) at identified problem circuit breaker (6). Discard lockwashers.
- 7 Remove circuit breaker (6).

b. Installation

WARNING

Ensure MASTER switch is OFF when working on hull electrical systems to avoid electrical shock and burns.

NOTE

Wiring of circuit breakers differs between M109A2/M109A3 Howitzers.

- 1 Install circuit breaker (6), two flat washers (8), two new lockwashers (9), two screws (7), and two nuts (10).
- 2 Connect 14 electrical leads (1) at circuit breaker (6).
- 3 Install circuit breaker panel (5).
- 4 Install two new lockwashers (4), two flat washers (3), and two screws (2).

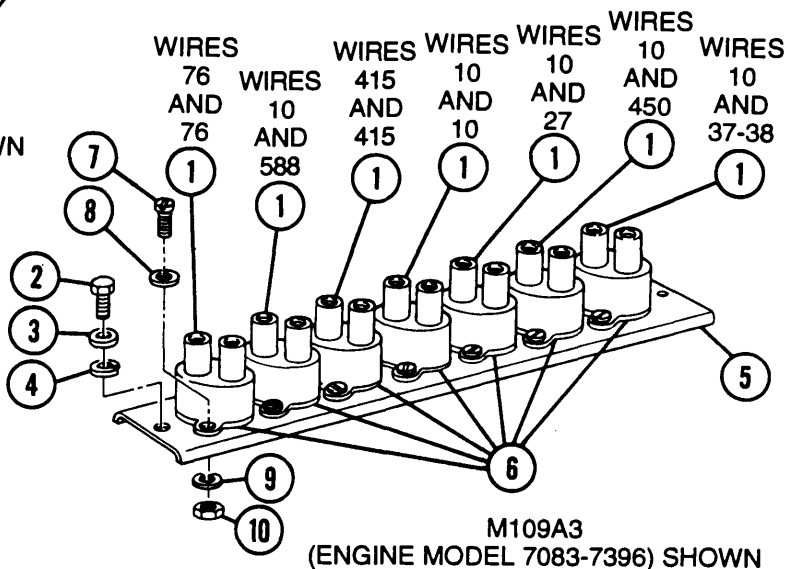
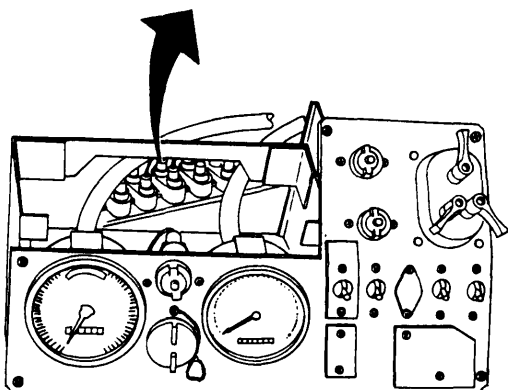
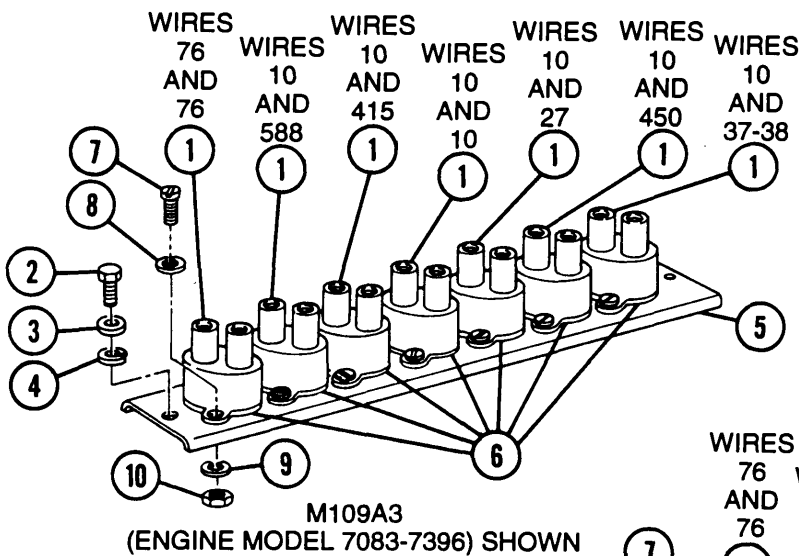

NOTE

FOLLOW-ON MAINTENANCE: Install driver's and portable instrument panels (para 8-17)

8-34 CIRCUIT BREAKERS (M109A4/M109A5)

This task covers: a. Removal b. Installation

INITIAL SETUP

Applicable Conditions

M1 09A4/M109A5

Materials/Parts

Lockwashers(16) (item 85, Appx G)

Lockwashers (2) (item 95, Appx G)

Tools

General mechanic's tool kit (item 64, Appx H)

Equipment Conditions

Portable and driver's instrument panels removed
(para 8-17)

a. Removal

WARNING

Ensure **MASTER** switch is **OFF** when working on hull electrical systems to avoid electrical shock and burns.

- 1 Identify and tag 16 electrical leads (1).
- 2 Remove two screws (2), two flat washers (3), and two lockwashers (4). Discard lockwashers.
- 3 Remove circuit breaker panel (5).
- 4 To remove individual circuits, first identify problem circuit. See wiring diagrams in Section III, this chapter and Appendix 1.
- 5 Disconnect 16 identified electrical leads (1) at circuit breaker (6).
- 6 Remove two screws (7), two flat washers (8), two lockwashers (9), and two nuts (1 O) at identified problem circuit breaker (6). Discard lockwashers.
- 7 Remove circuit breaker (6).

b. Installation

WARNING

Ensure MASTER switch is OFF when working on hull electrical systems to avoid electrical shock and burns.

- 1 Install circuit breaker (6), two flat washers (8), two new lockwashers (9), two screws (7), and two nuts (10).

- 2 Connect 16 electrical leads (1) at circuit breaker (6).
- 3 Install circuit breaker panel (5).
- 4 Install two new lockwashers (4), two flat washers (3), and two screws (2).

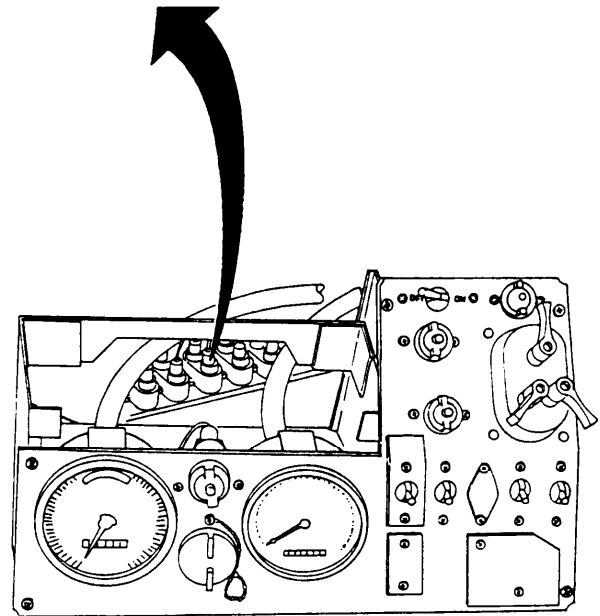
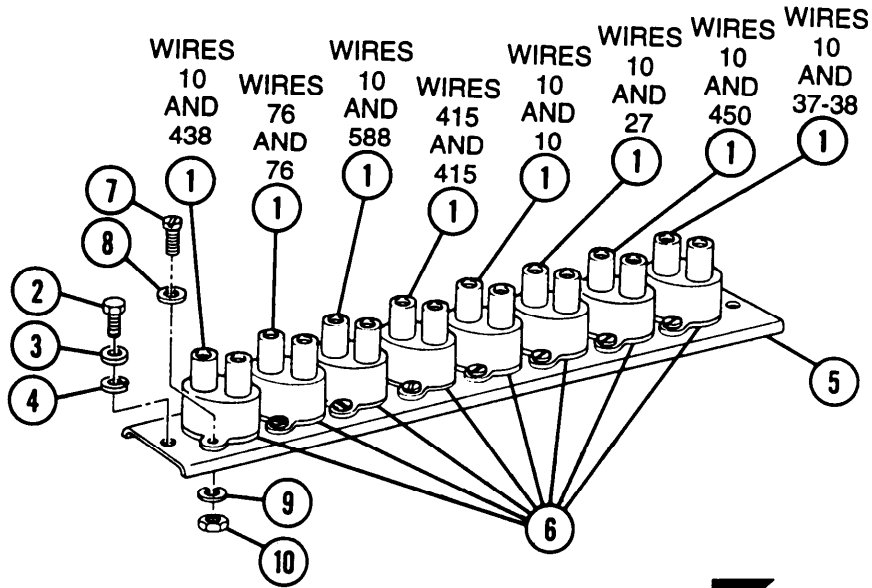

M109A4/M109A5
(ENGINE MODEL 7083-7396) SHOWN

NOTE

FOLLOW-ON MAINTENANCE: Install driver's and portable instrument panels (para 8-17)

8-35 IN-TANK FUEL PUMPS AND GENERATOR SYSTEM RELAY

This task covers: a. Removal b. Installation

INITIAL SETUP

Tools

General mechanic's tool kit (item 64, Appx H)

Equipment Conditions

Portable and driver's instrument panels removed
(para 8-17)

a. Removal

WARNING

Ensure MASTER switch is OFF when working on hull electrical systems to avoid electrical shock and burns.

- 1 Disconnect electrical connector (1).
- 2 Remove three nuts (2) and three washers (3).
- 3 Remove in-tank fuel pump and generator system relay (4).

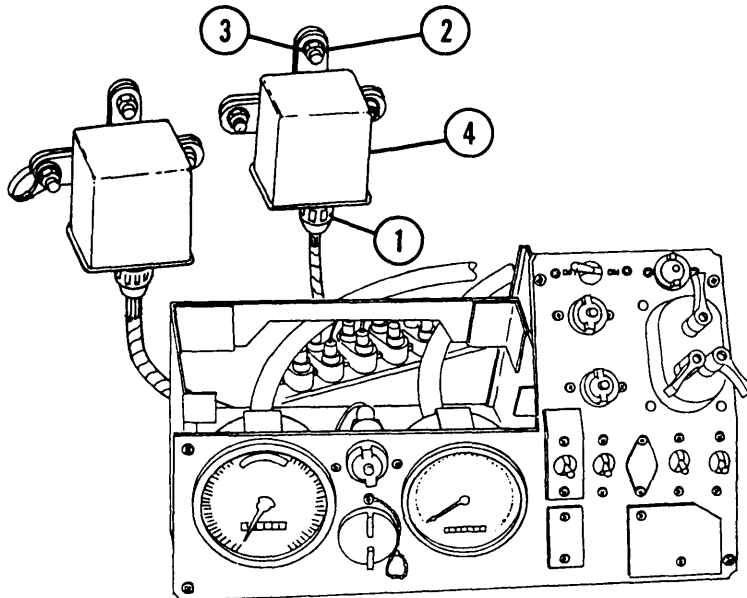

M109A4/M109A5
(ENGINE MODEL 7083-7396) SHOWN

b. Installation**WARNING**

Ensure MASTER switch is OFF when working on hull electrical systems to avoid electrical shock and burns.

- 1 Install air cleaner blower relay (M109A2/M109A3) or in-tank fuel pump and generator system relay (M109A4/M109A5) (4).
- 2 Install three flat washers (3) and three nuts (2).
- 3 Install electrical connector (1).

8-36 AIR CLEANER BLOWER RELAY AND AIR CLEANER BLOWER MOTORS

This task covers: a. Removal b. Installation

INITIAL SETUP

Applicable Configurations
M109A4/M109A5

Equipment Conditions
Portable instrument panel removed (para 8-17)

Tools
General mechanic's tool kit (item 64, Appx H)

a. Removal**WARNING**

Ensure MASTER switch is OFF when working on hull electrical systems to avoid electrical shock and burns.

- 1 Disconnect electrical connector (1).

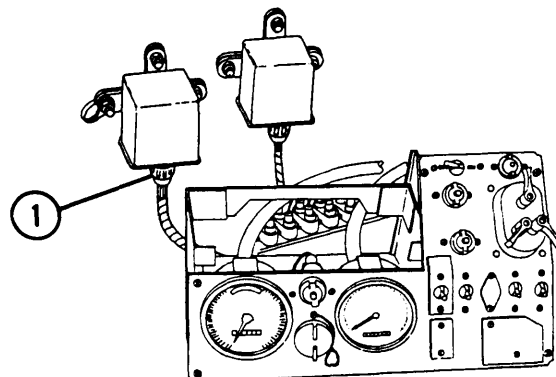

**M109A4/M109A5
(ENGINE MODEL 7083-7396) SHOWN**

6-36 AIR CLEANER BLOWER RELAY AND AIR CLEANER BLOWER MOTORS — CONTINUED

a. Removal — Continued

- 2 Remove nut (2), ground lead end (3), and washer (4).
- 3 Remove two nuts (5), flat washer (6), and air cleaner blower relay (7).
- 4 Remove bracket (8), three mounts (9), ground lead (10), and washer (11).
- 5 Disconnect two electrical leads (12).
- 6 Turn four screws (13) counterclockwise to loosen four clamps (1 4).
- 7 Disconnect four hoses (15) from blower motors (16).
- 8 Loosen two screws (17) to loosen clamps (18).
- 9 Pull blower motors (16) out of two clamps (18).

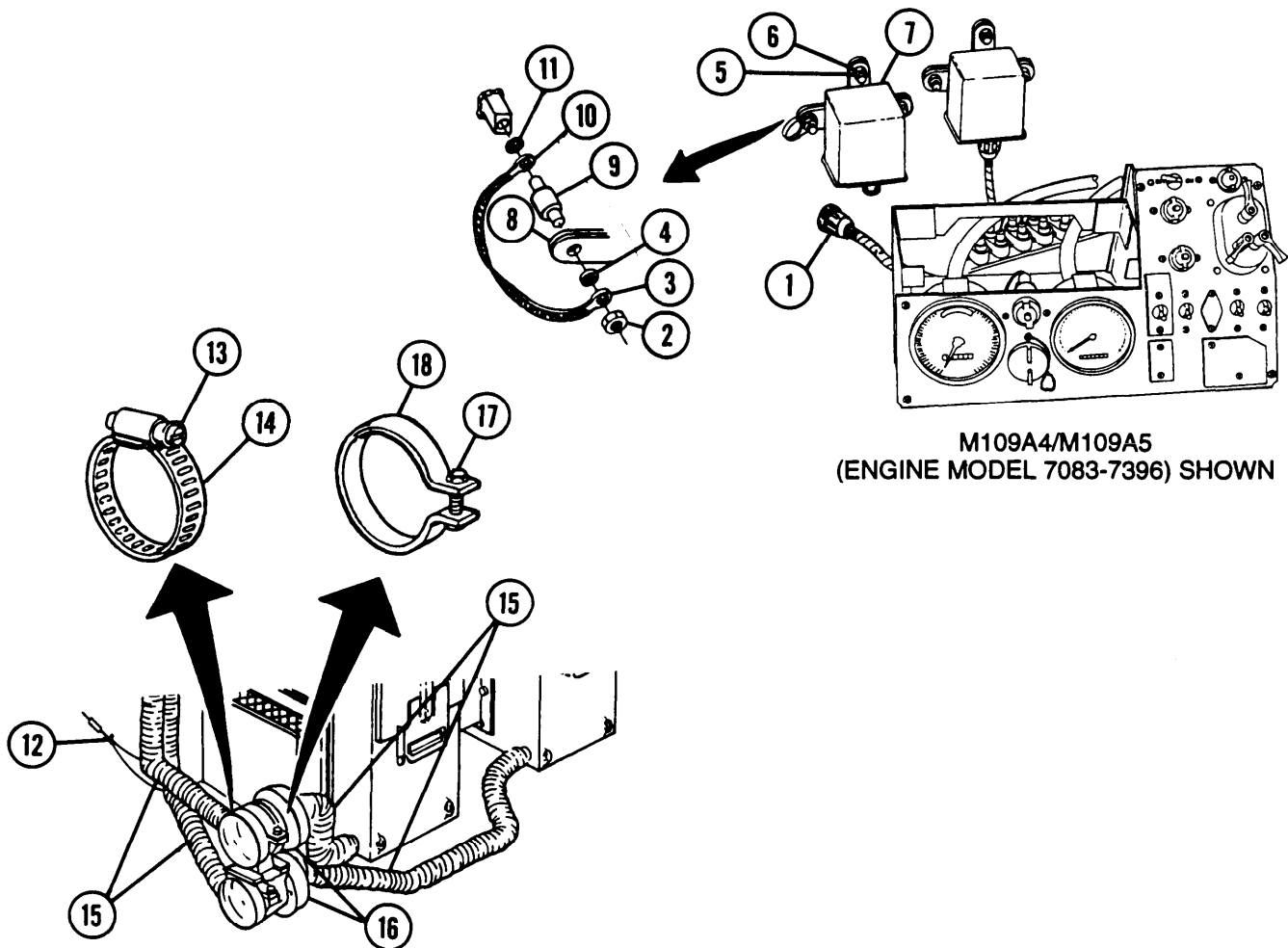

8-37 HEADLIGHT DIMMER AND STOP LIGHT SWITCHES — CONTINUED

a. Removal — Continued

- 1 Disconnect electrical plug (1).
- 2 Remove two nuts (2), two washers (3), two screws (4), and dimmer switch (5).
- 3 Disconnect two electrical connectors (6).
- 4 Remove two nuts (7), two washers (8), two screws (9), and stop light switch (10).

b. Installation

WARNING

Ensure MASTER switch is OFF when working with hull electrical systems to avoid electrical shock or burns.

- 1 Install stop light switch (10), two washers (8), two screws (9), and two nuts (7).
- 2 Connect two electrical connectors (6).
- 3 Install dimmer switch (5), two washers (3), two screws (4), and two nuts (2).
- 4 Connect electrical plug (1).

c. Adjustment

Adjust stop light switch (10) by loosening setscrew (11) and stop light actuator (12). Slide actuator right or left so that stop light goes on when brake pedal (13) is depressed approximately 0.75 in. (19.1 mm). Tighten setscrew.

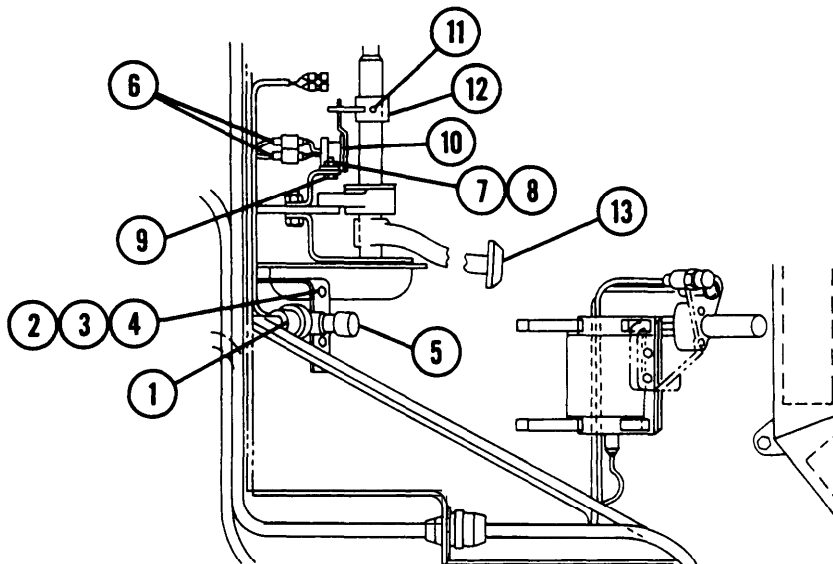

8-38 SLAVE START RECEPTACLE

This task covers: a. Removal b. installation

INITIAL SETUP

Tools

General mechanic's tool kit (item 64, Appx H)

Lockwashers (2) (item 86, Appx G)

Lockwashers (4) (item 89, Appx G)

Lockwashers (2) (item 101, Appx G)

Materials/Parts

Electrical tape — black (item 87, Appx D)

Gasket (item 162, Appx G)

Equipment Conditions

Batteries disconnected (8-28)

NOTE

The M109A2/M109A3 NATO slave start receptacle is located in the bulkhead of the battery compartment. The M1 09A4/M109A5 NATO slave start receptacle is located in the driver's compartment.

a. Removal

- 1 Cut away electrical tape and remove two screws (1) and two lockwashers (2) and disconnect power lead (3) and ground lead (4). Discard lockwashers.
- 2 Remove four nuts (5), four lockwashers (6), four flat washers (7), and four screws (8). Discard lockwashers.
- 3 Remove protective cover (9) from slave start receptacle assembly (10).
- 4 Remove receptacle assembly (10), gasket (11), and insulator (12). Discard gasket.
- 5 Remove screw (13), two lockwashers (14), and ground lead (4) from bulkhead. Discard lockwashers.

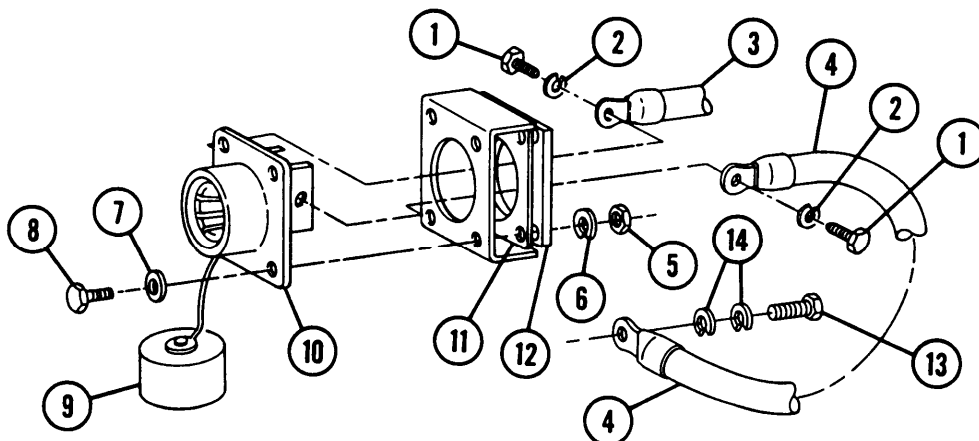

8-38 SLAVE START RECEPTACLE — CONTINUED

b. Installation

- 1 Install ground lead (4), two new lockwashers (14), and screw (13) to bulkhead.
- 2 Install insulator (12), new gasket (11), and slave start receptacle assembly (10).
- 3 Install protective cover (9) on receptacle assembly (10).
- 4 Install four flat washers (7), four new lockwashers (6), four screws (8), and four nuts (5). Ensure protective cover (9) cord is attached under one screw.
- 5 Connect ground lead (4) and power lead (3), two new lockwashers (2), and two screws (1). Wrap exposed wire connections with tape.

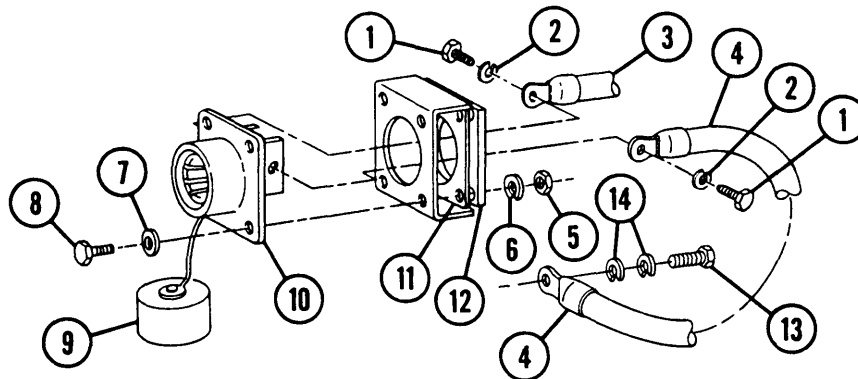

NOTE

FOLLOW-ON MAINTENANCE: Connect batteries (para 8-10)

8-39 EXTERNAL POWER RECEPTACLE (M109A4/M109A5)

This task covers: a. Removal b. Installation

INITIAL SETUP

Applicable Configurations

M109A4/M109A5

Gasket (item 162, Appx G)

Lockwasher (item 54, Appx G)

Lockwasher (item 80, Appx G)

Lockwasher (item 111, Appx G)

Lockwashers (4) (item 87, Appx G)

Tools

General mechanic's tool kit (item 64, Appx H)

Materials/Parts

Electrical tape — black (item 62, Appx D)

Equipment Conditions

Batteries disconnected (para 8-28)

a. Removal

- 1 Remove four screws (1), four lockwashers (2), and guard assembly (3). Discard lockwashers.
- 2 Remove two screws (4), two lockwashers (5), and bus bar (6) from external power receptacle (7). Discard lockwashers.
- 3 Remove screw (8) and lockwasher (9). Disconnect cable (10) and remove insulating boot (11). Discard lockwasher.
- 4 Remove four screws (12), four flat washers (13), and protective cover (14) with cable (16) from receptacle.
- 5 Remove receptacle (7) and gasket (15). Discard gasket.

b. Installation

- 1 Install new gasket (15) and external power receptacle (7).
- 2 Install protective cover (14), four flat washers (13), and four screws (12). Ensure protective cover cord (16) is attached under one screw.
- 3 Wrap exposed wire connections with electrical tape.
- 4 Install insulating boot (11), cable (10), new lockwasher (9), and screw (8).
- 5 Install bus bar (6), two new lockwashers (5), and two screws (4).
- 6 Install guard assembly (3), four new lockwashers (2), and four screws (1).

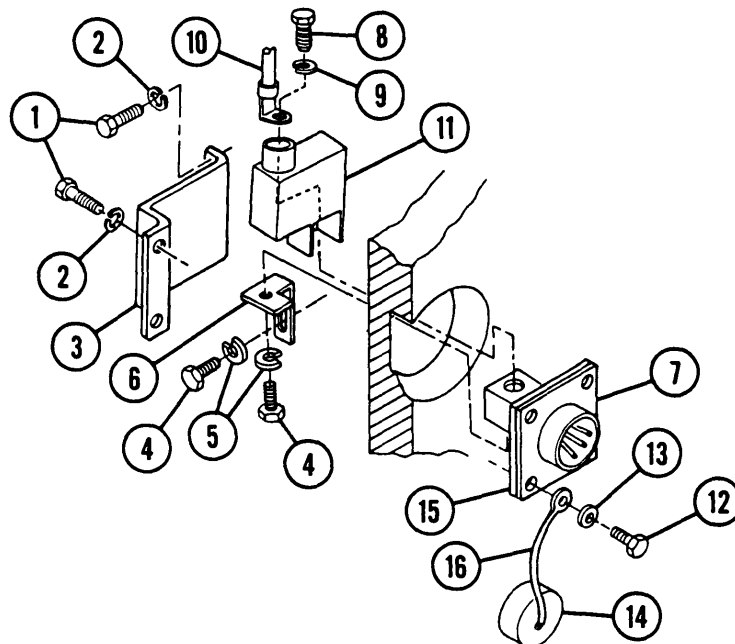
**NOTE**

FOLLOW-ON MAINTENANCE: Connect batteries (para 8-28)

8-40 COMBAT OVERRIDE SWITCH ASSEMBLY (M109A4/M109A5)

This task covers: a. Removal b. Installation

INITIAL SETUP

Applicable Configurations

M109A4/M109A5

Materials/Parts

Lockwashers (2) (item 82, Appx G)

Lockwashers (2) (item 192, Appx G)

Tools

General mechanic's tool kit (item 64, Appx H)

a. Removal

WARNING

Ensure MASTER switch is OFF when working on starter protection override switch to avoid electrical shocks and burns.

- 1 Disconnect two electrical connectors (1).
- 2 Remove two screws (2), two lockwashers (3), two washers (4), and combat override switch assembly (5). Discard lockwashers.
- 3 Remove two screws (6), two lockwashers (7), two washers (8), and switch (9) from bracket (10). Discard lockwashers.

b. Installation

WARNING

Ensure MASTER switch is OFF when working on starter protection override switch to avoid electrical shocks and burns.

- 1 Install switch (9), two washers (8), two new lockwashers (7), and two screws (6) on bracket (10).
- 2 Install combat override switch assembly (5), two washers (4), two new lockwashers (3), and two screws (2).
- 3 Connect two electrical connector (1).

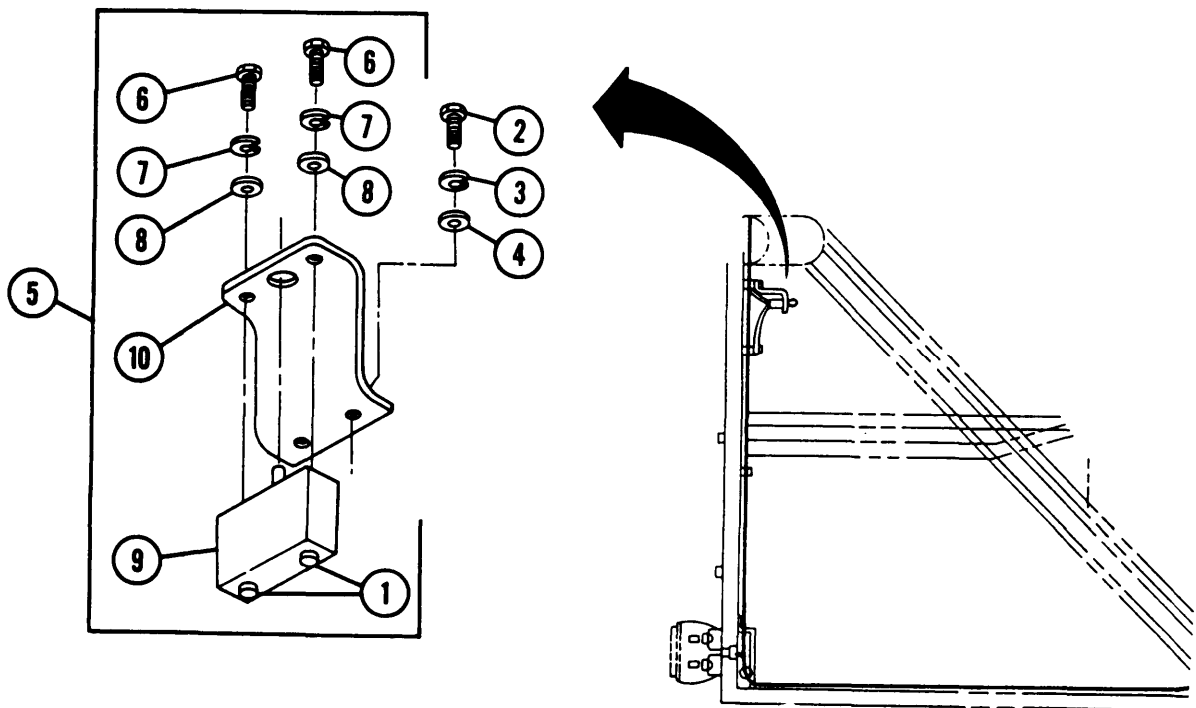

SECTION III. POWERPLANT AND HULL WIRING HARNESSSES

This section provides instructions for removal and installation of powerplant and hull wiring harnesses. Instructions for test, disassembly, and assembly of individual wiring harnesses are in Chapters 2 and 3.

8-41 CIRCUIT ID AND ILLUSTRATION OF WIRING HARNESSSES (M109A2M109A3)

NOTE

- Each electrical cable is marked with a wire-numbered metal tag attached to the junction of the terminal of the cable. All electrical circuits shown in schematics and wiring diagrams are identified by wire numbers listed in each area.
- See task sheets in this section, Appendix 1, and specific troubleshooting pages for detailed routing of wiring harnesses. See paragraph 2-13 for electrical repair kit data.

LEGEND

- | | |
|--|---|
| 1 Wiring harness 12268102— Alternator-to-rectifier | 15 Wiring harness 11594268— Bulkhead connector to driver's instrument panel |
| 2 Wire 82— From master relay to wire 82/49 | 16 Wire 68— Battery positive-to-negative connectors |
| 3 Wire 27B — From wiring harness 12268100 to voltage regulator | 17 Wire 81 — From batteries to master relay |
| 4 Wire 2 — From voltage regulator to wire 81 | 18 Wiring harness 11593806— Rectifier-to-voltage regulator |
| 5 Lead 11593784 or 12260266 — From bulkhead connector to slave start receptacle (wire 49) and to circuit breaker panel (wire 10) | 19 Wire 82/49— Engine starter from lower powerplant connector bracket to bulkhead connector |
| 6 Wiring harness 10925829— From accessory control box to air cleaner blower assembly | 20 Wiring harness 12268100— Engine instrumentation bulkhead connector-to-powerplant connector bracket |
| 7 Wiring harness 10925829— From accessory control box to heater fuel pump and personnel heater | 21 Ground wire — Powerplant to hull |
| 8 Lead 11593784 or 12260266 — From circuit breaker to: | 22 Wiring harness 12268102— From bulkhead connector to engine instrumentation |
| 9 Slip ring segment board (47) | 23 Wire 82— From bulkhead connector to engine starter |
| 10 Telephone terminal (21 and 22) | 24 Wiring harness 10921380— To headlight assemblies |
| 11 Accessory control box (37 and 38) | 25 Wire 452— Bilge pump relay to bilge pump |
| 12 Wiring harness 12260298— From driver's compartment/connector to portable instrument panel | 26 Wire 29-31 — To fuel level transmitters
Wires 76 — To fuel tank fuel pumps |
| 13 Wire 7— Battery to ground | 27 Wire 352A and 352B — From wiring harness 12268102 to aeration detector |
| 14 Wiring harness 12260287— Bulkhead connector to driver's compartment connector bracket | |

HULL ELECTRICAL HARNESS (M109A2/M109A3)

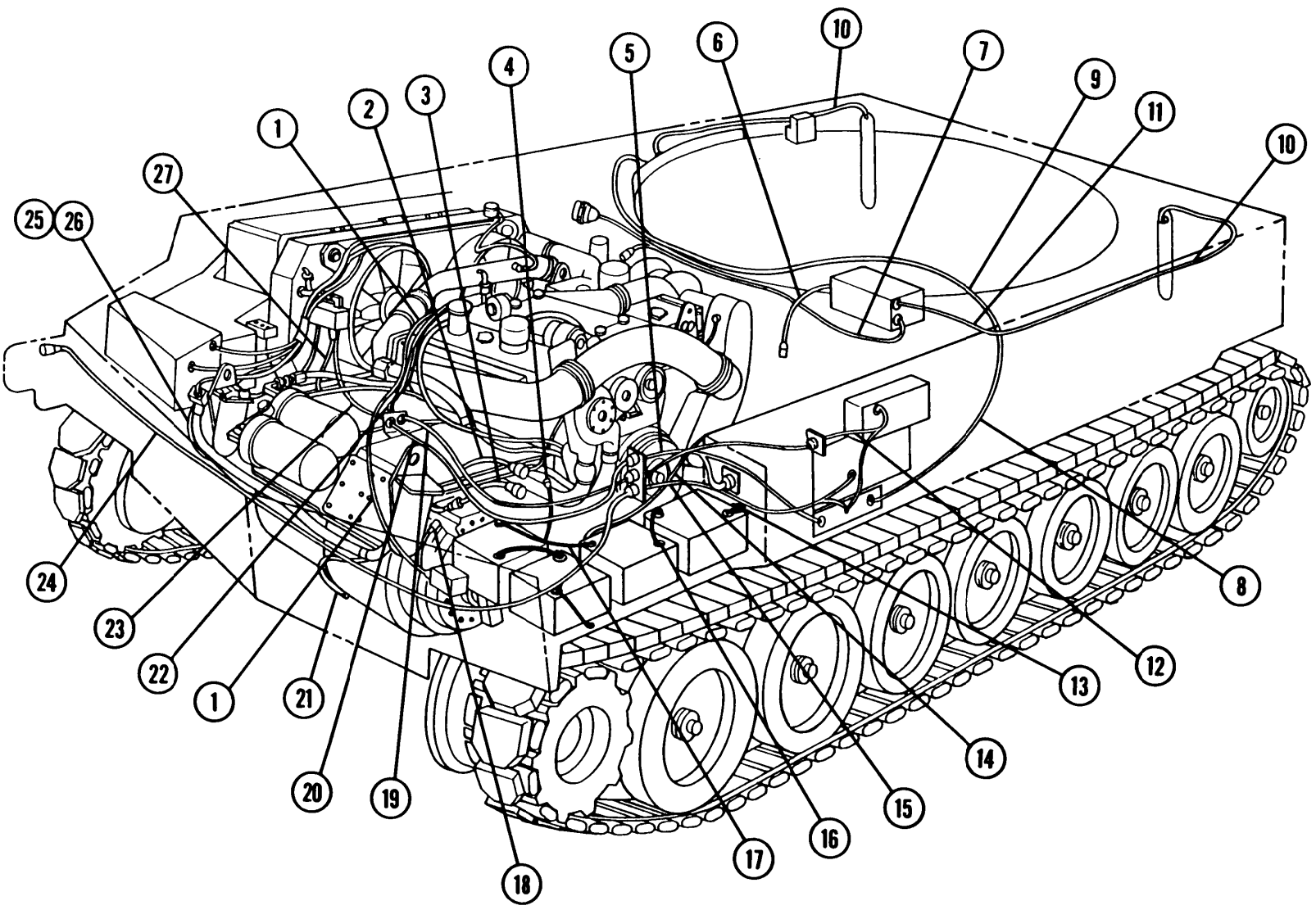

8-42 CIRCUIT ID AND ILLUSTRATION OF WIRING HARNESES (M109A4UM109A5)

NOTE

- Each electrical cable is marked with a wire-numbered metal tag attached to the junction of the terminal of the cable. All electrical circuits shown in schematics and wiring diagrams are identified by wire numbers listed in each area.
- See task sheets in this section, Appendix 1, and specific troubleshooting pages for detailed routing of wiring harnesses. See paragraph 2-13 for electrical repair kit data.

LEGEND

- | | | | |
|----|---|----|---|
| 1 | Wiring harness 12268308— Alternator to rectifier | 16 | Wire 7 — Battery to ground |
| 2 | Wire 82— From master relay to wire 82/49 | 17 | Wiring harness 12260287— Bulkhead connector to driver's compartment connector bracket |
| 3 | Wire 27B — From wiring harness 12268418 — Engine instrumentation bulkhead connector to powerplant connector bracket | 18 | Wiring harness 11594268 — bulkhead connector to driver's instrument panel |
| 4 | Wire 2 — From voltage regulator to wire 81 | 19 | Wire 68— Battery positive-to-negative connectors |
| 5 | Lead 12268304 — From bulkhead connector to slave start receptacle (wire 49) and to circuit breaker panel (wire 10) | 20 | Wiring harness 12353402 — Driver's bulkhead-to-batteries wiring harness |
| 6 | Wiring harness 12268308 — From bulkhead connector to engine instrumentation | 21 | Wire 81 — From batteries to master relay |
| 7 | Wiring harness 10925829 — From accessory control box to heater fuel pump and personnel heater | 22 | Wiring harness 12268303 — Rectifier-to-voltage regulator |
| 8 | Lead 12268419 — Bulkhead to override switch lead | 23 | Wiring harness 12353401 — Engine disconnect bracket-to-batteries lead assembly |
| 9 | Wiring harness 12353400 — NATO slave start-to-external power receptacle wiring harness | 24 | Wiring harness 12268418 — Engine instrumentation bulkhead connector-to-powerplant connector bracket |
| 10 | Wiring harness 12352794 — Ventilated facepiece system wiring harness | 25 | Wire 82— From bulkhead connector to engine starter |
| 11 | Lead 12268304 — From circuit breaker to: | 26 | Wiring harness 10921380 — To headlight assemblies |
| | 12 Slip ring segment board (47) | 27 | Wire 452 — Bilge pump relay to bilge pump |
| | 13 Telephone terminal (21 and 22) | 28 | Wire 29-31 — To fuel level transmitters |
| | 14 Accessory control box (37 and 38) | | Wires 76 — To fuel tank fuel pumps |
| 15 | Wiring harness 12260298 — From driver's compartment/connector to portable instrument panel | 29 | Starter to engine electrical disconnect — Wiring harness 12353072 |

HULL ELECTRICAL HARNESS (M109A4/M109A5)

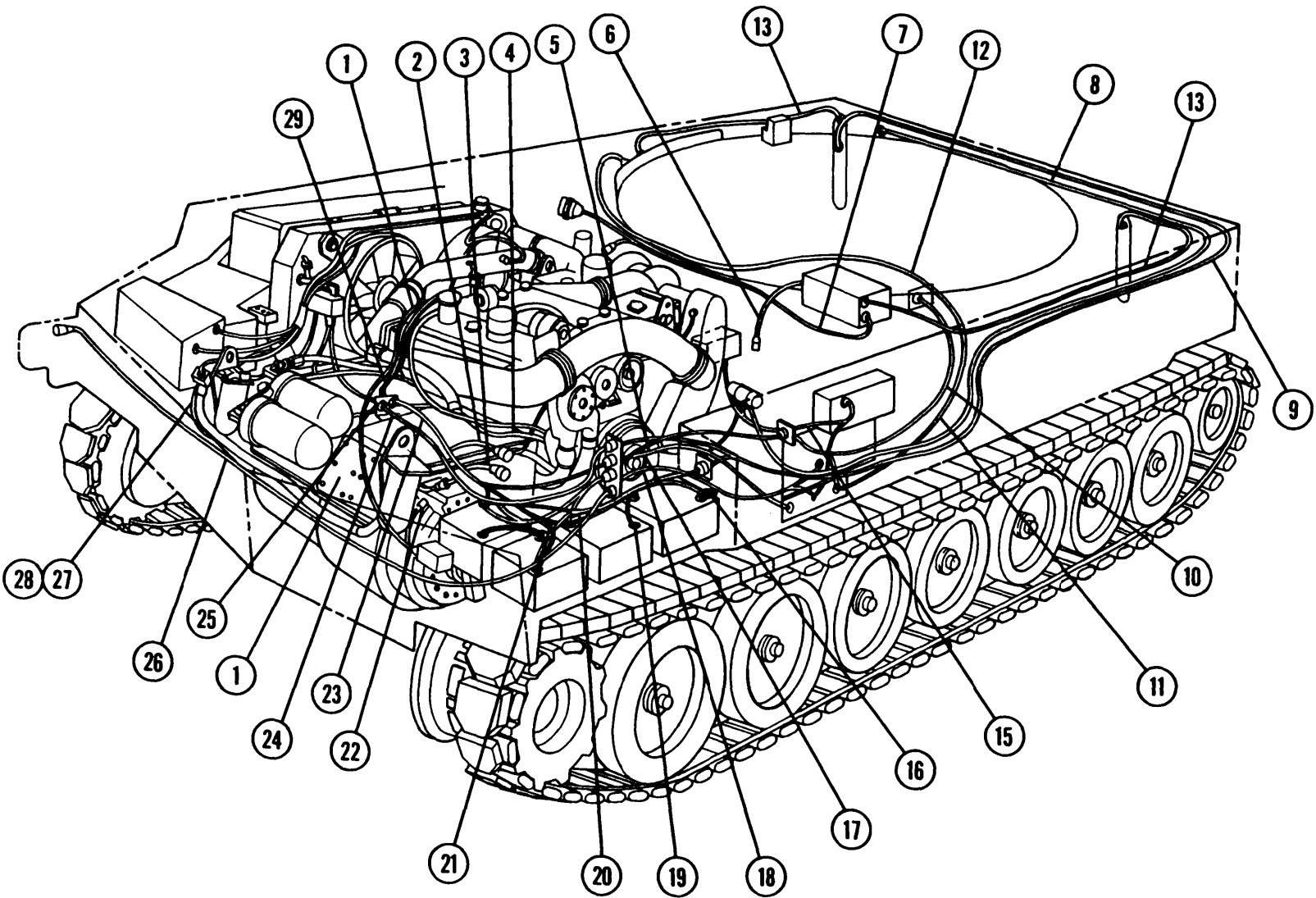

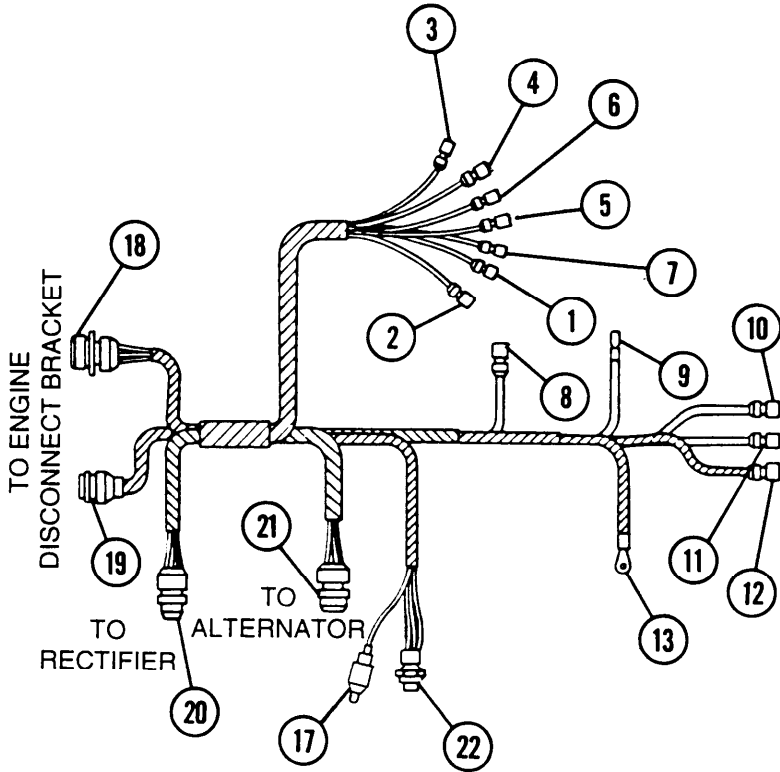
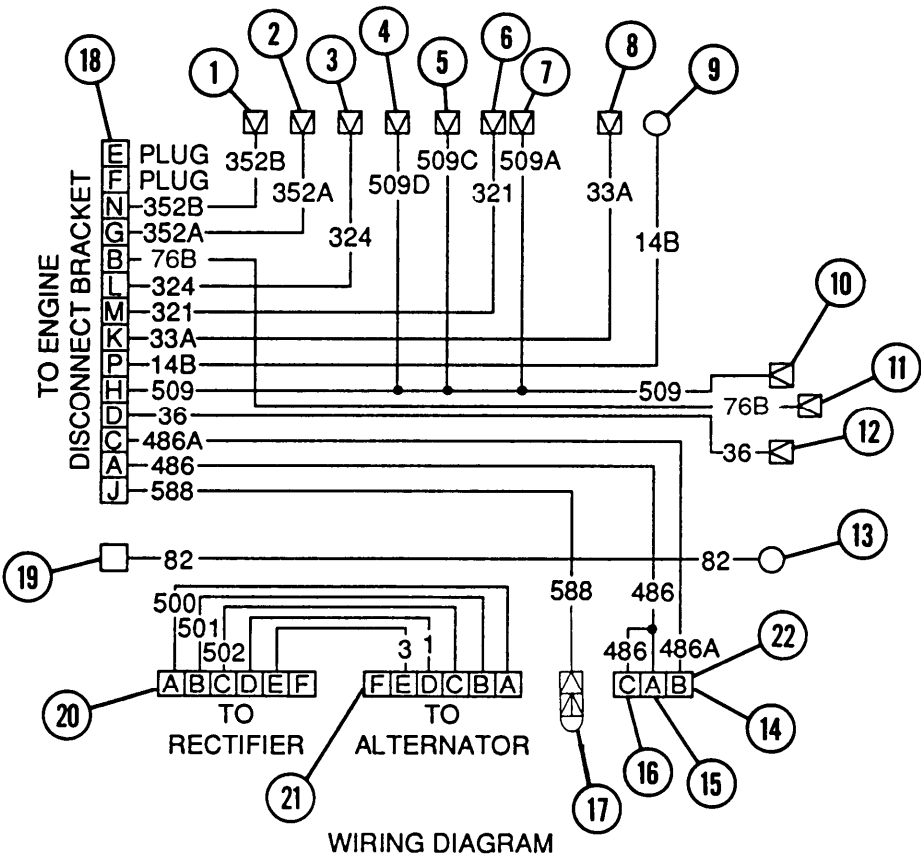

8-43 POWERPLANT WIRING HARNESS (M109A2/M109A3) — CONTINUED

a. Removal

WARNING

Ensure MASTER switch is OFF when working on hull electrical system to avoid electrical shocks and burns.

1 Disconnect five connectors (18 thru 22).

NOTE

- On vehicles with engine model 7083-7396, connectors 14, 15, and 16 are part of connector 22 and are used for the flame heater system. On vehicles with engine model 7083-7391, connectors 14, 15, and 16 are part of connector 22 and are used for the glow plug controller system.

Ž Access to wires 10 thru 12 will be through driver's compartment.

Ž Powerplant must be removed to remove starter leads (9 and 13) (para 4-5).

2 Disconnect 11 connectors (1 thru 8 and 10 thru 12).

3 Remove two nuts (23) and two flat washers (24). Remove two leads (9 and 13) at starter solenoid (25).

4 Remove two screws (26), two clamps (27), two screws (28), and two clamps (29). Place four screws back into engine.

5 Remove powerplant wiring harness.

b. Disassembly/Repair

1 Remove electrical tape where necessary for disassembly.

2 Isolate and separate wiring harness branches.

3 Disassemble wiring branch (para 2-13) of wires to be replaced.

c. Assembly

1 Assemble wiring branch (para 2-13) of wires replaced.

2 Apply electrical tape as necessary for assembly.

d. Installation

WARNING

Ensure MASTER switch is OFF when working on hull electrical system to avoid electrical shocks and burns.

NOTE

- On vehicles with engine model 7083-7396, connectors 14, 15, and 16 are part of connector 22 and are used for the flame heater system. On vehicles with engine model 7083-7391, connectors 14, 15, and 16 are part of connector 22 and are used for the glow plug controller system.
- Access to wires 10 thru 12 will be through driver's compartment.

- 1 Install powerplant wiring harness.
- 2 install two clamps (29), two screws (28), two clamps (27), and two screws (26).
- 3 Install two leads (13 and 9) at starter solenoid (25). Install two flat washers (24) and two nuts (23).
- 4 Connect 11 electrical connectors (1 thru 8 and 10 thru 12).
- 5 Connect five electrical connectors (18 thru 22).

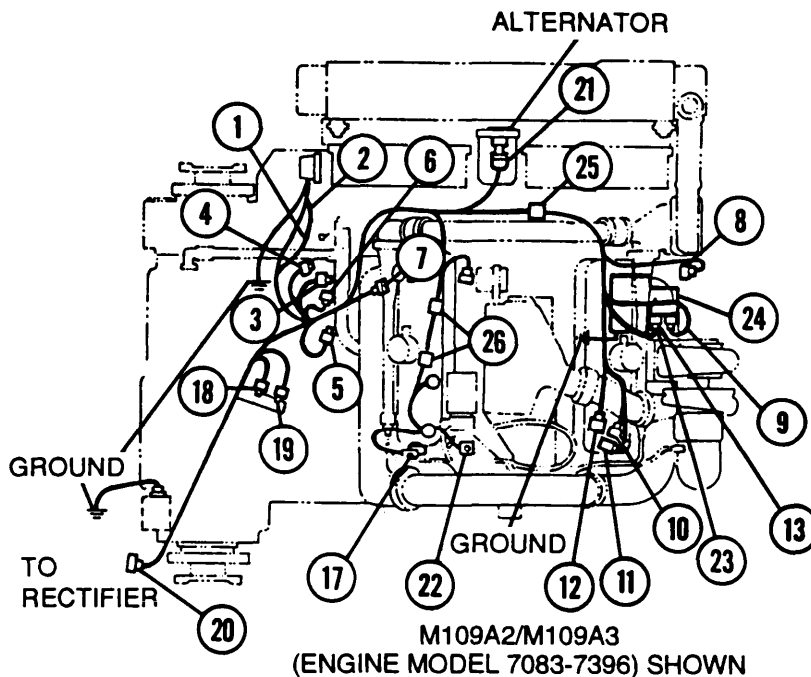
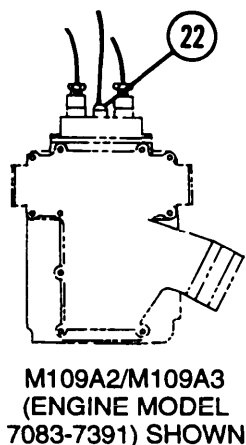

NOTE

- FOLLOW-ON MAINTENANCE:
- Close transmission access doors (para 11 -7)
 - Install engine access cover (para 11-5)
 - Connect batteries (para 8-28)
 - Close air intake grille (para 11 -8)

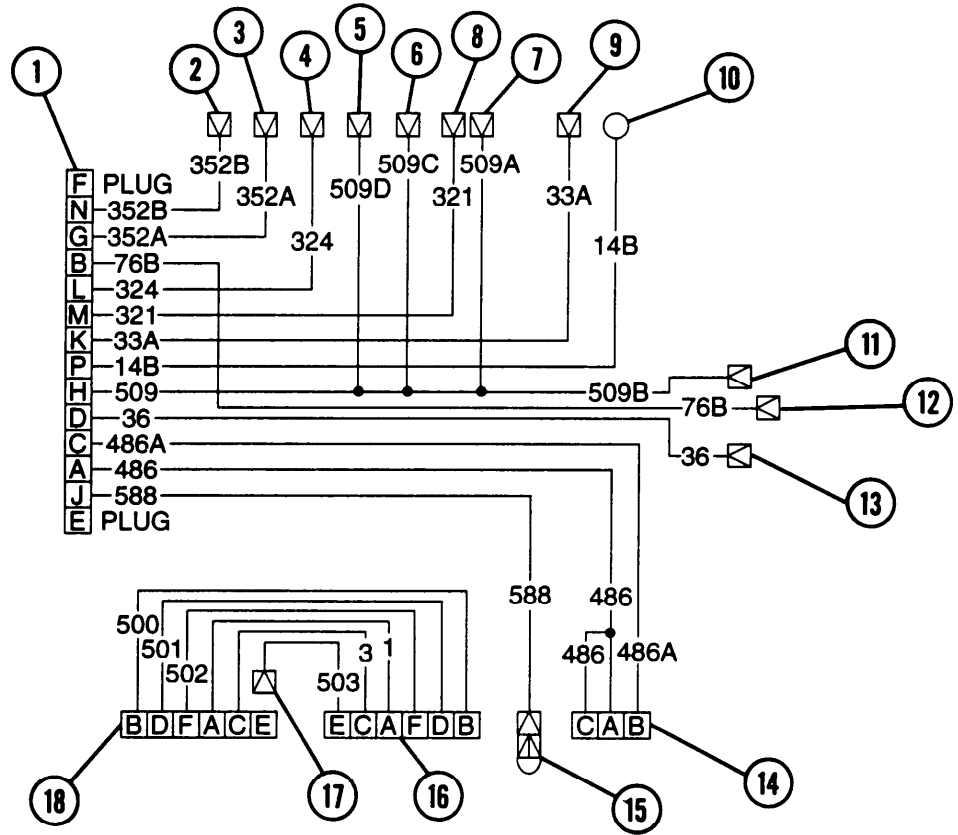

WIRING DIAGRAM

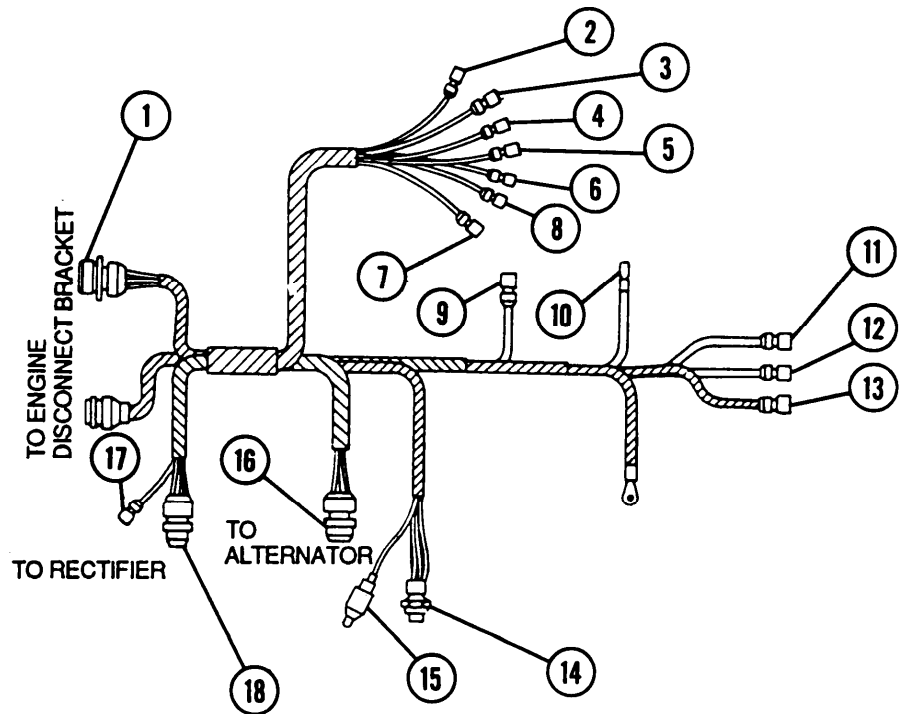

8-44 POWERPLANT WIRING HARNESS (M109A4/M109A5) — CONTINUED

a. Removal

WARNING

Ensure MASTER switch is OFF when working on hull electrical system to avoid electrical shocks and burns.

- 1 Disconnect driver's bulkhead-to-master relay wiring harness (19) at engine disconnect bracket (20).
- 2 Remove four nuts (21), four lockwashers (22), four washers (23), and four screws (24). Discard lockwashers.
- 3 Remove connector (1) from engine disconnect bracket (20).
- 4 Disconnect two electrical connectors (17 and 18).

NOTE

- Access to wires 11, 12, and 13 will be through driver's compartment.

ŽWire 15 is plugged.

ŽPowerplant must be removed to remove starter lead (10) (para 4-5).

- 5 Disconnect 13 electrical connectors (2 thru 9 and 11 thru 16).
- 6 Remove nut (25) and flat washer (26). Remove lead (10) at starter solenoid (27).
- 7 Remove two screws (28), two washers (29), two nuts (30), two clamps (31), four screws (32), four lockwashers (33), and four clamps (34). Place four screws (32) back into engine. Discard lockwashers.
- 8 Remove powerplant wiring harness.

b. Disassembly/Repair

- 1 Remove electrical tape where necessary for disassembly.
- 2 Isolate and separate wiring harness branches.
- 3 Disassemble wiring branch (para 2-13) of wires to be replaced.

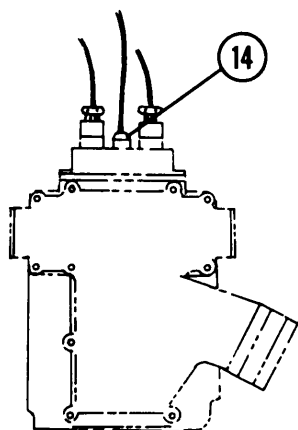

M109A4/M109A5
(ENGINE MODEL 7083-7391) SHOWN

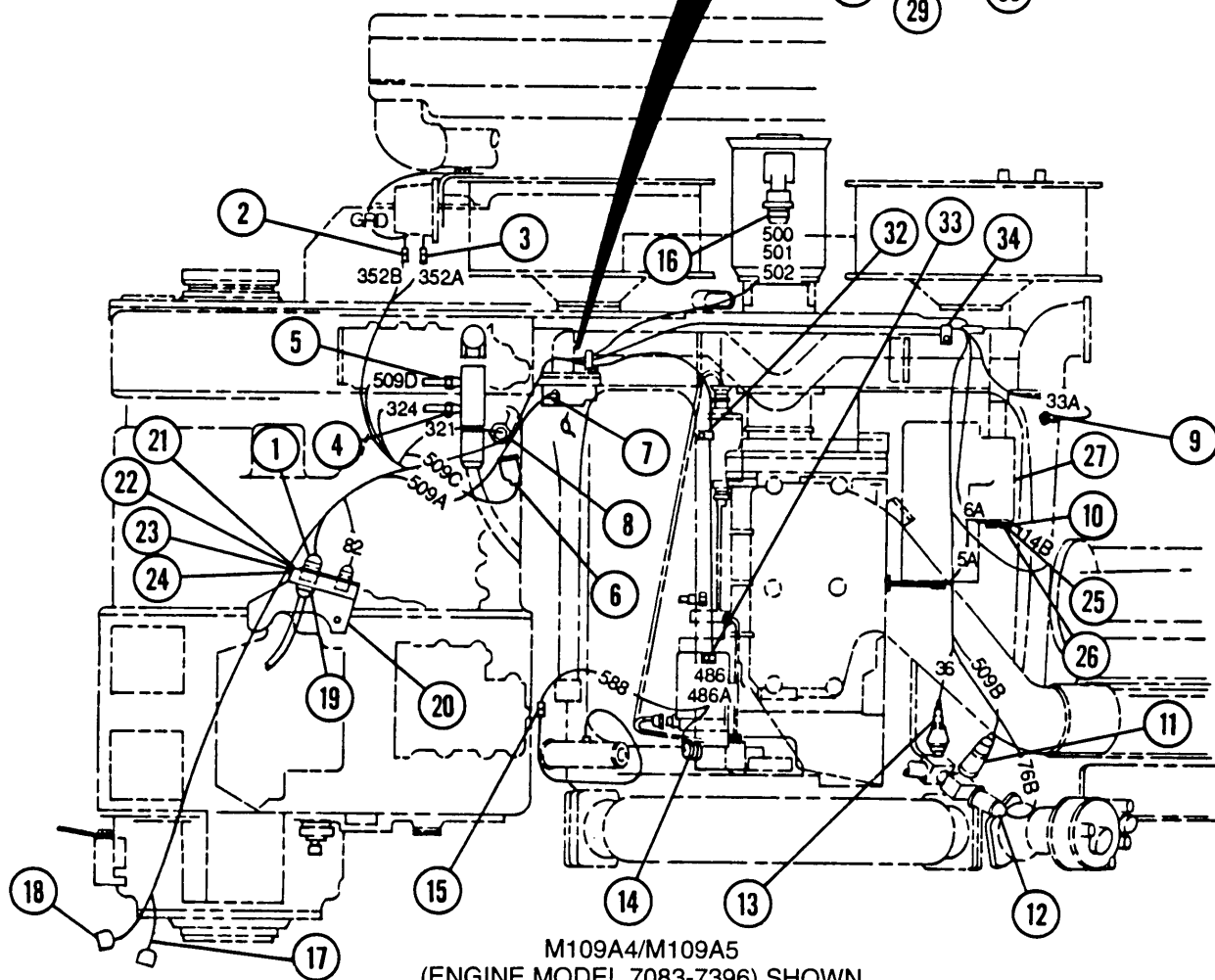
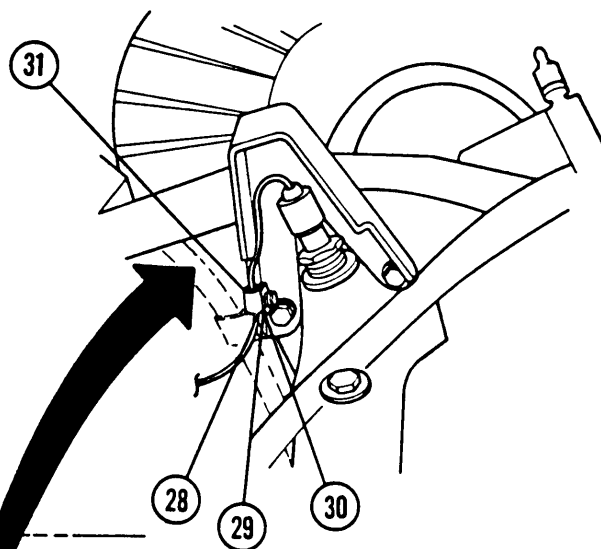

M109A4/M109A5
(ENGINE MODEL 7083-7396) SHOWN

8-44 POWERPLANT WIRING HARNESS (M109A4/M109A5) — CONTINUED

c. Assembly

- 1 Assemble wiring branch (para 2-12) of wires replaced.
- 2 Apply electrical tape as necessary for assembly.

d. Installation

WARNING

Ensure MASTER switch is OFF when working on hull electrical system to avoid electrical shocks and burns.

NOTE

- Access to wires 11, 12, and 13 will be through driver's compartment.

ŽWire 15 is plugged.

ŽPowerplant must be removed to remove starter lead (10) (para 4-5).

- 1 Install powerplant wiring harness.
- 2 Connect 13 electrical connectors (2 thru 9 and 11 thru 16).
- 3 Connect two electrical connectors (17 and 18).
- 4 Connect electrical connector (1) at engine disconnect bracket (20).
- 5 Install four new lockwashers (22), four washers (23), four screws (24), and four nuts (21).
- 6 Connect driver's bulkhead-to-master relay wiring harness (19) at engine disconnect bracket (20).
- 7 Install lead (10) at starter solenoid (27), flat washer (26), and nut (25).
- 8 Install four clamps (34), four new lockwashers (33), four screws (32), two clamps (31), two washers (29), two screws (28), and two nuts (30).

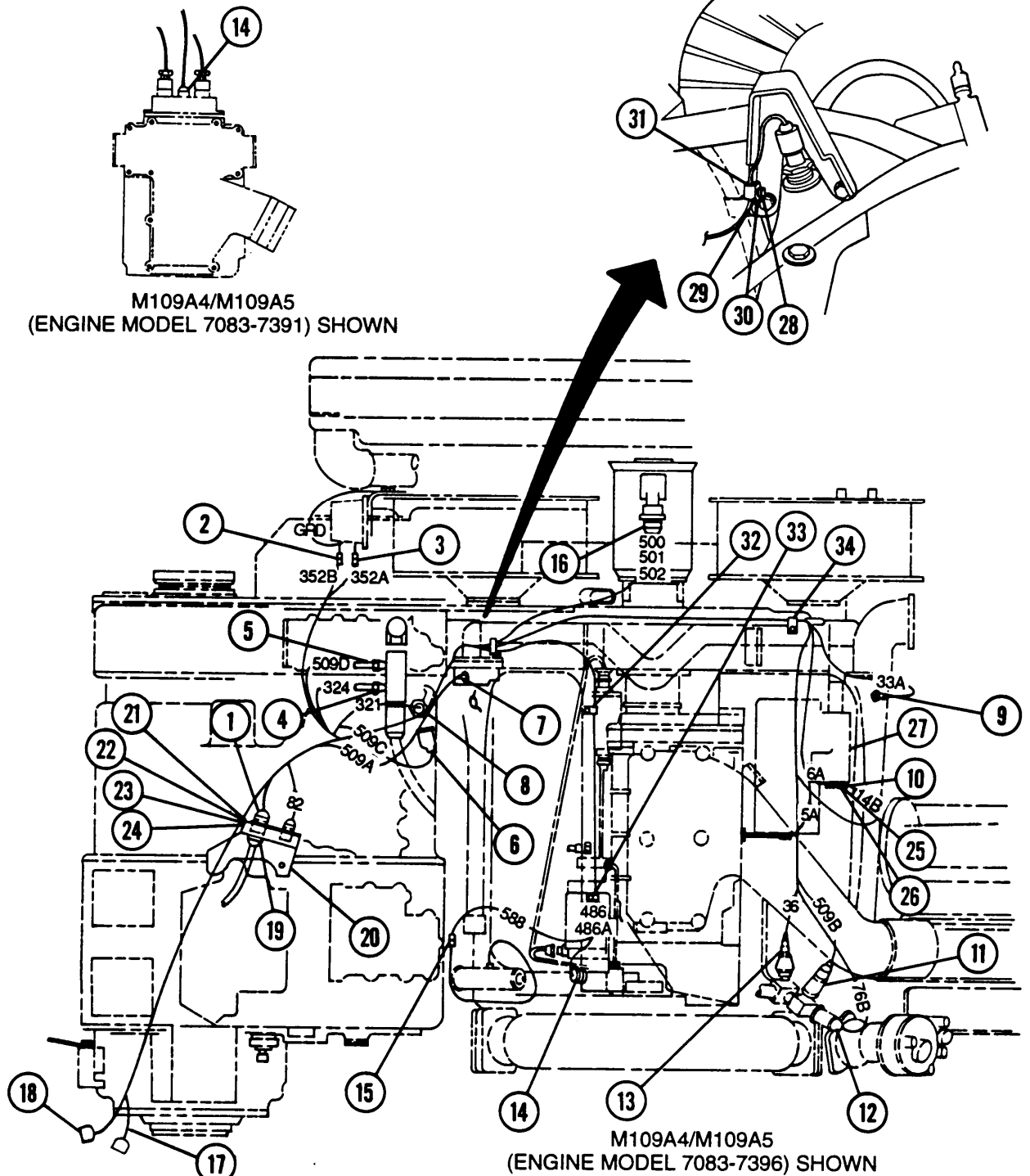

NOTE

FOLLOW-ON MAINTENANCE:

- Close transmission access doors (para 11-7)
- Install engine compartment access cover (para 11-5)
- Connect batteries (para 8-28)
- Close air intake grille (para 11-8)

8-45 ENGINE DISCONNECT BRACKET-TO-BULKHEAD WIRING HARNESS (M109A2/M109A3)

This task covers: a. Disassembly/Repair b. Assembly

INITIAL SETUP

Applicable Configurations

M109A2/M109A3

Materials/Parts

Electrical tape — black (item 62, Appx D)

Tools

General mechanic's tool kit (item 64, Appx H)

Equipment Conditions

Batteries disconnected (para 8-28)

NOTE

- For removal and installation of the engine disconnect bracket-to-bulkhead wiring harness, notify support maintenance.

Ž On vehicles with engine model 7083-7396, connectors 4 and 11 are used for the flame heater system. On vehicles with engine model 7083-7391, connectors 4 and 11 are used for the glow plug controller system.

Connector No.	Electrical Lead To:	Wire No.	Connector No.	Electrical Lead To:	Wire No.
1	Battery assembly to master relay	81	12	In-tank fuel pumps and generator system relay	76B
2	Aeration detector-to-coolant indicator	352B	13	Regulator cutoff relay coil energizer	27B
3	Aeration detector-to-coolant indicator	352A	14	Air cleaner blower motor circuit	415
4	Flame heater-to-flame heater switch (engine model 7083-7396) or glow plug controller-to-glow plug lamp (engine model 7083-7391)	486A	15	Master switch voltage regulator lead	400-459B
5	Engine oil pressure transmitter-to-engine oil pressure gage switch	36	16	Engine starter circuit (starter relay bilge pump circuit breaker neutral safety switch)	14/14B
6	Engine coolant temperature transmitter-to-engine water temperature gage	33A	17	Voltage regulator-to-master relay lead	2
7	Transmission oil temperature transmitter-to-transmission oil temperature gage	324	18	Ground wire	3
8	Transmission oil pressure transmitter-to-transmission oil pressure switch	321	19	Engine bracket disconnect connector	
9	High/low temperature and pressure switches/transmitters-to-master warning light	509	20	Voltage regulator connector	
10	Not used	588	21	Starter relay connector	
11	Flame heater motor pump-to-flame heater switch (engine model 7083-7396) or glow plug controller-to-glow plug switch (engine model 7083-7391)	486	22	Bilge pump circuit breaker lead	
			23	Driver's bulkhead connector	
			24	Battery connectors	
			25	Master relay connectors	

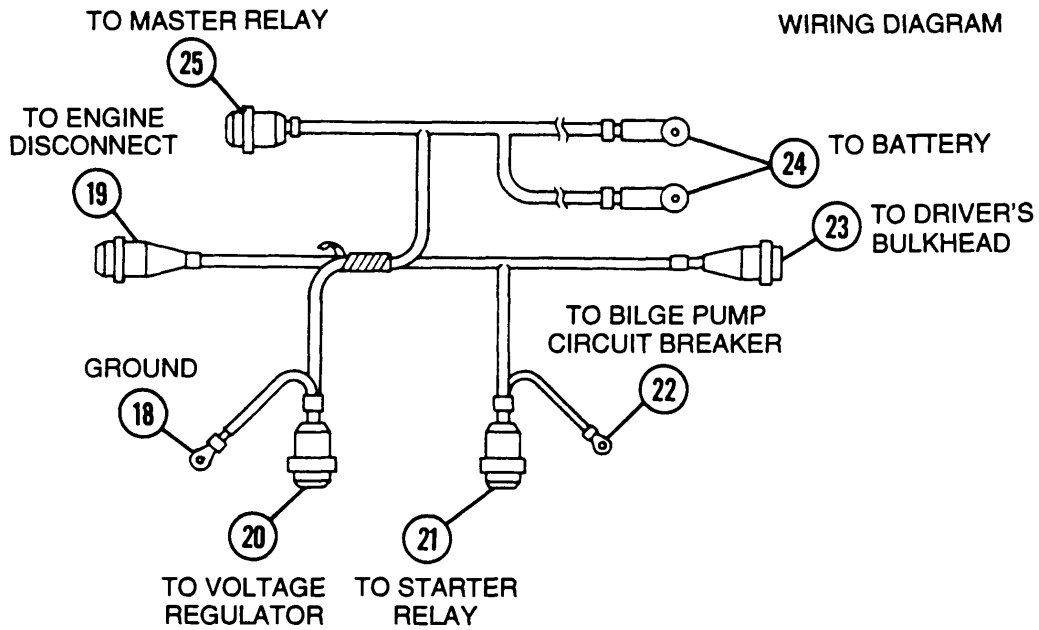
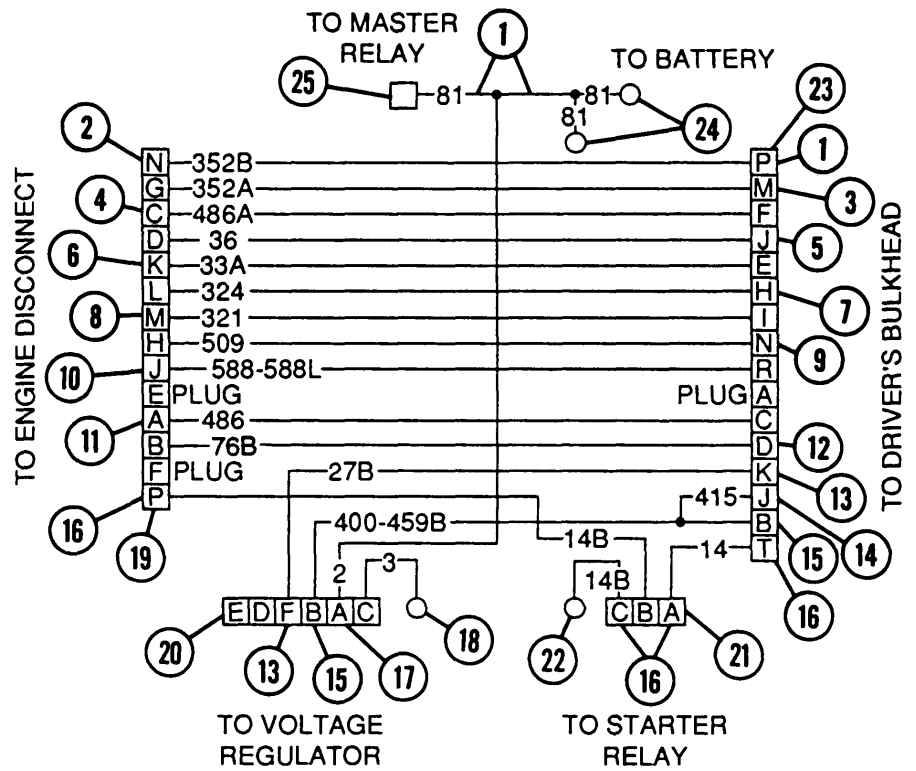

a. Disassembly/Repair

- 1 Remove electrical tape only for sections to be disassembled.
- 2 Isolate and separate wiring harness branches.
- 3 Disassemble wiring harness branch (para 2-13) of wires to be

8-45 ENGINE DISCONNECT BRACKET-TO-BULKHEAD WIRING HARNESS (M109A2/M109A3) — CONTINUED

b. Assembly

- 1 Assemble wiring harness branch (para 2-13) of wires replaced.
- 2 Apply electrical tape as necessary for assembly.

NOTE

FOLLOW-ON MAINTENANCE: Connect batteries (para 8-28)

8-46 DRIVER'S BULKHEAD-TO-MASTER RELAY WIRING HARNESS (M109A4/M109A5)

This task covers: a. Disassembly/Repair b. Assembly

INITIAL SETUP

Applicable Configurations
M109A4/M109A5

Materials/Parts

Electrical tape — black (item 62, Appx D)

Tools

General mechanic's tool kit (item 64, Appx H)

Equipment Conditions

Batteries disconnected (para 8-28)

NOTE

- For removal and installation of the driver's bulkhead-to-master relay wiring harness, notify support maintenance.
- On vehicles with engine model 7083-7396, connector 4 is used for the flame heater system. On vehicles with engine model 7083-7391, connector 4 is used for the glow plug controller system.

Connector No.	Electrical Lead To:	Wire No.	Connector No.	Electrical Lead To:	Wire No.
1	Battery assembly-to-master relay	81	6	Engine coolant temperature transmitter-to-engine water temperature gage	33A
2	Aeration detector-to-coolant indicator	352B	7	Transmission oil temperature transmitter-to-transmission oil temperature gage	324
3	Aeration detector-to-coolant indicator	352A	8	Transmission oil pressure transmitter-to-transmission oil pressure switch	321
4	Flame heater-to-flame heater switch (engine model 7083-7396) or glow plug controller-to-glow plug switch (engine model 7083-7391)	486A			
5	Engine oil pressure transmitter-to-engine oil pressure gage switch	36			

Connector No.	Electrical Lead To:	Wire No.	Connector No.	Electrical Lead To:	Wire No.
6	Engine coolant temperature transmitter-to-engine water temperature gage	33A	15	Voltage regulator to master relay lead	2
7	Transmission oil temperature transmitter-to-transmission oil temperature gage	324	16	Ground wire	4
8	Transmission oil pressure transmitter-to-transmission oil pressure switch	321	17	Engine bracket disconnect connector	
9	High/low temperature and pressure switches/transmitters-to-master warning light	509	18	Voltage regulator ground	
10	Air cleaner blower motor switch-to-air cleaner blower motor assembly	415B-76B	19	Engine disconnect	
11	Regulator cutoff relay coil energizer	27B	20	Voltage regulator connector	
12	Air cleaner blower motor circuit	415	21	Starter protection relay	503
13	Master switch voltage regulator lead	400-459B	22	Starter protection relay ground	
14	Engine starter circuit (starter relay bilge pump circuit breaker neutral safety switch)	14/14B/GND	23	Driver's bulkhead connector-to-starter protection relay	14C
			24	Driver's bulkhead	
			25	Driver's bulkhead	
			26	Battery positive terminal	81
			27	Master relay	81

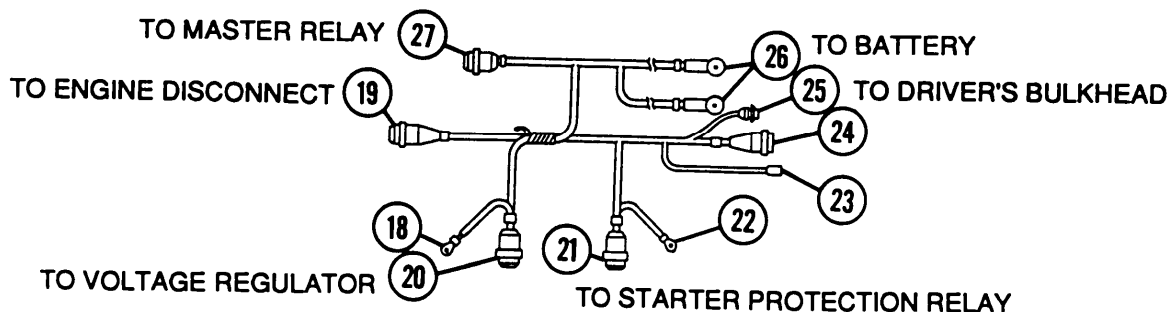
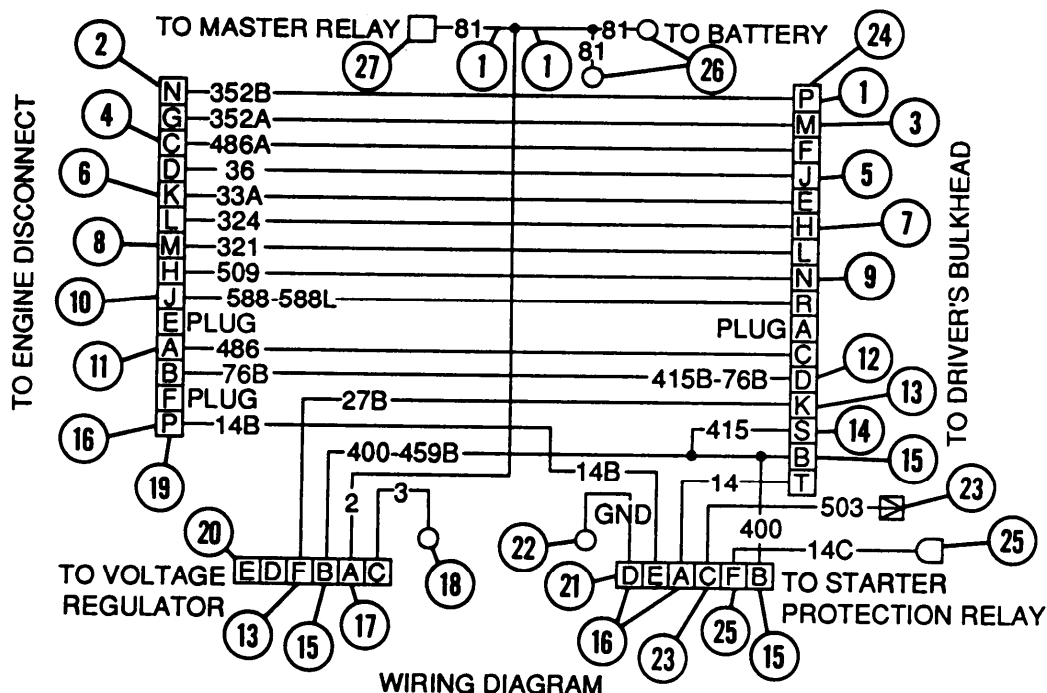

8-46 DRIVER'S BULKHEAD-TO-MASTER RELAY WIRING HARNESS (M109A4/M109A5) — CONTINUED

Disassembly/Repair

- 1 Remove electrical tape only for sections to be disassembled.
- 2 Isolate and separate wiring harness branches.
- 3 Disassemble wiring harness branch (para 2-13) of wires to be replaced.

b. Assembly

- 1 Assemble wiring harness branch (para 2-13) of wires replaced.
- 2 Apply electrical tape as necessary for assembly.

NOTE

FOLLOW-ON MAINTENANCE: Connect batteries (para 8-28)

8-47 BULKHEAD-TO-HEADLIGHTS/BILGE PUMP WIRING HARNESS

This task covers: a. Disassembly b. Assembly

INITIAL SETUP

Tools

General mechanic's tool kit (item 64, Appx H)

Equipment Conditions

Batteries disconnected (para 8-28)

Materials/Parts

Electrical tape — black (item 62, Appx D)

NOTE

For removal and installation of the bulkhead-to-headlights/bilge pump wiring harness, notify support maintenance.

Connector No.	Electrical Lead To:	Wire No.	Connector No.	Electrical Lead To:	Wire No.
1	Left fuel pump lead	76	12	Service headlight high beam	17
2	Left fuel pump	GND	13	Bilge pump motor connector	452
3	Right fuel pump	GND	14	Master relay connector	459
4	Right fuel pump lead	76	15	Bilge pump relay lead	452
5	Right upper and lower fuel tank	GND	16	Bilge pump relay energizing circuit	450
6	Right upper fuel tank transmitter lead	29	17	Bilge pump relay power lead	4526
7	Right lower fuel tank transmitter lead	31	18	Bilge pump circuit breaker connector 452B	
8	Not used	515	19	Not used	19
9	Not used	514	20	Bilge pump relay connector	
10	B.O. marker (front light assembly)	20	21	Bulkhead connector	
11	Service headlight low beam	18	22	Ground	

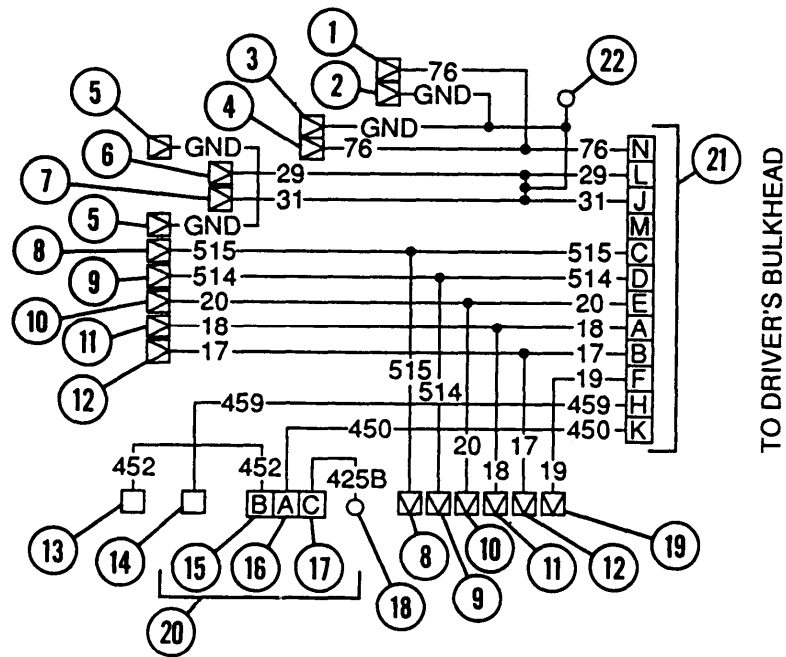

WIRING DIAGRAM

8-48 HEADLIGHT WIRING HARNESS

This task covers: a. Removal b. Installation

INITIAL SETUP

Materials/Parts

Electrical tape — black (item 62, Appx D)

Connector No.	Electrical Lead To:	Wire No.	Connector No.	Electrical Lead To:	Wire No.
1	Headlight resilient mount		5	Not used	515
2	Low beam service	18	6	Not used	514
3	High beam service	17	7	B.O. marker	20
4	Ground	91	8	Not used	19

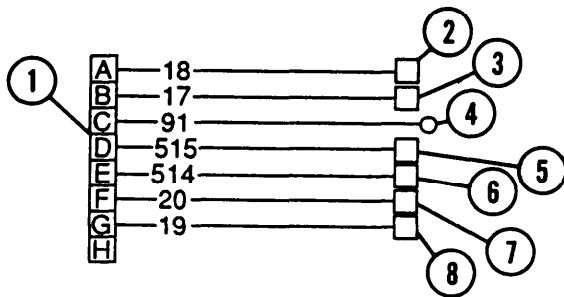

WIRING DIAGRAM

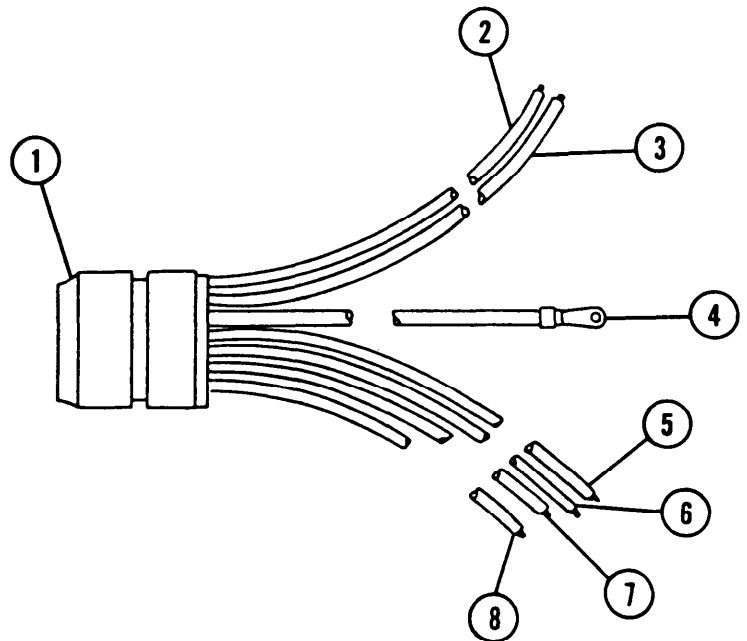

8-48 HEADLIGHT WIRING HARNESS — CONTINUED

a. Removal

WARNING

Ensure MASTER switch is OFF when working on hull electrical system to avoid electrical shocks and burns.

Remove headlight wiring harness (para 8-24).

b. Installation

WARNING

Ensure MASTER switch is OFF when working on hull electrical system to avoid electrical shocks and burns.

Install headlight harness (para 8-24).

8-49 BULKHEAD-TO-PORTABLE INSTRUMENT PANEL WIRING HARNESS

This task covers: a. Disassembly b. Assembly

INITIAL SETUP

Tools

General mechanic's tool kit (item 64, Appx H)

Equipment Conditions

Batteries disconnected (para 8-28)

Materials/Parts

Electrical tape — black (item 62, Appx D)

NOTE

ŽFor removal and installation of the bulkhead-to-portable instrument panel wiring harness, notify support maintenance.

ŽOn vehicles with engine model 7083-7396, connectors 19 and 22 are used for the flame heater system. On vehicles with engine model 7083-7391, connectors 19 and 22 are used for the glow plug controller system.

Connector No.	Electrical Lead To:	Wire No.	Connector No.	Electrical Lead To:	Wire No.
1	Aeration detector	352B	18	Starter switch — neutral safety switch	14
2	Aeration detector	352A	19	Flame heater electrical lead (engine model 7083-7396) or glow plug switch (engine model 7083-7391)	486A
3	Master switch	459B	20	Connector to 415 air cleaner blower motor relay	27B
4	Engine oil pressure gage	36	21	Accessory control box	400
5	Engine water temperature gage	33A	22	Flame heater electrical lead (engine model 7083-7396) or glow plug lamp (engine model 7083-7391)	486
6	Transmission oil temperature gage	324	23	Not used	415
7	Transmission oil pressure gage	321	24	Not used	588
8	Warning lamp switch	509	25	Not used	588L
9	Panel lights	40	26	Not used	588-588L
10	Fuel level gage and switch	29-31	27	Voltage regulator	400-459B
11	Engine instrument and master warning light	27	28	Bulkhead connector	
12	Master switch	459A	29	Portable instrument connector	
13	Master switch	459			
14	Ground	GND			
15	Parking brake warning switch and light	509E			
16	Parking brake warning light	509E			
17	In-tank fuel pump and generator system relay	76B			

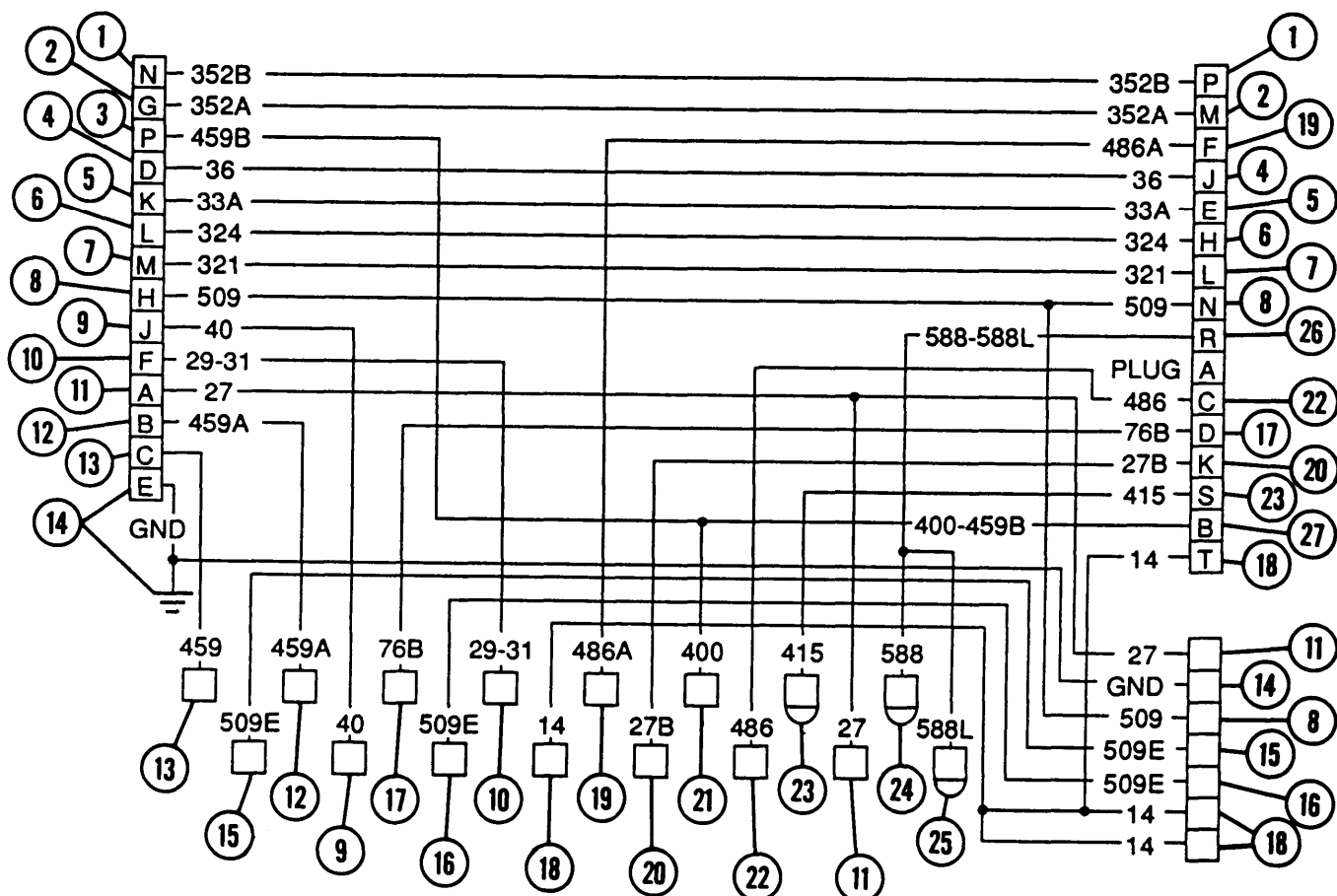

8-49 BULKHEAD-TO-PORTABLE INSTRUMENT PANEL WIRING HARNESS — CONTINUED

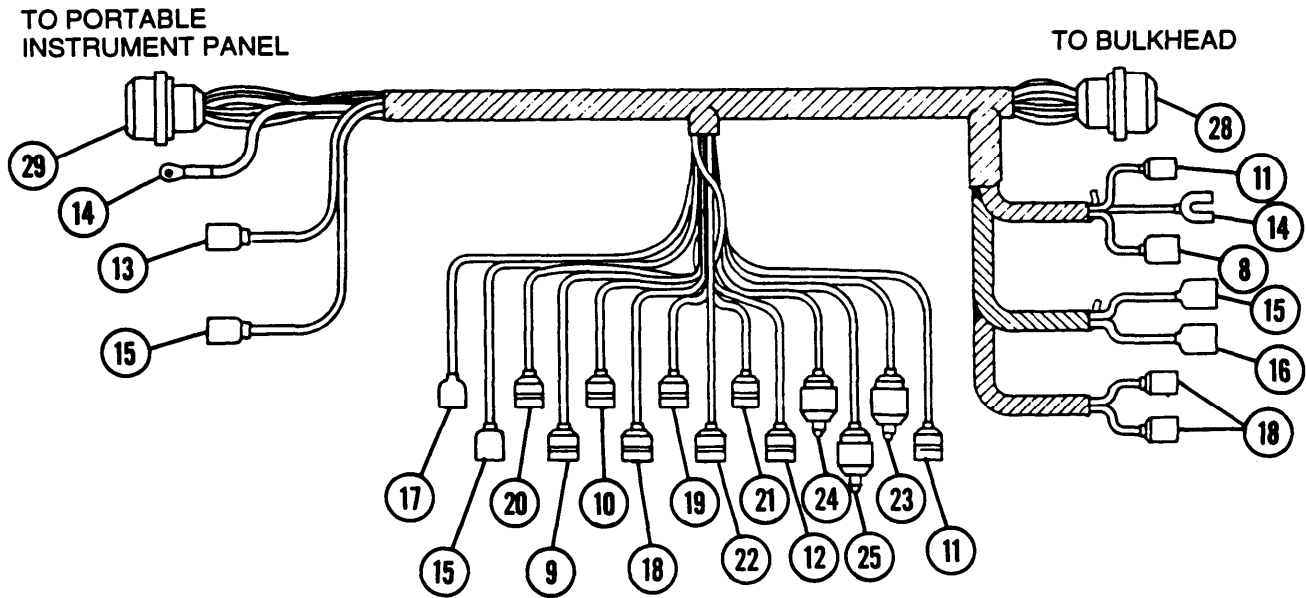

a. Disassembly

- 1 Remove electrical tape only for sections to be disassembled.
- 2 Isolate and separate wiring harness branches.
- 3 Disassemble wiring harness branch (para 2-13) of wires to be replaced.

b. Assembly

- 1 Assemble wiring harness branch (para 2-13) of wires replaced.
- 2 Apply electrical tape as necessary for assembly.

NOTE

FOLLOW-ON MAINTENANCE: Connect batteries (para 8-28)

8-50 BULKHEAD-TO-DRIVER'S INSTRUMENT PANEL WIRING HARNESS

This task covers: a. Disassembly b. Assembly

INITIAL SETUP**Tools**

General mechanic's tool kit (item 64, Appx H)

Materials/Parts

Electrical tape — black (item 62, Appx D)

NOTE

For removal and installation of the bulkhead-to-driver's instrument panel wiring harness, notify support maintenance.

8-50 BULKHEAD-TO-DRIVER'S INSTRUMENT PANEL WIRING HARNESS — CONTINUED

Connector No.	Electrical Lead To:	Wire No.	Connector No.	Electrical Lead To:	Wire No.
1	Service headlight dimmer switch — low beam	18	15	Main light switch — panel lights	40
2	Service headlight dimmer switch — high beam	17	16	Main light switch — B.O. marker rear	24
3	Service 6.0. IR headlight — low beam	515	17	Main light switch — B.O. stop light	23
4	Service 6.0. IR headlight — high beam	514	18	Main light switch — service stop light	22
5	Not used		19	Main light switch — service taillight	21
6	Master switch circuit	459	20	High beam indicator light	519
7	Blackout marker light — front	20	21	Not used	
8	Fuel level switch — right lower tank	31	22	Light circuits	20--24
9	Bilge pump switch — energizing circuit	450	23	Driver's dome light, auxiliary outlet, and trailer receptacle	37-38
10	Fuel level switch — right upper tank	29	24	Auxiliary outlet and trailer receptacle	37
11	Fuel prime switch	76	25	Not used	
12	Stop light switch — light switch	75	26	Driver's dome light	38
13	Light switch — dimmer switch	16	27	Connector dimmer switch	
14	Main light switch power lead	15	28	Connector dimmer switch	
			29	Connector lighting switch	
			30	Master warning switch	459L

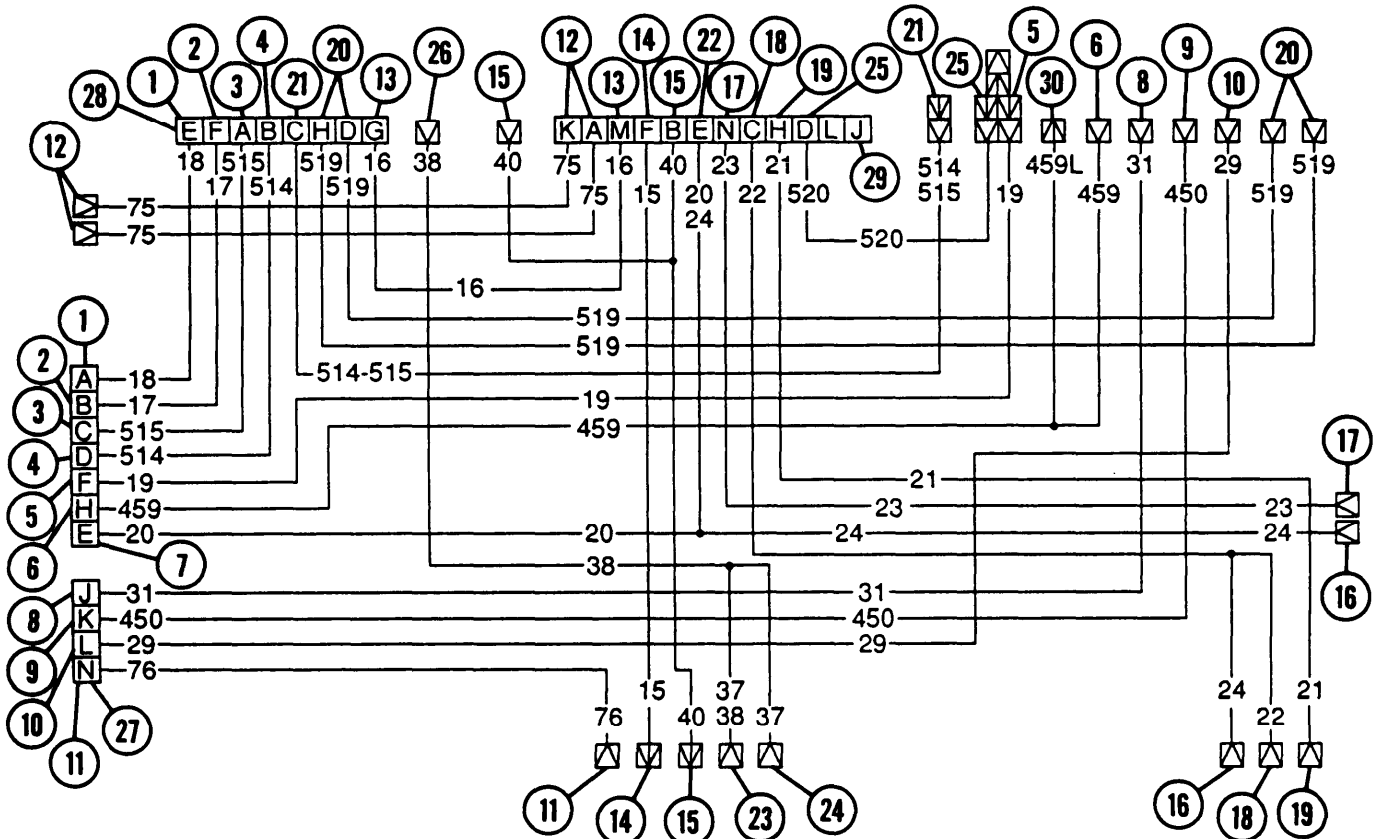

WIRING DIAGRAM

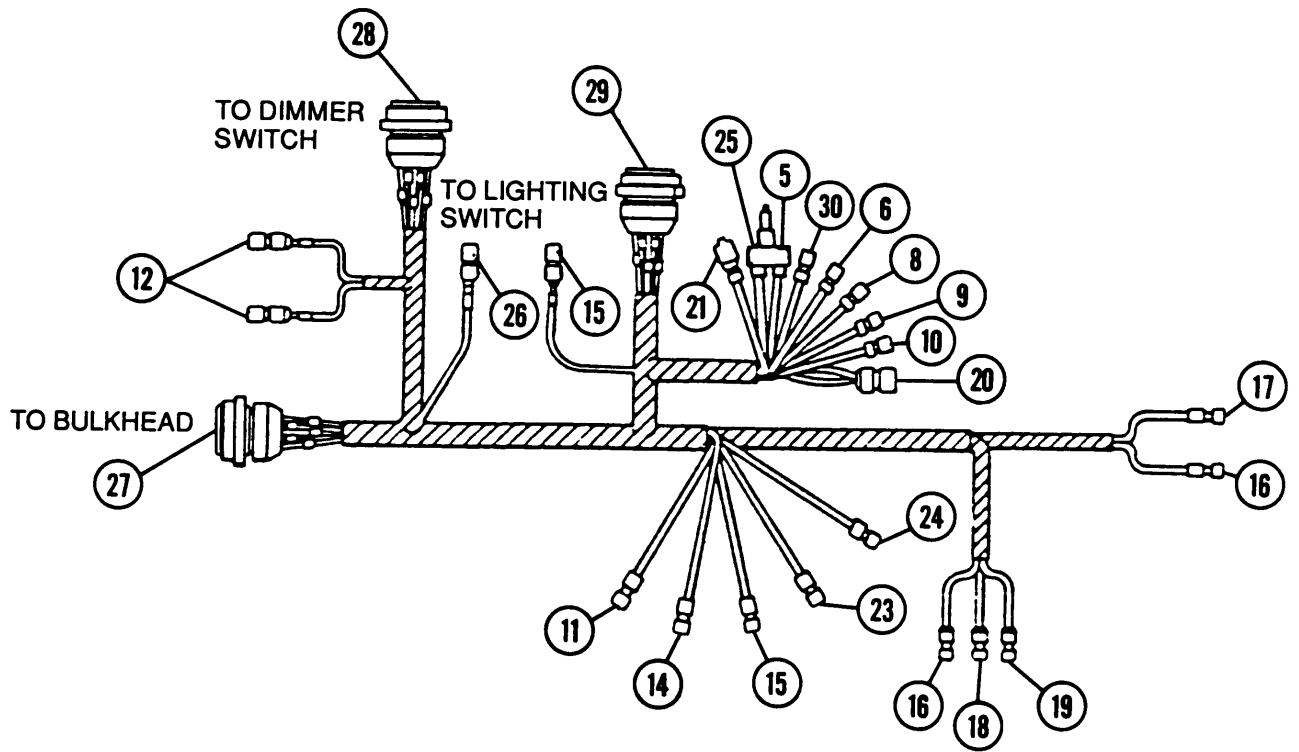

8-50 BULKHEAD-TO-DRIVER'S INSTRUMENT PANEL WIRING HARNESS — CONTINUED

a. Disassembly/Repair

WARNING

Ensure MASTER switch is OFF when working on hull electrical system to avoid electrical shocks and burns.

- 1 Remove electrical tape only for sections to be disassembled.
- 2 Isolate and separate wiring harness branches.
- 3 Disassemble wiring harness branch (para 2-13) of wires to be replaced.

b. Assembly

WARNING

Ensure MASTER switch is OFF when working on hull electrical system to avoid electrical shocks and burns.

- 1 Assemble wiring harness branch (para 2-13) of wires replaced.
- 2 Apply electrical tape as necessary for assembly.

8-51 DRIVER'S INSTRUMENT PANEL WIRING HARNESS

This task covers: a. Removal b. Installation

INITIAL SETUP

Materials/Parts

Electrical tape — black (item 62, Appx D)

Equipment Conditions

Batteries disconnected (para 8-28)
Portable instrument panel removed (para 8-17)

NOTE

On vehicles with engine model 7083-7396, connector 2 is used for the flame heater system. On vehicles with engine model 7083-7391, connector 2 is used for the glow plug controller system.

Connector No.	Electrical Lead To:	Wire No.	Connector No.	Electrical Lead To:	Wire No.
1	STARTER switch	10	5	Bilge pump switch	450
2	Flame heater switch (engine model 7083-7396) or glow plug switch (engine model 7083-7391)	10	6	Parking brake warning light	509E
3	Fuel prime switch	588	7	Circuit breaker	588
4	Terminal 459A of wiring harness 12260287	459A	8	Circuit breaker	458
		459A	9	Circuit breaker	10

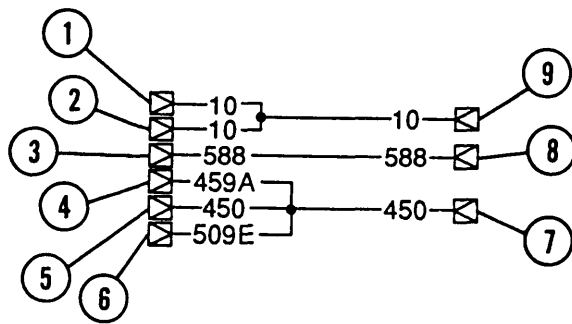

WIRING DIAGRAM

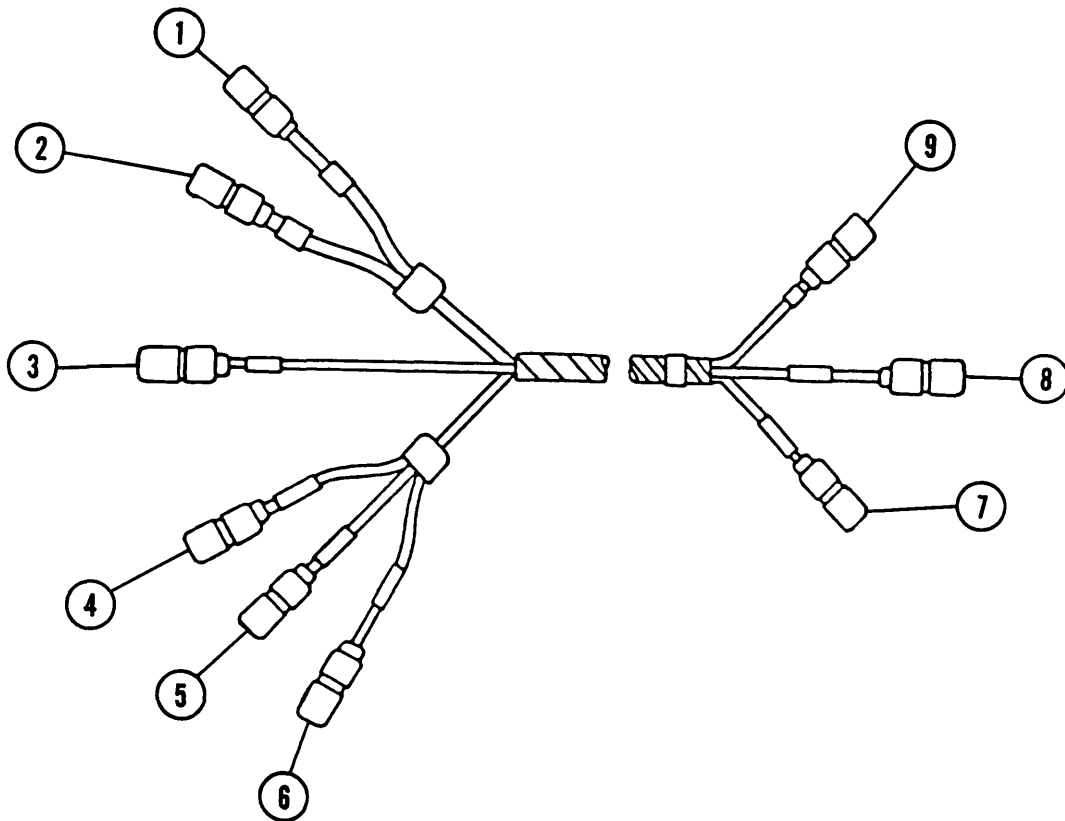

8-51 DRIVER'S INSTRUMENT PANEL WIRING HARNESS — CONTINUED

a. Removal

- 1 Disconnect connector wire 10 at STARTER switch (1).
- 2 Disconnect connector wire 10 at FLAME HEATER switch (2) (engine model 7083-7396) or GLOW PLUGS switch (2) (engine model 7083-7391).
- 3 Disconnect connector wire 588 at FUEL PRIME switch (3).
- 4 Disconnect connector wire 450 at BILGE PUMP switch (5).
- 5 Disconnect connector wire 509E at PARKING BRAKE warning light lead (6).
- 6 Disconnect connector wire 450 at circuit breaker (7).
- 7 Disconnect connector wire 588 at circuit breaker (8).
- 8 Disconnect connector wire 10 at circuit breaker (9).
- 9 Disconnect connector wire 459A at wiring harness (4).

b. Installation

- 1 Connect connector wire 459A at wiring harness (4).
- 2 Connect connector wire 10 at circuit breaker (9).
- 3 Connect connector wire 588 at circuit breaker (8).
- 4 Connect connector wire 450 at circuit breaker (7).
- 5 Connect connector wire 509E at PARKING BRAKE warning light lead (6).
- 6 Connect connector wire 450 at BILGE PUMP switch (5).
- 7 Connect connector wire 588 at FUEL PRIME switch (3).
- 8 Connect connector wire 10 at FLAME HEATER switch (2) (engine model 7083-7396) or GLOW PLUGS switch (2) (engine model 7083-7391).
- 9 Connect connector wire 10 at STARTER switch (1).

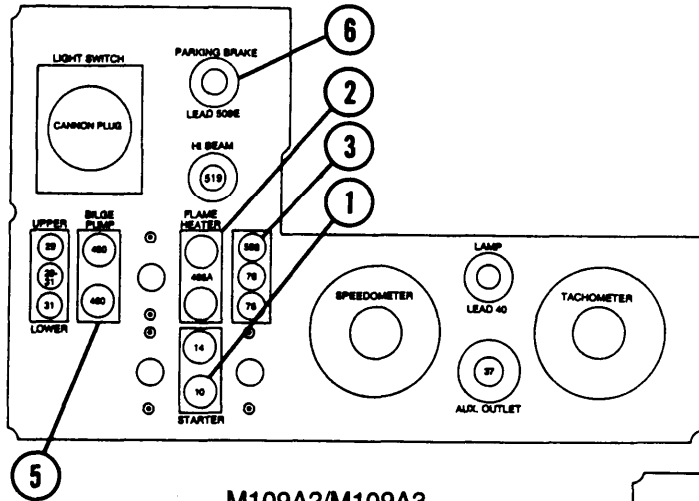

M109A2/M109A3
(ENGINE MODEL 7083-7396) SHOWN

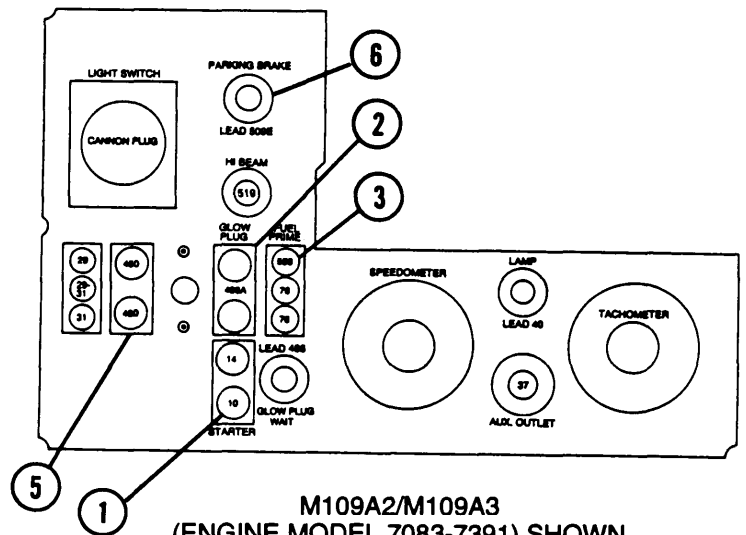
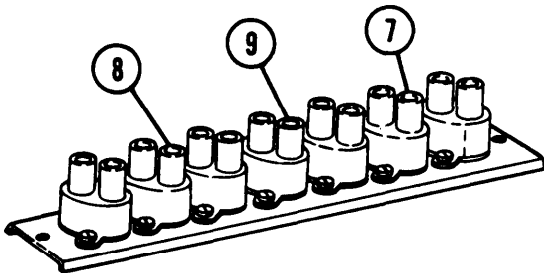

M109A2/M109A3
(ENGINE MODEL 7083-7391) SHOWN

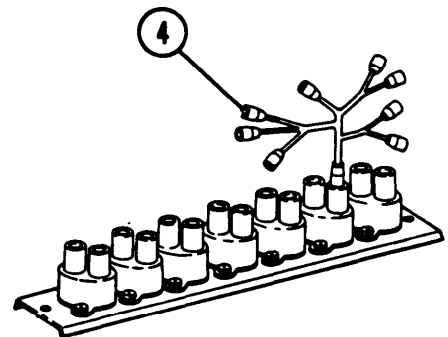
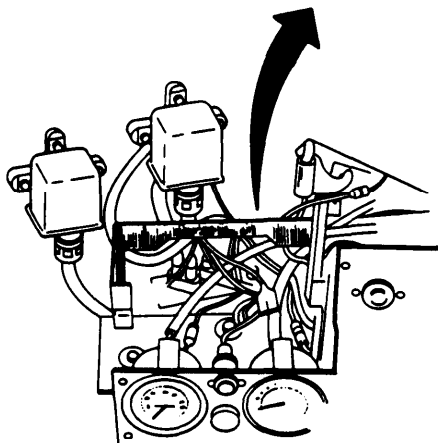

NOTE

FOLLOW-ON MAINTENANCE:

Connect batteries (para 8-28)
Install portable instrument panel (para 8-17)

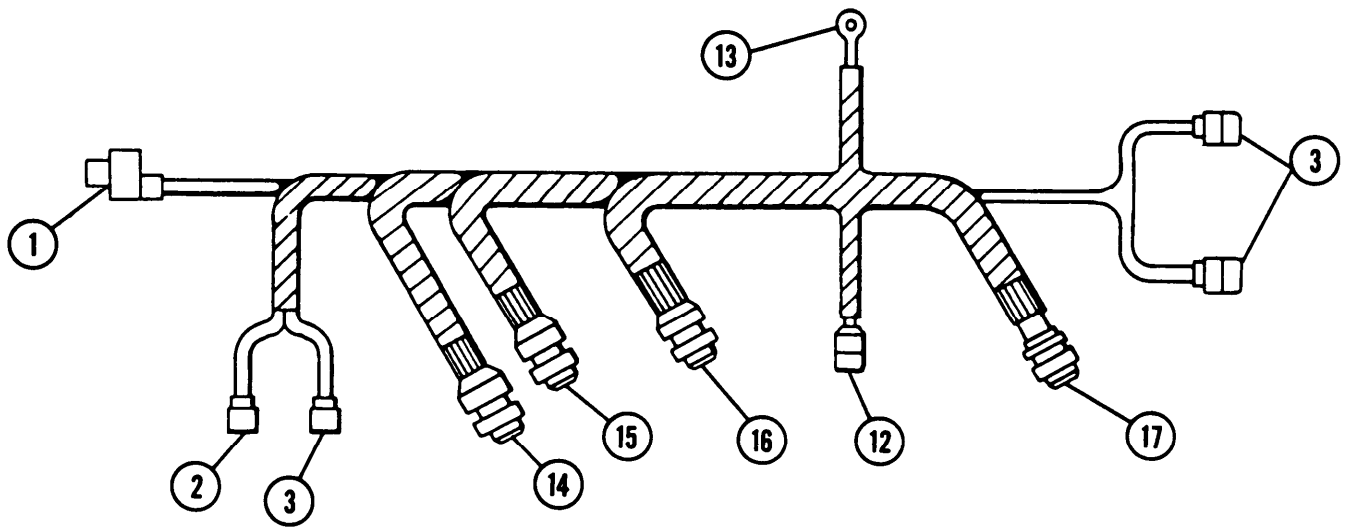

8-52 ACCESSORY CONTROL BOX-TO-HEATER/BLOWER WIRING HARNESS — CONTINUED

a. Removal

- 1 Disconnect two connectors (14 and 15) at accessory control box (19).
- 2 Disconnect connector (16) at personnel vent fan (20).
- 3 Disconnect connector (17) at personnel heater (21).
- 4 Disconnect connector wire 402A (12) at heater fuel pump (22).
- 5 Disconnect two connectors (23) at air cleaner blower motors (24).
- 6 Remove screw (25), washer (26), and plastic attaching strap (27) to disconnect ground wire (13).
- 7 Release wiring harness and reinstall plastic attaching strap (27), flat washer (26), and screw (25).
- 8 Disconnect three electrical connectors: wire 40 (1), wire 400 (2), and wire 415 (3) at well behind driver's instrument panel.

NOTE

Release wiring harness and reinstall strap assemblies for steps 9 and 10.

- 9 Remove nine plastic attaching straps (28), nine screws (29), and nine flat washers (30).
- 10 Remove two plastic attaching straps (31), four screws (32), and four flat washers (33).

b. Disassembly/Repair

- 1 Remove electrical tape only for sections to be disassembled.
- 2 Separate/isolate wiring harness branches.
- 3 Disassemble wiring harness branches (para 2-13).

c. Assembly

- 1 Assemble wiring harness branches (para 2-1 3).
- 2 Apply electrical tape to sections being assembled.

d. Installation

- 1 Remove two plastic attaching straps (31), four screws (32), and four flat washers (33).
- 2 Remove nine plastic attaching straps (28), nine screws (29), and nine flat washers (30).
- 3 Install wiring harness, nine plastic attaching straps (28), nine flat washers (30), and nine screws (29).

- 4 Install two plastic attaching straps (31), four flat washers (33), and four screws (32).
- 5 Connect three electrical connectors: wire 40 (1), wire 400 (2), and wire 415 (3) at well behind driver's instrument panel.
- 6 Install plastic attaching strap (27), flat washer (26), and screw (18) to connect ground wire (13) and secure wiring harness.
- 7 Connect two electrical connectors wire 415 (23) at air cleaner blower motors (24).
- 8 Connect electrical connector wire 402A (12) at heater fuel pump (22).
- 9 Connect electrical connector (17) at personnel heater (21).
- 10 Connect electrical connector (16) at personnel vent fan (20).
- 11 Connect two electrical connectors (14 and 15) at accessory control box (19).

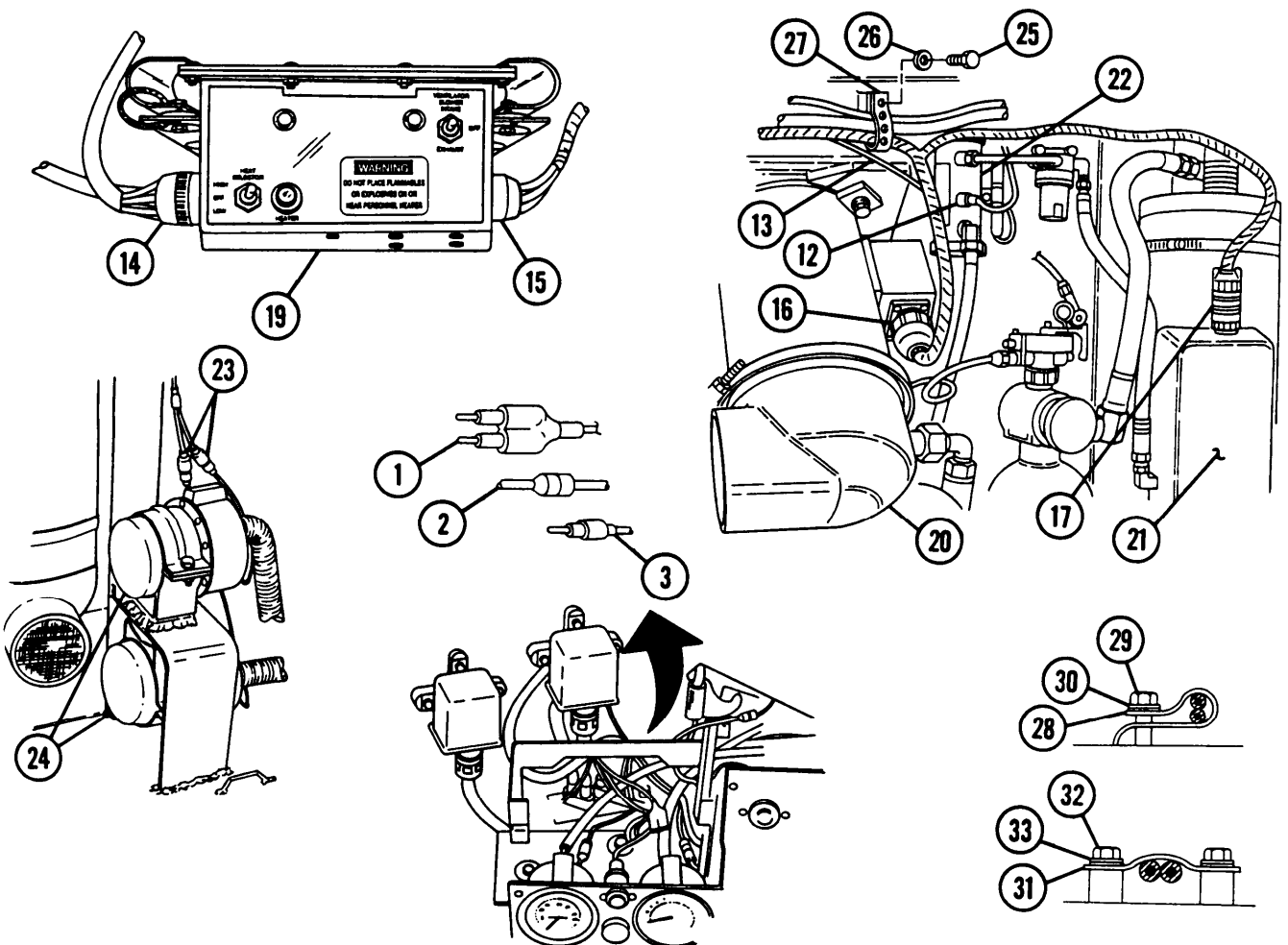

NOTE

FOLLOW-ON MAINTENANCE: Connect batteries (8-28)
Install portable instrument panel (para 8-17)

a. Removal**WARNING**

Ensure MASTER switch is OFF when working on hull electrical system to avoid electrical shocks and burns.

Remove accessory control box wiring harness (para 8-20).

b. Installation**WARNING**

Ensure MASTER switch is OFF when working on hull electrical system to avoid electrical shocks and burns.

Install accessory control box wiring harness (para 8-20).

NOTE

FOLLOW-ON MAINTENANCE: Connect batteries (para 8-28)

8-54 POWER LEAD WIRING HARNESS (M109A2)

This task covers: a. Disassembly/Repair b. Assembly

INITIAL SETUP**Applicable Configurations**

M109A2

Materials/Parts

Electrical tape — black (item 62, Appx D)

Tools

General mechanic's tool kit (item 64, Appx H)

NOTE

ŽFor removal and installation of the power lead wiring harness, notify support maintenance.

- On vehicles with engine model 7083-7396, connector 5 is used for the flame heater system. On vehicles with engine model 7083-7391, connector 5 is used for the glow plug system.

8-54 POWER LEAD WIRING HARNESS (M109A2) — CONTINUED

Connector No.	Electrical Lead To:	Wire No.	Connector No.	Electrical Lead To:	Wire No.
1	Connector bulkhead (to slave start receptacle)	49	7	Connector fuel prime pump switch circuit breaker (to wire 588)	10
2	Connector accessory control box	10	8	Connector master warning light/engine instrumentation circuit breaker (to wire 27)	10
3	Connector slip ring segment board	47	9	Connector bilge pump switch circuit breaker (to wire 450)	10
4	Connector hull lighting wiring harness (interconnects with wire 15)	10	10	Connector auxiliary outlet/dome light circuit breaker (to wires 37 and 38)	10
5	Connector starter switch/flame heater switch circuit breaker (to wire 15) (engine model 7083-7396) or connector starter switch/glow plug switch (engine model 7083-7391)	10	11	Connector slave start receptacle	49
6	Connector fuel pump circuit breaker (to wire 76)	10	12	Ground	50

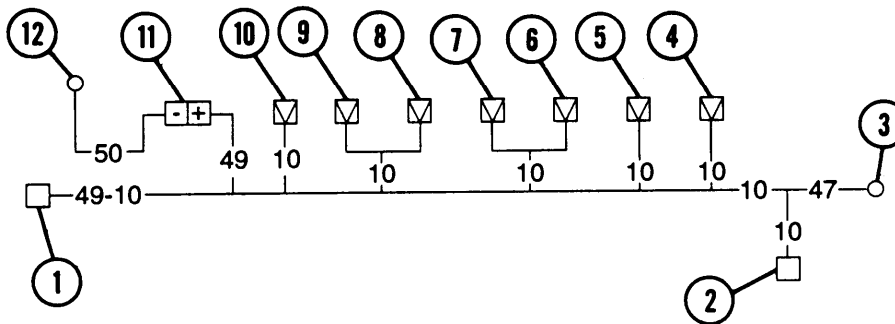

WIRING DIAGRAM

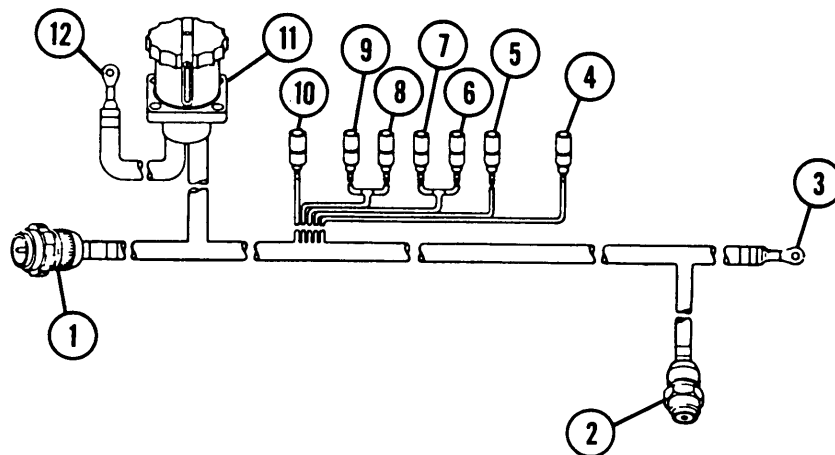

a. Disassembly/Repair**WARNING**

Ensure MASTER switch is OFF when working on hull electrical system to avoid electrical shocks and burns.

Disassemble wiring harness (para 2-13).

b. Assembly**WARNING**

Ensure MASTER switch is OFF when working on hull electrical system to avoid electrical shocks and burns.

Assemble wiring harness (para 2-13).

8-55 POWER LEAD (M109A2/M109A3)

This task covers: a. Disassembly/Repair b. Assembly

INITIAL SETUP**Applicable Configurations**

M109A2/M109A3

Materials/Parts

Electrical tape — black (item 62, Appx D)

Tools

General mechanic's tool kit (item 64, Appx H)

NOTE

- For removal and installation of the power lead, notify support maintenance.

Ž On vehicles with engine model 7083-7396, connector 5 is used for the flame heater system. On vehicles with engine model 7083-7391, connector 5 is used for the glow plug controller system.

8-55 POWER LEAD (M109A2/M109A3) — CONTINUED

Connector No.	Electrical Lead To:	Wire No.	Connector No.	Electrical Lead To:	Wire No.
1	Connector bulkhead (to NATO slave start receptacle)	49	6	Connector fuel prime pump switch circuit breaker (to wire 588)	10
2	Connector accessory control box	10	7	Connector master warning light/engine instrumentation circuit breaker (to wire 27)	10
3	Connector slip ring segment board	47	8	Connector bilge pump switch circuit breaker (to wire 450)	10
4	Connector hull lighting wiring harness (interconnects with wire 15)	10	9	Connector auxiliary outlet/dome light circuit breaker (to wires 37-38)	10
5	Connector starter switch/flame heater switch circuit breaker (to wire 10) (engine model 7083-7396) or connector starter switch/glow plug switch circuit breaker (to wire 10) (engine model 7083-7391)	10	10	Connector NATO slave start receptacle	49

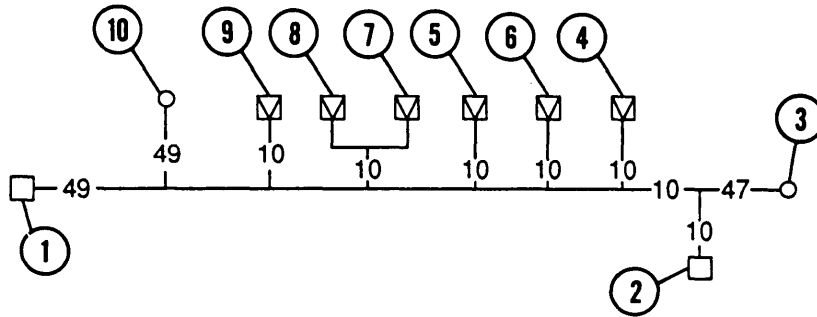

WIRING DIAGRAM

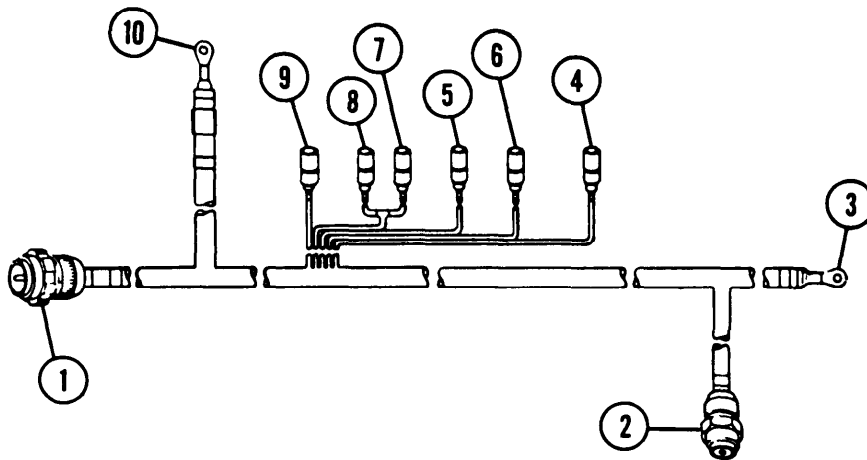

a. Disassembly/Repair**WARNING**

Ensure MASTER switch is OFF when working on hull electrical system to avoid electrical shocks and burns.

Disassemble wiring harness leads (para 2-13).

b. Assembly**WARNING**

Ensure MASTER switch is OFF when working on hull electrical system to avoid electrical shocks and burns.

Assemble wiring harness leads (para 2-13).

8-56 POWER LEAD (M109A4/M109A5)

This task covers: a. Disassembly/Repair b. Assembly

INITIAL SETUP**Applicable Configurations**

M109A2/M109A5

Materials/Parts

Electrical tape — black (item 62, Appx D)

Tools

General mechanic's tool kit (item 64, Appx H)

NOTE

ŽFor removal and installation of the power lead, notify support maintenance.

ŽOn vehicles with engine model 7083-7396, connector 8 is used for the flame heater system. On vehicles with engine model 7083-7391, connector 8 is used for the glow plug controller system.

8-56 POWER LEAD (M109A4/M109A5) — CONTINUED

Connector No,	Electrical Lead To:	Wire No.	Connector No.	Electrical Lead To:	Wire No.
1	Connector bulkhead	10	8	Connector starter switch/flare heater switch circuit breaker (to wire 10) (engine model 7083-7396) or connector starter switch/glow plug switch circuit (engine model 7083-7391)	10
2	Connector accessory control box	10	9	Connector master warning light/engine instrumentation circuit breaker (to wire 27)	10
3	Connector slip ring segment board	47	10	Connector bilge pump switch circuit breaker (to wire 450)	10
4	Connector hull lighting wiring harness (interconnects with wire 15)	10	11	Connector auxiliary outlet/dome light circuit breaker (to wires 37 and 38)	10
5	Connector NBC circuit breaker (to wire 438)	10			
6	Connector fuel prime pump switch circuit breaker (to wire 588)	10			
7	"Y" connector in-tank fuel pump system relay (to wire 10)	10			

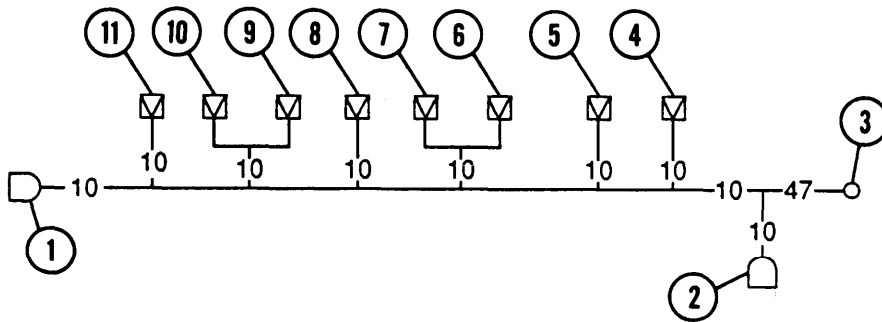

WIRING DIAGRAM

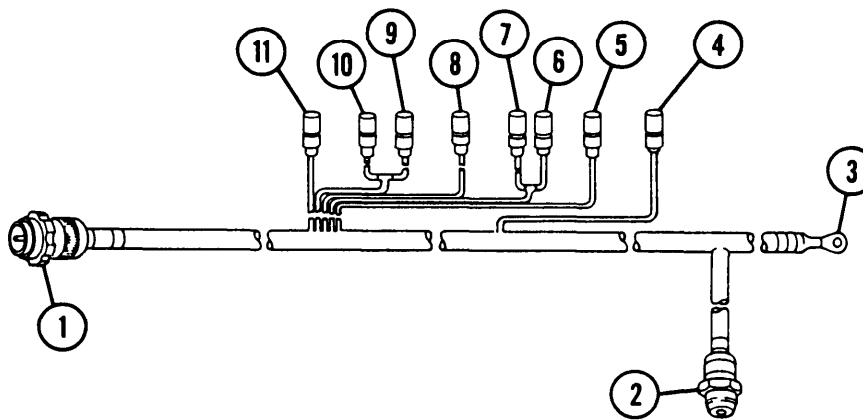

a. Disassembly/Repair

WARNING

Ensure MASTER switch is OFF when working on hull electrical system to avoid electrical shocks and burns.

Disassemble wiring harness leads (para 2-13).

b. Assembly

WARNING

Ensure MASTER switch is OFF when working on hull electrical system to avoid electrical shocks and burns.

Assemble wiring harness leads (para 2-13).

8-57 PORTABLE INSTRUMENT PANEL WIRING HARNESS

This task covers:	a. Removal	b. Disassembly/Repair
	c. Assembly	d. Installation

INITIAL SETUP

Tools

General mechanic's tool kit (item 64, Appx H)

Materials/Parts

Electrical tape — black (item 62, Appx D)
 Lockwasher (item 69, Appx G)

Equipment Conditions

Batteries disconnected (para 8-28)
 Portable instrument panel removed (para 8-17)

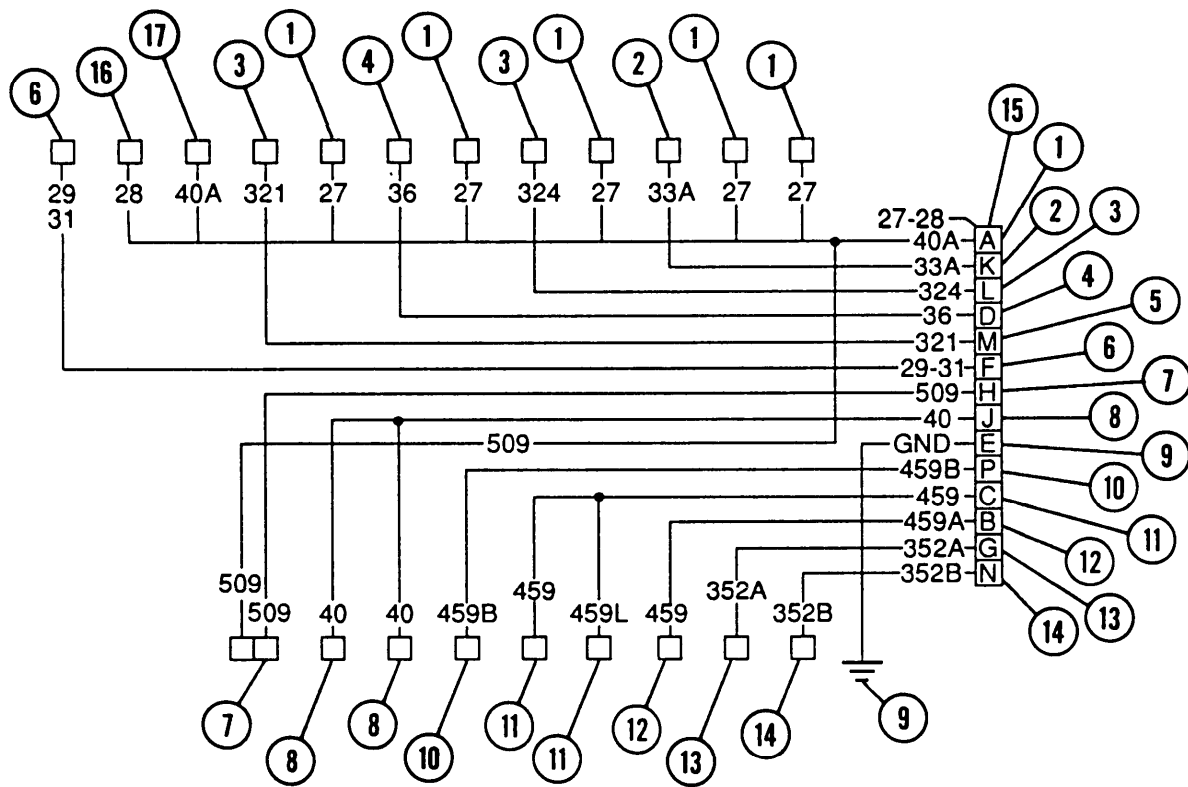

WIRING DIAGRAM

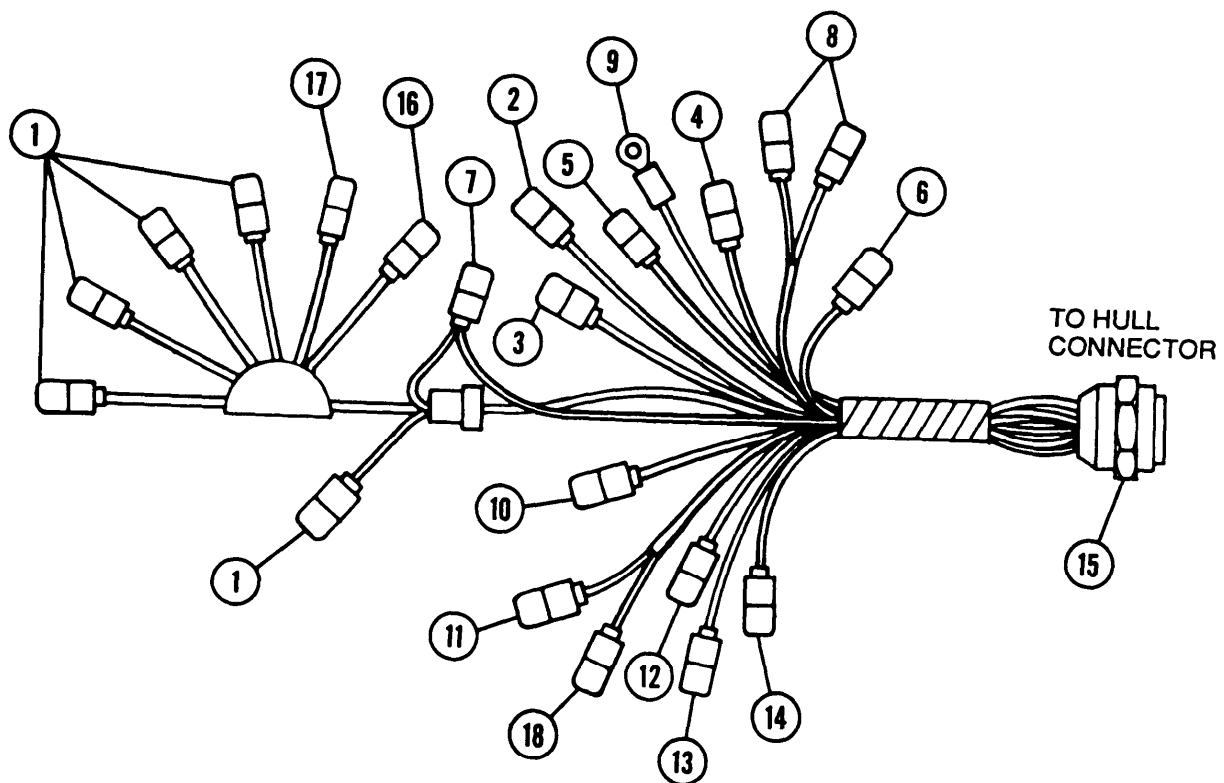

8-57 PORTABLE INSTRUMENT PANEL WIRING HARNESS — CONTINUED

a. Removal

- 1 Disconnect wiring harness connector (15) at hull bulkhead in driver's compartment.
- 2 Loosen four studs (19) at portable instrument panel (20). Pull cover (21) outward to expose electrical leads to instruments.
- 3 Remove nut (22) and lockwasher (23). Release ground lead (9) and replace nut and lockwasher on screw (24).
- 4 Disconnect 21 electrical connectors (1 thru 8, 10 thru 14, 16, 17, and 18) at instrument panel. Connector (12) is plugged on M109A4/M109A5 Howitzers.
- 5 Remove wiring harness (25) and grommet (26) from portable instrument panel (20).

b. Disassembly/Repair

Disassemble wiring harness (para 2-13).

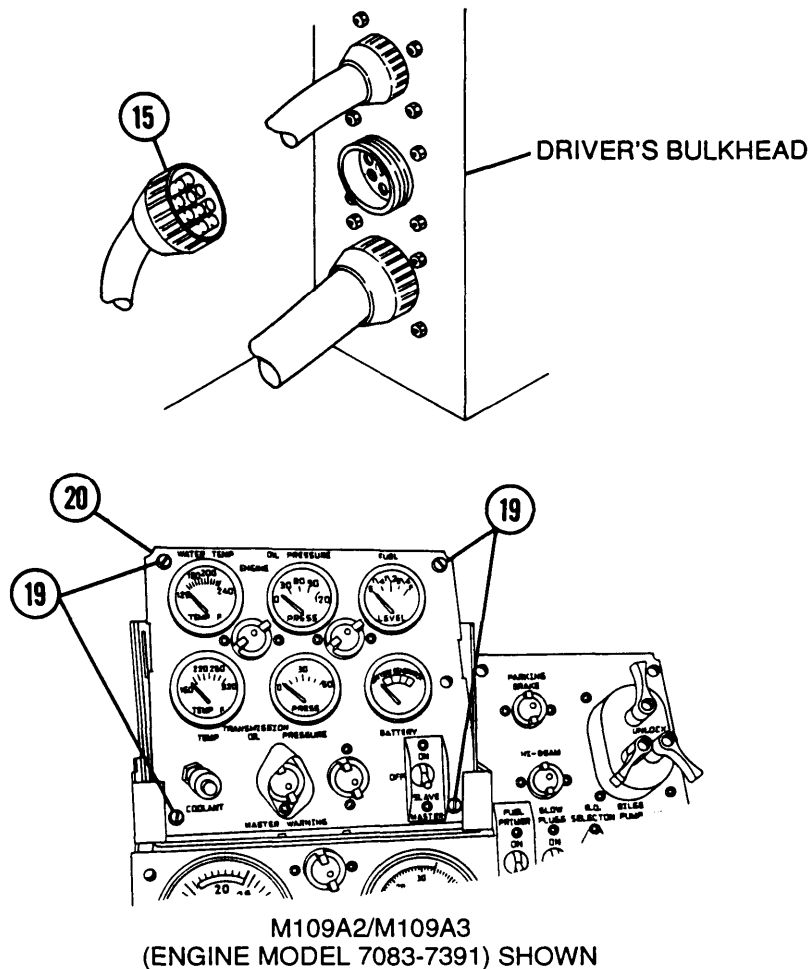

c. Assembly

Assemble wiring harness (para 2-13).

d. Installation

- 1 Install grommet (26) and wiring harness (25) on portable instrument panel (20).
- 2 Connect 21 electrical connectors (1 thru 8, 10 thru 14, 16, 17, and 18) at instrument panel (20). Connector (12) is plugged on M109A4/M109A5 Howitzers.
- 3 Remove nut (22) and lockwasher (23) and install ground lead on screw (24). Install new lockwasher and nut.
- 4 Push cover (21) inward to close and tighten four studs (19) at portable instrument panel (20).
- 5 Connect wiring harness connector (15) at hull bulkhead in driver's compartment.

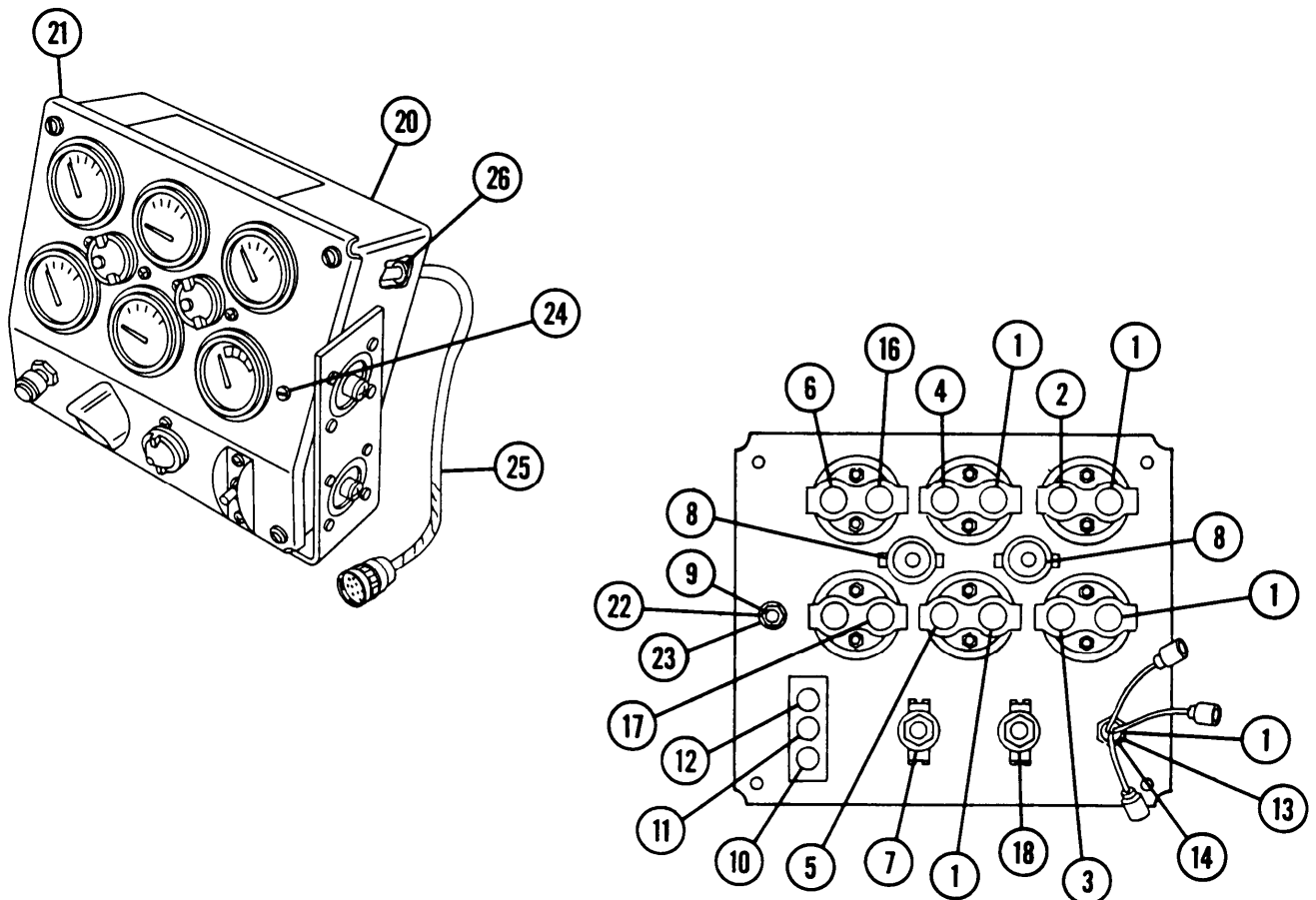

NOTE

FOLLOW-ON MAINTENANCE:

Connect batteries (para 8-28)
Install portable instrument panel (para 8-17)

8-58 INTERCOM/TELEPHONE WIRING HARNESS AND SLIP RING TELEPHONE FEED WIRING HARNESS

This task covers: a. Removal b. Installation

INITIAL SETUP

Tools

General mechanic's tool kit (item 64, Appx H)

Lockwasher (item 69, Appx G)

Lockwasher (item 73, Appx G)

Lockwashers (4) (item 87, Appx G)

Lockwashers (4) (item 94, Appx G)

Materials/Parts

Electrical tape — black (item 62, Appx D)

Connector No.	Electrical Lead To:	Wire No.	Connector No.	Electrical Lead To:	Wire No.
1	No. 1 circuit intercom	141	6	Telephone lead	L1
2	No. 2 circuit intercom	142	7	Telephone lead	L2
3	No. 3 circuit intercom	143	8	Ground	GND
4	Ground	GND	9	Connector	
5	Power lead	48			

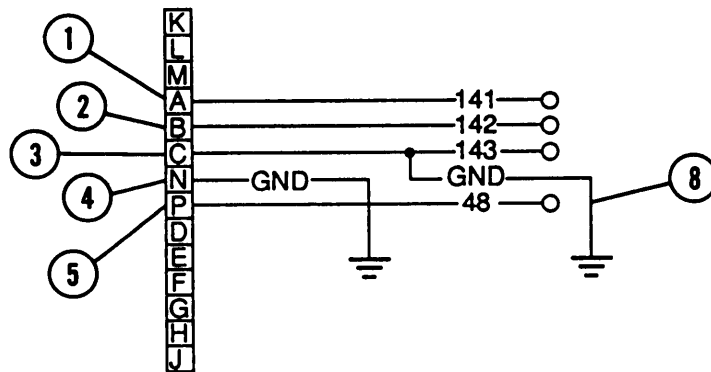

WIRING DIAGRAM

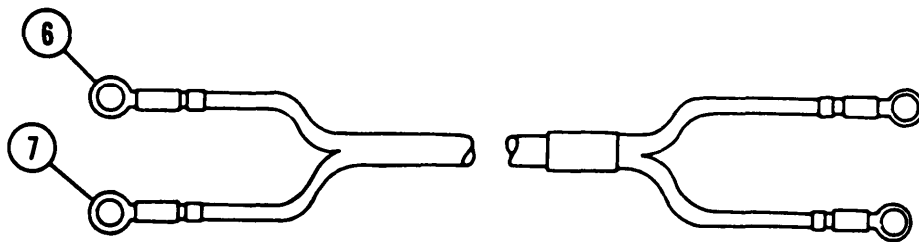
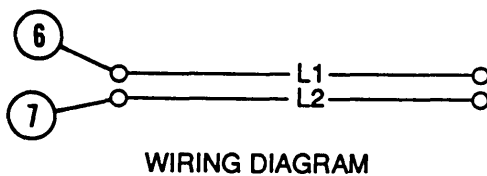
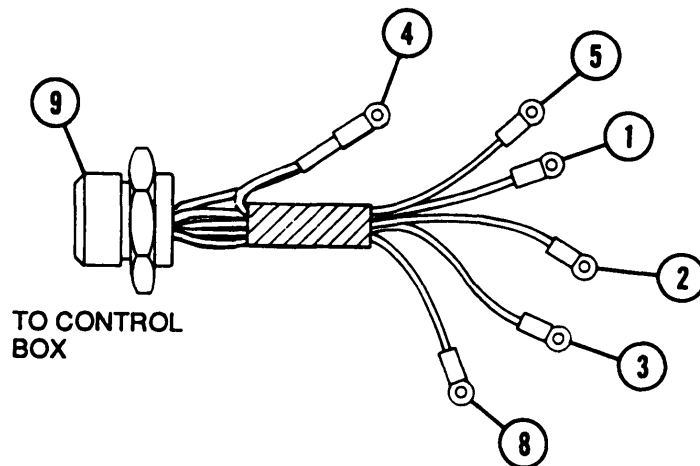

8-58 INTERCOM/TELEPHONE WIRING HARNESS AND SLIP RING TELEPHONE FEED WIRING HARNESS — CONTINUED

a. Removal

WARNING

Ensure MASTER switch is OFF when working on hull electrical system to avoid electrical shocks and burns.

- 1 Remove four nuts (10), lockwasher (11), ground lead (4), four screws (12), four lockwashers (13), and four flat washers (14) and disconnect connector (9). Discard lockwashers.
- 2 Remove two plastic attaching straps (15), four screws (16), and four flat washers (17) located over air cleaner blower relay (18).
- 3 Remove nine plastic attaching straps (19), nine screws (20), and nine flat washers (21) located between driver's instrument panel and segment board (22).
- 4 Remove screw (23), nut (24), and lockwasher (25) at segment board. Release wire 48 (5) and reinstall screw, nut, and lockwasher.
- 5 Remove five screws (26) at segment board (22). Release five wires 41, 42, 43, L1, and L2 (1, 2, 3, 6, and 7).
- 6 Remove screw (27) and flat washer (28) to release ground (8).

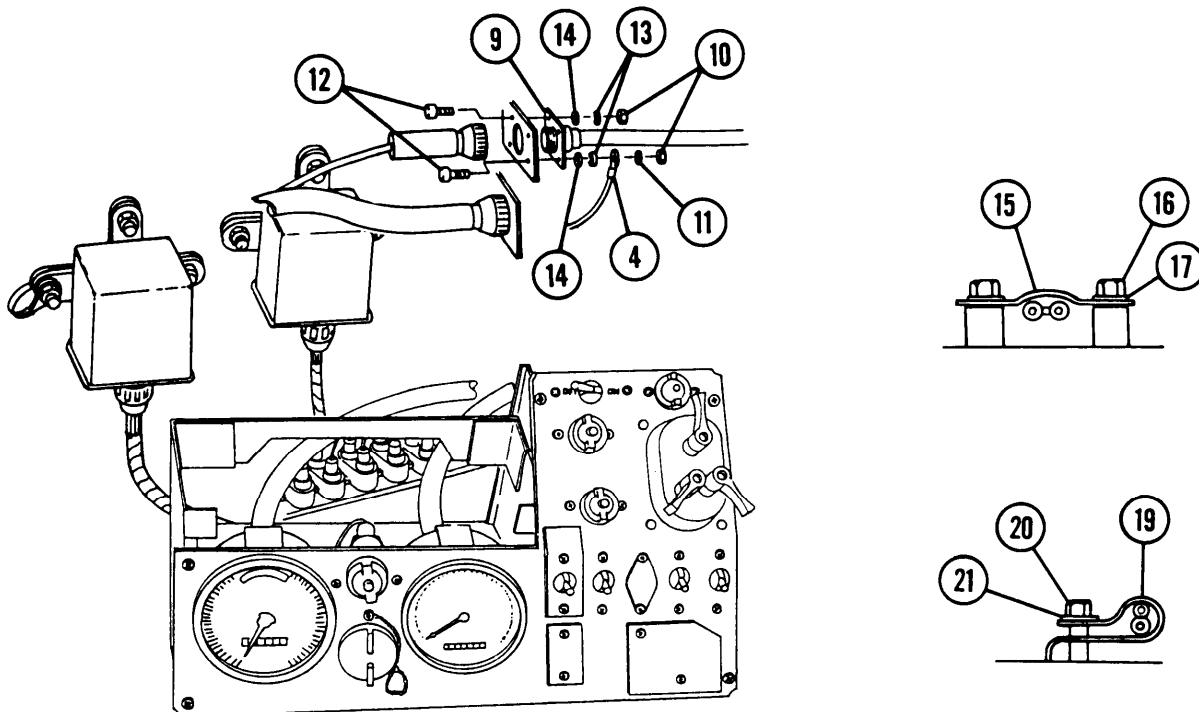

M109A4/M109A5
(ENGINE MODEL 7083-7396) SHOWN

NOTE

Wiring harness contains telephone leads L1 and L2 from segment board to hull terminals.

- 7 Remove seven plastic attaching straps (29), seven screws (30), and seven flat washers (31).
- 8 Remove two nuts (32) and release wires L1 and L2 (6 and 7).
- 9 On M109A4/M109A5 Howitzers, remove four screws (33), four lockwashers (34), and guard (35). Discard lockwashers.
- 10 Remove two plate screws (36), two spacers (37), and plate (38).
- 11 Remove wires L1 and L2 (6 and 7) from hull. Pull wire ends through hull.

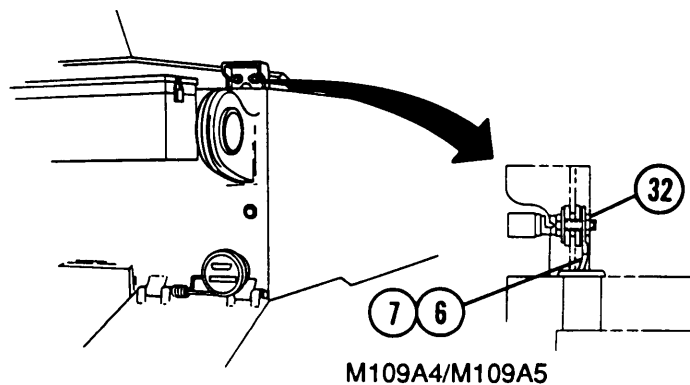
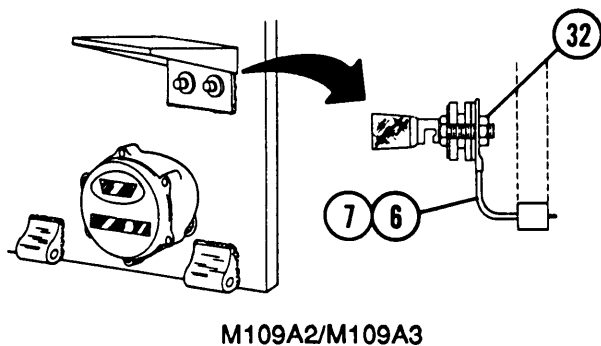
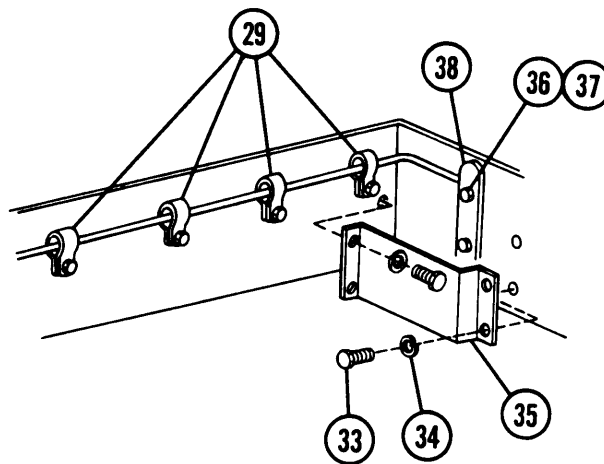
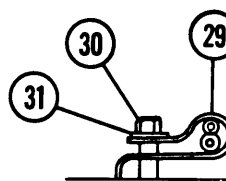
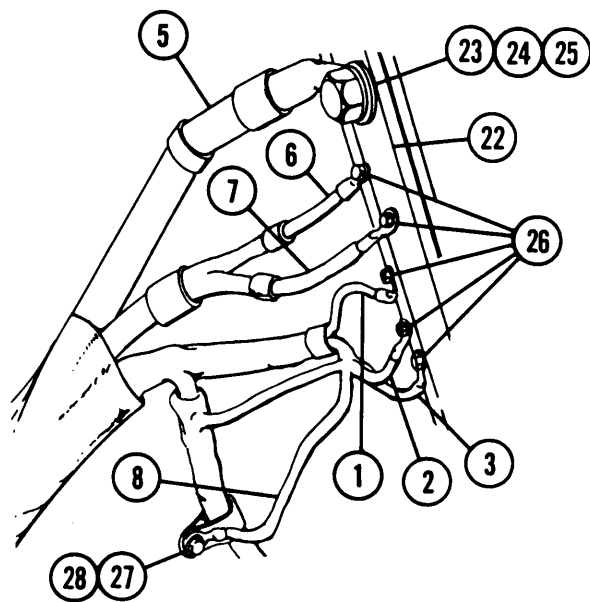

8-58 INTERCOM/TELEPHONE WIRING HARNESS AND SLIP RING TELEPHONE FEED WIRING HARNESS — CONTINUED

b. Installation

WARNING

Ensure MASTER switch is OFF when working on hull electrical system to avoid electrical shocks and burns.

NOTE

Wiring harness contains telephone leads L1 and L2 from segment board to hull terminals.

- 1 Install wire ends L1 and L2 (6 and 7) through hull.
- 2 Install two wires L1 and L2 (6 and 7) and two nuts (32).
- 3 Install two spacers (37), plate (38), and two plate screws (36).
- 4 On M109A4/M109A5 Howitzers, install guard (35), four new lockwashers (34), and four screws (33).
- 5 Install five wires 41,42,43, L1, and L2 (1, 2,3,6, and 7) and five screws (26) at segment board (22).
- 6 Install ground (8), flat washer (28), and screw (27).

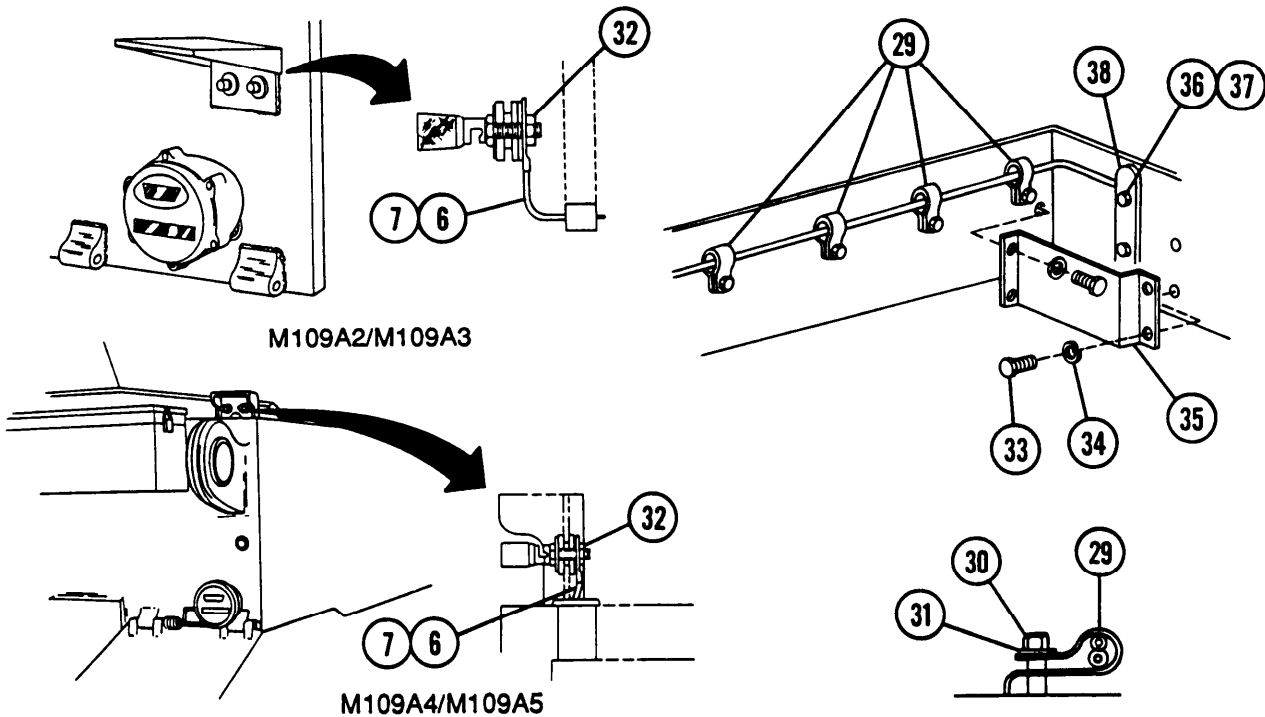

- 7 Remove screw (23), nut (24), and lockwasher (25). Discard lockwasher. Install wire 48 (5), new lockwasher, screw, and nut.
- 8 Install seven plastic attaching straps (29), seven flat washers (31), and seven screws (30).
- 9 Connect connector (9), and install four flat washer (14), four new lockwashers (13), four screws (12), ground lead (4), new lockwasher (11), and four nuts (10).
- 10 Install nine plastic attaching straps (19), nine flat washers (21), and nine screws (20) located between driver's instrument panel and segment board (22).
- 11 Install two plastic attaching straps (15), four flat washers (17), and four screws (16) located over air cleaner blower relay (18).

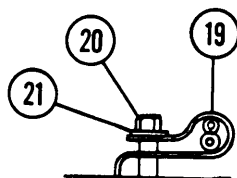
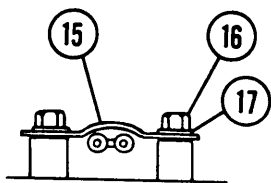
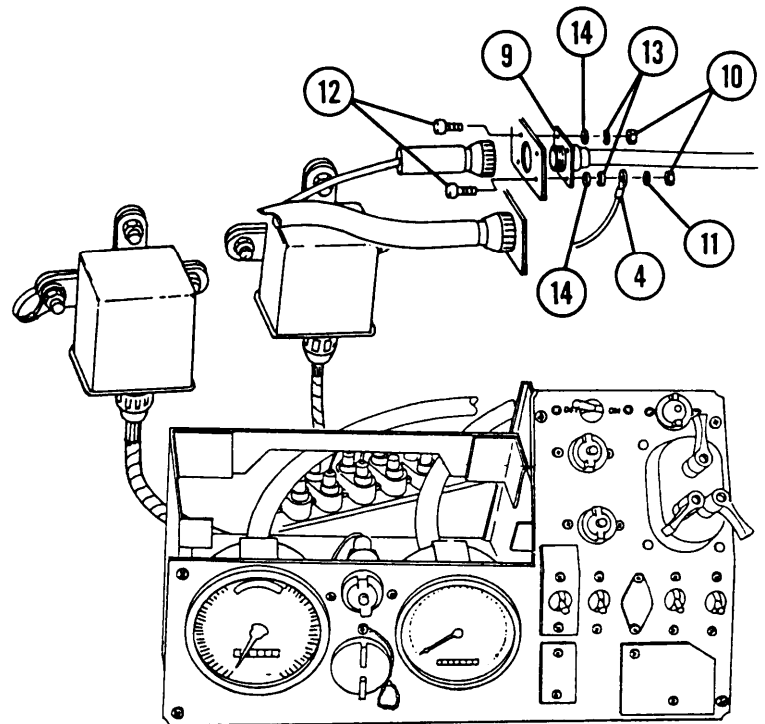
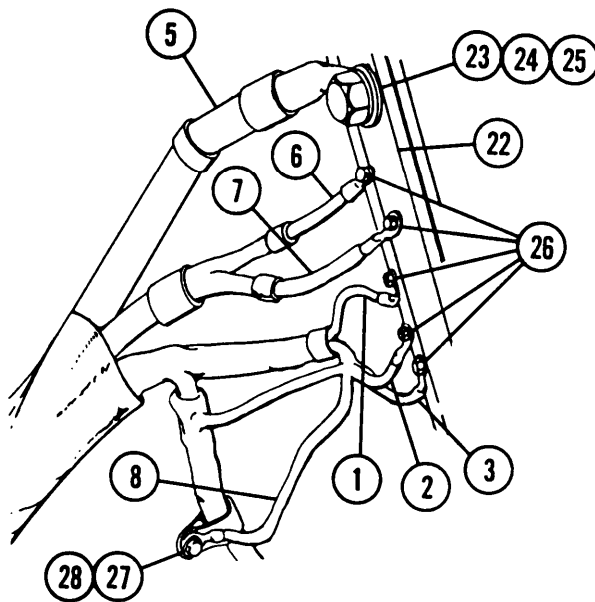

M109A4/M109A5
(ENGINE MODEL 7083-7396) SHOWN

8-59 RECTIFIER-TO-VOLTAGE REGULATOR WIRING HARNESS (M109A2/M109A3)

This task covers:

a. Removal	b. Disassembly/Repair
c. Assembly	d. Installation

INITIAL SETUP

Applicable Configurations

M109A2/M109A3

Materials/Parts

Electrical tape — black (item 62, Appx D)

Tools

General mechanic's tool kit (item 64, Appx H)

Equipment Conditions

Batteries disconnected (para 8-28)

Transmission access doors opened (para 11-7)

Connector No.	Electrical Lead To:	Wire No.
1	Radio noise filter circuit	1
2	Positive feed	2
3	Ground circuit	3

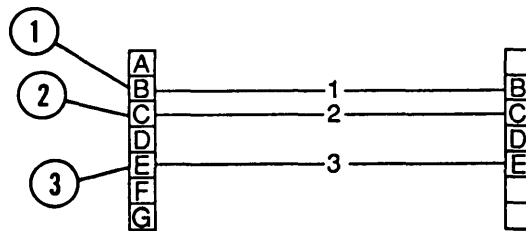

WIRING DIAGRAM

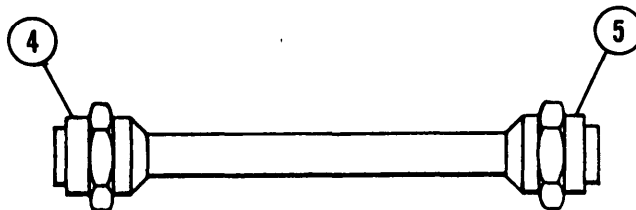

a. Removal

- 1 Remove connector (4) at rectifier (6).
- 2 Remove connector (5) at voltage regulator (7).
- 3 Remove wiring harness.

b. Disassembly/Repair

Disassemble wiring harness (para 2-13).

c. Assembly

Assemble wiring harness (para 2-13).

d. installation

- 1 Install wiring harness.
- 2 Install connector (5) at voltage regulator (7).
- 3 Install connector (4) at rectifier (6).

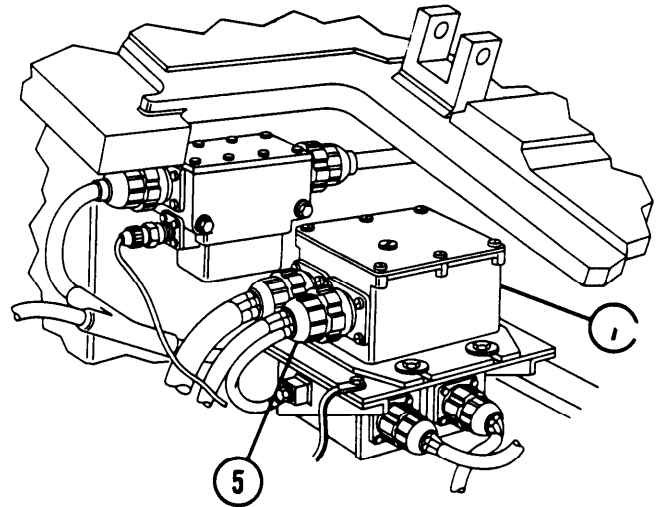
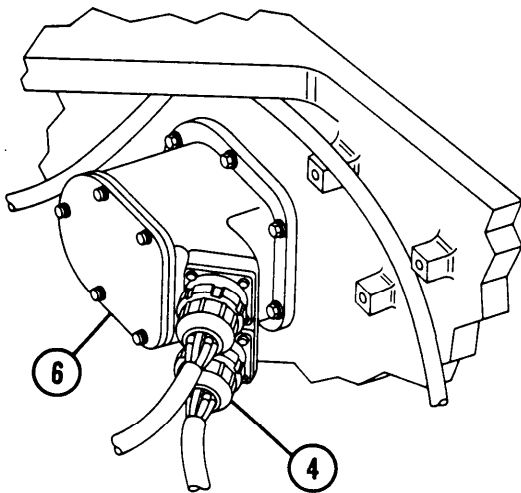

NOTE

FOLLOW-ON MAINTENANCE:

- Connect batteries (para 8-28)
- Close transmission access doors (para 11-7)

a. Removal

- 1 Remove connector (1) at rectifier (5).
- 2 Remove connector (4) at voltage regulator (6).
- 3 Remove screw (7), flatwasher (8), nut (9), lockwasher (10), and strap (11). Discard lockwasher.
- 4 Remove two leads (2 and 3) at battery terminals.
- 5 Remove wiring harness.

b. Disassembly/Repair

Disassemble wiring harness (para 2-13).

c. Assembly

Assemble wiring harness (para 2-13).

d. Installation

- 1 Install wiring harness.
- 2 Install two leads (2 and 3) at battery terminals.
- 3 Install connector (4) at voltage regulator (6).
- 4 Install strap (11), new lockwasher (10), nut (9), flatwasher (8), and screw (7).
- 5 Install connector (1) at rectifier (5).

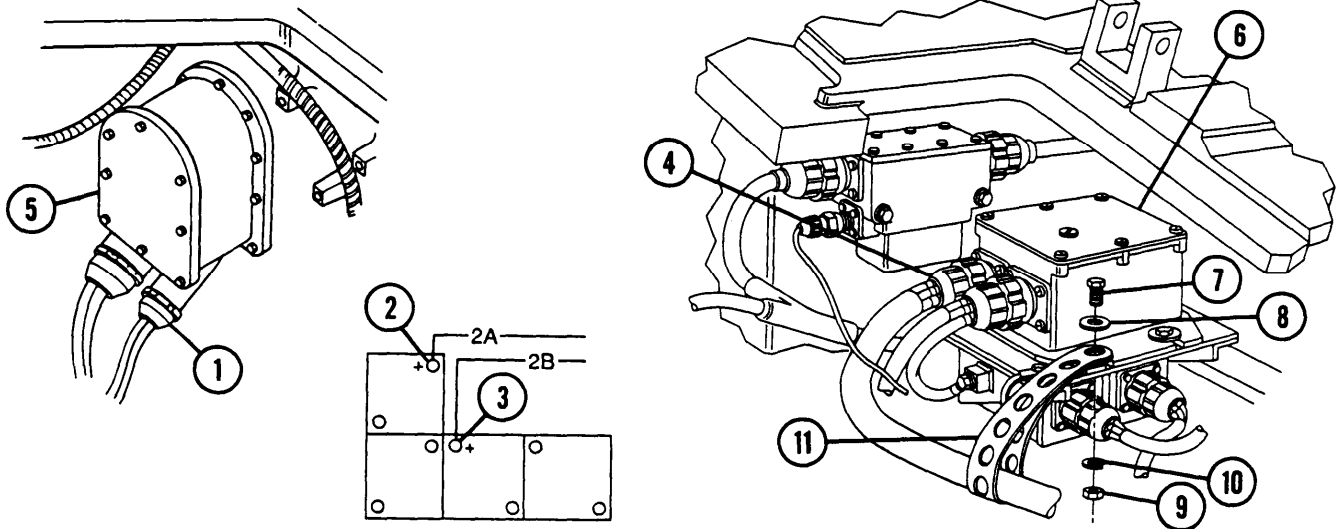

NOTE

FOLLOW-ON MAINTENANCE:

- Connect batteries (para 8-28)
- Close transmission access doors (para 11-7)

8-81 DIODE WIRING HARNESS (M109A4/M109A5)

This task covers: a. Removal b. Installation

INSTALLATION SETUP

Applicable Configurations

M109A4/M109A5

Equipment Conditions

Batteries disconnected (para 8-28)

Portable instrument panel removed (para 8-17)

Materials/Parts

Electrical tape —black (item 62, Appx D)

Connector No.	Electrical Lead To:	Wire No.	Connector No.	Electrical Lead To:	Wire No.
1	Starter		3	In-tank fuel pump system lead assembly	27B
2	Bulkhead-to-portable instrument panel wiring harness	27B	4	Bulkhead-to-portable instrument panel wiring harness	14

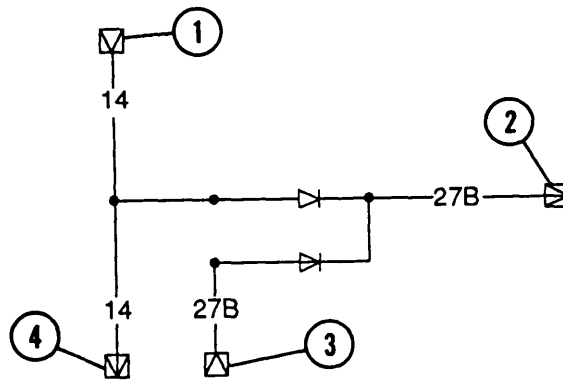

WIRING DIAGRAM

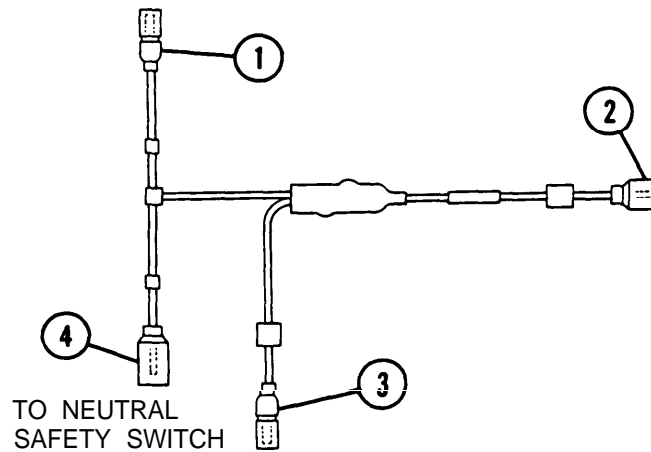

a. Removal

- 1 Disconnect connector (1) at starter switch.
- 2 Disconnect connector (2) at wire 27B.
- 3 Disconnect electrical connector (3) (wire 27B) at "Y" connector.
- 4 Disconnect electrical connector (4) at wire 14.

b. Installation

- 1 Connect electrical connector (4) at wire 14.
- 2 Connect electrical connector (3) (wire 27B) at "Y" connector.
- 3 Connect connector (2) at wire 27B.
- 4 Connect connector (1) at starter switch.

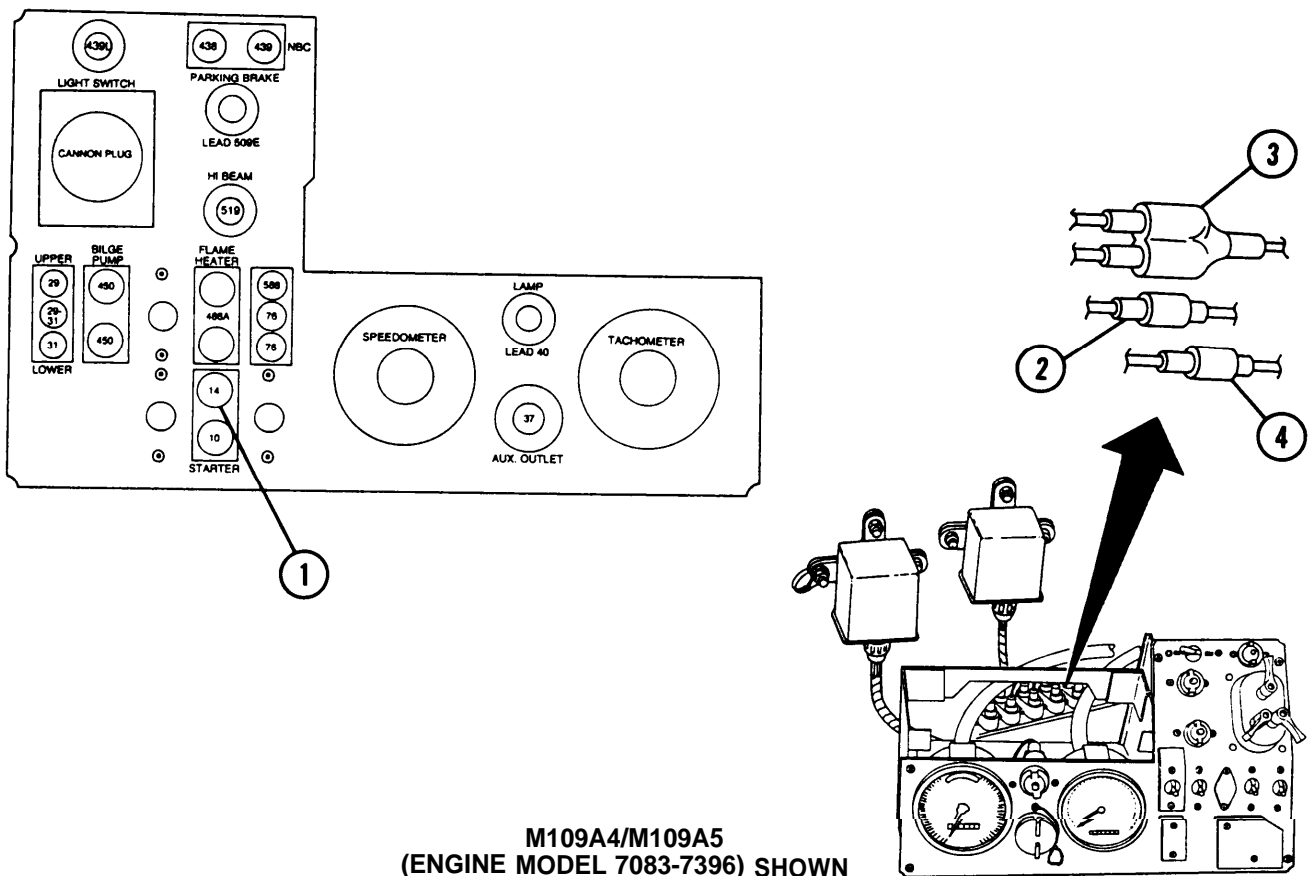

M109A4/M109A5
(ENGINE MODEL 7083-7396) SHOWN

NOTE

FOLLOW-ON MAINTENANCE:

Connect batteries (para 8-28)
Install portable instrument panel (para 8-17)

8-62 VENTILATED FACEPIECE SYSTEM POWER WIRING HARNESS (M109A4/M109A5)

This task covers: a. Removal b. Disassembly/Repair
 c. Assembly d. Installation

INITIAL SETUP

Applicable Configurations

M109A4/M109A5

Tools

General mechanic's tool kit (item 64, Appx H)

Materials/Parts

Electrical tape — black (item 62, Appx D)

LockWashers (7) (item 95, Appx G)

Straps (6) (item 67, Appx G)

Equipment Conditions

Batteries disconnected (para 8-28)

Connector No.	Electrical Lead To:	Wire No.	Connector No.	Electrical Lead To:	Wire No.
1	NBC air purifier	439A	4	NBC indicator light	439L
2	Gunners NBC heater	439C	5	NBC power switch	439
3	Driver's NBC heater	439B			

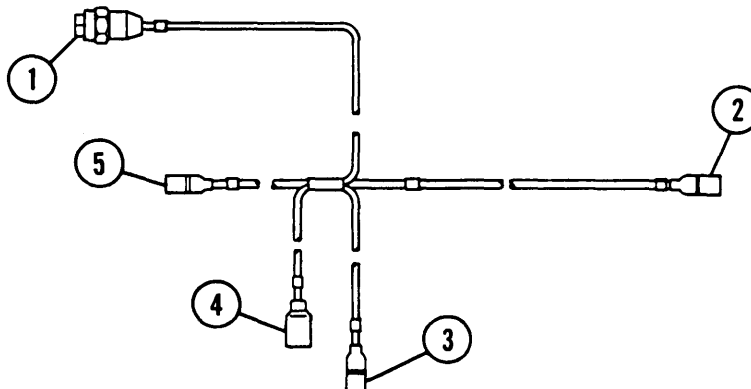
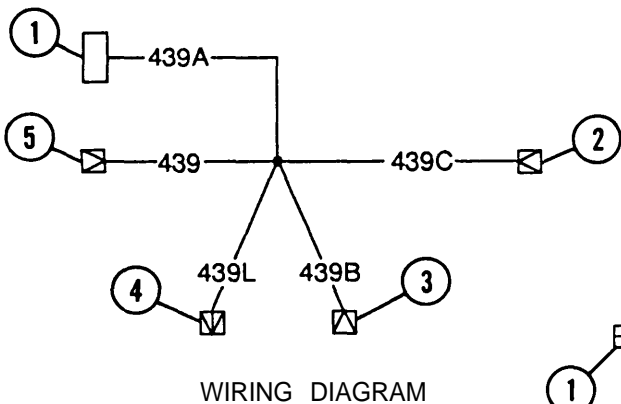

a. Removal

- 1 Disconnect connector (1) from NBC air purifier (6).
- 2 Disconnect connector (3) from driver's heater (7).
- 3 Remove portable instrument panel (para 8-17).
- 4 Disconnect connector (4) from NBC indicator light (8).
- 5 Disconnect connector (5) from NBC power switch (9).
- 6 Disconnect connector (2) from cannoneer's heater (10).
- 7 Remove seven screws (11), seven lockwashers (12), seven washers (13), and seven straps (14). Release wiring harness (15) and reinstall straps, washers, lockwashers, and screws.
- 8 Cut six straps (16) and remove wiring harness (15).

b. Disassembly/Repair

Disassemble wiring harness (para 2-13).

c. Assembly

Assemble wiring harness (para 2-13).

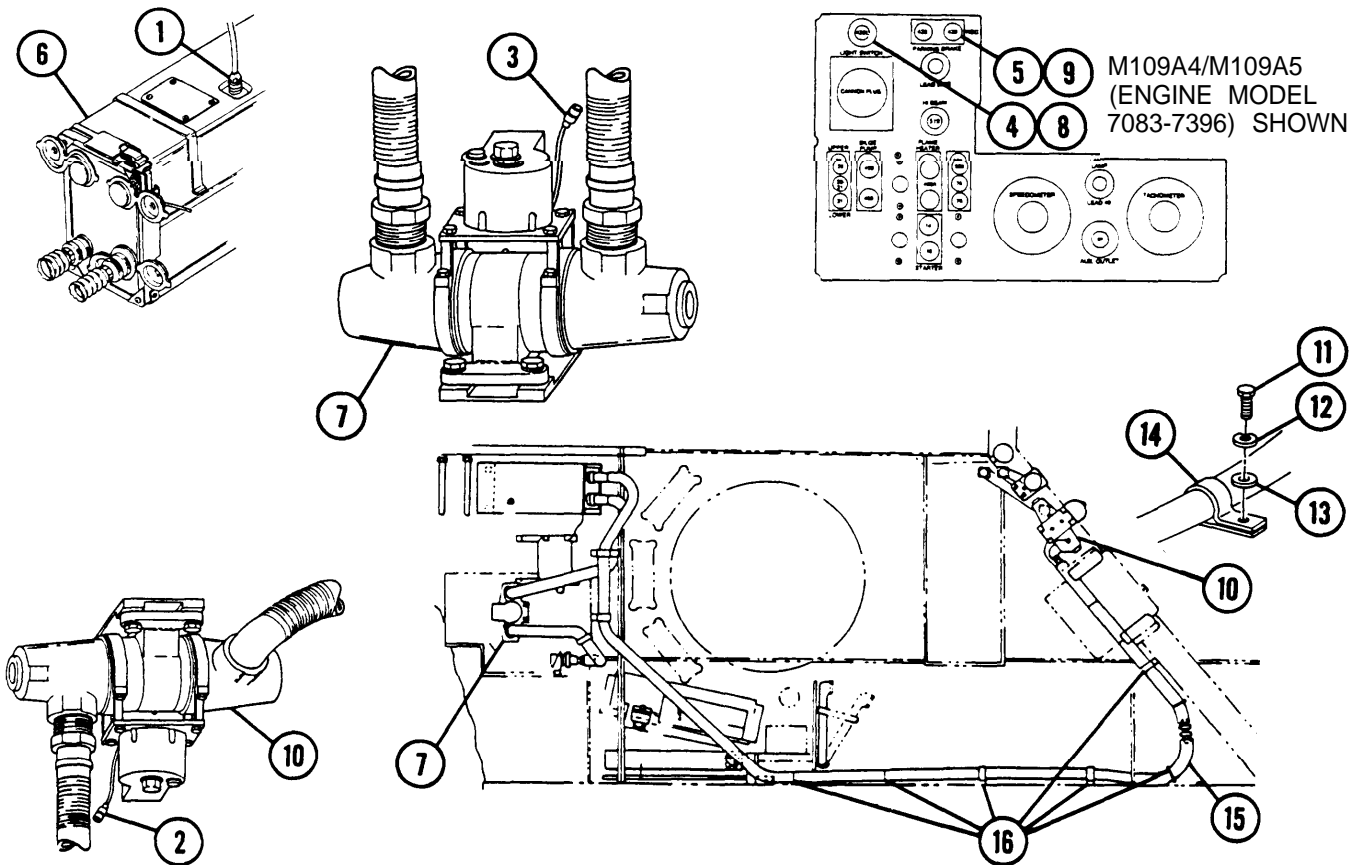

**8-62 VENTILATED FACEPIECE SYSTEM POWER WIRING HARNESS (M109A4/M109A5)
CONTINUED**

d. Installation

- 1 Install wiring harness (15) and connector (2) at cannoneer's heater (10).
- 2 Install connector (5) at NBC power switch (9).
- 3 install connector (4) at NBC indicator light (8).
- 4 Install portable instrument panel (para 8-18).
- 5 Install connector (3) at driver's heater (7).
- 6 Install connector (1) at NBC air purifier (6).
- 7 Remove seven screws (11), seven lockwashers (1 2), seven washers (1 3), and seven straps (1 4). Discard lockwashers.
- 8 Secure wiring harness (15) and install seven straps (14), seven washers (13), seven new lockwashers (12), and seven screws (11).
- 9 Install wiring harness (15) and six new straps (16).

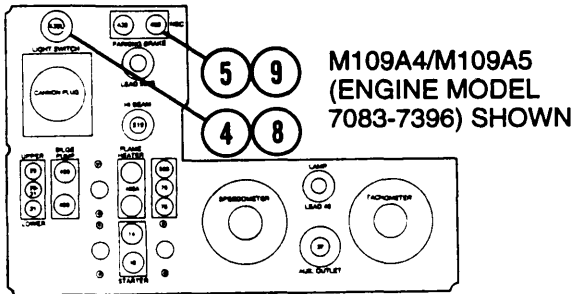
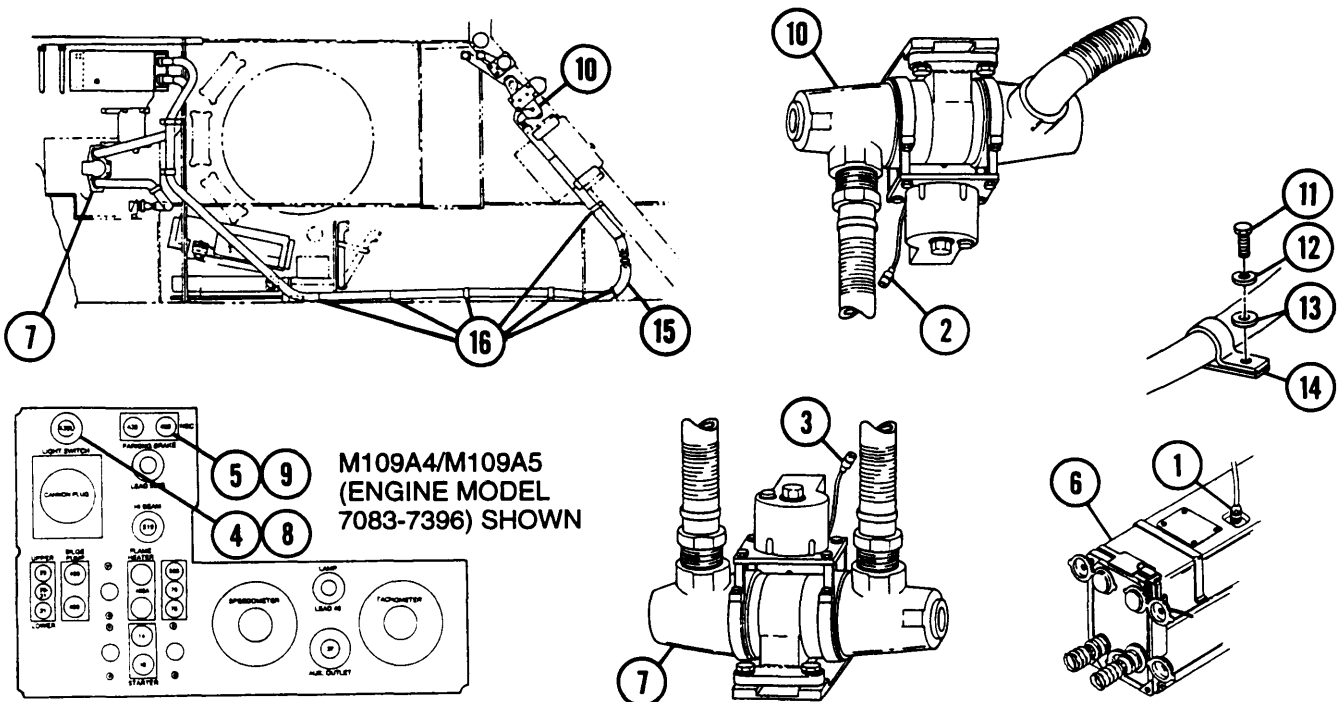

NOTE

FOLLOW-ON MAINTENANCE: Connect batteries (para 8-28)

8-83 NATO SLAVE START-TO-EXTERNAL POWER WIRING HARNESS (M109A4/M109A5) — CONTINUED

a. Removal

- 1 Cut electrical tape to expose slave start connections.
- 2 Remove two screws (5) and two lockwashers (6) to disconnect power (1) and ground lead (2) from slave start receptacle (7). Discard lockwashers.
- 3 Disconnect slave start connector (4) at driver's bulkhead (8).
- 4 Remove four screws (9), four lockwashers (10), and external power receptacle guard (11). Discard lockwashers.
- 5 Cut electrical tape to expose external power receptacle connections.
- 6 Remove screw (12) and lockwasher (13) to disconnect cable (3) from external power receptacle (14), and remove boot (15) from external power receptacle. Discard lockwasher.
- 7 Remove 14 screws (16), 14 lockwashers (17), 14 washers (18), and 14 straps (19) and lift out wiring harness (20). Discard lockwashers.

b. Disassembly/Repair

Disassemble wiring harness (para 2-13).

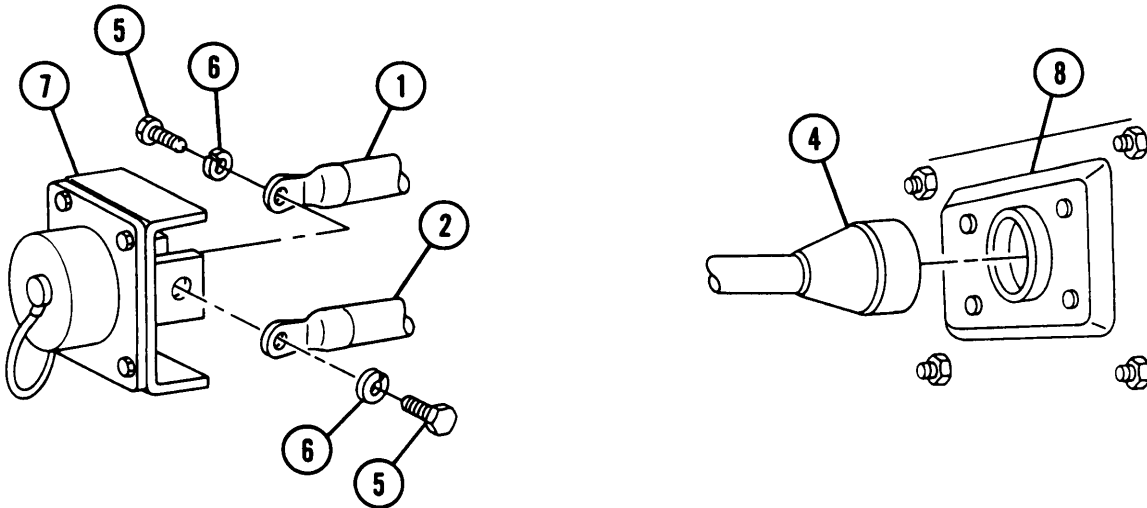

c. Assembly

Assemble wiring harness (para 2-13).

d. Installation

- 1 Install wiring harness (20). Connect cable (3), new lockwasher (13), screw (12), and boot (15) on external power receptacle (14).
- 2 Install external power receptacle guard (11), four new lockwashers (10), and four screws (9).
- 3 Connect slave start connector (4) at driver's bulkhead (8).
- 4 Install power (1) and ground lead (2), two new lockwashers (6), and two screws (5) to slave start receptacle (7).
- 5 Apply electrical tape to exposed slave start connections (1 and 2) and external power receptacle connection (3).
- 6 Install 14 straps (19), 14 flat washers (18), 14 new lockwashers (17), and 14 screws (16), securing wiring harness (20).

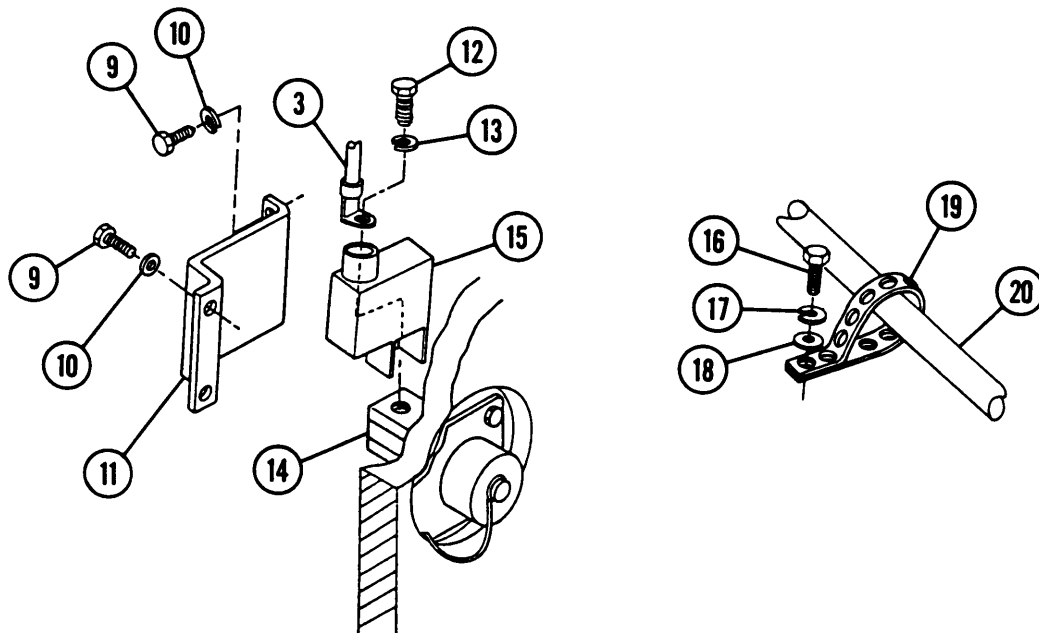

NOTE

FOLLOW-ON MAINTENANCE: Connect batteries (para 8-28)

SECTION IV. POWERPLANT AND HULL ELECTRICAL LEADS

8-84 ACCESSORY CONTROL BOX HEATER INDICATOR LIGHT LEAD

This task covers: a. Removal b. Installation

INITIAL SET UP

Tools

General mechanic's tool kit (item 64, **APPX H**)

Rivet gun (item 25, Appx H)

Materials/Parts

Lockwashers (2) (item 79, Appx G)

Rivet (item 66, Appx G)

Equipment Conditions

Accessory control box removed (para 8-20)

Accessory control box cover removed (para 8-20)

Connector No.	Electrical Lead To:	Wire No.
1	Indicator light	GRD
2	Ground	GRD

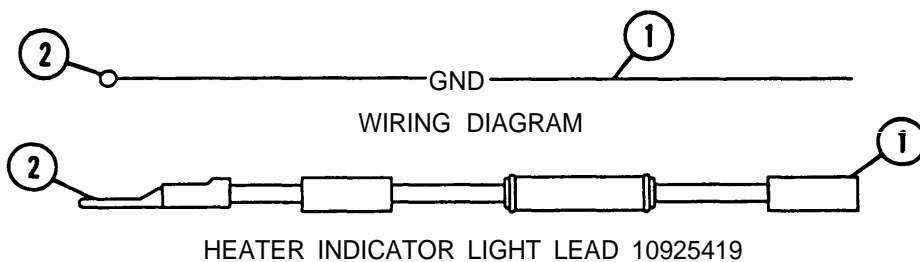

a. Removal

- 1 Remove indicator light lamp assembly (indicator lamp cap, LED, gasket, and hex nut) (1). Pull accessory control box heater indicator light lead (2) into accessory control box (3).
- 2 Remove screw (4), nut (5), lockwasher (6), terminal (7), nut, and lockwasher. Discard lockwashers.
- 3 Remove light lead (2).

b. Installation

- 1 Install light lead (2) through inside of accessory control box (3).
- 2 Install screw (4), new lockwasher (6), nut (5), terminal (7), new lockwasher, and nut.
- 3 Install indicator light assembly (indicator lamp cap, LED, gasket, and hex nut) (1).

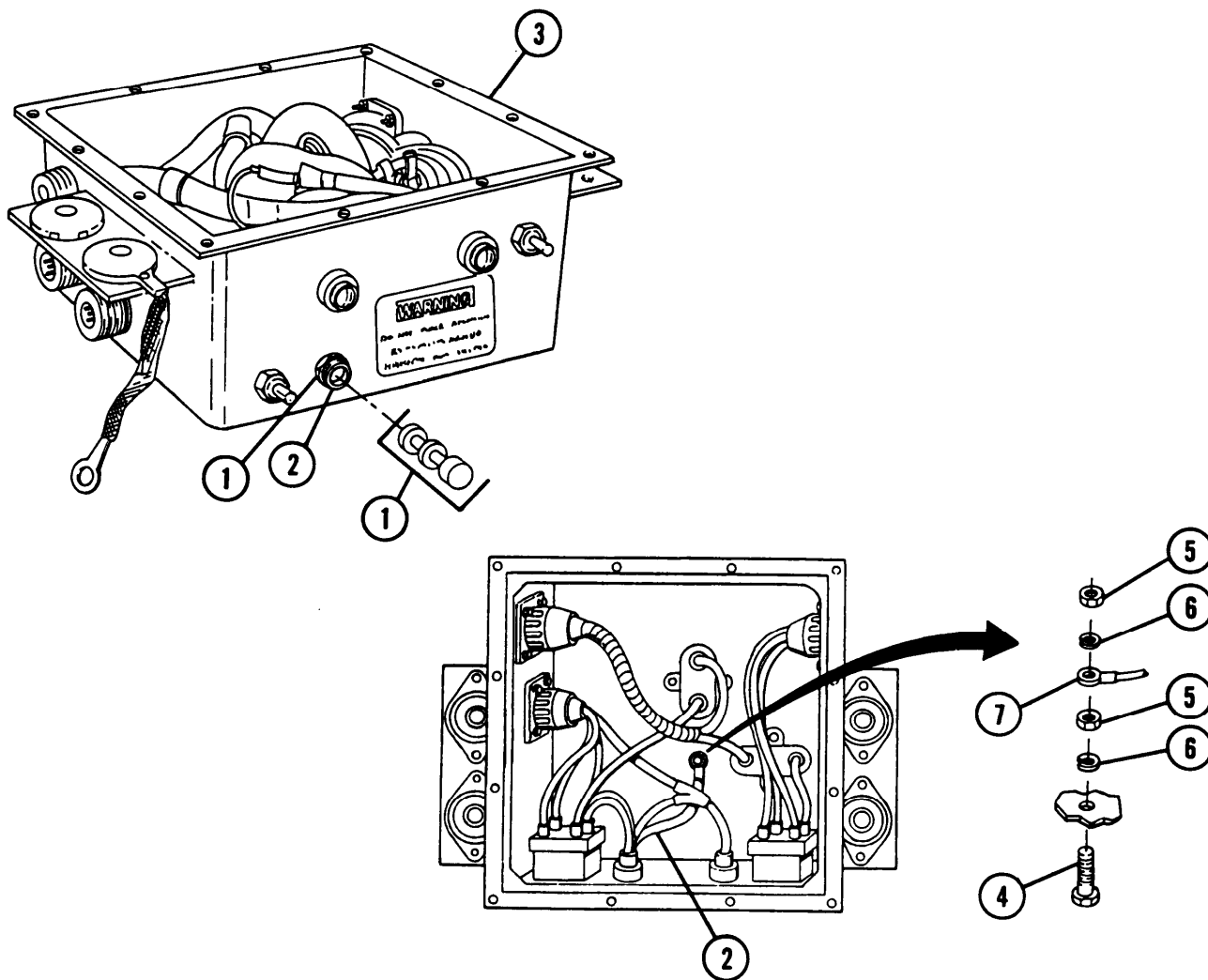

NOTE

FOLLOW-ON MAINTENANCE: Install accessory control box (para 8-20)

8-66 ACCESSORY CONTROL BOX VENTILATOR BLOWER SWITCH-TO-CIRCUIT BREAKER LEAD — CONTINUED

a. Removal

- 1 Remove screw (1) from switch (2).
- 2 Remove ventilator blower switch-to-circuit breaker lead (3) from circuit breaker (4).

b. Disassembly

Disassemble (para 2-13).

c. Assembly

Assemble (para 2-13).

d. Installation

- 1 Install ventilator blower switch-to-circuit breaker lead (3) to circuit breaker (4).
- 2 Install terminal (5) on switch (2) with screw (1).

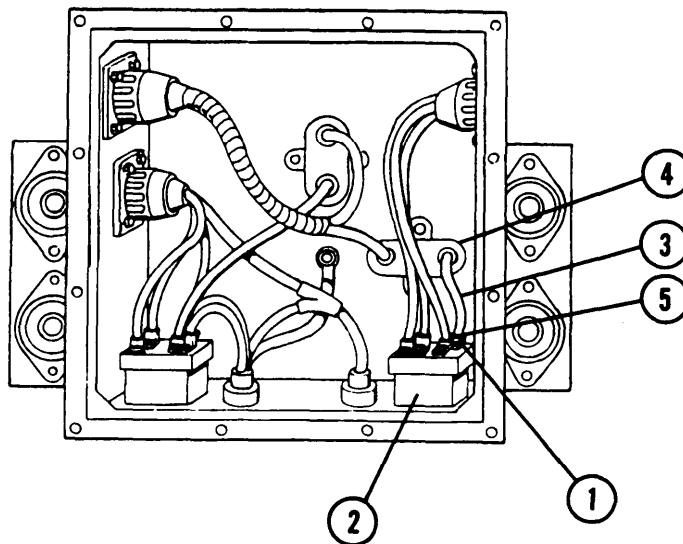

NOTE

FOLLOW-ON MAINTENANCE: Install accessory control box (para 8-20)

8-67 ACCESSORY CONTROL BOX VENTILATOR BLOWER SWITCH LEAD

This task covers: a. Removal b. Installation

INITIAL SETUP

Tools

General mechanic's tool kit (item 84, Appx H)

Materials/Parts

Lockwashers (4) (item 94, Appx G)

Equipment Conditions

Accessory control box removed (para 8-20)

Accessory control box cover removed (para 8-20)

Connector No.	Electrical Lead To:	Wire No.	Connector No.	Electrical Lead To:	Wire No.
1	Accessory control box to heater/blower wiring harness		3	Ventilator blower switch	159B
2	Ventilator blower switch	159A	4	Ventilator blower switch	159C

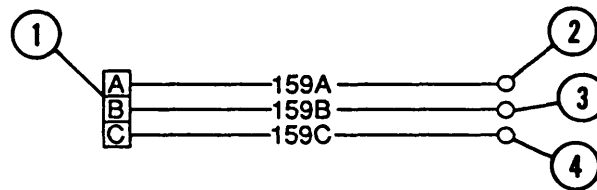

WIRING DIAGRAM

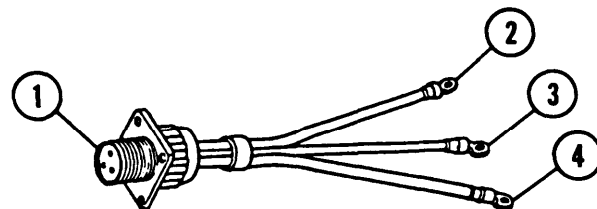

8-67 ACCESSORY CONTROL BOX VENTILATOR BLOWER SWITCH LEAD — CONTINUED

a. Removal

- 1 Remove three screws (1) and three lead terminals (2) from switch (3). Reinstall screws on switch.
- 2 Remove four screws (4), four flat washers (5), four lockwashers (6), and four nuts (7). Remove ventilator blower switch lead (8). Discard lockwashers.

b. Installation

- 1 Install ventilator blower switch lead (8), four flat washers (5), four new lockwashers (6), four screws (4), and four nuts (7).
- 2 Install three lead terminals (2) with three screws (1) on switch (3).

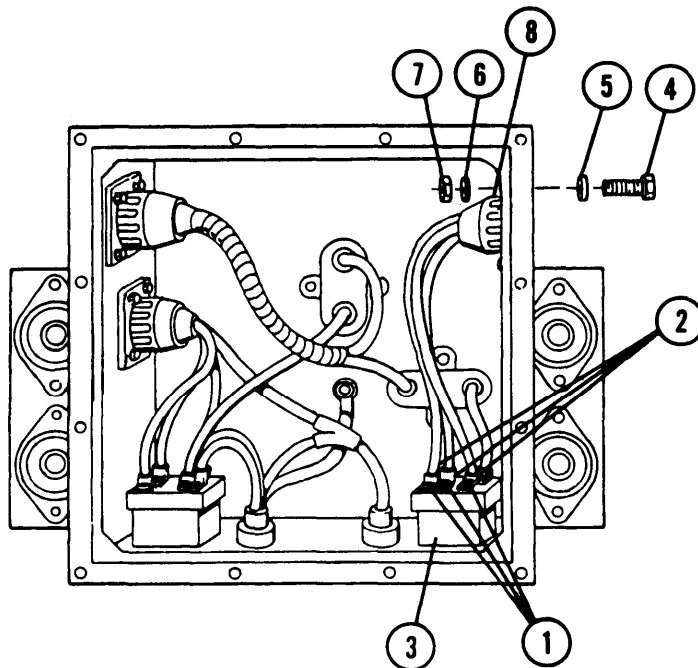

NOTE

FOLLOW-ON MAINTENANCE: Install accessory control box (8-20)

8-88 ACCESSORY CONTROL BOX POWER LEAD — CONTINUED

a. Removal

- 1 Remove four screws (1), four flat washers (2), four lockwashers (3), and four nuts (4). Discard lockwasher.
- 2 Remove accessory control box power lead (5) from two circuit breakers (6).

b. Installation

- 1 Install accessory control box power lead (5) on two circuit breakers (6).
- 2 Install power lead (5), four flat washers (2), four new lockwashers (3), four screws (1), and four nuts (4).

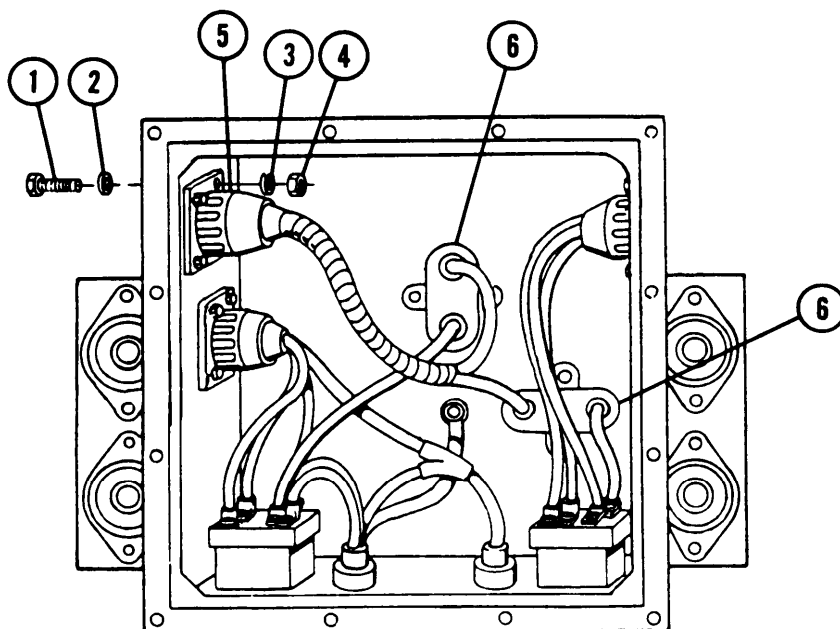

NOTE

FOLLOW-ON MAINTENANCE: Install accessory control box (para 8-20)

8-69 LOW-COOLANT INDICATOR LIGHT ASSEMBLY

This task covers: a. Removal b. Installation

INITIAL SETUP

Tools

General mechanic's tool kit (item 64, Appx H)

Equipment Conditions

Portable instrument panel removed (para 8-17)
 Portable instrument panel separated from bracket (para 8-17)

Connector No.	Electrical Lead To:	Wire No.
1	Low-coolant indicator light assembly terminal	352B
2	Low-coolant indicator light assembly terminal 1	27
3	Low-coolant indicator light assembly terminal 3	352A

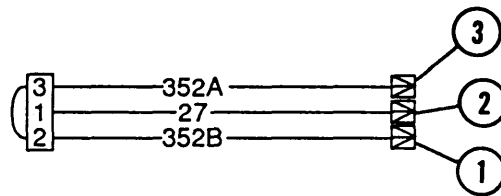

WIRING DIAGRAM

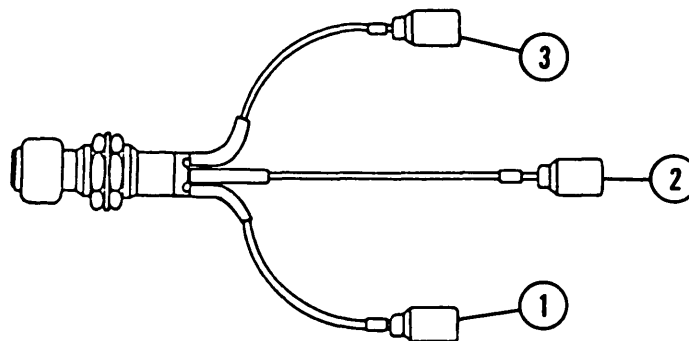

8-69 LOW-COOLANT INDICATOR LIGHT ASSEMBLY — CONTINUED

a. Removal

- 1 Remove lens (1) and hex nut (2).
- 2 Disconnect three connectors (3) and remove low-coolant indicator light assembly (4) through portable instrument panel (5).

b. Installation

- 1 Install low-coolant indicator light assembly (4) through portable instrument panel (5).
- 2 Connect three connectors (3), lens (1), and hex nut (2).

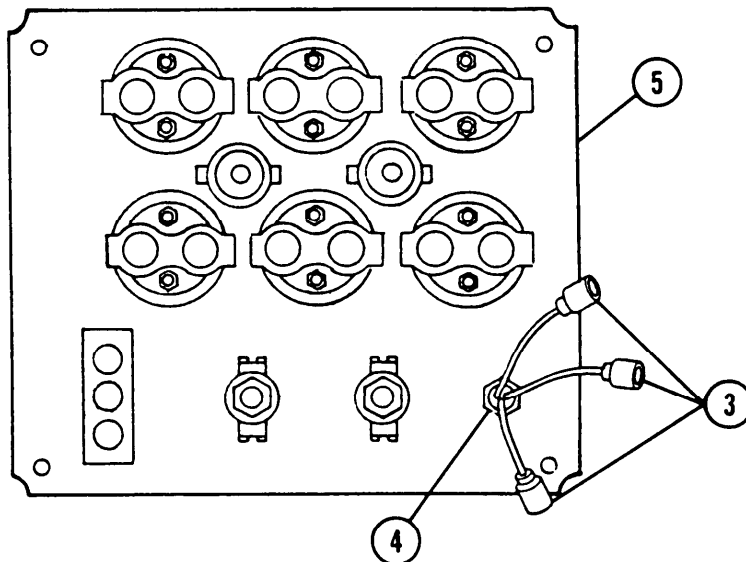
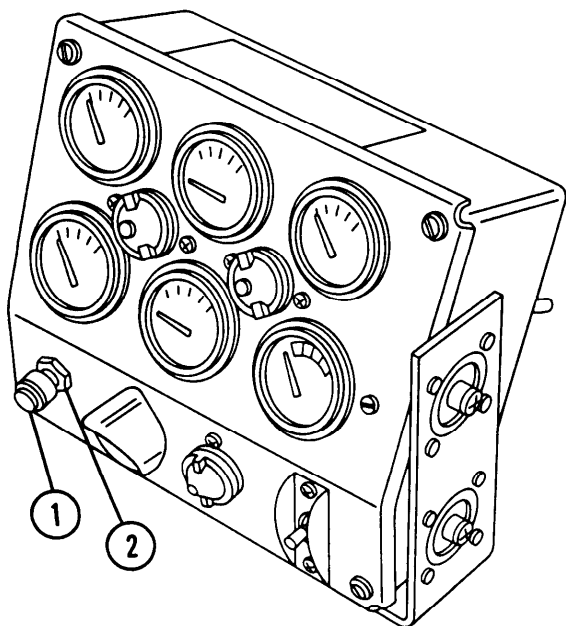

NOTE

FOLLOW-ON MAINTENANCE:

Install portable instrument panel (para 8-17)

8-70 FLAME HEATER SWITCH LEAD (ENGINE MODEL 7083-7396)

This task covers: a. Removal b. Installation

INITIAL SETUP

Equipment Conditions

Batteries disconnected (para 8-28)

Portable instrument panel removed (para 8-17)

Connector No.	Electrical Lead To:	Wire No.
1	Flame heater switch	486/486A
2	Bulkhead-to-portable instrument panel wiring harness	486
3	Bulkhead-to-portable instrument panel wiring harness	486A

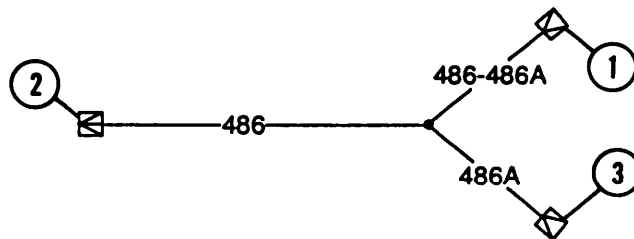

WIRING DIAGRAM

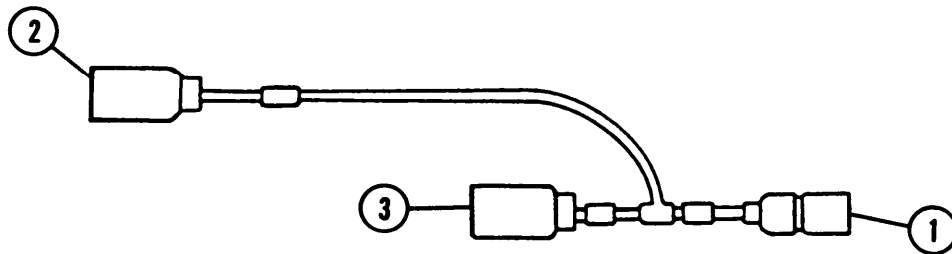

8-70 FLAME HEATER SWITCH LEAD (ENGINE MODEL 7083-7396) — CONTINUED

a. Removal

- 1 Disconnect connector (1) at flame heater switch.
- 2 Disconnect two connectors (2 and 3) at wires 486A and 486.

b. Installation

- 1 Connect two connectors (2 and 3) at wires 486A and 486.
- 2 Connect connector (1) at flame heater switch.

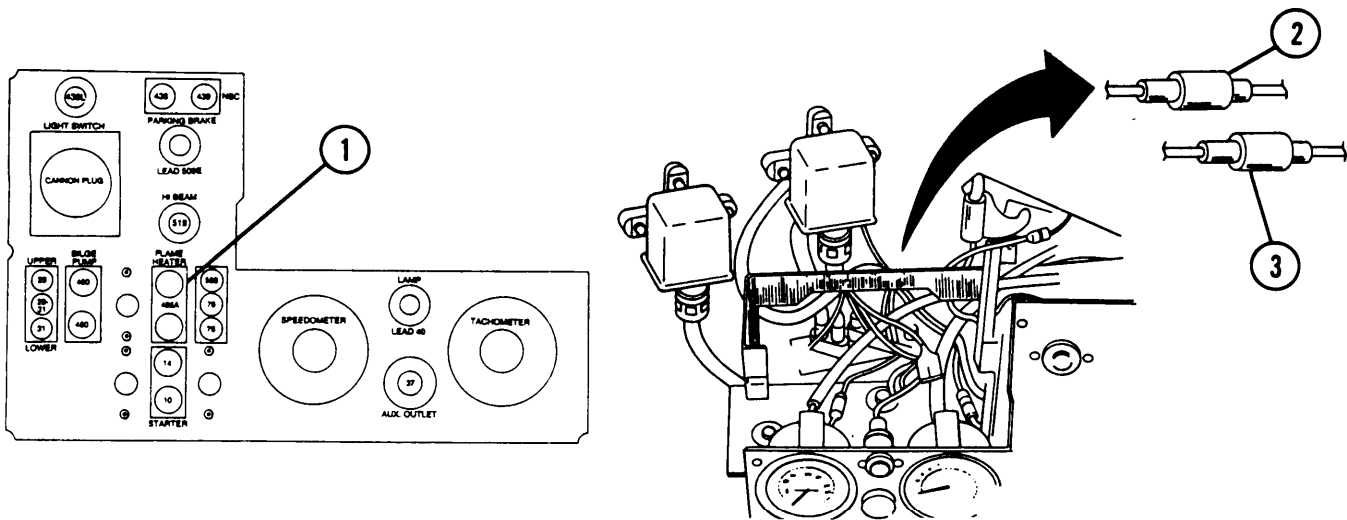

NOTE

FOLLOW-ON MAINTENANCE:

Connect batteries (para 8-28)
Install portable instrument panel (para 8-17)

8-71 CIRCUIT BREAKER-TO-"Y" CONNECTOR LEAD

This task covers: a. Removal b. Installation

INITIAL SETUP

Equipment Conditions

Batteries disconnected (para 8-28)
Portable instrument panel removed (para 8-17)

Connector No.	Electrical Lead To:	Wire No.
1	Power lead "Y" connector	415
2	Circuit breaker	415

a. Removal

- 1 Disconnect connector (2) at circuit breaker (3)
- 2 Disconnect connector (1) at wire 415 connector (4).

b. Installation

- 1 Connect connector (1) at wire 415 connector (4).
- 2 Connect connector (2) at circuit breaker (3).

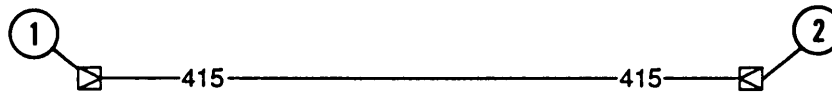

WIRING DIAGRAM

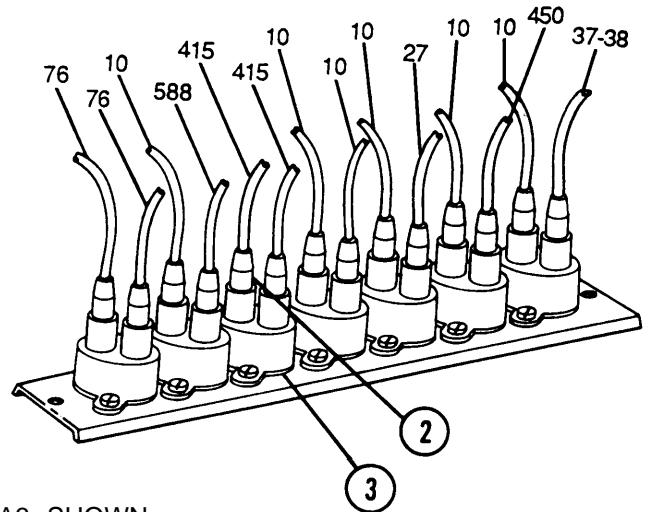
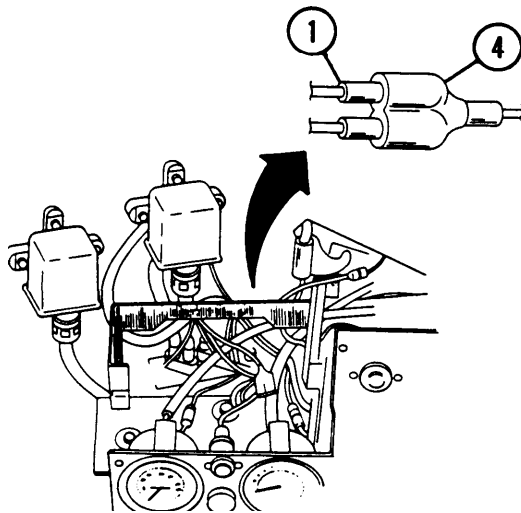
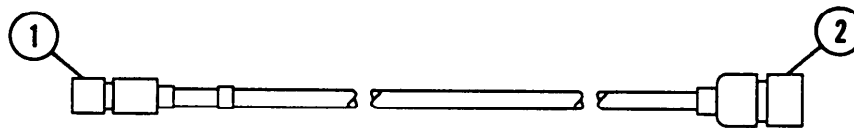

M109A2/M19A3 SHOWN

NOTE

FOLLOW-ON MAINTENANCE:

- Connect batteries (para 8-28)
- Install portable instrument panel (para 8-17)

8-72 AIR CLEANER BLOWER LEAD ASSEMBLY

This task covers: a. Removal b. Disassembly/Repair

INITIAL SETUP

Tools

General mechanic's tool kit (item 64, Appx H)

Equipment Conditions

Batteries disconnected (para 8-28)

Portable instrument panel removed (para 8-17)

Materials/Parts

Lockwashers (5) (item 95, Appx G)

Connector No.	Electrical Lead To:	Wire No.	Connector No.	Electrical Lead To:	Wire No.
1	Air cleaner blower motor relay		4	Neutral safety switch	415B
2	Circuit breaker	415	5	Air cleaner blower motors wiring harness	415
3	Neutral safety switch	415A			

a. Removal

- 1 Disconnect connector (1) at air cleaner blower motor relay (6).
- 2 Disconnect connector (2) wire 415 at circuit breaker (7).
- 3 Disconnect two connectors (3 and 4) at neutral safety switch (8).

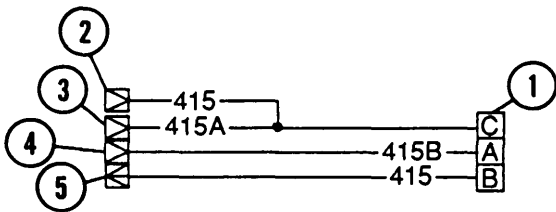

WIRING DIAGRAM

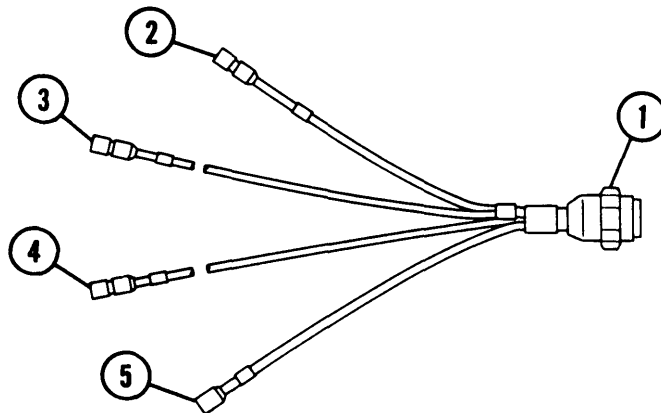

4 Disconnect connector (5) at air cleaner blower motor lead wire 415 (9).

5 Remove five screws (10), five lockwashers (11), five washers (12), and five straps (13). Remove wiring harness (14). Discard lockwashers.

b. Disassembly/Repair

Disassemble (para 2-13).

c. Assembly

Assemble (para 2-13).

d. Installation

1 Install connector (5) at air cleaner blower motor lead wire 415 (9).

2 Install two connectors (3 and 4) at neutral safety switch (8).

3 Install connector (2) wire 415 at circuit breaker (7).

4 Install connector (1) at air cleaner blower motor relay (6).

5 Install wiring harness (14), five straps (13), five washers (12), five new lockwashers (11), and five screws (10).

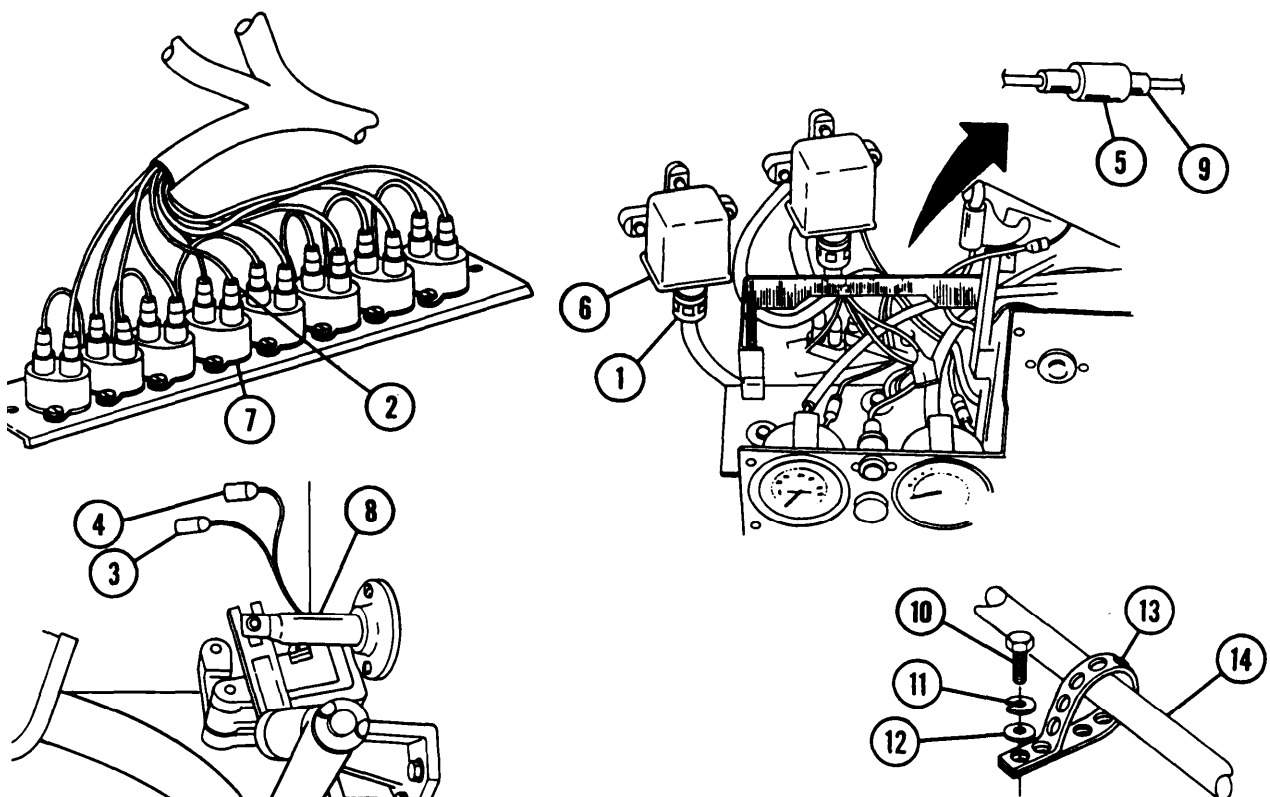

NOTE

Connect batteries (para 8-28)
Install portable instrument panel (8-17)

FOLLOW-ON MAINTENANCE:

8-73 IN-TANK FUEL PUMP LEAD ASSEMBLY

This task covers:

a. Removal	b. Disassembly
c. Assembly	d. Installation

INITIAL SETUP

Tools

General mechanic's tool kit (item 64, Appx H)

Equipment Conditions

Batteries disconnected (para 8-28)

Portable instrument panel removed (para 8-17)

Connector No.	Electrical Lead To:	Wire No.	Connector No.	Electrical Lead To:	Wire No.
1	In-tank fuel pump relay		3	Bulkhead-to-portable instrument panel wiring harness	
2	Diode wiring harness assembly and circuit breaker-to-"Y" connector lead		76	4	Power lead assembly and circuit breaker-to-"Y" connector lead
					10

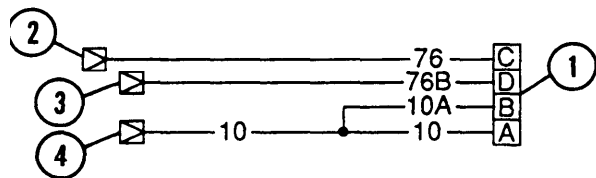

WIRING DIAGRAM

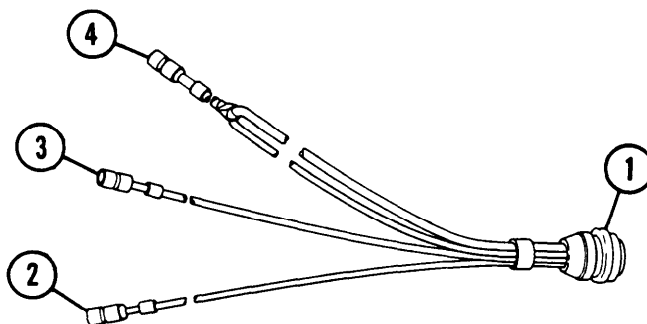

Removal

- 1 Disconnect connector (1) at fuel pump system relay (5).
- 2 Disconnect three connectors (2, 3, and 4).

Disassembly

Disassemble (para 2-13).

Assembly

Assemble (para 2-13).

Installation

- 1 Connect three connectors (2,3, and 4).
- 2 Connect connector (1) at fuel pump system relay (5).

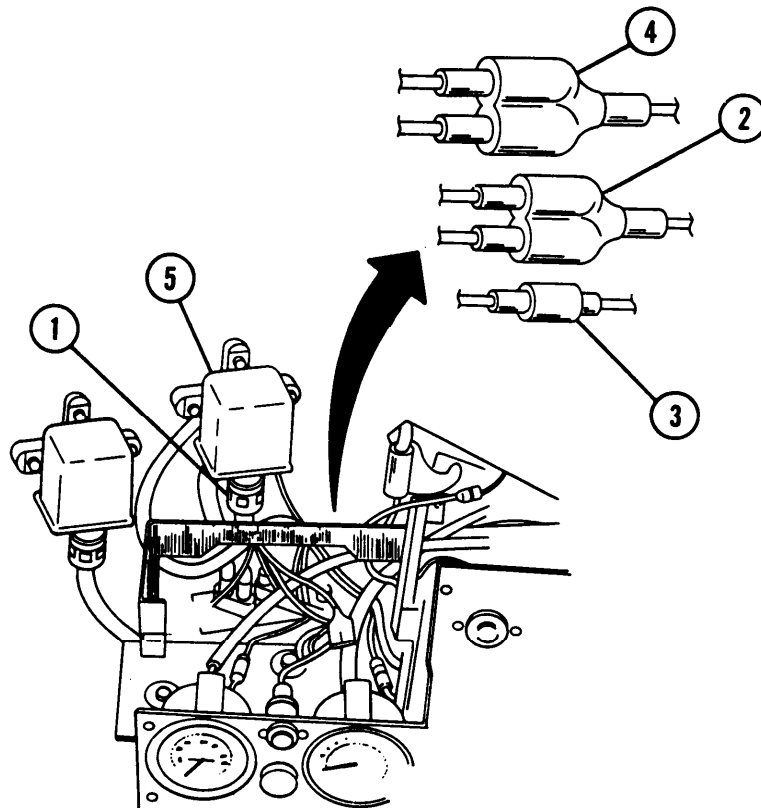

M1 09A2/M109A3
(ENGINE MODEL 7083-7396) SHOWN

NOTE**FOLLOW-ON MAINTENANCE:**

Connect batteries (para 8-28)
Install portable instrument panel (para 8-17)

8-74 FUEL PUMP CIRCUIT BREAKER LEAD ASSEMBLY

This task covers: a. Removal b. Installation

INITIAL SETUP

Equipment Conditions

Batteries disconnected (para 8-28)

Portable instrument panel removed (para 8-17)

Connector No.	Electrical Lead To:	Wire No.
1	In-tank fuel pump lead assembly	76
2	Circuit breaker	76



WIRING DIAGRAM

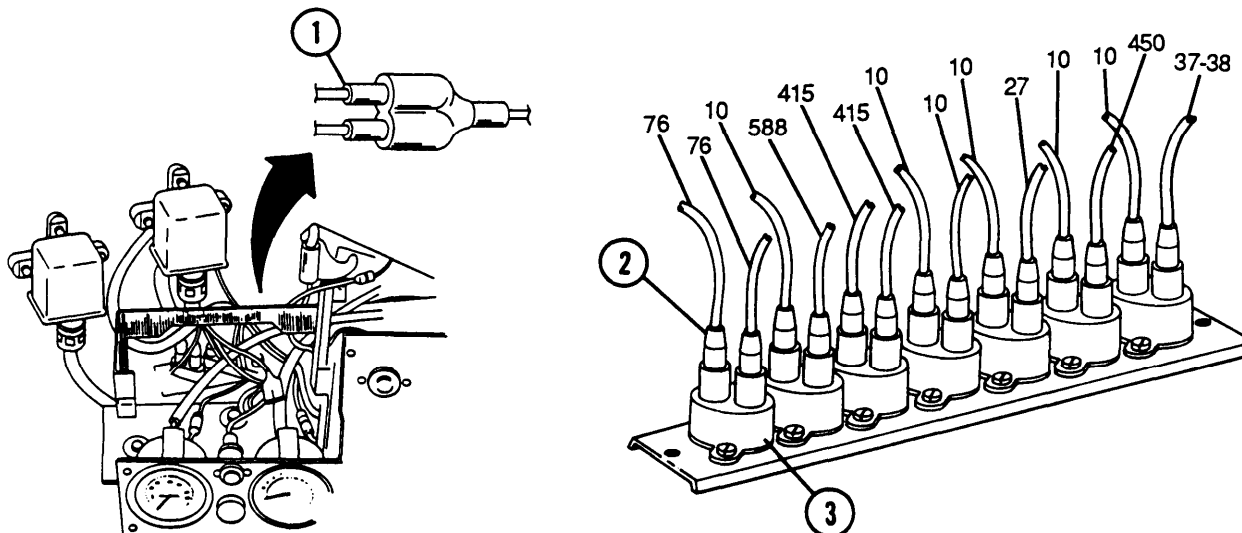
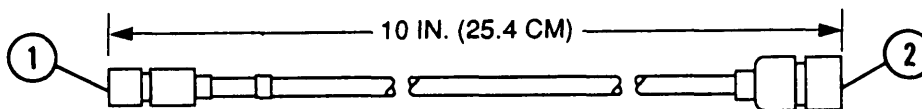

M109A2/M109A3
ENGINE MODEL 7083-7396) SHOWN

a. Removal

- 1 Disconnect connector (1) behind driver's instrument panel.
- 2 Disconnect connector (2) wire 76 at circuit breaker (3).

b. Installation

- 1 Connect connector (2) wire 76 at circuit breaker (3).
- 2 Connect connector(1) behind driver's instrument panel.

NOTE

FOLLOW-ON MAINTENANCE: Connect batteries (para 8-28)
Install portable instrument panel (para 8-17)

8-75 FUEL PUMP SWITCHCH-TO -TO CIRCUIT BREAKER LEAD ASSEMBLY

This task covers: a. Removal b. Installation

INITIAL SETUP

Equipment Conditions

Batteries disconnected (para 8-28)
Portable instrument panel removed (para 8-17)

Connector No.	Electrical Lead To:	Wire No.
1	Fuel prime switch terminal 2	76
2	Circuit breaker	76



WIRING DIAGRAM

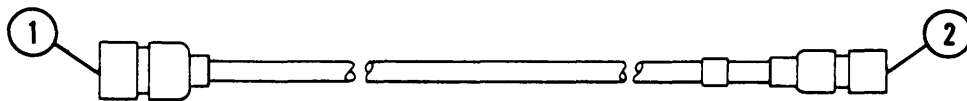

8-75 FUEL PUMP SWITCH-TO-CIRCUIT BREAKER LEAD ASSEMBLY — CONTINUED

a. Removal

- 1 Disconnect connector (1) behind driver's instrument panel at fuel prime switch terminal 2 (3).
- 2 Disconnect connector (2) wire 76 at circuit breaker panel (4).

b. Installation

- 1 Install connector (2) wire 76 at circuit breaker panel (4).
- 2 Install connector (1) wire 76 behind driver's instrument panel at fuel prime switch terminal 2 (3).

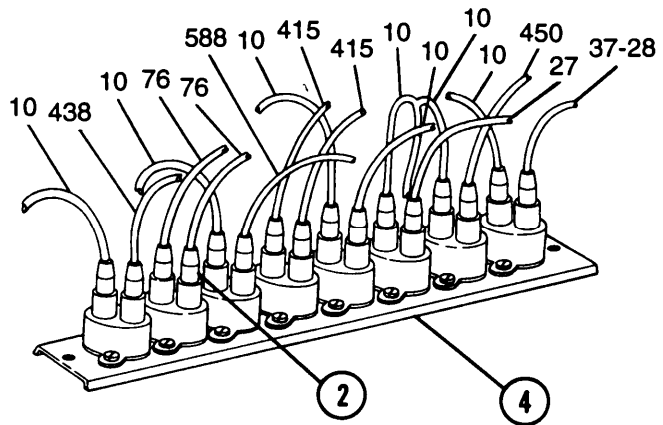
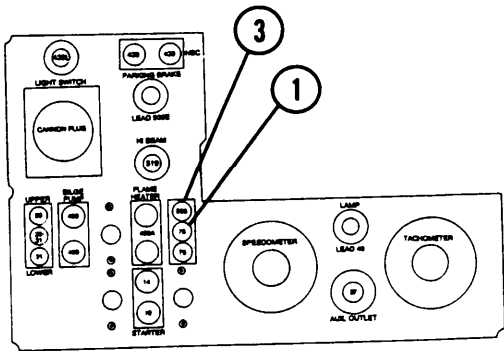

M109A4/M19A5
(ENGINE MODEL 7083-7396) SHOWN

NOTE

FOLLOW-ON MAINTENANCE:

- Connect batteries (para 8-28)
- Install portable instrument panel (para 8-17)

8-76 CIRCUIT BREAKER TO "Y" CONNECTOR LEAD

This task covers: a. Removal b. Installation

INITIAL SETUP

Equipment Conditions

- Batteries disconnected (para 8-28)
- Portable instrument panel removed (para 8-17)

Connector No.	Electrical Lead To:	Wire No.
1	Connector to power lead	10
2	Circuit breaker	10
3	In-tank fuel pump lead assembly "Y" connector	10

a. Removal

- 1 Disconnect connector (1) wire 10 from power lead wire 10 (4).
- 2 Disconnect connector (2) wire 10 at circuit breaker (5).
- 3 Disconnect connector (3) wire 10 at in-tank fuel pump lead assembly "Y" connector (6).

b. Installation

- 1 Install connector (3) wire 10 at in-tank fuel pump lead assembly "Y" connector (6).
- 2 Install connector (2) wire 10 at circuit breaker (5).
- 3 Install connector (1) wire 10 at power lead wire 10 (4).

M109A4/M109A5 (ENGINE MODEL 7083-7396) SHOWN

NOTE

FOLLOW-ON MAINTENANCE:

- Connect batteries (para 8-28)
- Install portable instrument panel (para 8-17)

8-77 GLOW PLUG WAIT LIGHT-TO-BULKHEAD TO PORTABLE INSTRUMENT PANEL WIRING HARNESS (ENGINE MODEL 7083-7391)

This task covers: a. Removal b. Installation

INITIAL SETUP

Batteries disconnected (para 8-28)
 Portable instrument panel removed (para 8-17)

Connector No.	Electrical Lead To:	Wire No.
1		486
2	Bulkhead to portable instrument panel wiring harness	486



WIRING DIAGRAM

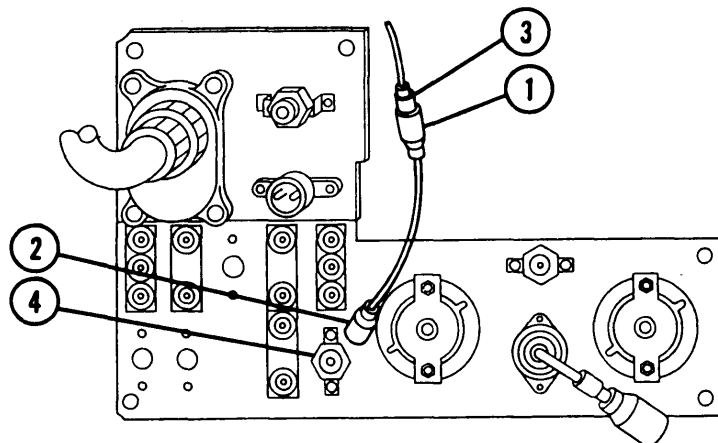
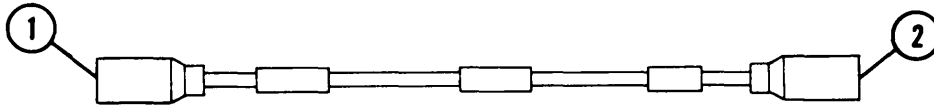

M109A2/M109A3
 (ENGINE MODEL 7083-7391) SHOWN

a. Removal

- 1 Remove glow plug light lead connector (1) from bulkhead-to-portable instrument panel wiring harness connector (3).
- 2 Remove glow plug light lead connector (2) from glow plug wait light (4).

b. Installation

- 1 Install glow plug light lead connector (2) in glow plug light (4).
- 2 Install glow plug light lead connector (1) to bulkhead-to-portable instrument panel wiring harness connector (3).

NOTE

FOLLOW-ON MAINTENANCE: Connect batteries (para 8-28)
Install portable instrument panel (para 8-17)

8-78 MASTER WARNING LIGHT ASSEMBLY (STEERING SHAFT)

This task covers: a. Removal b. Installation

INITIAL SETUP

Tools

General mechanic's tool kit (item 64, Appx H)

Materials/Parts

Lockwashers (3) (item 192, Appx G)
Self-locking nuts (2) (item 31, Appx G)

Connector No.	Electrical Lead To:	Wire No.	Connector No.	Electrical Lead To:	Wire No.
1	Wire GRD/wiring harness	GRD	4	Terminal 3/ master warning light	GRD
2	Wire 27/wiring harness	27	5	Terminal 1/master warning light	27
3	Wire 509/wiring harness	509	6	Terminal 2/master warning light	509

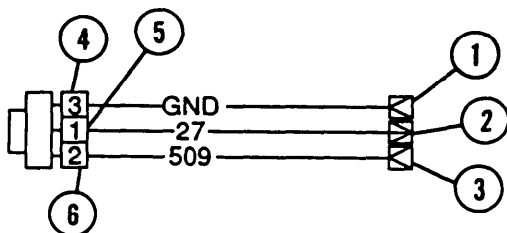

WIRING DIAGRAM

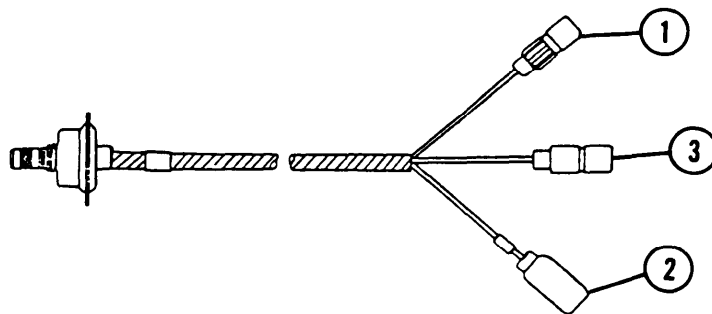

8-78 MASTER WARNING LIGHT ASSEMBLY (STEERING SHAFT) — CONTINUED

a. Removal



Ensure MASTER switch is OFF when working on hull electrical system to avoid electrical shocks or burns.

- 1 Disconnect three electrical connectors (1, 2, and 3) and remove two screws (7) and two self-locking nuts (8) located on top portion of mounting bracket (9). Discard self-locking nuts.
- 2 Remove master warning light (10).

NOTE

To remove mounting bracket, remove steering wheel (para 9-8).

- 3 Remove three screws (11), three lockwashers (12), and mounting bracket (9). Discard lockwashers.

b. Installation



Ensure MASTER switch is OFF when working on hull electrical system to avoid electrical shocks or burns.

- 1 Install mounting bracket (9), three new lockwashers (12), and three screws (11).

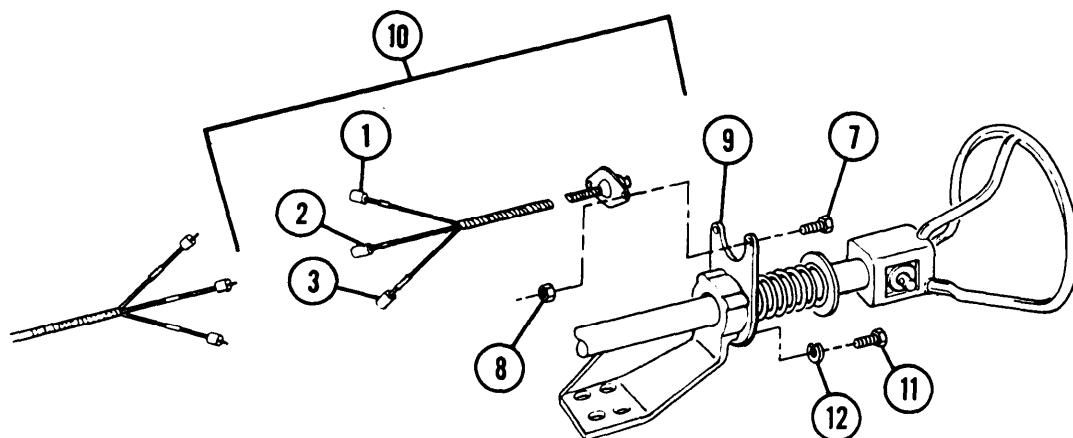

NOTE

If removed, install steering wheel (para 9-8).

2 Install two new self-locking nuts (8) and two screws (7) located on top portion of mounting bracket (9) and connect three electrical connectors (1, 2, and 3).

3 Install master warning light (10).

8-79 PARKING BRAKE LIGHT SWITCH ASSEMBLY

This task covers: a. Removal b. Installation

INITIAL SETUP

Tools

General mechanic's tool kit (item 64, Appx H)

LockWashers (2) (item 95, Appx G)

Equipment Conditions

Parking brake linkage removed (para 9-16)

Parking brake linkage disassembled (para 9-16)

Materials/Parts

Lockwasher (item 78, Appx G)

Connector No.	Electrical Lead To:	Wire No.
1	Wire 509 E/wiring harness 12260287	509E
2	Wire 509 E/wiring harness 12260287	509E

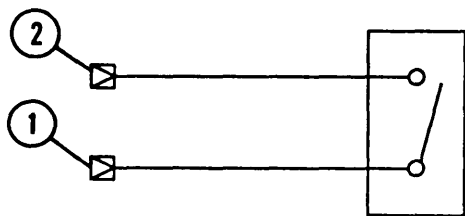

WIRING DIAGRAM

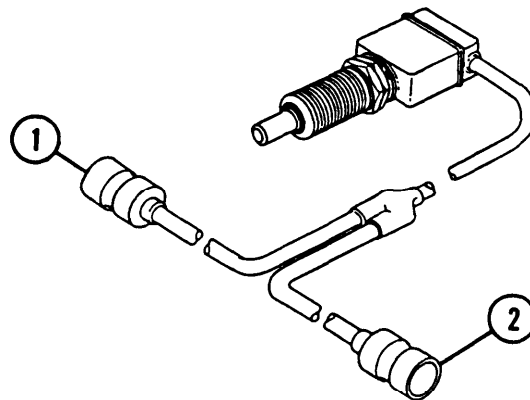

8-79 PARKING BRAKE LIGHT SWITCH ASSEMBLY — CONTINUED

a. Removal

- 1 Remove two screws (1), two lockwashers (2), and parking brake light switch (3) with bracket (4). Discard lockwashers.
- 2 Remove nut (5), lockwasher (6), two flat washers (7), and separate parking brake light switch (3) from bracket (4). Discard lockwasher.

b. Installation

- 1 Install parking brake light switch (3) on bracket (4) with two flat washers (7), new lockwasher (6), and nut (5).
- 2 Install parking brake light switch (3) and bracket (4) with two new lockwashers (2) and two screws (1).

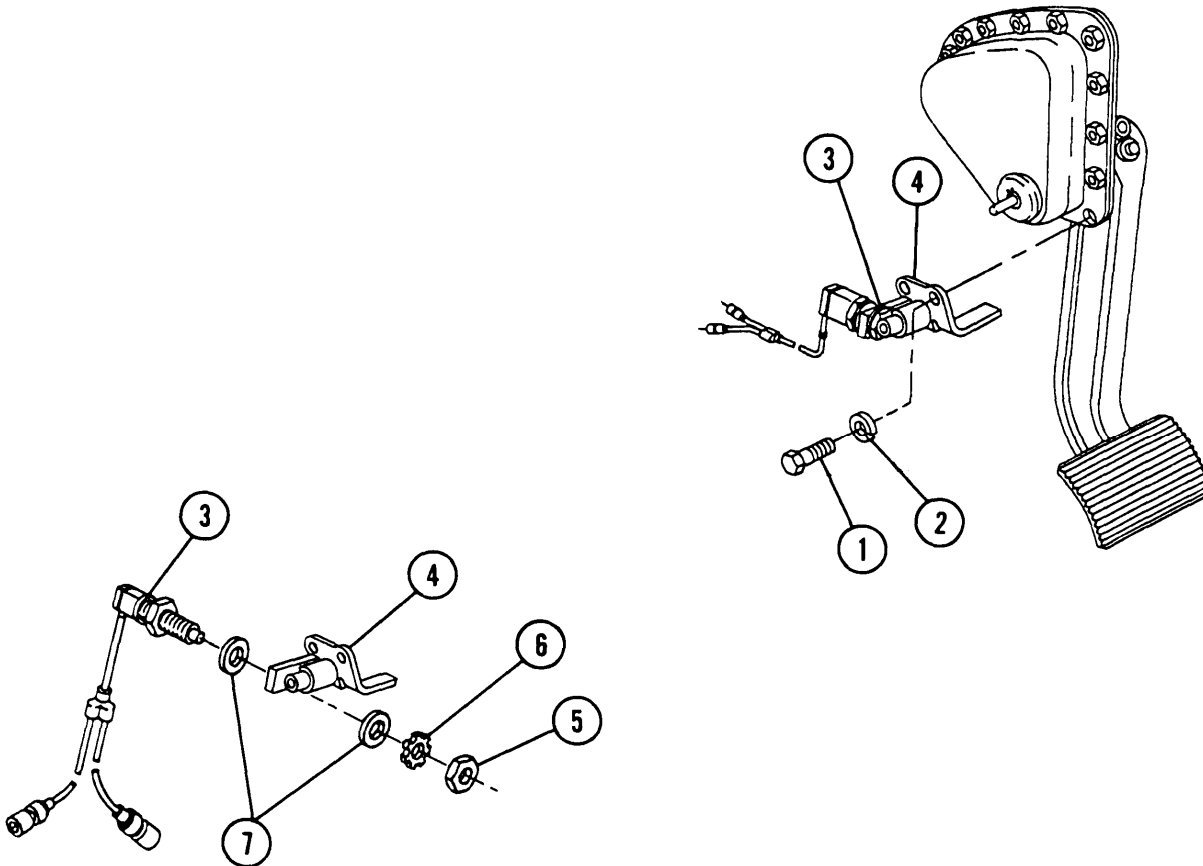

NOTE

FOLLOW-ON MAINTENANCE:

Assemble parking brake linkage (para 9-16)
 Install parking brake linkage (para 9-16)

8-80 BATTERY TERMINAL CONNECTOR AND GROUND CABLES

This task covers: a. Removal b. Installation

INITIAL SETUP

Tools

General mechanic's tool kit (item 64, **Appx H**)

Materials/Parts

Lockwashers (2) (item 77, Appx G)

Circuit

No. Cable Function:

7 Battery terminal connector

68 Ground cable

a. Removal

1 Remove two battery **ground** cables and two battery cables (1) with lugs (2) (para 8-28).

2 Remove lugs (2) from cables (1) by removing nut (3), lockwasher (4), and bolt (5). **Discard lockwasher.**

b. Installation

1 Install lugs (2) to cables (1) by installing bolt (5), new lockwasher (4), and nut (3).

2 Install two battery ground cables and two battery cables (1) with lugs (2) (para 8-28).



WIRING DIAGRAM

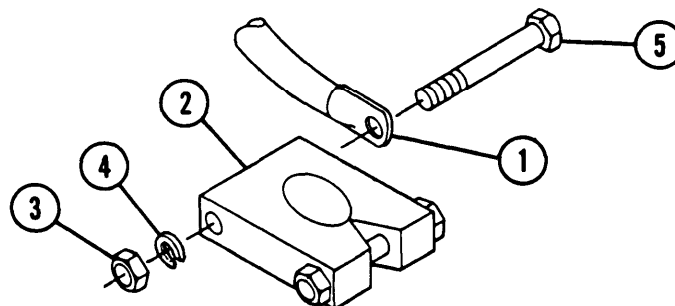
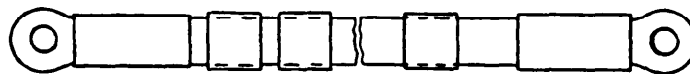

8-81 ENGINE BRACKET-TO-DRIVER'S BULKHEAD LEAD ASSEMBLY (M109AZM109A3)

This task covers: a. Removal b. Disassembly/Repair
 c. Assembly d. Installation

INITIAL SETUP

Applicable Configurations
 M109A2/M109A3

Equipment Conditions
 Batteries disconnected (para 8-28)

Tools
 General mechanic's tool kit (item 84, Appx H)

Connector No.	Electrical Lead To:	Wire No.	Connector No.	Electrical Lead To:	Wire No.
1	Engine disconnect bracket	82	3	Driver's bulkhead	49
2	Master relay	82	4	Bilge pump circuit breaker	452A

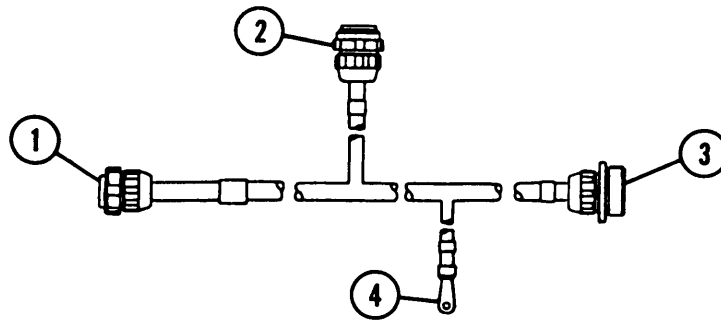
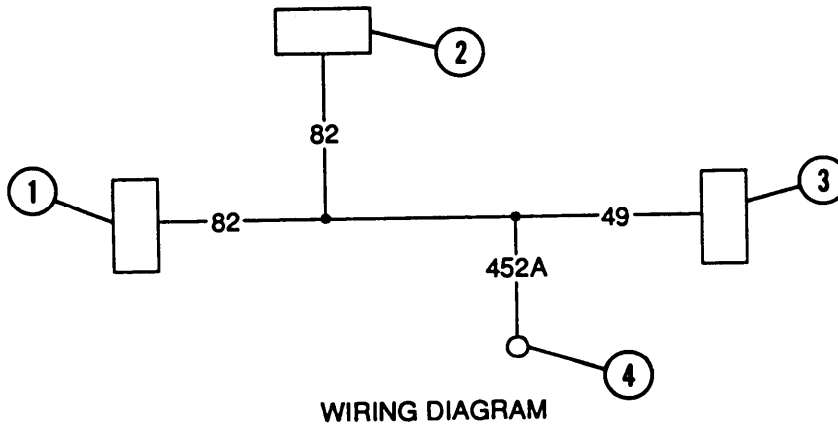

a. Removal

- 1 Disconnect connector (1) at engine disconnect bracket (5).
- 2 Disconnect connector (2) at master relay (6).
- 3 Disconnect connector (3) at driver's bulkhead (7).
- 4 Disconnect terminal (4) at bilge pump circuit breaker (8) by removing nut (5).

b. Disassembly/Repair

Disassemble lead assembly (para 2-13).

c. Assembly

Assemble lead assembly (para 2-13).

d. Installation

- 1 Connect terminal (4) at bilge pump circuit breaker (8) by installing nut (5).
- 2 Connect connector (3) at driver's bulkhead (7).
- 3 Connect connector (2) at master relay (6).
- 4 Connect connector (1) at engine disconnect bracket (5).

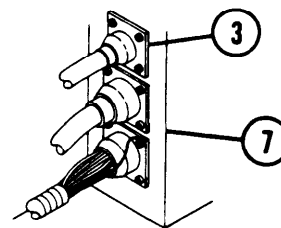
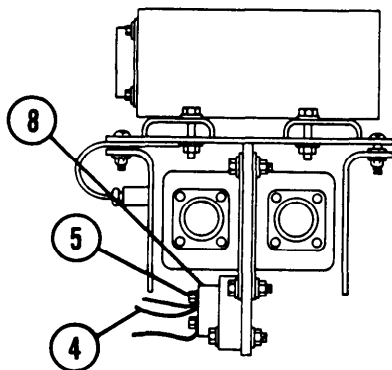
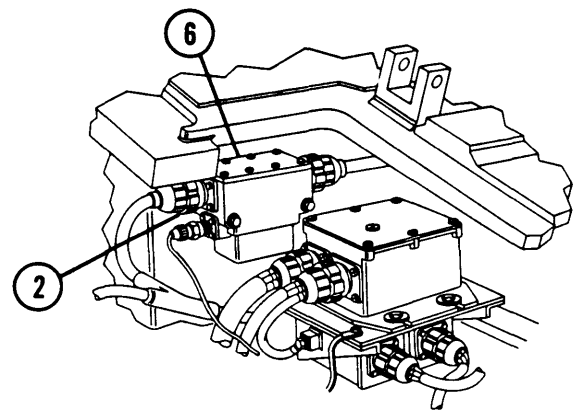
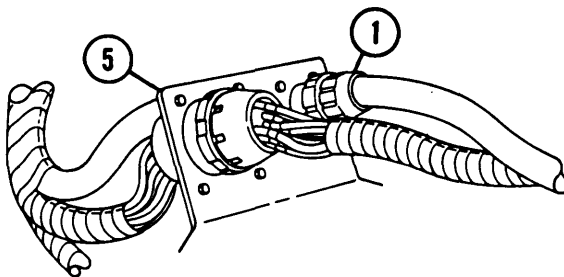

NOTE

FOLLOW-ON MAINTENANCE:

Connect batteries (para 8-28)

8-82 MASTER RELAY-TO-DRIVER'S BULKHEAD LEAD ASSEMBLY (M109A4/M109A5)

This task covers: a. Removal b. Disassembly
 c. Assembly d. Installation

INITIAL SETUP

Applicable Configurations
 M109A4/M109A5

Materials/Parts
 Lockwashers (4) (item 94, Appx G)

Tools
 General mechanic's tool kit (item 64, Appx H)

Equipment Conditions
 Batteries disconnected (para 8-28)

Connector No.	Electrical Lead To:	Wire No.
1	Master relay	82
2	Driver's bulkhead	82
3	Bilge pump circuit breaker	452A

a. Removal

- 1 Remove two batteries (4) and clamp (5).
- 2 Disconnect connector (3) at master relay (6).
- 3 Disconnect power lead wiring harness (7) from driver's bulkhead (8).
- 4 Remove four nuts (9), four lockwashers (10), four washers (11), four screws (12), and connector (13) from bulkhead. Discard lockwashers.

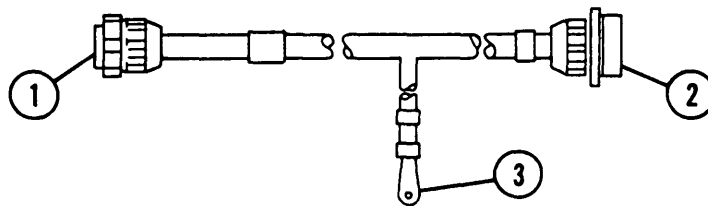
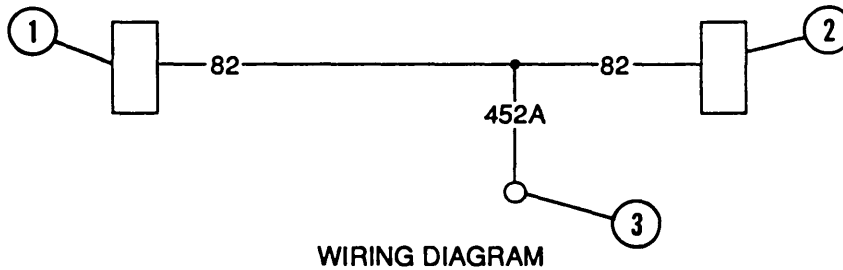

5 Disconnect terminal (14) at bilge pump circuit breaker (15) by removing nut (16).

b. Disassembly

Disassemble lead assembly (para 2-13).

c. Assembly

Assemble lead assembly (para 2-13).

d. Installation

- 1 Connect terminal (14) at bilge pump circuit breaker (15) by installing nut (1 6).
- 2 Install connector (13), four screws (12), four washers (11), four new lockwashers (10), and four nuts (9) to bulkhead (8).
- 3 Connect power lead wiring harness (7) to bulkhead (8).
- 4 Connect connector (3) at master relay (6).
- 5 Install two batteries (4) and clamp (5).

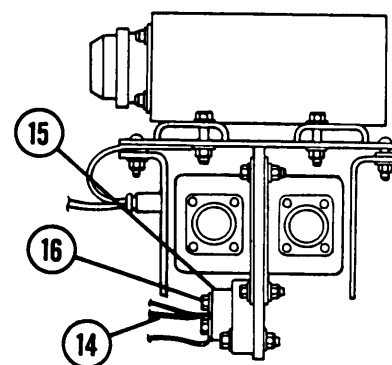
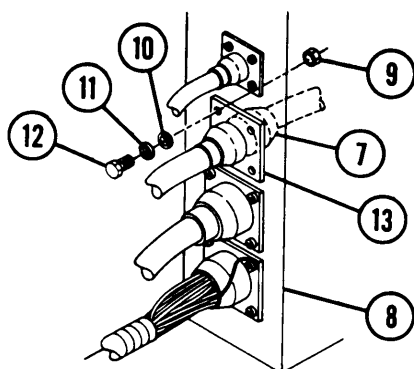
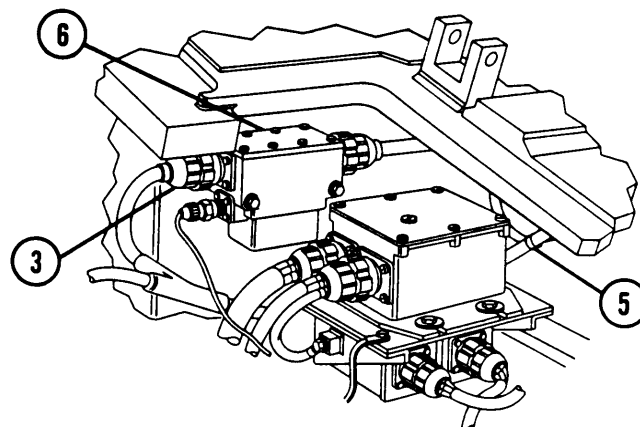
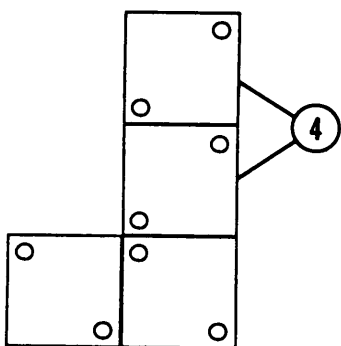

NOTE

FOLLOW-ON MAINTENANCE:

Connect batteries para 8-28)

8-83 ENGINE ELECTRICAL GROUND LEAD

This task covers: a. Removal b. Installation

INITIAL SETUP

Tools

General mechanic's tool kit (item 64, Appx H)

Equipment Conditions

Transmission access doors opened (para 11-7)

Materials/Parts

Lockwashers (4) (item 74, Appx G)

Connector No.	Electrical Lead To:	Wire No.
1	Transmission front	3
2	Vehicle hull	3

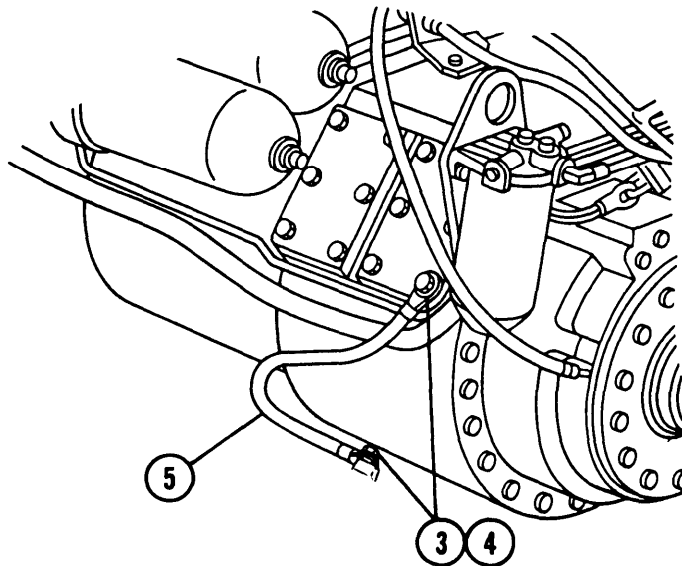
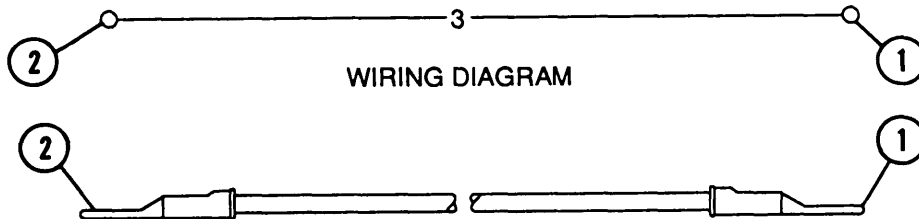

a. Removal

WARNING

Ensure MASTER switch is OFF when working on hull electrical system to avoid electrical shocks and burns.

Remove two bolts (3), four lockwashers (4), and engine electrical ground lead (5). Discard lockwashers.

b. Installation

WARNING

Ensure MASTER switch is OFF when working on hull electrical system to avoid electrical shocks and burns.

Install engine electrical ground lead (5), four new lockwashers (4), and two bolts (3).

NOTE

FOLLOW-ON MAINTENANCE: Close transmission access doors (para 11 -7)

8-84 STARTER-TO-ENGINE ELECTRICAL DISCONNECT (M109A4/M109A5)

This task covers:	a. Removal	b. Disassembly/Repair
	c. Assembly	d. Installation

INITIAL SETUP

Applicable Configurations
M109A4/M109A5

Lockwasher (item 87, Appx G)
Lockwasher (item 173, Appx G)
Lockwashers (4) (item 94, Appx G)

Tools
General mechanic's tool kit (item 64, Appx H)

Equipment Conditions
Powerplant removed (para 4-5)

Materials/Parts
Electrical tape — black (item 62, Appx D)

8-84 STARTER-TO-ENGINE ELECTRICAL DISCONNECT (M109A4/M109A5) — CONTINUED

Connector No.	Electrical Lead To:	Wire No.
1	Engine disconnect bracket	
2	Ground at starter	5A
3	Starter solenoid	6A

a. Removal

- 1 Remove four nuts (4), four screws (5), four lockwashers (6), four flat washers (7), and connector (1) from engine electrical disconnect bracket (8). Discard lockwashers.
- 2 Remove nut (9), lockwasher (10), and electrical lead 6A (3). Reinstall nut and lockwasher at starter solenoid (11).
- 3 Remove nut (12), lockwasher (13), and ground lead 5A (2). Reinstall nut and lockwasher at engine starter (14).
- 4 Remove two screws (15), two flat washers (16), two clamps (17), and wiring harness (18). Reinstall clamps, flat washers, and screws.

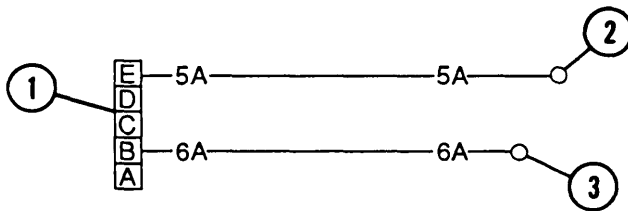

WIRING DIAGRAM

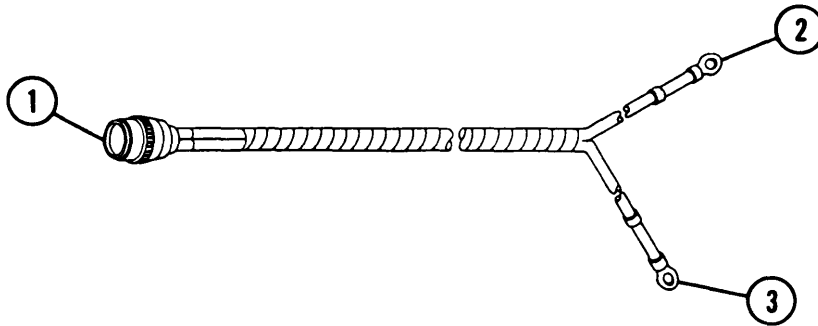

b. Disassembly/Repair

Disassemble wiring harness (para 2-13).

c. Assembly

Assemble wiring harness (para 2-13).

d. Installation

- 1 Remove nut (12) and lockwasher (13) at engine starter. Discard lockwasher.
- 2 Install ground lead 5A (2), new lockwasher (13), and nut (12) at engine starter (14).
- 3 Remove nut (9) and lockwasher (10) at starter solenoid. Discard lockwashers.
- 4 Install electrical lead 6A (3), new lockwasher (10), and nut (9) at starter solenoid (1 1).
- 5 Install connector (1), four flat washers (7), four new lockwashers (6), four screws (5), and four nuts (4) at engine electrical disconnect bracket (8).
- 6 Install two clamps (17), two flat washers (16), and two screws (15), securing wiring harness (18).

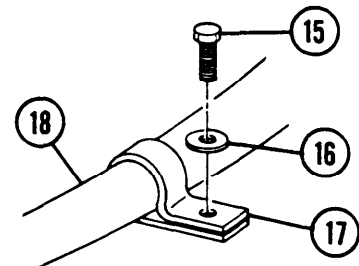
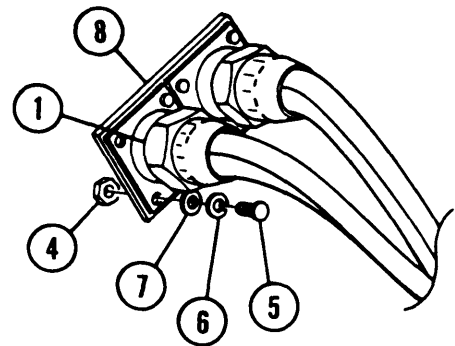
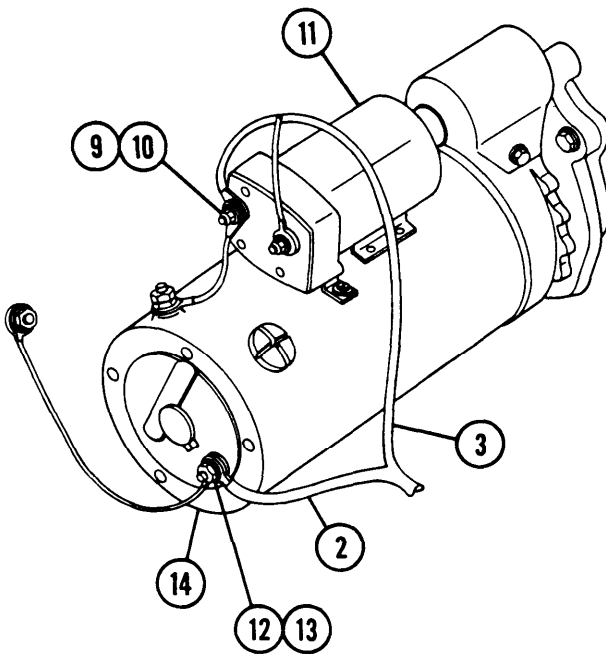
**NOTE**

FOLLOW-ON MAINTENANCE: Install powerplant (para 4-5)

8-85 NBC SWITCH-TO-CIRCUIT BREAKER LEAD ASSEMBLY (M109A4/M109A5)

This task covers: a. Removal b. Installation

INITIAL SETUP

Applicable Configurations
M109A4/M109A5

Equipment Conditions
Portable instrument panel removed (para 8-17)

Tools
General mechanic's tool kit (item 84, Appx H)

Connector No.	Electrical Lead To:	Wire No.
1	NBC switch	438
2	Circuit breaker	438

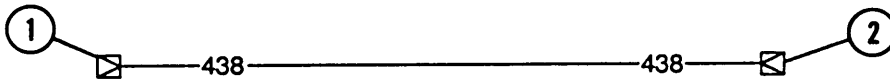

WIRING DIAGRAM

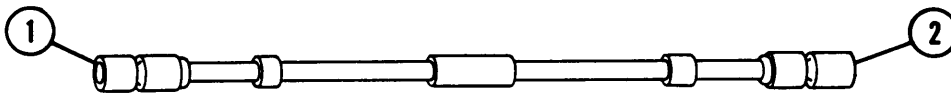

a. Removal

- 1 Disconnect connector (1) from NBC switch socket.
- 2 Disconnect connector (2) wire 438 from circuit breaker (3).

b. Installation

- 1 Connector connector (2) wire 438 to circuit breaker (3).
- 2 Connect connector (1) to NBC switch socket.

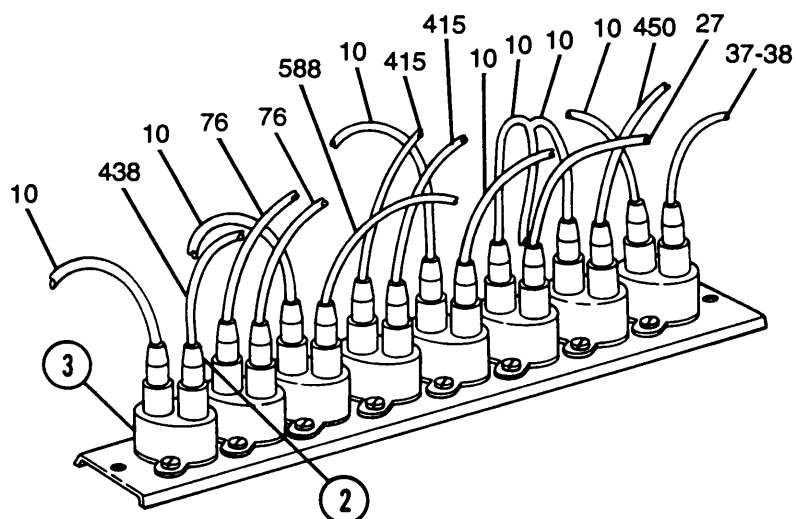
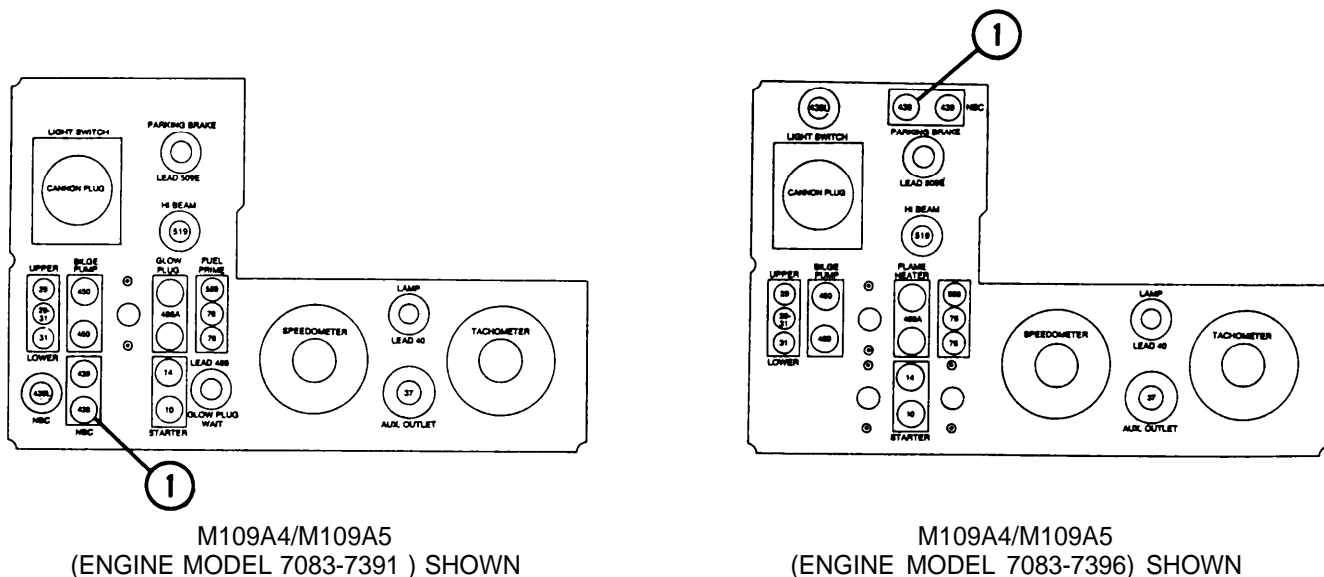

NOTE

FOLLOW-ON MAINTENANCE: Install portable instrument panel (para 8-17)

8-86 DRIVER'S BULKHEAD-TO-BATTERIES LEAD ASSEMBLY (M109A4/M109A5)

This task covers: a. Removal b. Disassembly
 c. Assembly d. Installation

INITIAL SETUP

Applicable Configurations
 M109A4/M109A5

Materials/Parts

Gasket (item 163, Appx G)
 Lockwasher (item 69, Appx G)
 Lockwashers (4) (item 87, Appx G)
 Lockwashers (4) (item 94, Appx G)

Tools

General mechanic's tool kit (item 64, Appx H)

Equipment Conditions

Batteries disconnected (ara 8-28)

Connector No.	Electrical Lead To:	Wire No.
1	Driver's bulkhead	49,50
2	Battery positive lead	49
3	Battery negative lead	50

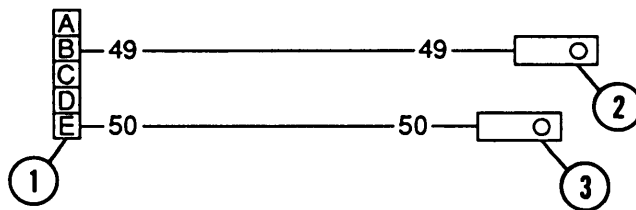

WIRING DIAGRAM

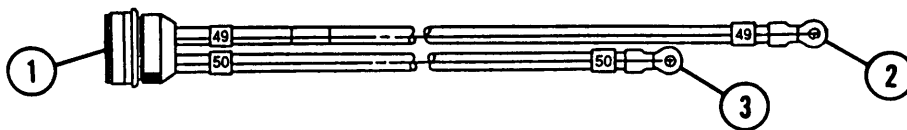

a. Removal

- 1 Disconnect connector (4) on inside of driver's compartment.
- 2 Remove four nuts (5), four lockwashers (6), four flat washers (7), lockwasher (8), and four screws (9), and disconnect connector (1) from driver's bulkhead. Discard lockwashers.
- 3 If replacement is necessary, remove four nuts (10), four lockwashers (11), four washers (12), four screws (13), gasket (14), and cover (15). Remove nut (16) and bolt (17) and disconnect positive lead (2) from battery terminal. Discard lockwashers and gasket.
- 4 Remove nut (18) and bolt (19) and disconnect ground lead (3) from battery terminal.

b. Disassembly

Disassemble lead assembly (para 2-13).

c. Assembly

Assemble lead assembly (para 2-13).

d. Installation

- 1 Connect ground lead (3) to battery terminal with bolt (19) and nut (18).
- 2 If replaced, connect positive lead (2) to battery terminal and install bolt (17) and nut (16). Install new gasket (14), cover (15), four screws (13), four washers (12), four new lockwashers (11), and four nuts (10).
- 3 Connect connector (1) to driver's bulkhead and install new lockwasher (8), four screws (9), four flat washers (7), four new lockwashers (6), and four nuts (5).
- 4 Connect connector (4) on inside of driver's compartment.

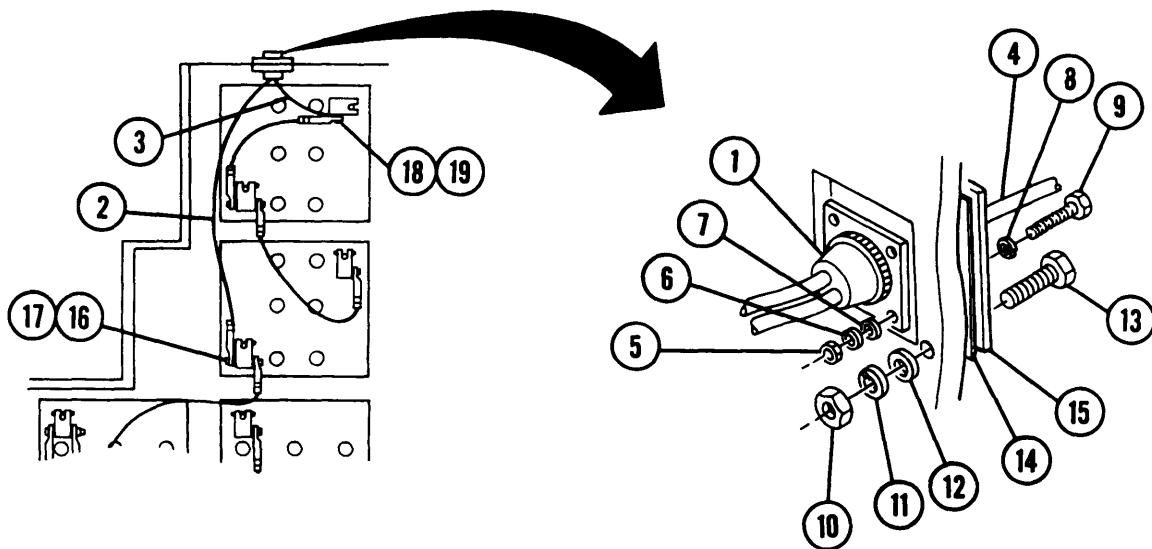

NOTE

FOLLOW-ON MAINTENANCE: Connect batteries (para 8-28)

8-87 ENGINE DISCONNECT BRACKET-TO-BATTERIES LEAD ASSEMBLY (M109A4/M109A5)

This task covers: a. Removal b. Disassembly/Repair
 c. Assembly d. Installation

INITIAL SETUP

Applicable Configurations
 M109A4/M109A5

Materials/Parts
 Electrical tape — black (item 62, Appx D)

Tools
 General mechanic's tool kit (item 64, Appx H)

Equipment Conditions
 Batteries disconnected (para 8-28)

Connector No.	Electrical Lead To:	Wire No.
1	Battery positive lead	6
2	STE/ICE-R battery negative lead	5
3	Engine bracket	

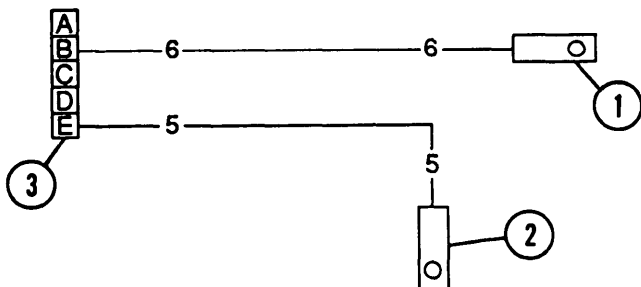

WIRING DIAGRAM

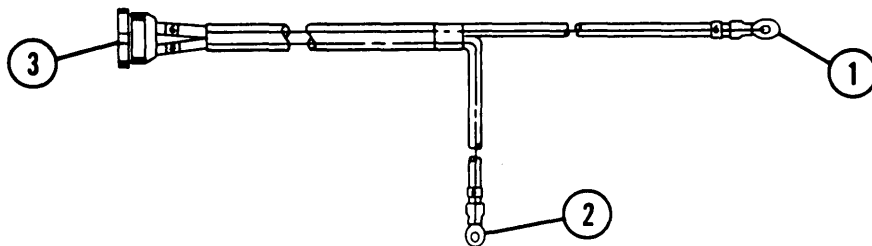

a. Removal

- 1 Remove nut (4) and bolt (5) and disconnect positive lead (1) from battery (6).
- 2 Remove nut (7) and bolt (8) and disconnect ground lead (2) from battery (9).
- 3 Disconnect connector (3) at engine bracket (10).

b. Disassembly/Repair

Disassemble lead assembly (para 2-13).

c. Assembly

Assemble lead assembly (para 2-13).

d. Installation

- 1 Connect connector (3) at engine bracket (10).
- 2 Connect ground lead (2) to battery (9) and install bolt (8) and nut (7).
- 3 Connect positive lead (1) to battery (6) and install bolt (5) and nut (4).

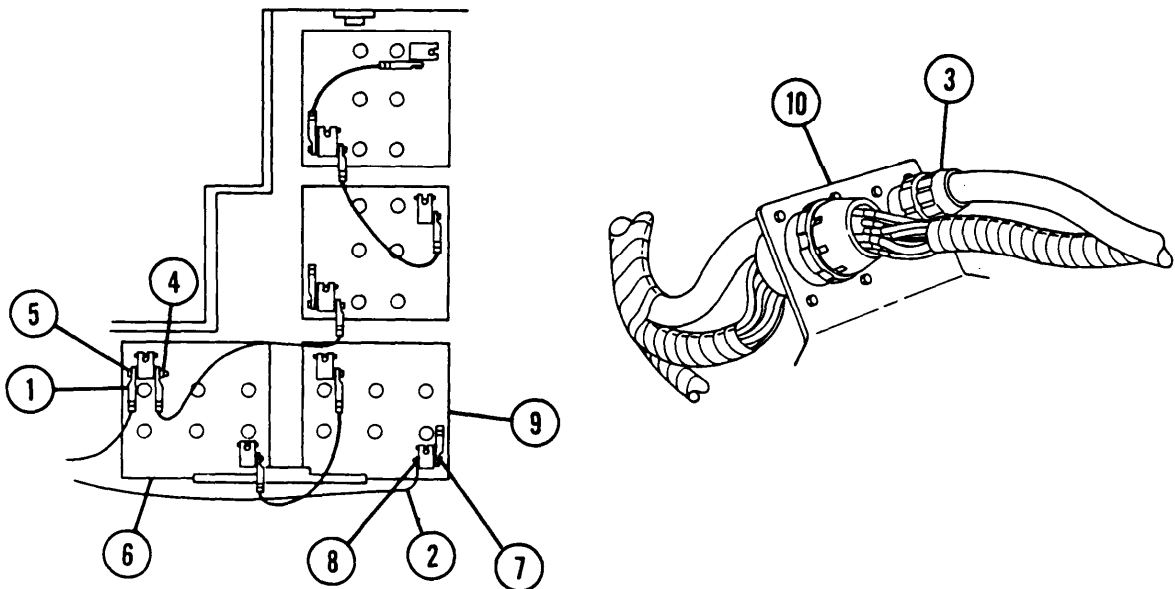
**NOTE**

FOLLOW-ON MAINTENANCE: Connect batteries (para 8-28)

8-88 BULKHEAD-TO-OVERRIDE SWITCH LEAD ASSEMBLY (M109A4/M109A5)

This task covers: a. Removal b. Disassembly/Repair
 c. Assembly d. Installation

INITIAL SETUP

Applicable Configurations

M109A4/M109A5

Materials/Parts

Electrical tape — black (item 62, Appx D)

Lockwashers (14) (item 95, Appx G)

Tools

General mechanic's tool kit (item 64, Appx H)

Equipment Conditions

Batteries disconnected (para 8-28)

Connector No.	Electrical Lead To:	Wire No.
1	Driver's bulkhead	14C
2	Starter protection override switch	14C

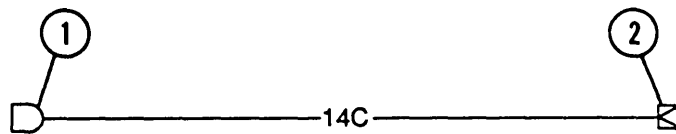

WIRING DIAGRAM

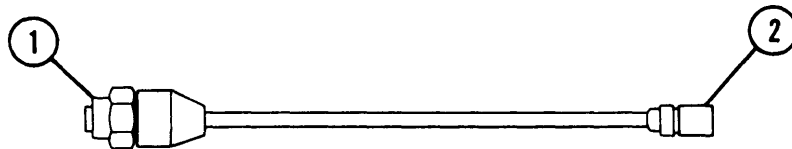

a. Removal

- 1 Disconnect electrical connector (1) at driver's bulkhead (2).
- 2 Disconnect electrical connector (3) at combat override switch assembly (4).
- 3 Remove 14 screws (5), 14 lockwashers (6), 14 flat washers (7), 14 straps (8), and lead assembly (9). Discard lockwashers.

b. Disassembly/Repair

Disassemble lead assembly (para 2-13).

c. Assembly

Assemble lead assembly (para 2-13).

d. Installation

- 1 Connect electrical connector (3) at combat override switch assembly (4).
- 2 Connect electrical connector (1) at driver's bulkhead (2).
- 3 Install lead assembly (9), 14 straps (9), 14 flat washers (7), 14 new lockwashers (6), and 14 screws (5).

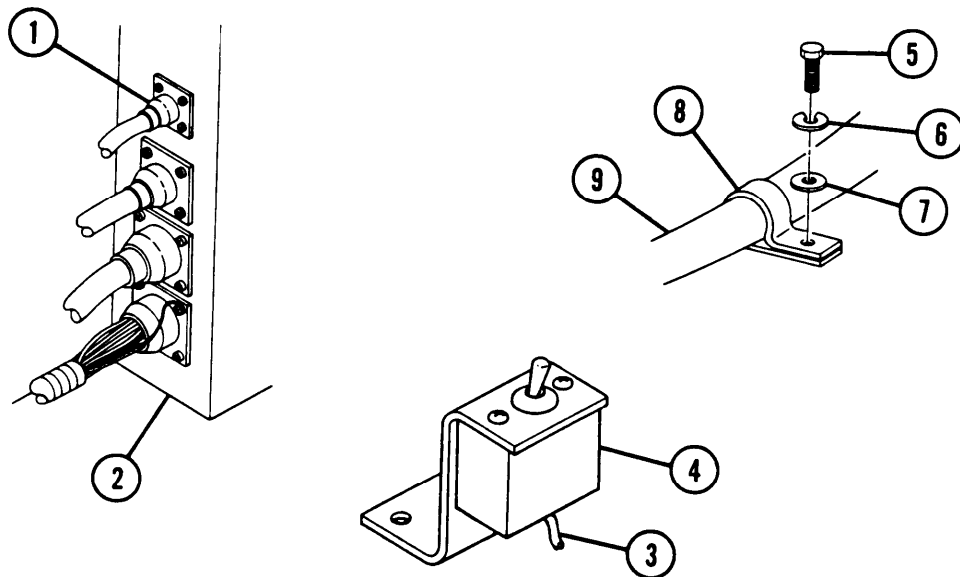

NOTE

FOLLOW-ON MAINTENANCE: Connect batteries (para 8-28)

8-89 COMBAT OVERRIDE SWITCH GROUND LEAD (M109A4/M109A5)

This task covers: a. Removal b. Installation

INITIAL SETUP

Applicable Configurations
M109A4/M109A5

Materials/Parts
Lockwasher (item 95, Appx G)

Tools
General mechanic's tool kit (item 64, Appx H)

Connector No.	Electrical Lead To:	Wire No.
1	Ground	GND
2	Combat override switch	GND

a. Removal

- 1 Disconnect connector (2) from override switch (3).
- 2 Remove screw (4), lockwasher (5), washer (6), and ground lead connector (1). Discard lockwasher.

b. Installation

- 1 Install ground lead connector (1), washer (6), new lockwasher (5), and screw (4).
- 2 Connect connector (2) to override switch (3).

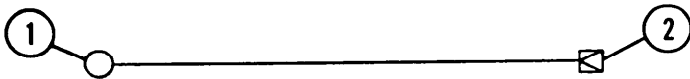

WIRING DIAGRAM

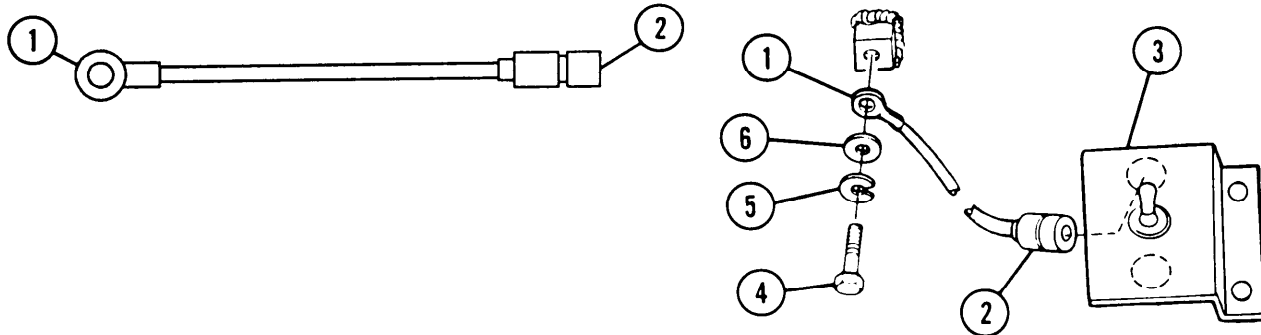

CHAPTER 9 TRANSMISSION, TRANSFER, AND DRIVE CONTROL ASSEMBLIES

GENERAL

This chapter provides instructions for checks, testing, adjustment, and common information for transmission and transfer assemblies, and provides instructions for the removal, installation, disassembly, assembly, and adjustment of driving controls and linkages.

<u>CONTENTS</u>	<u>PAGE</u>
Section I	TRANSMISSION AND TRANSFER ASSEMBLIES 9-2
9-1	TRANSMISSION OIL LEVEL 9-2
9-2	TRANSMISSION OIL PRESSURE CHECKS. 9-2
9-3	PRESSURE CHECKS 9-2
9-4	OIL FILTER AND OIL COOLER HOSES. 9-7
9-5	OIL FILTER 9-9
9-6	BREATHER, BREATHER TUBE, AND MOUNT. 9-11
9-7	TRANSMISSION OIL SAMPLING COMPONENTS 9-13
Section II	DRIVE CONTROL ASSEMBLIES 9-14
9-8	STEERING CONTROL LINKAGE 9-14
9-9	SHIFT CONTROL LINKAGE AND NEUTRAL SAFETY SWITCH ADJUSTMENT. 9-22
9-10	SERVICE AND PARKING BRAKE LINKAGE. 9-30
9-11	ACCELERATOR, THROTTLE, AND ENGINE CONTROL GOVERNOR 9-40
9-12	TRANSMISSION INTERNAL BRAKE.. . . . 9-49
9-13	TRANSMISSION THROTTLE VALVE.. . . . 9-51
9-14	ENGINE THROTTLE GOVERNOR CONTROL ROD 9-52
9-15	HAND THROTTLE GOVERNOR CONTROL ROD 9-53
9-16	ACCELERATOR PEDAL 9-55
9-17	WARNING LIGHT AND STOP LIGHT SWITCHES 9-56
9-18	SPEEDOMETER AND TACHOMETER SYSTEMS 9-57

SECTION I. TRANSMISSION AND TRANSFER ASSEMBLIES

9-1 TRANSMISSION OIL LEVEL

Cross-drive transmission is lubricated by oil. Low transmission oil level maybe caused by leakage. Source of leakage must be determined and condition corrected to avoid damage to transmission. Notify support maintenance.

Check oil level before starting engine (TM 9-2350-311-10). After engine starts, check lubricating oil pressure; minimum oil pressure is 10 psi (0.7 kg/sq cm) at 1000 rpm.

9-2 TRANSMISSION OIL PRESSURE CHECKS

During the following tests, observe oil pressure and oil temperature gages on portable instrument panel. Oil temperature should be approximately 220°F (105°C) for normal operation. If oil temperature exceeds 300°F (149°C) in any tests, engine should be stopped and cause determined. Small variations in pressure from those given in Table 9-1 do not necessarily mean that malfunctions exist. Malfunctions will cause radical changes in pressure.

9-3 PRESSURE CHECKS

This task covers: Pressure Checks

I INITIAL SETUP I

Tools

General mechanic's tool kit (item 64, Appx H)
Pressure gage assembly and tube (item 23, Appx H)

Personnel Required

Two

References

TM 9-2350-311-10

Equipment Conditions

Air intake grille opened and secured (para 11-8)
Brakes applied (TM 9-2350-311-10)
Cab traversed 90° (TM 9-2350-311-10)
Left and right universal joints removed (para 10-23)
Tracks blocked (12- by 12-by 24-in. [30.5-by 30.5-by 61.0-cm] wood block or equivalent under front and rear of each track)
Transmission oil level checked (TM 9-2350-311-10)
Vehicle parked on level ground (TM 9-2350-311-10)

Pressure Checks

WARNING

Vehicle has no brakes when final drives are disconnected. Failure to securely block vehicle tracks could injure personnel or damage vehicle or other equipment if vehicle rolls out of control.

- 1 Start engine and shift transmission into fourth gear.

CAUTION

If transmission oil temperature gets over 300°F (149°C) during any test, stop engine and troubleshoot transmission.

- 2 Run engine at 1200 to 1500 rpm for 3 to 8 minutes, or until transmission temperature reaches about 220°F (105°C).
- 3 Reduce engine speed to idle.
- 4 Shift transmission through all ranges several times.
- 5 Shift transmission to neutral (N).
- 6 Apply brakes.
- 7 Increase engine speed to 1350 (1200 to 1500) rpm.
- 8 Check transmission oil level. Oil level must be at FULL mark on dipstick.

WARNING

Oil is hazardous waste and must be disposed of in accordance with local procedures or direction of the local Hazardous Waste Management office.

- 9 Add or drain oil as necessary (TM 9-2350-311-10).
- 10 During warmup period, check transmission for leaks.
- 11 Stop engine.
- 12 Tighten loose bolts, plugs, and hose fittings. Replace defective hoses. If leakage cannot be stopped, notify support maintenance and stop pressure tests.

WARNING

Transmission contains hot oil under high pressure. Stop engine before removing or installing pipe plugs and gage adapter in pressure test points. Install pipe plug as soon as gage adapter is removed. Remove only pipe plug at test point.

9-3 PRESSURE CHECKS — CONTINUED

Pressure Checks — Continued

- 13 Remove pipe plug from test point to be pressure tested.
- 14 Install pressure gage tester.
- 15 Start engine.
- 16 Shift transmission to desired range (Table 9-1).
- 17 Slowly increase engine speed to desired rpm (Table 9-1).

NOTE

- When making steer clutch pressure tests, move steering bar slowly from horizontal to full steer in desired direction while watching pressure gage. Note pressure rise to maximum as steering bar moves to full steer.
- When making lockup engagement tests, increase engine speed slowly until lockup apply pressure is indicated on pressure gage. Record pressure and engine speed. Record governor pressure at lockup engagement.
- When making lockup release tests, first increase engine speed higher than lockup engagement speed, then slowly reduce engine speed while watching pressure gage. When pressure drops quickly, record governor pressure and engine speed.

- 18 Record readings for each test point.

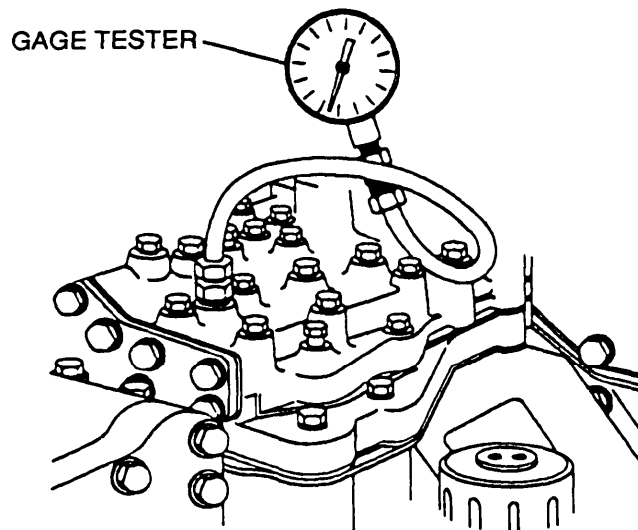

LEGEND

- | | | | |
|----|---|----|--------------------------|
| 1 | Transmission lubrication | 14 | Brake coolant |
| 2 | Transmission lubrication | 15 | Brake |
| 3 | Main | 16 | Brake |
| 4 | Third gear | 17 | Brake coolant |
| 5 | Fourth gear | 18 | Geared steer clutch |
| 6 | First and second gear | 19 | Geared steer coolant |
| 7 | First, neutral, and reverse one signal pressure | 20 | Transmission lubrication |
| 8 | Reverse | 21 | Output clutch |
| 9 | Reverse, third, and fourth signal pressure | 22 | Throttle |
| 10 | Geared steer clutch | 23 | Throttle valve |
| 11 | Transmission lubrication | 24 | Lockup |
| 12 | Geared steer coolant | 25 | Governor (pitot) |
| 13 | Output clutch | | |

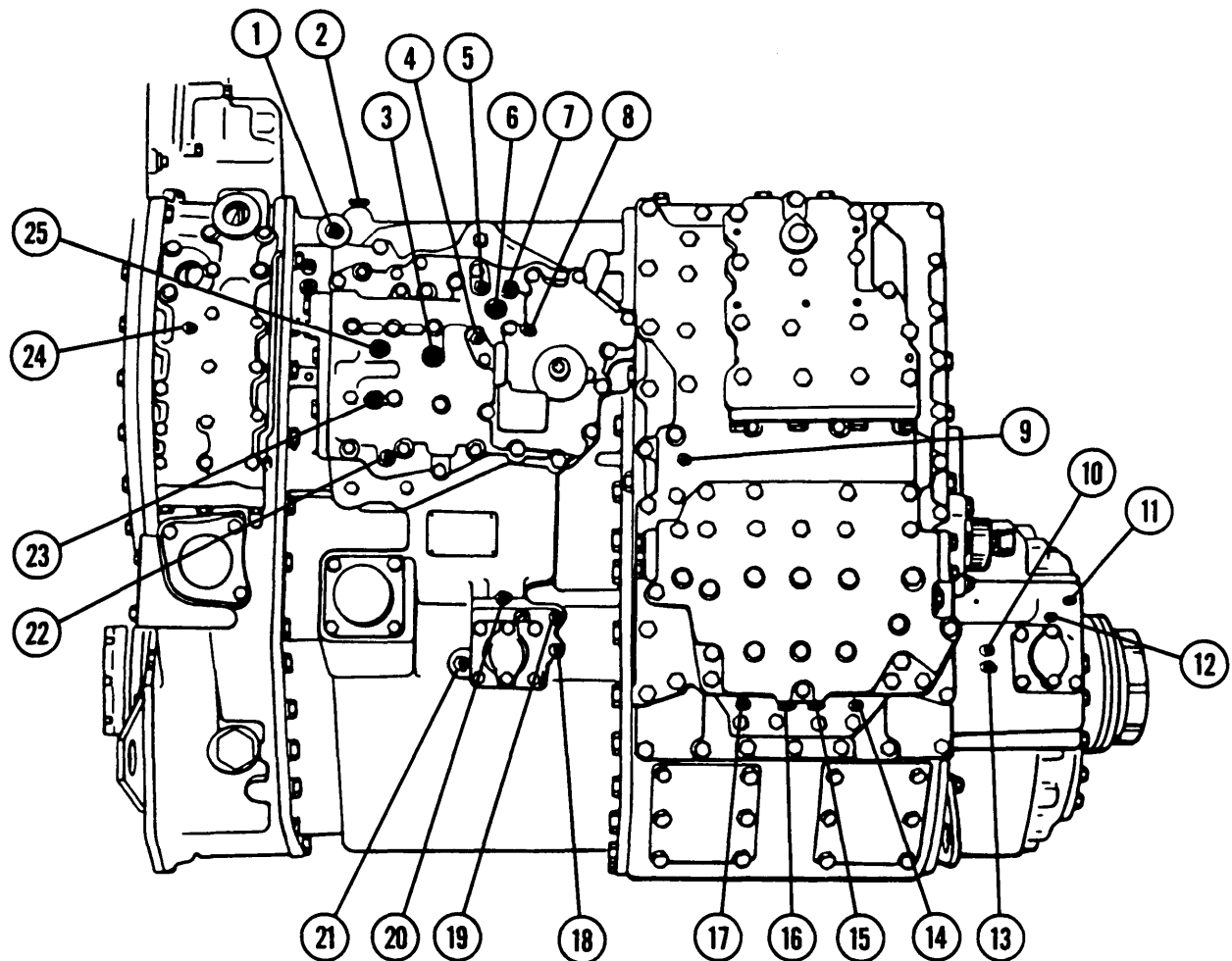

9-3 PRESSURE CHECKS - CONTINUED

TABLE 9-1 TRANSMISSION OIL PRESSURE

TEST	TEST POINT NO.	RPM	READING PSI (KPA)	NEUTRAL	1ST GEAR	2ND GEAR	3RD GEAR	4TH GEAR	REVERSE 1	REVERSE 2	RIGHT STEER	LEFT STEER	
Main pressure in converter	3	1000 to 1500	Normal	210-230 (1448-1586)	210-230 (1448-1586)	210-230 (1448-1586)	210-230 (1448-1586)	118-160 (814-1103)	300-320 (2069-2206)	300-320 (2069-2206)	Same as range reading		
			Actual										
Main pressure in lockup	3	1000 to 1500	Normal	118-160 (814-1103)	118-160 (814-1103)	118-160 (814-1103)	118-160 (814-1103)	160-190 (1103-1310)	160-190 (1103-1310)	160-190 (1103-1310)	Same as range reading		
			Actual										
Lockup and range clutch apply pressure	24	1000 to 1500	Normal	Same as main pressure for applicable gear									
			Actual										
1st, neutral, and reverse 1 signal pressure	7	1000 to 1500	Normal	Same as main pressure for applicable gear									
			Actual										
3rd, 4th, and reverse 2 signal pressure	9	1000 to 1500	Normal	Same as main pressure for applicable gear									
			Actual										
Geared steer apply pressure (no steer)	10, 18	1000 to 1500	Normal	210 (1448)	210 (1448)	0	0	0	0	210 (1448)	0	0	0
			Actual										
Geared steer apply pressure (during steer)	10, 18	1000 to 1500	Normal	0	0	0	0	0	0	0	0	74-127 (510-876)	74-127 (510-876)
			Actual										
Brake apply pressure	15, 16	1000 to 1500	Normal	0	0	0	0	0	0	0	0	74-127 (510-876)	74-127 (510-876)
			Actual										
Geared steer and brake coolant pressure	12, 19, 14, 17, 9	1000 to 1500	Normal	0	0	0	0	0	0	0	0	8-12 (55-83)	8-12 (55-83)
			Actual										
Output clutch pressure	21	1000 to 1500	Normal	0	0	210 (1448)	210 (1448)	118-160 (814-1103)	0	210 (1448)	0*	0*	
			Actual										
Governor pressure (pitot) at lockup engagement	25	Full throttle	Normal	82-88 (565-607)	82-88 (565-607)	82-88 (565-607)	82-88 (565-607)	82-88 (565-607)	82-88 (565-607)	82-88 (565-607)	82-88 (565-607)	82-88 (565-607)	
			Actual										
Lubrication pressure	1, 2, 11, 20	1835 to 1900	Normal	18-45 (124-310)	18-45 (124-310)	18-45 (124-310)	18-45 (124-310)	18-45 (124-310)	18-45 (124-310)	18-45 (124-310)	18-45 (124-310)	18-45 (124-310)	
			Actual										
Throttle (T) pressure	22	Full throttle	Normal	32-40 (221-276)	32-40 (221-276)	32-40 (221-276)	32-40 (221-276)	32-40 (221-276)	32-40 (221-276)	32-40 (221-276)	32-40 (221-276)	32-40 (221-276)	
			Actual										
Throttle valve (TV) pressure	23	Full throttle	Normal	32-40 (221-276)	32-40 (221-276)	32-40 (221-276)	32-40 (221-276)	32-40 (221-276)	32-40 (221-276)	32-40 (221-276)	32-40 (221-276)	32-40 (221-276)	
			Actual										

*Clutch pressure can be measured only when steering bar is turned toward side being tested.

NOTE

FOLLOW-ON MAINTENANCE: Close air intake grille (para 11-8)
 Install left and right universal joints (para 10-23)
 Unblock tracks

9-4 OIL FILTER AND OIL COOLER HOSES

This task covers: a. Removal b. Installation

INITIAL SETUP

Tools

General mechanic's tool kit (item 64, Appx H)
Adjustable wrench (item 66, Appx H)

Preformed packings (2) (item 1, Appx G)

Equipment Conditions

Powerplant removed (para 4-5)

Materials/Parts

Lockwashers (8) (item 98, Appx G)

a. Removal

WARNING

Ensure exhaust pipes are cool before removing hoses to avoid severe burns.

- 1 Unscrew nut (1) from hose fitting (2).
- 2 Remove four screws (3), four lockwashers (4), four nuts (5), preformed packing (6), and split flange (7).
Remove hose clamp (8). Discard lockwashers and preformed packing.
- 3 Remove transmission-to-transmission oil cooler hose (9).

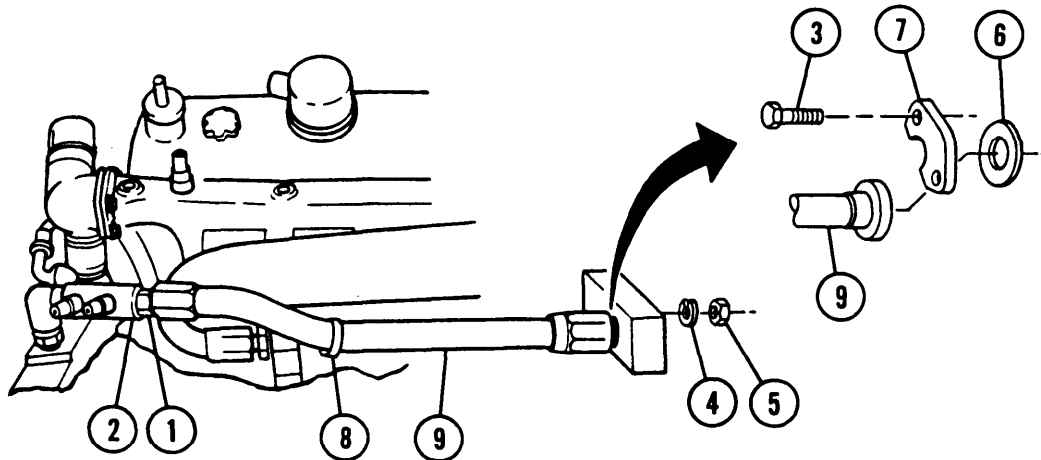

9-4 OIL FILTER AND OIL COOLER HOSES — CONTINUED

a. Removal — Continued

- 4 Unscrew nut (10) at elbow (11).
- 5 Remove four screws (12), four lockwashers (13), four nuts (14), preformed packing (15), and split flange (16). Discard lockwashers and preformed packing.
- 6 Remove transmission oil cooler-to-transmission hose (17).

b. Installation

- 1 Install transmission oil cooler-to-transmission hose (17).
- 2 Install four screws (12), four new lockwashers (13), four nuts (14), new preformed packing (15), and split flange (16).
- 3 Screw on nut (10) at elbow (11).
- 4 Install transmission-to-transmission oil cooler hose (9).
- 5 Install split flange (7), new preformed packing (6), four nuts (5), four new lockwashers (4), and four screws (3). Install hose clamp (8).
- 6 Install nut (1) and hose fitting (2). Provide 0.75 ± 0.12 in. (19.05 ± 3.05 mm) clearance between manifold (18) and hose (9).

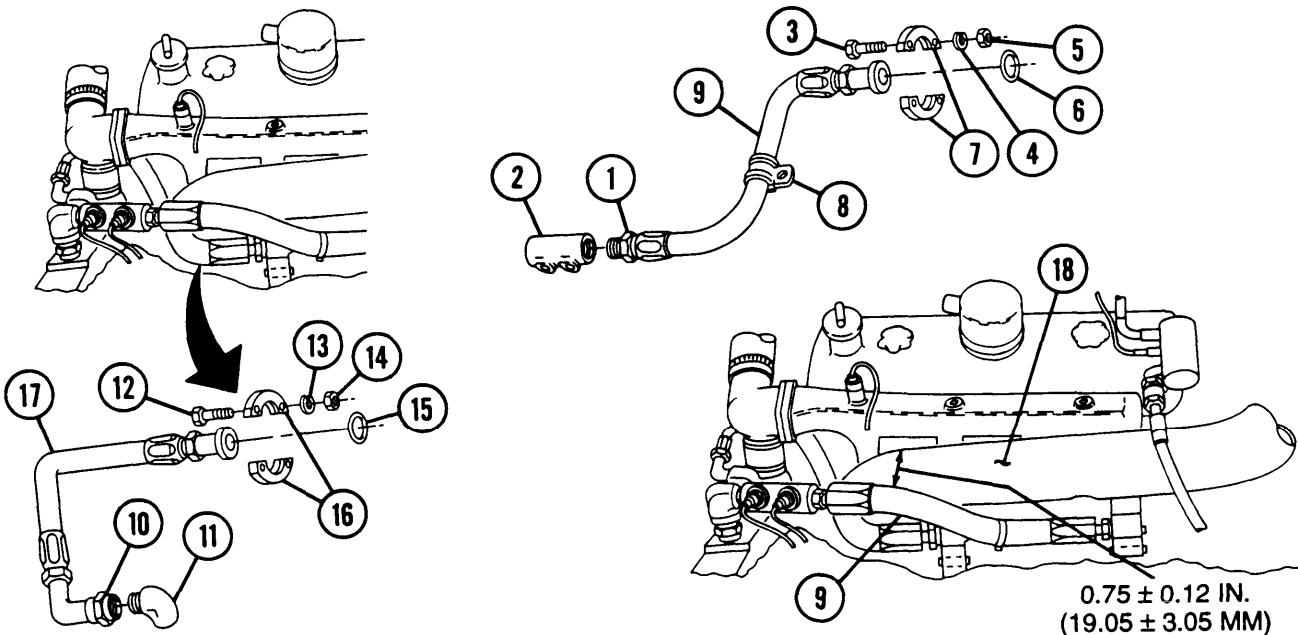

NOTE

FOLLOW-ON MAINTENANCE: Install powerplant (para 4-5)

9-5 OIL FILTER

This task covers:

a. Removal	b. Disassembly
c. Assembly	d. Installation

I INITIAL SETUP I

Tools

General mechanic's tool kit (item 64, Appx H)

Preformed packing (item 198, Appx G)

Self-locking nut (item 32, Appx G)

Materials/Parts

Filter element (item 218, Appx G)

Lockwashers (3) (item 89, Appx G)

Equipment Conditions

Front slope plate removed (para 4-5)

a. Removal

1 Remove three screws (1) and three lockwashers (2). Discard lockwashers.

2 Lift up on oil filter (3) to remove. If filter cannot be removed by hand, install two screws (1) in puller screw holes (4) and lift filter using screws.

b. Disassembly

1 Remove self-locking nut (5). Discard self-locking nut.

2 Separate filter element (6) and preformed packing (7) from rod assembly (8). Discard filter element and preformed packing.

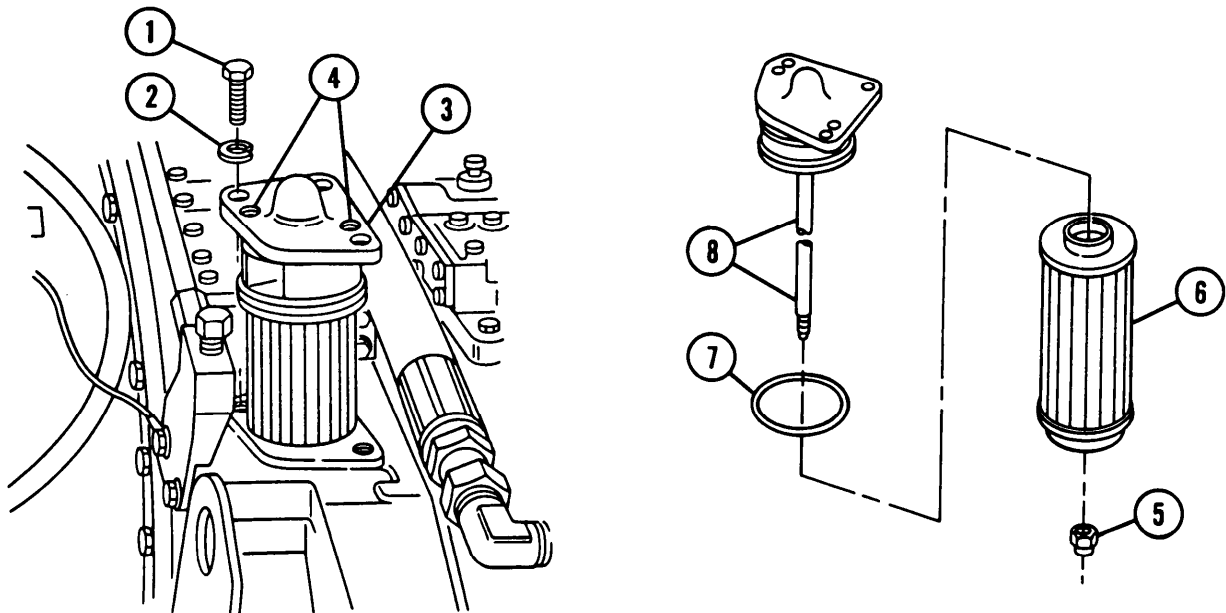

9-5 OIL FILTER — CONTINUED

c. Assembly

- 1 Install new preformed packing (7) and new filter element (6) on rod assembly (8).
- 2 Install new self-locking nut (5).

d. Installation

- 1 Position oil filter (3) into transmission.
- 2 If used, remove two screws (1) from puller holes (4).
- 3 Install three new lockwashers (2) and three screws (1).

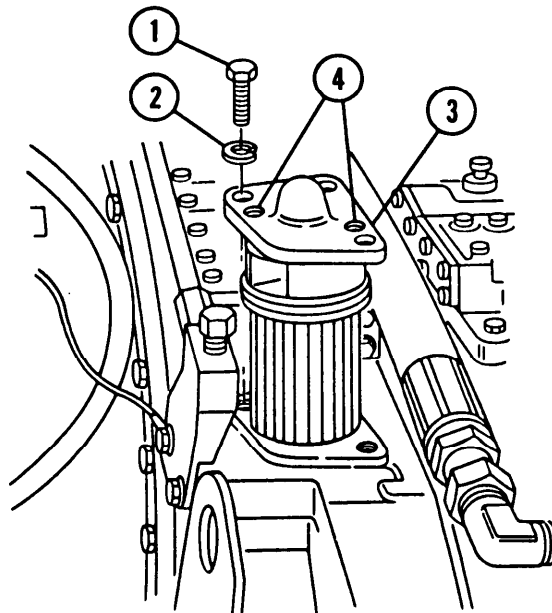
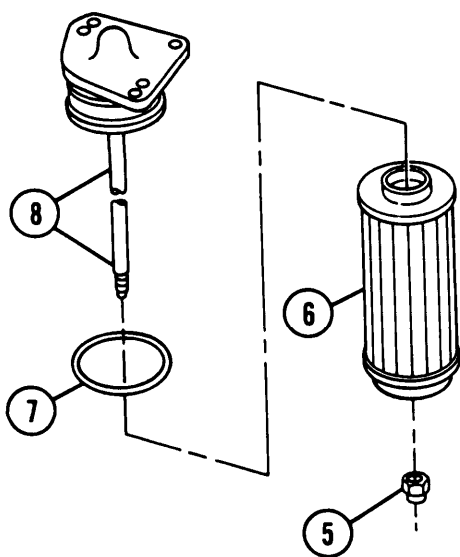

NOTE

FOLLOW-ON MAINTENANCE: Install front slope plate (para 4-5)

9-6 BREATHER, BREATHER TUBE, AND MOUNT

This task covers: a. Removal b. Installation

INITIAL SETUP

Tools

General mechanic's tool kit (item 64, Appx H)

Materials/Parts

Dry-cleaning solvent (item 22, Appx D)

Lockwashers (2) (item 112, Appx G)

a. Removal

- 1 Remove breather (1).

NOTE

Breather tube can be removed without removal of mount.

- 2 Loosen two tube nuts (2) at mount end of tube and at breather elbow (3).

- 3 Loosen two screws (4), two lockwashers (5), and two flat washers (6). Slide mount (7) toward front of vehicle and remove breather tube (8), two sleeves (9), and two tube nuts (2).

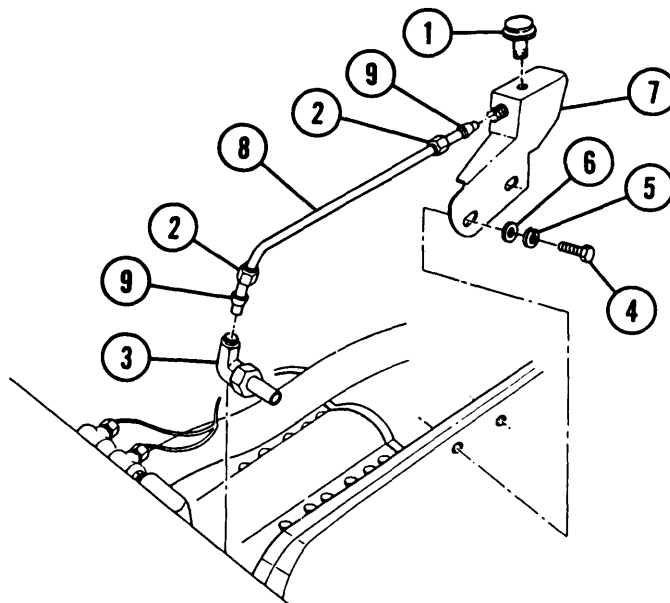

9-6 BREATHER, BREATHER TUBE, AND MOUNT — CONTINUED

a. Removal—Continued

WARNING

Dry-cleaning solvent (P-D-680) is toxic and flammable. Wear protective goggles and gloves and use only in a well-ventilated area. Avoid contact with skin, eyes, and clothes, and don't breathe vapors. Do not use near open flame or excessive heat. The flashpoint for type #1 is 100°F (38°C), and for type #2 is 138°F (59°C). If you become dizzy while using dry-cleaning solvent, get fresh air immediately and get medical aid. If contact with eyes is made, wash your eyes with water and get medical aid immediately.

- 4 Clean breather tube (8) using dry-cleaning solvent.
- 5 Remove breather elbow (3).
- 6 Remove two screws (4), two lockwashers (5), two flat washers (6), and mount (7). Discard lockwashers.

Installation

- 1 Install mount (7), two flat washers (6), two new lockwashers (5), and two screws (4); do not tighten screws.
- 2 Install breather elbow (3).
- 3 Install two sleeves (9) and breather tube (8). Tighten two tube nuts (2).
- 4 Tighten two screws (4), two lockwashers (5), and two flat washers (6) on mount (7).
- 5 Install breather (1).

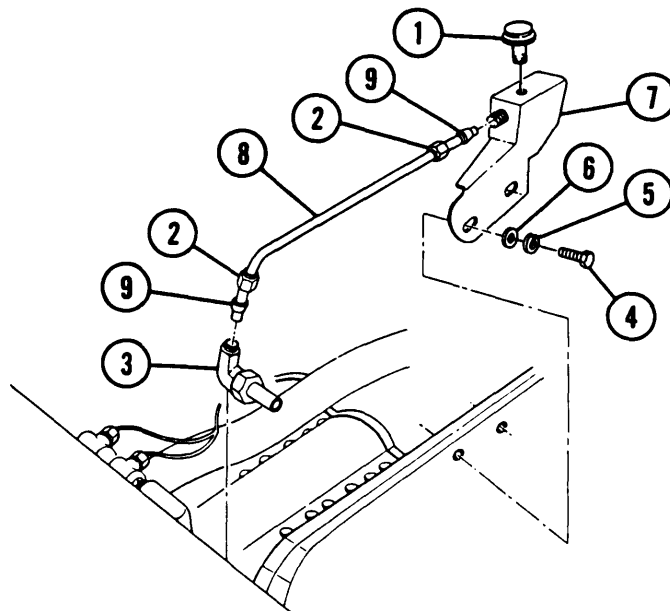

9-7 TRANSMISSION OIL SAMPLING COMPONENTS

This task covers: a. Removal b. Installation

INITIAL SETUP

Tools

General mechanic's tool kit (item 64, Appx H)

a. Removal

- 1 Remove tube assembly (1) from sampling valve adapter (2) and transmission adapter (3).
- 2 Remove adapter (3) and bushing (4) from pipe plug port hole (5). Install plug at transmission port to avoid contamination of transmission oil.
- 3 Remove adapter (2).
- 4 Loosen sampling valve locknut (6) on mounting bracket (7) marked "TRANS". Remove sampling valve (8).

b. Installation

- 1 Install sampling valve (8). Tighten sampling valve locknut (6) marked "TRANS" on mounting bracket (7).
- 2 install adapter (2) to sampling valve (8).
- 3 Remove plug and install bushing (4) and adapter (3) in pipe plug port hole (5).
- 4 Install tube assembly (1) to transmission adapter (3) and sampling valve adapter (2).

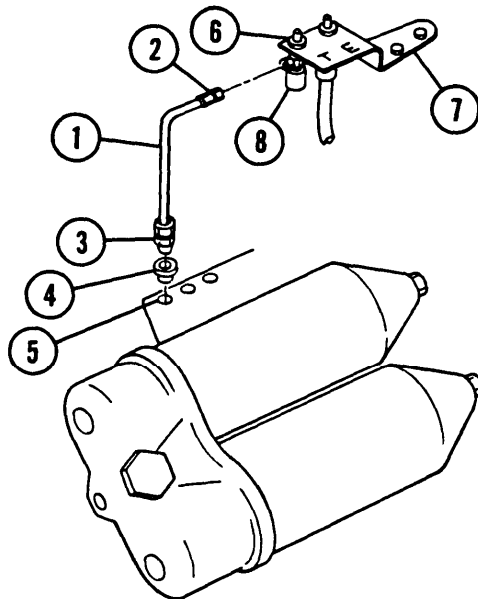

SECTION II. DRIVE CONTROL ASSEMBLIES

9-8 STEERING CONTROL LINKAGE

- This task covers:
- | | |
|---------------|-----------------|
| a. Removal | b. Disassembly |
| c. Assembly | d. Installation |
| e. Adjustment | |
-

I INITIAL SETUP I

Tools

General mechanic's tool kit (item 64, Appx H)

Lockwire (item 26, Appx G)

Lockwire (item 27, Appx G)

Retaining ring (item 15, Appx G)

Retaining rings (2) (item 226, Appx G)

Materials/Parts

Cotter pins (5) (item 40, Appx G)

Cotter pins (2) (item 204, Appx G)

Lockwashers (2) (item 95, Appx G)

Lockwashers (11) (item 96, Appx G)

Lockwashers (3) (item 192, Appx G)

Personnel Required

Two

Equipment Conditions

Master warning light assembly removed (para 8-78)

NOTE

Rod end bearings used on various control linkages are of similar design and construction. For replacement of rod end bearings on any linkages, see illustrations. Inspect rod ends during adjustment procedures. Replace damaged or defective rod ends. Ensure witness hole is closed after adjustment is completed.

a. Removal

- 1 Remove two cotter pins (1), two flat washers (2), two pins (3), and rod assembly (4). Rod assembly is connector between steering shaft and bulkhead mounted housing. Discard cotter pins.
- 2 Remove four screws (5) and four lockwashers (6) from bracket (7) and remove four screws (8), four lockwashers (9), and four flat washers (10) from bracket (11). Discard lockwashers.
- 3 Remove steering shaft assembly (12) with two brackets (7 and 11) and spacer (13) from driver's compartment.
- 4 Remove pin (14), lockwire (15), and chain (16). Discard lockwire.
- 5 Remove three screws (17), three lockwashers (18), and housing assembly (with rod and levers) (19) at bulkhead (20). Discard lockwashers.
- 6 Remove two screws (21), two lockwashers (22), and cover (23) at bulkhead. Discard lockwashers.
- 7 Remove pin (24), lockwire (25), chain (26), and rod assembly (27) with boot (28). Discard lockwire.

8 Remove retaining ring (29) and lever (30) from transmission stud. Discard retaining ring.

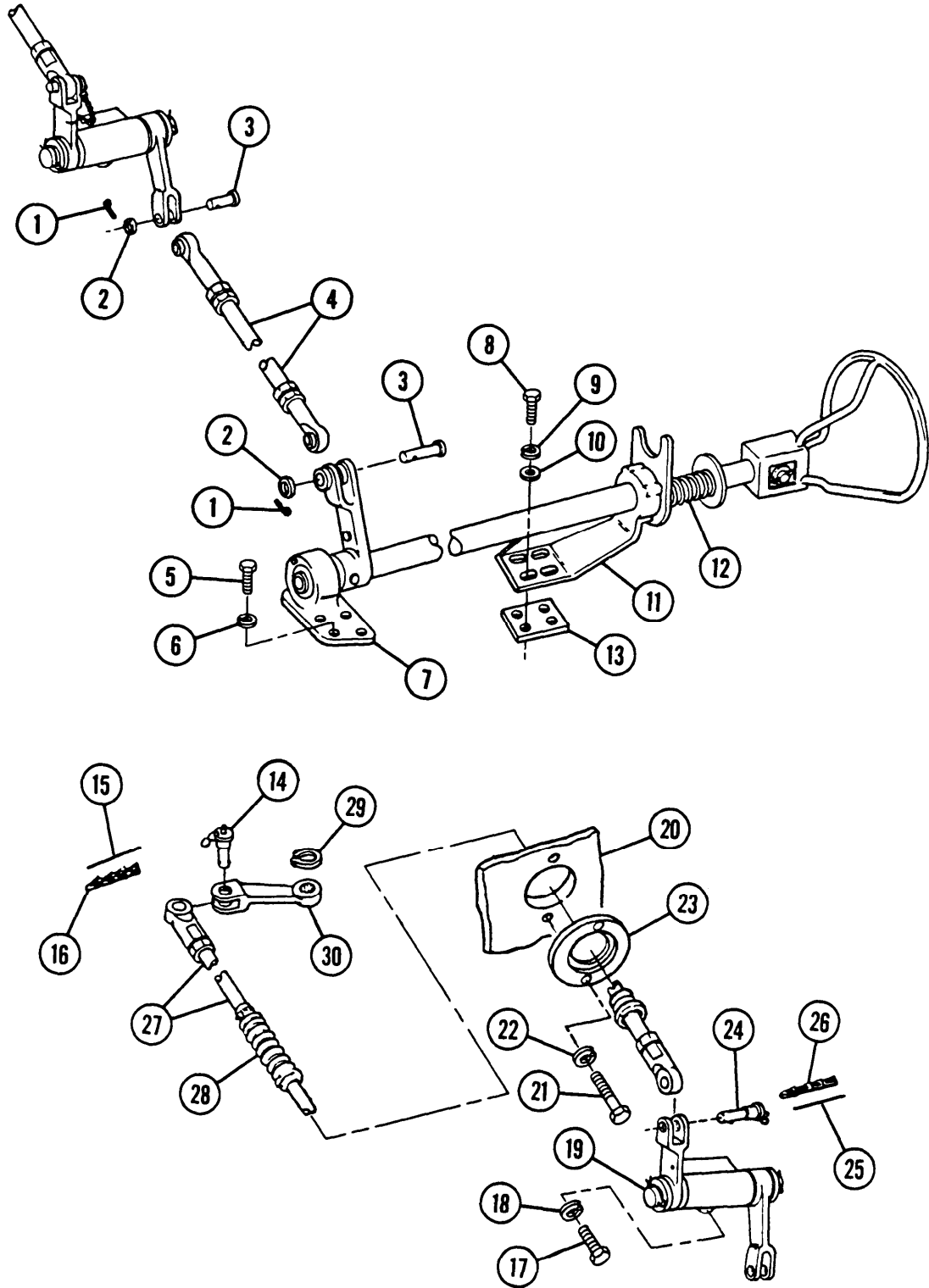

9-8 STEERING CONTROL LINKAGE — CONTINUED

b. Disassembly

- 1 Remove cotter pin (31), flat washer (32), pin (33), and steering wheel (34). Discard cotter pin.
- 2 Remove sleeve (35), spring (36), and washer (37).
- 3 Remove three screws (38), three lockwashers (39), and master warning light bracket (40) from bracket (11). Discard lockwashers.
- 4 Remove two retaining rings (41), bearing (42), and bracket (11) from shaft (43). Discard retaining rings.
- 5 Remove pin (44), lever (45), and spring (46) from shaft (43).

WARNING

Spring (46) is under compression. May cause injury to personnel.

- 6 Remove pin (47) from lever (45). Lever holds spring (46) under tension.
- 7 Remove pin (48) and shaft (43) from bracket (7).
- 8 Remove two cotter pins (49), two flat washers (50), two levers (51 and 52), and spacer (53) from shaft (54). Discard cotter pins.
- 9 Remove shaft (54) and two woodruff keys (55) from housing (56).

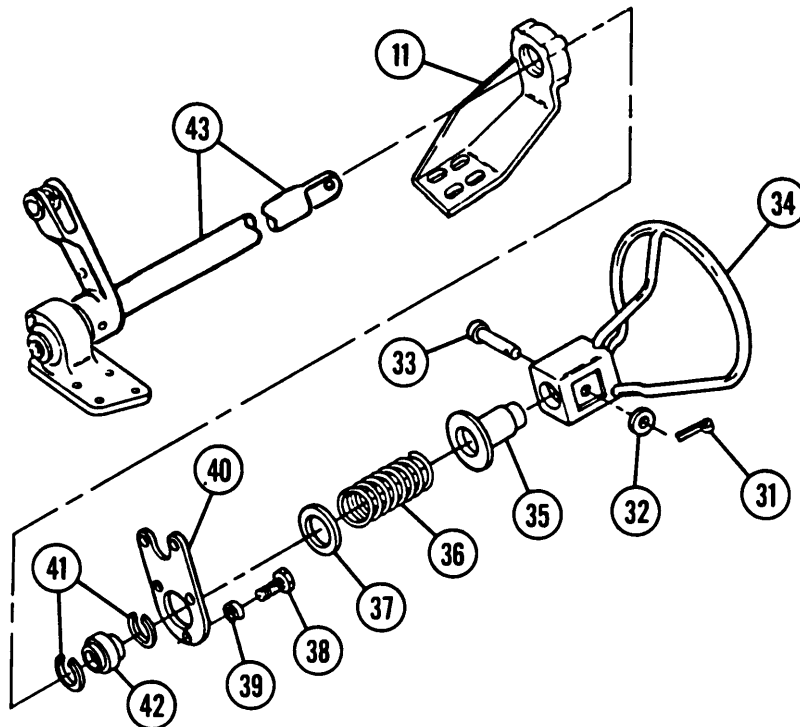

10 Loosen two nuts (57) at both ends of rod (58). Remove two rod ends (59) and two nuts.

11 Loosen clamp (60) and remove with boot (61) from rod (58).

12 Loosen two nuts (62) at both ends of rod (63). Unscrew two rod ends (64) and two nuts from rod.

c. Assembly

1 Install two nuts (62) on rod (63) and install two rod ends (64).

2 Slide clamp (60) and boot (61) onto rod (58). Do not tighten clamp.

3 Install two nuts (57) and two rod ends (59) on rod (58).

4 Install shaft (54) and two woodruff keys (55) in housing (56).

5 Install spacer (53), two levers (51 and 52), two flat washers (50), and two new cotter pins (49) onto shaft (54).

6 Install shaft (43) and pin (48) onto bracket (7).

7 Install pin (47) into lever (45). Lever holds spring (46) under tension.

8 Install spring (46), lever (45), and pin (44) onto shaft (43).

9 Install bracket (11), bearing (42), and two new retaining rings (41) onto shaft (43).

10 Install master warning light bracket (40), three new lockwashers (39), and three screws (38) onto bracket (11).

11 Install washer (37), spring (36), and sleeve (35) over shaft (43).

12 Install steering wheel (34), pin (33), flat washer (32), and new cotter pin (31) back onto shaft (43).

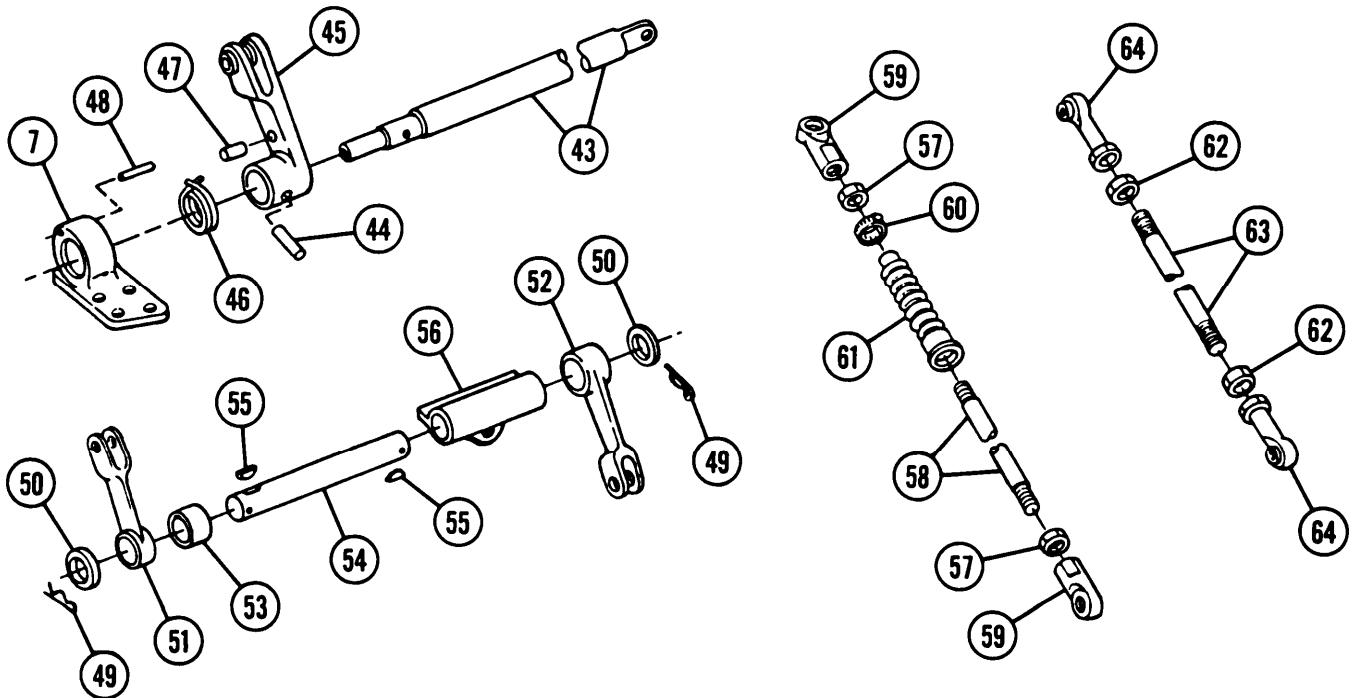

9-8 STEERING CONTROL LINKAGE — CONTINUED

d. Installation

- 1 Install lever (30) and new retaining ring (29) onto transmission stud.
- 2 Insert rod assembly (27) with boot (28) through bulkhead from engine compartment.
- 3 Install cover (23), two new lockwashers (22), and two screws (21) at bulkhead to secure boot (28).

NOTE

Install pin (24) with its head toward driver.

- 4 Install rod assembly (27) with boot (28) with two pins (14 and 24), two chains (16 and 26), and two new lockwires (15 and 25).
- 5 Install housing assembly (with rod and levers) (19), three new lockwashers (18), and three screws (17) at bulkhead (20).

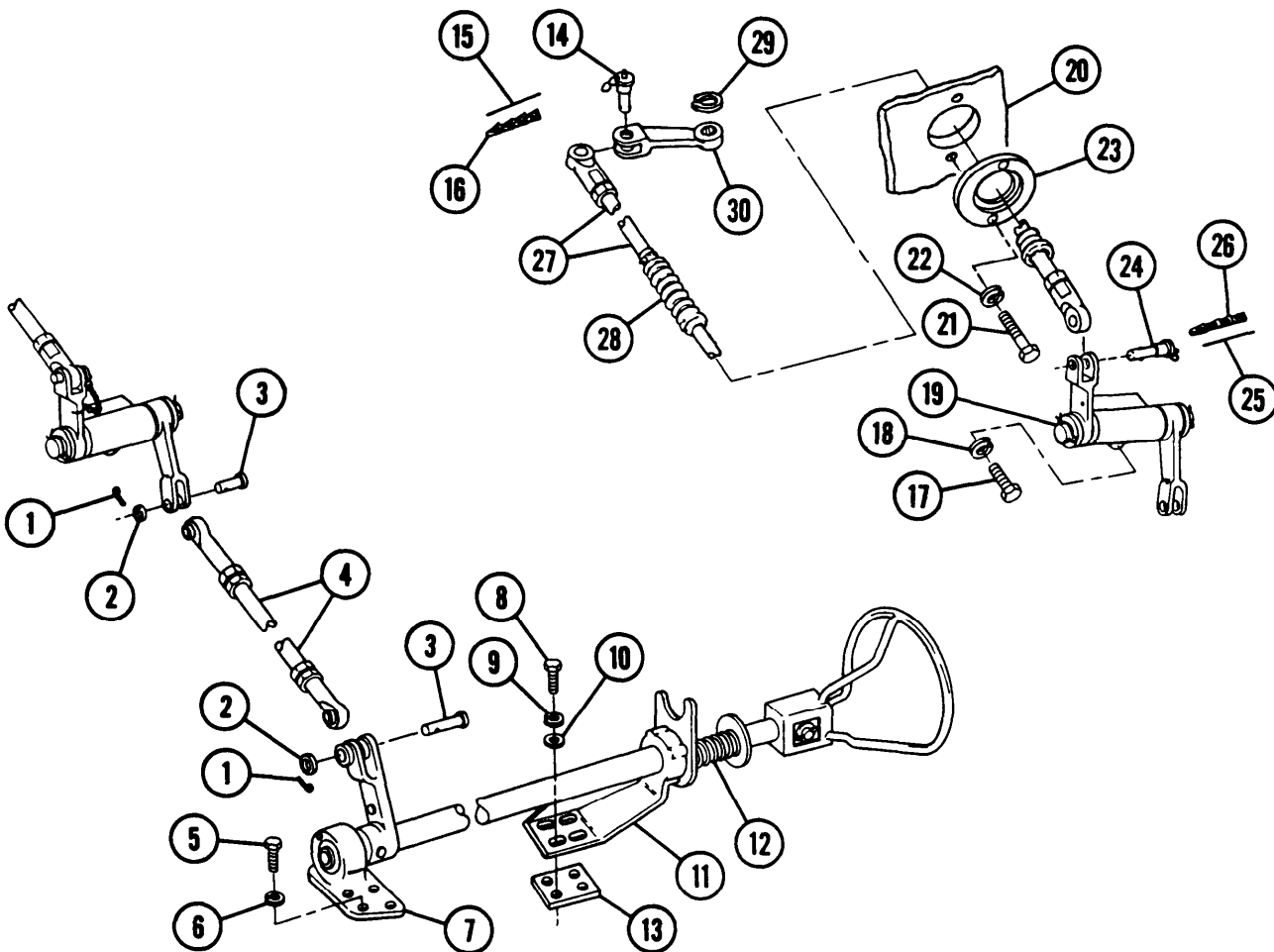

6 Install steering shaft assembly (12) with two brackets (7 and 11) and spacer (13) into driver's compartment.

7 Install four flat washers (10), four new lockwashers (9), and four screws (8) into bracket (11) and install four new lockwashers (6) and four screws (5) into bracket (7).

8 Install rod assembly (4), two pins (3), two flat washers (2), and two new cotter pins (1). Rod assembly is connector between steering shaft and bulkhead mounted housing.

9 Install master warning light assembly into steering shaft mount (para 8-78).

e. Adjustment

NOTE

- All adjustments to steering linkage must finish with lever (30) in neutral position (pointer on transmission steer shaft pointing to center made on screw) and steering wheel (34) in normal forward position (center wheel spoke vertical).
- If any adjustment is made to length of rod assembly (27), an equal and opposite adjustment must be made to rod assembly (4) in order to maintain forward steering position of steering wheel.

1 Turn steering wheel full left and hold. Check for contact between rod end (59) and bottom of bulkhead hole. If interference exists, go to step 2. If no interference is present, go to step 5.

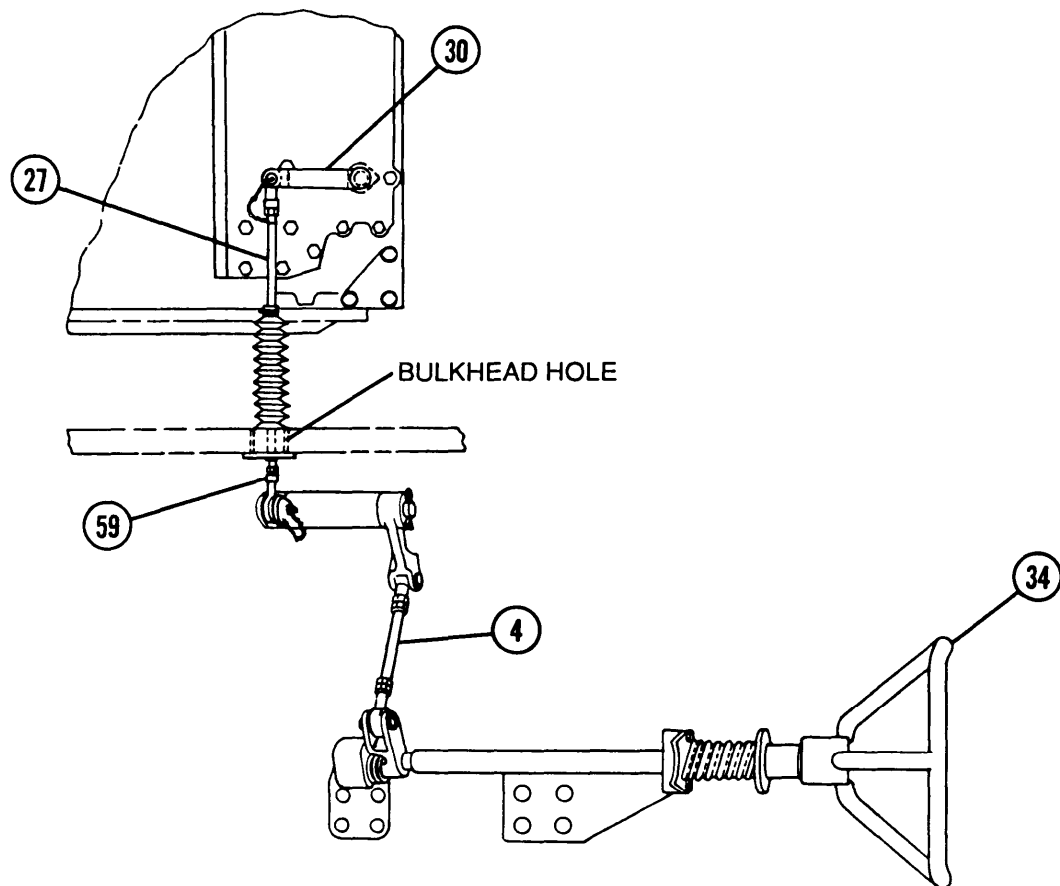

9-8 STEERING CONTROL LINKAGE — CONTINUED

e. Adjustment — Continued

- 2 Remove two pins (14 and 24) to disconnect rod assembly (27). Loosen two nuts (57).
- 3 Increase end-to-end rod length by turning two rod ends (59). Install rod assembly (27) with two pins (14 and 24). Tighten two nuts (57).
- 4 Turn steering wheel (34) full right and hold. Check for contact between rod end (59) and top of bulkhead hole. If interference exists, go to step 5. If no interference exists, go to step 10 and adjust location of boot (28).
- 5 Remove two pins (14 and 24) to disconnect rod assembly (27). Loosen two nuts (57).

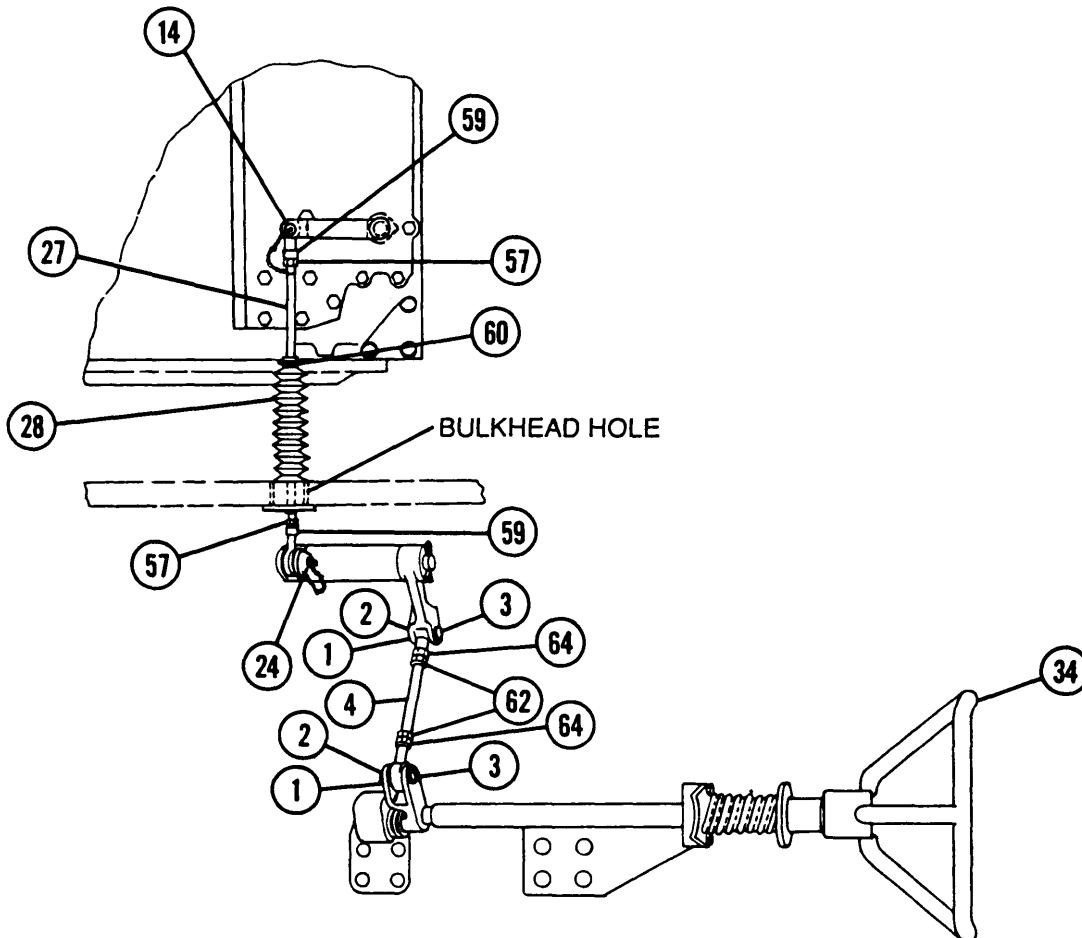

- 6 Decrease end-to-end rod length by turning two rod ends (59). Install rod assembly (27) with two pins (14 and 24). Tighten two nuts (57). Repeat check in step 4 and adjust if needed.
- 7 Remove two cotter pins (1), two washers (2), two pins (3), and rod assembly (4). Discard cotter pins.
- 8 Loosen two nuts (62) and increase or decrease end-to-end rod length by turning two rod ends (64). This length change must be equal but opposite that of rod assembly (27).
- 9 Install rod assembly (4) using two pins (3), two washers (2), and two new cotter pins (1). Ensure that steering wheel (34) is in normal forward position (center spoke vertical). If not, increase or decrease rod assembly length as necessary. Tighten two nuts (62).
- 10 Turn and hold steering wheel (34) full left. Move boot (28) so it is at its free length (not extended, not compressed) when wheel is in this position. Tighten clamp (60).
- 11 Turn steering wheel (34) to left and check for clearance between neutral safety switch (65) and lever (51) and/or pin (24). If clearance is less than 0.25 in. (6.4 mm), then remove lever and reinstall with spacer (53) as shown in illustration.

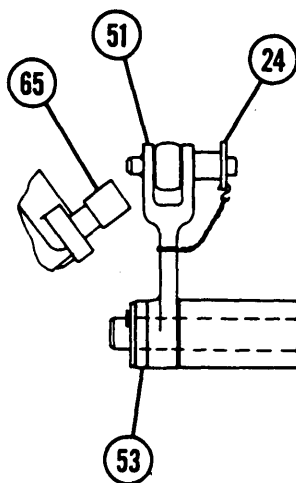
**NOTE**

FOLLOW-ON MAINTENANCE: Install master warning light assembly (para 8-78)

9-9 SHIFT CONTROL LINKAGE AND NEUTRAL SAFETY SWITCH ADJUSTMENT

- This task covers:
- | | |
|---------------|-----------------|
| a. Removal | b. Disassembly |
| c. Assembly | d. Installation |
| e. Adjustment | |

INITIAL SETUP

Tools

General mechanic's tool kit (item 64, Appx H)

Cotter pins (6) (item 39, Appx G)

Lockwashers (15) (item 95, Appx G)

Lockwashers (3) (item 96, Appx G)

Materials/Parts

Cotter pin (item 10, Appx G)

Cotter pin (item 29, Appx G)

Personnel Required

Two

a. Removal

- 1 Remove two cotter pins (1), two flat washers (2), two pins (3), and shift control inner rod (4). Discard cotter pins.
- 2 Remove three screws (5), three lockwashers (6), and shift control (7). Discard lockwashers.
- 3 Remove two cotter pins (8), flat washer (9), two pins (10), and shift control inner tube (11). Discard cotter pins.
- 4 Remove three screws (12), three lockwashers (13), and support assembly (14). Discard lockwashers.
- 5 Remove four screws (15), four lockwashers (16), quick-release pin (17), and base assembly with shaft (18). (Quick-release pin is located in powerplant compartment at bulkhead.) Discard lockwashers.

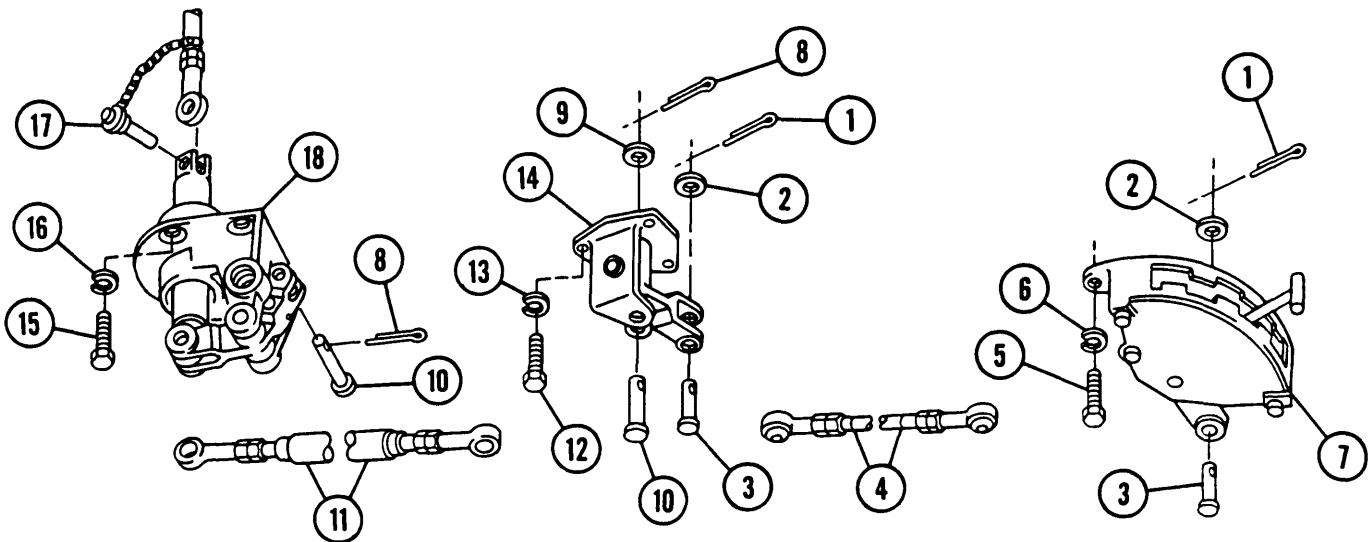

- 6 Remove screw (19), lockwasher (20), and shift control outer tube (21). Discard lockwasher.
- 7 Remove screw (22), lockwasher (23), cotter pin (24), flat washer (25), pin (26), and shift control outer rod (27). Discard lockwasher and cotter pin.
- 8 Remove screw (28), lockwasher (29), flat washer (30), bell crank (31), and spacer (32). Discard lockwasher.
- 9 Remove screw (33), flat washer (34), and lever (35).

b. Disassembly

- 1 Loosen two nuts (36).
- 2 Remove two rod ends (37) and two nuts (36) from rod (38).
- 3 Remove pin (39) and handle (40) to disassemble shift control. Remove three screws (41), three lockwashers (42), two machine screws (43), two lockwashers (44), cover (45), and shift guide (46). Discard lockwashers.
- 4 Remove two springs (47), two pins (48), and lever (49).

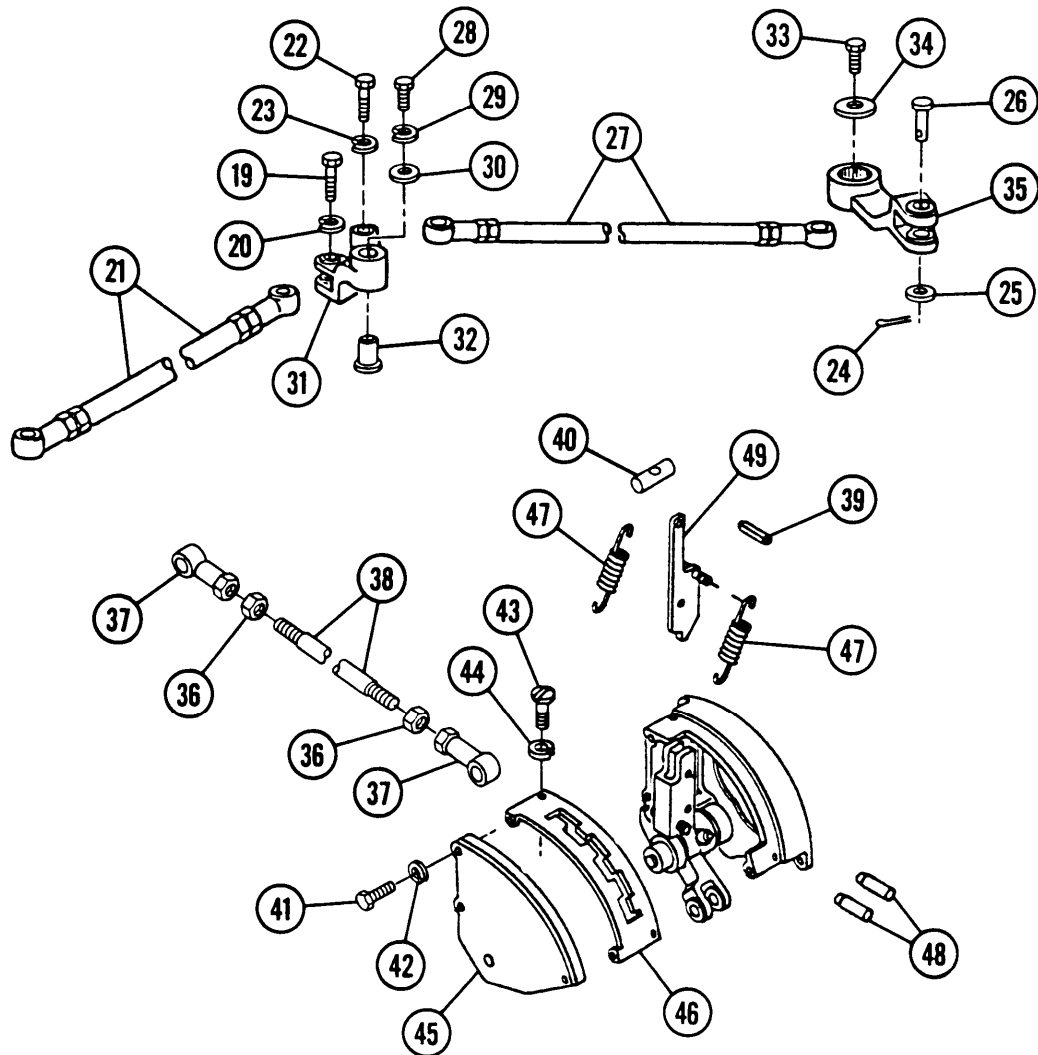

9-9 SHIFT CONTROL LINKAGE AND NEUTRAL SAFETY SWITCH ADJUSTMENT — CONTINUED

b. Disassembly—Continued

- 5 Remove lever (50) and shaft (51) from bracket (52). Remove grease fitting (53) from lever.
- 6 Remove pin (54), shaft (55), and bell crank (56) from support (57) to disassemble support assembly and base assembly.
- 7 Remove two pins (58), two shafts (59), shaft (60), and link (61) from base (62).
- 8 Disconnect neutral safety switch (63).
- 9 Remove neutral safety switch and pin (63) from adapter (64).
- 10 Remove adapter (64) from base (62).
- 11 Remove cotter pin (65), straight pin (66), and lever (67) from base (62). Discard cotter pin.
- 12 Remove pin (68), spring (69), and contact pin (70) from lever (67).

c. Assembly

- 1 Install contact pin (70), spring (69), and pin (68) on lever (67).
- 2 Install lever (67), straight pin (66), and new cotter pin (65) on base (62).
- 3 Install adapter (64) in base (62).
- 4 Connect neutral safety switch (63).
- 5 Install link (61), shaft (60), two shafts (59), and two pins (58) on base (62).
- 6 Install bell crank (56), shaft (55), and pin (54) on support (57).
- 7 Install grease fitting (53) on lever (50). Install shaft (51) and lever on bracket (52).
- 8 Install lever (49), two pins (48), and two springs (47).
- 9 Install shift guide (46), cover (45), two new lockwashers (44), two machine screws (43), three new lockwashers (42), and three screws (41). Install handle (40) and pin (39).
- 10 Install two nuts (36) and two rod ends (37) on rod (38). Tighten nuts.

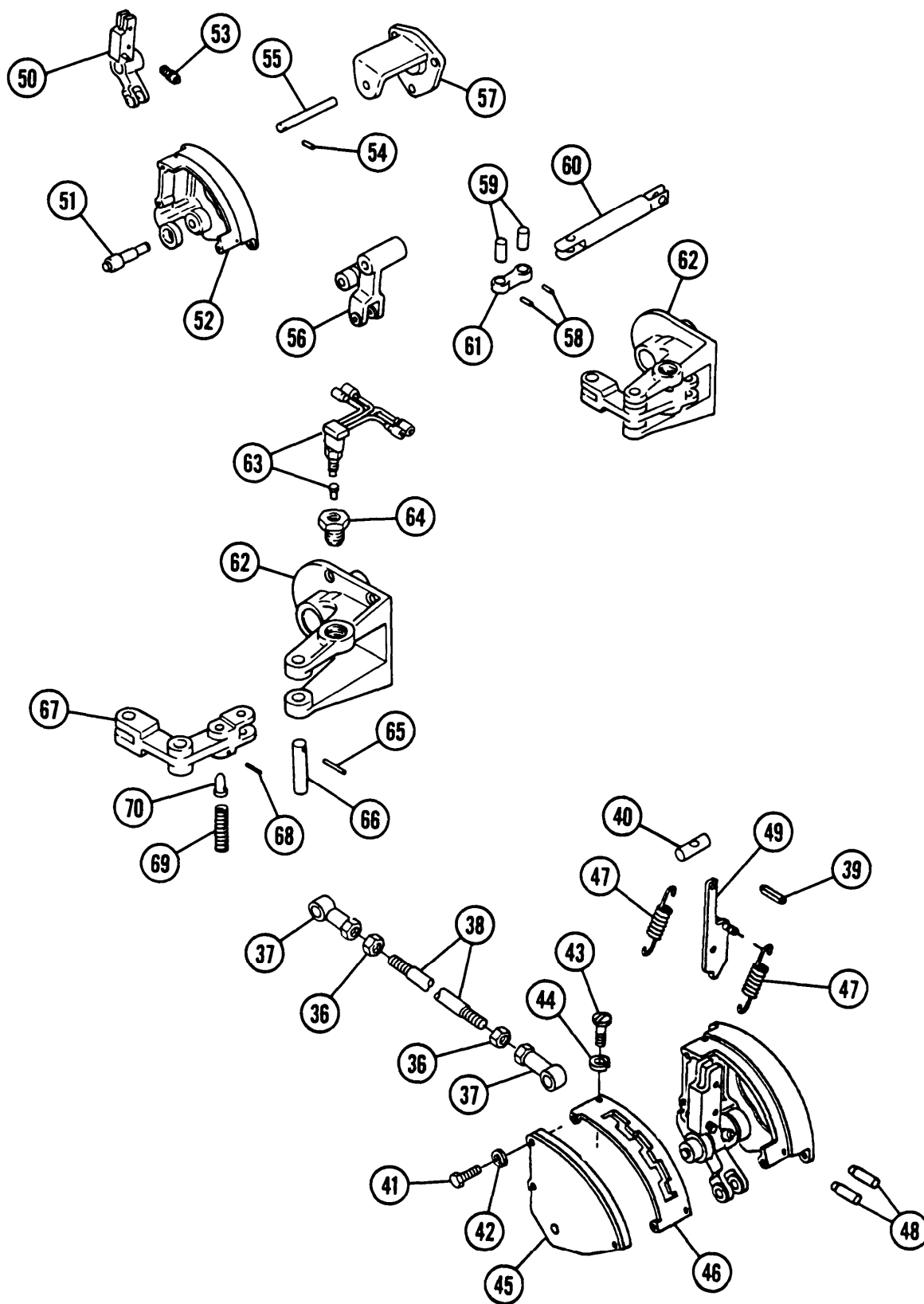

9-9 SHIFT CONTROL LINKAGE AND NEUTRAL SAFETY SWITCH ADJUSTMENT — CONTINUED

d. Installation

- 1 Install lever (35), flat washer (34), and screw (33).
- 2 Install spacer (32), bell crank (31), flat washer (30), new lockwasher (29), and screw (28).
- 3 Install shift control outer rod (27), pin (26), flat washer (25), new cotter pin (24), new lockwasher (23), and screw (22).
- 4 Install shift control outer tube (21), new lockwasher (20), and screw (19).
- 5 Install base assembly with shaft (18), quick-release pin (17), four new lockwashers (16), and four screws (15).
(Quick-release pin is located in powerplant compartment at bulkhead.)
- 6 Install support assembly (14), three new lockwashers (13), and three screws (12).
- 7 Install shift control inner tube (11), two pins (10), flat washer (9), and two new cotter pins (8).
- 8 Install shift control (7), three new lockwashers (6), and three screws (5).
- 9 Install shift control inner rod (4), two pins (3), two flat washers (2), and two new cotter pins (1).

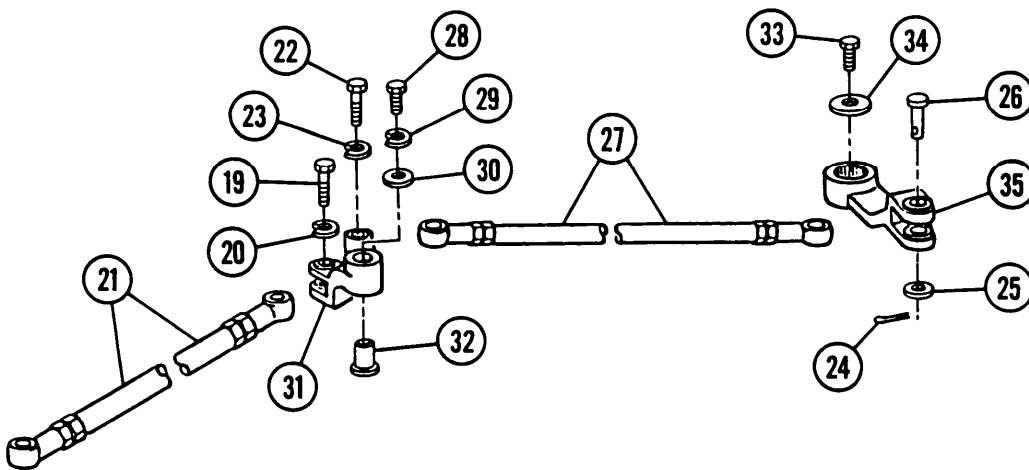

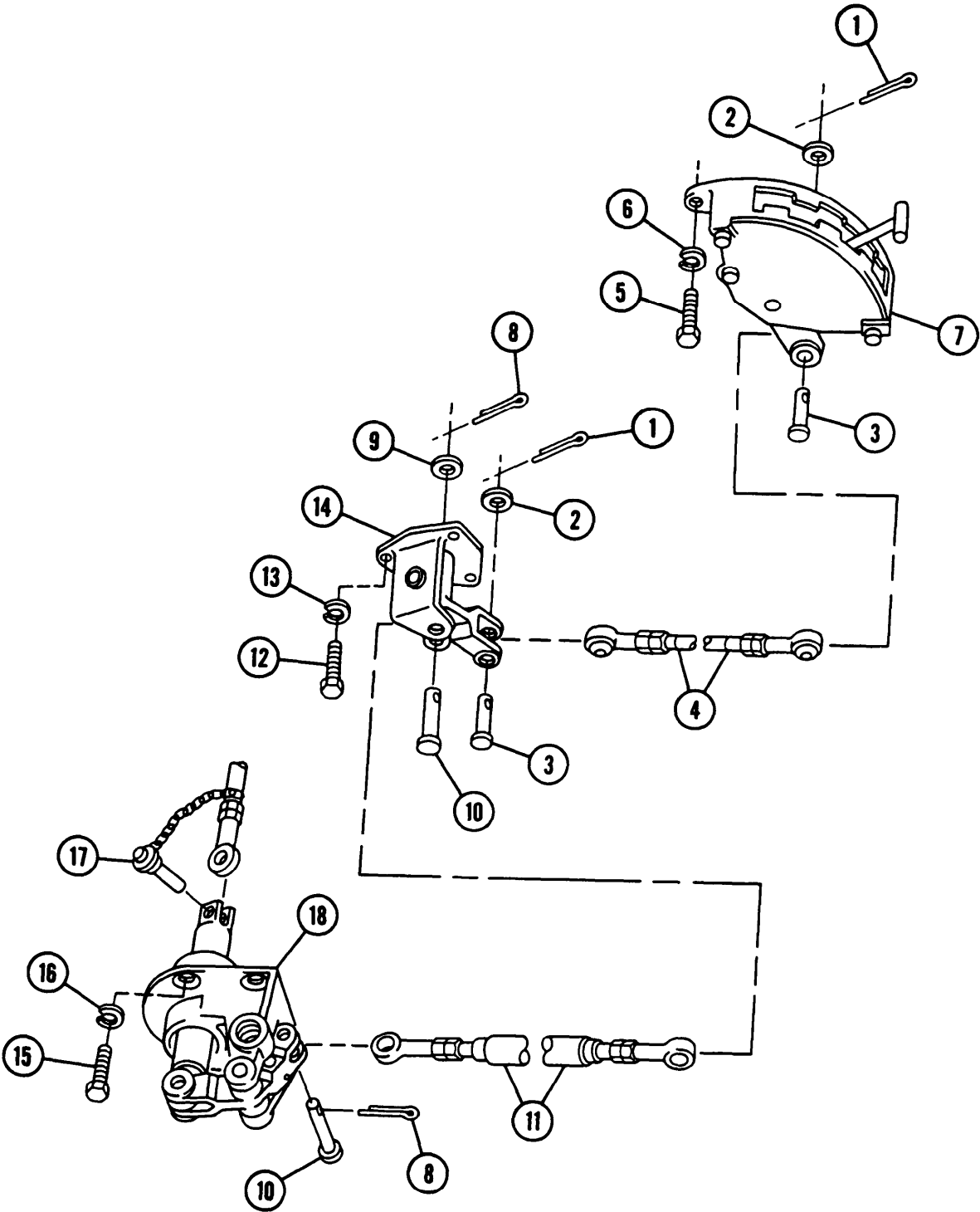

9-9 SHIFT CONTROL LINKAGE AND NEUTRAL SAFETY SWITCH ADJUSTMENT — CONTINUED

e. Adjustment

- 1 Place shift control lever (71) in neutral (N) position. Remove cotter pin (1), flat washer (2), and clevis pin (3) from bell crank (56) to disconnect shift control inner rod (4). Discard cotter pin.
- 2 Place bell crank (56) parallel with lever (50).
- 3 Loosen nut (72) and adjust shift control inner rod (4) until clevis pin (3) can be easily installed. Install flat washer (2) and new cotter pin (1). Tighten nut.
- 4 Remove cotter pin (8), flat washer (9), and clevis pin (10) to disconnect shift control inner tube (11). Discard cotter pin.
- 5 Set base lever (67) at neutral position with contact pin spherical end detent (70) in base lever engaged with neutral safety switch detent (73).
- 6 Verify that shift control lever (71) is in neutral (N) position.
- 7 Loosen nuts (74). Adjust shift control inner tube (11) until clevis pin (10) can be easily inserted into lever of bell crank (56).
- 8 Install flat washer (9) and new cotter pin (8). Tighten nuts (74) on shift control inner tube (11).
- 9 With shift control lever (71) in neutral (N) position, disconnect shift control outer rod (27) from transmission shift control lever (35) by removing cotter pin (24), flat washer (25), and clevis pin (26). Discard cotter pin.
- 10 Loosen nuts (75) and adjust rod to approximately 8.25 in. (21.0 cm) (centerline of bearing bore to centerline of bearing bore). Tighten nuts.
- 11 Disconnect shift control outer tube (21) by pulling quick-release pin (17). Ensure control lever (71) is in neutral (N) position and install shift control outer rod (27) in transmission shift control lever (35). Ensure lever is set in neutral position of lever index (76) on transmission.
- 12 Install clevis pin (26), flat washer (25), and new cotter pin (24).
- 13 Loosen nuts (77) and adjust shift control outer tube (21) until quick-release pin (17) can be easily inserted. Tighten nuts on shift control outer rod.
- 14 Move shift control lever (71) through all positions. In each position, check to see that transmission shift control lever index (76) (located under shift control lever at transmission) indicates same as shift control lever position.
- 15 Set shift control lever (71) in neutral (N) position. Ensure transmission shift control lever index (76) and transmission shift control lever (35) are set in neutral (N) position. Ensure neutral safety switch (63) is activated.

WARNING

Clear area of personnel and equipment in case of vehicle movement. Failure to do so may result in serious injury or death.

16 Pull fuel shutoff lever and crank engine. There must be no forward or reverse movement of vehicle.

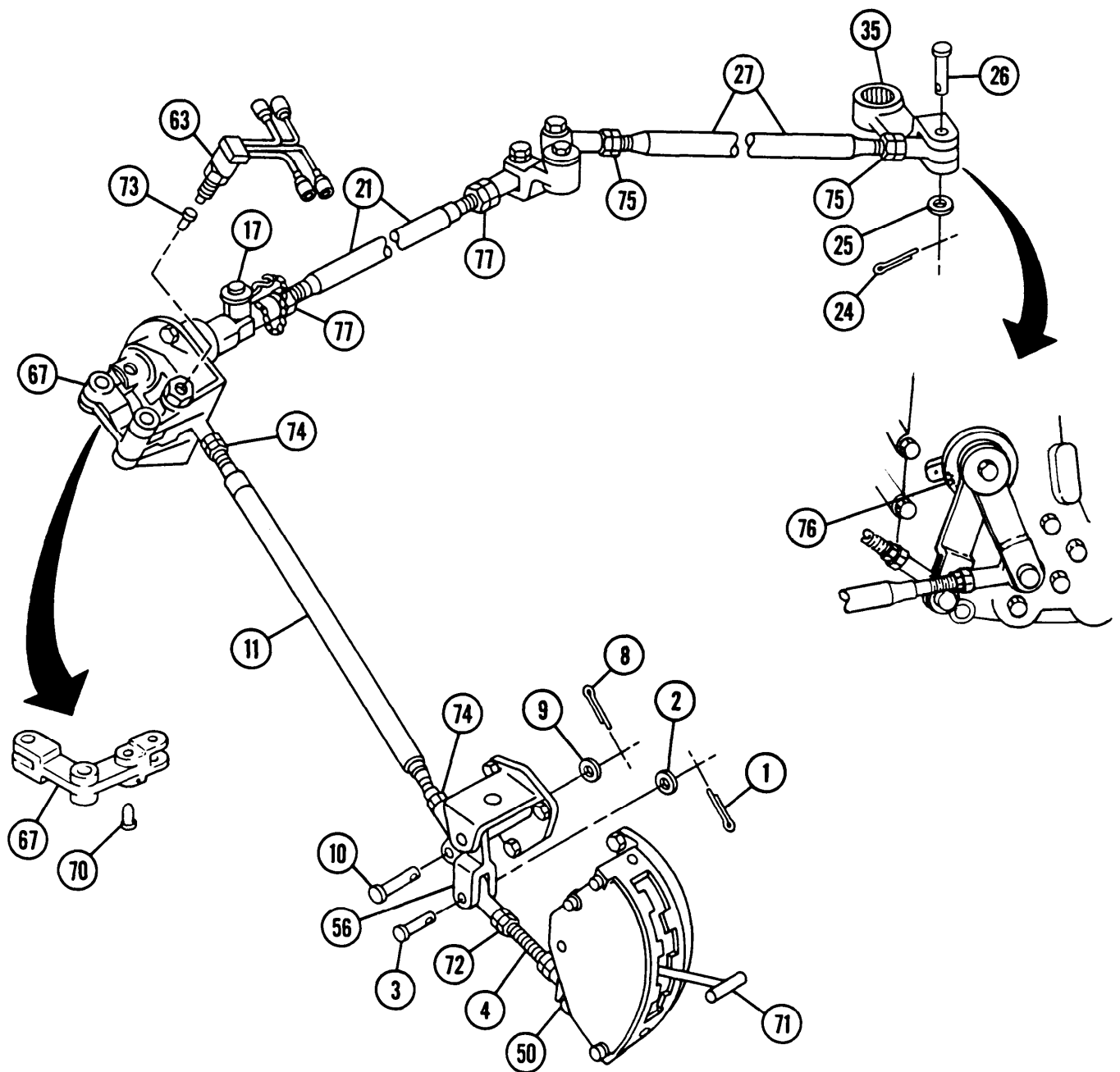

9-10 SERVICE AND PARKING BRAKE LINKAGE

- This task covers:
- | | |
|---------------|-----------------|
| a. Removal | b. Disassembly |
| c. Assembly | d. Installation |
| e. Adjustment | |

INITIAL SETUP

Tools

General mechanic's tool kit (item 64, Appx H)

Materials/Parts

Cotter Pin (item 49, Appx G)
 Cotter pins' (4) (item 40, Appx G)
 Cotter pins (2) (item 46, Appx G)
 Gasket (item 203, Appx G)

Lockwasher (item 78, Appx G)
 Lockwashers (11) (item 95, Appx G)
 Lockwashers (6) (item 108, Appx G)
 Lockwire (item 30, Appx G)
 Retaining ring (item 7, Appx G)
 Seal (item 135, Appx G)
 Seal (item 177, Appx G)

a. Removal

- 1 Remove screw (1) and lockwasher (2). Discard lockwasher.
- 2 Support parking brake linkage (3) and remove two screws (4) and two lockwashers (5). Discard lockwashers.
- 3 Pull bell crank at screw (1) off bracket spindle and remove parking brake linkage (3).
- 4 Disconnect electrical connector (6).
- 5 Remove two screws (7), two lockwashers (8), parking brake light switch (9), and bracket (10). Discard lockwashers.

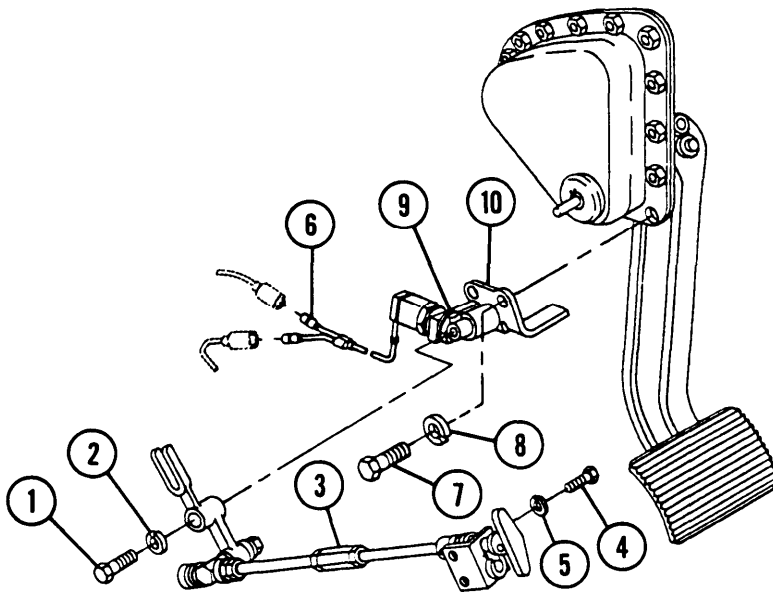

- 6 Through access to powerplant compartment, remove cotter pin (11 and pin (12). Discard cotter pin.
- 7 Remove screw (13), flat washer (14), and lever (15) from shaft. (For removal of clevis, chain sprocket, and brake apply levers, see below.)
- 8 Remove lockwire (16). Unscrew retainer plate (17) from end of bracket. Discard lockwire.

NOTE

Brake assembly may be removed without removing seal or before removing seal.

- 9 Remove seal (18). Discard seal.
- 10 Remove four screws (19), four lockwashers (20), and four flat washers (21) from driver's compartment bulkhead. Disconnect two electrical connectors (22) at brake warning light switch. Discard lockwashers.
- 11 Remove brake assembly (23) and shims (24).

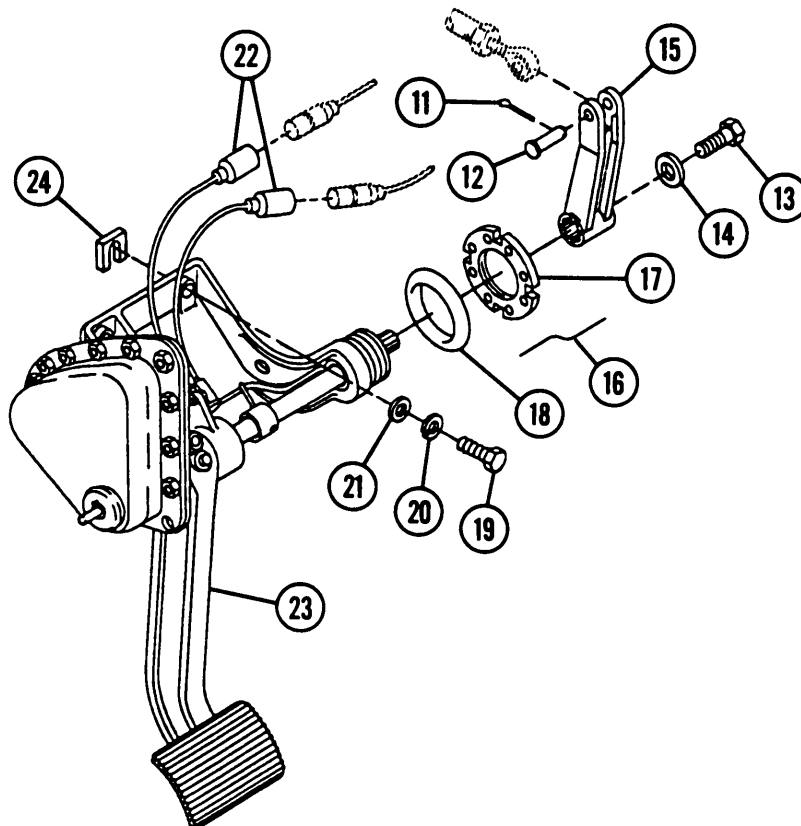

9-10 SERVICE AND PARKING BRAKE LINKAGE — CONTINUED

b. Disassembly

- 1 Remove pin (25) and T-handle (26) from end of rod (27).
- 2 Remove mounting bracket (28), two flat washers (29), and spring (30).
- 3 Remove pin (31) and collar (32). Remove cotter pin (33), two flat washers (34), and spring (35). Discard cotter pin.
- 4 Remove screw (36), lockwasher (37), flat washer (38), bell crank (39), and rod guide (40) from rod (27). Discard lockwasher.
- 5 Remove flat washer (41).

NOTE

Removal of nuts from rod ends is not necessary.

- 6 Remove two nuts (42). Loosen and unscrew rod (27) ends from nut (43).

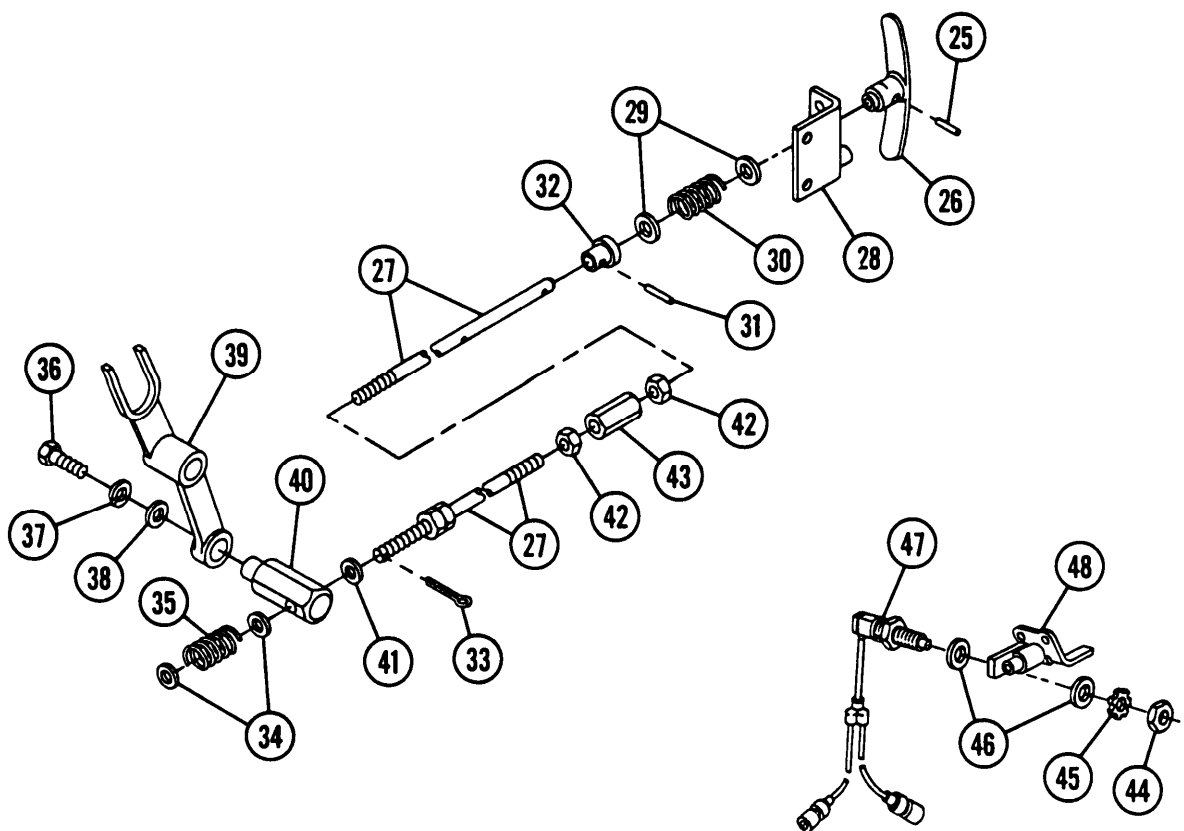

- 7 Unscrew and remove nut (44), lockwasher (45), and two flat washers (46). Discard lockwasher.
- 8 Separate parking brake light switch (47) and bracket (48).
- 9 Remove two cotter pins (49) and pin (50) at brake pedal (51). Discard cotter pins.
- 10 Remove screw (52), nut (53), and two flat washers (54) at brake pedal (51).
- 11 Loosen two setscrews (55) at actuator (56).
- 12 Remove two screws (57), two lockwashers (58), retaining ring (59), and boot (60) at parking brake latch assembly (61). Discard lockwashers and retaining ring.
- 13 Remove three nuts (62) and three lockwashers (63) at support bracket (64). Discard lockwashers.
- 14 Withdraw parking brake latch assembly (61) and shaft (65) from support bracket (64) to release actuator (56) and brake pedal (51).
- 15 Remove two screws (66), two lockwashers (67), and bracket with stop light switch (68) from support bracket (64). Discard lockwashers.
- 16 Remove 10 screws (69), 10 nuts (70), cover (71), gasket (72), and seal (73). Discard gasket and seal.
- 17 Remove latch (74) and shaft (65) from latch plate (75).

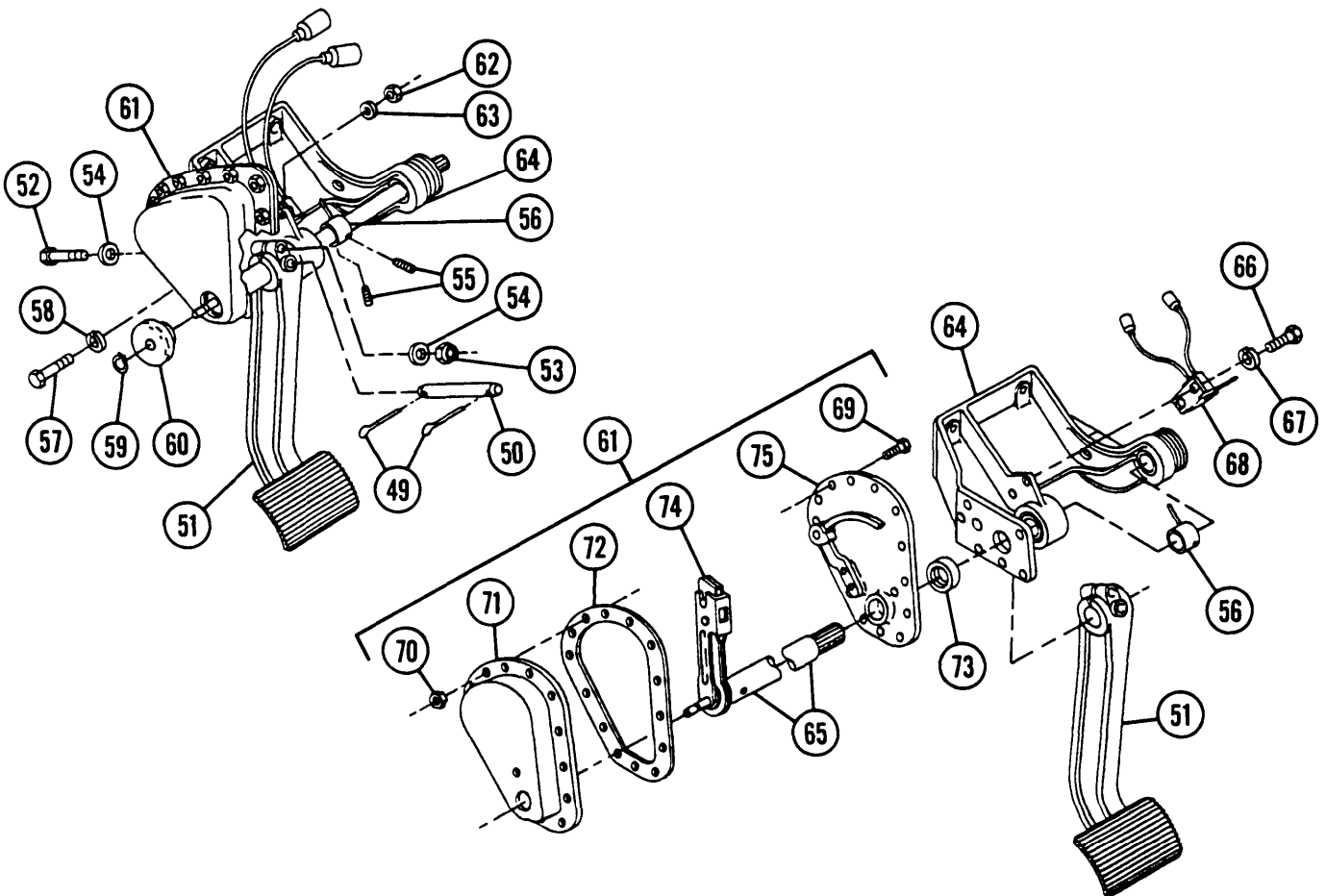

9-10 SERVICE AND PARKING BRAKE LINKAGE — CONTINUED

b. Disassembly — Continued

- 18 Loosen nut (76).
- 19 Remove cotter pin (77) and unscrew end (78) and clevis (79). Discard cotter pin.
- 20 Remove pin (80) and sprocket (81) (with chain) from clevis (79).
- 21 Remove two cotter pins (82), two clevis pins (83), and two clevises (84) (with chain) from right brake lever (85) and left brake lever (86). Discard cotter pins.
- 22 Remove two pins (87) and separate sprocket control chain (88) from two clevises (84).

c. Assembly

- 1 Install separate chain (88) and two pins (87) into two clevises to assemble brake linkage.
- 2 Install two clevises (84) (with chain), two pins (83), and two new cotter pins (82) onto right brake lever (85) and left brake lever (86).
- 3 Install sprocket (81) (with chain) and pin (80) into clevis (79).
- 4 Install new cotter pin (77) and screw end (78) into clevis.
- 5 Tighten nut (76).

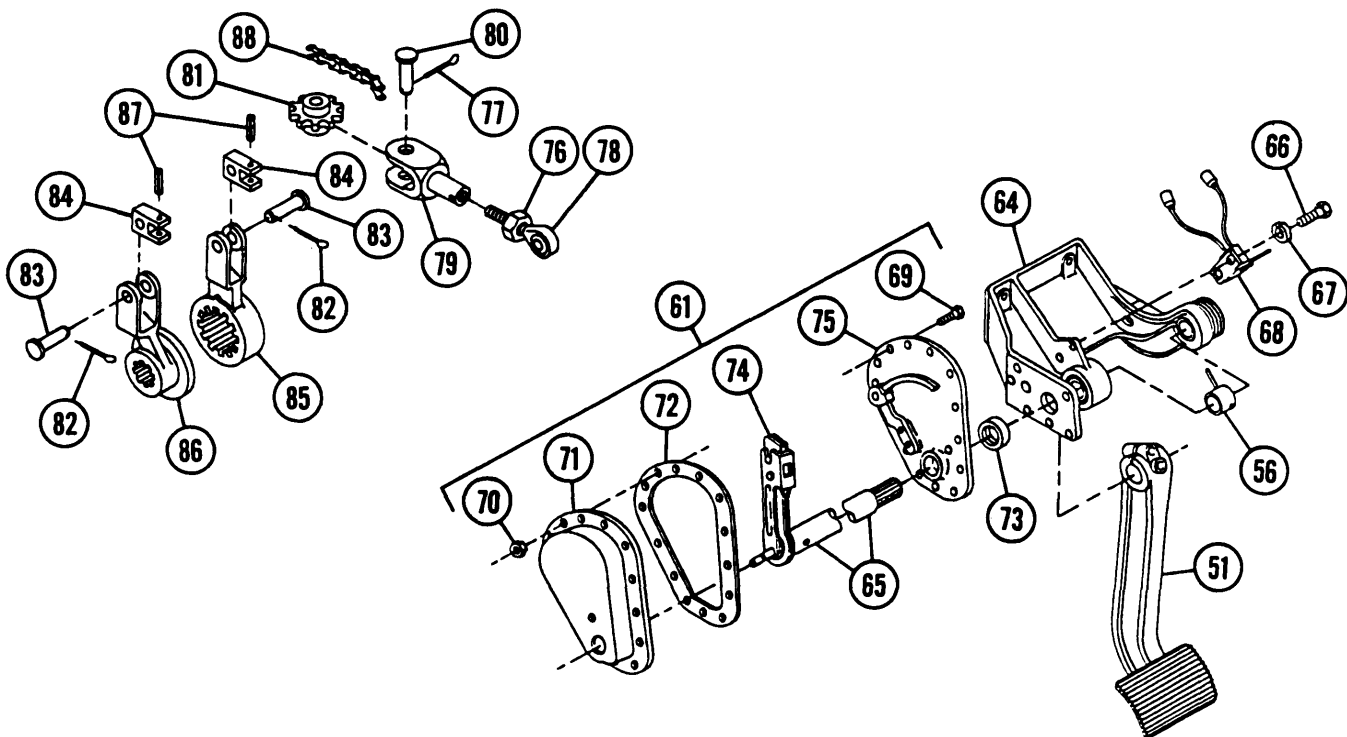

- 6 Insert shaft (65) with installed latch (74) into latch plate (75) to assemble brake assembly.
- 7 Install new seal (73), new gasket (72), cover (71), 10 nuts (70), and 10 screws (69).
- 8 Install bracket with stop light switch (68), two new lockwashers (67), and two screws (66) into support bracket (64).
- 9 Install shaft support bracket (64) and insert parking brake latch assembly (61) to tighten actuator (56) and brake pedal (51).
- 10 Install three washers (63) and three nuts (62) at support bracket (64).
- 11 Install boot (60), new retaining ring (59), two new lockwashers (58), and two screws (57) at parking brake latch assembly (61).
- 12 Tighten two setscrews (55) at actuator (56).
- 13 Install two flat washers (54), nut (53), and screw (52) at brake pedal (51).
- 14 Install pin (50) and two new cotter pins (49) at brake pedal (51).
- 15 Connect bracket (48) and brake light switch (47).
- 16 Install two flat washers (46), new lockwasher (45), and nut (44).

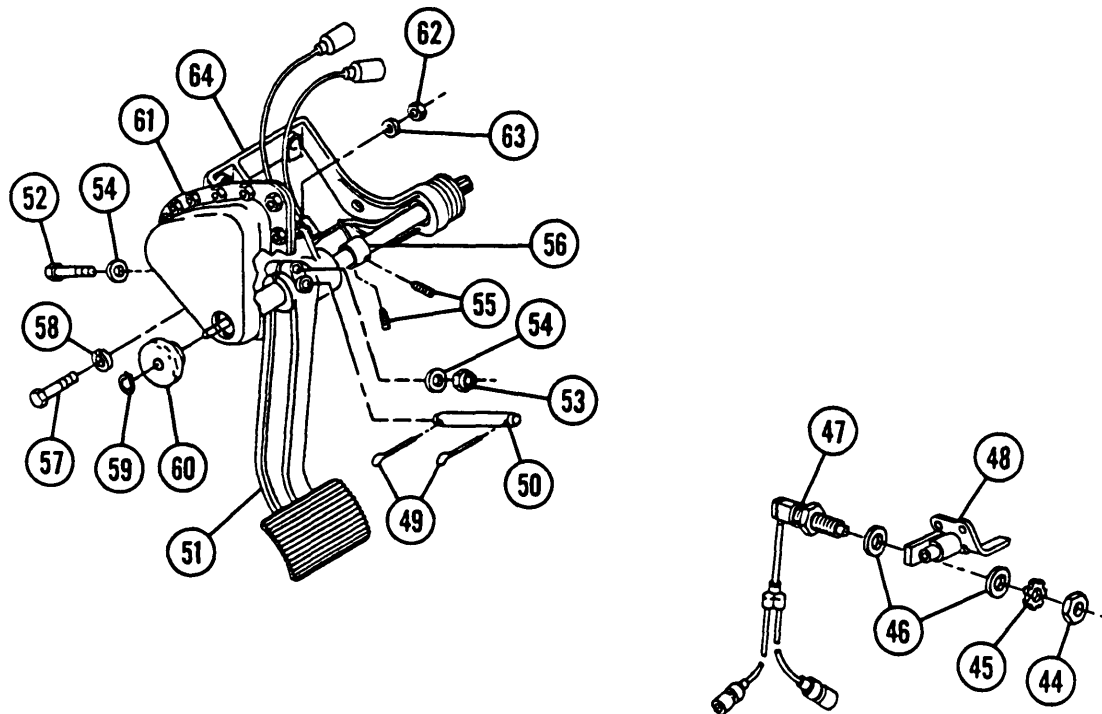

9-10 SERVICE AND PARKING BRAKE LINKAGE — CONTINUED

c. Assembly — Continued

- 17 Install two nuts (42) on rods (27) and screw rods onto nut (43) to assemble brake linkage. Tighten nuts (42) against nut (43).
- 18 Assemble bell crank (39), flat washer (38), new lockwasher (37), and screw (36) to rod guide (40).
- 19 Install flat washer (41), rod guide (40), spring (35), two flat washers (34), and new cotter pin (33).
- 20 Install collar (32), pin (31), spring (30), two flat washers (29), and mounting bracket (28).
- 21 Install T-handle (26) and pin (25) at end of rod (27).

d. Installation

- 1 Install brake assembly (23) with four flat washers (21), four new lockwashers (20), and four screws (19). Install shims (24) as required.
- 2 Reconnect two electrical connectors (22) at brake warning light switch.
- 3 Install new seal (18).
- 4 Screw on retainer plate (17) on end of bracket. Install new lockwire (16).
- 5 Install lever (15), flat washer (14), and screw (13) onto shaft. (For installation of clevis chain, sprocket, and brake apply levers, see above.)
- 6 Install pin (12) and new cotter pin (11) through powerplant compartment access.
- 7 Install bracket (10) with two new lockwashers (8) and two screws (7). Install parking brake light switch (9) and reconnect electrical connector (6).
- 8 Place new lockwasher (2) and bell crank of parking brake linkage (3) on screw (1) and screw onto bracket spindle to install parking brake.
- 9 Install two new lockwashers (5) and two screws (4), securing support of parking brake linkage (3).

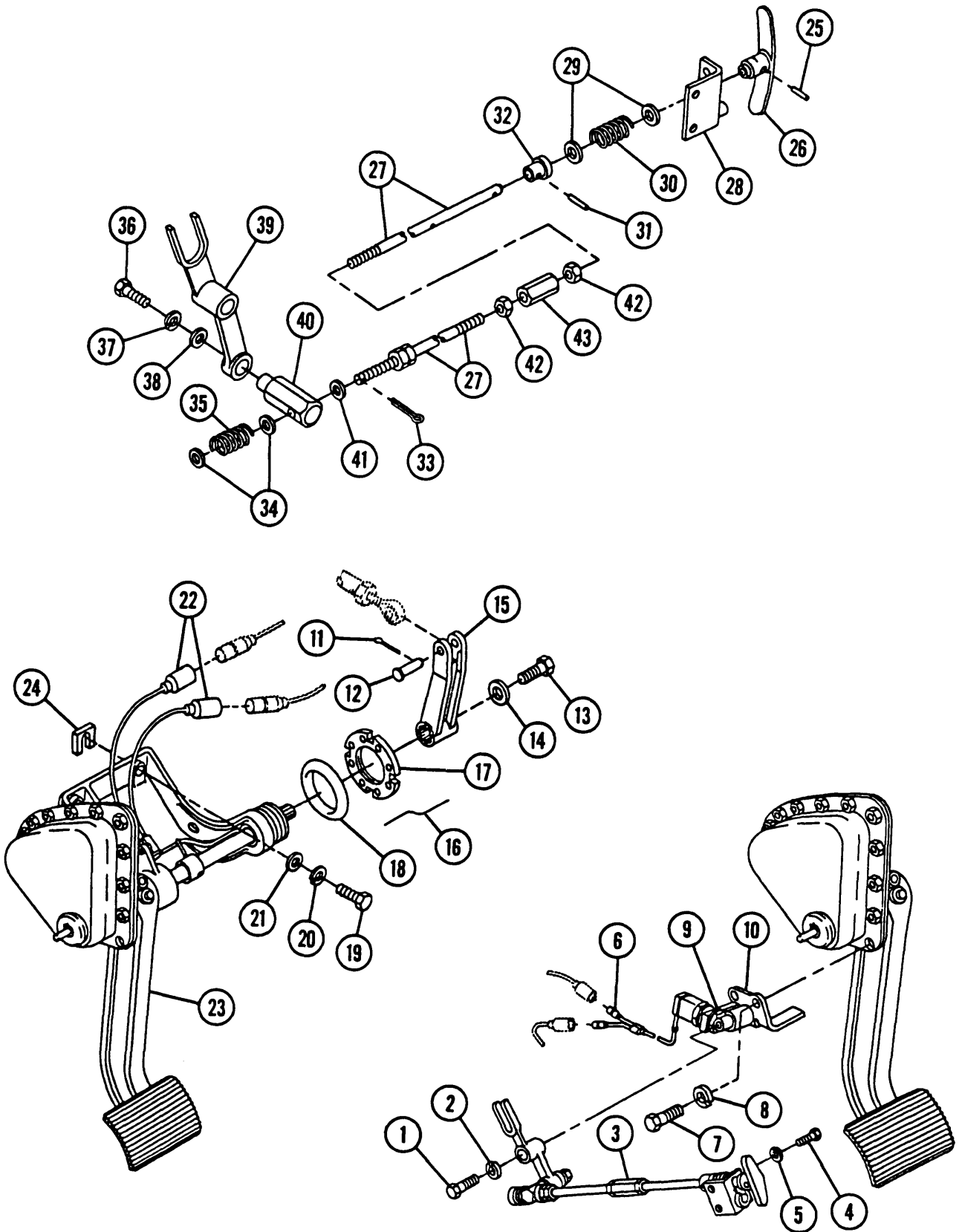

9-10 SERVICE AND PARKING BRAKE LINKAGE — CONTINUED

e. Adjustment

- 1 Release service brake. Check for slack in sprocket control chain (88). If no slack is present, go to step 2. If slack is present, remove cotter pin (82) and clevis pin (83) from brake shaft lever (85). Discard cotter pin. Loosen nut (76) and turn rod (78) clockwise to shorten. Replace clevis pin and check for slack again. If slack is still present, repeat as above. If no slack is present, install new cotter pin and go to step 2.
- 2 Check to ensure alinement of brake apply shaft index mark with release point (89). If linkage alinement is correct, go to step 3. If not alined, adjust length of rod (78) until they are alined.
- 3 After brake adjustment, loosen nut (90) on brake pedal lever stop screw (91). Adjust brake shaft lever stop screw so that pedal has 0.75 in. (19.1 mm) free travel. Tighten nut.
- 4 Loosen parking brake bracket (28) by removing screws (4) and lockwashers (5). Discard lockwashers.
- 5 Unlock parking brake handle (26) (up position). Loosen two nuts (42) on forward brake control rod (92) and rear brake control rod (93).
- 6 Turn connecting nut (43) in either direction until holes in parking brake bracket (28) aline with mating holes (hidden), and with no pressure on bell crank (39).
- 7 Secure bracket (28) to hull with two screws (4) and two new lockwashers (5). Tighten two nuts (42) on each of control rods (92 and 93).
- 8 Depress brake pedal (51). Pull back on parking brake handle (26). Remove foot from pedal. Brake should stay locked. To release parking brakes, lift up and in on parking brake handle; then depress and release brake pedal.

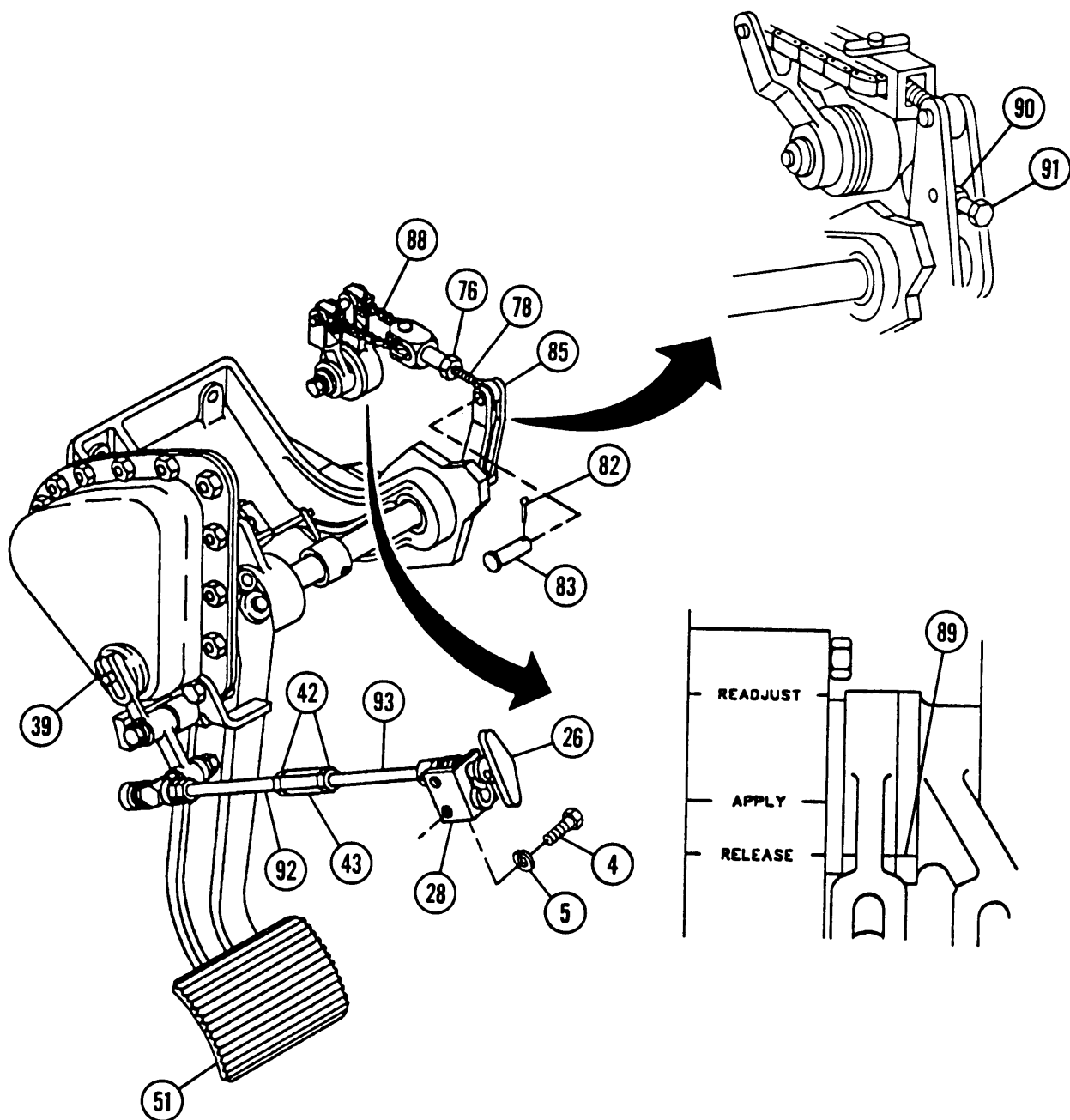

9-11 ACCELERATOR, THROTTLE, AND ENGINE CONTROL GOVERNOR

This task covers:

a. Removal	b. Disassembly
c. Assembly	d. Installation

INITIAL SETUP

Tools

General mechanic's tool kit (item 64, Appx H)

Materials/Parts

Cotter pin (item 43, Appx G)
Cotter pin (item 205, Appx G)

Cotter pins (6) (item 40, Appx G)
Cotter pins (2) (item 41, Appx G)
Key washer (item 186, Appx G)
Lockwashers (8) (item 95, Appx G)
Lockwashers (5) (item 96, Appx G)
Spring pins (2) (item 9, Appx G)

a. Removal

- 1 Remove cotter pin (1) and pin (2) at bell crank (3). Discard cotter pin.
- 2 Remove two cotter pins (4), three flat washers (5), spring (6), and rod assembly (7) from throttle control lever (8). Discard cotter pins.

NOTE

Remove throttle control lever (8), if damaged or requiring replacement at transmission, according to step 3.

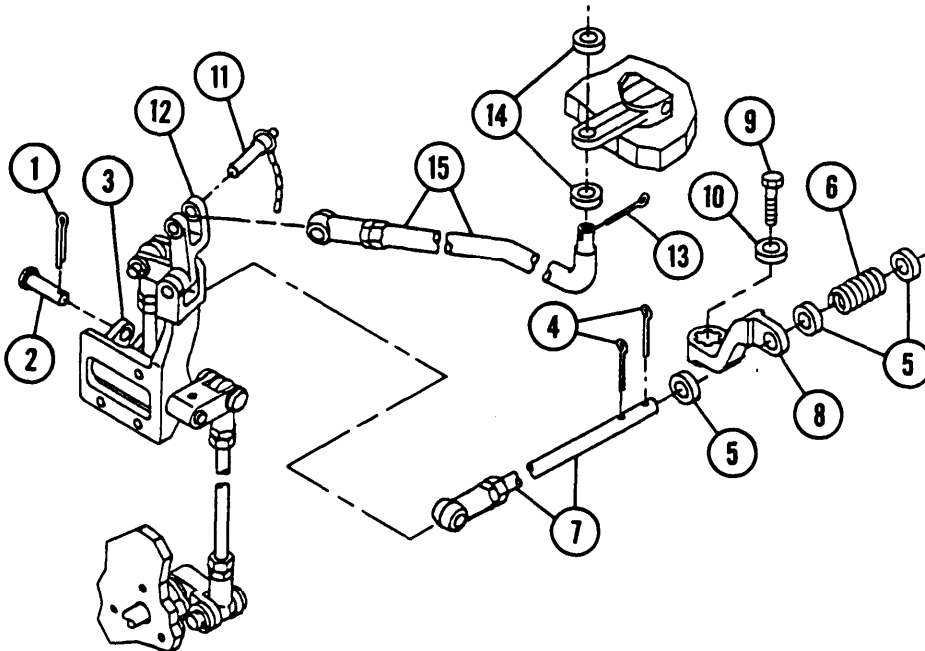

- 3 Remove screw (9), washer (10), and throttle control lever (8).
- 4 Remove quick-release pin (11) at bell crank (12).
- 5 Remove cotter pin (13) and two flat washers (14) from end of governor control rod assembly (15). Discard cotter pin.
- 6 Remove two cotter pins (16), two flat washers (17), two pins (18), and bell crank (3). Discard cotter pins.
- 7 Remove rod assembly (19).
- 8 Remove cotter pin (20) and pin (21) at bell crank (12). Discard cotter pin.
- 9 Remove bell crank (12).
- 10 Remove two cotter pins (22), two flat washers (23), and two pins (24) at rod assembly (25). Discard cotter pins.
- 11 Remove rod assembly (25).
- 12 Remove three screws (26), three lockwashers (27), three flat washers (28), and bracket assembly (29) from hull bulkhead. Discard lockwashers.

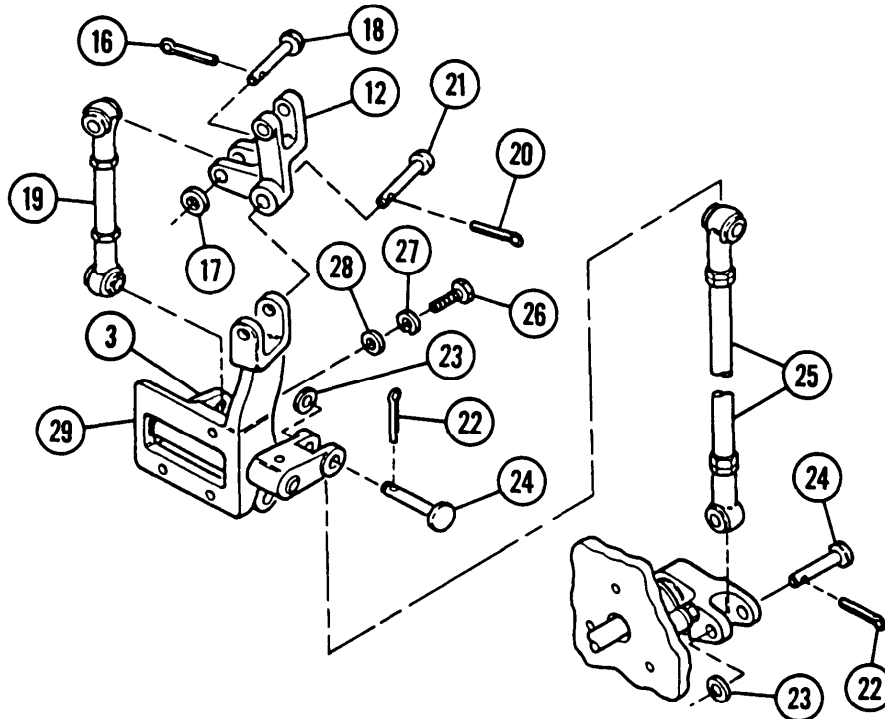

9-11 ACCELERATOR, THROTTLE, AND ENGINE CONTROL GOVERNOR — CONTINUED

a. Removal — Continued

- 13 Remove pin (30) and lever (31).

NOTE

Remove inserts (32 and 33) only if threads are damaged and inserts must be replaced.

- 14 Remove three screws (34), three lockwashers (35), and three inserts (32) at bracket support assembly (36). Discard lockwashers.

- 15 Remove bracket support assembly (36) from bulkhead.

- 16 Remove cotter pin (37) and pin (38) at end of throttle control rod (39) for removal of linkage in driver's compartment. Discard cotter pin.

NOTE

Throttle control rod (39) is part of hand throttle control assembly (40).

- 17 Remove screw (41), key washer (42), and throttle control assembly (40). Remove insert (33) if necessary. Discard key washer.

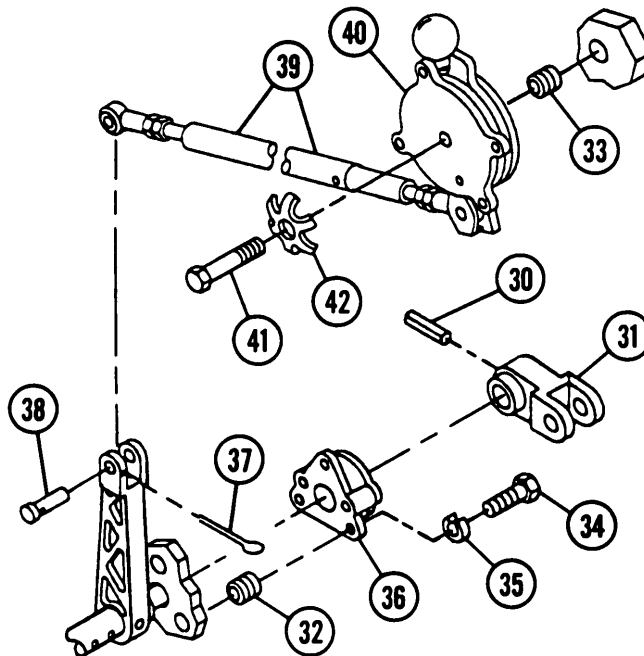

18 Remove spring (43), two screws (44), two lockwashers (45), two flat washers (46), and mounting bracket (47) at support bracket. Discard lockwashers.

19 Twist pedal and shaft assembly (48) to clear support bracket and withdraw from bulkhead bore to remove.

b. Disassembly

1 Loosen nut (49) and remove after unscrewing rod ends (50) from shaft (51) to disassemble rod assemblies.

2 Remove two spring pins (52), shaft (53), lever (54), bell crank (55), and bracket (56) to disassemble bracket assembly (57). Remove bearings (58) if damaged or worn. Discard spring pins.

3 Remove two screws (59) and two lockwashers (60) and disassemble bracket support assembly (61). Remove cap (62) and bearing (63) from bracket (64). Discard lockwashers.

4 Remove three screws (65) and three lockwashers (66). Remove cap (67) and bearing (68) from bracket (69). Discard lockwashers.

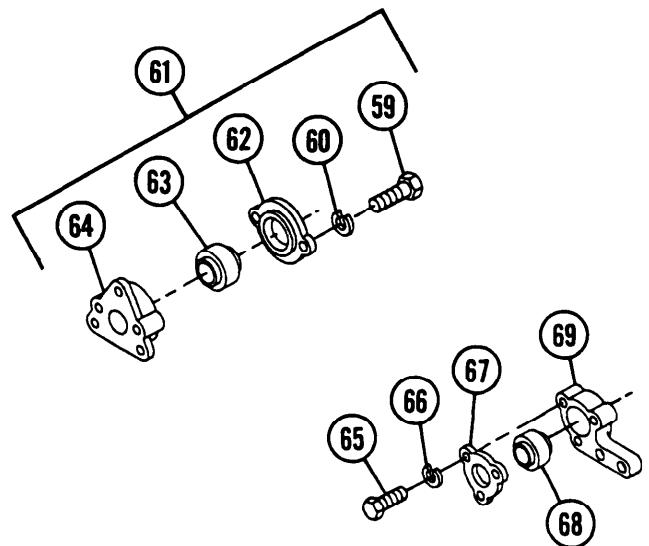
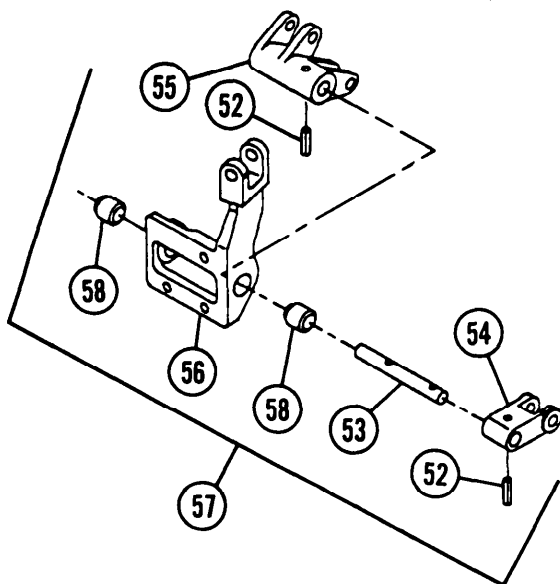
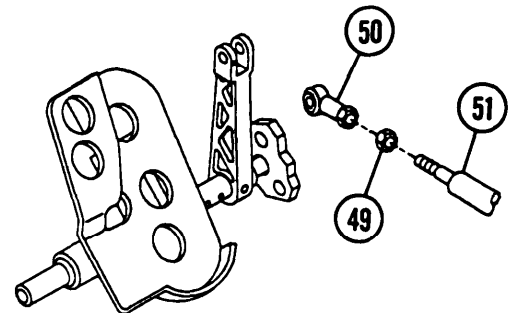
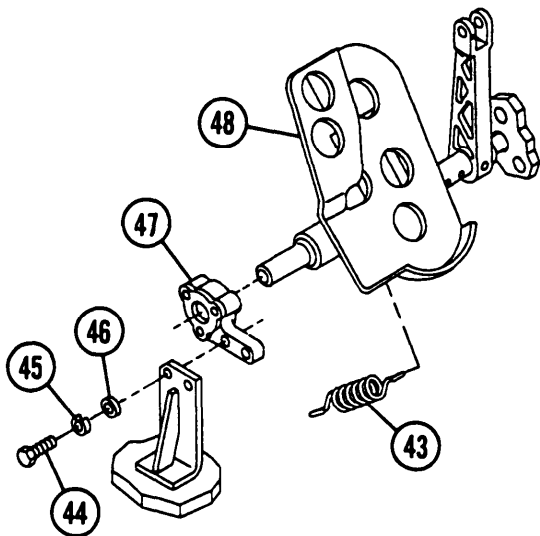

9-11 ACCELERATOR, THROTTLE, AND ENGINE CONTROL GOVERNOR — CONTINUED

b. Disassembly—Continued

- 5 Remove two pins (70), collar (71), and pedal (72) from shaft (73).
- 6 Remove pin (74) and separate shaft (73) from lever (75).
- 7 Separate cover (76), two disks (77), and lever with rod assembly (78) to disassemble hand throttle control assembly (40).
- 8 Loosen nut (79) and remove screw (80) with nut. Remove nut from screw.

c. Assembly

- 1 Screw nut (79) onto screw (80). Install screw with nut and tighten nut.
- 2 Attach cover (76), two disks (77), and lever with rod assembly (78) to assemble hand throttle control assembly (40).
- 3 Install pin (74) and lever (75) to shaft (73).
- 4 Install pedal (72), collar (71), and two pins (70) onto shaft (73).

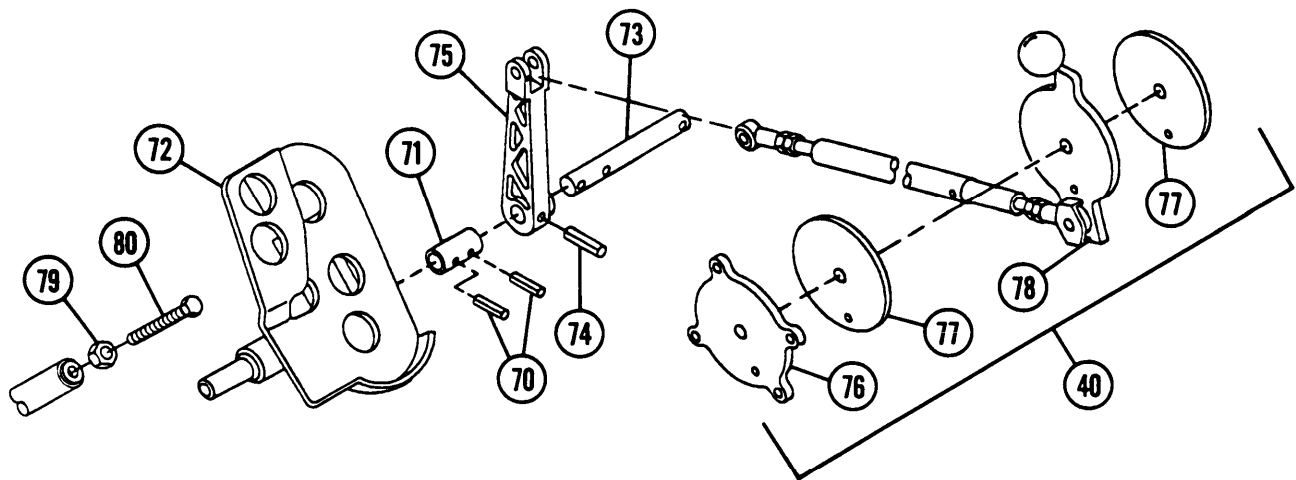

5 Install cap (67) and bearing (68) onto bracket (69). Install three new lockwashers (66) and three screws (65).

6 Install two screws (59), two new lockwashers (60), cap (62), and bearing (63) to bracket (64) to assemble bracket support assembly (61).

7 Replace bearings (58) if damaged. Install lever (54) and bell crank (55) by pushing shaft (53) into bracket (56). Install two new spring pins (52) to assemble bracket assembly (57).

8 Install nut (49) and tighten after screwing rod ends (50) onto shaft (51) to assemble rod assemblies.

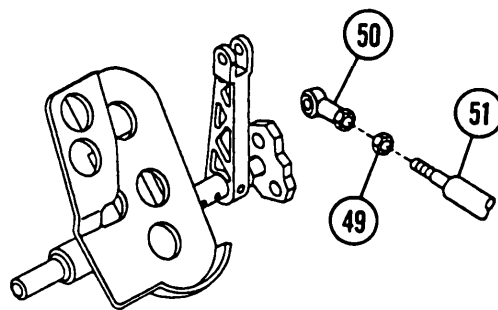
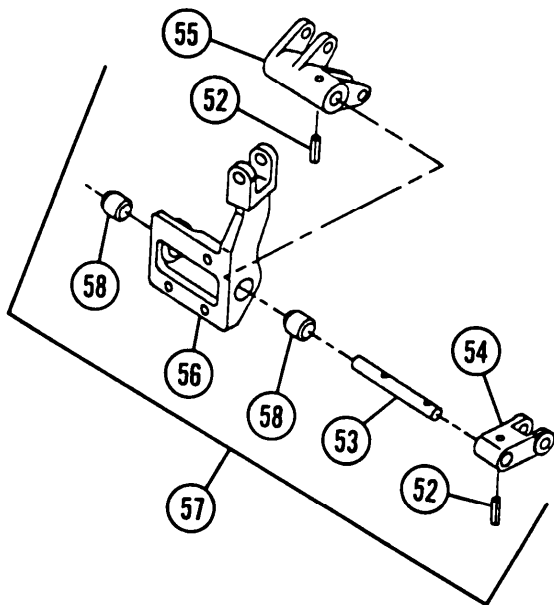
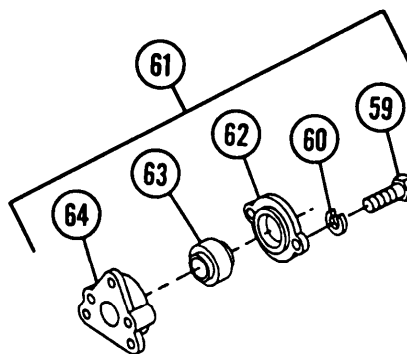
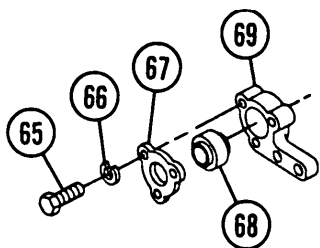

9-11 ACCELERATOR, THROTTLE, AND ENGINE CONTROL GOVERNOR — CONTINUED

d. Installation

- 1 Install pedal and shaft assembly (48), mounting bracket (47), two flat washers (46), two lockwashers (45), two screws (44), and spring (43) at support bracket.

NOTE

Replace inserts (32 and 33) only if threads are damaged.

- 2 Install throttle control assembly (40), new key washer (42), and screw (41). Install insert (33) if removed.
- 3 Install pin (38) and new cotter pin (37) at end of throttle control rod (39) to install in driver's compartment.
- 4 Install bracket support assembly (36) at bulkhead.
- 5 Install three inserts (32) if necessary. Install three new lockwashers (35) and three screws (34) at bracket support assembly (36).
- 6 Install lever (31) and pin (30).

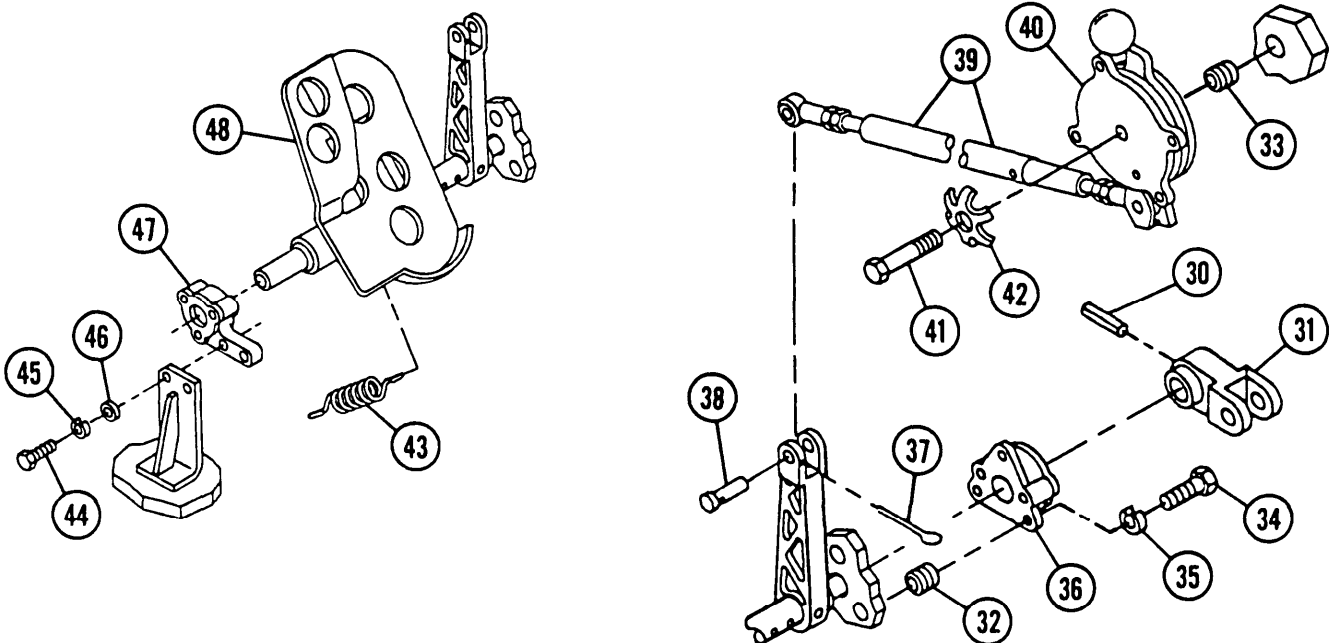

- 7 Install bracket assembly (29), three flat washers (28), three new lockwashers (27), and three screws (26) onto hull bulkhead.
- 8 Install rod assembly (25).
- 9 Install two pins (24), two flat washers (23), and two new cotter pins (22).
- 10 Install bell crank (12).
- 11 Install pin (21) and new cotter pin (20) at bell crank (1 2).
- 12 Install rod assembly (1 9).
- 13 Install two pins (18), two flat washers (17), and two new cotter pins (16) at bell crank (12) to install rod assembly (19).

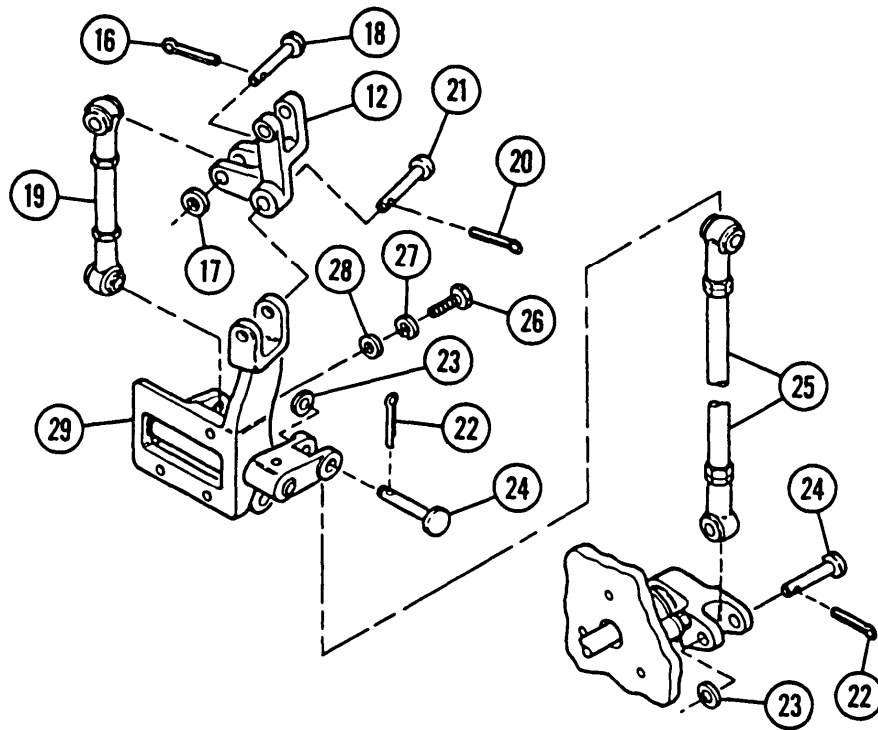

9-11 ACCELERATOR, THROTTLE, AND ENGINE CONTROL GOVERNOR — CONTINUED

d. Installation — Continued

- 14 Install two flat washers (14) and new cotter pin (13) at end of rod assembly (15) at engine throttle control lever (8).
- 15 Install quick-release pin (11) at bell crank (12).
- 16 Install throttle control lever (8), washer (10), and screw (9) if damaged or requiring replacement at transmission.
- 17 install rod assembly (7), spring (6), three flat washers (5), and two new cotter pins (4) at throttle control lever (8).
- 18 Install pin (2) and new cotter pin (1) at bell crank (3) to install linkage in powerplant.

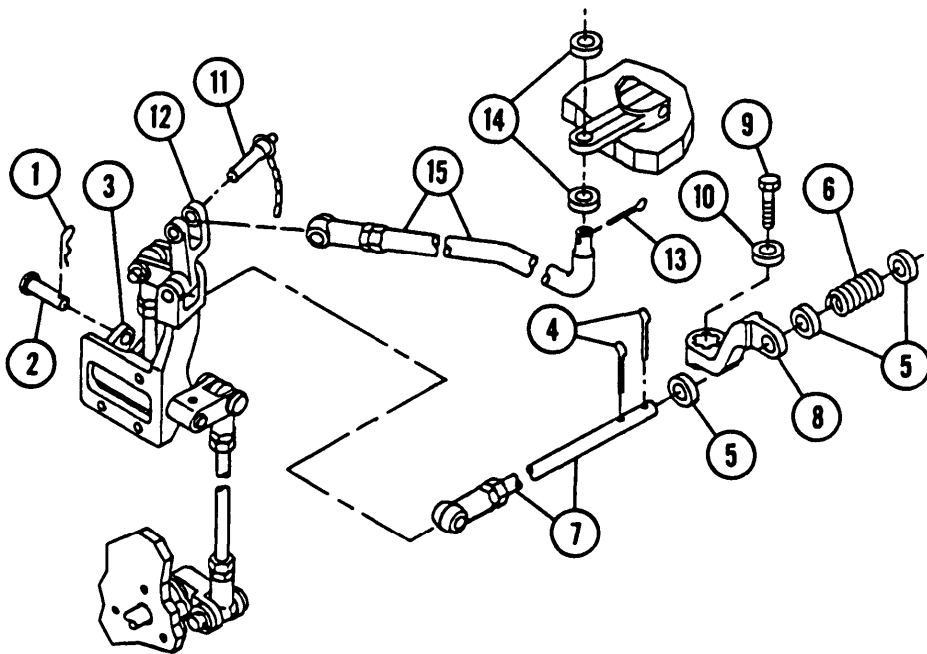

9-12 TRANSMISSION INTERNAL BRAKE

This task covers Adjustment

INITIAL SETUP

Tools

General mechanic's tool kit (item 64, Appx H)
 Brake adjustment wrench (item 70, Appx H)

Brake adjustment wrench (item 69, Appx H)
 Gage (item 21, Appx H)

Adjustment

NOTE

If brake linkage is not installed, brakes may be adjusted using same procedures as outlined, except that special wrenches for brake adjustment may be used to apply brakes. Brakes should be applied to approximately 90 lb-ft (122 N-m).

- 1 Check brake linkage adjustment.
- 2 Apply brakes fully and watch index marks (1) on brake levers (2). If index marks rotate to APPLY mark (3) on bearing retainer (4) but not to READJUST mark (5), brakes are properly adjusted. If index marks do not rotate to APPLY mark or rotate past READJUST mark, brakes must be adjusted.
- 3 Remove 12 screws (6), 12 washers (7), and 2 transmission covers (8).

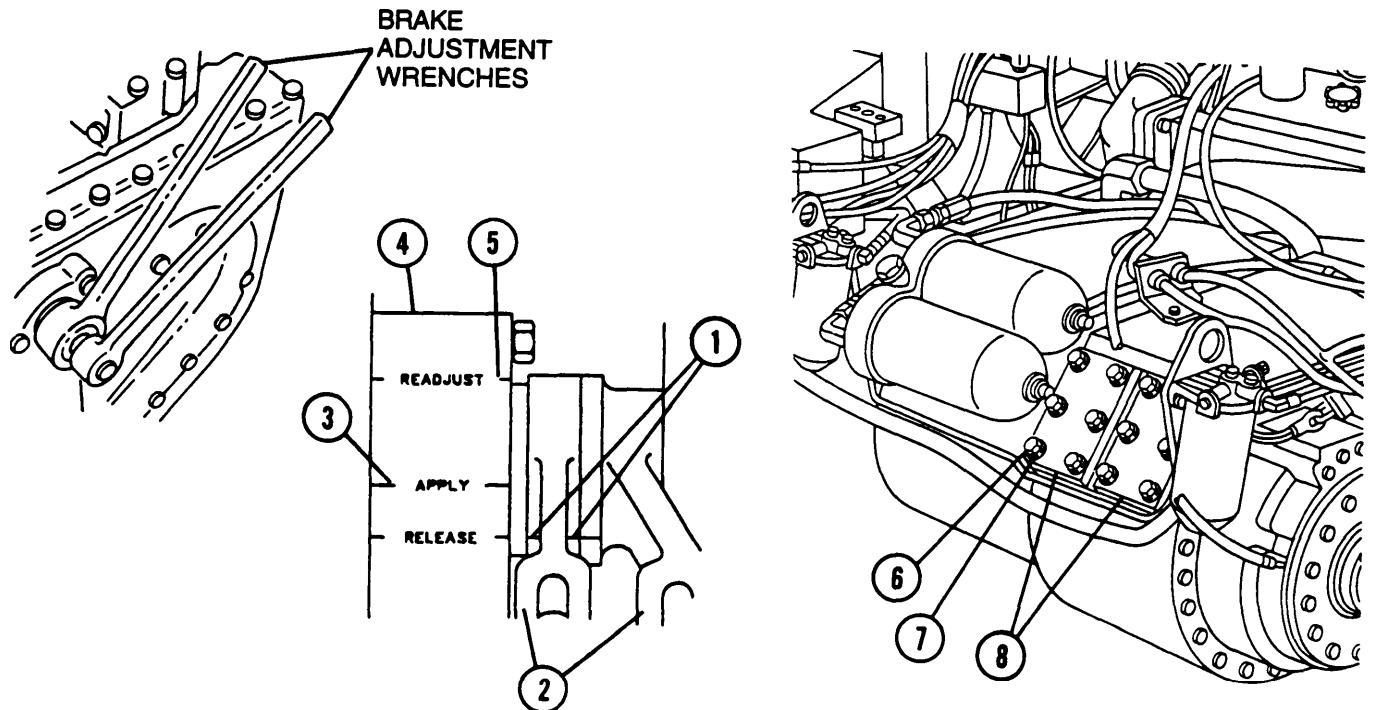

9-12 TRANSMISSION INTERNAL BRAKE — CONTINUED

Adjustment — Continued

- 4 Insert screwdriver into adjustment nuts (9) and turn to adjust brakes. Clockwise rotation will tighten brakes; counterclockwise will loosen brakes.
- 5 Adjust both brakes uniformly so that both index marks (1) align with APPLY mark (3) on bearing retainer (4) when brakes are applied.
- 6 Install 2 transmission covers (8), 12 screws (6), and 12 washers (7).
- 7 Clear area of personnel and equipment. Perform PMCS on brakes (para 2-15). If brakes do not hold vehicle, readjust brakes.

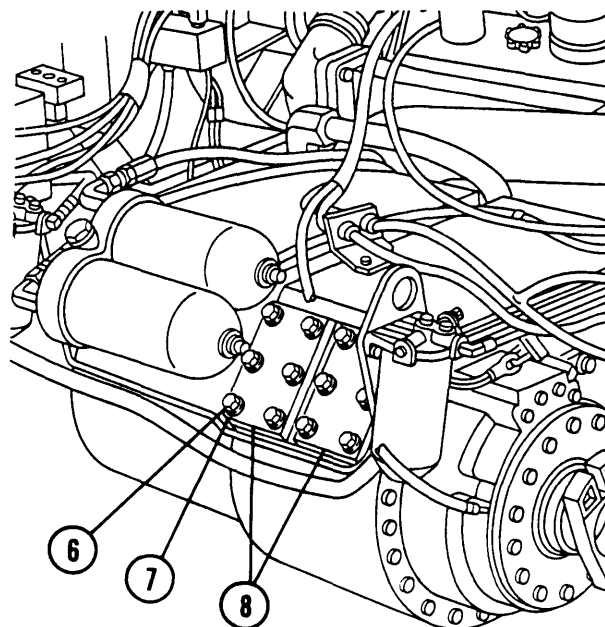
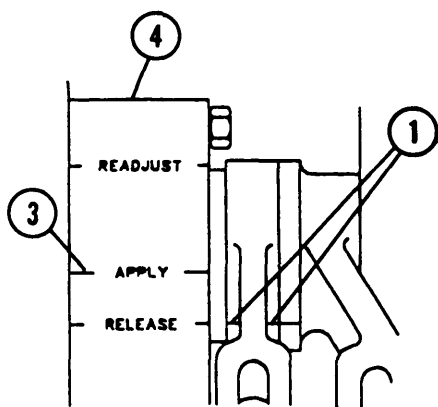
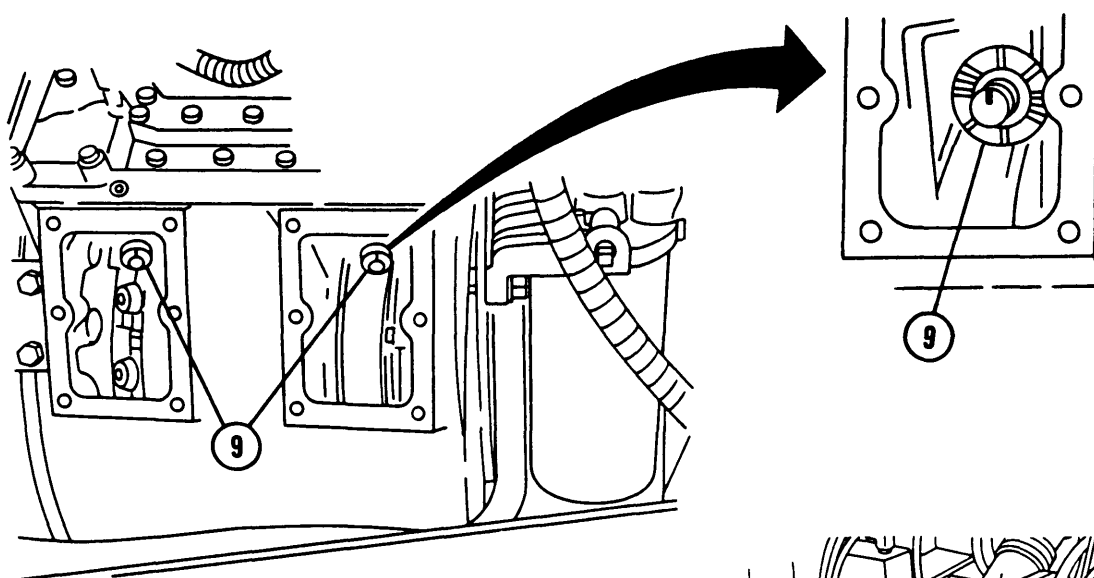

9-13 TRANSMISSION THROTTLE VALVE

This task covers: Adjustment

INITIAL SETUP

Tools

General mechanic's tool kit (item 64, Appx H)

Adjustment

NOTE

Perform after engine throttle governor control rod adjustment.

- 1 Remove quick-release pin (1) (hidden) and remove transmission throttle valve control rod (2) from lever on throttle control lever bracket assembly (3).
- 2 Fully depress accelerator pedal and hold in depressed position. (Lever on throttle control lever bracket will move towards driver's compartment bulkhead.)
- 3 Move transmission throttle valve lever against stop (toward driver's compartment bulkhead).
- 4 Loosen nut (4) on transmission throttle valve control rod and turn rod end (5) 1/2 turn at a time, until pin (1) will freely enter rod end and lever. Insert pin and release accelerator pedal.
- 5 Shorten transmission throttle valve control rod (2) to put spring (6) under compression by rotating rod end (5) clockwise 2 turns. This ensures full travel of transmission throttle lever. Tighten nut (4).
- 6 To adjust linkage properly, install transmission throttle valve control rod (2) to lever on throttle control lever bracket assembly (3). Linkage is adjusted properly.

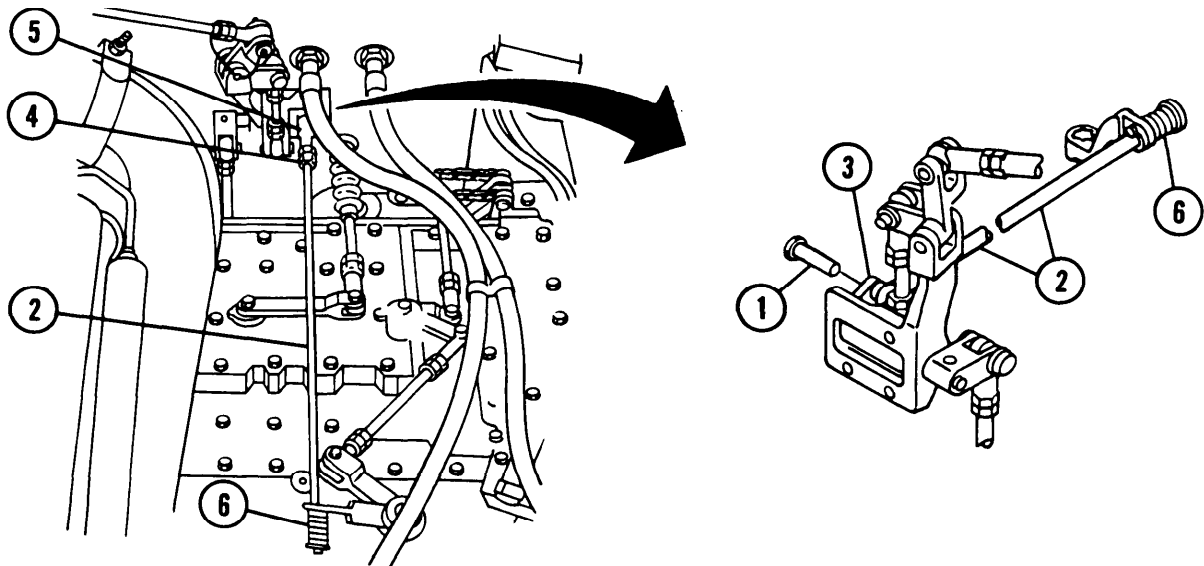

9-14 ENGINE THROTTLE GOVERNOR CONTROL ROD

This task covers: Adjustment

INITIAL SETUP

Tools

General mechanic's tool kit (item 64, APPX H)

Adjustment

- 1 Fully depress accelerator pedal to move engine throttle governor control rod lever (1) away from driver's compartment bulkhead.
- 2 Remove quick-release pin (2), and disconnect engine throttle governor control rod (3) from lever (1).
- 3 Push engine throttle governor control rod (3) towards rear of vehicle (accelerator still depressed) and loosen control rod nut (4).

NOTE

A 0.25-in. - (6.4-mm-) diameter dowel pin may be used. Fit will be tight. Pin fits through lever and into bulkhead pilot hole.

- 4 Note whether pin (2) removed in step 2 can be easily installed in lever (1) and control rod end (5). If it cannot, loosen nut (4) on control rod and twist rod end 1/2 turn at a time until pin can be installed. Tighten nut.
- 5 Install rod (3) and pin (2). Linkage is now adjusted properly.
- 6 Release accelerator pedal.

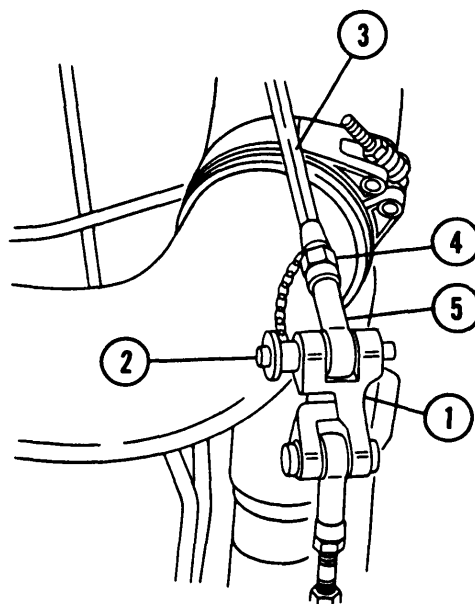

9-15 HAND THROTTLE GOVERNOR CONTROL ROD

This task covers: Adjustment

INITIAL SETUP

Tools

General mechanic's tool kit (item 64, Appx H)

Materials/Parts

Cotter pin (item 43, Appx G)

Adjustment

NOTE

A 0.25-in. - (6.4-mm-) diameter dowel pin may be used.

- 1 Insert 0.225-in. - (5.72-mm-) diameter dowel pin in positioning hole (1) of throttle lever cover (2).
- 2 Remove cotter pin (3), flat washer (4), and clevis pin (5). Discard cotter pin.
- 3 Remove control rod (6) from throttle lever (7).
- 4 Insert 0.225-in. - (5.72-mm-) diameter dowel pin in positioning hole (8) in throttle lever and bulkhead.
- 5 Loosen nut (9).
- 6 Adjust rod end (10) until pin (5) can be inserted easily.

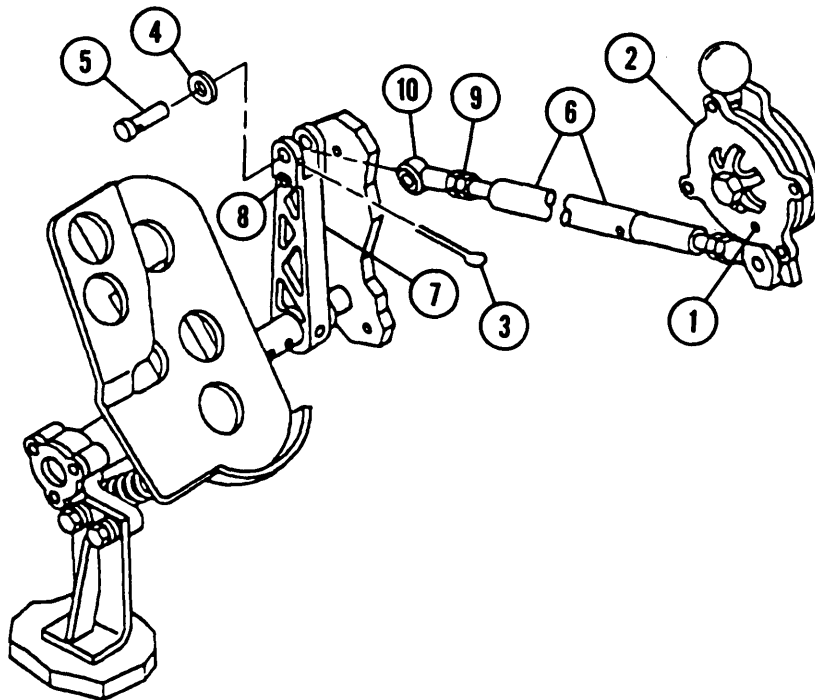

9-15 HAND THROTTLE GOVERNOR CONTROL ROD — CONTINUED

Adjustment — Continued

- 7 Tighten nut (9).
- 8 Install rod (6), flat washer (4), clevis pin (5), and new cotter pin (3).
- 9 Remove dowel pins in positioning holes (1 and 8).
- 10 Start engine with throttle control closed.
- 11 Check tachometer. Engine should beat idle speed (650 to 750 rpm).

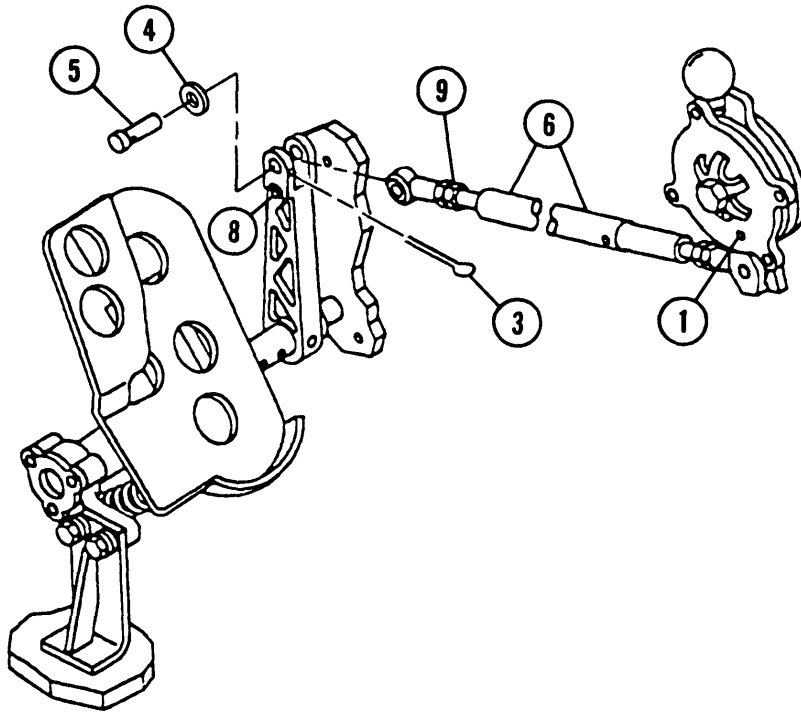

9-16 ACCELERATOR PEDAL

This task covers: Adjustment

INITIAL SETUP

Tools

General mechanic's tool kit (item 64, Appx H)

Adjustment

NOTE

Ensure hand throttle adjustment is correct (para 9-1 5).

- 1 Loosen nut (1) and then turn adjusting screw (2) completely in.
- 2 Depress accelerator pedal (3) until it stops. Hold pedal down in depressed position and unscrew adjusting screw (2) until it touches accelerator pedal.
- 3 Tighten nut (1).

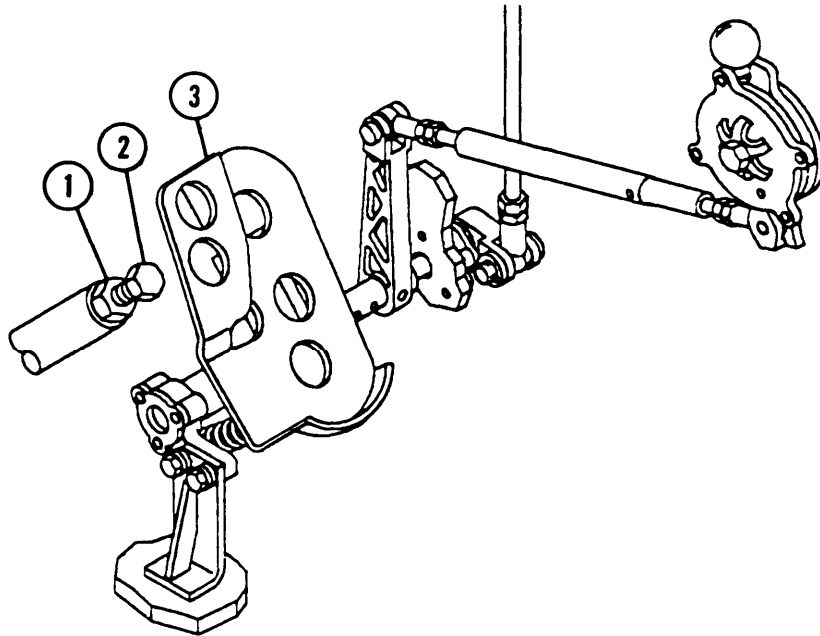

9-17 WARNING LIGHT AND STOP LIGHT SWITCHES

This task covers: Adjustment

INITIAL SETUP

Tools

General mechanic's tool kit (item 64, Appx H)

Adjustment

- 1 To adjust warning light switch, loosen two nuts (1) and move parking brake handle (2) out 0.375 in. (9.5 mm).
- 2 Adjust two nuts (1) until switch (3) touches arm (4). Tighten two nuts.
- 3 To adjust stop light switch, depress brake pedal (5) 0.75 in. (19.1 mm) and lock brakes.
- 4 Loosen socket head screws (6) and turn stop light actuator (7) until it touches stop light switch (8).
- 5 Tighten screws (6).

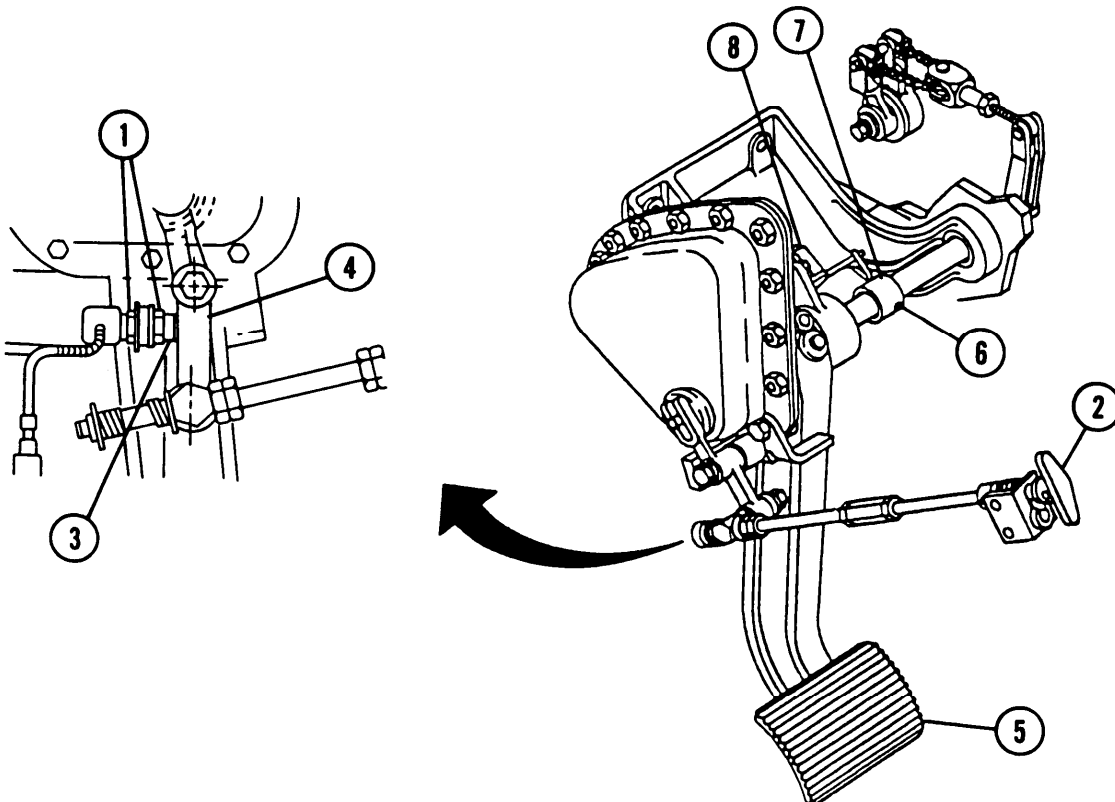

9-18 SPEEDOMETER AND TACHOMETER SYSTEMS

This task covers: a. Removal b. Installation

INITIAL SETUP

Tools

General mechanic's tool kit (item 64, Appx H)

Lockwashers (4) (item 192, Appx G)

Materials/Parts

Gasket (item 56, Appx G)
Lockwashers (2) (item 95, Appx G)

Equipment Conditions

Front slope plate removed (para 4-5)
Transmission access door opened (para 4-5)

a. Removal

- 1 Remove flexible driveshafts (1 and 2) from back of speedometer (3) and tachometer (4).
- 2 Remove screw (5), lockwasher (6), washer (7), and strap (8) in driver's compartment.
- 3 Remove four flexible driveshafts (1, 2, 9, and 10) from two couplings (11) at bulkhead.
- 4 Remove two couplings (11) from bulkhead.

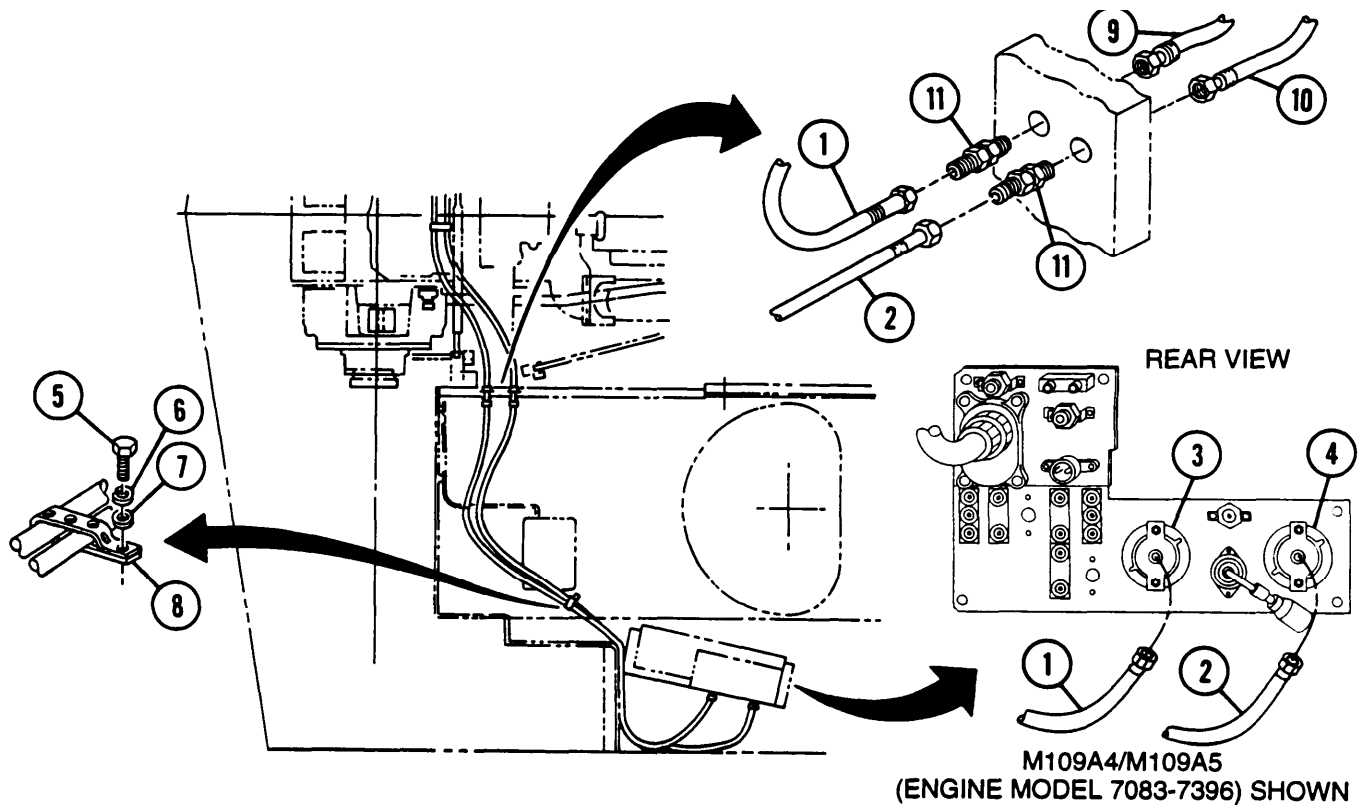

9-18 SPEEDOMETER AND TACHOMETER SYSTEMS — CONTINUED

a. Removal—Continued

5 Remove nut (12), lockwasher (13), screw (14), flat washer (15), and retaining strap (16) at support bracket (17) on transmission. Discard lockwasher.

6 Remove flexible driveshaft (9) from tachometer driveshaft adapter (18).

7 Remove flexible driveshaft (10) from speedometer driveshaft adapter (19).

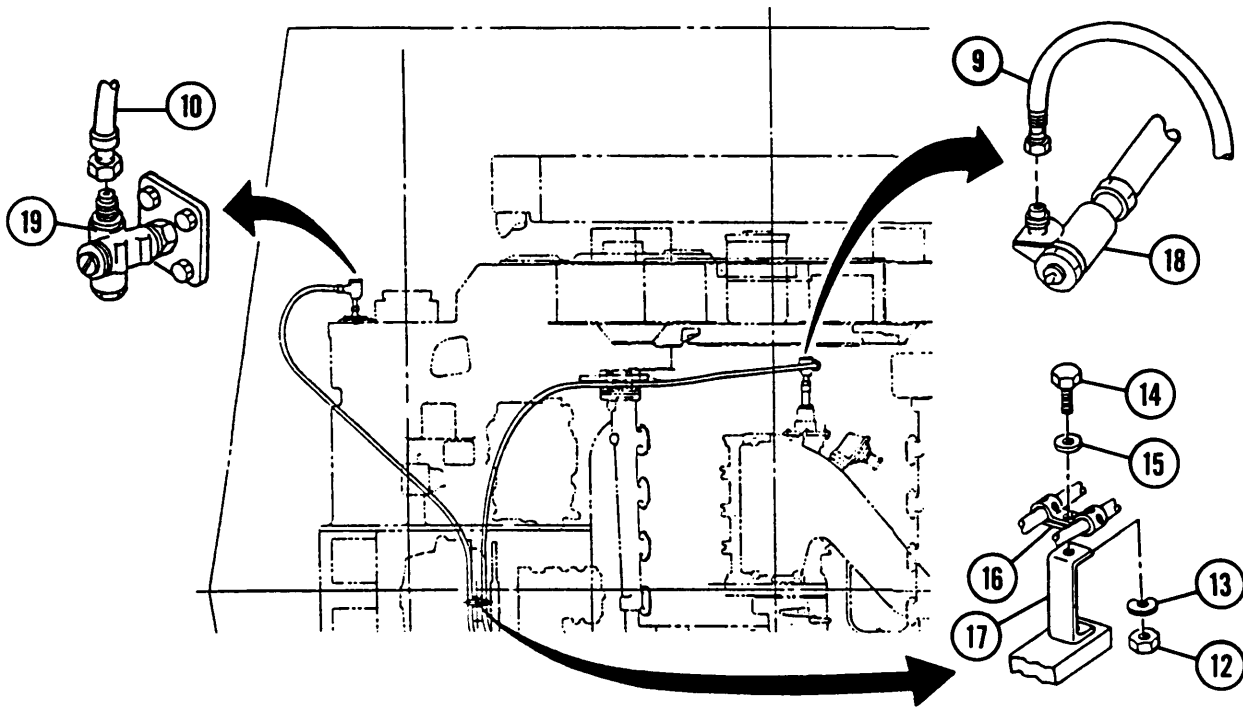

NOTE

Speedometer adapter (19) has a keyed pin. During removal of adapter, remove and store keyed pin until ready for installation. Speedometer will not work without pin.

8 Remove four screws (20), four lockwashers (21), and speedometer driveshaft adapter (19) with gasket (22) from transmission at right universal joint. Discard lockwashers and gasket.

9 Remove tachometer driveshaft adapter (18) from engine, adjacent to alternator housing.

b. Installation

1 Install tachometer driveshaft adapter (18) into engine, adjacent to alternator housing.

NOTE

Be sure to install keyed pin (saved during removal) so that speedometer will function.

2 Install new gasket (22), speedometer driveshaft adapter (19), four new lockwashers (21), and four screws (20).

3 Install speedometer flexible driveshaft (10) to speedometer driveshaft adapter (19) at drive joint.

4 Install tachometer flexible driveshaft (9) to tachometer driveshaft adapter (18) at drive joint.

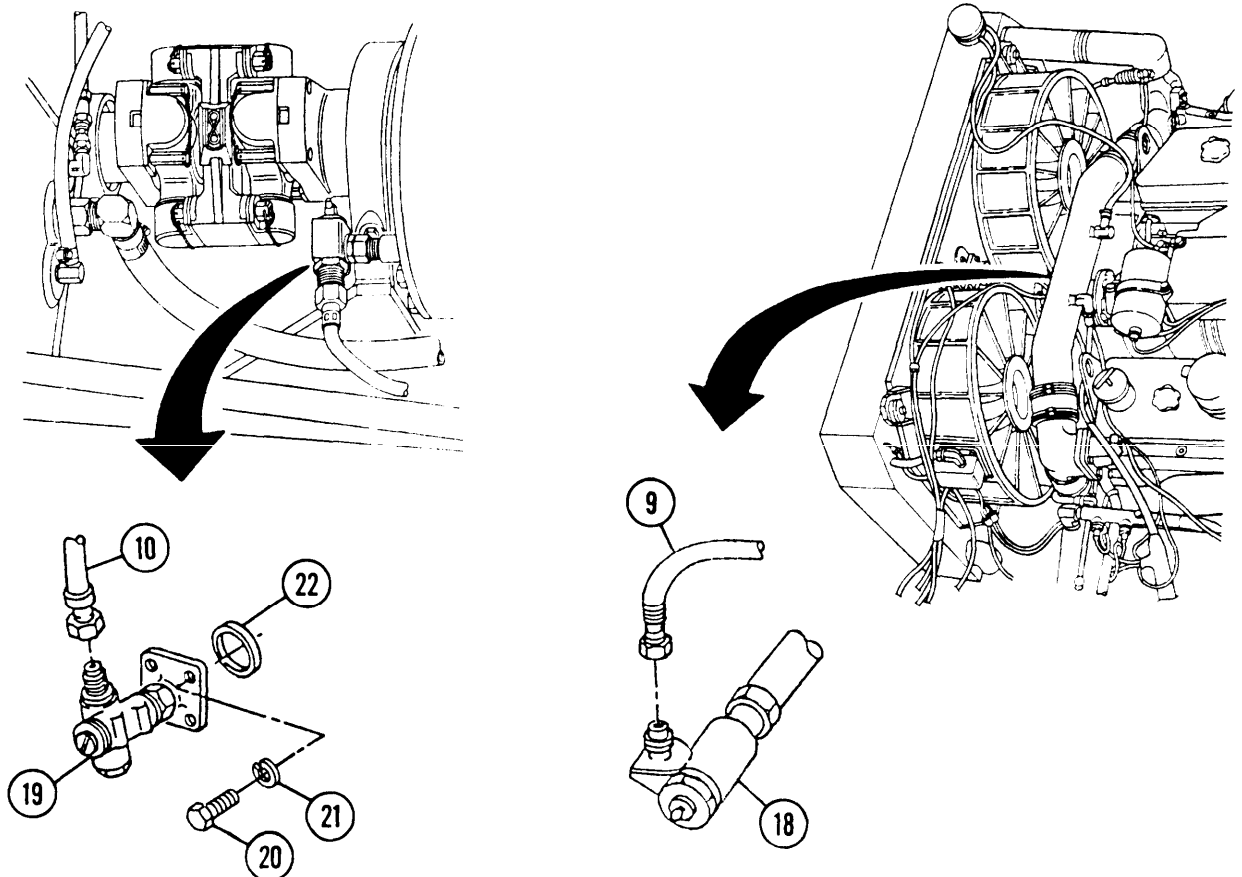

9-18 SPEEDOMETER AND TACHOMETER SYSTEMS — CONTINUED

b. Installation — Continued

5 Install two couplings (11) in bulkhead.

6 Install speedometer flexible driveshaft (9) and tachometer flexible driveshaft (10) to couplings (11) in bulkhead.

7 Install tachometer flexible driveshaft (10) and speedometer flexible driveshaft (9) with retaining strap (16) at support bracket (17) on transmission with flat washer (15), screw (14), new lockwasher (13), and nut (12).

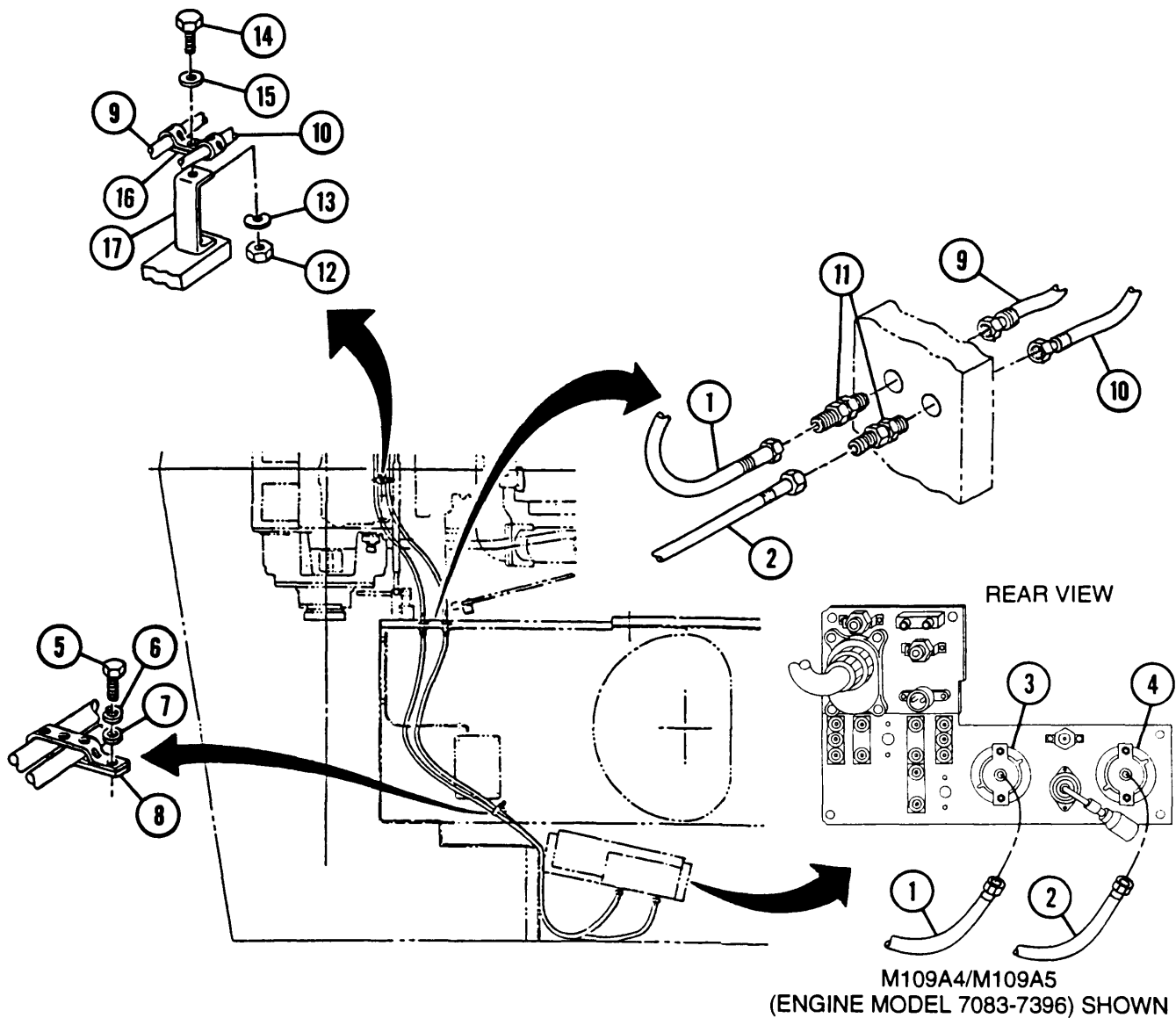

CHAPTER 10
TRACKS, SUSPENSION SYSTEM, FINAL DRIVES, AND UNIVERSAL JOINTS

GENERAL

This chapter provides instructions for removal, disassembly, assembly, installation, inspection, repair, checking, and adjusting tracks, suspension system, final drives, and universal joints.

<u>CONTENTS</u>	<u>PAGE</u>
Section I	TRACKS10-2
10-1	SUSPENSION IDENTIFICATION (ID).....10-2
10-2	TRACK PADS (T-136 TRACK)10-4
10-3	TRACK PADS (T-154 TRACK)10-5
10-4	TRACK SHOES (T-136 TRACK)10-6
10-5	TRACK SHOES (T-154 TRACK).....10-9
10-6	TRACKS (T-136 TRACK)10-11
10-7	TRACKS (T-154 TRACK)10-14
10-8	TRACK TENSION10-19
Section II	SUSPENSION SYSTEM10-21
10-9	TORSION BARS, ANCHORS, AND ROAD WHEEL ARM AND HUB ASSEMBLIES ID CHART ..10-21
10-10	ROAD WHEELS10-22
10-11	ROAD WHEEL HUBS10-26
10-12	ROAD WHEEL ARMS10-30
10-13	TORSION BARS10-31
10-14	TORSION BAR ANCHORS10-33
10-15	TRACK ADJUSTERS AND MOUNTING BRACKETS10-36
10-16	IDLER WHEELS AND HUBS.....10-39
10-17	IDLER ARM ASSEMBLIES10-43
10-18	IDLER ARM HOUSINGS10-47
10-19	SHOCK ABSORBERS10-48
10-20	SHOCK ABSORBER BEARINGS.....10-50
Section III	FINAL DRIVES AND UNIVERSAL JOINTS10-51
10-21	FINAL DRIVE SPROCKETS AND HUBS10-51
10-22	FINAL DRIVE ASSEMBLIES10-53
10-23	UNIVERSAL JOINTS10-57

SECTION I. TRACKS

10-1 SUSPENSION IDENTIFICATION (ID)

Removal and installation procedures are shown for:

- Track pads (para 10-2, T-136 track; para 10-4, T-154 track)
- Track shoes (para 10-4, T-136 track; para 10-6, T-154 track)
- Road wheels (para 10-10)
- Road wheel arms (para 10-12)
- Torsion bars (para 10-13)
- Torsion bar anchors (para 10-14)
- Track adjusters and mounting brackets (para 10-15)
- Idler wheels and hubs (para 10-16)
- Idler arm assemblies (para 10-17)
- Idler arm housings (para 10-18)
- Shock absorbers and mounts (para 10-19)
- Shock absorber bearings (para 10-20)
- Final drive sprockets and hubs (para 10-21)
- Final drive assemblies (para 10-22)
- Universal joints (para 10-23)

Disassembly and assembly procedures are given for road wheel hubs (para 10-11) and idler arm assemblies (para 10-17).

This chapter also illustrates and describes disconnecting tracks (para 10-4, T-136 track; para 10-5, T-154 track), installation of thrown tracks (para 10-6, T-136; para 10-7, T-154), and track replacement (para 10-6, T-136 track; para 10-7, T-154 track).

Checking and adjusting of track tension are described in paragraph 10-8.

Notify support maintenance for disassembly and assembly of road wheel arm upper spindle and housing groups.

Vehicle suspension system is illustrated. Numbers 1 thru 7 refer to road wheel removal procedures in paragraph 10-10.

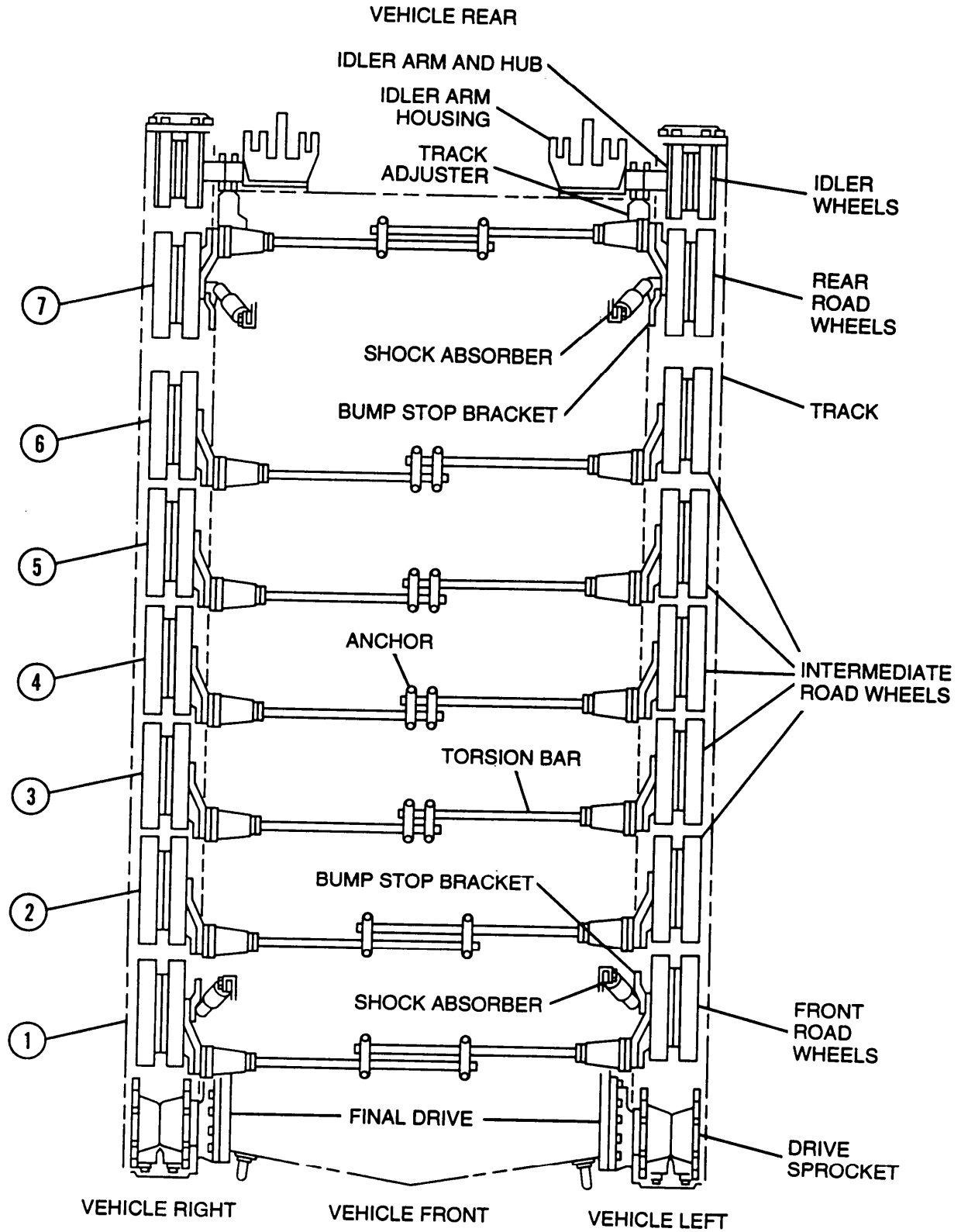

10-2 TRACK PADS (T-136 TRACK)

This task covers: a. Removal b. Installation

INITIAL SETUP

Tools

General mechanic's tool kit (item 64, Appx H)
Torque wrench (item 72, Appx H)

Materials/Parts

Pad nuts (2) (item 222, Appx G)
Track pad (item 149, Appx G)

NOTE

Only T-136 track pads can be installed on T-136 track.

a. Removal

- 1 Remove two pad nuts (1). Discard nuts.
- 2 Lift or pry track pad (2) from track shoe (3). Discard track pad.

b. Installation

- 1 Clean track shoe (3).
- 2 Install new track pad (2).
- 3 Install two new pad nuts (1). Torque to 40-45 lb-ft (54-61 N·m).

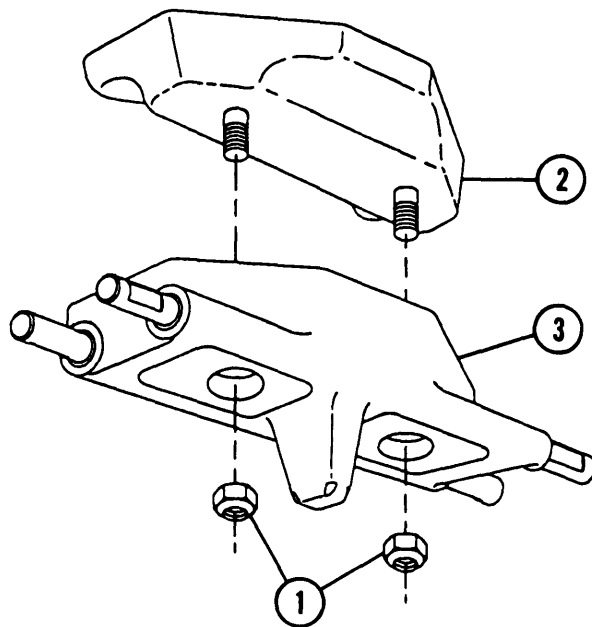

10-3 TRACK PADS (T-154 TRACK)

This task covers: a. Removal b. Installation

INITIAL SETUP**Tools**

General mechanic's tool kit (item 64, Appx H)
Torque wrench (item 72, Appx H)

Materials/Parts

Track pad nut (item 166, Appx G)
Track pad (item 165, Appx G)

NOTE

Only T-154 track pads can be installed on T-154 track.

a. Removal

- 1 Remove track pad nut (1). Discard nut.
- 2 Lift or pry track pad (2) from track shoe (3). Discard track pad.

b. Installation

- 1 Clean track shoe (3).
- 2 Install new track pad (2).
- 3 Install new track pad nut (1). Torque to 110-150 lb-ft (149-203 N·m).

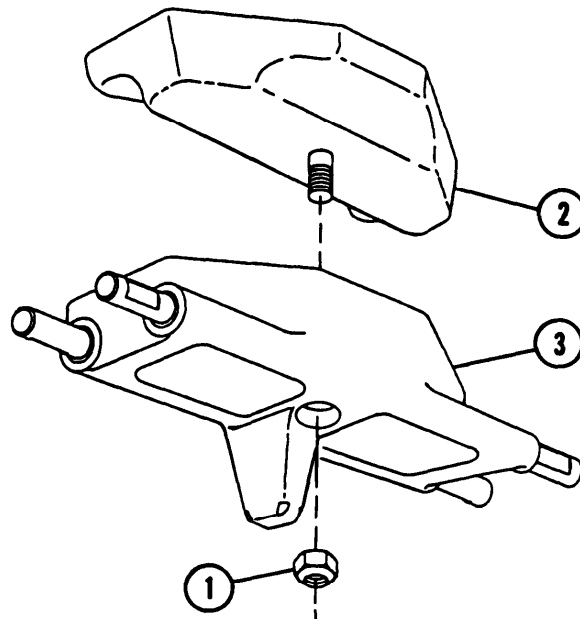

10-4 TRACK SHOES (T-136 TRACK)

This task covers: a. Removal b. Installation

INITIAL SETUP

Tools

General mechanic's tool kit (item 64, Appx H)
 Crowbar (item 15, Appx H)
 End connector puller (item 44, Appx H)
 Torque wrench (item 72, Appx H)
 Track-connecting fixtures (2) (item 20, Appx H)

Materials/Parts

Bolts (4) (item 114, Appx G)
 Retaining wedges (4) (item 153, Appx G)

Equipment Conditions

Track tension decreased (para 10-8)

a. Removal

WARNING

Track is heavy. Use caution when handling track to avoid serious injury.

NOTE

- Only T-136 track shoes can be installed on T-136 track.
- Move vehicle so that track shoe to be removed is off ground, either between road wheel and idler wheel or between drive sprocket and front road wheels.

1 Remove four bolts (1) and four retaining wedges (2) from four end connectors (3) from track shoe to be removed. Discard bolts and wedges.

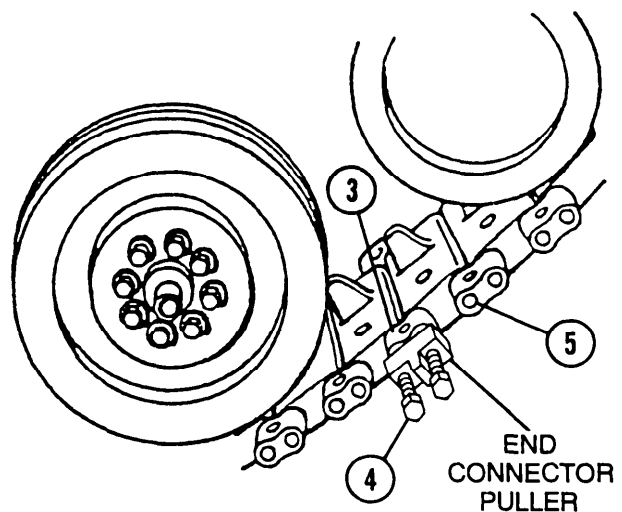
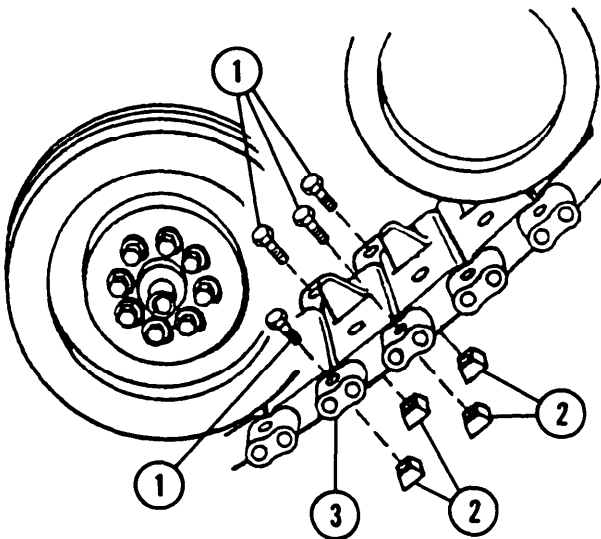

- 2 Install end connector puller. Tighten two screws (4) against ends of track link pins (5).
- 3 Tighten two screws (4) until end connector (3) moves out approximately 1 in. (25.4 mm). Repeat for remaining three end connectors.

NOTE

Tighten both fixtures equally removing tension from shoe or track connectors being removed.

- 4 Install track-connecting fixtures on both ends of shoe being removed, engaging track link pins (5) on adjacent shoes. Hold ends of track until shoe is replaced.
- 5 Remove four end connectors (3), end connector puller with screws (4), and track shoe (6).

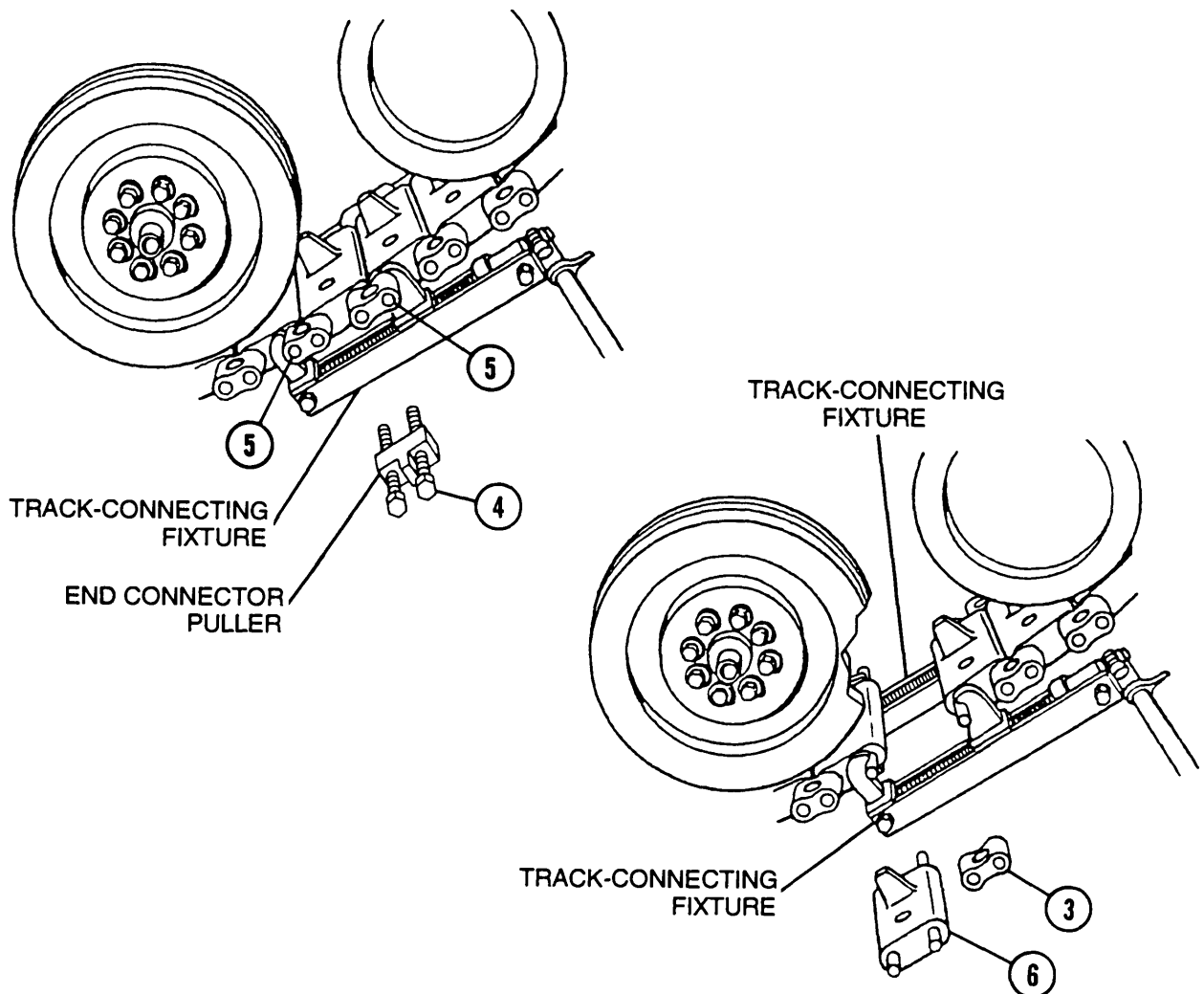

10-4 TRACK SHOES (T-136 TRACK) — CONTINUED

b. Installation

WARNING

Track is heavy. Before removing track-connecting fixtures, support weight of track with tanker bar to lower track to ground, to prevent possible injury.

- 1 Install track shoe (6) and four end connectors (3).
- 2 Install four new retaining wedges (2) and four new bolts (1) on four end connectors (3).
- 3 Torque four new bolts (1) and four new retaining wedges (2) to 90-100 lb-ft (122–136 N·m).
- 4 Remove track-connecting fixtures.

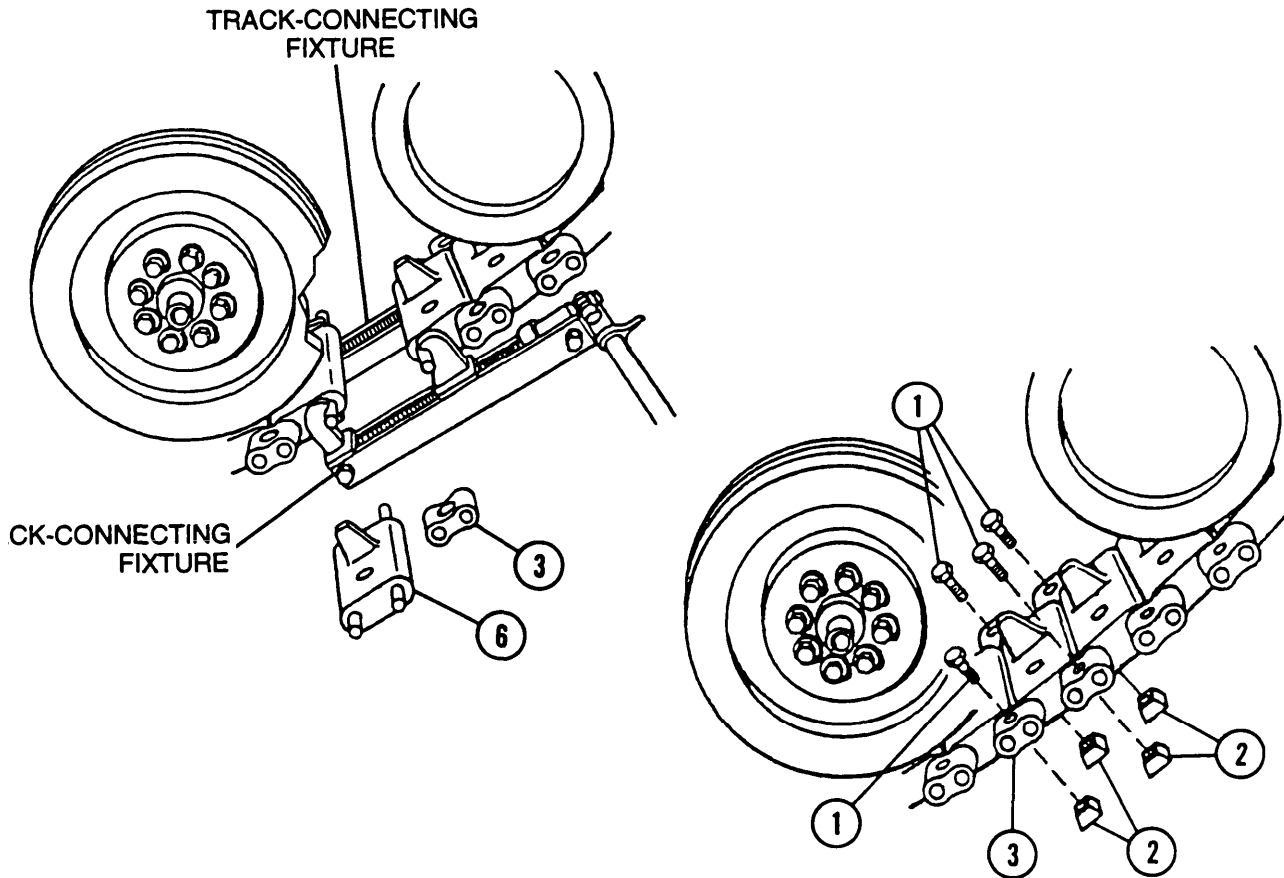

NOTE

FOLLOW-ON MAINTENANCE: Check and correct track tension (para 10-8)

10-5 TRACK SHOES (T-154 TRACK)

This task covers: a. Removal b. Installation

INITIAL SETUP

Tools

General mechanic's tool kit (item 64, Appx H)
 Crowbar (item 15, Appx H)
 Socket wrench set (item 56, Appx H)
 Torque multiplier (item 37, Appx H)
 Torque wrench (item 71, Appx H)
 Track-connecting fixtures (2) (item 20, APPX H)

Track connector puller (item 45, Appx H)

Materials/Parts

Connector bolts (4) (item 167, Appx G)

Equipment Conditions

Track tension decreased (para 10-8)

a. Removal

WARNING

Track is heavy. Use caution when handling track to avoid serious injury.

NOTE

- Only T-154 track shoes can be installed on T-154 track.
- Move vehicle so that track shoe to be removed is off ground, either between road wheel and idler wheel or between drive sprocket and front road wheels.

- 1 Block track that is not being broken.
- 2 Remove four connector bolts (1) on four end connectors (2) of the track shoe (3) to be removed. Discard connector bolts.
- 3 Install track connector puller on end connector (2) and tighten screws (4) against track link pins (5) until end connector moves out approximately 1 in. (2.5 cm). Repeat for remaining three end connectors.

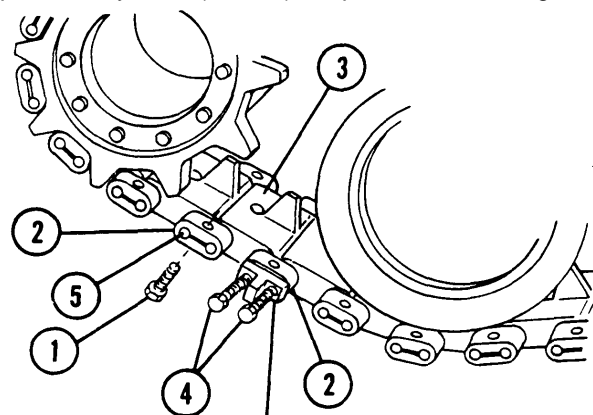

TRACK CONNECTOR PULLER

10-5 TRACK SHOES (T-154 TRACK) — CONTINUED

a. Removal — Continued

NOTE

Tighten both track-connecting fixtures equally, removing tension from shoe or connectors being removed.

- 4 Install two track-connecting fixtures on both ends of track shoe being removed, engaging track link pins (5) on adjacent shoe. Tighten fixtures until firmly clamped, holding ends of track until shoe is replaced.

WARNING

Track is heavy. Before removing track-connecting fixtures, support weight of track with crowbar to lower track to ground to prevent possible injury.

- 5 Remove four end connectors (2), track connector puller, and track shoe (3).
- 6 Leave two track-connecting fixtures connected.

b. Installation

WARNING

Track is heavy. Use caution when handling track to avoid serious injury.

- 1 Lift track (6) with crowbar and install track shoe (3), four end connectors (2), and four new end connector bolts (1) on track link pins (5).
- 2 Remove two track-connecting fixtures.
- 3 Torque four bolts (1) 380-420 lb-ft (515-569 N·m).

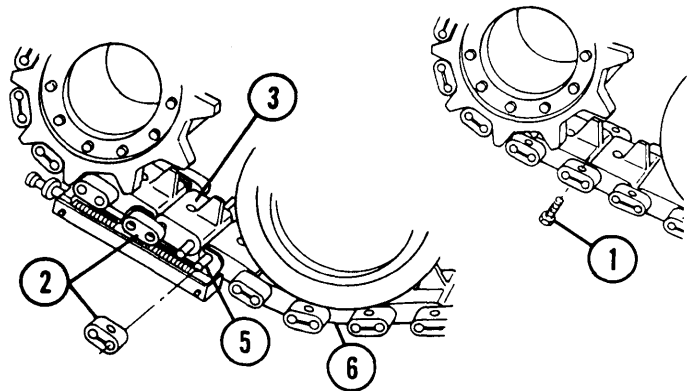
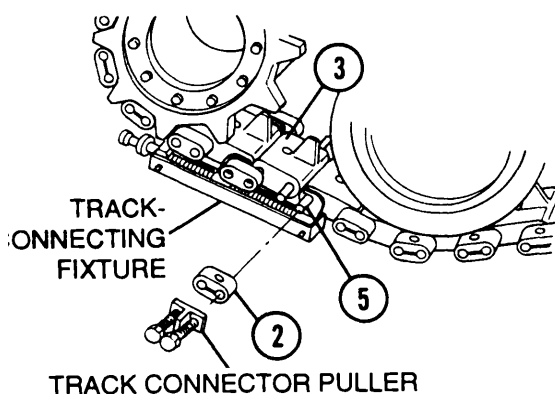

NOTE

FOLLOW-ON MAINTENANCE: Check and correct track tension (para 10-8)

10-6 TRACKS (T-136 TRACK)

This task covers: a. Removal b. Installation

INITIAL SETUP

Tools

General mechanic's tool kit (item 64, Appx H)
Crowbar (item 15, Appx H)
End connector puller (item 44, Appx H)
Socket wrench set (item 56, Appx H)
Torque multiplier (item 37, Appx H)
Torque wrench (item 71, Appx H)
Track-connecting fixtures (2) (item 20, Appx H)

Materials/Parts

Bolts (2) (item 114, Appx G)
Retaining wedges (2) (item 153, Appx G)

Personnel Required

Three

NOTE

Both left and right tracks must match. When installing T-136 track on one side of vehicle, other side must be T-136 track.

a. Removal

1 Perform steps 1 thru 5 of paragraph 10-4. Remove only two end connectors when removing whole track.

WARNING

Use extreme care when moving vehicle on only one track. Drive slowly, moving only short distances. Carelessness can result in injury or death to personnel or damage to equipment.

2 Pull straight forward slowly allowing track (1) to unravel from road wheels.

b. Installation

1 Raise rear fender (2) to upper position.

2 Lay track (1) out in front of vehicle in a straight line directly ahead of and touching first road wheel (3).

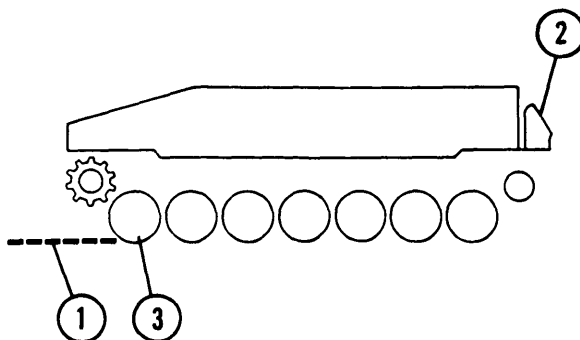

10-6 TRACKS (T-136 TRACK) — CONTINUED

b. Installation — Continued

WARNING

Use extreme care when moving vehicle on only one track. Drive slowly, moving only short distances. Carelessness can result in injury or death to personnel or damage to equipment.

3 Drive slowly onto track (1) until 11 track shoes (4) extended past centerline of last road wheel (5).

4 Lift track with crowbar over idler wheel (6) to top of last road wheel (5).

WARNING

Personnel raising track with crowbar must stand to side of track. Do not allow personnel in front of track. Injury could result if track suddenly separates.

5 Shift into F-1 and drive forward slowly.

6 Steer in direction of removed track (1).

7 Stop when track (1) can be laid on drive sprocket (7).

8 Steer toward opposite track.

9 Move forward slowly.

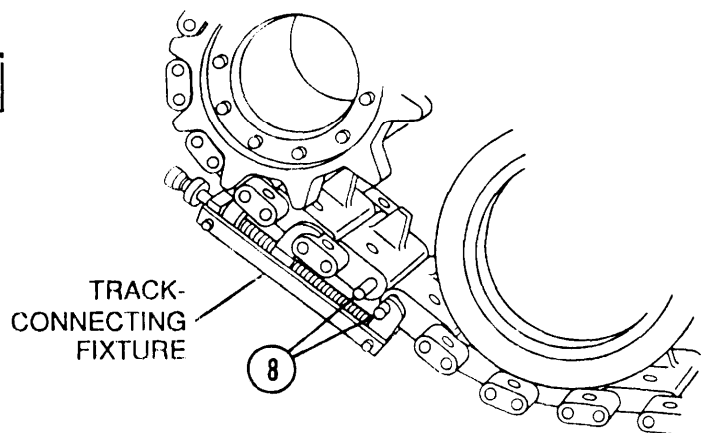
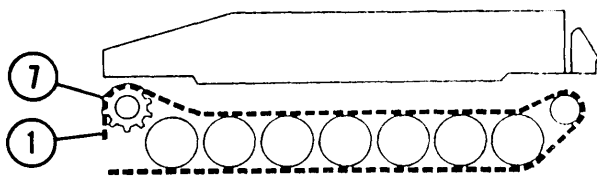
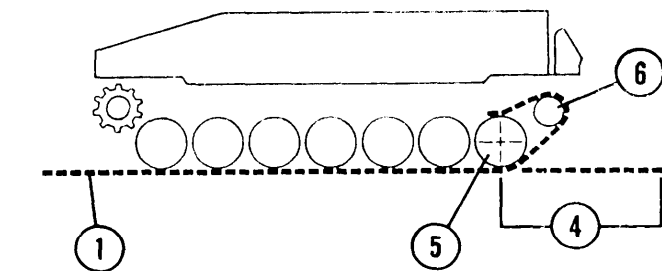

- 10 Stop vehicle when track-connecting fixture can be connected to track link pins (8) on both ends of track (1).
- 11 Apply parking brakes.
- 12 Install two track-connecting fixtures over track link pins (8).
- 13 Tighten two track-connecting fixtures until track link pins (8) are close enough for track-connecting fixtures to be installed on nearest end connectors (9).
- 14 Reinstall fixture on nearest end connector (9) and track link pins (8).
- 15 Tighten until end connectors can be installed on track link pins (8).
- 16 Install two end connectors (10) and tap lightly with hammer to secure connectors.
- 17 Remove two track-connecting fixtures.
- 18 Drive forward until two end connectors (10) are on idler wheel (6) at point (11). Point (11) on idler wheel positions adjacent track shoes at approximately a 12° angle between inner faces of track shoes.

CAUTION

Do not tighten wedge bolts when track shoes form a straight line.

- 19 Install two new bolts (12) and two new retaining wedges (13) in end connectors (10). Torque bolts to approximately 90-100 lb-ft (122–136 N·m). Torque bolts again after 50 miles (80 km) of operation.

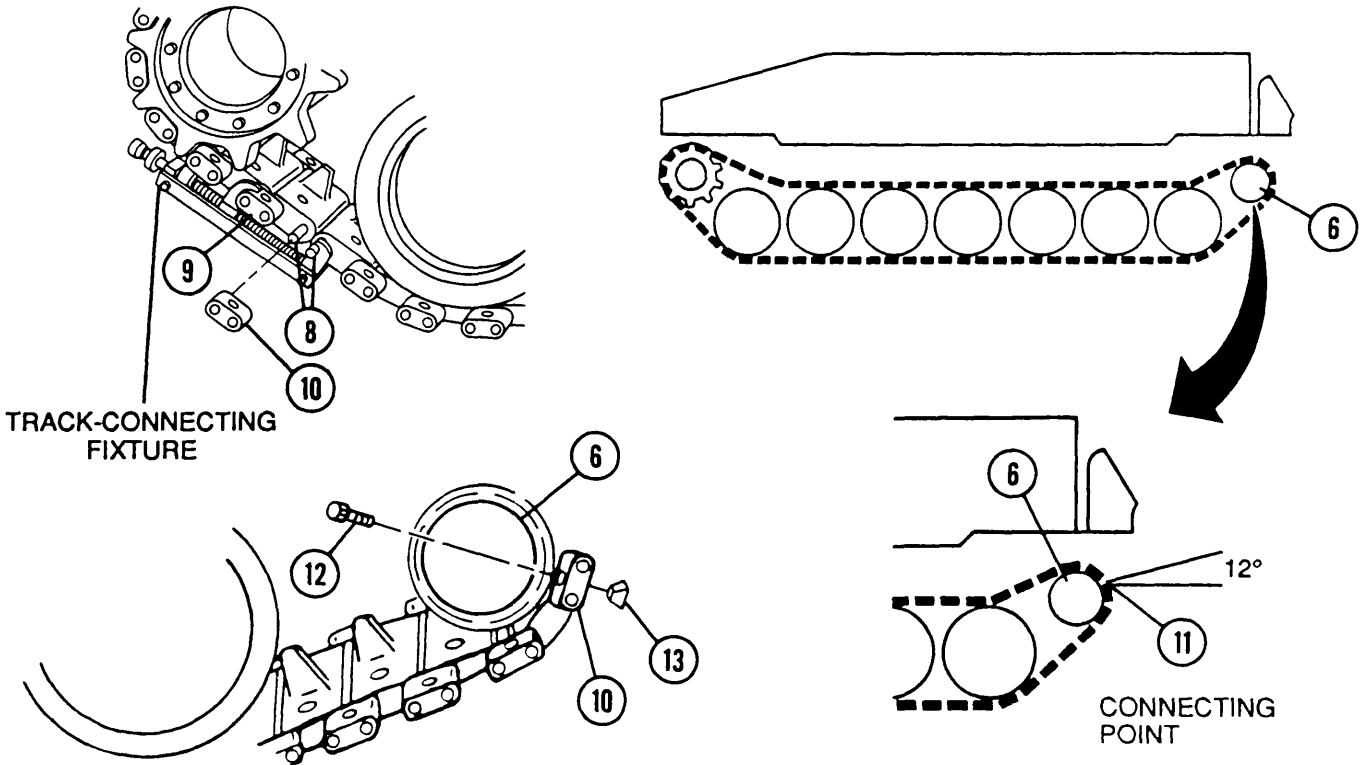

10-7 TRACKS (T-154 TRACK)

This task covers: a. Removal b. Installation

INITIAL SETUP

Tools

General mechanic's tool kit (item 64, Appx H)
Crowbar (item 15, Appx H)
End connector bar (item 1, Appx E)
Torque wrench (item 72, Appx H)
Track-connecting fixtures (2) (item 20, Appx H)
Track connector puller (item 45, Appx H)

Materials/Parts

Connector bolts (2) (item 167, Appx G)

Personnel Required

Three

Equipment Conditions

Track tension decreased (para 10-8)

a. Removal

WARNING

Track is heavy. Use caution when handling track to avoid serious injury.

NOTE

Ž Both left and right tracks must match. When installing T-154 track on one side of the vehicle, the other side must be T-154 track.

Ž Only T-154 final drive sprockets can be used with T-154 track.

1 Perform steps 1 thru 6 of paragraph 10-5. Remove only two end connectors when removing whole track.

WARNING

Use extreme care when moving vehicle on only one track. Drive slowly, moving only short distances. Carelessness can result in injury or death to personnel or damage to equipment.

2 Pull straight forward slowly allowing track to unravel from road wheels.

b. Installation

NOTE

Ž Each track shoe section contains eight track shoes.

Ž There are 10 track shoe sections per each T-154 track.

- Position track shoe so grouser chevron points toward rear of vehicle.

1 Loosen end connector bolt (1) of end connectors (2) of the linking sections of track shoes (3).

2 Insert end connector bar into end connector (2) and tighten bolt (1) to slightly widen end connector.

3 Install end connector (2) so track link pin (6) of linking section is flush within 0.07 in. (1.8 mm) of end connector face. Mark end connector bolts (1) of each linking section.

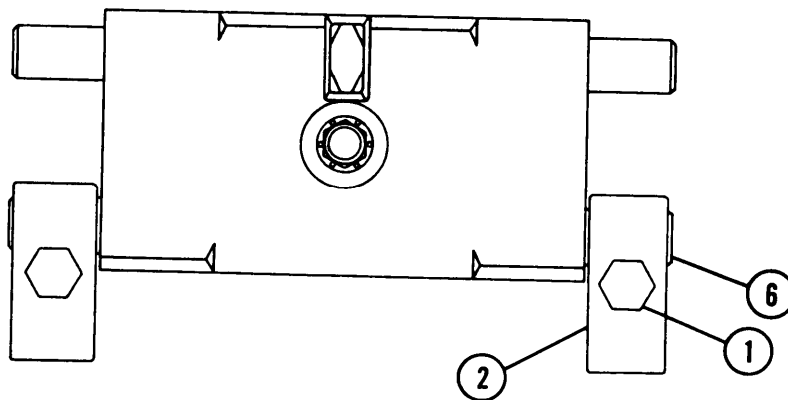
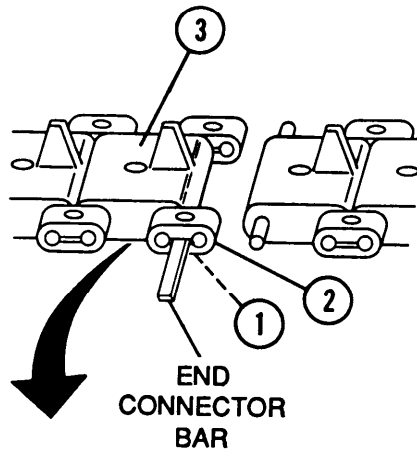

10-7 TRACKS (T-154 TRACK) — CONTINUED

b. Installation — Continued

- 4 Repeat steps 1 thru 3 for remaining nine track sections. Lay connected track (7) out in front of vehicle in straight line directly ahead of and touching first road wheel (5).
- 5 Raise rear fender (8) to upper position.

WARNING

Use extreme care when moving vehicle on only one track. Drive slowly, moving only short distances. Carelessness can result in death or injury to personnel, or damage to equipment.

- 6 Drive slowly onto track (7) until 11 track shoes (3) extend past centerline of last road wheel (5).

WARNING

Personnel raising track with crowbar must stand to the side of track. Do not allow personnel in front of track. Injury could result if track suddenly separates.

- 7 Lift track with crowbar over idler wheel (9) to top of last road wheel (5).

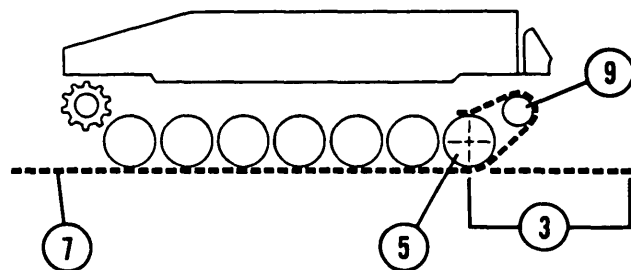
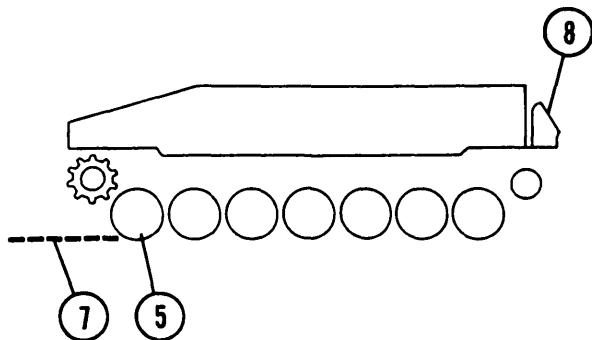
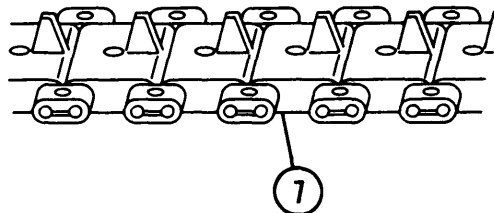

CAUTION

Raise end of track with crowbar to prevent it from getting caught between road wheels.

- 8 Drive forward slowly, in first gear.
- 9 Steer in direction of track (7) being installed.
- 10 Stop when track (7) can be laid on drive sprocket (10).
- 11 Steer toward opposite track.
- 12 Move forward slowly.
- 13 Stop vehicle when track-connecting fixture can be connected to track link pins (6) on both ends of track (7).
- 14 Apply parking brakes.
- 15 Remove two end connector bolts (1) and two end connectors (2) from last track shoe (3).
- 16 Install two track-connecting fixtures over track link pins (6).
- 17 Tighten two track-connecting fixtures until track link pins (6) are close enough for fixtures to be installed on nearest end connectors (2).

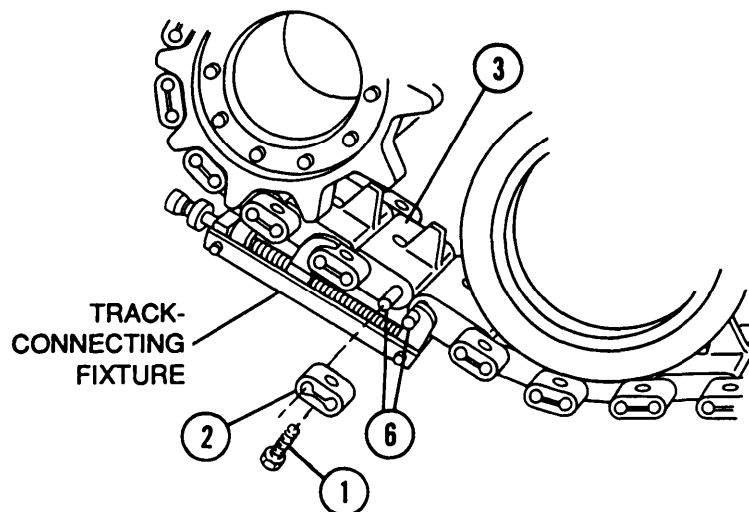
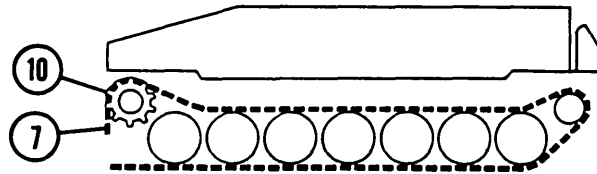

10-7 TRACKS (T-154 TRACK) — CONTINUED

b. Installation — Continued

- 18 Reinstall track-connecting fixture on track link pins (6) of last track shoe and track shoe to be connected.
- 19 Install two end connectors (2) and tap with hammer to secure. Track link pin (6) must be flush within 0.07 in (1.8 mm) of end connector face. Install two new end connector bolts (1) and torque to 380-420 lb-ft (515-569 N·m). Torque end connector bolts on marked end connectors to 380-420 lb-ft (515-569 N·m).
- 20 Repeat steps 17 thru 19 for opposite side of track.
- 21 Check track tension and adjust track if necessary (para 10-8).
- 22 Torque bolts again after 50 miles (81 km) of operation.

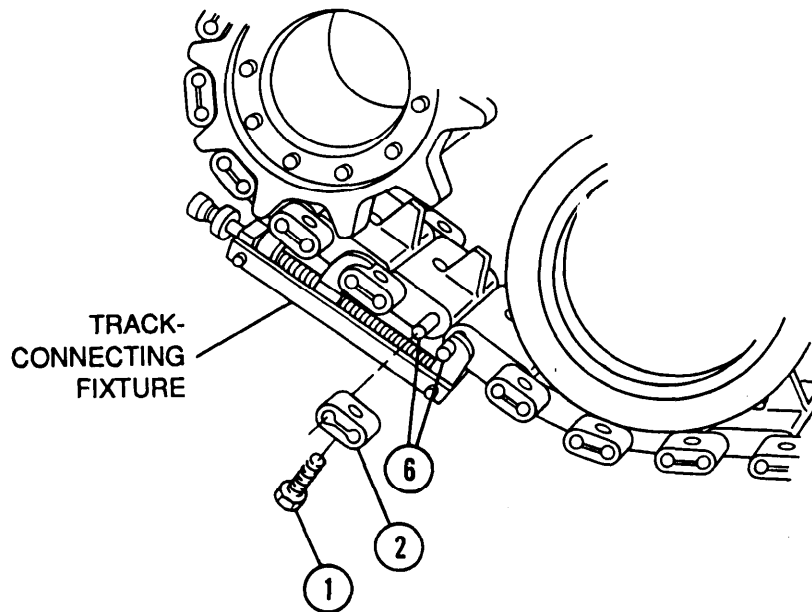

NOTE

FOLLOW-ON MAINTENANCE: Check and correct track tension (para 10-8)

10-8 TRACK TENSION

This task covers: a. Checking b. Adjusting

INITIAL SETUP

Tools

General mechanic's tool kit (item 64, Appx H)
Lubricating gun (item 24, Appx H)

Materials/Parts

GAA grease (item 27, Appx D)

a. Checking

- 1 To exercise tracks, drive vehicle forward and reverse several times.
- 2 Coast to a stop without using brakes.
- 3 Place transmission in neutral (N) position.
- 4 Shut off engine.
- 5 Measure distance from bottom of track (1) to top of third road wheel (2). Distance should be 0.25 in. (6.4 mm).
- 6 Adjust track tension if required.

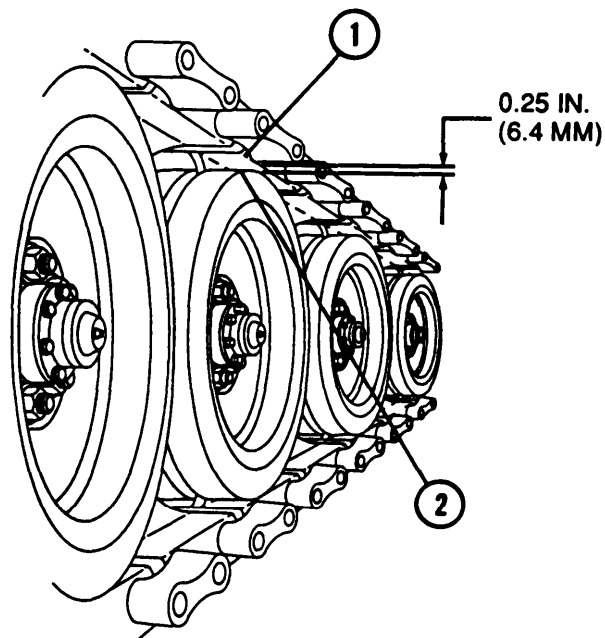

10-8 TRACK TENSION — CONTINUED

b. Adjusting

CAUTION

Do not allow track adjuster to extend more than 3.5 in. (8.9 cm). Remove a shoe to shorten track if necessary.



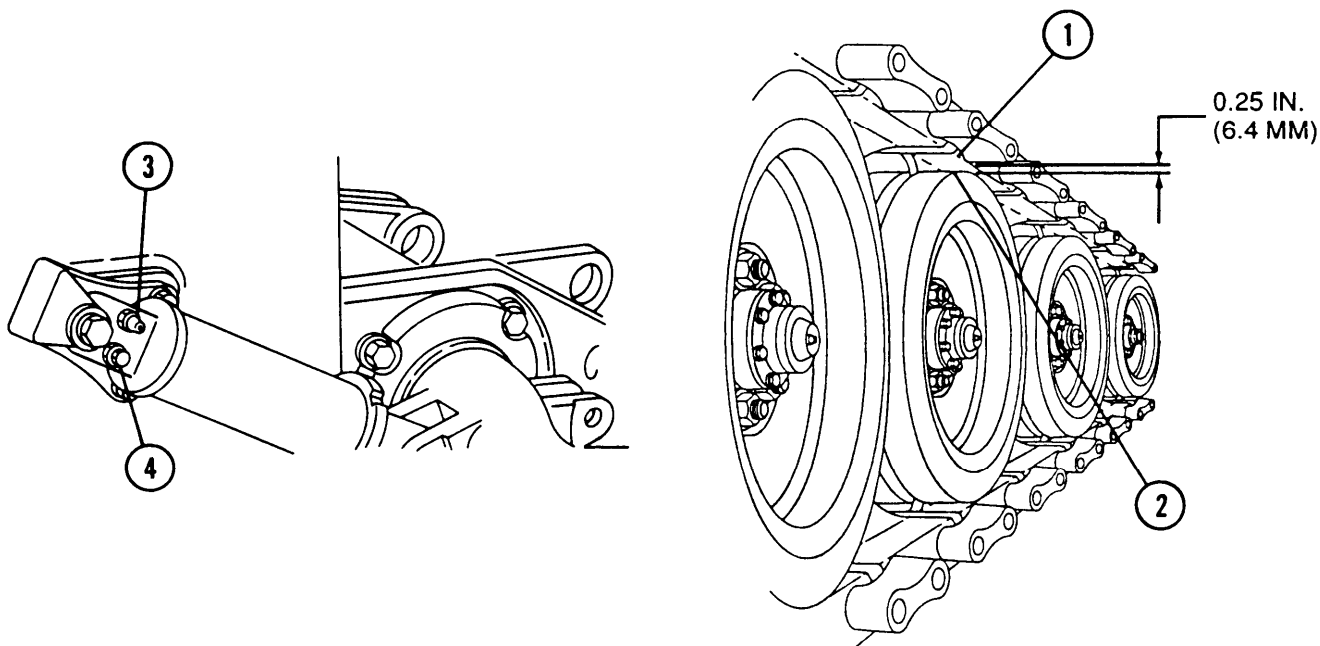



- 1 Clean input pressure fitting (3).
- 2 Add grease until distance from top of third road wheel (2) to bottom of track (1) is 0.25 in. (6.4 mm).
- 3 To increase track tension, raise track (1) away from third road wheel (2).
- 4 To decrease track tension, slowly loosen bleed plug (4).
- 5 Allow lubricant to escape until track (1) hangs loose.
- 6 Clean off excess lubricant.
- 7 Tighten bleed plug (4).
- 8 Adjust track to desired tension. Increase track tension to achieve 0.25-in. (6.4-mm) measurement between road wheel and track.









SECTION II. SUSPENSION SYSTEM

10-9 TORSION BARS, ANCHORS, AND ROAD WHEEL ARM AND HUB ASSEMBLIES ID CHART

TORSION BARS, ANCHORS, AND ROAD WHEEL ARM AND HUB ASSEMBLIES ID CHART (LEFT)

VEHICLE POSITION	TORSION BAR PN	IDENTIFYING ARROW (PRESET)	ANCHOR PN	LOCATION OF BLIND SPLINE IN ANCHOR	ROAD WHEEL ARM AND HUB ASSEMBLY PN
1 Front	10898191-1		10921192-1	12 o'clock	10925061-1
2 Intermediate	10898191-1		10921192-1	12 o'clock	10925059
3 Intermediate	10898193		10921192-1	12 o'clock	10925059
4 Intermediate	10898193		10921192-1	12 o'clock	10925059
5 Intermediate	10898193		10921192-1	12 o'clock	10925059
6 Intermediate	10898193-1		10921192-1	12 o'clock	10925059
7 Rear	10898191-2		10921192-2	12 o'clock	10925061-2

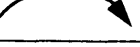
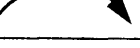
TORSION BARS, ANCHORS, AND ROAD WHEEL ARM AND HUB ASSEMBLIES ID CHART (RIGHT)

VEHICLE POSITION	TORSION BAR PN	IDENTIFYING ARROW (PRESET)	ANCHOR PN	LOCATION OF BLIND SPLINE IN ANCHOR	ROAD WHEEL ARM AND HUB ASSEMBLY PN
1 Front	10898191-2		10921192-2	12 o'clock	10925061-2
2 Intermediate	10898191-2		10921192-2	12 o'clock	10925059
3 Intermediate	10898194		10921192-2	12 o'clock	10925059
4 Intermediate	10898194		10921192-2	12 o'clock	10925059
5 Intermediate	10898194-1		10921192-2	12 o'clock	10925059
6 Intermediate	10898194-1		10921192-2	12 o'clock	10925059
7 Rear	10898191-1		10921192-1	12 o'clock	10925059-1 10925061-1*

*This PN applies to M109A2 only

10-10 ROAD WHEELS

This task covers: a. Removal b. Installation

INITIAL SETUP

Tools

General mechanic's tool kit (item 64, APPX H)
Road wheel lifter (item 35, Appx H)
Socket wrench set (item 56, APPX H)
Torque multiplier (item 37, APPX H)
Torque wrench (item 71, APPX H)
12-ton (10,886-kg) jack (item 32, APPX H)

Lubricating oil (item 37, APPX D)

Personnel Required

Two

Equipment Conditions

Track disconnected (para 10-6 or 10-7)

GAA grease (item 25 or 26, Appx D)

a. Removal

NOTE

Steps 1 thru 6 are to be followed for road wheels 2 thru 6 only. Steps 7 thru 10 are to be followed for road wheels 1 and 7 only.

- 1 Pull track away from top of road wheel (1).
- 2 Loosen, but do not remove 10 nuts (2) and 10 fiat washers (3).
- 3 Place lifter on road wheel arm hub (4) and on inner side of track (5).

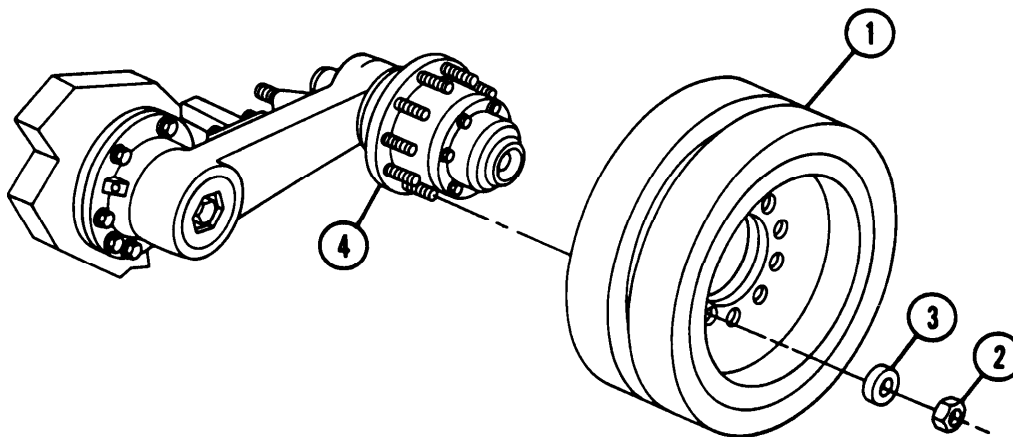

WARNING

When driving vehicle on or off lifters, clear area. Lifters may fly out from under vehicle and cause serious injury to personnel.

4 Drive forward slowly, only far enough to lift road wheel (1) off track (5).

5 Remove 10 nuts (2) with 10 flat washers (3).

6 Remove road wheel (1), tapping lightly with hammer.

WARNING

Use extreme caution when using hydraulic jack. Carelessness can result in injury to personnel or damage to equipment.

7 Loosen, but do not remove 10 nuts (2) with 10 flat washers (3).

8 Position jack base on track and locate head of jack under spindle extension of road wheel arm.

9 Move jack up until road wheel (1) clears track.

10 Remove 10 nuts (2) with 10 flat washers (3) and remove road wheel (1).

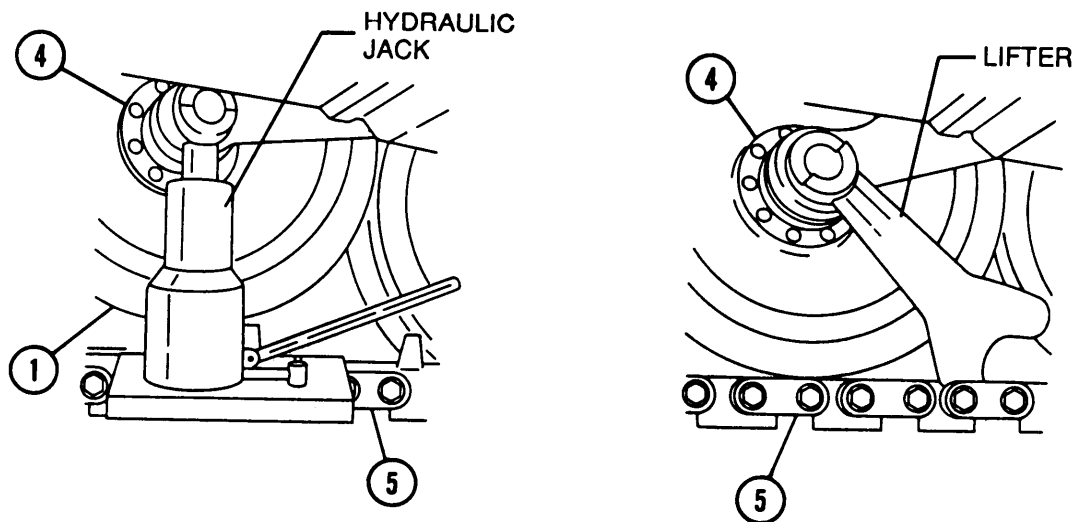

VIEW FROM UNDER VEHICLE

FRONT OF VEHICLE 

10-10 ROAD WHEELS — CONTINUED

b. Installation

WARNING

Use extreme caution when using hydraulic jack. Carelessness can result in injury to personnel or damage to equipment.

NOTE

Steps 1 thru 3 are to be used for road wheels 1 and 7 only.

- 1 Lubricate threads with oil or grease.
- 2 With jack in place and track (5) clearing road wheels (1), install road wheel, 10 flat washers (3), and 10 nuts (2).
- 3 Lower and remove jack. Torque 10 nuts (2) to 160-200 lb-ft (217-271 N·m).

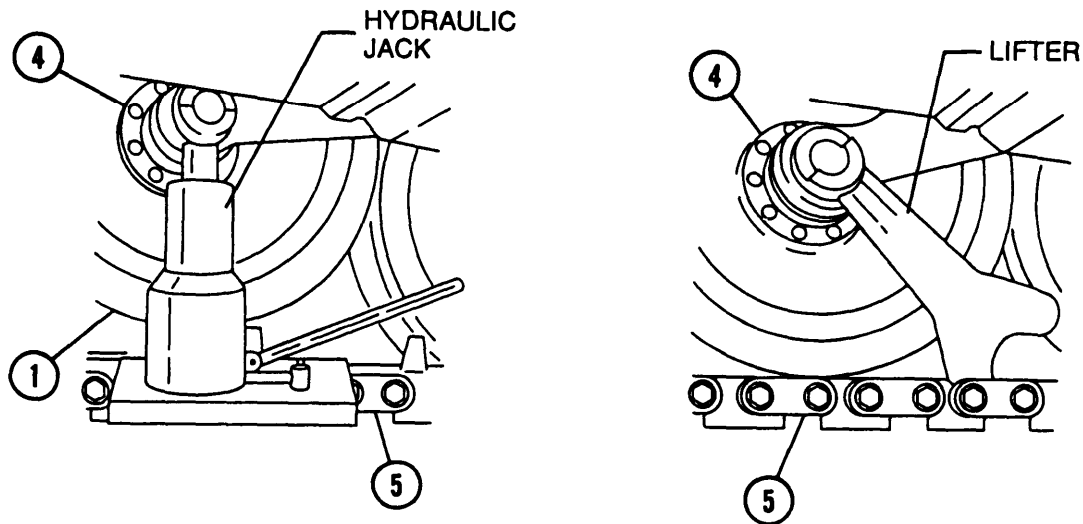

VIEW FROM UNDER VEHICLE

FRONT OF VEHICLE 

WARNING

When driving vehicle on or off lifters, clear area. Lifters may fly out from under vehicle and cause serious injury to personnel.

NOTE

Steps 4 thru 7 are to be followed for road wheels 2 thru 6 only.

4 Lubricate threads with oil or grease.

5 Install road wheel (1), 10 flat washers (3), and 10 nuts (2).

6 Drive backward slowly, only far enough for road wheel (1) to clear lifter. Remove lifter.

7 Torque 10 nuts (2) to 160-200 lb-ft (21 7–271 N-m).

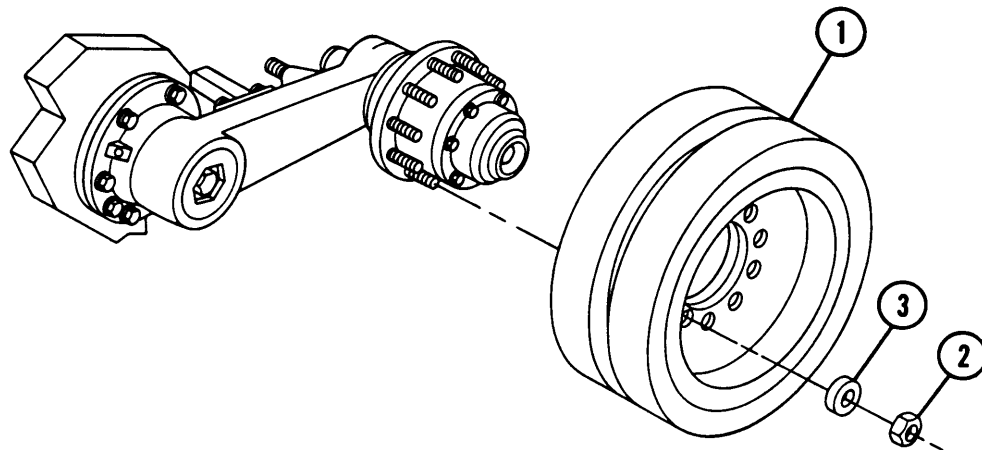
**NOTE**

FOLLOW-ON MAINTENANCE: Connect track (para 10-6 or 10-7)

10-11 ROAD WHEEL HUBS

This task covers:

- a. Disassembly
- b. Inspection and Repair
- c. Assembly

INITIAL SETUP

Tools

General mechanic's tool kit (item 64, Appx H)
Handle (item 28, Appx H)
Inner bearing cup remover/replacer (item 51, Appx H)
Inner seal replacer (item 50, Appx H)
Lubricating gun (item 24, Appx H)
Outer bearing cup remover/replacer (item 52, Appx H)
Torque wrench (item 72, Appx H)

Materials/Parts

Cotter pin (item 3, Appx G)

GAA grease (item 27, Appx D)
Inner hub seal (item 164, Appx G)
Key washer (item 185, Appx G)
Preformed packing (item 62, Appx G)

Personnel Required

Two

Equipment Conditions

Road wheels removed (para 10-10)

a. Disassembly

- 1 Remove grease fitting (1) from cap (2).
- 2 Remove relief valve (3) from hub assembly (4).
- 3 Remove six cap screws (5) and six washers (6). Remove cap (2).
- 4 Remove static spring (7), cotter pin (8), nut (9), key washer (10), and preformed packing (11). Discard cotter pin, key washer, and preformed packing.
- 5 Using both hands, carefully slide road wheel hub (4) from road wheel arm spindle (12).
- 6 Remove inner hub seal (13). Discard inner hub seal.
- 7 Remove bearing cones (14 and 15) from hub (4).
- 8 If damaged, remove bearing cups (16 and 17) from hub (4), using remover and handle.

b. Inspection and Repair

- 1 Inspect cap (2). Replace if cracked, damaged, or defective.
- 2 Inspect static spring (7). Replace if defective.
- 3 Inspect outer bearing cone (17) (TM 9-214).
- 4 Inspect inner bearing cone (16) (TM 9-214).

5 Inspect hub (4). Replace if cracked or damaged.

6 Inspect threads on studs (18). Replace if damaged.

7 Inspect road wheel arm spindle (12). Replace if damaged or defective (para 10-1 2).

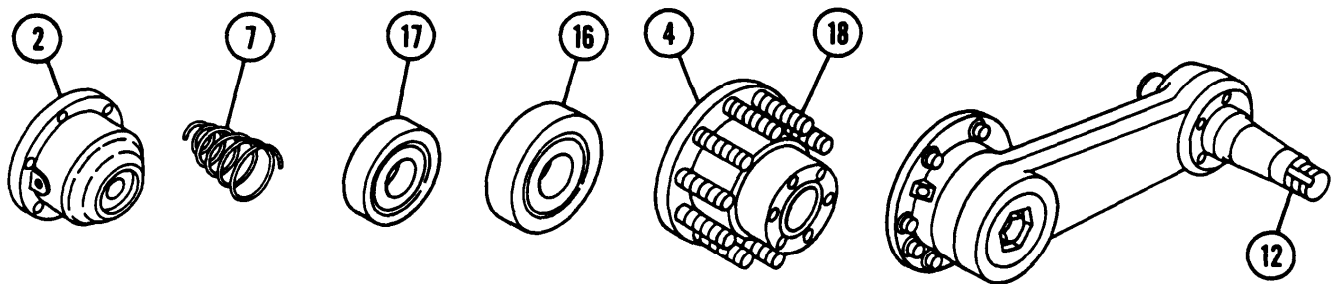
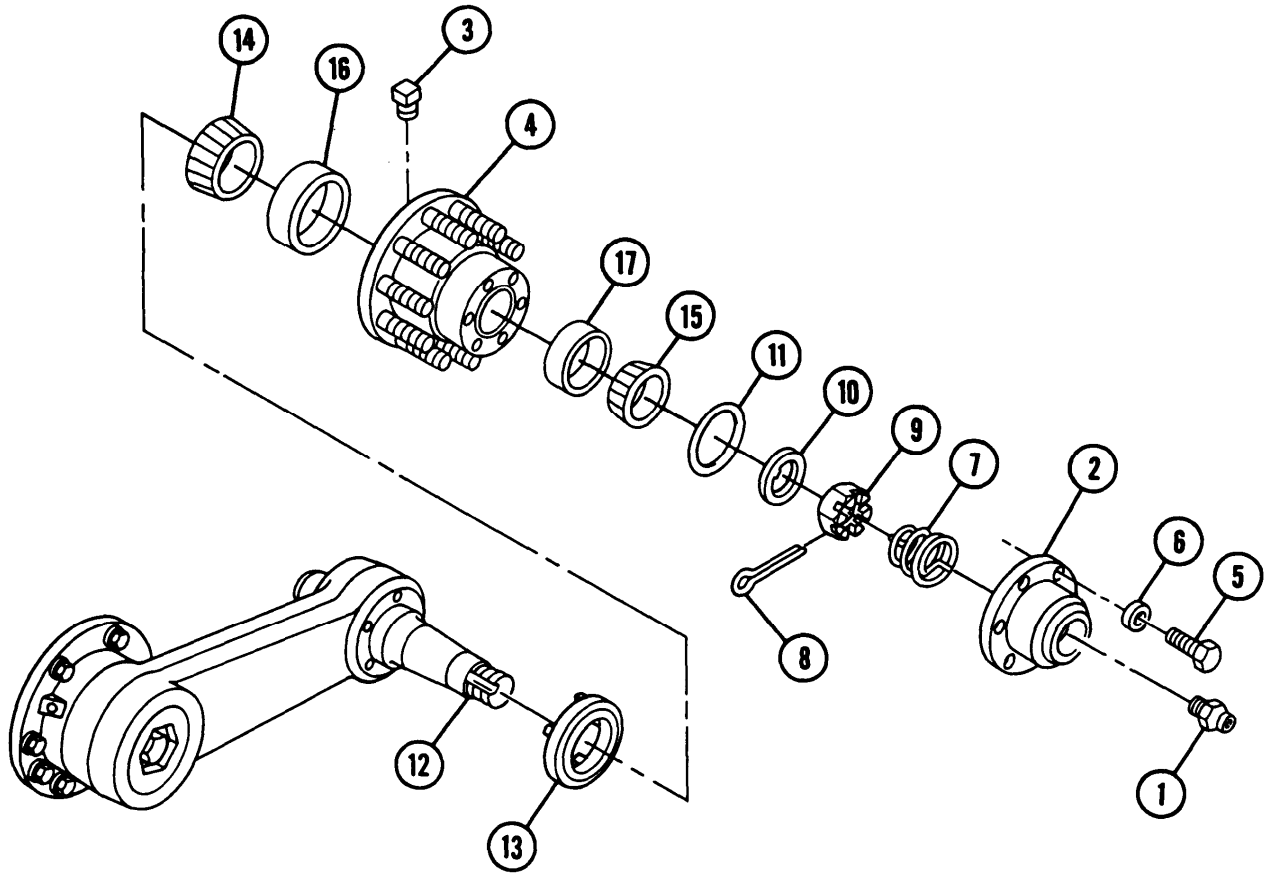

10-11 ROAD WHEEL HUBS — CONTINUED

c. Assembly

NOTE

- Do not prepack bearings with grease.

Ž Seal mating surface in hub must be free of grease, dirt, and oil prior to assembly.

- 1 Install inner bearing cup (16) using inner bearing cup replacer and handle.
- 2 Install inner bearing cone (14).

CAUTION

Be careful not to damage or deform inner hub seal or seal lip when installing inner hub seal in hub. Do not press on pins when installing inner hub seal.

- 3 Install new inner hub seal (13) using seal replacer and handle. Ensure inner hub seal is flush with road wheel hub (4).
- 4 Using outer bearing cup replacer and handle, install outer bearing cup (17).
- 5 Install outer bearing cone (15).
- 6 Assemble hub (4), new key washer (10), and nut (9) on spindle (12).

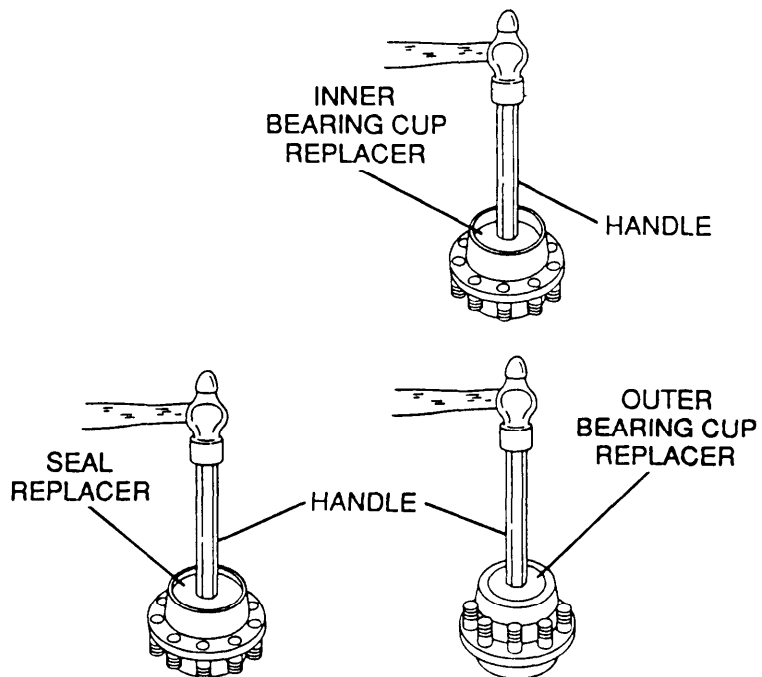
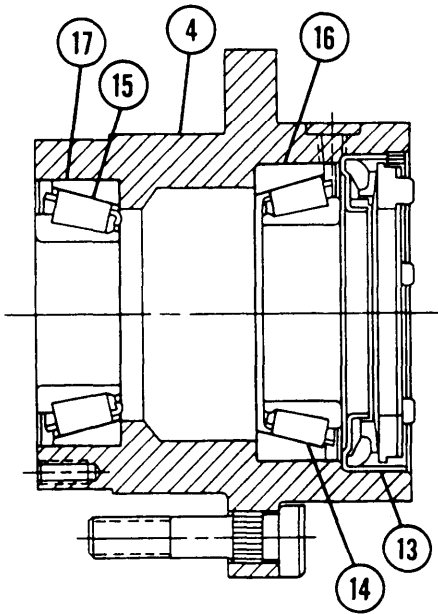

7 Torque nut (9) as follows:

- (a) Using torque wrench, tighten nut to 100 lb-ft (136 N-m).
- (b) Back off nut 1 complete turn.
- (c) Using torque wrench, tighten nut to 25-30 lb-ft (34-41 N-m) while rotating hub (4).
- (d) If slots in nut and hole in spindle align, install new cotter pin (8).
- (e) If slots in nut and hole in spindle are misaligned, back off nut to align with first hole in spindle, and install new cotter pin (8). Range of back-off is 0 to 30°.
- (f) After adjustment, hub (4) must rotate freely by hand.

8 Install new preformed packing (11), static spring (7), and cap (2). Install six washers (6) and six cap screws (5). Tighten screws to 12 lb-ft (16 N-m).

9 Install grease fitting (1) and relief valve (3).

10 Fill hub (18) with grease until air-free grease flows from relief valve.

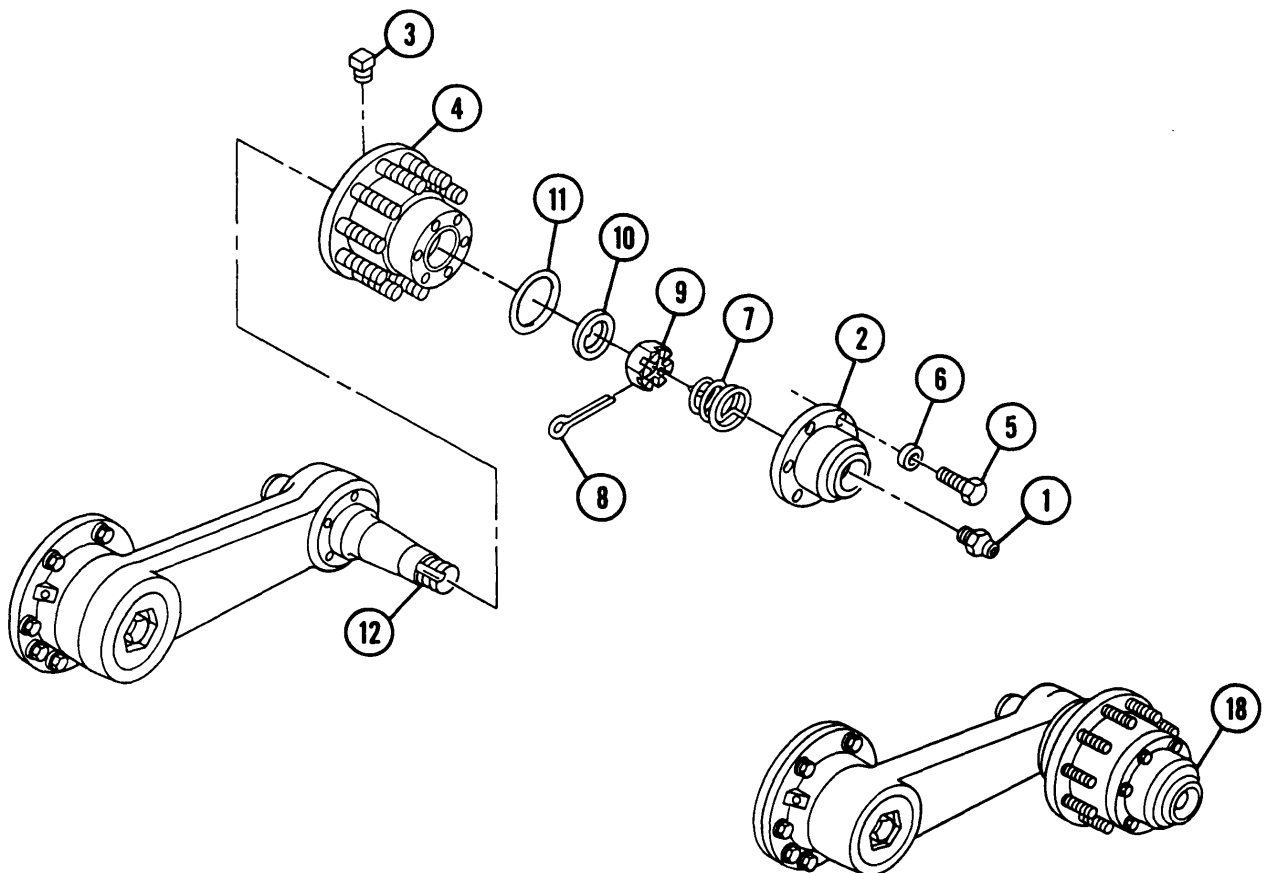

NOTE

FOLLOW-ON MAINTENANCE:

Install road wheels (para 10-10)

10-12 ROAD WHEEL ARMS

This task covers: a. Removal b. Installation

INITIAL SETUP

<u>Tools</u> General mechanic's tool kit (item 64, Appx H) Socket wrench adapter (item 3, APPX H) Socket wrench set (item 56, APPX H) Torque multiplier (item 37, APPX H) Torque wrench (item 71, APPX H)	<u>Personnel Required</u> Two
<u>Materials/Parts</u> Preformed packing (item 109, Appx G)	<u>Equipment Conditions</u> Road wheel removed (para 10-10) Shock absorber disconnected for road wheel arms 1 and 7 (para 10-19) Torsion bar removed (para 10-13)

a. Removal

- 1 Remove eight screws (1).

WARNING

Road wheel arm assembly is heavy: over 100 lb (45.4 kg). Two personnel are required to remove.

- 2 Lift off road wheel arm assembly (2) to remove.
- 3 Remove preformed packing (3) from road wheel arm assembly (2). Discard preformed packing.

b. Installation

WARNING

Road wheel arm assembly is heavy: over 100 lb (45.4 kg). Two personnel are required to install.

- 1 Install new preformed packing (3) on road wheel arm assembly (2).
- 2 Install eight screws (1) on road wheel arm assembly (2). Torque screws to 160-200 lb-ft (217-271 N-m).

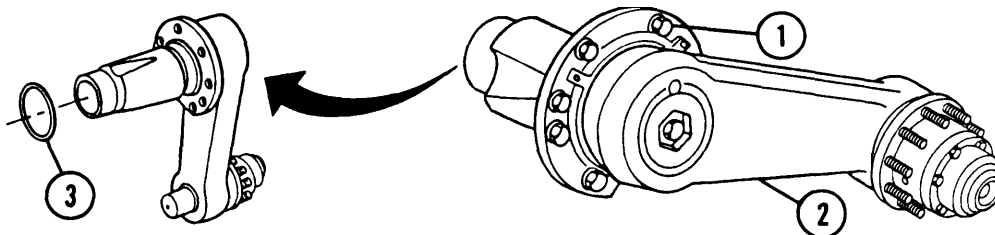

NOTE

FOLLOW-ON MAINTENANCE:

Install torsion bar (para 10-13)
 Connect shock absorber for road wheel arms 1 and 7 (para 10-19)
 Install road wheel (para 10-10)

10-13 TORSION BARS

This task covers: a. Removal b. Installation

INITIAL SETUP

Tools

General mechanic's tool kit (item 64, Appx H)
 Adapter (item 1, Appx H)
 Slide hammer puller (item 47, Appx H)
 Torque wrench (item 72, Appx H)
 Torsion bar wrench (item 74, Appx H)

Gasket (item 196, Appx G)

Personnel Required

Two

Equipment Conditions

Road wheels removed (para 10-10)

Materials/Parts

GAA grease (item 25 or 26, Appx D)

a. Removal

NOTE

When removing torsion bar at number 1 (front) or number 7 (rear) road wheel position, it will be necessary to disconnect shock absorber (para 10-19). Torsion bar anchor screws must be loosened 1 full turn before attempting to remove or install torsion bars (para 10-13).

- 1 Remove screw (1) from torsion bar plug (2).
- 2 Insert wrench in torsion bar plug (2). Turn counterclockwise and remove plug and gasket (3). Discard gasket.
- 3 Install adapter and slide hammer puller and remove torsion bar (4). Lift road wheel arm (5) enough to take weight off torsion bar.

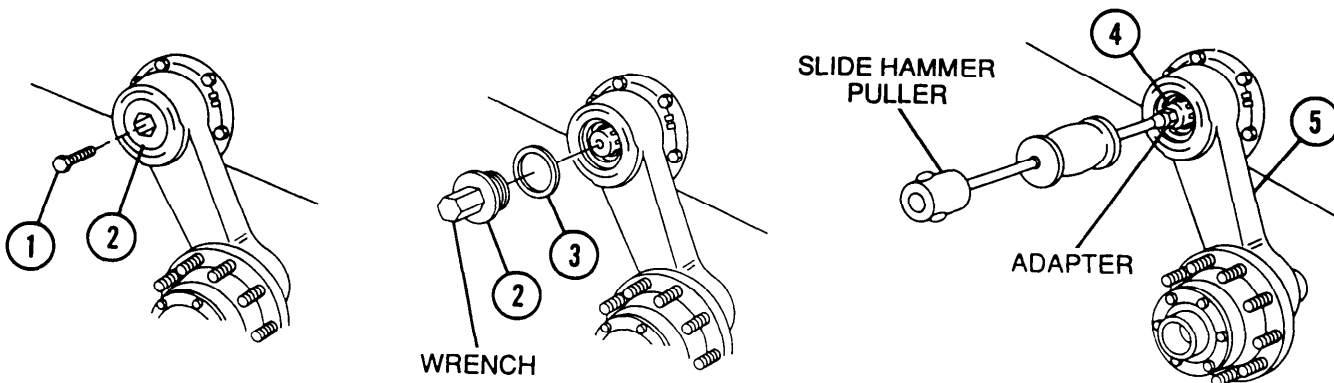

10-13 TORSION BARS — CONTINUED

b. Installation

1 See torsion bar ID chart information applicable to torsion bar (4) you are replacing (para 10-9).

2 Lubricate splines at end of torsion bar (4) with grease.

CAUTION

- Do not remove protective tape from ground (unsplined) surface of torsion bars.
- Do not use any tool other than torsion bar slide hammer puller.
- Torsion bar should slide in by hand. If not, use slide hammer puller as necessary.

3 Clean and dry torsion bar (4) anchor cavities (para 10-14).

NOTE

Hold road wheel arms 1 thru 6 at 4 o'clock position on vehicle left side and 8 o'clock position on right; hold number 7 road wheel arm at 8 o'clock on vehicle left side and 4 o'clock on right side while installing torsion bars.

4 Insert torsion bar (4) making certain splines on each end of torsion bar are aligned with blind splines in anchor and road wheel arm (5).

5 Torque torsion bar anchor screws and install lockwire (para 10-14).

6 Install new gasket (3) and torsion bar plug (2).

7 Install screw (1). Torque screw to 90 lb-ft (122 N·m).

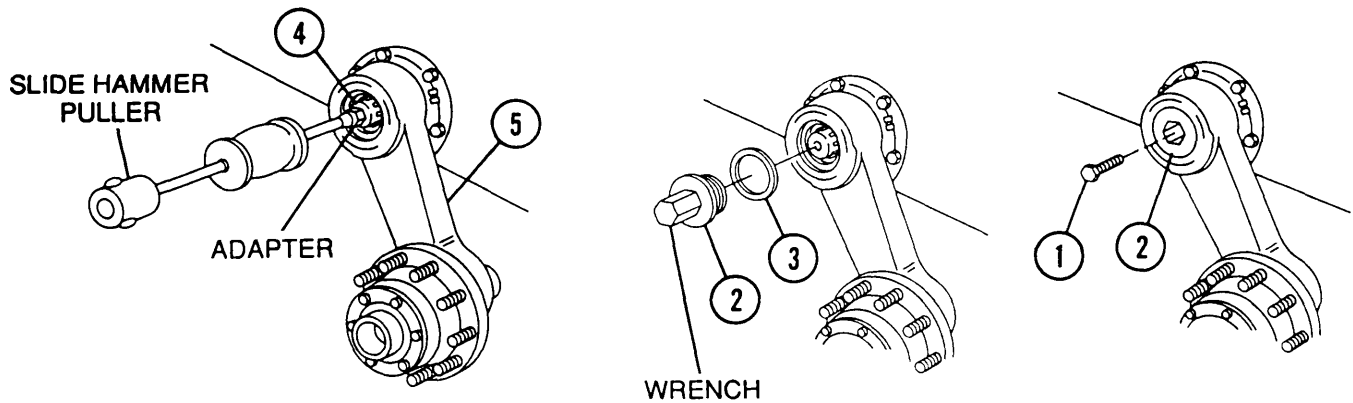

NOTE

FOLLOW-ON MAINTENANCE: Install road wheels (para 10-10)

10-14 TORSION BAR ANCHORS

This task covers: a. Removal b. Installation

INITIAL SETUP

Tools

General mechanic's tool kit (item 64, Appx H)
 Socket wrench set (item 56, Appx H)
 Torque multiplier (item 37, Appx H)
 Torque wrench (item 71, Appx H)
 Torque wrench (item 72, Appx H)

Wire twisting pliers (item 42, Appx H)

Material/parts

GAA grease (item 25, Appx D)
 LockWire (as required) (item 28, Appx G)
 Sealing compound (item 56, Appx D)

a. Removal

NOTE

Ž If torsion bar anchor for road wheels 1 or 2 must be removed, remove powerplant to gain access to cover plates (para 4-5).

Ž If torsion bar anchors for road wheel 3 must be removed, remove both powerplant and fuel tanks to gain access to cover plate (para 4-5) and notify support maintenance.

Ž There are five additional torsion bar anchor cover plates in crew compartment.

1 Remove each torsion bar anchor cover plate (1) by removing 10 screws (2).

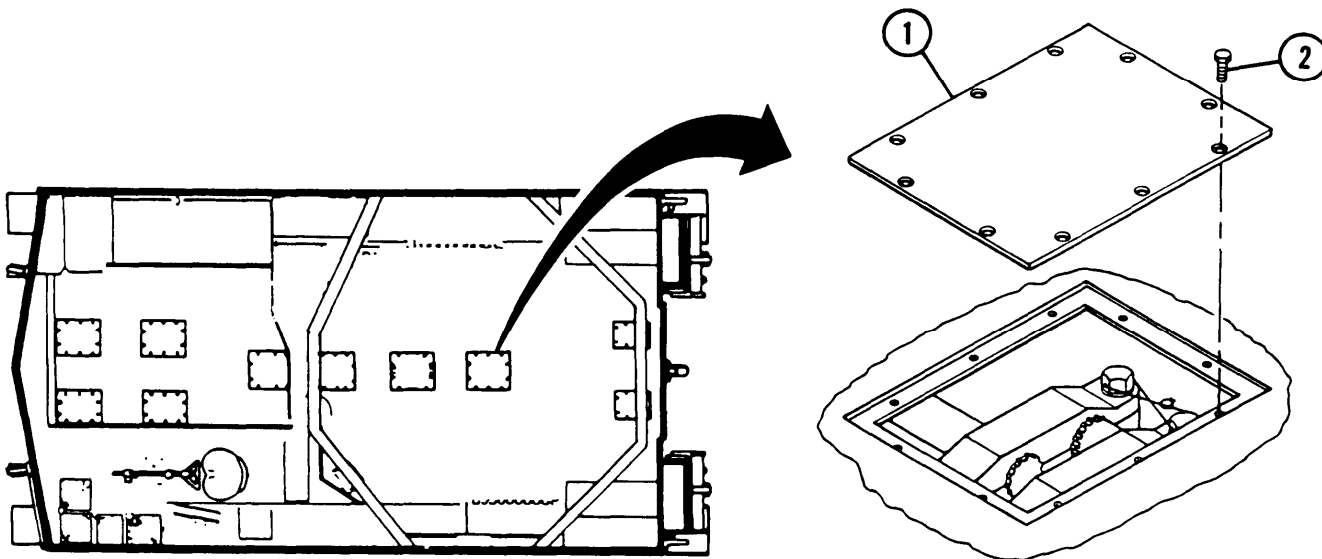

10-14 TORSION BAR ANCHORS — CONTINUED

a. Removal — Continued

- 2 Remove lockwire (3). Loosen two anchor bar screws (4) and four flat washers (5). Discard lockwire.
- 3 Remove torsion bars (para 10-13).
- 4 Remove two anchor bar screws (4) and four flat washers (5).
- 5 Remove 14 torsion bar anchors (6).

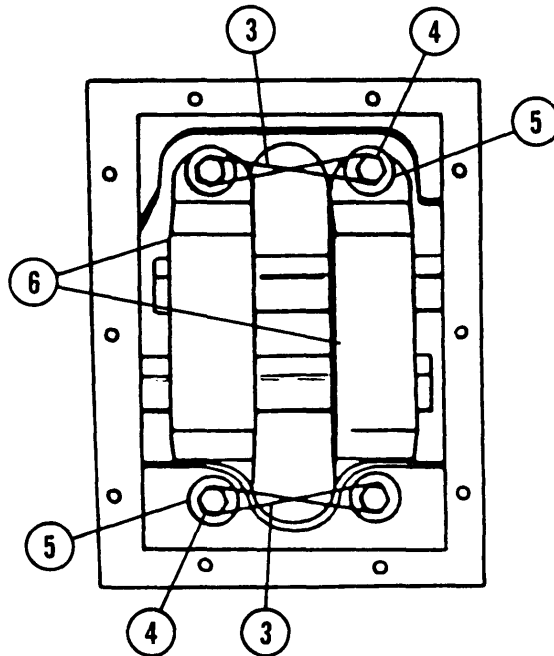

b. Installation

- 1 Remove any water accumulation or dirt in cavities and dry thoroughly.
- 2 Install torsion bar anchors (6).
- 3 Install torsion bars (para 10-13).
- 4 Install four flat washers (5) and two screws (4). Torque screws to 230-260 lb-ft (31 2-353 Nžm). Install new lockwire (3).
- 5 Cover accessible surfaces of torsion bars and anchors with film of preservative grease.
- 6 Place band of sealing compound 0.0625 in. (1.6 mm) wide around edges of each cover plate (3) (including screw holes).
- 7 Coat cover plate screw threads with sealing compound and install cover plates (1) with 10 screws (2). Tighten screws to 15-20 lb-ft (20-27 N•m).
- 8 Remove any excess sealing compound from around edges of covers.

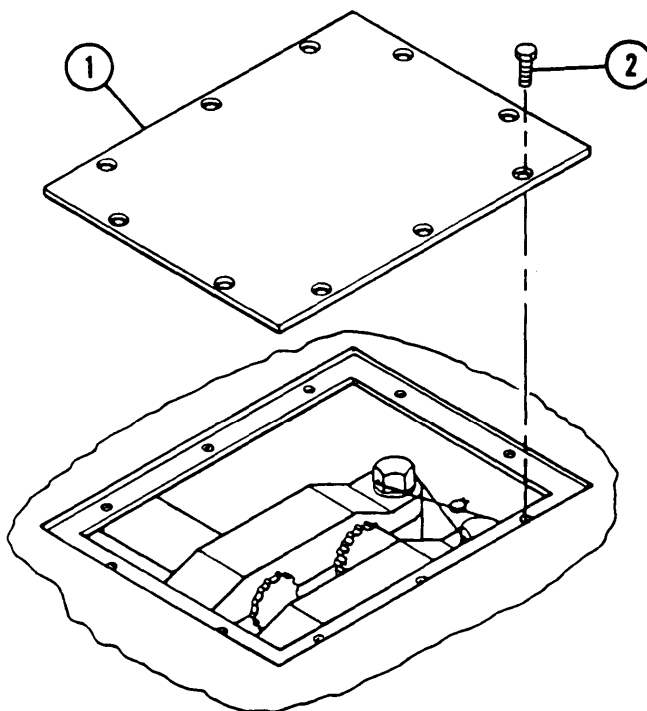

10-15 TRACK ADJUSTERS AND MOUNTING BRACKETS

This task covers: a. Removal b. Disassembly
 c. Assembly d. Installation

INITIAL SETUP

Tools

General mechanic's tool kit (item 64, Appx H)
Crowbar (item 15, Appx H)
Lubricating gun (item 24, Appx H)
Mechanical puller adapter (item 1, Appx H)
Slide hammer puller (item 47, Appx H)
Socket wrench set (item 56, Appx H)
Spanner wrench set (item 68, Appx H)

Torque multiplier (item 37, Appx H)
Torque wrench (item 71, Appx H)

Materials/Parts

Cotter pins (2) (item 53, Appx G)
GAA grease (item 27, Appx D)
Preformed packings (2) (item 57, Appx G)

a. Removal

WARNING

Lubricant is under high pressure. Loosen bleed plug slowly to avoid injury or severe burns.

NOTE

It is not necessary to disconnect track or remove idler wheels in order to remove or install track adjuster. Wheels are shown removed for clarity.

- 1 Loosen bleed plug (1) to reduce track tension.
- 2 Remove two cotter pins (2) and pin (3). Discard cotter pins.

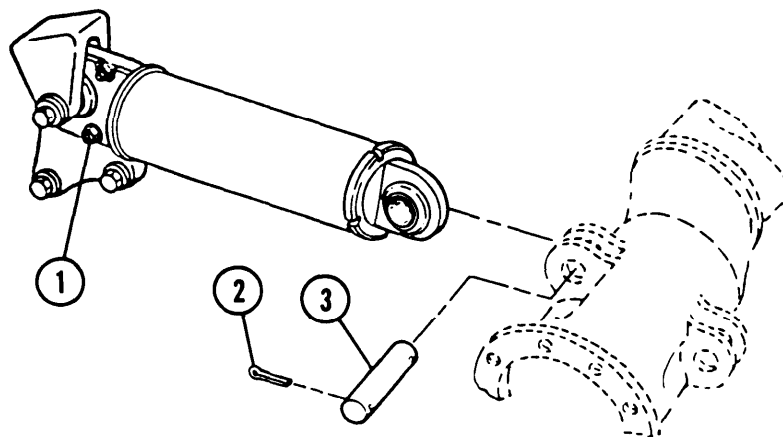

NOTE

Fabricate an adapter to pull pivot pin by welding a 1-in. NC thread nut to head of a 7/8-in, NF thread bolt, 2 in. (5.1 cm) long (item 2, Appx E). Use with puller when required.

3 Remove screw (4), flat washer (5), pivot pin (6), and adjuster (7).

4 Remove two screws (8) and mounting bracket (9).

5 Remove bleed plug (1), bleed plug body (1 O), and input pressure fitting (1 1).

b. Disassembly

1 Remove two bearings (12).

2 Remove nut (13), scraper (1 4), and preformed packing (15). Discard packing.

3 Remove piston (16), two retainers (17), and preformed packing (18) from cylinder (1 9). Discard packing.

c. Assembly

1 Install retainer (1 7), new preformed packing (1 8), retainer (17), and piston (16) in cylinder (1 9).

2 Install new preformed packing (15) and scraper (14) on nut (13).

3 Install nut(13) over piston (16). Torque nut to 180-220 lb-ft (244-298 Nžm).

4 Install two bearings (12).

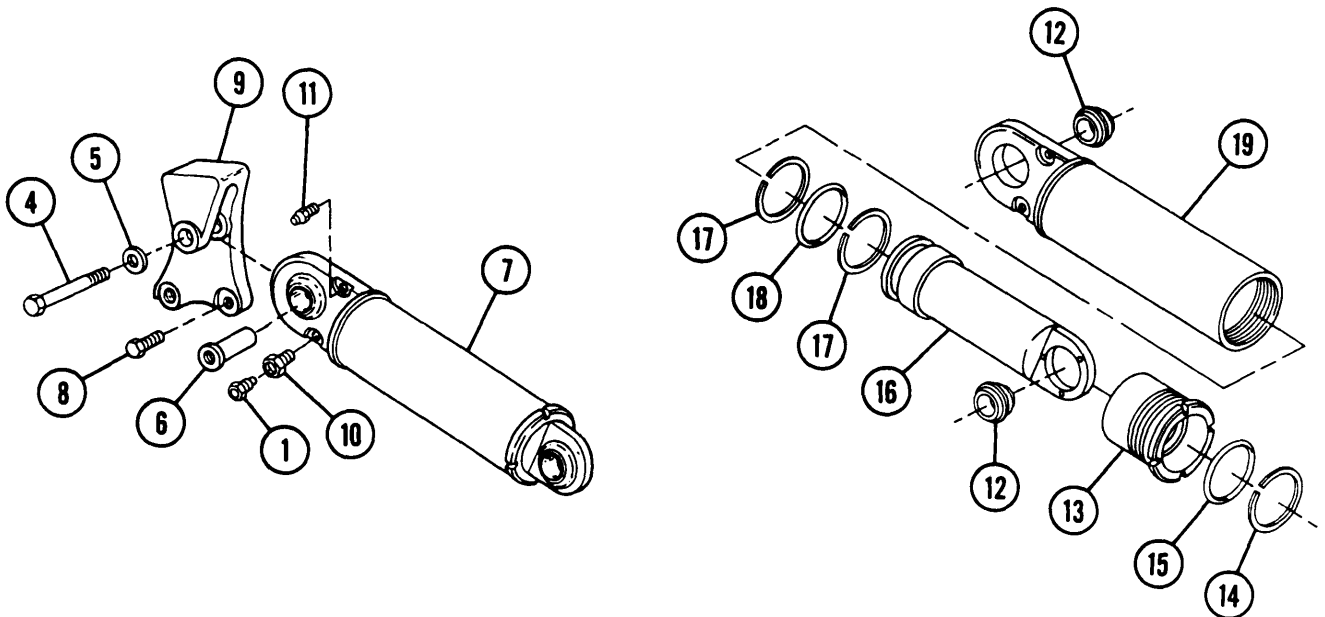

10-15 TRACK ADJUSTERS AND MOUNTING BRACKETS — CONTINUED

d. Installation

- 1 Install bleed plug (1) and input pressure fitting (11).
- 2 Add grease to adjuster (7) through input pressure fitting (11) until piston (16) is extended 0.5 to 1 in. (12.7 to 25.4 mm).
- 3 Install mounting bracket (9) and two screws (8). Torque screws to 300-350 lb-ft (407475 NŽm).
- 4 Install adjuster (7), pivot pin (6), flat washer (5), and screw (4). Torque screw to 300–350 lb-ft (407475 NŽm).
- 5 Install pin (3) in lug hole (20) of idler arm assembly (21).
- 6 Rotate assembly counterclockwise with crowbar. Remove pin (3).
- 7 Install adjuster (7), pin (3), and two new cotter pins (2). Adjust track (para 10-8).

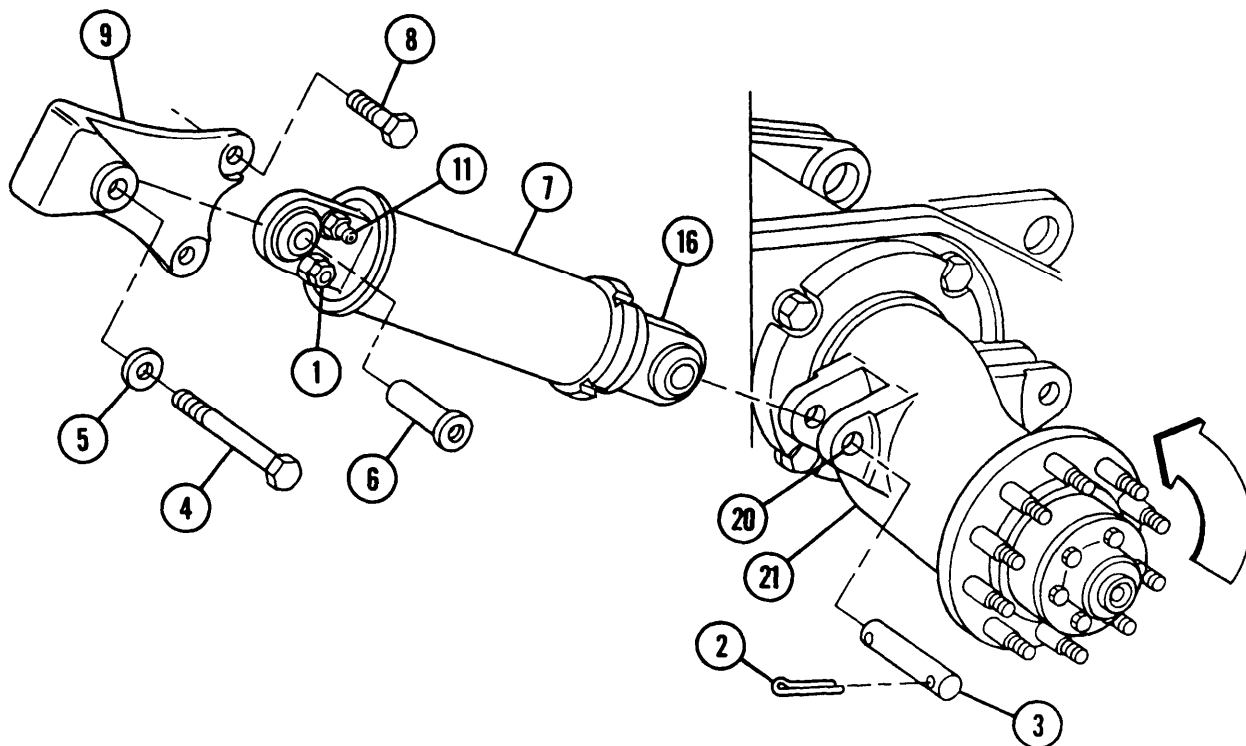

10-16 IDLER WHEELS AND HUBS

This task covers: a. Removal b. Installation

INITIAL SETUP

Tools

General mechanic's tool kit (item 64, Appx H)
 Handle (item 28, Appx H)
 Hand lubricating gun (item 24, Appx H)
 Inner bearing cup remover/replacer (item 51, Appx H)
 Inner seal replacer (item 50, Appx H)
 outer bearing cup remover/replacer (item 52, Appx H)
 Socket wrench set (item 56, Appx H)
 Torque multiplier (item 37, Appx H)
 Torque wrench (item 71, Appx H)
 Torque wrench (item 72, Appx H)

Materials/Parts

Cotter pins (1) (item 3, Appx G)
 GAA grease (item 25, Appx D)
 Inner hub seal (item 164, Appx G)
 Key washer (item 185, Appx G)
 Lubricating oil (item 37, Appx D)
 Preformed packing (item 57, Appx G)

Equipment Conditions

Track removed (para 10-6 or 10-7)

a. Removal

- 1 Remove 10 nuts (1).
- 2 Remove outer idler wheel (2), spacer (3), and inner idler wheel (4).

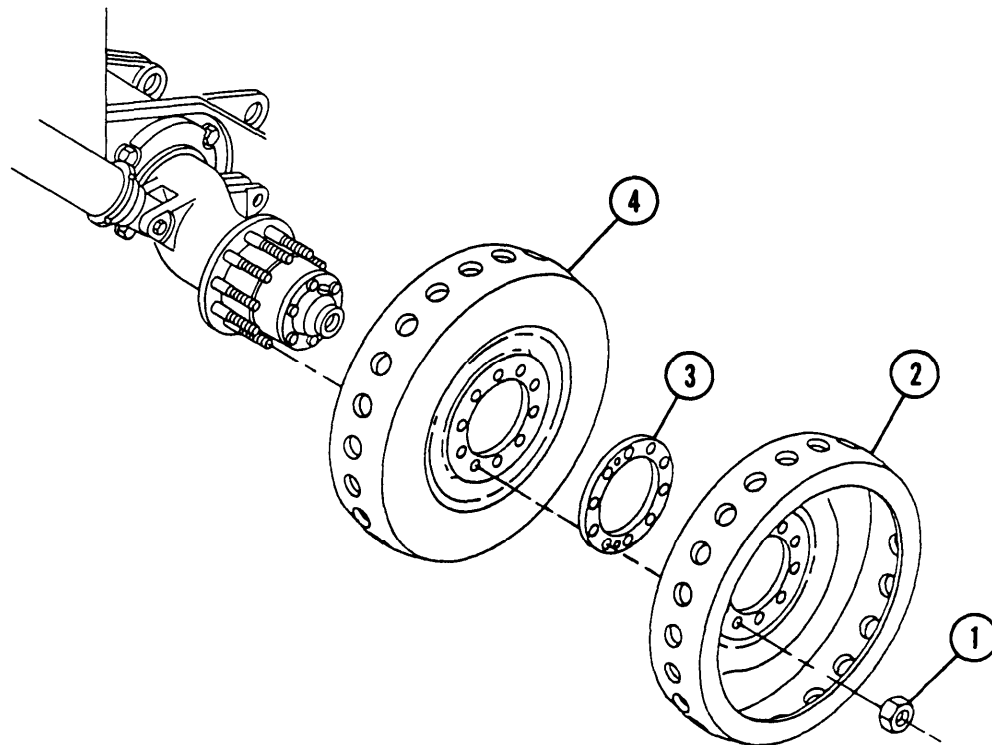

10-16 IDLER WHEELS AND HUBS — CONTINUED

a. Removal — Continued

- 3 Remove grease fitting (5) from cap (6).
- 4 Remove relief valve (7) from hub body (8).
- 5 Remove six screws (9), six flat washers (10), and cap (6).
- 6 Remove static spring (11), cotter pin (12), nut (13), key washer (14), preformed packing (15), and hub body (8). Discard cotter pin, key washer, and preformed packing.
- 7 Remove inner hub seal (16). Discard inner hub seal.
- 8 If damaged, remove bearings (17) from hub body (8) using removers and handle.

b. Installation

NOTE

Ž Do not prepack bearings with grease.

Ž Seal mating surface in hub must be free of grease, dirt, and oil prior to assembly.

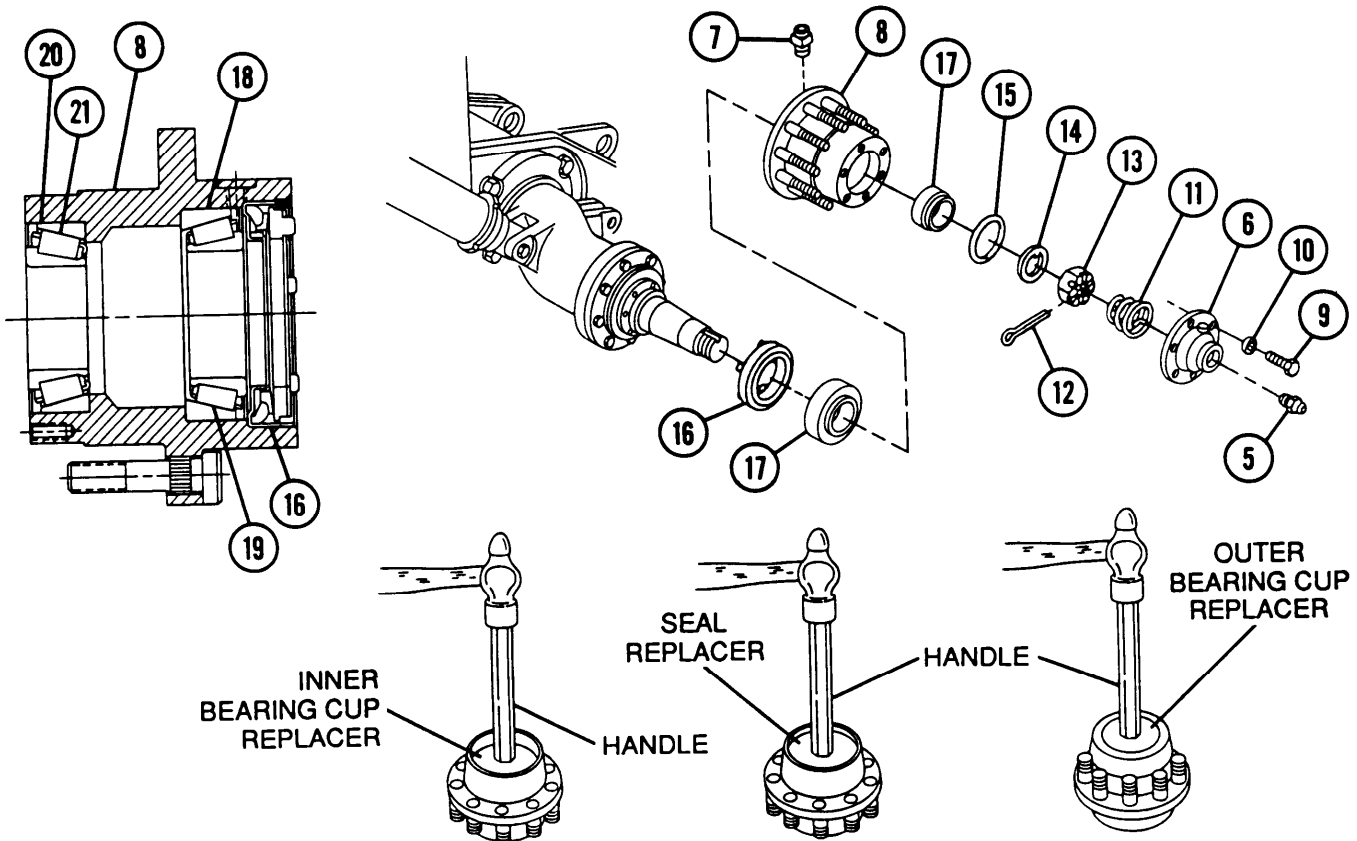

- 1 Install inner bearing cup (18) using inner bearing cup replacer and handle.
- 2 Install inner bearing cone (19).

CAUTION

Be careful not to damage or deform inner hub seal or inner hub seal lip when installing inner hub seal in hub. Do not press on pins when installing inner hub seal.

- 3 Install new inner hub seal (16) using seal replacer and handle. Ensure inner hub seal is flush with hub body (8).
- 4 Using outer bearing cup replacer and handle, install outer bearing cup (20).
- 5 Install outer bearing cone (21).
- 6 Assemble hub body (8), new key washer (14), and nut (13) on spindle (22).
- 7 Torque nut (13) as follows:
 - (a) Using torque wrench, tighten nut to 100lb-ft (136 Nǃm).
 - (b) Back off nut 1 complete turn.
 - (c) Using torque wrench, tighten nut to 30 lb-ft (41 Nǃm) while rotating hub.
 - (d) If slots in nut and hole in spindle line up, install new cotter pin (12).
 - (e) If slots in nut and hole in spindle are misaligned, back off nut to align with first hole in spindle, and then install new cotter pin (12). Range of back-off is 0 to 30°.
 - (f) After adjustment, hub assembly (23) must rotate freely by hand.

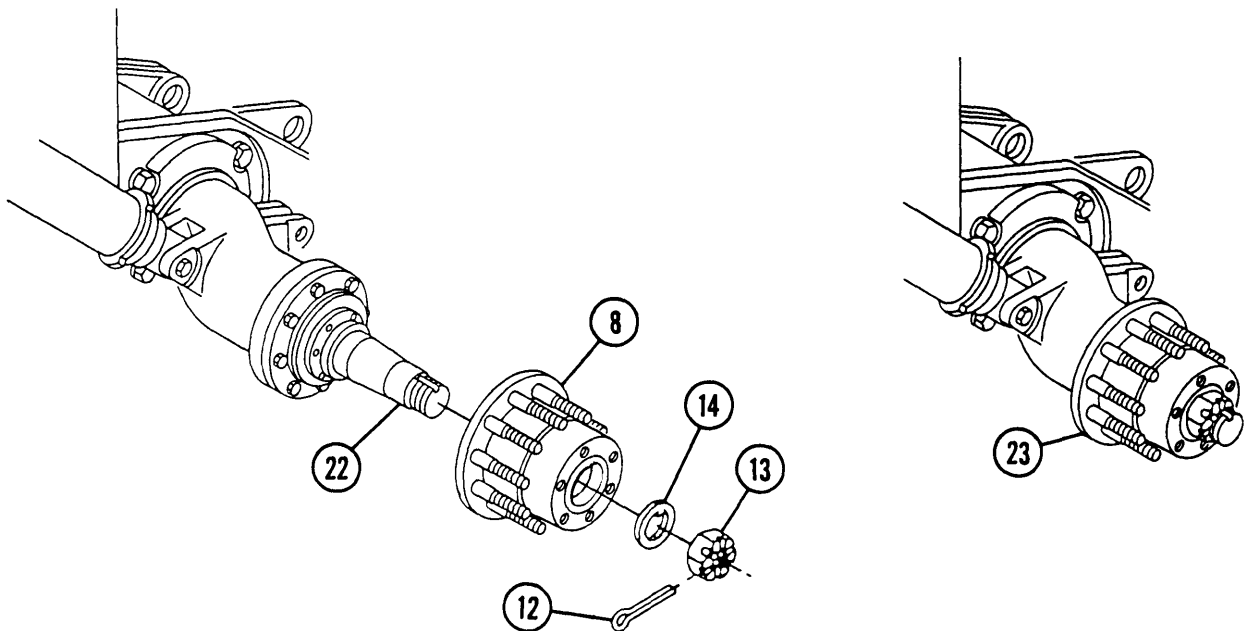

10-16 IDLER WHEELS AND HUBS — CONTINUED

b. Installation — Continued

- 8 install new preformed packing (15) and static spring (11) in hub assembly (23).
- 9 Install grease fitting (5) in cap (6).
- 10 Install relief valve (7).
- 11 Install cap (6), six flat washers (10), and six screws (9). Torque screws to 12lb-ft (16 N•m).
- 12 Fill hub assembly (23) with grease until air-free grease flows from relief valve (7).
- 13 Lubricate threads with grease or oil.
- 14 Install inner idler wheel (4), spacer (3), and outer idler wheel (2).

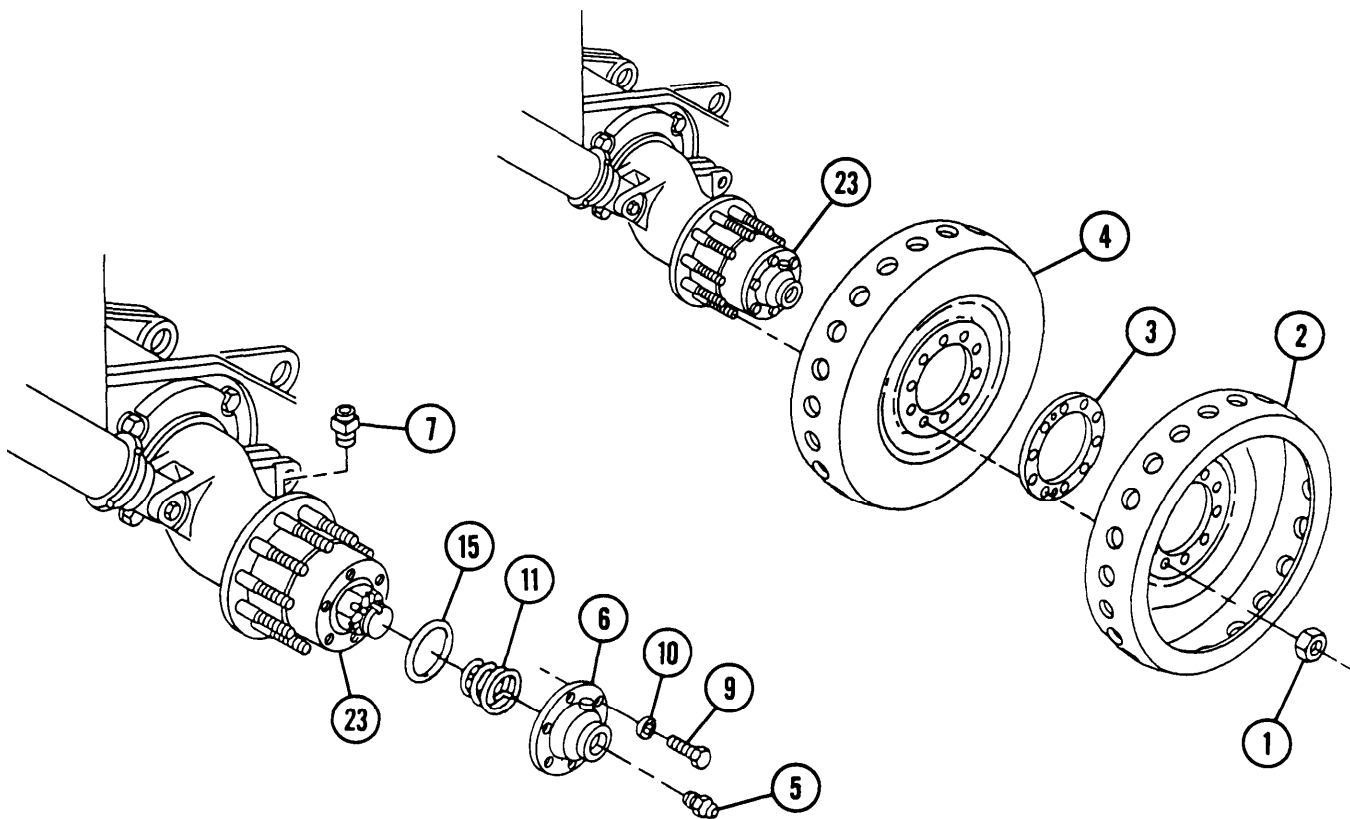

NOTE

FOLLOW-ON MAINTENANCE: Install track (para 10-6 or 10-7)

10-17 IDLER ARM ASSEMBLIES

This task covers:

a. Removal	b. Disassembly
c. Assembly	d. Installation

INITIAL SETUP

Tools

General mechanic's tool kit (item 64, Appx H)
 Lubricating gun (item 24, Appx H)
 Socket wrench set (item 56, Appx H)
 Torque multiplier (item 37, Appx H)
 Torque wrench (item 71, Appx H)
 Torque wrench (item 72, Appx H)

Materials/Parts

GAA grease (item 27, Appx D)
 Gasket (item 122, Appx G)

Plug (item 103, Appx G)
 Preformed packing (item 63, Appx G)
 Preformed packing (item 64, Appx G)
 Seal (item 157, Appx G)
 Spring pin (item 11, Appx G)

Equipment Condition~

Idler wheels and hubs removed (para 10-16)
 Track adjuster disconnected at idler arm assembly (para 10-15)

a. Removal

- 1 Remove four screws (1).
- 2 Remove idler arm assembly (2) and gasket (3) from idler arm housing (4). Discard gasket.

b. Disassembly

- 1 Remove screw (5), flat washer (6), idler arm cap (7), and spring pin (8). Discard spring pin.

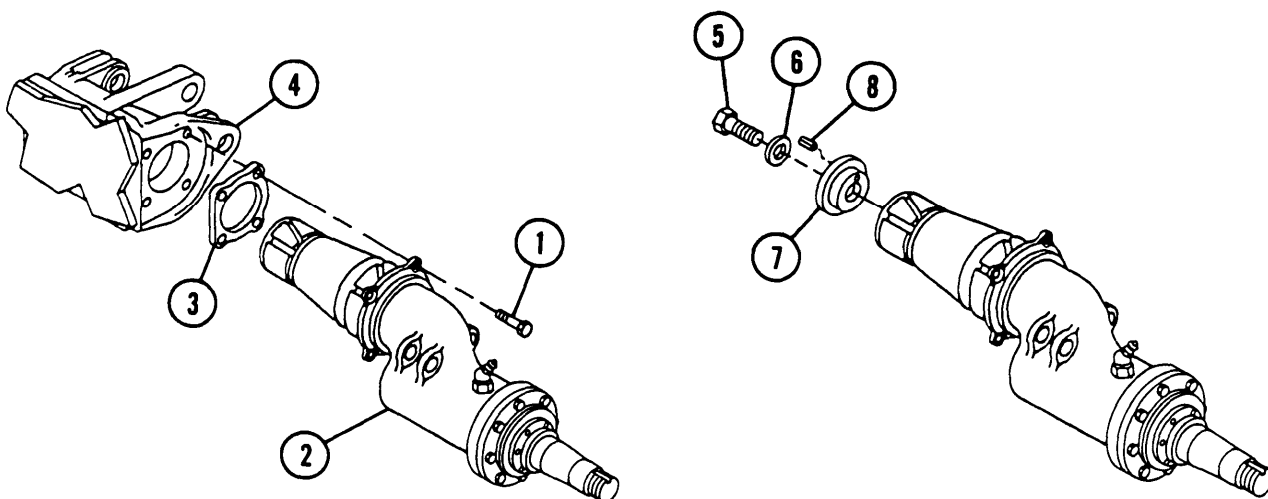

10-17 IDLER ARM ASSEMBLIES — CONTINUED

b. Disassembly — Continued

- 2 Remove inner sleeve bearing (9), bearing spacer (10), outer sleeve bearing (11), idler arm retainer (12), and preformed packing (13). Discard packing.
- 3 Remove eight screws (14), inner sleeve bearing (15), outer sleeve bearing (16), preformed packing (17), two retainers (18), retainer (19), spindle (20), seal (21), and plug (22) from idler arm (23). Discard packing, seal, and plug.

c. Assembly

- 1 Remove grease fitting (24) to release air from housing (25).
- 2 Install new plug (22), new seal (21), spindle (20), retainer (19), two retainers (18), new preformed packing (17), outer sleeve bearing (16), inner sleeve bearing (15), and eight screws (14) on idler arm (23). Torque screws to 30-40 lb-ft (41-54 N•m).
- 3 Install new preformed packing (13), idler arm retainer (12), outer sleeve bearing (11), bearing spacer (10), and inner sleeve bearing (9).
- 4 Install new spring pin (8), idler arm cap (7), flat washer (6), and screw (5). Torque screw to 290-350 lb-ft (393-475 N•m).
- 5 Pack idler arm (23) and idler arm housing (25) with grease.

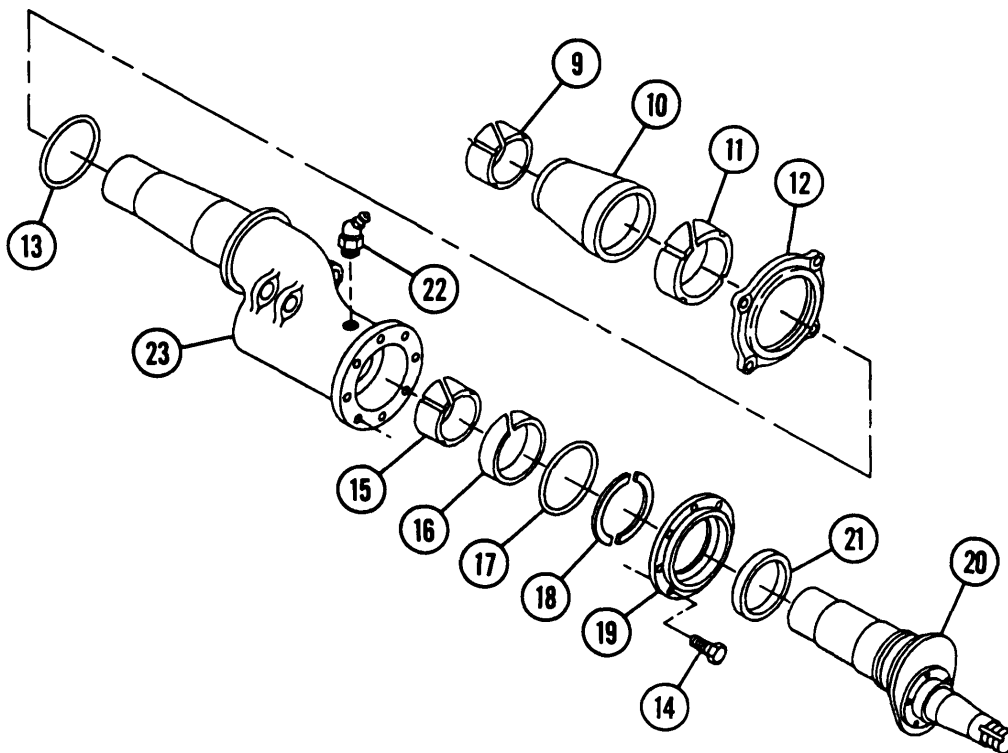

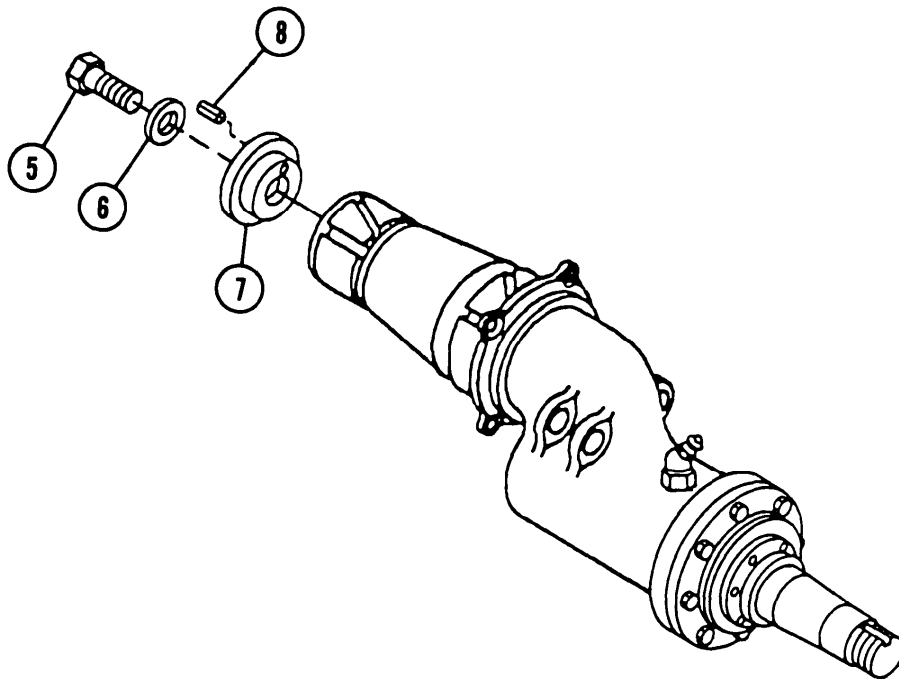
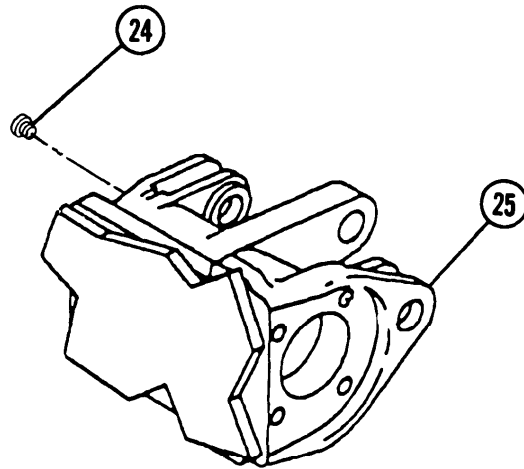

10-17 IDLER ARM ASSEMBLIES — CONTINUED

d. Installation

- 1 Install new plug (24).
- 2 Install new gasket (3) and idler arm assembly (2) in idler arm housing (4).
- 3 Install four screws (1). Torque screws to 80-100lb-ft(108-136 NŽm).

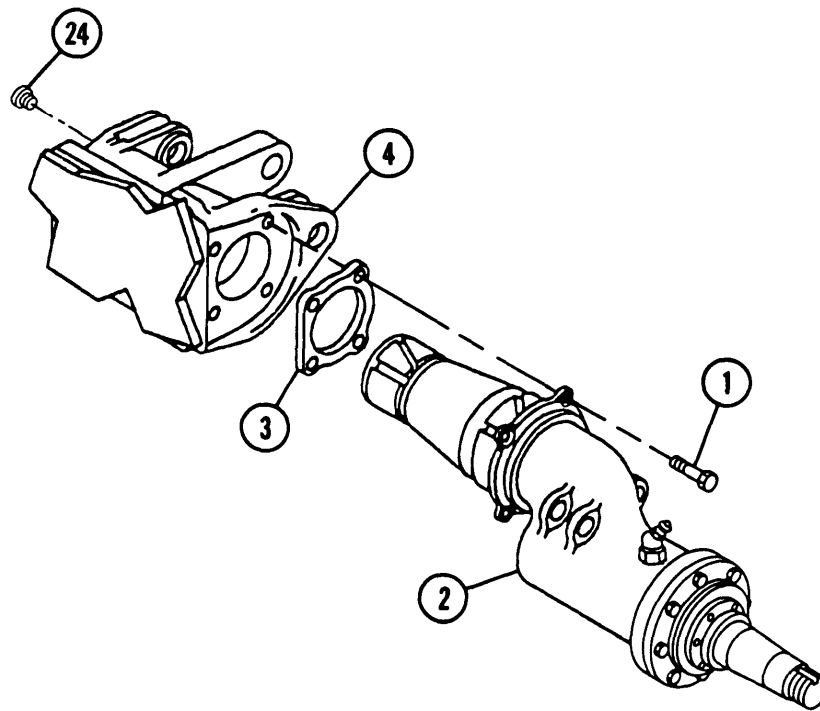

NOTE

FOLLOW-ON MAINTENANCE:

Install idler wheel and hub (para 10-16)
Connect track adjuster (para 10-15)

10-18 IDLER ARM HOUSINGS

This task covers: a. Removal b. Installation

Tools

General mechanic's tool kit (item 64, Appx H)
Socket adapter (item 3, Appx H)
Socket wrench set (item 56, Appx H)
Torque multiplier (item 37, Appx H)
Torque wrench (item 71, Appx H)

Equipment Conditions

Idler arm assembly removed (para 10-17)
Idler wheel and hub removed (para 10-16)
Track adjuster disconnected (para 10-15)
Track disconnected (para 10-6 or 10-7)

a. Removal

Remove eight screws (1) and idler arm housing (2).

b. Installation

Install idler arm housing (2) and eight screws (1).

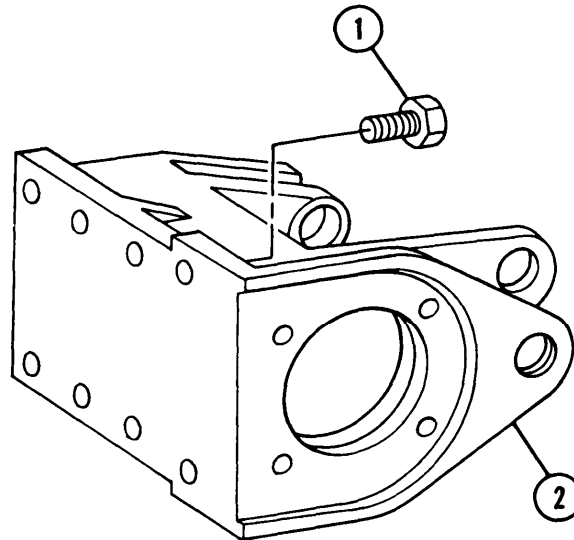

NOTE

FOLLOW-ON MAINTENANCE:

Install idler arm assembly (para 10-17)
Install idler wheel and hub (para 10-16)
Connect track adjuster (para 10-15)
Connect track (para 10-6 or 10-7)

10-19 SHOCK ABSORBERS

This task covers: a. Removal b. Installation

INITIAL SETUP

Tools

General mechanic's tool kit (item 64, Appx H)
Shock absorber puller (item 46, Appx H)
Torque wrench (item 72, Appx H)

Materials/Parts

Cotter pins (2) (item 48, Appx G)
Seals (2) (item 156, Appx G)

a. Removal

- 1 Remove cotter pin (1), nut (2), and flat washer (3). Discard cotter pin.
- 2 Screw shock absorber puller on threaded end of bearing. Turn screw head with wrench to pull shock absorber from arm spindle on mount.
- 3 Remove top end of shock absorber (4) from shock absorber mount (5). Use puller if required.
- 4 Remove cotter pin (6), nut (7), retainer (8), seal (9), and flat washer (10). Discard cotter pin and seal.
- 5 Remove bottom end of shock absorber (4). Use puller if required.
- 6 Remove seal (11) and retainer (12). Discard seal.
- 7 Remove four screws (13) and four flat washers (14) from shock absorber mount (5). Remove mount and plate (15) (front shock absorbers only).

b. Installation

- 1 Install shock absorber mount (5) and plate (15) (front shock absorbers only), four flat washers (14), and four screws (13). Torque screws to 80-100 lb-ft (108-136 N•m).
- 2 Install retainer (12) and new seal (11).
- 3 Install bottom end of shock absorber (4).
- 4 Install flat washer (10), new seal (9), retainer (8), nut (7), and new cotter pin (6). Torque nuts to 100-140 lb-ft (136-190 N•m).
- 5 Install top end of shock absorber (4) on mount (5).
- 6 install flat washer (3), nut (2), and new cotter pin (1). Torque nut to 100-140 lb-ft (136-190 N•m).

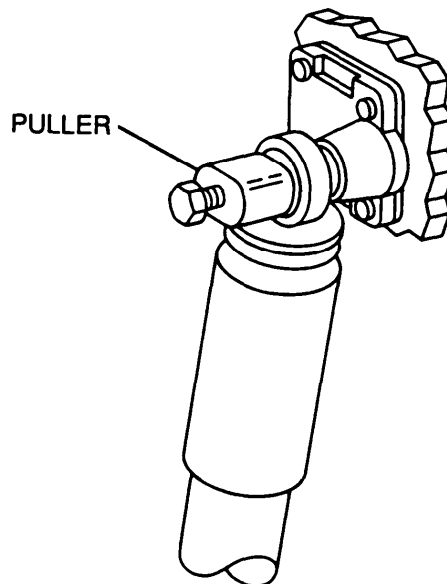
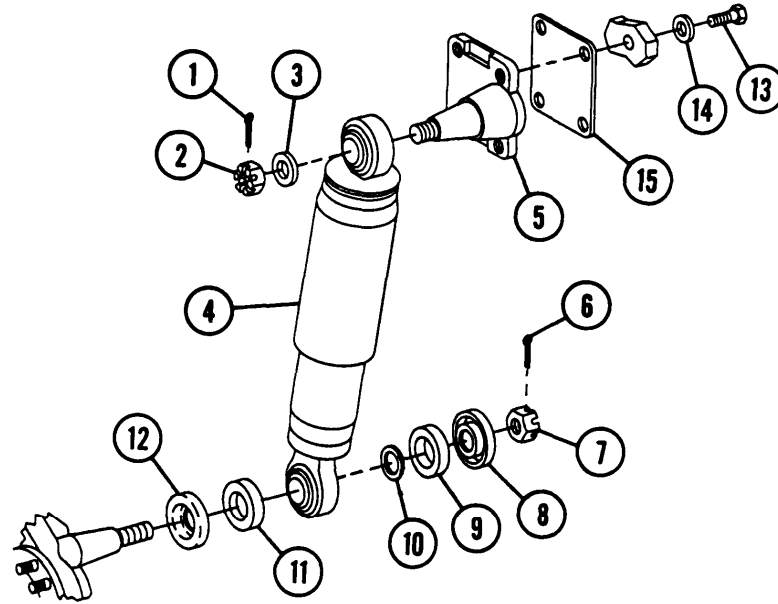

10-20 SHOCK ABSORBER BEARINGS

This task covers: a. Removal b. Installation

INITIAL SETUP

Tools

General mechanic's tool kit (item 84, Appx H)
Bearing remover and replacer (item 48, Appx H)

Materials/Parts

Bearing (item 133, Appx G)

a. Removal

- 1 Install bearing remover and replacer tool in shock absorber eye (1) of shock absorber (2).
- 2 Turn tool clockwise to remove bearing (3). Bearing will be pulled into collar (4) of tool. Discard bearing.

b. Installation

- 1 Use fine-mill file stone to remove stake marks and burrs from inner surface of shock absorber eye (1).
- 2 Start new bearing (2) into eye (1) of shock absorber (3) by hand.
- 3 Insert bearing remover and replacer through bearing (2).
- 4 Turn nut (5) clockwise to install bearing (2).
- 5 Stake bearing (2) at six equally spaced points on both sides.

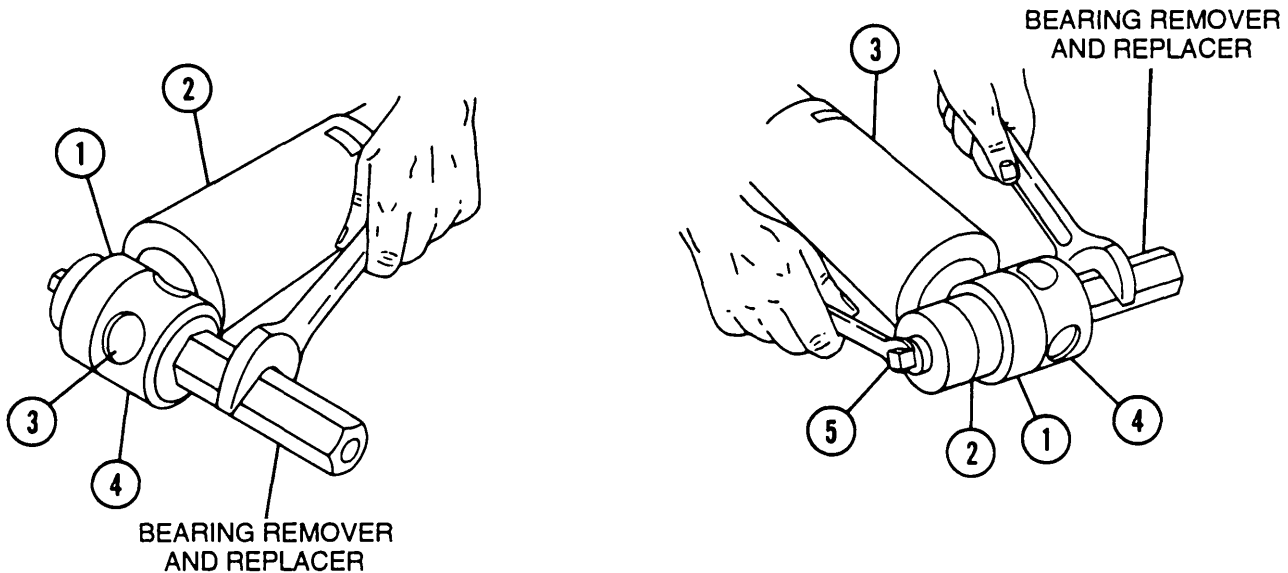

SECTION III. FINAL DRIVES AND UNIVERSAL JOINTS

10-21 FINAL DRIVE SPROCKETS AND HUBS

This task covers: a. Removal b. Installation

Tools

General mechanic's tool kit (item 64, Appx H)
 Socket wrench set (item 56, Appx H)
 Torque multiplier (item 37, Appx H)
 Torque wrench (item 71, Appx H)
 Torque wrench (item 72, Appx H)

Lubricating oil (item 49, Appx D)

Personnel Required

Two

Equipment Conditions

Track disconnected (para 10-6 or 10-7)

Materials/Parts

GAA grease (item 27, Appx D)

a. Removal

NOTE

Hub with inner and outer sprockets attached may be removed as an assembly by removing screws (1).

- 1 Remove 10 nuts (2) and 10 screws (3) from outer sprocket (4). Lift off sprocket.

WARNING

Hub is very heavy. At least two personnel are required to remove.

- 2 Remove eight screws (1) from hub (5). Insert two screws in hub pilot holes. Tighten screws to pull hub away from drive assembly (6). Lift off hub and inner sprocket (7) from drive assembly.
- 3 Remove 10 nuts (8) and 10 screws (9) holding hub (5) to inner sprocket (7). Lift off hub.

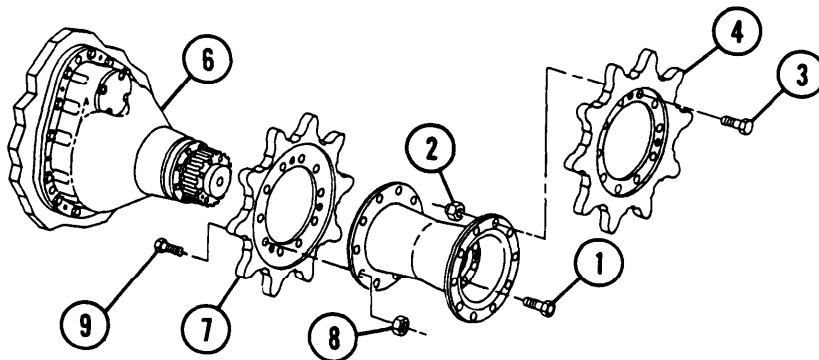

10-21 FINAL DRIVE SPROCKETS AND HUBS — CONTINUED

b. Installation

WARNING

Hub is very heavy. At least two personnel are required to install.

CAUTION

T-154 sprockets must be used with T-154 track and T-136 sprockets must be used with T-136 track.

- 1 Place inner sprocket (7) on sprocket hub (5) and install 10 screws (9) and 10 nuts (8), locking sprocket to hub. Torque screws to 80-100 lb-ft (108-136 Nžm).
- 2 Place hub on final drive assembly (6) and install eight screws (1), holding hub to final drive assembly. Lubricate screws and torque to 330-360 lb-ft (447488 Nžm).
- 3 Place outer sprocket (4) on hub and install 10 screws (3) and 10 nuts (2). Torque nuts to 80-100lb-ft(109-136 Nžm).

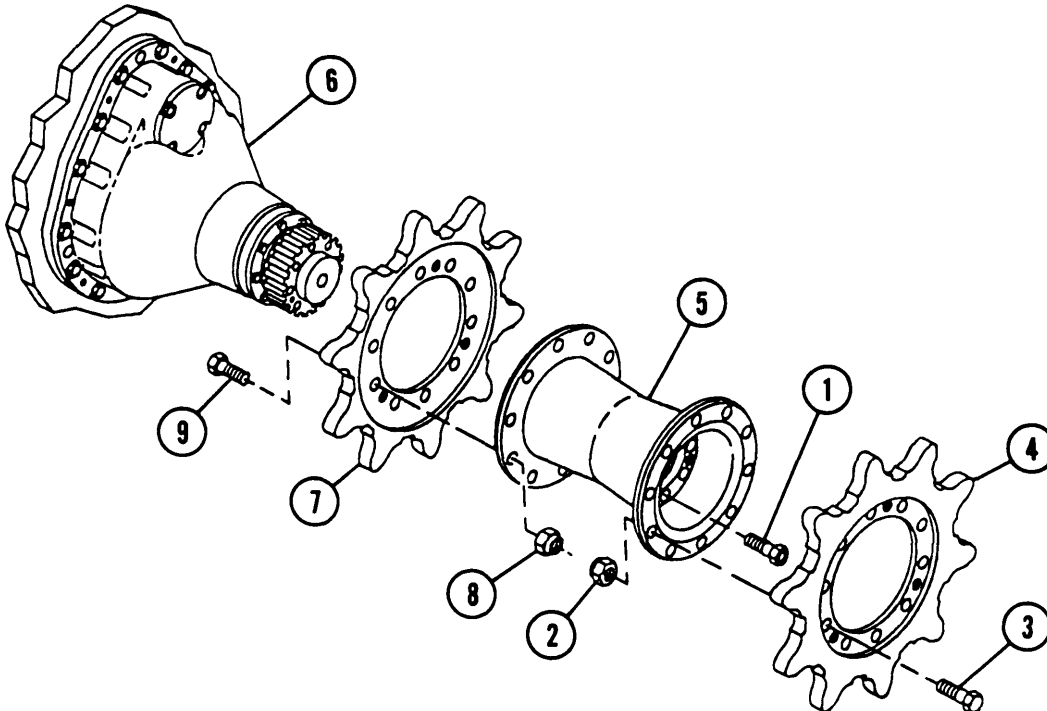

NOTE

FOLLOW-ON MAINTENANCE: Connect track (para 10-6 or 10-7)

10-22 FINAL DRIVE ASSEMBLIES

This task covers: a. Removal b. Inspection c. Installation

INITIAL SETUP

Tools

General mechanic's tool kit (item 64, Appx H)
 Eye bolt (item 5, Appx H)
 Guide pins (2) (item 38, Appx H)
 Lifting sling (item 58, Appx H)
 Socket wrench set (item 56, Appx H)
 Torque multiplier (item 37, Appx H)
 Torque wrench (item 71, Appx H)

LockWashers (14) (item 93, Appx G)
 Lockwashers (12) (item 96, Appx G)
 Lubricating oil (item 45, Appx D)
 Zinc chromate primer (item 54, Appx D)

Personnel Required

Two

Equipment Conditions

Final drive sprocket and hub removed (para 10-21)

Materials/parts

Gasket (item 121, Appx G)

a. Removal

NOTE

Final drive and bearing retaining nut may be inspected while installed in vehicle. See inspection procedure below.

- 1 Remove screw (1), washer (2), and clamp (3).
- 2 Unscrew tube hex nut connector (4).
- 3 Remove vent tube (5).

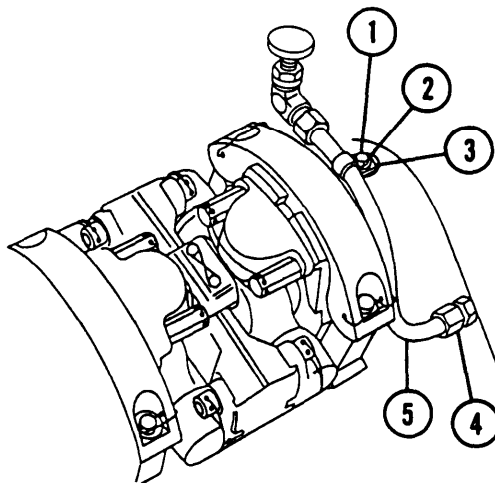

10-22 FINAL DRIVE ASSEMBLIES — CONTINUED

a. Removal — Continued

WARNING

Oil is hazardous waste and must be disposed of in accordance with local procedures or direction of the local Hazardous Waste Management office.

- 4 Remove drain plug (6) and drain oil from final drive assembly (7).
- 5 Remove two screws (8) and two lockwashers (9). Discard lockwashers.
- 6 Install two guide pins in screw holes.
- 7 Remove six screws (10) and six lockwashers(11). Leave top screw (12) and lockwasher (13) in place. Discard lockwashers.
- 8 Remove five screws (14), five lockwashers (15), five flat washers (16), and five nuts (17). Discard lockwashers.
- 9 Remove cap screw (18) at top of housing and install lifting eye bolt.
- 10 Attach lifting sling to eye bolt and to hoist.
- 11 Remove top screw (12) and lockwasher (13). Discard lockwasher.
- 12 Slide final drive assembly (7) away from vehicle.
- 13 Remove two guide pins.

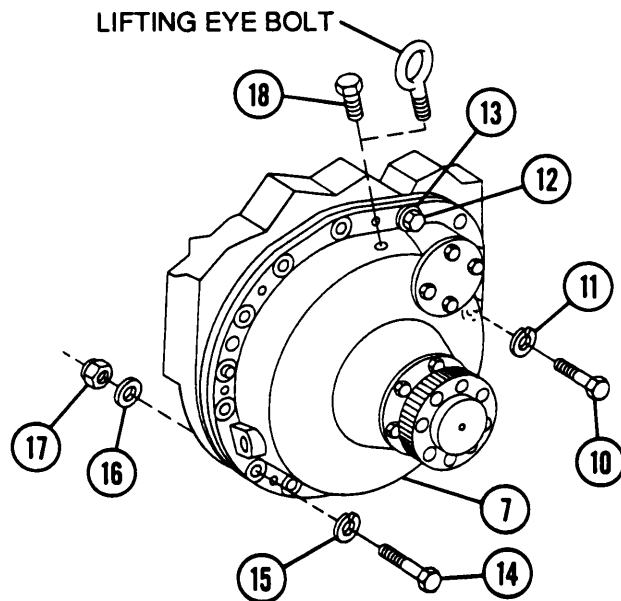
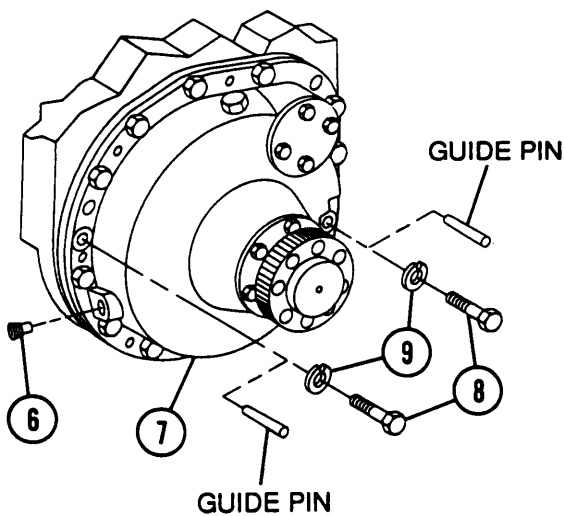

b. Inspection

WARNING

Compressed air for cleaning purposes will not exceed 30 psi (207 kPa). Use only with effective chip guarding and personnel protective equipment (goggles/shield, gloves etc.).

- 1 Inspect vent tube (5) and receptacle (19) for clogging. Clean tube with low-pressure compressed air, Clean receptacle with soft brush or rag.
- 2 Remove 12 screws (20), 12 lockwashers (21), end cover (22), and gasket (23). Discard lockwashers.
- 3 Inspect retaining nut (24). If there are any visual signs of loose nut or sheared cotter pin (25), remove and replace final drive assembly (7). Notify support maintenance.
- 4 Inspect gasket (23). Replace if worn or deteriorated.
- 5 Install gasket (23), end cover (22), 12 new lockwashers (21), and 12 screws (20).

c. Installation

- 1 Install guide pins.
- 2 Coat contact surfaces of hull and final drive assembly (7) with zinc chromate primer before installation.
- 3 Install lifting eye bolt and lifting sling on final drive assembly (7). Slide final drive assembly over guide pins.
- 4 Install new top lockwasher (13) and screw (12) and new bottom lockwasher (15), screw (14), flat washer (16), and nut (17) near bottom of final drive.
- 5 Remove guide pins, lifting eye bolt, and lifting sling. Install cap screw (18).
- 6 Install two new lockwashers (9) and two screws (8).

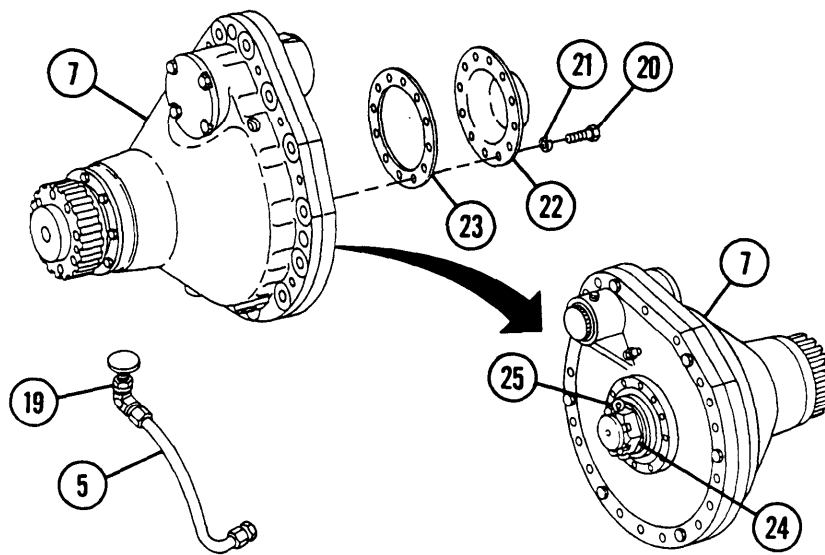

10-22 FINAL DRIVE ASSEMBLIES — CONTINUED

c. Installation — Continued

- 7 Install six new lockwashers (11) and six screws (10).
- 8 Install remaining new lockwasher (15), screws (14), flat washers (16), and nuts (17). Torque screws to 290-300 lb-ft (393-407 N•m).
- 9 Install vent tube (5), clamp (3), washer (2), and screw (1).
- 10 Install drain plug (6). Fill final drive assembly with oil (para 2-15). If leakage occurs, notify support maintenance..

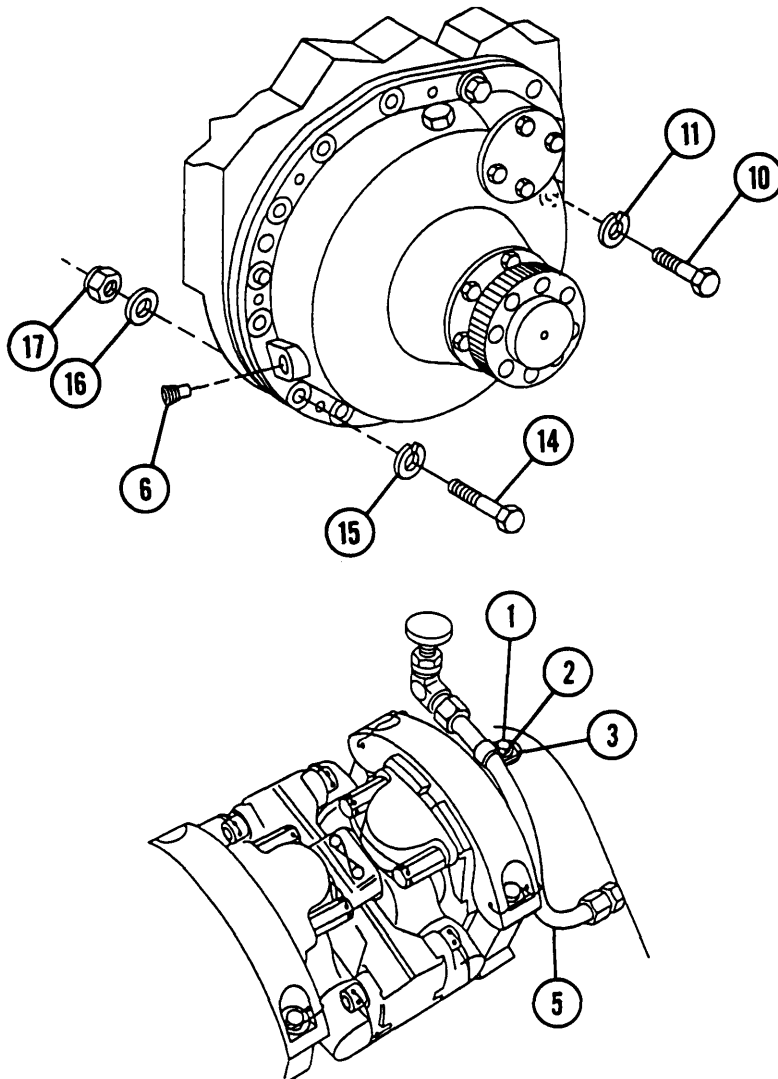

NOTE

FOLLOW-ON MAINTENANCE: Install final drive sprocket and hub (para 10-21)

10-23 UNIVERSAL JOINTS

This task covers:

a. Removal	b. Disassembly
c. Inspection and Repair	d. Assembly
e. Installation	

INITIAL SETUP

Tools

General mechanic's tool kit (item 64, Appx H)
 Torque wrench (item 72, Appx H)
 Wire twister pliers (item 42, Appx H)

LockWire (as required) (item 113, Appx G)

References

TM 9-2520-234-35

Materials/Parts

GAA grease (item 26, Appx D)

Equipment Conditions

Transmission access doors opened (para 11-7)

a. Removal

1 Remove lockwires (1). Discard lockwires.

NOTE

if flange and adapter screws are inaccessible, place transmission shift lever in neutral (N) position and push or tow vehicle until universal joint rotates sufficiently to allow access to screws.

2 Remove four screws (2) at flange assembly (3) and four screws (4) at adapter (5).

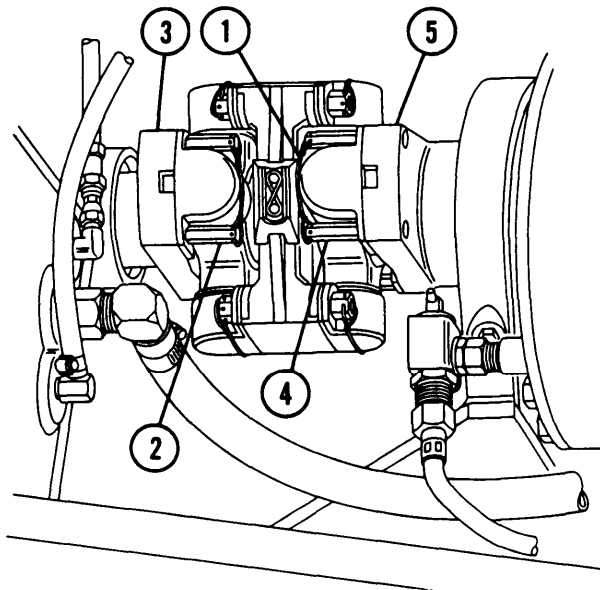

10-23 UNIVERSAL JOINTS — CONTINUED

a. Removal — Continued

3 Slide flange assembly (3) toward final drive, and adapter (5) toward transmission. Lift out joint assembly (6).

4 Slide flange assembly (3) off final drive. Flange plug is installed in flange assembly, do not remove.

5 Remove bolt (7) and adapter lockplate (8). Slide adapter (5) off transmission.

b. Disassembly

1 Remove four lockwires (9) and eight screws (10). Discard lockwires.

2 Separate two journal assemblies (11) from center plate (12).

3 Remove two lockwires (13), four screws (14), two bumper retainers (15), and two bumpers (16) from center plate (12). Discard lockwires.

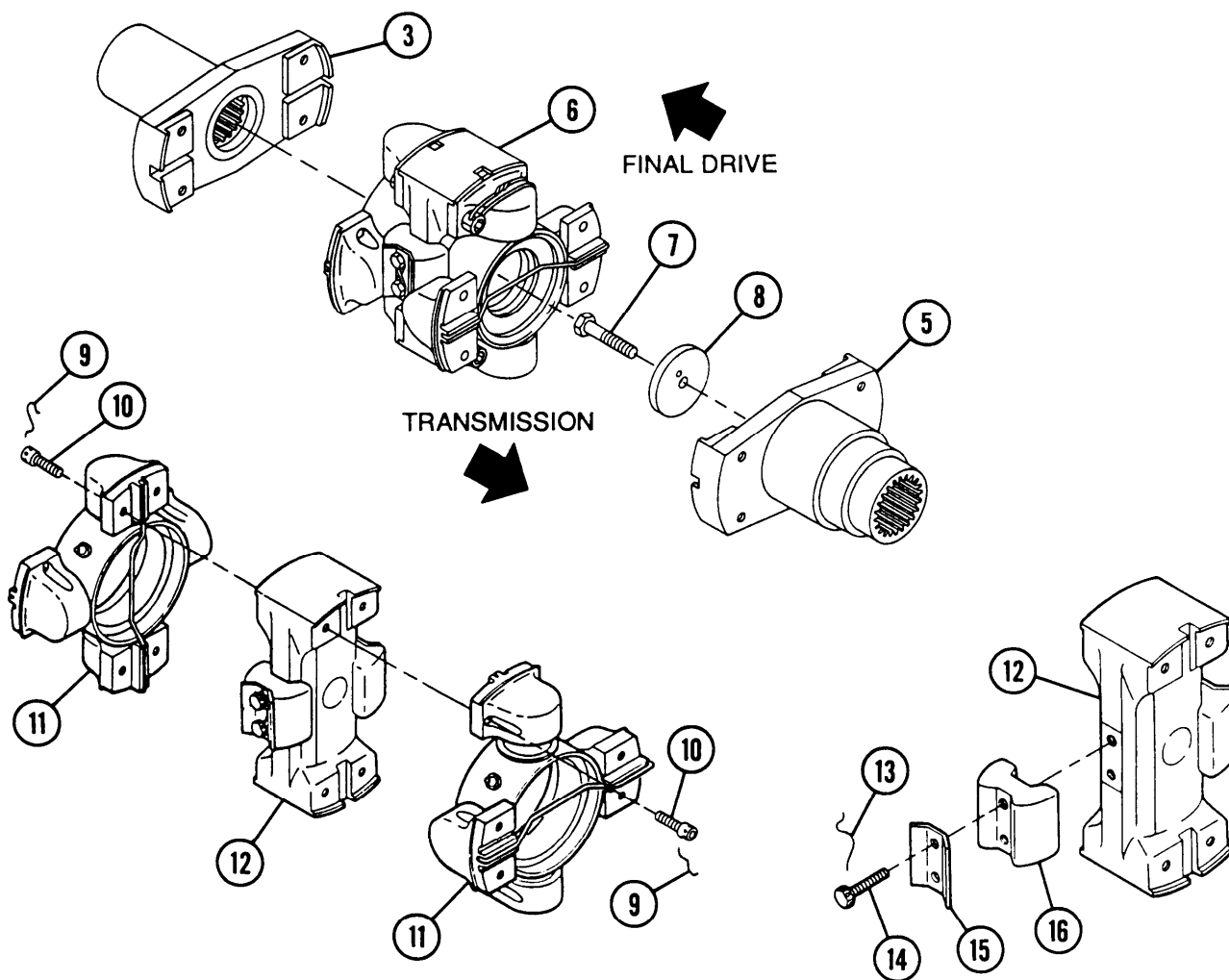

c. Inspection and Repair

NOTE

For definition of repair and inspection symbols, see paragraph 2-6.

- 1 Inspect flange (3) for cracks, distortion, and broken or missing splines. Replace if cracked, distorted, or splines are broken or missing.

NOTE

2.0490 to 2.0500 in. (5.2045 to 5.2070 cm) pitch diameter is reading over two pins (0.1406-in. [3.571-mm] diameters).

2 Check:

	Size and fit of new parts	Wear limits
(a) Pitch diameter (A)	2.0490 to 2.0500 in. (5.2045 to 5.2070 cm)	2.0515 in. (5.2108 cm)
(b) Major diameter (B)	2.3333 to 2.3383 in. (5.9266 to 5.9393 cm)	2.3405 in. (5.9449 cm)
(c) Minor diameter (C)	2.1800 to 2.1825 in. (5.5372 to 5.5436 cm)	2.1850 in. (5.5499 cm)

- 3 Inspect flange plug (17) for damage or distortion. Plug must provide water- and oil-tight seal. Replace flange assembly (3) if plug is damaged or distorted.

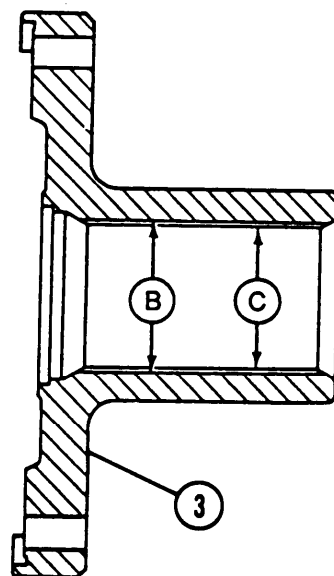
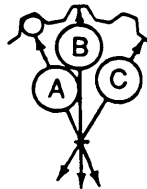

SHOWN REMOVED FOR CLARITY

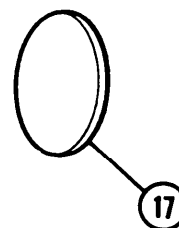

10-23 UNIVERSAL JOINTS — CONTINUED

c. Inspection and Repair — Continued

- 4 Inspect adapter (5) for cracks, distortion, and broken or missing splines. Replace adapter if cracked or distorted, or splines are broken or missing.
- 5 Check:

	Size and fit of new parts	Wear limits
(a) Pitch diameter (A)	TM 9-2520-234-35	
(b) Major diameter (B)	3.8800 to 3.8850 in. (9.8552 to 9.8679 cm)	3.8780 in. (9.8501 cm)
(c) Minor diameter (C)	3.3460 to 3.3470 in. (8.4988 to 8.5014 cm)	3.3445 in. (8.4950 cm)
(d) Finish (splines)	25 polished	
- 6 Check center plate (12) concentricity of mating surfaces with center bore, ensuring Total Indicator Reading (TIR) is within 0.0040 in. (0.102 mm). Inspect for distortion, ensuring mating surfaces square to within 0.0040 in. (0.102 mm) TIR.
- 7 Replace bumper retainers (15) as appropriate.
- 8 Replace bumpers (16) as appropriate.
- 9 Check two journal assemblies (11) for damage or defects. Check for play between bearing caps and spider. Replace universal joint if play is excessive.

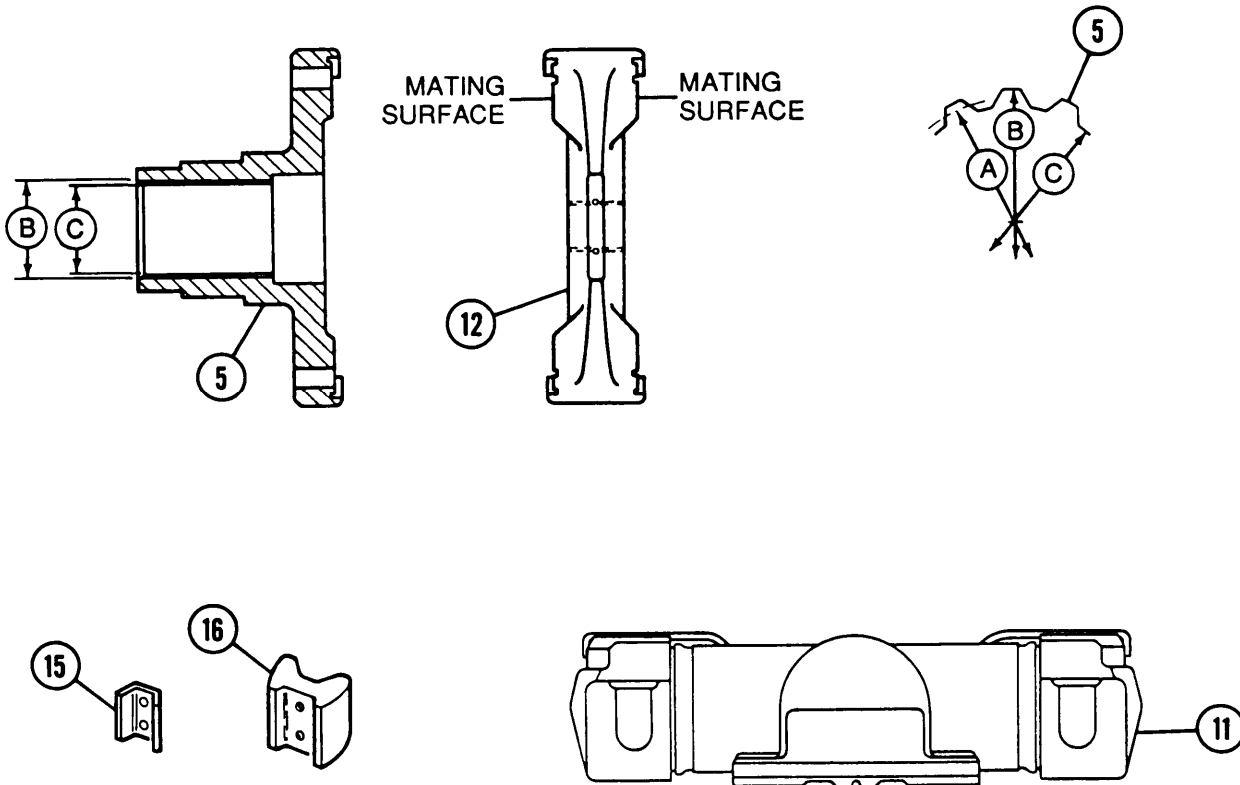

d. Assembly

- 1 Install two bumpers (1 6), two bumper retainers (15), four screws (14), and two new lockwires (13) onto center plate (12).
- 2 Assemble two journal assemblies (11) to center plate (1 2).
- 3 Install eight screws (10) and four new lockwires (9).
- 4 Install flange assembly (3), with flange plug installed, onto final drive splined shaft.
- 5 Install adapter (5) onto transmission splined shaft.
- 6 Install adapter lockplate (8) and bolt (7) onto transmission splined shaft.
- 7 Connect joint assembly (6) to adapter (5) and flange (3).

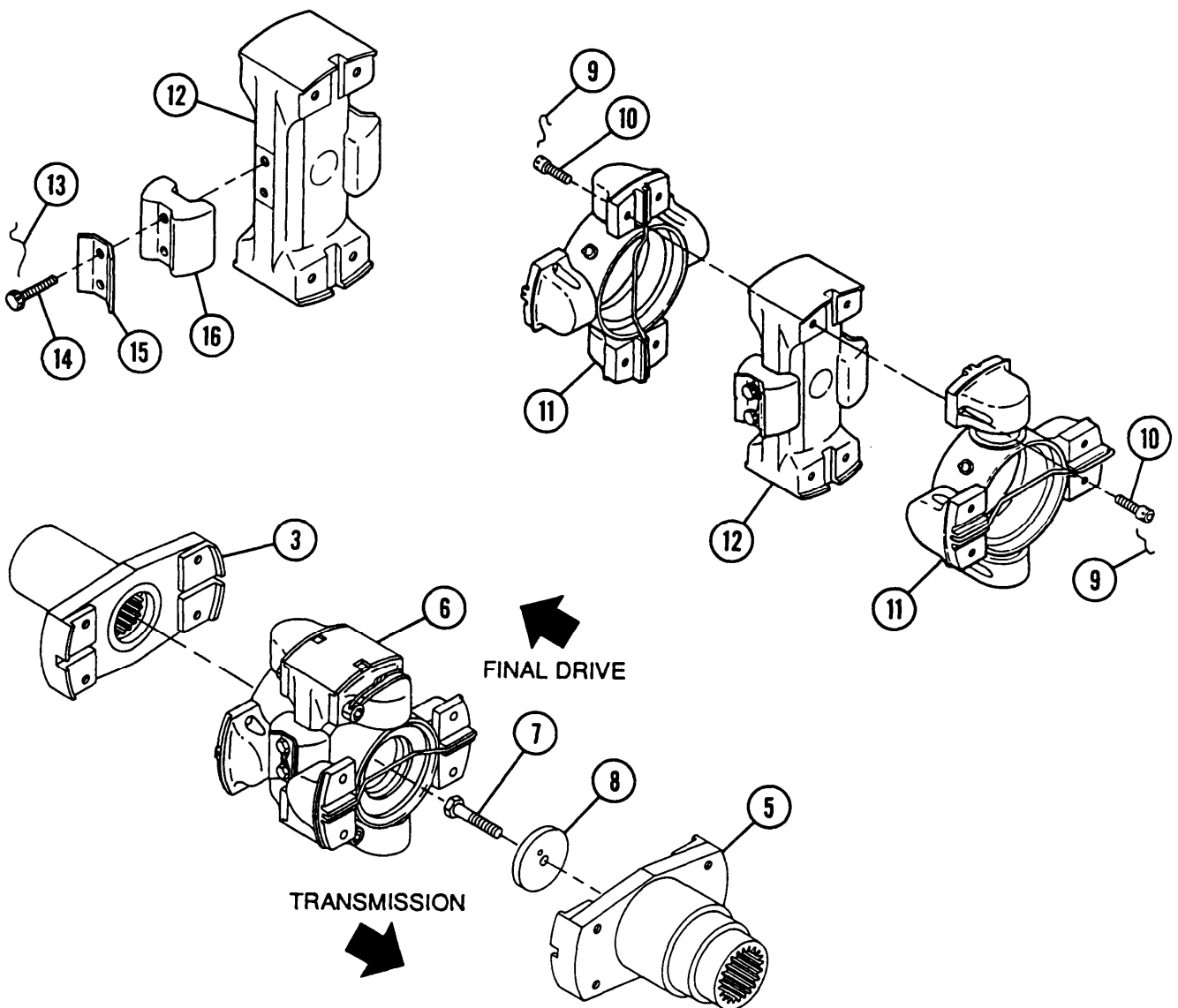

10-23 UNIVERSAL JOINTS — CONTINUED

e. Installation

CAUTION

U-joint screws must be torqued and secured with lockwire to prevent unsafe driving conditions and damage to vehicles.

Install eight screws (2 and 4). Torque screws to 90-100lb-ft(122–136 NŹm). Install new lockwires (1).

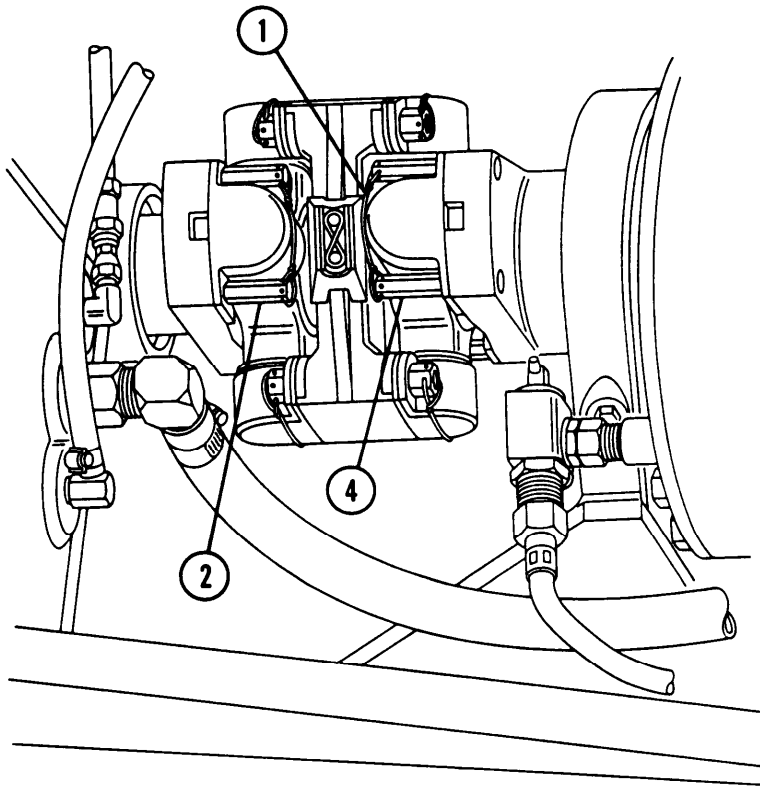

NOTE

FOLLOW-ON MAINTENANCE: Close transmission access doors (para 11-7)

CHAPTER 11

HULL-RELATED COMPONENTS

GENERAL

This chapter provides instructions for removal, disassembly, assembly, installation, inspection, repair, checking, and adjusting tracks, suspension system, final drives, and universal joints.

<u>CONTENTS</u>	<u>PAGE</u>
Section I DRIVER'S AND CANNONEER'S SEAT ASSEMBLIES	11-2
11-1 DRIVER'S SEAT ASSEMBLY	11-2
11-2 CANNONEER'S SEAT ASSEMBLIES (M109A2/M109A3)	11-11
11-3 CANNONEER'S SEATASSEMBLIES (M109A4/M109A5)	11-14
Section II HATCHES, LATCHES, LOCKS, AND COVER PLATES	11-18
11-4 DRIVER'S HATCH COVER AND LOCK COMPONENTS	11-18
11-5 ENGINE COMPARTMENT ACCESS COVER	11-22
11-6 BATTERY COMPARTMENT ACCESS DOORS	11-24
11-7 TRANSMISSION ACCESS DOORS.....	11-25
11-8 AIR INTAKE GRILLE	11-29
11-9 DRAIN COVERS AND PLUGS	11-34
11-10 SUBFLOOR DRAIN PLUGS (M109A4/M109A5)	11-36
11-11 PERISCOPE M45 COVER, DOORS, AND SLEEVES	11-37
11-12 HULL REAR DOOR, M13 KIT BRACKET, AND DOOR LATCH	11-39
11-13 HULL REAR DOOR HOLD-OPEN ROD AND HANDLE	11-42
Section III TRAVEL LOCK, SPADE, FENDERS, AND TOWING PINTLE	11-44
11-14 TRAVEL LOCK	11-44
11-15 SPADE	11-55
11-16 FENDERS	11-60
11-17 TOWING PINTLE	11-61
Section IV BILGE PUMP, PERSONNEL HEATER, PERSONNEL AIR VENTILATION SYSTEM, AND FIXED FIRE EXTINGUISHER SYSTEM.	11-62
11-18 BILGE PUMP	11-62
11-19 PERSONNEL HEATER SYSTEM DIAGRAM	11-64
11-20 PERSONNEL HEATER	11-66
11-21 PERSONNEL HEATER FUEL FILTER AND TUBES	11-68
11-22 PERSONNEL HEATER EXHAUST TUBE	11-70
11-23 PERSONNEL HEATER FUEL PUMP,	11-72
11-24 PERSONNEL AIR VENTILATION SYSTEM	11-73
11-25 FIXED FIRE EXTINGUISHER SYSTEM	11-75

SECTION 1. DRIVER'S AND CANNONEER'S SEAT ASSEMBLIES

11-1 DRIVER'S SEAT ASSEMBLY

This task covers:

a. Removal	b. Disassembly
c. Assembly	d. Installation

INITIAL SETUP

Tools

General mechanic's tool kit (item 64, Appx H)

Materials/Parts

Cotter pin (item 4, Appx G)
Cotter pin (item 36, Appx G)
Cotter pin (item 44, Appx G)
Self-locking nut (item 221, Appx G)
Self-locking nut (item 224, Appx G)

a. Removal

- 1 Remove two screws (1), two washers (2), and two plug nuts (3).
- 2 Remove two screws (4) and two pads (5).
- 3 Lift seat assembly (6) off vertical support (7).

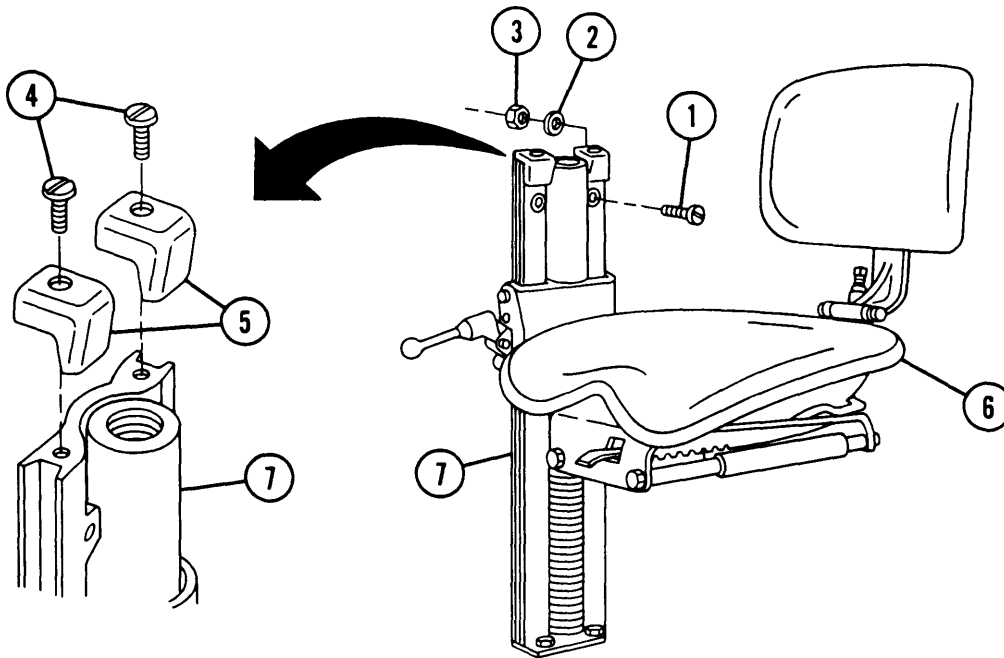

b. Disassembly

- 1 Remove cotter pin (8), hook (9), chain (10), and headed pin (11). Discard cotter pin.
- 2 Remove backrest assembly (12) from backrest support assembly (13).
- 3 Remove self-locking nut (14), two flat washers (15 and 16), and screw (17) from bracket (18). Discard self-locking nut.
- 4 Remove bracket (18) from backrest frame (19).
- 5 Remove self-locking nut (20), screw (21), and backrest support assembly (13). Discard self-locking nut.
- 6 Remove adjusting screw (22) and nut (23) from backrest support (24).

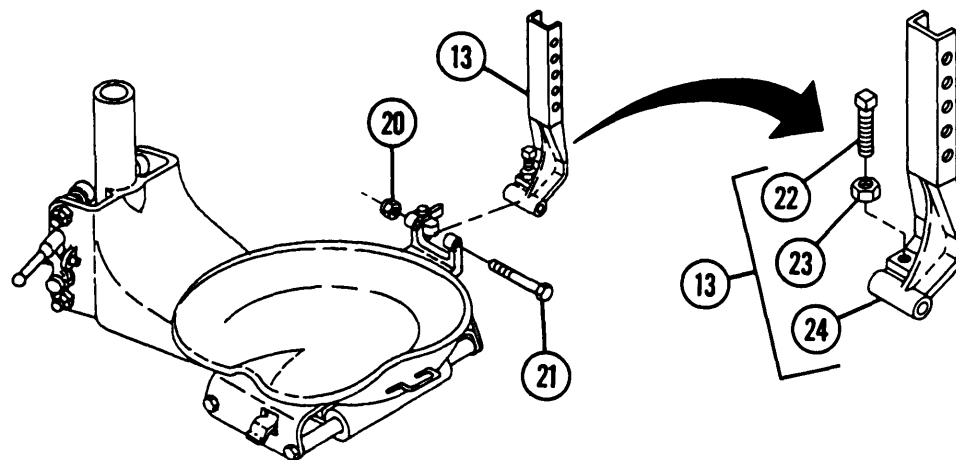
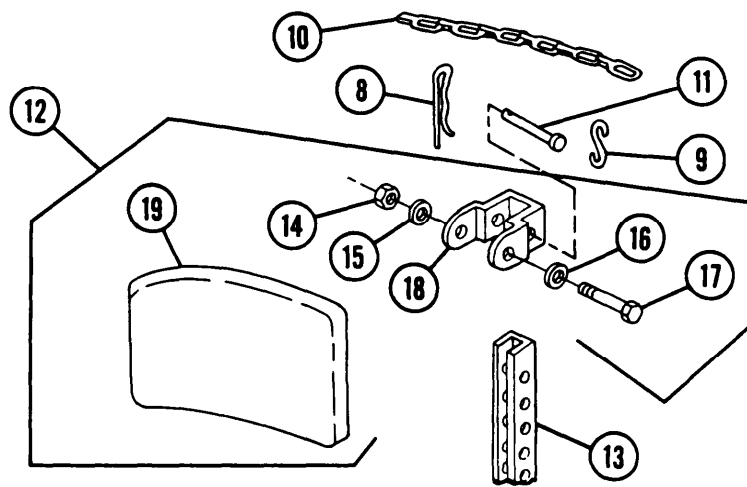

11-1 DRIVER'S SEAT ASSEMBLY — CONTINUED

b. Disassembly — Continued

- 7 Remove spring (25) and vertical guide (26) from vertical support (27).
- 8 Remove four screws (28) and vertical support (27) from driver's compartment.
- 9 Remove two screws (29) and base plate (30) from vertical support (27).
- 10 Remove four screws (31), four flat washers (32), two horizontal slide bars (33), and seat support bracket (34) from seat assembly (6).

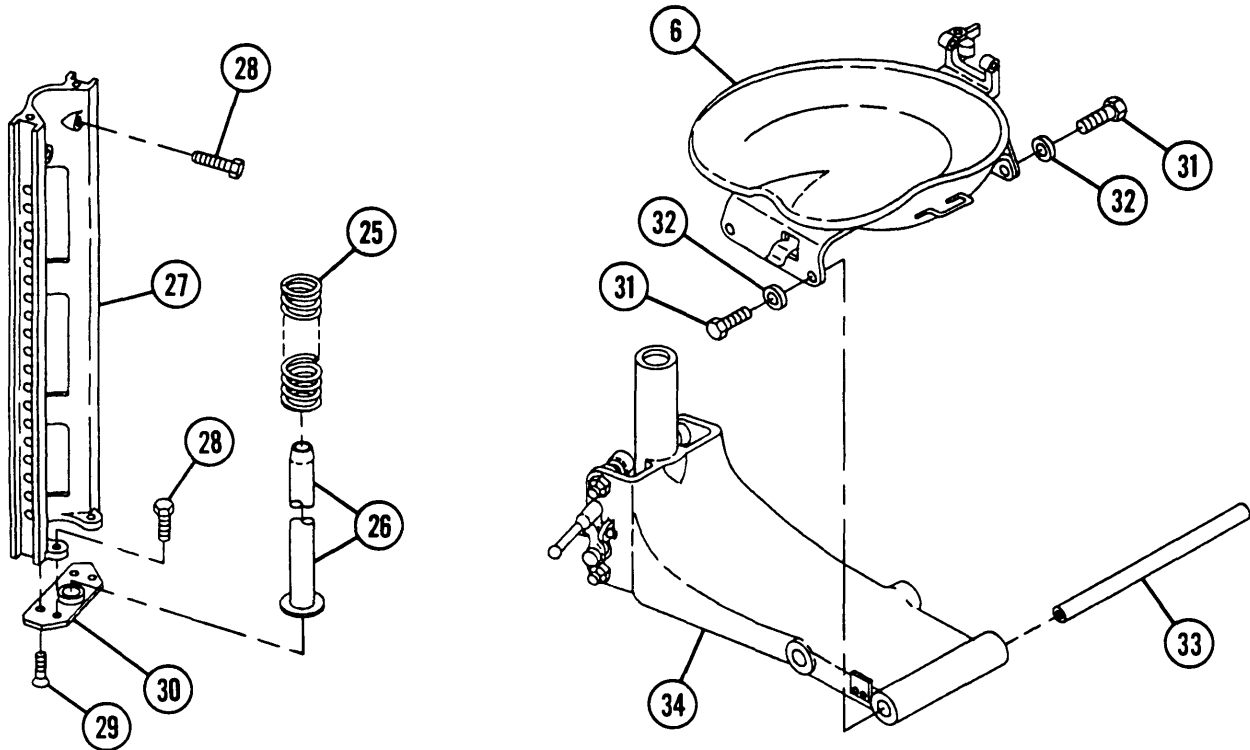

- 11 Remove cotter pin (35), headed pin (36), spring (37), and vertical adjusting lever (38) from vertical adjusting lever bracket (39) and seat support bracket (34). Discard cotter pin.
- 12 Remove threaded sleeve (40) and plunger (41).
- 13 Remove two screws (42), two nuts (43), and lockplate (44).
- 14 Remove two screws (45) and adjusting lever bracket (39).
- 15 Remove four nuts (46), shims (47), and four cam followers (48).

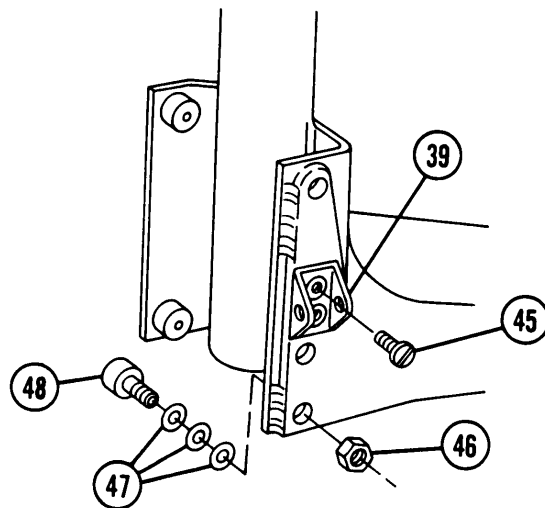
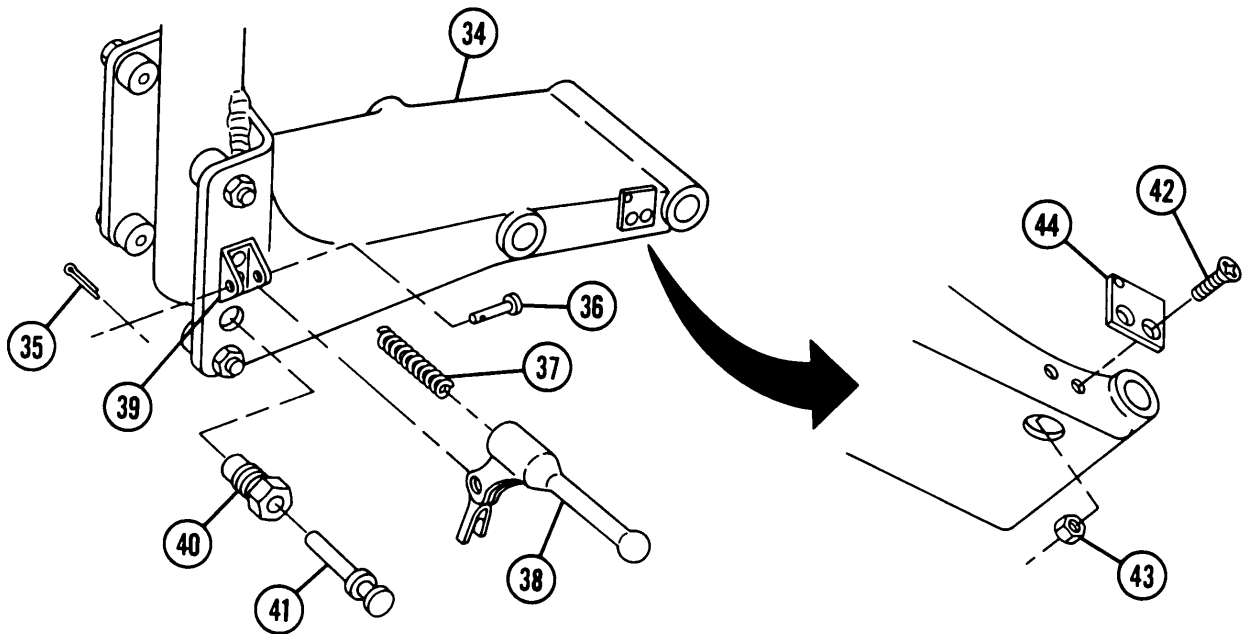

11-1 DRIVER'S SEAT ASSEMBLY — CONTINUED

b. Disassembly — Continued

- 16 Remove four nuts (49), four washers (50), reinforcement bracket (51), and backrest bracket group (52) at mounting studs (53).
- 17 Remove nut (54), flat washer (55), and horizontal adjusting group (56) at mounting stud (57).
- 18 Remove cotter pin (58) from headed pin (59) and release pawl (60) and spring (61) from backrest bracket group (52). Discard cotter pin.
- 19 Remove two nuts (62), two flat washers (63), two screws (64), and horizontal adjusting bar (65) from horizontal adjusting group (56).

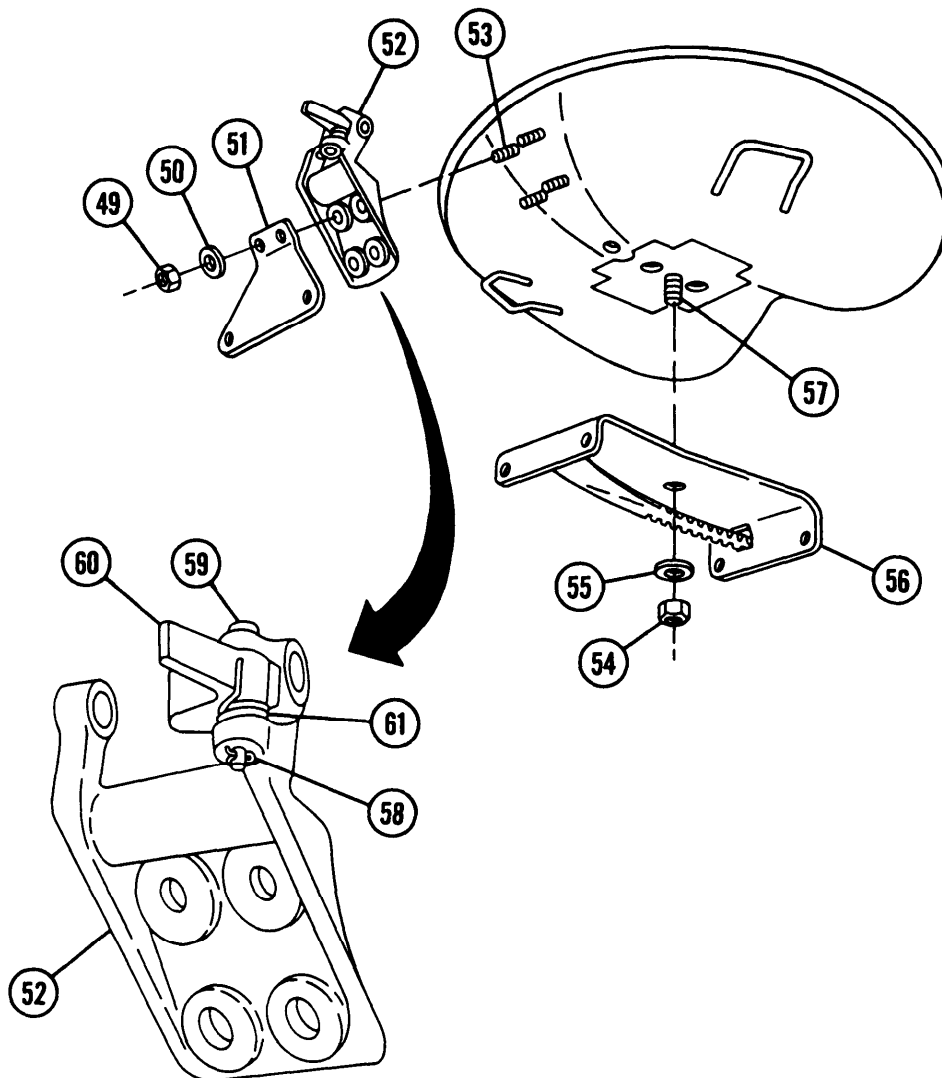

c. Assembly

- 1 install horizontal adjusting bar (65), two screws (64), two flat washers (63), and two nuts (62) onto horizontal adjusting group (56).
- 2 Position spring (61) between pawl (60) and backrest bracket group (52). Install headed pin (59) and new cotter pin (58).
- 3 Install horizontal adjusting group (56), flat washer (55), and nut (54) at mounting stud (57).
- 4 Install backrest bracket group (52), reinforcement bracket (51), four washers (50), and four nuts (49) at mounting studs (53).

NOTE

Install shims as required to provide a snug fit between cam follower and seat support bracket.

- 5 Install four cam followers (48), shims (47), and four nuts (46).
- 6 Install adjusting lever bracket (39) and two screws.

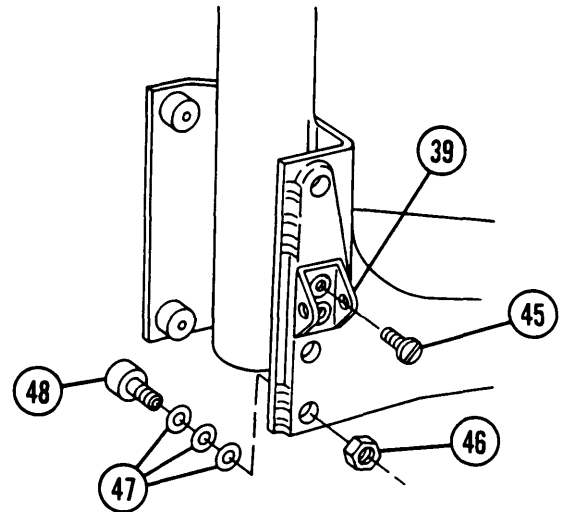
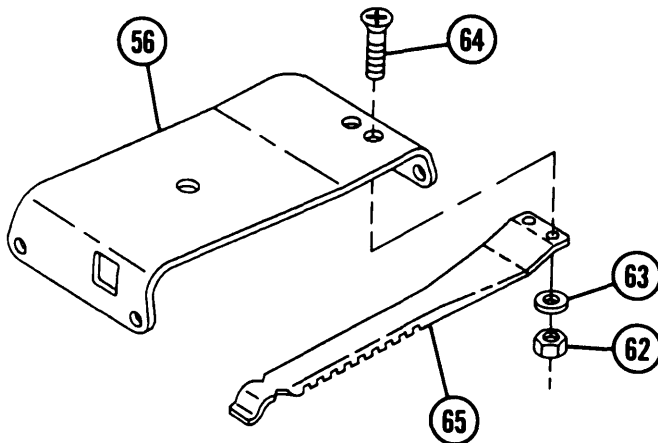

11-1 DRIVER'S SEAT ASSEMBLY — CONTINUED

c. Assembly — Continued

- 7 Install two screws (42), two nuts (43), and lockplate (44).
- 8 Install plunger (41) and threaded sleeve (40).
- 9 Install vertical adjusting lever (38), spring (37), headed pin (36), and new cotter pin (35) to vertical adjusting lever bracket (39) and seat support bracket (34).
- 10 Install seat support bracket (34), two horizontal slide bars (33), four flat washers (32), and four screws (31) onto seat assembly (6).

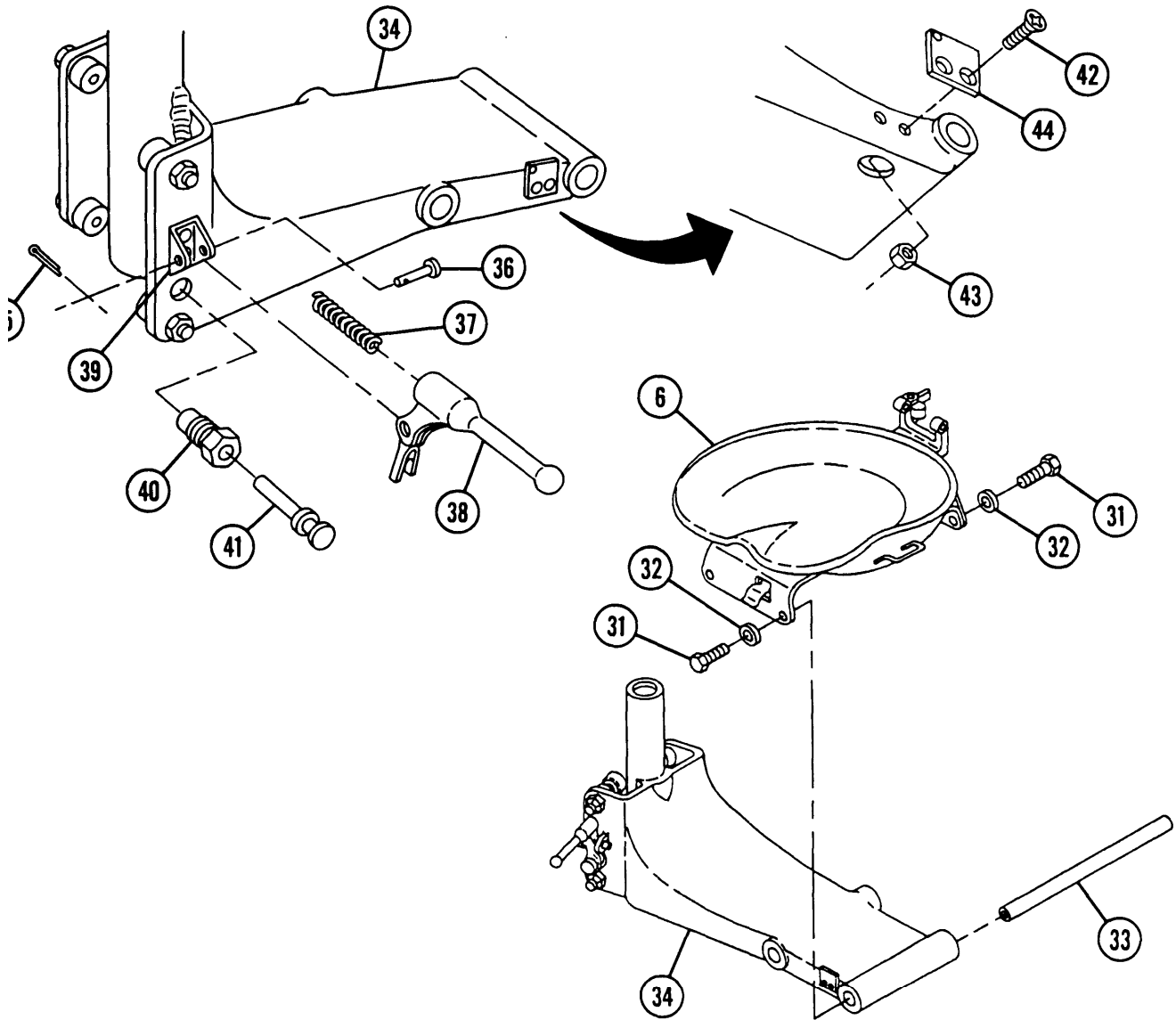

- 11 Install nut (23) and adjusting screw (22) onto backrest support (24),
- 12 Install backrest support assembly (13), new self-locking nut (20), and screw (21).
- 13 Attach bracket (18) to backrest frame (19) with screw (17), two flat washers (15 and 16), and new self-locking nut (14).
- 14 Install backrest assembly (12) onto backrest support assembly (13).
- 15 Install headed pin (11), chain (10), hook (9), and new cotter pin (8) onto bracket (18).

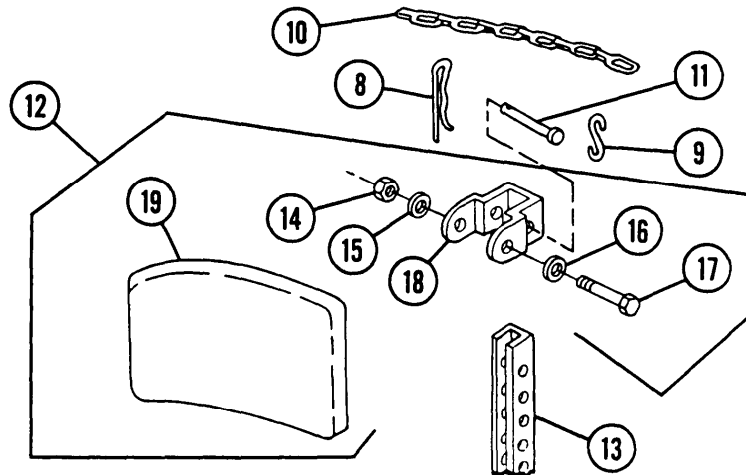
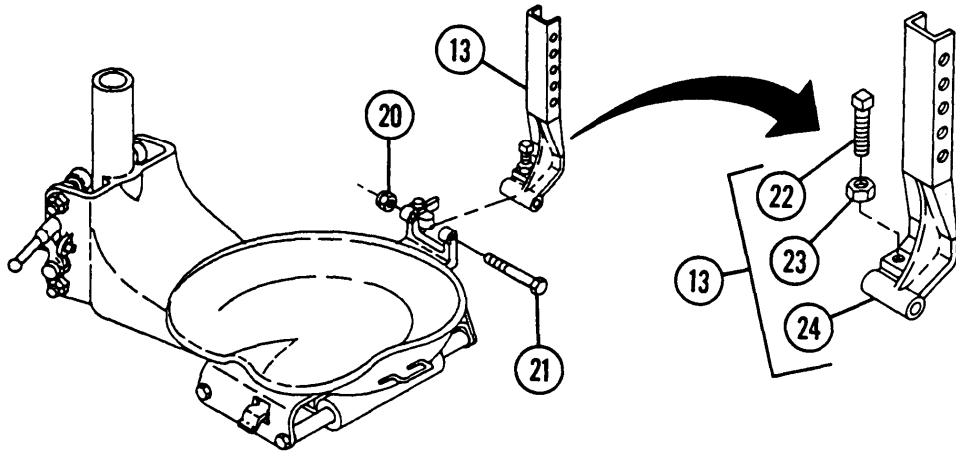

11-1 DRIVER'S SEAT ASSEMBLY — CONTINUED

c. Assembly — Continued

- 16 Install base plate (30) and two screws (29) on vertical support (27).
- 17 In driver's compartment, install vertical support (27) and four screws (28).
- 18 Install spring (25) over vertical guide (26) onto vertical support (27).

d. Installation

- 1 Place seat assembly (6) onto vertical support (7).
- 2 Install two pads (5) and two screws (4).
- 3 Install two plug nuts (3), two washers (2), and two screws (1).

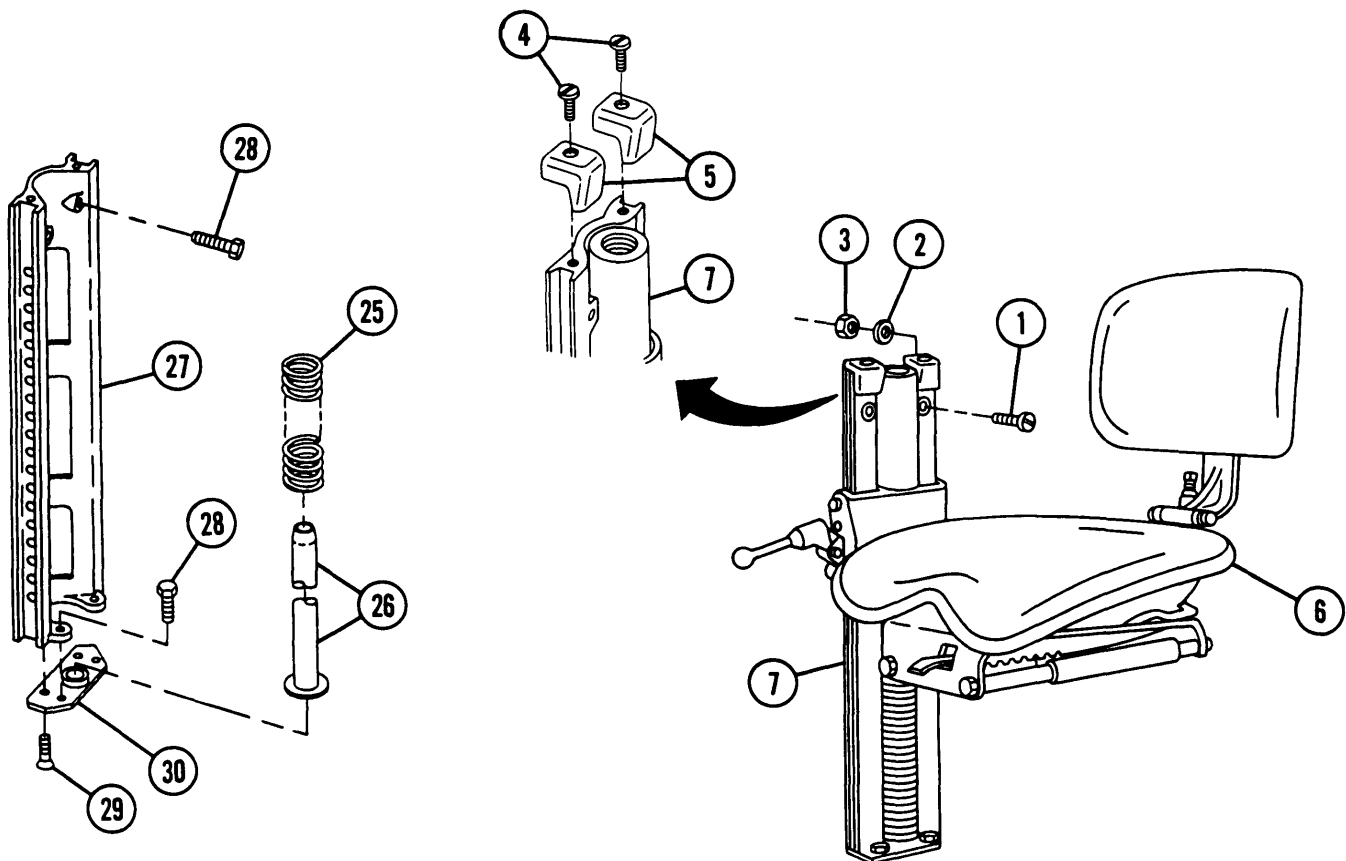

11-2 CANNONEER'S SEAT ASSEMBLIES (M109A2/M109A3)

This task covers: a. Removal b. Disassembly
 c. Assembly d. Installation

Applicable Configuration
M109A2/M109A3

Tools
General mechanic's tool kit (item 64, Appx H)

Materials/PartS
Grommet washers (144) (item 17, Appx G)
Grommets (144) (item 16, Appx G)
LockWashers (8) (item 95, Appx G)
Self-locking nuts (4) (item 33, Appx G)

a. Removal

NOTE

Left and right cannoneer's seat assemblies are removed using same procedure.

- 1 Place seat assembly (1) in folded down position.
- 2 Remove two snap rings (2) and two pins (3) from seat assembly (1).
- 3 Remove seat assembly (1).

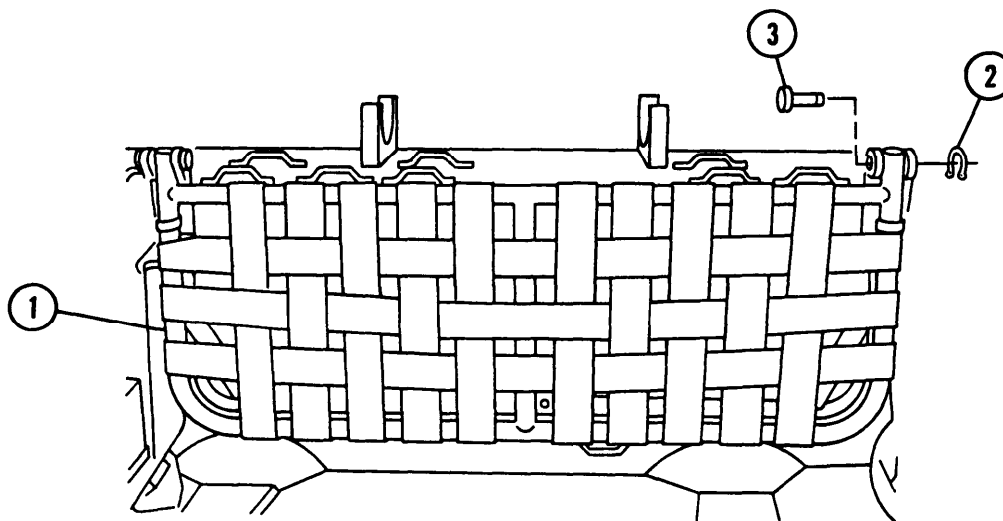

RIGHT SEAT ASSEMBLY SHOWN

11-2 CANNONEER'S SEAT ASSEMBLIES (M109A2/M109A3) — CONTINUED

b. Disassembly

- 1 Remove two self-locking nuts (4) and two screws (5) from two clamps (6). Discard self-locking nuts.
- 2 Remove two clamps (6) and two safety belts with plates (7).

NOTE

Step 3 refers to left seat assembly and step 4 refers to right seat assembly.

- 3 Remove 48 screws (8) from 8 short straps (9) and frame (10).
- 4 Remove 60 screws (8) from 10 short straps (9) and frame (10).
- 5 Remove 18 screws (11) from 3 long straps (12) and frame (10).
- 6 Remove six grommets (13) and six grommet washers (14) from short and long straps (9 and 12). Discard grommets and grommet washers.
- 7 Remove two snap rings (15) and two pins (16) from left and right support brackets (17 and 18) and frame (10).
- 8 Remove four nuts (19), four screws (20), and four lockwashers (21) from support bracket connector (22). Discard lockwashers.
- 9 Remove right support bracket (18) and left support bracket (17) from frame (10).

c. Assembly

- 1 Install right support bracket (18) and left support bracket (17) onto frame (10).
- 2 Install four new lockwashers (21), four screws (20), and four nuts(19) in support bracket connector (22).
- 3 Install two pins (16) and two snap rings (15) in left and right support brackets (17 and 18) and frame (10).
- 4 Install six new grommet washers (14) and six new grommets (13) on long straps (12) and short straps (9).
- 5 Install 3 long straps (12) and 18 screws (11) on each seat assembly.

NOTE

Step 6 applies to left seat assembly and step 7 applies to right seat assembly.

- 6 Install 8 short straps (9) and 48 screws (8).
- 7 Install 10 short straps (9) and 60 screws (8).
- 8 Install two safety belts with plates (7) and two clamps (6).
- 9 Install two screws (5) and two new self-locking nuts (4) in two clamps (6).

d. Installation

NOTE

Left and right cannoneer,s seat assemblies are installed using same procedure.

1 Position seat assembly (1) in folded down position.

2 Install two pins (2) and two snap rings (3).

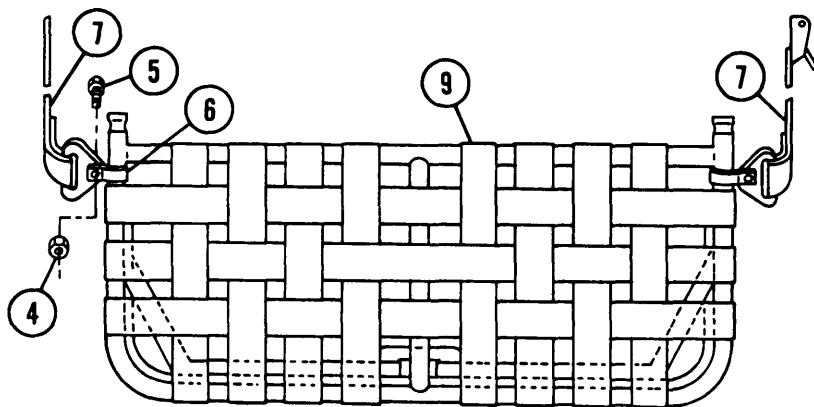

LEFT SEAT ASSEMBLY SHOWN

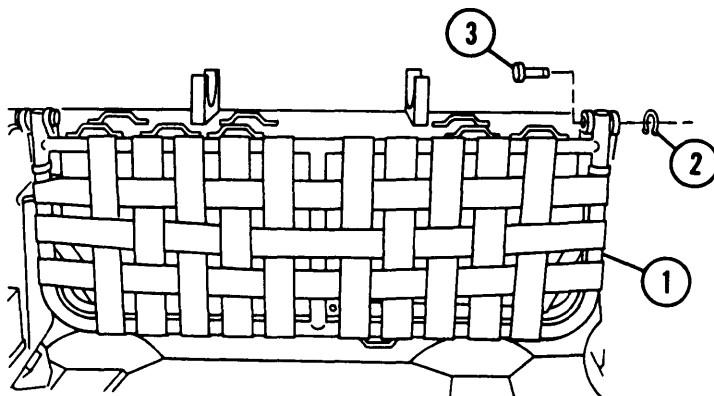
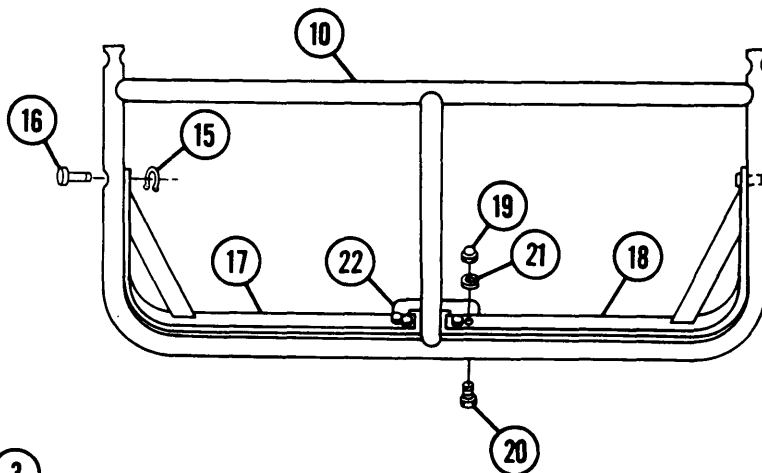
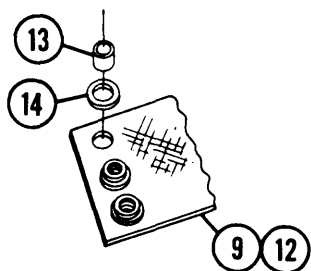
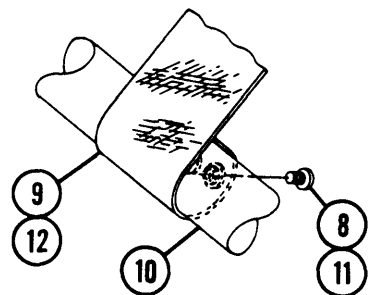

RIGHT SEAT ASSEMBLY SHOWN

11-3 CANNONEER'S SEAT ASSEMBLIES (M109A4/M109A5)

This task covers: a. Removal b. Disassembly
 c. Assembly d. Installation

Applicable Configuration
 M109A4/M109A5

Electric drill (item 17, Appx H)
 Rivet gun (item 25, Appx H)

Materials/Parts

General mechanic's tool kit (item 64, Appx H)
 Drill set (item 16, Appx H)

Lockwashers (2) (item 87, Appx G)
 Rivets (8) (item 24, Appx G)

a. Removal

NOTE

Left and right cannoneer's seat assemblies are removed using same procedure.

- 1 Remove strap (1).
- 2 Remove two slides (2) and belt (3).

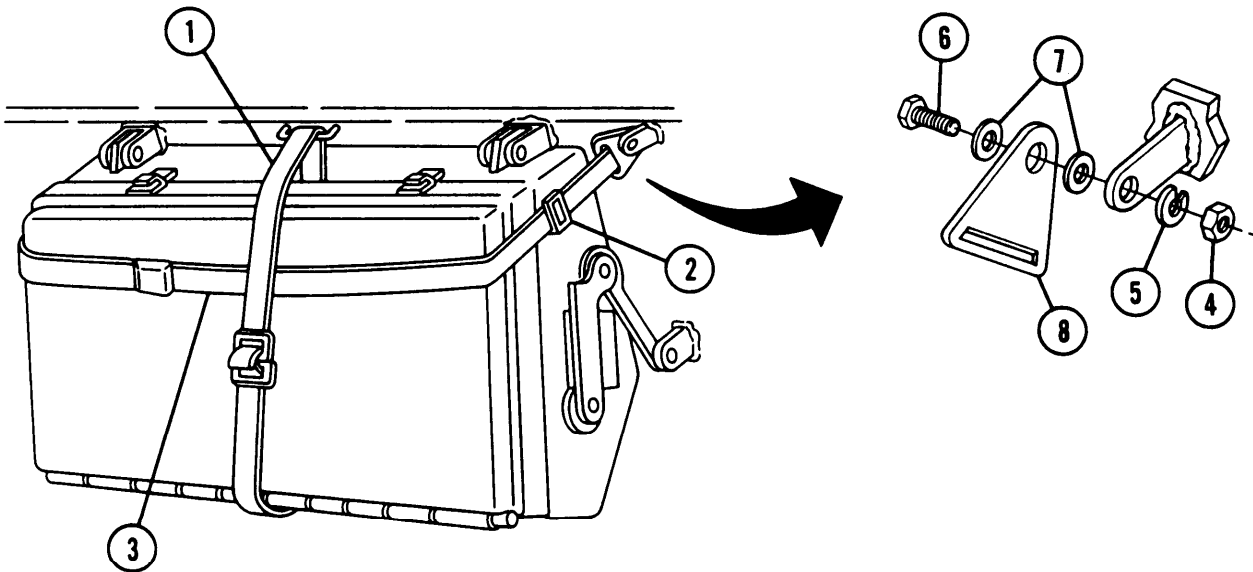

NOTE

Left seat assembly has only one nut (4).

- 3 Remove two nuts (4), two lockwashers (5), two screws (6), four washers (7), and two anchors (8). Discard lockwashers.
- 4 Place seat assembly (9) in upright position and support.
- 5 Remove three retaining rings (10), three pins (11), and two arms (12). Repeat for opposite side of seat assembly (9).
- 6 Lower seat assembly (9) and support.
- 7 Remove two retaining rings (13), two pins (14), four washers (15), and seat assembly (9).

b. Disassembly

- 1 Remove four screws (16) and cushion (17).

NOTE

Remove fastener latch (18) and catch (19) only if damaged.

- 2 Drill out eight rivets (20) and remove two fastener latches (18) and two catches (19). Discard rivets.

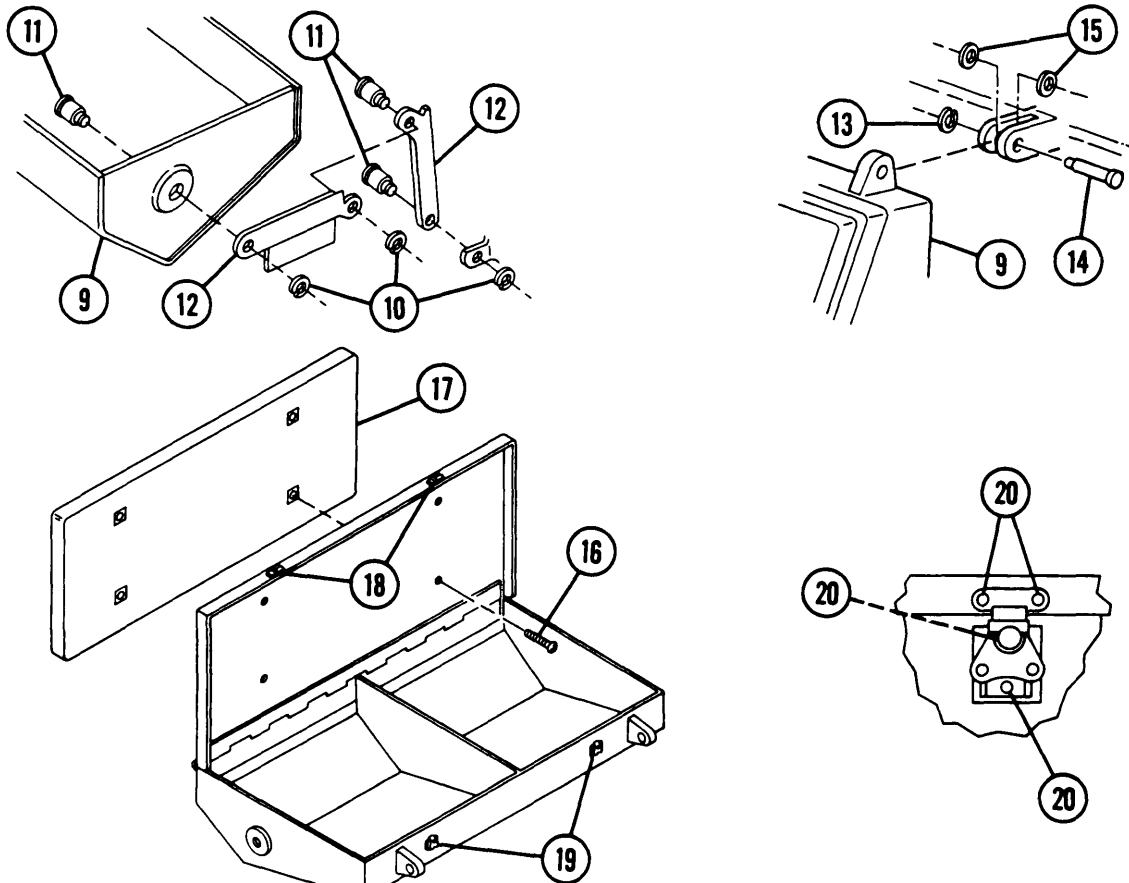

11-3 CANNONEER'S SEAT ASSEMBLIES (M109A4M109A5) — CONTINUED

c. Assembly

1 If removed, install two fastener latches (1 8), two catches (1 9), and eight new rivets (20).

2 Install cushion (17) and four screws (16).

d. Installation

NOTE

Left and right cannoneer's seat assemblies are installed using same procedure.

1 Place cannoneer's seat assembly (9) in folded down position and support.

2 Install four washers (1 5), two pins (1 4), and two retaining rings (13).

3 Place seat assembly (9) in upright position and support.

4 Install two arms (1 2), three pins (11), and three retaining rings (10). Repeat for opposite side of seat assembly (9).

NOTE

Left seat assembly has only one nut (4).

5 Install two screws (6), four washers (7), two anchors (8), two new lockwashers (5), and two nuts (4).

6 Install belt (3) and two slides (2).

7 Install strap (1).

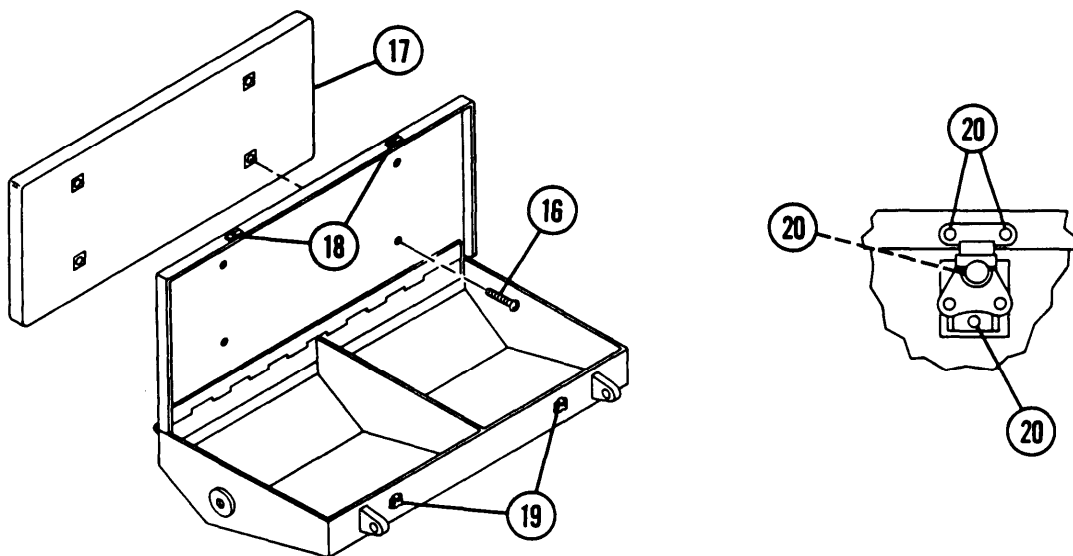

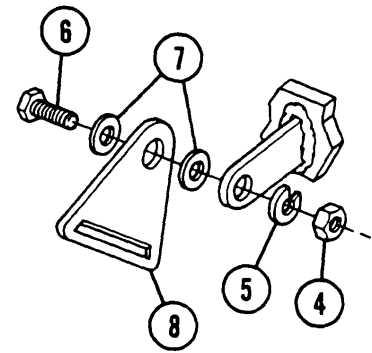
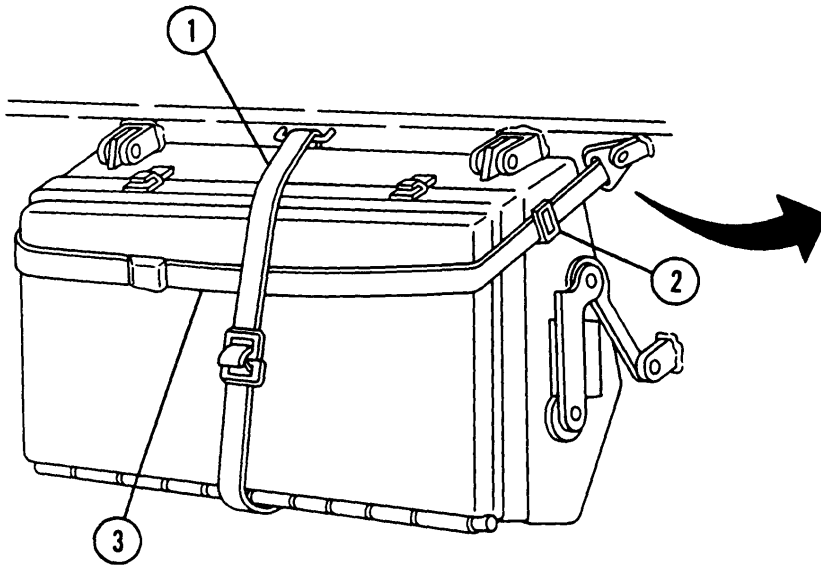
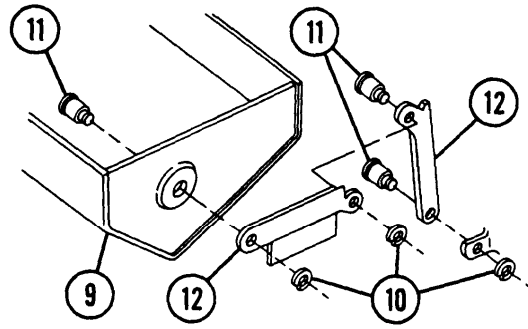
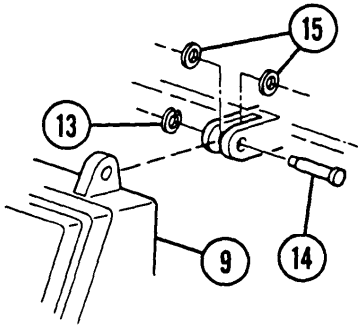

SECTION II. HATCHES, LATCHES, LOCKS, AND COVER PLATES

11-4 DRIVER'S HATCH COVER AND LOCK COMPONENTS

This task covers: a. Removal b. Installation

INITIAL SETUP

Tools

General mechanic's tool kit (item 64, Appx H)
Wire brush (item 6, Appx H)

Materials/Parts

Adhesive (item 5, Appx D)
Cotter pin (item 48, Appx G)
Dry-cleaning solvent (item 22, Appx D)

Lockspring (item 209, APPX G)
Lockwire (item 30, AppX G)
Preformed packing (item 168, APPX G)
Seal (item 119, APPX G)
Sealing compound (item 57, APPX D)
Spring pin (item 13, APPX G)
Spring pin (2) (item 110, APPX G)
Spring washer (item 193, APPX G)

a. Removal

- 1 Remove six screws (1), spring pin (2), and chuck (3) from closed hatch cover assembly. Discard spring pin.
- 2 Remove lockwire (4), two screws (5), two flat washers (6), and elevating cam (7). Discard lockwire.
- 3 Punch out spring pin (8). Discard spring pin.
- 4 Remove elevating handle (9), shaft (10), and ball bearing (11).
- 5 Swing latch (12) away from hatch cover (13) and lift off using handles (14).
- 6 Remove three screws (15), three washers (16), three flat washers (17), and housing (18).

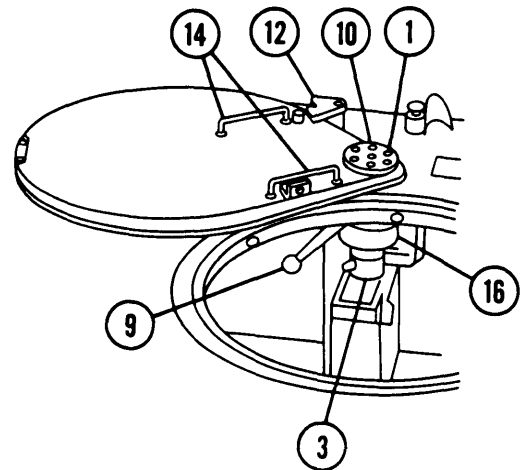
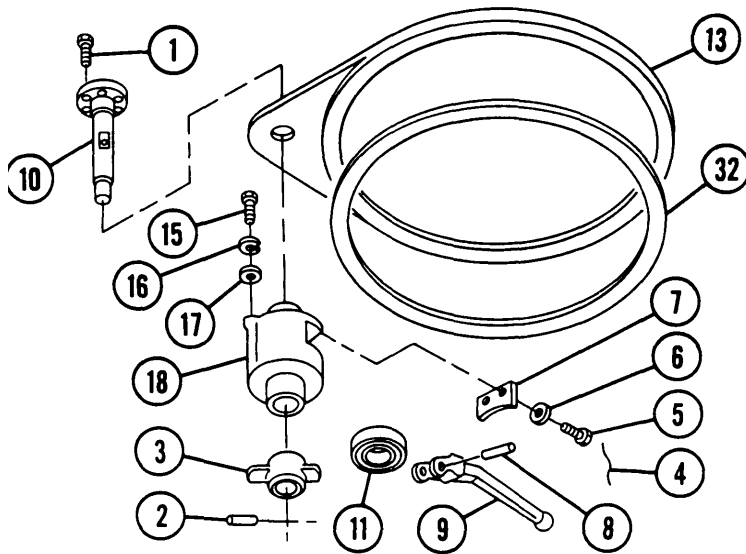

- 7 Remove (located inside hull) cotter pin (19), adjusting nut (20), locking lever (21), woodruff key (22), lockspring (23), and washer (24). Discard cotter pin and lockspring.
- 8 Remove (located outside hull) locking cam (25), spring washer (26), two flat washers (27), and sleeve bearing (28). Discard spring washer.
- 9 Remove six screws (29) and cover seal (30). Scrape off old sealant from seal ring (hatch opening) (31). Discard seal.

WARNING

Dry-cleaning solvent (P-D-680) is toxic and flammable. Wear protective goggles and gloves and use only in a well-ventilated area. Avoid contact with skin, eyes, and clothes, and don't breathe vapors. Do not use near open flame or excessive heat. The flashpoint for type #1 is 100°F (38°C), and for type #2 is 138°F (59°C). If you become dizzy while using dry-cleaning solvent, get fresh air immediately and get medical aid. If contact with eyes is made, wash your eyes with water and get medical aid immediately.

- 10 Remove preformed packing (32). Clean groove with dry-cleaning solvent. Discard preformed packing.

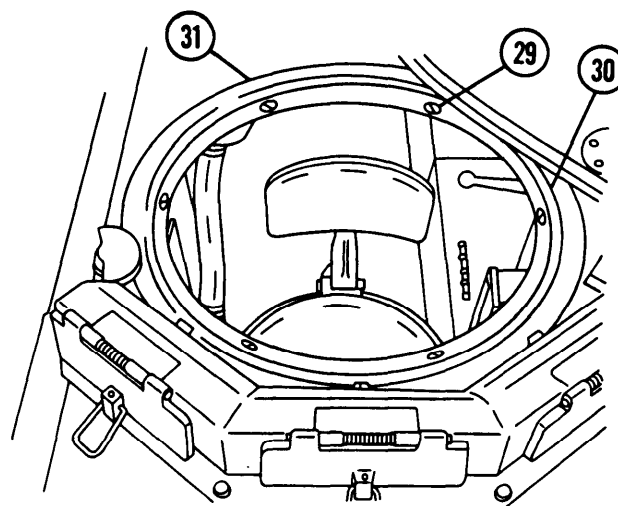
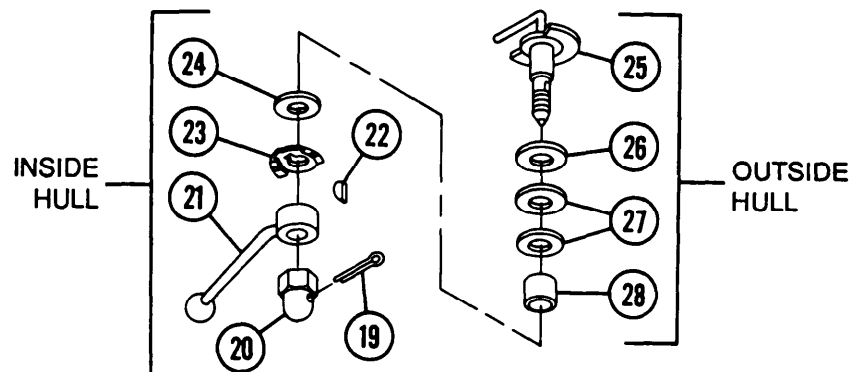

11-4 DRIVER'S HATCH COVER AND LOCK COMPONENTS — CONTINUED

a. Removal — Continued

- 11 Remove spring (33), nut (34), flat washer (35), and handle (36).
- 12 Remove nut (37) and washer (38).
- 13 Remove two screws (39), two washers (40), and holding lever stop (41).
- 14 Remove spring pin (42), hatch stop (43), locking shaft (44), bumper (45), and locking sleeve (46). Discard spring pin.

b. Installation

- 1 Install locking sleeve (46), bumper (45), locking shaft (44), hatch stop (43), and new spring pin (42).
- 2 Install lever stop (41), two washers (40), and two screws (39). Install washer (38) and nut (37).
- 3 Install handle (36), flat washer (35), and nut (34).
- 4 Install spring (33).

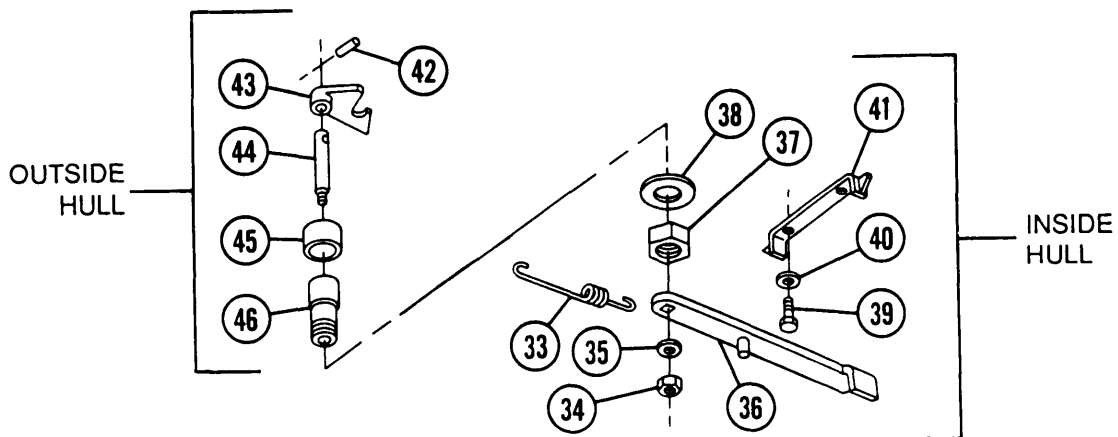
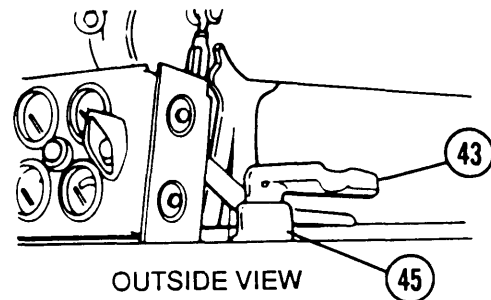
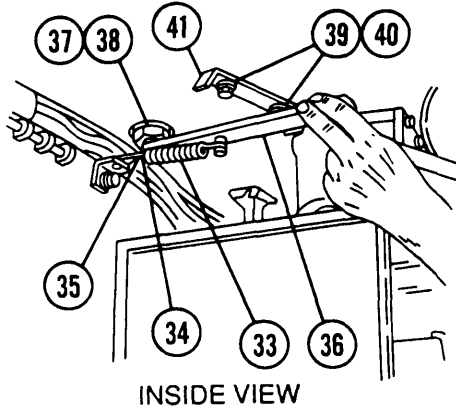

WARNING

Adhesives are toxic and flammable. Apply adhesives only in a well-ventilated area. Avoid contact with skin, eyes, and clothes, and don't breath vapors. Do not use near heat, sparks, or open flame. Read and follow all warnings and instructions on labels of adhesives. If contact with skin or eyes is made, wash area with water and seek medical aid immediately.

- 5 Apply adhesive inside hatch cover (13) seal groove.
- 6 Install new preformed packing (32) in cover (13) groove. Avoid stretching preformed packing.
- 7 Apply sealing compound to seal ring (hatch opening) (31).
- 8 Install new cover seal (30) with six screws (29). Ensure a complete seal is made.
- 9 Install sleeve bearing (28), two flat washers (27), new spring washer (26), and locking cam (25).
- 10 Install washer (24), new lockspring (23), woodruff key (22), locking lever (21), adjusting nut (20), and new cotter pin (19).

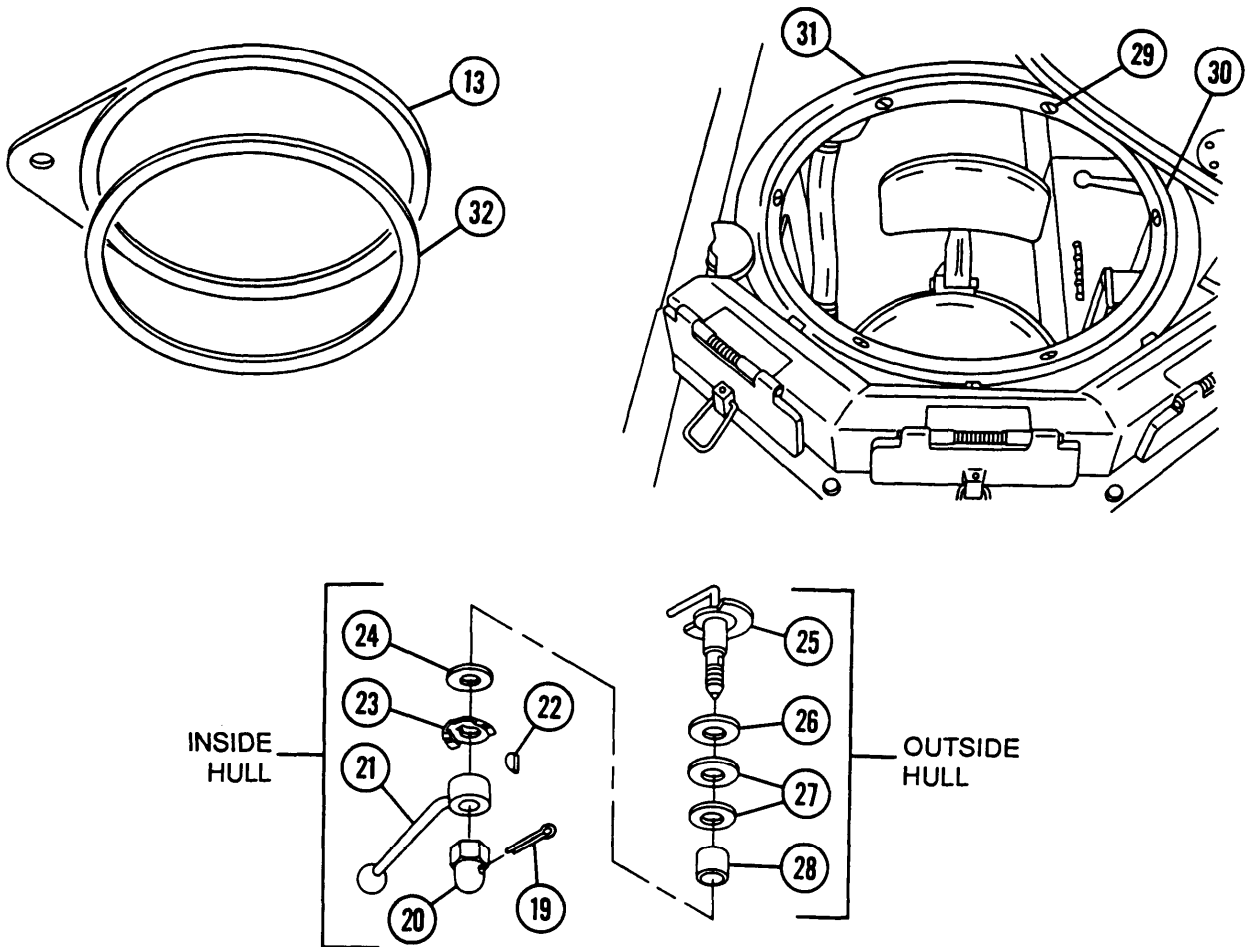

11-4 DRIVER'S HATCH COVER AND LOCK COMPONENTS — CONTINUED

b. Installation — Continued

- 11 Install ball bearing (11) in housing (1 8).
- 12 Install housing (18), three flat washers (17), three washers (16), and three **screws** (15).
- 13 Using handles (14), carefully lower hatch cover (13) to closed position.
- 14 Install shaft (10) and elevating handle (9).
- 15 Drive in new spring pin (8).
- 16 Install elevating cam (7), two flat washers (6), and two screws (5). Install new lockWire (4).
- 17 Install chuck (3), new spring pin (2), and six screws (1).

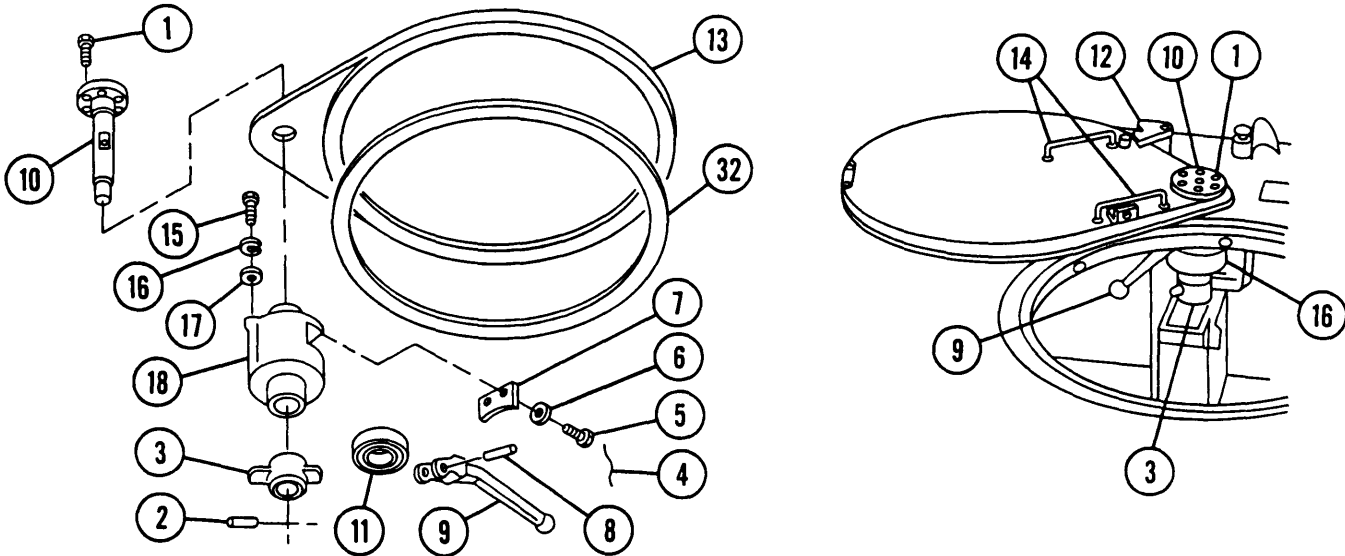

11-5 ENGINE COMPARTMENT ACCESS COVER

This task covers: a. Removal b. Installation

INITIAL SETUP

Tools
 General mechanic's tool kit (item 64, Appx H)

Materials/Parts
 Adhesive (item 7, Appx D)
 Lockwashers (12) (item 89, Appx G)
 Seal (item 155, Appx G)

a. Removal

- 1 Disconnect hose assembly (1) at clamp (2). Move hose assembly out of way.
- 2 Remove 12 screws (3), 12 lockwashers (4), engine compartment access cover (5), and seal (6). Discard lockwashers and seal.

b. Installation

WARNING

- When installing engine compartment access cover, ensure that all screws are secured. Carbon monoxide poisoning could result in serious injury or death if cover is loose.
 - Adhesives are toxic and flammable. Apply adhesives only in a well-ventilated area. Avoid contact with skin, eyes, and clothes, and don't breath vapors. Do not use near heat, sparks, or open flame. Read and follow all warnings and instructions on labels of adhesives. If contact with skin or eyes is made, wash area with water and seek medical aid immediately.
- 1 Apply adhesive to seal (6). Install seal (6), engine compartment access cover (5), 12 new lockwashers (4), and 12 screws (3).
 - 2 Connect hose assembly (1) and tighten clamp (2).

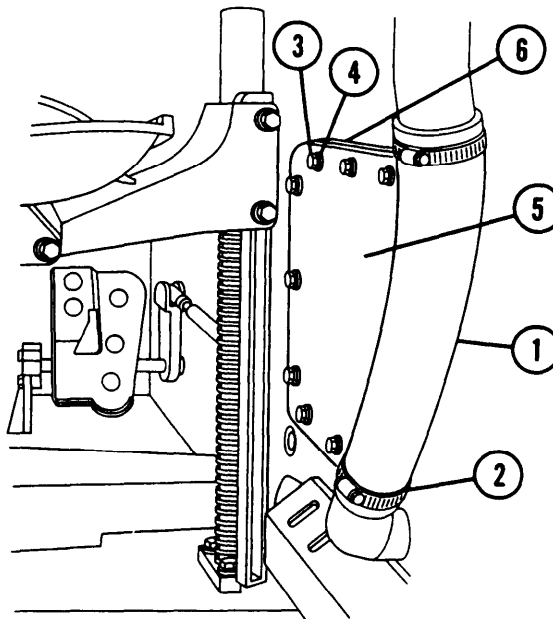

11-6 BATTERY COMPARTMENT ACCESS DOORS

This task covers: a. Removal b. Installation

INITIAL SETUP

Tools

General mechanic's tool kit (item 64, Appx H)

Materials/Parts

Adhesive (item 5, Appx D)

a. Removal

NOTE

Both battery compartment access doors are removed using same procedure.

- 1 Remove two nuts (1), two flat washers (2), and two screws (3).
- 2 Carefully lift and remove battery compartment access door (4).
- 3 Remove nut (5), screw (6), stud (7), and handle (8).

NOTE

Remove seal only if torn, worn, or deteriorating.

- 4 Remove seal (9).

b. Installation

WARNING

Adhesives are toxic and flammable. Apply adhesives only in a well-ventilated area. Avoid contact with skin, eyes, and clothes, and don't breath vapors. Do not use near heat, sparks, or open flame. Read and follow all warnings and instructions on labels of adhesives. If contact with skin or eyes is made, wash area with water and seek medical aid immediately.

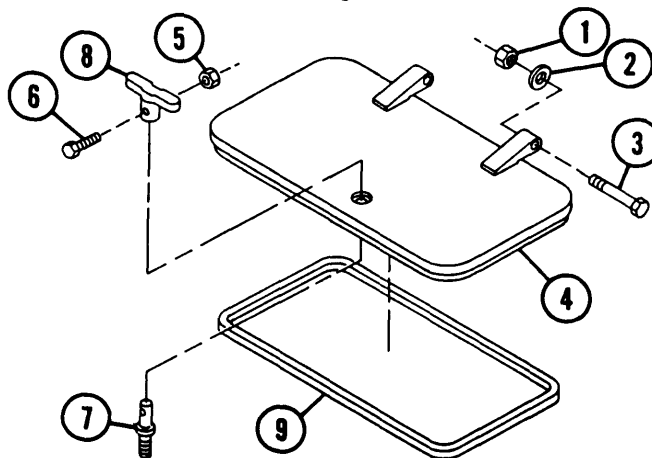

11-7 TRANSMISSION ACCESS DOORS — CONTINUED

a. Removal — Continued

WARNING

Doors are heavy. If hoist and sling are not available, two personnel are required to lift and move doors. Improper lifting of doors can result in serious injury.

- 3 Attach hoist and sling to right transmission access door (2) supporting door at 45° angle. Remove two self-locking nuts (7), two flat washers (8), and two screws (9). Repeat for left transmission access door (1). Discard self-locking nuts.

b. Disassembly

- 1 Remove self-locking nut (10), screw (11), handle (12), and stud (13) from right transmission access door (2). Discard self-locking nut.

NOTE

Remove seals only if torn, worn, or deteriorating.

- 2 Remove seal (14).

- 3 Remove three screws (15), three flat washers (16), access cover (17), and access cover gasket (18) from left transmission access door (1). Discard gasket.

- 4 Remove seal (19).

c. Assembly

WARNING

Adhesives are toxic and flammable. Apply adhesives only in a well-ventilated area. Avoid contact with skin, eyes, and clothes, and don't breath vapors. Do not use near heat, sparks, or open flame. Read and follow all warnings and instructions on labels of adhesives. If contact with skin or eyes is made, wash area with water and seek medical aid immediately.

- 1 Apply adhesive to seal (14), if removed.
- 2 Install seal (14) to right transmission access door (2).
- 3 Install stud (13), handle (12), screw (11), and new self-locking nut (10) to right transmission access door (2).
- 4 Apply adhesive to seal (19), if removed.
- 5 Install seal (19) to left transmission access door (1).

6 Install new access cover gasket (18) to access cover (17).

7 Install access cover (17), three flat washers (16), and three screws (15) to left transmission access door (1).

d. Installation

WARNING

Doors are heavy. If hoist and sling are not available, two personnel are required to lift and move doors. Improper lifting of doors can result in serious injury.

- 1 Install left transmission access door (1).
- 2 Install two screws (9), two flat washers (8), and two new self-locking nuts (7). Leave door open.
- 3 Install right transmission access door (2), two screws (9), two flat washers (8), and two new self-locking nuts (7).

NOTE

If access door support is damaged, notify support maintenance.

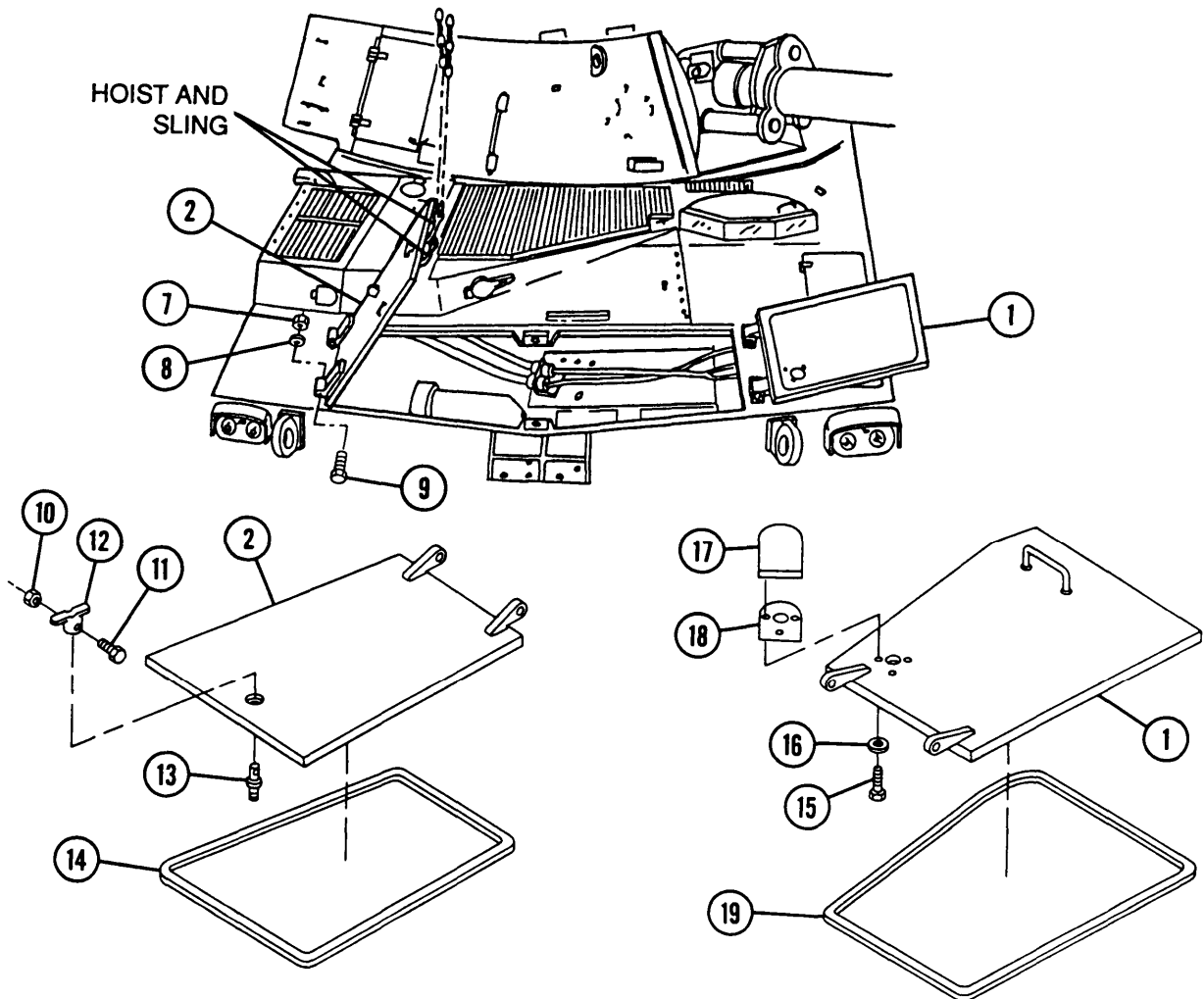

11-7 TRANSMISSION ACCESS DOORS — CONTINUED

d. Installation — Continued

- 4 Install transmission access door Support (6), two screws (5), two flat washers (4), and two nuts (3).
- 5 Close left and right transmission access doors (1 and 2) and tighten handle.

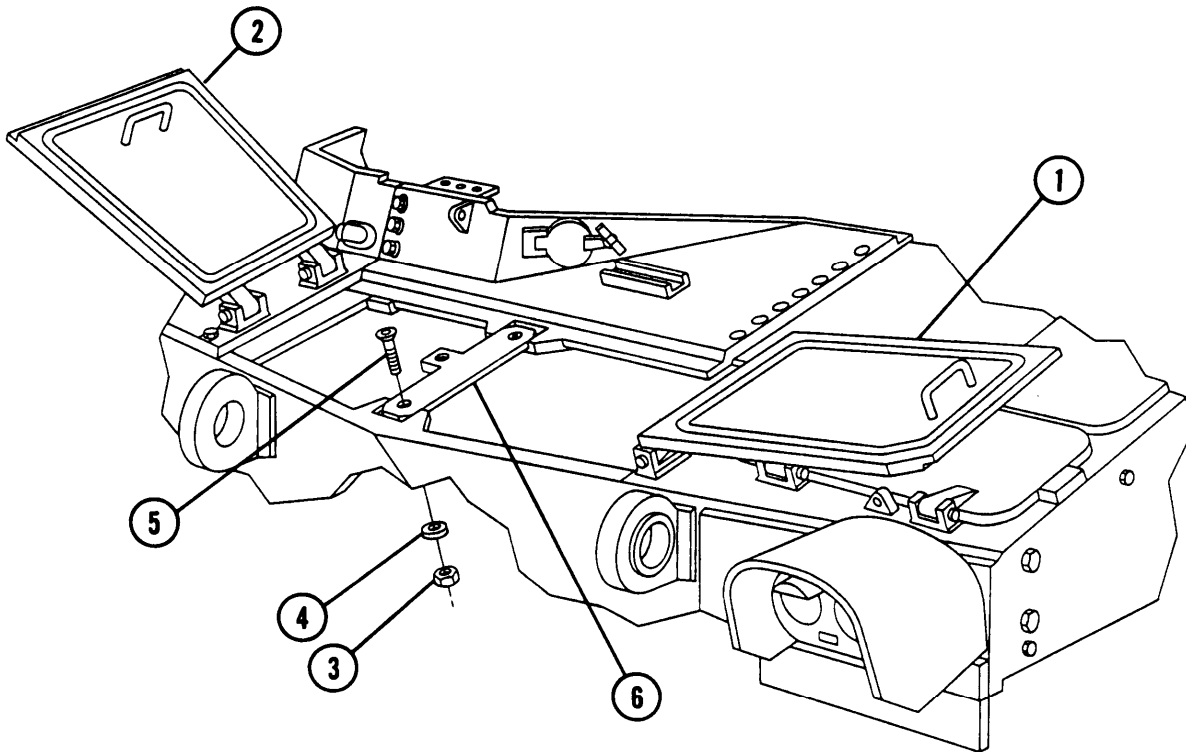

11-8 AIR INTAKE GRILLE

This task covers: a. Removal b. Installation

INITIAL SETUP

Tools

General mechanic's tool kit (item 64, Appx H)
Lifting sling (item 59, Appx H)
Suitable lifting device

Materials Parts

Antiseize compound (item 9, Appx D)
Packing (item 151, Appx G)
Lockwashers (2) (item 98, Appx G)

Self-locking nuts (2) (item 219, Appx G)
Self-locking nuts (2) (item 220, Appx G)

Personnel Required

Two

Equipment Conditions

Air intake grille open and secured (TM 9-2350-311-10)
Gun tube rotated 90° (TM 9-2350-311-10)

a. Removal

- 1 Remove two screws (1), two flat washers (2), two self-locking nuts (3), and anchor and shield (4) from right end torsion bar housing (5). Discard self-locking nuts.
- 2 Remove two screws (6), two self-locking nuts (7), two handles (8), and two studs (9). Discard self-locking nuts.
- 3 Remove four screws (10), exhaust deflector (11), and packing (12). Discard packing.

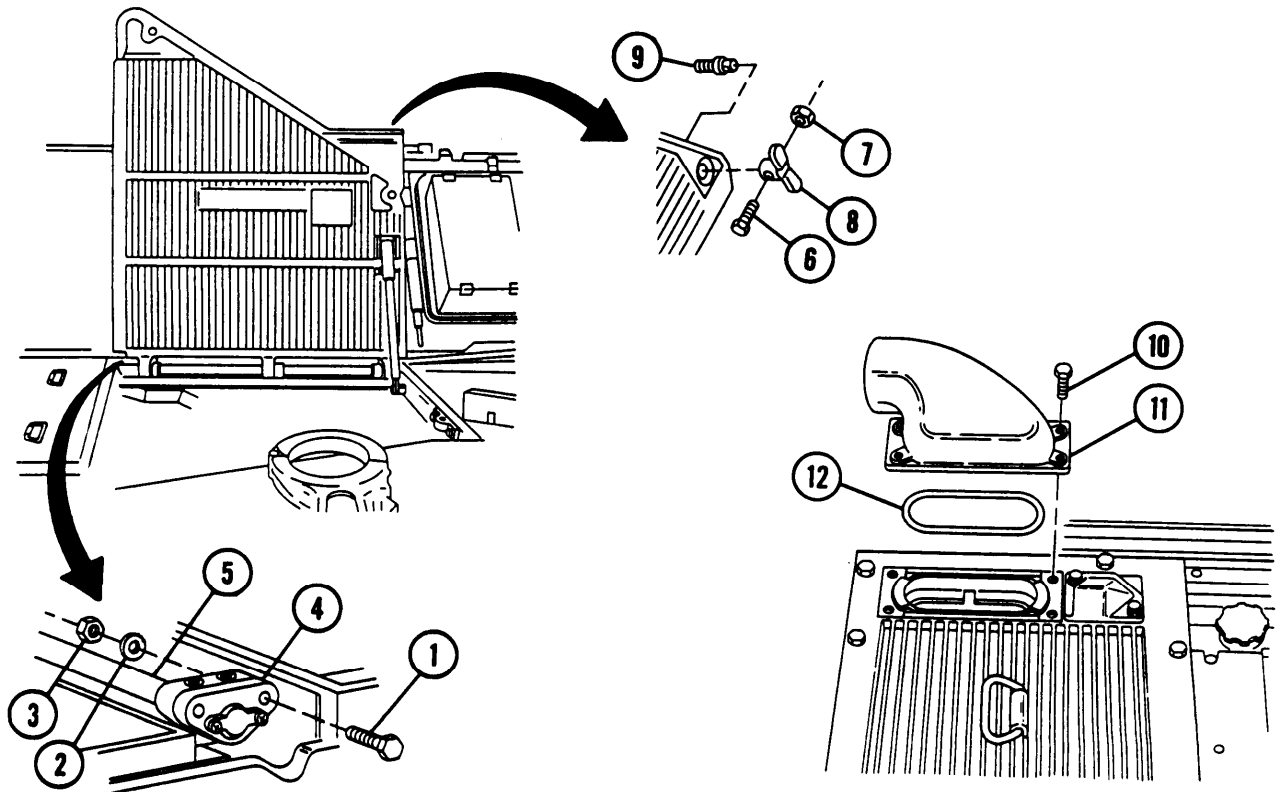

11-8 AIR INTAKE GRILLE — CONTINUED

a. Removal-Continued

WARNING

Grille is heavy. If hoist and sling are not available, at least four personnel are required to lift and move grille. Improper lifting of grille can result in serious injury.

- 4 Attach U-bolts and sling to air intake grille (13). Take up slack in sling using suitable lifting device.
- 5 Remove quick-release pin (14) from air intake grille support (15) and lower air intake grille (13).

NOTE

Screws securing right end cap will vary in length. Note length and location of screw during removal to aid in installation.

- 6 Remove four hex key screws (16 and 17) from right end cap (18).
- 7 Remove four hex key screws (19) from rear of torsion bar housing clamps (20).
- 8 Open air intake grille (13) and maintain tension with lifting device.
- 9 Remove four hex key screws (21) from front of torsion bar housing clamps (20).
- 10 Remove screw (22), flat washer (23), and intake grille support (15). Remove bearing (24) from end of air intake grille support.
- 11 Lift air intake grille (13) off vehicle.
- 12 Remove three screws (25), shield (26), and adapter (27) from left end of torsion bar housing (5).
- 13 Remove torsion bar housing (5), torsion bar (28), and torsion bar housing clamps (20) from air intake grille (13).
- 14 Disconnect two S-hooks (29) and remove chain (30) from quick-release pin (14) and air intake grille (13).
- 15 Remove two screws (31), two lockwashers (32), grille bracket (33), and shims (34). Discard lockwashers.

b. Installation

- 1 Connect chain (30) to quick-release pin (14) and air intake grille (13) with two S-hooks (29).
- 2 Install torsion bar clamps (20), torsion bar (28), and torsion bar housing (5) to air intake grille (13).
- 3 Install adapter (27) and shield (26) at left end of torsion bar housing (5) with three screws (25).

WARNING

Air intake grille is heavy. If hoist and sling are not available, at least four personnel are required to lift and move grille. Improper lifting of grille can result in serious injury.

- 4 Attach U-bolt and sling to air intake grille (13) and suitable lifting device. Lift air intake grille into position and align mounting holes.
- 5 Insert bearing (24) in end of air intake grille support (15). Install air intake grille support, screw (22), and flat washer (23).
- 6 Install four hex key screws (21) in front of torsion bar housing clamps (20).

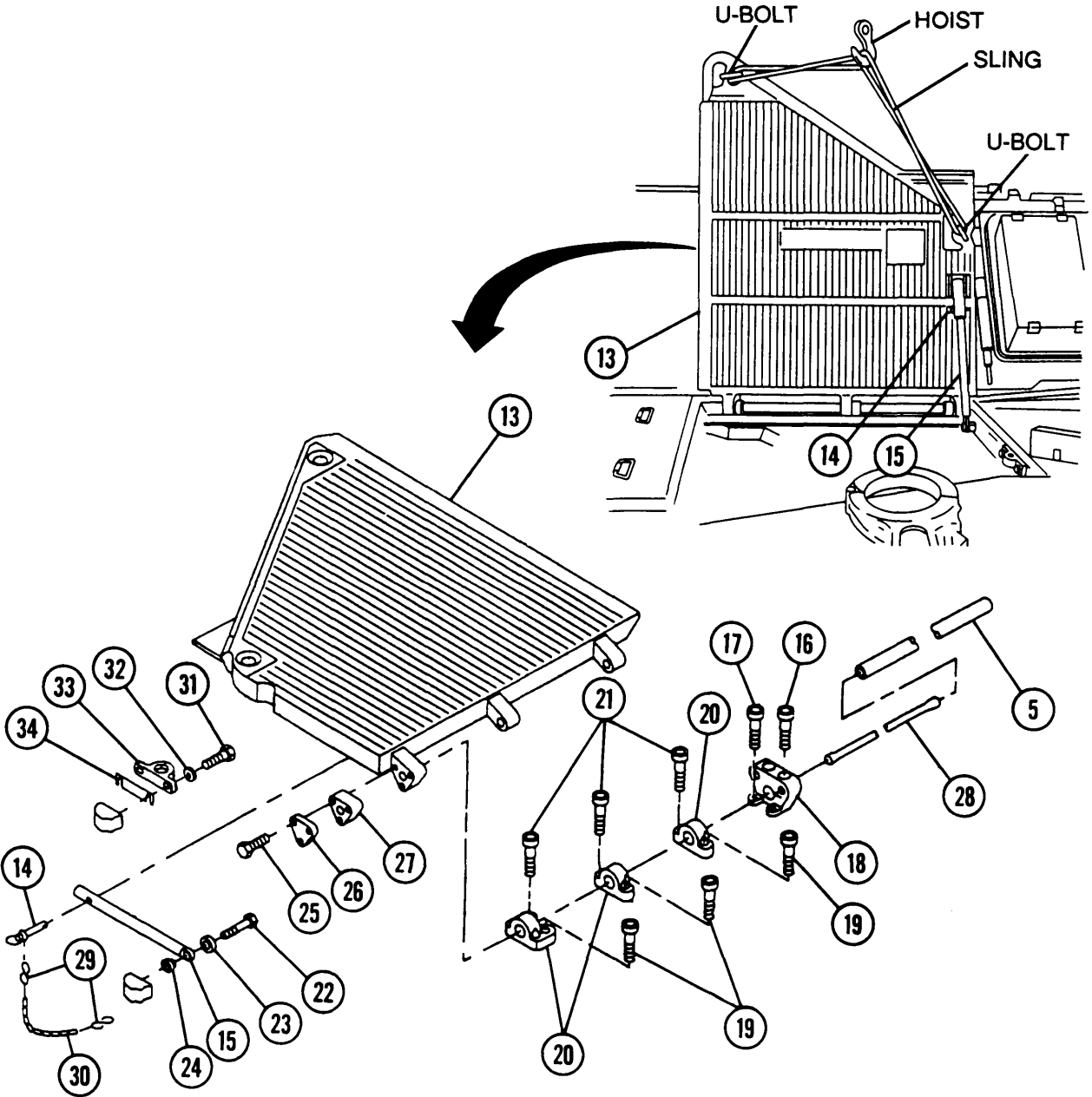

11-8 AIR INTAKE GRILLE — CONTINUED

b. Installation-Continued

- 7 Lower air intake grille (13).
- 8 Install four hex key screws (19) in rear of torsion bar housing clamps (20).
- 9 Install four hex key screws (16 and 17) in right end cap (18).
- 10 Raise air intake grille (13).
- 11 Secure grille (13) in upright position with quick release pin (14). Remove sling and U-bolts.
- 12 Apply antiseize compound to four screws (10) and install new packing (12), exhaust deflector (11), and four screws.
- 13 Insert two studs (9) from bottom side of air intake grille (13). Install two handles (8), two new self-locking nuts (7), and two screws (6).

NOTE

Steps 14 thru 16 apply only when installing a new air intake grille.

- 14 Install grille bracket (33) on handle (8) and close grille (13) to determine clearance between grille bracket and hull.

NOTE

Clearance = number of shims (use next whole number) to be used with bracket.
0.06

- 15 Select screw (31) size to be used with bracket (33):
 - zero or one shim — use 1.125-in. (2.86-cm) screw
 - two or three shims — use 1.25-in. (3.18-cm) screw
 - three or four shims — use 1.375-in. (3.49-cm) screw
- 16 Open grille (13) and disengage handle (8) from bracket (33).
- 17 Install shims (34) as required and bracket (33) on hull with two new lockwashers (32) and two screws (31).
- 18 Install shield and anchor (4) at right end of torsion bar housing (5) with two new self-locking nuts (3), two flat washers (2), and two screws (1).

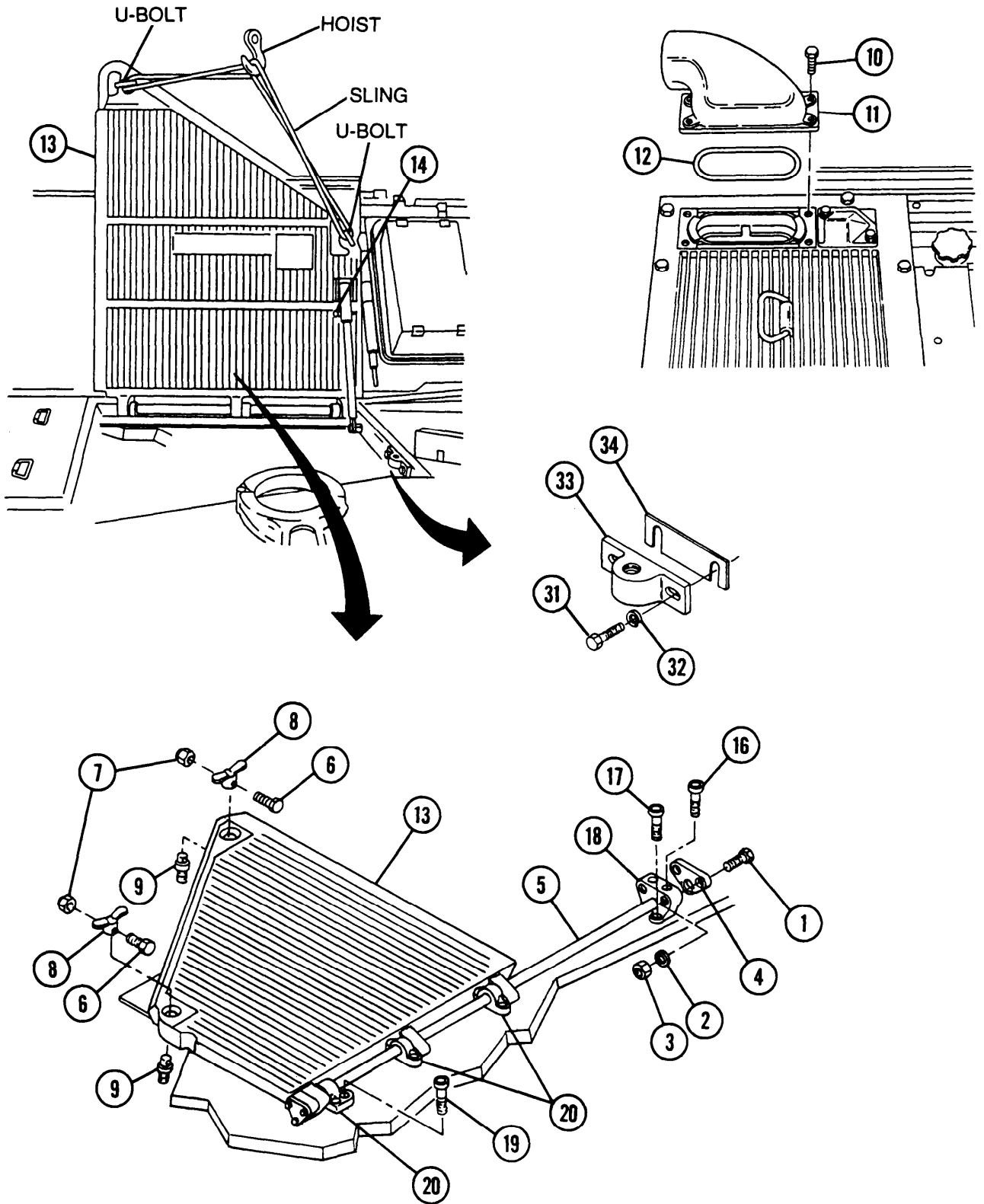

11-9 DRAIN COVERS AND PLUGS

This task covers: a. Removal b. Installation

INITIAL SETUP

Tools

General mechanic's tool kit (item 64, Appx H)
Suitable container

Materials/Parts

Gasket (item 105, Appx G)
Gasket (item 125, Appx G)
Gaskets (2) (item 134, Appx G)
Preformed packing (item 65, Appx G)

a. Removal

WARNING

- Allow engine to cool before removing engine coolant drain plug, engine oil drain plug, and transmission drain plug. Hot fluids will cause severe burns.
- Coolant, fuel, and oil are hazardous waste and must be disposed of in accordance with local procedures or direction of the local Hazardous Waste Management office.

- 1 Remove three screws (1), three flat washers (2), large cover (3), and gasket (4). Discard gasket.
- 2 Remove engine coolant drain plug (5).
- 3 Remove fuel drain plug (6).
- 4 Remove six screws (7), six flat washers (8), two small covers (9), and two gaskets (10). Discard gaskets.
- 5 Remove transmission oil drain plug (11) and gasket (12). Discard gasket.
- 6 Remove engine oil drain plug (13).
- 7 Remove four screws (14), four flat washers (15), drain cover (16), and performed packing (17). Discard preformed packing.

b. Installation

- 1 install new performed packing (17), drain cover (16), four flat washers (15), and four screws (14).
- 2 Install engine oil drain plug (13).
- 3 Install new gasket (12) and transmission oil drain plug (11).
- 4 Install two new gaskets (10), two small covers (9), six flat washers (8), and six screws (7).

- 5 Install fuel drain plug (6).
- 6 Install engine coolant drain plug (5).
- 7 Install new gasket (4), large cover (3), three flat washers (2), and three screws (1).

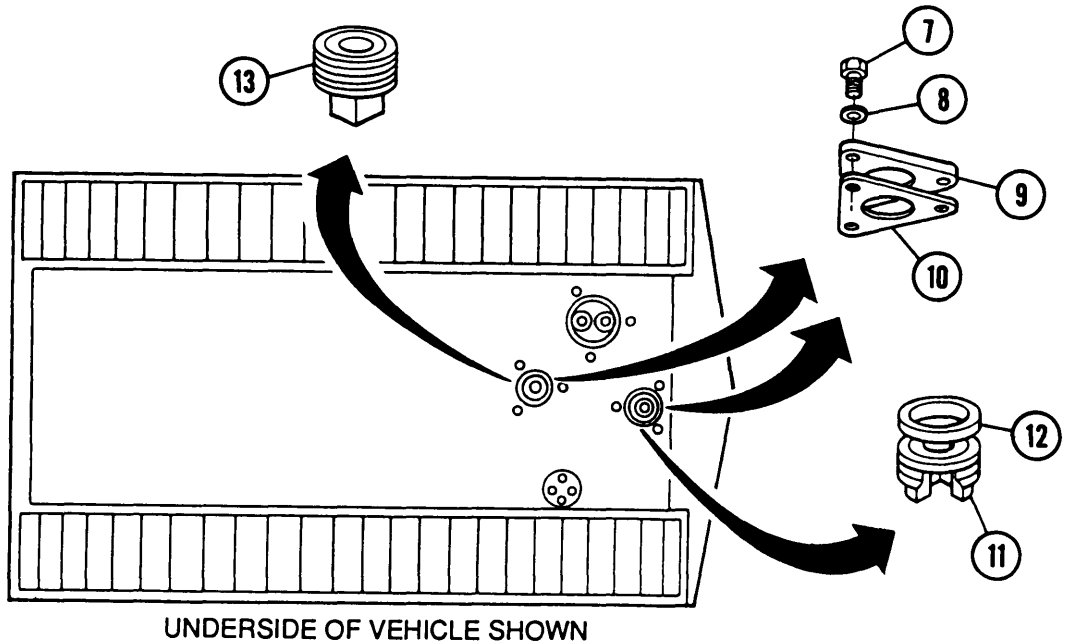
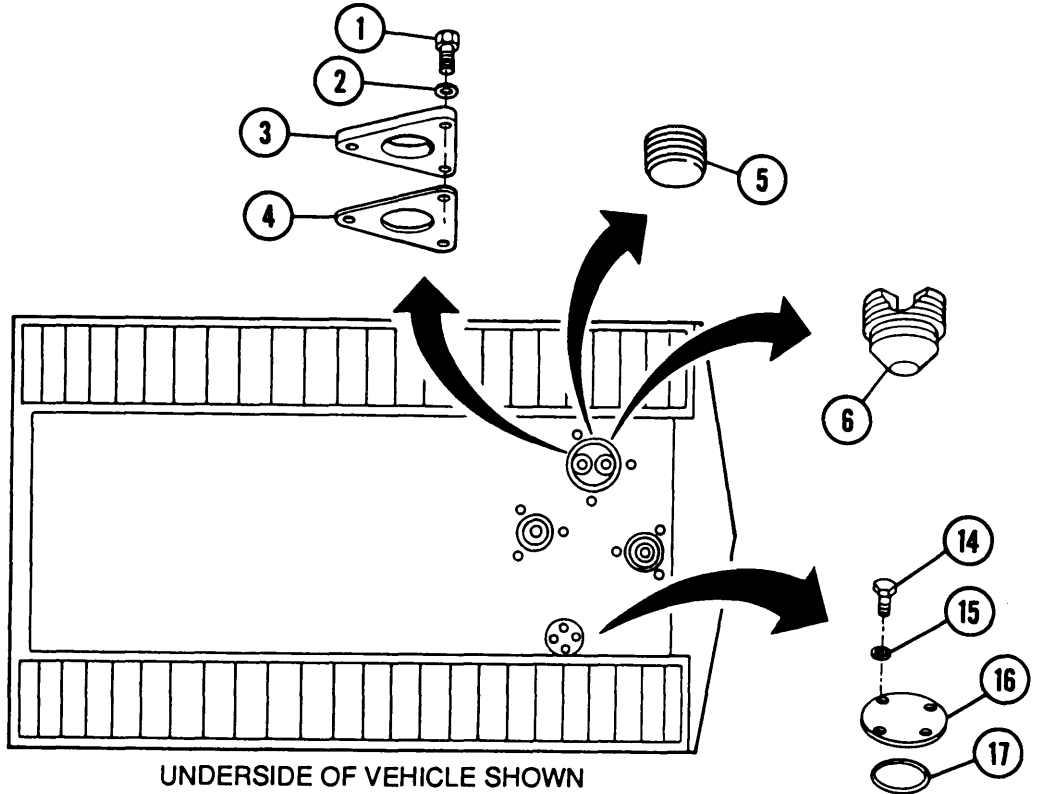

11-10 SUBFLOOR DRAIN PLUGS (M109A4/M109A5)

This task covers: a. Removal/Disassembly b. Assembly/installation

INITIAL SETUP

Applicable Configurations

M109A4/M109A5

Materials/Parts

Preformed packings (13) (item 58, Appx G)

Tools

General mechanic's tool kit (item 64, Appx H)

Socket head screw key (item 33, Appx H)

a. Removal/Disassembly

1 Remove 13 drain plug assemblies (1).

2 Remove 13 preformed packings (2) from 13 drain plug assemblies (1). Discard preformed packings.

b. Assembly/installation

1 Install 13 new preformed packings (2) on 13 drain plug assemblies (1).

2 Install 13 drain plug assemblies (1).

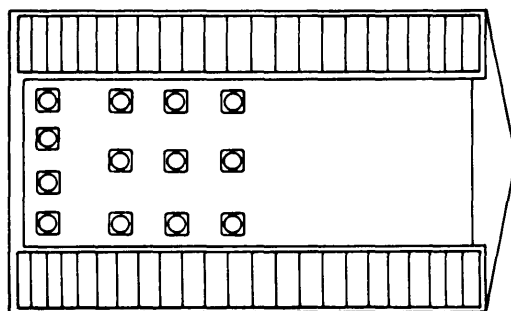
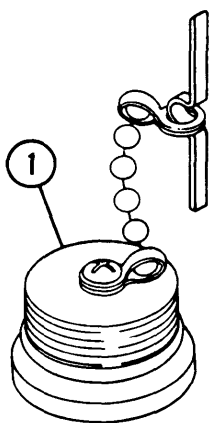

LOCATION OF SUBFLOOR DRAINS
UNDERSIDE OF VEHICLE SHOWN

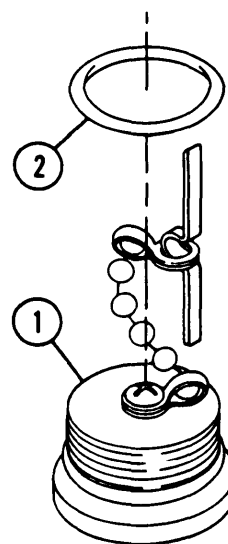

11-11 PERISCOPE M45 COVER, DOORS, AND SLEEVES

This task covers: a. Removal b. Disassembly

 c. Assembly d. Installation

INITIAL SETUP

Tools
General mechanic's tool kit (item 64, Appx H)

Materials/Parts
Adhesive (item 5, Appx D)
Gasket (item 120, Appx G)
Gaskets (3) (item 158, Appx G)

a. Removal

- 1 Remove six screws (1), cover (2), and gasket (3) from outside hull. Discard gasket.
- 2 Remove six wing nuts (4), six supports (5), and six rods (6) from inside hull.
- 3 Remove six screws (7), six flat washers (8), and three periscope sleeves (9) from inside hull.

b. Disassembly

- 1 Remove three pins (10) and three springs (11).
- 2 Remove three rings (12), three pins (13), and three springs (14).
- 3 Remove three doors (15) and three gaskets (16). Discard gaskets.

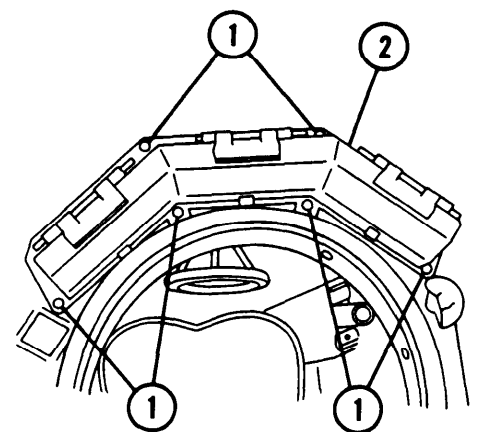
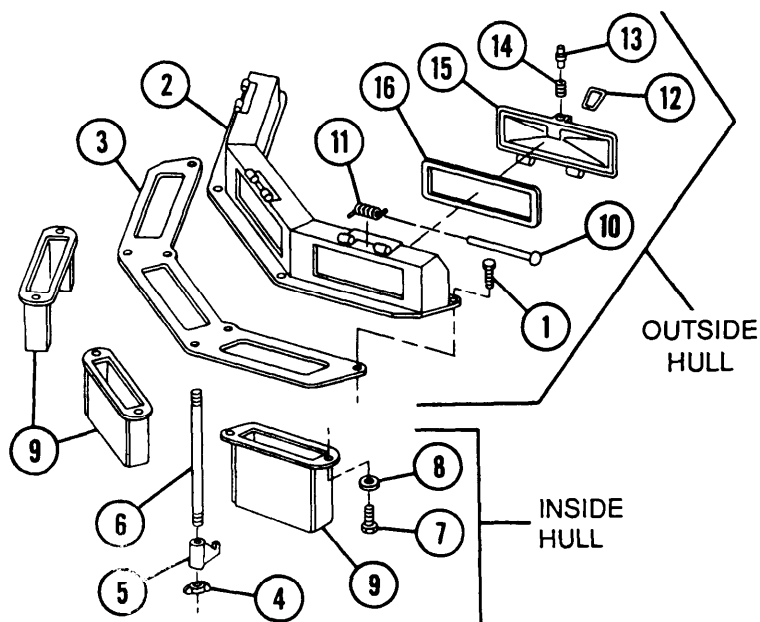

11-11 PERISCOPE M45 COVER, DOORS, AND SLEEVES — CONTINUED

c. Assembly

WARNING

Adhesives are toxic and flammable. Apply adhesives only in a well-ventilated area. Avoid contact with skin, eyes, and clothes, and don't breath vapors. Do not use near heat, sparks, or open flame. Read and follow all warnings and instructions on labels of adhesives. If contact with skin or eyes is made, wash area with water and seek medical aid immediately.

- 1 Apply adhesive to three new gaskets (16).
- 2 Install three new gaskets (16) on three doors (15). Install three doors.
- 3 Install three springs (14), three pins (13), and three rings (12).
- 4 Install three springs (11) and three pins (10).

d. Installation

- 1 Install three periscope sleeves (9), six flat washers (8), and six screws (7) inside hull.
- 2 Install six rods (6), six supports (5), and six wing nuts (4) inside hull.
- 3 Install new gasket (3), cover (2), and six screws (1).

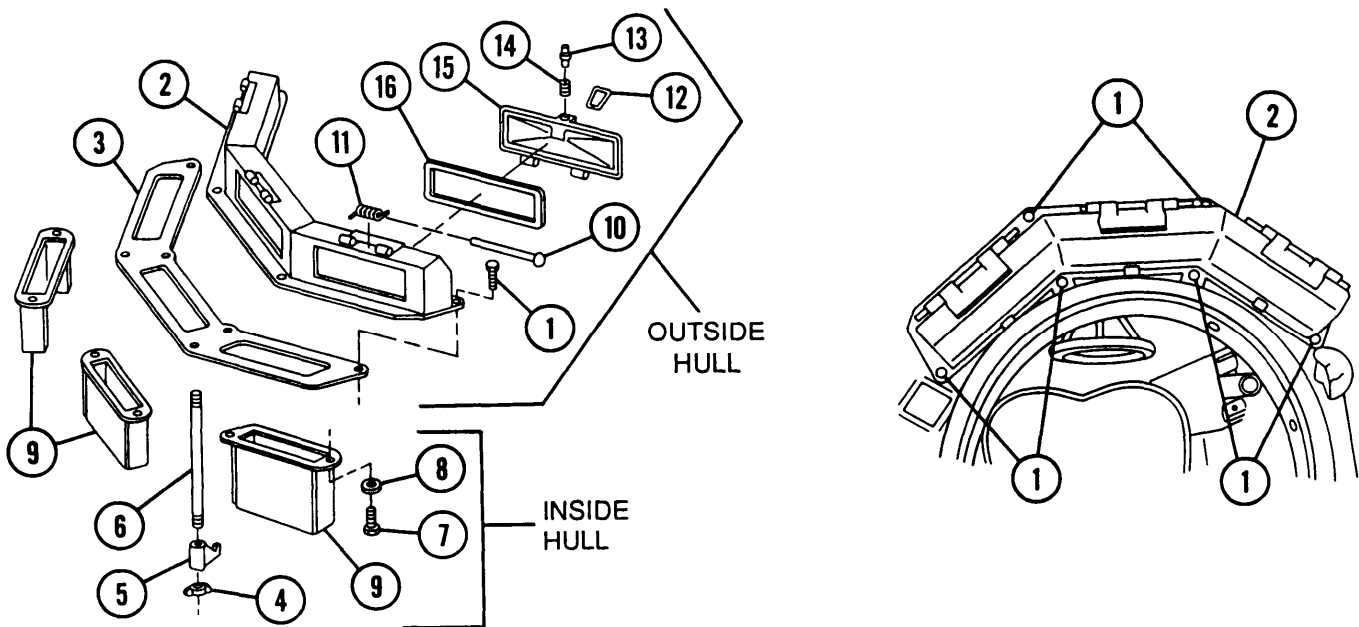

11-12 HULL REAR DOOR, M13 KIT BRACKET, AND DOOR LATCH

This task covers: a. Removal b. Installation

INITIAL SETUP

Tools

General mechanic's tool kit (item 64, Appx H)

Lockwashers (8) (item 112, Appx G)

Spring pins (2) (item 8, Appx G)

Materials/Parts

Lockwashers (4) (item 71, Appx G)

Personnel Required

Four

NOTE

Some M109A3 vehicles have two hull rear doors. Follow removal procedures for M109A2/M109A4/M109A5 vehicles, but remove both doors.

a. Removal

- 1 Remove four screws (1), four lockwashers (2), and two plates (3). Discard lockwashers.
- 2 Remove four screws (4), four lockwashers (5), and bracket (6). Discard lockwashers,
- 3 Remove four screws (7), four lockwashers (8), and bracket assembly (9). Discard lockwashers.
- 4 Remove two screws (10) and fastener (11).

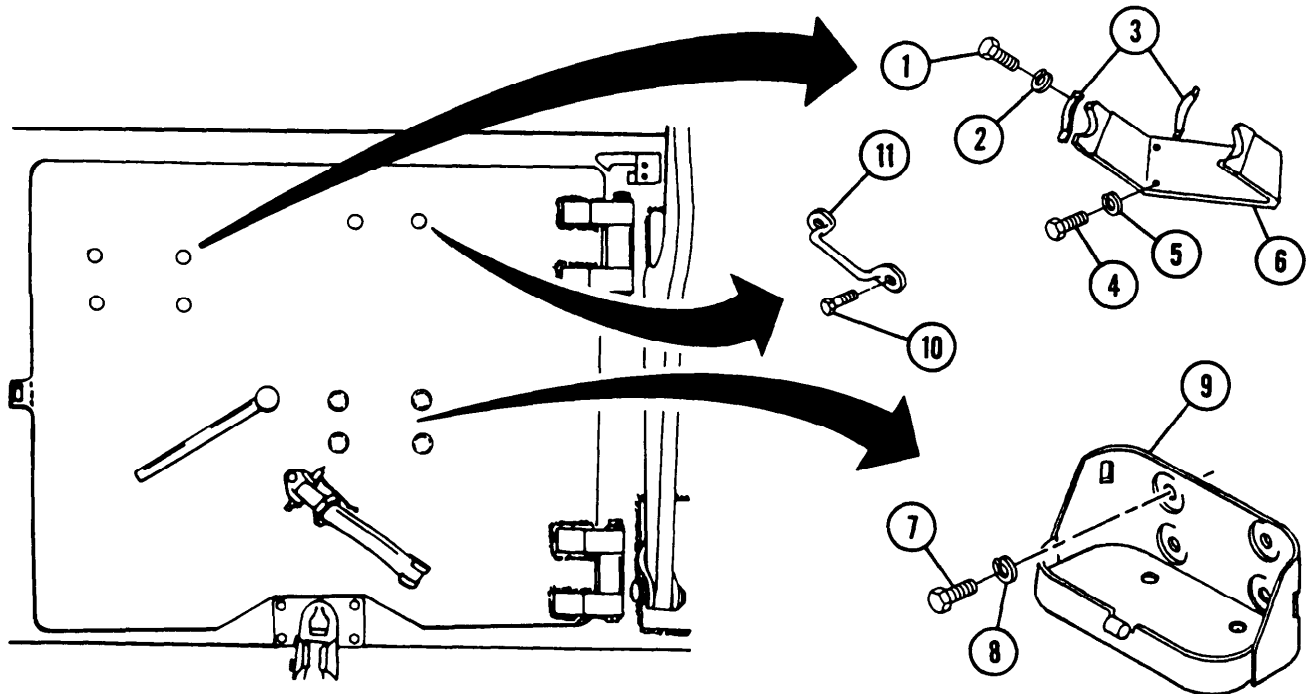

11-12 HULL REAR DOOR, M13 KIT BRACKET, AND DOOR LATCH — CONTINUED

a. Removal — Continued

WARNING

Door is heavy. At least four personnel are required to lift door. Improper removal of door can cause serious injury.

- 5 Open rear door (12) slightly and place support blocks under bottom edge.
- 6 Remove two nuts (13), four flat washers (14), and two screws (15).
- 7 Lift off rear door (12) from hinges.
- 8 Remove spring pin (16), latch (17), and spring (18). Discard spring pin.
- 9 Remove spring pin (19) and bumper (20). Discard spring pin.
- 10 Remove four screws (21) and bracket (22).

b. Installation

- 1 Install bracket (22) and four screws (21).
- 2 Install bumper (20) and new spring pin (19).
- 3 Install spring (18), latch (17), and new spring pin (16).

WARNING

Door is heavy. At least four personnel are required to lift door. Improper installation of door can cause serious injury.

- 4 Install rear door (12) on hinges.
- 5 Install two screws (15), four flat washers (14), and two nuts (13).
- 6 Install fastener (10) and two screws (11).
- 7 Install bracket assembly (9), four new lockwashers (8), and four screws (7).
- 8 Install bracket (6), four new lockwashers (5), and four screws (4).
- 9 Install two plates (3), four new lockwashers (2), and four screws (1).

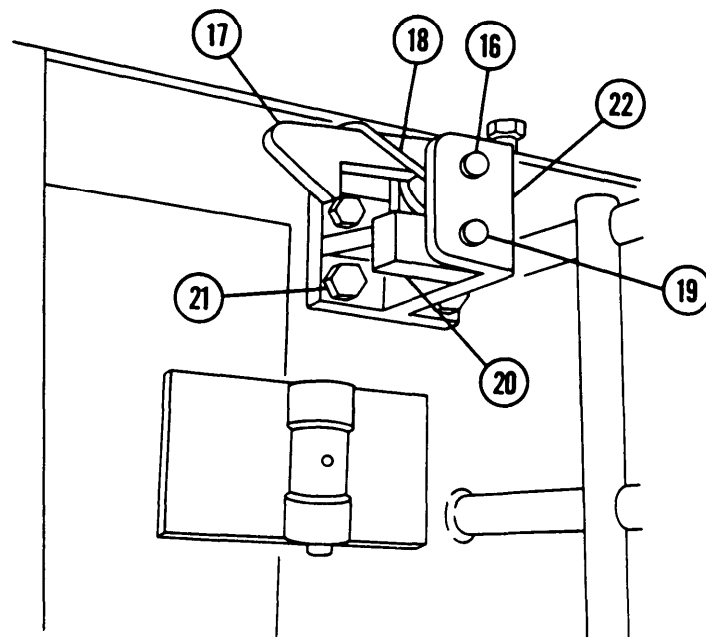
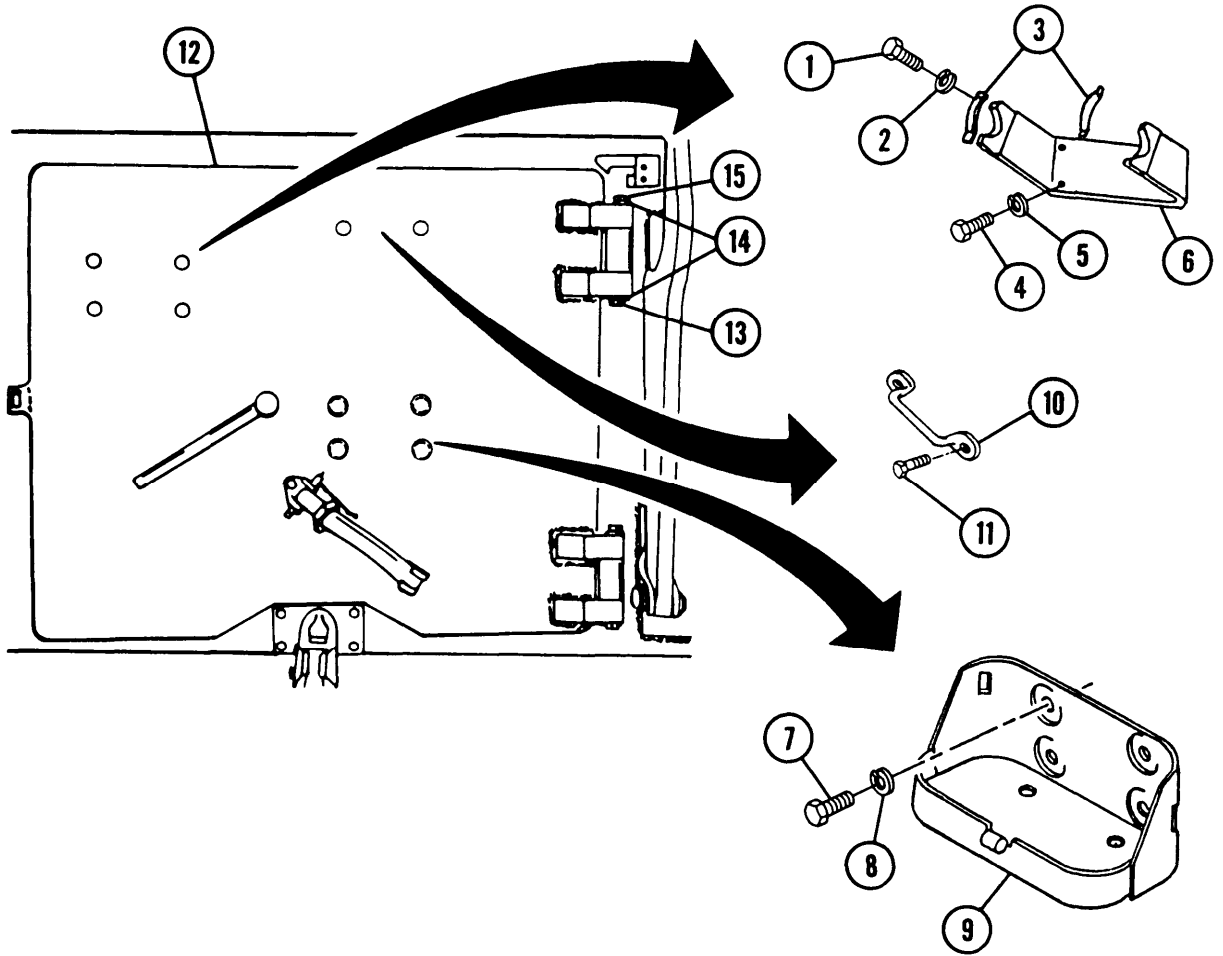

11-13 HULL REAR DOOR HOLD-OPEN ROD AND HANDLE

This task covers: a. Removal b. Installation

INITIAL SETUP

Tools

General mechanic's tool kit (item 64, Appx H)
 Adjustable wrench (item 65, Appx H)
 Adjustable wrench (item 66, Appx H)

Materials/Parts

Cotter pin (item 40, Appx G)
 Preformed packing (item 55, Appx G)
 Self-locking nut (item 107, Appx G)
 Spring pin (item 12, Appx G)

a. Removal

- 1 Remove pin (1), two screws (2), two flat washers (3), and bracket (4).
- 2 Remove cotter pin (5) and headed pin (6). Discard cotter pin.
- 3 Remove self-locking nut (7), flat washer (8), preformed packing (9), and rod assembly (10). Discard self-locking nut and preformed packing.

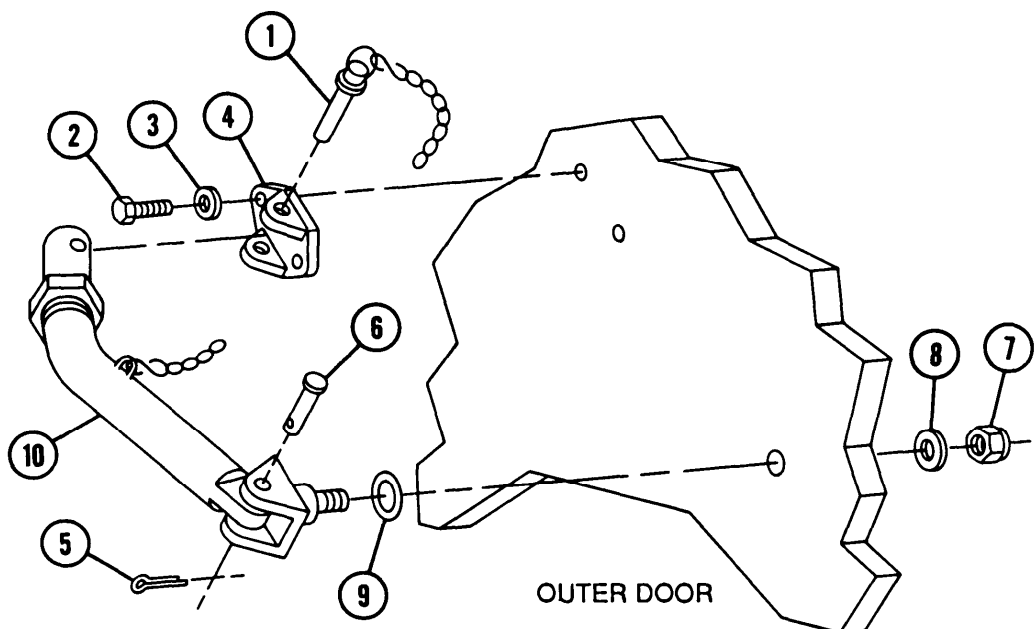

4 Remove spring pin (11). Discard spring pin.

5 Remove four screws (12), four flat washers (13), upper slide (14), lower slide (15), and shims (16).

6 Remove inside and outside handle assemblies (17) with components.

b. Installation

1 Install inside and outside handle assemblies (17) with components.

2 Install shims (16), lower slide (15), upper slide (14), four flat washers (13), and four screws (12).

3 Install new spring pin (11).

4 Install rod assembly (10), new preformed packing (9), flat washer (8), and new self-locking nut (7).

5 Install headed pin (6) and new cotter pin (5).

6 Install bracket (4), two flat washers (3), two screws (2), and pin (1).

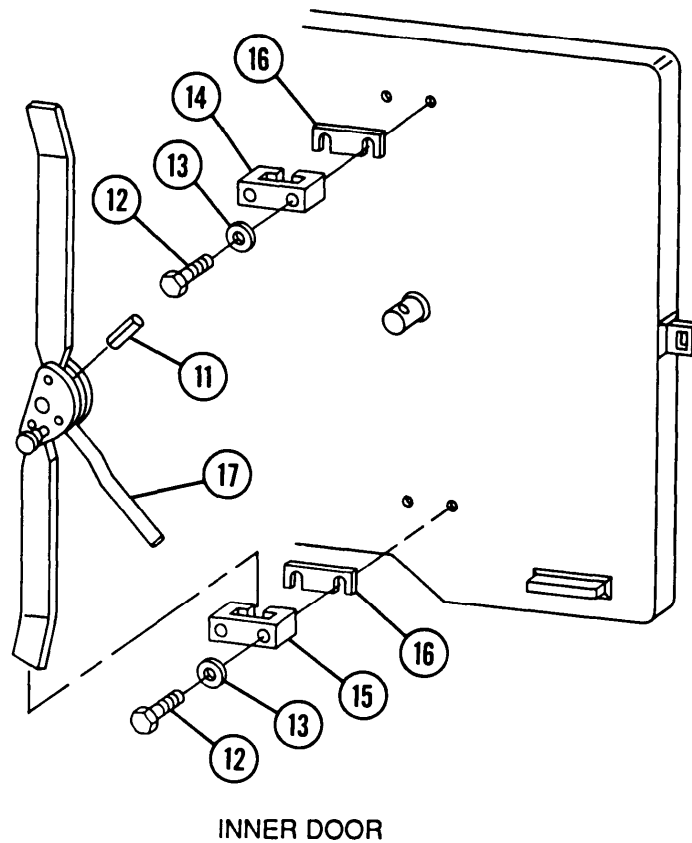

SECTION III. TRAVEL LOCK, SPADE, FENDERS, AND TOWING PINTLE

11-14 TRAVEL LOCK

- This task covers:
- a. Removal
 - b. Disassembly
 - c. Assembly
 - d. Installation and Adjustment
 - e. Adjustment
-

INITIAL SETUP

Tools

General mechanic's tool kit (item 64 Appx H)
Sling (item 60, Appx H)
Socket wrench set (item 56, Appx H)
Torque wrench (item 71, Appx H)

Cotter pins (2) (item 52, Appx G)
Cotter pins (3) (item 49, Appx G)
Lockwashers (6) (item 89, Appx G)
Primer (item 74, Appx D)
Self-locking nuts (7) (item 223, Appx G)
Wire rope sleeves (2) (item 152, Appx G)
Wire ropes (2) (item 159, Appx G)

Materials/Parts

Adhesive (item 2, Appx D)
Cap lining (item 161, Appx G)

Personnel Required

Three

a. Removal

WARNING

Gun tube must be out of support. Support arm is heavy and must be secured with hoist or laid down to prevent support arm falling and causing serious injury or death.

- 1 Remove pin assembly (1).
- 2 Lift handle (2) to unfasten travel lock cap (3).
- 3 Elevate and traverse cannon tube (4) to clear travel lock.

WARNING

Travel lock must be secured to avoid possible injury during removal.

- 4 Secure travel lock cap (3). Replace pin assembly (1).

NOTE

Steps 5 thru 13 remove travel lock without removing mounting bracket. Step 14 thru 17 removes travel lock with mounting bracket attached.

- 5 Remove four screws (5), four lockwashers (6), and two torsion spring retaining bars (7) on both sides of support arm (8). Discard lockwashers.
- 6 Remove four screws (9), four lockwashers (10), and two plates (11) on both sides of mounting bracket (1 2). Discard lockwashers.
- 7 Pull pin (13).

WARNING

Travel lock is heavy. Be careful when raising or lowering travel lock and during removal of counterbalance springs to avoid serious injury.

- 8 Move support arm (8) forward to unload springs (14).
- 9 Remove cotter pin (15) and washer (16) at right mounting lug (17). Discard cotter pin.
- 10 Record number of spacer washers (18) between each end of support arm (8) and left and right mounting lugs (17 and 19).

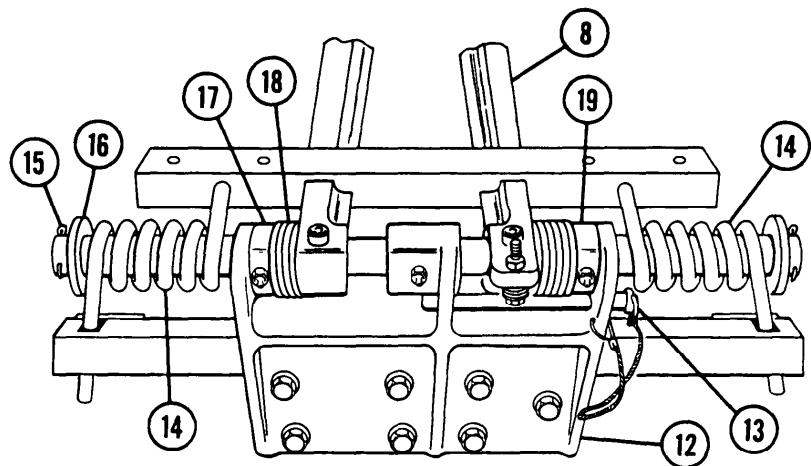
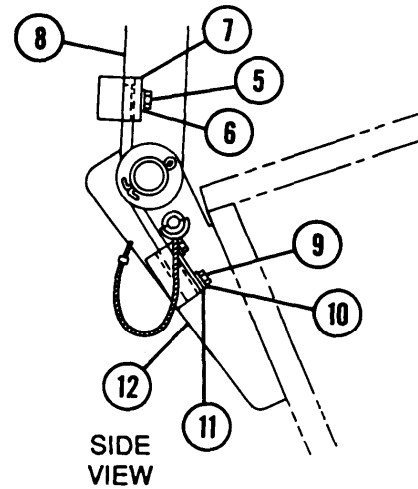
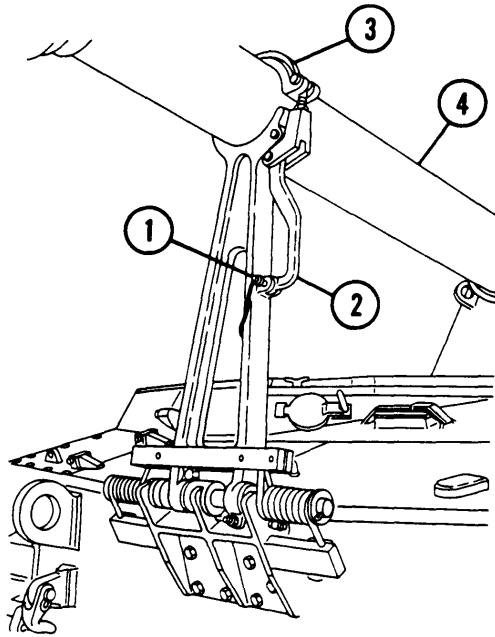

11-14 TRAVEL LOCK — CONTINUED

a. Removal — Continued

WARNING

Support arm is heavy. At least two personnel are required to assist in handling as pin is removed to avoid serious injury.

- 11 Remove pin (20) (drive pin from right to left), spacer washers (18), washer (21), and cotter pin (22). Discard cotter pin.
- 12 Remove two springs (14).
- 13 Remove support arm (8).

NOTE

Steps 14 thru 17 are for removal of travel lock with mounting bracket.

- 14 Release support arm (8) from tube. Secure with hoist.
- 15 Open transmission access doors (23).
- 16 Remove seven screws (24), seven self-locking nuts (25), and seven flat washers (26). Discard self-locking nuts.
- 17 Pull travel lock assembly (27) away from vehicle (28).

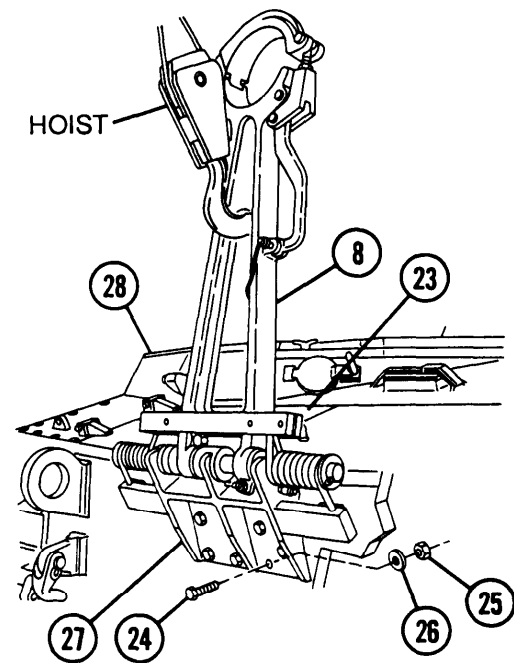
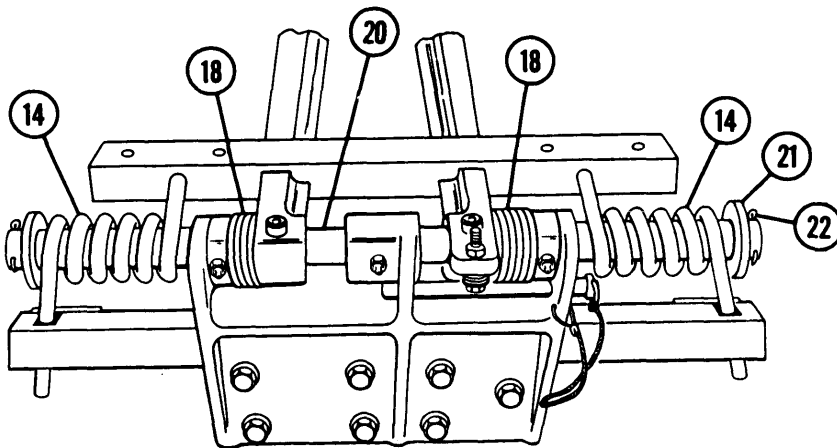

b. Disassembly

WARNING

Gun tube must be out of support arm before disassembly. Support arm is heavy and must be secured with hoist or laid down to prevent support arm from falling and causing serious injury or death.

- 1 Remove two cotter pins (29), two flat washers (30), and two headed pins (31). Discard cotter pins.
- 2 Remove travel lock cap (3) and cap lining (32). Discard lining.
- 3 Remove cotter pin (33), flat washer (34), headed pin (35), lockpin (1), wire rope assembly (36), clevis (37), and handle (2). Discard cotter pin and wire rope assembly.
- 4 Remove tee (38) and nut (39).

NOTE

Perform step 5 if travel lock was removed without removing mounting bracket.

- 5 Remove four screws (5), four lockwashers (6), and two torsion spring retaining bars (7). Discard lockwashers.

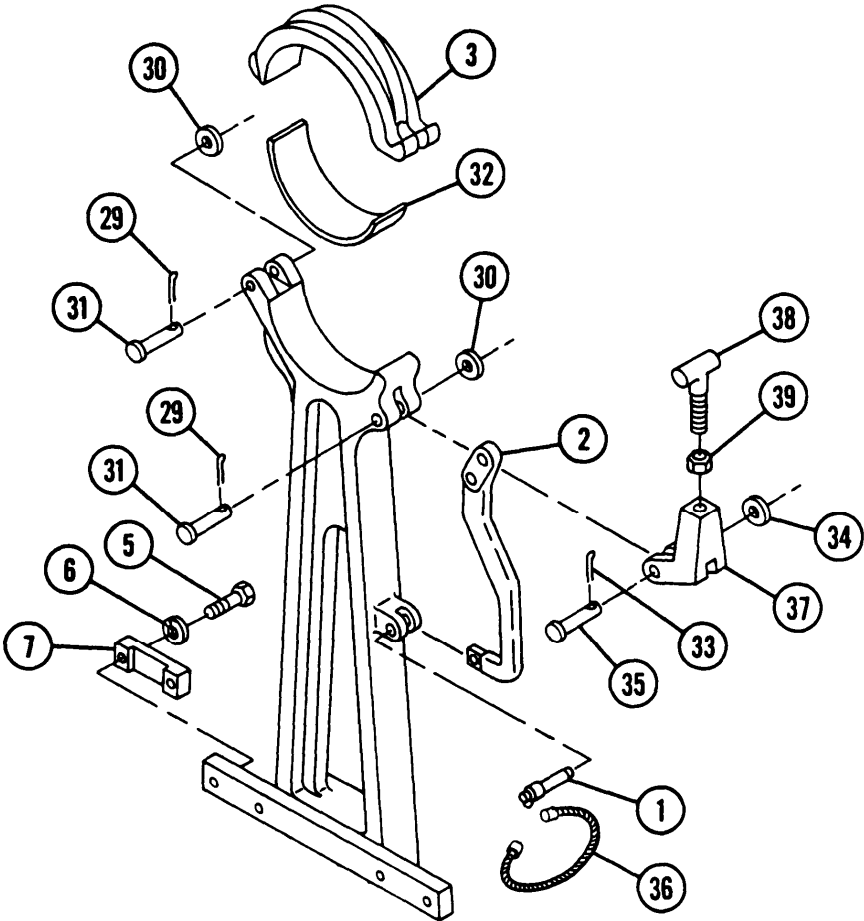

11-14 TRAVEL LOCK — CONTINUED

b. Disassembly — Continued

- 6 Remove lockpin (13) and wire rope assembly (40). Discard wire rope assembly.

WARNING

Support arm is heavy. At least two personnel are required to support arm during removal to avoid serious injury.

NOTE

If removal procedure followed was without removal of mounting bracket, items 15, 16, 18, 20,21, and 22 should already be disassembled.

- 7 Record number of spacer washers (18) and remove two cotter pins (15 and 22), two flat washers (16 and 21), pin (20), and spacer washers. Discard cotter pins.
- 8 Remove support arm (8).

WARNING

Mounting bracket is heavy. Two personnel are required to support bracket during removal to avoid serious injury.

NOTE

Perform steps 9 and 10 if travel lock was removed without mounting bracket.

- 9 Remove seven self-locking nuts (25) and seven flat washers (26) from inside engine compartment. Discard self-locking nuts.
- 10 Remove seven screws (24) and mounting bracket (12).

NOTE

Perform step 11 if travel lock was removed with mounting bracket.

- 11 Remove four screws (9), four lockwashers (10), two torsion bar retainers (11), and two torsion springs (14). Discard lockwashers.
- 12 Remove nut (41), screw (42), and flat washer (43).
- 13 Remove two screws (44), two lockwashers (45), strap (46), and bumper (47). Discard lockwashers.

c. Assembly

- 1 Apply primer to all contact surfaces.

2 Install bumper (47), strap (46), two new lockwashers (45), and two screws (44).

3 Install flat washer (43), screw (42), and nut (41) on support arm (8).

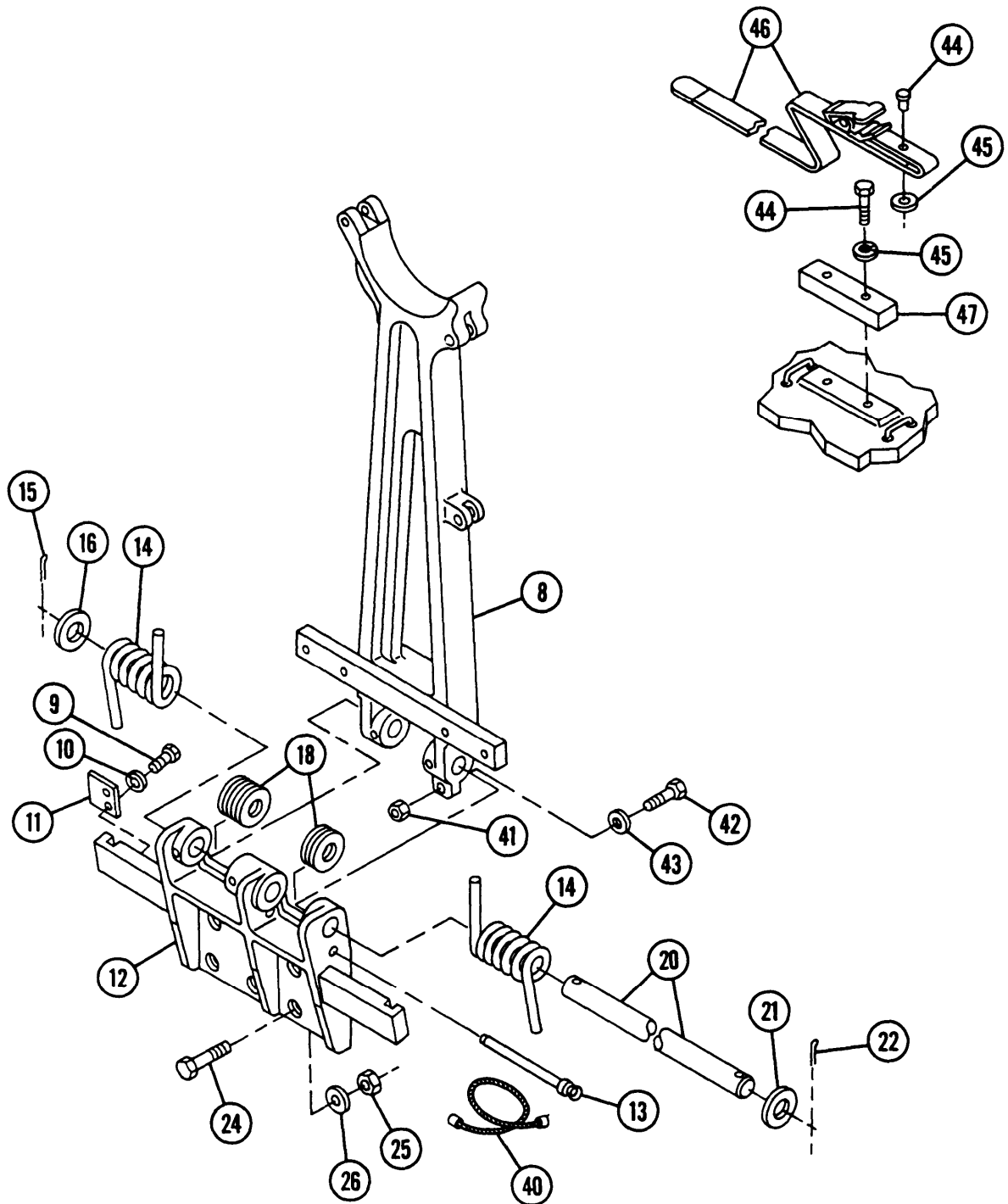

11-14 TRAVEL LOCK — CONTINUED

c. Assembly — Continued

WARNING

Mounting bracket is heavy. Two personnel are required to support bracket during installation to avoid serious injury.

- 4 Install mounting bracket (12) and seven screws (24). Install seven flat washers (26) and seven new self-locking nuts (25) from inside engine compartment. Torque nuts 350-370 lb-ft (475-502 N•m).
- 5 Install new wire rope assembly (40) on lockpin (13). Install wire rope assembly with lockpin on bracket (12).
- 6 Install nut (39) and tee (38) on clevis (37).
- 7 Install handle (2), headed pin (31), flat washer (30), and new cotter pin (29) on support arm (8).
- 8 Install clevis (37), pin (35), flat washer (34), and new cotter pin (33) on handle (2).
- 9 Install new wire rope assembly (36) and lockpin (1) on support arm (8).
- 10 Apply adhesive to new cap lining (32) surface and install new cap lining.
- 11 Install travel lock cap (3), headed pin (31), flat washer (30), and new cotter pin (29) on support arm (8).

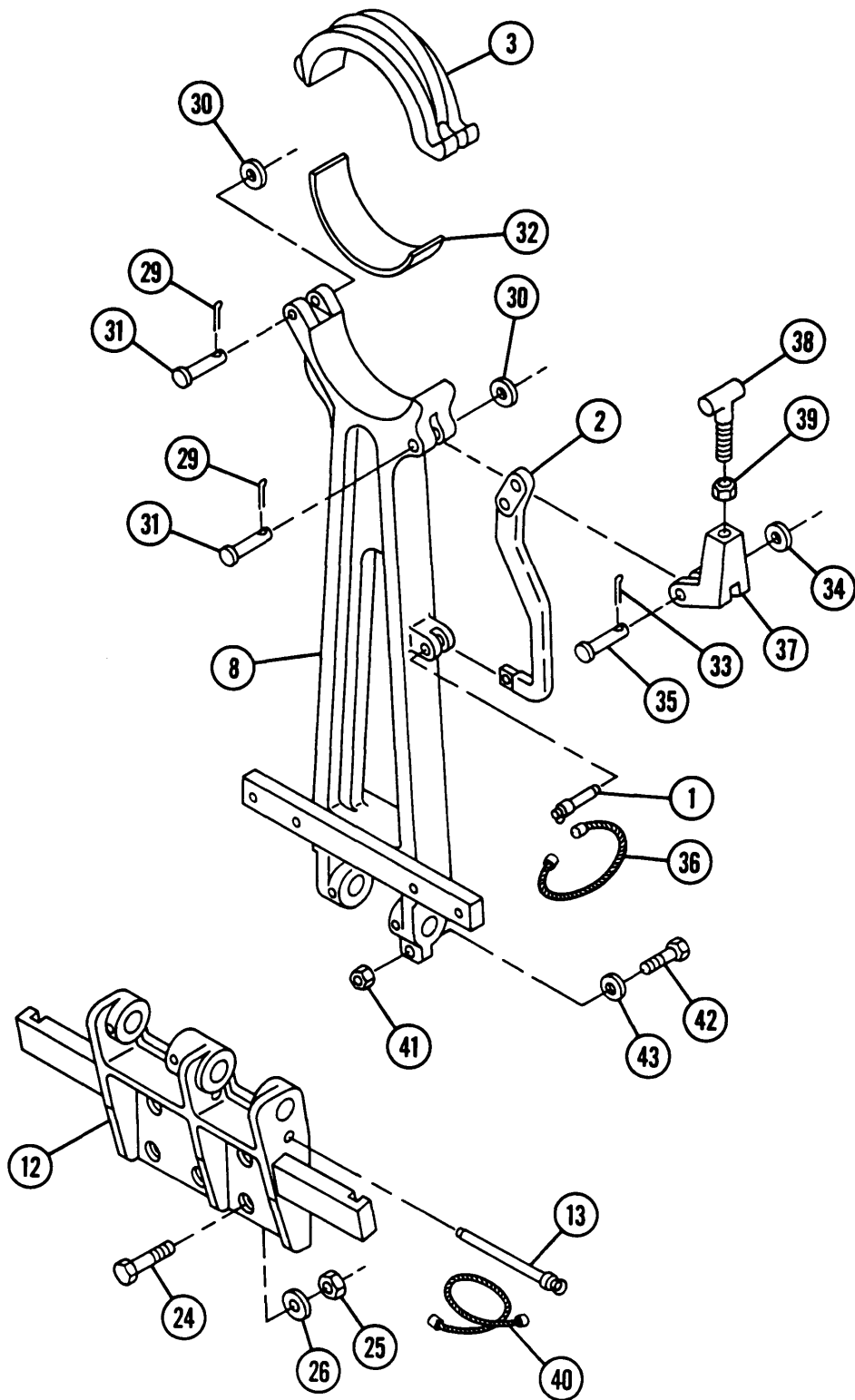

11-14 TRAVEL LOCK — CONTINUED

d. Installation and Adjustment

- 1 Traverse cannon tube (4) to forward center of vehicle.
- 2 Put cab in manual traverse mode and engage travel lock. Insure that lock is fully engaged by attempting to traverse.
- 3 Elevate cannon tube (4) to clear travel lock (8).

WARNING

Support arm is heavy. Be careful when raising or lowering travel lock and during installation of counterbalance springs to avoid serious injury.

- 4 Place support arm (8) in center of mounting bracket (12). Insert pin (20). Ensure support arm is still centered. Do not install spacer washers (18).
- 5 Lower gun tube (4) into support arm (8). Slide support arm (left to right) on pin (20) until center of arm is aligned with centerline of gun tube.
- 6 Rotate support arm (8) front to back on pin (20) until gun tube (4) lies flat on support arm cap lining surface.

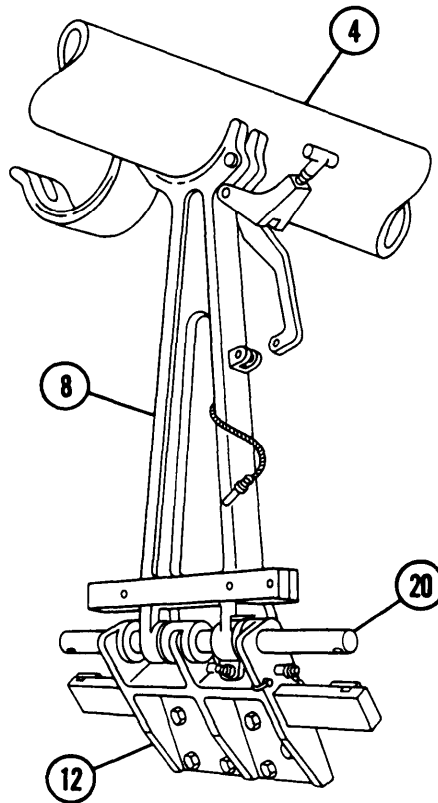

- 7 Close and lock cap (3). Adjust to provide a positive grip on tube (4) by adjusting tee (38) and nut (39) on clevis (37).
- 8 Install spacer washers (18) as follows:
 - (a) Drive pin (20) from right to left just far enough to install washers on pin between right mounting lug (17) and support arm (8).
 - (b) Install spacer washers to fill washer space.
 - (c) Drive pin from left to right just far enough to install spacer washers on pin between left mounting lug (19) and support arm.
 - (d) Install spacer washers to fill washer space.
 - (e) Return pin to center position.
- 9 Install springs (14) on pin (20).
- 10 Secure pin (20) with two washers (16 and 21) and two new cotter pins (15 and 22).

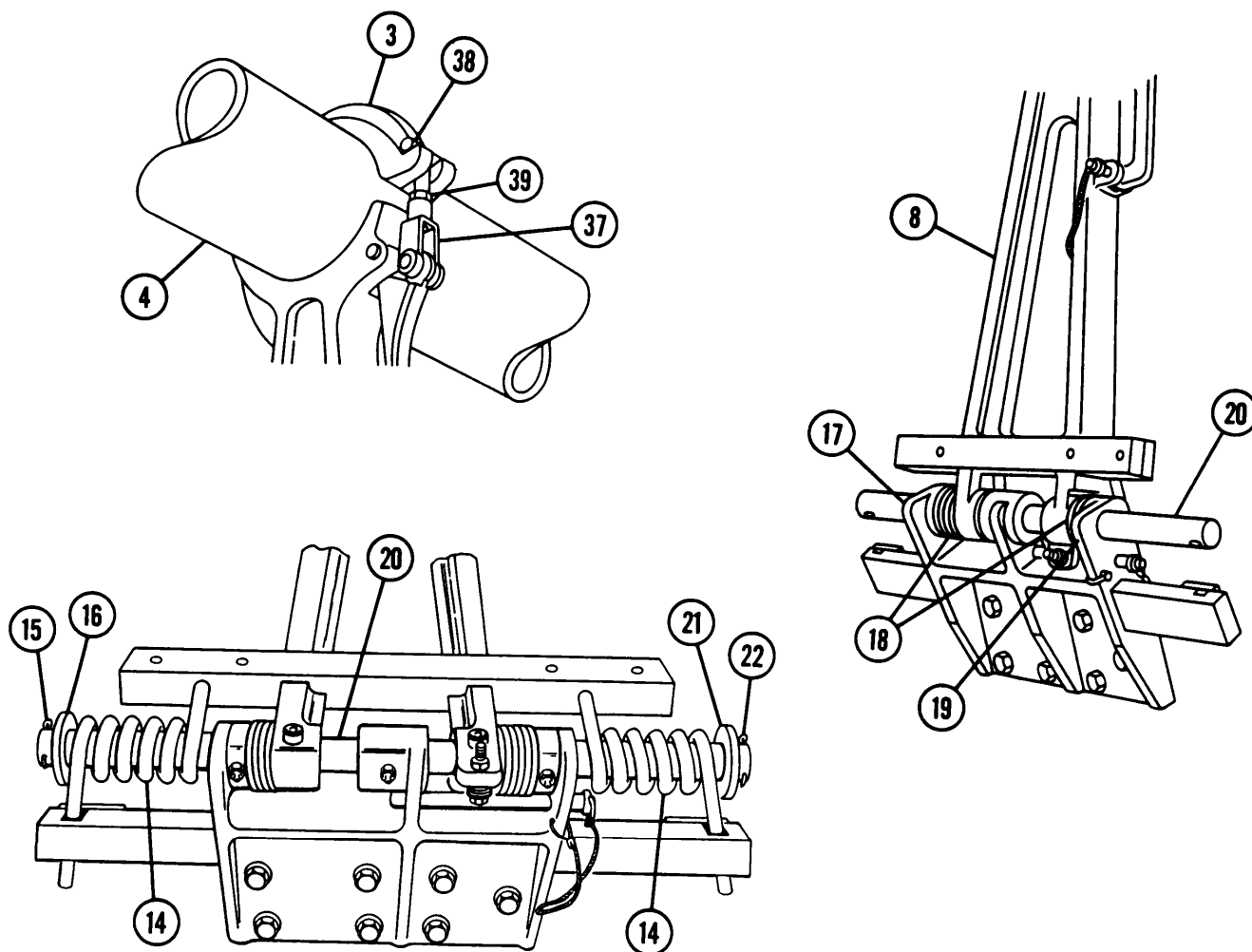

11-14 TRAVEL LOCK — CONTINUED

d. Installation and Adjustment — Continued

- 11 Secure springs (14) to both sides of support arm (8) with two torsion spring retainers (7), four new lockwashers (6), and four screws (5).
- 12 Secure springs (14) to both sides of mounting bracket with two plates (11), four new lockwashers (10), and four screws (9).

e. Adjustment

- 1 Remove nut (41). Adjust screw (42) until it contacts with pin (13). Note distance between head of screw and support arm (8).
- 2 Remove screw (42); install washers (43) on screw to fill required distance.
- 3 Install screw (42). Check fit and install nut (41).
- 4 Adjustment test:
 - (a) Release cap (3).
 - (b) Traverse cannon (4).
 - (c) Return to cannon centerline.
 - (d) Check alinement.

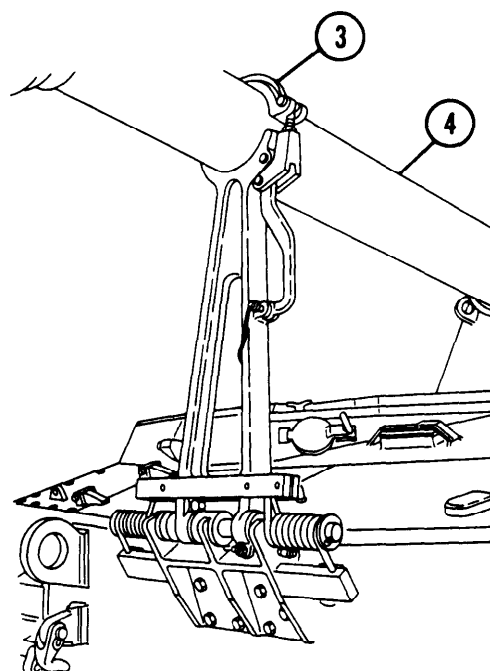
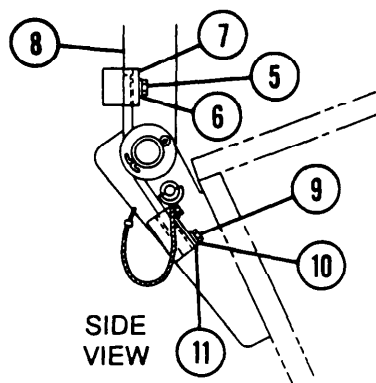
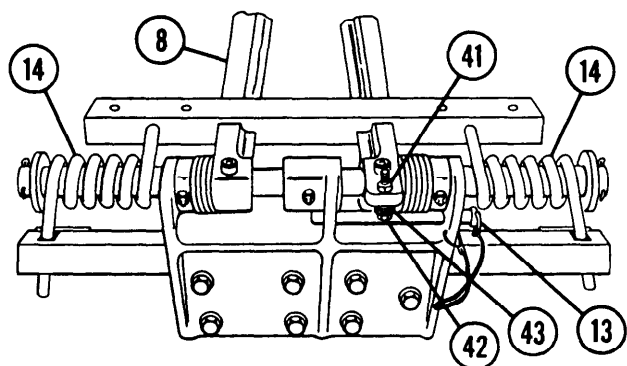

11-15 SPADE

- This task covers:
- | | |
|-----------------|-------------------------|
| a. Removal | b. Disassembly/Assembly |
| c. Installation | d. Adjustment |

INITIAL SETUP

Tools
 General mechanic's tool kit (item 64, Appx H)

Cotter pin (item 40, Appx G)
 Cotter pin (item 42, Appx G)
 Cotter pin (item 46, Appx G)
 Snap pins (2) (item 184, App G)

Materials/Parts

Bushing (item 116, Appx G)
 Bushing (item 117, Appx G)
 Bushing (item 118, Appx G)

personnel Required
 Three

a. Removal

WARNING

Spade is heavy. At least three personnel are required to assist in lowering and removing spade from hull to avoid serious injury.

- 1 Unlatch and lower spade assembly (1) to ground.
- 2 Remove two snap pins (2) and two spade pins (3). Discard snap pins.
- 3 Remove spade assembly (1).

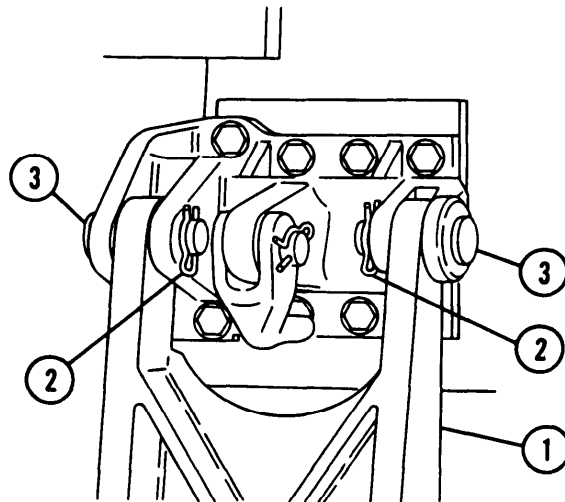

11-15 SPADE — CONTINUED

b. Disassembly/Assembly

For disassembly/assembly, follow illustration and legend as a guide.

LEGEND

4 Cotter pin*	30 Screw
5 Flat washer (2)	31 Spacer
6 Spring	32 Flat washer
7 Pin assembly	33 Screw
8 Pin	34 Clamp
9 Bumper	35 Spacer
10 Flat washer	36 Spring
11 Screw	37 Pedal
12 Latch	38 Flat washer
13 Snap ring	39 Screw
14 Pin	40 Pin
15 Bushing	41 Screw
16 Snap ring	42 Flat washer
17 Spade	43 Latch
18 Bushing*	44 Pin
19 Socket	45 Cotter pin*
20 Bushing*	46 Spring
21 Screw (2)	47 Spacer
22 Spring	48 Screw
23 Screw (2)	49 Latch
24 Plunger	50 Shaft
25 Nut (3)	51 Flat washer
26 Flat washer (2)	52 Cotter pin*
27 Strut	53 Sleeve
28 Flat washer	54 Clamp
29 Cable	55 Boot

* Discard item, install new

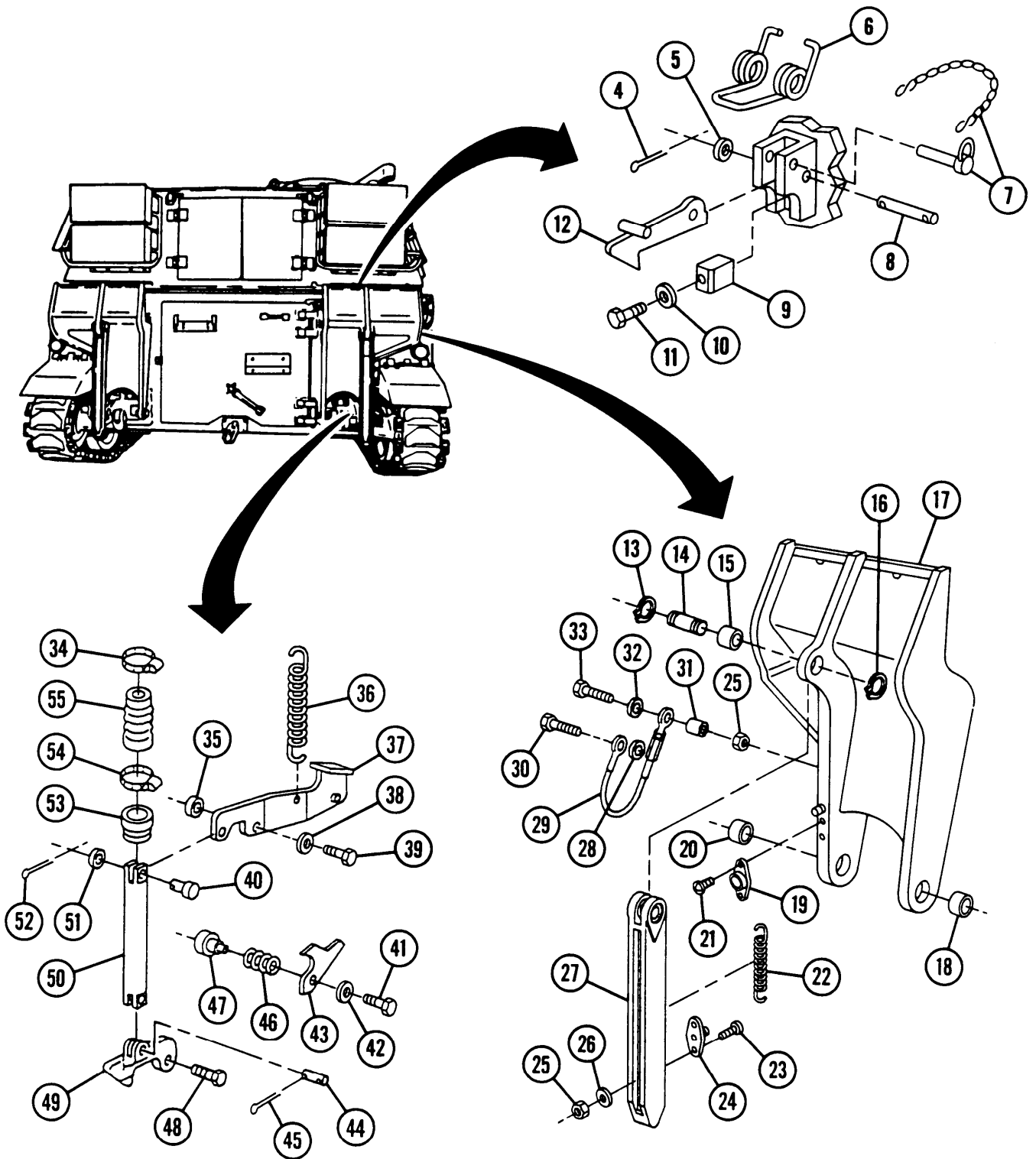

11-15 SPADE — CONTINUED

c. Installation

WARNING

Spade is heavy. At least three personnel are required to assist in raising and installing it to hull to avoid serious injury.

- 1 Position spade assembly (1) with blade resting on ground and with holes alined to allow spade pins (3) to be installed.
- 2 Install two spade pins (3) and two snap rings (2).
- 3 Check adjustment of spade to ensure proper operation (see below). Once adjustment is correct, stow in up position.

d. Adjustment

WARNING

Spade is heavy. At least three personnel are required to assist in raising, lowering, and installing it to hull to avoid serious injury.

- 1 Back up vehicle over log or other object (at least 18 in. [45.7 cm] high) to allow full extension of spade when lowered.
- 2 Lower spade (1).

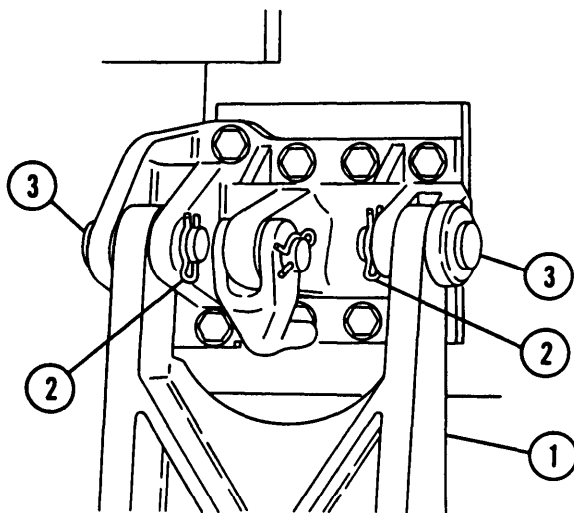

NOTE

When replacing old cable, do not attempt to adjust new cable to length of old cable.

- 3 Check strut (27) position relative to latch socket (56). Strut should be in latch socket. If strut is not in socket, continue adjustment step 4.
- 4 Remove screw (33) and cable (29).
- 5 Loosen nut (57) until strut (27) seats in latch socket (56), then tighten.
- 6 Reconnect cable (29) and install screw (33).

NOTE

Spade adjustment should be verified in firing position as soon as practical.

- 7 Raise and lower spade several times to verify adjustment.

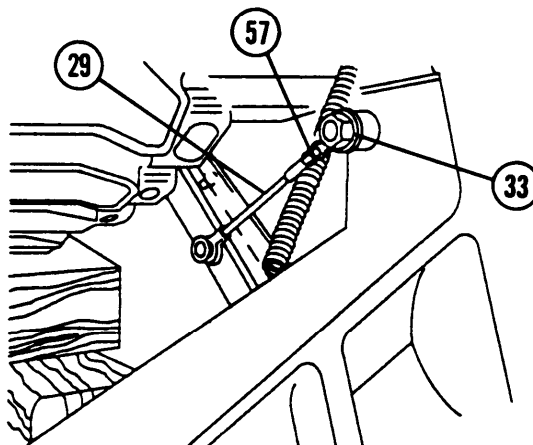
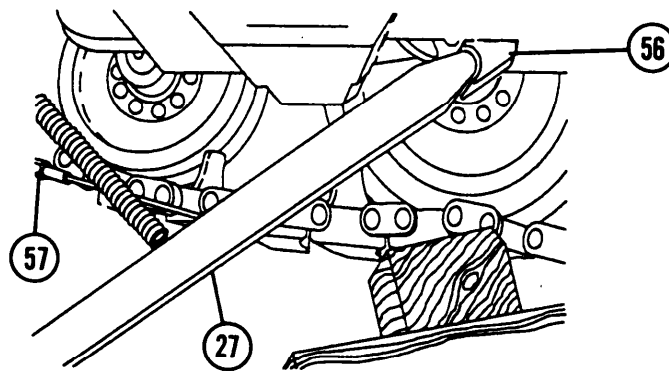

11-16 FENDERS

This task covers: a. Removal b. Installation

INITIAL SETUP

Tools

General mechanic's tool kit (item 64, Appx H)
Snap ring pliers (item 41, Appx H)

Materials/Parts

Cotter pins (2) (item 45, Appx G)

a. Removal

NOTE

Left and right fenders are removed using same procedure.

- 1 Remove three screws (1), front fender (2), and retainer (3).
- 2 Remove two cotter pins (4), straight pin (5), two washers (6), spring (7), and rear fender (8). Discard cotter pins.

b. Installation

NOTE

Left and right fenders are installed using same procedure.

- 1 Install rear fender (8), spring (7), two washers (6), straight pin (5), and two new cotter pins (4).
- 2 Install front fender (2), retainer (3), and three screws (1).

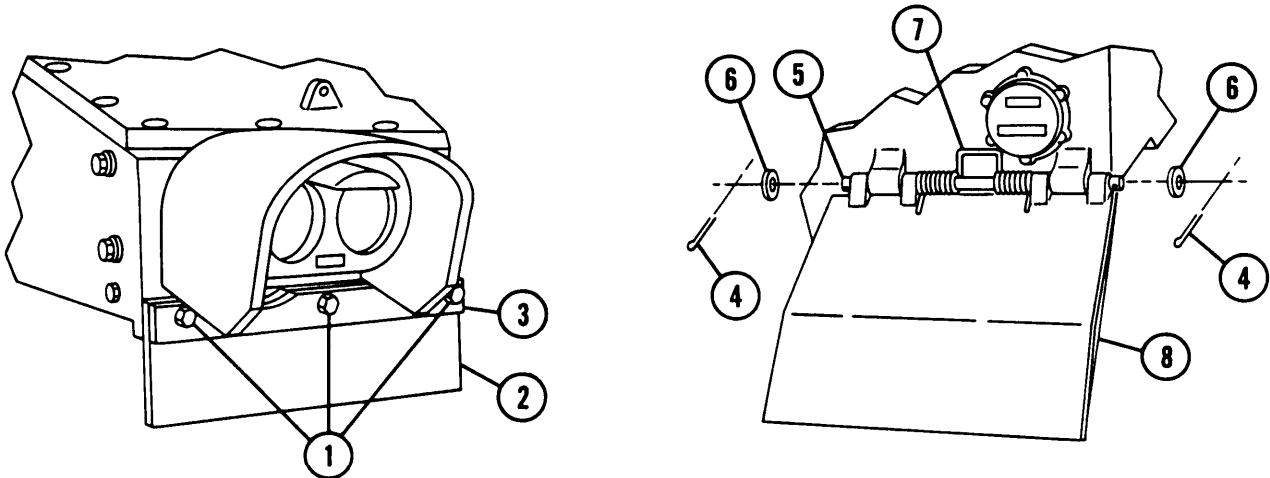

11-17 TOWING PINTLE

This task covers: a. Removal b. Installation

INITIAL SETUP

Tools

General mechanic's tool kit (item 64, Appx H)
Adjustable wrench (item 66, Appx H)

Materials/Parts

Cotter pin (item 35, Appx G)
Lockwashers (4) (item 99, Appx G)

a. Removal

1 Remove four screws (1), four lockwashers (2), and bracket (3). Discard lockwashers.

2 Remove cotter pin (4), castle nut (5), flat washer (6), and pintle (7). Discard cotter pin.

b. Installation

1 Install pintle (7), flat washer (6), castle nut (5), and new cotter pin (4).

2 Install bracket (3), four new lockwashers (2), and four screws (1).

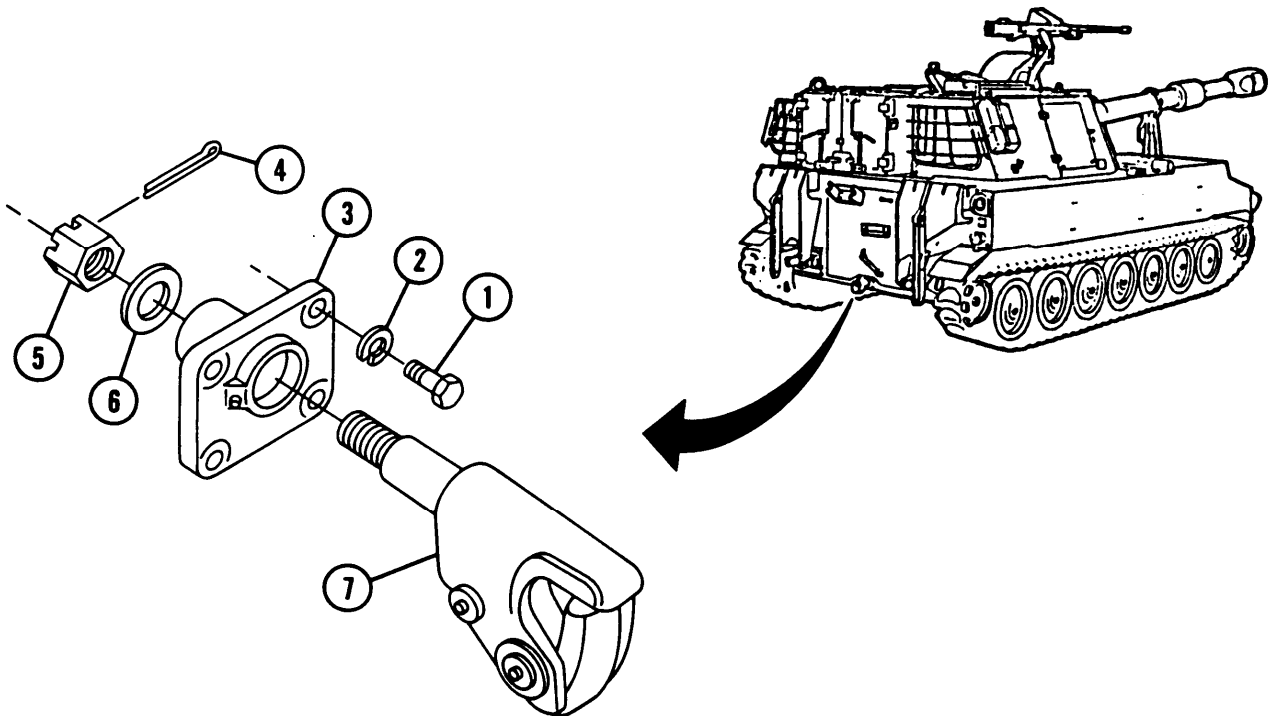

SECTION IV. BILGE PUMP, PERSONNEL HEATER, PERSONNEL AIR VENTILATION SYSTEM, AND FIXED FIRE EXTINGUISHER SYSTEM

11-18 BILGE PUMP

This task covers: a. Removal b. Installation

INITIAL SETUP

Tools

General mechanic's tool kit (item 64, Appx H)

Equipment Conditions

Powerplant removed (para 4-5)

a. Removal

- 1 Disconnect electrical connector (1).
- 2 Remove two clamps (2 and 3) and hose (4).
- 3 Remove three mount screws (5).
- 4 Remove bilge pump (6).

b. Installation

- 1 Install bilge pump (6) and three mount screws (5).
- 2 Install hose (4) and two clamps (2 and 3).
- 3 Connect electrical connector (1).

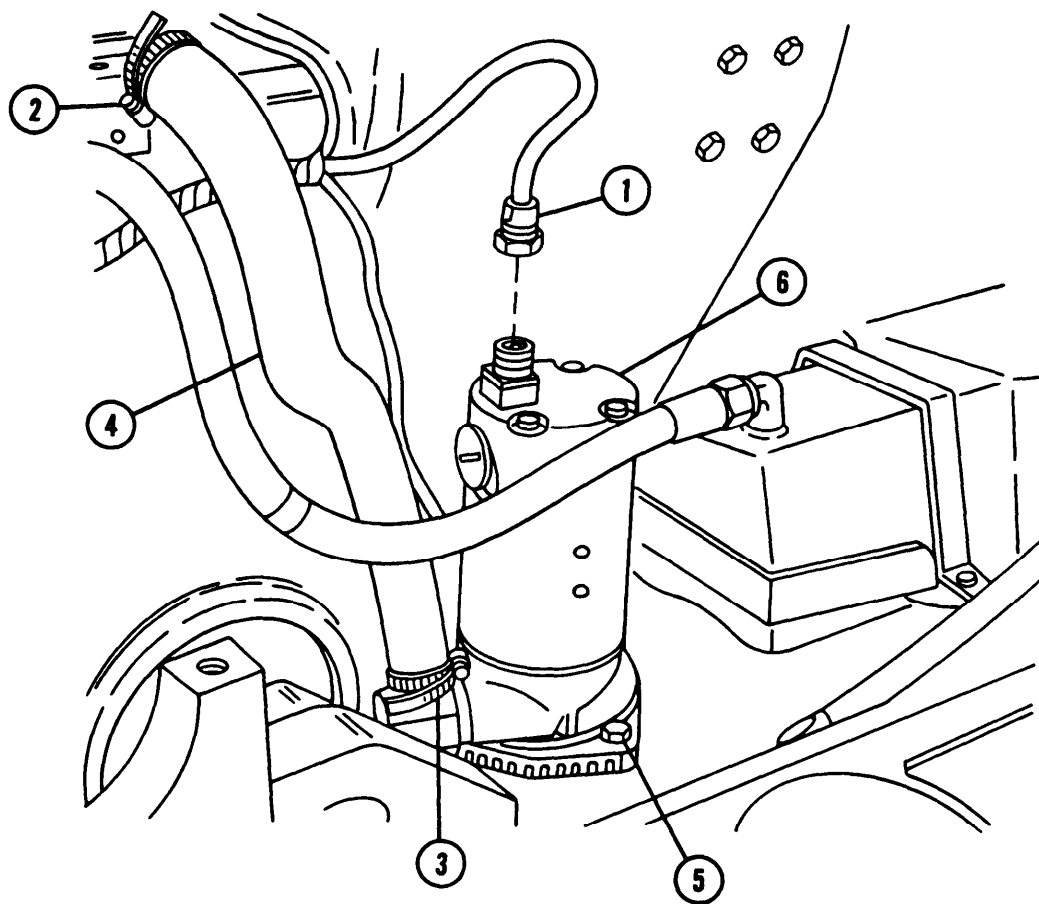

NOTE

FOLLOW-ON MAINTENANCE:

Install powerplant (para 4-5)

11-19 PERSONNEL HEATER SYSTEM DIAGRAM

LEGEND

1	Fuel filter	27	Bracket
2	Flat washer (2)	20	Flat washer
3	Lockwasher (2)	29	Screw
4	screw (2)	30	Outlet duet valve handle
5	Elbow	31	Outlet duct guard
6	Fuel filter-to-heater hose	32	Bracket
7	Resilient mount (2)	33	Spring
8	Bracket angle (4)	34	Outlet duct valve
9	screw (4)	35	Spring pin (2)
10	Bracket (2)	36	Flat washer (2)
11	screw (4)	37	Cotter pin
12	Flat washer (2)	36	Bulkhead-to-coupler hose
13	screw (4)	39	Coupler
14	Flat washer (4)	40	Coupler-to-fuel pump hose
15	Flat washer (4)	41	Elbow
16	Self-locking nut (4)	42	Fuel pump-to-fitter hose
17	Elbow	43	Elbow
18	Nipple	44	Adapter
19	Clamp (2)	45	Fuel pump
20	Personnel heater	46	screw (2)
21	Electrical connector	47	Lockwasher (2)
22	Lockwasher (4)	46	Exhaust tube
23	Screw (4)	49	Decal
24	Clamp (2)	50	Flange
25	Outlet hose	51	Clamp
26	Outlet duct	52	Sleeve

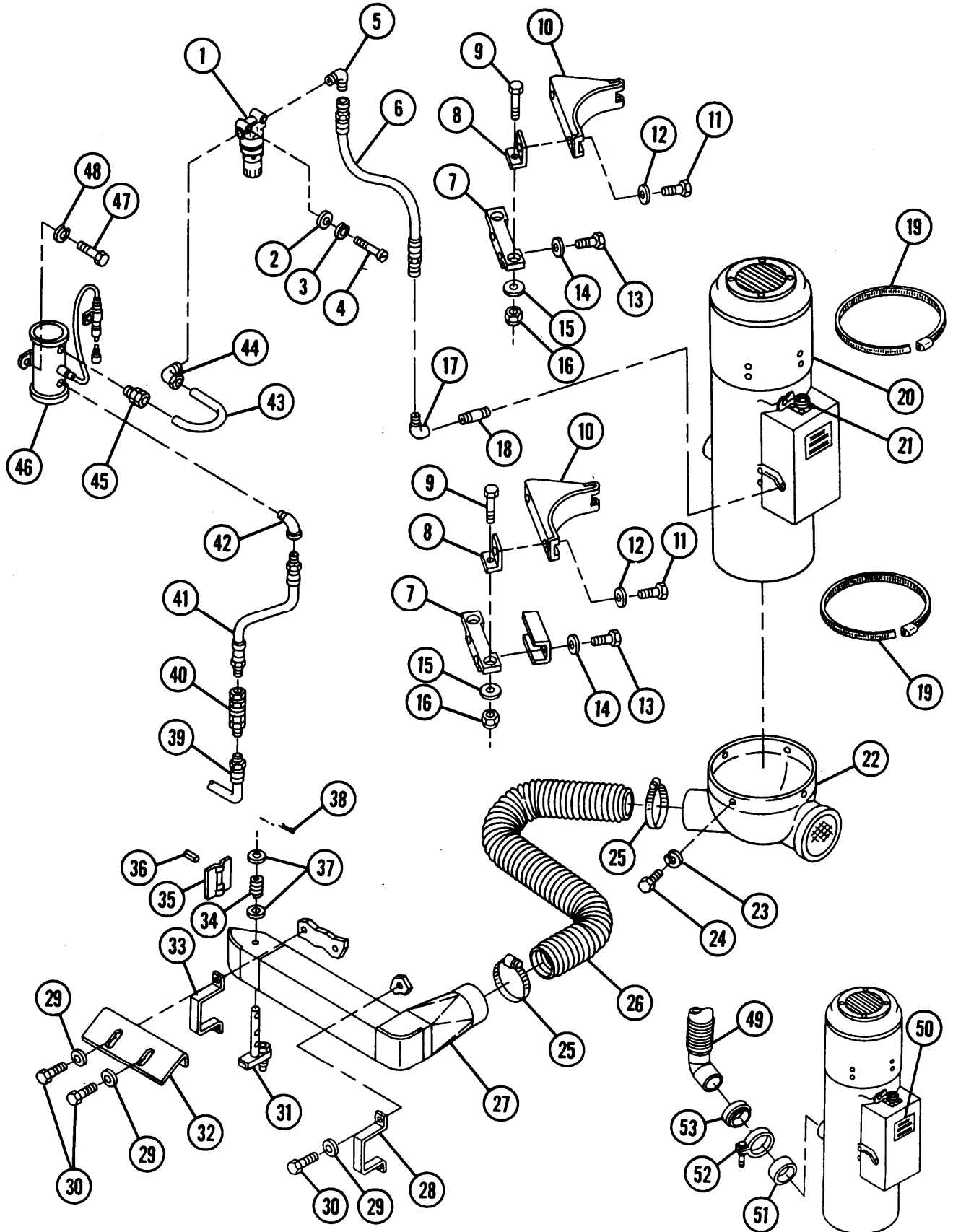

11-20 PERSONNEL HEATER

This task covers: a. Removal b. Installation

INITIAL SETUP

Tools

General mechanic's tool kit (item 64, Appx H)
Torque wrench (item 72, Appx H)

Materials/Parts

Lockwashers (4) (item 86, Appx G)

a. Removal

WARNING

Do not smoke or use open flame inside of or within 50 ft (15.24 m) of vehicle during personnel heater removal, installation, or repair. Heater may retain fuel which, if spilled, could explode and cause serious injury or death.

- 1 Disconnect electrical connector (1).
- 2 Unscrew nut (2) and unscrew and remove fuel line (3).
- 3 Loosen clamp (4) and remove outlet hose (5).
- 4 Remove clamp (6), sleeve (7), and flange (8) from exhaust tube (9).
- 5 Remove two clamps (10).

NOTE

For M109A3 personnel heaters, a clamp at rear of heater also may have to be removed in order to remove heater.

- 6 Remove four screws (11), four lockwashers (12), personnel heater (13), and lower duct (14). Discard lockwashers.

b. Installation

WARNING

Do not smoke or use open flame inside of or within 50 ft (15.24 m) of vehicle during personnel heater removal, installation, or repair. Heater may retain fuel which, if spilled, could explode and cause serious injury or death.

NOTE

For M109A3 personnel heaters, a clamp at rear of heater also may have to be installed in order to install heater.

- 1 Install lower duct (14), personnel heater (13), four new lockwashers (12), and four screws (11).
- 2 Install two clamps (10).
- 3 Install flange (8), clamp (6), and sleeve (7) to connect exhaust tube (9).
- 4 Install outlet hose (5) and tighten clamp (4). Torque screw to 90-95 ib-in. (10.2-10.7 N-m).
- 5 Connect fuel line (3) and install nut (2).
- 6 Connect electrical connector (1).

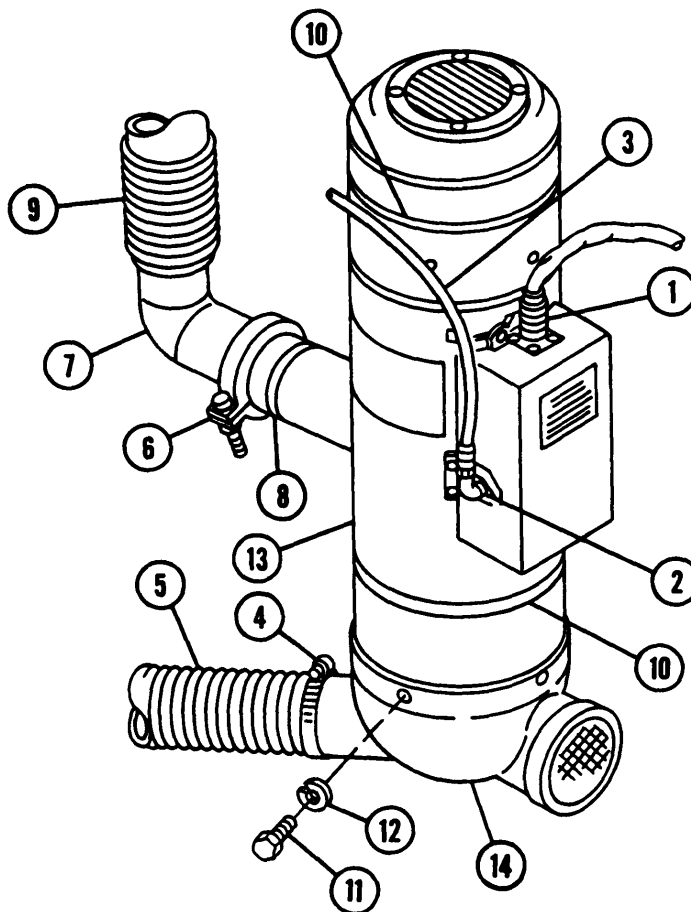

11-21 PERSONNEL HEATER FUEL FILTER AND TUBES

This task covers: a. Removal b. Disassembly
 c. Assembly d. Installation

INITIAL SETUP

Tools

General mechanic's tool kit (item 64 Appx H)

Materials/Parts

Filter element (item 115, Appx G)
Lockwashers (2) (item 86, Appx G)
Lockwires (2) (item 227, Appx G)
Preformed packing (item 199, Appx G)

a. Removal

WARNING

Close fuel shutoff valve to avoid fuel spill.

- 1 Disconnect fuel inlet tube (1) and fuel pump-to-filter hose (2) at fuel filter (3).
- 2 Remove two screws (4), two lockwashers (5), and two fiat washers (6).
- 3 Remove fuel filter (3).

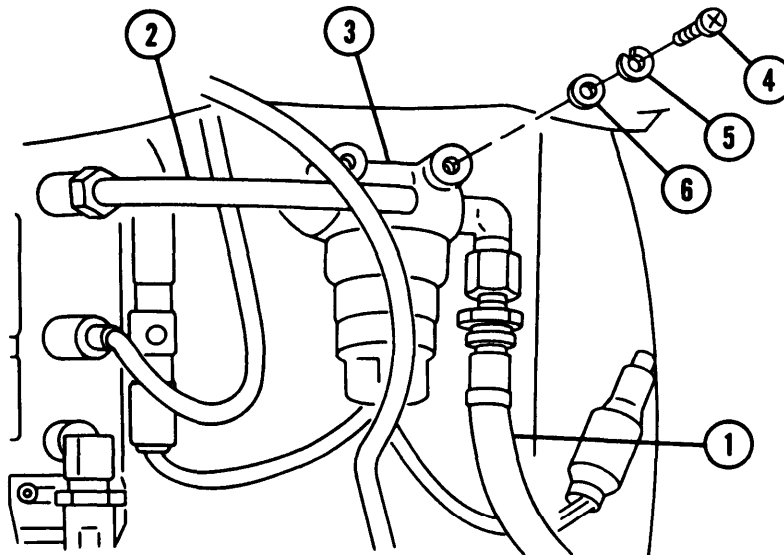

b. Disassembly

- 1 Remove two lockwires (7). Discard lockwires.
- 2 Unscrew filter head (8) from filter bowl (9).
- 3 Remove preformed packing (10) and filter element assembly (11). Discard preformed packing and filter element assembly.

c. Assembly

- 1 Install new filter element assembly (11) and new preformed packing (10).
- 2 Screw filter head (8) to filter bowl (9).
- 3 Install two new lockwires (7).

d. Installation

- 1 Install fuel filter (3).
- 2 Install two flat washers (6), two new lockwashers (5), and two screws (4).
- 3 Connect fuel pump-to-filter hose (2) and fuel inlet tube (1) at fuel filter (3).

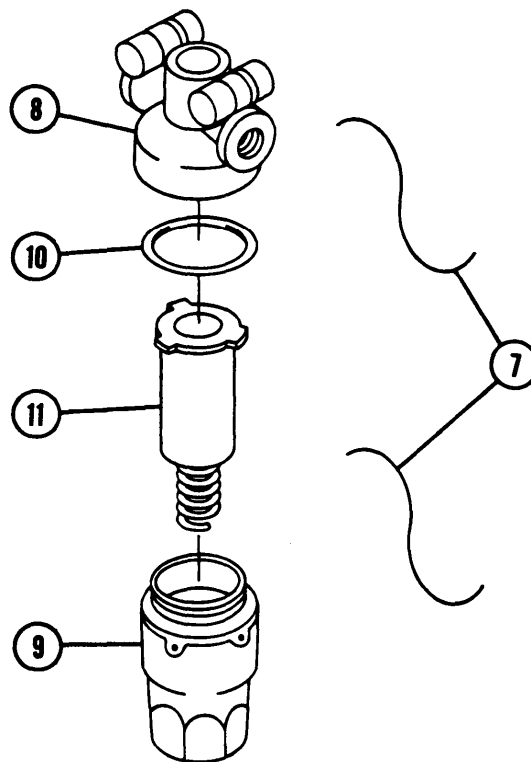

11-22 PERSONNEL HEATER EXHAUST TUBE

This task covers: a. Removal b. Installation

INITIAL SETUP

Tools

General mechanic's tool kit (item 64, Appx H)
Torque wrench (item 72, Appx H)

Lockwashers (5) (item 95, Appx G)
Spring washer (item 148, Appx G)

Materials/Parts

Antiseize compound (item 9, Appx D)
Gasket (item 147, Appx G)

Equipment Conditions

Air intake grille open (para 11-8)
Radiator fan access door removed (para 4-5)

a. Removal

- 1 Remove two screws (1), two flat washers (2), and deflector (3).
- 2 Remove gasket (4) and spring washer (5). Discard gasket and spring washer.
- 3 Loosen and slide two clamps (6) onto crossover tube (7).
- 4 Remove two screws (8), two lockwashers (9), exhaust tube (10), crossover tube (7), and two clamps (6). Discard lockwashers.
- 5 Remove three nuts (11) and three lockwashers (12) at bulkhead. Discard lockwashers.
- 6 Loosen clamp (13) and separate personnel heater exhaust tube (14) from personnel heater (15). Remove clamp, sleeve (16), and flange (17).

b. Installation

- 1 Install exhaust tube (10), two new lockwashers (9), and two screws (8).
- 2 Apply antiseize compound to two screws (1) and install new spring washer (5), new gasket (4), deflector (3), two flat washers (2), and two screws.
- 3 Install personnel heater exhaust tube (14) at bulkhead with three new lockwashers (12) and three nuts (11).
- 4 Install flange (17) and sleeve (16) onto personnel heater (15) outlet. Be sure to install sleeve 0.50 in. (12.7 mm) onto personnel heater outlet as shown in illustration.
- 5 Install clamp (13) over flange (17), sleeve (16), and personnel heater exhaust tube (14). Torque screw (18) on clamp to 45-55 lb-in. (5.1-6.2 N-m).
- 6 Slide two clamps (6) onto crossover tube (7) and install tube at bulkhead and exhaust tube (10). Tighten clamps.

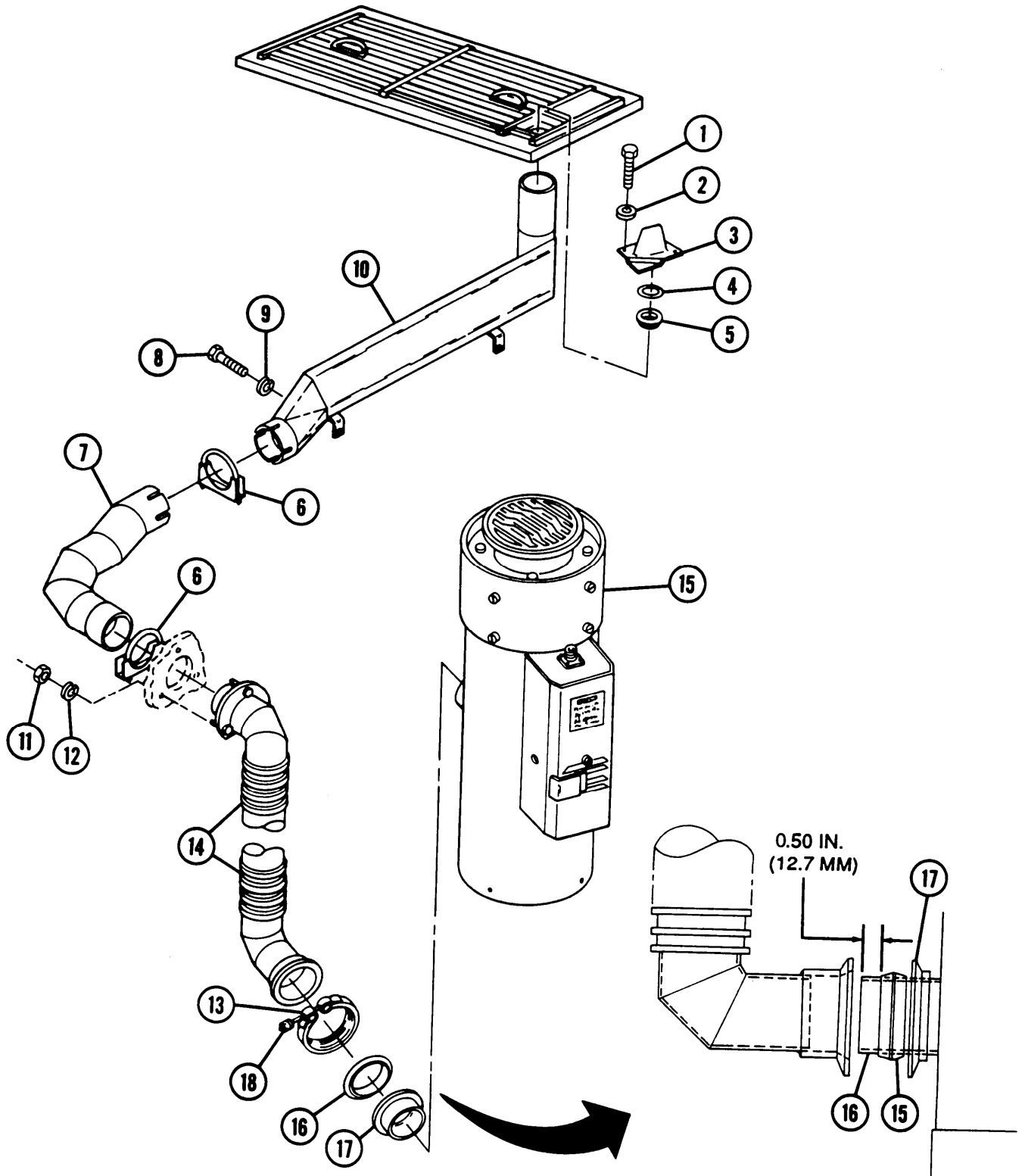

NOTE

FOLLOW-ON MAINTENANCE:

- Install radiator fan access door (para 4-5)
- Close air intake grille (para 11-8)

11-23 PERSONNEL HEATER FUEL PUMP

This task covers: a. Removal b. Installation

INITIAL SETUP

Tools

General mechanic's tool kit (item 64, Appx H)

Materials/Parts

LockWashers (2) (item 95, Appx G)

a. Removal

- 1 Disconnect fuel input hose (1) and fuel pump-to-fuel filter hose (2) at fuel pump (3).
- 2 Disconnect electrical connector (4).
- 3 Remove two screws (5) and two lockwashers (6). Discard lockwashers.
- 4 Remove fuel pump (3).

b. Installation

- 1 Install fuel pump (3).
- 2 Install two new lockwashers (6) and two screws (5).
- 3 Connect electrical connector (4).
- 4 Connect fuel input hose (1) and fuel pump-to-fuel filter hose (2) at fuel pump (3).

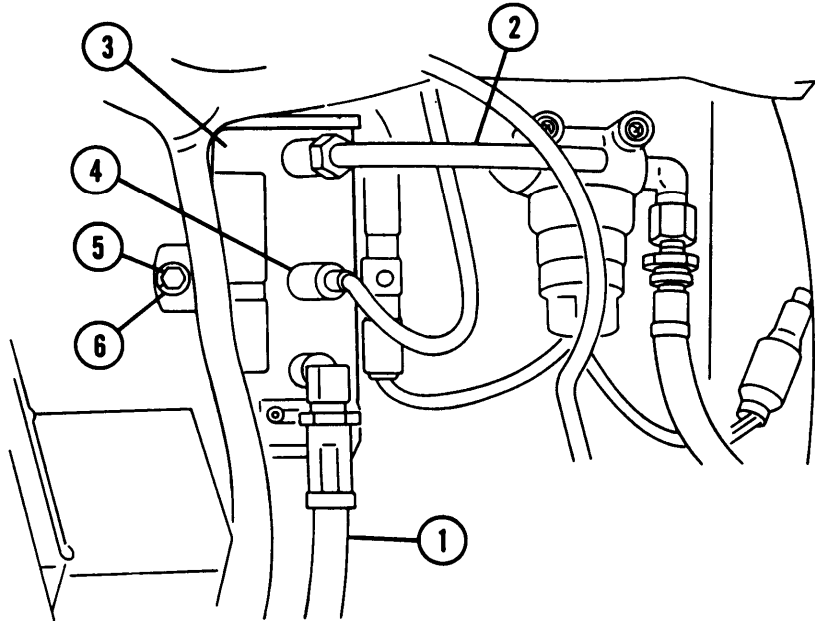

11-24 PERSONNEL AIR VENTILATION SYSTEM

This task covers a. Removal b. Installation

INITIAL SETUP

Tools

General mechanic's tool kit (item 84, Appx H)

Materials/Parts

Dry-cleaning solvent (item 22, Appx D)

a. Removal

WARNING

Ensure MASTER switch is OFF when working on hull electrical system to avoid electrical shocks and burns.

- 1 Disconnect electrical connector at electrical connector receptacle (1).
- 2 Remove clamp (2) and elbow (3).
- 3 Remove three screws (4), six flat washers (5), and three plates (6).
- 4 Remove fan assembly (7) and screen (8).

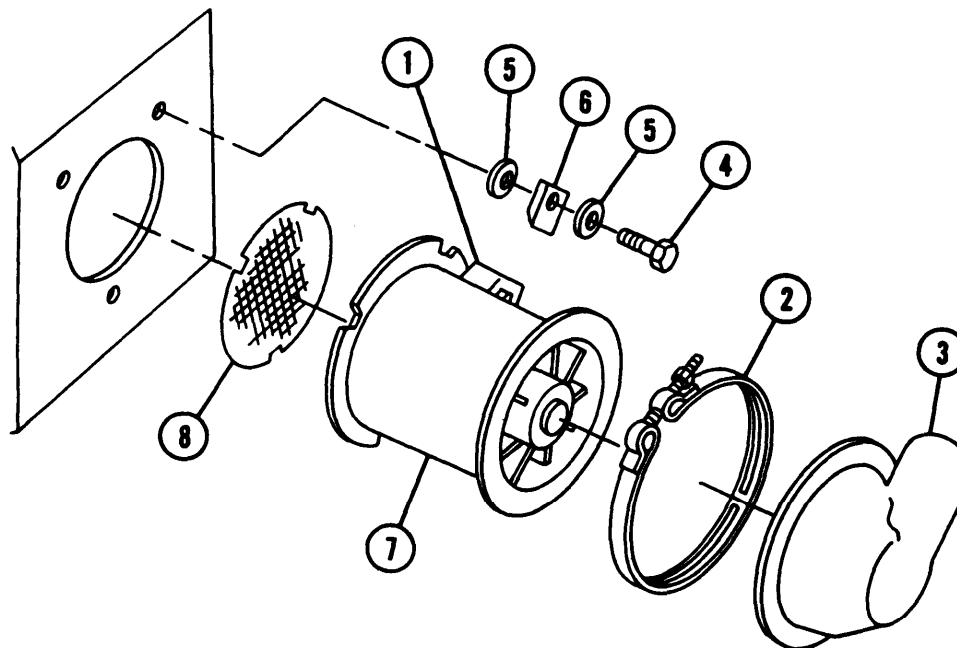

11-24 PERSONNEL AIR VENTILATION SYSTEM — CONTINUED

a. Removal — Continued

WARNING

Dry-cleaning solvent (P-D-680) is toxic and flammable. Wear protective goggles and gloves and use only in a well-ventilated area. Avoid contact with skin, eyes, and clothes, and don't breathe vapors. Do not use near open flame or excessive heat. The flashpoint for type #1 is 100°F (38°C), and for type #2 is 138°F (59°C). If you become dizzy while using dry-cleaning solvent, get fresh air immediately and get medical aid. If contact with eyes is made, wash your eyes with water and get medical aid immediately.

5 Clean screen (8) with dry-cleaning solvent or water and nonsudsing detergent.

b. installation

1 Install screen (8) and fan assembly (7).

2 Install three plates (6), six flat washers (5), and three screws (4).

3 Install elbow (3) and clamp (2).

4 Connect electrical connector at electrical connector receptacle (1).

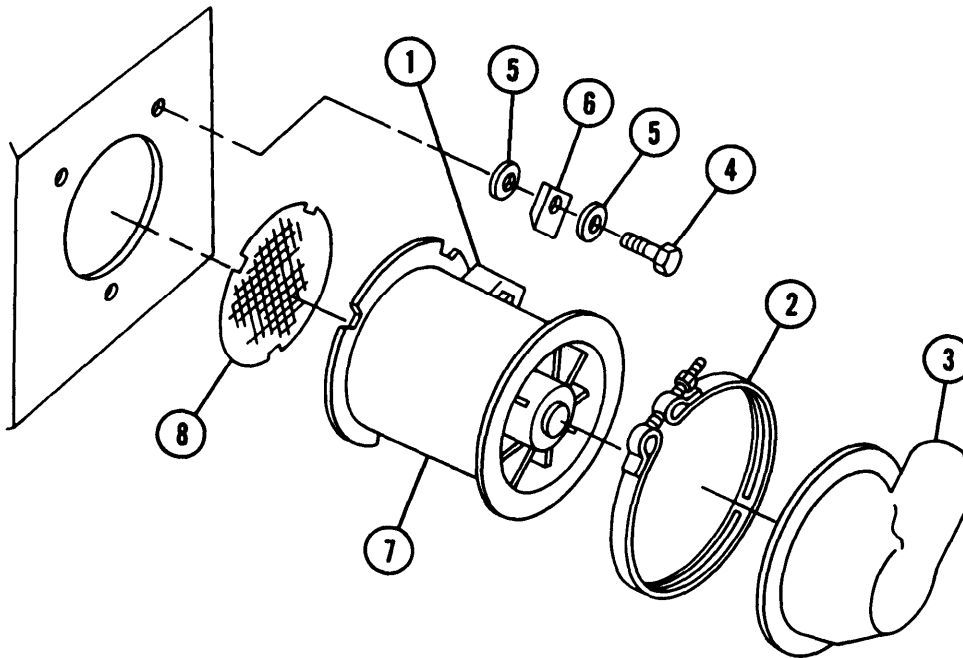

11-25 FIXED FIRE EXTINGUISHER SYSTEM — CONTINUED

b. Disassembly/Assembly

For disassembly/assembly of late model M109A3 and M109A2/M109A4N109A5 fixed fire extinguisher systems, follow illustration and legend as a guide.

LEGEND

5 Screw (2)	30 Tube
6 Flat washer (3)	31 Pad (2)**
7 Strap	32 Nut
8 Pull mechanism	33 Sleeve
9 Clamp	34 Connector
10 Pull mechanism	35 LockWasher (2)*
11 clip (2)	36 Screw (2)
12 Flat washer (2)	37 Flat washer (2)
13 Screw (2)	38 Bracket
14 Flexible conduit	39 Flat washer
15 Conduit connectors	40 LockWasher*
16 Washer (2)	41 Screw
17 Gasket (2)*	42 Nozzle
18 Washer (2)	43 Nozzle
19 Conduit nut (2)	44 Nipple
20 Pull handle assembly (2)	45 Elbow
21 Antipilferage seal (2)*	46 Elbow
22 Elbow	47 Hose assembly
23 Head	48 Retaining strap catch (2)
24 Hose assembly	49 Antipilferage seal (disassembly only)*
25 Elbow	50 Pulley
26 Nut	51 Tube assembly
27 Sleeve	52 Connector
28 Connector	53 Valve control
29 Retaining strap (2)	54 Cable assembly

*|Discard item, install new

**Replace if worn

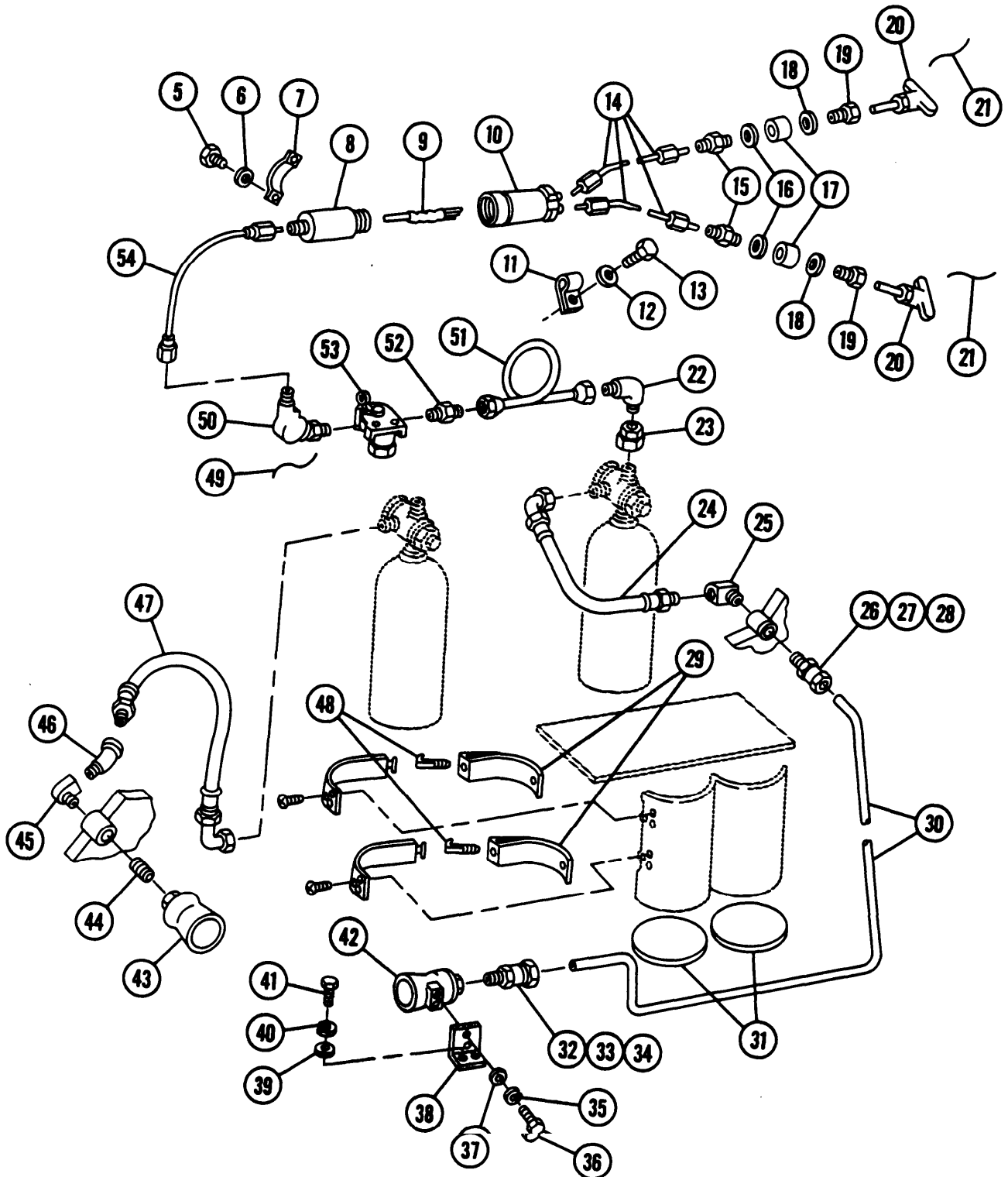

M109A2/M109A4/M109A5 AND LATE MODEL M109A3 FIXED FIRE EXTINGUISHER SYSTEM

11-25 FIXED FIRE EXTINGUISHER SYSTEM — CONTINUED

b. Disassembly/Assembly — Continued

For disassembly/assembly of early model M109A3 fixed fire extinguisher systems, follow illustration and legend as a guide.

LEGEND

55 Pulley mounting nut	93 Lockwasher (2)*
56 Pulley mounting screw (4)	94 Flat washer
57 Lockwasher (4)*	95 Nozzle bracket
58 90° pulley	96 Connector
59 Flexible conduit	97 Nozzle
60 Flexible conduit	98 Cylinder support (2)
61 Flexible conduit	99 Bracket screw (2)
62 Conduit connector (2)	100 Lockwasher (2)*
63 Washer (2)	101 Flat washer (2)
64 Gasket (2)*	102 Nozzle screw (2)
65 Washer (2)	103 Lockwasher (2)
66 Conduit nut (2)	104 Flat washer (2)
67 Pull handle assembly (2)	105 Nozzle bracket
68 Antipilferage seal (2)*	106 Elbow assembly
69 Pull mechanism	107 Nozzle
70 Conduit clamp	108 Nozzle adapter
71 Connector	109 Nipple
72 Tube assembly	110 Tube sleeve
73 Elbow	111 Tube nut
74 Head	112 Tube
75 Elbow assembly	113 Elbow
76 Tube sleeve	114 Tube sleeve
77 Tube nut	115 Tube nut
78 Elbow	116 Control valve
79 Tube nut	117 Angle pulley
80 Tube sleeve	118 Pulley mounting nut
81 Elbow	119 Pull mechanism
82 Adapter	120 Support mounting nut (2)
83 Tube sleeve	121 Pull mechanism support
84 Tube nut	122 flat washer
85 Tube	123 Support screw (2)
86 Support lockpin (2)	124 Pull mechanism clamp (2)
87 Tube sleeve	125 Clamp screw (5)
88 Tube nut	126 Flat washer (5)
89 Bracket screw (2)	127 Conduit clamp
90 Lockwasher (2)*	128 Flat washer (2)
91 Flat washer	129 Support screw (2)
92 Nozzle screw (2)	

* Discard item, install new

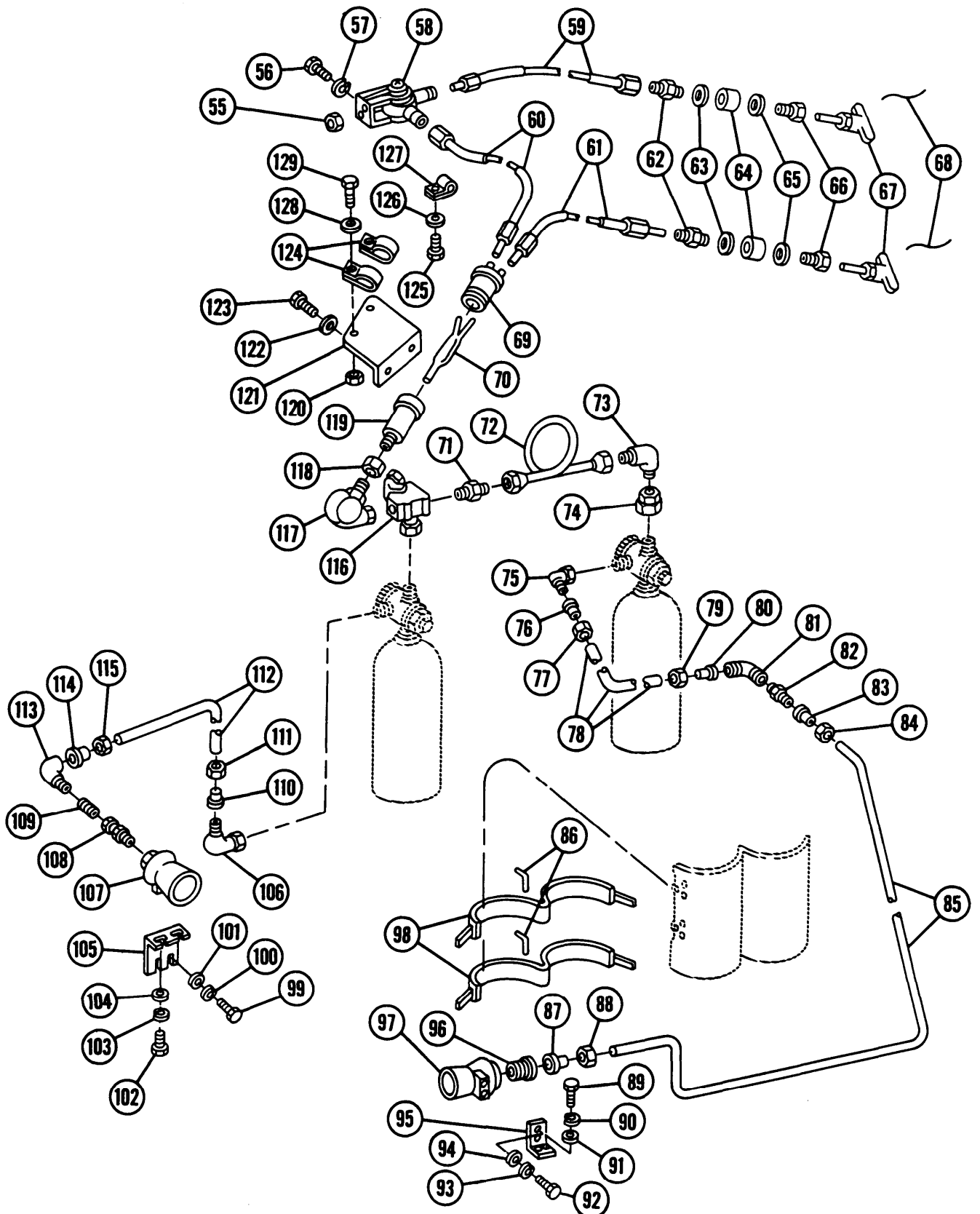

EARLY MODEL M109A3 FIXED FIRE EXTINGUISHER SYSTEM

11-25 FIXED FIRE EXTINGUISHER SYSTEM — CONTINUED

c. Installation

WARNING

Carbon dioxide cylinders must not be dropped, struck, or subjected to temperatures above 140°F (60°C).

- 1 Install two carbon dioxide cylinders (4).
- 2 Close two clamps (3).
- 3 Connect two head connectors (2).
- 4 Connect two hose connectors (1).

d. Safety Wiring

- 1 Align arrow on camshaft (130) with set arrow (131) on control plate (132) for safety wiring of control valves.
- 2 Start antipilferage seal (49) at hole in mounting screw (133).

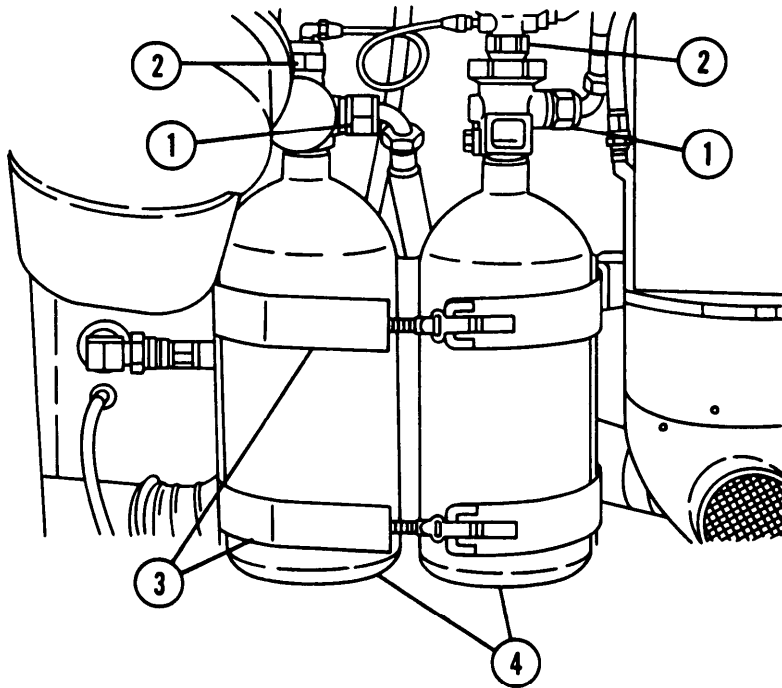

3 With antipilferage seal (49) go to hole in camshaft (130) and then to hole in lead seal (134).

NOTE

If lockpin is not equipped with safety clamp, follow steps 6 and 7.

4 Draw antipilferage seal (49) tight.

5 Crimp lead seal (134) securely on both ends at antipilferage seal (49).

6 Feed antipilferage seal (49) through lockpin (135).

7 Repeat steps 4 and 5.

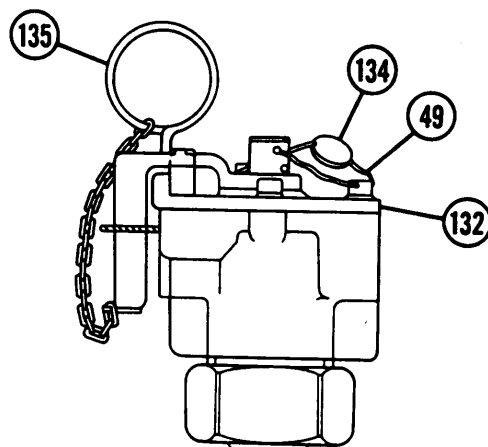
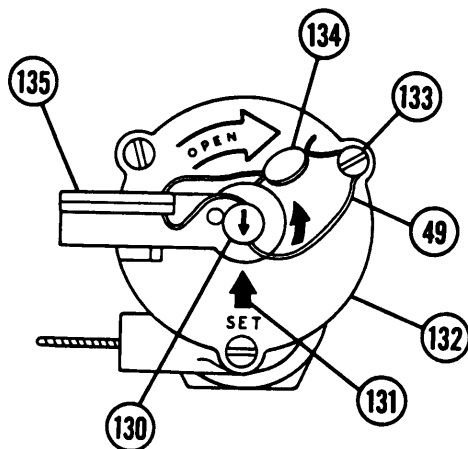

CHAPTER 12 NUCLEAR, BIOLOGICAL, AND CHEMICAL (NBC) PROTECTION EQUIPMENT

GENERAL

This chapter provides instructions for testing, removal, disassembly, inspection, assembly, and installation of the M109A4/M109A5 Ventilated Face Piece System (VFPS).

<u>CONTENTS</u>		<u>PAGE</u>
12-1	AIR PURIFIER	12-2
12-2	AIR PURIFIER BRACKET	12-8
12-3	HEATERS	12-9
12-4	HEATER LAMPS	12-12
12-5	HOSES AND FITTINGS	12-14
12-6	AIR OUTLET ORIFICE CONNECTORS	12-16



12-1 AIR PURIFIER

This task covers:

a. Testing	b. Removal
c. Disassembly	d. Assembly
e. Installation	

INITIAL SETUP

Applicable Configurations

M109A4/M109A5

Tools

General mechanic's tool kit (item 64, APPX H)
Airflow tester (item 62, APPX H)

Materials/Parts

Lockwashers (4) (item 85, APPX G)
Lockwasher (item 95, Appx G)

References

TM 3-6660-316-10
TM 10-277
FM 3-5

NOTE

For additional information, refer to TM 3-6660-316-10. For information on NBC decontamination refer to FM 3-5.

a. Testing

- 1 Remove spring clip (1) from air purifier (2).
- 2 Disconnect hose (3) from air purifier manifold (4). Cover opening with solid airflow cap (5).
- 3 Cover two purifier openings with airflow caps (5) having small holes.
- 4 Disconnect hose (6) at driver's heater.
- 5 Remove calibrated orifice from tester case.
- 6 Position magnehelic gage where it can be easily read, and zero gage using adjustment screw.
- 7 Attach hose (6) to calibrated orifice.
- 8 Turn on MASTER power switch.
- 9 Turn on NBC power switch.
- 10 Read gage. If airflow is from 2.0 to 4.7 in. H₂O (0.50 to 1.17 kPa), it is acceptable. Proceed to step 12. If airflow is not acceptable, proceed to step 11.
- 11 Adjust airflow by inserting screwdriver through left center slot (7) and into adjuster. Turn adjuster counterclockwise to increase and clockwise to decrease airflow.

- 13 Turn off MASTER power switch.
- 14 Remove calibrated orifice from hose (6) and return to tester case.
- 15 Connect hose (6) to driver's heater.
- 16 Remove airflow cap (5) and connect hose (3) to air purifier manifold (4).
- 17 Remove two airflow caps (5) having holes and install two solid airflow caps on remaining two manifold (4) openings.
- 18 Install spring clip (1).

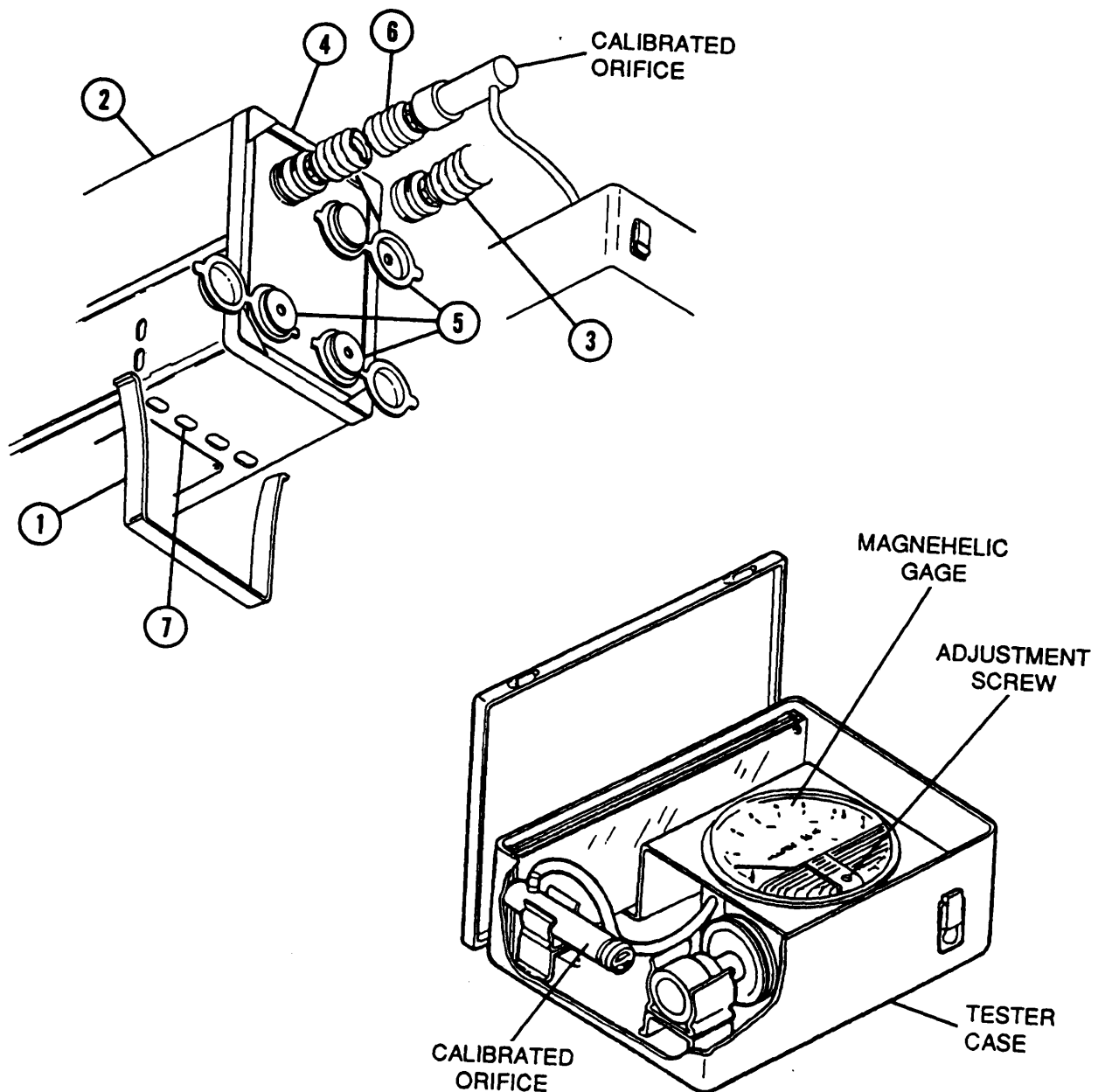

12-1 AIR PURIFIER — CONTINUED

b. Removal

- 1 Disconnect two hoses (3 and 6) from air purifier manifold (4).
- 2 Disconnect electrical connector (8).
- 3 Remove two screws (9 and 10), two lockwashers (11 and 12), and ground lead (13) from air purifier (2) and dome light (14). Install lockwashers and screws.
- 4 Release strap (15) on air purifier bracket (16).
- 5 Remove air purifier (2) from bracket (16).

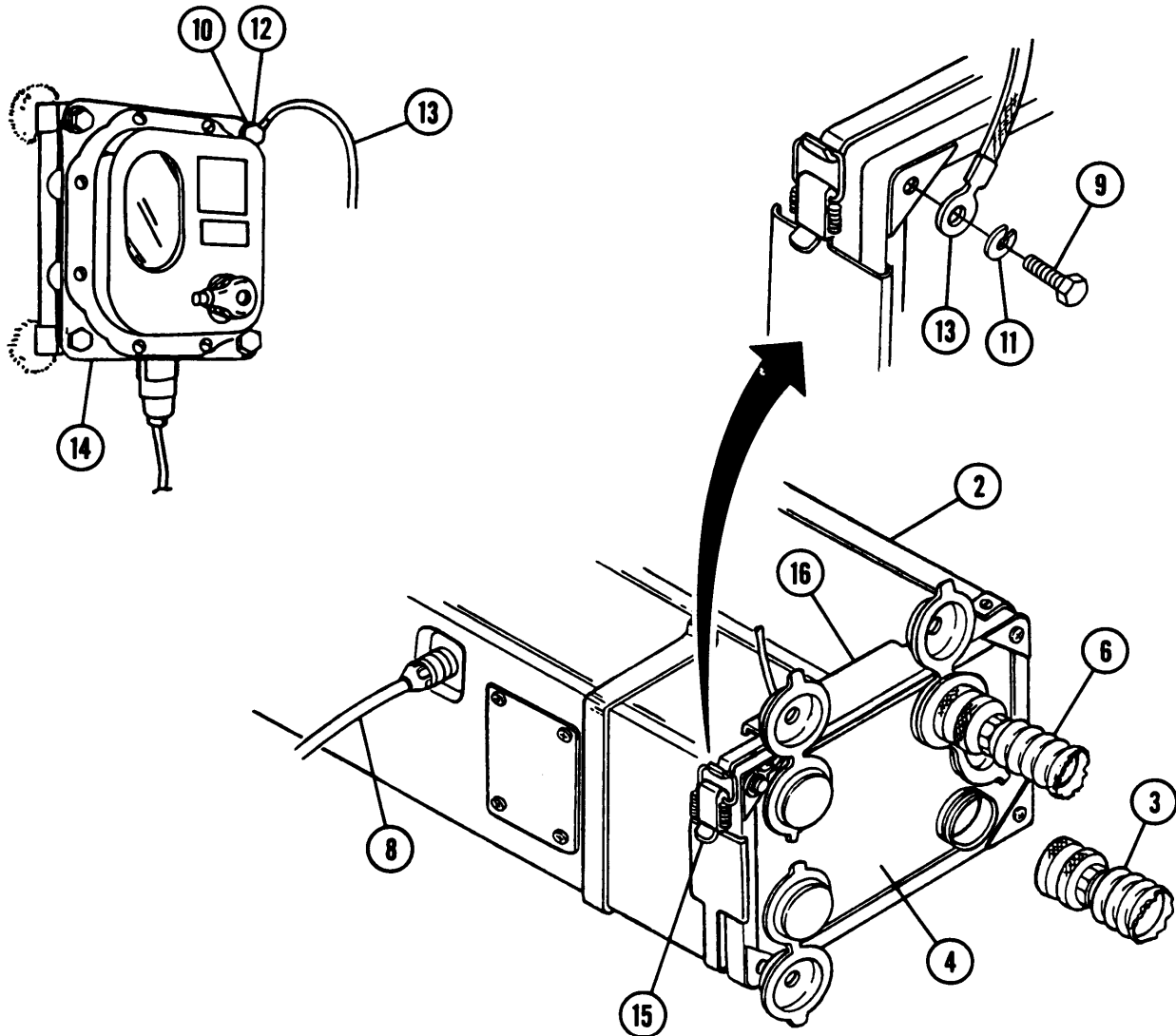

c. Disassembly**WARNING**

To prevent possible chemical or biological agent casualties, contaminated gas and particulate filters must be removed and disposed of only by adequately trained personnel. The unit commander or senior officer in charge of maintenance personnel assigned to remove and dispose of contaminated gas filters must prescribe necessary protective clothing (TM 10-277) to be worn during this operation. The officer must also prescribe necessary safety measures, including decontamination, that must be performed before new gas filters are installed in housing assembly (FM 3-5).

NOTE

If any part of air purifier is damaged, replace immediately.

- 1 Remove four airflow caps (5) from air purifier manifold (4).
- 2 Remove four screws (9), four lockwashers (11), and air purifier manifold (4) from housing (17). Discard lockwashers.

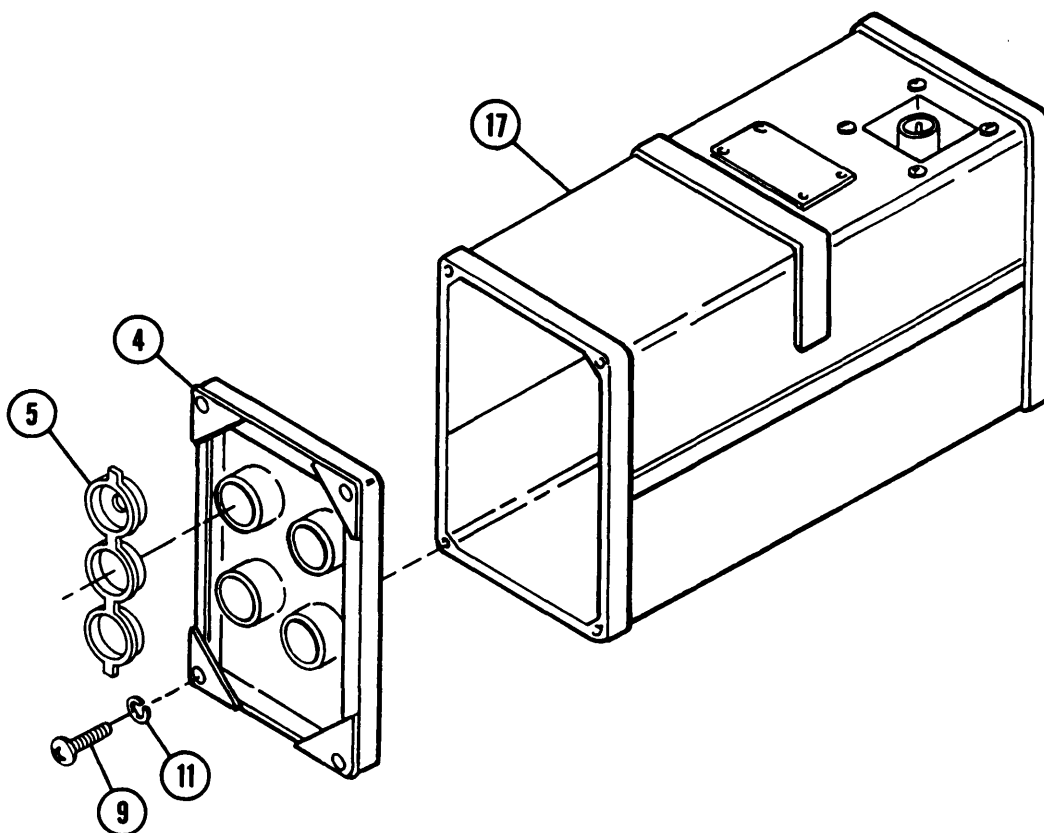

12-1 AIR PURIFIER — CONTINUED

c. Disassembly — Continued

CAUTION

Do not allow moisture to come into contact with filter material.

NOTE

If filters are to be reused, mark arrow on side showing direction of airflow.

3 Tilt housing (17) and remove gas filter (18) and particulate filter (19).

4 Remove spring clip (20).

d. Assembly

NOTE

Ensure filter rests against bulkhead inside housing.

1 Install spring clip (20).

2 Install particulate filter (19) in housing (17) so air will flow through it in direction marked on housing.

NOTE

Ensure felt gasket side of gas filter is toward manifold assembly end of purifier.

3 Install gas filter (18) in housing (17) so it rests on gasket of particulate filter (19) surface.

4 Install air purifier manifold (4), four new lockwashers (11), and four screws (9).

5 Install four airflow caps (5).

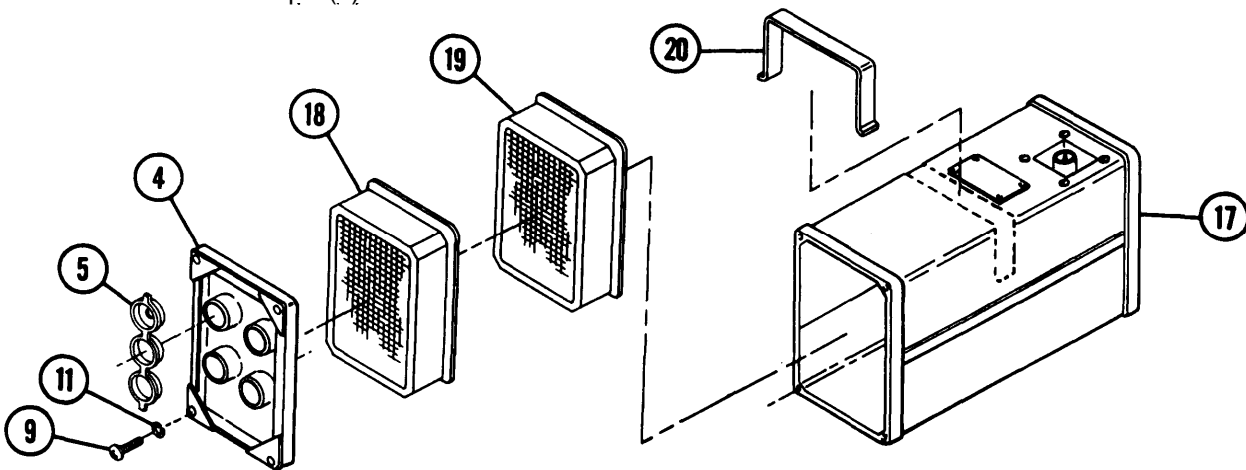

e. Installation

- 1 Install air purifier (2) in air purifier bracket (16) and secure with strap (15).
- 2 Remove two screws (9 and 10) and two lockwashers (11 and 12) from air purifier (2) and dome light (14). Discard lockwasher (12).
- 3 Install ground lead (13), lockwasher (11), screw (9), new lockwasher (12), and screw (10).
- 4 Connect electrical connector (8).
- 5 Connect two hoses (3 and 6).

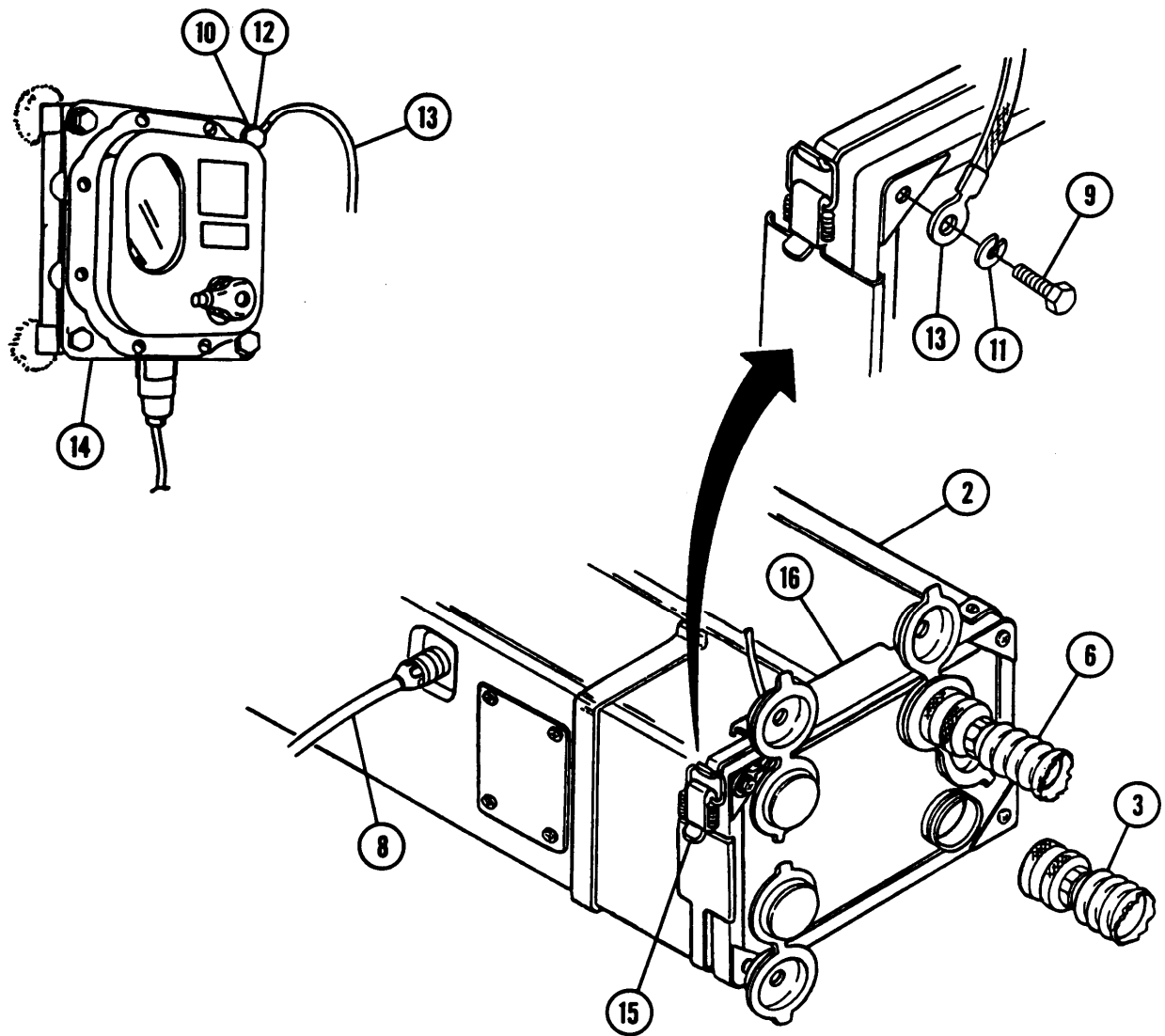

12-2 AIR PURIFIER BRACKET

This task covers: a. Removal b. Installation

INITIAL SETUP

Applicable Configurations
M109A4/M109A5

Materials/Parts
Lockwashers (4) (item 192, Appx G)

Tools
General mechanic's tool kit (item 64, Appx H)

Equipment Conditions
Air purifier removed (para 12-1)

a. Removal

Remove four screws (1), four lockwashers (2), and air purifier bracket (3). Discard lockwashers.

b. Installation

Install air purifier bracket (3), four new lockwashers (2), and four screws (1).

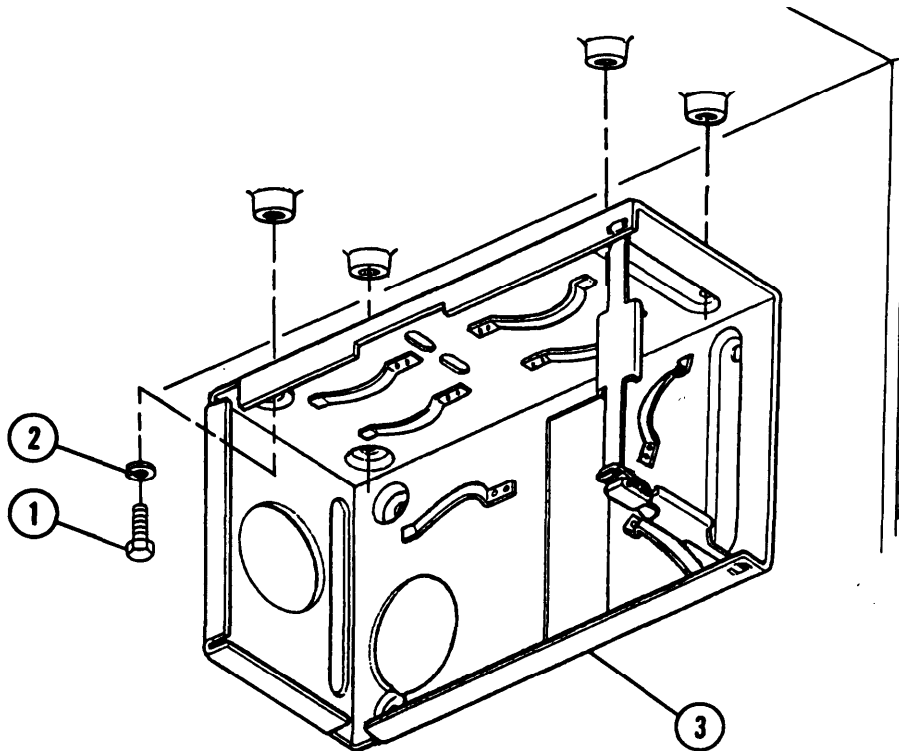

NOTE

FOLLOW-ON MAINTENANCE: Install air purifier (para 12-1)

12-3 HEATERS — CONTINUED

a. Removal — Continued

NOTE

Heater (2) at driver's station has two adapters. Heater(4) at cannoneer no. 2's station has one elbow and one adapter.

- 4 Remove two adapters (7) or adapter (8) and elbow (9) as required.
- 5 Remove four screws (10), four lockwashers (11), and four external-tooth lockwashers (12). Discard lockwashers and external-tooth lockwashers.
- 6 Remove heater (2 or 4).

NOTE

Step 7 applies to heater (4) at cannoneer no. 2's station.

- 7 Remove two screws (13), two lockwashers (14), and bracket (15). Discard external-tooth lockwashers.

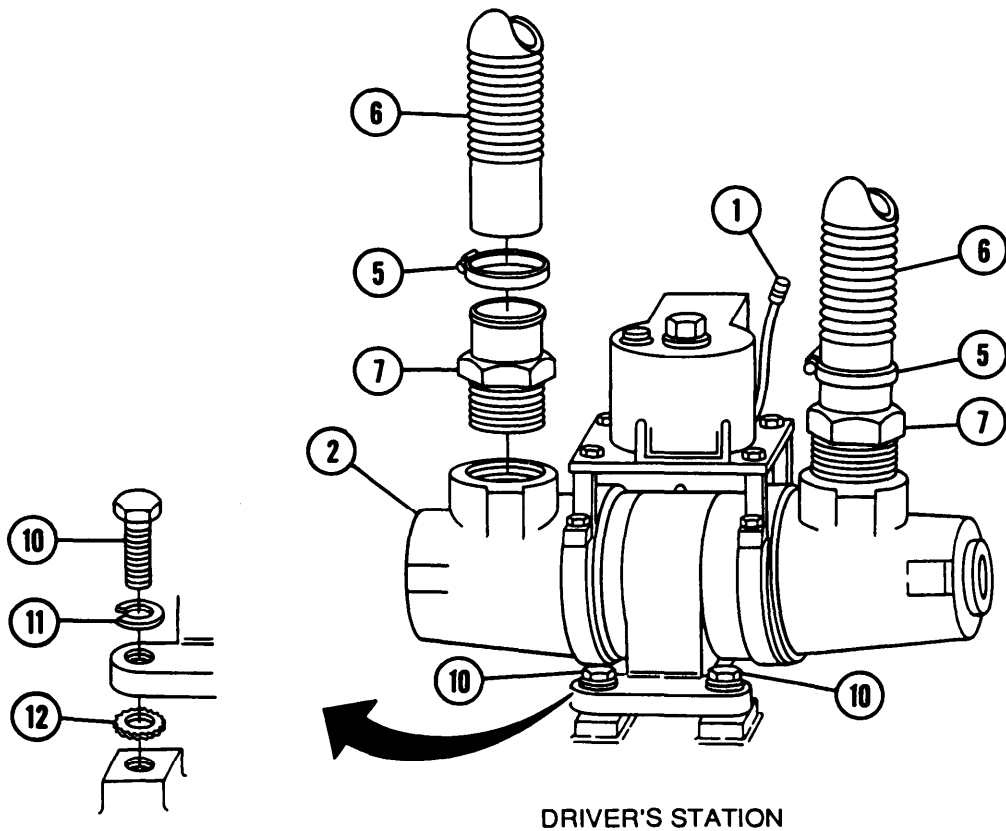

b. Installation

NOTE

- The following procedure applies to heaters at both driver's and cannoneer no. 2's stations.
- Some new heaters may require installation of a mounting plate kit to allow control knob to be seen. Instructions to install kit are included with heater.
- External-tooth lockwashers are to be installed between mounting blocks or bracket and heaters.
- Step 1 applies to heater (4) at cannoneer no. 2's station.

- 1 Install bracket (15), two new lockwashers (14), and two screws (13).
- 2 Install four new external-tooth lockwashers (12), four new lockwashers (11), four screws (10), and heater (2 or 4).

NOTE

Heater (2) at driver's station has two adapters. Heater (4) at cannoneer no. 2's station has one elbow and one adapter.

- 3 Install two adapters (7) or adapter (8) and elbow (9) as required.
- 4 Install two hoses (6) and two clamps (5) over two adapters (7) or adapter (8) and elbow (9) as required. Tighten clamps.
- 5 Connect electrical connector wire 439B (1) to heater (2) at driver's station or wire 439C (3) to heater (4) at cannoneer no. 2's station.

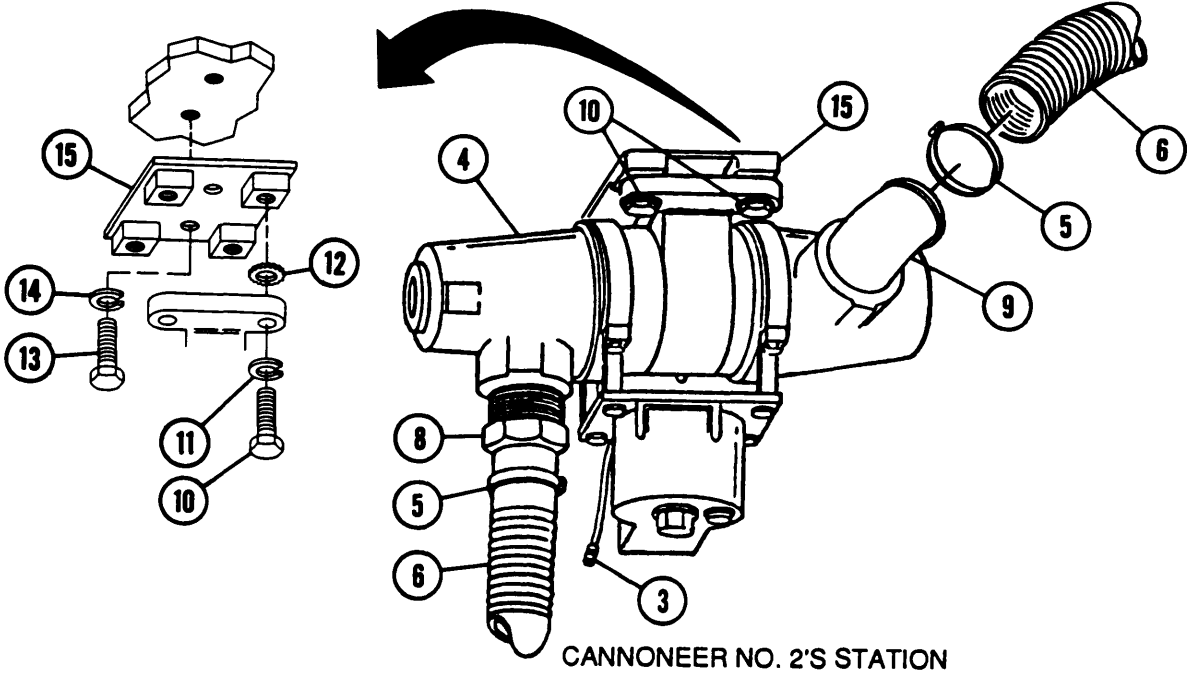

12-4 HEATER LAMPS

This task covers: a. Removal b. Installation

INITIAL SETUP

Applicable Configurations
M109A4/M109A5

Tools
General mechanic's tool kit (item 64, Appx H)

a. Removal

WARNING

Ensure MASTER switch is OFF when working on hull electrical system to avoid electrical shocks and burns.

NOTE

- The following procedure applies to heaters at both driver's and cannoneer no. 2's stations.
- Heaters come in various designs. The following procedure applies to all of these designs although actual heater may differ in appearance from those illustrated.

1 Turn lens (1) counterclockwise and remove.

2 Remove lamp (2).

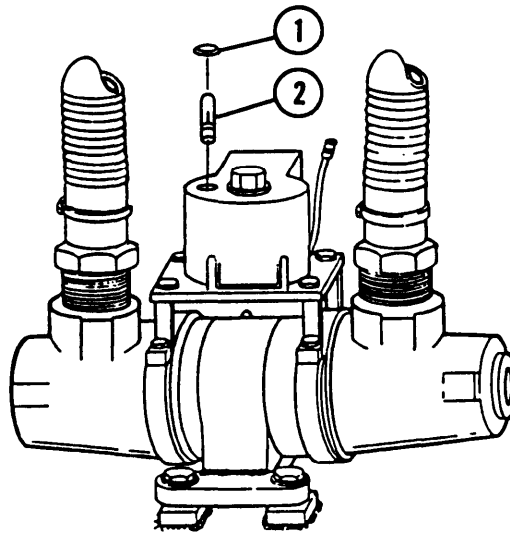

DRIVER'S STATION

b. Installation**WARNING**

Ensure MASTER switch is OFF when working on hull electrical system to avoid electrical shocks and burns.

NOTE

- The following procedure applies to heaters at both driver's and cannoneer no. 2's stations.
- Heaters come in various designs. The following procedure applies to all of these designs although actual heater may differ in appearance from those illustrated.

1 Install lamp (2).

2 Install lens (1).

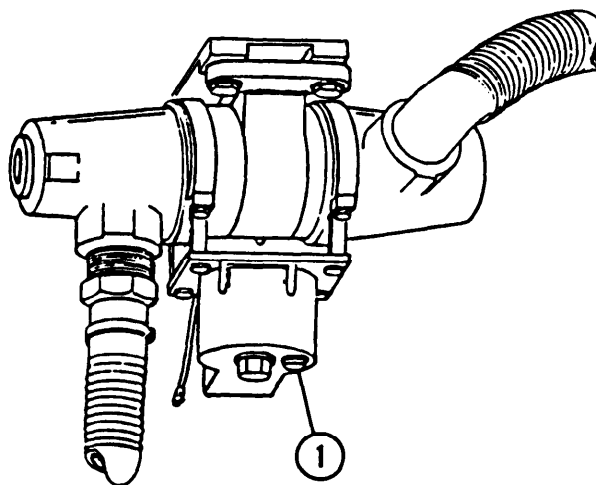

CANNONEER NO. 2'S STATION

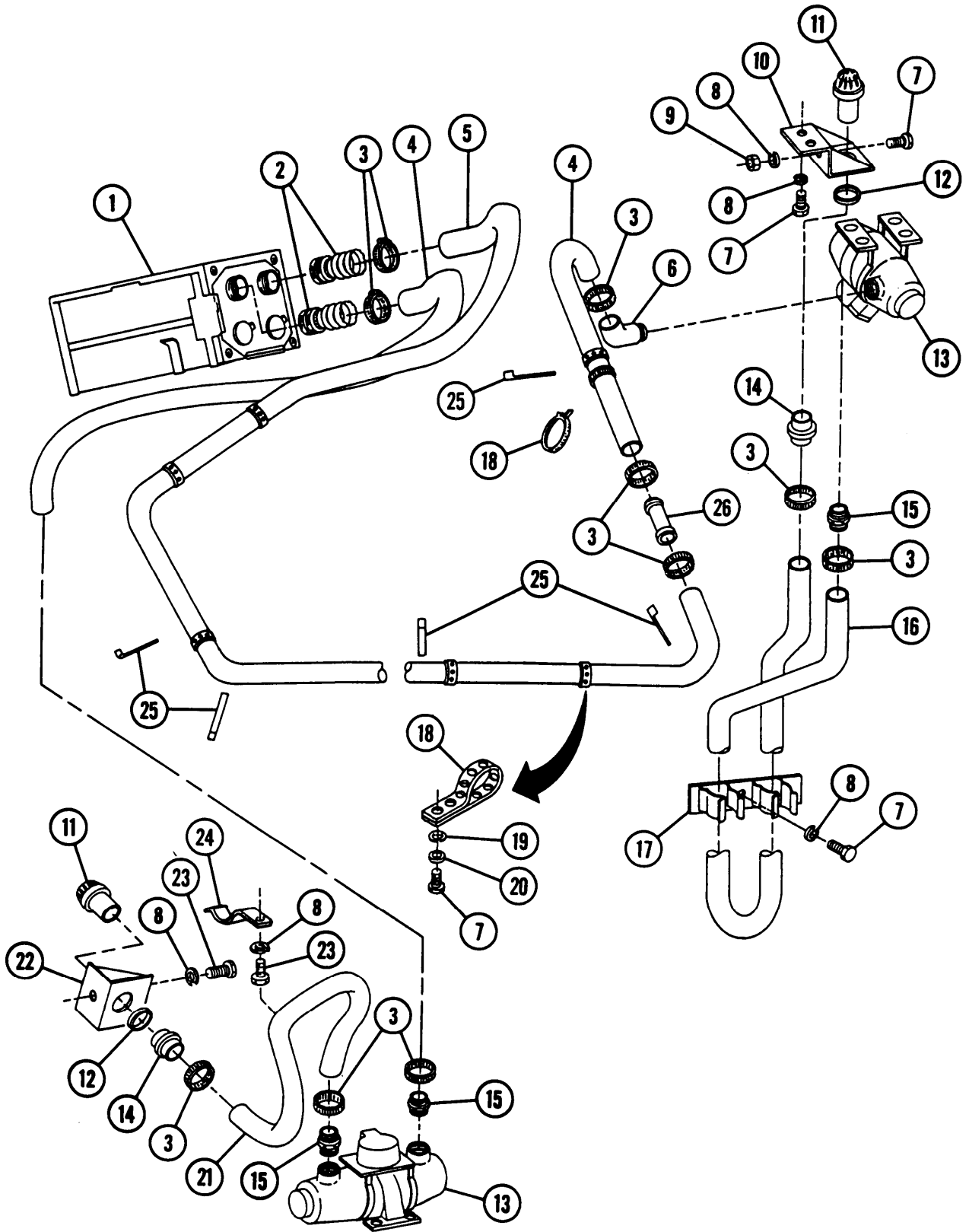

12-6 AIR OUTLET ORIFICE CONNECTORS

This task covers: a. Removal b. Installation

Applicable Configurations
M109A4/M109A5

Retaining ring pliers (item 40, Appx H)

Tools
General mechanic's tool kit (item 64, Appx H)

Materials/Parts
Lockwashers (3) (item 192, Appx G)
Retaining ring (item 14, Appx G)

a. Removal

- 1 Remove clamp (1) and hose assembly (2) from coupling (3).
- 2 Remove coupling (3).

NOTE

Step 3 applies to connector in crew compartment.

- 3 Remove two screws (4), two lockwashers (5), and orifice connector and bracket (6). Discard lockwashers.
- 4 Remove retaining ring (7) and connector (8). Discard retaining ring.

NOTE

Nut is in crew compartment only.

- 5 Remove screw (10), lockwasher (11), nut (9), and bracket (12). Discard lockwasher.

b. Installation

NOTE

Nut is in crew compartment only.

- 1 Install bracket (12), new lockwasher (11), screw (10), and nut (9).
- 2 Install connector (8) and new retaining ring (7).

NOTE

Step 3 applies to connector in crew compartment.

- 3 Install orifice connector and bracket (6), two new lockwashers (5), and two screws (4).
- 4 Install coupling (3).

5 Install hose assembly (2) and clamp (1) to coupling (3).

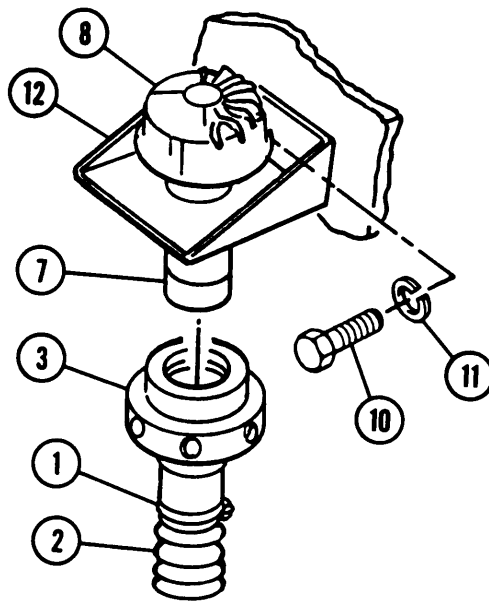

DRIVER'S COMPARTMENT

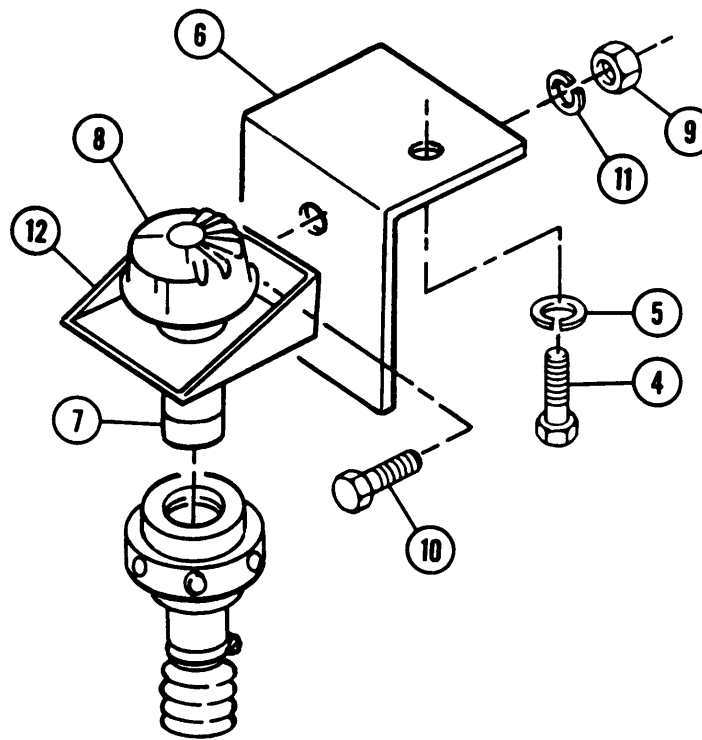

CREW COMPARTMENT

CHAPTER 13 HULL STOWAGE

GENERAL

This chapter provides instructions for removal, disassembly, assembly, and installation of stowage racks, boxes, and brackets. The location for stowage of Basic Issue Items (Bill) is also indicated within the chapter.

The procedures discussed in this chapter are in compliance with authorized unit maintenance responsibilities as defined in the Maintenance Allocation Chart (MAC).

CONTENTS	PAGE
13-1 HULL INTERIOR STOWAGE DIAGRAM	13-2
13-2 HULL AMMUNITION RACKS	13-3
13-3 SPARE M45PERISCOPE BOX	13-7
13-4 RATION BOXES	13-8
13-5 PORTABLE FIRE EXTINGUISHER MOUNTING BRACKET, PROJECTILE SPACER BOX, AND RIFLE STOWAGE CLIPS	13-9
13-6 FLASHLIGHT HOLDER AND CLGP EXTRACTOR	13-12
13-7 NBC SUIT STOWAGE BOXES	13-14

13-1 HULL INTERIOR STOWAGE DIAGRAM

LEGEND

- | | |
|--|--------------------------------|
| 1 155mm projectile stowage | 9 155mm projectile stowage |
| 2 CLGP extractor | 10 Fuze stowage |
| 3 155mm propelling charges and primers | 11 M13 decontamination stowage |
| 4 Projectile spacer box (M109A2/M109A3 location) | 12 Bucket |
| 5 Fire extinguisher (M109A2/M109A3 location) | 13 Telephone reel |
| 6 NBC suit stowage box (M109A4/M109A5) | 14 M14 aiming light |
| 7 Ration box | 15 Rifle |
| 8 Canteen | 16 Flashlight |
| | 17 Spare periscope (M45) |

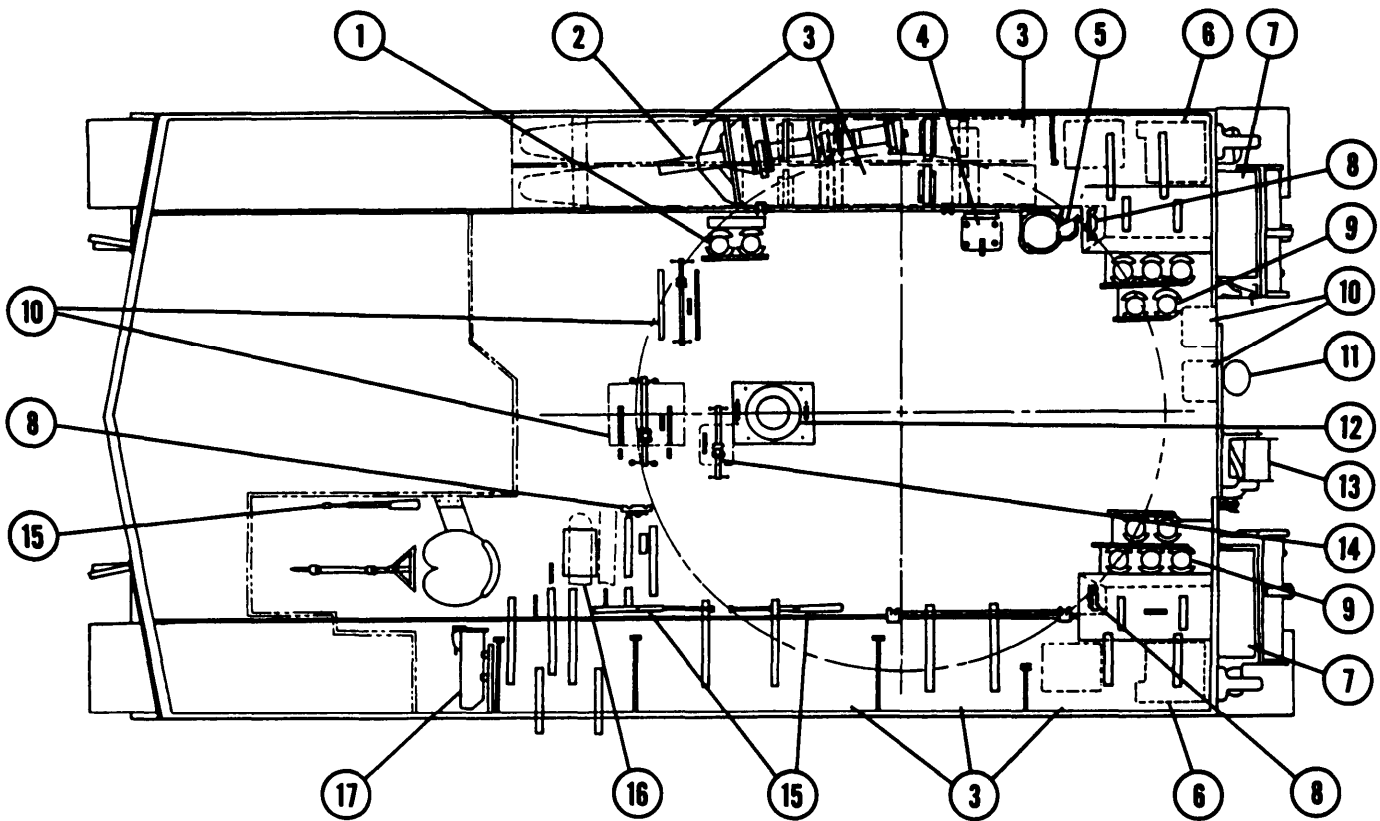

13-2 HULL AMMUNITION RACKS — CONTINUED

b. Disassembly

- 1 Remove two screws (15) and plate (16) from front right rack bracket (17).
- 2 Remove two nuts (18), two washers (19), two washers (20), two nuts (21), and two threaded rods (22) from plate (16).
- 3 Disconnect wire rope assembly (23) from two pins (24).
- 4 Remove two buckles (25) and two straps (26) from front right rack bracket (17).
- 5 Remove eight bumpers (27) and two pads (28 and 29). Discard pads.
- 6 Remove four screws (30), four washers (31), arm mounting bracket (32), and shim (33).
- 7 Remove cotter pin (34), headed pin (35), and eyebolt assembly (36). Discard cotter pin.
- 8 Remove screw (37), washer (38), two spring pins (39), and friction plate (40) from arm (8).
- 9 Remove two hooks (41) and two straps (42).
- 10 Remove 20 bumpers (43) and 5 pads (44). Discard pads.

c. Assembly

- 1 Install 20 bumpers (43) and 5 new pads (44).
- 2 Install two hooks (41) and two straps (42).

NOTE

Use sealing compound on all threads.

- 3 Install friction plate (40), spring pins (39), washer (38), and screw (37) on arm (8).
- 4 Install eyebolt assembly (36), headed pin (35), and new cotter pin (34).
- 5 Install shim (33), arm mounting bracket (32), four washers (31), and four screws (30).

WARNING

Adhesives are toxic and flammable. Apply adhesives only in a well-ventilated area. Avoid contact with skin, eyes, and clothes, and don't breathe vapors. Do not use near heat, sparks, or open flame. Read and follow all warnings and instructions on labels of adhesives. If contact with skin or eyes is made, wash area with water and seek medical aid immediately.

WARNING

Adhesives are toxic and flammable. Apply adhesives only in a well-ventilated area. Avoid contact with skin, eyes, and clothes, and don't breath vapors. Do not use near heat, sparks, or open flame. Read and follow all warnings and instructions on labels of adhesives. If contact with skin or eyes is made, wash area with water and seek medical aid immediately.

- 6 Apply adhesive to two pads (29 and 28). Install two new pads (29 and 28) and eight bumpers (27).
- 7 Install two straps (26) and two buckles (25) to front tight rack bracket (17).
- 8 Connect wire rope assembly (23) to two pins (24).
- 9 Install two threaded rods (22), two nuts (21), two washers (20), two washers (19), and two nuts (18) to plate (16).
- 10 Install plate (16) and two screws (15) to front right rack bracket (17).

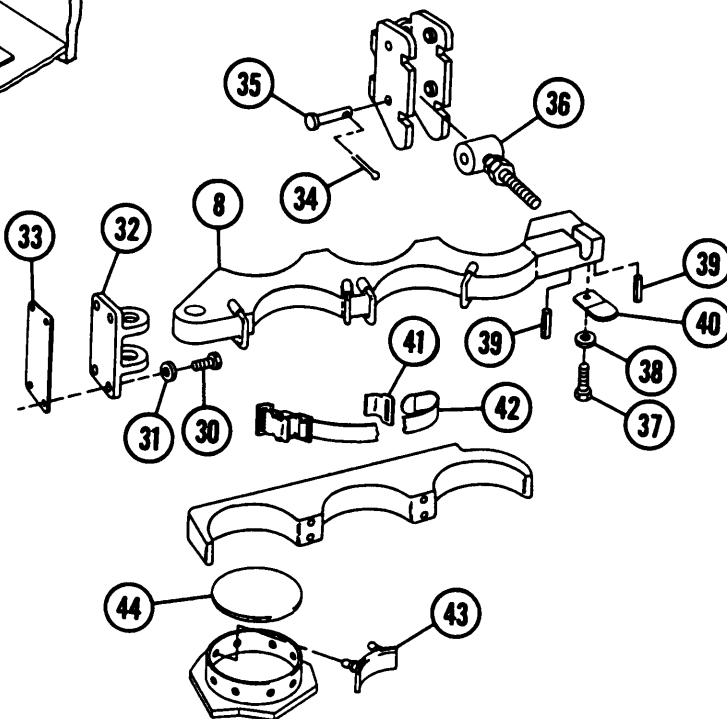
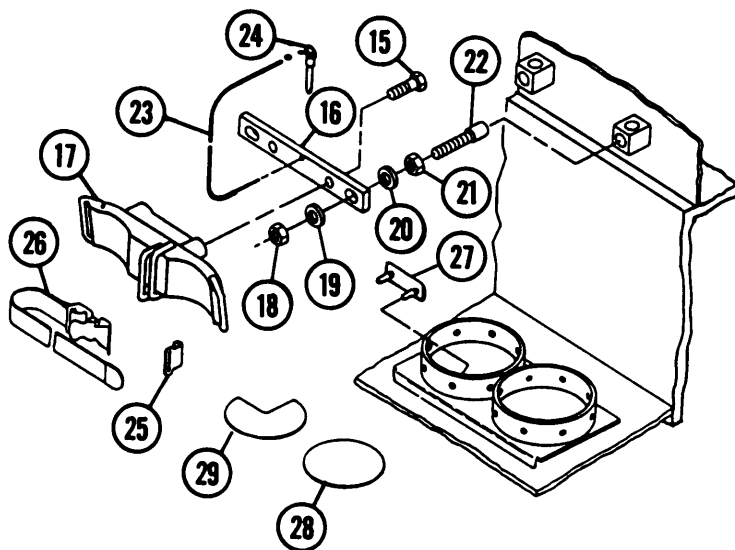

13-2 HULL AMMUNITION RACKS — CONTINUED

d. Installation

- 1 Install lock assembly (14), two washers (13), and two screws (12).
- 2 Install cradle (11), four washers (10), and four screws (9).
- 3 Install arm (8), wing nut (7), and pin (6).
- 4 Install headed pin (5).
- 5 Install new cotter pin (4).
- 6 Install bracket assembly (2) and two pins (1).

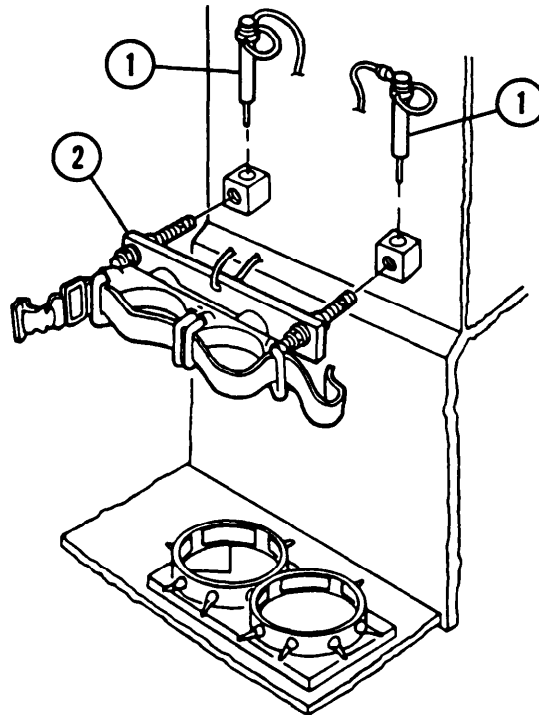
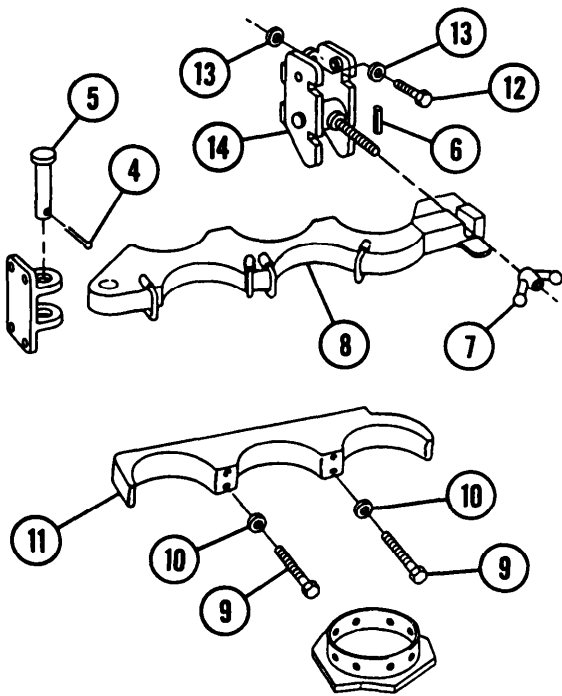

13-3 SPARE M45 PERISCOPE BOX

This task covers: a. Removal b. Installation

INITIAL SETUP

Tools

General mechanic's tool kit (item 64, **Appx H**)

Materials/Parts

Lockwashers (4) (item 192, **APPX G**)

a. Removal

Remove four screws (1), four lockwashers (2), and spare M45 periscope box (3). Discard lockwashers.

b. Installation

Install spare M45 periscope box (3), four new lockwashers (2), and four screws (1).

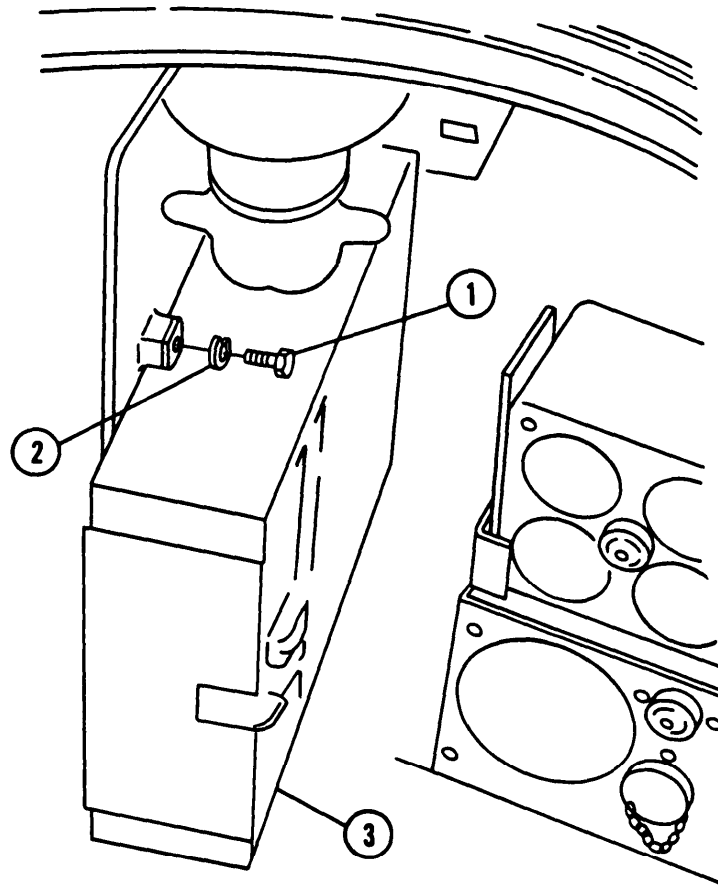

13-4 RATION BOXES

This task covers: a. Removal b. Installation

Tools
General mechanic's tool kit (item 84, **Appx H**)

Materials/Parts
Lockwashers (6) (item 89, Appx G)
Seals (6) (item 221, Appx G)

a. Removal

- 1 Release latch (1) and open cover (2).
- 2 Remove six screws (3), six lockwashers (4), six seals (5), and ration box (6). Discard lockwashers and seals.

b. Installation

- 1 Install ration box (6), six new seals (5), six new lockwashers (4), and six screws (3).
- 2 Close cover (2) and secure latch (1).

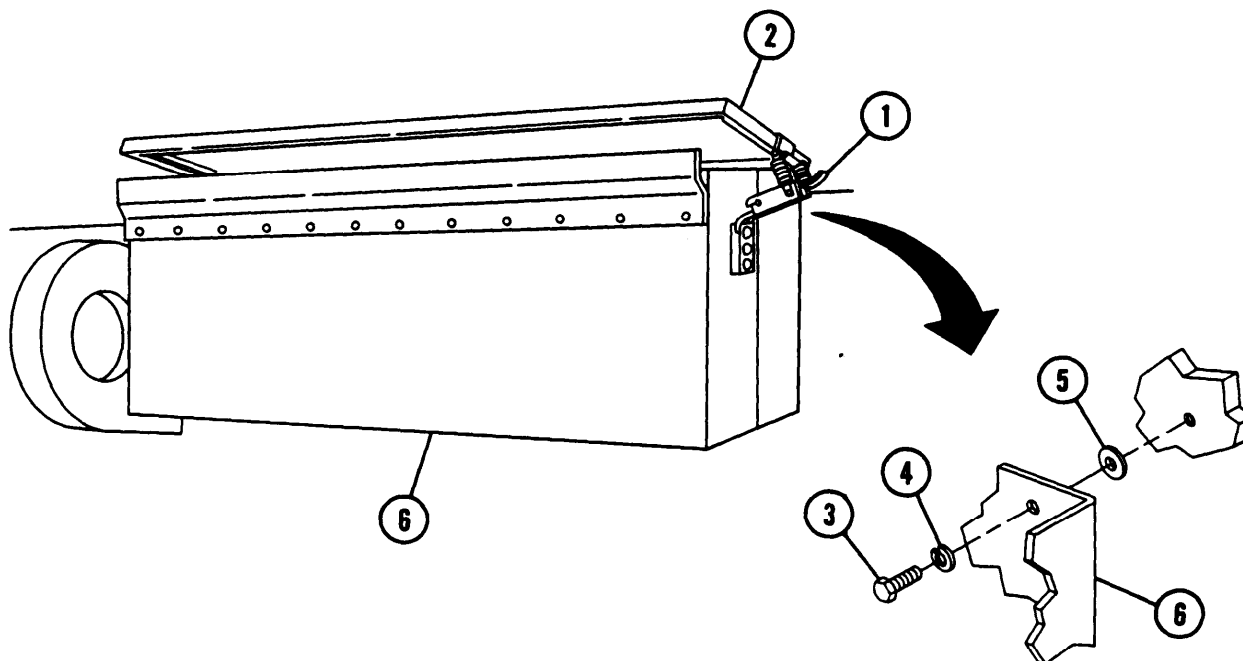

**13-5 PORTABLE FIRE EXTINGUISHER MOUNTING BRACKET, PROJECTILE SPACER BOX,
AND RIFLE STOWAGE CLIPS — CONTINUED**

a. Removal — Continued

NOTE

Steps 2 and 3 apply to projectile spacer box.

2 Remove projectile spacers (4) if present.

NOTE

Some projectile spacer boxes may have screws and lockwashers located on back of box instead of on bottom of box.

3 Remove four screws (5), four lockwashers (6), and projectile spacer box (7). Discard lockwashers.

NOTE

Steps 4 and 5 apply to rifle stowage clips.

4 Remove four screws (8), four lockwashers (9), four rifle stowage clips (10), eight washers (11), and four straps (12) in crew compartment. Discard lockwashers.

5 Remove screw (13), lockwasher (14), rifle stowage clip (15), and strap (16) in driver's compartment. Discard lockwasher.

b. Installation

NOTE

Steps 1 and 2 apply to rifle stowage clips.

1 Install strap (16), rifle stowage clip (15), new lockwasher (14), and screw (13) in driver's compartment.

2 Install four straps (12), eight washers (11), four rifle stowage clips (10), four new lockwashers (9), and four screws (8) in crew compartment.

NOTE

. Locations of portable fire extinguisher mounting bracket and projectile spacer box differ on M109A2/M109A3 and M109A4/M109A5 Howitzers. The following procedures apply no matter where the location. M109WM109A3 shown.

I Steps 3 and 4 apply to projectile spacer box.

I Some projectile spacer boxes may have screws and lockwashers located at back of box instead of at bottom of box.

3 Install projectile spacer box (7), four new lockwashers (6), and four screws (5).

4 Install projectile spacers (4) if present.

NOTE

Step 5 applies to portable fire extinguisher mounting bracket.

5 Install portable fire extinguisher mounting bracket (3), four new lockwashers (2), and four screws (1).

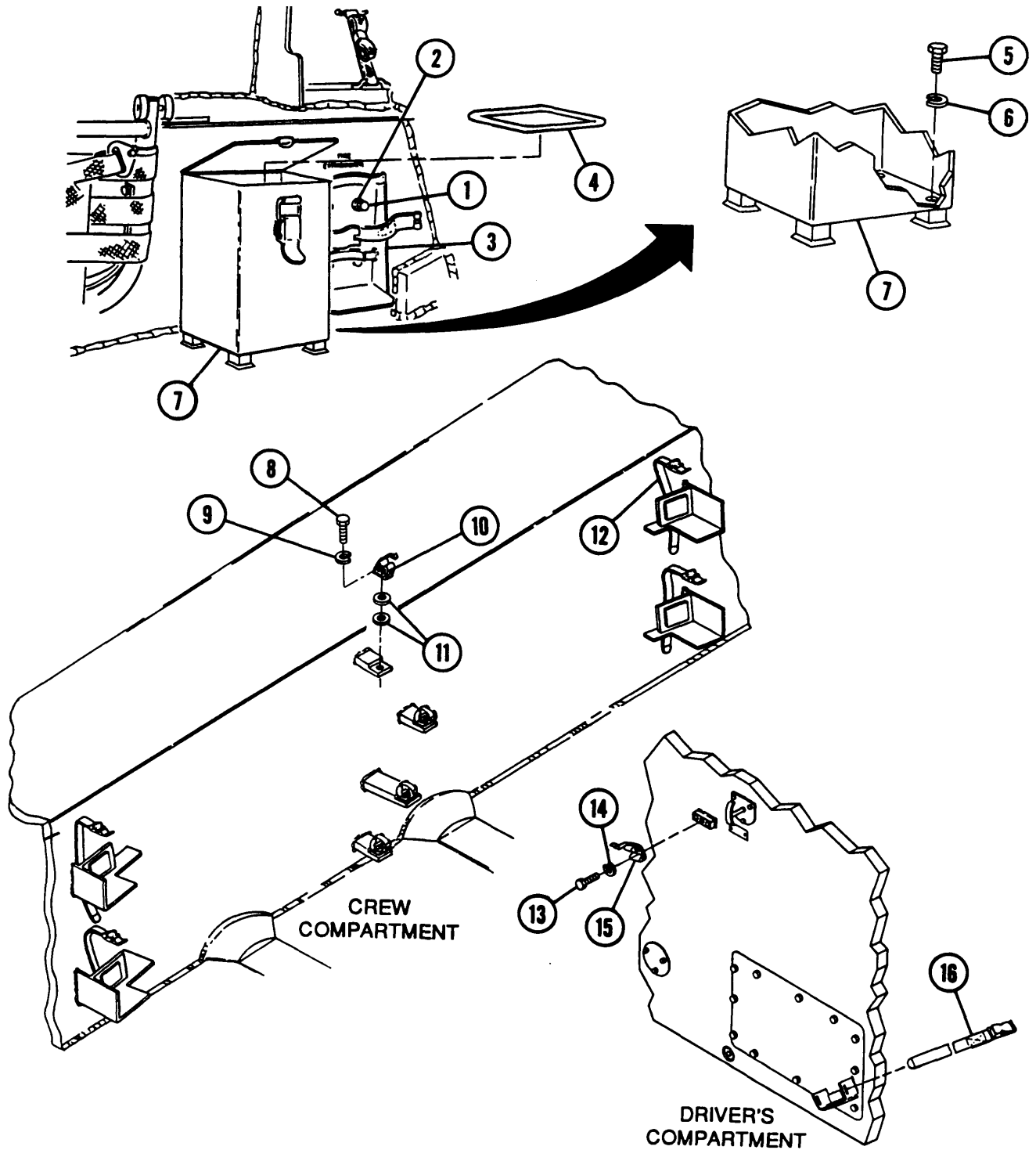

13-6 FLASHLIGHT HOLDER AND CLGP EXTRACTOR

This task covers: a. Removal b. Installation

INITIAL SETUP

Tools
General mechanic's tool kit (item 64, Appx H)

Materials/Parts
Cotter pins (2) (item 40, Appx G)
Lockwashers (2) (item 192, Appx G)

a. Removal

NOTE

Step 1 applies to flashlight holder.

1 Remove two screws (1), two lockwashers (2), and flashlight holder (3). Discard lockwashers.

NOTE

Step 2 applies to CLGP tactical extractor.

2 Remove two screws (4), two washers (5), two cotter pins (6), two headed pins (7), four washers (8), two clamps (9), and CLGP extractor (1 O). Discard cotter pins.

b. Installation

NOTE

Step 1 applies to CLGP tactical extractor.

1 Install CLGP extractor (10), two clamps (9), four washers (8), two headed pins (7), two new cotter pins (6), two washers (5), and two screws (4).

NOTE

Step 2 applies to flashlight holder.

2 Install flashlight holder (3), two new lockwashers (2), and two screws (1).

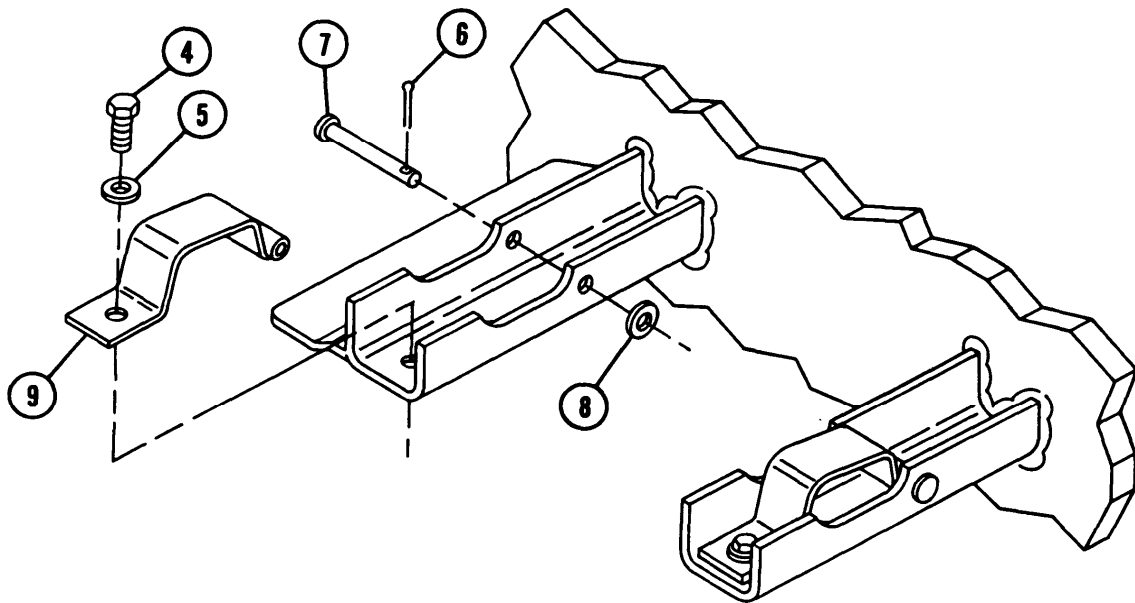
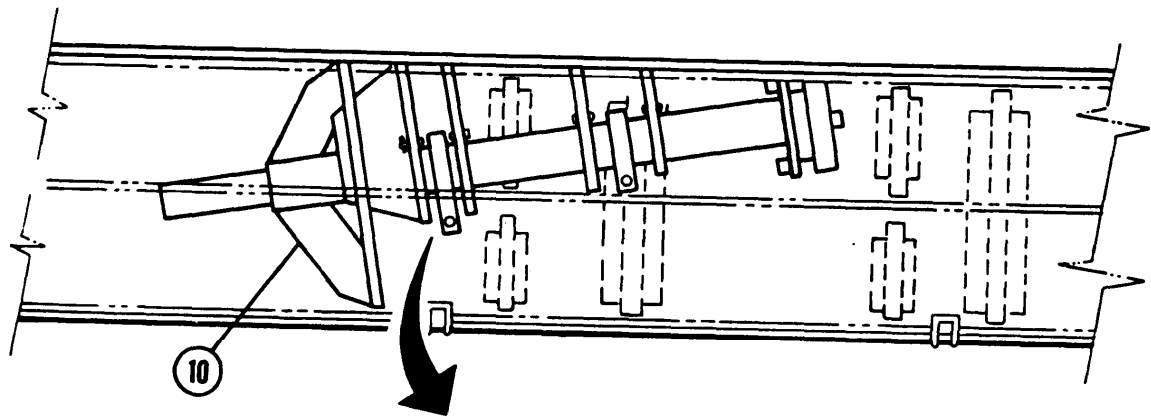
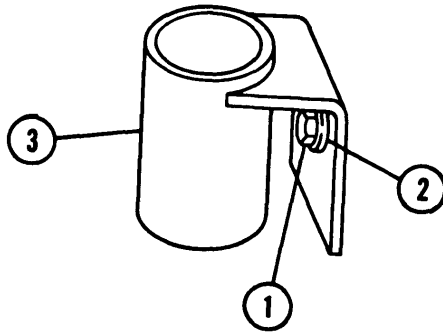

13-7 NBC SUIT STOWAGE BOXES

This task covers: a. Removal b. Installation

INITIAL SETUP

Tools

General mechanic's tool kit (item 64, Appx HI)

Materials/Parts

Lockwashers (6) (item 88, Appx G)

a. Removal

NOTE

Left and right NBC suit stowage boxes are removed using the same procedure.

- 1 Release latch (1) and open NBC suit stowage box (2).
- 2 Remove two screws (3), two lockwashers (4), and latch (5). Discard lockwashers.
- 3 Remove four screws (6), four lockwashers (7), and two washers (8) while supporting stowage box (2). Discard lockwashers.
- 4 Remove NBC suit stowage box (2).

b. Installation

NOTE

Left and right NBC suit stowage boxes are installed using the same procedure.

- 1 Install NBC suit stowage box (2), two washers (8), four new lockwashers (7), and four screws (6).
- 2 Install latch (5), two new lockwashers (4), and two screws (3).
- 3 Close NBC suit stowage box (2) and secure latch (1).

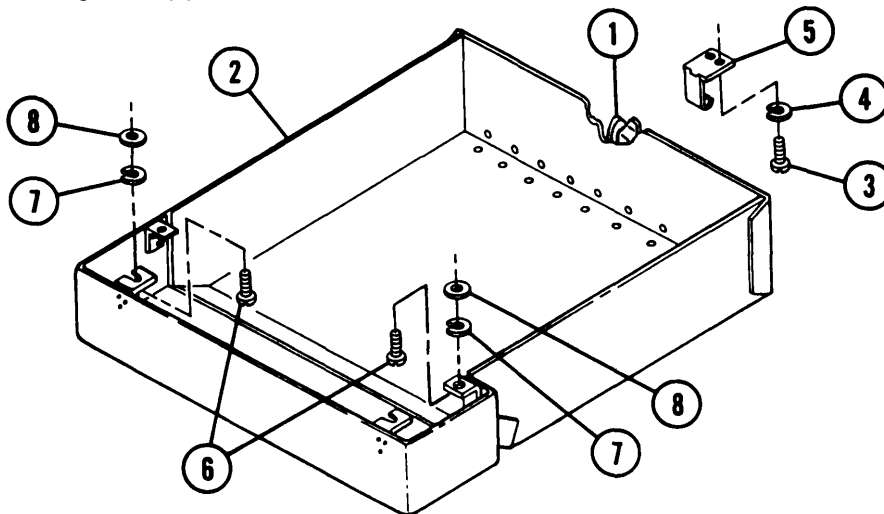

CHAPTER 14 ENGINE AND BATTERY WINTERIZATION KIT

GENERAL

This chapter provides instructions for removal, disassembly, assembly, and installation of specific components of the winterization kit. Since the kit encompasses several components, each with an individual set of procedures, the chapter has been divided into an overall diagram and nine major components of the winterization kit.

The winterization kit provides a standby heating system to prevent freezing of the engine coolant and battery electrolyte during shutdown periods in extreme cold or arctic temperatures. Coolant is circulated through the heater, engine, and battery heater by an electrically driven coolant pump furnished with the kit.

CONTENTS

	<u>PAGE</u>
14-1 WINTERIZATION KIT DIAGRAM	14-2
14-2 EXHAUST OUTLET ASSEMBLY	14-4
14-3 BATTERY HEATER AND INSULATION BOXES	14-5
14-4 COOLANT PUMP	14-7
14-5 FUEL PUMP	14-9
14-6 FUEL FILTER	14-10
14-7 COOLANT HEATER	14-12
14-8 COOLANT HEATER WIRING HARNESSSES	14-14
14-9 HEATER CONTROL BOX	14-16
14-10 GRILLE COVERS	14-17



14-1 WINTERIZATION KIT DIAGRAM

NOTE

This installed view of the winterization kit identifies all items in the kit. Those items which only need to be disconnected during powerplant removal are identified by a single asterisk (*). Those items that need to be removed during powerplant removal are identified by a double asterisk (~*).

LEGEND

- | | |
|--|---|
| 1 Connector (wire 459B) to MASTER switch | 16 Primary fuel filter-to-fuel filter fuel hose* |
| 2 Receptacle at driver's compartment bulkhead | 17 Coolant pump (electric)** |
| 3 Bulkhead-to-heater, fuel pump, and coolant pump harness (wires 402B, 402C, 403B, 403C, 406, and ground)* | 18 Engine coolant surge tank hose |
| 4 Battery insulation box | 19 Heater hose-to-surge tank hose Y-connector tube |
| 5 Battery heater plate parts | 20 Coolant pump-to-heater hose |
| 6 Exhaust outlet plug | 21 Engine coolant manifold-to-battery heater inlet hose* |
| 7 Exhaust outlet | 22 Engine manifold |
| 8 Transmission left access door | 23 Primary fuel filter |
| 9 Exhaust tube** | 24 Primary fuel filter-to-engine fuel tube |
| 10 Heater-to-surge tank hose connector tube* | 25 Fuel tank-to-primary fuel filter hose |
| 11 Fuel pump-to-heater fuel tube* | 26 Heater lead (wire 400) |
| 12 Coolant heater** | 27 Heater control box |
| 13 Fuel pump (electric)** | 28 Control box-to-master switch and bulkhead harness (wires 400, 402B, 402C, 406, and 459B) |
| 14 Fuel filter-to-fuel pump fuel tube** | 29 MASTER switch (reference) |
| 15 Fuel filter** | 30 Battery heater outlet-to-coolant pump hose* |

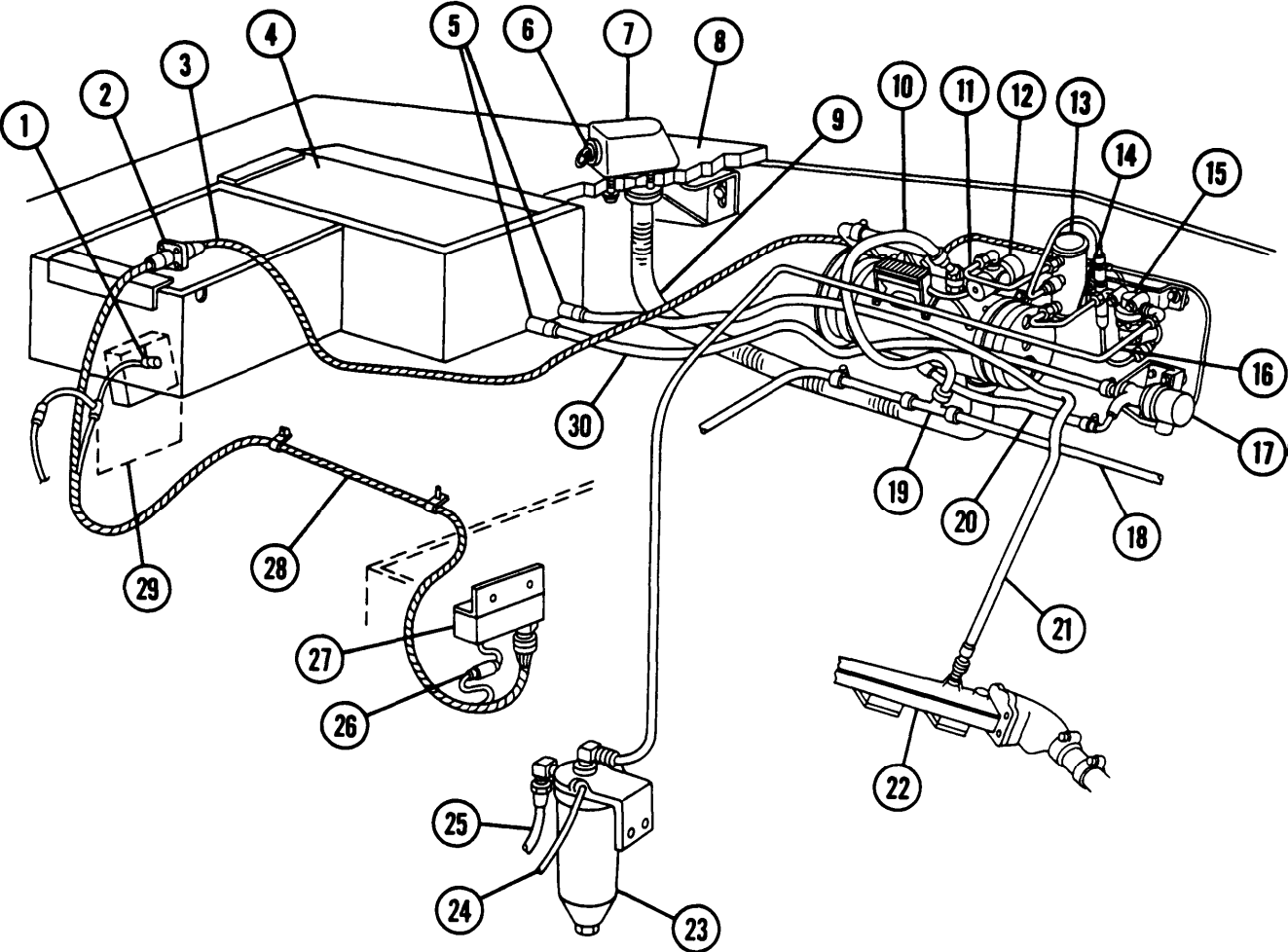

14-2 EXHAUST OUTLET ASSEMBLY

This task covers: a. Removal b. Installation

Tools

General mechanic's tool kit (item 64, Appx H)

Equipment Conditions

Left transmission access door opened (para 11 -7)

Materials/Parts

Gasket (item 144, Appx G)

a. Removal

- 1 Remove three screws (1) and three flat washers (2).
- 2 Remove exhaust outlet (3) and gasket (4). Discard gasket.

b. Installation

- 1 Install new gasket (4) and exhaust outlet (3).
- 2 Install three flat washers (2) and three screws (1).

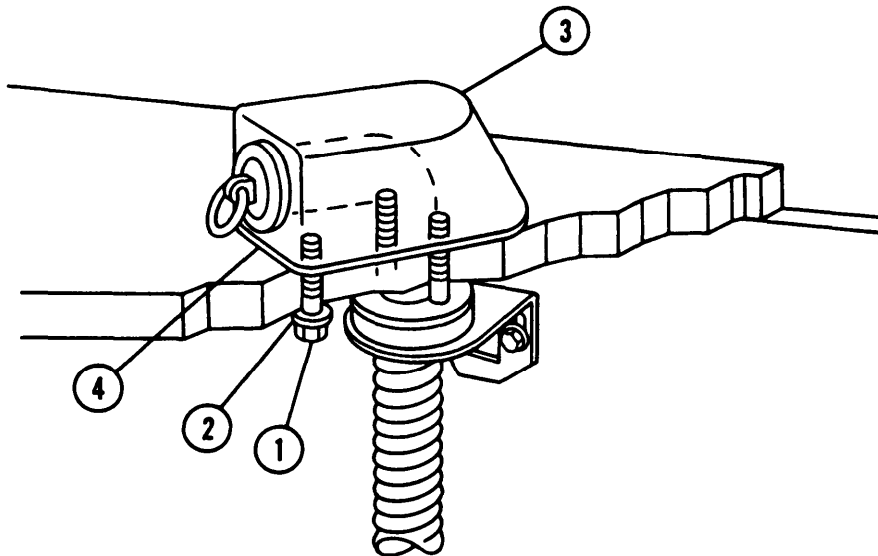

NOTE

FOLLOW-ON MAINTENANCE: Close left transmission access door (para 11-7)

14-3 BATTERY HEATER AND INSULATION BOXES

This task covers: a. Removal b. Installation

INITIAL SETUP

Tools

General mechanic's tool kti (item 64, Appx H)

TM 9-2350-311-10

Materials/Parts

Lockwasher (item 77, Appx G)

Lockwashers (8) (item 96, Appx G)

Lockwire (item 227, Appx G)

Equipment Conditions

Battery access doors opened (para 11 -6)

a. Removal

WARNING

Coolant is a hazardous waste and must be disposed of in accordance with local procedures or direction of the local Hazardous Waste Management office.

NOTE

If plugs are not used, coolant must be drained (TM 9-2350-311-1 O).

- 1 Disconnect battery heater inlet hose (1) and battery heater outlet hose (2). Install 5/8-in. - (16-mm-) diameter plugs in hoses.
- 2 Remove wing nut (3), flat washer (4), and front top insulation blanket (5).
- 3 Remove screw (6), lockwasher (7), and battery ground lead (8) at bulkhead. Discard lockwasher.
- 4 Remove rear top insulation blanket (9).

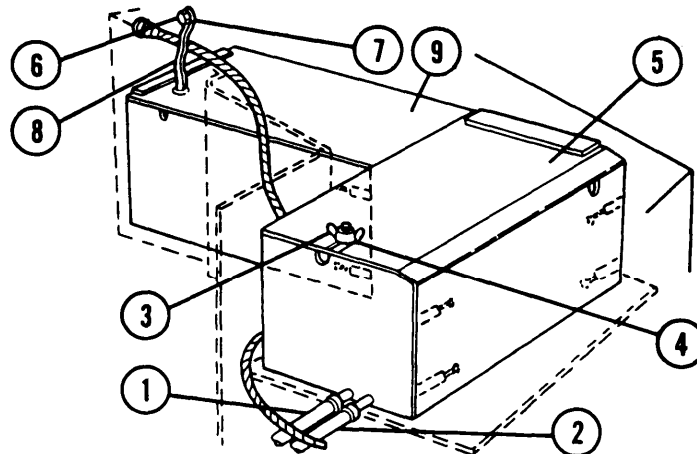

14-3 BATTERY HEATER AND INSULATION BOXES — CONTINUED

a. Removal — Continued

- 5 Remove batteries and supports (para 8-28).
- 6 Remove eight screws (1 O), eight lockwashers (11), and battery heater plate (12). Discard lockwashers.
- 7 Remove lockwire (13), six retaining pins (14) (inside boxes), and two winterization boxes (15). Discard lockwire.

b. Installation

- 1 Install two winterization boxes (15), six retaining pins (14) (inside boxes), and new lockwire(13).
- 2 Install battery heater plate (12), eight new lockwashers (11), and eight screws (10).
- 3 Install batteries and supports (para 8-28).
- 4 Install rear top insulation blanket (9).
- 5 Install battery ground lead (8), new lockwasher (7), and screw (6) at bulkhead.
- 6 Install front top insulation blanket (5), flat washer (4), and wing nut (3).
- 7 Remove plugs from battery heater inlet hose (1) and battery heater outlet hose (2) and connect hoses. If plugs were not used, refill coolant system (TM 9-2350-311-10).

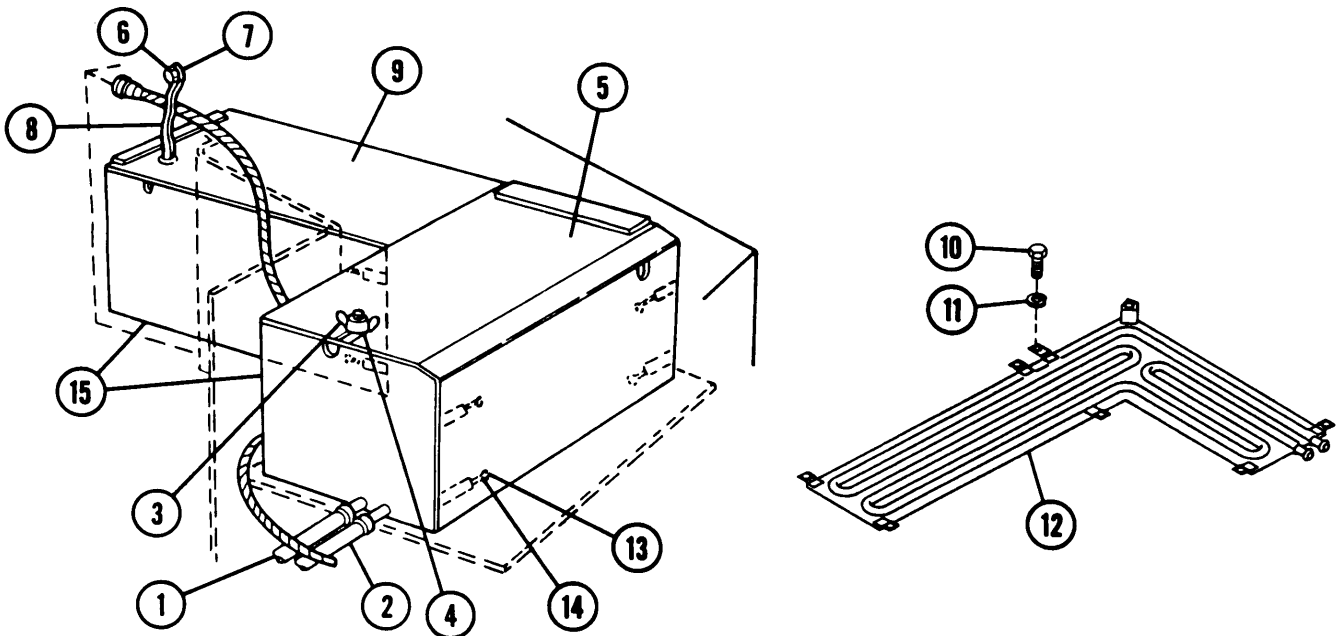

NOTE

FOLLOW-ON MAINTENANCE: Close battery access door (para 11 -6)

14-4 COOLANT PUMP

This task covers: a. Removal b. Installation

INITIAL SETUP

Tools

General mechanic's tool kit (item 64, Appx H)

References

TM 9-2350-311-10

a. Removal

- 1 Disconnect electrical lead (1).
- 2 Loosen two hose clamps (2) on coolant inlet hose (3) and coolant outlet hose (4).

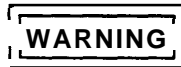

Coolant is a hazardous waste and must be disposed of in accordance with local procedures or direction of the local Hazardous Waste Management office.

NOTE

If plugs are not used, coolant system must be drained (TM 9-2350-311-10).

- 3 Disconnect hoses (3 and 4) from coolant pump (5). Install 5/8-in.- (16-mm-) diameter plugs in hoses.
- 4 Remove two nuts (6), two flat washers (7), two screws (8), and clamp bracket (9).
- 5 Remove three screws (10) and coolant pump (5).

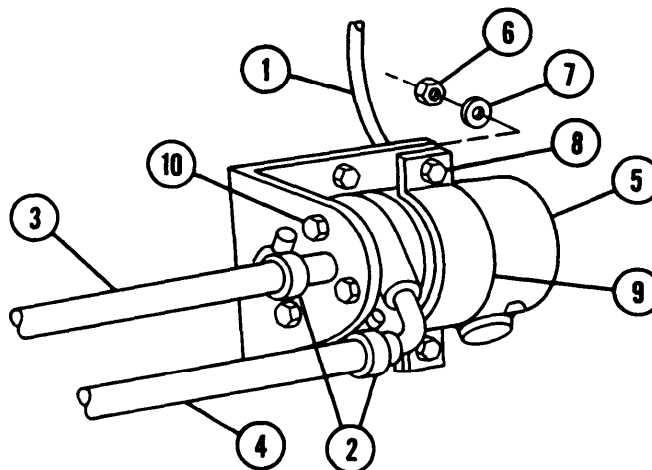

14-4 COOLANT PUMP — CONTINUED

b. Installation

- 1 Install coolant pump (5) and three screws (10).
- 2 Install clamp bracket (9), two screws (8), two flat washers (7), and two nuts (6).
- 3 Remove plugs from coolant inlet hose (3) and coolant outlet hose (4) and connect hoses to coolant pump (5). If plugs were not used, refill coolant system (TM 9-2350-311-10).
- 4 Tighten two hose clamps (2) on hoses (3 and 4).
- 5 Connect electrical lead (1).

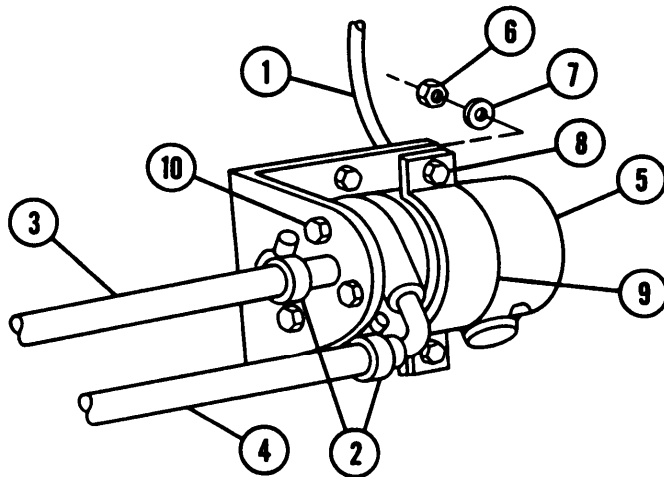

14-6 FUEL FILTER

This task covers: a. Removal b. Disassembly
 c. Assembly d. Installation

INITIAL SETUP

Tools

General mechanic's tool kit (item 64, Appx H)

Preformed packing (item 199, Appx G)

Materials/Parts

Filter element (item 115, Appx G)

Lockwires (2) (item 227, Appx G)

Equipment Conditions

Fuel inlet-to-fuel tank hose quick disconnect at primary fuel filter disconnected (para 6-6)

a. Removal

- 1 Disconnect primary fuel filter-to-fuel filter hose (1) at fuel filter (2).
- 2 Disconnect fuel filter-to-fuel pump tube (3) at fuel filter (2).
- 3 Remove two nuts (4), two flat washers (5), two screws (6), and fuel filter (2).

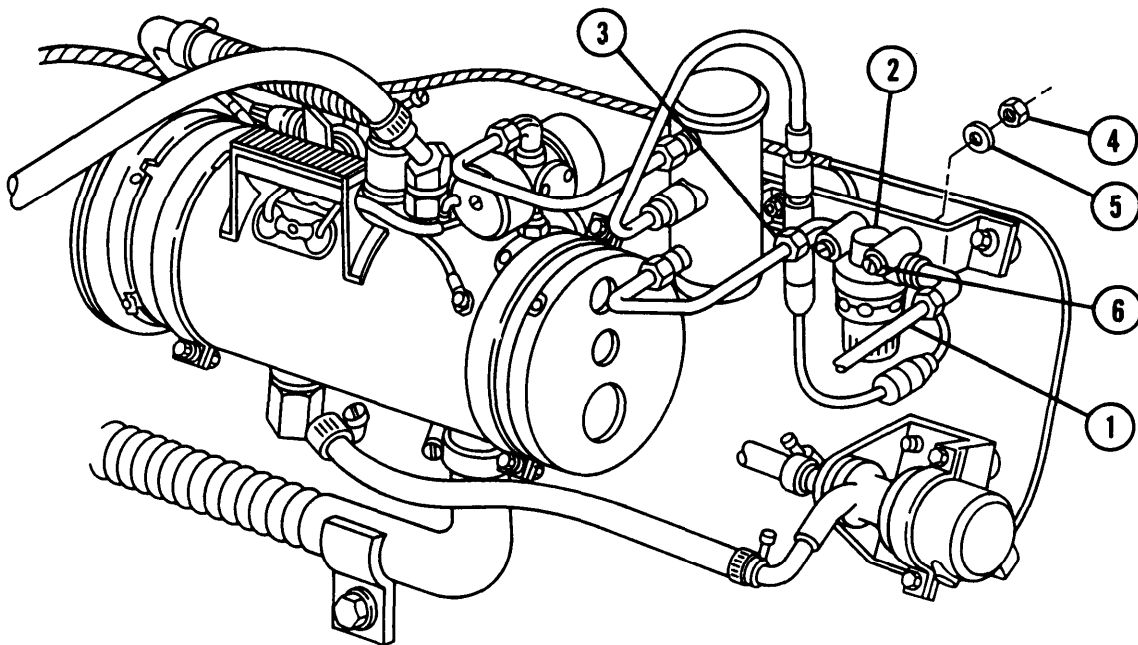

b. Disassembly

- 1 Remove two lockwires (7). Discard lockwires.
- 2 Unscrew filter head (8) from filter bowl (9).
- 3 Remove preformed packing (10) and filter element assembly (11). Discard preformed packing and filter element assembly.

c. Assembly

- 1 Install new filter element assembly (11) and new preformed packing (10) in filter bowl (9).
- 2 Install filter bowl (9) on filter head (8).
- 3 Install two new lockwires (7).

d. Installation

- 1 Install fuel filter (2), two nuts (4), two flat washers (5), and two screws (6).
- 2 Connect fuel filter-to-fuel pump tube (3) at fuel filter (2).
- 3 Connect primary fuel filter-to-fuel filter hose (1) at fuel filter (2).

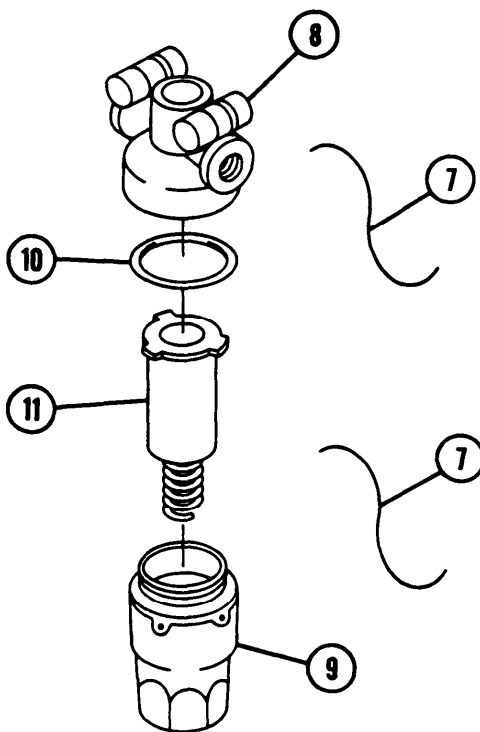
**NOTE**

FOLLOW-ON MAINTENANCE:

Conned fuel inlet-to-fuel tank hose at primary fuel filter (para 6-6)

b. Installation

NOTE

Coolant heater must be lifted or tilted in order to reach exhaust tube clamps.

- 1 Connect heater exhaust hose (18) with exhaust tube clamp (17) to coolant heater (2).
- 2 Position two coolant heater upper brackets (16) over coolant heater (2) and install four screws (15), four flat washers (14), and four nuts (13).
- 3 Secure heater exhaust hose (18) with bracket clamp (12), new lockwasher (11), and screw (10).
- 4 Connect fuel pump-to-coolant heater fuel tube (9) at coolant heater (2).
- 5 Remove coolant pump (8) outlet plug if necessary and install coolant inlet hose (7) with inlet hose clamp (6).
- 6 Remove heater coolant outlet (5) cap and plug from coolant outlet hose (4) if used. Install coolant outlet hose on coolant heater hose outlet with clamp (3). If caps and plugs were not used, refill coolant system (TM 9-2350-311-10).
- 7 Connect wiring harness (1) at coolant heater (2) plug.

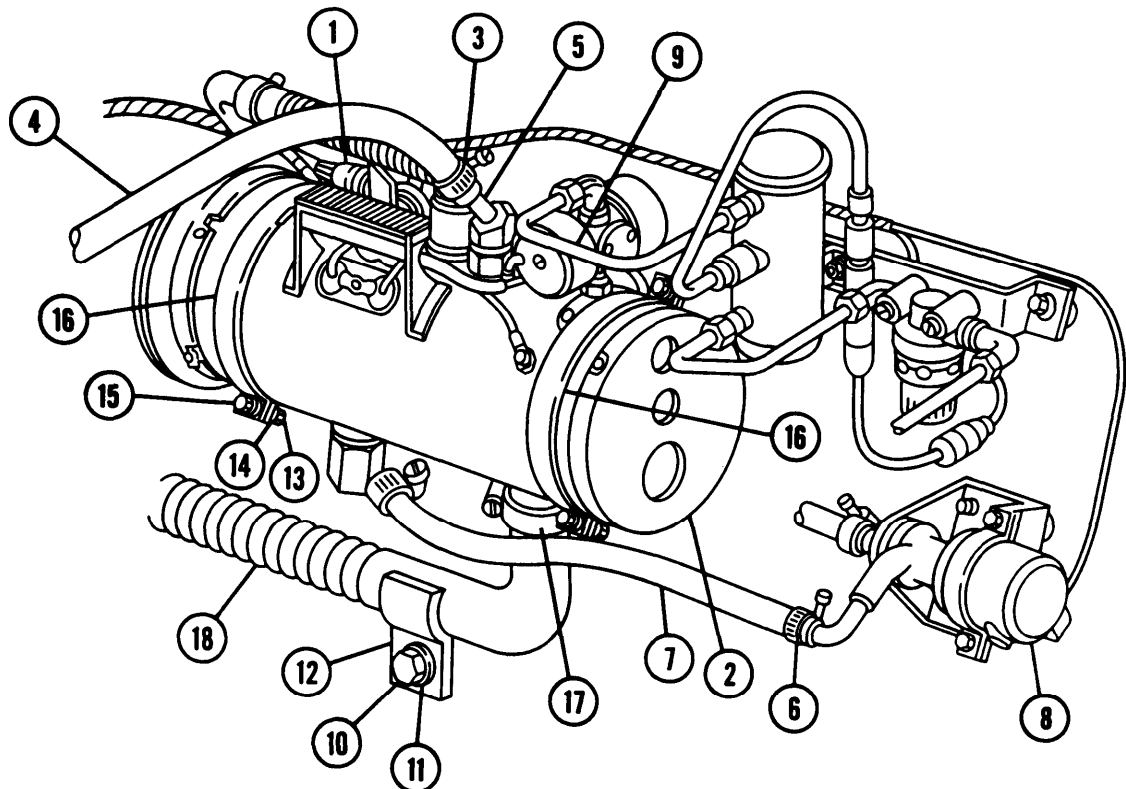

NOTE

FOLLOW-ON MAINTENANCE:

Connect fuel inlet-to-fuel tank hose quick disconnect at primary fuel filter (para 6-6)
Connect batteries (para 8-28)

14-8 COOLANT HEATER WIRING HARNESSES

This task covers: a. Removal b. Installation

INITIAL SETUP

Tools

General mechanic's tool kit (item 64, Appx H)

a. Removal

For removal, follow illustrations and legend as a guide.

b. Installation

For installation, follow illustrations and legend as a guide.

LEGEND

- | | |
|--|--|
| 1 Connector-to-driver's compartment bulkhead | 6 Connector heater control box |
| 2 Connector coolant heater | 7 Connector heater control box (wire 400) |
| 3 Terminal-circulating pump | 8 Connector wiring harness 10930473-to-MASTER switch |
| 4 Connector fuel pump | 9 Connector control circuit rectifier |
| 5 Terminal ground | 10 Connector driver's compartment bulkhead |

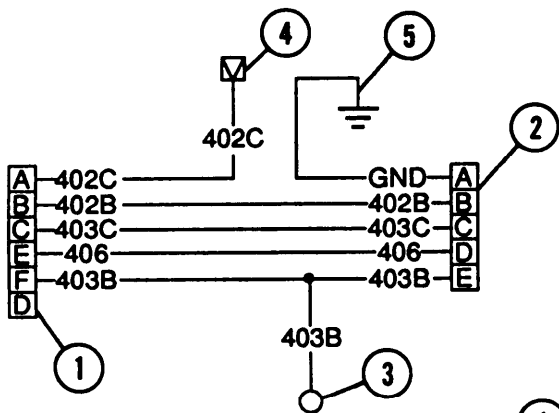

WIRING DIAGRAM

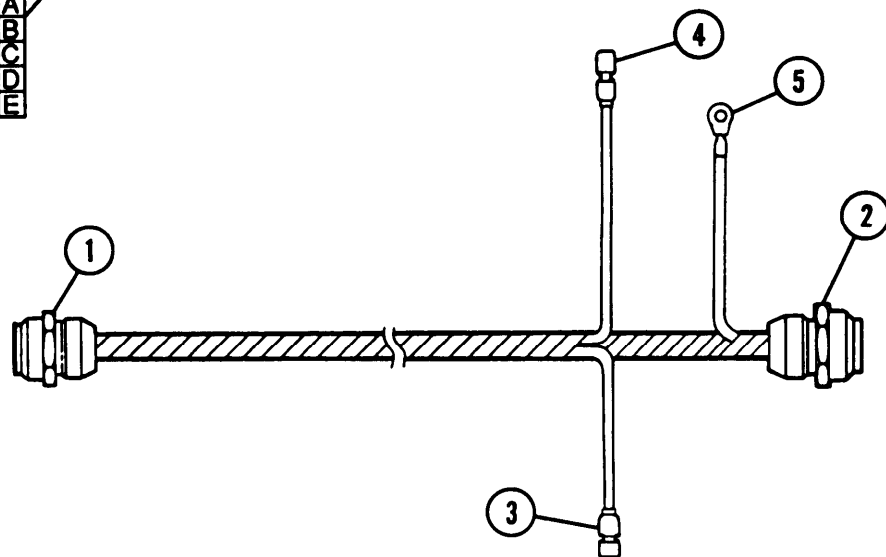

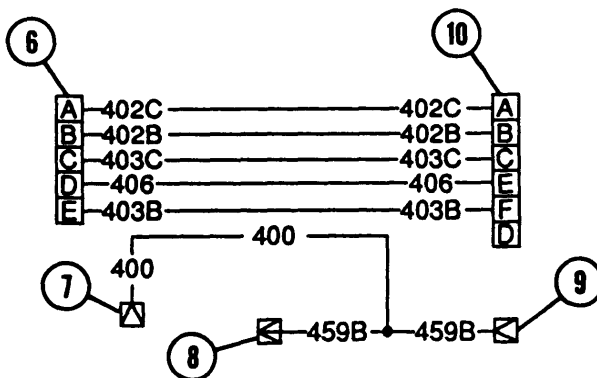

WIRING DIAGRAM

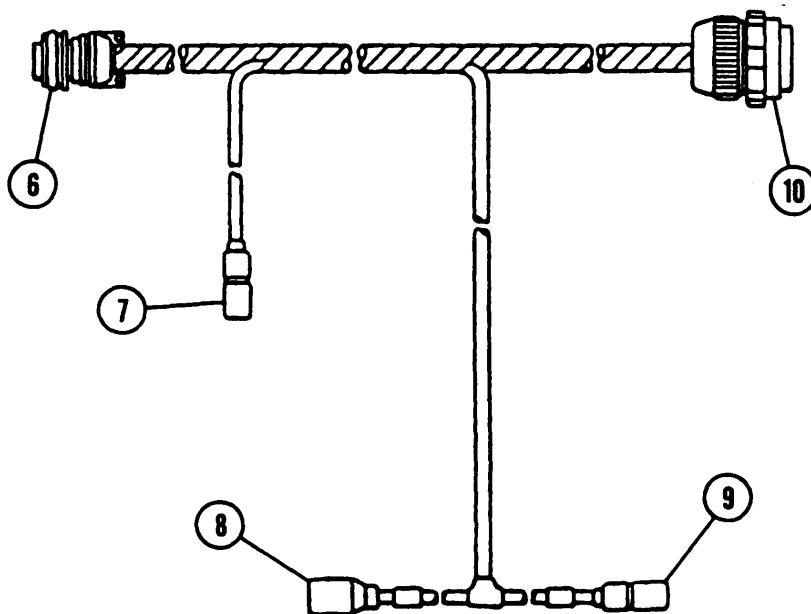

14-9 HEATER CONTROL BOX

This task covers: a. Removal b. Installation

INITIAL SETUP

Tools

General mechanic's tool kit (item 64, Appx H)

Materials/Parts

Lockwashers (2) (item 71, Appx G)

a. Removal

- 1 Disconnect plug (1) at heater control box (2).
- 2 Disconnect connector (3) at control box (2).
- 3 Remove two nuts (4), two lockwashers (5), and control box (2). Discard lockwashers.

b. Installation

- 1 Install heater control box (2), two new lockwashers (5), and two nuts (4).
- 2 Connect connector (3) at control box (2).
- 3 Connect plug (1) at control box (2).

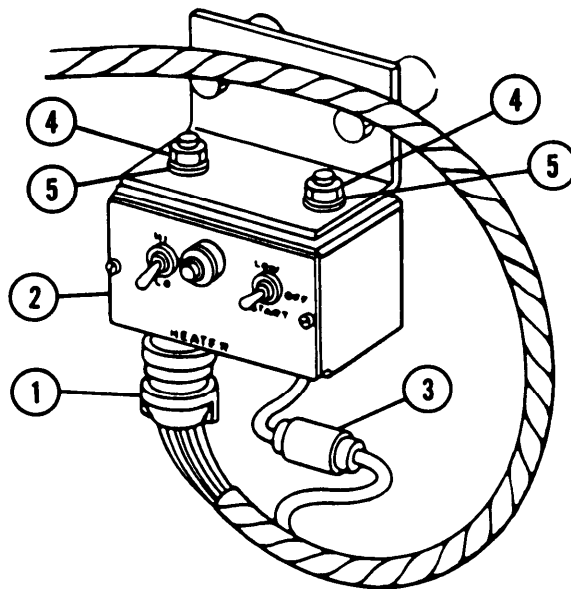

14-10 GRILLE COVERS

This task covers: a. Removal b. Installation

INITIAL SETUP

Tools

General mechanic's tool kit (item 64, Appx H)

a. Removal

NOTE

Steps 1 thru 3 apply to air intake grille cover (tarpaulin) removal.

- 1 Remove six screws (1) and six washers (2).
- 2 Disconnect 10 strap assemblies (3) and remove air intake grille cover (tarpaulin) (4).
- 3 Install six washers (2) and six screws (1).

NOTE

Steps 4 thru 6 apply to exhaust grille cover (tarpaulin) removal.

- 4 Remove five screws (5) and five washers (6).
- 5 Disconnect five strap assemblies (7) and remove exhaust grille cover (tarpaulin) (8).
- 6 Install five washers (6) and five screws (5).

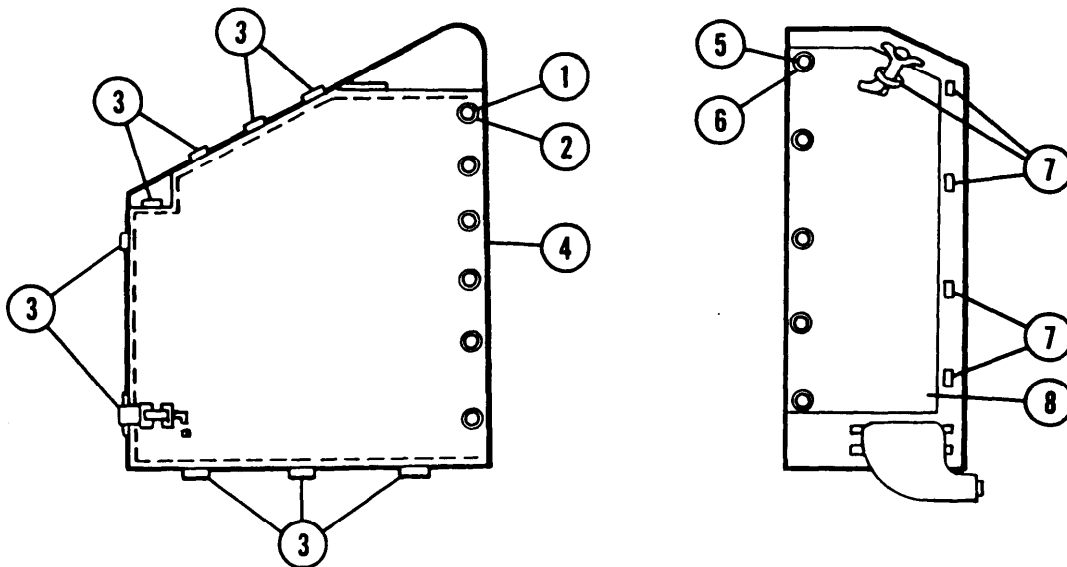

14-10 GRILLE COVERS — CONTINUED

b. Installation

NOTE

ŽPrior to installation, visually inspect for torn, deteriorated, or damaged covers (tarpaulins) and tiedown straps and repair or replace, or notify support maintenance.

ŽSteps 1 thru 3 apply to exhaust grille cover (tarpaulin) installation.

- 1 Remove five screws (5) and five washers (6).
- 2 Install exhaust grille cover (tarpaulin) (8) and connect five strap assemblies (7).
- 3 Install five washers (6) and five screws (5).

NOTE

Steps 4 thru 6 apply to air intake grille cover (tarpaulin) installation.

- 4 Remove six screws (1) and six washers (2).
- 5 Install air intake grille cover (tarpaulin) (4) and connect 10 strap assemblies (3).
- 6 Install six washers (2) and six screws (1).

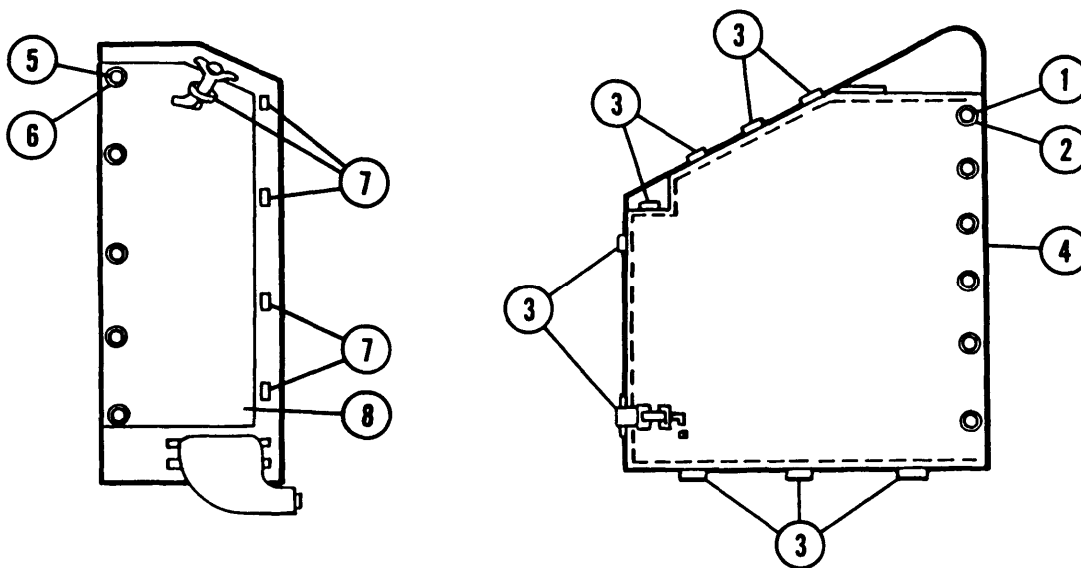

APPENDIX A REFERENCES

GENERAL

This appendix provides a list of regulations, tables, manuals, bulletins, forms, and pamphlets referenced in this manual. Appropriate indexes should be consulted frequently for latest applicable changes, revisions, and additions.

<u>CONTENTS</u>	<u>PAGE</u>
A-1 ARMY REGULATIONS	A-2
A-2 COMMON TABLES OF ALLOWANCES	A-2
A-3 DEPARTMENT OF DEFENSE FORMS	A-2
A-4 DEPARTMENT OF THE ARMY FORMS	A-2
A-5 DEPARTMENT OF THE ARMY PAMPHLETS	A-2
A-6 FIELD MANUALS	A-2
A-7 STANDARD FORMS	A-3
A-8 TECHNICAL BULLETINS	A-3
A-9 TECHNICAL MANUALS	A-3



A-1 ARMY REGULATIONS

Accident Reporting and Records	AR 385-40
Malfunctions Involving Ammunition and Explosives.	AR 75-1
Army Logistics Readiness and Sustainability.	AR 700-138

A-2 COMMON TABLES OF ALLOWANCES

Army Medical Department Expendable/Durable Items	CTA 8-100
Expendable/Durable Items (Except: Medical, Class V, Repair Parts and Heraldic Items).	CTA 50-970

A-3 DEPARTMENT OF DEFENSE FORMS

Preventative Maintenance Schedule and Record	DD Form 314
Processing and Reprocessing Record for Shipment, Storage, and Issue of Vehicles and Spare Engines	DD Form 1397

A-4 DEPARTMENT OF THE ARMY FORMS

Recommended Change to Publications and Blank Forms.	DA Form 2028
Recommended Change to Equipment Technical Manuals	DA Form 2028-2
Equipment inspection and Maintenance Worksheet	DA Form 2404
US Army Accident investigation Report.	DA Form 285

A-5 DEPARTMENT OF THE ARMY PAMPHLETS

The Army Maintenance Management System (TAMMS).	DA PAM 738-750
Functional Users Manual for The Army Maintenance Management System — Aviation (TAMMS_A)	DA PAM 738-751
Charging System Troubleshooting	DA PAM 750-33

A-6 FIELD MANUALS

NBC Decontamination	FM 3-5
Camouflage	FM 5-20
First Aid for Soldiers	FM 21-11

A-7 STANDARD FORMS

Report of Discrepancy SF 364
 Product Quality Deficiency Report.SF 368

A-8 TECHNICAL BULLETINS

Solder and Soldering TB SIG 222
 Use of Antifreeze Solutions and Cleaning Compounds in Engine Cooling Systems TB 750-651
 Domeight Lens ReplacementTB 9-2300-421-20
 Color Marking and Camouflage Painting of Military Vehicles, Construction Equipment
 and Materials Handling EquipmentTB 43-0209

A-9 TECHNICAL MANUALS

Chemical, Toxicological and Missile Fuel Handlers Protective Clothing TM 10-277
 Operator's Manual for Tester, Airflow, Gas Particulate Filter Unit: M39TM 3-6680-316-10
 Painting Instructions for Field Use..TM 43-0139
 Procedures for Destruction of Tank-Automotive Equipment to Prevent Enemy Use..... .TM 750-244-6
 Operator's Manual: Howitzer, Self-Propelled: 155MM, M109A2 (2350-01-031-0686),
 M109A3 (2350-01-031-8851), M109A4 (2350-01-277-5770) and M109A5
 (2350-01-281-1719) TM 9-2350-311-10
 Organizational Maintenance Manual for Cab, Armament, Sighting and Fire Control,
 Elevating and Traversing Systems and Associated Components Used on Howitzer,
 Medium, Self-Propelled: 155MM, M109A2 (2350-01-031-0586), M109A3
 (2350-01-031 -8851), M109A4 (2350-01-277-5770) and M109A5
 (2350-01-281-1719) TM 9-2350-311-20-2
 Organizational, Direct Support and General Support Maintenance Repair Parts and Special
 Tools Lists: Howitzer, Medium, Self-Propelled: 155MM, M109A2 (2350-01 -031 -0586),
 M109A3 (2350-01-031-8851), M109A4 (2350-01-277-5770) and M109A5
 (2350-01-281-1719) TM 9-2350-311-24P-1
 Field and Depot Maintenance Manual for Power Train Assembly (8351 100)
 (Allison Model XTG-411-2A). Composed of: Transfer Assembly, Transmission
 Input (NSN 2520-00-9535); Transmission Assembly (NSN 2520-00-894-9533); Drive
 Assembly, Transmission Output, Vehicle Left (NSN 2520-00-894-9534) and Drive
 Assembly, Transmission Output, Vehicle Right (NSN 2520-00-894-9532) TM 9-2520-234-35
 Standards for Inspection and Classification of Track Components and Solid
 Rubber Tires TM 9-2530-200-24
 General Maintenance Procedures for Fire Control Materiel TM 9-254
 Operator and Organizational Maintenance Manual Including Repair Parts and Special
 Tools Lists and Simplified Test Equipment for Internal Combustion Engines
 (STE/ICE) TM 9-4910-571-12&P
 Operator's, Organizational, Direct Support and General Support Maintenance
 Manual for Lead-Acid Storage Batteries TM 9-6140-200-14

APPENDIX B MAINTENANCE ALLOCATION CHART (MAC)

GENERAL

This Appendix contains the MAC and Tools and Test Equipment Requirements list.

<u>CONTENTS</u>		<u>PAGE</u>
Section I	INTRODUCTION	B-2
B-1	GENERAL	B-2
B-2	MAINTENANCE FUNCTIONS	B-2
B-3	EXPLANATION OF COLUMN ENTRIES IN THE MAC.	B-3
B-4	EXPLANATION OF COLUMNS IN TOOL AND TEST EQUIPMENT REQUIREMENTS	B-5
Section II	MAC	B-6
Section III	TOOL AND TEST EQUIPMENT REQUIREMENTS	B-24

SECTION I. INTRODUCTION

B-1 GENERAL

This introduction (Section 1) provides a general explanation of all maintenance and repair functions authorized at various maintenance levels under the standard Army Maintenance System concept. The MAC in Section II designates overall authority and responsibility for the performance of maintenance functions on the identified end item or component. The application of the maintenance function to the end item or component will be consistent with the capacities and capabilities of the designated maintenance levels. Section III lists the Special Tools and Test Equipment (both special tools and common tool sets) required for each maintenance function as referenced from Section II.

B-2 MAINTENANCE FUNCTIONS

Maintenance functions will be limited to and defined as follows (except for ammunition MAC):

a. Inspect

To determine the serviceability of an item by comparing its physical, mechanical and/or electrical characteristics with established standards through examination.

b. Test

To verify the serviceability by measuring the mechanical, pneumatic, hydraulic, or electrical characteristics of an item and comparing those characteristics with prescribed standards.

c. Service

Operations required periodically to keep an item in proper operating condition, i.e., to clean (decontaminate), to preserve, to drain, to paint, or to replenish fuel, lubricants, hydraulic fluids, or gasses.

d. Adjust

To maintain or regulate, within prescribed limits, by bringing into proper or exact position, or by setting the operating characteristics to specified parameters.

e. Aline

To adjust specified variable elements of an item to bring about optimum or desired performance.

f. Calibrate

To determine and cause corrections to be made or to be adjusted on instruments or test, measuring, and diagnostic equipment used in precision measurements. Consists of comparisons of two instruments, one of which is a certified standard of known accuracy, to detect and adjust any discrepancy in the accuracy of the instrument being compared.

g. Remove/Install

To remove and install the same item when required to perform service or other maintenance functions. Install may be

the act of emplacing, seating, or fixing into position an item, part, or module (component or assembly) in a manner to allow the proper functioning of the equipment or system.

h. Replace

The act of substituting of a serviceable like-type part, subassembly, or module (component or assembly) for an unserviceable counterpart.

i. Repair

The application of maintenance service or other maintenance actions to restore serviceability to an item by correcting specific damage, fault, malfunction, or failure in a part, subassembly, module (component or assembly), end item, or system.

j. Overhaul

That maintenance effort (service/action) necessary to restore an item to a completely serviceable/operational condition as prescribed by maintenance standards (i.e., DMWR) in appropriate technical publications. Overhaul is normally the highest degree of maintenance performed by the Army. Overhaul does not normally return an item to like-new condition.

k. Rebuild

Consists of those service/actions necessary for the restoration of unserviceable equipment to a like-new condition in accordance with original manufacturing standards. Rebuild is the highest degree of materiel maintenance applied to Army equipment. The rebuild operation includes the act of returning to zero those age measurements (hours/miles, etc.) considered in classifying Army equipment/components.

B-3 EXPLANATION OF COLUMN ENTRIES IN THE MAC

Columns used in the MAC will be limited to those shown. Entries for these columns are explained below:

a. Column 1

Group Number, Column 1 lists group numbers, the purpose of which is to identify components, assemblies, subassemblies, and modules with the next higher assembly.

b. Column 2

Component./Assembly, Column 2 contains the noun names of components, assemblies, subassemblies, and modules for which maintenance is authorized.

c. Column 3

Maintenance Functions, Column 3 lists the functions to be performed on the item listed in Column 2.

d. Column 4

Maintenance Category, Column 4 specifies, by the listing of a "work time" figure in the appropriate subcolumn(s), the lowest level of maintenance authorized to perform the function listed in Column 3. This figure represents the active time required to perform that maintenance function at the indicated category of maintenance. if the number or complexity of

B-3 EXPLANATION OF COLUMN ENTRIES IN THE MAC — CONTINUED

d. Column 4— Continued

the tasks within the listed maintenance function vary at different maintenance categories, the approximate "work time" figure represents the average time required to restore an item (assembly, subassembly, component, module, end item, or system) to a serviceable condition under typical operating condition. This time includes preparation time, troubleshooting time, and quality assurance/quality control time in addition to the time required to perform the specific tasks identified for the maintenance functions authorized in the MAC. This figure does not include anytime for performance of the preliminary tasks listed elsewhere in the MAC, e.g., removal of engine under repair of fuel pump when the engine is listed separately in the MAC. The symbol designations for the various maintenance levels are as follows:

- C — Operator or crew
- O — Unit maintenance
- F — Direct support maintenance
- H — General support maintenance
- P — Depot maintenance
- Work times are included in DMWR

e. Column 5

Tools and Equipment, Column 5 specifies by code, those common tool sets and special tools, test, and support equipment required to perform the designated function.

f. Column 6

Remarks, Column 6 contains an alphabetic code.

An exception is authorized for ammunition MAC to permit the redesignation of maintenance function headings to more adequately identify ammunition maintenance functions. The heading designations and definitions will be included in the appropriate technical manual for each category of ammunition.

Services — inspect, test, service, adjust, align, calibrate, or replace.

Actions — welding, grinding, riveting, straightening, facing, remachining, or resurfacing.

B-4 EXPLANATION OF COLUMNS IN TOOL AND TEST EQUIPMENT REQUIREMENTS

a. Reference Code

The tool and TMDE reference code correlates with a code used in the MAC, Section II, column 5.

b. Maintenance Level

The lowest level of maintenance authorized to use the tool or test equipment.

c. Nomenclature

Name or identification of the tool or test equipment.

d. National Stock Number

The national stock number or the tool or TMDE.

e. Tool Part No.

The user's part identification.

SECTION II. MAINTENANCE ALLOCATION CHART FOR M109A2/M109A3/M109A4/M109A5

(1) GROUP NO.	(2) COMPONENT/ASSEMBLY	(3) MAINTENANCE FUNCTION	(4) MAINTENANCE CATEGORY					(5) TOOLS AND EQUIP- MENT	(6) REMARKS
			c	O	F	H	D		
01	ENGINE								
0100	POWERPLANT	INSPECT		0.5					
		TEST		0.4				25,33	
		SERVICE	0.8					26,27, 29,31, 32,34	
		REPLACE		9.0				36	
	ENGINE	INSPECT		0.5					
		TEST		0.2				3	
		SERVICE	1.0						
		ADJUST			3.0				
		REPLACE			8.0			37	
		REPAIR			20.0	30.0			
		OVERHAUL					46.0		
	MOUNT, ENGINE	INSPECT		0.1					
		REPLACE		1.0				36	
		REPAIR		2.0					
0101	HEAD, CYLINDER	INSPECT			1.2				
		REPLACE			2.8				
		REPAIR			3.3	4.2			
0102	DAMPER, VIBRATION	INSPECT			0.5				
		REPLACE			0.5				
0103	FLYWHEEL	INSPECT			0.5				
		REPLACE			0.5				
		REPAIR			1.0				
3105	VALVES	INSPECT			3.4				
		ADJUST			1.0				
		REPLACE			1.0				

(1) GROUP NO.	(2) COMPONENT/ASSEMBLY	(3) MAINTENANCE FUNCTION	(4) MAINTENANCE CATEGORY					(5) TOOLS AND EQUIPMENT	(6) REMARKS
			c	o	F	H	D		
0106	VALVE FILLER CAP	REPAIR			1.0				
		INSPECT		0.3					
	FILTER, OIL	REPLACE		0.3					
		INSPECT		0.3					
		SERVICE		0.3					
		REPLACE		0.5					
	OIL PUMP	REPAIR		0.3					
		INSPECT			0.2				
		ADJUST				3.2			
		REPLACE				2.3			
		REPAIR				1.5			
	CORE, OIL COOLER	INSPECT			0.5				
		REPLACE			1.1				
		REPAIR			2.0				
0106	GAGE, OIL LEVEL	LINES AND FITTINGS (OIL EXTERNAL)	INSPECT	0.3					
		REPLACE		0.3					
0108	MANIFOLD, EXHAUST	INSPECT		0.1					
		REPLACE		0.3					
03	FUEL SYSTEM	INSPECT		0.2					
		REPLACE		2.0					
1301	INJECTOR, FUEL	INSPECT			3.2				
		TEST			0.2				
		ADJUST			0.1				
		REPLACE			0.2				
		REPAIR			0.7	1.5			
0302	PUMP, FUEL (AND HANGER ASSEMBLY), LEFT AND RIGHT	INSPECT		0.2					
		TEST		0.2					
		REPLACE		0.2					

**SECTION II. MAINTENANCE ALLOCATION CHART FOR M109A2/M109A3/M109A4/M109A5
— CONTINUED**

(1) GROUP NO.	(2) COMPONENT/ASSEMBLY	(3) MAINTENANCE FUNCTION	(4) MAINTENANCE CATEGORY					(5) TOOLS AND EQUIPMENT	(6) REMARKS	
			C	O	F	H	D			
0302 0304	PUMP, ENGINE FUEL	REPAIR			2.5					
		INSPECT		0.2						
	FUEL LINES, ENGINE	REPLACE		1.0						
		INSPECT		0.2						
	FUEL PUMP, ENGINE DRIVEN	REPLACE		0.5						
		INSPECT		0.5						
	FUEL PUMP, MECHANICAL	REPLACE		0.5						
		REPAIR		1.0						
	0304	AIR CLEANER (DRY)	REPLACE		0.1					
			INSPECT	0.1						
		FILTER	SERVICE	0.1						
			REPLACE		1.0					
		DUCTS	REPAIR		1.0					
			INSPECT	0.1						
HOSES		SERVICE	0.3							
		REPLACE		0.2						
MOTOR, AIR CLEANER BLOWER		INSPECT		0.3						
		REPLACE		1.0						
0305	BLOWER, INTAKE, ENGINE	REPAIR		1.5						
		INSPECT			0.1					
	BLOWER, INTAKE, ENGINE	REPLACE			0.4					
		REPAIR				0.2				

(1) GROUP NO.	(2) COMPONENT/ASSEMBLY	(3) MAINTENANCE FUNCTION	(4) MAINTENANCE CATEGORY					(5) TOOLS AND EQUIPMENT	(6) REMARKS
			c	o	F	H	D		
0306	SHAFT, BLOWER DRIVE	REPAIR				2.0			
		INSPECT			0.2				
		REPLACE			0.5				
	TURBOCHARGER LINES	INSPECT	0.3						
		REPLACE	0.5						
	TURBOCHARGER	INSPECT			0.2				
		REPLACE			0.3				
	HOUSING, AIR INLET	REPAIR				8.9			
		OVERHAUL							
	HOUSING HOSES, AIR INLET	INSPECT		0.1					
		REPLACE			0.2				
	TANK, FUEL	INSPECT	0.2	0.2					
		SERVICE	0.3	1.5					
		REPLACE			10.0				
REPAIR				16.0					
LINES AND FITTINGS	INSPECT	0.3							
	REPLACE		2.0						
GOVERNOR, ENGINE	FUEL SYSTEM AIR PURGE PUMP	TEST		0.1					
	REPLACE		2.0						
0308	GOVERNOR, ENGINE	INSPECT			0.2				
		TEST			0.2				
		SERVICE			0.2				
		ADJUST			0.2				
		REPLACE			0.3				
0309	ELEMENT AND GASKET, FUEL FILTER (PRIMARY)	REPAIR			0.3	2.6			
		REPLACE		0.2					

**SECTION II. MAINTENANCE ALLOCATION CHART FOR M109A2/M109A3/M109A4/M109A5
— CONTINUED**

(1) GROUP NO.	(2) COMPONENT/ASSEMBLY	(3) MAINTENANCE FUNCTION	(4) MAINTENANCE CATEGORY					(5) TOOLS AND EQUIP- MENT	(6) REMARKS
			c	O	F	H	D		
0311	ELEMENT AND GASKET, FUEL FILTER SECONDARY)	REPLACE		0.2					
		FILTER, FUEL (PRIMARY AND SECONDARY)	INSPECT	0.1					
	HEATER, ENGINE AIR BOX	SERVICE	0.2						
		REPLACE		0.3					
		INSPECT		0.2					
		TEST	0.3						
0312	CONTROLS AND LINKAGE, ACCELERATOR AND THROTTLE	REPLACE		2.0					
		REPAIR		3.0					
		INSPECT	0.2						
		SERVICE		0.2					
		ADJUST		0.2					
04	EXHAUST SYSTEM	REPLACE		2.0					
		REPAIR		1.0					
		INSPECT	0.2						
		REPLACE		0.5					
0401	PIPE, EXHAUST	INSPECT	0.2						
		REPLACE		0.5					
05	COOLING SYSTEM	INSPECT	0.2						
		SERVICE	0.1					45	
0501	RADIATOR	REPLACE		1.5					
		REPAIR			1.0				
		INSPECT	0.2						
		REPLACE		0.3					
		INSPECT		0.1					
	SURGE TANK	INSPECT	0.2						
		REPLACE		0.3					
	DETECTOR, AERATION	INSPECT		0.1					

(1) GROUP NO.	(2) COMPONENT/ASSEMBLY	(3) MAINTENANCE FUNCTION	(4) MAINTENANCE CATEGORY					(5) TOOLS AND EQUIPMENT	(6) REMARKS
			C	O	F	H	D		
0502	SHROUD, RADIATOR	REPLACE		0.3					
		INSPECT	0.2						
0503	OUTLET HOUSING, WATER	REPLACE		2.2					
		REPAIR			0.5				
		INSPECT	0.1						
		REPLACE		0.3					
0504	THERMOSTATS	REPAIR		0.4					
		INSPECT		0.1					
		REPLACE		0.5			54, 58		
		INSPECT	0.2						
0505	HOSES AND PIPES	REPLACE		0.4					
		INSPECT	0.1						
		REPLACE			1.0				
0506	PUMP, COOLANT	REPAIR			1.5				
		INSPECT	0.1						
		REPLACE			3.0				
		REPAIR			3.0				
0601	FAN DRIVE ASSEMBLY	INSPECT		0.2					
		SERVICE		0.2	0.2				
		REPLACE			3.5				
		REPAIR			3.0				
		INSPECT	0.1						
		REPLACE			0.3				
		INSPECT		1.9					
		SERVICE			0.5				
0602	HOUSING, FAN DRIVE	REPLACE			2.0		62		
		REPAIR			1.0	4.0			
		TEST			0.3				
		REPLACE			2.0				
0603	VANEAXIAL FAN ASSEMBLIES (OIL FILLED)	REPAIR			1.0				
		TEST			0.3				
		REPLACE			2.0				
		REPAIR			1.0				
0604	ELECTRICAL SYSTEM	TEST			0.3				
		REPLACE			2.0				
		REPAIR			1.0				
		REPAIR			0.3	2.4			
0605	ALTERNATOR	INSPECT		0.3					
		TEST		0.2					
		REPLACE		1.0					
		REPAIR			0.3	2.4			

**SECTION II. MAINTENANCE ALLOCATION CHART FOR M109A2/M109A3/M109A4/M109A5
— CONTINUED**

(1) GROUP NO.	(2) COMPONENT/ASSEMBLY	(3) MAINTENANCE FUNCTION	(4) MAINTENANCE CATEGORY					(5) TOOLS AND EQUIPMENT	(6) REMARKS
			c	O	F	H	D		
0602	REGULATOR, VOLTAGE	TEST		1.0					
		ADJUST		1.0					
		REPLACE		0.3					
0603	STARTER	INSPECT		0.2					
		TEST		0.5					
		REPLACE		1.0					
		REPAIR			2.0				
	RELAY, STARTER	INSPECT		0.1					
		TEST		0.2					
		REPLACE		0.2					
	RELAY, MASTER	INSPECT		0.1					
		TEST		0.2					
		REPLACE		0.2					
0606	RELAY, STARTER PROTECTION	INSPECT	0.1						
		TEST		0.3					
		REPLACE		1.0					
0607	INSTRUMENT CONTROL PANELS AND ACCESSORY PANEL ASSEMBLIES	INSPECT	0.1						
		TEST		0.3					
		REPLACE		2.0					
		REPAIR		0.6					
	LIGHT	INSPECT	0.1						
		TEST		0.2					
		REPLACE		0.2					
	SWITCHES	INSPECT	0.1						
		TEST		0.2					
		REPLACE		0.5					

(1) GROUP NO.	(2) COMPONENT/ASSEMBLY	(3) MAINTENANCE FUNCTION	(4) MAINTENANCE CATEGORY					(5) TOOLS AND EQUIPMENT	(6) REMARKS
			c	o	F	H	D		
0608	GAGES	INSPECT	0.1					40,41	
		TEST		0.3					
		REPLACE		1.0					
0609	RECTIFIER ASSEMBLY	TEST			0.2				
		REPLACE		0.2					
		REPAIR			2.0				
0610	LIGHTS	INSPECT	0.1						
		TEST		0.2					
		REPLACE		0.2					
		REPAIR		0.2					
0612	SWITCHES, WARNING	TEST		0.2					
		REPLACE		0.3					
		UNITS, SENDING		0.1					
0613	BATTERY, STORAGE	TEST		0.2					
		REPLACE		0.5					
		INSPECT	0.1						
		TEST		0.2					
		SERVICE	0.1	0.2					
0613	CABLE, BATTERY	REPLACE		1.0					
		REPAIR			1.0				
		INSPECT	0.1						
		TEST		0.2					
		SERVICE	0.1	0.2					
		REPLACE		0.6					
0613	WIRING HARNESS, HULL	INSPECT		0.3					
		TEST		0.5					
		REPLACE			2.0				
		REPAIR		1.5					
0613	ENGINE DISCONNECT BRACKET TO BULKHEAD WIRING HARNESS	INSPECT		0.3					
		TEST		0.5					
		REPLACE			2.0				
0613	REPAIR			1.5					

**SECTION II. MAINTENANCE ALLOCATION CHART FOR M109A2/M109A3/M109A4/M109A5
— CONTINUED**

(1) GROUP NO.	(2) COMPONENT/ASSEMBLY	(3) MAINTENANCE FUNCTION	(4) MAINTENANCE CATEGORY					(5) TOOLS AND EQUIP- MENT	(6) REMARKS
			c	o	F	H	D		
	POWER LEAD WIRING HARNESS	INSPECT		0.3					
		TEST		0.5					
		REPLACE			2.0				
		REPAIR		1.5					
	ACCESSORY CONTROL BOX TO HEATER/BLOWER WIRING HARNESS	INSPECT		0.3					
		TEST		0.5					
		REPLACE		2.0					
		REPAIR							
	PORTABLE INSTRUMENT PANEL WIRING HARNESS	INSPECT		0.3					
		TEST		0.5					
		REPLACE		2.0					
		REPAIR		1.5					
	DRIVER'S INSTRUMENT PANEL WIRING HARNESS	INSPECT		0.3					
		TEST		0.5					
		REPLACE		2.0					
		REPAIR							
	3ULKHEAD TO DRIVER'S INSTRUMENT PANEL WRING HARNESS	INSPECT		0.3					
		TEST		0.5					
		REPLACE			2.0				
		REPAIR			1.5				
	BULKHEAD TO HEAD- LIGHT/BILGE PUMP WIRING HARNESS	INSPECT		0.3					
		TEST		0.5					

(1) GROUP NO.	(2) COMPONENT/ASSEMBLY	(3) MAINTENANCE FUNCTION	(4) MAINTENANCE CATEGORY					(5) TOOLS AND EQUIPMENT	(6) REMARKS
			c	o	F	H	D		
		REPLACE			2.0				
		REPAIR		1.5					
	POWERPLANT WIRING HARNESS	INSPECT		0.2					
		TEST		1.0					
		REPLACE		2.0					
		REPAIR		2.0					
	MISC ACCESSORY LEADS AND HARNESSES	INSPECT		0.5					
		TEST		0.5					
		REPLACE		0.5					
		REPAIR		1.0					
	BULKHEAD-TO-PORTABLE INSTRUMENT PANEL WIRING HARNESS	INSPECT		0.3					
		TEST		0.5					
		REPLACE			2.0				
		REPAIR			1.5				
	RECTIFIER-TO-VOLTAGE REGULATOR WIRING HARNESS	INSPECT		0.3					
		TEST		0.5					
		REPLACE		2.0					
		REPAIR		0.5					
	DRIVER'S BULKHEAD-TO-MASTER RELAY WIRING HARNESS	INSPECT		0.3					
		TEST		0.5					
		REPLACE			0.5				
		REPAIR		0.5					
	DIODE HARNESS ASSEMBLY	INSPECT		0.3					
		TEST		0.5					
		REPLACE		2.0					

**SECTION II. MAINTENANCE ALLOCATION CHART FOR M109A2/M109A3/M109A4/M109A5
— CONTINUED**

(1) GROUP NO.	(2) COMPONENT/ASSEMBLY	(3) MAINTENANCE FUNCTION	(4) MAINTENANCE CATEGORY					(5) TOOLS AND EQUIP- MENT	(6) REMARKS
			c	O	F	H	D		
0616	BLOWER, VENTILATING	TEST		0.2					
		REPLACE		0.5					
		REPAIR			1.0				
07	TRANSMISSION								
0705	CONTROL ASSEMBLY, SHIFTING LINKAGE	INSPECT	0.2						
		SERVICE	0.2						
		ADJUST		0.2					
		REPLACE		3.6					
		REPAIR		2.0					
0710	TRANSMISSION ASSEMBLY CROSS-DRIVE	INSPECT	0.2						
		TEST		0.3				3	
		SERVICE	0.2						
		ADJUST		0.2					67,68, 51
		REPLACE			5.0				2,6
		REPAIR			11.0	14.0			
		OVERHAUL						*	
0721	FILTER, OIL	SERVICE		0.1					
		REPLACE		0.1					
08	FINAL DRIVE ASSEMBLY								
0801	POWER TRANSFER ASSEMBLY	INSPECT		0.1					
		REPLACE			1.0				
		REPAIR			2.0	3.0			
		OVERHAUL						*	
	DRIVE ASSEMBLY, FINAL	INSPECT	0.1						
		SERVICE		0.1					

(1) GROUP NO.	(2) COMPONENT/ASSEMBLY	(3) MAINTENANCE FUNCTION	(4) MAINTENANCE CATEGORY					(5) TOOLS AND EQUIPMENT	(6) REMARKS	
			c	o	F	H	D			
12	BRAKES	REPLACE		2.5				1,4, 5,7		
		REPAIR			7.0					
		OVERHAUL					4.0			
1201	PARKING BRAKES	INSPECT	0.1							
		ADJUST		0.2						
		REPLACE		1.5						
		REPAIR		1.0						
1206	MECHANICAL BRAKE SYSTEM, SERVICE BRAKE CONTROLS AND LINKAGE	INSPECT	0.2							
		SERVICE	0.2							
		ADJUST		0.5						
		REPLACE		1.0						
		REPAIR		1.0						
13	WHEELS AND TRACKS									
1301	ARM AND HUB ASSEMBLY, ROAD WHEEL	INSPECT	0.1							
		SERVICE	0.2							
		REPLACE		1.0						
		REPAIR		0.7	2.0	2.1		11, 17, 18, 19, 20, 21, 22		
		OVERHAUL								
	DISC ASSEMBLY, ROAD WHEEL	INSPECT		0.1				10		
		REPLACE		0.5				2		
		REBUILD								
	ANCHOR, TORSION BAR	REPLACE		1.0						
	TORSION BAR	INSPECT	0.2							
		REPLACE		1.0				8, 15,24		
303	ARM ASSEMBLY COMPENSATING IDLER	INSPECT	0.1							

**SECTION II. MAINTENANCE ALLOCATION CHART FOR M109A2/M109A3/M109A4/M109A5
— CONTINUED**

(1) GROUP NO.	(2) COMPONENT/ASSEMBLY	(3) MAINTENANCE FUNCTION	(4) MAINTENANCE CATEGORY					(5) TOOLS AND EQUIPMENT	(6) REMARKS
			C	O	F	H	D		
1304	IDLER WHEEL	SERVICE	0.2					9, 13 or 59	
		REPLACE		2.0					
		REPAIR		1.7	3.0				
		INSPECT	0.1						
		REPLACE		1.0					
	LINK COMPENSATING, TRACK ADJUSTING	INSPECT	0.1						
		ADJUST	0.3						
		REPLACE		1.5					
		REPAIR		1.0					
		INSPECT	0.2						
1305	HUB AND SPROCKETS, DRIVE	REPUCE		2.0					
		INSPECT	1.0						
		ADJUST	1.0						
14	TRACK ASSEMBLY	REPLACE		4.0					
		REPAIR		1.5					
		REPLACE		1.0					
	SHOE ASSEMBLY	REPAIR		0.5					
		STEERING CONTROLS							
		STEERING CONTROLS							
1401	STEERING CONTROLS	INSPECT	3.3						
		SERVICE	3.2						
		ADJUST		0.2					
		REPLACE		2.0					
		REPAIR		2.0					
		15	FRAME, TOWING ATTACHMENTS, AND DRAWBARS						

(1) GROUP NO.	(2) COMPONENT/ASSEMBLY	(3) MAINTENANCE FUNCTION	(4) MAINTENANCE CATEGORY					(5) TOOLS AND EQUIPMENT	(6) REMARKS
			C	O	F	H	D		
16	TOWING HOOKS	SERVICE	0.1						
		REPLACE		0.5					
		SERVICE	0.3						
		REPLACE	0.1						
1604	SHOCK ABSORBER	REPLACE		1.0					
		BEARING, SHOCK ABSORBER		0.5					
1801	BODY, CAB, HOOD AND HULL COVERS, PLATES, AND DOORS	INSPECT	0.5						
		REPLACE		2.0					
		REPAIR		2.0					
		TRAVEL LOCK	INSPECT	0.1					
		SERVICE	0.1						
		ADJUST		0.2					
		REPLACE		1.0					
		REPAIR		1.0					
		FENDERS	INSPECT	0.2					
		REPLACE		1.0					
		REPAIR		1.0					
		1803	DRIVER'S HATCH	INSPECT	0.2				
SERVICE	0.2								
REPLACE				1.0					
REPAIR				1.0					
1804	SUBFLOOR DRAINS	INSPECT	0.2						
		SERVICE		0.3					
		REPLACE		0.2					
		REPAIR		0.2					

**SECTION II. MAINTENANCE ALLOCATION CHART FOR M109A2/M109A3/M109A4/M109A5
— CONTINUED**

(1) GROUP NO.	(2) COMPONENT/ASSEMBLY	(3) MAINTENANCE FUNCTION	(4) MAINTENANCE CATEGORY					(5) TOOLS AND EQUIPMENT	(6) REMARKS
			c	O	F	H	D		
1806	SEAT ASSEMBLY, DRIVER'S AND CREW	INSPECT	0.1						
		SERVICE	0.2						
		REPLACE		2.0					
		REPAIR		1.5					
1808	STOWAGE BOXES BRACKETS AND STRAPS	INSPECT	0.5						
		SERVICE	0.2						
		REPLACE		2.0					
		REPAIR		2.5					
20	SPADE								
2005	SPADE AND RELATED PARTS	INSPECT	0.2						
		SERVICE	0.5						
		ADJUST		0.2					
		REPLACE		2.0					
		REPAIR		2.0					
22	BODY, CHASSIS, OR HULL ACCESSORY ITEMS								
2205	BILGE PUMP	INSPECT		0.2					
		REPLACE		0.5					
		REPAIR			1.0				
2207	HEATER, PERSONNEL	INSPECT	0.2						
		TEST		0.2					
		SERVICE		0.2					
		ADJUST		0.2					
		REPLACE		2.0					
		REPAIR			3.5				

(1) GROUP NO.	(2) COMPONENT/ASSEMBLY	(3) MAINTENANCE FUNCTION	(4) MAINTENANCE CATEGORY					(5) TOOLS AND EQUIPMENT	(6) REMARKS
			c	o	F	H	D		
2210	DATA PLATES & INSTRUCTION HOLDERS	INSPECT	0.2						
		REPLACE		0.5	0.5				
33	SPECIAL PURPOSE KITS								
3301	REUSABLE SHIPPING CONTAINERS	REPAIR		0.5	0.5				
		OVERHAUL							
3303	WINTERIZATION KIT	INSPECT		0.2					
		INSTALL		3.0	9.0				
		REPAIR		1.5	3.0				
3303	WINTERIZATION KIT, EXHAUST OUTLET	REPLACE		0.3					
	BATTERY HEATER AND INSULATION BOXES	REPLACE		1.0					
	COOLANT PUMP	REPLACE		0.3					
	FUEL PUMP	REPLACE		0.5					
	FUEL FILTER	INSPECT		0.3					
		REPLACE		0.3					
		REPAIR		0.5					
	COOLANT HEATER	INSPECT			0.5				
		TEST			1.0				
		REPLACE		1.0					
		REPAIR			2.0				
	COOLANT HEATER WIRING HARNESSSES	REPLACE		0.5					
	HEATER CONTROL BOX	REPLACE		0.5					
	GRILLE COVERS	REPLACE		0.5					
	WINTERIZATION KIT (COMPLETE)	INSTALL			9.0				
3307	AOAP ASSEMBLY	SERVICE	0.3						
		INSTALL		1.0					
		REPLACE		1.0					

**SECTION II. MAINTENANCE ALLOCATION CHART FOR M109A2/M109A3/M109A4/M109A5
— CONTINUED**

(1) GROUP NO.	(2) COMPONENT/ASSEMBLY	(3) MAINTENANCE FUNCTION	(4) MAINTENANCE CATEGORY					(5) TOOLS AND EQUIPMENT	(6) REMARKS
			c	o	F	H	D		
47	WEIGHING AND MEASURING DEVICES								
4701	SPEEDOMETER, TACHOMETER, AND RELATED PARTS	INSPECT	0.2						
		TEST		0.5					
		SERVICE			0.5				
		REPLACE			1.0				
4702	GAGES MOUNTINGS, LINES AND FITTINGS	INSPECT	0.1						
		REPLACE			0.5				
		REPAIR			0.5				
76	FIXED FIRE FIGHTING EQUIPMENT COMPONENTS								
7639	CONTROLS	INSPECT	0.2						
		REPLACE			1.0				
		REPAIR			1.0				
	CYLINDER ASSEMBLY, FIXED	INSPECT	0.1						
		REPLACE			1.0				
		REPAIR			1.0				
	LINES AND TUBES	INSPECT		0.3					
		REPLACE			1.0				
		REPAIR			1.0				
91	NUCLEAR, BIOLOGICAL AND CHEMICAL WARFARE EQUIPMENT								
9110	NBC HOSES AND CONNECTORS	INSPECT	0.2						
		REPLACE			0.3				

(1) GROUP NO.	(2) COMPONENT/ASSEMBLY	(3) MAINTENANCE FUNCTION	(4) MAINTENANCE CATEGORY					(5) TOOLS AND EQUIP- MENT	(6) REMARKS
			c	O	F	H	D		
9111	NBC HEATER	INSPECT	0.1						
		TEST		0.2					
	REPLACE		1.0						
	REPAIR		0.1						
	AIR PURIFIER	TEST		0.3					
		REPLACE		1.0					
		REPAIR		1.0	3.0				

SECTION III. TOOL AND TEST EQUIPMENT REQUIREMENTS

REFERENCE CODE	MAINTENANCE LEVEL	NOMENCLATURE	NATIONAL/NATO STOCK NUMBER	TOOL PART NO.
TRANSMISSION				
1	0	BOLT, EYE: Used with sling 5120-00-034-0875 to remove or install final drive assembly	5306-00-050-0347	MS51937-5 (96906)
2	F	BRACKET, LIFTING: Used with sling 4910-00-473-7556 to lift transmission after separation of engine and transmission	5340-00-977-5580	8355697
3	o	GAGE, PRESSURE, DIAL INDICATING: To check engine and transmission oil pressure	6685-00-572-8612	8356176
4	0	PIN, GUIDE: To install final drive assembly	5315-00-034-0883	10914195
5	0	SLING, LIFTING, FINAL DRIVE: Used with eye bolt 5306-00-050-0347 to remove or install final drive assembly	4910-00-034-0875	10914179
6	F	SLING, TRANSMISSION LIFTING: Used with bracket 4910-00-977-5580 to lift transmission after separation of engine and transmission	4910-00-473-7556	7081593
7	o	WRENCH, STRAP: To aline transmission output shaft and final drive input shaft	5120-00-357-9154	7676003 41-W-3382
SUSPENSION				
8	0	ADAPTER, MECHANICAL PULLER: used with puller 5120-00-557-3615 to remove or install torsion bars	5120-01-017-5328	12251805
9	c, o	FIXTURE, TRACK CONNECTING: To disconnect or connect track (with bar)	5120-00-605-3926	8741739
10	0	GAGE AND CASE ASSEMBLY: Road wheel wear plate	4910-00-034-0874	10911904
11	0, F	HANDLE, REPLACER: Used with bearing cup and oil seal replacers	5120-00-034-0884	10914196
12	o	LIFTER, ROAD WHEEL To raise road wheel	4910-00-912-4469	11593605
13	0	PULLER, END CONNECTOR, TRACK: To remove double pin track end connector	5120-01-051-4150	11669394-2
14	0	PULLER, SHOCK ABSORBER: To remove shock absorber	5120-00-084-7626	10913972
15	0	PULLER, SLIDE HAMMER TYPE: Used with adapter 5120-00-322-5953 to remove or install torsion bar	5120-00-557-3615	5573615
16	0	REMOVE AND REPLACER: To remove and replace shock absorber bearer	5120-00-084-7627	C-DTA-94390 10925993

REFERENCE CODE	MAINTENANCE LEVEL	NOMENCLATURE	NATIONAL/NATO STOCK NUMBER	TOOL PART NO.
17	O	REPLACER, BEARING CUP: Used with handle 5120-00-034-0884 to replace road wheel hub inner bearing cup	5120-00-034-0880	10914187
18	O, F	REPLACER, BEARING CUP: Used with handle 5120-00-034-0884 to replace road wheel hub outer bearing cup	5120-00-034-0885	10914197
19	F	REPLACER: Upper spindle arm retainer oil seal; used with handle 10914196	5120-00-034-0881	10914188
20	F	REPLACER: Upper spindle arm support housing oil seal; used with handle 10914196	5120-00-034-0878	10914185
21	O, F	REPLACER: Wheel hub inner oil seal; used with handle 10914196	5120-00-034-0879	10914186
22	F	WRENCH, PRONG: Used on spindle arm support bearing adjusting nut	5120-00-034-0867	10914193
23	o	WRENCH SET, SPANNER: Used on track adjuster nut	5120-00-516-3863	MS8516-1
24	O	WRENCH, TORSION BAR RETAINING NUT: To remove or install torsion bar retaining nut	5120-00-708-3642	7083642
POWERPLANT				
25	O, F	ADAPTER, STRAIGHT PIPE-TO-TUBE: Used with hose assembly 4720-00-080-8586 to operate powerplant out of vehicle	4730-00-266-0541	MS39158-7 (96906)
26	O, F	CABLE ASSEMBLY, GROUND: Powerplant-to-vehicle ground to operate powerplant out of vehicle	5995-00-084-0789	10913655
27	O, F	CABLE ASSEMBLY, POWER ELECTRICAL: Rectifier-to-alternator to operate powerplant out of vehicle	6145-00-930-8764	11605054
28	O, F	CABLE ASSEMBLY, POWER ELECTRICAL: Rectifier-to-alternator to operate powerplant out of vehicle	6150-01-320-4733	12268426
29	O, F	CABLE ASSEMBLY, POWER ELECTRICAL STARTER & MASTER WARNING CIRCUIT: To operate powerplant out of vehicle	6150-01-115-2276	12268162
30	O, F	CABLE ASSEMBLY, POWER ELECTRICAL STARTER CIRCUIT: To operate powerplant out of vehicle	6150-01-3244386	12268427
31	O, F	COUPLING ASSEMBLY, QUICK-DISCONNECT: Used with hose assembly 4720-00-080-8588 to operate powerplant out of vehicle	4730-00-738-8571	7388571

SECTION III. TOOL AND TEST EQUIPMENT REQUIREMENTS — CONTINUED

REFERENCE CODE	MAINTENANCE LEVEL	NOMENCLATURE	NATIONAL/NATO STOCK NUMBER	TOOL PART NO.
32	O, F	HOSE ASSEMBLY, NONMETALLIC: Used for fuel supply and fuel return to operate powerplant out of vehicle	4720-00-080-8586	8708306
33	O, F	LEAD, ELECTRICAL, ENGINE STARTER: Starter power to operate powerplant out of vehicle	5995-00-064-0793	10914183
34	O, F	SCREEN, SAFETY: Turbocharger inlet to operate powerplant out of vehicle	4910-00-084-0790	10913779
35	O, F	SCREEN, PROTECTIVE FAN: To protect mechanic's fingers when engine is running	2510-01-247-2976	12268262
36	O	SLING, LIFTING, POWERPLANT: To remove or install powerplant	4910-00-295-8074	11652649
37	O	SLING, MULTIPLE LEG: Used for lifting engine during and after separation of engine and transmission	3940-00-977-7398	10930560
38	O	WRENCH, BOX SPECIAL To remove or install powerplant mount support	5120-00-051-5567	11605662
MISCELLANEOUS				
39	O	ADAPTER SOCKET: 1/2 in. male square end, 3/8 in. female square end	5120-00-240-8703	GGG-W-641
40	O	AUTOMOTIVE MAINTENANCE COMMON NO. 1 TOOL KIT	4910-00-754-0654	SC 4910-95-A74
41	O	AUTOMOTIVE MAINTENANCE COMMON NO. 2 TOOL KIT	4910-00-754-0650	SC 4910-95-A72
42	F	BAR, MEASURING	Fabricated Tool	Appx D, TM 9-2350-311-34-1
43	F	BIT, DRILL	5130-00-189-9324	10034
44	F	BRACKET, FABRICATED	Fabricated Tool	Appx D, TM 9-2350-311-34-1
45	C, O	CLEANING TOOL, RADIATOR: To remove sand, oil, and other debris from radiator cooler fins	4910-00-494-8257	11641959
46	F, H	CRADLE ASSEMBLY	4910-00-795-0198	7950198
47	F, H	DRIP PAN	4930-00-545-8639	8708359
48	F, H	ENGINE MOUNTING BRACKET	5340-00-737-0432	10903999
49	F, H	ENGINE STAND: Used to support engine after separation from transmission and transfer case	4910-00-795-0189	7950189

REFERENCE CODE	MAINTENANCE LEVEL	NOMENCLATURE	NATIONAL/NATO STOCK NUMBER	TOOL PART NO.
50	F,H	FINAL DRIVE WORK STAND: Allow for torquing of final drive assembly nut	Fabricated Tool	Appx D, TM 9-2350-311-34-1
51	O	GAGE: Brake adjusting	5120-00-733-5005	8351213
52	O	GAGE, SPROCKET WEAR: To check sprocket wear	5120-00-757-2745	10941458
53	F	GROWLER	6625-00-828-5810	TS965U
54	O	HANDLE, INSTALLER: Used with installer 5120-00-977-5579 to install thermostat housing seal	5120-00-977-5578	J-7079-2 (33287)
55	O	HOSE: Three-foot length. Used to test operation of left and right in-tank fuel pumps	4720-01-081-2764	MS28759-G-0330
56	F	INDICATOR, DIAL	5210-00-277-8840	196A
57	F, H	INDICATOR, DIAL: Used to perform static balance test on air cleaner blower motor impeller	5210-01-145-5803	CM260
58	O	INSTALLER, SEAL: Used with handle 5120-00-977-5578 to install thermostat housing seal	5120-00-977-5579	J-8550 (33887)
59	O	KIT, T-154 TRACK CONNECTOR PULLER		57K3156
60	F	LATHE	1334-MIL	
61	F, H	REMOVAL/INSTALLATION TOOL: Used to remove nut from bilge pump	Fabricated Tool	Appx D, TM 9-2350-311-34-1
62	F, H	SOCKET: Used to remove and install fan impeller nut	5120-01-255-8232	12268253
63	F, H	SOCKET: Used to torque final drive assembly nut	5130-00-076-8631	IM 1123
64	O	TA-1 PROBE KIT: Used to troubleshoot electrical system	6625-01-102-6878	12303622
65	O	TESTER, AIRFLOW: Tests gas particulate filter unit	6680-00-436-4212	E5-77-2120
66	O	TEST SET, STE-ICE/R: Used for STE/ICE-R testing	4910-01-222-6589	12259266
67	O	WRENCH, SPLINED BRAKE ADJUSTMENT: To check left brake adjustment	3040-00-733-8912	8351387
68	O	WRENCH, SPLINED BRAKE ADJUSTMENT: To check right brake adjustment	3040-00-733-8909	8351386
69	O	WRENCH, TORQUE: Used to torque surge tank and pressure relief valve hose clamps	5120-00-221-7983	9177382

**APPENDIX C
REPAIR PARTS AND SPECIAL TOOLS LIST**

Refer to TM 9-2350-311-24P-1 for a complete list of repair parts and special tools.



APPENDIX D EXPENDABLE AND DURABLE ITEMS LIST

General

This appendix provides a list of expendable supplies and materials you will need to operate and maintain the M109A2/M109A3/M109A4/M109A5 Howitzer.

<u>CONTENTS</u>		<u>PAGE</u>
Section I	INTRODUCTION	D-2
D-1	SCOPE	D-2
D-2	EXPLANATION OF COLUMNS	D-2
Section II	EXPENDABLE AND DURABLE ITEMS LIST	D-3

SECTION I. INTRODUCTION

D-1 SCOPE

This appendix lists expendable supplies and materials you will need to operate and maintain the M109A2/M109A3/M109A4/M109A5 Howitzers. These items are authorized to you by CTA 50-970, Expendable Items (Except Medical, Class V, Repair Parts, and Heraldic Items).

D-2 EXPLANATION OF COLUMNS

a. Column (1) — ITEM NO.

This number is assigned to the entry in the listing and is referenced to identify the material, e.g., “Cleaning compound (item 14, Appx D).”

b. Column (2) — LEVEL

This column identifies the lowest level of maintenance that requires the listed items:

- C — Operator/crew
- O — Unit maintenance
- F — Direct support maintenance
- H — General support maintenance
- D — Depot maintenance

c. Column (3) — NATIONAL STOCK NUMBER

This is the national stock number assigned to the item; use it to requisition the item.

d. Column (4) — DESCRIPTION

Indicates the Federal item name and, if required, a description to identify the item. The last line for each item provides the Commercial and Government Entity Code (CAGEC) in parentheses followed by the part number.

e. Column (5) — UNIT OF MEASURE (U/M)

Indicates the measure used in performing the actual maintenance function. This measure is expressed by a two-character alphabetical abbreviation (e.g., EA, IN, PR). If the unit of measure differs from the unit of issue, as shown in the Army Master Data File (AMDF), requisition the lowest unit of issue that will satisfy your requirements.

<u>Abbreviation</u>	<u>Unit</u>	<u>Abbreviation</u>	<u>Unit</u>	<u>Abbreviation</u>	<u>Unit</u>
BD	bundle	CN	can	OZ	ounce
BE	bale	DM	drum	PG	package
BF	board foot	EA	each	PT	pint
BT	bottle	GL	gallon	RO	roll
BX	box	KT	kit	QT	quart
CA	cartridge	LB	pound	TU	tube

SECTION II. EXPENDABLE AND DURABLE ITEMS LIST

(1) ITEM NO.	(2) LEVEL	(3) NATIONAL STOCK NUMBER	(4) DESCRIPTION	(5) U/M
1		8040-00-273-8717	Adhesive, 1 pt (0.47 L) can: (81348) MMM-A-121	PT
2		8040-00-926-9133	Adhesive, 1 pt (0.47 L) can: (81349) MIL-A-46091	PT
3		8040-00-165-8614	Adhesive, 1 qt (0.9 L) can: (81348) MMM-A-121	QT
4		8040-00-845-4304	Adhesive, primer, 1 pt (0.47 L) can: (81349) MIL-A-46106	CN
5		8040-00-664-4318	Adhesive, rubber based, general purpose, type 11, 1 pt (0.47 L) can: (80244) MMM-A-1617	PT
6		8040-00-262-9026	Adhesive, type 1,0.5 pt (0.24 L) can: (81348) MMM-A-1617	PT
7		8040-00-262-9011	Adhesive, type III, 1 pt (0.47 L) can: (81348) MMM-A-1617	PT
8		8030-00-753-4953	Antiseize compound, 1 lb (0.5 kg) can: (81349) MIL-A-13881	LB
9		8030-00-087-8630	Antiseize compound, 1 lb (0.5 kg) can: (81349) MIL-T-83483	CN
10		8105-00-299-8532	Bag, plastic, 100 each box: (81348) PPP-B-26	EA
11		8115-00-190-5020	Box, shipping, 10 each bundle: (81348) PPP-B-636	BD
12		6850-00-224-6663	Cleaning compound, rifle bore, 1 gal (3.9 L) can: (81349) MIL-C-372	GL
13		6850-00-003-1194	Cleaning lubricant, 16 oz (473 mL) can: (81349) MIL-C-83360	OZ
14		8010-01-130-3345	Coating, aliphatic polyurethane, olive drab, (CARC), 1 gal (3.9 L) each component: (81349) MIL-C-46168	GL
15		8030-00-290-5141	Coating, compound, bituminous, 1 gal (3.9 L) can: (81349) MIL-C-450	GL

SECTION II. EXPENDABLE AND DURABLE ITEMS LIST — CONTINUED

(1) NEW NO.	(2) LEVEL	(3) NATIONAL STOCK NUMBER	(4) DESCRIPTION	(5) U/M
16		8010-01-313-8700	Coating, epoxy, VOC compliant, white, 1 qt (0.9L) each component: (81349) MIL-C-22750	KT
17		8010-01-278-8270	Coating system, nonskid, olive drab, 1 gal (3.9 L) kit: (81348) DOD-C-24667	KT
18		6850-01-137-8525	Compound, silicone, heat sink, 2 oz (59 mL) jar: (81349) MIL-C-47113	OZ
19		6580-00-109-4362	Compound, silicone, heat sink, 1 pt (0.47 L) can: (81349) MIL-C-47113	CN
20		7930-00-515-2477	Detergent, general purpose, liquid, heavy duty, 1 gal (3.9 L) bottle: (81348) P-D-223	GL
21		6850-00-281-1985	Dry-cleaning solvent, 1 gal (3.9L) can: (81348) P-D-680	GL
22		6850-00-281-3061	Dry-cleaning solvent, 4 oz (118 mL) can: (81348) P-D-680	CN
23		6615-01-150-2977 6615-01-150-2978 6615-01-150-2976	Gloves, patient, exam, package of 100: size large, (89875) E-011 size medium, (89875) E-012 size small, (89875) E-010	PG
24		9150-00-119-9291	Grease, aircraft, 2 oz (59 mL) tube: (81 349) MIL-G-4343	TU
25		9150-01-197-7690	Grease, automotive and artillery, 1.75 lb (0.79 kg) can: (81349) MIL-G-10924	LB
26		9150-01-197-7689	Grease, automotive and artillery, 6.5 lb (2.9 kg) can: (81349) MIL-G-10924	CN
27		9150-01-197-7693	Grease, automotive and artillery, 14 oz (414 mL) cartridge: (81349) MIL-G-10924	CA
28		9150-00-985-7316	Grease, general purpose, 1.75 lb (0.79 kg) can: (81 349) MIL-G-23549	CN

(1) NEW NO.	(2) LEVEL	(3) NATIONAL STOCK NUMBER	(4) DESCRIPTION	(5) U/M
29		9150-00-235-5555	Grease, general purpose, 6.5 lb (2.9 kg) can: (81349) MIL-G-23549	CN
30		9150-00-823-8047	Grease, general purpose, 35 lb (15.8 kg) can: (81349) MIL-G-23549	CN
31		9150-00-754-2595	Grease, molybdenum, disulfide, 1.75 lb (0.79 kg) can: (81349) MIL-G-21164	CN
32		9150-00-223-4004	Grease, molybdenum, disulfide, 6.5 lb (2.9 kg) can: (81349) MIL-G-21164	CN
33		9150-00-965-2003	Grease, molybdenum, disulfide, 35 lb (15.8 kg) can: (81349) MIL-G-21164	CN
34		9150-01-131-3324	Hydraulic fluid, fire resistant, PET, OHT, 1 gal (3.9 L) can: (81349) MIL-H-46170	GL
35		9150-01-131-3323	Hydraulic fluid, fire resistant, PET, OHT, 1 qt (0.9 L) can: (81349) MIL-H-46170	QT
36		9150-00-985-7099	Lubricating oil, aircraft, 1 qt (0.9 L) can: (81349) MIL-L-23699	QT
37		9150-00-186-6668	Lubricating oil, engine, 15/40 grade, 5 gal (18.9 L) can: (81349) MIL-L-2104	CN
38		9150-00-188-9858	Lubricating oil, engine, 30 grade, 5 gal (18.9 L) can: (81349) MIL-L-2104	CN
39		9150-00-186-6681	Lubricating oil, engine, 30 grade, 1 qt (0.9 L) can: (81349) MIL-L-2104	QT
40		9150-01-152-4118	Lubricating oil, engine multigrade, 15W-40 grade, 5 gal (18.9 L) can: (81349) MIL-L-2104	GL
41		9150-01-313-2191	Lubricating oil, gear, 80W-90 grade, 1 gal (3.9 L) can: (81349) MIL-L-2105	CN
42		9150-01-035-5392	Lubricating oil, gear, 80W-90 grade, 1 qt (0.9 L) can: (81349) MIL-L-2105	CN

SECTION II. EXPENDABLE AND DURABLE ITEMS LIST — CONTINUED

(1) NEW NO.	(2) LEVEL	(3) NATIONAL STOCK NUMBER	(4) DESCRIPTION	(5) U/M
43		9150-01-048-4593	Lubricating oil, gear, 75W grade, 1 gal (3.9 L) can: (81349) MIL-L-2105	CN
44		9150-01-035-5390	Lubricating oil, gear, 75W grade, 1 qt (0.9 L) can: (81349) MIL-L-2105	CN
45		9150-00-231-6689	Lubricating oil, general purpose, PL, SPC, 1 qt (0.9 L) can: (81348) VV-L-800	QT
46		9150-00-543-7220	Lubricating oil, molybdenum disulfide, silicone, 1 lb (0.5 kg) can: (81349) DOD-L-25681	LB
47		9150-00-402-2372	Lubricating oil, OEA, 5 gal (18.9 L) can: (81349) MIL-L-46167	CN
48		9150-00-491-7197	Lubricating oil, OEA, 55 gal (208 L) drum: (81349) MIL-L-46167	DM
49		9150-00-189-6727	Lubricating oil, OE10, internal combustion engine, 10W grade, 1 qt (0.9 L) can: (81349) MIL-L-2104	QT
50		9150-01-854-6453	Lubricant preservative, 4 oz (118 mL) bottle: (81349) MIL-C-83360	OZ
51		5510-00-274-5381	Lumber, hardwood, board foot: (81348) MM-L-736	BF
52		8010-01-193-0520	Primer, coating, (CARC), component A, 1 gal (3.9 L); component B, 1 qt (0.9 L): (81349) MIL-P-53030	KT
53		8010-01-158-2658	Primer coating, zinc chromate: (81348) TT-P-1757	QT
54		8010-00-209-8034	Primer coating, zinc chromate, low moisture sensitivity, 1 pt (0.47 L) can: (81349) TT-P-1757	PT
55		8010-01-309-0328	Primer, epoxy coating, (CARC), component A, 1 gal (3.9 L); component B, 1 qt (0.9 L): (81349) MIL-P-53022	KT

(1) NEW NO.	(2) LEVEL	(3) NATIONAL STOCK NUMBER	(4) DESCRIPTION	(5) U/M
56		8030-00-765-4507	Sealing, compound, 50 ft (15 m) roll: (19207) 11635660-2	RO
57		8030-00-935-7100	Sealing, locking and retaining compound, single component 50 cu cm bottle: (81349) MIL-S-22473	BT
58		3439-01-150-1051	Solder, rosin core, 1 lb (0.5 kg) roll: (17794) 1243-0001	LB
59		8030-00-398-4130	Tape, antiseizing, 260 in. (6.6 m) roll: (81349) MIL-T-27730	RO
60		7510-01-146-7767	Tape, pressure sensitive, 60 yd (65 m) roll: (81348) PPP-T-60	RO
61		5970-00-240-0617	Tape, rubber, insulation, electrical, 30 ft (9 m) roll: (81348) MIL-I-3825	RO
62		5970-00-816-6056	Tape insulation, electrical, pressure sensitive adhesive, plastic, black, 108 ft (33 m) roll: (81348) HH-I-595	RO
63		6630-01-011-5039	Test kit, antifreeze, 50 test strips: (1BY35) 1208	EA
64		8010-01-200-2637	Thinner, epoxy, type II, 1 gal (3.9 L) can: (81349) MIL-T-81772	GL
65		8010-01-168-0684	Thinner, epoxy, type II, 55 gal (208 L) drum: (81349) MIL-T-81772	GL
66		6810-00-682-6867	Water, distilled-deionized: (81346) ASTM 1193	BX

APPENDIX E ILLUSTRATED LIST OF MANUFACTURED ITEMS

GENERAL

This appendix provides complete instructions for making items authorized to be manufactured or fabricated at unit maintenance level. All bulk materials needed for manufacture of an item are listed on the illustration. An index in alphanumeric order is provided for cross-referencing the item to be manufactured to the figure that covers fabrication criteria.

<u>ITEM NO.</u>	<u>NOMENCLATURE</u>	<u>FIGURE NO.</u>
1	END CONNECTOR BAR	1
2	PULLER ADAPTER	2
3	WOOD BLOCK	3

ITEM 1 END CONNECTOR BAR

Material

0.30- x 0.75- x 5. 0-in. (7.6- x 19.1- x 127-mm) steel bar stock

Fabricate from steel bar stock.

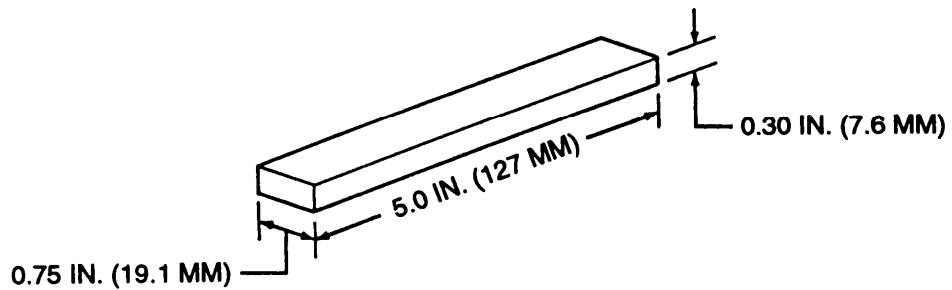

Figure 1

ITEM 2 PULLER ADAPTER

Callout

Callout	Material	PN
1	1 in. NC Nut	MS35691-73
2	7/8 in. NF by 2-in. - (51-mm-) long Bolt	MS90726-209

Weld nut (1) to bolt head (2).

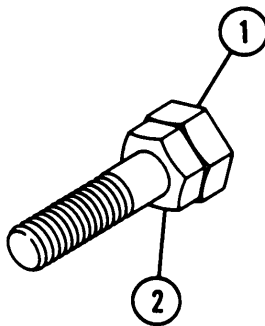

Figure 2

ITEM 3 WOOD BLOCK

Material

Hardwood lumber (item 51, Appx D)

Fabricate from hardwood lumber.

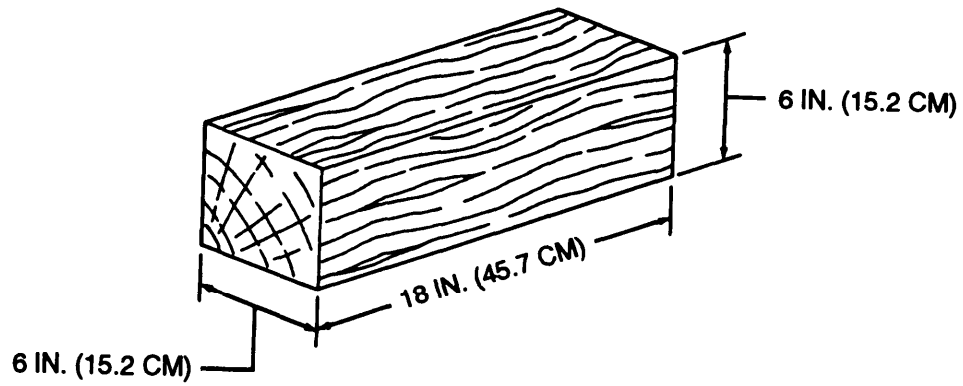

Figure 3

APPENDIX F TORQUE LIMITS

GENERAL

This appendix provides general wet torque limits for screws. Specific torque limits are indicated in the maintenance procedures for applicable components. The general torque limits given in this appendix shall be used when specific torque limits are not provided in the maintenance procedure.

These general torque limits cannot be applied to screws that retain rubber components; the rubber components will be damaged before the correct torque limit is reached. If a specific torque limit is not provided for screws that contain rubber components in the maintenance procedure, tighten the screw or nut until it touches the metal bracket, then tighten it one more turn.

This appendix also provides information on tightening metal fasteners, fastener size and thread pattern, and fastener grade.

<u>CONTENTS</u>	<u>PAGE</u>
F-1 TORQUE LIMITS	F-2
F-2 HOW TO USE TORQUE TABLE	F-2
F-3 TIGHTENING METAL FASTENERS	F-4
F-4 FASTENER SIZE AND THREAD PATTERN	F-4
F-5 FASTENER GRADE	F-5

F-1 TORQUE LIMITS

Table F-1 lists wet torque limits. Wet torque limits are used on screws that have high-pressure lubricants applied to threads.

F-2 HOW TO USE TORQUE TABLE

- 1 Measure diameter of screw you are installing.
- 2 Count number of threads per in. or use a pitch gage.
- 3 Under heading "SIZE", look down left column until you find diameter of screw being installed (there will usually be two lines beginning with same size).
- 4 In second column under "SIZE", find number of threads per in. that matches number of threads counted in step 2.
- 5 To find grade of screw being installed, match markings on head to correct picture of cap screw head markings in torque table.
- 6 Look down column under picture found in step 5 until you find torque limit in lb-ft or N·m for diameter and threads per in. of screw being installed.

NOTE

Manufacturer's cap screw head marking may vary. These are all SAE grade 5 (3 line).

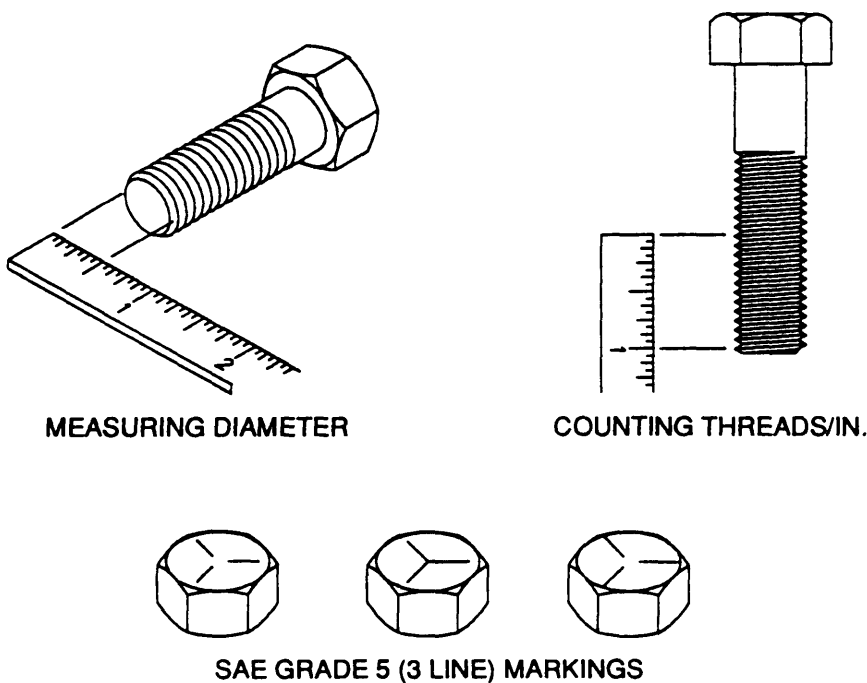
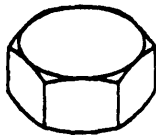
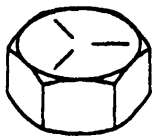
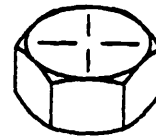
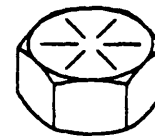

TABLE F-1 TORQUE LIMITS FOR WET FASTENERS

SIZE			TORQUE							
			SAE GRADE NO. 1 OR 2		SAE GRADE NO. 5		SAE GRADE NO.6 OR 7		SAE GRADE NO. 8	
										
DIA IN.	THREADS PER IN.	DIA MM	LB-FT	N•M	LB-FT	N•M	LB-FT	N•M	LB-FT	N•M
1/4	20	6.35	5	7	7	10	9	12	11	15
1/4	28	6.35	5	7	9	12	—	—	13	17
5/16	18	7.94	10	13	15	21	17	23	22	29
5/16	24	7.94	12	16	17	23	—	—	24	33
3/8	16	9.53	16	22	28	38	31	42	40	54
3/8	24	9.53	18	24	32	43	—	—	44	60
7/16	14	11.11	25	34	44	60	50	67	63	85
7/16	20	—	27	37	50	67	—	—	70	95
1/2	13	12.70	35	48	68	92	77	104	95	128
1/2	20	—	37	50	77	104	—	—	108	146
9/16	12	14.29	46	62	99	134	108	146	140	189
9/16	18	—	50	67	108	146	—	—	153	207
5/8	11	15.88	57	77	135	183	150	204	189	256
5/8	18	—	86	117	153	207	—	—	216	293
3/4	10	19.05	95	128	243	330	252	342	338	458
3/4	16	—	104	140	266	360	—	—	378	513
7/8	9	22.23	144	195	356	482	396	537	545	738
7/8	14	—	158	214	392	531	—	—	608	824
1	8	25.40	212	287	531	720	594	805	819	1110
1	14	—	225	305	594	805	—	—	891	1208
1-1/8	—	25.58	—	—	720	976	—	—	1152	1562
					792	1074			1296	1757
1-1/4	—	31.75	—	—	—	—	—	—	1638	2221
									1800	2441
1-3/8	—	34.93	—	—	1314	1782	—	—	2142	2904
					1512	2050			2448	3319
1-1/2	—	38.10	—	—	1746	2367	—	—	2844	3856
					1980	2684			3204	4344

F-3 TIGHTENING METAL FASTENERS

When torquing a fastener, select a torque wrench whose range (Table F-2) fits the required torque value. A torque wrench is most accurate from 25% to 75% of its stated range. A torque wrench with a stated range of 0-100 lb-ft (0-136 N.m) will be most accurate from 25-75 lb-ft (34-102 N.m). Accuracy of readings will decrease as you approach 0 lb-ft (0 N.m) or 100 lb-ft (136 N.m). The following ranges (Table F-2) are based on this principle.

TABLE F-2 TORQUE RANGES

STATED RANGE	MOST EFFECTIVE RANGE
0–200 lb-ft (0–271 N•m)	4–13 lb-ft (5–18 N•m)
0–600 lb-ft (0–813 N•m)	50–450 lb-ft (68–610 N•m)
0–170 lb-ft (0–230 N•m)	44–131 lb-ft (60–178 N•m)
15–75 lb-ft (20–102 N•m)	30–60 lb-ft (41–81 N•m)

F-4 FASTENER SIZE AND THREAD PATTERN

Threaded fasteners are categorized according to diameter of fastener shank. Thread styles are divided into broad groups, the two most common ranges being coarse (Unified Coarse-UNC) and fine (Unified Fine-UNF). These groups are defined by the number of threads per in. on the bolt shanks. In addition, threads are categorized by thread class (Table F-3), which is a measure of the degree of fit between the threads of the bolt or screw (external threads) and the threads of the attaching nut or tapped hole (internal threads). The most common thread class for bolts and screws is class 2.

TABLE F-3 THREAD CLASSES AND DESCRIPTION

EXTERNAL	INTERNAL	FIT
1A	1B	Loose fit
2A	2B	Medium fit
3A	3B	Close fit

Thread patterns are designed as follows:

NOTE

Unless followed with -LH (e.g., 3/4-10 UNC-2A-LH), threads are right-hand.

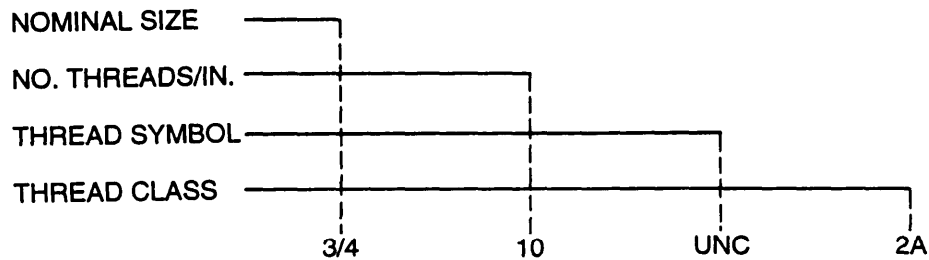

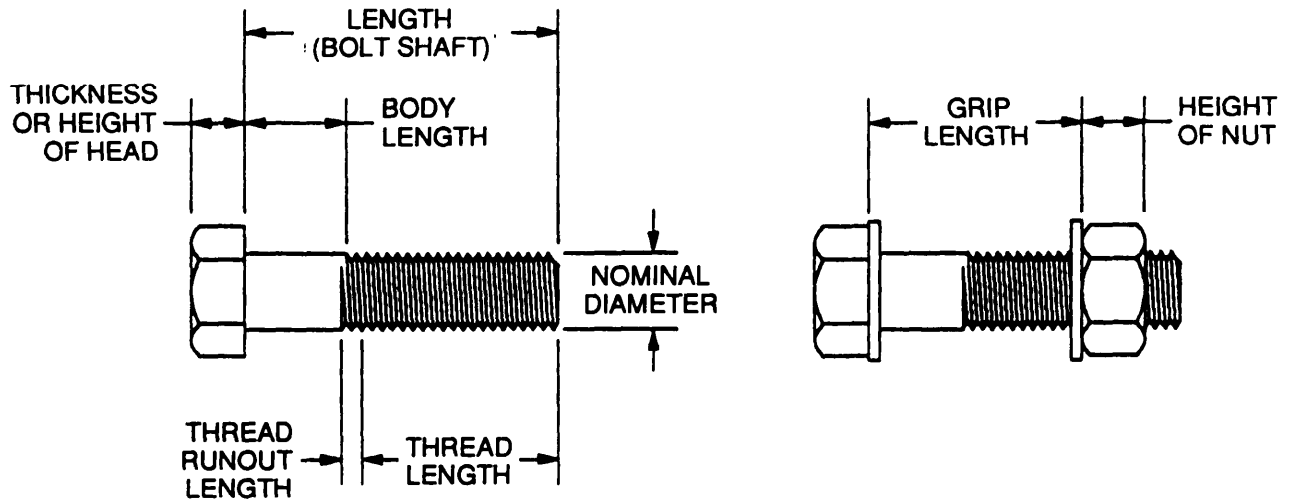

F-5 FASTENER GRADE

In addition to being classified by thread type, threaded fasteners are also classified by material. The most familiar fastener classification system is the SAE grading system (Table F-4).

TABLE F-4 SAE SCREW AND BOLT MARKINGS

SCREWS	BOLTS
SAE grade 2 No marking	SAE grade 6 Four radial dashes 90° apart
SAE grade 3 Two radial dashes 180° apart	SAE grade 7 Five radial dashes 72° apart
SAE grade 5 Three radial dashes 120° apart	SAE grade 8 Six radial dashes 60° apart

Markings On Hex Locknuts

Grade A — no marks
Grade B — three marks
Grade C — six marks

Grade A — no mark
Grade B — letter B
Grade C — letter C

Grade A — no notches
Grade B — one notch
Grade C — two notches

APPENDIX G MANDATORY REPLACEMENT PARTS

GENERAL

This appendix provides a cross-reference list of mandatory replacement parts and is included for that purpose.

CONTENTS

	<u>PAGE</u>
G-1	EXPLANATION OF COLUMNS G-2
G-2	MANDATORY REPLACEMENT PARTS LIST G-3

G-1 EXPLANATION OF COLUMNS

a. Column (1) — Item No.

This number is assigned to the entry in the listing for cross-referencing to the part number.

b. Column (2) — PN

Indicates the primary number used by the manufacturer (individual, company, firm, corporation, or Government activity), which controls the design and characteristics of the item by means of its engineering drawings, specification, standards, and inspection requirements to identify an item or range of items.

c. Column (3) — Description

This column contains the nomenclature that appears on the first page of the task under the subheading 'Materials/ Parts.'

G-2 MANDATORY REPLACEMENT PARTS LIST

(1) ITEM NO.	(2) PN	(3) DESCRIPTION
1	AN123888	Preformed packing
2	AN125630	Rivet
3	AN381-6-40	Cotter pin
4	AN415-2	Cotter pin
5	C921885-0	Preformed packing
6	CW226MP	Filter element
7	MS162241037	Retaining ring
8	MS16562-280	Spring pin
9	MS16562-39	Spring pin
10	MS16562-44	Cotter pin
11	MS16562-62	Spring pin
12	MS16562-72	Spring pin
13	MS16562-90	Spring pin
14	MS16624-4087	Retaining ring
15	MS16629-1143	Retaining ring
16	MS20230GBP20	Grommet
17	MS20230WBP20	Grommet washer
18	MS20426A3-5	Rivet
19	MS20470AD3-4	Rivet
20	MS20470AD5-6	Rivet
21	MS20470AD6-6	Rivet
22	MS20470AD6-7	Rivet
23	MS20470AD6-8	Rivet
24	MS20613-4P8	Rivet
25	MS20995-C41	Lockwire
26	MS20995-F32	Lockwire
27	MS20995-F32-6	Lockwire
28	MS20995C91	Lockwire
29	MS20995F20	Cotter pin
30	MS20995F47	Lockwire
31	MS21044N08	Self-locking nut
32	MS21044N5	Self-locking nut
33	MS21083N4	Self-locking nut
34	MS24662-233	Rivet
35	MS24665-109	Cotter pin
36	MS24665-132	Cotter pin
37	MS24665-135	Cotter pin
38	MS24665-153	Cotter pin
39	MS24665-210	Cotter pin
40	MS24665-283	Cotter pin

G-2 MANDATORY REPLACEMENT PARTS LIST — CONTINUED

(1) ITEM NO.	(2) PN	(3) DESCRIPTION
41	MS24665-285	Cotter pin
42	MS24665-287	Cotter pin
43	MS24665-289	Cotter pin
44	MS24665-299	Cotter pin
45	MS24665-300	Cotter pin
46	MS24665-353	Cotter pin
47	MS24665-355	Cotter pin
48	MS24665-357	Cotter pin
49	MS24665-418	Cotter pin
50	MS24665-425	Cotter pin
51	MS24665-497	Cotter pin
52	MS24665-626	Cotter pin
53	MS24665-639	Cotter pin
54	MS27183-42	Lockwasher
55	MS28775-121	Preformed packing
56	MS28775-222	Gasket
57	MS28775-230	Preformed packing
58	MS28778-8	Preformed packing
59	MS29513-145	Preformed packing
60	MS29513-159	Preformed packing
61	MS29513-222	Preformed packing
62	MS29513-241	Preformed packing
63	MS29513-352	Preformed packing
64	MS29513-427	Preformed packing
65	MS29561-2	Preformed packing
66	MS304AD5-6	Rivet
67	MS3367-1-0	Strap
68	MS35333-37	Lockwasher
69	MS35333-38	Lockwasher
70	MS35333-39	Lockwasher
71	MS35333-40	Lockwasher
72	MS35334-19	Lockwasher
73	MS35334-20	Lockwasher
74	MS35334-21	Lockwasher
75	MS35335-33	External-tooth lockwasher
76	MS35335-34	Lockwasher
77	MS35335-35	Lockwasher
78	MS35335-37	Lockwasher
79	MS35335-52	Lockwasher
80	MS35335-89	Lockwasher

(1) ITEM NO.	(2) PN	(3) DESCRIPTION
81	MS35335-91	Lockwasher
82	MS35338-137	Lockwasher
83	MS35338-38	Lockwasher
84	MS35338-40	Lockwasher
85	MS35338-42	Lockwasher
86	MS35338-43	Lockwasher
87	MS35338-44	Lockwasher
88	MS35338-45	Lockwasher
89	MS35338-46	Lockwasher
90	MS35338-47	Lockwasher
91	MS35338-48	Lockwasher
92	MS35338-50	Lockwasher
93	MS35338-60	Lockwasher
94	MS35338-61	Lockwasher
95	MS35338-63	Lockwasher
96	MS35338-65	Lockwasher
97	MS35338-66	Lockwasher
98	MS35338-67	Lockwasher
99	MS35338-69	Lockwasher
100	MS35338-9	Lockwasher
101	MS35339-89	Lockwasher
102	MS35643-2	Gasket
103	MS35670-4A	Plug
104	MS35692-62	Cotter pin
105	MS35769-21	Gasket
106	MS35802-3	Filter element
107	MS51922-68	Self-locking nut
108	MS6338-65	Lockwasher
109	MS9021-254	Preformed packing
110	MS90727-12	Spring pin
111	P49860-11	Lockwasher
112	P49866-11	Lockwasher
113	QQW461	Lockwire
114	S-21100	Bolt
115	10861673	Filter element
116	10888308	Bushing
117	10888346	Bushing
118	10888347	Bushing
119	10888632	Seal
120	10895744	Gasket
121	10898034	Gasket
122	10898122	Gasket
123	10903399	Gasket

G-2 MANDATORY REPLACEMENT PARTS LIST — CONTINUED

(1) ITEM NO.	(2) PN	(3) DESCRIPTION
124	10903593	Gasket
125	10903594	Gasket
126	10903595	Gasket
127	10909294	Pad
128	10910003	Gasket
129	10919232	Gasket
130	10919233	Gasket
131	10919234	Gasket
132	10920687	Seal
133	10920697	Bearing
134	10921234	Gasket
135	10921462	Seal
136	10921755-2	Thermostat
137	10921769	Strap
138	10922277	Gasket
139	10922286	Gasket
140	10922326	Gasket
141	10922805	Gasket
142	10925299	Gasket
143	10925300	Gasket
144	10925968	Gasket
145	10930331	Gasket
146	10935742	Pad
147	10936585	Gasket
148	10936588	Spring washer
149	10941376	Gasket
150	10941377	Gasket
151	10941532	Packing
152	10946907-3	Wire rope sleeve
153	10954041	Retaining wedge
154	10954048	Track pad
155	10954740	Seal
156	10956227	Seal
157	11604901	Seal
158	11605377	Gasket
159	11619082	Wire rope
160	11636132	Gasket
161	11644066	Cap lining
162	11674729	Gasket
163	12268164	Gasket

(1) ITEM NO.	(2) PN	(3) DESCRIPTION
164	12268221	Inner hub seal
165	12268557	Track pad
166	12268561	Track pad nut
167	12268563	Connector bolt
168	12278617	Preformed packing
169	12360844	Gasket
170	12368978	Gasket
171	1503536	Gasket
172	23505398	Self-locking nut
173	4024-32-00-0541	Lockwasher
174	443340	Self-locking nut
175	479136	Gasket
176	479729	Strainer element
177	500033	Seal
178	512227	Gasket
179	5113954	Gasket
180	5130995	Gasket
181	5145581	Gasket
182	5150193	Gasket
183	5187310	Preformed packing
184	5213744	Snap pin
185	5287404	Key washer
186	5411868	Key washer
187	5571024	Gasket
188	5574161	Gasket
189	5575032	Filter element
190	5575086	Gasket
191	5703114	Transmission parts kit
192	6220-21	Lockwasher
193	6299516	Spring washer
194	6437298	Gasket set
195	6473298	Gasket set
196	7098444	Gasket
197	7320658	Preformed packing
198	7374386	Preformed packing
199	7413738	Preformed packing
200	7413774	Gasket
201	7413775	Strainer element
202	7419324	Gasket
203	7419534	Gasket
204	7752864	Cotter pin
205	7753911	Cotter pin
206	7962242	Gasket

G-2 MANDATORY REPLACEMENT PARTS LIST — CONTINUED

(1) ITEM NO.	(2) PN	(3) DESCRIPTION
207	7962243	Gasket
208	7962254	Gasket
209	7962686	Lockspring
210	7972324	Gasket
211	7972326	Gasket
212	7972340	Gasket
213	7972345	Gasket
214	7972346	Gasket
215	7972350	Gasket
216	7995455-1	Nonmetallic washer
217	803336	Seal
218	8356203	Filter element
219	8712289	Self-locking nut
220	8712289-1	Self-locking nut
221	8712289-2	Self-locking nut
222	8712289-3	Pad nut
223	8712289-7	Self-locking nut
224	8712289-9	Self-locking nut
225	8720150	Antipilferage seal
226	8748475	Retaining ring
227	900010-32C	Lockwire

APPENDIX H TOOL IDENTIFICATION LIST

GENERAL

This appendix lists tools you will need from common tool sets to maintain the M109A2/M109A3/M109A4/M109A5 Howitzer.

<u>CONTENTS</u>		<u>PAGE</u>
H-1	EXPLANATION OF COLUMNS	H-2
H-2	TOOL IDENTIFICATION LIST	H-3

H-1 EXPLANATION OF COLUMNS

a. Column (1) — ITEM NO.

This number is assigned to the entry in the listing and is referenced in the initial setup of procedures to identify the tool.

b. Column (2) — NOMENCLATURE

Indicates the Federal item name.

c. Column (3) — NATIONAL STOCK NUMBER

Indicates the national stock number assigned to the tool.

d. Column (4) — PN

Indicates the manufacturer's part number for the tool.

H-2 TOOL IDENTIFICATION LIST

(1) ITEM NO.	(2) NOMENCLATURE	(3) NATIONAL STOCK NUMBER	(4) PN	(5) REFERENCE
1	Adapter, mechanical puller	5120-01-017-5328	12251805	TM 9-2350-311-24P
2	Adapter, socket	5120-00-240-8703	GGG-W-641	
3	Adapter, socket wrench	5120-00-227-6066	SH-131	
4	Adapter, straight pipe-to-tube	4730-00-266-0541	MS39158-7 (96906)	TM 9-2350-311-24P
5	Bolt, eye	5306-00-050-0347	MS51937-5 (96906)	TM 9-2350-311-24P
6	Brush, wire	7920-00-291-5515	8078883	SC 4910-95-CL-A74
7	Cable assembly, ground	5995-00-084-0789	10913655	
8	Cable assembly, power electrical	6145-00-930-6764	11605054	TM 9-2350-311-24P
9	Cable assembly, power electrical	6150-01-320-4733	12268426	TM 9-2350-311-24P
10	Cable assembly, power electrical starter circuit	6150-01-324-3386	12268427	TM 9-2350-311-24P
11	Cable assembly, power electrical starter & master warning circuit	6150-01-115-2276	12268162	TM 9-2350-311-24P
12	Cleaning tool, radiator	4910-00-494-8257	11641959	TM 9-2350-311-24P
13	Compressor, air	4310-00-542-4566		SC 4910-95-CL-A72
14	Coupling assembly, quick-disconnect	4730-00-738-8571	7388571	TM 9-2350-311-24P
15	Crowbar	5120-00-224-1390	1833244	TM 9-2350-311-10
16	Drill set, twist	5133-00-293-0983	800434	SC 4910-95-CL-A74
17	Drill, electric	5130-00-889-8993	W-D-661	SC 4910-95-CL-A74
18	Duo-tester	6630-00-105-1418	10425	SC 4910-95-CL-A74
19	Fitting, grease	4730-00-050-4208	MS15003-1	SC 4910-95-CL-A74
20	Fixture, track connecting	5120-00-605-3926	8741739	TM 9-2350-311-24P
21	Gage	5120-00-733-5005	8351213	TM 9-2350-311-24P
22	Gage and case assembly	4910-00-034-0874	10911904	TM 9-2350-311-24P
23	Gage, pressure, dial indicating	6685-00-572-8612	8356176	TM 9-2350-311-24P
24	Gun, lubricating	4930-00-253-2478	1142	SC 4910-95-CL-A74
25	Gun, rivet	5120-00-017-2849		CTA 50-970

(1) ITEM No.	(2) NOMENCLATURE	(3) NATIONAL STOCK NUMBER	(4) PN	(5) REFERENCE
26	Gun, solder	3439-00-618-6623	D550-3	SC 4910-95-CL-A72
27	Handle, installer	5120-00-977-5578	J-7079-2 (33287)	TM 9-2350-311-24P
28	Handle, replacer	5120-00-034-0884	10914196	TM 9-2350-311-24P
20	Hose	4720-01-081-2764	MS28759-G-0330	
30	Hose assembly, nonmetallic	4720-00-080-8586	8708306	TM 9-2350-311-24P
31	Installer, seal	5120-00-977-5579	J-8550 (33887)	TM 9-2350-311-24P
32	Jack, 12-ton (10,886-kg)	5120-00-224-7330	D120	SC 4910-95-CL-A72
33	Key, socket head screw	5120-00-240-5274	1112876	TM 9-2350-311-10
34	Lead, electrical, engine starter	5995-00-084-0793	10914183	TM 9-2350-311-24P
35	Lifter, road wheel	4910-00-912-4469	11593605	TM 9-2350-311-24P
38	Multimeter	6625-01-139-2512	T0037	SC 4910-95-CL-A72
37	Multiplier, torque wrench	5120-00-574-9318	T0-1000	SC 4910-95-CL-A72
38	Pin, guide	5315-00-034-0883	10914195	TM 9-2350-311-24P
39	Pinch bar	5120-00-224-1372		SC 4190-95-CL-A72
40	Pliers, retaining ring	5120-00-288-9717	T161-2	SC 4910-95-CL-A74
41	Pliers, snap ring	5120-00-789-0429	4440R	SC 4910-95-CL-A74
42	Pliers, wire twisting	5120-00-542-4171	8491162	SC 4910-95-CL-A74
43	Probe kit, TA-1	6625-01-102-6878	12303622	
44	Puller, end connector, track	5120-01-051-4150	11889394-2	TM 9-2350-311-24P
45	Puller kit, T-154 track connector		57K3156	
46	Puller, shock absorber	5120-00-084-7626	10913972	TM 9-2350-311-24P
47	Puller, slide hammer type	5120-00-557-3615	5573615	TM 9-2350-311-24P
48	Remover and replacer	5120-00-084-7627	C-DTA-94390 (10925993)	TM 9-2350-311-24P
49	Replacer	5120-00-034-0878	10914185	TM 9-2350-311 -24P
50	Replacer	5120-00-034-0879	10914186	TM 9-2350-311-24P
51	Replacer, beating cup	5120-00-034-0880	10914187	TM 9-2350-311-24P
52	Replacer, bearing cup	5120-00-034-0885	10914197	TM 9-2350-311-24P
53	Screen, protective fan	2510-01-247-2976	12268262	TM 9-2350-311-24P

(1) ITEM NO.	(2) NOMENCLATURE	(3) NATIONAL STOCK NUMBER	(4) PN	(5) REFERENCE
54	Screen, safety	4910-00-084-0790	10913779	
55	Set, socket wrench	5120-00-322-6231		SC 4910-95-CL-A72
56	Set, socket wrench	5120-00-204-1999	GGG-W-641	SC 4910-95-CL-A74
57	Set, socket wrench	5120-00-081-2305	137TMB	SC 4910-95-CL-A74
58	Sling, lifting, final drive	4910-00-034-0875	10914179	TM 9-2350-311-24P
59	Sling, lifting, powerplant	3940-01-280-0872	12355173	TM 9-2350-311-24P-1
60	Sling, multiple leg	3940-00-977-7398	10930560	TM 9-2350-311-24P
61	Test set. STE-ICE/R	4910-01-222-6589	12259266	TM 9-4910-571-12&P
62	Tester, airflow	6680-00-436-4212	E5-77-2120	TM 3-6680-316-10
83	Tool kit, electrical	5180-00-876-9336	7550526	SC 4910-95-CL-A72
64	Tool kit, general mechanic's	5180-00-177-7038		SC 5180-90-N26
65	Wrench, adjustable	5120-00-264-3796	11655778-5	SC 4910-95-CL-A72
66	Wrench, adjustable	5120-00-264-3793	664666	SC 4910-95-CL-A72
67	Wrench, box, special	5120-00-051-5567	11605662	TM 9-2350-311-24P
68	Wrench set, spanner	5120-00-516-3863	MS8516-1	SC 4910-95-CL-A72
69	Wrench, splined brake adjustment	3040-00-733-8909	8351386	TM 9-2350-311-24P
70	Wrench, splined brake adjustment	3040-00-733-8912	8351387	TM 9-2350-311-24P
71	Wrench, torque	5120-00-221-7983	SW130-301	SC 4910-95-CL-A72
72	Wrench, torque	5120-00-640-6364	1753LDF	SC 4910-95-CL-A72
73	Wrench, torque	5120-00-853-4538	F200-1	SC 4910-95-CL-A72
74	Wrench, torsion bar	5120-00-708-3642	7083642	
75	Wrench, torsion bar, retaining nut	5120-00-708-3642	7083642	TM 9-2350-311-24P

APPENDIX I

SIMPLIFIED TEST EQUIPMENT FOR INTERNAL COMBUSTION ENGINES- REPROGRAMMABLE (STE/ICE-R)

GENERAL

This appendix provides a general overview of STE/ICE-R equipment and operations, along with specific procedures in diagnosing and isolating malfunctions of the M109A2/M109A3/M109A4/M109A5 engines.

<u>CONTENTS</u>	<u>PAGE</u>
Section I INTRODUCTION	I-2
I-1 GENERAL	I-2
Section II ENGINE TESTING	I-2
I-2 GENERAL	I-2
I-3 PMCS TEST METHOD	I-2
I-4 STE/ICE-R TROUBLESHOOTING METHOD	I-4
I-5 GO CHAINS AND NO-GO CHAINS	I-4
Section III BATTERY TESTING	I-63
I-6 GENERAL	I-63
I-7 BATTERY PACKS	I-63
I-8 SERIES PAIRS	I-63
I-9 INDIVIDUAL BATTERIES	I-64
I-10 DESCRIPTION OF TEST CARDS	I-64
I-11 PROCEDURE TO MAKE A BATTERY EVALUATION ON THE M109A2/M109A3/M109A4/ M109A5 HOWITZER	I-64

SECTION I. INTRODUCTION

I-1 GENERAL

STE/ICE-R, a testing system for internal combustion engines, provides measurements on voltage, resistance, pressure, perature, and speed to analyze the condition of an engine system. Refer to TM 9-4910-571-12&P for description of STE/ICE-R equipment and general operating instructions.

STE/ICE-R will also provide a thorough preventive maintenance check on M109A2/M109A3 and M109A4/M109A5 engines as part of service upon receipt and as an annual check in the PMCS (para 2-15).

SECTION II. ENGINE TESTING

I-2 GENERAL

There are two different test methods involving the use of STE/ICE-R equipment. The PMCS test method uses STE/ICE-R to check the general condition of the howitzer engine. The STE/ICE-R engine troubleshooting method isolates a malfunction down to the defective part or assembly.

I-3 PMCS TEST METHOD

The PMCS test method consists of a pretest inspection and STE/ICE-R testing.

a. Pretest inspections

Before using STE/ICE-R to test the vehicles, perform the following pretest inspections:

- 1 Fan belts. Check for proper tension. Replace if cracked or frayed.
- 2 Ignition cables. Ensure they are securely connected and in good condition.
- 3 Oil level. Bring up to proper level if low (TM 9-2350-311-10).
- 4 Fuel level. Check that the fuel tank has enough fuel for testing (TM 9-2350-311-10).
- 5 Radiator. Bring up to proper level if low (TM 9-2350-311-10).
- 6 Battery. Replace the battery if the case is cracked or the terminal posts are damaged. Clean off all corrosion. Check that the battery connections to ground and to the starter motor are in good condition, securely connected, and clean. Check the electrolyte level. If low, bring up to proper level with distilled water (para 8-28).

b. STE/ICE-R testing procedures

The PMCS STE/ICE-R testing procedure consists of two different sequences of tests: GO and NO-GO CHAINS. A GO CHAIN is a logical sequence of tests performed to determine the general condition of the M109 engine. GO CHAINS are arranged so testing starts with GO 1 and proceeds through each GO CHAIN sequence until terminated. Termination will result from a pass or failure. If testing is terminated by the last GO CHAIN test, then the vehicle has no identifiable problems. If testing is terminated by a failed test, then the user will be directed to a specific NO-GO CHAIN where testing is to continue. The NO-GO CHAIN contains procedures to determine the cause of failure of a GO CHAIN test.

The rules to be followed when using the PMCS test method areas follows:

- 1 Always start at GO 1. Never enter in the middle of any GO or NO-GO CHAIN.
- 2 Follow each instruction in a GO CHAIN. Do not skip any instructions or procedures.
- 3 If a particular GO CHAIN fails a test, proceed to the indicated NO-GO CHAIN or to a higher level of maintenance.
- 4 After correcting a problem with a NO-GO CHAIN, return to GO 1 to restart testing. This will ensure that there are no other problems with the vehicle.
- 5 Each GO CHAIN test depends on the successful completion of the previous test. Do not skip any test under any circumstance.

c. Vehicle test card

Once familiar with STE/ICE-R testing procedures, the vehicle test card (Figure 1) can be used as a quick reference. The front of the test card contains all of the information, in abbreviated format, that the user will need to perform common measurements on the vehicle. The organization from the top of the card to the bottom represents a logical order of steps from powering up the VTM to completing a series of tests.

The top of the card describes the power-up sequence of STE/ICE-R for the vehicle. Next, a table is provided that lists many measurements that are useful in troubleshooting the vehicle. The table includes: the associated VTM test number, any required offset test limits, operating condition of the engine, special connection required, the expected limits for pass or fail, and the units of measurement. Also included on the front of the card are hookup diagrams.

The organization of the table allows measurements with the vehicle engine turned off to be performed first. These measurements will ensure that the starting system of the vehicle is in working order before proceeding. The order of the other measurements is as follows:

- 1 Measurements with the engine running but not warm
- 2 Measurements requiring the engine to be warm and running
- 3 Measurements requiring the engine to be warm and not running
- 4 Miscellaneous measurements

The back of the vehicle test card contains the hookups for measurements used to troubleshoot vehicle components. Measurements that require special hookups are also included on this side of the card. To start the PMCS test method, first perform the pretest inspections and then the GO 1 CHAIN.

I-4 STE/ICE-R ENGINE TROUBLESHOOTING METHOD

The STE/ICE-R engine troubleshooting method uses only the NO-GO chains. When a malfunction in the engine is recognized by the mechanic, the “Guide to Troubleshooting” will provide a reference to a specific NO-GO CHAIN to isolate the cause of the malfunction. To start the STE/ICE-R engine troubleshooting method, do the following:

a. Perform GO 1 CHAIN

First, perform GO 1 CHAIN to set up STE/ICE-R and check to see if it is in working order.

b. Perform NO-GO CHAIN

Now that STE/ICE-R is hooked up properly and checks out, perform the NO-GO CHAIN cited in the “Quick Guide to Troubleshooting.”

The rules to follow when using STE/ICE-R engine troubleshooting method are:

- 1 Never enter in the middle of a NO-GO CHAIN.
- 2 Follow each instruction in a GO CHAIN. Do not skip any instructions or procedures.
- 3 After correcting a problem with a NO-GO CHAIN, test-run the component, engine, or powerplant to ensure the problem does not still exist.

I-5 GO CHAINS AND NO-GO CHAINS

a. GO CHAINS

GO CHAINS are shown in Figure 2, sheets 1 thru 20.

b. NO-GO CHAINS

NO-GO CHAINS are shown in Figure 3, sheets 1 thru 36.

M109 VEHICLE TEST CARD — VID 11

PRETEST INSPECTION	POWERING UP VTM
1 Oil level 2 Coolant level 3 Fuel level 4 Batteries	1 Connect VTM to cable W5. Cable W5 attaches to batteries as shown in illustration 2. 2 Perform confidence test, test 66 (second entry 99).

MEASUREMENT NAME	VTM TEST NO.	VTM OFFSET LIMITS	OPERATING CONDITION	SPECIAL CONNECTIONS REQUIRED	LIMITS		UNITS
					MIN	MAX	
Battery voltage	67	—	Engine off		22	—	V
Current first peak	72	±225	Crank on GO	Current probe — illustration 1	875	1680	Amps
Vehicle gage oil pressure	10	—	Idle — use test 10 to check idle speed	Pulse tachometer — illustration 1	5	—	Psi
Charging voltage	1.67	—	Lights and accessories on 1000 to 1200 rpm	Pulse tachometer — illustration 1	27.5	28.5	V
Vehicle gage coolant temp	10	—	Warm engine		170	185	°F
Vehicle gage oil pressure	10	—	At 1000 rpm — use test 10	Pulse tachometer — illustration 1	30	50	Psi
Engine rpm (average)	10	—	Governor	Pulse tachometer — illustration 1	2350	2500	Rpm
*Power	13	—	Engine warm	Pulse tachometer — illustration 1	75		%
Engine rpm (average)	10	—	Idle	Pulse tachometer — illustration 1	550	600	Rpm
Compression unbalance	14	—	Warm engine — crank on GO		—	10	%
Cranking rpm	10	—	Cranking	Pulse tachometer — illustration 1	100	—	Rpm
Cranking voltage	67	—	Cranking		18	—	V
Cranking current	90	±225	Cranking	Current probe — illustration 2	350	550	Amps
Battery pack internal resistance	73	±225	Crank on GO	Current probe — illustration 2	—	13	Milliohms
Starter circuit resistance	74	±225	Crank on GO	Current probe — illustration 2	3	25	Milliohms
Battery pack resistance change	75	±225	Crank on GO	Current probe — illustration 2	—	50	Milliohms/sec

Test limits given are advisory only and are not necessarily the same as vehicle TM's specifications. If test limits are different, use vehicle TM's specifications.
 *If vehicle has a turbocharger or fuel limiter, go to vehicle TM for procedure to do power test.

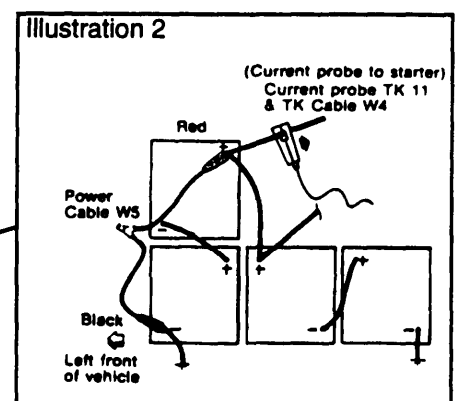
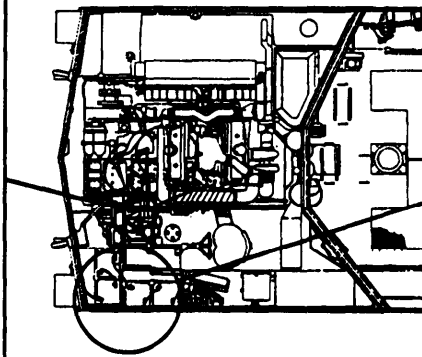
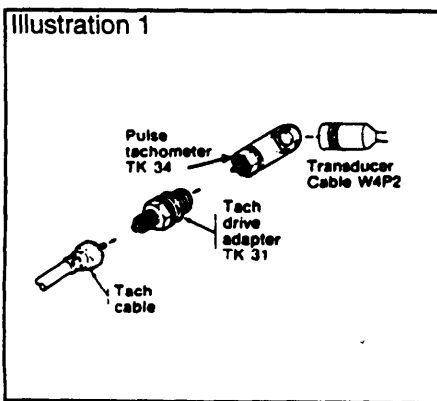

Figure 1, Sheet 1 of 2

M109 VEHICLE TEST CARD — VID 11 ADDITIONAL TEST CONNECTIONS

ALTERNATOR TESTS — M109A2/M109A3

NOTE

Picture shows conduction-cooled rectifier. Tests also apply to alternator cable in vehicles with fan-cooled rectifier.

NOTE

Perform the following tests with the alternator cable disconnected as shown.

Test 91, stator resistance measured from pin A to B, B to C, and A to C of alternator cable must be less than 5 ohms with engine off.
 Test 92, stator insulation measured from pin A to ground, B to ground, and C to ground, 9.9.9.9 with engine off.
 Test 93, alternator output volts, measured from pin A to B, B to C, and A to C, with engine idling and with 12 Vdc applied to pin D, and with pin E grounded, 30 to 34 Vac at idle.

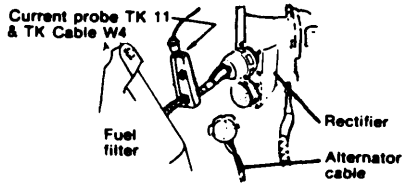

WARNING

When performing test 93, do not run engine above idle with voltage applied on pins D and E. Equipment damage and personal injury may result.

NOTE

Perform the following test with the alternator cable connected to the regulator and the current probe positioned as shown. Be sure the probe is 10 in. (25.4 cm) or more away from other wires.

Test 90, alternator output current, 30 amps minimum at 1000 to 1200 rpm (accessories on and partially discharged).

NOTE

Starting and charging circuits are in Chapter 3 (TM 9-2350-311-20-1).

FUEL PRESSURE TEST

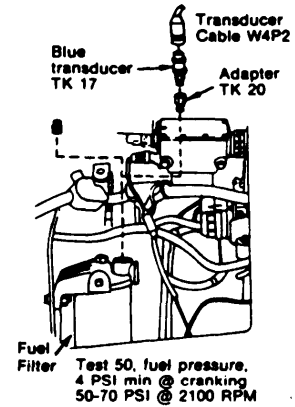

Test 50, fuel pressure, 4 PSI min @ cranking, 50-70 PSI @ 2100 RPM

ALTERNATOR TESTS — M109A4/M109A5

NOTE

Perform the following tests with the alternator cable disconnected as shown.

Test 91, stator resistance measured from pin B to D, D to F, and B to F of alternator cable must be less than 5 ohms with engine off.
 Test 92, stator insulation measured from pin B to ground, D to ground, and F to ground 9.9.9.9 with engine off.
 Test 93, alternator output volts, measured from pin B to D, D to F, and B to F, with engine idling and with 12 Vdc applied to pin A, and with pin C grounded, 30 to 34 Vac at idle.

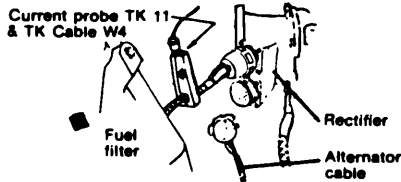

WARNING

When performing test 93, do not run engine above idle with voltage applied on pins D and E. Equipment damage and personal injury may result.

NOTE

Perform the following test with the alternator cable connected to the regulator and the current probe positioned as shown. Be sure the probe is 10 in. (25.4 cm) or more away from other wires.

Test 90, alternator output current, 30 amps minimum at 1000 to 1200 rpm (accessories on and partially discharged).

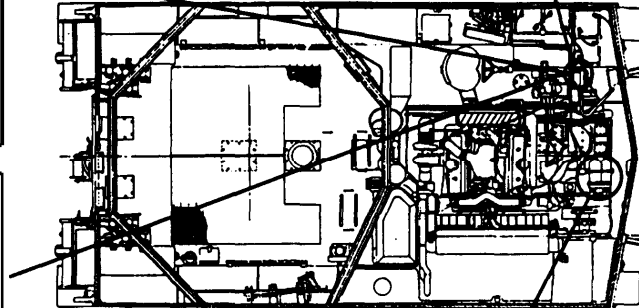

OIL PRESSURE TEST

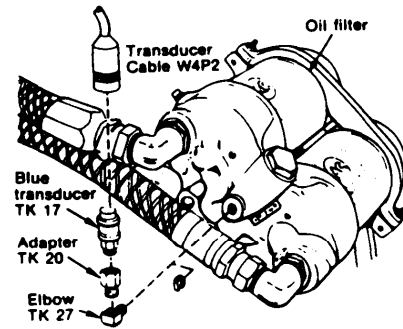

Test 50, oil pressure, 5 PSI min @ idle, 30-50 PSI @ 1000 RPM

Figure 1, Sheet 2 of 2

GO 1 VTM CONNECTIONS AND CHECKOUT**WARNING**

Do not connector disconnect VTM while VTM power switch is on.

On vehicles with MASTER switch in negative (-) battery cable, sparking may occur if VTM case touches vehicle while MASTER switch is off and VTM is on. Sparking in presence of fuel or fuel vapors presents potential hazard. Avoid hazard by doing all testing with vehicle MASTER switch on.

CAUTION

Do not connect VTM to battery charger unless charger is connected to battery.

Connect P1 of power cable W5 to J1 on VTM before connecting clip leads to battery.

Do not connector disconnect VTM while engine is running.

Go to Figure 2,
sheet 2.

Figure 2, Sheet 1 of 20

GO 1 VTM CONNECTIONS AND CHECKOUT CONTINUED

1

CONNECT BATTERY TO VTM:

- PULL OFF VTM power switch.
- Connect P1 of power cable W5 to J1 on VTM.
- Connect red clip E1 of cable W5 to positive terminal of M109A2/A3/A4/A5 battery.
- Connect black clip E2 of cable W5 to negative terminal of M109A2/A3/A4/A5 battery.

NOTE

Align white mark on connector P1 with large slot in keyway of J1. Twist locking ring until it clicks.

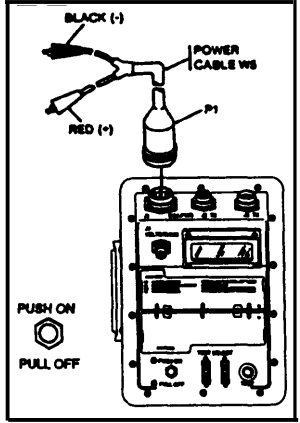

NOTE

Make sure all connections are correct and secure.

2

POWER UP:

- PUSH ON VTM power switch.
- Verify that display indicates .8.8.8.8 for approximately 2 seconds and then changes to ----

Does the VTM display .8.8.8.8 and then change to --- -?

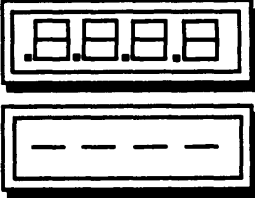
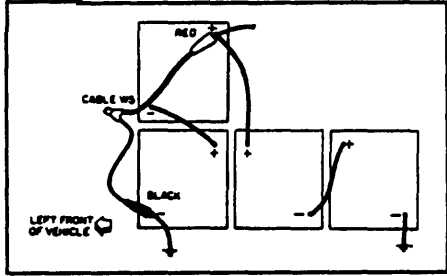

After 2 seconds

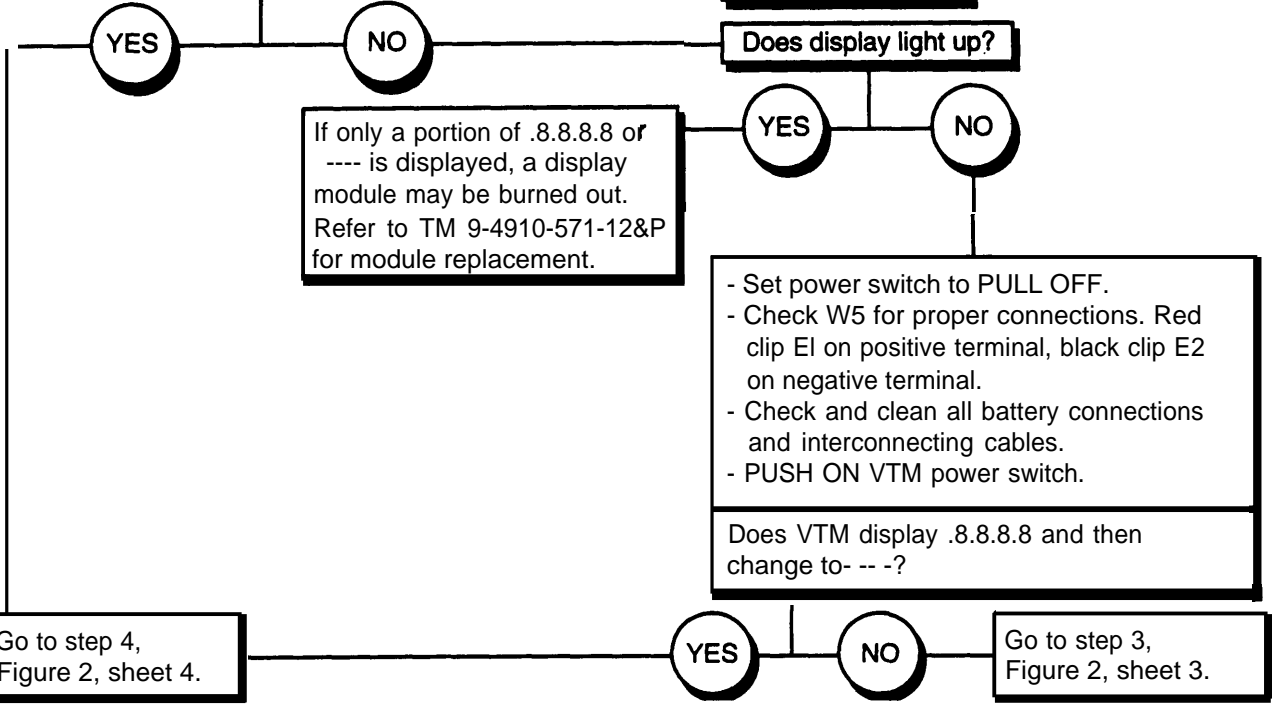

Figure 2, Sheet 2 of 20

GO 1 VTM CONNECTIONS AND CHECKOUT — CONTINUED

CONNECT TO KNOWN GOOD BATTERIES:

- Set power switch to PULL OFF.
- Connect power cable W5 to known good batteries.
- PUSH ON VTM power switch.

Does VTM display .8.8.8.8 and then change to----?

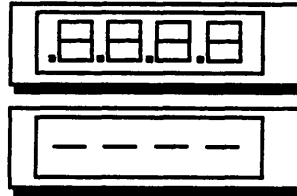

After 2 seconds

YES

NO

- Check vehicle electrolyte level.
- Clean battery terminals.
- Check battery specific gravity, as applicable (para 8-28).
- Charge batteries if necessary.
- Return to step 1, Figure 2, sheet 2.

- Refer to TM 9-4910-571-12&P for fault isolation of cable W5.
- If cable is bad, replace it.
- If cable is good, STE/ICE-R is bad.
- Replace STE/ICE-R.

Figure 2, Sheet 3 of 20

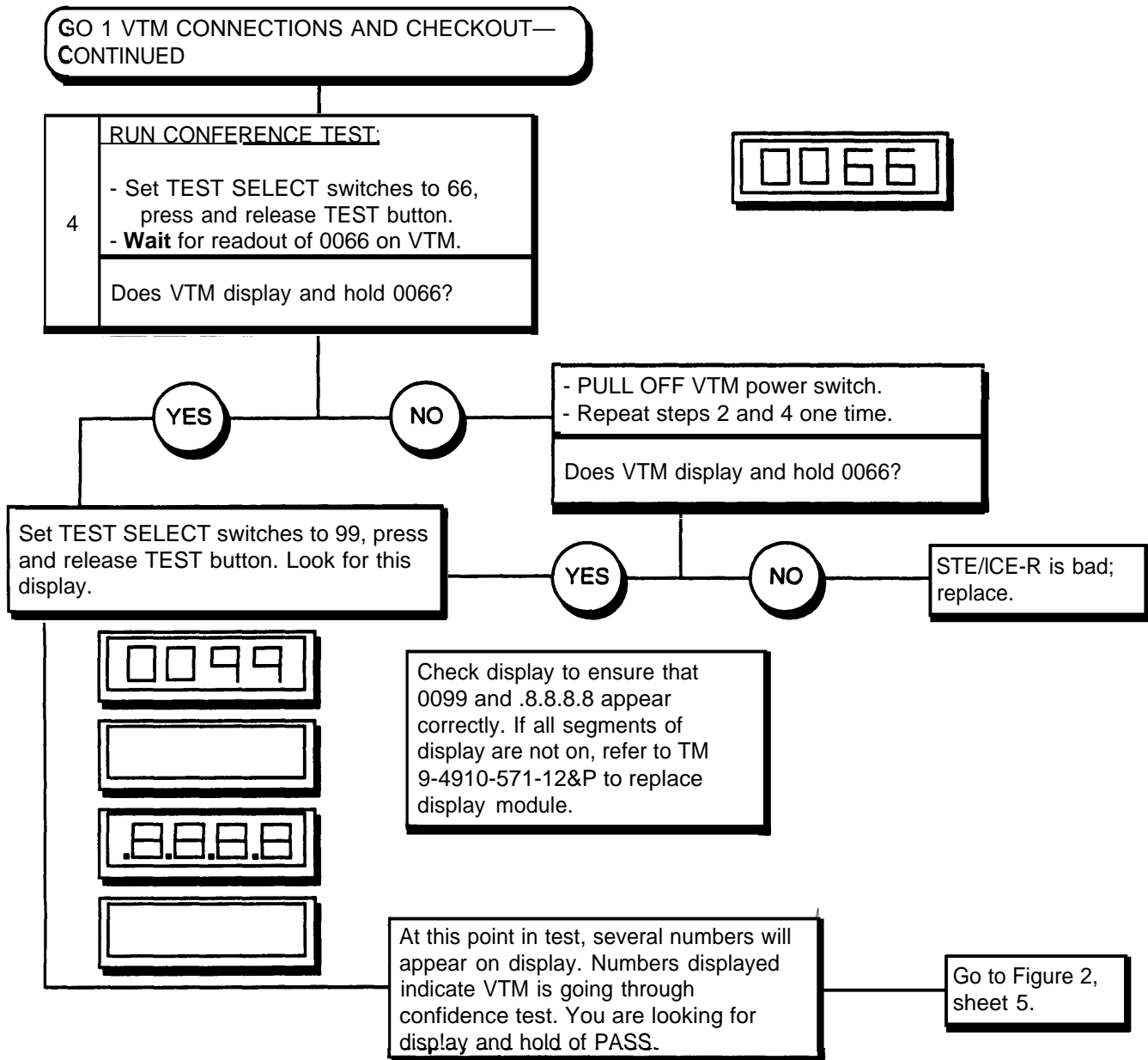

Figure 2, Sheet 4 of 20

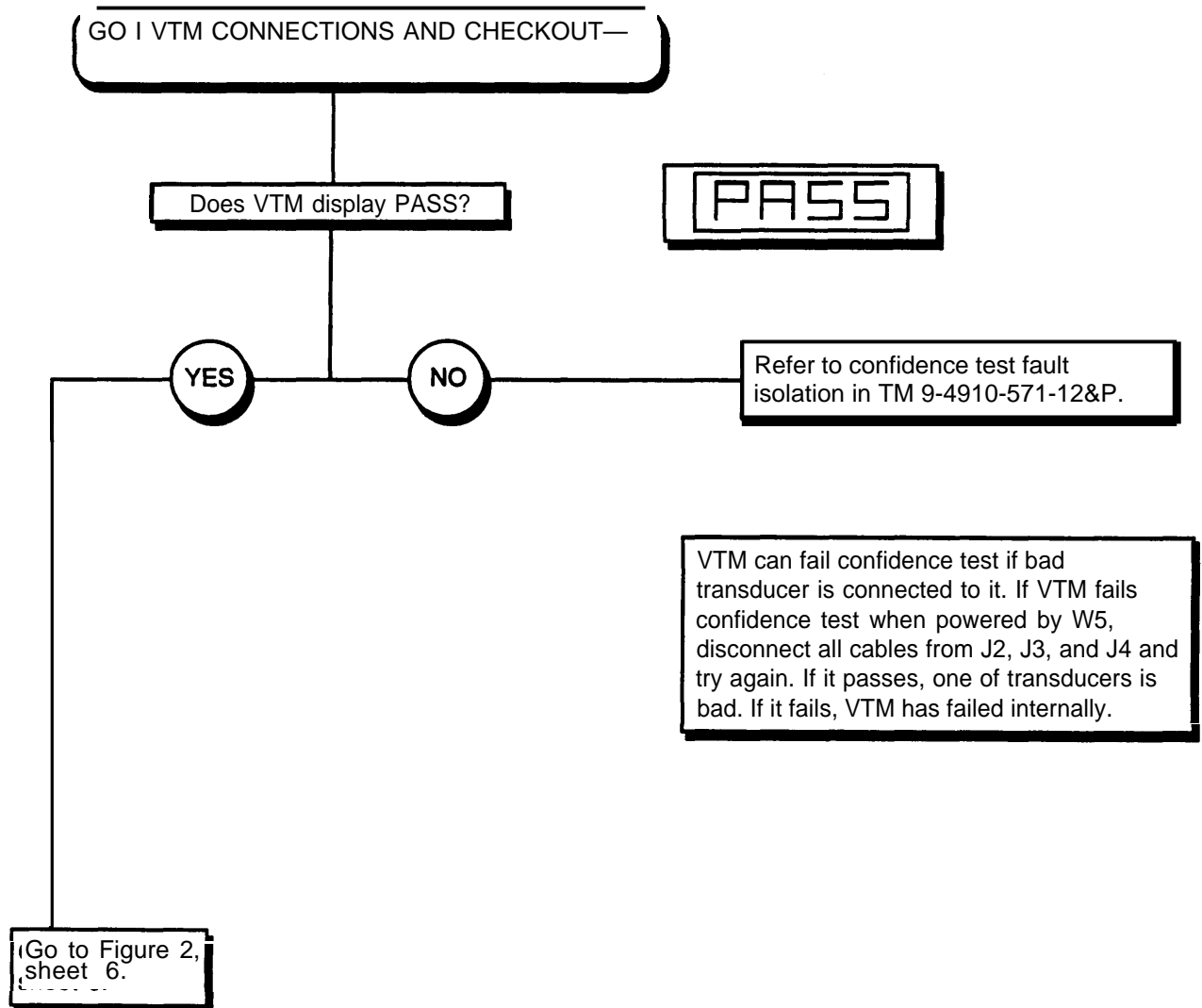

Figure 2, Sheet 5 of 20

**GO 1 VTM CONNECTIONS AND CHECKOUT —
CONTINUED**

- Set TEST SELECT switches to 67, press and release TEST button.
- Watch display and verify that battery voltage is above +22 Vdc.

Is battery voltage above +22 Vdc?

YES

NO

- Check VTM connections.
- Clean battery connections.
- Go to paragraph 8-28 to check battery specific gravity.
- Charge batteries if necessary.
- Refer to cable fault isolation procedure in TM 9-4910-571-12&P and troubleshoot cable W5.

NOTE

After completing repair, rerun the GO CHAIN tests to verify that problem is fixed and that no other problems exist. Start at GO 1 (Figure 2, sheet 1).

Go to step 5,
Figure 2, sheet 7.

Figure 2, Sheet 6 of 20

**GO 1 VTM CONNECTIONS AND CHECKOUT -
C CONTINUED**

WARNING

Turn engine off before installing pulse tachometer.

CAUTION

Clean all mounting surfaces before installing pulse tachometer to prevent entry of foreign substances that may damage engine or transducer.

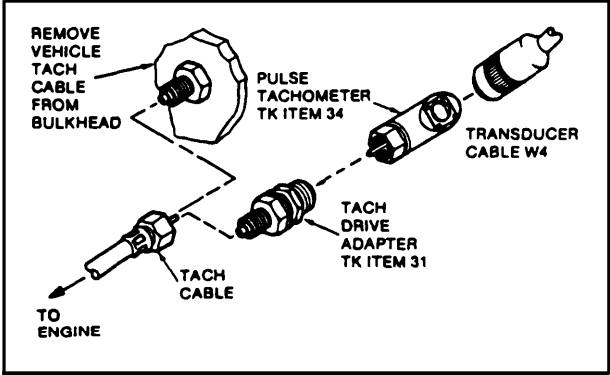

5 **INSTALL PULSE TACHOMETER (TK ITEM 34):**
 - Disconnect tachometer cable (para 9-18).
 - Install pulse tachometer in place of removed tachometer cable.

NOTE

If rpm or power tests vary more than 5%, remove tach drive adapter and pulse tachometer from tach cable. Connect pulse tachometer to tach cable interface on engine. Rotation of vehicle tach speed adapter may be required to connect pulse tachometer.

6 **MAKE CABLE CONNECTIONS:**
 - Connect P1 of transducer cable W4 to J2 on VTM.
 - Connect P2 of transducer cable to connector on pulse tachometer.

CAUTION

Be sure cable W4 is clear of belts and fan blades.

Go to GO 2 (Figure 2, sheet 8).

Figure 2, Sheet 7 of 20

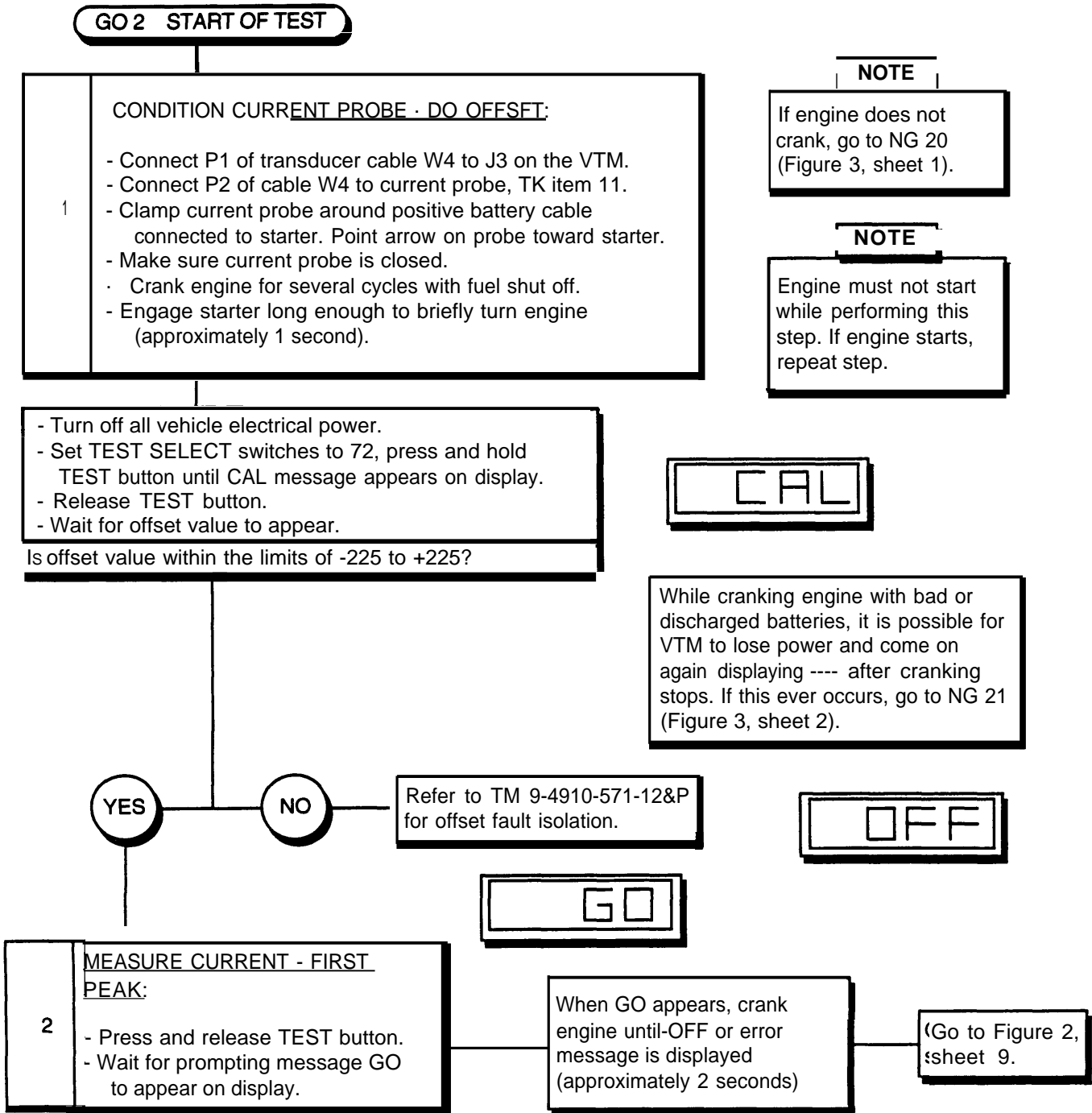

Figure 2, Sheet 8 of 20

(GO 2 START OF TEST — CONTINUED)

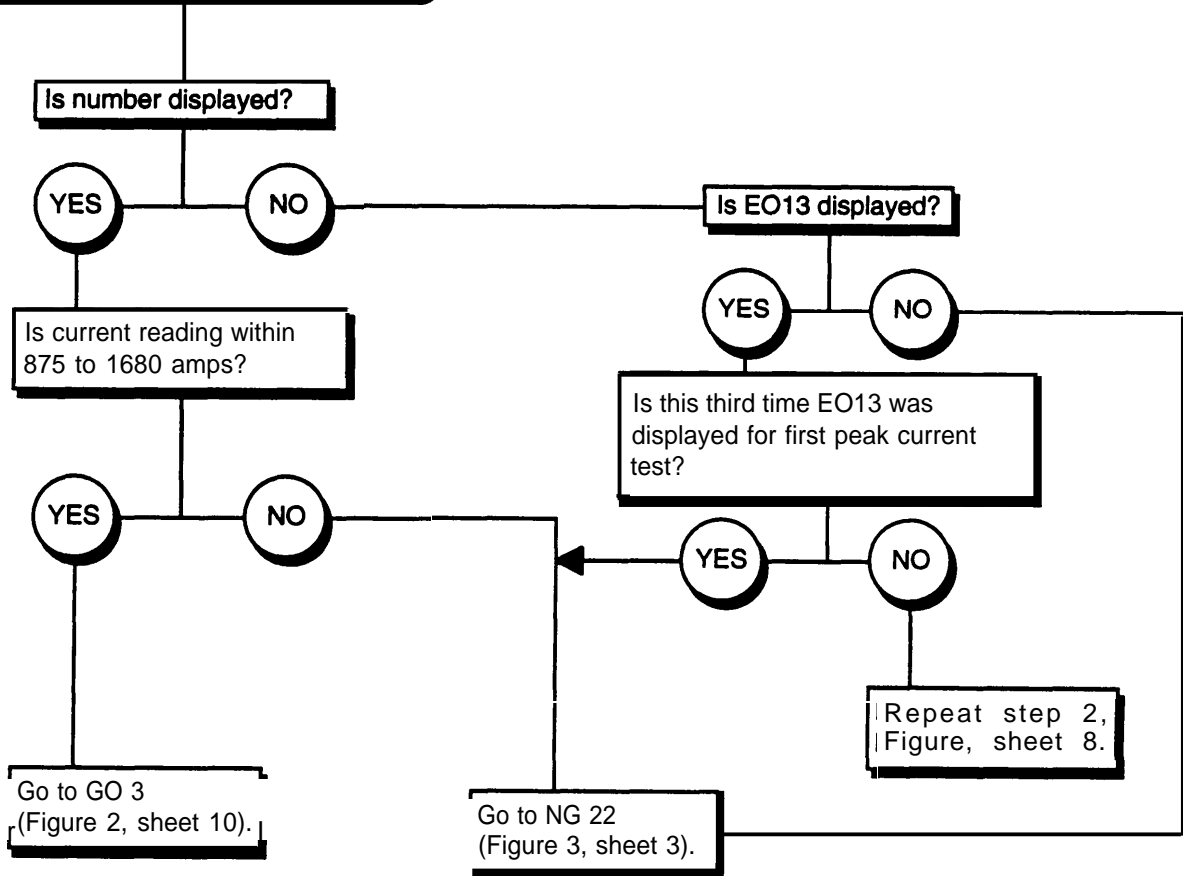

Figure 2, Sheet 9 of 20

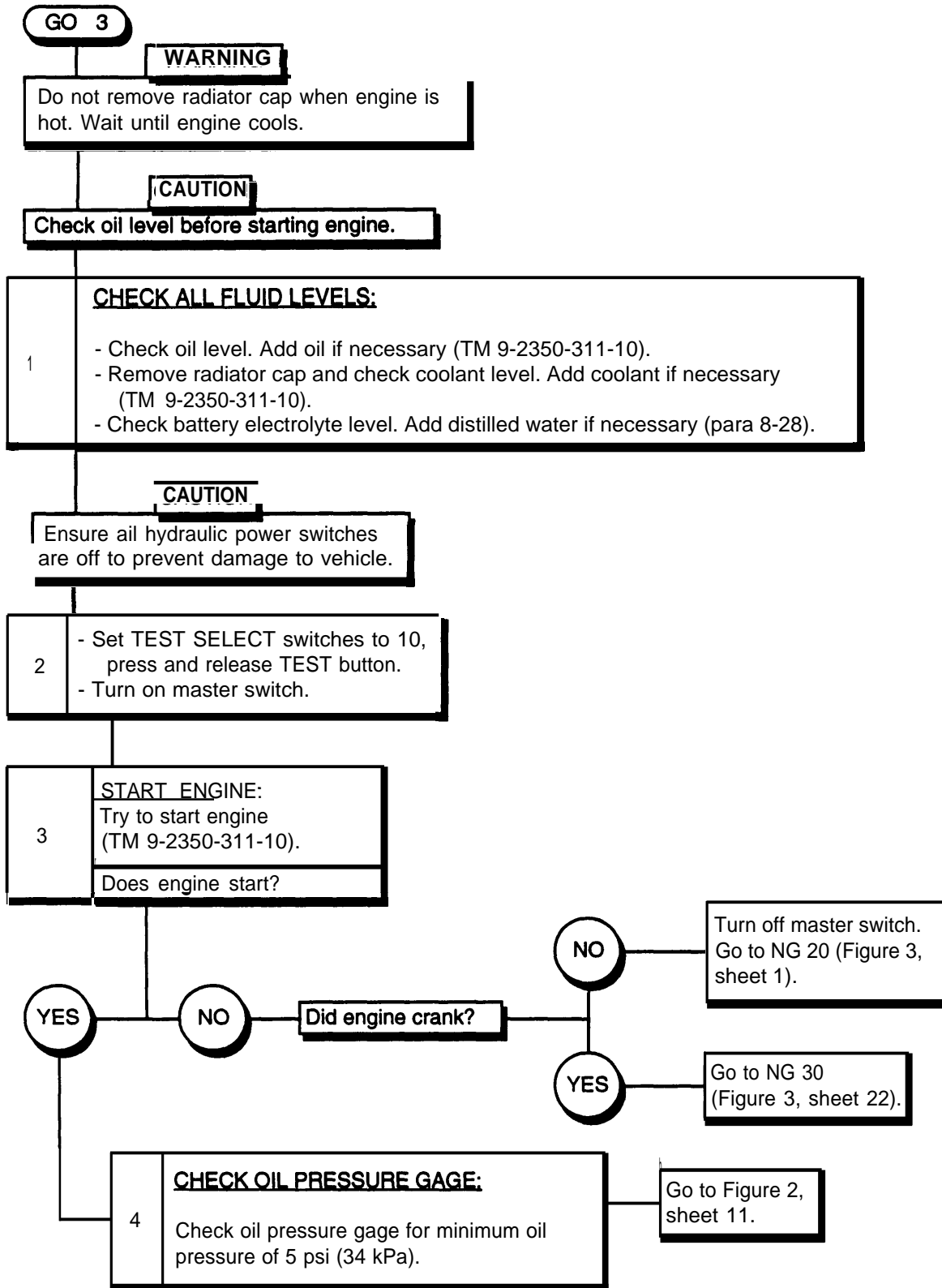

Figure 2, Sheet 10 of 20

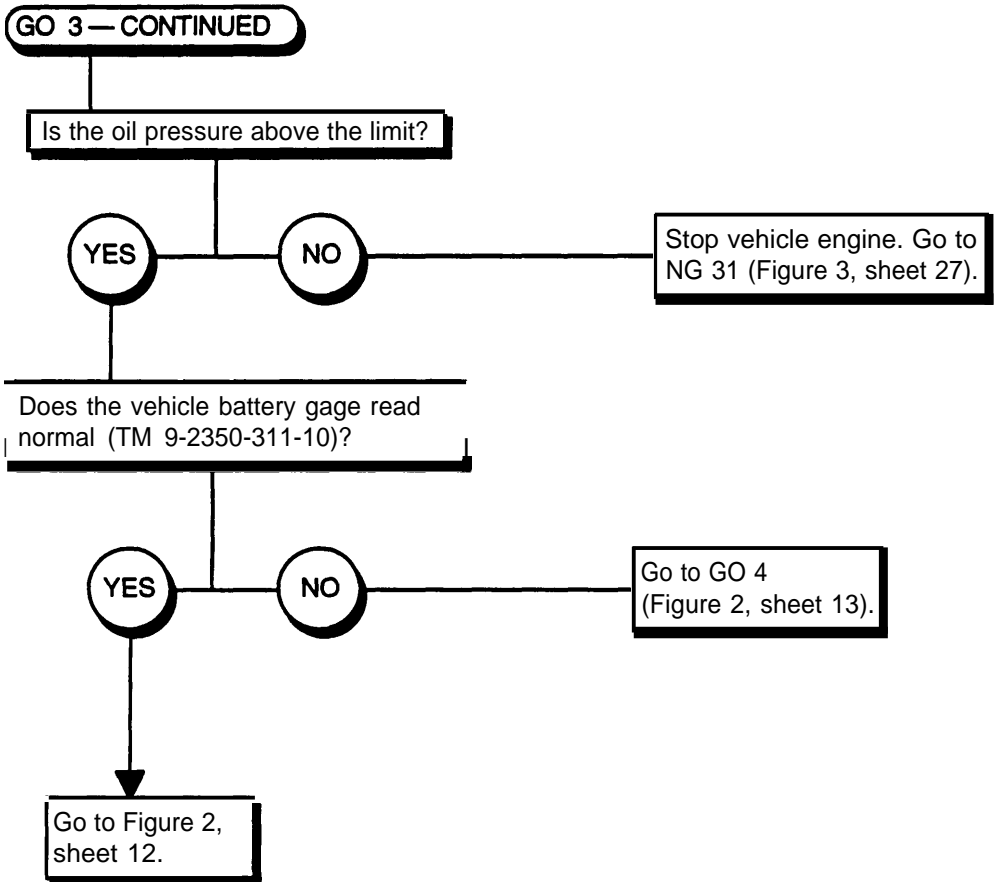

Figure 2, Sheet 11 of 20

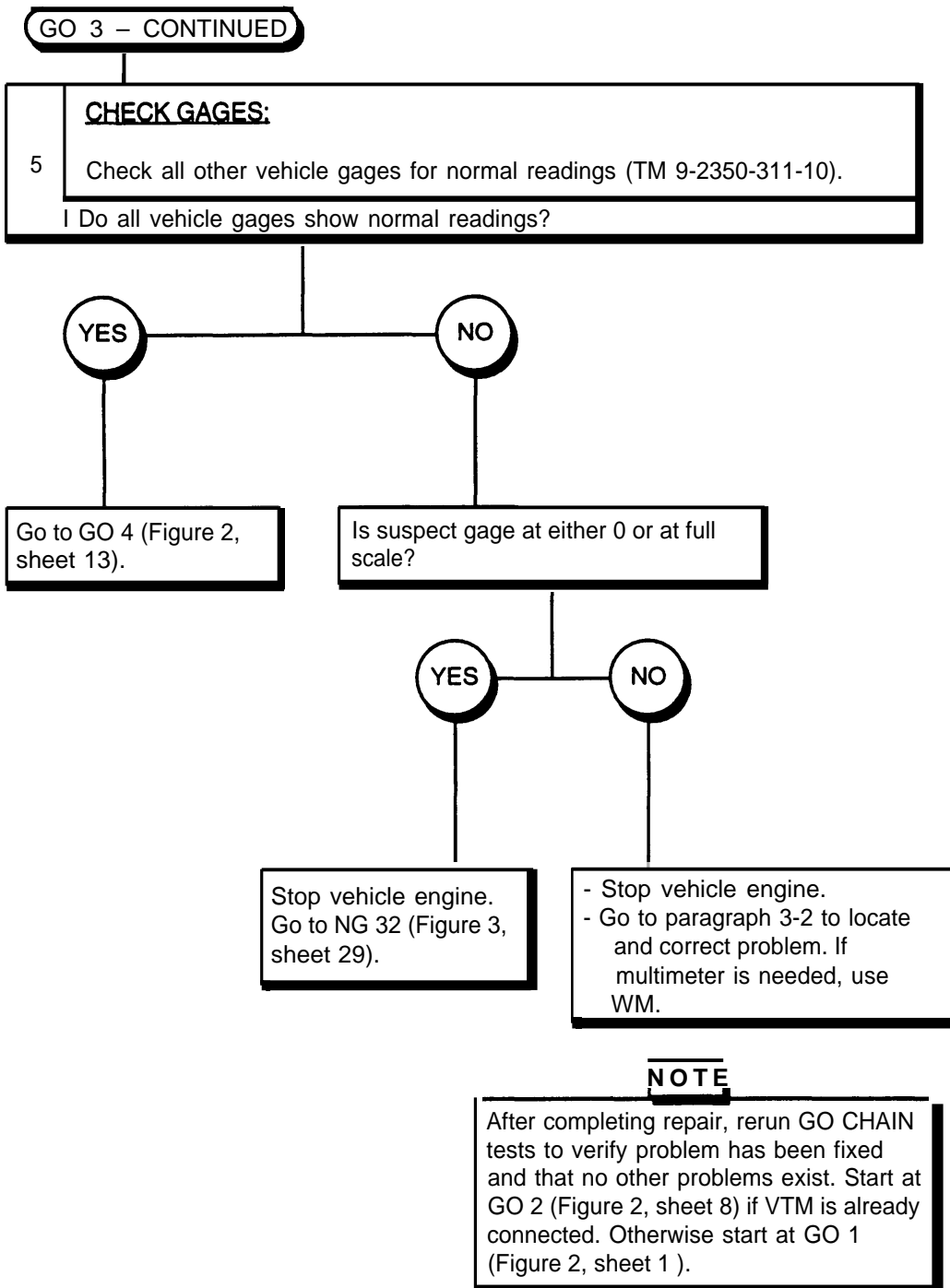

Figure 2, Sheet 12 of 20

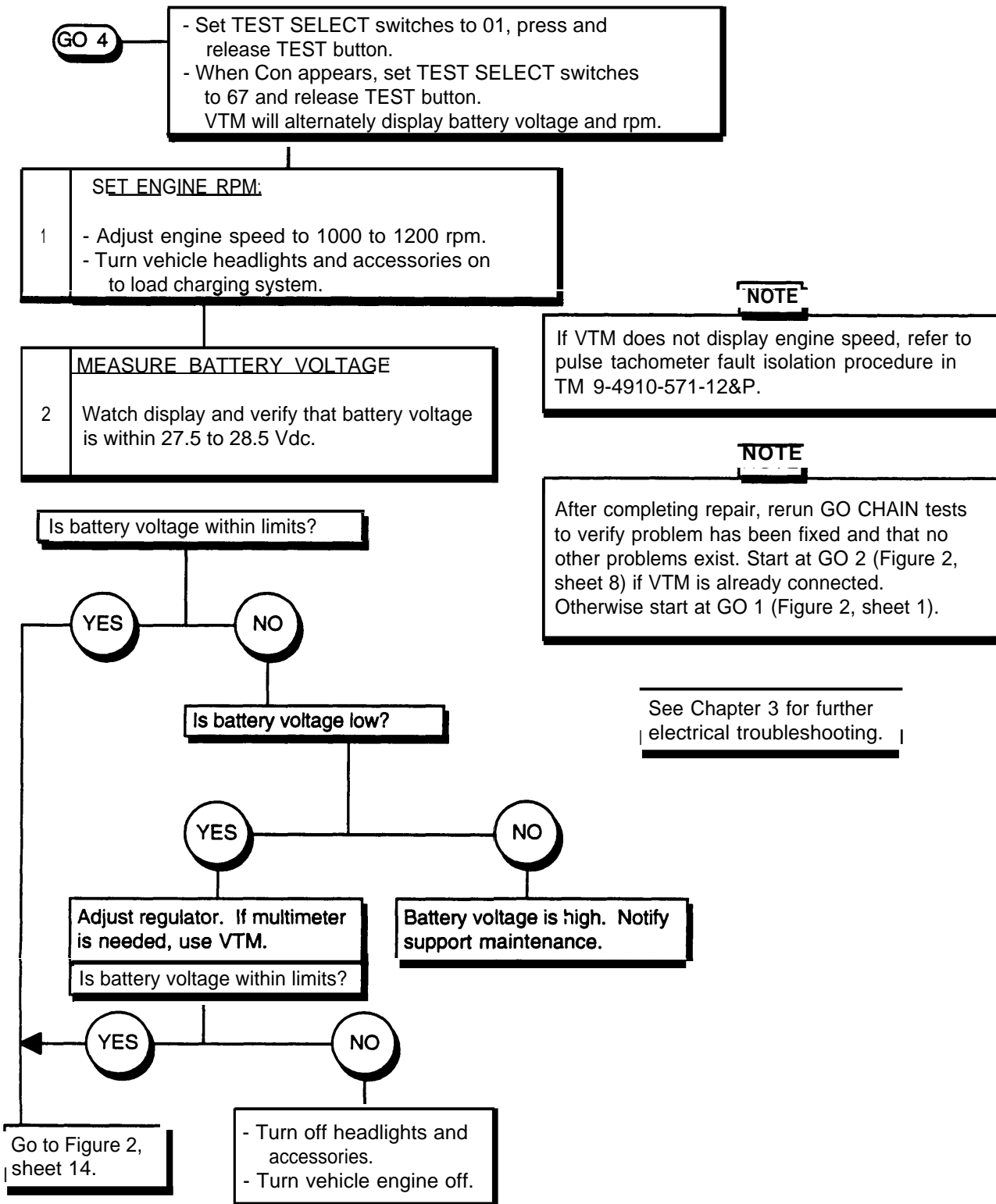

Figure 2, Sheet 13 of 20

GO 4 – CONTINUED

Does vehicle indicator or gage read normal?

YES

NO

Go to paragraph 3-3 to troubleshoot alternator indicator and wiring. If multimeter is needed, use VTM.

Turn off headlights and all accessories. Turn vehicle engine off. Go to GO 5 (Figure 2, sheet 15).

NOTE

After completing repair, rerun GO CHAIN tests to verify problem has been fixed and that no other problems exist. Start at GO 2 (Figure 2, sheet 8) if VTM is already connected. Otherwise start at GO 1 (Figure 2, sheet 1).

Figure 2, Sheet 14 of 20

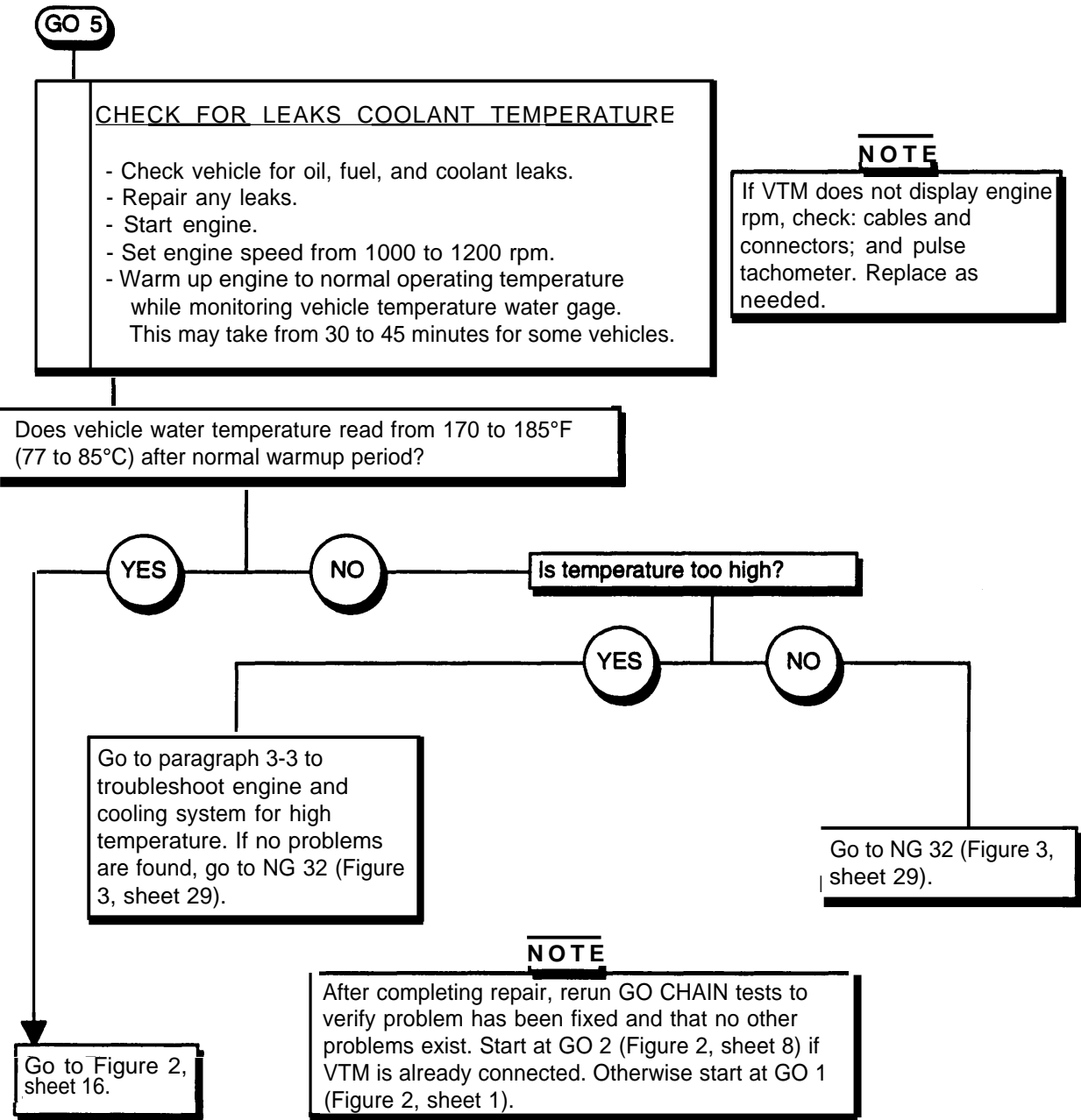

Figure 2, Sheet 15 of 20

GO 5 — CONTINUED

CHECK OIL PRESSURE:

- Set TEST SELECT switches to 10, press and release TEST button.
- Increase engine rpm to 2100 rpm.
- Watch engine oil pressure gage.

2

Is oil pressure from 40 to 70 psig (2.8 to 4.8 kg/sq cm)?

NOTE

If VTM does not display engine speed, refer to pulse tachometer fault isolation in TM 9-4910-571-12&P and correct problem.

YES

NO

Go to NG 31 (Figure 3, sheet 27).

Go to GO 6 (Figure 2, sheet 17).

Figure 2, Sheet 16 of 20

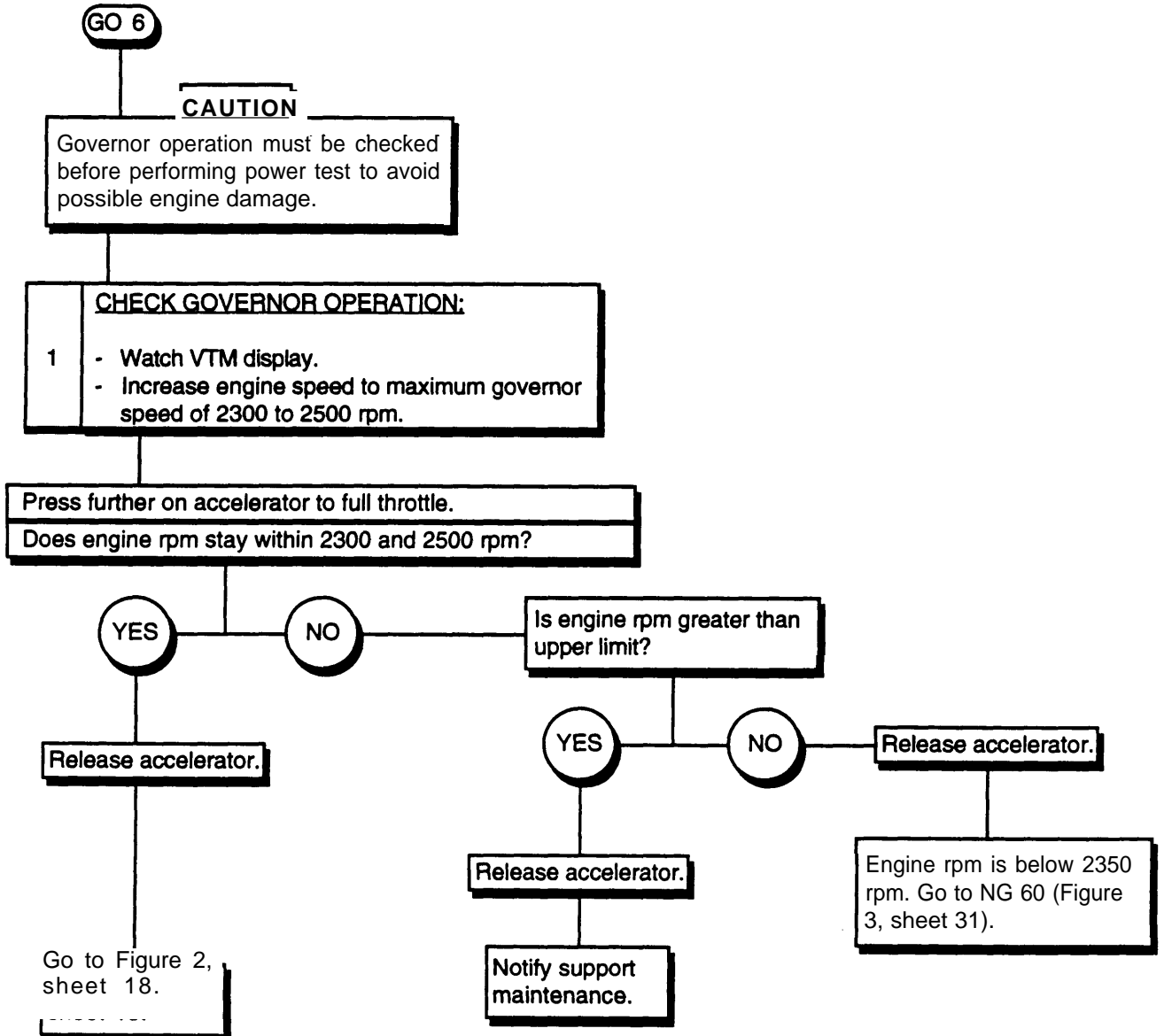

Figure 2, Sheet 17 of 20

GO 6 — CONTINUED

CAUTION

Do not perform power test if engine is above normal operating temperature. However, engine should beat operating temperature before performing power test.

NOTE

Engine has to be running below 1000 rpm before power test.

PERFORM POWER TEST:

- Set TEST SELECT switches to 13, press and release TEST button.
- Wait for prompting message UEH to appear.

Does VTM display UEH?



YES

NO

Go to step 4, Figure 2, sheet 19.

ENTER VID NUMBER:

Set TEST SELECT switches to 11, press and release TEST button.

Does VTM display number 11?



YES

NO

Does the VTM display an error message?

Go to step 4, Figure 2, sheet 19.

Refer to appropriate error message fault isolation procedure in TM 9-4910-571-12&P..

YES

NO

STE/ICE-R is bad; replace.

Figure 2, Sheet 18 of 20

GO 6 — CONTINUED

- 4
- Wait for prompting message CIP to appear.
 - When CIP appears, rapidly press down on accelerator and hold it to floor until VTM displays OFF.
 - When OFF appears, release accelerator.
 - A number representing % power will appear on VTM display. Compare this number to table below.



% POWER: MINIMUM TEST LIMIT		
0 to 2000 ft (0 to 610 m)	2001 to 4000 ft (610 to 1219 m)	Above 4000 ft (Above 1219 m)
75%	68%	60%

CAUTION

To prevent damage to equipment, allow engine to idle for at least 2 minutes after running power test.

Is power above minimum test limit noted in table above?

YES

NO

Go to Go 7 (Figure 2, sheet 20).

Go to NG 60 (Figure 3, sheet 31).

Figure 2, Sheet 19 of 20

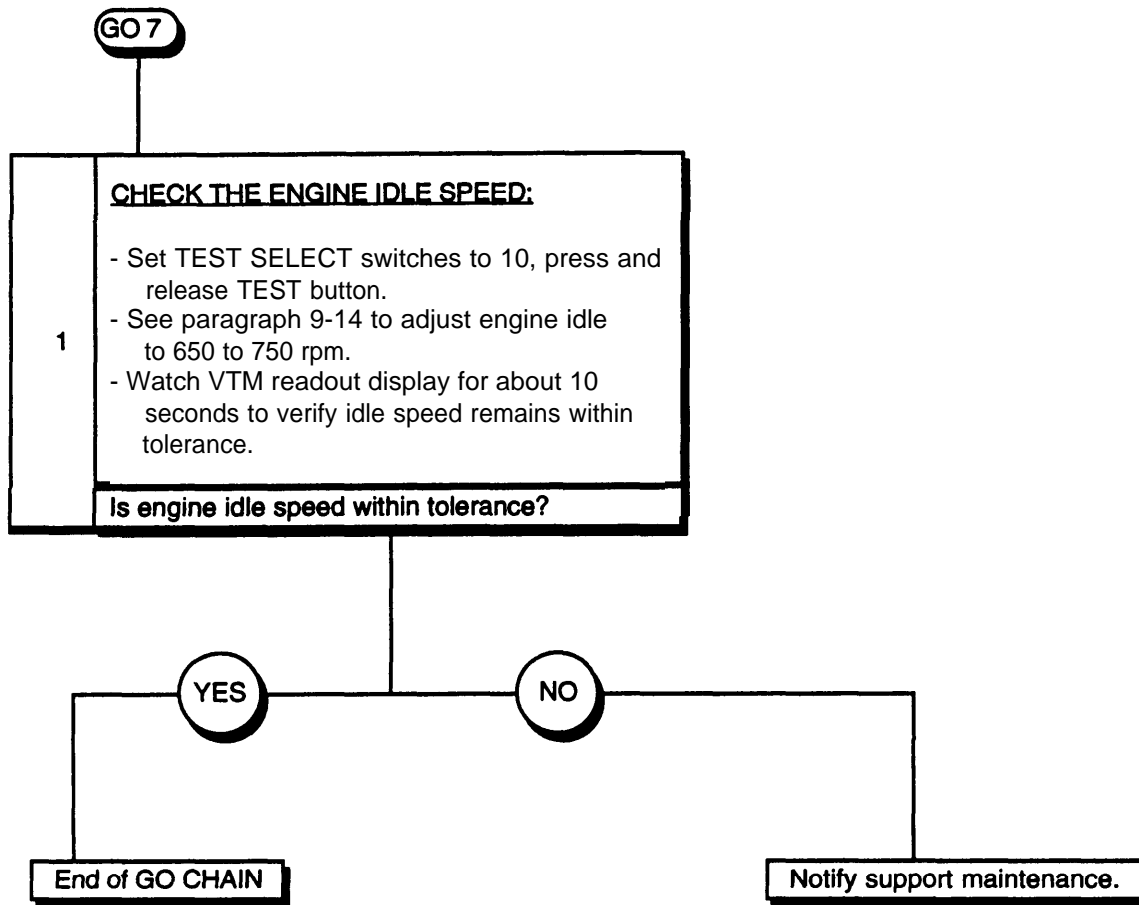

Figure 2, Sheet 20 of 20

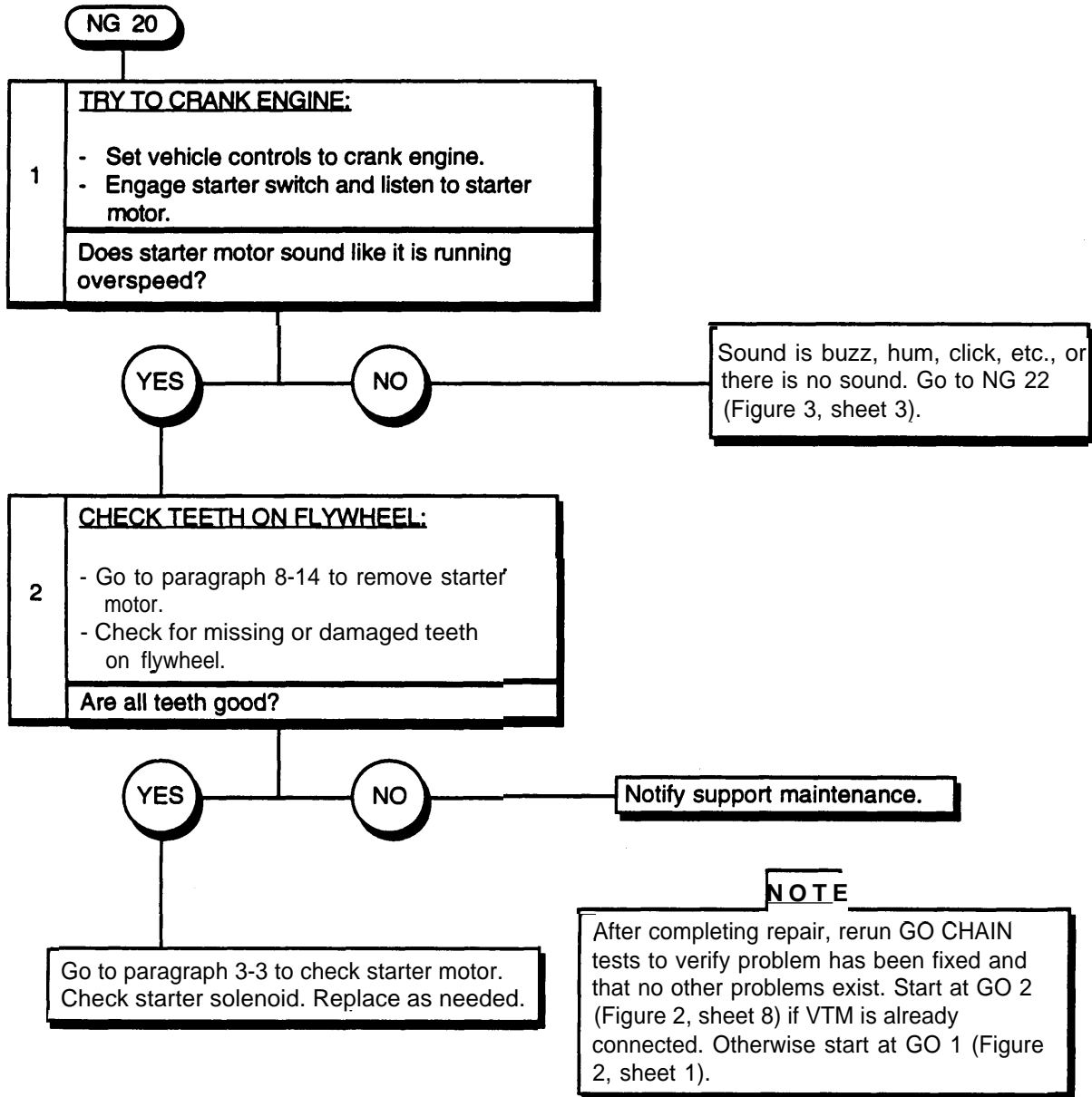

Figure 3, Sheet 1 of 36

NG 21

POWER THE VTM FROM ANOTHER VEHICLE'S BATTERY:

1

- PULL VTM power switch OFF.
- Disconnect leads of power cable W5 from batteries of vehicle under test.
- Go to GO 1 (Figure 1, sheet 1) and perform steps 1 thru 4 to power VTM from different vehicle with good batteries.

NOTE

Do not use vehicle under test to power VTM...

Go to NG 24 (Figure 3, sheet 15).

Figure 3, Sheet 2 of 36

NG 22

NOTE

While cranking engine with bad or discharged batteries, it is possible for VTM to lose power and come on again displaying ---- after cranking has stopped. If this occurs, clean battery posts and clamps and try again. If VTM still loses power, go to NG 21 (Figure 3, sheet 2).

CONDITION CURRENT PROBE:

- Clamp current probe around positive battery cable connected to starter. Point arrow toward starter.
- Make sure current probe is closed.
- Crank engine for several cycles with fuel shut off.

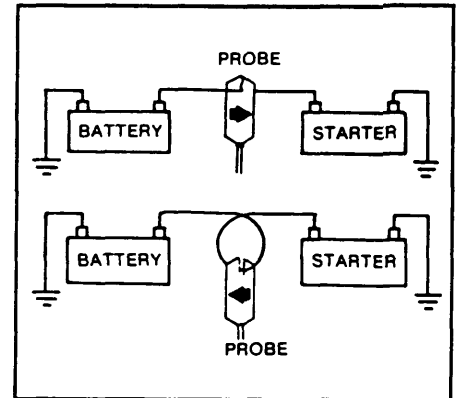

DO CURRENT PROBE OFFSET:

- 1
- Turn off all electrical power.
 - Set TEST SELECT switches to 74, press and hold TEST button until CAL message appears on display.
 - Release TEST button.
 - Wait for offset value to appear.

Is offset value within limits of -225 to +225?



YES

NO

Refer to TM 9-4910-571-12&P for offset fault isolation.



CHECK STARTER CIRCUIT RESISTANCE:

- 2
- Shut off fuel.
 - Press and release TEST button for 5 seconds until OFF appears or until error message is displayed.

Is number displayed?

Go to Figure 3, sheet 4.

Figure 3, Sheet 3 of 36

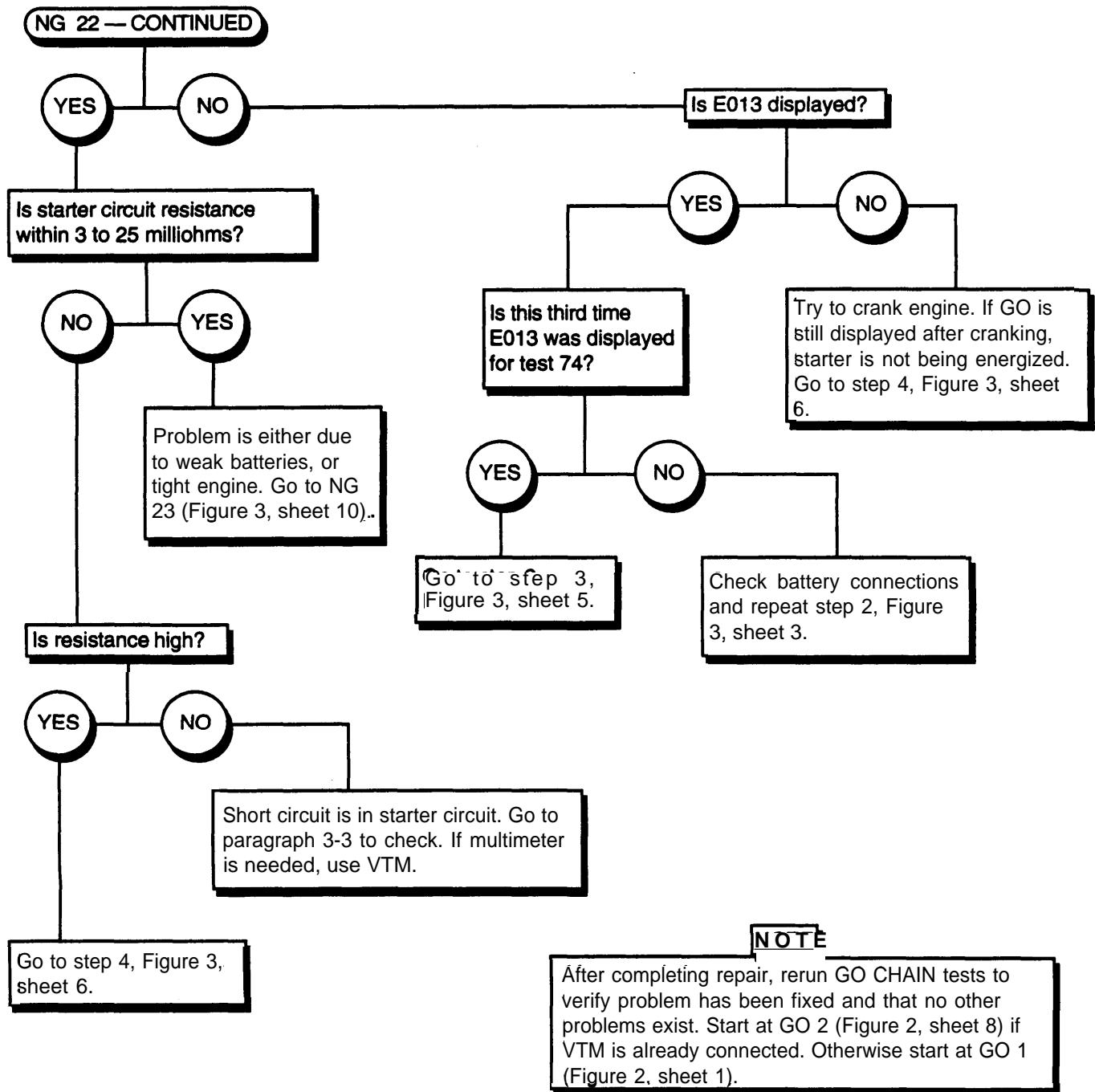

Figure 3 Sheet 4 of 36

NG 22 — CONTINUED

3 **CHECK STARTER CURRENT:**

- Turn off all electrical power.
- Set TEST SELECT switches to 90, press and hold TEST button until CAL message appears on display.
- Release TEST button.
- Wait for offset value to appear.

Is offset value within limits of -225 to +225?



Refer to TM 9-4910-571-12&P for offset fault isolation.

- Press and release TEST button.
- Crank engine for few seconds with fuel off.

Is starter current above 100 amps?

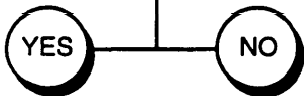

Go to NG 23 (Figure 3, sheet 10).

Error message E013 displayed in step 2 indicates short circuit, frozen starter, or tight engine.

Check wiring to starter for short circuits. Repair as needed (para 3-3).

If wiring is OK, engine may be tight. Notify support maintenance.

NOTE

After completing repair, rerun GO CHAIN tests to verify problem has been fixed and that no other problems exist. Start at GO 2 (Figure 2, sheet 8) if VTM is already connected. Otherwise start at GO 1 (Figure 1, sheet 2).

Figure 3, Sheet 5 of 36

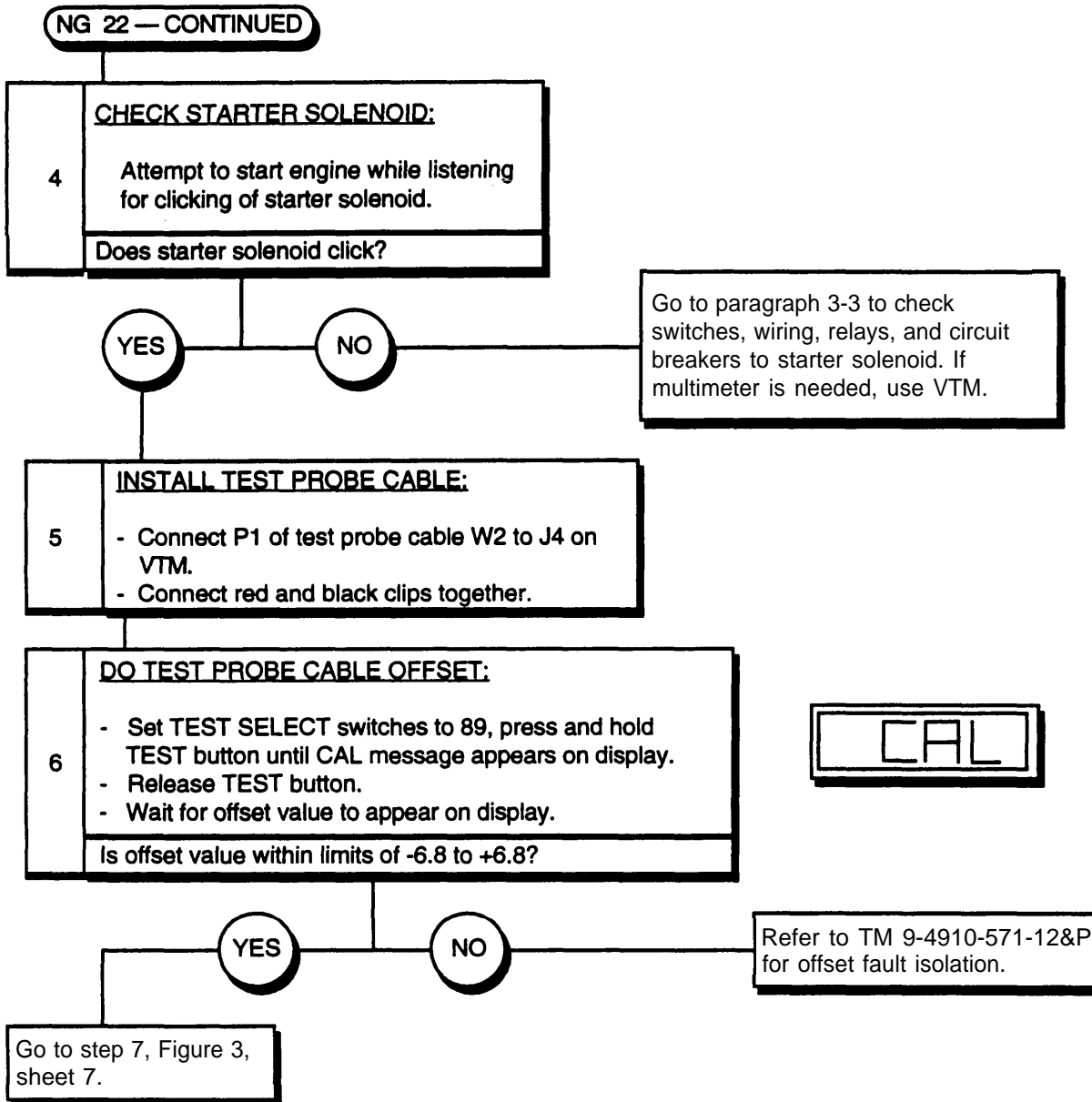

Figure 3, Sheet 6 of 36

NG 22 — CONTINUED

WARNING

Electrical shock hazard. Ensure circuit is off before attaching leads. Failure to heed warning could cause injury or death. If electrical shock occurs, administer first aid and seek medical assistance immediately.

7

CHECK STARTER VOLTAGE:

- Connect black clip E2 of test probe cable W2 to negative battery terminal.
- Connect red clip E1 of test probe cable W2 to positive terminal of starter motor.
- Turn on circuit to be tested.
- Press and release TEST button.
- Crank engine and observe display voltage.

Is the starter voltage above 17 V?

NOTE

Always attach red clip E1 to positive (+) side and black clip E2 to negative (-) side of item being measured. Otherwise, negative number may be displayed.

YES

NO

Go to step 9, Figure 3, sheet 8.

8

STARTER NEGATIVE VOLTAGE DROP:

- Move red clip of test probe cable W2 to ground terminal of starter motor.
- Crank engine and observe displayed voltage.

Does voltage drop less than limit of 18 V?

YES

NO

Inspect/repair/clean cables as needed.

Replace starter (para 8-14).

NOTE

After completing repair, rerun GO CHAIN tests to verify problem has been fixed and that no other problems exist. Start at GO 2 (Figure 2, sheet 8) if VTM is already connected. Otherwise start at GO 1 (Figure 2, sheet 1).

Figure 3, Sheet 7 of 36

NG 22 — CONTINUED

9	CHECK STARTER SOLENOID VOLTAGE:
	<ul style="list-style-type: none"> - Move red clip of test probe cable W2 to positive terminal of starter solenoid. - Crank engine and observe displayed voltage.
	Is starter solenoid voltage above 18 V?

YES

NO

10	CHECK BATTERY VOLTAGE WHILE CRANKING:
	<ul style="list-style-type: none"> - Set TEST SELECT switches to 67, press and release TEST button. - Crank engine and observe display.
	Was battery voltage above 18 V while cranking?

YES

NO

Go to step 11, Figure 3, sheet 9.

Go to paragraph 3-3 to check switches and wiring to starter solenoid. Notify support maintenance.

Go to NG 23 (Figure 3, sheet 10).

NOTE

After completing repair, rerun GO CHAIN tests to verify problem has been fixed and that no other problems exist. Start at GO 2 (Figure 2, sheet 8) if VTM is already connected. Otherwise start at GO 1 (Figure 2, sheet 1).

Figure 3, Sheet 8 of 36

NG 22 — CONTINUED

NOTE

Drop limits across a connection should be less than 0.1 V and drop across a cable should be less than 0.2 V.

Check voltage drop across solenoid, all cables, and connections in positive side of starter circuit.

MEASURE VOLTAGE DROP:

11

- Set TEST SELECT switches to 89.
- Connect clip leads of test probe cable W2 across part (solenoid, cable, or connection) to be measured.
- Press and release TEST button.
- Engage starter.
- Compare voltage drop on display with guidelines mentioned in above NOTE.

Repair or replace defective part tested.

NOTE

After completing repair, rerun GO CHAIN tests to verify problem has been fixed and that no other problems exist. Start at GO 2 (Figure 2, sheet 8) if VTM is already connected. Otherwise start at GO 1 (Figure 2, sheet 1).

Figure 3, Sheet 9 of 36

NG 23

- Check all battery electrolyte levels.
- Clean all battery terminals.
- Check batteries' specific gravities (para 8-28).
- Charge batteries if they haven't already been charged.

Each series of batteries are tested. During this test, fuel supply must be shut off to keep engine from starting.

- 1**
- INSTALL CURRENT PROBE W4:**
- Connect P1 of W4 to J3 of the VTM.
 - Attach connector P2 of cable W4 to current probe, TK item 11.

- 2**
- Clamp current probe, TK item 11, around battery cable that connects series pair of batteries. Make sure current probe is closed.
 - Point arrow on current probe toward negative post as shown in paragraph 1-11.
 - Engage starter only long enough to briefly turn engine (approximately 1 second).

- Turn off vehicle electrical power.
- Set TEST SELECT switches to 75, press and hold TEST button until CAL message appears on display.
- Release TEST button.
- Wait for offset value to appear.



Is offset value within limits of -225 to +225?

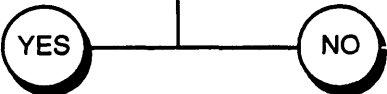

Refer to TM 9-4910-571-12&P for offset fault isolation.

Go to step 3, Figure 3, sheet 24.

Figure 3, Sheet 10 of 36

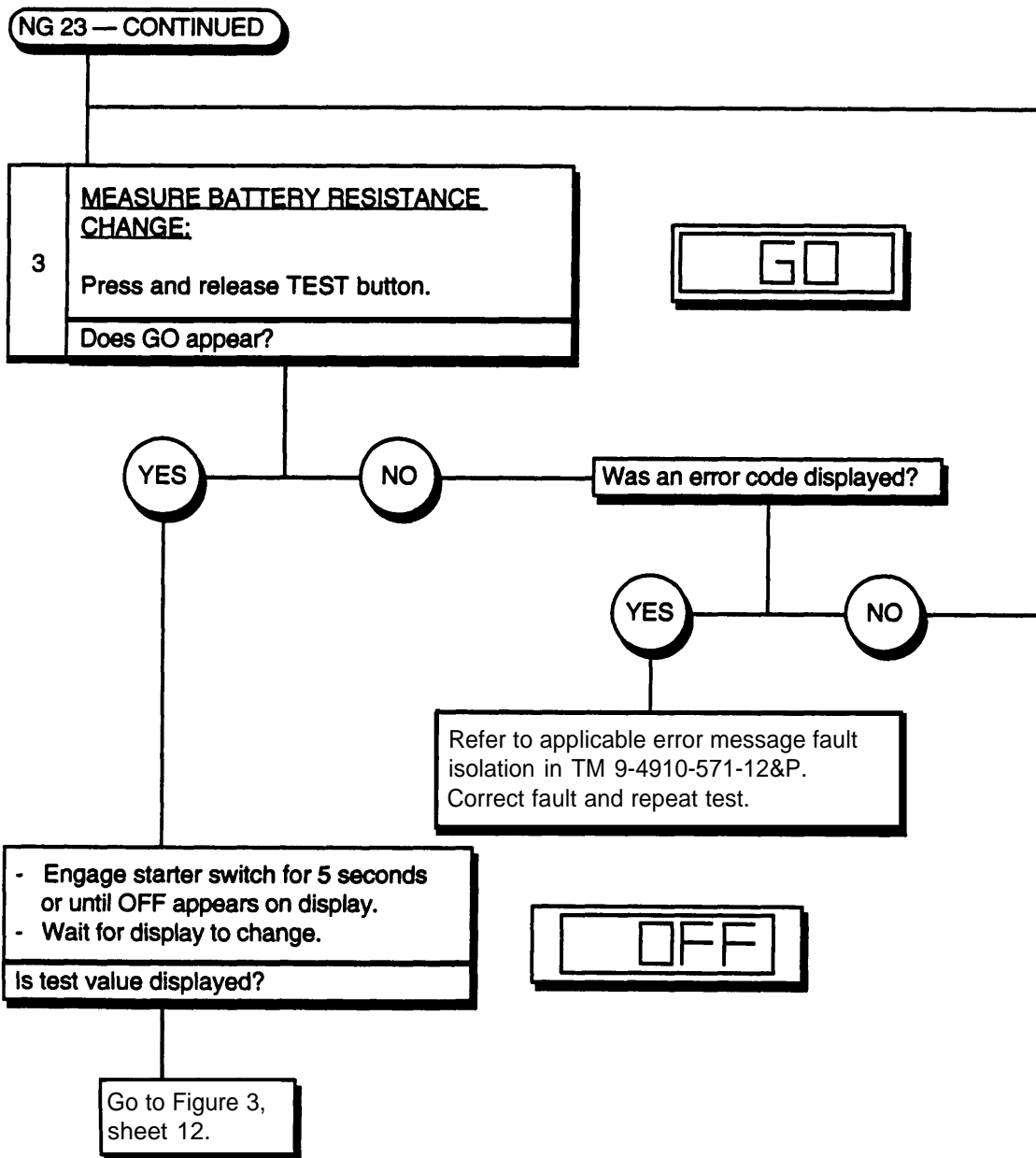

Figure 3, Sheet 11 of 36

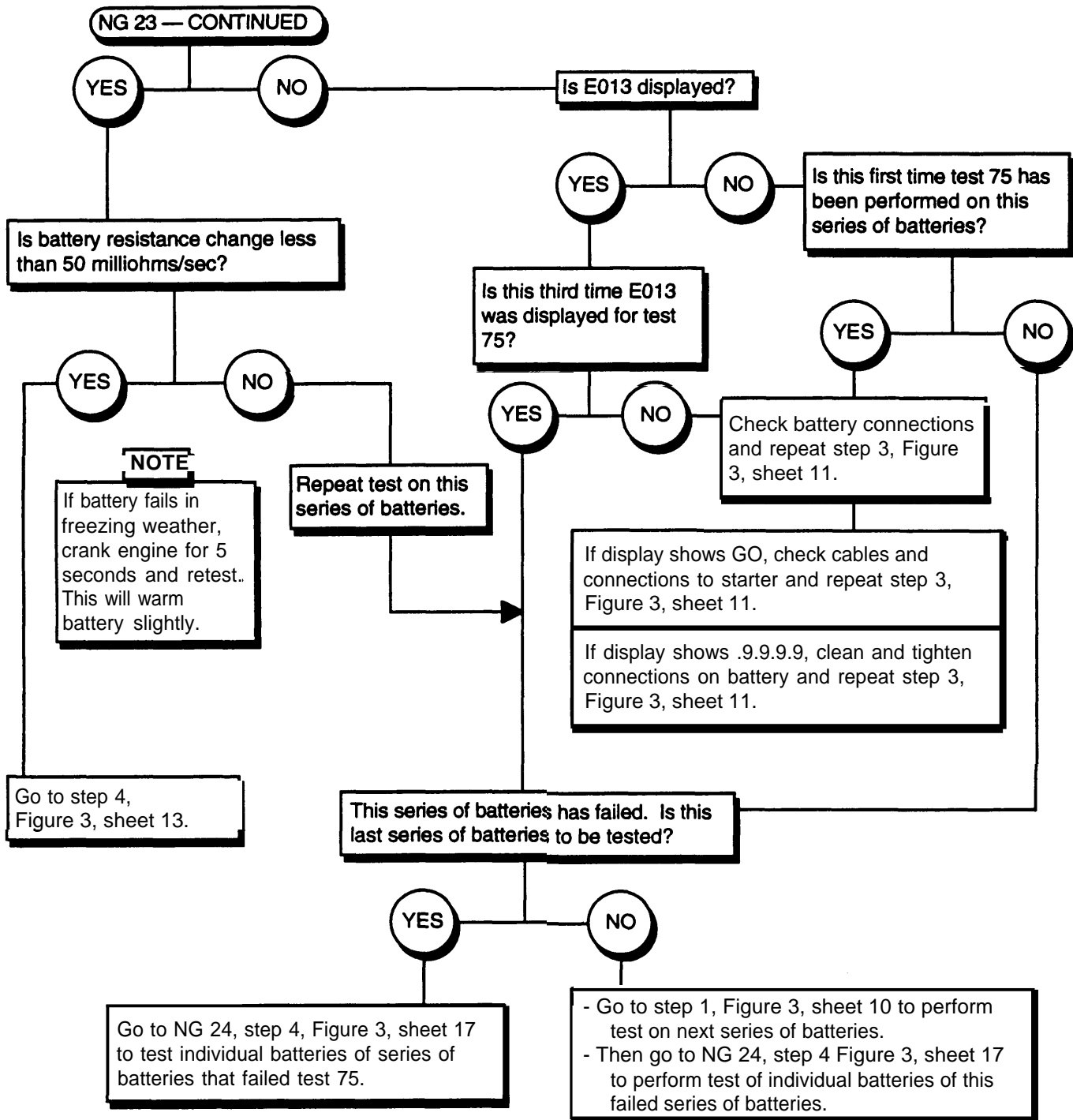

Figure 3, Sheet 12 of 36

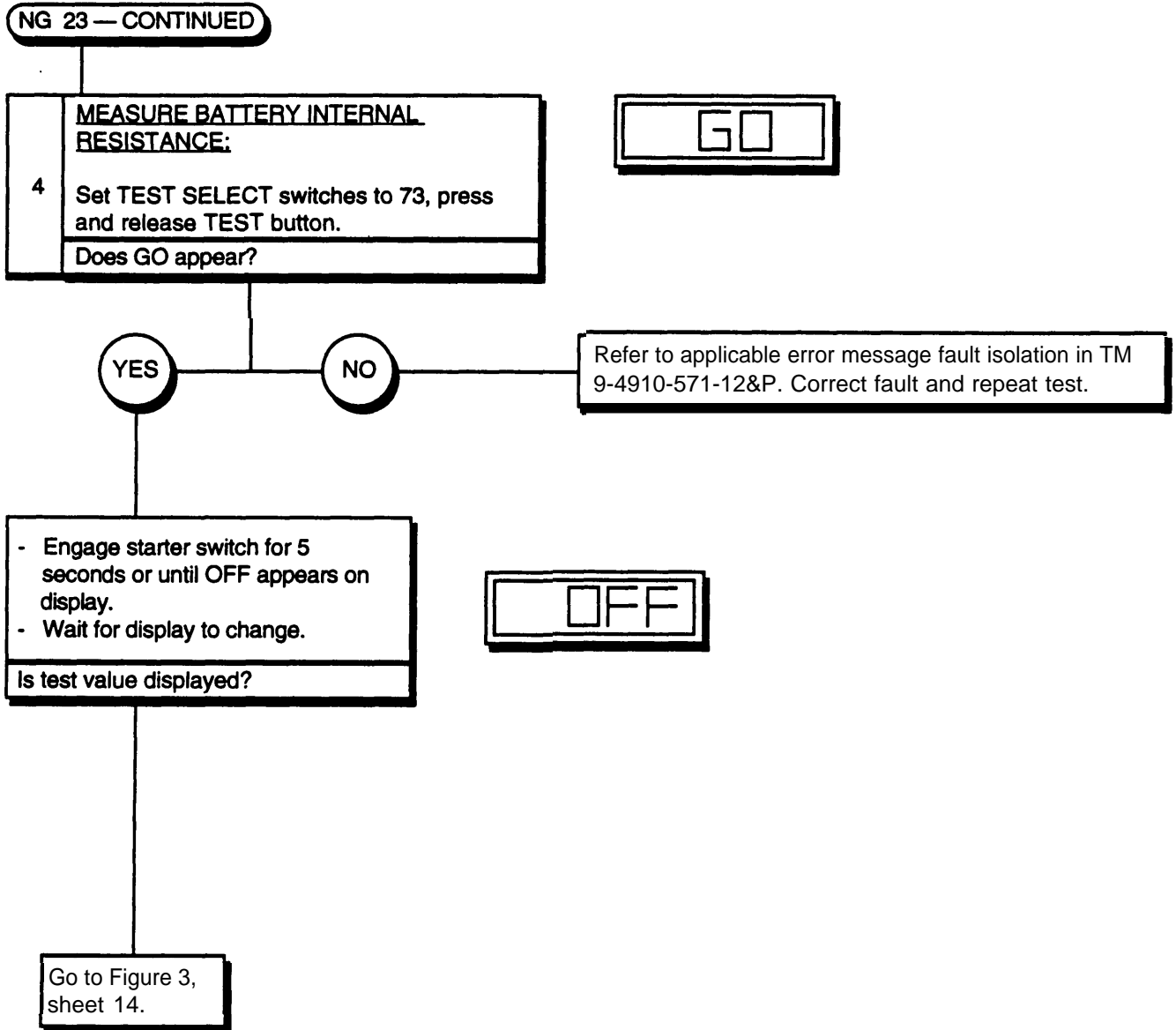

Figure 3, Sheet 13 of 36

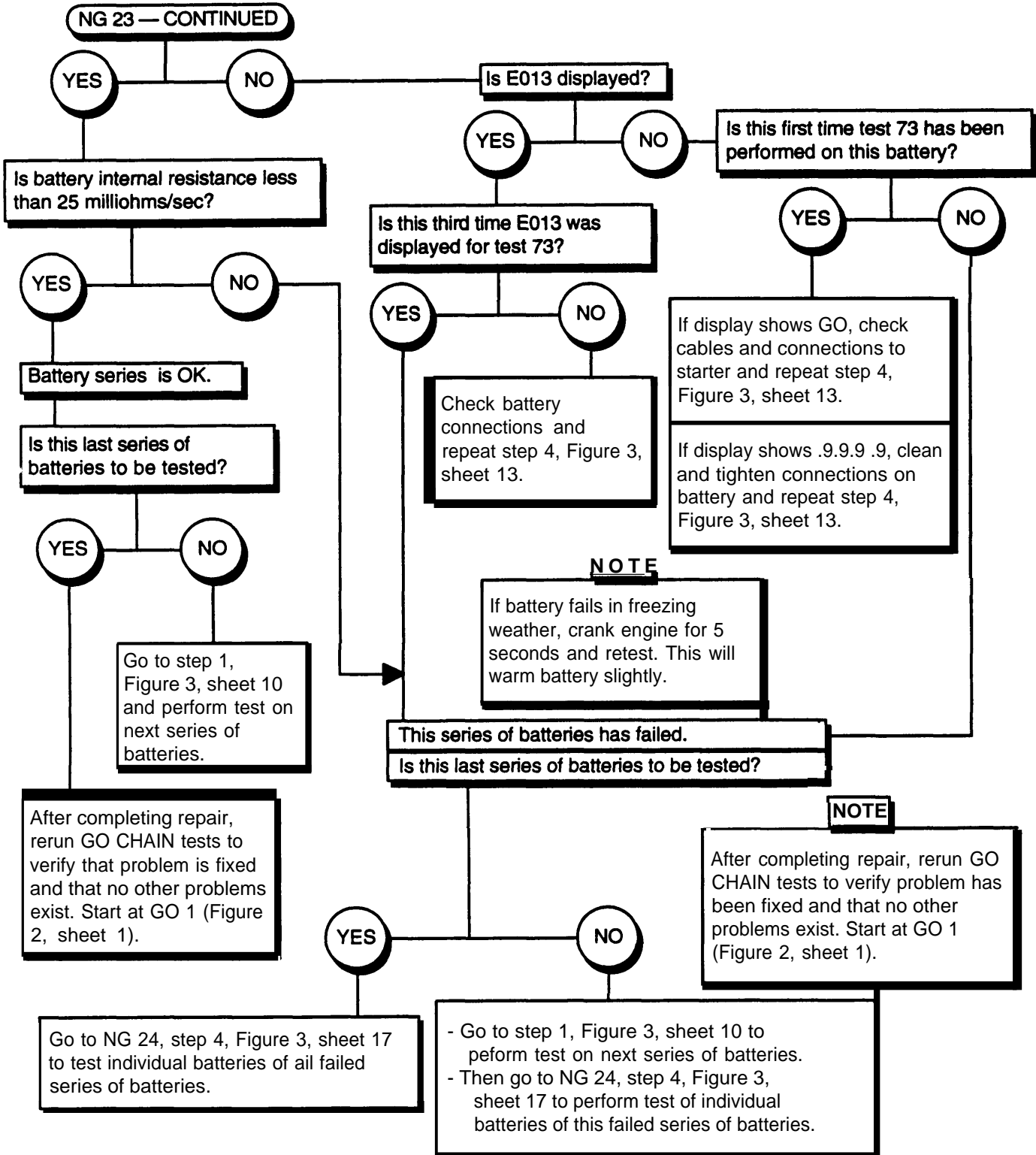

Figure 3, Sheet 14 of 36

NG 24

- Check all battery electrolyte levels.
- Clean all battery terminals.
- Check batteries' specific gravities (para 8-28).
- Charge batteries if they haven't already been charged.

- 1**
- INSTALL TEST PROBE W2:**
- Connect P1 of W2 to J4 of VTM.
 - Connect red clip E1 of cable W2 to positive (+) battery terminal closest to starter of vehicle being tested.
 - Attach black clip E2 of cable W2 to negative (-) battery terminal closest to ground of vehicle being tested.

- Clamp current probe, TK item 11, to battery cable connected to starter.
- Point arrow on probe toward starter.
- Make sure current probe is closed.
- Engage starter long enough to briefly turn engine (approximately 1 second).

- 2**
- MEASURE CURRENT - FIRST PEAK:**
- Turn off all electrical power.
 - Set TEST SELECT switches to 76, press and hold TEST button until CAL appears on display.
 - Release TEST button.
 - Wait for offset value to appear on display.
- Is offset value within limits of -225 to +225?



NOTE

- Engine must not start while performing this step. If engine starts, repeat step.
- Locate and hold fuel shutoff closed while cranking.

YES

NO

Refer to TM 9-4910-571-12&P for offset fault isolation.

- 3**
- Press and release TEST button.
 - Wait for GO to appear on display.
 - When GO appears, shut off fuel and engage starter switch for 5 seconds or until OFF appears on display.
- Is number displayed?



Go to Figure 3, sheet 16.

Figure 3, Sheet 15 of 36

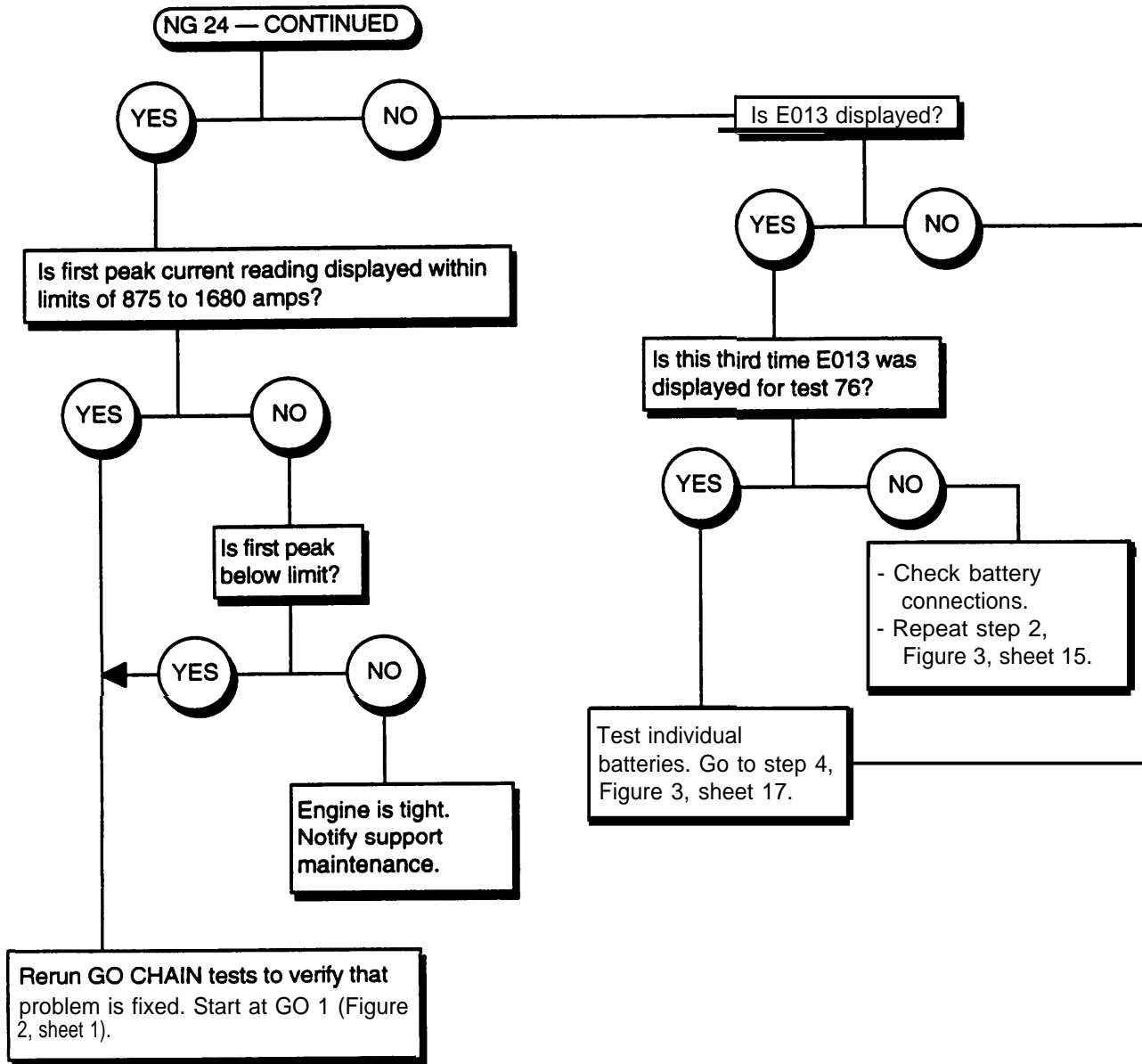

Figure 3, Sheet 16 of 36

NG 24 — CONTINUED

4 TEST INDIVIDUAL BATTERIES:

- Connect P1 of W2 to J4 of VTM if it has not already been connected.
- Connect red clip E1 of cable W2 to positive post of battery being tested.
- Connect black clip E2 of cable W2 to negative post of battery being tested.

Each battery is tested individually. During this test, fuel supply must be shut off to keep engine from starting.

5 CONDITION CURRENT PROBE:

- Clamp current probe, TK item 11, around battery cable that connects series pair of batteries containing battery to be tested. Make sure current probe is closed.
- Point arrow on current probe toward negative post.
- Engage starter long enough to briefly turn engine, approximately 1 second, with fuel shutoff closed.

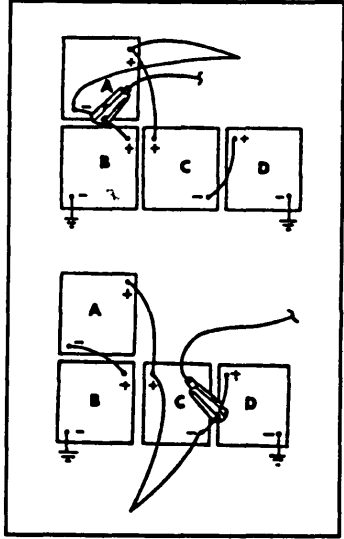

Is offset value within limits of -225 to +225?

- Turn off all vehicle electrical power.
- Set TEST SELECT switches to 79, press and hold TEST button until CAL message appears on display.
- Release TEST button.
- Wait for offset value to appear.



YES

NO

Refer to TM 9-4910-571-12&P for offset fault isolation.

Go to step 6, Figure 3, sheet 18.

Figure 3, Sheet 17 of 36

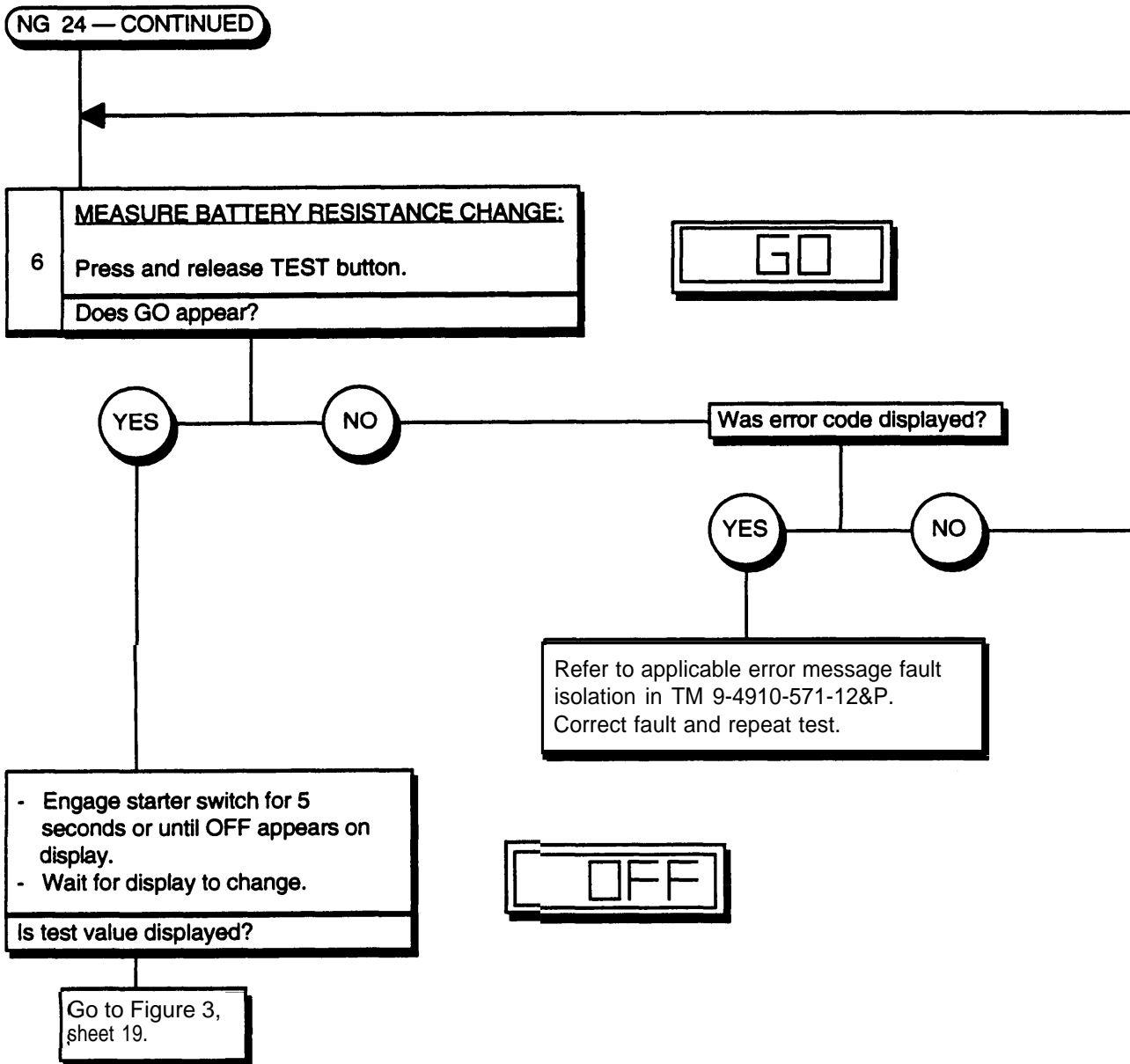

Figure 3, Sheet 18 of 36

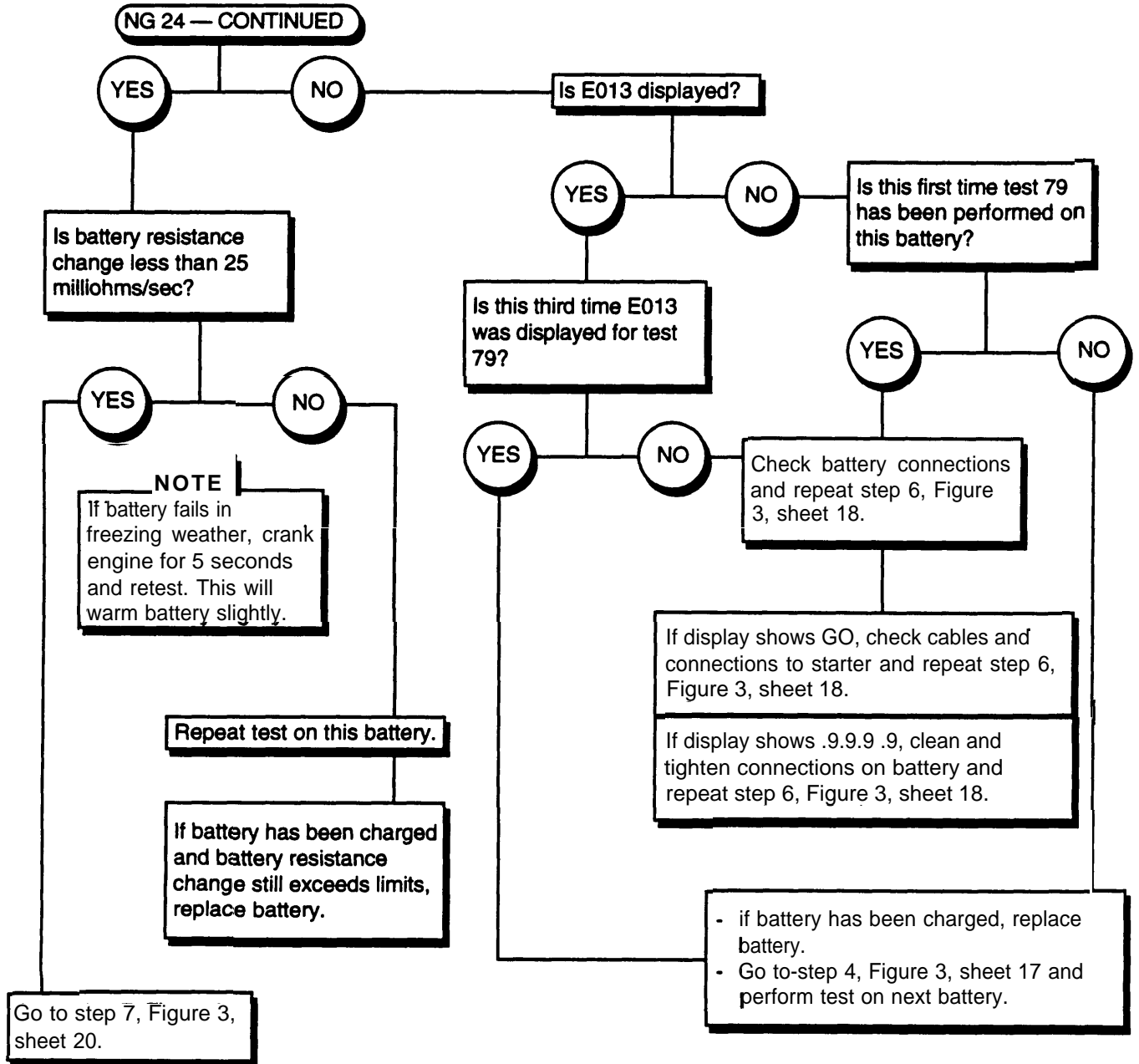

Figure 3, Sheet 19 of 36

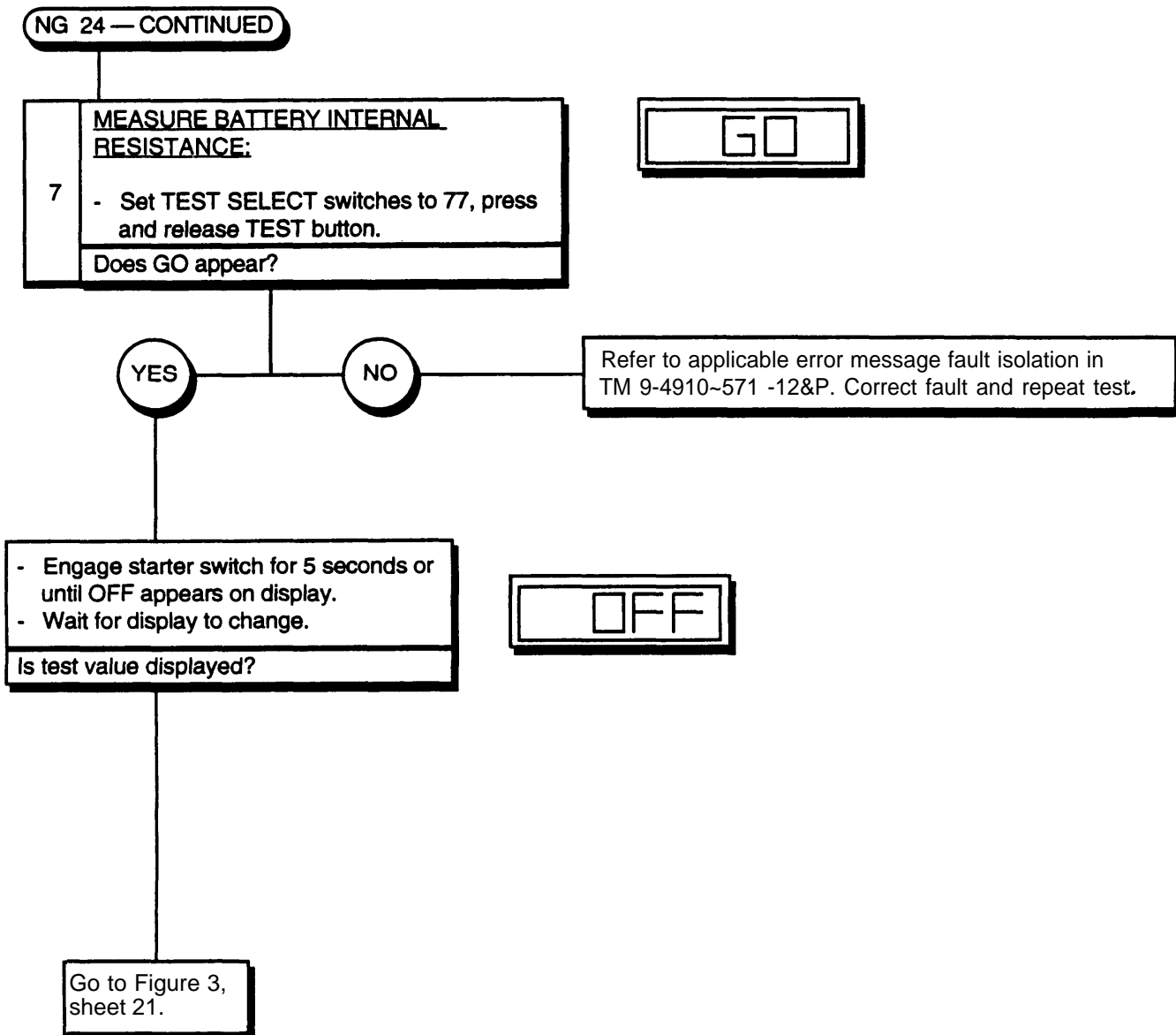

Figure 3, Sheet 20 of 36

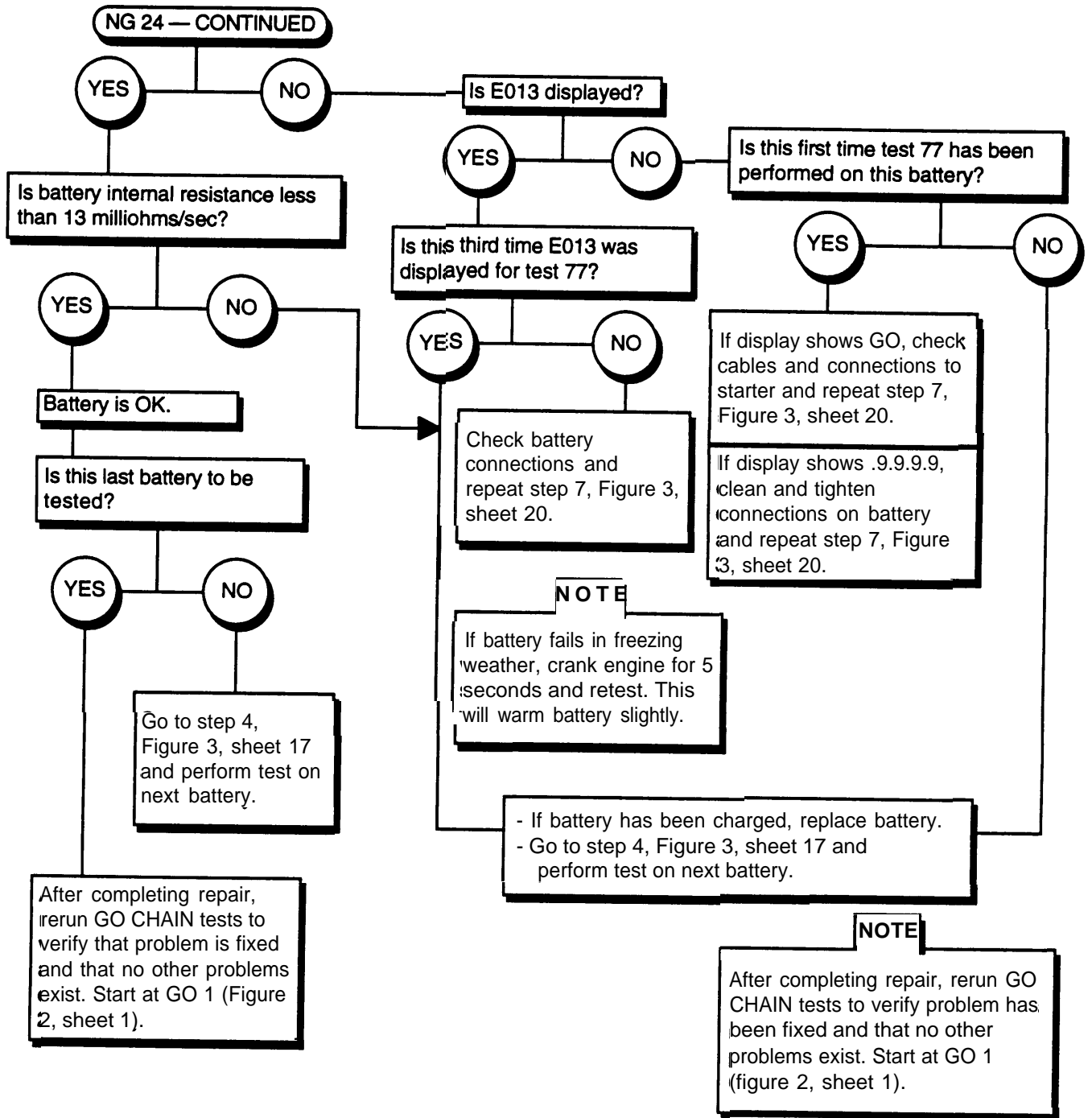

Figure 3, Sheet 21 of 36

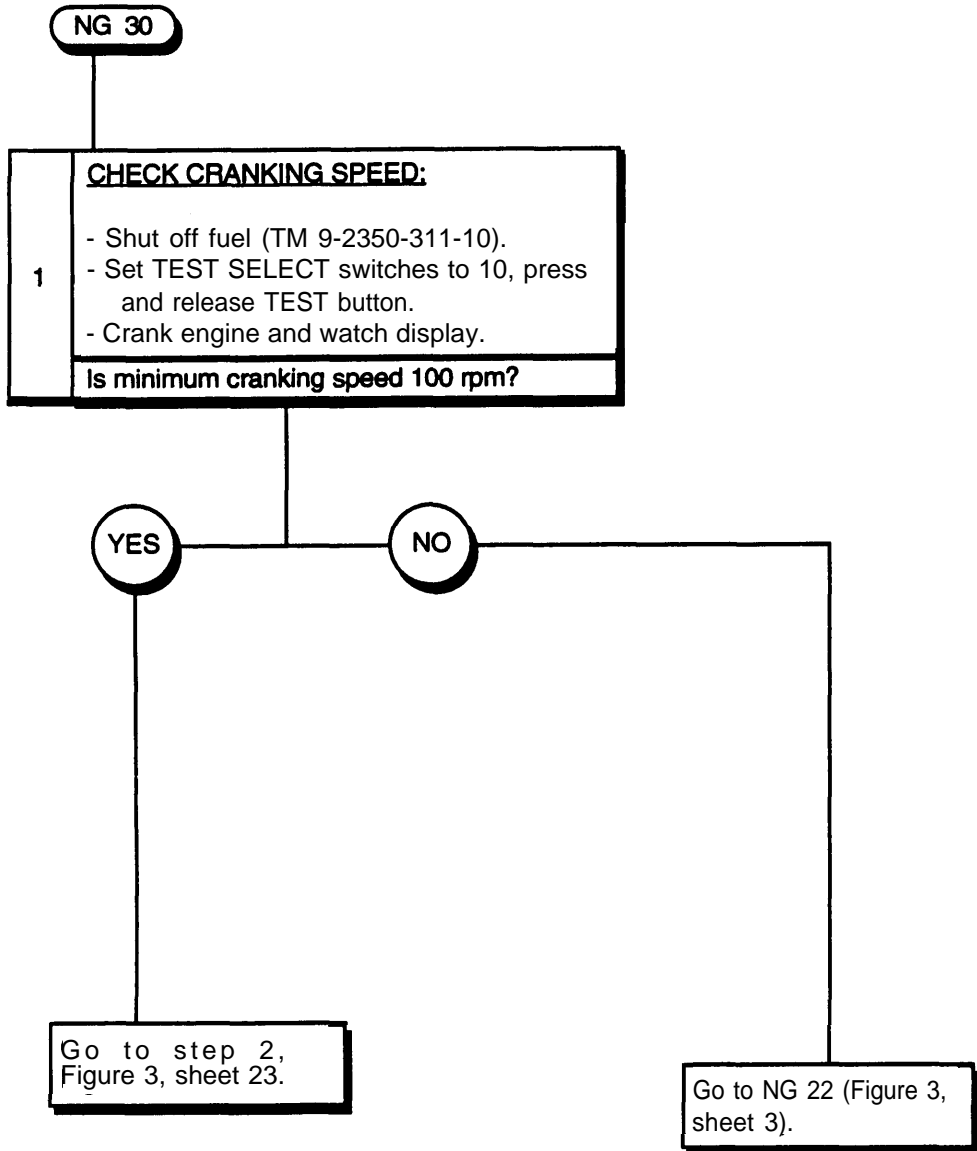

Figure 3, Sheet 22 of 36

NG 30 — CONTINUED

- 2**
- CHECK FUEL SUPPLY:**
- Verify that there is fuel in tank (TM 9-2350-311-10).
 - If fuel filters have been changed or fuel tank has run dry, notify support maintenance.
 - Drain any water from primary fuel filter and continue to drain until fuel appears (para 6-6).
 - Check for kinked, flattened, or broken fuel lines from tank to filters and engine (para 6-1).
 - Check for blockage in quick disconnect fittings (para 6-1).
 - Check pumps to make sure they are in working order (para 6-5 and 6-6).
 - Check fuel shutoff (para 5-8).

WARNING

On some vehicles that have MASTER switch in negative battery cable, sparking may occur if VTM case touches vehicle while MASTER switch is off and VTM power is on. Sparking in presence of fuel or vapors presents potential hazard. Avoid hazard by doing all testing with vehicle MASTER switch on.

CAUTION

Before opening fuel line, make sure that area around fuel line is clean. Operation of engine with red-striped transducer, TK item 22, installed could damage transducer. During this test, be prepared to shut off fuel immediately if engine starts. Remove transducer before attempting to start engine.

Excessive pressure can damage transducer. Pressure being measured should not exceed -15 to +25 psig (-1.0 to +1.7 kg/sq cm).

Go to Figure 3, sheet 24.

Figure 3, Sheet 23 of 36

NG 30 — CONTINUED

3 **INSTALL TRANSDUCER:**

- Install red-striped pressure transducer, TK item 22, in the outlet side of secondary fuel filter (para 6-7).
- Connect P1 of transducer cable W4 to J3 on the VTM.
- Connect P2 of transducer cable W4 to connector on transducer.

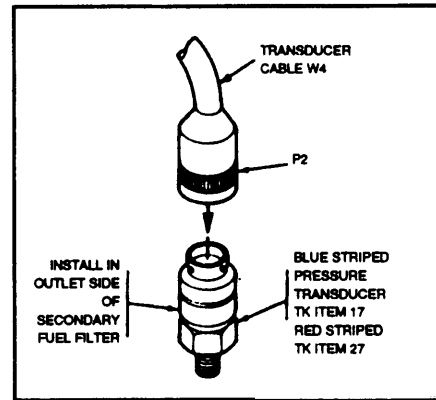

NOTE

During offset test, system being measured must be depressurized.

- Turn off vacuum pressure source.
- Set TEST SELECT switches to 49, press and hold TEST button until CAL message appears on display.
- Release TEST button.
- Wait for offset value to appear on display.

Is offset value within limits of -4 to +4?



YES

NO

Go to step 4,
Figure 3, sheet 25.

Refer to TM 9-4910-571-12&P
for offset fault isolation.

Figure 3, Sheet 24 of 36

NG 30 — CONTINUED

4	<p>MEASURE FUEL PRESSURE DURING CRANKING:</p> <ul style="list-style-type: none"> - Press and release TEST button. - Turn on fuel and accessory switch. - Crank engine and watch readout display.
	<p>Is minimum fuel pressure displayed greater than 4 psi (28 kPa)?</p>

NO

YES

- Remove red-striped pressure transducer, TK item 22.
- Refer to TM 9-2350-311-10 for proper operation of engine fuel shutoff.
- Check for restricted air intake.
- If engine does not start and weather is cold, check cold start devices (TM 9-2350-311-10).
- If still no start, notify support maintenance.

Go to Figure 3, sheet 26.

NOTE

After completing repair, rerun GO CHAIN tests to verify problem has been fixed and that no other problems exist. Start at GO 2 (Figure 2, sheet 8) if VTM is already connected. Otherwise start at GO 1 (Figure 2, sheet 1).

Figure 3, Sheet 25 of 36

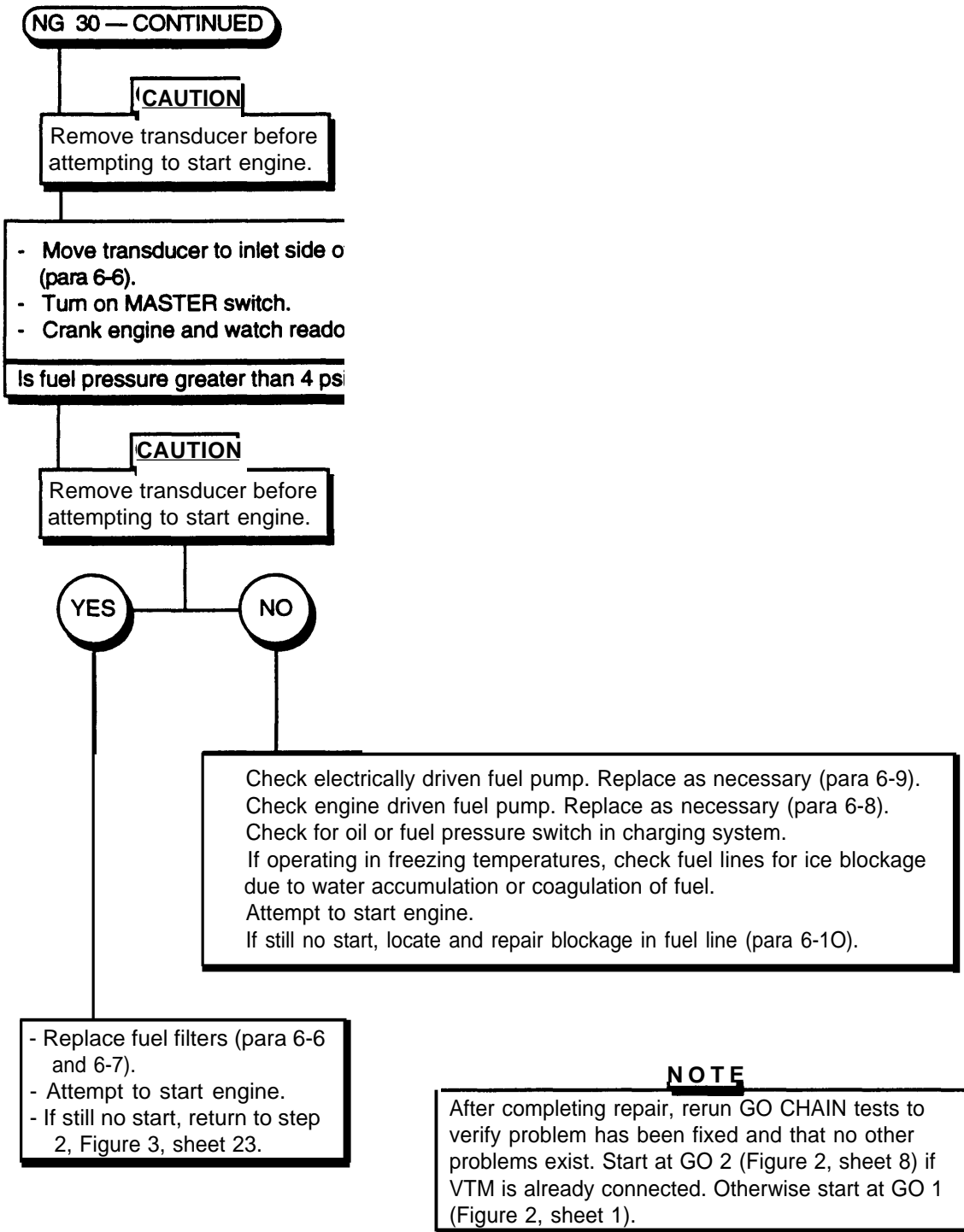

Figure 3, Sheet 26 of 36

NG 31

WARNING

On some vehicles that have MASTER switch in negative battery cable, sparking may occur if VTM case touches vehicle while MASTER switch is off and VTM is on. Sparking in presence of fuel or vapors presents hazard. Avoid hazard by doing all testing with vehicle MASTER switch on.

CAUTION

Excessive pressure can damage transducer. Pressure being measured should not exceed 1000 psig (68.9 kg/sq cm).

1 INSTALL TRANSDUCER - DO OFFSET:

- Stop vehicle engine.
- Remove oil pressure sending unit (para 8-8).
- Install blue-striped pressure transducer (TK item 17) in place of sending unit on engine.
- Connect P1 of transducer cable W4 to J3 on VIM.
- Connect P2 of transducer cable to connector on pressure transducer.

NOTE

During offset test, system being measured must be repressurized.

- Turn off vehicle pressure source.
- Set TEST SELECT switches to 50, press and hold TEST until CAL message appears on display.
- Release TEST button.
- Wait for offset value to appear on display.



Is offset value within limits of -150 to +150?

YES

NO

Refer to TM 9-4910-571-12&P for offset fault isolation.

Go to Figure 3, sheet 28.

Figure 3, Sheet 27 of 36

NG 31 — CONTINUED

2

CHECK OIL PRESSURE:

- Set TEST SELECT switches to 01, press and release TEST button.
- When prompting message Con appears, set TEST SELECT switches to 50, press and release TEST button.
- VTM will now display oil pressure and rpm alternately.
- Start engine and hold rpm at 1000 rpm.
- Check VTM display for correct oil pressure between 30 to 50 psi (207 to 345 kPa).

Is oil pressure within limits?



NOTE

Speeds are approximate. If exact speed cannot be reached, check oil pressure at closest possible speed.

YES

NO

- Stop engine immediately.
- Refer to paragraph 2-15 to check oil type.
- Replace oil filters (para 5-4).

If reading is still bad, notify support maintenance.

NOTE

After completing repair, rerun GO CHAIN tests to verify problem has been fixed and that no other problems exist. Start at GO 2 (Figure 2, sheet 8) if VTM is already connected. Otherwise start at GO 1 (Figure 2, sheet 1).

Go to NG 32 (Figure 3, sheet 29).

Figure 3, Sheet 28 of 36

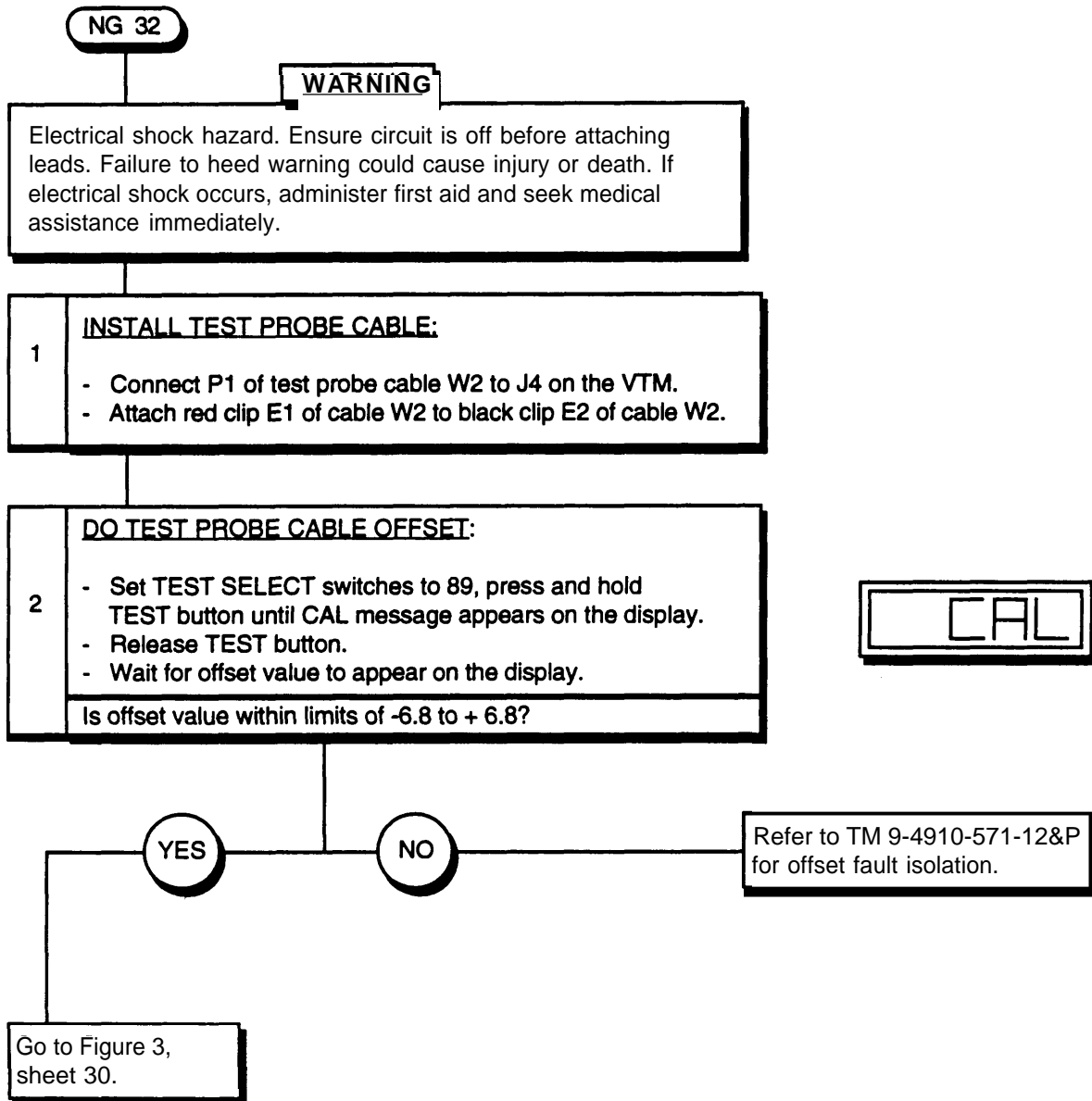

Figure 3, Sheet 29 of 36

NG 32 — CONTINUED

3

ISOLATE FAULT TO SENDING UNIT OR GAGE:

- Remove wire from sending unit of suspect gage on vehicle.
- Connect red clip E1 lead of W2 to wire removed from sending unit.
- Connect black clip E2 lead to a good ground.
- Turn vehicle accessory switch on.
- Press and release TEST button.

Does VTM indicate at or near battery voltage (24 Vdc)?

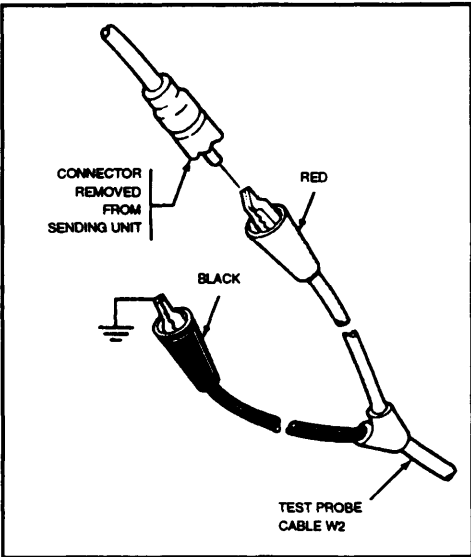

NOTE

Always attach red clip E1 to positive (+) side and black clip E2 to negative (-) side of item being measured. Otherwise, a negative number may be displayed.

Check and isolate fault to wiring harness or gage. If multimeter is needed, use VTM.



Replace sending unit.

NOTE

After completing repair, rerun GO CHAIN tests to verify problem has been fixed and that no other problems exist. Start at GO 2 (Figure 2, sheet 8) if VTM is already connected. Otherwise start at GO 1 (Figure 2, sheet 1).

Figure 3, Sheet 30 of 36

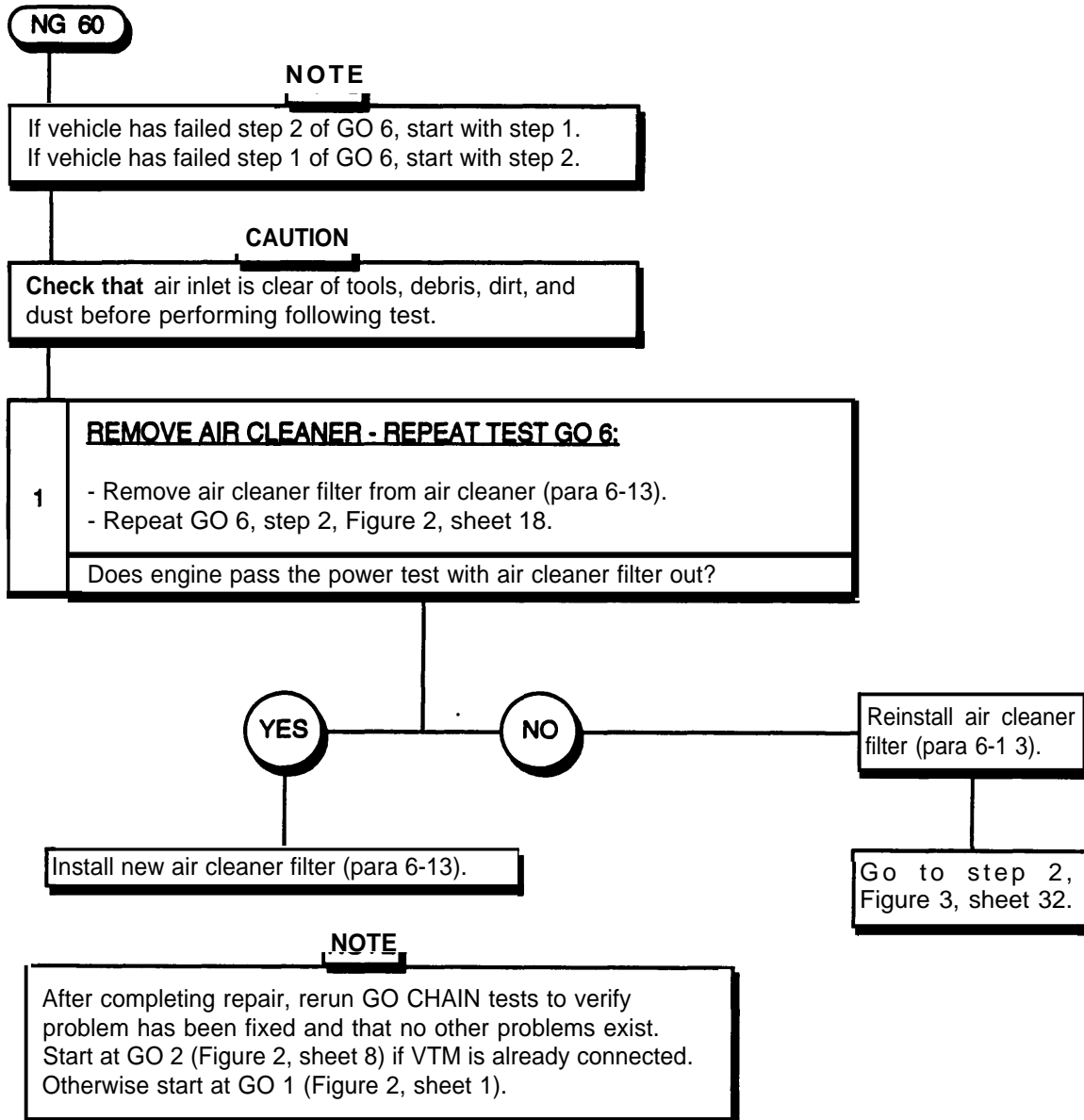

Figure 3, Sheet 31 of 36

NG 60 — CONTINUED

INSTALL TRANSDUCER:

2

- Install blue-striped transducer, TK item 17, in outlet side of secondary fuel filter.
- Connect P1 of transducer cable W4 to J3 on VTM.
- Connect P2 of cable W4 to the connector on transducer.

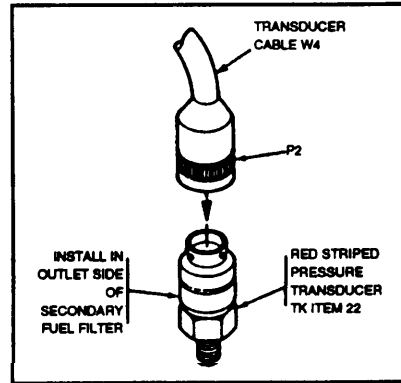

WARNING

On some vehicles that have the MASTER switch in negative battery cable, sparking may occur if VTM case touches vehicle while MASTER switch is off and STE/ICE-R power is on. This sparking in presence of fuel or vapors presents potential hazard. Avoid hazard by doing all testing with vehicle MASTER switch on.

CAUTION

Excessive pressure can damage transducer. Pressure being measured should not exceed 1000 psig (68.9 kg/sq cm)

NOTE

During offset test, system must be depressurized.

- Set TEST SELECT switches to 50.
- Turn off vehicle pressure source.
- Press and hold TEST button until CAL appears on display.
- Release TEST button.
- Wait for offset value to appear on display.



Is offset value within the range of -150 to +150?

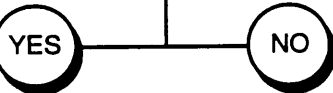

Refer to TM 9-4910-571-12&P for offset fault isolation.

Go to step 3, Figure 3, sheet 33.

Figure 3, Sheet 32 of 36

NG 60 — CONTINUED

MEASURE FUEL PRESSURE AT HIGH IDLE:

3

- Set TEST SELECT switches to 01, press and release TEST button.
- When PASS appears, set TEST SELECT switches to 50.
- Press and release TEST button.
- Start engine and watch display.
- Accelerate engine and hold at 2100 rpm.

Is fuel pressure above 50 psi (345 kPa)?

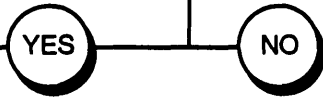

NOTE

After completing repair, rerun GO CHAIN tests to verify problem has been fixed and that no other problems exist. Start at GO 2 (Figure 2, sheet 8) if VTM is already connected. Otherwise start at GO 1 (Figure 2, sheet 1).

Go to Figure 3, sheet 34.

- Check for crimped, broken, cracked, or loose fuel lines (para 6-1 and 6-6).
- Replace fuel filters (para 6-6 and 6-7).
- Check vehicle throttle linkage for full travel and proper adjustment (para 9-1 5). Repair if necessary.
- Check fuel shutoff for proper operation (TM 9-2350-311-10).
- Repeat step 3.

If reading is still low, notify support maintenance.

Figure 3, Sheet 33 of 36

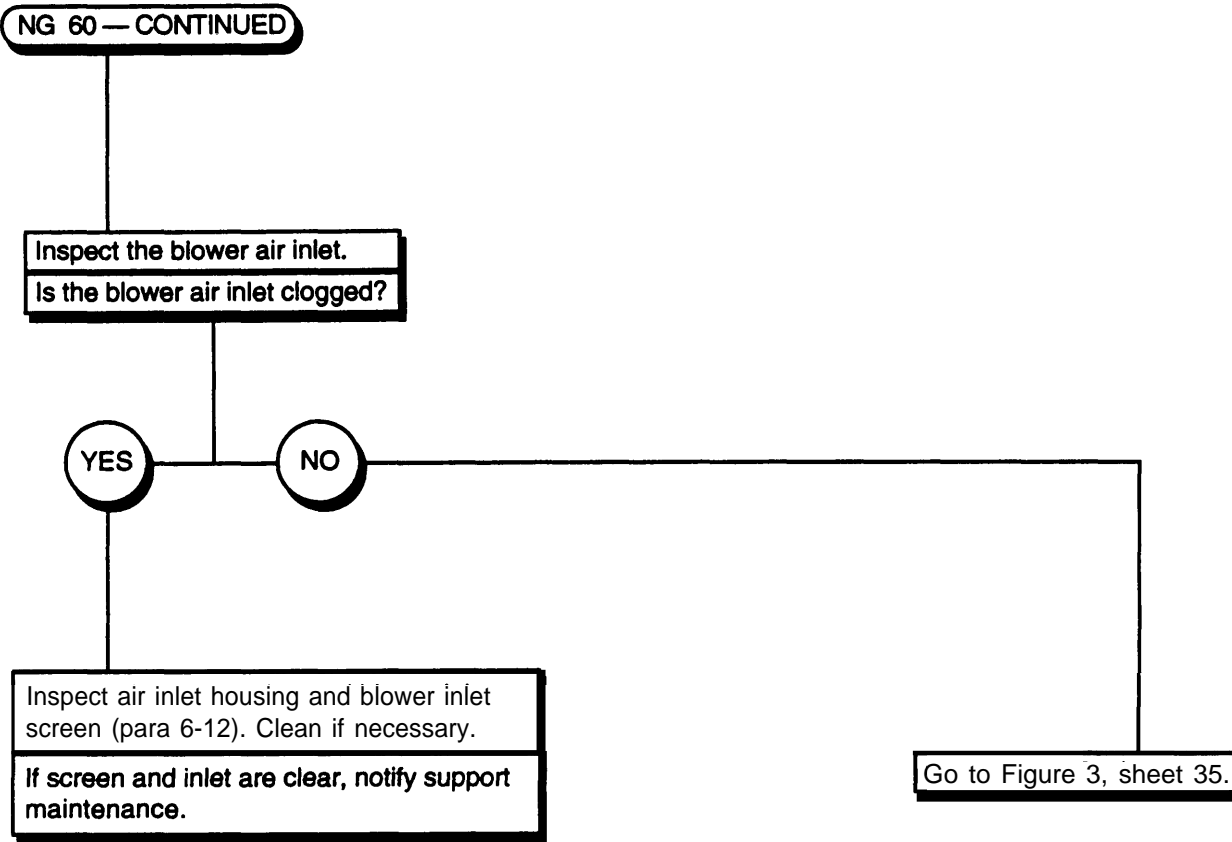

NOTE

After completing repair, rerun GO CHAIN tests to verify problem has been fixed and that no other problems exist. Start at GO 2 (Figure 2, sheet 8) if VTM is already connected. Otherwise start at GO 1 (Figure 2, sheet 1).

Figure 3, Sheet 34 of 36

NG 60 — CONTINUED

CAUTION

Do not perform more than two compression unbalance tests in a row to prevent discharge of batteries.

NOTE

Engine must be at normal operating temperature before performing compression unbalance test.

5

RUN COMPRESSION UNBALANCE TEST:

- Shut off fuel supply so engine will not start (TM 9-2350-311-10).
- Crank engine with fuel inhibited for 5 seconds to clear fuel from cylinders.
- Set TEST SELECT switches to 14, press and release TEST button.
- Wait for prompting message GO to appear.

Does GO appear?

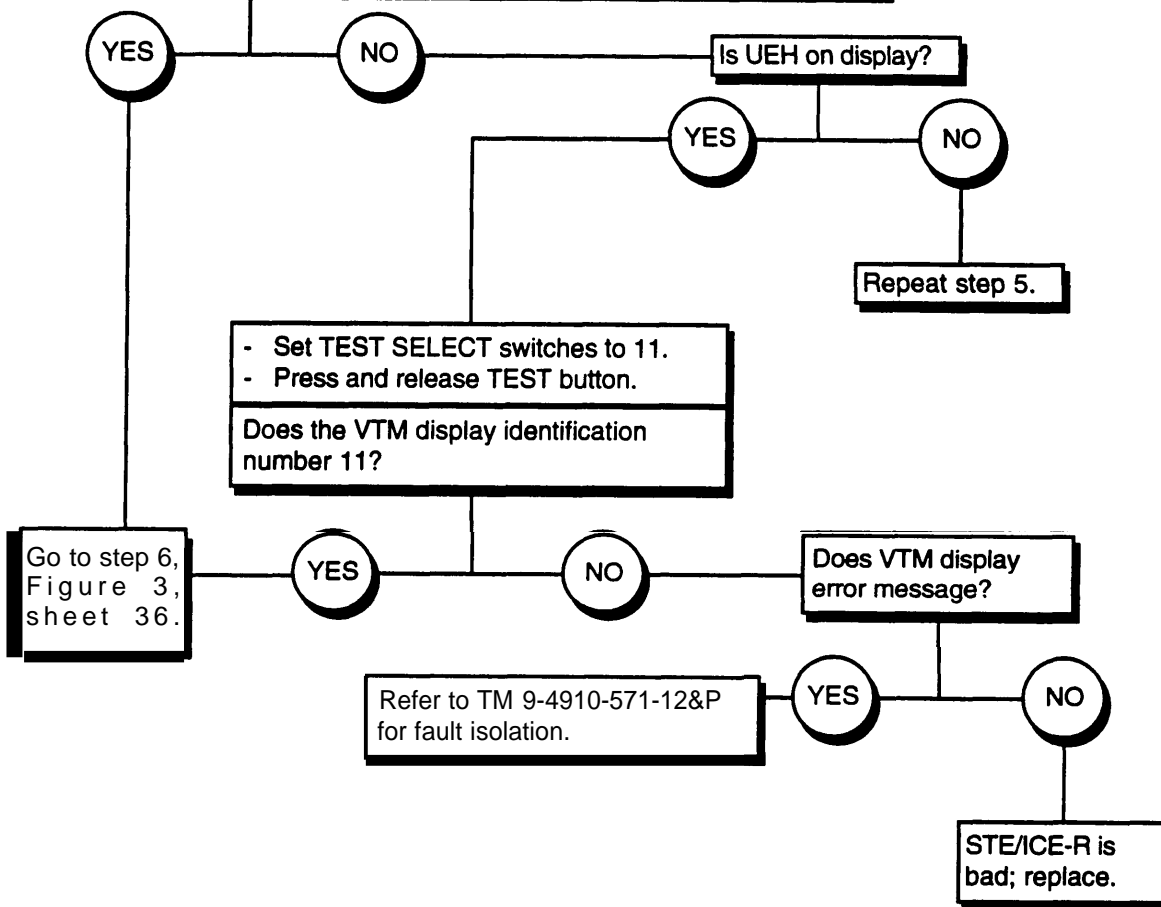

Figure 3, Sheet 35 of 36

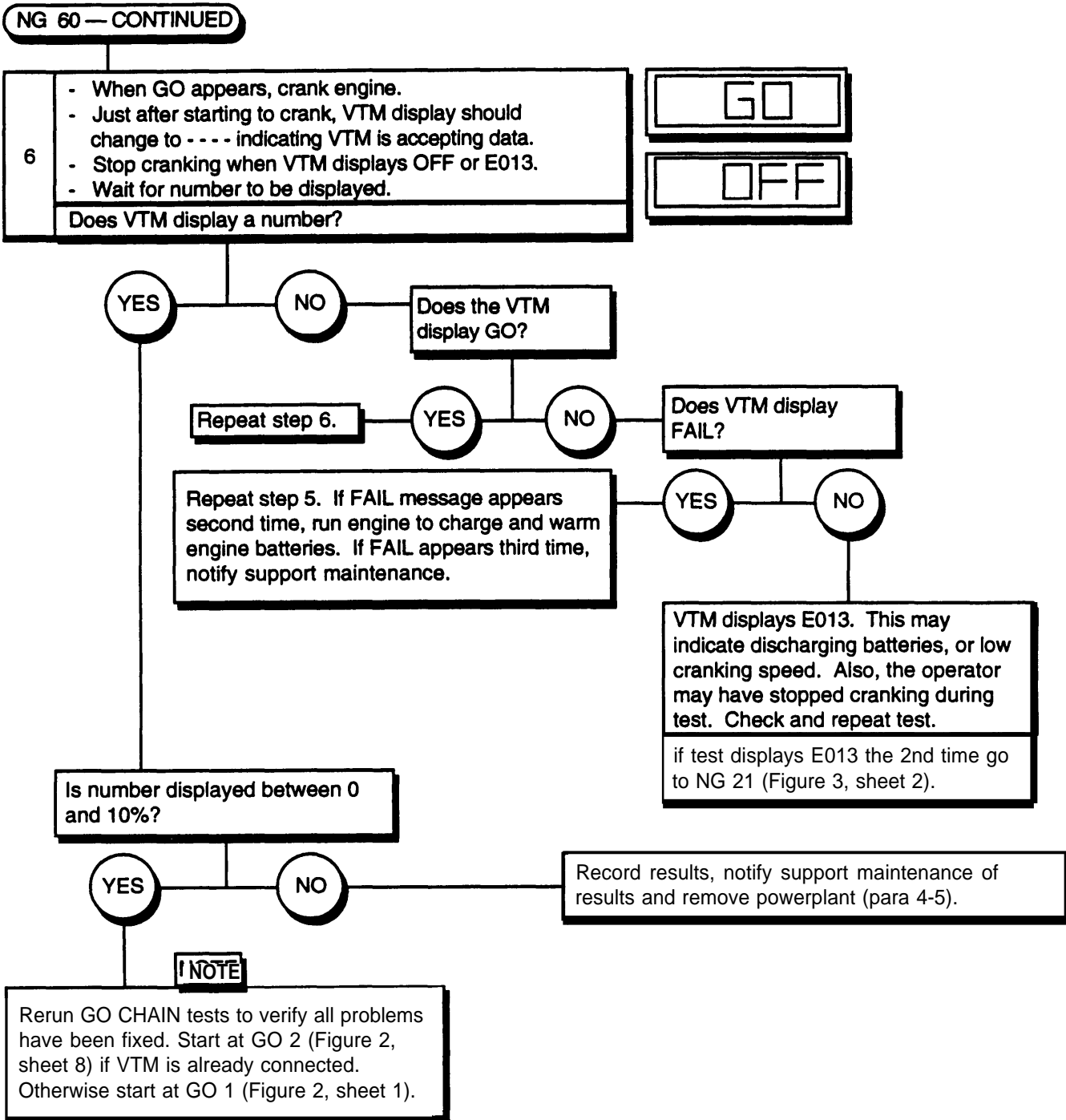

Figure 3, Sheet 36 of 36

SECTION III. BATTERY TESTING

I-6 GENERAL

The STE/ICE-R battery test procedures allow the user to evaluate the condition and state of charge of vehicle/equipment batteries. These procedures use the battery internal resistance and battery resistance change measurements. Battery internal resistance evaluates the state of charge of the battery. Battery resistance change evaluates the battery condition.

The battery state of charge is a measure of the amount of energy stored in the battery. A fully charged battery contains the maximum amount of energy stored. If the battery fails the battery state of charge evaluation, the battery may be recharged to return the battery to full charge.

The battery condition is a measure of the battery's ability to accept and maintain a good charge. A battery in poor condition may be able to be fully recharged. However, a battery in poor condition with a full charge will lose its charge more quickly than a battery in good condition with a full charge. If a battery fails the battery condition evaluation, the battery should be replaced.

The procedures for testing the M109 batteries are listed on three battery test cards. Each card describes procedures for evaluating the different combinations of batteries:

- Complete battery pack
- Series pair of batteries
- Individual batteries

I-7 BATTERY PACKS

A battery pack is the combination of four or more batteries in a particular circuit of a vehicle/equipment, i.e., the starting circuit. Testing the batteries in a pack evaluates the general condition of the pack as a whole. Note: the results of a battery pack test may be misleading. A single battery from a pack of four may be bad, even though the pack as a whole may pass the tests. This can happen if the other three batteries in the pack are in very good condition.

I-8 SERIES PAIRS

A series pair is one in which the negative terminal of one battery is connected by a cable to the positive terminal of another battery. This test configuration should be used when the battery pack test has failed and the user wants to further identify any bad battery pair.

NOTE

Testing both series pairs yields a better evaluation than testing the pack as a whole.

I-9 INDIVIDUAL BATTERIES

An individual battery test refers to the process of testing one battery at a time. The battery could be part of a pack, a series pair, or a single battery. Test the batteries individually if a battery series pair failed the tests and it is desired to isolate to a single battery. Testing individual batteries gives the best evacuation.

I-10 DESCRIPTION OF TEST CARDS

The front of each test card has three sections. The top of the card explains how to connect the VTM to the batteries being tested. The middle part of the card describes the procedure to follow in order to evaluate the batteries. The bottom of the card contains illustrations showing typical vehicle hookups.

The back of each card also has three sections. The upper left-hand block lists the possible VTM displays and explains their meanings. This block suggests corrective actions for the user. The right-hand side of the card contains battery test limits for three common military batteries. These limits may be used if the vehicle/equipment TM does not provide limits. The lower left-hand portion of the card contains a table showing how to apply the limits to evaluate the battery condition and state of charge.

1-11 PROCEDURE TO MAKE A BATTERY EVALUATION ON THE M109A2/M109A3/M109A4/M109A5 HOWITZER

a. Hookup

Use procedure on battery test card to hook-up VTM. The following information will enable the user to determine the correct tests to use:

1 Use test series 73 and 75 for the following conditions:

- (a) Testing a battery pack that is also powering the VTM
- (b) Testing a battery series pair that is also powering the VTM
- (c) Testing an individual battery that is the only battery in the circuit and is powering the VTM

2 Use test series 77 and 79 for the following conditions:

- (a) Testing a battery pack that is not powering the VTM
- (b) Testing a battery series pair that is not powering the VTM
- (c) Testing an individual battery that is not the only battery in a circuit or is not powering the VTM

b. Test

Use test procedure on battery test card to complete evaluation of the M109A2/M109A3/M109A4/M109A5 batteries.

- 1 Evaluate battery pack, battery series, or individual condition using battery resistance change test (series 75 or 79). Note the results.
- 2 Evaluate battery pack, battery series, or individual state of charge using the battery internal resistance test (series 73 or 77). Note the result.
- 3 Compare test results to limits on the back of the battery test cards. If the battery internal resistance test passes, the batteries are fully charged. If the battery internal resistance test fails, the batteries are not adequately charged. If the battery resistance change test passes, the batteries are good and will retain their charge. If the battery resistance change test fails, the batteries are bad and will not retain their charge.
- 4 If batteries are out of limits, perform one or all of the following:
 - (a) Check battery electrolyte level.
 - (b) Check battery connections and terminals. Clean or tighten if necessary. Check connections between VTM and batteries.
 - (c) Check battery specific gravity (para 8-28).
 - (d) Repeat battery resistance change and internal battery resistance tests one time. If internal battery resistance result (test 73 or 77) is out of limits, then charge batteries. If battery resistance change result (test 75 or 79) is out of limits, then continue testing to isolate bad batteries.

INDEX

CONTENTS

PAGE

A

Accelerator pedal9-55

Accessory control box8-51

Accessory control box heater indicator light lead (10925419)8-166

Accessory control box heat selector switch-to-circuit breaker lead (10930337-1)8-168

Accessory control box-to-heater/blower wiring harness (10925829)8-132

Accessory control box power lead (10925418)8-173

Accessory control box ventilator blower switch-to-circuit breaker lead (10930337-2)8-169

Accessory control box ventilator blower switch lead (10925421)8-171

Accessory control box wiring harness (10925417)8-136

Administrative Storage1-6

Aeration detector8-32

Air box heater5-15

Air cleaner, air intake system6-30

Air cleaner blower lead assembly.8-180

Air cleaner blower relay8-91

Air cleaner blower motors8-91

Air cleanerblower relay and motors, troubleshooting3-3

Air cleanerlead assembly (12353259) (M109A4/M109A5)8-180

Air intake grille11-29

Air intake system6-30

 Air cleaner6-30

 Ducts and hoses6-36

 Air cleaner filter6-34

Air outlet orifice connectors12-16

Air pump5-16

Air purifier12-2

Air purifier bracket12-8

Alternator8-6

 Troubleshooting3-3

Assembly of equipment2-4

Authorized equipment configuration changes1-7

B

Batteries8-76

 Specific gravity checks8-76

 Troubleshooting3-3

Batteries, connecting and servicing2-5

Battery heater and insulation boxes.14-5

Battery support trays8-76

Battery terminal connector (10897992) and ground cables (10897993).8-193

Bilge pump11-62

 Troubleshooting3-3

Blackout markers and blackout drive lights, troubleshooting3-3

Blackout stoplights, troubleshooting3-3

Breather tube and mount, transmission9-11

Buffer plate, exhaust system.6-41

CONTENTS

PAGE

B — CONTINUED

Bulkhead-to-drivets instrument panel wiring harness (11594268)8-125
 Bulkhead-to-headlights/bilge pump wiring harness (10921380).....8-118
 Bulkhead-to-override switch lead assembly (12268419) (M109A4/M109A5).....8-208
 Bulkhead-to-portable instrument panel wiring harness (12260287)8-122
 Bypass thermostat and housing assembly7-36

C

Cable terminals **and connectors** replacement2-18
 Cannoneer's seat assembly (M109A2/M109A3)11-11
 Cannoneer's seat assembly (M109A4/M109A5)11-14
 Capabilities and features1-9
 Checking unpacked equipment.....2-3
 Circuit breaker (M109A2/M109A3).....8-86
 Circuit breaker (M109A4/M109A5).....8-88
 Circuit breaker-to-"Y" connector lead (12268157)8-178
 Circuit breaker-to-"Y" connector lead (12268348)8-186
 Circuit identification and illustration of wiring harnesses (M109A4/M109A5)8-102
 Circuit identification and illustration of wiring harnesses (M109A2/M109A3)8-103
 Combat override switch assembly (M109A4/M109A5).....8-98
 Combat override switch ground lead (12353074) (M109A4/M109A5).....8-210
 Common tools2-2
 Coolant heater14-12
 Coolant heater wiring harnesses (10922776 and 10922777)14-14
 Cooling system7-1
 Crossover tube5-31

D

Destruction of materiel to prevent enemy use1-5
 Differences between models1-14
 Diode wiring harness (12268417) (M109A4/M109A5)8-158
 Dome light8-71
 Dome light circuit troubleshooting3-3
 Drain covers and plugs11-34
 Driver's and cannoneer's seat assemblies11-2
 Cannoneer's seat assembly (M109A2/M109A3)11-11
 Cannoneer's seat assembly (M109A4/M109A5)11-14
 Driver's seat assembly11-2
 Driver's bulkhead-to-batteries lead assembly (12353402) (M109A4/M109A5)8-204
 Driver's instrument panel8-34
 Driver's instrument panel wiring harness (12268104).....8-128
 Driver's seat assembly11-2
 Ducts and hoses, air intake system6-36
 Driver's hatch cover and lock components.....11-18

E

Electric fuel pumps, fuel system.....6-12

CONTENTS

PAGE

Electric fuel pump, troubleshooting.3-3

Electrical systems8-1

Engine1-15

 Troubleshooting3-3

Engine air inlet housing hose.5-27

Engine and battery winterization kit14-1

 Troubleshooting3-3

Engine bracket-to-driver's bulkhead lead assembly (11593782) (M109A2/M109A3)8-194

Engine compartment access cover11-23

Engine components5-1

 Engine inspection5-2

 Fuel shutoff assembly5-14

 Mount base assembly5-10

 Oil cooler hoses5-5

 Oil filter5-7

 Oil sampling components5-7

 Shock mount and bracket5-12

Engine coolant, check level and specific gravity2-7

Engine coolant high temperature switch8-17

Engine coolant lower tubes7-8

Engine coolant main tubes7-6

Engine coolant temperature transmitter.8-15

Engine cooling system7-2

 Aeration detector8-32

 Bypass thermostat and housing assembly.7-36

 Cooling system components (M109A2/M109A4/M109A5)7-2

 Cooling system components (M109A3).7-4

 Inlet thermostats and housing assembly7-32

 Lower tubes7-8

 Main tubes7-6

 Radiator and shroud (M109A3)7-22

 Radiator and shroud (M109A2/M109A4/M109A5)7-13

 Radiator cleaning2-33

 Surge tank and pressure relief valve.7-10

Engine disconnect bracket-to-batteries lead assembly (12353401) (M109A4/M109A5)8-206

Engine disconnect bracket-to-bulkhead wiring harness (12268100) (M109A2/M109A3)8-114

Engine-driven fuel pump, fuel systems6-20

Engine electrical ground lead (MS35915-10).8-198

Engine exhaust manifold5-31

Engine fuel lines6-26

Engine inspection5-2

Engine master warning lights, troubleshooting3-3

Engine oil pressure transmitter.8-19

Engine oil low pressure switch.8-21

Engine throttle governor control rod, transmission9-52

Engine valve filler cap5-23

Equipment data1-15

Equipment description and data.1-9

 Capabilities and features1-9

 Equipment data1-15

 Location of major components1-10

 Serial number locations1-12

CONTENTS

PAGE

E — CONTINUED

Exhaust crossover tube, exhaust system6-39
 Exhaust duct, exhaust system6-41
 Exhaust outlet assembly14-4
 Exhaust system6-39
 Exhaust crossover tube6-39
 Exhaust duct6-41
 Exhaust tube, personnel heater.. . . .11-70
 Expendable and durable items listD-1
 External power receptacle (M109A4/M109A5).8-96
 Troubleshooting3-3

F

Female cable connector (with sleeve)2-19
 Female cable connector (with washer).2-19
 Fenders11-60
 Filter, air intake system6-34
 Final drive10-51
 Final drive assemblies10-53
 Final drive hub10-51
 Final drive sprockets10-51
 Fixed fire extinguisher system11-75
 Flame heater switch lead (12268224)8-177
 Flame heater, troubleshooting3-3
 Flashlight holder, clgp extractor.13-12
 Foldouts, electrical schematics.FP-1
 Fuel, air intake, and exhaust system6-1
 Fuel check valves, fuel system.. . . .6-10
 Fuel filter and tubes, personnel heater.11-68
 Fuel filter assembly (primary).....6-14
 Fuel filter assembly (secondary).6-17
 Fuel flow test, fuel systems6-28
 Fuel prime pump, troubleshooting.3-3
 Fuel pump, personnel heater11-72
 Fuel pump14-9
 Fuel pump circuit breaker lead assembly (11682358-1) (M109A4/M109A5).8-184
 Fuel pump switch-to-circuit breaker lead assembly (11682358-2)8-185
 Fuel shutoff assembly, engine components5-14
 Fuel systems6-2
 Electric fuel pump (tank)6-12
 Fuel pump, engine-driven6-20
 Fuel check valves6-10
 Fuel filter assembly (primary)6-14
 Fuel filter assembly (secondary)6-17
 Fuel flow test6-28
 Fuel tank filler assemblies (cap, seal, and filter)6-4
 Fuel tank level transmitter (upper and lower)6-6
 Hoses, tubes, and fittings6-2
 Powerplant fuel hose, tubes, and fittings6-23
 Fuel tank filler assembly (cap, seal, and filler)6-4

CONTENTS

PAGE

Fuel tank heat shield6-44
 Fuel tank level transmitters (upper and lower)6-6

G

Gages, troubleshooting3-3
 General hull maintenance2-1
 Grille covers, tarpaulin14-17
 Glow plug wait light-to-bulkhead to portable instrument panel wiring harness lead (12389711)..8-188

H

Hand throttle governor control rod, transmission9-53
 Headlight dimmer switch8-93
 Headlight wiring harness (8744300)8-121
 Heaters12-9
 Heater control box14-16
 Heater lamps12-12
 Hoses and fittings12-14
 Hoses, tubes, and fittings, fuel system6-2
 How to use this manualx
 Hull accessory control box.....8-51
 Hull air cleaner blower relay and motor8-91
 Hull ammunition racks13-3
 Hull battery8-76
 Specific gravity tests8-76
 Troubleshooting3-3
 Hull bilge pump relay8-81
 Hull circuit breaker (M109A2/M109A3)8-86
 Hull circuit breaker (M109A4/M109A5)8-88
 Hull dome light8-71
 Hull electrical systems8-1
 Hull headlights8-57
 Hull headlight assembly group8-61
 Hull headlight dimmer switch8-93
 Hull headlight mount8-64
 Hull headlight sealed-beam and incandescent lamps8-59
 Hull main electrical harnesses, troubleshooting3-3
 Hull master relay box8-80
 Troubleshooting3-3
 Hull portable and driver's instrument panels8-34
 Hull rear door, M13 kit bracket, and door latch11-39
 Hull rear door— hold open rod, and handle11-42
 Hull-related components11-1
 Driver's and cannoneer's seat assemblies11-2
 Hatches, latches, locks, and cover plates11-18
 Travel lock, spades, fenders, and towing pintle11-44
 Hull service lights8-66
 Hull starter relay box8-83
 Hull stop light switch8-93
 Hull stowage13-1
 Hull telephone terminal8-70

CONTENTS

PAGE

I

Idler arm assemblies, suspension10-43
 Idler arm housings, suspension10-47
 Idler wheels and hubs10-39
 Ignition coil5-19
 In-tank fuel pump lead assembly (12353646)8-182
 In-tank fuel pumps and generator system relay (M109A4/M109A5)8-90
 Incandescent lamps8-59
 Indexingxi
 Inlet thermostats and housing assembly7-32
 Inspection, engine5-2
 Installation instructions, service upon receipt2-4
 Instrument panel lights, troubleshooting.3-3
 Instrument panel support assembly8-48
 Intercom/telephone wiring harness (10942317)8-148
 Intervals, preventive maintenance checks and services2-20
 Introduction1-1

L

Location of major components.1-10
 Low-coolant indicator light assembly (12260297)8-175
 Lubrication, engine5-2

M

Major components 1-10
 Maintenance Allocation Chart.... .B-1
 MACB-6
 Tool and test equipment requirementsB-24
 Maintenance Allocation Chart for M109A2/M109A3/M109A4/M109A5 B-6
 Maintenance forms, records, and reports1-5
 Maintenance of hull2-1
 Operational checks2-8
 Preventive maintenance checks and services2-20
 Repair parts, special tools, TMDE, and support equipment2-2
 Service upon receipt2-2
 Troubleshooting3-3
 Manuals, field, references, appendix AA-2
 Male cable connector (with washer)2-19
 Master relay box8-80
 Master relay-to-driver's bulkhead lead assembly (12353403) (M109A4/M109A5)8-196
 Master warning light assembly (steering shaft) (10922337)8-189
 Measuring continuity2-10
 Mount base assembly, engine.. . . .5-10

N

Nato slave start-to-external power wiring harness (12353400) (M109A4/M109A5)8-163
 NBC suit stowage boxes13-14

CONTENTS

PAGE

NBC switch-to-circuit breaker lead assembly (12352790) (M109A4/M109A5)8-202
 Neutral safety switch8-30
 Neutral safety switch adjustment, transmission9-22
 Nonskid areas2-52
 Nuclear, biological, and chemical (NBC) protection equipment (M109A4/M109A5)12-1

O

Oil cooler hoses, engine5-5
 Oil filter, engine5-7
 Oil filter and oil cooler hoses, transmission9-7
 Oil filter assembly, transmission9-9
 Oil level rod5-26
 Oil level, transmission9-2
 Oil sampling components, engine5-7
 Oil pressure check, transmission9-2
 Oil temperature check, transmission9-2
 Operational checks, maintenance of hull2-8
 Performing electrical tests and equipment checks2-8
 Wiring harness and cable repairs2-11

P

Painting2-50
 Nonskid areas2-52
 Painting instructions2-50
 Stencil location for basic issue items1-12
 Painting instructions2-50
 Parking brake, troubleshooting3-3
 Parking brake light switch assembly (10930467)8-191
 Performing electrical tests and equipment checks2-8
 Periscope M45 cover, doors and sleeve assembly11-37
 Personnel air ventilation system11-73
 Personnel heater, fixed fire extinguisher, bilge pump, and personnel air ventilation system11-62
 Personnel heater11-66
 Exhaust tube11-70
 Fuel filter and tubes11-68
 Fuel pump11-72
 System diagram11-64
 Troubleshooting3-3
 Personnel ventilation blower, troubleshooting3-3
 Pipe insulation, exhaust system6-41
 Portable fire extinguisher mounting bracket, projectile spacer
 Box and rifle stowage clip13-9
 Portable instrument panel cover and bracket assemblies8-49
 Portable instrument panel wiring harness (12260298)8-143
 Power lead (12260266) (M109A2/M109A3)8-139
 Power lead (12268304) (M109A4/M109A5)8-141
 Power lead wiring harness (11593784) (M109A2)8-137
 Powerplant4-1
 Powerplant components4-2, 4-6

CONTENTS

PAGE

P — CONTINUED

Powerplant disconnects	4-4, 4-8
Powerplant electrical system	8-4
Powerplant fuel hoses, tubes and fittings	6-2
Powerplant wiring harness (12268102) (M109A2/M109A3)	8-104
Pre-operational procedures	2-5
Pressure checks, transmission pressure check points	9-2
Pressure tests, transmission	9-2
Principles of operation	1-17
Cooling system	1-24
Drive control assemblies	1-30
Driver's instrument panel	1-28
Drivetrain	1-18
Electrical system	1-26
Flame heater system	1-22
Fuel system	1-20
Glow plugs system	1-23
Preventive maintenance checks and services	2-20
General	2-20
Intervals	2-20
Lubrication	2-20
Procedures	2-20
Procedures for semiannual/annual service	2-21
Scheduled preventive maintenance checks and services	2-25
Procedures	2-25
Preventive maintenance checks and services	2-20
Procedures for semiannual/annual services	2-21

Q

Quick guide to troubleshooting	3-3
--	-----

R

Radiator and shroud (M109A2/M109A4/M109A5)	7-13
Radiator and shroud (M109A3)	7-22
Ration boxes	13-8
Rectifier (M109A2/M109A3)	8-11
Rectifier (M109A4/M109A5)	8-13
Rectifier-to-voltage regulator wiring harness (11593806) (M109A2/M109A3)	8-154
Rectifier-to-voltage regulator wiring harness (12268303) (M109A4/M109A5)	8-156
References	A-1
Army regulations	A-2
Common tables of allowances	A-2
Department of Defense forms	A-2
Department of the Army forms	A-2
Department of the Army pamphlets	A-2
Field manuals	A-2
Standard forms	A-2
Technical bulletins	A-3

CONTENTS

PAGE

Technical manualsA-3

Repair parts

 Common tools and equipment2-2

 General2-2

 Special tools2-2

 Support equipment2-2

Reporting Equipment improvement Recommendations (EIR's)1-7

Road wheel arms10-30

Road wheels10-22

S

Safety wiring —fixed fire extinguisher system.....11-75

Scheduled preventive maintenance checks and services2-20

Scope1-5

Serial number locations1-10

Service headlights, taillights and stop lights, troubleshooting3-3

Service upon receipt2-2

 Assembly of equipment2-4

 Batteries, connecting and servicing2-5

 Checking unpacked equipment2-3

 Checking vehicle systems2-7

 Processing unpacked equipment.....2-3

 Engine coolant, check level and specific gravity2-7

 Engine oil, check level2-7

 Equipment installation instructions2-4

 Equipment faults2-8

 Fire extinguisher cylinders2-7

 Fuel, fuel vehicle2-7

 Initial procedures2-3

 Initial starting and break-in2-7

 Operational procedures2-7

 Operations test2-7

 Pre-operational procedures2-5

 Reporting design and material faults.....2-8

 Transmission oil, check level2-7

 Vehicle operation, road test2-7

Shock absorbers10-4.8

Shock absorber bearings10-50

Shock mount and bracket10-48

Shift control linkage, transmission9-22

Slave start receptacle8-95

 Troubleshooting3-3

Slave starting2-49

Slip ring telephone feed wiring harness8-148

Solenoid valve and bracket5-21

Spade11-55

Spare M45 periscope box.....13-7

Special equipment hook-ups, powerplant4-10

Special tools2-2

Service upon receipt2-2

Speedometer and tachometer systems, transmission9-57

CONTENTS

PAGE

S — CONTINUED

Starter relay box 8-83

Starter-to-engine electrical disconnect (1235M03) (M109A4/M109A5). 8-199

STE/ICE-R procedures I-1

 Battery testing I-63

 Engine testing I-8

Stencil location for Basic issue items. 1-12

Steering control linkage,transmission 9-14

Stop light switches 8-93

Subfloor drain plugs (M109A4/M109A5) 11-36

Surge tank and pressure relief valve 7-10

Suspension 10-21

 Idler arm assemblies 10-43

 Idler arm housings 10-47

 Idler wheels and hubs 10-39

 Road wheel arm 10-30

 Road wheel hubs 10-26

 Road wheels 10-22

 Shock absorber and shock absorber mount 10-48

 Torsion bars 10-31

 Torsion bar anchors 10-33

 Torsion bars, anchors, road wheel arm and hub assembly identification chat. 10-21

 Track adjusters and mounting brackets 10-36

T

Terminal-type cable connectors

 Replacement 2-11

 Hull battery 8-76

Testing fo rcontinuity 2-10

Testing for short circuits 2-9

Thrown track and track replacement (T-154 track) 10-14

 installation (T-154 track) 10-15

Thrown track and track replacement (T-136 track) 10-11

 installation (T-136 track) 10-11

Tools 2-2

Torsion bar anchors 10-33

Torsion bars, anchor, road wheel arm and hub assembly identification chart 10-21

Torsion bars, suspension 10-31

Towing pintle 11-61

Track adjusters and mounting brackets, suspension 10-36

Track pads (T-136 track) 10-4

Track pads (T-154 track) 10-5

Track shoes (T-136 track) 10-6

Track shoes (T-154 track) 10-9

Track tension 10-19

Tracks (T-136 track) 10-11

 Thrown track and track replacement (T-136 track) 10-6

 Track pads (T-136 track) 10-4

 Track shoes (T-136 track) 10-6

<u>CONTENTS</u>	<u>PAGE</u>
Track (T-154 track)	10-14
Thrown track and track replacement (T-154 track)	10-14
Track pads (T-154 track)	10-5
Track shoes (T-154 track)	10-9
Tracks and suspension, troubleshooting	3-3
Tracks, suspension system, final drives and universal joints	10-1
Final drive and universal joints	10-53
Suspension system	10-21
Tracks	10-2
Transmission access doors	11-25
Transmission and driving controls, troubleshooting	3-3
Transmission and transfer assemblies	9-2
Transmission internal brake, transmission.	9-49
Transmission oil pressure transmitter and oil low pressure switch	8-27
Transmission oil temperature transmitter and transmission oil high temperature switch	8-25
Transmission oil temperature transmitter and transmission oil high temperature switch protective cover (M109A4/M109A5)	8-24
Transmission throttle valve	9-51
Transmission, transfer, and drive control assemblies	9-1
Accelerator pedal	9-55
Fenders	11-60
Hand throttle governor control rod.	9-53
Main and lubricating oil pressure and oil temperature check	9-2
Oil check	9-2
Pressure check	9-2
Service parking brake	9-30
Shift control linkage	9-22
Spades	11-55
Speedometer and tachometer.	9-57
Steering control linkage	9-14
Engine throttle governor control rod	9-52
Transmission internal brake	9-49
Transmission throttle valve	9-51
Warning light and stop light switches	9-56
Travel lock	11-44
Towing pintle	11-61
Travel lock	11-44
Troubleshooting	3-1
General instructions	3-2
Quick guide to troubleshooting	3-3
Troubleshooting chart	3-11
Turbocharger lines	5-29
Types of multimeter	2-8
Typical female-type panel mounting receptacle	2-13
Typical female-type panel mounting plug with ridged locking nut.	2-14
Typical female-type plug with ridged locking nut	2-16
Typical male-type panel mounting receptacle	2-13
Typical male-type panel mounting plug with ridged locking nut	2-15
Typical male-type plug with ridged locking nut	2-17

CONTENTS

PAGE

U

Unit preventative maintenance checks and services2-20
Universal joints10-57
Unpacking
 Service upon receipt2-2
Using the ohms scale2-9

V

Valve cover breather hose5-25
Ventilated face piece system power wiring harness (12352794) (M109A4/M109A5)8-160
 Troubleshooting3-3
Voltage regulator8-10

W

Warning light8-189
Winterization kit14-1
 Troubleshooting3-3
Wiring harness and cable repairs.2-11

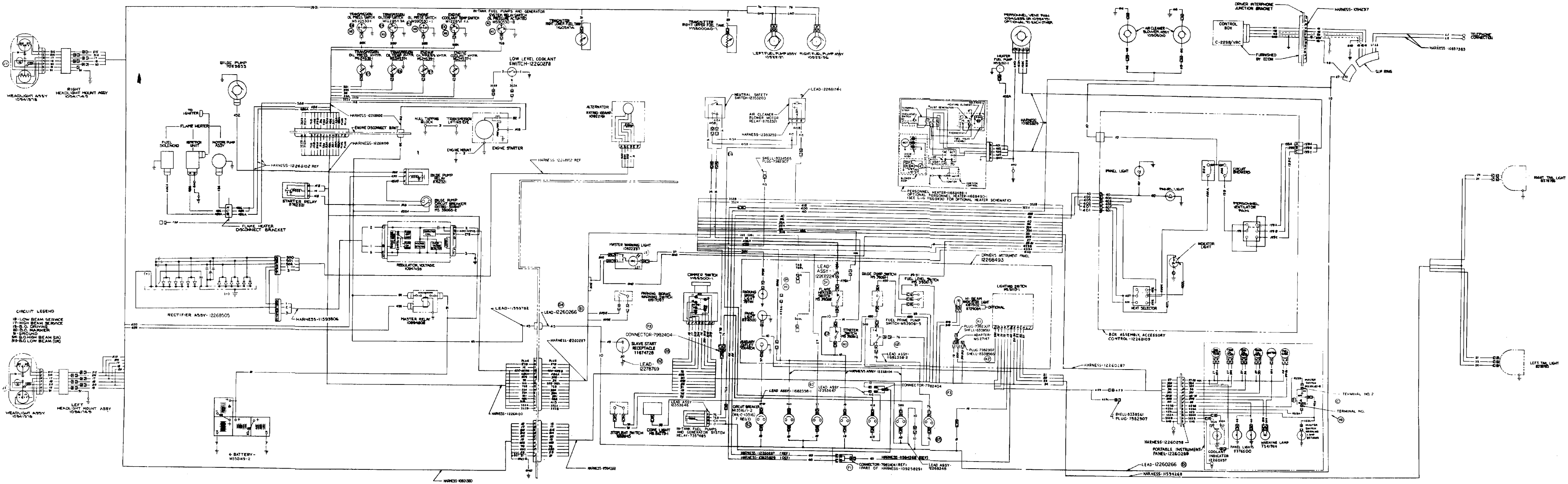

FIGURE FO-1. M109A2 (ENGINE MODEL 7083-7396) HULL ELECTRICAL SCHEMATIC.

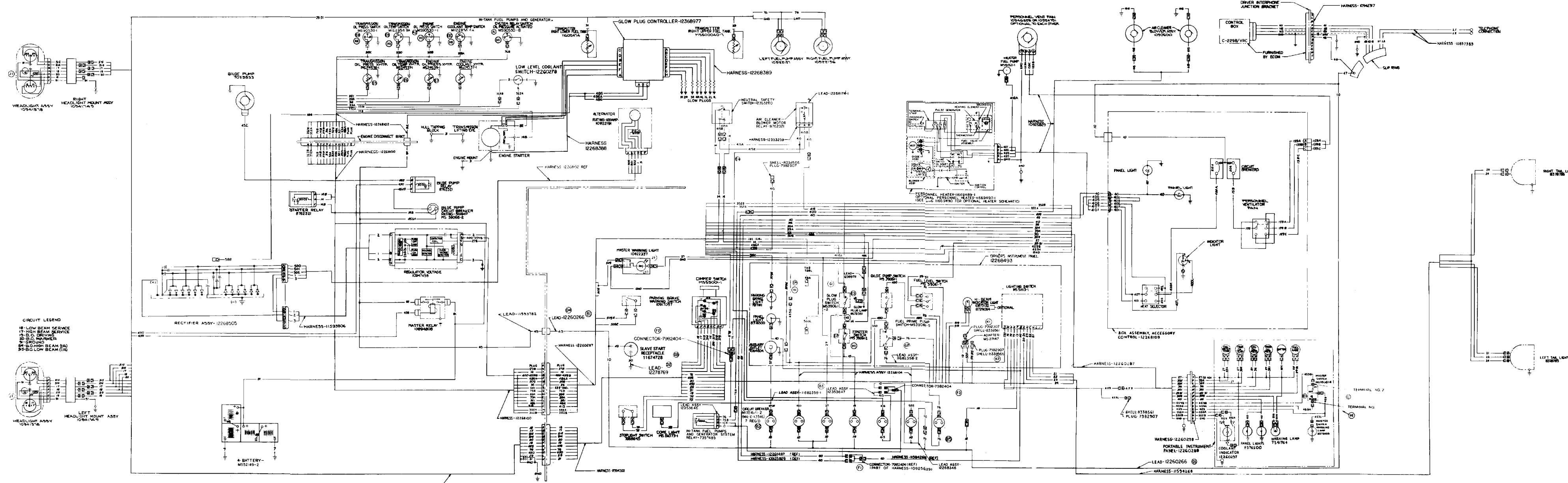

FIGURE FO-2. M109A2 (ENGINE MODEL 7083-7391) HULL ELECTRICAL SCHEMATIC.

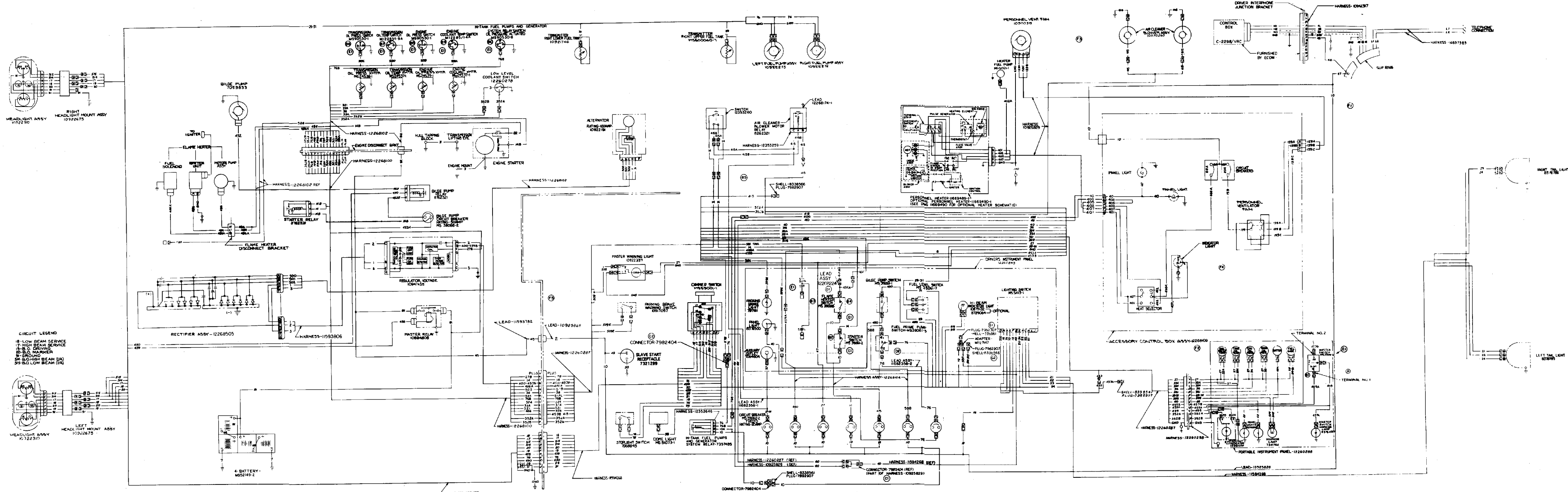

FIGURE FO-3. M109A3 (S/N 1122 AND AFTER) (ENGINE MODEL 7083-7398) HULL ELECTRICAL SCHEMATIC.

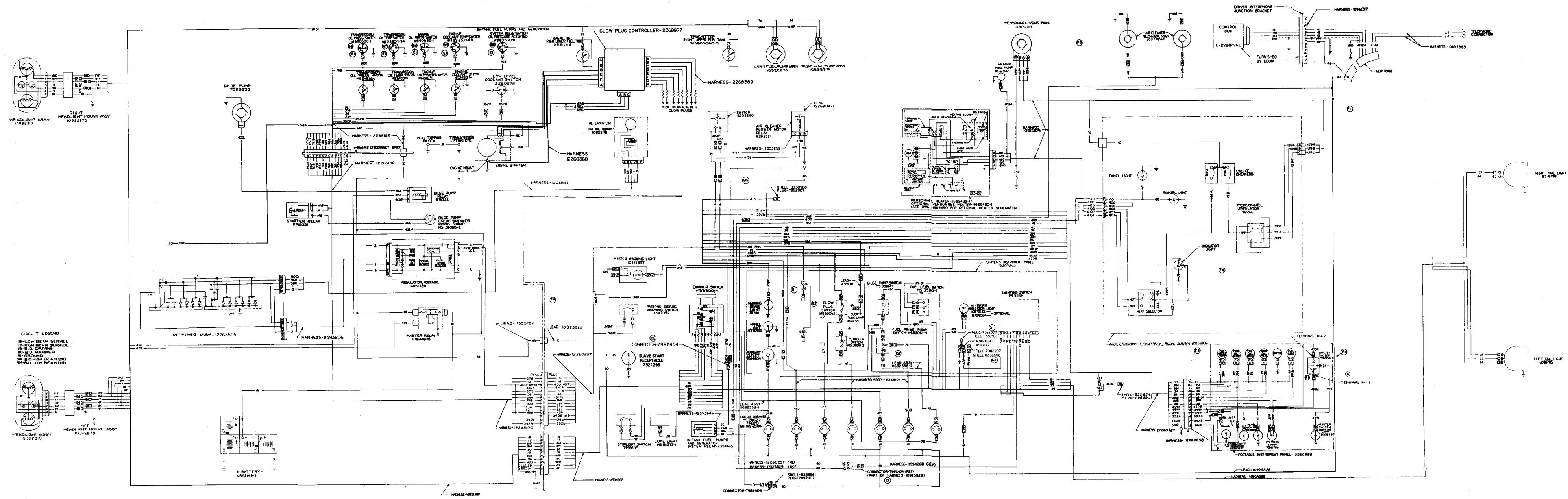

FIGURE FO-4. M109A3 (S/N 1122 AND AFTER) (ENGINE MODEL 7083-7391) HULL ELECTRICAL SCHEMATIC.

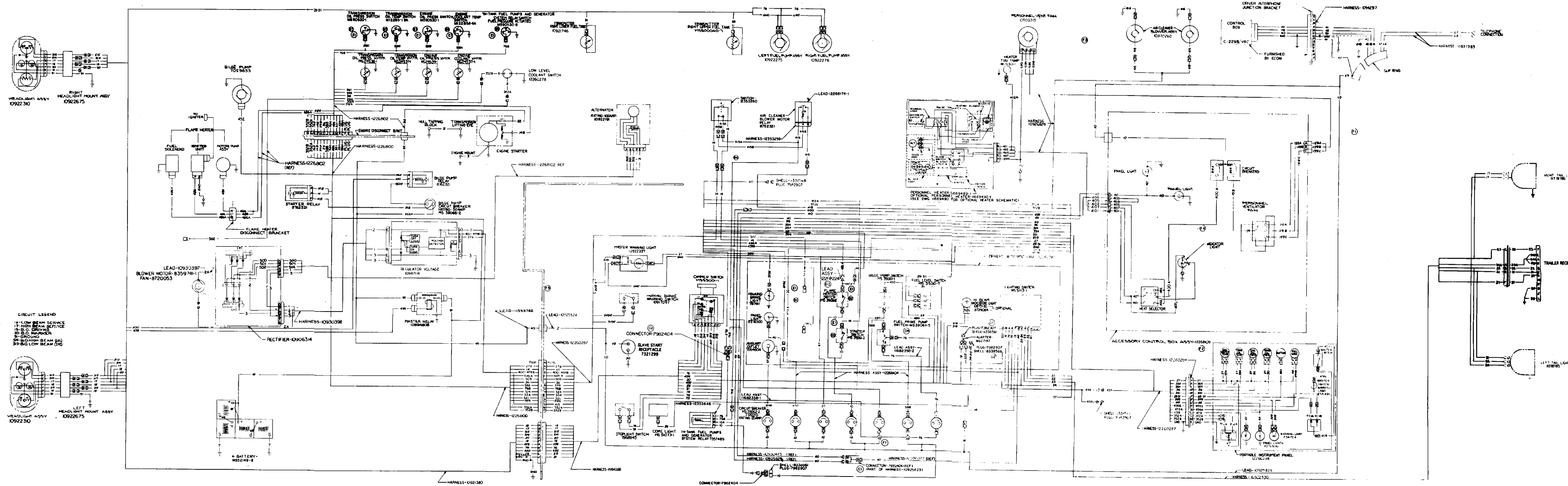

FIGURE FO-5. M109A3 (BEFORE S/N 1122) (ENGINE MODEL 7083-7396)

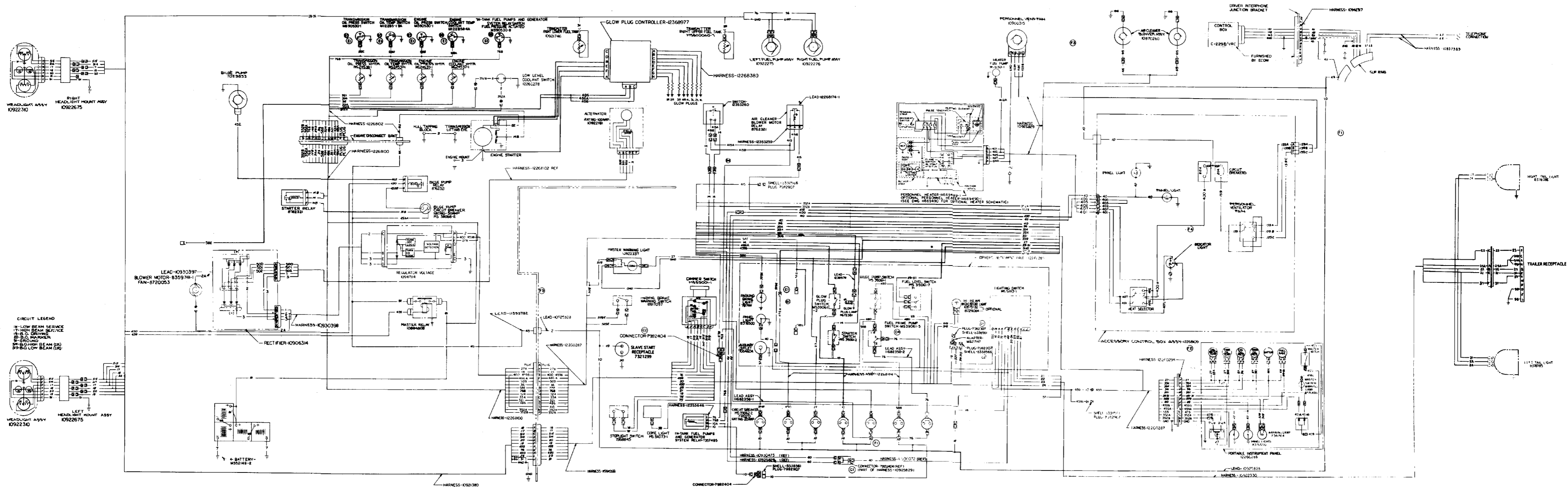

FIGURE FO-6. M109A3 (BEFORE S/N 1122) (ENGINE MODEL 7063-7391) HULL ELECTRICAL SCHEMATIC.

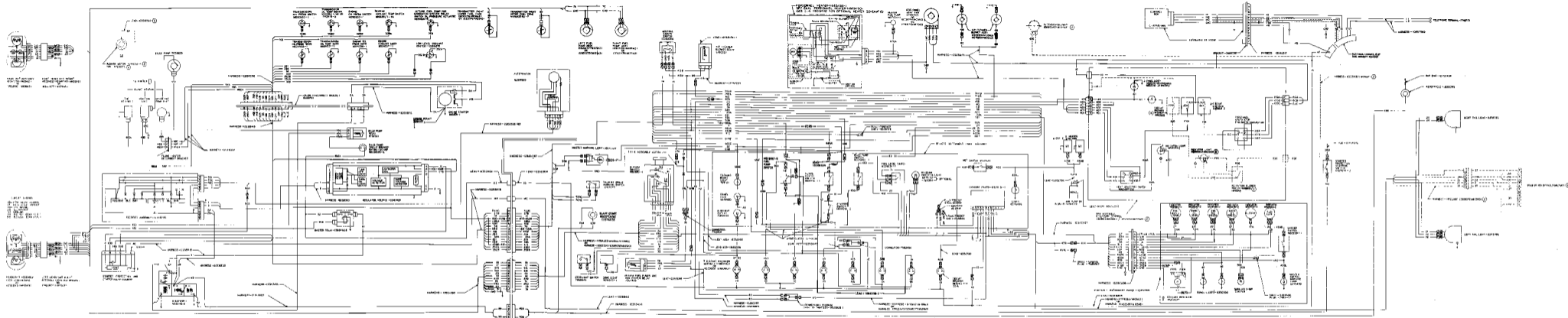

FIGURE PD-7. M108A4/M108A5 (ENGINE MODEL 7063-7306) HULL ELECTRICAL SCHEMATIC.

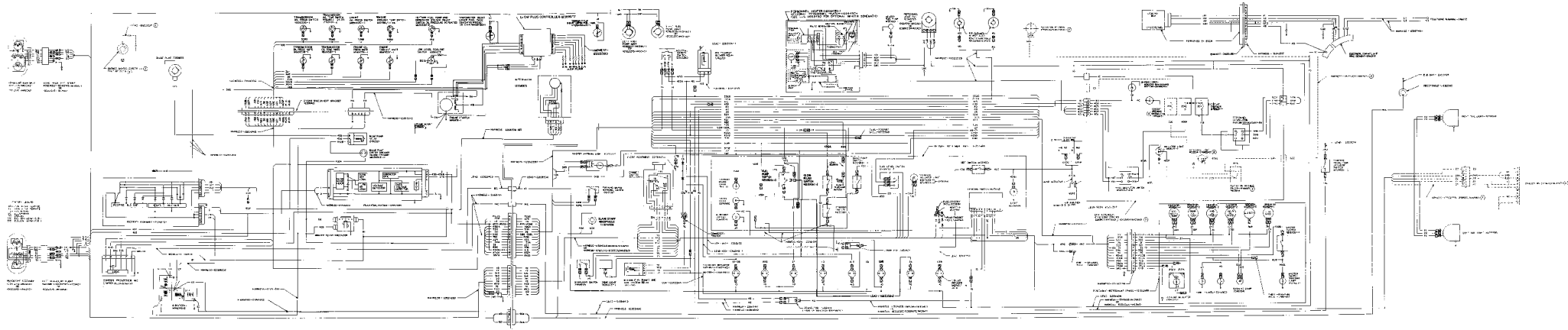
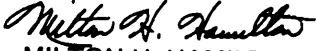

FIGURE FO-4. M109A4/108AS (ENGINE MODEL T90-7391) HULL ELECTRICAL SCHEMATIC.

By Order of the Secretary of the Army:

Official:

MILTON H. HAMILTON
*Administrative Assistant to the
Secretary of the Army*
07388

GORDON R. SULLIVAN
*General, United States Army
Chief of Staff*

DISTRIBUTION:

To be distributed in accordance with DA Form 12-37-E, block 1239,
requirements for TM 9-2350-311-20-1.

•U.S. GOVERNMENT PRINTING OFFICE:1994-546-017/00163

RECOMMENDED CHANGES TO EQUIPMENT TECHNICAL PUBLICATIONS



THEN... JOT DOWN THE DOPE ABOUT IT ON THIS FORM. CAREFULLY TEAR IT OUT. FOLD IT AND DROP IT IN THE MAIL!

SOMETHING WRONG WITH THIS PUBLICATION?

FROM: (PRINT YOUR UNIT'S COMPLETE ADDRESS)

Your mailing address

DATE SENT

Date you fill out this form

PUBLICATION NUMBER

TM X-XXXX-XXX-XX

PUBLICATION DATE

Date of TM

PUBLICATION TITLE

Title of TM

BE EXACT PIN-POINT WHERE IT IS

PAGE NO	PARA-GRAPH	FIGURE NO	TABLE NO
3		2	
109		51	
2-8			2-1
12	1-6a		

IN THIS SPACE TELL WHAT IS WRONG AND WHAT SHOULD BE DONE ABOUT IT:

Item 10. Change illustration. Reason: Tube end shown assembled on wrong side of lever cam.

Item 3. The NSN and P/N are not listed on the AMDF nor the MCRL. Request correct NSN and P/N be furnished.

Preventive Maintenance Checks and Services. Item 7 under "Items to be inspected" should be changed to read as follows: Firing linkage and firing mechanism pawl.

Since there are both 20- and 30- round magazines for this rifle, data on both should be listed.

SAMPLE

PRINTED NAME, GRADE OR TITLE, AND TELEPHONE NUMBER

SIGN HERE

FILL IN YOUR
UNIT'S ADDRESS



FOLD BACK

TEAR ALONG PERFORATED LINE

DEPARTMENT OF THE ARMY

OFFICIAL BUSINESS

Commander
U.S. Army Tank-Automotive and Armaments Command
ATTN: AMSTA-MMAA
Warren, MI 48397-5000

RECOMMENDED CHANGES TO EQUIPMENT TECHNICAL PUBLICATIONS



THEN... JOT DOWN THE DOPE ABOUT IT ON THIS FORM. CAREFULLY TEAR IT OUT. FOLD IT AND DROP IT IN THE MAIL!

SOMETHING WRONG WITH THIS PUBLICATION?

FROM: (PRINT YOUR UNIT'S COMPLETE ADDRESS)

DATE SENT

PUBLICATION NUMBER

TM 9-2350-311-20-1

PUBLICATION DATE

29 AUG 94

PUBLICATION TITLE UNIT MAINTENANCE MANUAL FOR HULL, POWERPLANT, DRIVE HOWITZER, MEDIUM, SELF-PROPELLED, 155MM.

BE EXACT. PIN-POINT WHERE IT IS

PAGE NO	PARA-GRAPH	FIGURE NO	TABLE NO
---------	------------	-----------	----------

IN THIS SPACE TELL WHAT IS WRONG AND WHAT SHOULD BE DONE ABOUT IT:

PRINTED NAME, GRADE OR TITLE, AND TELEPHONE NUMBER

SIGN HERE

FILL IN YOUR
UNIT'S ADDRESS

FOLD BACK

TEAR ALONG PERFORATED LINE

DEPARTMENT OF THE ARMY

OFFICIAL BUSINESS

Commander
U.S. Army Tank-Automotive and Armaments Command
ATTN: AMSTA-MMAA
Warren, MI 48397-5000

RECOMMENDED CHANGES TO EQUIPMENT TECHNICAL PUBLICATIONS



THEN... JOT DOWN THE DOPE ABOUT IT ON THIS FORM. CAREFULLY TEAR IT OUT. FOLD IT AND DROP IT IN THE MAIL!

SOMETHING WRONG WITH THIS PUBLICATION?

FROM: (PRINT YOUR UNIT'S COMPLETE ADDRESS)

DATE SENT

PUBLICATION NUMBER
TM 9-2350-311-20-1

PUBLICATION DATE
29 AUG 94

PUBLICATION TITLE
UNIT MAINTENANCE MANUAL FOR HULL, POWERPLANT, DRIVE HOWITZER, MEDIUM, SELF-PROPELLED, 155MM

BE EXACT. PIN-POINT WHERE IT IS

PAGE NO	PARA-GRAPH	FIGURE NO	TABLE NO

IN THIS SPACE TELL WHAT IS WRONG AND WHAT SHOULD BE DONE ABOUT IT:

PRINTED NAME, GRADE OR TITLE, AND TELEPHONE NUMBER

SIGN HERE

FILL IN YOUR
UNIT'S ADDRESS

FOLD BACK

DEPARTMENT OF THE ARMY

OFFICIAL BUSINESS

Commander
U.S. Army Tank-Automotive and Armaments Command
ATTN: AMSTA-MMAA
Warren, MI 48397-5000

TEAR ALONG PERFORATED LINE

FILL IN YOUR
UNIT'S ADDRESS

FOLD BACK

DEPARTMENT OF THE ARMY

OFFICIAL BUSINESS

Commander
U.S. Army Tank-Automotive and Armaments Command
ATTN: AMSTA-MMAA
Warren, MI 48397-5000

TEAR ALONG PERFORATED LINE

THE METRIC SYSTEM AND EQUIVALENTS

LINEAR MEASURE

1 Centimeter=10 Millimeters=0.01 Meters=0.3937 Inches
 1 Meter=100 Centimeters=1000 Millimeters=39.37 Inches
 1 Kilometer=1000 Meters=0.621 Miles

WEIGHTS

1 Gram=0.001 Kilograms=1000 Milligrams=0.035 Ounces
 1 Kilogram=1000 Grams=2.2 Lb
 1 Metric Ton=1000 Kilograms=1 Megagram=1.1 Short Tons

LIQUID MEASURE

1 Milliliter=0.001 Liters=0.0338 Fluid Ounces
 1 Liter=1000 Milliliters=33.82 Fluid Ounces

SQUARE MEASURE

1 Sq Centimeter=100 Sq Millimeters=0.155 Sq Inches
 1 Sq Meter=10,000 Sq Centimeters=10.76 Sq Feet
 1 Sq Kilometer=1,000,000 Sq Meters=0.386 Sq Miles

CUBIC MEASURE

1 Cu Centimeter=1000 Cu Millimeters=0.06 Cu Inches
 1 Cu Meter=1,000,000 Cu Centimeters=35.31 Cu Feet

TEMPERATURE

5/9 (° F - 32) = ° C
 212° Fahrenheit is equivalent to 100° Celsius
 90° Fahrenheit is equivalent to 32.2° Celsius
 32° Fahrenheit is equivalent to 0° Celsius
 9/5 C° + 32 = F°

APPROXIMATE CONVERSION FACTORS

<u>TO CHANGE</u>	<u>TO</u>	<u>MULTIPLY BY</u>
Inches	Centimeters	2.540
Feet	Meters	0.305
Yards	Meters	0.914
Miles	Kilometers	1.609
Square Inches	Square Centimeters	6.451
Square Feet	Square Meters	0.093
Square Yards	Square Meters	0.836
Square Miles	Square Kilometers	2.590
Acres	Square Hectometers	0.405
Cubic Feet	Cubic Meters	0.028
Cubic Yards	Cubic Meters	0.765
Fluid Ounces	Milliliters	29.573
Pints	Liters	0.473
Quarts	Liters	0.946
Gallons	Liters	3.785
Ounces	Grams	28.349
Pounds	Kilograms	0.454
Short Tons	Metric Tons	0.907
Pound-Feet	Newton-Meters	1.356
Pounds per Square Inch	Kilopascals	6.895
Miles per Gallon	Kilometers per Liter	0.425
Miles per Hour	Kilometers per Hour	1.609

<u>TO CHANGE</u>	<u>TO</u>	<u>MULTIPLY BY</u>
Centimeters	Inches	0.394
Meters	Feet	3.280
Meters	Yards	1.094
Kilometers	Miles	0.621
Square Centimeters	Square Inches	0.155
Square Meters	Square Feet	10.764
Square Meters	Square Yards	1.196
Square Kilometers	Square Miles	0.386
Square Hectometers	Acres	2.471
Cubic Meters	Cubic Feet	35.315
Cubic Meters	Cubic Yards	1.308
Milliliters	Fluid Ounces	0.034
Liters	Pints	2.113
Liters	Quarts	1.057
Liters	Gallons	0.264
Grams	Ounces	0.035
Kilograms	Pounds	2.205
Metric Tons	Short Tons	1.102
Newton-Meters	Pound-Feet	0.738
Kilopascals	Pounds per Square Inch	0.145
Kilometers per Liter	Miles per Gallon	2.354
Kilometers per Hour	Miles per Hour	0.621

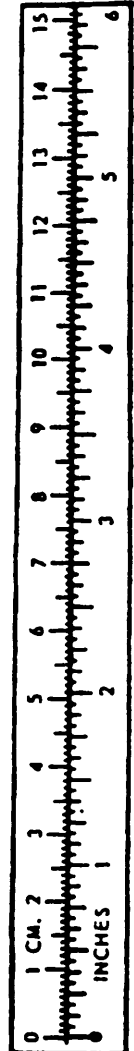

PIN: 060798-000