**FABRICATION AND OPERATION
OF
POWERPLANT TEST STAND**

**M113A2/M113A3/M548A1/M548A3 FAMILY OF VEHICLES
INCLUDING OPPOSING FORCES SURROGATE VEHICLE (OSV)**

HEADQUARTERS, DEPARTMENT OF THE ARMY, Washington, D.C.

22 February 2003

REPORTING ERRORS AND RECOMMENDING IMPROVEMENTS

You can help improve this publication. If you find any mistakes or if you know of a way to improve the procedures, please let us know. Submit your DA Form 2028 (Recommended Changes to Publications and Blank Forms), through the Internet, on the Army Electronic Product Support (AEPS) **website**. The Internet address is <http://aeprs.ria.army.mil>. If you need a password, scroll down and click on "ACCESS REQUEST FORM". The DA Form 2028 is located in the ONLINE FORMS PROCESSING section of the AEPS. Fill out the form and click on SUBMIT. Using this form on the AEPS will enable us to respond quicker to your comments and better manage the DA Form 2028 program. You may also mail, fax or E-mail your letter, DA Form 2028 direct to: AMSTA-LC-CI/TECH PUBS, TACOM-RI. 1 Rock Island Arsenal, Rock Island, IL **61299-7630**. The **email** address is TACOM-TECH-PUBS@ria.army.mil. The fax number is DSN **793-0726** or Commercial (309) 782-0726.

Distribution Statement A: Approved for public release; distribution is unlimited.

**This TB includes instructions for fabrication and operation of this stand.
However, it may be purchased completely fabricated and ready to operate.
Contact:**

**SUPERINTENDENT
IDAHO ARMY NATIONAL GUARD,
CSMS office Bld 578
JACOBS Street
Boise, IDAHO 83707
DSN: 422-3885/3886 /Commercial (208) 422-3855/3886**

They will provide you with cost and warranty information.

SAFETY SUMMARY

This list summarizes critical WARNINGS in this Technical Bulletin. They are repeated here to let you know how important they are. Study these WARNINGS carefully; they can save your life and the lives of personnel with whom you work. Also, you should become familiar with all the warnings in the appropriate technical manuals for each engine/transmission that you are working on.

WARNING

Solvents can burn easily, can give off harmful vapors, and are harmful to skin and clothing. To avoid injury or death, keep away from open fire and use in well-ventilated area. If solvent gets on skin or clothing, wash immediately with soap and water.

WARNING

Hanging loads can kill or injure you. Keep away from hanging loads and overhead equipment. Keep hands out of area while power plant is being lifted or lowered on power plant stand.

WARNING

Noises from the exhaust without muffler can damage hearing of personnel. All personnel MUST WEAR DOUBLE HEARING PROTECTION whether exhaust system is used or not.

WARNING

The turbocharger can grind off part or all of your hand. Place a screen or some type of guard over turbocharger intake manifold if air cleaner system is not used.

WARNING

Engine exhaust fumes contain deadly poisonous gases. Exhaust gases are most dangerous in places with poor airflow. Direct engine exhaust up and away from personnel whether exhaust system is used or not.

WARNING

Gas from batteries can explode and injure you Do not have open flames, make sparks, or smoke near batteries. Battery acid can burn or blind you. Do not get acid on your skin or eyes.

WARNING

Battery posts and cables touched by metal objects can short circuit and burn or injure you. Use caution when you work with tools or other metal objects. Do NOT wear jewelry when you work on electrical systems.

WARNING

Sparks from static electricity can cause a fire or explosion. Metal nozzle must touch metal in filler neck when fueling the powerplant test stand, or a ground wire must be used.

WARNING

Hot oil, water, and engine parts can burn you. Let power plant cool before you start work.

WARNING

A fire can break out any time. Personnel can be injured or killed. Equipment can be damaged. Make sure fire extinguisher is ready for use before you operate engine.

WARNING

Hot radiator water can burn you. Use hand to remove cap only if cool to the touch. Turn cap slowly to release pressure. Replace cap by pressing down and turning cap until tight.

WARNING

Loose clothing is dangerous around moving belts and pulleys. You could get injured if your clothes get caught in moving parts.

WARNING

Energized systems and equipment can burn you. If MASTER SWITCH is ON, electrical system and equipment will be energized. Make sure MASTER SWITCH is OFF when you work on electrical system or equipment.

WARNING

Start up of equipment or moving parts could injure you or others. If other personnel are working on you engine, be sure you know what they are doing. Place DO NOT OPERATE tag on MASTER SWITCH when needed to prevent startup.

WARNING

Exhaust gases can make you ill or kill you. Signs of exhaust gas poison are dizziness, headache, loss of muscle control, sleepiness, coma, or death. If anyone shows signs of exhaust gas poisoning:

- Get medical help.
- Make sure personnel have lots of fresh air.
- Keep personnel warm.
- Do not let anyone do hard exercise.

If anyone stops breathing, give artificial respiration.

WARNING

If you work on an engine that has been running, you could be burned. All tasks begin with a cooled down engine. Allow engine to cool, or use care if you work on a hot engine.

WARNING

Unsafe use of chemical products, tools and equipment can injure you. Read and follow warnings and instruction on labels of all chemical products. Follow all general shop safety procedures. See your commander for further instructions on safety.

WARNING

Starting engine right after a fire could restart the fire or injure you. Do not turn MASTER SWITCH ON until cause of fire has been repaired or removed.

WARNING

Damaged lifting slings can fail with load. Soldiers can be injured or killed. Inspect all slings before use. Do not use damaged slings.

WARNING

Moving powerplant parts could injure you. Stay clear of moving parts when powerplant is running.

LIST OF EFFECTIVE PAGES

NOTE: The portion of text effected by changes is indicated by a vertical line in the outer margins of the page. Changes to illustrations are indicated by miniature pointing hands.

Dates of issue for original and changed pages are:

Original..... 0.....22 February 2003

TOTAL NUMBER OF PAGES FOR FRONT AND REAR MATTER IS 120,
CONSISTING OF THE FOLLOWING:

Page No.	*Change No.	Page No.	*Change No.
Cover.....	0		
a-d(blank).....	0		
A/B(blank).....	0		
i-ii	0		
1-1 - 1-4.....	0		
2-1 - 2-50(blank).....	0		
3-1 - 3-8(blank).....	0		
4-1 - 4-26(blank).....	0		
5-1 - 5-4.....	0		
A-1 - A-6.....	0		

*Zero in this column indicates an original page

TABLE OF CONTENTS

	Title	Page
	Safety Summary.....	i
	Table of Contents.....	i
	List of Illustrations.....	iv
CHAPTER 1.	INTRODUCTION.....	1-1
Section I.	General Information.....	1-1
II.	Description and Data.....	1-1
CHAPTER 2.	FABRICATION.....	2-1
Section I.	General Information.....	2-1
II.	Frame and Mounts.....	2-1
III.	Fuel System.....	2-23
IV.	Cooling System.....	2-25
V.	Electrical System.....	2-28
VI.	Instrument Panel.....	2-41
VII.	Test Equipment Fabrication.....	2-44
VIII.	Hydraulic System.....	2-49
IX.	Miscellaneous.....	2-49
CHAPTER 3	INSTALLATION.....	3-1
Section I.	General Information.....	3-1
II.	Installation of Components on Test Stand.....	3-1
CHAPTER 4.	OPERATION.....	4-1
Section I.	Introduction.....	4-1
II.	Maintenance.....	4-3
	M113A3/M548A3 OSV Powerplant.....	4-3
	M113A2/M548A1 Powerplant.....	4-14
	Testing Engine Only.....	4-21
CHAPTER 5	POWERPLANT TEST STAND.....	5-1
Section I.	Maintenance.....	5-1
II.	Troubleshooting.....	5-1
APPENDIX A	BILL OF MATERIALS/SCHEMATICS.....	A-1
	Bill of Materials.....	A-1
	Schematics.....	A-3

LIST OF ILLUSTRATIONS

Fig	Title	Page
1-1	M113A3 Powerplant.....	1-3
1-2	M113A2 Powerplant.....	1-3
1-3	M548A3 Powerplant.....	1-4
1-4	M548A1 Powerplant.....	1-4
2-1	Frame Assembly Layout—Top View.....	2-2
2-2	Frame Assembly Dimensions—Top View.....	2-3
2-3	Frame Assembly Supports—Bottom View.....	2-4
2-4	Forklift Pockets.....	2-5
2-5	Floor Plate Dimensions and Locations.....	2-6
2-6	Front-Engine Mount Fabrication.....	2-8
2-7	Transmission Mount Fabrication—M113A3/M548A3 FOV.....	2-9
2-8	Transfer-Gearcase Mount Fabrication—M113A2/M548A1.....	2-11
2-9	Powerplant Mount Location.....	2-13
2-10	Engine-Only-Rear Mount Fabrication.....	2-15
2-11	Battery Box Fabrication.....	2-17
2-12	100/200-Amp Regulator Mounting Hole Template.....	2-18
2-13a	Instrument Panel Hinge Points.....	2-20
2-13b	Instrument Panel Support.....	2-21
2-14	Powerplant Test Stand—Bottom View.....	2-22
2-15	Fuel Line Adapter.....	2-24
2-16	Radiator Bracket/Support.....	2-26
2-17	Air Bleed Valve.....	2-27
2-18	100-Amp Connector Panel.....	2-28
2-19	Transmission Controller.....	2-30
2-20	Accessory Cable (M113A2/M113A3/M548A1 Only).....	2-33
2-21	Regulator Cable (Three Leads).....	2-35
2-22	Regulator Cable (Four Leads) (M113A2/M113A3/M548A1 Only).....	2-37
2-23	Transmission Cable.....	2-38
2-24	Starter Cable (M113A3/M548A3).....	2-39
2-25	Starter Cable (M113A2/M548A1).....	2-40
2-26	Instrument Panel/Box.....	2-43
2-27	Transmission Stall Test Tool.....	2-45
2-28	Brake Stall Test Tool (M113A3/M548A3).....	2-48
2-29	Hydraulic System Loop Fabrication.....	2-49
3-1	Instrument Panel Components.....	3-7
4-1	M113A3/M548A3 Powerplant.....	4-4
4-2	Powerplant Installed on Test Stand.....	4-5
4-3	Bleeder Hose Assembly.....	4-6
4-4	Placement of Turbocharger Inlet Shield.....	4-7
4-5	Ground Bolt.....	4-8
4-6	Hook-Up List (M113A3/M548A3).....	4-9
4-7	Throttle and Shutoff Levers.....	4-11
4-8	Hook-up List (M113A2/M548A1).....	4-17
5-1	Instrument Panel Box—Circuit Breakers.....	5-2
A-1	200-Amp System (M113A3 FOV).....	A-3
A-2	100-Amp System (M113A2 FOV).....	A-4
A-3	200-Amp System (M113A2 FOV).....	A-5
A-4	200-Amp Engine Charging System.....	A-6

CHAPTER 1

INTRODUCTION

SECTION I. GENERAL INFORMATION

1-1. PURPOSE. The purpose of this technical bulletin is to provide general instructions for the fabrication and operation of a powerplant test stand designed for the M113/M548 Family of Vehicles (FOV). Although this test stand is primarily intended for the M113/M548 FOV, it can be adapted to accept all variants of the 6V53 engine. The Opposing Forces Surrogate Vehicle (OSV) is and A3 variant that includes the A3 engine and TX200-4/4A transmission.

Diagnostic testing, inspection, and repair of the 6V53 engine, as it applies to the M113 FOV, currently cannot be performed at the DS/GS level without first installing the powerpack in the vehicle. Many hours can be wasted installing a powerpack, only to find it faulty. Preventive Maintenance, Checks, and Services (PMCS) and troubleshooting procedures found in the respective operator's and unit maintenance manuals apply as if the system were installed in the vehicle. To insure safety, reference to the appropriate manuals is mandatory.

SECTION II. DESCRIPTION AND DATA

1-2. COMPONENTS. The majority of the parts and fabricated components for the M113 powerplant test stand are listed in TM 9-2350-277-24P and can be procured from that source. However, these parts and fabricated components are suggestions and they may be procured locally or replaced with similar materials. This test stand may be mounted on wheels or a pallet configuration according to the user requirements. The air intake system needs to be covered to protect personnel from danger, therefore a guard has been used. If preferred, the M113A2 air intake system can be adapted for use. The same applies for the exhaust system. Exhaust elbows have been added to direct exhaust heat away from personnel.

The M113A3 FOV is equipped with a glow plug cold weather starting system. The glow plug indicator light is found in center of instrument panel on right side. Troubleshoot using applicable TM series.

1-3. CAPABILITIES. The powerplant test stand is equipped with the capabilities and service test options normally found at all maintenance levels for the M113A2, M548A1, M113A3, M548A3 vehicles. The powerplant test stand can store 10 to 20 gallons of DF2-DF1 and JP8 fuel. It has a self-contained 24-volt electrical system using four 6 TL batteries connected in parallel series. It can isolate problems to a particular circuit using four circuit breakers. Select any transmission range (1-2, 1-3, 1-4, PV, R, SL) by using a fabricated/standard electrical transmission controller (M113A3 and M548A3 only). The M113A2 and M548A1 uses the transmission selector lever which is mounted on the transmission. The powerplant test stand is equipped with charging system regulators for both the 100-amp and 200-amp generators. The powerplant test stand is equipped with most of the capabilities normally found on the M113/M548 FOV instrument panel such as: master switch indicator, transmission filter clogged indicator, transmission high oil temperature indicator, transmission low oil pressure indicator, fuel gauge, battery generator indicator gauge, starter switch, air box heater switch, and glow plug light indicator. The test stand has the following systems installed and the ability to perform stall checks and other on-line tests. This powerplant test stand can be adapted to feed many types of powerpacks using 6V53 engine.

TB 9-2350-368-25

1. Starting system
2. Charging system (100-amp and 200-amp)
3. Fuel system
4. Cooling system
5. Instrument panel, including:
 - (a) Transmission range selector (M113A3/M548A3 only)
 - (b) Circuit breakers used to fault isolate
 - (c) Gauges and indicators
 - (d) Preheat and starter switches
 - (e) STE-ICE system (M113A3/M548A3 only)
6. Stall check hardware
7. Motor and transmission mounts
8. Cables
 - (a) Starter
 - (b) Alternator to generator
 - (c) Alternator
 - (d) Accessory
 - (e) Transmission (M113A3/M548A3 only)

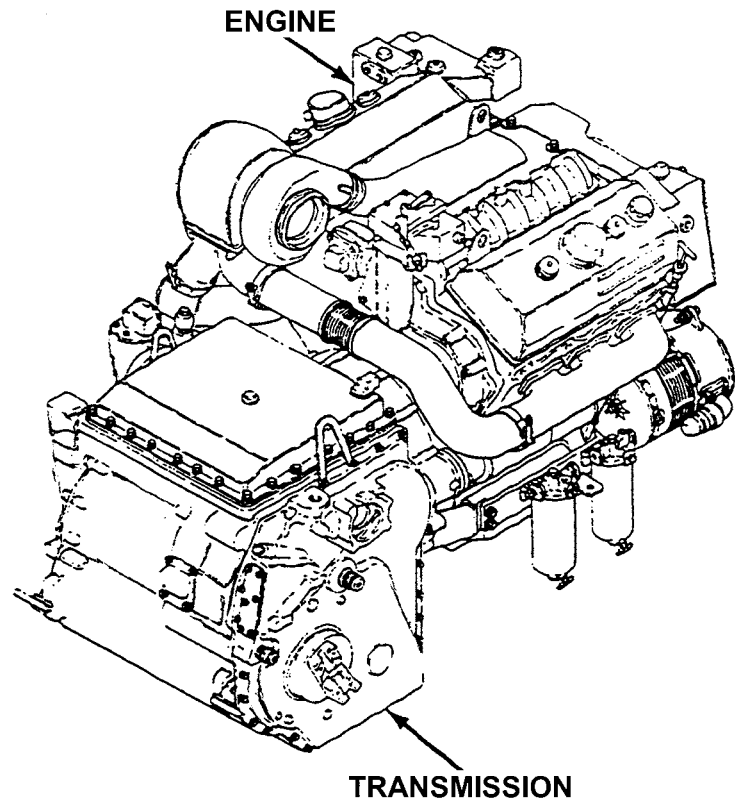

Figure 1-1. M113A3 Powerplant

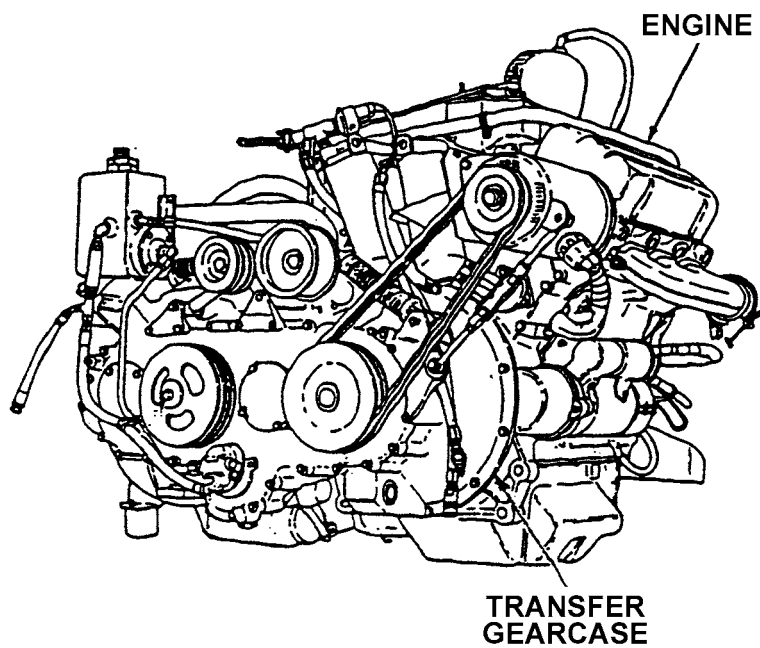

Figure 1-2. M113A2 Powerplant

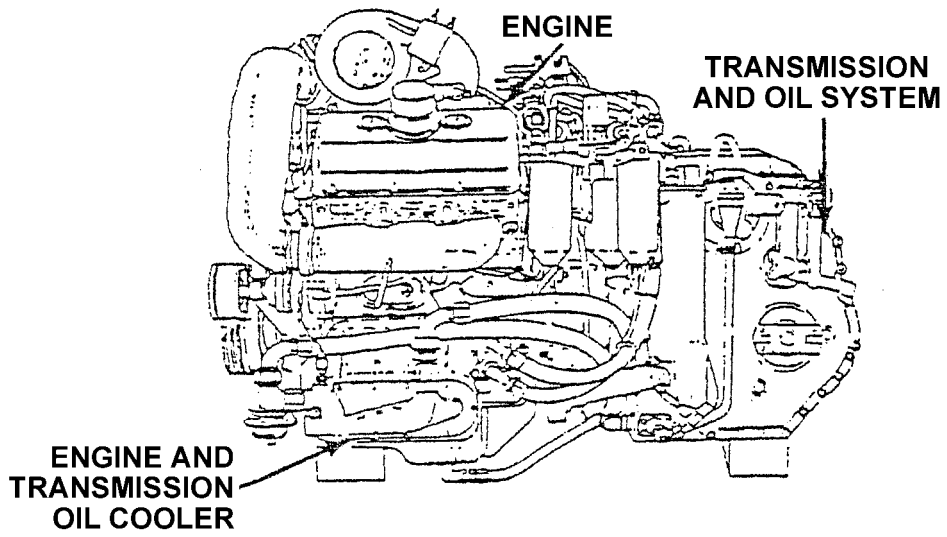

Figure 1-3. M548A3 Powerplant

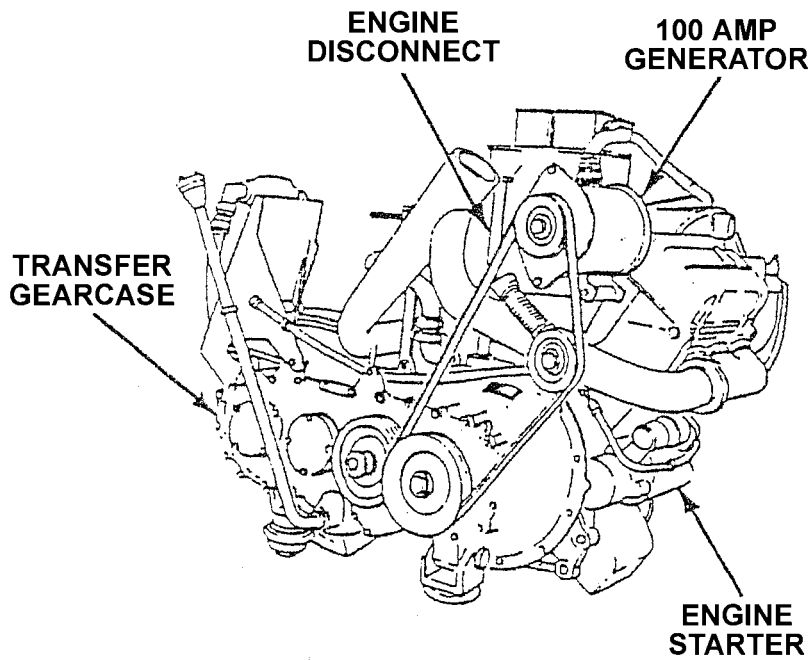

Figure 1-4. M548A1 Powerplant

CHAPTER 2

FABRICATION

SECTION I. GENERAL INFORMATION

2-1. SCOPE. This chapter provides fabrication instructions for the M113A3/M113A2/M548A1&A3 Powerplant Test stand. It is assumed that fabrication will take place at Direct Support/General Support or similar facility with access to welding equipment and expertise. Fabrication is provided by system and in the recommended sequence. Each subsystem begins with a suggested Bill Of Materials. If appropriate, the respective M113 part number and NSN are provided. Throughout the fabrication process, items may be purchased locally or cannibalized to expedite or make fabrication less expensive. All dimensions are given in US measurements followed by Metric measurements in parenthesis.

SECTION II. FRAME AND MOUNTS

2-2. TEST STAND BASE. The powerplant test stand is supported on a metal tube frame. The frame may be mounted on a skid and moved with a forklift or the frame may be mounted on axles and wheels and towed with a small tractor or similar apparatus.

a. Frame Assembly

Bill Of Materials Location			
Item	Nomenclature	Location	Qty
	4" by 2" by 1/4" Rectangular Steel Tubing	Main Frame	
1	96 inches (243.8 cm)		2
2	51 inches (129.5 cm)		2
3	48 inches (121.9 cm)		2
4	46 inches (116.8 cm)		2
5	20 inches (50.8 cm)		4
6	6 inches (15.2 cm)		1
7	4 inches (10.2 cm)		1
	4" by 3" by 1/4" Steel Angle	Transmission Mount (A3)	
8	32 inches (81.3 cm)		2
9	19 inches (48.3 cm)		2
	4" by 6" by 5/16" Angle	Front Leg Mount	
	3" by 2" by 1/4" Rectangular Steel Tubing	Rear Engine Battery Box	
10	10-1/2 inches (26.7 cm)		4
11	15-1/2 inches (39.4 cm)		4
12	18 inches (45.7 cm)		2
	4" by 6" by 3/8" Steel Tubing	Forklift Pockets	
	1/4" Tread Plate	Top Plate of Stand	
13	12 by 20 inches (30.5 by 50.8 cm)		4
14	18 by 20 inches (45.7 by 50.8 cm)		1
15	6 by 23 inches (15.2 by 58.4 cm)		1
16	4 by 23 inches (10.2 by 58.4 cm)		2
17	15 by 18 inches (38.1 by 45.7 cm)		1

1. Cut ends of rectangular steel tubes (1, 2) at 45° angle, final length to be 96 inches (243.8 cm) and 50 inches (127.0 cm) respectively. Lay steel tubes on flat level surface in accordance with Figure 2-1. Weld ends together. (See TM 9-237.)
2. Lay rectangular steel tubes (3, 4, and 5) inside box frame in accordance with art in Figure 2-1 and dimensions in Figure 2-2. Tack weld all steel tubes together.
3. Align steel angles (6 and 7) within welded framework in accordance with art in Figure 2-1 and dimensions in Figure 2-2. Tack weld all joints.
4. Hard weld, if all items are in proper place, in accordance with welding specification QQ-A-250.

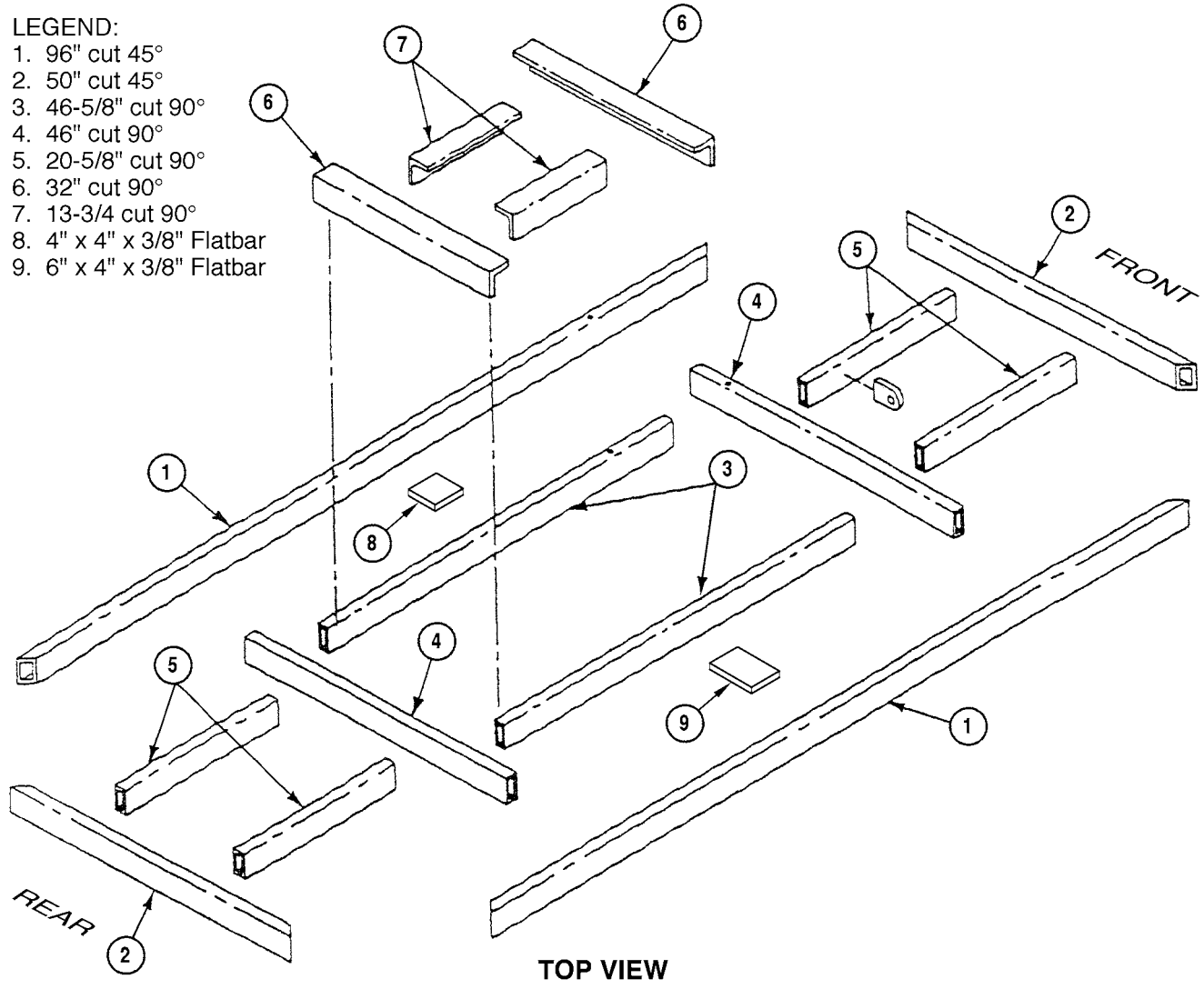

Figure 2-1. Frame Assembly Layout—Top View

NOTE

Fabrication/installation of all components that go on bottom of stand may be fabricated/installed while stand is inverted.

5. Flip frame assembly over, locate and weld four 15-inch steel tubes (10) vertically on frame 2-1/2 inches from each corner. Cut one end at a 45° angle.
6. Position and tack weld two 50-inch 2" by 4" tubes (11) cut on a 45° angle on both ends. One on each end of stand on vertical tubes.
7. Hard weld if all items are in proper alignment, in accordance with welding specification QQ-A-250.

LEGEND:

10. 15" w/45° cut one end @ 4 each (2" x 4" Tubing)
11. 50" w/45° cut both ends @ 2 each (2" x 4" Tubing)

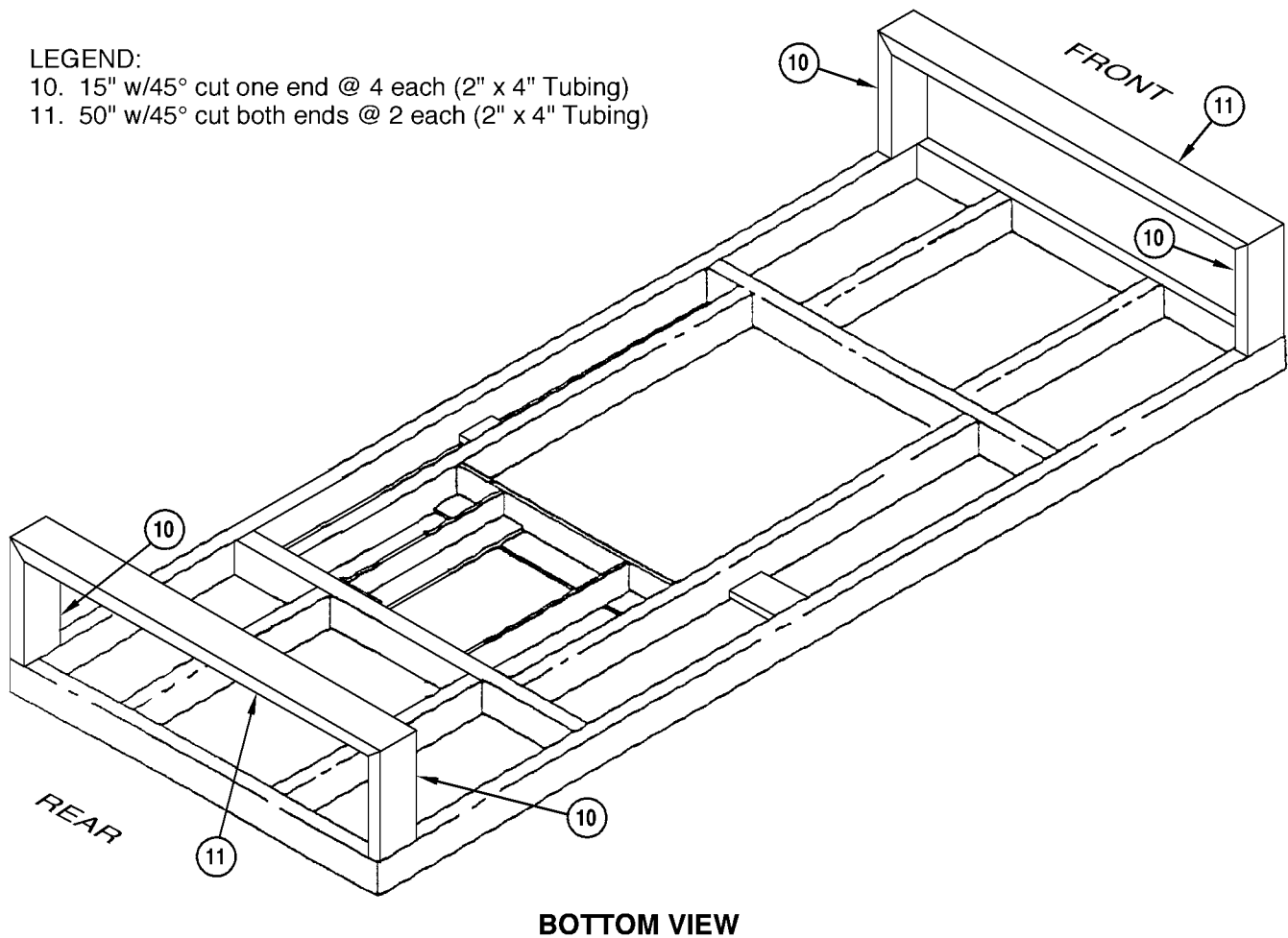

Figure 2-3. Frame Assembly Supports—Bottom View

NOTE

Total outside measurement of the forklift pockets must be 36 inches to fit a standard forklift.

8. From bottom of frame, 26 inches from the end, weld two 9" vertical 2" by 4" supports on internal 2" by 4" in accordance with Figure 2-4.
9. Center and weld 4" by 6" steel tubing on 9" vertical 2" by 4" supports.
10. Repeat steps 9 and 10 for the second forklift pocket and support.

LEGEND:

1. 4" x 6" Tubing @ 46" (2)
2. 2" x 4" Tubing @ 9" (4)
3. 4" x 10" x 1/4" plate Gusset (2)
4. 6" x 10" x 1/4" plate Gusset (2)

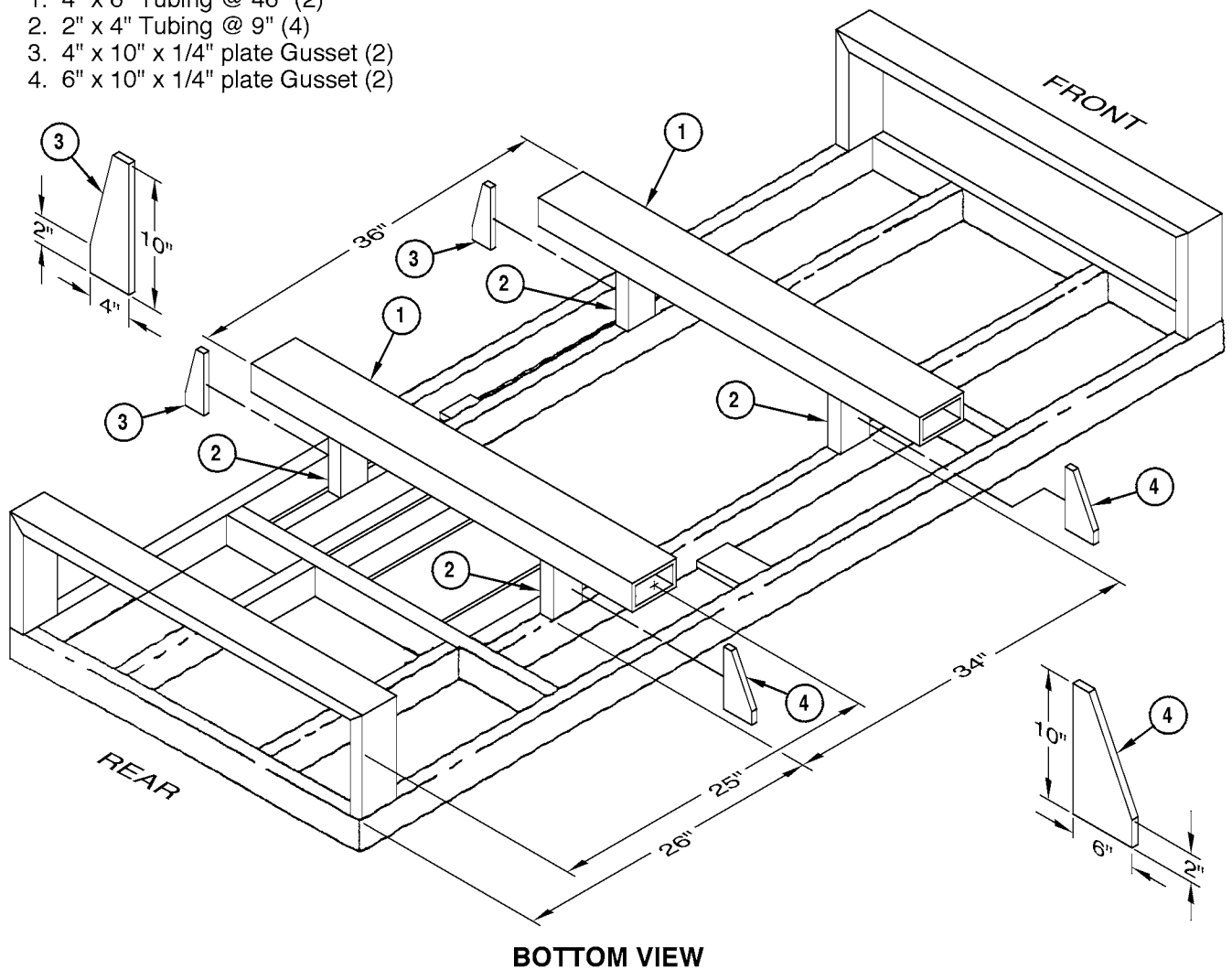

Figure 2-4. Forklift Pockets

11. Cut floor plates (1 through 7) to dimensions shown in Figure 2-5. Tack weld in place as indicated in Figure 2-4. (Items 13 through 17 on Bill of Materials list). Hard weld, if all items are in proper alignment, in accordance with welding specification QQ-A-250.
12. Drill four holes in plate (2) for mounting the 100 amp regulator, using voltage regulator/200 amp regulator face plate (1, Figure 2-12).
13. Test stand base may now be placed on axles and wheels or a skid according to facility requirements.

LEGEND:

1. 12-3/4 x 20-5/8
2. 18" x 20"
3. 12" x 20" (2)
4. 6" x 23"
5. 12" x 20"
6. 18" x 15"
7. 4" x 23" (2)
8. 5-1/4" x 18"

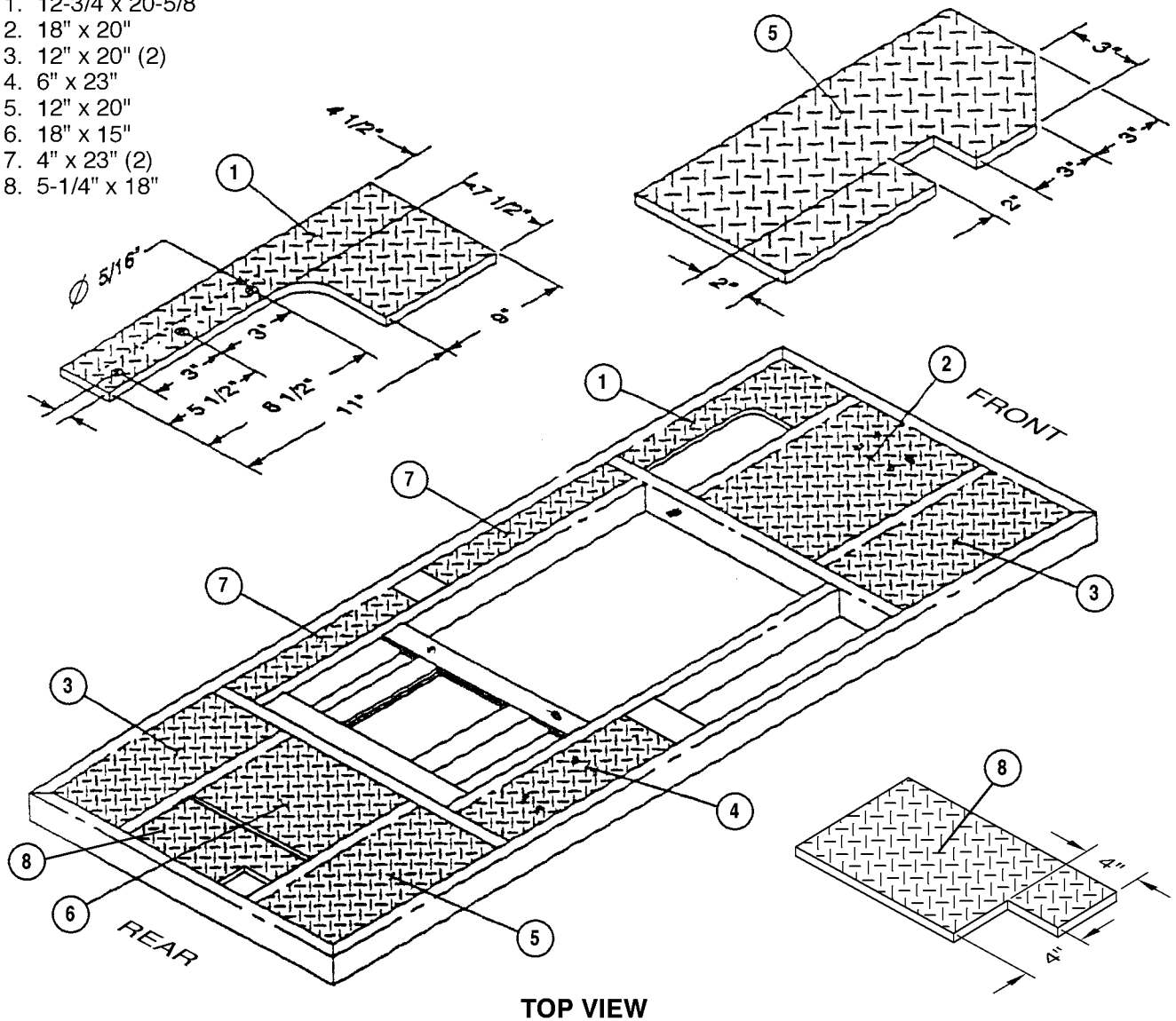

Figure 2-5. Floor Plate Dimensions and Locations

b. Front Engine Mount (Common)

Bill Of Materials				
Item	Nomenclature	Part Number	NSN	Qty
1	4" by 6" by 1/4" Steel Angle 27-1/2 inches (69.9 cm)			1
2	1/4" Tread Plate 4 by 6 inches (10.2 by 15.2 cm)			2
3	2-1/2" by 2-1/2" by 1/4" Steel Angle 1-1/4 inches (3.2 cm)			2
4	3/8" Threaded Rod 1 to 2 inches (2.5 to 5.1 cm)			1
Hardware				
5	Lockwasher	MS35335-63	5310-00-209-0790	1
6	Wingnut	MS35425-74	5310-01-088-2490	1

NOTE

- **You may want to install fuel cell while frame is inverted.**
- **Before you install front engine mount place stand upright in legs.**

1. Locate, cut, and drill five 3/4 by 1-3/4 inch slots in steel angle (1) per Figure 2-6.
2. Locate two tread plate stiffeners (2) left 7 inches from end, right flush with end, on angle per Figure 2-6. Weld stiffeners in place.
3. Locate tread plate stop guides (3) flush on front of mount, 3-1/2 inches from outside edge per Figure 2-6. Weld guides in place.
4. Drill 3/8 inch hole 2 inches from end of mount and 1-1/2 inches from bottom. Place bolt through hole and weld head in place. Put nut and star washer on threaded end. Use for grounding.
5. Install lockwasher (5) and wingnut (6) on threaded rod (4).

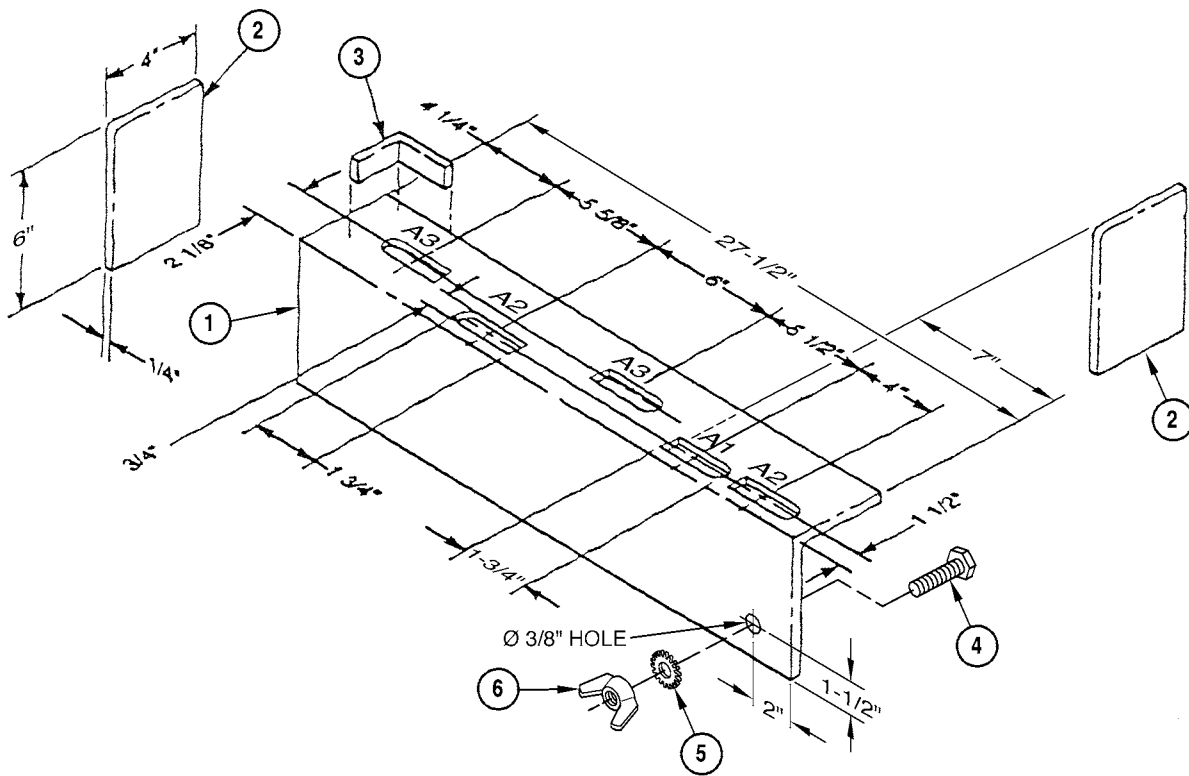

Figure 2-6. Front-Engine Mount Fabrication

c. Transmission Mount (M113A3/M548A3)

Bill Of Materials				
Item	Nomenclature	Part Number	NSN	Qty
1	4" by 3" by 1/4" Steel Angle 27 inches (68.6 cm)			1
2	1/2" Steel Plate 4-1/2 by 5-1/2 inches (11.4 by 14.0 cm)			2
3	1/2" Rubber Pad 3 by 26 inches (7.6 by 66.0 cm)			1

1. Cut steel angle (1) so that it measure 3 inches (7.6 cm) and 4 inches (10.2 cm) per Figure 2-7. The 3-inch length should face forward.
2. Cut two side guides (2) and weld to steel angle (1), cut away external material from two guides (2) inside of steel angle (1).
3. Rubber pad (3) may be layered or a single thickness of 3 inches (7.6 cm).

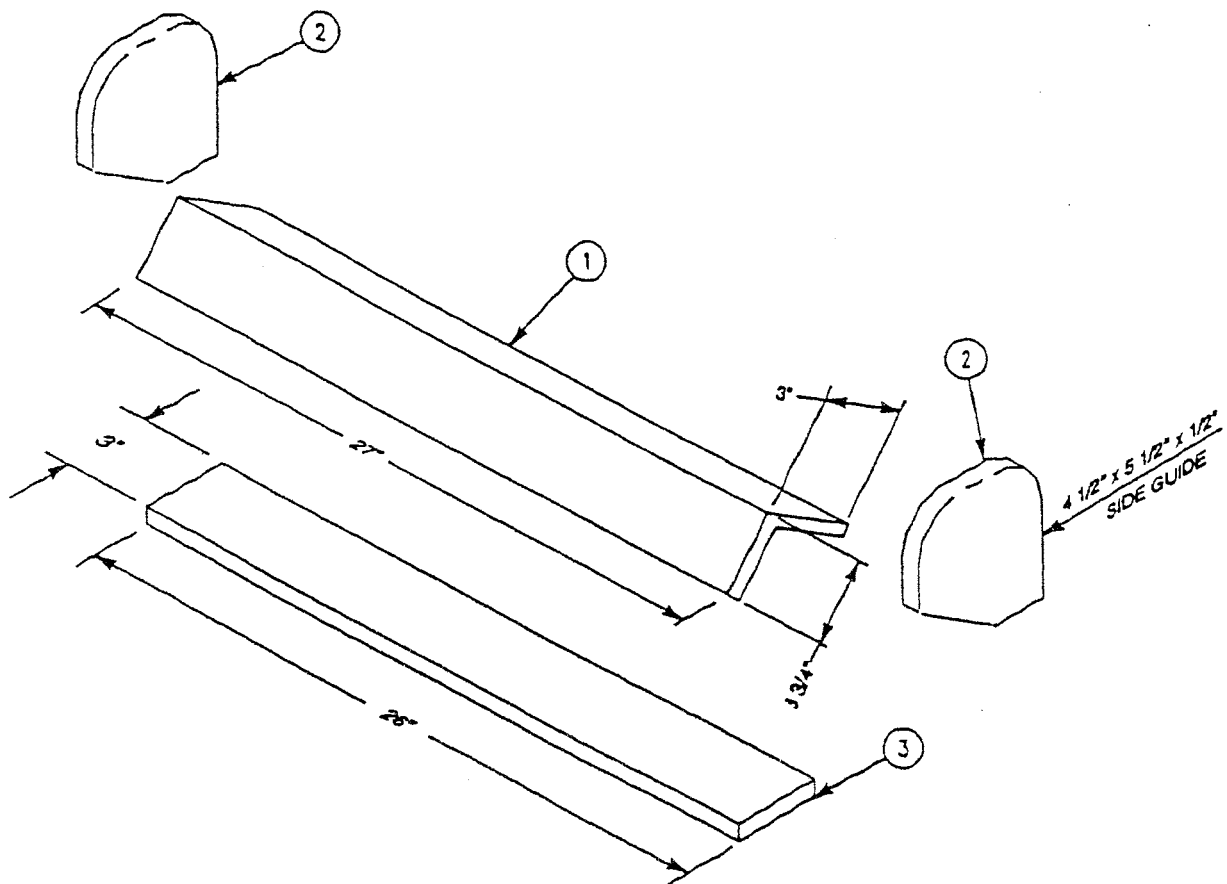

Figure 2-7. Transmission Mount Fabrication—M113A3/M548A3 FOV

d. Transfer Gearcase Mount (M113A2/M548A1)

Bill Of Materials				
Item	Nomenclature	Part Number	NSN	Qty
1	3/8" Steel Plate 4 by 26-3/4 inches (10.2 by 68.0 cm)			1
2	1/4" Steel Plate 3 by 1-1/4 inches (7.6 by 3.2 cm)			1
3	3" by 1-1/4" by 1/4" Steel Channel 6-3/4 inches (17.2 cm)			2
4	4-3/4 inches (12.1 cm)			1
	Hardware			
5	Screw	B1821BH056C550N		2
6	Washer	MS27183-17		2
7	Nut	MS51967-13		2
8	Screw	B1821BH100C600N		1
9	Washer	MS27183-27		1
10	Nut	MS51967-29		1
11	Screw	B1821BH063C300N		1
12	Washer	MS27183-21		1
13	Nut	MS51967-20		1

1. Locate and drill two 1/2-inch (12.7 mm) holes in steel plate (1). See Figure 2-8.
2. Locate and drill a 1/2-inch (12.7 mm) hole in plate (2). Chamfer two corners (3). See Figure 2-8.
3. Locate and drill a 1-inch (2.5 cm) hole in each 6-3/4 inch (17.2 cm) channel (3). See Figure 2-8.
4. Weld plate (2) to steel channel (4). See Figure 2-7. Locate channel (4) and weld to plate (1). See Figure 2-8.
5. Center two steel channels (3) and weld to plate (1). See Figure 2-8.

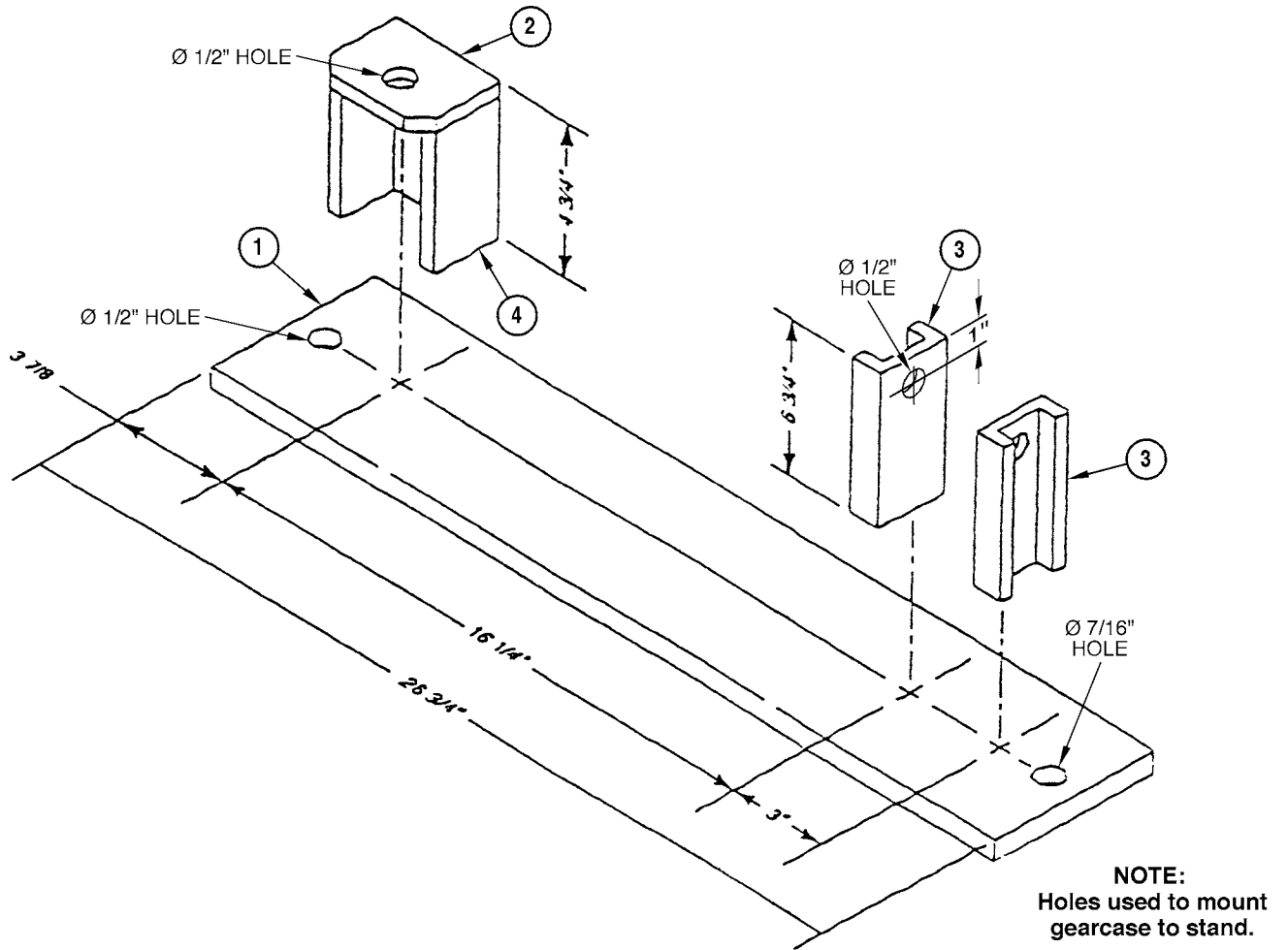

Figure 2-8. Transfer-Gearcase Mount Fabrication—M113A2/M548A1

e. Powerplant Mount Location

Bill Of Materials				
Item	Nomenclature	Part Number	NSN	Qty
1	3" Wide High Density Rubber Pad			
2	Adhesive (or similar)	MMM-A-132	8040-01-102-2098	Kit
	26 inches (66.0 cm)			A/R
	Hardware			
3	Screw	B1821BH750C150N		3
4	Washer	10910174-3		3
5	Nut	MS51922-57		3
6	Screw	B1821BH750C400N		1
7	Screw	B1821BH375C150N		2
8	Washer	10910174-8		3
9	Nut	MS51922-17		3
10	Screw	B1821BH375C550N		2

1. Measure 20 inches (50.8 cm) from front of test stand frame along left and right forward spacers. Measure 2 inches (5.1 cm) to the left of the left spacer and mark the intersection of the 20 inch mark. Align the front edge of the engine mount with the three alignment marks and tack weld to frame. See Figure 2-9.

WARNING

Hanging loads can kill or injure you. Keep away from hanging loads and overhead equipment. Keep hands out of area while powerplant is being lifted or lowered on powerplant test stand.

2. Measure 51 inches (129.5 cm) from centerline of welded front engine mount. Scribe a line across frame at this point. Align transmission mount angle apex with scribed line. Lower a M113A3 powerpack and connect to front engine mount with two screws (3), washers (4), and nuts (5). Continue to lower powerpack and align transmission mount with transmission. Tack weld transmission mount. Remove two screws (3), washers (4), nuts (5) and engine from powerplant test stand. Weld transmission mount onto test stand frame in accordance with welding specification (ANSI/AWSD1.2). See Figure 2-9.
3. Apply adhesive (1) to rubber (2) pad and to surface test stand frame in front of transmission mount. Allow both surfaces to become tacky. Press rubber pad to test stand frame. Repeat process until a thickness of 1 inch (2.5 cm) is established.
4. Install transfer gearcase mount on either a M113A2 or M548A1 powerpack with two screws (6 and 7), washers (4 and 8), and nuts (5 and 9).
5. Position M113A2 or M548A1 powerpack on powerplant test stand and secure to front engine mount with two screws (3), washers (4), and nuts (5).
6. Use gearcase mount as guide, mark holes. Remove powerpack, and drill two 1/2 inch (1.27 cm) holes through powerplant test stand angle using transfer gearcase mount as a guide for holes. (See Figure 2-8).

NOTE

The following dimensions are critical dimensions/measurements. Step 6 above is a better method of aligning the transfer gearcase, but if M113A2 or M548A1 is not available, do the following.

- Measure 56-1/2 inches (143.5 cm) from front of test stand. Measure 9-1/2 inch (24.1 cm) from the left and drill 1/2-inch (12.7 mm) hole through angle. Measure 24-3/4 inches (62.9 cm) to the right of the hole and drill another 1/2-inch (12.7 mm) hole through angle. For M113A2/M548A1 only, align transfer gearcase mount with holes and secure with two screws, washers, and nuts. See Figure 2-9.

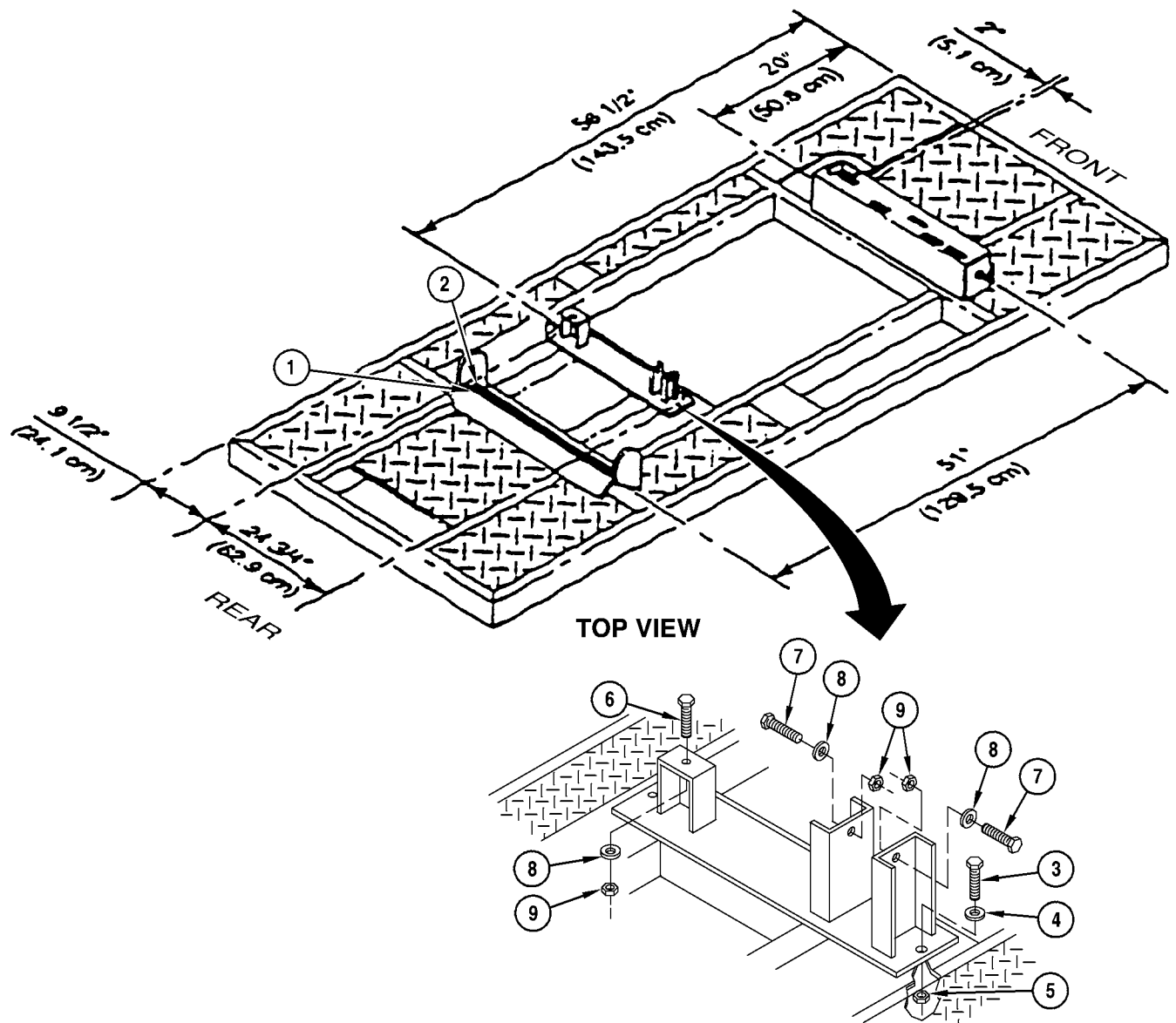

Figure 2-9. Powerplant Mount Location

f. Engine-Only-Rear Mount

Bill Of Materials				
Item	Nomenclature	Part Number	NSN	Qty
1	2" by 3" by 1/4" Steel Tubing 48 inches (121.9 cm)			1
2	1/2" Steel Plate 7-1/2 by 7-1/2 inches (19.1 by 19.1 cm)			2
Hardware				
3	Cap Screw	B1821BH075C375N	5305-00-947-4357	6
4	Washer	MS27183-23	5310-00-809-8533	12
5	Nut	MS51967-23	5310-00-763-8921	6

1. Drill one 3/4-inch hole, 4-1/2 inches from end of steel tubing (1) and 1-1/2 inch from the 3-inch edge (centered). See Figure 2-9.
2. Drill one 3/4-inch hole 3-1/2 inches from the other end of steel tubing (1) and 1-1/2 inch from the 3 inch edge (centered). See Figure 2-9.
3. Cut two 1/2-inch steel plates (2) so that the top is 2 inches and the bottom is 7-1/2 inches. See Figure 2-9.
4. Scribe a line 1-1/4 inches up from the bottom (7-1/2 inches) and another 2-3/8 inches from the side on 1/2-inch steel plate (2). See Figure 2-9.
5. Scribe a line 4-3/4 inches up from the bottom (7-1/2 inches) and another 1-1/4 inches from the side on 1/2-inch steel plate (2). See Figure 2-9.
6. Drill two 3/4-inch holes on 1/2-inch steel plate (2) where scribed lines intersect.
7. Bolt two brackets (1/2-inch steel plate (2)) to engine with four screws (3), washers (4), and nuts (5).

WARNING

Hanging loads can kill or injure you. Keep away from hanging loads and overhead equipment. Keep hands out of area while powerplant is being lifted or lowered on powerplant test stand.

8. Install engine on powerplant test stand with 3-inch side of steel tubing (1) centered under two brackets (2) and across powerplant test stand. Tack weld brackets (2) to 1/4-inch steel tubing (1) and tubing to powerplant test stand. Remove engine from powerplant test stand.
9. Spot weld two brackets (2) to 1/4-inch steel tubing (1). Do not hard weld 1/4-inch steel tubing to powerplant test stand.
10. Scribe location of two 3/4-inch holes on powerplant test stand using two holes drilled through 1/4-inch steel tubing (1) as template.
11. Remove spot weld from powerplant test stand and 1/4-inch steel tubing (1). Remove engine only rear mount from powerplant test stand.
12. Drill two 3/4-inch holes in powerplant test stand.
13. Install engine-only-rear mount on powerplant test stand with two screws (3), washers (4), and nuts (5). Make corrections if necessary. Remove two screws (3), washers (4), nuts (5), and engine-only-rear mount from powerplant test stand.

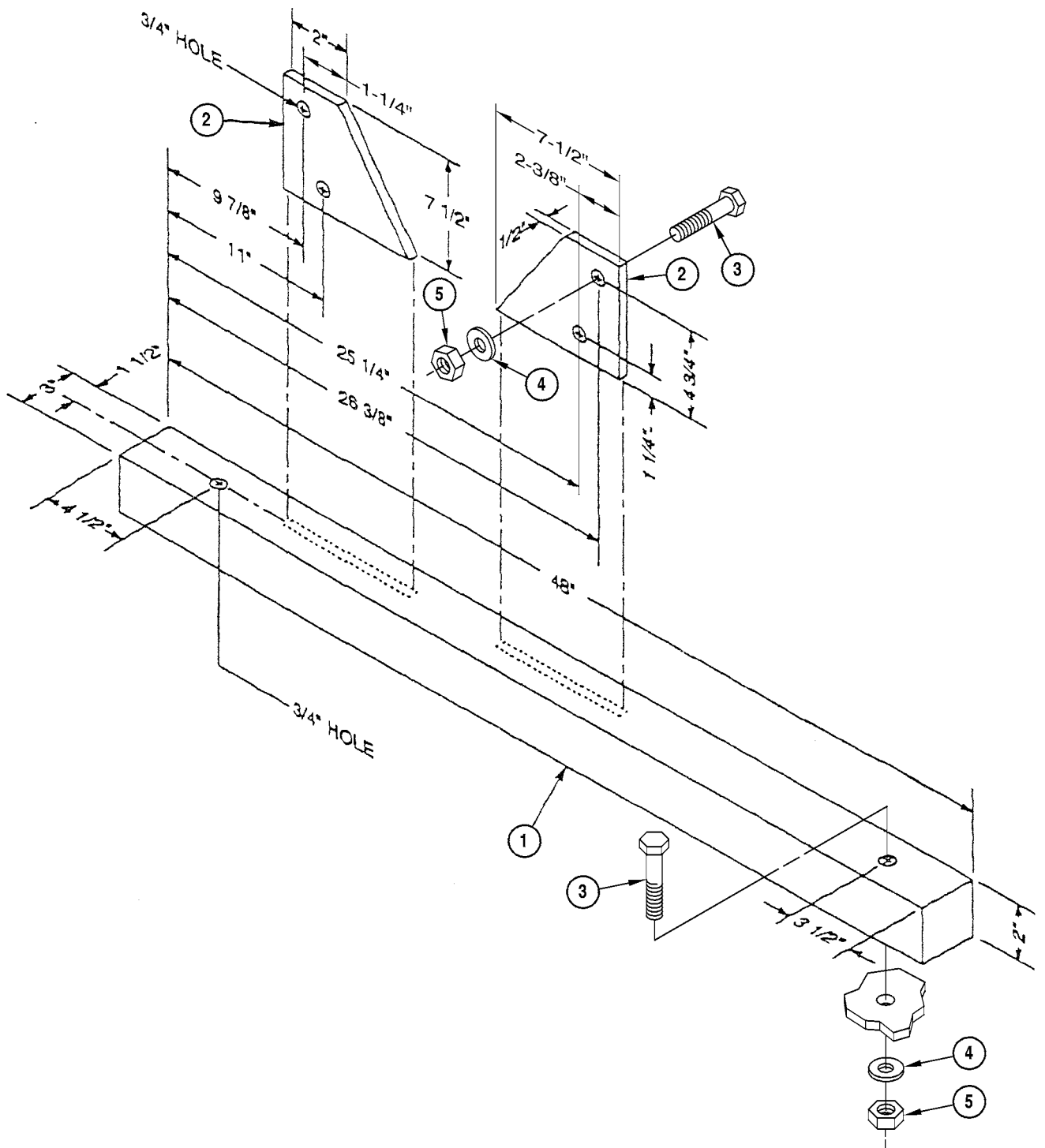

Figure 2-10. Engine-Only-Rear Mount Fabrication

g. Battery Box

Bill Of Materials				
Item	Nomenclature	Part Number	NSN	Qty
1	2" by 2" by 1/4" Steel Angle 48 inches (121.9 cm)			2
2	2" by 3" by 1/4" Steel Angle 11-1/4 inches (28.6 cm)			2
3	2" by 2" by 1/4" Steel Angle 15 inches (38.1 cm)			4

1. Cut two steel angles (1) final length of 48 inches with 45° angle on each end. See Figure 2-11.
2. Cut two steel angles (2) final length of 11-1/4 inches with 45° angle on each end. See Figure 2-11.
3. Weld two steel angles (1) and two steel angles (2) together. See Figure 2-11.
4. On the 3-inch side, scribe a line 7 inches down from the top of steel angle (3) and another 6-7/8 inches from the 7-inch line.
5. Scribe two lines 5/8 inch on the 3-inch side from each side of steel angle (3).
6. Drill four 9/32-inch holes where the scribed lines intersect, to mount the STE/ICE shunt. See Figure 2-11.
7. Scribe a line 9-1/4 inches down from the top of steel angle (3) and another 2-53/64 inches down from 9-1/4 inch line. See Figure 2-11.
8. Scribe a line 7/8 inch from edge of steel angle (3). See Figure 2-11.
9. Drill two 7/16-inch holes where the scribed lines intersect, to mount bus bar. See Figure 2-11.
10. Weld four steel angles (3) 12 inches from ends of two steel angles (1) on center tubing. See Figure 2-11.
11. Position and weld four steel angles (3) on the rear cross horizontal tubing, and the other on rear perpendicular tubing. See Figure 2-11.

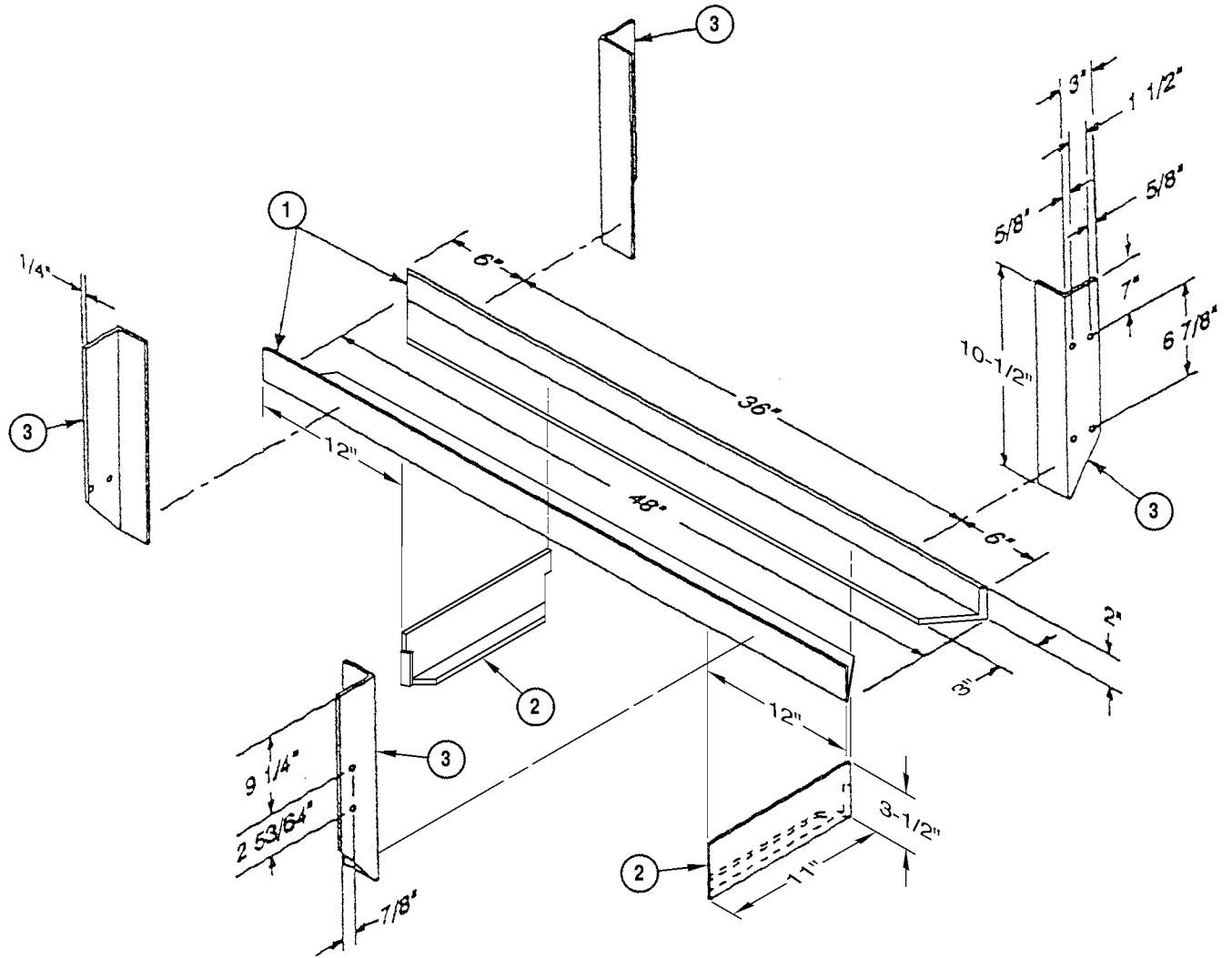

Figure 2-11. Battery Box Fabrication

h. Regulator Mount/Bracket

Bill Of Materials				
Item	Nomenclature	Part Number	NSN	Qty
	1/8" Steel Plate			
1	5 by 7-1/2 inches (12.7 by 19.1 cm)			1
2	2 by 7-1/2 inches (5.1 by 19.1 cm)			1

1. Cut 1/8-inch steel plate 5 inches by 7-1/2 inches (1) and 2 inches by 7-1/2 inches (2). See Figure 2-12.
2. Measure 3/4 inch from each side and end of 1/8-inch steel plate (1) and scribe a line.
3. Drill four 5/32-inch holes where scribed lines intersect.

NOTE

Face plate (1) with holes drilled can be used as template to locate and drill 100 amp regulator mounting holes on plate (2, Figure 2-5).

4. Cut 1/8-inch steel plate (2) as shown in Figure 2-12 so that one side measures 3 inches.
5. Assemble face plate (1) and bottom plate (2) and weld assembly.
6. Weld 3-inch side of bottom steel plate (2) to powerplant test stand left rear support.

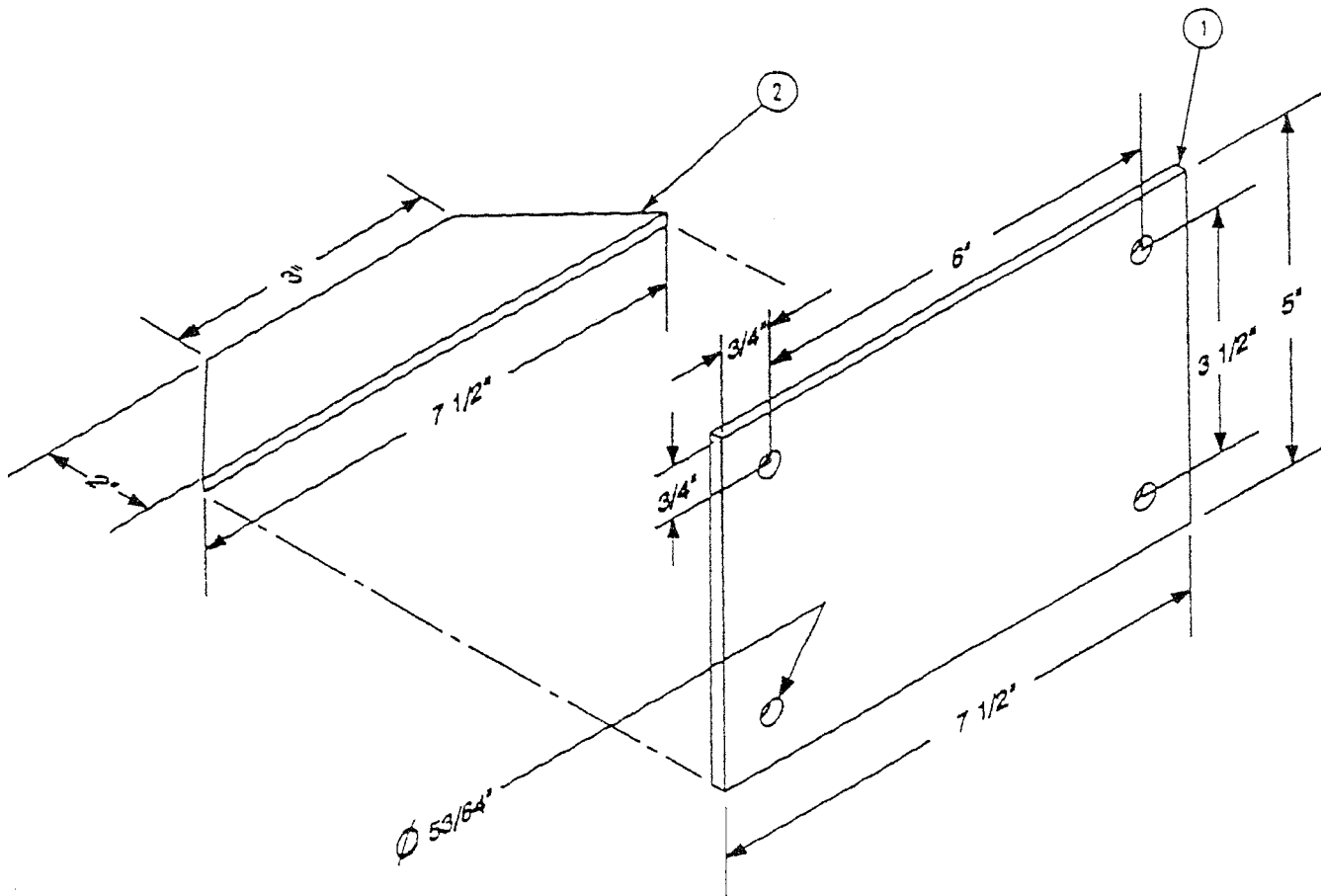

Figure 2-12. 100/200-Amp Regulator Mounting Hole Template

i. Instrument Panel Support

Bill Of Materials				
Item	Nomenclature	Part Number	NSN	Qty
1	1" by 1" by 1/4" Steel Angle 15 inches (38.1 cm)			1
2	1" by 2" by 1/4" Steel Angle 1 inch (2.540 cm)			1
3	1/4" Steel Plate 1 by 3/4 inch (2.540 by 1.905 cm)			2
4	1/4" Rubber Bumper 3/4 by 3/4 inch (1.905 by 1.905 cm)			1
	Hardware/Components			
5	Washer	MS27183-6		1
6	Quick Release Pin	MS17984-C705		1
7	1/8" Aluminum Plate 11-7/8 by 14-7/8 inch (30.2 by 37.8 cm)			1

NOTE

Dimension/measurements are not critical. The support is just a brace to support the instrument panel in the raised position.

1. Create hinge points and weld on left rear side 1/2" from rear, 1/2" from left side. Hinge is 2" wide and 2" high drilled with 3/8" hole centered 9/16" from top.
2. Fabricate 11-7/8" by 14-7/8" aluminum plate. Drill 3/4" hole 6-3/4" from top, 5" from right side. Mount rubber grommet in hole.
3. See Figure 2-13b for instructions on drilling holes so that wiring can be mounted in back.
4. Fabricate support rod to securely hold instrument panel upright. Exact fabrication can vary as long as the panel is secure.

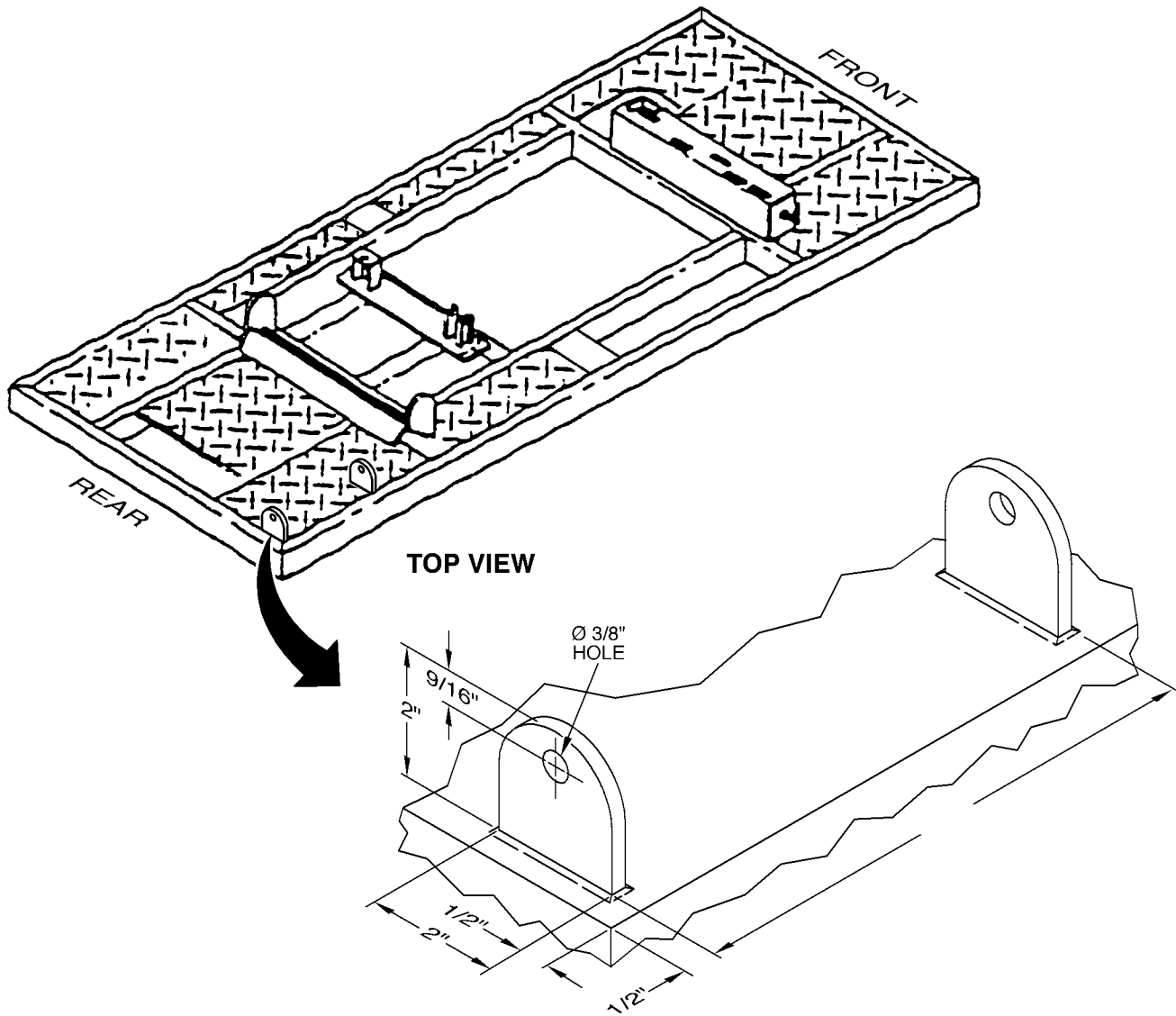

Figure 2-13a. Instrument Panel Hinge Points

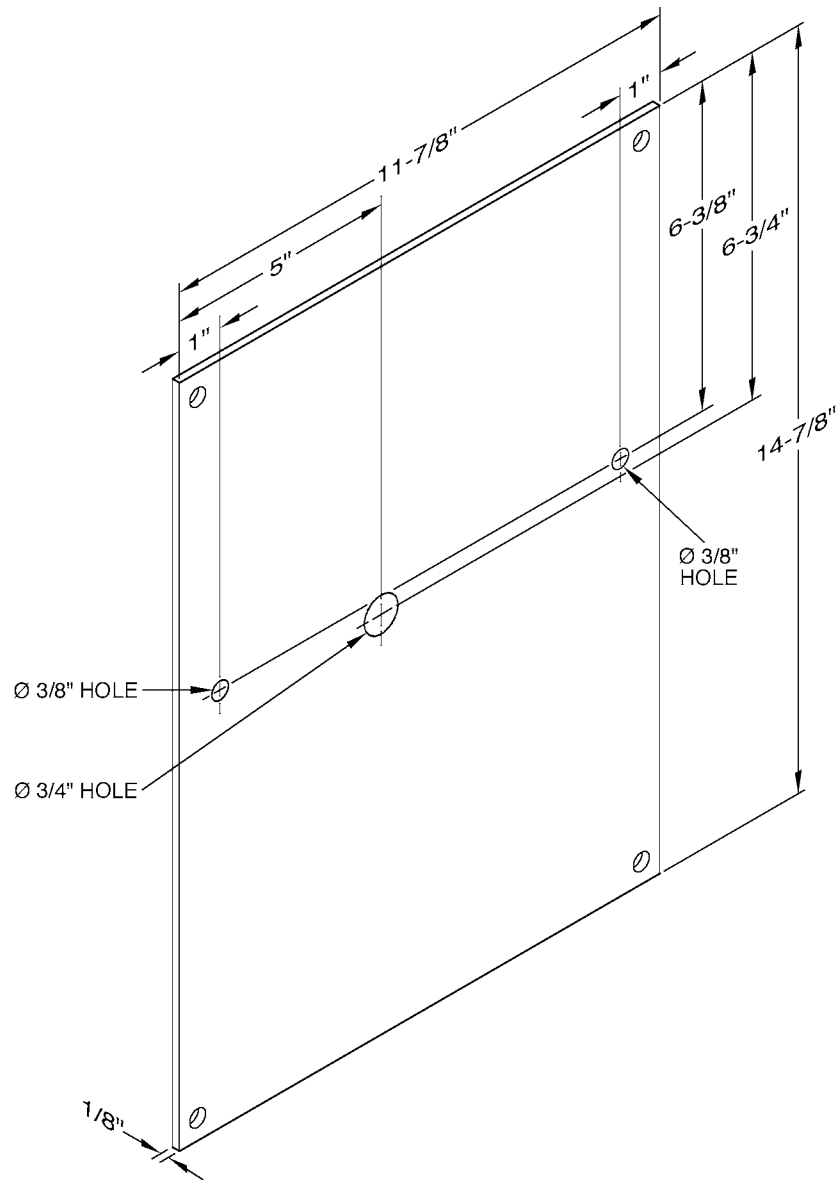

Figure 2-13b. Instrument Panel Support

5. Weld 1/8-inch aluminum plate to powerplant frame. See Figure 2-13b. This is where the instrument panel support will pivot.

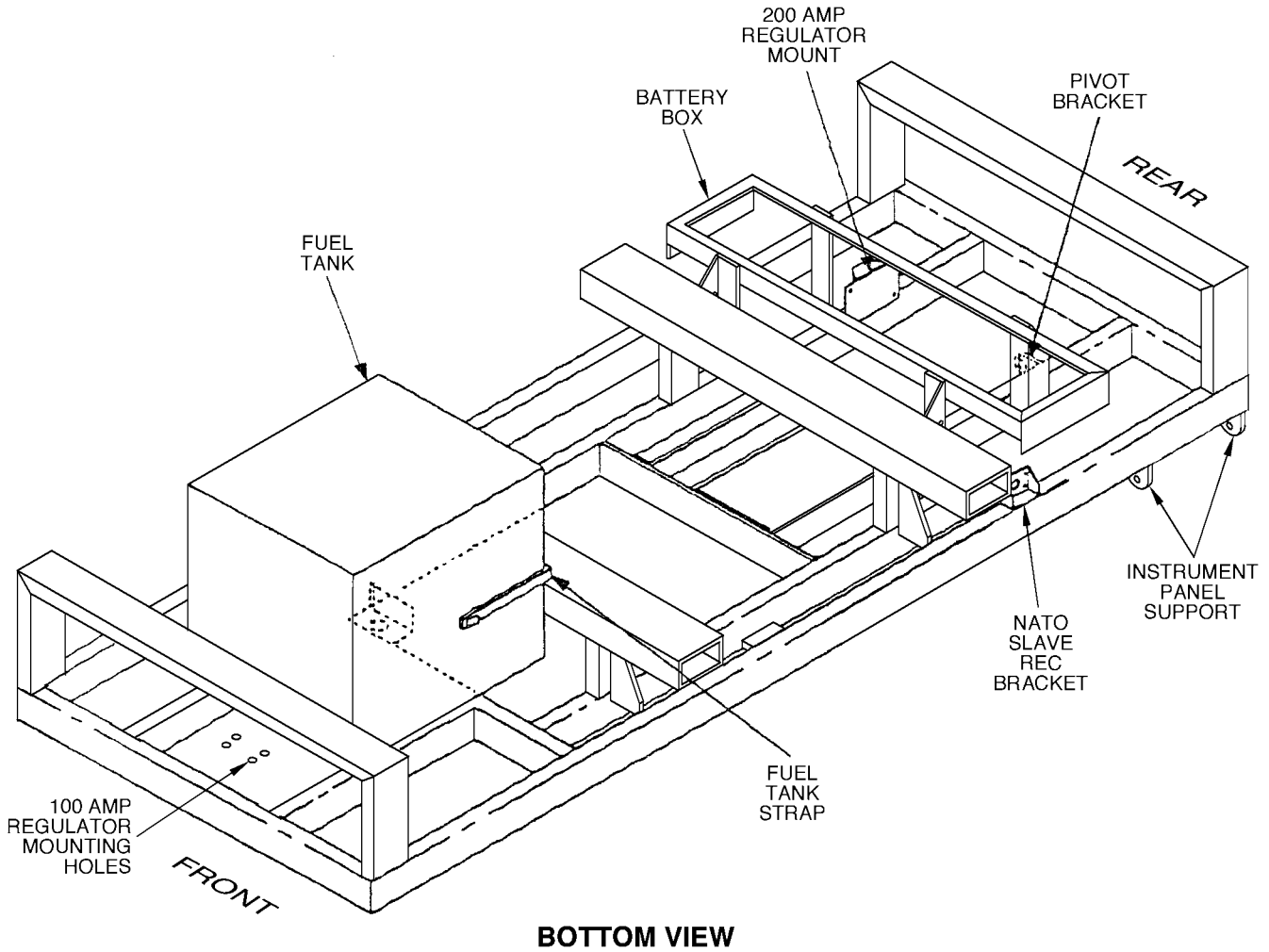

Figure 2-14. Powerplant Test Stand—Bottom View

SECTION III. FUEL SYSTEM

2-3. FUEL SYSTEM.

a. Fuel Tank

The fuel tank and components can be fabricated from stock or purchased locally. It can be metal or fiberglass composition. It should hold at least 10 gallons of fuel. Any similar fuel tank may be used as long as it can be mounted in the area below the forward framework. A fabricated tank and system can be used, however, local stores sell complete fiberglass or aluminum fuel tanks that will work as well and will save time and material.

b. Fuel Tank Supports

Fuel tank supports shall be fabricated to hold the fabricated or purchased tank securely to the frame. There should be at least one fuel tank strap. The stand will be moved by forklift and the fuel tank must be secure during transport.

c. Fuel Line Adapter

Bill Of Materials				
Item	Nomenclature	Part Number	NSN	Qty
	Hardware/Components			
1	Coupling Half, Quick Disconnect	10942651	4720-00-999-2384	2
2	Washer, Flat	8906-055	4720-00-122-4962	1
3	Pipe, Bushing	WW-P-471-BDQBDC	4730-00-903-7204	1
4	Coupling Half, Quick Disconnect	8906-061		1
5	Coupling Half, Quick Disconnect	12297003-1	4730-01-149-4010	1

1. Assemble hose assembly (1) and coupling half (2). See Figure 2-15.
2. Assemble hose assembly (3), pipe bushing (4), and coupling half (5). See Figure 2-15.

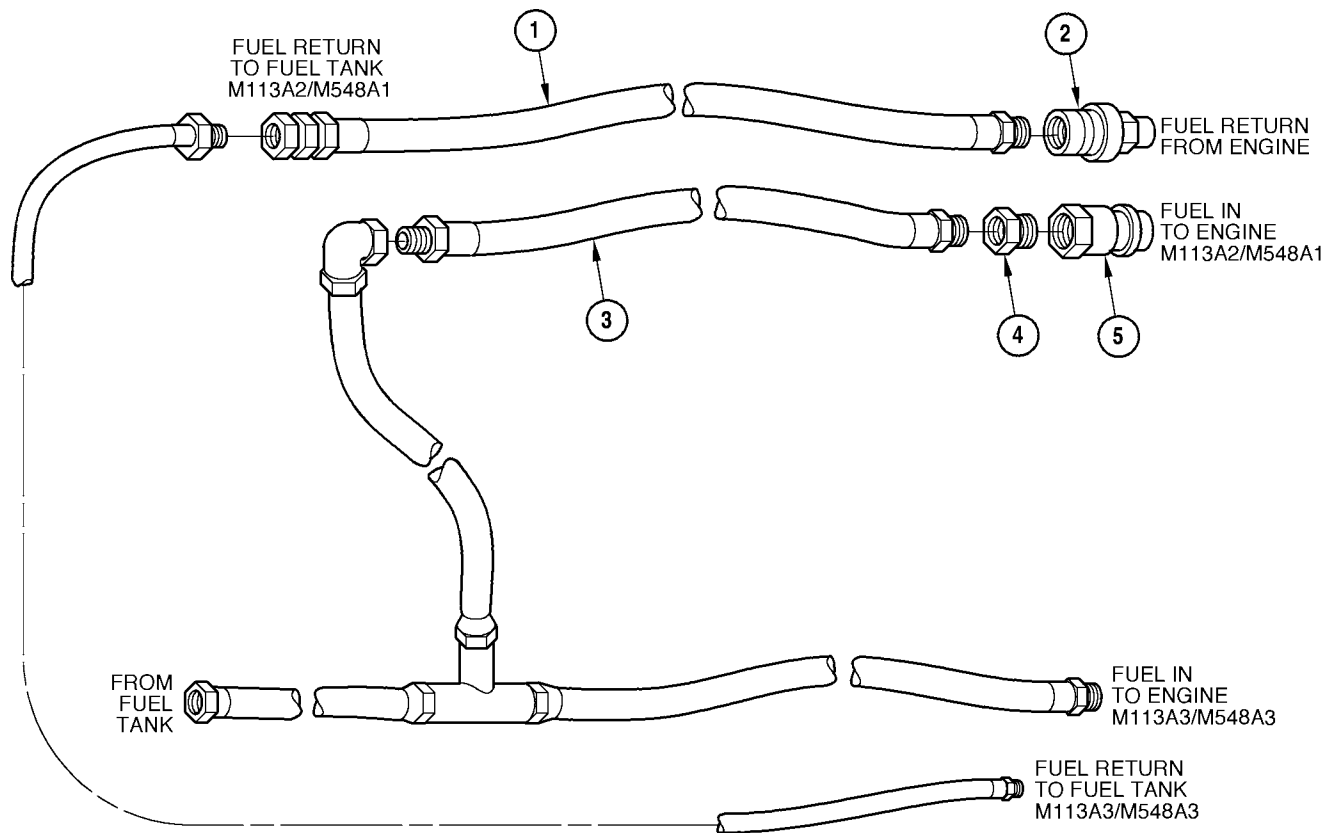

Figure 2-15. Fuel Line Adapter

SECTION IV. COOLING SYSTEM

2-4. COOLING SYSTEM. The radiator can be purchased or acquired from stores. The radiator can be salvaged from local can point or from DRMO. The recommended radiator is one taken from a 2-1/2 or 5-ton truck. Any radiator will work if the radiator is mounted higher than the engine. Straight radiator hose with fabricated elbows, and clamps for upper and lower connections will ease installation and removal. To prevent any airlocks, the radiator must be mounted six inches above the top of engine. If weather is above 32°, antifreeze is not necessary. A 12-volt fan, the type used on most newer cars or trucks, may be used to cool the radiator. Power for 12-volt fan can be obtained through a manual switch connected to one 12-volt battery. Make hose assembly for bleeding air from engine cooling system when running. Any large capacity radiator, tubes, and hoses may be utilized to cool the powerplant being tested.

NOTE

The following are fabricating instructions for the radiator. These instructions are recommended but are not mandatory. Any support that holds the radiator securely 6 inches above the engine is satisfactory.

a. Radiator, Bracket, Support, and Hardware

Bill Of Materials				
Item	Nomenclature	Part Number	NSN	Qty
1	3/4" by 3/4" by 1/4" 30 inches (76.2 cm)			2
2	3 inches (7.62 cm)			2
	2" by 2" by 1/4"			
3	18 inch (45.72 cm)			1
4	3 inches (5.08 cm)			2
	Hardware			
5	Radiator	2 1/2 or 5 ton truck		1
6	Radiator elbow	12253525	4730-01-060-9526	1
7	Gasket	10932933	5330-00-058-9263	2
8	Clamp	MS35842-14	4730-00-908-6792	4
9	Hose	11662995	4720-00-177-0671	A/R
10	Hose	11662999	4720-00-150-5970	A/R
11	Tee, pipe	2090-4-4S	4730-01-048-9769	1
12	Clamp	B54-32780	4730-00-908-3195	4
13	Drain cock	MS35783-2	4820-00-845-1096	1
14	Straight adapter	4738-4-6B	4730-00-088-7242	2
15	Plug, elbow flange	2028-16S		1

1. Cut two 1- by 1/4-inch flat bar (1), adjust length to height of radiator. Bend top and bottom of bar to fit against the top of radiator and floor of stand. See Figure 2-16.
2. Cut 3- by 2-inch by 1/4-inch steel angle 20-1/2 inches long (3) with 45° angle. See Figure 2-16.
3. Cut 2- by 2-inch by 1/4-inch steel angle 10 inches long (4) with 45° angle.
4. Measure studs on radiator of your choice. Use these dimensions to drill two holes in steel angle (3).
5. Weld two steel angles (4) to steel angle (3).
6. Weld radiator bracket/support to powerplant test stand frame on front.

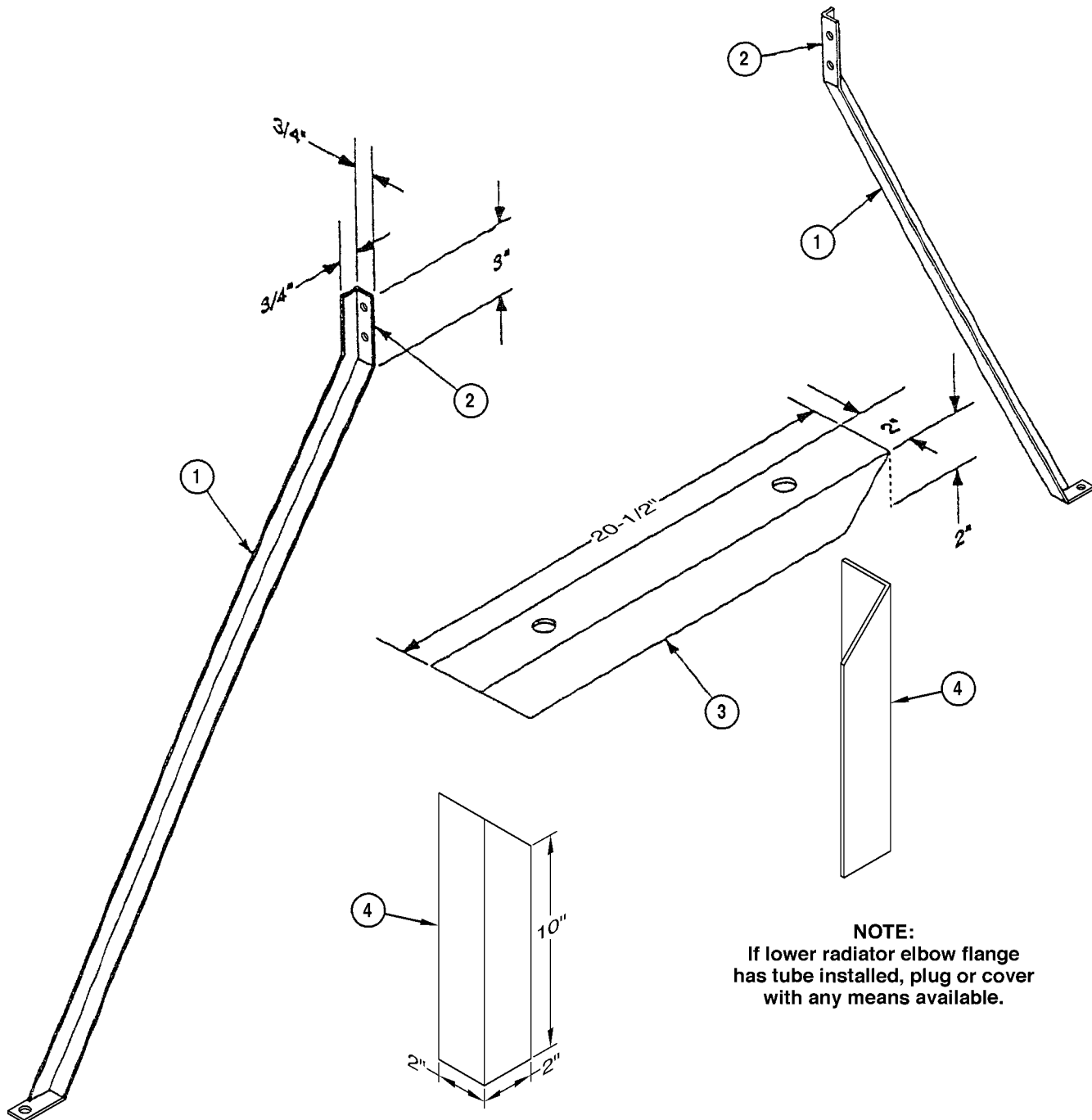

Figure 2-16. Radiator Bracket/Support

7. Cut length of hose (10), with arc at the middle, long enough to reach from deaeration elbow to thermostat housing. See Figure 2-17.
8. Position and cut hose (10) at highest point of arc and install pipe tee (11), two straight adapters (14), and two clamps (12) between cut hose (10). See Figure 2-17.
9. Install drain cock (13) in pipe tee (11). See Figure 2-17.
10. Install assembled air bleed valve (13) on adapter of deaeration with clamp (12).
11. Install other end of air bleed valve (13) on thermostat housing adapter with clamp (12).
12. M113A2 or M548A1 only. If lower radiator elbow flange has tube/adaptor installed, plug or cover opening by any means available. If it does not have a tube/adaptor, use plug (15).

NOTE

If lower radiator elbow flange on engine has tube/adaptor installed, plug or cover opening by any means available, e.g. tinfoil and clamp.

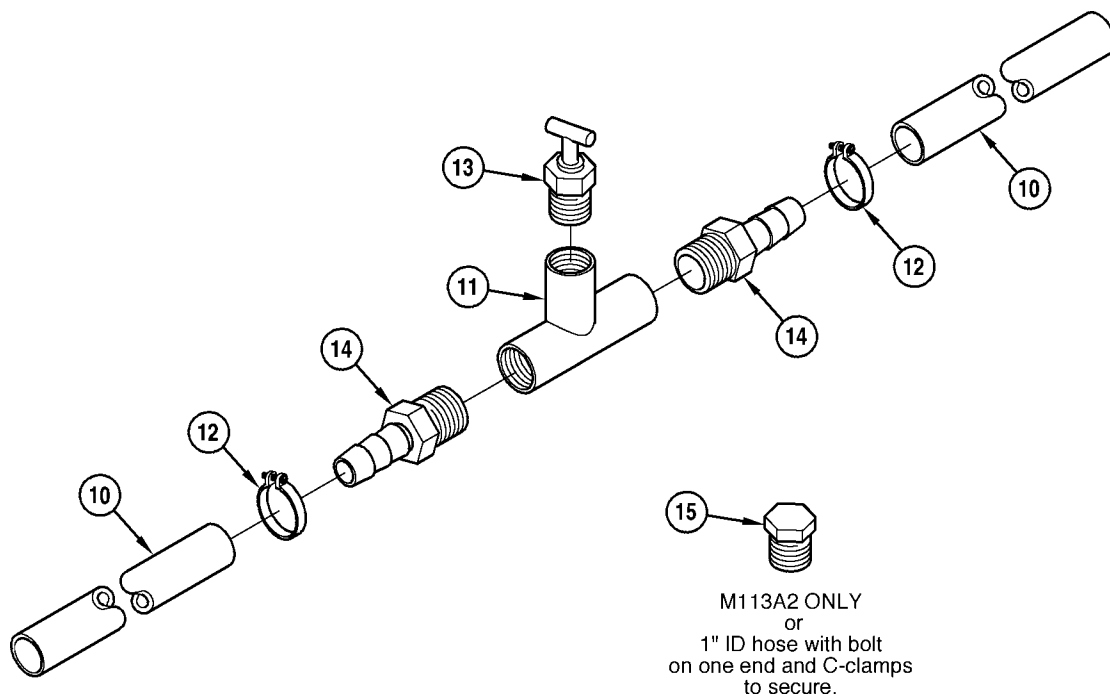

Figure 2-17. Air Bleed Valve

SECTION V. ELECTRICAL SYSTEM

2-5. ELECTRICAL SYSTEM. The electrical system is a 24-volt system using four 6 TL batteries arranged in parallel series. The master switch is installed in the negative return. Four circuit breakers are used to isolate problems to a particular circuit, reducing troubleshooting time. An electrical transmission controller selects all of the ranges in the M113A3 transmission. Both 100-amp and 200-amp generator regulators are provided so that any 6V53 engine may be operated and tested without being damaged. A connector panel is provided for connecting the 100-amp generator system. An instrument panel is also provided. See Section VI for instrument panel.

a. 100-Amp Connector Panel

Bill Of Materials				
Item	Nomenclature	Part Number	NSN	Qty
1	1/8" Aluminum Plate 9 by 4-1/4 inches (22.86 by 10.795 cm)			1

1. Drill two 1-3/8-inch connector holes and eight 5/16-inch screw holes per Figure 2-18.
2. Drill 1-3/4-inch connector hole and four 5/16-inch screw holes per Figure 2-18.
3. Scribe identification information on panel or make labels per Figure 2-18.
4. Drill three 5/16-inch mounting holes spaced three inches apart. See Figure 2-18.

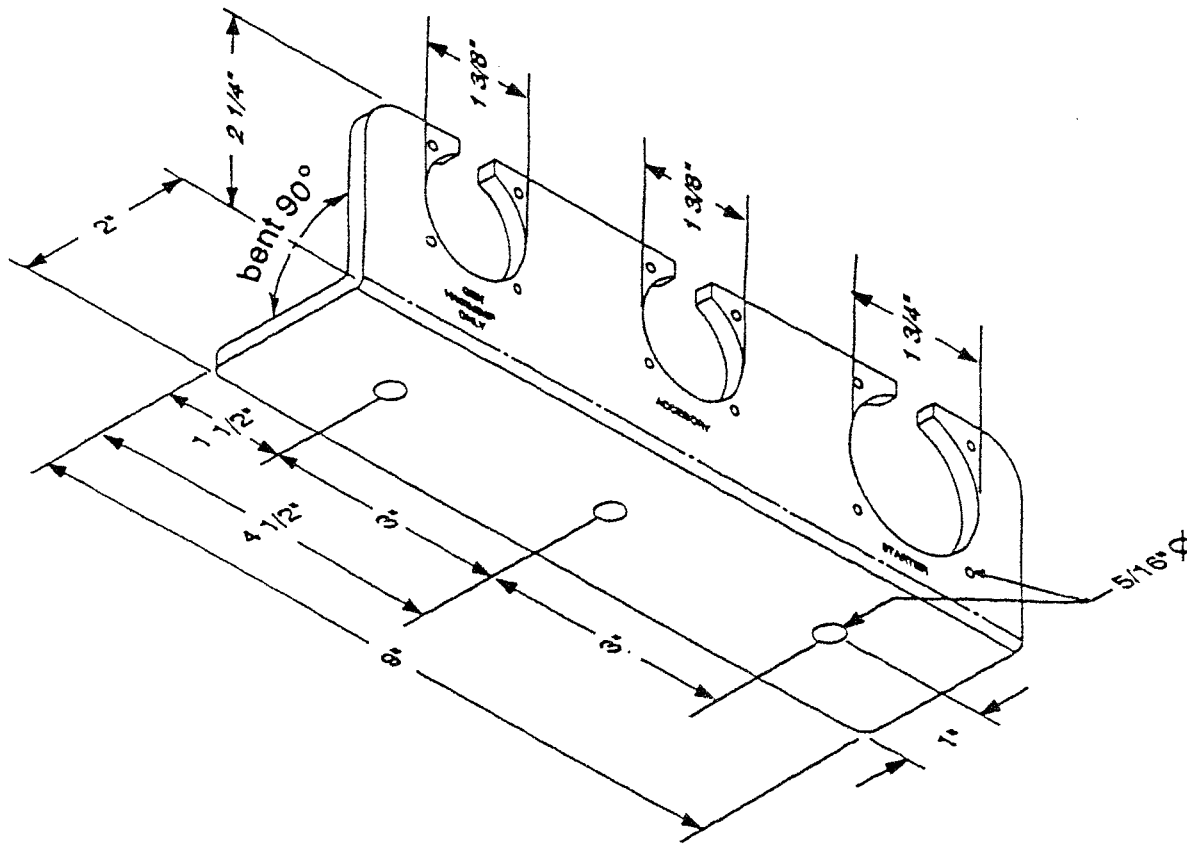

Figure 2-18. 100-Amp Connector Panel

NOTE

An M113A3 shift controller (NSN 3010-01-331-2675 or NSN 3010-01-245-2442) can be attached to the instrument panel and used in lieu of fabricating the controller pictured in Figure 2-19. However, use the schematic to troubleshoot the system.

b. Transmission Controller

Bill Of Materials				
Item	Nomenclature	Part Number	NSN	Qty
	CRL Components Inc. Parts			
1	Detent Switch	71590 P-272	5930-00-548-6782	1
2	Switch Section, Rotary	71590 JD	5930-00-817-3738	7
3	Solder			A/R
4	Wire, 16 AWG			A/R
5	Wire insulator			A/R

1. Assemble seven rotary switch section (2) starting with 364/A. Put the remaining six in numerical/alphabetical order. See Figure 2-19.

NOTE

Make sure leads are not touching unused connectors.

2. Solder a lead long enough to reach circuit breaker number 1 and connect all pins seven connectors together. See Figure 2-19.
3. Solder a lead on the first rotary switch section (2), connecting pins 12, 1, 2, 3, and long enough to reach the connector on the side of panel. Label this lead, A.
4. Solder a lead on the second rotary switch section (2), connecting pins 4, 5, 6, and long enough to reach the connector on the side of panel. Label this lead, B.
5. Solder a lead on the third rotary switch section (2), connecting pins 12, 1, 2, 3, 5, and long enough to reach the connector on the side of panel. Label this lead, C. Insulate lead from pin 4.
6. Solder a lead on the fourth rotary switch section (2), connecting pins 4, 6, and long enough to reach the connector on the side of panel. Label this lead D. Insulate lead from pin 5.
7. Solder a lead on the fifth rotary switch section (2), connecting pins 12, 1, 2, 4, 5, 6, and long enough to reach the connector on the side of panel. Label this lead, E. Insulate lead from pin 3.
8. Solder a lead on the sixth rotary switch section (2), connecting pin 2 and long enough to reach the connector on the side of panel. Label this lead, F.
9. Solder a lead on the seventh rotary switch section (2), connecting pins 1, 2, and long enough to reach the connector on the side of panel. Label this lead, G-N.
10. Test transmission controller after all connections have been made using multimeter. See table in Figure 2-19.

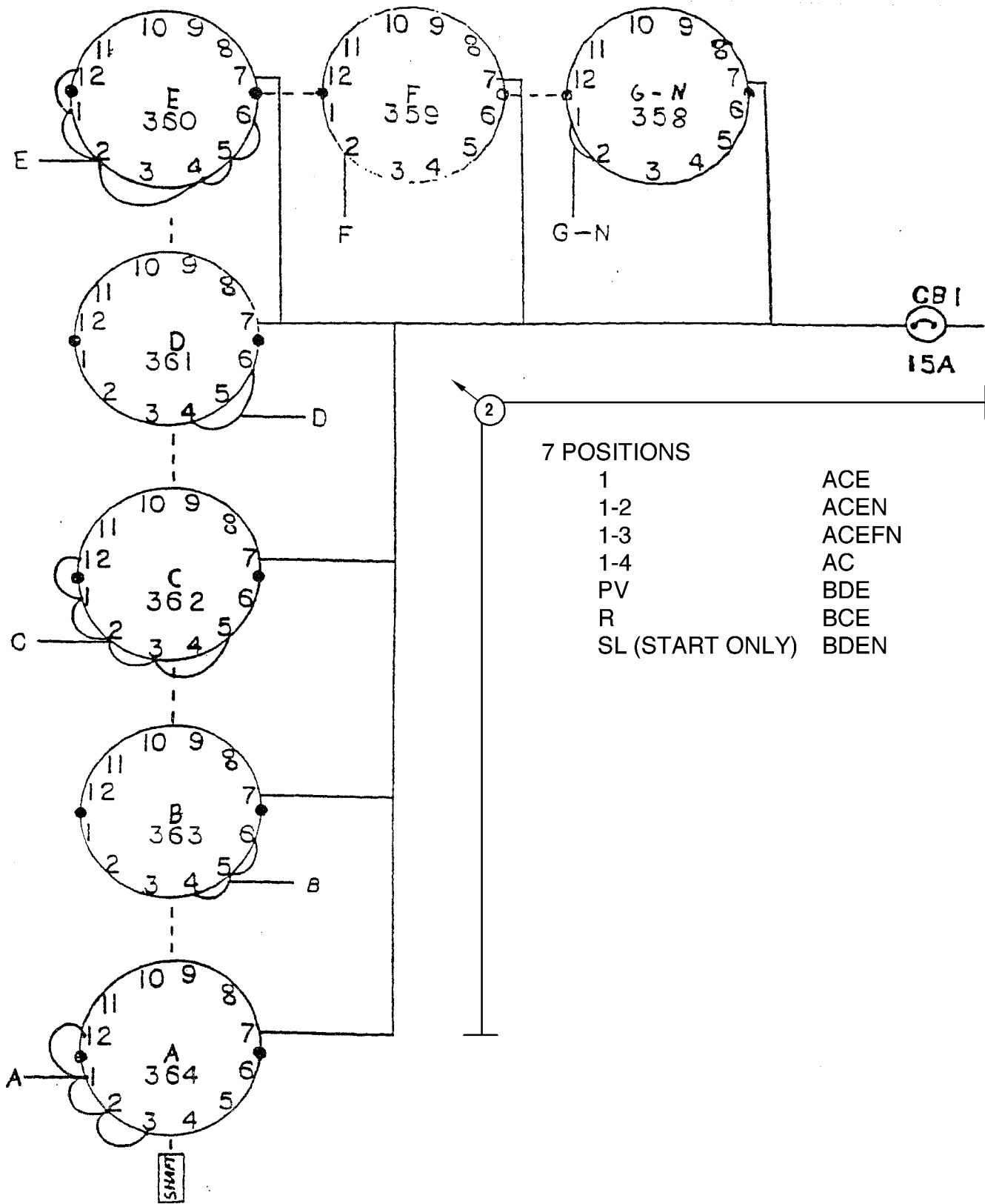

Figure 2-19. Transmission Controller

c. Accessory Cable

Bill Of Materials				
Item	Nomenclature	Part Number	NSN	Qty
	M113A3 Hardware			
1	Receptacle	7388359	5935-00-178-6075	1
2	Grommet	7388366	5365-00-507-8766	1
3	Grommet Nut	7723309	5310-00-393-6685	1
4	Electrical Wire	M13486/1-5	6145-00-152-6499	A/R
5	Electrical Insulation Tape	07099 - MS70T09-S	5970-00-955-9956	A/R
	Electrical Insulation Sleeving	78286-S6132-61003-9	5970-00-004-4056	A/R
6	Band Marker	M43436/1-1	9905-00-752-4649	23
	M113A2/M548A1 Hardware			
7	Receptacle/Connector	7722354	5935-00-772-2354	1
8	Bushing	7722322	5365-00-772-2322	1
9	Bushing Nut	7723308	5935-00-333-9414	1
10	Electrical Wire	M13486/1-5	6145-00-152-6499	1
11	Electrical Insulation Tape	07099 - MS70T09-S	5970-00-955-9976	A/R
12	Band Marker	M43436/1-1	9905-00-752-4649	23
	COMMON to M113A3/M113A2/M548A1			
13	Electrical Plug Connector	MS27145-1	5935-00-767-7936	2
14	Electrical Connector Shell	8338561	5935-00-833-8561	1
15	Insulation Bushing	8338562	5935-00-833-8562	7
16	Terminal Assembly	8338564	5940-00-399-6676	7
17	Electrical Connector Shell	7982401	5935-00-399-6673	1
18	Terminal	MS25036-109	5940-00-283-5281	1
19	Terminal	MS25036-153	5940-00-143-4774	3
	M548A3 Hardware			
20	Connector	7722354		1
21	Bushing	7722322		1
22	Nut	7723308		1
23	Electrical Wire	M13486/1-5	6145-00-152-6499	1
24	Connector	872455		1
25	Bushing	7388366		1
26	Nut	7716634		1
27	Electrical Insulation Tape	07099 - MS70T09-S	5970-00-955-9956	A/R
	Electrical Insulation Sleeving	78286-S6132-61003-9	5970-00-004-4056	A/R

1. Measure from the M113A2 panel/bracket (Figure 2-18) to instrument panel/box (Figure 2-26).

NOTE

See Figure 2-20 for accessory cable art.

2. Connect seven AWG 14 electrical leads (4), two or three inches longer than measurement in step 1, to receptacle (7).
3. Label leads (4) from pin B, 1B; pin C, 406; pin D, 34; pin E, 33; pin F, 1A; pin G, 327; and pin H, 74A.

4. Measure from the M113A3 engine cable to instrument panel/box components.
5. Connect seven AWG 14 electrical leads (4), two or three inches longer than measurement in step 4, to receptacle (1).
6. Label leads (4) from pin B, 1B (14); pin C, 406 (11); pin D, 34 (10); pin E, 33 (14); pin F, 1C (16); pin G, 327 (10); and pin H, 74 (15).
7. Splice six leads from M113A2 receptacle (7) to six common leads from M113A3 receptacle (1).
8. Install electrical insulation tape/sleeving (5) on all leads except 2 circuit leads 1B.
9. Add terminals and connectors to ends of circuit leads.

NOTE

Steps 10 through 14 are only for fabricating an adapter to connect the M113A3 accessory cable to the M548A3 powerplant.

10. Cut six AWG 14 electrical leads 18 inches long.
11. Connect six AWG 14 electrical leads to pins C, D, E, F, G, and H of connectors, bushings, and nuts.
12. Label leads from pin C, 406; pin D, 34; pin E, 33; pin F, 1C; pin G, 327; and pin H, 74.
13. Install electrical insulation tape/sleeving on all leads.
14. Label this harness adapter, M548A3 only.

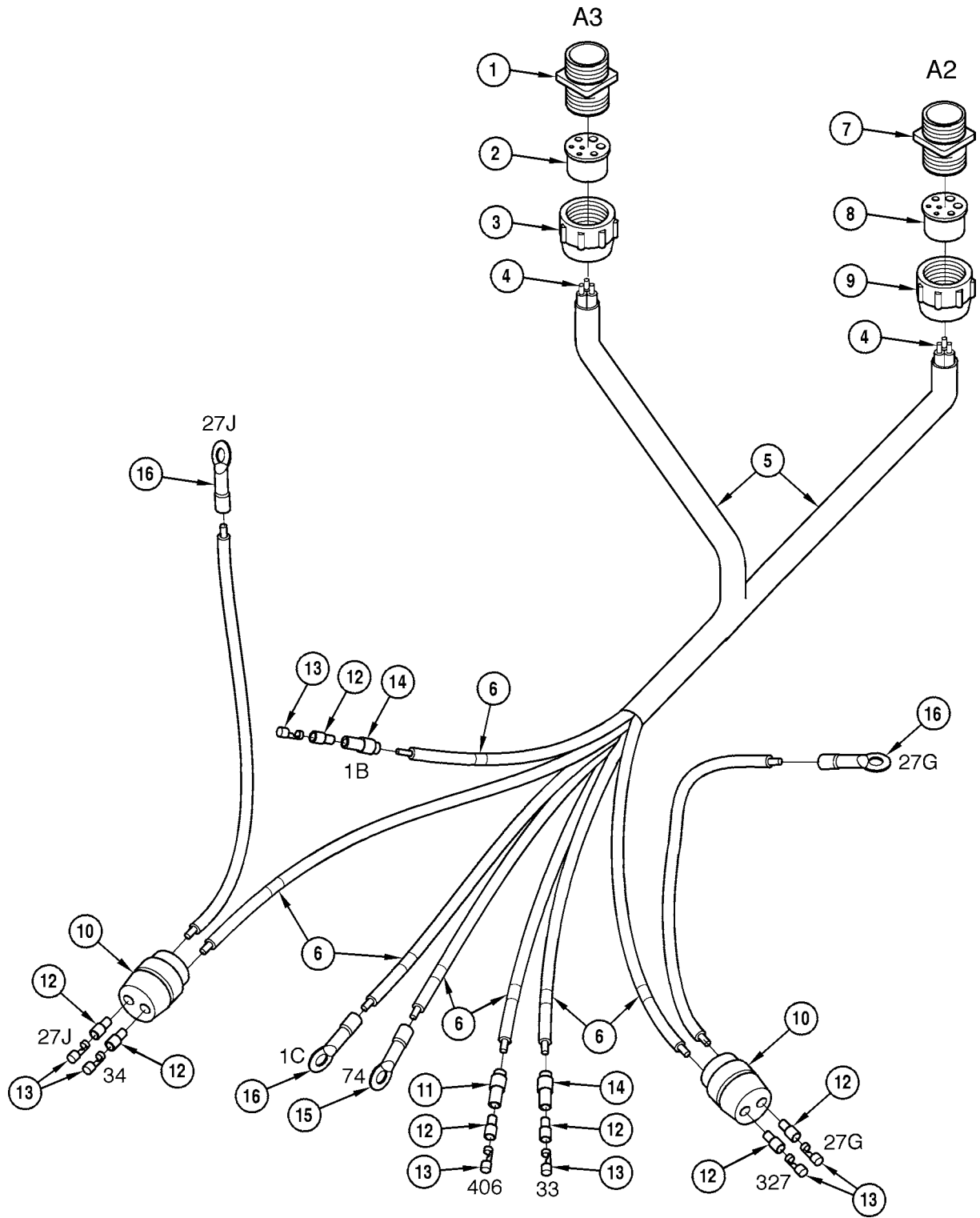

Figure 2-20. Accessory Cable (M113A2/M113A3/M548A1 Only)

d. Regulator Cable (Three Leads)

Bill Of Materials				
Item	Nomenclature	Part Number	NSN	Qty
1	Shell Assembly	8724262	5935-00-730-7325	1
2	Nut	7716634-1	5975-01-151-7033	1
3	Grommet	10874855	5935-00-784-1701	1
4	Nut	7723309	5310-01-248-3077	1
5	Electrical Wire	M13486/1-5	6145-00-152-6499	A/R
			or	
			6150-01-032-4556	
6	Band Marker	M43436/1-1	9905-00-752-4649	6
7	Terminal	MS25036-153	5940-00-143-4774	2
8	Electrical Connector Shell	8338566	5935-00-572-9180	1
9	Slotted Washer	8338567	5310-00-833-8567	1
10	Electrical Contact	MS27148-2		1
11	Electrical Insulation Tape	07099 - MS70T09-S	5970-00-955-9956	A/R
	Electrical Insulation Sleeving	78286-S6132-61003-9	5970-00-004-4056	A/R

NOTE

See Figure 2-21 for regulator cable art.

1. Measure from the regulator to power buss bar and to accessory cable circuit lead 1B.
2. Connect three AWG 14 electrical leads (5), two or three inches longer than measurement in step 1, to receptacle (1-4).
3. Label leads (5), using band markers (7), from pin F, 1B; pin C, 2; and pin A, 2A.
4. Add connector (8), slotted washer (9), and electrical contact (10) to end of circuit lead 1B.
5. Add terminal (7) to ends of circuit leads 2 and 2A.
6. Install electrical insulation tape/sleeving (11) on all leads (5).

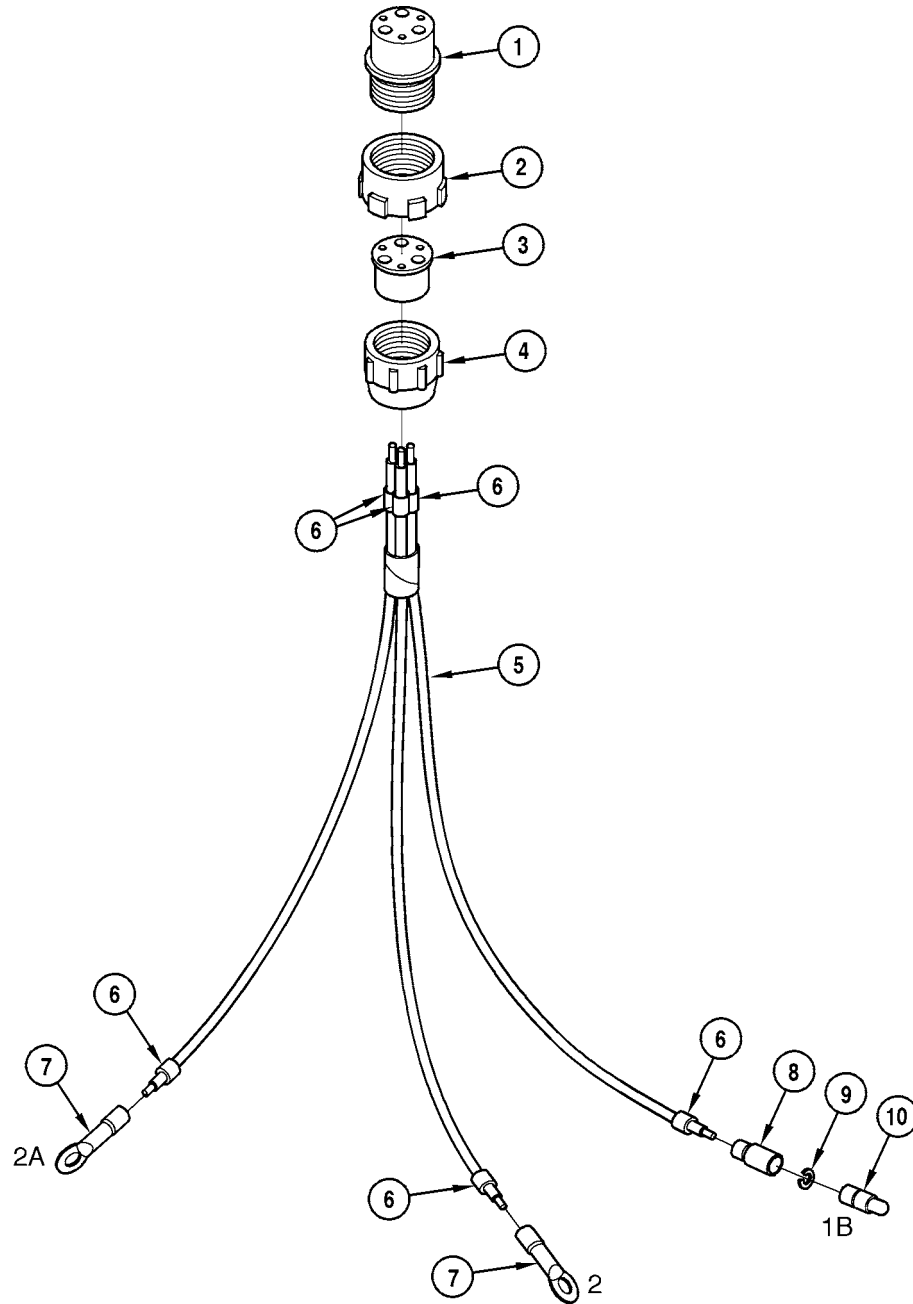

Figure 2-21. Regulator Cable (Three Leads)

e. Regulator Cable (Four Leads)

Bill Of Materials				
Item	Nomenclature	Part Number	NSN	Qty
	M113A2/M113A3/M548A1 Hardware			
1	Receptacle Connector	8713567	5935-00-502-9262	1
2	Nonmetallic Bushing	8341848	5365-00-303-4841	2
3	Knurled Plain Nut	7723309	5310-00-393-6685	2
4	Electrical Connector Plug	8724259	5935-00-081-0400	1
5	Electrical Coupling Nut	7716634-1	5975-01-151-7033	1
6	Electrical Wire	M13486/1-11	6145-00-538-8219	A/R
7	Electrical Insulation Tape	07099 - MS70T09-S	5970-00-955-9956	A/R
	Electrical Insulation Sleeving	78286-S6132-61003-9	5970-00-004-4056	A/R
8	Band Marker	M43436/1-1	9905-00-752-4649	8
	M548A3 Hardware			
9	Connector	MS3456W32-1P		1
10	Connect	8713567		1
11	Bushing	8341848		1
12	Nut	7723309		1
13	Connect	7716781		1
14	Bushing	8376776		1
15	Nut	7723308		1
16	Electrical Wire AWG 0	M13486/1-11	6145-00-538-8219	A/R
17	Electrical Wire AWG 4	M13486/1-11	6145-00-538-8219	A/R
18	Electrical Wire AWG 14	M13486/1-11	6145-00-538-8219	A/R
19	Electrical Insulation Tape	07099 - MS70T09-S	5970-00-955-9956	A/R
	Electrical Insulation Sleeving	78286-S6132-61003-9	5970-00-004-4056	A/R

NOTE

Although circuit leads numbers between the 200-amp voltage system and the 100-amp voltage systems are different, the same harness may be used. The important thing is the location of the regulators. The circuit leads must be long enough to reach from the 100-amp regulator to the 100-amp generator system and the 200-amp regulator leads must reach the 200-amp generator system.

1. Measure from the 100-amp regulator to generator and from the 200-amp regulator to the generator.

NOTE

See Figure 2-22 for regulator cable art.

2. This cable can be used for either the 100-amp or 200-amp regulator, so cut the wires about two or three inches longer than farthest distance.
3. Connect four AWG 4 electrical leads (6) measured in step 1, to two receptacles (1-5).
4. Label leads (6), using band markers (8), from pin B, 2A; pin C, 2; pin D, 1; and pin E, 1A.
5. Install electrical insulation tape/sleeving (7) on all leads (6).

NOTE

Steps 6 through 13 are only for fabricating an adapter to connect the M113A3 regulator cable to the M548A3 powerplant.

6. Cut one AWG 0 electrical lead (16) as needed.
7. Connect AWG 0 electrical lead (16) to pin E of connector (9). Label this lead circuit 6.
8. Splice two AWG 4 electrical leads (17) into the AWG 0 lead (16). Label these leads circuit 2 and circuit 2A.
9. Splice AWG 14 electrical lead (18) into the AWG 0 lead (16). Label this lead circuit 567.
10. Connect AWG 0 electrical lead (16) to pin A of connector (13), bushing (14), and nut (15).
11. Connect two AWG 4 electrical leads (17) (pins A and C) and one AWG 14 electrical lead (18) (pin E) to connector (10), bushing (11), and nut (12).
12. Install electrical insulation tape/sleeving (19) on all leads.
13. Label this harness adapter, M548A3 only.

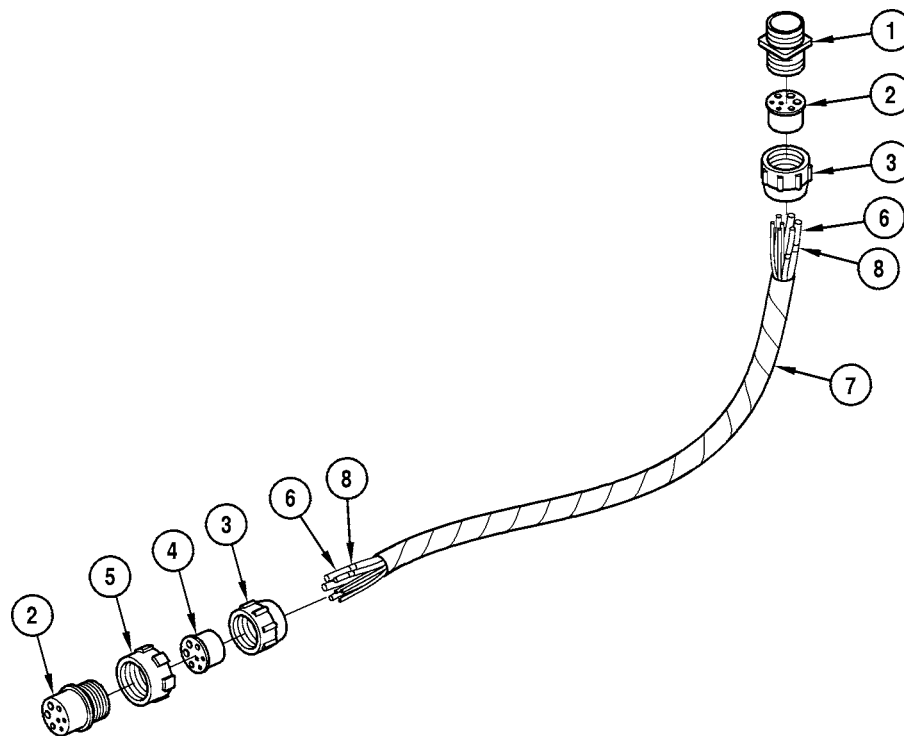

Figure 2-22. Regulator Cable (Four Leads) (M113A2/M113A3/M548A1 Only)

f. Transmission Cable

Bill Of Materials				
Item	Nomenclature	Part Number	NSN	Qty
1	Electrical Plug Connector	MS3100R24-7S	5935-00-853-3135	1
2	Electrical Wire	M13486/1-11	6145-00-538-8219	A/R
3	Electrical Insulation Tape	07099 - MS70T09-S	5970-00-955-9976	A/R
	Electrical Insulation Sleeving	78286-S6132-61003-9	5970-00-004-4056	A/R
4	Band Marker	M43436/1-1	9905-00-752-4649	14

1. Measure from the M113A3 engine harness to instrument panel/box.
2. Connect seven AWG 4 electrical leads (2) measured in step 1, to electrical plug connector (1).
3. Label leads (2), using band markers (4), from pin A, 364; pin B, 363; pin C, 362; pin D, 361; pin E, 360; pin F, 359; and pin G, 358.
4. Install electrical insulation tape/sleeving (3) on all leads (2). See Figure 2-23.

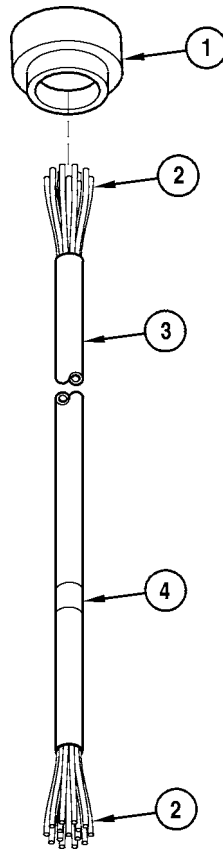

Figure 2-23. Transmission Cable

g. Starter Cable (M113A3/M548A3)

Bill Of Materials				
Item	Nomenclature	Part Number	NSN	Qty
1	Electrical Plug Connector	MS3456W32-1P	5935-01-181-8997	1
2	Lug Terminal	MS20659-135	5940-00-155-5001	2
3	Electrical Wire	M13486/1-14	6145-00-705-6674	A/R
4	Electrical Insulation Tape Electrical Insulation Sleeving	07099 - MS70T09-S 78286-S6132- 61003-9	5970-00-955-9976 5970-00-004-4056	A/R A/R
5	Band Marker	M43436/1-1	9905-00-752-4649	4

1. Measure from the M113A3 engine harness to power bus bar.
2. Connect two AWG 1/0 electrical leads (3) measured in step 1, to electrical plug connector (1).
3. Label leads (3), using band markers (5), from pin E, 6; and pin B, 6A.
4. Install lug terminal (2) on each lead (3).
5. Install electrical insulation tape/sleeving (4) on both leads (3). See Figure 2-24.

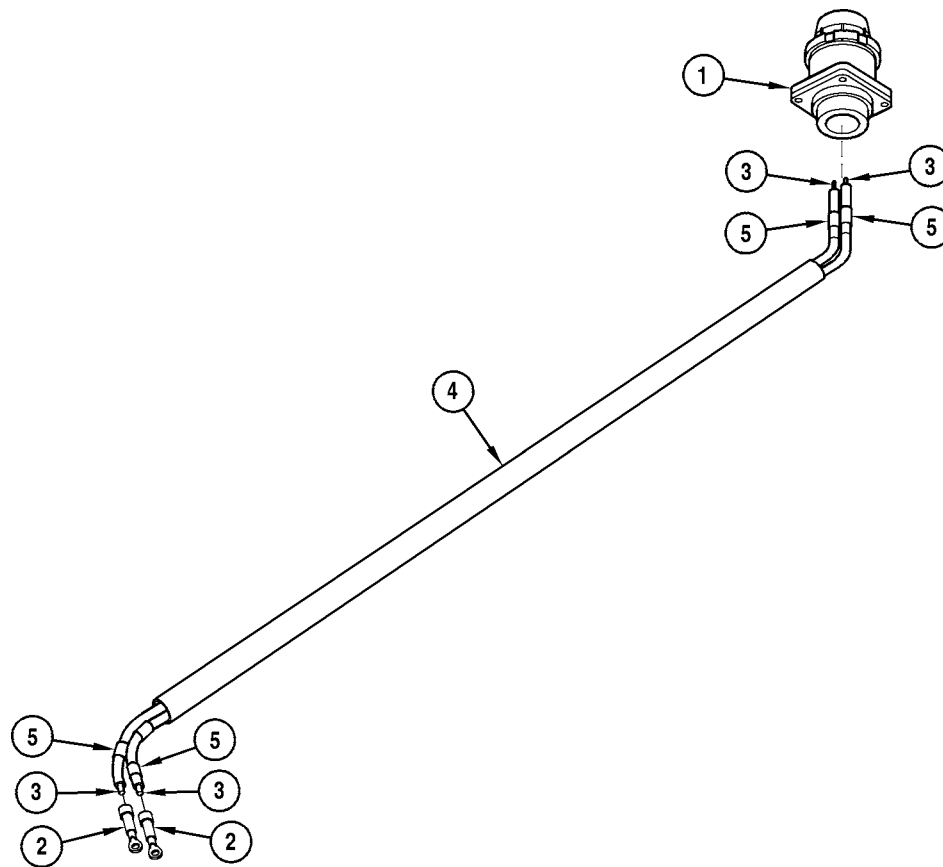

Figure 2-24. Starter Cable (M113A3/M548A3)

h. Starter Cable (M113A2/M548A1)

Bill Of Materials				
Item	Nomenclature	Part Number	NSN	Qty
1	Receptacle Connector	7715781		1
2	Nonmetallic Bushing	8376776	5365-00-318-8184	1
3	Bushing Retainer Nut	7723308	5935-00-333-9414	1
4	Lug Terminal	MS20659-135	5940-00-115-5001	1
5	Electrical Wire	M13486/1-14	6145-00-705-6674	A/R
6	Band Marker	M43436/1-1	9905-00-752-4649	2

1. Measure from the M113A2 engine harness to power bus bar.
2. Connect AWG 1/0 electrical lead (5) measured in step 1, to receptacle connector (1-3).
3. Label leads (5), using band markers (6) as circuit 6.
4. Install lug terminal (4) on lead (5). See Figure 2-25.

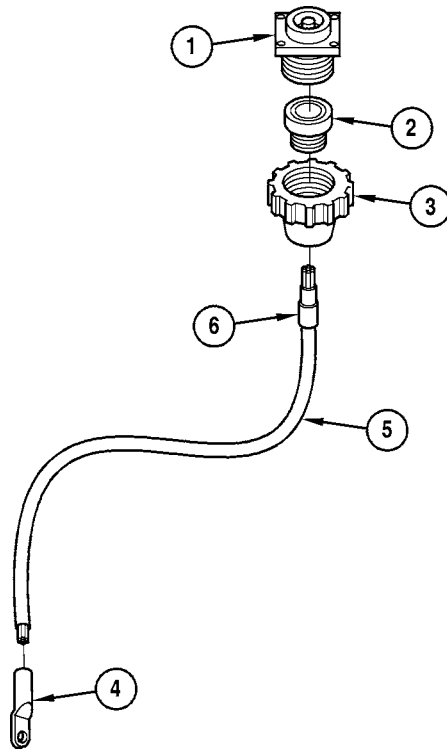

Figure 2-25. Starter Cable (M113A2/M548A1)

SECTION VI. INSTRUMENT PANEL

2-6. INSTRUMENT PANEL. The instrument panel contains the following gages, switches, and indicators: water temp, engine low oil pressure, trans clogged filter, trans high temp, trans low pressure, master power, fuel, battery voltage, fuel pump, glow plug, starter, and preheater. STE-ICE is also contained within the instrument panel with external connectors. The tachometer MS35916-2 (6680-00-825-2076) may or may not be in the instrument panel. It was found that the tachometer, when hand-held and attached directly to the engine, works better for moving around the engine and making adjustments.

a. Instrument Panel/Box

Bill Of Materials				
Item	Nomenclature	Part Number	NSN	Qty
	1/8" Aluminum Plate			
1	15 by 12 inches (38.1 by 30.5 cm)			2
2	4 by 12 inches (10.2 by 30.5 cm)			2
3	4 by 15 inches (10.2 by 38.1 cm)			2
4	2 by 2 inches (5.1 by 5.1 cm)			2
	Hardware			
5	Black Spring Steel U-Nut			4
6	Weldnut	12296904-32		4

1. Cut two 1/8-inch aluminum plates, 15 inches by 12 inches (1). See Figure 2-26.
2. Cut two 1/8-inch aluminum plates, 4 inches by 12 inches (2). See Figure 2-26.
3. Cut two 1/8-inch aluminum plates, 4 inches by 15 inches (3). See Figure 2-26.
4. Measure 2, 3, 2, 3, and 2 inches across the 12-inch side of front panel (1). See Figure 2-26.
5. Measure 2, 3, and 3 inches down 15-inch side of front panel (1). See Figure 2-26.
6. Scribe four lines as measured in step 4 above and three lines as measured in step 5 above.
7. Drill three 2.108-inch diameter holes in front panel (1). See Figure 2-26.
8. Drill six 0.656-inch diameter holes in front panel (1). See Figure 2-26.
9. Drill twelve 0.177-inch diameter holes in front panel (1). See Figure 2-26.
10. Drill two 0.438-inch diameter holes in front panel (1). See Figure 2-26.
11. Weld four weldnuts (6) to inside of front panel (1). Use STE/ICE circuit card to layout weldnut pattern or space them 2-1/2 inches by 4-1/2 inches—leave room for card. See Figure 2-26.
12. Measure 1, 3/4, 3/4, and 3/4 inch from top of side panel (3) and scribe four lines.
13. Measure 1 inch from side of back side panel (3) and scribe a line.
14. Drill four 0.468-inch holes for circuit breakers where scribe lines intersect in side panel (3).

NOTE

Connector holes in side panel (3) are unnecessary. Skip step 15 if you do not want the extra expense of using connectors in the side panel. Wire through to the gage or switch directly. See FO-5, wiring schematic.

15. Layout and drill five connector holes in side panel (3). See Figure 2-26. The top two holes will depend on which connectors will be used. The bottom two holes are for STE/ICE. Drill one hole, 1-13/16-inch diameter and the other 2-1/2-inch diameter.
16. Using the starter relay as a template drill two mounting holes in the bottom 4- by 12- by 1/8-inch aluminum plate (2).
17. Weld one 1/8-inch aluminum plate (1), two aluminum plates (2), and two aluminum plates (3) to form a box. See Figure 2-26.
18. Cut two 2- by 2- by 1/8-inch aluminum plates (4) diagonally. Drill one hole in the center of each triangle. The size of hole is determined by the availability of black spring steel U-nuts (5). See Figure 2-26.
19. Weld four triangle (4) in each corner of the box flush with the edge of panels (2 and 3). See Figure 2-26.
20. Install four black spring steel U-nuts (5) on four triangle (4).
21. Drill four holes in 12- by 15- by 1/8-inch aluminum rear panel (1) the same size as the holes drilled in four triangles (4). See Figure 2-26.

NOTE

It is recommended to put a waterproof cover over instrument panel to prevent damage in inclement weather.

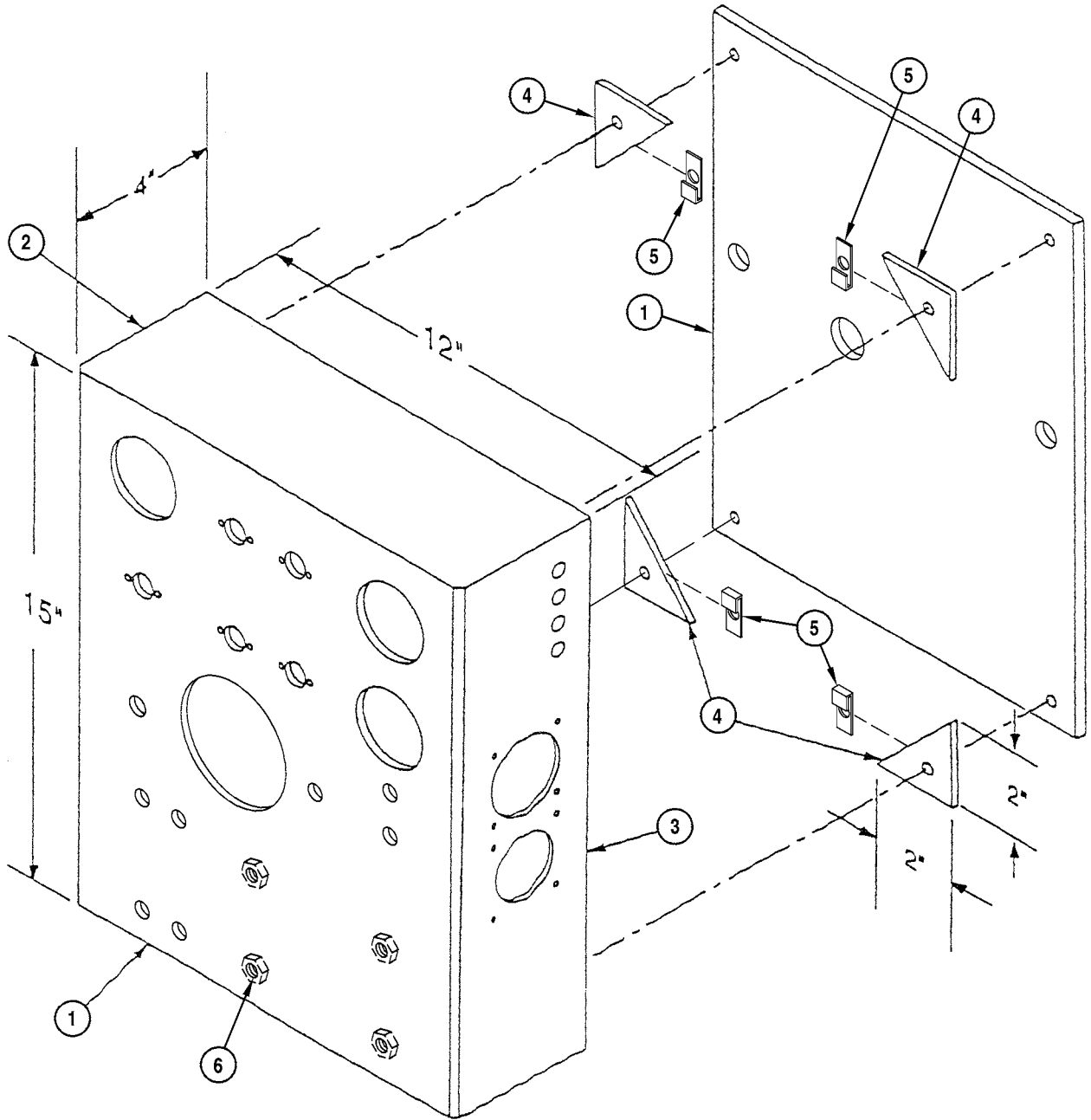

Figure 2-26. Instrument Panel/Box

SECTION VII. TEST EQUIPMENT FABRICATION

2-7. TEST EQUIPMENT. The fabricated test tools consist of transmission stall test tool and brake stall test tool. These tools are needed because without the carrier, there is no way to apply the brakes to prevent the transmission from moving.

a. Transmission Stall Test Tool

Bill Of Materials				
Item	Nomenclature	Part Number	NSN	Qty
	3/8" Steel Plate			
1	6 by 14-1/2 inches (15.2 by 36.8 cm)			1
2	7-5/8 by 14-1/2 inches (19.4 by 36.8 cm)			1
	1/2" Steel Plate			
3	3 by 5-27/32 inches (7.62 by 14.8 cm)			1
	2 1/4" by 2 1/4" Block Steel			
4	14-1/4 inches (36.8 cm)			1
	Hardware			
5	Cap Screw (7C)	B1821BH050F200N	5305-00-719-5238	4
6	Washer (7C)	11678182	5310-00-011-5730	4
7	Cap Screw (6C)	B1821BH037F100N		4
8	Washer (6C)	10910174-33		4
9	Cap Screw	B1821BH044C550N		3
10	Washer	MS27183-60		3
11	Nut	MS51967-11		3

1. Cut one 6- by 14-1/2- by 3/8-inch steel plate (1). Scribe a line 8-1/4 inches from the end of plate (1). Scribe another line 2-1/4 inches from the first scribe line. See Figure 2-27.
2. Scribe a line 2-1/4 inches from the side of 3/8-inch steel plate (1). See Figure 2-27.
3. Cut 2-1/4-inch square where scribed lines meet on 3/8-inch steel plate (1).
4. Drill a 17/32-inch hole next to the square one inch from the side and six inches from the end of 3/8 inch steel plate (1).
5. Drill two 17/32 inch holes one inch from the end and one inch from the side of 3/8-inch steel plate (1). See Figure 2-27.
6. Cut 7-5/8- by 14-1/2- by 3/8-inch steel plate (4). Cut the corners of as shown in Figure 2-27.
7. Weld 3/8-inch steel plates (1) and (4) per Figure 2-27.
8. Make a 3- by 5-27/32-inch plate (2). Drill four holes and round off corners to match the transmission yoke. See Figure 2-27.
9. Cut 2-1/4 inch by 2-1/4 inch block steel (3) 14-1/4 inch long. See Figure 2-27.
10. Weld 1/2-inch steel plate (2) to end of 2-1/4 inch block steel (3) at the same height as the transmission yoke.
11. Weld 2-1/4 inch block steel (3) after inserting into square in 3/8-inch steel plate (1).

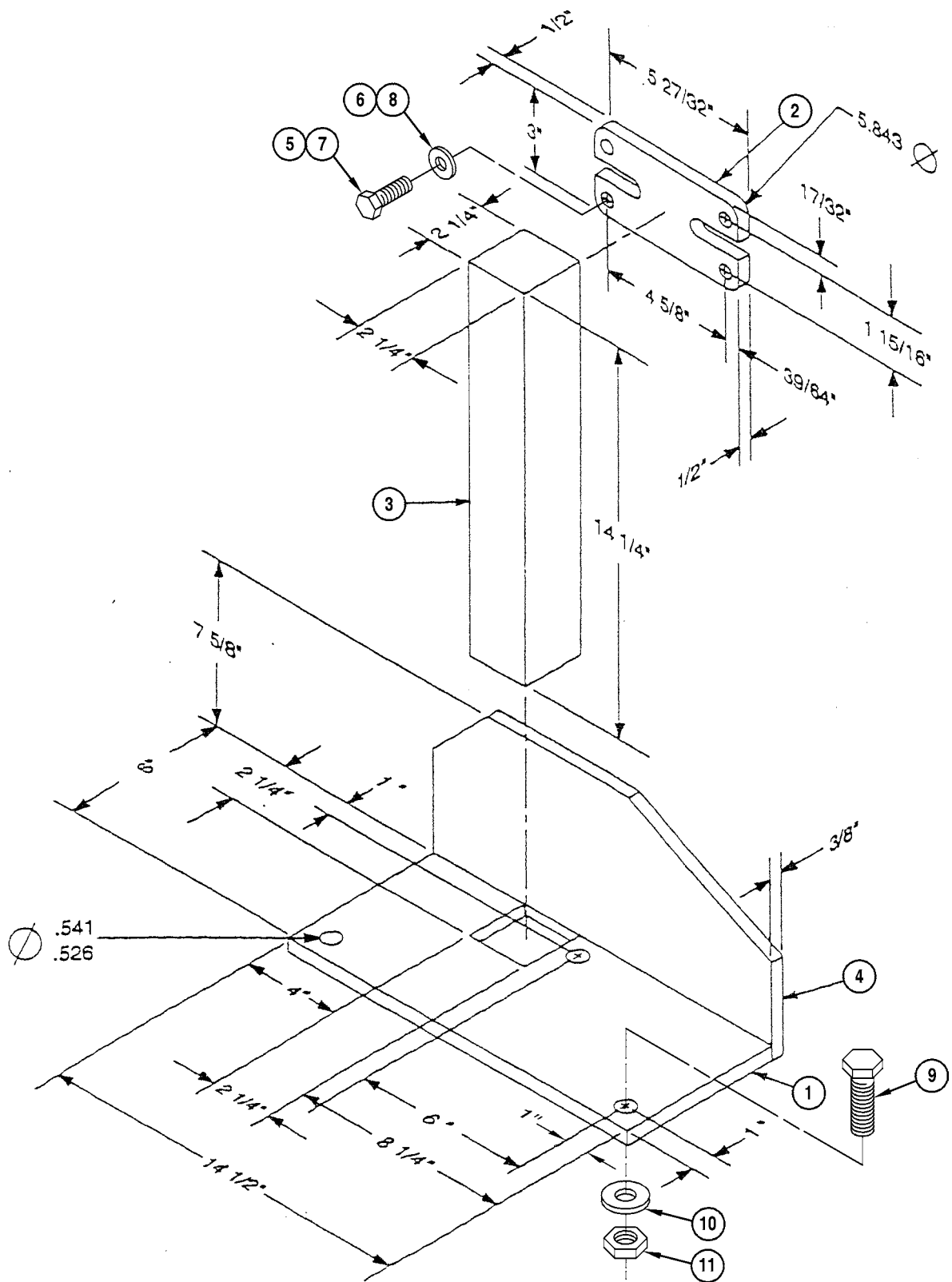

Figure 2-27. Transmission Stall Test Tool

b. Brake Stall Test Tool

Bill Of Materials				
Item	Nomenclature	Part Number	NSN	Qty
1	2" by 3" by 1/4" Steel Angle 10 inches (25.4 cm)			1
2	4 inches (10.2 cm)			1
	1/4" Steel Plate			
3	20 by 1 inch (50.8 by 2.5 cm)			1
4	1/4 by 3-1/4 inches (6.4 by 83 mm)			2
	1/8" Steel Plate			
5	6 by 1/8 inches (152 by 3.2 mm)			1
	Rubber Hose			
6	8 by 1 inch ID (20.3 by 2.5 cm)			1
	7/16" ID Roll Steel			
7	2 inches (5.1 cm)			1
	Hardware/Components			
8	Quick Release Pin	MS17984		1
9	Chain			1
10	Washer	MS27183-283		6
11	Nut	MS51922-18		3
12	Clevis Rod End Connector	MS35812-2		1
13	Screw	B1821BH038C300N		3
14	Screw	24617-9425094		2
15	Washer	23018199	5310-01-216-1367	2

1. Measure 9 inches on one side of steel angle (1) and 10 inches on the other side. Scribe a line joining the marks.
2. Cut steel angle (1) at approximately 60° along scribed lines.
3. Measure 3 inches on one side of steel angle (2) and 4 inches on the other side. See Figure 2-28. Scribe a line joining the marks.
4. Cut steel angle (2) at approximately 60° along scribed lines.
5. Weld steel angles (1) and (2) along 60° angle. See Figure 2-28.
6. Scribe a line one inch from end of 1/4-inch steel plate (3) and four inches from the one inch scribe line. Scribe a line centered lengthwise (1/2 inch from edge). See Figure 2-28.
7. Drill two 3/8-inch diameter holes where scribe lines intersect.
8. Measure down the middle of 1/8-inch plate (4) and scribe a line.
9. Starting about 3/4-inch from end of 1/8-inch steel plate (4), scribe ten lines evenly spaced (approximately every 29/64).
10. Drill ten 1/4-inch holes where scribe lines intersect. See Figure 2-28.
11. Bend 1/4 inch on both ends of 1/8-inch steel plate (4) approximately 90°.
12. Using 1/8-inch plate (4) as template, drill ten 1/4-inch holes in 1/4-inch steel angle (1).

13. Drill 3/8-inch pivot hole on the 9-inch side of 1/4-inch steel angle (1). See Figure 2-28.
14. Measure 5/8 inch and scribe a line on two 1/4-inch steel plates (5), centered.
15. Scribe three lines 1/2 inch, 1-1/2 inch, and 3/4 inch from end of 1/4-inch steel plate (5). See Figure 2-28.
16. Drill 3/8-inch hole where first line intersect and two 1/2-inch holes where the remaining two lines intersect in two 1/4-inch steel plates (5). See Figure 2-28.
17. Cut rubber hose (6) approximately 8 inches to be used as a handle for steel plate (3). See Figure 2-28.
18. Align holes in the angle (1) and adjusting plate (4) weld plate (4) to angle (1). Insert handle (3) between plates (4) and angle (1) secure with one screw (13), two washers (10), roll spacer (7), and nut (11). Attach rod-end clevis (12), screw (13), two washers (10), and nut (11) to handle (3). Attach two plates (5) to rod-end clevis connector (12) with one screw (13), two washers (10), and nut (11). Push rubber hose (6) onto handle (3).

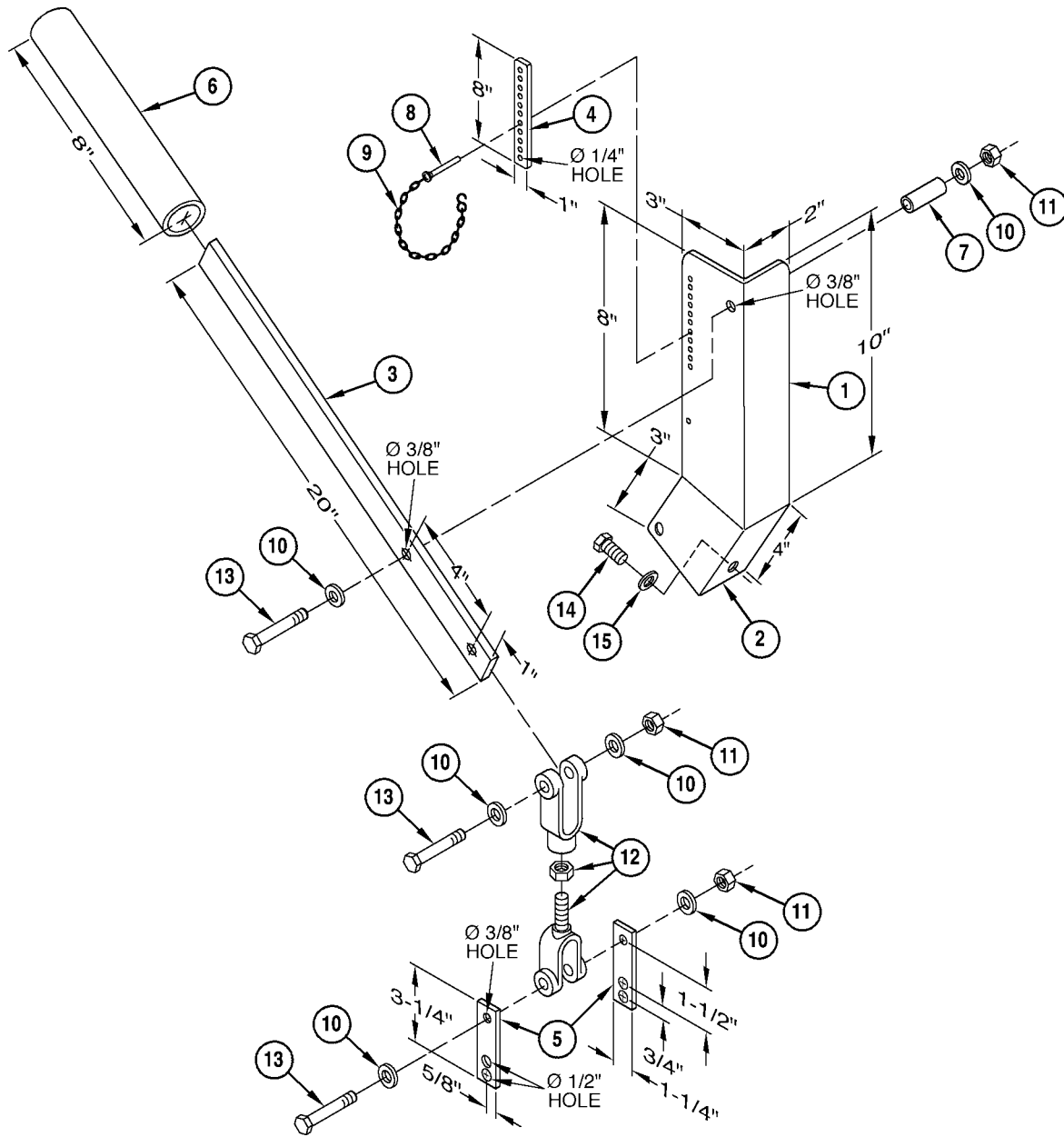

Figure 2-28. Brake Stall Test Tool (M113A3/M548A3)

SECTION VIII. HYDRAULIC SYSTEM

2-8. HYDRAULIC SYSTEM. Part and components for the hydraulic system can be fabricated or purchased from stock.

a. Hydraulic Loop (M113A2/M548A1)

Bill Of Materials				
Item	Nomenclature	Part Number	NSN	Qty
1	Coupling half quick disconnect	10865913	4730-00-800-2828	2
2	Nipple pipe	Bench stock		1

NOTE

Only the nose piece of the coupling half quick disconnect assembly (1) is needed.

1. Thread nipple pipe (2) to match the threads of two nose pieces (1).
2. Connect nipple pipe (2) between two nose pieces (1). See Figure 2-29.

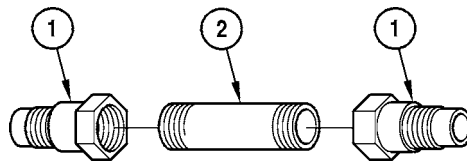

Figure 2-29. Hydraulic System Loop Fabrication

SECTION IX. MISCELLANEOUS

2-9. MISCELLANEOUS. This section tells you how to make several brackets. Some are very simple and need no instructions. These will be left up to the maker as to what design and size are needed (if needed at all).

Bill Of Materials				
Item	Nomenclature	Part Number	NSN	Qty
1	Bracket, mild steel	Bench stock		A/R

a. NATO Slave Receptacle Bracket

1. Fabricate NATO slave receptacle bracket from 1/8-inch mild steel stock.
2. Weld NATO slave receptacle bracket to powerplant frame, located at left rear corner.

CHAPTER 3

INSTALLATION

SECTION I. GENERAL INFORMATION

3-1. SCOPE. This chapter provides installation instructions of components on the M113A2/M548A1 or M113A3/M548A3 Powerplant Test Stand. Clearly mark or identify M113A2/M548A1 to M113A3/ M548A3 OSV hook-ups. Some items will be assembled and installed on the powerplant test stand when making the part, such as the instrument panel. Other items are made in Chapter 2 and are installed on the powerplant test stand or powerplant when needed. Some items are installed on the powerplant when it has been secured to the powerplant test stand, such as the transmission stall test tool. This chapter also instructs you to install components in the instrument panel. However, again, the instructions are designed to aid you. The components chosen are not necessary the ones that you must use. You may salvage the components from any 24-volt system or purchase them from your local store.

SECTION II. INSTALLATION

3-2. INSTALLATION OF COMPONENTS ON TEST STAND.

WARNING

Make sure of connections on regulators are installed correctly or personnel may be killed or injured and equipment damaged if the wrong components are connected. Clearly mark which connector is for the 100-amp or 200-amp system.

NOTE

Installation of components may be different for your powerplant test stand if you use different parts from the ones recommended in this Technical Bulletin (TB). Locate items so they work safely for the personnel who will operate it.

Bill Of Materials				
Item	Nomenclature	Part Number	NSN	Qty
	Hardware			
1	200 Amp Regulator	12358708	2920-01-147-1574	1
2	Screw	MS35207-264	5305-00-989-7435	12
3	Lockwasher	MS45904-60	5310-00-080-9786	8
4	Ground Lead	10886459	6150-00-999-2100	1
5	Lockwasher	MS35333-40	5310-00-550-1130	3
6	Nut	MS51967-2	5310-00-761-6882	2
7	Screw	B1821BH025C125N	5305-00-068-0509	1
8	100 Amp Regulator	10947439	2920-00-900-7993	1
9	Battery	MS52149-1	6140-01-210-1964	4
10	Battery Terminal Cover	10942521	5940-00-738-6272	8
11	Battery Lug Terminal	MS75004-1	5940-00-549-6581	4
12	Battery Lug Terminal	MS75004-2	5940-00-549-6583	4

Bill Of Materials—Continued				
Item	Nomenclature	Part Number	NSN	Qty
13	Battery Lead	8763430	5995-00-679-9217	4
14	Battery Lead	12349945-1	6150-01-247-7953	2
15	Battery Lead	12349946-1	6140-01-244-6011	4
16	Shunt	12258973-2	6625-01-175-2503	1
17	Screw	B182BH025C113N	5305-00-225-3842	4
18	Washer	MS27183-10	5310-00-809-4058	10
19	Locknut	MS51922-1	5310-00-088-1251	7
20	Electrical Lead	7766534		1
21	Screw	B1821BH088C375N	5305-01-277-0452	1
22	Lockwasher	MS35338-103	5310-00-184-8971	1
23	Screw	B1821AH038C125N	5305-00-068-0511	3
24	Washer	MS27183-14	5310-00-080-6004	2
25	Locknut	MS51922-17	5310-00-087-4652	2
26	Cover, Shunt	12359729		1
27	Switch, Master	MS27200-1 or 81349- M13625/2-1	5930-00-930-5016	1
28	Switch Plate	8341861	9905-00-602-5775	1
29	Screw	B1821BH025C075N	5305-00-068-0508	16
30	Locknut	MS51943-31	5310-00-061-4650	2
31	Receptacle, NATO Slave	11682345	5935-01-044-8382	1
32	Gasket	11674729	5330-01-059-4286	1
33	Insulator Plate	11674730	5970-01-044-8391	1
34	Washer	MS27183-42	5310-00-014-5850	4
35	Locknut	MS21083N3	5310-00-902-6676	4
36	Electrical Lead	12350256-1	6150-01-248-9560	1
		or	or	
		12313107-1	6150-01-252-0256	
37	Plastic Terminal Block	12354708	6110-01-249-1603	1
38	Screw	B1821BH031C050N	5306-00-226-4822	2
39	Lockwasher	MS35333-41	5310-00-167-0721	2
40	Electrical Bus Bar	8756776	6150-00-770-9474	1
41	Lockwasher	MS45904-76	5310-00-061-1258	2
42	Screw	MS90727-5	5305-00-267-8953	2
43	Lockwasher	MS45904-68	5310-00-889-2528	2
44	Fuel Pump	MS51321-2	2910-00-930-9367	1
45	Locknut	7341628	5310-00-758-1900	2
46	Lockwasher	MS45904-69	5310-00-067-6357	
47	Switch, Fuel Pump	MS35058-22	5930-00-655-1514	1
48	14 AWG Wire		Bulk	A/R
49	Shell	8338572	5935-00-695-9077	1
50	Washer	8338573	5310-00-595-7044	1
51	Nipple	MS51953-75	4730-00-188-1877	1
52	Elbow	MS51506-A8-8S	4730-00-973-8962	1
53	Adapter	MS51500-A8-8S	4730-00-511-7988	2
54	Valve, Shutoff	12298210-2	4820-01-252-7379	1
55	Hose	MS52103Z080092R	4720-01-254-9873	A/R
56	Elbow	MS51506-A8-4	4730-00-915-4634	1
57	Elbow	MS51521A8	4730-00-812-2434	1
58	Nut, Coupling Half	MS51531B12	4730-00-812-0924	1

Bill Of Materials—Continued				
Item	Nomenclature	Part Number	NSN	Qty
59	Tube Reducer	MS51534A12-8	4730-00-675-9216	2
60	Quick Disconnect Coupling Half	12297003-3	4730-01-140-8250	1
61	Nut	MS51860-58	4730-01-093-8464	2
62	Quick Disconnect Coupling Half	12297003-4	4730-01-140-8251	1
63	Elbow	MS51522A12	4730-00-434-6394	1
64	Nipple	MS51953-52	4730-00-861-8538	1
65	Gasket, Fuel Filler	8756391	5330-00-679-9729	1
66	Radiator	Any 2 1/2 or 5 Ton Truck		1
67	Gasket	10932933	5330-00-058-9263	2
68	Elbow, Radiator	12253525	4730-01-060-9526	1
69	Hose, Radiator	11662999	4720-00-150-5970	A/R
70	Elbow	Fabricated		A/R
71	Screw	B1821BH025C100N	5305-00-225-3843	3
72	Screw	MS35206-281	5305-00-988-1725	12
73	Locknut	MS51922-2	5310-00-929-1807	12

1. Install 200-amp regulator (1) on floor plate under powerplant test stand frame, see Figures 2-12 and 2-14, with four screws (2) and lockwashers (3). Connect ground lead (4), lockwasher (5), and nut (6) to regulator. Connect ground lead (4) to mounting bracket with mounting screw (7) and lockwasher (5).
2. Install 100-amp regulator (8) on powerplant test stand floorplate (2, Figure 2-4), under powerplant test stand frame with four screws (2) and lockwashers (3). Connect ground lead (4), lockwasher (5), and nut (6) to regulator. Connect ground lead (4) to floorplate with mounting screw (7) and lockwasher (5). Location is under powerplant test stand and wherever there is room to position it.
3. Install four batteries (9) in battery box under powerplant test stand frame. Install eight battery terminal covers (10), four lug terminals (11), lug terminals (12), lead (13), and lead (14) on batteries (wired in series/parallel). Connect two leads (14) between batteries positive terminals and bus bar. Connect two leads (15) between batteries negative terminals and master switch. See Figure 2-14 for location of batteries under powerplant test stand.
4. Install shunt (16) on battery box support with four screws (17), eight washers (18), and four locknuts (19). Install electrical lead (20) on shunt with screw (31) and lockwasher (32). Connect other end to battery support with screw (23), two washers (24), and locknut (25). Install electrical lead (20) on shunt with screw (3) and lockwasher (22). Connect other end to master switch. Shunt cover is not necessary, however if desired, you must fabricate it yourself or order shunt cover (26) and modify to use on your powerplant test stand.
5. Install master switch (27) and identification plate (28) on powerplant test stand floor plate 4, see Figure 2-4. Use two screws (29) and locknut (30). Master switch is connected to battery negative terminal with 1/0 AGW lead and ground. Drill two 0.265-inch diameter holes. Distance from center to center of holes is 1.875 inch.
6. Install NATO slave receptacle (31), gasket (32), and insulator plate (33) on powerplant test stand frame, or assemble (11674728) (need to attach mounting bracket to frame). Install NATO slave receptacle (31) in mounting bracket with four screws (2), washers (34), and locknuts (35). Connect electrical lead (36) circuit 49 between receptacle and bus bar and ground the other terminal.
7. Install two plastic terminal blocks (37) on battery box support with two screws (38) and lockwashers (39).
8. Install electrical bus bar (40) on two plastic terminal blocks (37) with two screws (23) and lockwashers (41). Install two screws (42) and lockwashers (43) in electrical bus bar (40).

9. Install fuel pump (44), two screws (29), washers (18), locknuts (45), and four lockwashers (46) on powerplant test stand frame.
10. Install fuel pump switch (47) in instrument panel. Connect 14 AWG lead (48) with shell (49) and washer (50) to fuel pump (44) and switch (47).
11. Install fuel tank in space provided under powerplant test stand frame. See Figure 2-14. Install nipple (51), elbow (52), adapter (53), shutoff valve (54), adapter (53), hose (55), elbow (56) from fuel tank supply boss (72) and fuel pump inlet.
12. Install elbow (56), hose (55), elbow (57), nut coupling half (58), and tube body reducer (59) on fuel pump (44) outlet.
13. Install quick disconnect coupling half (60) and nut (61) on fuel line bracket.
14. Connect adapter (59) to coupling half (60).
15. Install quick disconnect coupling half (62) and nut (61) on fuel line bracket.
16. Install elbow (63), hose (55), elbow (56), and nipple (64) from coupling half (62) and fuel tank return boss (10917702-12).
17. Install any available radiator from 2-1/2 or 5-ton truck on powerplant test stand. Secure bottom radiator mounts to powerplant test stand with nuts and washers supplied with radiator. Attach each side support to top side of radiator (66), secure with same size screws and washers used in the vehicle (2-1/2 or 5-ton truck) from which it came.
18. Connect radiator (66) to engine coolant outlet and inlet using radiator hoses, clamps, and fabricated elbows for upper and lower radiator connections to the radiator, this will ease installation and removal. To prevent any airlocks, mount the radiator so that the top of radiator is six inches above the top of the engine being tested. If weather conditions are above 32 degrees, antifreeze will not be necessary. Fill the radiator with plain clean water. Radiator (66) can be cooled by using a 12-volt fan commonly used on most newer cars or trucks. It can be powered by one 12-volt battery with an on/off switch. Since there is not enough load when testing the engine, the water temperature will not overheat unless left running for an extended period at a high idle.
19. Install two gaskets (67) and radiator elbows (68) on radiator.
20. Install radiator hoses (69) and elbows (70) on two radiator elbows (68).
21. Connect circuit leads 6 and 6A of "starter to bus bar harness" to bus bar (40).
22. Install 100-amp connector panel, three screws (71), and locknuts (19) on floorplate number 1, see Figures 2-4 and 2-18.
23. Connect M113A2/M548A1 starter, accessory, and 100-amp generator connectors to 100-amp connector panel (see Figure 2-18). Secure with twelve screws (72) and locknuts (73). Mark each connector clearly with a permanent ink or stencil to identify each connector.

3-3. INSTALLATION OF COMPONENTS IN INSTRUMENT PANEL.

Bill Of Materials				
Item	Nomenclature	Part Number	NSN	Qty
	Hardware			
1	Circuit Card	12354615	5999-01-246-1023	1
2	Screw	MS35206-262		4
3	Washer	MS27183-42	5310-00-014-5850	4
4	Lockwasher	MS35333-39	5310-00-576-5752	4
5	Wiring Harness STE/ICE	12354594	5995-01-239-1971	1
6	Gasket	MS52000-10	5330-00-948-0704	1
7	Gasket	MS52000-12	5330-00-827-2815	1
8	Screw	MS35190-239	5305-00-958-5451	8
9	Washer	MS15795-903		8
10	Nut	MS21083N6	5310-00-926-1852	8
11	Cap	12258943	5935-01-114-5354	1
12	Screw	MS35207-264		1
13	Nut	MS21083N3		1
14	Circuit Breaker	MS25244-15	5925-00-686-3301	4
15	Gage, Water Temperature	MS24543-2	6685-00-936-2139	1
16	Gage, Voltage	MS24532-2	6625-01-086-9580	1
17	Indicator Light	8376499	6210-00-699-9457	5
18	Gage, Fuel	EGO375	6680-00-933-3600	1
19	Switch, Starter	12313366	5930-01-204-4458	1
20	Switch, Preheater	3101-0018	5935-00-075-7006	1
21	Gage, Tachometer	MS35916-2	6680-00-825-2076	1
22	Relay, Electromagnetic, Starter	1114536	5945-00-735-9542	1
23	Controller, Transmission	Fabricated		1
24	Controller, Transmission	12349915	3010-01-245-2442	1

1. Install STE/ICE circuit card assembly (1) on four weldnuts in instrument panel with four screws (2), washers (3), and lockwashers (4) (see Figure 3-1).
2. Connect STE/ICE harness to STE/ICE circuit card assembly (1) in instrument panel.
3. Install wiring harness connectors (5 and 6) and gaskets in instrument panel with eight screws, washers, and nuts.
4. Install cap on DEC connector (J2) and secure chain to box with screw and nut.

NOTE

Connector J1 should be connected to the engine connector.

Connector J2 should be connected to the DEC for testing.

5. Install four circuit breakers (7) in instrument panel.
6. Install engine water temperature gage (8) in instrument panel.
7. Install voltage gage (9) in instrument panel.
8. Install engine low oil press indicator light (10) in instrument panel.
9. Install transmission clogged filter indicator light (11) in instrument panel.
10. Install master power indicator light (12) in instrument panel.

11. Install transmission high temp indicator light (13) in instrument panel.
12. Install transmission low oil pressure indicator light (14) in instrument panel.
13. Install fuel gage (15) in instrument panel.
14. Install starter switch (16) in instrument panel.
15. Install preheat switch (17) in instrument panel.
16. Install tachometer (18) in instrument panel only if space is available, otherwise the tachometer should be connected to tachometer cable and hand held.
17. Install starter relay (19) in instrument panel.
18. Install fabricated transmission controller (20) in instrument panel or vehicle transmission controller (21) with four lockwashers (22) and four screws (23).
19. Install a 16 gage wire from Pin K at pack accessory cable on cart side. Run wire into instrument panel and install glow plug indicator light assembly (24) in face of instrument panel. Connect wire to light and connect a short piece of wire from other terminal to panel ground.
20. Install fuel switch (25) in instrument panel.
21. Install connectors (26 and 27) and gaskets in instrument panel.

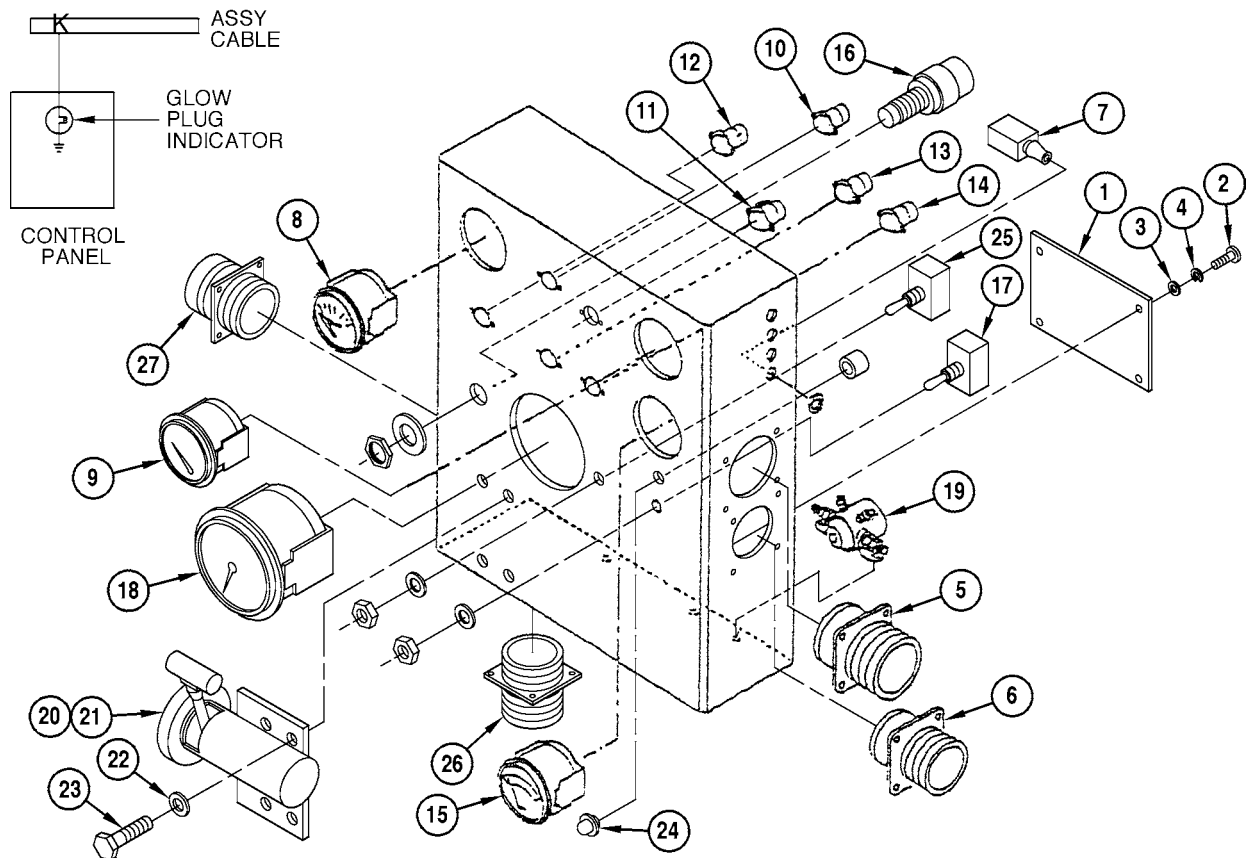

Figure 3-1. Instrument Panel Components

CHAPTER 4

OPERATION

SECTION I. INTRODUCTION

NOTE

- OSV has A3 engine and TX200-4/4A transmission.
- If testing OSV, refer to TM 9-2350-366 series.

4-1. **GENERAL.** This chapter tells you how to install the complete powerplant or the engine by itself on the powerplant test stand. Task will instruct you on how to connect the engine and how to start it. You should clean, inspect, check for leaks, and obey warnings from this TB and from the applicable Technical Manuals (TM 9-2350-277-20 Series for the M113A3 FOV, TM 9-2350-261-20 Series for the M113A2 FOV, TM 9-2350-247-20 Series for the M548A1 & M548A3, TM 9-2815-205-34 for all 6V53 engines, TM 9-2520-254-34 for TX 100-1 transmissions, and TM 9-2520-272-34&P for X200-4 & 4A transmissions). Be sure to read all warnings, cautions, and notes in this TB. They help you avoid harm to yourself, other personnel, and equipment. They also tell you things you should know about the task.

4-2. DESCRIPTION/OPERATION.

WARNING

- Severe equipment damage will always result and personal injury can occur if the wrong voltage regulator is used.
- Always disconnect the batteries' ground cable(s) before removing or connecting cables to the regulator to avoid personal injury or equipment damage from the high amperage supplied by the batteries.

CAUTION

- The 100-amp voltage regulator, NSN: 2920-00-900-7993 is presently used in the M113A2 FOV. Late models M577A2s and M1068s have 200-amp voltage regulator, NSN: 2920-01-147-1574. Do not make connections to the 200-amp regulator if the engine is equipped with 100-amp generator.
- The 200-amp voltage regulator, NSN: 2920-01-174-1574 is used in all M113A3/M548A3 FOVs. Do not make connections to the 100-amp regulator if the engine is equipped with a 200-amp generator.
- Pin C of the regulator connector is the positive battery lead on the 200-amp regulator and pin C on the 100-amp regulator is the negative battery lead. Ensure that you have the right regulator for the application. If the regulator is not identified, do not use it. Using the wrong regulator will damage the alternator, engine wiring harness, the powerplant test stand's wiring harness, and powerplant test stand's regulator.

NOTE

M113A3 engines equipped with glow plug cold weather starting system can be tested. The glow plug indicator light is found in center of instrument panel on right side. Troubleshoot using applicable TM series.

Both the 100 and 200-amp regulators come from the manufacture with a stick-on label listing the NSN, nomenclature, and output. They are look-alike and use the same case and electrical connectors; however, they cannot be interchanged in their application. Severe equipment damage will always result and personal injury can occur. The 100-amp regulator is located near the front of powerplant test stand. The 200-amp regulator is located near the rear of powerplant test stand. There is a definite size and weight difference between the 100 and 200-amp alternator when you look at the powerplant. The 200-amp alternator weighs approximately 80 lb. and looks almost twice the size of the 100-amp alternator. Always disconnect the batteries' ground cable(s) before removing or connecting cables to the regulator to avoid personal injury or equipment damage from the high amperage supplied by the batteries. It is not necessary to disconnect battery ground cables when connecting the powerplant harness to the powerplant test stand harness, just make sure the master switch is off.

Section II. MAINTENANCE

TESTING M113A3/M548A3 OSV POWERPLANT

DESCRIPTION

This task covers: Install (page 4-3). Start (page 4-10). Stop (page 4-12). Remove (page 4-12).

INITIAL SETUP

Tools:

General Mechanic's Tool Kit
 Powerplant Sling
 Turbocharger Inlet Shield 4910-01-127-7959

Materials/Parts:

Grease
 Locknuts (2)
 Exhaust Elbow
 Suitable Container

Personnel Required:

Unit Mechanic
 Helper

References:

LO 9-2350-247-12
 LO 9-2350-277-12
 TM 9-2350-247 Series
 TM 9-2350-277 Series
 TM 9-2350-366 Series
 TM 9-2815-205-34
 TM 38-260

Equipment Conditions:

Powerplant on Blocks
 Powerplant Test Stand blocked

INSTALL

WARNING

- **Damaged lifting slings can fail with load. Personnel can be killed or injured. Inspect all slings before use. Do not use damaged slings.**
- **Hanging loads can kill or injure you. Keep away from hanging loads and overhead equipment. Keep hands out of area while powerplant is being lifted for removal or lowered for installation.**

NOTE

- **STE-ICE transducers and harness are only on the M113A3 FOV powerplants.**
- **OSV has A3 engine and TX200-4/4A transmission.**
- **If testing OSV, refer to TM 9-2350-366 series.**

1. Attach powerplant sling (1) to lifting device (2) of at least 3,000 pounds (1,362 kg) capacity. See Figure 4-1.
2. Attach powerplant sling (1) to lifting brackets (3) and lift powerplant assembly (4). Have helper assist. See Figure 4-1.

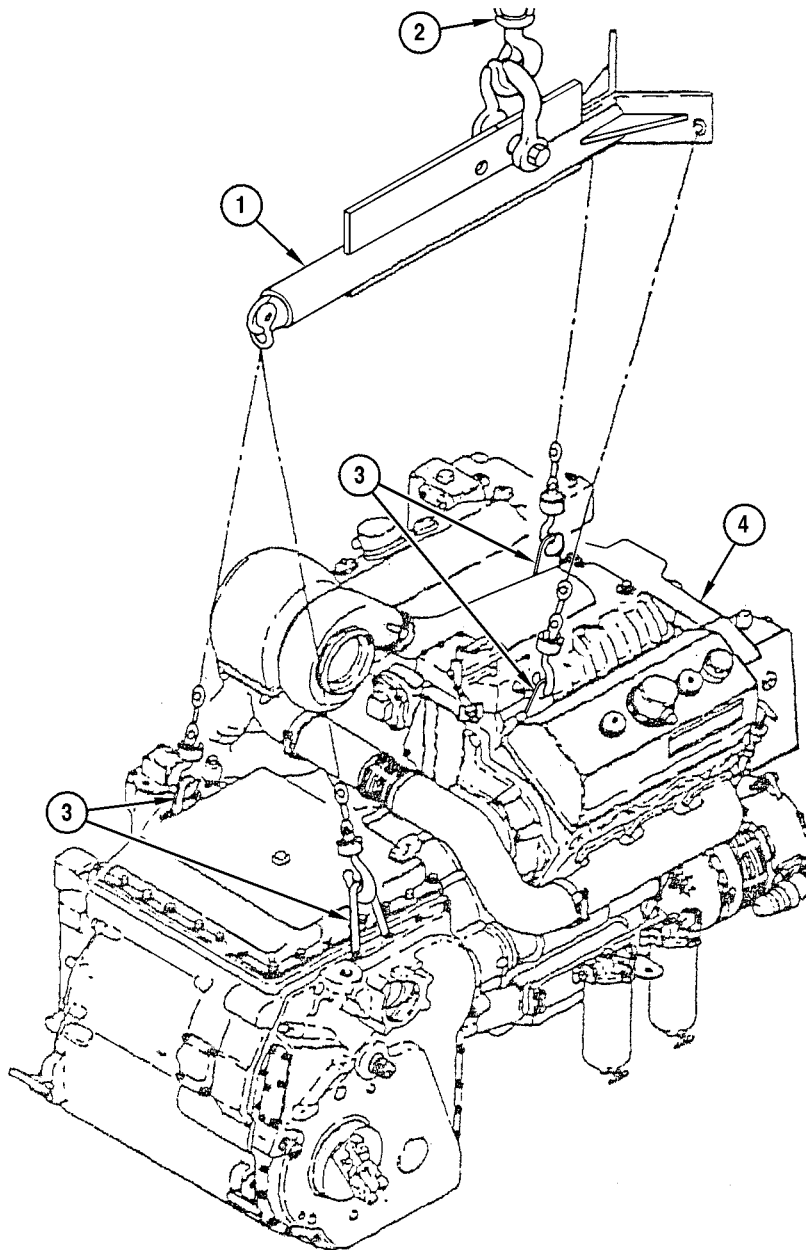

Figure 4-1. M113A3/M548A3 Powerplant

NOTE

See Figure 4-8 for partial guide and check list of items to be connected.

3. Place powerplant assembly (4) on powerplant test stand (5). Have helper assist.
4. Check that powerplant (4) is position within transmission brackets (6) (Figures 2-6 and 2-7) and firmly supported.
5. Secure engine front mount to powerplant test stand front mount (7) (Figure 2-6) with two screws, four washers, and two nuts. See Figure 4-2.

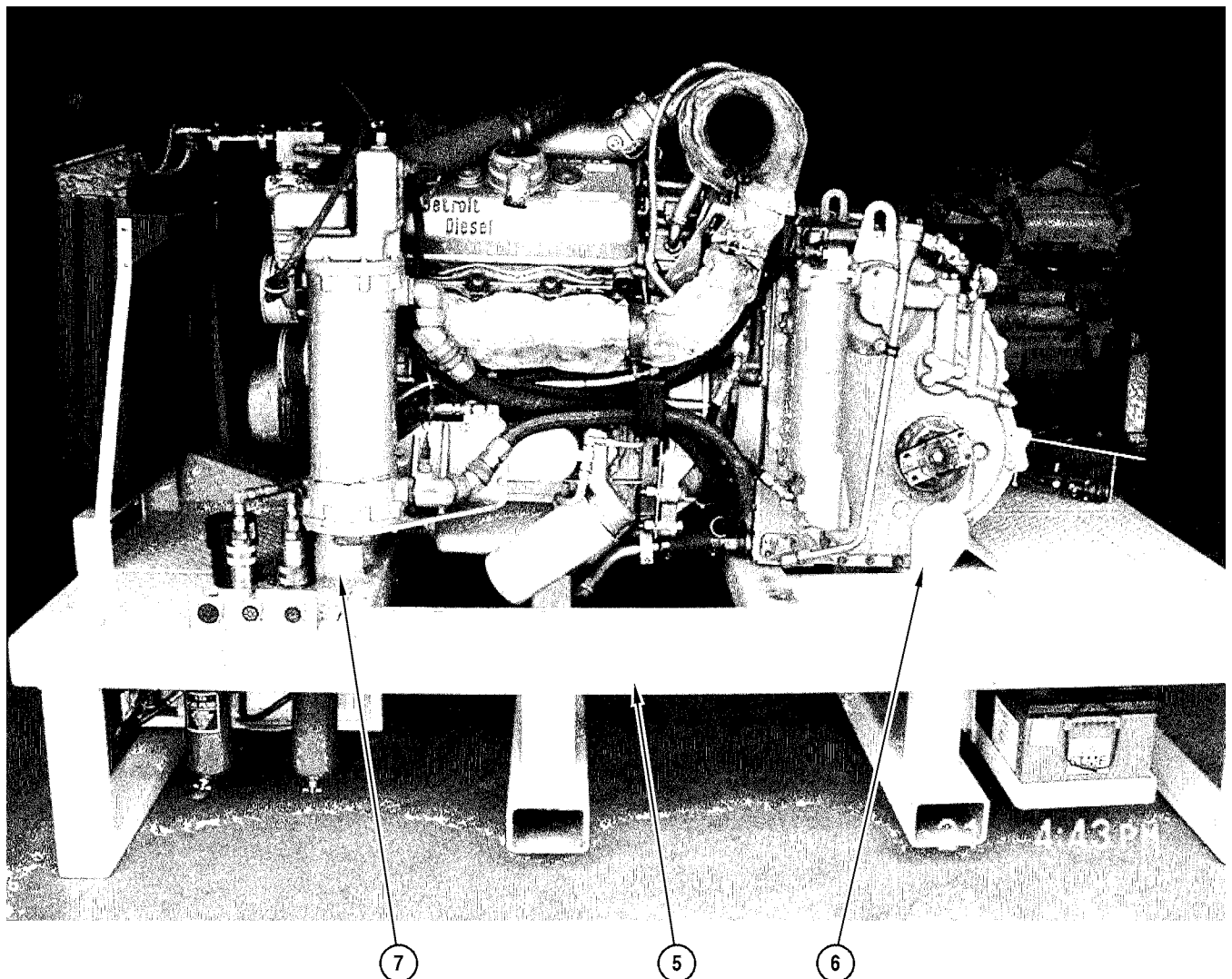

Figure 4-2. Powerplant Installed on Test Stand

6. Fabricate and connect top and bottom radiator hoses as needed.
7. Connect bleeder hose assembly (8) between elbow (9) on flange elbow (deaeration elbow) (10) and elbow (11) on thermostat housing (12) with two clamps (13) (Figure 2-17). See Figure 4-3.

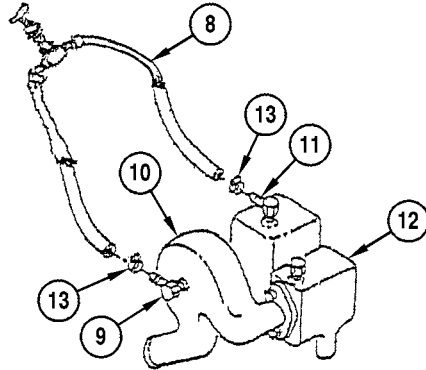

Figure 4-3. Bleeder Hose Assembly

8. Fill radiator and engine with water. Coolant is not necessary for testing.
9. Check all fluid levels and fill as necessary. Refer to LO 9-2350-277-12 or LO 9-2350-247-12.

WARNING

The turbocharger can grind off a part or all of your hand. Place a screen or some type of guard over turbocharger intake manifold if air cleaner system is not used. Any objects that are ingested into the intake will damage the engine.

10. Install turbocharger inlet shield (14) (2351171ASH—Detroit Diesel; NSN 4910-01-127-7959) on engine turbocharger inlet or any screen that prevents ingestion of debris and protects fingers. If air flow is restricted, testing results may be skewed. If another shield is used, stall check results may be affected. Also, excessive black smoke will occur. See Figure 4-4.

WARNING

Noise from powerplant could damage hearing. Use double ear protection when powerplant is operated.

11. Install elbow and clamp on engine turbocharger exhaust outlet. Adjust elbow so that exhaust is directed away from personnel.

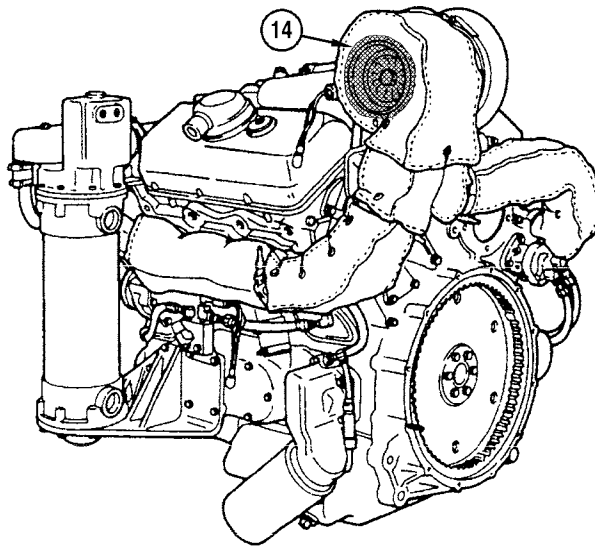

Figure 4-4. Placement of Turbocharger Inlet Shield

12. Connect generator ground lead and starter ground lead to ground bolt (15) on front engine mount with wingnut and lockwasher.

NOTE

Tachometer is not necessary when using STE-ICE. If tachometer is needed, a hand held tachometer is better suited for making adjustments. Only the M113A3 FOV powerplant is wired with STE-ICE transducers and harness connected on the engine.

13. Install tachometer cable on engine tachometer adapter and connect to tachometer.

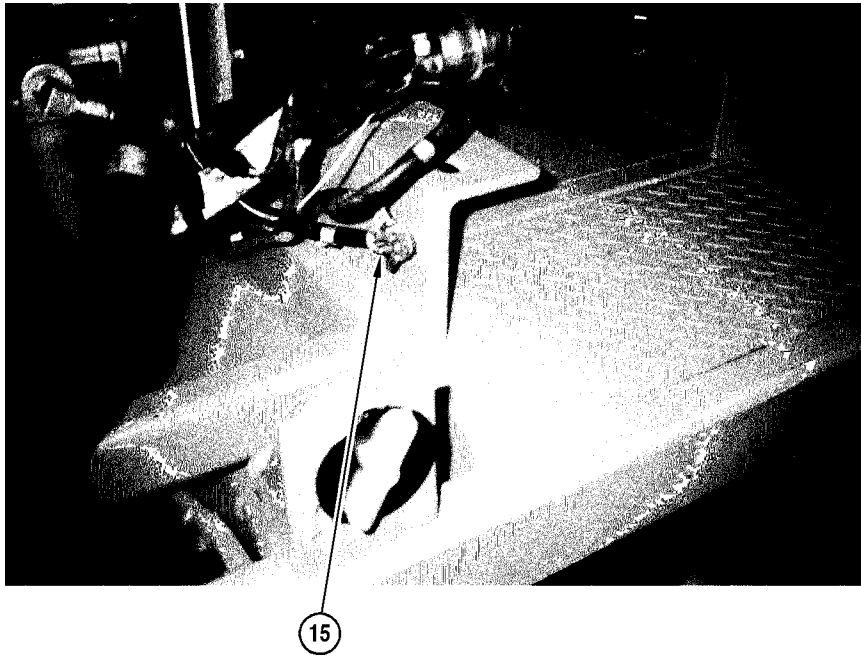

Figure 4-5. Ground Bolt

14. Connect alternator, accessory, starter, and transmission cables to powerplant test stand cables. Ensure that connections are for M113A3/M548A3 only.
15. Connect STE/ICE harness to instrument panel/box (M548A3 must connect STE/ICE and transducers to powerplant) and make connections to engine components, shunt, and batteries. Refer to TM 9-2350-277-20.
16. Connect engine fuel line quick disconnect halves to powerplant test stand quick disconnect halves.

17. Install right brake connecting links, two screws, lockwashers, and flat washers on right transmission brake. See Figure 4-6.

CAUTION

Do not use screws removed from transmission. Damage of screws may damage transmission.

18. Remove two screws from the right side of transmission. Save transmission screws. Install brake stall test tool (Figure 2-28), secure with two screws. Connect brake stall test tool to braking hardware. Use rod-end clevis and rod-end connector. Connect rigid connecting link between two 1/4 inch steel plates and secure with headed pin, washer, and cotter pin. See Figure 4-6.
19. Fill engine and transmission with oil. Refer to LO 9-2350-277-12 (M113A3 FOV) or LO 9-2350-247-12 (M548A3).

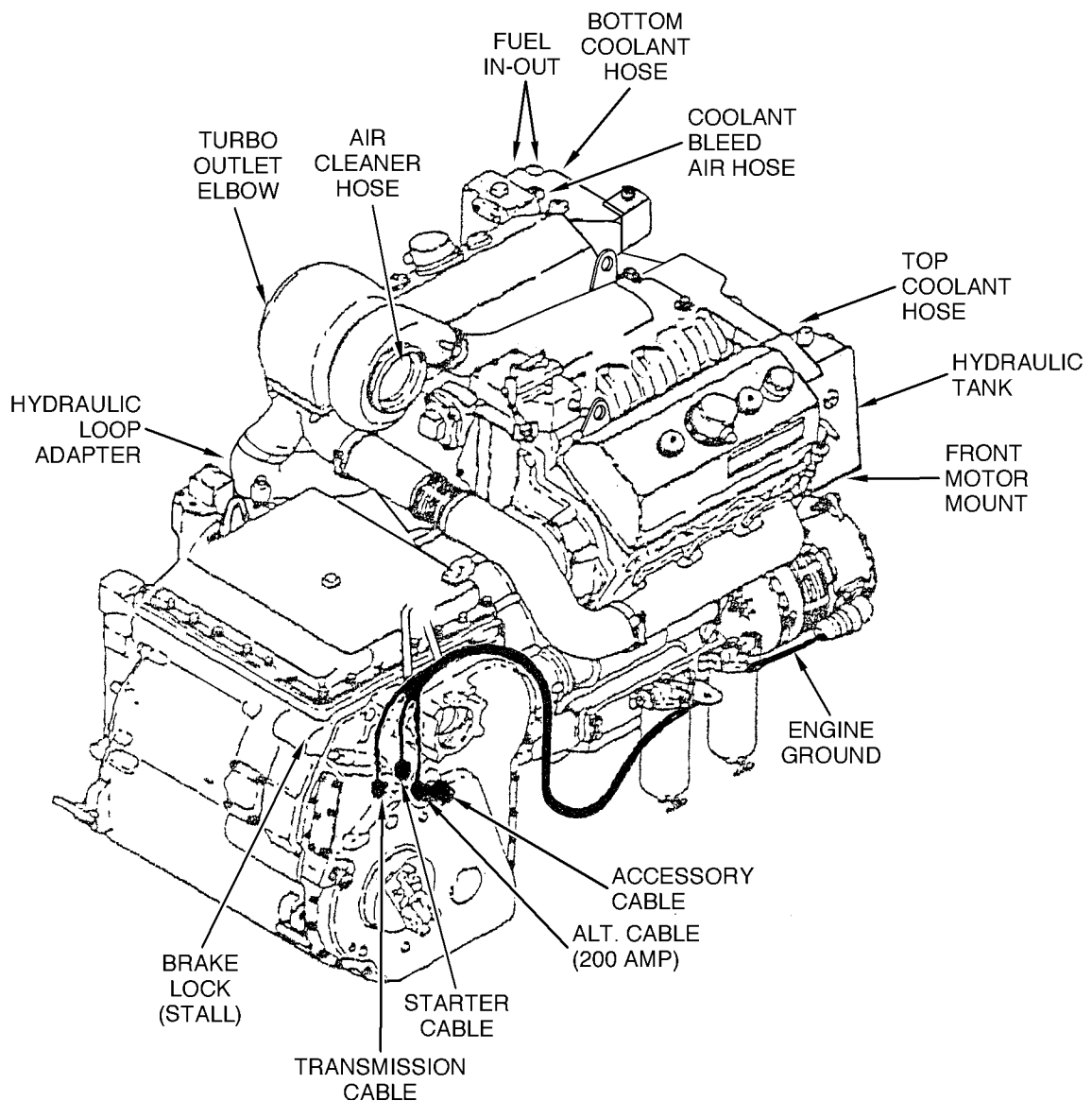

Figure 4-6. Hook-Up List (M113A3/M548A3)

START

20. Place transmission controller in neutral position.
21. Move master switch to **ON** position.
22. Check powerplant test stand's instrument panel, gages, and indicators.
23. Move fuel pump switch to **ON** position.

WARNING

- **Moving powerplant parts could injure you. Stay clear of moving parts when powerplant is running.**
- **Noise from powerplant could damage hearing. Use double ear protection when powerplant is operated.**

CAUTION

Starter can be damaged. Do not hold start switch in start position for more than 15 seconds at a time.

NOTE

If engine does not start on first try, wait one minute and try again. If engine does not start after three tries, troubleshoot engine. Refer to TM 9-2350-247-20-1, TM 9-2350-277-20-1, TM 9-2350-366-20-1, or TM 9-2815-205-34.

24. Push start switch (instrument panel) until engine starts, but no longer than 15 seconds.
25. Check that transmission oil pressure light and engine low pressure light go off.

WARNING

Hot radiator water can burn you. Use hand to remove cap only if cool to touch. Turn cap slowly to release pressure. Replace cap by pressing down and turning cap until tight.

26. Run engine for 15 minutes. Stop engine and refill radiator. Use caution, water can burn.
27. Check for leaks and other problems. Check all fluid levels and fill as necessary. Restart the engine.
28. Check transmission controller, if all ranges are operational, warm up transmission.
29. To troubleshoot/test the powerplant, refer to TM 9-2350-247-20-1, TM 9-2350-277-20-1, TM 9-2350-366-20-1, or TM 9-2815-205-34 for the engine and TM 9-2520-272-34&P for the transmission.
30. If the engine runs away (rpm is maximum) and the throttle is in the idle position, first move shutoff lever on governor to close position then cut off air intake (use newspaper or book). See Figure 4-7 for position of shut-off lever. Then troubleshoot the problem. Refer to TM 9-2815-205-34 if it is an internal engine problem. Refer to TM 9-2350-247-20-1, TM 9-2350-366-20-1, and TM 9-2350-277-20-1 if it is an external engine problem.

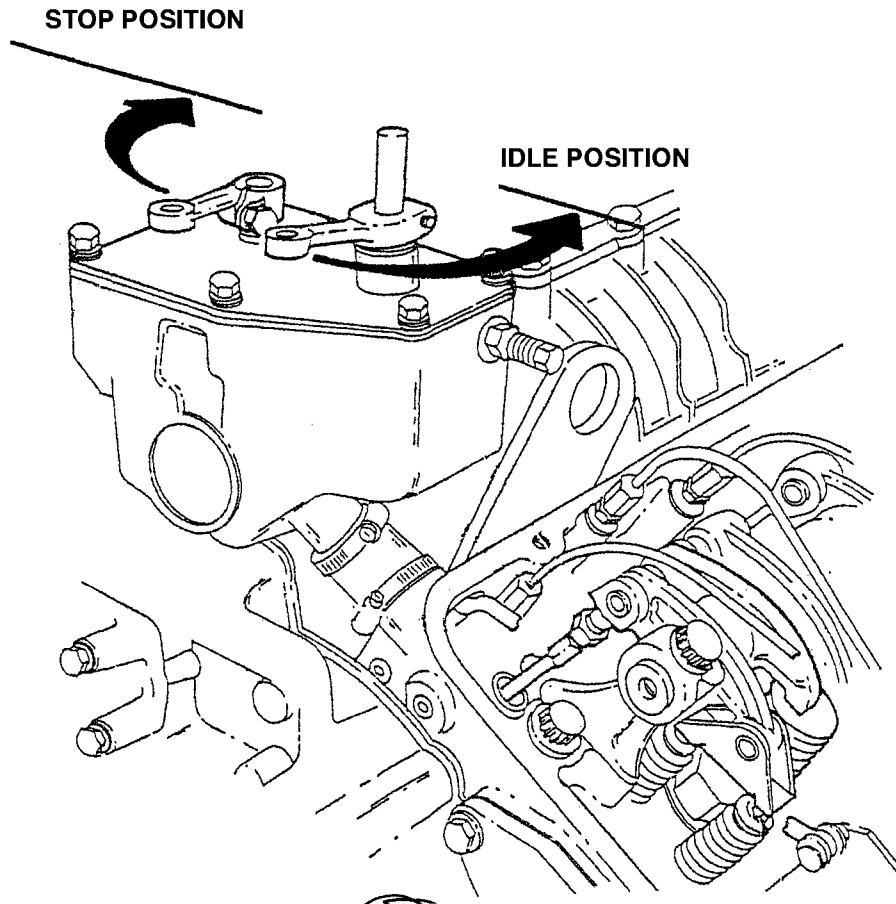

Figure 4-7. Throttle and Shutoff Levers

31. Perform stall test as follows:

CAUTION

The stall check in this procedure is not allowed when engine is in vehicle. Using stall check can harm engine and/or transmission if not conducted properly.

NOTE

- The stall check will tell you if the powerplant is producing maximum power. If it is not, the check will tell you whether the engine or transmission is at fault. This check is to be used only if no other check is available.
- M113A3/M548A3 OSV engines with X200-4 or X200-4A transmissions shall be rated at 275 horsepower +/- 5 percent at 2800 rpm, using DF2 fuel. There will be an additional 10% decrease in horsepower when using JP8 fuel. The minimum horsepower allowed is 235.12.

- Run engine at 800 rpm for 3–5 minutes with range selector in 1 range and brakes locked until normal engine operating temperature is reached.

- b) In outside temperature is less than 85°F (29°C), normal operating temperature should be 160° to 200°F (71° to 90°C). If outside air temperature is greater than 85°F (29°C), normal operating temperature should be 160° to 225°F (71° to 107°C).

CAUTION

Limit stall test to 30 seconds. Full throttle use with brakes locked overheats oil and will damage powerplant. If you suspect a bad governor, do not perform stall check. Unless absolutely necessary do NOT use stall check, use alternate test.

- c) Lock brakes, move range selector to range 1 and push accelerator all the way down.

NOTE

Extremely high ambient temperature and high altitude will reduce stall speed.

- d) If carrier is equipped with an X200-4 transmission, tachometer readings above 2450 means transmission problems and readings below 2350 means engine problems. Troubleshoot suspect systems or check for wrong tachometer adapter. If fault cannot be found, notify direct support maintenance.
- e) If carrier is equipped with an X200-4A transmission, tachometer readings above 2300 means transmission problems and readings below 1900 means engine problems. Troubleshoot suspect systems or check for wrong tachometer adapter. If fault cannot be found, notify direct support maintenance.

STOP

- 32. Pull stop lever to stop position.
- 33. Turn master switch to **OFF** position.

REMOVE

WARNING

Hot oil, water, and engine parts can burn you. Let powerplant cool before you start work.

- 34. Remove turbocharger inlet shield from engine turbocharger inlet.
- 35. Remove clamp and elbow from engine turbocharger exhaust outlet.

WARNING

Hot radiator water can burn you. Use hand to remove cap only if cool to touch. Turn cap slowly to release pressure. Replace cap by pressing down and turning cap until tight.

- 36. Open and drain engine water drain cocks both right and left side. Open transmission oil cooler and radiator drain cocks. Use caution, hot water can burn you. Place a suitable container under drain cocks.
- 37. Remove two cotter pin and shoulder pin from brake stall tool and brake linkage rod.

38. Remove two screws, brake stall test tool, and brake connecting link from transmission.
39. Reinstall two transmission screws that were saved during installation of stall test tool.
40. Disconnect engine fuel line quick disconnect halves from powerplant test stand quick disconnect halves.
41. Disconnect alternator, accessory, starter, transmission cables, and STE/ICE harness from powerplant test stand cables.
42. Disconnect tachometer cable from engine tachometer adapter.
43. Remove wingnut, lockwasher, generator ground lead, and starter ground lead from ground bolt on front engine mount.
44. Remove two clamps and bleeder hose assembly from elbows on deaeration elbow and thermostat housing.
45. Remove radiator hose assembly and clamps from lower engine tube and radiator.
46. Remove radiator hose assembly and clamps from engine deaeration elbow and radiator.
47. Disconnect two hydraulic quick disconnect couplings on hydraulic tank return hose and hydraulic pump outlet hose.
48. Remove two screws, nuts, and four washers from engine front mount.

WARNING

- **Damaged lifting slings can fail with load. Personnel can be killed or injured. Inspect all slings before use. Do not use damaged slings.**
- **Hanging loads can kill or injure you. Keep away from hanging loads and overhead equipment. Keep hands out of area while powerplant is being lifted for removal or lowered for installation.**

49. Attach powerplant sling to lifting brackets and lift powerplant assembly from powerplant test stand. Have helper assist.
50. Remove powerplant from powerplant test stand and place on blocks or prepare it for work or storage area. Refer to TM 38-260. Ensure that powerplant is stable before removing sling.

END OF TASK

TESTING M113A2/M548A1 POWERPLANT

DESCRIPTION

This task covers: Install (page 4-14). Start (page 4-18). Stop (page 4-18). Remove (page 4-19).

INITIAL SETUP

Tools:

General Mechanic's Tool Kit
Powerplant Sling
Turbocharger Inlet Shield 4910-01-127-7959

Materials/Parts:

Grease
Locknuts (2)

Personnel Required:

Unit Mechanic
Helper

References:

TM 9-2350-247-20-1
TM 9-2350-261-20-1
TM 9-2520-254-34
TM 9-2815-205-34
TM 9-4910-571-12&P
TM 38-260

Equipment Conditions:

Powerplant on Blocks
Powerplant Test Stand blocked

INSTALL

WARNING

- **Damaged lifting slings can fail with load. Personnel can be killed or injured. Inspect all slings before use. Do not use damaged slings.**
- **Hanging loads can kill or injure you. Keep away from hanging loads and overhead equipment. Keep hands out of area while powerplant is being lifted for removal or lowered for installation.**

1. Attach powerplant sling to lifting device of at least 3,000 pounds (1,362 kg) capacity.
2. Attach powerplant sling to lifting brackets and lift powerplant assembly from blocks. Have helper assist.

NOTE

Use transfer gearcase mount (see Figures 2-6, 2-8, and 2-9).

3. Install transfer gearcase mount (see Figure 2-8), screw, nut, and two washers in the left transfer gearcase hole.
4. Install screw, nut, and washer in right transfer gearcase hole.
5. Place powerplant assembly on powerplant test stand. Have helper assist.

NOTE

If mount is missing, install engine base mount (10932827 for M113A2 FOV or 5186647 for M548A1), engine support cap, two key washers, and screws on engine.

6. Secure engine front mount to powerplant test stand front mount with two screws, four washers, and two nuts.
7. Secure transfer gearcase mount to powerplant test stand with two screws, washers, and nuts.

NOTE

See Figure 4-8 for partial guide and check list of items to be connected.

8. Install hydraulic system loop between two hydraulic quick disconnect couplings, hydraulic tank outlet hose and hydraulic pump inlet hose. See Figure 2-29.
9. Connect top radiator hose assembly to engine deaeration elbow with clamp.
10. Connect bottom radiator hose assembly to engine flange elbow with clamp. Install pipe plug in engine flange elbow.
11. Connect bleeder hose assembly (see paragraph 2-4, step 10, and Figure 2-17) between elbow on flange elbow (deaeration elbow) and elbow on thermostat housing with two clamps.
12. Fill radiator and engine with water. Coolant is not necessary for testing if weather conditions are above 32°F (0°C).
13. Check all fluid levels and fill as necessary, refer to appropriate TM.
14. Install turbocharger protective shield on engine blower inlet.

WARNING

Noise from powerplant could damage hearing. Use double ear protection when powerplant is operated.

15. Install two elbows and clamps on engine exhaust manifolds. Adjust elbows so that exhaust is directed away from personnel.
16. Connect generator ground lead and starter ground lead to ground bolt on front engine mount with wingnut and lockwasher.

17. Install tachometer cable on engine tachometer adapter and connect to tachometer.
18. Connect alternator, accessory, and starter cables to 100-amp connector panel (Figure 2-18). Ensure that connections are for M113A2/M548A1 only.
19. Connect STE/ICE-R set to engine components, shunt, and batteries. Refer to TM 9-2350-261-20-1 and TM 9-4910-571-12&P for TK mode connections.
20. Connect engine fuel line quick disconnect halves to fuel line adapter (see Figure 2-15) and fuel line adapter to powerplant test stand quick disconnect halves.
21. Install transmission stall test tool (see Figure 2-27) on powerplant test stand with three screws, washers, and nuts.
22. Connect transmission stall test tool to transmission output shaft with four screws and washers.
23. Fill transmission and engine with oil. Refer to appropriate TM.
24. Perform stall test as follows:

CAUTION

The stall check in this procedure is not allowed when engine is in vehicle. Using stall check can harm engine and/or transmission if not conducted properly.

NOTE

- **The stall check will tell you if the powerplant is producing maximum power. If it is not, the check will tell you whether the engine or transmission is at fault.**
 - **If check fails and a faulty tachometer is suspected, verify tachometer reading by performing STE-ICE check number 10 before sending to next higher level of maintenance.**
 - **M113A2/M548A1 210 hp non-turbocharged engines shall be rated at 210 horsepower +/- 5 percent at 2800 rpm, using DF2 fuel. There will be an additional 10% decrease in horsepower when using JP8 fuel. The minimum horsepower allowed is 179.5.**
- a) Run engine at 800 rpm for 3–5 minutes with range selector in 2–3 range until normal engine operating temperature is reached.
 - b) In outside temperature is less than 85°F (29°C), normal operating temperature should be 160° to 200°F (71° to 90°C). If outside air temperature is greater than 85°F (29°C), normal operating temperature should be 160° to 225°F (71° to 107°C).

CAUTION

Limit stall test to 30 seconds. If you suspect a bad governor, do not perform stall check.

- c) Move range selector to the 2–3 range and push accelerator all the way down. Tachometer reading of 1900 to 2300 rpm indicates powerplant is operating correctly.

NOTE

- Extremely high ambient temperature and high altitude will lower stall speed.
 - Use STE-ICE to verify the tachometer is calibrated or to get a reading when performing a stall check.
 - If check fails and a faulty tachometer is suspected, verify tachometer reading by performing STE-ICE check number 10 before sending to next higher level of maintenance.
- d) Tachometer reading above 2100 indicates transmission problems. Tachometer reading below 1900 rpm indicates a faulty engine. Troubleshoot fuel system. Check for correct vehicle tachometer adapter. If no fault can be found, contact next higher level of maintenance.

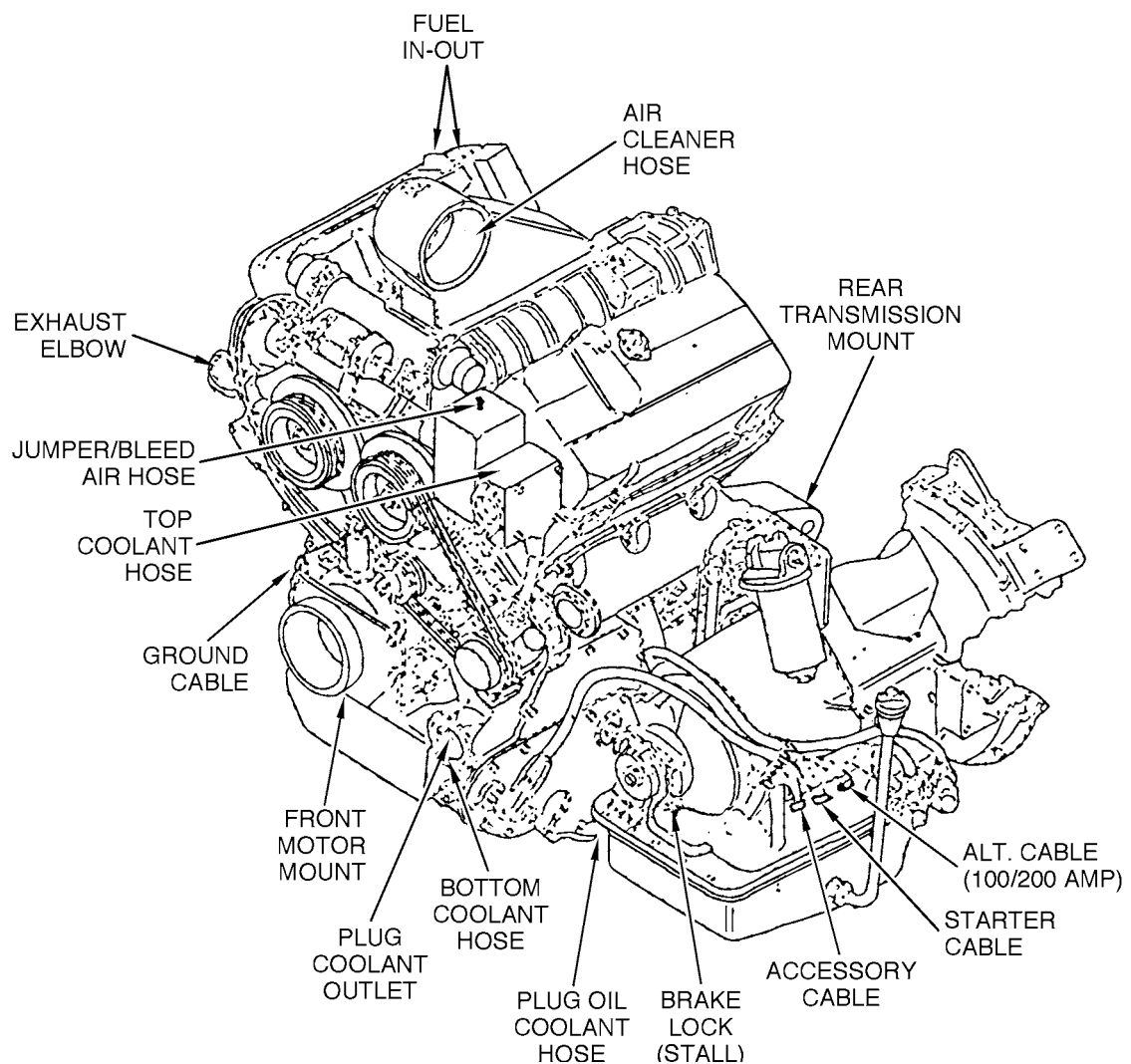

Figure 4-8. Hook-up List (M113A2/M548A1)

START

WARNING

Engine does not have neutral safety switch and will start in any gear.

25. Move transmission arm to neutral position (one detent down from the top).
26. Move master switch to **ON** position.
27. Check instrument panel/box, gages, and indicators.
28. Move fuel pump switch to **ON** position.

WARNING

- **Moving powerplant parts could injure you. Stay clear of moving parts when powerplant is running.**
- **Noise from powerplant could damage hearing. Use double ear protection when powerplant is operated.**

CAUTION

Starter can be damaged. Do not hold start switch in start position for more than 15 seconds at a time.

NOTE

If engine does not start on first try, wait 1 minute and try again. If engine does not start after three tries, troubleshoot engine. Refer to TM 9-2350-261-20.

29. Push start switch (instrument panel/box) until engine starts, but no longer than 15 seconds.
30. Check that transmission oil pressure light and engine low pressure light go off.

WARNING

Hot oil, water, and engine parts can burn you. Let powerplant cool before you start work.

31. Check for leaks and other problems. Stop engine. Check all fluid levels and fill as necessary. Restart engine.
32. Troubleshoot/test powerplant, refer to TM 9-2350-247-20-1, TM 9-2350-261-20-1, TM 9-2520-254-34, or TM 9-2815-205-34.

STOP

33. Move fuel pump switch to **OFF** position and pull lever to stop position (see Figure 4-8).
34. Turn master switch to **OFF** position.

REMOVE**WARNING**

Hot oil, water, and engine parts can burn you. Let powerplant cool before you start work.

35. Remove turbocharger protective shield from engine blower inlet. Cover engine blower inlet with aluminum foil and tape to keep out debris when storing (TM 38-260) the engine or for transporting it.
36. Remove two clamps and elbows from engine exhaust manifolds.

WARNING

Hot radiator water can burn you. Use hand to remove cap only if cool to touch. Turn cap slowly to release pressure. Replace cap by pressing down and turning cap until tight.

37. Place a suitable container under drain cocks. Open and drain engine water drain cocks both right and left side. Open transmission oil cooler and radiator drain cocks.
38. Disconnect transmission stall test tool, four screws, and washers from transmission output shaft (see Figure 2-28).
39. Remove transmission stall test tool, three screws, washers, and nuts from powerplant test stand.
40. Disconnect engine fuel line quick disconnect halves from fuel line adapter and powerplant test stand quick disconnect halves.
41. If used, disconnect STE/ICE-R set from engine. Refer to TM 9-4910-571-12&P.
42. Disconnect alternator, accessory, and starter cables from 100-amp connector panel.
43. Disconnect tachometer cable from engine tachometer adapter.
44. Remove wingnut, lockwasher, generator ground lead, and starter ground lead from ground bolt on front engine mount.
45. Remove two clamps and bleeder hose assembly from elbows on deaeration elbow and thermostat housing.
46. Remove radiator hose assembly and clamp from lower engine flange elbow.
47. Remove radiator hose assembly and clamp from deaeration elbow.
48. Disconnect hydraulic system loop from hydraulic tank outlet hose and hydraulic pump inlet hose.
49. Remove two screws, locknuts, and four washers from engine front mount and powerplant test stand front mount.
50. Remove two screws, washers, and nuts from transfer gearcase mount and powerplant test stand.

WARNING

- **Damaged lifting slings can fail with load. Personnel can be killed or injured. Inspect all slings before use. Do not use damaged slings.**
- **Hanging loads can kill or injure you. Keep away from hanging loads and overhead equipment. Keep hands out of area while powerplant is being lifted for removal or lowered for installation.**

51. Attach powerplant sling to lifting brackets and lift powerplant assembly from powerplant test stand. Have helper assist.
52. Remove screw, nut, and washer from right transfer gearcase hole.
53. Remove transfer gearcase mount, screw, nut, and two washers from the left transfer gearcase hole.
54. Prepare powerplant for work or storage area. Refer to TM 38-260. Ensure that powerplant is stable before removing sling.

END OF TASK

TESTING ENGINE ONLY

DESCRIPTION

This task covers: Install (page 4-21). Start (page 4-23). Shutoff (page 4-24). Remove (page 4-24).

INITIAL SETUP

Tools:

General Mechanic's Tool Kit

Engine Sling

Turbocharger Inlet Shield 4910-01-127-7959

Materials/Parts:

Grease

Locknuts (2)

Personnel Required:

Unit Mechanic

Helper

References:

LO 9-2350-247-12

LO 9-2350-261-12

LO 9-2350-277-12

TM 9-2350-247-20-1

TM 9-2350-261-20-1

TM 9-2350-277-20-1

TM 9-2350-366 Series

TM 9-2815-205-34

TM 38-260

Equipment Conditions:

Engine on maintenance stand or blocks

Powerplant test stand blocked

INSTALL

WARNING

- **Damaged lifting slings can fail with load. Personnel can be killed or injured. Inspect all slings before use. Do not use damaged slings.**
- **Hanging loads can kill or injure you. Keep away from hanging loads and overhead equipment. Keep hands out of area while engine is being lifted for removal or lowered for installation.**

NOTE

- **OSV has A3 engine and TX200-4/4A transmission.**
- **If testing OSV, refer to TM 9-2350-366 series.**

1. Attach engine sling to lifting brackets and lift engine. Have helper assist.
2. Attach appropriate engine sling to lifting device of at least 2,000 pounds (908 kg) capacity.

3. Install four screws, washers, nuts, and engine-only rear mount bracket on engine flywheel housing (Figure 2-10). Have helper assist.
4. Place engine on powerplant test stand. Have helper assist.
5. Secure the engine only rear mount (see Figure 2-10) to powerplant test stand with two screws, flat washers, and nuts.
6. Secure engine front mount to powerplant test stand front mount (see Figure 2-6) with two screws, washers, and nuts.
7. Connect two hydraulic quick disconnect couplings, hydraulic tank return (male coupling half) hose and hydraulic pump outlet (female coupling half).
8. Connect top radiator hose assembly to engine deaeration elbow with clamp.
9. Connect bottom radiator hose assembly to engine tube with clamp.
10. Connect bleeder hose assembly between elbow on flange elbow (deaeration elbow) and elbow on thermostat housing with two clamps (see paragraph 2-4, step 10, and Figure 2-17).
11. Fill radiator and engine with water. Coolant is not necessary for testing.
12. Check all fluid levels and filled as necessary. Refer to LO 9-2350-277-12 or LO 9-2350-247-12.

WARNING

The turbocharger can grind off a part or all of your hand. Place a screen or some type of guard over turbocharger intake manifold if air cleaner system is not used. Any objects that are ingested into the intake will damage the engine.

13. Install turbocharger inlet shield on engine turbocharger inlet.

WARNING

Noise from powerplant could damage hearing. Use double ear protection when powerplant is operated.

14. Install elbow and clamp on engine turbocharger exhaust outlet. Adjust elbow so that exhaust is directed away from personnel.
15. Connect generator ground lead and starter ground lead to ground bolt on front engine mount with wingnut and lockwasher.

NOTE

Tachometer is not necessary when using STE-ICE. If tachometer is needed, a hand held tachometer is better suited for making adjustments. Only the M113A3 FOV powerplant is wired with STE-ICE transducers and harness connected on the engine.

16. Install tachometer cable on engine tachometer adapter and connect to tachometer.
17. Connect alternator, accessory, starter, and transmission cables to instrument panel/box cables (M113A3/M548A3 only) or 100-amp connector panel (M113A2/M548A1 only).
18. Connect STE/ICE harness to instrument panel/box (M548A3, M548A1, and M113A2 FOV must connect STE/ICE and transducers to powerplant) and make connections to engine components, shunt, and batteries. Refer to TM 9-2350-277-20.
19. Connect engine fuel line quick disconnect halves to powerplant test stand quick disconnect halves.
20. Install right brake connecting links, two screws, lockwashers, and flat washers on right transmission brake (M113A3 and M548A3 only).

CAUTION

Do not use screws removed from transmission. Damage of screws may damage transmission.

21. Remove two screws from the right side of transmission (M113A3 and M548A3 only). Save transmission screws. Install brake stall test tool (see Figure 2-28) and secure with two screws. Connect brake stall test tool to braking hardware. Use rod-end clevis and rod-end connector. Connect rigid connecting link between two 1/4 inch steel plates and secure with headed pin, washer, and cotter pin.
22. Install transmission stall test tool (M548A1 and M113A2 FOV only) (Figure 2-27) on powerplant test stand with three screws, washers, and nuts .
23. Connect transmission stall test tool to transmission output shaft with four screws and washers.
24. Fill engine and transmission with oil. Refer to LO 9-2350-277-12 (M113A3 FOV) or LO 9-2350-247-12 (M548A1 and M548A3) or LO 9-2350-261-12 (M113A2 FOV).
25. The engine will need to have plugs or caps installed in the engine/transmission oil cooler. This prevents oil from spilling out during operation.
26. Check engine oil level. Fill if required. Refer to LO 9-2350-277-12 for M113A3 FOV, LO 9-2350-261-12 for M113A2 FOV, and LO 9-2350-247-12 for M548A1/A3.

START

NOTE

Engine does not have neutral safety switch and will start in any gear.

27. Move transmission arm to neutral position (one detent down from the top) (M548A1 and M113A2 FOV).
28. Move master switch to **ON** position.
29. Check instrument panel/box, gages, and indicators.
30. Move fuel pump switch to **ON** position.

WARNING

- **Moving powerplant parts could injure you or foreign objects will damage the flywheel or engine. Stay clear of moving parts when powerplant is running.**
- **Noise from powerplant could damage hearing. Use double ear protection when powerplant is operated.**

CAUTION

Starter can be damaged. Do not hold start switch in start position for more than 15 seconds at a time

NOTE

If engine does not start on first try, wait one minute and try again. If engine does not start after three tries, troubleshoot engine. Refer to TM 9-2350-261-20.

31. Push start switch (instrument panel/box) until engine starts, but no longer than 15 seconds.
32. Check that transmission oil pressure light and engine low pressure light go off.

WARNING

Hot oil, water, and engine parts can burn you. Let powerplant cool before you start work.

33. Follow procedures for operating the engine. Run the engine for 10 minutes and check for leaks. Check all fluid levels and fill as necessary.
34. Make any adjustments or repairs to engine as required. Refer to the appropriate technical manual. TM 9-2815-205-34 covers all M113 FOV.
35. Troubleshoot/test engine, refer to TM 9-2350-261-20-1, TM 9-2350-247-20-1, TM 9-2350-277-20-1, or TM 9-2815-205-34.

SHUTOFF

36. Move fuel pump switch to off position and pull stop lever to stop position (see Figure 4-8).
37. Turn master switch to off position.

REMOVE

WARNING

Hot oil, water, and engine parts can burn you. Let powerplant cool before you start work.

38. Remove turbocharger protective shield from engine blower inlet. Cover engine blower inlet with tape or cardboard and tape to keep out debris when storing (TM 38-260) the engine or for transporting it.

39. Remove two clamps and elbows (M548A1 and M113A2 FOV) from engine exhaust manifolds.

WARNING

Hot radiator water can burn you. Use hand to remove cap only if cool to touch. Turn cap slowly to release pressure. Replace cap by pressing down and turning cap until tight.

40. Open and drain engine drain water cocks both right and left side. Open transmission oil cooler and radiator drain cocks. Use caution, hot water can burn you. Place a suitable container under drain cocks.
41. Attach engine sling or powerplant sling to engine lifting eyes.
42. Remove two screws, washers, and nuts securing front engine mount to engine test stand.
43. Using a lifting device that can lift 2,000 lb. (908 kg), lift engine off powerplant test stand.
44. Remove four screws, washers, nuts, and engine-only rear mount bracket from engine flywheel housing (see Figure 2-10). Have helper assist.
45. Place in engine container or on maintenance stand. Refer to TM 38-260. Have helper assist.

END OF TASK

CHAPTER 5

POWERPLANT TEST STAND

SECTION I. MAINTENANCE

5.1. PURPOSE. The purpose of this chapter is to give some ideas of how to maintain the powerplant test stand and ways of finding out if the powerplant test stand is at fault when you get the wrong readings while testing a powerplant.

The powerplant test stand is a very simple test stand. It contains all the necessary indicators and gauges needed to verify that everything is working.

The only maintenance that should be done on a regular schedule is cleaning and charging of the batteries. If the powerplant test stand has axles and wheels, some lubricating may be needed.

CAUTION

Instrument panel/box is not sealed and water or moisture may cause electrical short. Never steam clean or wash with water under pressure.

When cleaning instrument panel/box, clean the same as you would clean the instrument panel in a vehicle or by hand wiping using any authorized cleaning agent available.

SECTION II. TROUBLESHOOTING

5.2. INTRODUCTION. This section is about troubleshooting. Troubleshooting is limited to checking wiring of the powerplant test stand. For troubleshooting of the powerplant, refer to TM 9-2350-277-20-1 or to the technical manual of the powerplant that is being tested. For troubleshooting the batteries, refer to TM 9-6140-200-14. The cooling system should not need troubleshooting. If a leak occurs, repair it.

The only difference in troubleshooting the powerplant is that additional circuit breakers have been added at the instrument panel/box to aid you in isolating electrical circuit. See wiring diagram.

Circuit breaker number 1: This circuit breaker tells you that something is wrong with the starting system/transmission controller (A3 only).

Circuit breaker number 2: This circuit breaker tells you that something is wrong with charging system/alternator field switch.

Circuit breaker number 3: This circuit breaker tells you that something is wrong with air box heater/cold start system.

Circuit breaker number 4: This circuit breaker tells you that something is wrong with instrument panel system—lights/ gauges etc.

When a circuit breaker trips, do not assume that the problem is in the powerplant. Like any troubleshooting, you must consider everything in the particular electrical string. For example, if circuit breaker number 1 trips, you must verify that the components in the instrument panel/box are working properly before condemning the powerplant starter. You must also verify that there is not a short in the wiring harness.

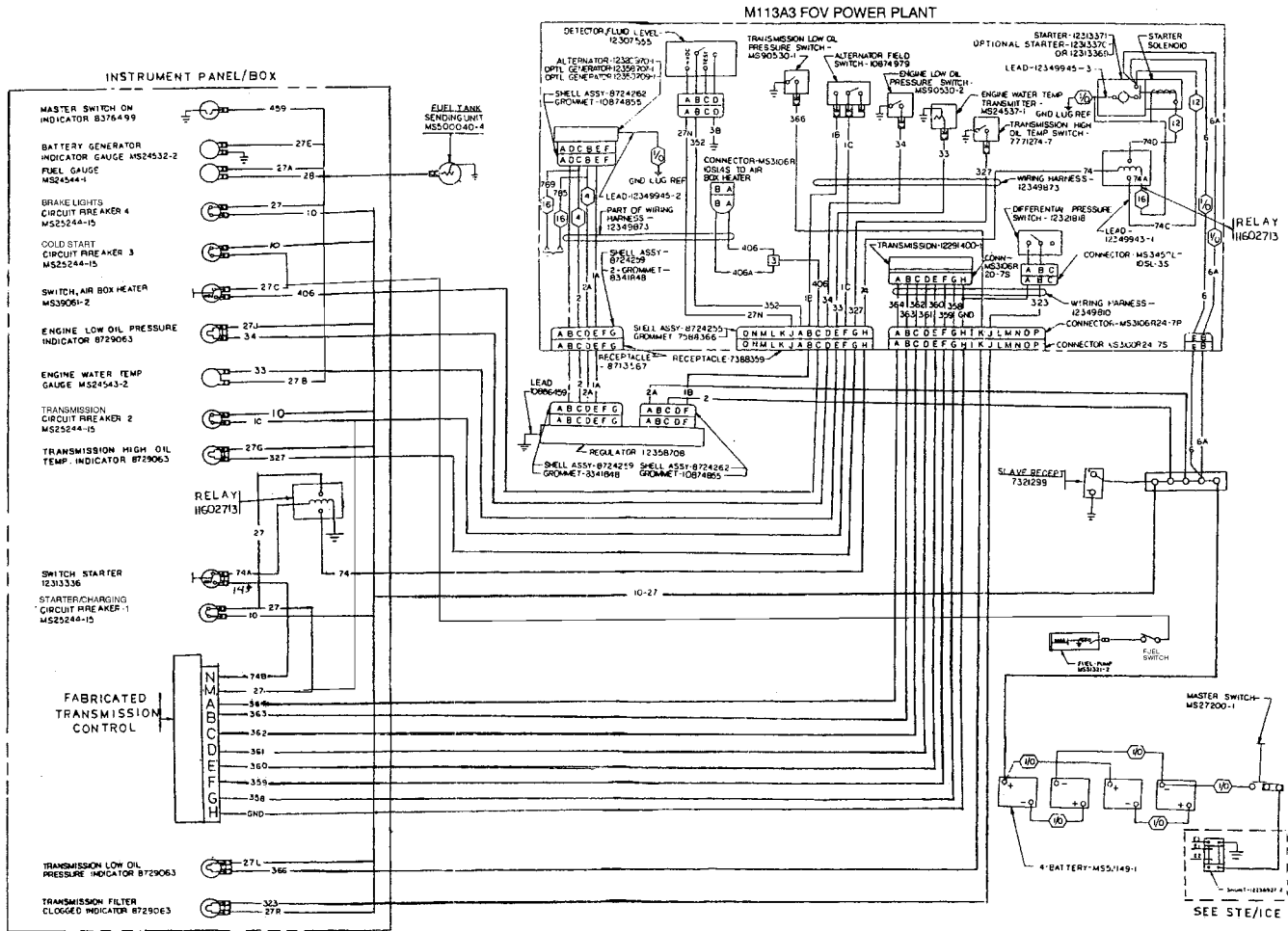

Figure 5-1. Instrument Panel Box—Circuit Breakers

NOTE

- All checks should be made with suitable multimeter and powerplant test stand master switch in the on position.
- Battery voltage can range from 22 to 26 volts without the engine running.

5-3. A3 WIRING HARNESS

1. Turn master switch on. Check four wire **regulator harness** at the end that connects to the regulator. You should get the following readings:

Pin A	Not used	
Pin B	Circuit number 1	Battery voltage
Pin C	Circuit number 2	Battery voltage
Pin D	Circuit number 2A	Battery voltage
Pin E	Circuit number 1A	0 volts
Pin F	Not used	
Pin G	Not used	

2. Turn master switch on. Check three wire **regulator harness** at the end that connects to the regulator. You should get the following readings:

Pin A	Circuit number 2A	Battery voltage
Pin B	Not used	
Pin C	Circuit number 2	Battery voltage
Pin D	Not used	
Pin E	Not used	
Pin F	Circuit number 1B	0 volts

3. Turn master switch on. Check **accessory harness** at the end. You should get the following readings:

Pin A	Not used	
Pin B	Circuit number 1B	0 volts
Pin C	Circuit number 406	Battery voltage (with air box heater switch on.)
Pin D	Circuit number 34	Battery voltage
Pin E	Circuit number 33	14 volts
Pin F	Circuit number 1C	Battery voltage
Pin G	Circuit number 327	Battery voltage
Pin H	Circuit number 74	Battery voltage
Pin J	Not used	
Pin K	Circuit Number 406A	0 volts
Pin L	Not used	
Pin M	Not used	
Pin N	Not used	
Pin O	Not used	

4. Turn master switch on. Check **starter harness** at the end. You should get the following readings:

Pin A	Not used	
Pin B	Circuit number 6A	Battery voltage
Pin C	Not used	
Pin D	Not used	
Pin E	Circuit number 6	Battery voltage

5. Turn master switch on. Check **transmission harness** at the end. You should get the following readings:

SL position	Battery voltage on pins BDEJ
R position	Battery voltage on pins BCEJK
PV position	Battery voltage on pins BDEJK
1-4 position	Battery voltage on pins ACJK
1-3 position	Battery voltage on pins ACEFNJK
1-2 position	Battery voltage on pins ACENJK
1 position	Battery voltage on pins ACEJK

5-4. A2 WIRING HARNESS

1. Turn master switch on. Check four wire **regulator harness** at the end that connects to the regulator. You should get the following readings:

Pin A	Not used	
Pin B	Circuit number 1	0 volts
Pin C	Circuit number 2	0 volts
Pin D	Circuit number 2A	0 volts
Pin E	Circuit number 3A	0 volts
Pin F	Not used	
Pin G	Not used	

2. Turn master switch on. Check three wire **regulator harness** at the end that connects to the regulator. You should get the following readings:

Pin A	Circuit number 2	Battery voltage
Pin B	Not used	
Pin C	Circuit number 3	0 volts
Pin D	Not used	
Pin E	Not used	
Pin F	Circuit number 1B	0 volts

3. Turn master switch on. Check **accessory harness** at the end. You should get the following readings:

Pin A	Not used	
Pin B	Circuit number 1B	0 volts
Pin C	Circuit number 406	0 volts
Pin D	Circuit number 34	Battery voltage
Pin E	Circuit number 33	Battery voltage
Pin F	Circuit number 1A	Battery voltage
Pin G	Circuit number 327	Battery voltage
Pin H	Circuit number 74A	0 volts

4. Turn master switch on. Check **starter harness** at the end. You should get the following readings:

Pin A	Circuit number 6	Battery voltage
-------	------------------	-----------------

APPENDIX A

BILL OF MATERIALS/SCHEMATICS

A-1. BILL OF MATERIALS.

Refer to Table A-1 for the Bill of Materials.

Table A-1. Bill of Materials.

Item	Nomenclature	Part Number	NSN	Qty
	FRAME INSTALLED PARTS			
	Switch pull on/off, master		5930-00-930-5016	1
	Cap filler, radiator		2930-00-770-2677	1
	Radiator, 2-1/2 ton		2930-00-862-6936	1
	Plastic terminal block		5940-00-950-7783	1
	Bus conductor		6150-01-159-6901	1
	Wire, electrical #4		6145-00-337-3188	50 ft
	INSTRUMENT PANEL			
	Gage, fuel	MS24544-2	6680-00-933-3600	1
	Gage, temperature	MS24543-2	6625-00-936-2139	1
	Gage, amp	MS24532-2	6625-01-086-9580	1
	Tachometer		6680-00-825-2067	1
	Shaft assembly, tachometer		6680-00-080-8587	1
	Switch, fuel	MS35058-22	5930-00-655-1514	1
	Switch, glow plug		5930-00-075-7006	1
	Switch, start	12313336	5930-01-704-4458	1
	Light, indicator		6210-00-745-7649	5
	Shifter, M113A3		3010-01-331-2675	1
	Card, circuit, STE-ICE	12354615	5999-01-246-1023	1
	Circuit breaker	MS25244-15	5925-00-686-3301	4
	Harness, wiring, STE-ICE	12354594	4910-01-239-1971	1
	Connector, M113A3, shifter	MS3456W24-7S	5935-01-048-0080	2
	Connector, electrical	MS3450W24-7S	5935-01-013-4479	2
	Connector, electrical	MS3100R24		1
	Connector, electrical, STE-ICE cable	MS3456W28-21S	5935-01-061-1468	2
	Connector, electrical, STE-ICE cable	MS3450W28-15S	5935-01-077-2644	2
	Shunt, STE-ICE	12258937-2	6625-01-175-2503	1
	Relay, electrical	1114536	5945-00-735-9542	1
	Glow plug indicator	12296787-2	6210-01-128-2719	6
	Connector, electrical		5935-00-767-7936	3
	Connector, shell, rubber		5935-00-399-6673	1
	Clamp, cable, right angle		5935-01-193-8434	3
	Connector, shell, rubber		5935-00-833-8561	5
	Insulator, plastic		5970-00-833-8562	5
	Terminal assembly		5940-00-399-6676	1
	Connector, plug		5935-01-047-7976	2
	Clamp, cable		5935-01-174-3669	

Table A-1. Bill of Materials—Continued.

Item	Nomenclature	Part Number	NSN	Qty
	M11A3 CABLES			
	Nut		5935-00-770-8274	2
	Bushing, rubber		5365-00-507-8766	2
	Connector, electrical		5935-01-246-9207	2
	Connector		5935-00-502-9262	1
	Connector		5935-00-178-6075	2
	Bushing		5865-00-303-4841	1
	Loop clamp		5340-00-598-0146	5
	Loop clamp		5340-00-689-9514	6
	Back shell connector		5935-01-193-5694	1
	Back shell connector		5935-01-174-3672	1
	Back shell connector		5935-01-189-3225	1
	Nut, plain		5310-00-393-6685	2
	Nut, coupling		5975-00-771-6634	1
	Bushing, nonmetallic		5365-00-507-8766	2
	Connector plug, electrical		5935-00-080-1020	2
	FUEL SYSTEM			
	Coupling half, quick disconnect		4730-01-140-8250	1
	Coupling half, quick disconnect		4730-01-140-8251	1
	Locknut, tubing		4730-01-093-8464	2
	Elbow, tube		4730-00-434-6394	1
	Reducer body, tube		4730-00-675-9216	2
	Nut, tube, coupling		4730-00-812-2434	3
	Pump, fuel		2910-00-930-9367	1
	Elbow, tube		4730-00-891-9967	2
	Cap, filler		2590-01-155-5063	1
	Filler neck		2590-01-155-5148	1
	Hose, preformed		4720-01-155-8062	1
	Hose, preformed		4720-01-148-6984	1
	Clamp, hose		4730-00-909-8627	1
	Clamp, hose		4730-00-908-3195	12
	Filter, fluid		2910-00-781-1354	1
	Filter, fluid strainer		2910-00-050-9838	1
	Clamp, loop		5340-00-664-8163	6
	Hose assembly		4720-01-254-9873	2
	Coupling, quick disconnect		4730-00-904-8104	1
	Coupling, quick disconnect		4730-00-800-2828	1
	Plug, pipe		4730-00-011-2578	4
	Elbow, pipe to tube		4730-00-230-8731	2
	Bushing, pipe		4730-00-580-7417	2
	Clamp, hose		4730-00-908-3195	6
	HYDRAULIC LOOP			
	Coupling half, quick disconnect	10865913	4730-00-800-2828	2
	Nipple, pipe	Bench stock		1

A-2. SCHEMATICS.

Refer to Figures A-1 thru A-4 for schematics.

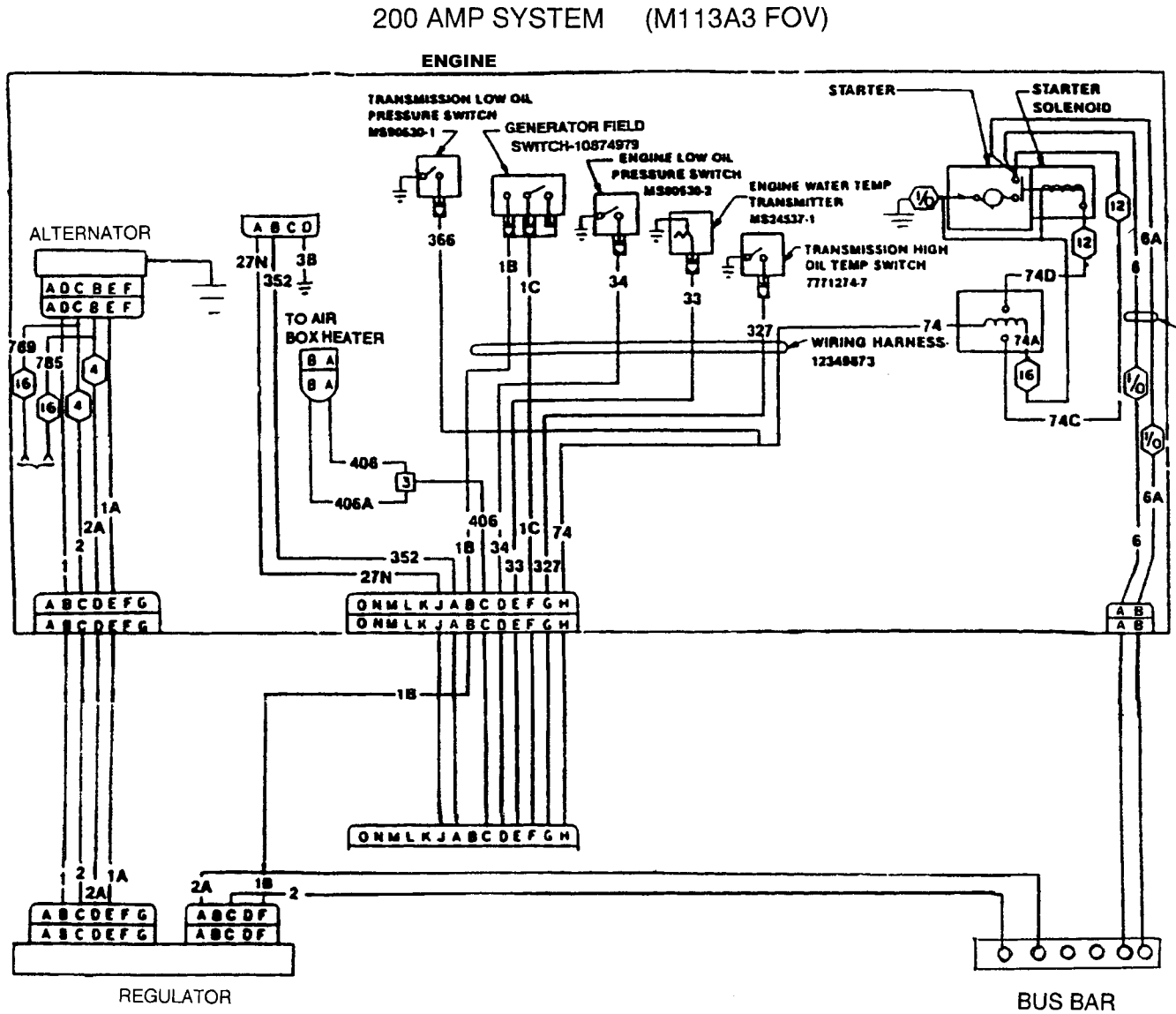

Figure A-1. 200-Amp System (M113 FOV)

100 AMP SYSTEM (M113A2 FOV)

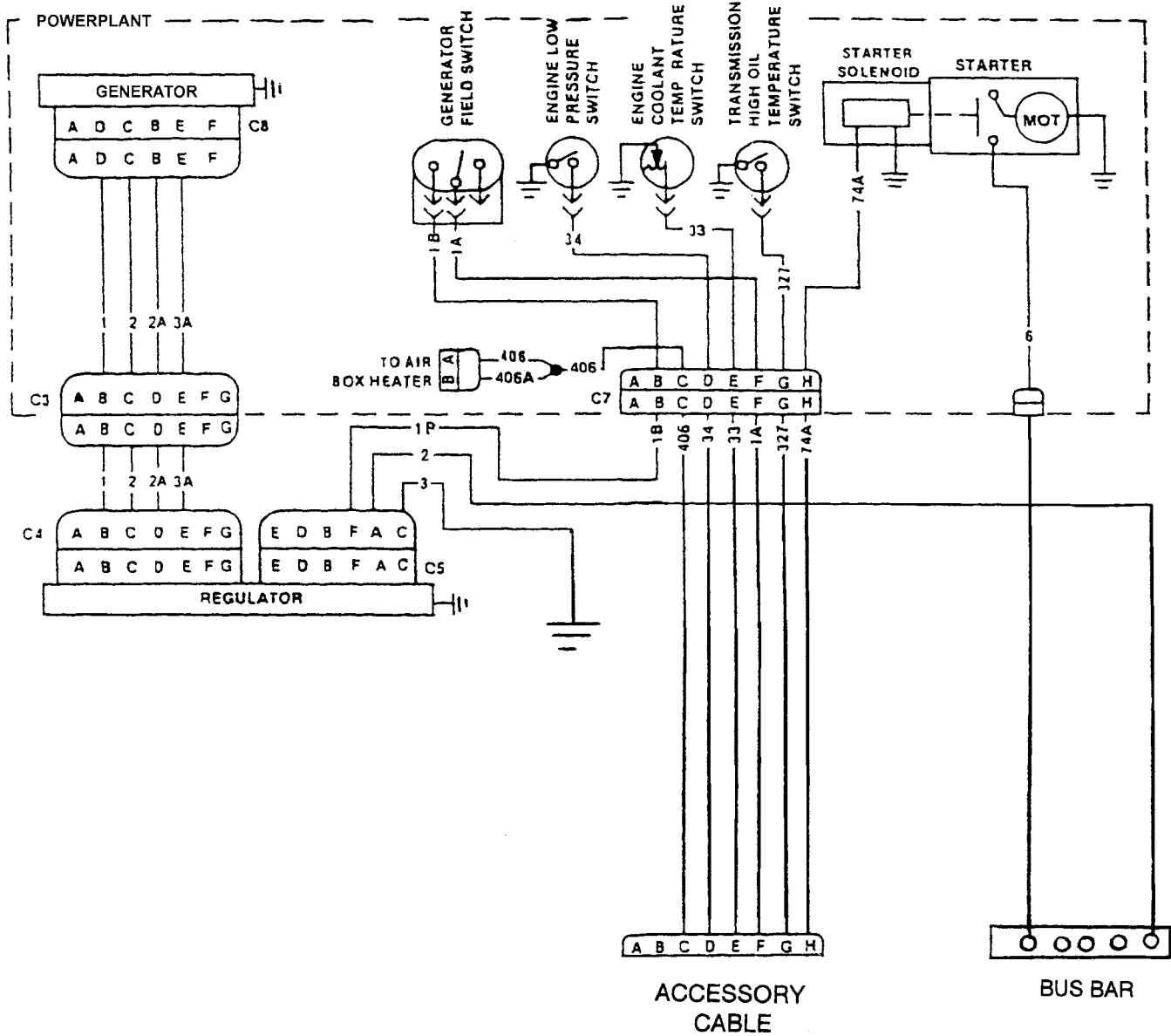

Figure A-2. 100-Amp System (M113A2 FOV)

200 AMP SYSTEM (M113A2 FOV)

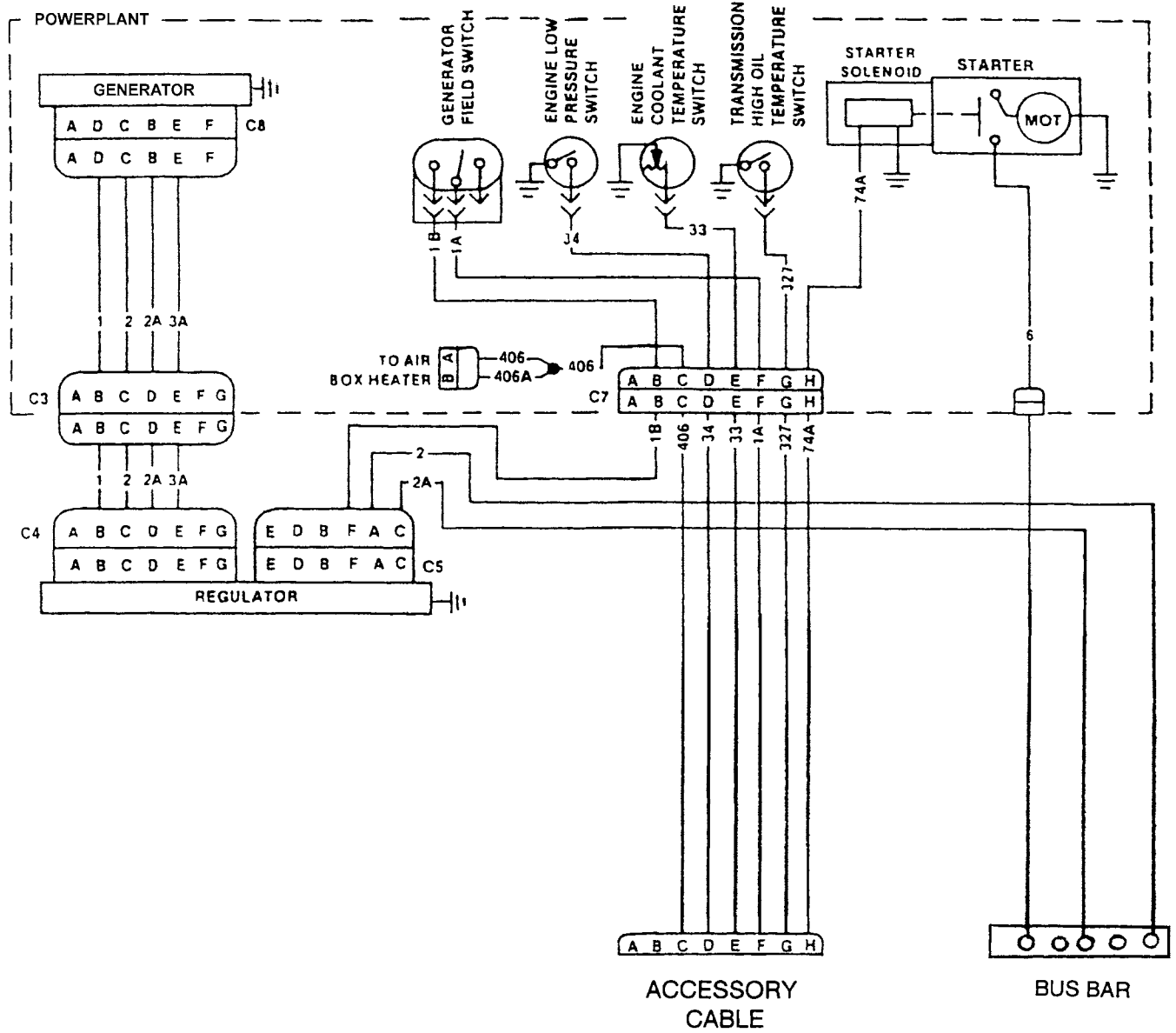

Figure A-3. 200-Amp System (M113A2 FOV)

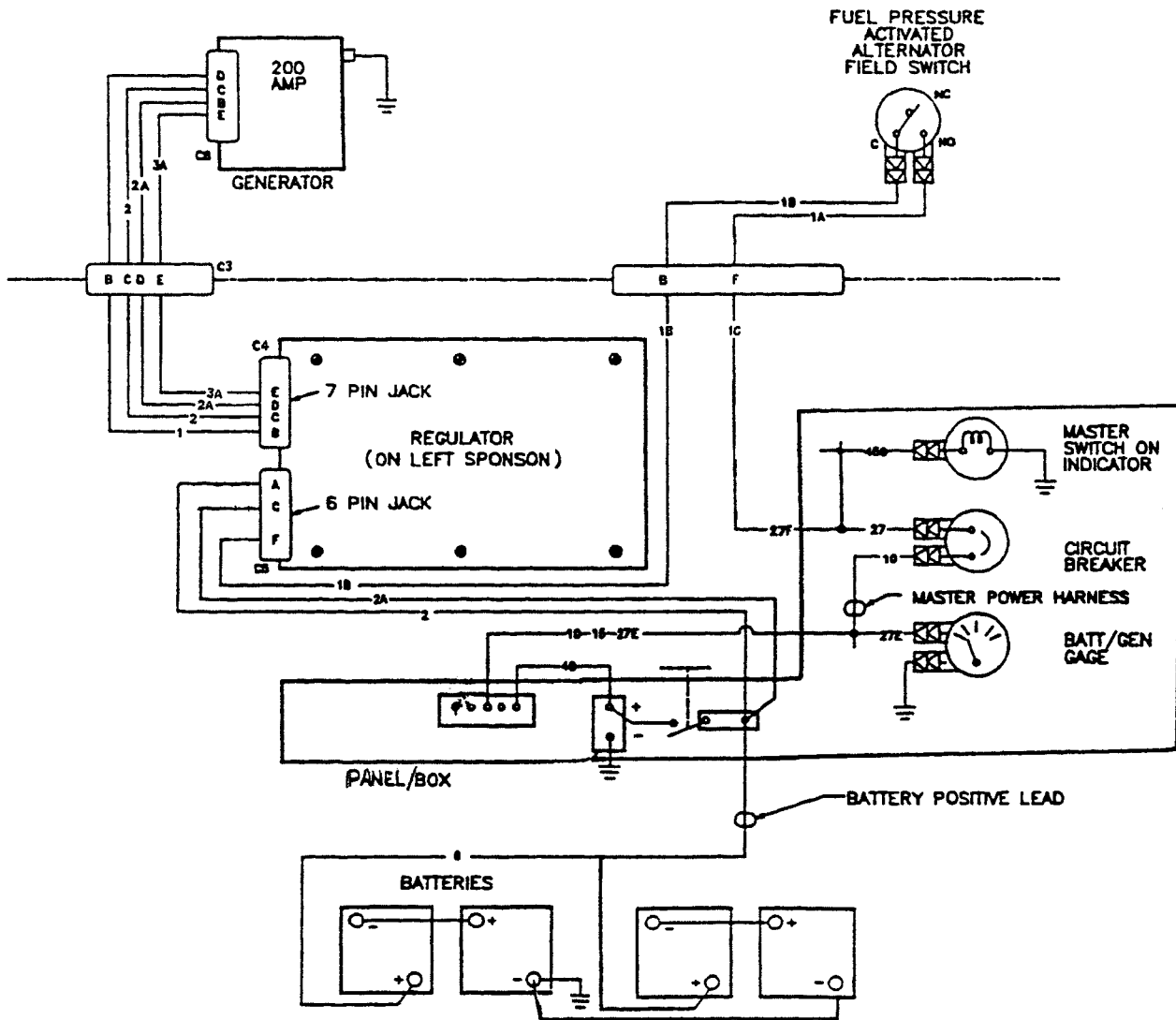

Figure A-4. 200-Amp Charging System

By Order of the Secretary of the Army:

Official:



JOEL B. HUDSON

*Administrative Assistant to the
Secretary of the Army*

0225509

ERIC K. SHINSEKI
*General, United States Army
Chief of Staff*

DISTRIBUTION: To be distributed in accordance with the initial distribution number (IDN) 372571, requirements for TB 9-2350-368-25.

<p align="center">RECOMMENDED CHANGES TO PUBLICATIONS AND BLANK FORMS</p> <p align="center"><small>For use of this form, see AR 25-30; the proponent agency is ODISC4.</small></p>	<p>Use Part II (reverse) for Repair Parts and Special Tool Lists (RPSTL) and Supply Catalogs/Supply Manuals (SC/SM).</p>	<p>DATE</p>
---	--	-------------

<p>TO: (Forward to proponent of publication or form) (Include ZIP Code)</p>	<p>FROM: (Activity and location) (Include ZIP Code)</p>
--	--

PART I - ALL PUBLICATIONS (EXCEPT RPSTL AND SC/SM) AND BLANK FORMS

<p>PUBLICATION/FORM NUMBER</p>	<p>DATE</p>	<p>TITLE</p>
--------------------------------	-------------	--------------

ITEM	PAGE	PARA-	LINE	FIGURE NO.	TABLE	RECOMMENDED CHANGES AND REASON

** Reference to line numbers within the paragraph or subparagraph.*

<p>TYPED NAME, GRADE OR TITLE</p>	<p>TELEPHONE EXCHANGE/AUTOVON, PLUS EXTENSION</p>	<p>SIGNATURE</p>
-----------------------------------	---	------------------

TO: <i>(Forward direct to addressee listed in publication)</i>	FROM: <i>(Activity and location) (Include ZIP Code)</i>	DATE
---	--	-------------

PART II - REPAIR PARTS AND SPECIAL TOOL LISTS AND SUPPLY CATALOGS/SUPPLY MANUALS

PUBLICATION NUMBER			DATE	TITLE				
PAGE NO.	COLM NO.	LINE NO.	NATIONAL STOCK NUMBER	REFERENCE NO.	FIGURE NO.	ITEM NO.	TOTAL NO. OF MAJOR ITEMS SUPPORTED	RECOMMENDED ACTION

PART III - REMARKS *(Any general remarks or recommendations, or suggestions for improvement of publications and blank forms. Additional blank sheets may be used if more space is needed.)*

TYPED NAME, GRADE OR TITLE	TELEPHONE EXCHANGE/AUTOVON, PLUS EXTENSION	SIGNATURE
----------------------------	--	-----------

<p align="center">RECOMMENDED CHANGES TO PUBLICATIONS AND BLANK FORMS</p> <p align="center"><small>For use of this form, see AR 25-30; the proponent agency is ODISC4.</small></p>	<p><small>Use Part II (reverse) for Repair Parts and Special Tool Lists (RPSTL) and Supply Catalogs/Supply Manuals (SC/SM).</small></p>	<p><small>DATE</small></p>
---	---	----------------------------

<p><small>TO: (Forward to proponent of publication or form) (Include ZIP Code)</small></p>	<p><small>FROM: (Activity and location) (Include ZIP Code)</small></p>
--	--

PART I - ALL PUBLICATIONS (EXCEPT RPSTL AND SC/SM) AND BLANK FORMS

<p><small>PUBLICATION/FORM NUMBER</small></p>	<p><small>DATE</small></p>	<p><small>TITLE</small></p>
---	----------------------------	-----------------------------

<small>ITEM</small>	<small>PAGE</small>	<small>PARA-</small>	<small>LINE</small>	<small>FIGURE NO.</small>	<small>TABLE</small>	<small>RECOMMENDED CHANGES AND REASON</small>

* Reference to line numbers within the paragraph or subparagraph.

<p><small>TYPED NAME, GRADE OR TITLE</small></p>	<p><small>TELEPHONE EXCHANGE/AUTOVON, PLUS EXTENSION</small></p>	<p><small>SIGNATURE</small></p>
--	--	---------------------------------

TO: <i>(Forward direct to addressee listed in publication)</i>	FROM: <i>(Activity and location) (Include ZIP Code)</i>	DATE
---	--	-------------

PART II - REPAIR PARTS AND SPECIAL TOOL LISTS AND SUPPLY CATALOGS/SUPPLY MANUALS

PUBLICATION NUMBER			DATE	TITLE				
PAGE NO.	COLM NO.	LINE NO.	NATIONAL STOCK NUMBER	REFERENCE NO.	FIGURE NO.	ITEM NO.	TOTAL NO. OF MAJOR ITEMS SUPPORTED	RECOMMENDED ACTION

PART III - REMARKS *(Any general remarks or recommendations, or suggestions for improvement of publications and blank forms. Additional blank sheets may be used if more space is needed.)*

TYPED NAME, GRADE OR TITLE	TELEPHONE EXCHANGE/AUTOVON, PLUS EXTENSION	SIGNATURE
----------------------------	--	-----------

<p align="center">RECOMMENDED CHANGES TO PUBLICATIONS AND BLANK FORMS</p> <p align="center"><small>For use of this form, see AR 25-30; the proponent agency is ODISC4.</small></p>	<p><small>Use Part II (reverse) for Repair Parts and Special Tool Lists (RPSTL) and Supply Catalogs/Supply Manuals (SC/SM).</small></p>	<p align="center"><small>DATE</small></p>
---	---	---

<p>TO: <i>(Forward to proponent of publication or form) (Include ZIP Code)</i></p>	<p>FROM: <i>(Activity and location) (Include ZIP Code)</i></p>
---	---

PART I - ALL PUBLICATIONS (EXCEPT RPSTL AND SC/SM) AND BLANK FORMS

<p><small>PUBLICATION/FORM NUMBER</small></p>	<p><small>DATE</small></p>	<p><small>TITLE</small></p>
---	----------------------------	-----------------------------

<small>ITEM</small>	<small>PAGE</small>	<small>PARA-</small>	<small>LINE</small>	<small>FIGURE NO.</small>	<small>TABLE</small>	<small>RECOMMENDED CHANGES AND REASON</small>

** Reference to line numbers within the paragraph or subparagraph.*

<p><small>TYPED NAME, GRADE OR TITLE</small></p>	<p><small>TELEPHONE EXCHANGE/AUTOVON, PLUS EXTENSION</small></p>	<p><small>SIGNATURE</small></p>
--	--	---------------------------------

TO: <i>(Forward direct to addressee listed in publication)</i>	FROM: <i>(Activity and location) (Include ZIP Code)</i>	DATE
---	--	-------------

PART II - REPAIR PARTS AND SPECIAL TOOL LISTS AND SUPPLY CATALOGS/SUPPLY MANUALS

PUBLICATION NUMBER			DATE	TITLE				
PAGE NO.	COLM NO.	LINE NO.	NATIONAL STOCK NUMBER	REFERENCE NO.	FIGURE NO.	ITEM NO.	TOTAL NO. OF MAJOR ITEMS SUPPORTED	RECOMMENDED ACTION

PART III - REMARKS *(Any general remarks or recommendations, or suggestions for improvement of publications and blank forms. Additional blank sheets may be used if more space is needed.)*

TYPED NAME, GRADE OR TITLE	TELEPHONE EXCHANGE/AUTOVON, PLUS EXTENSION	SIGNATURE
----------------------------	--	-----------

<p align="center">RECOMMENDED CHANGES TO PUBLICATIONS AND BLANK FORMS</p> <p align="center"><small>For use of this form, see AR 25-30; the proponent agency is ODISC4.</small></p>	<p><small>Use Part II (reverse) for Repair Parts and Special Tool Lists (RPSTL) and Supply Catalogs/Supply Manuals (SC/SM).</small></p>	<p><small>DATE</small></p>
---	---	----------------------------

<p>TO: <i>(Forward to proponent of publication or form) (Include ZIP Code)</i></p>	<p>FROM: <i>(Activity and location) (Include ZIP Code)</i></p>
---	---

PART I - ALL PUBLICATIONS (EXCEPT RPSTL AND SC/SM) AND BLANK FORMS

<p><small>PUBLICATION/FORM NUMBER</small></p>	<p><small>DATE</small></p>	<p><small>TITLE</small></p>
---	----------------------------	-----------------------------

<small>ITEM</small>	<small>PAGE</small>	<small>PARA-</small>	<small>LINE</small>	<small>FIGURE NO.</small>	<small>TABLE</small>	<small>RECOMMENDED CHANGES AND REASON</small>

** Reference to line numbers within the paragraph or subparagraph.*

<p><small>TYPED NAME, GRADE OR TITLE</small></p>	<p><small>TELEPHONE EXCHANGE/AUTOVON, PLUS EXTENSION</small></p>	<p><small>SIGNATURE</small></p>
--	--	---------------------------------

TO: <i>(Forward direct to addressee listed in publication)</i>	FROM: <i>(Activity and location) (Include ZIP Code)</i>	DATE
---	--	-------------

PART II - REPAIR PARTS AND SPECIAL TOOL LISTS AND SUPPLY CATALOGS/SUPPLY MANUALS

PUBLICATION NUMBER			DATE	TITLE				
PAGE NO.	COLM NO.	LINE NO.	NATIONAL STOCK NUMBER	REFERENCE NO.	FIGURE NO.	ITEM NO.	TOTAL NO. OF MAJOR ITEMS SUPPORTED	RECOMMENDED ACTION

PART III - REMARKS *(Any general remarks or recommendations, or suggestions for improvement of publications and blank forms. Additional blank sheets may be used if more space is needed.)*

TYPED NAME, GRADE OR TITLE	TELEPHONE EXCHANGE/AUTOVON, PLUS EXTENSION	SIGNATURE
----------------------------	--	-----------

THE METRIC SYSTEM AND EQUIVALENTS

LINEAR MEASURE

1 Centimeter = 10 Millimeters = 0.01 Meters = 0.3937 Inches
 1 Meter = 100 Centimeters = 1000 Millimeters = 39.37 Inches
 1 Kilometer = 1000 Meters = 0.621 Miles

WEIGHTS

1 Gram = 0.001 Kilograms = 1000 Milligrams = 0.035 Ounces
 1 Kilogram = 1000 Grams = 2.2 Lb.
 1 Metric Ton = 1000 Kilograms = 1 Megagram = 1.1 Short Tons

LIQUID MEASURE

1 Milliliter = 0.001 Liters = 0.0338 Fluid Ounces
 1 Liter = 1000 Milliliters = 33.82 Fluid Ounces

SQUARE MEASURE

1 Sq. Centimeter = 100 Sq. Millimeters = 0.155 Sq. Inches
 1 Sq. Meter = 10,000 Sq. Centimeters = 10.76 Sq. Feet
 1 Sq. Kilometer = 1,000 Sq. Meters = 0.386 Sq. Miles

CUBIC MEASURE

1 Cu. Centimeter = 1000 Cu. Millimeters = 0.06 Cu. Inches
 1 Cu. Meter = 1,000,000 Cu. Centimeters = 35.31 Cu. Feet

TEMPERATURE

$5/9 (^{\circ}\text{F} - 32) = ^{\circ}\text{C}$
 212° Fahrenheit is equivalent to 100° Celsius
 90° Fahrenheit is equivalent to 32.2° Celsius
 32° Fahrenheit is equivalent to 0° Celsius
 $(9/5 \times ^{\circ}\text{C}) + 32 = ^{\circ}\text{F}$

TO CHANGE	TO	MULTIPLY BY
Inches	Centimeters	2.540
Feet	Meters	0.305
Yards	Meters	0.914
Miles	Kilometers	1.609
Square Inches	Square Centimeters	6.451
Square Feet	Square Meters	0.093
Square Yards	Square Meters	0.836
Square Miles	Square Kilometers	2.590
Acres	Square Hectometers	0.405
Cubic Feet	Cubic Meters	0.028
Cubic Yards	Cubic Meters	0.765
Fluid Ounces	Milliliters	29.573
Pints	Liters	0.473
Quarts	Liters	0.946
Gallons	Liters	3.785
Ounces	Grams	28.349
Pounds	Kilograms	0.454
Short Tons	Metric Tons	0.907
Pound-Feet	Newton-Meters	1.356
Pounds per Square Inch	Kilopascals	6.895
Miles per Gallon	Kilometers per Liter	0.425
Miles per Hour	Kilometers per Hour	1.609

TO CHANGE	TO	MULTIPLY BY
Centimeters	Inches	0.394
Meters	Feet	3.280
Meters	Yards	1.094
Kilometers	Miles	0.621
Square Centimeters	Square Inches	0.155
Square Meters	Square Feet	10.764
Square Meters	Square Yards	1.196
Square Kilometers	Square Miles	0.386
Square Hectometers	Acres	2.471
Cubic Meters	Cubic Feet	35.315
Cubic Meters	Cubic Yards	1.308
Milliliters	Fluid Ounces	0.034
Liters	Pints	2.113
Liters	Quarts	1.057
Liters	Gallons	0.264
Grams	Ounces	0.035
Kilograms	Pounds	2.205
Metric Tons	Short Tons	1.102
Newton-Meters	Pound-Feet	0.738
Kilopascals	Pounds per Square Inch	0.145
Kilometers per Liter	Miles per Gallon	2.354
Kilometers per Hour	Miles per Hour	0.621

