

TECHNICAL BULLETIN

**INSTALLATION OF COMPARTMENT HEATER
EXHAUST CABLE GUIDE BRACKET
MODIFICATION KIT 57K4278 (6150-01-527-8071)
FOR
CARRIER, M577A2 (2350-01-068-4089)
CARRIER, M1068 (2350-01-354-5657)
CARRIER, M577A3 (2350-01-369-6085)
CARRIER, M1068A3 (2350-01-369-6086)**

DISTRIBUTION STATEMENT A: Approved for public release, distribution is unlimited.

INSERT LATEST UPDATED PAGES/WORK PACKAGES. DESTROY SUPERSEDED DATA.

LIST OF EFFECTIVE PAGES/WORK PACKAGES

Date of issue for original and updated pages/work packages are:

Original 0 29 June 2007

TOTAL NUMBER OF PAGES FOR FRONT AND REAR MATTER IS 20 AND TOTAL NUMBER OF WORK PACKAGES IS 5 CONSISTING OF THE FOLLOWING:

Page/WP No.	*Change No.
Cover	0
A/B blank	0
i/ii blank	0
WP 0001 00 – 0005 00	0
Index-1/2 blank	0
DA 2028 Sample/Reverse	0
DA 2028/Reverse (2)	0
Authentication	0
Metric Chart	0
Back Cover	0

*Zero in this column indicates an original page

A/B blank

Technical Bulletin

**INSTALLATION OF COMPARTMENT HEATER EXHAUST CABLE GUIDE
BRACKET MODIFICATION KIT 57K4278 (6150-01-527-8071)**

FOR

- CARRIER, M577A2 (2350-01-068-4089)**
- CARRIER, M1068 (2350-01-354-5657)**
- CARRIER, M577A3 (2350-01-369-6085)**
- CARRIER, M1068A3 (2350-01-369-6086)**

REPORTING ERRORS AND RECOMMENDING IMPROVEMENTS

You can help improve this publication. If you find any mistakes or if you know of a way to improve the procedures, please let us know. Submit your DA Form 2028 (Recommended Changes to Equipment Technical Publications), through the Internet, on the Army Electronic Product Support (AEPS) website. The Internet address is <http://aeps.ria.army.mil>. If you need a password, scroll down and click on "ACCESS REQUEST FORM". The DA 2028 is located in the ONLINE FORMS PROCESSING section of the AEPS. Fill out the form and click on SUBMIT. Using form on the AEPS will enable us to respond quicker to your comments and better manage the DA Form 2028 program. You may also mail, fax, or E-mail your letter or DA Form 2028 directly to: TACOM Life Cycle Management Command, ATTN: AMSTA-LC-LPIT, 1 Rock Island Arsenal, Rock Island, IL 61299-7630. The email address is: ROCK-TACOM-TECH-PUBS@ria.army.mil. The fax number is DSN 793-0726 or Commercial (309) 782-0726.

DISTRIBUTION STATEMENT A: Approved For Public Release, Distribution Is Unlimited

TABLE OF CONTENTS

	Work Package
Introduction.....	0001 00
Removal Procedures.....	0002 00
Installation Procedures	0003 00
Tool Identification List.....	0004 00
Modification Parts List	0005 00
Index.....	Index-1

INTRODUCTION

0001 00**PURPOSE.**

This bulletin provides instructions and guidance on the method of modifying the M577A2, M1068, M1068A3, or M577A3 vehicles to install the compartment heater exhaust cable guide bracket. The cable guide bracket keeps the wiring harnesses, leads, and cables away from the personnel heater exhaust pipe to prevent burning them. The cable guide bracket also acts as a heat shield to prevent damage to the wiring harnesses, leads, and cables due to long term exposure to the heat produced from operating the personnel heater. Differences between models are noted in the procedures.

SCOPE.

This publication provides for the addition of items required to mount the compartment heater exhaust cable guide bracket on the M577A2, M1068, M577A3, and M1068A3. Units need to order Modification Kit 57K4278 for the new parts required in this technical bulletin (WP 0005 00). The changes will be made to the technical manuals at the next authorized update.

GENERAL.

Standard welding practices will NOT be required for the installation of the compartment heater exhaust cable guide bracket. All existing mounting provisions will be utilized for the purpose of installing the compartment heater exhaust cable guide bracket. To install this kit the personnel heater is not required to be removed.

REMOVAL PROCEDURES**0002 00**

THIS WORK PACKAGE COVERS:

Removal (page 0002 00-1)

INITIAL SETUP**Maintenance Level**

Field

Equipment ConditionsVehicle blocked (TM 9-2350-277-10 or
TM 9-2350-261-10)**Tools and Special Tools**

General Mechanic's Tool Kit (WP 0004 00, Item 1)

REMOVAL**NOTE**

The Personnel Heater Assembly does not have to be removed to install the cable guide bracket. Heater assembly is not shown for clarity to view the proper orientation of the wiring harnesses, cables, and leads. STE-ICE is only on the M577A3 and M1068A3.

1. Battery power leads and STE-ICE wiring harness

- a. Remove strap (1), screw (7), lockwasher (6), and clamp (4) from leads and STE-ICE harness (M577A3 and M1068A3 only) (5), compartment heater ground wire (3), and lockwasher (2). Discard strap, clamp, and lockwashers.

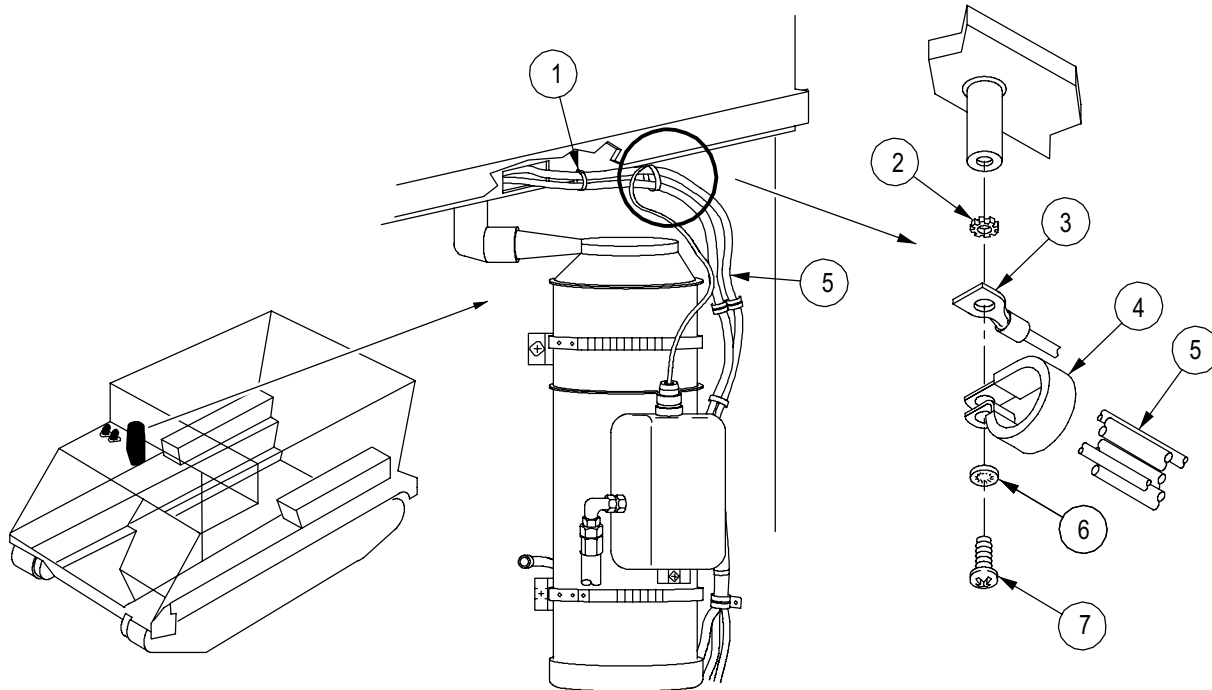
**M577A3/M1068A3 Shown**

REMOVAL PROCEDURES – (continued)**0002 00****2. Personnel Heater Exhaust Clamp**

- a. Remove two nuts (1), U-bolt (2), and clamp (4) from exhaust pipe (3). Discard nuts, U-bolt, and clamp.

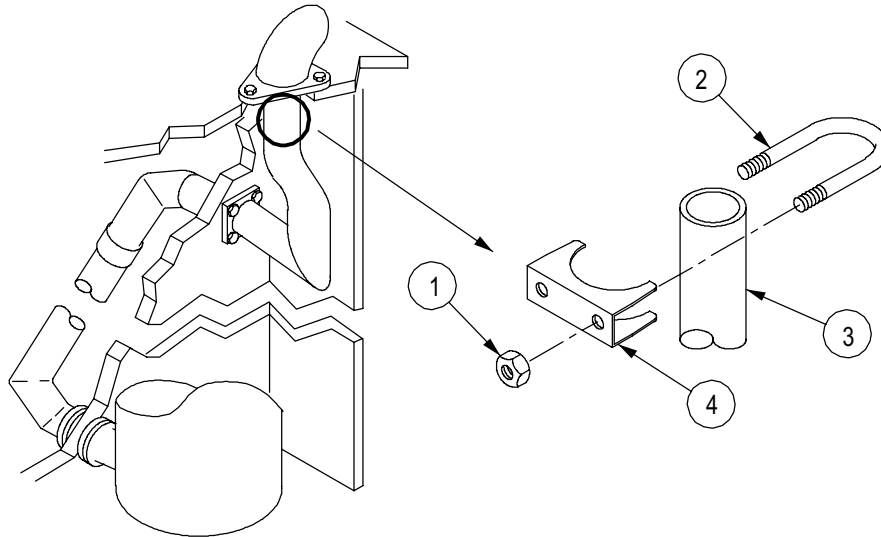
**END OF WORK PACKAGE**

INSTALLATION PROCEDURES

0003 00

THIS WORK PACKAGE COVERS:

Installation (page 0003 00-1)

INITIAL SETUP**Maintenance Level**

Field

Materials/Parts

Modification Kit (WP 0005 00)

Tools and Special Tools

General Mechanic's Tool Kit (WP 0004 00, Item 1)

Equipment ConditionsVehicle blocked (TM 9-2350-277-10 or
TM 9-2350-261-10)

INSTALLATION**1. Personnel Heater Exhaust Clamp**

- a. Install new clamp (1) on exhaust pipe (2).

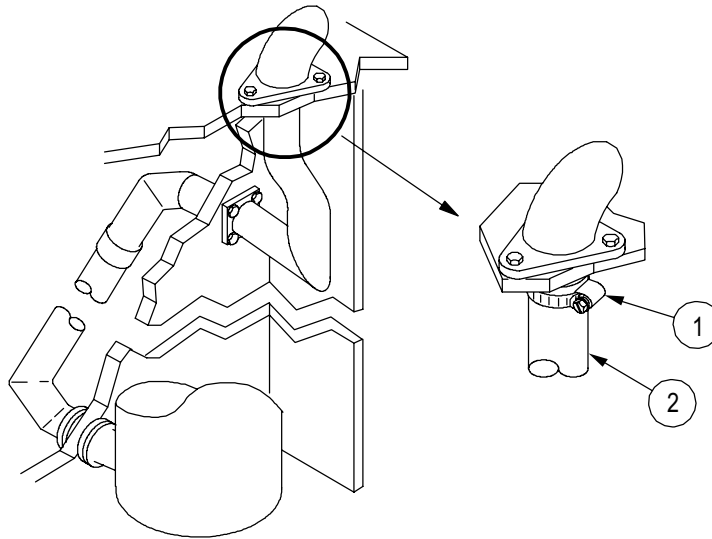

INSTALLATION PROCEDURES

0003 00**2. Install Cable Guide Bracket**

- a. Position the V-bend (1) of the cable guide bracket (5) into the opening (11) of the traverse beam (12).
- b. Position cables and harnesses (10) in front of cable guide bracket (5) and away from compartment heater exhaust.

NOTE

Make sure lockwasher (3) is installed between weldnut (2) and compartment heater ground wire (4). Make sure lockwasher (8) is installed between clamp (6) and screw (7).

NOTE

When installing new clamp (6), make sure clamp NAS1713D26N from modification kit is used on M577A3 and M1068A3. For M577A2 and M1068, use clamp NAS1713D22N.

- c. Install new lockwasher (internal/external teeth) (3), compartment heater ground wire (4), cable guide bracket (5), new clamp (6) with harnesses (10), new lockwasher (internal teeth) (8), and screw (7) on overhead weldnut (2).
- d. Install two new straps (9) on cables and harnesses (10).

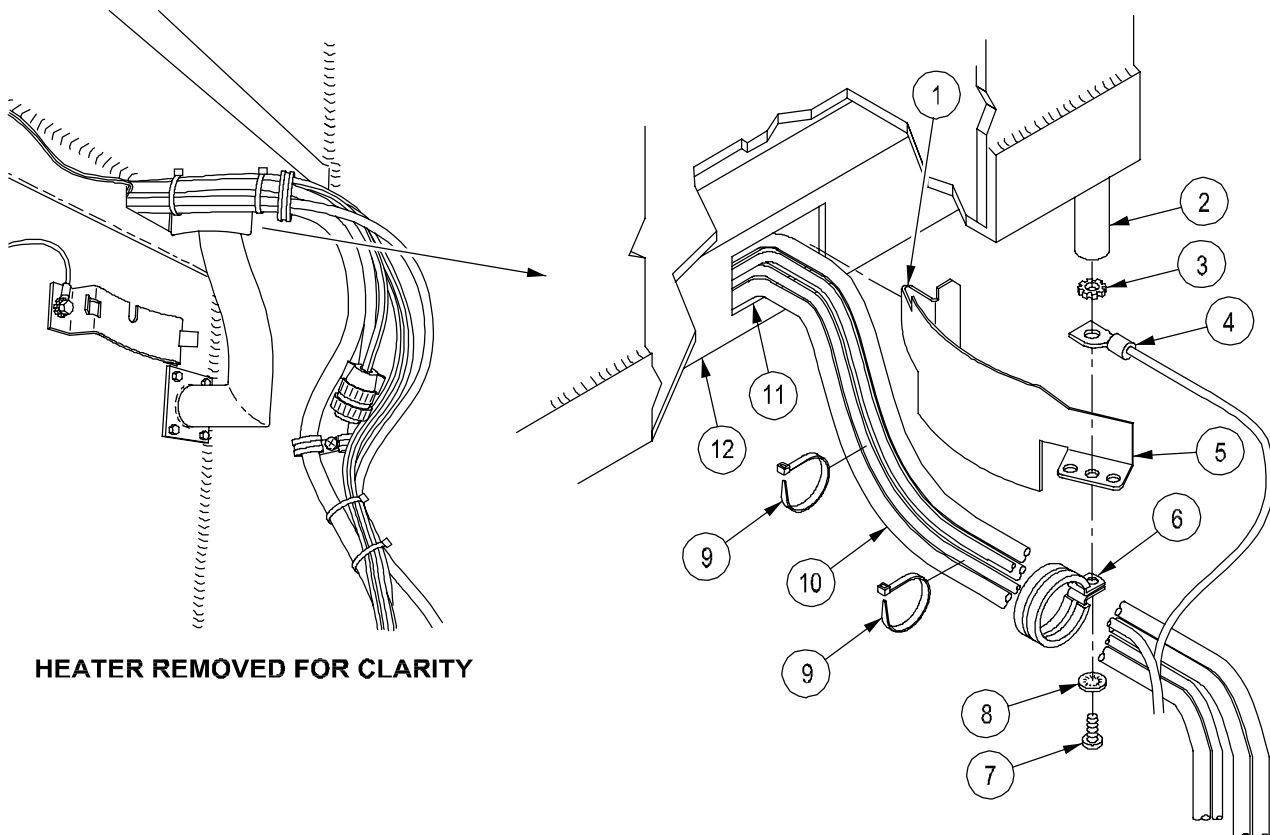

HEATER REMOVED FOR CLARITY

END OF WORK PACKAGE

TOOL IDENTIFICATION LIST**0004 00****SCOPE**

This work package lists all common tools, supplements, and special tools/fixtures needed.

Explanation of Columns in the Tool Identification List

Column (1) – Item Number. This number is assigned to the entry in the list and is referenced in the initial setup to identify the item (e.g., “General Mechanic’s Tool Kit (WP 0004 00, Item 1)”).

Column (2) – Item Name. This column lists the item by noun nomenclature and other descriptive features (e.g. “Tool Kit, General Mechanic’s”).

Column (3) – National Stock Number. This is the National Stock Number (NSN) assigned to the item; use it to requisition the item.

Column (4) – Part Number/CAGEC. Indicates the primary number used by the manufacturer (individual, company, firm, corporation, or Government activity) which controls the design and characteristics of the item by means of its engineering drawings, specifications, standards, and inspection requirements to identify an item or range of items. The manufacturer’s Commercial and Government Entity Code (CAGEC) is also included.

Column (5) – Reference. This column identifies the authorizing Supply Catalog (SC) for Repair Parts and Special Tools List (RPSTL) for items listed in this appendix.

Table 1. TOOL IDENTIFICATION LIST

(1) ITEM NO.	(2) ITEM NAME	(3) NATIONAL STOCK NUMBER	(4) PART NUMBER / CAGEC	(5) REFERENCE
1	Tool Kit, General Mechanic's	5180-00-177-7033	SC 5180-90-CL-N26 (50980)	

MODIFICATION LIST**0005 00****Table 1: MODIFICATION KIT 57K4278 (6150-527-8071)**

NSN	CAGE	PART NUMBER	DESCRIPTION	QTY	LEGEND
5340-01-527-8203	19207	12474921	BRACKET, CABLE GUIDE	1	NEW
5975-01-034-5871	81343	MS3367-7-0	STRAP	2	NEW
5340-01-456-4902	80205	NAS1713D26N	CLAMP, LOOP *	1	NEW
5310-00-080-9786	96906	MS45904-60	WASHER, LOCK #	1	NEW
5310-00-576-5752	80205	MS35333-39	WASHER, LOCK ##	1	NEW
5305-00-984-6204	96906	MS35206-265	SCREW, MACHINE	1	NEW
4730-01-473-4735	81343	J1508-F-36	CLAMP, HOSE	1	NEW
5340-01-511-6963	80205	NAS1713D22N	CLAMP, LOOP **	1	NEW

* Used on M577A3/M1068A3 only

** Used on M577A2/M1068 only

External/internal teeth

Internal teeth

INDEX

A – H

I

Installation Procedures.....0003 00-1

Introduction

 General.....0001 00-1

 Purpose0001 00-1

 Scope0001 00-1

J – L

M

Modification Kit List0005 00-1

N – Q

R

Removal Procedures.....0002 00-1

S

T

Tool Identification List.....0004 00-1

U – Z

RECOMMENDED CHANGES TO PUBLICATIONS AND BLANK FORMS For use of this form, see AR 25-30; the proponent agency is ODISC4.	Use Part II (reverse) for Repair Parts and Special Tools Lists (RPSTL) and Supply Catalogs/Supply Manuals SC/SM).	Date
---	---	------

TO: (Forward to proponent of publication or form) (Include ZIP Code)	FROM: (Activity and location) (include ZIP code)
---	---

PART I – ALL PUBLICATIONS (EXCEPT RPSTL AND SC/SM) AND BLANK FORMS

PUBLICATION/FORM NUMBER TB 9-2350-376-23-1	DATE 29 June 2007	TITLE Installation of Compartment Heater Exhaust Cable Guide Bracket Modification Kit for M577A2, M1068, M577A3, M1068A3
---	----------------------	---

ITEM	PAGE	PARA	LINE	FIGURE NO.	TABLE	RECOMMENDED CHANGES AND REASON
0052 00-4						Inspection Step 1 WP reference should be (WP 0003 00)

SAMPLE

--	--	--	--	--	--	--

<i>*Reference to line numbers within the paragraph or subparagraph.</i> TYPED, GRADE OR TITLE	TELEPHONE EXCHANGE/AUTOVON, PLUS EXTENSION	SIGNATURE
--	--	-----------

TO: (Forward direct to addressee listed in publication)	FROM: (Activity and location) (Include Zip Code)	Date
---	--	------

PART II – REPAIR PARTS AND SPECIAL TOOL LISTS AND SUPPLY CATALOGS/SUPPLY MANUALS

PUBLICATION/FORM NUMBER TB 9-2350-376-20	DATE 29 June 2007	TITLE Installation of Compartment Heater Exhaust Cable Guide for M577A2, M1068, M577A3, M1068A3
---	----------------------	--

PAGE NO.	COLM NO.	LINE NO.	NATIONAL STOCK NUMBER	REFERENCE NO.	FIGURE NO.	ITEM NO.	TOTAL NO. OF MAJOR ITEMS SUPPORTED	RECOMMENDED ACTION

SAMPLE

PART III – REMARKS (Any sheets may be used if more

and blank forms. Additional blank

TYPED, GRADE OR TITLE	TELEPHONE EXCHANGE/AUTOVON, PLUS EXTENSION	SIGNATURE
-----------------------	--	-----------

RECOMMENDED CHANGES TO PUBLICATIONS AND BLANK FORMS For use of this form, see AR 25-30; the proponent agency is ODISC4.	Use Part II (reverse) for Repair Parts and Special Tools Lists (RPSTL) and Supply Catalogs/Supply Manuals SC/SM).	Date
---	---	------

TO: (Forward to proponent of publication or form) (Include ZIP Code)	FROM: (Activity and location) (include ZIP code)
---	---

PART I – ALL PUBLICATIONS (EXCEPT RPSTL AND SC/SM) AND BLANK FORMS

PUBLICATION/FORM NUMBER TB 9-2350-376-23-1	DATE 29 June 2007	TITLE Installation of Compartment Heater Exhaust Cable Guide Bracket Modification Kit for M577A2, M1068, M577A3, M1068A3
---	----------------------	---

ITEM	PAGE	PARA	LINE	FIGURE NO.	TABLE	RECOMMENDED CHANGES AND REASON

**Reference to line numbers within the paragraph or subparagraph.*

TYPED, GRADE OR TITLE	TELEPHONE EXCHANGE/AUTOVON, PLUS EXTENSION	SIGNATURE
-----------------------	--	-----------

TO: (Forward direct to addressee listed in publication)	FROM: (Activity and location) (Include Zip Code)	Date
---	--	------

PART II – REPAIR PARTS AND SPECIAL TOOL LISTS AND SUPPLY CATALOGS/SUPPLY MANUALS

PUBLICATION/FORM NUMBER TB 9-2350-376-23-1	DATE 29 June 2007	TITLE Installation of Compartment Heater Exhaust Cable Guide Bracket Modification Kit for M577A2, M1068, M577A3, M1068A3
---	----------------------	---

PAGE NO.	COLM NO.	LINE NO.	NATIONAL STOCK NUMBER	REFERENCE NO.	FIGURE NO.	ITEM NO.	TOTAL NO. OF MAJOR ITEMS SUPPORTED	RECOMMENDED ACTION

PART III – REMARKS (Any general remarks or recommendations, or suggestions for improvement of publications and blank forms. Additional blank sheets may be used if more space is needed).

TYPED, GRADE OR TITLE	TELEPHONE EXCHANGE/AUTOVON, PLUS EXTENSION	SIGNATURE
-----------------------	--	-----------

RECOMMENDED CHANGES TO PUBLICATIONS AND BLANK FORMS For use of this form, see AR 25-30; the proponent agency is ODISC4.	Use Part II (reverse) for Repair Parts and Special Tools Lists (RPSTL) and Supply Catalogs/Supply Manuals SC/SM).	Date
---	---	------

TO: (Forward to proponent of publication or form) (Include ZIP Code)	FROM: (Activity and location) (include ZIP code)
---	---

PART I – ALL PUBLICATIONS (EXCEPT RPSTL AND SC/SM) AND BLANK FORMS

PUBLICATION/FORM NUMBER TB 9-2350-376-23-1	DATE 29 June 2007	TITLE Installation of Compartment Heater Exhaust Cable Guide Bracket Modification Kit for M577A2, M1068, M577A3, M1068A3
---	----------------------	---

ITEM	PAGE	PARA	LINE	FIGURE NO.	TABLE	RECOMMENDED CHANGES AND REASON

**Reference to line numbers within the paragraph or subparagraph.*

TYPED, GRADE OR TITLE	TELEPHONE EXCHANGE/AUTOVON, PLUS EXTENSION	SIGNATURE
-----------------------	--	-----------

TO: (Forward direct to addressee listed in publication)	FROM: (Activity and location) (Include Zip Code)	Date
---	--	------

PART II – REPAIR PARTS AND SPECIAL TOOL LISTS AND SUPPLY CATALOGS/SUPPLY MANUALS

PUBLICATION/FORM NUMBER TB 9-2350-376-23-1	DATE 29 June 2007	TITLE Installation of Compartment Heater Exhaust Cable Guide Bracket Modification Kit for M577A2, M1068, M577A3, M1068A3
---	----------------------	---

PAGE NO.	COLM NO.	LINE NO.	NATIONAL STOCK NUMBER	REFERENCE NO.	FIGURE NO.	ITEM NO.	TOTAL NO. OF MAJOR ITEMS SUPPORTED	RECOMMENDED ACTION

PART III – REMARKS (Any general remarks or recommendations, or suggestions for improvement of publications and blank forms. Additional blank sheets may be used if more space is needed).

--

TYPED, GRADE OR TITLE	TELEPHONE EXCHANGE/AUTOVON, PLUS EXTENSION	SIGNATURE
-----------------------	--	-----------

By Order of the Secretary of the Army:

Official:



JOYCE E. MORROW
*Administrative Assistant to the
Secretary of the Army*

0716206

GEORGE W. CASEY, JR.
*General, United States Army
Chief of Staff*

Distribution:

To be distributed in accordance with the initial distribution number (IDN) 344842 requirements for TB 9-2350-376-23-1.

THE METRIC SYSTEM AND EQUIVALENTS

LINEAR MEASURE

1 Centimeter = 10 Millimeters = 0.01 Meters = 0.3937 Inches
 1 Meter = 100 Centimeters = 1000 Millimeters = 39.37 Inches
 1 Kilometer = 1000 Meters = 0.621 Miles

WEIGHTS

1 Gram = 0.001 Kilograms = 1000 Milligrams = 0.035 Ounces
 1 Kilogram = 1000 Grams = 2.2 Pounds
 1 Metric Ton = 1000 Kilograms = 1 Megagram = 1.1 Short Tons

LIQUID MEASURE

1 Milliliter = 0.001 Liters = 0.0338 Fluid Ounces
 1 Liter = 1000 Milliliters = 33.82 Fluid Ounces

SQUARE MEASURE

1 Sq. Centimeter = 100 Sq. Millimeters = 0.155 Sq. Inches
 1 Sq. Meter = 10,000 Sq. Centimeters = 10.76 Sq. Feet
 1 Sq. Kilometer = 1,000 Sq. Meters = 0.386 Sq. Miles

CUBIC MEASURE

1 Cu. Centimeter = 1000 Cu. Millimeters = 0.06 Cu. Inches
 1 Cu. Meter = 1,000,000 Cu. Centimeters = 35.31 Cu. Feet

TEMPERATURE

$5/9 (^{\circ}\text{F} - 32) = ^{\circ}\text{C}$
 212° Fahrenheit is equivalent to 100° Celsius
 90° Fahrenheit is equivalent to 32.2° Celsius
 32° Fahrenheit is equivalent to 0° Celsius
 $(9/5 \times ^{\circ}\text{C}) + 32 = ^{\circ}\text{F}$

TO CHANGE	TO	MULTIPLY BY
Inches.....	Centimeters.....	2.540
Feet.....	Meters.....	0.305
Yards.....	Meters.....	0.914
Miles.....	Kilometers.....	1.609
Square Inches.....	Square Centimeters.....	6.451
Square Feet.....	Square Meters.....	0.093
Square Yards.....	Square Meters.....	0.836
Square Miles.....	Square Kilometers.....	2.590
Acres.....	Square Hectometers.....	0.405
Cubic Feet.....	Cubic Meters.....	0.028
Cubic Yards.....	Cubic Meters.....	0.765
Fluid Ounces.....	Millimeters.....	29.573
Pints.....	Liters.....	0.473
Quarts.....	Liters.....	0.946
Gallons.....	Liters.....	3.785
Ounces.....	Grams.....	28.349
Pounds.....	Kilograms.....	0.454
Short Tons.....	Metric Tons.....	0.907
Pound-Feet.....	Newton-Meters.....	1.356
Pounds per Square Inch.....	Kilopascals.....	6.895
Miles per Gallon.....	Kilometers per Liter.....	0.425
Miles per Hour.....	Kilometers per Hour.....	1.609

TO CHANGE	TO	MULTIPLY BY
Centimeters.....	Inches.....	0.394
Meters.....	Feet.....	3.280
Meters.....	Yards.....	1.094
Kilometers.....	Miles.....	0.621
Square Centimeters.....	Square Inches.....	0.155
Square Meters.....	Square Feet.....	10.764
Square Meters.....	Square Yards.....	1.196
Square Kilometers.....	Square Miles.....	0.386
Square Hectometers.....	Acres.....	2.471
Cubic Meters.....	Cubic Feet.....	35.315
Cubic Meters.....	Cubic Yards.....	1.308
Milliliters.....	Fluid Ounces.....	0.034
Liters.....	Pints.....	2.113
Liters.....	Quarts.....	1.057
Liters.....	Gallons.....	0.264
Grams.....	Ounces.....	0.035
Kilograms.....	Pounds.....	2.205
Metric Tons.....	Short Tons.....	1.102
Newton-Meters.....	Pound-Feet.....	0.738
Kilopascals.....	Pounds per Square Inch.....	0.145
Kilometers per Liter.....	Miles per Gallon.....	2.354
Kilometers per Hour.....	Miles per Hour.....	0.621

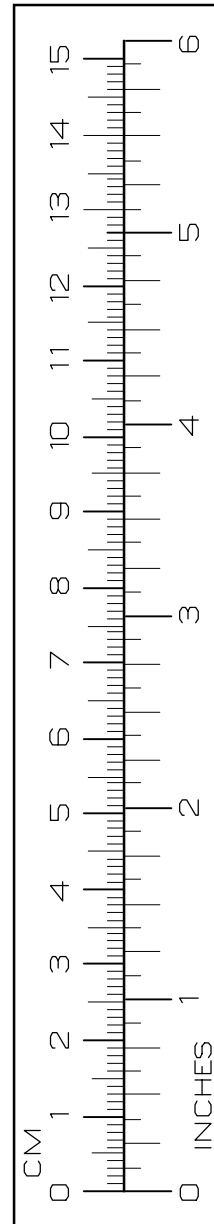

PIN: 084067-000